

RICOH



SERVICE MANUAL

D197/D198/D199/
D200/D201/D202

LANIER RICOH SAVIN™

It is the reader's responsibility when discussing the information contained within this document to maintain a level of confidentiality that is in the best interest of Ricoh Americas Corporation and its member companies.

NO PART OF THIS DOCUMENT MAY BE REPRODUCED IN ANY FASHION AND DISTRIBUTED WITHOUT THE PRIOR PERMISSION OF RICOH AMERICAS CORPORATION.

All product names, domain names or product illustrations, including desktop images, used in this document are trademarks, registered trademarks or the property of their respective companies.

They are used throughout this book in an informational or editorial fashion only and for the benefit of such companies. No such use, or the use of any trade name, or web site is intended to convey endorsement or other affiliation with Ricoh products.

WARNING

The Service Manual contains information regarding service techniques, procedures, processes and spare parts of office equipment distributed by Ricoh Americas Corporation. Users of this manual should be either service trained or certified by successfully completing a Ricoh Technical Training Program.

Untrained and uncertified users utilizing information contained in this service manual to repair or modify Ricoh equipment risk personal injury, damage to property or loss of warranty protection.

Ricoh Americas Corporation

LEGEND

PRODUCT CODE	COMPANY		
	LANIER	RICOH	SAVIN
D197	MP 2554SP	MP 2554SP	MP 2554SP
D198	MP 3054SP	MP 3054SP	MP 3054SP
D199	MP 3554SP	MP 3554SP	MP 3554SP
D200	MP 4054SP	MP 4054SP	MP 4054SP
D201	MP 5054SP	MP 5054SP	MP 5054SP
D202	MP 6054SP	MP 6054SP	MP 6054SP

DOCUMENTATION HISTORY

REV. NO.	DATE	COMMENTS
*	11/2014	Original Printing

D197/D198/D199/D200/D201/D202

TABLE OF CONTENTS

1. PRODUCT INFORMATION	1-1
1.1 PRODUCT OVERVIEW	1-1
1.1.1 COMPONENT LAYOUT	1-1
1.1.2 PAPER PATH	1-3
1.1.3 DRIVE LAYOUT	1-6
1.1.4 PARTS LAYOUT	1-8
Scanner Unit	1-8
Paper Feed Unit	1-9
Laser Unit/ PCDU	1-10
Fusing Unit	1-11
Waste Toner Bottle	1-12
Duplex/Bypass Unit	1-13
Paper Exit/ Reverse Unit	1-14
Air Flow	1-15
Drive Unit	1-16
Electrical Component	1-17
1.2 MACHINE CODES AND PERIPHERALS CONFIGURATION	1-18
1.2.1 SYSTEM CONFIGURATION AND OPTIONS	1-18
D197/D198/D199 (NA)	1-18
D200/D201 (NA)	1-20
D202 (NA)	1-22
D197/D198/D199 (EU)	1-24
D200/D201 (EU)	1-26
D202 (EU)	1-28
D197/D198/D199 (Asia)	1-30
D200/D201 (Asia)	1-32
D202 (Asia)	1-33
Guidance for Those Who are Familiar with The Predecessor Product	1-35
1.2.2 DIFFERENCES BETWEEN SIMILAR MODELS	1-35
D182/D183 vs. D197/D199	1-35
D129/D130 vs. D200/D201/D202	1-36
Differences between D146 Series	1-37
2. INSTALLATION	2-1
2.1 INSTALLATION REQUIREMENTS	2-1

2.1.1 ENVIRONMENT	2-1
2.1.2 MACHINE LEVEL	2-1
2.1.3 MINIMUM SPACE REQUIREMENTS.....	2-1
2.1.4 MACHINE DIMENSIONS.....	2-2
2.1.5 POWER REQUIREMENTS	2-3
2.2 MAIN MACHINE INSTALLATION	2-4
2.2.1 IMPORTANT NOTICE ON SECURITY ISSUES.....	2-4
Overview	2-4
Password Setting Procedure.....	2-5
2.2.2 INSTALLATION FLOW CHART.....	2-9
D197/D198/D199.....	2-9
D200/D201/D202.....	2-10
2.2.3 ACCESSORY CHECK.....	2-11
2.2.4 INSTALLATION PROCEDURE	2-12
Unloading.....	2-12
Tapes and Retainers.....	2-12
Toner Bottle.....	2-15
Paper Exit Tray Stopper	2-20
Emblem, Decals	2-21
Completion	2-22
2.2.5 SECURITY SETTINGS.....	2-22
2.2.6 CHECK IMAGE QUALITY / SETTINGS.....	2-23
Loading Paper.....	2-23
Checking the copy image with the test chart.....	2-23
SP Settings	2-23
Upper Tray (Size Adjust Tray 1).....	2-23
Lower Tray (Size Adjust Tray 2).....	2-23
By-Pass Tray (By-Pass Size Detection).....	2-24
2.2.7 MOVING THE MACHINE.....	2-24
2.2.8 TRANSPORTING THE MACHINE	2-25
2.3 PAPER FEED UNIT PB3210/ PB3220	2-26
2.3.1 ACCESSORY CHECK.....	2-26
2.3.2 INSTALLATION PROCEDURE	2-26
2.4 PAPER FEED UNIT PB3150	2-32
2.4.1 ACCESSORY CHECK.....	2-32
2.4.2 INSTALLATION PROCEDURE	2-32
2.5 LCIT PB3170/ PB3230.....	2-37
2.5.1 ACCESSORY CHECK.....	2-37
2.5.2 INSTALLATION PROCEDURE	2-37

Changing the paper size	2-42
2.6 LCIT RT3030	2-44
2.6.1 ACCESSORY CHECK.....	2-44
2.6.2 INSTALLATION PROCEDURE	2-44
Changing the Paper Size	2-50
2.7 CASTER TABLE TYPE M3.....	2-52
2.7.1 ACCESSORY CHECK.....	2-52
2.7.2 INSTALLATION PROCEDURE	2-52
For Installing Directly under the Main Machine	2-53
For Installing under PB3150.....	2-54
2.8 PLATEN COVER PN2000 (D700)	2-56
2.8.1 ACCESSORY CHECK.....	2-56
2.8.2 INSTALLATION PROCEDURE	2-56
2.9 ARDF DF3090	2-59
2.9.1 ACCESSORY CHECK.....	2-59
2.9.2 INSTALLATION PROCEDURE	2-59
When feeding thin paper	2-63
2.10 SPDF DF3080.....	2-65
2.10.1 ACCESSORY CHECK	2-65
2.10.2 INSTALLATION PROCEDURE.....	2-66
Attaching the SPDF.....	2-66
Attaching the Sub IPU.....	2-68
Adjust SP Settings.....	2-73
2.11 BRIDGE UNIT BU3070	2-74
2.11.1 ACCESSORY CHECK	2-74
2.11.2 INSTALLATION PROCEDURE.....	2-74
2.12 1 BIN TRAY BN3110.....	2-78
2.12.1 ACCESSORY CHECK	2-78
2.12.2 INSTALLATION PROCEDURE.....	2-78
2.13 INTERNAL SHIFT TRAY SH3070.....	2-85
2.13.1 ACCESSORY CHECK	2-85
2.13.2 INSTALLATION PROCEDURE.....	2-85
2.14 SIDE TRAY TYPE M3.....	2-90
2.14.1 ACCESSORY CHECK	2-90
2.14.2 INSTALLATION PROCEDURE.....	2-91
2.15 BOOKLET FINISHER SR3170 / FINISHER SR3160	2-94
2.15.1 ACCESSORY CHECK	2-94
Booklet Finisher SR3170 (D688) / Finisher SR3160 (D689)	2-94
2.15.2 INSTALLATION PROCEDURE.....	2-95

2.15.3	ADJUSTMENT AFTER INSTALLING THE FINISHER.....	2-101
	How to Check and Adjust the Side-to-Side Registration	2-101
2.15.4	AUXILIARY TRAY	2-102
2.16	PUNCH UNIT PU3060	2-103
2.16.1	ACCESSORY CHECK	2-103
2.16.2	INSTALLATION PROCEDURE	2-104
2.17	BOOKLET FINISHER SR3150 / FINISHER SR3140	2-114
2.17.1	ACCESSORY CHECK	2-114
	Booklet Finisher SR3150 / Finisher SR3140	2-114
2.17.2	INSTALLATION PROCEDURE	2-115
	SR3150	2-118
	SR3140	2-118
2.17.3	ADJUSTMENT AFTER INSTALLING FINISHER	2-120
	How to Check and Adjust the Side-to-Side Registration	2-120
2.18	PUNCH UNIT PU3050	2-121
2.18.1	COMPONENT CHECK	2-121
2.18.2	INSTALLATION PROCEDURE	2-122
2.19	INTERNAL FINISHER SR3180.....	2-134
2.19.1	ACCESSORY CHECK	2-134
2.19.2	INSTALLATION PROCEDURE	2-135
	Staple Setting as an Initial Setting.....	2-144
2.20	INTERNAL FINISHER SR3130.....	2-146
2.20.1	ACCESSORY CHECK	2-146
2.20.2	INSTALLATION PROCEDURE	2-146
2.21	PUNCH UNIT PU3040	2-155
2.21.1	ACCESSORY CHECK	2-155
2.21.2	INSTALLATION PROCEDURE	2-156
2.22	SMART OPERATION PANEL TYPE M3.....	2-161
2.22.1	ACCESSORY CHECK	2-161
2.22.2	INSTALLATION PROCEDURE	2-161
2.23	ANTI-CONDENSATION HEATER TYPE M12	2-165
2.23.1	ACCESSORY CHECK	2-165
2.23.2	INSTALLATION PROCEDURE	2-166
	Anti-Condensation Heater (Scanner)	2-166
	Anti-Condensation Heater (PCU)	2-176
2.24	ANTI-CONDENSATION HEATER FOR TRAYS	2-180
2.24.1	ACCESSORY CHECK	2-180
2.24.2	INSTALLATION PROCEDURE	2-181
	Anti-Condensation Heater for Paper Feed Tray (Main Unit).....	2-181

Anti-Condensation Heater for Paper Feed Unit PB3210 / PB3220 ..	2-188
Anti-Condensation Heater for Paper Feed Unit PB3150	2-190
Anti-Condensation Heater for LCIT PB3170/ PB3230.....	2-192
2.25 CARD READER BRACKET TYPE 3352	2-195
2.25.1 ACCESSORY CHECK	2-195
2.25.2 INSTALLATION PROCEDURE	2-196
Scanner Right Cover	2-198
Upper Rear Cover	2-198
2.26 KEY COUNTER BRACKET TYPE M3	2-199
2.26.1 ACCESSORY CHECK	2-199
2.26.2 INSTALLATION PROCEDURE	2-199
2.27 OPTIONAL COUNTER INTERFACE UNIT TYPE M12.....	2-203
2.27.1 ACCESSORY CHECK	2-203
2.27.2 INSTALLATION PROCEDURE	2-203
2.28 SMART CARD READER BUILT-IN UNIT TYPE M12	2-206
2.28.1 ACCESSORY CHECK	2-206
2.28.2 INSTALLATION PROCEDURE	2-207
2.29 INTERNAL OPTIONS	2-215
2.29.1 LIST OF SLOTS.....	2-215
2.30 PRINTER/SCANNER UNIT TYPE M12	2-216
2.30.1 COMPONENT CHECK	2-216
2.30.2 INSTALLATION PROCEDURE	2-217
2.31 IEEE 1284 INTERFACE BOARD TYPE A	2-221
2.31.1 COMPONENT CHECK	2-221
2.31.2 INSTALLATION.....	2-222
2.32 IEEE 802.11A/G/N INTERFACE UNIT TYPE M2.....	2-223
2.32.1 ACCESSORY CHECK	2-223
2.32.2 INSTALLATION.....	2-224
2.32.3 USER TOOL SETTINGS FOR IEEE 802.11A/G/N	2-226
SP Mode Settings for IEEE 802.11 Wireless LAN.....	2-228
2.33 BLUETOOTH INTERFACE UNIT TYPE D.....	2-229
2.33.1 COMPONENT CHECK	2-229
2.33.2 INSTALLATION PROCEDURE	2-229
2.34 FILE FORMAT CONVERTER TYPE E	2-230
2.34.1 COMPONENT CHECK	2-230
2.34.2 INSTALLATION.....	2-230
2.35 USB DEVICE SERVER OPTION TYPE M12.....	2-232
2.35.1 COMPONENT CHECK	2-232
Interface Board Surface	2-232

2.35.2	INSTALLATION PROCEDURE	2-233
	What Do the LED Indications Mean?	2-236
	Notes for Energy Save Mode Setting	2-236
2.35.3	IP ADDRESS SETTING	2-237
2.36	COPY DATA SECURITY UNIT TYPE G	2-239
2.36.1	COMPONENT CHECK	2-239
2.36.2	INSTALLATION.....	2-239
	User Tool Setting.....	2-241
2.37	HARD DISK DRIVE OPTION TYPE M12	2-242
2.37.1	ACCESSORY CHECK	2-242
2.37.2	INSTALLATION.....	2-243
2.38	SD CARD OPTION	2-245
2.38.1	SD CARD SLOTS	2-245
2.38.2	LIST OF SLOTS USED	2-246
2.39	SD CARD APPLI MOVE	2-247
2.39.1	OVERVIEW	2-247
2.39.2	MOVE EXEC.....	2-247
2.39.3	UNDO EXEC.....	2-248
2.40	OCR UNIT TYPE M2.....	2-249
2.40.1	ACCESSORY CHECK	2-249
2.40.2	INSTALLATION PROCEDURE.....	2-249
2.40.3	RECOVERY PROCEDURE	2-252
2.41	BROWSER UNIT TYPE M12	2-253
2.41.1	COMPONENT CHECK	2-253
2.41.2	INSTALLATION PROCEDURE.....	2-253
	To update EXJS.....	2-255
	When checking the version of EXJS	2-256
	Browser unit uninstallation procedure	2-257
2.41.3	SETTINGS	2-257
	Browser default setting.....	2-257
2.42	SD CARD FOR NETWARE PRINTING TYPE M12	2-258
2.42.1	COMPONENT CHECK	2-258
2.42.2	INSTALLATION PROCEDURE.....	2-258
2.43	POSTSCRIPT3 UNIT TYPE M12.....	2-260
2.43.1	COMPONENT CHECK	2-260
2.43.2	INSTALLATION PROCEDURE.....	2-260
2.44	XPS DIRECT PRINT OPTION TYPE M12	2-262
2.44.1	COMPONENT CHECK	2-262
2.44.2	INSTALLATION PROCEDURE.....	2-262

2.45	IPDS UNIT TYPE M12	2-264
2.45.1	ACCESSORIES	2-264
2.45.2	INSTALLATION.....	2-264
2.46	EXTERNAL KEYBOARD BRACKET TYPE M3 (D739-10)	2-267
2.46.1	COMPONENT CHECK	2-267
2.46.2	INSTALLATION PROCEDURE	2-267
2.47	DATA OVERWRITE SECURITY UNIT TYPE I (D362)	2-272
2.47.1	OVERVIEW	2-272
2.47.2	COMPONENT LIST	2-272
2.47.3	BEFORE YOU BEGIN THE PROCEDURE.....	2-272
	Seal Check and Removal.....	2-273
2.47.4	INSTALLATION PROCEDURE	2-274
2.48	SECURITY SETTING.....	2-275
2.48.1	SECURITY FUNCTION INSTALLATION	2-275
2.48.2	DATA OVERWRITE SECURITY	2-276
	Before You Begin the Procedure.....	2-276
	Using Auto Erase Memory	2-276
2.48.3	HDD ENCRYPTION.....	2-278
	Before You Begin the Procedure:.....	2-278
	Enable Encryption Setting	2-278
	Backing Up the Encryption Key.....	2-280
	Encryption Key Restoration.....	2-281
2.49	@REMOTE SETTINGS	2-283
2.50	OPERATION GUIDANCE FOR USERS	2-288

3. PREVENTIVE MAINTENANCE..... 3-1

3.1	PREVENTIVE MAINTENANCE TABLES.....	3-1
3.2	IMAGE QUALITY STANDARDS	3-2
3.2.1	RESOLUTION	3-2
3.2.2	MAGNIFICATION RATIO ERROR MARGIN	3-3
3.2.3	MAGNIFICATION RATIO ERROR MARGIN DEVIATION	3-4
3.2.4	PITCH ERROR MARGIN.....	3-4
3.2.5	PERPENDICULARITY	3-4
3.2.6	LINEARITY	3-5
3.2.7	PARALLELISM	3-5
3.2.8	MISSING IMAGE AREA	3-6
3.2.9	MARGIN POSITION	3-6
3.3	PAPER TRANSFER QUALITY STANDARDS	3-7
3.3.1	REGISTRATION.....	3-7
3.3.2	SKEW	3-7

Exposure glass.....	3-7
ADF	3-8
3.4 PM PARTS SETTINGS.....	3-9
3.4.1 PM PARTS REPLACEMENT PROCEDURE.....	3-9
3.4.2 AFTER INSTALLING THE NEW PM PARTS	3-10
3.4.3 OPERATION CHECK	3-10
4. REPLACEMENT AND ADJUSTMENT	4-1
4.1 NOTES ON THE MAIN POWER SWITCH.....	4-1
4.1.1 PUSH SWITCH.....	4-1
Characteristics of the Push Switch (DC Switch).....	4-1
Shutdown Method	4-3
Forced Shutdown	4-3
4.2 BEFOREHAND	4-4
4.3 SPECIAL TOOLS AND LUBRICANTS	4-5
4.3.1 SPECIAL TOOLS	4-5
4.3.2 LUBRICANTS.....	4-5
4.4 COVER REMOVAL ORDER.....	4-6
4.4.1 COVER LAYOUTS	4-6
4.4.2 COVER REMOVAL ORDER.....	4-8
4.5 EXTERIOR COVERS	4-9
4.5.1 FRONT COVER.....	4-10
4.5.2 CONTROLLER COVER.....	4-11
4.5.3 LEFT UPPER COVER	4-12
4.5.4 LEFT REAR COVER	4-13
4.5.5 LEFT COVER	4-14
4.5.6 CONTROLLER REAR COVER.....	4-15
4.5.7 REAR LEFT COVER	4-16
4.5.8 REAR RIGHT COVER	4-16
4.5.9 REAR LOWER GAP COVER	4-17
4.5.10 REAR LOWER COVER	4-17
4.5.11 SCANNER REAR COVER.....	4-18
4.5.12 RIGHT REAR COVER	4-18
4.5.13 RIGHT UPPER COVER	4-19
4.5.14 RIGHT COVER	4-20
4.5.15 MAIN POWER SWITCH COVER.....	4-22
4.5.16 INVERTER TRAY.....	4-22
4.5.17 PAPER EXIT TRAY.....	4-23
4.5.18 PAPER EXIT COVER	4-23
4.5.19 PAPER EXIT LOWER COVER	4-24

4.5.20	UPPER INNER COVER	4-25
4.5.21	PAPER EXIT FRONT COVER	4-26
4.5.22	INNER COVER	4-26
4.5.23	TONER SUPPLY HOUSING	4-27
4.6	OPERATION PANEL	4-29
4.6.1	OPERATION PANEL	4-29
4.6.2	KEY CONTROL BOARD	4-30
4.6.3	INTERFACE BOARD	4-32
4.6.4	LCD PANEL	4-32
4.6.5	LCD	4-33
	Notes when replacing the LCD	4-33
	Replacement procedure	4-35
4.7	SCANNER UNIT	4-36
4.7.1	SCANNER EXTERIOR	4-36
	Scanner Upper Cover	4-36
	Scanner Right Cover	4-36
	Scanner Front Cover	4-37
	Scanner Left Cover	4-38
4.7.2	EXPOSURE GLASS	4-38
4.7.3	SCANNER LAMP	4-40
4.7.4	SCANNER MOTOR	4-41
4.7.5	LENS BLOCK	4-43
4.7.6	ORIGINAL SIZE SENSORS (APS)	4-44
4.7.7	SIO	4-44
4.7.8	SCANNER HP SENSOR	4-45
4.7.9	DF POSITION SENSOR	4-46
4.7.10	ADJUSTING THE SCANNER WIRE	4-46
	Scanner Wire (Front)	4-46
	Scanner Wire Assembly (Front)	4-49
	Scanner Position Adjustment	4-53
	Scanner Wire (Rear)	4-54
	Scanner Wire Assembly (Rear)	4-57
4.7.11	MODIFYING THE SCANNER (CONTACT/CONTACTLESS) WHEN USING ARDF	4-60
	Procedure for the ADF	4-60
	Procedure for the Scanner	4-62
4.7.12	MODIFYING THE SCANNER (CONTACT/CONTACTLESS) WHEN USING SPDF	4-63
	Procedure for the SPDF	4-63

Procedure for the Scanner	4-65
4.8 LASER UNIT	4-66
4.8.1 CAUTION DECAL LOCATION	4-66
4.8.2 LASER UNIT	4-67
Removing the Laser Unit.....	4-67
Installing a New Laser Unit.....	4-68
Mainframe Claws.....	4-68
Laser Unit Claws	4-69
After Installing the New Laser Unit	4-70
4.8.3 QUENCHING LAMP	4-70
4.8.4 PCL (PRE CLEANING LIGHT)	4-71
4.9 PCDU.....	4-72
4.9.1 BEFORE REPLACING A PCU OR DEVELOPMENT UNIT.....	4-72
4.9.2 PCDU.....	4-72
4.9.3 PCU/DEVELOPMENT UNIT	4-74
Notes When Installing the Face Plates.....	4-74
Face plate for front side.....	4-75
Face plate for rear side	4-75
Installing a PCU.....	4-75
Installing a Development Unit.....	4-75
4.9.4 OPC DRUM	4-77
4.9.5 CHARGE ROLLER, CLEANING ROLLER.....	4-78
4.9.6 PICK-OFF PAWLS.....	4-79
4.9.7 CLEANING BLADE	4-80
4.9.8 DEVELOPER	4-81
4.9.9 DEVELOPMENT FILTER	4-87
4.9.10 TD SENSOR	4-88
4.9.11 DEVELOPMENT MIXING AUGER BEARINGS	4-89
4.9.12 DEVELOPMENT MIXING AUGER (L / R).....	4-91
4.10 WASTE TONER.....	4-93
4.10.1 WASTE TONER BOTTLE	4-93
4.10.2 TONER COLLECTION FULL SENSOR	4-93
4.10.3 RECYCLING SHUTTER SOLENOID	4-94
4.10.4 RECYCLING SHUTTER	4-97
4.11 TRANSFER UNIT.....	4-99
4.11.1 TRANSFER UNIT.....	4-99
4.11.2 TRANSFER ROLLER UNIT	4-101
4.11.3 ID SENSOR	4-102
Before Replacing the ID Sensor.....	4-102

Replacement Procedure.....	4-102
4.11.4 TRANSFER UNIT OPEN/CLOSE LED	4-103
4.11.5 TEMPERATURE/HUMIDITY SENSOR.....	4-104
4.11.6 FUSING ENTRANCE SENSOR.....	4-105
4.11.7 TRANSFER UNIT OPEN/CLOSE SENSOR	4-106
4.12 DRIVE UNIT.....	4-107
4.12.1 DRUM/WASTE TONER MOTOR.....	4-107
4.12.2 DEVELOPMENT MOTOR.....	4-107
4.12.3 FUSING/PAPER EXIT MOTOR (D197/D199 ONLY)	4-107
4.12.4 FUSING MOTOR (D200/D201/D202 ONLY).....	4-108
4.12.5 PAPER EXIT MOTOR (D200/D201/D202 ONLY)	4-108
4.12.6 REGISTRATION MOTOR.....	4-108
4.12.7 PAPER FEED MOTOR	4-109
4.12.8 VERTICAL TRANSPORT MOTOR	4-109
4.12.9 TRANSFER ROLLER CONTACT MOTOR.....	4-109
4.12.10 TONER HOPPER.....	4-110
4.12.11 TONER SUPPLY MOTOR.....	4-112
4.13 FUSING UNIT	4-114
4.13.1 FUSING UNIT	4-114
Replacement	4-114
4.13.2 FUSING ENTRANCE GUIDE PLATE	4-117
Cleaning the Fusing Entrance Guide Plate	4-117
4.13.3 FUSING EXIT GUIDE PLATE.....	4-118
4.13.4 FUSING UPPER COVER.....	4-119
4.13.5 FUSING LOWER COVER.....	4-120
4.13.6 HEATING SLEEVE BELT UNIT	4-121
Replacement.....	4-122
To Clear SC544-02 or SC554-02	4-123
4.13.7 PRESSURE ROLLER AND PRESSURE ROLLER BEARINGS.....	4-124
Adjustment before Replacing the Pressure Roller and Pressure Roller Bearings.....	4-124
Replacement	4-124
4.13.8 THERMOSTAT UNIT	4-126
4.13.9 FUSING ROLLER TEMPERATURE SENSOR	4-126
4.13.10 PRESSURE ROLLER TEMPERATURE SENSOR.....	4-126
4.13.11 FUSING THERMOPILE.....	4-127
4.13.12 NOTES WHEN REASSEMBLING THE FUSING UNIT	4-128
Harness route: when looking at the bottom of the fusing unit.....	4-128
Harness route: when looking at the side of the fusing unit.....	4-128

4.14	PAPER EXIT	4-129
4.14.1	PAPER EXIT UNIT	4-129
4.14.2	PAPER EXIT SWITCHING SOLENOID	4-130
4.14.3	PAPER EXIT SENSOR	4-131
4.14.4	REVERSE SENSOR	4-132
4.14.5	PAPER EXIT FULL SENSOR	4-133
4.14.6	REVERSE MOTOR	4-134
4.14.7	FUSING EXIT SENSOR	4-135
4.15	PAPER FEED	4-136
4.15.1	PAPER FEED UNIT	4-136
	1st Paper Feed Unit	4-136
	2nd Paper Feed Unit	4-137
4.15.2	PAPER DUST COLLECTION UNIT	4-139
4.15.3	PICK-UP ROLLER, PAPER FEED ROLLER, SEPARATION ROLLER, TORQUE LIMITER	4-141
4.15.4	1ST / 2ND PAPER FEED TRAY LIFT MOTOR	4-143
4.15.5	1ST / 2ND PAPER FEED SENSOR	4-144
4.15.6	VERTICAL TRANSPORT SENSOR	4-145
4.15.7	LIMIT SENSOR	4-146
4.15.8	1ST PAPER END SENSOR / 2ND PAPER END SENSOR	4-146
4.15.9	REGISTRATION SENSOR	4-148
4.16	DUPLEX UNIT	4-149
4.16.1	DUPLEX/BY-PASS MOTOR	4-149
4.16.2	DUPLEX ENTRANCE MOTOR	4-150
4.16.3	DUPLEX ENTRANCE SENSOR	4-151
4.16.4	DUPLEX EXIT SENSOR	4-153
4.17	BYPASS TRAY UNIT	4-154
4.17.1	BYPASS TRAY	4-154
4.17.2	BYPASS PAPER END SENSOR	4-156
4.17.3	BYPASS PICK-UP ROLLER	4-157
4.17.4	BYPASS PAPER FEED ROLLER	4-158
4.17.5	BYPASS SEPARATION ROLLER	4-158
4.17.6	TORQUE LIMITER	4-158
4.17.7	BYPASS WIDTH SENSOR	4-159
4.17.8	BYPASS LENGTH SENSOR	4-161
4.18	PCBS AND OTHER ITEMS	4-162
4.18.1	OVERVIEW	4-162
	Around the Controller Box	4-162
	Around the Power Supply Box	4-163

4.18.2	IPU	4-164
	IPU Sub (If SPDF is installed)	4-164
4.18.3	BCU.....	4-165
	When installing the new BCU	4-165
	Replacing the NVRAM (EEPROM) on the BCU	4-166
4.18.4	CONTROLLER BOARD	4-167
	NVRAM on the controller board	4-170
4.18.5	HDD	4-173
	Adjustment after replacement	4-173
4.18.6	HVPS	4-174
4.18.7	PSU.....	4-175
	PSU Fuse Location	4-176
4.18.8	HEATER BOARD	4-176
4.18.9	CONTROLLER BOX	4-177
4.18.10	TEMPERATURE SENSOR	4-179
4.19	FANS/FILTERS.....	4-180
4.19.1	ODOR FILTER.....	4-180
4.19.2	DUST FILTER.....	4-181
4.19.3	DEVELOPMENT EXHAUST FAN	4-182
4.19.4	PAPER EXIT COOLING FAN	4-183
4.19.5	FUSING FAN	4-184
4.19.6	DEVELOPMENT BEARING COOLING FAN (D200/D201/D202 ONLY)	4-185
4.19.7	PSU COOLING FAN (D200/D201/D202 ONLY)	4-186
4.20	ADJUSTMENT AFTER REPLACEMENT.....	4-187
4.20.1	PRINTING.....	4-187
	Registration - Leading Edge/Side-to-Side	4-187
	Blank Margin	4-191
	Main Scan Magnification	4-193
	Parallelogram Image Adjustment	4-193
4.20.2	SCANNING	4-195
	Registration: Platen Mode	4-195
	Magnification	4-196
4.20.3	SCANNER WIRE	4-197
4.20.4	ADF IMAGE ADJUSTMENT	4-197
	Registration.....	4-197
	Sub Scan Magnification.....	4-198
4.20.5	TOUCH SCREEN CALIBRATION.....	4-199

5. SYSTEM MAINTENANCE..... 5-1

5.1 SERVICE PROGRAM MODE	5-1
5.1.1 ENABLING AND DISABLING SERVICE PROGRAM MODE	5-1
Entering SP Mode	5-1
Exiting SP Mode.....	5-1
5.1.2 TYPES OF SP MODES	5-1
SP Mode Button Summary.....	5-2
Switching Between SP Mode and Copy Mode for Test Printing.....	5-3
Selecting the Program Number	5-3
Exiting Service Mode.....	5-4
Service Mode Lock/Unlock.....	5-4
PM Counter/ Firmware Update.....	5-5
5.1.3 REMARKS	5-7
Others	5-8
The following symbols are used in the SP mode tables.	5-8
5.2 SP MODE TABLES - SP1000.....	5-9
5.2.1 SP1-XXX (FEED).....	5-9
5.3 SP MODE TABLES - SP2000.....	5-33
5.3.1 SP2-XXX (DRUM).....	5-33
5.4 SP MODE TABLES - SP3000.....	5-42
5.4.1 SP3-XXX (PROCESS).....	5-42
*SP3-012 Display result detail.....	5-43
5.5 SP MODE TABLES - SP4000.....	5-63
5.5.1 SP4-XXX (SCANNER).....	5-63
5.6 SP MODE TABLES - SP5000-1.....	5-84
5.6.1 SP5-XXX (MODE).....	5-84
5.7 SP MODE TABLES - SP5000-2.....	5-125
5.7.1 SP5-XXX (MODE).....	5-125
Bit assignment for SP5-828-087	5-156
5.8 SP MODE TABLES - SP5000-3.....	5-164
5.8.1 SP5-XXX (MODE).....	5-164
5.9 SP MODE TABLES - SP6000-1.....	5-200
5.9.1 SP6-XXX (PERIPHERALS)	5-200
5.10 SP MODE TABLES - SP6000-2.....	5-219
5.10.1 SP6-XXX (PERIPHERALS).....	5-219
5.11 SP MODE TABLES - SP7000-1	5-237
5.11.1 SP7-XXX (DATA LOG).....	5-237
5.12 SP MODE TABLES - SP7000-2.....	5-257
5.12.1 SP7-XXX (DATA LOG).....	5-257
5.13 SP MODE TABLES - SP8000-1	5-276

5.13.1	SP8-XXX (DATA LOG 2).....	5-276
	Keys and abbreviations in Data Log 2.....	5-277
5.14	SP MODE TABLES - SP8000-2.....	5-310
5.14.1	SP8-XXX (DATA LOG 2).....	5-310
5.15	PRINTER SP MODE.....	5-335
5.15.1	SP1-XXX (SERVICE MODE).....	5-335
5.16	SCANNER SP MODE.....	5-349
5.16.1	SP1-XXX (SYSTEM AND OTHERS).....	5-349
5.16.2	SP2-XXX (SCANNING-IMAGE QUALITY).....	5-353
5.17	INPUT CHECK TABLE.....	5-355
5.17.1	MAIN MACHINE – INPUT CHECK.....	5-355
5.17.2	ADF D779 – INPUT CHECK.....	5-368
5.17.3	1-PASS ADF D683 – INPUT CHECK.....	5-369
5.17.4	2000/3000 SHEETS FINISHER D688 / D689 – INPUT CHECK.....	5-372
5.17.5	INTERNAL FINISHER D690 – INPUT CHECK.....	5-379
5.17.6	1000 SHEETS FINISHER D687 – INPUT CHECK.....	5-380
5.17.7	BRIDGE UNIT D685 – INPUT CHECK.....	5-384
5.17.8	INTERNAL FINISHER D766 – INPUT CHECK.....	5-385
5.17.9	INTERNAL SHIFT TRAY D691 – INPUT CHECK.....	5-386
5.17.10	1 BIN TRAY D692 – INPUT CHECK.....	5-386
5.18	OUTPUT CHECK TABLE.....	5-387
5.18.1	MAIN MACHINE – OUTPUT CHECK.....	5-387
5.18.2	ADF D779 – OUTPUT CHECK.....	5-397
5.18.3	1-PASS ADF D683 – OUTPUT CHECK.....	5-398
5.18.4	2000/3000 SHEETS FINISHER D688 / D689 – OUTPUT CHECK 5-399	
5.18.5	INTERNAL FINISHER D690 – OUTPUT CHECK.....	5-403
5.18.6	1000 SHEETS FINISHER D687 – OUTPUT CHECK.....	5-404
5.18.7	BRIDGE UNIT D685 – OUTPUT CHECK.....	5-406
5.18.8	INTERNAL SHIFT TRAY D691 – OUTPUT CHECK.....	5-406
5.18.9	INTERNAL FINISHER D766 – OUTPUT CHECK.....	5-407
5.19	TEST PATTERN PRINTING.....	5-408
5.20	FIRMWARE UPDATE.....	5-410
5.20.1	OVERVIEW.....	5-410
5.20.2	FIRMWARE TYPE.....	5-410
5.20.3	PROCEDURE.....	5-411
	Update procedure.....	5-412
5.20.4	ERROR SCREENS DURING UPDATING.....	5-416
5.21	UPDATING JAVAVM.....	5-424

5.21.1	CREATING AN SD CARD FOR UPDATING.....	5-424
	Updating Procedure	5-424
	List of Error Messages	5-425
5.22	UPDATING THE EXJS.....	5-428
5.22.1	TO UPDATE EXJS.....	5-428
5.22.2	WHEN CHECKING THE VERSION OF EXJS	5-430
5.23	NVRAM DATA UPLOAD/DOWNLOAD	5-431
5.23.1	UPLOADING CONTENT OF NVRAM TO AN SD CARD	5-431
5.23.2	DOWNLOADING AN SD CARD TO NVRAM.....	5-432
5.24	UP/SP DATA IMPORT/EXPORT	5-433
5.24.1	OVERVIEW	5-433
	Import/export conditions.....	5-433
5.24.2	UP DATA IMPORT/EXPORT	5-433
	Data that can be imported and exported	5-433
	Data that cannot be imported or exported.....	5-434
	Exporting Device Information	5-434
	Importing Device Information	5-435
5.24.3	SP DATA IMPORT/EXPORT	5-437
	Data that can be imported and exported	5-437
	Exporting Device Information	5-437
	Importing Device Information	5-439
5.24.4	POSSIBLE SOLUTIONS FOR IMPORT/EXPORT PROBLEMS.....	5-440
5.25	ADDRESS BOOK EXPORT/IMPORT	5-443
5.25.1	EXPORT	5-443
5.25.2	IMPORT	5-444
5.25.3	SPECIFICATION.....	5-444
5.26	RFU UPDATING THE FIRMWARE.....	5-445
5.26.1	RFU PERFORMABLE CONDITION.....	5-445
5.27	PACKAGE FIRMWARE UPDATE	5-446
5.27.1	OVERVIEW	5-446
	Types of firmware update files, supported update methods:	5-447
5.27.2	IMMEDIATE UPDATE	5-447
5.27.3	UPDATE AT THE NEXT VISIT (RESERVE)	5-450
	How to Set the Machine to Download Firmware Later (RESERVE).	5-450
	How to Check if the Firmware Downloaded with RESERVE	5-452
	How to Install Firmware Downloaded with RESERVE.....	5-454
5.27.4	UPDATE VIA SD CARD.....	5-456
5.28	CAPTURING THE DEBUG LOGS	5-459
5.28.1	OVERVIEW	5-459

Types of debug logs that can be saved.....	5-459
Security of the Operation Log.....	5-460
5.28.2 RETRIEVING THE DEBUG LOGS.....	5-461
Procedure for Retrieving the Debug Log.....	5-461
5.29 SP TEXT MODE (SAVING SMC LIST TO SD CARD)	5-463
5.29.1 OVERVIEW	5-463
SP Text Mode	5-463
5.29.2 PROCEDURE	5-463
5.29.3 FILE NAMES OF THE SAVED SMC LISTS.....	5-465
5.29.4 ERROR MESSAGES	5-465

6. TROUBLESHOOTING..... 6-1

6.1 SELF-DIAGNOSTIC MODE.....	6-1
6.1.1 SERVICE CALL CODES	6-1
Service Call Conditions	6-1
6.1.2 SC LOGGING.....	6-2
6.1.3 SC AUTOMATIC REBOOT.....	6-3
6.2 SC TABLES: SC1XX (SCANNING)	6-5
6.2.1 SC101-01 TO SC195-00.....	6-5
6.3 SC TABLES: SC2XX (EXPOSURE)	6-15
6.3.1 SC202-00 TO SC270-10.....	6-15
6.4 SC TABLES: SC3XX (IMAGE PROCESSING1 (CHARGE, DEVELOPMENT))	
6-21	
6.4.1 SC302-00 TO SC392-01.....	6-21
6.5 SC TABLES: SC4XX (IMAGE PROCESSING2 (AROUND THE DRUM))	6-27
6.5.1 SC440-00 TO SC498-00.....	6-27
6.6 SC TABLES: SC5XX (PAPER FEED AND FUSING)	6-31
6.6.1 SC501-01 TO SC589-02.....	6-31
6.7 SC TABLES: SC6XX (COMMUNICATION AND OTHERS).....	6-69
6.7.1 SC620-01 TO SC687-00.....	6-69
6.8 SC TABLES: SC7XX (PERIPHERALS)	6-90
6.8.1 SC700-01 TO SC792-00.....	6-90
6.9 SC TABLES: SC8XX	6-128
6.9.1 SC816 TO SC899.....	6-128
6.10 SC TABLES: SC9XX (OTHERS).....	6-165
6.10.1 SC900-00 TO SC995-04.....	6-165
6.11 WHEN SC549 IS DISPLAYED.....	6-171
6.11.1 TROUBLESHOOTING FLOWCHART.....	6-171
6.11.2 FUSING SHIELD CHECK	6-172
6.11.3 SOLUTION.....	6-175

6.12	JAM DETECTION	6-176
6.12.1	PAPER JAM DISPLAY	6-176
6.12.2	JAM CODES AND DISPLAY CODES	6-177
	Main Machine	6-177
	ARDF DF3090.....	6-180
	ARDF DF3080.....	6-181
	Booklet Finisher SR3170/ Finisher SR3160	6-181
	Booklet Finisher SR3150/ Finisher SR3140	6-183
	Internal Finisher SR3130.....	6-185
	Internal Finisher SR3180.....	6-186
6.12.3	SENSOR LOCATIONS	6-187
6.12.4	PAPER SIZE CODES	6-188
6.13	OTHER PROBLEMS.....	6-189
6.13.1	WHEN SC670 IS DISPLAYED.....	6-189
6.13.2	MARKS (VERTICAL STREAKS) ON PRINTS AND COPIES DUE TO SCANNING PROBLEMS	6-190
6.13.3	FINISHER REGISTRATION ADJUSTMENT.....	6-191
	For SR3170/SR3160.....	6-191
	For SR3150/SR3140.....	6-193
6.13.4	STACKING PROBLEM AT THE 1000-SHEET FINISHER	6-196
	Installation procedure for attaching the sheet.....	6-196
	Installation procedure for attaching the auxiliary tray to the 1000-sheet finisher.....	6-197
6.13.5	EARLY PAPER FULL DETECTION AT THE 1000-SHEET FINISHER 6-199	
	Installation procedure	6-199
6.13.6	FINISHER JOGGER PROBLEM.....	6-200
	Jogger Width Adjustment Procedure.....	6-200
6.13.7	EARLY PAPER FULL DETECTION MYLAR FOR INTERNAL FINISHER SR3130 (D690)	6-201
	Pasting Mylar Procedure	6-201
6.13.8	HOW TO RE-INSTALL THE OCR UNIT TYPE M2	6-205
6.13.9	PAPER CURL PROBLEM FOR SR3180	6-205
6.14	BLOWN FUSE CONDITION	6-208
	Fuse: NA	6-208
	Fuse: EU	6-209
	Fuse Location.....	6-210
7.	ENERGY SAVING	7-1
	7.1 ENERGY SAVING	7-1

7.1.1 ENERGY SAVE	7-1
If the Energy Saver Button Is Pressed During Machine Operation.....	7-1
7.1.2 ENERGY SAVER TIMER	7-3
7.2 PAPER SAVE	7-4
7.2.1 EFFECTIVENESS OF DUPLEX/COMBINE FUNCTION	7-4
1. Duplex:	7-4
2. Combine mode:	7-4
3. Duplex + Combine:.....	7-5
Paper Savings and Counter	7-5
Duplex mode:	7-6
2 in 1 mode:	7-7
Duplex + 2 in 1 mode:	7-8

READ THIS FIRST

Important Safety Notices

Safety

Prevention of Physical Injury

1. Before disassembling or assembling parts of the machine and peripherals, make sure that the machine and peripheral power cords are unplugged.
2. The plug should be near the machine and easily accessible.
3. Note that some components of the machine and the paper tray unit are supplied with electrical voltage even if the main power switch is turned off.
4. If any adjustment or operation check has to be made with exterior covers off or open while the main switch is turned on, keep hands away from electrified or mechanically driven components.
5. If the [Start] key is pressed before the machine completes the warm-up period (the [Start] key starts blinking red and green), keep hands away from the mechanical and the electrical components as the machine starts making copies as soon as the warm-up period is completed.
6. The inside and the metal parts of the fusing unit become extremely hot while the machine is operating. Be careful to avoid touching those components with your bare hands.
7. To prevent a fire or explosion, keep the machine away from flammable liquids, gases, and aerosols.

Health Safety Conditions

1. Never operate the machine without the ozone filters installed.
2. Always replace the ozone filters with the specified types at the proper intervals.
3. Toner and developer are non-toxic, but if you get either of them in your eyes by accident, it may cause temporary eye discomfort. Try to remove with eye drops or flush with water as first aid. If unsuccessful, get medical attention.

Observance of Electrical Safety Standards

1. The machine and its peripherals must be installed and maintained by a customer service representative who has completed the training course on those models.

Safety and Ecological Notes for Disposal

1. Do not incinerate toner bottles or used toner. Toner dust may ignite suddenly when exposed to an open flame.
2. Dispose of used toner, developer, and organic photoconductors in accordance with local

regulations. (These are non-toxic supplies.)

3. Dispose of replaced parts in accordance with local regulations.
4. When keeping used lithium batteries in order to dispose of them later, do not put more than 100 batteries per sealed box. Storing larger numbers or not sealing them apart may lead to chemical reactions and heat build-up.

CAUTION

- The danger of explosion exists if a battery of this type is incorrectly replaced. Replace only with the same or an equivalent type recommended by the manufacturer. Discard used batteries in accordance with the manufacturer's instructions.

Handling Toner

- Work carefully when removing paper jams or replacing toner bottles or cartridges to avoid spilling toner on clothing or the hands.
- If toner is inhaled, immediately gargle with large amounts of cold water and move to a well ventilated location. If there are signs of irritation or other problems, seek medical attention.
- If toner gets on the skin, wash immediately with soap and cold running water.
- If toner gets into the eyes, flush the eyes with cold running water or eye wash. If there are signs of irritation or other problems, seek medical attention.
- If toner is swallowed, drink a large amount of cold water to dilute the ingested toner. If there are signs of any problem, seek medical attention.
- If toner spills on clothing, wash the affected area immediately with soap and cold water. Never use hot water! Hot water can cause toner to set and permanently stain fabric.
- Always store toner and developer supplies such as toner and developer packages, cartridges, and bottles (including used toner and empty bottles and cartridges) out of the reach of children.
- Always store fresh toner supplies or empty bottles or cartridges in a cool, dry location that is not exposed to direct sunlight.

Laser Safety

The Center for Devices and Radiological Health (CDRH) prohibits the repair of laser-based optical units in the field. The optical housing unit can only be repaired in a factory or at a location with the requisite equipment. The laser subsystem is replaceable in the field by a qualified Customer Engineer. The laser chassis is not repairable in the field. Customer engineers are therefore directed to return all chassis and laser subsystems to the factory or service depot when replacement of the optical subsystem is required.

WARNING

- Use of controls, or adjustment, or performance of procedures other than those specified in this manual may result in hazardous radiation exposure.

WARNING FOR LASER UNIT

WARNING:

Turn off the main switch before attempting any of the procedures in the Laser Unit section. Laser beams can seriously damage your eyes.

CAUTION MARKING:











Safety Precautions for This Machine



Before moving the mainframe:

- Disconnect all peripheral units (finisher, LCT, etc.) from the mainframe.
- Pull the slide handles out of the mainframe and use them to lift the mainframe.

Symbols, Abbreviations and Trademarks

This manual uses several symbols and abbreviations. The meaning of those symbols and abbreviations are as follows:

	Screw
	Shoulder screw
	Black screw (TCRU)
	Connector
	FFC (Flat Film Connector)
	Harness clamp
	Clip
	E-ring
	C-ring

	Timing belt
	Spring
SEF	Short Edge Feed
LEF	Long Edge Feed

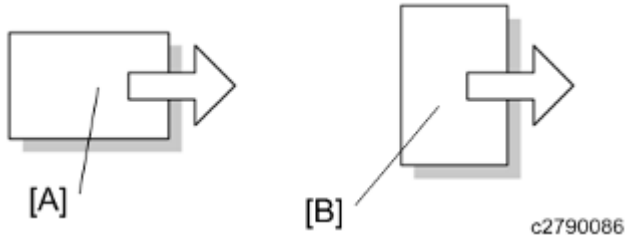

[A] Short Edge Feed (SEF)

[B] Long Edge Feed (LEF)

Trademarks

Microsoft[®], Windows[®], and MS-DOS[®] are registered trademarks of Microsoft Corporation in the United States and /or other countries. PostScript[®] is a registered trademark of Adobe Systems, Incorporated.

PCL[®] is a registered trademark of Hewlett-Packard Company.

Ethernet[®] is a registered trademark of Xerox Corporation.

PowerPC[®] is a registered trademark of International Business Machines Corporation.

Other product names used herein are for identification purposes only and may be trademarks of their respective companies. We disclaim any and all rights involved with those marks.

PRODUCT INFORMATION

REVISION HISTORY		
Page	Date	Added/Updated/New
		None

1. PRODUCT INFORMATION

1.1 PRODUCT OVERVIEW

1.1.1 COMPONENT LAYOUT

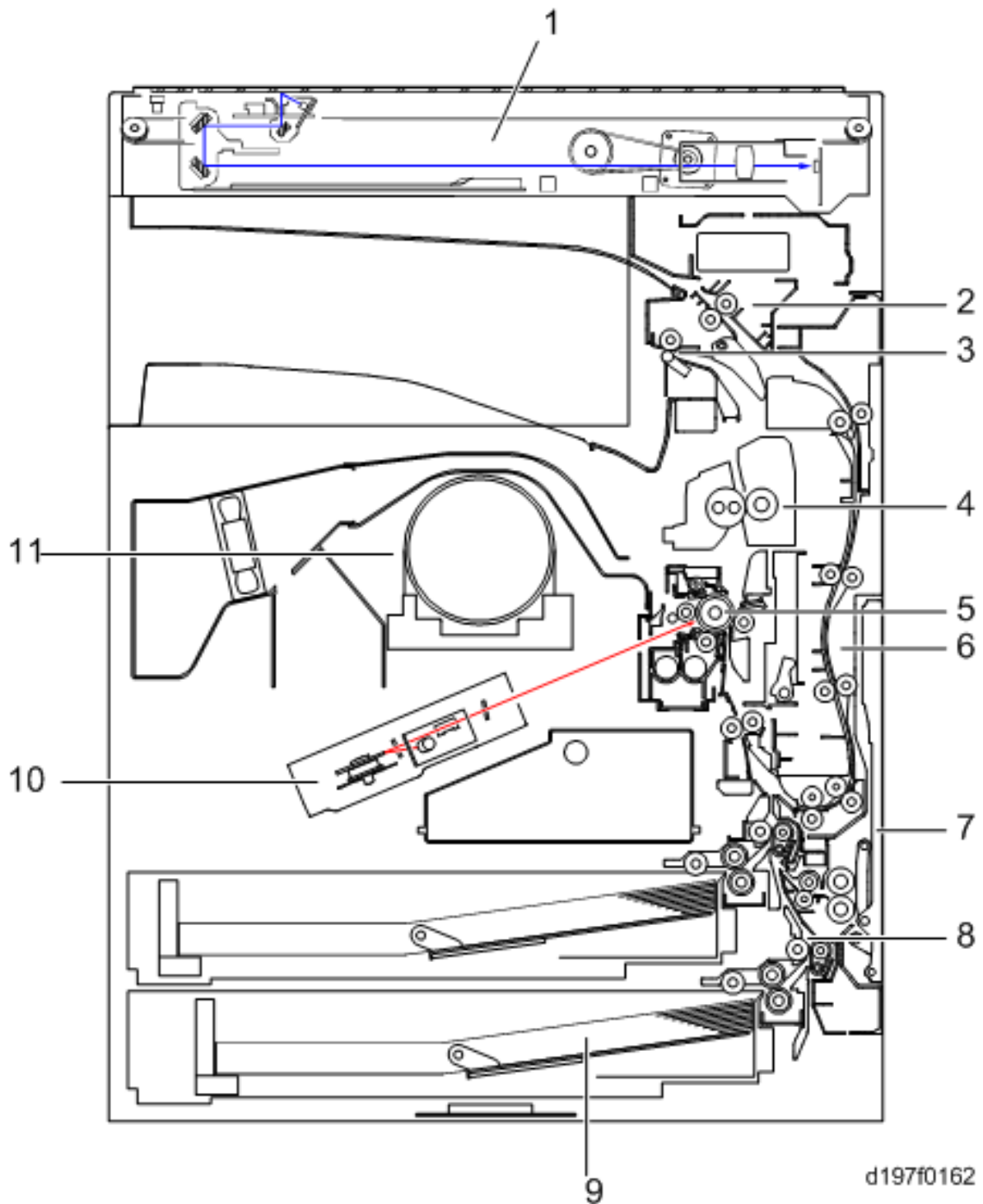

Product Overview

No.	Description	No.	Description
1	Scanner Unit	7	Bypass Tray Unit
2	Reverse Unit	8	Vertical Transport
3	Paper Exit Unit	9	Paper Feed Unit
4	Fusing Unit	10	Laser Unit
5	OPC Drum	11	Toner Supply Unit
6	Duplex Unit		

1.1.2 PAPER PATH

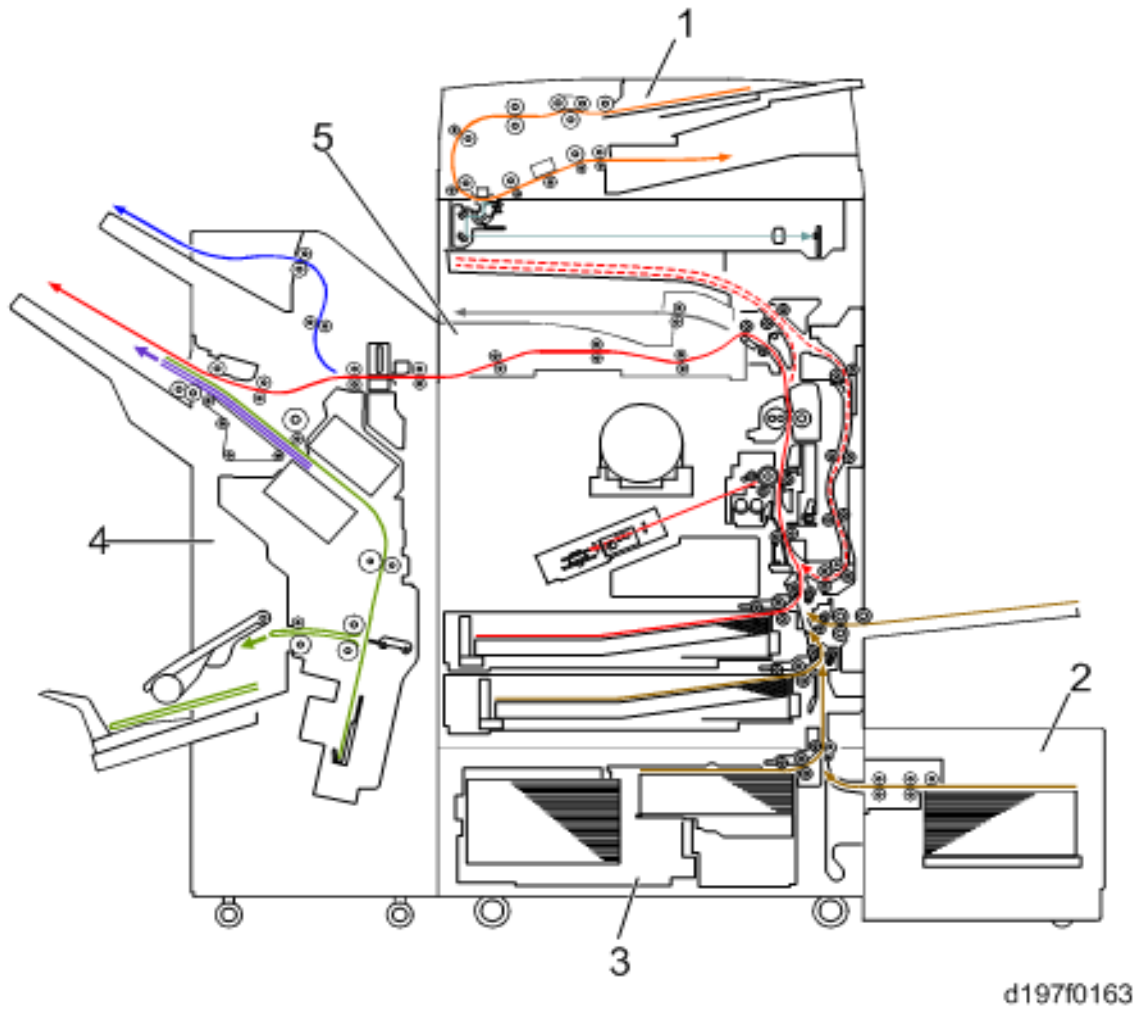

No.	Description	No.	Description
1	ARDF	4	Booklet Finisher
2	LCIT	5	Bridge Unit
3	LCIT (Tandem Tray)		

Product Overview

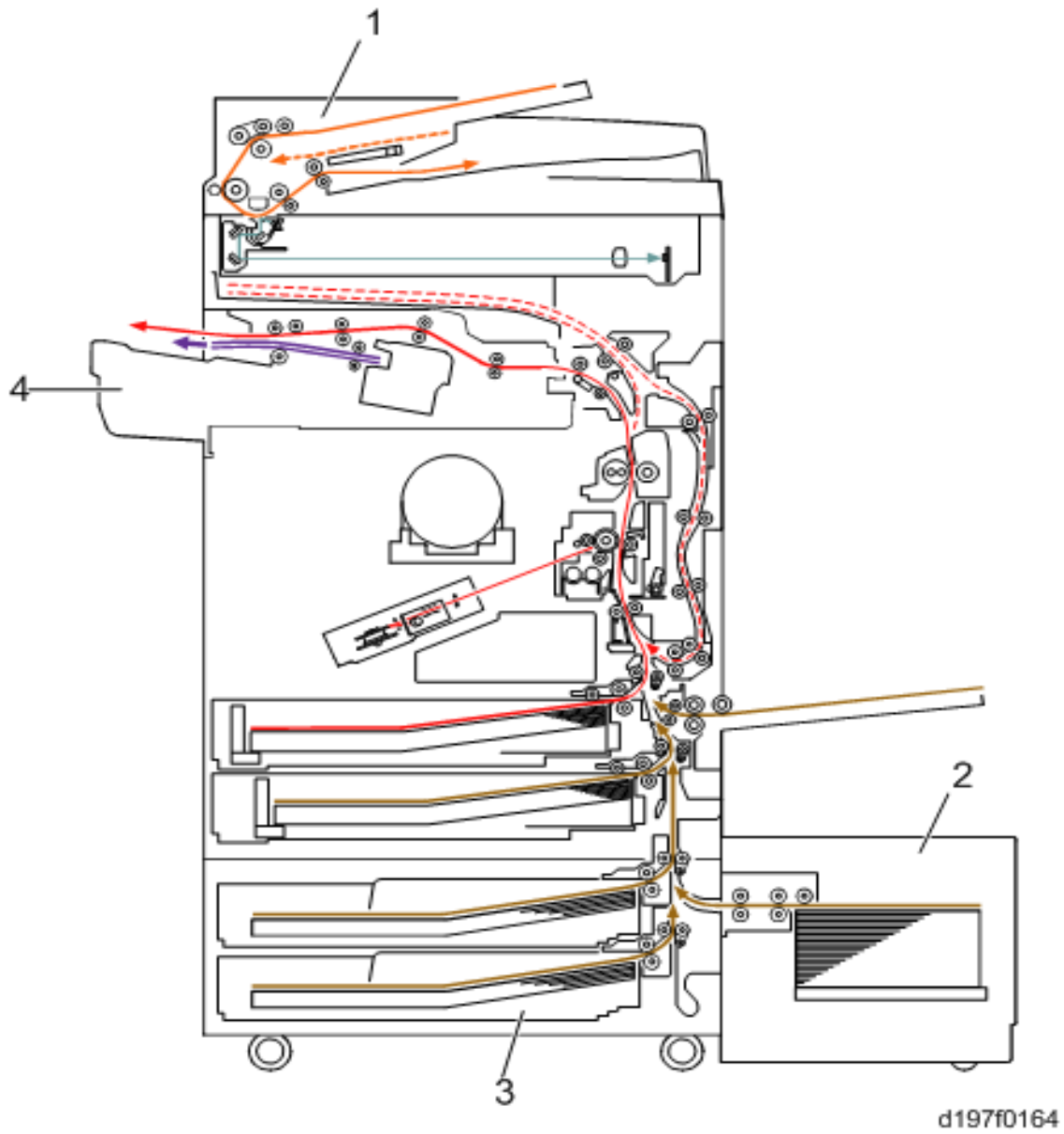

No.	Description	No.	Description
1	ARDF	3	Paper Feed Unit
2	LCIT	4	Internal Finisher

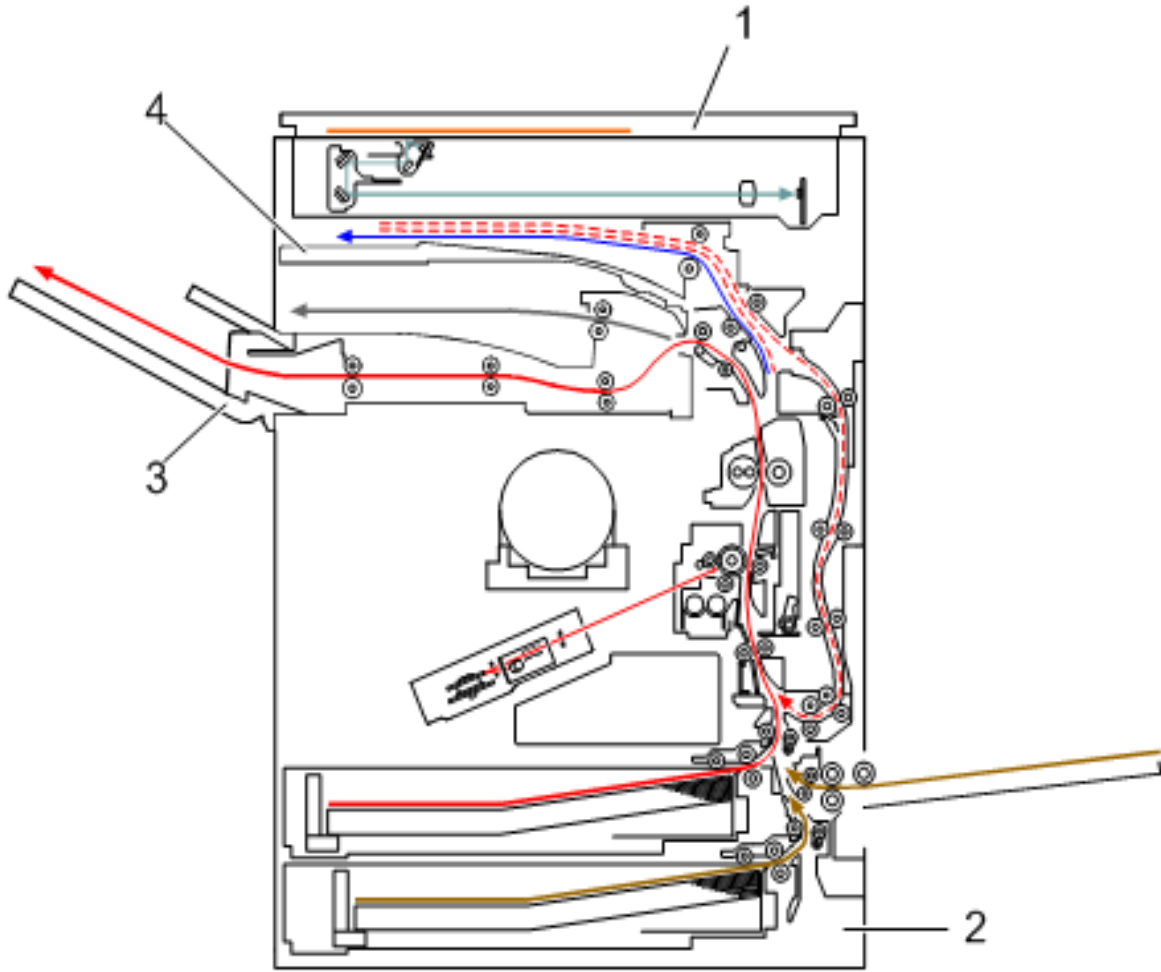

d197f0165

No.	Description	No.	Description
1	Platen Cover	3	Side Tray Unit
2	Paper Feed Unit	4	1 Bin Tray Unit

1.1.3 DRIVE LAYOUT

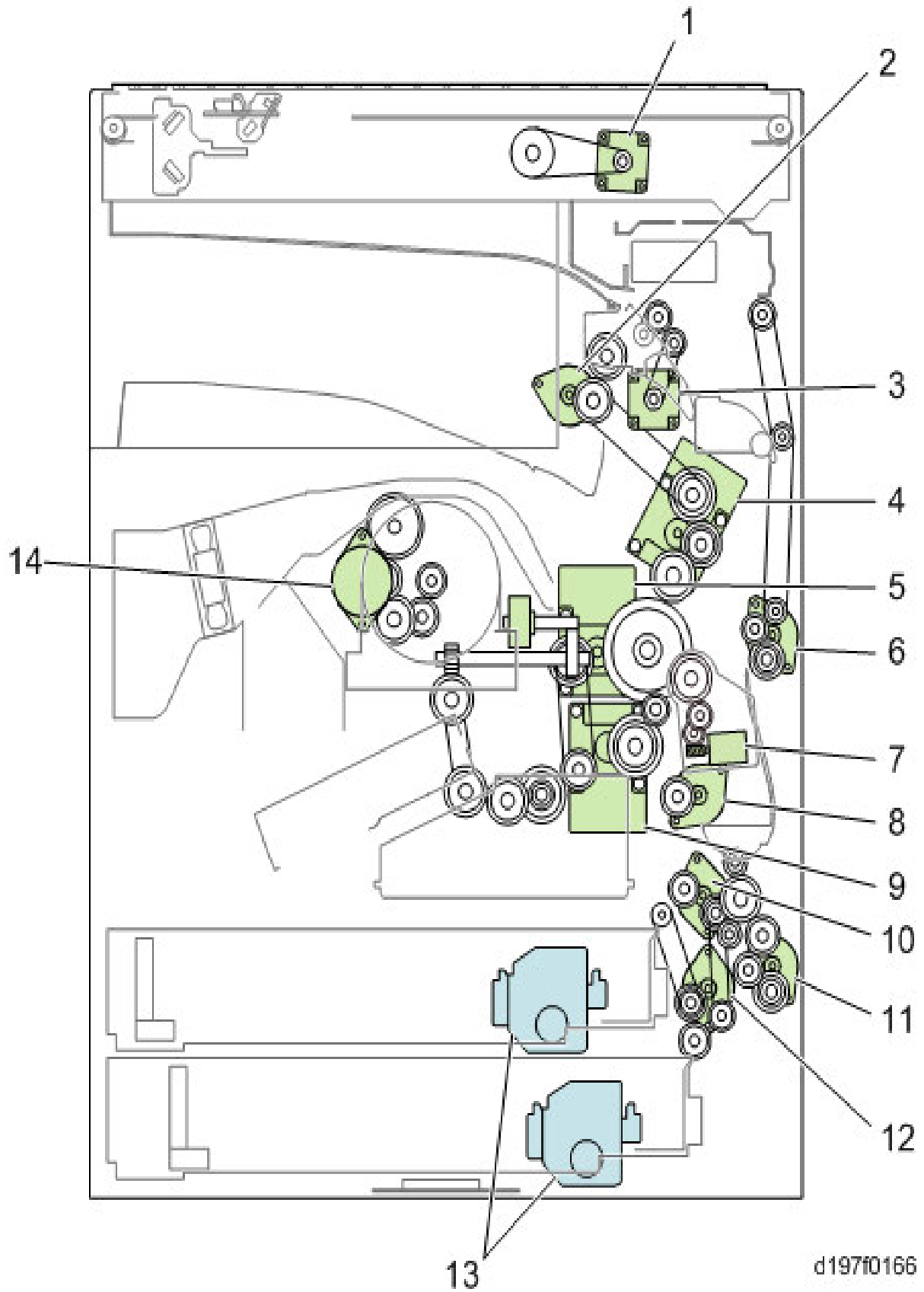

No.	Description	No.	Description
1	Scanner motor	8	Registration motor
2	Paper exit motor (D200/D201/D202 only)	9	Development motor
3	Reverse motor	10	Vertical transport motor
4	Fusing motor (D200/D201/D202 only) Fusing/paper exit motor (D197/D198/D199 only)	11	Duplex/bypass motor
5	Drum/waste toner motor	12	Paper feed motor
6	Duplex entrance motor	13	Paper feed tray lift motor
7	Transfer roller contact motor	14	Toner supply motor

1.1.4 PARTS LAYOUT

Scanner Unit

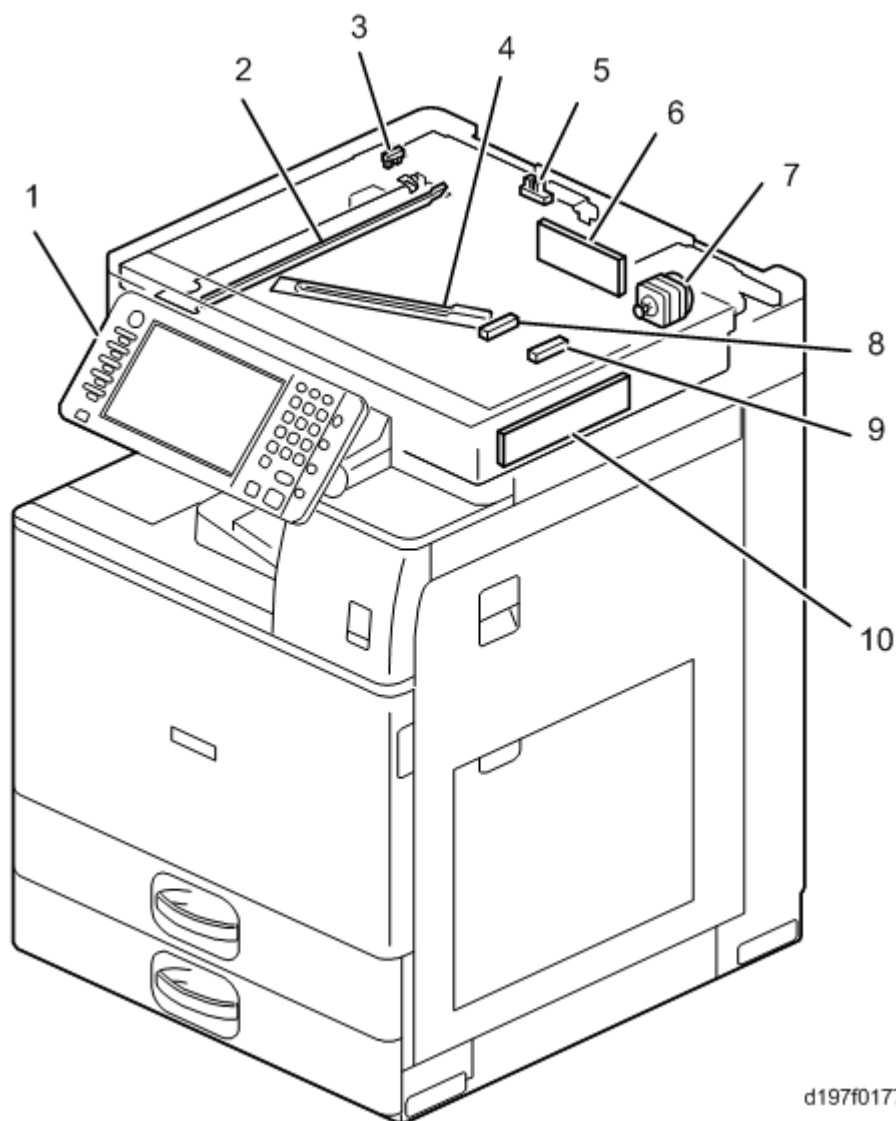

d197f0177

No.	Description	No.	Description
1	Operation panel	6	SIO
2	Scanner lamp unit (LED)	7	Scanner motor
3	Scanner HP sensor	8	APS sensor
4	Anti-condensation heater (Scanner) *Option	9	APS sensor
5	DF-position sensor	10	SBU

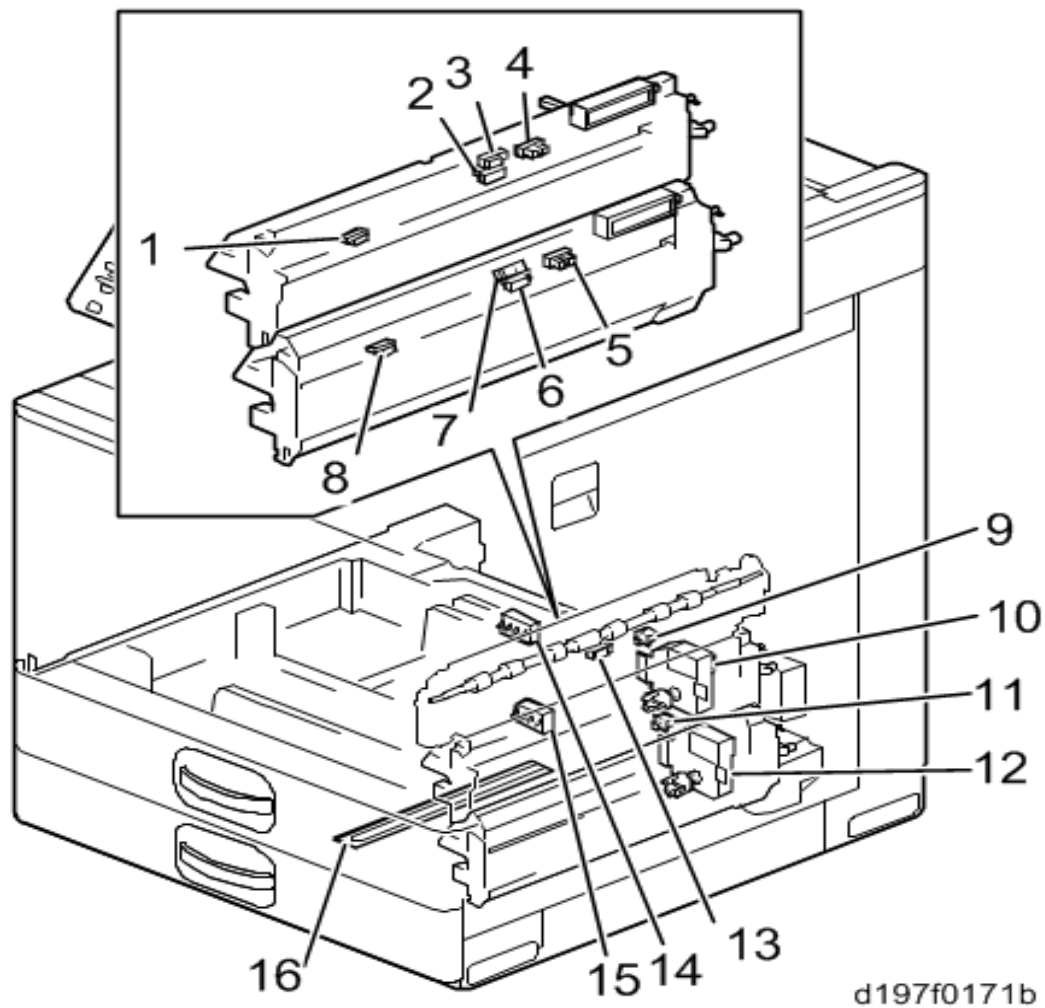
Paper Feed Unit

No.	Description	No.	Description
1	1st paper feed sensor	9	1st paper feed tray set switch
2	1st vertical transport sensor	10	1st paper feed tray lift motor
3	1st paper end sensor	11	2nd paper feed tray set switch
4	1st paper feed tray limit sensor	12	2nd paper feed tray lift motor
5	2nd paper feed tray limit sensor	13	Registration sensor
6	2nd vertical transport sensor	14	1st paper feed tray size switch
7	2nd paper end sensor	15	2nd paper feed tray size switch
8	2nd paper feed sensor	16	Anti-condensation heater *Option

Laser Unit/ PCDU

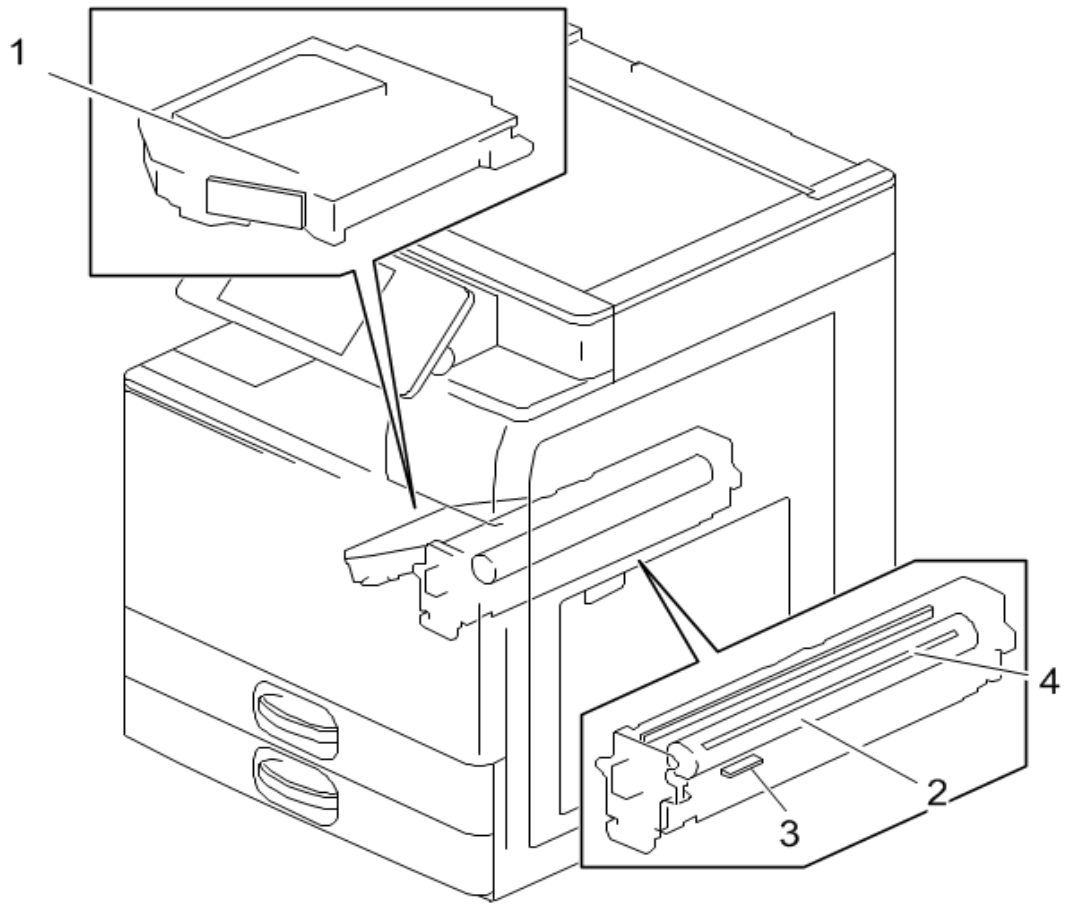

d197f0168

No.	Description	No.	Description
1	Laser Unit	3	TD sensor
2	Quenching lamp	4	PCL (Pre Cleaning Light)

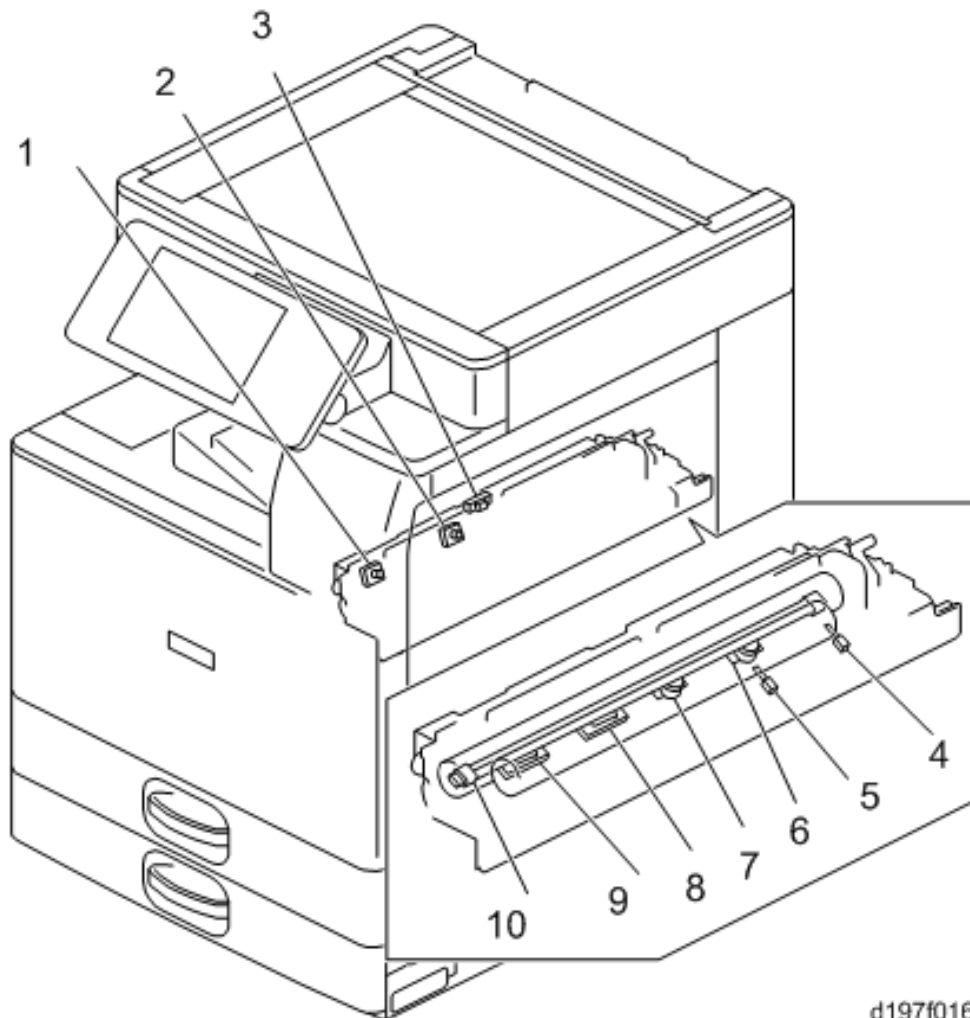
Fusing Unit

d197f0169

No.	Description	No.	Description
1	Fusing thermopile (End)	6	Thermostat (End)
2	Fusing thermopile (Center)	7	Thermostat (Center)
3	Fusing exit sensor	8	Fusing roller temperature sensor (Center)
4	Pressure roller temperature sensor (End)	9	Fusing roller temperature sensor (End)
5	Pressure roller temperature sensor (Center)	10	Fusing lamp

Waste Toner Bottle

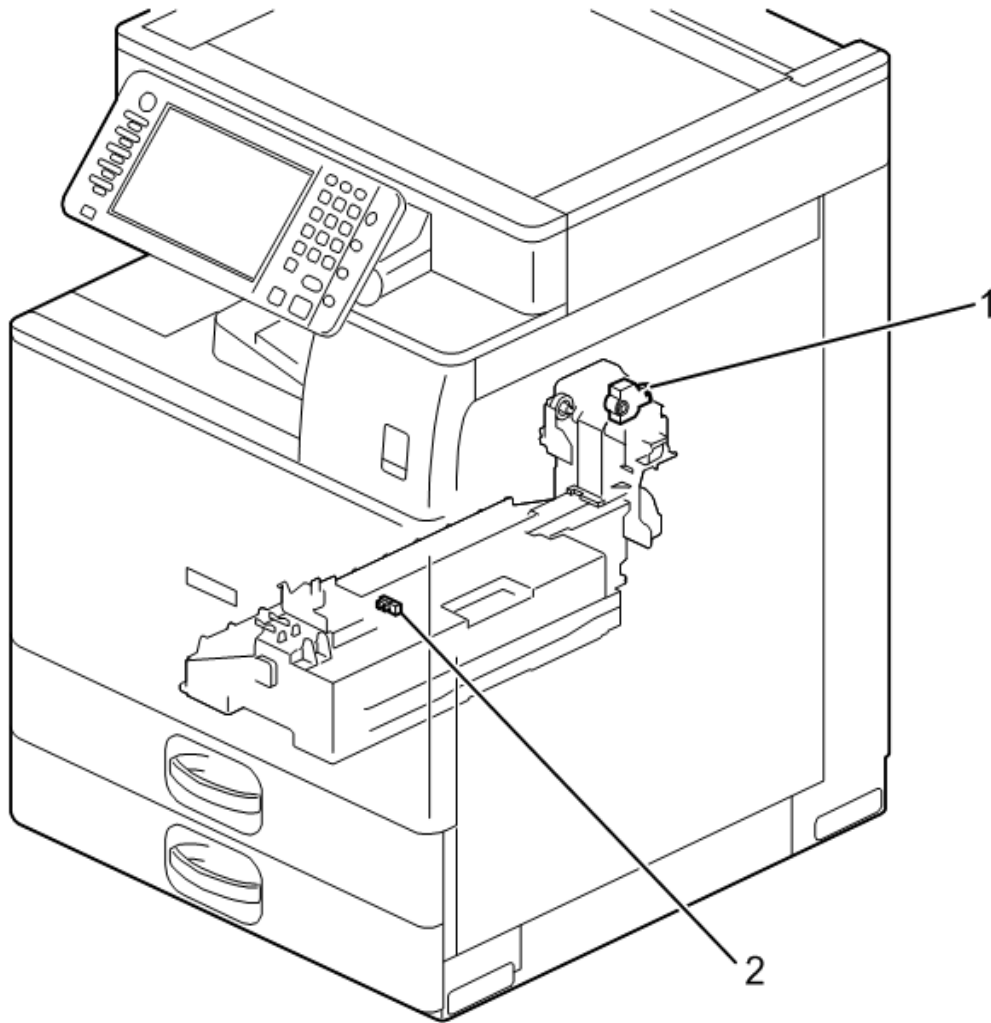

d197f0170

No.	Description	No.	Description
1	Drum/waste toner motor	2	Toner collection full sensor

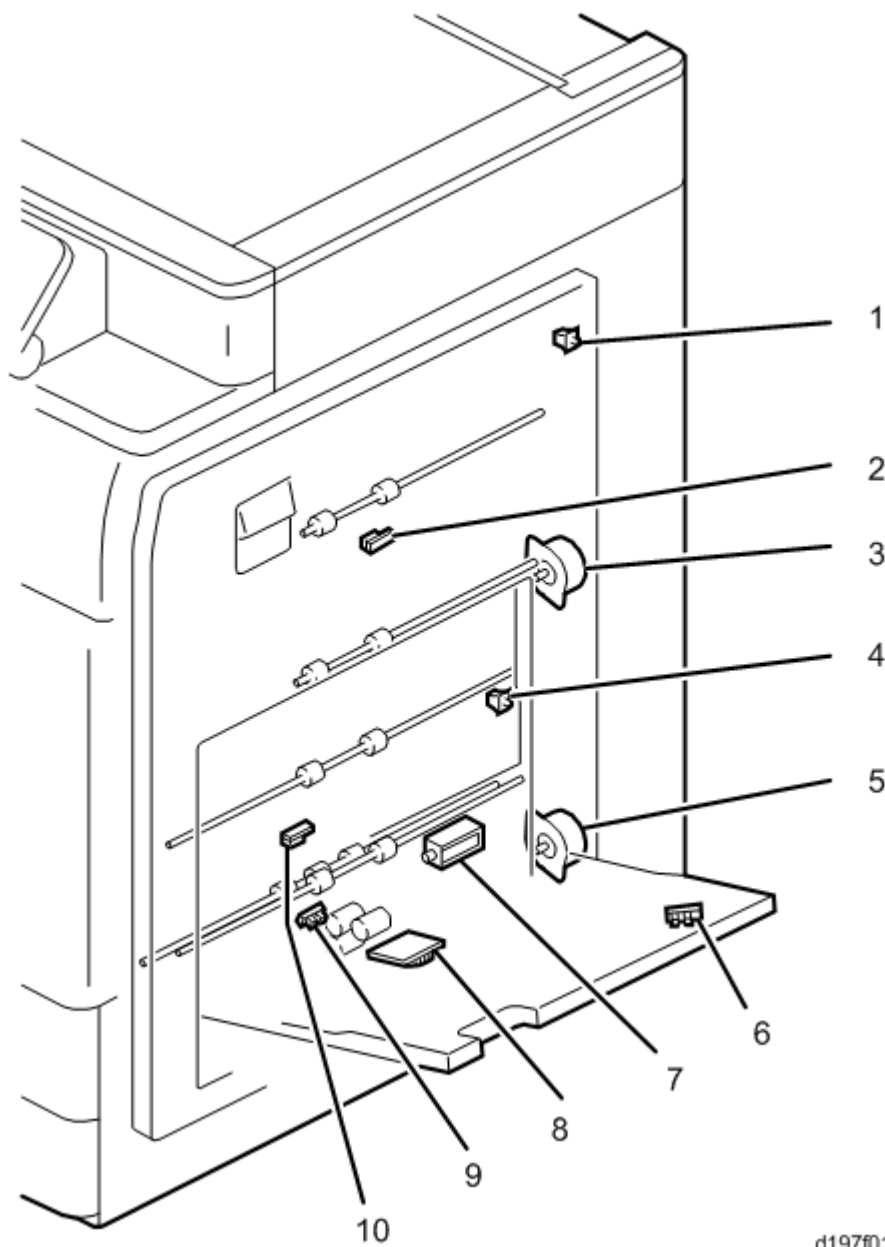
Duplex/Bypass Unit

d197f0172

No.	Description	No.	Description
1	Right cover open/close switch	6	Bypass length sensor
2	Duplex entrance sensor	7	Bypass pickup solenoid
3	Duplex entrance motor	8	Bypass width switch
4	Duplex guide switch	9	Bypass paper end sensor
5	Duplex/bypass motor	10	Duplex exit sensor

Paper Exit/ Reverse Unit

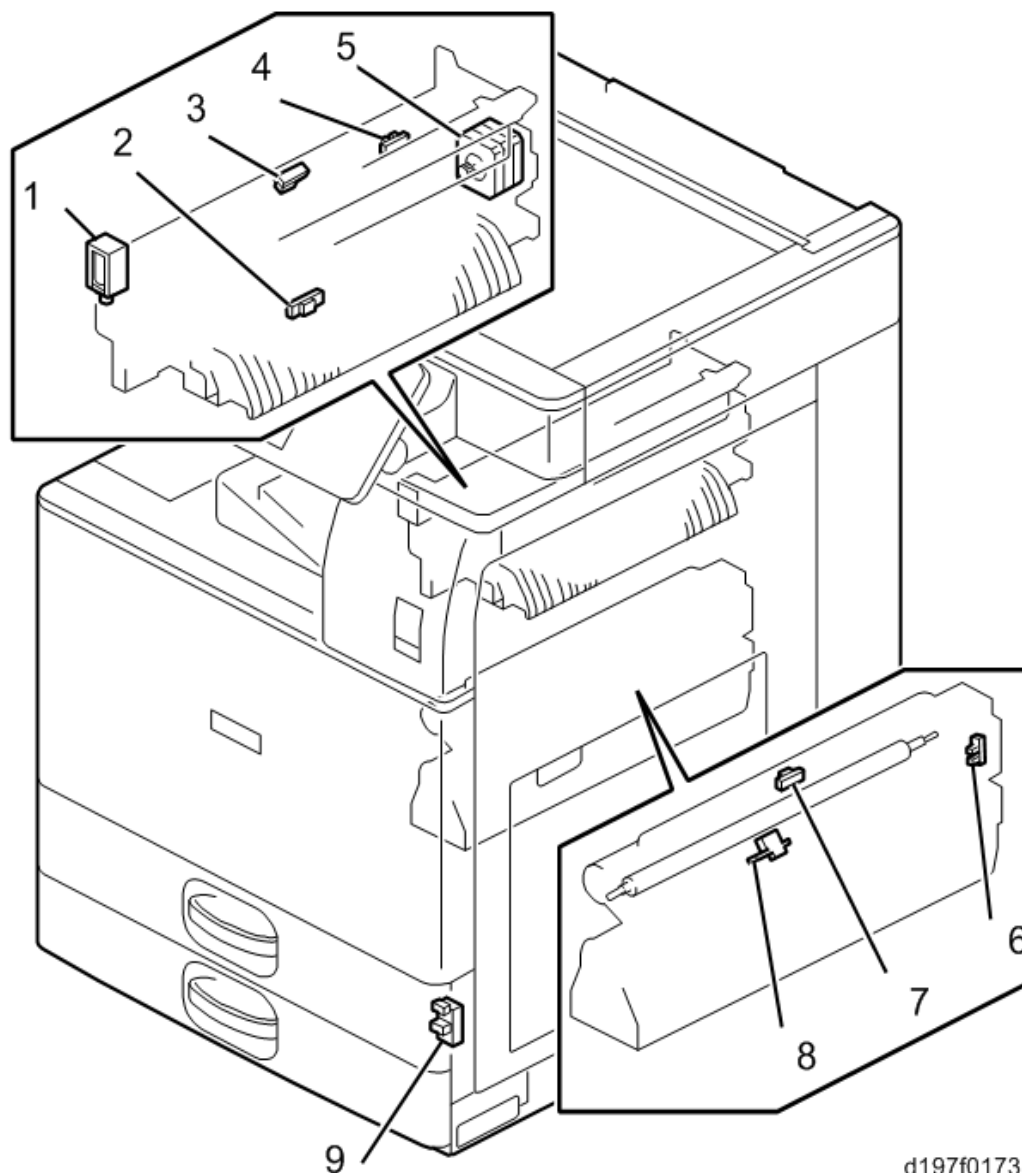

d197f0173

No.	Description	No.	Description
1	Paper exit switching solenoid	6	Transfer unit open/close sensor
2	Paper exit sensor	7	Fusing entrance sensor
3	Reverse sensor	8	Transfer Contact Sensor
4	Paper exit full sensor	9	Temperature/Humidity Sensor
5	Reverse motor		

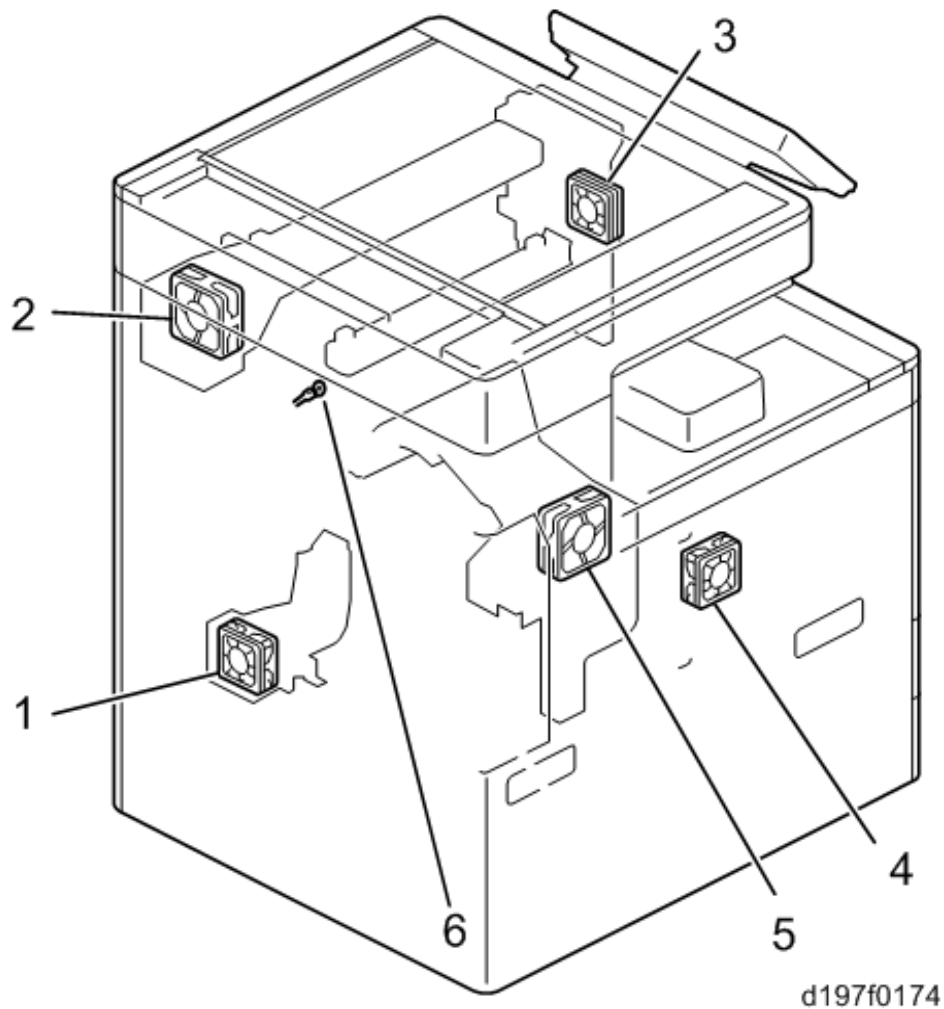
Air Flow

d197f0174

No.	Description	No.	Description
1	Development bearing cooling fan (D200/D201/D202 only)	4	PSU cooling fan(D200/D201/D202 only)
2	Fusing fan	5	Development exhaust fan
3	Paper exit cooling fan	6	Temperature sensor

Drive Unit

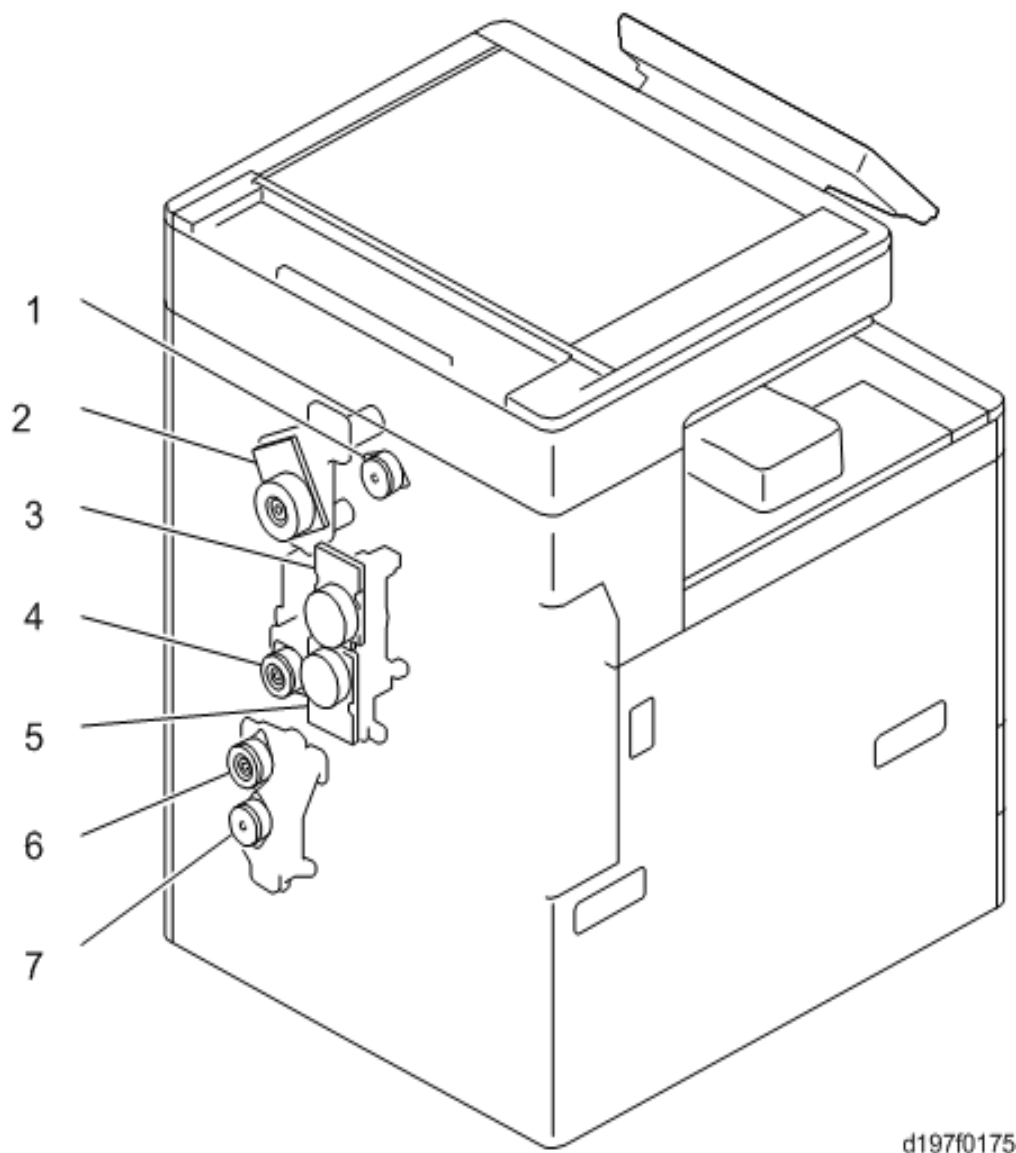

d197f0175

No.	Description	No.	Description
1	Paper exit motor (D200/D201/D202 only)	5	Development motor
2	Fusing motor (D200/D201/D202 only) Fusing/paper exit motor (D197/D198/D199 only)	6	Vertical transport motor
3	Drum/Waste toner motor	7	Paper feed motor
4	Registration motor		

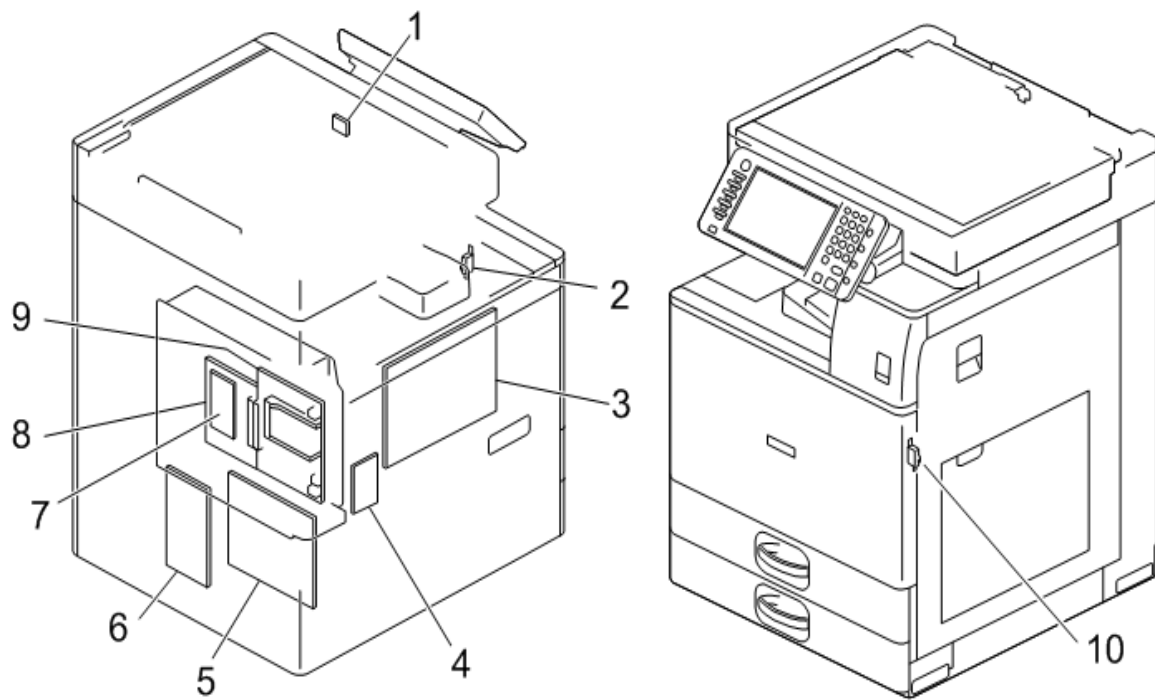
Electrical Component

d197z0408

No.	Description	No.	Description
1	Main power switch	6	HVP
2	Interlock switch (Front Cover)	7	IPU-sub (only for machines with an SPDF installed)
3	PSU	8	IPU
4	DHB (Option)	9	Controller Board
5	BCU	10	Interlock Switch (Right Cover)

1.2 MACHINE CODES AND PERIPHERALS CONFIGURATION

1.2.1 SYSTEM CONFIGURATION AND OPTIONS

D197/D198/D199 (NA)

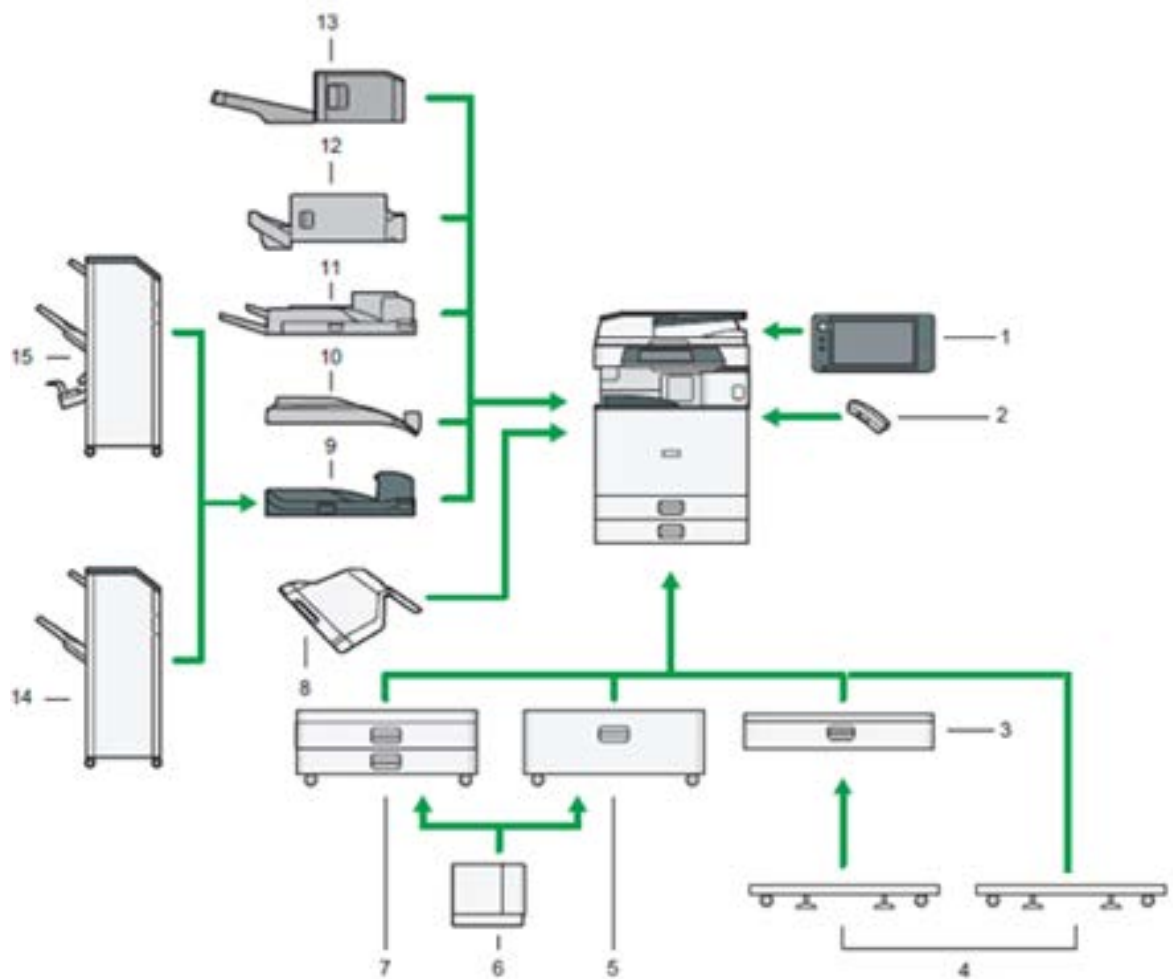

d197f0203

No.	Item	Machine Code
1	Smart Operation Panel Type M3	D148
2	Handset HS3020	D739
3	Paper Feed Unit PB3150	D694
4	Caster Table Type M3	D178

No.	Item	Machine Code
5	LCIT PB3170	D695
6	LCIT RT3030	D696
7	Paper Feed Unit PB3210	D787
8	1 Bin Tray BN3110	D692
9	Bridge Unit BU3070	D685
10	Internal Shift Tray SH3070	D691
11	Side Tray Type M3	D725
12	Internal Finisher SR3130	D690
13	Internal Finisher SR3180	D766
14	Finisher SR3140	D687
15	Booklet Finisher SR3150	D686

D200/D201 (NA)

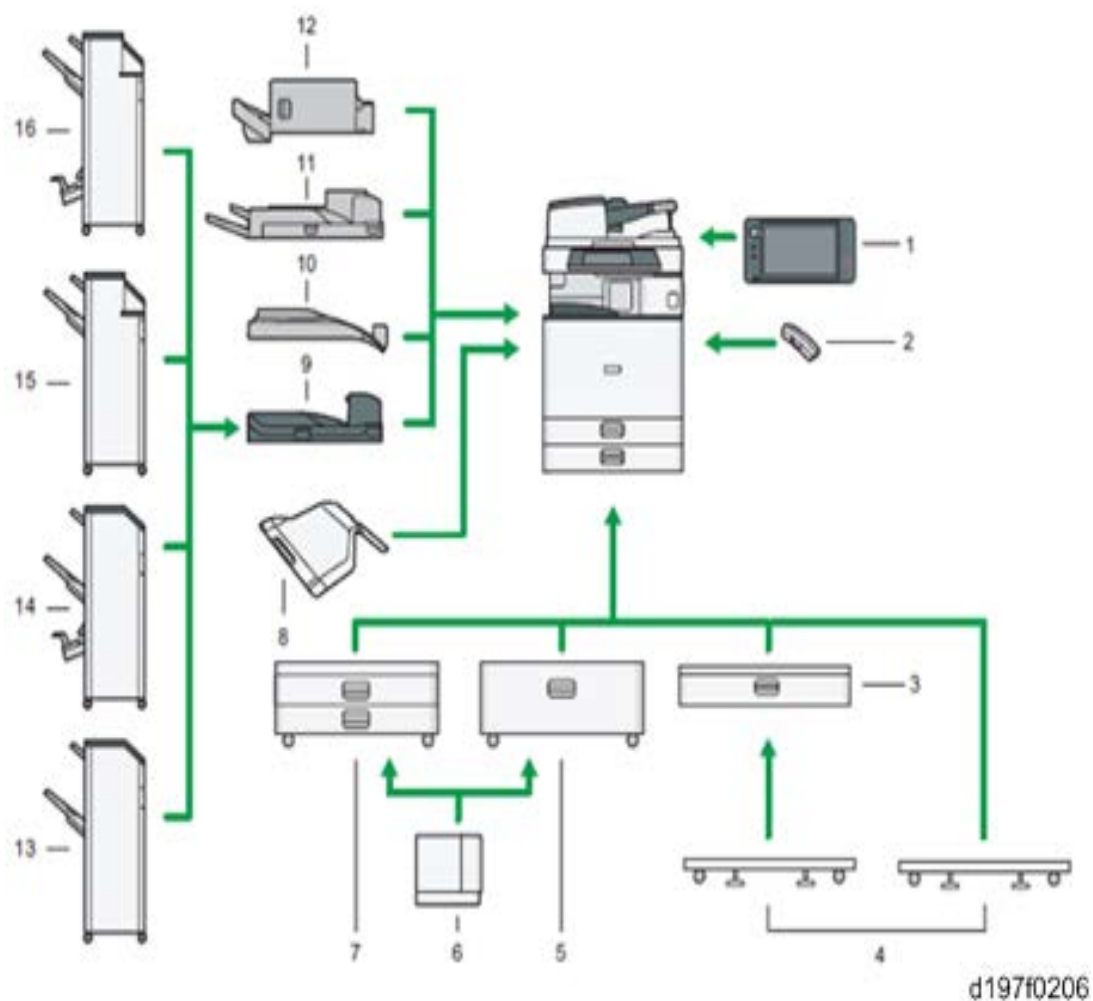

No.	Item	Machine Code
1	Smart Operation Panel Type M3	D148
2	Handset HS3020	D739
3	Paper Feed Unit PB3150	D694
4	Caster Table Type M3	D178
5	LCIT PB3170	D695
6	LCIT RT3030	D696
7	Paper Feed Unit PB3210	D787
8	1 Bin Tray BN3110	D692

No.	Item	Machine Code
9	Bridge Unit BU3070	D685
10	Internal Shift Tray SH3070	D691
11	Side Tray Type M3	D725
12	Internal Finisher SR3130	D690
13	Finisher SR3140	D687
14	Booklet Finisher SR3150	D686
15	Finisher SR3160	D689
16	Booklet Finisher SR3170	D688

D202 (NA)

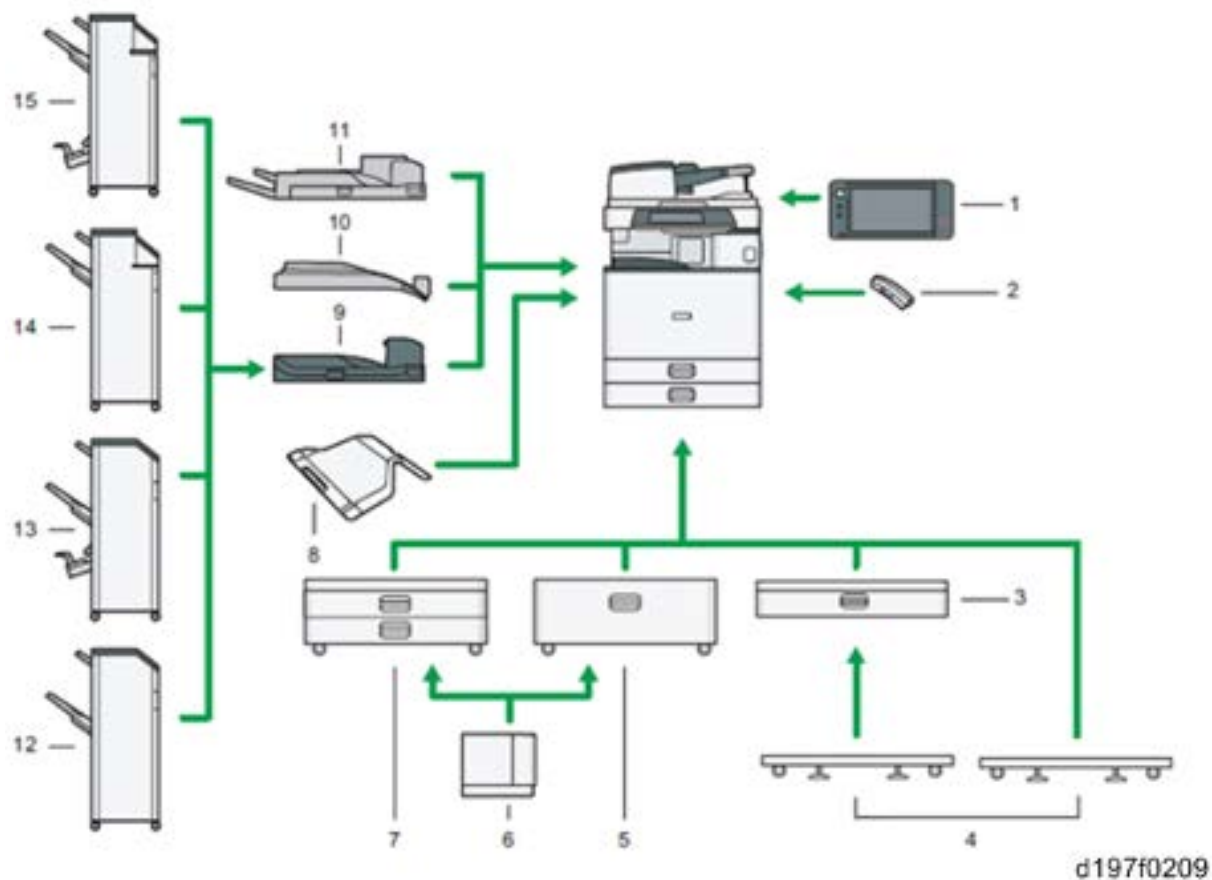

No.	Item	Machine Code
1	Smart Operation Panel Type M3	D148
2	Handset HS3020	D739
3	Paper Feed Unit PB3150	D694
4	Caster Table Type M3	D178
5	LCIT PB3170	D695
6	LCIT RT3030	D696
7	Paper Feed Unit PB3210	D787
8	1 Bin Tray BN3110	D692
9	Bridge Unit BU3070	D685
10	Internal Shift Tray SH3070	D691

No.	Item	Machine Code
11	Side Tray Type M3	D725
12	Finisher SR3140	D687
13	Booklet Finisher SR3150	D686
14	Finisher SR3160	D689
15	Booklet Finisher SR3170	D688

D197/D198/D199 (EU)

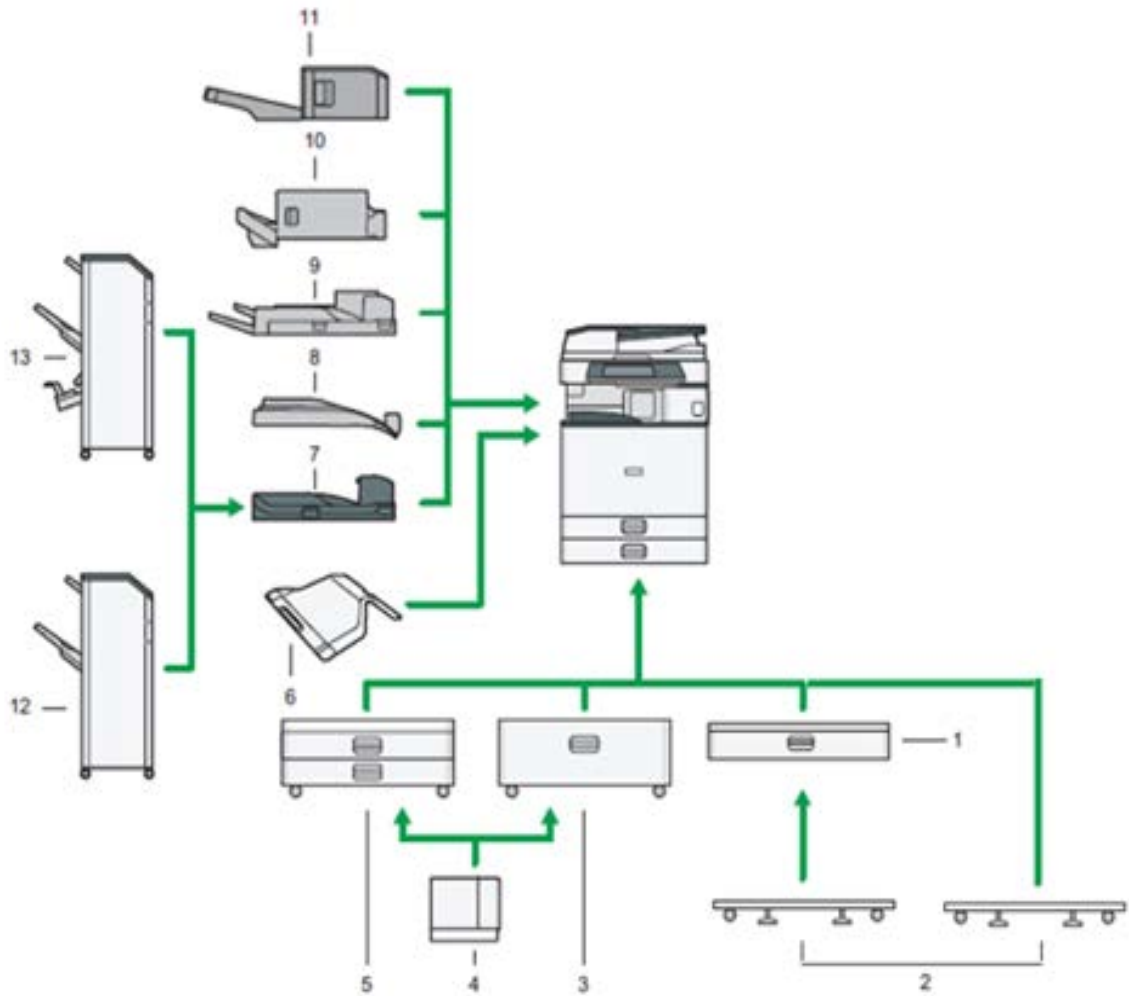

d197f0201

No.	Item	Machine Code
1	Paper Feed Unit PB3150	D694
2	Caster Table Type M3	D178
3	LCIT PB3170	D695
4	LCIT RT3030	D696
5	Paper Feed Unit PB3210	D787
6	1 Bin Tray BN3110	D692
7	Bridge Unit BU3070	D685
8	Internal Shift Tray SH3070	D691

No.	Item	Machine Code
9	Side Tray Type M3	D725
10	Internal Finisher SR3130	D690
11	Internal Finisher SR3180	D766
12	Finisher SR3140	D687
13	Booklet Finisher SR3150	D686

* Smart Operation Panel Type M3 (D148) is not provided as an option for Europe; however, Smart Operation Panel embedded models are provided.

D200/D201 (EU)

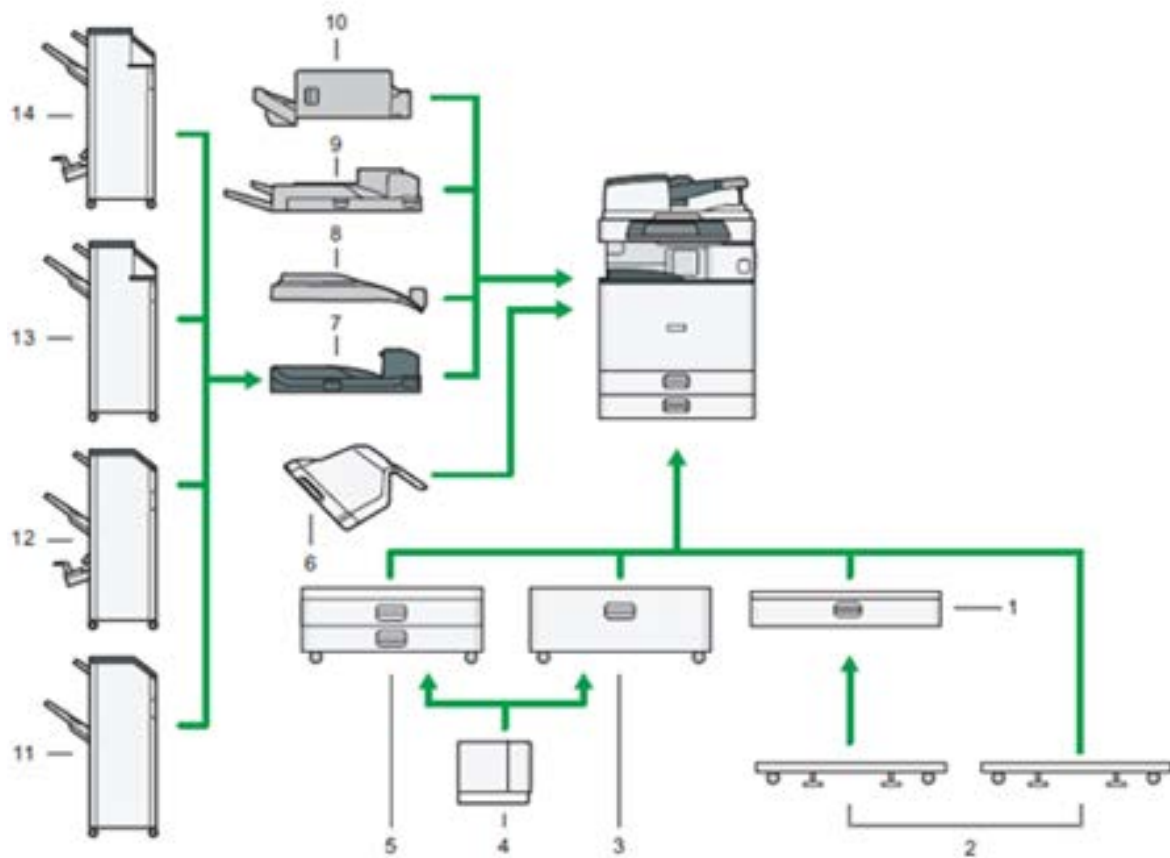

d197f0204

No.	Item	Machine Code
1	Paper Feed Unit PB3150	D694
2	Caster Table Type M3	D178
3	LCIT PB3170	D695
4	LCIT RT3030	D696
5	Paper Feed Unit PB3210	D787
6	1 Bin Tray BN3110	D692
7	Bridge Unit BU3070	D685
8	Internal Shift Tray SH3070	D691
9	Side Tray Type M3	D725

No.	Item	Machine Code
10	Internal Finisher SR3130	D690
11	Finisher SR3140	D766
12	Booklet Finisher SR3150	D686
13	Finisher SR3160	D689
14	Booklet Finisher SR3170	D688

* Smart Operation Panel Type M3 (D148) is not provided as an option for Europe; however, Smart Operation Panel embedded models are provided.

D202 (EU)

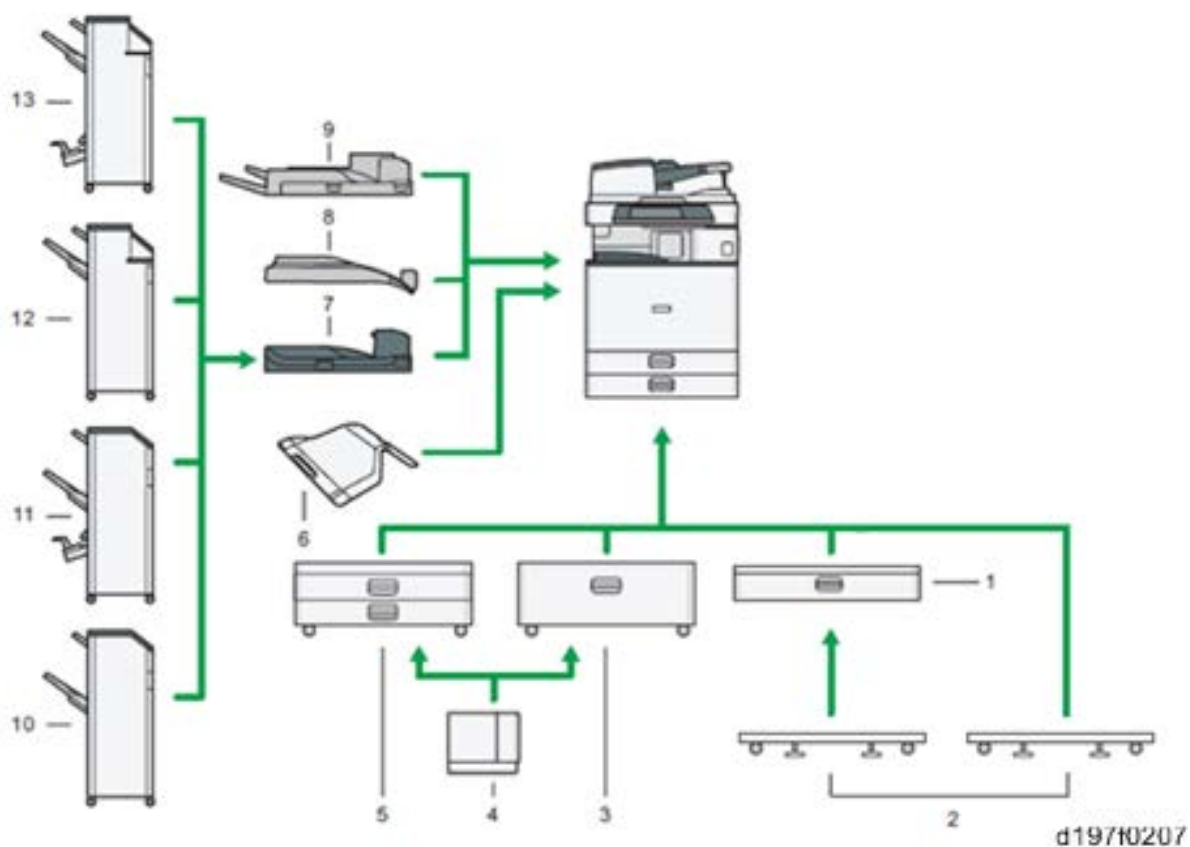

No.	Item	Machine Code
1	Paper Feed Unit PB3150	D694
2	Caster Table Type M3	D178
3	LCIT PB3170	D695
4	LCIT RT3030	D696
5	Paper Feed Unit PB3210	D787
6	1 Bin Tray BN3110	D692
7	Bridge Unit BU3070	D685
8	Internal Shift Tray SH3070	D691
9	Side Tray Type M3	D725
10	Finisher SR3140	D687

No.	Item	Machine Code
11	Booklet Finisher SR3150	D686
12	Finisher SR3160	D689
13	Booklet Finisher SR3170	D688

* Smart Operation Panel Type M3 (D148) is not provided as an option for Europe; however, Smart Operation Panel embedded models are provided.

D197/D198/D199 (Asia)

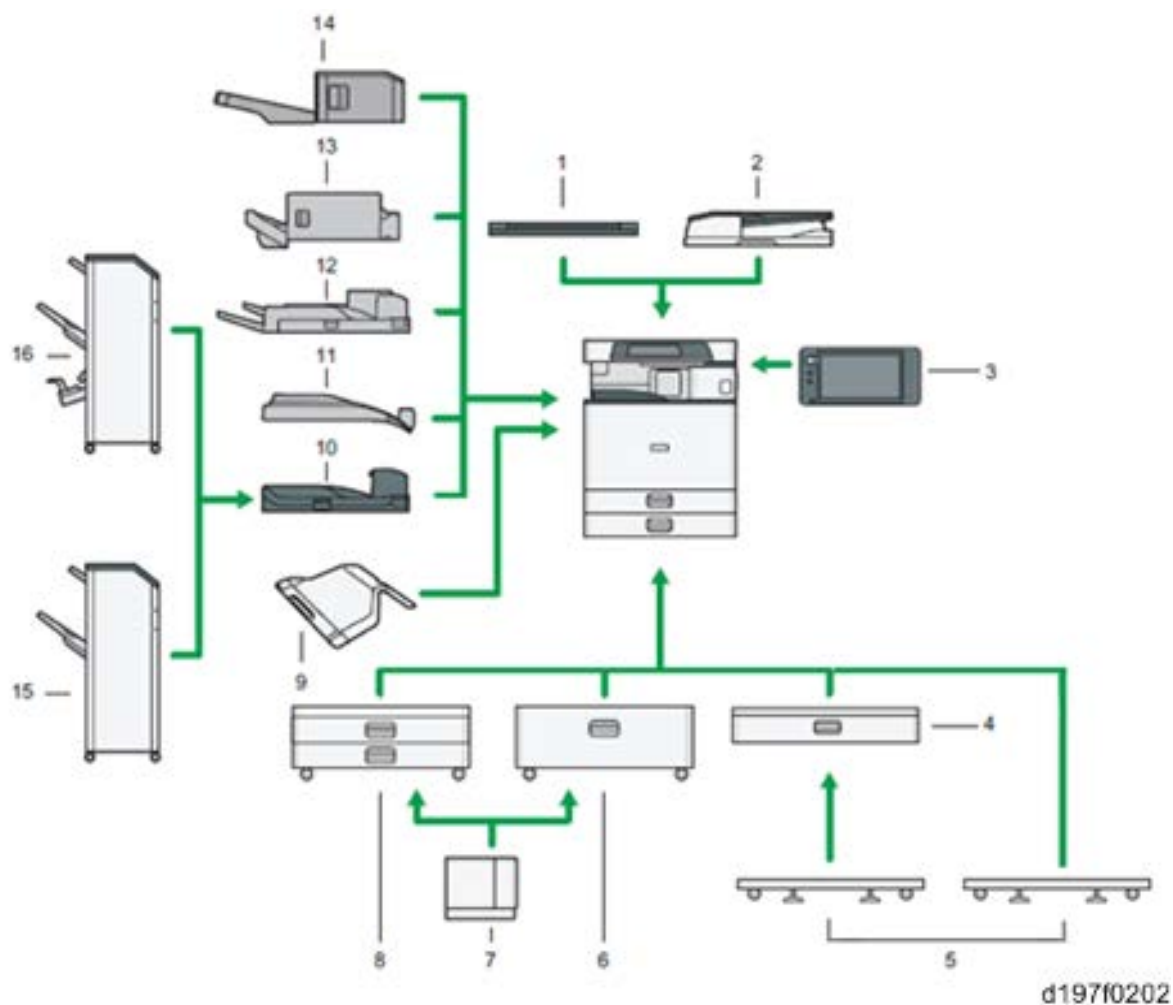

No.	Item	Machine Code
1	Platen Cover PN2000	D700
2	ARDF DF3090	D779
3	Smart Operation Panel Type M3	D148
4	Paper Feed Unit PB3150	D694
5	Caster Table Type M3	D178
6	LCIT PB3170	D695
7	LCIT RT3030	D696
8	Paper Feed Unit PB3210	D787
9	1 Bin Tray BN3110	D692

No.	Item	Machine Code
10	Bridge Unit BU3070	D685
11	Internal Shift Tray SH3070	D691
12	Side Tray Type M3	D725
13	Internal Finisher SR3130	D690
14	Internal Finisher SR3180	D766
15	Finisher SR3140	D687
16	Booklet Finisher SR3150	D686

D200/D201 (Asia)

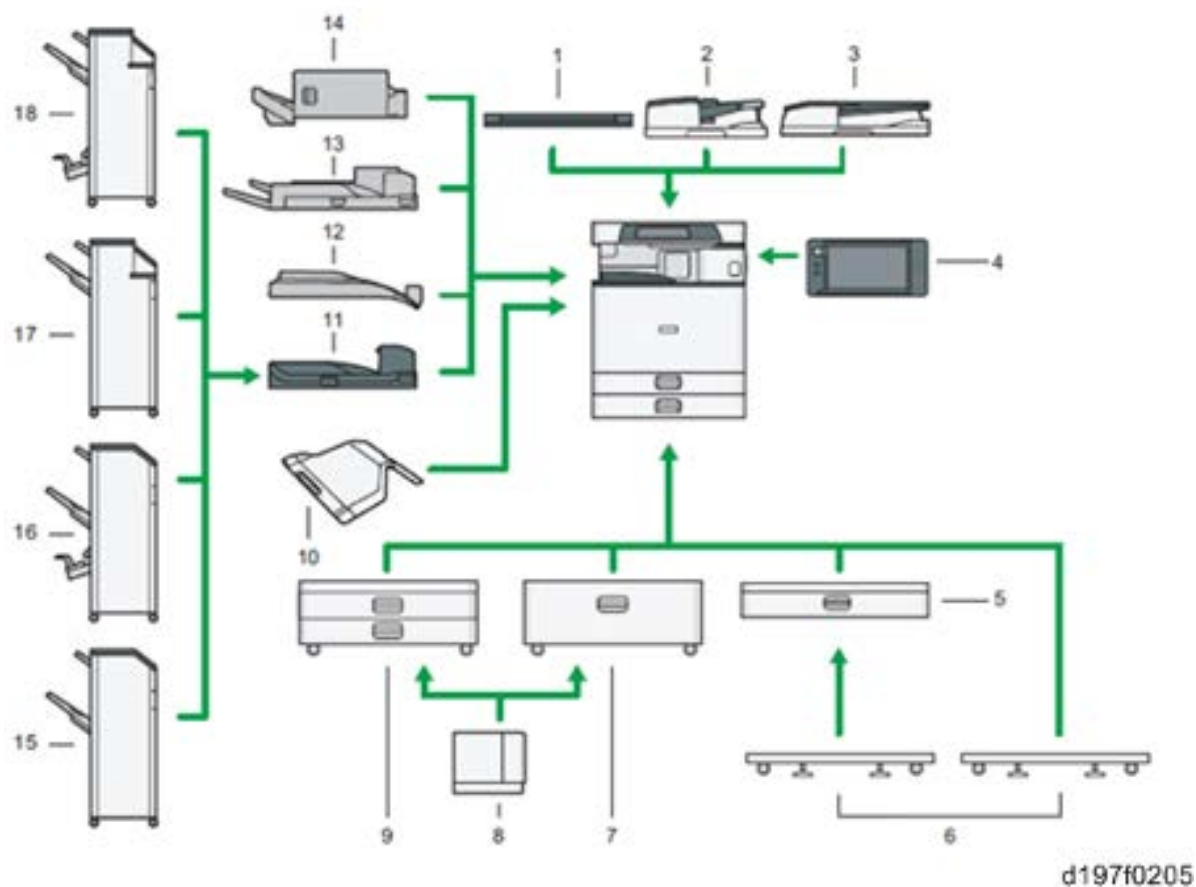

No.	Item	Machine Code
1	Platen Cover PN2000	D700
2	SPDF DF3080	D683
3	ARDF DF3090	D779
4	Smart Operation Panel Type M3	D148
5	Paper Feed Unit PB3150	D694
6	Caster Table Type M3	D178
7	LCIT PB3170	D695
8	LCIT RT3030	D696
9	Paper Feed Unit PB3210	D787
10	1 Bin Tray BN3110	D692

No.	Item	Machine Code
11	Bridge Unit BU3070	D685
12	Internal Shift Tray SH3070	D691
13	Side Tray Type M3	D725
14	Internal Finisher SR3130	D690
15	Finisher SR3140	D687
16	Booklet Finisher SR3150	D686
17	Finisher SR3160	D689
18	Booklet Finisher SR3170	D688

D202 (Asia)

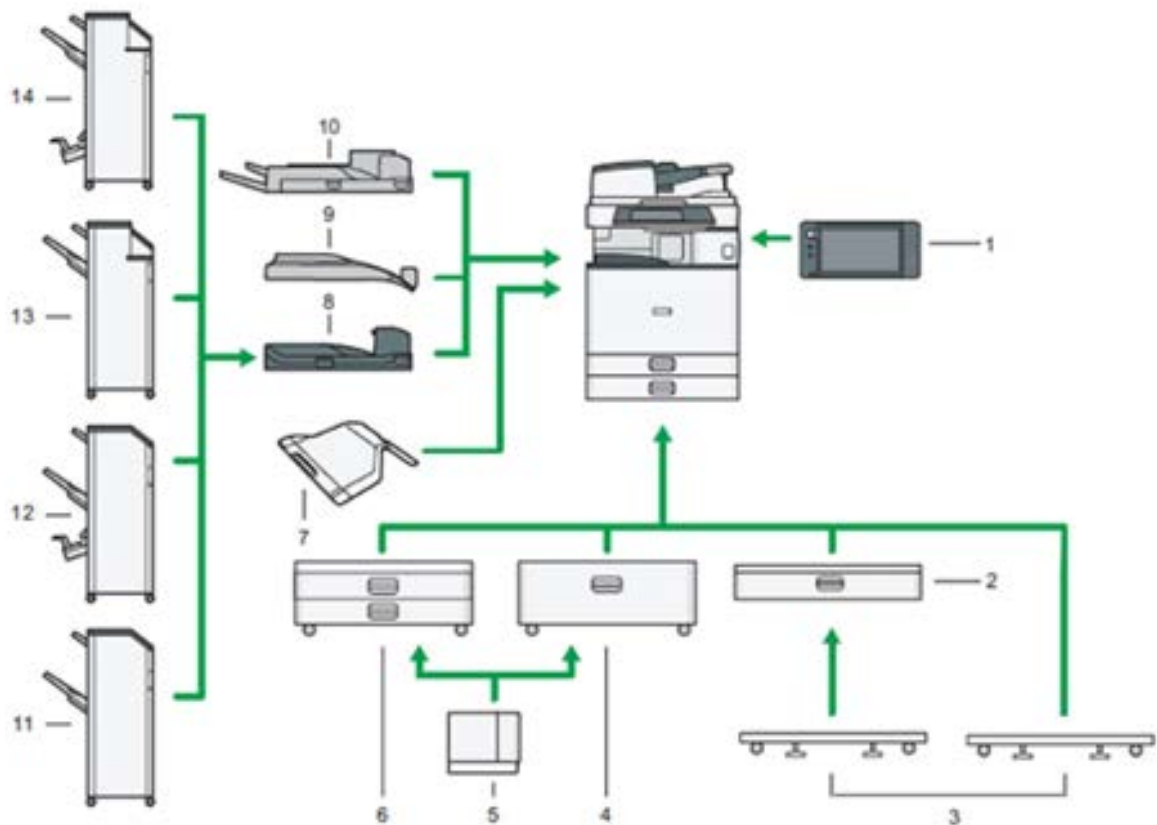

d197f0208

Machine Codes and Peripherals Configuration

No.	Item	Machine Code
1	Smart Operation Panel Type M3	D148
2	Paper Feed Unit PB3150	D694
3	Caster Table Type M3	D178
4	LCIT PB3170	D695
5	LCIT RT3030	D696
6	Paper Feed Unit PB3210	D787
7	1 Bin Tray BN3110	D692
8	Bridge Unit BU3070	D685
9	Internal Shift Tray SH3070	D691
10	Side Tray Type M3	D725
11	Finisher SR3140	D687
12	Booklet Finisher SR3150	D686
13	Finisher SR3160	D689
14	Booklet Finisher SR3170	D688

Guidance for Those Who are Familiar with The Predecessor Product**1.2.2 DIFFERENCES BETWEEN SIMILAR MODELS****D182/D183 vs. D197/D199**

Item		D182/D183	D197/D199
Paper Feed	Mainframe	FRR (Friction Reverse Roller)	RF (Roller Friction)
ADF	Scan Method	Non-Contact	Non-Contact
PCDU	Service Unit	PCDU	PCU + Development unit (preset developer)
Fusing	Method	Fusing roller	QSU-DH
	Fusing Web	No	No
Image Transfer	Method	Transfer roller	Transfer roller with Contact and Release mechanism
	Service Unit	Main-unit	Main-unit
Toner Recycle	Method	All recycle	No recycle or All discard
	Waste Toner Bottle	No	Yes
Laser	LD	1ch-LD	1ch-LD
	Parts Unit	Sub parts	Main-unit
Electrical Component	CTL board	Common	Not common between Basic and SP models
VM		Standard	Standard
Stapleless Stapler Option		Not Available	Available
PM	Method	Logging Counter	Remaining Counter (New PM)

D129/D130 vs. D200/D201/D202

Item		D129/D130	D200/D201/D202
Paper Feed	Mainframe	FRR (Friction Reverse Roller)	RF (Roller Friction)
ADF	Scan Method	Contact	Non-Contact
PCDU	Service Unit	PCU + Developer	PCU + Development unit (preset developer)
Fusing	Method	Fusing roller	QSU-DH
	Fusing Web	Yes	No
Image Transfer	Method	Transfer roller	Transfer roller with Contact and Release mechanism
	Service Unit	Sub part	Main-unit
Toner Recycle	Method	All recycle	No recycle
	Waste Toner Bottle	No	Yes
Laser	LD	2ch-LD	2ch-LD
	Parts Unit	Sub parts	Main-unit
Electrical Component	CTL board	Common	Not common between Basic and SP models
VM		Option	Standard
Stapleless Stapler Option		Not Available	Available
PM	Method	Logging Counter	Remaining Counter (New PM)

Differences between D146 Series

Item		D146	D197/D199/D200/D201/D202
Paper Feed	1st Tray	A4 fixed	A3 universal
	2nd Tray	Up to A3 full-bleed	Up to A3
Tray pull-in mechanism		Tray pull-in mechanism	No Tray pull-in mechanism
Toner Recycle	Method	No recycle	No recycle
	Waste Toner Bottle	PM Parts	EM Parts

INSTALLATION

REVISION HISTORY		
Page	Date	Added/Updated/New
		None

2. INSTALLATION

2.1 INSTALLATION REQUIREMENTS

2.1.1 ENVIRONMENT

1. Temperature Range: 10 °C to 32 °C (50 °F to 89.6 °F)
2. Humidity Range: 15% to 80% RH
3. Ambient Illumination: Less than 1,500 lux (do not expose to direct sunlight.)
4. Ventilation: Room air should turn over at least 3 times/hr/person
5. Ambient Dust: Less than 0.10 mg/m³
6. Avoid an area which is exposed to sudden temperature changes. This includes:
 - Areas directly exposed to cool air from an air conditioner.
 - Areas directly exposed to heat from a heater.
7. Do not place the machine in an area where it will be exposed to corrosive gases.
8. Do not install the machine at any location over 2,000 m (6,500 ft.) above sea level. (NA can be installed only up to 2,500m (8,202 ft.))
9. Place the copier on a strong and level base. (Inclination on any side should be no more than 5 mm.)
10. Do not place the machine where it may be subjected to strong vibrations.

2.1.2 MACHINE LEVEL

Front to back: Within 5 mm (0.2") of level

Right to left: Within 5 mm (0.2") of level

2.1.3 MINIMUM SPACE REQUIREMENTS

Place the copier near the power source, and provide clearance as shown:

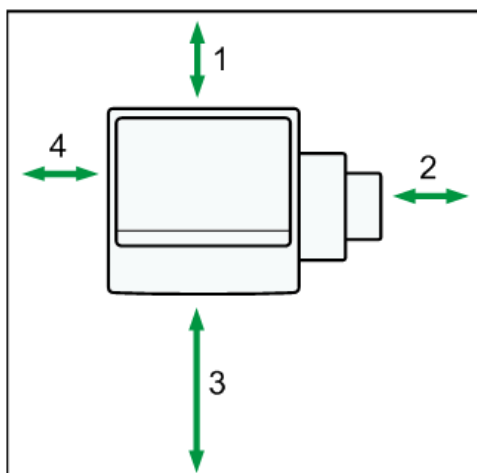

d1822005

Installation Requirements

1. Rear: Over 101 mm (4")
2. Right: Over 432 mm (17")
3. Front: Over 750 mm (15.8")
4. Left: Over 100 mm (4")

ⓘ Note

- The 400 mm recommended for the space at the front is only for pulling out the paper tray. If an operator stands at the front of the copier, more space is required.

2.1.4 MACHINE DIMENSIONS

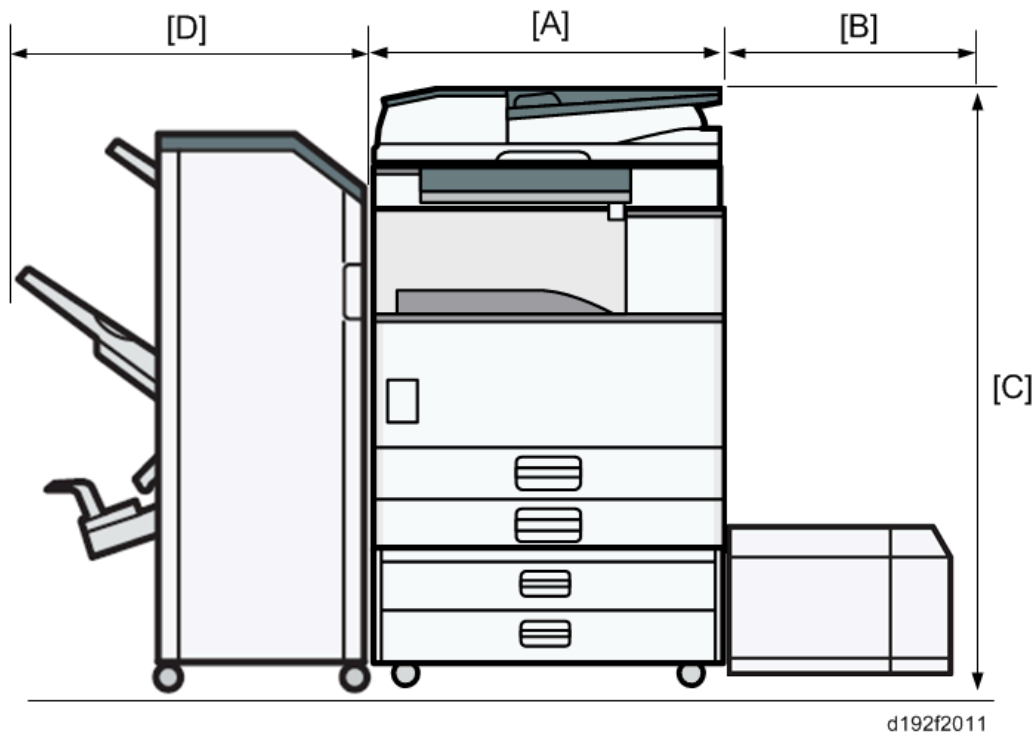

[A]: 587 mm (23.1")

[B]: 340mm (with D696)

[C]: 1210 mm (with D683), 1160 mm (with D779)

[D]: 657 mm (with D688 or D689)

2.1.5 POWER REQUIREMENTS

CAUTION

- Make sure that the wall outlet is near the copier and easily accessible.
- Make sure the plug is firmly inserted in the outlet.
- Avoid multi-wiring.
- Be sure to ground the machine.

Input voltage level

- 120 V to 127 V, 60 Hz: More than 12 A: NA
- 220 V to 240 V, 50 Hz/60 Hz: More than 8A: EU/AP
- 110V, 60 Hz: More than 13.6 A: Taiwan
- 220V,60Hz More than 8A:KO

Voltage tolerance

- Voltage must not fluctuate by more than +8.66% or less than -10%.: NA
- Voltage must not fluctuate by more than 10%.: EU/AP

2.2 MAIN MACHINE INSTALLATION

2.2.1 IMPORTANT NOTICE ON SECURITY ISSUES

In order to increase the security of the MFP, and to ensure that the customer sets the administrator password, an administrator set/change prompt display is shown up at the first power-up.

Overview

- The following Program/Change Administrator screen is displayed at the first power-up.



- When the customers set the administrator/supervisor login password, the display disappears and the home display will appear. The customers, however, can erase this screen with the following procedure if they think there is no need to set the password.
1. **On the Program/Change Administrator screen, press [Change] next to Supervisor and then touch [OK] without inputting any password.**
 2. **Touch [OK] again when the Confirm password display shows up.**
 3. **For Administrator 1, do the same procedure as steps 1 and 2.**
 4. **Press the [OK] button, then the home display appears.**
- SP5-755-002 allows you to skip this screen temporarily and continue the installation procedure without setting an administrator password. However, the Program/Change Administrator screen appears every time you turn the power OFF/ON, if the password is not set.

Password Setting Procedure

Note

- For more details about this security issue, see “Notes on Using Multi-Function Printers Safely” supplied with the MFP.

CAUTION

- When Supervisor / Administrator 1-4 passwords are configured via network, the “Change Supervisor login password” window will not display.
- The passwords for Supervisor or Administrator 1 to 4 can be set via “System Settings”. But the Program/Change Administrator screen appears every time the power switch is turned ON if the passwords are input this way. So we recommend the customers to set the passwords via network or the Program/Change Administrator screen.

1. Install the MFP.
2. Turn the main power switch ON.
3. Change the Supervisor login password.



d176f2101

4. Input the password.



d176f2102

5. Press [OK].

Main Machine Installation



d176f2103

6. Confirm the Password.



d176f2104

7. Press [OK].



d176f2105

8. Change the Administrator 1 login password.

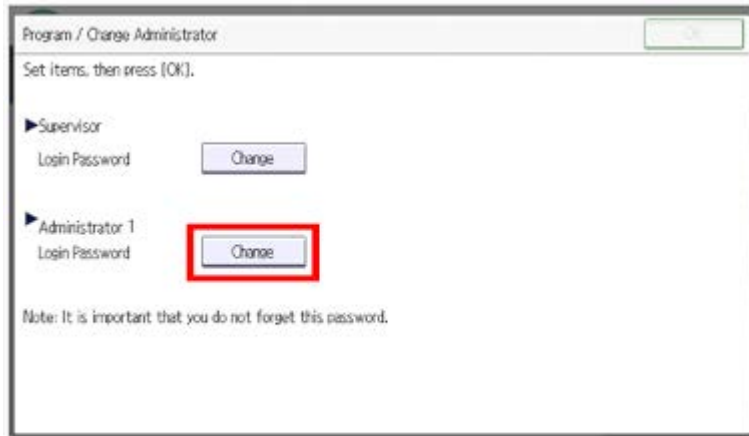

d176f2106

9. Input the password.

d176f2102

10. Press [OK].

d176f2103

11. Confirm the password.

Main Machine Installation



d176f2104

12. Press [OK].



d176f2105

13. Cycle the power OFF/ON.

2.2.2 INSTALLATION FLOW CHART

D197/D198/D199

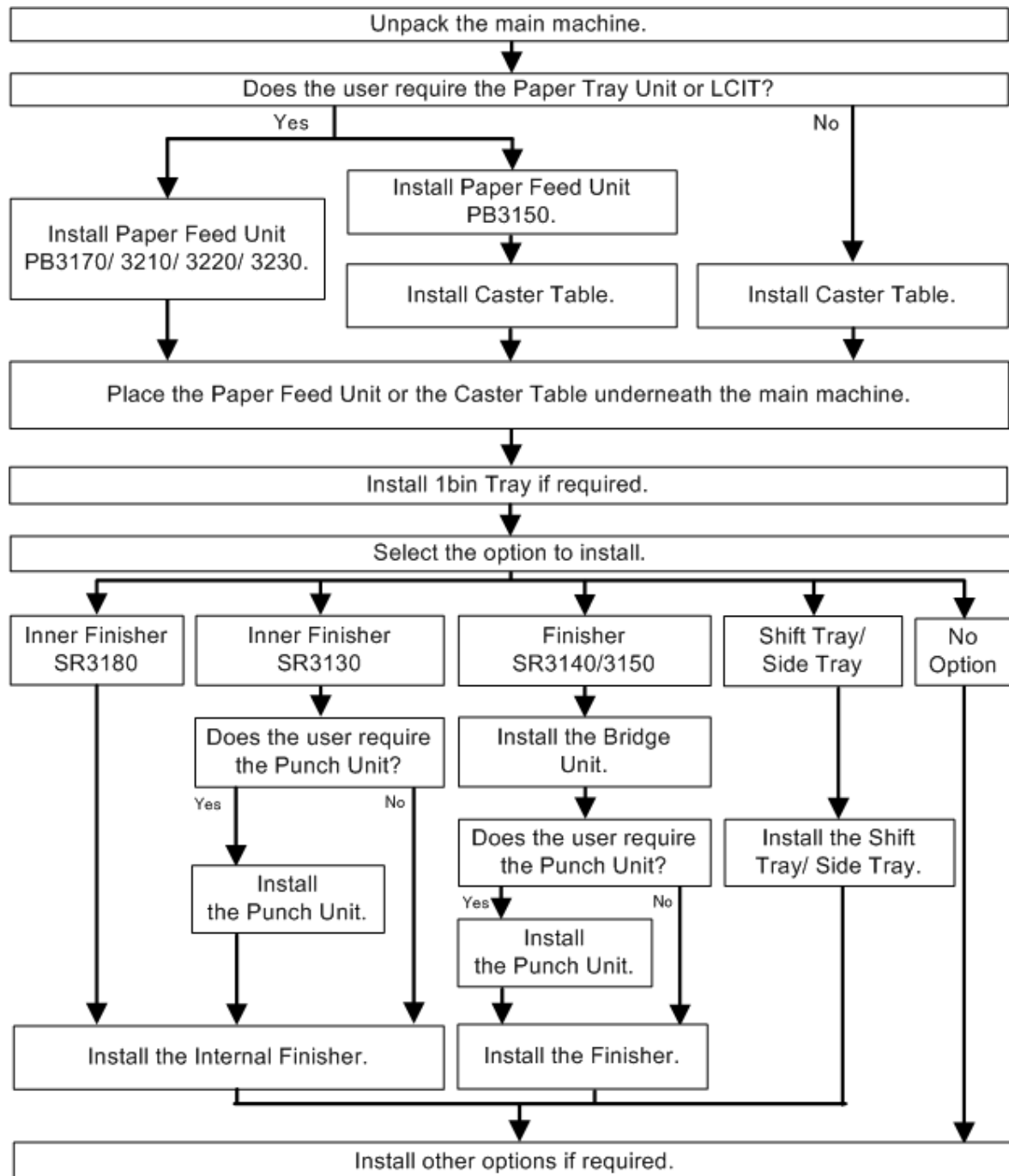

w_d197f0130

D200/D201/D202

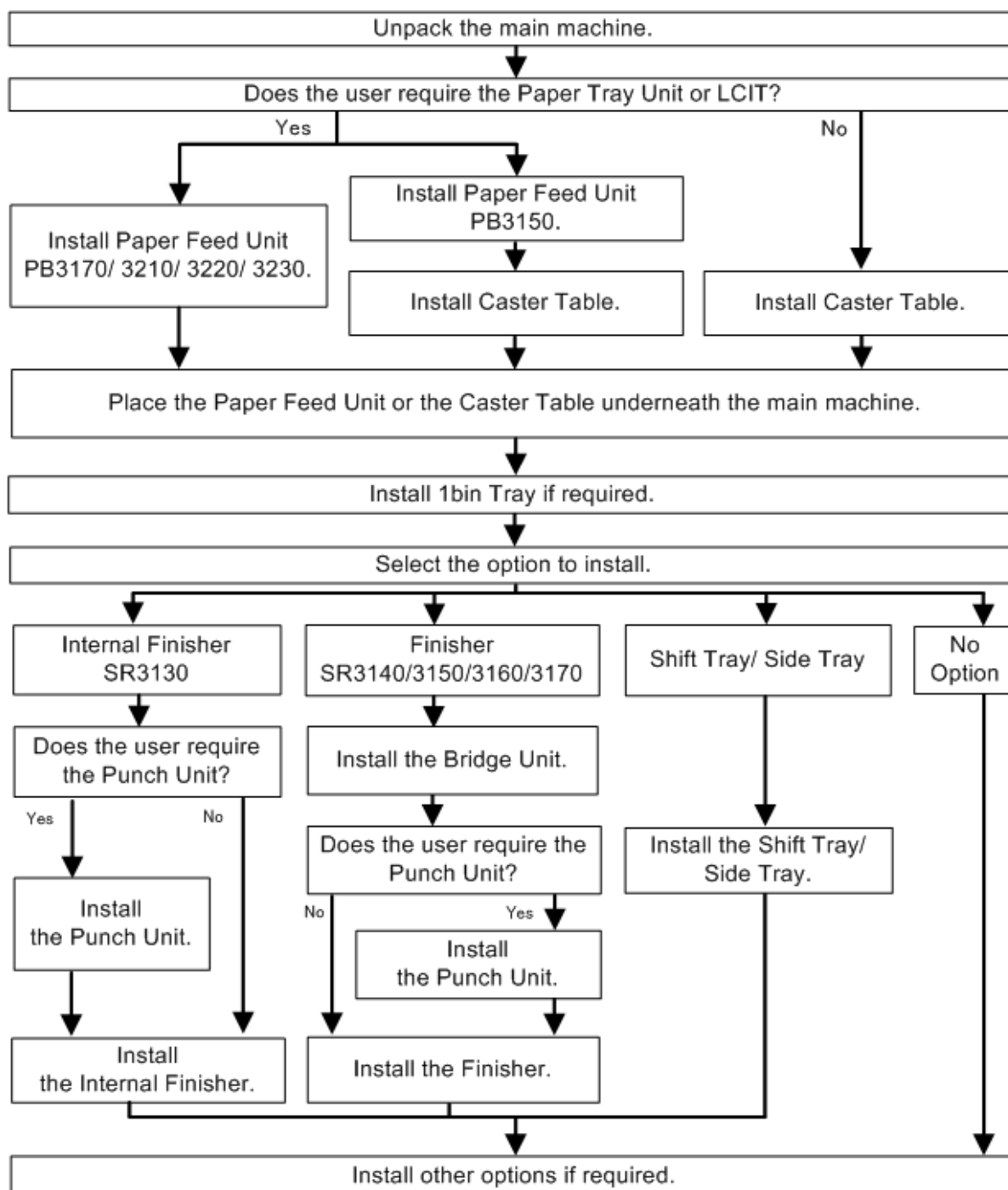

w_d197f0133

2.2.3 ACCESSORY CHECK

Check the quantity and condition of the accessories in the box against the following list:

No.	Description	Q'ty	Remarks
1	Rear Lower Gap Cover	1	
2	Original Caution Decal: English	1	
3	Original Caution Decal: Multi-Language	1	
4	Main Switch On-Standby Decal	1	
5	Model Name Plate	1	
6	Original Table Decal	1	
7	Glass Cleaner Holder	1	
8	Logo Plate: Type GES	1	
9	Logo Plate: Type LAN	1	
10	:Logo Plate: Type RIC	1	
11	Power Supply Cord (120V:15A:NA)	1	NA only
12	Power Supply Cord (250V:10A:EU)	1	EU and Asia only
13	Exposure Glass Sheet:	1	
14	Stopper: Paper Exit Tray	1	

2.2.4 INSTALLATION PROCEDURE

Unloading

★ Important

- When unloading the main machine from a pallet, hold the specified locations. Holding the scanner unit may deform the main machine. Note that the grip at the front right is hidden by the cushioning material [A]. Remove the material to grip it.
- Lift the main machine slowly, using two people.

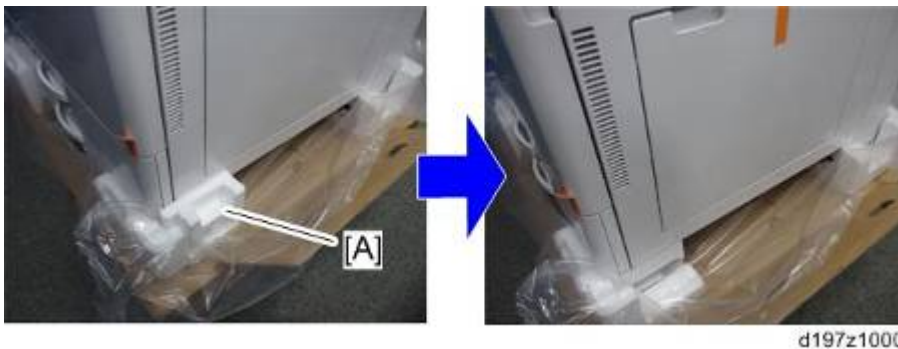

Tapes and Retainers

⚠ CAUTION

- Unplug the machine power cord before you start the following procedure.

If the optional paper feed unit, the optional LCT or the caster table is going to be installed now, put the copier on these options, and then install the copier and options.

⬇ Note

- Keep the shipping retainers after installing the machine. They will be reused if the machine is moved to another location in the future.

1. Remove the tapes on the exterior of the copier.



Note

- If the ADF is installed, remove the tapes and retainers on the ADF as well.



2. Remove the cushioning material [A] on the exposure glass.



3. Pull out the 1st and 2nd paper feed trays and remove the tapes and accessories.

Main Machine Installation



4. Remove the scanner support [A]



5. Open the front cover and store the scanner support [A] in the storage location.

ⓘ Note

- The factory setting sheet is kept in the storage location.

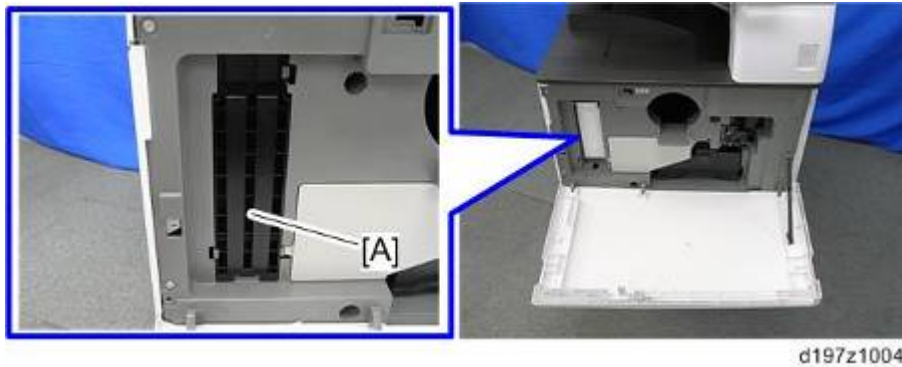

6. Close the front cover.

Toner Bottle

↓ Note

- This machine has toner bottle set detection and does not operate without the toner bottle.
- D197, D198, and D199 toner bottles are compatible with D200, D201, and D202. However, D200, D201, and D202 toner bottles are incompatible with D197, D198, and D199.

1. Open the front cover.
2. Make sure that the black cap of the toner bottle is firmly tightened, then shake the toner bottle up and down seven or eight times while the cap faces upward.

↓ Note

- Shaking the bottle while the cap faces downward causes a possible toner blockage.

3. Remove the toner bottle protection cap [A].



4. Push the toner bottle [A] into the machine slowly.



5. Turn on the main power switch while the front cover is open to execute the initial toner supply.

Main Machine Installation

↓ Note

- If the front cover is closed when executing the initial toner supply, the machine starts a normal toner supply.

6. Enter SP mode from the copy application window, and then press [System Sp].



d197f3001

↓ Note

- Initializing messages do not show up if you enter SP mode from the home screen, so please make sure that you enter SP mode from the copy window.

7. Set the setting of SP3-510-031(ImgQtyAdj :ExeFlag: Init Toner Replenish: K) to “1”, and then press “#” on the operation panel.

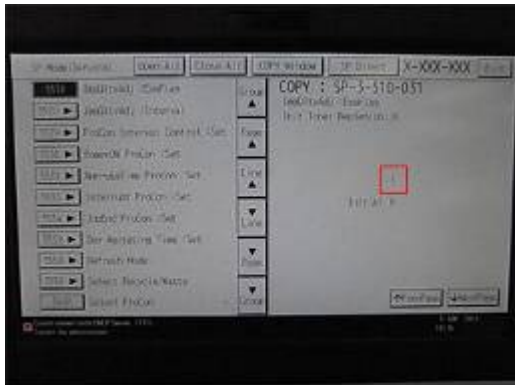

d197f3004

8. Press [EXIT] to end the SP mode.

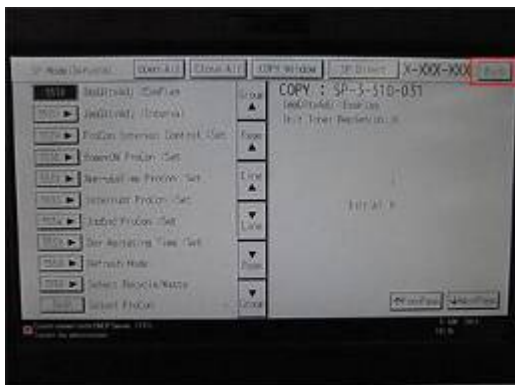

d197f3005



d197f3006

9. Close the front cover.
10. The machine automatically starts the initial toner supply.



d197f3009

⚠ CAUTION

- It takes about one to two minutes to finish the initial toner supply. If the toner has not been shaken well, it may take up to about 10 minutes.
- If a toner bottle has not been set, the machine does not work because there is a toner bottle set detection mechanism.
- If you turn on the machine without closing the front cover, the initial toner supply is not performed at installation, and the machine goes to the toner end condition even if the machine has plenty of toner in the toner bottle.

11. Enter SP mode again, and then press [System Sp].



d197f3001

12. Enter SP7-622-250 (PM Counter Reset: SCS), and then press [Execute].

Main Machine Installation

Note

- This procedure updates the replacement year/date.
- The SP has an initial value that was set in the factory. Update this value so that the estimated remaining days counters will work correctly.



d197f3002

13. Press [Exit] when completed.

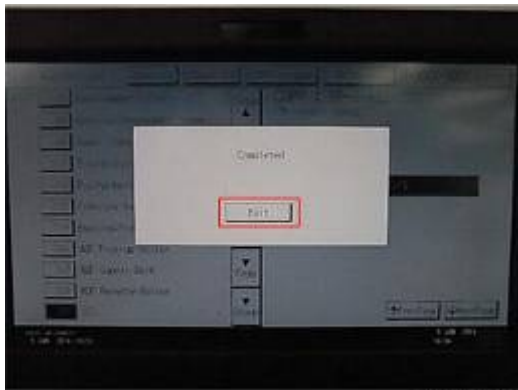

d197f3003

14. Enter SP3-011-001 (Manual ProCon :Exe), and then press [Execute].

Note

- Be sure to do this procedure in the main machine installation. Otherwise, abnormal images may be developed until the next process control.

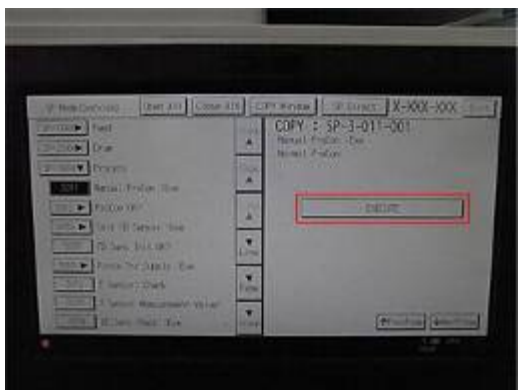

d197f3007

15. Press [Exit] when completed.

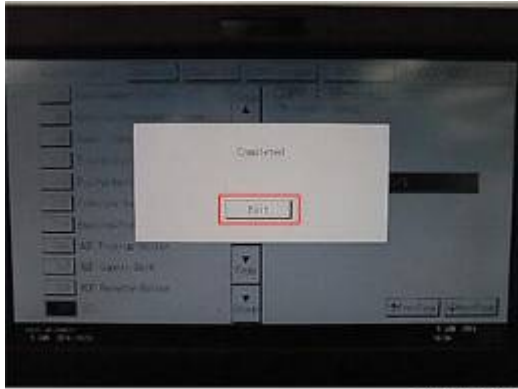

d197f3003

16. Press [EXIT] to end the SP mode.



d197f3008



d197f3006

Note if the initial toner supply has not been performed

If you start printing without executing the initial toner supply at installation, the machine goes to the toner end condition even if the machine has plenty of toner in the toner bottle. Do the following procedure to perform the toner end recovery if the machine has entered the toner end condition.

1. **Open the front cover for five seconds or more.**
2. **Make sure that the toner bottle is set properly.**
3. **Close the front cover.**
4. **The toner end recovery automatically starts**

Paper Exit Tray Stopper

1. **Attach the stopper [A] to the paper exit tray.**

★ Important

- **Before installing the stopper, move the bar inside the stopper in order to avoid damaging the bar.**



2. **Hook the bar [A] onto the paper exit tray.**

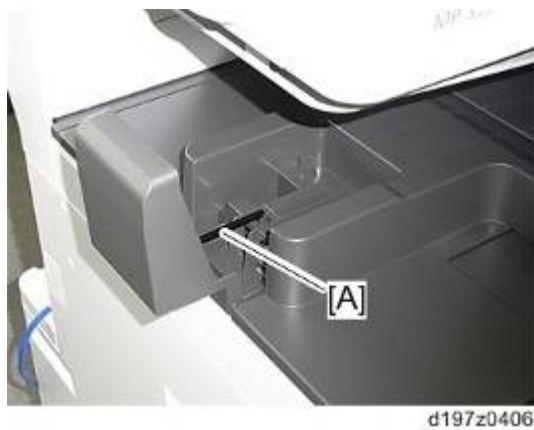

Emblem, Decals

1. Paste the decals on the specified locations.

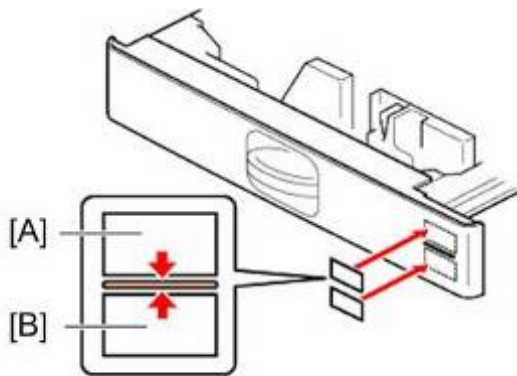

[A]: Tray number decal

[B]: Paper size decal

Completion

1. If the optional bridge unit is not to be installed, swing the sensor feeler [A] out.



2. Install the optional ARDF or the optional platen cover (page 2-59, page 2-56).
3. Pull out trays, and then adjust the side fences and end fence to match the paper size.

↓ Note

- To move the side fences, first pull out the tray fully, then push down the green lock at the rear of the tray.
4. Connect the power cord to the inlet of the main machine.



2.2.5 SECURITY SETTINGS

The machine contains the Security functions (Data Overwrite Security and HDD Encryption unit) in the controller board.

When installing a new machine, it is recommended to activate the Data Overwrite Security and HDD Encryption by selecting "Format All Data" from "System Settings" on the operation panel. For details, refer to the "Security Settings page 2-275".

2.2.6 CHECK IMAGE QUALITY / SETTINGS

Loading Paper

When there are other options to be installed, install according to the procedure for each.

1. **Connect the power plug to the wall socket.**
2. **Turn the main power ON.**
3. **Check that the operation panel shows the following display.**
"Please supply the tray with paper."
4. **Square the paper and load it print side up.**
5. **The paper size is basically detected automatically.**
 1. Pull out the paper feed tray slowly until it stops.
 2. While pressing the release lever, adjust the side fence to the paper size to be set.
 3. Set the end fence.

Checking the copy image with the test chart

Check the copy image with the test chart.

SP Settings

1. **Go into the SP mode.**
2. **Do SP5-181 and SP1-007-001 to change automatic paper size selection for the upper tray, lower tray, and by-pass tray if necessary.**

Upper Tray (Size Adjust Tray 1)

5-181-001	Tray 1: 1	0: A4LEF or 1: LT LEF
5-181-002	Tray 1: 2	0: A3 or 1: DLT
5-181-003	Tray 1: 3	0: B4 or 1: LG
5-181-004	Tray 1: 4	0: B5 LEF or 1: Exe LEF

Lower Tray (Size Adjust Tray 2)

5-181-005	Tray 2: 1	0: A4LEF or 1: LT LEF
5-181-006	Tray 2: 2	0: A3 or 1: DLT
5-181-007	Tray 2: 3	0: B4 or 1: LG
5-181-008	Tray 2: 4	0: B5 LEF or 1: Exe LEF

By-Pass Tray (By-Pass Size Detection)

1-007-001*	By-pass Tray	0: LT SEF or 1: LG SEF
------------	--------------	------------------------

* This setting is necessary only for NA models (SP5-131-001: "1").

3. For basic models, enable the NIB and/or USB function if you install the Printer/Scanner option or @Remote.

Note

- This step is for Basic models only. Enable these functions if you install the Printer/Scanner option and/or @remote option; keep these functions disabled if neither of these options are installed.
- To enable the NIB function if you install a printer/scanner option, with or without @Remote, enter the SP mode and set SP5-985-001 (On Board NIC) to "1"(Enable). However, if @Remote is to be used for a basic model without printer/scanner option, this SP must be set to "2".
- To enable the USB function, enter the SP mode and set SP5-985-002 (On Board USB) to "1"(Enable).
- You must turn the machine off/on after changing these settings, because these settings only take effect after the machine is restarted.

4. Exit SP mode.

5. Do some test copies to make sure that the machine operates correctly.

2.2.7 MOVING THE MACHINE

This section shows you how to manually move the machine from one floor to another floor. See the section "Transporting the Machine" if you have to pack the machine and move it a longer distance.

- Turn the main power OFF and pull out the plug.
- Close all the covers and trays.
- Remove peripherals physically attached to the main machine: Paper feed unit, LCT and finisher.
- Keep the machine horizontal and move it slowly. Tipping and excess vibrations may damage the machine.

2.2.8 TRANSPORTING THE MACHINE

1. Do SP4-806-001 to move the scanner carriage from the home position. This prevents dust from falling into the machine during transportation.
2. Remove the toner cartridges. This prevents toner leak, which is caused by vibration during transport.
3. Make sure there is no paper left in the paper trays. Then fix down the bottom plates with a sheet of paper and tape.
4. Take out the scanner stay from inside the front cover and install the scanner stay.
5. Do one of the following steps:
 - Attach shipping tape to the covers and doors.
 - Shrink-wrap the machine tightly.

2.3 PAPER FEED UNIT PB3210/ PB3220

2.3.1 ACCESSORY CHECK

No.	Description	Q'ty
1	Screws (M4 x 10)	2
2	Screw with Spring Washer (M4 x 10)	1
3	Securing Bracket	2

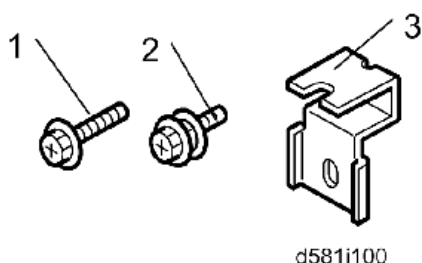

2.3.2 INSTALLATION PROCEDURE

⚠ CAUTION

- The machine should be held at the correct locations and lifted gently.
- If it is lifted without care, handled carelessly or dropped, it may result in an injury.
- When installing this option, turn the machine power OFF, and unplug the power supply cord from the wall socket.
- If this option is installed with the power on, it may result in an electric shock or a malfunction.
- Be sure to join the machine to the paper feed unit so as to prevent equipment from falling over.
- If they are not connected, they may move and fall over, resulting in injury.

1. Remove the orange tape and retainers.



- Remove the items provided (fixing screws, etc.) from the package.

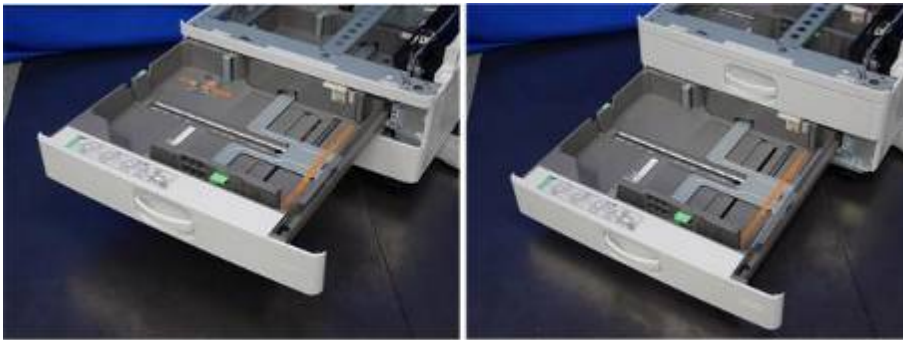

d197z1012

- Holding the grips on the machine, align it with the locating pin [A], and place the machine on the paper feed unit.

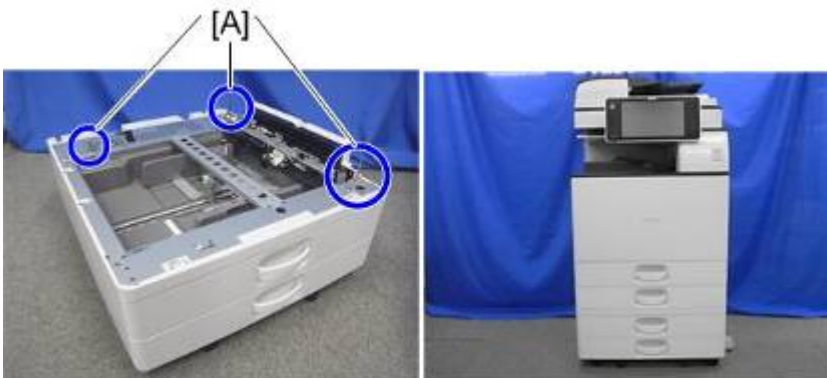

d197f0604

Note

- When you lift the machine, hold the correct locations.
- In particular, do not lift the machine by holding the scanner unit, etc, because this may cause the machine to deform.
- Do not put the machine down on the paper feed unit as a temporary resting place. This may cause the paper feed unit to deform. Always connect the machine and paper feed unit properly.

- Pull out the 2nd paper feed tray.
- Using securing bracket as a screwdriver, fix the machine to the feed unit (spring washer: screw: M4×10: 1).



d197f0113

6. Attach the securing brackets [A] to two positions on the left and right at the rear of the machine (screws: 1 each).

Note

- If the anti-condensation heater for this optional tray is to be installed, connect its heater harness prior to this step (step 6) (page 2-188).
- If "LCIT RT3030" is to be installed, connect its harness prior to this step (step 6) (page 2-44).

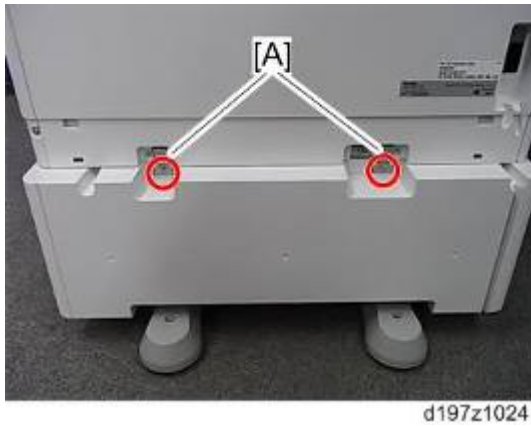

7. Attach the rear lower gap cover [A] (x 2)



8. Return the paper feed tray to the machine

9. Attach the decals as shown below.

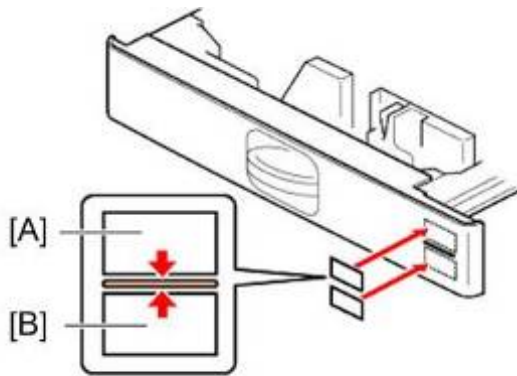

d1462230

[A]: Tray number decal [B]: Paper size decal

Note

- The tray number decal and paper size decal are packaged together with the machine.

10. Lock the casters of the paper feed unit.



d1462439

11. Connect the power cord to the machine.

Note

- Stabilizers are attached to the machine when it is shipped. Do not remove it.



d197f2003

12. Turn the main power ON.

13. Set the paper, and check that the paper size set in the paper feed tray is displayed on the operation panel.

- Paper size for the paper feed unit can be changed with following SPs.
 SP5-181-009 (0: A4 LEF or 1: LT LEF) for Tray 3
 SP5-181-010 (0: A3 or 1: DLT) for Tray 3
 SP5-181-011 (0: B4 or 1: LG) for Tray 3
 SP5-181-012 (0: B5 LEF or 1: Exe LEF) for Tray 3
 SP5-181-014 (0: A4 LEF or 1: LT LEF) for Tray 4
 SP5-181-015 (0: A3 or 1: DLT) for Tray 4
 SP5-181-016 (0: B4 or 1: LG) for Tray 4
 SP5-181-017 (0: B5 LEF or 1: Exe LEF) for Tray 4

14. Adjust the registration for the paper feed unit.

- For Tray 3
 SP1-001-0xx (Leading Edge Registration Tray 3)

-055	Tray3: Thin	-062	Tray3: Thin:1200
-056	Tray3: Plain	-063	Tray3: Plain:1200
-057	Tray3: Mid-thick	-064	Tray3: Mid-thick:1200
-058	Tray3: Thick 1	-065	Tray3: Thick 1:1200
-059	Tray3: Thick 2	-066	Tray3: Thick 2:1200
-060	Tray3: Thick 3	-067	Tray3: Thick 3:1200
-061	Tray3: Thick 4	-068	Tray3: Thick 4:1200

SP1-002-004 (Side-to-Side Registration Paper Tray 3)

- For Tray 4
 SP1-001-0xx (Leading Edge Registration Tray 4)

-069	Tray4: Thin	-076	Tray4: Thin:1200
-070	Tray4: Plain	-077	Tray4: Plain:1200
-071	Tray4: Mid-thick	-078	Tray4: Mid-thick:1200
-072	Tray4: Thick 1	-079	Tray4: Thick 1:1200
-073	Tray4: Thick 2	-080	Tray4: Thick 2:1200
-074	Tray4: Thick 3	-081	Tray4: Thick 3:1200
-075	Tray4: Thick 4	-082	Tray4: Thick 4:1200

SP1-002-005 (Side-to-Side Registration Paper Tray 4)

2.4 PAPER FEED UNIT PB3150

2.4.1 ACCESSORY CHECK

No.	Description	Q'ty
1	Screws - M4 x 10	2
2	Screw with Spring Washer - M4 x 10	1
3	Securing Bracket	2

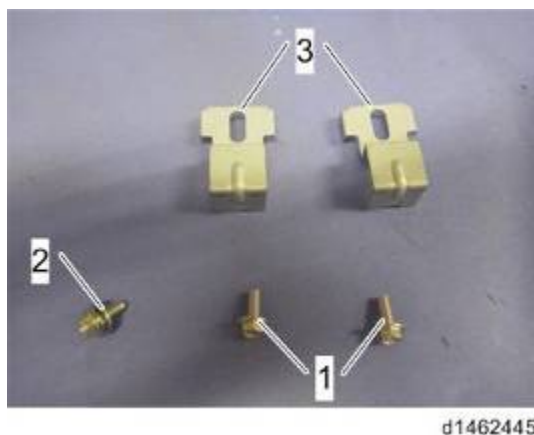

2.4.2 INSTALLATION PROCEDURE

⚠ CAUTION

- The machine should be held at the correct locations and lifted gently by two people.
- If it is lifted without care, handled carelessly or dropped, it may result in injury.
- When installing this option, turn the machine power OFF, and unplug the power supply cord from the wall socket.
- If this option is installed with the power on, it may result in an electric shock or a malfunction.
- Be sure to join the machine to the paper feed unit so as to prevent equipment from falling over.
- If they are not connected, they may move and fall over, resulting in injury.

📌 Note

- "Caster Table Type M3" is necessary to use this option.

1. Remove the orange tape and retainers.

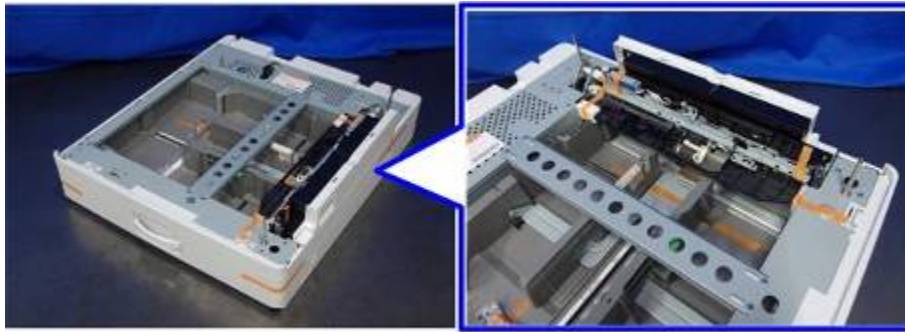

d197z1013

2. Remove the items provided (fixing screws, etc.) from the package.



d197z1014

3. Install this option on the Caster Table (page 2-52).
4. Holding the grips on the machine, align it with the locating pin [A], and place the machine on the paper feed unit.

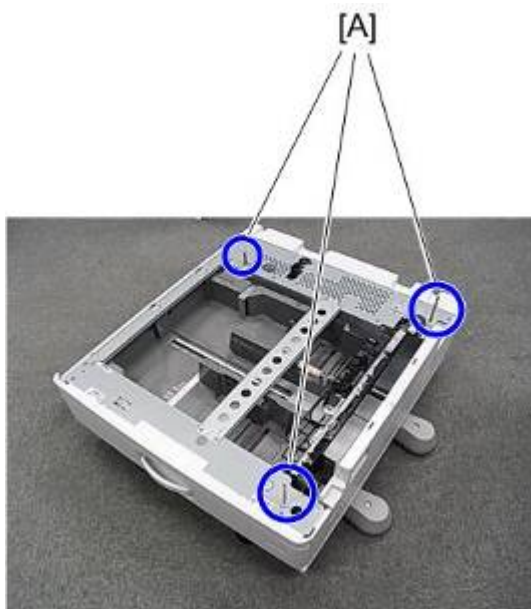

d197f0114

Note

- When you lift the machine, hold the correct locations.
- In particular, do not lift the machine by holding the scanner unit, etc., because this may cause the machine to deform.
- Do not put the machine down on the paper feed unit as a temporary resting place. This may cause the paper feed unit to deform. Always connect the machine and paper feed unit properly.

5. Pull out the 2nd paper feed tray of the main machine.
6. Using a securing bracket as a screwdriver, fix the machine to the feed unit (spring washer: screw: M4×10: 1).



7. Attach the securing brackets [A] to two positions on the left and right at the rear of the machine (screws: 1 each).

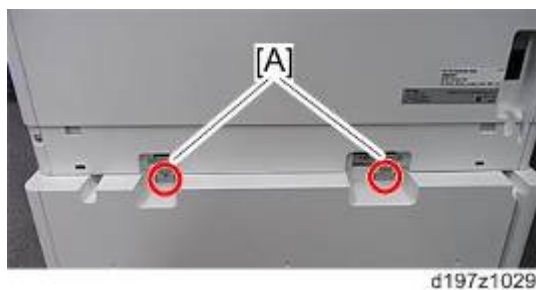

8. Attach the rear lower gap cover [A] (▼ x 2)



9. Return the paper feed tray to the machine.

10. Attach the decals as shown below.

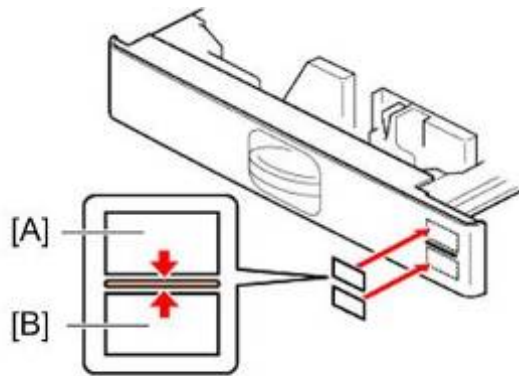

d1462230

[A]: Tray number decal

[B]: Paper size decal

ⓘ Note

- The tray number decal and paper size decal are packaged together with the machine.

11. Lock the casters of the paper feed unit.



d1462439

12. Connect the power cord to the machine.

ⓘ Note

- Stabilizers are attached to the paper feed unit when it is shipped. Do not remove them.



d197f2003

13. Turn the main power switch ON.

14. Set the paper, and check that the paper size set in the paper feed tray is displayed on the operation panel.

- Paper size for the paper feed unit can be changed with following SP.
 SP5-181-009 (0: A4 LEF or 1: LT LEF)
 SP5-181-010 (0: A3 or 1: DLT)
 SP5-181-011 (0: B4 or 1: LG)
 SP5-181-012 (0: B5 LEF or 1: Exe LEF)

15. Adjust the registration for the paper feed unit.

SP1-001-0xx (Leading Edge Registration Tray 3)

-055	Tray3: Thin	-062	Tray3: Thin:1200
-056	Tray3: Plain	-063	Tray3: Plain:1200
-057	Tray3: Mid-thick	-064	Tray3: Mid-thick:1200
-058	Tray3: Thick 1	-065	Tray3: Thick 1:1200
-059	Tray3: Thick 2	-066	Tray3: Thick 2:1200
-060	Tray3: Thick 3	-067	Tray3: Thick 3:1200
-061	Tray3: Thick 4	-068	Tray3: Thick 4:1200

SP1-002-004 (Side-to-Side Registration Paper Tray 3)

2.5 LCIT PB3170/ PB3230

2.5.1 ACCESSORY CHECK

No.	Description	Q'ty
1	Securing Bracket	2
2	Screw(M4x10)	2
3	Hexagonal Bolt	1

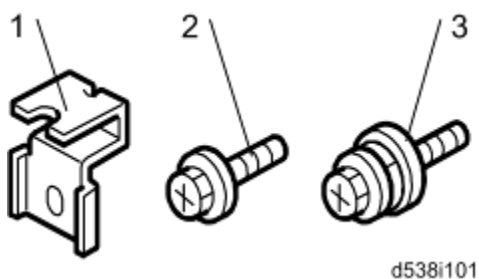

2.5.2 INSTALLATION PROCEDURE

⚠ CAUTION

- The machine should be held at the correct locations and lifted gently.
- If it is lifted without care, handled carelessly or dropped, it may result in an injury.
- When installing this option, turn the machine power OFF, and unplug the power supply cord from the wall socket.
- If this option is installed with the power on, it may result in an electric shock or a malfunction.
- Be sure to join the machine to the paper feed unit so as to prevent equipment from falling over.
- If they are not connected, they may move and fall over, resulting in injury.

1. Remove the orange tape and retainers.

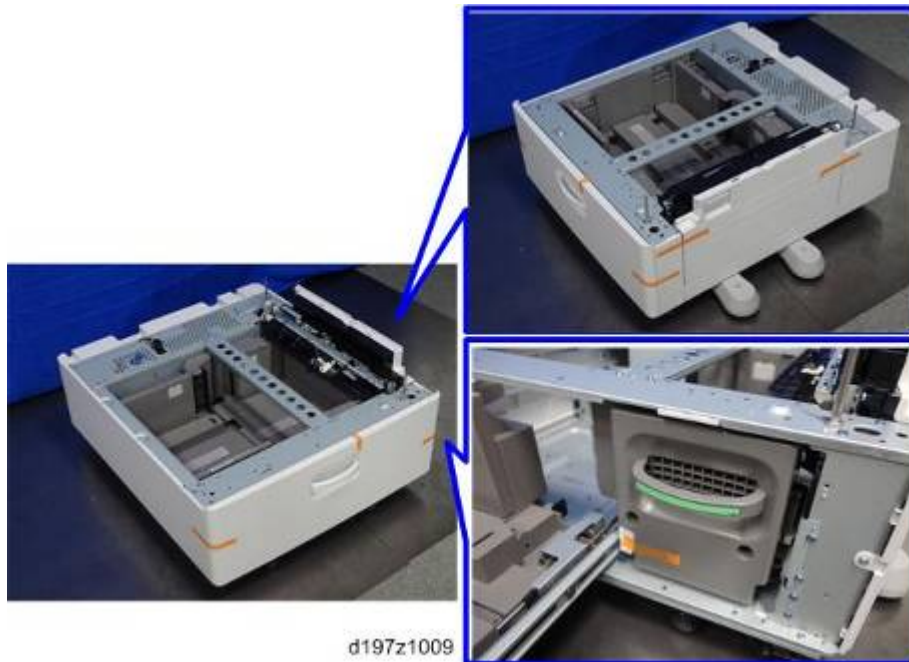

2. Remove the items provided (fixing screws, etc.) from the package.

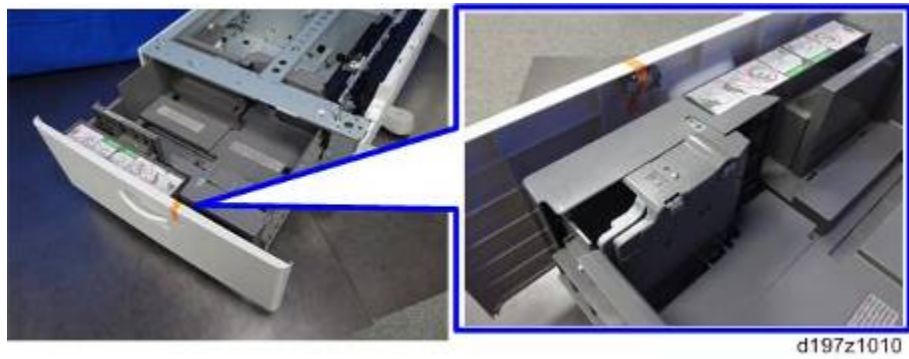

3. Holding the grips on the machine, align it with the locating pin [A], and place the machine on the paper feed unit.

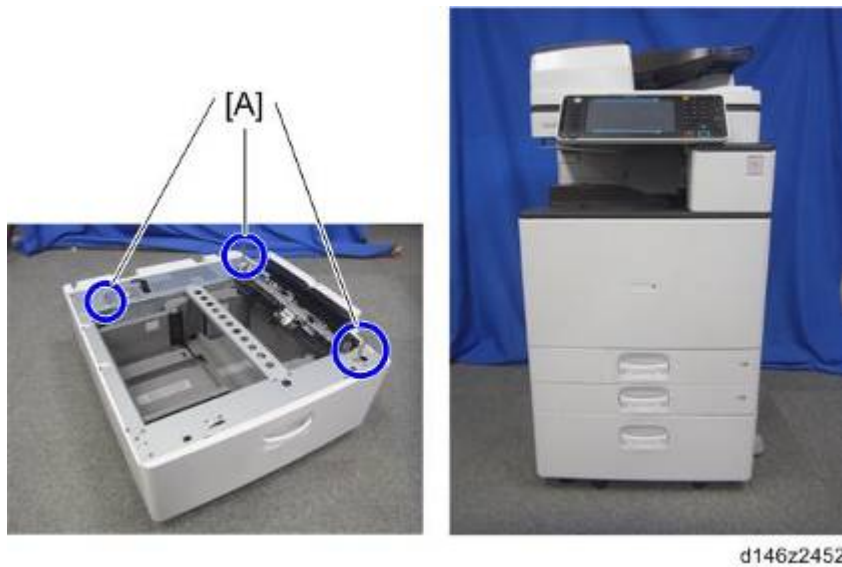

↓ Note

- When you lift the machine, be sure to hold the grips on the machine.
- In particular, do not lift the machine by holding the scanner unit, etc., because this may cause the machine to deform.
- Do not put the machine down on the paper feed unit as a temporary resting place. This may cause the paper feed unit to deform. Always connect the machine and paper feed unit properly.

4. Pull out the 2nd paper feed tray of the machine.
5. Using a securing bracket as a screwdriver, secure the machine to the LCT unit (spring washer: screw: M4×10: 1).



6. Attach the securing brackets [A] to two positions on the left and right at the rear of the machine (screws: 1 each).

↓ Note

- If the anti-condensation heater for this optional tray is to be installed, connect its heater harness prior to this step (step 6) (page 2-192).
- If "LCIT RT3030" is to be installed, connect its harness prior to this step (step 6) (page 2-44).

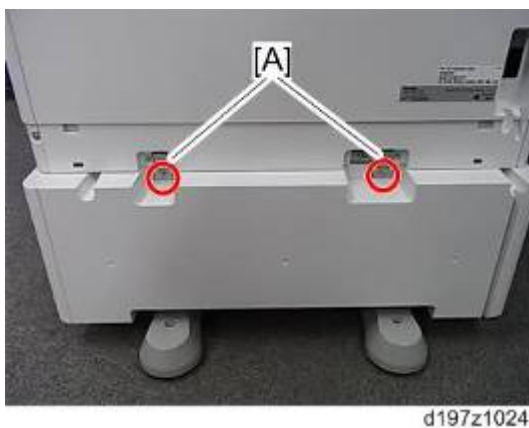

7. Attach the rear lower gap cover [A] (↖ x2)

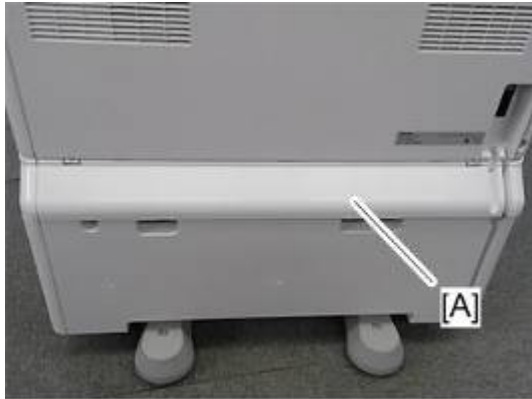

d197f2002

8. Return the paper feed tray to the machine.

9. Attach the decals as shown below.

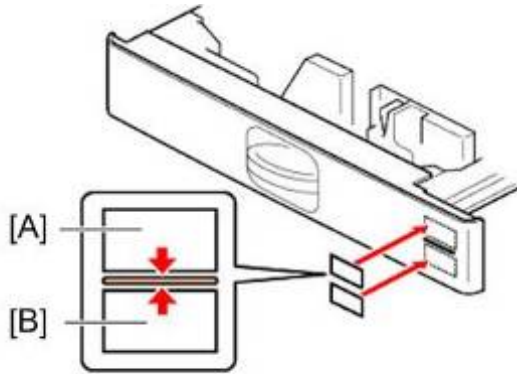

d1462230

[A]: Tray number decal

[B]: Paper size decal

Note

- The tray number decal and paper size decal are packaged together with the machine.

10. Lock the casters of the paper feed unit.



d1462439

11. Connect the power cord to the machine.

Note

- Stabilizers are attached to the LCIT when it is shipped. Do not remove any of them.



d197f2003

12. Turn the power switch ON.
13. Set the paper, and check that the paper size set in the paper feed tray is displayed on the operation panel.
14. Adjust the registration for the paper feed unit.
SP1-001-0xx (Leading Edge Registration Tray 3)

-055	Tray3: Thin	-062	Tray3: Thin:1200
-056	Tray3: Plain	-063	Tray3: Plain:1200
-057	Tray3: Mid-thick	-064	Tray3: Mid-thick:1200
-058	Tray3: Thick 1	-065	Tray3: Thick 1:1200
-059	Tray3: Thick 2	-066	Tray3: Thick 2:1200
-060	Tray3: Thick 3	-067	Tray3: Thick 3:1200
-061	Tray3: Thick 4	-068	Tray3: Thick 4:1200

SP1-002-004 (Side-to-Side Registration Paper Tray 3)

Changing the paper size

Paper size is set as shown below when the machine is shipped from the factory.

NA: LT LEF

EU.AA.CHN: A4 LEF

The paper size can be changed to A4 LEF or LT LEF.

1. Pull out the left tray and right tray.
2. Remove the right tray side fence (front) [A], right tray side fence (rear) [B] and right tray end fence [C] (🔩 x3).

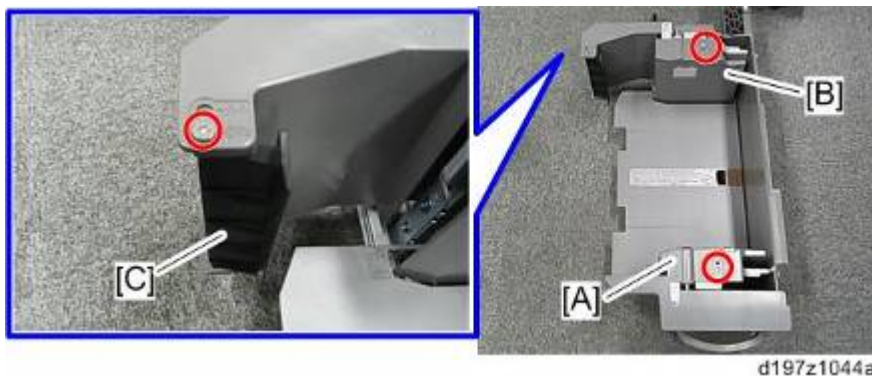

3. Attach the fences to the required position (A4 or LT) (🔩 x3).

⬇ Note

- Make sure that the spring [B] of end fence [A] is attached



4. Remove the left tray side fence (front) [A] and left tray side fence (rear) [B] (🔩 x2).

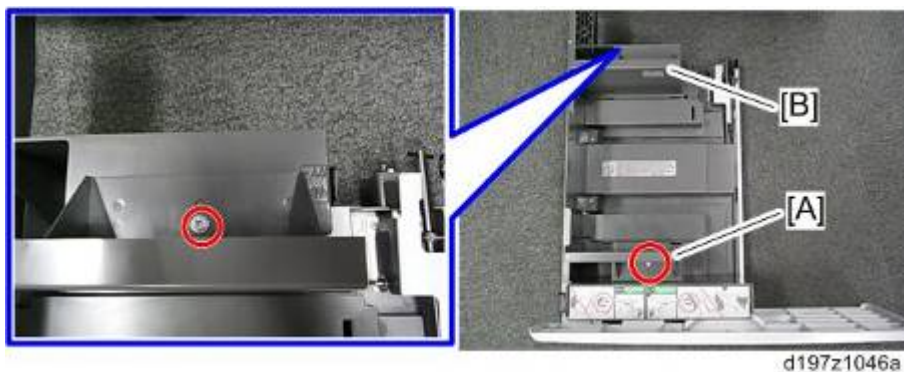

5. **Attach the fences to the required position (A4 or LT) (🔧x2).**
6. **Set the paper size setting.**
 - SP5-181-009 (0: A4 LEF or 1: LT LEF)

2.6 LCIT RT3030

2.6.1 ACCESSORY CHECK

No.	Description	Q'ty
1	Rear Bracket	1
2	Front Bracket	1
3	Connector Cover	1
4	Harness	1
5	Screws – M3 x 6	1
5	Tapping Screw – M3 x 6	1
5	Joint Pins	2
5	Stud screw	4
5	Joint Bracket	1

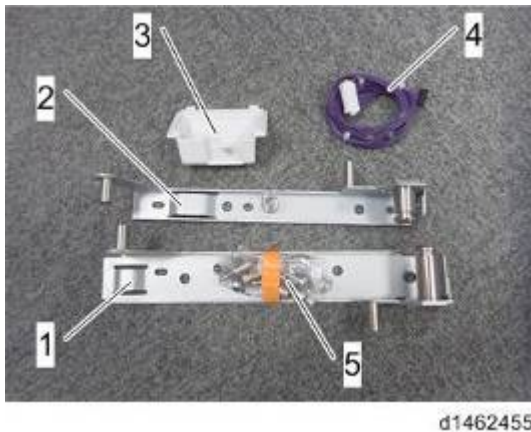

2.6.2 INSTALLATION PROCEDURE

⚠ CAUTION

- When installing this option, turn the power of the machine off, and unplug the power plug from the wall socket.
- If this option is installed when the power is on, it will result in an electric shock or a malfunction.

Note

- Before installing this option, first attach the “Paper Feed Unit PB3210/ PB3220” or “LCIT PB3170/ PB3230”.

1. Remove the orange tape and retainers.
2. Remove the enclosed items (stud screws, etc.).
3. Remove the eight covers on the right of the paper feed unit.

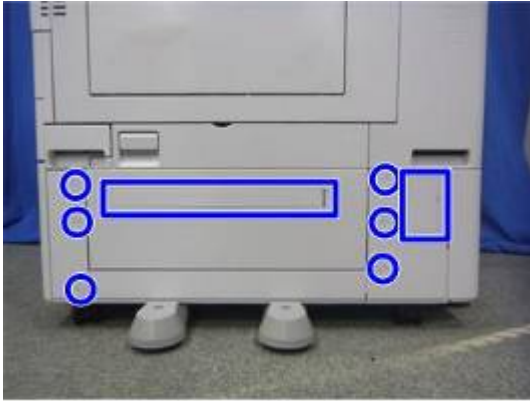

d1462457

4. Attach the joint pins [A] to the front and rear on the right of the paper feed unit.

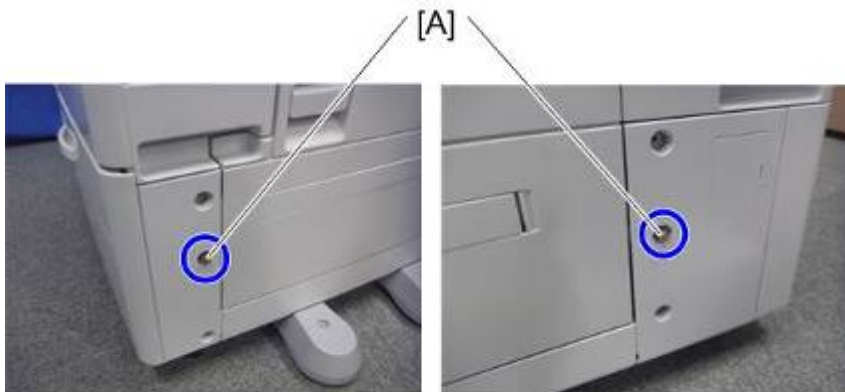

d1462458

5. Attach the brackets [A], [B] at the positions of the joint pins (⚙️ x4).

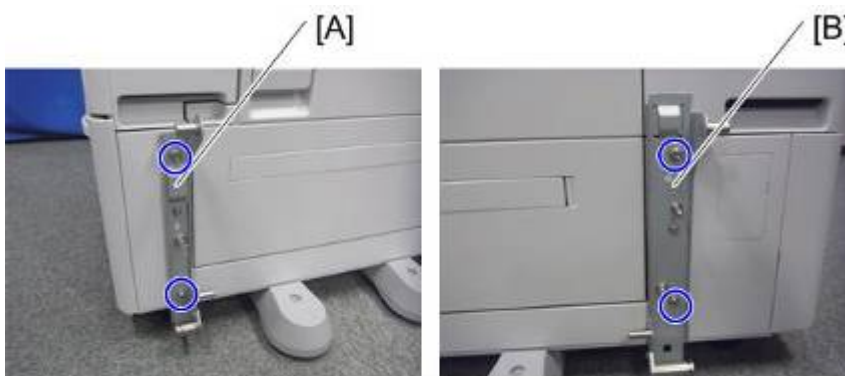

d146z2459

6. Remove the rear lower gap cover [A] (▼ x2)

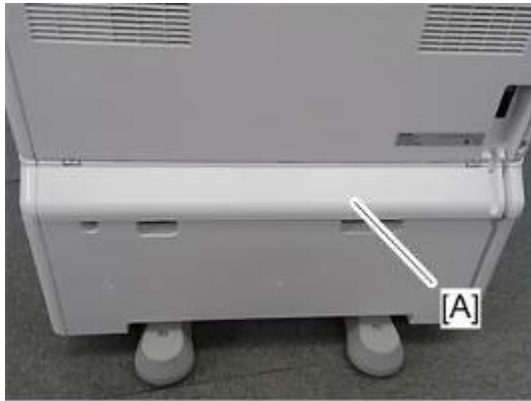

d197f2002

7. Take off the securing brackets [A] from the two positions on the left and right at the rear of the machine (🔧 : 1 each).

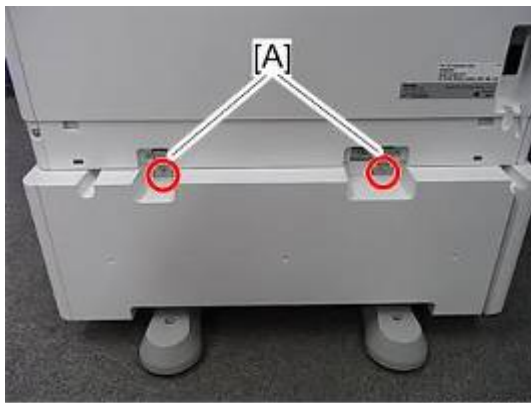

d197z1024

8. Remove the paper feed unit rear cover [A] (🔧 x2).

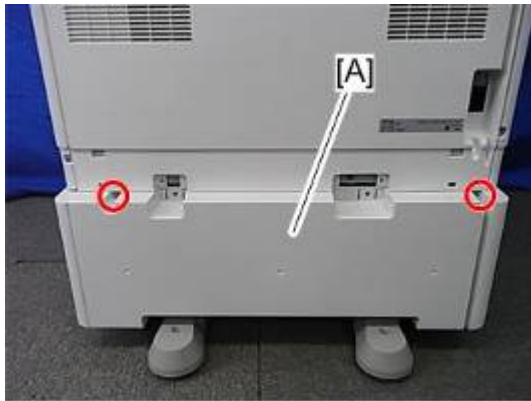

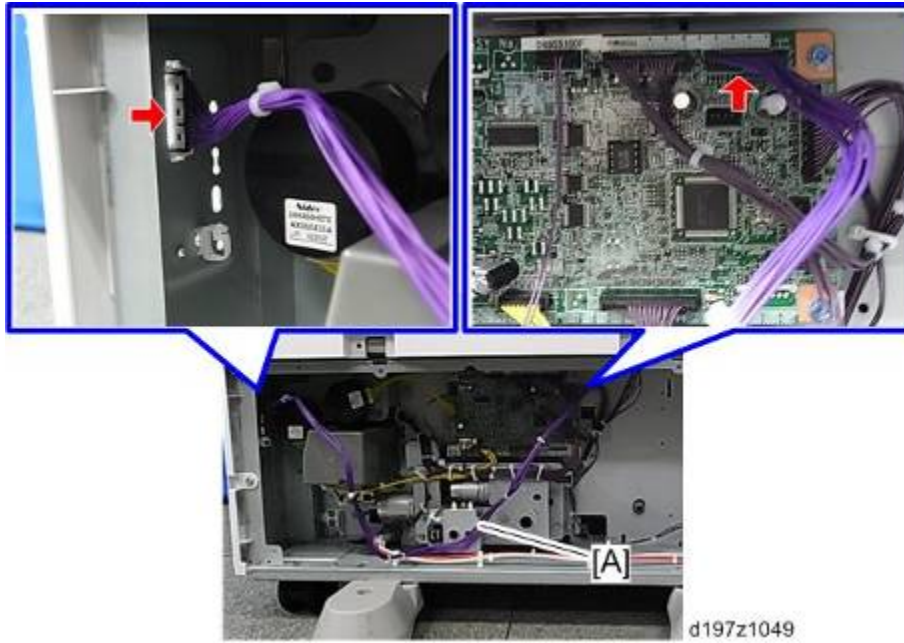

d197z1048

9. Connect the harness [A] (🔧 x2).
For the machine with Paper Feed Unit PB3170/ PB3230

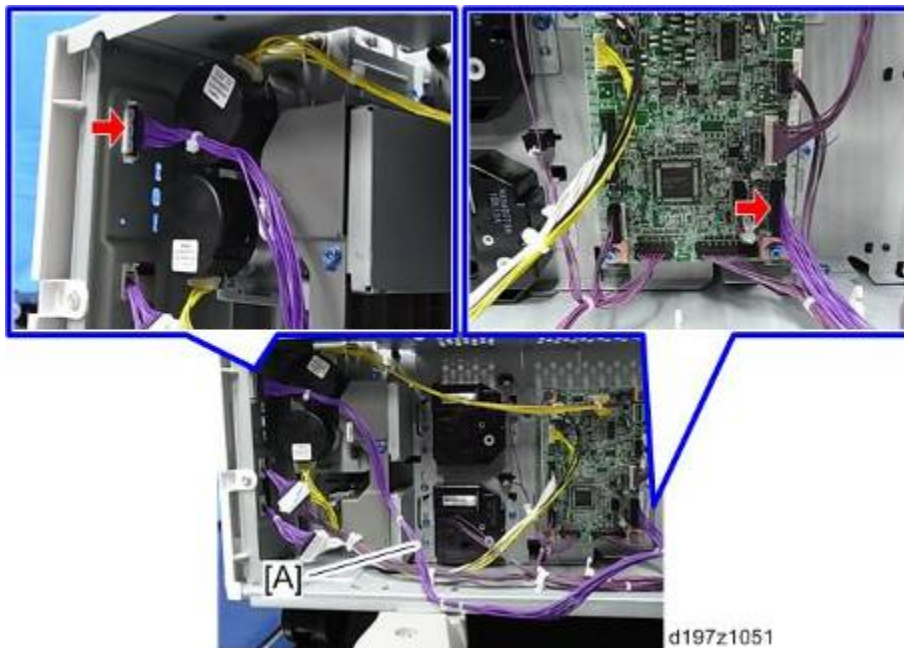

For the machine with Paper Feed Unit PB3210/ PB3220



10. Clamp the harness (PB3170/ PB3230: x9, PB3210/ PB3220: x5).
 For the machine with Paper Feed Unit PB3170/ PB3230

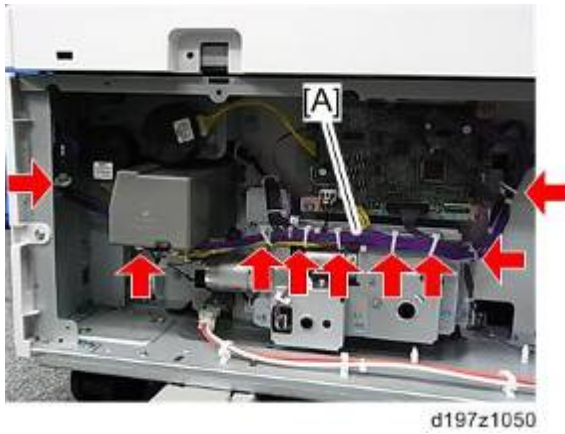

For the machine with Paper Feed Unit PB3210/ PB3220

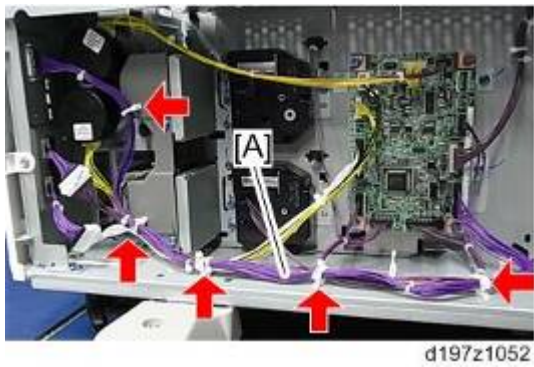

11. Attach the paper feed unit rear cover.
12. Attach the rear lower gap cover [A] (↖ x2).



13. Attach the hook of the side LCT to the bracket.

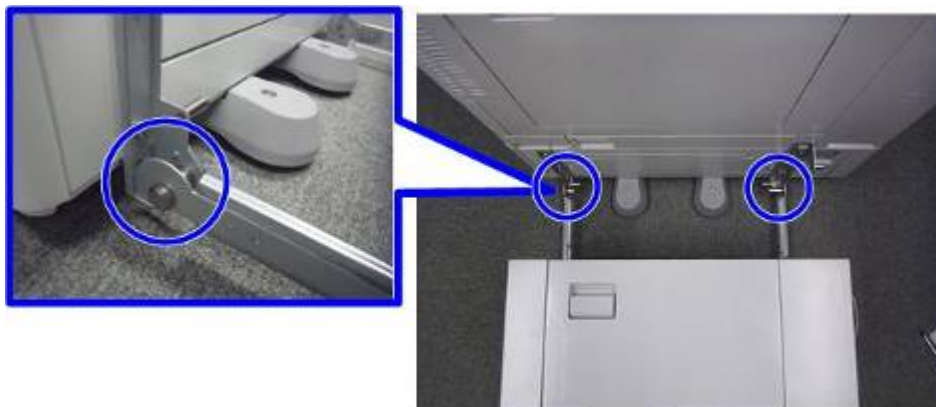

14. Connect the cable [A] of the side LCT to the machine (🔧 x1).



d1462463

15. Attach the cable cover [A] (🔧 x1).



d1462464

16. Push the side LCT towards the machine.



d1462465

17. Turn the power switch ON.
18. Set the paper, and check that the paper size set in the paper feed tray is displayed on the control unit.

19. Do the registration adjustment for the large capacity tray.

SP1-001-0xx (Leading Edge Registration Tray 5(LCT))

-083	Tray5(LCT): Thin	-090	Tray5(LCT): Thin:1200
-084	Tray5(LCT): Plain	-091	Tray5(LCT): Plain:1200
-085	Tray5(LCT): Mid-thick	-092	Tray5(LCT): Mid-thick:1200
-086	Tray5(LCT): Thick 1	-093	Tray5(LCT): Thick 1:1200
-087	Tray5(LCT): Thick 2	-094	Tray5(LCT): Thick 2:1200
-088	Tray5(LCT): Thick 3	-095	Tray5(LCT): Thick 3:1200
-089	Tray5(LCT): Thick 4	-096	Tray5(LCT): Thick 4:1200

SP1-002-007 (Side-to-Side Registration Large Capacity Tray)

Changing the Paper Size

Paper size is set as shown below when the machine is shipped from the factory.

NA: LT LEF

EU.AA.CHN: A4 LEF

The paper size can be changed to A4 LEF, LT LEF, or B5 LEF.

- 1. Open the tray cover.**
- 2. Remove the upper screw at the front side fence, and after setting the side fence to the position of the paper (outer: A4 LEF, center: LT LEF, inner: B5 LEF), tighten the screw that was removed.**



d1462466

- 3. Also change the rear side fence to the same size position.**

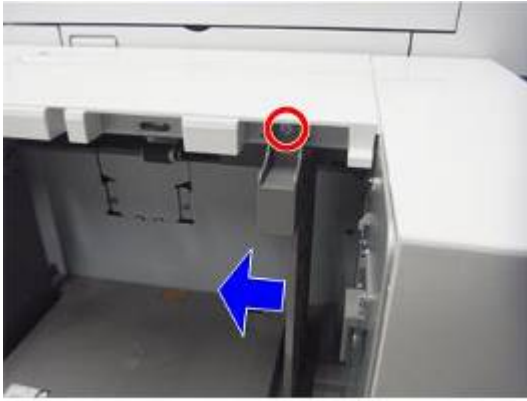

d1462467

4. Change the paper size according to the new side fence position.

SP5-181-024 (Size Adjust LCT)

0: A4 LEF, 1: LT LEF, 2: B5 LEF

2.7 CASTER TABLE TYPE M3

2.7.1 ACCESSORY CHECK

No.	Description	Q'ty
1	Right Lower Cover*	1
2	Screw with Spring Washer (M4 x 10)	1
3	Screws (M4 x 10)	2
4	Securing Bracket	2
5	Locating pin	3

* Used only when the main machine is installed on this option directly.

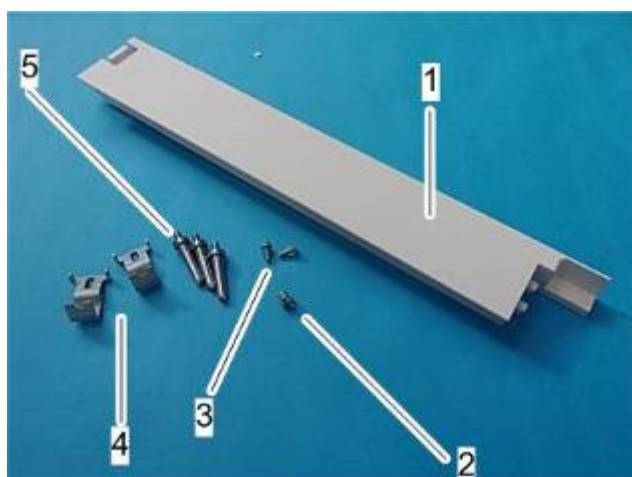

d197f0129

2.7.2 INSTALLATION PROCEDURE

⚠ CAUTION

- The machine must be held at the correct locations, and must be lifted slowly.
- If it is lifted with force, handled carelessly or dropped, it will result in an injury.
- If installing this option, turn the power to the machine off, and unplug the power plug from the wall socket.
- If this option is installed when the power is on, it will result in an electric shock or malfunction.
- Be sure to join the machine and caster table to prevent equipment from falling over.
- If it is not joined, the machine will move or fall over, which will result in an injury.

For Installing Directly under the Main Machine

1. Attach the 3 locating pins.

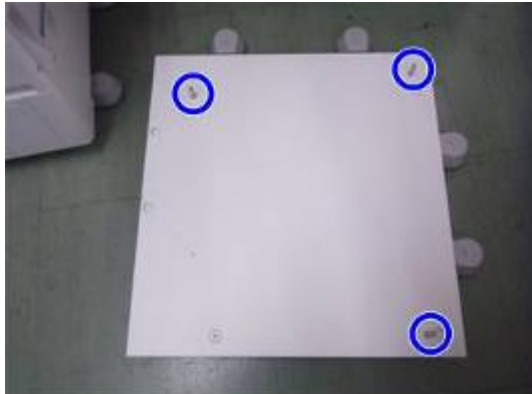

d1463030

2. Holding the grips on the machine, align with the locating pin, and place the machine on the caster table.

↓ Note

- When you lift the machine, hold the lifting handles.
- In particular, do not lift it by holding the scanner unit, etc., (as it may deform).
- Do not put the machine down on the caster table as a temporary resting place. This may cause the machine to deform. Always connect the machine and caster unit properly.

3. Attach the right lower cover between the right side of the main machine and the caster table.
4. Pull out the 2nd paper feed tray of the machine.
5. Using a securing bracket, fix the machine or paper feed unit to the caster table (spring washer : screw: M4×10: 1).



d197z1027

6. Attach the securing brackets [A] at 2 positions to left and right at the rear of the machine or paper feed unit (screws: 1 each).

Caster Table Type M3

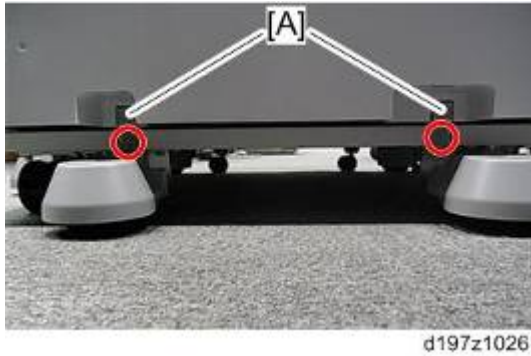

7. Attach the right lower cover provided with this option to the right lower side of the main machine.
8. Return the paper feed tray to the machine or paper feed unit on the caster table.

For Installing under PB3150

1. Attach the three locating pins.
2. Mount the PB3150 on the caster table while fitting with the locating pins
3. Pull out the paper feed tray of the PB3150.
4. Secure the caster table and PB3150 (M4×10:  x1)



5. Install the securing bracket [A] at the rear of the PB3150 ( x2)

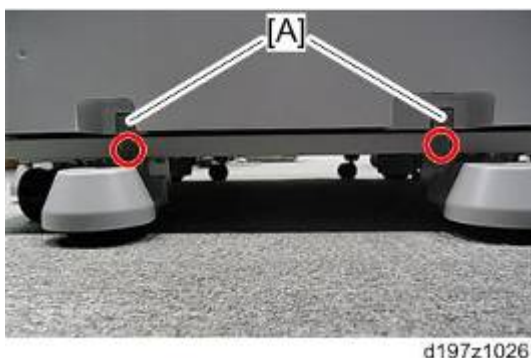

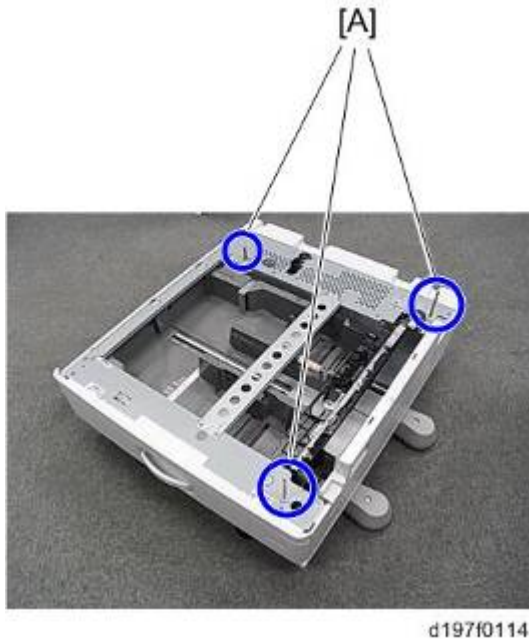

6. Put back the tray of the PB3150 in place.
7. By holding the grips on the main machine, mount the main machine on the PB3150 while fitting the locating pins.



Note

- Be sure to use the specified grips on the main machine. Using any other positions may damage the machine.
- Do not put the machine down on the PB3150 as a temporary resting place. This may cause the PB3150 to deform.

8. Pull out the 2nd paper feed tray of the main machine.
9. Secure the main machine and PB3150 (M4×10:  ×1).
10. Attach the securing bracket [A] to the rear of the main machine ( ×2).

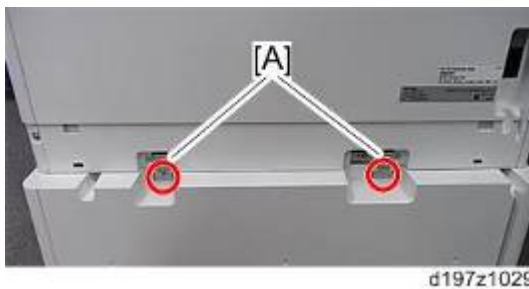

11. Attach the rear lower gap cover [A] ( ×2).



12. Return the 2nd paper feed tray to the main machine.

2.8 PLATEN COVER PN2000 (D700)

2.8.1 ACCESSORY CHECK

No.	Description	Q'ty
1	Feeler Guide	1
2	Stepped Screw	2

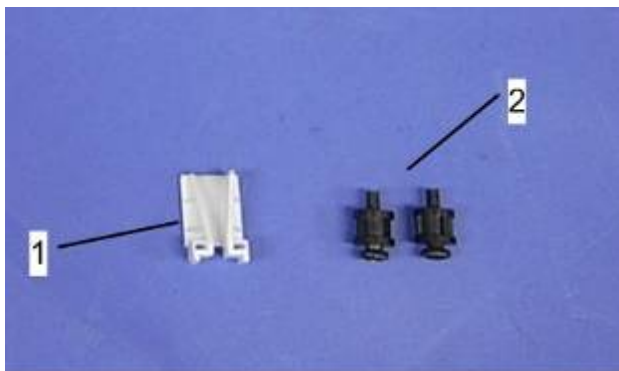

d1588041

2.8.2 INSTALLATION PROCEDURE

⚠ CAUTION

- Unplug the machine power cord before starting the following procedure.

1. Install the stepped screws (🔩 x 2).

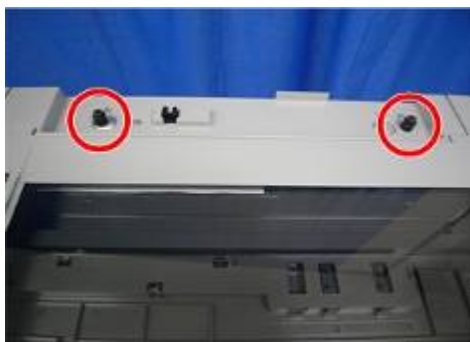

d1582019

2. Install the feeler guide [A].

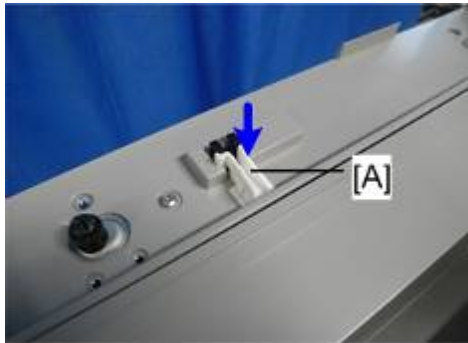

d1582020

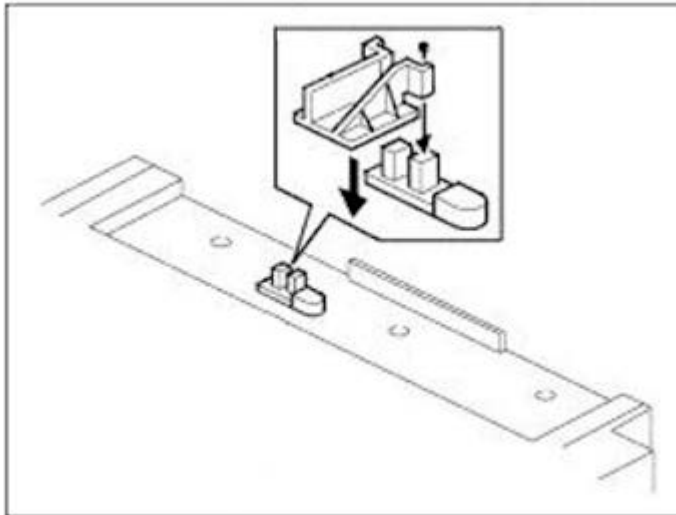

d197f2001

3. Install the platen cover [A].

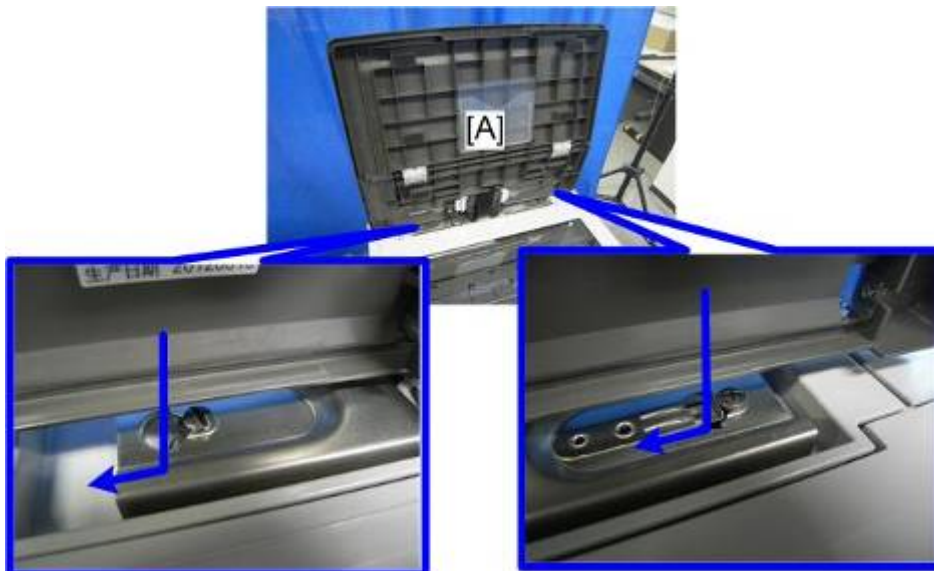

d158z2021

4. Place the platen sheet [A] on the exposure glass.
5. Line up the rear left corner of the platen sheet flush against corner [B] on the exposure glass.

Platen Cover PN2000 (D700)

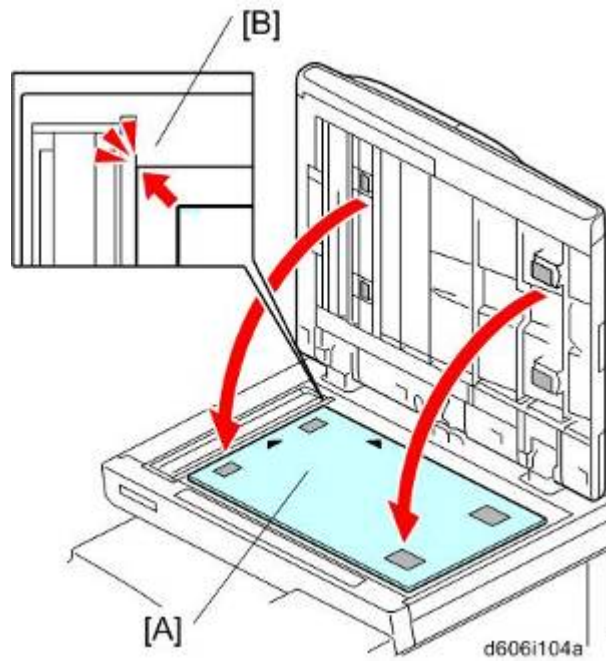

6. Close the platen cover.
7. Open the platen cover.
8. Press the surface of the platen sheet gently to fix it on the platen cover securely.
9. Connect the power cord and turn on the main power.
10. Place an original on the platen and make a copy to check the installation.

2.9 ARDF DF3090

2.9.1 ACCESSORY CHECK

No.	Description	Q'ty
1	ARDF	1
2	Screw	2
3	Knob Screw	2
4	Stud Screw (Small)	1
5	Stud Screw (Large)	1
6	Attention Decal - Top Cover	1

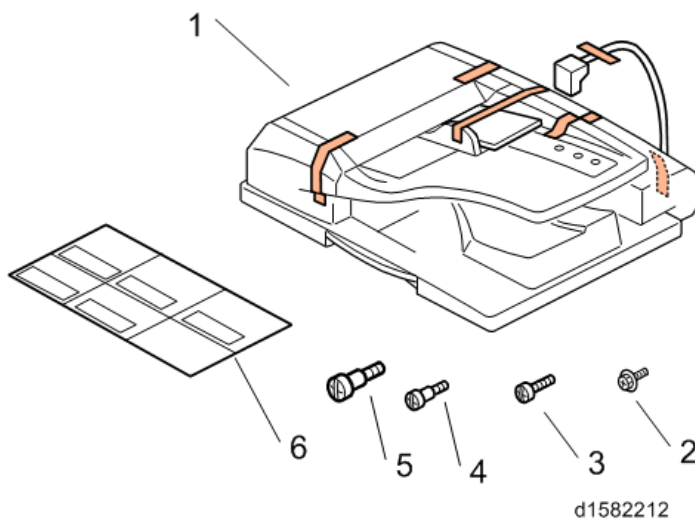

2.9.2 INSTALLATION PROCEDURE

⚠ CAUTION

- Unplug the copier power cord before starting the following procedure.
1. Remove all tapes and shipping retainers.
 2. Insert the two stud screws ([A] is the larger stud, [B] is the smaller stud).

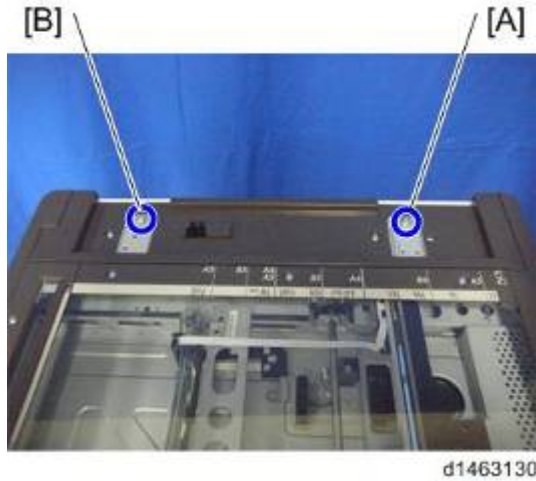

3. Mount the ARDF [A] by aligning the screw keyholes [B] of the ARDF support plate over the stud screws.
4. Slide the ARDF toward the front of the machine.
5. Secure the ARDF with the two knob screws [C].

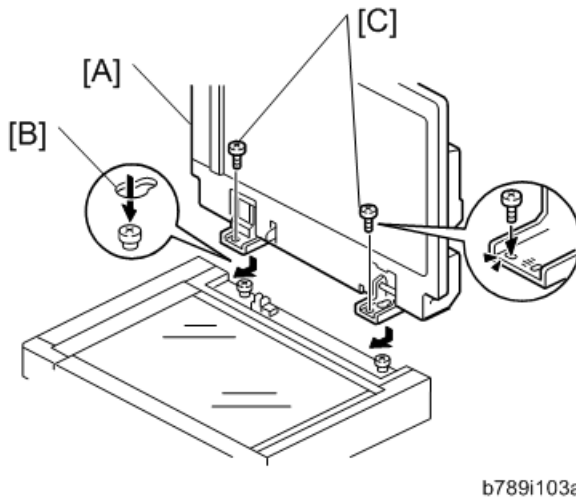

6. Align the rear left corner of the platen sheet [A] with the corner [B] on the exposure glass.
7. Close the ARDF.

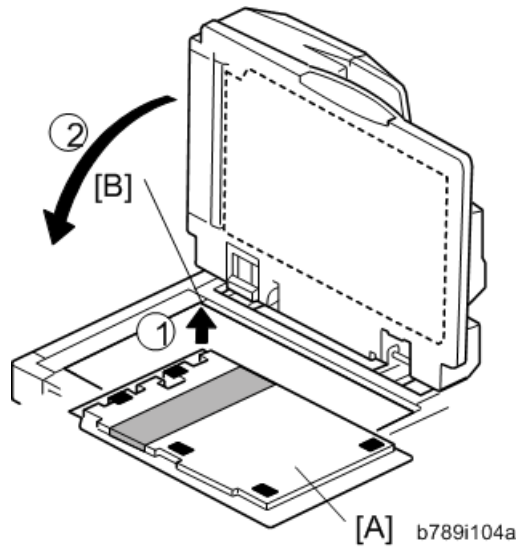

8. Open the ARDF and check that the platen sheet is correctly attached.
9. Lift the ARDF original tray.
10. Slide the stamp holder [A] out and install the stamp cartridge in it, if necessary.

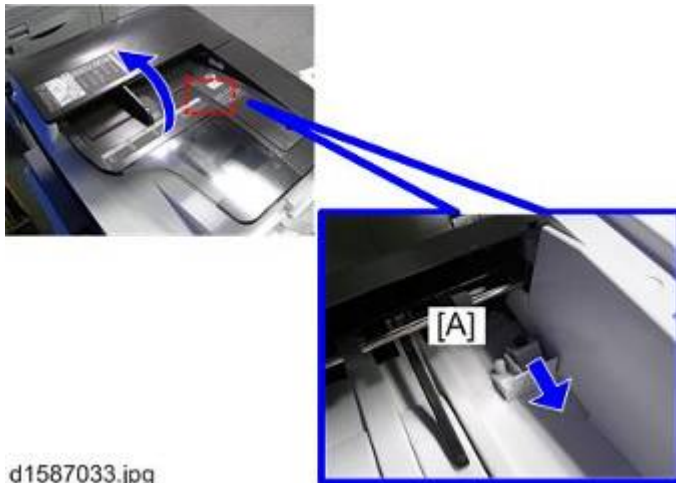

d1587033.jpg

Note

- After the stamp installation, be sure to slide the holder in correctly. If not, jam detection (J001) will occur.

11. Attach the decals [A] [B] to the top cover as shown. Choose the language that you want.

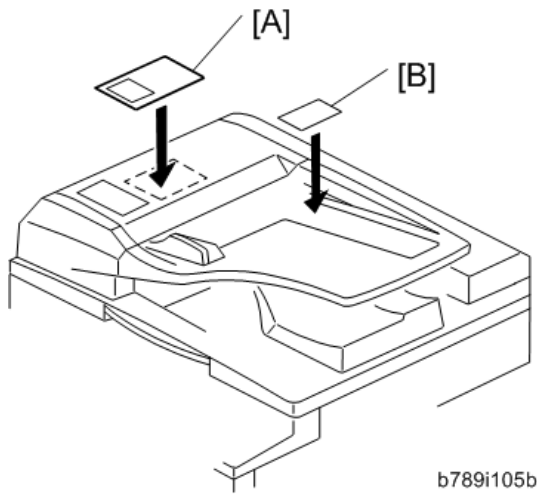

12. Remove the scanner rear cover [A] (⚙️ x3).

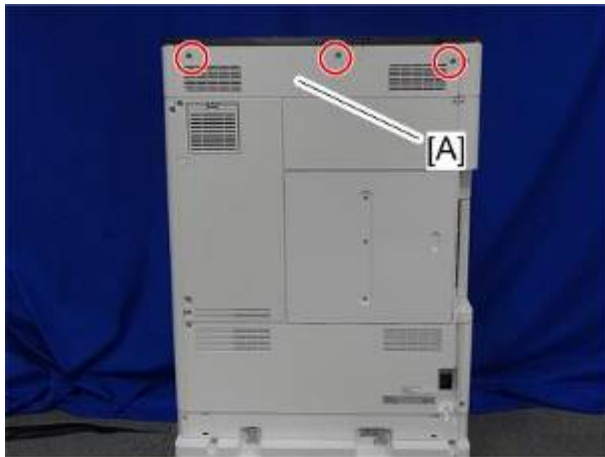

13. Connect the harness to the SIO (CN315) [A].



14. Attach the bracket [A] (🔩 x1).



15. Fasten the grounding wire [A] (🔩 x1).



16. Attach the scanner rear cover.
17. Plug in and turn on the main power switch of the machine, and then check the ARDF operation.
18. Make a full size copy. Check that the registrations (side-to-side and leading edge) and image skew are correct. If they are not, adjust the registrations and image skew.

When feeding thin paper

When feeding thin paper, adjust the sliding tray to the point shown below [A].

When feeding normal paper, adjust the sliding tray to the point shown below [B].

If not, it may cause problems as follows:

- Original jam
- Original curl
- Originals cannot be stacked neatly



2.10 SPDF DF3080

2.10.1 ACCESSORY CHECK

No.	Description	Q'ty	Remarks
1	Original Caution Decal: Multiple Languages	1	
2	Original Set Decal Sheet	1	
3	Coin Screw	2	
	Stepped Screw	2	
4	1 Pass ADF Bracket:	1	Not used for this model
5	Sub IPU Bracket	1	Not used for this model
6	Ferrite Core: K3 NF-75(N)BK0	1	
7	Ferrite Core: K3 NF-70-A(N)BK0	1	
8	Clamp: LWS-0711A	2	
9	Tapping Screw: M3x6	10	Use eight screws for this model
10	BCU Board	1	Not used for this model
11	IPU-sub Board	1	
12	Spacer	1	
-	Serial Number Decal	1	

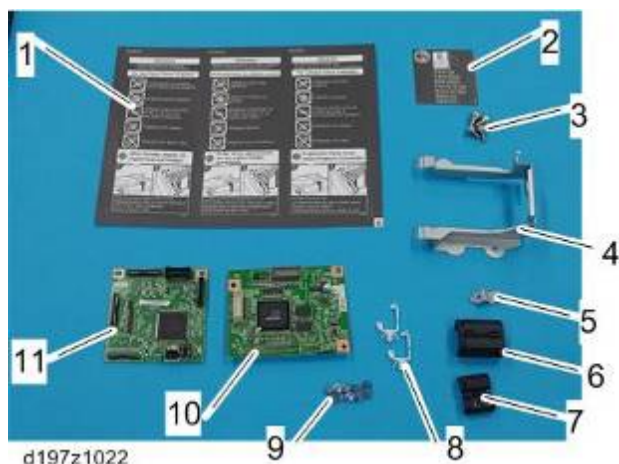

2.10.2 INSTALLATION PROCEDURE

⚠ CAUTION

- When you install this option, turn off the power supply to the machine, and unplug the power plug from the wall socket.
- If this option is installed when the power is ON, it will result in an electric shock or a malfunction.

⚠ CAUTION

- Do not turn the power on until you perform “adjustment after installation”. Otherwise, it may not start normally.

Attaching the SPDF

1. Place the unit on the machine temporarily, and remove the orange tapes and shipping retainers.
2. Remove the items in the package (boards, fixing screws, etc.).
3. Attach the two stepped screws to the machine.

ⓘ Note

- The larger-stepped screw [A] is for the right side and the smaller-stepped screw [B] is for the left side of the main machine.

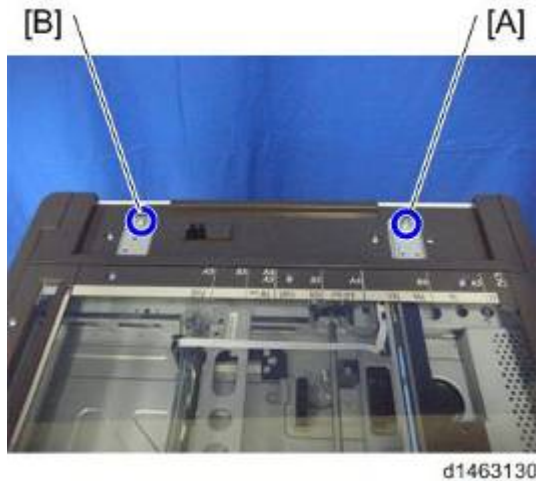

4. Align the hinges of the SPDF [A] with the hole [B] for stepped screws, and attach them by sliding them in.
5. Fix the SPDF to the machine (coin screws [C] ×2).

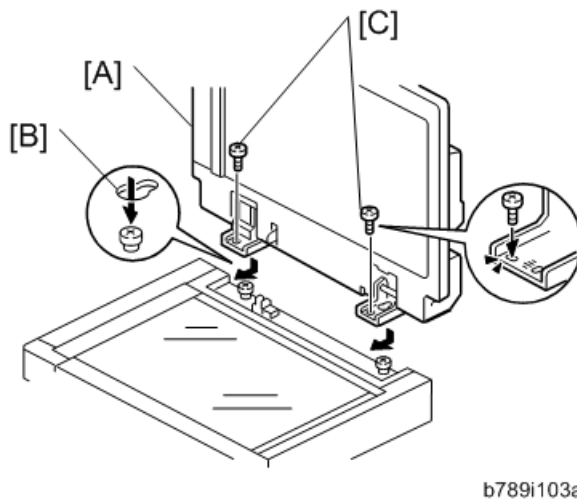

6. Place the platen sheet [A] on the exposure glass.
Align the platen sheet with the left-rear scale [B] of the machine.

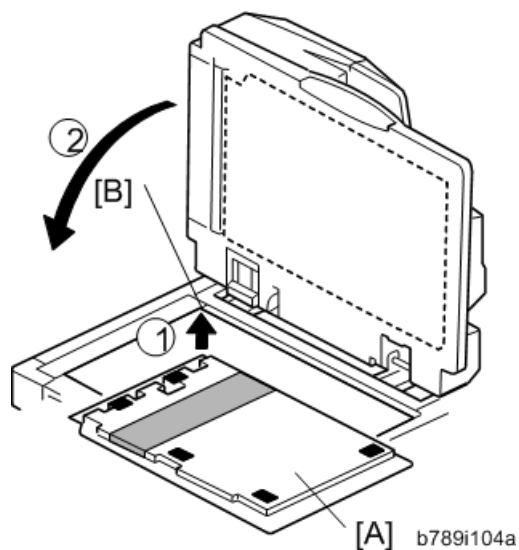

7. Lower the SPDF slowly to attach the platen sheet to the SPDF.
8. Open the DF again and make sure that the platen sheet is firmly attached to the exposure glass.
9. Paste the decal (CAUTION:ORIGINAL) to the point [A].
10. Paste the decal (SET:ORIGINAL TABLE) to the point [B] as shown in the following picture.

Note

- This decal must be pasted without projecting over the gap in the original table.

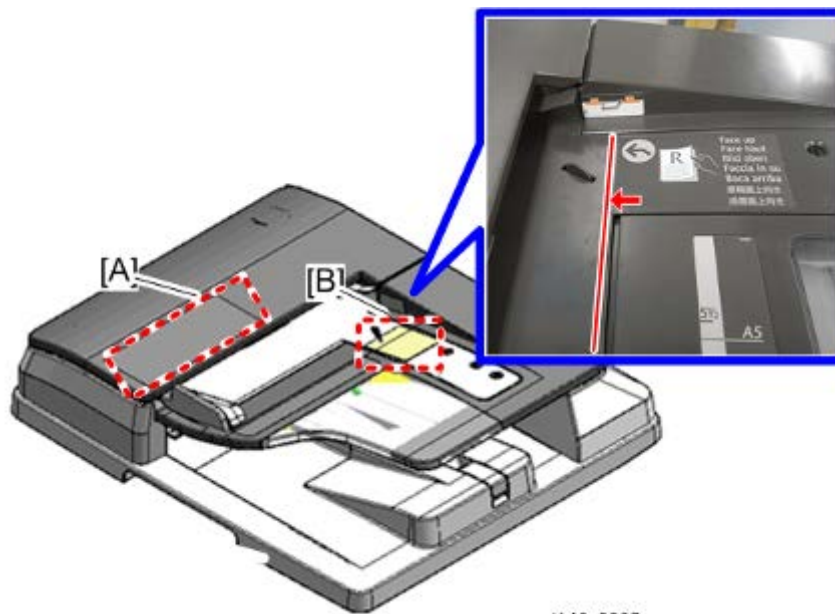

d146z0027

Attaching the Sub IPU

1. Remove the scanner rear cover [A] (🔩×3).

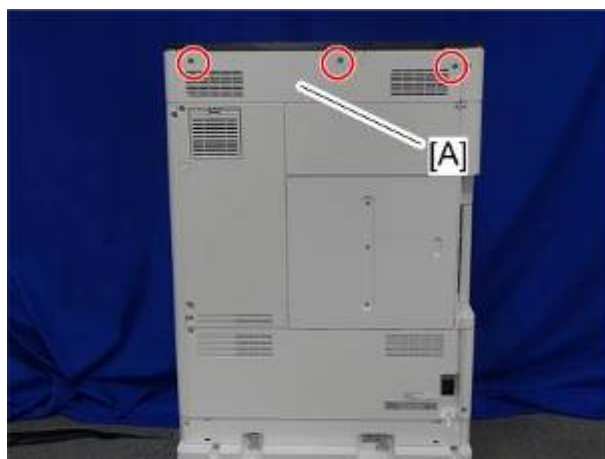

d197f0051

2. Remove the controller cover [A] (🔩×4).



d197f0042

3. Remove the controller rear cover [A] (🔩 x5).

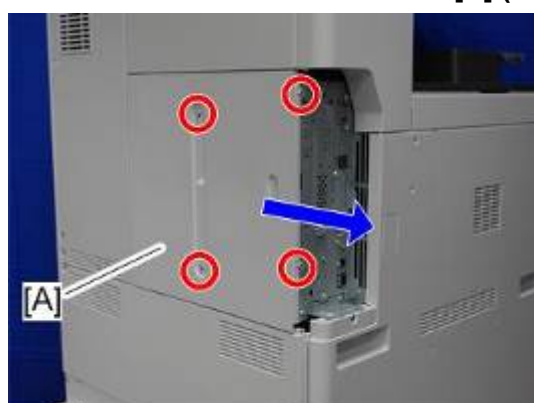

d197f0048

4. Remove the rear left cover [A] (🔩 x3).



d197f0050_1

5. Disconnect the scanner cable [A] and SIO harness [B] from the IPU board.

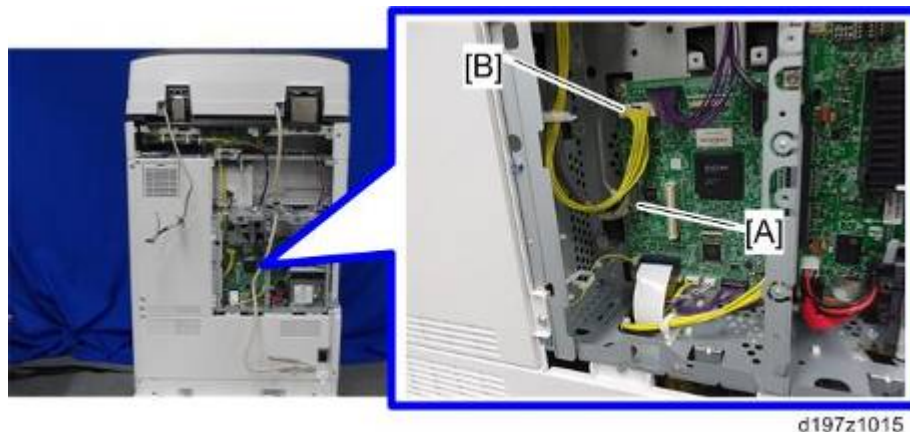

d197z1015

6. Attach the spacer [A] to the IPU board.

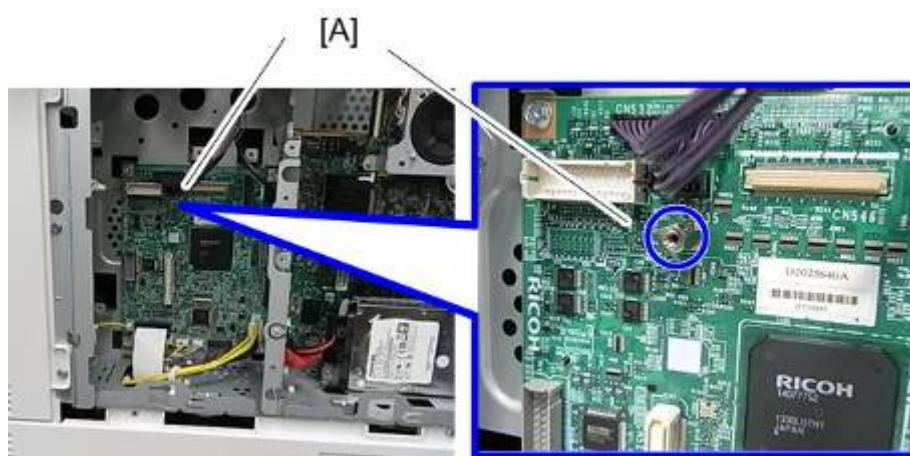

d197z1152

7. Connect CN593 [A] on the IPU-sub board [C] with CN529 [B] on the IPU board to attach the IPU-sub board (⚙️x3).

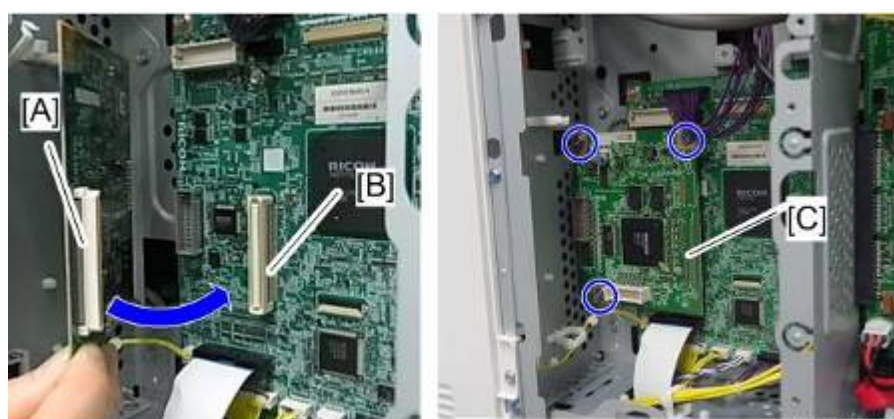

d197z1016

8. Attach the DF cable bracket [A] on the scanner rear frame (⚙️x1).
9. Attach the ground wire [B] (⚙️x1).
10. Attach the DF harness [C] to CN312 on the SIO.

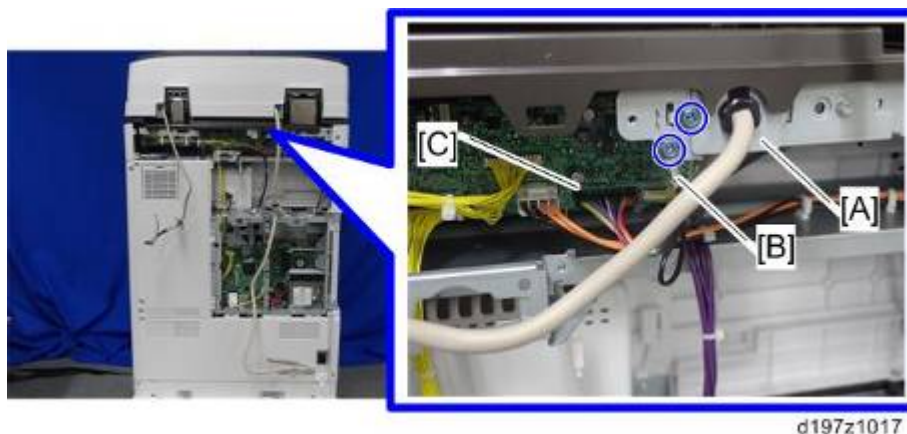

d197z1017

11. Attach the CIS cable [A] to the bracket (🔩 x1).



d197z1018

12. Clamp the CIS cable [A] under the bracket and the upper side of the controller box [B].

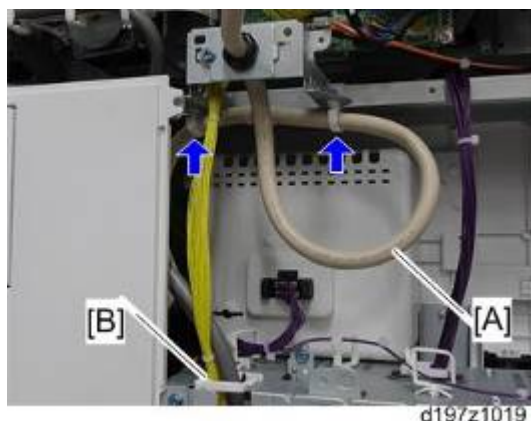

d197z1019

13. Attach the CIS cable clamp [A] to the bracket in the controller box (🔩 x1).
14. Attach the scanner cable [B] to CN590 on the IPU-sub board (🔩 x1), CIS cable [C] to CN592 on the IPU-sub board (🔩 x1), and the SIO harness [D] to CN531 on the IPU board (🔩 x1).

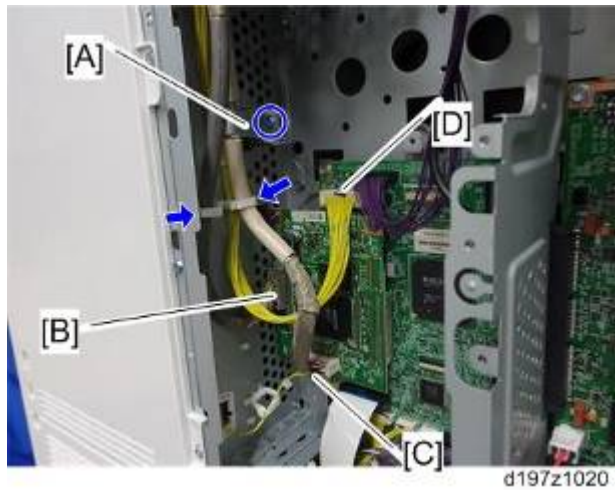

15. Attach the ferrite cores to the DF cable and the CIS cable.

- Ferrite core: K3 NF-70-A (N) BK0 is for the DF cable
- Ferrite core: K3 NF-75 (N) BK0 is for the CIS cable.

16. Remove the scanner cable gap cover from the scanner rear cover.

- DF cable gap [A], CIS cable gap [B]

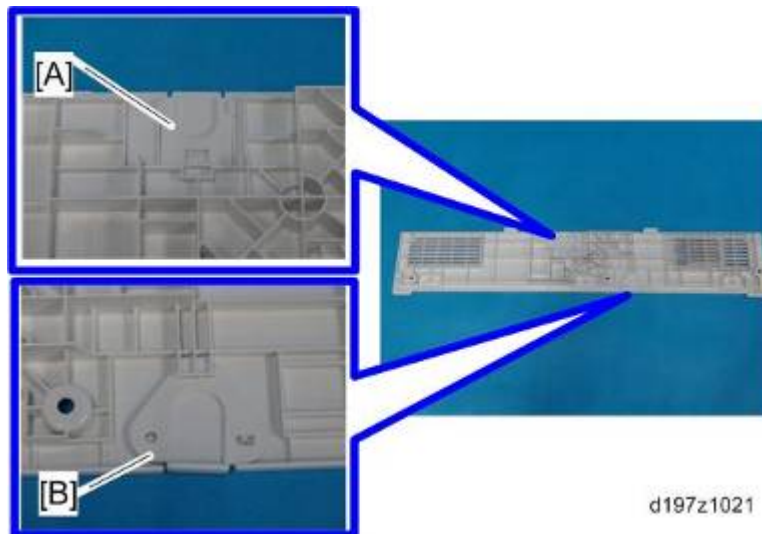

17. Reassemble the machine.

18. Attach the decals: “Original” [A] and “Original table set” [B].

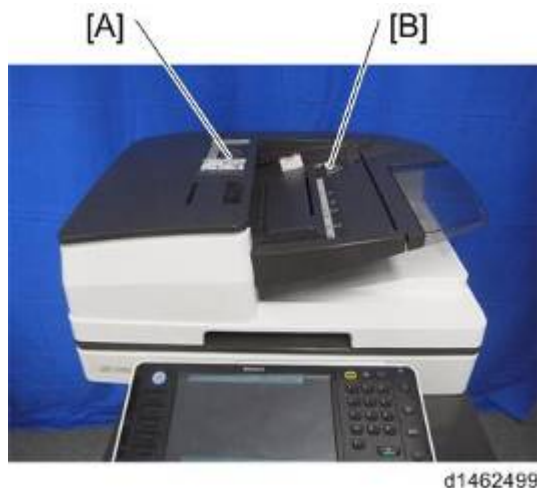

Adjust SP Settings

1. Turn the power ON.
2. Enter the SP values marked on the paper provided, in the following SP.
 1. SP4-712-001: CIS GB Adj. Value: R
 2. SP4-713-001: CIS GB Adj. Value: G
 3. SP4-714-001: CIS GB Adj. Value: B
3. Adjust the registration for the SPDF.
 - SP6-006-010: ADF Adjustment L-Edge Regist (1-Pass): Front
 - SP6-006-011: ADF Adjustment L-Edge Regist (1-Pass): Rear
 - SP6-006-001: ADF Adjustment Side-to-Side Regist: Front
 - SP6-006-002: ADF Adjustment Side-to-Side Regist: Rear
4. If there is skew, loosen the fixing screw [A] and swivel the SPDF slightly to the left or right. Then tighten coin screw [A] and make a test copy to check that there is no skew.

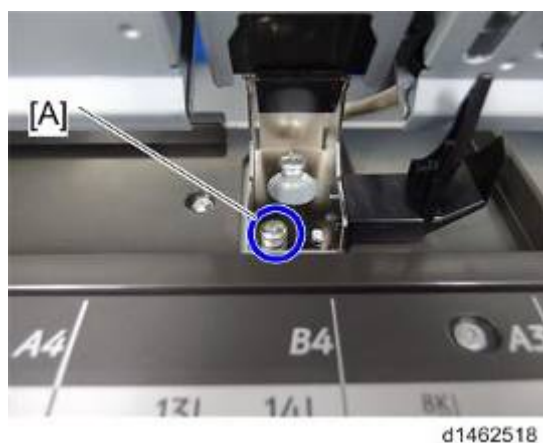

2.11 BRIDGE UNIT BU3070

2.11.1 ACCESSORY CHECK

No.	Description	Q'ty
1	Tapping screw- M3 x 8	1
2	Screw - M4	1
3	Knob Screw - M4	1
4	Right Front Bracket	1
5	Left Lower Cover	1
6	Left Front Bracket	1

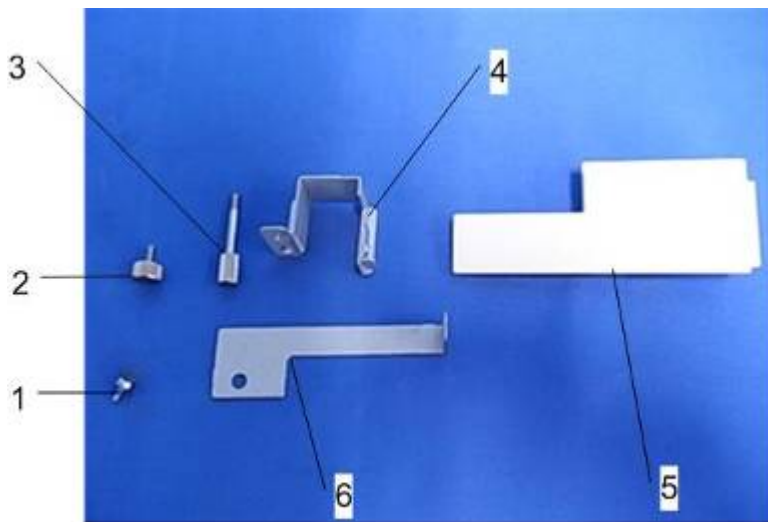

d1465001

2.11.2 INSTALLATION PROCEDURE

⚠ CAUTION

- When installing this option, turn the power of the machine off, and unplug the power plug from the wall socket.
- If this option is installed when the power is on, it will result in an electric shock or a malfunction.

Note

- The bridge unit cannot be used together with “Internal Shift Tray SH3070”, “Side Tray Type M3”, “Internal Finisher SR3180” or “Internal Finisher SR3130”.
- To use together with the “1 Bin Tray BN3110”, attach the “1 Bin Tray BN3110” first before installing the bridge unit.

1. Remove the orange tape and shipping retainers.
2. Remove the enclosed items (fixing screws, etc.).

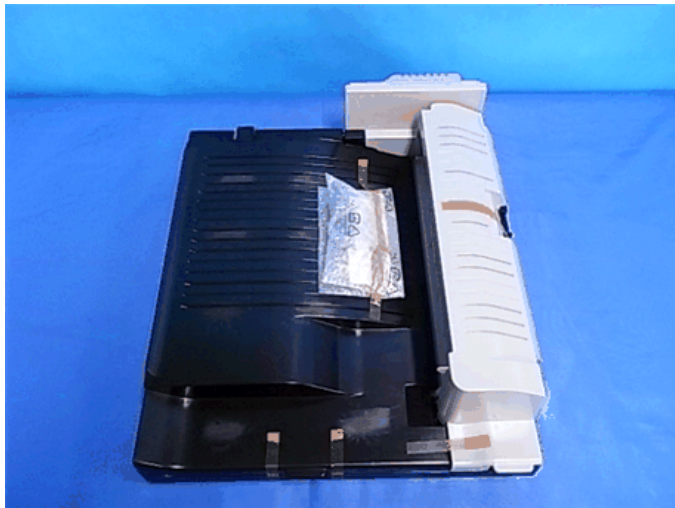

d1465002

3. Remove the paper exit tray [A].



d197z0407

4. Remove the connector cover [A].



d1462470

5. Open the front cover.
6. Remove the left upper cover [A] (🔩×1).

⬇ Note

- This removed screw is used again in step 13.

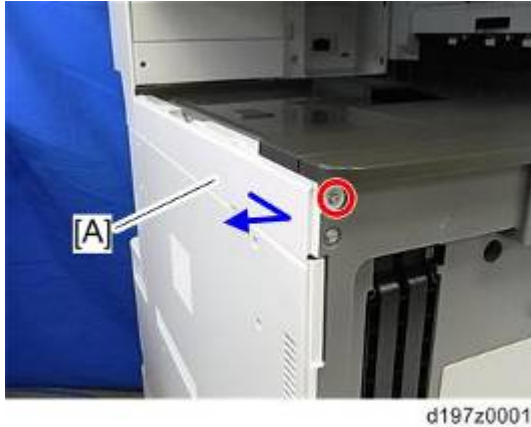

7. Open the right cover.
8. Remove the main power switch cover [A] (🔩×1).

⬇ Note

- The main power switch cover has three tabs: two on the left side (paper exit) and one on the right side (right cover).



9. Attach the bracket [A] (🔩×1).



10. Attach the main power switch cover, and close the right cover.

11. Open the bridge unit right cover, and then attach the bridge unit to the machine (🔩 x2, knob screw [A]).



12. Close the bridge unit right cover.
13. Attach the upper left cover provided with the bridge unit.



14. Referring to the finisher's installation procedure, attach the L type connecting bracket [A], but do not tighten the screws yet.



15. After the finisher is installed, turn the main power switch ON.
16. Check that the finisher can be selected at the operation panel.

2.12 1 BIN TRAY BN3110

2.12.1 ACCESSORY CHECK

No.	Description	Q'ty
1	Tray support bar	1
2	Harness cover	1
3	Tray	1
4	Screw: M3 x 8	2
5	Gear	1

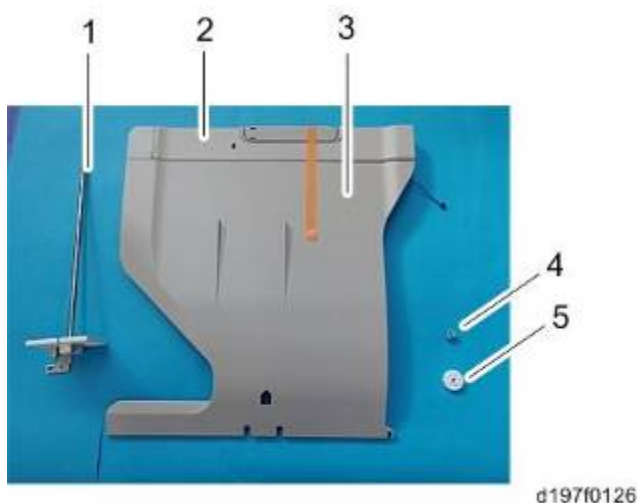

2.12.2 INSTALLATION PROCEDURE

⚠ CAUTION

- When installing this option, turn the machine power off, and unplug the power plug from the wall socket.
- If this option is installed with the power on, it will result in an electric shock or a malfunction.

📌 Note

- If you install this option together with “Bridge Unit BU3070”, “Internal Shift Tray SH3070” or “Side Tray Type M3”, install this option first.

1. Remove the orange tapes and shipping retainers.

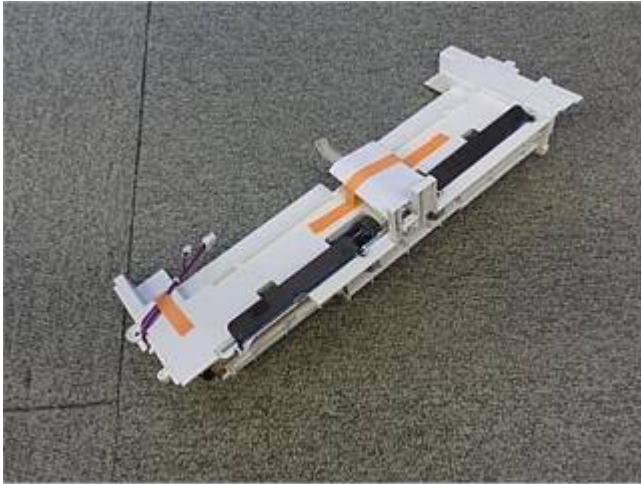

d197f0127

2. Remove the enclosed items (fixing screws, etc.).
3. Open the right cover.
4. Remove the main power switch cover [A] (🔩×1).

⬇️ Note

- The main power switch cover has three tabs: two on the left side (paper exit) and one on the right side (right cover).



d197f0052

5. Remove the Paper exit tray [A].



d197z0407

6. Open the front cover.
7. Remove the left upper cover [A] (🔩×1).

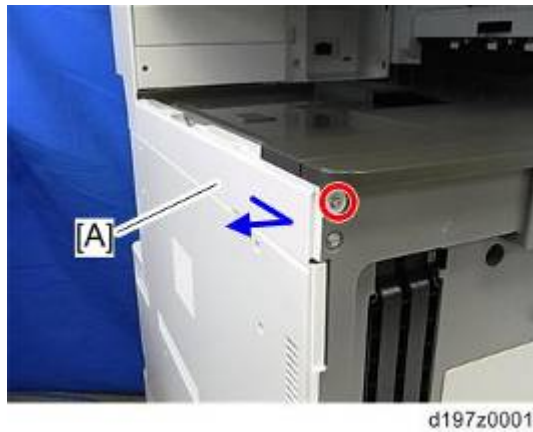

8. Remove the controller cover [A] (🔩 x4).

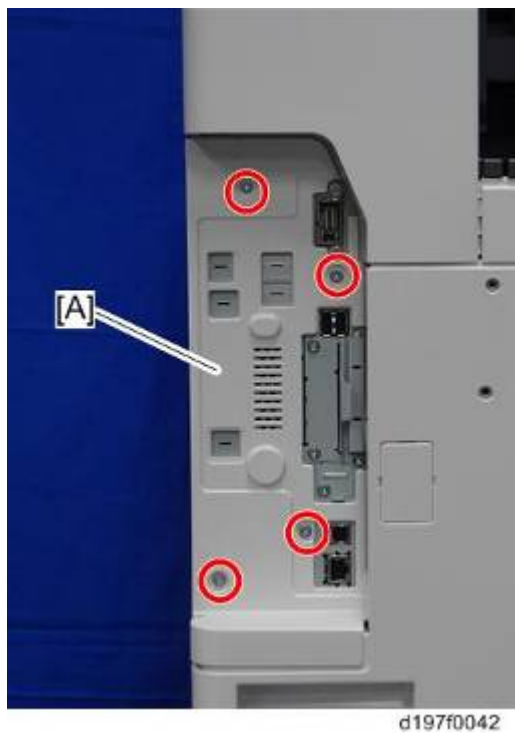

9. Remove the left rear cover [A] (🔩 x2).



10. Remove the inverter tray [A] and tray support rod cover [B] (🔩 x1).

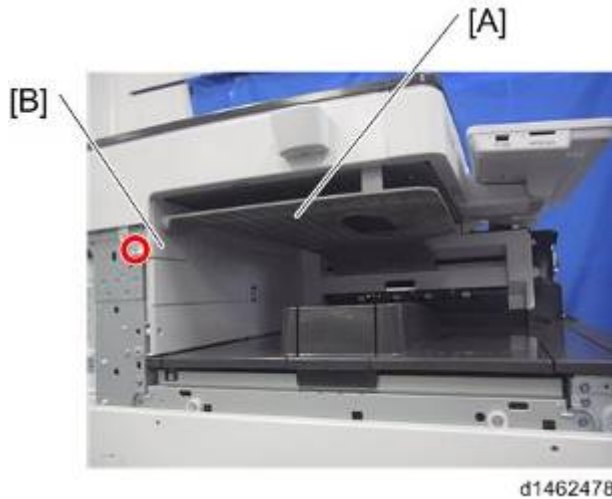

11. Remove the paper output cover [A] (🔧 x1).

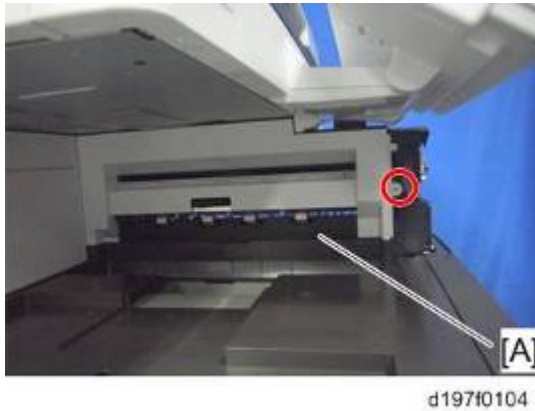

12. Attach the gear [A] provided with this option.



13. Attach the 1 bin tray unit [A] (🔧 x1, 📦 x2).

⚠ CAUTION

- Take care that the harness is not trapped between the 1 bin tray unit and the machine frame.

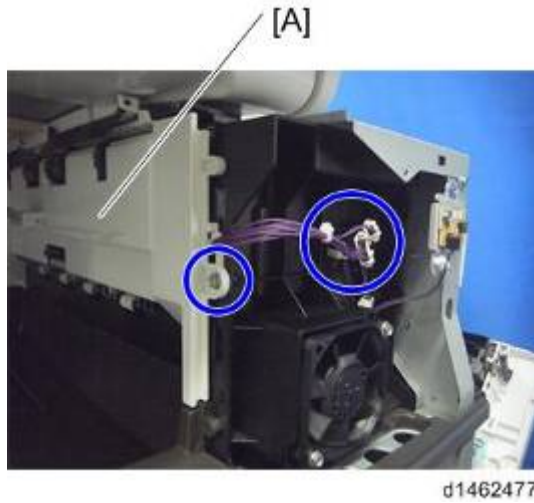

14. Open the harness cover [A], then remove the harness [B].



Note

- Slowly and carefully lift up the harness cover to remove. Removing the harness cover while moving it round can break the harness because the inner hook catches the harness.

15. Attach the harness removed in the previous step.



16. Attach the tray support bar [A] (🔩×1).

Note

- Pass the harness attached in the previous step through the position in the blue circle.

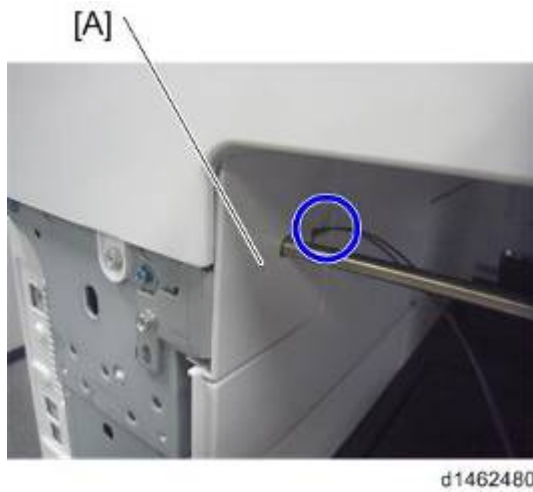

17. Hook the 1 bin tray [A] onto the 1 bin tray unit, aligning the positions in the blue circles.

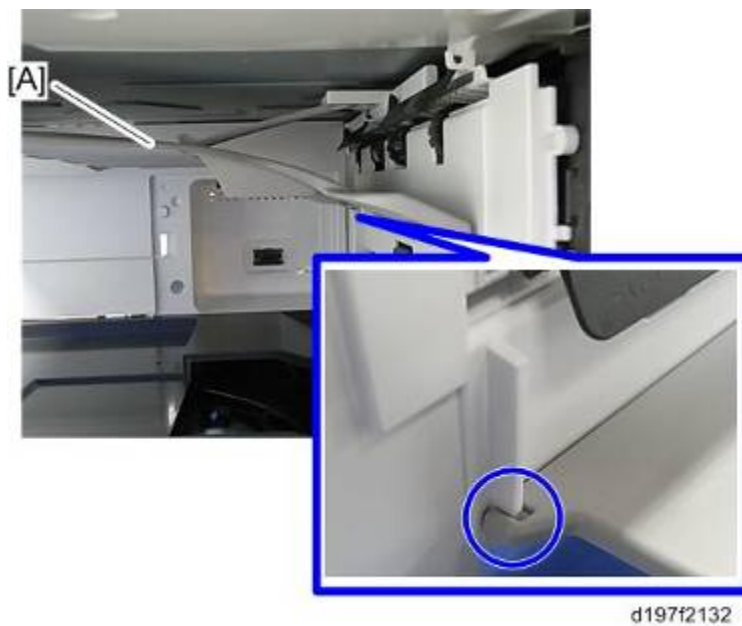

18. Connect the harness to the 1 bin tray, and bring it around (🔗 x1).



- 19. Insert the tray support bar firmly in the 1 bin tray, and attach the harness cover [A].**



- 20. Attach the left rear cover, left upper cover and main power switch cover, and then close the right cover.**
- 21. Turn the main power switch ON.**
- 22. Check that output to this tray can be selected on the operation panel, and check operation.**

2.13 INTERNAL SHIFT TRAY SH3070

2.13.1 ACCESSORY CHECK

No.	Description	Q'ty
1	Tray Cover	1
2	Sheet	2
3	Feeler	1

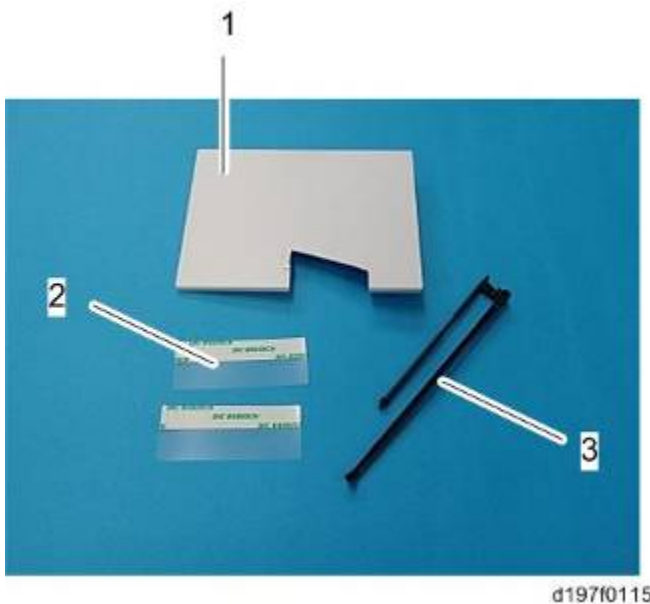

d197f0115

2.13.2 INSTALLATION PROCEDURE

⚠ CAUTION

- When installing this option, turn the power to the machine off, and unplug the power plug from the wall socket.
- If this option is installed when the power is on, it will result in an electric shock or a malfunction.

↓ Note

- Cannot be used together with “Bridge Unit BU3070”, “Side Tray Type M3”, “Internal Finisher SR3130”, or “Internal Finisher SR3180”.
- For using this option together with “1 Bin Tray BN3110”, attach the bottom plate of this option at the beginning, then install the “1 Bin Tray BN3110”, followed by installing this option.

Internal Shift Tray SH3070

1. Remove the filament tape and packing material.
2. Remove the enclosed items.
3. Attach the tray cover [B] to the shift tray [A].

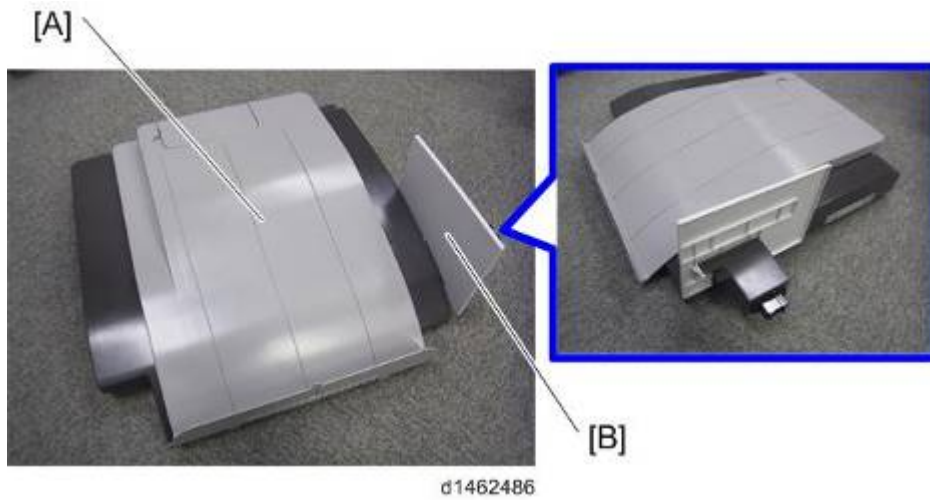

4. Remove the paper exit tray [A].



5. Remove the connector cover [A].



6. Attach the shift tray [A].

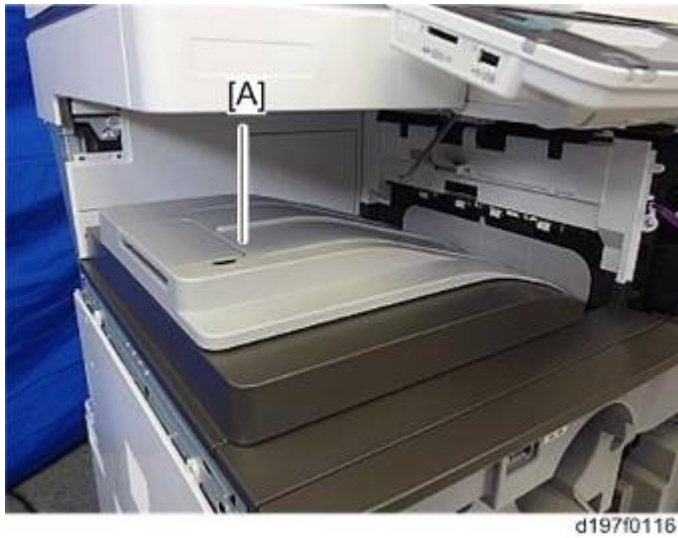

7. Open the right cover.

8. Remove the main power switch cover [A] (🔩 x1).

⬇ Note

- The main power switch cover has three tabs: two on the left side (paper exit) and one on the right side (right cover).



9. Remove the paper exit cover [A] (🔩 x1).



10. Remove the feeler [A].



11. Attach the shift tray feeler [A].



12. Attach the sheets [A] at the edge of the paper exit cover.

13. Attach the paper exit cover and main power switch cover, and then close the right cover.
14. Turn the main power switch ON.
15. Check that paper output to the shift tray can be selected at the operation panel, and check the operation.

2.14 SIDE TRAY TYPE M3

2.14.1 ACCESSORY CHECK

No.	Description	Q'ty
1	Left Extension Tray	1
2	Upper Extension Tray	1
3	Fixing Plate	1
4	Knob Screw	1
5	Tapping screw - M4 x 14	1
6	Tapping screw - M3 x 8	1
7	Bracket	1

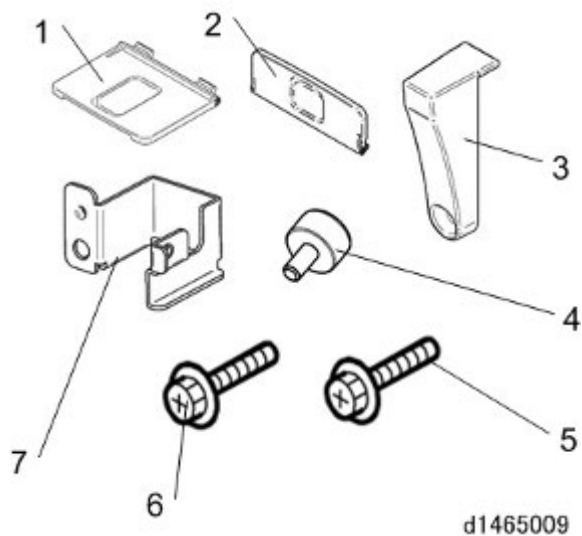

2.14.2 INSTALLATION PROCEDURE

⚠ CAUTION

- When installing this option, turn the power to the machine off, and unplug the power plug from the wall socket.
- If this option is installed when the power is on, it will result in an electric shock or a malfunction.

↓ Note

- The side tray cannot be used together with “Bridge Unit BU3070”, “Internal Shift Tray SH3070”, “Internal Finisher SR3180” or “Internal Finisher SR3130”.
- To use together with the “1 Bin Tray BN3110”, attach the “1 Bin Tray BN3110” first before installing the side tray.

1. Remove the orange tape and shipping retainers.
2. Remove the enclosed items (fixing screws, etc.).
3. Remove the paper exit tray [A].



d197z0407

4. Open the right cover.
5. Remove the main power switch cover [A] (⚙️ x1).

↓ Note

- The main power switch cover has three tabs: two on the left side (paper exit) and one on the right side (right cover).



d197f0052

6. Remove the connector cover [A].



d1462470

7. Attach the bracket [A] (🔩 x1).

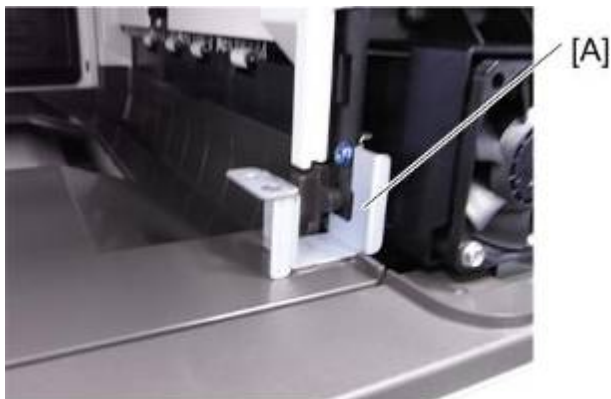

d1462471

8. Attach the main power switch cover, and then close the right cover.
9. Attach the side tray unit [A] to the machine, and fix with a knob screw (🔩 x1).

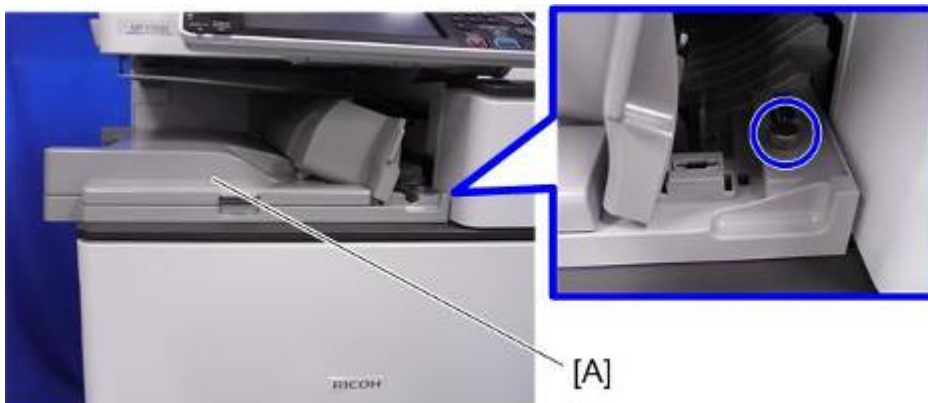

d1462492

10. Attach the fixing plate [A] (🔩 x1).



d1462493

11. Attach the upper extension tray [A] and the left extension tray [B].



d1462494

12. Turn the main power switch ON.
13. Check that paper output of the side tray can be selected at the operation panel, and check the operation.

2.15 BOOKLET FINISHER SR3170 / FINISHER SR3160

2.15.1 ACCESSORY CHECK

Booklet Finisher SR3170 (D688) / Finisher SR3160 (D689)

No.	Description	Q'ty	Note
1	Guide Plate	1	
2	Shift Tray	1	
3	Ground Plate	1	
4	Screws: M4x12	4	
	Rivets	2	
5	Cushion	1	
6	Booklet Tray	1	D688 only
7	Joint Bracket	1	
8	Tapping Screw: M3x8	D688: 2 D689: 1	
9	Tapping Screw: M3x6	4	
10	Tray Holder	1	
11	Hopper Cover	1	D688 only
12	Proof Support Tray	1	
-	EMC Address	1	

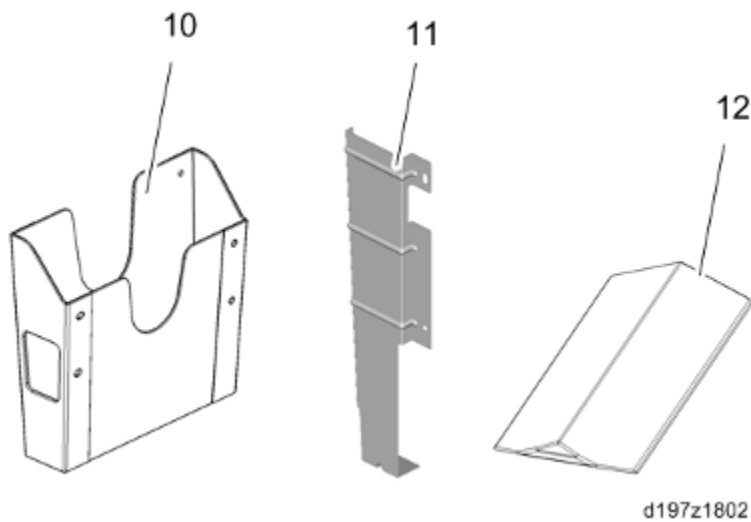
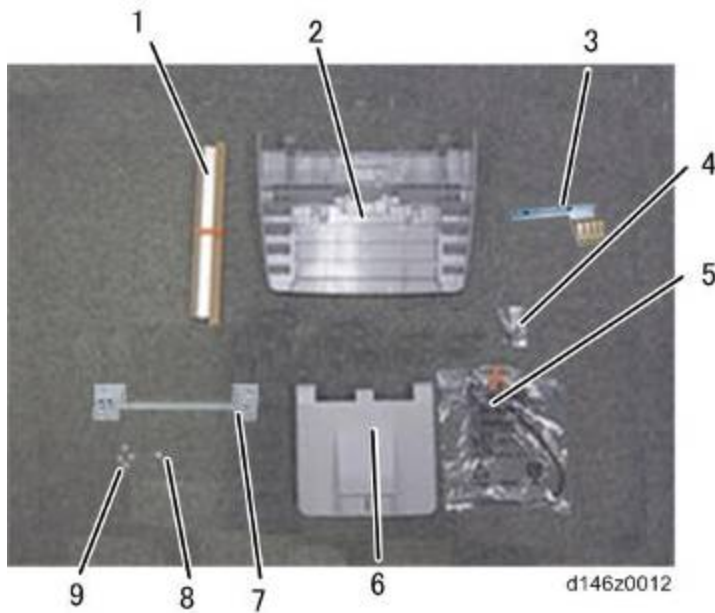

2.15.2 INSTALLATION PROCEDURE

⚠ CAUTION

- When you install this option, turn off the power to the machine, and unplug the power plug from the wall socket.
- If this option is installed when the power is on, it will result in an electric shock or a malfunction.

ⓘ Note

- Before installing this option, attach the “Bridge Unit BU3070” first.
- Attach the “LCIT PB3170/ PB3230” or “Paper Feed Unit PB3210/ PB3220” first before installing this option.

1. Remove the external orange tape and shipping retainers.



d1462541

2. Open the front cover [A], and remove the orange tapes, shipping retainers and fixing bracket [B] (x2)



d197z8005

Note

- **Additional Step only for D688:** Pull out the saddle stitch unit [A] to remove the orange tapes, shipping retainer and fixing bracket [B] attached on the bottom frame (x1).

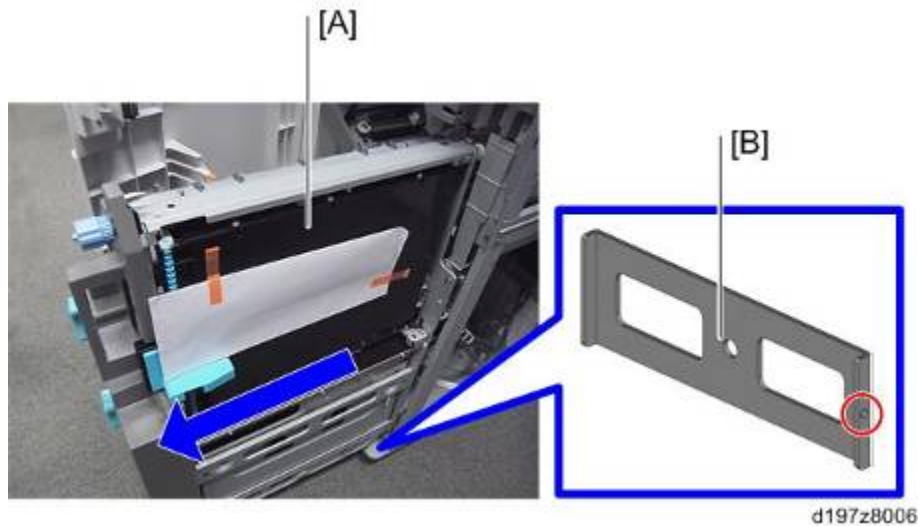

3. For D688 only, install the hopper cover.

⬇ Note

- If optional punch unit PU3050 is to be installed, attach the hopper packed with the punch unit. See the Installation Procedure for PU3050 (page 2-121).

4. Remove the items in the package (fixing screws, etc.).

5. Clean the right side of the upper cover with an alcohol cloth, and then attach the cushion to the finisher.

- Make sure that the cushion is aligned with the rear-lower edge [A] of the upper cover.

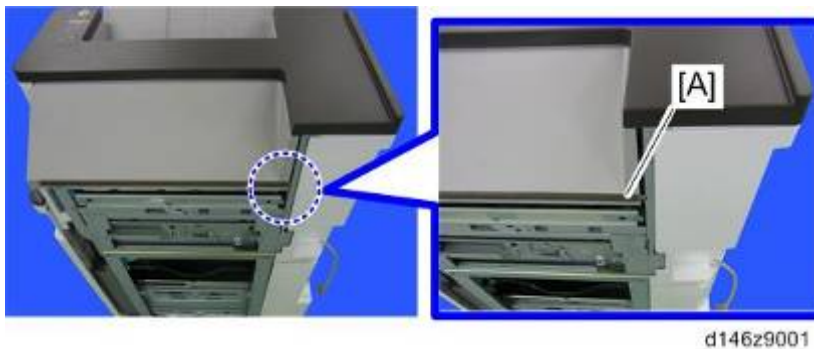

6. Attach the shift tray [A] (🔩 x1).



7. Only for D688, attach the booklet tray [A].



d146z0024

8. Attach the relay guide plate [A] (⚙️ x2).

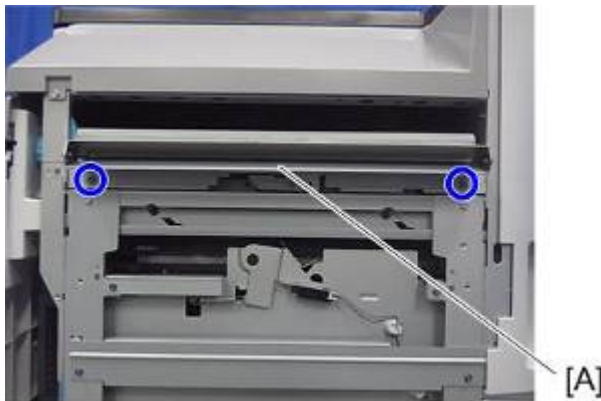

d1462546

9. Attach the ground plate [A] (⚙️ x2).



d1462547

10. Attach the joint bracket [A] to the machine (⚙️ x4).

At this time, tighten the bracket [A] and the bridge unit bracket [B] together.

⚠️ Note

- As the default setting, the screw head is placed at the center of the scale of the rear side.
- The joint bracket [A] must be placed under the bridge unit bracket [B].

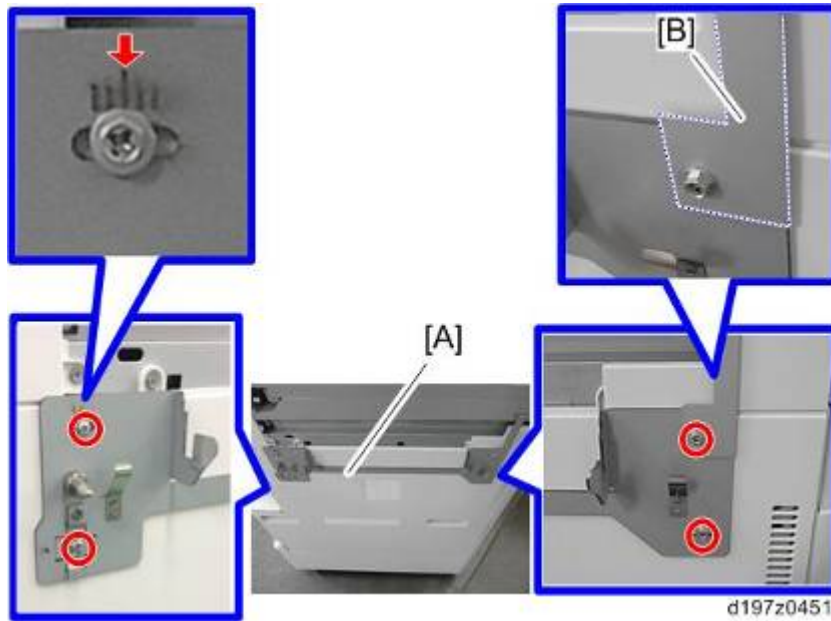

Note

- When adjusting registration, change the screw hole of the adjusting bracket [A] from the upper position [B] to the rear (left) position [C] so that the adjusting bracket can be adjusted horizontally.

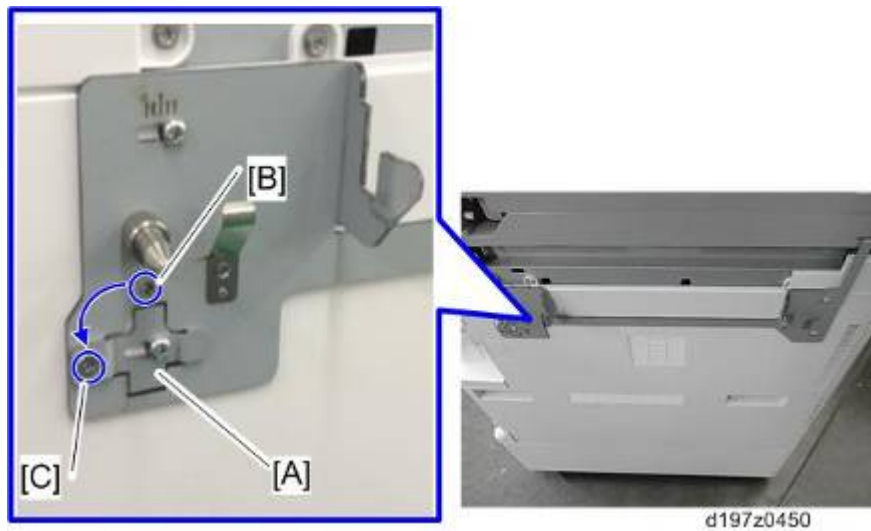

11. Open the front cover.

12. Connect the finisher to the machine with the lock lever [A] (🔒×1).



13. Connect the interface cable to the machine.



d1462550

14. Set the stapler [A].

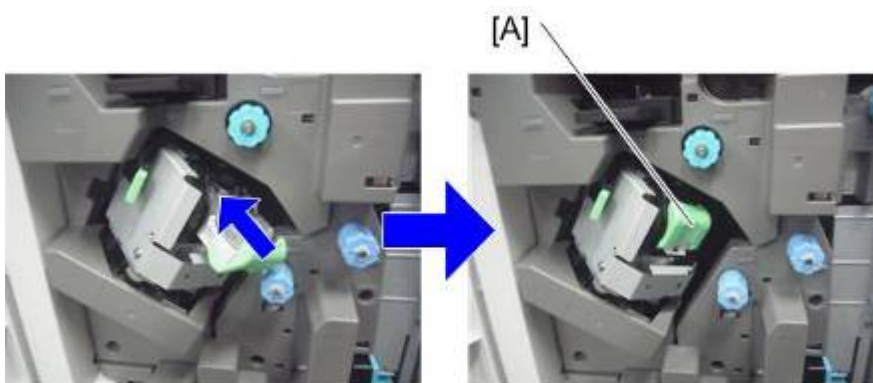

d1462551

15. Close the front cover.

16. Attach the tray holder (🔩 x2).



d1462552

17. Turn the main power switch on.

18. Check that the finisher can be selected on the operation panel, and check the finisher's operation.

2.15.3 ADJUSTMENT AFTER INSTALLING THE FINISHER

After installing a finisher, make sure that the Side-to-Side registration of the finisher matches that of the main machine.

How to Check and Adjust the Side-to-Side Registration

Check the side-to-side registration by exiting to the proof tray. Print out an A3 sheet to the proof tray. Using the markings on the front-most exit roller, check to see where the paper edge is located when the paper is exited. For purposes of accuracy, print out about 5 sets. If side-to-side registration shift occurs, see the Troubleshooting section and make adjustments (page 6-189).

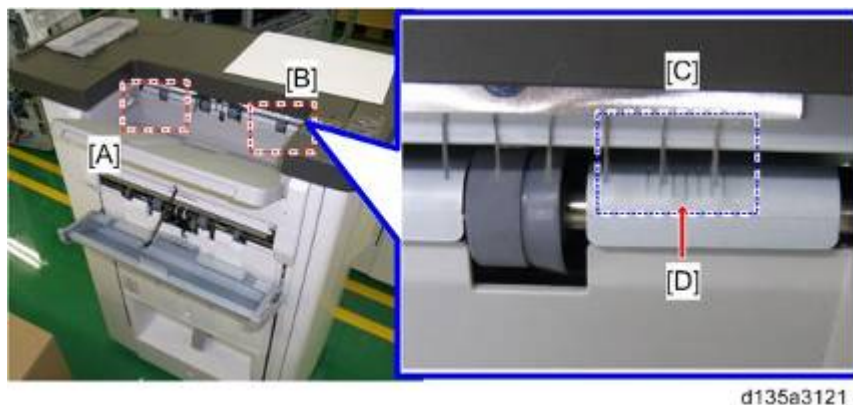

[A]: Scale marks for DLT

[B]: Scale marks for A3

[C]: 7 scale marks at 2mm intervals

[D]: Center mark

ⓘ Note

- Each marking represents 2mm.
 - If the paper edge is lined up with the center marking, this means the paper is aligned correctly.
 - If the paper edge is lined up with any marking to the right of center, this means the paper is shifted toward the front.
 - If the paper edge is lined up with any marking to the left of center, this means the paper is shifted toward the rear.

2.15.4 AUXILIARY TRAY

Make sure that the customer understands the following points about these auxiliary trays:

- The trailing edges of excessively curled paper can activate the tray full sensors before the tray is actually full.
- Once the "Exit Tray Full" message displays, the job cannot continue until some sheets are removed from the tray which is only partially full. The trays are designed to prevent this problem.

Proof Support Tray

Install the proof support tray [A] on the proof tray when the trailing edges of paper are excessively curled.



d1351199

2.16 PUNCH UNIT PU3060

2.16.1 ACCESSORY CHECK

No.	Description	Q'ty
1	Hopper	1
2	Punch Unit	1
3	Registration Guide Plate	1
4	Registration Mobile Unit	1
5	Paper Chip Guide	1
6	Punch Unit Stay	1
7	Punch Stepping Motor Unit	1
8	Clip Ring	1
9	Tapping Screw- M3x6	14
10	Hopper Bracket	1

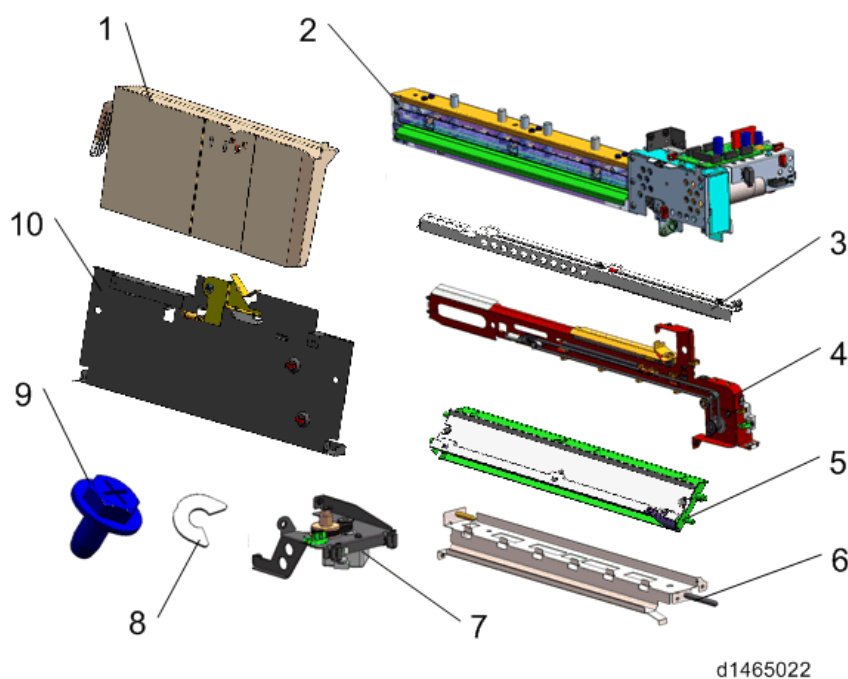

2.16.2 INSTALLATION PROCEDURE

⚠ CAUTION

- When installing this option, turn the power source of the machine off, and unplug the power plug from the wall socket.
- If this option is installed when the power is on, it will result in an electric shock or a malfunction.

↓ Note

- This option is only for Booklet Finisher SR3170 / Finisher SR3160.

1. Remove the rear upper cover [A] (🔩 x2).



2. Remove the rear lower cover [A] (🔩 x2).



3. Remove the inner cover [A] (🔩 x3, 🗑 x1).

↓ Note

- There is a connector on the back of the inner cover.



4. Remove the punch guide plate [A] (⚙️ x1).

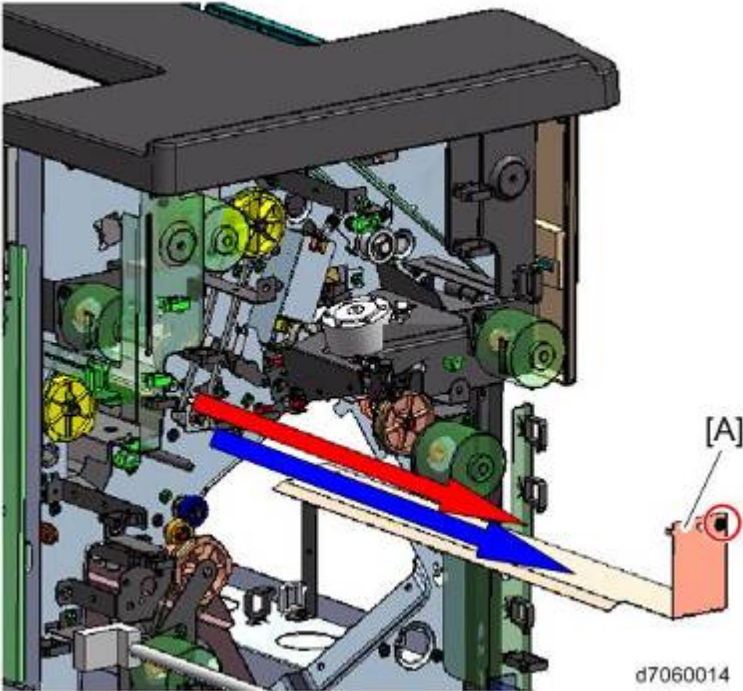

5. Attach the punch unit stay [A] (⚙️ x4).

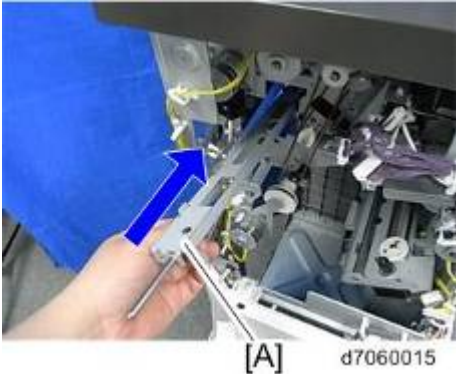

Rear-----Front



6. Attach the paper chip guide [A] (1x1).

↓ Note

- First insert the front tab of the paper chip guide into the frame [B] of the finisher, and then insert the rear tab into the frame [C].

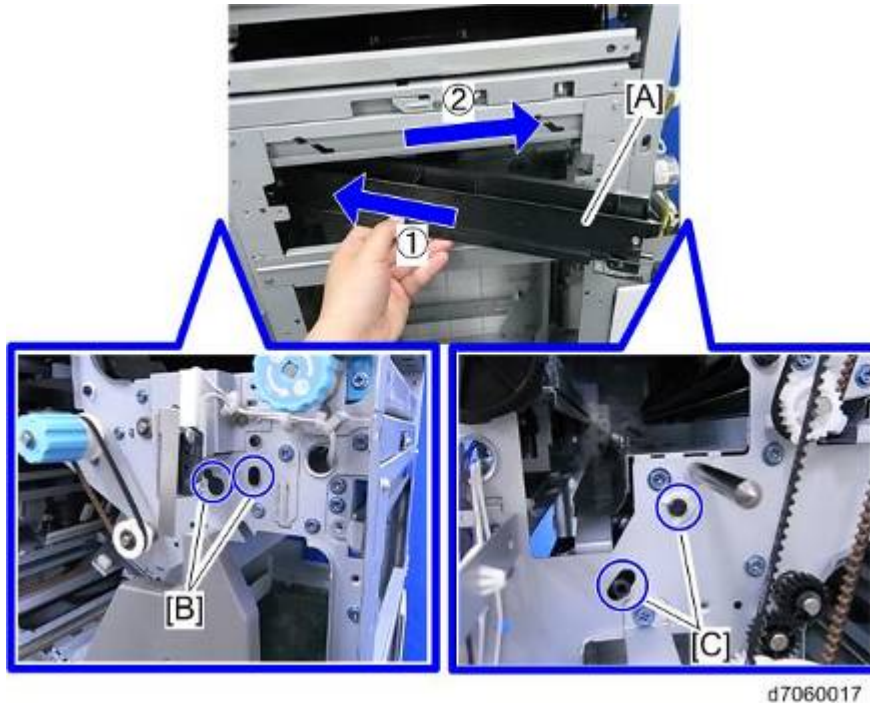

7. Attach the hopper bracket [A], inserting from the outside frame of the finisher (2x2, 2 hooks).

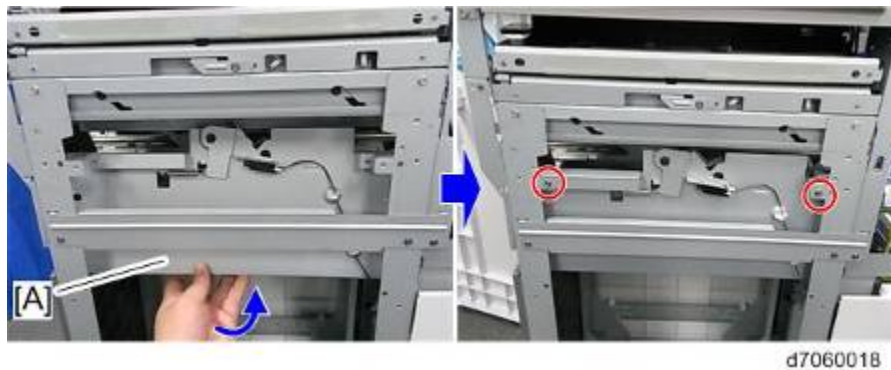

↓ Note

- Hook the hooks of the hopper bracket onto the back side of the frame.

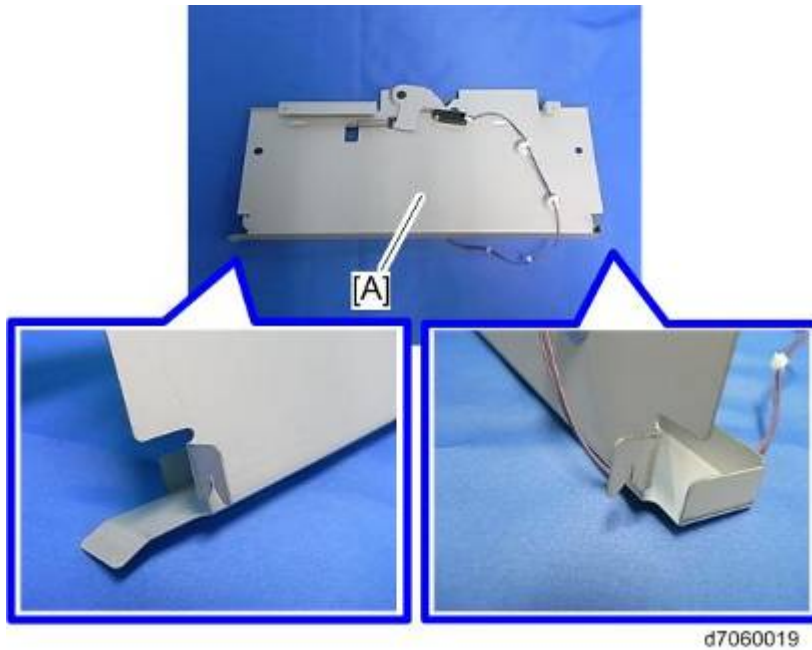

- Hook the upper frame of the hopper bracket onto the outside frame of the finisher.



8. Connect the harness of the hopper sensor (🔩x1).

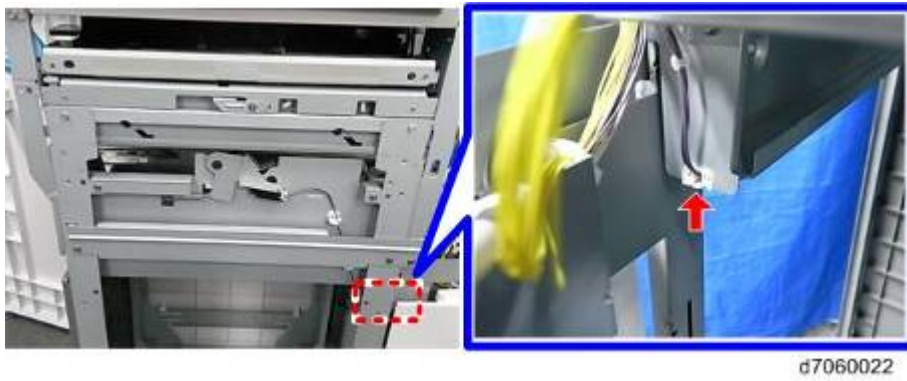

9. Attach the registration guide plate [A] (🔩x2).

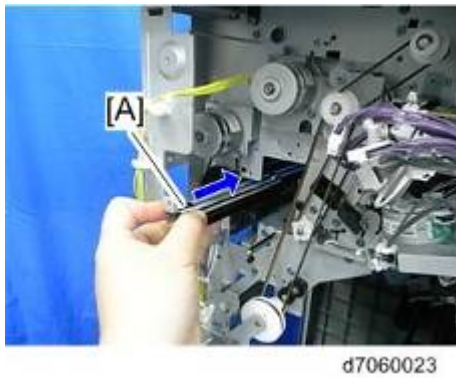

10. Attach the registration mobile unit [A] (🔩x2).

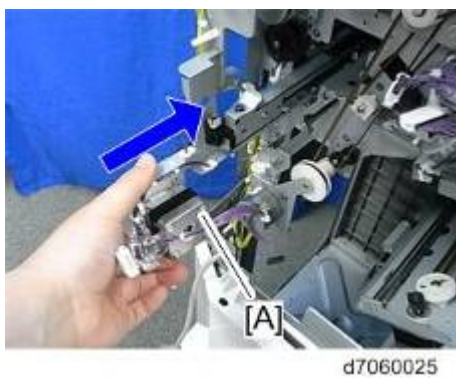

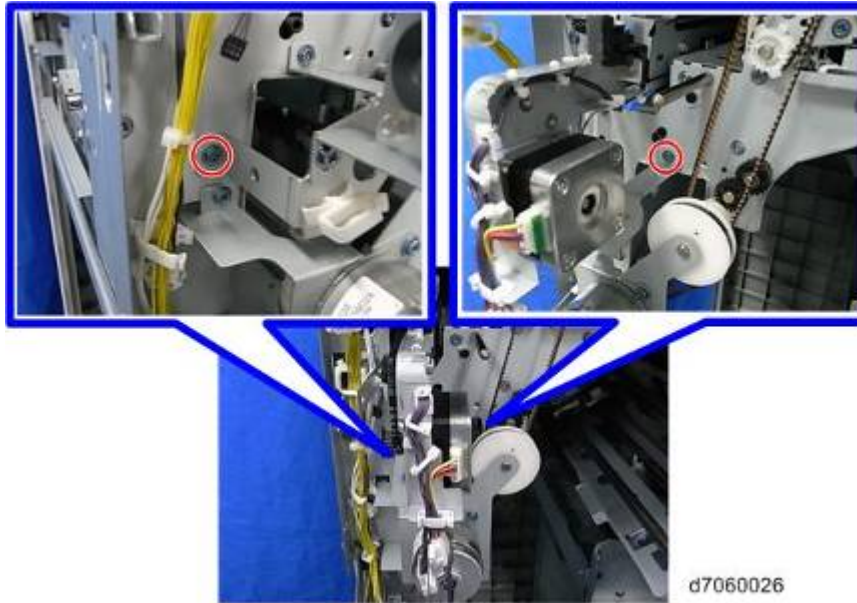

↓ Note

- Insert the front pins of the registration mobile unit into the holes of the frame.



11. Attach the punch unit [A] (x2).

↓ Note

- After inserting the pins [B] of the punch unit stay [A] into the front and rear holes of the punch unit, fix the punch unit with two screws.

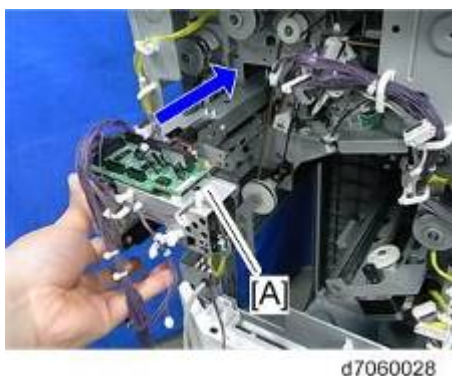

Punch Unit PU3060

- Rear

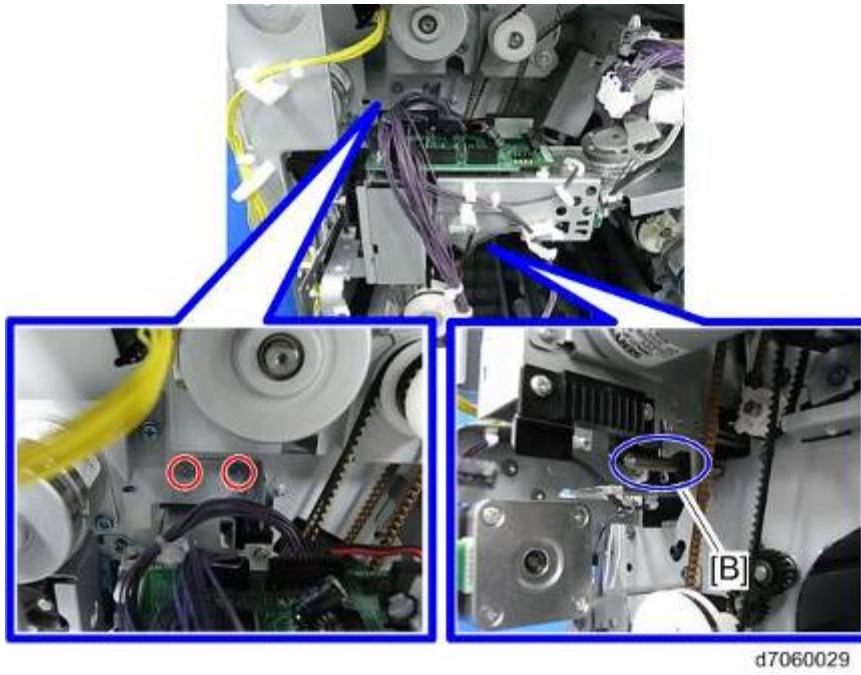

- Front



12. Attach the punch stepping motor unit [A] (🔧x2).

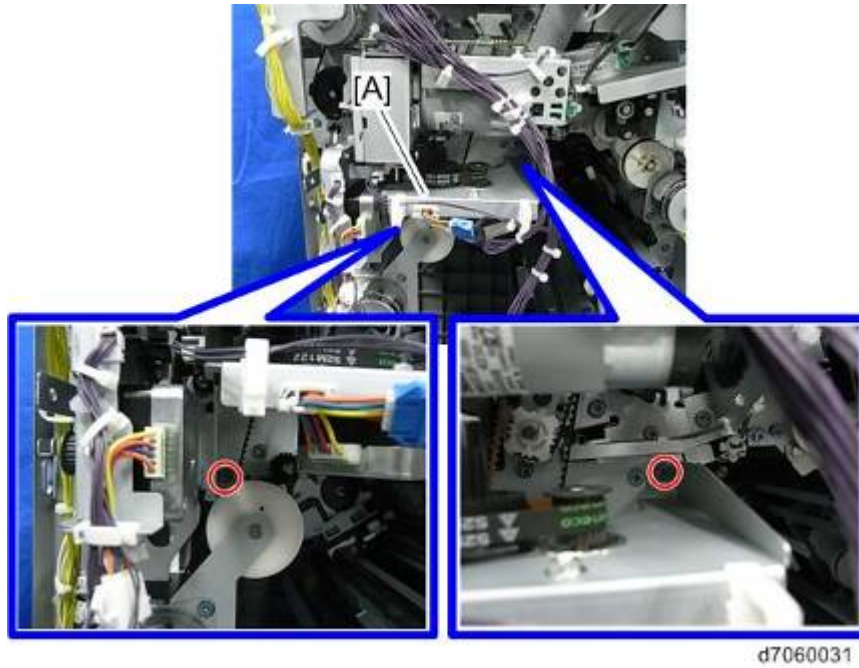

⬇ Note

- Engage the gear [B] of the punch stepping motor unit with the rack [C] of the punch unit.

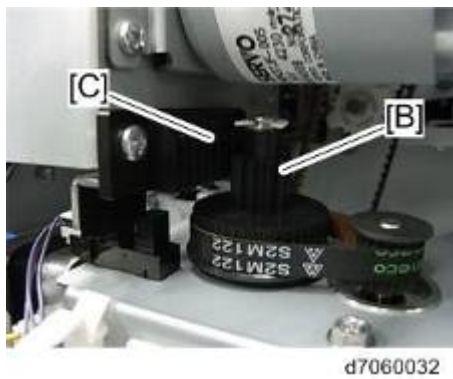

13. Connect the harness of the hopper sensor to the connector of the finisher.



14. Connect the harness of the punch unit to the connector of the registration drive unit.

Punch Unit PU3060

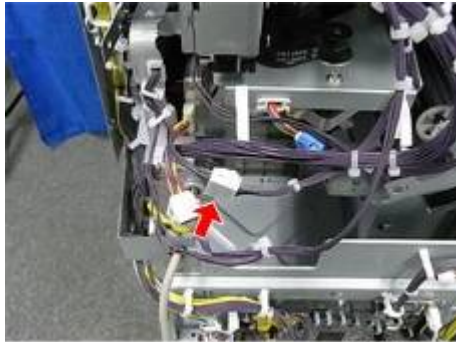

d7060034

15. Connect the harness of the punch unit to the connector of the main board, and then fix it (🔧 x2, 🛠️ x2).

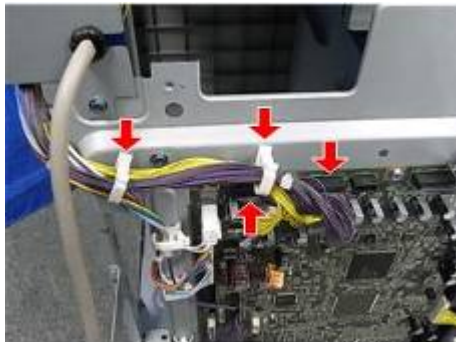

d7060035

16. Connect the harness [B] of the punch stepping motor unit and the harness [C] of the registration mobile unit to the connector of the punch unit board [A].

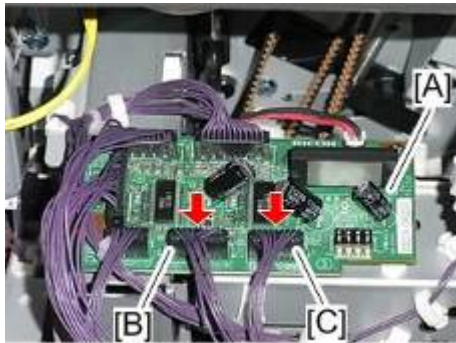

d7060036

17. Clamp all the harnesses of the punch unit PU3060 (🔧 x8).

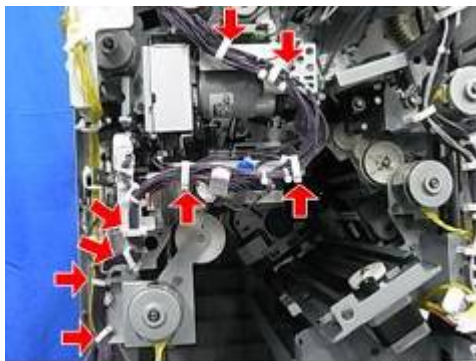

d7060037

18. Attach the hopper [A].



19. Attach the rear upper cover, the rear lower cover, the inner cover, and the punch guide plate.

2.17 BOOKLET FINISHER SR3150 / FINISHER SR3140

2.17.1 ACCESSORY CHECK

Booklet Finisher SR3150 / Finisher SR3140

No.	Description	Q'ty	Remarks
1	Booklet Tray	1	SR3150 only
2	Relay Guide Plate	1	Not used
3	Ground Plate Bracket	1	
4	Screws: M4x12	4	Not used
	Tapping screws: M3x6	2	
	Tapping screw : M4x8	1	
5	Shift Tray	1	
6	Connecting Bracket	1	
7	Stabilizer	1	SR3140 only
8	Cushion	1	Not used
-	EMC Address	1	

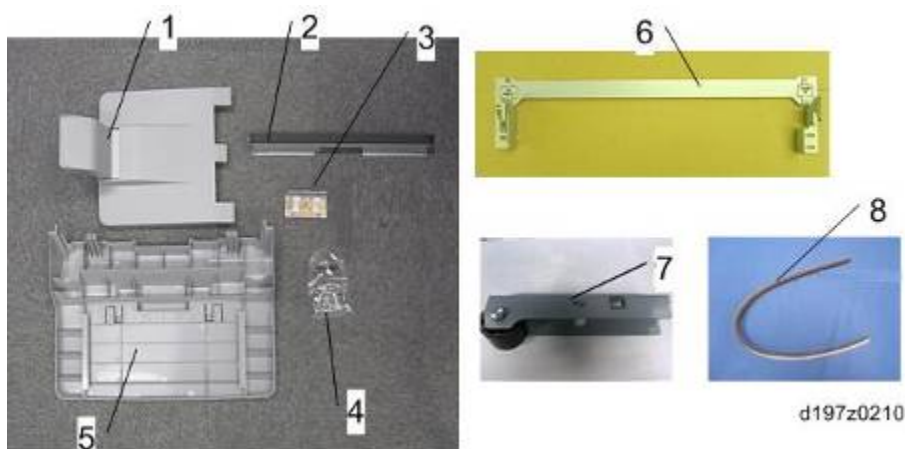

2.17.2 INSTALLATION PROCEDURE

★ Important

- Only for SR3140, two stabilizers are included as accessories.
- They must be attached to the finisher just after it is taken out of the shipping box.

⚠ CAUTION

- When you install this option, turn off the power to the machine, and unplug the power plug from the wall socket.
- If this option is installed when the power is on, it will result in an electric shock or a malfunction.

↓ Note

- Before installing this option, attach the “Bridge Unit BU3050” first.
- Attach the “LCIT PB3170/ PB3230” or “Paper Feed Unit PB3210/ PB3220” first before installing this option.

1. For SR3140 only, install the stabilizer [A] (🔩x1).



d1465019

2. Remove the external orange tape and shipping retainers.



d197f0121

3. Open the front cover [A], and remove the filament tape and packing materials.
4. For SR3150 only, remove the bracket [B] (🔩 ×1).



5. Pull out the booklet stitching unit [A] or stapling unit, and remove the filament tape and packing materials.

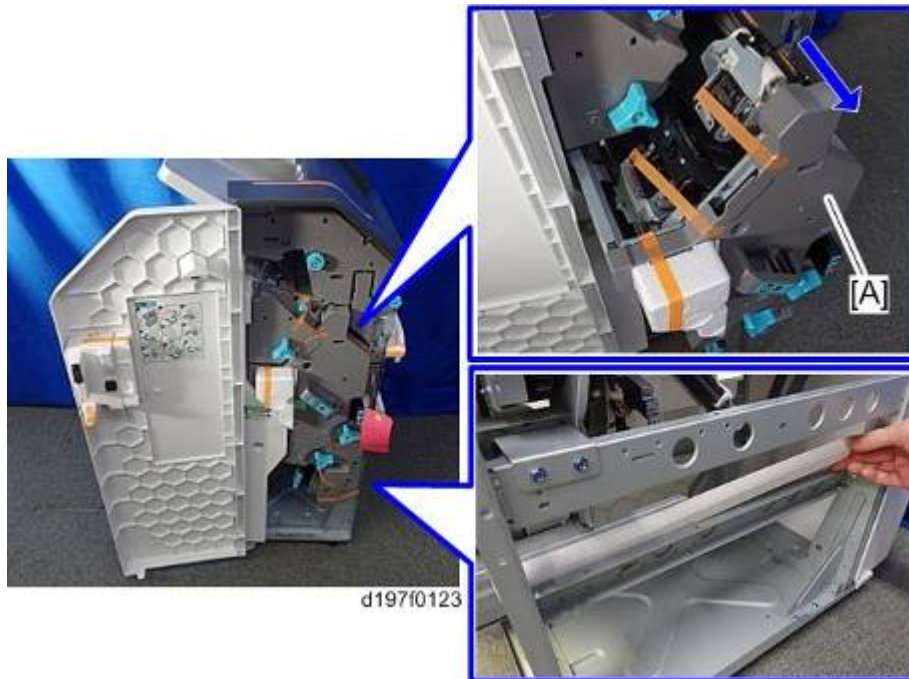

6. Wipe the surface of the top cover with alcohol, and then attach the cushion [A] (supplied with the finisher adapter) to the top cover.

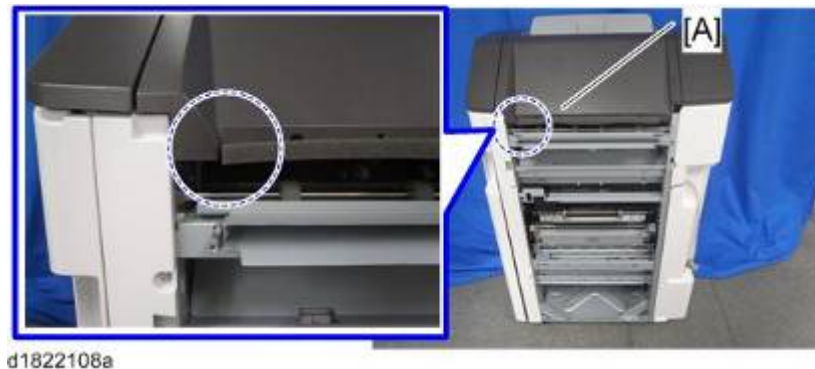

7. Attach the shift tray [A] (🔩 x1; M4 x 8).



d1462529

8. For SR3150 only, attach the booklet tray [A].



d1462530

9. Attach the relay guide plate [A] supplied with the finisher adapter to the finisher (🔩 x 2 (M3 x 6)).

⬇ Note

- There are two screw holes at each edge of the frame. Use the screw holes which are the front side on each edge when attaching the relay guide plate [A].

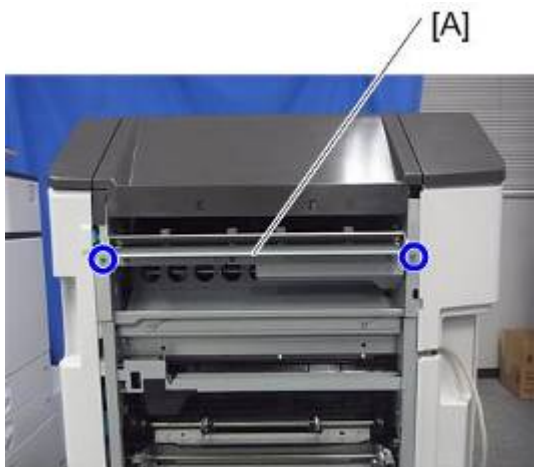

d1462531

10. Attach the ground plate bracket [A] (🔩 x2; M3 x 6).

SR3150



SR3140

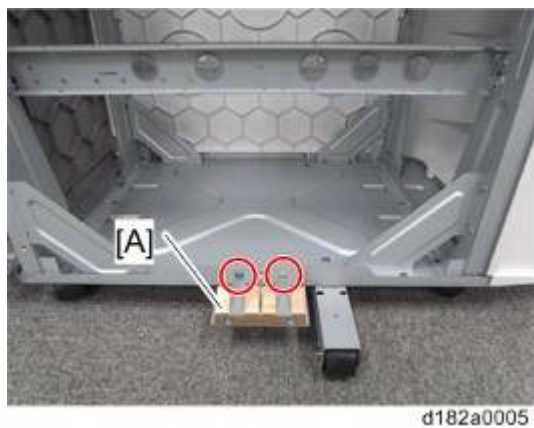

11. Attach the connecting bracket [A] that comes with the finisher adapter to the finisher (x4).

Note

- Secure the connecting bracket [A] together with the bridge unit bracket [B]. Also note that the connecting bracket [A] must be placed under the bridge unit bracket [B].
- Make sure that the screw head is placed at the center of the scale as shown by the blue arrow below.

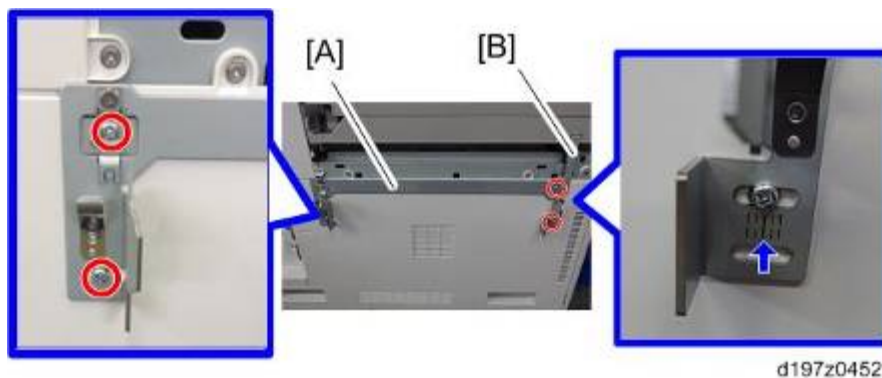

Note

- When adjusting registration, reattach the adjusting bracket [A], so that the inscribed line turns upside down. The screw is to be secured with the elongated screw slot.

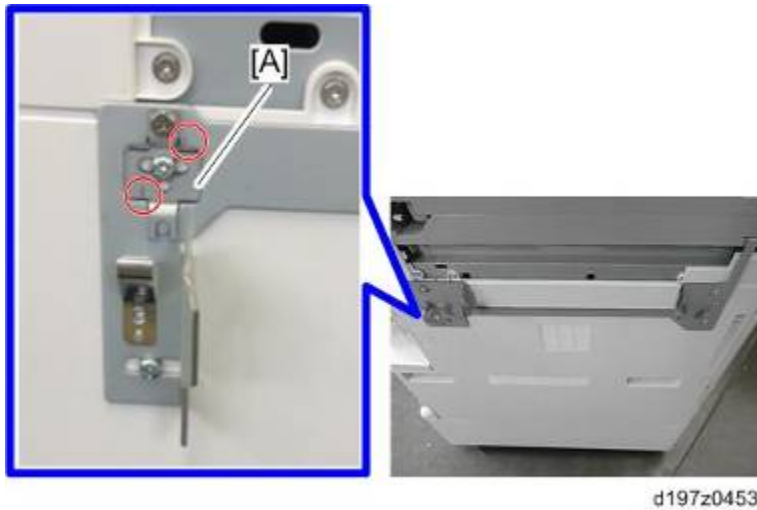

12. Connect the finisher to the machine with the lock lever [A] (🔑 x1).



13. Connect the interface cable to the machine.



14. Turn the main power switch on.
 15. Check that the finisher can be selected on the operation panel, and check the finisher's operation.

2.17.3 ADJUSTMENT AFTER INSTALLING FINISHER

After installing a finisher, make sure that the Side-to-Side registration of the finisher matches with that of the main machine.

How to Check and Adjust the Side-to-Side Registration

Check the side-to-side registration by exiting to the proof tray. Print out an A3 sheet to the proof tray. Using the markings on the front-most exit roller, check to see where the paper edge is located when the paper is exited. For purposes of accuracy, print out about 5 sets. If side-to-side registration shift occurs, see the Troubleshooting section and make adjustments (page 6-189).

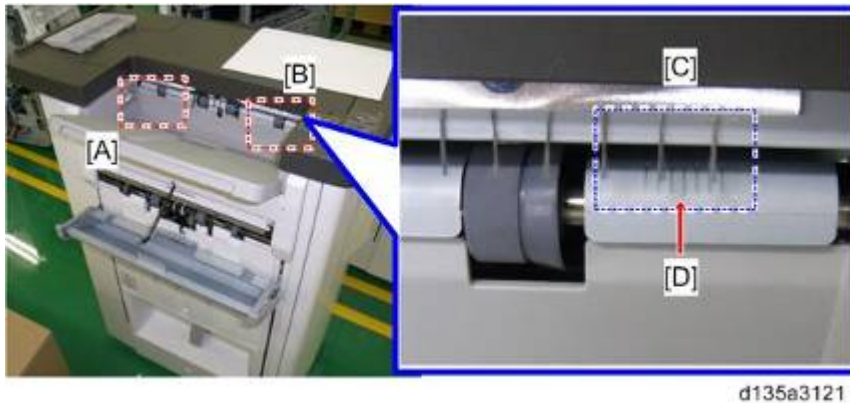

[A]: Scale marks for DLT

[B]: Scale marks for A3

[C]: 7 scale marks in 2mm intervals

[D]: Center mark

Note

- Each marking represents 2mm.
 - If the paper edge is lined up with the center marking, this means the paper is aligned correctly.
 - If the paper edge is lined up with any marking to the right of center, this means the paper is shifted toward the front.
 - If the paper edge is lined up with any marking to the left of center, this means the paper is shifted toward the rear.

2.18 PUNCH UNIT PU3050

2.18.1 COMPONENT CHECK

No.	Description	Q'ty
1	Punch unit	1
2	Registration Sensor unit	1
3	Registration Guide Plate	1
4	Hopper Guide Plate	1
5	Punch Unit Stay	1
6	Hopper	1
7	Punch Drive Motor	1
8	Harness: punch: main	1
9	Tapping screws: M3x6	15



d182a0011

2.18.2 INSTALLATION PROCEDURE

⚠ CAUTION

- When installing this option, turn the power source of the machine off, and unplug the power plug from the wall socket.
- If this option is installed when the power is on, it will result in an electric shock or a malfunction.

↓ Note

- This option is only for Booklet Finisher SR3150 / Finisher SR3140.

1. **Unpack the box, and remove the filament tape and packing material.**
2. **Pull out the finisher interface cable, and move it away from the machine.**
3. **Remove the finisher rear cover [A] (🔩 x2).**



4. **Open the finisher front cover [A].**



5. **Remove the three knobs [A] (🔩 x1).**

↓ Note

- Remove the knobs with the lock mechanism using a knob screwdriver or similar tool while releasing the lock.

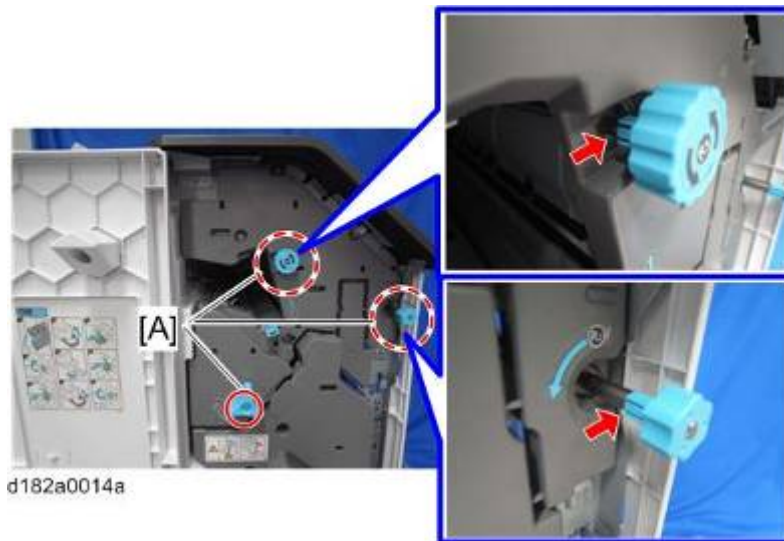

6. Remove three screws of the finisher inner cover [A] (🔩 x3).



7. Pull out the booklet stitching unit [A] a little.



8. Remove the inner cover [A] (🔩 x1).

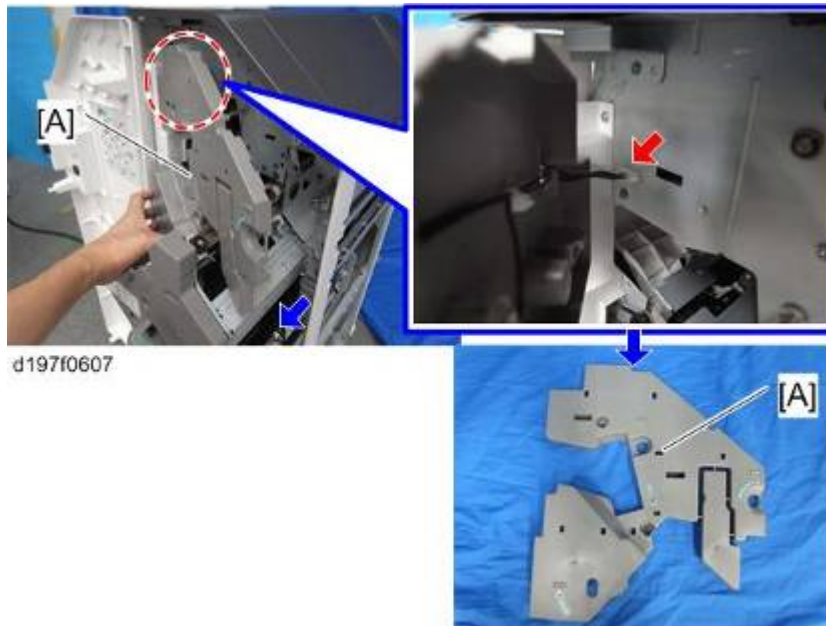

9. Open the upper cover [A] and remove the arm of the guide plate [B] from the finisher upper cover (⚙️x1).

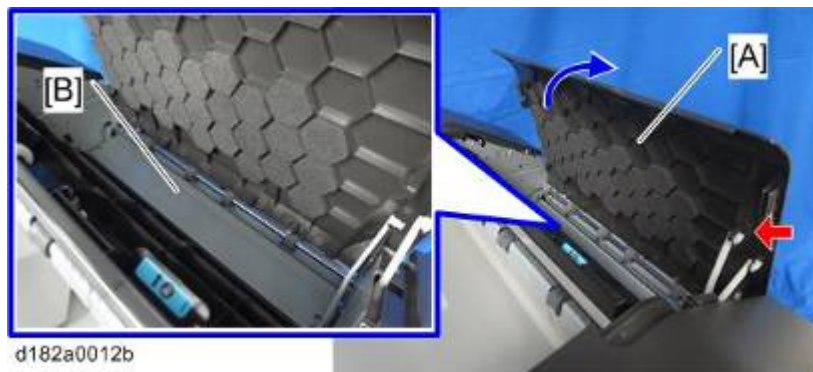

10. Remove the guide plate [A] (⚙️x4).

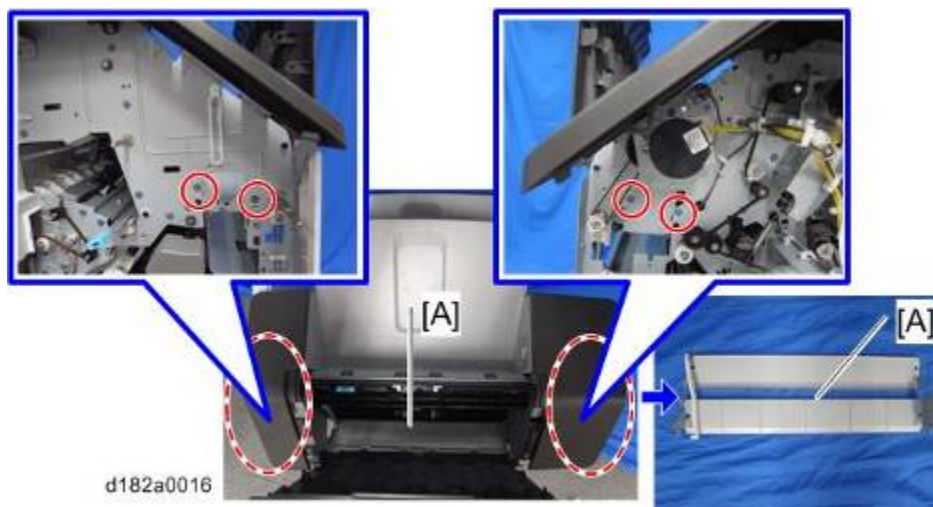

⚠️ Note

- The removed guide plate is not used. Please check with the customer when you discard it.

11. Insert the hopper guide plate [A] from the front.



12. Secure the hopper guide plate [A] (⚙️ x4, ⚙️ x1).

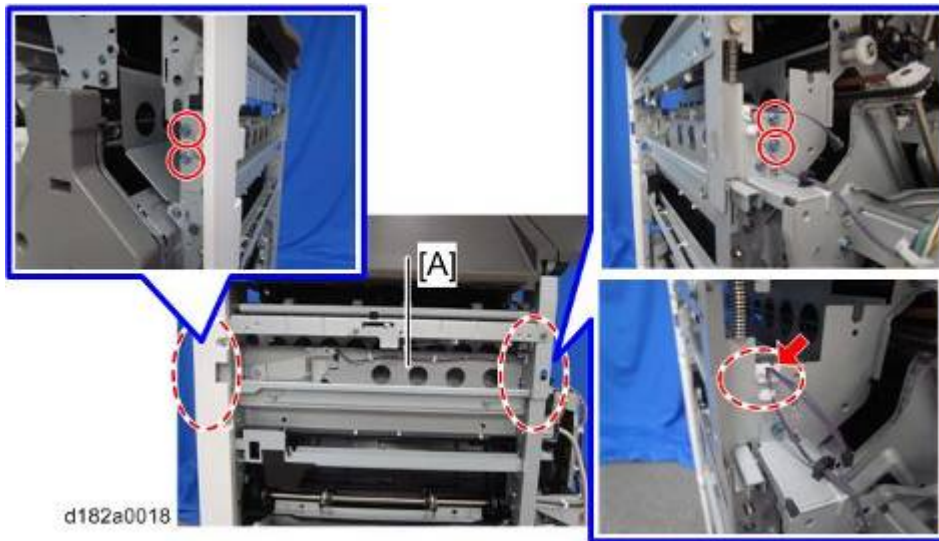

13. Insert the punch unit stay [A] from the front.

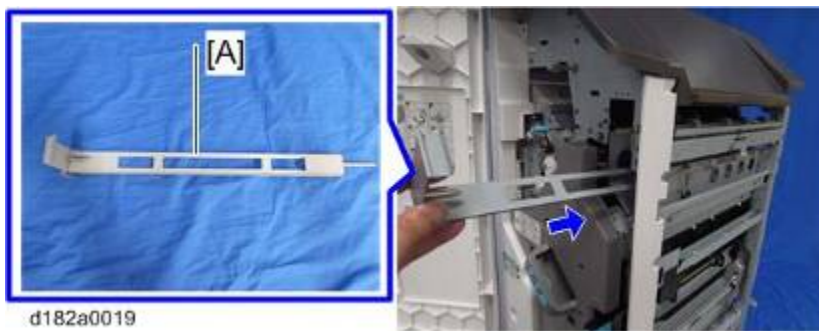

⚠️ Note

- Set the shaft [B] of the punch unit stay in the U-shaped gutter [A].

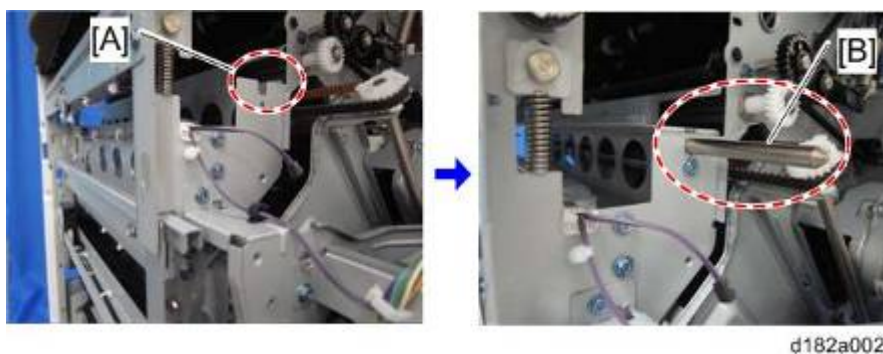

14. Secure the punch unit stay [A] (🔩 x3).



15. Insert the registration guide plate [A] from the rear.



16. Secure the registration guide plate [A] (🔩 x2).

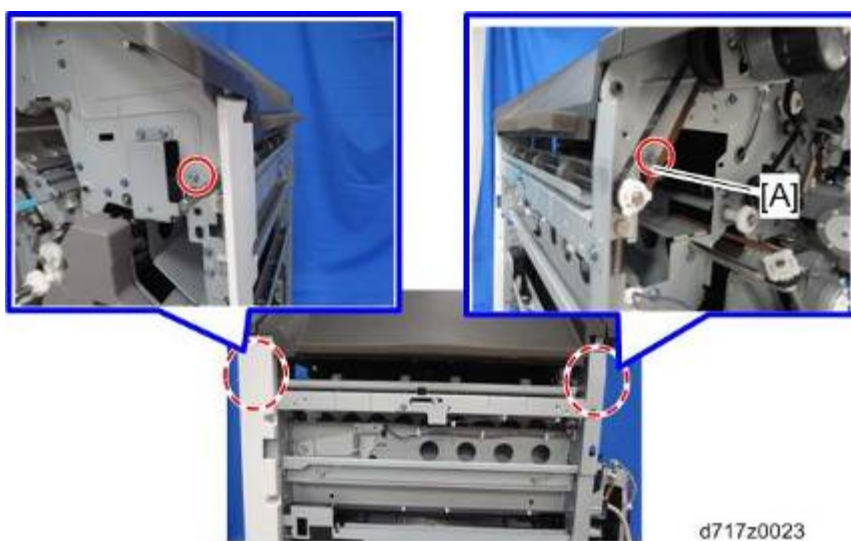

17. Insert the registration sensor unit [A] from the rear.

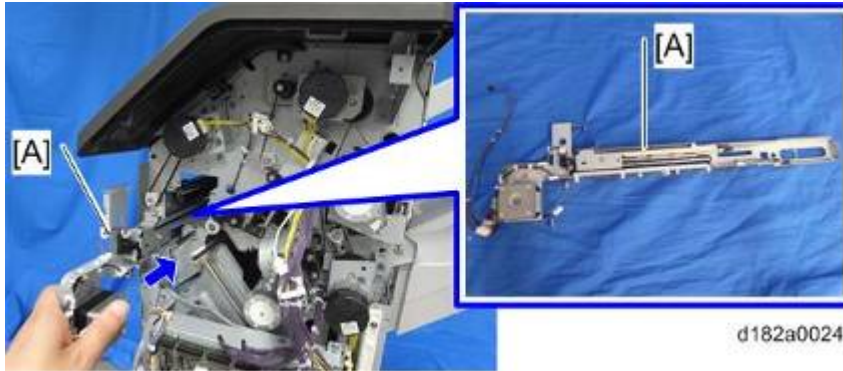

Note

- Insert the shafts [C] of the registration sensor unit [B] into the bearings [A].



18. Secure the registration sensor unit [A] (⚙️x2).

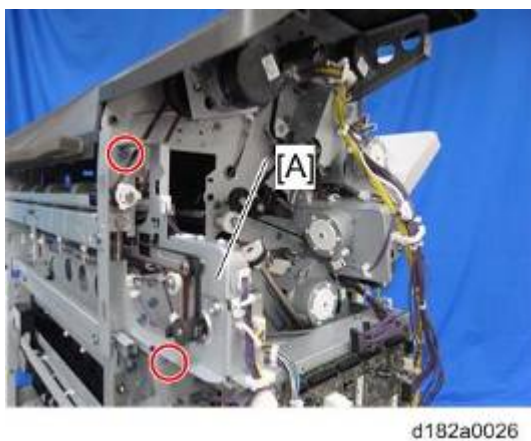

19. Connect the hopper guide plate harness [A] to the registration sensor unit relay connector [B] (🔌x1).

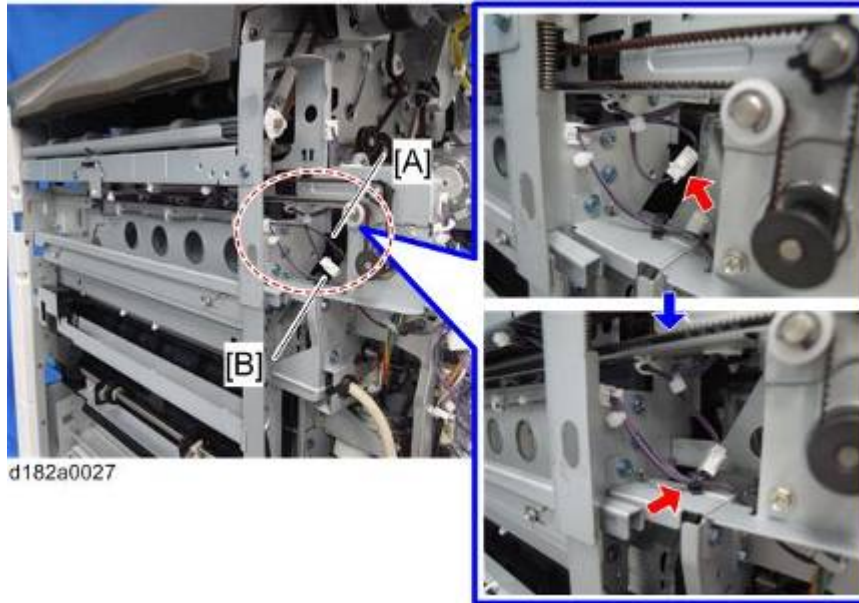

20. Insert the punch unit [A] from the rear.

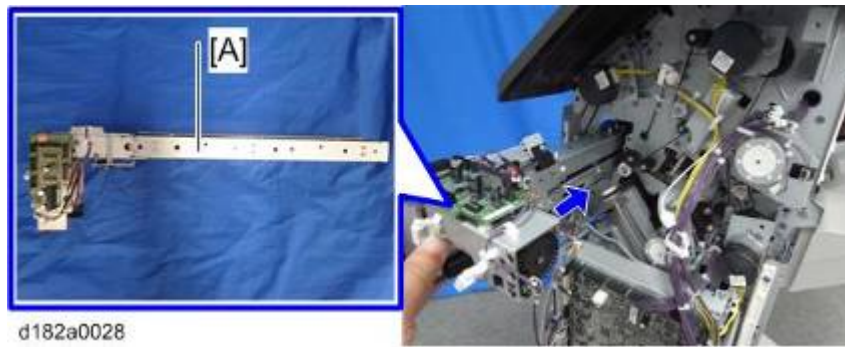

Note

- The bracket [A] must be in the right position as shown when inserting.

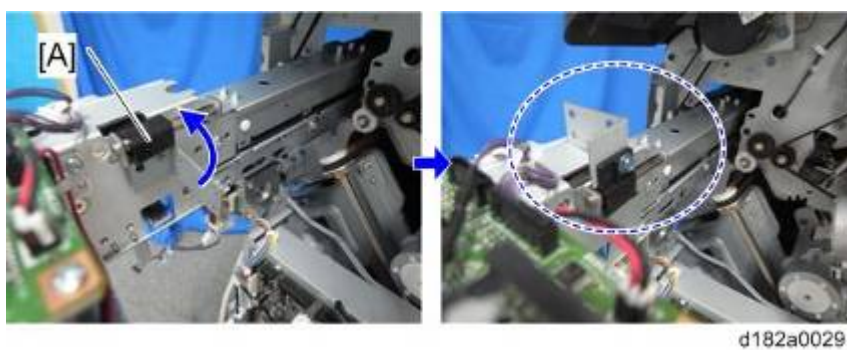

21. Secure the punch unit [A] (🔩 x2).



22. Insert the punch drive motor from the rear of the finisher.

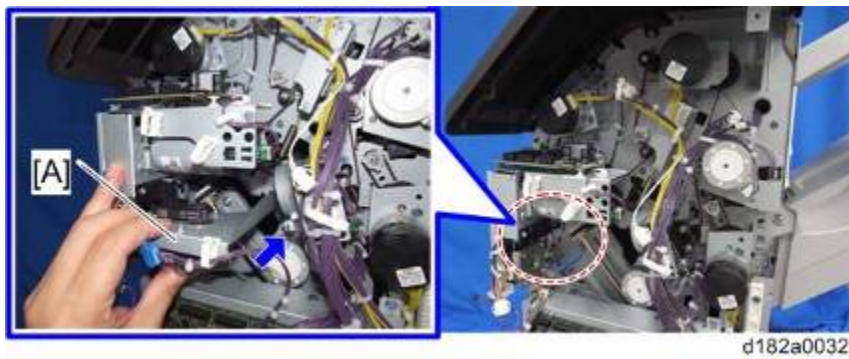

Note

- Put the shaft of the stay [A] through the hole of the motor bracket [B].

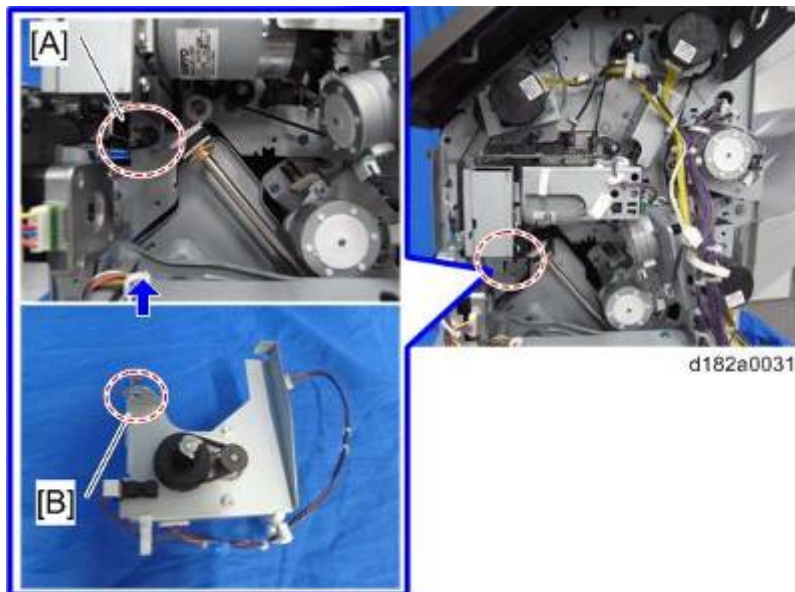

- Make sure that the rack of the punch unit [A] and the pinion of the bracket [B] are correctly engaged with each other.

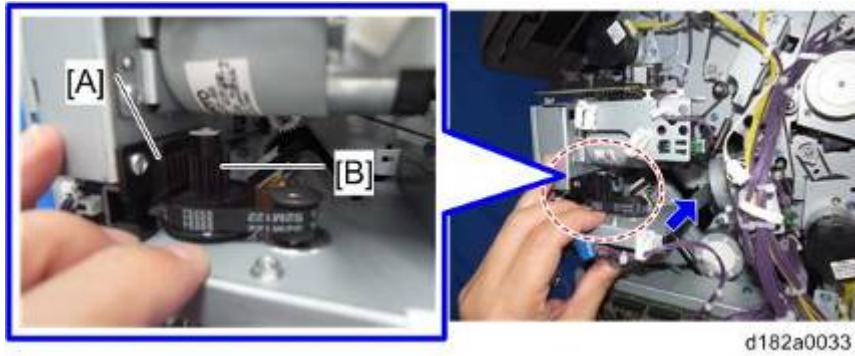

23. Secure the punch drive motor [A] (🔩 x2).



24. Connect the harness [B], provided as an accessory, to the main board of the punch unit [A] (🔌 x3).

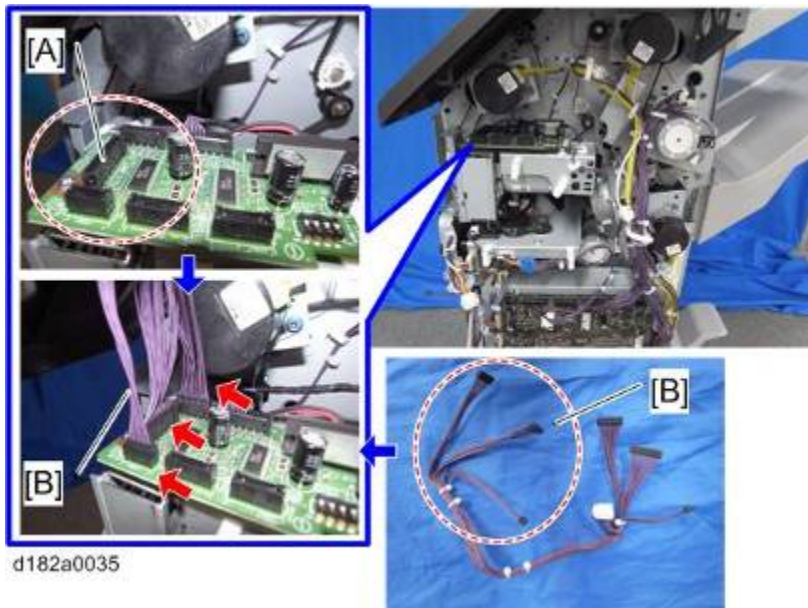

25. Connect the harness [B] provided as an accessory, to the main board [A] of the finisher (🔌 x3).

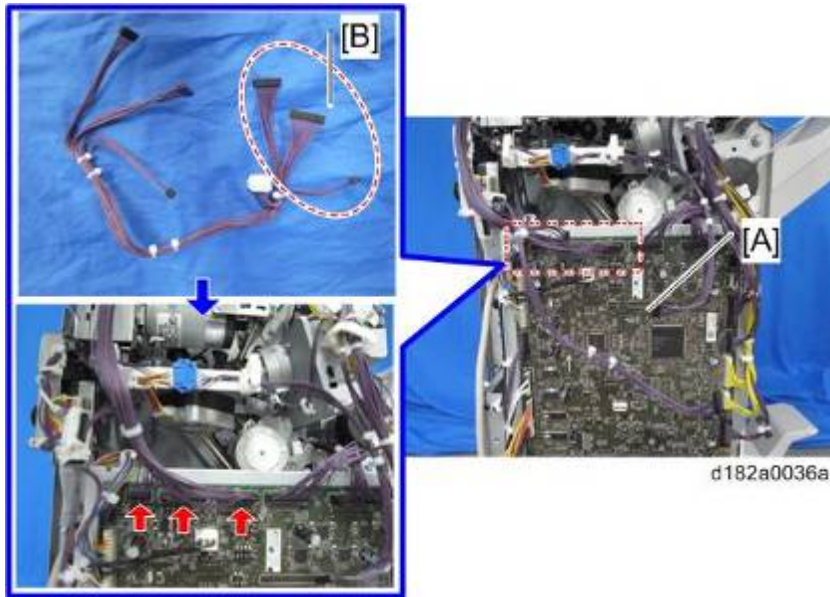

26. Connect the harness [B], provided as an accessory, to the harness of the registration sensor unit [A] (🔧 x1).

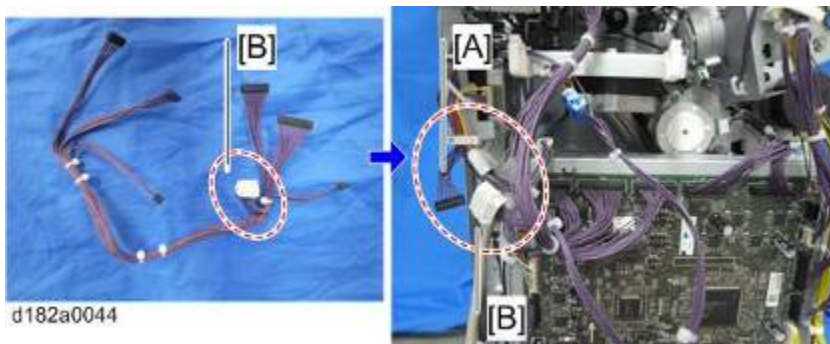

27. Remove the harness [A] from the clamp [B], and connect it to the main board of the punch unit [C] (🔧 x1).

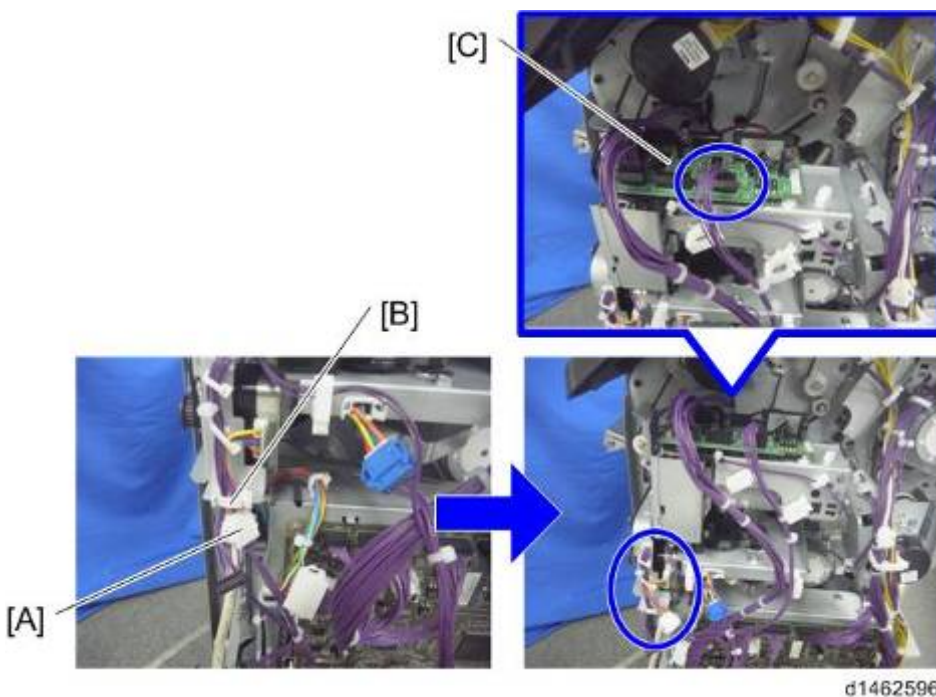

28. Connect the harness of the punch drive motor [A] to the main board [B] of the punch unit.

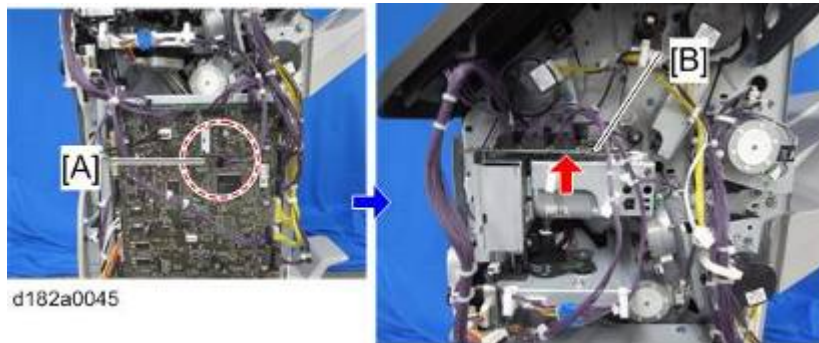

29. Clamp the harnesses (🔧x4).

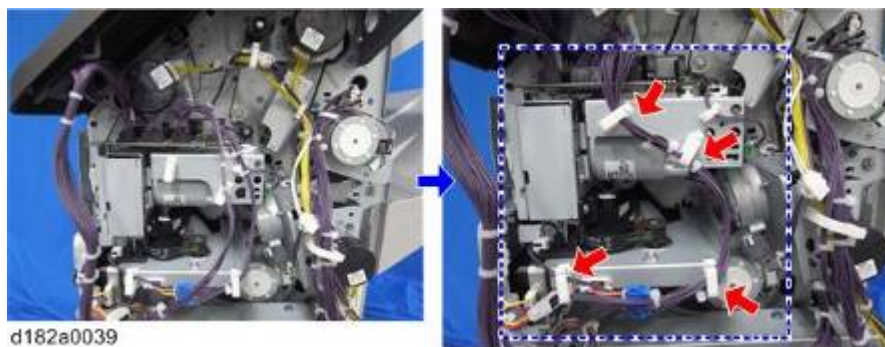

30. Insert the hopper [A].

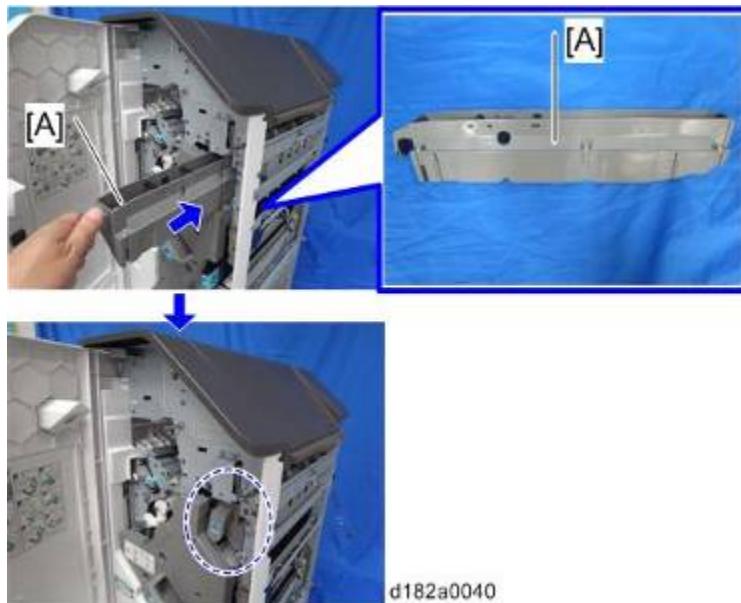

31. Cut off the part [A] of the finisher inner cover, then attach the inner cover [B] (🔪 x1).

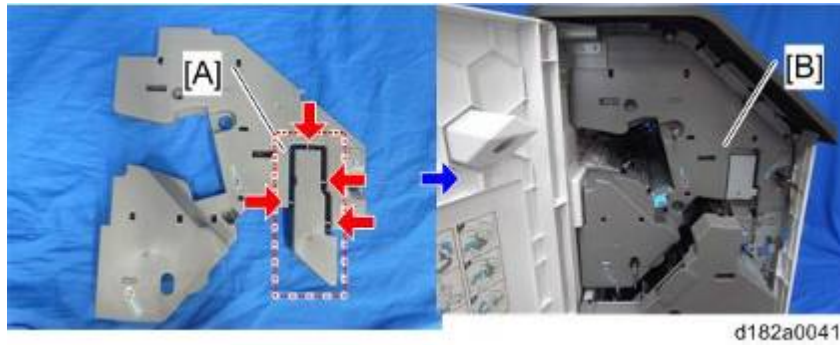

32. Attach the inner cover (🔩 x3).
33. Attach three knobs(🔩 x1).
34. Attach the finisher rear cover (🔩 x2).
35. Close the front cover.
36. Close the top cover.
37. Attach the finisher to the machine, and connect the interface cable.
38. Connect the power cord of the machine, and turn the main power on.
39. Check that the punch can be selected at the operation panel, and check the operation.

2.19 INTERNAL FINISHER SR3180

2.19.1 ACCESSORY CHECK

No.	Description	Q'ty
1	Bottom Plate	1
2	Left Lower Cover	1
3	Paper Output Tray	1
4	Tapping Screw: M3X8	2
5	Tapping Screw: M3X8	2
6	Tapping Screw: M3X8	2
7	Screw: M3X6	3
8	Tapping Screw: M3X6	1
9	Tapping Screw: M4X8	1
10	Slide Rail	1
11	Nylon Clamp	1



d766z0001



2.19.2 INSTALLATION PROCEDURE

⚠ CAUTION

- When you install this option, turn off the power to the machine, and unplug the power plug from the wall socket.
- If this option is installed with the power on, it will result in an electric shock or a malfunction.

↓ Note

- Cannot be used together with “Bridge Unit BU3070”, “Internal Shift Tray SH3070”, “Side Tray Type M3” or “Internal Finisher SR3130”.
- For using this option together with “1 Bin Tray BN3110”, attach the bottom plate of this option at the beginning, then install the “1 Bin Tray BN3110”, followed by installing this option.

1. Remove the orange tape and shipping retainers.



d766z0002

2. Remove the screw [A] securing the unit (🔩 x 1).

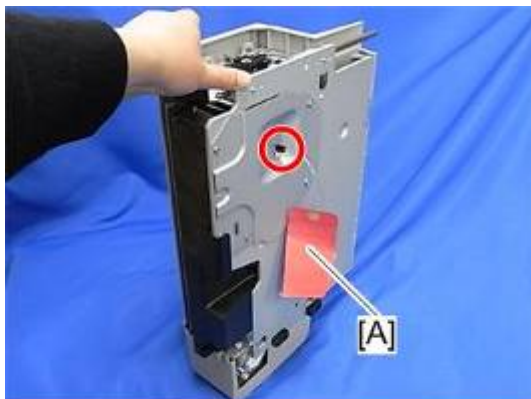

d7662074

3. Remove the shaft [B] from the slide rail [A] (🔩 x 1).

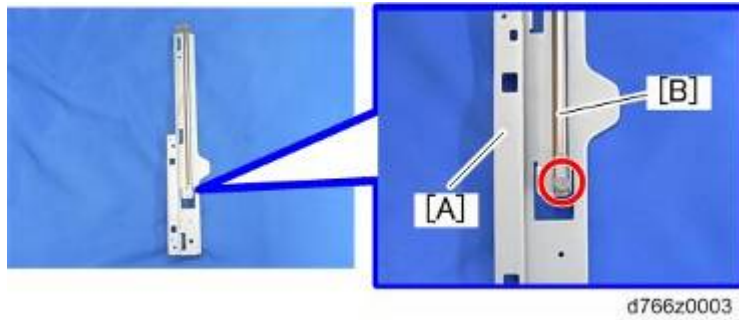

4. Remove the paper output cover [A] (🔩 x 2).



5. Place the slide rail [A] under the internal finisher [B].

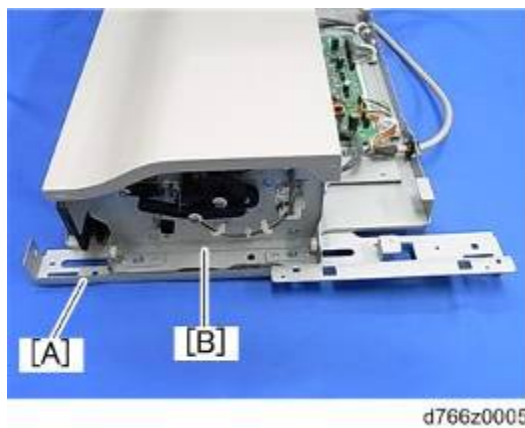

6. Insert the shaft [A] into the holes located in the slide rail and internal finisher, and then fasten with the screw (🔩 x 1).



7. Attach the paper output cover (removed in step 4) [A] (🔩 x 2).

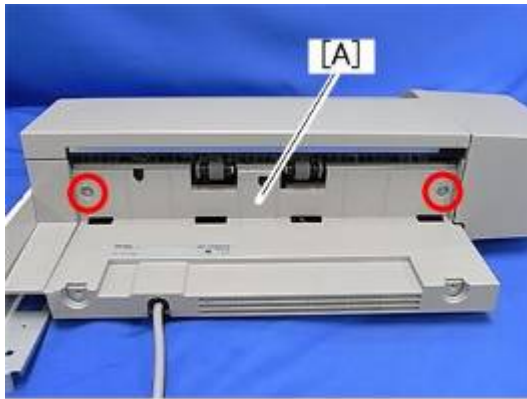

d177z4578

8. Remove the Paper exit tray [A].



d197z0407

9. Open the front cover.

10. Remove the left upper cover [A] (🔩 x 1).

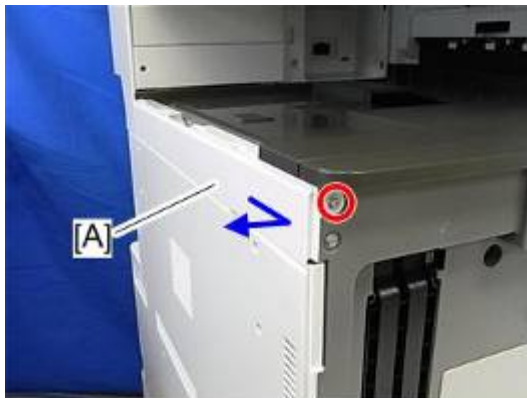

d197z0001

11. Remove the left rear cover [A] (🔩 x 2).



12. Remove the inverter tray [A].

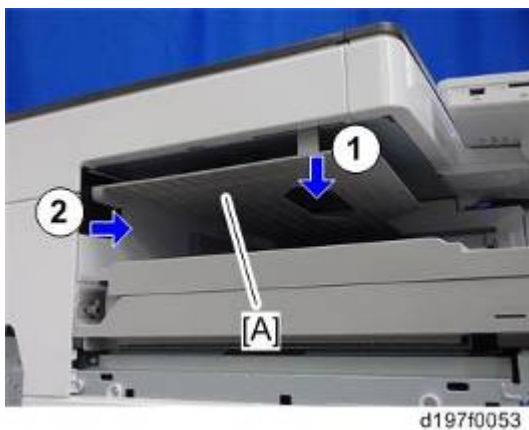

13. Open the right cover.

14. Remove the main power switch cover [A] (🔩 x 1).

⬇ Note

- The main power switch cover has three tabs: two on the left side (paper exit) and one on the right side (right cover).



15. Remove the paper exit cover [A] (🔩 x 1).

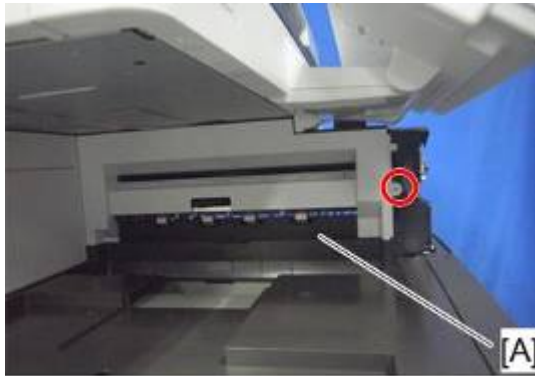

d197f0104

16. Remove the connector cover [A].



d7662066

17. Remove the paper exit lower cover [A] (🔩 x 2).

⏴ Note

- The lower inside cover can be removed together with the paper exit lower cover, since the inside cover is secured on the paper exit lower cover with two screws.

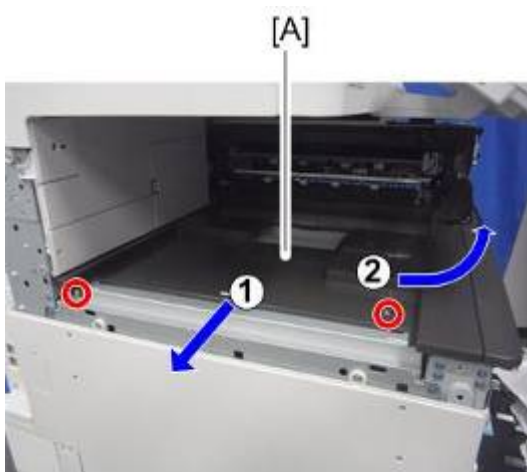

d197f0105

18. Remove the lower inside cover [B] from the paper exit lower cover [A] (🔩 x 2).

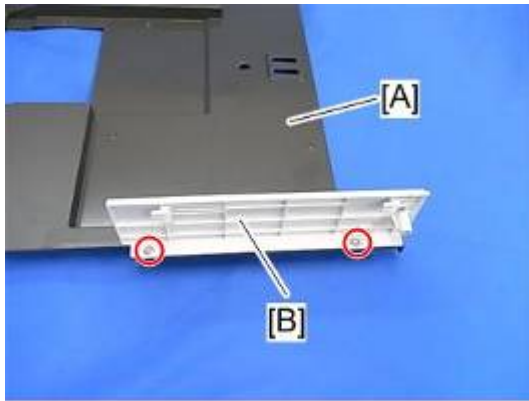

d7662050

19. While pressing the bottom plate [A] into the area [B] shown by the red-dashed line, insert the tabs of the bottom plate into the slots [C] [D] shown by the blue circles.

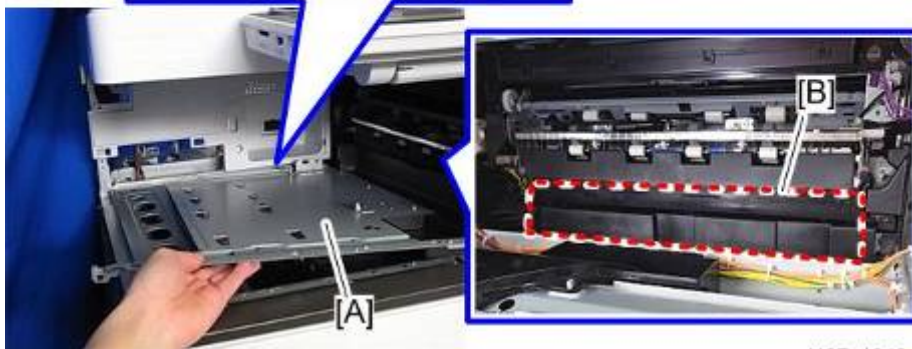
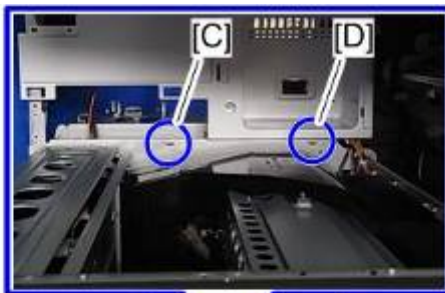

d197z1042

20. Secure the bottom plate [A] (Ⓜ x 3, Accessory No. 7).



d197z1056

Install the lower inside cover (removed in step 18) [A] in the finisher (🔩 x 2, Accessory No.5).

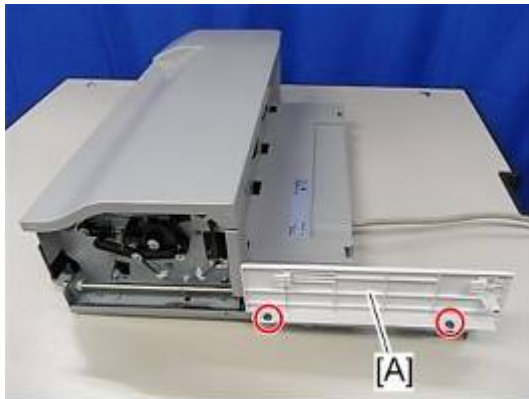

d7662051

21. Attach the paper exit cover [A] and the connector cover [B] (removed in step 15 and step 16).

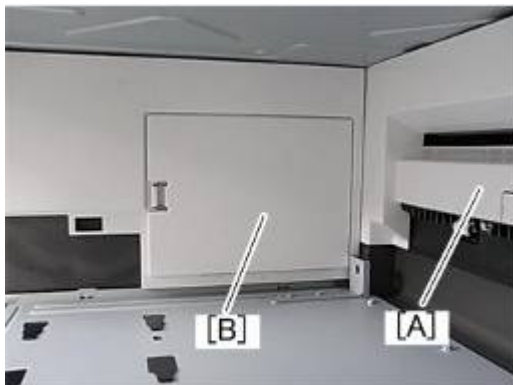

d766z0007

22. Attach the main power switch cover [A], and then close right cover.

23. Attach the finisher [B].



d7662055

24. Secure the finisher (🔩 x 1, Accessory No.8).



d7662056

25. Attach the left upper cover [A] and the left rear cover [B] (removed in step 10 and step 11).



d7662071

26. Attach the left lower cover [A] (🔩 x 2, Accessory No.6).



d7662072

27. Attach the paper output tray [A] (🔩 x 2, Accessory No.4).

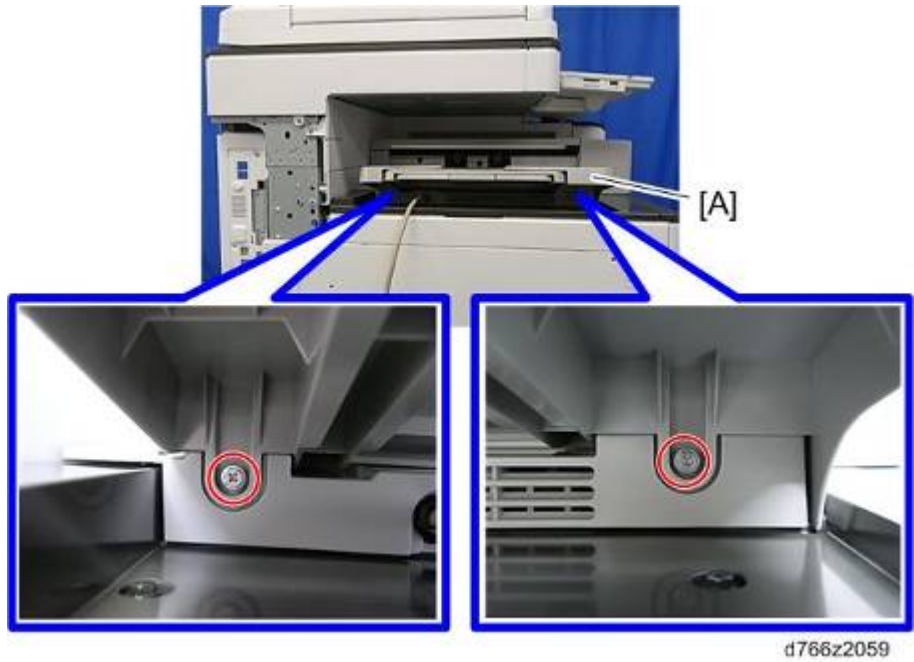

28. Reattach the Inverter tray [A] removed in step 12.



29. Remove the connector cover [A] (▼).



30. Connect the interface cable [A].

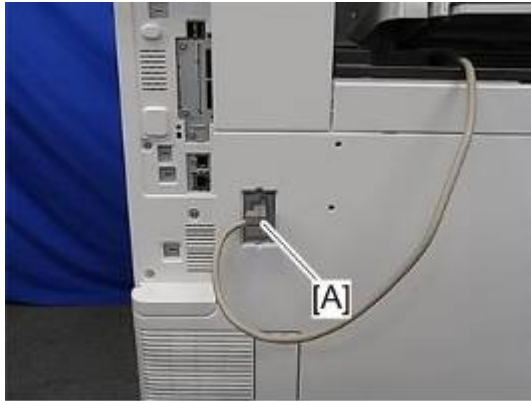

d7662077

31. Attach the nylon clamp [A] as shown below (tapping screw 4x8: x1).

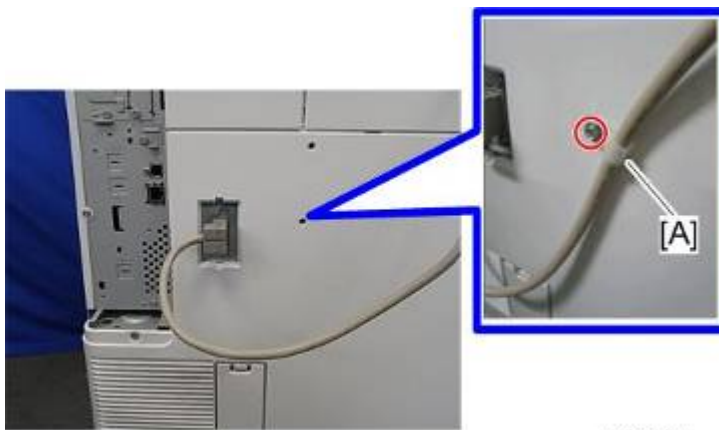

d7662079

32. Turn the main power ON.

33. Ensure that the operation panel displays finisher jobs properly and that it works properly.

Staple Setting as an Initial Setting

Note

- To adjust the strength of crimp between sheets of paper stapled, there is a setting which makes single/ double staple changeable into each other.
- The power of crimp is weakened when there is an image (toner) on the point where is to be stapled. There also is a setting to mask the image on the point for staple, in order to avoid the strength of crimp to be weakened.
- Depending on users demands, explain the settings/ methods of the settings by checking the following instruction.

<How to change the setting of Staple Method (Single/ Double) for Stapleless Stapler>

1. [User Mode/ counter]
2. [System Setting]
3. [General Setting] and [next]
4. [Stapling Method for Stapleless Stapler]

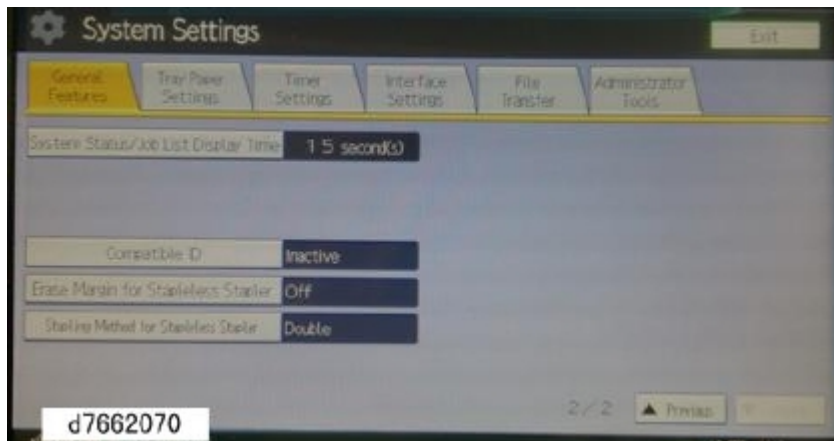

<How to set Margin Erase for Stapleless Stapler>

1. [User Mode/ counter]
2. [System Setting]
3. [General Setting] and [next]
4. [Erase Margin for Stapleless Stapler]

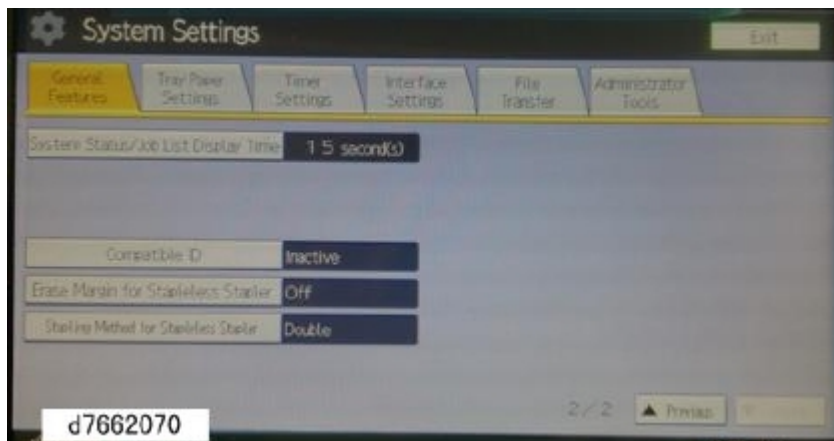

2.20 INTERNAL FINISHER SR3130

2.20.1 ACCESSORY CHECK

No.	Description	Q'ty
1	Staple Cartridge	1
2	Front Right Cover	1
3	Caster Stand	2
4	Bottom Plate	1
5	Left Upper Cover	1
6	Entrance Guide Plate	1
-	Screw: M3 x 6	6
-	Tapping Screw: M4 x 6	1
-	Decal - EMC Address	1

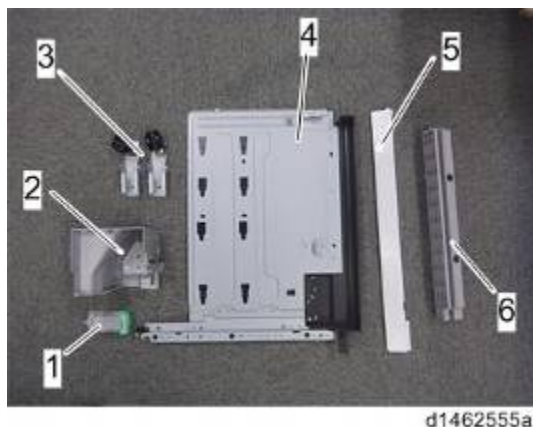

2.20.2 INSTALLATION PROCEDURE

⚠ CAUTION

- When you install this option, turn off the power to the machine, and unplug the power plug from the wall socket.
- If this option is installed with the power on, it will result in an electric shock or a malfunction.

↓ Note

- Cannot be used together with “Internal Shift Tray SH3070”, “Side Tray Type M3”, “Bridge Unit BU3070”, “Finisher SR3140”, “Booklet Finisher SR3150”, “Finisher SR3160”, or “Booklet Finisher SR3170”.
- To use together with the “1 Bin Tray BN3110”, after attaching the bottom plate of this option, attach the “1 Bin Tray BN3110”, and then install this option.
- To use together with the “Punch Unit PU3040”, first attach the “Punch Unit PU3040” before installing this option.

1. Remove the orange tape and shipping retainers.



d1462556

- 2. Remove the package items (fixing screws, etc.).**
- 3. Open the front cover.**
- 4. Remove the paper exit tray [A].**



d197z0407

5. Remove the left upper cover [A] (⊙ ×1).

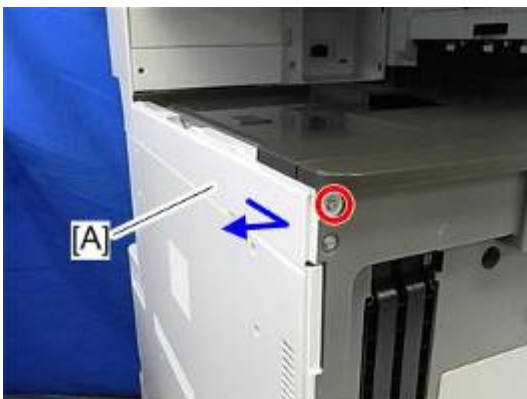

d197z0001

6. Remove the left rear cover [A] (🔩 x2).



7. Remove the inverter tray [A].

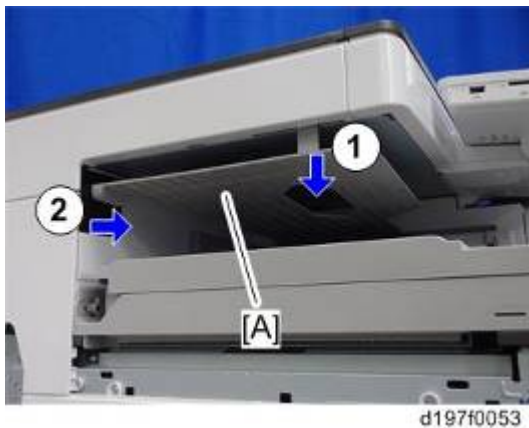

8. Open the right cover.

9. Remove the main power switch cover [A] (🔩 x1).

⬇ Note

- The main power switch cover has three tabs: two on the left side (paper exit) and one on the right side (right cover).



10. Remove the paper exit cover [A] (🔩 x1).

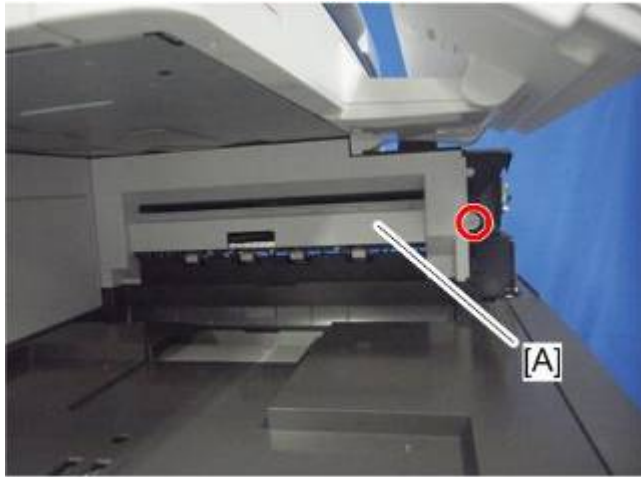

d197f2006

11. Remove the connector cover [A].



d7662066

12. Remove the paper exit lower cover [A] (⚙️ x2).

⚙️ Note

- After removing the screws, slide the paper exit lower cover toward the left side, then pull the cover up.

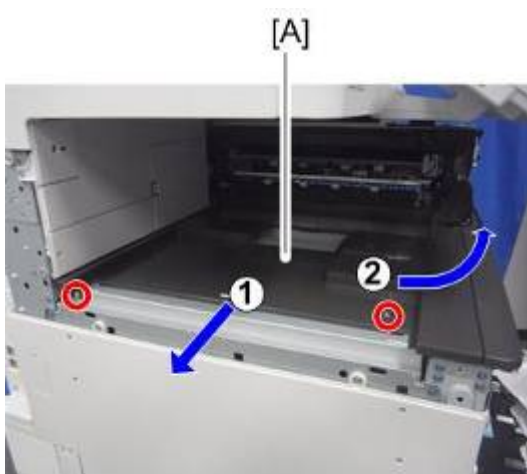

d197f0105

⚙️ Note

- Install a screw [A] removed in step 12.



13. While pressing the bottom plate [A] into the area [B] shown by the red-dashed line, insert the tabs of the bottom plate into the slots [C][D] shown by the blue circles.

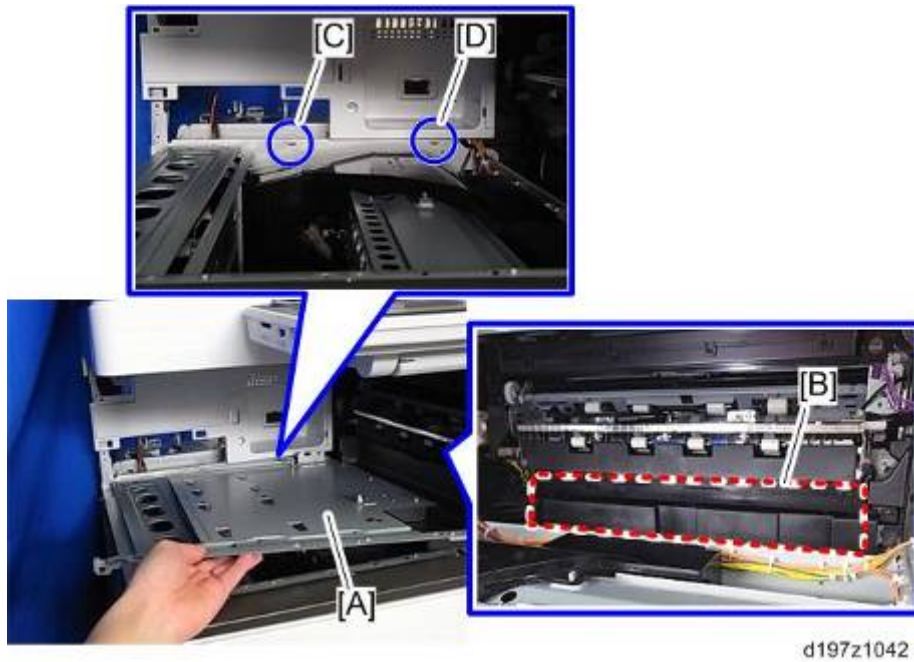

Note

- The following procedure is the easiest way to set this component.
 - 1) Slip the bottom plate [A] into the position [B].
 - 2) Insert the bottom plate [A] into the hole in the blue circle [C].
 - 3) When the bottom plate [A] is picked up (see below), it can be inserted into the hole in the blue circle [D].

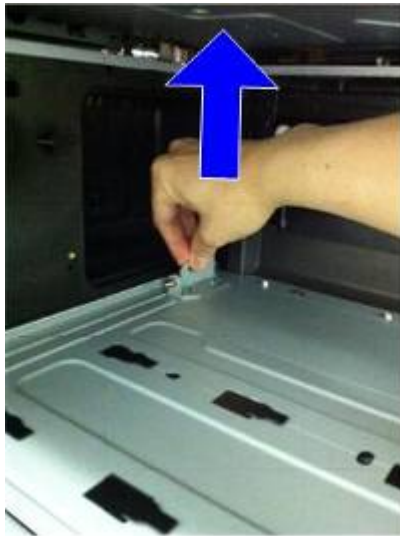

d1462566

14. Secure the bottom plate [A] (🔩 x3).



d197z1056

15. Attach the paper exit cover [A] and the connector cover [B].

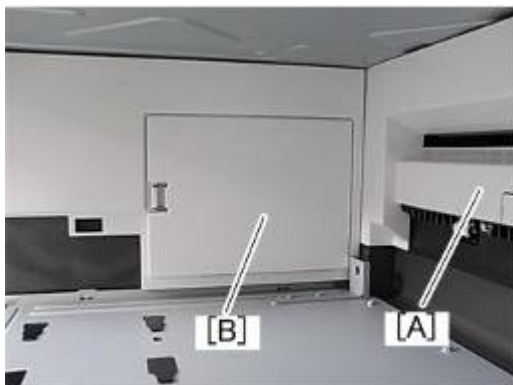

d766z0007

⬇️ Note

- Up to this point, the procedure is the same as punch unit installation. If the Punch Unit PU3040 is to be installed, refer to the Step 3 and later of the installation procedure (page 2-155).

16. Attach the main power switch cover and close the right cover (🔩 x1).
17. Slide the finisher front right cover [A] from left to right, and then attach it (🔩 x1).

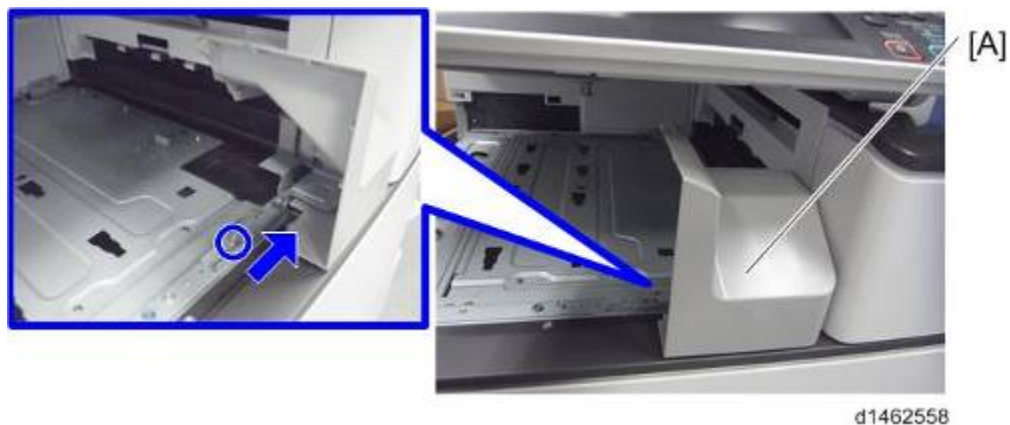

18. Attach the inverter tray to the machine.

19. Attach the entrance guide plate [B] to the finisher [A] (⚙️ x2).

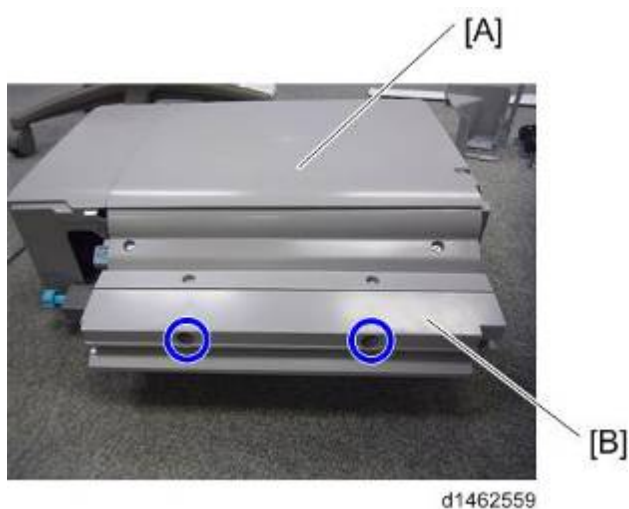

Note

- The entrance guide plate has one or more tabs underneath. Fit the tabs when fastening the entrance guide plate.

20. Keep the paper exit feeler [A] in the cover.

- If this step is not done, the feeler may be damaged when closing the finisher from left to right.

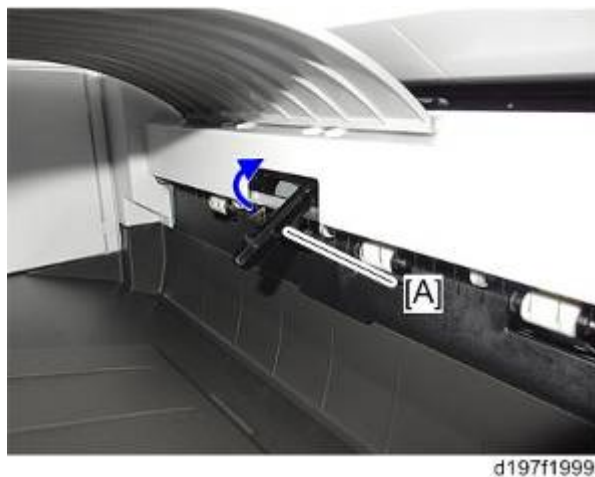

21. Slide the finisher [A] along the rail of the bottom plate from the left side of the machine, and then attach it (🔩 x1).



⬇ Note

- Hold the front side [A] of the inner finisher as shown below to check if the inner finisher is correctly set in the rail of the bottom plate.

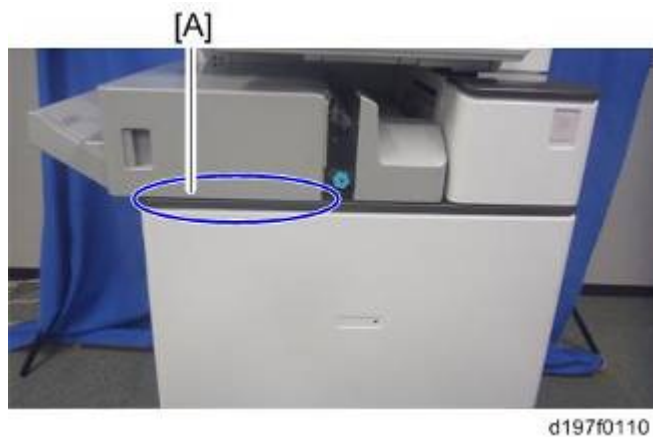

22. Attach the left rear cover to the machine (🔩 x2).
23. Insert the left upper cover [A] provided with this option from the front, and then attach it (🔩 x1).



24. Attach caster stands [A] (🔩 x2).

⬇️ Note

- This step is required only for machines that have “Paper Feed Tray PB3210/ PB3220” or “LCIT PB3170/ PB3230”.

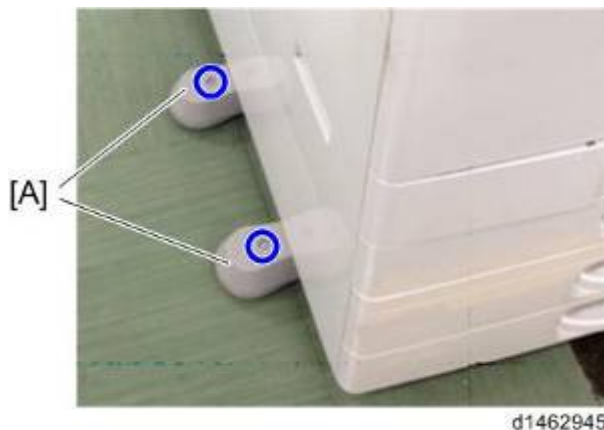

25. Connect the interface cable to the machine.

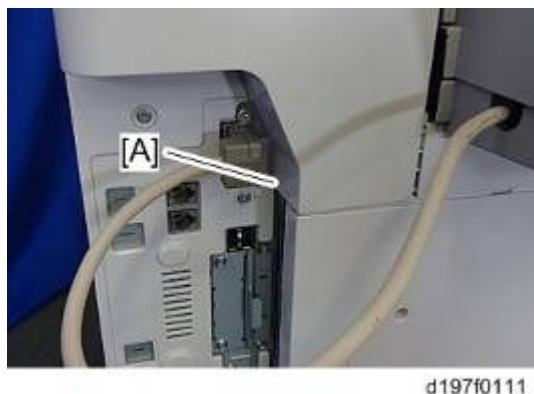

26. Open the stapler unit [A], and then set the staple cartridge [B].



27. Turn the power switch on.

28. Check that the finisher can be selected at the operation panel, and check the finisher operation. In addition, when punch unit is installed, check the punching operation.

2.21 PUNCH UNIT PU3040

2.21.1 ACCESSORY CHECK

No.	Description	Q'ty
1	Hopper	1
2	Punch Unit Cover	1
3	Lower Front Cover	1
4	Lower Rear Cover	1
5	Holder	1
-	Knob Screw - M4	1
-	Tapping screws: M3x6	3
-	Decal - EMC Address	1

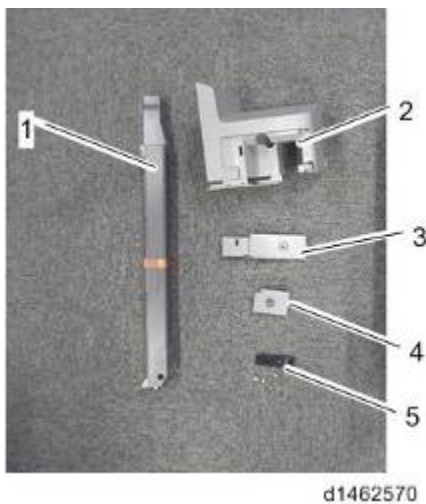

2.21.2 INSTALLATION PROCEDURE

⚠ CAUTION

- When installing this option, turn the power to the machine off, and unplug the power plug from the wall socket.
- If this option is installed when the power is on, it will result in an electric shock or a malfunction.

↓ Note

- When installing this option together with the "Internal Finisher SR3130", attach this option first before installing the "Internal Finisher SR3130"

1. Take out from the box, and remove the filament tape and packing material.
2. Perform steps 1 to 15 of the installation procedure for the "Internal finisher SR3130".
3. Change the position of the bracket [A] on the bottom plate (🔩 ×1).

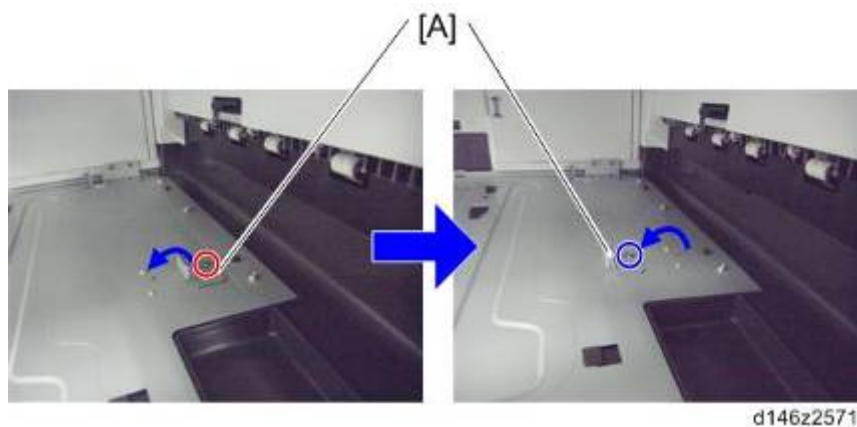

4. Replace the lock holder of the bottom plate with the lock holder [A] provided (🔩 ×1).



5. Fasten the bottom plate with screws (🔩 ×3).



6. Attach the main power switch cover.
7. Pass the shafts [B] of the punch unit [A] through the bearings [C] of the bottom plate, and attach the punch unit to the machine (🔩 x1, knob screw).

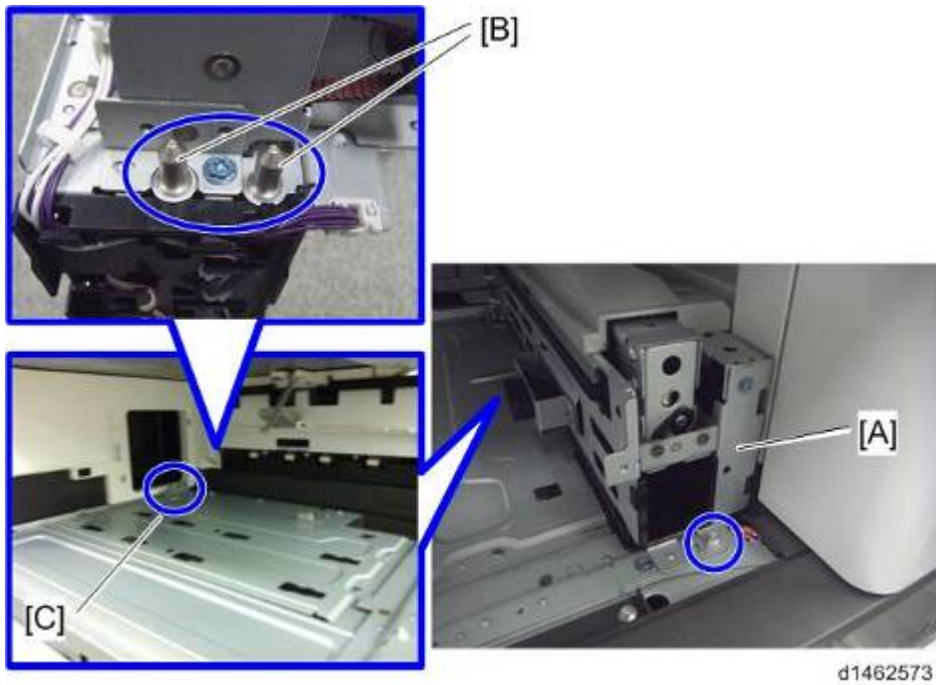

8. Attach the front right cover [A] provided, inserting the claws (🔩 x2).

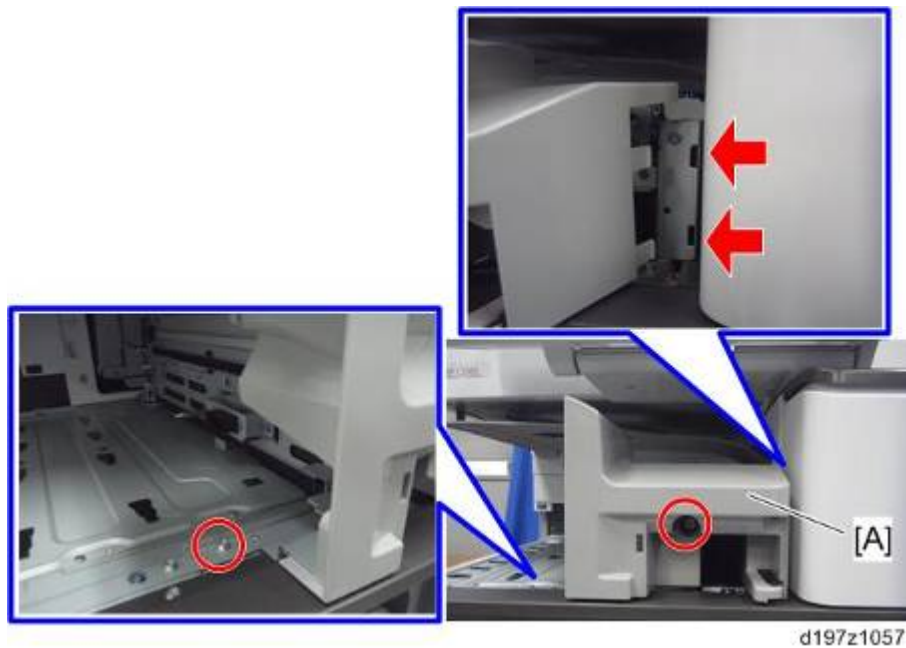

9. Insert the hopper [A].



10. Slide the finisher [A] along the rail of the bottom plate from the left of the machine, and then attach it (🔩 x1).



↓ Note

- Before fastening the screw, make sure that the finisher is correctly set in the rail of the bottom plate.



d197z1150

↓ Note

- When installing the punch unit in the finisher which is already installed, remove the entrance guide plate [A] (⚙️ x2).



d1462574

- Note that this step is unnecessary when installing the finisher and punch unit at the same time.

11. Attach the lower rear cover [A] and lower front cover [B] to the finisher (⚙️ x2).



d197z1151

12. Attach the left rear cover to the machine.

13. Insert the upper left cover [A] from the front, and then attach it (🔩 x1).



d197f0109

14. Connect the interface cable to the machine.



d197f0111

15. Turn the main power switch on.
16. Check that the finisher can be selected at the operation panel, and check the finisher and punch operation.

2.22 SMART OPERATION PANEL TYPE M3

2.22.1 ACCESSORY CHECK

No.	Description	Q'ty
1	Brand Logo	1

2.22.2 INSTALLATION PROCEDURE

↓ Note

- When changing the screen in the field (standard panel → smart operation panel), perform the following steps.
- Smart Operation Panel Type M3 is not the option for EU region. (Standard model)

1. Change the SP modes below before changing the operation panel.

- Change the setting of bit 0 in SP5-748-101 to "1".
- Change the setting of SP5-748-201 to "1".

2. Turn the main power OFF.

3. Open the ARDF or platen cover.

4. Scanner front cover [A] (🔩 x2)



↓ Note

- There are two tabs [A] inside this cover: the left side and the right upper side. Release these tabs after removing the two screws of the scanner front cover. First, carefully and slightly pull the left side of the cover towards the outside and release the left side tab, then pull up the right upper side tab and release it.



5. Remove the operation panel upper cover [A] (hooks).

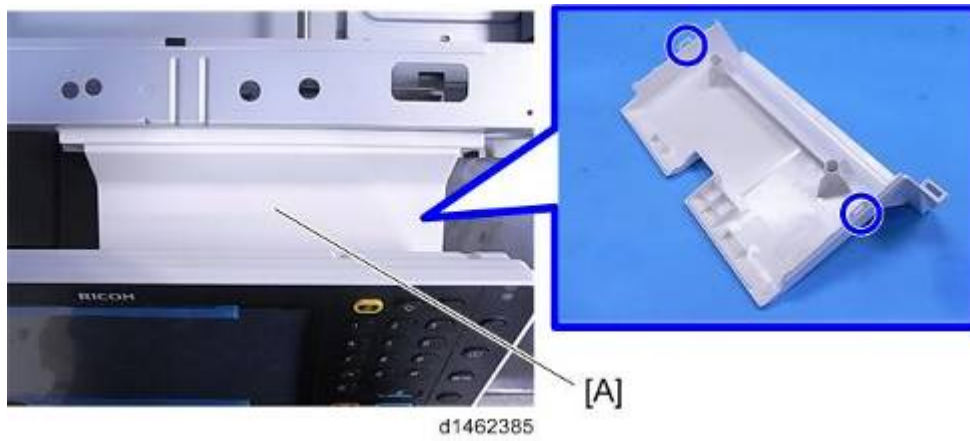

6. Remove the standard operation panel [A] (🔩 x5, 🪪 x2).

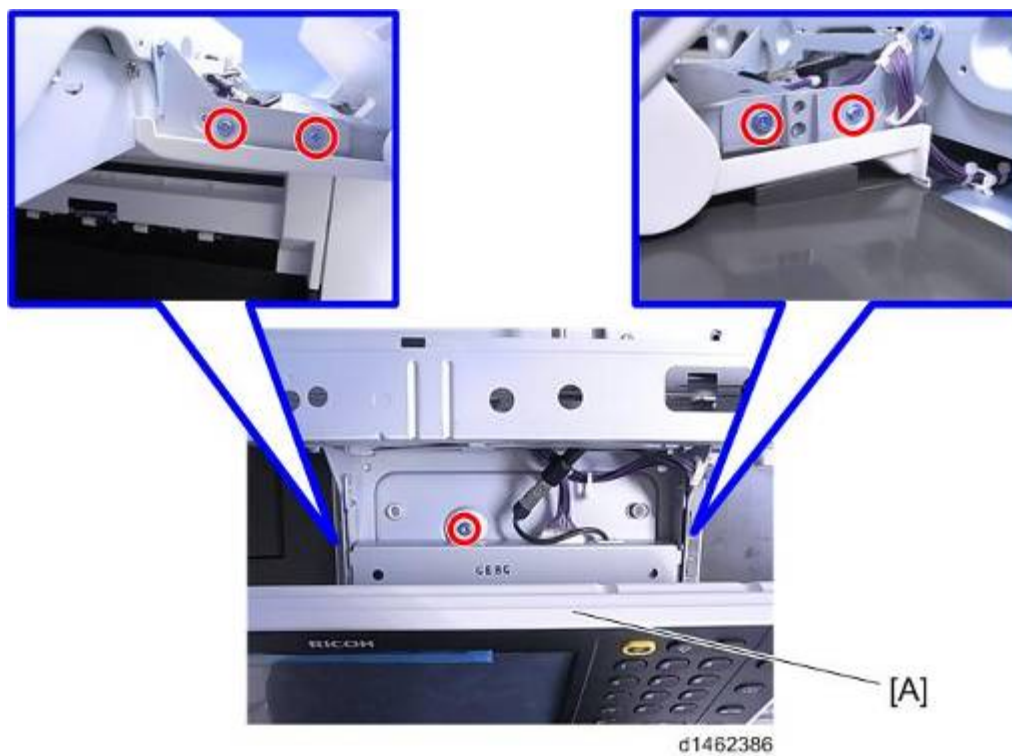

7. Attach the brand logo to the place [A] on the smart operation panel if necessary.



d197z0466

8. Attach the Smart Operation Panel Type M3 [A] (⚙️ x5, 🔩 x3, 📌 x2).

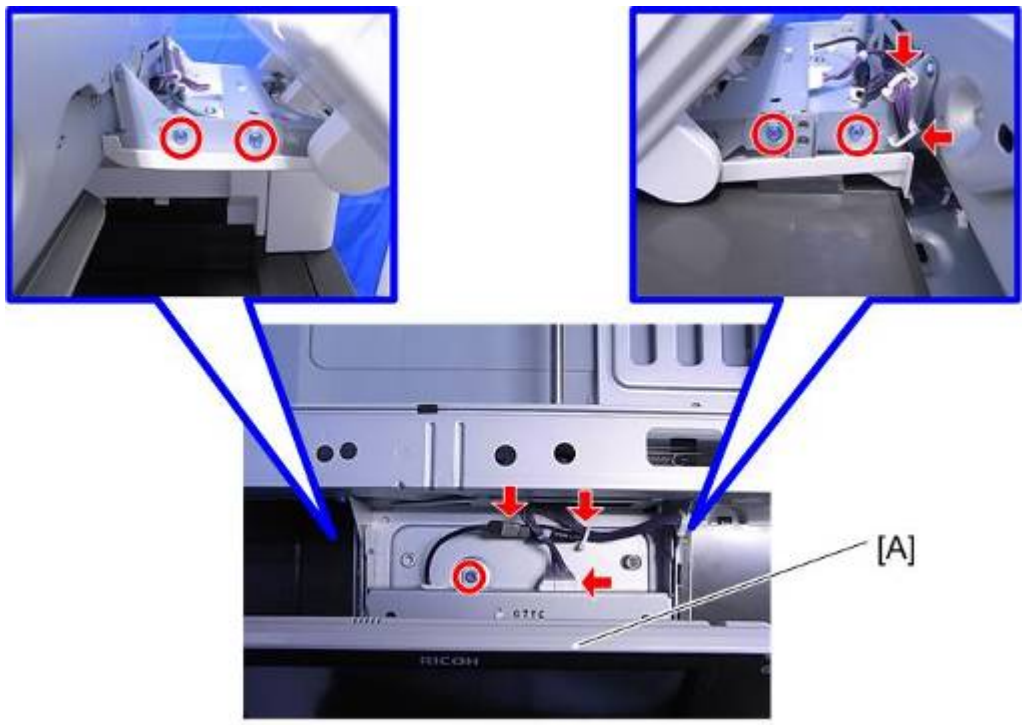

d1480011

9. Attach the operation panel upper cover [A] (hook x2).

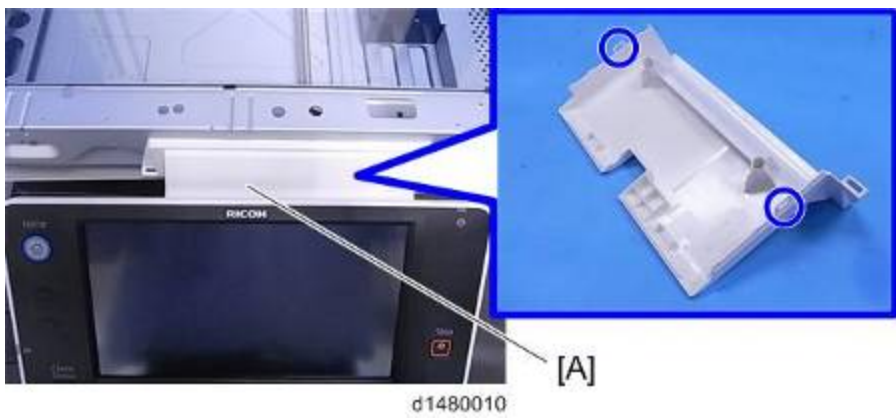

d1480010

10. Attach the scanner front cover.
11. Turn the main power ON.

12. Change the SP modes below.

- Change the setting of bit 0 in System SP5-752-001 to “1”.
- Change the setting of bit 0 in Scanner SP1-041-001 to “1”.

If fax option is installed,

- Change the setting of bit 0 in Fax SP3-301-001 to “1”.

13. Turn the main power OFF/ON. If it is connected normally, the default setting icons are displayed.

2.23 ANTI-CONDENSATION HEATER TYPE M12

CAUTION

- Turn off the main power and disconnect the power supply cord when installing this option.

2.23.1 ACCESSORY CHECK

Description	Q'ty
Tapping Screw: M3x6	3
Clamp: LWSM-0306A	7
Clamp: LWSM-0511A	8
Clamp: LWS-1211A	1
Heater Board	1
BCU Harness	1
PSU Harness	1
Scanner/ PCU Harness	1
Thermostat unit	1

2.23.2 INSTALLATION PROCEDURE

Anti-Condensation Heater (Scanner)

1. Open the front cover [A].



d197f0040

2. Remove the paper exit tray [A].



d197z0407

3. Remove the left upper cover [A] (⚙️ ×1).

Note

- Slide the cover in the direction of the blue arrow.

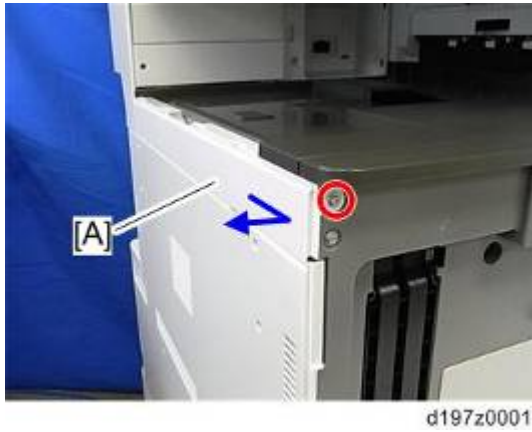

d197z0001

4. Remove the controller cover [A] (⊗ x4).



d197f0042

5. Open the 1st and 2nd paper feed trays slightly.

6. Remove the left cover [A] (⚙️ x5).

Remove it while pressing down.

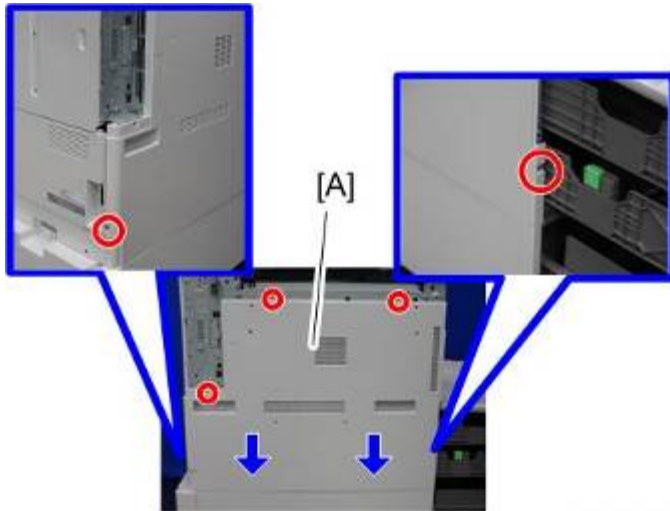

d197f0046

7. Remove the scanner rear cover [A] (⚙️ x3).

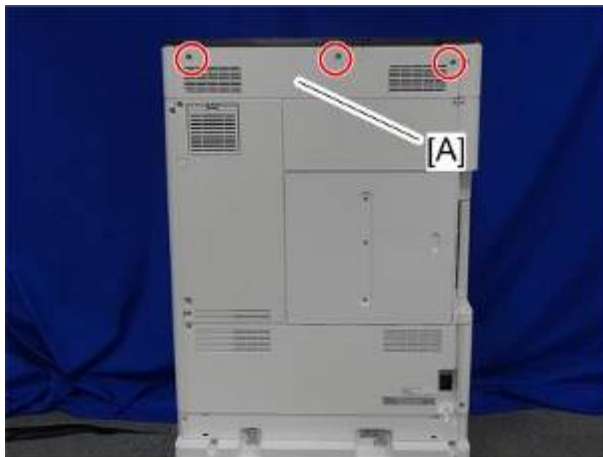

d197f0051

8. Remove the controller rear cover [A] (⚙️ x4).

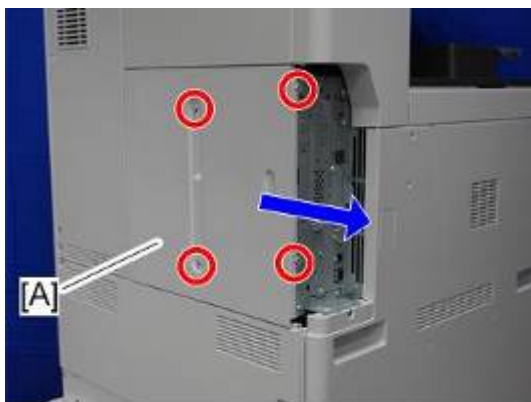

d197f0048

9. Remove the rear lower gap cover [A] (hook×2).

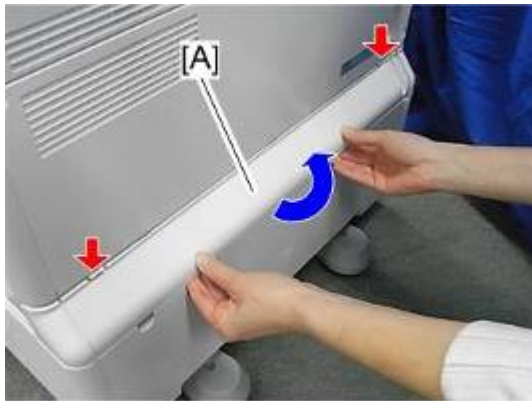

d197z1155

10. Remove the rear lower cover [A] (⚙️×5).

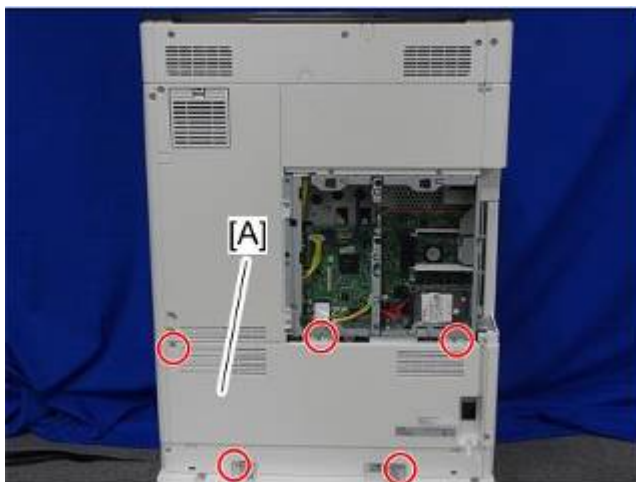

d197f0050

11. Remove the rear left cover (⚙️×3).



d197f0050_1

12. Remove the rear right cover [A] (🔩x5).



d197f0049

13. Attach the heater board [A] (🔩x3).



d197z1060

14. Connect the harness [A] to CN904 of the PSU and CN920 of the heater board.

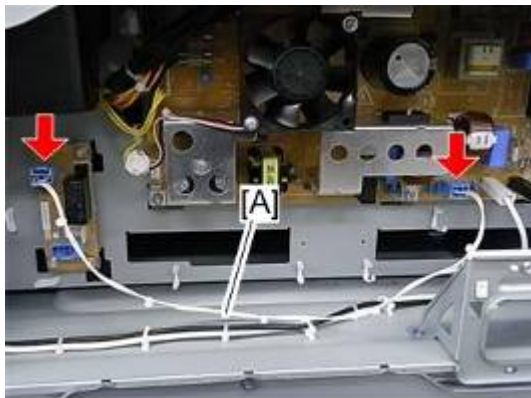

d197z1061

15. Clamp the harness which is connected in step 14 (🔧x6).

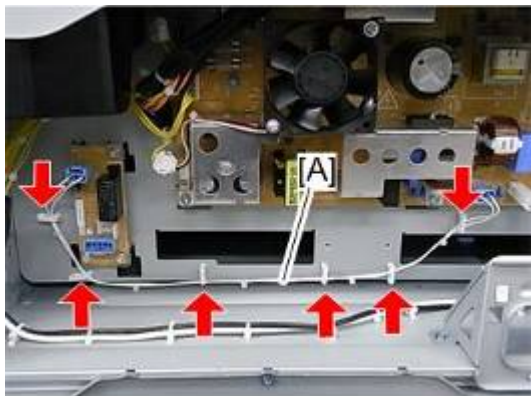

d197z1062

16. Connect the harness [A] to CN121 of the BCU and CN930 of the heater board.

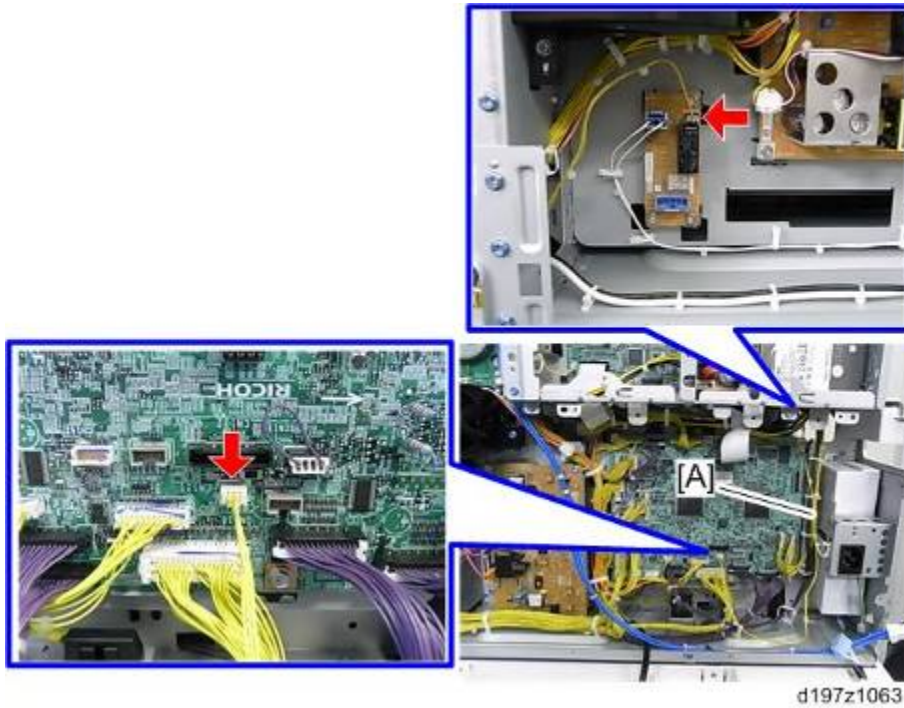

17. Clamp the harness [A] which is connected in step 16 (x7).

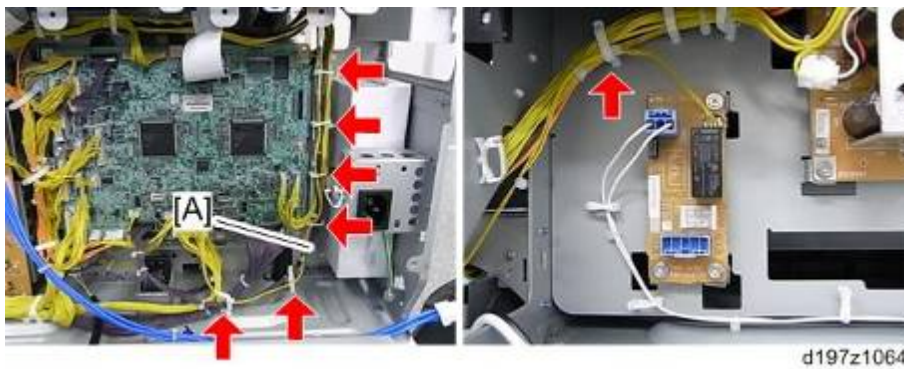

18. Connect the heater cable [A] to CN922 of the heater board [B].



19. Route the heater cable to the rear of the main unit (🔩x6).

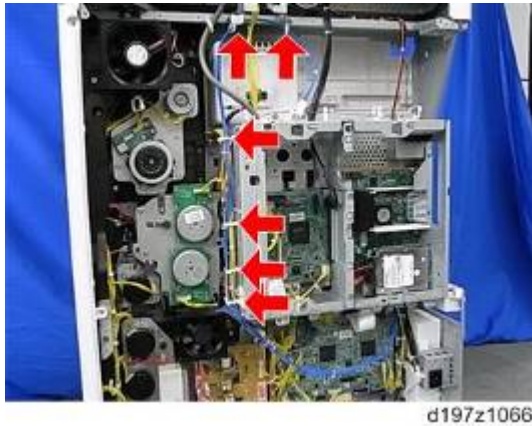

20. Open the platen cover or ADF.

21. Remove the guide scale [A] (🔩x3).

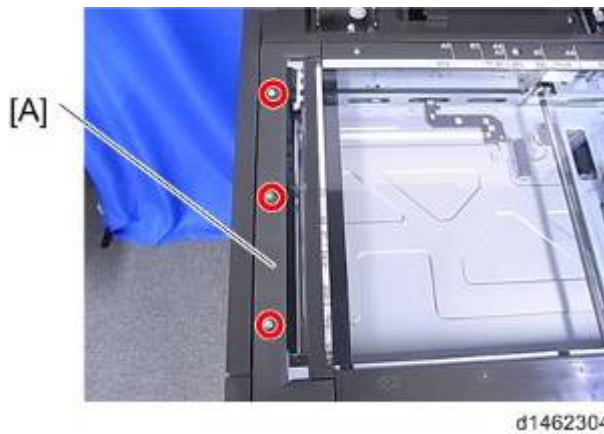

22. Remove the ADF exposure glass [A].

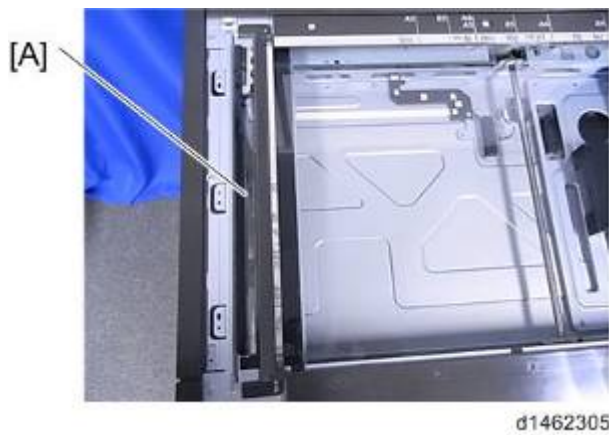

23. Remove the rear scale [A] (⊙ x3).

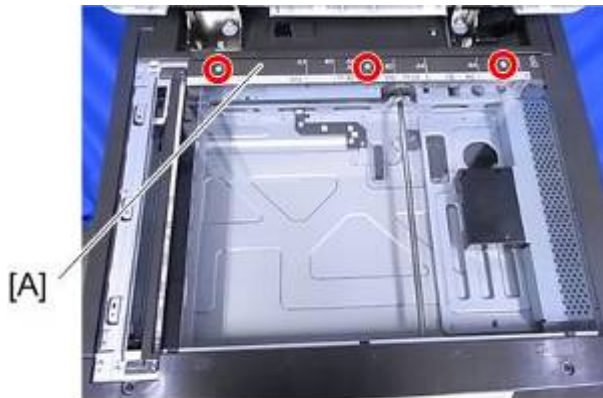

d1462306

24. Remove the left scale and exposure glass [A].

↓ Note

- The exposure glass and the left scale are attached with double-sided tape.

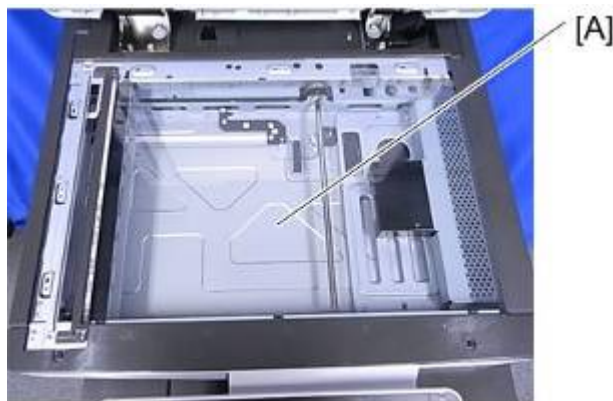

d1462307

25. Move the carriage to the center.

26. Attach the bracket [A] to the left side of the scanner.



d197z1067

27. Attach the scanner heater [A] (🔩 x2).

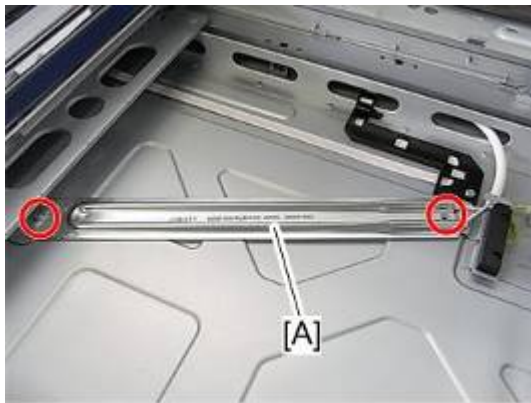

d197z1087

28. Route the harness on the hook which is indicated with the blue circle in the picture below.



d1463041

29. Pass the harness out through the hole of the frame.



d1463042

30. Remove the screw of the cable guide [A].



d197z1088

31. Attach the heater cover [A] (🔩 x1).

⬇️ Note

- Secure the screw in the same position as step 30.

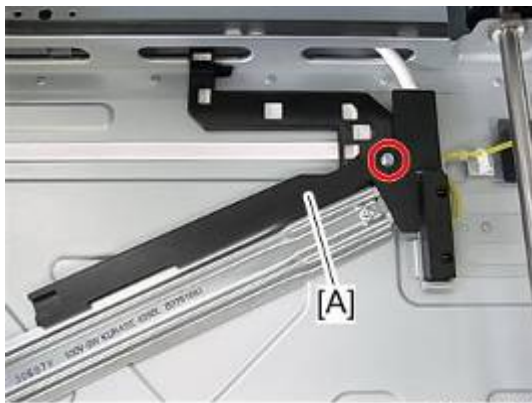

d197z1089

32. Remove the DF harness with the bracket [A] if the DF is installed (🔩 x1).



d197z1068

33. Remove the SIO board [A] if the DF is installed (🔩 x4, 🗑️ x6, flat cable x1).

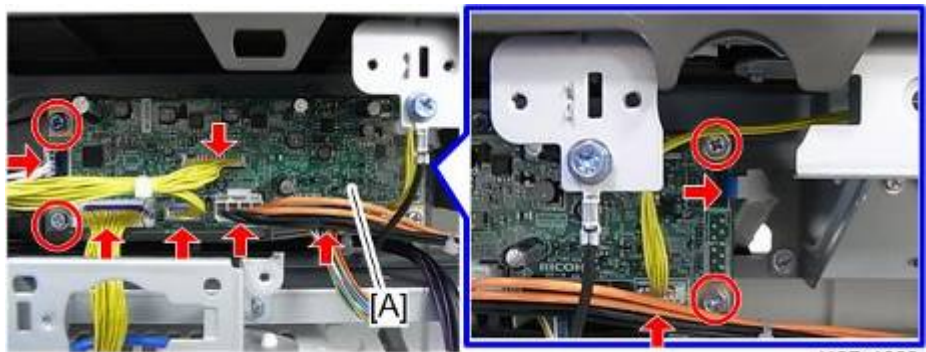

d197z1069

34. Connect the heater cable [B] which is shown in step 29 to another harness [A] which is shown in step 19.

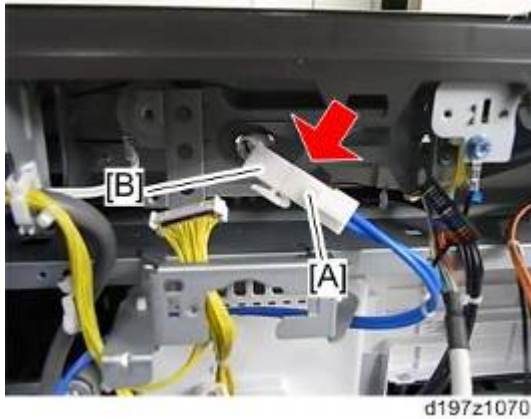

35. Attach all covers which have been removed.

Anti-Condensation Heater (PCU)

1. Open the front cover.
2. Open the right cover.
3. Open the transfer unit [A].



4. PCDU [A] (🔩 x1, 📦 x1)

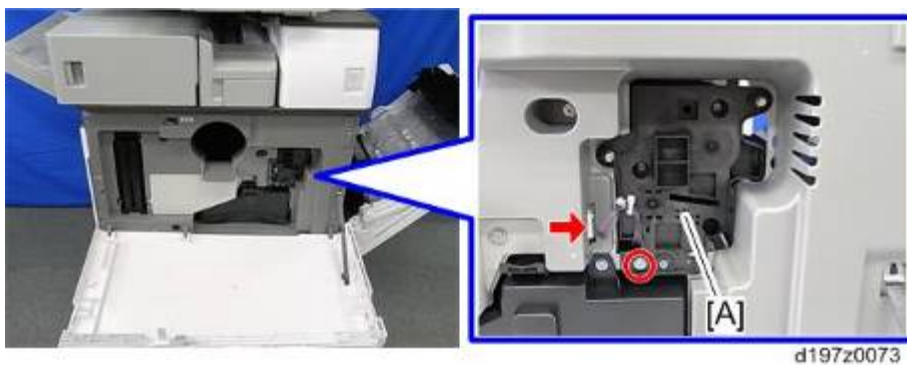

5. Pull out the waste toner bottle [A] (🗑️ x1).

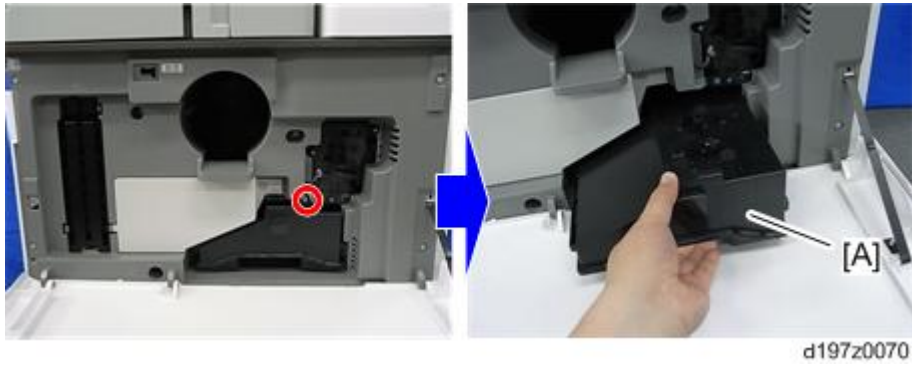

6. Take off the heater bracket [A].

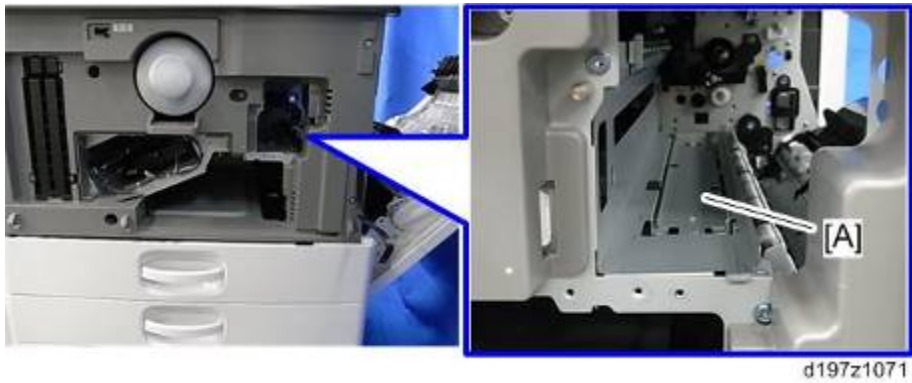

7. Attach the anti-condensation heater (PCU) [A] to the heater bracket [B].

Note

- Fit the anti-condensation heater (PCU) [A] into the tab [C] on the heater bracket [B].

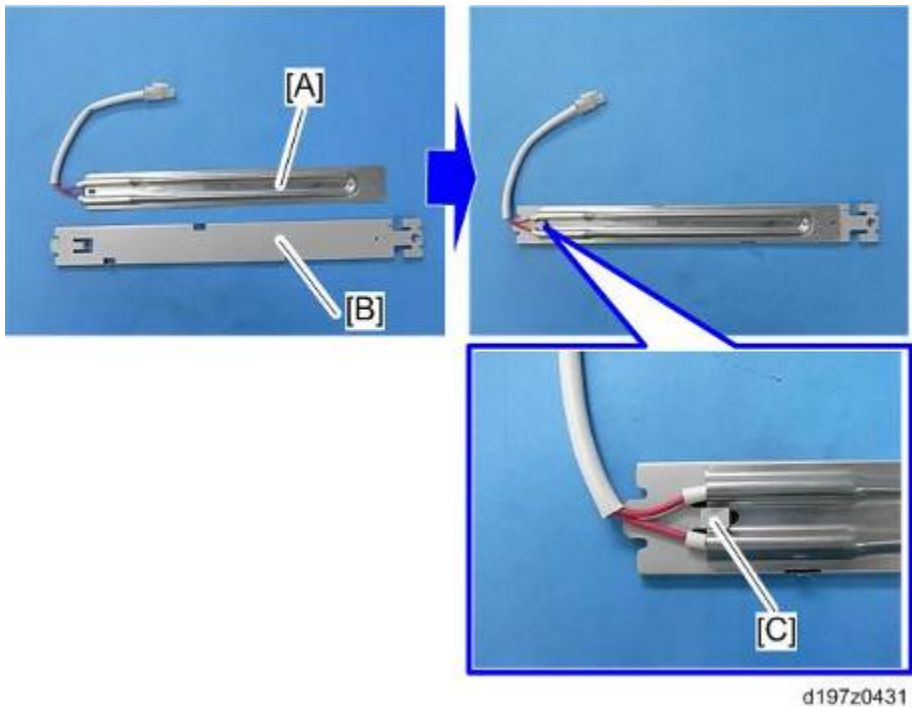

8. Attach the thermostat [A] to the Anti-condensation heater (PCU) [B] (⚙️x1).

Note

- Fit the thermostat [A] into the tab [C] on the heater bracket [B].

Anti-Condensation Heater Type M12

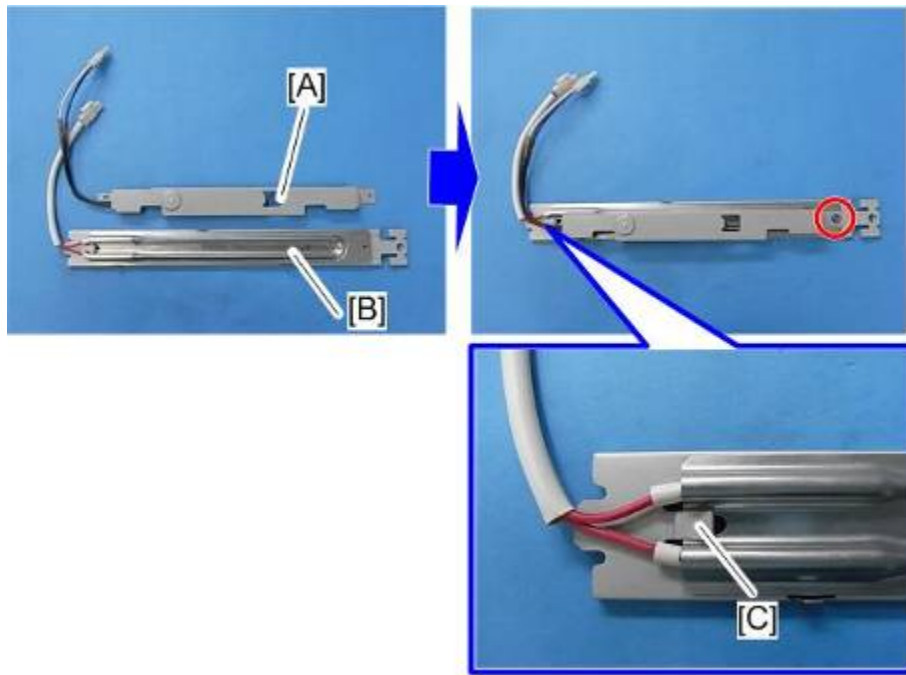

d197z0432

9. Put back the anti-condensation heater (PCU) [A], and then pass the heater harnesses out through the opening [B] at the inner rear side of the main unit.

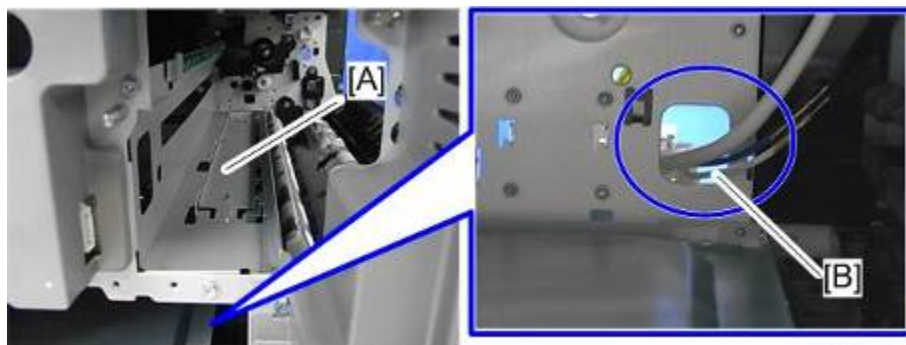

d197z0433

10. For D200/D201/D202 only, remove the development bearing cooling fan [A] (⚙️ x2, 📦 x1).

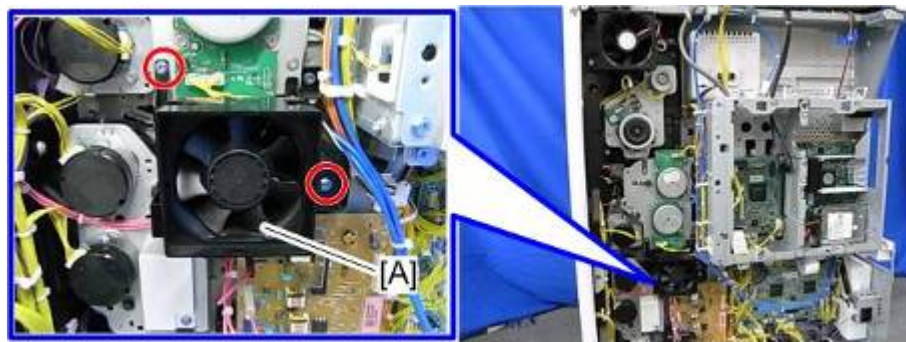

d197z1074

11. Connect the harnesses of the thermostat [A] and of the anti-condensation heater (PCU) [B] to the harnesses [C] which is routed in step 19 of the procedure for the Anti-Condensation Heater (Scanner).

Note

- You can connect the harnesses [C] up to either the harness [A] or [B].

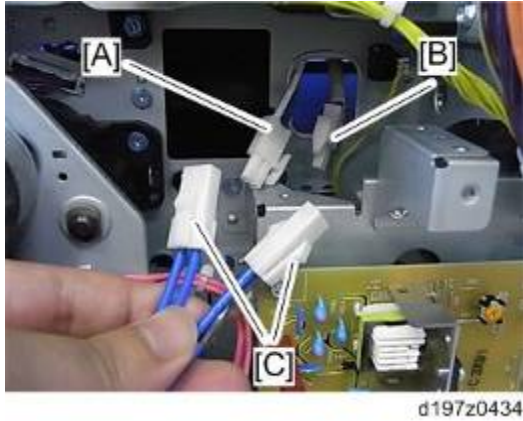

12. Reattach the development bearing cooling fan, PCDU, waste toner bottle and covers which have been removed.

2.24 ANTI-CONDENSATION HEATER FOR TRAYS

CAUTION

- Turn off the main power switch and disconnect the power supply cord when installing this option.

2.24.1 ACCESSORY CHECK

Anti-Condensation Heater (Service Option) for Main Unit

Description	Q'ty
Tapping Screw: M3x6	3
Clamp: LWSM-0306A	7
Clamp: LWS-1211A	1
Heater Board	1
BCU Harness	1
PSU Harness	1
PFU Harness	1

Anti-Condensation Heater (Service Option) for Optional PFU and LCIT

Description	Q'ty
PFU Harness	1
Heater Board	1
Clamp: LWSM-0306A	4
Screw: M4x10	1

2.24.2 INSTALLATION PROCEDURE

Anti-Condensation Heater for Paper Feed Tray (Main Unit)

1. Turn off the main power and disconnect the power supply cord.
2. Open the front cover.
3. Remove the paper exit tray [A].



d197z0407

4. Remove the left upper cover [A] (⚙️ x1).

⬇️ Note

- Slide the cover in the direction of the blue arrow.

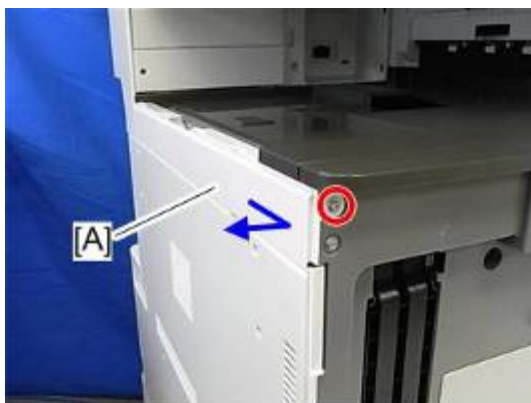

d197z0001

5. Remove the controller cover [A] (🔩 x4).



d197f0042

6. Open the 1st and 2nd paper feed trays slightly.

7. Remove the left cover [A] (🔩 x5).

Remove it while pressing down.

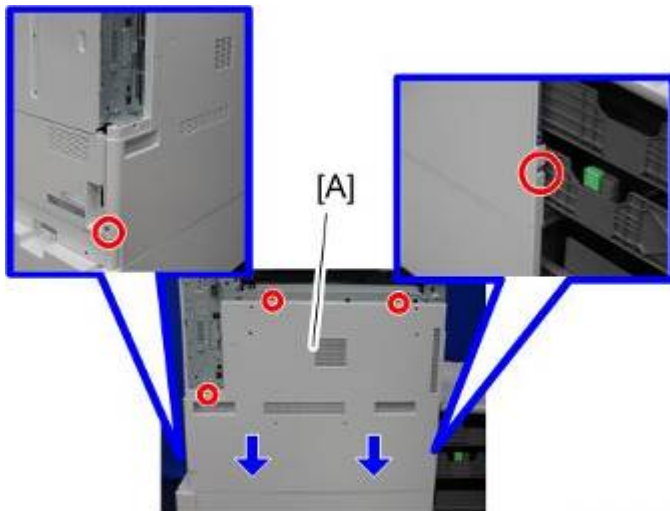

d197f0046

8. Remove the controller rear cover [A] (⚙️ x4).

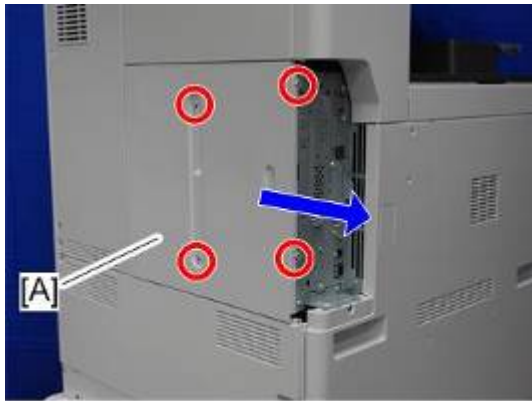

d197f0048

9. Remove the rear lower gap cover [A] (hook x2).

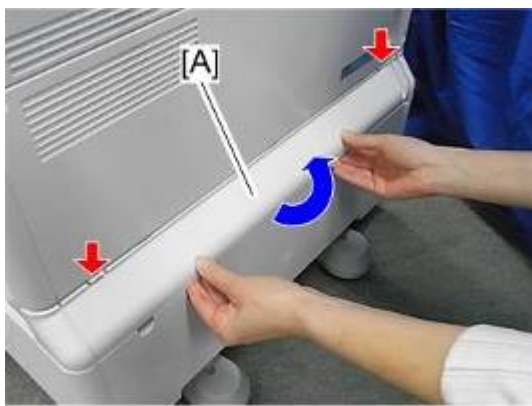

d197z1155

10. Remove the rear lower cover [A] (⚙️ x5).

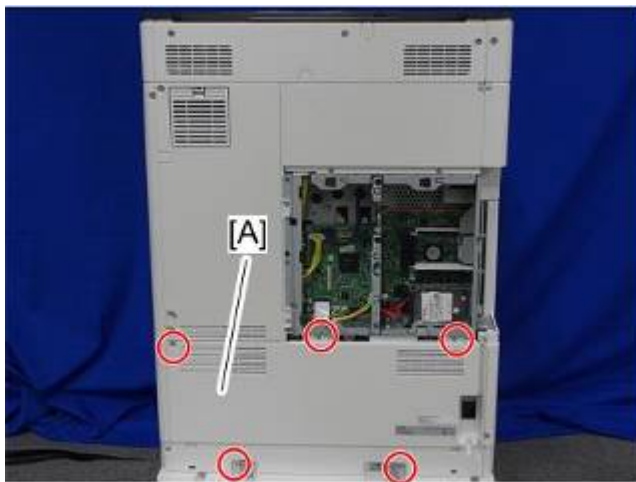

d197f0050

11. Attach the heater board [A] (⚙️x3).



12. Connect the harness [A] to CN904 of the PSU and CN920 of the heater board.

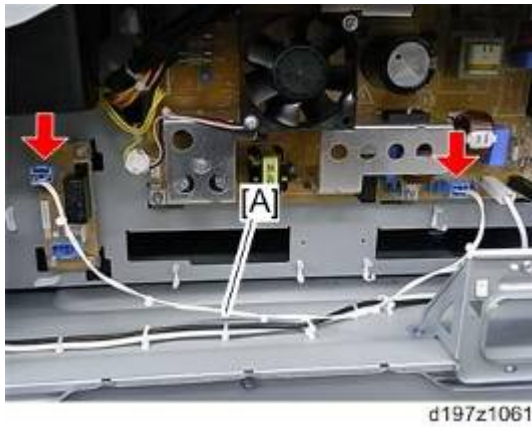

13. Clamp the harness which is connected in step 5 (🔧x6).

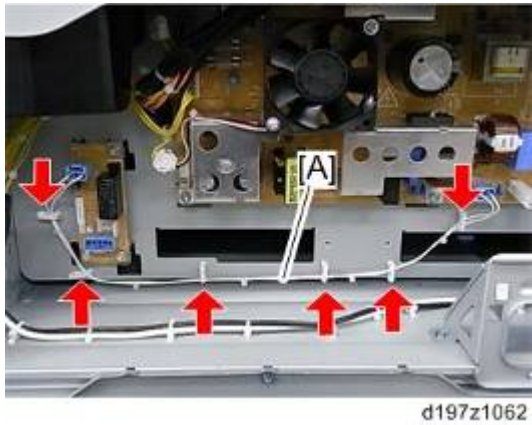

14. Connect the harness [A] to CN121 of the BCU and CN930 of the heater board.

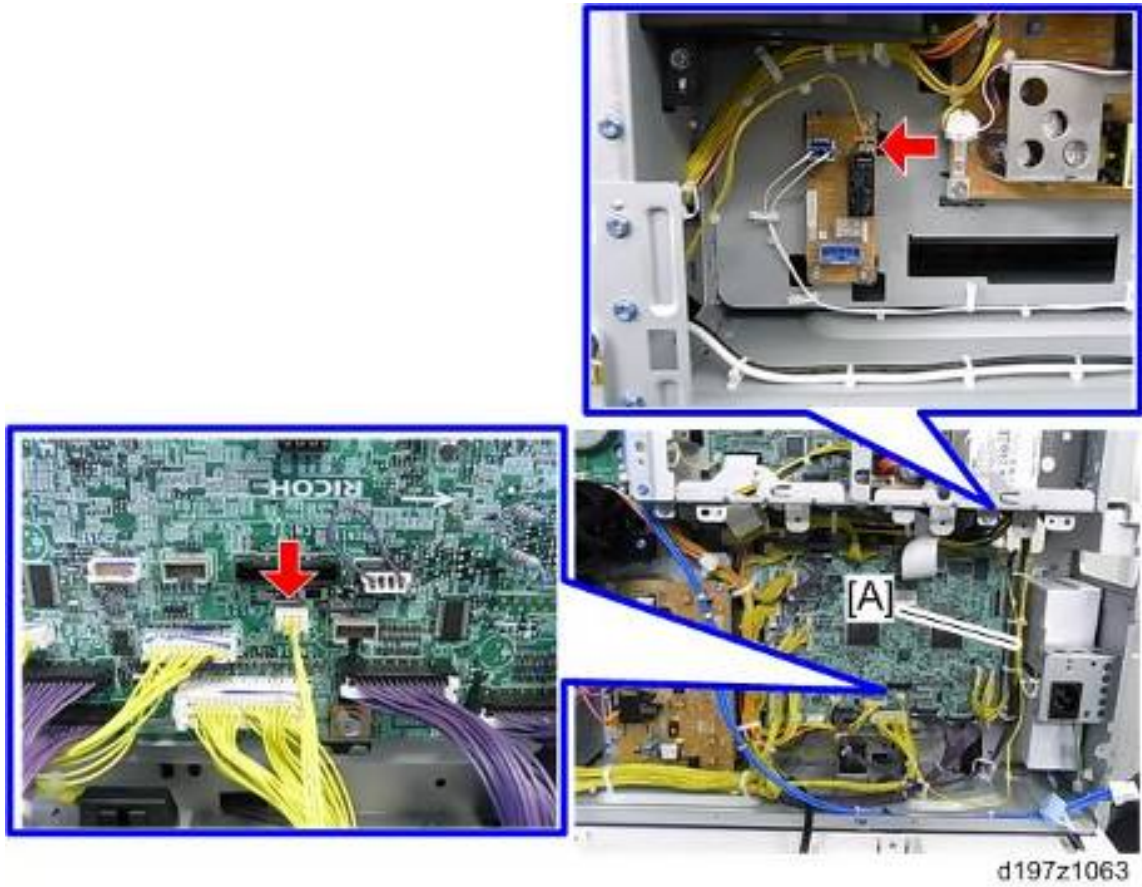

15. Clamp the harness [A] which is connected in step 7 (7x7).

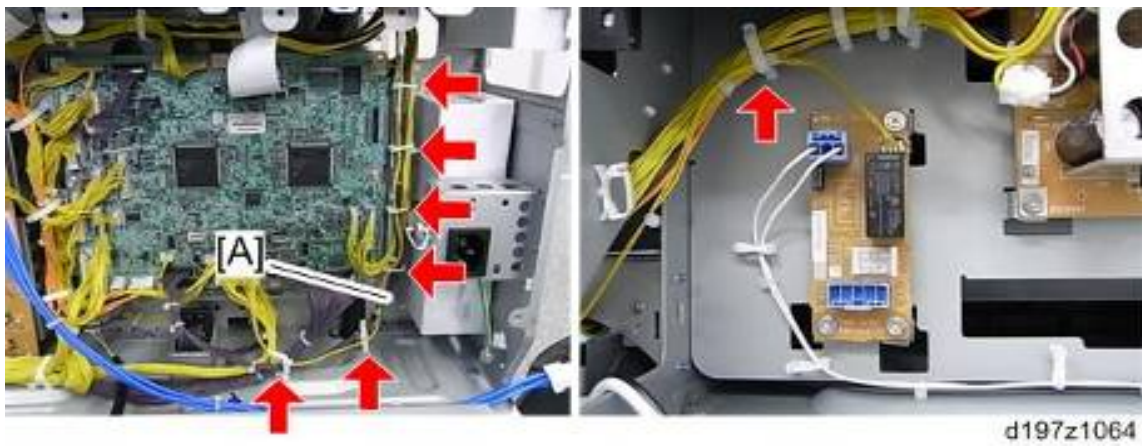

16. Connect the heater harness [A] to CN921 of the heater board, and then attach the plug-in of the heater harness to the rear frame of the main unit.

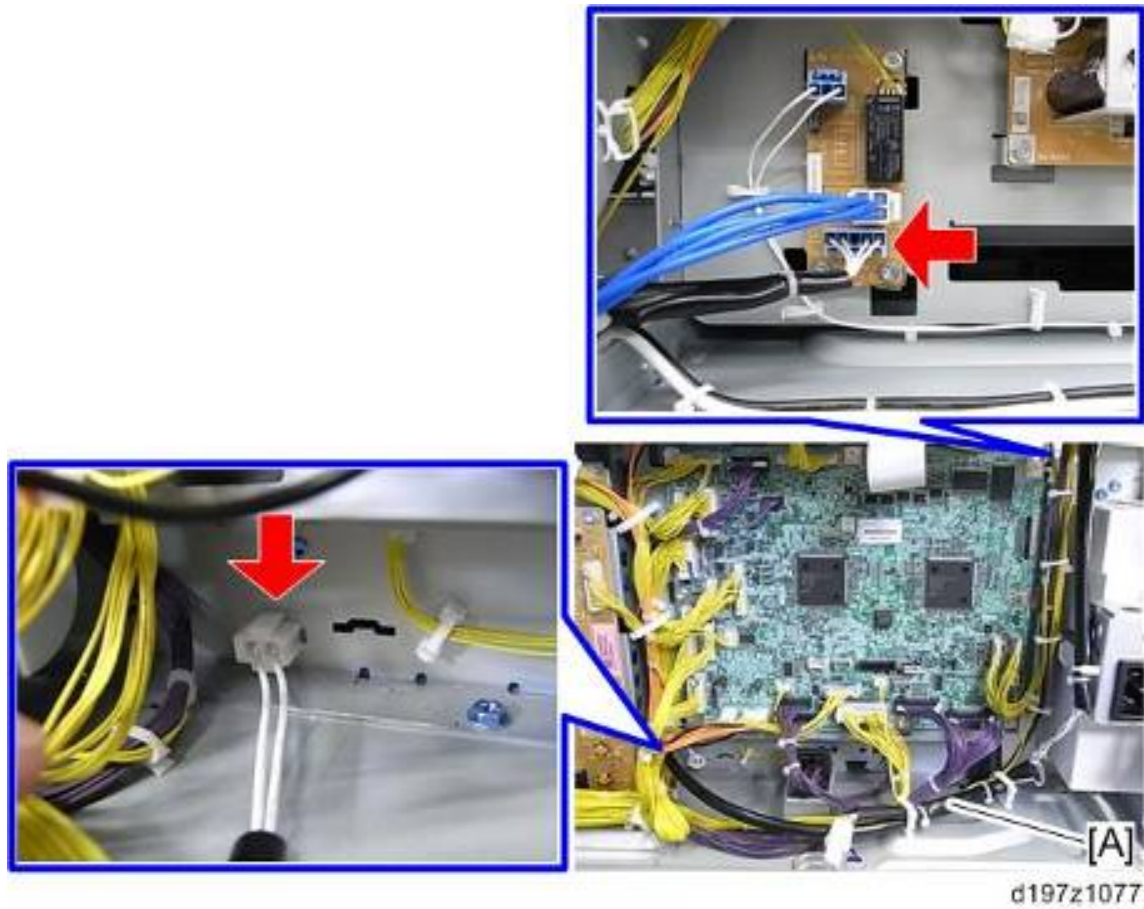

17. Clamp the heater harness which is routed in step 9 (4x3).



18. Pull out the first and second paper feed trays.

19. Connect the harness of the tray heater [A] for the main unit to the plug-in at the inner rear frame of the main unit.

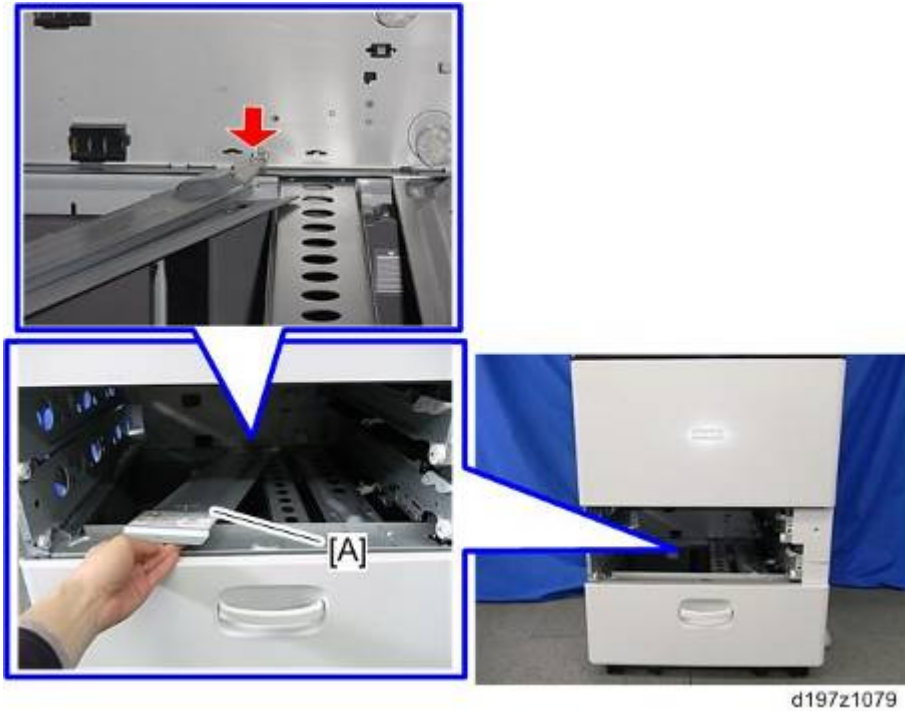

20. Insert the tabs of the tray heater for the main unit in the cutouts in the inner rear frame of the main unit, and then attach it (⚙️ x1).



21. Reattach all the paper feed trays, covers, etc. which have been taken off.

Do the following two steps to set the Anti-Condensation Heater to be constantly ON.

1. Set the setting of SP5-805-001 (Anti-Condensation Heater ON/OFF setting) to [1].
2. Manually disconnect the PCU and scanner heaters.

★ Important

- The PCU and scanner heaters must be disabled because the temperature in the machine could become too high, causing problems with toner clogging, or damage to the scanner lamp stabilizer.

Anti-Condensation Heater for Paper Feed Unit PB3210 / PB3220

1. Implement steps 1 to 17 of the procedure for the Anti-Condensation Heater for Tray (page 2-181).
2. Pull out the 1st and 2nd paper feed trays of the paper feed unit.
3. Pass the harness of the heater [A] for the optional paper feed unit through the hole in the inner rear frame of the optional paper feed unit, and then attach it (🔩 x1).

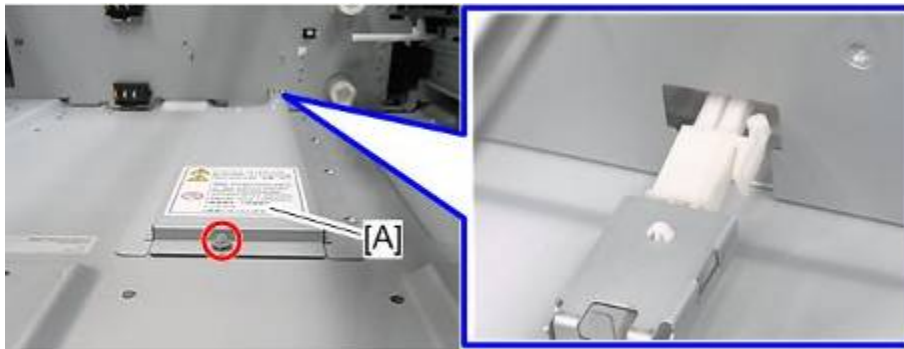

4. Remove the securing brackets [A] of the optional paper feed unit (🔩 x2).

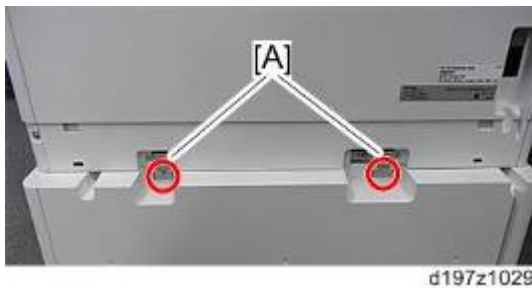

5. Remove the rear cover [A] of the optional paper feed unit (🔩 x2).

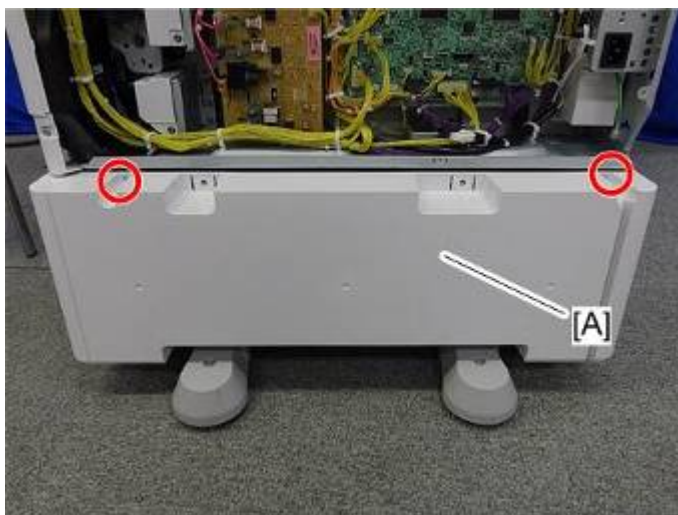

6. Remove the bracket [A] on the bottom of the main unit (🔩 x1).

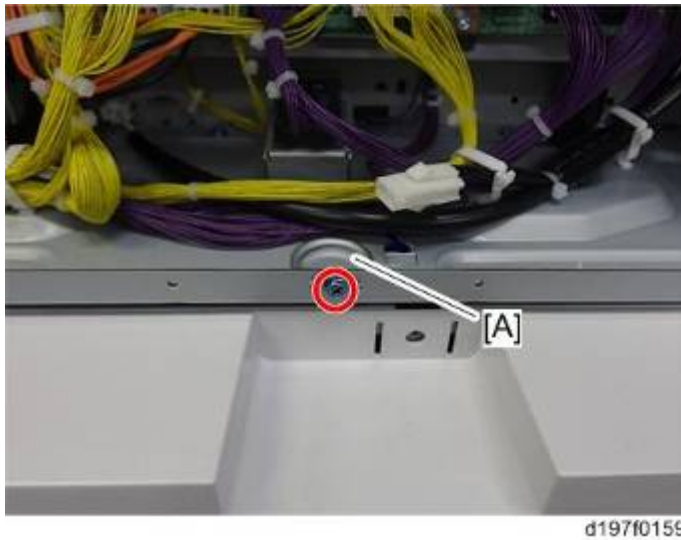

7. Connect the PFU harness [A] of the optional paper feed unit to the relay harness [B] of the main unit and the heater harness [C] (🔩 x4).

⬇ Note

- Put the PFU harness through the hole which is revealed when the bracket is removed in step 7.

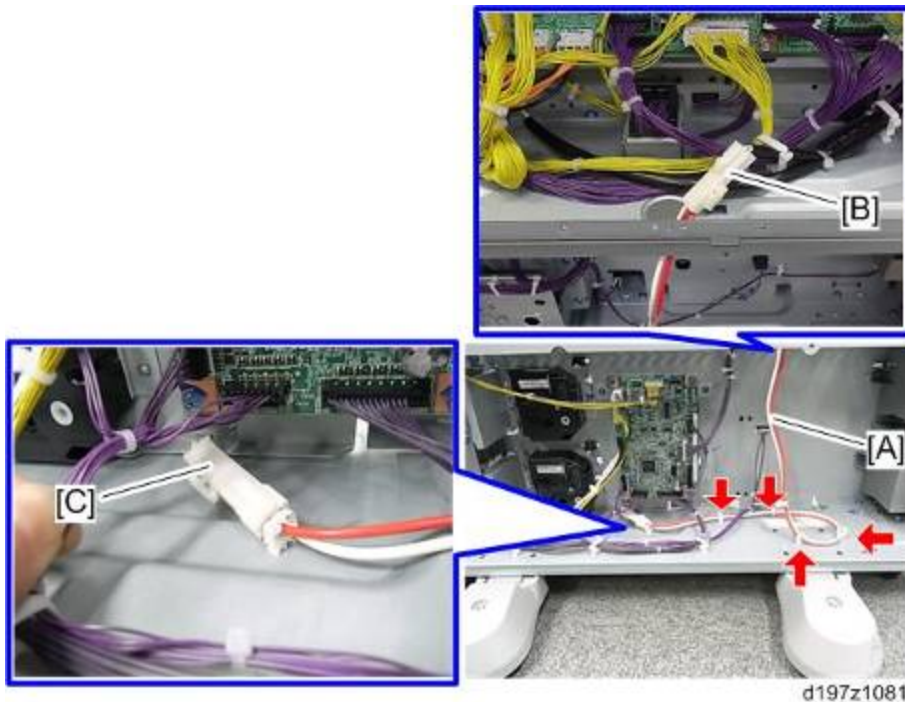

8. Reattach the rear cover of the optional paper feed unit, securing brackets, and rear lower cover of the main unit.
9. Connect the power supply cord and turn ON the main power.
- Do the following two steps to set the anti-condensation heater to be constantly ON.
- Set the setting of SP5-805-001 (Anti-Condensation Heater ON/OFF setting) to [1].
 - Manually disconnect the PCU and scanner heaters.

★ Important

- The PCU and scanner heaters must be disabled because the temperature in the machine could become too high, causing problems with toner clogging, or damage to the scanner lamp stabilizer.

Anti-Condensation Heater for Paper Feed Unit PB3150

1. Implement the step1 to 17 of the procedure for the Anti-Condensation Heater for Tray (page 2-181).
2. Pull out the paper feed tray of PB3150.
3. Put the harness of the heater [A] for the optional paper feed unit through the hole at the inner rear frame, and then attach it (🔩 x1).



4. Remove the securing brackets [A] of Paper Feed Unit PB3150 (🔩 x2).

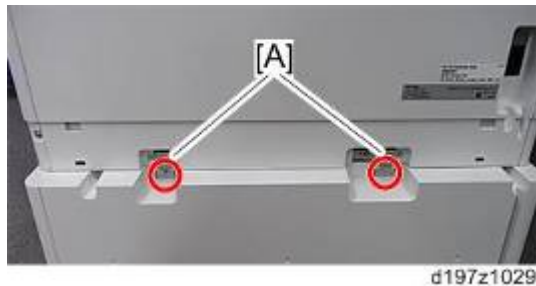

5. Remove the rear cover [A] of Paper Feed Unit PB3150 (🔩 x4).

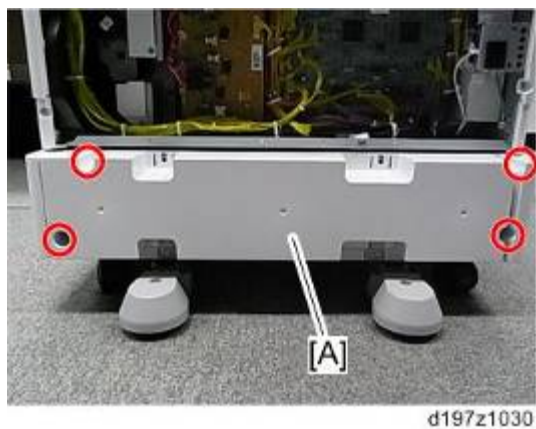

6. Remove the bracket [A] on the bottom of the main unit (🔩x1)

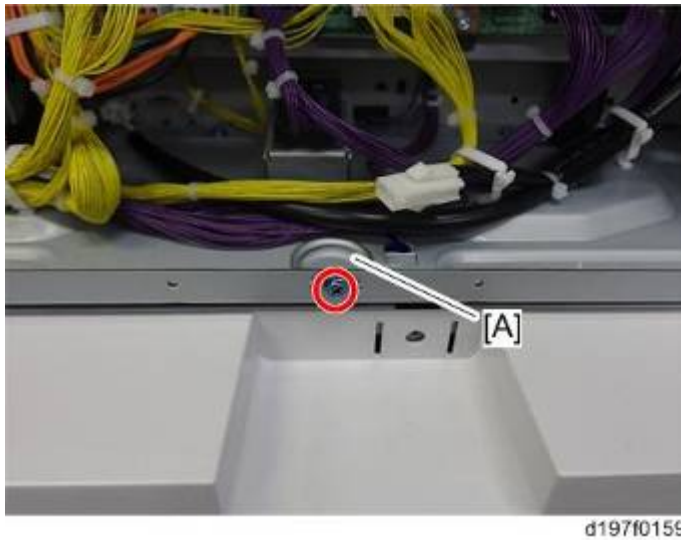

7. Connect the PFU harness [A] of the optional paper feed unit to the relay harness [B] of the main unit and the heater harness [C] (🔩x4).

⬇ Note

- Put the PFU harness through the hole which is revealed when the bracket is removed in step 7.

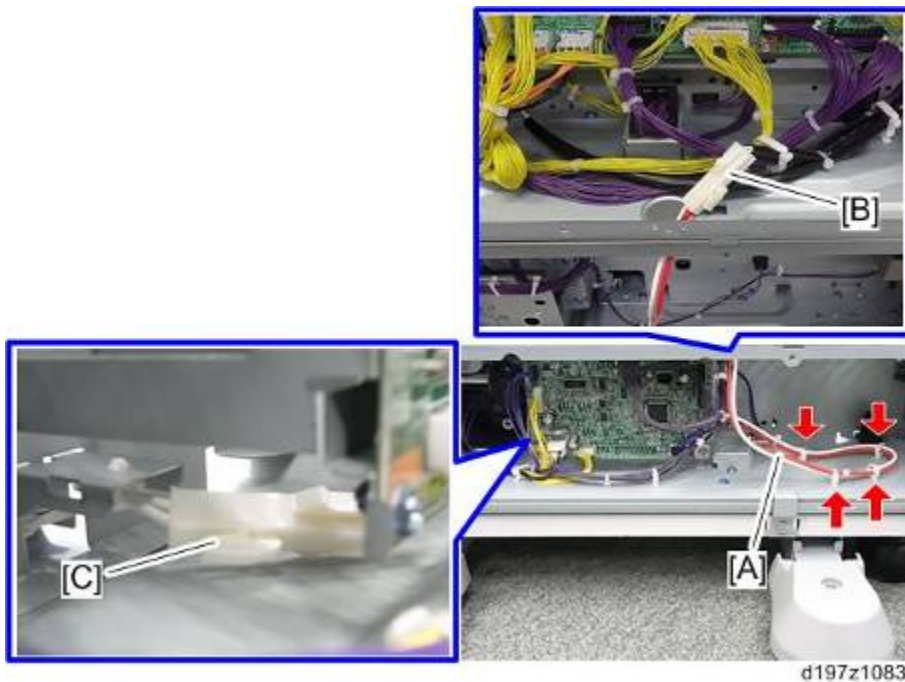

8. Reattach the rear cover of the paper feed unit PB3150, securing brackets, and rear lower cover of the main unit.
9. Connect the power supply code and turn ON the main power.
- Do the following two steps to set the anti-condensation heater to be constantly ON.
- Set the setting of SP5-805-001 (Anti-Condensation Heater ON/OFF setting) to [1].
 - Manually disconnect the PCU and scanner heaters.

★ Important

- The PCU and scanner heaters must be disabled because the temperature in the machine could become too high, causing problems with toner clogging, or damage to the scanner lamp stabilizer.

Anti-Condensation Heater for LCIT PB3170/ PB3230

1. Implement steps 1 to 17 of the procedure for the Anti-Condensation Heater for Tray (page 2-181).
2. Pull out the paper feed tray of the optional LCT unit.
3. Pass the harness of the heater [A] for the optional tray out through the hole in the inner rear frame of the optional LCT unit, and then attach it (🔩x1).



4. Remove the securing brackets [A] of the optional LCT unit (🔩x2).

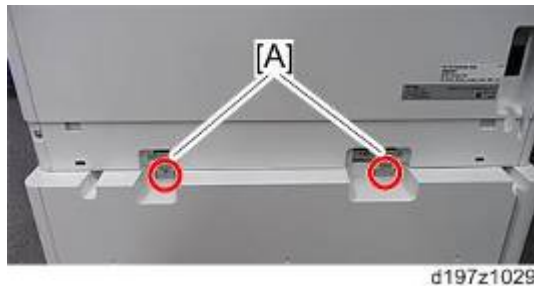

5. Remove the rear cover [A] of the optional LCT unit (🔩x2).

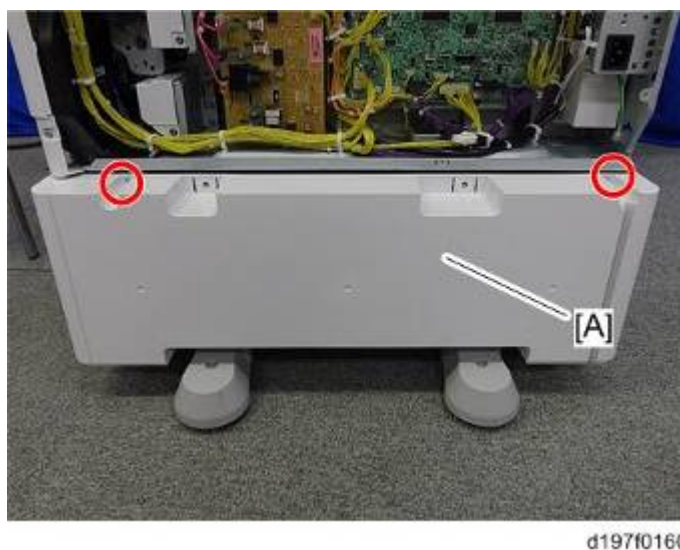

6. Remove the bracket [A] on the bottom of the main unit (🔩 x1).

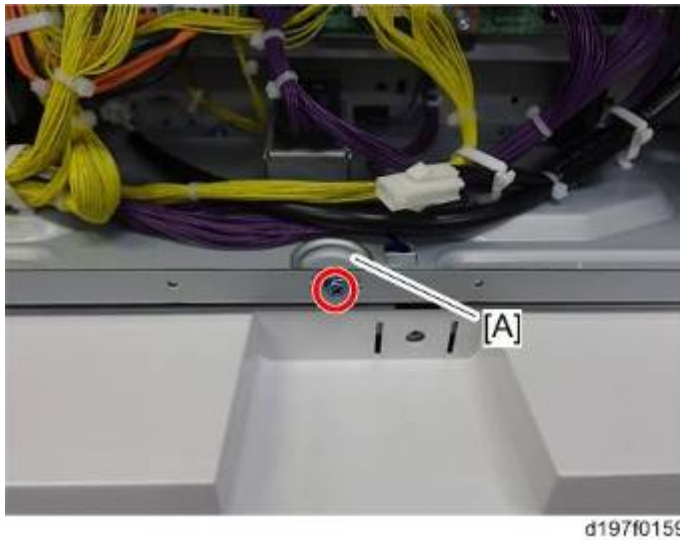

7. Connect the PFU harness [A] of the optional LCT unit to the relay harness [B] of the main unit and the heater harness [C] (🔩 x3).

⬇ Note

- Put the PFU harness through the hole which is revealed when the bracket is removed in step 6.

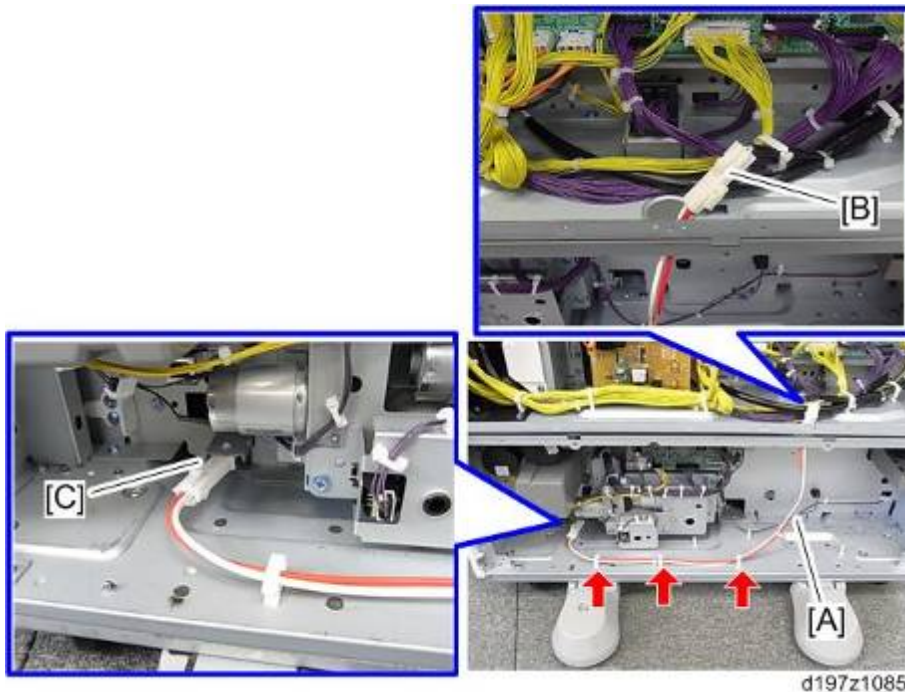

8. Reattach the rear cover of the optional LCT unit, securing brackets, and rear lower cover of the main unit.
9. Connect the power supply cord and turn ON the main power.
- Do the following two steps to set the anti-condensation heater to be constantly ON.
- Set the setting of SP5-805-001 (Anti-Condensation Heater ON/OFF setting) to [1].
 - Manually disconnect the PCU and scanner heaters.

Anti-Condensation Heater for Trays

Important

- The PCU and scanner heaters must be disabled because the temperature in the machine could become too high, causing problems with toner clogging, or damage to the scanner lamp stabilizer.

2.25 CARD READER BRACKET TYPE 3352

2.25.1 ACCESSORY CHECK

No.	Description	Q'ty	For This Model
1	Screw: M3 x 8	2	Yes
2	Screw: M3 x 14	1	Not used
3	Screw: M4 x 25	1	Yes
4	Tapping Screw: M3 x 10	3	Yes
5	Upper Tray	1	Yes
6	Lower Tray	1	Yes
7	Tray Bracket	1	Yes
8	Clamp	5	Yes

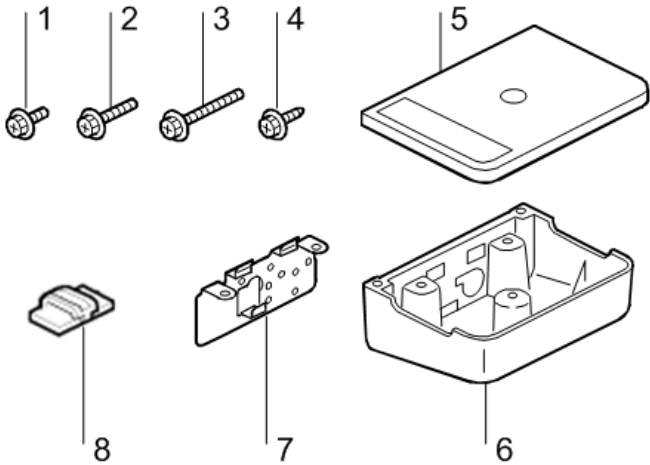

d1822512

2.25.2 INSTALLATION PROCEDURE

1. Remove the scanner rear cover [A] (🔩 x3).

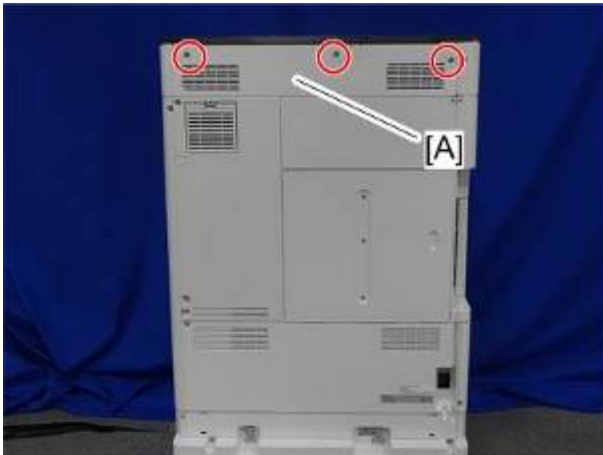

d197f0051

2. Remove the scanner right cover [A] (🔩 x1)



d197f0020

3. Make two screw holes in the removed scanner right cover with a screwdriver or drill.

★ Important

- Make the screw hole to be smaller than the screw size.

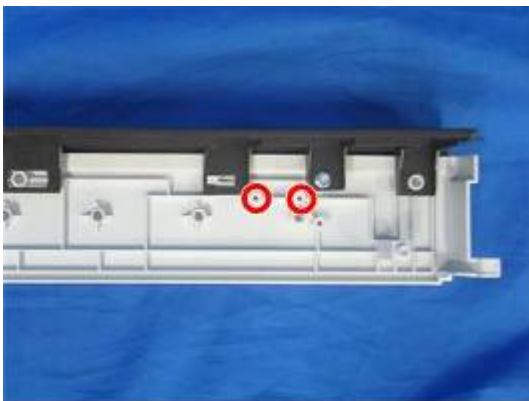

d197z1054

4. Reattach the scanner right cover (🔩 x2).

- 5. Attach the tray bracket [A] to the scanner right cover (⚙️ x2: M3x10 tapping screw).
 - For this model, use the screw holes marked "3" on the table bracket.

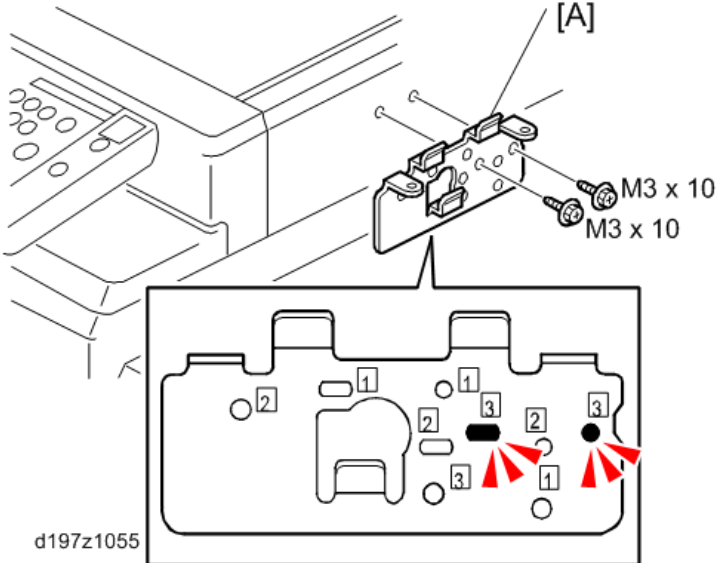

- 6. Attach the lower tray [A] to the tray bracket (⚙️ x2: M3 x 8).
- 7. Attach the upper tray [B] to the tray bracket (⚙️ x1: M3 x 10).

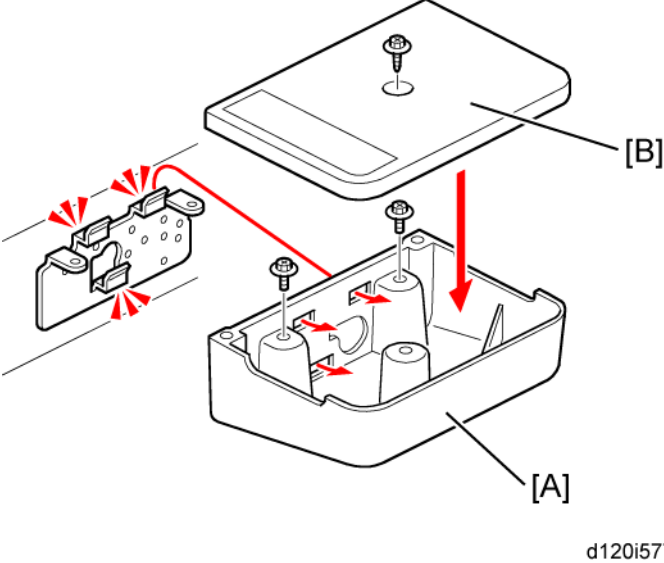

- 8. Attach the clamps ([1] to [5]) and route the harness around the machine as shown.

Scanner Right Cover



Upper Rear Cover

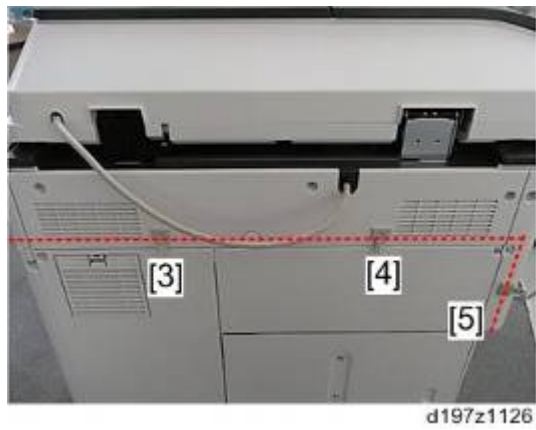

9. Clamp the USB cable and connect it to the USB connector.

2.26 KEY COUNTER BRACKET TYPE M3

2.26.1 ACCESSORY CHECK

Description	Q'ty
Screw: M3X8	1
Binding Self-Tapping Screw: M4X8	3
Clamp:LWS-1211Z	2
Clamp:NK-3N	1
Double Sided Tape	2
Key Counter Plate Nut	2
Key Counter Harness	1

2.26.2 INSTALLATION PROCEDURE

1. Hold the key counter plate nuts [A] on the inside of the key counter bracket [B] and insert the key counter holder [C].
2. Secure the key counter holder to the bracket (🔩x2).
3. Install the key counter cover [D] (🔩x2).

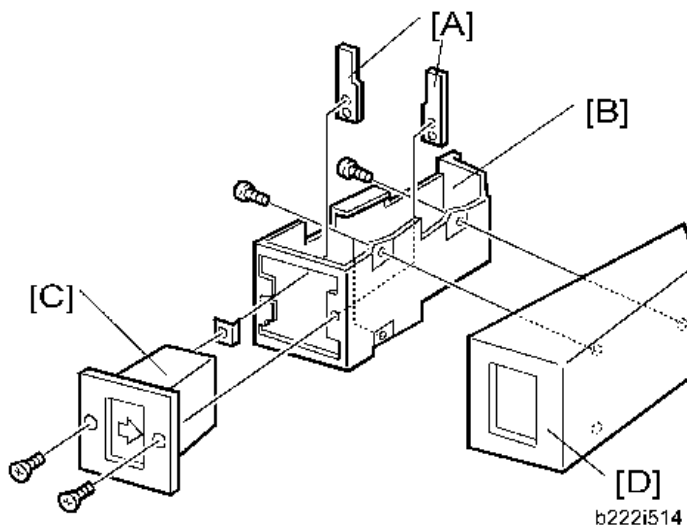

4. Attach the harness that comes from the key counter to the right side of the main machine with the two clamps provided (CLAMP:LWS-1211Z).

5. Remove the controller cover [A] (🔩 x4).



d197f0042

6. Remove the controller rear cover [A] (🔩 x5).

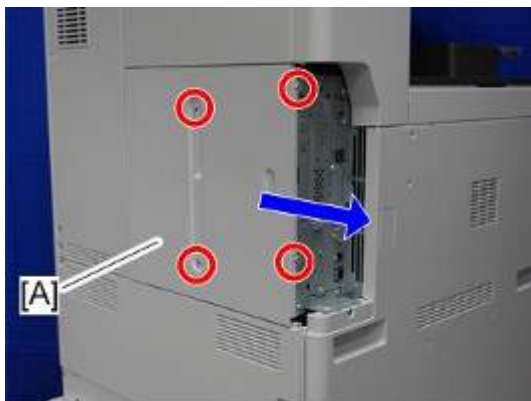

d197f0048

7. Remove the rear left cover (🔩 x3).



d197f0050_1

8. Remove the rear right cover [A] (⚙️ x5).



d197f0049

9. Remove the rear lower cover [A] (⚙️ x5).

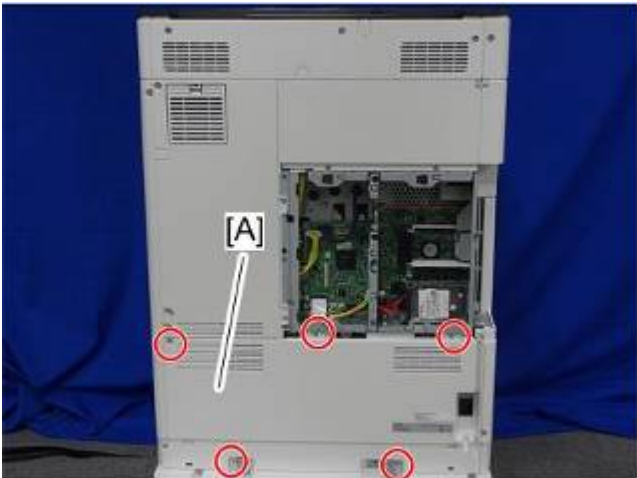

d197f0050

10. Remove the connector on CN133 [A] of the BCU, and then connect the key counter harness to CN133.



d197z1140

11. Secure the harness to the inside of the main frame with a clamp.

12. Remove the cut off part [A] of the rear right cover.



13. Pass the harness from the key counter through the cut off part [A] of the right rear cover.

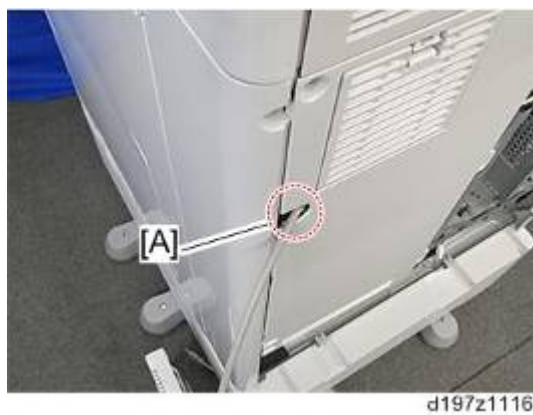

14. Reinstall all the covers on the main machine.
15. Peel off double sided tape on the key counter bracket and attach the key counter to the scanner right cover.
16. Reassemble the machine.

2.27 OPTIONAL COUNTER INTERFACE UNIT TYPE M12

2.27.1 ACCESSORY CHECK

Description	Q'ty
MKB Board	1
Tapping Screw: M3x6	4
Harness Band	1
Stud	4
Harness Clamp: LWS-0711	1
EMC Address Decal	1
Harness	1

2.27.2 INSTALLATION PROCEDURE

1. Exterior Covers (page 4-9)

- Controller Cover
- Controller Rear Cover
- Rear Lower Cover

2. Install the four stud stays in the location [A] as shown below.

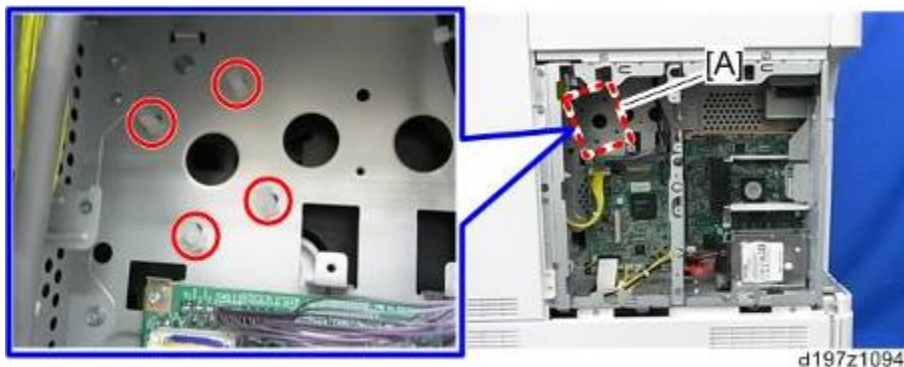

3. Install the optional counter interface board [A] on the four stud stays.



4. Connect the supplied harness (13 pins) to CN3 [A] on the optional counter interface board and CN132 [A] on the BCU.

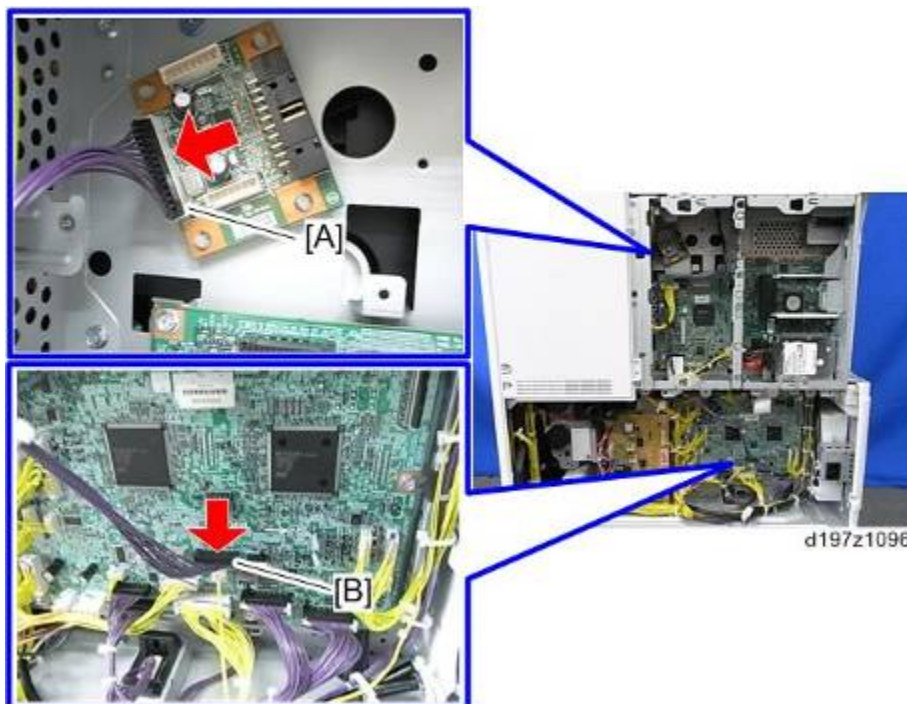

5. Route the harness [A] and clamp it as shown below (x1).



6. Remove the cable cover [A] and pass the harness from the optional counter device.

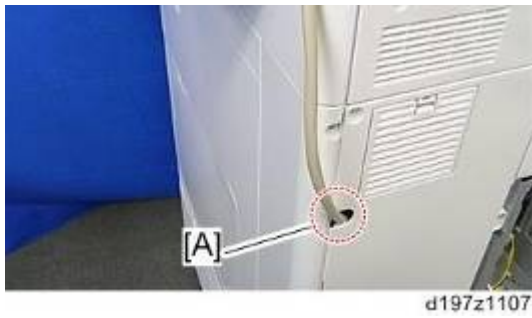

7. Reassemble the machine.

2.28 SMART CARD READER BUILT-IN UNIT TYPE M12

2.28.1 ACCESSORY CHECK

No.	Description	Q'ty	Remark
1	IC Card Cover	1	
2	Clamp:LWSM-0605A	4	
3	Decal	1	
4	Sponge:20X20	2	
5	Upper Cover	1	
-	Operating Instructions	1	
-	MY Bank & QA Registration Card	1	
-	Operation Manual	1	

Note

- IC card reader and USB cable are not provided with this option.

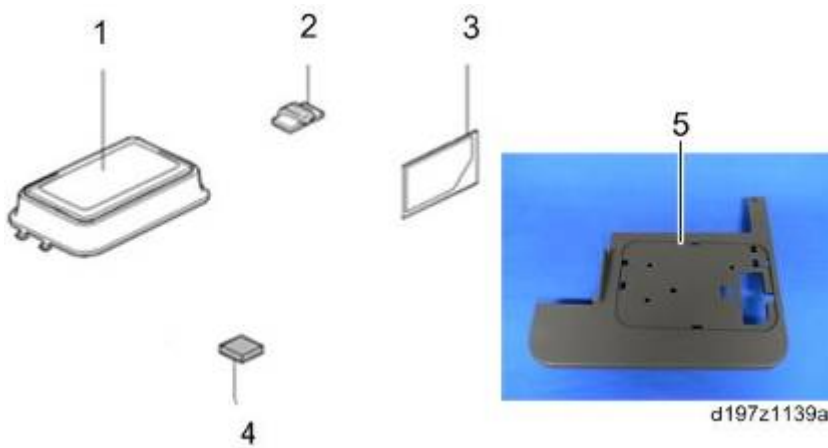

2.28.2 INSTALLATION PROCEDURE

1. Open the right cover.
2. Remove the main power switch cover (🔩 x1).

⬇️ **Note**

- The main power switch cover has three tabs: two on the left side (paper exit) and one on the right side (right cover).



d197f0052

3. Remove the scanner rear cover [A] (🔩 x3).

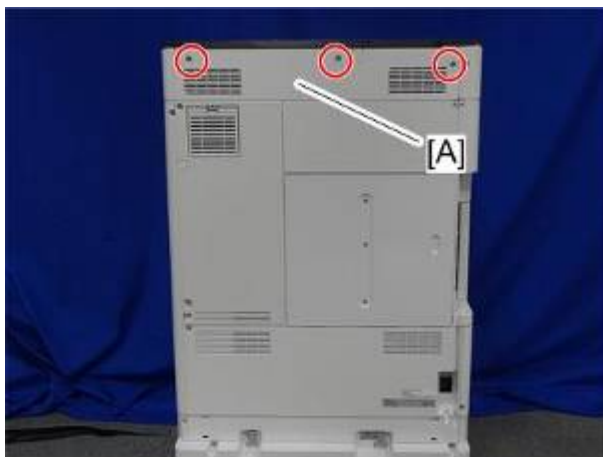

d197f0051

4. Remove the scanner right cover [A] (🔩 x1).



d1462300

5. Remove the controller cover [A] (🔩 x4).

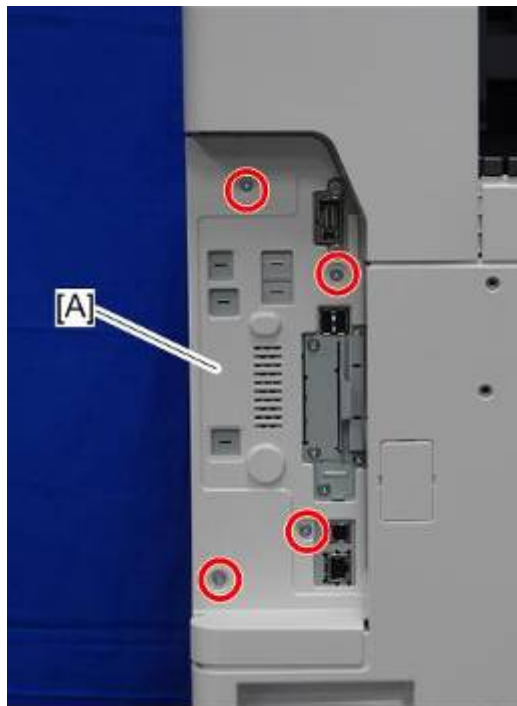

d197f0042

6. Slide the controller rear cover [A] to remove it (🔩 x4).

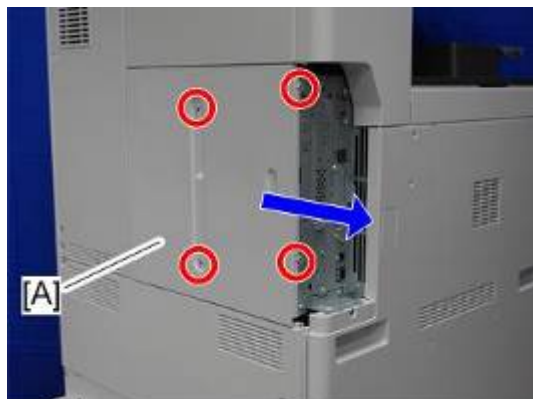

d197f0048

7. Remove the rear left cover [A] (🔩 x3).



d197f0050_1

8. Pass a USB cable through the opening on the upper cover.



d197z1200

9. Put an IC card reader [A] on the upper cover, and connect the USB cable.

Note

- An IC card reader is not provided with this option.
- Pull the cable down through the opening on the upper cover to adjust the excess length of the cable. This prevents the cable from getting sandwiched when you attach the IC card cover.



d197z1201

10. Attach the IC card cover [A] provided, to cover the IC card reader (Tab × 4).

Note

- Do not sandwich the USB cable with this cover.
- Make sure that the reading area on the IC card reader is in contact with the IC card cover. If they are not contacted with each other, put the sponge(s) provided underneath the IC card reader to fill the gap. Otherwise, the IC card reader will not work properly.

Smart Card Reader Built-in Unit Type M12

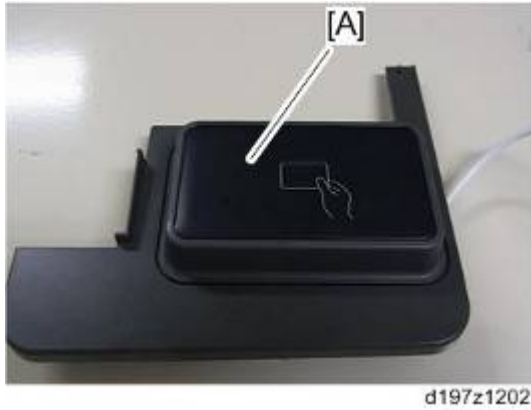

11. Turn the upper cover upside down.



12. Route the cable as shown below (Tab x 2).



13. Remove the screws on the main power switch cover [A] removed in step 2 (🔩 x2).

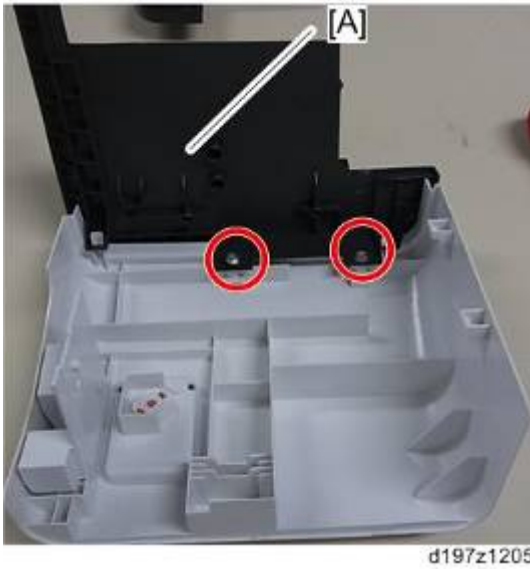

14. Attach the upper cover [A] assembled in step 8 through step 12 to the main power switch cover (🔩 x2).

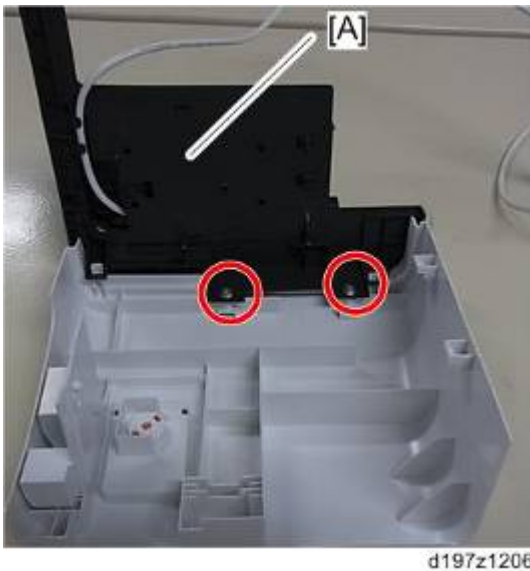

15. Attach the clamps provided along from the right side to the rear side of the main frame (🔩 x3).



16. Attach the main power switch cover with IC card reader [A].



17. Tighten the screw to secure the main power switch cover (🔩 x1).



⬇ Note

- Lead the USB cable into the right side of the main frame as shown below.



d197z1210

18. Clamp the USB cable at the four positions (🔗x4).



d197z1211

19. Clamp the USB cable at the five positions (🔗x5).

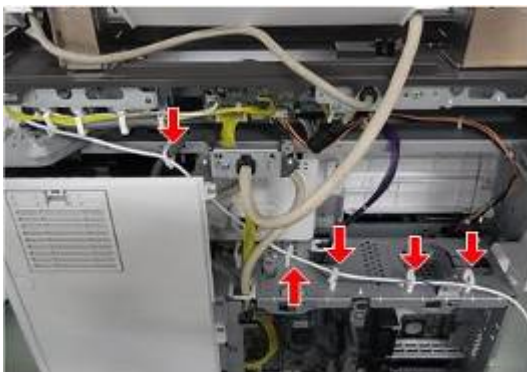

d197z1212

⬇️ Note

- If the USB cable is too long, loop and clamp the cable to adjust the length as shown below.

Smart Card Reader Built-in Unit Type M12



d197z1213

20. Cut out the hole cover [A] and insert the harness.



d197z1134a

21. Reinstall all the covers removed.
22. Connect the USB cable [A] to the USB port of the main machine.



d197z1133

23. Install the IC card cover provided with this option on the IC card reader (▼ x4).
24. Turn the main power switch ON, and make sure that the value of SP5-985-002 is set to "1".

2.29 INTERNAL OPTIONS

2.29.1 LIST OF SLOTS

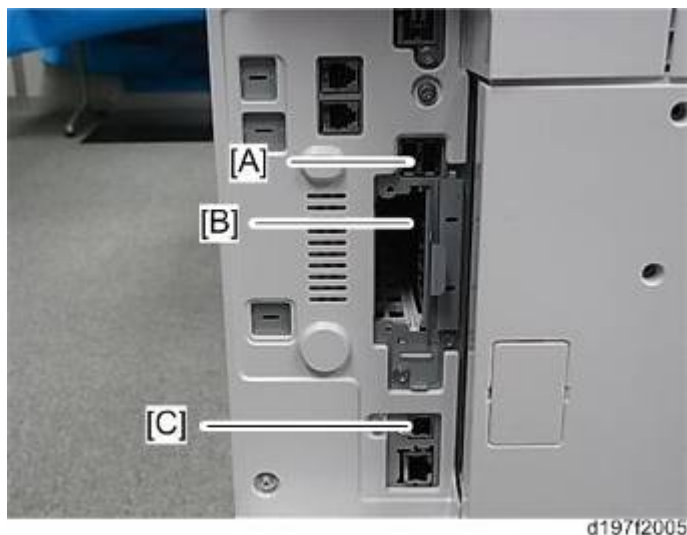

Slot		Option
[A]	USB ports ^{*1}	Bluetooth Interface Unit Type D
		Smart Card Reader Built-in Unit Type M12
[B]	I/F slot A	IEEE 1284 Interface Board Type A
		IEEE 802.11a/g/n Interface Unit Type M2
		File Format Converter Type E
		USB Device Server Option Type M12
[C]	Mini USB port	

*1 There is no difference between the left and right USB ports.

2.30 PRINTER/SCANNER UNIT TYPE M12

Note

- This option is for basic models only.

2.30.1 COMPONENT CHECK

No.	Description	Q'ty
1	HDD Unit	1
2	Cable	1
3	Cable	1
-	SD-Card	1
-	Screw - M3x6	3
-	Sheet: Application: Document Box	1
-	Sheet: Application: Scanner	1
-	Sheet: Application: Printer	1
-	PDF Decal	1
-	CD-ROM	1
-	Caution Decal Sheet	1
-	EMC Address Sheet	1
-	EULA Sheet	1



2.30.2 INSTALLATION PROCEDURE

⚠ CAUTION

- Turn off the main power and disconnect the power supply cord.

- Remove the controller rear cover (page 4-15).
- Connect the cables [A] [B] to the HDD [C], and then attach the HDD to the bracket [D] of the HDD (🔩 x4).

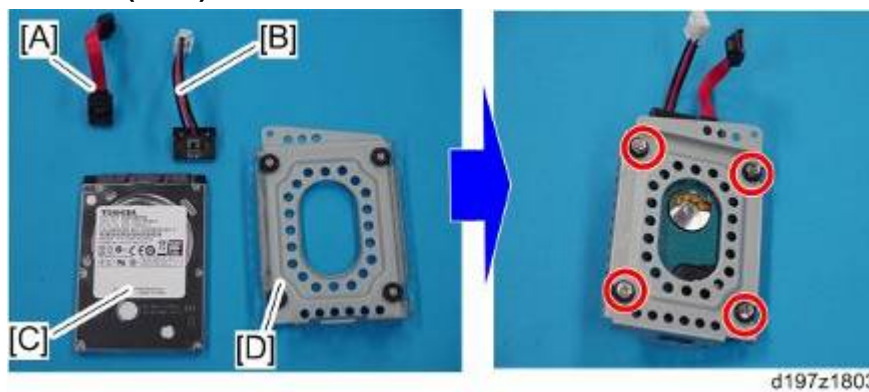

- Connect the cables of the HDD to the controller board [A], and then hang the HDD [B] on the hook of the controller box (🔩 x2).

4. Secure the HDD [B] (⚙️ x3).

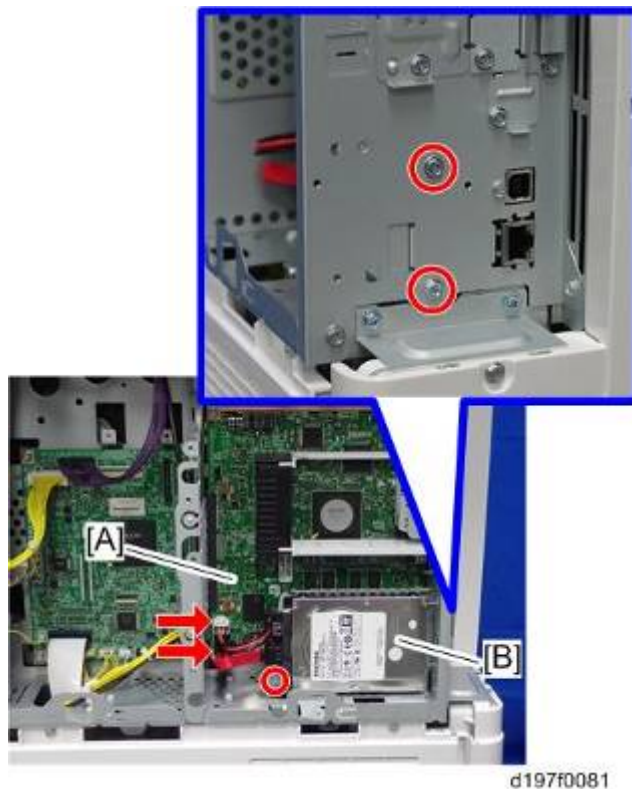

5. Reattach the removed covers.
6. Plug the power cord and turn on the main power of the machine.
7. Do SP5-832-001 to format the hard disk.
8. Do SP5-853-001 to copy the preset stamp data from the firmware to the hard disk.
9. Do SP5-846-040 to copy the address book to the hard disk from the controller board.
10. Do SP5-846-041 to let the user get access to the address book.
11. Turn the main power off and on.
12. Enable the on-board NIC and USB in the SP mode.
 - SP5-985-001 (On-board NIC): 1 (Enabled)
 - SP5-985-002 (On-board USB): 1 (Enabled)You must turn the machine off/on because the setting only takes effect after the machine is restarted.
13. Turn off the main power after the power indicator turns off.

14. Remove the SD slot cover [A] (🔧 x1).

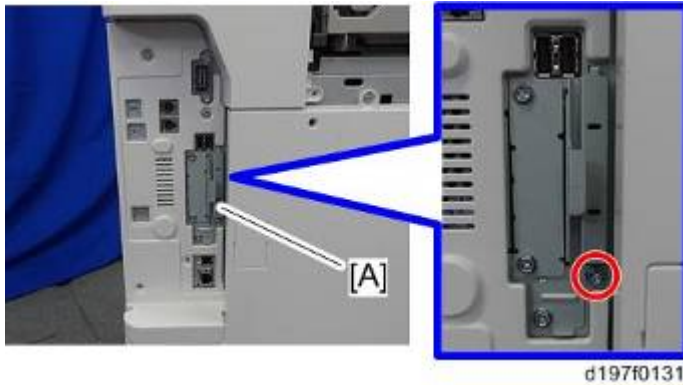

15. Insert the SD card in SD card Slot 1 [A] or Slot 2 [B].

⬇ Note

- Be sure that you have set the On-board Device settings (SP5-985-001 and -002, as explained above) before inserting the SD card..

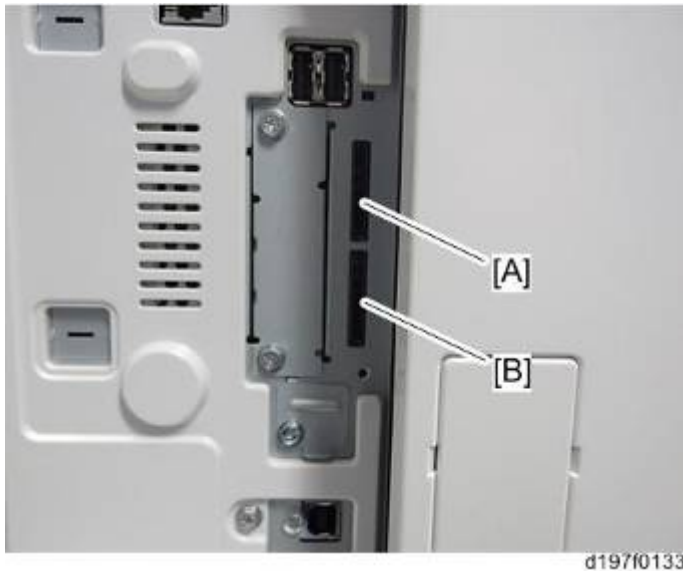

16. Do SP5-853-001 to copy the preset stamp data from the firmware to the hard disk.

17. Attach the PDF decal [A] to the bottom right of the front door.

If there is another decal already attached, attach the PDF decal to the left of the decal.

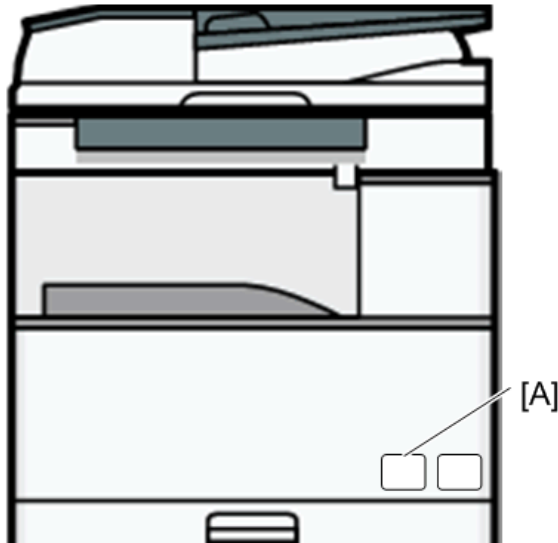

d1822507

18. Connect the Ethernet cable to the Ethernet I/F [A].

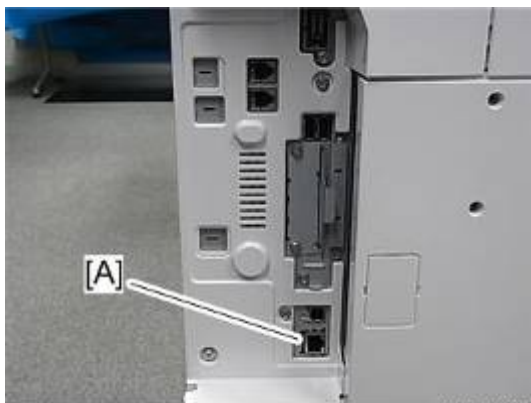

d197z1037

Note

- When adding the Printer/Scanner Unit to a machine with the Fax Unit installed, additional procedures are required.
 1. Turn on the main power.
 2. Do SP5-846-040 to copy the address book to the hard disk from the controller board.
 3. Turn off the main power after the power indicator is unlit.

2.31 IEEE 1284 INTERFACE BOARD TYPE A

2.31.1 COMPONENT CHECK

No.	Description	Q'ty
1	IEEE 1284 Interface Board	1
-	UL Sheet	1
-	EMC Address Sheet	1
-	FCC Sheet	1
-	ROHS Sheet	1
-	Caution Sheet	1

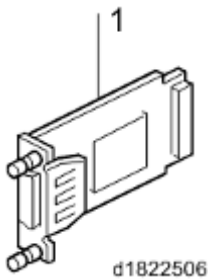

2.31.2 INSTALLATION

⚠ CAUTION

- Turn off the main power and disconnect the power supply cord.

1. Remove the I/F slot cover [A] (🔩 x2).

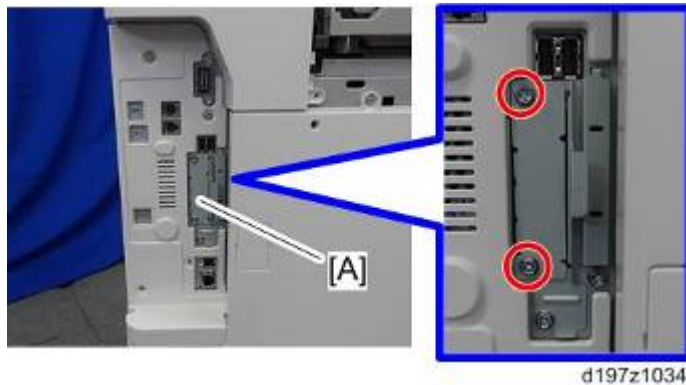

2. Install the IEEE 1284 Interface Board in the I/F slot [A] (🔩 x2).



3. Plug in and turn ON the main machine.

ⓘ Note

- Use a screwdriver to tighten the knob-screws. Do not tighten manually, because this can disconnect the board.

4. Print out the “Configuration Page”, and then check if this option is correctly recognized.

- User Tools/Counter > Printer Features > List/Test Page > Configuration Page

2.32 IEEE 802.11A/G/N INTERFACE UNIT TYPE M2

2.32.1 ACCESSORY CHECK

No.	Description	Q'ty
1	IEEE 802.11a/g/n Interface Board	1
2	Velcro Fasteners	2
3	Antenna Clamps	8
-	EMC Address Sheet	1
-	FCC Sheet	1
-	Caution Sheet: Each Area	4
-	Setup Sheet	1

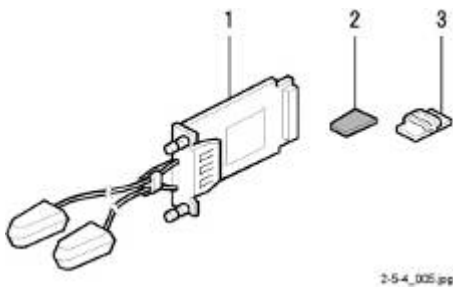

2.32.2 INSTALLATION

⚠ CAUTION

- Turn off the main power and disconnect the power supply cord.

1. Remove the I/F slot cover [A] (🔩 x2).

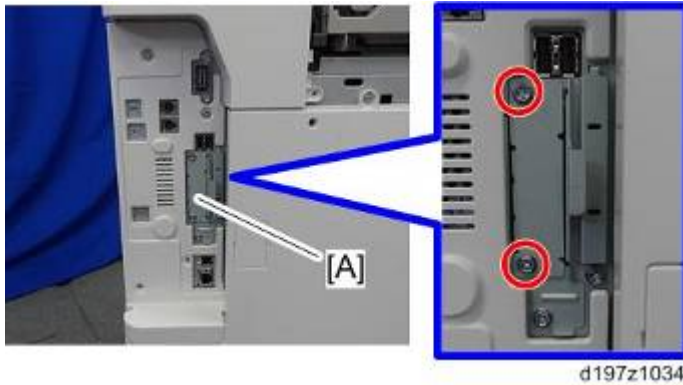

2. Install the IEEE 802.11 interface board in the I/F slot [A] (🔩 x2).



ⓘ Note

- Use a screwdriver to tighten the knob-screws. Do not tighten manually, because this can disconnect the board.

3. Look at the markings on the antenna bracket.

4. Look at the ferrite core of the antenna cable.

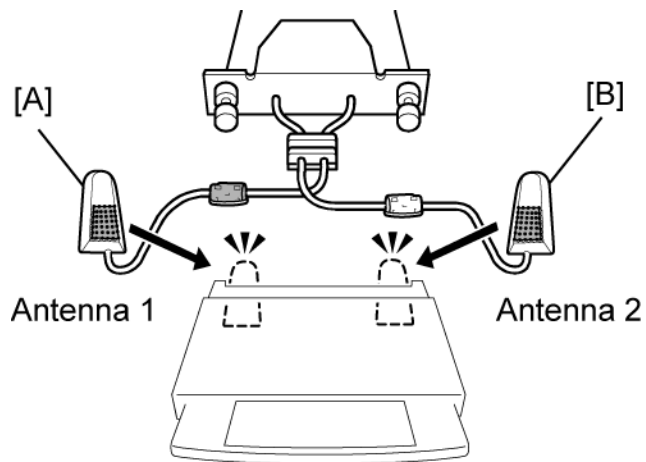

d596i509

- **ANT1.** Antenna 1 [A] transmits and receives. It must be installed on the left rear corner of the main machine. (The core on the Antenna 1 cable is black.)
 - **ANT2.** Antenna 2 [B] only receives. It is installed on the right rear corner of the machine. (The core on the Antenna 2 cable is white.)
5. Peel off the double-sided tapes on the Velcro fasteners, and then attach them to the right rear [A] and left rear [A] of the machine.



d197z1041

6. Attach Antenna 1 [B] to the left rear of the machine. (The core on the Antenna 1 cable is black.)
7. Attach Antenna 2 [A] to the right rear of the machine. (The core on the Antenna 2 cable is white.)
8. Attach the clamps as shown below.

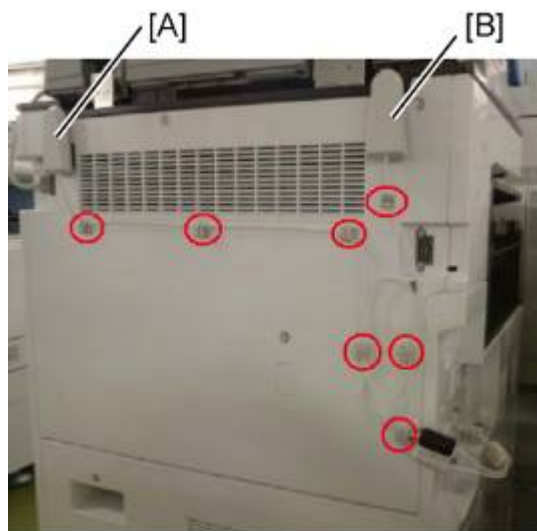

d596i511

9. Set the cables of Antenna 1 and Antenna 2 in the clamps and close them.
10. Print out the “Configuration Page”, and then check if this option is correctly recognized.
 - User Tools/Counter > Printer Features > List/Test Page > Configuration Page

2.32.3 USER TOOL SETTINGS FOR IEEE 802.11A/G/N

Go into the User Tools mode and do the procedure below. These settings take effect every time the machine is powered on.

↓ Note

- You cannot use IEEE 802.11a/g/n if you use Ethernet.

1. Press the “User Tools” key.
2. On the touch panel, touch “System Settings”.

↓ Note

- Select “Interface Settings”> “Network” > “LAN Type”. The “LAN Type” (default: Ethernet) must be set for either Ethernet or wireless LAN.

3. Select “Interface Settings”> “Wireless LAN”. Only the wireless LAN options show.
4. Set the “Communication Mode”.
5. Enter the “SSID setting”. (The setting is case sensitive.)
6. Set the “Ad-hoc Channel”. You need this setting when Ad Hoc Mode is selected.
Range: 1-13, 36, 40, 44 and 48 channels (default: 11)
7. Set the “Security Method” to specify the encryption of the Wireless LAN.

- The “WEP” (Wired Equivalent Privacy) setting is designed to protect wireless data transmission. The same WEP key is required on the receiving side in order to unlock encoded data. There are 64 bit and 128 bit WEP keys.

Range of Allowed Settings:

64 bit: 10 characters

128 bit: 26 characters

- Specify “WPA2” when “Communication Mode” is set to “Infrastructure Mode”. Set the “WPA2 Encryption Method” and “WPA2 Authent. Method”.
 - WPA2 Encryption Method:
CCMP (AES) is fixed.
 - WPA2 Authent. Method:
Select either “WPA2-PSK” or “WPA2”.
If you select “WPA2-PSK”, enter the pre-shared key (PSK) of 8 - 63 characters in ASCII code.
When “WPA2” are selected, authentication settings and certificate installation settings are required.
- 8. Press “Wireless LAN Signal” to check the machine's radio wave status using the operation panel.
- 9. Press “Restore Factory Defaults” to initialize the wireless LAN settings. Press “Yes” to initialize the following settings:
 - Transmission mode
 - Channel
 - Transmission Speed
 - WEP
 - SSID
 - WEP Key

SP Mode Settings for IEEE 802.11 Wireless LAN

The following SP commands and UP modes can be set for IEEE 802.11

SP No.	Name	Function
SP5-840-011	WEP Key Select	Used to select the WEP key (Default: 00).
UP mode	Name	Function
	SSID	Used to confirm the current SSID setting.
	WEP Key	Used to confirm the current WEP key setting.
	WEP Mode	Used to show the maximum length of the string that can be used for the WEP Key entry.
	WPA2 Encryption Method	Used to confirm the current WPA2 encryption setting.
	WPA2 Authent. Method	Used to confirm the current WPA2 authentication setting and pre-shared key.

2.33 BLUETOOTH INTERFACE UNIT TYPE D

2.33.1 COMPONENT CHECK

No.	Description	Q'ty
1	Bluetooth Interface Unit	1
-	EMC Address Sheet	1
-	CD-ROM	1
-	Caution Sheet	2
-	FCC Sheet	2



2-5-6_002.jpg

2.33.2 INSTALLATION PROCEDURE

⚠ CAUTION

- Turn off the main power and disconnect the power supply cord.

1. Insert the Bluetooth unit [A] into one of the USB slots.



d197z1040

- Plug in and turn ON the main power.
- Print out the “Configuration Page”, and then check if this option is correctly recognized.
 - User Tools/Counter > Printer Features > List/Test Page > Configuration Page

2.34 FILE FORMAT CONVERTER TYPE E

2.34.1 COMPONENT CHECK

No.	Description	Q'ty
1	File Format Converter (MLB: Media Link Board)	1
-	EMC Address Sheet	1
-	FCC Sheet	1
-	ROHS Decal Sheet	1

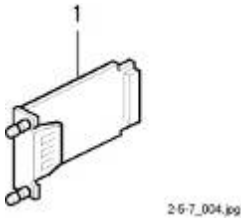

2.34.2 INSTALLATION

⚠ CAUTION

- Turn off the main power and disconnect the power supply cord.

1. Remove the I/F slot cover [A] (⚙ x2).

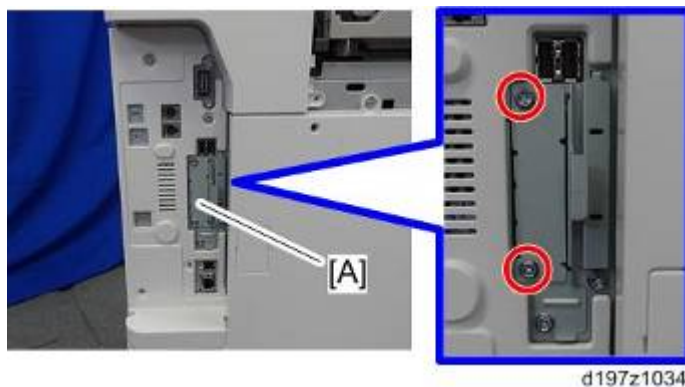

2. Install the board of the file format converter in the I/F slot [A] (⚙️ x2).



3. Turn on the main power of the machine.
4. Print out the “Configuration Page”, and then check if this option is correctly recognized.
 - User Tools/Counter > Printer Features > List/Test Page > Configuration Page

2.35 USB DEVICE SERVER OPTION TYPE M12

2.35.1 COMPONENT CHECK

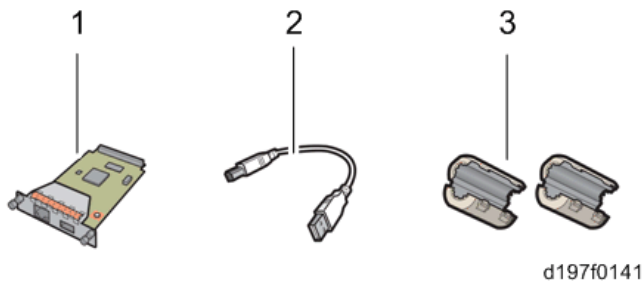

No	Items	Q'ty
1	Interface Board	1
2	USB Cable	1
3	Ferrite Core	4

Note

- An Ethernet cable is not packed with this option.

Interface Board Surface

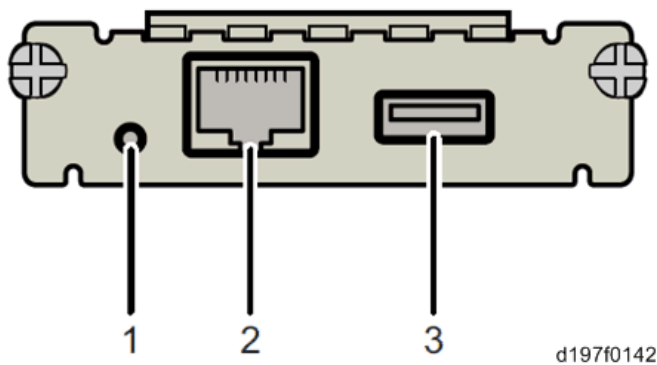

No.	Item	Description
1	Switch	Used to reset to the factory settings.
2	Ethernet port	Used to connect the Ethernet cable.
3	USB port	Used to connect this option to the main machine. Do not use this port with other options.

2.35.2 INSTALLATION PROCEDURE

⚠ CAUTION

- Turn off the main power and disconnect the power supply cord.

★ Important

- When you install this option on the main machine for the first time, the interface board must be connected directly to your PC to set up the IP address and other network settings.

1. Turn off the main power of the machine, and unplug the power cord from the wall socket.
2. Remove the interface slot cover [A] (🔩 x 2).

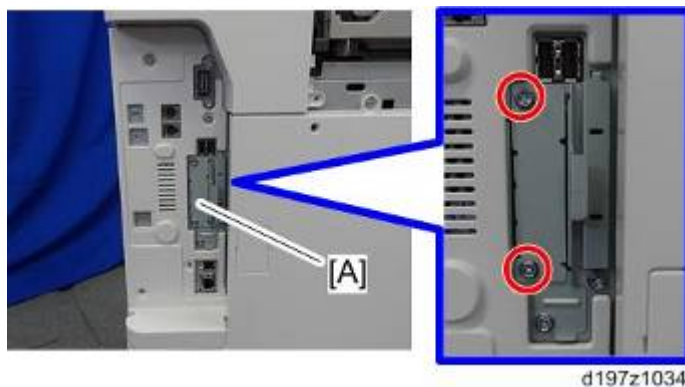

3. Install the interface board in the interface slot [A] (🔩 x 2).



4. Insert the USB cable into the USB port on this option.

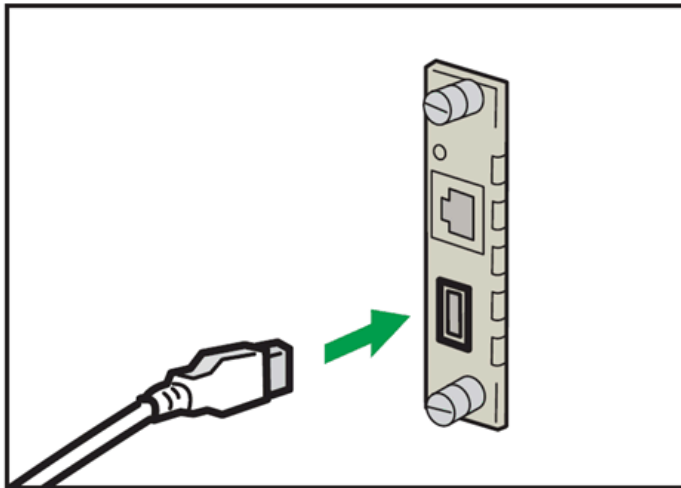

d197f0145

5. Insert the other side of the USB cable into the USB port B on the main machine.

Note

- The machine shape and/or USB port location differs depending on the machine.

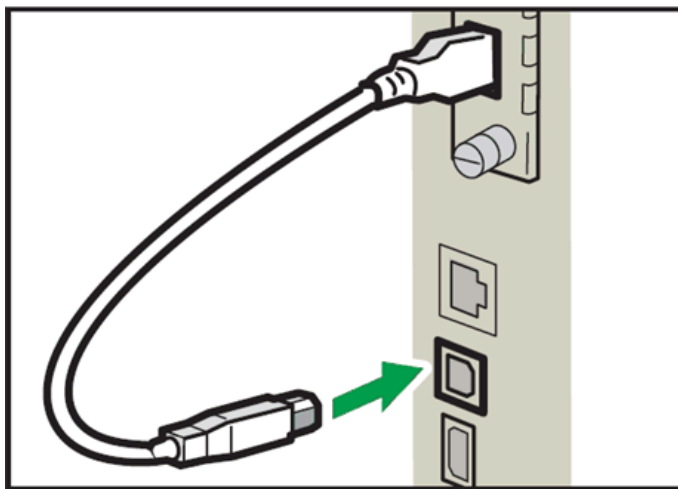

d197f0146

6. Attach the ferrite cores to the Ethernet cable, while looping the cable at 3 cm (approx. 1.2 inch) [A] from the each end of the cable.

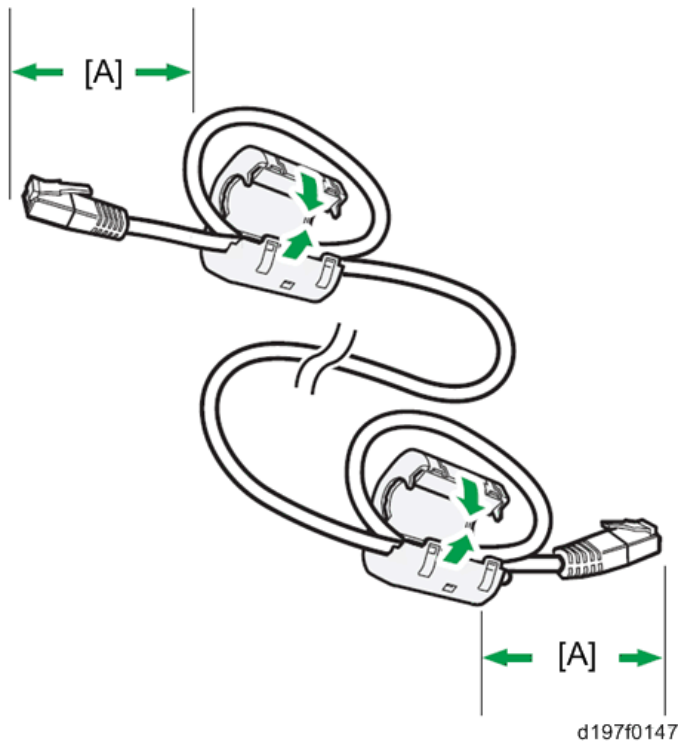

7. Insert the Ethernet cable into the Ethernet port on this option.

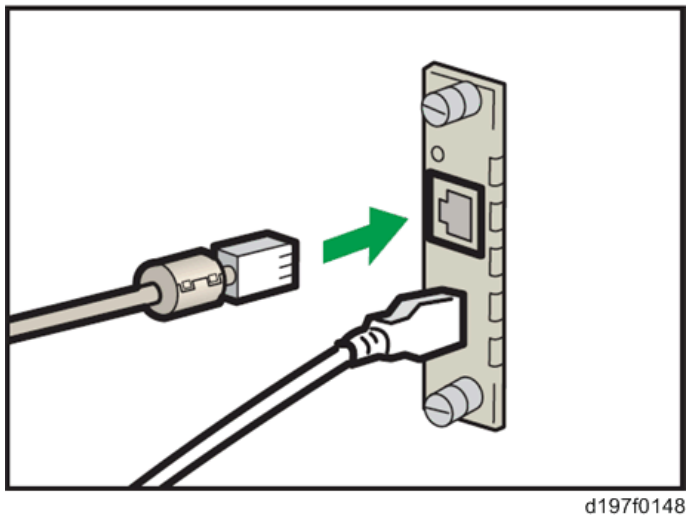

8. Insert the other end of the Ethernet cable to a PC for network setting.
9. Plug the power cord into the wall socket and turn on the main power of the machine.

Note

- Do not unplug the USB cable while the machine is recognizing this option. It may take between 30 seconds to 1 minute to finish recognizing it (the LEDs on the Ethernet port of this option light up after recognizing this option; see below). If unplugged, connect the cable again.

10. Print out the “Configuration Page”, and then check if this option is correctly recognized.

- User Tools/Counter > Printer Features > List/Test Page > Configuration Page

What Do the LED Indications Mean?

When this option is properly installed and recognized by the main machine, the LED indicators light up under the following conditions.

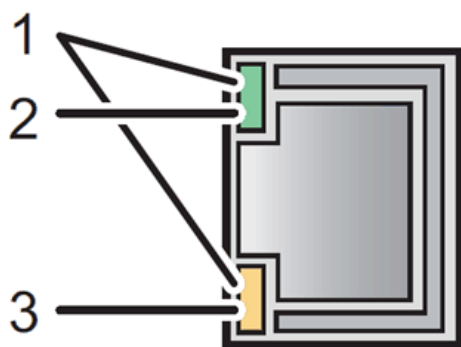

d197f0149

No.	Light Color	Lights Up When:
1	Green and Yellow	1000BASE-T operates
2	Green	10BASE-T operates
3	Yellow	100BASE-TX operates

Notes for Energy Save Mode Setting

If the machine which has this option enters into the energy save mode, you cannot print because there will be a communication error. Follow the instructions below to disable the machine’s entering into the energy save mode.

1. Press [Features Settings] on the operation panel.
2. Press [Administrator Tools] in [System Settings].
3. Press [Energy Saver Mode to Disable Print Server].
4. Press [Disable Mode].
5. Press [OK].
6. Press [Features Settings].

2.35.3 IP ADDRESS SETTING

This section describes how to set an IP address on this option manually. Note that you can set an IP address which is not only on the same network segment but also on a different network segment to share a single printer with devices in multiple networks.

★ Important

- You cannot change the IP address for this option from the operation panel of the main machine. The setting must be done from a web browser on your PC.
- The network setting of this option is initially assigned as follows:
IP address: 192.168.100.100 / Subnet mask: 255.255.255.0
- The network setting of your PC must be in the same network segment to change the network setting of this option.

1. Make a note of the current network settings of your PC.
2. Change the IP address on your PC to [192.168.100.xxx (*0 - 255)].
3. Change the subnet mask on your PC to [255.255.255.0].
4. Open a web browser.
5. Type [http://192.168.100.100/] in the address bar.
6. Press the “Enter” key.

↓ Note

- The setting screen for this option appears.

7. Click [Network Setting].

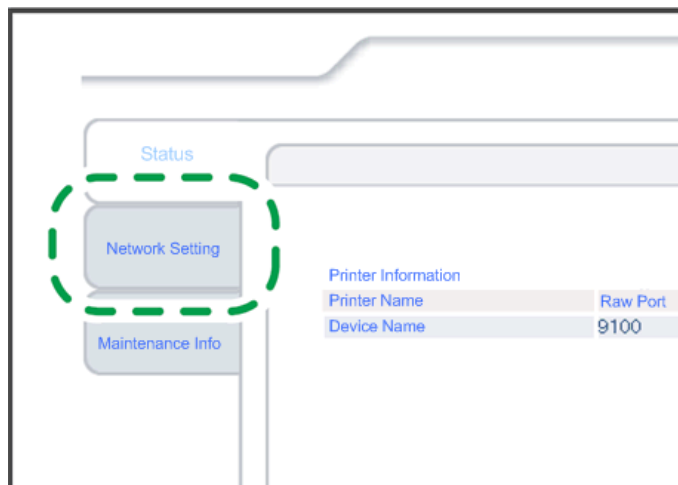

d197f0134

8. Type [root] in the user name textbox and click [OK].
9. Input [IP Address], [Subnet Mask] and [Default Gateway].

USB Device Server Option Type M12

Item	Value
IPv4	ENABLE ▾
DHCPv4	DISABLE ▾
IPv4 address	192.168.100.100
Subnet Mask	255.255.255.0
Default Gateway	0.0.0.0

d197f0135a

10. Set other items if needed.
11. Press [Set]
12. Close the web browser.
13. Disconnect the Ethernet cable from the PC.
14. Connect the Ethernet cable to a network device (e.g. switching hub).
15. Set the IP address of this option in the printer driver which you use.

2.36 COPY DATA SECURITY UNIT TYPE G

2.36.1 COMPONENT CHECK

No.	Description	Q'ty	For this model
1	ICIB-3	1	Yes
2	Bracket	1	Yes
3	Screws: M3x6	4	Yes
4	Small bracket	1	Not used
5	Screws: M3x4	2	Yes
6	Spacer:SQ-7	1	Not used
7	Screws: M3x8	2	Yes

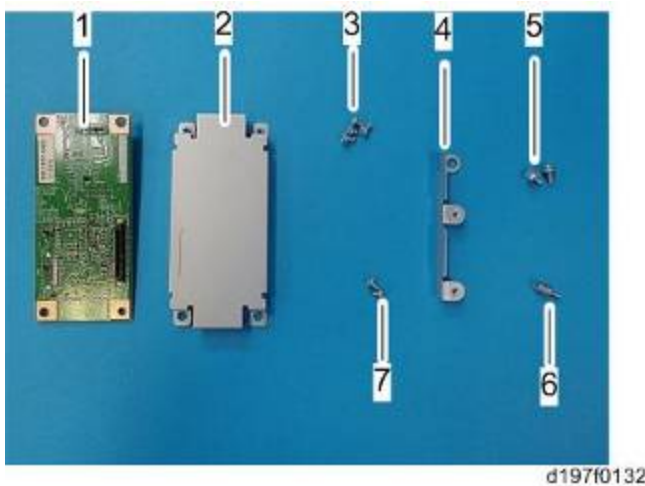

2.36.2 INSTALLATION

⚠ CAUTION

- Turn off the main power and disconnect the power supply cord.

1. Attach the bracket [A] to the ICIB-3 [B] (🔩 x2; M3 x 4).

Copy Data Security Unit Type G



1. Remove the controller cover [A] (⚙️ x4).

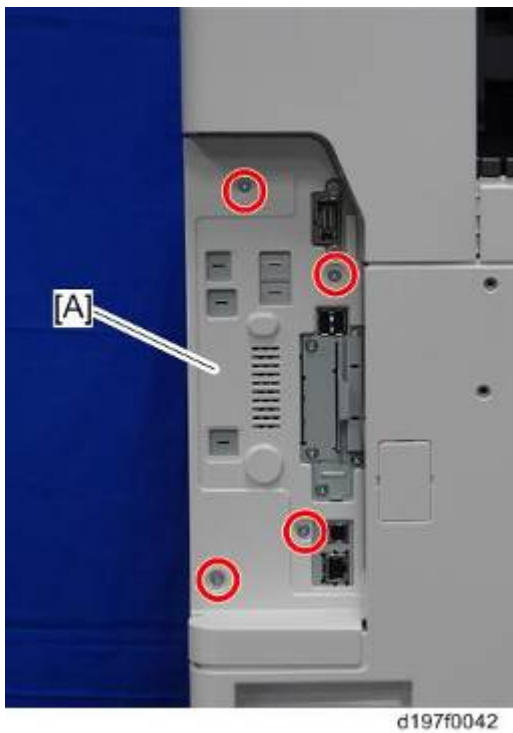

2. Remove the controller rear cover [A] (⚙️ x4).

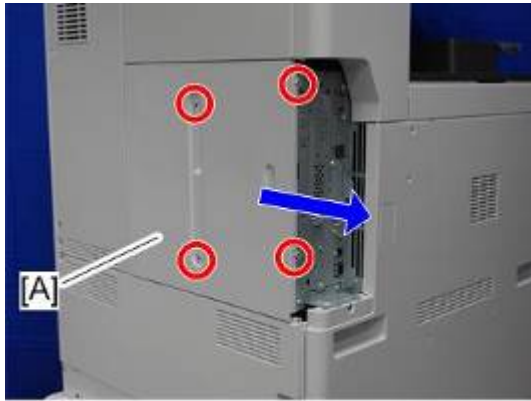

d197f0048

3. Attach the ICIB-3 bracket [A] to the IPU (⚙️ x2; M3 x 6).



d197z1804

4. Reassemble the machine.

User Tool Setting

1. Plug in the machine and turn on the main power switch.
2. Go into the User Tools mode, and select System Settings > Administrator Tools > Copy Data Security Option > "On".
3. Exit User Tools.
4. Check the operation.

⚠️ Note

- The machine will issue an SC165 error if the machine is powered on with the ICIB-3 removed and the "Data Security for Copying" feature set to "ON".
- The machine will issue an uncertain SC165 error if ICIB-3 is defective when the machine is powered on and the "Data Security for Copying" feature is set to "OFF".
- When you remove this option from the machine, first set this feature to "OFF" with the user tool before removing this board. If you forget to do this, "Data Security for Copying" feature cannot appear in the user tool setting. Also, SC165 will appear every time the machine is switched on, and the machine cannot be used.

5. Make sure that the machine can recognize the option.

2.37 HARD DISK DRIVE OPTION TYPE M12

2.37.1 ACCESSORY CHECK

No.	Description	Q'ty
1	HDD Unit	1
2	Cable	1
3	Cable	1
-	Screw	3
-	Sheet: Application: Document Server: NA	1
-	Sheet: Application: Document Server: EU	1
-	Sheet: Application: Document Server: CHN	1
-	Sheet: Application: Document Server: TWN	1
-	EMC Address Sheet	1
-	ROHS Decal Sheet	1
-	ROHS Label	1



d197z1039

2.37.2 INSTALLATION

⚠ CAUTION

- Turn off the main power and disconnect the power supply cord.

1. Remove the controller cover (page 4-11).
2. Remove the controller rear cover (page 4-15).
3. Connect the cables [A] [B] to the HDD [C], and then attach the HDD [C] to the bracket [D] (🔩 x4).

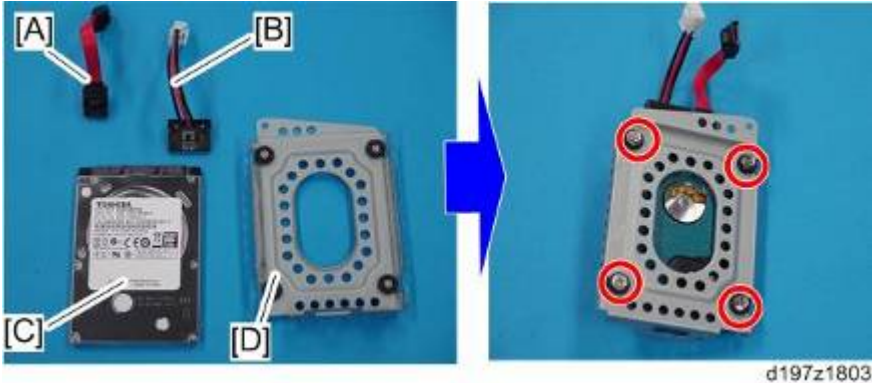

4. Connect the cables of the HDD to the controller board [A], and then hang the HDD [B] on the hook of the controller box (🔩 x2).
5. Secure the HDD [B] (🔩 x3).

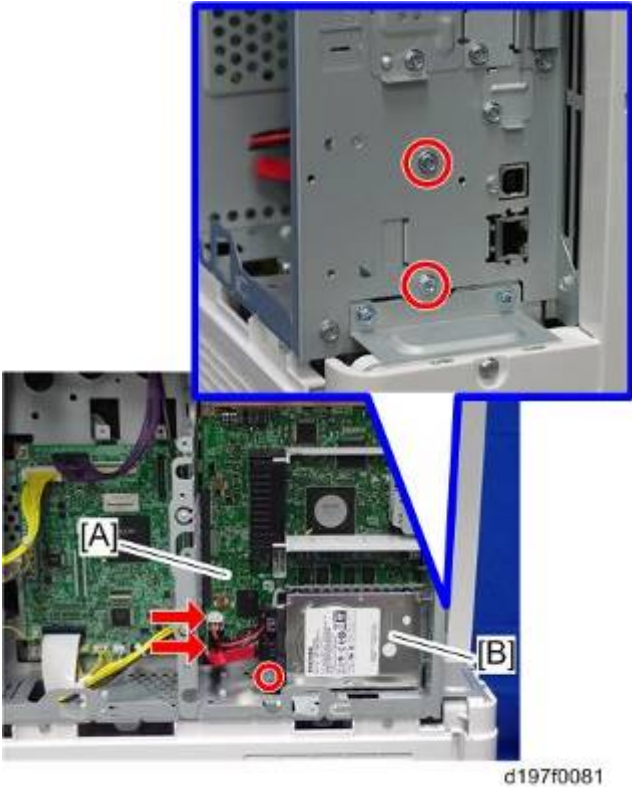

6. Reassemble the removed covers.
7. Plug the power cord and turn on the main power of the machine.

8. Do SP5-832-001 to format the hard disk.
9. Do SP5-853-001 to copy the preset stamp data from the firmware to the hard disk.
10. Do SP5-846-040 to copy the address book to the hard disk from the controller board.
11. Do SP5-846-041 to let the user get access to the address book.
12. Turn the main power off and on.

2.38 SD CARD OPTION

2.38.1 SD CARD SLOTS



[A]: SD card slot 1 (option slot)

[B]: SD card slot 2 (service slot)

2.38.2 LIST OF SLOTS USED

Optional SD cards can be set in either slot 1 or slot 2. However, slot 2 is the service slot, so we recommend that you use slot 1 to install the SD card options.

Note

- In this machine, it is possible to transfer data from a "Postscript3 Unit" SD card, unlike in earlier models, due to a change in the software licensing (the part of the Postscript software that requires licensing is now built into the controller, so the portion on the SD card can be moved to another SD card).

	Option Name	Slot	Remarks
1	Printer/Scanner Options	Slot 1 (Basic model only)	When merging, the card in slot 1 acts as the destination
2	OCR Unit Type M2	Slot 1 or Slot 2	-
3	Browser Unit Type M12		-
4	SD card for NetWare printing Type M12		-
5	PostScript3 Unit Type M12		-
6	XPS Direct Print Option Type M12		-
7	IPDS Unit Type M7		-
8	Fax Connection Unit Type M12		

2.39 SD CARD APPLI MOVE

2.39.1 OVERVIEW

The service program "SD Card Appli Move" (SP5-873) lets you move application programs from one SD card to another SD card.

If more than one application is required, the applications must be moved to one SD card with SP5873-1 (PostScript 3, IPDS unit, etc.).

Be very careful when you do the SD Card Appli Move procedure:

- The data necessary for authentication is transferred with the application program from an SD card to another SD card. Authentication fails if you try to use the SD card after you move the application program from one card to another card.
- Do not use the SD card if it has been used before for other purposes. Normal operation is not guaranteed when such an SD card is used.
- Store the vacant SD card in the storage space inside the main power switch cover as shown below.



This is done for the following reasons:

- The SD card can be the only proof that the user is licensed to use the application program.
- You may need to check the SD card and its data to solve a problem in the future.

2.39.2 MOVE EXEC

The menu "Move Exec" (SP5-873-001) lets you move application programs from the original SD card to another SD card.

★ Important

- Do not turn ON the write protect switch of the system SD card or application SD card on the machine. If the write protect switch is ON, a download error (e.g. Error Code 44) occurs during a firmware upgrade or application merge.
- If the printer/scanner unit or the printer unit has been installed, the destination card should be those SD cards.

1. Turn off the main power.
2. Make sure that a target SD card is in SD Card Slot 1. The application program is moved to this SD card.
3. Insert the source SD card with the application program in SD Card Slot 2. The application program is copied from this source SD card.
4. Turn on the main power.
5. Start the SP mode.
6. Select SP5-873-001 "Move Exec".
7. Follow the messages shown on the operation panel.
8. Turn off the main power.
9. Remove the source SD card from SD Card Slot 2.
10. Turn the main power on.
11. Check that the application programs run normally.

2.39.3 UNDO EXEC

"Undo Exec" (SP5-873-002) lets you move back application programs from an SD card in SD Card Slot 1 to the original SD card in SD Card Slot 2. You can use this program when, for example, you have mistakenly copied some programs by using Move Exec (SP5-873-001).

Important

- Do not turn ON the write protect switch of the system SD card or application SD card on the machine. If the write protect switch is ON, a download error (e.g. Error Code 44) occurs during a firmware upgrade or application merge.

1. Turn off the main power.
2. Insert the original SD card in SD Card Slot 2. The application program is copied back into this card.
3. Insert the SD card with the application program in SD Card Slot 1. The application program is copied back from this SD card.
4. Turn on the main power.
5. Start the SP mode.
6. Select SP5-873-002 "Undo Exec."
7. Follow the messages shown on the operation panel.
8. Turn off the main power.
9. Remove the SD card from SD Card Slot 2.
10. Turn on the main power.
11. Check that the application programs run normally.

2.40 OCR UNIT TYPE M2

This option adds a searchable PDF function to the scanning function.

2.40.1 ACCESSORY CHECK

No.	Description	Q'ty
1	SD Card	1

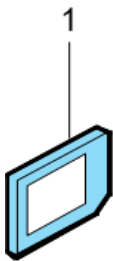

d595i900b

2.40.2 INSTALLATION PROCEDURE

1. Turn OFF the main power.
2. Remove the SD card slot cover (🔩 x1)

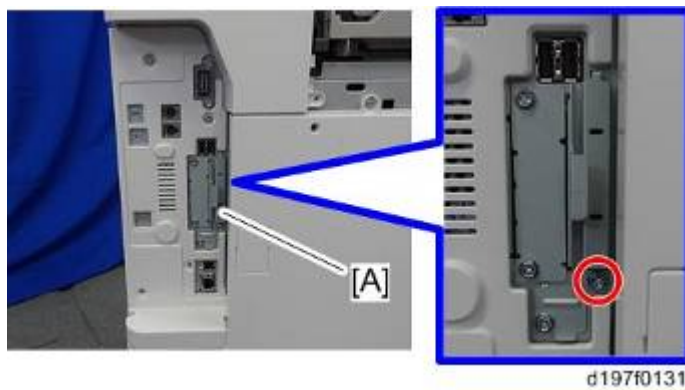

3. Insert the OCR module SD card in SD card slot 1 [A] or slot 2 [B].

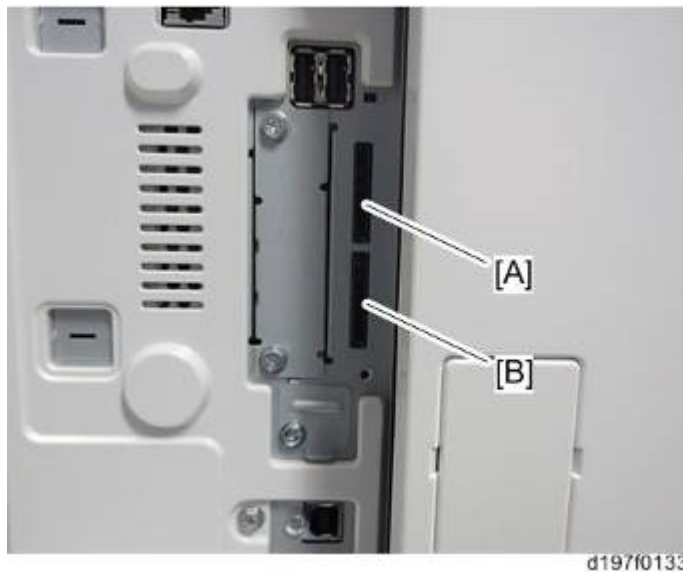

4. Turn on the main power.
5. Press “Enter” in SP5-878-004 (Option Setup: OCR Dictionary).
The SD card ID is saved in the NVRAM, and the ID of the MFP is saved on the SD card. The MFP and SD card are thereby linked.
6. When “operation complete” is displayed, press “Close”.
 - Ⓣ Note
 - If installation fails, “Failed” is displayed.
 - If installation fails, perform the following steps.
 1. Check whether it is a used SD card.
 2. Turn the main power OFF, and repeat steps 1-5.
7. Turn the main power OFF/ON.
8. Press “Enter” in SP5-878-004 (Option Setup: OCR Dictionary).
Dictionary data is copied to the HDD.
 - Ⓣ Note
 - On the first run, SP5-878-004 links the SD card, and on the second run, copies dictionary data.
9. Turn the main power OFF, and remove the SD card from the SD card slot.

Note

- Keep the SD card in the SD card storage location of the MFP. The original SD card is needed in the event of a HDD malfunction.

- Return the SD card slot cover to the original position.
- Turn the main power ON.
- Press [Send File Type / Name] on the [Scanner] screen.

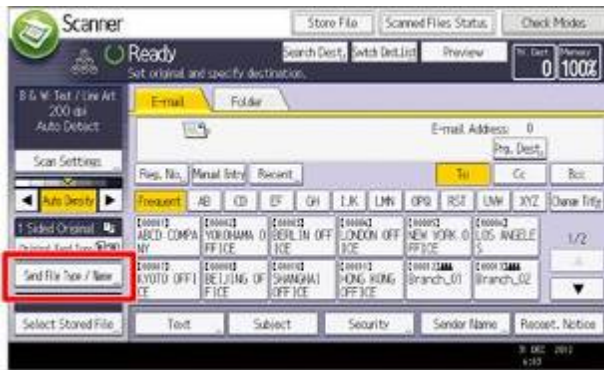

w_d1351739

- Check if [OCR Settings] is displayed on the [Send File Type / Name] screen.



w_d1351740

Note

- After installation, the OCR setting can be changed on the "OCR setting" screen.
- When setting OCR, set [OCR setting] to [Yes]. (Default setting: [No])

2.40.3 RECOVERY PROCEDURE

When this option is installed, a function is saved on the HDD, and ID information on the SD card is saved in the NVRAM. Therefore, when replacing the HDD and/or NVRAM, this option must be reinstalled.

When storing the original SD card

- When only the HDD is replaced
Reinstall using the original SD card.
- When only the NVRAM is replaced
When performing upload/download of NVRAM data, reinstall using the original SD card.
When not performing upload/download of NVRAM data, order and reinstall a new SD card (service part).
- When the HDD and NVRAM are replaced simultaneously
Reinstall using the original SD card.

If the original SD card is lost

Order and reinstall a new SD card (service part).

Note

- Perform reinstallation in the same way as installation.

2.41 BROWSER UNIT TYPE M12

2.41.1 COMPONENT CHECK

No.	Description	Q'ty
1	SD Card	1

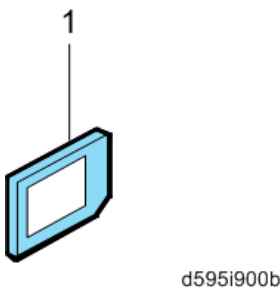

2.41.2 INSTALLATION PROCEDURE

The browser unit uses a native application such as a full browser in order to improve web browsing.

Also, to provide a solution utilizing the web as in previous machines, Extended JavaScript is also provided as an SDK application.

Due to the above, the browser unit for this model has two firmware modules, native application firmware, and Type-C application EXJS firmware.

The browser for these models is not installed in the HDD, therefore it must be operated with the SD card inserted in order to start up using the data on the SD card.

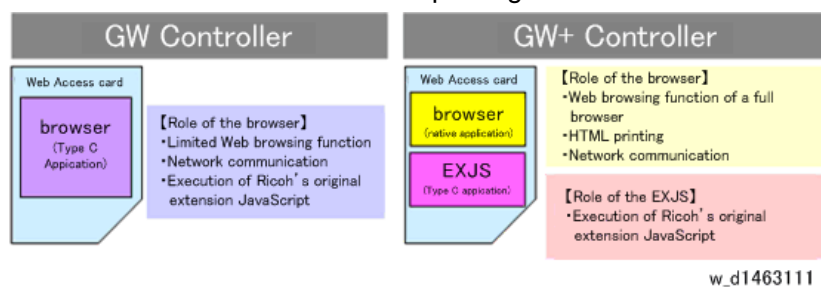

Note

- In addition to link-up with the conventional Scan Router and MFP, the browser unit has the following functions.
- For scanning, arbitrary distribution types and preset values are selected/set and delivered.
- Mail is delivered (login transmission) to an address previously set in the profile of the user who logged in.

1. Turn the main power OFF.
2. Remove the SD card slot cover (🔩 x1).

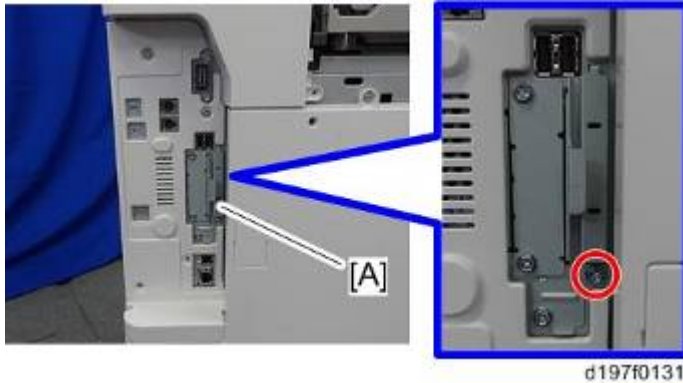

3. Insert the browser unit SD card in SD card slot 1 [A] or slot 2 [B].

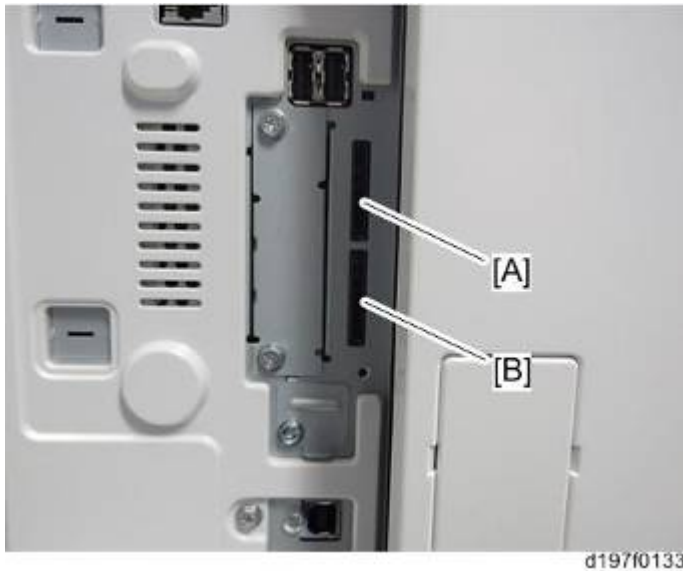

4. Turn the main power ON.
5. Press the [Default setting/Counter] key.
6. Press the [Extension function default setting] button.
7. Press the [Extension function default setting] button on the [Extension function default menu setting] screen.
8. On the [Startup setting] tab, check that "Extended JS" was installed automatically and has started.
9. Turn the main power OFF/ON.
10. Perform the merge operation if necessary (page 2-247).
 1. Turn the main power OFF after completing the merge operation.
 2. Remove the empty SD card from SD card slot 2.
11. Reattach the cover and turn on the main power.
12. Press the [Default setting/Counter] key.
13. Press the [Home editing] button.
14. Press the [Add icon] button.

15. Press the [Browser] button displayed on the "Application" tab.
16. Select the position at which [Blank] is displayed, and press the [OK] button.
17. Check that the [Browser] icon has been added to the Home screen.

To update EXJS

1. Put the SD card containing the firmware of the browser application to update with in SD card slot 2 [B], and then turn on the main power.

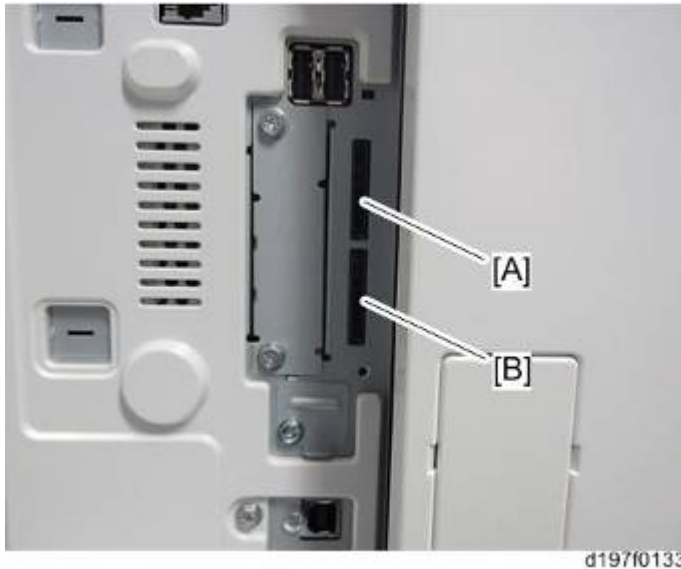

2. Wait until the update screen starts.
3. When the update screen is displayed, select [Browser], and press the [Update (#)] button.
4. When "Update done." is displayed, turn the main power OFF, and remove the SD card from SD card slot 2.

When updating Extension JavaScript, add the following steps.

5. Turn the main power ON.
6. Press the [Default setting/counter] key.
7. Press the [Extension function default setting] button.
8. Press the [Extension function default setting] button on the [Extension function default menu setting] screen.
9. Stop "Extended JS" on the "Startup setting" condition with a tab.
10. Turn the main power OFF.
11. Insert the Extended JavaScript upgrade SD card in SD card slot 2.
12. Turn the main power ON.
13. Press the [Default setting/counter] key.
14. Press the [Extension function default setting] button.
15. Press the [Extension function default setting] button on the [Extension function default menu setting] screen.
16. Press the [Install] tab.

17. Press [SD card], and select "Extended JS" from the list of extension functions.
18. Select [MFP hard disk] as the installation location, and press [Next].
19. After checking extension function information on the "Installation preparation complete" screen, press the [Enter] button.
20. "The following extension functions are already installed. The message "Overwrite extension function?" is displayed. Press the [Continue] button.
21. When installation is complete, the message "Extension function has been installed" is displayed. Press the [OK] button.
22. On the "Startup settings" tab, set [Extended JS] to the startup standby state, and turn the main power OFF.
23. Remove the SD card from SD card slot 2, and return the SD slot cover.
24. Turn the main power ON.
25. Press the [Default setting/counter] key.
26. Press the [Extension function default setting] button.
27. Press the [Extension function default setting] button on the [Extension function default menu setting] screen.
28. Check the version of [Extended JS] on the "Startup settings tab" is the latest version.

 Note

- If the power is ON before starting Step 1, turn the main power OFF after first performing Steps 5-9, and perform Step 1 and subsequent steps. In that case, skip Steps 5-10. (This saves time.)
- If you do not plan to update Extension JavaScript, return the SD slot cover to the original position after performing Step 5.

When checking the version of EXJS

1. Turn the main power ON.
2. Press the [Default setting/counter] key.
3. Press the [Extension function default setting] button.
4. Press the [Extension function default setting] button on the [Extension function default menu setting] screen.
5. Check the version of [Extended JS] on the "Startup settings tab" is the latest version.

 Note

- If checked apart from the above procedure (firmware version displayed in system default settings), a different version from the actual version may be displayed.

Browser unit uninstallation procedure

EXJS uninstallation procedure

1. Turn the main power ON.
2. Press the [Default settings/counter] key.
3. Press the [Login/Logout] key, and log in with an administrator account (login user name, login password).
4. Press [Extension function default setting], and when the screen changes, press [Extension function default setting] again.
5. Press the [Uninstall] tab.
6. When “Browser” is pressed, a message screen is displayed, press [Continue].
7. When a message reconfirming uninstallation is displayed, press [Continue].
8. When the message "Extended functions have been uninstalled", press [Confirm] and the display returns to the setting screen.
9. Close [Default settings/counter] settings, and turn OFF the main power.

Note

- Uninstall is not completed before removing the SD card. This is because the SD card has the browser application data.

2.41.3 SETTINGS

Browser default setting

Register the browser default settings. For details, refer to the following.

1. Turn ON the main power.
2. Press the [Default settings/counter] key.
3. Press the [Browser default settings] button.
4. Press the [Home screen] button on the “Browser Settings” tab.
5. Press the [URL input] button.
6. Input the URL, and press the [OK] button.
7. Press the [Settings] button.
8. Press the [End] button twice, and finish.

2.42 SD CARD FOR NETWARE PRINTING TYPE M12

2.42.1 COMPONENT CHECK

No.	Description	Q'ty
1	SD Card	1
-	EMC Address Sheet	1
-	ROHS Decal Sheet	1
-	ROHS Label	1

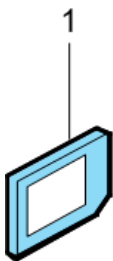

d595i900b

2.42.2 INSTALLATION PROCEDURE

1. Turn OFF the main power.
2. Remove the SD card slot cover (🔩 x1)

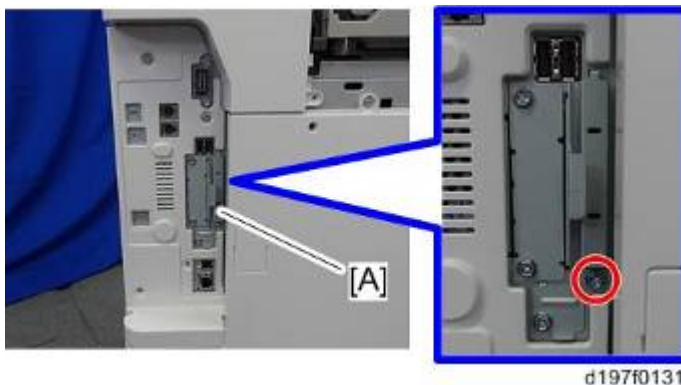

3. Insert the Netware printing SD card in SD card slot 1 [A] or slot 2 [B].

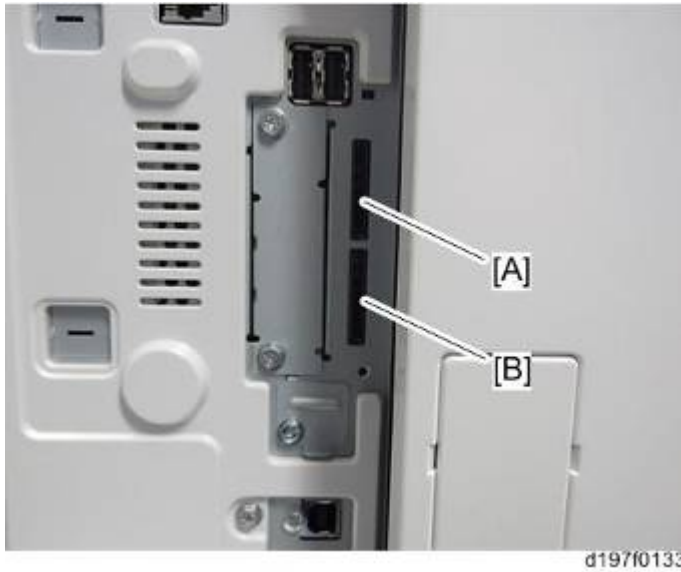

4. Perform the merge operation if necessary (page 2-247).
5. Attach the SD card slot cover (🔑 x1).
6. Turn ON the main power.
7. Print out the “Configuration Page”, and then check if this option is correctly recognized.
 - User Tools/Counter > Printer Features > List/Test Page > Configuration Page

2.43 POSTSCRIPT3 UNIT TYPE M12

2.43.1 COMPONENT CHECK

No.	Description	Q'ty
1	SD Card	1
-	PS3 Decal	1



d595i900b

2.43.2 INSTALLATION PROCEDURE

1. Turn the main power OFF.
2. Remove the SD card slot cover [A] (🔩 x1)

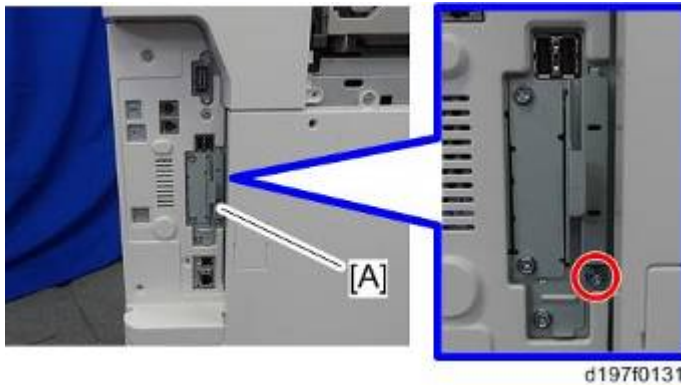

3. Insert the PS3 SD card in SD card slot 1 [A] or 2 [B].

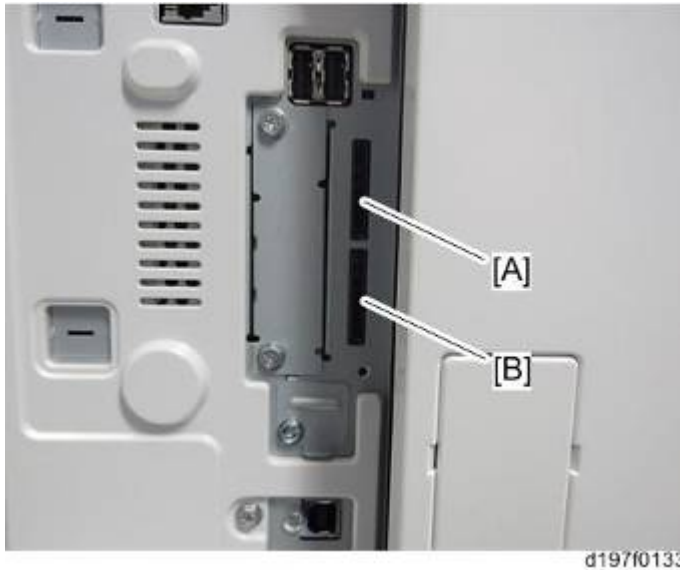

4. If necessary, perform the merge operation. (page 2-247)
5. Reattach the SD card slot cover (🔩 x1).
6. Stick the "Adobe PostScript3" decal on the front face of the MFP.
7. Turn ON the main power.
8. Print out the "Configuration Page", and then check if this option is correctly recognized.
 - User Tools/Counter > Printer Features > List/Test Page > Configuration Page

Note

- The PDF firmware installed as standard contains a program required to print PS3 data as default. However, this PS3 program is normally disabled.
- The PS3 firmware is a dongle (key) which enables PS3 data printing functions. When the PS3 firmware is installed, the PS3 program in the PDF firmware is enabled. Due to this specification, the self-diagnosis result report shows the ROM part number/software version of the PDF firmware contained in the PS3 program.

2.44 XPS DIRECT PRINT OPTION TYPE M12

2.44.1 COMPONENT CHECK

Check the quantity and condition of the accessories in the box against the following list and diagram.

No.	Description	Qty
1	XPS Direct Print SD Card	1

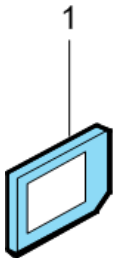

d595i900b

2.44.2 INSTALLATION PROCEDURE

1. Turn off the main power.
2. Remove the SD card slot cover [A] (🔩 x 1).

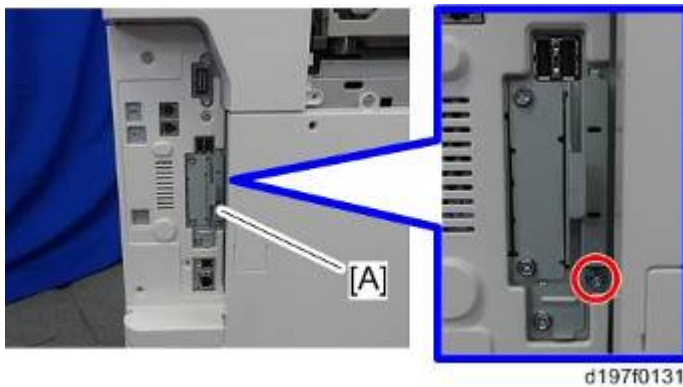

d197f0131

3. Slowly, insert the XPS SD card in Slot 1 with its label face towards the front of the machine.

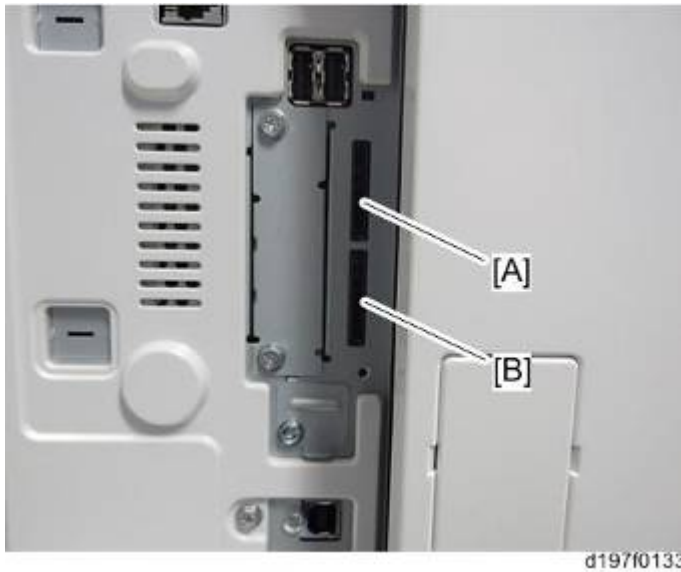

4. Perform the merge operation if necessary (page 2-247).
5. Attach the SD card slot cover (🔩 x 1).
6. Turn on the machine.
7. Print out the “Configuration Page”, and then check if this option is correctly recognized.
 - User Tools/Counter > Printer Features > List/Test Page > Configuration Page

2.45 IPDS UNIT TYPE M12

2.45.1 ACCESSORIES

Check the accessories and their quantities against the table below.

No.	Description	Q'ty
1	IPDS Emulation SD Card	1
-	Decal	1
-	EULA Sheet	1
-	Caution Sheet	1
-	CD-ROM	1

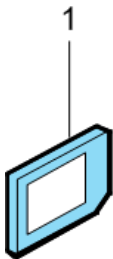

d595i900b

2.45.2 INSTALLATION

1. Turn the main power OFF.
2. Remove the SD card slot cover [A] (🔩 x1)

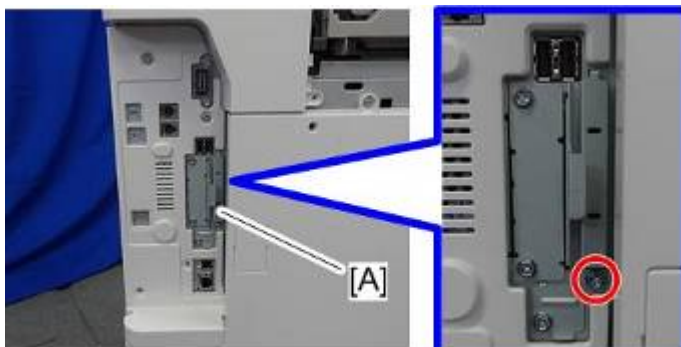

d197f0131

3. Insert the IPDS SD card in SD card slot 1 [A] or 2 [B].

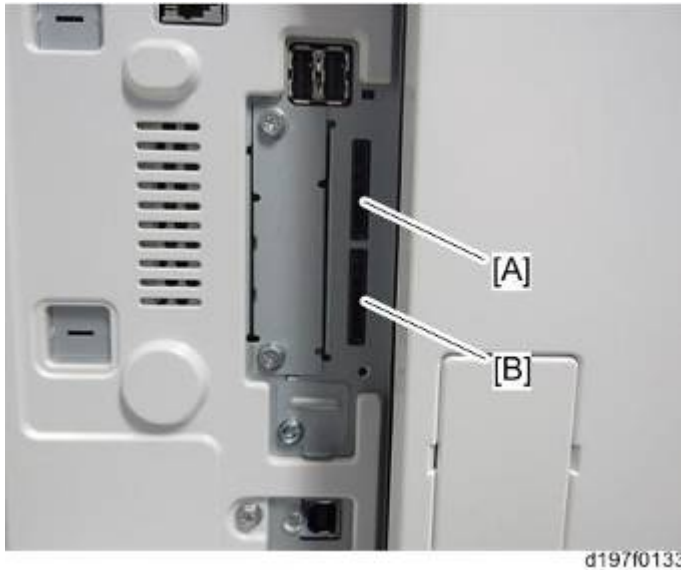

4. Turn the main power ON.
5. Perform the merge operation if necessary (page 2-247).
 1. Switch the power OFF after completing the merge operation.
 2. Remove the empty SD card from SD card slot 2.
6. Reattach the cover.
7. Do one of the following ("A" or "B") to enable the IPDS function.
 - A. [Enable the IPDS function via telnet]
 1. Connect the machine via telnet.
 2. Execute the following commands:
 msh> **set ipds up**
 ***If you want to stop the function.
 msh> **set ipds down**
 - B. [Enable the IPDS option via WebImageMonitor]
 1. Log in to WebImageMonitor.
 2. Change the setting to enable IPDS.

8. Attach the decal [A] as shown below.

- Line up the left side of the decal with the left edge of the main power switch. ([B]: 10 mm or more)

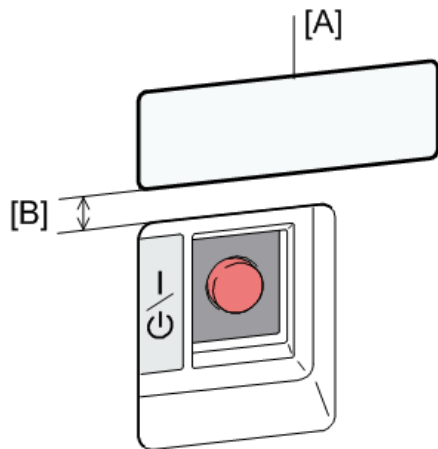

d1829012

9. Print out the “Configuration Page”, and then check if this option is correctly recognized.

- User Tools/Counter > Printer Features > List/Test Page > Configuration Page

2.46 EXTERNAL KEYBOARD BRACKET TYPE M3 (D739-10)

2.46.1 COMPONENT CHECK

Description	Q'ty
Keyboard Stand Bracket	1
Keyboard Stand	1
Screw: M4 x 12	2
Screw: M3 x 8	4
Screw: M3 x 12	1
ROHS Decal Sheet	1
ROHS Label	1

2.46.2 INSTALLATION PROCEDURE

1. Open the right cover.
2. Remove the main power switch cover [A] (🔩x1, hooks).

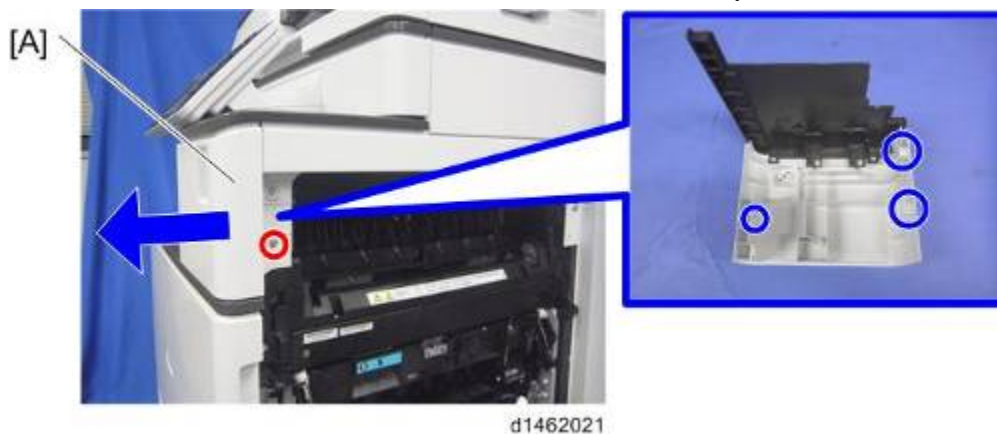

3. Remove the screw [A] on the frame of the machine.



d739z0601

4. Make 3 screw holes [A] in the main power switch cover, and then reattach it to the machine (🔩 x1, hooks).



d739z0602

5. Attach the keyboard stand bracket [A] on the main power switch cover (🔩 x3).

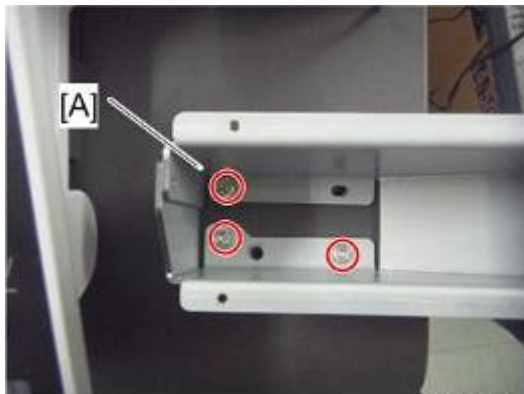

d739z0603

6. Attach the keyboard stand [A] on the keyboard stand bracket (🔩 x4).

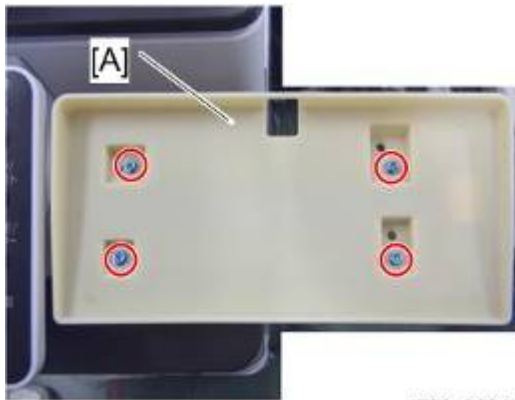

d739z0604

7. Place a keyboard [A] on the keyboard stand, and then pass the keyboard cable through the hole [B] in the keyboard stand.
 8. Scanner rear cover [A] (🔩 x3)

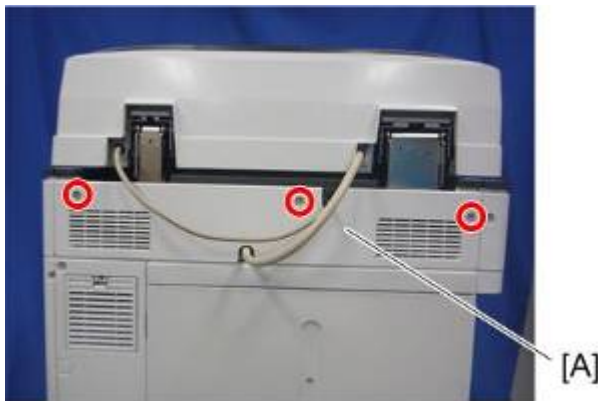

d1462016

9. Scanner right cover [A] (🔩 x1)



d1462300

10. Route the keyboard cable along the right side of the scanner unit as shown below.

External Keyboard Bracket Type M3 (D739-10)



11. Route the keyboard cable along the rear side of the scanner unit (x1).
12. Adjust the keyboard cable by making loops if the keyboard cable has too much slack.



13. Remove the cutout [A] in the left rear cover to make a cable hole, and then pass the keyboard cable [B] through it.

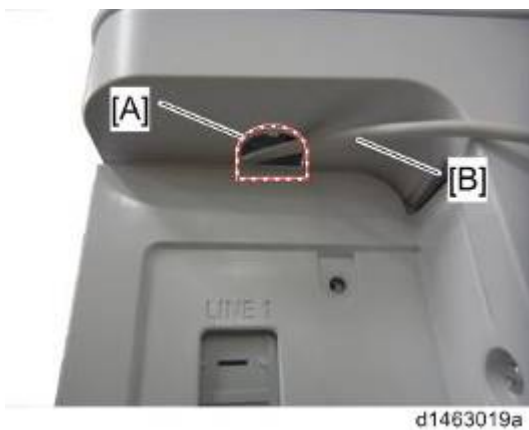

14. Connect the keyboard cable to the USB slot.



d1463020

15. Reattach the scanner right cover [A] (🔩 x1).
16. Reattach the scanner rear cover [A] (🔩 x3).
17. Close the right cover.

2.47 DATA OVERWRITE SECURITY UNIT TYPE I (D362)

2.47.1 OVERVIEW

This option should be installed only for the customer who requires the **CC certified Data Overwrite Security function**.

The function of this option is completely the same as the Data Overwrite Security in Security Functions, which is standard on this machine.

2.47.2 COMPONENT LIST

Check the quantity and condition of the accessories in the box against the following list.

No.	Description	Q'ty
1.	SD Card	1

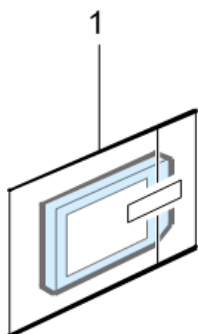

d1351921

2.47.3 BEFORE YOU BEGIN THE PROCEDURE

1. Confirm that the Data Overwrite Security unit SD card is the correct type for the machine. The correct type for this machine is **"Type I"**.

★ Important

- If you install any version other than **"Type I"**, you have to replace the NVRAM and do this installation procedure again.
2. Make sure that the following settings are not at their factory default values:
 - Supervisor login password
 - Administrator login name
 - Administrator login password

If any of these settings is at a factory default value, tell the customer these settings must be changed before you do the installation procedure.

3. Make sure that “Admin. Authentication” is ON.
[System Settings] – [Administrator Tools] – [Administrator Authentication Management] - [Admin. Authentication]
If this setting is OFF, tell the customer this setting must be ON before you do the installation procedure.
4. Make sure that “Administrator Tools” is enabled (selected).
[System Settings] – [Administrator Tools] – [Administrator Authentication Management] - [Available Settings]
If this setting is disabled (not selected), tell the customer this setting must be enabled (selected) before you do the installation procedure.

Seal Check and Removal

⚠ CAUTION

- You must check the box seals to make sure that they are not removed after the items have been sealed in the box at the factory before you do the installation.
1. **Check the box seals [A] on each corner of the box.**
 - Make sure that a tape is attached to each corner.
 - The surfaces of the tapes must be blank. If you see “VOID” on the tapes, do not install the components in the box.
 2. **If the surfaces of the tapes do not show “VOID”, remove them from the corners of the box.**
 3. **You can see the “VOID” marks [B] when you remove each seal. In this condition, they cannot be attached to the box again.**

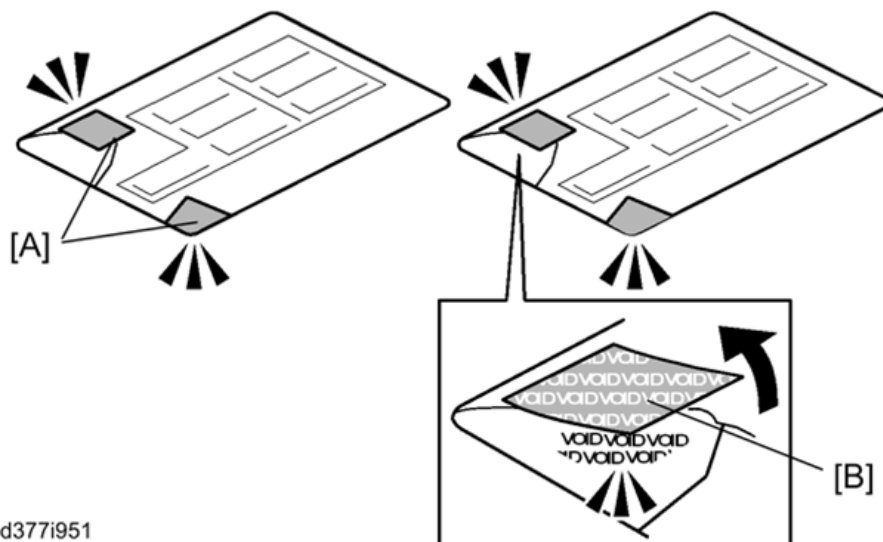

d377i951

2.47.4 INSTALLATION PROCEDURE

1. Turn the main power OFF.
2. Remove the SD card slot cover (🔩 x1)

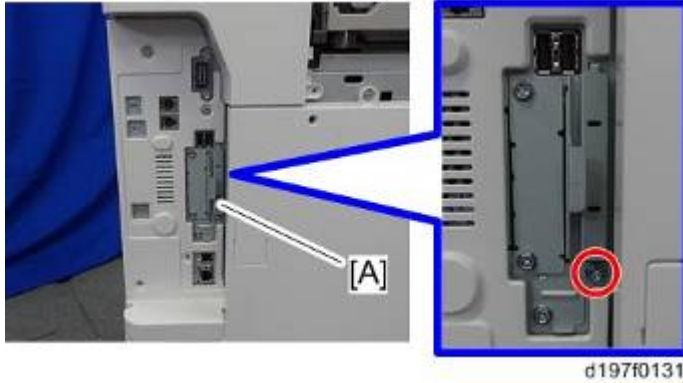

3. Insert the SD card (DataOverwriteSecurity Unit) in SD slot 1 (upper) [A] with its label face towards the front of the machine. Then push it slowly into SD slot 1 (upper) until you hear a click.

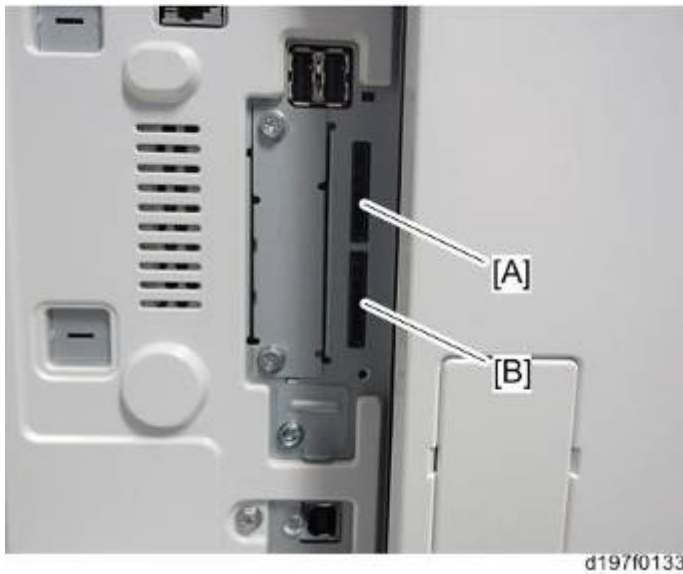

4. Install the application using SP5-878-001.

2.48 SECURITY SETTING

2.48.1 SECURITY FUNCTION INSTALLATION

The machine contains the Security functions (Data Overwrite Security and HDD Encryption unit) in the controller board.

If you are installing a new machine, it is recommended to activate the Data Overwrite Security and HDD Encryption by selecting "Format All Data" from "System Settings" on the operation panel.

Note

- This method is recommended because there is no user data on the hard drive yet (Address Book data, image data, etc.).

If the customer wishes to activate the Data Overwrite Security and HDD Encryption unit on a machine that is already running, it is recommended to activate the unit by selecting "All Data" from "System Settings" on the operation panel.

Important

- **Selecting "All Data" will preserve the data that has already been saved to the HDD. (If "Format All Data" is selected, all user data saved to the HDD up to that point will be erased).**

Immediately after encryption is enabled, the encryption setting process will take several minutes to complete before you can begin using the machine.

Note

- If encryption is enabled after data has been stored on the HDD, or if the encryption key is changed, this process can take up to three and a half hours or more.

The machine cannot be operated while data is being encrypted.

Once the encryption process begins, it cannot be stopped.

Make sure that the machine's main power is not turned off while the encryption process is in progress.

If the machine's main power is turned off while the encryption process is in progress, the HDD will be damaged and all data on it will be unusable.

Print the encryption key and keep the encryption key (which is printed as a paper sheet).

Keep the encryption key in a safe place. If the encryption key is lost and is needed, the controller board, HDD and NVRAM must all be replaced at the same time.

Note

- "NVRAM" mentioned in here means the NVRAM on the Controller Board.
- "NVRAM" or EEPROM on the BCU has nothing to do with this.

Please use the following procedure when the Data Overwrite Security and HDD Encryption are reinstalled.

2.48.2 DATA OVERWRITE SECURITY

Before You Begin the Procedure

1. **Make sure that the following settings (1) to (3) are not at their factory default values.**

- (1) Supervisor login password
- (2) Administrator login name
- (3) Administrator login password

If any of these settings is at a factory default value, tell the customer these settings must be changed before you do the installation procedure.

2. **Make sure that “Admin. Authentication” is on.**

[System Settings] -> [Administrator Tools] -> [Administrator Authentication Management] -> [Admin. Authentication]

If this setting is off, tell the customer this setting must be on before you do the installation procedure.

3. **Make sure that “Administrator Tools” is enabled (selected).**

[System Settings] -> [Administrator Tools] -> [Administrator Authentication Management] -> [Available Settings]

If this setting is disabled (not selected), tell the customer this setting must be enabled (selected) before you do the installation procedure.

Using Auto Erase Memory

The Auto Erase Memory function can be enabled by the following procedure.

1. **Log in as the machine administrator from the control panel.**
2. **Press [System Settings].**
3. **Press [Administrator Tools].**
4. **Press [Next] three times.**
5. **Press [Auto Erase Memory Setting].**

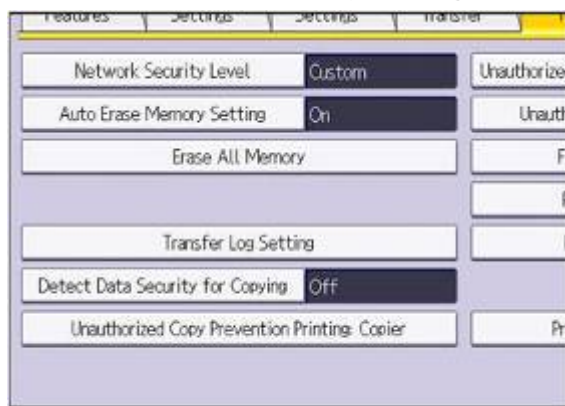

6. **Press [On].**



7. **Select the method of overwriting.**
 If you select [NSA] or [DoD], proceed to step 10.
 If you select [Random Numbers], proceed to step 8.
8. **Press [Change].**
9. **Enter the number of times that you want to overwrite using the number keys, and then press [#].**
10. **Press [OK]. Auto Erase Memory is set.**
11. **Log out.**
12. **Check the display and make sure that the overwrite erase icon appears.**
13. **Check the overwrite erase icon.**

The icon [1] is lit when there is temporary data to be overwritten, and blinks during overwriting.

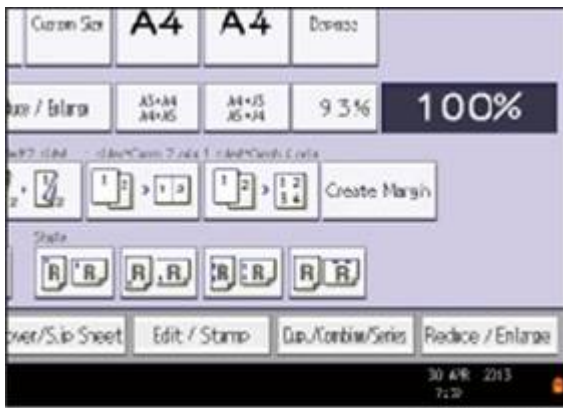
The icon [2] is lit when there is no temporary data to be overwritten.



w_d1822516

	<p>Icon [1]</p>	<p>This icon is lit when there is temporary data to be overwritten, and blinks during overwriting.</p>
	<p>Icon [2]</p>	<p>This icon is lit when there is no temporary data to be overwritten.</p>

2.48.3 HDD ENCRYPTION

Before You Begin the Procedure:

1. **Make sure that the following settings (1) to (3) are not at the factory default settings.**

- (1) Supervisor login password
- (2) Administrator login name
- (3) Administrator login password

If any of these settings is at a factory default value, tell the customer these settings must be changed before you do the installation procedure.

2. **Confirm that "Admin. Authentication" is on: [User tools/Counter] key - [System Settings] - [Administrator Tools] - [Administrator Authentication Management] - [Admin. Authentication] - [On]**

If this setting is off, tell the customer that this setting must be on before you can do the installation procedure.

3. **Confirm that "Administrator Tools" is selected and enabled.**

[User tools/Counter] key - [System Settings] - [Administrator Tools] - [Administrator Authentication Management] - [Available Settings]

"Available Settings" is not displayed until step 2 is done.

If this setting is not selected, tell the customer that this setting must be selected before you can do the installation procedure.

Enable Encryption Setting

Machine Data Encryption Settings can be enabled by the following procedure.

★ Important

- **When setting up encryption, specify whether to start encryption after deleting data (initialize) or encrypt and retain existing data. If data is retained, it may take some time to encrypt it.**

1. **Turn on the main power.**
2. **Log in as the machine administrator from the control panel.**
3. **Press [System Settings].**
4. **Press [Administrator Tools].**
5. **Press [Next] three times.**
6. **Press [Machine Data Encryption Settings].**



w_d1822518

7. Press [Encrypt].

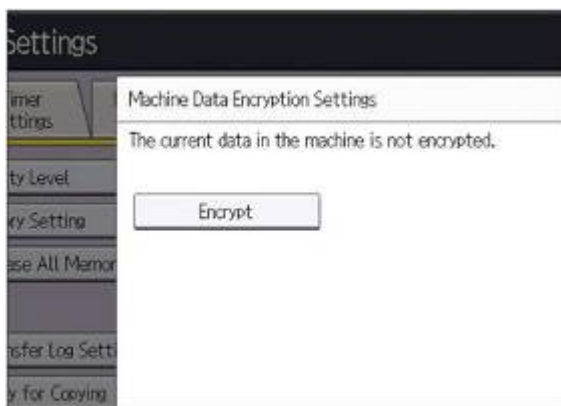

w_d1822519

8. Select the data to be carried over to the HDD and not be reset.

To carry all of the data over to the HDD, select [All Data].

To carry over only the machine settings data, select [File System Data Only].

To reset all of the data, select [Format All Data].

9. Select the backup method.

If you have selected [Save to SD Card], load an SD card into the media slot on the side of the control panel and press [OK] to back up the machine's data encryption key.

If you have selected [Print on Paper], press the [Start] key. Print out the machine's data encryption key.

10. Press [OK].

11. Press [Exit].

12. Press [Exit].

13. Log out.

14. Turn off the main power, and then turn the main power back on.

The machine will start to convert the data on the memory after you turn on the machine. Wait until the message "Memory conversion complete. Turn the main power switch off." appears, and then turn the main power off again.

Check the Encryption Settings

1. Press the [User tools/Counter] key.
2. Press [System Settings].
3. Press [Administrator Tools].
4. Press [Machine Data Encryption Settings].
5. Confirm whether the encryption has been completed or not on this display.

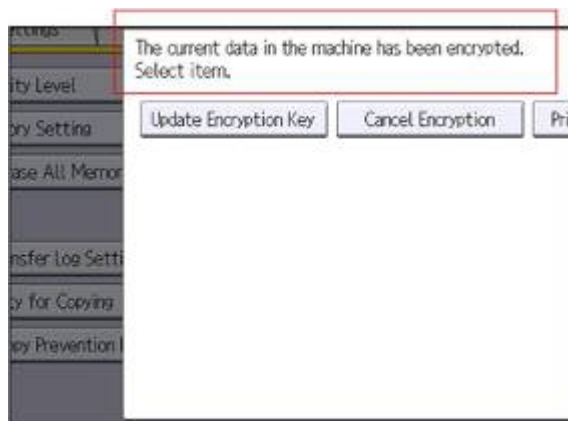

w_d1822520

Backing Up the Encryption Key

The encryption key can be backed up. Select whether to save it to an SD card or to print it.

★ Important

- The encryption key is required for data recovery if the machine malfunctions. Be sure to store the encryption key safely for retrieving backup data.

1. Log in as the machine administrator from the control panel.
2. Press [System Settings].
3. Press [Administrator Tools].
4. Press [Next] three times.
5. Press [Machine Data Encryption Settings].
6. Press [Print Encryption Key].



w_d1822515

7. Select the backup method.

If you have selected [Save to SD Card], load an SD card into the media slot on the side of the control panel and press [OK]; once the machine's data encryption key is backed up, press [Exit].

If you have selected [Print on Paper], press the [Start] key. Print out the machine's data encryption key.

8. Press [Exit].**9. Log out.*****Encryption Key Restoration*****How to restore the old encryption key to the machine**

The following message appears after the controller board is replaced. In such a case, it is necessary to restore the encryption key to the new controller board.

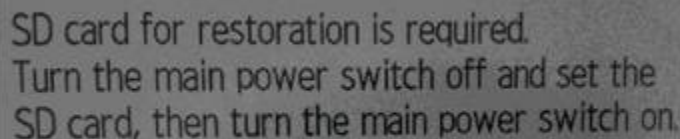

SD card for restoration is required.
Turn the main power switch off and set the
SD card, then turn the main power switch on.

d1420101

To do this, follow the procedure below.

1. **Prepare an SD card that has been initialized in FAT16 format.**
2. **Using a PC, create a folder in the SD card and name it "restore_key".**
3. **Create a folder in the "restore_key" folder and name it the same as machine's serial number, "xxxxxxxxxx" (11 digits).**
4. **Create a text file called "key_xxxxxxxxx.txt" and save it in the "xxxxxxxxxx" folder. Write the encryption key in the text file.**

/restore_key/xxxxxxxxxx/key_xxxxxxxxx.txt

Note

- Ask an Administrator to enter the encryption key. The key has already been printed out by the user and may have been saved in the "key_xxxxxxxxx.txt" file. (The function of back-up the encryption key to the SD card directly is provided 11A products or later.)
5. **Turn on the machine's main power.**
 6. **Confirm that a message is displayed on the LCD telling to insert the SD card that contains the encryption key.**
 7. **Turn off the main power.**
 8. **Insert the SD card that contains the encryption key into SD card slot 2 (the lower slot).**
 9. **Turn on the main power.**

Note

- The machine will automatically restore the encryption key to the flash memory on the controller board.

10. Turn off the main power when the machine has returned to normal status.

11. Remove the SD card from SD card slot 2.

How to do a forced start up with no encryption key

If the encryption key back-up has been lost, follow the procedure below to do a forced start-up.

Important

- The HDD will be formatted after the forced start-up.
- Encrypted data will be deleted.
- User settings will be cleared.

1. Prepare an SD card.

2. Create a directory named “restore_key” inside the root directory of the SD card. Then, save the “nvram_key.txt” file using the following name:

/restore_key/nvram_key.txt

3. Create a text file and write "nvclear".

Important

- Write this string at the head of the file.
- Use all lower-case letters.
- Do not use quotation marks or blank spaces.
- It is judged that a forced start has been selected when the content of "nvclear" is executed and the machine shifts to the alternate system (forced start).

4. Confirm that a message is displayed on the LCD telling to insert the SD card that contains the encryption key.

5. Turn off the main power.

6. Insert the SD card that contains the encryption key into SD card slot 2 (the lower slot).

7. Turn on the main power.

8. Turn on the main power switch, the machine automatically clear the HDD encryption.

9. Turn off the main power when the machine has returned to normal status.

10. Remove the SD card from SD card Slot 2.

11. Turn on the main power.

12. Memory clear SP5-801-xx (Exclude SP-5-801-001: All Clear and SP-5-801-002: Engine), and clear SP5-846-046: address book.

13. Set necessary user settings in User Tools key.

2.49 @REMOTE SETTINGS

Note

- Prepare and check the following check points before you visit the customer site. For details, ask the @Remote key person.

Check points before making @Remote settings

1. **The setting of SP5816-201 in the mainframe must be "0".**
2. **Print the SMC with SP5990-002 and then check if a device ID2 (SP5811-003) must be correctly programmed.**
 - 6 spaces must be put between the 3-digit prefix and the following 8-digit number (e.g. xxx_____xxxxxxxx).
 - ID2 (SP5811-003) and the serial number (SP5811-001) must be the same (e.g. ID2: A01_____23456789 = serial No. A0123456789)
3. **The following settings must be correctly programmed.**
 - Proxy server IP address (SP5816-063)
 - Proxy server Port number (SP5816-064)
 - Proxy User ID (SP5816-065)
 - Proxy Password (SP5816-066)

4. Get a Request Number

Execute the @Remote Settings

1. **Enter the SP mode.**
2. **Input the Request number which you have obtained from @Remote Center GUI, and then enter [OK] with SP5816-202.**
3. **Confirm the Request number, and then click [EXECUTE] with SP5816-203.**

4. Check the confirmation result with SP5816-204.

Value	Meaning	Solution/ Workaround
0	Succeeded	-
3	Communication error (proxy enabled)	Check the network condition.
4	Communication error (proxy disabled)	Check the network condition.
5	Proxy error (authentication error)	Check Proxy user name and password.
6	Communication error	Check the network condition.
8	Other error	See "SP5816-208 Error Codes" below this.
9	Request number confirmation executing	Processing... Please wait.
11	Already registered	-
12	Parameter error	-
20	Dial-up authentication error	* These errors occur only in the modems that support @Remote.
21	Answer tone detection error	
22	Carrier detection error	
23	Invalid setting value (modem)	
24	Low power supply current	
25	unplugged modem	
26	Busy line	

5. Make sure that the screen displays the Location Information with SP5816-205 only when it has been input at the Center GUI.

6. Click [EXECUTE] to execute the registration with SP5816-206.
7. Check the registration result with SP5816-207.

Value	Meaning	Solution/ Workaround
0	Succeeded	-
1	Request number error	Check the request number again.
2	Already registered	Check the registration status.
3	Communication error (proxy enabled)	Check the network condition.
4	Communication error (proxy disabled)	Check the network condition.
5	Proxy error (Authentication error)	Check Proxy user name and password.
8	Other error	See "SP5816-208 Error Codes" below this.
9	Request number confirmation executing	Processing... Please wait.
11	Already registered	-
12	Parameter error	-
20	Dial-up authentication error	* These errors occur only in the modems that support @Remote.
21	Answer tone detection error	
22	Carrier detection error	
23	Invalid setting value (modem)	
24	Low power supply current	
25	unplugged modem	
26	Busy line	

8. Exit the SP mode.

SP5816-208 Error Codes

Caused by Operation Error, Incorrect Setting

Code	Meaning	Solution/ Workaround
-12002	Inquiry, registration attempted without acquiring Request No.	Obtain a Request Number before attempting the Inquiry or Registration.
-12003	Attempted registration without execution of a confirmation and no previous registration.	Perform Confirmation before attempting the Registration.
-12004	Attempted setting with illegal entries for certification and ID2.	Check ID2 of the mainframe.
-12005	@Remote communication is prohibited. The device has an Embedded RC gate-related problem.	Make sure that "Remote Service" in User Tools is set to "Do not prohibit".
-12006	A confirmation request was made after the confirmation had been already completed.	Execute registration.
-12007	The request number used at registration was different from the one used at confirmation.	Check Request No.
-12008	Update certification failed because mainframe was in use.	Check the mainframe condition. If the mainframe is in use, try again later.
-12009	The ID2 in the NVRAM does not match the ID2 in the individual certification.	Check ID2 of the mainframe.
-12010	The certification area is not initialized.	Initialize the certification area.

Error Caused by Response from GW URL

Code	Meaning	Solution/ Workaround
-2385	Other error	
-2387	Not supported at the Service Center	
-2389	Database out of service	
-2390	Program out of service	
-2391	Two registrations for the same mainframe	Check the registration condition of the mainframe
-2392	Parameter error	
-2393	External RCG not managed	
-2394	Mainframe not managed	
-2395	Box ID for external RCG is illegal.	
-2396	Mainframe ID for external RCG is illegal.	
-2397	Incorrect ID2 format	Check the ID2 of the mainframe.
-2398	Incorrect request number format	Check the Request No.

2.50 OPERATION GUIDANCE FOR USERS

Function/Operation	Instruction to provide
Basic machine functions, operations	<ul style="list-style-type: none"> ▪ How to load the toner bottle ▪ How to load paper and other consumables/supplies ▪ How to turn the main power switch ON/OFF ▪ How to clear paper jams ▪ How to program, modify, and delete Address Book entries ▪ How to customize the UI and home screen ▪ Overview of machine options/peripherals ▪ How to take the proper action for SC errors (clearing the error, contacting service and support, etc.), how to interpret @Remote notifications ▪ Important notes to keep in mind whenever moving the machine ▪ Product limitations
Copier	<ul style="list-style-type: none"> ▪ Basic Copier operations ▪ How to load an original in the ARDF or place it on the exposure glass for scanning ▪ How to use thick paper and other specialized paper/media ▪ How to configure the Copier main screen (duplex/simplex, auto color selection, User Codes, etc.) ▪ Basic Document Server operations
Fax (when installed)	<ul style="list-style-type: none"> ▪ How to send a fax (Memory Transmission, Direct Transmission)
Printer (when installed)	<ul style="list-style-type: none"> ▪ How to install printer drivers (using the recommended method) ▪ How to connect to a PC (performing the port settings) ▪ How to print out a test page ▪ Overview of various settings inside each tab in the printer driver (e.g. duplex printing)
Scanner (when installed)	<ul style="list-style-type: none"> ▪ How to install printer drivers (using the recommended method) ▪ How to connect to a PC and perform a test scan

PREVENTIVE MAINTENANCE

REVISION HISTORY		
Page	Date	Added/Updated/New
		None

3. PREVENTIVE MAINTENANCE

3.1 PREVENTIVE MAINTENANCE TABLES

See “Appendices” for the following information:

- Preventive Maintenance Tables

3.2 IMAGE QUALITY STANDARDS

3.2.1 RESOLUTION

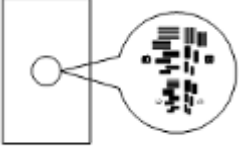
Item	Specification	Chart	Measuring method
Copy (100%/Enlargement), Black and White (1C)	Ave 5.0 lines/mm or more Min 4.5lines/mm or more	Book: S-5 (revised)	Copy onto plain paper using Auto Image Density/5 notches and then determine resolution.
Copy (Reduction), Black and White (1C)	Min 4.5×M lines/mm or more	DF: S-5Y (revised)	 <p>d1354027</p>

3.2.2 MAGNIFICATION RATIO ERROR MARGIN

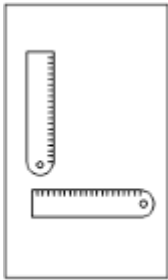
Item	Specification	Chart	Measuring method
Engine, Main Scan, Black and White (1C)	$\pm 0.50\%$ or less	Mono_CCD	<p>Copy the scale and compare it with the scale at 100 mm to see if it is within specification. Leave the sheet for 3 minutes or more after it has been output before measuring.</p>  <p>d1354028</p> <p>The swelling/shrinkage of paper caused by humidity are excluded. First side of the sheet only.</p>
Engine, Sub Scan, Black and White (1C)	$\pm 0.50\%$ or less	Scale chart	
Copy (100%), Main Scan, Black and White (1C)	$\pm 0.80\%$ or less		
Copy (100%), Sub Scan, Black and White (1C)	$\pm 1.00\%$ or less		
Copy (Reduction), Main Scan/Sub Scan, Black and White (1C)	$\pm 1.00\%$ or less		
Copy (Enlargement), Main Scan/Sub Scan, Black and White (1C)	$\pm 1.00\%$ or less		

3.2.3 MAGNIFICATION RATIO ERROR MARGIN DEVIATION

Item	Specification	Chart	Measuring method
Copy (100% / Enlargement / Reduction), Black and White (1C)	1.00% or less	Scale chart	Leave the sheet for 3 minutes or more after it has been output before measuring.

3.2.4 PITCH ERROR MARGIN

Item	Specification	Chart	Measuring method
Engine, Black and White(1C)	1.50% or less	Mono_CCD	For a line of about 1/2 inch in length.

3.2.5 PERPENDICULARITY

Item	Specification	Chart	Measuring method
Engine, Black and White(1C)	$\pm 1.25\text{mm}/200\text{mm}$ or less ($90^\circ \pm 0.35^\circ$)	Mono_CCD	Measure with the full length and width of the image.
Copy (100%), Black and White (1C)	$\pm 1.75\text{mm}/200\text{mm}$ or less ($90^\circ \pm 0.5^\circ$)	Scale chart	

3.2.6 LINEARITY

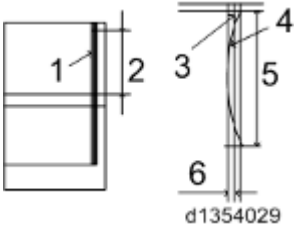
Item	Specification	Chart	Measuring method
Engine, Black and White(1C)	$\pm 0.20\text{mm}/100\text{mm}$ or less	Mono_CCD	Measure with the full length and width of the image.
Copy, Black and White (1C)	$\pm 0.50\text{mm}/100\text{mm}$ or less	Scale chart	 <ol style="list-style-type: none"> 1. Inner line 2. 100mm 3. Base line 4. Copy 5. 100mm 6. 0.5mm

3.2.7 PARALLELISM

Item	Specification	Chart	Measuring method
Engine, Black and White(1C)	$\pm 1.8\text{mm}$ or less	Mono_CCD	Measure with the full length and width of the image.

3.2.8 MISSING IMAGE AREA

Item	Specification	Chart	Measuring method
Engine/Copy (leading edge), Black and White(1C)	4.2±1.5%	Trim	Since there is a variability of about 1 mm in the sizes of sheets of paper, correct the size of the sheet before measuring.
Engine/Copy (left/right), Black and White(1C)	0.5 to 4.0mm		
Engine/Copy (trailing edge), Black and White(1C)	0.5 to 6.0mm (Duplex: 3.0 to 6.0mm)		

3.2.9 MARGIN POSITION

Item	Specification	Chart	Measuring method
Engine (simplex), Main Scan/Sub Scan, Black and White (1C)	0±1.5mm	Mono_CCD	
Engine (duplex), Main Scan/Sub Scan, Black and White (1C)	0±3mm		

3.3 PAPER TRANSFER QUALITY STANDARDS

3.3.1 REGISTRATION

Item	Specification	Note
Simplex (1st print side), 100% or reduction	0±2mm (Vertically and horizontally)	
Simplex (1st print side), enlargement	0±2mm × M mm (Vertically and horizontally)	M: Magnification ratio
Duplex (2nd print side), 100% or reduction	0±4mm (Vertically and horizontally)	
Duplex (2nd print side), enlargement	0±2mm × (2×M+2) mm (Vertically and horizontally)	M: Magnification ratio

3.3.2 SKEW

Exposure glass

Item	Specification	Note
1st side, B5 SEF or less	0±1.3mm/100mm or less	
1st side, B5 SEF or more	0±0.9mm/100mm or more	
2nd side, B5 SEF or less	0±1.8mm/100mm or less	
2nd side, B5 SEF or more	±1.3mm/100mm or more	

ADF

Item	Specification	Note
1st side, B5 SEF or less	0±2.3mm/100mm or less	
1st side, B5 SEF or more	0±1.4mm/100mm or more	
2nd side, B5 SEF or less	0±2.8mm/100mm or less	
2nd side, B5 SEF or more, DF3080	0±1.8mm/100mm or more	
2nd side, B5 SEF or more, DF3090	0±2.3mm/100mm or more	

3.4 PM PARTS SETTINGS

3.4.1 PM PARTS REPLACEMENT PROCEDURE

Note

- Since the machine detects a new PCDU and fusing unit automatically, you do not need to set "Manual New Unit Set" with an SP.

- Enter the SP mode.
- Output the SMC logging data with SP5-990-004.
- Set the following SPs to "1".

Item	SP
PCU	PCU: SP3-701-002 Cleaning Blade: SP3-701-009 Charge Roller: SP3-701-018 Cleaner: Charge Roller (Cleaning Roller): SP3-701-019 OPC: SP3-701-021 Separation Pawl (Pick-off Pawls): SP3-701-022
Development Unit	Development Unit: SP3-701-023 Development (Developer): SP3-701-024 Development Filter: SP3-701-025 Bearings: Development Screw (Development Mixing Auger Bearings): SP3-701-028
PTR (Paper Transfer) Unit	SP3-701-108
Fusing Unit	Fusing Unit: SP3-701-115 Fusing Belt (Heating Sleeve Belt Unit): SP3-701-116 Pressure Roller: SP3-701-118 Pressure Roller Bearings: SP3-701-119
ADF	ADF: Pick-up Roller: SP3-701-206 ADF: Feeding Belt: SP3-701-207 ADF: Reverse Roller: SP3-701-208

4. **Exit the SP mode.**
5. **Turn off the main power.**
6. **Replace the PM parts and turn the power on**

The machine will reset the PM counters and the remaining day counters. The machine will also do the developer initialization..

★ Important

- **After the PM counter for the Fusing Belt (heating sleeve belt unit) reaches its PM cycle, the machine stops the operation automatically. Replace the heating sleeve belt unit before the machine stops its operation (stop warning: 240K pages, stop: 260K pages for D197/D198/D199, stop warning: 320K pages, stop: 350K pages for D200/D201/D202).**

3.4.2 AFTER INSTALLING THE NEW PM PARTS

1. **Turn on the main power.**
2. **Output the SMC logging data with SP5-990-004 and check the counter values.**
3. **Make sure that the PM counters for the replaced units are "0" with SP7-621 and SP7-944. If the PM counter for a unit has not been reset, then reset that counter with SP 7-622.**

3.4.3 OPERATION CHECK

Check if the sample image has been copied normally.

REPLACEMENT AND ADJUSTMENT

REVISION HISTORY		
Page	Date	Added/Updated/New
		None

4. REPLACEMENT AND ADJUSTMENT

4.1 NOTES ON THE MAIN POWER SWITCH

4.1.1 PUSH SWITCH

The main power button of this machine has been changed to a push-button switch (push button) from the conventional rocker switch. The push switch has characteristics and specifications different from the rocker switch. Care must be taken when replacing and adjusting parts.

Characteristics of the Push Switch (DC Switch)

Power is supplied to the machine even when the main power switch is turned OFF.

The push switch in this machine uses DC (direct current). Therefore, if the AC power cord is connected to an electrical outlet, power is supplied to the controller board, the operation unit and other modules even when the main power is turned OFF. When replacing the controller board and the operation unit in this state, not only these boards, it will damage other electrical components.

In 100V models, only one of the AC lines for the fusing unit is shut off when you turn off the main power; the other line carries current even when you turn off the main power switch.

So, when performing maintenance work such as replacing parts, in addition to turning off the main power with the push switch, always unplug the AC power cord.

When you disconnect the power cord from the AC wall outlet, inside the machine there is still residual charge.

When you disconnect the power cord from the AC wall outlet, inside the machine for a while there is still residual charge. Therefore, if you remove boards in this state, it can cause a blown fuse or memory failure.

- How to remove the residual charge inside the machine

After you unplug the power cord from the AC wall outlet, in order to remove the residual charge from inside the machine, be sure to press the main power switch. Thus, the charge remaining in the machine is released, and it is possible to remove boards.

When you reconnect the AC power cord into an AC wall outlet, the machine will start automatically.

In order to remove the residual charge, push the main power switch while you disconnect the AC power cord. At that time, the power ON flag inside the machine is set. Therefore, after you finish work on the machine and reconnect the power cord to the AC, even if you do not press the main power switch, the machine will start automatically and the moving parts will begin to move. **When working on moving parts, be careful that fingers or clothes do not get caught.**

 **Note**

- Automatic restart deals with cases when you accidentally unplugged the AC power cord or unexpected power outages. By keeping the power flag ON, after the resumption of power, the machine will start up automatically.

In rare cases, when you reconnect the AC power cord to a power outlet, the machine does not start automatically. In this case, the machine has not failed. The cause is due to the timing of releasing the residual charge. If you press the main power switch while the residual charge was already released, the power ON flag will not be set. At this time, start the machine manually by pressing the main power switch.

Shutdown Method

1. Press the main power switch [A] on the front of the machine.
2. Take out the power cord
3. Wait 3 minutes (this is the time required if you will remove the rear cover and access the interior of the machine, to take out the controller board for example).

Note: If some LEDs on any of the boards are blinking or lit, current is still flowing.

After the shutdown process, the main power is turned off automatically.



When the shutdown is complete

Main power LED: Off

Operation panel LED: Off

ⓘ Note

- How to start from shutdown
- To start the machine, press the main power switch. However, if you press the main power switch between the beginning and the end of a shutdown, the machine will not start.

Forced Shutdown

In case normal shutdown does not complete for some reason, the machine has a forced shutdown function.

To make a forced shutdown, press and hold the main power switch for 6 seconds.

In general, do not use the forced shutdown.

★ Important

- **Forced shutdown may damage the hard disk and memory, and can cause damage to the machine. Use a forced shutdown only if it is unavoidable.**

4.2 BEFOREHAND

WARNING

- Turn off the main power switch and disconnect the power cord.
- After replacing, make sure that all removed harnesses are connected up again and secured in their clamps.

4.3 SPECIAL TOOLS AND LUBRICANTS

The following special tools should be prepared for maintenance of this model in the field.

Unique or Common:

U: Unique for this model

C: Common with listed model

4.3.1 SPECIAL TOOLS

No.	Part Number	Description	Q'ty	Unique or Common
1	A0069104	Scanner Positioning Pin (4pcs/set)	1	C (General)
2	D1979010	Adjustment Seal (4pcs/set) – Laser Unit	1	U
3	B6455020	SD Card (1GB)	1	C (General)
4	C4019503	20X Magnification Scope	1	C (General)
5	VSSG9002	FLUOTRIBO MG GREASE: 100G	1	C (General)
6	A2929500	Test Chart – S5S(10pcs/set)	1	C (General)

Note

- A PC (Personal Computer) is required for creating the Encryption key file to an SD card when replacing the controller board for a model in which HDD encryption has been enabled.

4.3.2 LUBRICANTS

No.	Part No.	Description	Q'ty	Unique or Common
1	52039502	Silicone Grease G-501	1	C (General)
2	A2579300	Grease Barrierta – S552R	1	C (General)

4.4 COVER REMOVAL ORDER

4.4.1 COVER LAYOUTS

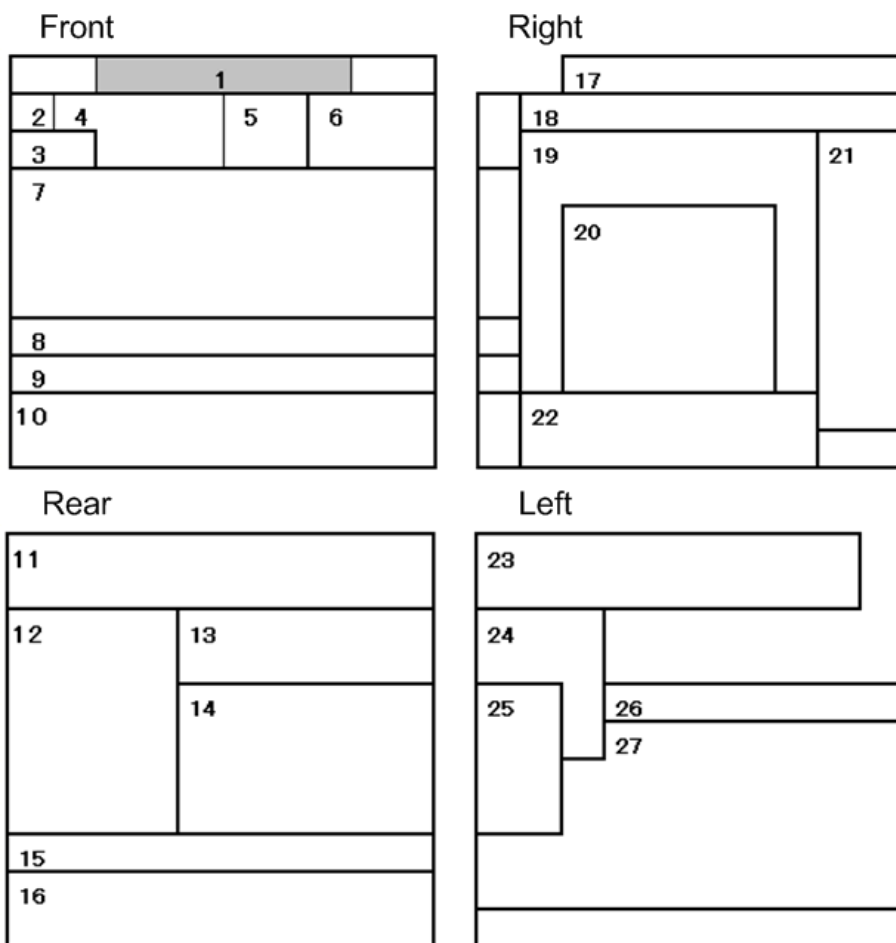

w_d197f0737

No.	Name	No.	Name
1	Operation Panel	15	Rear Lower Gap Cover
2	Tray Support Rod Cover	16	Rear Lower Cover
3	Paper Exit Tray	17	Scanner Right Cover
4	Upper Inner Cover	18	Right Upper Cover
5	Connector Cover	19	Right Cover
6	Main Power Switch Cover	20	Bypass Tray
7	Front Cover	21	Right Rear Cover

No.	Name	No.	Name
8	1st Paper Feed Tray	22	Right Lower Cover
9	2nd Paper Feed Tray	23	Scanner Left Cover
10	Bank	24	Left Rear Cover
11	Scanner Rear Cover	25	Controller Cover
12	Rear Right Cover	26	Left Upper Cover
13	Rear Left Cover	27	Left Cover
14	Controller Rear Cover	-	

4.4.2 COVER REMOVAL ORDER

How to use this chart:

Example—To remove the right cover, remove the rear lower cover, right rear cover, and 1st Paper Feed Tray Right Cover.

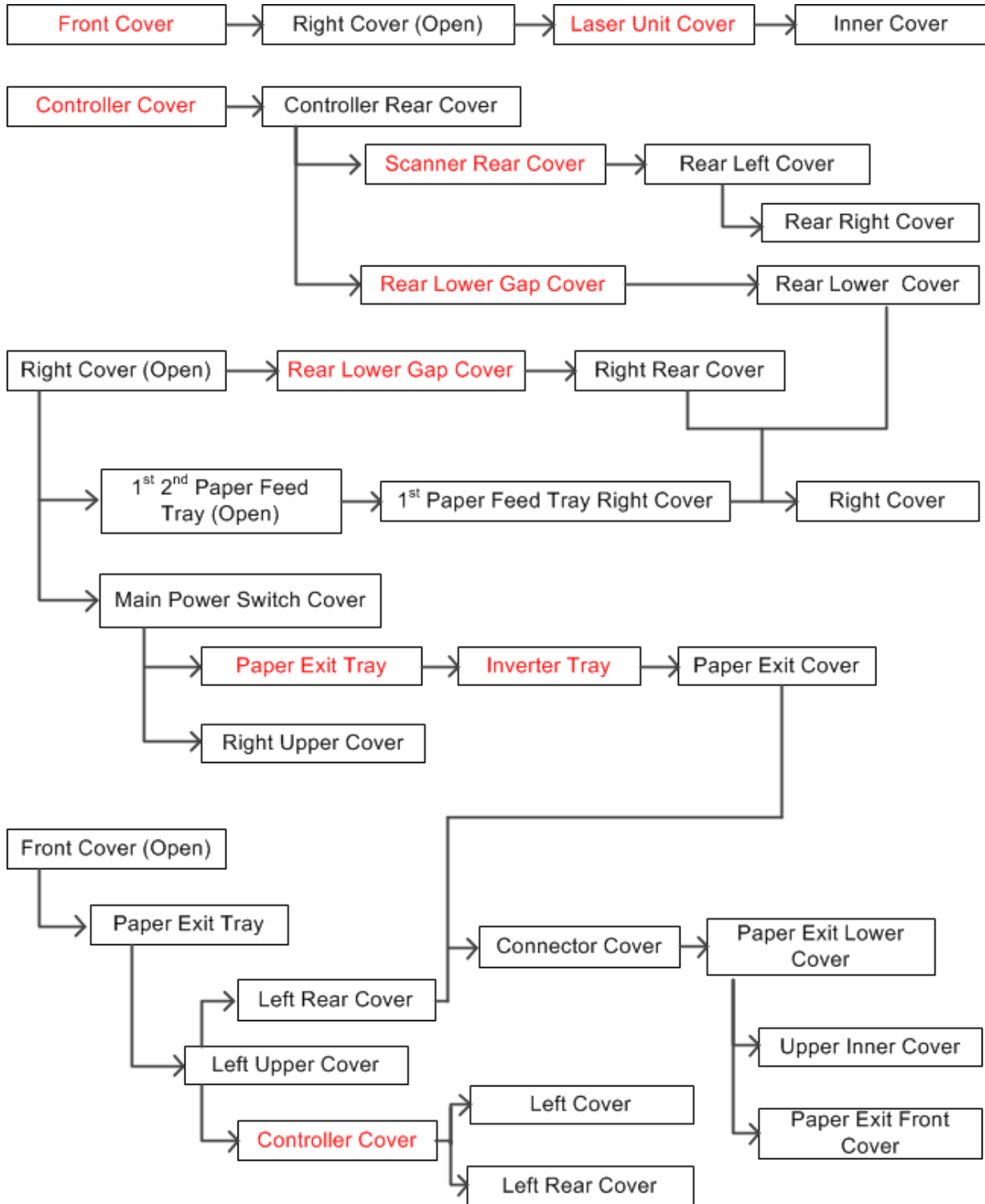

w_197f0736

* Red parts can be removed itself without removing other parts.

4.5 EXTERIOR COVERS

The Aim of Anti-tip Components and Precautions

The anti-tip components [A] are necessary for meeting the requirements of IEC60950-1, the international standard for safety.

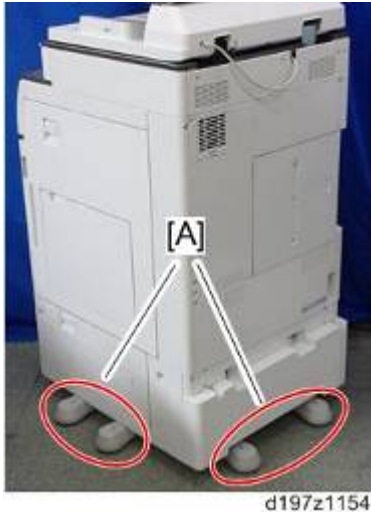

The aim of these components is to prevent the products, which are heavy, from toppling as a result of people running into or leaning onto the products, which can lead to serious accidents such as persons becoming trapped under the product. (U.S.: UL60950-1, Europe: EN60950-1)

4.5.1 FRONT COVER

1. Open the front cover [A].



d197f0040

2. Belt [A] and front cover

Note

- The front cover can be removed by sliding it in the direction of the blue arrow.

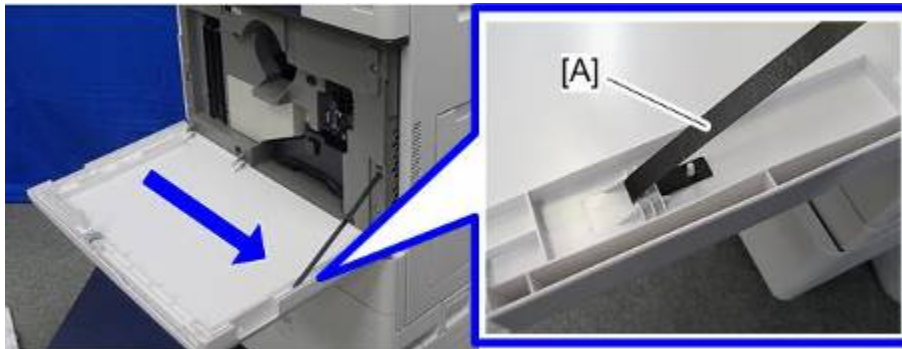

d197f0041

4.5.2 CONTROLLER COVER

1. Controller cover [A] (🔩x4)

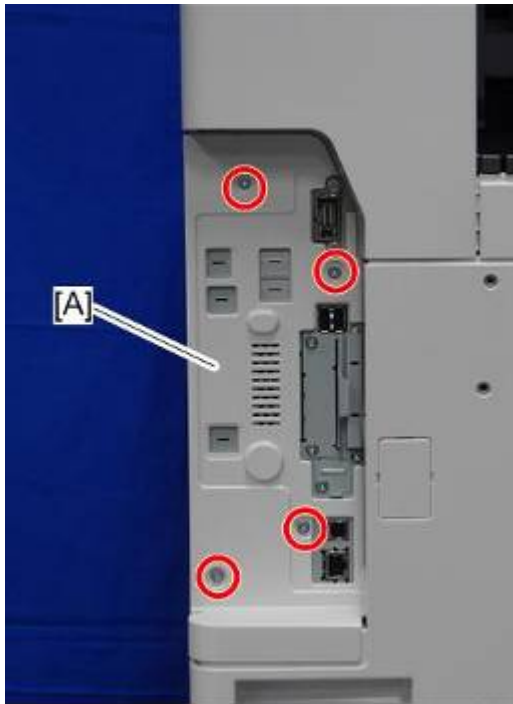

4.5.3 LEFT UPPER COVER

⚠ CAUTION

- Each part enclosed by a blue circle has a tab. Be careful not to damage it when attaching and detaching.

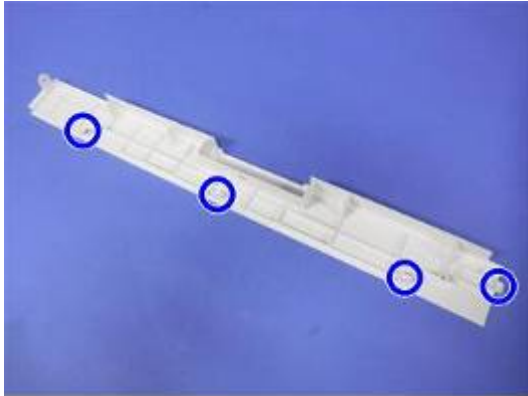

d1462009

1. Open the front cover (page 4-10).
2. Paper exit tray (page 4-23)
3. Left upper cover [A] (🔩 x1)

⬇ Note

- Slide the cover in the direction of the blue arrow.

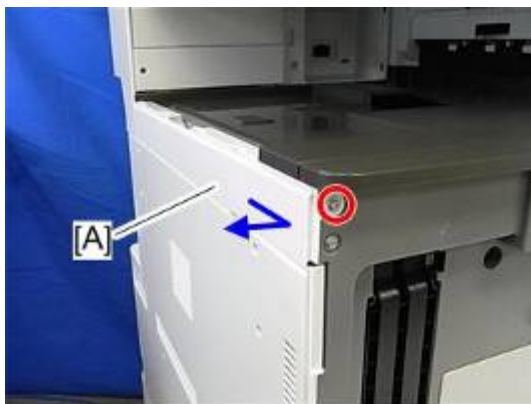

d197z0001

4.5.4 LEFT REAR COVER

1. Left upper cover (page 4-12)
2. Rear lower gap cover (page 4-17)
3. Left Rear Cover [A] (⊗ x2, ▽ x1)



4.5.5 LEFT COVER

↓ Note

- Each part enclosed by a blue circle has a tab. Be careful not to damage it when attaching and detaching.

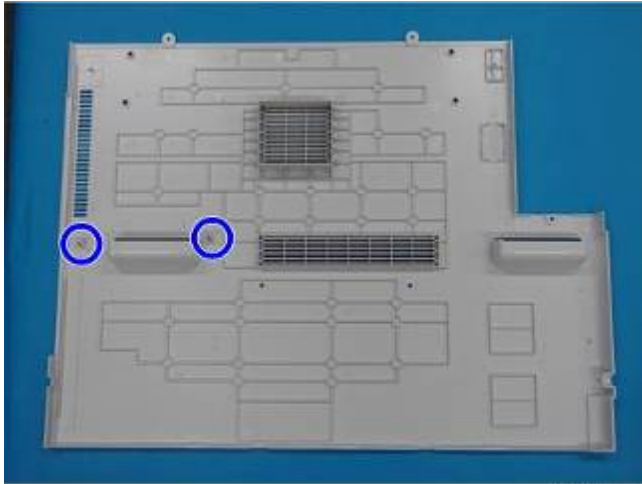

d197f0044

1. Left upper cover (page 4-12)
2. Controller cover (page 4-11)
3. Pull out the 1st and 2nd paper feed trays.
4. Open the front cover.
5. Left cover [A] (🔩 x5)

Remove it while pressing down.

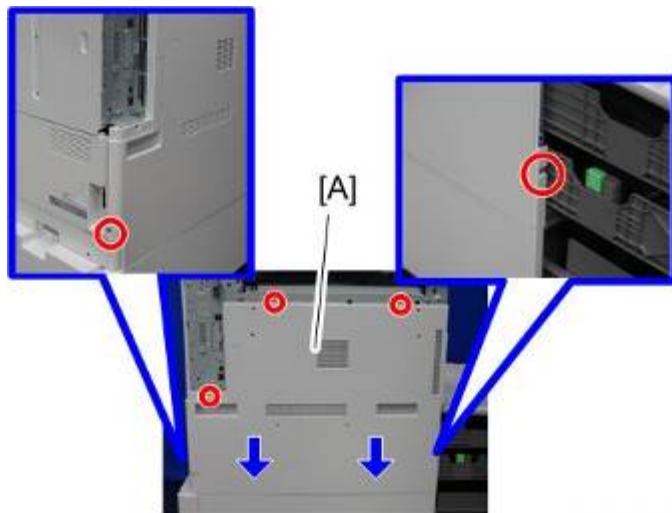

d197f0046

4.5.6 CONTROLLER REAR COVER

Note

- There are some claws on the back face of the controller rear cover. When fitting or removing the cover, take care not to damage them.

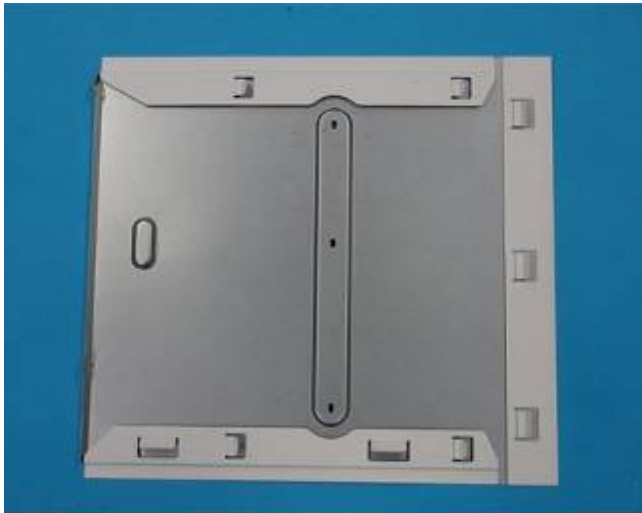

d197f0047

1. Controller cover (page 4-11)
2. Controller rear cover [A] (⚙️ x4)

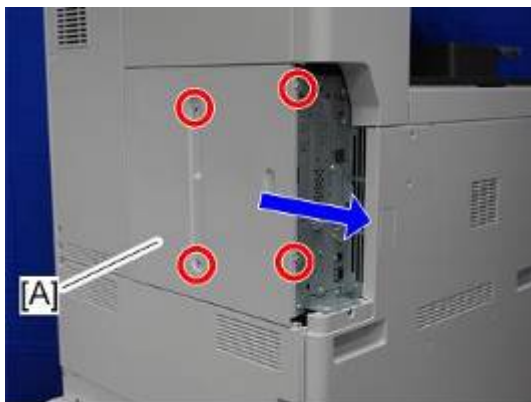

d197f0048

4.5.7 REAR LEFT COVER

1. Controller rear cover (page 4-15)
2. Scanner rear cover (page 4-18)
3. Rear left cover (🔩 x3)



4.5.8 REAR RIGHT COVER

1. Rear left cover (page 4-16)
2. Rear Right Cover [A] (🔩 x5)



4.5.9 REAR LOWER GAP COVER

1. Rear lower gap cover [A] (hookx2)

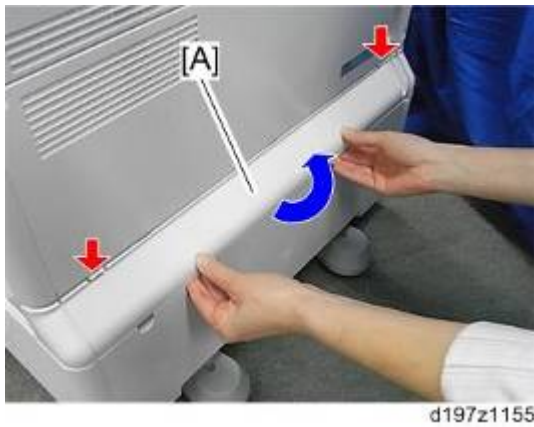

4.5.10 REAR LOWER COVER

1. Controller rear cover (page 4-15)
2. Rear lower gap cover (page 4-17)
3. Rear lower cover [A] (🔩x5)

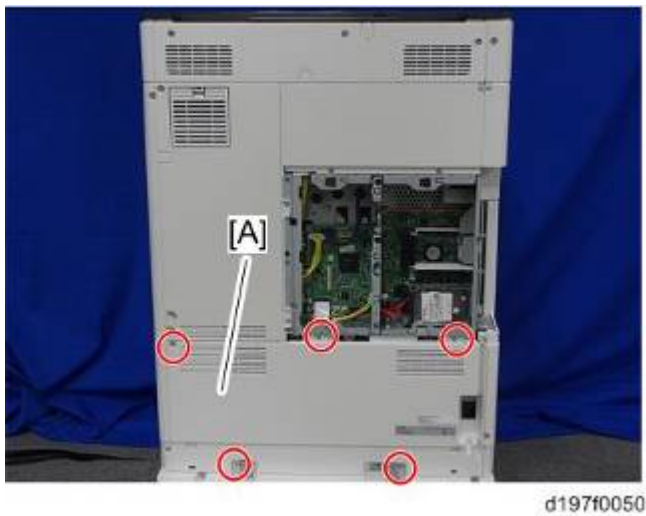

4.5.11 SCANNER REAR COVER

1. Scanner rear cover [A] (🔩 x3)



d197f0051

4.5.12 RIGHT REAR COVER

1. Open the right cover.
2. Rear lower gap cover (page 4-17)
3. Right rear cover [A] (🔩 x4)



d197z0002

Note

- When installing, insert the projections [A] in the holes [B], taking care not to trap the harness inside.

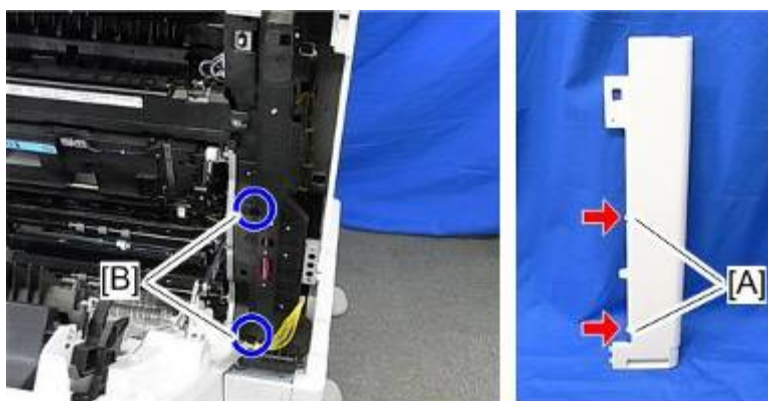

d197z0003

4.5.13 RIGHT UPPER COVER

1. Main Power Switch Cover (page 4-22)
2. Right upper cover [A] (🔩 x2)

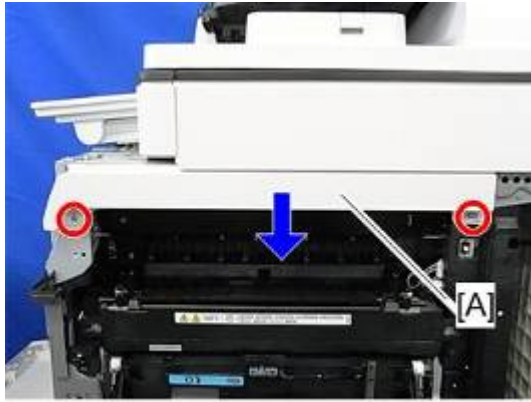

d197z0004

4.5.14 RIGHT COVER

1. Open the 1st paper feed tray [A], 2nd paper feed tray [B] and right cover [D]
2. 1st paper feed tray right cover [C] (🔩 x1).

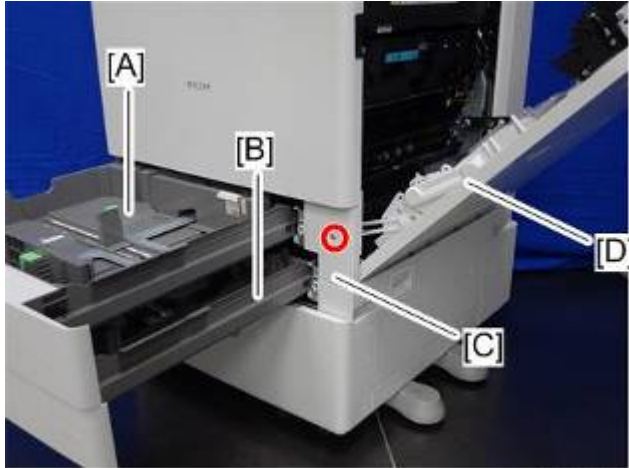

d197f0054

3. Right rear cover (page 4-18)
4. Rear lower cover (page 4-17)
5. Remove clamps and connectors. (🔧 x6, 📎 x2)

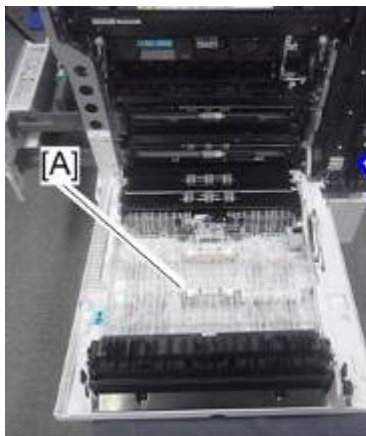

d197z0439

6. Right cover arms [A] [B] (🔩 x2)

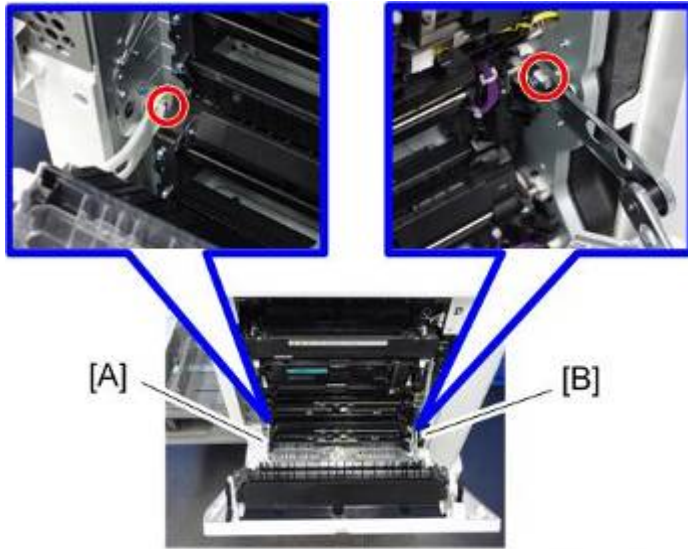

d197f0055

7. Slide to the left and remove right cover [A] (0x1).



d197z0440

4.5.15 MAIN POWER SWITCH COVER

1. Open the right cover.
2. Main power switch cover [A] (🔧 x1)

📌 Note

- The main power switch cover has three tabs: two on the left side (paper exit) and one on the right side (right cover).



d197f0052

4.5.16 INVERTER TRAY

1. Inverter Tray [A]



d197f0053

4.5.17 PAPER EXIT TRAY

1. Paper Exit Tray [A]



4.5.18 PAPER EXIT COVER

1. Main power switch cover (page 4-22)
2. Paper exit tray (page 4-23)
3. Inverter Tray (page 4-22)
4. Paper exit cover [A] (🔩 x1)

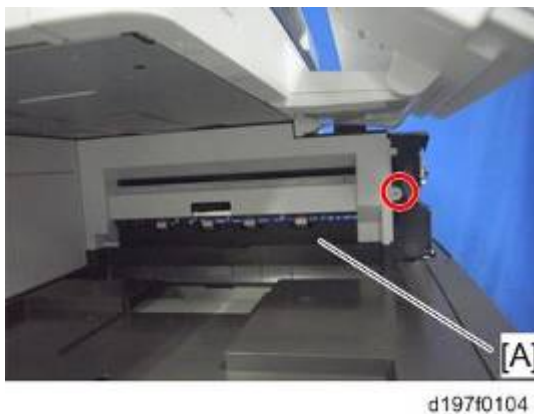

4.5.19 PAPER EXIT LOWER COVER

1. Left rear cover (page 4-13)
2. Paper exit cover (page 4-23)
3. Connector cover [A].



d1462090

4. Paper exit lower cover [A] (🔩x2)

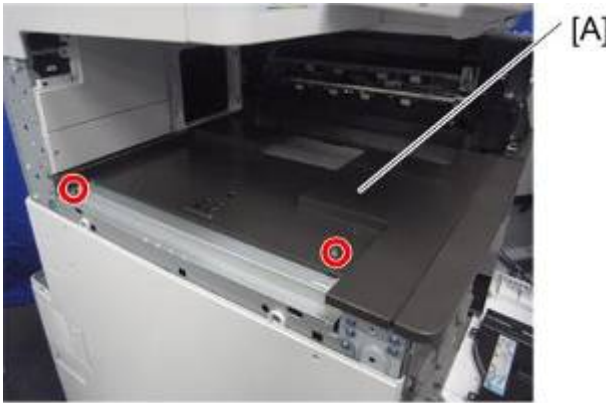

d1462093

4.5.20 UPPER INNER COVER

1. Left upper cover (page 4-12)
2. Paper exit cover (page 4-23)
3. Paper exit lower cover (page 4-24)
4. Tray support rod cover [A] (🔩 x1)

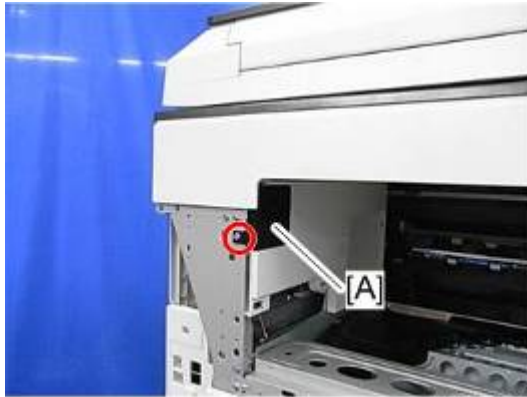

d197z0427

5. Two screws on the upper inner cover [A] (🔩 x2)

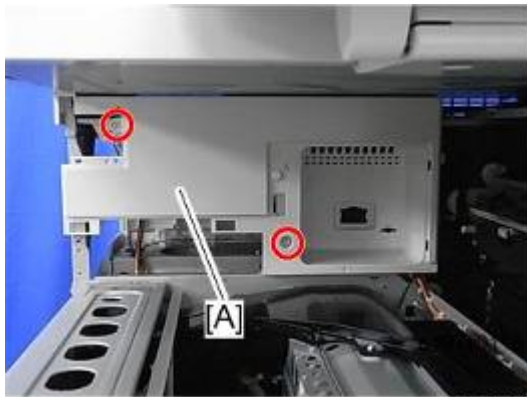

d197z0428

6. Upper inner cover [A] (📦 x2)



d197z0429

4.5.21 PAPER EXIT FRONT COVER

1. Paper exit lower cover (page 4-24)
2. Paper exit front cover [A] (🔩 x4)

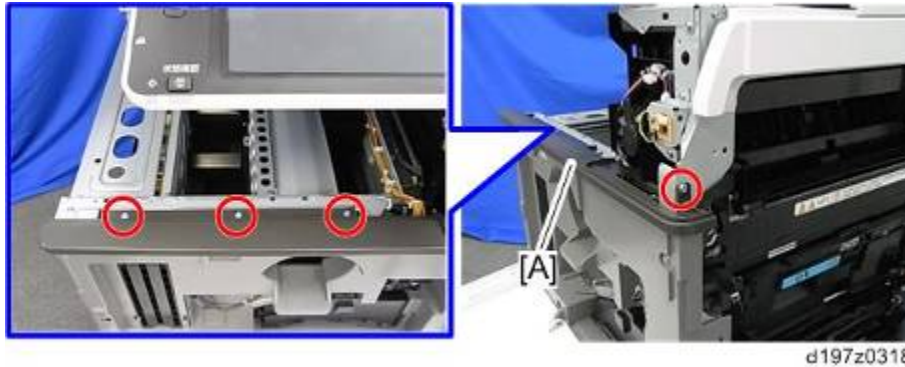

4.5.22 INNER COVER

1. Front cover (page 4-10)
2. Open the right cover.
3. Laser unit cover (🔩 x1)



4. Inner cover [A] (🔩 x7, 🗝️ x1)

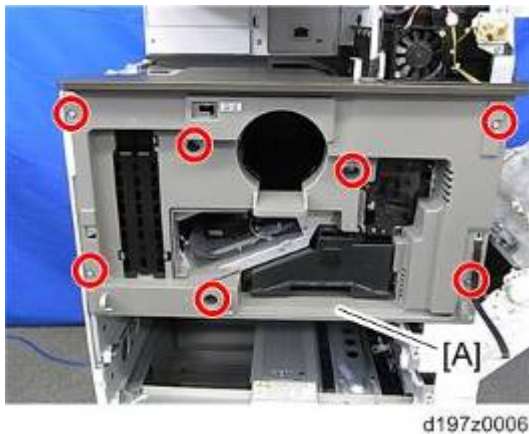

4.5.23 TONER SUPPLY HOUSING

1. Pull out the toner bottle
2. Paper exit lower cover (page 4-24)
3. Upper inner cover (page 4-25)
4. Development exhaust fan (page 4-182)
5. Fan [A] with duct (🔩 x2)

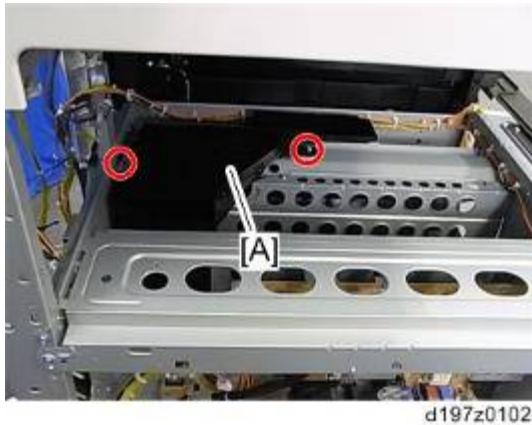

6. Bracket [A] [B] (🔩 x6)

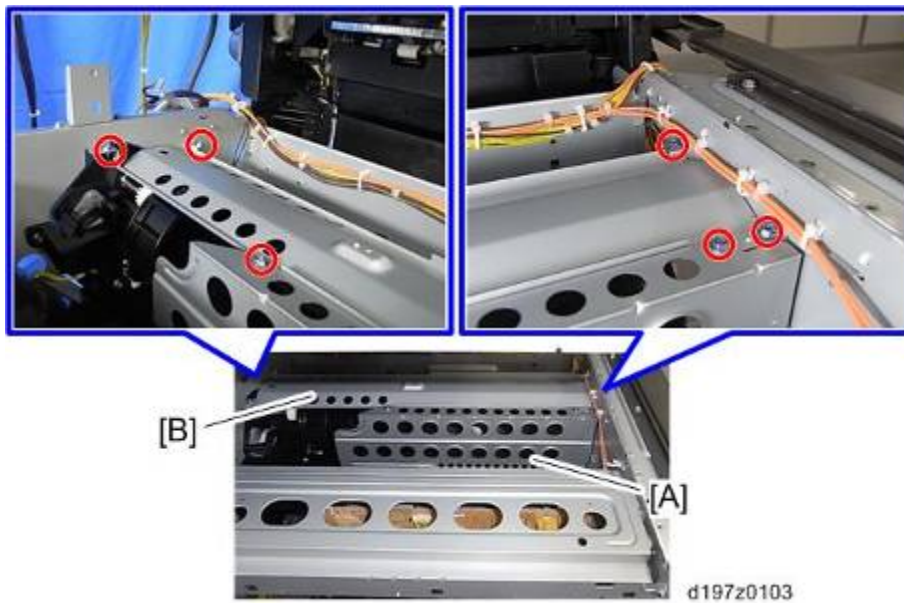

7. Four screws on the toner supply housing (🔩 x4)

Exterior Covers

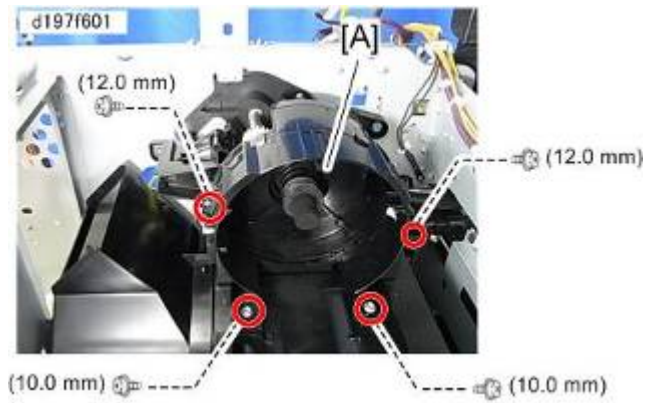

8. Toner supply housing [A]

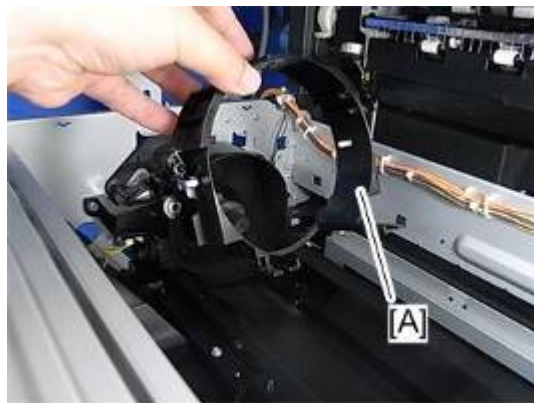

d197z0117

4.6 OPERATION PANEL

4.6.1 OPERATION PANEL

1. Scanner front cover (page 4-37)
2. Operation panel upper cover [A]

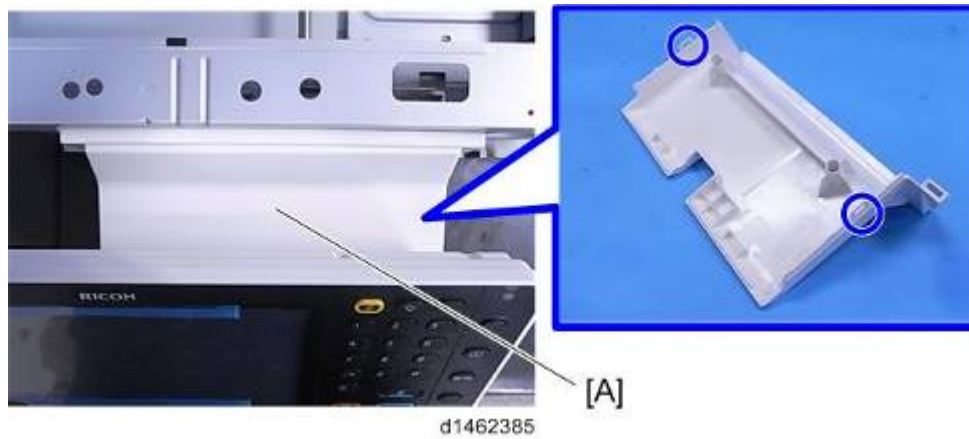

3. Operation panel [A] (⚙️ x5, 🛠️ x2)

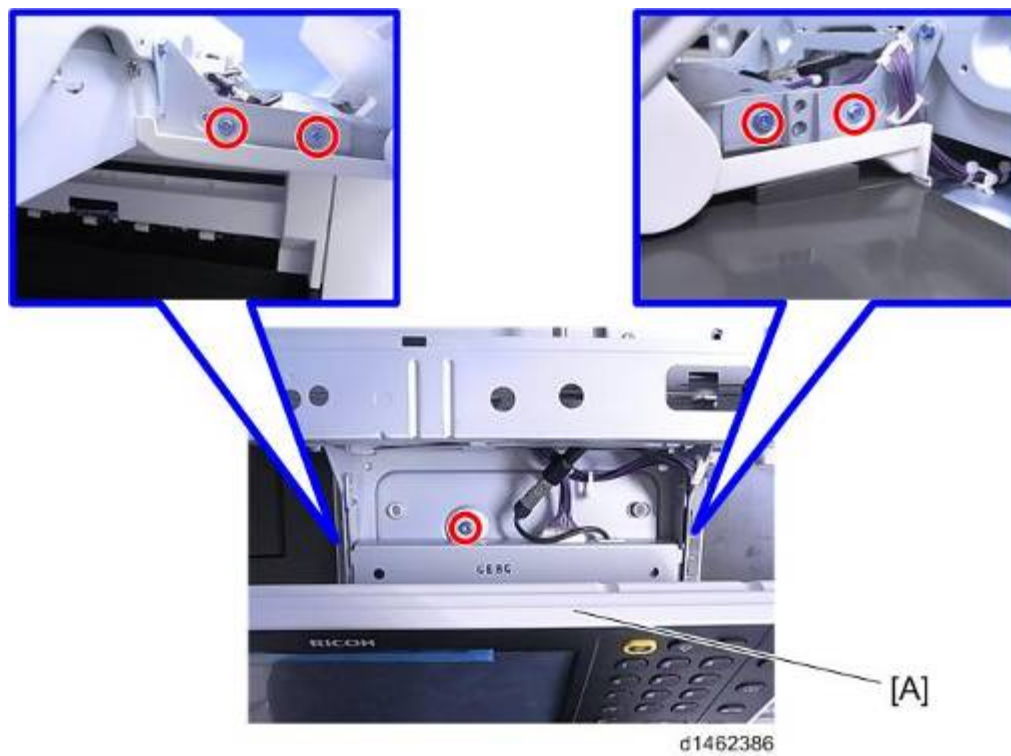

4.6.2 KEY CONTROL BOARD

1. Operation panel (page 4-29)
2. Operation panel lower cover [A] (🔩x6)

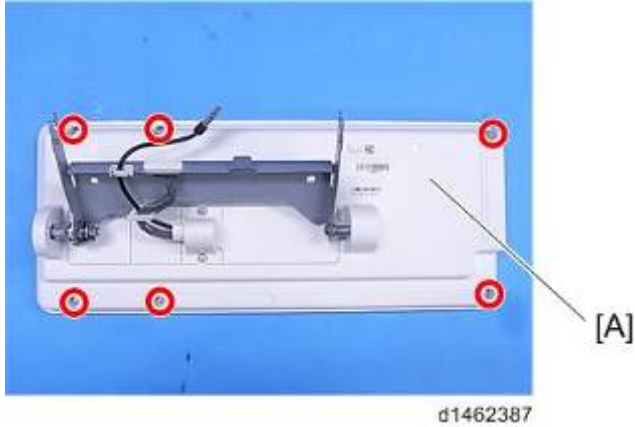

3. Harness guide [A] (🔩x2)

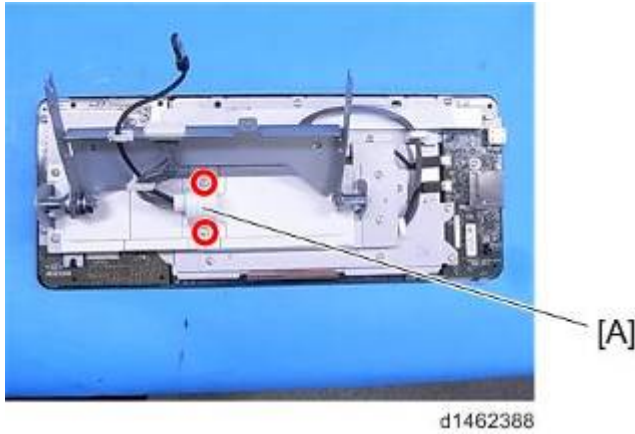

4. Bracket covers [A] [B]

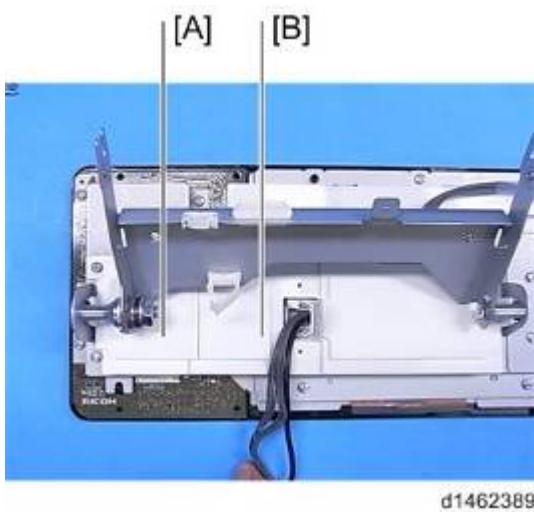

5. Operation panel arm bracket [A] (🔩x6)

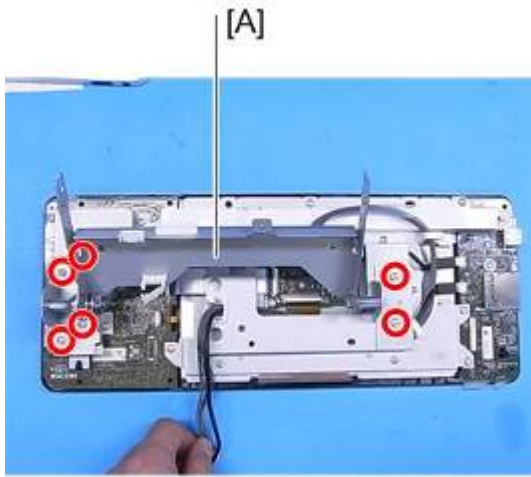

d1462390

6. Key control board [A] (🔩 x8, 📏 x1, 📜 x2)

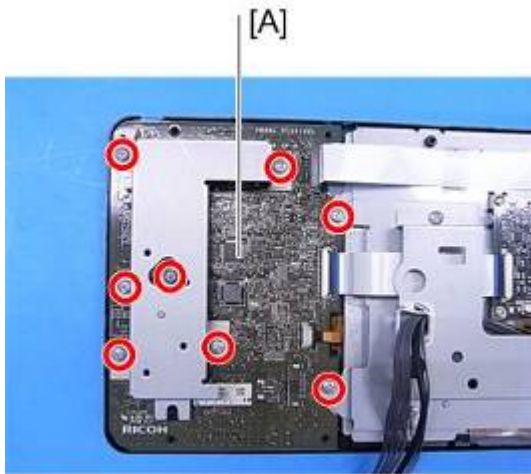

d1462391

4.6.3 INTERFACE BOARD

1. Operation panel (page 4-29)
2. Operation panel lower cover (page 4-30 "Key Control Board")
3. Harness guide (page 4-30 "Key Control Board")
4. Bracket covers (page 4-30 "Key Control Board")
5. Operation panel arm bracket (page 4-30 "Key Control Board")
6. Interface board [A] (🔩x4, 📧x1, USBx2)

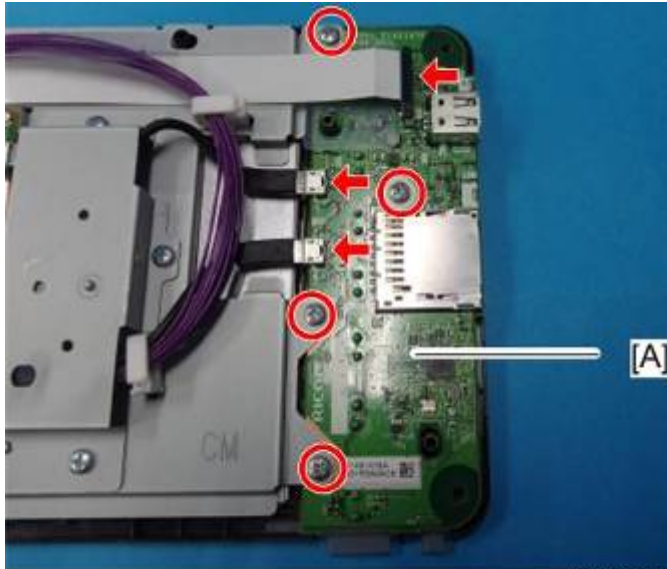

4.6.4 LCD PANEL

1. Operation panel (page 4-29)
2. Operation panel lower cover (page 4-30 "Key Control Board")
3. Harness guide (page 4-30 "Key Control Board")
4. Bracket covers (page 4-30 "Key Control Board")
5. Operation panel arm bracket (page 4-30 "Key Control Board")
6. LCD panel unit [A] (🔩x6, 📧x5, USBx2)

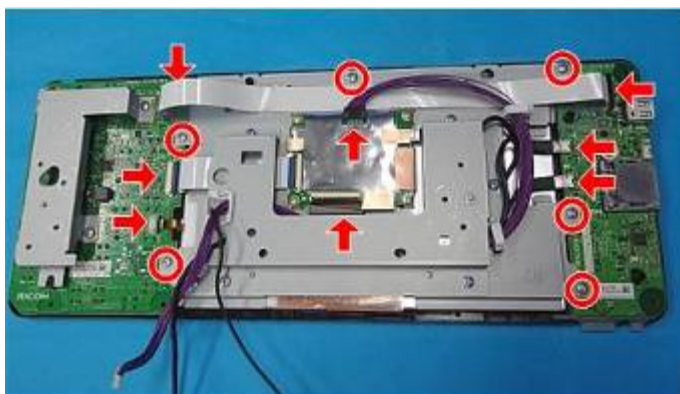

4.6.5 LCD

Notes when replacing the LCD

Since LCD panels from 2 vendors are used, the replacement parts are different. When replacing, check the vendor used, and ensure that you use the correct part.

Distinguishing method

Of the 3 labels on the rear of the operation panel, the center label shows the LCD model number.

Operation panel rear surface

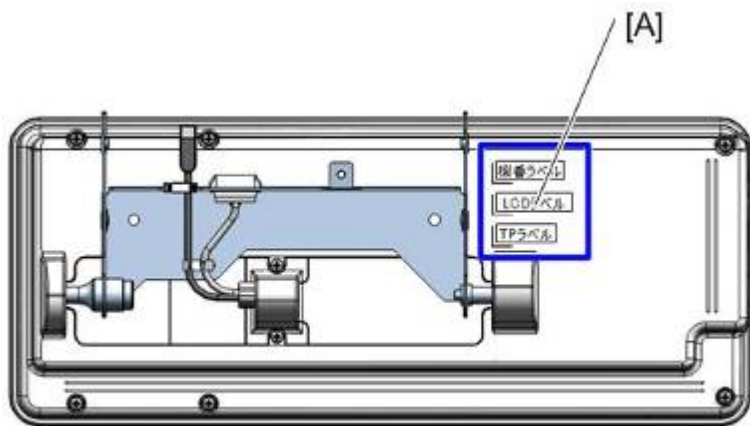

d1462396

[A]: Label attachment position

Label



[A]

[B]

d1462397

[A]: S Co. LCD: Printed as Sxxxxx...

[B]: C Co. LCD: Printed as Cxxxxx...

Differences between operation panels from 2 vendors

- Operation panel upper cover
There is no difference in appearance, but there is a difference in internal layout.
- LCD bracket
There is a difference in the shape of the bracket and the stamp inside the blue circle.
S Co.: S stamp
C Co.: CM stamp

Operation Panel



d1462398

- Use of FFC (Flexible Flat Cable)
For S Co., FFC is used, but for C Co., instead of an FFC, a cable integrated with the LCD (orange) is used.

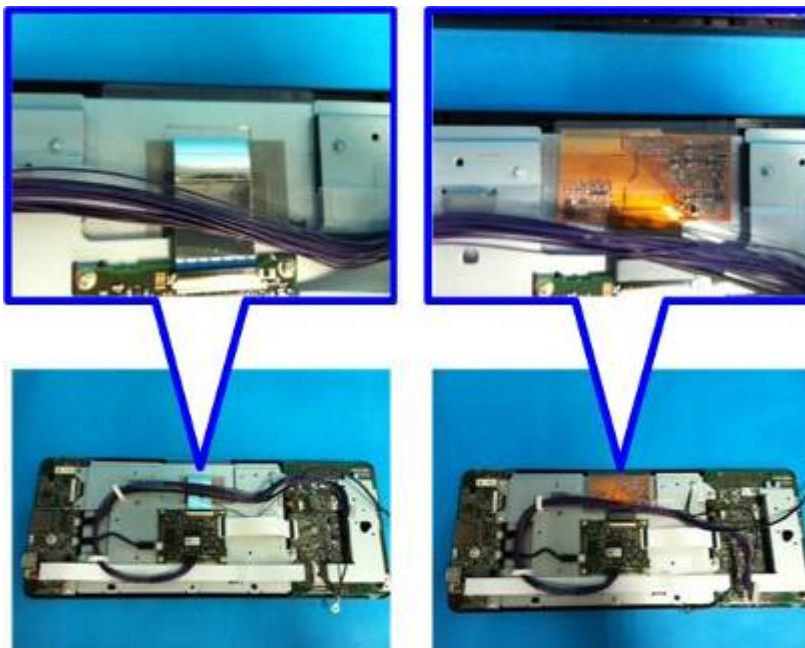

d1462399

Replacement procedure

1. Operation panel (page 4-29)
2. Operation panel lower cover (page 4-30 "Key Control Board")
3. Harness guide (page 4-30 "Key Control Board")
4. Bracket covers (page 4-30 "Key Control Board")
5. Operation panel arm bracket (page 4-30 "Key Control Board")
6. LCD Panel (page 4-32)
7. LCD [A]



d197f0101

4.7 SCANNER UNIT

Note

- When you replace the scanner wire, use the standard positioning pins.

4.7.1 SCANNER EXTERIOR

Scanner Upper Cover

- Platen cover or ADF
 - Remove either unit, referring to the installation procedure for the platen cover or DF.
- Scanner rear cover (page 4-18)
- Scanner Upper Cover [A] (🔩 x2)

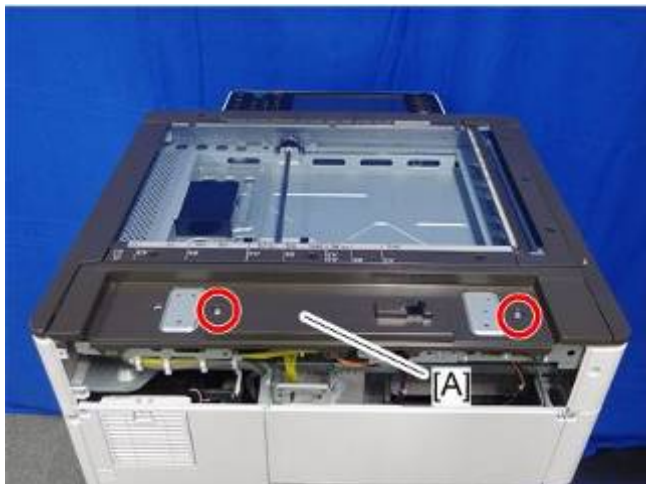

d197f0019

Scanner Right Cover

- Scanner rear cover (page 4-18)
- Scanner right cover [A] (🔩 x1)



d197f0020

Scanner Front Cover

1. Open the ARDF or platen cover.
2. Scanner front cover [A] (🔩 x2)



Note

- There is a tab [A] inside this cover at the left side. Release the left tab after removing the two screws of the scanner front cover. First, carefully and slightly pull the left side of the cover towards the outside and release the left side tab, then pull up the right upper side tab and release it.

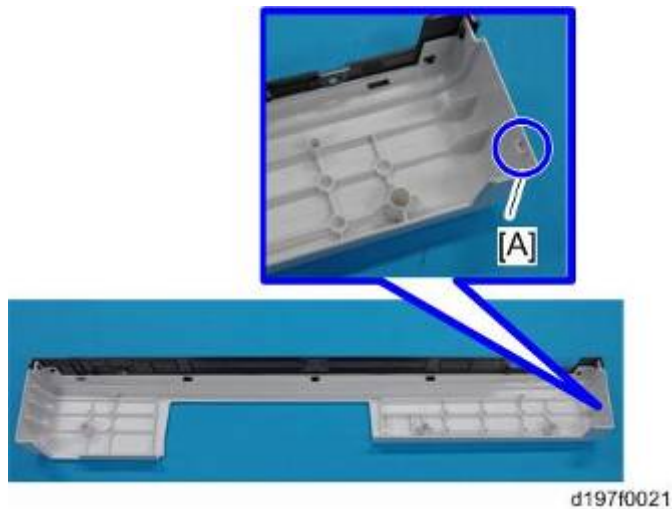

Scanner Left Cover

1. Scanner front cover (page 4-37)
2. Scanner left cover [A] (🔩 x3)

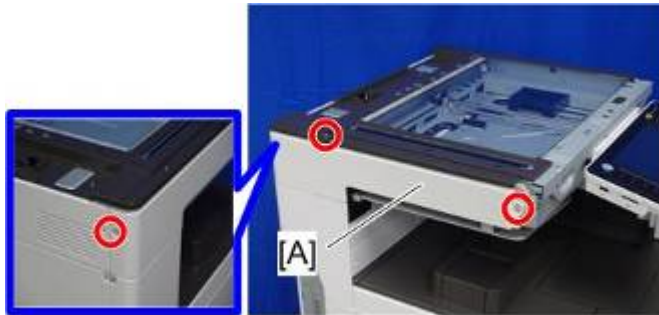

d197f0022

4.7.2 EXPOSURE GLASS

1. Open the platen cover or ADF
2. Guide Scale [A] (🔩 x3)

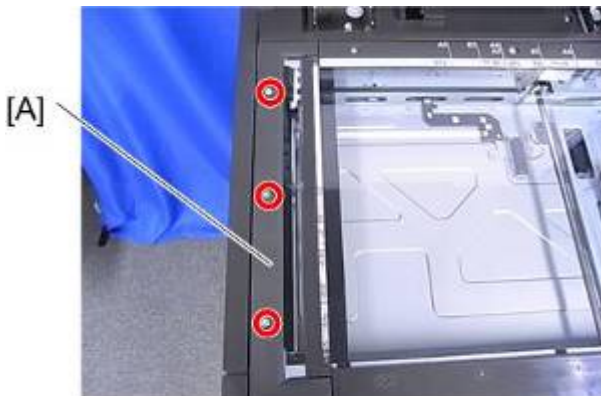

d1462304

3. ADF exposure glass [A]

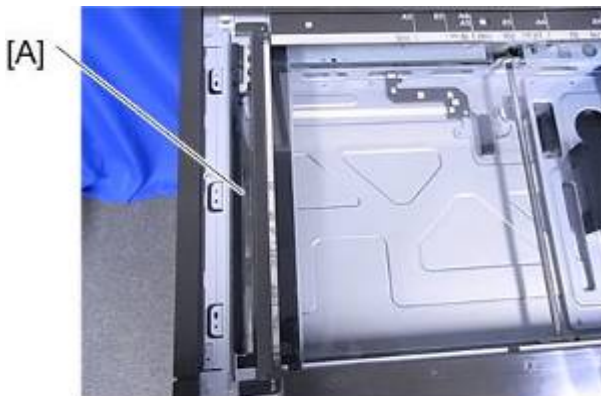

d1462305

4. Rear scale [A] (🔩 x3)

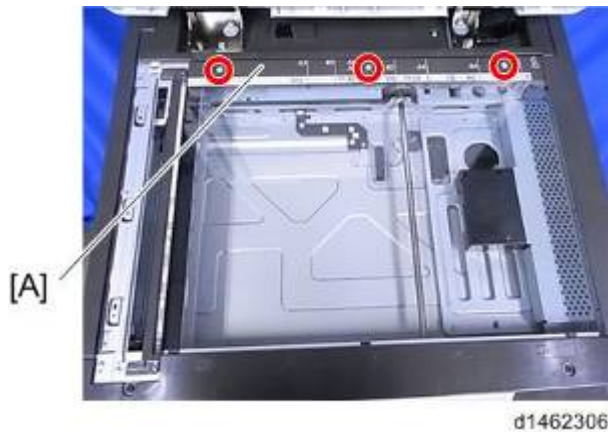

5. Left scale and exposure glass [A]

⚠ CAUTION

- The exposure glass and the left scale are attached with double-sided tape.

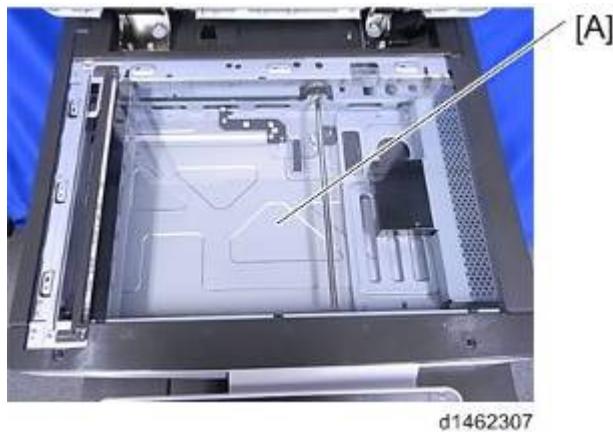

↓ Note

- When installing, please follow the points below:
 - The red mark [A] of the ADF exposure glass is on the left at the rear of the operation panel.
 - The locating holes of the left scale fit over the locating bosses of the front/rear frame.



4.7.3 SCANNER LAMP

1. Exposure glass (page 4-38)
2. Move the exposure lamp (1st scanner carriage) [A] to position [B].

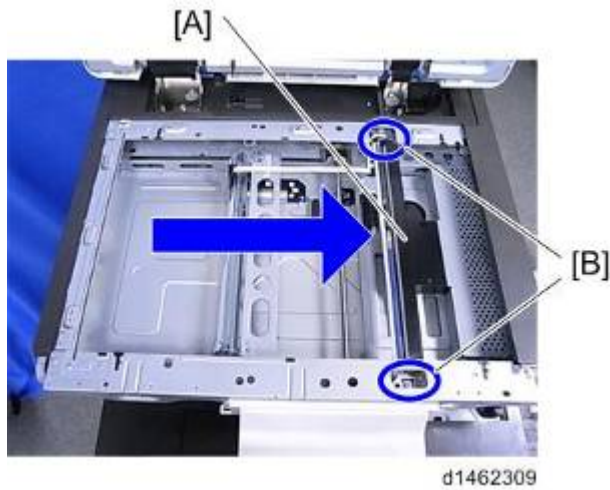

3. Scanner lamp [A] (🔩 x2, 📦 x1)

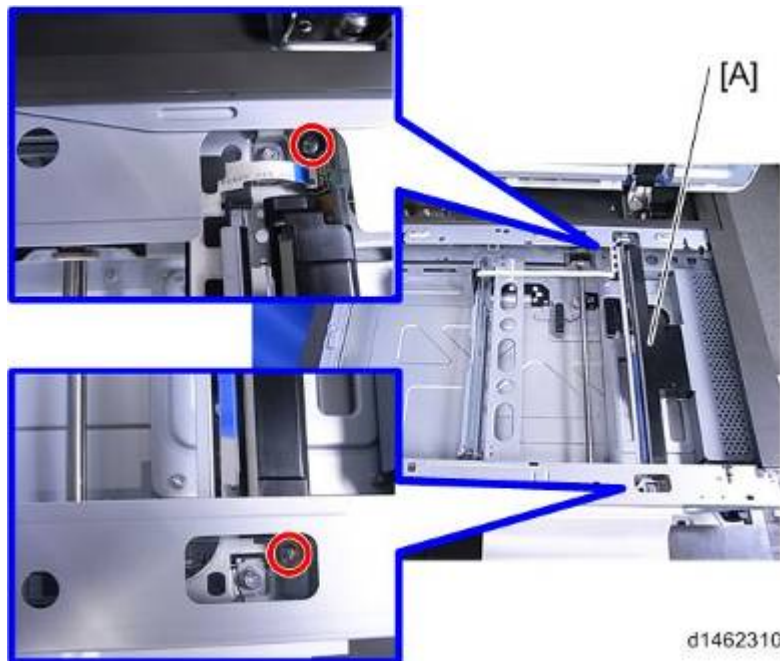

4.7.4 SCANNER MOTOR

1. Scanner upper cover (page 4-36)
2. Scanner motor frame [A] (⚙️ x4, 🔩 x3)

⬇️ Note

- To remove the inner two screws, insert your screwdriver as shown by the blue arrows below.

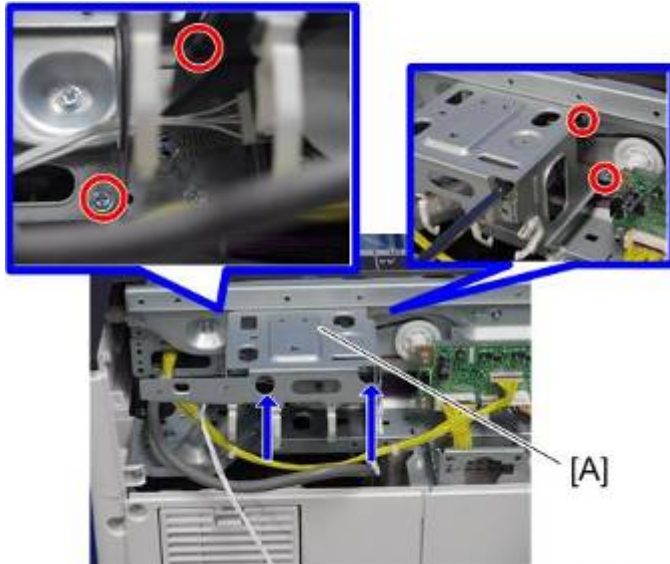

d197f0024

3. Spring [A]

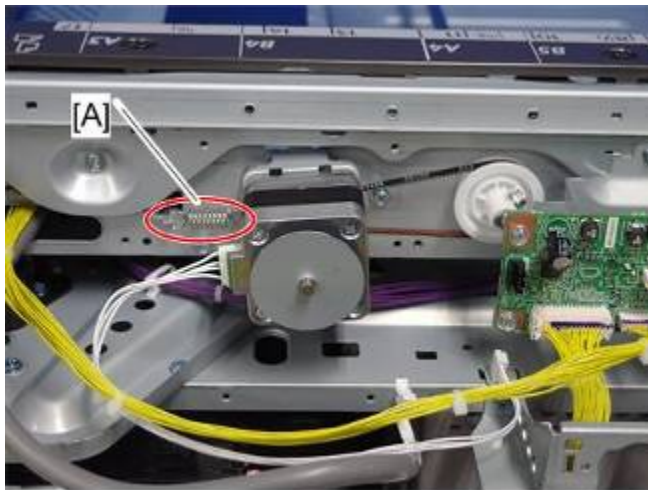

d197f0025

4. Scanner motor unit [A] (⚙️ x2, 🔩 x1)

Scanner Unit

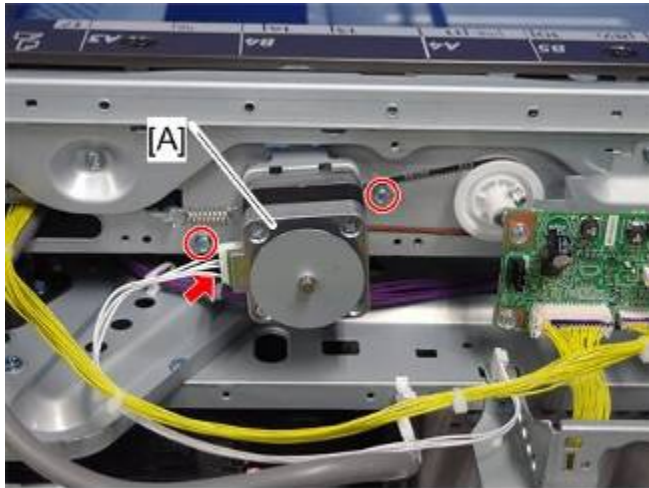

d197f0026

5. Scanner motor [A] (🔩 x2)



d1462315

4.7.5 LENS BLOCK

1. Exposure Glass (page 4-38)
2. Lens block cover [A] (🔩 x2)

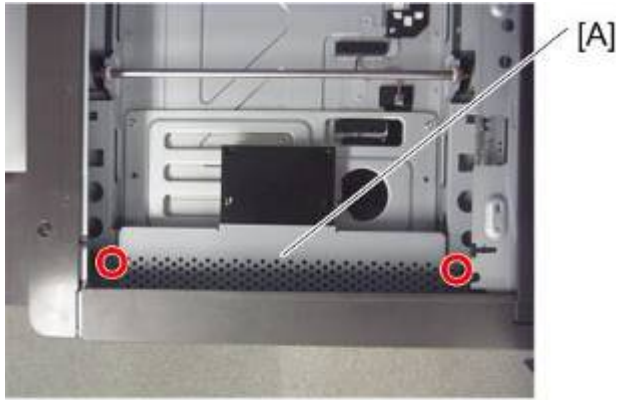

d1462316

3. Lens block [A] (🔩 x5, 🛠️ x2)

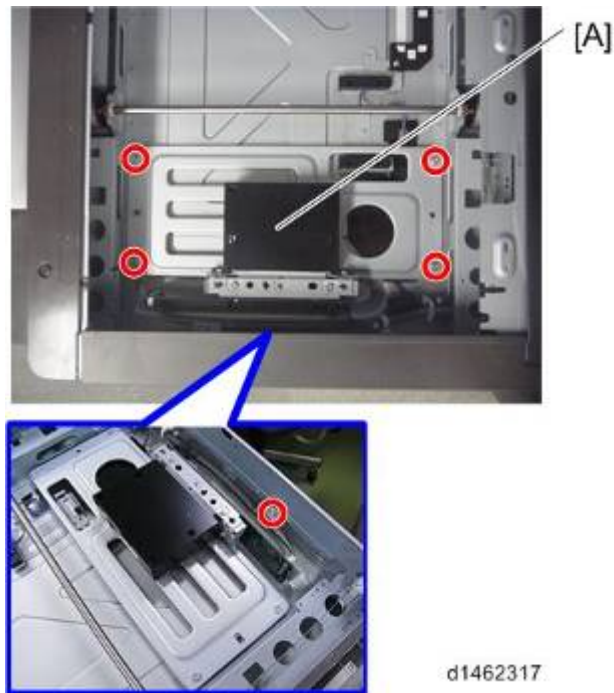

d1462317

4.7.6 ORIGINAL SIZE SENSORS (APS)

1. Exposure glass (page 4-38)
2. Original size sensors [A] (🔧 x2)

⬇ Note

- When a screw driver is inserted, the tab can be removed smoothly.

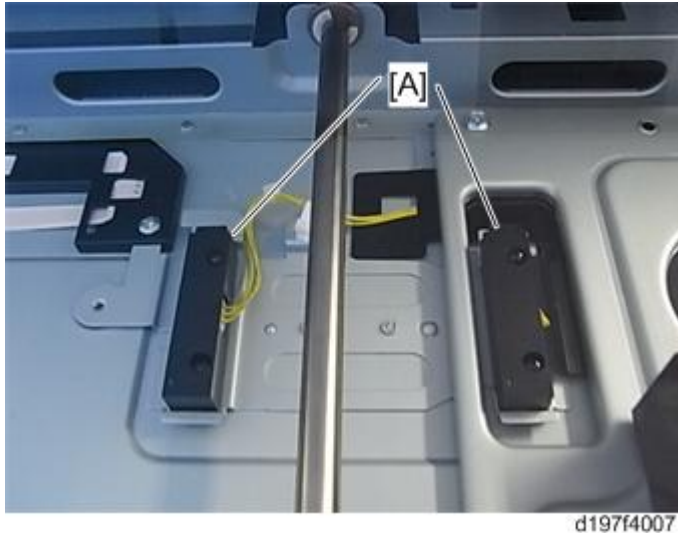

4.7.7 SIO

1. Scanner rear cover (page 4-18)
2. Scanner upper cover (page 4-36)
3. SIO [A] (🔧 x4, 🗑️ x6)



4.7.8 SCANNER HP SENSOR

1. Scanner upper cover (page 4-36)
2. Exposure glass (page 4-38)
3. Slide the exposure lamp (1st scanner carriage) [A] in the direction of the arrow a little.

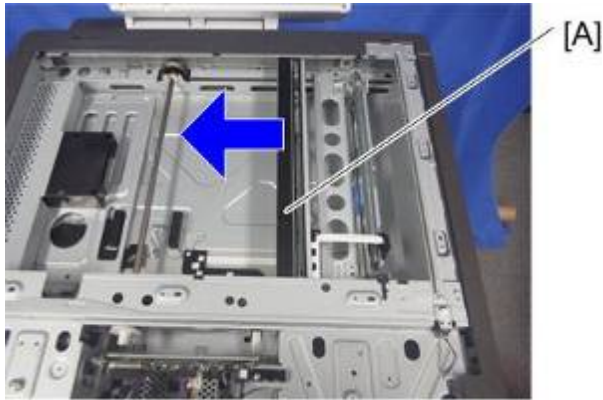

d1462320

4. Peel off the sensor stopper [A].



d1462321

5. Scanner HP Sensor [A] (🔑 x1)

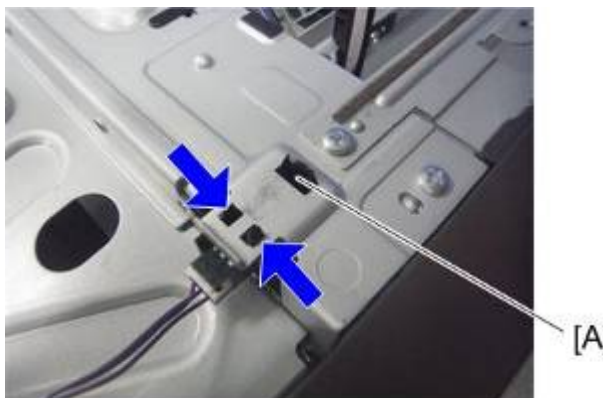

d1462322

4.7.9 DF POSITION SENSOR

1. Scanner upper cover (page 4-36)
2. DF Position sensor [A] (🔩 x1, 🛠️ x1)

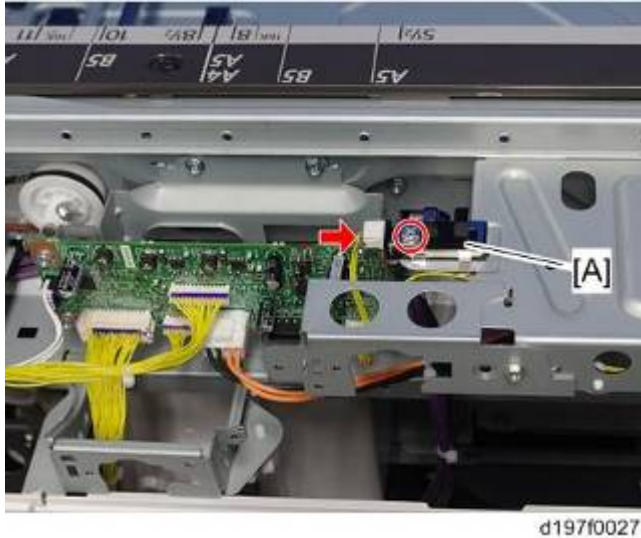

4.7.10 ADJUSTING THE SCANNER WIRE

Note

- Be sure to use the special tool for scanner wire adjustment. (page 4-5)

Scanner Wire (Front)

1. Exposure glass (page 4-38)
2. Scanner right cover (page 4-36)
3. Operation panel (page 4-29)
4. Main power switch cover (page 4-22)
5. Lower bracket [A] of the operation panel (🔩 x6, 🛠️ x3)

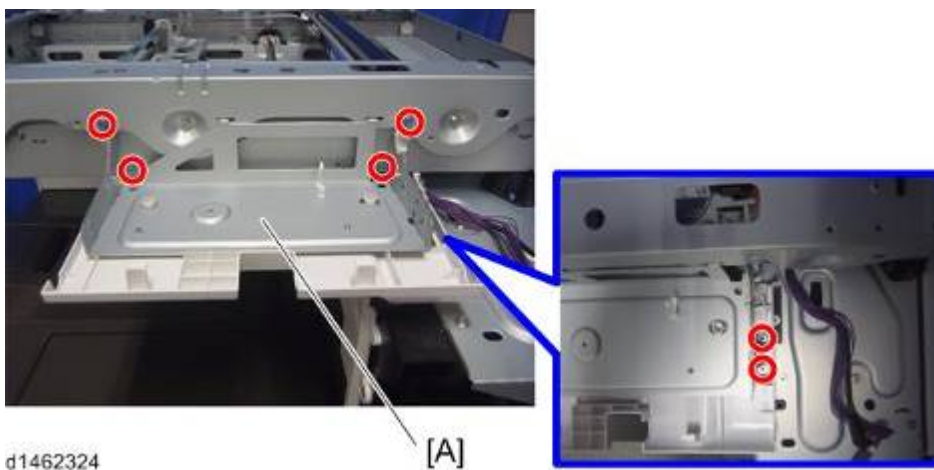

6. Scanner front frame [A] (⚙️ x6)

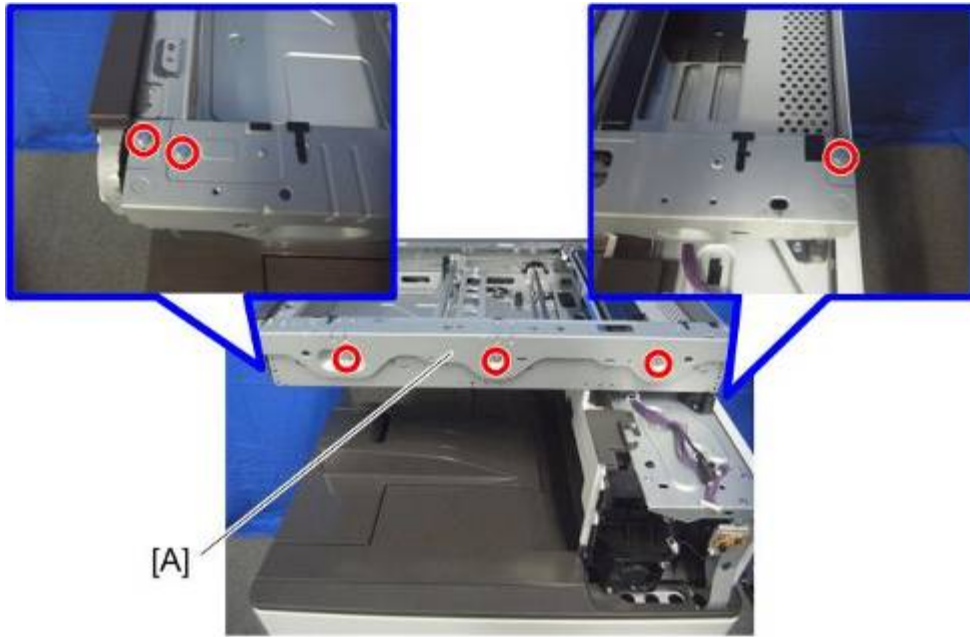

d1462325

7. Move the 1st scanner carriage to the set position of the scanner fixing pin.

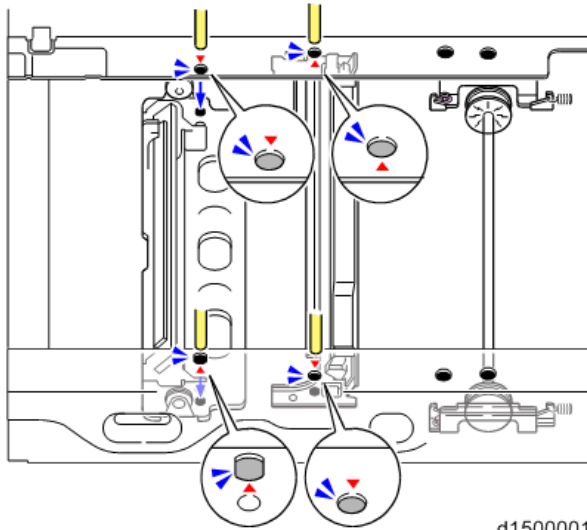

d1500001b

8. Wire clamp [A] (⚙️ x1)

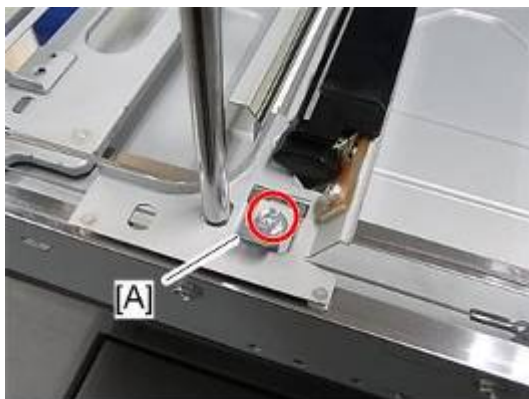

d197z0300

9. Wire fixing bracket [A], spring [B] (🔩 x1)

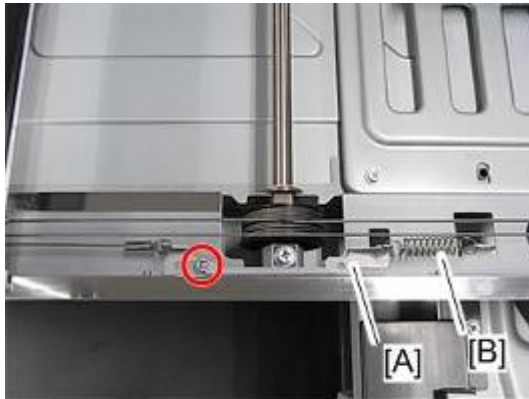

d197z0301

10. Wire pulley [A] (🔩 x 1, 🌀 x 1, bearing x 1)

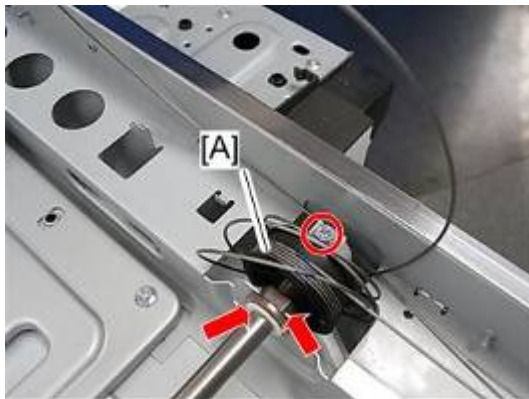

d197z0302

⬇ Note

- Do not touch the mirror and the lamp.
- When you move the carriage, hold the central part and move it gently.

Scanner Wire Assembly (Front)

1. Pass the ball-shaped end of the wire through the boss of the pulley [A].

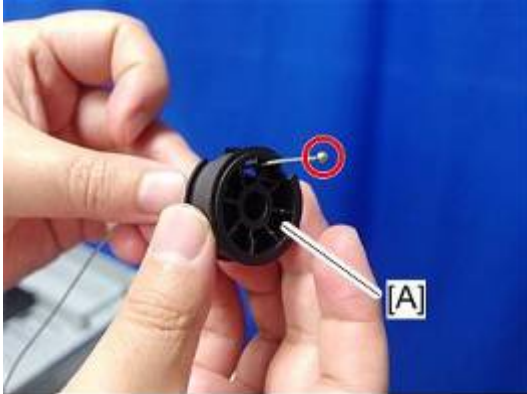

d197z0303

2. Fit the ball at the middle of the wire into the cutout in the pulley [A].

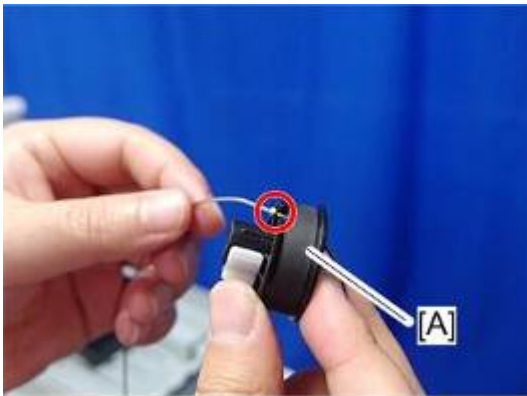

d197z0304

3. Coil up the ball-shaped end of the wire counter clockwise (when looking at the boss of the pulley) four and half times, next to the rim at the rear side of the pulley.



d197z0305

4. Coil up the ball-shaped end of the wire clockwise (when looking at the boss of the pulley) three and half times, next to the rim at the front side of the pulley.



d197z0306

5. Make sure that blue markings of the wire are aligned, and then fix the wire temporarily with tape.



d197z0307

6. Set the pulley [A] on the drive shaft [B] (⚙️ x1, 🌀 x1, bearing x 1).

⬇️ Note

- Fasten the screw temporarily.

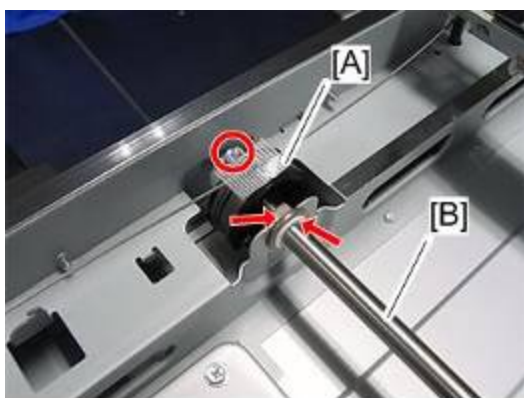

d197z0308

7. Set the ball-shaped end of the wire with the following procedure.
 1. Route the wire from under side of the pulley [A] of the left frame toward the upside and hook the wire on the outer edge of the pulley [A].



d197z0309

2. Route the wire over the 2nd carriage pulley [A] in the direction of the blue arrow.



d197z0310

3. Hook the ball-shaped end of the wire in the slit [A] in the left frame.



d197z0311

8. Set the ring-shaped end of the wire with the following procedure.

1. Route the wire from the underside of the pulley [A] of the right frame toward upside and hook the wire on the outer edge of the pulley [A].

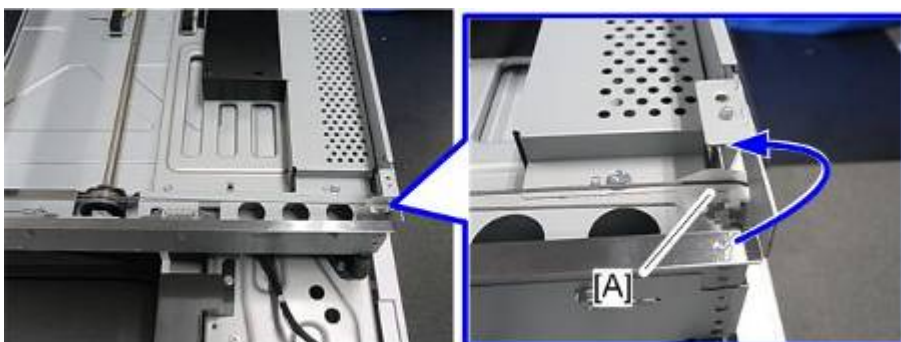

d197z0312

2. Route the wire over the 2nd carriage pulley [A] in the direction of the blue arrow.

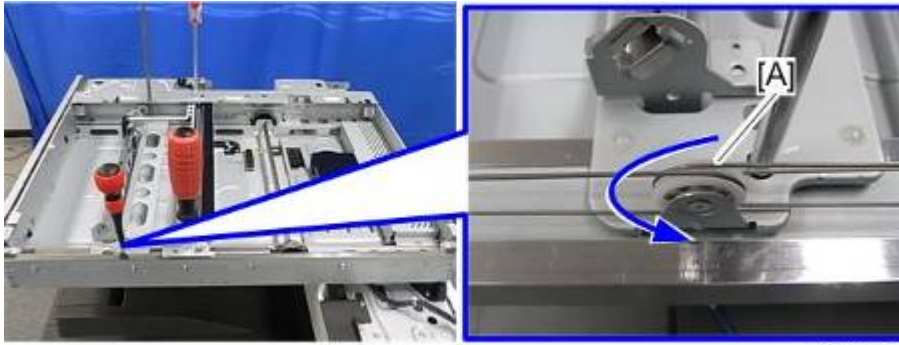

d197z0313

3. Attach the wire to the fixing bracket [A].
4. Attach the fixing bracket [A] (⊗ × 1: temporary securing, spring × 1)

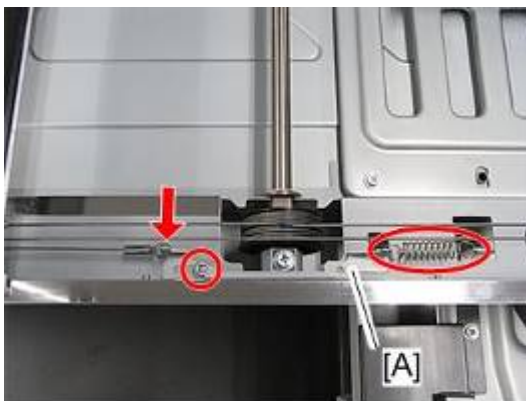

d197z0316

5. Hook the wire [B] on the notch of the carriage [A].

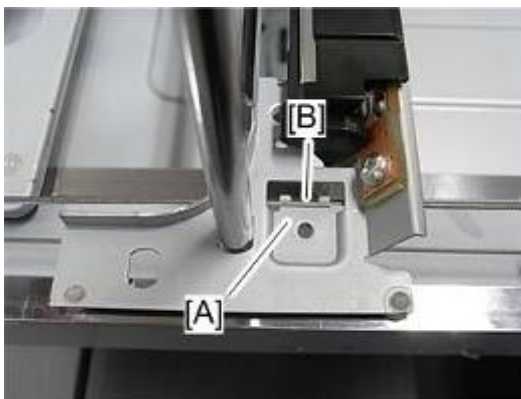

d197z0314

6. Attach the wire clamp [A] (🔩 ×1).

⬇️ **Note**

- Fasten the screw temporarily for the wire clamp.



d197z0315

9. Peel off the tape secured in step 5.

10. Attach the spring.

Scanner Position Adjustment

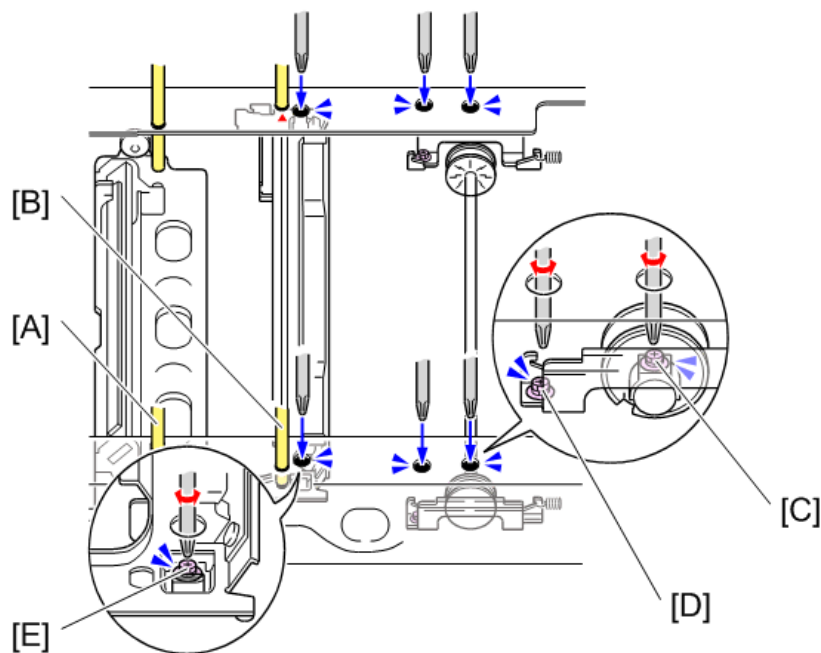

d1462336

1. **Set the scanner positioning pins (x4).**

- 2nd scanner carriage and frame hole [A]
- 1st scanner carriage and frame hole [B]
- Same position as [A] on the rear side
- Same position as [B] on the rear side

2. **Tighten the screw [C] of the pulley which was temporarily tightened.**

3. **Tighten the screw [D] of the fixing bracket which was temporarily tightened.**

4. **Attach the scanner fixing bracket [E].**

5. Pull out the scanner positioning pins.
6. Holding the center part of the 1st scanner carriage, move it to the left and right to ensure it moves smoothly.

If it does not move smoothly, loosen the scanner wire, and perform the scanner position adjustment procedure again.

Note

- After replacing the wire, make a test copy, and check skew, magnification, and whether there is a registration gap. If there is a gap, adjust the scanner wire position again, or perform Scan Registration Adjustment (SP4010 - SP4011).

Scanner Wire (Rear)

1. Scanner wire (front)
2. Bracket [A] (🔧 x4, 📦 x7)

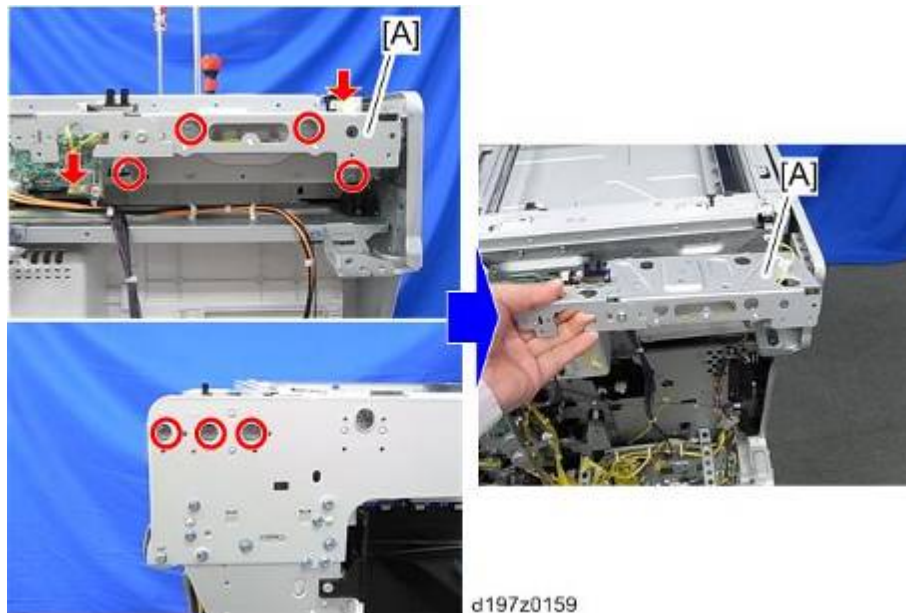

3. Release the harness (🔧 x5, 📦 x1)

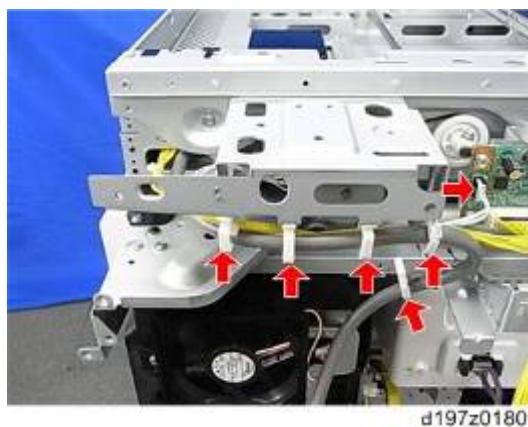

4. Bracket [A] (🔧 x4)



5. SIO with bracket (⚙️ x2, 📦 x5).

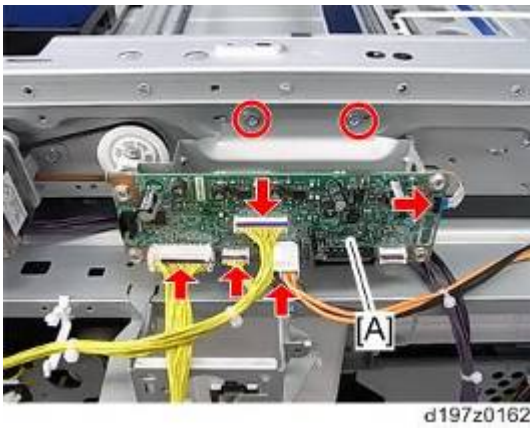

6. Scanner rear frame [A] (⚙️ x6)

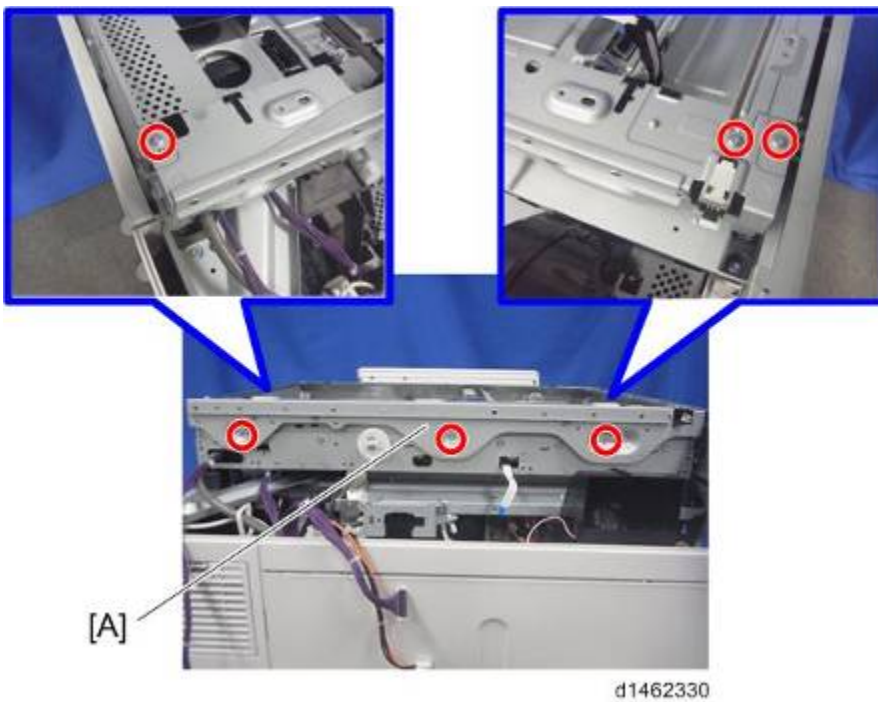

7. Move the 1st scanner carriage to the set position of the scanner fixing pin.

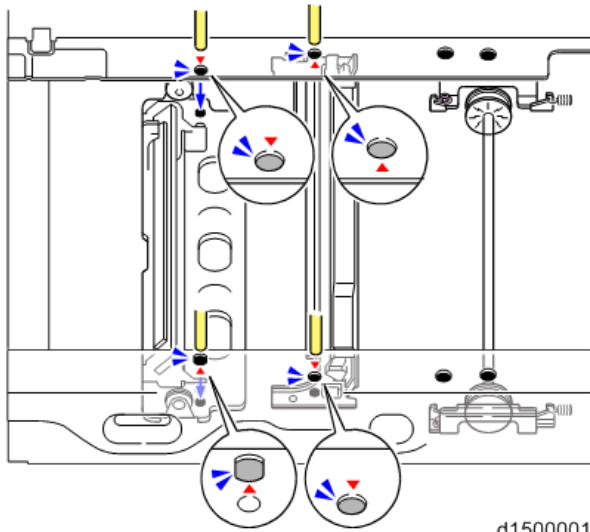

8. Wire clamp [A] (🔩 x1)



9. Loosen the belt tension [A] (🔩 x2, spring x1) and remove the scanner drive gear [B] (🔩 x1).

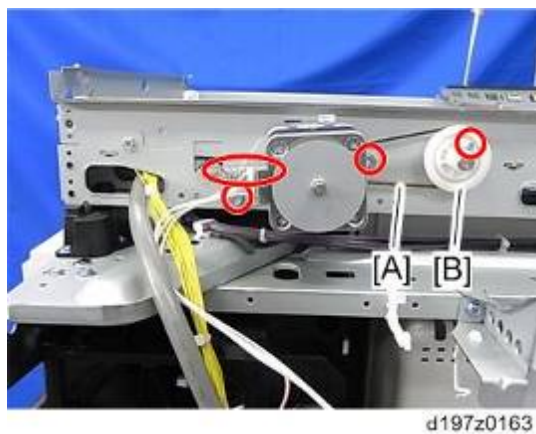

10. Spring, screws, bearing, clip and wire securing bracket

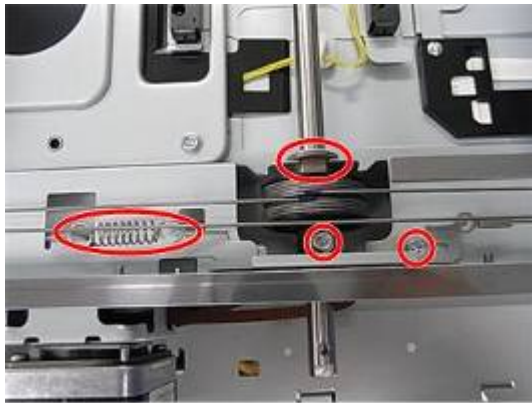

d197z0164

11. Pull out the scanner drive shaft [B] and remove the pulley [A].

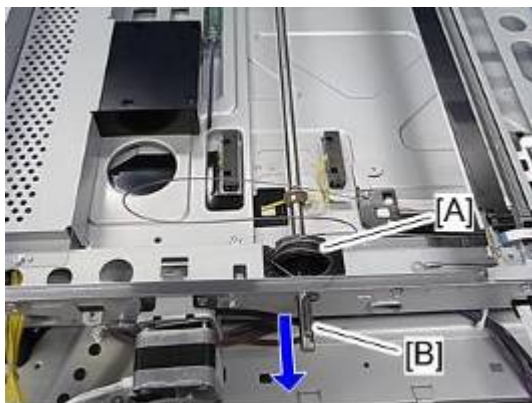

d197z0165

Scanner Wire Assembly (Rear)

1. Pass the ball-shaped end of the wire end through the boss in the pulley [A].



d197z0166

2. Fit the ball of the middle of wire in the cutout of the pulley [A].



3. Coil up the ball-shaped end of the wire counter clockwise (when looking at the boss of the pulley) four and half times, next to the rim at the rear side of the pulley.



4. Coil up the ball-shaped end of the wire clockwise (when looking at the boss of the pulley) three and half times, next to the rim at the front side of the pulley.



5. Make sure that blue markings of the wire are aligned.



d197z0171

6. Fix the wire temporarily with tape.

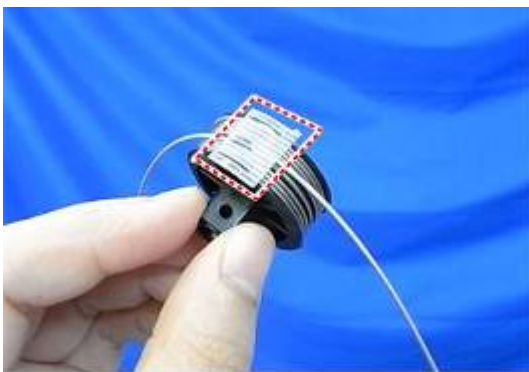

d197z0172

7. Set the pulley on the scanner drive shaft (⚙️ x1, bearing x1, 🌀 x1).

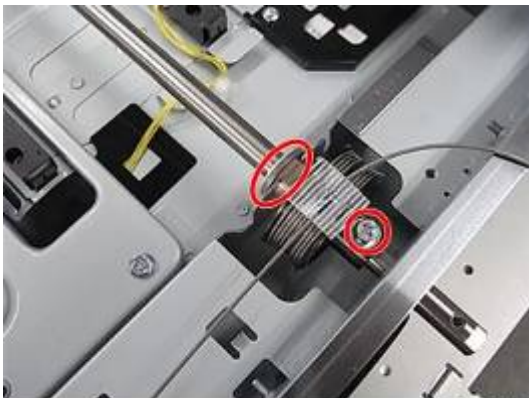

d197z0173

8. Attach the scanner drive gear [A], and then tighten the scanner motor bracket (⚙️ x3, spring x1, belt x1).

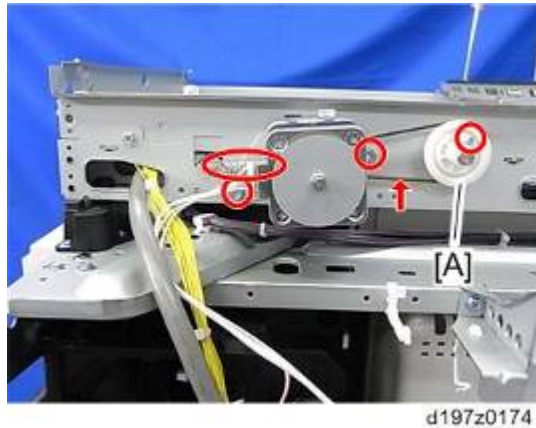

9. Reassemble the rear scanner wire with the same procedure as the front.
10. Reassemble the scanner wire (front).
11. Do the scanner adjustment.

4.7.11 MODIFYING THE SCANNER (CONTACT/CONTACTLESS) WHEN USING ARDF

Procedure for the ADF

1. ADF front cover [A] (🔑x1)

⏴ Note

- Remove with the document table [B] lifted up.



2. Document reader guide plate [A] (🔑x1)

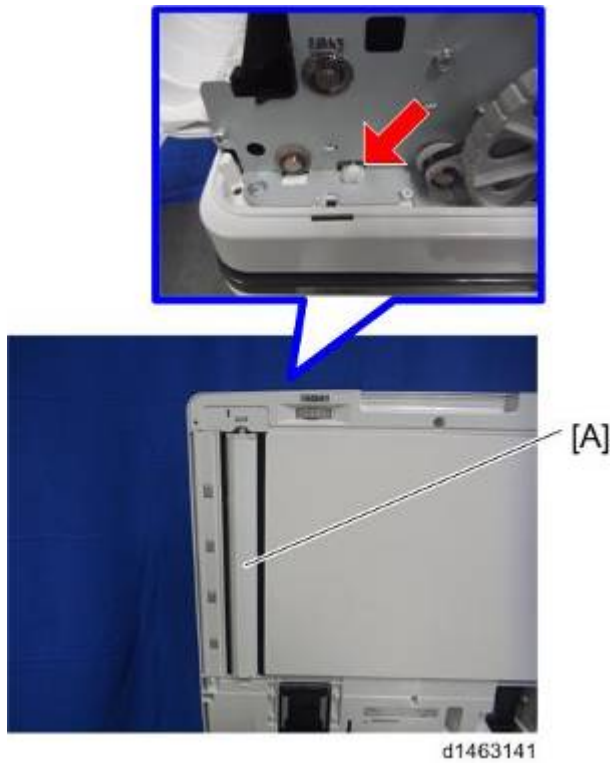

3. Replace the contactless guide plate (front) [A] with the contact guide plate (front) [B] (⚙️ ×1).

There is a hole in the contact guide plate (front).

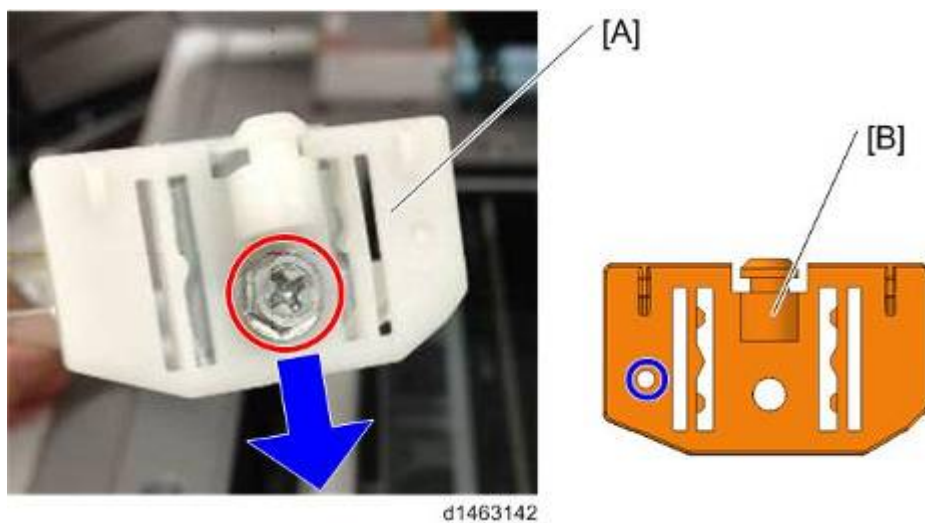

4. Replace the contactless guide plate (rear) [A] with the contact guide plate (rear) [B].

There is a hole in the contact guide plate (rear).

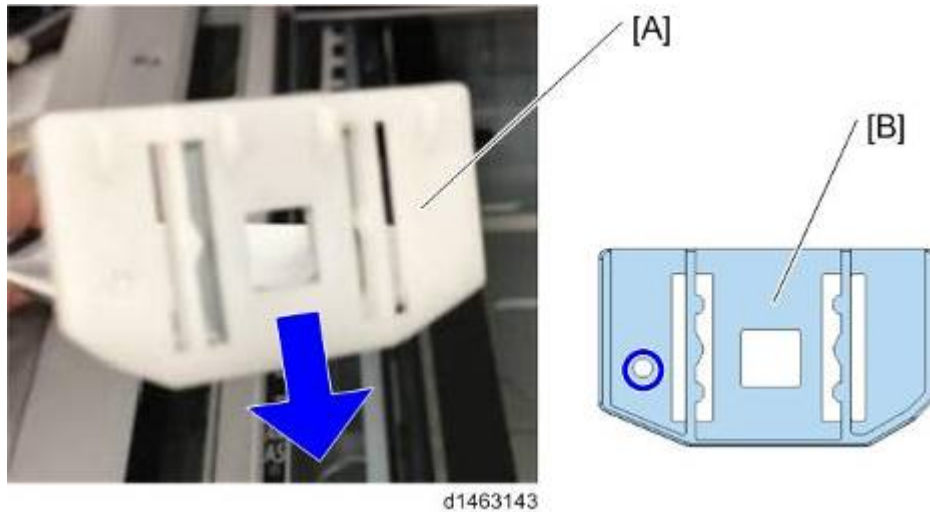

5. Attach the document reader guide plate. Be careful not to scratch the sheet [A].

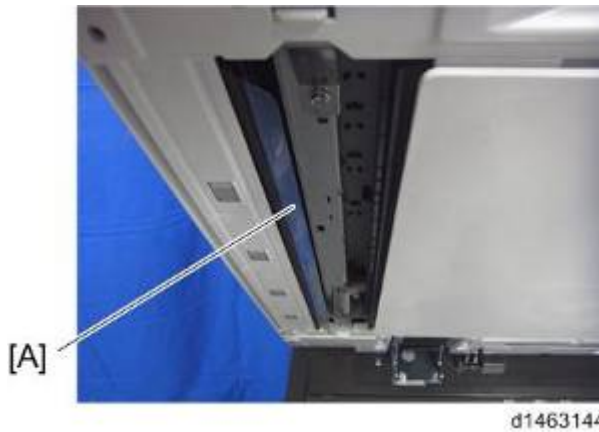

6. Attach the ADF front cover, and return the ADF to its original position.
7. Enter SP mode, and then change the DF density setting (SP4-688-001) from [102%] to [97%].

Procedure for the Scanner

1. Remove the exposure glass, and peel off the black sheet [A]

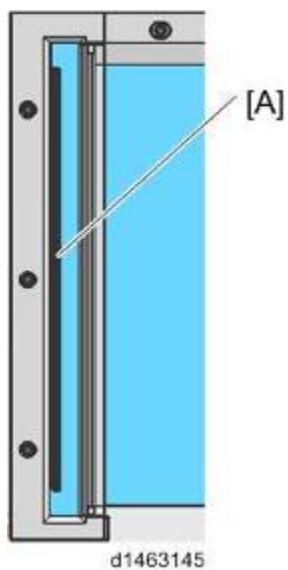

- Wipe the exposure glass with alcohols so that no glue remains from the double-sided tape.

Note

- Remember that if any glue remains, it will cause a paper jam in the ADF.

4.7.12 MODIFYING THE SCANNER (CONTACT/CONTACTLESS) WHEN USING SPDF

When changing from contactless to contact original feed, some parts of the ADF and scanner must be replaced.

Procedure for the SPDF

- Open the SPDF.
- Lower entrance guide unit [A] (x2)

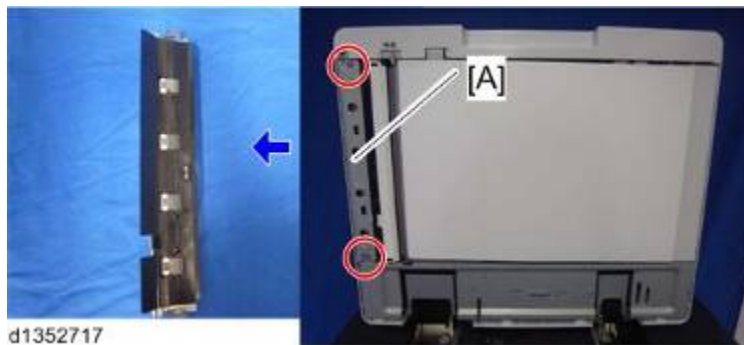

Note

- The part below the contactless lower entrance guide unit is black [A].
- The part below the contact lower entrance guide unit is colorless and transparent [B].

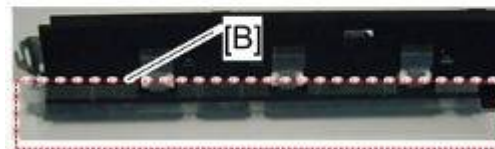

d1352723

- Document reader guide plate [A]



Note

- The part below the contactless document reader guide plate is black [A].
- The part below the contact document reader guide plate is white [B].

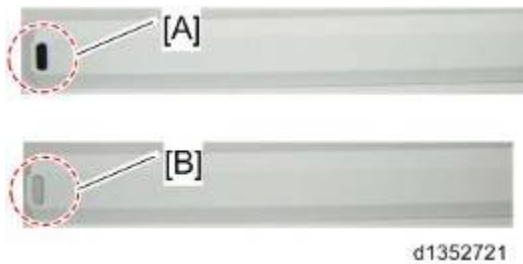

4. Attach the contact document reader guide plate [A].
5. Attach the contact lower entrance guide unit [B] (x2).

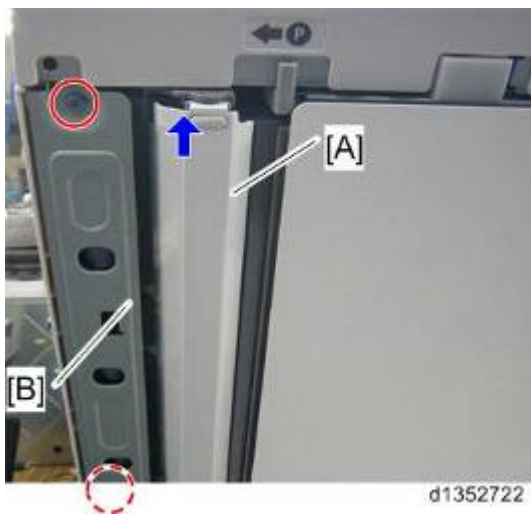

6. Enter SP mode, and then change the Scan Image Density Adjustment (SP4-688-002) from [103] to [98].

Procedure for the Scanner

1. Exposure glass (page 4-38)
2. Peel off the gap sheet (black) [A] from the sheet-through glass [B].

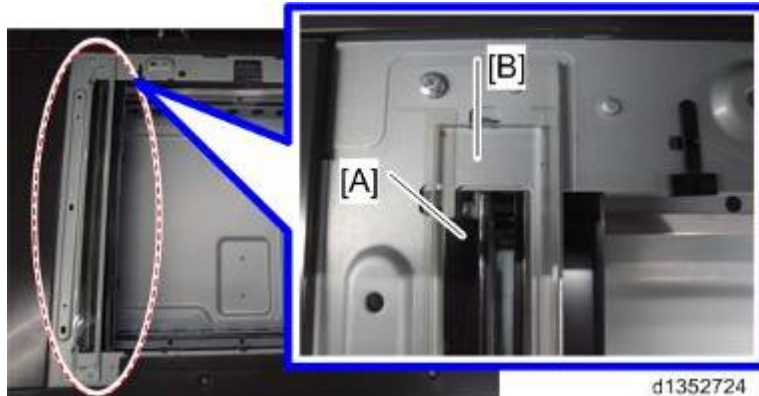

3. Wipe the exposure glass with alcohol, etc., so that no glue remains from the double-sided tape.

Note

- Remember that if any glue remains, it will cause a paper jam in the ADF.

4.8 LASER UNIT

⚠ WARNING

- Turn off the main power switch and unplug the machine before beginning any of the procedures in this section. Laser beams can cause serious eye injury.

4.8.1 CAUTION DECAL LOCATION

Caution decals are placed as shown below.



d197f0015

⚠ WARNING

- Be sure to turn off the main power switch and disconnect the power plug from the power outlet before beginning any disassembly or adjustment of the laser unit. This copier uses a class IIIb laser beam with a wavelength of 660 nm and an output of 17 mW. The laser can cause serious eye injury.

4.8.2 LASER UNIT

Removing the Laser Unit

1. Open the front cover.
2. Laser unit cover [A] (🔩 x 1)

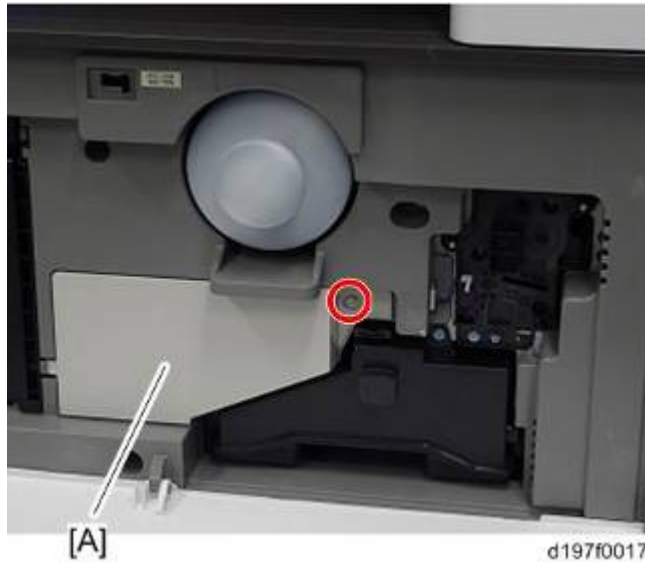

3. Release the stopper [A].



4. Pull out the laser unit [A] (🔧 x 3).



Installing a New Laser Unit

1. Replace the laser unit with a new laser unit.
2. Insert the new laser unit [A] halfway.



3. Connect three harnesses to the new laser unit (🔌 x 3).



4. Insert the new laser unit along the guide frame [A].

Note

- Make sure that the new laser unit claws fit into two mainframe claws as shown below.

Mainframe Claws



Laser Unit Claws

d197f0327

5. Set the laser unit with the stopper [A].
 - Use a screw driver to pry in the stopper.



d197f0009

6. Attach the laser unit cover [A] (⊗ x 1).

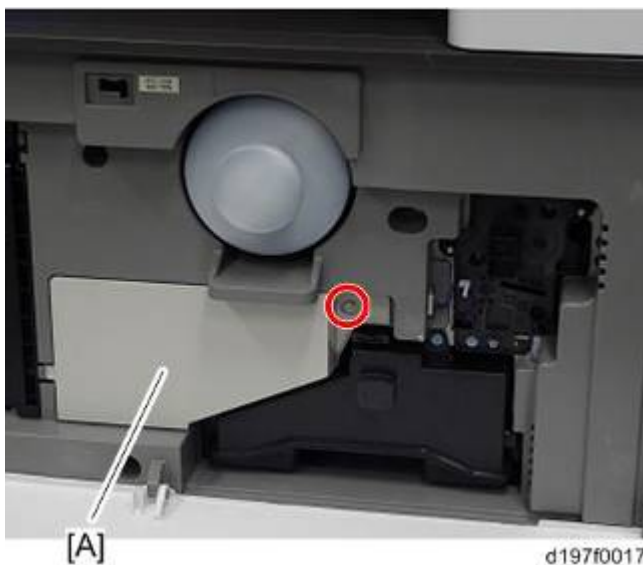

d197f0017

After Installing the New Laser Unit

Download new data stored in a new laser unit to the mainframe.

1. Close the front cover.
2. Plug in and turn on the main power switch.
3. Enter the SP mode.
4. Download the new data stored in the new laser unit to the mainframe with SP2-110-005.

Note

- If the result of SP2-110-005 is not successful, execute SP2-110-005 again.
- If this step is not correctly done, an image problem may occur on printouts.

5. Perform image adjustments if needed (page 4-197).

4.8.3 QUENCHING LAMP

1. Right cover (page 4-20)
2. Fusing unit (page 4-114)
3. Tabs and connector for the quenching lamp [A] (⏏ x 3, ⏏ x 1)

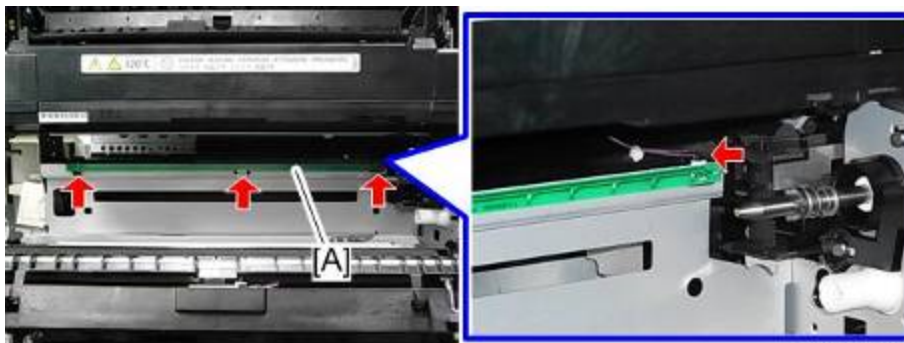

d197z0188

4. Quenching lamp [A]



d197z0189

4.8.4 PCL (PRE CLEANING LIGHT)

1. PCDU (page 4-72)
2. Fusing Unit (page 4-114)
3. PCL [A] (⚙️ x3, 🔩 x3, 📦 x1).

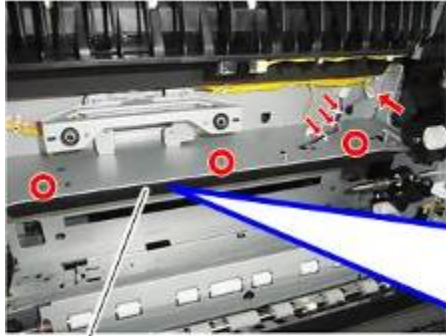

[A]



d197z0484

4.9 PCDU

4.9.1 BEFORE REPLACING A PCU OR DEVELOPMENT UNIT

★ Important

- To prevent damage from toner spillage during the PCDU removal, be sure to place a ground cloth on the floor.
- To prevent damage from excess light, wrap the OPC drum with protective paper and store the OPC drum in a cool dark place.
- **Do not** touch the OPC drum, cleaning blade, or any seals or tapes.
- **Do not** use any alcohols or solvents to clean the OPC drum; Be sure to wipe with a dry cloth. If excess dirt exists, first wipe with a damp cloth, and next wipe off completely with a dry cloth.
- **Do not** rotate the OPC drum clockwise after the PCDU has been installed.

4.9.2 PCDU

↓ Note

- If you replace the PCDU, you do not need to perform SP 3-701. This is because the machine detects a new unit automatically when you cycle the main power off/on, and performs the initial adjustment automatically.

1. Open the front cover
2. Open the right cover
3. Tilt the transfer unit [A].



d197z0072

4. PCDU [A] (🔧 x1, 📦 x1)

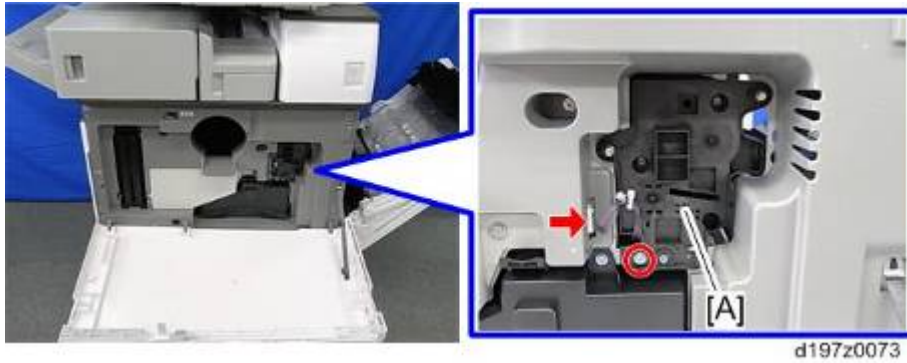

Note

- Carefully and slowly pull out the PCDU without tilting, to prevent toner spillage.



Important

- When installing the PCDU, push the PCDU into the machine while screwing it in, as shown below, and then secure the PCDU. If the PCDU is not installed straight, the transfer roller contact and release mechanism does not work properly and dirt may appear on the 2nd side of outputs.



4.9.3 PCU/DEVELOPMENT UNIT

1. PCDU (page 4-72)
2. Face plates [A][B] (🌀 x4, 🌀 x1)

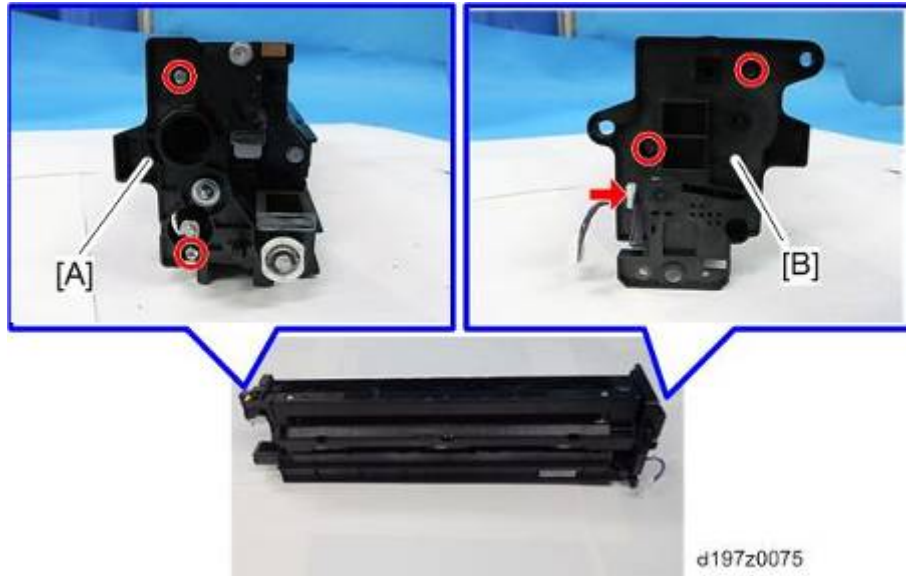

3. Split the assembly into the PCU [A] and development unit [B].



Notes When Installing the Face Plates

When installing the face plates, check the fitting points as shown below.

[A]: The bearing of the face plate fits together with the OPC drum.

[B]: The bearing of the face plate fits together with the bearing of the development roller.

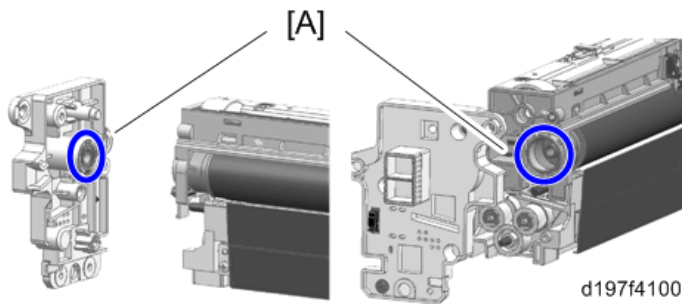
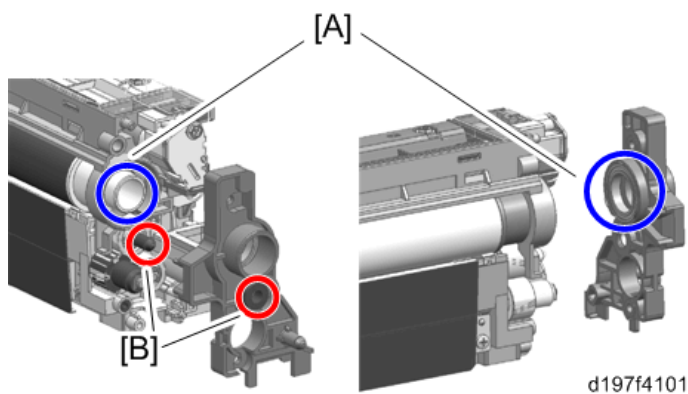
Face plate for front side**Face plate for rear side****Installing a PCU****★ Important**

- Before replacing the PCU, set the setting of SP3-701-002 to “1” and turn off the main power switch.
- If you have to turn the power on again before replacing the part, execute the SP again before replacing the part.
- After replacing the PCU, turn on the main power on.

1. Disassemble the PCDU into PCU and development unit (page 4-74).
2. Replace the used PCU with a new one.
3. Reassemble the PCDU.

Installing a Development Unit**★ Important**

- Before replacing the development unit, set the setting of SP3-701-023 to “1” and turn off the main power switch.
- If you have to turn the power on again before replacing the part, execute the SP again before replacing the part.
- After replacing the development unit, turn on the main power on.

1. Disassemble the PCDU into PCU and development unit (page 4-74).

PCDU

2. Replace the used development unit with a new one.
3. Reassemble the PCDU.
4. Pull out the heat seal [A].



d197z0198

5. Remove the cap [A].



d197z0430

ⓘ Note

- Attach the removed cap to the used development unit.

4.9.4 OPC DRUM

★ Important

- Before replacing the OPC drum, set the setting of SP3-701-021 to “1” and turn off the main power switch.
- If you have to turn the power on again before replacing the part, execute the SP again before replacing the part.
- After replacing the OPC drum, turn on the main power on.

1. PCU (page 4-74)

2. Stopper [A] for the PCU

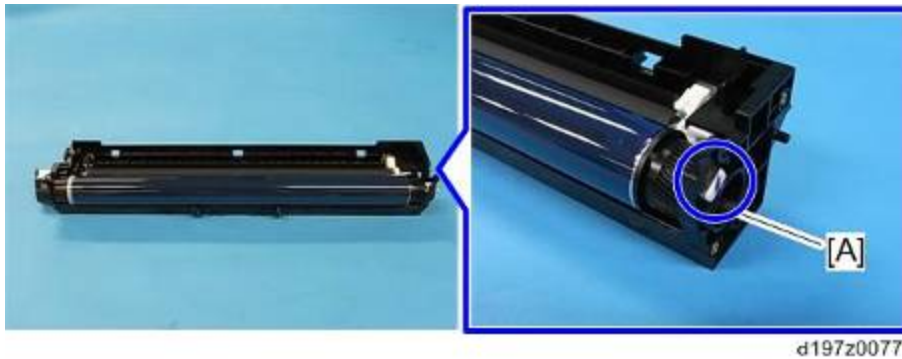

3. Pull out the OPC drum [A].



4.9.5 CHARGE ROLLER, CLEANING ROLLER

Important

- Before replacing these rollers, set the setting of SP3-701-018 for the charge roller and/or SP3-701-019 for the cleaning roller to "1" and turn the main power switch OFF.
- If you have to turn the power on again before replacing the part, execute the SP again before replacing the part.
- After replacing the rollers, turn the main power switch ON.

1. PCU (page 4-74)
2. OPC drum (page 4-77)
3. Charge roller and cleaning roller [A] with its bearing



4. Split the assembly into the charge roller [A] and cleaning roller [B].

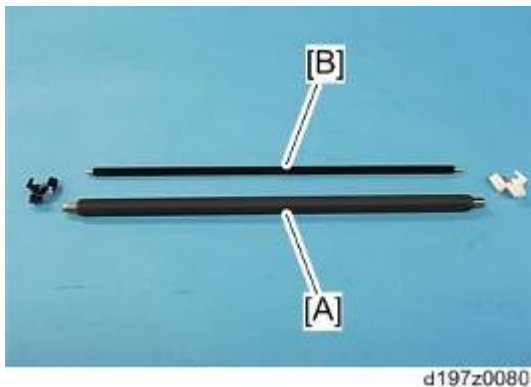

4.9.6 PICK-OFF PAWLS

★ Important

- Before replacing the pick-off pawls, set the setting of SP3-701-022 to “1” and turn off the main power switch.
- If you have to turn the power on again before replacing the part, execute the SP again before replacing the part.
- After replacing the pick-off pawls, turn on the main power on.

1. PCU (page 4-74)

2. Pick-off pawls [A]

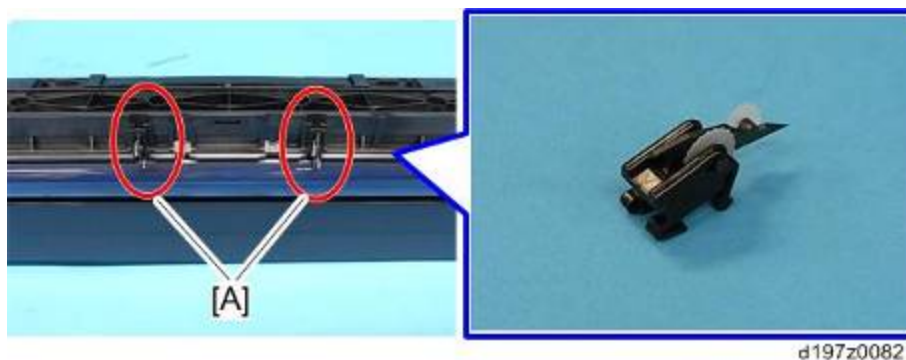

↓ Note

- Use a screw driver to pry away the tabs of the pick-off pawl. If the pick-off pawl has marked the drum with a line, the pick-off pawl position can be adjusted.



4.9.7 CLEANING BLADE

★ Important

- Before replacing the cleaning blade, set the setting of SP3-701-009 to “1” and turn the main power switch OFF.
- If you have to turn the power on again before replacing the part, execute the SP again before replacing the part.
- After replacing the cleaning blade, turn the main power switch ON.

1. PCU (page 4-74)
2. OPC drum (page 4-77)
3. Charge roller and cleaning roller (page 4-78)
4. Cleaning blade [A] (🔩 x2)



↓ Note

- The cleaning blade [A] has two different types of holes: a circle (○), and an oval (◌). Remove the screw on the circle side first, and then, remove the oval side.

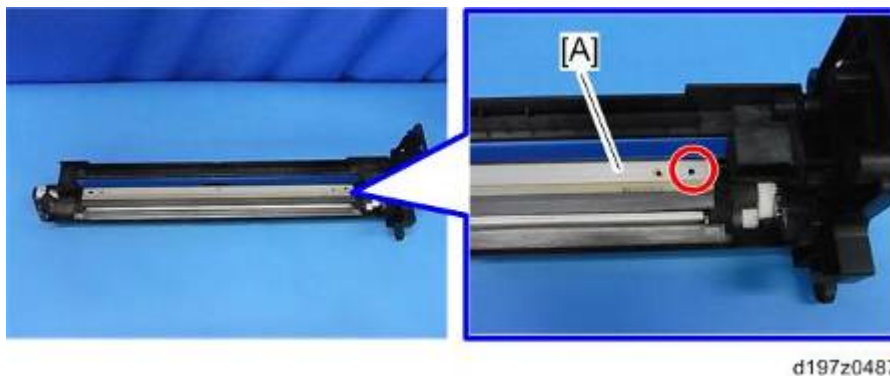

4.9.8 DEVELOPER

Preparation

- These sheets used in steps 6, 11, and 12 are not provided as accessories; please do not forget to order with the developer.



d197f0608

Important

- Before replacing the developer, set the setting of SP3-701-024 to "1" and turn the main power switch OFF.
- If you have to turn the power on again before replacing the part, execute the SP again before replacing the part.
- After replacing the developer, turn the main power switch ON.

Note

- If you replace developer together with the development filter, firstly replace the developer, next replace the filter.

- Development unit (page 4-74)
- Bearing (front) [A] (E-ring x1)



d197z0087

3. Pull the shaft toward the blue arrow shown below, then remove the pin [A] and gear [B].

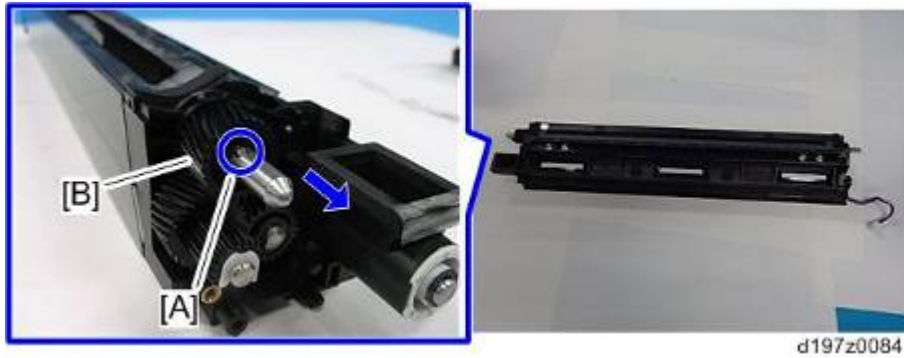

4. Gear [A] (1x1)

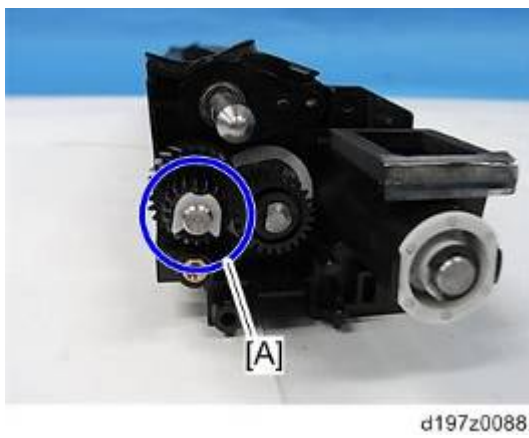

5. Bearing (rear) [A].



6. Development side seal and development case entrance seal [A] at each end.



7. Lift up the development sleeve unit [A].



⚠ CAUTION

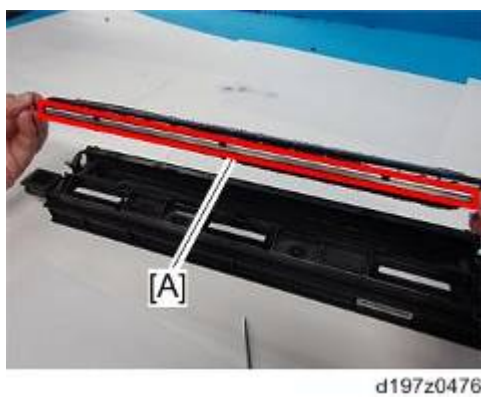

- Do not touch or hold the development sleeve edge [A] when holding the sleeve unit. Otherwise, it may cause an injury.

8. Remove the developer after turning the development unit upside down in the reverse direction of the development filter.

↓ Note

- Rotate the gear to remove as much toner as you can.



d197z0090

9. Stand the development unit up, and add new developer evenly across the width of the development unit while rotating the gear.



d197f4081

10. Reassemble the development sleeve unit, gear and bearing.

↓ Note

- The sheets for the development sleeve unit [A] must be under the sheets [B] for the development unit.



d197z0319



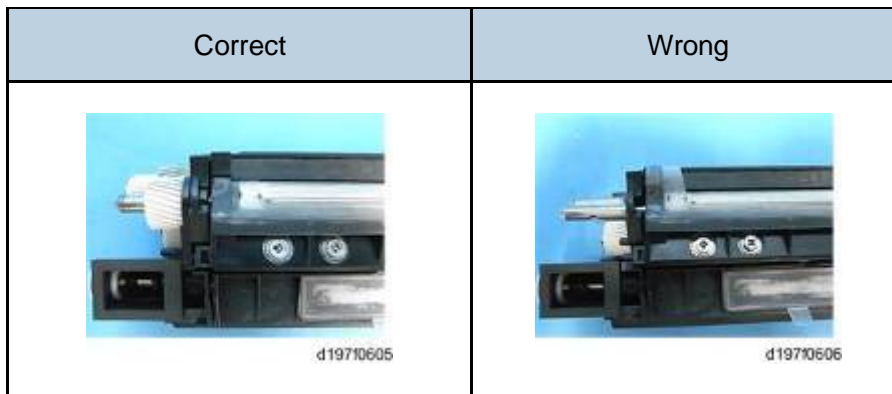

11. Wipe off the areas [A] indicated by the red-dashed line and paste new development case entrance seals to cover the blue-circled position.

- These seals are part of the development seal set, which must be ordered together with the new developer.

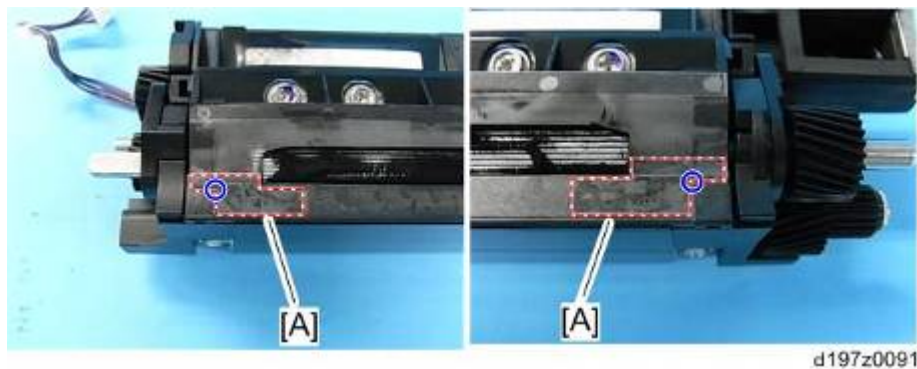

Note

- The seal [A] for the front side is not the same shape as the one [B] for the rear side as shown below. Be careful when you paste them.

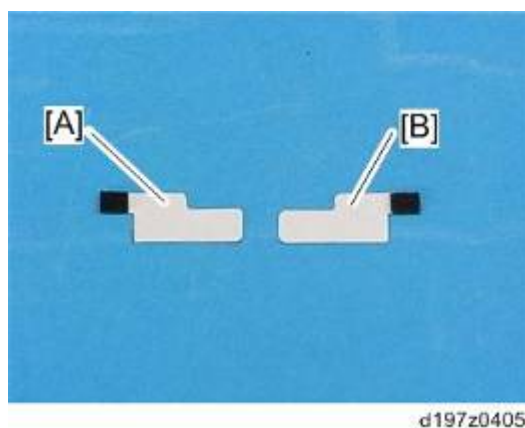

12. Paste the new development side seals [A] on the face of the development sleeve unit as shown below.

- These seals are part of the development seal set, which must be ordered together with the new developer.

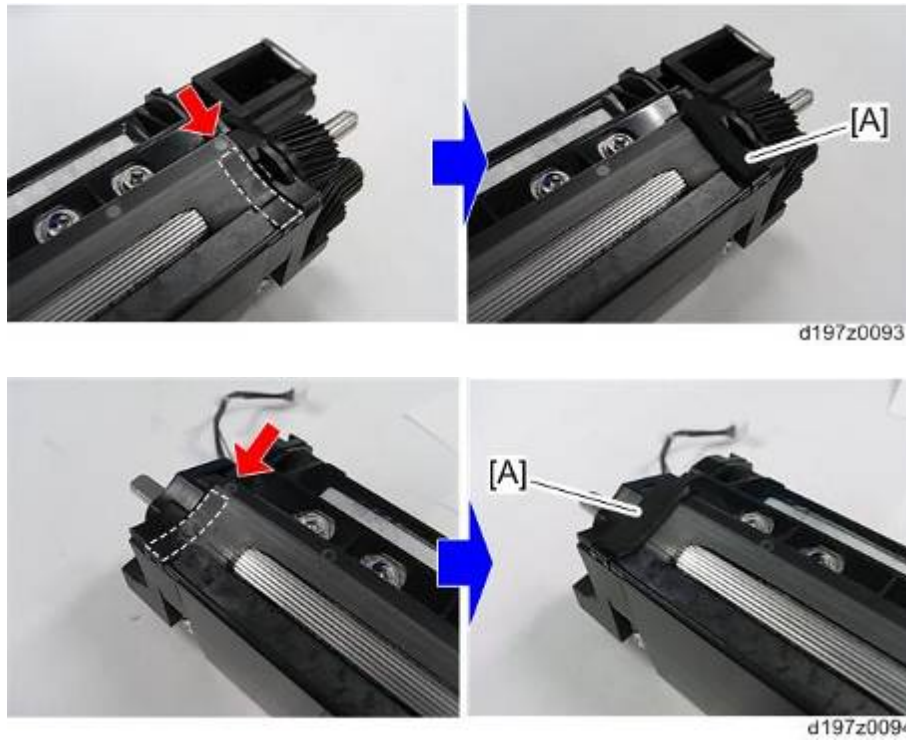

13. Reassemble the PCU and development unit.

14. Turn on the main power switch.

The machine detects the new developer and starts the initial adjustment.

4.9.9 DEVELOPMENT FILTER

★ Important

- Before replacing the development filter, set the setting of SP3-701-025 to “1” and turn the main power switch OFF.
- If you have to turn the power on again before replacing the part, execute the SP again before replacing the part.
- After replacing the development filter, turn the main power switch ON.

↓ Note

- If you replace the development filter together with developer, firstly replace the developer, next replace the filter.

1. Development unit (page 4-74)

2. Development filter [A]



d197z0095

4.9.10 TD SENSOR

1. Development unit (page 4-74)
2. TD sensor cover [A].

Note

- Use a screw driver to release the tab(s) of the cover.

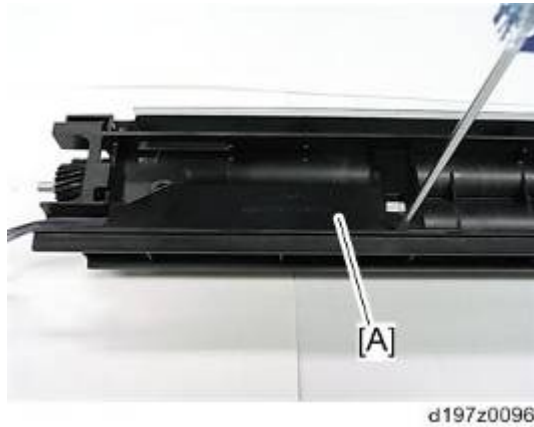

3. TD sensor [A] (📦 x1)



4.9.11 DEVELOPMENT MIXING AUGER BEARINGS

★ Important

- Before replacing the development mixing auger bearings, set the setting of SP3-701-028 to "1" and turn the main power switch OFF.
- If you have to turn the power on again before replacing the part, execute the SP again before replacing the part.
- After replacing the development mixing auger bearings, turn the main power switch ON.

1. Development unit (page 4-74)
2. Pull the shaft toward you, and then pull out the pin [A] and remove the gear [B].

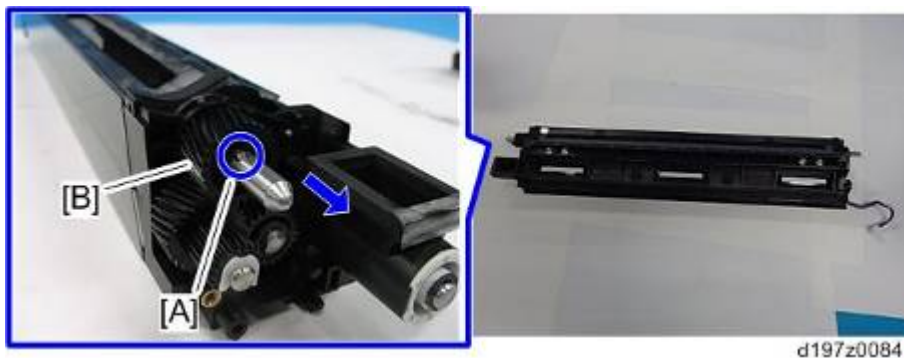

3. Gears [A] [B] (E-ring x1)

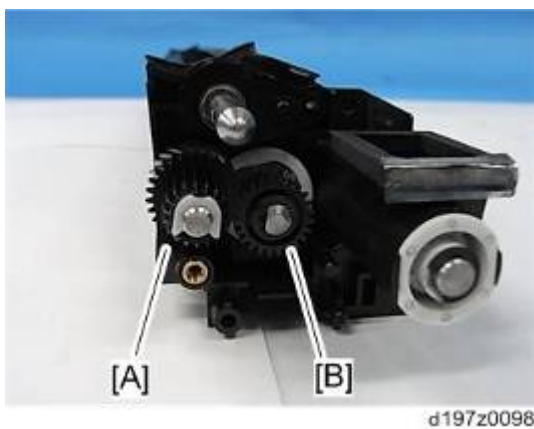

4. Two development mixing auger bearings [A] (E-ring x1).



5. Gears [A] [B] [C] (E-ring x2)

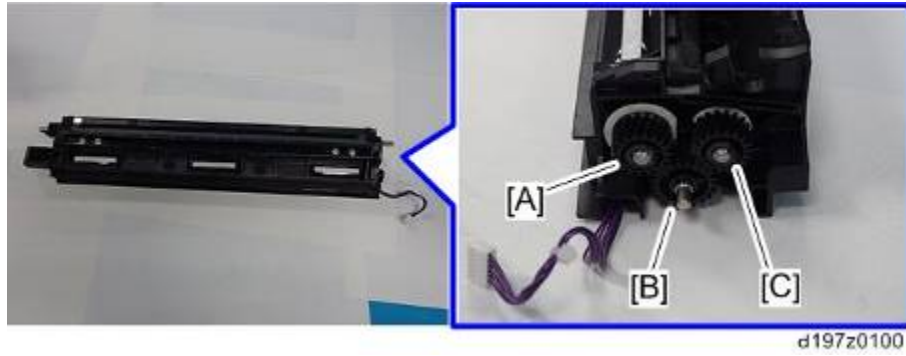

6. Two development mixing auger bearings [A].

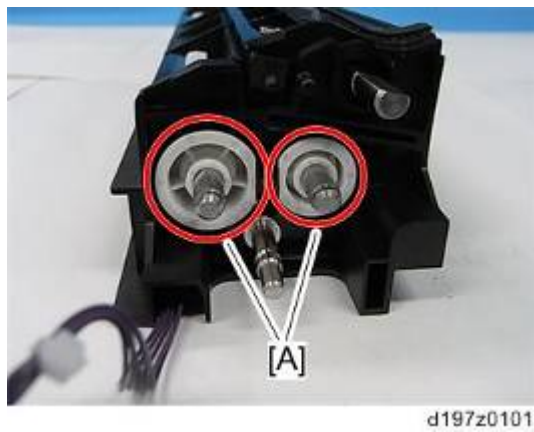

Note

- The development mixing auger bearings are D-shaped. Make sure that you install them in the orientation exactly as shown above.

4.9.12 DEVELOPMENT MIXING AUGER (L / R)

Note

- [A]: Development Mixing Auger (L)
- [B]: Development Mixing Auger (R)



1. Development Unit (page 4-74)
2. Developer (page 4-81)
3. Development Mixing Auger Bearings (page 4-89)
4. Development Mixing Auger (L) [A]

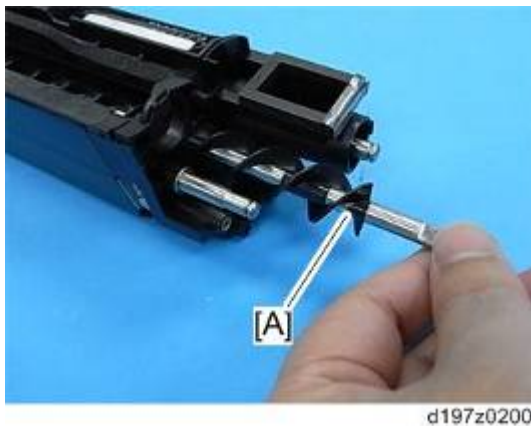

5. Development Mixing Auger (R) [A]

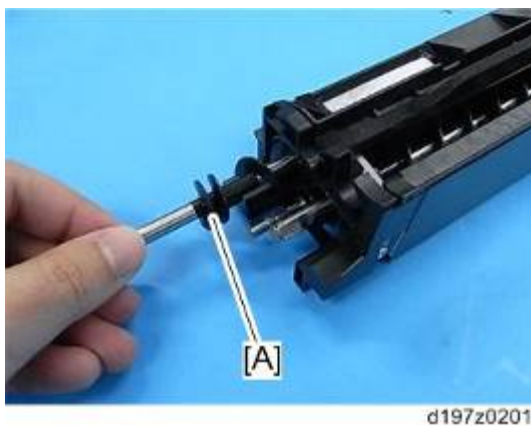

↓ Note

- Each auger is different; please make sure that the augers are attached correctly.
- [A]: Development Mixing Auger (L)
- [B]: Development Mixing Auger (R)



4.10 WASTE TONER

4.10.1 WASTE TONER BOTTLE

1. Open the front cover.
2. Pull out the waste toner bottle [A] (🔑 x1, 🗑️ x1).

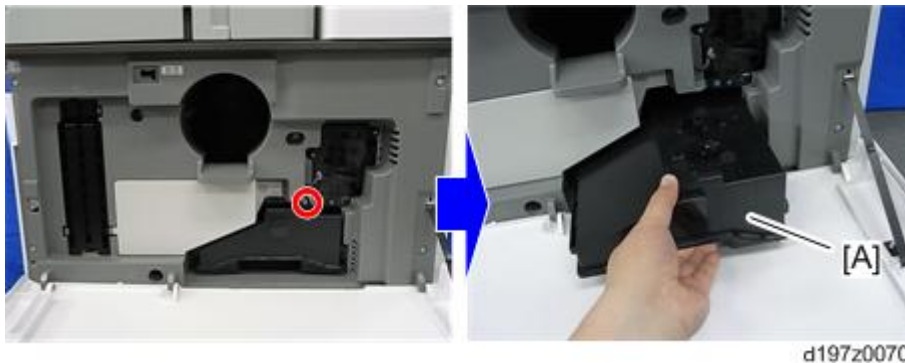

⬇ Note

- There is no waste toner bottle set switch. If you remove the waste toner bottle, be sure to replace it before you finish work on the machine.

4.10.2 TONER COLLECTION FULL SENSOR

1. Waste toner bottle (page 4-93).
2. Tone collection full sensor [A] (🔑 x1).

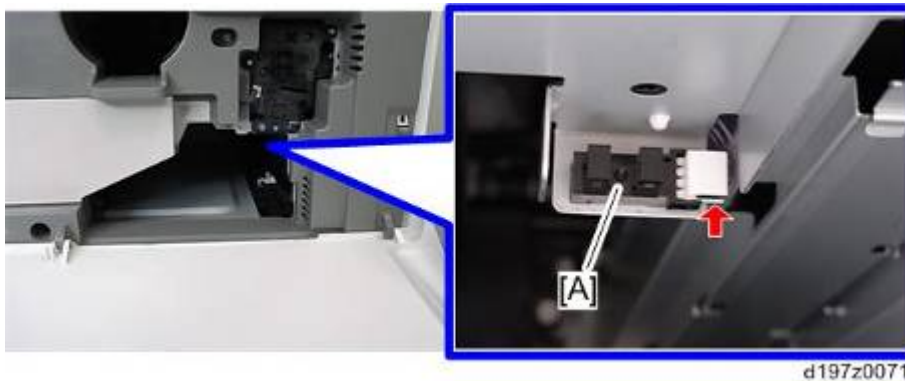

4.10.3 RECYCLING SHUTTER SOLENOID

1. Waste toner bottle (page 4-93).
2. PCDU (page 4-72).
3. Controller box (page 4-177).
4. Development Bearing Cooling Fan for D200/D201/D202 models only (page 4-185).
5. Duct [A] (🌀 x2).

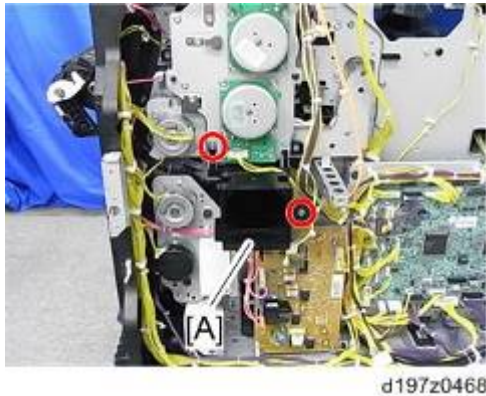

6. 📦 x3.



7. Motor unit [A] (🌀 x8).

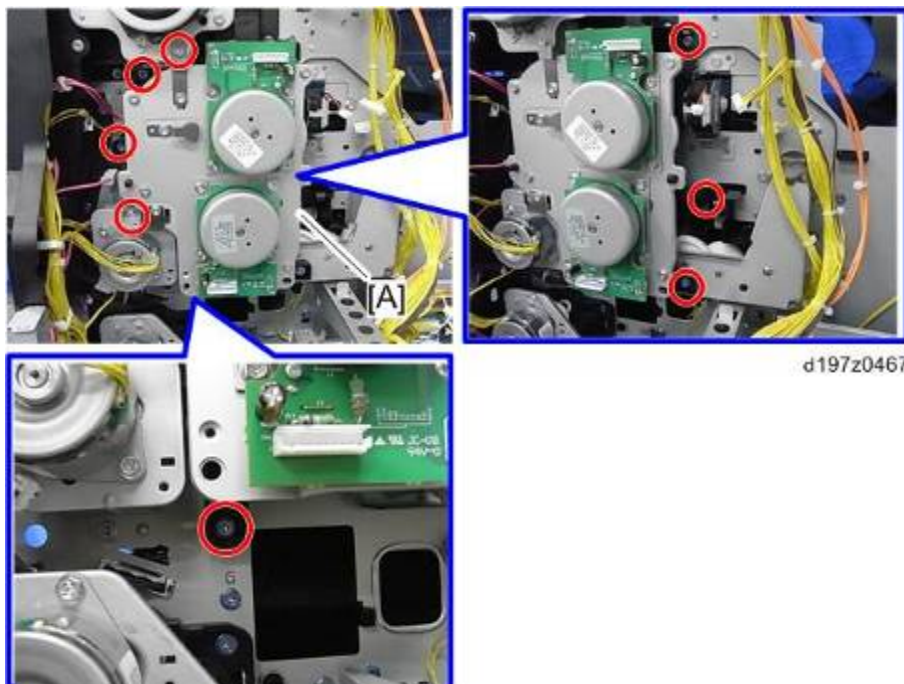

8. Bracket [A] (⚙️ x4, washer x 1).

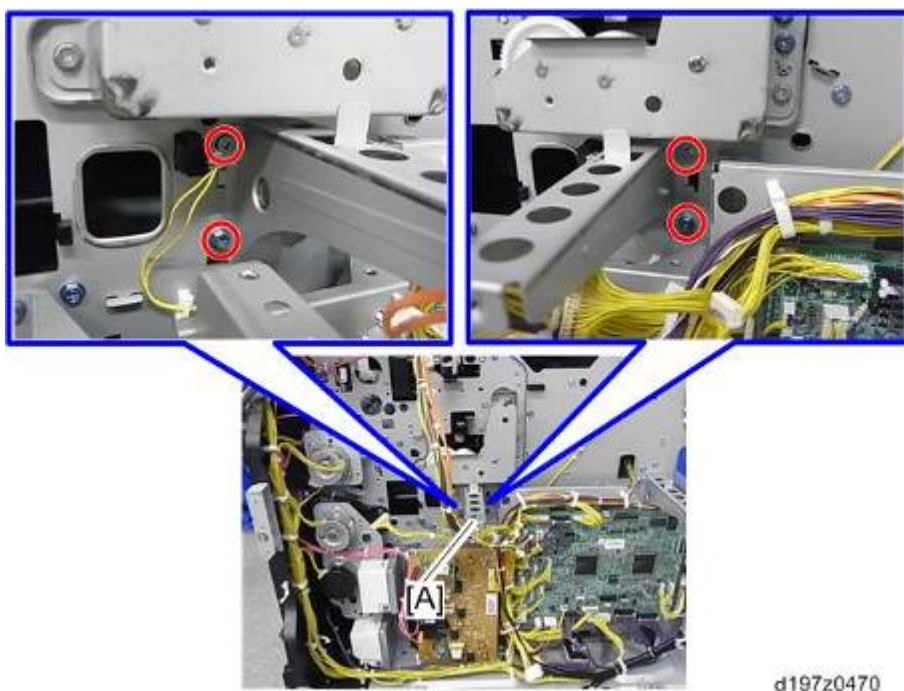

9. Recycling shutter bracket [A] (⚙️ x4).

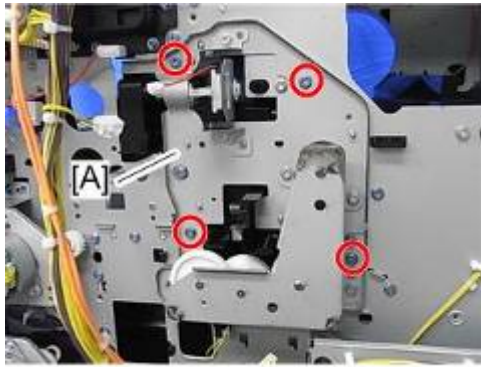

d197z0472

↓ Note

- Spread paper on the floor to catch possible toner spills.

10. Recycling shutter solenoid [A] (⚙️ x2, ⚙️ x1).

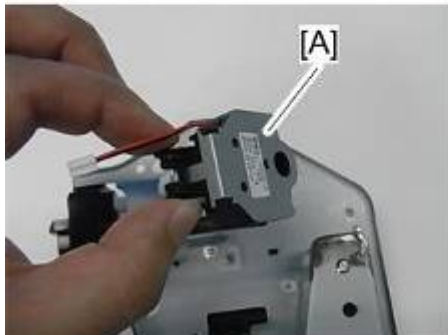
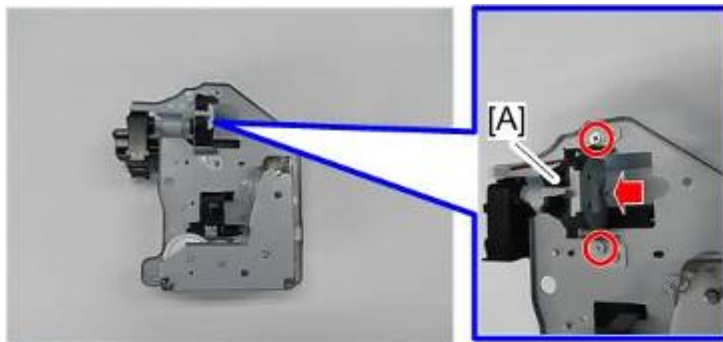

d197z0473

4.10.4 RECYCLING SHUTTER

1. Recycling shutter solenoid (page 4-94).
2. Bracket [A] (⚙️ x4).

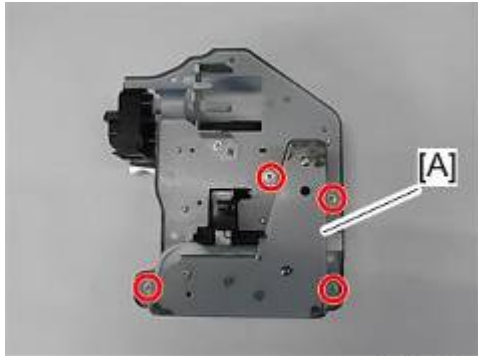

d197z0480

3. Two pulleys [A] [B] and belt [C] (⚙️ x1).

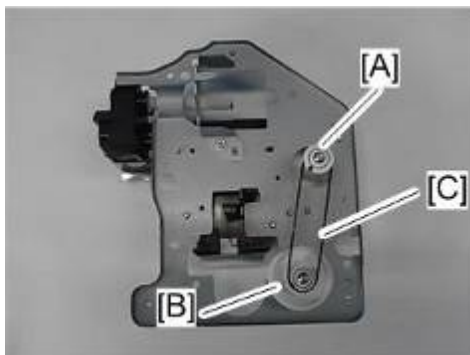

d197z0481

4. Bracket [A] (⚙️ x2, ⚙️ x1, bearing x 1).

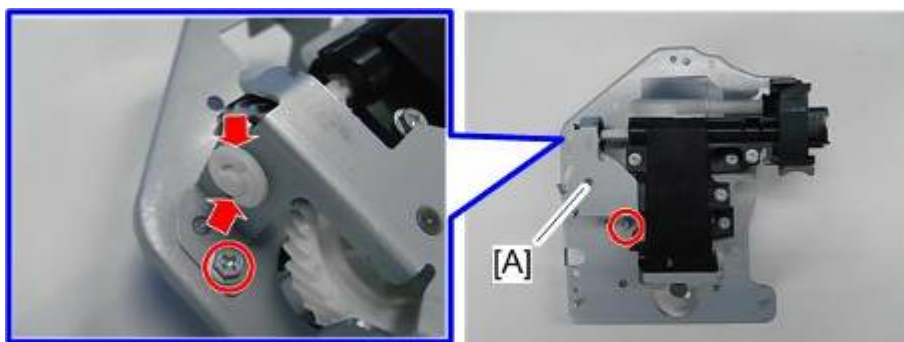

d197z0482

⚠️ Note

- Place a sheet of paper underneath the bracket, and then put the bracket on the sheet. Otherwise, the grease applied to the gear in the bracket may adhere to the floor.

5. Recycling shutter unit [A] (⚙️ x3, Gear x 1).

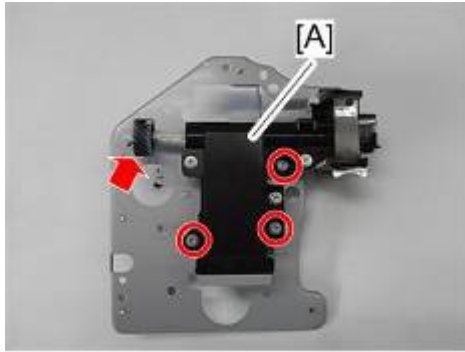

d197z0483

⬇️ **Note**

- Place a sheet of paper underneath the recycling shutter unit, and then put the recycling shutter unit on the sheet. Otherwise, the grease applied to the gear in the unit may adhere to the floor.

4.11 TRANSFER UNIT

4.11.1 TRANSFER UNIT

1. Open the right cover.
2. Close the transfer unit [A]

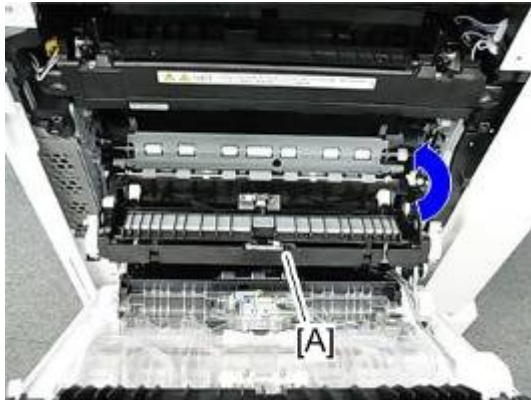

d197z0140

3. Remove the clip of the transfer unit [A] and disconnect the connector.

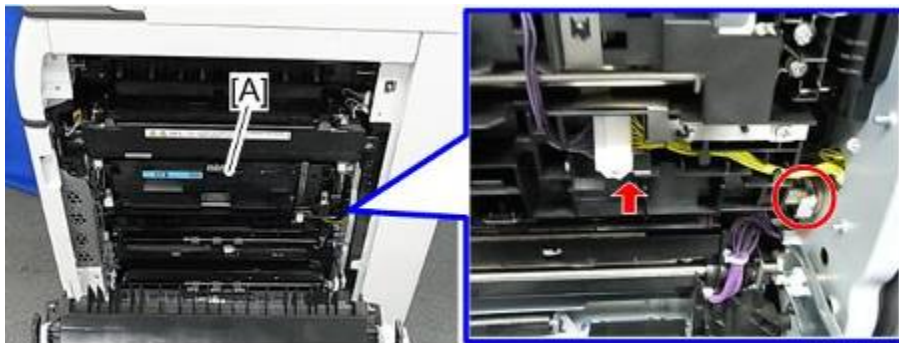

d197z0141

4. Slide the bearing in the blue arrow direction to release it from the frame of the main machine



d197z0142

Transfer Unit

5. Open the transfer unit [A].



d197z0143

6. Release the arm of the transfer unit [A] (0x1).

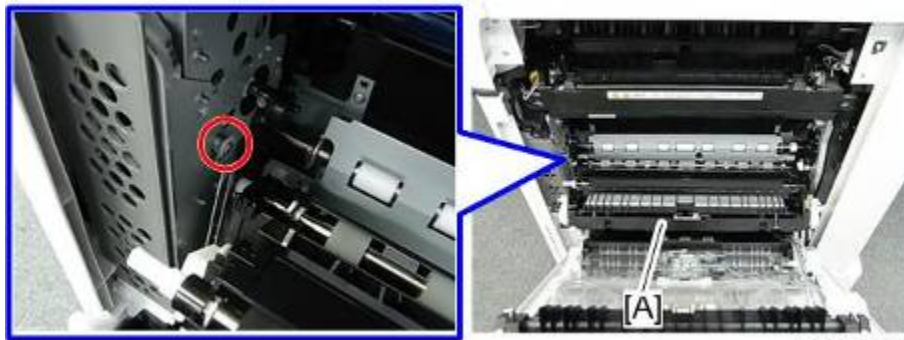

d197z0144

7. Transfer unit [A]



d197z0145

4.11.2 TRANSFER ROLLER UNIT

★ Important

- Before replacing the Transfer roller unit, set the setting of SP3-701-108 to "1" and turn off the main power switch.
- If you have to turn the power on again before replacing the part, execute the SP again before replacing the part.
- After replacing the Transfer roller unit, turn on the main power on.

1. Open the right cover.
2. Release the claws of the transfer roller unit [A].

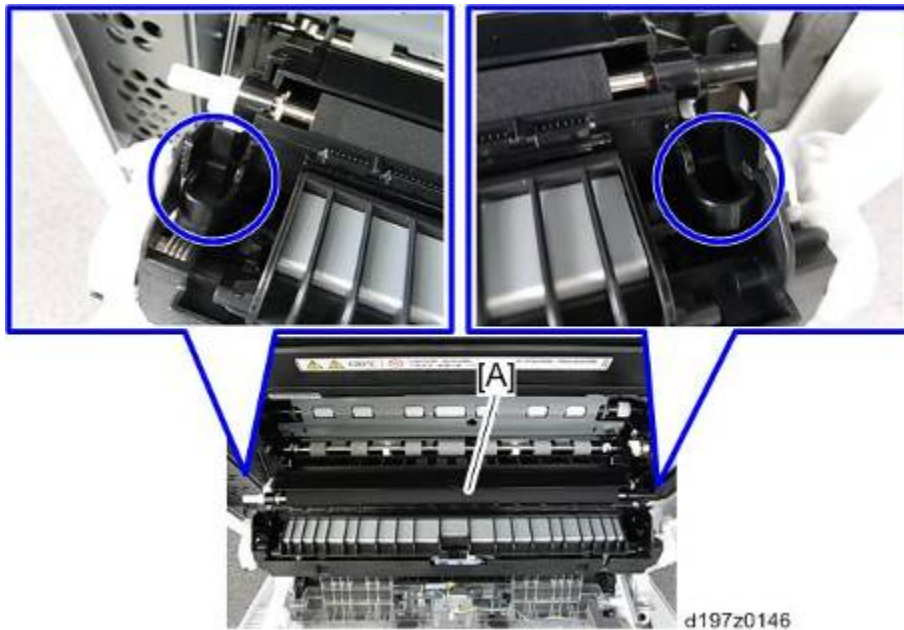

3. Transfer roller unit [A]



4.11.3 ID SENSOR

Before Replacing the ID Sensor

Note

- You must take note of the original value of SP3-331-061 to prepare for the possibility that the process control after replacement will not be done properly.

A QR-code is pasted on the sensor head of an ID sensor, which includes the characteristic value for the sensor. This characteristic value must be input to SP3-331-061 before replacing the ID sensor.

1. Take a note of the characteristic value in the following red-dashed part on the new ID sensor.



d197z0181

2. Turn the main power ON and enter SP mode.
3. Input the characteristic value to SP3-331-061.

Replacement Procedure

1. Open the right cover.
2. ID sensor [A] (🔧 x1, 🛠️ x1)

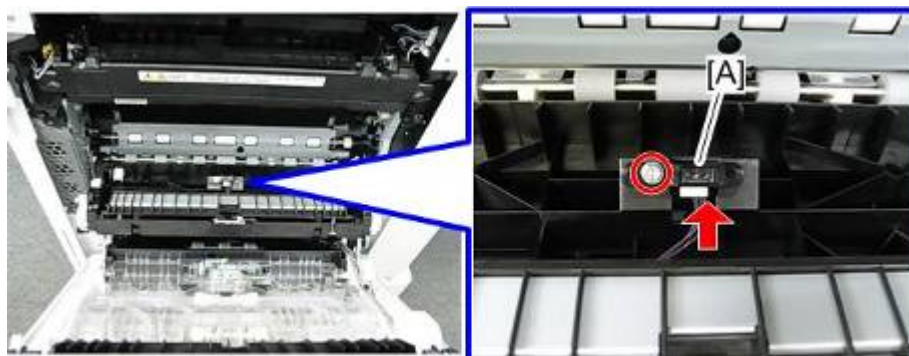

d197z0153

4.11.4 TRANSFER UNIT OPEN/CLOSE LED

1. Open the right cover.
2. Guide plate [A] (▼ x2)

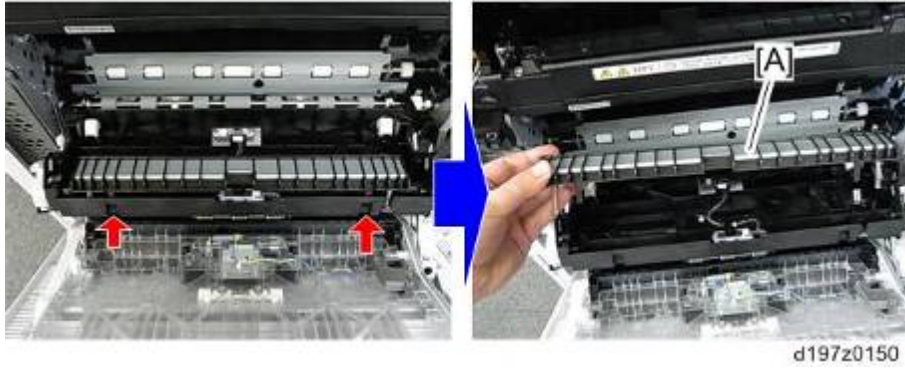

3. LED cover [A] (⊗ x1)

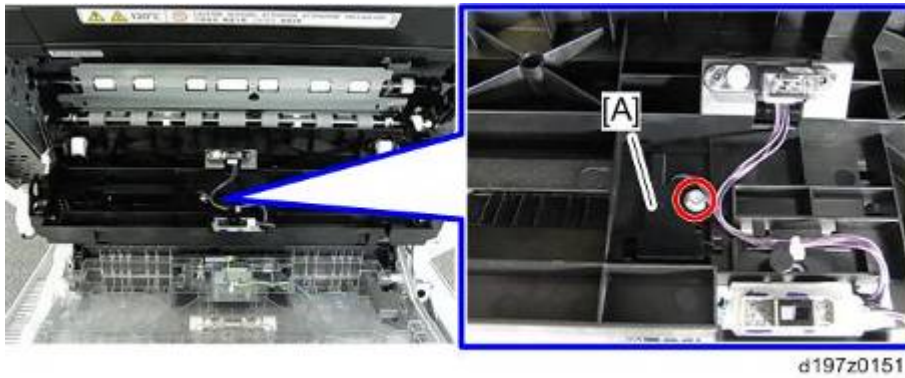

4. Transfer unit open/close LED [A] (⊗ x1)

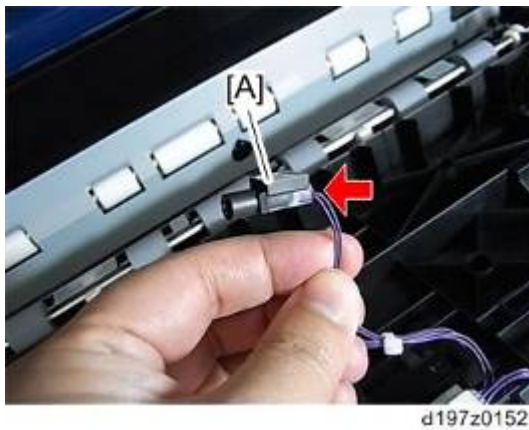

4.11.5 TEMPERATURE/HUMIDITY SENSOR

1. Pull out the 1st and 2nd paper feed trays.
2. Right lower cover [A] (🔩 x1)



3. Inserting a driver from the frame hole, remove the screw of the temperature/humidity sensor [A] (🔩 x1)



4. Temperature/humidity sensor [A] (🔩 x1, 📦 x1)



4.11.6 FUSING ENTRANCE SENSOR

1. Open the right cover.
2. Fusing entrance sensor [A] with bracket (🔩 x1)

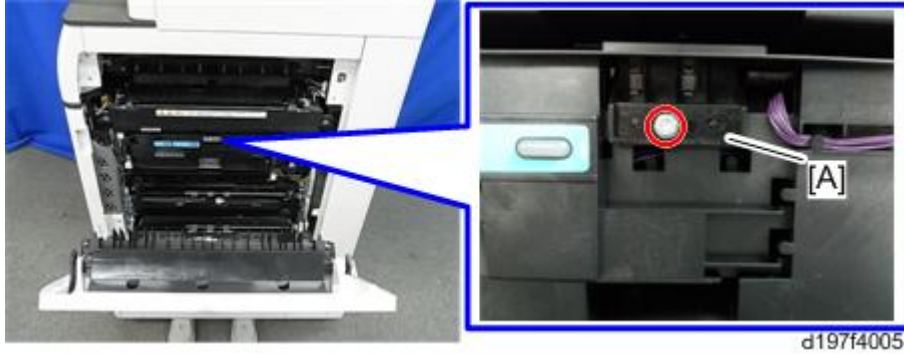

3. Fusing entrance sensor [A] (🔩 x1)



4.11.7 TRANSFER UNIT OPEN/CLOSE SENSOR

1. Open the right cover.
2. Transfer unit open/close sensor [A] (🔧 x1, hooks)

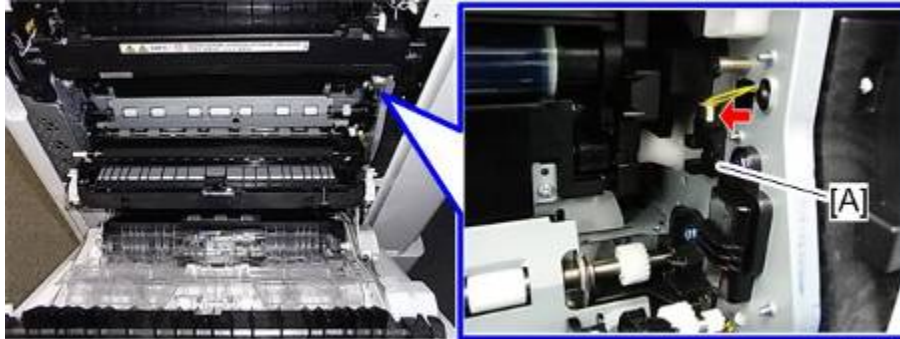

d197z0185

4.12 DRIVE UNIT

4.12.1 DRUM/WASTE TONER MOTOR

1. Rear right cover (page 4-16)
2. Drum/Waste Toner Motor [A] (⚙️ x4, 🛠️ x1)

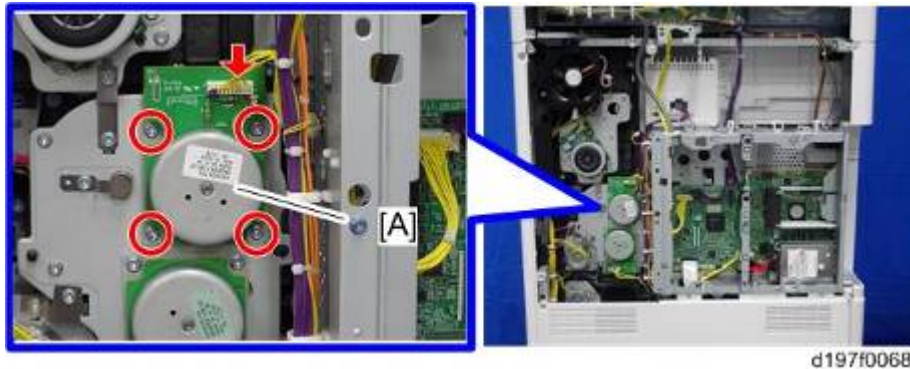

4.12.2 DEVELOPMENT MOTOR

1. Rear right cover (page 4-16)
2. Development Motor [A] (⚙️ x4, 🛠️ x1)

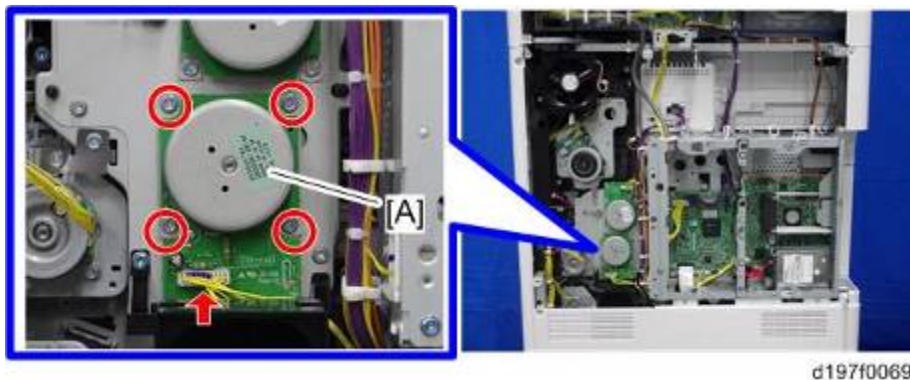

4.12.3 FUSING/PAPER EXIT MOTOR (D197/D199 ONLY)

1. Rear right cover (page 4-16)
2. Fusing/paper exit motor [A] (⚙️ x4, 🛠️ x1)



4.12.4 FUSING MOTOR (D200/D201/D202 ONLY)

1. Rear right cover (page 4-16)
2. Fusing motor [A] (⚙️ x4, 🔌 x1)

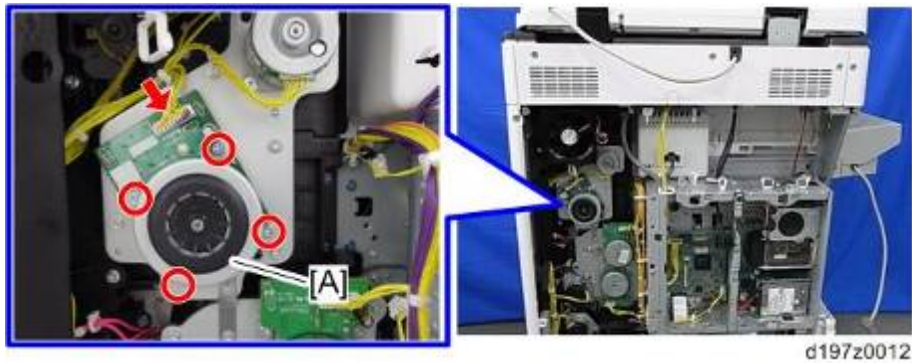

4.12.5 PAPER EXIT MOTOR (D200/D201/D202 ONLY)

1. Rear right cover (page 4-16)
2. Paper exit motor [A] (⚙️ x2, 🔌 x1)



4.12.6 REGISTRATION MOTOR

1. Rear right cover (page 4-16)
2. Registration motor [A] (⚙️ x2, 🔌 x1)



4.12.7 PAPER FEED MOTOR

1. Rear lower cover (page 4-17)
2. Paper feed motor (⚙️ x2, 🔑 x1)

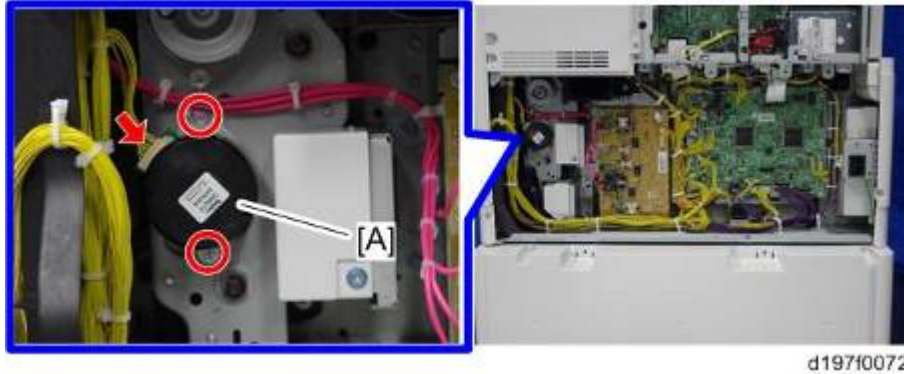

4.12.8 VERTICAL TRANSPORT MOTOR

1. Rear lower cover (page 4-17)
2. Vertical transport motor (⚙️ x2, 🔑 x1)



4.12.9 TRANSFER ROLLER CONTACT MOTOR

1. Front cover (page 4-10)
2. Inner cover (page 4-26)
3. Transfer roller contact motor [A] (⚙️ x3, 🔑 x2)

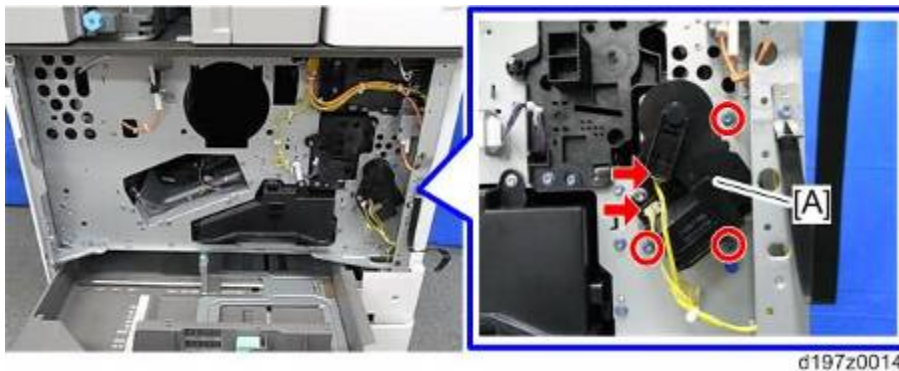

4.12.10 TONER HOPPER

1. Toner supply housing (page 4-27)
2. Controller box (page 4-177)
3. Screws on the toner hopper [A] (🔩x3)



4. Gear [B] on the gearbox [A] (🔩x1)

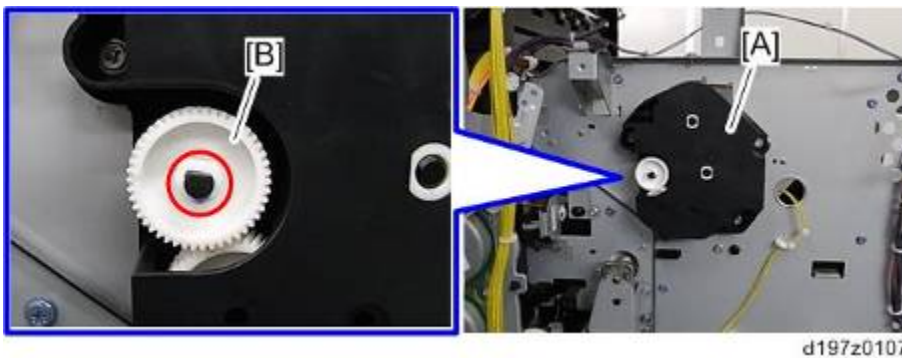

5. Screws and tab on the gearbox [A] (🔩x3, tabx1)

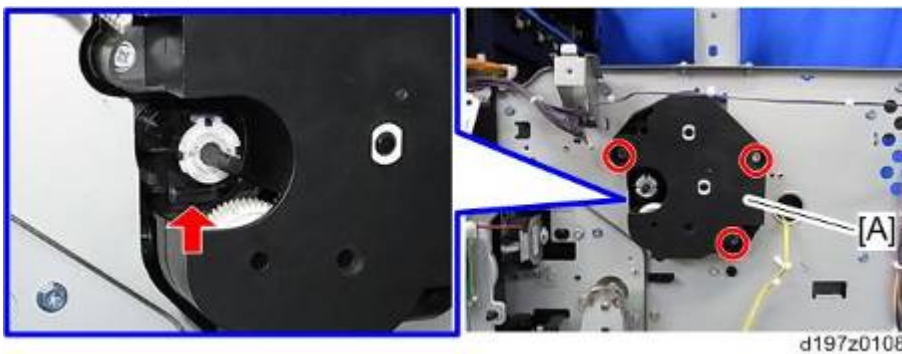

6. Toner hopper [A]

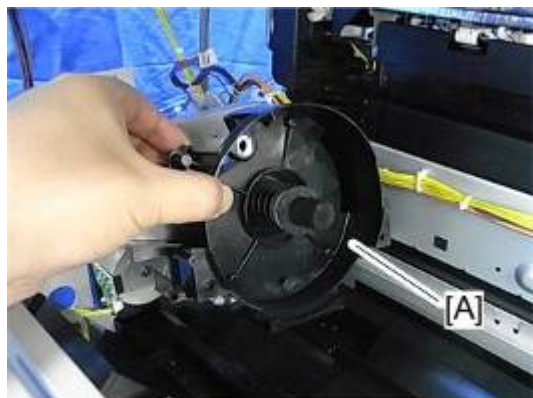

d197z0109

Note

- Toner remains in the toner hopper [A]. Be sure to place the toner hopper on a sheet of paper to protect against toner spillage.



d197z0110

Important

- Attach the toner supply pipe [A] before installing the gear box and toner hopper.
- Fit the hole of the supply pipe to the pin [B] and then stabilize the pipe (⚙️ x1).

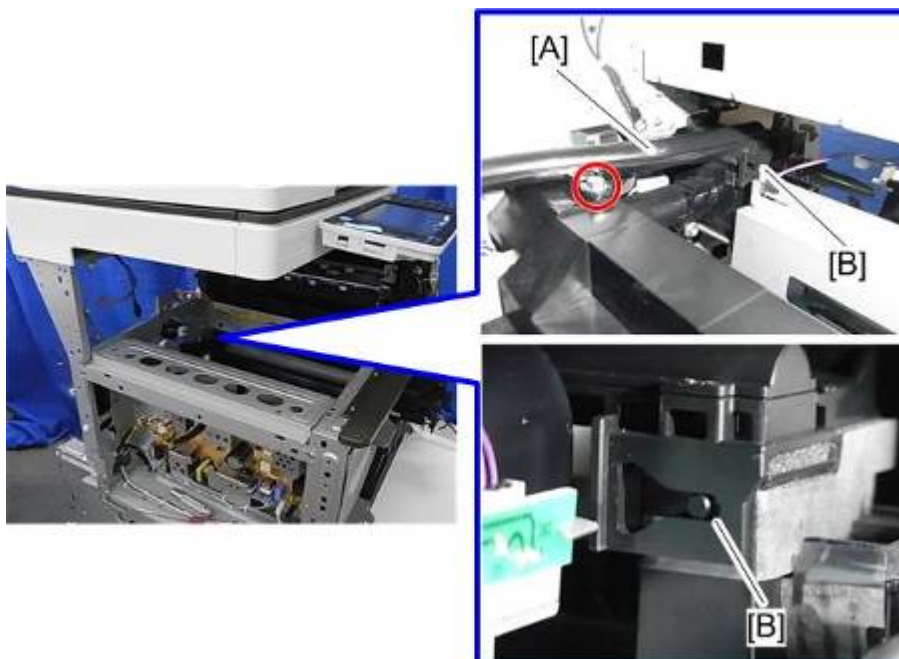

d197z0475

4.12.11 TONER SUPPLY MOTOR

1. Toner Hopper (page 4-110)
2. Screws and connector on the gearbox [A] (🔩 x3, 📌 x1).

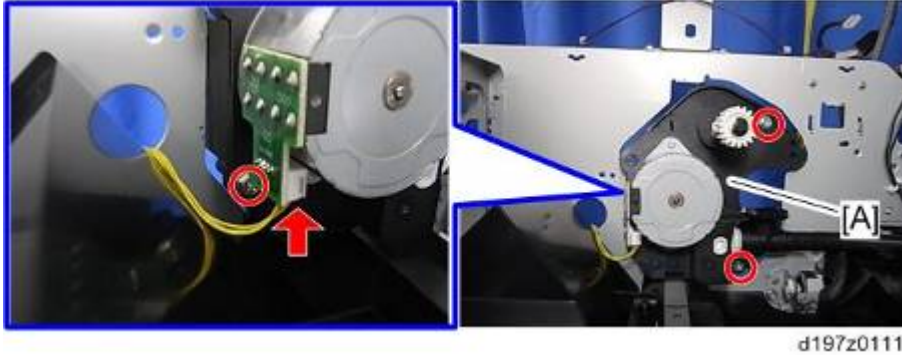

3. Remove the gear [A] and part [B] from the gear box cover [C].

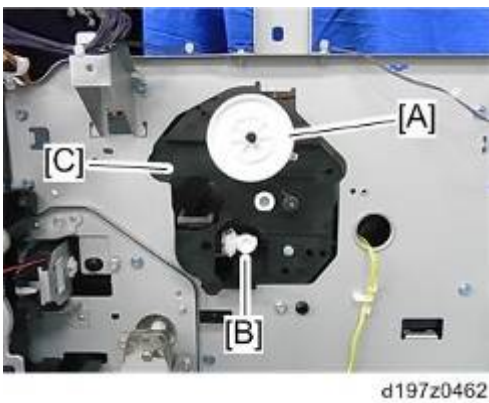

⬇ Note

- Make sure that the angle of the part [B] is as shown below when attaching the part [B] to the gear box cover.

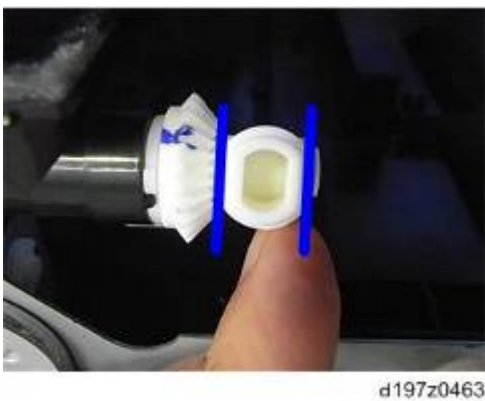

4. Gear box cover [A].

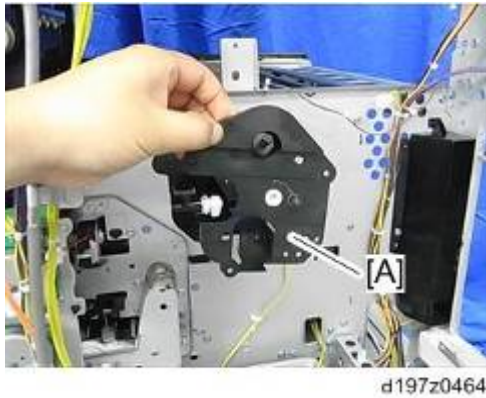

5. Remove the Toner supply motor [B] with its spacer from the gear box cover [A] (⚙️ x2).

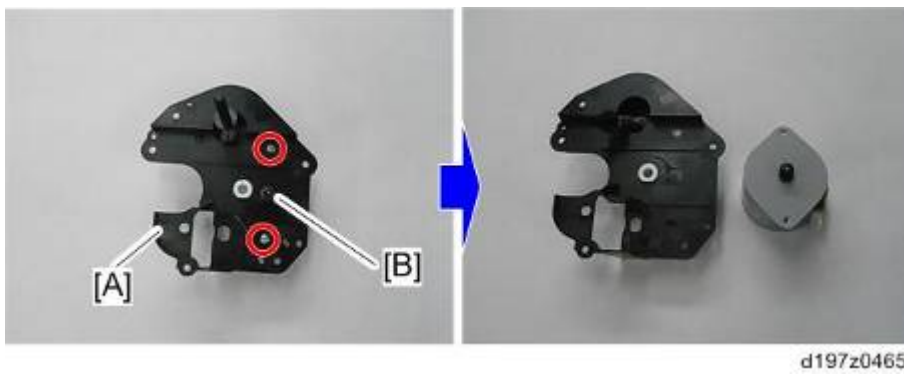

6. Spacer [B] from toner supply motor [A].

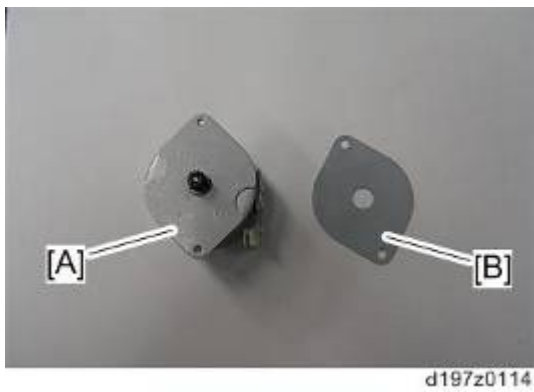

4.13 FUSING UNIT

4.13.1 FUSING UNIT

Replacement

CAUTION

- In 100 V models, only one of the AC lines for the fusing unit is shut off when you turn off the main power; the other line carries current even when you turn off the main power switch. Thus, not only turn off the main power switch, but also always pull out the AC power cord from the wall socket before doing replacement.
- Because there is a danger of burns on contact with hot parts of the fusing unit, start work when the temperature drops to a low enough temperature.
- To clear SC544-02 or SC554-02, replacing the fusing unit or installing a fuse (provided in the heating sleeve belt unit) in the fusing unit must be required. Follow the procedure below to clear SC544-02 or SC554-02.
 - 1. Installing a new fusing unit.
 - 2. Clear SC544-02 or SC554-02 with SP5-810-002
 - 3. Turn off and on the machine.

Note

- D197/D198/D199
When the fusing unit is used past its PM cycle, the fusing unit may break, causing a service call. Therefore, the machine displays a warning on the operation panel at 240K pages and stops at 260K pages.
- D200/D201/D202
When the fusing unit is used past its PM cycle, the fusing unit may break, causing a service call. Therefore, the machine displays a warning on the operation panel at 320K pages and stops at 350K pages.

Note

- If you replace a whole fusing unit, you do not need to perform SP 3-701. This is because the machine detects a new unit automatically. If you replace only a part of the fusing unit, however, such as the pressure roller, you must set the setting of SP3-701 for that part.

1. Open the right cover.

2. Remove the screws on the Fusing unit [A] and disconnect the connectors (🔌 x2, 🛠️ x2).

- Do not pull out the fusing unit now. The fusing unit is still connected to the machine.

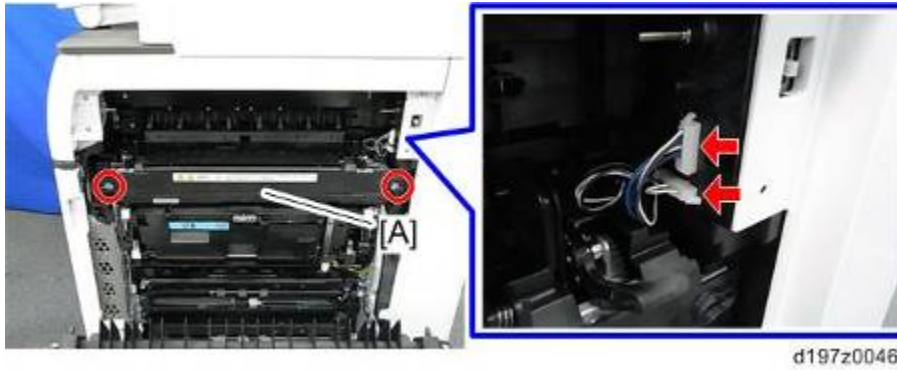

⬇️ Note

- When disconnecting the harness, hold the connector as shown below in order to avoid breaking the connector pins.



3. Fusing unit connector cover [A]



Fusing Unit

Note

- Attach the fusing unit connector cover by fitting the space on the connector cover [A] (surrounded by red dashes in the diagram) and the frame of the fusing unit [B] together when installing.

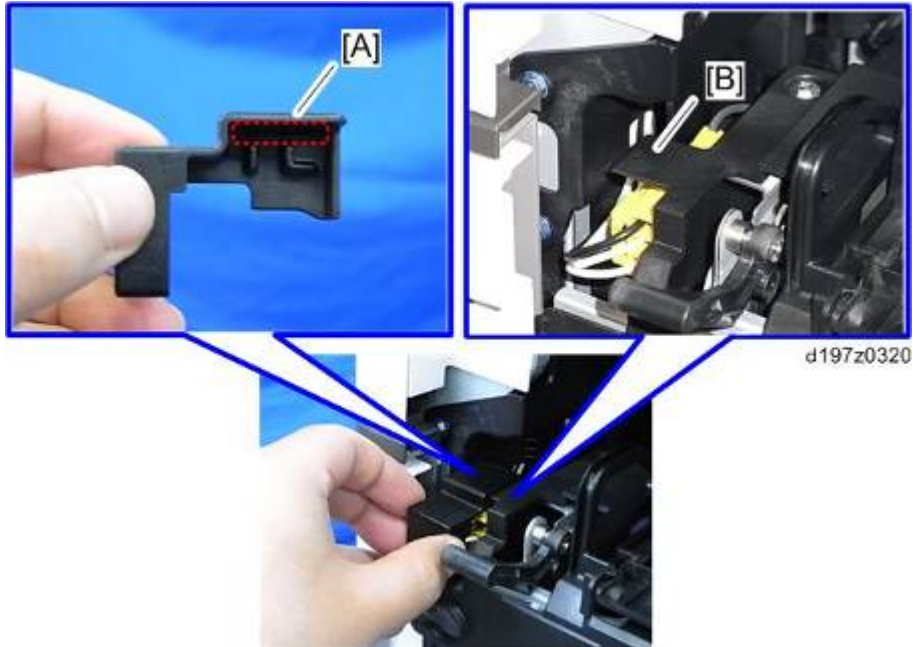

- The connector cover must be attached **before** screwing in the fusing unit.

4. Connector [A] (🔩 x1)



5. Pull out the fusing unit [A].

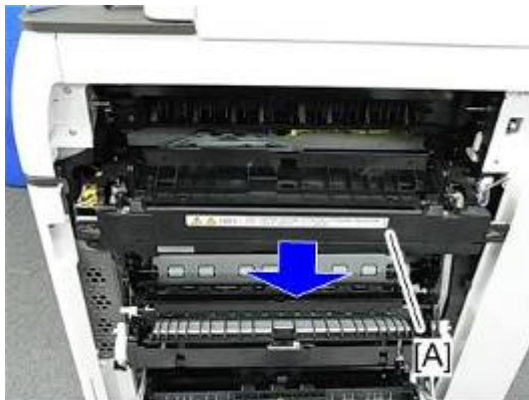

Note

- When installing the fusing unit, attach the rear screw first, then attach the front screw.

4.13.2 FUSING ENTRANCE GUIDE PLATE

- Fusing unit (page 4-114)
- Fusing entrance guide plate [A] (🔑 x3)

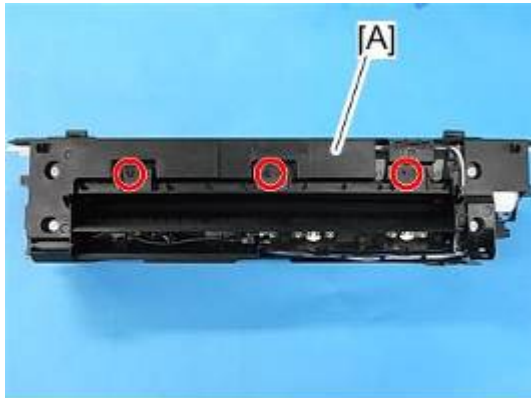

d197z0050

Cleaning the Fusing Entrance Guide Plate

Carefully remove toner adhering as shown in the diagram below with a dry cloth. Then, wipe with a cloth moistened with alcohol.

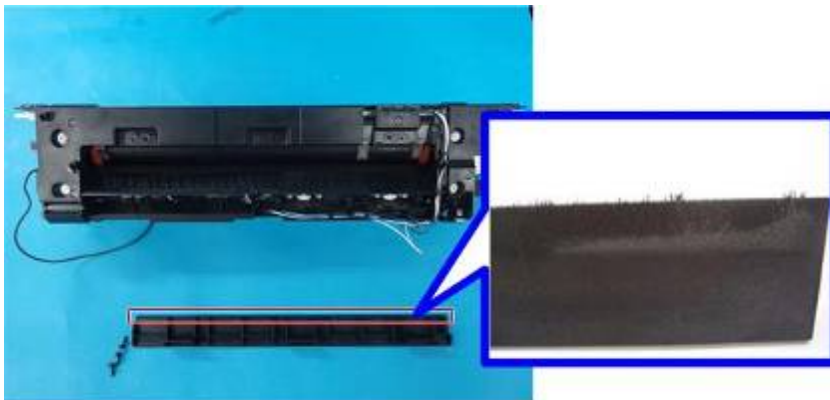

d197f4001

4.13.3 FUSING EXIT GUIDE PLATE

1. Fusing unit (page 4-114)
2. Open the fusing exit guide plate [A].

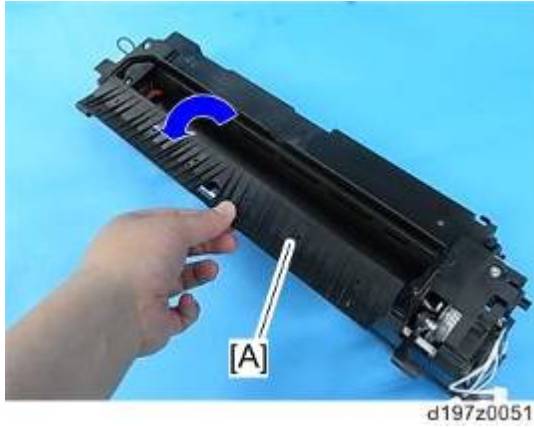

Note

- Wipe clean with a dry cloth. Then wipe clean with a cloth dampened with alcohol.

4.13.4 FUSING UPPER COVER

1. Fusing unit (page 4-114)
2. Release the two harnesses [A].



d197z0054

3. Connector [A] (🔌 x1)



d197z0055

4. Fusing upper cover [A] (🔩 x4)

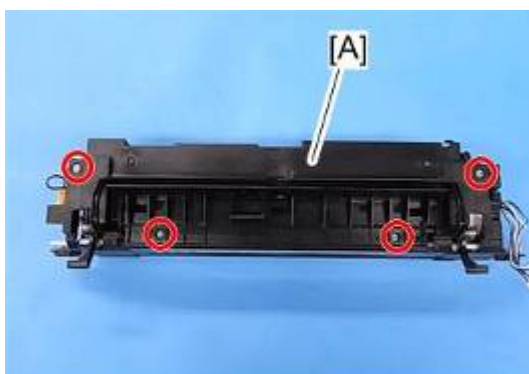

d197z0056

ⓘ Note

- You must route the harnesses for the pressure roller temperature sensor and the fusing roller temperature sensor correctly when reassembling the fusing unit. See the notes when reassembling the fusing unit. (Notes When Reassembling the Fusing Unit)

4.13.5 FUSING LOWER COVER

1. Fusing unit (page 4-114)
2. Earth [A] (🔩 x1)



3. Fusing lower cover [A] (🔩 x1, 🌀 x5)

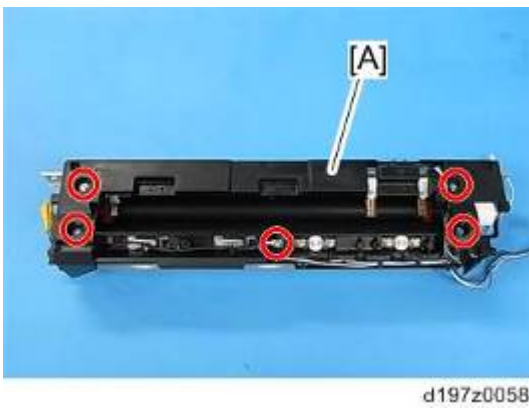

⚠ Note

- The earth plate [A] is uncovered after the fusing lower cover removal. Be careful not to damage it.

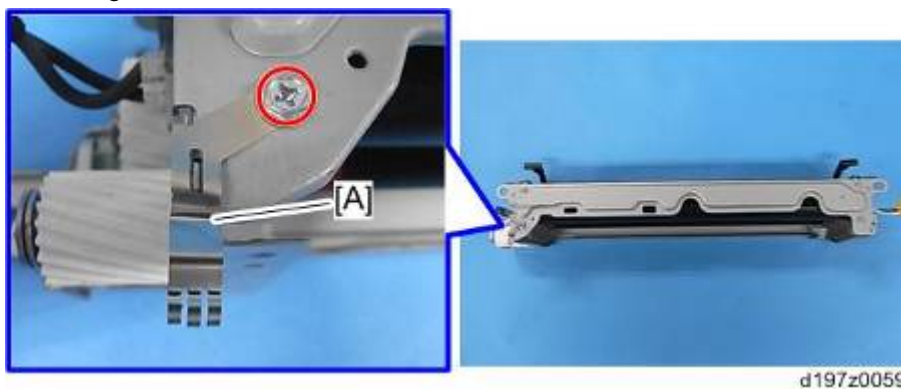

⚠ Note

- You must route the harnesses for the pressure roller temperature sensor and the fusing roller temperature sensor correctly when reassembling the fusing unit. See the notes when reassembling the fusing unit. (Notes When Reassembling the Fusing Unit)

4.13.6 HEATING SLEEVE BELT UNIT

Preparation

- Set the setting of SP3-701-116 to “1” and turn the main power OFF before replacing.
- If you have to turn the power on again before replacing the part, execute the SP again before replacing the part.
- After replacing the unit, turn the main power ON.

CAUTION

- To clear SC544-02 or SC554-02, replacing the fusing unit or installing a fuse (provided in the heating sleeve belt unit) in the fusing unit must be required.
- When clearing SC544-02 or SC554-02 by installing a fuse (provided in the heating sleeve belt unit) in the fusing unit, follow the procedure below for replacing the heating sleeve belt unit.
 1. Installing a new fusing unit.
 2. Clear SC544-02 or SC554-02 with SP5-810-002
 3. Turn off and on the machine.
- When replacing the heating sleeve belt unit at EM replacement, installing a fuse is not necessary. Do not use the fuse for EM replacement.

CAUTION

- The new unit detection fuse packed with the heating sleeve belt unit is used to cancel SC544-02/554-02. Discard the fuse if these SCs did not occur.

Replacement

1. Fusing upper cover (page 4-119)
2. Fusing lower cover (page 4-120)
3. Two pressure springs ( x2)



4. Left and right frame ( x2 for each frame)



5. Heating sleeve belt unit [A]



d197z0062

To Clear SC544-02 or SC554-02

⚠ CAUTION

- To clear SC544-02 or SC554-02, attach the new unit detection fuse provided with the heating sleeve belt unit or replace the fusing unit.

1. Prepare a new fuse provided with the heating sleeve belt unit.



d197z0334

2. Connect the fuse pins into the fusing unit connector.

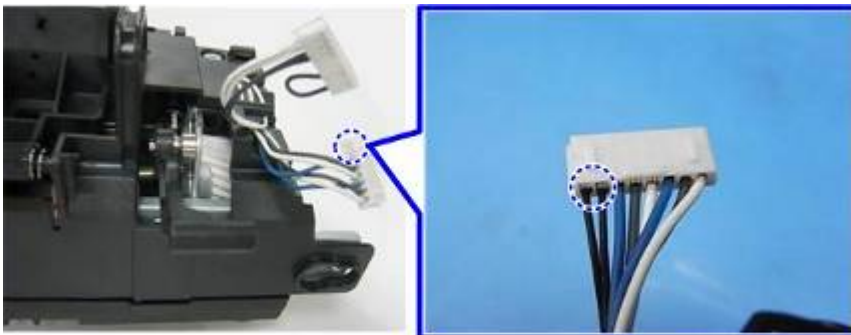

d197z0335

3. Route the harness of the fuse through the slit (arrow-pointed).

4. Install the fuse in the notch (circled place).



d197z0336

5. Reassemble the fusing unit.
6. Install the fusing unit in the machine.
7. Enter the SP mode, and then clear SC544-02 or SC554-02 with SP5-810-002.
8. Turn off and on the machine.

4.13.7 PRESSURE ROLLER AND PRESSURE ROLLER BEARINGS

Adjustment before Replacing the Pressure Roller and Pressure Roller Bearings

Before replacing the pressure roller, set the setting of SP3-701-118 to "1" and switch the power OFF. Then replace the pressure roller and turn the main power ON.

Before replacing the pressure roller bearings, set the setting of SP3-701-119 to "1" and turn the main power OFF. Then replace the pressure roller bearings and turn the main power ON.

If you have to turn the power on again before replacing the part, execute the SP again before replacing the part.

Replacement

1. Heating sleeve belt unit (page 4-121)
2. Pressure roller gear [A] (C-ring x1)



d197z0063

3. Pressure roller rear bearing [A]



d197z0064

4. Pressure roller front bearing [A] (C-ring x1)



d197z0065

5. Pressure roller [A]



d197z0066

4.13.8 THERMOSTAT UNIT

1. Fusing unit (page 4-114)
2. Thermostats [A] (🔩 x2 for each thermostat)

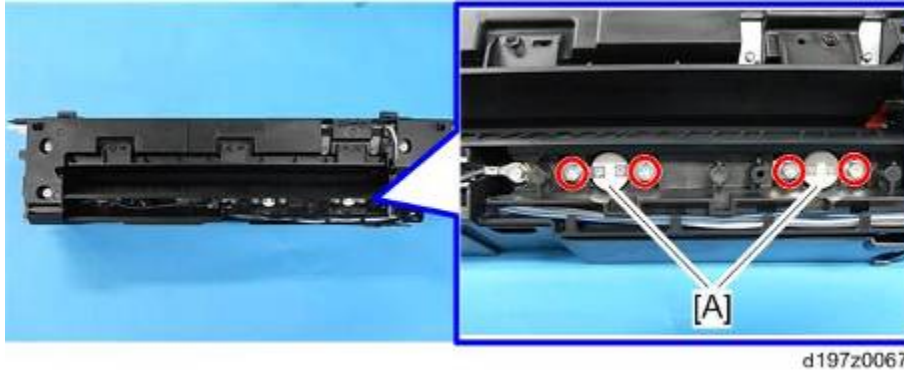

4.13.9 FUSING ROLLER TEMPERATURE SENSOR

1. Fusing lower cover (page 4-120)
2. Fusing roller temperature sensors [A]



4.13.10 PRESSURE ROLLER TEMPERATURE SENSOR

1. Fusing lower cover (page 4-120)
2. Pressure roller temperature sensors (🔩 x1, for each)

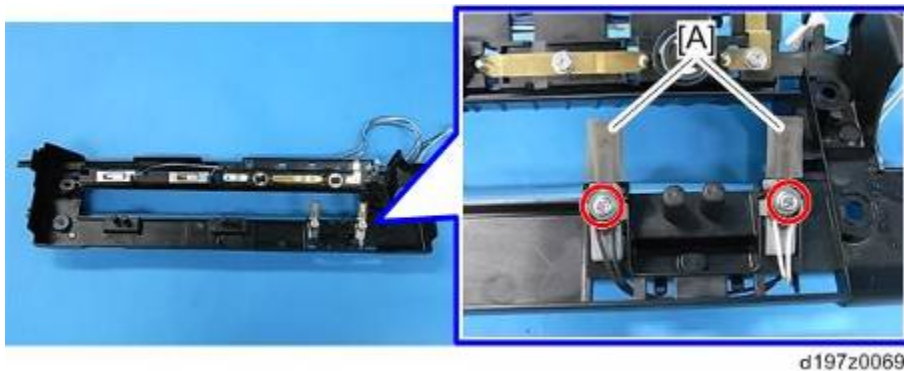

4.13.11 FUSING THERMOPILE

1. Fusing unit (page 4-114)
2. Fusing thermopile unit [A] (🔩 x2)



3. Fusing thermopiles [A] (🔩 x2, 📦 x2)

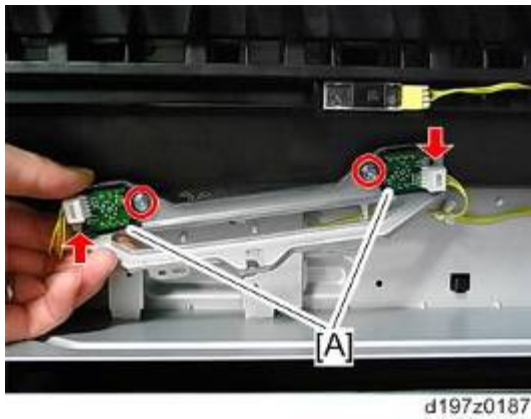

4.13.12 NOTES WHEN REASSEMBLING THE FUSING UNIT

Route the harnesses for the pressure roller temperature sensor [A] and the fusing roller temperature sensor [B] correctly when reassembling the fusing unit.

Harness [A] for the pressure roller temperature sensor has black and white wires. Routing starts from the bottom of the fusing unit, then the rear, and to the side.

Harness [B] for the fusing roller temperature sensor has black, white, and blue wires. Routing starts from the bottom of the fusing unit, then the rear, and to the top.

Harness route: when looking at the bottom of the fusing unit

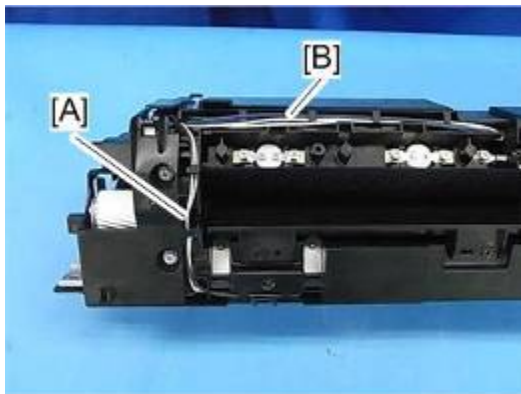

d197z0438

Harness route: when looking at the side of the fusing unit



d197z0437

4.14 PAPER EXIT

4.14.1 PAPER EXIT UNIT

1. Open the right cover.
2. Fusing unit (page 4-114)
3. Paper exit cover (page 4-23)
4. Inner cover [A] (🔩 x2)



d197z0031

5. Paper exit unit [A] (🔩 x1, 📦 x1)

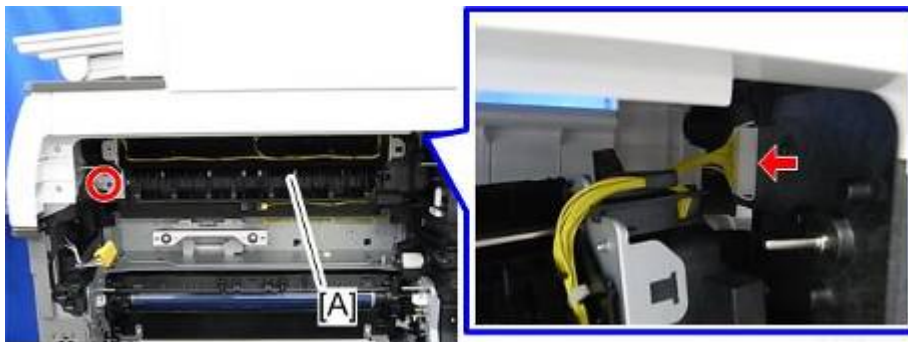

d197z0032

4.14.2 PAPER EXIT SWITCHING SOLENOID

1. Paper exit unit (page 4-129)
2. Paper exit switching solenoid [A] (⚙️ x2, 📦 x1, 🛠️ x1)

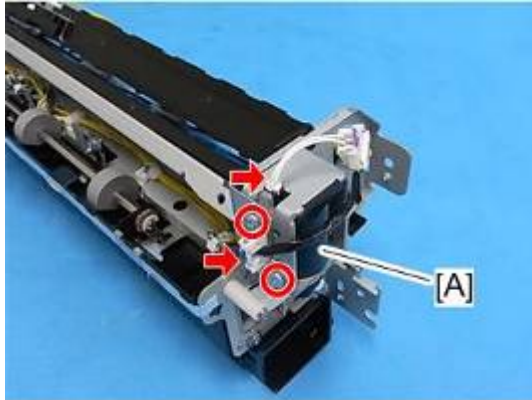

d197z0033

4.14.3 PAPER EXIT SENSOR

1. Paper exit unit (page 4-129)
2. Feeler [A]

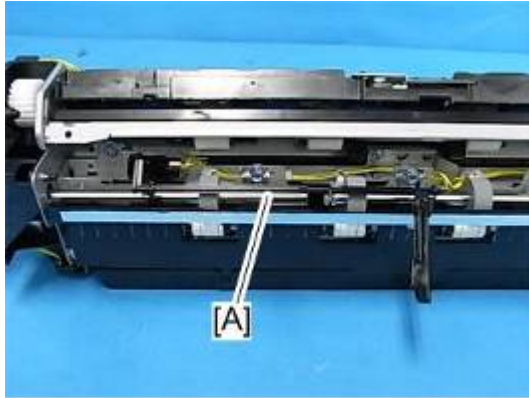

d197z0034

3. Paper exit sensor with bracket [A] (⚙️ x1, ⚙️ x2)

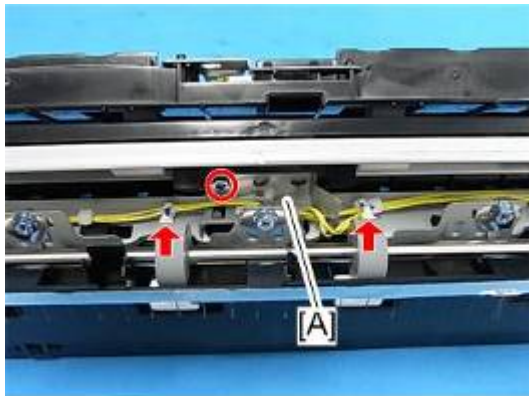

d197z0035

4. Paper exit sensor [A] (hooks, ⚙️ x1, ⚙️ x1)

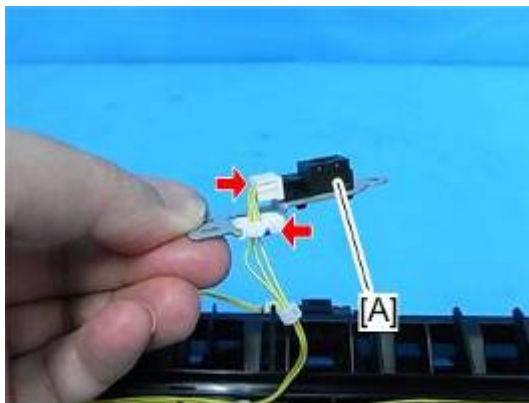

d197z0036

4.14.4 REVERSE SENSOR

1. Paper exit unit (page 4-129)
2. Reverse sensor with bracket [A] (🔧 x1)



d197z0037

3. Reverse sensor [A] (hooks, 📌 x1)

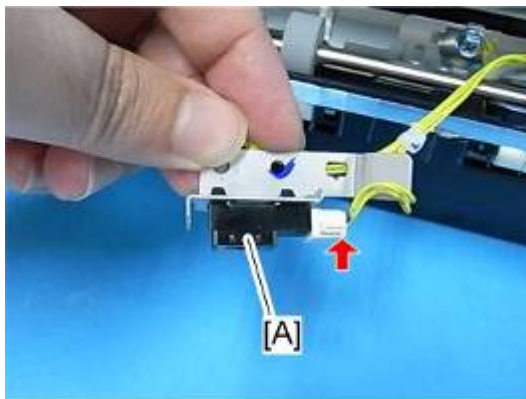

d197z0038

4.14.5 PAPER EXIT FULL SENSOR

1. Paper exit unit (page 4-129)
2. Paper exit full sensor with bracket [A] (⚙️ x1, 🛠️ x1)

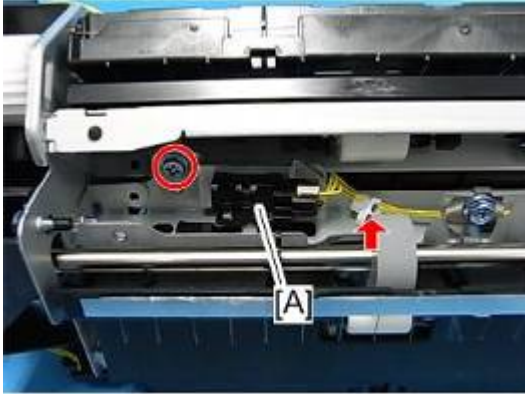

d197z0039

3. Paper exit full sensor [A] (hooks, 🛠️ x1)

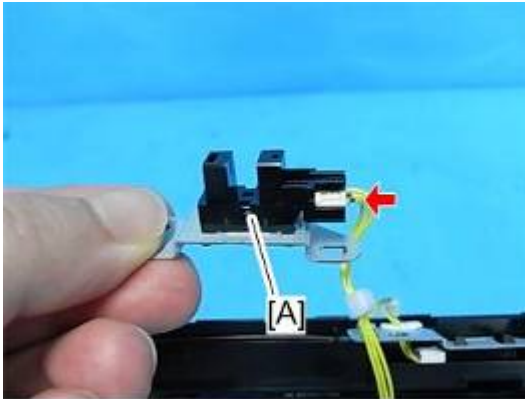

d197z0040

4.14.6 REVERSE MOTOR

1. Paper exit unit (page 4-129)
2. Gear [A]



d197z0041

3. Release the harness (🔧 x1, 🛠️ x2).

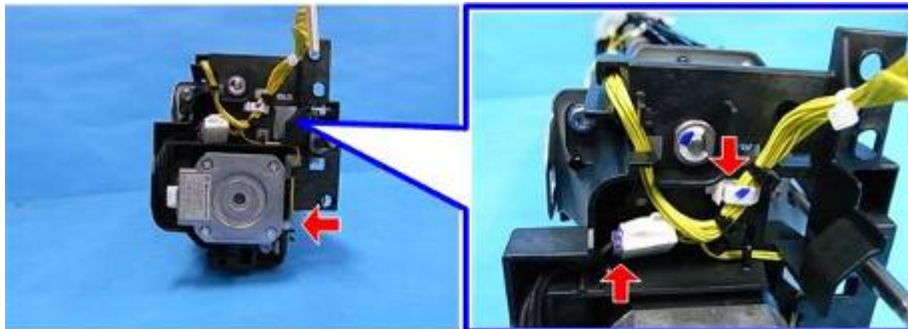

d197z0042

4. Bearings[A] (🛠️ x1)

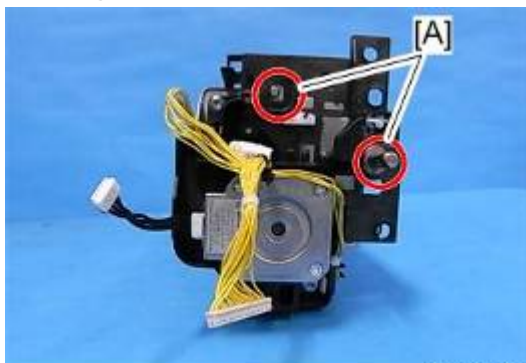

d197z0043

5. Reverse motor with bracket [A] (🛠️ x3)

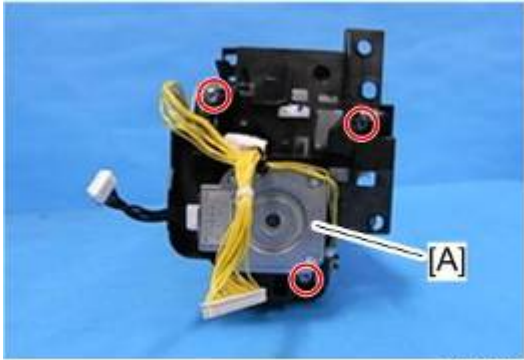

d197f4043

6. Reverse motor [A] (🔩 x2, 🌀 x1)

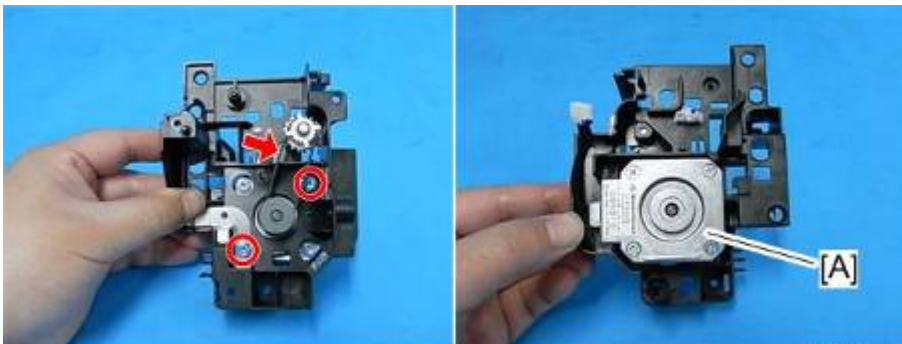

d197z0044

4.14.7 FUSING EXIT SENSOR

1. Paper exit unit (page 4-129)
2. Fusing exit sensor [A] (hooks, 📌 x1)



d197z0045

4.15 PAPER FEED

Note

- The 1st paper feed unit can be removed without removing the duplex unit (just open the right cover), and you can remove the paper feed unit after pulling out the paper tray.
- Note that the 1st paper feed unit and 2nd paper feed unit are not interchangeable.

4.15.1 PAPER FEED UNIT

1st Paper Feed Unit

1. Right cover (page 4-20).
2. Pull out the 1st paper feed tray.
3. Remove the screws attached to the 1st paper feed unit [A] (x2).



d197z0328

4. Pull out the 1st paper feed unit [A] slightly toward the front, and then take off the paper feed guide plate [B].
 - Release the rear side of the shaft first to remove the paper feed guide plate.

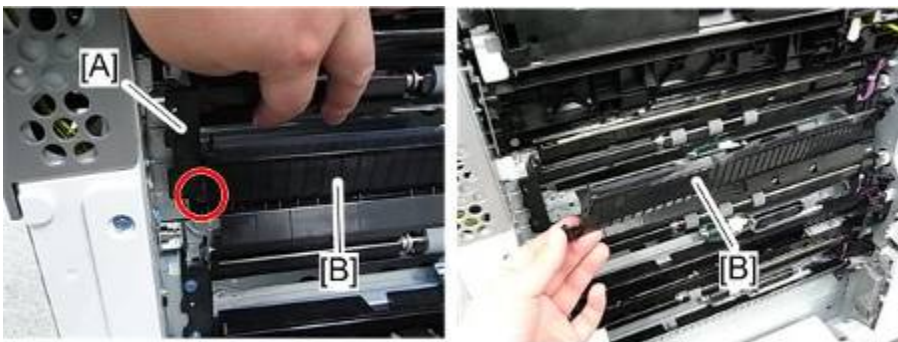

d197z0329

Note

- The following picture shows the rear side shape of the shaft.



d197z0007

5. 1st paper feed unit [A] (🔑 x1)



d197z0330

2nd Paper Feed Unit

1. Right cover (page 4-20).
2. Pull out the 2nd paper feed tray [A].

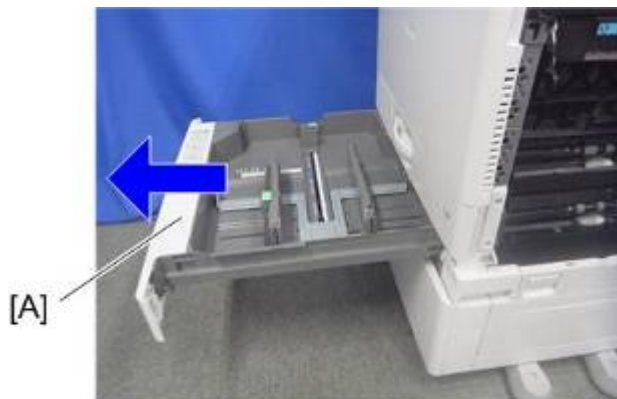

d1462184

ⓘ Note

- Depending on the model, remove the right lower cover or open the paper transport cover.

3. Bracket [A] (🔑 x1)

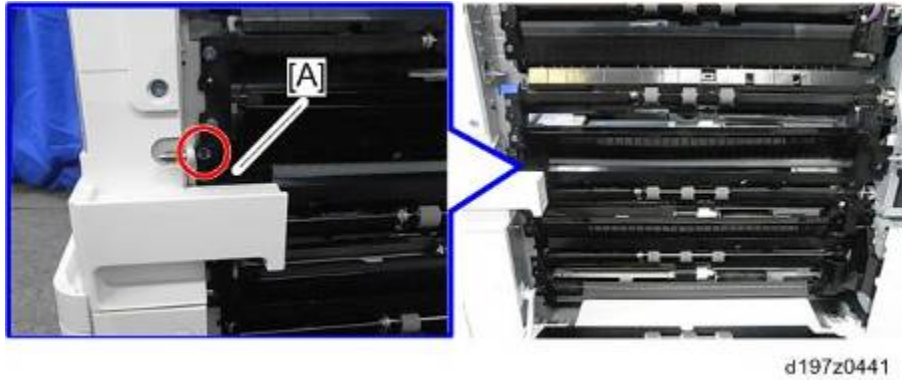

4. Lift the harness guide [A], and then remove it (🔧 x1).



⬇ Note

- The harness guide has a claw, so make sure that you do not break it when removing.



5. Remove the paper feed guide plate [A].

- Release the rear side of the shaft first to remove the paper feed guide plate.



6. 2nd paper feed unit [A] (🔧 x2, 📦 x1)



4.15.2 PAPER DUST COLLECTION UNIT

1. Open the right cover.
2. Screw on the paper dust collection unit [A] (⊗ x1)

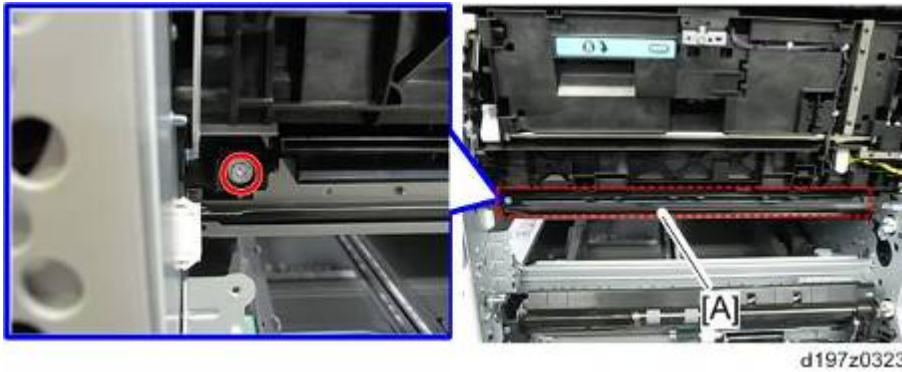

3. Release the tab on the paper dust collection unit [A] (↙ x1).

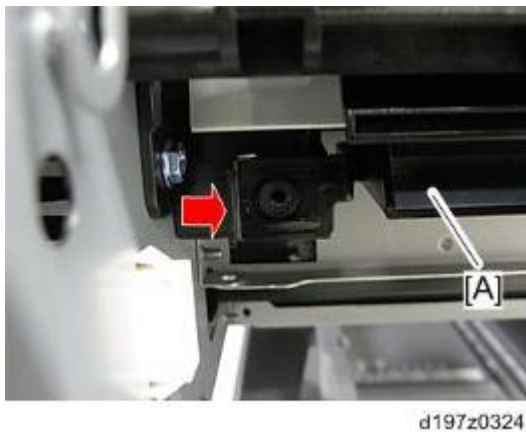

4. While slightly opening and holding the transfer unit [A] with your hand, remove the paper dust collection unit [B] in the order shown in the picture below (🔧 ×1).

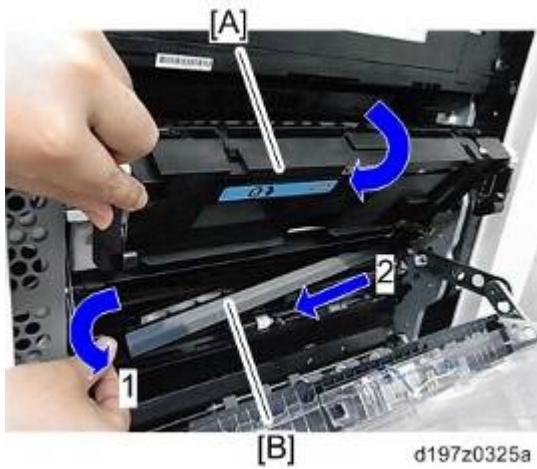

ⓘ Note

- The right side of the paper dust collection unit has a C-shaped cutout. Do not pull the unit by force during removal. When installing, open the transfer unit [A] to prevent the sheet [B] from breaking.



4.15.3 PICK-UP ROLLER, PAPER FEED ROLLER, SEPARATION ROLLER, TORQUE LIMITER

1. Roller holder [A] (1x1)



d1462188

2. Pickup roller [A]

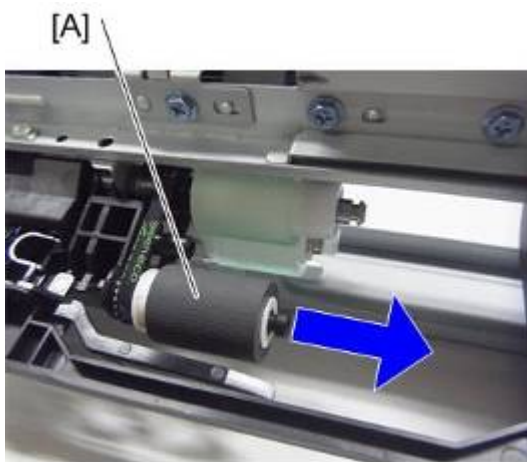

d1462189

3. Paper feed roller [A]

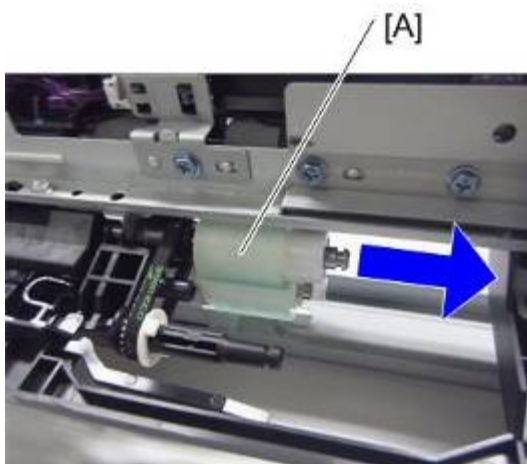

d1462190

4. Separation roller [A] (1x1)

Paper Feed

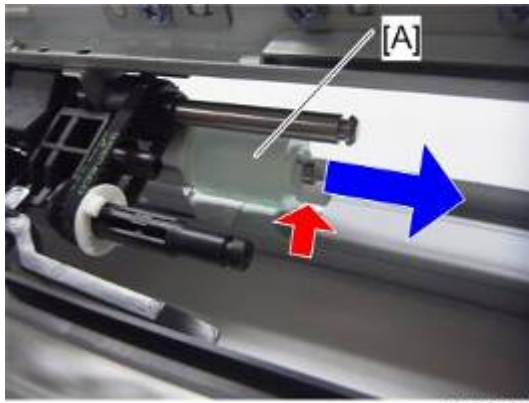

d1462191

5. Torque limiter [A]

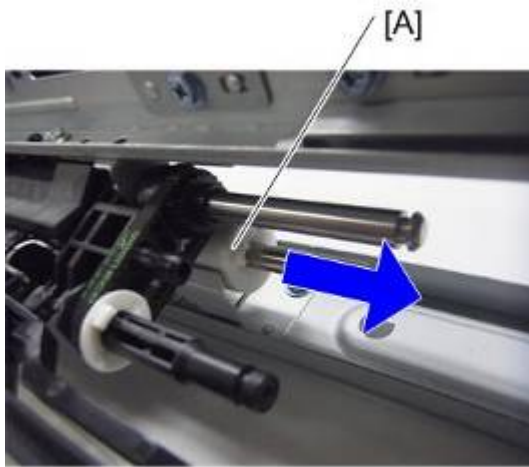

d1462192

4.15.4 1ST / 2ND PAPER FEED TRAY LIFT MOTOR

1. HVPS (page 4-174)
2. 1st paper feed tray lift motor [A] (⚙️ x2, 📡 x1)

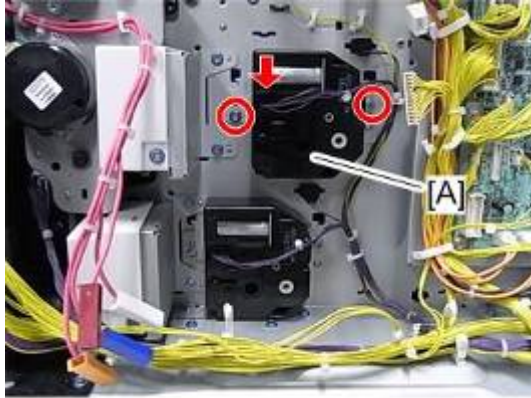

d197z0008

3. 2nd paper feed tray lift motor [A] (⚙️ x2, 📡 x1)



d197z0009

4.15.5 1ST / 2ND PAPER FEED SENSOR

Note

- There is no difference in removal procedure between 1st paper feed sensor and 2nd paper feed sensor.

- Paper feed unit (page 4-136)
- Paper feed sensor bracket [A] (🔩 x1, 🛠️ x1)

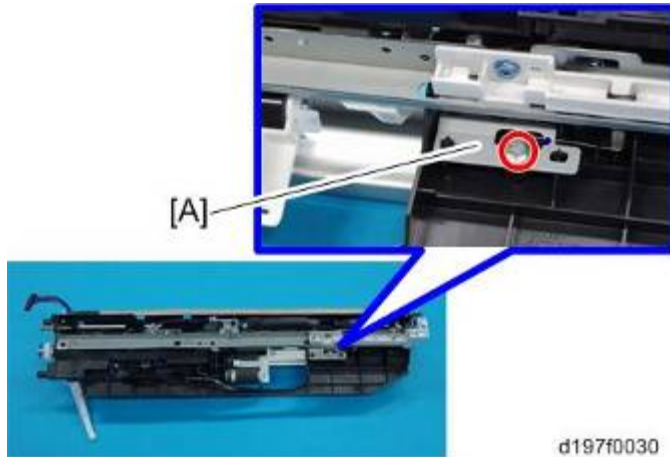

- Paper feed sensor [A] (hooks)



Note

- Make sure that the end of the spring on the sensor unit is in the hole.

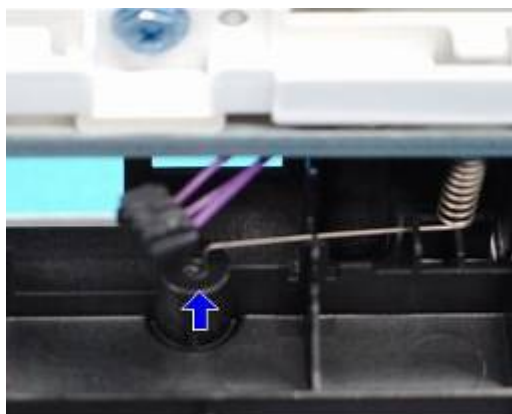

d197f0032

4.15.6 VERTICAL TRANSPORT SENSOR

1. Paper feed unit (page 4-136)
2. Vertical transport sensor unit [A] (⚙️ x1, 📦 x1)



d197f0033

3. Vertical transport sensor [A] (hooks)

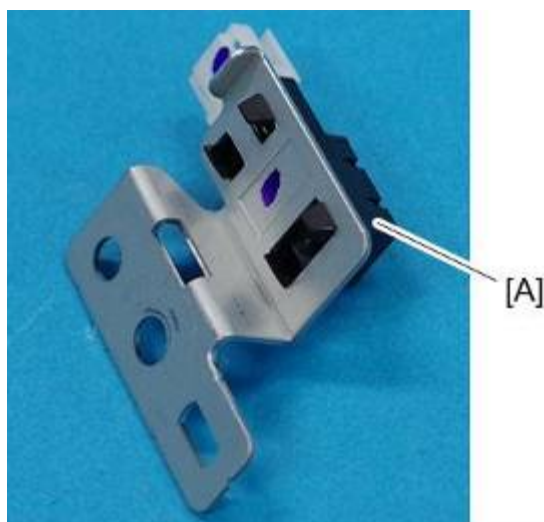

d197f0034

4.15.7 LIMIT SENSOR

↓ Note

- There are two limit sensors in this model but the removal procedure is the same.

1. Paper feed unit (page 4-136)
2. Limit sensor [A] (🔑 x1)

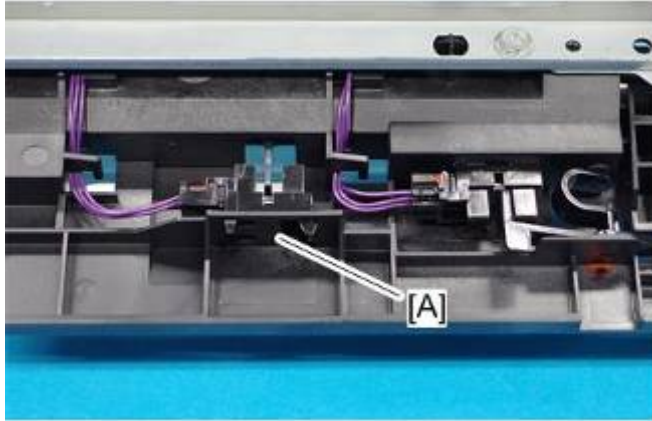

d197f0035

4.15.8 1ST PAPER END SENSOR / 2ND PAPER END SENSOR

↓ Note

- There is no difference in removal procedure between 1st paper end sensor and 2nd paper end sensor.

1. Paper feed unit (page 4-136)
2. Feeler [A] (🔑 x1)

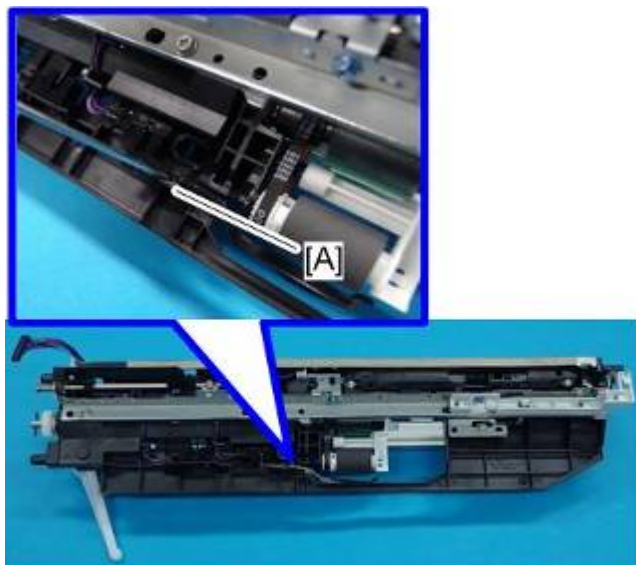

d197f0036

3. Paper end sensor [A] (🔑 x1)

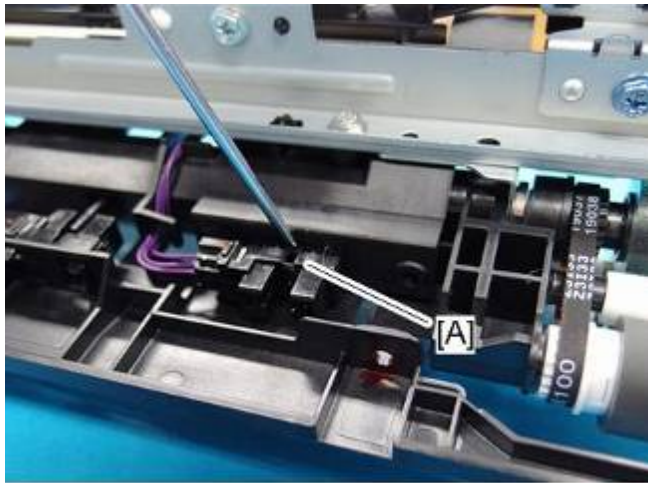

d197f0037

4. After reinstalling the paper end sensor, check the operation of the actuator [A].

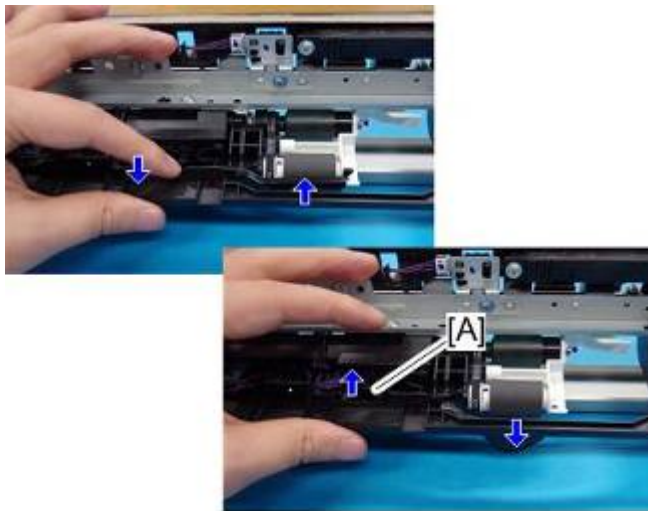

d197f0038

4.15.9 REGISTRATION SENSOR

1. Open the right cover (page 4-20).
2. Transfer unit (page 4-99)
3. Inner guide bracket [A] (🔩 x2)



d197z0126

4. Remove the registration sensor (hooks, 📌 x1, 📌 x1).

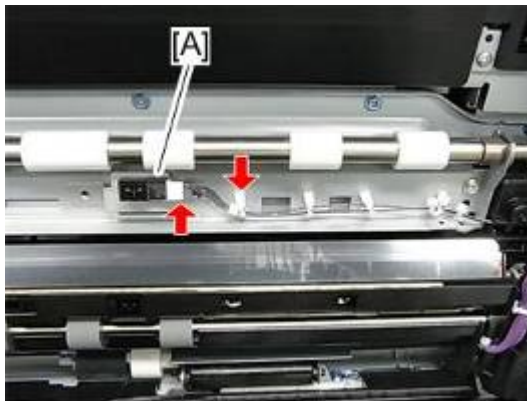

d197z0127

4.16 DUPLEX UNIT

4.16.1 DUPLEX/BY-PASS MOTOR

1. Right Cover (page 4-20)
2. Duplex inner cover [A] (🔩 x4)

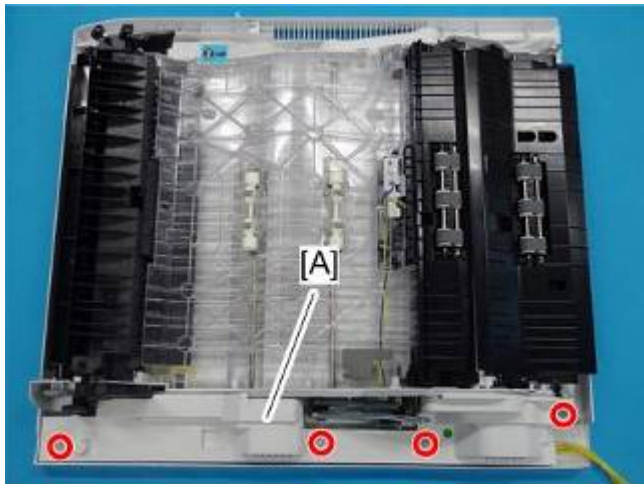

d197f0057

3. Duplex/by-pass motor unit [A] (🔩 x3, 📦 x1)



d197f0058

4. Duplex/By-pass Motor [A] (🔩 x2)



d197f0059

4.16.2 DUPLEX ENTRANCE MOTOR

1. Right Cover (page 4-20)
2. Duplex inner cover [A] (🔩 x4)

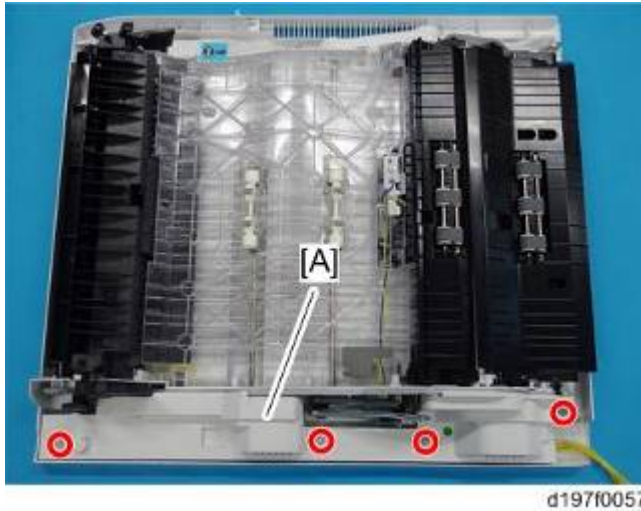

3. Duplex entrance motor bracket [A] (🔩 x2, 🗝️ x1)

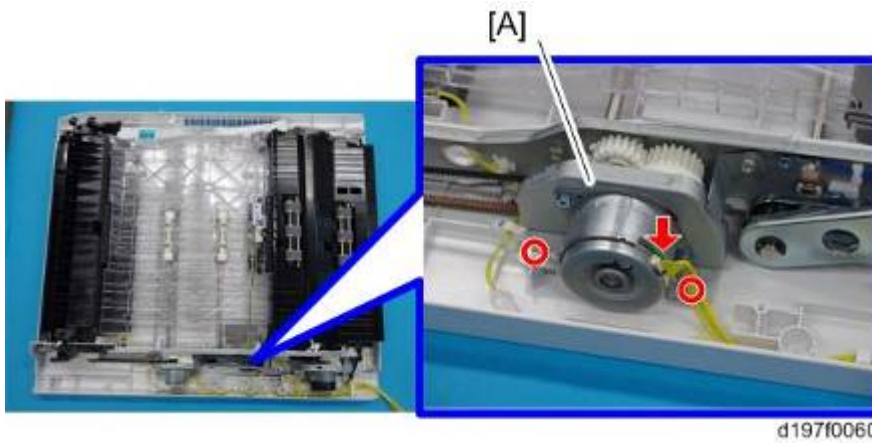

4. Duplex entrance motor [A] (🔩 x2)

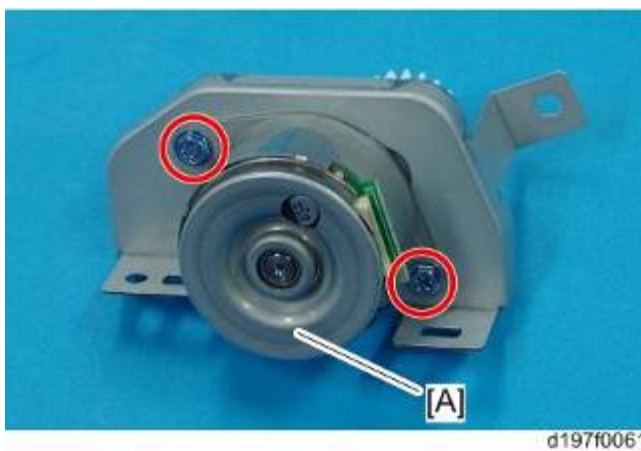

4.16.3 DUPLEX ENTRANCE SENSOR

1. Right Cover (page 4-20)
2. Screws and stoppers for the paper transfer guide plate [A] (⊗ x2, ▽ x1)



3. Duplex inner entrance guide [A]

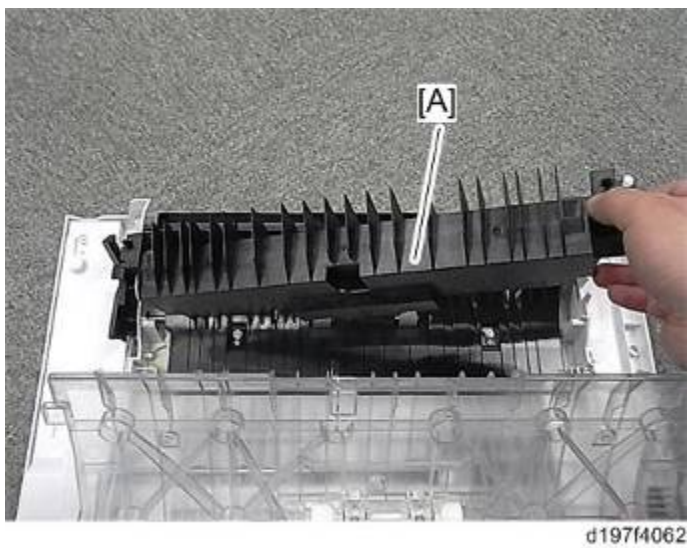

4. Duplex outer entrance guide [A] (⊗ x8, ⊞ x1, ⊞ x1)

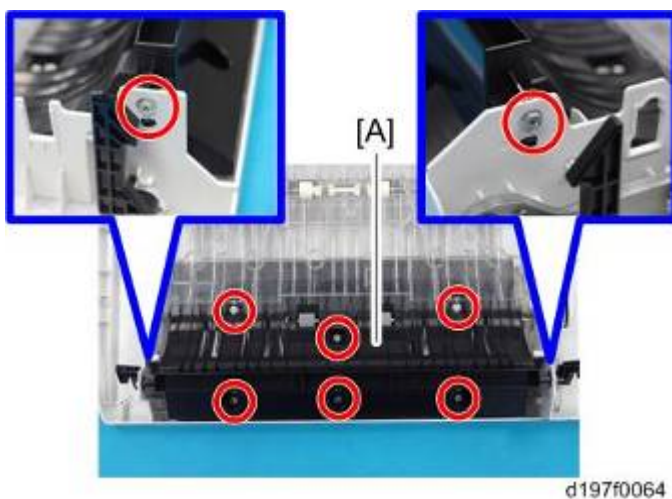

Duplex Unit



d197f0065

5. Duplex entrance sensor [A] (hooks)

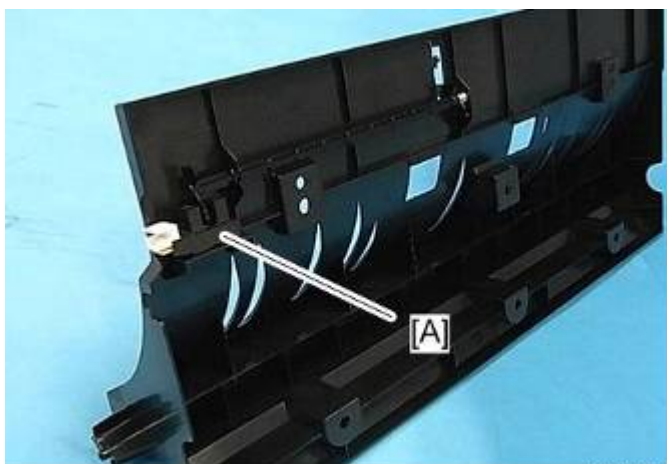

d197f4063

4.16.4 DUPLEX EXIT SENSOR

1. Open the right cover.
2. Duplex exit sensor bracket [A] (🔩 x1, 🛠 x1)

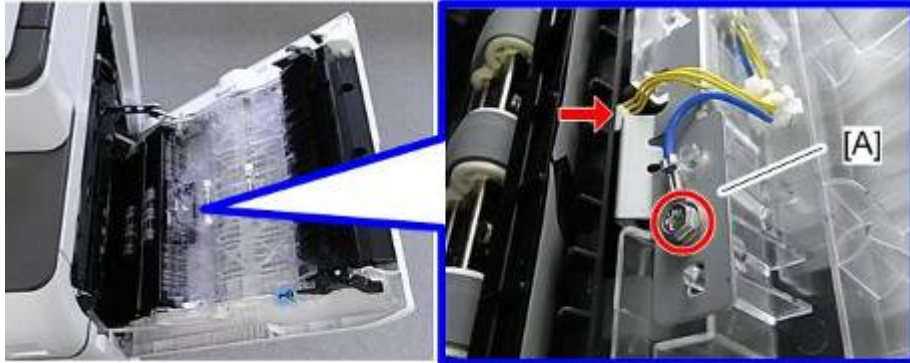

d197f0066

3. Duplex exit sensor [A] (hooks)

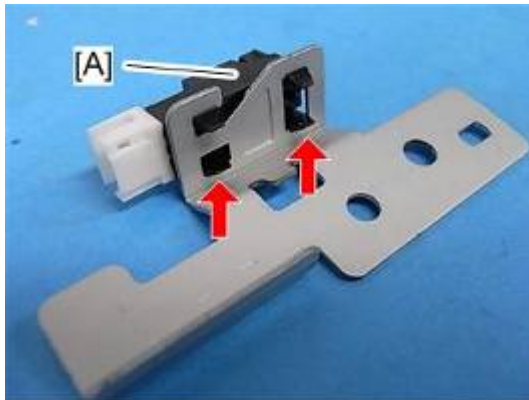

d197z0403

4.17 BYPASS TRAY UNIT

4.17.1 BYPASS TRAY

1. Open the right cover.
2. Wire [A] (⊗x1)

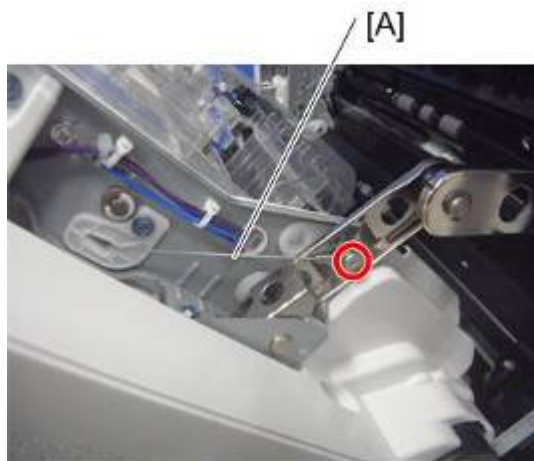

d1462410

3. Release two arms [A] [B] (⊗x2).



d197z0447

4. Open the right cover wide.

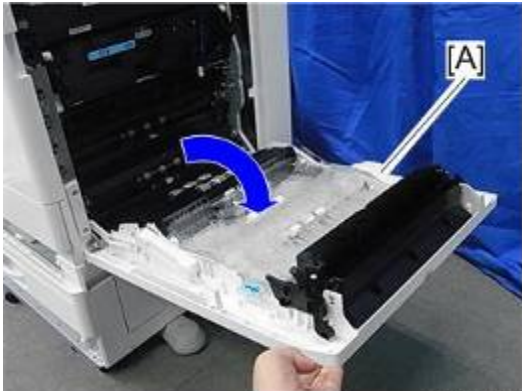

d197z0448

5. Paper transport guide [A] (🔩 x2)



d1462411

6. Harness (🔧 x1, 🔩 x1, 🌀 x1)

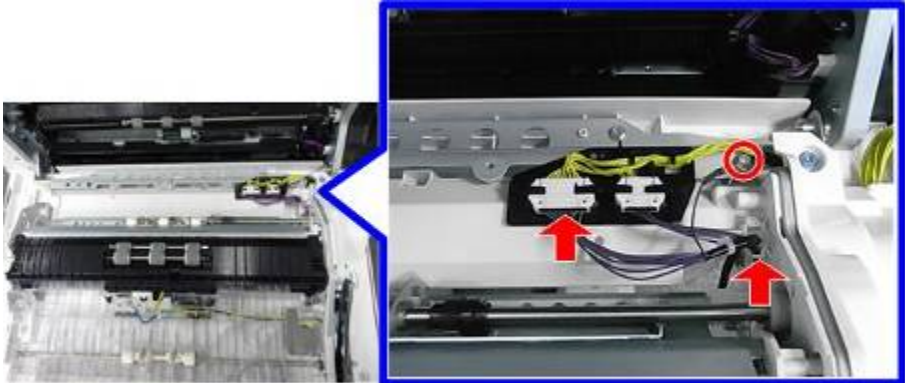

d197f0097

7. Bypass tray [A] (🌀 x4)

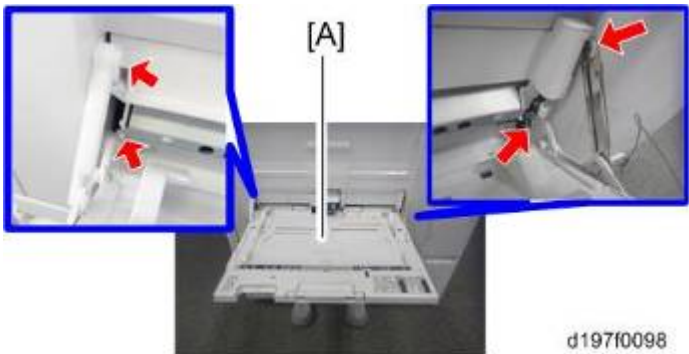

d197f0098

4.17.2 BYPASS PAPER END SENSOR

1. Open the bypass tray [A].

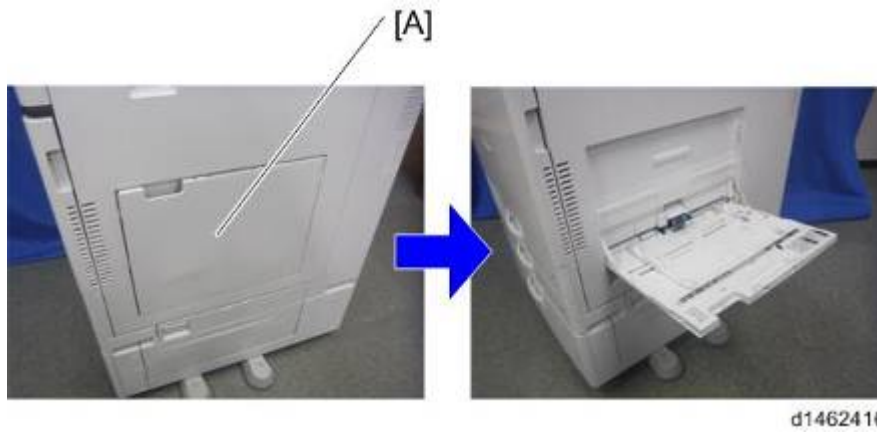

2. Bypass paper end sensor cover [A]

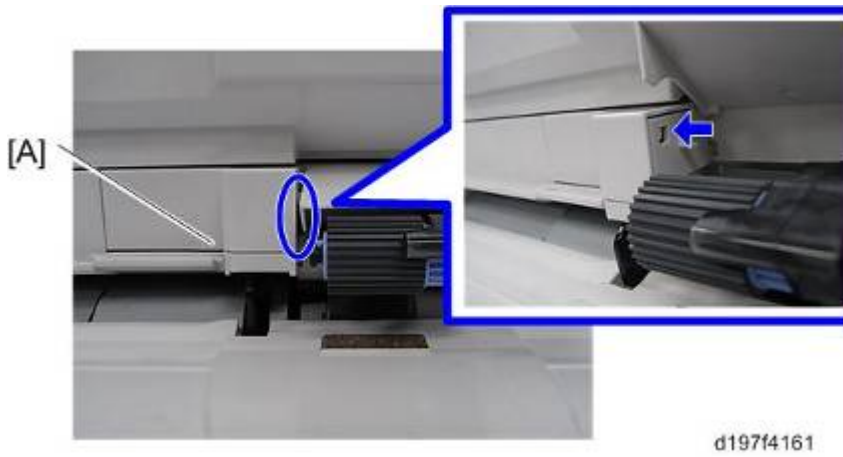

3. Bypass paper end sensor unit [A] (⊗ x1, ⊞ x1)

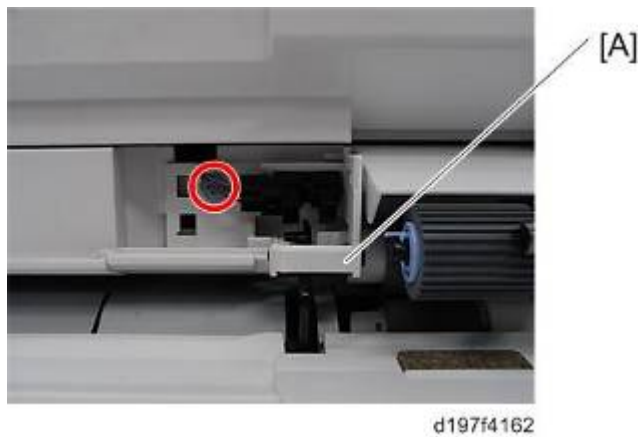

4. Bypass paper end sensor [A] (hooks)

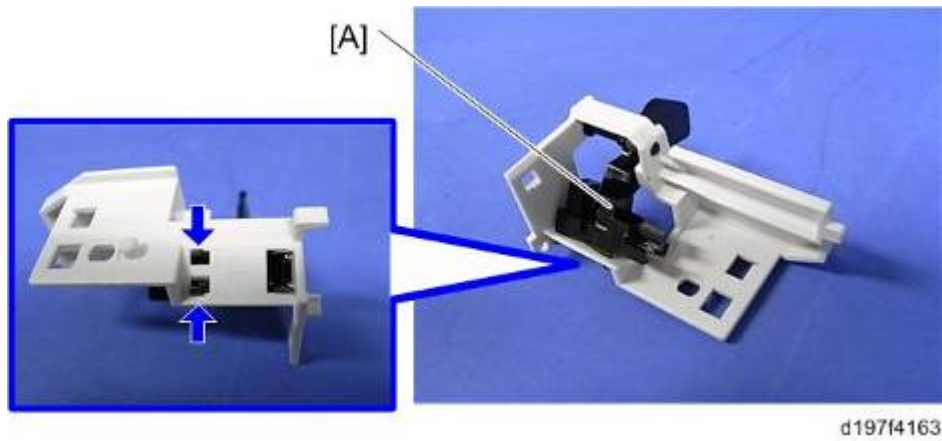

4.17.3 BYPASS PICK-UP ROLLER

1. Open the bypass tray (page 4-154).
2. Bypass pick-up roller [A] (1x1)



4.17.4 BYPASS PAPER FEED ROLLER

1. Bypass paper end sensor unit (page 4-156 "Bypass Paper End Sensor")
2. Bypass paper feed roller [A] (03x1)

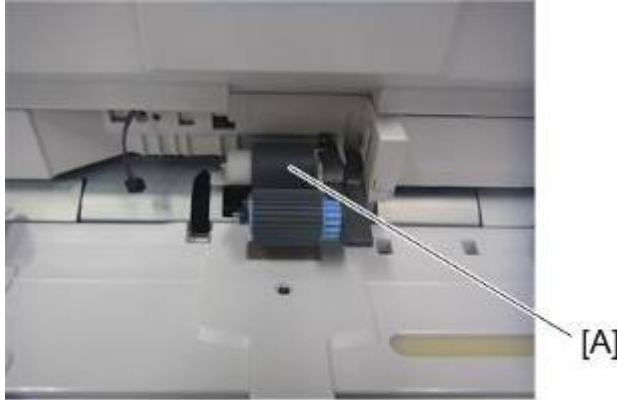

d1462418

4.17.5 BYPASS SEPARATION ROLLER

1. Paper transport guide (page 4-154)
2. Bypass separation roller [A] (03x1)



d1462419

4.17.6 TORQUE LIMITER

1. Bypass separation roller (page 4-158)
2. Torque limiter [A]



d1462420

4.17.7 BYPASS WIDTH SENSOR

- 1. Bypass tray (page 4-154)
- 2. Six screws on the bypass tray [A] (⌀ x6).

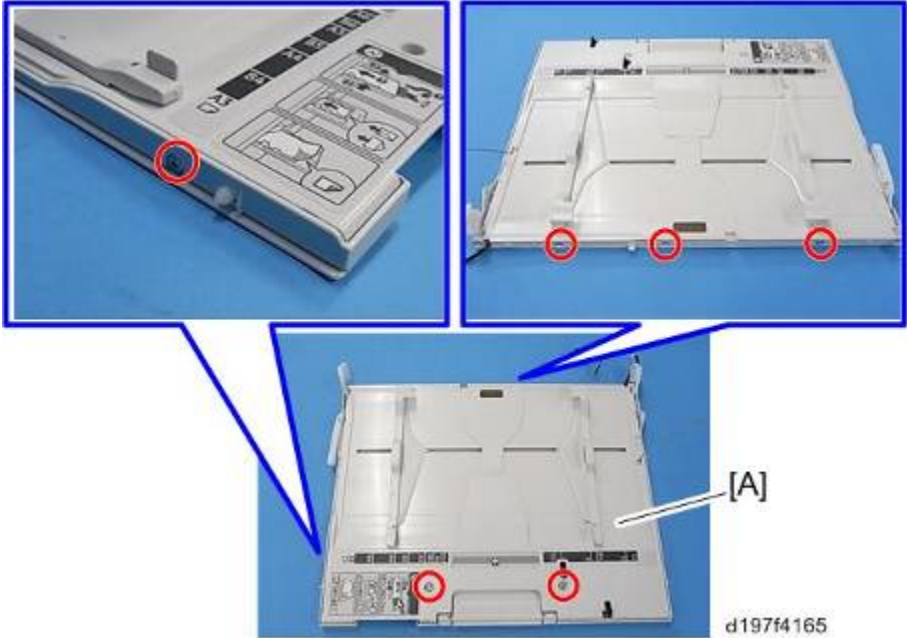

- 3. Release the hooks around the bypass tray [A]

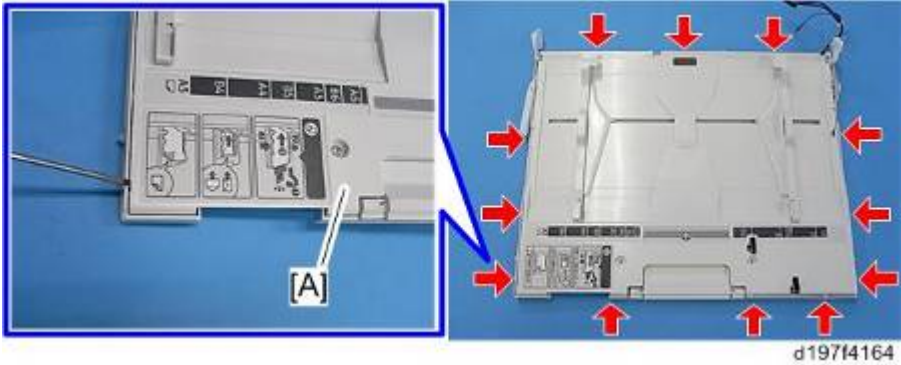

Note

- There is a hook in the tray cover. Be careful not to damage it during removal or installation.

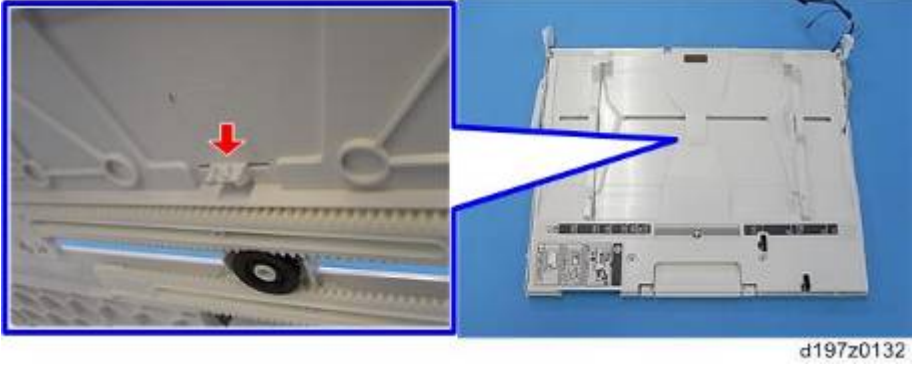

- 4. Release the links.

Bypass Tray Unit

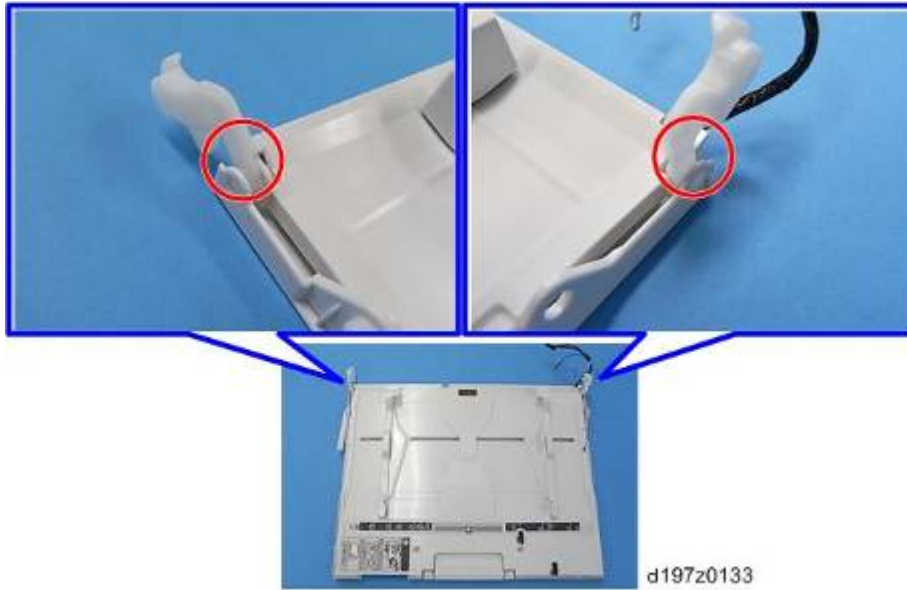

5. Bypass tray upper cover [A] (pin x 1, x1)

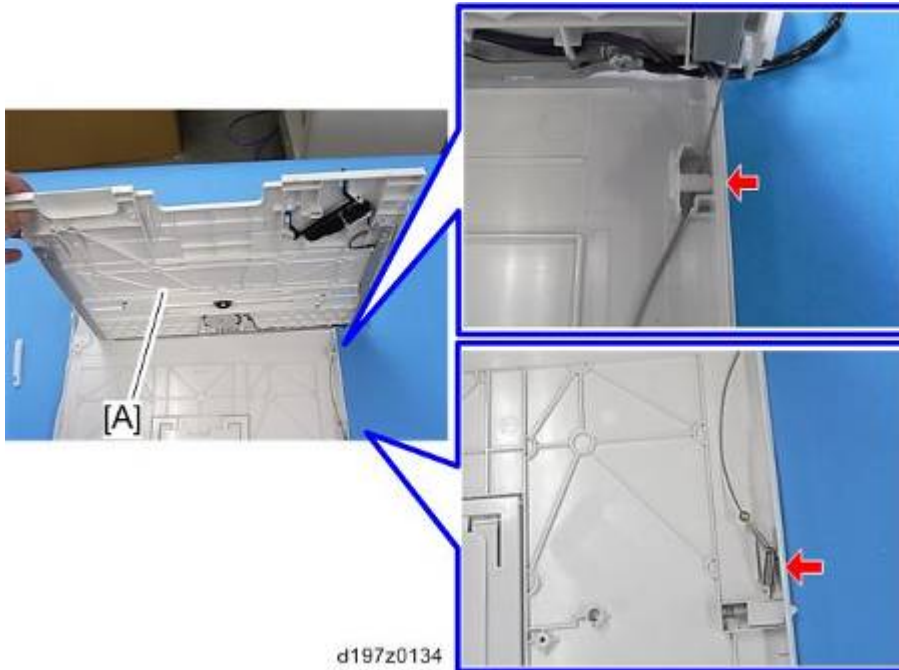

6. Bypass width sensor [A] (x1, x2)

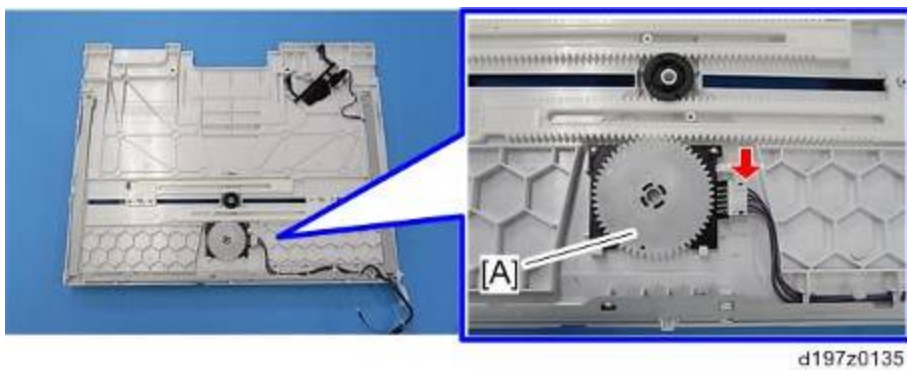

Note

- When installing, the holes must align as shown below.

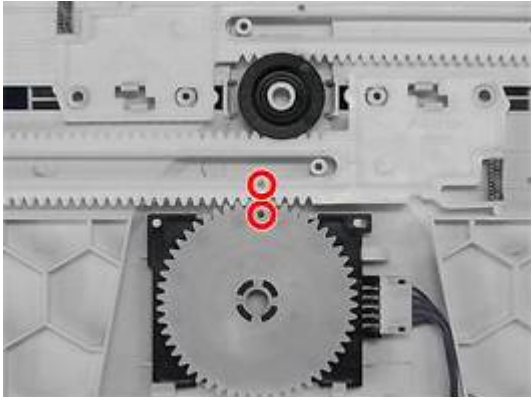

d197z0449

4.17.8 BYPASS LENGTH SENSOR

- Bypass tray upper cover (page 4-159).
- Bypass length sensor [A] (🔧 x1, hooks)



d197z0136

4.18 PCBS AND OTHER ITEMS

4.18.1 OVERVIEW

Around the Controller Box

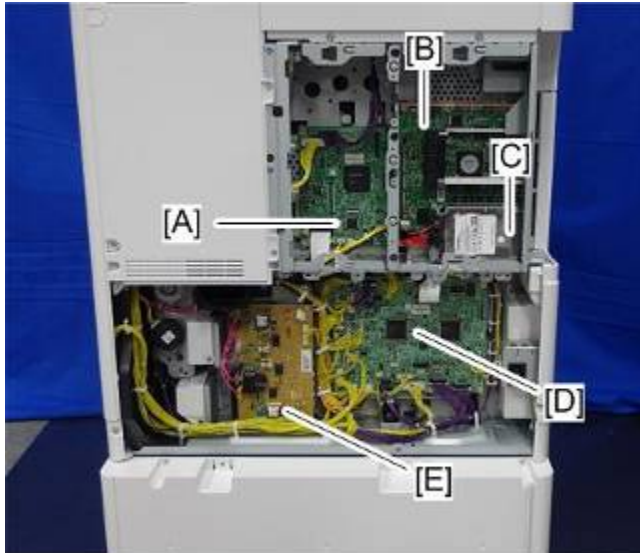

d197f0078

[A]	IPU
[B]	Controller Board
[C]	HDD
[D]	BCU
[E]	HVPS

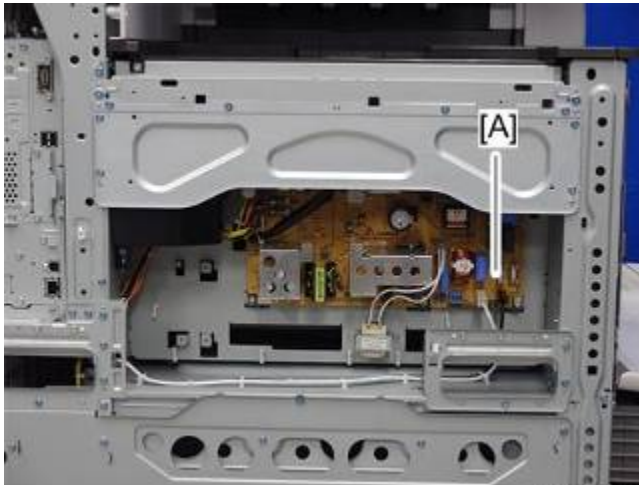
Around the Power Supply Box

d197f0079

[A]	PSU
-----	-----

4.18.2 IPU

⚠ CAUTION

- The FFC connector has a lock mechanism. Do not use force to pull it out.

1. Controller rear cover (page 4-15)
2. IPU Sub if SPDF is installed.
3. IPU [A] (🔩 x4, 📧 x9, 📀 x1, USBx1)

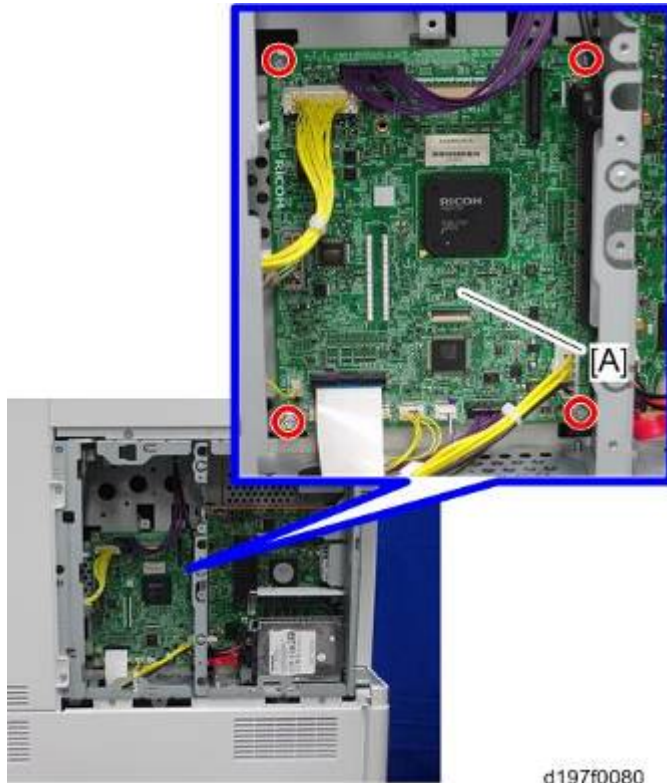

IPU Sub (If SPDF is installed)

1. Controller rear cover (page 4-15)
2. IPU Sub [A] (🔩 x3, 📧 x2)

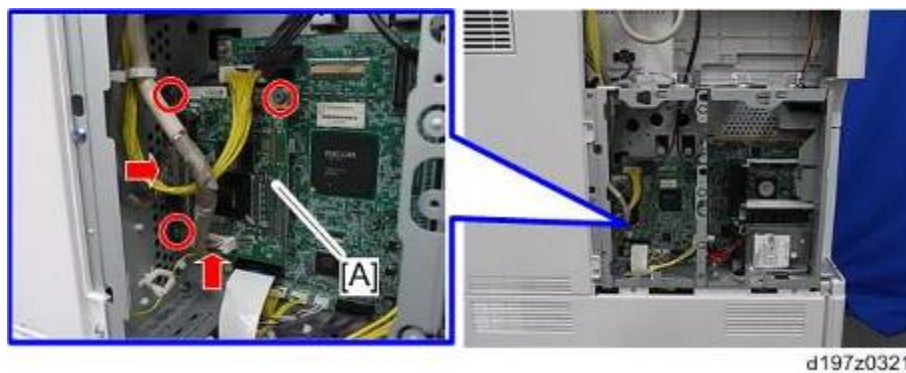

4.18.3 BCU

⚠ CAUTION

- The FFC connector has a lock mechanism. Do not use force to pull it out.

1. Rear lower cover (page 4-17)
2. BCU [A] (⚙️ x8, 🔑 xALL, FFCx1)



d197f0083

When installing the new BCU

Remove the NVRAM (EEPROM) from the old BCU. Then install it on the new BCU after you replace the BCU.

Replace the NVRAM (page 4-166) if the NVRAM on the old BCU is defective.

ⓘ Note

- Make sure you print out the SMC reports ("SP Mode Data" and "Logging Data") before you replace the NVRAM (EEPROM).

⚠ CAUTION

- Keep NVRAMs (EEPROM) away from any objects that can cause static electricity. Static electricity can damage NVRAM data.
- Make sure the serial number is input in the machine for the NVRAM data with SP5-811-004, if not, SC995-001 occurs

Replacing the NVRAM (EEPROM) on the BCU

1. Make sure that you have the SMC report (factory settings). This report comes with the machine.
2. Output the SMC data (“ALL”) using SP5-990-001/SP5-992-001.
3. Turn off the main switch.
4. Insert a blank SD card in the SD slot #2, and then turn on the main switch.
5. Use SP5-824-001 to upload the NVRAM data from the BCU.
6. Turn off the main power switch and unplug the power cord.
7. Replace the NVRAM [A] on the BCU with a new one.

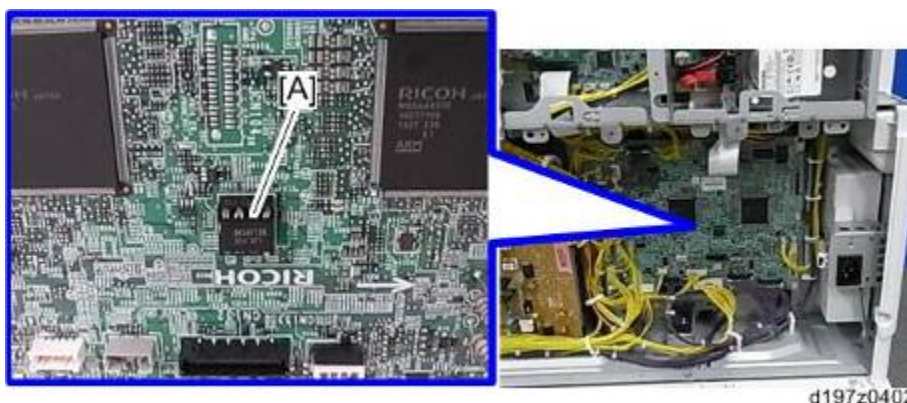

↓ Note

- Install a new NVRAM [C] so that the indentation [B] on the NVRAM corresponds with the mark [A] on the BCU. Incorrect installation of the NVRAM will damage both the BCU and NVRAM.

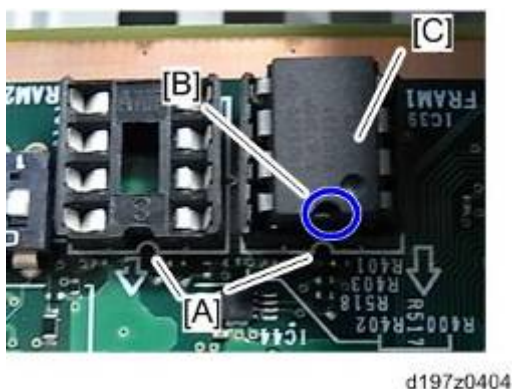

8. Plug in, and then turn on the main switch.

↓ Note

- When the power is turned ON, SC195-00 appears, but continue with the following steps.
9. Select the destination setting. (SP5-131-001) (JPN: 0, NA: 1, EU/AA/TWN/CHN: 2)
 10. Check the machine serial number with SP5-811-004, and then set the machine serial number of SP5-811-001.

Note

- For information on how to configure SP5-811-001, contact the supervisor in your branch office.

11. Set the area selection with SP5-807-001.**Note**

- For information on how to configure SP5-807-001, contact the supervisor in your branch office.

12. Turn off the machine, and then turn it back on.**13. Use SP5-801-002 “Memory Clear Engine”.****Important**

- **After changing the EEPROM, Some SPs do not have appropriate initial values. Because of this, steps 10 to 12 must be done.**

14. Turn off the machine, and then turn it back on.**15. From the SD card where you saved the NV-RAM data in step 5, download the NV-RAM data with SP5-824-002.****16. Turn off the machine, and then remove the SD card from SD slot 2.****17. Turn on the main switch.****18. Check the factory setting sheet and the SMC data printout from step 2, and set the user tool and SP settings so they are the same as before.**

4.18.4 CONTROLLER BOARD

Note

- Keep NVRAM away from any objects that can cause static electricity. Static electricity can damage NVRAM data.

Note

- **Special Procedure for Machines that have a Self Encrypting Drive (SED) Installed**
- The machine holds data, linking the controller board and SED, created automatically during SED installation. The data, however, will not be deleted automatically at controller board replacement. Therefore, before replacing a controller board, you must delete the link data manually so that the machine can create new link data.
- Do the following steps when doing the replacement.
 1. Execute [Erase All Memory] on the operation panel
[System Settings] – [Administrator Tools] – [Erase All Memory]
 2. Turn OFF the main power switch
 3. Replace the controller board
 4. Turn ON the main power switch
- **Do not** turn the main power ON after step 2, until after you replaced the board.

1. Controller rear cover (page 4-15)**2. HDD bracket (page 4-173)**

3. Controller bracket [A] (🔩 x5, 🗝️ x2)

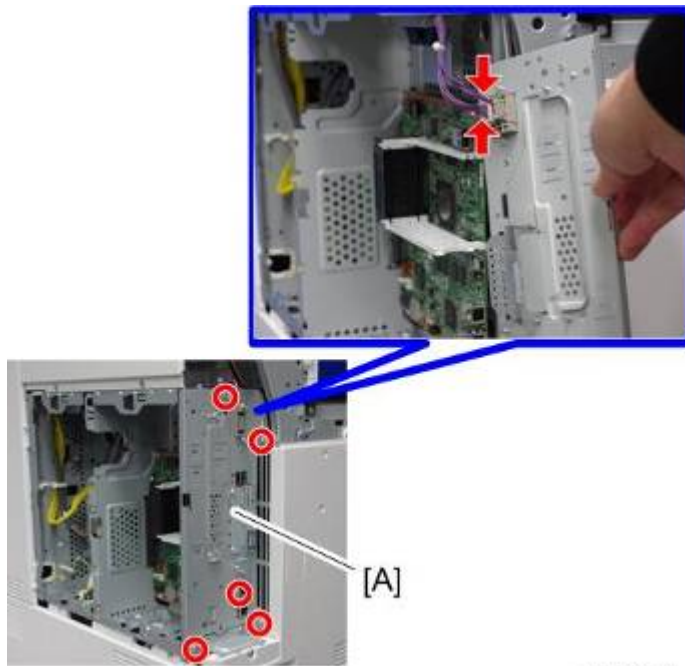

d197f0084

4. Controller board (🔩 x4)



d197f0085

5. Release the guide rail [A]

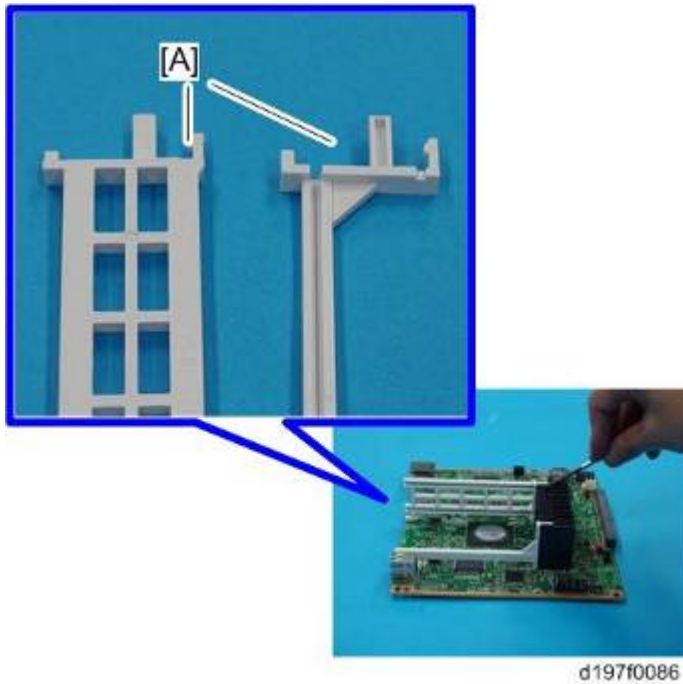

d197f0086

6. Remove the NVRAM on the controller board.

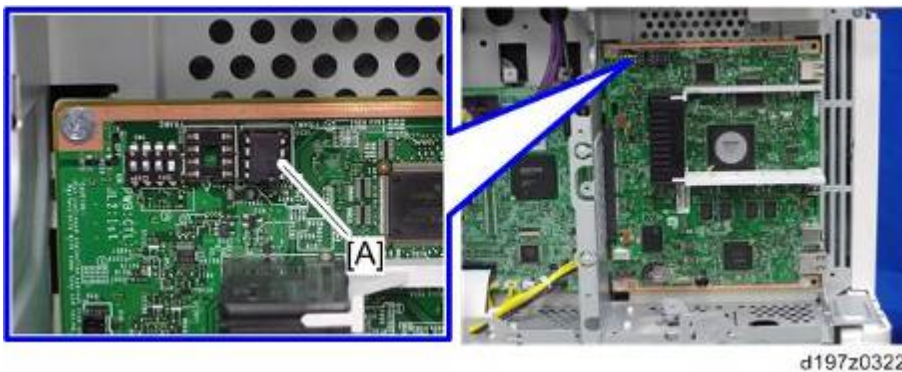

d197z0322

Note

- When installing a new controller board, Install a removed or a new NVRAM [C] so that the indentation [B] on the NVRAM corresponds with the mark [A] on the controller board. Incorrect installation of the NVRAM will damage both the controller board and NVRAM.

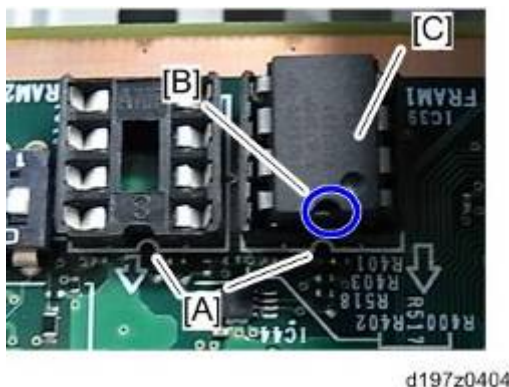

d197z0404

NVRAM on the controller board

⚠ CAUTION

- Referring to the previous procedure, be sure that there are no mistakes in the mounting position and orientation of the NVRAM.

⚠ CAUTION

- SC195 (Machine serial number error) will be displayed if you forget to attach the NVRAM.
- If you mounted the NVRAM in the wrong direction, each component needs to be replaced because a short circuit was caused in the controller board and the NVRAM.

1. **Make sure you have the SMC report (factory settings). This report comes with the machine.**
2. **Output all the SMC data using SP5-990-001 (SP Print Mode: All (Data List)).**
3. **Turn off the main power switch.**
4. **Insert a blank SD card in the SD slot 2, and then turn on the main power switch.**
5. **Use SP5-824-001 to upload the NVRAM data from the controller board.**
6. **Make sure the customer has a backup of their address book data. If not, obtain the backup by referring to the following procedure.**

1. Insert an SD card into SD slot 2, and then turn the main power ON.
2. Save the address book data in the SD card using SP5-846-051.

★ Important

- **The address data stored in the machine will be discarded later during this procedure. So be sure to obtain a backup of the customer's address book data.**
- **Note that the counters for the user will be reset when doing the backup/restore of the address book data.**
- **If they have a backup of the address book data, use their own backup data for restoring. This is because there is a risk that the data cannot be backed up properly depending on the NVRAM condition.**

7. **Do the following steps if the machine has the fax unit. If not, skip this step.**

1. Print the Box List by with the User Tools/Counter.
 - [User Tools/Counter] - [Facsimile Features] - [General Settings] - [Box Setting: Print List]
2. Print the Special Sender List by pressing these buttons in the following order.
 - [User Tools/Counter] - [Facsimile Features] - [Reception Settings] - [Program Special Sender: Print List]
3. Write down the following fax settings.
 - [Receiver] in [User Tools/Counter] - [Facsimile Features] - [Reception Settings] - [Reception File Settings] - [Forwarding].
 - [Notify Destination] in [User Tools/Counter] - [Facsimile Features] - [Reception Settings] - [Reception File Settings] - [Store].
 - [Specify User] in [User Tools/Counter] - [Facsimile Features] - [Reception Settings] -

[Stored Reception File User Setting].

- [Notify Destination] in [User Tools/Counter] - [Facsimile Features] - [Reception Settings] - [Folder Transfer Result Report].
- Specified folder in [User Tools/Counter] - [Facsimile Features] - [Send Settings] - [Backup File TX Setting].
- [Receiver] in [User Tools/Counter] - [Facsimile Features] - [Reception Settings] - [Reception File Settings] - [Output Mode Switch Timer].
- [Store: Notify Destination] in [User Tools/Counter] - [Facsimile Features] - [Reception Settings] - [Output Mode Switch Timer].
- All the destination information shown on the display.

Note

- In the fax settings, address book data is stored with entry IDs, which the system internally assigns to each data. The entry IDs may be changed due to re-assigning in backup/restore operations.

4. Make sure that there is no transmission standby file. If any standby file exists, ask the customer to delete it or complete the transmission.

8. Turn the main power OFF and unplug the power supply cord.

9. Push the main power switch ON again to discharge the residual charge.

10. Replace the NV-RAM with a brand-new one.

11. Turn the power ON.

Important

- After turning the power ON, SC995 will be displayed except for machines that have a smart operation panel.
- For machines that have a smart operation panel, SC673 will occur and SC995 might be internally issued after turning the power ON.
- After turning the power ON, SC870 will occur and the address book data will be cleared.

<Additional procedure only for machines that have the Smart Operation Panel

installed>

Note

- SC673 will be displayed at start-up, but this is normal behavior. This is because the controller and the smart operation panel cannot communicate with each other due to changing the SP settings for the operation panel.

1. Change the SP settings for the operation panel.

- SP5-748-101: (OpePanel Setting: Op Type Action Setting): Change bit 0 from "0" to "1".
- SP5-748-201: (OpePanel Setting: Cheetah Panel Connect Setting): Change the value from "0" to "1".

2. Change the Flair API SP values.
 - SP5-752-001 (Copy FlairAPI Setting) in System SP: Change bit 0 from “0” to “1”.
 - SP1-041-001 (Scan:FlairAPI Setting) in Scanner SP: Change bit 0 from “0” to “1”.
 - SP3-301-001 (FAX:FlairAPI Setting) in Fax SP: Change bit 0 from “0” to “1”.
12. Turn the main power OFF/ON with the SD card where the NV-RAM data has been uploaded in SD slot 2.
13. Download the NV-RAM data stored in the SD card to the brand-new NV-RAM using SP5-825-001 (NV-RAM Data Download).
 - ⓘ Note
 - The download will take a couple of minutes.
14. Turn the main power OFF and remove the SD card from SD slot 2.
15. Turn the main power ON.
16. Restore the original settings of the following SPs, referring to the SMC data obtained in step 2.
 - ⓘ Note
 - SP5-825-001 does not download the following SP data to the new NV-RAM. So you must set them manually.
 - a. SP5-985-001 (Device Setting: On Board NIC)
 - b. SP5-985-002 (Device Setting: On Board USB)
17. If the security functions (HDD Encryption and HDD Data Overwrite Security) were applied, set the functions again.
18. Ask the customer to restore their address book. Or restore the address book data using SP5-846-052 (UCS Setting: Restore All Addr Book), and ask the customer to ensure the address book data has been restored properly.
 - ★ Important
 - If you have obtained the backup of the customer’s address book data, delete the backup immediately after the NV-RAM replacement to avoid accidentally taking out the customer’s data.
19. Output all the SMC data with SP5-990-001 and make sure all the SP/UP settings except for counter information are properly restored, by checking the SMC data obtained.
 - ⓘ Note
 - The counters will be reset.
20. Make sure that the list output in steps 4 to 6 matches the destination information in step 6. If not, set it to the setting before replacement.
21. Execute the process control (SP3-011-001).
 - ⓘ Note
 - If a message tells you need an SD card to restore displays after the NV-RAM replacement, create a “SD card for restoration” and restore with the SD card.

4.18.5 HDD

Note

- Before replacing the HDD, copy the address book data to an SD card with SP5-846-051 if possible.
- If the customer is using the Data Overwrite Security, the Data Encryption feature or OCR Scanned PDF, these applications must be installed again.

1. Controller rear cover (page 4-15)

2. HDD with bracket [A] (⚙️ x3, 🔑 x2)



3. HDD [A] (⚙️ x4, 🔑 x2)

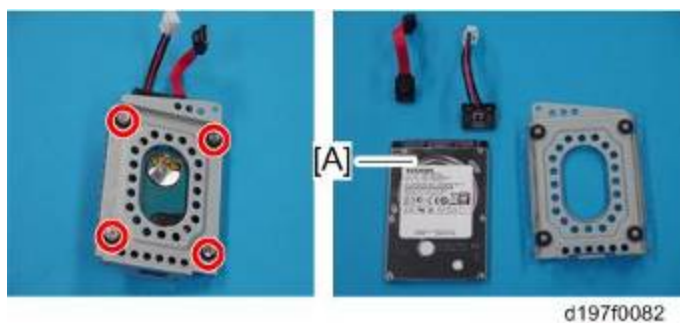

Adjustment after replacement

1. Execute SP5-832-001 to initialize the hard disk.
Even if you use an HDD that is already formatted, it is recommended that you re-initialize.
2. Execute SP5-853-001 to install the fixed stamps.
3. Execute SP5-846-052 to copy the address book from the SD card to the HDD.
4. Turn off the machine, and then turn it back on.

4.18.6 HVPS

1. Rear lower cover (page 4-17)
2. HVPS [A] (🔩 x4, 🗝️ x5)

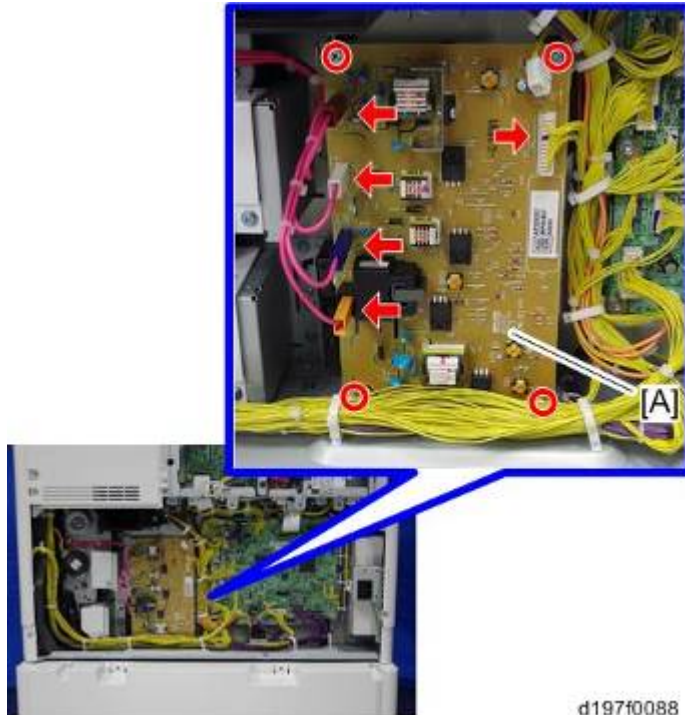

d197f0088

4.18.7 PSU

1. Left cover (page 4-14)
2. Bracket [A] (🔩 x8)

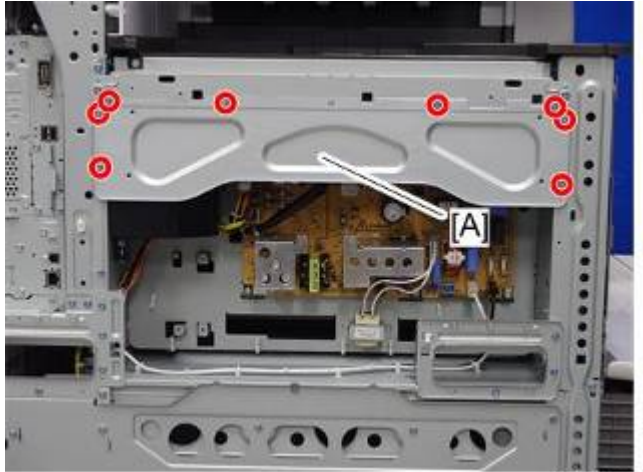

d197f0089

3. PSU [A] (🔩 x5, 📦 x7 for EU/AA)

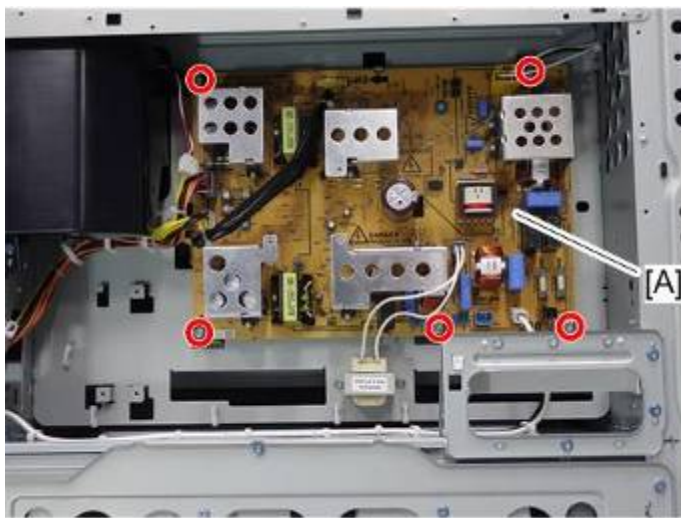

d197f0091

PSU Fuse Location

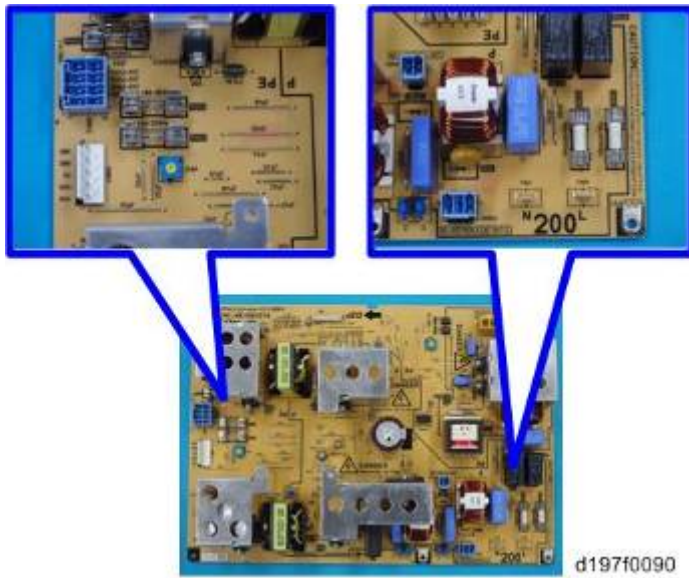

4.18.8 HEATER BOARD

1. Left cover (page 4-14)
2. Heater board [A] (🔩 x3, 📦 x3)

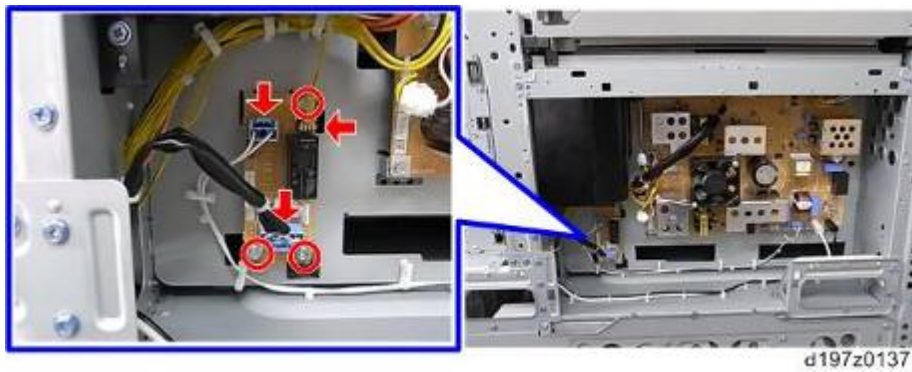

4.18.9 CONTROLLER BOX

1. Upper inner cover (page 4-25)
2. Rear left cover (page 4-16)
3. Left cover (page 4-14)
4. Rear right cover (page 4-16)
5. Rear lower cover (page 4-17)
6. Release the clamps on the upper side of the controller box (🔧x8).

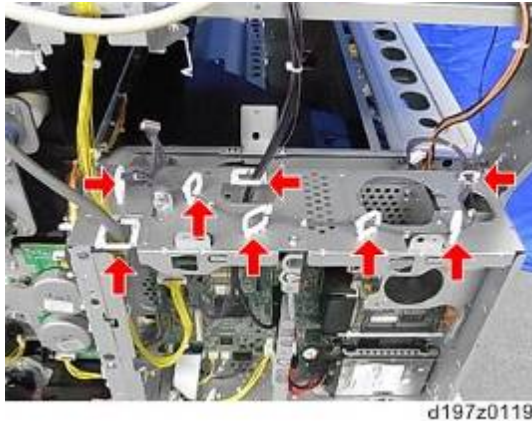

d197z0119

7. Release the clamps on the flank of the controller box (🔧x4).

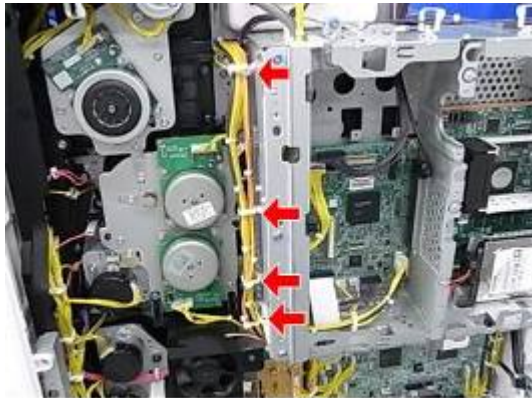

d197z0120

8. Release the clamps in the controller box (🔧x4).

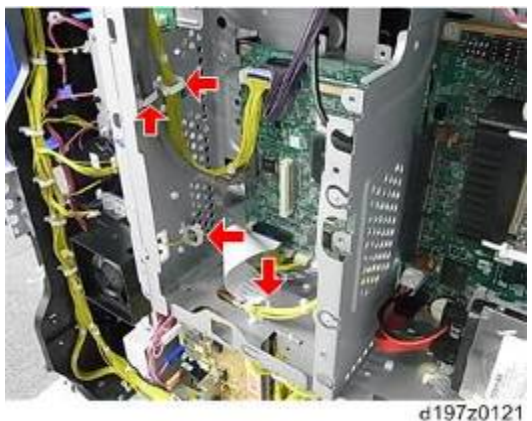

d197z0121

9. Remove the connectors on the IPU [A] (🔌 x10, USBx1).

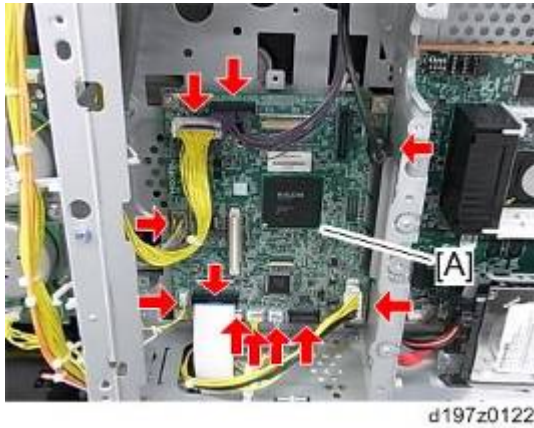

10. Remove the FFC on the BCU [A].

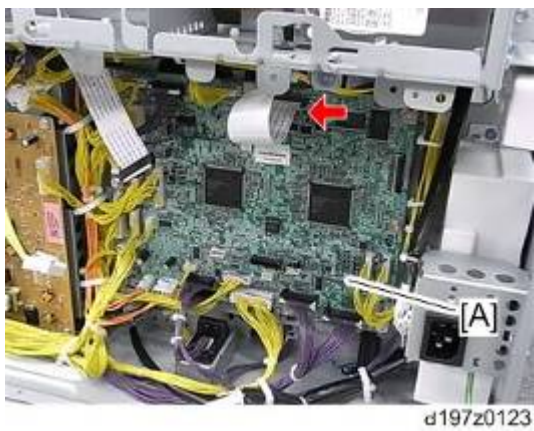

11. Relay connector [A] (🔌 x2, 📏 x2)

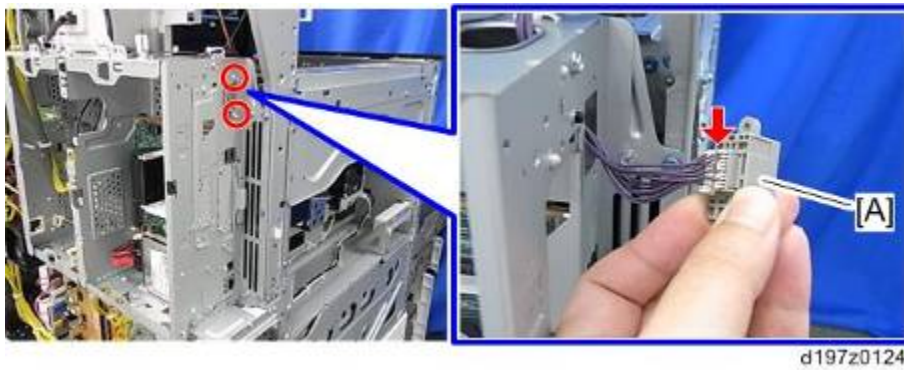

12. Controller box [A] (🔩 x9)

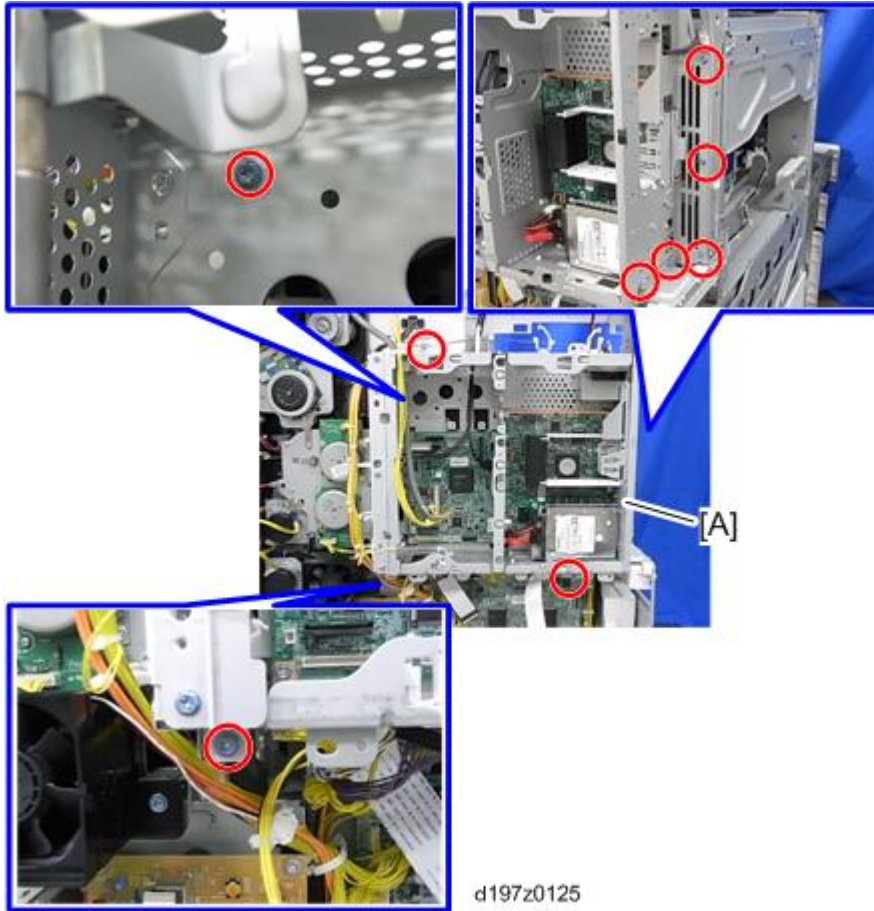

4.18.10 TEMPERATURE SENSOR

1. Open the transfer unit (page 4-99).
2. Fusing unit (page 4-114).
3. Temperature sensor (🔩 x1, 🛠️ x2, 📦 x1).



4.19 FANS/FILTERS

4.19.1 ODOR FILTER

1. Odor filter box [A]



2. Odor filter [A]



4.19.2 DUST FILTER

1. PCDU (page 4-72)
2. Mount the dust filter on the duct.[A]

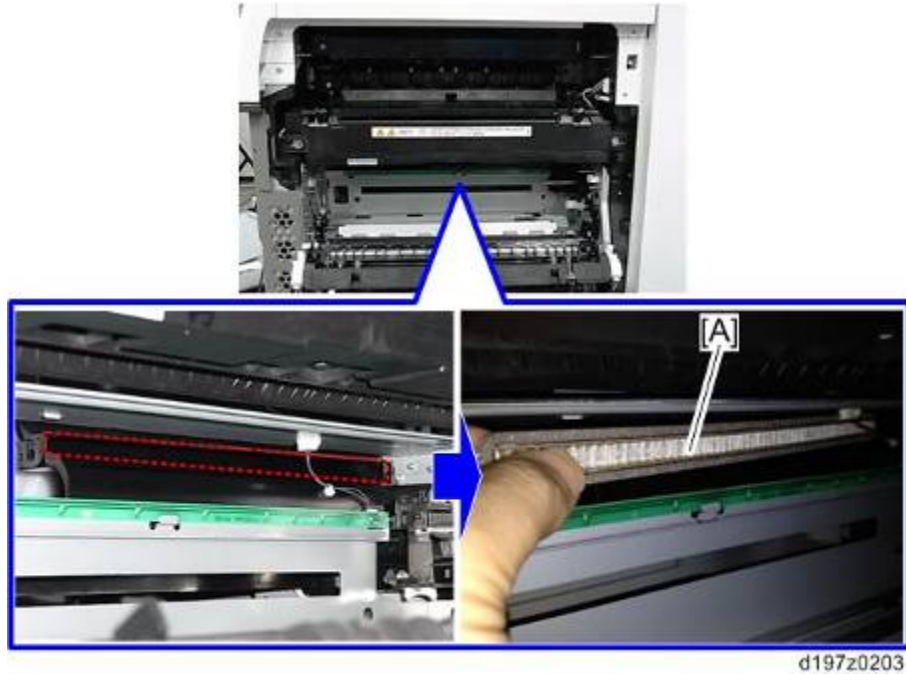

Note

- Attach the right side of the filter first when you mount it.



4.19.3 DEVELOPMENT EXHAUST FAN

1. Left cover (page 4-14)
2. Bracket [A] (🔩 x8)

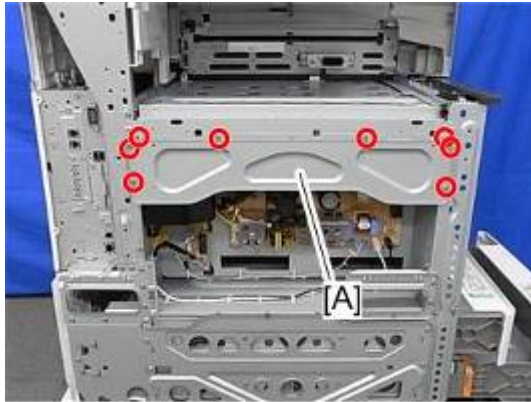

d197z0017

3. Development exhaust fan with duct [A] (🔩 x2, 📦 x1)



d197z0018

4. Dismantle the duct [A] (🔧 x4)

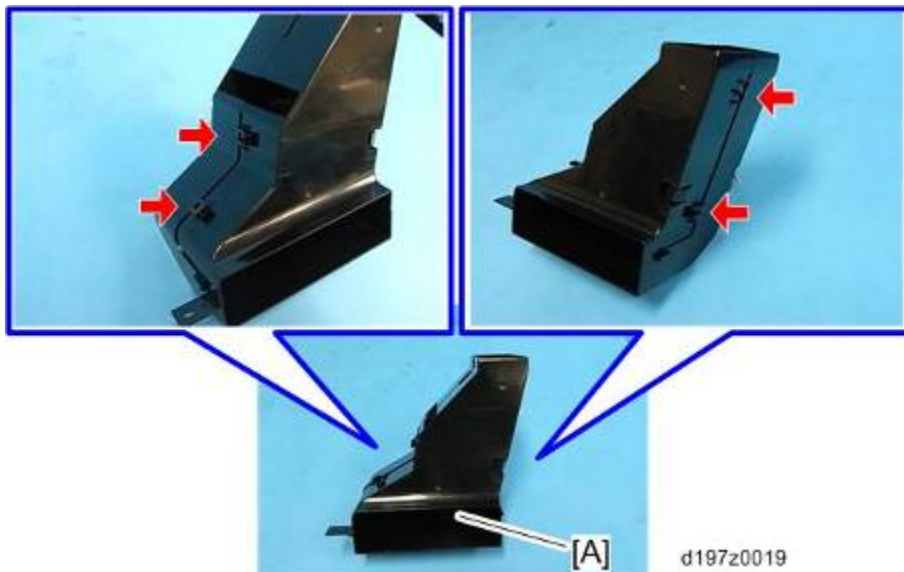

d197z0019

5. Development exhaust fan [A]



d197z0020

Note

- Pay attention to the direction of the fan when installing. The decal pasted on the fan must face the outside.



d197z0021

4.19.4 PAPER EXIT COOLING FAN

- Main power switch cover (page 4-22)
- Paper exit cooling fan [A] (⚙️ x2, 📦 x1, 📦 x2)



d197z0022

Note

- Pay attention to the direction of the fan when installing. The decal pasted on the fan must face the inside.

4.19.5 FUSING FAN

1. Rear right cover (page 4-16)
2. Fusing exhaust heat fan [A] with duct (🔩 x2, 📦 x1, 🛠️ x1)

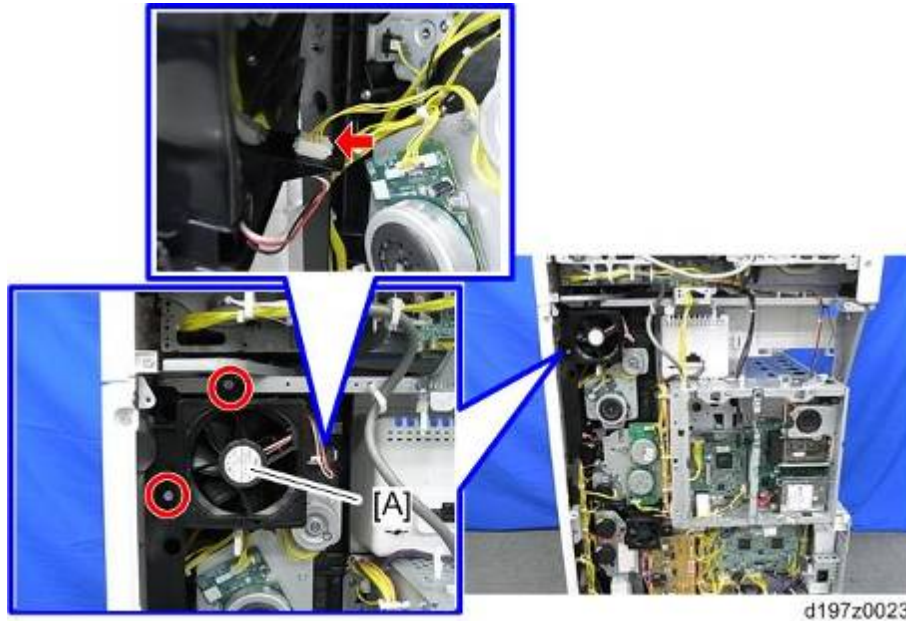

3. Fusing exhaust heat fan [A] (🔩 x4)

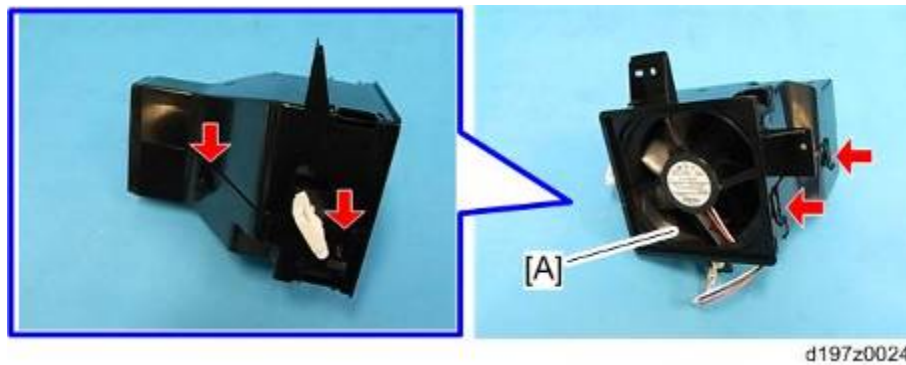

⚠ Note

- Pay attention to the direction of the fan when installing. The decal pasted on the fan must face the outside.



d197z0025

4.19.6 DEVELOPMENT BEARING COOLING FAN (D200/D201/D202 ONLY)

1. Rear lower cover (page 4-17)
2. Development bearing cooling fan with duct [A] (🌀 x2, 🛠️ x1)

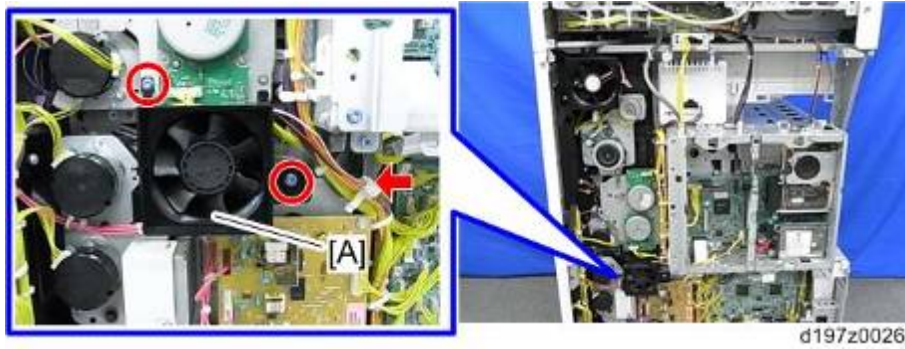

3. Dismantle the duct [A] (🔧 x4)

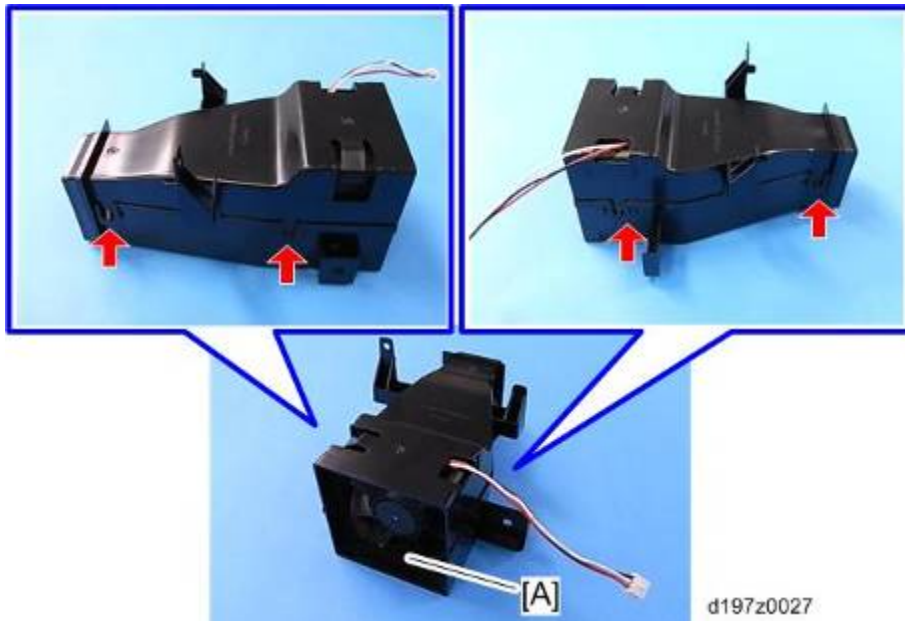

4. Development bearing cooling fan [A]



Note

- Pay attention to the direction of the fan when installing. The decal pasted on the fan must face the outside.



4.19.7 PSU COOLING FAN (D200/D201/D202 ONLY)

1. Left cover (page 4-14)
2. PSU cooling fan [A] (⚙️ x2, 🛠️ x1, 📦 x1)

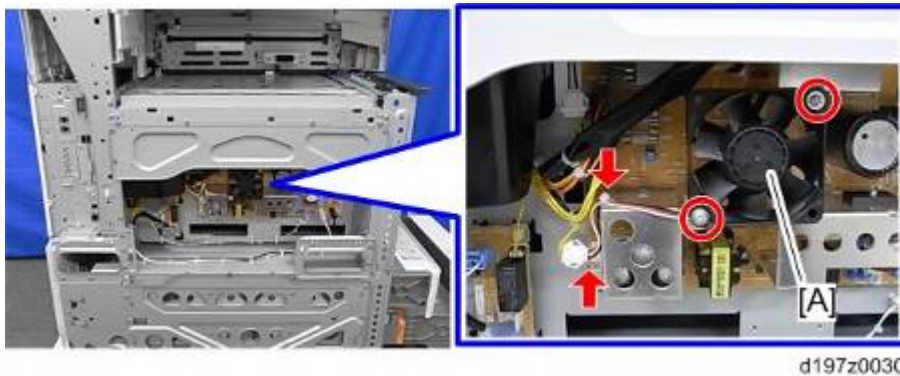

Note

- Pay attention to the direction of the fan when installing. The decal pasted on the fan must face the inside.

4.20 ADJUSTMENT AFTER REPLACEMENT

4.20.1 PRINTING

Note

- Make sure the paper is installed correctly in each paper tray before you start these adjustments.
- Use the Trimming Area Pattern (SP2-109-003, No.14) to print the test pattern for the following procedures.
- Set the setting of SP 2-109-003 to "0" again after completing these printing adjustments.

Registration - Leading Edge/Side-to-Side

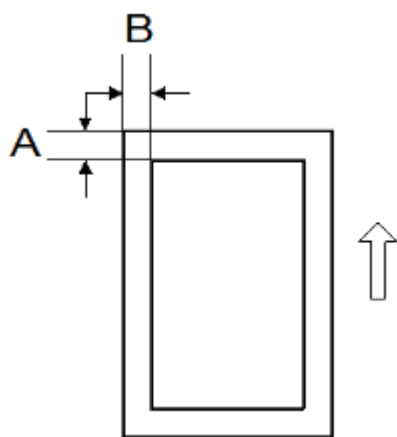

A: Leading Edge Registration (4.2 ± 1.5 mm)

B: Side-to-side Registration (2 ± 1.5 mm)

- Check the leading edge registration [A] for each paper feed station, and adjust them using SP1-001.

Tray	SP No.	Threshold
Tray1: Thin	SP1-001-001	4.2 ± 1.5 mm
Tray1: Plain	SP1-001-002	
Tray1: MidThick	SP1-001-003	
Tray1: Thick1	SP1-001-004	
Tray1: Thick2	SP1-001-005	
Tray1: Thick3	SP1-001-006	
Tray1: Thick4	SP1-001-007	

Adjustment after Replacement

Tray	SP No.	Threshold
Tray2: Thin	SP1-001-008	4.2 ± 1.5 mm
Tray2: Plain	SP1-001-009	
Tray2: MidThick	SP1-001-010	
Tray2: Thick1	SP1-001-011	
Tray2: Thick2	SP1-001-012	
Tray2: Thick3	SP1-001-013	
Tray2: Thick4	SP1-001-014	
Bypass: Thin	SP1-001-015	4.2 ± 1.5 mm
Bypass: Plain	SP1-001-016	
Bypass: MidThick	SP1-001-017	
Bypass: Thick1	SP1-001-018	
Bypass: Thick2	SP1-001-019	
Bypass: Thick3	SP1-001-020	
Bypass: Thick4	SP1-001-021	
Duplex: Thin	SP1-001-022	4.2 ± 1.5 mm
Duplex: Plain	SP1-001-023	
Duplex: MidThick	SP1-001-024	
Duplex: Thick1	SP1-001-025	
Duplex: Thick2	SP1-001-026	
Duplex: Thick3	SP1-001-027	
Tray1: Thin: 1200	SP1-001-028	4.2 ± 1.5 mm
Tray1: Plain: 1200	SP1-001-029	
Tray1: MidThick: 1200	SP1-001-030	

Tray	SP No.	Threshold
Tray1: Thick1: 1200	SP1-001-031	
Tray1: Thick2: 1200	SP1-001-032	
Tray1: Thick3: 1200	SP1-001-033	
Tray1: Thick4: 1200	SP1-001-034	
Tray2: Thin: 1200	SP1-001-035	4.2 ± 1.5 mm
Tray2: Plain: 1200	SP1-001-036	
Tray2: MidThick: 1200	SP1-001-037	
Tray2: Thick1: 1200	SP1-001-038	
Tray2: Thick2: 1200	SP1-001-039	
Tray2: Thick3: 1200	SP1-001-040	
Tray2: Thick4: 1200	SP1-001-041	
Bypass: Thin: 1200	SP1-001-042	4.2 ± 1.5 mm
Bypass: Plain: 1200	SP1-001-043	
Bypass: MidThick: 1200	SP1-001-044	
Bypass: Thick1: 1200	SP1-001-045	
Bypass: Thick2: 1200	SP1-001-046	

Adjustment after Replacement

Tray	SP No.	Threshold
Bypass: Thick3: 1200	SP1-001-047	
Bypass: Thick4: 1200	SP1-001-048	
Duplex: Thin: 1200	SP1-001-049	4.2 ± 1.5 mm
Duplex: Plain: 1200	SP1-001-050	
Duplex: MidThick: 1200	SP1-001-051	
Duplex: Thick1: 1200	SP1-001-052	
Duplex: Thick2: 1200	SP1-001-053	
Duplex: Thick3: 1200	SP1-001-054	

2. Check the side-to-side registration [B] for each paper feed station, and adjust them using SP1-002.

Tray	SP No.	Threshold
Tray 1	SP1-002-002	2 ±1.5 mm
Tray 2	SP1-002-003	
Tray 3 (Optional PFU tray 1 or LCT)	SP1-002-004	
Tray 4 (Optional PFU tray 2)	SP1-002-005	
Duplex (side 1)	SP1-002-006	
LCT	SP1-002-007	

Blank Margin

ⓘ Note

- If the leading edge/side-to-side registration cannot be adjusted within the specifications, adjust the leading/left side edge blank margin.

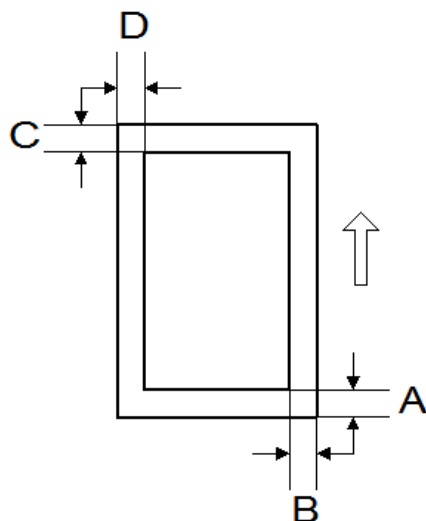

- A: Trailing Edge Blank Margin
- B: Right Edge Blank Margin
- C: Leading Edge Blank Margin
- D: Left Edge Blank Margin

1. Check the trailing edge [A], right edge [B], leading edge [C], left edge [D] blank margins, and adjust them using the following SP modes.

Adjustment after Replacement

Edge	SP No.	Adjustment Range
Leading Edge	SP2-103-001	4.2 ± 1.5 mm (Plain, Thin)
Trailing Edge	SP2-103-002	More than 0.5 mm
Left Edge	SP2-103-003	2.0 ±1.5 mm
Right Edge	SP2-103-004	2.0 +2.5 /-1.5 mm
Duplex: Trailing Edge: L Size: Plain	SP2-103-006	2.0 ±2.0 mm
Duplex: Trailing Edge: M Size: Plain	SP2-103-007	
Duplex: Trailing Edge: S Size: Plain	SP2-103-008	
Duplex: Left Edge Plain	SP2-103-009	-2.0 ±1.5 mm
Duplex: Right Edge: Plain	SP2-103-010	2.0 +2.5 /-1.5 mm
Duplex: Trailing Edge: L Size: Thick	SP2-103-011	2.0 ±2.0 mm
Duplex: Trailing Edge: M Size: Thick	SP2-103-012	
Duplex: Trailing Edge: S Size: Thick	SP2-103-013	
Duplex: Left Edge Thick	SP2-103-014	-2.0 ±1.5 mm
Duplex: Right Edge: Thick	SP2-103-015	2.0 +2.5 /-1.5 mm
Duplex Trail. L Size:Thin	SP2-103-016	-4.0 ± 4.0 mm
Duplex Trail. M Size:Thin	SP2-103-017	
Duplex Trail. S Size:Thin	SP2-103-018	

Edge	SP No.	Adjustment Range
Lead Edge Width:Thin	SP2-103-019	0.0 ± 9.9 mm
Trail. Edge Width:Thin	SP2-103-020	

- L Size: Paper Length is 297.1 mm or more
- M Size: Paper Length is 216.1 to 297 mm
- S Size: Paper Length is 216 mm or less.

Main Scan Magnification

1. Use SP2-109-003, no.5 (Grid Pattern) to print the single-dot grid pattern.
2. Check the magnification, and adjust the magnification using SP2-102-001 (Magnification Adjustment Main Scan) if necessary. The specification is ± 1%.

Parallelogram Image Adjustment

Laser unit adjustment is to fix parallelogram images that developed as a result of the laser operation, by means of adjusting the physical angle of the laser unit itself. This adjustment must be done after the skew-correction for the paper feed unit.

If parallelogram images are caused by the scanner after doing the laser unit adjustment, scanner unit adjustment must also be performed to correct this.

1. Enter into the SP mode.
2. Using SP2-109-003, output a trimming pattern to measure the parallelogram.

- It is not necessary to do this step if output image is developed properly.

Note

- If the laser unit causes a parallelogram image, there is a slanted line in the main-scan direction, and there is a straight line in the sub-scan direction.

3. Remove the laser unit (page 4-66).
4. Paste the adjustment sheet(s) on the reference points located on the back side of the laser unit (two points on the inside and/or one point on the front side).

Note

- A set of four sheets is provided as service parts. The number of sheets to be pasted depends on the condition of the image.
 - If lines slant down to the left [A], paste one or two sheets on the front side.
 - If lines slant down to the right [B], paste one or two sheets at each position on the rear side.
- Adjustable amount: 0.5mm – 0.6mm/sheet

Adjustment after Replacement

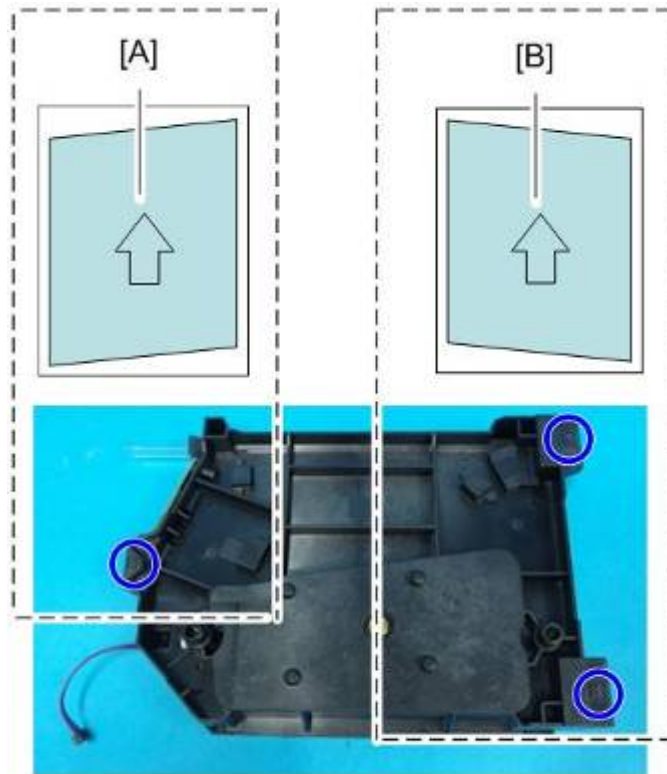

d197f0092

5. Do step 1 and 2 again to check that there is no parallelogram image.

4.20.2 SCANNING

Note

- Before doing the following scanner adjustments, perform or check the printing registration /side-to-side adjustment and the blank margin adjustment.
- Use an S5S test chart to perform the following adjustments.

Registration: Platen Mode

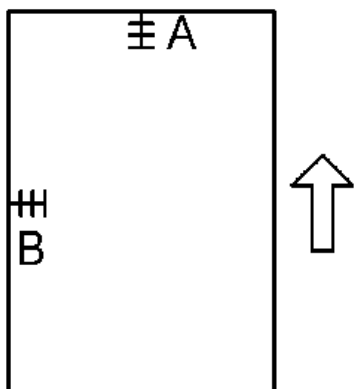

A: Leading Edge Registration (Sub Scan Registration Adj)

B: Side-to-side Registration (Main Scan Reg)

- Place the test chart on the exposure glass and make a copy from one of the feed stations.
- Check the leading edge and side-to-side registration, and adjust them using the following SP modes if necessary.

SP No.	SP Name	Adjustment Range
SP4-010-001	Sub Scan Registration Adj	±2.0 mm
SP4-011-001	Main Scan Reg	±2.5 mm

Magnification

Note

- Use an S5S test chart to do the following adjustment.

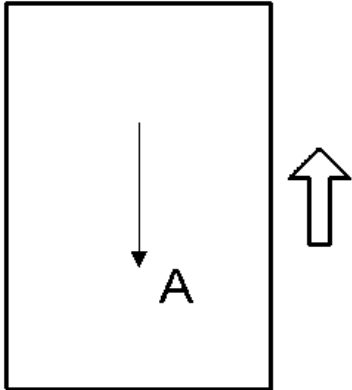

A: Sub-scan magnification

- Place the test chart on the exposure glass and make a copy from one of the feed stations.
- Check the magnification ratio and adjust using the following SP mode if necessary.

SP No.	SP Name	Adjustment Range
SP4-008-001	Sub Scan Magnification Adj	±1.0 %

4.20.3 SCANNER WIRE

See the Adjusting the Scanner Wire. (page 4-46)

4.20.4 ADF IMAGE ADJUSTMENT

Registration

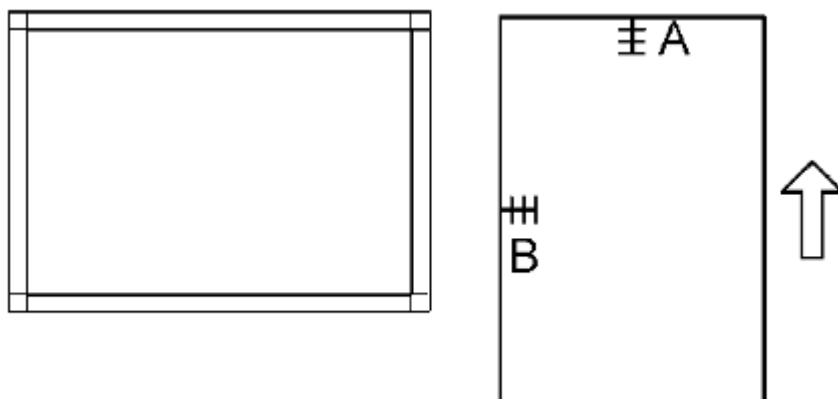

A: Leading Edge Registration

B: Side-to-side Registration

Note

- Make a temporary test chart as shown above using A3/DLT paper.
1. Place the temporary test chart on the ADF and make a copy from one of the feed stations.
 2. Check the registration, and adjust using the following SP modes if necessary.

SP No.	SP Name	Adjustment Range
SP6-006-001	ADF Adjustment Side-to-Side Regist: Front	±3.0 mm
SP6-006-002	ADF Adjustment Side-to-Side Regist: Rear	±3.0 mm
SP6-006-003	ADF Adjustment Leading Edge Registration: Front	±5.0 mm
SP6-006-004	ADF Adjustment Leading Edge Registration: Rear	±5.0 mm
SP6-006-005	ADF Adjustment Buckle: Duplex Front	±5.0 mm
SP6-006-006	ADF Adjustment Buckle: Duplex Rear	±5.0 mm

Adjustment after Replacement

SP No.	SP Name	Adjustment Range
SP6-006-007	ADF Adjustment Rear Edge Erase Front	±10.0 mm
SP6-006-008	ADF Adjustment Rear Edge Erase Rear	±10.0 mm

Sub Scan Magnification

Note

- Make a temporary test chart as shown above using A3/DLT paper.
- 1. Place the temporary test chart on the ADF and make a copy from one of the feed stations.**
 - 2. Check the magnification, and adjust using the following SP modes if necessary.**

SP No.	SP Name	Adjustment Range
SP6-017-001	DF Magnification Adj.	±5.0 %

4.20.5 TOUCH SCREEN CALIBRATION

After clearing the memory, or if the touch panel detection function is not working correctly, follow this procedure to calibrate the touch screen.

Note

- Do not attempt to use items [2] to [5] and [7] to [9] on the Self-Diagnostic Menu. These items are for design use only.

- Plug in the AC power cord, and then turn on the main power switch.
- When Home or Copy screen appears, press the [Energy Saver] key.
- Press [1], [9], [9], and [3] at the ten-key pad, and then press [C] (Clear) 5 times to open the "Self Diagnostics Menu."
- Press [[1] Touch Screen Adjust] (or press [1] on the ten-key pad).

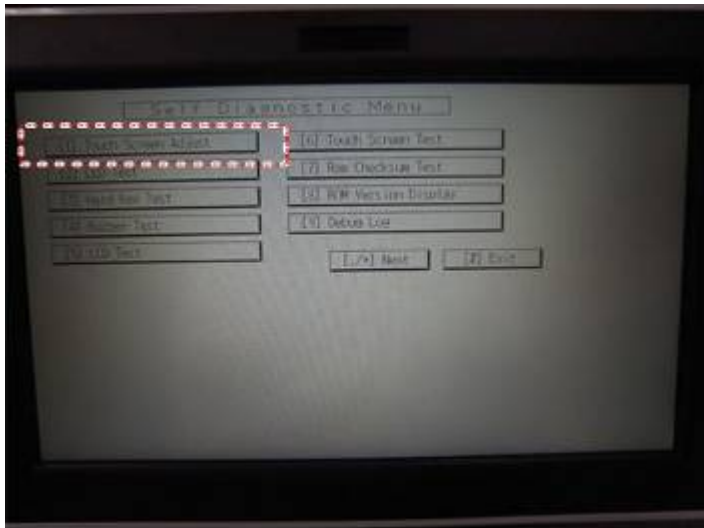

d1824064

- Use a pointed (not sharp!) tool to press the mark (+) at the upper left of the screen.



d1824065

- Press in order the lower right, lower left, middle, and upper right of the screen (+).
- Press [[#] OK] on the screen (or press [#] on the ten-key pad) to save.

8. Press **[6] Touch Screen Test**.



d1824066

9. Press the points (upper left, lower left, upper right and lower right) and confirm that each value is within ± 5 dots.



d1824067a

10. Press **[#] Exit** on the screen (or press **[#]** on the ten-key pad) to close the “Self Diagnostic Menu”.

SYSTEM MAINTENANCE

REVISION HISTORY		
Page	Date	Added/Updated/New
		None

5. SYSTEM MAINTENANCE

5.1 SERVICE PROGRAM MODE

CAUTION

- Make sure that the data-in LED (↻) is not on before you go into the SP mode. This LED indicates that some data is coming to the machine. When the LED is on, wait for the copier to process the data.

5.1.1 ENABLING AND DISABLING SERVICE PROGRAM MODE

Note

- The Service Program Mode is for use by service representatives only. If this mode is used by anyone other than service representatives for any reason, data might be deleted or settings might be changed. In such case, product quality cannot be guaranteed any more.

Entering SP Mode

For details, ask your supervisor.

Exiting SP Mode

- Press "Exit" on the LCD twice to return to the copy window.

5.1.2 TYPES OF SP MODES

- System SP: SP modes related to the engine functions
- Printer SP: SP modes related to the controller functions
- Scanner SP: SP modes related to the scanner functions
- Fax SP: SP modes related to the fax functions

Select one of the Service Program modes (System, Printer, Scanner, or Fax) from the touch panel as shown in the diagram below after you access the SP mode. This section explains the functions of the System/Printer/Scanner SP modes. Refer to the Fax service manual for the Fax SP modes.

Service Program Mode



SP Mode Button Summary

Here is a short summary of the touch-panel buttons.

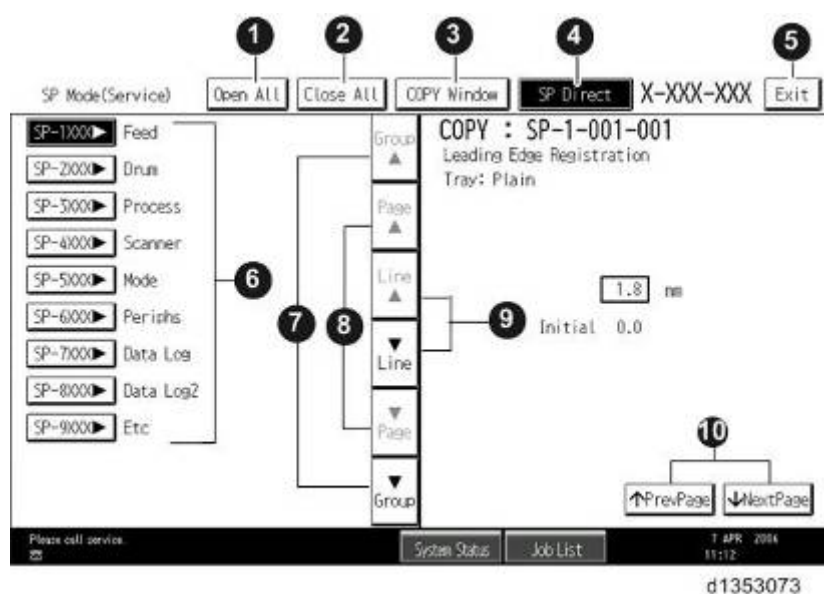

1	Opens all SP groups and sublevels.
2	Closes all open groups and sublevels and restores the initial SP mode display.
3	Opens the copy window (copy mode) so you can make test copies. Press SP Mode (highlighted) in the copy window to return to the SP mode screen,
4	Enter the SP code directly with the number keys if you know the SP number. Then press [#]. The required SP Mode number will be highlighted when pressing [#]. If not, just press the required SP Mode number.)

5	Press two times to leave the SP mode and return to the copy window to resume normal operation.
6	Press any Class 1 number to open a list of Class 2 SP modes.
7	Press to scroll the show to the previous or next group.
8	Press to scroll to the previous or next display in segments the size of the screen display (page).
9	Press to scroll the show the previous or next line (line by line).
10	Press to move the highlight on the left to the previous or next selection in the list.

Switching Between SP Mode and Copy Mode for Test Printing

1. In the SP mode, select the test print. Then press "Copy Window".
2. Use the copy window (copier mode), to select the appropriate settings (paper size, etc.) for the test print.
3. Press [Start] key to start the test print.
4. Press SP Mode (highlighted) to return to the SP mode screen and repeat from step 1.

Selecting the Program Number

Program numbers have two or three levels.

1. Refer to the Service Tables to find the SP that you want to adjust before you begin.
2. Press the Group number on the left side SP Mode window that contains the SP that you want to adjust.
3. Use the scrolling buttons in the center of the SP mode window to show the SP number that you want to open. Then press that number to expand the list.
4. Use the center touch-panel buttons to scroll to the number and title of the item that you want to set and press it. The small entry box on the right activates and shows the below default or the current settings.

Service Program Mode

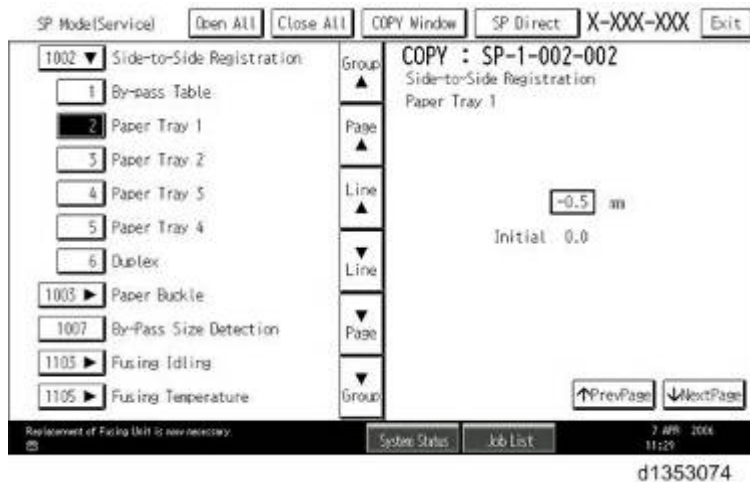

Note

- Refer to the Service Tables for the range of allowed settings.
5. Do this procedure to enter a setting:
 - Press \ominus to toggle between plus and minus and use the keypad to enter the appropriate number. The number you enter writes over the previous setting.
 - Press [#] to enter the setting. (The value is not registered if you enter a number that is out of range.)
 - Press "Yes" when you are prompted to complete the selection.
 6. If you need to perform a test print, press Copy Window to open the copy window and select the settings for the test print. Press [Start] key and then press SP Mode (highlighted) in the copy window to return to the SP mode display.
 7. Press Exit two times to return to the copy window when you are finished.

Exiting Service Mode

Press the Exit key on the touch-panel.

Service Mode Lock/Unlock

At locations where the machine contains sensitive data, the customer engineer cannot operate the machine until the Administrator turns the service mode lock off. This function makes sure that work on the machine is always done with the permission of the Administrator.

1. If you cannot go into the SP mode, ask the Administrator to log in with the User Tool and then set "Service Mode Lock" to OFF after he or she logs in:
User Tools > System Settings > Administrator Tools > Service Mode Lock > OFF
 - This unlocks the machine and lets you get access to all the SP codes.
 - The CE can service the machine and turn the machine power switch off and on. It is not necessary to ask the Administrator to log in again each time the main power switch is turned on.
2. Go into the SP mode and set SP5-169 to "1" if you must use the printer bit switches.

3. After machine servicing is completed:
 - Change SP5-169 from "1" to "0".
 - Turn the machine power switch off and on. Tell the administrator that you have completed servicing the machine.
 - The Administrator will then set the "Service Mode Lock" to ON.

PM Counter/ Firmware Update

PM Counter and Firmware Update can be entered in the SP mode main screen.

- PM Counter: PM counters for each PM part
- Firmware Update: Immediate remote update and remote update at next visit



<How to Check the PM Counter>

1. Enter the SP mode, and then press [PM Counter].



2. Press [Estimated Usage Rate/Estimated Remain Days].

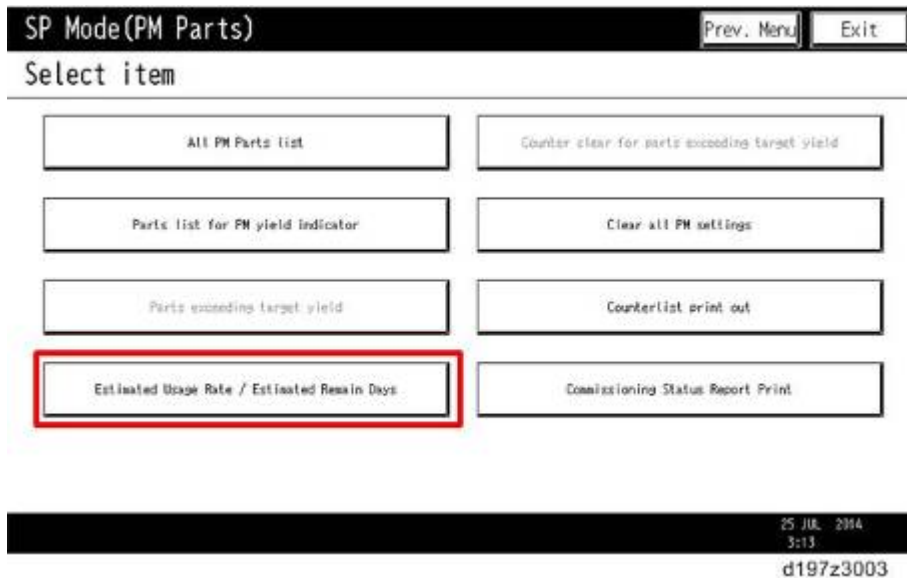

3. You can see the “Remaining Days for each part”.

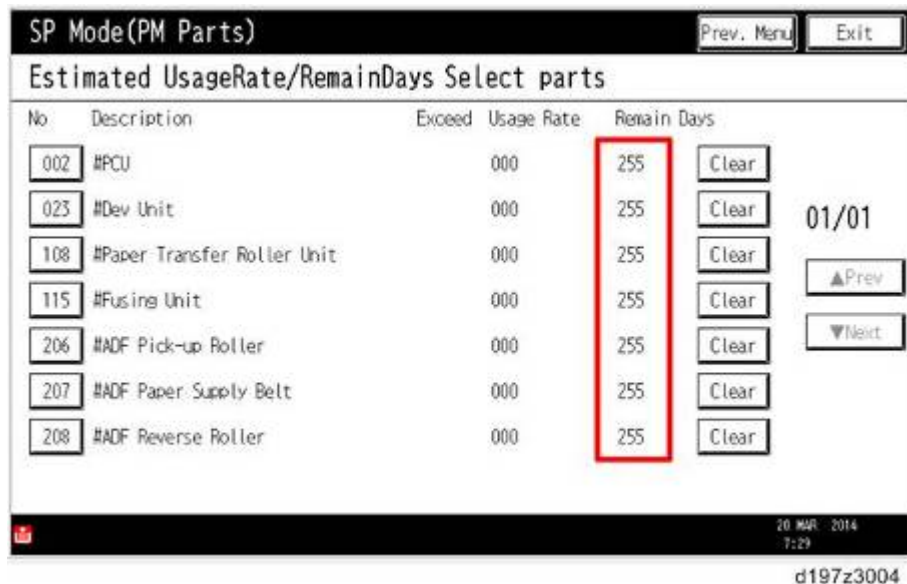

<How to Use the Firmware Update>

For details about how to use the Firmware Update, refer to page 5-446 "Package Firmware Update".

5.1.3 REMARKS

The maximum number of characters which can show on the control panel screen is limited to 30 characters. For this reason, some of the SP modes shown on the screen need to be abbreviated. The following are abbreviations used for the SP modes for which the full description is over 20 characters.

Item	Description
Paper Weight	Thin paper: 52-59 g/m ² , 13.9-15.7lb. Plain Paper1: 60-74 g/m ² , 16-19.7lb. Plain Paper2: 75-81 g/m ² , 20-21.6lb. Middle Thick: 82-105 g/m ² , 21.9-28lb. Thick Paper1: 106-157 g/m ² , 28.3-41.9lb.
Paper Type	N: Normal paper MTH: Middle thick paper TH: Thick paper
Paper Feed Station	P: Paper tray B: By-pass table
Print Mode	S: Simplex D: Duplex

Others

The settings of each SP mode are explained in the right-hand column of the SP table in the following way.

[Adjustable range / **Default setting** / Step] Alphanumeric

ⓘ Note

- If "Alphanumeric" is written to the right of the bracket as shown above, the setting of the SP mode shows on the screen using alphanumeric characters instead of only numbers. However, the settings in the bracket in the SP mode table are explained by using only the numbers.

The following symbols are used in the SP mode tables.

Notation	What it means
ENG	Engine SP
CTL	Controller SP
FA	Factory setting: Data may be adjusted from the default setting at the factory. Refer to the factory setting sheets enclosed. You can find it in the front cover.
DFU	Design/Factory Use only: Do not touch these SP modes in the field.
*	An asterisk (*) to the left side of ENG/CTL column means that this mode is stored in the NVRAM. If you do a RAM clear, this SP mode will be reset to the default value. "ENG" and "CTL" show which NVRAM contains the data. <ul style="list-style-type: none"> ▪ *ENG: NVRAM on the BCU board ▪ *CTL: NVRAM on the controller board
SSP	This denotes a "Special Service Program" mode setting.

5.2 SP MODE TABLES - SP1000

5.2.1 SP1-XXX (FEED)

1001	[Leading Edge Registration]		
	<p>Adjusts the leading edge registration by changing the registration motor operation timing for each mode.</p> <ul style="list-style-type: none"> ▪ Increasing a value: an image is moved to the trailing edge of paper. (This makes the writing timing later.) ▪ Decreasing a value: an image is moved to the leading edge of paper. (This makes the writing timing earlier.) 		
1-001-001	Tray1: Thin	ENG	[-9.0 to 9.0 / 0.0 / 0.1mm/step]
1-001-002	Tray1: Plain	ENG	[-9.0 to 9.0 / 0.0 / 0.1mm/step]
1-001-003	Tray1: Mid-thick	ENG	[-9.0 to 9.0 / 0.0 / 0.1mm/step]
1-001-004	Tray1: Thick 1	ENG	[-9.0 to 9.0 / 0.0 / 0.1mm/step]
1-001-005	Tray1: Thick 2	ENG	[-9.0 to 9.0 / 0.0 / 0.1mm/step]
1-001-006	Tray1: Thick 3	ENG	[-9.0 to 9.0 / 0.0 / 0.1mm/step]
1-001-007	Tray1: Thick 4	ENG	[-9.0 to 9.0 / 0.0 / 0.1mm/step]
1-001-008	Tray2: Thin	ENG	[-9.0 to 9.0 / 0.0 / 0.1mm/step]
1-001-009	Tray2: Plain	ENG	[-9.0 to 9.0 / 0.0 / 0.1mm/step]
1-001-010	Tray2: Mid-thick	ENG	[-9.0 to 9.0 / 0.0 / 0.1mm/step]
1-001-011	Tray2: Thick 1	ENG	[-9.0 to 9.0 / 0.0 / 0.1mm/step]
1-001-012	Tray2: Thick 2	ENG	[-9.0 to 9.0 / 0.0 / 0.1mm/step]
1-001-013	Tray2: Thick 3	ENG	[-9.0 to 9.0 / 0.0 / 0.1mm/step]
1-001-014	Tray2: Thick 4	ENG	[-9.0 to 9.0 / 0.0 / 0.1mm/step]
1-001-015	By-pass: Thin	ENG	[-9.0 to 9.0 / 0.0 / 0.1mm/step]

1-001-016	By-pass: Plain	ENG	[-9.0 to 9.0 / 0.0 / 0.1mm/step]
1-001-017	By-pass: Mid-thick	ENG	[-9.0 to 9.0 / 0.0 / 0.1mm/step]
1-001-018	By-pass: Thick 1	ENG	[-9.0 to 9.0 / 0.0 / 0.1mm/step]
1-001-019	By-pass: Thick 2	ENG	[-9.0 to 9.0 / 0.0 / 0.1mm/step]
1-001-020	By-pass: Thick 3	ENG	[-9.0 to 9.0 / 0.0 / 0.1mm/step]
1-001-021	By-pass: Thick 4	ENG	[-9.0 to 9.0 / 0.0 / 0.1mm/step]
1-001-022	Duplex: Thin	ENG	[-9.0 to 9.0 / 0.0 / 0.1mm/step]
1-001-023	Duplex: Plain	ENG	[-9.0 to 9.0 / 0.0 / 0.1mm/step]
1-001-024	Duplex: Mid-thick	ENG	[-9.0 to 9.0 / 0.0 / 0.1mm/step]
1-001-025	Duplex: Thick 1	ENG	[-9.0 to 9.0 / 0.0 / 0.1mm/step]
1-001-026	Duplex: Thick 2	ENG	[-9.0 to 9.0 / 0.0 / 0.1mm/step]
1-001-027	Duplex: Thick 3	ENG	[-9.0 to 9.0 / 0.0 / 0.1mm/step]
1-001-028	Tray1: Thin:1200	ENG	[-9.0 to 9.0 / 0.0 / 0.1mm/step]
1-001-029	Tray1: Plain:1200	ENG	[-9.0 to 9.0 / 0.0 / 0.1mm/step]
1-001-030	Tray1: Mid-thick:1200	ENG	[-9.0 to 9.0 / 0.0 / 0.1mm/step]
1-001-031	Tray1: Thick 1:1200	ENG	[-9.0 to 9.0 / 0.0 / 0.1mm/step]
1-001-032	Tray1: Thick 2:1200	ENG	[-9.0 to 9.0 / 0.0 / 0.1mm/step]
1-001-033	Tray1: Thick 3:1200	ENG	[-9.0 to 9.0 / 0.0 / 0.1mm/step]
1-001-034	Tray1: Thick 4:1200	ENG	[-9.0 to 9.0 / 0.0 / 0.1mm/step]
1-001-035	Tray2: Thin:1200	ENG	[-9.0 to 9.0 / 0.0 / 0.1mm/step]
1-001-036	Tray2: Plain:1200	ENG	[-9.0 to 9.0 / 0.0 / 0.1mm/step]
1-001-037	Tray2: Mid-thick:1200	ENG	[-9.0 to 9.0 / 0.0 / 0.1mm/step]
1-001-038	Tray2: Thick 1:1200	ENG	[-9.0 to 9.0 / 0.0 / 0.1mm/step]

1-001-039	Tray2: Thick 2:1200	ENG	[-9.0 to 9.0 / 0.0 / 0.1mm/step]
1-001-040	Tray2: Thick 3:1200	ENG	[-9.0 to 9.0 / 0.0 / 0.1mm/step]
1-001-041	Tray2: Thick 4:1200	ENG	[-9.0 to 9.0 / 0.0 / 0.1mm/step]
1-001-042	By-pass: Thin:1200	ENG	[-9.0 to 9.0 / 0.0 / 0.1mm/step]
1-001-043	By-pass: Plain:1200	ENG	[-9.0 to 9.0 / 0.0 / 0.1mm/step]
1-001-044	By-pass: Mid-thick:1200	ENG	[-9.0 to 9.0 / 0.0 / 0.1mm/step]
1-001-045	By-pass: Thick 1:1200	ENG	[-9.0 to 9.0 / 0.0 / 0.1mm/step]
1-001-046	By-pass: Thick 2:1200	ENG	[-9.0 to 9.0 / 0.0 / 0.1mm/step]
1-001-047	By-pass: Thick 3:1200	ENG	[-9.0 to 9.0 / 0.0 / 0.1mm/step]
1-001-048	By-pass: Thick 4:1200	ENG	[-9.0 to 9.0 / 0.0 / 0.1mm/step]
1-001-049	Duplex: Thin:1200	ENG	[-9.0 to 9.0 / 0.0 / 0.1mm/step]
1-001-050	Duplex: Plain:1200	ENG	[-9.0 to 9.0 / 0.0 / 0.1mm/step]
1-001-051	Duplex: Mid-thick:1200	ENG	[-9.0 to 9.0 / 0.0 / 0.1mm/step]
1-001-052	Duplex: Thick 1:1200	ENG	[-9.0 to 9.0 / 0.0 / 0.1mm/step]
1-001-053	Duplex: Thick 2:1200	ENG	[-9.0 to 9.0 / 0.0 / 0.1mm/step]
1-001-054	Duplex: Thick 3:1200	ENG	[-9.0 to 9.0 / 0.0 / 0.1mm/step]

1001	[Leading Edge Registration]		
	Adjusts the leading edge registration by changing the registration motor operation timing for each mode. <ul style="list-style-type: none"> ▪ Increasing a value: an image is moved to the trailing edge of paper. (This makes the writing timing later.) ▪ Decreasing a value: an image is moved to the leading edge of paper. (This makes the writing timing later.) 		
1-001-055	Tray3: Thin	ENG	[-9.0 to 9.0 / 0.0 / 0.1mm/step]
1-001-056	Tray3: Plain	ENG	[-9.0 to 9.0 / 0.0 / 0.1mm/step]
1-001-057	Tray3: Mid-thick	ENG	[-9.0 to 9.0 / 0.0 / 0.1mm/step]
1-001-058	Tray3: Thick 1	ENG	[-9.0 to 9.0 / 0.0 / 0.1mm/step]
1-001-059	Tray3: Thick 2	ENG	[-9.0 to 9.0 / 0.0 / 0.1mm/step]
1-001-060	Tray3: Thick 3	ENG	[-9.0 to 9.0 / 0.0 / 0.1mm/step]
1-001-061	Tray3: Thick 4	ENG	[-9.0 to 9.0 / 0.0 / 0.1mm/step]
1-001-062	Tray3: Thin:1200	ENG	[-9.0 to 9.0 / 0.0 / 0.1mm/step]
1-001-063	Tray3: Plain:1200	ENG	[-9.0 to 9.0 / 0.0 / 0.1mm/step]
1-001-064	Tray3: Mid-thick:1200	ENG	[-9.0 to 9.0 / 0.0 / 0.1mm/step]
1-001-065	Tray3: Thick 1:1200	ENG	[-9.0 to 9.0 / 0.0 / 0.1mm/step]
1-001-066	Tray3: Thick 2:1200	ENG	[-9.0 to 9.0 / 0.0 / 0.1mm/step]
1-001-067	Tray3: Thick 3:1200	ENG	[-9.0 to 9.0 / 0.0 / 0.1mm/step]
1-001-068	Tray3: Thick 4:1200	ENG	[-9.0 to 9.0 / 0.0 / 0.1mm/step]
1-001-069	Tray4: Thin	ENG	[-9.0 to 9.0 / 0.0 / 0.1mm/step]
1-001-070	Tray4: Plain	ENG	[-9.0 to 9.0 / 0.0 / 0.1mm/step]
1-001-071	Tray4: Mid-thick	ENG	[-9.0 to 9.0 / 0.0 / 0.1mm/step]
1-001-072	Tray4: Thick 1	ENG	[-9.0 to 9.0 / 0.0 / 0.1mm/step]

1-001-073	Tray4: Thick 2	ENG	[-9.0 to 9.0 / 0.0 / 0.1mm/step]
1-001-074	Tray4: Thick 3	ENG	[-9.0 to 9.0 / 0.0 / 0.1mm/step]
1-001-075	Tray4: Thick 4	ENG	[-9.0 to 9.0 / 0.0 / 0.1mm/step]
1-001-076	Tray4: Thin:1200	ENG	[-9.0 to 9.0 / 0.0 / 0.1mm/step]
1-001-077	Tray4: Plain:1200	ENG	[-9.0 to 9.0 / 0.0 / 0.1mm/step]
1-001-078	Tray4: Mid-thick:1200	ENG	[-9.0 to 9.0 / 0.0 / 0.1mm/step]
1-001-079	Tray4: Thick 1:1200	ENG	[-9.0 to 9.0 / 0.0 / 0.1mm/step]
1-001-080	Tray4: Thick 2:1200	ENG	[-9.0 to 9.0 / 0.0 / 0.1mm/step]
1-001-081	Tray4: Thick 3:1200	ENG	[-9.0 to 9.0 / 0.0 / 0.1mm/step]
1-001-082	Tray4: Thick 4:1200	ENG	[-9.0 to 9.0 / 0.0 / 0.1mm/step]
1-001-083	Tray5(LCT): Thin	ENG	[-9.0 to 9.0 / 0.0 / 0.1mm/step]
1-001-084	Tray5(LCT): Plain	ENG	[-9.0 to 9.0 / 0.0 / 0.1mm/step]
1-001-085	Tray5(LCT): Mid-thick	ENG	[-9.0 to 9.0 / 0.0 / 0.1mm/step]
1-001-086	Tray5(LCT): Thick 1	ENG	[-9.0 to 9.0 / 0.0 / 0.1mm/step]
1-001-087	Tray5(LCT): Thick 2	ENG	[-9.0 to 9.0 / 0.0 / 0.1mm/step]
1-001-088	Tray5(LCT): Thick 3	ENG	[-9.0 to 9.0 / 0.0 / 0.1mm/step]
1-001-089	Tray5(LCT): Thick 4	ENG	[-9.0 to 9.0 / 0.0 / 0.1mm/step]
1-001-090	Tray5(LCT): Thin:1200	ENG	[-9.0 to 9.0 / 0.0 / 0.1mm/step]
1-001-091	Tray5(LCT): Plain:1200	ENG	[-9.0 to 9.0 / 0.0 / 0.1mm/step]
1-001-092	Tray5(LCT): Mid-thick:1200	ENG	[-9.0 to 9.0 / 0.0 / 0.1mm/step]

1-001-093	Tray5(LCT): Thick 1:1200	ENG	[-9.0 to 9.0 / 0.0 / 0.1mm/step]
1-001-094	Tray5(LCT): Thick 2:1200	ENG	[-9.0 to 9.0 / 0.0 / 0.1mm/step]
1-001-095	Tray5(LCT): Thick 3:1200	ENG	[-9.0 to 9.0 / 0.0 / 0.1mm/step]
1-001-096	Tray5(LCT): Thick 4:1200	ENG	[-9.0 to 9.0 / 0.0 / 0.1mm/step]

1002	[Side-to-Side Registration]		
	Adjusts the side-to-side registration by changing the laser main scan start position for each mode and tray. <ul style="list-style-type: none"> ▪ Increasing a value: an image is moved to the rear edge of paper. ▪ Decreasing a value: an image is moved to the front edge of paper. 		
1-002-001	By-pass Tray	*ENG	[-4.0 to 4.0 / 0.0 / 0.1mm/step]
1-002-002	Paper Tray 1	*ENG	
1-002-003	Paper Tray 2	*ENG	
1-002-004	Paper Tray 3	*ENG	
1-002-005	Paper Tray 4	*ENG	
1-002-006	Duplex	*ENG	
1-002-007	Large Capacity Tray	*ENG	

1003	[Paper Buckle]		
	Adjusts the amount of paper buckle at the registration roller by changing the paper feed timing. (A "+" setting causes more buckling.)		
1-003-001	Paper Tray1: Thin	ENG	[-4.0 to 5.0 / 0.0 / 0.1mm/step]
1-003-002	Paper Tray1: Plain	ENG	[-4.0 to 5.0 / 0.0 / 0.1mm/step]
1-003-003	Paper Tray 1: Mid-thick	ENG	[-4.0 to 5.0 / 0.0 / 0.1mm/step]
1-003-004	Paper Tray1: Thick1	ENG	[-4.0 to 5.0 / -2.0 / 0.1mm/step]
1-003-005	Tray2/3/4/5/LCT: Thin	ENG	[-4.0 to 5.0 / 0.0 / 0.1mm/step]
1-003-006	Tray2/3/4/5/LCT: Plain	ENG	[-4.0 to 5.0 / 0.0 / 0.1mm/step]
1-003-007	Tray 2/3/4/5/LCT: Mid-thick	ENG	[-4.0 to 5.0 / 0.0 / 0.1mm/step]
1-003-008	Tray2/3/4/5/LCT: Thick 1	ENG	[-4.0 to 5.0 / -2.0 / 0.1mm/step]
1-003-009	By-pass: Thin	ENG	[-4.0 to 5.0 / 0.0 / 0.1mm/step]
1-003-010	By-pass: Plain	ENG	[-4.0 to 5.0 / 0.0 / 0.1mm/step]
1-003-011	By-pass: Mid-thick	ENG	[-4.0 to 5.0 / 0.0 / 0.1mm/step]
1-003-012	By-pass:Thick1	ENG	[-4.0 to 5.0 / -1.0 / 0.1mm/step]
1-003-013	Duplex:Thin	ENG	[-4.0 to 5.0 / 0.0 / 0.1mm/step]
1-003-014	Duplex:Plain	ENG	[-4.0 to 5.0 / 0.0 / 0.1mm/step]
1-003-015	Duplex: Mid-thick	ENG	[-4.0 to 5.0 / 0.0 / 0.1mm/step]
1-003-016	Duplex:Thick1	ENG	[-4.0 to 5.0 / -1.0 / 0.1mm/step]
1-003-017	Paper Tray1: Thin:1200	ENG	[-4.0 to 5.0 / 0.0 / 0.1mm/step]
1-003-018	Paper Tray1: Plain:1200	ENG	[-4.0 to 5.0 / 0.0 / 0.1mm/step]
1-003-019	Paper Tray 1: Mid-thick:1200	ENG	[-4.0 to 5.0 / 0.0 / 0.1mm/step]
1-003-020	Paper Tray1: Thick1:1200	ENG	[-4.0 to 5.0 / -2.0 / 0.1mm/step]

SP Mode Tables - SP1000

1-003-021	Tray2/3/4/5/LCT: Thin:1200	ENG	[-4.0 to 5.0 / 0.0 / 0.1mm/step]
1-003-022	Tray2/3/4/5/LCT: Plain:1200	ENG	[-4.0 to 5.0 / 0.0 / 0.1mm/step]
1-003-023	Tray2/3/4/5/LCT: Mid:1200	ENG	[-4.0 to 5.0 / 0.0 / 0.1mm/step]
1-003-024	Tray2/3/4/5/LCT: Thick 1:1200	ENG	[-4.0 to 5.0 / -2.0 / 0.1mm/step]
1-003-025	By-pass: Thin:1200	ENG	[-4.0 to 5.0 / 0.0 / 0.1mm/step]
1-003-026	By-pass: Plain:1200	ENG	[-4.0 to 5.0 / 0.0 / 0.1mm/step]
1-003-027	By-pass: Mid-thick:1200	ENG	[-4.0 to 5.0 / 0.0 / 0.1mm/step]
1-003-028	By-pass:Thick1:1200	ENG	[-4.0 to 5.0 / -1.0 / 0.1mm/step]
1-003-029	Duplex:Thin:1200	ENG	[-4.0 to 5.0 / 0.0 / 0.1mm/step]
1-003-030	Duplex:Plain:1200	ENG	[-4.0 to 5.0 / 0.0 / 0.1mm/step]
1-003-031	Duplex: Mid-thick:1200	ENG	[-4.0 to 5.0 / 0.0 / 0.1mm/step]
1-003-032	Duplex:Thick1:1200	ENG	[-4.0 to 5.0 / -1.0 / 0.1mm/step]

1007	[By-Pass Size Detection]		
1-007-001	Switch LT SEF/LG SEF	*ENG	[0 or 1 / 0 / 1/step] 0: 0.5x11SEF 1: 8.5x14SEF
	Selects either LT SEF or LG SEF to detect 8.5 inches paper size when using the bypass tray.		
1-007-002	By-Pass Jam Detection Set	*ENG	[0 or 1 / 0 / 1/step] 0: Normal 1: Simple Detect
	<p>Selects the paper jam detection when receiving long length FAX. Enter the maximum value for the custom paper size if “1: Simple Detection” is to be activated.</p> <p>0: Normal: Paper jam is detected when paper size fed from the tray is different from selected paper size.</p> <p>1: Simple Detect: Paper jam is detected only when paper size fed from the tray is longer than selected paper size.</p>		

1009	[Initial Operation Setting]		
	<p>Enables or disables the registration gear backlash cut when recovering from the sleep mode.</p> <p>If the registration roller is rotated with the machine’s right door open, the leading edge registration may be slightly shifted (0.3 mm) because of the backlash between the drive motor gear and registration roller gear. Select “1: ON” to prevent the leading edge registration shifting. The side effect of turning on this SP is making some noise.</p>		
1-009-001	Registration Gear Backlash Cut	*ENG	[0 or 1 / 0 / 1/step] 0:OFF 1:ON

1009	[Solenoid Initial movement]		
	<p>Selects either On or Off to control the pick-up solenoid's Initial movement. When the pick-up solenoid operates for the first time after loading the paper tray, its stroke and accompanied vibration is markedly greater than usual, and this may cause banding on the sheet that is fed first.</p> <p>If you set this SP to "ON", the pick-up solenoid is energized after the paper tray is loaded and the bottom plate rises. By making this setting, you can prevent the banding caused by the vibration of the solenoid when feeding the first sheet.</p> <p>As the default, it is set to "OFF" to minimize the noise.</p>		
1-009-002	Control ON/OFF 0:OFF/1:ON	*ENG	[0 or 1 / 0 / 1/step] 0:OFF 1:ON

1101	[Flicker Control]		
1-101-030	Flicker Control	*ENG	[0 to 2 / 0 / 1/step]
	<p>Extends the control cycle to make the flicker less noticeable.</p> <p>0: Normal (default)</p> <p>1: Flicker control mode (Use this SP if the flicker is occurred.)</p>		

1105	[Print Target Temp.]		
1-105-003	Plain1:BW:Center	*ENG	[100 to 180 / * / 1deg/step] * The default is different with models. D197/D198: 123 D199/D200: 130 D201/D202: 147
	Paper through target temperature: Standard paper 1: BW: center Fusing malfunction might improve by setting value larger. Paper curl might improve by setting value smaller. Adjusting range is +/- 5°C against the default setting.		
1-105-007	Plain2:BW:Center	*ENG	[100 to 180 / * / 1deg/step] * The default is different with models. D197/D198: 128 D199/D200: 135 D201/D202: 157
	Paper through target temperature: Standard paper 2: BW: center Fusing malfunction might improve by setting value larger. Paper curl might improve by setting value smaller. Adjusting range is +/- 5 deg. celsius.		
1-105-011	Thin:BW:Center	*ENG	[100 to 180 / * / 1deg/step] * The default is different with models. D197/D198: 119 D199/D200: 120 D201/D202: 132
	Paper through target temperature: thin paper: BW: center Fusing malfunction might improve by setting value larger. Paper curl might improve by setting value smaller. Adjusting range is +/- 5 deg. celsius.		

1-105-015	M-thick:BW:Center	*ENG	[100 to 180 / * / 1deg/step] * The default is different with models. D197/D198: 140 D199/D200: 143 D201/D202: 157
	Paper through target temperature: middle thick paper: BW: center Fusing malfunction might improve by setting value larger. Paper curl might improve by setting value smaller. Adjusting range is +/- 5 deg. celsius.		
1-105-019	Thick1:BW:Center	*ENG	[100 to 180 / 145 / 1deg/step]
	Paper through target temperature: thick paper 1: BW: center Fusing malfunction might improve by setting value larger. Paper curl might improve by setting value smaller. Adjusting range is +/- 5 deg. celsius.		
1-105-023	Thick2:BW:Center	*ENG	[100 to 180 / 130 / 1deg/step]
	Paper through target temperature: thick paper 2: BW: center Fusing malfunction might improve by setting value larger. Paper curl might improve by setting value smaller. Adjusting range is +/- 5 deg. celsius.		
1-105-027	Thick3:BW:Center	*ENG	[100 to 180 / 135 / 1deg/step]
	Paper through target temperature: thick paper 3: BW: center Fusing malfunction might improve by setting value larger. Paper curl might improve by setting value smaller. Adjusting range is +/- 5 deg. celsius.		
1-105-031	Special1:BW:Center	*ENG	[100 to 180 / * / 1deg/step] * The default is different with models. D197/D198: 123 D199/D200: 130 D201/D202: 152

	Paper through target temperature: special paper 1: BW: center Fusing malfunction might improve by setting value larger. Paper curl might improve by setting value smaller. Adjusting range is +/- 5 deg. celsius.		
1-105-035	Special2:BW:Center	*ENG	[100 to 180 / 145 / 1deg/step]
	Paper through target temperature: special paper 2: BW: center Fusing malfunction might improve by setting value larger. Paper curl might improve by setting value smaller. Adjusting range is +/- 5 deg. celsius.		
1-105-039	Special3:BW:Center	*ENG	[100 to 180 / 130 / 1deg/step]
	Paper through target temperature: special paper 3: BW: center Fusing malfunction might improve by setting value larger. Paper curl might improve by setting value smaller. Adjusting range is +/- 5 deg. celsius.		
1-105-041	Envelop:Center	*ENG	[100 to 180 / 135 / 1deg/step]
	Paper through target temperature: envelope: center Fusing malfunction might improve by setting value larger. Paper curl might improve by setting value smaller. Adjusting range is +/- 5 deg. celsius.		
1-105-053	Special1:BW:Center:Middle Speed	*ENG	[100 to 180 / 140 / 1deg/step]
	Paper through target temperature: special paper 1: BW: center Fusing malfunction might improve by setting value larger. Paper curl might improve by setting value smaller. Adjusting range is +/- 5 deg. celsius.		
1-105-057	Special2:BW:Center:Middle Speed	*ENG	[100 to 180 / 145 / 1deg/step]
	Paper through target temperature: special paper 2: BW: center Fusing malfunction might improve by setting value larger. Paper curl might improve by setting value smaller. Adjusting range is +/- 5 deg. celsius.		

1-105-061	Special3:BW:Center:Middle Speed	*ENG	[100 to 180 / 150 / 1deg/step]
	Paper through target temperature: special paper 3: BW: center Fusing malfunction might improve by setting value larger. Paper curl might improve by setting value smaller. Adjusting range is +/- 5 deg. celsius.		
1-105-103	Plain1:BW:Center:Low Speed	*ENG	[100 to 180 / 110 / 1deg/step]
	Paper through target temperature: Standard 1: BW: center: low speed Fusing malfunction might improve by setting value larger. Paper curl might improve by setting value smaller. Adjusting range is +/- 5 deg. celsius.		
1-105-107	Plain2:BW:Center:Low Speed	*ENG	[100 to 180 / 110 / 1deg/step]
	Paper through target temperature: Standard 2: BW: center: low speed Fusing malfunction might improve by setting value larger. Paper curl might improve by setting value smaller. Adjusting range is +/- 5 deg. celsius.		
1-105-111	M-thick:BW:Center:Low Speed	*ENG	[100 to 180 / 115 / 1deg/step]
	Paper through target temperature: middle thick paper: BW: center: low speed Fusing malfunction might improve by setting value larger. Paper curl might improve by setting value smaller. Adjusting range is +/- 5 deg. celsius.		

1-105-115	Thick1:BW:Center:Low Speed	*ENG	[100 to 180 / 120 / 1deg/step]
	Paper through target temperature: Thick paper 1: BW: center: low speed Fusing malfunction might improve by setting value larger. Paper curl might improve by setting value smaller. Adjusting range is +/- 5 deg. celsius.		
1-105-119	Special1:BW:Center:Low Speed	*ENG	[100 to 180 / 110 / 1deg/step]
	Paper through target temperature: special paper 1: BW: center: low speed Fusing malfunction might improve by setting value larger. Paper curl might improve by setting value smaller. Adjusting range is +/- 5 deg. celsius.		
1-105-123	Special2:BW:Center:Low Speed	*ENG	[100 to 180 / 120 / 1deg/step]
	Paper through target temperature: special paper 2: BW: center: low speed Fusing malfunction might improve by setting value larger. Paper curl might improve by setting value smaller. Adjusting range is +/- 5 deg. celsius.		
1-105-125	Plain1:Glossy:Center	*ENG	[100 to 180 / 110 / 1deg/step]
	Paper through target temperature: Standard paper 1: coat: center Fusing malfunction might improve by setting value larger. Paper curl might improve by setting value smaller. Adjusting range is +/- 5 deg. celsius.		
1-105-127	Plain2:Glossy:Center	*ENG	[100 to 180 / 110 / 1deg/step]
	Paper through target temperature: Standard paper 2: coat: center Fusing malfunction might improve by setting value larger. Paper curl might improve by setting value smaller. Adjusting range is +/- 5 deg. celsius.		

1-105-129	M-thick:Glossy:Center	*ENG	[100 to 180 / 115 / 1deg/step]
	Paper through target temperature: Standard paper 2: coat: center Fusing malfunction might improve by setting value larger. Paper curl might improve by setting value smaller. Adjusting range is +/- 5 deg. celsius.		
1-105-131	OHP:Center	*ENG	[100 to 180 / 160 / 1deg/step]
	Paper through target temperature OHP: center Fusing malfunction might improve by setting value larger. Paper curl might improve by setting value smaller. Adjusting range is +/- 5 deg. celsius.		
1-105-133	Envelop:Center:Low Speed	*ENG	[100 to 180 / 135 / 1deg/step]
	Paper through target temperature: envelope: center: low speed Fusing malfunction might improve by setting value larger. Paper curl might improve by setting value smaller. Adjusting range is +/- 5 deg. celsius.		
1-105-137	Thin:BW:Center:Low Speed	*ENG	[100 to 180 / 110 / 1deg/step]
	Paper through target temperature: thin paper: BW: center: low speed Fusing malfunction might improve by setting value larger. Paper curl might improve by setting value smaller. Adjusting range is +/- 5 deg. celsius.		
1-105-141	Thick4:BW:Center	*ENG	[100 to 180 / 140 / 1deg/step]
	Paper through target temperature: thick paper 4: BW: center Fusing malfunction might improve by setting value larger. Paper curl might improve by setting value smaller. Adjusting range is +/- 5 deg. celsius.		

1-105-143	Postcard:Center	*ENG	[100 to 180 / 118 / 1deg/step]
	Paper through target temperature post card: center Fusing malfunction might improve by setting value larger. Paper curl might improve by setting value smaller. Adjusting range is +/- 5 deg. celsius.		
1-105-147	Special3:BW:Center:Middle Speed	*ENG	[100 to 180 / 130 / 1deg/step]
	Paper through target temperature: special paper 1: BW: center: low speed Fusing malfunction might improve by setting value larger. Paper curl might improve by setting value smaller. Adjusting range is +/- 5 deg. celsius.		

1106	[Fusing Temp. Display]		
1-106-001	Heat Center	ENG	[-10 to 250 / 0 / 1deg/step] Displays the temperature of the heating roller detected by the thermistor at the center of the heating roller.
1-106-002	Heat End	ENG	[-10 to 250 / 0 / 1deg/step] Displays the temperature of the heating roller detected by the thermistors at the ends of the heating roller.
1-106-003	Press Center	ENG	[-10 to 250 / 0 / 1deg/step] Displays the temperature of the hot roller detected by the thermistors at the center of the pressure roller.
1-106-004	Press End	ENG	[-10 to 250 / 0 / 1deg/step] Displays the temperature of the hot roller detected by the thermistors at the ends of the pressure roller.

1112	[Image Processing Temp. Correct] DFU		
1-112-002	Temp.:Plain:Center:Energy Saving	*ENG	[-30 to 20 / * / 1deg/step]
	For design use. Do not change.		

1113	[Curl Correction] DFU		
1-113-001	Execute Pattern	*ENG	[0 to 2 / 0 / 1/step] 0: OFF 1: ON(No Decurl) 2: ON
	If curling occurs in a humid environment, switching this to ON may reduce the problem.		

1116	[Heat Storage FB Control] DFU		
For design use. Do not change.			
1-116-002	Correction Formula Judge Temp	*ENG	[0 to 200 / * / 1/step] * The default is different with models. D197: 102 D198/D199/D200/D201/D202: 97
1-116-003	Heat Gap Correction Temp	*ENG	[0 to 200 / 0 / 1/step]
1-116-012	Time Out:Energy Saving	*ENG	[0 to 500 / * / 1 sec/step] * The default is different with models. D197/D198/D199/D200 (NA/TWN)/D201/ D202: 3 D200 (EU/AS/ CHN/KOR): 15
1-116-024	Delay:Middle Speed:BW:1	*ENG	[0 to 20000 / 1320 / 1msec/step]
1-116-026	Delay:Low Speed:BW:1	*ENG	[0 to 20000 / 2640 / 1msec/step]

1-116-034	Delay:Middle Speed:BW:2	*ENG	[0 to 20000 / 1320 / 1msec/step]
1-116-036	Delay:Low Speed:BW:2	*ENG	[0 to 20000 / 2640 / 1msec/step]
1-116-044	Press Reference Temp.:Energy Saving	*ENG	[0 to 200 / 75 / 1 deg /step]
1-116-045	Temp. Correction Lower Limit:Energy Saving	*ENG	[-30 to 0 / -1 / deg/step]
1-116-046	Temp. Correction Upper Limit:Energy Saving	*ENG	[-30 to 0 / 0 / deg/step]
1-116-053	Paper Thickness Coefficient:Thin	*ENG	[-100 to 100 / -50 / 1/step]
1-116-054	Paper Thickness Coefficient:M-thick	*ENG	[-100 to 100 / 0 / 1/step]
1-116-073	Paper Thickness Coefficient:Low Speed	*ENG	[-100 to 100 / 0 / 1/step]
1-116-074	Paper Thickness Coefficient:Energy Saving	*ENG	[-100 to 100 / 10 / 1/step] * The default is different with models. D197/D198/D199/D200 (NA/TWN)/D201/ D202: 30 D200 (EU/AS/CHN/KOR): 100

1133	[Voltage Detection]		
1-133-001	Voltage Detection	*ENG	[0.0 to 350.0 / * / 0.1V/step] * The default is different with regions. NA : 117 EU/AU, CHN, KOR: 227 TWN : 107
Displays the voltage of the connected power source applied to turn the heater on.			

1135	[Inrush Control]		
1-135-001	Inrush Control	*ENG	[0 or 1 / 0 / 1/step] 0: Normal (Default) 1: Inrush Control mode
	<p>If the heater's surge current flows into the UPS or power circuit breaker, the power may be cut. Is you set this to "1", the heater's surge current on startup is controlled, allowing continual use even if the current flows into the UPS or power circuit breaker.</p> <p>However, setting this to ON will extend the initialization time by approximately one second.</p>		

1141	[Fusing SC Error Time Info]		
1-141-001	SC Number	*ENG	[0 to 99999 / 0 / 1/step]
	Display occurring SC.		
1-141-101	Htg Roller:Ctr Det1	*ENG	[-5 to 300 / 0 / 1deg/step]
	Display detailed conditions when an SC occurs. Displayed content is temp.: center: occurred time.		
1-141-102	Htg Roller:End Det1	*ENG	[-5 to 300 / 0 / 1deg/step]
	Display detailed conditions when an SC occurs. Displayed content is temp.: center: occurred time.		
1-141-103	Press Roller:Ctr Det1	*ENG	[-5 to 300 / 0 / 1deg/step]
	Display detailed conditions when an SC occurs. Displayed content is temp.: center: occurred time.		
1-141-104	Press Roller:End Det1	*ENG	[-5 to 300 / 0 / 1deg/step]
	Display detailed conditions when an SC occurs. Displayed content is temp.: edge: occurred time.		

1-141-151	Htg Roller:Ctr Det2	*ENG	[-5 to 300 / 0 / 1deg/step]
	Display detailed conditions when an SC occurs. Displayed content is temp.: center: 1 cycle a head of occurred time.		
1-141-152	Htg Roller:End Det2	*ENG	[-5 to 300 / 0 / 1deg/step]
	Display detailed conditions when an SC occurs. Displayed content is temp.: center: 1 cycle a head of occurred time.		
1-141-153	Press Roller:Ctr Det2	*ENG	[-5 to 300 / 0 / 1deg/step]
	Display detailed conditions when an SC occurs. Displayed content is temp.: center: 1 cycle a head of occurred time.		
1-141-154	Press Roller:End Det2	*ENG	[-5 to 300 / 0 / 1deg/step]
	Display detailed conditions when an SC occurs. Displayed content is temp.: edge: 1 cycle a head of occurred time.		
1-141-201	Htg Roller:Ctr Det3	*ENG	[-5 to 300 / 0 / 1deg/step]
	Display detailed conditions when an SC occurs. Displayed content is temp.: center: 2 cycle a head of occurred time.		
1-141-202	Htg Roller:End Det3	*ENG	[-5 to 300 / 0 / 1deg/step]
	Display detailed conditions when an SC occurs. Displayed content is temp.: center: 2 cycle a head of occurred time.		
1-141-203	Press Roller:Ctr Det3	*ENG	[-5 to 300 / 0 / 1deg/step]
	Display detailed conditions when an SC occurs. Displayed content is temp.: center: 2 cycle a head of occurred time.		
1-141-204	Press Roller:End Det3	*ENG	[-5 to 300 / 0 / 1deg/step]
	Display detailed conditions when an SC occurs. Displayed content is temp.: edge: 2 cycle a head of occurred time.		

1142	[Fusing Jam Detection]		
1-142-001	SC Display	*ENG	[0 or 1 / 0 / 1/step] 0: OFF 1: ON
	Display SC or not when detecting a fusing jam 3 times in a roll.		

1152	[Fusing Nip Band Check]		
1-152-001	Execute	ENG	[0 or 1 / 0 / 1/step]
	Measure nip. The standard specification of this machine is +/-0.8 mm. if the value is out of range, the fusing unit needs to be replaced.		

1153	[Abnormal Noise Confirmation] DFU		
1-153-001	Unit: Execute	ENG	[0 or 1 / 0 / 1/step]
1-153-002	No Unit: Execute	ENG	[0 or 1 / 0 / 1/step]
1-153-003	Operation Line Speed	ENG	[0 to 2 / 0 / 1/step] 0: Std Speed 1: Mid Speed 2: Low Speed
1-153-004	Operation Time	ENG	[0 to 240 / 60 / 1sec/step]
1-153-005	Heat Center Target Temp	ENG	[100 to 180 / 130 / 1deg/step]
1-153-006	Heat End Target Temp	ENG	[100 to 180 / 130 / 1deg/step]
1-153-007	Press Target Temp	ENG	[0 to 200 / 0 / 1deg/step]

1154	[Switch:Rotation Start/Stop] DFU		
	For design use. Do not change.		
1-154-001	Judging Method Change	*ENG	[0 or 1 / 0 / 1/step] 0: ON 1: OFF
1-154-005	Heater ON Timing	*ENG	[0 to 250 / 0 / 10msec/step]
1-154-006	Overshoot Prevent Temp.:SC	*ENG	[0 to 250 / * / 1deg/step] * The default is different with models. D197: 185 D198: 185 D199: 185 D200: 195 D201: 200 D202: 200

1155	[Small Size Paper Control] DFU		
	For design use. Do not change.		
1-155-001	Print Width	ENG	[0 to 300 / 0 / 1mm/step]

1907	[Paper Feed Timing Adj.]		
1-907-029	By-pass Size Decision Timing	*ENG	[1 to 3 / 3 / 1/step]
	Adjusts waiting time till fix a size from size detector's output when paper is set with standard bypass or one action bypass function is OFF. Will have more time till start button to turn green when setting waiting time longer, but time for setting paper will also be loner. Side effect might occur such as paper feed starts before finish setting paper if waiting time is set shot.		

1955	[Fan ON/OFF Switch Set]		
1-955-021	Front Development	*ENG	[0 to 1/ 0 / 1/step] 0: Off (Stop) 1: On (Rotation)
	Specifies the movement of PSU cooling fan. This SP is only for D200, D201, and D202.		

1955	[Fan ON/OFF Switch Set]		
1-955-022	Toner Bottle	*ENG	[0 to 1/ 0 / 1/step] 0: Off (Stop) 1: On (Rotation)
	Specifies the movement of development bearing Cooling Fan. This SP is only for D197, D198, and D199.		

5.3 SP MODE TABLES - SP2000

5.3.1 SP2-XXX (DRUM)

2101	[Registration Correction]		
	Main Dot	*ENG	[-512 to 511 / 0 / 1dot/step]
2-101-001	Adjusts the main scan registration. <ul style="list-style-type: none"> ▪ Value increase: image shifts to right facing the paper. ▪ Value decrease: image shifts to left facing the paper. 		

	[LSU Adjustment]		
2102	Adjusts the main scan magnification. <ul style="list-style-type: none"> ▪ Value increase: image stretches. ▪ Value decrease: image shrinks. 		
2-102-001	Main Mag.	*ENG	[-1.0 to 1.0 / 0.0 / 0.1%/step]

2103	[Erase Margin Adjustment]		
	Lead Edge Width	ENG	[0.0 to 9.9 / 4.2 / 0.1mm/step]
2-103-001	Adjusts trimming margine at the leading edge for the sub scan. <ul style="list-style-type: none"> ▪ Value increase: Trim becomes wider. ▪ Value decrease: Trim becomes narrower. 		
	Trail. Edge Width	ENG	[0.0 to 9.9 / 4.2 / 0.1mm/step]
2-103-002	Adjusts trimming margine at the trailing edge for the sub scan. <ul style="list-style-type: none"> ▪ Value increase: Trim becomes wider. ▪ Value decrease: Trim becomes narrower. When using the printer mode, the margin setting of the printer mode is prior to this setting.		

2-103-003	Left	ENG	[0.0 to 9.9 / 2.0 / 0.1mm/step]
	Adjusts trimming margine at the left edge for sub scan. <ul style="list-style-type: none"> ▪ Value increase: Trim becomes wider. ▪ Value decrease: Trim becomes narrower. When using the printer mode, the margin setting of the printer mode is prior to this setting.		
2-103-004	Right	ENG	[0.0 to 9.0 / 2.0 / 0.1mm/step]
	Adjusts trimming margine at the right edge for sub scan. <ul style="list-style-type: none"> ▪ Value increase: Trim becomes wider. ▪ Value decrease: Trim becomes narrower. When using the printer mode, the margin setting of the printer mode is prior to this setting.		

2103	[Erase Margin Adjustment]		
	Sets trimming margine for the second side of the paper. <ul style="list-style-type: none"> ▪ Value increase: Trim becomes wider. ▪ Value decrease: Trim becomes narrower. 		
2-103-006	Duplex Trail. L Size	ENG	[-4.0 to 4.0 / 1.0 / 0.1mm/step]
	Adjusts trimming margine at the trailing edge on the 2nd side for sub scan when using large size paper.		
2-103-007	Duplex Trail. M Size	ENG	[-4.0 to 4.0 / 0.8 / 0.1mm/step]
	Adjusts trimming margine at the trailing edge on the 2nd side for sub scan when using middle size paper.		
2-103-008	Duplex Trail. S Size	ENG	[-4.0 to 4.0 / 0.6 / 0.1mm/step]
	Adjusts trimming margine at the trailing edge on the 2nd side for sub scan when using small size paper.		

2-103-009	Duplex Left Edge	ENG	[0.0 to 1.5 / 0.3 / 0.1mm/step]
	Adjusts trimming margine at the left edge on the 2nd side for main scan.		
2-103-010	Duplex Right Edge	ENG	[0.0 to 1.5 / 0.3 / 0.1mm/step]
	Adjusts trimming margine at the right edge on the 2nd side for main scan.		
2-103-011	Duplex Trail. L Size:Thick	ENG	[-4.0 to 4.0 / 1.0 / 0.1mm/step]
	Adjusts trimming margine at the trailing edge on the 2nd side for sub scan when using large thick size paper.		
2-103-012	Duplex Trail. M Size:Thick	ENG	[-4.0 to 4.0 / 0.8 / 0.1mm/step]
	Adjusts trimming margine at the trailing edge on the 2nd side for sub scan when using middle thick size paper.		
2-103-013	Duplex Trail. S Size:Thick	ENG	[-4.0 to 4.0 / 0.6 / 0.1mm/step]
	Adjusts trimming margine at the trailing edge on the 2nd side for sub scan when using small thick size paper.		
2-103-014	Duplex Left Edge:Thick	ENG	[0.0 to 1.5 / 0.3 / 0.1mm/step]
	Adjusts trimming margine at the left edge on the 2nd side for main scan when using thick paper.		
2-103-015	Duplex Right Edge:Thick	ENG	[0.0 to 1.5 / 0.3 / 0.1mm/step]
	Adjusts trimming margine at the right edge on the 2nd side for main scan when using thick paper.		
2-103-016	Duplex Trail. L Size:Thin	ENG	[-4.0 to 4.0 / 1.0 / 0.1mm/step]
	Adjusts trimming margine at the trailing edge on the 2nd side for sub scan when using large thin paper.		

2-103-017	Duplex Trail. M Size:Thin	ENG	[-4.0 to 4.0 / 0.8 / 0.1mm/step]
	Adjusts trimming margine at the trailing edge on the 2nd side for sub scan when using middle thin paper.		
2-103-018	Duplex Trail. S Size:Thin	ENG	[-4.0 to 4.0 / 0.6 / 0.1mm/step]
	Adjusts trimming margine at the trailing edge on the 2nd side for sub scan when using small thin paper.		
2-103-019	Lead Edge Width:Thin	ENG	[0.0 to 9.9 / 4.2 / 0.1mm/step]
	Adjusts trimming margin at the left edge on the 2nd side for main scan when using thin paper.		
2-103-020	Trail. Edge Width:Thin	ENG	[0.0 to 9.9 / 4.2 / 0.1mm/step]
	Adjusts trimming margin at the right edge on the 2nd side for main scan when using thin paper.		

2107	[Image Parameter] DFU		
	For design use. Do not change.		
2-107-001	Image Gamma Flag	*ENG	[0 or 1 / 1 / 1/step]
2-107-002	Shading Correction Flag	*ENG	[0 or 1 / 0 / 1/step]

2109	[Test Pattern]			
	Pattern Selection	ENG	[0 to 24 / 0 / 1/step]	
	Select patterns.			
2-109-003	0	None	13	4dot Ind. Pptrn.
	1	1dot Vertical	14	Trimming Area
	2	2dot Vertical	15	HoundstoothH
	3	1dot Horizontal Line	16	Houndstooth V
	4	2dot Horizontal Line	17	Black Band H
	5	Grid Vert	18	Black Band V
	6	Grid Horizontal	19	Checker Flag Pattern
	7	Grid Pattern Small	20	Grayscale V
	8	Grid Pattern Large	21	Grayscale H
	9	Argyle Pattern Small	22	2 Beam Density Pptrn.
	10	Argyle P : L	23	Full Dot Pattern
	11	1dot Ind. Pptrn.	24	All White Pattern
	12	2dot Ind. Pptrn.	-	-
	Density	ENG	[0 to 15 / 15 / 1/step]	
2-109-006	Sets test patterns density. <ul style="list-style-type: none"> ▪ Value increase: Density becomes darker. ▪ Value decrease: Density becomes lighter. 			

2110	[LD Driver]		
2-110-001	Error	*ENG	[0x0000 to 0xFFFF / 0x0000 / 1/step] DFU For design use. Do not change.
2-110-005	Memory Transfer	ENG	[Execute]
	Execution flag to download the adjustment values of the laser unit to the machine. Executes when replacing the laser unit or assembling main machine.		
2-110-006	Revision Number	*ENG	[0x00 to 0xFF / - / 1/step] DFU For design use. Do not change.

2115	[Gamma Correction]		
2-115-001	Low CPP edge Correction	*ENG	[0 to 100 / 80 / 1%/step]
	Sets gamma correction value of valid pixel for the edge process in the low CPP condition. <ul style="list-style-type: none"> ▪ Value increase: Density becomes darker. ▪ Value decrease: Density becomes lighter. 		

2152	[Shad. Correct Setting] DFU		
	For design use. Do not change.		
2-152-001	Standard Speed	*ENG	[50.0 to 150.0 / 100.0 / 0.1%/step]
2-152-005	Middle Speed	*ENG	
2-152-009	Low Speed	*ENG	

2160	[Vertical Line Width] DFU		
	For design use. Do not change.		
2-160-001	1dot Line	*ENG	[0 to 31 / 31 / 1/step]
2-160-002	2 or more dots Line	*ENG	[0 to 31 / 31 / 1/step]

2242	[TS Operation Env. Log]		
2-242-100	Log Clear	ENG	[Execute]
	Clears the environment log for the image processing temperature.		

2400	[Paper Transfer Roller Settings]		
2-400-002	Detach timing in waiting	*ENG	[0 to 600 / 240 / 1min/step]
	If the transfer roller remains in contact with the OPC drum for a long time, the deformation of the transfer roller occurs, causing black streaks. To prevent the deformation, the transfer roller is disengaged after the specified time set in this SP has elapsed.		

2970	[Interrupt Transfer CL]		
	Enables or disables the interruption cleaning for the transfer roller during the multiple outputs.		
2-970-004	Low-temperature, low-humidity	ENG	[0 or 1 / 0 / 1 / -] 0: Disabled, 1: Enabled
2-970-005	Moderate temperature and humidity	ENG	[0 or 1 / 0 / 1 / -] 0: Disabled, 1: Enabled
2-970-006	High-temperature and high-humidity	ENG	[0 or 1 / 0 / 1 / -] 0: Disabled, 1: Enabled

2990	[Print Duty Control]		
2-990-004	Forced CPM Down Thresh: No Duty Control: MM	*ENG	[0 to 5000 / 0 / 1page/step]
	Sets the threshold for the CPM down in MM condition when the imaging duty is not restricted.		
2-990-007	Forced CPM Down Thresh: Duty Control	*ENG	[0 to 5000 / 16 / 1page/step]
	Sets the threshold for the CPM down when the imaging duty is restricted.		
2-990-008	Down-time_BW: Duty Control	*ENG	[0 to 240000 / 25000 / 10msec/step]
	Sets the down-time for the BW mode printing when the imaging duty is restricted.		
2-990-011	Execution Temp. Threshold	*ENG	[20 to 70 / 45.5 / 0.1deg/step]
	Sets the temperature threshold for the imaging duty restriction.		
2-990-101	Forced CPM Down Thresh: No Duty Control: LL	*ENG	[0 to 5000 / 0 / 1page/step]
	Sets the threshold for the CPM down in LL condition when the imaging duty is not restricted.		
2-990-102	Forced CPM Down Thresh: No Duty Control: ML	*ENG	[0 to 5000 / 0 / 1page/step]
	Sets the threshold for the CPM down in ML condition when the imaging duty is not restricted.		

2-990-103	Forced CPM Down Thresh: No Duty Control: HH	*ENG	[0 to 5000 / 0 / 1page/step]
Sets the threshold for the CPM down in HH condition when imaging duty is not restricted.			



5.4 SP MODE TABLES - SP3000

5.4.1 SP3-XXX (PROCESS)

3011	[Manual ProCon :Exe]		
3-011-001	Normal ProCon	ENG	[Execute]
	Executes the process control mode.		

3012	[ProCon OK?]		
	Displays the result of the process control for each SP number.		
3-012-001	History:Last	*ENG	[0 to 99 / 0 / 1/step]
	Displays the latest result of the process control execution.		
3-012-002	History:Last 2	*ENG	[0 to 99 / 0 / 1/step]
	Displays the result before the last result of the process control execution.		
3-012-003	History:Last 3	*ENG	[0 to 99 / 0 / 1/step]
	Displays the result before the last 2 result of the process control execution.		
3-012-004	History:Last 4	*ENG	[0 to 99 / 0 / 1/step]
	Displays the result before the last 3 result of the process control execution.		
3-012-005	History:Last 5	*ENG	[0 to 99 / 0 / 1/step]
	Displays the result before the last 4 result of the process control execution.		
3-012-006	History:Last 6	*ENG	[0 to 99 / 0 / 1/step]
	Displays the result before the last 5 result of the process control execution.		
3-012-007	History:Last 7	*ENG	[0 to 99 / 0 / 1/step]

	Displays the result before the last 6 result of the process control execution.		
3-012-008	History:Last 8	*ENG	[0 to 99 / 0 / 1/step]
	Displays the result before the last 7 result of the process control execution.		
3-012-009	History:Last 9	*ENG	[0 to 99 / 0 / 1/step]
	Displays the result before the last 8 result of the process control execution.		
3-012-010	History:Last 10	*ENG	[0 to 99 / 0 / 1/step]
	Displays the result before the last 9 result of the process control execution.		

***SP3-012 Display result detail**

Category	Code	Result name	Description
00 or more	00	Not executed	Factory default setting (SP default)
10 or more Result (Normal)	11	Succeed	-
20 or more: ID Sensor	21	ID Sensor Vsg adjust error	Out of range from Vsg_reg = 4.0 ± x.x[V/step]
	22	ID Sensor LED Adjust error	lfsg > Max
	23	ID Sensor Output error (regular reflect)	Vsg_reg < Min (Max)
	24	ID Sensor output error (diffusion reflect)	Vsg_dif < Min(Max)
	25	ID Sensor offset Voltage error (regular reflect)	Voffset_reg > Max
	26	ID Sensor offset Voltage error (diffusion reflect)	Voffset_dif > Max

40 or more: TD sensor	41	TD Sensor Output error (Max)	Vt > Max
	42	TD Sensor Output error (Min)	Vt < Min
45 or more: ID Pattern detect	46	Vsp error (Max)	Vsp > Max
	47	Vsp error (Min)	Vsp < Min
	48	Vsp error (Max)	Vsp > Max
	49	Vsp error (Min)	Vsp < Min
90 or more: Result (End)	99	Forced termination	Forced termination by door open, power off, external cause.

3030	[Init TD Sensor :Exe]		
3-030-001	Execute	ENG	[Execute]
	Executes TD sensor initial setting (K).		
3-030-071	Init Temp: K	*ENG	[-100.0 to 100.0 / 23.0 / 0.1deg/step]
	Displays the ambient temperature at the TD sensor initialization.		
3-030-081	Init Rel Hum: K	*ENG	DFU [0 to 100.0 / 50.0 / 0.1%RH/step] For design use. Do not change.
3-030-091	Init Abs Hum: K	*ENG	DFU [0 to 100.00 / 10.30 / 0.01g/m ³ /step] For design use. Do not change.
3-030-101	Init Coverage: K DFU	*ENG	DFU [0 to 2147483647 / 0 / 1%/ step] For design use. Do not change.
3-030-111	Total DC: Dev: K	*ENG	DFU [0 to 2147483647 / 0 / 1%/step] For design use. Do not change.

3031	[TD Sens Init OK?]		
3-031-001	K	ENG	[0 to 9 / 0 / 1/step] 0: No execution 1: Success 2: No developer error 3: Out of target range 9: Forced termination
	Displays execution result of TD sensor initial setting.		

3050	[Force Tnr Supply :Exe]		
3-050-001	Execute	ENG	[Execute]
	Executes the forced toner supply (K).		
3-050-021	Supply Quantity	*ENG	[0 to 5/ 0.5 / 0.1/wt%]
	Sets the supply quantity (K) for the forced toner supply by [wt%] step. A larger value increases the toner supply amount.		

3072	[T Sensor: Check]		
	Executes testing mode to test TD sensor's output (Vt) without starting up the engine.		
3-072-001	Execute Check	ENG	[Execute]

3073	[T Sensor Measurement Value:]		
	Displays TD sensor output voltage (mu count) when SP3-072-001 is executed. Normal value is approximately 6000 to 6200.		
3-073-001	mu count	*ENG	[0 to 65535 / 0 / 1/step]

3074	[ID.Sens Check :Exe]		
	Executes ID sensor inspection check.		
3-074-001	All Sensors	ENG	[Execute]

3075	[ID.Sens Chk :Disp]		
	Display the result (Vsg_reg/ Offset voltage) of SP3-074-001.		
3-075-001	Vsg_reg	*ENG	[0.00 to 5.50 / 0.00 / 0.01V/step]
3-075-011	Voffset	*ENG	[0.00 to 5.50 / 0.00 / 0.01V/step]

3100	[Toner End Detection: Set]		
3-100-001	ON/OFF	*ENG	[0 or 1 / 0 / 1/step] 0: Enable 1: Disable
	Selects the toner near end and toner end detection.		
3-100-003	TE Detection	*ENG	[0 to 2 / 1 / 1/step] 0:Page & Vt 1:Vt Only 2:Page Counter Only
	Selects the toner end detection method.		

3101	[Toner Status :Disp]		
	Displays remaining toner.		
3-101-001	K	*ENG	[0 to 2 / 2 / 1/step] 2: Full 1: Near end 0: Toner end

3133	[TE Detect :Set]		
3-133-001	Set Sheets	*ENG	[0 to 5000 / 90 / 1sheet/step]
	Sets the number of sheets to display toner end after toner near end is detected.		

3133	[TE Detect :Set]		
	Displays the amount of sheets printed after toner near end is fixed.		
3-133-011	Page Cnt:K	*ENG	[0 to 5000 / 0 / 1sheet/step]

3200	[TnrDensity]		
	Displays toner density (wt%).		
3-200-001	K	*ENG	[0 to 25.5 / 0 / 0.1 wt%/step]

3201	[TnrDensity] DFU		
	For design use. Do not change.		
3-201-001	Upper TC	*ENG	[1.0 to 15.0 / 5.5 / 0.1wt%/step]
3-201-002	Lower TC	*ENG	[1.0 to 15.0 / 2.7 / 0.1wt%/step]

3205	[TDSensSensitivity] DFU		
	For design use. Do not change.		
3-205-061	BD Cnv Coef: K	*ENG	[-999.0 to 0 / -280.0 / 0.1 count/g/m ³ /step]
3-205-071	AH Cnv Coef: K	*ENG	[0 to 0.9999 / 0 / 0.0001 /step]
3-205-101	Bulk Density: K	*ENG	[-5.00 to 5.00 / 0 / 0.01V/step]

3210	[TD.Sens:Vt :Disp]		
	Displays latest T sensor output.		
3-210-001	Current	*ENG	[0.00 to 5.50 / 0.00 / 0.01V/step]

3212	[Vt Shift :set] DFU		
	For design use. Do not change.		
3-212-101	TC Cor.(ON/OFF)	*ENG	[0 or 1 / 0 / 1/step] 0:OFF 1:ON

3214	[Vt Save :Set] DFU		
	For design use. Do not change.		
3-214-001	Coverage Thresh	*ENG	[0 to 100 / 20 / 1%/step]

3230	[Vtref :Disp/Set]		
3-230-001	Current	*ENG	[0.00 to 5.00 / 2.50 / 0.01V/step]
	Displays / Sets current target value of TD sensor's output voltage: Vtref (K).		

3250	[ImgArea :Disp]		
	Displays image area (K) for the latest page.		
3-250-001	ImgArea	*ENG	[0 to 9999 / 0 / 1cm ² /step]

3251	[DotCoverage :Disp]		
3-251-001	DotCoverage	*ENG	[0.00 to 100.00 / 0.00 / 0.01%/step]
	Displays image area rate (K) for the latest page.		

3252	[AccumImgArea :Disp]		
	Displays accumulated image area (K).		
3-252-001	ImgArea	*ENG	[0 to 65535 / 0 / 1cm ² /step]

3260	[Temperature/Humidity: Display]		
3-260-001	Temperature	ENG	[-5.0 to 45.0 / 0.0 / 0.1deg]
	Displays temperature of environment sensor output.		
3-260-002	Relative Humidity	ENG	[0.0 to 100.0 / 0.0 / 0.1%RH/step]
	Displays relative humidity of environment sensor output.		
3-260-003	Absolute Humidity	ENG	[0.00 to 100.00 / 0.00 / 0.01g/m ³ /step]
	Displays absolute humidity of environment sensor output.		

3310	[ID.Sens :Voffset]		
	Displays the regular reflection output of ID sensor when the LED of the ID sensor is off. Normal condition: Approximately 0.1V or less.		
3-310-001	Voffset reg	*ENG	[0.00 to 5.50 / 0.00 / 0.01V/step]

3310	[ID.Sens :Voffset]		
3-310-021	Voffset TM(Front)	*ENG	[0.00 to 5.50 / 0.00 / 0.01V/step]
	Displays the regular reflection output of ID sensor when the LED of the ID sensor is off. Normal condition: Approximately 0.1V or less.		

3320	[Vsg Adj: Execute]		
3-320-001	P Sensor	ENG	[Execute]
	Execute the Vsg adjustment for the ID sensor.		
3-320-011	Vsg Error Counter	*ENG	[0 to 99 / 0 / 1times/step]
	Displays Vsg error counter.		

3321	[Adjusted Vsg]		
	Displays regular reflection output of the bare ITB area at the Vsg adjustment. Normal condition: 3.5 to 4.5V		
3-321-001	Vsg reg	*ENG	[0.00 to 5.50 / 0.00 / 0.01V/step]

3322	[Adjusted Ifsg]		
	Displays the LED current of the ID sensor. If it differs greatly from the value in SP3-322-011, the ID sensor may be stained, the OPC drum may have deteriorated, the ID sensor may be out of alignment, or there may be some other problem.		
3-322-001	Ifsg	*ENG	[0.0 to 50.0 / 10.0 / 0.001mA/step]

3322	[Adjusted Ifsg]		
	Displays the minimum LED current of the ID sensor for the Vsg adjustment.		
3-322-011	Ifsg Min	*ENG	[0.0 to 50.0 / 27.0 / 0.001mA/step]

3323	[Vsg Adj OK?]		
	Displays Vsg adjustment result (SP assign for compatibility with unification model sires).		
	Code	Result	detail
	0	Not executed	(SP default)
	1	Succeed	-
	2	ID sensor proofread error	Out of range from Vsg= Vsg_reg(target value)±x.x[V/step]
	3	Offset voltage error	Voffset_reg>Max. or Voffset_dif>Max.
	4	LED Ampere Max. error.	Ifsg>Max.
	5	ID sensor output error.	Vsg< Vsg_reg(error)
	9	Forced termination	Forced termination by door open, power off, external cause.
3-323-001	Latest	*ENG	[0 to 9 / 0 / 1/step]
3-323-002	Latest 2	*ENG	
3-323-003	Latest 3	*ENG	
3-323-004	Latest 4	*ENG	
3-323-005	Latest 5	*ENG	
3-323-006	Latest 6	*ENG	
3-323-007	Latest 7	*ENG	
3-323-008	Latest 8	*ENG	
3-323-009	Latest 9	*ENG	
3-323-010	Latest 10	*ENG	

3331	[ID.Sens Coef :Set]		
	This is the coefficient used for adjusting Vsp/Vsg in accordance with the ID sensor test data. Input this coefficient, supplied with the sensor, to correct the variation of each sensor.		
3-331-061	Vsp Coef	*ENG	[0.500 to 1.500 / 1.000 / 0.001/step]
3-331-071	Vsdp Coef	*ENG	[0.500 to 1.500 / 1.000 / 0.001/step]

3400	[Toner Supply Type]		
	Selects toner supply method.		
3-400-001	K	*ENG	[0 to 2 / 2 / 1/step] 0: Fixed 2: PID

3411	[Toner Supply Qty]		
	Displays latest value of supply amount calculated from toner supply amount computation formula.		
3-411-001	K	ENG	[0.0 to 40000.0 / 0.0 / 0.1mg/step]

3420	[DeveloperWeight] DFU		
	For design use. Do not change.		
3-420-001	Total_Weight	*ENG	[50 to 2000 / 315 / 1g/step]

3421	[TnrSplyAbility] DFU		
	For design use. Do not change.		
3-421-001	K	*ENG	[0.001 to 2.000 / 0.670 / 0.001mg/msec]

3422	[Tnr Supply Limits :Set] DFU		
	For design use. Do not change.		
3-422-001	Max Supply Rate	*ENG	[0 to 255 / 100 / 1%/step]
3-422-011	Min Supply Time	*ENG	[0 to 255 / 100 / 1msec/step]

3428	[TnrSplyDelay : Setting] DFU		
	For design use. Do not change.		
3-428-001	Delay	*ENG	[0 to 255 / 0 / 1msec/step]

3440	[Fixed Supply Mode]		
	Sets toner supplying rate for fixed amount supplying mode. <ul style="list-style-type: none"> ▪ Increasing value: Increases the toner supply rate. ▪ Decreasing value: Decreases the toner supply rate. 		
3-440-001	Fixed Rate	*ENG	[0 to 100 / 10 / 1%/step]

3500	[ImgQtyAdj :ON/OFF]		
3-500-001	ALL DFU	*ENG	[0 or 1 / 1 / 1/step] 0: OFF 1: ON
	For design use. Do not change.		
3-500-002	ProCon	*ENG	[0 or 1 / 1 / 1/step] 0: OFF 1: ON
	Sets execution judge to OFF of electric potential control.		
3-500-004	Init TD Sensor DFU	*ENG	[0 or 1 / 1 / 1/step] 0: OFF 1: ON
	For design use. Do not change.		

3510	[ImgQtyAdj :ExeFlag]		
	Sets the execution flag for the initial toner supply.		
3-510-031	Init Toner Replenish: K	*ENG	[0 or 1 / 0 / 1/step] 0: No execution, 1: Execution flag

3520	[ImgQtyAdj :Interval]		
	Sets image adjust judgment page interval for during print.		
3-520-001	During Job	*ENG	[0 to 100 / 30 / 1page/step]
3-520-002	During Stand-by	*ENG	[0 to 100 / 5 / 1minute/step]
	Sets image adjust judgment time interval for during standby.		

3529	[ProCon Interval Control :Set] DFU		
	For design use. Do not change.		
3-529-001	Gamma Corr	*ENG	[0 or 1 / 1 / 1/step] 0: OFF 1: ON
3-529-002	Environ Corr	*ENG	[0 or 1 / 1 / 1/step] 0: OFF 1: ON
3-529-003	AbsHum Threshold	*ENG	[0.0 to 99.0 / 4.3 / 0.1g/m ³ /step]
3-529-004	Max Cnt Threshold	*ENG	[0 to 99 / 2 / 1counts/step]
3-529-005	Exe Cnt	ENG	[0 to 255 / 0 / 1counts/step]
3-529-006	Page Cnt:BW	*ENG	[0 to 5000 / 0 / 1sheet/step]

3530	[PowerON ProCon :Set] DFU		
	For design use. Do not change.		
3-530-001	Non-use Time Setting	*ENG	[0 to 1440 / 360 / 1minute/step]
3-530-002	Temperature Range	*ENG	[0 to 99 / 10 / 1deg/step]
3-530-003	Relative Humidity Range	*ENG	[0 to 99 / 50 / 1%RH/step]
3-530-004	Absolute Humidity Range	*ENG	[0 to 99 / 6 / 1g/m ³ /step]
3-530-005	Interval:BW	*ENG	[0 to 5000 / 100 / 1sheet/step]
3-530-007	Page Cnt:BW	*ENG	[0 to 5000 / 0 / 1 sheet/step]

3531	[Non-useTime Procon :Set] DFU		
	For design use. Do not change.		
3-531-001	Non-use Time Setting	*ENG	[0 to 1440 / 360 / 1minute/step]
3-531-002	Temperature Range	*ENG	[0 to 99 / 10 / 1deg/step]
3-531-003	Relative Humidity Range	*ENG	[0 to 99 / 50 / 1%RH/step]
3-531-004	Absolute Humidity Range	*ENG	[0 to 99 / 6 / 1g/m ³ /step]
3-531-005	Maximum Execution Number	*ENG	[0 to 99 / 10 / 1times/step]

3533	[Interrupt ProCon :Set]		
3-533-001	Interval:Set:BW	*ENG	[0 to 5000 / 100 / 1sheet/step]
	Sets number of sheets interval for the interrupt process control (BW). <ul style="list-style-type: none"> ▪ Increasing value: Increases the number of sheets printed for the interval between executing each interrupt process control. ▪ Decreasing value: Decreases the number of sheets printed for the interval between executing each interrupt process control. 		
3-533-002	Interval:Disp:BW	*ENG	[0 to 5000 / 100 / 1sheet/step]
	Displays number of sheets interval for the interrupt process control (BW).		
3-533-003	Corr(Short):BW DFU	*ENG	[0.00 to 1.00 / 0.50 / 0.01/step] For design use. Do not change.
3-533-004	Corr(Mid):BW DFU	*ENG	[0.00 to 1.00 / 1.00 / 0.01/step] For design use. Do not change.

3534	[JobEnd ProCon :Set]		
3-534-001	Interval:Set:BW	*ENG	[0 to 5000 / 100 / 1sheet/step]
	Sets number of sheets interval for the job end process control (BW). <ul style="list-style-type: none"> ▪ Increasing value: Increases the number of sheets printed for the interval between executing each job end process control. ▪ Decreasing value: Decreases the number of sheets printed for the interval between executing each job end process control. 		
3-534-002	Interval:Disp:BW	*ENG	[0 to 5000 / 100 / 1sheet/step]
	Displays number of sheets interval for the job end process control (BW).		
3-534-003	Corr(Short):BW DFU	*ENG	[0.00 to 1.00 / 0.50 / 0.01/step] For design use. Do not change.
3-534-004	Corr(Mid):BW DFU	*ENG	[0.00 to 1.00 / 1.00 / 0.01/step] For design use. Do not change.

3539	[Dev Agitating Time :Set] DFU		
	For design use. Do not change.		
3-539-011	by RelHum:1	*ENG	[0 to 3000 / 0 / 1sec/step]
3-539-012	by RelHum:2	*ENG	[0 to 3000 / 5 / 1sec/step]
3-539-013	by RelHum:3	*ENG	
3-539-014	by RelHum:4	*ENG	
3-539-015	by RelHum:5	*ENG	
3-539-016	by RelHum:6	*ENG	
3-539-021	RelHum Threshold:1	*ENG	[0 to 65.0 / 4.0 / 0.1g/m ³ /step]
3-539-022	RelHum Threshold:2	*ENG	[0 to 65.0 / 8.0 / 0.1g/m ³ /step]
3-539-023	RelHum Threshold:3	*ENG	[0 to 65.0 / 12.0 / 0.1g/m ³ /step]
3-539-024	RelHum Threshold:4	*ENG	[0 to 65.0 / 16.0 / 0.1g/m ³ /step]
3-539-025	RelHum Threshold:5	*ENG	[0 to 65.0 / 24.0 / 0.1g/m ³ /step]

3550	[Refresh Mode] DFU		
	For design use. Do not change.		
3-550-001	Required Area	*ENG	[0 to 65535 / 0 / 1cm ²]
3-550-031	Refresh Threshold: BK:MM	*ENG	[0 to 255 / 51 / 1cm ²]
3-550-101	Refresh Threshold: BK:LL	*ENG	[0 to 255 / 51 / 1cm ²]
3-550-102	Refresh Threshold: BK:ML	*ENG	[0 to 255 / 51 / 1cm ²]
3-550-103	Refresh Threshold: BK:HH	*ENG	[0 to 255 / 51 / 1cm ²]

3551	[Select Recycle/Waste]		
3-551-009	Select Control	*ENG	[0 to 3 / 2 / 1/step] 1: Sw Auto 2: Dispose All 3: Recycle All
	DFU		
3-551-010	Select Status	*ENG	[0 or 1 / 0 / 1/step] 0: Recycle 1: Waste
	Displays the status of toner recycle mode.		

3600	[Select ProCon] DFU		
	For design use. Do not change.		
3-600-001	Potential Control	*ENG	[0 or 1 / 1 / 1/step] 0: OFF 1: ON

3611	[Chrg DC Control]		
	Displays the DC bias decided by the process control for the chare unit.		
3-611-001	Std Speed	*ENG	[300 to 2000 / 790 / 1-V/step]

3612	[Dev DC Control]		
3-612-001	Std Speed	*ENG	[200 to 800 / 590 / 1-V/step]
	Displays the development bias decided by the process control.		
3-612-201	Now:Std Speed: K	ENG	[200 to 800 / 690 / 1-V/step]
	Displays the actual development bias.		

3613	[LD Power Control] DFU		
	For design use. Do not change.		
3-613-101	PrCsCntrlCorrect	ENG	[0 to 200 / 130 / 1%/step]

3623	[LD Power :Set] DFU		
	For design use. Do not change.		
3-623-001	Std Speed Slope	*ENG	[-1000 to 1000 / 105 / 1/step]
3-623-011	Std Speed intercept	*ENG	[-1000 to 1000 / 16 / 1/step]
3-623-021	Mid Speed Slope	*ENG	[-1000 to 1000 / 102 / 1/step]
3-623-031	Mid Speed intercept	*ENG	[-1000 to 1000 / 14 / 1/step]
3-623-041	Low Speed Slope	*ENG	[-1000 to 1000 / 90 / 1/step]
3-623-051	Low Speed intercept	*ENG	[-1000 to 1000 / 33 / 1/step]

3623	[LD Power :Set]		
	Sets LD power upper/lower limit.		
3-623-101	UpperLimit	*ENG	[100 to 200 / 132 / 1%/step]
	<ul style="list-style-type: none"> ▪ Increasing value: Increases the value of upper limit for LD power. ▪ Decreasing value: Decreases the value of upper limit for LD power. 		
3-623-111	LowerLimit	*ENG	[0 to 100 / 67 / 1%/step]
	<ul style="list-style-type: none"> ▪ Increasing value: Increases the value of lower limit for LD power. ▪ Decreasing value: Decreases the value of lower limit for LD power. 		

3628	[ID Pattern Timing :Set] DFU		
	For design use. Do not change.		
3-628-001	Scan	*ENG	[-500.0 to 500.0 / 0.0 / 0.1mm/step]
3-628-002	Detection Delay Time	*ENG	[0 to 2500 / 0 / 1msec/step]
3-628-003	Delay Time	*ENG	[0 to 2500 / 700 / 1msec/step]
3-628-004	MUSIC Delay Time	*ENG	[0 to 2500 / 300 / 1msec/step]

3630	[Vsp :Disp/Set]		
3-630-001	Current	*ENG	[0.00 to 5.50 / 0.00 / 0.01V/step]
	Displays the latest Vsp (K).		

3630	[Dev gamma :Disp/Set]		
3-630-011	Target:K	*ENG	[0.50 to 2.55 / 0.95 / 0.01 mg/cm2/-kV/step]
	Displays the target value for the development gamma (K).		
3-630-061	TnrDensity	*ENG	[0.0 to 25.5 / 0.0 / 0.1 wt%/step]
	Displays the toner density (K) converted based on the TD Sensor output.		

3631	[Vsdp :Disp]		
	Displays latest Vsdp value.		
3-631-001	Current	*ENG	[0 to 5.50 / 0 / 0.01V/step]

3700	[New Unit Detection]		
	Enables or disables the new unit detection.		
3-700-001	ON/OFF Setting	*ENG	[0 or 1 / 1 / 1/step] 1: Enable 0: Disable

3701	[Manual New Unit Set]		
	Set the new unit detection for each unit manually. 0: Disables the new unit detection for specified unit. 1: Enables the new unit detection for specified unit.		
3-701-002	#PCU	*ENG	[0 or 1 / 0 / 1/step]
3-701-009	Cleaning Blade	*ENG	[0 or 1 / 0 / 1/step]
3-701-018	Charge Roller	*ENG	[0 or 1 / 0 / 1/step]
3-701-019	Cleaner:Charge Roller	*ENG	[0 or 1 / 0 / 1/step]
3-701-021	OPC	*ENG	[0 or 1 / 0 / 1/step]
3-701-022	Separation Pawl	*ENG	[0 or 1 / 0 / 1/step]
3-701-023	#Development Unit	*ENG	[0 or 1 / 0 / 1/step]
3-701-024	Development	*ENG	[0 or 1 / 0 / 1/step]
3-701-025	Development Filter	*ENG	[0 or 1 / 0 / 1/step]
3-701-028	Bearing:Development Screw	*ENG	[0 or 1 / 0 / 1/step]
3-701-108	#PTR Unit	*ENG	[0 or 1 / 0 / 1/step]
3-701-115	#Fusing Unit	*ENG	[0 or 1 / 0 / 1/step]
3-701-116	Fusing Belt	*ENG	[0 or 1 / 0 / 1/step]
3-701-118	Pressure Roller	*ENG	[0 or 1 / 0 / 1/step]
3-701-119	Pressure Roller Bearings	*ENG	[0 or 1 / 0 / 1/step]
3-701-206	ADF:Pick-up Roller	*ENG	[0 or 1 / 0 / 1/step]
3-701-207	ADF:Feeding Belt	*ENG	[0 or 1 / 0 / 1/step]
3-701-208	ADF:Reverse Roller	*ENG	[0 or 1 / 0 / 1/step]

3710	[mu Concentration Control: Set] DFU		
	For design use. Do not change.		
3-710-011	mu sensor resolution	*ENG	[0 to 3 / 1 / 1/step]
3-710-012	Ini mu count offset	*ENG	[0 to 10000 / 6000 / 1/step]

3711	[mu Concent Ctrl:K] DFU		
	For design use. Do not change.		
3-711-031	Init Temp.	*ENG	[-100.0 to 100.0 / 0.0 / 0.1deg/step]
3-711-032	Init RH	*ENG	[0.0 to 100.0 / 0.0 / 0.1%RH/step]
3-711-033	Init AH	*ENG	[0.00 to 100.00 / 0.0 / 0.01g/m ³ /step]
3-711-041	Total DC: Dev	*ENG	[0 to 2147483647 / 0 / 1%/step]

3800	[Waste Toner Full Detection]		
3-800-014	Threshold : Remainder days	*ENG	[1 to 255 / 15 / 1 /step]
	<p>Specifies the threshold value for determining when to display the operation panel message reporting that the waste toner bottle is nearly full once the machine detects it. If the number of remaining days (SP7-951-142) falls below this threshold value, the message appears.</p> <ul style="list-style-type: none"> ▪ Increasing value: Decreases the number of days before displaying the message once the machine detects that the waste toner bottle is nearly full. ▪ Decreasing value: Increases the number of days before displaying the message once the machine detects that the waste toner bottle is nearly full. 		

5.5 SP MODE TABLES - SP4000

5.5.1 SP4-XXX (SCANNER)

4008	[Sub Scan Magnification Adj]		
	Adjusts Sub Scan Magnification by 0.1% each step. <ul style="list-style-type: none"> ▪ Picture stretches as value increases. ▪ Picture shrinks as value decreases. 		
4-008-001	-	ENG	[-1.0 to 1.0 / 0.0 / 0.1 %/step]

4010	[Sub Scan Registration Adj]		
	Adjusts Sub Scan Registration position of book scanner by 0.1mm each step. <ul style="list-style-type: none"> ▪ Picture moves to trailing edge of sub scan as value increases. ▪ Picture moves to leading edge of sub scan as value decreases. 		
4-010-001	-	ENG	[-2.0 to 2.0 / 0.0 / 0.1 mm/step]

4011	[Main Scan Reg]		
	Adjust Main Scan Registration position by 0.1mm each step. <ul style="list-style-type: none"> ▪ Picture moves to right as value increases. ▪ Picture moves to left as value decreases. 		
4-011-001	-	ENG	[-2.5 to 2.5 / 0.0 / 0.1 mm/step]

4012	[Set Scale Mask]		
	Adjusts scanning margins for the leading and trailing edges (sub scan) and right and left edge (main scan). <p> Note</p> <ul style="list-style-type: none"> ▪ Do not adjust unless the customer desires a scanner margin greater than the printer margin. These settings are adjusted to erase shadows caused by the gap between the original and the scale of the scanner unit. 		

4-012-001	Book:Sub LEdge	ENG	[0.0 to 3.0 / 1.0 / 0.1 mm/step]
	Sets mask area to erase scale shadow of sub scan leading edge (left side or original table) when scanning with book scanner.		
4-012-002	Book:Sub TEdge	ENG	[0.0 to 3.0 / 0.0 / 0.1 mm/step]
	Sets mask area to erase scale shadow of sub scan trailing edge (right side or original table) when scanning with book scanner.		
4-012-003	Book:Main:LEdge	ENG	[0.0 to 3.0 / 1.0 / 0.1 mm/step]
	Sets mask area to erase scale shadow of main scan leading edge (rear side or original table) when scanning with book scanner.		
4-012-004	Book:Main:TEdge	ENG	[0.0 to 3.0 / 0.0 / 0.1 mm/step]
	Sets mask area to erase scale shadow of main scan trailing edge (front side or original table) when scanning with book scanner.		
4-012-005	ADF: Leading Edge	*ENG	[0.0 to 3.0 / 0.0 / 0.1 mm/step]
	Sets mask area to erase scale shadow of sub scan leading edge when scanning with ADF.		
4-012-007	ADF: Right	*ENG	[0.0 to 3.0 / 0.0 / 0.1 mm/step]
	Sets mask area to erase scale shadow of main scan leading edge when scanning with ADF.		
4-012-008	ADF: Left	*ENG	[0.0 to 3.0 / 0.0 / 0.1 mm/step]
	Sets mask area to erase scale shadow of main scan trailing edge when scanning with ADF.		

4020	[Dust Check]		
4-020-001	Dust Detect:On/Off	ENG	[0 or 1 / 0 / 1/step] 0: OFF, 1: ON
	Sets DF Dust Detection ON/OFF.		
4-020-002	Dust Detect:Lvl	ENG	[0 to 8 / 4 / 1/step] 0: lowest detection level 8: highest detection level
	Sets DF Dust Detect Level. It is easier to detect as the value increases.		
4020	[Dust Check Lvl]		
4-020-003	Dust Reject:Lvl	ENG	[0 to 4 / 0 / 1/step]
	Sets ON/OFF and switches level of Vertical stripes correction. 0=OFF, sets level to 1 from 4. The correction for the vertical stripes is stronger as value increases.		
4020	[DF Dust Check]		
4-020-011	Dust Detect Level:Rear	ENG	[0 or 1 / 0 / 1/step] 0: OFF, 1: ON
	Sets ON/OFF DF: Rear (2nd side) dust detection setting.		
4-020-012	Correction Level:Rear	ENG	[0 to 8 / 4 / 1/step] 0:Lowest level 8:Highest level
	Sets DF: Rear (2nd side) dust detection level. As the value enlarges, it is easier to detect.		

4201	[LoCPP edge level:K]		
4-201-005	600dpi 1bit edge1	*ENG	[0 to 15 / 11 / 1/step]
	Sets the parameters for the upper threshold of the small edge.		
4-201-006	600dpi 1bit edge23	*ENG	[0 to 15 / 11 / 1/step]
	Sets the parameters for the upper threshold of the large edge.		

4201	[LoCPP edge off/on:K]		
Off/on for Smaller/larger edge: 1200dpi 1bit			
4-201-011	1200dpi 1bit edge12	*ENG	[0 or 1 / 1 / 1/step] 0: Off, 1: On
	ON/OFF for smaller edge: 1200dpi 1bit Select ON/OFF for low CPP edge correction with 1200dpi 1bit.		
4-201-012	1200dpi 1bit edge345	*ENG	[0 or 1 / 1 / 1/step] 0: Off, 1: On
	ON/OFF for larger edge: 1200dpi 1bit Select ON/OFF for low CPP edge correction with 1200dpi 1bit.		

4301	[Operation Check APS Sensor]		
4-301-001	Operation Check APS Sensor	ENG	[0 to 255 / 0 / 1/step] 0: Not detected 1: Detected
	SP for testing APS Sensor function.		

4303	[Min Size for APS]		
4-303-001	-	*ENG	[0 or 1 / 0 / 1/step] 0 : No Original 1: A5-Lengthwise
	Sets display when non-standard (small size) size original is detected. Note <ul style="list-style-type: none"> ▪ Sets display when non-standard (small size) size original is detected. ▪ When "2:EU" is selected at SP5-131-001 and "3:8K 16K" is selected at SP4-305-001, "1" of SP4-303-001 will be "1:16K Vertical". 		

4305	[8K/16K Detection]		
4-305-001	-	*ENG	[0 to 3 / 0 / 1/step] 0: Normal Detect 1: LT-LEF LT-SEF 2: LT-LEF A4-SEF 3: 8K 16K
	Sets assign of decision size when original size is detected. If this setting is set to "0: Normal Detection", the machine determines the paper size according to the region of use when detecting A4/LT size paper, regardless of whether the paper is loaded in portrait or landscape orientation. Note <ul style="list-style-type: none"> ▪ When "0: JA" or "1: NA" is set at SP5-131-001, "3: 8K 16K series" can not be selected with SP4-305-001. 		

4308	[Scan Size Detection]		
4-308-001	Detection ON/OFF	*ENG	[0 to 2 / 1 / 1/step] 0: OFF 1: ON 2: APS
	Switch Original size detection ON/OFF. 0: Not detect original size 1: Detect original size by the CCD unit 2: APS is used for detecting original size.		

4309	[Scan Size Detect:Setting]		
4-309-001	Original Density Thresh	*ENG	[0 to 255 / 12 / 1digit/step]
	Sets the scanned image density threshold for the scan size detection. <ul style="list-style-type: none"> ▪ Increasing value: Detects originals with higher brightness. (Detection error for the non originals decreases, but detection error for the darker original increases.) ▪ Decreasing value: Detects originals with lower brightness. (Detection error for the darker originals decreases, but detection error for the non originals increases.) 		
4-309-002	Detection Time	*ENG	[20 to 100 / 60 / 20 msecstep]
	Sets the time to end detection after ADF/Platen cover closing. <ul style="list-style-type: none"> ▪ Increasing value: Detects originals with longer time. ▪ Decreasing value: Detects originals with shorter time. 		
4-309-003	Lamp ON:Delay Time	*ENG	[40 to 200 / 40 / 10 msec/step]
	Sets the time to start LED lamp on after ADF/Platen cover closing. <ul style="list-style-type: none"> ▪ Increasing value: LED lamp lights later. ▪ Decreasing value: LED lamp lights earlier. 		
4-309-004	LED PWM Duty	*ENG	[0 to 100 / 45 / 1/step]
	Adjusts lamp light timing for scan size detection. <ul style="list-style-type: none"> ▪ Increasing value: Increases the light quantity. ▪ Decreasing value: Decreases the light quantity. 		

4310	[Scan Size Detect Value]		
	Checks the density of scanning data for the scan size detection. The machine detects the original if the value in this SP is greater than that specified in SP4-309-00x.		
4-310-001	S1:R	ENG	[0 to 255 / 0 / 1digit/step]
	Displays the Red density of the image (Rear side) previously scanned using original size detection. S1: Original width is within 182 mm to 210 mm.		
4-310-002	S1:G	ENG	[0 to 255 / 0 / 1digit/step]
	Displays the Green density of the image (Rear side) previously scanned using original size detection. S1: Original width is within 182 mm to 210 mm.		
4-310-003	S1:B	ENG	[0 to 255 / 0 / 1digit/step]
	Displays the Blue density of the image (Rear side) previously scanned using original size detection. S1: Original width is within 182 mm to 210 mm.		
4-310-004	S2:R	ENG	[0 to 255 / 0 / 1digit/step]
	Displays the Red density of the image (Center) previously scanned using original size detection. S2: Original width is within 215.9 mm to 254mm.		
4-310-005	S2:G	ENG	[0 to 255 / 0 / 1digit/step]
	Displays the Green density of the image (Center) previously scanned using original size detection. S2: Original width is within 215.9 mm to 254mm.		
4-310-006	S2:B	ENG	[0 to 255 / 0 / 1digit/step]
	Displays the Blue density of the image (Center) previously scanned using original size detection. S2: Original width is within 215.9 mm to 254mm.		

4-310-007	S3:R	ENG	[0 to 255 / 0 / 1digit/step]
	Displays the Red density of the image (Front side) previously scanned using original size detection. S3: Original width is within 257 mm to 279.4 mm.		
4-310-008	S3:G	ENG	[0 to 255 / 0 / 1digit/step]
	Displays the Green density of the image (Front side) previously scanned using original size detection. S3: Original width is within 257 mm to 279.4 mm.		
4-310-009	S3:B	ENG	[0 to 255 / 0 / 1digit/step]
	Displays the Blue density of the image (Front side) previously scanned using original size detection. S3: Original width is within 257 mm to 279.4 mm.		

4350	[Intermittent Shading : BW]		
4-350-001	Switch On/Off	ENG	[0 or 1 / 1 / 1/step] 0: Every time shading 1: Interval shading
	Switches On/OFF for Intermittent Shading when scanning in BW mode (Simplex/Duplex).		

4351	[Intermittent Shading : FC]		
4-351-001	Switch On/Off	ENG	[0 or 1 / 1 / 1/step] 0: Every time shading 1: Interval shading
	Selects shading operation for color scanning.		

4400	[Org Edge Mask]		
	Compared with SP4-012 (Set Scale Mask), which is used to adjust the scanning margin regardless of the original paper size, this SP can be used to adjust the scanning margin according to the original paper size. (This SP can be used to adjust the trim margin from the original paper edge.)		
4-400-001	Book:Sub:LEdge(Left)	ENG	[0.0 to 3.0 / 0.0 / 0.1 mm/step]
	Sets mask area to erase original shadow of sub scan leading edge (left side or original table) when scanning with book scanner.		
4-400-002	Book:Sub:TEdge(Right)	ENG	[0.0 to 3.0 / 0.0 / 0.1 mm/step]
	Sets mask area to erase original shadow of sub scan trailing edge (right side or original table) when scanning with book scanner.		
4-400-003	Book:Main:LEdge(Rear)	ENG	[0.0 to 3.0 / 0.0 / 0.1 mm/step]
	Sets mask area to erase original shadow of main scan leading edge (rear side or original table) when scanning with book scanner.		
4-400-004	Book:Main:Tedge(Front)	ENG	[0.0 to 3.0 / 0.0 / 0.1 mm/step]
	Sets mask area to erase original shadow of main scan trailing edge (front side or original table) when scanning with book scanner.		

4400	[Scanner Erase Margin]		
4-400-005	ADF:Sub:LEdge(Left)	*ENG	[0.0 to 3.0 / 0.0 / 0.1 mm/step]
	Sets mask area to erase original shadow of sub scan leading edge when scanning with ADF.		
4-400-007	ADF:Main:LEdge(Rear)	*ENG	[0.0 to 3.0 / 0.0 / 0.1 mm/step]
	Sets mask area to erase original shadow of main scan leading edge when scanning with ADF.		
4-400-008	ADF:Main:TEdge(Front)	*ENG	[0.0 to 3.0 / 0.0 / 0.1 mm/step]
	Sets mask area to erase original shadow of main scan trailing edge when scanning with ADF.		

4417	[IPU Test Pattern]		
4-417-001	Test Pattern	ENG	[0 to 8 / 0 / 1/step] 0: Scanned image 1: Gradation main A 2: Patch 16C 3: Grid pattern A 4: Slant grid pattern B 5: Argyle P:C 6: Argyle P:D 7: Scanned+Argyle P:D 8: Scanned+ArgyleP:D
	Selects test pattern packaged with IPU ASIC. Pattern is for design purpose, content of pattern will be omit,		

4429	[Select Copy Data Security]		
4-429-001	Copying	*ENG	[0 to 3 / 3 / 1/step]
	Switches unjust copy output pattern density for copy. As the value enlarges, gets deeper.		
4-429-002	Scanning	*ENG	[0 to 3 / 3 / 1/step]
	Switches unjust copy output pattern density for scan. As the value enlarges, gets deeper.		
4-429-003	Fax Operation	*ENG	[0 to 3 / 3 / 1/step]
	Switches unjust copy output pattern density for fax. As the value enlarges, gets deeper.		

4600	[SBU Version Display] DFU		
	For design use. Do not change.		
4-600-001	SBU ID	ENG	[0x00 to 0xFF / 0 / 1/step]
4-600-002	SCAT ID	ENG	[0x00 to 0xFF / 0 / 1/step]

4609	[Gray Balance Set: R]		
4-609-001	Book Scan	*ENG	[-384 to 255 / -100 / 1digit/step]
	Displays/Saves gray balance adjustment value (RED) of scanners face side (Book). Adjusted value by the factory adjustment is saved. <ul style="list-style-type: none"> ▪ Value increase: Increases red. ▪ Value decrease: Increases red. 		
4-609-002	DF Scan	*ENG	[-384 to 255 / -100 / 1digit/step]
	Displays/Saves gray balance adjustment value (RED) of scanners face side (ADF). Adjusted value by the factory adjustment is saved. <ul style="list-style-type: none"> ▪ Value increase: Increases red. ▪ Value decrease: Increases red. <p>Note</p> <ul style="list-style-type: none"> ▪ Gray balance adjustment value of DF scan can be corrected with SP4-688-001/002: DF density adjust. (These SPs can adjust the density difference correction between Book scanning and DF face side scanning.) 		

4610	[Gray Balance Set: G]		
4-610-001	Book Scan	*ENG	[-384 to 255 / -100 / 1digit/step]
	<p>Displays/Saves gray balance adjustment value (GREEN) of scanners face side (Book).</p> <p>Adjusted value by the factory adjustment is saved.</p> <ul style="list-style-type: none"> ▪ Value increase: Increases green. ▪ Value decrease: Increases green. 		
4-610-002	DF Scan	*ENG	[-384 to 255 / -100 / 1digit/step]
	<p>Displays/Saves gray balance adjustment value (GREEN) of scanners face side (ADF).</p> <p>Adjusted value by the factory adjustment is saved.</p> <ul style="list-style-type: none"> ▪ Value increase: Increases green. ▪ Value decrease: Increases green. <p>Note</p> <ul style="list-style-type: none"> ▪ Gray balance adjustment value of DF scan can be corrected with SP4-688-001/002: DF density adjust. (These SPs can adjust the density difference correction between Book scanning and DF face side scanning.) 		

4611	[Gray Balance Set: B]		
4-611-001	Book Scan	*ENG	[-384 to 255 / -100 / 1digit/step]
	<p>Displays/Saves gray balance adjustment value (BLUE) of scanners face side (Book).</p> <p>Adjusted value by the factory adjustment is saved.</p> <ul style="list-style-type: none"> ▪ Value increase: Increases blue. ▪ Value decrease: Increases blue. 		
4-611-002	DF Scan	*ENG	[-384 to 255 / -100 / 1digit/step]
	<p>Displays/Saves gray balance adjustment value (BLUE) of scanners face side (ADF).</p> <p>Adjusted value by the factory adjustment is saved.</p> <ul style="list-style-type: none"> ▪ Value increase: Increases blue. ▪ Value decrease: Increases blue. <p>Note</p> <ul style="list-style-type: none"> ▪ Gray balance adjustment value of DF scan can be corrected with SP4-688-001/002: DF density adjust. (These SPs can adjust the density difference correction between Book scanning and DF face side scanning.) 		

4635	[SSCG Correction Set]		
	Mode Selection	*ENG	<p>[0 to 3 / 1 / 1/step]</p> <p>0: Do not noise correct SSCG.</p> <p>1: Only adjust analog (initial value)</p> <p>2: Only adjust digital</p> <p>3: Adjust both analog/digital</p>
4-635-001	<p>Selects SSCG noise correction mode.</p> <p>Use one of these modes as a temporal correspondence when SSCG does not work correctly due to an unexpected malfunction.</p> <p>Temporarily changing settings may improve slant stripes, horizontal stripes caused by scanner when SSCG correction does not work correctly.</p> <p> Note</p> <ul style="list-style-type: none"> ▪ SSCG correction is a control technology to correct the image quality deterioration as a side effect of SSCG (Safety Standard Control Technology) to reduce electromagnetic radiation noise. 		

4646	[Scan Adjust Error]		
	Displays error value of scanning adjustment.		
4-646-001	White level	*ENG	[0 to 65535 / 0 / 1/step]
	<p>Shows cause of error when an error occurs during the white level adjustment when scanner turns on. When an error, SC142-00 (F side/white level adjustment error) will be given.</p> <p>Bit15:Unused, Bit14: Unused</p> <p>Bit13:White level abnormal (F side/RED/EVEN pixel)</p> <p>Bit12: White level abnormal (F side /RED/ODD pixel)</p> <p>Bit11: White level abnormal (F side /GREEN/EVEN pixel)</p> <p>Bit10: White level abnormal (F side /GREEN/ODD pixel)</p> <p>Bit9: White level abnormal (F side /BLUE/EVEN pixel)</p> <p>Bit8:White level abnormal (F side /BLUE/ODD pixel)</p> <p>Bit7: Unused, Bit6: Unused</p> <p>Bit5:gain abnormal (F side /RED/EVEN pixel)</p> <p>Bit4: gain abnormal (F side /RED/ODD pixel)</p> <p>Bit3: gain abnormal (F side /GREEN/EVEN pixel)</p> <p>Bit2: gain abnormal (F side /GREEN/ODD pixel)</p> <p>Bit1: gain abnormal (F side /BLUE/EVEN pixel)</p> <p>Bit0: gain abnormal (F side /BLUE/ODD pixel)</p> <p>[format] binary</p> <p>Scan adjust error (F side/White level) flag= (b15,b14,b13,b12,b11,b10,b9,b8,b7,b6,b5,b4,b3,b2,b1,b0)</p>		

<p>4-646-002</p>	<p>Black level</p>	<p>*ENG</p>	<p>[0 to 65535 / 0 / 1/step]</p>
<p>Shows cause of error when an error occurs With the Black level check when scanner turns on. When an error, SC141-00 (F side/Black level adjustment error) will be given. Bit7: Unused, Bit6: Unused Bit5: Black level abnormal (F side/RED/EVEN Pixel) Bit4: Black level abnormal (F side /RED/ODD Pixel) Bit3: Black level abnormal (F side /GREEN/EVEN Pixel) Bit2: Black level abnormal (F side /GREEN/ODD Pixel) Bit1: Black level abnormal (F side /BLUE/EVEN Pixel) Bit0: Black level abnormal (F side /BLUE/ODD Pixel) [format] binary Scan adjust error (F side/Black level) flag=(b7,b6,b5,b4,b3,b2,b1,b0)</p>			
<p>4-646-003</p>	<p>SSCG Correction</p>	<p>*ENG</p>	<p>[0 to 65535 / 0 / 1/step]</p>
<p>Shows cause of error when an error occurs With the SSCG Noise correction when scanner turns on. When an error, Correction turns off. Bit7: Unused, Bit6: Unused Bit5: SSCG correction error (Fside/RED/EVEN Pixel) Bit4: SSCG correction error (Fside/RED/ODD Pixel) Bit3: SSCG correction error (Fside/GREEN/EVEN Pixel) Bit2: SSCG correction error (Fside/GREEN/ODD Pixel) Bit1: SSCG correction error (Fside/BLUE/EVEN Pixel) Bit0: SSCG correction error (Fside/BLUE/ODD Pixel) [format] binary Scan adjust error (F side/SSCG correction) flag= (b7,b6,b5,b4,b3,b2,b1,b0)</p>			

4647	[Scanner Hard Error]		
	Displays result of SBU connection check.		
4-647-001	Power-ON	ENG	[0 to 65535 / 0 / 1/step]
	<p>Shows cause of error when an error occurs with the SBU connection detect when Scanner turns on. When an error, SC144-00 (SBU Communication error) will be given.</p> <p>Bit15: Unused Bit14:SBU hardware error (Power ON/un-reset error) Bit13:SBU hardware error (Serial communication error: F side) Bit12:SBU hardware error (Reset error: F side) Bit11: Unused, Bit10: Unused Bit9:SBU hardware error (Version error) Bit8: Unused, Bit7: Unused, Bit6: Unused Bit5:SBU hardware error (Serial communication error: L side) Bit4:SBU hardware error (Reset error:Lside) Bit3: Unused, Bit2: Unused, Bit1: Unused</p> <p>[format] binary Scan adjust error (SSCG correction) flag= (b15,b14,b13,b12,b11,b10,b9,b8,b7,b6,b5,b4,b3,b2,b1,b0)</p>		

4688	[DF Density Adjustment]		
4-688-001	ARDF	*ENG	[80 to 120 / 102 / 1 %/step]
	<p>For the ARDF only. Adjusts density difference between Book and ADF.</p> <ul style="list-style-type: none"> ▪ Value increase: ADF density deeper. ▪ Value decrease: ADF density thinner. 		
4688	[Scan Image Density Adjustment]		
4-688-002	1-pass DF	*ENG	[80 to 120 / 103 / 1 %/step]
	For the SPDF only. Adjusts density difference between Book and ADF.		

4699	[SBU Test Pattern Change] DFU		
4-699-001	-	ENG	[0 to 255 / 0 / 1/step]

4700	[CIS ID Display]		
4-700-001	-	ENG	[0x00 to 0xFF / 0 / 1/step]
	When CIS's ID is not normal, an error flag is set to SP4-747-001 and the machine issues SC185-00.		

4745	[CIS Image Level Error Flag] DFU		
	For design use. Do not change.		
4-745-001	-	ENG	[0 to 65535 / 0 / 1/step]

4746	[CIS GB Adj Error Flag] DFU		
	For design use. Do not change.		
4-746-001	CIS GB Adj Error Flag	ENG	[0 to 7 / 0 / 1/step]

4747	[CIS Hard Error Flag] DFU		
	For design use. Do not change.		
4-747-001	CIS Hard Error Flag	ENG	[0 to 7 / 0 / 1/step]

4797	[Rear Side: Digital AE]		
4-797-002	Background Erase Level	*ENG	[512 to 1535 / 932 / 1/step]
	Sets background level to decide output value for background erase when scanning the rear side (2nd side) of an original in DF scanning mode. When scanning a darker original in DF scanning mode, the background of the original may appear on the copy. In such a case, increase this value to make the background disappear.		

4798	[CIS LED Duty] DFU		
	For design use. Do not change.		
4-798-001	CIS LED Duty	*ENG	[0 to 65535 / 0 / 1/step]

4799	[CIS TEST Pattern] DFU		
	For design use. Do not change.		
4-799-001	Select	ENG	[0 to 5 / 0 / 1/step] 0: Normal Scan 1: Fix Value Output 2: EO Fix Value Output 3: Main Scan Gradation 4: Sub Scan Gradation 5: Grid Pattern
4-799-002	Even Output Level Setting	ENG	[0 to 4095 / 0 / 1digit/step]
4-799-003	Odd Output Level Setting	ENG	[0 to 4095 / 0 / 1digit/step]

4860	[Scan Size Detect:Setting]		
4-860-001	Shading Data	*ENG	[512 to 1023 / 800 / 1digit/step]
	Displays shading date for original size detection with CCD at the first scanning after main power switch "on". Every scan job renews the value of shading data.		

4903	[Filter Setting]		
4-903-001	Ind Dot Erase: Text	*ENG	[0 to 7 / 0 / 1/step]
	Sets the threshold value for independent dot erase using Copier "Text" mode. <ul style="list-style-type: none"> ▪ The "0" setting disables independent dot erase. ▪ A higher setting detects more spurious dots for erasing. However, this could cause dots to erase in images that contain areas filled by dithering. 		
4-903-002	Ind Dot Erase: Generation Copy	*ENG	[0 to 7 / 0 / 1/step]
	Sets the threshold value for independent dot erase using Copier "Generation Copy" mode. <ul style="list-style-type: none"> ▪ The "0" setting disables independent dot erase. ▪ A higher setting detects more spurious dots for erasing. However, this could cause dots to erase in images that contain areas filled by dithering. 		

4939	[ACS:Color Range]		
4-939-001	-	*ENG	[-2 to 2 / 0 / 1/step]
	Adjust the tone (color gamut) for determining whether the original is full color or black and white in 5 adjustment levels. (-2 to +2. As the default, it is set to 0.) Adjusting this toward "-" prompts the machine to determine the original more as black and white. Adjusting this toward "+" prompts the machine to determine the original more as full color.		

4994	[Adj Txt/Photo Recog Level]		
4-994-001	High Compression PDF	ENG	[0 to 2 / 1 / 1/step]
	Adjusts the guide for recognizing the text area or image area. 0: Prior to text recognition , 1: Basic, 2: Prior to image recognition		

4996	[White Paper Detection Level]		
4-996-001	-	ENG	[0 to 6 / 3 / 1/step]
	<p>Selects the threshold level of the original background density. Increasing this threshold level machine easily judge that an original is white. For example, increasing this value allows the machine to determine the colored background of originals scanned as a white background.</p>		

5.6 SP MODE TABLES - SP5000-1

5.6.1 SP5-XXX (MODE)

5009	[Add Display Language]		
	<p>Adds language available in user choice. (Only the languages registered in the machine)</p> <p>Refer to the displayed language list to set in the way showed below.</p> <p>List Number Assigned Bit Switch</p> <p>No.1 to 8: BIT1 to 8 (SP5009-201)</p> <p>No.9 to 16: BIT1 to 8 (SP5009-202)</p> <p>No.17 to 24: BIT1 to 8 (SP5009-203)</p> <p>No.25 to 32: BIT1 to 8 (SP5009-204)</p> <p>Example: To add American (No.3 in the list) or Czech (No.15)</p> <p>Turn Bit 3 of "SP5009-201" 0 to 1 for American.</p> <p>Turn Bit 7 of "SP5009-202" 0 to 1 for Czech.</p> <p>After setting, turn the main power switch off and on to make the setting valid.</p>		
	5-009-201	1-8	*CTL [1 to 255 / 0 / 1/step]
	5-009-202	9-16	*CTL [1 to 255 / 0 / 1/step]
	5-009-203	17-24	*CTL [1 to 255 / 0 / 1/step]
5-009-204	25-32	*CTL [1 to 255 / 0 / 1/step]	

5024	[mm/inch Display Selection]		
	Display units (mm or inch) for custom paper sizes.		
5-024-001	0:mm 1:inch	*CTL	[0 or 1 / 1 (USA), 0 (Europe/Asia) / 1/step] 0: mm 1: inch

5045	[Accounting counter]		
	Selects the counting method.  Note <ul style="list-style-type: none"> ▪ Do not change the counter method except contract reason. 		
5-045-001	Counter Method	*CTL	[0 or 1 / 0 / step] 0: 1 count 1: 2 counts

5047	[Paper Display]		
	Turns on or off the printed paper display on the LCD.		
5-047-001	Backing Paper	*CTL	[0 or 1 / 0 / 1/step] 0: OFF 1: ON

5055	[Display IP Address]		
	Display or does not display the IP address on the operation panel.		
5-055-001	-	*CTL	[0 or 1 / 0 / 1/step] 0: OFF 1: ON

5061	[Toner Remaining Icon Display Change]		
	Display or does not display the remaining toner display icon on the LCD.		
5-061-001	-	*CTL	[0 or 1 / 0 / 1/step] 0: No display 1: Display

5062	[Parts Replacement Alert Display]		
	Display or does not display the PM part yield on the LCD.		
5-062-002	#PCU	*CTL	[0 or 1 / 0 / 1/step] 0: No display 1: Display
5-062-009	Cleaning Blade	*CTL	[0 or 1 / 0 / 1/step] 0: No display 1: Display
5-062-018	Charge Roller	*CTL	[0 or 1 / 0 / 1/step] 0: No display 1: Display
5-062-019	Cleaner: Charge Roller	*CTL	[0 or 1 / 0 / 1/step] 0: No display 1: Display
5-062-021	OPC	*CTL	[0 or 1 / 0 / 1/step] 0: No display 1: Display
5-062-022	Stripper	*CTL	[0 or 1 / 0 / 1/step] 0: No display 1: Display
5-062-023	#Dev Unit	*CTL	[0 or 1 / 0 / 1/step] 0: No display 1: Display
5-062-024	Developer	*CTL	[0 or 1 / 0 / 1/step] 0: No display 1: Display
5-062-025	Development Filter	*CTL	[0 or 1 / 0 / 1/step] 0: No display 1: Display
5-062-028	Bearing: Development Screw	*CTL	[0 or 1 / 0 / 1/step] 0: No display 1: Display

5-062-108	Paper Transfer Roller Unit	*CTL	[0 or 1 / 0 / 1/step] 0: No display 1: Display
5-062-115	Fusing Unit	*CTL	[0 or 1 / 0 / 1/step] 0: No display 1: Display
5-062-116	Fusing Belt	*CTL	[0 or 1 / 0 / 1/step] 0: No display 1: Display
5-062-118	Pressure Roller	*CTL	[0 or 1 / 0 / 1/step] 0: No display 1: Display
5-062-119	Bearing: Pressure Roller	*CTL	[0 or 1 / 0 / 1/step] 0: No display 1: Display
5-062-206	ADF Pick-up Roller	*CTL	[0 or 1 / 0 / 1/step] 0: No display 1: Display
5-062-207	ADF Paper Supply Belt	*CTL	[0 or 1 / 0 / 1/step] 0: No display 1: Display
5-062-208	ADF Reverse Roller	*CTL	[0 or 1 / 0 / 1/step] 0: No display 1: Display

5066	[PM Parts Display]		
	Display or does not display the "PM parts" button on the LCD.		
5-066-001	-	*CTL	[0 or 1 / 0 / 1/step] 0: No display 1: Display

5067	[Part Replacement Operation Type]		
	Selects the service maintenance or user maintenance for each PM parts. If the user service is selected, PM alert is displayed on the LCD		
5-067-002	#PCU	*CTL	[0 or 1 / 0 / 1/step] 0: Service 1: User
5-067-009	Cleaning Blade	*CTL	[0 or 1 / 0 / 1/step] 0: Service 1: User
5-067-018	Charge Roller	*CTL	[0 or 1 / 0 / 1/step] 0: Service 1: User
5-067-019	Cleaner: Charge Roller	*CTL	[0 or 1 / 0 / 1/step] 0: Service 1: User
5-067-021	OPC	*CTL	[0 or 1 / 0 / 1/step] 0: Service 1: User
5-067-022	Stripper	*CTL	[0 or 1 / 0 / 1/step] 0: Service 1: User
5-067-023	#Dev Unit	*CTL	[0 or 1 / 0 / 1/step] 0: Service 1: User
5-067-024	Developer	*CTL	[0 or 1 / 0 / 1/step] 0: Service 1: User

5-067-025	Development Filter	*CTL	[0 or 1 / 0 / 1/step] 0: Service 1: User
5-067-028	Bearing: Development Screw	*CTL	[0 or 1 / 0 / 1/step] 0: Service 1: User
5-067-108	Paper Transfer Roller Unit	*CTL	[0 or 1 / 0 / 1/step] 0: Service 1: User
5-067-115	Fusing Unit	*CTL	[0 or 1 / 0 / 1/step] 0: Service 1: User
5-067-116	Fusing Belt	*CTL	[0 or 1 / 0 / 1/step] 0: Service 1: User
5-067-118	Pressure Roller	*CTL	[0 or 1 / 0 / 1/step] 0: Service 1: User
5-067-119	Bearing: Pressure Roller	*CTL	[0 or 1 / 0 / 1/step] 0: Service 1: User
5-067-206	ADF Pick-up Roller	*CTL	[0 or 1 / 0 / 1/step] 0: Service 1: User
5-067-207	ADF Paper Supply Belt	*CTL	[0 or 1 / 0 / 1/step] 0: Service 1: User
5-067-208	ADF Reverse Roller	*CTL	[0 or 1 / 0 / 1/step] 0: Service 1: User

5071	[Set Bypass Paper Size Display]		
	Turn on or off the paper size confirmation pop-up on the LED. This pop-up prevents mismatching between a paper size selected by the operation panel and an actual paper size on the by-pass tray.		
5-071-001	-	CTL	[0 or 1 / 0 / 1/step] 0: Off 1: On

5074	[Home Key Customization]		
	Sets applications that appear on the operation panel when “home key” is pressed.		
5-074-002	Login Setting	*CTL	[0 to 0xFF / 00000000 / 1/step] Bit0: Sets login operation mode for panel display. 0: Displayed 1: Not display Bit1 to bit7: Not used
5-074-050	Show Home Edit Menu	CTL	[0 to 2 / 0 / 1/step] 0: Auto 1: Displayed 2: Not displayed
5-074-091	Function Setting	*CTL	[0 to 2 / 0 / 1/step] 0: Function disable 1: SDK application 2: Browser application
5-074-092	Product ID	*CTL	[0 to 0xFFFF FFFF / 0 / 1/step] Sets the application product ID.
5-074-093	Application Screen ID	*CTL	[0 to 255 / 0 / 1/step] Sets the display category of the extended application.

5081	[ServiceSP Entry Code Setting] DFU		
	-		
5-081-001	ServiceSP Entry Code Setting	*CTL	-

5083	[LED Light Switch Setting]		
	Turns LED lighting ON and OFF at Toner Near End or Waste Toner Near End.		
5-083-001	Toner Near End	*CTL	[0 or 1 / 0 / 1/step] 0: OFF 1: ON
5-083-002	Waste Toner Near End	*CTL	[0 or 1 / 0 / 1/step] 0: OFF 1: ON

5101	[Timer Set]		
	Enables or disables the low power mode.		
5-101-104	Low Power Set	*CTL	[0 or 1 / 0 / 1/step] 0: Disable 1: Enable

5113	[Optional Counter Type]		
	Sets the counter device number for the optional unit or external unit.		
5-113-001	Default Optional Counter Type	*CTL	<p>[0 to 12 / 0 / 1/step]</p> <p>0: None, 1: Key Card(RK3,4) 2: Key Card(down), 3: PrepaidCard 4: Coin Rack 5: MFKeyCard 11: Exp.KeyCard(Add) 12: Exp.KeyCard(Deduct)</p> <p>This program specifies the counter type.</p>
5-113-002	External Optional Counter Type	*CTL	<p>[0 to 3 / 0 / 1/step]</p> <p>0: None 1: Expansion Device 1 1: Expansion Device 2 1: Expansion Device 3</p> <p>This program specifies the external counter type.</p>

5114	[Optional Counter I/F]		
	Sets this SP for connecting to an optional counter which uses MF key card I/F.		
5-114-001	MF Key Card Extension	*CTL	<p>[0 or 1 / 0 / 1/step]</p> <p>0: Not installed 1: Installed (scanning accounting)</p>

5118	[Disable Copying]		
	This program disables copying.		
5-118-001	-	*CTL	[0 or 1 / 0 / 1/step] 0: Not disabled 1: Disabled

5120	[Mode Clear Opt. Counter Removal]		
	This program updates the information on the optional counter. When you install or remove an optional counter, check the settings.		
5-120-001	-	*CTL	[0 to 2 / 0 / 1/step] 0: Yes (removed) 1: Standby (installed but not used) 2: No (not removed)

5121	[Counter Up Timing]		
	This program specifies when the counter goes up. The settings refer to "paper feed" and "paper exit" respectively.		
5-121-001	0:Feed 1:Exit	*CTL	[0 or 1 / 0 / 1/step] 0: Feed 1: Exit

5126	[Set F-size Document]		
	Selects the paper size for the F-size original.		
5-126-001	-	ENG	[0 to 2 / 0 / 1/step] 0: 8 1/2 x 13 1: 8 1/4 x 13 2: 8 x 13

5127	[APS OFF Mode]		
	This program disables the APS.		
5-127-001	-	*CTL	[0 or 1 / 0 / 1/step] 0: Not disabled 1: Disabled

5131	[Paper Size Type Selection]		
	The region setting of SP5-181-xxx (Size Adjust) is all specified by using this SP.		
5-131-001	-	*ENG	[0 to 2 / @ / 1/step] "@ " depends on the destination area. 0: JP (Japan) 1: NA 2: EU

5150	[Bypass Length Setting]		
	Normally the paper length for sub scanning paper from the by-pass tray is limited to 600 mm, but this can be extended with this SP to 1260 mm. Image quality is not assured for the length over 600mm. When printing/feeding over 600mm length paper, customization request is required for a customized printer driver.		
5-150-001	0: OFF 1: ON	CTL	[0 or 1 / 0 / 1/step] 0: OFF 1: ON

5162	[App. Switch Method]		
	Determines whether the application screen is switched with a hardware switch or software switch.		
5-162-001	-	*CTL	[0 or 1 / 0 / 1/step] 0: Soft Key Set 1: Hard Key Set

5167	[Fax Printing Mode at Optional Counter Off]		
	Enables or disables the automatic print out without an accounting device. This SP is used when the receiving fax is accounted by an external accounting device.		
5-167-001	-	*CTL	[0 or 1 / 0 / 1/step] 0: Automatic printing 1: No automatic printing

5169	[CE Login]		
	Continues login status by service after SP mode end.		
5-169-001	CE Login	*CTL	[0 or 1 / 0 / 1/step] 0: Disabled 1: Enabled

5181	[Size Adjust]		
5-181-001	TRAY 1: 1	*ENG	[0 to 1 / 1 (NA), 0 (EU, AA, CHN, TWN, KOR) / 1/step] 0: A4 LEF 1: 8 1/2x11 LEF
	Sets tray 1 detection size (A4 LEF or LT LEF) when "Auto Detect" is selected in the [Tray Paper Settings].		
5-181-002	TRAY 1: 2	*ENG	[0 or 1 / 1 (NA), 0 (EU, AA, CHN, TWN, KOR) / 1/step] 0: A3 1: 11x17
	Sets tray 1 detection size (A3 or DLT) when "Auto Detect" is selected in the [Tray Paper Settings].		

5-181-003	TRAY 1: 3	*ENG	[0 or 1 / 1 (NA), 0 (EU, AA, CHN, TWN, KOR) / 1/step] 0: B4 1: 8 1/2x14 SEF
	Sets tray 1 detection size (B4 or GL SEF) when "Auto Detect" is selected in the [Tray Paper Settings].		
5-181-004	TRAY 1: 4	*ENG	[0 or 1 / 1 (NA), 0 (EU, AA, CHN, TWN, KOR) / 1/step] 0: B5 LEF 1: 7 1/4x10 1/2 LEF
	Sets tray 1 detection size (B5 LEF or Exe LEF) when "Auto Detect" is selected in the [Tray Paper Settings].		
5-181-005	TRAY 2: 1	*ENG	[0 or 1 / 1 (NA), 0 (EU, AA, CHN, TWN, KOR) / 1/step] 0: A4 LEF 1: 8 1/2x11 LEF
	Sets tray 2 detection size (A4 LEF or TL LEF) when "Auto Detect" is selected in the [Tray Paper Settings].		
5-181-006	TRAY 2: 2	*ENG	[0 or 1 / 1 (NA), 0 (EU, AA, CHN, TWN, KOR) / 1/step] 0: A3 1: 11x17
	Sets tray 2 detection size (A3 or DLT) when "Auto Detect" is selected in the [Tray Paper Settings].		
5-181-007	TRAY 2: 3	*ENG	[0 or 1 / 1 (NA), 0 (EU, AA, CHN, TWN, KOR) / 1/step] 0: B4 1: 8 1/2x14 SEF
	Sets tray 2 detection size (B4 or GL SEF) when "Auto Detect" is selected in the [Tray Paper Settings].		

5-181-008	TRAY 2: 4	*ENG	[0 or 1 / 1 (NA), 0 (EU, AA, CHN, TWN, KOR) / 1/step] 0: B5 LEF 1: 7 1/4x10 1/2 LEF
	Sets tray 2 detection size (B5 LEF or Exe LEF) when "Auto Detect" is selected in the [Tray Paper Settings].		
5-181-009	TRAY 3/T-LCT: 1	*ENG	[0 or 1 / 1 (NA), 0 (EU, AA, CHN, TWN, KOR) / 1/step] 0: A4 LEF 1: LT LEF
	Sets tray 3 (LCT) detection size (A4 LEF or LT LEF) when "Auto Detect" is selected in the [Tray Paper Settings].		
5-181-010	TRAY 3: 2	*ENG	[0 or 1 / 1 (NA), 0 (EU, AA, CHN, TWN, KOR) / 1/step] 0: A3 1: DLT
	Sets tray 3 detection size (A3 or DLT) when "Auto Detect" is selected in the [Tray Paper Settings].		
5-181-011	TRAY 3: 3	*ENG	[0 or 1 / 1 (NA), 0 (EU, AA, CHN, TWN, KOR) / 1/step] 0: B4 1: LG
	Sets tray 3 detection size (B4 or LG) when "Auto Detect" is selected in the [Tray Paper Settings].		
5-181-012	TRAY 3: 4	*ENG	[0 or 1 / 1 (NA), 0 (EU, AA, CHN, TWN, KOR) / 1/step] 0: B5 LEF 1: Exe LEF
	Sets tray 3 detection size (B5 LEF or Exe LEF) when "Auto Detect" is selected in the [Tray Paper Settings].		

5-181-013	TRAY 3: 5	*ENG	[0 or 1 / 1 (NA), 0 (EU, AA, CHN, TWN, KOR) / 1/step] 0: 12.6x17.7 1: 12x18
	Sets tray 3 detection size (12.6x17.7 or 12x18) when "Auto Detect" is selected in the [Tray Paper Settings].		
5-181-014	TRAY 4: 1	*ENG	[0 or 1 / 1 (NA), 0 (EU, AA, CHN, TWN, KOR) / 1/step] 0: A4 LEF 1: LT LEF
	Sets tray 4 detection size (A4 LEF or LT LEF) when "Auto Detect" is selected in the [Tray Paper Settings].		
5-181-015	TRAY 4: 2	*ENG	[0 or 1 / 1 (NA), 0 (EU, AA, CHN, TWN, KOR) / 1/step] 0: A3 1: DLT
	Sets tray 4 detection size (A3 or DLT) when "Auto Detect" is selected in the [Tray Paper Settings].		
5-181-016	TRAY 4: 3	*ENG	[0 or 1 / 1 (NA), 0 (EU, AA, CHN, TWN, KOR) / 1/step] 0: B4 1: LG
	Sets tray 4 detection size (B4 or LG) when "Auto Detect" is selected in the [Tray Paper Settings].		
5-181-017	TRAY 4: 4	*ENG	[0 to 1 / 1 (NA), 0 (EU, AA, CHN, TWN, KOR) / 1/step] 0: B5 LEF 1: Exe LEF
	Sets tray 4 detection size (B5 LEF or Exe LEF) when "Auto Detect" is selected in the [Tray Paper Settings].		

5-181-018	TRAY 4: 5	*ENG	[0 to 1 / 1 (NA), 0 (EU, AA, CHN, TWN, KOR) / 1/step] 0: 12.6x17.7 1: 12x18
	Sets tray 4 detection size (12.6x17.7 or 12x18) when "Auto Detect" is selected in the [Tray Paper Settings].		
5-181-019	TRAY 5: 1	*ENG	[0 to 1 / 1 (NA), 0 (EU, AA, CHN, TWN, KOR) / 1/step] 0: A4 LEF 1: LT LEF
	Sets tray 5 detection size (A4 LEF or LT LEF) when "Auto Detect" is selected in the [Tray Paper Settings].		
5-181-020	TRAY 5: 2	*ENG	[0 to 1 / 1 (NA), 0 (EU, AA, CHN, TWN, KOR) / 1/step] 0: A3 1: DLT
	Sets tray 5 detection size (A3 or DLT) when "Auto Detect" is selected in the [Tray Paper Settings].		
5-181-021	TRAY 5: 3	*ENG	[0 to 1 / 1 (NA), 0 (EU, AA, CHN, TWN, KOR) / 1/step] 0: B4 1: LG
	Sets tray 5 detection size (B4 or LG) when "Auto Detect" is selected in the [Tray Paper Settings].		
5-181-022	TRAY 5: 4	*ENG	[0 to 1 / 1 (NA), 0 (EU, AA, CHN, TWN, KOR) / 1/step] 0: B5 LEF 1: Exe LEF
	Sets tray 5 detection size (B5 LEF or Exe LEF) when "Auto Detect" is selected in the [Tray Paper Settings].		

5-181-023	TRAY 5: 5	*ENG	[0 to 1 / 1 (NA), 0 (EU, AA, CHN, TWN, KOR) / 1/step] 0: 12.6X17.7 1: 12X18
	Sets tray 5 detection size (12.6x17.7 or 12x18) when "Auto Detect" is selected in the [Tray Paper Settings].		
5-181-024	LCT	*ENG	[0 to 2 / 1 (NA), 0 (EU, AA, CHN, TWN, KOR) / 1/step] 0: A4 LEF 1: LT LEF 2: B5 LEF
	Sets LCT detection size when "Auto Detect" is selected in the [Tray Paper Settings].		

5186	[RK4]		
	Enables or disables the prevention for RK4 (accounting device) disconnection. If the RK4 is disconnected for 10 seconds when this SP is set to "1 (Enable)", the machine automatically jams a sheet of paper and stops.		
5-186-001	-	*ENG	[0 or 1 / 0 / 1/step]

5188	[Copy Nv Version]		
	Displays the version number of the NVRAM on the controller board.		
5-188-001	-	*CTL	[- / - / -]

5191	[Mode Set]		
	Shifts to the power save mode or not.		
5-191-001	Power Str Set	*CTL	[0 or 1 / 1 / 1/step] 0: OFF 1: ON

5195	[Limitless SW]		
	Selects the paper feed mode. Productivity priority: This changes the feeding tray as soon as the machine detects the priority tray even the paper still remains in the feeding tray. Tray priority: This changes the feeding tray after the paper in the tray where the machine has been feeding paper has been run out of. This SP is activated only when a customer selects the "Auto Paper Select".		
5-195-001	-	*CTL	[0 or 1 / 0 / 1/step] 0: Productivity Precede 1: Use paper up

5199	[Paper Exit After Staple End]		
	Enables or disables the paper feeding out from the finisher without stapling. <ul style="list-style-type: none"> ▪ If this setting is "1: ON", paper is fed out without stapling at the maximum number of the finisher stapling when the machine gets a multiple printing job (over maximum number). ▪ If this setting is "0: OFF", paper is fed out with stapling at the maximum number of the finisher stapling when the machine gets a multiple printing job (over maximum number). 		
5-199-001	0: OFF 1: ON	CTL	[0 or 1 / 0 / 1/step] 0: OFF 1: ON

5212	[Page Numbering]		
	This program adjusts the position of the second side page numbers in the duplex mode with two in one. <ul style="list-style-type: none"> ▪ "- value" moves the page number positions to the right edge or leading edge. ▪ "+ value" moves the page number positions to the left edge or trailing edge. 		

5-212-003	Duplex Printout Right/Left Position	*CTL	[-10 to 10 / 0.00 / 1mm/step] Specifies relative positions between the face page numbering position against the back page numbering position.
5-212-004	Duplex Printout High/Low Position	*CTL	[-10 to 10 / 0.00 / 1mm/step] Specifies relative positions between the face page numbering position against the back page numbering position.

5227	[Page Numbering]		
5-227-201	Allow Page No. Entry	*CTL	[2 to 9 / 9 / 1/step] Specifies input available figure length of "Job serial numbers page print out starts number" that specified by optional text print out.
5-227-202	Zero Surplus Setting	*CTL	[0 or 1 / 0 / 1/step] 0:OFF 1:ON Specifies zero suppression of "Job serial numbers page print out starts number" that specified by optional text print out.

5302	[Set Time]		
	Adjusts the RTC (real time clock) time setting for the local time zone. Examples: For Japan (+9 GMT), enter 540 (9 hours x 60 min.) DOM: +540 (Tokyo) NA: -300 (New York) EU: + 60 (Paris) CHN: +480 (Beijing) TWN: +480 (Taipei) AA: +480 (Hong Kong) KO: +540 (Korea)		
5-302-002	Time Difference	*CTL	[-1440 to 1440 / @ / 1min./step] "@" depends on the destination area." n the duplex mode with two in one

5305	[Auto Off Set]		
	Turns on or off the limitation for the auto power off function.		
5-305-101	Auto Off Limit Set	*CTL	[0 to 1 / 0 / 1/step] 0: Limitation off 1: Limitation on

5307		[Daylight Saving Time]	
5-307-001	Setting	*CTL	<p>[0 to 1 / 1 / 1/step] 0: Disabled 1: Enabled (Default) 1: NA and EUR 0: ASIA and others Enables or disables the summer time mode.</p> <p>Note</p> <ul style="list-style-type: none"> Make sure that both SP5-307-3 and -4 are correctly set. Otherwise, this SP is not activated even if this SP is set to "1".
5-307-003	Rule Set (Start)	*CTL	<p>[0 to 0xffffffff / Default / 1hex/step] (Default) NA: 0x11100200 EUR: 0x10500100 ASIA: 0x03100000 Other: 0x00000000</p>
	<p>Specifies the start setting for the summer time mode. There are 8 digits in this SP. For months 1 to 9, the "0" cannot be input in the first digit, so the eight-digit setting for -2 or -3 becomes a seven-digit setting.</p> <p>1st and 2nd digits: The month. [1 to 12] 3rd digit: The week of the month. [1 to 5] 4th digit: The day of the week. [0 to 6 = Sunday to Saturday] 5th and 6th digits: The hour. [00 to 23] 7th digit: The length of the advanced time. [0 to 9 / 1 hour /step] 8th digit: The length of the advanced time. [0 to 5 / 10 minutes /step]</p> <ul style="list-style-type: none"> The digits are counted from the left. Make sure that SP5-307-1 is set to "1". 		

5-307-004	Rule Set (End)	*CTL	[- / - / -] * See the detail below
	<p>Specifies the end setting for the summer time mode.</p> <p>There are 8 digits in this SP.</p> <p>1st and 2nd digits: The month. [1 to 12]</p> <p>3rd digit: The week of the month. [0 to 5]</p> <p>4th digit: The day of the week. [0 to 7 = Sunday to Saturday]</p> <p>5th and 6th digits: The hour. [00 to 23]</p> <p>The 7th and 8 digits must be set to "00".</p> <ul style="list-style-type: none"> ▪ The digits are counted from the left. ▪ Make sure that SP5-307-1 is set to "1". 		

5401	[Access Control]		
5-401-103	Default Document ACL	*CTL	<p>[0 to 3 / 0 / 1/step]</p> <p>0: Read Only</p> <p>1: Edit</p> <p>2: Edit/Delete</p> <p>3: Full control</p> <p>Whenever a new login user is added to the address book in external certification mode (for Windows, LDAP, RDH), the default document ACL is updated according to this SP setting.</p>
5-401-104	Authentication Time	*CTL	<p>[0 to 255 / 0 / 1sec/step]</p> <p>Specifies the timeout of the authentication.</p>

5-401-162	Extend Certification Detail	*CTL	[0 to 0xFF / 00000000 / 1/step] Selects the log out type for the extend authentication device.
<ul style="list-style-type: none"> ▪ Bit 0: Log-out without an IC card 0: Not allowed (default), 1: Allowed ▪ Bit1: Log out with IC card 0: Not allowed (default), 1: Allowed ▪ Bit2: Return from energy save mode with IC card 0: Not allowed (default), 1: Allowed ▪ Bit3, Bit4: Password manual entry 00: Mode 0 (default), 01: Mode 1 10: Mode 2, 11: Mode 3 ▪ Bit5: PIN entry with alphanumeric character 0: Not allowed (default), 1: Allowed ▪ Bit6: Restrict card scanning 0: Not allowed (default), 1: Allowed ▪ Bit7: Panel lock when log out failed 0: Not allowed (default), 1: Allowed 			
5-401-200	SDK1 UniqueID	*CTL	[0 to 0xFFFFFFFF / 0 / 1/step] "SDK" is the "Software Development Kit". This data can be converted from SAS (VAS) when installed or uninstalled.
5-401-201	SDK1 Certification Method	*CTL	[0 to 0xFF / 0 / 1 /step] "SDK" is the "Software Development Kit". This data can be converted from SAS (VAS) when installed or uninstalled.
5-401-210	SDK2 UniqueID	*CTL	[0 to 0xFFFFFFFF / 0 / 1/step] "SDK" is the "Software Development Kit". This data can be converted from SAS (VAS) when installed or uninstalled.

5-401-211	SDK2 Certification Method	*CTL	[0 to 0xFF / 0 / 1/step] "SDK" is the "Software Development Kit". This data can be converted from SAS (VAS) when installed or uninstalled.
5-401-220	SDK3 UniqueID	*CTL	[0 to 0xFFFFFFFF / 0 / 1/step] "SDK" is the "Software Development Kit". This data can be converted from SAS (VAS) when installed or uninstalled.
5-401-221	SDK3 Certification Method	*CTL	[0 to 0xFF / 0 / 1/step] "SDK" is the "Software Development Kit". This data can be converted from SAS (VAS) when installed or uninstalled.
5-401-230	SDK Certification Device	*CTL	[- / 00000000 / 1 /-]
	<ul style="list-style-type: none"> ▪ Bit0: SDK authentication 0: Disable, 1: Enable ▪ Bit1: SKB Display 0: Disable, 1: Enable ▪ Bit2: Administrator login 0: Disable, 1: Enable ▪ Bit3 to Bit7: Reserved (set "0" only) 		

5-401-240	Detail Option	*CTL	[0 to 0xFF / 00000000 / 1/step]
	<ul style="list-style-type: none"> ▪ Bit0: Logout confirm option 0: OFF, 1: ON ▪ Bit1, Bit2: Auto-logout timer (retry timer) 00: 60sec, 01: 10sec, 10: 20sec, 11: 30sec, ▪ Bit3: Personal authority / Group authority and operation 0: OFF, 1: ON ▪ Bit4: Skip password entry 0: OFF, 1: ON ▪ Bit5: Set the display of the remaining Frequency 0: OFF, 1: ON, ▪ Bit6, Bit7: Set the display time 00: 3sec, 01: 6sec, 10: 9sec, 11: 12sec 		

5402	[Access Control]		
5-402-101 to 5-402-130	SDKJ1 Limit Setting - SDKJ30 Limit Setting	*CTL	[0 to 0xFF / 00000000 / 1/step]
	<ul style="list-style-type: none"> ▪ Bit0: SDKJ Authentication 0: Panel Type, 1: Remote Type ▪ Bit1: Using user code setup 0: OFF, 1: ON ▪ Bit2: Using key-counter setup 0: OFF, 1: ON ▪ Bit3: Using external billing device setup 0: OFF, 1: ON ▪ Bit4: Using extended external billing device setup 0: OFF, 1: ON ▪ Bit5, Bit6: Not used ▪ Bit7: Using extended function J limit users 0: OFF, 1: ON 		
5-402-141 to 5-402-170	SDKJ1 ProductID - SDKJ30 ProductID	*CTL	[0 to 0xFFFFFFFF / 0 / 1/step]

5404	[User Code Count Clear] Clears all counters for users.		
5-404-004	-	*CTL	[Execute]

5411	[LDAP-Certification] Sets description of LDAP certification.		
5-411-004	Simplified Authentication	*CTL	[0 or 1 / 1 / 1/step] 0: OFF 1: ON
5-411-005	Password Null Not Permit	*CTL	[0 or 1 / 1 / 1/step] 0: Password NULL permitted. 1: Password NULL not permitted. This SP is referenced only when SP5411-4 is set to "1" (On).
5-411-006	Detail Option	*CTL	[0 or 1 / 00000000 / 1/step] 0: Anonymous authentication OFF 1: Anonymous authentication ON

5412	[Krb-Certification]		
5-412-100	Encrypt Mode	*CTL	[- / 11111111 / 1/step] 0x01:AES256-CTS-HMAC-SHA1-96 0x02:AES128-CTS-HMAC-SHA1-96 0x04:DES3-CBC-SHA1 0x08:RC4-HMAC 0x10:DES-CBC-MD5 0xFF(0x1F):ALL Executes kerberos certification according to certified encryption strength.

5413	[Lockout Setting] Switches on/off the lock on the local address book account.		
5-413-001	Lockout On/Off	*CTL	[0 or 1 / 0 / 1/step] 0: OFF 1: ON
5-413-002	Lockout Threshold	*CTL	[1 to 10 / 5 / 1time/step]
5-413-003	Cancelation On/Off	*CTL	[0 or 1 / 0 / 1/step] 0:OFF, 1:ON
5-413-004	Cancelation Time	*CTL	[1 to 9999 / 60 / 1minute/step] Sets release time of lockout release function.

5414	[Access Mitigation] -		
5-414-001	Mitigation On/Off	*CTL	[0 or 1 / 0 / 1/step] 0: OFF, 1: ON Switches on/off masking of continuously used IDs and passwords that are identical.
5-414-002	Mitigation Time	*CTL	[0 to 60 / 15 / 1minute/step] Sets the length of time for excluding continuous access for identical user IDs and passwords.

5415	[Password Attack] -		
5-415-001	Permissible Number	*CTL	[0 to 100 / 30 / 1time/step] Sets the number of attempts to attack the system with random passwords to gain illegal access to the system.
5-415-002	Detect Time	*CTL	[0 to 10 / 5 / 1second/step] Sets the time limit to stop a password attack once such an attack has been detected.

5416	[Access Information] -		
5-416-001	Access User Max Num	*CTL	[50 to 200 / 200 / 1/step] Limits the number of users used by the access exclusion and password attack detection functions.
5-416-002	Access Password Max Num	*CTL	[50 to 200 / 200 / 1/step] Limits the number of passwords used by the access exclusion and password attack detection functions.
5-416-003	Monitor Interval	*CTL	[1 to 10 / 3 / 1second/step] Sets the processing time interval for referencing user ID and password information.

<p>5417</p>	<p>[Access Attack] -</p>		
<p>5-417-001</p>	<p>Access Permissible Number</p>	<p>*CTL</p>	<p>[0 to 500 / 100 / 1time/step] Sets a limit on access attempts when an excessive number of attempts are detected for MFP features.</p>
<p>5-417-002</p>	<p>Attack Detect Time</p>	<p>*CTL</p>	<p>[10 to 30 / 10 / 1second/step] Sets the length of time for monitoring the frequency of access to MFP features.</p>
<p>5-417-003</p>	<p>Productivity Fall Waite</p>	<p>*CTL</p>	<p>[0 to 9 / 3 / 1second/step] Sets the wait time to slow down the speed of certification when an excessive number of access attempts have been detected.</p>
<p>5-417-004</p>	<p>Attack Max Num</p>	<p>*CTL</p>	<p>[50 to 200 / 200 / 1/step] Sets a limit on the number of requests received for certification in order to slow down the certification speed when an excessive number of access attempts have been detected.</p>

5420	[User Authentication] These functions are enabled only after the user access feature has been enabled.		
5-420-001	Copy	*CTL	[0 or 1 / 0 / 1/step] 0: Authentication ON 1: Authentication OFF
5-420-011	DocumentServer	*CTL	[0 or 1 / 0 / 1/step] 0: Authentication ON 1: Authentication OFF
5-420-021	Fax	*CTL	[0 or 1 / 0 / 1/step] 0: Authentication ON 1: Authentication OFF
5-420-031	Scanner	*CTL	[0 or 1 / 0 / 1/step] 0: Authentication ON 1: Authentication OFF
5-420-041	Printer	*CTL	[0 or 1 / 0 / 1/step] 0: Authentication ON 1: Authentication OFF
5-420-051	SDK1	*CTL	[0 or 1 / 0 / 1/step] 0: Authentication ON 1: Authentication OFF
5-420-061	SDK2	*CTL	
5-420-071	SDK3	*CTL	
5-420-081	Browser	*CTL	[0 or 1 / 0 / 1/step] 0: Authentication ON 1: Authentication OFF

5430	[Auth Dialog Message Change] -		
5-430-001	Message Change On/Off	*CTL	[0 or 1 / 0 / 1/step] 0: Function OFF 1: Function ON Turns on or off the displayed message change for the authentication.
5-430-002	Message Text Download	CTL	[Execute] Executes the message download for the authentication.
5-430-003	Message Text ID	CTL	[Char:Up to 16 bytes / - / -] Inputs message text for the authentication.

5431	[External Auth User Preset] Turns on or off the copy permission for the external authentication.		
5-431-010	Tag	*CTL	[0 or 1 / 1 / 1/step] 0: Not permit, 1: Permit
5-431-011	Entry	*CTL	[0 or 1 / 1 / 1/step] 0: Not permit, 1: Permit
5-431-012	Group	*CTL	[0 or 1 / 1 / 1/step] 0: Not permit, 1: Permit
5-431-020	Mail	*CTL	[0 or 1 / 1 / 1/step] 0: Not permit, 1: Permit
5-431-030	FAX	*CTL	[0 or 1 / 1 / 1/step] 0: Not permit, 1: Permit
5-431-031	FAXSub	*CTL	[0 or 1 / 1 / 1/step] 0: Not permit, 1: Permit
5-431-032	Folder	*CTL	[0 or 1 / 1 / 1/step] 0: Not permit, 1: Permit

5-431-033	ProtectCode	*CTL	[0 or 1 / 1 / 1/step] 0: Not permit, 1: Permit
5-431-034	SmtphAuth	*CTL	[0 or 1 / 1 / 1/step] 0: Not permit, 1: Permit
5-431-035	LdapAuth	*CTL	[0 or 1 / 1 / 1/step] 0: Not permit, 1: Permit
5-431-036	Smb Ftp Fldr Auth	*CTL	[0 or 1 / 1 / 1/step] 0: Not permit, 1: Permit
5-431-037	AcntAcl	*CTL	[0 or 1 / 1 / 1/step] 0: Not permit, 1: Permit
5-431-038	DocumentAcl	*CTL	[0 or 1 / 1 / 1/step] 0: Not permit, 1: Permit
5-431-040	CertCrypt	*CTL	[0 or 1 / 0 / 1/step] 0: Not permit, 1: Permit
5-431-050	UserLimitCount	*CTL	[0 or 1 / 1 / 1/step] 0: Not permit, 1: Permit

5481	[Authentication Error Code] These SP codes determine how the authentication failures are displayed.		
5-481-001	System Log Disp	*CTL	[0 or 1 / 0 / 1/step] 0: Display OFF 1: Display ON
5-481-002	Panel Disp	*CTL	[0 or 1 / 1 / 1/step] 0: Display OFF 1: Display ON

5490	[MF KeyCard] Sets up operation of the machine with a keycard (Japan only).		
5-490-001	Job Permit Setting	*CTL	[0 or 1 / 0 / 1/step] 0: Disabled. Cancels operation without a user code. 1: Enabled. Allows operation without a user code.

5491	[Optional Counter] -		
5-491-001	Detail Option	*CTL	[0 or 1 / 00000000 / 1/step] Bit0: 0: Forced Job Canceling OFF 1: Forced Job Canceling ON Bit1 to Bit7: Not used

5501	[PM Alarm] Sets PM count level that emits PM alarm call.		
5-501-001	PM Alarm Level	*CTL	[0 to 9999 / 0 / 1/step] 0: Alarm off 1 to 9999: Alarm goes off when Value (1 to 9999) x 1000 > PM counter

5504	[Jam Alarm] Sets the alarm to sound for the specified jam level (document miss feeds are not included).		
5-504-001	-	*CTL	[0 to 3 / 3 / 1/step] 0(Z): Jam alarm prohibited 1(L): level H 1/4 2(M): level H 1/2 3(H): Jam occurrence interval sheets of indicated paper that indicated product proposal.

5505	[Error Alarm]		
	Sets the error alarm level. The error alarm counter counts "1" when any SC is detected. However, the error alarm counter decreases by "1" when an SC is not detected during a set number of copied sheets.		
5-505-001	Error Alarm	*CTL	[0 to 255 / Default / hundred/step] 0: Alarm Off [Default] D197: 20 D198: 25 D199: 35 D200: 45 D201: 60 D202: 75

5507	[Supply/CC Alarm] Enables or disables the notifying a supply call via the @Remote.		
5-507-001	Paper Supply Alarm	*CTL	[0 or 1 / 0 / 1/step] 0: OFF 1: ON
5-507-002	Staple Supply Alarm	*CTL	[0 or 1 / 1 / 1/step] 0: OFF 1: ON
5-507-003	Toner Supply Alarm	*CTL	[0 or 1 / 1 / 1/step] 0: OFF 1: ON
5-507-080	Toner Call Timing	*CTL	[0 or 1 / 0 / 1/step] 0: At replacement 1: AtLessThanThresh
5-507-081	Toner Call Threshold	*CTL	[10 to 90 / 10 / 10%/step] This program enables only if SP5-507-080 is "1"
5-507-128	Interval :Others	*CTL	[250 to 10000 / 1000 / 1/step] Sets report level of paper supply administration call.
5-507-132	Interval :A3	*CTL	[250 to 10000 / 1000 / 1/step] Sets report level of paper supply administration call.
5-507-133	Interval :A4	*CTL	[250 to 10000 / 1000 / 1/step] Sets report level of paper supply administration call.
5-507-134	Interval :A5	*CTL	[250 to 10000 / 1000 / 1/step] Sets report level of paper supply administration call.

5-507-141	Interval :B4	*CTL	[250 to 10000 / 1000 / 1/step] Sets report level of paper supply administration call.
5-507-142	Interval :B5	*CTL	[250 to 10000 / 1000 / 1/step] Sets report level of paper supply administration call.
5-507-160	Interval :DLT	*CTL	[250 to 10000 / 1000 / 1/step] Sets report level of paper supply administration call.
5-507-164	Interval :LG	*CTL	[250 to 10000 / 1000 / 1/step] Sets report level of paper supply administration call.
5-507-166	Interval :LT	*CTL	[250 to 10000 / 1000 / 1/step] Sets report level of paper supply administration call.
5-507-172	Interval :HLT	*CTL	[250 to 10000 / 1000 / 1/step] Sets report level of paper supply administration call.

5508	[CC Call] Sets PM count level that emits PM alarm call.		
5-508-001	Jam Remains	*CTL	[0 or 1 / 1 / 1/step] 0: Disable 1: Enable
5-508-002	Continuous Jams	*CTL	[0 or 1 / 1 / 1/step] 0: Disable 1: Enable
5-508-003	Continuous Door Open	*CTL	[0 or 1 / 1 / 1/step] 0: Disable 1: Enable

5-508-011	Jam Detection: Time Length	*CTL	[3 to 30 / 10 / 1min/step]
5-508-012	Jam Detection: Continuous Count	*CTL	[2 to 10 / 5 / 1time/step]
5-508-013	Door Open: Time Length	*CTL	[3 to 30 / 10 / 1min/step]

5513	[PartsAlermlevelCount] Call in at the point that the counter of "PM Parts Counter Display: Normal (SP7-617-001)" reaches this level (K).		
5-513-001	Normal	*CTL	[0 to 9999 / 300 / 1K/step] 0: OFF 1: ON
5-513-002	Df	*CTL	[1 to 9999 / 300 / 1K/step]

5514	[PartsAlermlev] PM report alarm for each CSS parts: Sets DF paper feed criteria On/Off (report or not).		
5-514-001	Nomal	*CTL	[0 or 1 / 1 / 1/step] 0: OFF 1: ON
5-514-002	Df	*CTL	[0 or 1 / 0 / 1/step] 0: OFF 1: ON

5515	[SC/Alarm Setting] With @Remote in use, these SP codes can be set to issue an SC call when an SC error occurs. If this SP is switched off, the SC call is not issued when an SC error occurs.		
5-515-001	SC Call	*CTL	[0 or 1 / 1 / 1/step] 0: OFF 1: ON
5-515-002	Service Parts Near End Call	*CTL	[0 or 1 / 1 / 1/step] 0: OFF 1: ON
5-515-003	Service Parts End Call	*CTL	[0 or 1 / 1 / 1/step] 0: OFF 1: ON
5-515-004	User Call	*CTL	[0 or 1 / 1 / 1/step] 0: OFF 1: ON
5-515-006	Communication Test Call	*CTL	[0 or 1 / 1 / 1/step] 0: OFF 1: ON
5-515-007	Machine Information Notice	*CTL	[0 or 1 / 1 / 1/step] 0: OFF 1: ON
5-515-008	Alarm Notice	*CTL	[0 or 1 / 1 / 1/step] 0: OFF 1: ON
5-515-010	Supply Automatic Ordering Call	*CTL	[0 or 1 / 1 / 1/step] 0: OFF 1: ON

5-515-011	Supply Management Report Call	*CTL	[0 or 1 / 1 / 1/step] 0: OFF 1: ON
5-515-012	Jam/Door Open Call	*CTL	[0 or 1 / 1 / 1/step] 0: OFF 1: ON

5517	[Get Machine Information]		
5-517-031	Get SMC Info: Retry Interval	*CTL	[0 to 255 / 10 / 1min/step] When SMC info collect is interrupt, retries during the time between receiving Request for obtaining SMC info, to value set with this setting.

5728	[Network Setting]		
	Displays and sets the port numbers of the port forward for transferring to the Android operation panel.		
5-728-001	NAT Machine Port1	*CTL	[1 to 65535 / 49101 / 1/step]
5-728-002	NAT UI Port1	*CTL	[1 to 65535 / 55101 / 1/step]
5-728-003	NAT Machine Port2	*CTL	[1 to 65535 / 49102 / 1/step]
5-728-004	NAT UI Port2	*CTL	[1 to 65535 / 55102 / 1/step]
5-728-005	NAT Machine Port3	*CTL	[1 to 65535 / 49103 / 1/step]
5-728-006	NAT UI Port3	*CTL	[1 to 65535 / 55103 / 1/step]
5-728-007	NAT Machine Port4	*CTL	[1 to 65535 / 49104 / 1/step]
5-728-008	NAT UI Port4	*CTL	[1 to 65535 / 55104 / 1/step]
5-728-009	NAT Machine Port5	*CTL	[1 to 65535 / 49105 / 1/step]
5-728-010	NAT UI Port5	*CTL	[1 to 65535 / 55105 / 1/step]

5-728-011	NAT Machine Port6	*CTL	[1 to 65535 / 49106 / 1/step]
5-728-012	NAT UI Port6	*CTL	[1 to 65535 / 55106 / 1/step]
5-728-013	NAT Machine Port7	*CTL	[1 to 65535 / 49107 / 1/step]
5-728-014	NAT UI Port7	*CTL	[1 to 65535 / 55107 / 1/step]
5-728-015	NAT Machine Port8	*CTL	[1 to 65535 / 49108 / 1/step]
5-728-016	NAT UI Port8	*CTL	[1 to 65535 / 55108 / 1/step]
5-728-017	NAT Machine Port9	*CTL	[1 to 65535 / 49109 / 1/step]
5-728-018	NAT UI Port9	*CTL	[1 to 65535 / 55109 / 1/step]
5-728-019	NAT Machine Port10	*CTL	[1 to 65535 / 49110 / 1/step]
5-728-020	NAT UI Port10	*CTL	[1 to 65535 / 55110 / 1/step]

5730	[Extended Function Setting]		
	-		
5-730-001	Java™ Platform setting	*CTL	[0 or 1 / 1 / 1/step] 0: OFF 1: ON Turns on or off the Java™ platform.
5-730-010	Expiration Prior Alarm Set	*CTL	[0 to 999 / 20 / 1day/step] Sets the remaining days until the SDK application expires.

5731	[Counter Effect]		
	This SP is used only for Japan machines.		
5-731-001	Change MK1 Cnt (Paper -> Combine)	*CTL	[0 or 1 / 0 / 1/step] 0: OFF 1: ON

5734	[PDF Setting] Limits PDF file type when operating Scan to, fax send, and web download.		
5-734-001	PDF/A Fixed	*CTL	[0 or 1 / 0 / 1/step] 0: non-fixed setting 1: fixed setting (PDF/A use only)

5741	[Node Authentication Timeout] Specifies the timeout of the node authentication.		
5-741-001	-	*CTL	[1 to 255 / 60 / 1 / sec]

5745	[DeemedPowerConsumption]		
5-745-211	Controller Standby	*CTL	[0 to 9999 / 0 / 1/step]
5-745-212	STR	*CTL	[0 to 9999 / 0 / 1/step]
5-745-213	Main Power Off	*CTL	[0 to 9999 / 0 / 1/step]
5-745-214	Scanning and Printing	*CTL	[0 to 9999 / 0 / 1/step]
5-745-215	Printing	*CTL	[0 to 9999 / 0 / 1/step]
5-745-216	Scanning	*CTL	[0 to 9999 / 0 / 1/step]
5-745-217	Engine Standby	*CTL	[0 to 9999 / 0 / 1/step]
5-745-218	Low Power Consumption	*CTL	[0 to 9999 / 0 / 1/step]
5-745-219	Silent Condition	*CTL	[0 to 9999 / 0 / 1/step]
5-745-220	Heater Off	*CTL	[0 to 9999 / 0 / 1/step]

5.7 SP MODE TABLES - SP5000-2

5.7.1 SP5-XXX (MODE)

5747	[Browser Setting]		
	-		
5-747-201	JPEG Quality	*CTL	[0 to 100 / 100 / 1%/step]
5-747-203	Extended Memory Limit	*CTL	[0 or 1 / 0 / 1/step] 0: Use extended memory 1: Not use extended memory
5-747-204	Vertical Scroll Display Setting	*CTL	[0 or 1 / 0 / 1/step] 0: Fixed 1: Not fixed
5-747-205	Warning Confirmation Setting	*CTL	[0 to 3 / 0 / 1/step] 0: Confirmation dialog for page moving: displayed/ security warning: displayed 1: Confirmation dialog for page moving: not displayed/ security warning: displayed 2: Confirmation dialog for page moving: not displayed/ security warning: not displayed 3: Confirmation dialog for page moving: displayed/ security warning: not displayed
5-747-206	Browser3	CTL	[0 to 255 / 0 / 1/step]
5-747-207	Browser4	CTL	[0 to 255 / 0 / 1/step]
5-747-208	Browser5	CTL	[0 to 255 / 0 / 1/step]
5-747-209	Browser6	CTL	[0 to 255 / 0 / 1/step]

5-747-210	Browser7	CTL	[0 to 255 / 0 / 1/step]
5-747-211	Browser8	CTL	[0 to 255 / 0 / 1/step]
5-747-212	Browser9	CTL	[0 to 255 / 0 / 1/step]
5-747-213	Browser10	CTL	[0 to 255 / 0 / 1/step]

5748	[OpePanel Setting] Sets operation of related operational panel.		
5-748-101	Op Type Action Setting	CTL	[0 to 0xFF / 00000000 / 1/step] Bit0: Not used Bit1: Job stop setting at operational panel communication error 0: Job duration 1: Job stop Bit2: Smart Operation Panel mode 0: Common boot 1: Secure boot Bit3 to Bit7: Not used
5-748-201	Cheetah Panel Connect Setting	CTL	[0 or 1 / 0 / 1/step] 0: Not connected 1: Connected Select "1" when the optional smart operation panel is to be installed.

5749	[Import/Export]		
	Imports and exports preference information.		
5-749-001	Export	CTL	[- / - / -] Target: System, Printer, Fax, Scanner Option: Unique, Secret Copy config: Encryption, Encryption key (if selected) [Execute]
5-749-101	Import	CTL	[- / - / -] Option: Unique Copy config: Encryption, Encryption key (if selected) [Execute]

5751	[Key Event Encryption Setting]		
	Sets encryption key to encrypt key information.		
5-751-001	Password	*CTL	[32characters / - / 1/step]

5752	[Copy:FlairAPI Setting]		
	Sets copy FlairAPI functions ON/OFF.		
5-752-001	0x00 - 0xff	*CTL	[0 to 0xFF / 00000000 / 1/step] Bit0: FlairAPI server start up 0:Off, 1: On Bit1: Access permission from FlairAPI external device 0: Disabled, 1: Enabled Bit2: Switching dedicated IPv6 0: IPv6 only, 1: IPv4 priority Bit3:Remote UI function 0: Disabled, 1: Enabled Bit4 to Bit7: Not used

5754	[Cloud Fax: Set Function] DFU		
5-754-001	-	*CTL	[0 or 1 / 0 / 1/step]

5755	[Display Setting] Sets the display for the administrator password.		
5-755-001	Disp Administrator Password Change Scrn	CTL	[- / - / -] [Execute] Displays the password setting screen for the supervisor and administrator 1 at the startup after the execution of this SP is done.
5-755-002	Hide Administrator Password Change Scrn	CTL	[- / - / -] [Execute] Hides the input screen of the administrator password temporarily after the execution of this SP is done.

5758	[Remote UI Setting] Enabels or disables the authentication function for the Remote UI.		
5-758-001	Authentication	*CTL	[0 or 1 / 0 / 1/step] 0: Disable 1: Enable

5801	[Memory Clear] Resets NVRAM data to the default settings. Before executing any of these SP codes, print an SMC Report.		
5-801-001	All Clear	CTL	[- / - / -] [Execute]

5-801-002	Engine	ENG	[- / - / -] [Execute] Initializes all registration settings for the engine and copy process settings.
5-801-003	SCS	CTL	[- / - / -] [Execute] Initializes default system settings, SCS (System Control Service) settings, operation display coordinates, and ROM update information.
5-801-004	IMH Memory Clr	CTL	[- / - / -] [Execute] Clears Image Memory Handler which manages memory and HDD access.
5-801-005	MCS	CTL	[- / - / -] [Execute] Initializes the automatic delete time setting for stored documents. (MCS: Memory Control Service)
5-801-006	Copier application	CTL	[- / - / -] [Execute] Initializes all copier application settings.
5-801-007	Fax Application	CTL	[- / - / -] [Execute] Initializes all fax application settings.

5-801-008	Printer Application	CTL	<p>[- / - / -] [Execute] Initializes the printer defaults, programs registered, the printer SP bit switches, and the printer CSS counter. The following service setting:</p> <ul style="list-style-type: none"> ▪ Bit switches ▪ Gamma setting (User & Service) ▪ Toner Limit <p>The following user setting:</p> <ul style="list-style-type: none"> ▪ Tray Priority ▪ Menu protect ▪ System Setting except for setting of Energy Saver ▪ I/F Setup (I/O Buffer and I/O Timeout) ▪ PCL Menu
5-801-009	Scanner Application	CTL	<p>[- / - / -] [Execute] Initializes the scanner defaults for the scanner and all the scanner SP modes.</p>
5-801-010	Web Service	CTL	<p>[- / - / -] [Execute] Deletes the Netfile (NFA) management files and thumbnails, and initializes the Job login ID. Netfiles are jobs to be printed from the document server using a PC and the DeskTopBinder software.</p>

5-801-011	NCS	CTL	[- / - / -] [Execute] Initializes the system defaults and interface settings (IP addresses also), the SmartNetMonitor for Admin settings, WebStatusMonitor settings, and the TELNET settings.
5-801-012	R-FAX	CTL	[- / - / -] [Execute] Initializes the remote fax settings.
5-801-014	Clear DCS Setting	CTL	[- / - / -] [Execute] Initializes the DCS (Delivery Control Service) settings.
5-801-015	Clear UCS Setting	CTL	[- / - / -] [Execute] Initializes the UCS (User Information Control Service) settings.
5-801-016	MIRS Setting	CTL	[- / - / -] [Execute] Initializes the MIRS (Machine Information Report Service) settings.
5-801-017	CCS	CTL	[- / - / -] [Execute] Initializes the CCS (Certification and Charge-control Service) settings.
5-801-018	SRM Memory Clr	CTL	[- / - / -] [Execute] Initializes the SRM (System Resource Manager) settings.

5-801-019	LCS	CTL	[- / - / -] [Execute] Initializes the LCS settings.
5-801-020	Web Uapli	CTL	[- / - / -] [Execute] Initializes the web user application settings.
5-801-021	ECS	CTL	[- / - / -] [Execute] Initializes the ECS settings.
5-801-023	AICS	CTL	[- / - / -] [Execute]
5-801-024	BROWSER	CTL	[- / - / -] [Execute]
5-801-025	Websys	CTL	[- / - / -] [Execute]
5-801-026	PLN	CTL	[- / - / -] [Execute]
5-801-027	SAS	CTL	[- / - / -] [Execute]

5803	[INPUT Check]
	See page 5-355 "Input Check Table".

5804	[OUTPUT Check]
	See page 5-387 "Output Check Table".

5805	[Anti-Condensation Heater]		
	Switches ON/OFF dehumidify heater / dew condensation preventing heater during standby. If set to "ON", the anti-condensation heater remains in operation even while the machine is in standby, energy saving mode, or trouble (SC, etc.). However, the heater is off while warming up, printing, and in the sleep state.		
5-805-001	0:OFF / 1:ON	*ENG	[0 or 1 / 0 / 1/step] 0: OFF (Switches OFF when the machine is in standby mode.) 1: ON (Switches ON when the machine is in standby mode.)

5811	[MachineSerial]		
5-811-002	Display	*ENG	[0 to 255 / 0 / 1/step]
	Displays serial number.		

5811	[MachineSerial Set]		
5-811-004	BCU	ENG	[0 to 255 / 0 / 1/step]
	Displays/Enters serial number of BCU EEPROM same as SP5-811-001. Sets this SP when replacing the BCU with a new BCU.		

5812	[Service Tel. No. Setting]		
5-812-001	Service	*CTL	<p>[up to 20 / - / 1/step]</p> <p>Sets the telephone number for a service representative. This number is printed on the Counter List, which can be printed with the user's "Counter" menu. This can be up to 20 characters (both numbers and alphabetic characters can be input).</p>
5-812-002	Facsimile	*CTL	<p>[up to 20 / - / 1/step]</p> <p>Sets the fax or telephone number for a service representative. This number is printed on the Counter List. This can be up to 20 characters (both numbers and alphabetic characters can be input).</p>
5-812-003	Supply	*CTL	<p>[up to 20 / - / 1/step]</p> <p>Use this to input the telephone number of your supplier for consumables. Enter the number and press #.</p>
5-812-004	Operation	*CTL	<p>[up to 20 / - / 1/step]</p> <p>Use this to input the telephone number of your sales agency. Enter the number and press #.</p>

5816	<p>[Remote Service] Use it for Network remote diagnosis.</p>		
5-816-001	I/F Setting	*CTL	<p>[0 to 2 / 2 / 2/step] 0: Remote service off 1: CSS remote service on 2: NRS remote service on Selects the remote service setting.</p>
5-816-002	CE Call	*CTL	<p>[0 or 1 / 1 / 1/step] 0: Start of the service 1: End of the service Performs the CE Call at the start or end of the service. Note <ul style="list-style-type: none"> This SP is activated only when SP 5816-001 is set to "2". </p>
5-816-003	Function Flag	*CTL	<p>[0 or 1 / 0 / 1/step] 0: Disabled, 1: Enabled Enables or disables the remote service function. Note <ul style="list-style-type: none"> This SP setting is changed to "1" after @Remote register has been completed. </p>
5-816-007	SSL Disable	*CTL	<p>[0 or 1 / 0 / 1/step] 0: Uses the RCG certification 1: Does not use the RCG certification Uses or does not use the RCG certification by SSL when calling the RCG.</p>
5-816-008	RCG Connect Timeout	*CTL	<p>[1 to 90 / 30 / 1second/step] Specifies the connect timeout interval when calling the RCG.</p>

5-816-009	RCG Write Timeout	*CTL	[0 to 100 / 60 / 1second/step] Specifies the write timeout interval when calling the RCG.
5-816-010	RCG Read Timeout	*CTL	[0 to 100 / 60 / 1second/step] Specifies the read timeout interval when calling the RCG.
5-816-011	Port 80 Enable	*CTL	[0 or 1 / 0 / 1/step] 0: No. Access denied 1: Yes. Access granted. Enables/disables access via port 80 to the SOAP method.
5-816-013	RFU Timing	*CTL	[0 or 1 / 1 / 1/step] 0: RFU is executed whenever update request is received. 1: RFU is executed only when the machine is in the sleep mode. Selects the RFU timing.
5-816-014	RCG Error Cause	CTL	[0 or 1 / 0 / 1/step] 0:Normal condition 1:Error Displays the cause of an RCG error. When @Remote is used, normally displays "0". If "1" is displayed, this means that the authentication from client to server failed when the network re-booted. To restore normal operation, cycle the machine off/on to return a "0" (normal condition).

5-816-021	RCG-C Registered	CTL	[0 or 1 / 0 / 1/step] 0: Installation not completed 1: Installation completed This SP displays the Embedded RC Gate installation end flag.
5-816-023	Connect Type (N/M)	*CTL	[0 or 1 / 0 / 1/step] 0: Internet connection 1: Dial-up connection This SP displays and selects the Embedded RC Gate connection method.
5-816-061	Cert Expire Timing DFU	*CTL	[0 to 0xFFFFFFFF / 0 / 1second/step] Proximity of the expiration of the certification.
5-816-062	Use Proxy	*CTL	[0 or 1 / 0 / 1/step] 0: Not use 1: Use This SP setting determines if the proxy server is used when the machine communicates with the service center.

5-816-063	Proxy Host	*CTL	<p>[- / - / -]</p> <p>This SP sets the address of the proxy server used for communication between the RCG Device and the gateway. Use this SP to set up or display the customer proxy server address</p> <p>The address is necessary to set up the embedded RCG-N.</p> <p>Note</p> <ul style="list-style-type: none"> The address display is limited to 128 characters. Characters beyond the 128 characters are ignored. This address is customer information and is not printed in the SMC report.
5-816-064	Proxy PortNumber	*CTL	<p>[0 to 0xFFFF / 0 / 1/step]</p> <p>This SP sets the port number of the proxy server used for communication between the Embedded RCG-N and the gateway. This setting is necessary to set up the embedded RC Gate-N.</p> <p>Note</p> <ul style="list-style-type: none"> This port number is customer information and is not printed in the SMC report.

5-816-065	Proxy User Name	*CTL	<p>[- / - / -]</p> <p>This SP sets the HTTP proxy certification user name.</p> <p>Note</p> <ul style="list-style-type: none"> The length of the name is limited to 31 characters. Any character beyond the 31st character is ignored. This name is customer information and is not printed in the SMC report.
5-816-066	Proxy Password	*CTL	<p>[- / - / -]</p> <p>This SP sets the HTTP proxy certification password.</p> <p>Note</p> <ul style="list-style-type: none"> The length of the password is limited to 31 characters. Any character beyond the 31st character is ignored. This name is customer information and is not printed in the SMC report.
5-816-067	CERT:Up State	*CTL	<p>[0 to 255 / 0 / 1/step]</p> <p>Displays the status of the certification update.</p>
	0	The certification used by RCG-N is set correctly.	
	1	The certification request (setAuthKey) for update has been received from the GW URL and certification is presently being updated.	
	2	The certification update is completed and the GW URL is being notified of the successful update.	
	3	The certification update failed, and the GW URL is being notified of the failed update.	
	4	The period of the certification has expired and new request for an update is being sent to the GW URL.	

	11	A rescue update for certification has been issued and a rescue certification setting is in progress for the rescue GW connection.	
	12	The rescue certification setting is completed and the GW URL is being notified of the certification update request.	
	13	The notification of the request for certification update has completed successfully, and the system is waiting for the certification update request from the rescue GW URL.	
	14	The notification of the certification request has been received from the rescue GW controller, and the certification is being stored.	
	15	The certification has been stored, and the GW URL is being notified of the successful completion of this event.	
	16	The storing of the certification has failed, and the GW URL is being notified of the failure of this event.	
	17	The certification update request has been received from the GW URL, the GW URL was notified of the results of the update after it was completed, but a certification error has been received, and the rescue certification is being recorded.	
	18	The rescue certification of No. 17 has been recorded, and the GW URL is being notified of the failure of the certification update.	
5-816-068	CERT:Error		*CTL [0 to 255 / 0 / 1/step] Displays a number code that describes the reason for the request for update of the certification.
	0	Normal. There is no request for certification update in progress.	
	1	Request for certification update in progress. The current certification has expired.	
	2	An SSL error notification has been issued. Issued after the certification has expired.	
	3	Notification of shift from a common authentication to an individual certification.	
	4	Notification of a common certification without ID2.	

	5	Notification that no certification was issued.	
	6	Notification that GW URL does not exist.	
5-816-069	CERT:Up ID	*CTL	[- / - / -] The ID of the request for certification.
5-816-083	Firm Up Status	*CTL	[0 to 5 / 0 / 1/step] Displays the status of the firmware update. 0: Farm update reception standby 1: Farm update start schedule standby. 2: User confirmation standby. 3: Device farm update preparation is executing. 4: Device farm update process is executing. 5: Device farm update end process is executing.
5-816-085	Firm Up User Check	*CTL	This SP setting determines if the operator can confirm the previous version of the firmware before the firmware update execution. If the option to confirm the previous version is selected, a notification is sent to the system manager and the firmware update is done with the firmware files from the URL.
5-816-086	Firmware Size	*CTL	Allows the service technician to confirm the size of the firmware data files during the firmware update execution.
5-816-087	CERT: Macro Ver.	CTL	[- / - / -] Displays the macro version of the @Remote certification. Max. 8digits.

5-816-088	CERT: PAC Ver.	CTL	[- / - / -] Displays the macro version of the @Remote certification. Max. 16 digits.
5-816-089	CERT: ID2 Code	CTL	[- / - / -] Displays ID2 for the @Remote certification. Spaces are displayed as underscores (_). Asterisks (*) indicate that no @Remote certification exists. "000000_____" indicates "Common certification". Max. 16 digits.
5-816-090	CERT: Subject	CTL	[- / - / -] Displays the common name of the @Remote certification subject. CN = the following 17 bytes. Spaces are displayed as underscores (_). Asterisks (*) indicate that no @Remote certification exists. "000000_____" indicates "Common certification". Max. 16 digits.
5-816-091	CERT: Serial No	CTL	[- / - / -] Displays serial number for the @Remote certification. Asterisks (*) indicate that no @Remote certification exists. Max. 7 digits.
5-816-092	CERT: Issuer	CTL	[- / - / -] Displays the common name of the issuer of the @Remote certification. CN = the following 30 bytes. Asterisks () indicate that no @Remote certification exists. Max. 7 digits.
5-816-093	CERT: Valid Start	CTL	[- / - / -] Displays the start time of the period for which the current @Remote certification is enabled. Max. 10 digits.

5-816-094	CERT: Valid End	CTL	<p>[- / - / -]</p> <p>Displays the end time of the period for which the current @Remote certification is enabled. Max. 10 digits.</p>			
5-816-102	CERT: Encrypt Level	*CTL	<p>[1 to 2 / 1 / 1/step]</p> <p>1:512bit 2:2048bit</p> <p>Displays the strength of encryption used for NRS authentication. The displayed value is not the value acquired from the authentication domain, rather it is the value stored in NVRAM when authentication is written. When NRS starts up, if there is a mismatch between this SP setting and the authentication encryption, then the SP value is updated.</p>			
5-816-103	Client Communication Method	*CTL	<p>[0 to 3 / 0/ 1/step]</p> <p>Saves the communication type that the machine succeeded in @Remote client communication</p> <p>0: Not communicated (initial setting) 1: IPv4 2: IPv6 3: Hostname</p>			
5-816-104	Client Communication Limit	*CTL	<p>[1 to 7 / 7 / 1/step]</p> <p>Determines the destinations of NRSGateway that the machine can use during @Remote communication. If NRS device runs, the setting specified here will be invalid.</p> <p>Enable: Uses as the destinations Disable: Does not use as the destinations</p>			
			Value	Hostname	IPv6 Address	IPv4 Address
			1	Disable	Disable	Enable
			2	Disable	Enable	Disable

			3	Disable	Enable	Enable
			4	Enable	Disable	Disable
			5	Enable	Disable	Enable
			6	Enable	Enable	Disable
			7	Enable	Enable	Enable
5-816-115	Network Information Waiting timer	*CTL	<p>[5 to 255 / 5 / 1/sec]</p> <p>Saves the time until the latest network information is determined.</p> <p>If SCS does not notify a boot of the network or IPv6 address event, NRS determines the network information and notifies the setting change(s) to intermediary device(s).</p>			
5-816-150	Selection Country	CTL	<p>[0 to 10 / NA:1, EU:3, Other:0 / 1/step]</p> <p>0: Japan 1: USA 2: Canada 3: UK 4: Germany 5: France 6: Italy 7: Netherlands 8: Belgium 9: Luxembourg 10: Spain</p>			
5-816-151	Line Type Automatic Judgement	CTL	<p>[- / - / -]</p> <p>[Execute]</p>			
5-816-152	Line Type Judgement Result	CTL	<p>[0 to 255 / 0 / 0]</p>			

5-816-153	Selection Dial / Push	CTL	[0 or 1 / 0 / -] 0: Tone dialing phone 1: Pulse dialing phone
5-816-154	Outside Line Outgoing Number	CTL	[char (4 digits) / - / -]
5-816-156	Dial Up User Name	CTL	[char (32 digits) / * / -] * Initial user name is displayed.
5-816-157	Dial Up Password	CTL	[char (32 digits) / * / -] * Initial password is displayed.
5-816-161	Local Phone Number	CTL	[numeric (24 digits) / - / -]
5-816-162	Connection Timing Adjustment Incoming	CTL	[0 to 24 / 1 / 1/step]
5-816-163	Access Point	CTL	[char (16 digits) / - / -]
5-816-164	Line Connecting	CTL	[0 or 1 / 0 / 1/step] 0: Sharing FAX 1: No Sharing FAX
5-816-173	Modem Serial No.	CTL	[- / - / -] Displays the modem serial number.
5-816-174	Retransmission Limit	CTL	[- / - / -] [Execute]
5-816-187	FAX TX Priority	CTL	[0 or 1 / 0 / 1/step] 0: OFF 1: ON
5-816-200	Manual Polling	CTL	[- / - / -] [Execute] Executes the manual polling.

	Regist Status	CTL	[0 to 4 / 0 / 1/step]
5-816-201	<p>Displays a number that indicates the status of the @Remote service device.</p> <p>0: Neither the registered device by the external nor embedded RCG device is set.</p> <p>1: The embedded RCG device is being set. Only Box registration is completed. In this status, this unit cannot answer a polling request from the external RCG.</p> <p>2. The embedded RCG device is set. In this status, the external RCG unit cannot answer a polling request.</p> <p>3. The registered device by the external RCG is being set. In this status the embedded RCG device cannot be set.</p> <p>4 The registered module by the external RCG has not started.</p>		
5-816-202	Letter Number	*CTL	<p>[- / - / -]</p> <p>Allows entry of the number of the request needed for the RCG-N device.</p>
5-816-203	Confirm Execute	CTL	<p>[- / - / -]</p> <p>[Execute]</p> <p>Executes the inquiry request to the @Remote GW URL.</p> <p>If SP5-816-202 was not entered, an error occurs.</p>
5-816-204	Confirm Result	CTL	<p>[0 to 255 / 0 / 1/step]</p> <p>Displays a number that indicates the result of the inquiry executed with SP5-816-203.</p>
5-816-205	Confirm Place	CTL	<p>[- / - / -]</p> <p>Displays the result of the notification sent to the device from the GW URL in answer to the inquiry request. Displayed only when the result is registered at the GW URL.</p>

5-816-206	Register Execute	CTL	[- / - / -] [Execute] Executes "Embedded RCG Registration".
5-816-207	Register Result	CTL	[0 to 255 / 0 / 1/step] Displays a number that indicates the registration result.
<p>Displays a number that indicates the registration result.</p> <p>0: Succeeded</p> <p>2: Registration in progress</p> <p>3: Proxy error (proxy enabled)</p> <p>4: Proxy error (proxy disabled)</p> <p>5: Proxy error (Illegal user name or password)</p> <p>6: Communication error</p> <p>7: Certification update error</p> <p>8: Other error</p> <p>9: Registration executing</p> <p>10: Request paper number registration error (Hit device is not registered when request area of installation information was device transfer)</p> <p>11: Request paper number registration error (Hit device have been registered already)</p> <p>12: Request paper number registration error (parameter error)</p> <p>20: Dial-up confirmation failure</p> <p>21: Answer tone detection error</p> <p>22: Carrier detection failure</p> <p>23: Modem setting value injustice</p> <p>24: Supply current shortage</p> <p>25: Modem circuit failing out</p> <p>26: Circuit is in use</p>			
5-816-208	Error Code	CTL	[-2147483647 to 2147483647 / 0 / 1/step] Displays a number that describes the error code that was issued when either SP5816-204 or SP5816-207 was executed.

Cause	Code	Meaning
Illegal Modem Parameter	-11001	Chat parameter error
	-11002	Chat execution error
	-11003	Unexpected error
	-11004	Cutting process occurs during modem connecting.
	-11005	NCS reboot occurs during modem connecting.
Operation Error, Incorrect Setting	-12002	Inquiry, registration attempted without acquiring device status.
	-12003	Attempted registration without execution of an inquiry and no previous registration.
	-12004	Attempted setting with illegal entries for certification and ID2.
	-12005	@Remote communication is prohibited. The device has an Embedded RC gate-related problem.
Operation Error, Incorrect Setting	-12006	A confirmation request was made after the confirmation had been already completed.
	-12007	The request number used at registration was different from the one used at confirmation.
	-12008	Update certification failed because mainframe was in use.
	-12009	D2 mismatch between an individual certification and NVRAM.
	-12010	Certification area is not initialized.

Error Caused by Response from GW URL	-2385	Attempted dial up overseas without the correct international prefix for the telephone number.	
	-2387	Not supported at the Service Center	
	-2389	Database out of service	
	-2390	Program out of service	
	-2391	Two registrations for same device	
	-2392	Parameter error	
	-2393	Basil not managed	
	-2394	Device not managed	
	-2395	Box ID for Basil is illegal	
	-2396	Device ID for Basil is illegal	
	-2397	Incorrect ID2 format	
-2398	Incorrect request number format		
5-816-209	Instl Clear	CTL	[- / - / -] [Execute]
5-816-240	CommErrorTime	CTL	[- / - / -]
5-816-241	CommErrorCode 1	CTL	[- / - / -]
5-816-242	CommErrorCode 2	CTL	[- / - / -]
5-816-243	CommErrorCode 3	CTL	[- / - / -]
5-816-244	CommErrorSate 1	CTL	[- / - / -]
5-816-245	CommErrorSate 2	CTL	[- / - / -]
5-816-246	CommErrorSate 3	CTL	[- / - / -]
5-816-247	SSL Err Count	CTL	[0 to 255 / 0 / 1]
5-816-248	Other Err Count	CTL	[0 to 255 / 0 / 1]

5-816-250	CommLog Print	CTL	[- / - / -] [Execute] Prints the communication log.
-----------	---------------	-----	---

5821	[Remote Service RCG Setting]		
	-		
5-821-002	RCG IPv4 Address	*CTL	[00000000h to FFFFFFFFh / 00000000h / 1/step] Sets the IP address of the RCG (Remote Communication Gate) destination for call processing at the remote service center.
5-821-003	RCG Port	*CTL	[0 to 65535 / 443 / 1/step] Sets destination port number of RCG (Remote Communication Gate) at call process against center.
5-821-004	RCG IPv4 URL Path	*CTL	[0 to 15 / "/RCG/services/" /-] Sets the IPv4 address of the RCG destination URL path for call processing at the remote service center.
5-821-005	RCG IPv6 Address	*CTL	[- / - / -] Sets the IPv6 address of the RCG destination for call processing at the remote service center.
5-821-006	RCG IPv6 URL Path	*CTL	[0 to 15 / "/RCG/services/" /-] Sets the IPv6 address of the RCG destination URL path for call processing at the remote service center.

5-821-007	RCG Host Name	*CTL	Sets the IPv6 address of the RCG destination host name for call processing at the remote service center.
5-821-008	RCG Host URL Path	*CTL	[0 to 15 / "/RCG/services/" /-] Sets the IPv6 address of the RCG host name destination URL path for call processing at the remote service center.

5824	[NV-RAM Data Upload].		
5-824-001	NV-RAM Upload	CTL	[- / - / -] [Execute]

5825	[NV-RAM Data Download] Downloads data from an SD card to the NVRAM in the machine. After downloading is completed, remove the SD card and turn the machine power off and on.		
5-825-001	NV-RAM Download	CTL	[- / - / -] [Execute]

<p>5828</p>	<p>[Network Setting] Sets interface of Ethernet and wireless LAN.</p>		
<p>5-828-050</p>	<p>1284 Compatibility (Centro)</p>	<p>*CTL</p>	<p>[0 or 1 / 1 / 1/step] Enables or disables 1284 Compatibility. 0: Disabled, 1: Enabled</p>
<p>5-828-052</p>	<p>ECP (Centro)</p>	<p>*CTL</p>	<p>[0 or 1 / 1 / 1/step] Enables or disables ECP Compatibility. 0: Disabled, 1: Enabled Note <ul style="list-style-type: none"> ▪ This SP is activated only when SP5-828-50 is set to "1". </p>
<p>5-828-065</p>	<p>Job Spooling</p>	<p>*CTL</p>	<p>[0 or 1 / 0 / 1/step] Enables/disables Job Spooling. 0: Disabled, 1: Enabled</p>
<p>5-828-066</p>	<p>Job Spooling Clear: Start Time</p>	<p>*CTL</p>	<p>[0 or 1 / 1 / 1/step] Treatment of the job when a spooled job exists at power on. 0: ON (Data is cleared) 1: OFF (Automatically printed)</p>
<p>5-828-069</p>	<p>Job Spooling (Protocol)</p>	<p>*CTL</p>	<p>[- / 0111111 / -] Validates or invalidates the job spooling function for each protocol. 0: Validates 1: Invalidates bit0: LPR bit1: FTP bit2: IPP bit3: SMB bit4: BMLinkS bit5: DIPRINT bit6: sftp bit7: (Reserved)</p>

5-828-087	Protocol usage	*CTL	[each bit value / 0x00000000 / bit / -] 1: It has been processed by hit protocol. 0: It has Never processed by hit protocol. See [Bit assignment for SP5-828-087] below.
5-828-090	TELNET (0: OFF 1: ON)	*CTL	[0 or 1 / 1 / 1/step] Enabled or disabled the Telnet protocol. 0: Disable, 1: Enable
5-828-091	Web (0: OFF 1: ON)	*CTL	[0 or 1 / 1 / 1/step] Enables or disables the Web operation. 0: Disable, 1: Enable
5-828-145	Active IPv6 Link Local Address	CTL	This is the IPv6 local address link referenced on the Ethernet or wireless LAN in the format: "Link Local Address" + "Prefix Length" The IPv6 address consists of a total 128 bits configured in 8 blocks of 16 bits each.
5-828-147	Active IPv6 Stateless Address 1	CTL	SP codes 147 to 155 are the IPv6 status addresses (1 to 5) referenced on the Ethernet or wireless LAN in the format: "Status Address" + "Prefix Length" The IPv6 address consists of a total 128 bits configured in 8 blocks of 16 bits each.
5-828-149	Active IPv6 Stateless Address 2	CTL	
5-828-151	Active IPv6 Stateless Address 3	CTL	
5-828-153	Active IPv6 Stateless Address 4	CTL	

5-828-155	Active IPv6 Stateless Address 5	CTL	
5-828-156	IPv6 Manual Address	*CTL	<p>This SP is the IPv6 manually set address referenced on the Ethernet or wireless LAN in the format: "Manual Set Address" + "Prefix Length"</p> <p>The IPv6 address consists of a total 128 bits configured in 8 blocks of 16 bits each.</p>
5-828-158	IPv6 Gateway Address	*CTL	<p>This SP is the IPv6 gateway address referenced on the Ethernet or wireless LAN. The IPv6 address consists of a total 128 bits configured in 8 blocks of 16 bits each.</p>
5-828-161	IPv6 Stateless Auto Setting	CTL	<p>[0 or 1 / 1 / 1/step] 0: Disable, 1: Enable Enables or disables the automatic setting for IPv6 stateless.</p>
5-828-219	IPsec Aggressive Mode Setting	CTL	<p>[0 or 1 / 0 / 1/step] 0: Disable, 1: Enable</p>
5-828-236	Web Item visible	*CTL	<p>[0x0000 to 0xffff / FFFFh / -] Displays or does not display the Web system items. 0: Not displayed, 1:Displayed bit0: Net RICOH bit1: Consumable Supplier bit2-15: Reserved (all)</p>

5-828-237	Web shopping link visible	*CTL	[0 or 1 / 1 / 1/step] Displays or does not display the link to Net RICOH on the top page and link page of the web system. 0: Not display, 1:Display
5-828-238	Web supplies Link visible	*CTL	[0 or 1 / 1 / 1/step] Displays or does not display the link to Consumable Supplier on the top page and link page of the web system. 0: Not display, 1:Display
5-828-239	Web Link1 Name	*CTL	[character strings(maximum 31byte) / URL1 / -] This SP confirms or changes the URL1 name on the link page of the web system. The maximum characters for the URL name are 31 characters.
5-828-240	Web Link1 URL	*CTL	[character strings(maximum 127byte) / - / -] This SP confirms or changes the link to URL1 on the link page of the web system. The maximum characters for the URL are 127 characters.
5-828-241	Web Link1 visible	*CTL	[0 or 1 / 1 / 1/step] Displays or does not display the link to URL1 on the top page of the web system. 0: Not display, 1:Display
5-828-242	Web Link2 Name	*CTL	[character strings(maximum 31byte) / URL2 / -] Same as "-239"
5-828-243	Web Link2 URL	*CTL	[character strings(maximum 127byte) / - / -] Same as "-240"

5-828-244	Web Link2 visible	*CTL	[0 or 1 / 1 / 1/step] Same as "-241"
5-828-249	DHCPv6 DUID	*CTL	[0 or 1 / 0000000000000000 / 1/step] This SP confirms or changes the value of DUID.

Bit assignment for SP5-828-087

bit	Item	bit	Item
0	IPsec	16	SMB printing
1	IPv6	17	WSD-Printer
2	IEEE 802.1X	18	WSD-Scanner
3	Wireless LAN	19	Scan to SMB
4	security mode level setting	20	Scan to NCP
5	Appletalk	21	Reserve
6	DHCP	22	Bluetooth
7	DHCPv6	23	IEEE 1284
8	telnet	24	USB printing
9	SSL	25	Dynamic DNS
10	HTTPS	26	Netware printing
11	BMLinkS printing	27	LLTD
12	diprint printing	28	IPP printing
13	LPRprinting	29	IPP printing (SSL)
14	ftp printing	30	Ssh
15	rsh printing	31	Sftp



5832	[HDD] Enter the SP number for the partition to initialize, then press #. When the execution ends, cycle the machine power off and on.		
5-832-001	HDD Formatting (ALL)	CTL	[- / - / -] [Execute]
5-832-002	HDD Formatting (IMH)	CTL	[- / - / -] [Execute]
5-832-003	HDD Formatting (Thumbnail/OCR)	CTL	[- / - / -] [Execute]
5-832-004	HDD Formatting (Job Log)	CTL	[- / - / -] [Execute]
5-832-005	HDD Formatting (Printer Fonts)	CTL	[- / - / -] [Execute]
5-832-006	HDD Formatting (User Info)	CTL	[- / - / -] [Execute]
5-832-007	Mail RX Data	CTL	[- / - / -] [Execute]
5-832-008	Mail TX Data	CTL	[- / - / -] [Execute]
5-832-009	HDD Formatting (Data for a Design)	CTL	[- / - / -] [Execute]
5-832-010	HDD Formatting (Log)	CTL	[- / - / -] [Execute]
5-832-011	HDD Formatting (Ridoc I/F)	CTL	[- / - / -] [Execute]
5-832-012	HDD Formatting (Thumbnail)	CTL	[- / - / -] [Execute]

<p>5836</p>	<p>[Capture Setting]</p> <p>-</p>		
<p>5-836-001</p>	<p>Capture Function (0:Off 1:On)</p>	<p>*CTL</p>	<p>[0 or 1 / 0 / 1/step] 0: Disable 1: Enable With this function disabled, the settings related to the capture feature cannot be initialized, displayed, or selected.</p>
<p>5-836-002</p>	<p>Panel Setting</p>	<p>*CTL</p>	<p>[0 or 1 / 0 / 1/step] 0: Displayed 1: Not displayed Determines whether each capture related setting can be changed in the system settings or not.</p>
<p>5-836-072</p>	<p>Reduction for Copy B&W Text</p>	<p>*CTL</p>	<p>[0 to 6 / 0 / 1/step] 0: 1, 1: 1/2 2: 1/3 3: 1/4 6: 2/3</p>
<p>5-836-073</p>	<p>Reduction for Copy B&W Other</p>	<p>*CTL</p>	<p>[0 to 6 / 0 / 1/step] 0: 1, 1: 1/2 2: 1/3 3: 1/4 6: 2/3</p>
<p>5-836-075</p>	<p>Reduction for Printer B&W</p>	<p>*CTL</p>	<p>[0 to 6 / 0 / 1/step] 0: 1, 1: 1/2 2: 1/3 3: 1/4 6: 2/3</p>

5-836-082	Format for Copy B&W Text	*CTL	[0 to 3 / 1 / 1/step] 0: JFIF/JPEG 1: TIFF/MMR 2: TIFF/MH 3: TIFF/MR
5-836-083	Format for Copy B&W Other	*CTL	[0 to 3 / 1 / 1/step] 0: JFIF/JPEG 1: TIFF/MMR 2: TIFF/MH 3: TIFF/MR
5-836-085	Format for Printer B&W	*CTL	[0 to 3 / 1 / 1/step] 0: JFIF/JPEG 1: TIFF/MMR 2: TIFF/MH 3: TIFF/MR
5-836-091	Default for JPEG	*CTL	[5 to 95 / 50 / 1/step] Sets the JPEG format default for documents sent to the document management server with the MLB, with JPEG selected as the format. Enabled only when optional File Format Converter (MLB: Media Link Board) is installed.
5-836-101	Primary srv IP address	*CTL	[000.000.000.000 to 255.255.255.255 / 000.000.000.000 / 1/step] Sets the IP address of the PC designated to operate as the primary capture server (CS).
5-836-102	Primary srv scheme	*CTL	[Char: Max. 6 / - / -]
5-836-103	Primary srv port number	*CTL	[1 to 65535 / 80 / 1/step] Use to set the IO device for the primary CS remotely.

5-836-104	Primary srv URL path	*CTL	[0 to 16 / - / -] Use to set the IO device for the primary CS remotely. Max. characters: 16
5-836-111	Secondary srv IP address	*CTL	[000.000.000.000 to 255.255.255.255 / 000.000.000.000 / 1/step] Sets the IP address of the PC designated to operate as the secondary capture server (CS).
5-836-112	Secondary srv scheme	*CTL	[Char: Max. 6 / - / -] Sets the IO device of the secondary CS remotely. Max. characters: 6
5-836-113	Secondary srv port number	*CTL	[1 to 65535 / 80 / 1/step] Sets the IO device of the secondary CS remotely. Max. characters: 6
5-836-114	Secondary srv URL path	*CTL	[0 to 16 / - / -] Sets the IO device of the secondary CS remotely. Max. characters: 6
5-836-120	Default Reso Rate Switch	*CTL	[0 or 1 / 0 / 1/step] Sets the IO device of the CS remotely.
5-836-122	Reso: Copy(Mono)	*CTL	[0 to 255 / 3 / 1/step] Sets the IO device of the CS remotely: 0: 600dpi, 1: 400dpi, 2: 300dpi, 3: 200dpi, 4: 150dpi, 5: 100dpi, 6: 75dpi
5-836-124	Reso: Print(Mono)	*CTL	[0 to 255 / 3 / 1/step] Sets the IO device of the CS remotely: 0: 600dpi, 1: 400dpi, 2: 300dpi, 3: 200dpi, 4: 150dpi, 5: 100dpi, 6: 75dpi

5-836-126	Reso: FAX(Mono)	*CTL	[0 to 255 / 3 / 1/step] 0: 600dpi, 1: 400dpi, 2: 300dpi, 3: 200dpi, 4: 150dpi, 5: 100dpi, 6: 75dpi
5-836-127	Reso: Scan(Color)	*CTL	[0 to 255 / 4 / 1/step] 0: 600dpi, 1: 400dpi, 2: 300dpi, 3: 200dpi, 4: 150dpi, 5: 100dpi, 6: 75dpi
5-836-128	Reso: Scan(Mono)	*CTL	[0 to 255 / 3 / 1/step] 0: 600dpi, 1: 400dpi, 2: 300dpi, 3: 200dpi, 4: 150dpi, 5: 100dpi, 6: 75dpi
5-836-141	All addr Info Switch	*CTL	[0 or 1 / 1 / 1/step] Expands the scope of used resources and performance. Switch this off if this feature is not being used. 1: ON, 0: OFF
5-836-142	Stand-by Doc Max Number	*CTL	[10 to 10000 / 2000 / 1/step] Expands the scope of used resources and performance. Switch this off if this feature is not being used.

5840	[IEEE 802.11] -		
5-840-006	Channel MAX	*CTL	<p>[1 to 14 / 14 / 1/step]</p> <p>Sets the maximum number of channels available for data transmission via the wireless LAN. The number of channels available varies according to location. The default settings are set for the maximum end of the range for each area. Adjust the upper 4 bits to set the maximum number of channels. DFU</p> <p> Note</p> <ul style="list-style-type: none"> ▪ Do not change the setting. <p>Europe/Asia: 1 to 13 NA/ Asia: 1 to 11</p>
5-840-007	Channel MIN	*CTL	<p>[1 to 11 / 1 / 1/step]</p> <p>Sets the minimum number of channels available for data transmission via the wireless LAN. The number of channels available varies according to location. The default settings are set for the minimum end of the range for each area. Adjust the lower 4 bits to set the minimum number of channels. DFU</p> <p> Note</p> <ul style="list-style-type: none"> ▪ Do not change the setting. <p>Europe: 1 to 13 NA/ Asia: 1 to 11</p>
5-840-011	WEP Key Select	*CTL	<p>[00 to 11 / 00000000 / 1 binary/step]</p> <p>Selects the WEP key.</p> <p>00: Key #1 01: Key #2 (Reserved) 10: Key #3 (Reserved) 11: Key #4 (Reserved)</p>

5-840-045	WPA Debug Lvl	*CTL	[1 to 3 / 3 / 1/step] 1: info 2: warning 3: error
5-840-046	11w	*CTL	[0 to 2 / 0 / 1/step] 0: Not used 1: preferentially used 2: Required
5-840-047	PSK Set Type	*CTL	[0 or 1 / 0 / 1/step] 0: Passphrase 1: PSK

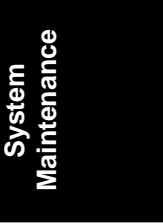

5.8 SP MODE TABLES - SP5000-3

5.8.1 SP5-XXX (MODE)

<p>5841</p>	<p>[Supply Name Setting] Press the [User Tools] key. These names appear when the user presses the Inquiry button on the User Tools screen.</p>		
<p>5-841-001</p>	<p>Toner Name Setting: Black</p>	<p>*CTL</p>	<p>[- / - / -]</p>
<p>5-841-007</p>	<p>OrgStamp</p>	<p>*CTL</p>	<p>[- / - / -]</p>
<p>5-841-011</p>	<p>StapleStd1</p>	<p>*CTL</p>	<p>[- / - / -]</p>
<p>5-841-012</p>	<p>StapleStd2</p>	<p>*CTL</p>	<p>[- / - / -]</p>
<p>5-841-013</p>	<p>StapleStd3</p>	<p>*CTL</p>	<p>[- / - / -]</p>
<p>5-841-014</p>	<p>StapleStd4</p>	<p>*CTL</p>	<p>[- / - / -]</p>
<p>5-841-021</p>	<p>StapleBind1</p>	<p>*CTL</p>	<p>[- / - / -]</p>
<p>5-841-022</p>	<p>StapleBind2</p>	<p>*CTL</p>	<p>[- / - / -]</p>
<p>5-841-023</p>	<p>StapleBind3</p>	<p>*CTL</p>	<p>[- / - / -]</p>

5842	[GWWS Analysis] These settings select the output mode for debugging information as each network file is processed.		
5-842-001	Setting 1	*CTL	Default: 00000000 Do not change Netfiles: Jobs to be printed from the document server using a PC and the DeskTopBinder software
5-842-002	Setting 2	*CTL	Default: 00000000 Adjusts the debug program mode setting. Bit7: 5682 mmseg-log setting 0: Date/Hour/Minute/Second 1: Minute/Second/Msec. 0 to 6: Not used

5844	[USB] -		
5-844-001	Transfer Rate	*CTL	Sets the speed for USB data transmission. [0x01:Full Speed] [0x04Auto Change]
5-844-002	Vendor ID	*CTL	Sets the vendor ID: Initial Setting: 0x05A Ricoh Company [0x0000 to 0xFFFF/1] DFU
5-844-003	Product ID	*CTL	Sets the product ID. [0x0000 to 0xFFFF/1] DFU
5-844-004	Device Release Number	*CTL	[0 to 9999 / 100 / 1/step] Sets the device release number of the BCD (binary coded decimal) display. Enter as a decimal number. NCS converts the number to hexadecimal number recognized as the BCD.

5-844-005	Fixed USB Port	*CTL	[0 to 2 / 0 / 1/step] Selects the PnP name standardization mode. 0: OFF 1: Level 1 2: Level 2
5-844-006	PnP Model Name	*CTL	Specifies PnP name for USB device.
5-844-007	PnP Serial Number	*CTL	[12 characters / NULL / -] Specifies PnP serial number for USB device.
5-844-008	Mac Supply Level	*CTL	[0 or 1 / 1 / 1/step] 0: OFF 1: ON
5-844-100	Notify Unsupport	*CTL	[0 to 1 / 1 / 1/step] Displays or does not display USB unsupported message. 0: Not display 1: Display

5845	<p>[Delivery Server Setting] Provides items for delivery server settings.</p>		
5-845-001	FTP Port No.	*CTL	<p>[1 to 65535 / 3670 / 1 /step] Sets the FTP port number used when image files to the Scan Router Server.</p>
5-845-002	IP Address (Primary)	*CTL	<p>[000.000.000.000 to 255.255.255.255 / 000.000.000.000 / 1/ -] Use this SP to set the Scan Router Server address. The IP address under the transfer tab can be referenced by the initial system setting.</p>
5-845-006	Delivery Error Display Time	*CTL	<p>[0 to 999 / 300 / 1 / second] Use this setting to determine the length of time the prompt message is displayed when a test error occurs during document transfer with the NetFile application and an external device.</p>
5-845-008	IP Address (Secondary)	*CTL	<p>[000.000.000.000 to 255.255.255.255 / 000.000.000.000 / 1/step] Specifies the IP address assigned to the computer designated to function as the secondary delivery server of Scan Router. This SP allows only the setting of the IP address without reference to the DNS setting.</p>
5-845-009	Delivery Server Model	*CTL	<p>[0 to 4 / 0 / 1/step] 0: Unknown 1: SG1 Accessory version 2: SG1 package version 3: SG2 Accessory version 4: SG2 package version Allows changing the model of the delivery server registered by the I/O device.</p>

5-845-010	Delivery Svr. Capability	*CTL	[0 to 255 / 00000000 / 1/step]
	Bit7 = 1 Comment information exists		Changes the capability of the registered that the I/O device registered.
	Bit6 = 1 Direct specification of mail address possible		
	Bit5 = 1 Mail RX confirmation setting possible		
	Bit4 = 1 Address book automatic update function exists		
	Bit3 = 1 Fax RX delivery function exists		Changes the capability of the registered that the I/O device registered.
	Bit2 = 1 Sender password function exists		
	Bit1 = 1 Function to link MK-1 user and Sender exists		
	Bit0 = 1 Sender specification required (if set to 1, Bit6 is set to "0")		
5-845-011	Delivery Svr. Capability(Ext)	*CTL	[0 to 255 / 00000000 / 1/step] Changes the capability of servers that is registered as I/O devices. Bit7 = 1 Address book usage limitation (Limitation for each authorized user) Bit6 = 1 RDH authorization link Bit5 to 0: Not used
5-845-013	Server Scheme (Primary) DFU	*CTL	[- / - / -] This is used for the scan router program. 6 Character strings.
5-845-014	Server Port Number (Primary) DFU	*CTL	[1 to 65535 / 80 / 1/step] This is used for the scan router program.

5-845-015	Server URL Path (Primary) DFU	*CTL	[- / - / -] Character strings 16byte. This is used for the scan router program.
5-845-016	Server Scheme (Secondary) DFU	*CTL	[- / - / -] This is used for the scan router program. 6 character strings.
5-845-017	Server Port Number (Secondary) DFU	*CTL	[1 to 65535 / 80 / 1/step] This is used for the scan router program.
5-845-018	Server URL Path (Secondary) DFU	*CTL	[- / - / -] Character strings 16byte. This is used for the scan router program.
5-845-022	Rapid Sending Control	*CTL	[0 or 1 / 1 / 1/step] Enables or disables the prevention function for the continuous data sending error. 0: Disable, 1: Enable Note <ul style="list-style-type: none"> ▪ If it is set wrong network setting, the machines will continue to sending data over a network. If you switch off this SP, machine stops communication to network when it found wrong setting in its self. ▪ This setting would reduce network traffic by wrong setting.

<p>5846</p>	<p>[UCS Setting] -</p>		
<p>5-846-001</p>	<p>Machine ID (For Delivery Server)</p>	<p>*CTL</p>	<p>[- / - / -] Displays the unique device ID in use by the delivery server directory. The value is only Displayed and cannot be changed. This ID is created from the NIC MAC or IEEE 1394 EUI. The ID is displayed as either 6-byle or 8-byte binary.</p>
<p>5-846-002</p>	<p>Machine ID Clear (for Delivery Server)</p>	<p>*CTL</p>	<p>[- / - / -] [Execute] Clears the unique ID of the device used as the name in the file transfer directory. Execute This SP if the connection of the device to the delivery server is unstable. After clearing the ID, the ID will be established again automatically by cycling the machine off and on.</p>
<p>5-846-003</p>	<p>Maximum Entries</p>	<p>*CTL</p>	<p>[2000 to 20000 / 2000 / 1/step] Changes the maximum number of entries that UCS can handle. If a value smaller than the present value is set, the UCS managed data is cleared, and the data (excluding user code information) is displayed</p>
<p>5-846-006</p>	<p>Delivery Server Retry Timer</p>	<p>*CTL</p>	<p>[0 to 255 / 0 / 1 / second] Sets the interval for retry attempts when the delivery server fails to acquire the delivery server address book. 0: retry OFF Retry time x retry count has to be set in 180second (SC reboot compatible model).</p>

5-846-007	Delivery Server Retry Times	*CTL	<p>[0 to 255 / 0 / 1time/step]</p> <p>Sets the number of retry attempts when the delivery server fails to acquire the delivery server address book.</p> <p>0: retry OFF</p> <p>Retry time x retry count has to be set in a 180 seconds (SC reboot compatible model).</p>
5-846-008	Delivery Server Maximum Entries	*CTL	<p>[2000 to 20000 / 2000 / 1/step]</p> <p>Sets the maximum number account entries of the delivery server user information managed by UCS.</p> <p>This SP would be reflected after rebooting the machine.</p>
5-846-010	LDAP Search Timeout	*CTL	<p>[1 to 255 / 60 / 1/step]</p> <p>Sets the length of the timeout for the search of the LDAP server.</p>
5-846-020	WSD Maximum Entries	*CTL	<p>[50 to 250 / 250 / 1/step]</p> <p>Sets the maximum entries for the address book of the WSD (WS-scanner).</p> <p>This SP would be reflected after rebooting the machine.</p>
5-846-021	Folder Auth Change	*CTL	<p>[0 or 1 / 0 / 1/step]</p> <p>0: Uses certification information of device login user.</p> <p>1: Uses certification information of address.</p> <p>This SP would be reflected after rebooting the machine.</p>

5-846-040	Addr Book Migraion(USB->HDD)	CTL	[- / - / -] [Execute] Transfers address book from SD/USB FlashROM to HDD when the model has address book in SD/USB FlashROM. After the transfer, change its Model that has address book in HDD.
5-846-041	Fill Addr Acl Info.	CTL	[- / - / -] [Execute]
<p>This SP must be executed immediately after installation of an HDD unit in a basic machine that previously had no HDD. The first time the machine is powered on with the new HDD installed; the system automatically takes the address book from the NVRAM and writes it onto the new HDD. However, the new address book on the HDD can be accessed only by the system administrator at this stage. Executing this SP by the service technician immediately after power on grants full address book access to all users.</p> <p>Procedure</p> <ol style="list-style-type: none"> 1. Turn the machine off. 2. Install the new HDD. 3. Turn the machine on. 4. The address book and its initial data are created on the HDD automatically. 5. However, at this point the address book can be accessed by only the system administrator or key operator. 6. Enter the SP mode and do SP5846-041. After this SP executes successfully, any user can access the address book 			
5-846-043	Addr Book Media	*CTL	[0 to 30 / 0 / 1/step] Displays the slot number where an address book data is in. 0: Unconfirmed 1: SD Slot 1 2: SD Slot 2 4: USB Flash ROM 20: HDD 30: Nothing

5-846-047	Initialize Local Addr Book	CTL	[- / - / -] [Execute] Clears the local address book information, including the user code.
5-846-048	Initialize Delivery Addr Book	CTL	[- / - / -] [Execute] Clears the distribution address book information, except the user code.
5-846-049	Initialize LDAP Addr Book	CTL	[- / - / -] [Execute] Clears the LDAP address book information, except the user code.
5-846-050	Initialize All Addr Book	CTL	[- / - / -] [Execute] Clears the LDAP address book information, except the user code. However administrator account (login ID & password) is not deleted. Administrator account is set at initialization of security setting.
5-846-051	Backup All Addr Book	CTL	[- / - / -] [Execute] Uploads all directory information to the SD card.
5-846-052	Restore All Addr Book	CTL	[- / - / -] [Execute] Downloads all directory information from the SD card.

<p>5-846-053</p>	<p>Clear Backup Info</p>	<p>CTL</p>	<p>[- / - / -] [Execute] Deletes the address book data from the SD card in the service slot. Deletes only the files that were uploaded from this machine. This feature does not work if the card is write-protected.</p> <p>Note</p> <ul style="list-style-type: none"> ▪ After you do this SP, go out of the SP mode, and then turn the power off. ▪ Do not remove the SD card until the Power LED stops flashing.
<p>5-846-060</p>	<p>Search option</p>	<p>*CTL</p>	<p>[0x00 to 0xff / 00001111 / 1/step] This SP uses bit switches to set up the fuzzy search options for the UCS local address book. [0: OFF,1: ON] Bit: Meaning 0: Checks both upper/lower case characters 1: Japan Only 2: Japan Only 3: Japan Only 4 to 7: Not Used</p>

<p>5-846-062</p>	<p>Complexity option 1</p>	<p>*CTL</p>	<p>[0 to 32 / 0 / 1/step]</p> <p>Use this SP to set the conditions for password entry to access the local address book.</p> <p>Specifically, this SP limits the password entry to upper case and sets the length of the password.</p> <p>Note</p> <ul style="list-style-type: none"> ▪ This SP does not normally require adjustment. ▪ This SP is enabled only after the system administrator has set up a group password policy to control access to the address book.
<p>5-846-063</p>	<p>Complexity Option 2 DFU</p>	<p>*CTL</p>	<p>[0 to 32 / 0 / 1/step]</p> <p>Use this SP to set the conditions for password entry to access the local address book.</p> <p>Specifically, this SP limits the password entry to lower case and sets the length of the password.</p> <p>Note</p> <ul style="list-style-type: none"> ▪ This SP does not normally require adjustment. ▪ This SP is enabled only after the system administrator has set up a group password policy to control access to the address book.

5-846-064	Complexity Option 3 DFU	*CTL	<p>[0 to 32 / 0 / 1/step]</p> <p>Use this SP to set the conditions for password entry to access the local address book.</p> <p>Specifically, this SP limits the password entry to numeric character and sets the length of the password.</p> <p>Note</p> <ul style="list-style-type: none"> ▪ This SP does not normally require adjustment. ▪ This SP is enabled only after the system administrator has set up a group password policy to control access to the address book.
5-846-065	Complexity Option 4 DFU	*CTL	<p>[0 to 32 / 0 / 1/step]</p> <p>Use this SP to set the conditions for password entry to access the local address book.</p> <p>Specifically, this SP limits the password entry to symbolic number and sets the length of the password.</p> <p>Note</p> <ul style="list-style-type: none"> ▪ This SP does not normally require adjustment. ▪ This SP is enabled only after the system administrator has set up a group password policy to control access to the address book.
5-846-091	FTP Auth Port Setting	*CTL	<p>[0 to 65535 / 3671 / 1/step]</p> <p>Specifies the FTP port for getting a distribution server address book that is used in the identification mode.</p>
5-846-094	Encryption Stat	*CTL	<p>[0 to 255 / - / 1/step]</p> <p>Shows the status of the encryption function for the address book data.</p>

	<p>0: Plain text in-operation. (in-use)</p> <p>1: Encryption in-operation. (in use) Encryption process finished.</p> <p>2: Encryption ->plain text in-conversion in-combined treatment.</p> <p>3: Plain-text->encryption in-conversion in-encryption.</p> <p>4: Encryption-> Plain-text double sign is completed.</p> <p>5: Plain-text-> Encryption is completed.</p> <p>6: Security in-change Encryption key change in-process</p> <p>7: Security change is completed Encryption key change is completed.</p> <p>8: Previous security key change file default is completed.</p> <p>9: C security key change is completed. Encryption key change is completed.</p>
--	--

5847	<p>[Rep Resolution Reduction]</p> <p>5847-002 through 5847-006 changes the default settings of image data sent externally by the Net File page reference function.</p> <p>5847 21 sets the default for JPEG image quality of image files controlled by NetFile.</p> <p>"Repository" refers to jobs to be printed from the document server with a PC and the DeskTopBinder software.</p>		
5-847-002	Rate for Copy B&W Text	*CTL	<p>[0 to 6 / 0 / 1/step]</p> <p>0: 1x</p> <p>1: 1/2x</p> <p>2: 1/3x</p> <p>3: 1/4x</p> <p>4: 1/6x</p> <p>5: 1/8x</p> <p>6: 2/3x</p>
5-847-003	Rate for Copy B&W Other	*CTL	<p>[0 to 6 / 0 / 1/step]</p> <p>0: 1x</p> <p>1: 1/2x</p> <p>2: 1/3x</p> <p>3: 1/4x</p> <p>4: 1/6x</p> <p>5: 1/8x</p> <p>6: 2/3x</p>

5-847-005	Rate for Printer B&W	*CTL	[0 to 6 / 0 / 1/step] 0: 1x 1: 1/2x 2: 1/3x 3: 1/4x 4: 1/6x 5: 1/8x 6: 2/3x
5-847-007	Rate for Printer B&W 1200dpi	*CTL	[0 to 6 / 1 / 1/step] 0: 1x 1: 1/2x 2: 1/3x 3: 1/4x 4: 1/6x 5: 1/8x 6: 2/3x
5-847-021	Network Quality Default for JPEG	*CTL	[5 to 95 / 50 / 1 /step] Sets the default value for the quality of JPEG images sent as NetFile pages. This function is available only with the MLB (Media Link Board) option installed.

5848	<p>[Web Service] 5848-002 sets the 4-bit switch assignment for the access control setting. Setting of 0001 has no effect on access and delivery from Scan Router. 5848-100 sets the maximum size allowed for downloaded images. The default is equal to 1 gigabyte.</p>		
5-848-002	Access Ctrl: Repository (only Lower 4bits)	*CTL	[0000 to 0010 / 00000010 / 4bit assign] 0000: access enabled 0001: access disabled 0010: read only
5-848-003	Access Control: Doc. Svr. Print (Lower 4bits)	*CTL	[0000 to 0010 / 00000000 / 4bit assign] 0000: access enabled 0001: access disabled 0010: read only

5-848-004	Access Control: udirectory (Lower 4bits)	*CTL	[0000 to 0010 / 00000000 / 4bit assign] 0000: access enabled 0001: access disabled 0010: read only
5-848-007	Access Control: Comm. Log Fax(Lower 4bits)	*CTL	[0000 to 0010 / 00000000 / 4bit assign] 0000: access enabled 0001: access disabled 0010: read only
5-848-009	Access Ctrl: Job Ctrl (Lower 4bits)	*CTL	[0000 to 0010 / 00000000 / 4bit assign] 0000: access enabled 0001: access disabled 0010: read only
5-848-011	Access Ctrl: Devicemanagement (Lower 4bits)	*CTL	[0000 to 0010 / 00000000 / 4bit assign] 0000: access enabled 0001: access disabled 0010: read only
5-848-021	Access Ctrl: Delivery (Lower 4bits)	*CTL	[0000 to 0010 / 00000000 / 4bit assign] 0000: access enabled 0001: access disabled 0010: read only
5-848-022	Access Ctrl: uadministration (Lower 4bits)	*CTL	[0000 to 0010 / 00000000 / 4bit assign] 0000: access enabled 0001: access disabled 0010: read only
5-848-024	Access Ctrl: Log Service (Lower 4bits)	*CTL	[0000 to 0010 / 00000000 / 4bit assign] 0000: access enabled 0001: access disabled 0010: read only

5-848-099	Repository: Download Image Setting	*CTL	[0000 to 0111 / 00000000 / 1/step] 0: setting 0, 1: setting 1 Bit0: Images download setting for MacOS. Bit1: Images download setting for windows. Bit2: For other OS setting (except Mac and windows)
5-848-100	Repository: Download Image Max. Size	*CTL	[1 to 2048 / 2048 / 1MByte/step] Specifies the max size of the image data that the machine can download.
5-848-217	Setting: Timing	*CTL	[0 to 2 / 0 / 1/step] 0: Transfer OFF 1: Successively transfer 2: Regular transfer

5849	[Installation Date] Displays or prints the installation date of the machine.		
5-849-001	Display	*CTL	[- / - / -] The "Counter Clear Day" has been changed to "Installation Date" or "Inst. Date".
5-849-002	Switch to Print	*CTL	[0 or 1 / 1 / 1/step] Determines whether the installation date is printed on the printout for the total counter. 0: OFF (No Print) 1: ON (Print)
5-849-003	Total Counter	*CTL	[0 to 999999999 / 0 / 1/step] Displays total count value from establishment data (SP5-849-001).

5850	[Address Book Function] Japanes Use Only -		
5-850-003	Replacement of Circuit Classifications	CTL	[- / - / - / -] [Replacement]

5851	[Bluetooth] Sets the operation mode for the Bluetooth unit. Press either key.		
5-851-001	Mode	CTL	[0 or 1 / 0 / 1/step] 0: Public 1: Private

5853	<p>[Stamp Data Download]</p> <p>Push [Execute] to download the fixed stamp data from the machine ROM onto the hard disk. Then these stamps can be used by the system. If this is not done, the user will not have access to the fixed stamps ("Confidential", "Secret", etc.).</p> <p>You must always execute this SP after replacing the HDD or after formatting the HDD.</p> <p>Always switch the machine off and on after executing this SP.</p> <p> Note</p> <ul style="list-style-type: none"> ▪ This SP can be executed only with the hard disks installed. 		
5-853-001	-	CTL	[- / - / -] [Execute]

5856	[Remote ROM Update] Allows the technician to upgrade the firmware using a local port (IEEE1284) when updating the remote ROM.		
5-856-002	Local Port	CTL	<p>[0 or 1 / 0 / 1/step]</p> <p>0: Disable 1: Enable</p> <p>When set to "1" allows reception of firmware data via the local port (IEEE 1284) during a remote ROM update.</p> <p>This setting is reset to zero after the machine is cycled off and on.</p> <p>Allows the technician to upgrade the firmware using a parallel cable.</p>

5857	[Save Debug Log] -		
5-857-001	On/Off	*CTL	<p>[0 or 1 / 0 / 1/step]</p> <p>0: OFF 1: ON</p> <p>Switches the debug log feature on and off. The debug log cannot be captured until this feature is switched on.</p>
5-857-002	Target(2:HDD 3:SD)	*CTL	<p>[1 to 3 / 2 / 1/step]</p> <p>1: IC card 2: HDD 3: SD card</p> <p>Selects the storage device to save debug logs information when the conditions set with SP5-858 are satisfied.</p>

5-857-101	Debug Logging Start Date	*CTL	[- / 20120101 / 1/step] Sets start date of the debug log output.
5-857-102	Debug Logging End Date	*CTL	[- / 20371212 / 1/step] Sets end date of the debug log output.
5-857-103	Acquire All Debug Logs	*CTL	[- / - / -] [Execute] Obtains all debug logs.
5-857-104	Acquire Only Controller Debug Logs	*CTL	[- / - / -] [Execute] Obtains controller debug log only.
5-857-105	Acquire Only Engine Debug Logs	*CTL	[- / - / -] [Execute] Obtains engine debug log only.
5-857-107	Acquire Only Opepanel Debug Logs	*CTL	[- / - / -] [Execute] Outputs the controller debug log to the media inserted front I/F
5-857-120	Make LogTrace Dir	*CTL	[- / - / -] [Execute] Makes a folder for the log trace in the SD card.
5-857-151	Get All Debug Logs Time Dips	*CTL	[- / - / -] [Execute] Displays the total time to get the all debug logs.
5-857-152	Get Controller Debug Logs Time Dips	*CTL	[- / - / -] [Execute] Displays the total time to get the controller debug logs.

5-857-153	Get Engine Debug Logs Time Disp	*CTL	[- / - / -] [Execute] Displays the total time to get the engine debug logs.
5-857-154	Get Opepanel Debug Logs Time Dips	*CTL	[- / - / -] [Execute] Displays the total time to get the operation panel debug logs.
5-857-155	Get SMC Time Dips	*CTL	[- / - / -] [Execute] Displays the total time to get the SMC data.

5860	[SMTP/POP3/IMAP4]		
	-		
5-860-020	Partial Mail Receive Timeout	*CTL	[1 to 168 / 72 / 1hour/step] Sets the amount of time to wait before saving a mail that breaks up during reception. The received mail is discarded if the remaining portion of the mail is not received during this prescribed time.
5-860-021	MDN Response RFC2298 Compliance	*CTL	[0 or 1 / 1 / 1/step] Determines whether RFC2.5298 compliance is switched on for MDN reply mail. 0: No 1: Yes Sends MAIL FROM SMTP Commands as empty (<>) when conforming to RFC2298.

5-860-022	SMTP Auth. From Field Replacement	*CTL	<p>[0 or 1 / 0 / 1/step]</p> <p>Determines whether the FROM item of the mail header is switched to the validated account after the SMTP server is validated.</p> <p>0: No. "From" item not switched. 1: Yes. "From item switched.</p>
5-860-025	SMTP Auth. Direct Setting	*CTL	<p>[0 to 255 / 00000000 / Multiple of 2/step]</p> <p>Selects the authentication method for SMPT.</p> <p>Bit switch: Bit 0: LOGIN Bit 1: PLAIN Bit 2: CRAM MD5 Bit 3: DIGEST MD5 Bit 4 to 7: Not used</p> <p>Note</p> <ul style="list-style-type: none"> Set 0 this SP usually.
5-860-026	S/MIME: MIME Header Setting	*CTL	<p>[0 to 2 / 0 / 1/step]</p> <p>Selects the MIME header type of an E-mail sent by S/MIME.</p> <p>0: Microsoft Outlook Express standard 1: Internet Draft standard 2: RFC standard</p>
5-860-028	S/MIME: Authentication Check	*CTL	<p>[0 or 1 / 0 / 1/step]</p> <p>0: non-check, 1: check</p> <p>Specifies whether to check or non-check address certification at sending S/MIME mail.</p>

5866	[E-Mail Report] This SP controls operation of the email notification function.		
5-866-001	Report Validity	CTL	[0 or 1 / 0 / 1/step] 0: Enabled, 1: Disabled Enables or disables the e-mail notification to @Remote.
5-866-005	Add Date Field	CTL	[0 or 1 / 0 / 1/step] 0: Enabled, 1: Disabled Disables and re-enables the addition of a date field to the email notification.

5870	[Common Key Info Writing] Writes to flash ROM the common proof for validating the device for NRS specifications.		
5-870-001	Writing	CTL	[- / - / -] [Execute]
5-870-003	Initialize	CTL	[- / - / -] [Execute] Initializes the set certification. When the GW controller board is replaced with a new one for repair, you must execute the "Inititalize (-003)" and "Writing (-001)" just after the new board replacement. NOTE: Turn off and on the main power switch after the "Initialize (-003)" and "Writing (-001)" have been done.
5-870-004	Writing: 2048bit	CTL	[- / - / -] [Execute] Writes the authentication data used for @Remote into the flash ROM.

<p>5873</p>	<p>[SDCardAppliMove] Allows you to move applications from one SD card to another.</p>		
<p>5-873-001</p>	<p>MoveExec</p>	<p>CTL</p>	<p>[- / - / -] [Execute] This SP copies the application programs from the original SD card in SD card slot 2 to an SD card in SD card slot 1.</p>
<p>5-873-002</p>	<p>UndoExec</p>	<p>CTL</p>	<p>[- / - / -] [Execute] This SP copies back the application programs from an SD card in SD Card Slot 2 to the original SD card in SD card slot 1. Use this menu when you have mistakenly copied some programs by using "Move Exec" (SP5873-1).</p>

<p>5875</p>	<p>[SC Auto Reboot] This SP determines whether the machine reboots automatically when an SC error occurs.  Note <ul style="list-style-type: none"> ▪ The reboot does not occur for Type A and C SC codes. </p>		
<p>5-875-001</p>	<p>Reboot Setting</p>	<p>*CTL</p>	<p>[0 or 1 / 0 / 1/step] Enables or disables the automatic reboot function when an SC error occurs. 0: The machine reboots automatically when the machine issues an SC error and logs the SC error code. If the same SC occurs again, the machine does not reboot. 1: The machine does not reboot when an SC error occurs. The reboot is not executed for Type A or C SC codes.</p>
<p>5-875-002</p>	<p>Reboot Type</p>	<p>*CTL</p>	<p>[0 or 1 / 0 / 1/step] This setting determines how the machine reboots after an SC code is issued. 0: Manual reboot 1: Automatic reboot.</p>

<p>5878</p>	<p>[Option Setup] This SP enables the DOS application (Data Overwrite Security). Do this SP after installing Data Overwrite Security Unit.)</p>		
<p>5-878-001</p>	<p>Data Overwrite Security</p>	<p>CTL</p>	<p>[- / - / -] [Execute] Enables the Data Overwrite Security unit. Press "EXECUTE" on the operation panel. Then reboot the machine.</p>
<p>5-878-002</p>	<p>HDD Encryption</p>	<p>CTL</p>	<p>[- / - / -] [Execute] Enables the Copy Data Security unit. Press "EXECUTE" on the operation panel. Then reboot the machine.</p>
<p>5-878-004</p>	<p>OCR Dictionary</p>	<p>CTL</p>	<p>[- / - / -] [Execute] Installation Process 1: Put the SD card in the SD slot (service slot), then start the device. 2: Execute SP5-878-004. 3: Reboot the machine. 4: Execute SP5-878-004. *This SP executes linking SD card and copying OCR dictionary. Step 2 executes linking SD card, and Step 4 executes copying dictionary. And be sure to turn Off the main power supply between step 2 (linking SD card) and step 4 (copying dictionary). * OCR dictionary is able to overwrite. Overwrite process is same as initial installation process. Use new SD card to execute Installation process 1 to 4.</p>

5879	[Editing Option] Japan Use Only		
5-879-001	-	*CTL	[- / - / -] [Execute]

5881	[Fixed Phrase Block Erasing] Touch [EXECUTE] on the operation panel. Then erase all the fixed phrase block.		
5-881-001	-	*CTL	[- / - / -] [Execute]

5885	[CPM Set] Sets access control for document box on Web Image Monitor.		
5-885-020	DocSvr Acc Ctrl	*CTL	[8bit / 00000000 / -] Sets access control for document box on Web Image Monitor. bit0: Forbid all document sever access (1) bit1: Forbid user mode access (1) bit2: Forbid print function (1) bit3: Forbid fax TX (1) bit4: Forbid scan sending (1) bit5: Forbid downloading (1) bit6: Forbid delete (1) bit7: Reserved
5-885-050	DocSvr Format	*CTL	[0 to 2 / 0 /1/step] 0: Thumbnail 1: Icon 2: Detail Sets the default display format for document list in document box.
5-885-051	DocSvr Trans	*CTL	[5 to 20 / 10 / 1/step] Sets the default display number of items per page in the document list in document box.

5-885-100	Set Signature	*CTL	[0 to 2 / 0 / 1/step] Sets whether to put signature or not when transferring mails that is scanned and stored from WIM.
5-885-101	Set Encrypsion	*CTL	[0 or 1 / 0 / 1/step] Determines whether the scanned documents with the WIM are encrypted when they are transmitted by an e-mail.
5-885-200	Detect Mem Leak	*CTL	[8bit / 00000000 / -] Controls memory leak detection of Web Image Monitor. Changed value of this SP will be available when displaying document list in document box on a new HTTP session.

5886	[Farm Update Setting]		
5-886-100	Skip Version Chech	-	[0 or 1 / 0 / 1/step] 0: Version check for package firmware 1: No version check for package firmware When selecting "0", only new firmware against the firmware in the machine is updated at the package firmware updating. Do not change this setting to "1" normally. The setting "1" is only used for a special order.

5-886-101	Skip LR Chech	-	<p>[0 or 1 / 0 / 1/step]</p> <p>0: Version check for indivisual firmware 1: No version check for indivisual firmware</p> <p>When selecting "0", indivisual firmware in the machine is not updated at the package firmware updating.</p> <p>Do not change this setting to "1" normally. The setting "1" is only used for a special order.</p>
-----------	---------------	---	---

5887	<p>[SD GetCounter]</p> <p>This SP determines whether the ROM can be updated.</p> <p>This SP sends a text file to an SD card inserted in SD card Slot 2 (lower slot). The operation stores. The file is stored in a folder created in the root directory of the SD card called SD_COUNTER. The file is saved as a text file (*.txt) prefixed with the number of the machine.</p> <ol style="list-style-type: none"> 1. Insert the SD card in SD card Slot 2 (lower slot). 2. Select SP5887 then touch [EXECUTE]. 3. Touch [Execute] in the message when you are prompted. 		
5-887-001	-	*CTL	<p>[- / - / -]</p> <p>[Execute]</p>

5888	<p>[Personal Information Protect]</p> <p>Selects the protection level for logs.</p>		
5-888-001	-	*CTL	<p>[0 or 1 / 0 / 1/step]</p> <p>0: No authentication, No protection for logs 1: No authentication, Protected logs (only an administrator can see the logs)</p>

5900	[Engine Log Upload] DFU		
	For design use. Do not change.		
5-900-001	Pattern	*ENG	[0 to 4 / 0 / 1/step]
5-900-002	Trigger	*ENG	[0 to 3 / 0 / 1/step]

5893	[SDK Application Counter]			
	Displays the counter name of each SDK application.			
	5-893-001	SDK-1	CTL	[- / - / -] [text display type]
	5-893-002	SDK-2	CTL	[- / - / -] [text display type]
	5-893-003	SDK-3	CTL	[- / - / -] [text display type]
	5-893-004	SDK-4	CTL	[- / - / -] [text display type]
	5-893-005	SDK-5	CTL	[- / - / -] [text display type]
	5-893-006	SDK-6	CTL	[- / - / -] [text display type]
	5-893-007	SDK-7	CTL	[- / - / -] [text display type]
	5-893-008	SDK-8	CTL	[- / - / -] [text display type]
	5-893-009	SDK-9	CTL	[- / - / -] [text display type]
	5-893-010	SDK-10	CTL	[- / - / -] [text display type]
	5-893-011	SDK-11	CTL	[- / - / -] [text display type]
5-893-012	SDK-12	CTL	[- / - / -] [text display type]	

5894	[External Mech Count Setting]		
	<p>Selects the charge mode of the external mechanical counter.</p> <p>0: The machine recognizes the B&W and color copier job.</p> <p>1: The machine recognizes the B&W and color copier, B&W and color printer job. But printer job counts as the copier job.</p> <p>2: The machine recognizes the B&W and color copier, B&W and color printer job.</p>		
5-894-001	Mech Counter Switch Setting	*ENG	[0 to 2 / 0 / 1/step]

5907	[Plug & Play Maker/Model Name]		
	<p>Selects the brand name and the production name for Windows Plug & Play. This information is stored in the NVRAM. If the NVRAM is defective, these names should be registered again.</p> <p>After selecting, press the "Original Type" key and "#" key at the same time. When the setting is completed, the beeper sounds five times.</p>		
5-907-001	-	*CTL	<p>Brand name (domestic B/W type is less than 7byte, domestic color type and abroad type are less than 15byte).</p> <p>Selects and sets model name (less than 16byte) by choosing from displayed on it.</p> <p>Set data on every Ricoh, OEM by CSS at the factory shipment already.</p> <p>And We set this SP that can select it from list for occurrence of error at NV-RAM.</p> <p>The setting can do at market too.</p> <p>The act of showing brand name and model name as character strings during choosing.</p> <p>The act of displaying selected maker name and model name as priority when access This SP item.</p>

5-907-001	-	*CTL	<p>[Operation on data entry.] Depress enter key (#) after choosing number. The act of displayed maker name and model name is changed this time.</p>
5-907-001	-	*CTL	<p>[data] Do not enter maker name and model name imperfectly at every word and every phrase. If it has wrong word, it cannot plug and play understandably. So we check the characters fully, the text is single byte character or double character? Is it space or under score? Is it capital letter or small letter? You have to check requirements specification fully. notice of entering following select parameter</p> <p>Note</p> <ul style="list-style-type: none"> ▪ The act of deleting a ruled line so that you will be required 2character at double character entry, or fill its back end with the grey. ▪ Consider the space that after character stings, enclose specified character strings by heavy ruled line.

5913	[Switchover Permission Time]		
	-		
5-913-002	Print Application Timer	*CTL	[3 to 30 / 3 / 1/step] Sets the amount of time to elapse while the machine is in standby mode (and the operation panel keys have not been used) before another application can gain control of the display.

5967	[Copy Server : Set Function]		
	-		
5-967-001	(0:ON 1:OFF)	*CTL	[0 or 1 / 0 / 1/step] Enables and disables the document server. This is a security measure that prevents image data from being left in the temporary area of the HDD. After changing this setting, you must switch the main switch off and on to enable the new setting.

5973	[User Stamp Registration]		
	-		
5-973-101	Frame deletion setting	*CTL	[0 to 3 / 0 / 0.1mm/step] Sets the margin for the user stamp registration for each edge of paper.

5974	[Cherry Server] -		
5-974-001	(0:Light 1:Full)	*CTL	[0 or 1 / 0 / 1/step] 0: Light version 1: Full version Selects which version of the Scan Router application program, "Light" or "Full (Professional)", is installed.

5985	[Device Setting] The NIC and USB support features are built into the GW controller. Use this SP to enable and disable these features. In order to use the NIC and USB functions built into the controller board, these SP codes must be set to "1".		
5-985-001	On Board NIC	CTL	[- / 0 / -]
5-985-002	On Board USB	CTL	[- / 0 / -]

5990	[SP print mode] Prints the SMC report. In the SP mode, press Copy Window to move to the copy screen, select the paper size, then press Start. Select A4/LT (Sideways) or larger to ensure that all the information prints. Press SP Window to return to the SP mode, select the desired print, and press Execute.		
5-990-001	All (Data List)	CTL	[- / - / -] [Execute]
5-990-002	SP (Mode Data List)	CTL	[- / - / -] [Execute]
5-990-003	User Program	CTL	[- / - / -] [Execute]
5-990-004	Logging Data	CTL	[- / - / -] [Execute]
5-990-005	Diagnostic Report	CTL	[- / - / -] [Execute]

5-990-006	Non-Default	CTL	[- / - / -] [Execute]
5-990-007	NIB Summary	CTL	[- / - / -] [Execute]
5-990-008	Capture Log	CTL	[- / - / -] [Execute]
5-990-021	Copier User Program	CTL	[- / - / -] [Execute]
5-990-022	Scanner SP	CTL	[- / - / -] [Execute]
5-990-023	Scanner User Program	CTL	[- / - / -] [Execute]
5-990-024	SDK/J Summary	CTL	[- / - / -] [Execute]
5-990-025	SDK/J Application Info	CTL	[- / - / -] [Execute]
5-990-026	Printer SP	CTL	[- / - / -] [Execute]

5992	<p>[SP Text mode] Prints the SMC report to a file on an SD card inserted into the SD card slot on the right side of the machine operation panel. 1: front SD slot 2: back SD slot (service slot)</p>		
5-992-001	All (Data List)	CTL	[- / - / -] [Execute]
5-992-002	SP (Mode Data List)	CTL	[- / - / -] [Execute]
5-992-003	User Program	CTL	[- / - / -] [Execute] This SP for only MFP model.

5-992-004	Logging Data	CTL	[- / - / -] [Execute]
5-992-005	Diagnostic Report	CTL	[- / - / -] [Execute]
5-992-006	Non-Default	CTL	[- / - / -] [Execute]
5-992-007	NIB Summary	CTL	[- / - / -] [Execute]
5-992-008	Capture Log	CTL	[- / - / -] [Execute] This SP for only MFP model.
5-992-021	Copier User Program	CTL	[- / - / -] [Execute] This SP for only MFP model.
5-992-022	Scanner SP	CTL	[- / - / -] [Execute] This SP for only MFP model.
5-992-023	Scanner User Program	CTL	[- / - / -] [Execute] This SP for only MFP model.
5-992-024	SDK/J Summary	CTL	[- / - / -] [Execute]
5-992-025	SDK/J Application Info	CTL	[- / - / -] [Execute]
5-992-026	Printer SP mode	CTL	[- / - / -] [Execute]

5.9 SP MODE TABLES - SP6000-1

5.9.1 SP6-XXX (PERIPHERALS)

6006	[ADF Adjustment]		
6-006-001	Side-to-Side Regist: Front	*ENG	[-3.0 to 3.0 / 0.0 / 0.1 mm/step]
	Adjusts the main scan registration of the front original for ADF. <ul style="list-style-type: none"> ▪ Value increase: an image is moved to the right side of paper. ▪ Value decrease: an image is moved to the left side of paper. 		
6-006-002	Side-to-Side Regist: Rear	*ENG	[-3.0 to 3.0 / 0.0 / 0.1 mm/step]
	Adjusts the main scan registration of the rear original for ADF. <ul style="list-style-type: none"> ▪ Value increase: an image is moved to the right side of paper. ▪ Value decrease: an image is moved to the left side of paper. 		
6-006-003	Leading Edge Registration: Front	*ENG	[-5.0 to 5.0 / 0.0 / 0.1 mm/step]
	Adjusts the DFGATE assert timing of the front original for ADF. If the leading edge margin of image is wide, increase value. If the part of image is missing, decrease value. <ul style="list-style-type: none"> ▪ Value increase: an image is moved to the leading edge of paper. ▪ Value decrease: an image is moved to the trailing edge of paper. 		
6-006-004	Leading Edge Registration: Rear	*ENG	[-5.0 to 5.0 / 0.0 / 0.1 mm/step]
	Adjusts the DFGATE assert timing of the rear original for ADF. If the leading edge margin of image is wide, increase value. If the leading edge of image is missing, decrease value. <ul style="list-style-type: none"> ▪ Value increase: an image is moved to the leading edge of paper. ▪ Value decrease: an image is moved to the trailing edge of paper. 		

6-006-005	Buckle: Duplex Front	*ENG	[-5.0 to 5.0 / 0.0 / 0.1 mm/step]
	Adjusts the buckle amount (skew correct amount) of the front original for ADF. If the original skew is unacceptable, increase value. If the leading edge of original is damaged, decrease value. <ul style="list-style-type: none"> ▪ Value increase: increases front side buckle amount. ▪ Value decrease: decreases front side buckle amount. 		
6-006-006	Buckle: Duplex Rear	*ENG	[-5.0 to 5.0 / 0.0 / 0.1 mm/step]
	Adjusts the buckle amount (skew correct amount) of the rear original for ADF. If the original skew is unacceptable, increase value. If the leading edge of original is damaged, decrease value. <ul style="list-style-type: none"> ▪ Value increase: increases rear side buckle amount. ▪ Value decrease: decreases rear side buckle amount. 		
6-006-007	Rear Edge Erase Front	*ENG	[-10.0 to 10.0 / 0.0 / 0.1 mm/step]
	Adjusts the DFGATE negate timing of the front original for ADF. If the trailing edge of the front original has the shadow, use this SP to erase it. <ul style="list-style-type: none"> ▪ Value increase: Decreases scanning range of the trailing edge of original. ▪ Value decrease: Increases scanning range of the trailing edge of original. 		
6-006-008	Rear Edge Erase Rear	*ENG	[-10.0 to 10.0 / 0.0 / 0.1 mm/step]
	Adjusts the DFGATE negate timing of the rear original for ADF. If the trailing edge of the rear original has the shadow, use this SP to erase it. <ul style="list-style-type: none"> ▪ Value increase: Decreases scanning range of the trailing edge of original. ▪ Value decrease: Increases scanning range of the trailing edge of original. 		

6-006-010	L-Edge Regist (1-Pass): Front	*ENG	[-5.0 to 5.0 / 0.0 / 0.1 mm/step]
	For SPDF models only. Adjusts the leading edge registration of the front original for SPDF. <ul style="list-style-type: none"> ▪ Value Increase: Registration start timing is later. ▪ Value decrease: Registration start timing is earlier. 		
6-006-011	L-Edge Regist (1-Pass): Rear	*ENG	[-5.0 to 5.0 / 0.0 / 0.1 mm/step]
	For SPDF models only. Adjusts the leading edge registration of the rear original for SPDF. <ul style="list-style-type: none"> ▪ Value Increase: Registration start timing is later. ▪ Value decrease: Registration start timing is earlier. 		
6-006-012	1st Buckle (1-Pass)	*ENG	[-3.0 to 3.0 / 0.0 / 0.1 mm/step]
	For SPDF models only. Adjusts the buckle amount (skew correct amount) of the front original for SPDF. <ul style="list-style-type: none"> ▪ Value Increase: Buckling amount decreases. ▪ Value decrease: Buckling amount increases. 		
6-006-013	2nd Buckle (1-Pass)	*ENG	[-2.0 to 3.0 / 0.0 / 0.1 mm/step]
	For SPDF models only. Adjusts the buckle amount (skew correct amount) of the rear original for SPDF.		
6-006-014	T-Edge Erase (1-Pass): Front	*ENG	[-5.0 to 5.0 / -1.5 / 0.1 mm/step]
	For SPDF models only. Adjusts the erase margin of the front side at the original trailing edge for SPDF. <ul style="list-style-type: none"> ▪ Value increase: Dereases scanning range of the trailing edge of original. ▪ Value decrease: Increases scanning range of the trailing edge of original. 		

6-006-015	T-Edge Erase (1-Pass): Rear	*ENG	[-5.0 to 5.0 / -1.5 / 0.1 mm/step]
	For SPDF models only. Adjusts the erase margin of the rear side at the original trailing edge for SPDF. <ul style="list-style-type: none"> ▪ Value increase: add trailing edge to image. ▪ Value decrease: erases trailing edge of image. 		

6007	[ADF INPUT Check]		
	See page 5-355 "Input Check Table".		

6008	[ADF OUTPUT Check]		
	See page 5-387 "Output Check Table".		

6010	[Stamp Position Adj.]		
	Adjusts stamping position of DONE stamp. <ul style="list-style-type: none"> ▪ Value increase: Moves stamp position towards original trailing edge. ▪ Value decrease: Moves stamp position towards original leading edge. 		
6-010-001	-	*ENG	[-5.0 to 5.0 / 0.0 / 0.1 mm/step]

6011	[1-Pass ADF INPUT Check]		
	See page 5-355 "Input Check Table".		

6012	[1-Pass ADF OUTPUT Check]		
	See page 5-387 "Output Check Table".		

6016	[Original Size Detect Setting]		
	Sets to judge as witch original size for two original sizes that can not be judged with ADF. Size of each bit is different depending on region. Set corresponding bit to "0" when to prior the default size. Set "1" to let the switching size judge.		
6-016-001	-	*ENG	[0 to 255 / 00000000 / 1/step]

6017	[DF Magnification Adj.]		
	Changes the line speed corresponding to the magnification setting value. The scanning magnification is slightly affected by causes such as the tolerance of the transfer roller diameter. Use this to adjust the scanning magnification for customer's demand. Adjust the scanning magnification in units of 0.1% to the paper transfer speed. Adjusting the value to "+" shortens the image.		
6-017-001	-	*ENG	[-5.0 to 5.0 / 0.0 / 0.1 %/step]

6020	[Skew Correction Moving Setting]		
	Selects the paper size for the original skew correction.		
6-020-001	-	*ENG	[0 or 1 / 0 / 1/step] 0: Small sizes (B6, A5, HLT) 1: All sizes

6100	[Sub-scanPunchPosAdj:2K/3K FIN]		
	Adjusts the punch position in the sub scan direction. <ul style="list-style-type: none"> ▪ Adjusting value to -: Punch position moves toward trailing edge of paper. ▪ Adjusting value to +: Punch position moves toward leading edge of paper. 		
6-100-001	JPN/EU: 2-Hole	ENG	[-7.5 to 7.5 / 0.0 / 0.5mm/step]
6-100-002	NA: 3-Hole	ENG	
6-100-003	Europe: 4-Hole	ENG	
6-100-004	NEU: 4-Hole	ENG	
6-100-005	NA: 2-Hole	ENG	

6101	[Main-scanPunchPosAdj:2K/3K FIN]		
	Adjusts the punch position in the main scan direction. <ul style="list-style-type: none"> ▪ Adjusting value to -: Punch position moves toward front side of machine. ▪ Adjusting value to +: Punch position moves toward rear side of machine. 		
6-101-001	JPN/EU: 2-Hole	ENG	[-2.0 to 2.0 / 0.0 / 0.4mm/step]
6-101-002	NA: 3-Hole	ENG	
6-101-003	Europe: 4-Hole	ENG	
6-101-004	NEU: 4-Hole	ENG	
6-101-005	NA: 2-Hole	ENG	

6102	[SkewCorrectBuckleAdj:2K/3K FIN]		
	Adjusts the skew correction amount in the punch mode for each paper size. <ul style="list-style-type: none"> ▪ Adjusts value to -: Buckling amount decreases ▪ Adjusts value to +: Buckling amount increases. 		
6-102-001	A3 SEF	ENG	[-5.0 to 5.0 / 0.0 / 0.2mm/step]
6-102-002	B4 SEF	ENG	
6-102-003	A4 SEF	ENG	
6-102-004	A4 LEF	ENG	
6-102-005	B5 SEF	ENG	
6-102-006	B5 LEF	ENG	[-5.0 to 5.0 / 0.0 / 0.2mm/step]
6-102-007	A5 LEF	ENG	
6-102-008	DLT SEF	ENG	
6-102-009	LG SEF	ENG	
6-102-010	LT SEF	ENG	
6-102-011	LT LEF	ENG	[-5.0 to 5.0 / 0.0 / 0.2mm/step]
6-102-012	HLT LEF	ENG	
6-102-013	12x18	ENG	
6-102-014	8K SEF	ENG	
6-102-015	16K SEF	ENG	
6-102-016	16K LEF	ENG	
6-102-017	Other	ENG	[-5.0 to 5.0 / 0.0 / 0.2mm/step]
	Adjusts the skew correction amount in the punch mode for non specified paper. <ul style="list-style-type: none"> ▪ Adjusts value to -: Buckling amount decreases ▪ Adjusts value to +: Buckling amount increases. 		

6103	[SkewCorrectCtrlSW:2K/3K FIN]		
	Enables or disables the skew correction in the punch mode for each paper size.		
6-103-001	A3 SEF	ENG	[0 or 1 / 0 / 1/step] 0: BuckleAdj On 1: BuckleAdj Off
6-103-002	B4 SEF	ENG	
6-103-003	A4 SEF	ENG	
6-103-004	A4 LEF	ENG	
6-103-005	B5 SEF	ENG	
6-103-006	B5 LEF	ENG	[0 or 1 / 0 / 1/step] 0: BuckleAdj On 1: BuckleAdj Off
6-103-007	A5 LEF	ENG	
6-103-008	DLT SEF	ENG	
6-103-009	LG SEF	ENG	
6-103-010	LT SEF	ENG	
6-103-011	LT LEF	ENG	[0 or 1 / 0 / 1/step] 0: BuckleAdj On 1: BuckleAdj Off
6-103-012	HLT LEF	ENG	
6-103-013	12x18	ENG	
6-103-014	8K SEF	ENG	
6-103-015	16K SEF	ENG	
6-103-016	16K LEF	ENG	
6-103-017	Other	ENG	[0 or 1 / 0 / 1/step] 0: BuckleAdj On 1: BuckleAdj Off
	Enables or disables the skew correction in the punch mode for non specified paper.		

6104	[ShiftTrayJogPosAdj:2K/3K FIN]		
	These SPs are not used for the finisher D688/D689.		
6-104-001	A3 SEF	ENG	[-1.5 to 1.5 / 0.0 / 0.5mm/step]
6-104-002	B4 SEF	ENG	
6-104-003	A4 SEF	ENG	
6-104-004	A4 LEF	ENG	
6-104-005	B5 LEF	ENG	
6-104-006	A5 LEF	ENG	[-1.5 to 1.5 / 0.0 / 0.5mm/step]
6-104-007	DLT SEF	ENG	
6-104-008	LG SEF	ENG	
6-104-009	LT SEF	ENG	
6-104-010	LT LEF	ENG	
6-104-011	HLT LEF	ENG	[-1.5 to 1.5 / 0.0 / 0.5mm/step]
6-104-012	8K SEF	ENG	
6-104-013	16K LEF	ENG	
6-104-014	Other	ENG	[-1.5 to 1.5 / 0.0 / 0.5mm/step]

6105	[ShftTJogRtrctAngAdj:2K/3K FIN]		
	These SPs are not used for the finisher D688/D689.		
6-105-001	A3 SEF	ENG	[-10 to 10 / 0 / 5deg/step]
6-105-002	B4 SEF	ENG	
6-105-003	A4 SEF	ENG	
6-105-004	DLT SEF	ENG	
6-105-005	LG SEF	ENG	
6-105-006	LT SEF	ENG	
6-105-007	8K SEF	ENG	
6-105-008	Other	ENG	[-10 to 10 / 0 / 5deg/step]

6106	[Use Paper Jogger: 2K/3K FIN]		
	These SPs are not used for the finisher D688/D689.		
6-106-001	A3 SEF	ENG	[0 or 1 / 0 / 1/step] 0: Jogging On 1: Jogging Off
6-106-002	B4 SEF	ENG	
6-106-003	A4 SEF	ENG	
6-106-004	A4 LEF	ENG	
6-106-005	B5 LEF	ENG	[0 or 1 / 0 / 1/step] 0: Jogging On 1: Jogging Off
6-106-006	A5 LEF	ENG	
6-106-007	DLT SEF	ENG	
6-106-008	LG SEF	ENG	
6-106-009	LT SEF	ENG	
6-106-010	LT LEF	ENG	[0 or 1 / 0 / 1/step] 0: Jogging On 1: Jogging Off
6-106-011	HLT LEF	ENG	
6-106-012	8K SEF	ENG	

6-106-013	16K LEF	ENG	
6-106-014	Other	ENG	[0 or 1 / 0 / 1/step] 0: Jogging On 1: Jogging Off

6107	[JogPosAdj(CrnStplr):2K/3K FIN]		
	<p>Adjusts the width (main scan direction) of the jogger fences on the corner stapling unit for each paper size.</p> <ul style="list-style-type: none"> ▪ Adjusts value to -: Width between jogger fences becomes shorter than the default value. ▪ Adjusts value to +: Width between jogger fences becomes wider than the default value. 		
6-107-001	A3 SEF	ENG	[-1.5 to 1.5 / 0.0 / 0.5mm/step]
6-107-002	B4 SEF	ENG	
6-107-003	A4 SEF	ENG	
6-107-004	A4 LEF	ENG	
6-107-005	B5 SEF	ENG	
6-107-006	B5 LEF	ENG	[-1.5 to 1.5 / 0.0 / 0.5mm/step]
6-107-007	DLT SEF	ENG	
6-107-008	LG SEF	ENG	
6-107-009	LT SEF	ENG	
6-107-010	LT LEF	ENG	
6-107-011	8K SEF	ENG	[-1.5 to 1.5 / 0.0 / 0.5mm/step]
6-107-012	16K SEF	ENG	
6-107-013	16K LEF	ENG	
6-107-014	Other	ENG	

	<p>Adjusts the width (main scan direction) of the jogger fences on the corner stapling unit for non specified paper.</p> <ul style="list-style-type: none"> ▪ Adjusts value to -: Width between jogger fences becomes shorter than the default value. ▪ Adjusts value to +: Width between jogger fences becomes wider than the default value.
--	---

6108	[JogPosAdj(BookStplr):2K/3K FIN]		
	<p>Adjusts the width (main scan direction) of the jogger fences on the booklet stapling unit for each paper size.</p> <ul style="list-style-type: none"> ▪ Adjusts value to -: Width between jogger fences becomes shorter than the default value. ▪ Adjusts value to +: Width between jogger fences becomes wider than the default value. 		
	6-108-001	A3 SEF	ENG
	6-108-002	B4 SEF	ENG
	6-108-003	A4 SEF	ENG
	6-108-004	B5 SEF	ENG
	6-108-005	DLT SEF	ENG
	6-108-006	LG SEF	ENG
	6-108-007	LT SEF	ENG
	6-108-008	12x18	ENG
6-108-009	8K SEF	ENG	
6-108-010	Other	ENG	

[-1.5 to 1.5 / **0.0** / 0.5mm/step]

6109	[CnrStplrJogTimeAdj:2K/3K FIN]		
	Adjusts the jogging times of the jogger fences on the corner stapling unit for each paper size.		
6-109-001	A3 SEF	*ENG	[0 to 2 / 0 / 1time/step]
6-109-002	B4 SEF	*ENG	
6-109-003	A4 SEF	*ENG	
6-109-004	A4 LEF	*ENG	
6-109-005	B5 SEF	*ENG	
6-109-006	B5 LEF	*ENG	[0 to 2 / 0 / 1time/step]
6-109-007	DLT SEF	*ENG	
6-109-008	LG SEF	*ENG	
6-109-009	LT SEF	*ENG	
6-109-010	LT LEF	*ENG	
6-109-011	8K SEF	*ENG	[0 to 2 / 0 / 1time/step]
6-109-012	16K SEF	*ENG	
6-109-013	16K LEF	*ENG	
6-109-014	Other	*ENG	[0 to 2 / 0 / 1time/step]

6110	[BookStplrJogTimeAdj:2K/3K FIN]		
	Adjusts the jogging times of the jogger fences on the booklet stapling unit for each paper size.		
6-110-001	A3 SEF	ENG	[0 to 2 / 0 / 1time/step]
6-110-002	B4 SEF	ENG	
6-110-003	A4 SEF	ENG	
6-110-004	B5 SEF	ENG	
6-110-005	DLT SEF	ENG	[0 to 2 / 0 / 1time/step]

6-110-006	LG SEF	ENG	
6-110-007	LT SEF	ENG	
6-110-008	12x18	ENG	
6-110-009	8K SEF	ENG	
6-110-010	Other	ENG	[0 to 2 / 0 / 1time/step]

6111	[Staple Position Adj: 2K/3K FIN]		
	<p>Adjusts the staple position of the corner stapling unit in the main scan direction for each paper size.</p> <p>Adjusting value to -: Staple position moves toward the front side of machine.</p> <p>Adjusting value to +: Staple position moves toward the rear side of machine.</p>		
6-111-001	A3 SEF	ENG	
6-111-002	B4 SEF	ENG	
6-111-003	A4 SEF	ENG	[-3.5 to 3.5 / 0.0 / 0.5mm/step]
6-111-004	A4 LEF	ENG	
6-111-005	B5 SEF	ENG	
6-111-006	B5 LEF	ENG	
6-111-007	DLT SEF	ENG	
6-111-008	LG SEF	ENG	[-3.5 to 3.5 / 0.0 / 0.5mm/step]
6-111-009	LT SEF	ENG	
6-111-010	LT LEF	ENG	
6-111-011	8K SEF	ENG	
6-111-012	16K SEF	ENG	[-3.5 to 3.5 / 0.0 / 0.5mm/step]
6-111-013	16K LEF	ENG	
6-111-014	Other	ENG	[-3.5 to 3.5 / 0.0 / 0.5mm/step]

6112	[BookletStaplerPosAdj:2K/3K FIN]		
	<p>Adjusts the staple position of the booklet stapling unit in the sub scan direction for each paper size.</p> <ul style="list-style-type: none"> ▪ Adjusting value to -: Staple position moves toward the trailing edge of paper. ▪ Adjusting value to +: Staple position moves toward the leading edge of paper. 		
6-112-001	A3 SEF	ENG	[-3.0 to 3.0 / 0.0 / 0.2mm/step]
6-112-002	B4 SEF	ENG	[-3.0 to 3.0 / 0.0 / 0.2mm/step]
6-112-003	A4 SEF	ENG	[-3.0 to 3.0 / 0.0 / 0.2mm/step]
6-112-004	B5 SEF	ENG	[-3.0 to 3.0 / 0.0 / 0.2mm/step]
6-112-005	DLT SEF	ENG	[-3.0 to 3.0 / 0.0 / 0.2mm/step]
6-112-006	LG SEF	ENG	[-3.0 to 3.0 / 0.0 / 0.2mm/step]
6-112-007	LT SEF	ENG	[-3.0 to 3.0 / 0.0 / 0.2mm/step]
6-112-008	12x18	ENG	[-1.8 to 1.8 / 0.0 / 0.2mm/step]
6-112-009	8K SEF	ENG	[-3.0 to 3.0 / 0.0 / 0.2mm/step]
6-112-010	Other	ENG	[-1.8 to 1.8 / 0.0 / 0.2mm/step]

6113	[BookletFolderPosAdj:2K/3K FIN]		
	<p>Adjusts the folding position of the booklet stapling unit in the sub scan direction for each paper size.</p> <ul style="list-style-type: none"> ▪ Adjusting value to -: Folding position moves toward the trailing edge of paper. ▪ Adjusting value to +: Folding position moves toward the leading edge of paper. 		
6-113-001	A3 SEF	ENG	[-3.0 to 3.0 / 0.0 / 0.2mm/step]
6-113-002	B4 SEF	ENG	[-3.0 to 3.0 / 0.0 / 0.2mm/step]
6-113-003	A4 SEF	ENG	[-3.0 to 3.0 / 0.0 / 0.2mm/step]
6-113-004	B5 SEF	ENG	[-3.0 to 3.0 / 0.0 / 0.2mm/step]

6-113-005	DLT SEF	ENG	[-3.0 to 3.0 / 0.0 / 0.2mm/step]
6-113-006	LG SEF	ENG	[-3.0 to 3.0 / 0.0 / 0.2mm/step]
6-113-007	LT SEF	ENG	[-3.0 to 3.0 / 0.0 / 0.2mm/step]
6-113-008	12x18	ENG	[-3.0 to 3.0 / 0.0 / 0.2mm/step]
6-113-009	8K SEF	ENG	[-3.0 to 3.0 / 0.0 / 0.2mm/step]
6-113-010	Other	ENG	[-3.0 to 3.0 / 0.0 / 0.2mm/step]

6114	[Fold Speed Adj.: 2K/3K FIN]		
	Adjusts the folding speed (extra folding time) of booklet stapling unit for each paper size. <ul style="list-style-type: none"> ▪ Adjust value: 0 (Standard) ▪ Adjust value: 1 (Middle speed: Standard +2.6 sec.) ▪ Adjust value: 2 (Low speed: Standard +5.2 sec.) 		
6-114-001	A3 SEF	ENG	[0 to 2 / 0 / 1/step]
6-114-002	B4 SEF	ENG	[0 to 2 / 0 / 1/step]
6-114-003	A4 SEF	ENG	[0 to 2 / 0 / 1/step]
6-114-004	B5 SEF	ENG	[0 to 2 / 0 / 1/step]
6-114-005	DLT SEF	ENG	[0 to 2 / 0 / 1/step]
6-114-006	LG SEF	ENG	[0 to 2 / 0 / 1/step]
6-114-007	LT SEF	ENG	[0 to 2 / 0 / 1/step]
6-114-008	12x18	ENG	[0 to 2 / 0 / 1/step]
6-114-009	8K SEF	ENG	[0 to 2 / 0 / 1/step]
6-114-010	Other	ENG	[0 to 2 / 0 / 1/step]

6116	[CnrStplrMxPrstkShAdj:2K/3KFIN]		
	Adjusts the maximum number of the pre-stack sheets on the corner stapling unit for each paper size. <ul style="list-style-type: none"> ▪ Adjust value: 0; 1 sheet pre-stack (standard) ▪ Adjust value: -1; No pre-stack 		
6-116-001	A3 SEF	ENG	[-1 to 0 / 0 / 1sheet/step]
6-116-002	B4 SEF	ENG	
6-116-003	A4 SEF	ENG	
6-116-004	A4 LEF	ENG	
6-116-005	B5 SEF	ENG	
6-116-006	B5 LEF	ENG	[-1 to 0 / 0 / 1sheet/step]
6-116-007	DLT SEF	ENG	
6-116-008	LG SEF	ENG	
6-116-009	LT SEF	ENG	
6-116-010	LT LEF	ENG	
6-116-011	8K SEF	ENG	[-1 to 0 / 0 / 1sheet/step]
6-116-012	16K SEF	ENG	
6-116-013	16K LEF	ENG	
6-116-014	Other	ENG	[-1 to 0 / 0 / 1sheet/step]

6117	[BookStplrMxPrstkShAdj:2K/3KFIN]		
	Adjusts the maximum number of the pre-stack sheets on the booklet stapling unit for each paper size. <ul style="list-style-type: none"> ▪ Adjust value: 0; 3 sheets pre-stack (standard) ▪ Adjust value: -1; 2 sheets pre-stack ▪ Adjust value: -2; 1 sheet pre-stack ▪ Adjust value: -3 to -7; no pre-stack. 		
6-117-001	A3 SEF	ENG	[-7 to 0 / 0 / 1sheet/step]
6-117-002	B4 SEF	ENG	
6-117-003	A4 SEF	ENG	
6-117-004	B5 SEF	ENG	
6-117-005	DLT SEF	ENG	[-7 to 0 / 0 / 1sheet/step]
6-117-006	LG SEF	ENG	
6-117-007	LT SEF	ENG	
6-117-008	12x18	ENG	
6-117-009	8K SEF	ENG	
6-117-010	Other	ENG	

6118	[CnrStplrPrstkOffsAdj:2K/3KFIN]		
	Adjusts the pre-stack offset amount between stacked paper on the corner stapling unit for each paper size. Default offset: 20mm <ul style="list-style-type: none"> ▪ Adjusting value to -: Offset amount decreases. ▪ Adjusting value to +: Offset amount increases. 		
6-118-001	A3 SEF	ENG	[-16 to 16 / 0 / 2mm/step]
6-118-002	B4 SEF	ENG	
6-118-003	A4 SEF	ENG	
6-118-004	A4 LEF	ENG	
6-118-005	B5 SEF	ENG	
6-118-006	B5 LEF	ENG	[-16 to 16 / 0 / 2mm/step]
6-118-007	DLT SEF	ENG	
6-118-008	LG SEF	ENG	
6-118-009	LT SEF	ENG	
6-118-010	LT LEF	ENG	
6-118-011	8K SEF	ENG	[-16 to 16 / 0 / 2mm/step]
6-118-012	16K SEF	ENG	
6-118-013	16K LEF	ENG	
6-118-014	Other	ENG	[-16 to 16 / 0 / 2mm/step]

5.10 SP MODE TABLES - SP6000-2

5.10.1 SP6-XXX (PERIPHERALS)

6119	[BookStplrPrstkOffsAdj:2K/3KFIN]		
	Adjusts pre-stack offset amount (sub scan direction shearing amount of 1st and 2nd, 2nd and 3rd sheet) when saddle stitching specified paper. Default is No offset, when adjusting value to +, offset amount enlarges, when adjusting value to -, reduces.		
6-119-001	A3 SEF	ENG	[-30 to 30 / 0 / 2mm/step]
6-119-002	B4 SEF	ENG	
6-119-003	A4 SEF	ENG	
6-119-004	B5 SEF	ENG	
6-119-005	DLT SEF	ENG	[-30 to 30 / 0 / 2mm/step]
6-119-006	LG SEF	ENG	
6-119-007	LT SEF	ENG	
6-119-008	12x18	ENG	
6-119-009	8K SEF	ENG	
6-119-010	Other	ENG	[-30 to 30 / 0 / 2mm/step]
	Adjusts pre-stack offset amount (sub scan direction shearing amount of 1st and 2nd, 2nd and 3rd sheet) when saddle stitching except the specified paper. Default is No offset, when adjusting value to +, offset amount enlarges, when adjusting value to -, reduces.		

6120	[CrnStpPosExFeedAmtAdj:2K/3KFIN]		
	Adjusts over sending amount (sub scan direction) of positioning roller when edge stitching specified paper.		
6-120-001	A3 SEF	ENG	[0 to 30 / 0 / 10mm/step]
6-120-002	B4 SEF	ENG	
6-120-003	A4 SEF	ENG	
6-120-004	A4 LEF	ENG	
6-120-005	B5 SEF	ENG	
6-120-006	B5 LEF	ENG	[0 to 30 / 0 / 10mm/step]
6-120-007	DLT SEF	ENG	
6-120-008	LG SEF	ENG	
6-120-009	LT SEF	ENG	
6-120-010	LT LEF	ENG	
6-120-011	8K SEF	ENG	[0 to 30 / 0 / 10mm/step]
6-120-012	16K SEF	ENG	
6-120-013	16K LEF	ENG	
	Other	ENG	
6-120-014	Adjusts over sending amount (sub scan direction) of positioning roller when edge stitching except the specified paper.		

6122	[BkFoldJogSolMovAmtAdj:2K/3KFIN]		
	Adjusts move amount of saddle stitch conformity claw when saddle stitching specified paper. <ul style="list-style-type: none"> ▪ Adjusts value to +: towards up ▪ Adjusts value to -: towards down 		
6-122-001	A3 SEF	ENG	[-5 to 5 / 0 / 1mm/step]
6-122-002	B4 SEF	ENG	
6-122-003	A4 SEF	ENG	
6-122-004	B5 SEF	ENG	
6-122-005	DLT SEF	ENG	[-5 to 5 / 0 / 1mm/step]
6-122-006	LG SEF	ENG	
6-122-007	LT SEF	ENG	
6-122-008	12x18	ENG	
6-122-009	8K SEF	ENG	
6-122-010	Other	ENG	Adjusts move amount of saddle stitch conformity claw when saddle stitching except the specified paper. <ul style="list-style-type: none"> ▪ Adjusts value to +: towards up ▪ Adjusts value to -: towards down

6123	[INPUT Check: 2K/3K FIN]		
	See page 5-355 "Input Check Table".		

6124	[OUTPUT Check: 2K/3K FIN]		
	See page 5-387 "Output Check Table".		

6130	[Sub-scan PunchPosAdj:FrontFIN]		
	Adjusts position of carry direction (sub scan direction) for punch. <ul style="list-style-type: none"> ▪ Adjusting value to -: hole position moves toward trailing edge of paper when intaking. ▪ Adjusting value to +: hole position moves toward leading edge of paper when intaking. 		
6-130-001	Domestic 2Hole(Europe 2Hole)	*ENG	[-7.5 to 7.5 / 0.0 / 0.5mm/step]
6-130-002	North America 3Hole	*ENG	
6-130-003	Europe 4Hole	*ENG	
6-130-004	North Europe 4Hole	*ENG	
6-130-005	North America 2Hole	*ENG	

6131	[Main-scan PunchPosAdj:FrontFIN]		
	Adjusts position of width direction (main scan direction) for punch. <ul style="list-style-type: none"> ▪ Adjusting value to -: hole position moves toward front side of machine. ▪ Adjusting value to +: hole position moves toward rear side of machine. 		
6-131-001	Domestic 2Hole(Europe 2Hole)	*ENG	[-2.0 to 2.0 / 0.0 / 0.4mm/step]
6-131-002	North America 3Hole	*ENG	
6-131-003	Europe 4Hole	*ENG	
6-131-004	North Europe 4Hole	*ENG	
6-131-005	North America 2Hole	*ENG	

6132	[Jogger Fence Fine Adj:FrontFIN]		
	Adjusts width (main scan direction) of edge stitch jogger when running specified paper conformity. <ul style="list-style-type: none"> ▪ Adjusts value to -: move towards jogger width is tighter than base value. ▪ Adjusts value to +: move towards jogger width is wider than base value. 		
6-132-001	A3T	ENG	[-1.5 to 1.5 / 0.0 / 0.5mm/step]
6-132-002	B4T	ENG	[-3.0 to 3.0 / 0.0 / 0.5mm/step]
6-132-003	A4T	ENG	[-3.0 to 3.0 / 0.0 / 0.5mm/step]
6-132-004	A4Y	ENG	[-1.5 to 1.5 / 0.0 / 0.5mm/step]
6-132-005	B5T	ENG	[-3.0 to 3.0 / 0.0 / 0.5mm/step]
6-132-006	B5Y	ENG	[-3.0 to 3.0 / 0.0 / 0.5mm/step]
6-132-007	DLT-T	ENG	[-3.0 to 3.0 / 0.0 / 0.5mm/step]
6-132-008	LG-T	ENG	[-3.0 to 3.0 / 0.0 / 0.5mm/step]
6-132-009	LT-T	ENG	[-3.0 to 3.0 / 0.0 / 0.5mm/step]
6-132-010	LT-Y	ENG	[-3.0 to 3.0 / 0.0 / 0.5mm/step]
6-132-011	8K-T	ENG	[-3.0 to 3.0 / 0.0 / 0.5mm/step]
6-132-012	16K-T	ENG	[-3.0 to 3.0 / 0.0 / 0.5mm/step]
6-132-013	16K-Y	ENG	[-3.0 to 3.0 / 0.0 / 0.5mm/step]
6-132-014	Other	ENG	[-3.0 to 3.0 / 0.0 / 0.5mm/step]

6133	[Staple Position Adj: FrontFIN]		
	Adjusts staple position (main scan direction) for the near side parallel stitch/ far side parallel stitch of specified paper. <ul style="list-style-type: none"> ▪ Adjusting value to -: staple position moves toward front side of machine. ▪ Adjusting value to +: staple position moves toward rear side of machine. 		
6-133-001	Finisher1	*ENG	[-2.0 to 2.0 / 0.0 / 0.5mm/step]

6135	[INPUT Check: FrontFIN]		
	See page 5-355		

6136	[OUTPUT Check: FrontFIN]		
	See page 5-355		

6140	[Staple Position Adj: 1K FIN]		
	Adjusts staple position (main scan direction) for near side trailing edge parallel stitch / far side trailing edge parallel stitch. <ul style="list-style-type: none"> ▪ Adjusting value to -: staple position moves toward front side of machine. ▪ Adjusting value to +: staple position moves toward rear side of machine. 		
6-140-001	-	ENG	[-3.5 to 3.5 / 0.0 / 0.5mm/step]

6141	[Booklet Stapler Pos Adj:1K FIN]		
	Adjusts saddle stitch staple position (sub scan direction) of specified paper. <ul style="list-style-type: none"> ▪ Adjusting value to -: staple position moves toward trailing edge of paper when intaking. ▪ Adjusting value to +: folding position moves toward leading edge of paper when intaking. 		

6-141-001	A3 SEF	ENG	[-3.0 to 3.0 / 0.0 / 0.2mm/step]
6-141-002	B4 SEF	ENG	[-3.0 to 3.0 / 0.0 / 0.2mm/step]
6-141-003	A4 SEF	ENG	[-3.0 to 3.0 / 0.0 / 0.2mm/step]
6-141-004	B5 SEF	ENG	[-3.0 to 3.0 / 0.0 / 0.2mm/step]
6-141-005	DLT SEF	ENG	[-3.0 to 3.0 / 0.0 / 0.2mm/step]
6-141-006	LG SEF	ENG	[-3.0 to 3.0 / 0.0 / 0.2mm/step]
6-141-007	LT SEF	ENG	[-3.0 to 3.0 / 0.0 / 0.2mm/step]
6-141-008	12x18	ENG	[-3.0 to 3.0 / 0.0 / 0.2mm/step]

6142	[Sub-scan Punch Pos Adj:1K FIN]		
	Adjusts position of carry direction (sub scan direction) for punch. <ul style="list-style-type: none"> ▪ Adjusting value to -: hole position moves toward trailing edge of paper when intaking. ▪ Adjusting value to +: hole position moves toward leading edge of paper when intaking. 		
6-142-001	JPN/EU: 2-Hole	ENG	[-7.5 to 7.5 / 0.0 / 0.5mm/step]
6-142-002	NA: 3-Hole	ENG	
6-142-003	Europe: 4-Hole	ENG	
6-142-004	NEU: 4-Hole	ENG	
6-142-005	NA: 2-Hole	ENG	

6143	[Jogger Pos Adj:1K FIN]		
	Adjusts width (main scan direction) of jogger when running specified paper conformity. <ul style="list-style-type: none"> ▪ Adjusts value to -: move towards jogger width is tighter than base value. ▪ Adjusts value to +: move towards jogger width is wider than base value. 		
6-143-001	A3 SEF	ENG	[-1.5 to 1.5 / 0.0 / 0.5mm/step]
6-143-002	B4 SEF	ENG	
6-143-003	A4 SEF	ENG	
6-143-004	A4 LEF	ENG	
6-143-005	B5 SEF	ENG	[-1.5 to 1.5 / 0.0 / 0.5mm/step]
6-143-006	B5 LEF	ENG	
6-143-007	DLT SEF	ENG	
6-143-008	LG SEF	ENG	
6-143-009	LT SEF	ENG	
6-143-010	LT LEF	ENG	
6-143-011	12x18	ENG	
6-143-012	8K SEF	ENG	[-1.5 to 1.5 / 0.0 / 0.5mm/step]
6-143-013	16K SEF	ENG	
6-143-014	16K LEF	ENG	
6-143-015	Other	ENG	[-1.5 to 1.5 / 0.0 / 0.5mm/step]
	Adjusts width (main scan direction) of jogger when running conformity to except the specified paper. <ul style="list-style-type: none"> ▪ Adjusts value to -: move towards jogger width is tighter than base value. ▪ Adjusts value to +: move towards jogger width is wider than base value. 		

6144	[Main-scan Punch Pos Adj:1K FIN]		
	Adjusts position of width direction (main scan direction) for punch. <ul style="list-style-type: none"> ▪ Adjusting value to -: hole position moves toward front side of machine. ▪ Adjusting value to +: hole position moves toward rear side of machine. 		
6-144-001	JPN/EU: 2-Hole	ENG	[-2.0 to 2.0 / 0.0 / 0.4mm/step]
6-144-002	NA: 3-Hole	ENG	
6-144-003	Europe: 4-Hole	ENG	
6-144-004	NEU: 4-Hole	ENG	
6-144-005	NA: 2-Hole	ENG	

6145	[Skew Correct Buckle Adj:1K FIN]		
	Adjusts the skew correction bending amount when punching specified paper. <ul style="list-style-type: none"> ▪ Adjusts value to -: buckling amount decreases ▪ Adjusts value to +: buckling amount increases. 		
6-145-001	A3 SEF	ENG	[-5.0 to 5.0 / 0.0 / 0.2mm/step]
6-145-002	B4 SEF	ENG	
6-145-003	A4 SEF	ENG	
6-145-004	A4 LEF	ENG	
6-145-005	B5 SEF	ENG	
6-145-006	B5 LEF	ENG	[-5.0 to 5.0 / 0.0 / 0.2mm/step]
6-145-007	A5 LEF	ENG	
6-145-008	DLT SEF	ENG	
6-145-009	LG SEF	ENG	
6-145-010	LT SEF	ENG	
6-145-011	LT LEF	ENG	

6-145-012	HLT LEF	ENG	
6-145-013	12x18	ENG	
6-145-014	8K SEF	ENG	
6-145-015	16K SEF	ENG	
6-145-016	16K LEF	ENG	
6-145-017	Other	ENG	[-5.0 to 5.0 / 0.0 / 0.2mm/step]
	Adjusts the skew correction bending amount when punching except the specified paper. <ul style="list-style-type: none"> ▪ Adjusts value to -: buckling amount decreases ▪ Adjusts value to +: buckling amount increases. 		

6146	[Skew Correct Ctrl SW:1K FIN]		
	Switches way to control (Still buckling 0: enable / 1: disable) skew correction when punching specified paper.		
6-146-001	A3 SEF	ENG	[0 or 1 / 0 / 1/step] 0: enable 1: disable
6-146-002	B4 SEF	ENG	[0 or 1 / 0 / 1/step] 0: enable 1: disable
6-146-003	A4 SEF	ENG	[0 or 1 / 0 / 1/step] 0: enable 1: disable
6-146-004	A4 LEF	ENG	[0 or 1 / 0 / 1/step] 0: enable 1: disable
6-146-005	B5 SEF	ENG	[0 or 1 / 0 / 1/step] 0: enable 1: disable

6-146-006	B5 LEF	ENG	[0 or 1 / 0 / 1/step] 0: enable 1: disable
6-146-007	A5 LEF	ENG	[0 or 1 / 0 / 1/step] 0: enable 1: disable
6-146-008	DLT SEF	ENG	[0 or 1 / 0 / 1/step] 0: enable 1: disable
6-146-009	LG SEF	ENG	[0 or 1 / 0 / 1/step] 0: enable 1: disable
6-146-010	LT SEF	ENG	[0 or 1 / 0 / 1/step] 0: enable 1: disable
6-146-011	LT LEF	ENG	[0 or 1 / 0 / 1/step] 0: enable 1: disable
6-146-012	HLT LEF	ENG	[0 or 1 / 0 / 1/step] 0: enable 1: disable
6-146-013	12x18	ENG	[0 or 1 / 0 / 1/step] 0: enable 1: disable
6-146-014	8K SEF	ENG	[0 or 1 / 0 / 1/step] 0: enable 1: disable
6-146-015	16K SEF	ENG	[0 or 1 / 0 / 1/step] 0: enable 1: disable

6-146-016	16K LEF	ENG	[0 or 1 / 0 / 1/step] 0: enable 1: disable
6-146-017	Other	ENG	[0 or 1 / 0 / 1/step] 0: enable 1: disable
	Switches way to control (Still buckling 0: enable / 1: disable) skew correction when punching except the specified paper.		

6147	[Booklet Folder Pos Adj:1K FIN]		
	<p>Adjusts saddle stitch folding position (sub scan direction) of specified paper.</p> <ul style="list-style-type: none"> ▪ Adjusting value to -: folding position moves toward trailing edge of paper when intaking. ▪ Adjusting value to +: folding position moves toward leading edge of paper when intaking. 		
6-147-001	A3 SEF	ENG	[-3.0 to 3.0 / 0.0 / 0.2mm/step]
6-147-002	B4 SEF	ENG	[-3.0 to 3.0 / 0.0 / 0.2mm/step]
6-147-003	A4 SEF	ENG	[-3.0 to 3.0 / 0.0 / 0.2mm/step]
6-147-004	B5 SEF	ENG	[-3.0 to 3.0 / 0.0 / 0.2mm/step]
6-147-005	DLT SEF	ENG	[-3.0 to 3.0 / 0.0 / 0.2mm/step]
6-147-006	LG SEF	ENG	[-3.0 to 3.0 / 0.0 / 0.2mm/step]
6-147-007	LT SEF	ENG	[-3.0 to 3.0 / 0.0 / 0.2mm/step]
6-147-008	12x18	ENG	[-3.0 to 3.0 / 0.0 / 0.2mm/step]

6148	[Fold Times Adj: 1K FIN]		
	Adjusts extra folding times (time) for folding when saddle stitching.		
6-148-001	-	ENG	[0 to 29 / 0 / 1sec/step]

6149	[Last Paper Pos Time Adj:1K FIN]		
	Adjust positioning times to last paper of set.		
6-149-001	-	ENG	[0 to 1 / 0 / 1time/step]

6150	[PositioningStrtTimingAdj:1KFIN]		
	Adjusts the positioning roller operation start timing when positioning specified paper. <ul style="list-style-type: none"> ▪ Adjusts value to -: forwards the start timing ▪ Adjusts value to +: delays the start timing 		
6-150-001	A3 SEF	ENG	[-100 to 100 / 0 / 10msec/step]
6-150-002	B4 SEF	ENG	
6-150-003	A4 SEF	ENG	
6-150-004	A4 LEF	ENG	
6-150-005	B5 SEF	ENG	
6-150-006	B5 LEF	ENG	
6-150-007	DLT SEF	ENG	
6-150-008	LG SEF	ENG	
6-150-009	LT SEF	ENG	
6-150-010	LT LEF	ENG	
6-150-011	12x18	ENG	
6-150-012	8K SEF	ENG	
6-150-013	16K SEF	ENG	

6-150-014	16K LEF	ENG	
6-150-015	Other	ENG	
	Adjusts the positioning roller operation start timing when positioning except the specified paper. <ul style="list-style-type: none"> ▪ Adjusts value to -: forwards the start timing ▪ Adjusts value to +: delays the start timing 		

6151	[PosTimeAdj(LstPr2ndTime):1KFIN]		
	Adjusts 2nd time to positioning the last sheet of the set. <ul style="list-style-type: none"> ▪ Adjusts the value to -: shortens the positioning time ▪ Adjusts the value to +: extends the positioning time The positioning for the last sheet is done when [Last Paper Pos Time Adj:1K FIN] adjust value is set to 1.		
6-151-001	-	ENG	[-100 to 100 / 0 / 10msec/step]

6152	[PosTiAdj(ExcLstPr3rdTi):1KFIN]		
	Adjust positioning time for specified paper except the last sheet 2nd time. <ul style="list-style-type: none"> ▪ Adjusts the value to -: shortens the positioning time ▪ Adjusts the value to +: extends the positioning time 		
6-152-001	A3 SEF	ENG	[-100 to 100 / 0 / 10msec/step]
6-152-002	B4 SEF	ENG	[-100 to 100 / 0 / 10msec/step]
6-152-003	A4 SEF	ENG	[-100 to 100 / 0 / 10msec/step]
6-152-004	A4 LEF	ENG	[-100 to 100 / 0 / 10msec/step]
6-152-005	B5 SEF	ENG	[-100 to 100 / 0 / 10msec/step]
6-152-006	B5 LEF	ENG	[-100 to 100 / 0 / 10msec/step]
6-152-007	DLT SEF	ENG	[-100 to 100 / 0 / 10msec/step]
6-152-008	LG SEF	ENG	[-100 to 100 / 0 / 10msec/step]

6-152-009	LT SEF	ENG	[-100 to 100 / 0 / 10msec/step]
6-152-010	LT LEF	ENG	[-100 to 100 / 0 / 10msec/step]
6-152-011	12x18	ENG	[-100 to 100 / 0 / 10msec/step]
6-152-012	8K SEF	ENG	[-100 to 100 / 0 / 10msec/step]
6-152-013	16K SEF	ENG	[-100 to 100 / 0 / 10msec/step]
6-152-014	16K LEF	ENG	[-100 to 100 / 0 / 10msec/step]
6-152-015	Other	ENG	[-100 to 100 / 0 / 10msec/step]
	Adjust positioning time for other than the specified paper except the last sheet 2nd time. <ul style="list-style-type: none"> ▪ Adjusts the value to -: shortens the positioning time ▪ Adjusts the value to +: extends the positioning time 		

6154	[Pos Time Adj By Sheet: 1K FIN]		
	Adjusts the positioning time when stocked specified amount. <ul style="list-style-type: none"> ▪ Adjusts the value to -: shortens the positioning time ▪ Adjusts the value to +: extends the positioning time 		
6-154-001	1 - 10 Sheets	ENG	[-100 to 100 / 0 / 10msec/step]
6-154-002	11 - 20 Sheets	ENG	
6-154-003	21 - 30 Sheets	ENG	
6-154-004	31 - 40 Sheets	ENG	
6-154-005	41 - 50 Sheets	ENG	

6161	[FIN (1K FIN) INPUT Check]		
	See page 5-355		

6162	[FIN (1K FIN) OUTPUT Check]		
	See page 5-355		

6180	[M-ScanBindPosAdj:NoStpIBindFIN]		
6-180-001	-	ENG	[-1.0 to 1.0 / 0.0 / 0.5mm/step]
	Adjusts the position of width direction (main scan direction) for binding. <ul style="list-style-type: none"> ▪ Value increase: The bind position moves toward outside of sheets. ▪ Value decrease: The bind position moves toward inside of sheets. 		

6181	[BindSpeedSetting:NoStpIBindFIN]		
6-181-001	-	ENG	[1 to 3 / 3 / 2/step]
	Improves the noise for bind finishing by adjusting the bind speed. 1: Bind Spd1(L) (Low noise mode) 3: Bind Speed 3 (Productivity mode)		

6182	[ExitSpeedSwitch:NoStpIBindFIN]		
	Adjusts the paper exit speed to align the stacked sheets properly. <ul style="list-style-type: none"> ▪ Value increase: increases the paper exit speed. ▪ Value decrease: decreases the paper exit speed. 1:Exit Spd1(L) 2:Exit Speed 2 3:Exit Speed 3 4:Exit Speed 4 5:Exit Speed 5(High)		
6-182-001	PaperLength:297.0-457.2mm,Thick(106-300g/m2)	ENG	[1 to 5 / 2 / 1/step]
6-182-002	PaperLength:297.0-457.2mm,Plain(60-105g/m2)	ENG	[1 to 5 / 2 / 1/step]
6-182-003	PaperLength:297.0-457.2mm,Thin(52-59g/m2)	ENG	[1 to 5 / 4 / 1/step]
6-182-004	PaperLength:210.0-296.9mm,Thick(106-300g/m2)	ENG	[1 to 5 / 2 / 1/step]

6-182-005	PaperLength:210.0-296.9mm,Plain(60-105g/m2)	ENG	[1 to 5 / 2 / 1/step]
6-182-006	PaperLength:210.0-296.9mm,Thin(52-59g/m2)	ENG	[1 to 5 / 4 / 1/step]
6-182-007	PaperLength:148.0-209.9mm,Thick(106-300g/m2)	ENG	[1 to 5 / 2 / 1/step]
6-182-008	PaperLength:148.0-209.9mm,Plain(60-105g/m2)	ENG	[1 to 5 / 2 / 1/step]
6-182-009	PaperLength:148.0-209.9mm,Thin(52-59g/m2)	ENG	[1 to 5 / 4 / 1/step]

6184	[Input Check:NoStplBindFIN]		
	See page 5-355		

6185	[Output Check:NoStplBindFIN]		
	See page 5-355		

6186	[BindTimes NoStplBindFIN]		
6-186-001	-	*ENG	[1 to 2 / 2 / 1/step]
	Specifies the paper binding strength by changing the number of binds. 1: 1 time binding (high productivity) 2: 2 times binding (low productivity)		

6801	[1-pass Stamp Unit]		
6-801-001	-	*ENG	[0 or 1 / 0 / 1/step] 0: No 1: Yes
	For 1 path simultaneous duplex models only. Sets installed/not installed of DONE stamp unit.		

6830	[Extra]		
	<p>More than the standard number of sheets can be stapled. This SP sets the additional number of sheets (This Setting + Standard Number = maximum number of sheets).</p> <ul style="list-style-type: none"> ▪ If the number of the maximum for staples is increased, and the mechanical warranty of the unit can be guaranteed, then the setting can take effect without changing the controller software. <p>However, assurance that mechanical performance can be guaranteed is required before changing the setting to increase the staple load for more than the maximum in the feed/exit specifications. Raising this setting without quality assurance could damage the machine.</p>		
6-830-001	Staples 0 to 50 (Initial: 0)	*CTL	[0 to 50 / 0 / 1/step]
6-830-002	Saddles 0 to 50 (Initial: 0)	*CTL	[0 to 50 / 0 / 1/step]
6-830-003	Half-Fold 0 to 50 (Initial: 0)	*CTL	[0 to 50 / 0 / 1/step]

5.11 SP MODE TABLES - SP7000-1

5.11.1 SP7-XXX (DATA LOG)

7401	[Total SC] Displays the number of SC codes detected.		
7-401-001	SC Counter	*CTL	[00000 to 65535 / 0 / 1/step]
7-401-002	Total SC Counter	*CTL	[00000 to 65535 / 0 / 1/step]

7403	[SC History] Logs the SC codes detected. The 10 most recently detected SC Codes are not displayed on the screen, but can be seen on the SMC (logging) outputs.		
7-403-001	Latest	*CTL	[00000 to 65535 / 0 / 1/step]
7-403-002	Latest 1	*CTL	[00000 to 65535 / 0 / 1/step]
7-403-003	Latest 2	*CTL	[00000 to 65535 / 0 / 1/step]
7-403-004	Latest 3	*CTL	[00000 to 65535 / 0 / 1/step]
7-403-005	Latest 4	*CTL	[00000 to 65535 / 0 / 1/step]
7-403-006	Latest 5	*CTL	[00000 to 65535 / 0 / 1/step]
7-403-007	Latest 6	*CTL	[00000 to 65535 / 0 / 1/step]
7-403-008	Latest 7	*CTL	[00000 to 65535 / 0 / 1/step]
7-403-009	Latest 8	*CTL	[00000 to 65535 / 0 / 1/step]
7-403-010	Latest 9	*CTL	[00000 to 65535 / 0 / 1/step]

7404	[SC990 / SC991 History]			
	Logs the SC991 detected.			
	The 10 most recently detected SC991 are not displayed on the screen, but can be seen on the SMC (logging) outputs.			
	 Note			
	<ul style="list-style-type: none"> If the same SC codes are detected continuously and total counter is not increasing, it only logs once in case of deleting other SC code logs. 			
	7-404-001	Latest	*CTL	[- / - / -]
	7-404-002	Latest 1	*CTL	[- / - / -]
	7-404-003	Latest 2	*CTL	[- / - / -]
	7-404-004	Latest 3	*CTL	[- / - / -]
	7-404-005	Latest 4	*CTL	[- / - / -]
	7-404-006	Latest 5	*CTL	[- / - / -]
7-404-007	Latest 6	*CTL	[- / - / -]	
7-404-008	Latest 7	*CTL	[- / - / -]	
7-404-009	Latest 8	*CTL	[- / - / -]	
7-404-010	Latest 9	*CTL	[- / - / -]	

7502	[Total Paper Jam]		
	Displays the total number of jams detected.		
	7-502-001	Jam Counter	*CTL
7-502-002	Total Jam Counter	*CTL	[00000 to 65535 / 0 / 1/step]

7503	[Total Original Jam Counter]		
	Displays the total number of original jams.		
	7-503-001	-	*CTL
7-503-002	Total Original Counter	*CTL	[00000 to 65535 / 0 / 1/step]

7504	[Paper Jam Location] Displays the number of jams according to the location where jams were detected.		
7-504-001	At Power On	*CTL	[0000 to 9999 / - / 1/step]
7-504-003	Tray1: On	*CTL	[0000 to 9999 / - / 1/step]
7-504-004	Tray2: On	*CTL	[0000 to 9999 / - / 1/step]
7-504-005	Tray3: On	*CTL	[0000 to 9999 / - / 1/step]
7-504-006	Tray4: On	*CTL	[0000 to 9999 / - / 1/step]
7-504-007	LCT: On	*CTL	[0000 to 9999 / - / 1/step]
7-504-008	Bypass: On	*CTL	[0000 to 9999 / - / 1/step]
7-504-009	Duplex: On	*CTL	[0000 to 9999 / - / 1/step]
7-504-010	Timing: On	*CTL	[0000 to 9999 / - / 1/step]
7-504-011	Transport 1: On	*CTL	[0000 to 9999 / - / 1/step]
7-504-012	Transport 2: On	*CTL	[0000 to 9999 / - / 1/step]
7-504-013	Vertical Trans. 3: On	*CTL	[0000 to 9999 / - / 1/step]
7-504-014	Vertical Trans. 4: On	*CTL	[0000 to 9999 / - / 1/step]
7-504-015	LCT Transport: On	*CTL	[0000 to 9999 / - / 1/step]
7-504-017	Registration: On	*CTL	[0000 to 9999 / - / 1/step]
7-504-018	Fusing Entrance: On	*CTL	[0000 to 9999 / - / 1/step]
7-504-019	Fusing Exit: On	*CTL	[0000 to 9999 / - / 1/step]
7-504-020	Paper Exit: On	*CTL	[0000 to 9999 / - / 1/step]
7-504-021	Bridge Tray Exit: On	*CTL	[0000 to 9999 / - / 1/step]
7-504-022	Bridge Relay: On	*CTL	[0000 to 9999 / - / 1/step]
7-504-024	Inverter: On	*CTL	[0000 to 9999 / - / 1/step]
7-504-025	Duplex Exit: On	*CTL	[0000 to 9999 / - / 1/step]

7-504-027	Duplex Entrance: On	*CTL	[0000 to 9999 / - / 1/step]
7-504-051	Transport 1: Off	*CTL	[0000 to 9999 / - / 1/step]
7-504-052	Transport 2: Off	*CTL	[0000 to 9999 / - / 1/step]
7-504-053	Vertical Trans. 3: Off	*CTL	[0000 to 9999 / - / 1/step]
7-504-054	Vertical Trans. 4: Off	*CTL	[0000 to 9999 / - / 1/step]
7-504-055	LCT Feed Sensor: Off	*CTL	[0000 to 9999 / - / 1/step]
7-504-057	Registration Sensor: Off	*CTL	[0000 to 9999 / - / 1/step]
7-504-060	Paper Exit: Off	*CTL	[0000 to 9999 / - / 1/step]
7-504-061	Bridge: Exit: Off	*CTL	[0000 to 9999 / - / 1/step]
7-504-062	Bridge: Transport: Off	*CTL	[0000 to 9999 / - / 1/step]
7-504-064	Inverter: Off	*CTL	[0000 to 9999 / - / 1/step]
7-504-065	Duplex Exit: Off	*CTL	[0000 to 9999 / - / 1/step]
7-504-067	Duplex Entrance: Off	*CTL	[0000 to 9999 / - / 1/step]
7-504-099	Double-Feed Detection	*CTL	[0000 to 9999 / - / 1/step]
7-504-100	Entrance: On	*CTL	[0000 to 9999 / - / 1/step]
7-504-101	Entrance: Off	*CTL	[0000 to 9999 / - / 1/step]
7-504-102	Transport : On	*CTL	[0000 to 9999 / - / 1/step]
7-504-103	Transport: Off	*CTL	[0000 to 9999 / - / 1/step]
7-504-104	Paper Exit	*CTL	[0000 to 9999 / - / 1/step]
7-504-105	Front Jogger Motor	*CTL	[0000 to 9999 / - / 1/step]
7-504-106	Rear Jogger Motor	*CTL	[0000 to 9999 / - / 1/step]
7-504-107	Shift Roller Motor	*CTL	[0000 to 9999 / - / 1/step]
7-504-108	Positioning Motor	*CTL	[0000 to 9999 / - / 1/step]

7-504-109	Exit Guide Plate Motor	*CTL	[0000 to 9999 / - / 1/step]
7-504-110	Stapler Shift Motor	*CTL	[0000 to 9999 / - / 1/step]
7-504-111	Tray Lift Motor	*CTL	[0000 to 9999 / - / 1/step]
7-504-112	Staple Motor	*CTL	[0000 to 9999 / - / 1/step]
7-504-113	Stack Height Motor	*CTL	[0000 to 9999 / - / 1/step]
7-504-114	Punch Motor	*CTL	[0000 to 9999 / - / 1/step]
7-504-115	Punch Move Motor	*CTL	[0000 to 9999 / - / 1/step]
7-504-116	S-to-S Registration Move Motor	*CTL	[0000 to 9999 / - / 1/step]
7-504-148	No Exit Response	*CTL	[0000 to 9999 / - / 1/step]
7-504-149	Main Machine Setting Incorrect	*CTL	[0000 to 9999 / - / 1/step]
7-504-150	Entrance Sensor: On	*CTL	[0000 to 9999 / - / 1/step]
7-504-151	Entrance Sensor: Off	*CTL	[0000 to 9999 / - / 1/step]
7-504-152	Horizontal Transport Sensor: On	*CTL	[0000 to 9999 / - / 1/step]
7-504-153	Horizontal Transport Sensor: Off	*CTL	[0000 to 9999 / - / 1/step]
7-504-154	Switchback Transport Sensor: On	*CTL	[0000 to 9999 / - / 1/step]
7-504-155	Switchback Transport Sensor: Off	*CTL	[0000 to 9999 / - / 1/step]
7-504-156	Proof Tray Exit	*CTL	[0000 to 9999 / - / 1/step]
7-504-157	Shift Tray Exit	*CTL	[0000 to 9999 / - / 1/step]

7-504-158	Booklet Stapler Exit	*CTL	[0000 to 9999 / - / 1/step]
7-504-159	Entrance Motor	*CTL	[0000 to 9999 / - / 1/step]
7-504-160	Horizontal Transport Motor	*CTL	[0000 to 9999 / - / 1/step]
7-504-161	Pre-Stack Transport Motor	*CTL	[0000 to 9999 / - / 1/step]
7-504-162	ITB Transport Motor	*CTL	[0000 to 9999 / - / 1/step]
7-504-163	Exit Motor	*CTL	[0000 to 9999 / - / 1/step]
7-504-164	TE Press Motor	*CTL	[0000 to 9999 / - / 1/step]
7-504-165	Ext Plate Guide Motor	*CTL	[0000 to 9999 / - / 1/step]
7-504-166	Punching Motor	*CTL	[0000 to 9999 / - / 1/step]
7-504-167	Punch Move Motor	*CTL	[0000 to 9999 / - / 1/step]
7-504-168	S-to-S Regist Move Motor	*CTL	[0000 to 9999 / - / 1/step]
7-504-169	Lower junction Solenoid Motor	*CTL	[0000 to 9999 / - / 1/step]
7-504-170	Jogger Motor	*CTL	[0000 to 9999 / - / 1/step]
7-504-171	Positioning Motor	*CTL	[0000 to 9999 / - / 1/step]
7-504-172	Feed Out Motor	*CTL	[0000 to 9999 / - / 1/step]
7-504-173	Corner Stapler Move Motor	*CTL	[0000 to 9999 / - / 1/step]
7-504-174	Corner Stapler Motor	*CTL	[0000 to 9999 / - / 1/step]
7-504-175	Saddle Stitch Stapler Jogger Motor	*CTL	[0000 to 9999 / - / 1/step]

7-504-176	Saddle Stitch Stapler Jog SOL Motor	*CTL	[0000 to 9999 / - / 1/step]
7-504-177	Saddle Stitch Stapler Standard Fence Motor	*CTL	[0000 to 9999 / - / 1/step]
7-504-178	Saddle Stitch Stapler Motor	*CTL	[0000 to 9999 / - / 1/step]
7-504-179	Dynamic Roller Transport Mt	*CTL	[0000 to 9999 / - / 1/step]
7-504-180	Folder Transport Motor	*CTL	[0000 to 9999 / - / 1/step]
7-504-181	Saddle Stitch Stplr Positioning Motor	*CTL	[0000 to 9999 / - / 1/step]
7-504-182	Press-Fold Motor	*CTL	[0000 to 9999 / - / 1/step]
7-504-183	Output Tray Motor	*CTL	[0000 to 9999 / - / 1/step]
7-504-184	Shift Motor	*CTL	[0000 to 9999 / - / 1/step]
7-504-185	Shift Tray Jogger Front Motor	*CTL	[0000 to 9999 / - / 1/step]
7-504-186	Shift Tray Jogger Rear Motor	*CTL	[0000 to 9999 / - / 1/step]
7-504-187	Shift Tray Jogger Retraction Motor	*CTL	[0000 to 9999 / - / 1/step]
7-504-188	Stack Roller Motor	*CTL	[0000 to 9999 / - / 1/step]
7-504-189	Leading Edge Guide Motor	*CTL	[0000 to 9999 / - / 1/step]
7-504-190	Job Data Error	*CTL	[0000 to 9999 / - / 1/step]
7-504-200	Entrance: On	*CTL	[0000 to 9999 / - / 1/step]
7-504-201	Entrance: Off	*CTL	[0000 to 9999 / - / 1/step]
7-504-202	Proog Tray Exit: On	*CTL	[0000 to 9999 / - / 1/step]

7-504-203	Proog Tray Exit: Off	*CTL	[0000 to 9999 / - / 1/step]
7-504-204	Right Relay: On	*CTL	[0000 to 9999 / - / 1/step]
7-504-205	Left Relay: On	*CTL	[0000 to 9999 / - / 1/step]
7-504-206	Left Relay: Off	*CTL	[0000 to 9999 / - / 1/step]
7-504-207	Shift Tray Exit: On	*CTL	[0000 to 9999 / - / 1/step]
7-504-208	Shift Tray Exit: Off	*CTL	[0000 to 9999 / - / 1/step]
7-504-209	Stack: On	*CTL	[0000 to 9999 / - / 1/step]
7-504-210	TE Stopper: On	*CTL	[0000 to 9999 / - / 1/step]
7-504-211	TE Stopper: Off	*CTL	[0000 to 9999 / - / 1/step]
7-504-212	Booklet Folder Exit: On	*CTL	[0000 to 9999 / - / 1/step]
7-504-213	Booklet Folder Exit: Off	*CTL	[0000 to 9999 / - / 1/step]
7-504-220	Entrance Motor	*CTL	[0000 to 9999 / - / 1/step]
7-504-221	Proof Motor	*CTL	[0000 to 9999 / - / 1/step]
7-504-222	Exit Transport/Positioning Roller Motor	*CTL	[0000 to 9999 / - / 1/step]
7-504-223	Shift Motor	*CTL	[0000 to 9999 / - / 1/step]
7-504-224	Jogger Motor	*CTL	[0000 to 9999 / - / 1/step]
7-504-225	Exit Guide Plate Motor	*CTL	[0000 to 9999 / - / 1/step]
7-504-226	Feed Out Motor	*CTL	[0000 to 9999 / - / 1/step]
7-504-227	Output Tray Motor	*CTL	[0000 to 9999 / - / 1/step]
7-504-228	Positioning Motor	*CTL	[0000 to 9999 / - / 1/step]
7-504-229	Stapler Shift Motor	*CTL	[0000 to 9999 / - / 1/step]
7-504-230	Stapler Motor	*CTL	[0000 to 9999 / - / 1/step]

7-504-231	Punch Motor	*CTL	[0000 to 9999 / - / 1/step]
7-504-232	Stack Transport Motor	*CTL	[0000 to 9999 / - / 1/step]
7-504-233	LE Stopper Motor	*CTL	[0000 to 9999 / - / 1/step]
7-504-234	Folder Blade Motor	*CTL	[0000 to 9999 / - / 1/step]
7-504-248	No Exit Response	*CTL	[0000 to 9999 / - / 1/step]
7-504-249	Main Machine Setting Incorrect	*CTL	[0000 to 9999 / - / 1/step]

7505	[Original Jam Detection] Displays the total number of original jams according to the location where jams were detected.		
7-505-001	At Power On	*CTL	[0000 to 9999 / 0 / 1/step]
7-505-013	Separation Sensor:On	*CTL	[0000 to 9999 / 0 / 1/step]
7-505-014	Skew Correction Sn:On	*CTL	[0000 to 9999 / 0 / 1/step]
7-505-015	Scanning Entrance Sn:On	*CTL	[0000 to 9999 / 0 / 1/step]
7-505-016	Registration Sensor:On	*CTL	[0000 to 9999 / 0 / 1/step]
7-505-017	Original Exit Sensor:On	*CTL	[0000 to 9999 / 0 / 1/step]
7-505-063	Separation Sensor:Off	*CTL	[0000 to 9999 / 0 / 1/step]
7-505-064	Skew Correction Sn:Off	*CTL	[0000 to 9999 / 0 / 1/step]
7-505-065	Scanning Entrance Sn:Off	*CTL	[0000 to 9999 / 0 / 1/step]
7-505-066	Registration Sensor:Off	*CTL	[0000 to 9999 / 0 / 1/step]
7-505-067	Original Exit Sensor:Off	*CTL	[0000 to 9999 / 0 / 1/step]
7-505-239	Original Pull	*CTL	[0000 to 9999 / 0 / 1/step]

7506	[Jam Count by Paper Size] Displays the number of jams according to the paper size.		
7-506-005	A4 LEF	*CTL	[0000 to 9999 / 0 / 1/step]
7-506-006	A5 LEF	*CTL	[0000 to 9999 / 0 / 1/step]
7-506-014	B5 LEF	*CTL	[0000 to 9999 / 0 / 1/step]
7-506-038	LT LEF	*CTL	[0000 to 9999 / 0 / 1/step]
7-506-044	HLT LEF	*CTL	[0000 to 9999 / 0 / 1/step]
7-506-132	A3 SEF	*CTL	[0000 to 9999 / 0 / 1/step]
7-506-133	A4 SEF	*CTL	[0000 to 9999 / 0 / 1/step]
7-506-134	A5 SEF	*CTL	[0000 to 9999 / 0 / 1/step]
7-506-141	B4 SEF	*CTL	[0000 to 9999 / 0 / 1/step]
7-506-142	B5 SEF	*CTL	[0000 to 9999 / 0 / 1/step]
7-506-160	DLT SEF	*CTL	[0000 to 9999 / 0 / 1/step]
7-506-164	LG SEF	*CTL	[0000 to 9999 / 0 / 1/step]
7-506-166	LT SEF	*CTL	[0000 to 9999 / 0 / 1/step]
7-506-172	HLT SEF	*CTL	[0000 to 9999 / 0 / 1/step]
7-506-255	Others	*CTL	[0000 to 9999 / 0 / 1/step]

7507	<p>[Plotter Jam History] Displays the copy jam history (the most recent 10 jams)</p> <p>Sample Display: CODE:007 SIZE:05h TOTAL:0000334 DATE:Mon Mar 15 11:44:50 2000 where: CODE is the SP7504-* number (see above). SIZE is the ASAP paper size code in hex. TOTAL is the total jam error count DATE is the date the jams occurred.</p>
-------------	---

7-507-001	Latest	*CTL	[- / - / -]
7-507-002	Latest 1	*CTL	[- / - / -]
7-507-003	Latest 2	*CTL	[- / - / -]
7-507-004	Latest 3	*CTL	[- / - / -]
7-507-005	Latest 4	*CTL	[- / - / -]
7-507-006	Latest 5	*CTL	[- / - / -]
7-507-007	Latest 6	*CTL	[- / - / -]
7-507-008	Latest 7	*CTL	[- / - / -]
7-507-009	Latest 8	*CTL	[- / - / -]
7-507-010	Latest 9	*CTL	[- / - / -]

7508	<p>[Original Jam History] Displays the original jam history of the transfer unit in groups of 10, starting with the most recent 10 jams. Display contents are as follows: CODE is the SP7-505-* number. SIZE is the paper size code in hex. (See "Paper Size Hex Codes" below.) TOTAL is the total jam error count (SP7003) DATE is the date the previous jam occurred</p> <p>Sample Display: CODE: 007 SIZE: 05h TOTAL: 0000334 DATE: Mon Mar 15 11:44:50 2000</p>		
7-508-001	Latest	*CTL	[- / - / -]
7-508-002	Latest 1	*CTL	[- / - / -]
7-508-003	Latest 2	*CTL	[- / - / -]
7-508-004	Latest 3	*CTL	[- / - / -]
7-508-005	Latest 4	*CTL	[- / - / -]
7-508-006	Latest 5	*CTL	[- / - / -]
7-508-007	Latest 6	*CTL	[- / - / -]

SP Mode Tables - SP7000-1

7-508-008	Latest 7	*CTL	[- / - / -]
7-508-009	Latest 8	*CTL	[- / - / -]
7-508-010	Latest 9	*CTL	[- / - / -]

Paper Size Hex Codes

These codes are displayed by SP7507 and SP7508.

Size	Code	Size	Code	Size	Code
A4 (S)	05	A3 (L)	84	DLT (L)	A0
A5 (S)	06	A4 (L)	85	LG (L)	A4
B5 (S)	0E	A5 (L)	86	LT (L)	A6
LT (S)	26	B4 (L)	8D	HLT (L)	AC
HLT (S)	2C	B5 (L)	8E	Others	FF

7509	[Paper Jam Count by Location2] Displays the total number of jams according to the location where jams were detected.		
7-509-045	Entrance: On	*CTL	[0000 to 9999 / 0 / 1/step]
7-509-046	Entrance: Off	*CTL	[0000 to 9999 / 0 / 1/step]
7-509-047	Original Exit Sensor: On	*CTL	[0000 to 9999 / 0 / 1/step]
7-509-048	Original Exit Sensor: Off	*CTL	[0000 to 9999 / 0 / 1/step]
7-509-049	Shift Motor	*CTL	[0000 to 9999 / 0 / 1/step]
7-509-050	Junction Motor	*CTL	[0000 to 9999 / 0 / 1/step]
7-509-051	Exit Pressure Release Motor	*CTL	[0000 to 9999 / 0 / 1/step]

7-509-052	Staple Motor	*CTL	[0000 to 9999 / 0 / 1/step]
7-509-053	Feed-Out: Off	*CTL	[0000 to 9999 / 0 / 1/step]
7-509-093	No Exit Release	*CTL	[0000 to 9999 / 0 / 1/step]
7-509-094	Main Machine Setting Incorrect	*CTL	[0000 to 9999 / 0 / 1/step]

7514	[Paper Jam Count by Location] Displays the total number of jams according to the location where jams were detected.		
7-514-001	At Power On	*CTL	[0000 to 9999 / - / 1/step]
7-514-003	Tray1: On	*CTL	[0000 to 9999 / - / 1/step]
7-514-004	Tray2: On	*CTL	[0000 to 9999 / - / 1/step]
7-514-005	Tray3: On	*CTL	[0000 to 9999 / - / 1/step]
7-514-006	Tray4: On	*CTL	[0000 to 9999 / - / 1/step]
7-514-007	LCT: On	*CTL	[0000 to 9999 / - / 1/step]
7-514-008	Bypass: On	*CTL	[0000 to 9999 / - / 1/step]
7-514-009	Duplex: On	*CTL	[0000 to 9999 / - / 1/step]
7-514-010	Timing: On	*CTL	[0000 to 9999 / - / 1/step]
7-514-011	Transport 1: On	*CTL	[0000 to 9999 / - / 1/step]
7-514-012	Transport 2: On	*CTL	[0000 to 9999 / - / 1/step]
7-514-013	Vertical Trans. 3: On	*CTL	[0000 to 9999 / - / 1/step]
7-514-014	Vertical Trans. 4: On	*CTL	[0000 to 9999 / - / 1/step]
7-514-015	LCT Transport: On	*CTL	[0000 to 9999 / - / 1/step]
7-514-017	Registration: On	*CTL	[0000 to 9999 / - / 1/step]
7-514-018	Fusing Entrance: On	*CTL	[0000 to 9999 / - / 1/step]

7-514-019	Fusing Exit: On	*CTL	[0000 to 9999 / - / 1/step]
7-514-020	Paper Exit: On	*CTL	[0000 to 9999 / - / 1/step]
7-514-021	Bridge Tray Exit: On	*CTL	[0000 to 9999 / - / 1/step]
7-514-022	Bridge Relay: On	*CTL	[0000 to 9999 / - / 1/step]
7-514-024	Inverter: On	*CTL	[0000 to 9999 / - / 1/step]
7-514-025	Duplex Exit: On	*CTL	[0000 to 9999 / - / 1/step]
7-514-027	Duplex Entrance: On	*CTL	[0000 to 9999 / - / 1/step]
7-514-051	Transport 1: Off	*CTL	[0000 to 9999 / - / 1/step]
7-514-052	Transport 2: Off	*CTL	[0000 to 9999 / - / 1/step]
7-514-053	Vertical Trans. 3: Off	*CTL	[0000 to 9999 / - / 1/step]
7-514-054	Vertical Trans. 4: Off	*CTL	[0000 to 9999 / - / 1/step]
7-514-055	LCT Feed Sensor: Off	*CTL	[0000 to 9999 / - / 1/step]
7-514-057	Registration Sensor: Off	*CTL	[0000 to 9999 / - / 1/step]
7-514-060	Paper Exit: Off	*CTL	[0000 to 9999 / - / 1/step]
7-514-061	Bridge: Exit: Off	*CTL	[0000 to 9999 / - / 1/step]
7-514-062	Bridge: Transport: Off	*CTL	[0000 to 9999 / - / 1/step]
7-514-064	Inverter: Off	*CTL	[0000 to 9999 / - / 1/step]
7-514-065	Duplex Exit: Off	*CTL	[0000 to 9999 / - / 1/step]
7-514-067	Duplex Entrance: Off	*CTL	[0000 to 9999 / - / 1/step]
7-514-099	Double-Feed Detection	*CTL	[0000 to 9999 / - / 1/step]
7-514-100	Entrance: On	*CTL	[0000 to 9999 / - / 1/step]
7-514-101	Entrance: Off	*CTL	[0000 to 9999 / - / 1/step]
7-514-102	Transport : On	*CTL	[0000 to 9999 / - / 1/step]

7-514-103	Transport: Off	*CTL	[0000 to 9999 / - / 1/step]
7-514-104	Paper Exit	*CTL	[0000 to 9999 / - / 1/step]
7-514-105	Front Jogger Motor	*CTL	[0000 to 9999 / - / 1/step]
7-514-106	Rear Jogger Motor	*CTL	[0000 to 9999 / - / 1/step]
7-514-107	Shift Roller Motor	*CTL	[0000 to 9999 / - / 1/step]
7-514-108	Positioning Motor	*CTL	[0000 to 9999 / - / 1/step]
7-514-109	Ext Guide Plate Motor	*CTL	[0000 to 9999 / - / 1/step]
7-514-110	Stapler Shift Motor	*CTL	[0000 to 9999 / - / 1/step]
7-514-111	Tray Lift Motor	*CTL	[0000 to 9999 / - / 1/step]
7-514-112	Staple Motor	*CTL	[0000 to 9999 / - / 1/step]
7-514-113	Stack Height Motor	*CTL	[0000 to 9999 / - / 1/step]
7-514-114	Punch Motor	*CTL	[0000 to 9999 / - / 1/step]
7-514-115	Punch Move Motor	*CTL	[0000 to 9999 / - / 1/step]
7-514-116	S-to-S Registration Move Motor	*CTL	[0000 to 9999 / - / 1/step]
7-514-148	No Exit Response	*CTL	[0000 to 9999 / - / 1/step]
7-514-149	Main Machine Setting Incorrect	*CTL	[0000 to 9999 / - / 1/step]
7-514-150	Entrance Sensor: On	*CTL	[0000 to 9999 / - / 1/step]
7-514-151	Entrance Sensor: Off	*CTL	[0000 to 9999 / - / 1/step]
7-514-152	Horizontal Transport Sensor: On	*CTL	[0000 to 9999 / - / 1/step]
7-514-153	HorizontalTransportSensor: Off	*CTL	[0000 to 9999 / - / 1/step]

7-514-154	Switchback Transport Sensor: On	*CTL	[0000 to 9999 / - / 1/step]
7-514-155	Switchback Transport Sensor: Off	*CTL	[0000 to 9999 / - / 1/step]
7-514-156	Proof Tray Exit	*CTL	[0000 to 9999 / - / 1/step]
7-514-157	Shift Tray Exit	*CTL	[0000 to 9999 / - / 1/step]
7-514-158	Booklet Stapler Exit	*CTL	[0000 to 9999 / - / 1/step]
7-514-159	Entrance Motor	*CTL	[0000 to 9999 / - / 1/step]
7-514-160	Horizontal Transport Motor	*CTL	[0000 to 9999 / - / 1/step]
7-514-161	Pre-Stack Transport Motor	*CTL	[0000 to 9999 / - / 1/step]
7-514-162	ITB Transport Motor	*CTL	[0000 to 9999 / - / 1/step]
7-514-163	Exit Motor	*CTL	[0000 to 9999 / - / 1/step]
7-514-164	TE Press Motor	*CTL	[0000 to 9999 / - / 1/step]
7-514-165	Exit Plate Guide Motor	*CTL	[0000 to 9999 / - / 1/step]
7-514-166	Punching Motor	*CTL	[0000 to 9999 / - / 1/step]
7-514-167	Punch Move Motor	*CTL	[0000 to 9999 / - / 1/step]
7-514-168	S-to-S Regist Move Motor	*CTL	[0000 to 9999 / - / 1/step]
7-514-169	Lower junction Solenoid Motor	*CTL	[0000 to 9999 / - / 1/step]
7-514-170	Jogger Motor	*CTL	[0000 to 9999 / - / 1/step]
7-514-171	Positioning Motor	*CTL	[0000 to 9999 / - / 1/step]
7-514-172	Feed Out Motor	*CTL	[0000 to 9999 / - / 1/step]

7-514-173	Corner Stapler Move Motor	*CTL	[0000 to 9999 / - / 1/step]
7-514-174	Corner Stapler Motor	*CTL	[0000 to 9999 / - / 1/step]
7-514-175	Saddle Stitch Stapler Jogger Motor	*CTL	[0000 to 9999 / - / 1/step]
7-514-176	Saddle Stitch Stapler Jog Solenoid Motor Mr	*CTL	[0000 to 9999 / - / 1/step]
7-514-177	Saddle Stitch Stapler Standard Fence Motor	*CTL	[0000 to 9999 / - / 1/step]
7-514-178	Saddle Stitch Stapler Motor	*CTL	[0000 to 9999 / - / 1/step]
7-514-179	Dynamic Roller Transport Mt	*CTL	[0000 to 9999 / - / 1/step]
7-514-180	Folder Transport Motor	*CTL	[0000 to 9999 / - / 1/step]
7-514-181	Saddle Stitch Stplr Positioning Roller Motor	*CTL	[0000 to 9999 / - / 1/step]
7-514-182	Press-Fold Motor	*CTL	[0000 to 9999 / - / 1/step]
7-514-183	Output Tray Motor	*CTL	[0000 to 9999 / - / 1/step]
7-514-184	Shift Motor	*CTL	[0000 to 9999 / - / 1/step]
7-514-185	Shift Tray Jogger Front Motor	*CTL	[0000 to 9999 / - / 1/step]
7-514-186	Shift Tray Jogger Rear Motor	*CTL	[0000 to 9999 / - / 1/step]
7-514-187	Shift Tray Jogger Retraction Motor	*CTL	[0000 to 9999 / - / 1/step]
7-514-188	Stack Roller Motor	*CTL	[0000 to 9999 / - / 1/step]

7-514-189	Leading Edge Guide Motor	*CTL	[0000 to 9999 / - / 1/step]
7-514-190	Job Data Error	*CTL	[0000 to 9999 / - / 1/step]
7-514-200	Entrance: On	*CTL	[0000 to 9999 / - / 1/step]
7-514-201	Entrance: Off	*CTL	[0000 to 9999 / - / 1/step]
7-514-202	Proog Tray Exit: On	*CTL	[0000 to 9999 / - / 1/step]
7-514-203	Proof Tray Exit: Off	*CTL	[0000 to 9999 / - / 1/step]
7-514-204	Right Relay: On	*CTL	[0000 to 9999 / - / 1/step]
7-514-205	Left Relay: On	*CTL	[0000 to 9999 / - / 1/step]
7-514-206	Left Relay: Off	*CTL	[0000 to 9999 / - / 1/step]
7-514-207	Shift Tray Exit: On	*CTL	[0000 to 9999 / - / 1/step]
7-514-208	Shift Tray Exit: Off	*CTL	[0000 to 9999 / - / 1/step]
7-514-209	Stack: On	*CTL	[0000 to 9999 / - / 1/step]
7-514-210	TE Stopper: On	*CTL	[0000 to 9999 / - / 1/step]
7-514-211	TE Stopper: Off	*CTL	[0000 to 9999 / - / 1/step]
7-514-212	Booklet Folder Exit: On	*CTL	[0000 to 9999 / - / 1/step]
7-514-213	Booklet Folder Exit: Off	*CTL	[0000 to 9999 / - / 1/step]
7-514-220	Entrance Motor	*CTL	[0000 to 9999 / - / 1/step]
7-514-221	Proof Motor	*CTL	[0000 to 9999 / - / 1/step]
7-514-222	Exit Transport/Positioning Roller Motor	*CTL	[0000 to 9999 / - / 1/step]
7-514-223	Shift Motor	*CTL	[0000 to 9999 / - / 1/step]
7-514-224	Jogger Motor	*CTL	[0000 to 9999 / - / 1/step]
7-514-225	Exit Guide Plate Motor	*CTL	[0000 to 9999 / - / 1/step]

7-514-226	Feed Out Motor	*CTL	[0000 to 9999 / - / 1/step]
7-514-227	Output Tray Motor	*CTL	[0000 to 9999 / - / 1/step]
7-514-228	Positioning Motor	*CTL	[0000 to 9999 / - / 1/step]
7-514-229	Stapler Shift Motor	*CTL	[0000 to 9999 / - / 1/step]
7-514-230	Stapler Motor	*CTL	[0000 to 9999 / - / 1/step]
7-514-231	Punch Motor	*CTL	[0000 to 9999 / - / 1/step]
7-514-232	Stack Transport Motor	*CTL	[0000 to 9999 / - / 1/step]
7-514-233	LE Stopper Motor	*CTL	[0000 to 9999 / - / 1/step]
7-514-234	Folder Blade Motor	*CTL	[0000 to 9999 / - / 1/step]
7-514-248	No Exit Response	*CTL	[0000 to 9999 / - / 1/step]
7-514-249	Main Machine Setting Incorrect	*CTL	[0000 to 9999 / - / 1/step]

7515	[Original Jam Count by Detection] Displays the number of original jams detected.		
7-515-001	At Power On	*CTL	[0000 to 9999 / 0 / 1/step]
7-515-013	Separation Sensor:On	*CTL	[0000 to 9999 / 0 / 1/step]
7-515-014	Skew Correction Sn: On	*CTL	[0000 to 9999 / 0 / 1/step]
7-515-015	Scanning Entrance Sn:On	*CTL	[0000 to 9999 / 0 / 1/step]
7-515-016	Registration Sensor:On	*CTL	[0000 to 9999 / 0 / 1/step]
7-515-017	Original Exit Sensor:On	*CTL	[0000 to 9999 / 0 / 1/step]
7-515-063	Separation Sensor:Off	*CTL	[0000 to 9999 / 0 / 1/step]
7-515-064	Skew Correction Sn:Off	*CTL	[0000 to 9999 / 0 / 1/step]
7-515-065	Scanning Entrance Sn:Off	*CTL	[0000 to 9999 / 0 / 1/step]
7-515-066	Registration Sensor:Off	*CTL	[0000 to 9999 / 0 / 1/step]
7-515-067	Original Exit Sensor:Off	*CTL	[0000 to 9999 / 0 / 1/step]
7-515-239	Original Pull	*CTL	[0000 to 9999 / 0 / 1/step]

5.12 SP MODE TABLES - SP7000-2

5.12.1 SP7-XXX (DATA LOG)

7516	[Jam Paper Size Cnt] Displays the number of jams according to the paper size.		
7-516-005	A4 LEF	*CTL	[0000 to 9999 / 0 / 1/step]
7-516-006	A5 LEF	*CTL	[0000 to 9999 / 0 / 1/step]
7-516-014	B5 LEF	*CTL	[0000 to 9999 / 0 / 1/step]
7-516-038	LT LEF	*CTL	[0000 to 9999 / 0 / 1/step]
7-516-044	HLT LEF	*CTL	[0000 to 9999 / 0 / 1/step]
7-516-132	A3 SEF	*CTL	[0000 to 9999 / 0 / 1/step]
7-516-133	A4 SEF	*CTL	[0000 to 9999 / 0 / 1/step]
7-516-134	A5 SEF	*CTL	[0000 to 9999 / 0 / 1/step]
7-516-141	B4 SEF	*CTL	[0000 to 9999 / 0 / 1/step]
7-516-142	B5 SEF	*CTL	[0000 to 9999 / 0 / 1/step]
7-516-160	DLT SEF	*CTL	[0000 to 9999 / 0 / 1/step]
7-516-164	LG SEF	*CTL	[0000 to 9999 / 0 / 1/step]
7-516-166	LT SEF	*CTL	[0000 to 9999 / 0 / 1/step]
7-516-172	HLT SEF	*CTL	[0000 to 9999 / 0 / 1/step]
7-516-255	Others	*CTL	[0000 to 9999 / 0 / 1/step]

7519	[Paper Jam Count by Location] Displays the total number of jams according to the location where jams were detected.		
7-519-045	Entrance: On	*CTL	[0000 to 9999 / 0 / 1/step]
7-519-046	Entrance: Off	*CTL	[0000 to 9999 / 0 / 1/step]
7-519-047	Original Exit Sensor: On	*CTL	[0000 to 9999 / 0 / 1/step]
7-519-048	Original Exit Sensor: Off	*CTL	[0000 to 9999 / 0 / 1/step]
7-519-049	Shift Motor	*CTL	[0000 to 9999 / 0 / 1/step]
7-519-050	Junction Motor	*CTL	[0000 to 9999 / 0 / 1/step]
7-519-051	Exit Pressure Release Motor	*CTL	[0000 to 9999 / 0 / 1/step]
7-519-052	Staple Motor	*CTL	[0000 to 9999 / 0 / 1/step]
7-519-053	Feed-Out: Off	*CTL	[0000 to 9999 / 0 / 1/step]
7-519-093	No Exit Response	*CTL	[0000 to 9999 / 0 / 1/step]
7-519-094	Main Machine Setting Incorrect	*CTL	[0000 to 9999 / 0 / 1/step]

7520	[Update Log] Displays error history of firmware update in the past 10 times. [-001] is the latest error history, and [-010] is the most old error history.		
7-520-001	ErrorRecord1	*CTL	[1 to 255 / 0 / 1/step]
7-520-002	ErrorRecord2	*CTL	[1 to 255 / 0 / 1/step]
7-520-003	ErrorRecord3	*CTL	[1 to 255 / 0 / 1/step]
7-520-004	ErrorRecord4	*CTL	[1 to 255 / 0 / 1/step]
7-520-005	ErrorRecord5	*CTL	[1 to 255 / 0 / 1/step]
7-520-006	ErrorRecord6	*CTL	[1 to 255 / 0 / 1/step]
7-520-007	ErrorRecord7	*CTL	[1 to 255 / 0 / 1/step]
7-520-008	ErrorRecord8	*CTL	[1 to 255 / 0 / 1/step]
7-520-009	ErrorRecord9	*CTL	[1 to 255 / 0 / 1/step]
7-520-010	ErrorRecord10	*CTL	[1 to 255 / 0 / 1/step]

7617	[PM Parts Counter Display] -		
7-617-001	Normal	*CTL	[0000 to 9999999 / 0 / 1/step]
7-617-002	Df	*CTL	[0000 to 9999999 / 0 / 1/step]

7618	[PM Parts Counter Reset]		
	-		
7-618-001	Normal	*CTL	[- / - / -] [Execute] Clears the counter of SP7617-001. Push [Execute] to clear the parts replacement alarm counter for the main machine.
7-618-002	Df	*CTL	[- / - / -] [Execute] Clears the counter of SP7617-002. Push [Execute] to clear the parts replacement alarm counter for the ADF.

7621	[PM Counter Display: Pages]		
	Displays the PM counter for each unit.		
7-621-002	#PCU	ENG	[0 to 99999999 / 0 / 1page/step]
7-621-009	Cleaning Blade	ENG	[0 to 99999999 / 0 / 1page/step]
7-621-018	Charge Roller	ENG	[0 to 99999999 / 0 / 1page/step]
7-621-019	Cleaner:Charge Roller	ENG	[0 to 99999999 / 0 / 1page/step]
7-621-021	OPC	ENG	[0 to 99999999 / 0 / 1page/step]
7-621-022	Stripper	ENG	[0 to 99999999 / 0 / 1page/step]
7-621-023	#Dev Unit	ENG	[0 to 99999999 / 0 / 1page/step]
7-621-024	Developer	ENG	[0 to 99999999 / 0 / 1page/step]
7-621-025	Development Filter	ENG	[0 to 99999999 / 0 / 1page/step]

7-621-028	Bearing:Development Screw	ENG	[0 to 99999999 / 0 / 1page/step]
7-621-108	Paper Transfer Roller Unit	ENG	[0 to 99999999 / 0 / 1page/step]
7-621-115	Fusing Unit	ENG	[0 to 99999999 / 0 / 1page/step]
7-621-116	Fusing Belt	ENG	[0 to 99999999 / 0 / 1page/step]
7-621-118	Pressure Roller	ENG	[0 to 99999999 / 0 / 1page/step]
7-621-119	Bearing:Pressure Roller	ENG	[0 to 99999999 / 0 / 1page/step]
7-621-142	Waste Toner bottle	ENG	[0 to 999999999 / 0 / 1mg]
7-621-206	ADF Pick-up Roller	ENG	[0 to 99999999 / 0 / 1page/step]
7-621-207	ADF Supply Belt	ENG	[0 to 99999999 / 0 / 1page/step]
7-621-208	ADF Reverse Roller	ENG	[0 to 99999999 / 0 / 1page/step]

7622	[PM Counter Reset]		
	Clears the PM counter for each unit.		
7-622-002	#PCU	ENG	[0 or 1 / 0 / 1/step]
7-622-009	Cleaning Blade	ENG	[0 or 1 / 0 / 1/step]
7-622-018	Charge Roller	ENG	[0 or 1 / 0 / 1/step]
7-622-019	Cleaner:Charge Roller	ENG	[0 or 1 / 0 / 1/step]
7-622-021	OPC	ENG	[0 or 1 / 0 / 1/step]
7-622-022	Stripper	ENG	[0 or 1 / 0 / 1/step]
7-622-023	#Dev Unit	ENG	[0 or 1 / 0 / 1/step]
7-622-024	Developer	ENG	[0 or 1 / 0 / 1/step]

7-622-025	Development Filter	ENG	[0 or 1 / 0 / 1/step]
7-622-028	Bearing:Development Screw	ENG	[0 or 1 / 0 / 1/step]
7-622-108	Paper Transfer Roller Unit	ENG	[0 or 1 / 0 / 1/step]
7-622-115	Fusing Unit	ENG	[0 or 1 / 0 / 1/step]
7-622-116	Fusing Belt	ENG	[0 or 1 / 0 / 1/step]
7-622-118	Pressure Roller	ENG	[0 or 1 / 0 / 1/step]
7-622-119	Bearing:Pressure Roller	ENG	[0 or 1 / 0 / 1/step]
7-622-206	ADF Pick-up Roller	ENG	[0 or 1 / 0 / 1/step]
7-622-207	ADF Supply Belt	ENG	[0 or 1 / 0 / 1/step]
7-622-208	ADF Reverse Roller	ENG	[0 or 1 / 0 / 1/step]
7-622-250	SCS	ENG	[0 or 1 / 0 / 1/step]

7624	[Part Replacement Operation ON/OFF]		
7-624-002	#PCU	ENG	[0 or 1 / 0 / 1/step]
7-624-009	Cleaning Blade	ENG	
7-624-018	Charge Roller	ENG	
7-624-019	Cleaner:Charge Roller	ENG	
7-624-021	OPC	ENG	
7-624-022	Stripper	ENG	
7-624-023	#Dev Unit	ENG	
7-624-024	Developer	ENG	

7-624-025	Development Filter	ENG	
7-624-028	Bearing:Development Screw	ENG	[0 or 1 / 0 / 1/step]
7-624-108	Paper Transfer Roller Unit	ENG	
7-624-115	Fusing Unit	ENG	
7-624-116	Fusing Belt	ENG	
7-624-118	Pressure Roller	ENG	
7-624-119	Bearing:Pressure Roller	ENG	
7-624-206	ADF Pick-up Roller	ENG	
7-624-207	ADF Supply Belt	ENG	
7-624-208	ADF Reverse Roller	ENG	

7625	[Previous Unit Counter: Pages]		
7-625-028	Bearing:Development Screw	ENG	[0 to 99999999 / 0 / 1page]
	Displays the page counter for the previous development mixing auger bearings.		

7626	[Previous Unit Counter2: Pages]		
7-626-028	Bearing:Development Screw	ENG	[0 to 99999999 / 0 / 1page]
	Displays the page counter for the 2nd previous development mixing auger bearings.		

7628	[PM Counter Reset]		
	Resets all counts for PM Counter.		
7-628-002	SCS	ENG	Executes the counter clear for all PM counters.

7801	[ROM No./ Firmware Version]		
	Displays firmware information for main machine and all other connected devices.		
7-801-255	-	CTL	-

7803	[PM Counter Display]		
	<p>Displays the number of sheets printed for each current maintenance unit. PM counters click up based on the number of A4 (LT) LEF size sheets printed. Therefore, the A3 (DLT) Double Count is activated. The Double Count cannot be deactivated.</p> <p>When a unit is replaced, the machine automatically detects that the new unit is installed.</p>		
7-803-001	Paper	*CTL	[0 to 9999999 / 0 / 1/step]

7804	[PM Counter Reset]		
	<p>Clears the PM counter.</p> <p>Press [EXECUTE] to reset the PM count.</p>		
7-804-001	Paper	CTL	[- / - / -] [Execute]

7807	[SC/Jam Counter Reset]		
	Clears the counters related to SC codes and paper jams.		
7-807-001	-	CTL	[- / - / -] [Execute]

7826	[MF Error Counter] Displays the number of counts requested of the card/key counter.		
7-826-001	Error Total	*CTL	[0 to 9999999 / 0 / 1/step] A request for the count total failed at power on. This error will occur if the device is installed but disconnected.
7-826-002	Error Staple	*CTL	[0 to 9999999 / 0 / 1/step] The request for a staple count failed at power on. This error will occur if the device is installed but disconnected.

7827	[MF Error Counter Clear] Clears MF Error Counter. Only valid when the MK-1 has been connected.		
7-827-001	-	CTL	[- / - / -] [Execute]

7832	[Self-Diagnose Result Display] Displays the result of the diagnostics.		
7-832-001	-	CTL	[- / - / -] [Execute]

7836	[Total Memory Size] Displays the memory capacity of the controller system.		
7-836-001	Total Memory Size	CTL	[- / - / -]

7840	[ServiceSP Entry Code Chg Hist]		
	Records dates and times of resetting / changing "Service SP mode switch code setting" for the recent 2 times. (Decides whether the record is for setting changes or resets by branch number.)		
	7-840-001	Change Time :Latest	*CTL [- / - / -]
	7-840-002	Change Time : Last1	*CTL [- / - / -]
	7-840-101	Initialize Time : Latest	*CTL [- / - / -]
7-840-102	Initialize Time : Last1	*CTL [- / - / -]	

7852	[DF Glass Dust Check]		
	001	Dust Detection Counter	*ENG [0 to 65535 / 0 / 1/step]
		Records the times detecting dust at all points of front side scan position. When there is a dust even when before starting the next job, consider as same dust and doesn't count. Counts when SP4-020-001: DF scan glass part dust detect front is ON.	
	002	Dust Counter Clear Counter	*ENG [0 to 65535 / 0 / 1/step]
		For checking front side scan position move effect. Counts the times that strips were avoided by detecting dust and move the sheet through DF scan position. Counts when SP4-020-001: DF scan glass part dust detect front is ON.	
	003	Dust Detection Counter: Back	*ENG [0 to 65535 / 0 / 1/step]
For Single Path simultaneous duplex models only. Records the times detecting dust at all points of rear side scan position. When there is a same dust even when before starting the next job, consider as same dust and doesn't count. * Counts when SP4-020-011: DF			

7901	[Assert Info.]		
	Records the location where a problem is detected in the program. Used for debugging.		
	7-901-001	File Name	*CTL [- / - / -]
	7-901-002	Number of Lines	*CTL [- / - / -]
7-901-003	Location	*CTL [- / - / -]	

7942	[PM Counter Display:Distance(%)]		
	Displays the PM counter (distance (%)) for each unit.		
7-942-002	#PCU	ENG	[0 to 255 / 0 / 1%/step]
7-942-009	Cleaning Blade	ENG	[0 to 255 / 0 / 1%/step]
7-942-018	Charge Roller	ENG	[0 to 255 / 0 / 1%/step]
7-942-019	Cleaner:Charge Roller	ENG	[0 to 255 / 0 / 1%/step]
7-942-021	OPC	ENG	[0 to 255 / 0 / 1%/step]
7-942-022	Stripper	ENG	[0 to 255 / 0 / 1%/step]
7-942-023	#Dev Unit	ENG	[0 to 255 / 0 / 1%/step]
7-942-024	Developer	ENG	[0 to 255 / 0 / 1%/step]
7-942-025	Development Filter	ENG	[0 to 255 / 0 / 1%/step]
7-942-028	Bearing:Development Screw	ENG	[0 to 255 / 0 / 1%/step]
7-942-108	Paper Transfer Roller Unit	ENG	[0 to 255 / 0 / 1%/step]
7-942-115	Fusing Unit	ENG	[0 to 255 / 0 / 1%/step]
7-942-116	Fusing Belt	ENG	[0 to 255 / 0 / 1%/step]

7-942-118	Pressure Roller	ENG	[0 to 255 / 0 / 1%/step]
7-942-119	Bearing:Pressure Roller	ENG	[0 to 255 / 0 / 1%/step]

7944	[PM Counter Display: Distance]		
	Displays the PM counter (distance (mm)) for each unit.		
7-944-002	#PCU	*ENG	[0 to 4294967295 / 0 / 1mm/step]
7-944-009	Cleaning Blade	*ENG	[0 to 4294967295 / 0 / 1mm/step]
7-944-018	Charge Roller	*ENG	[0 to 4294967295 / 0 / 1mm/step]
7-944-019	Cleaner:Charge Roller	*ENG	[0 to 4294967295 / 0 / 1mm/step]
7-944-021	OPC	*ENG	[0 to 4294967295 / 0 / 1mm/step]
7-944-022	Stripper	*ENG	[0 to 4294967295 / 0 / 1mm/step]
7-944-023	#Dev Unit	*ENG	[0 to 4294967295 / 0 / 1mm/step]
7-944-024	Developer	*ENG	[0 to 4294967295 / 0 / 1mm/step]
7-944-025	Development Filter	*ENG	[0 to 4294967295 / 0 / 1mm/step]
7-944-028	Bearing:Development Screw	*ENG	[0 to 4294967295 / 0 / 1mm/step]
7-944-108	Paper Transfer Roller Unit	*ENG	[0 to 4294967295 / 0 / 1mm/step]
7-944-115	Fusing Unit	*ENG	[0 to 4294967295 / 0 / 1mm/step]
7-944-116	Fusing Belt	*ENG	[0 to 4294967295 / 0 / 1mm/step]
7-944-118	Pressure Roller	*ENG	[0 to 4294967295 / 0 / 1mm/step]
7-944-119	Bearing:Pressure Roller	*ENG	[0 to 4294967295 / 0 / 1mm/step]

7951	[Remain Day Counter: Pages]		
	-		
7-951-002	#PCU	ENG	[0 to 255 / 255 / 1day/step]
7-951-009	Cleaning Blade	ENG	[0 to 255 / 255 / 1day/step]
7-951-018	Charge Roller	ENG	[0 to 255 / 255 / 1day/step]
7-951-019	Cleaner:Charge Roller	ENG	[0 to 255 / 255 / 1day/step]
7-951-021	OPC	ENG	[0 to 255 / 255 / 1day/step]
7-951-022	Stripper	ENG	[0 to 255 / 255 / 1day/step]
7-951-023	#Dev Unit	ENG	[0 to 255 / 255 / 1day/step]
7-951-024	Developer	ENG	[0 to 255 / 255 / 1day/step]
7-951-025	Development Filter	ENG	[0 to 255 / 255 / 1day/step]
7-951-028	Bearing:Development Screw	ENG	[0 to 255 / 255 / 1day/step]
7-951-108	Paper Transfer Roller Unit	ENG	[0 to 255 / 255 / 1day/step]
7-951-115	Fusing Unit	ENG	[0 to 255 / 255 / 1day/step]
7-951-116	Fusing Belt	ENG	[0 to 255 / 255 / 1day/step]
7-951-118	Pressure Roller	ENG	[0 to 255 / 255 / 1day/step]
7-951-119	Bearing:Pressure Roller	ENG	[0 to 255 / 255 / 1day/step]
7-951-142	Waste Toner bottle	ENG	[0 to 255 / 255 / 1day/step]
7-951-206	ADF Pick-up Roller	ENG	[0 to 255 / 255 / 1day/step]
7-951-207	ADF Supply Belt	ENG	[0 to 255 / 255 / 1day/step]
7-951-208	ADF Reverse Roller	ENG	[0 to 255 / 255 / 1day/step]

7952	[Remain Day Counter: Distance]		
	-		
7-952-002	#PCU	ENG	[0 to 255 / 255 / 1day/step]
7-952-009	Cleaning Blade	ENG	[0 to 255 / 255 / 1day/step]
7-952-018	Charge Roller	ENG	[0 to 255 / 255 / 1day/step]
7-952-019	Cleaner:Charge Roller	ENG	[0 to 255 / 255 / 1day/step]
7-952-021	OPC	ENG	[0 to 255 / 255 / 1day/step]
7-952-022	Stripper	ENG	[0 to 255 / 255 / 1day/step]
7-952-023	#Dev Unit	ENG	[0 to 255 / 255 / 1day/step]
7-952-024	Developer	ENG	[0 to 255 / 255 / 1day/step]
7-952-025	Development Filter	ENG	[0 to 255 / 255 / 1day/step]
7-952-028	Bearing:Development Screw	ENG	[0 to 255 / 255 / 1day/step]
7-952-108	Paper Transfer Roller Unit	ENG	[0 to 255 / 255 / 1day/step]
7-952-115	Fusing Unit	ENG	[0 to 255 / 255 / 1day/step]
7-952-116	Fusing Belt	ENG	[0 to 255 / 255 / 1day/step]
7-952-118	Pressure Roller	ENG	[0 to 255 / 255 / 1day/step]
7-952-119	Bearing:Pressure Roller	ENG	[0 to 255 / 255 / 1day/step]

7954	[PM Counter Display: Pages (%)]		
	-		
7-954-002	#PCU	ENG	[0 to 255 / 0 / 1%/step]
7-954-009	Cleaning Blade	ENG	[0 to 255 / 0 / 1%/step]
7-954-018	Charge Roller	ENG	[0 to 255 / 0 / 1%/step]
7-954-019	Cleaner:Charge Roller	ENG	[0 to 255 / 0 / 1%/step]
7-954-021	OPC	ENG	[0 to 255 / 0 / 1%/step]
7-954-022	Stripper	ENG	[0 to 255 / 0 / 1%/step]
7-954-023	#Dev Unit	ENG	[0 to 255 / 0 / 1%/step]
7-954-024	Developer	ENG	[0 to 255 / 0 / 1%/step]
7-954-025	Development Filter	ENG	[0 to 255 / 0 / 1%/step]
7-954-028	Bearing:Development Screw	ENG	[0 to 255 / 0 / 1%/step]
7-954-108	Paper Transfer Roller Unit	ENG	[0 to 255 / 0 / 1%/step]
7-954-115	Fusing Unit	ENG	[0 to 255 / 0 / 1%/step]
7-954-116	Fusing Belt	ENG	[0 to 255 / 0 / 1%/step]
7-954-118	Pressure Roller	ENG	[0 to 255 / 0 / 1%/step]
7-954-119	Bearing:Pressure Roller	ENG	[0 to 255 / 0 / 1%/step]
7-954-142	Waste Toner bottle	ENG	[0 to 255 / 0 / 1%/step]
7-954-206	ADF Pick-up Roller	ENG	[0 to 255 / 0 / 1%/step]
7-954-207	ADF Supply Belt	ENG	[0 to 255 / 0 / 1%/step]
7-954-208	ADF Reverse Roller	ENG	[0 to 255 / 0 / 1%/step]

7955	[Estimated Remain Pages]		
	-		
7-955-002	#PCU	ENG	[0 to 9999999 / 0 / 1page/step]
7-955-009	Cleaning Blade	ENG	[0 to 9999999 / 0 / 1page/step]
7-955-018	Charge Roller	ENG	[0 to 9999999 / 0 / 1page/step]
7-955-019	Cleaner:Charge Roller	ENG	[0 to 9999999 / 0 / 1page/step]
7-955-021	OPC	ENG	[0 to 9999999 / 0 / 1page/step]
7-955-022	Stripper	ENG	[0 to 9999999 / 0 / 1page/step]
7-955-023	#Dev Unit	ENG	[0 to 9999999 / 0 / 1page/step]
7-955-024	Developer	ENG	[0 to 9999999 / 0 / 1page/step]
7-955-025	Development Filter	ENG	[0 to 9999999 / 0 / 1page/step]
7-955-028	Bearing:Development Screw	ENG	[0 to 9999999 / 0 / 1page/step]
7-955-108	Paper Transfer Roller Unit	ENG	[0 to 9999999 / 0 / 1page/step]
7-955-115	Fusing Unit	ENG	[0 to 9999999 / 0 / 1page/step]
7-955-116	Fusing Belt	ENG	[0 to 9999999 / 0 / 1page/step]
7-955-118	Pressure Roller	ENG	[0 to 9999999 / 0 / 1page/step]
7-955-119	Bearing:Pressure Roller	ENG	[0 to 9999999 / 0 / 1page/step]

7956	[Estimated Remain Days]		
	-		
7-956-002	#PCU	ENG	[0 to 255 / 255 / 1day/step]
7-956-009	Cleaning Blade	ENG	[0 to 255 / 255 / 1day/step]
7-956-018	Charge Roller	ENG	[0 to 255 / 255 / 1day/step]
7-956-019	Cleaner:Charge Roller	ENG	[0 to 255 / 255 / 1day/step]
7-956-021	OPC	ENG	[0 to 255 / 255 / 1day/step]
7-956-022	Stripper	ENG	[0 to 255 / 255 / 1day/step]
7-956-023	#Dev Unit	ENG	[0 to 255 / 255 / 1day/step]
7-956-024	Developer	ENG	[0 to 255 / 255 / 1day/step]
7-956-025	Development Filter	ENG	[0 to 255 / 255 / 1day/step]
7-956-028	Bearing:Development Screw	ENG	[0 to 255 / 255 / 1day/step]
7-956-108	Paper Transfer Roller Unit	ENG	[0 to 255 / 255 / 1day/step]
7-956-115	Fusing Unit	ENG	[0 to 255 / 255 / 1day/step]
7-956-116	Fusing Belt	ENG	[0 to 255 / 255 / 1day/step]
7-956-118	Pressure Roller	ENG	[0 to 255 / 255 / 1day/step]
7-956-119	Bearing:Pressure Roller	ENG	[0 to 255 / 255 / 1day/step]
7-956-142	Waste Toner bottle	ENG	[0 to 255 / 255 / 1day/step]
7-956-206	ADF Pick-up Roller	ENG	[0 to 255 / 255 / 1day/step]
7-956-207	ADF Supply Belt	ENG	[0 to 255 / 255 / 1day/step]
7-956-208	ADF Reverse Roller	ENG	[0 to 255 / 255 / 1day/step]

7960	[Estimated Usage Rate]		
	-		
7-960-002	#PCU	ENG	[0 to 255 / 0 / 1%/step]
7-960-009	Cleaning Blade	ENG	[0 to 255 / 0 / 1%/step]
7-960-018	Charge Roller	ENG	[0 to 255 / 0 / 1%/step]
7-960-019	Cleaner:Charge Roller	ENG	[0 to 255 / 0 / 1%/step]
7-960-021	OPC	ENG	[0 to 255 / 0 / 1%/step]
7-960-022	Stripper	ENG	[0 to 255 / 0 / 1%/step]
7-960-023	#Dev Unit	ENG	[0 to 255 / 0 / 1%/step]
7-960-024	Developer	ENG	[0 to 255 / 0 / 1%/step]
7-960-025	Development Filter	ENG	[0 to 255 / 0 / 1%/step]
7-960-028	Bearing:Development Screw	ENG	[0 to 255 / 0 / 1%/step]
7-960-108	Paper Transfer Roller Unit	ENG	[0 to 255 / 0 / 1%/step]
7-960-115	Fusing Unit	ENG	[0 to 255 / 0 / 1%/step]
7-960-116	Fusing Belt	ENG	[0 to 255 / 0 / 1%/step]
7-960-118	Pressure Roller	ENG	[0 to 255 / 0 / 1%/step]
7-960-119	Bearing:Pressure Roller	ENG	[0 to 255 / 0 / 1%/step]
7-960-142	Waste Toner bottle	ENG	[0 to 255 / 0 / 1%/step]
7-960-206	ADF Pick-up Roller	ENG	[0 to 255 / 0 / 1%/step]
7-960-207	ADF Supply Belt	ENG	[0 to 255 / 0 / 1%/step]
7-960-208	ADF Reverse Roller	ENG	[0 to 255 / 0 / 1%/step]

7970	[Cumulative Counter]		
7-970-001	Rotation:Opc Drive Unit	*ENG	[0 to 9999999 / 0 / 1m/step]
	Displays running distance count since first use.		
7-970-008	Rotation:Fusing Drive Unit	*ENG	[0 to 9999999 / 0 / 1m/step]
	Displays running distance count since first use.		
7-970-010	Count:Paper Transfer On-Off Drive Unit	*ENG	[0 to 9999999 / 0 / 1/step]
	Displays operating time count since first use.		
7-970-011	Page:Feed Drive Unit	*ENG	[0 to 9999999 / 0 / 1page/step]
	Displays sheets count since first use.		
7-970-012	Page:Registration Drive Unit	*ENG	[0 to 9999999 / 0 / 1page/step]
	Displays sheets count since first use.		
7-970-014	Page:Exit Drive Unit	*ENG	[0 to 9999999 / 0 / 1page/step]

5.13 SP MODE TABLES - SP8000-1

5.13.1 SP8-XXX (DATA LOG 2)

Many of these counters are provided for features that are currently not available, such as sending color faxes, and so on. However, here are some Group 8 codes that when used in combination with others, can provide useful information.

SP Numbers	What They Do
SP8211 to SP8216	The number of pages scanned to the document server.
SP8401 to SP8406	The number of pages printed from the document server
SP8691 to SP8696	The number of pages sent from the document server

Specifically, the following questions can be answered:

- How is the document server actually being used?
- What application is using the document server most frequently?
- What data in the document server is being reused?

Most of the SPs in this group are prefixed with a letter that indicates the mode of operation (the mode of operation is referred to as an "application"). Before reading the Group 8 Service Table, make sure that you understand what these prefixes mean.

Prefixes	What it means	
T:	Total: (Grand Total).	Grand total of the items counted for all applications (C, F, P, etc.).
C:	Copy application.	Totals (pages, jobs, etc.) executed for each application when the job was not stored on the document server.
F:	Fax application.	
P:	Print application.	
S:	Scan application.	

L:	Local storage (document server)	Totals (jobs, pages, etc.) for the document server. The L: counters work differently case by case. Sometimes, they count jobs/pages stored on the document server; this can be in document server mode (from the document server window), or from another mode, such as from a printer driver or by pressing the Store File button in the Copy mode window. Sometimes, they include occasions when the user uses a file that is already on the document server. Each counter will be discussed case by case.
O:	Other applications (external network applications, for example)	Refers to network applications such as Web Image Monitor. Utilities developed with the SDK (Software Development Kit) will also be counted with this group in the future.

The Group 8 SP codes are limited to 17 characters, forced by the necessity of displaying them on the small LCDs of printers and faxes that also use these SPs. Read over the list of abbreviations below and refer to it again if you see the name of an SP that you do not understand.

Keys and abbreviations in Data Log 2

Abbreviation	What it means
/	"By", e.g. "T:Jobs/Apl" = Total Jobs "by" Application
>	More (2> "2 or more", 4> "4 or more")
AddBook	Address Book
Apl	Application
B/W	Black & White
Bk	Black
C	Cyan
ColCr	Color Create
ColMode	Color Mode

Abbreviation	What it means
Comb	Combine
Comp	Compression
Deliv	Delivery
DesApl	Designated Application. The application (Copy, Fax, Scan, Print) used to store the job on the document server, for example.
Dev Counter	Development Count, no. of pages developed.
Dup, Duplex	Duplex, printing on both sides
Emul	Emulation
FC	Full Color
FIN	Post-print processing, i.e. finishing (punching, stapling, etc.)
Full Bleed	No Margins
GenCopy	Generation Copy Mode
GPC	Get Print Counter. For jobs 10 pages or less, this counter does not count up. For jobs larger than 10 pages, this counter counts up by the number that is in excess of 10 (e.g., for an 11-page job, the counter counts up 11-10 =1)
IFax	Internet Fax
ImgEdt	Image Edit performed on the original with the copier GUI, e.g. border removal, adding stamps, page numbers, etc.
K	Black (YMCK)
LS	Local Storage. Refers to the document server.
LSize	Large (paper) Size
Mag	Magnification
MC	One color (monochrome)

Abbreviation	What it means
NRS	New Remote Service, which allows a service center to monitor machines remotely. "NRS" is used overseas, "CSS" is used in Japan.
Org	Original for scanning
OrgJam	Original Jam
Palm 2	Print Job Manager/Desk Top Editor: A pair of utilities that allows print jobs to be distributed evenly among the printers on the network, and allows files to moved around, combined, and converted to different formats.
PC	Personal Computer
PGS	Pages. A page is the total scanned surface of the original. Duplex pages count as two pages, and A3 simplex count as two pages if the A3/DLT counter SP is switched ON.
PJob	Print Jobs
Ppr	Paper
PrtJam	Printer (plotter) Jam
PrtPGS	Print Pages
R	Red (Toner Remaining). Applies to the wide format model A2 only. This machine is under development and currently not available.
Rez	Resolution
SC	Service Code (Error SC code displayed)
Scn	Scan
Sim, Simplex	Simplex, printing on 1 side.
S-to-Email	Scan-to-E-mail
SMC	SMC report printed with SP5990. All of the Group 8 counters are recorded in the SMC report.
Svr	Server

Abbreviation	What it means
TonEnd	Toner End
TonSave	Toner Save
TXJob	Send, Transmission
YMC	Yellow, Magenta, Cyan
YMCK	Yellow, Magenta, Cyan, Black

Note

- All of the Group 8 SPs are able to reset by "SP5 801 1 Memory All Clear".

8001	[T:Total Jobs]	*CTL	These SPs count the number of times each application is used to do a job. [0 to 99999999 / - / 1] Note: The L: counter is the total number of times the other applications are used to send a job to the document server, plus the number of times a file already on the document server is used.
8002	[C:Total Jobs]	*CTL	
8003	[F:Total Jobs]	*CTL	
8004	[P:Total Jobs]	*CTL	
8005	[S:Total Jobs]	*CTL	
8006	[L:Total Jobs]	*CTL	

- These SPs reveal the number of times an application is used, not the number of pages processed.
- When an application is opened for image input or output, this counts as one job.
- Interrupted jobs (paper jams, etc.) are counted, even though they do not finish.
- Only jobs executed by the customer are counted. Jobs executed by the customer engineer using the SP modes are not counted.
- When using secure printing (when a password is required to start the print job), the job is counted at the time when either "Delete Data" or "Specify Output" is specified.
- A job is counted as a fax job when the job is stored for sending.
- When a fax is received to fax memory, the F: counter increments but the L: counter does not (the document server is not used).
- A fax broadcast counts as one job for the F: counter (the fax destinations in the broadcast are not counted separately).

- A fax broadcast is counted only after all the faxes have been sent to their destinations. If one transmission generates an error, then the broadcast will not be counted until the transmission has been completed.
- A printed fax report counts as one job for the F: counter.
- The F: counter does not distinguish between fax sending or receiving.
- When a copy job on the document server is printed, SP8022 also increments, and when a print job stored on the document server is printed, SP8024 also increments.
- When an original is both copied and stored on the document server, the C: and L: counters both increments.
- When a print job is stored on the document server, only the L: counter increments.
- When the user presses the Document Server button to store the job on the document server, only the L: counter increments.
- When the user enters document server mode and prints data stored on the document server, only the L: counter increments.
- When an image received from Palm 2 is received and stored, the L: counter increments.
- When the customer prints a report (user code list, for example), the O: counter increments. However, for fax reports and reports executed from the fax application, the F: counter increments.

8011	[T:Jobs/LS]	*CTL	These SPs count the number of jobs stored to the document server by each application, to reveal how local storage is being used for input. [0 to 9999999 / 0 / 1] The L: counter counts the number of jobs stored from within the document server mode screen at the operation panel.
8012	[C:Jobs/LS]	*CTL	
8013	[F:Jobs/LS]	*CTL	
8014	[P:Jobs/LS]	*CTL	
8015	[S:Jobs/LS]	*CTL	
8016	[L:Jobs/LS]	*CTL	
8017	[O:Jobs/LS]	*CTL	

- When a scan job is sent to the document server, the S: counter increments. When you enter document server mode and then scan an original, the L: counter increments.
- When a print job is sent to the document server, the P: counter increments.
- When a network application sends data to the document server, the O: counter increments.
- When an image from Palm 2 is stored on the document server, the O: counter increments.
- When a fax is sent to the document server, the F: counter increments.

8021	[T:Pjob/LS]	*CTL	These SPs reveal how files printed from the document server were stored on the document server originally. [0 to 9999999 / 0 / 1] The L: counter counts the number of jobs stored from within the document server mode screen at the operation panel.
8022	[C:Pjob/LS]	*CTL	
8023	[F:Pjob/LS]	*CTL	
8024	[P:Pjob/LS]	*CTL	
8025	[S:Pjob/LS]	*CTL	
8026	[L:Pjob/LS]	*CTL	
8027	[O:Pjob/LS]	*CTL	

- When a copy job stored on the document server is printed with another application, the C: counter increments.
- When an application like DeskTopBinder merges a copy job that was stored on the document server with a print job that was stored on the document server, the C: and P: counters both increment.
- When a job already on the document server is printed with another application, the L: counter increments.
- When a scanner job stored on the document server is printed with another application, the S: counter increments. If the original was scanned from within document server mode, then the L: counter increments.
- When images stored on the document server by a network application (including Palm 2), are printed with another application, the O: counter increments.
- When a copy job stored on the document server is printed with a network application (Web Image Monitor, for example), the C: counter increments.
- When a fax on the document server is printed, the F: counter increments.

8031	[T:Pjob/DesApl]	*CTL	These SPs reveal what applications were used to output documents from the document server. [0 to 9999999 / 0 / 1] The L: counter counts the number of jobs printed from within the document server mode screen at the operation panel.
8032	[C:Pjob/DesApl]	*CTL	
8033	[F:Pjob/DesApl]	*CTL	
8034	[P:Pjob/DesApl]	*CTL	
8035	[S:Pjob/DesApl]	*CTL	
8036	[L:Pjob/DesApl]	*CTL	
8037	[O:Pjob/DesApl]	*CTL	

- When documents already stored on the document server are printed, the count for the application that started the print job is incremented.
- When the print job is started from a network application (Desk Top Binder, Web Image Monitor, etc.) the L: counter increments.

8041	[T:TX Jobs/LS]	*CTL	These SPs count the applications that stored files on the document server that were later accessed for transmission over the telephone line or over a network (attached to an e-mail, or as a fax image by I-Fax). [0 to 9999999 / 0 / 1] Note: Jobs merged for sending are counted separately. The L: counter counts the number of jobs scanned from within the document server mode screen at the operation panel.
8042	[C:TX Jobs/LS]	*CTL	
8043	[F:TX Jobs/LS]	*CTL	
8044	[P:TX Jobs/LS]	*CTL	
8045	[S:TX Jobs/LS]	*CTL	
8046	[L:TX Jobs/LS]	*CTL	
8047	[O:TX Jobs/LS]	*CTL	

- When a stored copy job is sent from the document server, the C: counter increments.
- When images stored on the document server by a network application or Palm2 are sent as an e-mail, the O: counter increments.

8051	[T:TX Jobs/DesApl]	*CTL	These SPs count the applications used to send files from the document server over the telephone line or over a network (attached to an e-mail, or as a fax image by I-Fax). Jobs merged for sending are counted separately. [0 to 9999999 / 0 / 1] The L: counter counts the number of jobs sent from within the document server mode screen at the operation panel.
8052	[C:TX Jobs/DesApl]	*CTL	
8053	[F:TX Jobs/DesApl]	*CTL	
8054	[P:TX Jobs/DesApl]	*CTL	
8055	[S:TX Jobs/DesApl]	*CTL	
8056	[L:TX Jobs/DesApl]	*CTL	
8057	[O:TX Jobs/DesApl]	*CTL	

- If the send is started from Desk Top Binder or Web Image Monitor, for example, then the O: counter increments.

8061	[T:FIN Jobs]
	These SPs total the finishing methods. The finishing method is specified by the application.
8062	[C:FIN Jobs]
	These SPs total finishing methods for print jobs only. The finishing method is specified by the application.
8063	[F:FIN Jobs]
	These SPs total finishing methods for fax jobs only. The finishing method is specified by the application. Note: Finishing features for fax jobs are not available at this time.
8064	[P:FIN Jobs]
	These SPs total finishing methods for print jobs only. The finishing method is specified by the application.

8065	[S:FIN Jobs]		
	<p>These SPs total finishing methods for scan jobs only. The finishing method is specified by the application.</p> <p>Note: Finishing features for scan jobs are not available at this time.</p>		
8066	[L:FIN Jobs]		
	<p>These SPs total finishing methods for jobs output from within the document server mode screen at the operation panel. The finishing method is specified from the print window within document server mode.</p>		
8067	[O:FIN Jobs]		
	<p>These SPs total finishing methods for jobs executed by an external application, over the network. The finishing method is specified by the application.</p>		
001	Sort	*CTL	[0 to 9999999 / 0 / 1 / step]
	Number of jobs started in Sort mode.		
002	Stack	*CTL	[0 to 9999999 / 0 / 1 / step]
	Number of jobs started out of Sort mode.		
003	Staple	*CTL	[0 to 9999999 / 0 / 1 / step]
	Number of jobs started in Staple mode.		
004	Booklet	*CTL	[0 to 9999999 / 0 / 1 / step]
	Number of jobs started in Booklet mode. If the machine is in staple mode, the Staple counter also increments.		
005	Z-Fold	*CTL	[0 to 9999999 / 0 / 1 / step]
	Number of jobs started In any mode other than the Booklet mode and set for folding (Z-fold).		
006	Punch	*CTL	[0 to 9999999 / 0 / 1 / step]
	Number of jobs started in Punch mode. When Punch is set for a print job, the P: counter increments. (See SP8-064-6.)		

007	Other	*CTL	[0 to 9999999 / 0 / 1 / step]
	(Reserved)		
008	Inside-Fold	*CTL	[0 to 9999999 / 0 / 1 / step]
009	Three-IN-Fold	*CTL	[0 to 9999999 / 0 / 1 / step]
010	Three-OUT-Fold	*CTL	[0 to 9999999 / 0 / 1 / step]
011	Four-Fold	*CTL	[0 to 9999999 / 0 / 1 / step]
012	KANNON-Fold	*CTL	[0 to 9999999 / 0 / 1 / step]
013	Perfect-Bind	*CTL	[0 to 9999999 / 0 / 1 / step]
014	Ring-Bind	*CTL	[0 to 9999999 / 0 / 1 / step]

8071	[T:Jobs/PGS]
	These SPs count the number of jobs broken down by the number of pages in the job, regardless of which application was used.
8072	[C:Jobs/PGS]
	These SPs count and calculate the number of copy jobs by size based on the number of pages in the job.
8073	[F:Jobs/PGS]
	These SPs count and calculate the number of fax jobs by size based on the number of pages in the job.
8074	[P:Jobs/PGS]
	These SPs count and calculate the number of print jobs by size based on the number of pages in the job.
8075	[S:Jobs/PGS]
	These SPs count and calculate the number of scan jobs by size based on the number of pages in the job.

8076	[L:Jobs/PGS]		
	These SPs count and calculate the number of jobs printed from within the document server mode window at the operation panel, by the number of pages in the job.		
8077	[O:Jobs/PGS]		
	These SPs count and calculate the number of "Other" application jobs (Web Image Monitor, Palm 2, etc.) by size based on the number of pages in the job.		
001	1 Page	*CTL	[0 to 99999999 / 0 / 1 / step]
002	2 Pages	*CTL	[0 to 99999999 / 0 / 1 / step]
003	3 Pages	*CTL	[0 to 99999999 / 0 / 1 / step]
004	4 Pages	*CTL	[0 to 99999999 / 0 / 1 / step]
005	5 Pages	*CTL	[0 to 99999999 / 0 / 1 / step]
006	6 to 10 Pages	*CTL	[0 to 99999999 / 0 / 1 / step]
007	11 to 20 Pages	*CTL	[0 to 99999999 / 0 / 1 / step]
008	21 to 50 Pages	*CTL	[0 to 99999999 / 0 / 1 / step]
009	51 to 100 Pages	*CTL	[0 to 99999999 / 0 / 1 / step]
010	101 to 300 Pages	*CTL	[0 to 99999999 / 0 / 1 / step]
011	301 to 500 Pages	*CTL	[0 to 99999999 / 0 / 1 / step]
012	501 to 700 Pages	*CTL	[0 to 99999999 / 0 / 1 / step]
013	701 to 1000 Pages	*CTL	[0 to 99999999 / 0 / 1 / step]
014	1001 to Pages	*CTL	[0 to 99999999 / 0 / 1 / step]

- For example: When a copy job stored on the document server is printed in document server mode, the appropriate L: counter (SP8076 0xx) increments.
- Printing a fax report counts as a job and increments the F: counter (SP 8073).
- Interrupted jobs (paper jam, etc.) are counted, even though they do not finish.
- If a job is paused and re-started, it counts as one job.
- If the finisher runs out of staples during a print and staple job, then the job is counted at the time the error occurs.

- For copy jobs (SP 8072) and scan jobs (SP 8075), the total is calculated by multiplying the number of sets of copies by the number of pages scanned. (One duplex page counts as 2.)
- The first test print and subsequent test prints to adjust settings are added to the number of pages of the copy job (SP 8072).
- When printing the first page of a job from within the document server screen, the page is counted.

8111	[T:FAX TX Jobs]		
	These SPs count the total number of jobs (color or black-and-white) sent by fax, either directly or using a file stored on the document server, on a telephone line. Note: Color fax sending is not available at this time.		
001	B/W	*CTL	[0 to 99999999 / 0 / 1 / step]

8113	[F: FAX TX Jobs]		
	These SPs count the total number of jobs (color or black-and-white) sent by fax directly on a telephone line. Note: Color fax sending is not available at this time.		
001	B/W	*CTL	[0 to 99999999 / 0 / 1 / step]

- These counters count jobs, not pages.
- This SP counts fax jobs sent over a telephone line with a fax application, including documents stored on the document server.
- If the mode is changed during the job, the job will count with the mode set when the job started.
- If the same document is faxed to both a public fax line and an I-Fax at a destination where both are available, then this counter increments, and the I-Fax counter (8 12x) also increments.
- The fax job is counted when the job is scanned for sending, not when the job is sent.

8121	[T:IFAX TX Jobs]		
	These SPs count the total number of jobs (color or black-and-white) sent, either directly or using a file stored on the document server, as fax images using I-Fax. Note: Color fax sending is not available at this time.		
8123	[F: IFAX TX Jobs]		
	These SPs count the number of jobs (color or black-and-white) sent (not stored on the document server), as fax images using I-Fax. Note: Color fax sending is not available at this time.		
001	B/W	*CTL	[0 to 9999999 / 0 / 1 / step]

- These counters count jobs, not pages.
- The counters for color are provided for future use; the color fax feature is not available at this time.
- The fax job is counted when the job is scanned for sending, not when the job is sent.

8131	[T:S-to-Email Jobs]		
	These SPs count the total number of jobs (color or black-and-white) scanned and attached to an e-mail, regardless of whether the document server was used or not.		
8135	[S: S-to-Email Jobs]		
	These SPs count the number of jobs (color or black-and-white) scanned and attached to e-mail, without storing the original on the document server.		
001	B/W	*CTL	[0 to 9999999 / 0 / 1 / step]
002	Color	*CTL	[0 to 9999999 / 0 / 1 / step]
003	ACS	*CTL	[0 to 9999999 / 0 / 1 / step]

- These counters count jobs, not pages.
- If the job is stored on the document server, after the job is stored it is determined to be color or black-and-white then counted.
- If the job is cancelled during scanning, or if the job is cancelled while the document is waiting to be sent, the job is not counted.
- If the job is cancelled during sending, it may or may not be counted, depending on what stage of the process had been reached when the job was cancelled.
- If several jobs are combined for sending to the Scan Router, Scan-to-Email, or Scan-to-PC, or if one job is sent to more than one destination. each send is counted separately. For example, if the same document is sent by Scan-to-Email as well as Scan-to-PC, then it is counted twice (once for Scan-to-Email and once for Scan-to-PC).

8141	[T:Deliv Jobs/Svr]		
	These SPs count the total number of jobs (color or black-and-white) scanned and sent to a Scan Router server.		
8145	[S: Deliv Jobs/Svr]		
	These SPs count the number of jobs (color or black-and-white) scanned in scanner mode and sent to a Scan Router server.		
001	B/W	*CTL	[0 to 9999999 / 0 / 1 / step]
002	Color	*CTL	[0 to 9999999 / 0 / 1 / step]
003	ACS	*CTL	[0 to 9999999 / 0 / 1 / step]

- These counters count jobs, not pages.
- The jobs are counted even though the arrival and reception of the jobs at the Scan Router server cannot be confirmed.
- If even one color image is mixed with black-and-white images, then the job is counted as a "Color" job.
- If the job is cancelled during scanning, or if the job is cancelled while the document is waiting to be delivered, the job is not counted.
- If the job is cancelled during sending, it may or may not be counted, depending on what stage of the process had been reached when the job was cancelled.
- Even if several files are combined for sending, the transmission counts as one job.

8151	[T:Deliv Jobs/PC]		
	These SPs count the total number of jobs (color or black-and-white) scanned and sent to a folder on a PC (Scan-to-PC). Note: At the present time, 8 151 and 8 155 perform identical counts.		
8155	[S:Deliv Jobs/PC]		
	These SPs count the total number of jobs (color or black-and-white) scanned and sent with Scan-to-PC.		
001	B/W	*CTL	[0 to 9999999 / 0 / 1 / step]
002	Color	*CTL	[0 to 9999999 / 0 / 1 / step]
003	ACS	*CTL	[0 to 9999999 / 0 / 1 / step]

- These counters count jobs, not pages.
- If the job is cancelled during scanning, it is not counted.
- If the job is cancelled while it is waiting to be sent, the job is not counted.
- If the job is cancelled during sending, it may or may not be counted, depending on what stage of the process had been reached when the job was cancelled.
- Even if several files are combined for sending, the transmission counts as one job.

8161	[T:PCFAX TX Jobs]	*CTL	These SPs count the number of PC Fax transmission jobs. A job is counted from when it is registered for sending, not when it is sent. [0 to 9999999 / 0 / 1 / step] Note: At the present time, these counters perform identical counts.
8163	[F:PCFAX TX Jobs]	*CTL	

- This counts fax jobs started from a PC using a PC fax application, and sending the data out to the destination from the PC through the copier.

8171	[T:Deliv Jobs/WSD/DSM]		
	These SPs count the pages scanned by WS.		
8175	[S:Deliv Jobs/WSD/DSM]		
	These SPs count the pages scanned by WS.		
001	B/W	*CTL	[0 to 9999999 / 0 / 1 / step]
002	Color	*CTL	[0 to 9999999 / 0 / 1 / step]
003	ACS	*CTL	[0 to 9999999 / 0 / 1 / step]

8181	[T:Scan to Media Jobs]		
	These SPs count the scanned pages in a media by the scanner application.		
8185	[S:Scan to Media Jobs]		
	These SPs count the scanned pages in a media by the scanner application.		
001	B/W	*CTL	[0 to 9999999 / 0 / 1 / step]
002	Color	*CTL	[0 to 9999999 / 0 / 1 / step]
003	ACS	*CTL	[0 to 9999999 / 0 / 1 / step]

8191	[T:Total Scan PGS]	*CTL	These SPs count the pages scanned by each application that uses the scanner to scan images. [0 to 9999999 / 0 / 1]
8192	[C:Total Scan PGS]	*CTL	
8193	[F:Total Scan PGS]	*CTL	
8195	[S:Total Scan PGS]	*CTL	
8196	[L:Total Scan PGS]	*CTL	

- SP 8 191 to 8 196 count the number of scanned sides of pages, not the number of physical pages.
- These counters do not count reading user stamp data, or reading color charts to adjust color.
- Previews done with a scanner driver are not counted.
- A count is done only after all images of a job have been scanned.
- Scans made in SP mode are not counted.

Examples

- If 3 B5 pages and 1 A3 page are scanned with the scanner application but not stored, the S: count is 4.
- If both sides of 3 A4 sheets are copied and stored to the document server using the Store File button in the Copy mode window, the C: count is 6 and the L: count is 6.
- If both sides of 3 A4 sheets are copied but not stored, the C: count is 6.
- If you enter document server mode then scan 6 pages, the L: count is 6.

8201	[T:LSize Scan PGS]	*CTL	[0 to 9999999 / 0 / 1 / step]
	These SPs count the total number of large pages input with the scanner for scan and copy jobs. Large size paper (A3/DLT) scanned for fax transmission are not counted. Note: These counters are displayed in the SMC Report, and in the User Tools display.		
8203	[F: LSize Scan PGS]	*CTL	[0 to 9999999 / 0 / 1 / step]
	These SPs count the total number of large pages input with the scanner for fax transmission. Note: These counters are displayed in the SMC Report, and in the User Tools display.		
8205	[S:LSize Scan PGS]	*CTL	[0 to 9999999 / 0 / 1 / step]
	These SPs count the total number of large pages input with the scanner for scan jobs only. Large size paper (A3/DLT) scanned for fax transmission are not counted. Note: These counters are displayed in the SMC Report, and in the User Tools display.		

8211	[T:Scan PGS/LS]	*CTL	These SPs count the number of pages scanned into the document server. [0 to 9999999 / 0 / 1] The L: counter counts the number of pages stored from within the document server mode screen at the operation panel, and with the Store File button from within the Copy mode screen
8212	[C:Scan PGS/LS]	*CTL	
8213	[F:Scan PGS/LS]	*CTL	
8215	[S:Scan PGS/LS]	*CTL	
8216	[L:Scan PGS/LS]	*CTL	

- Reading user stamp data is not counted.
- If a job is cancelled, the pages output as far as the cancellation are counted.
- If the scanner application scans and stores 3 B5 sheets and 1 A4 sheet, the S: count is 4.
- If pages are copied but not stored on the document server, these counters do not change.
- If both sides of 3 A4 sheets are copied and stored to the document server, the C: count is 6 and the L: count is 6.
- If you enter document server mode then scan 6 pages, the L: count is 6.

8221	[ADF Org Feeds]		
	These SPs count the number of pages fed through the ADF for front and back side scanning.		
001	Front	*CTL	[0 to 9999999 / 0 / 1 / step]
	Number of front sides fed for scanning: With an ADF that can scan both sides simultaneously, the Front side count is the same as the number of pages fed for either simplex or duplex scanning. With an ADF that cannot scan both sides simultaneously, the Front side count is the same as the number of pages fed for duplex front side scanning. (The front side is determined by which side the user loads face up.)		
002	Back	*CTL	[0 to 9999999 / 0 / 1 / step]
	Number of rear sides fed for scanning: With an ADF that can scan both sides simultaneously, the Back count is the same as the number of pages fed for duplex scanning. With an ADF that cannot scan both sides simultaneously, the Back count is the same as the number of pages fed for duplex rear-side scanning.		

- When 1 sheet is fed for duplex scanning the Front count is 1 and the Back count is 1.
- If a jam occurs during the job, recovery processing is not counted to avoid double counting. Also, the pages are not counted if the jam occurs before the first sheet is output.

8231	[Scan PGS/Mode]		
	These SPs count the number of pages scanned by each ADF mode to determine the work load on the ADF.		
001	Large Volume	*CTL	[0 to 9999999 / 0 / 1 / step]
	Selectable. Large copy jobs that cannot be loaded in the ADF at one time.		
002	SADF	*CTL	[0 to 9999999 / 0 / 1 / step]
	Selectable. Feeding pages one by one through the ADF.		
003	Mixed Size	*CTL	[0 to 9999999 / 0 / 1 / step]
	Selectable. Select "Mixed Sizes" on the operation panel.		
004	Custom Size	*CTL	[0 to 9999999 / 0 / 1 / step]
	Selectable. Originals of non-standard size.		
005	Platen	*CTL	[0 to 9999999 / 0 / 1 / step]
	Book mode. Raising the ADF and placing the original directly on the platen.		
006	Mixed 1side/ 2side	*CTL	[0 to 9999999 / 0 / 1 / step]
	Simplex and Duplex mode.		

- If the scan mode is changed during the job, for example, if the user switches from ADF to Platen mode, the count is done for the last selected mode.
- The user cannot select mixed sizes or non-standard sizes with the fax application so if the original's page sizes are mixed or non-standard, these are not counted.
- If the user selects "Mixed Sizes" for copying in the platen mode, the Mixed Size count is enabled.
- In the SADF mode if the user copies 1 page in platen mode and then copies 2 pages with SADF, the Platen count is 1 and the SADF count is 3.

8241	[T:Scan PGS/Org]	*CTL	[0 to 9999999 / 0 / 1 / step				
	These SPs count the total number of scanned pages by original type for all jobs, regardless of which application was used.						
8242	[C:Scan PGS/Org]	*CTL	[0 to 9999999 / 0 / 1 / step				
	These SPs count the number of pages scanned by original type for Copy jobs.						
8243	[F:Scan PGS/Org]	*CTL	[0 to 9999999 / 0 / 1 / step				
	These SPs count the number of pages scanned by original type for Fax jobs.						
8245	[S:Scan PGS/Org]	*CTL	[0 to 9999999 / 0 / 1 / step				
	These SPs count the number of pages scanned by original type for Scan jobs.						
8246	[L:Scan PGS/Org]	*CTL	[0 to 9999999 / 0 / 1 / step				
	These SPs count the number of pages scanned and stored from within the document server mode screen at the operation panel, and with the Store File button from within the Copy mode screen						
			8241	8242	8243	8245	8246
001	Text		Yes	Yes	Yes	Yes	Yes
002	Text/Photo		Yes	Yes	Yes	Yes	Yes
003	Photo		Yes	Yes	Yes	Yes	Yes
004	GenCopy, Pale		Yes	Yes	No	Yes	Yes
005	Map		Yes	Yes	No	No	Yes
006	Normal/Detail		Yes	No	Yes	No	No
007	Fine/Super Fine		Yes	No	Yes	No	No
008	Binary		Yes	No	No	Yes	No
009	Grayscale		Yes	No	No	Yes	No
010	Color		Yes	No	No	Yes	No
011	Other		Yes	Yes	Yes	Yes	Yes

- If the scan mode is changed during the job, for example, if the user switches from ADF to Platen mode, the count is done for the last selected mode.

8251	[T:Scan PGS/ImgEdt]	*CTL	<p>These SPs show how many times Image Edit features have been selected at the operation panel for each application. Some examples of these editing features are:</p> <p>Erase> Border</p> <p>Erase> Center</p> <p>Image Repeat</p> <p>Centering</p> <p>Positive/Negative</p> <p>[0 to 9999999 / 0 / 1 / step]</p> <p>Note: The count totals the number of times the edit features have been used. A detailed breakdown of exactly which features have been used is not given.</p>
8252	[C:Scan PGS/ImgEdt]	*CTL	
8255	[S:Scan PGS/ImgEdr]	*CTL	
8256	[L:Scan PGS/ImgEdt]	*CTL	
8257	[O:Scan PGS/ImgEdt]	*CTL	

The L: counter counts the number of pages stored from within the document server mode screen at the operation panel, and with the Store File button from within the Copy mode screen.

8281	[T:Scan PGS/TWAIN]	*CTL	<p>These SPs count the number of pages scanned using a TWAIN driver. These counters reveal how the TWAIN driver is used for delivery functions.</p> <p>[0 to 9999999 / 0 / 1 / step]</p> <p>Note: At the present time, these counters perform identical counts.</p>
8285	[S:Scan PGS/TWAIN]	*CTL	

8291	[T:Scan PGS/Stamp]	*CTL	<p>These SPs count the number of pages stamped with the stamp in the ADF unit. [0 to 9999999 / 0 / 1 / step]</p> <p>The L: counter counts the number of pages stored from within the document server mode screen at the operation panel, and with the Store File button from within the Copy mode screen</p>
8293	[F:Scan PGS/Stamp]	*CTL	
8295	[S:Scan PGS/Stamp]	*CTL	

8301	[T:Scan PGS/Size]	<p>These SPs count by size the total number of pages scanned by all applications. Use these totals to compare original page size (scanning) and output (printing) page size [SP 8-441].</p>
8302	[C:Scan PGS/Size]	<p>These SPs count by size the total number of pages scanned by the Copy application. Use these totals to compare original page size (scanning) and output (printing) page size [SP 8-442].</p>
8303	[F:Scan PGS/Size]	<p>These SPs count by size the total number of pages scanned by the Fax application. Use these totals to compare original page size (scanning) and output page size [SP 8-443].</p>
8305	[S:Scan PGS/Size]	<p>These SPs count by size the total number of pages scanned by the Scan application. Use these totals to compare original page size (scanning) and output page size [SP 8-445].</p>

8306	[L:Scan PGS/Size]		
	These SPs count by size the total number of pages scanned and stored from within the document server mode screen at the operation panel, and with the Store File button from within the Copy mode screen. Use these totals to compare original page size (scanning) and output page size [SP 8-446].		
001	A3	*CTL	[0 to 9999999 / 0 / 1 / step]
002	A4	*CTL	[0 to 9999999 / 0 / 1 / step]
003	A5	*CTL	[0 to 9999999 / 0 / 1 / step]
004	B4	*CTL	[0 to 9999999 / 0 / 1 / step]
005	B5	*CTL	[0 to 9999999 / 0 / 1 / step]
006	DLT	*CTL	[0 to 9999999 / 0 / 1 / step]
007	LG	*CTL	[0 to 9999999 / 0 / 1 / step]
008	LT	*CTL	[0 to 9999999 / 0 / 1 / step]
009	HLT	*CTL	[0 to 9999999 / 0 / 1 / step]
010	Full Bleed	*CTL	[0 to 9999999 / 0 / 1 / step]
254	Other (Standard)	*CTL	[0 to 9999999 / 0 / 1 / step]
255	Other (Custom)	*CTL	[0 to 9999999 / 0 / 1 / step]

8311	T:Scan PGS/Rez	*CTL	[0 to 9999999/ 0 / 1]
	These SPs count by resolution setting the total number of pages scanned by applications that can specify resolution settings.		

8315	S: Scan PGS/Rez	*CTL	[0 to 9999999/ 0 / 1]
	These SPs count by resolution setting the total number of pages scanned by applications that can specify resolution settings. Note: At the present time, SP8-311 and SP8-315 perform identical counts.		
001	1200dpi <	*CTL	[0 to 9999999 / 0 / 1 / step]
002	600dpi to 1199dpi	*CTL	[0 to 9999999 / 0 / 1 / step]
003	400dpi to 599dpi	*CTL	[0 to 9999999 / 0 / 1 / step]
004	200dpi to 399dpi	*CTL	[0 to 9999999 / 0 / 1 / step]
005	< 199dpi	*CTL	[0 to 9999999 / 0 / 1 / step]

- Copy resolution settings are fixed so they are not counted.
- The Fax application does not allow finely-adjusted resolution settings so no count is done for the Fax application.

8381	[T:Total PrtPGS]	*CTL	These SPs count the number of pages printed by the customer. The counter for the application used for storing the pages increments. [0 to 99999999 / 0 / 1 / step]
8382	[C:Total PrtPGS]	*CTL	
8383	[F:Total PrtPGS]	*CTL	
8384	[P:Total PrtPGS]	*CTL	
8385	[S:Total PrtPGS]	*CTL	
8386	[L:Total PrtPGS]	*CTL	
8387	[O:Total PrtPGS]	*CTL	

- When the A3/DLT double count function is switched on with SP5104, 1 A3/DLT page is counted as 2.
- When several documents are merged for a print job, the number of pages stored are counted for the application that stored them.
- These counters are used primarily to calculate charges on use of the machine, so the following pages are not counted as printed pages:
 - Blank pages in a duplex printing job.
 - Blank pages inserted as document covers, chapter title sheets, and slip sheets.
 - Reports printed to confirm counts.

- All reports done in the service mode (service summaries, engine maintenance reports, etc.)
- Test prints for machine image adjustment.
- Error notification reports.
- Partially printed pages as the result of a copier jam.

8391	LSize PrtPGS	*CTL	[0 to 99999999 / 0 / 1 / step]
	These SPs count pages printed on paper sizes A3/DLT and larger. Note: In addition to being displayed in the SMC Report, these counters are also displayed in the User Tools display on the copy machine.		

8401	[T:PrtPGS/LS]	*CTL	These SPs count the number of pages printed from the document server. The counter for the application used to print the pages is incremented. The L: counter counts the number of jobs stored from within the document server mode screen at the operation panel. [0 to 9999999 / 0 / 1 / step]
8402	[C:PrtPGS/LS]	*CTL	
8403	[F:PrtPGS/LS]	*CTL	
8404	[P:PrtPGS/LS]	*CTL	
8405	[S:PrtPGS/LS]	*CTL	
8406	[L:PrtPGS/LS]	*CTL	

- Print jobs done with Web Image Monitor and Desk Top Binder are added to the L: count.
- Fax jobs done with Web Image Monitor and Desk Top Binder are added to the F: count.

8411	Prints/Duplex	*CTL	This SP counts the amount of paper (front/back counted as 1 page) used for duplex printing. Last pages printed only on one side are not counted. [0 to 99999999 / 0 / 1]
-------------	---------------	------	---

8421	[T:PrtPGS/Dup Comb]		
	These SPs count by binding and combine, and n-Up settings the number of pages processed for printing. This is the total for all applications.		
8422	[C:PrtPGS/Dup Comb]		
	These SPs count by binding and combine, and n-Up settings the number of pages processed for printing by the copier application.		
8423	[F:PrtPGS/Dup Comb]		
	These SPs count by binding and combine, and n-Up settings the number of pages processed for printing by the fax application.		
8424	[P:PrtPGS/Dup Comb]		
	These SPs count by binding and combine, and n-Up settings the number of pages processed for printing by the printer application.		
8425	[S:PrtPGS/Dup Comb]		
	These SPs count by binding and combine, and n-Up settings the number of pages processed for printing by the scanner application.		
8426	[L:PrtPGS/Dup Comb]		
	These SPs count by binding and combine, and n-Up settings the number of pages processed for printing from within the document server mode window at the operation panel.		
8427	[O:PrtPGS/Dup Comb]		
	These SPs count by binding and combine, and n-Up settings the number of pages processed for printing by Other applications		
001	Simplex> Duplex	*CTL	[0 to 99999999 / 0 / 1 / step]
002	Duplex> Duplex	*CTL	[0 to 99999999 / 0 / 1 / step]
003	Book> Duplex	*CTL	[0 to 99999999 / 0 / 1 / step]
004	Simplex Combine	*CTL	[0 to 99999999 / 0 / 1 / step]
005	Duplex Combine	*CTL	[0 to 99999999 / 0 / 1 / step]
006	2in1	*CTL	[0 to 99999999 / 0 / 1 / step]

	2 pages on 1 side (2-Up)		
007	4 in1	*CTL	[0 to 99999999 / 0 / 1 / step]
	4 pages on 1 side (4-Up)		
008	6 in1	*CTL	[0 to 99999999 / 0 / 1 / step]
	6 pages on 1 side (6-Up)		
009	8 in1	*CTL	[0 to 99999999 / 0 / 1 / step]
	8 pages on 1 side (8-Up)		
010	9 in1	*CTL	[0 to 99999999 / 0 / 1 / step]
	9 pages on 1 side (9-Up)		
011	16 in1	*CTL	[0 to 99999999 / 0 / 1 / step]
	16 pages on 1 side (16-Up)		
012	Booklet	*CTL	[0 to 99999999 / 0 / 1 / step]
013	Magazine	*CTL	[0 to 99999999 / 0 / 1 / step]
014	2in1 + Booklet	*CTL	[0 to 99999999 / 0 / 1 / step]
015	4in1 + Booklet	*CTL	[0 to 99999999 / 0 / 1 / step]
016	6in1 + Booklet	*CTL	[0 to 99999999 / 0 / 1 / step]
017	8in1 + Booklet	*CTL	[0 to 99999999 / 0 / 1 / step]
018	9in1 + Booklet	*CTL	[0 to 99999999 / 0 / 1 / step]
019	2in1 + Magazine	*CTL	[0 to 99999999 / 0 / 1 / step]
020	4in1 + Magazine	*CTL	[0 to 99999999 / 0 / 1 / step]
021	6in1 + Magazine	*CTL	[0 to 99999999 / 0 / 1 / step]
022	8in1 + Magazine	*CTL	[0 to 99999999 / 0 / 1 / step]
023	9in1 + Magazine	*CTL	[0 to 99999999 / 0 / 1 / step]
024	16in1 + Magazine	*CTL	[0 to 99999999 / 0 / 1 / step]

- These counts (SP8 421 to SP8 427) are especially useful for customers who need to improve their compliance with ISO standards for the reduction of paper consumption.
- Pages that are only partially printed with the n-Up functions are counted as 1 page.
- Here is a summary of how the counters work for Booklet and Magazine modes:

	8421	8422	8423	8424	8425	8426	8427
001	Yes	Yes	Yes	Yes	Yes	Yes	Yes
002	Yes	Yes	No	No	No	No	Yes
003	Yes	Yes	No	No	No	No	Yes
004	Yes	Yes	Yes	Yes	Yes	Yes	Yes
005	Yes	Yes	Yes	Yes	Yes	Yes	Yes
006	Yes	Yes	Yes	Yes	Yes	Yes	Yes
007	Yes	Yes	Yes	Yes	Yes	Yes	Yes
008	Yes	No	No	Yes	No	No	Yes
009	Yes	Yes	Yes	Yes	Yes	Yes	Yes
010	Yes	No	No	Yes	Yes	No	Yes
011	Yes	No	Yes	Yes	Yes	Yes	Yes
012	Yes	Yes	Yes	Yes	Yes	Yes	Yes
013	Yes	Yes	Yes	Yes	Yes	Yes	Yes
014	Yes	Yes	Yes	Yes	Yes	Yes	Yes
015	Yes	Yes	Yes	Yes	Yes	Yes	Yes
016	Yes	No	No	Yes	No	No	Yes
017	Yes	Yes	Yes	Yes	Yes	Yes	Yes
018	Yes	No	No	Yes	Yes	No	Yes
019	Yes	Yes	Yes	Yes	Yes	Yes	Yes
020	Yes	Yes	Yes	Yes	Yes	Yes	Yes
021	Yes	No	No	Yes	No	No	Yes

022	Yes	Yes	Yes	Yes	Yes	Yes	Yes
023	Yes	No	No	Yes	Yes	No	Yes
024	Yes	No	Yes	Yes	Yes	Yes	Yes

Booklet		Magazine	
Original Pages	Count	Original Pages	Count
1	1	1	1
2	2	2	2
3	2	3	2
4	2	4	2
5	3	5	4
6	4	6	4
7	4	7	4
8	4	8	4

8431	[T:PrtPGS/ImgEdt]
	These SPs count the total number of pages output with the three features below, regardless of which application was used.
8432	[C:PrtPGS/ImgEdt]
	These SPs count the total number of pages output with the three features below with the copy application.
8434	[P:PrtPGS/ImgEdt]
	These SPs count the total number of pages output with the three features below with the print application.
8436	[L:PrtPGS/ImgEdt]
	These SPs count the total number of pages output from within the document server mode window at the operation panel with the three features below.
8437	[O:PrtPGS/ImgEdt]

	These SPs count the total number of pages output with the three features below with Other applications.		
001	Cover/Slip Sheet	*CTL	[0 to 99999999 / 0 / 1 / step]
	Total number of covers or slip sheets inserted. The count for a cover printed on both sides counts 2.		
002	Series/Book	*CTL	[0 to 99999999 / 0 / 1 / step]
	The number of pages printed in series (one side) or printed as a book with booklet right/left pagination.		
003	User Stamp	*CTL	[0 to 99999999 / 0 / 1 / step]
	The number of pages printed where stamps were applied, including page numbering and date stamping.		

8441	[T:PrtPGS/Ppr Size]
	These SPs count by print paper size the number of pages printed by all applications.
8442	[C:PrtPGS/Ppr Size]
	These SPs count by print paper size the number of pages printed by the copy application.
8443	[F:PrtPGS/Ppr Size]
	These SPs count by print paper size the number of pages printed by the fax application.
8444	[P:PrtPGS/Ppr Size]
	These SPs count by print paper size the number of pages printed by the printer application.
8445	[S:PrtPGS/Ppr Size]
	These SPs count by print paper size the number of pages printed by the scanner application.
8446	[L:PrtPGS/Ppr Size]

	These SPs count by print paper size the number of pages printed from within the document server mode window at the operation panel.		
8447	[O:PrtPGS/Ppr Size]		
	These SPs count by print paper size the number of pages printed by Other applications.		
001	A3	*CTL	[0 to 99999999 / 0 / 1 / step]
002	A4	*CTL	[0 to 99999999 / 0 / 1 / step]
003	A5	*CTL	[0 to 99999999 / 0 / 1 / step]
004	B4	*CTL	[0 to 99999999 / 0 / 1 / step]
005	B5	*CTL	[0 to 99999999 / 0 / 1 / step]
006	DLT	*CTL	[0 to 99999999 / 0 / 1 / step]
007	LG	*CTL	[0 to 99999999 / 0 / 1 / step]
008	LT	*CTL	[0 to 99999999 / 0 / 1 / step]
009	HLT	*CTL	[0 to 99999999 / 0 / 1 / step]
010	Full Bleed	*CTL	[0 to 99999999 / 0 / 1 / step]
254	Other (Standard)	*CTL	[0 to 99999999 / 0 / 1 / step]
255	Other (Custom)	*CTL	[0 to 99999999 / 0 / 1 / step]

- These counters do not distinguish between LEF and SEF.

8451	[PrtPGS/Ppr Tray]		
	These SPs count the number of sheets fed from each paper feed station.		
001	Bypass Tray	*CTL	Bypass Tray [0 to 99999999 / 0 / 1 / step]
002	Tray 1	*CTL	Copier [0 to 99999999 / 0 / 1 / step]
003	Tray 2	*CTL	
004	Tray 3	*CTL	Paper Tray Unit (Option) [0 to 99999999 / 0 / 1 / step]
005	Tray 4	*CTL	
006	Tray 5	*CTL	LCT (Option) [0 to 99999999 / 0 / 1 / step]
007	Tray 6	*CTL	Currently not used.
008	Tray 7	*CTL	Currently not used.
009	Tray 8	*CTL	Currently not used.
010	Tray 9	*CTL	Currently not used.
011	Tray 10	*CTL	Currently not used.
012	Tray 11	*CTL	Currently not used.
013	Tray 12	*CTL	Currently not used.
014	Tray 13	*CTL	Currently not used.
015	Tray 14	*CTL	Currently not used.
016	Tray 15	*CTL	Currently not used.

5.14 SP MODE TABLES - SP8000-2

5.14.1 SP8-XXX (DATA LOG 2)

8461	[T:PrtPGS/Ppr Type]		
	<p>These SPs count by paper type the number pages printed by all applications.</p> <ul style="list-style-type: none"> ▪ These counters are not the same as the PM counter. The PM counter is based on feed timing to accurately measure the service life of the feed rollers. However, these counts are based on output timing. ▪ Blank sheets (covers, chapter covers, slip sheets) are also counted. ▪ During duplex printing, pages printed on both sides count as 1, and a page printed on one side counts as 1. 		
8462	[C:PrtPGS/Ppr Type]		
	<p>These SPs count by paper type the number pages printed by the copy application.</p>		
8463	[F:PrtPGS/Ppr Type]		
	<p>These SPs count by paper type the number pages printed by the fax application.</p>		
8464	[P:PrtPGS/Ppr Type]		
	<p>These SPs count by paper type the number pages printed by the printer application.</p>		
8466	[L:PrtPGS/Ppr Type]		
	<p>These SPs count by paper type the number pages printed from within the document server mode window at the operation panel.</p>		
001	Normal	*CTL	[0 to 99999999 / 0 / 1 / step]
002	Recycled	*CTL	[0 to 99999999 / 0 / 1 / step]
003	Special	*CTL	[0 to 99999999 / 0 / 1 / step]
004	Thick	*CTL	[0 to 99999999 / 0 / 1 / step]
005	Normal (Back)	*CTL	[0 to 99999999 / 0 / 1 / step]

006	Thick (Back)	*CTL	[0 to 99999999 / 0 / 1 / step]
007	OHP	*CTL	[0 to 99999999 / 0 / 1 / step]
008	Other	*CTL	[0 to 99999999 / 0 / 1 / step]

8471	[PrtPGS/Mag]		
	These SPs count by magnification rate the number of pages printed.		
001	< 49%	*CTL	[0 to 99999999 / 0 / 1 / step]
002	50% to 99%	*CTL	
003	100%	*CTL	
004	101% to 200%	*CTL	
005	201% <	*CTL	

Counts are done for magnification adjusted for pages, not only on the operation panel but performed remotely with an external network application capable of performing magnification adjustment as well.

Magnification adjustments done with printer drivers with PC applications such as Excel are also counted.

Magnification adjustments done for adjustments after they have been stored on the document server are not counted.

Magnification adjustments performed automatically during Auto Reduce/Enlarge copying are counted.

The magnification rates of blank cover sheets, slip sheets, etc. are automatically assigned a rate of 100%.

8481	[T:PrtPGS/TonSave]	*CTL	[0 to 99999999 / 0 / 1 / step]
8484	[P:PrtPGS/TonSave]	*CTL	
These SPs count the number of pages printed with the Toner Save feature switched on. Note: These SPs return the same results as this SP is limited to the Print application.			

8511	[T:PrtPGS/Emul]		
	These SPs count by printer emulation mode the total number of pages printed.		
8514	[P:PrtPGS/Emul]		
	These SPs count by printer emulation mode the total number of pages printed.		
001	RPCS	*CTL	[0 to 99999999 / 0 / 1 / step]
002	RPDL	*CTL	[0 to 99999999 / 0 / 1 / step]
003	PS3	*CTL	[0 to 99999999 / 0 / 1 / step]
004	R98	*CTL	[0 to 99999999 / 0 / 1 / step]
005	R16	*CTL	[0 to 99999999 / 0 / 1 / step]
006	GL/GL2	*CTL	[0 to 99999999 / 0 / 1 / step]
007	R55	*CTL	[0 to 99999999 / 0 / 1 / step]
008	RTIFF	*CTL	[0 to 99999999 / 0 / 1 / step]
009	PDF	*CTL	[0 to 99999999 / 0 / 1 / step]
010	PCL5e/5c	*CTL	[0 to 99999999 / 0 / 1 / step]
011	PCL XL	*CTL	[0 to 99999999 / 0 / 1 / step]
012	IPDL-C	*CTL	[0 to 99999999 / 0 / 1 / step]
013	BM-Links	*CTL	Japan Only
014	Other	*CTL	[0 to 99999999 / 0 / 1 / step]
015	IPDS	*CTL	[0 to 99999999 / 0 / 1 / step]
016	XPS	-	-

- SP8 511 and SP8 514 return the same results as they are both limited to the Print application.
- Print jobs output to the document server are not counted.

8521	[T:PrtPGS/FIN]		
	These SPs count by finishing mode the total number of pages printed by all applications.		
8522	[C:PrtPGS/FIN]		
	These SPs count by finishing mode the total number of pages printed by the Copy application.		
8523	[F:PrtPGS/FIN]		
	These SPs count by finishing mode the total number of pages printed by the Fax application. NOTE: Print finishing options for received faxes are currently not available.		
8524	[P:PrtPGS/FIN]		
	These SPs count by finishing mode the total number of pages printed by the Print application.		
8525	[S:PrtPGS/FIN]		
	These SPs count by finishing mode the total number of pages printed by the Scanner application.		
8526	[L:PrtPGS/FIN]		
	These SPs count by finishing mode the total number of pages printed from within the document server mode window at the operation panel.		
001	Sort	*CTL	[0 to 99999999 / 0 / 1 / step]
002	Stack	*CTL	[0 to 99999999 / 0 / 1 / step]
003	Staple	*CTL	[0 to 99999999 / 0 / 1 / step]
004	Booklet	*CTL	[0 to 99999999 / 0 / 1 / step]
005	Z-Fold	*CTL	[0 to 99999999 / 0 / 1 / step]
006	Punch	*CTL	[0 to 99999999 / 0 / 1 / step]
007	Other	*CTL	[0 to 99999999 / 0 / 1 / step]

008	Inside Fold	*CTL	[0 to 99999999 / 0 / 1 / step]
	Half-Fold (FM2) (Multi Fold Unit)		
009	Three-IN-Fold	*CTL	[0 to 99999999 / 0 / 1 / step]
	Letter Fold-in (FM4) (Multi Fold Unit)		
010	Three-OUT-Fold	*CTL	[0 to 99999999 / 0 / 1 / step]
	Letter Fold-out (FM3) (Multi Fold Unit)		
011	Four Fold	*CTL	[0 to 99999999 / 0 / 1 / step]
	Double Parallel Fold (FM5) (Multi Fold Unit)		
012	KANNON-Fold	*CTL	[0 to 99999999 / 0 / 1 / step]
	Gate Fold (FM6) (Multi Fold Unit)		
013	Perfect-Bind	*CTL	[0 to 99999999 / 0 / 1 / step]
	Perfect Binder		
014	Ring-Bind	*CTL	[0 to 99999999 / 0 / 1 / step]
	Ring Binder		

 **Note**

- If stapling is selected for finishing and the stack is too large for stapling, the unstapled pages are still counted.
- The counts for staple finishing are based on output to the staple tray, so jam recoveries are counted.

8531	[Staples]	*CTL	This SP counts the amount of staples used by the machine. [0 to 99999999 / 0 / 1 / step]
-------------	------------------	------	---

8551	[T:PrtBooks/FIN]		
001	Perfect-Bind	*CTL	Booklet finishing
002	Ring-Bind	*CTL	Not used

8552	[C:PrtBooks/FIN]		
001	Perfect-Bind	*CTL	Booklet finishing
002	Ring-Bind	*CTL	Not used

8554	[P:PrtBooks/FIN]		
001	Perfect-Bind	*CTL	Booklet finishing
002	Ring-Bind	*CTL	Not used

8556	[L:PrtBooks/FIN]		
001	Perfect-Bind	*CTL	Booklet finishing
002	Ring-Bind	*CTL	Not used

8561	[T:A Sheet Of Paper]		
001	Total: Over A3/DLT	*CTL	[0 to 99999999 / 0 / 1]
002	Total: Under A3/DLT	*CTL	
003	Duplex: Over A3/DLT	*CTL	
004	Duplex: Under A3/DLT	*CTL	

8562	[C:A Sheet Of Paper]		
001	Total: Over A3/DLT	*CTL	[0 to 99999999 / 0 / 1]
002	Total: Under A3/DLT	*CTL	
003	Duplex: Over A3/DLT	*CTL	
004	Duplex: Under A3/DLT	*CTL	

8563	[F:A Sheet Of Paper]		
001	Total: Over A3/DLT	*CTL	[0 to 99999999 / 0 / 1]
002	Total: Under A3/DLT	*CTL	
003	Duplex: Over A3/DLT	*CTL	
004	Duplex: Under A3/DLT	*CTL	

8564	[P:A Sheet Of Paper]		
001	Total: Over A3/DLT	*CTL	[0 to 99999999 / 0 / 1]
002	Total: Under A3/DLT	*CTL	
003	Duplex: Over A3/DLT	*CTL	
004	Duplex: Under A3/DLT	*CTL	

8566	[L:A Sheet Of Paper]		
001	Total: Over A3/DLT	*CTL	[0 to 99999999 / 0 / 1]
002	Total: Under A3/DLT	*CTL	
003	Duplex: Over A3/DLT	*CTL	
004	Duplex: Under A3/DLT	*CTL	

8567	[O:A Sheet Of Paper]		
001	Total: Over A3/DLT	*CTL	[0 to 99999999 / 0 / 1]
002	Total: Under A3/DLT	*CTL	
003	Duplex: Over A3/DLT	*CTL	
004	Duplex: Under A3/DLT	*CTL	

8581	[T:Counter]		
	These SPs count the total output broken down by output, regardless of the application used. In addition to being displayed in the SMC Report, these counters are also displayed in the User Tools display on the copy machine.		
001	Total	*CTL	[0 to 99999999 / 0 / 1]
032	Total(A3)	-	-

8591	[O:Counter]		
	These SPs count the totals for A3/DLT paper use, number of duplex pages printed, and the number of staples used. These totals are for Other (O:) applications only.		
001	A3/DLT	*CTL	[0 to 99999999 / 0 / 1 / step]
002	Duplex	*CTL	

8601	[T:Coverage Counter]		
	These SPs count the total coverage for the total printout pages for each printing mode.		
001	B/W	*CTL	[0 to 2147483647 / 0 / 1% / step]
011	B/W Printing Pages	*CTL	[0 to 9999999 / 0 / 1 / step]

8602	[C:Coverage Counter]		
	-		
001	B/W	*CTL	[0 to 2147483647 / 0 / 1% / step]

8603	[F:Coverage Counter]		
	-		
001	B/W	*CTL	[0 to 2147483647 / 0 / 1% / step]

8604	[P:Coverage Counter]		
	-		
001	B/W	*CTL	[0 to 2147483647 / 0 / 1% / step]

8606	[L:Coverage Counter]		
	-		
001	B/W	*CTL	[0 to 2147483647 / 0 / 1% / step]

8617	[SDK Apli Counter]		
	These SPs count the total printout pages for each SDK application.		
001	SDK-1	*CTL	[0 to 99999999 / 0 / 1 / step]
002	SDK-2	*CTL	
003	SDK-3	*CTL	
004	SDK-4	*CTL	
005	SDK-5	*CTL	
006	SDK-6	*CTL	
007	SDK-7	*CTL	[0 to 99999999 / 0 / 1 / step]
008	SDK-8	*CTL	

009	SDK-9	*CTL	
010	SDK-10	*CTL	
011	SDK-11	*CTL	
012	SDK-12	*CTL	

8621	Func Use Counter		
	-		
001	Function-001	*CTL	[0 to 99999999 / 0 / 1 / step]
002	Function-002	*CTL	
003	Function-003	*CTL	
004	Function-004	*CTL	
005	Function-005	*CTL	
006	Function-006	*CTL	[0 to 99999999 / 0 / 1 / step]
007	Function-007	*CTL	
008	Function-008	*CTL	
009	Function-009	*CTL	
010	Function-010	*CTL	
011	Function-011	*CTL	[0 to 99999999 / 0 / 1 / step]
012	Function-012	*CTL	
013	Function-013	*CTL	
014	Function-014	*CTL	
015	Function-015	*CTL	
016	Function-016	*CTL	[0 to 99999999 / 0 / 1 / step]
017	Function-017	*CTL	

018	Function-018	*CTL	
019	Function-019	*CTL	
020	Function-020	*CTL	
021	Function-021	*CTL	[0 to 99999999 / 0 / 1 / step]
022	Function-022	*CTL	
023	Function-023	*CTL	
024	Function-024	*CTL	
025	Function-025	*CTL	
026	Function-026	*CTL	
027	Function-027	*CTL	
028	Function-028	*CTL	[0 to 99999999 / 0 / 1 / step]
029	Function-029	*CTL	
030	Function-030	*CTL	
031	Function-031	*CTL	
032	Function-032	*CTL	[0 to 99999999 / 0 / 1 / step]
033	Function-033	*CTL	
034	Function-034	*CTL	
035	Function-035	*CTL	
036	Function-036	*CTL	
037	Function-037	*CTL	
038	Function-038	*CTL	
039	Function-039	*CTL	
040	Function-040	*CTL	

041	Function-041	*CTL	[0 to 99999999 / 0 / 1 / step]
042	Function-042	*CTL	
043	Function-043	*CTL	
044	Function-044	*CTL	
045	Function-045	*CTL	
046	Function-046	*CTL	
047	Function-047	*CTL	
048	Function-048	*CTL	
049	Function-049	*CTL	
050	Function-050	*CTL	
051	Function-051	*CTL	[0 to 99999999 / 0 / 1 / step]
052	Function-052	*CTL	
053	Function-053	*CTL	
054	Function-054	*CTL	
055	Function-055	*CTL	
056	Function-056	*CTL	
057	Function-057	*CTL	
058	Function-058	*CTL	
059	Function-059	*CTL	
060	Function-060	*CTL	
061	Function-061	*CTL	[0 to 99999999 / 0 / 1 / step]
062	Function-062	*CTL	
063	Function-063	*CTL	
064	Function-064	*CTL	

8631	[T:FAX TX PGS]		
	These SPs count the number of pages sent by fax to a telephone number.		
001	B/W	*CTL	[0 to 9999999 / 0 / 1 step]

8633	[F:FAX TX PGS]		
	These SPs count the number of pages sent by fax to a telephone number.		
001	B/W	*CTL	[0 to 9999999 / 0 / 1 step]

- If a document has color and black-and-white pages mixed, the pages are counted separately as B/W.
- At the present time, this feature is provided for the Fax application only so SP8631 and SP8633 are the same.
- The counts include error pages.
- If a document is sent to more than one destination with a Group transmission, the count is done for each destination.
- Polling transmissions are counted but polling RX are not.
- Relay, memory, and confidential mailbox transmissions and are counted for each destination.

8641	[T:IFAX TX PGS]		
	These SPs count the number of pages sent by fax to as fax images using I-Fax.		
001	B/W	*CTL	[0 to 9999999 / 0 / 1 step]

8643	[F:IFAX TX PGS]		
	These SPs the number of pages sent by Fax as fax images using I-Fax.		
001	B/W	*CTL	[0 to 9999999 / 0 / 1 step]

- If a document has black-and-white pages mixed, the pages are counted separately as B/W.
- At the present time, this feature is provided for the Fax application only so SP8641 and SP8643 are the same.
- The counts include error pages.
- If a document is sent to more than one destination with a Group transmission, the count is done for each destination.

- Polling transmissions are counted but polling RX are not.
- Relay, memory, and confidential mailbox transmissions and are counted for each destination.

8651	[T:S-to-Email PGS]		
	These SPs count by color mode the total number of pages attached to an e-mail for both the Scan and document server applications.		
001	B/W	*CTL	[0 to 9999999 / 0 / 1 step]
002	Color	*CTL	[0 to 9999999 / 0 / 1 step]

8655	[S:S-to-Email PGS]		
	These SPs count by color mode the total number of pages attached to an e-mail for both the Scan and document server applications.		
001	B/W	*CTL	[0 to 9999999 / 0 / 1 step]
002	Color	*CTL	[0 to 9999999 / 0 / 1 step]

Note

- The count for B/W and Color pages is done after the document is stored on the HDD. If the job is cancelled before it is stored, the pages are not counted.
- If Scan-to-Email is used to send a 10-page document to 5 addresses, the count is 10 (the pages are sent to the same SMTP server together).
- If Scan-to-PC is used to send a 10-page document to 5 folders, the count is 50 (the document is sent to each destination of the SMB/FTP server).
- Due to restrictions on some devices, if Scan-to-Email is used to send a 10-page document to a large number of destinations, the count may be divided and counted separately. For example, if a 10-page document is sent to 200 addresses, the count is 10 for the first 100 destinations and the count is also 10 for the second 100 destinations, for a total of 20).

8661	[T:Deliv PGS/Svr]		
	These SPs count by color mode the total number of pages sent to a Scan Router server by both Scan and LS applications.		
001	B/W	*CTL	[0 to 9999999 / 0 / 1 step]
002	Color	*CTL	[0 to 9999999 / 0 / 1 step]

8665	[S:Deliv PGS/Svr]		
	These SPs count by color mode the total number of pages sent to a Scan Router server by the Scan application.		
001	B/W	*CTL	[0 to 9999999 / 0 / 1 step]
002	Color	*CTL	[0 to 9999999 / 0 / 1 step]

Note

- The B/W and Color counts are done after the document is stored on the HDD of the Scan Router server.
- If the job is canceled before storage on the Scan Router server finishes, the counts are not done.
- The count is executed even if regardless of confirmation of the arrival at the Scan Router server.

8671	[T:Deliv PGS/PC]		
	These SPs count by color mode the total number of pages sent to a folder on a PC (Scan-to-PC) with the Scan and LS applications.		
8675	[S: Deliv PGS/PC]		
	These SPs count by color mode the total number of pages sent with Scan-to-PC with the Scan application.		
001	B/W	*CTL	[0 to 9999999 / 0 / 1 step]
002	Color	*CTL	[0 to 9999999 / 0 / 1 step]

8681	[T:PCFAX TXPGS]	*CTL	These SPs count the number of pages sent by PC Fax. These SPs are provided for the Fax application only, so the counts for SP8 681 and SP8 683 are the same. [0 to 9999999 / 0 / 1 / step]
8683	[F:PCFAX TXPGS]	*CTL	

- This counts pages sent from a PC using a PC fax application, from the PC through the copier to the destination.
- When sending the same message to more than one place using broadcasting, the pages are only counted once. (For example, a 10-page fax is sent to location A and location B. The counter goes up by 10, not 20.)

8691	[T:TX PGS/LS]	*CTL	These SPs count the number of pages sent from the document server. The counter for the application that was used to store the pages is incremented. [0 to 9999999/ 0 / 1 / step] The L: counter counts the number of pages stored from within the document server mode screen at the operation panel. Pages stored with the Store File button from within the Copy mode screen go to the C: counter.
8692	[C:TX PGS/LS]	*CTL	
8693	[F:TX PGS/LS]	*CTL	
8694	[P:TX PGS/LS]	*CTL	
8695	[S:TX PGS/LS]	*CTL	
8696	[L:TX PGS/LS]	*CTL	

 **Note**

- Print jobs done with Web Image Monitor and Desk Top Binder are added to the count.
- If several documents are merged for sending, the number of pages stored are counted for the application that stored them.
- When several documents are sent by a Fax broadcast, the F: count is done for the number of pages sent to each destination.

8701	[TX PGS/Port]		
	These SPs count the number of pages sent by the physical port used to send them. For example, if a 3-page original is sent to 4 destinations via ISDN G4, the count for ISDN (G3, G4) is 12.		
001	PSTN-1	*CTL	[0 to 9999999/ 0 / 1 / step]
002	PSTN-2	*CTL	[0 to 9999999/ 0 / 1 / step]
003	PSTN-3	*CTL	[0 to 9999999/ 0 / 1 / step]
004	ISDN (G3,G4)	*CTL	[0 to 9999999/ 0 / 1 / step]
005	Network	*CTL	[0 to 9999999/ 0 / 1 / step]

8711	[T:Scan PGS/Comp]		
8715	[S:Scan PGS/Comp]		
	These SPs count the number of pages sent by each compression mode.		
001	JPEG/JPEG2000	*CTL	[0 to 9999999/ 0 / 1 / step]
002	TIFF(Multi/Single)	*CTL	[0 to 9999999/ 0 / 1 / step]
003	PDF	*CTL	[0 to 9999999/ 0 / 1 / step]
004	Other	*CTL	[0 to 9999999/ 0 / 1 / step]
005	PDF/Comp	*CTL	[0 to 9999999/ 0 / 1 / step]
006	PDF/A	*CTL	[0 to 9999999/ 0 / 1 / step]
007	PDF(OCR)	*CTL	[0 to 9999999/ 0 / 1 / step]
008	PDF/Comp(OCR)	*CTL	[0 to 9999999/ 0 / 1 / step]
009	PDF/A(OCR)	-	-

8721	[T:Deliv PGS/WSD/DSM]		
8725	[S: Deliv PGS/WSD/DSM]		
	These SPs count the number of pages scanned by each scanner mode.		
001	B/W	*CTL	[0 to 9999999/ 0 / 1 / step]
002	Color	*CTL	[0 to 9999999/ 0 / 1 / step]

8731	[T:Scan PGS/Media]		
8735	[S:Scan PGS/Media]		
	These SPs count the number of pages scanned and saved in a media by each scanner mode.		
001	B/W	*CTL	[0 to 9999999/ 0 / 1 / step]
002	Color	*CTL	[0 to 9999999/ 0 / 1 / step]

8741	[RX PGS/Port]		
	These SPs count the number of pages received by the physical port used to receive them.		
001	PSTN-1	*CTL	[0 to 9999999/ 0 / 1 / step]
002	PSTN-2	*CTL	[0 to 9999999/ 0 / 1 / step]
003	PSTN-3	*CTL	[0 to 9999999/ 0 / 1 / step]
004	ISDN (G3,G4)	*CTL	[0 to 9999999/ 0 / 1 / step]
005	Network	*CTL	[0 to 9999999/ 0 / 1 / step]

8771	[Dev Counter]		
	These SPs count the frequency of use (number of rotations of the development rollers) for black toner.		
001	Total	*CTL	[0 to 99999999 / 0 / 1 / step]

8781	Toner_Bottle_Info.	*CTL	[0 to 9999999 / 0 / 1 / step]
	These SPs display the number of already replaced toner bottles. NOTE: Currently, the data in SP7-833-011 through 014 and the data in SP8-781-001 through 004 are the same.		
001	Toner: BK	The number of black-toner bottles	

8791	[LS Memory Remain]	*CTL	This SP displays the percent of space available on the document server for storing documents. [0 to 100 / 0 / 1 / step]
-------------	---------------------------	------	--

8801	[Toner Remain]		
	These SPs display the percent of toner remaining for each color. This SP allows the user to check the toner supply at any time.		
001	K	*CTL	[0 to 100 / 0 / 10% / step]

8811	[Eco Counter]		
	-		
001	Eco Total	*CTL	[0 to 99999999 / 0 / 1 / step]
004	Duplex	*CTL	[0 to 99999999 / 0 / 1 / step]
005	Combine	*CTL	[0 to 99999999 / 0 / 1 / step]
008	Duplex (%)	*CTL	[0 to 100 / 0 / 1% / step]
009	Combine (%)	*CTL	[0 to 100 / 0 / 1% / step]
010	Paper Cut (%)	*CTL	[0 to 100 / 0 / 1% / step]
101	Eco Totalr>Last	*CTL	[0 to 99999999 / 0 / 1 / step]
104	Duplex>Last	*CTL	[0 to 99999999 / 0 / 1 / step]
105	Combine>Last	*CTL	[0 to 99999999 / 0 / 1 / step]
108	Duplex (%):Last	*CTL	[0 to 100 / 0 / 1% / step]
109	Combine (%):Last	*CTL	[0 to 100 / 0 / 1% / step]
110	Paper Cut (%):Last	*CTL	[0 to 100 / 0 / 1% / step]

8851	[Cvr Cnt: 0-10%]		
	These SPs display the number of scanned sheets on which the coverage of each color is from 0% to 10%.		
011	0 to 2%: BK	*CTL	[0 to 99999999 / 0 / 1 / step]
021	3 to 4%: BK	*CTL	[0 to 99999999 / 0 / 1 / step]
031	5 to 7%: BK	*CTL	[0 to 99999999 / 0 / 1 / step]
041	8 to 10%: BK	*CTL	[0 to 99999999 / 0 / 1 / step]

8861	[Cvr Cnt: 11-20%]		
	These SPs display the number of scanned sheets on which the coverage of each color is from 11% to 20%.		
001	BK	*CTL	[0 to 99999999 / 0 / 1 / step]

8871	[Cvr Cnt: 21-30%]		
	These SPs display the number of scanned sheets on which the coverage of each color is from 21% to 30%.		
001	BK	*CTL	[0 to 99999999 / 0 / 1 / step]

8881	[Cvr Cnt: 31%-]		
	These SPs display the number of scanned sheets on which the coverage of each color is 31% or higher.		
001	BK	*CTL	[0 to 99999999 / 0 / 1 / step]

8891	[Page/Toner Bottle]		
	These SPs display the amount of the remaining current toner for each color.		
001	BK	*CTL	[0 to 99999999 / 0 / 1 / step]

8901	[Page/Toner_Prev1]		
	These SPs display the amount of the remaining previous toner for each color.		
001	BK	*CTL	[0 to 99999999 / 0 / 1 / step]

8911	[Page/Toner_Prev2]		
	These SPs display the amount of the remaining 2nd previous toner for each color.		
001	BK	*CTL	[0 to 99999999 / 0 / 1 / step]

8921	[Cvr Cnt/Total]		
	Displays the total coverage and total printout number for each color.		
001	Coverage (%) Bk	*CTL	[0 to 2147483647 / 0 / 1% / step]
011	Coverage /P: Bk	*CTL	[0 to 99999999 / 0 / 1 / step]

8941	[Machine Status]		
	These SPs count the amount of time the machine spends in each operation mode. These SPs are useful for customers who need to investigate machine operation for improvement in their compliance with ISO Standards.		
001	Operation Time	*CTL	[0 to 99999999 / 0 / 1 / step]
	Engine operation time. Does not include time while controller is saving data to HDD (while engine is not operating).		
002	Standby Time	*CTL	[0 to 99999999 / 0 / 1 / step]
	Engine not operating. Includes time while controller saves data to HDD. Does not include time spent in Energy Save, Low Power, or Off modes.		
003	Energy Save Time	*CTL	[0 to 99999999 / 0 / 10 / step]
	Includes time while the machine is performing background printing.		
004	Low Power Time	*CTL	[0 to 99999999 / 0 / 1 / step]
	Includes time in Energy Save mode with Engine on. Includes time while machine is performing background printing.		
005	Off Mode Time	*CTL	[0 to 99999999 / 0 / 1 / step]
	Includes time while machine is performing background printing. Does not include time machine remains powered off with the power switches.		
006	SC	*CTL	[0 to 99999999 / 0 / 1 / step]
	Total time when SC errors have been staying.		

007	PrtJam	*CTL	[0 to 99999999 / 0 / 1 / step]
	Total time when paper jams have been staying during printing.		
008	OrgJam	*CTL	[0 to 99999999 / 0 / 1 / step]
	Total time when original jams have been staying during scanning.		
009	Supply PM Unit End	*CTL	[0 to 99999999 / 0 / 1 / step]
	Total time when toner end has been staying		

8951	[AddBook Register]		
	These SPs count the number of events when the machine manages data registration.		
001	User Code/User ID	*CTL	[0 to 9999999 / 0 / 1 / step]
	User code registrations.		
002	Mail Address	*CTL	[0 to 9999999 / 0 / 1 / step]
	Mail address registrations.		
003	Fax Destination	*CTL	[0 to 9999999 / 0 / 1 / step]
	Fax destination registrations.		
004	Group	*CTL	[0 to 9999999 / 0 / 1 / step]
	Group destination registrations.		
005	Transfer Request	*CTL	[0 to 9999999 / 0 / 1 / step]
	Fax relay destination registrations for relay TX.		
006	F-Code	*CTL	[0 to 9999999 / 0 / 1 / step]
	F-Code box registrations.		
007	Copy Program	*CTL	[0 to 255 / 0 / 255 / step]
	Copy application registrations with the Program (job settings) feature.		

008	Fax Program	*CTL	[0 to 255 / 0 / 255 / step]
	Fax application registrations with the Program (job settings) feature.		
009	Printer Program	*CTL	[0 to 255 / 0 / 255 / step]
	Printer application registrations with the Program (job settings) feature.		
010	Scanner Program	*CTL	[0 to 255 / 0 / 255 / step]
	Scanner application registrations with the Program (job settings) feature.		

8961	[Electricity Status]		
	-		
001	Ctrl Standby Time	*CTL	[0 to 99999999 / 0 / 1 / step]
002	STR Time	*CTL	
003	Main Power Off Time	*CTL	
004	Reading and Printing Time	*CTL	
005	Printing Time	*CTL	[0 to 99999999 / 0 / 1 / step]
006	Reading Time	*CTL	
007	Eng Waiting Time	*CTL	
008	Low Power State Time	*CTL	
009	Silent State Time	*CTL	
010	Heater Off State Time	*CTL	
011	LCD on Time	*CTL	

8971	[Unit Control]		
	-		
001	Engine Off Recovery Count	*CTL	[0 to 99999999 / 0 / 1 / step]
002	Power Off Count	*CTL	
003	Force Power Off Count	*CTL	

8999	[Admin. Counter List]		
	Displays each total print out and total coverage.		
001	Total	*CTL	[0 to 99999999 / 0 / 1 / step]
003	Copy: BW	*CTL	[0 to 99999999 / 0 / 1 / step]
007	Printer: BW	*CTL	[0 to 99999999 / 0 / 1 / step]
010	Fax Print: BW	*CTL	[0 to 99999999 / 0 / 1 / step]
012	A3/DLT	*CTL	[0 to 99999999 / 0 / 1 / step]
013	Duplex	*CTL	[0 to 99999999 / 0 / 1 / step]
023	Copy: BW (%)	*CTL	[0 to 2147483647 / 0 / 1% / step]
027	Printer: BW (%)	*CTL	[0 to 2147483647 / 0 / 1% / step]
030	Fax Print: BW (%)	*CTL	[0 to 2147483647 / 0 / 1% / step]
101	Transmission Total: Color	*CTL	[0 to 99999999 / 0 / 1 / step]
102	Transmission Total: BW	*CTL	[0 to 99999999 / 0 / 1 / step]
103	Fax Transmission	*CTL	[0 to 99999999 / 0 / 1 / step]
104	Scanner Transmission: Color	*CTL	[0 to 99999999 / 0 / 1 / step]
105	Scanner Transmission: BW	*CTL	[0 to 99999999 / 0 / 1 / step]

5.15 PRINTER SP MODE

5.15.1 SP1-XXX (SERVICE MODE)

1001	[Bit Switch]			
001	Bit Switch 1 Setting		0	1
	bit 0	DFU	-	-
	bit 1	You can switch the information displayed under the "sysName" standard MIB object between the normal data (PnP model name) and data for a custom model (host name). The host name is the name appearing under SP5-828-080.	Normal	Host Name (Custom)
	bit 2	DFU	-	-
	bit 3	No I/O Timeout	Disabled	Enabled
		Enables/Disables MFP I/O Timeouts. If enabled, the MFP I/O Timeout setting will have no affect. I/O Timeouts will never occur.		
	bit 4	SD Card Save Mode	Disabled	Enabled
		If this bit switch is enabled, print jobs will be saved to the GW SD slot and not output to paper.		
	bit 5	DFU	-	-
	bit 6	DFU	-	-
bit 7	[RPCS,PCL]: Printable area frame border	Disabled	Enabled	
	Prints all RPCS and PCL jobs with a border around the printable area.			

1001	[Bit Switch]			
002	Bit Switch 2 Setting		0	1
	bit 0	DFU	-	-
	bit 1	DFU	-	-
	bit 2	Applying a Collate Type	Shift Collate	Normal Collate
	<p>A collate type (shift or normal) will be applied to all jobs that do not explicitly define a collate type.</p> <p>Note: If #5-0 is enabled, this BitSwitch has no effect.</p>			
	bit 3	[PCL5e/c,PS]: PDL Auto Switching	Enabled	Disabled
	<p>Enables/Disables the MFPs ability to change the PDL processor mid-job. Some host systems submit jobs that contain both PS and PCL5e/c. If Auto PDL switching is disabled, these jobs will not be printed properly.</p>			
	bit 4	DFU	-	-
	bit 5	DFU	-	-
bit 6	DFU	-	-	
bit 7	DFU	-	-	

1001	[Bit Switch]			
003	Bit Switch 3 Setting		0	1
	bit 0	DFU	-	-
	bit 1	DFU	-	-
	bit 2	[PCL5e/c]: Legacy HP compatibility	Disabled	Enabled
		Uses the same left margin as older HP models such as HP4000/HP8000. In other words, the left margin defined in the job (usually "<ESC>*r0A") will be changed to "<ESC>*r1A".		
	bit 3	DFU	-	-
	bit 4	DFU	-	-
	bit 5	DFU	-	-
	bit 6	DFU	-	-
	bit 7	DFU	-	-

1001	[Bit Switch]			
004	Bit Switch 4 Setting		0	1
	bit 0	DFU	-	-
	bit 1	DFU	-	-
	bit 2	DFU	-	-
	bit 3	IPDS print-side reversal	Disabled	Enabled
		If enabled, the simplex pages of IPDS jobs will be printed on the front side because of printing on the back side of the page. This might reduce printing speed.		
	bit 4	DFU	-	-
	bit 5	DFU	-	-
	bit 6	DFU	-	-
bit 7	You can enable/disable the port for IPDS printing.	OFF	ON	

1001	[Bit Switch]			
005	Bit Switch 5 Setting	0	1	
	bit 0	Show "Collate Type", "Staple Type" and "Punch Type" buttons on the operation panel.	Disabled	Enabled
		<p>If enabled, users will be able to configure a Collate Type, Staple Type, and Punch Type from the operation panel. The available Types will depend on the device and configured options.</p> <p>After enabling this BitSw, the settings will appear under: "User Tools > Printer Features > System"</p>		
	bit 1	Multiple copies if a paper size or type mismatch occurs	Disabled (single copy)	Enabled (multiple)
		<p>If a paper size or type mismatch occurs during the printing of multiple copies, only a single copy is output by default. Using this BitSw, the device can be configured to print all copies even if a paper mismatch occurs.</p>		
	bit 2	Prevent SDK applications from altering the contents of a job.	Disabled	Enabled
		<p>If this BitSw is enabled, SDK applications will not be able to alter print data. This is achieved by preventing SDK applications from accessing a module called the "GPS Filter".</p> <p>Note: The main purpose of this BitSw is for troubleshooting the effects of SDK applications on data.</p>		
	bit 3	[PS] PS Criteria	Pattern3	Pattern1
		<p>Change the number of PS criterion used by the PS interpreter to determine whether a job is PS data or not.</p>		
	bit 4	Increase max. number of stored jobs.	Disabled (100)	Enabled (750)
		<p>Changes the maximum number of jobs that can be stored on the HDD. The default (disabled) is 100. If this is enabled, the max. will be raised to 750 or 1000 depending on the model.</p>		

	bit 5	DFU	-	-
	bit 6	Method for determining the image rotation for the edge to bind on.	Disabled	Enabled
		<p>If enabled, the image rotation will be performed as they were in the specifications of older models for the binding of pages of mixed orientation jobs.</p> <p>The old models are below:</p> <ul style="list-style-type: none"> - PCL: Pre-04A models - PS/PDF/RPCS:Pre-05S models 		
	bit 7	Letterhead mode printing	Disabled	Enabled (Duplex)
		<p>Routes all pages through the duplex unit.</p> <p>If this is disabled, simplex pages or the last page of an odd-paged duplex job, are not routed through the duplex unit. This could result in problems with letterhead/pre-printed pages.</p> <p>Only affects pages specified as Letterhead paper.</p>		

1001	[Bit Switch]			
006	Bit Switch 6 Setting		0	1
	bit 0	DFU	-	-
	bit 1	DFU	-	-
	bit 2	DFU	-	-
	bit 3	DFU	-	-
	bit 4	DFU	-	-
	bit 5	DFU	-	-
	bit 6	DFU	-	-
	bit 7	DFU	-	-

1001	[Bit Switch]			
007	Bit Switch 7 Setting		0	1
		Print path	Disabled	Enabled
	bit 0	If enabled, simplex pages (in mixed simplex/duplex PS/PCL5 jobs only) and the last page of an odd paged duplex job (PS, PCL5, PCL6), are always routed through the duplex unit. Not having to switch paper paths increases the print speed slightly.		
	bit 1	DFU	-	-
	bit 2	DFU	-	-
	bit 3	DFU	-	-
	bit 4	DFU	-	-
	bit 5	DFU	-	-
	bit 6	DFU	-	-
bit 7	DFU	-	-	

1001	[Bit Switch]			
008	Bit Switch 8 Setting		0	1
	bit 0	DFU	-	-
	bit 1	DFU	-	-
	bit 2	DFU	-	-
	bit 3	[PCL,PS]: Allow BW jobs to print without requiring User Code	Disabled	Enabled (allow BW jobs to print without a user code)
	BW jobs submitted without a user code will be printed even if usercode authentication is enabled. Note: Color jobs will not be printed without a valid user code.			

	bit 4	DFU	-	-
	bit 5	DFU	-	-
	bit 6	PCL, RPCS, PS: Forced BW print	Enabled	Disabled
	Switches whether to ignore PDL color command.			
	bit 7	[PDF]: Orientation Auto Detect Fuction	Enabled	Disabled
	Automatically chooses page orientations of PDF jobs (Landscape or Portrait) based on the content.			

1001	[Bit Switch]			
009	Bit Switch 9 Setting		0	1
	bit 0	PDL Auto Detection timeout of jobs submitted via USB or Parallel Port (IEEE 1284).	Disabled (Immediately)	Enabled (10 seconds)
To be used if PDL auto-detection fails. A failure of PDL autodetection doesn't necessarily mean that the job can't be printed. This bit switch tells the device whether to time-out immediately (default) upon failure or to wait 10 seconds.				
	bit 1	DFU	-	-
	bit 2	Job Cancel	Disabled (Not cancelled)	Enabled (Cancelled)
	<p>If this bit switch, all jobs will be cancelled after a jam occurs.</p> <p>Note: If this bitsw is enabled, printing under the following conditions might result in problems:</p> <ul style="list-style-type: none"> - Job submission via USB or Parallel Port - Spool printing (WIM >Configuration > Device Settings > System) 			

bit 3	PCL/PS bypass tray paper rotation (SEF/LEF)	Disabled	Enabled
	<p>This bitsw causes the device to revert to the behavior of previous generations. It only takes effect if "Bypass Tray Setting Priority" = "Driver/Command".</p> <p>Previous spec (bitsw=1): If a standard sized paper mismatch occurred in the bypass tray, the MFP always prompted for SEF paper.</p> <p>If this bitsw=0 (default) then in the event of a standard sized paper mismatch, the MFP will always prompt for paper of the rotation (SEF/LEF) determined by the MFP bypass tray paper setting or by the bypass tray sensor.</p>		
bit 4	Timing of the PjL Status ReadBack (JOB END) when printing multiple collated copies.	Disable	Enable
	<p>This bitsw determines the timing of the PjL USTATUS JOB END sent when multiple collated copies are being printed.</p> <p>0 (default): JOB END is sent by the device to the client after the first copy has completed printing. This causes the page counter to be incremented after the first copy and then again at the end of the job.</p> <p>1: JOB END is sent by the device to the client after the last copy has finished printing. This causes the page counter to be incremented at the end of each job.</p>		
bit 5	Display UTF-8 text in the operation panel	Enabled	Disabled
	<p>Enabled (=0): Text composed of UTF-8 characters can be displayed in the operation panel.</p> <p>Disabled (=1): UTF-8 characters cannot be displayed in the operation panel.</p> <p>For example, job names are sometimes stored in the MIB using UTF-8 encoded characters. When these are displayed on the operation panel, they will be garbled unless this BitSw is enabled (=0).</p>		

	bit 6	Disable super option	Enabled	Disabled
		Switches super option disable on / off. If this is On, multiple jobs are grouped at LPR port. PJP settings are enabled even jobs that are specified queue names are sent.		
	bit 7	Enable/Disable Print from USB/SD's Preview function	Enabled	Disabled
		Determines whether Print from USB/SD will have the Preview function. Enabled (=0): Print from USB/SD will have the Preview function. Disabled (=1): Print from USB/SD will not have the Preview function.		

1001	[Bit Switch]			
010	Bit Switch A Setting		0	1
	bit 0	DFU	-	-
	bit 1	DFU	-	-
	bit 2	DFU	-	-
	bit 3	DFU	-	-
	bit 4	DFU	-	-
	bit 5	Store and Skip Errored Job locks the queue	Queue is not locked after SSEJ	Queue locked after SSEJ
		If this is 1, then after a job is stored using Store and Skip Errored Job (SSEJ), new jobs cannot be added to the queue until the stored job has been completely printed.		

	bit 6	Allow use of Store and Skip Errored Job if connected to an external charge device.	Does not allow SSEJ with ECD	Allows SSEJ with ECD
		<p>If this is 0, Store and Skip Errored Job (SSEJ) will be automatically disabled if an external charge device is connected.</p> <p>Note: We do not officially support enabling this bitsw (1). Use it at your own risk.</p>		
	bit 7	Job cancels remaining pages when the paid-for pages have been printed on an external charge device	Job does not cancel	Job cancels
		<p>When setting 1 is enabled, after printing the paid-for pages on an external charge device, the job that includes any remaining pages will be canceled.</p> <p>This setting will prevent the next user from printing the unnecessary pages from the previous user's print job.</p>		

1001	[Bit Switch]			
011	Bit Switch B Setting	0	1	
	bit 0	Show Menu List	Hide Menu List	Show Menu List
		If this is 0, the Menu List button will be removed from Printer Features.		
	bit 1	Print job interruption	Does not allow interruption	Allow interruption
		<p>0 (default): Print jobs are not interrupted. If a job is promoted to the top of the print queue, it will wait for the currently printing job to finish.</p> <p>1: If a job is promoted to the top of the queue, it will interrupt the currently printing job and start printing immediately.</p>		

Printer SP Mode

	bit 2	DFU You can specify whether or not to apply "Extended Auto Tray Switching" to the bypass tray when Printer Features > System > Tray Setting Priority > Bypass Tray is set to "Any Size/Type" (when the bypass tray is set to receive any type of paper).	Off	On
	bit 3	Error setting for booklet printing	Job cancel	Continue
	bit 4	If this BitSwitch is set to "1" (enabled), the "Apply Auto Paper Select" setting will decide if the paper size or paper type that is specified in the device settings should be overwritten by the job's commands when "Tray Setting Priority" is set to "Driver/Command" or "Any Type". - Apply Auto Paper Select = OFF: Overwritten (priority is given to the job's commands) - Apply Auto Paper Select = ON: Not overwritten (priority is given to the device settings)	Disabled	Enabled
	bit 5	DFU	-	-
	bit 6	DFU	-	-
	bit 7	DFU	-	-

1001	[Bit Switch]			
012	Bit Switch C Setting		0	1
	bit 0	DFU	-	-
	bit 1	DFU	-	-
	bit 2	DFU	-	-
	bit 3	DFU	-	-
	bit 4	DFU	-	-
	bit 5	DFU	-	-
	bit 6	DFU	-	-
	bit 7	DFU	-	-

1003	[Clear Setting]		
1-003-001	Initialize System	*CTL	[- / - / -] [Execute]
	Initializes settings in the "System" menu of the user mode.		
1-003-003	Delete Program	*CTL	[- / - / -] [Execute]

1004	[Print Summary]		
	Prints the service summary sheet (a summary of all the controller settings).		
1-004-001	Print Summary	*CTL	[- / - / -] [Execute]

1005	[Display Version]		
1-005-002	Printer Version	*CTL	[- / - / -]
	Displays the version of the controller firmware.		

1006	[Sample/Locked Print]		
1-006-002	Sample / Locked Print	*CTL	[0 or 1 / 0 / 1 /step] 0: Linked, 1: On
	Enables and disables the document server. When you select "0," the document server is enabled or disabled in accordance with Copy Service Mode SP5-967. When you select "1," the document server is enabled regardless of Copy Service Mode SP5-967.		

1110	[Media Print Device Setting]		
	Selects the setting for the media print device.		
1-110-002	0: Disable 1: Enable	*CTL	[0 or 1 / 1 / 1 / step]

1111	[All Job Delete Mode]		
1-111-001	-	*CTL	[0 or 1 / 1 / 1 / step] 0: Excluding New Job 1: Including New Job
	Selects whether to include an image processing job in jobs subject to full cancellation from the SCS job list.		

5.16 SCANNER SP MODE

5.16.1 SP1-XXX (SYSTEM AND OTHERS)

1001	[Scan Nv Version]		
	Displays the scanner firmware version stored in NVRAM in a 9-digit format: Func. Name_Model Name_History No.		
1-001-005	-	*CTL	[- / - / -]

1005	[Erase Margin(Remote scan)]		
	Creates an erase margin for all edges of the scanned image. If the machine has scanned the edge of the original, create a margin. This SP is activated only when the machine uses TWAIN scanning.		
1-005-001	Range from 0 to 5 mm	*CTL	[0 to 5 / 0 / 1 mm / step]

1009	[Remote scan disable]		
1-009-001	0: Enable 1: Disable	*CTL	[0 or 1 / 0 / 1 / step] 0: Enable 1: Disable
	This SP switches the TWAIN scanner function on/off. This is one of the scanner application functions.		

1010	[Non Display ClearLight PDF]		
1-010-001	0: Display 1: Nondisplay	*CTL	[0 or 1 / 0 / 1 / step] 0: Display, 1: Nondisplay
	Display or Non display remote scan.		

1011	[Org Count Display]		
1-011-001	0: ON 1: OFF	*CTL	[0 or 1 / 0 / 1 / step] 0: ON (count displays) 1: OFF (no display)
	This SP codes switches the original count display on/off.		

1012	[UserInfo Release]		
1-012-001	0: NO 1: YES	*CTL	[0 or 1 / 1 / 1 / step] 1: No 0: Yes
	<p>This SP code sets the machine to release or not release the following items at job end.</p> <ul style="list-style-type: none"> ▪ Destination (E-mail/Folder/CS) ▪ Sender name ▪ Mail Text ▪ Subject line ▪ File name 		

1013	[Scan to Media Device Setting]		
1-013-002	0: OFF 1: ON	*CTL	[0 or 1 / 1 / 1 / step] 0: OFF 1: ON
	<p>Sets enable or disable multi-media function. Default is different with operation panel type. If media slot (USB/SD) mounted on the operation panel is standard, default is "1". If media slot (USB/SD) mounted on the operation panel is optional, default is "0".</p>		

1013	[Scan to Media Device Setting]		
1-013-003	0: OFF 1: ON	*CTL	[0 or 1 / 1 / 1 / step] 0: OFF 1: ON
	Determines to disable/enable Scan-To-Media. 0: Disables 1: Enables		

1014	[Scan to Folder Pass Input Set]		
1-014-001	0: OFF 1: ON	*CTL	[0 or 1 / 0 / 1 / step] 0: OFF 1: ON
	Sets enable or disable the password setting when make a Scan to Folder job.		

1041	[Scan:FlairAPI Setting]			
1-041-001	0x00 – 0xff	*CTL	* see BitSwitch below:	
	Sets Scanner FlairAPI Function enable / disable. This SP is set by BitSwitch and needs to reboot the machine after making changes.			
bit	Setting	meanings		Description
		0	1	
bit 0	Start of FlairAPI Server	Off (Do not Start)	On (Start)	Sets whether to start exclusive FlairAPI http server. If it is 0, scanning FlairAPI function and simple UI function will be disabled. The machine installed Android operating panel option, set "1", others set "0".

Scanner SP Mode

bit 1	Access permission of FlairAPI from outside of the machine	Disabled	Enabled	If it is "0", accessing is limited from the machine only, such as operating panel, SDK/J, MFP browsers etc... If it is "1", accessing is allowed from outside of FlairAPI such as PC, Remote UI, IT-Box etc...
bit 2	Reserved	-	-	-
bit 3	Reserved	-	-	-
bit 4	Reserved	-	-	Reserved
bit 5	Reserved	-	-	Reserved
bit 6	Reserved	-	-	-
bit 7	Reserved	-	-	-

5.16.2 SP2-XXX (SCANNING-IMAGE QUALITY)

2021	[Compression Level (Grayscale)]		
	Selects the compression ratio for grayscale processing mode (JPEG) for the five settings that can be selected at the operation panel.		
2-021-001	Comp1:5-95	*CTL	[5 to 95 / 20 / 1 / step]
2-021-002	Comp2:5-95	*CTL	[5 to 95 / 40 / 1 / step]
2-021-003	Comp3:5-95	*CTL	[5 to 95 / 65 / 1 / step]
2-021-004	Comp4:5-95	*CTL	[5 to 95 / 80 / 1 / step]
2-021-005	Comp5:5-95	*CTL	[5 to 95 / 95 / 1 / step]

2024	[Compression ratio of ClearLight PDF]		
	Selects the compression ratio for clearlight PDF for the two settings that can be selected at the operation panel.		
2-024-001	Compression Ratio (Normal)	*CTL	[5 to 95 / 25 / 1 / step]
2-024-002	Compression Ratio (High)	*CTL	[5 to 95 / 20 / 1 / step]

2025	[Compression ratio of ClearLightPDF JPEG2000]		
	Selects the compression ratio for clearlight PDF for the two settings that can be selected at the operation panel.		
2-025-001	Compression Ratio (Normal) JPEG2000	*CTL	[5 to 95 / 25 / 1 / step]
2-025-002	Compression Ratio (High) JPEG2000	*CTL	[5 to 95 / 20 / 1 / step]

2030	[OCR PDF DetectSens]		
2-030-001	White Lumi Value: 0 - 255	*CTL	[0 to 255 / 250 / 1 / step]
2-030-002	White Pix Ratio: 0 - 100	*CTL	[0 to 100 / 80 / 1 / step]
2-030-003	White Tile Ratio: 0 -100	*CTL	[0 to 100 / 80 / 1 / step]

5.17 INPUT CHECK TABLE

5.17.1 MAIN MACHINE – INPUT CHECK

5803	[INPUT Check]		
5-803-001	Registration Sensor	ENG	[0 or 1 / 0 / 1/step] 0: paper exist 1: paper non exist
	Responds to paper existence on register sensor position. (0: paper exist, 1: paper non exist)		
5-803-002	Paper Feed Sensor 1	ENG	[0 or 1 / 0 / 1/step] 0: paper exist 1: paper non exist
	Responds to paper existence on 1st paper feed sensor position. (0: paper exist, 1: paper non exist)		
5-803-003	Transport Sensor 1	ENG	[0 or 1 / 0 / 1/step] 0: paper exist 1: paper non exist
	Responds to paper existence on 1st carry sensor position. (0: paper exist, 1: paper non exist)		
5-803-004	Paper Feed Sensor 2	ENG	[0 or 1 / 0 / 1/step] 0: paper exist 1: paper non exist
	Responds to paper existence on 2nd paper feed sensor position. (0: paper exist, 1: paper non exist)		
5-803-005	Transport Sensor 2	ENG	[0 or 1 / 0 / 1/step] 0: paper exist 1: paper non exist
	Responds to paper existence on 2nd carry sensor position. (0: paper exist, 1: paper non exist)		

Input Check Table

5-803-006	Fusing Exit Sensor	ENG	[0 or 1 / 0 / 1/step] 0: paper exist 1: paper non exist
	Responds to paper existence on fusing exit sensor position. (0: paper exist, 1: paper non exist)		
5-803-007	Fusing Entrance Sensor	ENG	[0 or 1 / 0 / 1/step] 0: paper exist 1: paper non exist
	Responds to paper existence on fusing entrance sensor position. (0: paper exist, 1: paper non exist)		
5-803-008	Paper Exit Sensor	ENG	[0 or 1 / 0 / 1/step] 0: paper exist 1: paper non exist
	Responds to paper existence on paper exit sensor position. (0: paper exist, 1: paper non exist)		
5-803-009	Inverter Sensor	ENG	[0 or 1 / 0 / 1/step] 0: paper exist 1: paper non exist
	Responds to paper existence on reverse sensor position. (0: paper exist, 1: paper non exist)		
5-803-010	Duplex Exit Sensor	ENG	[0 or 1 / 0 / 1/step] 0: paper exist 1: paper non exist
	Responds to paper existence on duplex exit sensor position. (0: paper exist, 1: paper non exist)		
5-803-011	Duplex Entrance Sensor	ENG	[0 or 1 / 0 / 1/step] 0: paper exist 1: paper non exist
	Responds to paper existence on duplex entrance sensor position. (0: paper exist, 1: paper non exist)		

5-803-012	Paper Exit Tray Full Sensor	ENG	[0 or 1 / 0 / 1/step] 0: Not full 1: full
	Detects paper full of main unit paper exit tray. (0: Not full, 1: full)		
5-803-013	Tray 1 Remain Switch	ENG	[0 to 3 / 0 / 1/step] When full is 100%, 11: 71 to 100% 01: 31 to 70% 00: 11 to 30% 10: 1 to 10%
	Detects remaining paper amount of 1st paper feed tray. (When full is 100%, 11: 71 to 100%, 01: 31 to 70%, 00: 11 to 30%, 10: 1 to 10%) *Check SP5-803-015 for paper end.		
5-803-014	Tray 1: Upper Limit Sensor	ENG	[0 or 1 / 0 / 1/step] 0: less then limit 1: high then limit
	Detects the height of paper loaded in 1st paper feed tray. (0: less then limit, 1: high then limit)		
5-803-015	Tray 1 Paper End Sensor	ENG	[0 or 1 / 0 / 1/step] 0: No paper 1: paper remaining
	Detects paper is running out on 1st paper feed tray. (0: No paper, 1: paper remaining)		
5-803-016	Tray 1 Set Switch	ENG	[0 or 1 / 0 / 1/step] 0: set 1: not set
	Detects that 1st paper feed tray is set to main unit. (0: set, 1: not set)		

Input Check Table

5-803-017	Tray 2 Remain Switch	ENG	[0 to 3 / 0 / 1/step] When full is 100%, 11: 71 to 100% 01: 31 to 70% 00: 11 to 30% 10: 1 to 10%
	Detects remaining paper amount of 2nd paper feed tray. (When full is 100%, 11: 71 to 100%, 01: 31 to 70%, 00: 11 to 30%, 10: 1 to 10%) *Check SP5-803-019 for paper end.		
5-803-018	Tray 2 Upper Limit Sensor	ENG	[0 or 1 / 0 / 1/step] 0: less then limit 1: high then limit
	Detects the height of paper loaded in 2nd paper feed tray. (0: less then limit, 1: high then limit)		
5-803-019	Tray 2 Paper End Sensor	ENG	[0 or 1 / 0 / 1/step] 0: No paper 1: paper remaining
	Detects paper running out of 2nd paper feed tray. (0: No paper, 1: paper remaining)		
5-803-020	Tray 2 Set Switch	ENG	[0 or 1 / 0 / 1/step] 0: set 1: not set
	Detects that 2nd paper feed tray is set to main unit. (0: set, 1: not set)		
5-803-021	Tray 2 Size Switch	ENG	[0 to 15 / 0 / 1/step]
	Value changes depending on paper size (fence position) set to 2nd paper feed tray.		

5-803-022	By-pass: Paper End Sensor	ENG	[0 or 1 / 0 / 1/step] 0: No paper 1: paper remaining
	Detects paper is running out on bypass tray. (0: No paper, 1: paper remaining)		
5-803-023	Bypass Main Scan Length Switch	ENG	[0 to 31 / 0 / 1/step]
	Value changes depending on main scan direction of paper set to bypass tray.		
5-803-024	Bypass Sub Scan Length Sensor	ENG	[0 or 1 / 0 / 1/step]
	Value changes depending on sub scan direction of paper set to bypass tray.		
5-803-025	Main Door Interlock Switch	ENG	[0 to 1 / 0 / 1/step] 00: Unlocked 11: Locked
	Detects open/close of interlock switch (front cover/right cover). (00: Unlocked, 11: Locked)		
5-803-026	Right Door Open/Close Switch	ENG	[0 or 1 / 0 / 1/step] 0: close 1: open
	Detects right door status. (0: close, 1: open)		
5-803-027	Duplex Guide Plate Open/Close Switch	ENG	[0 or 1 / 0 / 1/step] 0: close 1: open
	Detects duplex guide plate status. (0: close, 1: open)		

Input Check Table

5-803-028	Transfer Open/Close Sensor	ENG	[0 or 1 / 0 / 1/step] 0: open 1: close
	Detects paper transfer unit status. (0: open, 1: close)		
5-803-029	Transfer Contact Sensor	ENG	[0 or 1 / 0 / 1/step] 0: Abutting 1: Alienate
	Detects image transfer roller and photoreceptors distance. (0: Abutting, 1: Alienate)		
5-803-032	Waste Toner Bottle Near Full Sensor	ENG	[0 or 1 / 0 / 1/step] 0: Not full 1: full
	Detects full of waste toner bottle. (0: Not full, 1: full)		
5-803-033	Toner Bottle Set Switch	ENG	[0 or 1 / 0 / 1/step] 0: set 1: not set
	Detects that toner bottle is set to main unit. (0: set, 1: not set)		
5-803-038	Fusing Set & Country Detection	ENG	[0 to 15 / 0 / 1/step] 0111:200V system 1011:100V System
	Detects region of fusing unit. (0111: 200V system, 1011: 100V System)		

5-803-039	Fusing New Fuse Blown Detection	ENG	[0 or 1 / 0 / 1/step] 0: New 1: Old
	Detects New/Old of fusing unit. (0: New, 1: Old)		
5-803-048	Fusing Exit Fan:Lock	ENG	[0 or 1 / 0 / 1/step] 0: Running 1: Stopped, or locked
	Detects locking of fusing exit fan. (0: Running, 1: Stopped, or locked)		
5-803-051	PSU Cooling Fan:Lock	ENG	[0 or 1 / 0 / 1/step] 0: Running 1: Stopped, or locked
	Detects locking of PSU cooling fan. (0: Running, 1: Stopped, or locked)		
5-803-057	Main Exhaust Fan:Lock	ENG	[0 or 1 / 0 / 1/step] 0: Running 1: Stopped, or locked
	Detects locking of main unit exhaust heat fan. (0: Running, 1: Stopped, or locked)		
5-803-058	Paper Exit Cooling Fan: Lock	ENG	[0 or 1 / 0 / 1/step] 0: Running 1: Stopped, or locked
	Detects locking of paper exit cooling fan. (0: Running, 1: Stopped, or locked)		

Input Check Table

5-803-060	Toner Bottle Cooling Fan:Lock	ENG	[0 or 1 / 0 / 1/step] 0: Running 1: Stopped, or locked
	Detects locking of toner supply bottle cooling fan. (0: Running, 1: Stopped, or locked)		
5-803-061	Development Motor : Lock	ENG	[0 or 1 / 0 / 1/step] 0: Running 1: Stopped, or locked
	Detects locking of developer motor (K). (0: Running, 1: Stopped, or locked)		
5-803-065	Fusing/Fusing Exit Motor:Lock	ENG	[0 or 1 / 0 / 1/step] 0: Running 1: Stopped, or locked
	Detects locking of fusing motor. (0: Running, 1: Stopped, or locked)		
5-803-066	Drum Motor:Lock	ENG	[0 or 1 / 0 / 1/step] 0: Running 1: Stopped, or locked
	Detects locking of transfer drum motor K. (0: Running, 1: Stopped, or locked)		
5-803-067	HVP/Separation DC/(-):Abnormal Detection	ENG	[0 or 1 / 0 / 1/step] 0: SC detected 1: Normal
	Detects SC of HVP (secession). (0: SC detected, 1: Normal)		

5-803-068	HVP/ChargeDC/(-):Abnormal Detection	ENG	[0 or 1 / 0 / 1/step] 0: SC detected 1: Normal
	Detects SC of HVP (electrify/develop). (0: SC detected, 1: Normal)		
5-803-069	HVP/PTR DC/(+)&(-):Abnormal Detection	ENG	[0 or 1 / 0 / 1/step] 0: SC detected 1: Normal
	Detects SC of HVP (transfer). (0: SC detected, 1: Normal)		
5-803-070	HVP/Development DC/(-):Abnormal Detection	ENG	[0 or 1 / 0 / 1/step] 0: SC detected 1: Normal
	Detects SC of HVP (Development). (0: SC detected, 1: Normal)		
5-803-072	Key Counter:Set Sensor 1	ENG	[0 or 1 / 0 / 1/step] 0: set 1:unset key counter: set 1=0, 2=1 for set, others for unset
	Detects setting of key counter. (0: set, 1:unset) (key counter: set 1=0, 2=1 for set, others for unset)		

Input Check Table

5-803-073	Key Counter:Set Sensor 2	ENG	[0 or 1 / 0 / 1/step] 0: set 1:unset key counter: set 1=0, 2=1 for set, others for unset
	Detects setting of key counter. (0: unset, 1:set) (key counter: set 1=0, 2=1 for set, others for unset)		
5-803-074	Key Card: Set Detection	ENG	[0 or 1 / 0 / 1/step] 0: set 1: not set
	Detects that key card is set to main unit. (0: set, 1:not set)		
5-803-075	1-Bin Remain Paper Detection	ENG	[0 or 1 / 0 / 1/step] 0: paper exist 1: paper non exist
	Detects that paper is left upon the tray. (0: paper exist, 1: paper non exist)		
5-803-076	1-Bin Set Detection	ENG	[0 or 1 / 0 / 1/step] 0: paper exist 1: paper non exist
	Detects that tray is set to main unit. (0: set, 1:not set)		
5-803-077	Bridge Relay Sensor	ENG	[0 or 1 / 0 / 1/step] 0: paper exist 1: paper non exist
	Responds to paper existence on carry sensor position or bridge unit. (0: paper exist, 1: paper non exist)		

5-803-078	Bridge Exit Sensor	ENG	[0 or 1 / 0 / 1/step] 0: Paper exist 1: Paper do not exist
	Responds to paper existence on paper exit sensor position or bridge unit. (0: paper exist, 1: paper non exist)		
5-803-079	Relay Set Detection Mechanism	ENG	[0 or 1 / 0 / 1/step] 0: set 1: not set
	Detects that bridge unit is set to main unit. (10: set, 11: not set)		
5-803-082	RelayTransCov OP Detect/LeftTransCov OP Sn	ENG	[0 or 1 / 0 / 1/step] 0: close 1: open
	Detects open/close of the relay exit cover open/close sensor (bridge unit) and the left transport cover open/close sensor (left exit tray). (0: close, 1: open)		
5-803-083	RelayPprExitCovOP Detect/UpperTransCovOP Sn	ENG	[0 or 1 / 0 / 1/step] 0: close 1: open
	Detects open/close of the relay exit cover open/close sensor (bridge unit) and the upper transport cover open/close sensor (left exit tray). (0: close, 1: open)		
5-803-084	Shift Tray Set Detection Mechanism	ENG	[0 or 1 / 0 / 1/step] 01: set 11: not set
	Detects that shift tray is set to main unit. (01: set, 11: not set)		

Input Check Table

5-803-085	Shift Tray: Position Sensor 1	ENG	[0 or 1 / 0 / 1/step] 0: Stop on this side. during moving towards inner 1: Stop on inner side. during moving towards this side
	Detects shift tray position. (0: Stop on this side. during moving towards inner, 1: Stop on inner side. during moving towards this side)		
5-803-094	GAVD Open/Close Detection	ENG	[0 or 1 / 0 / 1/step]
	For checking door open/close during process. No need to operate.		
5-803-095	Relay Fuse Blown Detection +24V	ENG	[0 or 1 / 0 / 1/step] 0: Not cut 1: Cut
	Detects state of 24V fuse on the bridge unit. (0: Not cut, 1: Cut)		
5-803-096	Relay Fuse Blown Detection +5V	ENG	[0 or 1 / 0 / 1/step] 0: Not cut 1: Cut
	Detects state of 5V fuse on the bridge unit. (0: Not cut, 1: Cut)		
5-803-100	PCB Ver Management	ENG	[0 to 31 / 0 / 1/step]
	Displays PCB version management ID. Displays in order of ID0, ID1, ID2, ID3, ID4 from the left.		
5-803-101	Tray 1 Size Switch	ENG	[0 to 15 / 0 / 1/step]
	Value changes depending on paper size of tray 1.		
5-803-102	Controller Fan:Lock	ENG	[0 or 1 / 0 / 1/step] 0: Running 1: Stopped, or locked
	Detects CTL fan lock status.		

5-803-200	HP Sensor	ENG	[0 or 1 / 0 / 1/step]
	Tests the scanner HP sensor.		
5-803-201	Platen Cover Sensor	ENG	[0 or 1 / 0 / 1/step]
	Tests the book open/close sensor.		
5803	[INPUT Check]		
	Gets information of specified sensor.		
5-803-211	Bank: Tray3: Feed Sensor	ENG	[0 or 1 / 0 / 1/step] 0: paper not detected 1: paper detected.
5-803-212	Bank: Tray4: Feed Sensor	ENG	
5-803-213	Bank: Tray5: Feed Sensor	ENG	
5-803-214	Bank: Tray3: Transport Sensor	ENG	
5-803-215	Bank: Tray4: Transport Sensor	ENG	
5-803-216	Bank: Tray5: Transport Sensor	ENG	
5-803-217	Bank: Feed Cover Open Detection 1	ENG	[0 or 1 / 0 / 1/step] 0: cover open 1: cover closed
5-803-218	Bank: Feed Cover Open Detection 2	ENG	
5-803-219	LCT Paper Supply Open/Close	ENG	
5-803-220	LCT Slide Open/Close	ENG	[0 or 1 / 0 / 1/step] 0: slide open 1: slide closed

5.17.2 ADF D779 – INPUT CHECK

6007	[ADF INPUT Check]		
	Gets sensor information from ADF. Displays signal level of sensor as it is.		
6-007-001	Original Length 1 (B5 Detection Sensor)	ENG	[0 or 1 / 0 / 1/step]
6-007-002	Original Length 2 (A4 Detection Sensor)	ENG	[0 or 1 / 0 / 1/step]
6-007-003	Original Length 3 (LG Detection Sensor)	ENG	[0 or 1 / 0 / 1/step]
6-007-004	Original Width 1	ENG	[0 or 1 / 0 / 1/step]
6-007-005	Original Width 2	ENG	[0 or 1 / 0 / 1/step]
6-007-006	Original Width 3	ENG	[0 or 1 / 0 / 1/step]
6-007-007	Original Width 4	ENG	[0 or 1 / 0 / 1/step]
6-007-008	Original Width 5	ENG	[0 or 1 / 0 / 1/step]
6-007-009	Original Detection	ENG	[0 or 1 / 0 / 1/step]
6-007-011	Skew Correction	ENG	[0 or 1 / 0 / 1/step]
6-007-013	Registration Sensor	ENG	[0 or 1 / 0 / 1/step]
6-007-014	Exit Sensor	ENG	[0 or 1 / 0 / 1/step]
6-007-015	Feed Cover Sensor	ENG	[0 or 1 / 0 / 1/step]
6-007-016	Lift Up Sensor	ENG	[0 or 1 / 0 / 1/step]
6-007-023	Rear Edge Detection	ENG	[0 or 1 / 0 / 1/step]

5.17.3 1-PASS ADF D683 – INPUT CHECK

6011	[1-Pass ADF INPUT Check]		
	For Single-Pass simultaneous duplex models only.		
6-011-001	Original Length 1 (B5 Sensor)	ENG	[0 or 1 / 0 / 1/step]
	Gets sensor information from ADF. Gives 1 when there is a paper at sensor area.		
6-011-002	Original Length 2 (A4 Sensor)	ENG	[0 or 1 / 0 / 1/step]
	Gets sensor information from ADF. Gives 1 when there is a paper at sensor area.		
6-011-003	Original Length 3 (LG Sensor)	ENG	[0 or 1 / 0 / 1/step]
	Gets sensor information from ADF. Gives 1 when there is a paper at sensor area.		
6-011-004	Original Width 1	ENG	[0 or 1 / 0 / 1/step]
	Gets sensor information from ADF. Gives 1 when there is a paper at sensor area.		
6-011-005	Original Width 2	ENG	[0 or 1 / 0 / 1/step]
	Gets sensor information from ADF. Gives 1 when there is a paper at sensor area.		
6-011-006	Original Width 3	ENG	[0 or 1 / 0 / 1/step]
	Gets sensor information from ADF. Gives 1 when there is a paper at sensor area.		

Input Check Table

6-011-007	Original Width 4	ENG	[0 or 1 / 0 / 1/step]
	Gets sensor information from ADF. Gives 1 when there is a paper at sensor area.		
6-011-008	Original Width 5	ENG	[0 or 1 / 0 / 1/step]
	Gets sensor information from ADF. Gives 1 when there is a paper at sensor area.		
6-011-009	Original Detection	ENG	[0 or 1 / 0 / 1/step]
	Gets sensor information from ADF. Gives 1 when original is set.		
6-011-010	Separation Sensor	ENG	[0 or 1 / 0 / 1/step]
	Gets sensor information from ADF. Gives 1 when there is a paper at sensor area.		
6-011-011	Skew Correction	ENG	[0 or 1 / 0 / 1/step]
	Gets sensor information from ADF. Gives 1 when there is a paper at sensor area.		
6-011-012	Scan Entrance Sensor	ENG	[0 or 1 / 0 / 1/step]
	Gets sensor information from ADF. Gives 1 when there is a paper at sensor area.		
6-011-013	Registration Sensor	ENG	[0 or 1 / 0 / 1/step]
	Gets sensor information from ADF. Gives 1 when there is a paper at sensor area.		
6-011-014	Exit Sensor	ENG	[0 or 1 / 0 / 1/step]
	Gets sensor information from ADF. Gives 1 when there is a paper at sensor area.		

6-011-015	Feed Cover Sensor	ENG	[0 or 1 / 0 / 1/step]
	Gets sensor information from ADF. Gives 1 when cover is open.		
6-011-016	Lift Up Sensor	ENG	[0 or 1 / 0 / 1/step]
	Gets sensor information from ADF. Gives 1 when lift up.		
6-011-018	Pick-Up Roller HP Sensor	ENG	[0 or 1 / 0 / 1/step]
	Gets sensor information from ADF. Gives 1 when pick up roller is not in home position.		
6-011-021	Bottom Plate HP Sensor	ENG	[0 or 1 / 0 / 1/step]
	Gets sensor information from ADF. Gives 1 when bottom plate is not in home position.		
6-011-022	Bottom Plate Position Sensor	ENG	[0 or 1 / 0 / 1/step]
	Gets sensor information from ADF. Gives 1 when pick up roller is not in the correct position.		
6-011-023	Original Length 4 (LT/A4 Tail Sensor)	ENG	[0 or 1 / 0 / 1/step]
	Gets sensor information from ADF. Gives 1 when there is a paper at sensor area.		

5.17.4 2000/3000 SHEETS FINISHER D688 / D689 – INPUT CHECK

6123	[INPUT Check: 2K/3K FIN]		
6-123-001	Entrance Sensor	ENG	[0 or 1 / 0 / 1/step]
	Gets information of specified sensor. Displays signal level of sensor as it is.		
6-123-002	Horizontal Transport Sensor	ENG	[0 or 1 / 0 / 1/step]
	Gets information of specified sensor. Displays signal level of sensor as it is.		
6-123-003	Switchback Transport Sensor	ENG	[0 or 1 / 0 / 1/step]
	Gets information of specified sensor. Displays signal level of sensor as it is.		
6-123-004	Proof Tray Exit Sensor	ENG	[0 or 1 / 0 / 1/step]
	Gets information of specified sensor. Displays signal level of sensor as it is.		
6-123-005	Shift Tray Exit Sensor	ENG	[0 or 1 / 0 / 1/step]
	Gets information of specified sensor. Displays signal level of sensor as it is.		
6-123-006	Booklet Stapler Exit Sensor	ENG	[0 or 1 / 0 / 1/step]
	Gets information of specified sensor. Displays signal level of sensor as it is.		
6-123-007	Paper Exit Open/Close Guide HP Sensor	ENG	[0 or 1 / 0 / 1/step]
	Gets information of specified sensor. Displays signal level of sensor as it is.		
6-123-008	Punch HP Sensor	ENG	[0 or 1 / 0 / 1/step]
	Gets information of specified sensor. Displays signal level of sensor as it is.		
6-123-009	Punch Move HP Sensor	ENG	[0 or 1 / 0 / 1/step]
	Gets information of specified sensor. Displays signal level of sensor as it is.		

6-123-010	S-to-S Registration Detection HP Sensor	ENG	[0 or 1 / 0 / 1/step]
	Gets information of specified sensor. Displays signal level of sensor as it is.		
6-123-011	Lower Junction Solenoid HP Sensor	ENG	[0 or 1 / 0 / 1/step]
	Gets information of specified sensor. Displays signal level of sensor as it is.		
6-123-012	Jogger HP Sensor	ENG	[0 or 1 / 0 / 1/step]
	Gets information of specified sensor. Displays signal level of sensor as it is.		
6-123-013	Positioning Roller HP Sensor	ENG	[0 or 1 / 0 / 1/step]
	Gets information of specified sensor. Displays signal level of sensor as it is.		
6-123-014	Feed-out HP Sensor	ENG	[0 or 1 / 0 / 1/step]
	Gets information of specified sensor. Displays signal level of sensor as it is.		
6-123-015	Stapler Moving HP Sensor	ENG	[0 or 1 / 0 / 1/step]
	Gets information of specified sensor. Displays signal level of sensor as it is.		
6-123-016	Booklet Stapler HP Sensor	ENG	[0 or 1 / 0 / 1/step]
	Gets information of specified sensor. Displays signal level of sensor as it is.		
6-123-017	Booklet Jogger HP Sensor	ENG	[0 or 1 / 0 / 1/step]
	Gets information of specified sensor. Displays signal level of sensor as it is.		
6-123-018	Booklet Jog Solenoid HP Sensor	ENG	[0 or 1 / 0 / 1/step]
	Gets information of specified sensor. Displays signal level of sensor as it is.		

Input Check Table

6-123-019	Booklet Standard Fence HP Sensor	ENG	[0 or 1 / 0 / 1/step]
	Gets information of specified sensor. Displays signal level of sensor as it is.		
6-123-020	Booklet Stapler HP Sensor	ENG	[0 or 1 / 0 / 1/step]
	Gets information of specified sensor. Displays signal level of sensor as it is.		
6-123-022	Folder Blade Cam HP Sensor	ENG	[0 or 1 / 0 / 1/step]
	Gets information of specified sensor. Displays signal level of sensor as it is.		
6-123-023	Folder Blade HP Sensor	ENG	[0 or 1 / 0 / 1/step]
	Gets information of specified sensor. Displays signal level of sensor as it is.		
6-123-024	Shift Roller HP Sensor	ENG	[0 or 1 / 0 / 1/step]
	Gets information of specified sensor. Displays signal level of sensor as it is.		
6-123-025	Shift Jogger HP Sensor: Front	ENG	[0 or 1 / 0 / 1/step]
	Gets information of specified sensor. Displays signal level of sensor as it is. * Not Use: Currently, Booklet Finisher SR3170 (D688) / Finisher SR3160 (D689) do not have setting jogger in system configuration.		
6-123-026	Shift Jogger HP Sensor: Rear	ENG	[0 or 1 / 0 / 1/step]
	Gets information of specified sensor. Displays signal level of sensor as it is. * Not Use: Currently, Booklet Finisher SR3170 (D688) / Finisher SR3160 (D689) do not have setting jogger in system configuration.		
6-123-027	Shift Jogger Retraction HP Sensor	ENG	[0 or 1 / 0 / 1/step]
	Gets information of specified sensor. Displays signal level of sensor as it is. * Not Use: Currently, Booklet Finisher SR3170 (D688) / Finisher SR3160 (D689) do not have setting jogger in system configuration.		

6-123-028	Drag Roller Vibrating HP Sensor	ENG	[0 or 1 / 0 / 1/step]
	Gets information of specified sensor. Displays signal level of sensor as it is.		
6-123-029	LE Guide HP Sensor	ENG	[0 or 1 / 0 / 1/step]
	Gets information of specified sensor. Displays signal level of sensor as it is.		
6-123-030	TE Stack Plate HP Sensor	ENG	[0 or 1 / 0 / 1/step]
	Gets information of specified sensor. Displays signal level of sensor as it is.		
6-123-031	Staple Tray Paper Sensor	ENG	[0 or 1 / 0 / 1/step]
	Gets information of specified sensor. Displays signal level of sensor as it is.		
6-123-032	ITB Paper Sensor	ENG	[0 or 1 / 0 / 1/step]
	Gets information of specified sensor. Displays signal level of sensor as it is.		
6-123-033	Booklet Stapler Transport Paper Sn: Upper	ENG	[0 or 1 / 0 / 1/step]
	Gets information of specified sensor. Displays signal level of sensor as it is.		
6-123-034	Booklet Stapler Transport Paper Sn: Lower	ENG	[0 or 1 / 0 / 1/step]
	Gets information of specified sensor. Displays signal level of sensor as it is.		
6-123-035	Paper Height Sensor: Shift	ENG	[0 or 1 / 0 / 1/step]
	Gets information of specified sensor. Displays signal level of sensor as it is.		
6-123-036	Corner Stapler Paper Height Sensor 1	ENG	[0 or 1 / 0 / 1/step]
	Gets information of specified sensor. Displays signal level of sensor as it is.		
6-123-037	Corner Stapler Paper Height Sensor 2	ENG	[0 or 1 / 0 / 1/step]
	Gets information of specified sensor. Displays signal level of sensor as it is.		

Input Check Table

6-123-038	Proof Tray Full Sensor	ENG	[0 or 1 / 0 / 1/step]
	Gets information of specified sensor. Displays signal level of sensor as it is.		
6-123-039	Booklet Stapler Full Sensor 1	ENG	[0 or 1 / 0 / 1/step]
	Gets information of specified sensor. Displays signal level of sensor as it is.		
6-123-040	Booklet Stapler Full Sensor 2	ENG	[0 or 1 / 0 / 1/step]
	Gets information of specified sensor. Displays signal level of sensor as it is.		
6-123-041	S-to-S Registration Detection Sensor	ENG	[0 or 1 / 0 / 1/step]
	Gets information of specified sensor. Displays signal level of sensor as it is.		
6-123-042	Punch RPS Sensor	ENG	[0 or 1 / 0 / 1/step]
	Gets information of specified sensor. Displays signal level of sensor as it is.		
6-123-043	Corner Stapler Leading Edge Detection Sensor	ENG	[0 or 1 / 0 / 1/step]
	Gets information of specified sensor. Displays signal level of sensor as it is.		
6-123-044	Corner Stapler Staple End Sensor	ENG	[0 or 1 / 0 / 1/step]
	Gets information of specified sensor. Displays signal level of sensor as it is.		
6-123-045	Booklet Stapler Staple End Sensor: Front	ENG	[0 or 1 / 0 / 1/step]
	Gets information of specified sensor. Displays signal level of sensor as it is.		
6-123-046	Booklet Stapler Staple End Sensor: Rear	ENG	[0 or 1 / 0 / 1/step]
	Gets information of specified sensor. Displays signal level of sensor as it is.		

6-123-047	Shift Tray Lower Limit Sensor 1	ENG	[0 or 1 / 0 / 1/step]
	Gets information of specified sensor. Displays signal level of sensor as it is.		
6-123-048	Shift Tray Lower Limit Sensor 2	ENG	[0 or 1 / 0 / 1/step]
	Gets information of specified sensor. Displays signal level of sensor as it is.		
6-123-049	Shift Tray Lower Limit Sensor 3	ENG	[0 or 1 / 0 / 1/step]
	Gets information of specified sensor. Displays signal level of sensor as it is.		
6-123-050	Shift Tray Lower Limit Sensor 4	ENG	[0 or 1 / 0 / 1/step]
	Gets information of specified sensor. Displays signal level of sensor as it is.		
6-123-051	Shift Tray Lower Limit Sensor 5	ENG	[0 or 1 / 0 / 1/step]
	Gets information of specified sensor. Displays signal level of sensor as it is.		
6-123-052	Punch Chad Full Sensor	ENG	[0 or 1 / 0 / 1/step]
	Gets information of specified sensor. Displays signal level of sensor as it is.		
6-123-053	Punch Set Detection	ENG	[0 or 1 / 0 / 1/step] 0: connected 1: not connected
	Gets connection status of punch unit.		
6-123-054	Shift Jogger Set Detection	ENG	[0 or 1 / 0 / 1/step] 0: connected 1: not connected
	Gets connection status of setting jogger unit. * Not Use: Currently, Booklet Finisher SR3170 (D688) / Finisher SR3160 (D689) do not have setting jogger in system configuration.		

Input Check Table

6-123-055	Booklet Stapler Set Detection	ENG	[0 or 1 / 0 / 1/step] 0: not connected 1: connected
	Gets connection status of saddle stitch unit.		
6-123-056	Front Door SW	ENG	[0 or 1 / 0 / 1/step]
	Gets information of specified switch. Displays signal level of switch as it is.		
6-123-057	Dynamic Roller Open/Close Guide Plate Sensor	ENG	[0 or 1 / 0 / 1/step]
	Gets information of specified switch. Displays signal level of switch as it is.		
6-123-058	Tray Upper Limit SW	ENG	[0 or 1 / 0 / 1/step]
	Gets information of specified switch. Displays signal level of switch as it is.		
6-123-059	Paper Exit Open/Close Guide Plate Limit SW	ENG	[0 or 1 / 0 / 1/step]
	Gets information of specified switch. Displays signal level of switch as it is.		
6-123-060	Punch Selection DIPSW 1	ENG	[0 or 1 / 0 / 1/step]
	Gets information of specified switch. Displays signal level of switch as it is.		
6-123-061	Punch Selection DIPSW 2	ENG	[0 or 1 / 0 / 1/step]
	Gets information of specified switch. Displays signal level of switch as it is.		

5.17.5 INTERNAL FINISHER D690 – INPUT CHECK

6135	[INPUT Check: FrontFIN]		
	Gets information of specified sensor. Displays signal level of sensor as it is.		
6-135-001	Entrance Sensor	ENG	[0 or 1 / 0 / 1/step]
6-135-002	Carry Sensor	ENG	[0 or 1 / 0 / 1/step]
6-135-003	Exit Sensor	ENG	[0 or 1 / 0 / 1/step]
6-135-004	Staple Tray Paper Sensor	ENG	[0 or 1 / 0 / 1/step]
6-135-005	Front Jogger HP Sensor	ENG	[0 or 1 / 0 / 1/step]
6-135-006	Rear Jogger HP Sensor	ENG	[0 or 1 / 0 / 1/step]
6-135-007	Sft Roller HP Sensor	ENG	[0 or 1 / 0 / 1/step]
6-135-008	Hitroll HP Sensor	ENG	[0 or 1 / 0 / 1/step]
6-135-009	Ext Guide Plate HP Sensor	ENG	[0 or 1 / 0 / 1/step]
6-135-010	Staple Moving HP Sensor	ENG	[0 or 1 / 0 / 1/step]
6-135-011	Shift Tray Paper Sensor	ENG	[0 or 1 / 0 / 1/step]
6-135-012	Shift Tray Limit Sensor	ENG	[0 or 1 / 0 / 1/step]
6-135-013	Staple Rotation Sensor	ENG	[0 or 1 / 0 / 1/step]
6-135-014	Staple Near End Sensor	ENG	[0 or 1 / 0 / 1/step]
6-135-015	Self Priming Sensor	ENG	[0 or 1 / 0 / 1/step]
6-135-016	Stopper HP Sensor	ENG	[0 or 1 / 0 / 1/step]
6-135-017	Punch HP Sensor	ENG	[0 or 1 / 0 / 1/step]
6-135-018	Punch Pluse Count Sensor	ENG	[0 or 1 / 0 / 1/step]

Input Check Table

6-135-019	Punch Chad Full Sensor	ENG	[0 or 1 / 0 / 1/step]
6-135-020	Punch Moving HP Sensor	ENG	[0 or 1 / 0 / 1/step]
6-135-021	Punch Registration Detection HP Sensor	ENG	[0 or 1 / 0 / 1/step]
6-135-022	Punch Registration Detection Sensor	ENG	[0 or 1 / 0 / 1/step]
6135	[INPUT Check: FrontFIN]		
	Gets information of specified switch. Displays signal level of switch as it is.		
6-135-023	Slide Door SW	ENG	[0 or 1 / 0 / 1/step]
6-135-024	Shift Tray Upper Limit SW	ENG	[0 or 1 / 0 / 1/step]

5.17.6 1000 SHEETS FINISHER D687 – INPUT CHECK

6161	[FIN (1K FIN) INPUT Check]		
	Gets information of specified sensor. Displays signal level of sensor as it is.		
6-161-001	Entrance Sensor	ENG	[0 or 1 / 0 / 1/step]
6-161-002	Upper Cover Open/Close Sensor	ENG	[0 or 1 / 0 / 1/step]
6-161-003	Proof Tray Exit Sensor	ENG	[0 or 1 / 0 / 1/step]
6-161-004	Proof Tray Full Sensor	ENG	[0 or 1 / 0 / 1/step]
6-161-005	Shift HP Sensor	ENG	[0 or 1 / 0 / 1/step]
6-161-006	Exit Guide Plate Open/Close HP Sensor	ENG	[0 or 1 / 0 / 1/step]
6-161-007	Shift Paper Exit (Lift Tray Exit) Sensor	ENG	[0 or 1 / 0 / 1/step]
6-161-008	Positioning Roller HP Sensor	ENG	[0 or 1 / 0 / 1/step]

6-161-009	Lift Tray Paper Sensor	ENG	[0 or 1 / 0 / 1/step]
6-161-010	Jogger HP Sensor	ENG	[0 or 1 / 0 / 1/step]
6-161-011	Feed Out HP Sensor	ENG	[0 or 1 / 0 / 1/step]
6-161-012	Lift Tray Lower Limit Sensor (Upper)	ENG	[0 or 1 / 0 / 1/step]
6-161-013	Lift Tray Lower Limit Sensor (Lower)	ENG	[0 or 1 / 0 / 1/step]
6-161-014	Staple Tray Paper Sensor	ENG	[0 or 1 / 0 / 1/step]
6-161-015	Stapler Moving HP Sensor	ENG	[0 or 1 / 0 / 1/step]
6-161-016	Near End Sensor (Common: Corner/Bklt Stplr)	ENG	[0 or 1 / 0 / 1/step]
6-161-017	Self Priming Sensor (Common:Crnr/Bklt Stplr)	ENG	[0 or 1 / 0 / 1/step]
6-161-018	Driver HP Sensor (Corner/Booklet Stapler)	ENG	[0 or 1 / 0 / 1/step]
6-161-019	Driver Timing Sensor(Corner/Booklet Stapler)	ENG	[0 or 1 / 0 / 1/step]
6-161-020	Clincher HP Sensor (Corner/Booklet Stapler)	ENG	[0 or 1 / 0 / 1/step]
6-161-021	Clincher Timing Sensor (Corner/Bklt Stapler)	ENG	[0 or 1 / 0 / 1/step]
6-161-022	Stapler Retraction Sensor	ENG	[0 or 1 / 0 / 1/step]
6-161-023	Punch HP Sensor	ENG	[0 or 1 / 0 / 1/step]
6-161-024	Punch RP Sensor	ENG	[0 or 1 / 0 / 1/step]
6-161-025	Punch Hopper Full Sensor	ENG	[0 or 1 / 0 / 1/step]

Input Check Table

6-161-026	Punch Move HP Sensor	ENG	[0 or 1 / 0 / 1/step]
6-161-027	S-to-S Registration Detection HP Sensor	ENG	[0 or 1 / 0 / 1/step]
6-161-028	S-to-S Registration Detection Sensor	ENG	[0 or 1 / 0 / 1/step]
6161	[FIN (1K FIN) INPUT Check]		
	Gets information of specified switch. Displays signal level of switch as it is.		
6-161-029	Punch Selection DIPSW 1	ENG	[0 or 1 / 0 / 1/step]
6-161-030	Punch Selection DIPSW 2	ENG	[0 or 1 / 0 / 1/step]
6161	[FIN (1K FIN) INPUT Check]		
	Gets information of specified sensor. Displays signal level of sensor as it is.		
6-161-031	ITB Transport Sensor: Right	ENG	[0 or 1 / 0 / 1/step]
6-161-032	ITB Transport Sensor: Left	ENG	[0 or 1 / 0 / 1/step]
6-161-033	Stack Transport Sensor	ENG	[0 or 1 / 0 / 1/step]
6-161-034	Stack Trans Upper Pressure Release HP Sensor	ENG	[0 or 1 / 0 / 1/step]
6-161-035	Stack Trans Lower Pressure Release HP Sensor	ENG	[0 or 1 / 0 / 1/step]
6-161-036	Fold Blade HP Sensor	ENG	[0 or 1 / 0 / 1/step]
6-161-037	Fold Cam HP Sensor	ENG	[0 or 1 / 0 / 1/step]
6-161-038	TE Stopper Transport Sensor	ENG	[0 or 1 / 0 / 1/step]

6-161-039	TE Stopper HP Sensor	ENG	[0 or 1 / 0 / 1/step]
6-161-040	Booklet Folder Exit Sensor	ENG	[0 or 1 / 0 / 1/step]
6-161-041	Booklet Folder Tray Full Sensor: Upper	ENG	[0 or 1 / 0 / 1/step]
6-161-042	Booklet Folder Tray Full Sensor: Lower	ENG	[0 or 1 / 0 / 1/step]
6161	[FIN (1K FIN) INPUT Check]		
	Gets information of specified switch. Displays signal level of switch as it is.		
6-161-043	Door Open/Close SW	ENG	[0 or 1 / 0 / 1/step]
6-161-044	Lift Tray Upper Limit SW	ENG	[0 or 1 / 0 / 1/step]

5.17.7 BRIDGE UNIT D685 – INPUT CHECK

6170	[Bridge: INPUT Check]		
6-170-001	Bridge Exit Sensor	ENG	[0 or 1 / 0 / 1/step]
	Gets information from sensor (relay paper exit sensor... internal paper exit part) of bridge unit.		
6-170-002	Bridge Relay Sensor	ENG	[0 or 1 / 0 / 1/step]
	Gets information from sensor (relay carry sensor... relay carry to finisher) of bridge unit.		
6-170-003	Bridge Set Detection	ENG	[0 or 1 / 0 / 1/step]
	Gets connection information of bridge unit and main unit. When connected, 1.		
6-170-004	Bridge Exit Cover	ENG	[0 or 1 / 0 / 1/step]
	Gets micro SW information of bridge unit. When cover open, 1. Main unit paper exit cover.		
6-170-005	Bridge Relay Cover	ENG	[0 or 1 / 0 / 1/step]
	Gets micro SW information of bridge unit. When cover open, 1. Finisher side cover.		

5.17.8 INTERNAL FINISHER D766 – INPUT CHECK

6184	[Input Check:NoStpIBindFIN]		
6-184-001	Entrance Sensor	ENG	[0 or 1 / 0 / 1/step]
	Gets the entrance sensor information of non staple finisher. (0: Sensor Off, 1: Sensor On)		
6-184-002	Exit Sensor	ENG	[0 or 1 / 0 / 1/step]
	Gets the paper exit sensor information of non staple finisher. (0: Sensor Off, 1: Sensor On)		
6-184-003	Horizontal Registration Detection Sensor	ENG	[0 or 1 / 0 / 1/step]
	Gets the horizontal registration sensor information of non staple finisher. (0: Sensor Off, 1: Sensor On)		
6-184-004	Shift HP Sensor	ENG	[0 or 1 / 0 / 1/step]
	Gets the shift HP sensor information of non staple finisher. (0: Sensor Off, 1: Sensor On)		
6-184-005	Junction Solenoid HP Sensor	ENG	[0 or 1 / 0 / 1/step]
	Gets the junction solenoid HP sensor information of non staple finisher. (0: Sensor Off, 1: Sensor On, "0" appears if sensor detects home position)		
6-184-006	Exit Pressure Release HP Sensor	ENG	[0 or 1 / 0 / 1/step]
	Gets the exit pressure release HP sensor information of non staple finisher. (0: Sensor Off, 1: Sensor On)		
6-184-007	Stapler HP Sensor	ENG	[0 or 1 / 0 / 1/step]
	Gets the stapler HP sensor information of non staple finisher. (0: Sensor Off, 1: Sensor On, "0" appears if sensor detects home position)		
6-184-008	Tray Full Detection Sensor 1	ENG	[0 or 1 / 0 / 1/step]
	Gets the tray full detection sensor 1 information of non staple finisher. (0: Paper overflow)		

Input Check Table

6-184-009	Tray Full Detection Sensor 2	ENG	[0 or 1 / 0 / 1/step]
	Gets the tray full detection sensor 2 information of non staple finisher. (0: Paper overflow)		
6-184-010	Slide Door Open/Close Door SW	ENG	[0 or 1 / 0 / 1/step]
	Gets the slide door switch information of non staple finisher. (0: Close, 1: Open)		

5.17.9 INTERNAL SHIFT TRAY D691 – INPUT CHECK

6172	[Shift Tray: INPUT Check]		
6-172-001	Shift Tray Set Detection	ENG	[0 or 1 / 0 / 1/step]
	Gets connection information of shift tray and main unit. When connected, 1.		
6-172-002	Shift Tray Position Sensor	ENG	[0 or 1 / 0 / 1/step]
	Gets shift tray position sensor information.		

5.17.101 BIN TRAY D692 – INPUT CHECK

6174	[1 Bin: INPUT Check]		
6-174-001	1 Bin Set Detection	ENG	[0 or 1 / 0 / 1/step]
	Gets connection information of 1 bin and main unit. When connected, 1.		
6-174-002	1bin Paper Detection Sensor	ENG	[0 or 1 / 0 / 1/step]
	Gets paper existence sensor information from 1 bin.		

5.18 OUTPUT CHECK TABLE

5.18.1 MAIN MACHINE – OUTPUT CHECK

5804	[OUTPUT Check]		
5-804-001	Tray 1 Pickup Solenoid	ENG	[0 or 1 / 0 / 1/step]
	Moves 1st paper feed tray pick up solenoid.		
5-804-002	Tray 2 Pickup Solenoid	ENG	[0 or 1 / 0 / 1/step]
	Moves 2nd paper feed tray pick up solenoid.		
5-804-003	Bypass Pickup Solenoid	ENG	[0 or 1 / 0 / 1/step]
	Moves bypass pick up solenoid.		
5-804-004	Paper Exit Junction Gate Solenoid	ENG	[0 or 1 / 0 / 1/step]
	Moves output paper divide solenoid.		
5804	[OUTPUT Check]		
	Moves paper feed tray rising motor.		
5-804-005	Tray 1 Lift Motor:CW	ENG	[0 or 1 / 0 / 1/step]
5-804-006	Tray 1 Lift Motor:CCW	ENG	
5-804-007	Tray 2 Lift Motor:CW	ENG	
5-804-008	Tray 2 Lift Motor:CCW	ENG	
5804	[OUTPUT Check]		
	Moves register motor.		
5-804-009	Registration Motor:CCW:Std Speed	ENG	[0 or 1 / 0 / 1/step]
5-804-010	Registration Motor:CCW:Mid Speed	ENG	
5-804-011	Registration Motor:CCW:Low Speed	ENG	

Output Check Table

5-804-012	Registration Motor:CCW:Std Speed:IncSpd	ENG	[0 or 1 / 0 / 1/step]
5804	[OUTPUT Check]		
5-804-015	Registration Motor:CCW:Position Hold	ENG	[0 or 1 / 0 / 1/step]
	Holds position of register motor.		
5804	[OUTPUT Check]		
	Moves paper feed motor.		
5-804-016	Feed Motor:CW:Std Speed	ENG	[0 or 1 / 0 / 1/step]
5-804-017	Feed Motor:CW:Mid Speed	ENG	[0 or 1 / 0 / 1/step]
5-804-018	Feed Motor:CW:Low Speed	ENG	[0 or 1 / 0 / 1/step]
5-804-019	Feed Motor:CW:Std Speed:IncSpd	ENG	[0 or 1 / 0 / 1/step]
5-804-022	Feed Motor:CCW:Std Speed	ENG	[0 or 1 / 0 / 1/step]
5-804-023	Feed Motor:CCW:Mid Speed	ENG	[0 or 1 / 0 / 1/step]
5-804-024	Feed Motor:CCW:Low Speed	ENG	[0 or 1 / 0 / 1/step]
5-804-025	Feed Motor:CCW:Std Speed:IncSpd	ENG	[0 or 1 / 0 / 1/step]
5804	[OUTPUT Check]		
	Moves vertical carry motor.		
5-804-028	Vertical Transport Motor:CW:Std Speed	ENG	[0 or 1 / 0 / 1/step]
5-804-029	Vertical Transport Motor:CW:Mid Speed	ENG	
5-804-030	Vertical Transport Motor:CW:Low Speed	ENG	
5-804-031	Vertical Transport Motor:CW:Std Speed:IncSpd	ENG	[0 or 1 / 0 / 1/step]

5804	[OUTPUT Check]		
5-804-034	Vertical Transport Motor:Position Hold	ENG	[0 or 1 / 0 / 1/step]
	Holds position of vertical carry motor.		
5804	[OUTPUT Check]		
	Moves paper exit motor.		
5-804-041	Paper Exit Motor:CW:Std Speed	ENG	[0 or 1 / 0 / 1/step]
5-804-042	Paper Exit Motor:CW:Mid Speed	ENG	
5-804-043	Paper Exit Motor:CW:Low Speed	ENG	
5-804-044	Paper Exit Motor:CW:Std Speed:IncSpd		
5804	[OUTPUT Check]		
	Moves inverter motor.		
5-804-047	Inverter Motor:CW:Std Speed	ENG	[0 or 1 / 0 / 1/step]
5-804-048	Inverter Motor:CW:Mid Speed	ENG	[0 or 1 / 0 / 1/step]
5-804-049	Inverter Motor:CW:Low Speed	ENG	[0 or 1 / 0 / 1/step]
5-804-052	Inverter Motor:CW:Std Speed:Feed Speed	ENG	[0 or 1 / 0 / 1/step]
5-804-054	Inverter Motor:CW:Low Speed:Feed Speed	ENG	[0 or 1 / 0 / 1/step]
5-804-055	Inverter Motor:CW:Mid Speed:Feed Speed	ENG	[0 or 1 / 0 / 1/step]
5-804-056	Inverter Motor:CCW:Std Speed	ENG	[0 or 1 / 0 / 1/step]
5-804-057	Inverter Motor:CCW:Mid Speed	ENG	[0 or 1 / 0 / 1/step]
5-804-058	Inverter Motor:CCW:Low Speed	ENG	[0 or 1 / 0 / 1/step]
5-804-061	Inverter Motor:CCW:Std Speed:IncSpd	ENG	[0 or 1 / 0 / 1/step]

Output Check Table

5-804-062	Inverter Motor:CCW:Mid Speed:IncSpd	ENG	[0 or 1 / 0 / 1/step]
5-804-063	Inverter Motor:CCW:Low Speed:IncSpd	ENG	[0 or 1 / 0 / 1/step]
5804	[OUTPUT Check]		
	Moves duplex entrance motor.		
5-804-065	Duplex Entrance Motor:CW:Std Speed	ENG	[0 or 1 / 0 / 1/step]
5-804-066	Duplex Entrance Motor:CW:Mid Speed	ENG	
5-804-067	Duplex Entrance Motor:CW:Low Speed	ENG	
5-804-068	Duplex Entrance Motor:CW:Std Speed:FeedSpeed	ENG	
5-804-069	Duplex Entrance Motor:CW:Low Speed:FeedSpeed	ENG	
5-804-070	Duplex Entrance Motor:CW:Std Speed:IncSpd	ENG	
5804	[OUTPUT Check]		
	Moves duplex bypass motor.		
5-804-071	Duplex Bypass Motor:CW:Std Speed	ENG	[0 or 1 / 0 / 1/step]
5-804-072	Duplex Bypass Motor:CW:Mid Speed	ENG	[0 or 1 / 0 / 1/step]
5-804-073	Duplex Bypass Motor:CW:Low Speed	ENG	[0 or 1 / 0 / 1/step]
5-804-074	Duplex Bypass Motor:CW:Std Speed:Feed Speed	ENG	[0 or 1 / 0 / 1/step]
5-804-075	Duplex Bypass Motor:CW:Low Speed:Feed Speed	ENG	[0 or 1 / 0 / 1/step]
5-804-077	Duplex Bypass Motor:CCW:Std Speed	ENG	[0 or 1 / 0 / 1/step]
5-804-078	Duplex Bypass Motor:CCW:Mid Speed	ENG	[0 or 1 / 0 / 1/step]
5-804-079	Duplex Bypass Motor:CCW:Low Speed	ENG	[0 or 1 / 0 / 1/step]

5-804-080	Duplex Bypass Motor:CCW:Std Speed:Feed Speed	ENG	[0 or 1 / 0 / 1/step]
5-804-081	Duplex Bypass Motor:CCW:Low Speed:Feed Speed	ENG	[0 or 1 / 0 / 1/step]
5-804-082	Duplex Bypass Motor:CW:Std Speed:IncSpd	ENG	[0 or 1 / 0 / 1/step]
5804	[OUTPUT Check]		
5-804-083	Duplex Bypass Motor:Position Hold	ENG	[0 or 1 / 0 / 1/step]
	Holds position of duplex bypass motor.		
5804	[OUTPUT Check]		
	Moves fusing motor. *See Important below		
5-804-092	Fusing/Fusing Exit Motor:CCW:Std Speed	ENG	[0 or 1 / 0 / 1/step]
5-804-093	Fusing/Fusing Exit Motor:CCW:Mid Speed	ENG	
5-804-094	Fusing/Fusing Exit Motor:CCW:Low Speed	ENG	
5-804-098	Fusing/Fusing Exit Motor:CW:Low Speed	ENG	

Output Check Table

Important: Use the procedure below to do the output checks for the fusing exit motor. If you do not follow this procedure, a kink will form in the fusing belt sleeve, and the fusing sleeve belt unit will need to be replaced.

1. Do one of the following:

- Open the right cover of the paper bank
- Remove one of the toner bottles
- Pull out the waste toner bottle half-way
- Remove the fusing unit

2. Enter SP mode.

3. Do the following out output checks:

- SP5-804-092 (Fusing Motor: CW: Standard Speed)
- SP5-804-093 (Fusing Motor: CW: Middle Speed)
- SP5-804-094 (Fusing Motor: CW: Low Speed)
- SP5-804-098 (Fusing Motor: CCW: Low Speed)

4. **Without exiting SP mode**, turn the main power switch off and then on again.

Important: If you exit SP mode before you turn the main power switch off, the fusing exit motor will stay off when the machine warms up. Heat will be concentrated in one area of the fusing belt sleeve and cause a kink to form. If this happens, you will need to replace the fusing sleeve belt unit.

5. Do the reverse of what you did in step 1 (for example, reattach the fusing unit).

5804	[OUTPUT Check]		
5-804-104	Polygon Motor: L	ENG	[0 or 1 / 0 / 1/step]
	Runs motor with 30236 rpm.		
5-804-105	Polygon Motor: M	ENG	[0 or 1 / 0 / 1/step]
	Runs motor with 35433 rpm.		
5-804-106	Polygon Motor: H	ENG	[0 or 1 / 0 / 1/step]
	Runs motor with 38267 rpm.		
5-804-110	Fusing Fan: Full Speed	ENG	[0 or 1 / 0 / 1/step]
	Moves fusing exhaust heat fan.		
5-804-111	Fusing Fan: Half Speed	ENG	[0 or 1 / 0 / 1/step]
	Moves fusing exhaust heat fan.		

5-804-112	Dev Fan: Left/Toner Supply Cooling Fan	ENG	[0 or 1 / 0 / 1/step]
	Moves develop left exhaust air fan and toner supply cooling fan.		
5-804-113	PSU Cooling Fan	ENG	[0 or 1 / 0 / 1/step]
	Moves PSU cooling fan and exhaust heat fan.		
5-804-114	Toner Bottle Cooling Fan	ENG	[0 or 1 / 0 / 1/step]
	Moves ozone exhaust heat fan.		
5-804-115	Main Exhaust Fan:Half Speed	ENG	[0 or 1 / 0 / 1/step]
	Moves electric BOX cooling fan.		
5-804-116	Main Exhaust Fan:Full Speed	ENG	[0 or 1 / 0 / 1/step]
	Moves electric BOX cooling fan.		
5-804-118	Paper Exit Cooling Fan:Half Speed	ENG	[0 or 1 / 0 / 1/step]
	Moves paper exit cooling fan.		
5-804-119	Paper Exit Cooling Fan:Full Speed	ENG	[0 or 1 / 0 / 1/step]
	Moves develop solenoid.		
5804	[OUTPUT Check]		
	Moves develop motor.		
5-804-120	Development Motor:Std Speed	ENG	[0 or 1 / 0 / 1/step]
5-804-121	Development Motor:Mid Speed	ENG	[0 or 1 / 0 / 1/step]
5-804-122	Development Motor:Low Speed	ENG	[0 or 1 / 0 / 1/step]
5-804-124	Drum Motor:Std Speed	ENG	[0 or 1 / 0 / 1/step]
5-804-125	Drum Motor:Mid Speed	ENG	[0 or 1 / 0 / 1/step]
5-804-126	Drum Motor:Low Speed	ENG	[0 or 1 / 0 / 1/step]

Output Check Table

5804	[OUTPUT Check]		
	Moves paper transfer divide motor.		
5-804-140	Transfer Contact Motor:CW	ENG	[0 or 1 / 0 / 1/step]
5-804-141	Transfer Contact Motor:CCW	ENG	
5804	[OUTPUT Check]		
	Moves toner bottle drive motor.		
5-804-162	Toner Bottle Motor	ENG	[0 or 1 / 0 / 1/step]
5804	[OUTPUT Check]		
	Moves relay carry motor (bridge unit)/left paper exit carry motor (left paper exit tray).		
5-804-163	Bridge Relay/Left Paper Feed Motor:Std Speed	ENG	[0 or 1 / 0 / 1/step]
5-804-164	Bridge Relay/Left Paper Feed Motor:Mid Speed	ENG	
5-804-165	Bridge Relay/Left Paper Feed Motor:Low Speed	ENG	
5-804-166	BridgeRelay/LefExit Motor:Std Speed:IncSpd	ENG	
5804	[OUTPUT Check]		
5-804-169	BridgeRelay/LeftExit Junction Gate Solenoid	ENG	[0 or 1 / 0 / 1/step]
	Moves relay divide solenoid (bridge unit)/left paper exit divide solenoid (left paper exit tray).		
5-804-170	<Shift Tray> Lift Motor:CW	ENG	[0 or 1 / 0 / 1/step]
	Moves shift tray motor.		
5-804-171	<Shift Tray> Lift Motor:CCW	ENG	[0 or 1 / 0 / 1/step]
	Moves shift tray motor.		

5804	[OUTPUT Check]		
	Outputs PWM for electrify HVP (DC/AC)		
5-804-179	HVP/ChargeDC/(-):PWM	ENG	[0 or 1 / 0 / 1/step]
5804	[OUTPUT Check]		
	Outputs PWM for develop HVP.		
5-804-187	HVP/Development DC/(-):PWM	ENG	[0 or 1 / 0 / 1/step]
5804	[OUTPUT Check]		
	Outputs PWM for divide HVP.		
5-804-194	HVP/Separation DC/(-):PWM	ENG	[0 or 1 / 0 / 1/step]
5804	[OUTPUT Check]		
	Outputs PWM for transfer HVP (paper transfer: +/-).		
5-804-199	HVP/PTR DC/(+):PWM	ENG	[0 or 1 / 0 / 1/step]
5-804-200	HVP/PTR DC/(-):PWM	ENG	
5804	[OUTPUT Check]		
5-804-202	Scanner Lamp	ENG	[0 or 1 / 0 / 1/step]
	Checks output of scanner lamp. Use to check light source malfunction when SC101-01, SC101-02, SC102-00, SC142-00 occurs.		
5-804-206	Transfer Open/Close LED	ENG	[0 or 1 / 0 / 1/step]
	Lights paper transfer open/close LED.		
5-804-209	ID Sensor	ENG	[0 or 1 / 0 / 1/step]
	Lights TM/P sensor: Center glowing part.		
5-804-211	ID Tag Power	ENG	[0 or 1 / 0 / 1/step]
	Powers the HST sensor.		

Output Check Table

5804	[OUTPUT Check]		
	Continuously drives specified motor for operation test.		
5-804-241	Bank: Tray3: Feed Mt: Standard Speed	ENG	[0 or 1 / 0 / 1/step]
5-804-242	Bank: Tray4: Feed Mt: Standard Speed	ENG	
5-804-243	Bank: Tray5: Feed Mt: Standard Speed	ENG	
5-804-244	Bank: Tray3: Transport Mt: Standard Speed	ENG	
5-804-245	Bank: Tray4: Transport Mt: Standard Speed	ENG	
5-804-246	Bank: Tray5: Transport Mt: Standard Speed	ENG	
5804	[OUTPUT Check]		
	Drives specified motor for a certain period of time to test operation.		
5-804-247	Bank: Tray3: PU Solenoid	ENG	[0 or 1 / 0 / 1/step]
5-804-248	Bank: Tray4: PU Solenoid	ENG	
5-804-249	Bank: Tray5: PU Solenoid	ENG	
5804	[OUTPUT Check]		
5-804-251	OPC Quenching LCD	ENG	[0 or 1 / 0 / 1/step]
	Turns OPC quenching LCD on		
5-804-252	Waste Toner Open/Close Solenoid: CW	ENG	[0 or 1 / 0 / 1/step]
	Moves waste toner open/close solenoid clockwise.		
5-804-253	Anti-Condensation Heater Relay	ENG	[0 or 1 / 0 / 1/step]
	Turns Anti-Condensation Heater Relay on		

5-804-254	Waste Toner Open/Close Solenoid:CCW	ENG	[0 or 1 / 0 / 1/step]
	Moves waste toner open/close solenoid counterclockwise.		

5.18.2 ADF D779 – OUTPUT CHECK

6008	[ADF OUTPUT Check]		
	Checks operation of the load of ADF.		
6-008-003	Feed Motor Forward	ENG	[0 or 1 / 0 / 1/step]
	Rotates paper feed motor forward.		
6-008-004	Feed Motor Reverse	ENG	[0 or 1 / 0 / 1/step]
	Rotates paper feed motor backward.		
6-008-005	Relay Motor Forward	ENG	[0 or 1 / 0 / 1/step]
	Rotates carry motor forward.		
6-008-006	Relay Motor Reverse	ENG	[0 or 1 / 0 / 1/step]
	Rotates carry motor backward.		
6-008-011	Inverter Solenoid	ENG	[0 or 1 / 0 / 1/step]
	Interval drives reverse solenoid.		
6-008-012	Stamp	ENG	[0 or 1 / 0 / 1/step]
	Interval drives DONE stamp.		
6-008-013	Fan Motor	ENG	[0 or 1 / 0 / 1/step]
	Interval drives FAN motor.		
6-008-014	Feed Clutch	ENG	[0 or 1 / 0 / 1/step]
	Interval drives paper feed clutch.		
6-008-015	Feed Solenoid	ENG	[0 or 1 / 0 / 1/step]
	Interval drives paper feed solenoid.		

5.18.3 1-PASS ADF D683 – OUTPUT CHECK

6012	[1-Pass ADF OUTPUT Check]		
	For Single-Pass simultaneous duplex models only.		
6-012-001	Pick-Up Motor Forward	ENG	[0 or 1 / 0 / 1/step] 0:Off 1:On
	Forwardly rotates ADF pick up motor.		
6-012-003	Feed Motor Forward	ENG	[0 or 1 / 0 / 1/step] 0:Off 1:On
	Forwardly rotates ADF paper feed motor.		
6-012-005	Relay Motor Forward	ENG	[0 or 1 / 0 / 1/step] 0:Off 1:On
	Forwardly rotates ADF paper carry motor.		
6-012-009	Exit Motor Forward	ENG	[0 or 1 / 0 / 1/step] 0:Off 1:On
	Forwardly rotates ADF paper exit motor.		
6-012-010	Bottom Plate Motor For/Rev	ENG	[0 or 1 / 0 / 1/step] 0:Off 1:On
	Moves up/down the bottom plate by driving the ADF bottom plate motor forward, backward.		
6-012-012	Stamp	ENG	[0 or 1 / 0 / 1/step] 0:Off 1:On
	Stamps the DONE stamp.		

6-012-015	Pull-Out Motor Forward	ENG	[0 or 1 / 0 / 1/step] 0:Off 1:On
	Forwardly rotates ADF pull out motor.		
6-012-016	Middle Motor Forward	ENG	[0 or 1 / 0 / 1/step] 0:Off 1:On
	Forwardly rotates ADF middle motor.		

5.18.4 2000/3000 SHEETS FINISHER D688 / D689 – OUTPUT CHECK

6124	[OUTPUT Check: 2K/3K FIN]		
6-124-001	Entrance Transport Motor	ENG	[0 or 1 / 0 / 1/step]
	Drives specified motor for a certain period of time to test operation.		
6-124-002	Horizontal Transport Motor	ENG	[0 or 1 / 0 / 1/step]
	Drives specified motor for a certain period of time to test operation.		
6-124-003	Pre-Stack Transport Motor	ENG	[0 or 1 / 0 / 1/step]
	Drives specified motor for a certain period of time to test operation.		
6-124-004	ITB Transport Motor	ENG	[0 or 1 / 0 / 1/step]
	Drives specified motor for a certain period of time to test operation.		
6-124-005	Paper Exit Motor	ENG	[0 or 1 / 0 / 1/step]
	Drives specified motor for a certain period of time to test operation.		
6-124-006	Upper Junction Solenoid	ENG	[0 or 1 / 0 / 1/step]
	Turns NO/OFF specified solenoid for validation.		
6-124-007	TE Stack Plate Motor	ENG	[0 or 1 / 0 / 1/step]

Output Check Table

	Drives specified motor for a certain period of time to test operation.		
6-124-008	Paper Exit Open/Close Guide Plate Motor	ENG	[0 or 1 / 0 / 1/step]
	Drives specified motor for a certain period of time to test operation.		
6-124-009	Punching Motor	ENG	[0 or 1 / 0 / 1/step]
	Drives specified motor for a certain period of time to test operation.		
6-124-010	Punch Move Motor	ENG	[0 or 1 / 0 / 1/step]
	Drives specified motor for a certain period of time to test operation.		
6-124-011	S-to-S Registration Detection Move Motor	ENG	[0 or 1 / 0 / 1/step]
	Drives specified motor for a certain period of time to test operation.		
6-124-012	Lower Junction Solenoid Motor	ENG	[0 or 1 / 0 / 1/step]
	Drives specified motor for a certain period of time to test operation.		
6-124-013	Jogger Motor	ENG	[0 or 1 / 0 / 1/step]
	Drives specified motor for a certain period of time to test operation.		
6-124-014	Positioning Roller Rotation Motor	ENG	[0 or 1 / 0 / 1/step]
	Drives specified motor for a certain period of time to test operation.		
6-124-015	Feed-out Motor	ENG	[0 or 1 / 0 / 1/step]
	Drives specified motor for a certain period of time to test operation.		
6-124-016	Booklet Stapler Move Motor	ENG	[0 or 1 / 0 / 1/step]
	Drives specified motor for a certain period of time to test operation.		

6-124-017	Corner Stapler Motor	ENG	[0 or 1 / 0 / 1/step]
	Drives specified motor for a certain period of time to test operation.		
6-124-018	Booklet Stapler Jogger Motor	ENG	[0 or 1 / 0 / 1/step]
	Drives specified motor for a certain period of time to test operation.		
6-124-019	Booklet Stapler Jog Solenoid Move Motor	ENG	[0 or 1 / 0 / 1/step]
	Drives specified motor for a certain period of time to test operation.		
6-124-020	Booklet Stapler Standard Fence Motor	ENG	[0 or 1 / 0 / 1/step]
	Drives specified motor for a certain period of time to test operation.		
6-124-021	Booklet Stapler Motor	ENG	[0 or 1 / 0 / 1/step]
	Drives specified motor for a certain period of time to test operation.		
6-124-022	Dynamic Roller Transport Motor	ENG	[0 or 1 / 0 / 1/step]
	Drives specified motor for a certain period of time to test operation.		
6-124-023	Folder Transport Motor	ENG	[0 or 1 / 0 / 1/step]
	Drives specified motor for a certain period of time to test operation.		
6-124-025	Press-fold Motor	ENG	[0 or 1 / 0 / 1/step]
	Drives specified motor for a certain period of time to test operation.		
6-124-026	Tray Lift Motor	ENG	[0 or 1 / 0 / 1/step]
	Drives specified motor for a certain period of time to test operation.		
6-124-027	Shift Motor	ENG	[0 or 1 / 0 / 1/step]
	Drives specified motor for a certain period of time to test operation.		

Output Check Table

6-124-028	Front Shift Jogger Motor	ENG	[0 or 1 / 0 / 1/step]
	Drives specified motor for a certain period of time to test operation. * Not Use: Currently, Booklet Finisher SR3170 (D688) / Finisher SR3160 (D689) do not have setting jogger in system configuration.		
6-124-029	Rear Shift Jogger Motor	ENG	[0 or 1 / 0 / 1/step]
	Drives specified motor for a certain period of time to test operation. * Not Use: Currently, Booklet Finisher SR3170 (D688) / Finisher SR3160 (D689) do not have setting jogger in system configuration.		
6-124-030	Shift Jogger Retraction Motor	ENG	[0 or 1 / 0 / 1/step]
	Drives specified motor for a certain period of time to test operation. * Not Use: Currently, Booklet Finisher SR3170 (D688) / Finisher SR3160 (D689) do not have setting jogger in system configuration.		
6-124-031	Drag Roller Vibrating Motor	ENG	[0 or 1 / 0 / 1/step]
	Drives specified motor for a certain period of time to test operation.		
6-124-032	LE Guide Motor	ENG	[0 or 1 / 0 / 1/step]
	Drives specified motor for a certain period of time to test operation.		
6-124-033	Navigation LED (All)	ENG	[0 or 1 / 0 / 1/step]
	Lights all guide LED.		

5.18.5 INTERNAL FINISHER D690 – OUTPUT CHECK

6136	[OUTPUT Check: FrontFIN]		
	Continuously drives specified motor for operation test.		
6-136-001	Entrance Motor	ENG	[0 or 1 / 0 / 1/step]
6-136-002	Carry Motor	ENG	[0 or 1 / 0 / 1/step]
6-136-003	Exit Motor	ENG	[0 or 1 / 0 / 1/step]
6136	[OUTPUT Check: FrontFIN]		
	Drives specified motor for a certain period of time to test operation.		
6-136-004	Front Jogger Motor	ENG	[0 or 1 / 0 / 1/step]
6-136-005	Rear Jogger Motor	ENG	[0 or 1 / 0 / 1/step]
6-136-006	Shift Motor	ENG	[0 or 1 / 0 / 1/step]
6-136-007	Hitroll Motor	ENG	[0 or 1 / 0 / 1/step]
6-136-008	Exit Guide Plate Motor	ENG	[0 or 1 / 0 / 1/step]
6-136-009	Staple Moving Motor	ENG	[0 or 1 / 0 / 1/step]
6-136-010	Tray Motor	ENG	[0 or 1 / 0 / 1/step]
6-136-011	Staple Motor	ENG	[0 or 1 / 0 / 1/step]
6-136-012	Stopper Motor	ENG	[0 or 1 / 0 / 1/step]
6-136-013	Punch Motor	ENG	[0 or 1 / 0 / 1/step]
6-136-014	Punch Moving Motor	ENG	[0 or 1 / 0 / 1/step]
6-136-015	Punch Registration Moving Motor	ENG	[0 or 1 / 0 / 1/step]

5.18.6 1000 SHEETS FINISHER D687 – OUTPUT CHECK

6162	[FIN (1K FIN) OUTPUT Check]		
	Continuously runs specified motor for operation test.		
6-162-001	Entrance Transport Motor	ENG	[0 or 1 / 0 / 1/step]
6-162-002	Proof Transport Motor	ENG	[0 or 1 / 0 / 1/step]
6-162-003	Paper Feed/Positioning & Move Roller Motor	ENG	[0 or 1 / 0 / 1/step]
6162	[FIN (1K FIN) OUTPUT Check]		
	Drives specified motor for a certain period of time to test operation.		
6-162-004	Junction Solenoid	ENG	[0 or 1 / 0 / 1/step]
6-162-005	Shift Motor	ENG	[0 or 1 / 0 / 1/step]
6-162-006	Jogger Motor	ENG	[0 or 1 / 0 / 1/step]
6-162-007	Exit Guide Plate Open/Close Motor	ENG	[0 or 1 / 0 / 1/step]
6-162-008	Feed-out Motor	ENG	[0 or 1 / 0 / 1/step]
6-162-009	Tray Lift Motor	ENG	[0 or 1 / 0 / 1/step]
6-162-011	Positioning Roller Motor	ENG	[0 or 1 / 0 / 1/step]
6-162-012	Stapler Shift Motor	ENG	[0 or 1 / 0 / 1/step]
6-162-013	Stapler Motor	ENG	[0 or 1 / 0 / 1/step]
6-162-014	Punch Motor	ENG	[0 or 1 / 0 / 1/step]
6-162-015	Punch Move Motor	ENG	[0 or 1 / 0 / 1/step]
6-162-016	S-to-S Registration Detection Move Motor	ENG	[0 or 1 / 0 / 1/step]
6-162-017	Stack Transport Motor: Upper	ENG	[0 or 1 / 0 / 1/step]

6-162-018	Stck Trns Uppr Prss Rls/Stndrd Fence Rtrct M	ENG	[0 or 1 / 0 / 1/step]
6-162-019	Stack Lower Pressure Release Motor	ENG	[0 or 1 / 0 / 1/step]
6162	[FIN (1K FIN) OUTPUT Check]		
	Continuously runs specified motor for operation test.		
6-162-020	Folder Transport Motor	ENG	[0 or 1 / 0 / 1/step]
6162	[FIN (1K FIN) OUTPUT Check]		
	Drives specified motor for a certain period of time to test operation.		
6-162-021	TE Stopper Motor	ENG	[0 or 1 / 0 / 1/step]
6-162-022	Folder Blade Motor	ENG	[0 or 1 / 0 / 1/step]
6162	[FIN (1K FIN) OUTPUT Check]		
	Lights all guide LED.		
6-162-023	Navigation LED (All)	ENG	[0 or 1 / 0 / 1/step]

5.18.7 BRIDGE UNIT D685 – OUTPUT CHECK

6171	[Bridge: OUTPUT Check]		
6-171-009	Bridge Relay Motor: Low Speed	ENG	[0 or 1 / 0 / 1/step]
	Checks operation of the load of relay motor. Rotates forward the carry motor for 73 mm/s.		
6-171-010	Bridge Relay Motor: Middle Speed	ENG	[0 or 1 / 0 / 1/step]
	Checks operation of the load of relay motor. Rotates forward the carry motor for 256 mm/s.		
6-171-011	Bridge Relay Motor: Standard Speed	ENG	[0 or 1 / 0 / 1/step]
	Checks operation of the load of relay motor. Rotates forward the carry motor for 450 mm/s.		
6-171-012	Junction Solenoid	ENG	[0 or 1 / 0 / 1/step]
	Checks operation of the load of solenoid. Turns ON the solenoid.		

5.18.8 INTERNAL SHIFT TRAY D691 – OUTPUT CHECK

6173	[Shift Tray: OUTPUT Check]		
6-173-001	Shift Tray Motor	ENG	[0 or 1 / 0 / 1/step]
	Checks operation of the load of shift tray motor. Rotates forward.		

5.18.9 INTERNAL FINISHER D766 – OUTPUT CHECK

6185	[Output Check:NoStplBindFIN]		
6-185-001	Transport Motor	ENG	[0 or 1 / 0 / 1/step]
	Checks the transport motor's movement of non staple finisher. Turn the motor clockwise at 256 mm/sec.		
6-185-002	Shift Motor	ENG	[0 or 1 / 0 / 1/step]
	Checks the shift motor's movement of non staple finisher.		
6-185-003	Junction Solenoid Motor	ENG	[0 or 1 / 0 / 1/step]
	Checks the junction solenoid motor's movement of non staple finisher.		
6-185-004	Exit Pressure Release Motor	ENG	[0 or 1 / 0 / 1/step]
	Checks the exit pressure release motor's movement of non staple finisher.		
6-185-005	Stapler Motor	ENG	[0 or 1 / 0 / 1/step]
	Checks the stapler motor's movement of non staple finisher.		

5.19 TEST PATTERN PRINTING

Printing Test pattern: SP2-109

Some of these test patterns are used for copy image adjustments but most are used primarily for design testing.

Note

- Do not operate the machine until the test pattern is printed out completely. Otherwise, SC will occur.

1. Enter the SP mode then select SP2-109-003 “Pattern Selection”.
2. Select test pattern for print from the list then press [OK].
3. To change the density of the test pattern, select the density with SP2-109-006, then press [#].

Note

- If select "0" with SP2-109-006, the color adjusted so will not show up in the test pattern.

4. To print, touch [Copy Window], then set settings within the following window for test print (paper size etc...).
5. Press "Start" key to start test print.
6. After checking test pattern, touch "SP Mode" on the LCD to return to SP mode display.
7. Reset all settings to the default values (SP2-109-003, SP2-109-006).
8. Exit SP mode.

No.	Pattern	No.	Pattern
0	None	13	4dot Ind. Pptrn (4dot Independent Pattern)
1	1dot Vertical Line	14	Trimming Area
2	2dot Vertical Line	15	Hounds tooth H
3	1dot Horizontal Line	16	Hounds tooth V
4	2dot Horizontal Line	17	Black Band H (Horizontal)
5	Grid Vert (Grid Vertical Line)	18	Black Band V (Vertical)
6	Grid Horizontal (Grid Horizontal Line)	19	Checker Flag Pattern
7	Grid Pattern Small	20	Grayscale V (Vertical)
8	Grid Pattern Large	21	Grayscale H (Horizontal)

No.	Pattern	No.	Pattern
9	Argyle Pattern Small	22	2 Beam Density Ptrn
10	Argyle P:L (Argyle Pattern Large)	23	Full Dot Pattern
11	1dot Ind. Ptrn (1dot Independent Pattern)	24	All White Pattern
12	2dot Ind. Ptrn (2dot Independent Pattern)	-	-

5.20 FIRMWARE UPDATE

5.20.1 OVERVIEW

In order to update the firmware of this machine, it is necessary to download the latest version of firmware on a SD card.

Insert the SD card in SD card slot 2 beside the left rear of the controller box.

5.20.2 FIRMWARE TYPE

Firmware type	Function	Firmware position	Message display
System/Copy	Operating system	Controller board	System/Copy
Engine		BCU	Engine
Control panel		Control panel	Lcdc
Network support		Controller board	Network Support
Language 1		Control panel	Language 1
Language 2		Controller board	Language 2
RPCS		Controller board	RPCS
PCL (PCLXL)		Controller board	PCL (PCLXL)
Media print JPEG/TIFF		Controller board	MediaPrint:JPEG/TIF
Font		Controller board	FONT
Font 1		Controller board	FONT1
Network document box		Controller board	NetworkDocBox
Printer		Controller board	Printer
Scanner		Controller board	Scanner
Web support		Controller board	Websupport
Web Application		Controller board	WebUapl

Note

- Even when not using a RPCS driver, the XPS driver requires RPCS firmware.

5.20.3 PROCEDURE**Important**

- A SD card is a precision device, so when you handle an SD card, respect the following.
- When the power is switched ON, do not insert or remove a card.
- During installation, do not switch the power OFF.
- Since the card is manufactured to high precision, do not store it in a hot or humid location, or in direct sunlight.
- Do not bend the card, scratch it, or give it a strong shock.
- Before downloading firmware on an SD card, check whether write-protection of the SD card is canceled. If write-protection is enabled, an error code (error code 44, etc.) will be displayed during download, and the download will fail.
- Before updating firmware, remove the network cable from this machine.
- If SC818 is generated during software update, switch the power OFF -> ON, and complete the update which was interrupted.
- During software update, network cables, remove interface cables, wireless boards, etc., (so that they are not accessed during update).

Update procedure

1. First download the software to be updated to the SD card.
2. Switch the power OFF.
3. Remove the SD card slot cover [A]. (🔧×1)

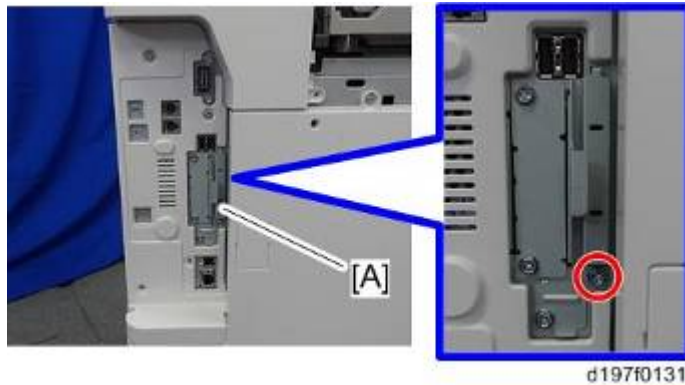

4. Insert the SD card [A] straight in slot 2.

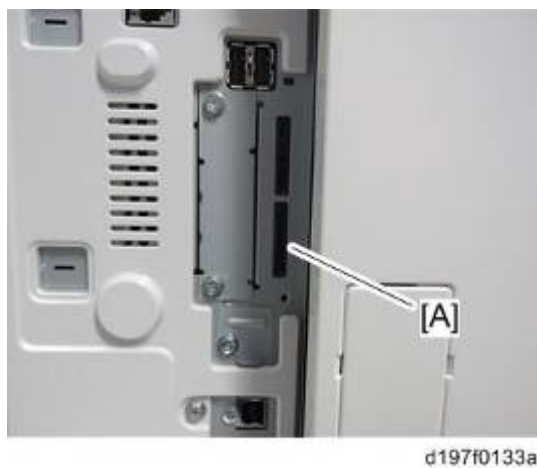

Note

- Check whether the card is properly in the SD card slot. When a SD card is inserted, a click is heard, and it is locked.
 - To remove the card, release by pressing once in the set state.
5. Switch the power ON.
 6. Wait until the update screen starts (about 45 seconds).
When it appears, "Please Wait" is displayed.
 7. Check whether a program installation screen is displayed. (English display) When two or more software modules are contained in the SD card, they are displayed as follows.

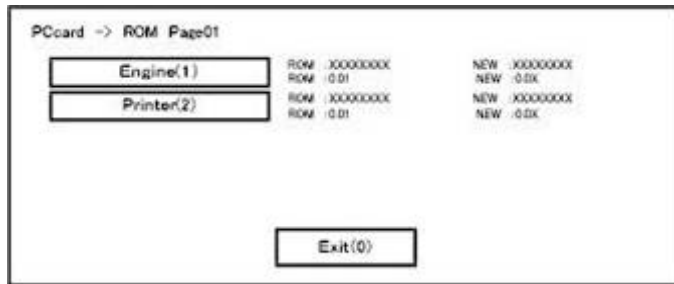

When two or more software names are displayed

1. Press the module selection button or 10 keypad [1] - [5].
2. Choose the appropriate module. (If already selected, cancel the selection)

Operation of keys or buttons

Keys or buttons to press	Contents
[Exit] or 10 key [0]	Returns to normal screen.
[Start] Key	Select all modules.
[Clear/Stop] key	Cancel all selection states.

Display contents

On the above screen, two programs, i.e., engine firmware and printer application are displayed. (The screen may change depending on the firmware or application).

The display contents are as follows:

Display	Contents
ROM:	Display installed module number / version information.
NEW:	Display module number / version information in the card.

* The upper row corresponds to the module number, the lower row corresponds to the version name.

8. Select the module with the module selection button or 10 key operation. The selected module is highlighted, and [Verify] and [Update] are displayed.

↓ Note

- Depending on the combination of update software, it may not be possible to select simultaneously.

Firmware Update

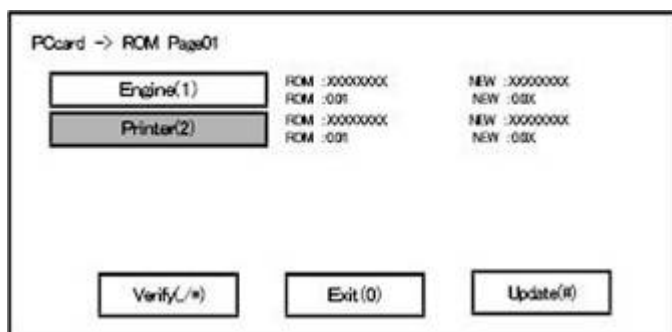

Key or button operations

Keys or buttons to press	Contents
[Update] or [#] key	Update the ROM of the selected module.
[Verify] button or [./*] key	Perform verification of the selected module.

9. Press the [Update] or [#] key, and perform software update.
10. During firmware update, a "firmware update/ verification progress screen" is displayed. When firmware update is complete, a "firmware update end screen" is displayed.

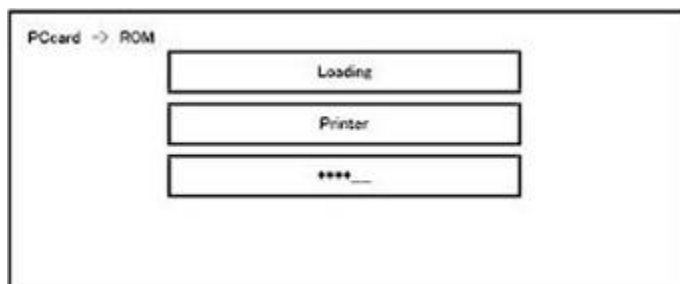

- In the middle row, the name of the module currently being updated is displayed. (in this case, the printer is being updated)
- In the lower row, a progress bar is displayed in ten steps. (The more *, the more the progress.)
- When updating the control unit program, since progress cannot be displayed on the screen, the ROM update process is determined when the LED of the [Start] key changes from red to green.

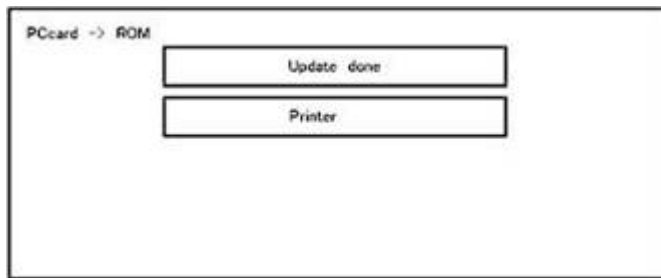
Firmware update end screen

- This screen is displayed when all selected firmware modules are to be updated. "printer" in the second row shows that the module updated last is the printer. (When more than one are updated simultaneously, only what was updated last is displayed.)
- When Verify has completed normally, the Update done display of the above screen is "Verify done." If "Verify Error" is displayed, reinstall the software of the application displayed in the lower row.

11. After switching power OFF, remove the SD card.

12. Again, switch the power ON, and check whether the machine is operating normally.

13. Return the SD card slot cover to the original position.

Note

- When the power supply is switched OFF during firmware update, update is interrupted, and the power is switched ON again, normal operation cannot be guaranteed.
- To guarantee operation, an update error continues to be displayed until update is successful.
- In this case, insert the SD card again, switch the power ON, and continue download of firmware from the SD card automatically.
- Web access card software: EXJS (EXTended Java Script) is a Type-C ESA application, and like a conventional Web access card, update using an sdk folder is required.
- The PS3 firmware program is included in the preinstalled PDF firmware.
- In the default state, although the PS3 firmware program is hidden in the disabled state, the function is enabled by installing the PS3 card.
- (The program installed in the PS3 card is a dongle (key) for enabling PS3 function).
- Due to the above specification, the self-diagnosis result report shows the ROM module number / software version of the PDF firmware at the PS location.

5.20.4 ERROR SCREENS DURING UPDATING

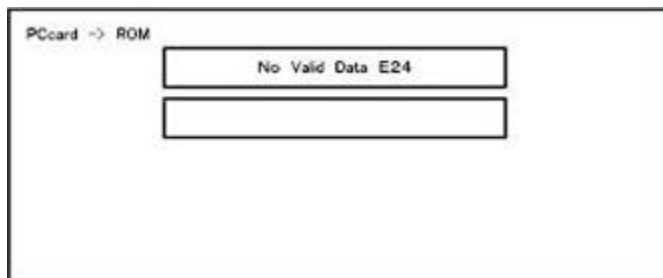

EXX shows an error code.

(This error is generated if update was performed when a printer application startup card is removed after system startup. An error indicating failure of card access is displayed on the screen.)

For error codes, refer to the following table:

Error Code List

Code	Contents	Solutions
20	Physical address mapping cannot be performed.	<ul style="list-style-type: none"> ▪ Switch the main power supply off and on to try again. ▪ Re-insert the SD card to reboot it. ▪ Replace the controller board if the above solutions do not solve the problem.
21	Insufficient memory for the download	<ul style="list-style-type: none"> ▪ Switch the main power supply off and on to try again. ▪ Replace the controller board if the updating cannot be done by switching the power off and on.
22	Decompression of compressed data failed.	<ul style="list-style-type: none"> ▪ Switch the main power supply off and on to try again. ▪ Replace the SD card used for the update. ▪ Replace the controller board if the above solutions do not solve the problem.

Code	Contents	Solutions
24	SD card access error	<ul style="list-style-type: none"> ▪ Re-insert the SD card. ▪ Switch the main power supply off and on to try again. ▪ Replace the SD card used for the update. ▪ Replace the controller board if the above solutions do not solve the problem.
32	<p>The SD card used after download suspension is incorrect.</p> <p>SD cards are different between the one which was inserted before power interruption and the one which was inserted after power interruption.</p>	<ul style="list-style-type: none"> ▪ Insert the SD card containing the same program as when the firmware update was suspended, and then switch the main power supply off and on to try again. ▪ There is a possibility that the SD card is damaged if the update cannot be done after the correct SD card has been inserted. In this case, try again with a different SD card. ▪ Replace the controller board if the above solutions do not solve the problem. <p>Replace all relevant boards if the update is done for the BCU and FCU.</p> <p>Replace the operation panel unit if the update is done for the operation panel.</p>
33	<p>Card version error.</p> <p>The wrong card version is downloaded.</p>	<ul style="list-style-type: none"> ▪ Install the correct ROM update data for each version in the SD card.
34	<p>Destination error.</p> <p>A card for the wrong destination is inserted.</p>	<ul style="list-style-type: none"> ▪ Install the correct ROM update data for each destination (JPN/ EXP/ OEM) in the SD card.
35	<p>Model error.</p> <p>A card for the wrong model is inserted.</p>	<ul style="list-style-type: none"> ▪ Install the correct ROM update data for each model in the SD card.

Code	Contents	Solutions
36	<p>Module error.</p> <p>The program to be downloaded does not exist on the main unit.</p> <p>The download destination specified by the card does not match up to the destination for the main unit's program.</p>	<ul style="list-style-type: none"> ▪ Install the program to be updated in advance. ▪ There is a possibility that the SD card containing the program to be updated has not been mounted. Check to confirm that the SD card has been correctly mounted. ▪ The SD card is incorrect if the program to be updated has been correctly installed. In this case, insert the correct SC card.
38	<p>The version of the downloaded program has not been authorized for the update.</p>	<ul style="list-style-type: none"> ▪ Make sure that the program to be overwritten is the specified version.
40	<p>Engine download fails.</p>	<ul style="list-style-type: none"> ▪ Switch the main power supply off and on to try again. ▪ If the download fails again, replace the controller board and the BCU.
41	<p>Fax download fails.</p>	<ul style="list-style-type: none"> ▪ Switch the main power supply off and on to try again. ▪ If the download fails again, replace the controller board and the FCU board.
42	<p>Control panel / language download fails.</p>	<ul style="list-style-type: none"> ▪ Switch the main power supply off and on to try again. ▪ If the download fails again, replace the controller board and the operation panel unit.
43	<p>Printing download fails.</p>	<ul style="list-style-type: none"> ▪ Switch the main power supply off and on to try again. ▪ The SD card media is damaged if the update fails again. Replace the SD card media.

Code	Contents	Solutions
44	The data to be overwritten cannot be accessed when controller-related programs are downloaded.	<ul style="list-style-type: none"> ▪ Switch the main power supply off and on to try again. ▪ Install the correct ROM update data in the SD card. ▪ Replace the controller board if the data to be overwritten is contained on the controller board.
49	Firmware updates are currently prohibited.	<ul style="list-style-type: none"> ▪ The setting of Update Firmware in the Administrator Tools has been set to [Prohibit] by an administrator. Amend the setting to [Do not Prohibit] and try again.
50	The results of the electronic authorization check have rejected the update data.	<ul style="list-style-type: none"> ▪ Install the correct ROM update data in the SD card.
57	@Remote is not connected at the date/time reserved for receiving the package firmware update from the network.	<ul style="list-style-type: none"> ▪ Check the @Remote connection.
58	Update cannot be done due to a reception route problem.	<ul style="list-style-type: none"> ▪ Check the @Remote connection.
59	HDD is not mounted.	<ul style="list-style-type: none"> ▪ Check the HDD connection.
60	HDD could not be used during the package firmware update.	<ul style="list-style-type: none"> ▪ Try again. ▪ Replace the HDD if the download fails again.
61	The module ID for the package firmware update is incorrect.	<ul style="list-style-type: none"> ▪ Prepare the correct package files.
62	The configuration of the package firmware update files is incorrect.	<ul style="list-style-type: none"> ▪ Prepare the correct package files.

Code	Contents	Solutions
63	Reception fails due to the power off at the reserved date/time of the remote firmware update from the network.	<ul style="list-style-type: none"> ▪ Update is to be done automatically when the next reception time has elapsed.
64	Reception fails due to the power off at the reserved date/time of the package firmware update from the network.	<ul style="list-style-type: none"> ▪ Reset the reservation date/time for the remote update.
65	Reception fails due to the status error of the machine at the reserved date/time of the remote firmware update from the network.	<ul style="list-style-type: none"> ▪ Update is to be done automatically when the next reception time has elapsed.
66	Reception failed due to the status error of the machine at the reserved date/time of the package firmware update from the network.	<ul style="list-style-type: none"> ▪ Reset the reservation date/time for the remote update.
67	Acquisition of the latest version information from the Gateway fails at the reserved date/time of the remote firmware update from the network.	<ul style="list-style-type: none"> ▪ Check that the network is connected correctly.
68	Acquisition of the latest version information from the Gateway fails.	<ul style="list-style-type: none"> ▪ Check that the network is connected correctly.
69	Download fails at the reserved date/time of the remote firmware update from the network.	<ul style="list-style-type: none"> ▪ Check that the network is connected correctly.

Code	Contents	Solutions
70	Package firmware download from the network fails.	<ul style="list-style-type: none"> Check that the network is connected correctly.
71	Network communication error occurs at the reserved date/time of the package firmware update from the network.	<ul style="list-style-type: none"> Check that the network is connected correctly.
72	The setting of @Remote is invalid at the reserved date/time of the package firmware update from the network.	<ul style="list-style-type: none"> Set the setting of @Remote Service in the Administrator Tools to [Do not Prohibit].
57	@Remote is not connected at the date/time reserved for receiving the package firmware update from the network.	<ul style="list-style-type: none"> Check the @Remote connection.
58	Update cannot be done due to a reception route problem.	<ul style="list-style-type: none"> Check the @Remote connection.
59	HDD is not mounted.	<ul style="list-style-type: none"> Check the HDD connection.
60	HDD could not be used during the package firmware update.	<ul style="list-style-type: none"> Try again. Replace the HDD if the download fails again.
61	The module ID for the package firmware update is incorrect.	<ul style="list-style-type: none"> Prepare the correct package files.
62	The configuration of the package firmware update files is incorrect.	<ul style="list-style-type: none"> Prepare the correct package files.

Code	Contents	Solutions
63	Reception fails due to the power off at the reserved date/time of the remote firmware update from the network.	<ul style="list-style-type: none"> Update is to be done automatically when the next reception time has elapsed.
64	Reception fails due to the power off at the reserved date/time of the package firmware update from the network.	<ul style="list-style-type: none"> Reset the reservation date/time for the remote update.
65	Reception fails due to the status error of the machine at the reserved date/time of the remote firmware update from the network.	<ul style="list-style-type: none"> Update is to be done automatically when the next reception time has elapsed.
66	Reception failed due to the status error of the machine at the reserved date/time of the package firmware update from the network.	<ul style="list-style-type: none"> Reset the reservation date/time for the remote update.
67	Acquisition of the latest version information from the Gateway fails at the reserved date/time of the remote firmware update from the network.	<ul style="list-style-type: none"> Check that the network is connected correctly.
68	Acquisition of the latest version information from the Gateway fails.	<ul style="list-style-type: none"> Check that the network is connected correctly.
69	Download fails at the reserved date/time of the remote firmware update from the network.	<ul style="list-style-type: none"> Check that the network is connected correctly.

Code	Contents	Solutions
70	Package firmware download from the network fails.	<ul style="list-style-type: none"> Check that the network is connected correctly.
71	Network communication error occurs at the reserved date/time of the package firmware update from the network.	<ul style="list-style-type: none"> Check that the network is connected correctly.
72	The setting of @Remote is invalid at the reserved date/time of the package firmware update from the network.	<ul style="list-style-type: none"> Set the setting of @Remote Service in the Administrator Tools to [Do not Prohibit].

⬇ Note

- The PDF firmware installed as standard contains a program required to print PS3 data as default. However, this PS3 program is normally disabled.
- The PS3 firmware is a dongle (key) which enables PS3 data printing functions. When the PS3 firmware is installed, the PS3 program in the PDF firmware is enabled. Due to this specification, the self-diagnosis result report shows the ROM part number/software version of the PDF firmware contained in the PS3 program.

5.21 UPDATING JAVAVM

5.21.1 CREATING AN SD CARD FOR UPDATING

1. Download the update modules from Firmware Download Center. As one of the model modules, "Java VM v11 UpdateTool" is available for download. (The version differs depending on the model.)
2. Unzip the downloaded file. Copy the whole "sdk" folder to the root of the SD card directly below.

↓ Note

- When unzipping the downloaded file, two subfolders ("update" and "sdk") exist in the "sdk" folder. Rather than just copying the subfolder "sdk", copy the whole folder "sdk".

Updating Procedure

⚠ CAUTION

- SD card can be inserted with the machine power off.
 - During the updating process, do not turn off the power.
 - If you turn off the power during the updating, the machine performance is not guaranteed. (There is a possibility that an SC and boot failure occurs.)
 - If you accidentally turn off the power during the updating, retry the updating procedure from the beginning. (If the update fails again, you will need to replace the controller board.)
1. If the boot priority application is set to the ESA application, switch to the copy application. ([System Settings]-[General Features]-[Function Priority])
 2. Insert the SD card you created into the service slot, and then turn ON the main power switch.
 3. After booting Java VM, update of the application is started. "Updating SDK/J" appears in the banner message of the touch panel display. (Estimated time: about 2 minutes)



4. When the update is complete, "Update SDK / J done SUCCESS" will appear in the banner message of the touch panel display. After turning off the power, remove the SD card from the slot.

When you fail to update, "Update SDK/J done FAIL" is displayed. You can confirm the cause of the error message below.

5. Reconfigure the Heap size. ([Extended Feature Settings]-[Administrator Tools]-[Heap/Stack Size Settings]).

See the manual for the ESA application to know what value to set for the heap size.

6. Return to the previous setting for the boot priority application.

List of Error Messages

Update results are output as a text file on the SD card called "sdkjversionup.log" in the "¥sdk ¥update" folder.

Result	File contents	Description of the output
Success	script file = /mnt/sd0/sdk/update/bootscrip 2012/08/22 17:57:47 start 2012/08/22 17:59:47 end SUCCESS	Boot script path Boot scripts processing start time End time boot script processing, the results
Failure	script file = /mnt/sd0/sdk/update/bootscrip 2012/08/22 17:57:47 start XXXX Error 2012/08/22 17:57:57 end FAIL	Boot script path Boot scripts processing start time Error message (Possibly multiple) End time boot script processing, the results

Error Message	Cause	Remedy
PIECEMARK Error,machine=XXXXX	Applied the wrong updating tool (Using the updating tool of a different model)	Use the correct updating tool for this model.
pasePut() - error : The file of the copy origin is not found Put Error!	Inadequacy with the SD card for updating (Files are missing in the updating tool)	Re-create the SD card for updating.
paseCopy() - error : The file of the copy origin is not found. Copy Error!	Inadequacy SD card for updating (Files in the updating tool are missing)	Inadequacy SD card for updating (Files in the updating tool are missing)
[file name: XX] error,No space left on device pasePut() - error : The destination directory cannot be made. pasePut() - error : fileCopy Error. Put Error!	Writing destination is full. (The NAND flash memory on the controller board is full.)	Uninstall the unnecessary SDK applications. If you can not uninstall it, implement escalation, stating the "model name, application configuration, SMC sheet (SP5-990-006/024/025), and error file."
[file name: XX] error,No space left on device paseCopy() - error : The destination directory cannot be made. paseCopy() - error : fileCopy Error. Copy Error!	Writing destination is full. (The NAND flash memory on the controller board is full.)	Uninstall the unnecessary SDK applications. If you can not uninstall it, implement escalation stating the "model name, application configuration, SMC sheet (SP5-990-006/024/025), and error file."
Put Error! *1	Error, not normally expected to occur	If you cannot uninstall it, implement escalation
Copy Error! *1		

Error Message	Cause	Remedy
Delete Error!		stating the "model name, application configuration, SMC sheet (SP5-990-006/024/025), and error file." *1 Without the foregoing error message, only "Put Error / Copy Error" will be displayed
[XXXXXX] is an unsupported command.		
Version Error		

5.22 UPDATING THE EXJS

5.22.1 TO UPDATE EXJS

1. Remove the SD card slot cover [A] (🔩 x1).

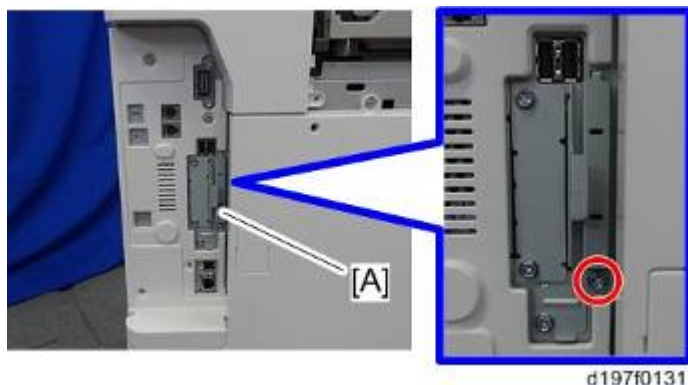

2. Put the SD card containing the firmware to install in SD card slot 2 [A].



3. Turn on the main power switch.
4. Wait until the update screen starts.
5. When the update screen is displayed, select [browser], and press the [Update (#)] button.
6. When "Update done." is displayed, switch the power OFF, and remove the SD card from SD card slot 2.
<When updating Extension JavaScript, add the following steps>
7. Switch the power ON.
8. Press the [Default setting/counter] key.
9. Press the [Extension function default setting] button.
10. Press the [Extension function default setting] button on the [Extension function default menu setting] screen.
11. Stop "Extended JS" on the "Startup setting" condition with a tab.
12. Switch the power OFF.

13. Insert the Extended JavaScript upgrade SD card in SD card slot 2.
14. Switch the power ON.
15. Press the [Default setting/counter] key.
16. Press the [Extension function default setting] button.
17. Press the [Extension function default setting] button on the [Extension function default menu setting] screen.
18. Press the [Install] tab.
19. Press [SD card], and select "Extended JS" from the list of extension functions.
20. Select [MFP hard disk] as the installation location, and press [Next].
21. After checking extension function information on the "Installation preparation complete" screen, press the [Enter] button.
22. "The following extension functions are already installed. The message "Overwrite extension function?" is displayed. Press the [Continue] button.
23. When installation is complete, the message "Extension function has been installed" is displayed. Press the [OK] button.
24. On the [Startup settings] tab, set [Extended JS] to the startup standby state, and switch the power OFF.
25. Remove the SD card from SD card slot 2, and return the controller cover.
26. Switch the power ON.
27. Press the [Default setting/counter] key.
28. Press the [Extension function default setting] button.
29. Press the [Extension function default setting] button on the [Extension function default menu setting] screen.
30. Check the version of [Extended JS] on the [Startup settings] tab is the latest version.

 Note

- If the power is ON before starting Step 1, switch the power OFF after first performing Steps 5-9, and perform Step 1 and subsequent steps. In that case, skip Steps 5-10. (This saves time.)
- If you do not plan to update Extension JavaScript, return the controller cover to the original position after performing Step 5.

5.22.2 WHEN CHECKING THE VERSION OF EXJS

1. Switch the power ON.
2. Press the [Default setting/counter] key.
3. Press the [Extension function default setting] button.
4. Press the [Extension function default setting] button on the [Extension function default menu setting] screen.
5. Check the version of [Extended JS] on the [Startup settings] tab is the latest version.

Note

- If checked apart from the above procedure (firmware version displayed in system default settings), a different version from the actual version may be displayed.

5.23 NVRAM DATA UPLOAD/DOWNLOAD

5.23.1 UPLOADING CONTENT OF NVRAM TO AN SD CARD

Do the following procedure to upload SP code settings from NVRAM to an SD card.

Note

- This data should always be uploaded to an SD card before the NVRAM is replaced.
- Make sure that the write protection of an SD card is unlocked

1. Do SP5-990-001 (SMC Print) before you switch the machine off. You will need a record of the NVRAM settings if the upload fails.
2. Switch the copier main power switch off.
3. Remove the SD card slot cover [A] (⊗x1).

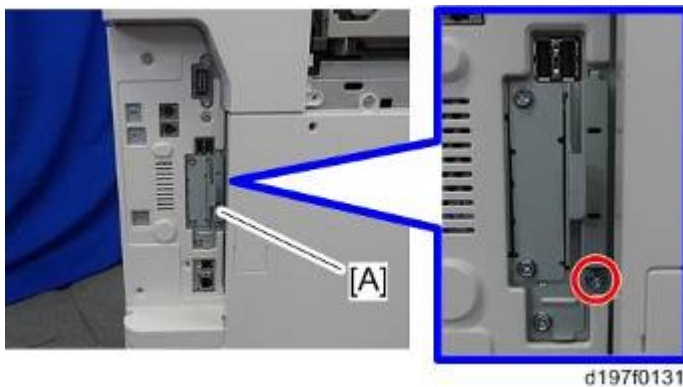

4. Insert the SD card into SD slot 2 [A].



5. Turn on the main power switch.
6. Execute SP5-824-001 (NVRAM Data Upload) and then press the “Execute” key.

- 7. The following files are copied to an NVRAM folder on the SD card when the upload procedure is finished.**

The file is saved to the path and the following filename:

NVRAM¥<serial number>.NV

Here is an example with Serial Number “K5000017114”:

NVRAM¥K5000017114.NV

- 8. In order to prevent an error during the download, be sure to mark the SD card that holds the uploaded data with the number of the machine from which the data was uploaded.**

 **Note**

- You can upload NVRAM data from more than one machine to the same SD card.

5.23.2 DOWNLOADING AN SD CARD TO NVRAM

Do the following procedure to download SP data from an SD card to the NVRAM in the machine.

- The NVRAM data download may fail if the SD card with the NVRAM data is damaged, or if the connection between the controller and BCU is defective.
 - Do the download procedure again if the download fails.
 - Do the following procedure if the second attempt fails:
 - Enter the NVRAM data manually using the SMC print you created before uploading the NVRAM data.
- 1. Switch the copier main power switch off.**
 - 2. Remove the controller cover (🔧 x1).**
 - 3. Insert the SD card with the NVRAM data into SD slot 2.**
 - 4. Switch the copier main power switch on.**
 - 5. Do SP5-825-001 (NVRAM Data Download) and press the “Execute” key.**

 **Note**

- The serial number of the file on the SD card must match the serial number of the machine for the NVRAM data to download successfully. The download fails if the serial numbers do not match.

This procedure does not download the following data to the NVRAM:

- Total Count
- C/O, P/O Count

5.24 UP/SP DATA IMPORT/EXPORT

5.24.1 OVERVIEW

Import/export conditions

Import/export is possible between devices only if their model type, region of use, and the following device configurations match.

- Input Tray
- Output Tray
- ARDF
- Whether or not equipped with a hard disk
- Whether or not equipped with a finisher and the type of finisher

5.24.2 UP DATA IMPORT/EXPORT

Data that can be imported and exported

- Copier / Document Server Features
- Printer Features
- Scanner Features
- Facsimile Features
- Browser Features
- Extended Feature Settings
- Program (Document Server)
- Program (Copier)
- Program (Scanner)
- Web Image Monitor Setting
- Web Service Settings
- System Settings

Data that cannot be imported or exported

- Some System Settings *1 *2
 - *1 The setting for the date, settings that require the device certificate, and settings that need to be adjusted for each machine (for example, image adjustment settings) cannot be imported or exported.
 - *2 Settings only for executing functions and settings only for viewing cannot be imported or exported.
- Extended Feature Settings
- Address book
- Programs (fax function)
- Programs (printer function)
- User stamp in Copier / Document Server Features
- Settings that can be specified via telnet
- @Remote-related data
- Counters
- EFI printer unit settings
- Settings that can only be specified via Web Image Monitor or Web Service (for example, Bonjour, SSDP setting)

Exporting Device Information

This can be exported / imported by an administrator with all privileges.

When exporting SP device information from the control panel, the data is saved on an SD card.

1. **Insert an SD card into the media slot on the side of the control panel.**
2. **Log in from the control panel as an administrator with all privileges.**
3. **Press [System Settings].**
4. **Press [Administrator Tools].**
5. **Press [Next] four times.**
6. **Press [Device Setting Information: Export (Memory Storage Device)].**



w_d1825501

7. **Set the export conditions.**

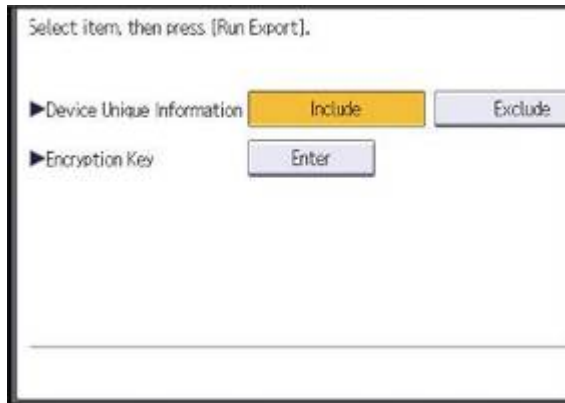

w_d1825502

- Specify whether to [Include] or [Exclude] the "Device Unique Information". "Device Unique Information" includes the IP address, host name, fax number, etc.
- Specify an encryption key.

8. Press [Run Export].

9. Press [OK].

10. Press [Exit].

11. Log out.

ⓘ Note

- If data export fails, the details of the error can be viewed in the log.
- When device Information is periodically imported, it is necessary to create the device setting information file with special software and store it on the web server.

Importing Device Information

This can be exported / imported by an administrator with all privileges.

Import device information saved on an SD card.

1. Insert an SD card into the media slot on the side of the control panel.
2. Log in from the control panel as an administrator with all privileges.
3. Press [System Settings].
4. Press [Administrator Tools].
5. Press [Next] four times.
6. Press [Device Setting Information: Import (Memory Storage Device)].
7. Configure the import conditions.

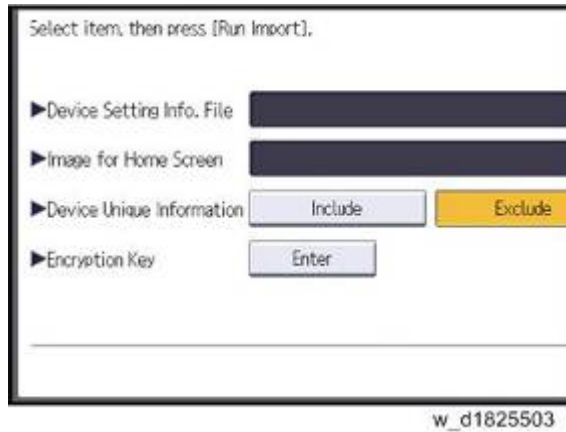

- Press [Select] of the "Device Setting Info. File" to select the file(s) to import.
- When inserting a file into a home screen, press [Select] for the Image for Home screen and select the file. You cannot use this setting when using the Smart Operation Panel.
- Specify whether to [Include] or [Exclude] the "Device Unique Information". "Device Unique Information" includes the IP address, host name, fax number, etc.
- Enter the encryption key that was specified when the file was exported.

8. Press [Run Import].

9. Press [OK].

10. Press [Exit].

The machine restarts.

Note

- If data export fails, the details of the error can be viewed in the log.

5.24.3 SP DATA IMPORT/EXPORT

Data that can be imported and exported

- System SP
- Printer SP
- Fax SP
- Scanner SP

Exporting Device Information

When exporting SP device information from the control panel, the data is saved on an SD card.

1. **Insert an SD card into the media slot on the side of the control panel.**
2. **Enter SP mode.**
3. **Press SP5-749-001 (Import/Export: Export)**
4. **Select “Target” SP settings (System/Printer/Fax/Scanner) to be exported.**
5. **Select “Option” settings (Unique/Secret).**

Item	Specification	Note
Unique	Unique information of the machine is included in the exported file if you select "Unique" setting.	<p>Unique information that can be updated</p> <p>#1. Items that are to be used to identify the machine. Example: Network Information/ Host name / Information related to fax number /Mail address assigned to the machine</p> <p>#2. Items for specifying the options equipped on the machine. Example: Lot number for developer</p> <p>Unique information that cannot be updated</p> <p>#1. Items that may cause a problem if imported Example: Serial number / Information related to @Remote</p> <p>#2. Items for managing the history of the machine Example: Time and date / Counter information / Installation date</p> <p>#3. Setting values for the Engine</p>

Item	Specification	Note
Secret	Secret information is exported if you select "Secret" setting.	<p>Secret information</p> <p>#1. Data that cannot be exported without being encrypted. (Exported data is encrypted.) Example: Password / Encryption key / PIN code</p> <p>#2. Confidential information for the customer Example: User name / User ID / Department code / Mail address / Phone number</p> <p>#3. Personal information Example: Document name / Image data</p> <p>#4. Sensitive information for the customer Example: MAC address / Network parameters</p>

* The IP address is exported when both 'Unique' and 'Secret' are selected.

6. Select "Crpt config" setting (Encryption).

Encryption	<p>Select whether to encrypt or not when exporting.</p> <p>If you push the "Encryption" key, you can export secret information.</p>	<p>If the encryption function is used, setting of an encryption key is required by direct input.</p> <ul style="list-style-type: none"> ▪ Type the arbitrary password using the soft keyboard ▪ Can enter up to 32 characters
------------	---	---

7. Press [Execute].

8. Press [OK].

Note

- If data export fails, the details of the error can be viewed in the log.

Importing Device Information

Import device information saved on an SD card.

1. **Insert an SD card into the media slot on the side of the control panel.**
2. **Enter SP mode.**
3. **Press SP5-749-101(Import/Export: Import)**
4. **Select a unique setting.**
5. **Press [Encryption Key], if the encryption key was created when the file was exported.**
6. **Select an encryption setting.**

Unique	If you want to apply the unique information to the target machine, select the "Unique" key.	Refer to the above information.
Encryption	If an encrypted file is selected as the import file, this setting is required.	

7. **Press [Execute].**
8. **Press [OK].**

Note

- If data export fails, the details of the error can be viewed in the log.

5.24.4 POSSIBLE SOLUTIONS FOR IMPORT/EXPORT PROBLEMS

The access log file is created when export/import is executed. The file is stored in the same location as the exported device setting information file.

If an error occurs, check the log's result code in the access log file first. Values other than 0 indicate that an error occurred.

The result code will appear in the circled area illustrated below.

- Example of a log file

```

*1,0,0*
*ExecType*, *Date*, *SerialNo*, *PnP*, *Model*, *Destination*, *IP*, *Host*, *Storage*, *FileName*
*FileID*, *TotalItem*, *NumOfOkItem*, *ResultCode*, *ResultName*, *Identifier*
*IMPORT*
*2012-07-05T15:29:16+09:00*
*3C35-7M0014*
*Brand Name*
*Product Name*
*0*
*10*
*10.250.155.125*
*RNP00267332582D*
*SD*
*201207051519563C35-710220.csv*
*201207051519563C35-710220*
* 0*
* 2*
*.....ID REQUEST*
*TargetID*, *ModuleID*, *PrefID*, *Item*, *NgCode*, *NgName*
  
```

w_d1825500

If you cannot solve the problem or do not know how to solve it after checking the code, note down the error log entry, then contact your supervisor.

Result Code	Cause	Solutions
2 (INVALID REQUEST)	A file import was attempted between different models or machines with different device configurations.	Import files exported from the same model with the same device configurations.
4 (INVALID OUTPUT DIR)	Failed to write the device information to the destination device.	Check whether the destination device is operating normally.
7 (MODULE ERROR)	An unexpected error occurred during import or export.	Switch the power off and then back on, and then try the operation again. If the error persists, contact your supervisor.

Result Code	Cause	Solutions
8 (DISK FULL)	The available storage space on the external medium is insufficient.	Execute the operation again after making sure there is enough storage space.
9 (DEVICE ERROR)	Failed to write or read the log file.	Check whether the path to the folder for storing the file or the folder in which the file is stored is missing.
10 (LOG ERROR)	The hard disk is faulty.	Contact your supervisor.
20 (PART FAILED)	Failed to import some settings.	<p>The reason for the failure is logged in "NgCode". Check the code.</p> <p>Reason for the Error (Ng-Name)</p> <p>2. INVALID VALUE The specified value exceeds the allowable range.</p> <p>3. PERMISSION ERROR The permission to edit the setting is missing.</p> <p>4. NOT EXIST The setting does not exist in the system.</p> <p>5. INTERLOCK ERROR The setting cannot be changed because of the system status or interlocking with other specified settings.</p> <p>6. OTHER ERROR The setting cannot be changed for some other reason.</p>
21 (INVALID FILE)	Failed to import the file because it is in the wrong format in the external medium.	<p>Check whether the file format is correct.</p> <p>The import file should be a CSV file.</p>
22 (INVALID KEY)	The encryption key is not valid.	Use the correct encryption key.

 **Note**

- When exporting device information from the control panel, the data can be saved only on an SD card.
- The file format for exports is CSV.

5.25 ADDRESS BOOK EXPORT/IMPORT

5.25.1 EXPORT

Backup address book information on SD card formatted with the specified software.

1. Switch the power OFF.
2. Remove the SD slot cover [A] (🔩 x1).

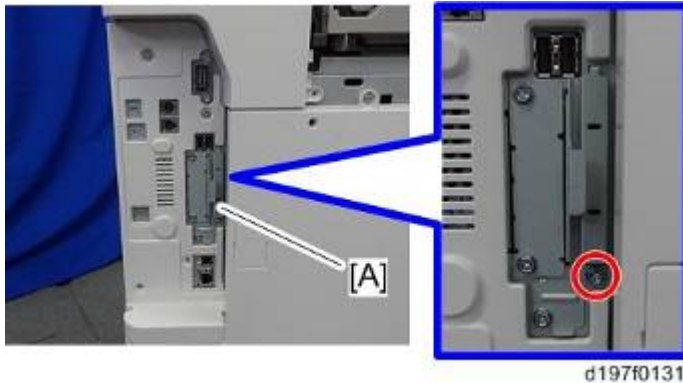

3. Insert the SD card in the service slot [A].

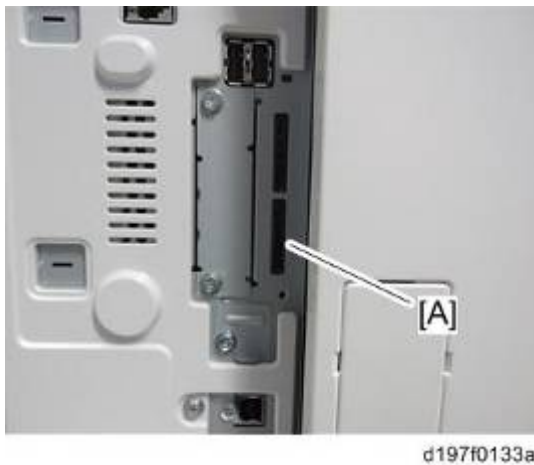

4. Switch the power ON.
5. Execute SP5-846-051 full address book backup.
6. Switch the power OFF.
7. Remove the SD card.
8. Attach the SD slot cover to the original position (🔩 x1).

ⓘ Note

- When local user information to be uploaded is not contained in the SD card, an execute malfunction is displayed. It cannot be used in the write-protect state.
- Since the address book is the customer's information, take care about handling it, and never bring it back.

5.25.2 IMPORT

1. **Switch the power OFF.**
2. **After removing the SD slot cover of the controller unit, set the SD card in the service slot.**
3. **Switch the power ON.**
4. **Execute SP5-846-052 (address book information restore).**
5. **Switch the power OFF.**
6. **Remove the SD card.**
7. **Attach the SD slot cover to the original position (🔒 x1).**
8. **Switch the power ON, and check that the address book has been restored.**

Note

- User code counter information is initialized.
- Administrator and supervisor information is not backed up. Also, it is not erased during restore.
- If a download file does not exist, or if erasure is complete, execution malfunction is displayed.

5.25.3 SPECIFICATION

The information which can be exported /imported is the following items.

- Entry information
- User code information
- E-mail information
- Protection code information
- Fax information
- Fax additional information
- Group information
- Title information
- Title position information
- Folder information
- SMTP attestation
- Local authorization
- Folder authorization information
- Account ACL information
- New document initial ACL information
- LDAP authorization information

5.26 RFU UPDATING THE FIRMWARE

In this machine, software can be updated by remote control using @Remote.

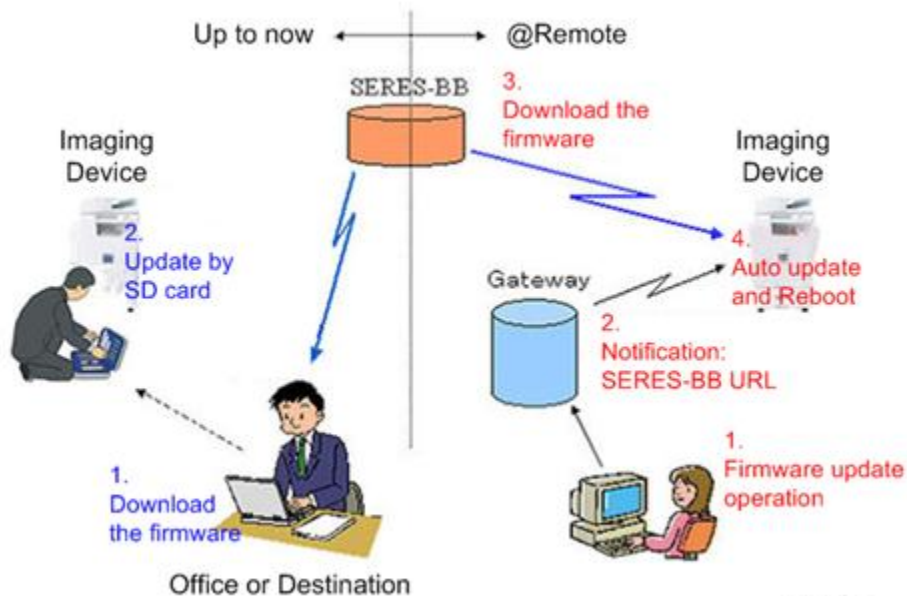

w_d1463115a

5.26.1 RFU PERFORMABLE CONDITION

RFU is performable for a device which meets the following conditions.

1. The customer consents to the use of RFU.
2. The device is connected to a network via TCP/IP for @Remote.

5.27 PACKAGE FIRMWARE UPDATE

⚠ CAUTION

- The HDD unit must be installed on the machine to enable the SFU or the package firmware update via SD card.

5.27.1 OVERVIEW

Each firmware module (such as System/Copy, Engine, etc) used to be updated individually. However, an all-inclusive firmware package (package_ALL) is now available.

There are two ways to update using the firmware package.

- Package Firmware Update via a network: SFU (Smart Firmware Update)
- Package Firmware Update with an SD card

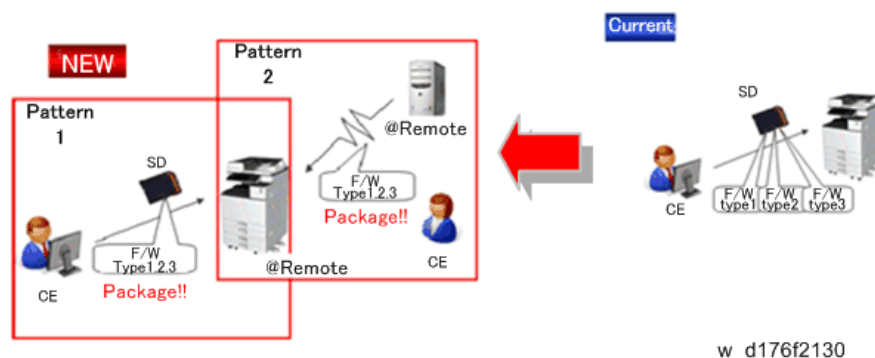

Package Firmware Update via a network: SFU (Smart Firmware Update)

- There are two methods for SFU.
 - Immediate Update: To update the firmware when visiting
 - Update at the next visit: To set the date and time for downloading. The firmware will be automatically downloaded beforehand and updated at the following visit.
- “Update at the next visit” is recommended since firmware download may take some minutes due to the network condition.

⬇ Note

- SFU requires the connection to @Remote via a device which has the embedded @Remote communicating function. When a machine is connected to @Remote via an intermediate device (RC Gate), the SFU function is disabled.

Package Firmware Update via an SD Card

Package firmware update can also be performed using the conventional SD card method by writing the package firmware directly to the SD card.

Types of firmware update files, supported update methods:

	SFU	SD	RFU
Individual firmware	N/A	Available	Available
Package firmware	Available	Available	N/A

5.27.2 IMMEDIATE UPDATE

Enter the [Firmware Update] menu in the SP mode and update the package firmware.

Note

- The [Firmware Update] button will appear even when a machine is connected to @Remote with a device which does not have an embedded @Remote communicating function.
- If an error code is displayed, refer to Error screens during updating (page 5-416).

1. Enter the SP mode.
2. Touch [Firmware Update].

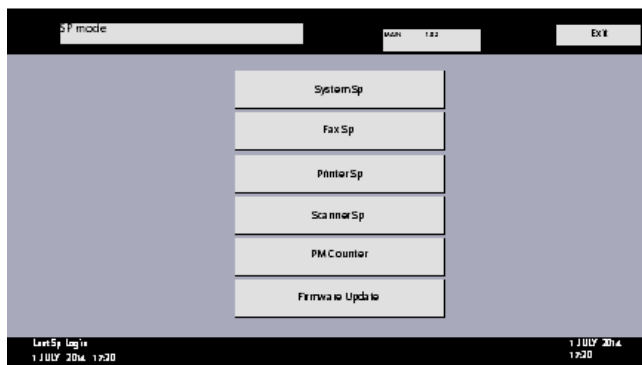

3. Touch [Update].

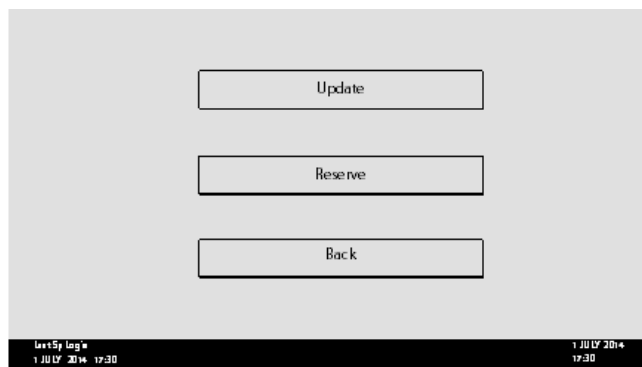

4. Touch [Execute Update].

Package Firmware Update

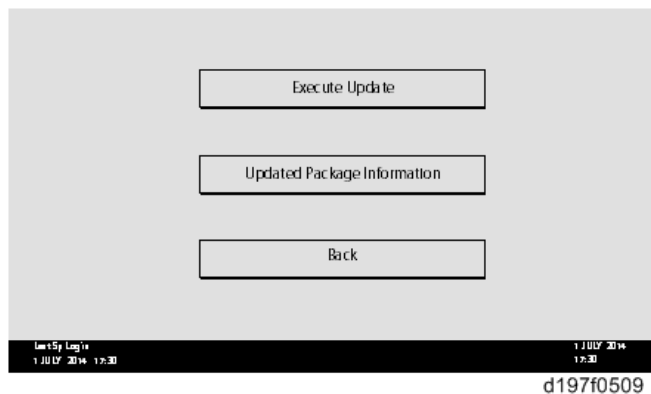

5. Touch [YES].

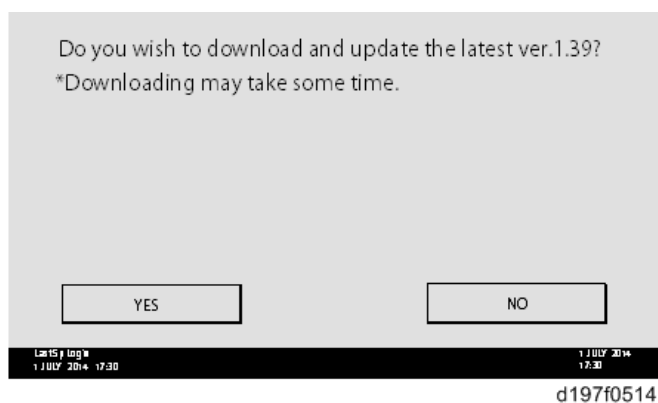

6. The following display will be displayed.

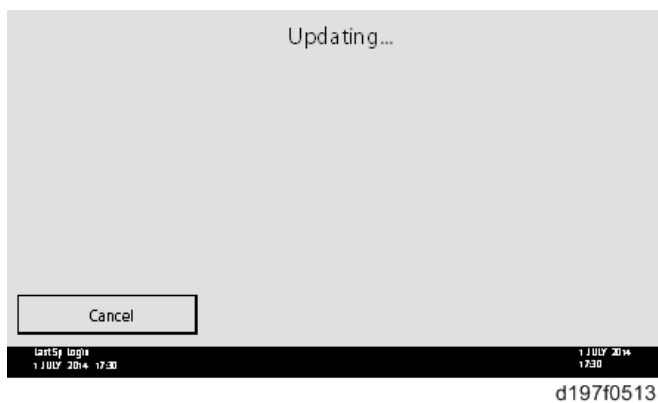

↓ Note

- If the error code E66, which indicates that the download of the firmware has failed, is displayed, implement this procedure from step 1.
- Update will be started automatically after the download is finished.
- When the machine is in the update mode, the automatic update is suspended if a print job is implemented. After the print job is finished, touch [YES] on the display shown with the following picture to restart updating.

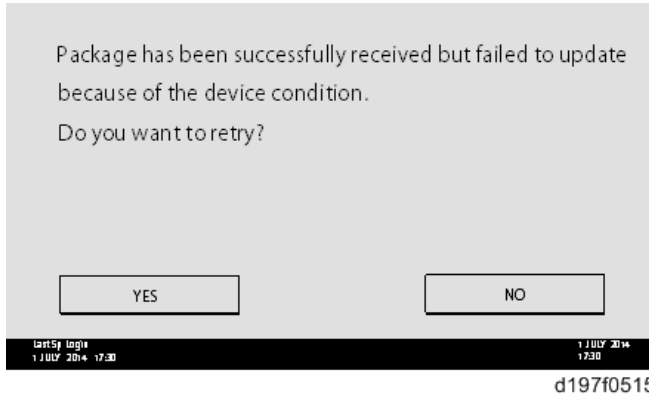

1. [Update done] is displayed.

- The machine will automatically reboot itself.

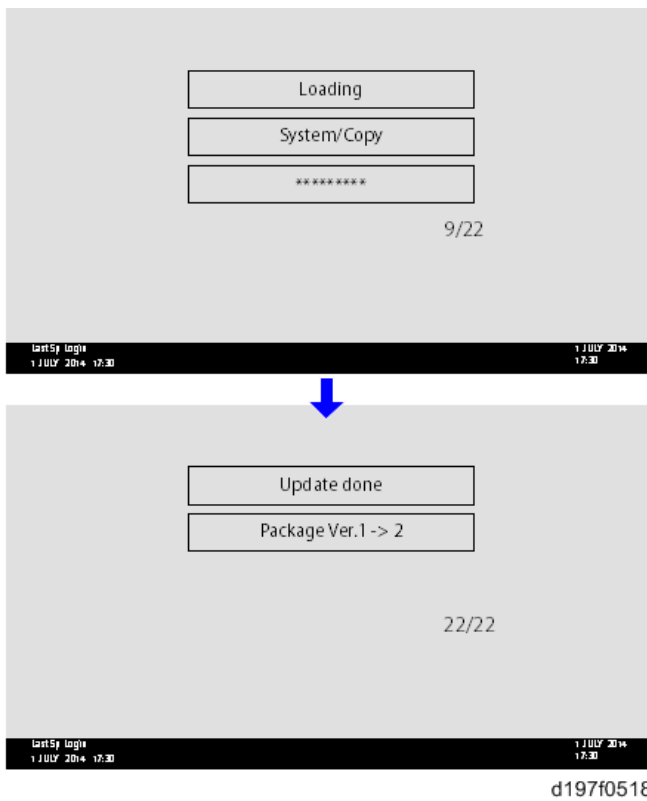

ⓘ Note

- The figures at the lower right of the display indicate “Number of updated items/ All items to be updated”.

5.27.3 UPDATE AT THE NEXT VISIT (RESERVE)

It is possible to set the machine to download the package firmware which is necessary for SFU in advance, and then perform the actual installation at the next service visit. This saves waiting time for the firmware to download at the service visit.

How to Set the Machine to Download Firmware Later (RESERVE)

Enter the [Firmware Update] menu in the SP mode and update the package firmware.

Note

- The [Firmware Update] button will appear even when a machine is connected to @Remote with a device which does not have an embedded @Remote communicating function. If an error code is displayed, refer to page 5-416.

1. Enter the SP mode.
2. Touch [Firmware Update].

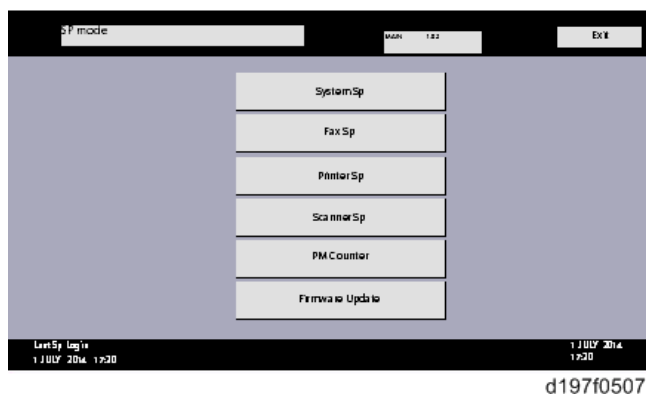

3. Touch [Reserve].

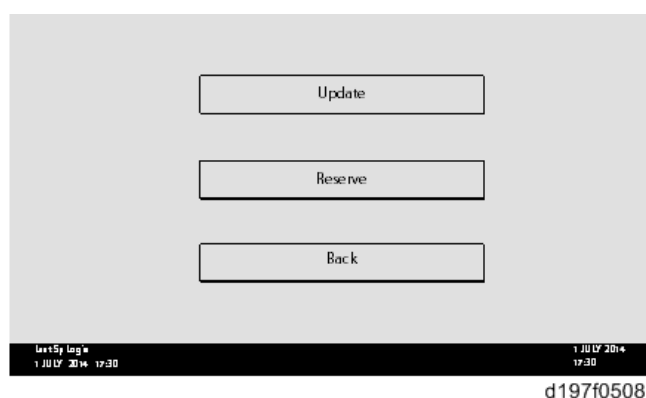

4. Touch [Reservation setting].

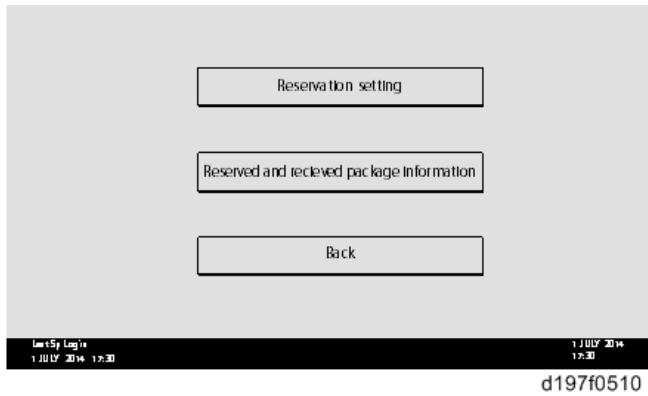

5. Enter the dates and times of next visit and start of receiving data.

- "Next time to visit this customer": The package firmware will be automatically downloaded by this time/date.
- "When to receive? (1-7)": The download of the package firmware will begin this number of days before the next visit.

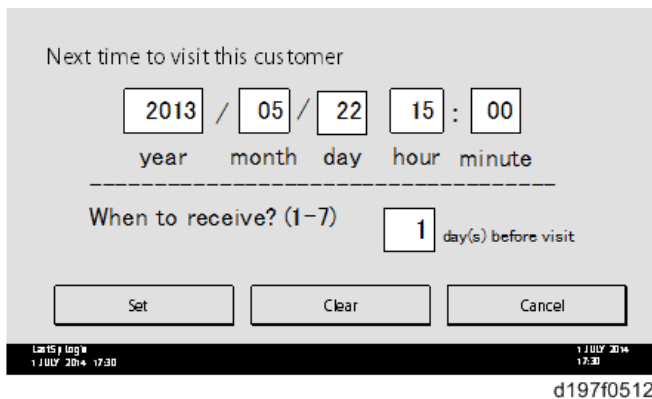

Successful Download

In the two diagrams below, the firmware is set to be downloaded by the day before the next scheduled visit. In the first diagram, the download is successful on the first try. In the second diagram, the download fails three times and is successful on the fourth try.

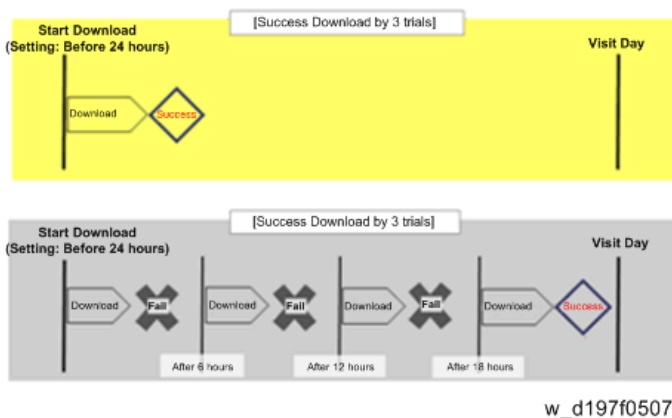

- If the firmware download fails or cannot be completed due to the network settings/condition, no power to the machine, or other reason, the machine will continue retrying every six hours until the scheduled deadline (up to a maximum of four tries). For example, if the download is

Package Firmware Update

set for the day before the next visit, the machine will attempt the download at 24 hours before the visit, and then continue trying every six hours (max. four tries total).

- The retry is only performed in cases when the firmware download has failed.
- If the machine is in Energy Saver mode when the download is scheduled to begin, the download will be performed in the background and the machine/panel will stay in Energy Saver mode.
- The download will continue uninterrupted even if the customer initiates a print job, copy job, fax receiving or other operation while the download is in progress.
- The download will be terminated if the customer turns the power off while the download is in progress.
- If the download cannot be completed successfully by the time of the next scheduled visit, the machine will stop trying to download the firmware.

How to Check if the Firmware Downloaded with RESERVE

1. Enter the SP mode.
2. Touch [Firmware Update].

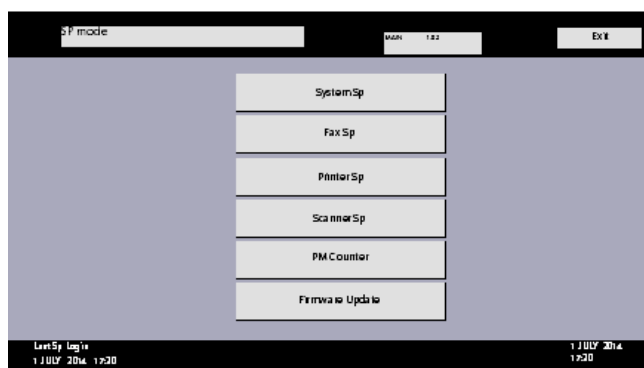

d197f0507

3. Touch [Reserve].

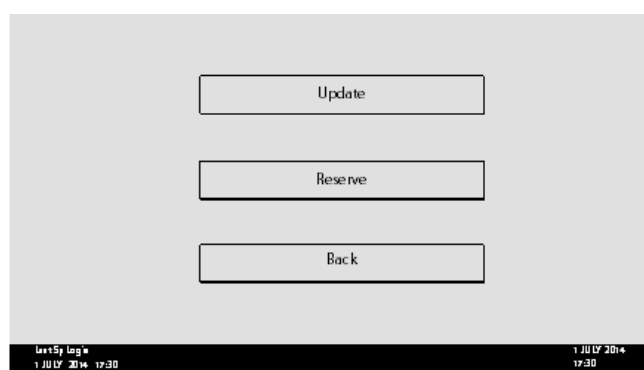

d197f0508

4. Touch [Reserve and received package information].

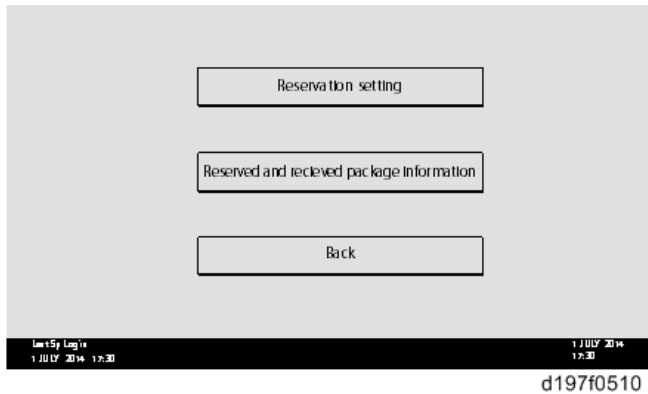

5. Check the information displayed.

When the package firmware is downloaded successfully, the details of the download result are displayed as the following picture shows.

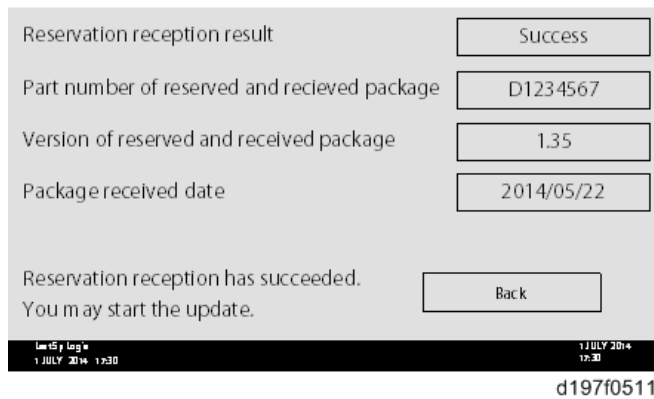

ⓘ Note

- This information will only be displayed if the reserved firmware has already been downloaded. If not, all the data items are indicated with "-".

How to Install Firmware Downloaded with RESERVE

1. Enter the SP mode.
2. Touch [Firmware Update].

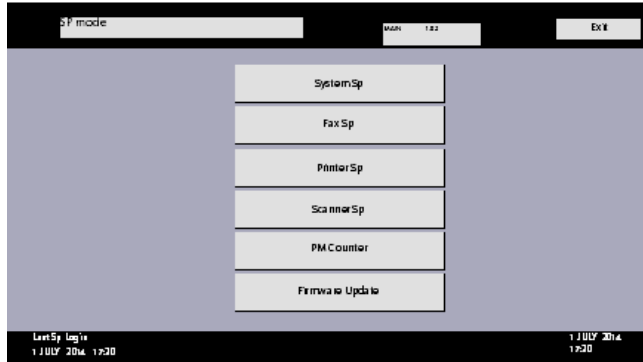

d197f0507

3. Touch [Update].

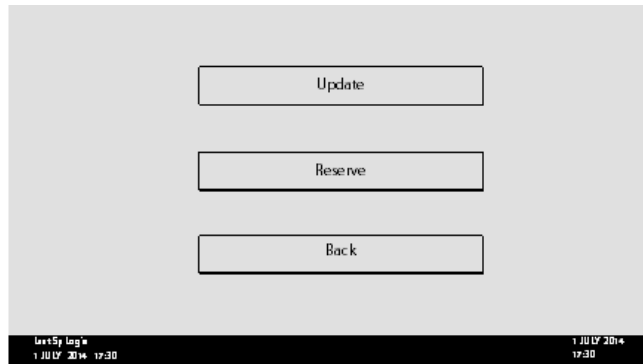

d197f0508

4. Touch [Execute Update].

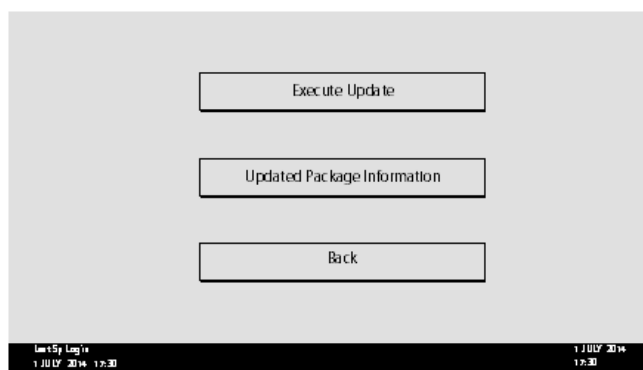

d197f0509

5. Check the version of the received package firmware, and then touch [YES].
 - Update is started.

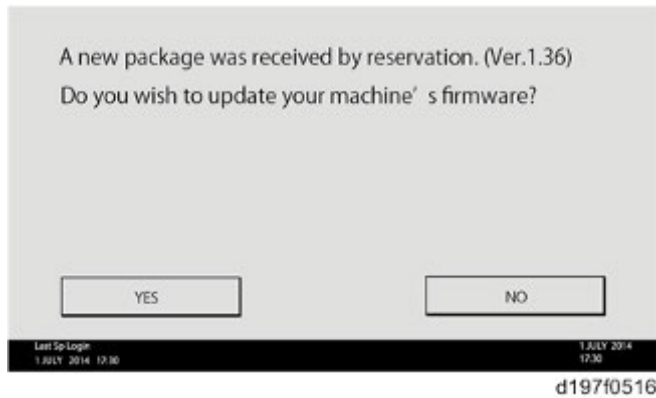

↓ Note

- If the version of the reserved package in the HDD is older than the latest version, the messages shown in the following picture are displayed.

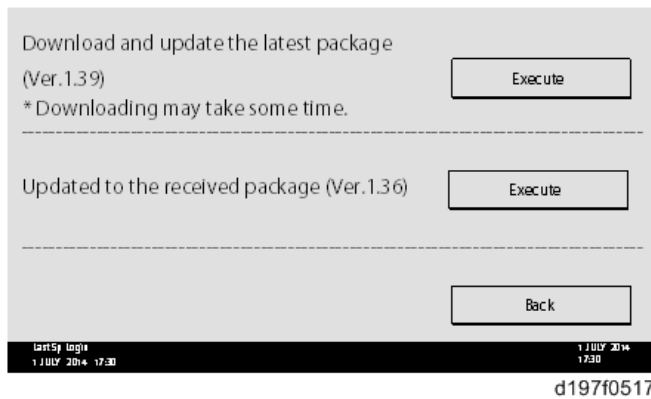

- If you wish to download the latest version, touch [Execute] beside the message “Download and update the latest package.” Then update of the package firmware will be started.
- If you wish to update using the firmware in the HDD (old version), touch [Execute] beside the message “Update to the received package.”

6. [Update done] message is displayed.

- The machine will automatically reboot itself.

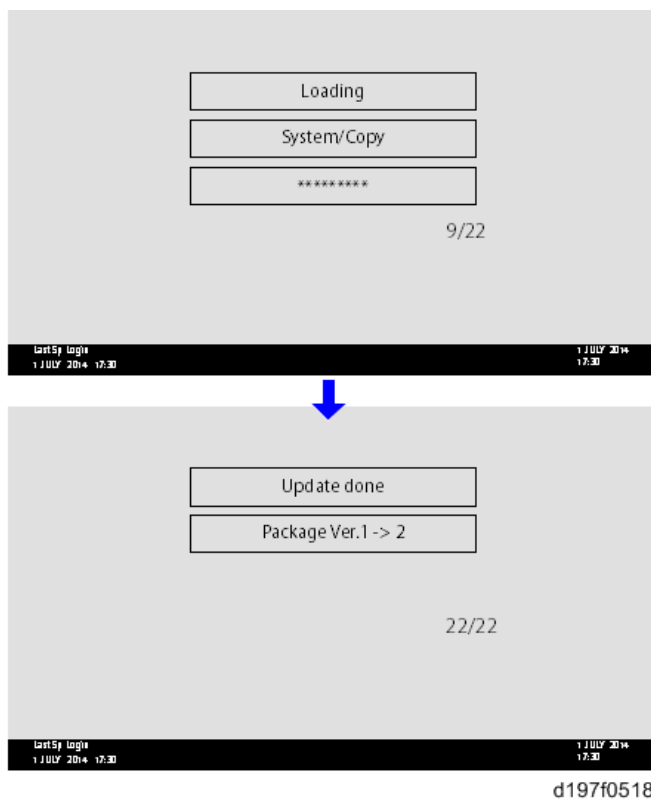

Note

- The figures at the lower right of the display indicate “Number of updated items/ All items to be updated”.

5.27.4 UPDATE VIA SD CARD

Update with an SD card, which is the conventional method, is available if you write the package firmware to the SD card.

Note

- If an error code is displayed, refer to page 5-416.
1. Create a new folder in the SD card, and then name it “package”.
 2. Copy the package firmware (xxxxxxx.pkg) to this folder.



Important

- If you copy the package firmware into the conventional “romdata” folder, the update will not work.

- Only one version of the package firmware should be copied into the folder. If you copy multiple versions of package firmware to the SD card, the machine will select only one version of the firmware randomly.
3. Turn the power OFF.
 4. Insert the SD card which contains the package into SD card slot 2 (for service).
 5. Turn the power ON and touch [Update].

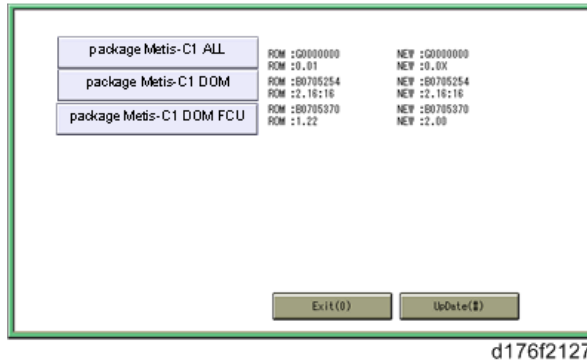

Note

- When the SD card contains both a firmware package and one or more modules, the following display may show up. Select [Package] and touch [OK] to move to step 4 above.

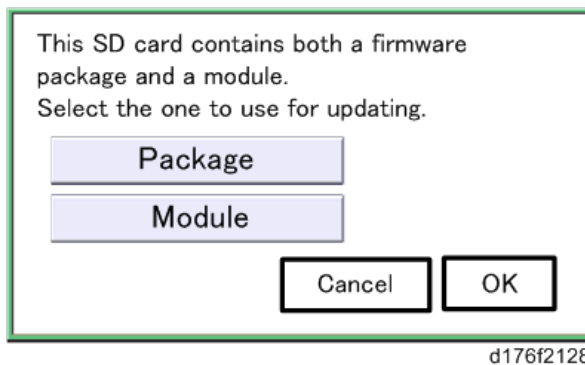

6. Update is started automatically after the package firmware download to the HDD has been completed.
7. When update is completed, "Update done" is displayed.

Package Firmware Update

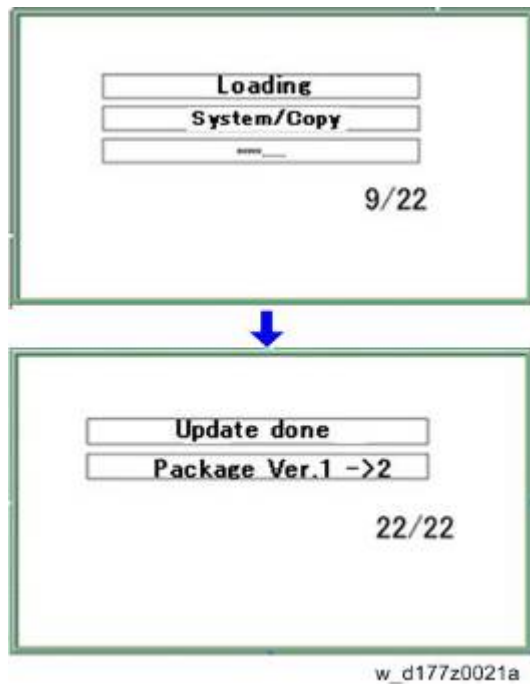

ⓘ Note

- The figures at the lower right of the display indicate “Number of updated items/ All items to be updated”.

8. Turn the main power switch OFF, and then pull out the SD card from SD card slot 2.
9. Turn the power ON.

5.28 CAPTURING THE DEBUG LOGS

5.28.1 OVERVIEW

With this feature, you can save debug logs that are stored in the machine (HDD or operation panel) on an SD card. It allows the Customer Engineer to save and retrieve error information for analysis.

The Capturing Log feature saves debug logs for the following three.

- Controller debug log
- Engine debug log
- Debug log of the operation panel

★ Important

- In older models, a technician enabled the logging tool after a problem occurred. After that, when the problem had been reproduced, the technician was able to retrieve the debug log.
- However, this new feature saves the debug logs at the time that problems occur. Then you can copy the logs to an SD card.
- You can retrieve the debug logs using a SD card without a network.
- Analysis of the debug log is effective for problems caused by the software. Analysis of the debug log is not valid for the selection of defective parts or problems caused by hardware.

Types of debug logs that can be saved

Type	Storage Timing	Destination (maximum storage capacity)
Controller debug log (GW debug log)	<ul style="list-style-type: none"> ▪ Saved at all times 	HDD (4 GB) Compressed when written to an SD card from the HDD (from 4 GB to about 300 MB)
Engine debug log	<ul style="list-style-type: none"> ▪ When an engine SC occurs ▪ When paper feeding/output stop by jams ▪ When the machine doors are opened during normal operation 	HDD (Up to 300 times)

Type	Storage Timing	Destination (maximum storage capacity)
Operation panel debug log	<ul style="list-style-type: none"> ▪ When a controller SC occurs ▪ When saving by manual operation with the Number keys and the Reset key (Press "Reset", "0", "1" and "C"(hold for 3 seconds)) ▪ When the operation unit detects an error ▪ When the operation panel detects an error 	<p>Operation panel (400 MB /Up to 30 times)</p> <p>When updating the firmware for the operation panel, the debug logs are erased.</p>

Note

- Debug logs are not saved in the following conditions.
- While erasing all memory
- While data encryption equipment is installed
- While changing the firmware configuration
- Forced power OFF (accidentally disconnecting the outlet)
- Engine debug log in shutdown
- When the power supply to the HDD is off because of energy saving (engine OFF mode /STR mode)

Security of the Operation Log

The following operation logs related to security are not saved.

- User ID
- Password
- IP address
- Telephone number
- Encryption key
- Transition to SP mode

Also the following operation logs are not saved.

- Number keys (0 to 9) on the operation panel
- Soft keyboard on the touch panel display
- External keyboard

5.28.2 RETRIEVING THE DEBUG LOGS

★ Important

- Retrieve debug logs to identify the date of occurrence of the problems and to find details of the problems
- e.g.: At around 8:00 am on March 10, an engine stall occurred. The operation panel does not respond. Turn the main power supply off / on.
- You need to retrieve the debug logs dating back three days from the date of the problem.
- Analysis of the debug log is effective for problems caused by the software. Analysis of the debug log is not valid for the selection of defective parts or problems caused by hardware.

Procedure for Retrieving the Debug Log

1. Insert the SD card into the slot on the side of the operation panel.

★ Important

- It is recommended to use the SD card provided as a service part. This is because the log data can be acquired much faster than when using commercially available SD cards.

2. Enter SP mode.
3. Set the start date of the log with SP5-857-101 (Start date of debug log output)
e.g.: March 28, 2013: input 20130328 (yyyymmdd)

↓ Note

- Set the date three days earlier than the occurrence of the problems.

4. Set the end date of the log with SP5-857-102 (End date of debug log output)
e.g.: March 31, 2013: input 20130331 (yyyymmdd)
5. Execute SP5-857-103 (Get a debug log of all) to write the debug log to the SD card.
If the transfer is finished successfully, 'completed' is displayed on the touch panel display.

↓ Note

- The approximate time it takes to transfer the debug log is as follows. Transfer time may be affected by the type or format of the SD card. (It is recommended that you format the SD card using the Panasonic SD Formatter (freeware)).
- Controller debug log (GW debug log): 2 - 20 minutes
- Engine debug log: 2 minutes
- Operation panel debug log: 2 - 20 minutes

6. Make sure that the SD card access LED is off, then remove the SD card.

↓ Note

- If 'failed' appears on the touch panel display, turn the power off, and then recover from step 1 again.

Capturing the Debug Logs

The debug logs are saved with the following file names.

Controller debug log (GW debug log)	/LogTrace/machine number/watching/yyyymmdd_hhmmss_unique identification number.gz
Engine debug log	/LogTrace/machine number/engine/yyyymmdd_hhmmss.gz
Operation panel debug log	/LogTrace/machine number/opepanel/yyyymmdd_hhmmss.tar.gz

5.29 SP TEXT MODE (SAVING SMC LIST TO SD CARD)

5.29.1 OVERVIEW

SP Text Mode

This function is used to save the SMC list as CSV files to the SD card inserted into service slot 2 or the operation panel card slot.

5.29.2 PROCEDURE

1. Turn the main power switch **OFF**.
2. Insert the SD card into slot 2 or the operation panel SD card slot. Then turn the power **ON**.
3. Enter **SP mode**.
4. Select **“Copy SP”**.

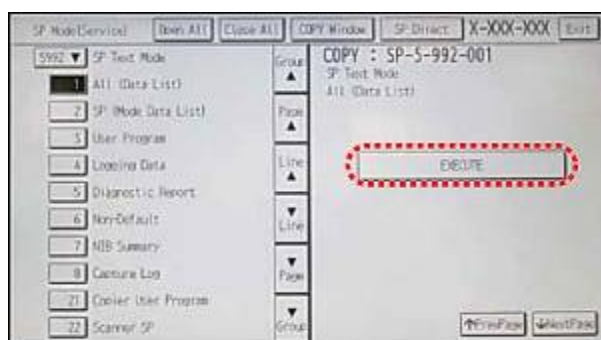

d1440127

5. Select **SP5-992 (SP Text Mode)**.
6. Select a detail SP number shown below to save data on the SD card.
SP5-992-xxx (SP Text Mode)

Detail No.	SMC Categories to Save
001	All (Data List)
002	SP (Mode Data List)
003	User Program
004	Logging Data
005	Diagnostic Report
006	Non-Default
007	NIB Summary

SP Text Mode (Saving SMC List to SD Card)

Detail No.	SMC Categories to Save
008	Capture Log
021	Copier User Program
022	Scanner SP
023	Scanner User Program
024	SDK/J Summary
025	SDK/J Application Info
026	Printer SP

7. Press [EXECUTE].

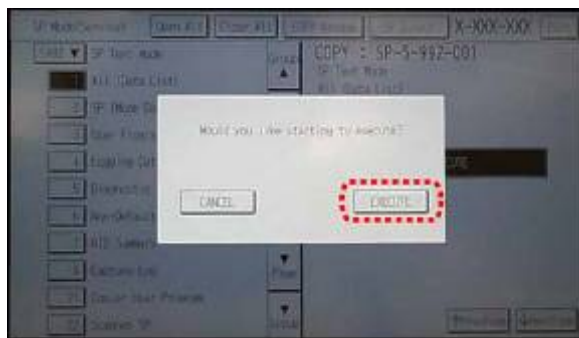

d1440128

8. Press [EXECUTE] again to start. Press [CANCEL] to cancel the saving.



d1440130

9. "It is executing it" is shown on the screen while executing.

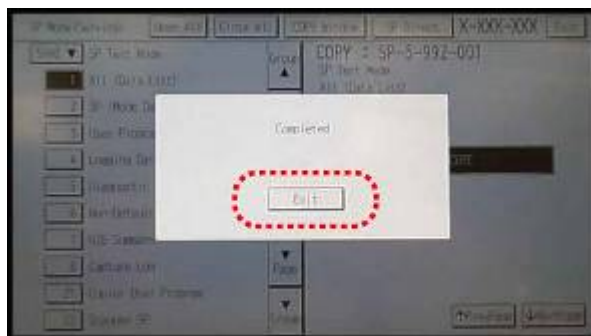

d1440129

10. Wait for 2 to 3 minutes until “Completed” is shown.

Note

- The SMC list saving may take from 2 to 3 minutes to complete.
- Press [CANCEL] to abort executing.

11. Press [Exit] to exit from SP mode.

5.29.3 FILE NAMES OF THE SAVED SMC LISTS

The SMC list data saved on the SD card will be named automatically. The file naming rules are as follows.

Example:

W490M000006_5992001_20130214_053902.csv

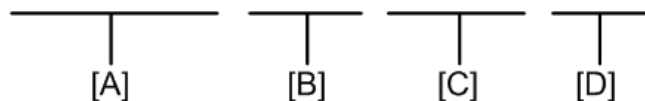

d1822109

A: Machine serial number (fixed for each machine)

B: The first four digits indicate the SP number. The last three digits indicate the branch number.

C: File creation date (YYYY/MM/DD)

D: File creation time (HH/MM/SS)

Note

- A folder named by the machine serial number will be created on the SD card when this function is executed.

5.29.4 ERROR MESSAGES

▪ **Failed:**

Read-only file system, No space left on device. If an error occurs, pressing “Exit” will cause the device to discard the job and return to the ready state.

TROUBLESHOOTING

6. TROUBLESHOOTING

6.1 SELF-DIAGNOSTIC MODE

6.1.1 SERVICE CALL CODES

Service Call Conditions

Pattern	Display	How to reset	SC call or SC alarm in customer support system
A	The SC is displayed on the operation panel, and the machine cannot be used (safety-related SC).	Execute CE reset SP mode, and switch main power from OFF to ON. ⚠ CAUTION <ul style="list-style-type: none"> When canceling a fusing unit SC, (SC544-00/SC554-00/SC564-00/SC574-00), perform part replacement in accordance with the above procedure. 	Occurrence & alarm count ↓ Immediate alarm
B	When a function is selected, the SC is displayed on the operation panel, and the machine cannot be used (down-time mitigation).	Switch main power from OFF to ON.	Occurrence & alarm count ↓ Power OFF → ON ↓ Alarm count and alarm only if recurrence
C	No display on the operation panel, and use is permitted.	Count only logging.	Occurrence ↓ Logging count & alarm count

Pattern	Display	How to reset	SC call or SC alarm in customer support system
D	The SC is displayed on the operation panel, and the machine cannot be used (machine-error SC).	Switch main power from OFF to ON.	Occurrence & alarm count ↓ Power OFF → ON ↓ Alarm count and alarm only if recurrence

↓ Note

- When an ordinary SC (type D) is generated, an automatic reboot is performed. When an event is reported by the customer support system, even in the event of an ordinary SC, reboot is not performed. During automatic reboot, a confirmation screen is displayed after the reboot.
- When automatic reboot occurs twice continuously, an SC is displayed without rebooting, and logging count is performed. Also, when an SMC print is output, an * mark is added alongside the SC number for clarity.
- Automatic reboot can be enabled or disabled with SP5-875-001 (SC automatic reboot setting) (default value: ON).

6.1.2 SC LOGGING

When an SC is generated, the "total count value when the SC is generated" and the "SC code" are logged. However, if the total count value during the SC is the same as last time, logging is not performed.

Logged data can be checked by outputting an administrative report (SMC print). The SC history is logged up to the last 10 entries, and if there are more than 10 entries, data are progressively deleted starting from the oldest.

6.1.3 SC AUTOMATIC REBOOT

When an ordinary SC (pattern D) is generated, automatically reboot is performed. Automatic reboot or reboot by user operation can be set by SP5-875-001 (SC automatic reboot setting out) (default value: 0 "Automatic reboot").

When a type D occurs, automatic reboot is done or the machine display asks the customer if it can reboot. However, when the SC occurs twice in a short time, the machine sends a report to the @Remote server without rebooting. This is because just rebooting may not be a good solution if an SC occurs twice.

When an automatic reboot is performed, a confirmation screen is displayed after reboot. The confirmation screen can be cancelled by pressing the [OK] key (display is not cancelled only when the main power switch is switched OFF to ON).

Screen display during reboot

- Status display on the current screen
 - Post-processing Post-processing during printing, etc.
 - Automatic reboot After operation end
- Post-processing
- ■ □ □ □ □ □ □ □ □
- Until automatic reboot
- □ □ □ □ □ □ □ □ □
- Reset key (Reboot key)
- Key to perform reboot
- # Cancel key is not displayed.
- Turn on spanner LED (same as when an SC is generated).

Operation during SC reboot

- Timing of SC reboot

When @Remote is enabled, and when a NRS alarm*1 is not generated, the corresponding SC is the object of an automatic reboot.

*1 NRS alarm: Issued when an ordinary SC (type D) is generated twice while the total counter counts 10 times.
- Time to automatic reboot

Reboot is performed 30 seconds after an engine reboot is possible, after the end of post-processing during printing, etc.

At that time, a reboot is performed even if the MFP is operating. The engine does not start process control when a reboot is possible.
- Automatic reboot

See the flowchart below.

Self-Diagnostic Mode

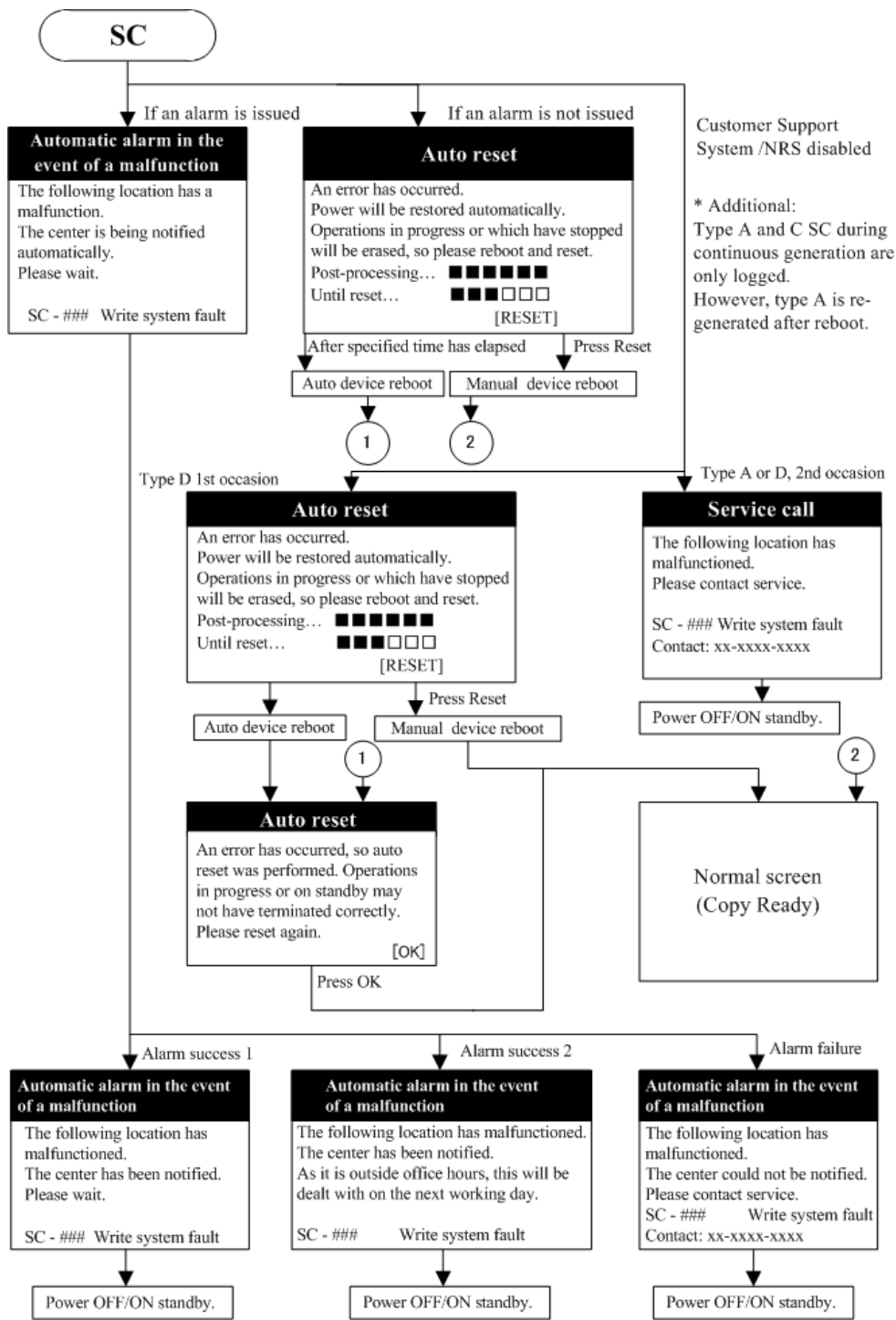

Customer Support System /NRS disabled

* Additional:
Type A and C SC during continuous generation are only logged. However, type A is re-generated after reboot.

w_d1462643

6.2 SC TABLES: SC1XX (SCANNING)

6.2.1 SC101-01 TO SC195-00

SC No.	Level	Error Name/Error Condition/Major Cause/Solution
SC101-01	D	Lamp Error (Scanning)
		<p>The white level peak did not reach the prescribed threshold when the white plate was scanned.</p> <ul style="list-style-type: none"> ▪ LED defective ▪ IDB (LED driver) defective ▪ SBU defective ▪ IPU defective ▪ Power/signal harness defective ▪ Condensation in scanner unit ▪ Mirrors or lenses dirty or positioned incorrectly ▪ White plate dirty or installed incorrectly
		<ol style="list-style-type: none"> 1. Turn the power off/on. 2. Perform the following operations: <ul style="list-style-type: none"> ▪ Reconnect the power/signal harness. ▪ Reattach/clean the mirrors/lenses. ▪ Reattach/clean the white plate. 3. Replace the following parts: <ul style="list-style-type: none"> ▪ Replace the scanner lamp (LED board). ▪ Replace the SIO board. ▪ Replace the lens block (SBU board). ▪ Replace the IPU board. ▪ Replace the power/signal harness.

SC No.	Level	Error Name/Error Condition/Major Cause/Solution
SC101-02	D	Lamp Error (LED illumination adjustment)
		LED error was detected.
		<ul style="list-style-type: none"> ▪ LED defective ▪ IDB (LED driver) defective ▪ Power/signal harness defective
		<ol style="list-style-type: none"> 1. Turn the power off/on. 2. Perform the following operations: <ul style="list-style-type: none"> ▪ Reconnect the power/signal harness. 3. Replace the following parts: <ul style="list-style-type: none"> ▪ Replace the scanner lamp (LED board). ▪ Replace the SIO board. ▪ Replace the power/signal harness.

SC No.	Level	Error Name/Error Condition/Major Cause/Solution
SC102-00	D	LED Illumination Adjustment Error
		The white level peak reached the prescribed threshold when the white plate was scanned after a specified number of adjustments.
		<ul style="list-style-type: none"> ▪ LED defective ▪ IDB (LED driver) defective ▪ SBU defective ▪ IPU defective ▪ Power/signal harness defective
		<ol style="list-style-type: none"> 1. Turn the power off/on. 2. Reconnect the power/signal harness. 3. Replace the following parts: <ul style="list-style-type: none"> ▪ Replace the scanner lamp (LED board). ▪ Replace the lens block (SBU board). ▪ Replace the SIO board. ▪ Replace the IPU board. ▪ Replace the power/signal harness.

SC No.	Level	Error Name/Error Condition/Major Cause/Solution
SC120-00	D	Scanner Home Position Error 1
		<p>The scanner home position sensor does not go OFF.</p> <p>Details:</p> <p>Error detection timing</p> <ul style="list-style-type: none"> ▪ During homing (when the machine is turned ON or when it returns from energy save mode) ▪ During an automatic adjustment (when the machine is turned ON or when it returns from energy save mode) ▪ During a scan from the ADF or exposure glass.
		<ul style="list-style-type: none"> ▪ Scanner motor driver defective ▪ Scanner motor defective ▪ Scanner HP sensor defective ▪ Harness defective ▪ Timing belt, pulley, wire, or carriage not installed correctly
		<p>Replace the following parts:</p> <ul style="list-style-type: none"> ▪ Replace the HP sensor ▪ Replace the scanner motor ▪ Replace the harness. ▪ Reattach or replace the timing belt, pulleys, wires, or carriage unit.

SC No.	Level	Error Name/Error Condition/Major Cause/Solution
SC121-00	D	Scanner Home Position Error 2
		The scanner home position sensor does not go ON. Details: Error detection timing <ul style="list-style-type: none"> ▪ During homing ▪ During an automatic adjustment ▪ During a scan from the ADF or exposure glass.
		<ul style="list-style-type: none"> ▪ Scanner motor driver defective ▪ Scanner motor defective ▪ Scanner HP sensor defective ▪ Harness defective ▪ Timing belt, pulley, wire, or carriage not installed correctly
		Replace the following parts: <ul style="list-style-type: none"> ▪ Replace the home position sensor ▪ Replace the scanner motor ▪ Replace the harness. ▪ Reattach or replace the timing belt, pulleys, wires, or carriage unit.

SC No.	Level	Error Name/Error Condition/Major Cause/Solution
SC141-00	D	Black Level Detection Error
		The black level cannot be adjusted within the target during auto gain control.
		<ul style="list-style-type: none"> ▪ SBU defective ▪ IPU defective ▪ Power/signal harness defective
		<ol style="list-style-type: none"> 1. Turn the power off/on. 2. Reconnect the power/signal harness. 3. Replace the following parts: <ul style="list-style-type: none"> ▪ Replace the lens block (SBU board). ▪ Replace the IPU board. ▪ Replace the power/signal harness.

SC No.	Level	Error Name/Error Condition/Major Cause/Solution
SC142-00	D	White Level Detection Error
		<p>The white level cannot be adjusted to the second target level within the target during auto gain control.</p> <ul style="list-style-type: none"> ▪ SBU defective ▪ LED defective ▪ IDB (LED driver) defective ▪ IPU defective ▪ Power/signal harness defective ▪ Scanner drive error ▪ Condensation in scanner unit ▪ Mirrors or lenses dirty or positioned incorrectly ▪ White plate dirty or installed incorrectly
		<ol style="list-style-type: none"> 1. Turn the power off/on. 2. Perform the following operations: <ul style="list-style-type: none"> ▪ Reconnect the power/signal harness. ▪ Reattach/clean the mirrors/lenses. ▪ Reattach/clean the white plate. 3. Replace the following parts: <ul style="list-style-type: none"> ▪ Replace the lens block (SBU board). ▪ Replace the scanner lamp (LED board). ▪ Replace the IPU board. ▪ Replace the SIO board. ▪ Replace the power/signal harness.

SC No.	Level	Error Name/Error Condition/Major Cause/Solution
SC144-00	D	SBU Communication Error
		<ul style="list-style-type: none"> ▪ Connection to SBU cannot be confirmed. (Connection detection error) ▪ Cannot communicate with the SBU, or the communication result is abnormal.
		<ul style="list-style-type: none"> ▪ SBU defective ▪ The other side of the communication (BCU, IPU etc.) defective ▪ Power/signal harness defective
		<ol style="list-style-type: none"> 1. Turn the power off/on. 2. Reconnect the power/signal harness. 3. Replace the following parts: <ul style="list-style-type: none"> ▪ Replace the lens block (SBU board). ▪ Replace the IPU board. ▪ Replace the BCU board. ▪ Replace the power/signal harness.

SC No.	Level	Error Name/Error Condition/Major Cause/Solution
SC165-00	D	Copy Data Security Unit Error
		<ul style="list-style-type: none"> ▪ The copy data security option is enabled in the User Tools but the option board is detected as missing or defective. ▪ The copy data security option was detected as defective when the machine was turned on or returned from energy save mode.
		<ul style="list-style-type: none"> ▪ Copy data security unit board not installed correctly ▪ Copy data security unit board defective
		<ul style="list-style-type: none"> ▪ Reinstall the copy data security unit board. ▪ Replace the copy data security unit board.

SC No.	Level	Error Name/Error Condition/Major Cause/Solution
SC185-00	D	CIS Transmission Error
		<p>The data read from the ASIC register on the CIS were not as expected.</p> <p>Details:</p> <ul style="list-style-type: none"> ▪ Occurs when a serial communication error between the CIS board and the DF board is detected. Occurs also when an error is detected during initialization of the ASIC on the CIS. ▪ This can happen during initialization and feeding. The first and second consecutive occurrences of each constitute jams. The third occurrence constitutes an SC.
		<ul style="list-style-type: none"> ▪ Connector or harness between DF board and CIS board is disconnected or defective ▪ ASIC on the CIS is defective ▪ Boot failure of ASIC on the CIS <hr/> <ul style="list-style-type: none"> ▪ Reconnect the power/signal harness. ▪ Replace the CIS unit (CIS and CIPB). ▪ Replace the ADF control board. ▪ Replace the power/signal harness.

SC No.	Level	Error Name/Error Condition/Major Cause/Solution
SC186-00	D	CIS LED Error
		<p>During initialization:</p> <ul style="list-style-type: none"> ▪ The ratio between the average values of leading-edge area and rear-edge area is out of specification. ▪ Shading data peak value is below specification. <p>During scanning:</p> <ul style="list-style-type: none"> ▪ Shading data peak value is below specification. <p>Details:</p> <p>During initialization:</p> <ul style="list-style-type: none"> ▪ Occurs when one out of two CIS LEDs is malfunctioning, causing the difference between the average values of leading-edge area and rear-edge area to be large (CIS LED error detection). ▪ Occurs when both of the CIS LEDs are malfunctioning (unlit), causing the shading data peak value to be extremely low (CIS white level adjustment). <p>During scanning:</p> <ul style="list-style-type: none"> ▪ Occurs when both of the CIS LEDs are malfunctioning (unlit), causing the shading data peak value to be extremely low (CIS scan control, gray balance adjustment / confirmation). ▪ The first and second consecutive occurrences of each constitute initial/feed jams. The third occurrence constitutes an SC.
		<p>During initialization:</p> <ul style="list-style-type: none"> ▪ One or two out of two CIS LEDs are defective <p>During scanning:</p> <ul style="list-style-type: none"> ▪ Both of the CIS LEDs are defective.
		<ul style="list-style-type: none"> ▪ Reconnect the power/signal harness. ▪ Replace the CIS unit (CIS and CIPB). ▪ Replace the CIS background white roller. ▪ Replace the power/signal harness. ▪ Replace the ADF main control board.

SC No.	Level	Error Name/Error Condition/Major Cause/Solution
SC187-00	D	CIS Black Level Error
		<p>The black level scanned by CIS is abnormal.</p> <p>Details:</p> <ul style="list-style-type: none"> ▪ Occurs when abnormality is detected in the process of black level generation – detection. ▪ The first and second consecutive occurrences constitute initial jams. The third occurrence constitutes an SC.
		CIS defective
		Replace the CIS unit (CIS and CIPB).

SC No.	Level	Error Name/Error Condition/Major Cause/Solution
SC188-00	D	CIS White Level Error
		<ul style="list-style-type: none"> ▪ The shading data peak value read out from the CIS is abnormal. <p>Details:</p> <ul style="list-style-type: none"> ▪ Occurs when abnormality is detected in the process of CIS shading data peak detection. ▪ The first and second consecutive occurrences constitute initial jams. The third occurrence constitutes an SC.
		<ul style="list-style-type: none"> ▪ CIS defective ▪ CIS background white roller is scratched, dirt, or improperly connected.
		<ul style="list-style-type: none"> ▪ Reconnect the power/signal harness. ▪ Replace the CIS unit (CIS and CIPB). ▪ Replace the CIS background white roller. ▪ Replace the power/signal harness.

SC No.	Level	Error Name/Error Condition/Major Cause/Solution
SC189-00	D	CIS Gray Balance Adjustment Error
		The difference between gray balance adjustment target value and the value scanned from the GS20 chart was out of specification upon execution of gray balance adjustment confirmation (SP4-705-002). Details:
		<ul style="list-style-type: none"> ▪ Occurs when gray balance adjustment fails. ▪ The first occurrence constitutes an SC (not an initial jam).
		<ul style="list-style-type: none"> ▪ CIS defective ▪ The GS20 chart is scratched or deteriorated due to dirty.
		<ul style="list-style-type: none"> ▪ Replace the GS20 chart. ▪ Replace the CIS unit.

SC No.	Level	Error Name/Error Condition/Major Cause/Solution
SC195-00	D	Machine Serial Number Error
		Comparison of the product identification code in the machine serial number (11 digits).
		The product identification code in the machine serial number (11 digits) does not match.
		Re-enter the machine serial number.

6.3 SC TABLES: SC2XX (EXPOSURE)

6.3.1 SC202-00 TO SC270-10

SC No.	Level	Error Name/Error Condition/Major Cause/Solution
SC202-00	D	Polygon Motor: ON Timeout Error
		After the polygon motor turned on, or within 10 sec. after the rpm's changed, the motor did not enter READY status.
		<ul style="list-style-type: none"> ▪ The interface harness to the polygon motor driver damaged or not connected correctly. ▪ Polygon motor or polygon motor driver defective ▪ Polygon motor drive pulse cannot be output correctly. (Polygon controller) ▪ XSCRDY signal observation failing (Polygon controller)
		<ul style="list-style-type: none"> ▪ Turn the power off/on. ▪ Replace the laser unit. ▪ Replace the harness. ▪ Replace the IPU board.

SC No.	Level	Error Name/Error Condition/Major Cause/Solution
SC203-00	D	Polygon Motor: OFF Timeout Error
		The XSCRDY signal (polygon ready) never becomes inactive (H) within 3 sec. after the polygon motor went OFF.
		<ul style="list-style-type: none"> ▪ The interface harness to the polygon motor driver damaged or not connected correctly. ▪ Polygon motor or polygon motor driver defective ▪ Polygon motor drive pulse cannot be output correctly. (Polygon controller) ▪ XSCRDY signal observation failing (Polygon controller)
		<ul style="list-style-type: none"> ▪ Turn the power off/on. ▪ Replace the laser unit. ▪ Replace the harness. ▪ Replace the IPU board.

SC No.	Level	Error Name/Error Condition/Major Cause/Solution
SC204-00	D	Polygon Motor: XSCRDY Signal Error
		During polygon motor rotation, the XSCRDY signal was inactive (H) for longer than one rotation of the polygon.
		<ul style="list-style-type: none"> ▪ The interface harness to the polygon motor driver damaged or not connected correctly. ▪ Polygon motor or polygon motor driver defective
		<ul style="list-style-type: none"> ▪ Turn the power off/on. ▪ Replace the laser unit. ▪ Replace the harness. ▪ Replace the IPU board.

SC No.	Level	Error Name/Error Condition/Major Cause/Solution
SC220-00	D	Laser Synchronization Detection Error: Leading Edge
		The laser synchronizing detection signal for the start position of the LD was not output for 200msec. after LDB unit turned on with the polygon motor rotating normally.
		<ul style="list-style-type: none"> ▪ The interface harness to the synchronization detection unit damaged or not connected correctly. ▪ Synchronization detection board defective ▪ Beam does not enter photo detector. ▪ Abnormality around GAVD ▪ IDB (LED driver) defective ▪ LDB defective ▪ IPU defective
		<ul style="list-style-type: none"> ▪ Turn the power off/on. ▪ Replace the laser unit. ▪ Replace the harness. ▪ Replace the IPU board

SC No.	Level	Error Name/Error Condition/Major Cause/Solution
SC230-00	D	FGATE ON Error
		The FGATE signal did not turn ON within the given time period after the writing process started.
		<ul style="list-style-type: none"> ▪ GAVD defective ▪ Image processing ASIC defective ▪ BCU, controller board not connected correctly or defective ▪ Harness between BCU and LDB defective
		<ul style="list-style-type: none"> ▪ Turn the power off/on. ▪ Replace the harness between IPU and laser unit. ▪ Replace the IPU board. ▪ Replace the controller board.

SC No.	Level	Error Name/Error Condition/Major Cause/Solution
SC231-00	D	FGATE OFF Error
		The FGATE signal did not turn OFF within the given time period after the writing process ended.
		<ul style="list-style-type: none"> ▪ GAVD defective ▪ Image processing ASIC defective ▪ IPU, controller board not connected correctly or defective ▪ Harness between IPU and LDB defective
		<ul style="list-style-type: none"> ▪ Turn the power off/on. ▪ Replace the harness between IPU and laser unit. ▪ Replace the IPU board. ▪ Replace the controller board.

SC No.	Level	Error Name/Error Condition/Major Cause/Solution
SC240-00	D	LD Error
		<ul style="list-style-type: none"> ▪ The LD error status of LD driver is asserted after the LD is initialized. ▪ The LD driver's error signal is detected during LD initialization.
		<ul style="list-style-type: none"> ▪ LD degradation (LD broken, shift of output characteristics etc.) ▪ The interface harness damaged or not connected correctly. ▪ LD driver defective
		<ul style="list-style-type: none"> ▪ Cycle the main power off/on. ▪ Replace the laser unit. ▪ Replace the harness. ▪ Replace the IPU board.

SC No.	Level	Error Name/Error Condition/Major Cause/Solution
SC270-00	D	GAVD Communication Error
		When machine starts or cancels the energy saving
		<ul style="list-style-type: none"> ▪ GAVD defective ▪ CPU defective ▪ BCU defective
		<ul style="list-style-type: none"> ▪ Cycle the main power off/on. ▪ Replace the IPU board. ▪ Replace the controller board. ▪ Replace the BCU board. ▪ Set the FCC between BCU and IPU.

SC No.	Level	Error Name/Error Condition/Major Cause/Solution
SC272-01	D	LD Driver Communication Error
		<p>If the value is not same when the machine reads and writes the same registration at the machine start-up.</p> <p>If the communication parity retries three consecutive times, the SC is generated.</p>
		<ul style="list-style-type: none"> ▪ CPU defective ▪ IPU defective ▪ BCU defective ▪ Harness defective
		<ul style="list-style-type: none"> ▪ Cycle the main power off/on. ▪ Replace the laser unit. ▪ Replace the harness ▪ Replace the IPU board
SC272-10	D	LD Driver Communication Error: Others
		<p>If the “Door Open” status does not change to “Door Close” after closing the door.</p>
		<ul style="list-style-type: none"> ▪ CPU defective ▪ IPU defective ▪ BCU defective ▪ Harness defective
		<ul style="list-style-type: none"> ▪ Cycle the main power off/on. ▪ Replace the laser unit. ▪ Replace the harness. ▪ Replace the IPU board.

6.4 SC TABLES: SC3XX (IMAGE PROCESSING1 (CHARGE, DEVELOPMENT))

6.4.1 SC302-00 TO SC392-01

SC No.	Level	Error Name/Error Condition/Major Cause/Solution
SC302-00	D	High Voltage Power Source: Charge: Output Error
		The machine detects the error detection signal "L (unexpected)" 10 times for 200 msec consecutively when monitoring the error signal every 20 msec during outputting the PWM signal.
		<p>Hardware error</p> <ul style="list-style-type: none"> ▪ Input / Output connector is disconnected. ▪ Input / Output harness is short-circuited. ▪ Surface/air clearance insufficient (arc discharge) ▪ BCU error (signal error) ▪ HVPS defective <p>Load error</p> <ul style="list-style-type: none"> ▪ Grounding fault of charging output, short-circuit with other outputs ▪ Surface/air clearance insufficient in charging output path (including distance from other outputs) ▪ Unexpected deterioration of drum and over current due to pinholes gap error between the drum and charge roller (PCU error). ▪ Over current due to drum surface condensation ▪ PCU is disconnected.
		<ul style="list-style-type: none"> ▪ Cycle the main power off/on. ▪ Replace the high HVPS. ▪ Replace the harness of the HVPS. ▪ Replace the harness of the PCU. ▪ Replace the PCU.

SC Tables: SC3xx (Image Processing1 (Charge, Development))

SC No.	Level	Error Name/Error Condition/Major Cause/Solution
SC324-01	D	Development Motor: Bk: Lock
		Lock signals are observed at 2 sec intervals during motor ON, and a High level is detected at least 20 times
		<ul style="list-style-type: none"> ▪ Motor defective ▪ Connector disconnected ▪ Harness broken ▪ IOB defective ▪ Unit torque increased
		<ul style="list-style-type: none"> ▪ Replace the development motor. ▪ Reconnect the connector. ▪ Replace the harness. ▪ Replace the IOB. ▪ Replace the development unit. ▪ Replace the driven unit.

SC No.	Level	Error Name/Error Condition/Major Cause/Solution
SC360-01	D	TD Sensor Adjustment Error
		<ul style="list-style-type: none"> ▪ When Mu count exceeds the judgment threshold of no developer status. ▪ When Mu count does not satisfy the following target ranges for 3 times in a row. <ul style="list-style-type: none"> ▪ Upper threshold ▪ Lower threshold
		<ul style="list-style-type: none"> ▪ TD sensor defective ▪ Loose connection ▪ Harness broken ▪ Developer toner density differs from initial developer
		<ul style="list-style-type: none"> ▪ Replace the TD sensor. ▪ Replace the development unit.

SC No.	Level	Error Name/Error Condition/Major Cause/Solution
SC361-01	D	TD Sensor Output Error: Upper Limit (K)
		The following condition continuously exceeds the upper limit threshold value (SP3-211-003). <ul style="list-style-type: none"> ▪ TD sensor output: Vt (SP3-210-001) > output upper limit error threshold (SP3-211-002)
		<ul style="list-style-type: none"> ▪ TD sensor connector dropout (connection fault)
		<ul style="list-style-type: none"> ▪ Check if the TD sensor connector is connected. ▪ Check the harness of the TD sensor (disconnection, etc.). ▪ Replace the TD sensor.

SC No.	Level	Error Name/Error Condition/Major Cause/Solution
SC362-01	D	TD Sensor Output Error: Lower limit (K)
		TD sensor output: Vt (SP3-210-001) < output lower limit error threshold (SP3-211-004) is continuously below the lower limit occurrence threshold value (SP3-211-005)
		TD sensor connector missing/dropout
		<ul style="list-style-type: none"> ▪ Check if the TD sensor connector is connected. ▪ Check the harness of the TD sensor (disconnection, etc.). ▪ Replace the TD sensor.

SC No.	Level	Error Name/Error Condition/Major Cause/Solution
SC370-00	C	ID Sensor Calibration Error
		Regular reflection optical output voltage of the ID sensor: Vsg_reg cannot be adjusted to within target range. Upper limit (SP3-320-013: initial value 4.5V) Lower limit (SP3-320-014: initial value 3.5V)
		<ul style="list-style-type: none"> ▪ ID sensor connector missing/ connection fault ▪ ID sensor detection window dirt ▪ ID sensor malfunction
		<ul style="list-style-type: none"> ▪ Check for ID sensor connector missing. If it is missing, reconnect it. ▪ Check for dirt on the ID sensor detection window. If the detection window is dirty, clean by predetermined method (do not wipe dry). ▪ If neither of the above have occurred, perform ID sensor replacement.

SC No.	Level	Error Name/Error Condition/Major Cause/Solution
SC391-00	D	High Voltage Power Source: Development : Output Error
		When the machine detects the error detection signal “L (abnormal)” 10 times for 200 ms consecutively by monitoring the error detection signal every 20ms during output of the PWM signal used as an error detection target.
		<p>Hardware error</p> <ul style="list-style-type: none"> ▪ Input / Output connector is disconnected. ▪ Surface/air clearance insufficient (arc discharge) ▪ Input / Output harness is short-circuited. ▪ BCU error (signal error) ▪ HVPS defective <p>Load error</p> <ul style="list-style-type: none"> ▪ Grounding fault of charging output, short-circuit with other outputs ▪ Surface/air clearance insufficient in charging output path (including distance from other outputs) ▪ Unexpected deterioration of drum, and over current due to pinholes ▪ Over current due to drum surface condensation ▪ PCDU is not set properly.
		<ul style="list-style-type: none"> ▪ Cycle the main power off/on ▪ Replace the harness between the BCU and HVPS. ▪ Reconnect or replace the harness between the BCU and HVPS. ▪ Reinstall or replace the development unit. ▪ Check if the contact and separation movement of the transfer works correctly. ▪ Replace the HVPS. ▪ Replace the BCU.

SC No.	Level	Error Name/Error Condition/Major Cause/Solution
SC396-01	D	Drum Motor Lock
		Lock signals are observed at 2 sec intervals during motor ON, and a High level is detected at least 20 times.
		<ul style="list-style-type: none"> ▪ Motor defective ▪ Connector disconnected ▪ Harness broken ▪ IOB defective ▪ PCU torque increased
		<ul style="list-style-type: none"> ▪ Reconnect the connector. ▪ Replace the harness of the drum/waste toner motor. ▪ Replace the drum/waste toner motor. ▪ Replace the PCU. ▪ Replace the IOB.

6.5 SC TABLES: SC4XX (IMAGE PROCESSING2 (AROUND THE DRUM))

6.5.1 SC440-00 TO SC498-00

SC No.	Level	Error Name/Error Condition/Major Cause/Solution
SC440-00	D	High Voltage Power Source: Paper Transfer : Output Error
		The machine detects the error detection signal "L (unexpected)" 10 times for 200 msec consecutively when monitoring the error signal every 20 msec during outputting the PWM signal.
		<p>Hardware error</p> <ul style="list-style-type: none"> ▪ Input / Output connector is disconnected. ▪ Input / Output harness is short-circuited. ▪ IOB error (signal error) ▪ HVPS defective <p>Load error</p> <ul style="list-style-type: none"> ▪ Transfer roller's impedance increases. ▪ Transfer unit is not set properly.
		<ul style="list-style-type: none"> ▪ Cycle the main power off/on. ▪ Reconnect or replace the harness of the HVPS (power pack). ▪ Reconnect or replace the harness between the BCU and the HVPS. ▪ Rset or replacee the transfer unit. ▪ Check if the contact and separation movement of the transfer unit works correctly. ▪ Replace the HVPS. ▪ Replace the BCU.

SC No.	Level	Error Name/Error Condition/Major Cause/Solution
SC452-00	D	Transfer Roller Contact Motor Error
		When the machine does not detect the high/low signal for a specified time after the transfer roller contact motor has been turned on.
		<ul style="list-style-type: none"> ▪ Motor overload, Motor defective ▪ Connector disconnected ▪ Harness broken ▪ Interlock mechanism is defective.
		<ul style="list-style-type: none"> ▪ Cycle the main power off/on ▪ Check if the contact and separation movement of the transfer unit works correctly. ▪ Replace the transfer roller contact motor.

SC No.	Level	Error Name/Error Condition/Major Cause/Solution
SC460-00	D	High Voltage Power Source: Separation : Output Error
		The machine detects the error detection signal "L (unexpected)" 10 times for 200 msec consecutively when monitoring the error signal every 20 msec during outputting the PWM signal.
		<p>Hardware error</p> <ul style="list-style-type: none"> ▪ Input / Output connector is disconnected. ▪ Input / Output harness is short-circuited. ▪ Transfer unit is not set properly. ▪ IOB error (signal error) ▪ HVPS defective <p>Load error</p> <ul style="list-style-type: none"> ▪ Grounding fault of separation power output, short-circuit with other outputs ▪ Surface/air clearance insufficient in separation power output path (including distance from other outputs)

SC No.	Level	Error Name/Error Condition/Major Cause/Solution
		<ul style="list-style-type: none"> ▪ Cycle the main power off/on ▪ Reconnect or replacethe harness of the HVPS (power pack). ▪ Reconnect or replace the harness between the BCU to the HVPS. ▪ Reset or replace the trausfer unit. ▪ Check if the contact and separation movement of the transfer unit works correctly. ▪ Replace the HVPS. ▪ Replace the BCU.

SC No.	Level	Error Name/Error Condition/Major Cause/Solution
SC497-00	C	Machine Temperature Detection Thermistor Error
		The output of the temperature sensor is out of the following range.
		<ul style="list-style-type: none"> ▪ 0.56 V or less (90°C or more) ▪ 3.0 V or more (-18°C or less)
		<ul style="list-style-type: none"> ▪ Connector disconnected or broken ▪ Temperature sensor defective
		<ul style="list-style-type: none"> ▪ Reconnect or replace the harness. ▪ Replace the temperature sensor.

SC No.	Level	Error Name/Error Condition/Major Cause/Solution
SC498-00	C	Temperature and Humidity Sensor Error (Main machine)
		The output of the temperature/humidity sensor is out of the following range. <ul style="list-style-type: none"> ▪ 0.76 V or less/ 2.90 V or more (temperature sensor) ▪ 2.4 V or more (humidity sensor)
		<ul style="list-style-type: none"> ▪ Connector disconnected or broken ▪ Temperature/Humidity sensor defective
		<ul style="list-style-type: none"> ▪ Reconnect or replace the harness. ▪ Replace the temperature/humidity sensor.

6.6 SC TABLES: SC5XX (PAPER FEED AND FUSING)

6.6.1 SC501-01 TO SC589-02

SC No.	Level	Error Name/Error Condition/Major Cause/Solution
SC501-01	B	1st Tray Lift Error
		<p>The machine detects the error of the 1st tray lift motor 3 times consecutively when the 1st tray is lifted.. (The message of resetting the tray is displayed when the machine detects the error consecutively 2 times or less.)</p> <ul style="list-style-type: none"> ▪ 1st tray limit sensor connector disconnection, malfunction or sensor's dirt. ▪ 1st tray lift motor connector disconnection, malfunction ▪ Foreign matter, such as paper scrap, is caught between the paper feed tray and the tray lift motor. ▪ Paper set fault <ul style="list-style-type: none"> ▪ Reset the paper. ▪ Remove the foreign matter. <p>1st tray limit sensor, 1st tray lift motor</p> <ul style="list-style-type: none"> ▪ Check the harness. ▪ Reset the connector. ▪ Replacement <p>1st paper feed unit, 1st tray</p> <ul style="list-style-type: none"> ▪ Replacement <p>Paper transport IOB</p> <ul style="list-style-type: none"> ▪ Replacement
SC501-02	B	1st Tray Lowering Error
		<p>The machine detects the error of the 1st tray lift motor 5 times consecutively when the 1st tray is lowered. (The message of resetting the tray is displayed when the machine detects the error consecutively 4 times or less.)</p>

SC Tables: SC5xx (Paper Feed and Fusing)

SC No.	Level	Error Name/Error Condition/Major Cause/Solution
		<ul style="list-style-type: none"> ▪ 1st tray limit sensor connector disconnection, malfunction or sensor's dirt. ▪ 1st tray lift motor connector disconnection, malfunction ▪ Foreign matter, such as paper scrap, is caught between the paper feed tray and the tray lift motor. ▪ Paper set fault ▪ Paper overload
		<ul style="list-style-type: none"> ▪ Reset the paper. ▪ Remove the foreign matter. <p>1st tray limit sensor, 1st tray lift motor</p> <ul style="list-style-type: none"> ▪ Check the harness. ▪ Reset the connector. ▪ Replacement <p>1st paper feed unit, 1st tray</p> <ul style="list-style-type: none"> ▪ Replacement <p>Paper transport IOB</p> <ul style="list-style-type: none"> ▪ Replacement

SC No.	Level	Error Name/Error Condition/Major Cause/Solution
SC502-01	B	2nd Tray Lift Error
		<p>The machine detects the error of the 2nd tray lift motor 3 times consecutively when the 2nd tray is lifted.. (The message of resetting the tray is displayed when the machine detects the error consecutively 2 times or less.)</p>
		<ul style="list-style-type: none"> ▪ 2nd tray limit sensor connector disconnection, malfunction, dirt ▪ 2nd tray lift motor connector disconnection, malfunction ▪ Foreign matter, such as paper scrap, is caught between the paper feed tray and the tray lift motor ▪ Paper set fault

SC No.	Level	Error Name/Error Condition/Major Cause/Solution
		<ul style="list-style-type: none"> ▪ Reset the paper. ▪ Remove the foreign matter. <p>2nd tray limit sensor, 2nd tray lift motor</p> <ul style="list-style-type: none"> ▪ Check the harness. ▪ Reset the connector. ▪ Replacement <p>2nd paper feed unit, 2nd tray</p> <ul style="list-style-type: none"> ▪ Replacement <p>Paper transport IOB</p> <ul style="list-style-type: none"> ▪ Replacement
SC502-02	B	<p>2nd Tray Lowering Error</p> <p>The machine detects the error of the 2nd tray lift motor 5 times consecutively when the 2nd tray is lowered. (The message of resetting the tray is displayed when the machine detects the error consecutively 4 times or less.)</p> <ul style="list-style-type: none"> ▪ The 2nd paper feed tray limit sensor connector disconnection, malfunction, and dirt ▪ 2nd tray lift motor connector disconnection, malfunction ▪ Foreign matter, such as paper scrap, is caught between the paper feed tray and the tray lift motor ▪ Paper set fault ▪ Paper overload <ul style="list-style-type: none"> ▪ Reset the paper. ▪ Remove the foreign matter. <p>2nd tray limit sensor, 2nd tray lift motor</p> <ul style="list-style-type: none"> ▪ Check the harness. ▪ Reset the connector. ▪ Replacement <p>2nd paper feed unit, 2nd tray</p> <ul style="list-style-type: none"> ▪ Replacement <p>Paper transport IOB</p> <ul style="list-style-type: none"> ▪ Replacement

SC No.	Level	Error Name/Error Condition/Major Cause/Solution
SC503-01	B	3rd Tray Lift Error (D694)
		<p>The machine detects the lift error of the tray lift motor for the PFU (D694) 3 times consecutively when the 3rd tray is lifted at the machine's initialization.</p> <p>(The message of resetting the tray is displayed when the machine detects the error consecutively 2 times or less.)</p>
		<ul style="list-style-type: none"> ▪ Tray lift motor connector disconnected ▪ Limit sensor harness disconnected or broken ▪ Control board defective ▪ Foreign matter, such as paper scrap, is caught between the paper feed tray and the tray lift motor ▪ Paper set fault
		<ul style="list-style-type: none"> ▪ Reset the paper. ▪ Remove the foreign matter. ▪ Replace the tray lift motor. ▪ Reset the connector. ▪ Replace the harness. ▪ Replace the limit sensor. ▪ Replace the control board for the optional PFU (D694). ▪ Replace the tray. ▪ Replace the paper feed roller. ▪ Replace the pick-up arm.
SC503-02	B	3rd Tray Lowering Error (D694)
		<p>The machine detects the lowering error of the tray lift motor for the PFU (D694) 3 times consecutively when the 3rd tray is lowered at the machine's initialization.</p> <p>(The message of resetting the tray is displayed when the machine detects the error consecutively 2 times or less.)</p>

SC No.	Level	Error Name/Error Condition/Major Cause/Solution
		<ul style="list-style-type: none"> ▪ Tray lift motor connector disconnected ▪ Limit sensor harness disconnected or broken ▪ Control board defective ▪ Paper overload ▪ Foreign matter, such as paper scrap, is caught between the paper feed tray and the tray lift motor ▪ Paper set fault <hr/> <ul style="list-style-type: none"> ▪ Reset the paper. ▪ Remove the foreign matter. ▪ Replace the tray lift motor. ▪ Reset the connector. ▪ Replace the harness. ▪ Replace the limit sensor. ▪ Replace the control board for the optional PFU (D694). ▪ Replace the tray. ▪ Replace the paper feed roller. ▪ Replace the pick-up arm.
SC503-11	B	<p data-bbox="507 1149 826 1182">3rd Tray Lift Error (D787)</p> <hr/> <p data-bbox="507 1227 1294 1350">The machine detects the lift error of the tray lift motor for the PFU (D787) 3 times consecutively when the 3rd tray is lifted at the machine's initialization.</p> <p data-bbox="507 1368 1219 1447">(The message of resetting the tray is displayed when the machine detects the error consecutively 2 times or less.)</p> <hr/> <ul style="list-style-type: none"> ▪ Tray lift motor connector disconnected ▪ Limit sensor harness disconnected or broken ▪ Control board defective ▪ Foreign matter, such as paper scrap, is caught between the paper feed tray and the tray lift motor ▪ Paper set fault

SC No.	Level	Error Name/Error Condition/Major Cause/Solution
		<ul style="list-style-type: none"> ▪ Reset the paper. ▪ Remove the foreign matter. ▪ Replace the tray lift motor. ▪ Reset the connector. ▪ Replace the harness. ▪ Replace the limit sensor. ▪ Replace the control board for the optional PFU (D787). ▪ Replace the tray. ▪ Replace the paper feed roller. ▪ Replace the pick-up arm.
SC503-12	B	3rd Tray Lowering Error (D787)
		<p>The machine detects the lowering error of the tray lift motor for the PFU (D787) 3 times consecutively when the 3rd tray is lowered at the machine's initialization. (The message of resetting the tray is displayed when the machine detects the error 2 times consecutively.)</p>
		<ul style="list-style-type: none"> ▪ Tray lift motor connector disconnected ▪ Limit sensor harness disconnected or broken ▪ Control board defective ▪ Paper overload ▪ Foreign matter, such as paper scrap, is caught between the paper feed tray and the tray lift motor ▪ Paper set fault
<ul style="list-style-type: none"> ▪ Reset the paper. ▪ Remove the foreign matter. ▪ Replace the tray lift motor. ▪ Reset the connector. ▪ Replace the harness. ▪ Replace the limit sensor. ▪ Replace the control board for the optional PFU (D787). ▪ Replace the tray. ▪ Replace the paper feed roller. ▪ Replace the pick-up arm. 		

SC No.	Level	Error Name/Error Condition/Major Cause/Solution
SC503-31	B	<p data-bbox="512 331 895 365">3rd Tray Lift Error (LCIT: D695)</p> <ul style="list-style-type: none"> <li data-bbox="512 409 1310 533">▪ The machine detects the lift error of the tray lift motor for the LCIT (D695) 3 times consecutively when the 3rd tray is lowered at the machine's initialization. <li data-bbox="512 551 1310 674">▪ The machine detects the lift error of the tray lift motor for the LCIT (D695) 3 times consecutively when the 3rd tray is lifted at the machine's initialization. <p data-bbox="512 696 1214 775">(The message of resetting the tray is displayed when the machine detects the error consecutively 2 times or less.)</p>
		<ul style="list-style-type: none"> <li data-bbox="512 815 1038 848">▪ Tray lift motor connector disconnected <li data-bbox="512 866 1126 900">▪ Limit sensor harness disconnected or broken <li data-bbox="512 918 855 952">▪ Control board defective <li data-bbox="512 969 1302 1048">▪ Foreign matter, such as paper scrap, is caught between the right tray and the tray lift motor. <li data-bbox="512 1066 751 1099">▪ Paper set fault <li data-bbox="512 1117 951 1151">▪ Timing belt damage or dropout <li data-bbox="512 1169 975 1202">▪ Timing pulley damage or dropout <li data-bbox="512 1220 1142 1254">▪ Base plate damaged or plate horizontality fault <li data-bbox="512 1272 871 1305">▪ Paper feed roller missing <li data-bbox="512 1323 815 1357">▪ Pickup arm damage <li data-bbox="512 1375 1270 1453">▪ Foreign matter, such as paper scrap, is caught inside the right tray. <ul style="list-style-type: none"> <li data-bbox="512 1476 767 1509">▪ Reset the paper. <li data-bbox="512 1527 903 1561">▪ Remove the foreign matter. <li data-bbox="512 1579 887 1612">▪ Replace the tray lift motor. <li data-bbox="512 1630 815 1664">▪ Reset the connector. <li data-bbox="512 1682 823 1715">▪ Replace the harness. <li data-bbox="512 1733 863 1767">▪ Replace the limit sensor. <li data-bbox="512 1785 1246 1818">▪ Replace the control board for the optional LCIT (D695). <li data-bbox="512 1836 767 1870">▪ Replace the tray. <li data-bbox="512 1888 935 1921">▪ Replace the paper feed roller. <li data-bbox="512 1939 871 1973">▪ Replace the pick-up arm. <li data-bbox="512 1991 855 2024">▪ Replace the timing belt. <li data-bbox="512 2042 879 2076">▪ Replace the timing pulley. <li data-bbox="512 2094 855 2128">▪ Replace the base plate.

SC No.	Level	Error Name/Error Condition/Major Cause/Solution
SC503-32	B	<p data-bbox="512 286 975 320">3rd Tray Lowering Error (LCIT: D695)</p> <ul style="list-style-type: none"> <li data-bbox="512 360 1310 488">▪ The machine detects the lift error of the tray lift motor for the LCIT (D695) 3 times consecutively when the 3rd tray is lowered at the machine's initialization. <li data-bbox="512 506 1310 633">▪ The machine detects the lift error of the tray lift motor for the LCIT (D695) 3 times consecutively when the 3rd tray is lifted at the machine's initialization. <p data-bbox="512 651 1214 730">(The message of resetting the tray is displayed when the machine detects the error consecutively 2 times or less.)</p>
		<ul style="list-style-type: none"> <li data-bbox="512 775 1038 808">▪ Tray lift motor connector disconnected <li data-bbox="512 819 1198 853">▪ Lower limit sensor harness disconnected or broken <li data-bbox="512 864 855 898">▪ Control board defective <li data-bbox="512 909 1310 999">▪ Foreign matter, such as paper scrap, is caught between the right tray and the tray lift motor. <li data-bbox="512 1010 743 1043">▪ Paper set fault <li data-bbox="512 1055 951 1088">▪ Timing belt damage or dropout <li data-bbox="512 1099 975 1133">▪ Timing pulley damage or dropout <li data-bbox="512 1144 1142 1178">▪ Base plate damaged or plate horizontality fault <li data-bbox="512 1189 1270 1279">▪ Foreign matter, such as paper scrap, is caught inside the right tray. <hr/> <ul style="list-style-type: none"> <li data-bbox="512 1323 767 1357">▪ Reset the paper. <li data-bbox="512 1368 903 1402">▪ Remove the foreign matter. <li data-bbox="512 1413 887 1447">▪ Replace the tray lift motor. <li data-bbox="512 1458 823 1491">▪ Reset the connector. <li data-bbox="512 1503 831 1536">▪ Replace the harness. <li data-bbox="512 1547 943 1581">▪ Replace the lower limit sensor. <li data-bbox="512 1592 1142 1626">▪ Replace the control board for the LCIT (D695). <li data-bbox="512 1637 775 1671">▪ Replace the tray. <li data-bbox="512 1682 855 1715">▪ Replace the timing belt. <li data-bbox="512 1727 887 1760">▪ Replace the timing pulley. <li data-bbox="512 1771 855 1805">▪ Replace the base plate.

SC No.	Level	Error Name/Error Condition/Major Cause/Solution
SC503-33	B	3rd Tray Paper Overload Error (LCIT: D695)
		<p>Both of the upper limit and lower limit detects the base plate 3 times consecutively at the machine's initialization. (The message of resetting the tray is displayed when the both sensors detect the error consecutively 2 times or less.)</p>
		<ul style="list-style-type: none"> ▪ Paper overload ▪ Paper set fault ▪ Limit sensor harness disconnected or broken ▪ Lower limit sensor harness disconnected or broken ▪ Control board defective ▪ Foreign matter, such as paper scrap, is caught inside the right tray.
		<ul style="list-style-type: none"> ▪ Reset the paper. ▪ Remove the foreign matter. ▪ Reset the connector. ▪ Replace the harness. ▪ Replace the limit sensor. ▪ Replace the lower limit sensor. ▪ Replace the control board for the LCIT (D695).
SC503-34	B	3rd Tray Paper Position Error (LCIT: D695)
		<p>During left/right tray set, or when power is switched ON, or when transfer is complete, "open" is detected 3 times consecutively by end fence open/close detection. (The message of resetting the tray is displayed when the both sensors detect the error consecutively 2 times or less.)</p>
		<ul style="list-style-type: none"> ▪ Paper set fault (paper is offset from position for pushing end fence) ▪ Foreign matter entry (foreign matter is caught in the position for pushing end fence) ▪ End fence open/close sensor error/connector missing ▪ Harness broken ▪ Bank control board defective

SC No.	Level	Error Name/Error Condition/Major Cause/Solution
		<ul style="list-style-type: none"> ▪ Reset the paper. ▪ Remove the foreign matter. ▪ Reset the connector. ▪ Replace the harness. ▪ Replace the sensor. ▪ Replace the control board for the optional paper feed tray.
SC503-35	B	<p data-bbox="510 591 965 629">3rd Tray Transfer Error (LCIT: D695)</p> <ul style="list-style-type: none"> ▪ Transfer end detection error At right tray paper end (right tray lower limit detection, left tray paper detection), left tray paper is transferred to the right tray, but the left tray paper sensor is detected although a predetermined time elapsed (transfer paper missing is not detected), for 3 times consecutively. (The message of resetting the tray is displayed when the both sensors detect the error consecutively 2 times or less.) ▪ Transfer motor error/connector missing ▪ Left tray paper sensor error/connector missing ▪ Harness broken ▪ Bank control board defective ▪ Paper overload ▪ Foreign matter, such as paper scrap, is caught between the left tray and the tray transfer motor ▪ Paper set fault ▪ Timing belt damage/dropout ▪ Timing pulley damage/dropout ▪ Transfer fence defective ▪ Foreign matter, such as paper scrap, is caught inside the left tray

SC No.	Level	Error Name/Error Condition/Major Cause/Solution
		<ul style="list-style-type: none"> ▪ Replace the motor. ▪ Reset the connector. ▪ Replace the harness. ▪ Replace the sensor. ▪ Replace the control board for the optional paper feed tray. ▪ Reset the paper. ▪ Remove the foreign matter. ▪ Replace the tray. ▪ Replace the timing belt. ▪ Replace the timing pulley. ▪ Replace the end fence of the left tray.
SC503-36	B	<p>3rd Tray Transfer HP Error (LCIT: D695)</p> <ul style="list-style-type: none"> ▪ HP detection error (during transfer start) At right tray paper end (right tray lower limit detection, left tray paper detection), left tray paper is transferred to the right tray, but the left tray transfer fence HP sensor is detected although a predetermined time elapsed (HP sensor missing cannot be detected). ▪ HP detection error (during transfer fence HP return) During left tray transfer fence HP not detected (stop after paper transfer, during power supply ON, during left tray set), the left tray transfer fence is moved to HP, but the left tray HP sensor is not detected although a predetermined time elapsed. *If an error occurs 3 times consecutively: LCIT transmits "3rd paper feed tray transfer HP error" to the main machine. (The message of resetting the tray is displayed when the both sensors detect the error consecutively 2 times or less.)

SC No.	Level	Error Name/Error Condition/Major Cause/Solution
		<ul style="list-style-type: none"> ▪ Transfer motor error/connector missing ▪ Left tray transfer fence HP sensor error/connector missing ▪ Harness broken ▪ Bank control board defective ▪ Paper overload ▪ Foreign matter, such as paper scrap, is caught between the left tray and the tray transport motor ▪ Paper set fault ▪ Timing belt damage/dropout ▪ Timing pulley damage/dropout ▪ Transfer fence defective ▪ Foreign matter, such as paper scrap, is caught inside the left tray <hr/> <ul style="list-style-type: none"> ▪ Replace the motor. ▪ Reset the connector. ▪ Replace the harness. ▪ Replace the sensor. ▪ Replace the control board for the optional paper feed tray. ▪ Reset the paper. ▪ Remove the foreign matter. ▪ Replace the tray. ▪ Replace the timing belt. ▪ Replace the timing pulley. ▪ Replace the end fence of the left tray.

SC No.	Level	Error Name/Error Condition/Major Cause/Solution
SC504-21	B	4th Tray Lift Error (D787)
		<ul style="list-style-type: none"> ▪ Lift motor ascent error detection During tray initialization (upper limit not detected/lower limit detection), the tray base plate is raised to check the tray base plate position, but the limit sensor is not detected although a predetermined time elapsed, for 3 times consecutively. (The message of resetting the tray is displayed when the both sensors detect the error consecutively 2 times or less.)
		<ul style="list-style-type: none"> ▪ Lift motor error/connector missing ▪ Limit sensor error/connector missing ▪ Harness broken ▪ Bank control board defective ▪ Foreign matter, such as paper scrap, is caught between the paper feed tray and the tray lift motor ▪ Paper set fault
		<ul style="list-style-type: none"> ▪ Reset the paper. ▪ Remove the foreign matter. ▪ Replace the motor. ▪ Reset the connector. ▪ Replace the harness. ▪ Replace the sensor. ▪ Replace the control board for the optional paper feed tray. ▪ Replace the tray. ▪ Replace the paper feed roller. ▪ Replace the pick-up arm.
SC504-22	B	4th Tray Lowering Error (D787)
		<ul style="list-style-type: none"> ▪ Lift motor descent error detection During tray initialization, the tray base plate is lowered to check the tray base plate position, but the limit sensor is detected although a predetermined time elapsed, for 3 times consecutively. (The message of resetting the tray is displayed when the both sensors detect the error consecutively 2 times or less.)

SC Tables: SC5xx (Paper Feed and Fusing)

SC No.	Level	Error Name/Error Condition/Major Cause/Solution
		<ul style="list-style-type: none"> ▪ Lift motor error/connector missing ▪ Limit sensor error/connector missing ▪ Harness broken ▪ Bank control board defective ▪ Paper overload ▪ Foreign matter, such as paper scrap, is caught between the paper feed tray and the tray lift motor ▪ Paper set fault <hr/> <ul style="list-style-type: none"> ▪ Reset the paper. ▪ Remove the foreign matter. ▪ Replace the motor. ▪ Reset the connector. ▪ Replace the harness. ▪ Replace the sensor. ▪ Replace the control board for the optional paper feed tray. ▪ Replace the tray. ▪ Replace the paper feed roller. ▪ Replace the pick-up arm.

SC No.	Level	Error Name/Error Condition/Major Cause/Solution
SC505-41	B	<p>Side LCIT Limit Detection Error (D696)</p> <ul style="list-style-type: none"> ▪ Upper limit detection error (during descent) During tray initialization (upper limit detection/lower limit not detected), the tray base plate is lowered to check the tray base plate position, but the limit sensor is detected although a predetermined time elapsed. ▪ Upper limit detection error (during ascent) During tray initialization (upper limit not detected /lower limit detection), the tray base plate is raised to check the tray base plate position, but the limit sensor is not detected although a predetermined time elapsed. *If an error occurs for 3 times consecutively: the side LCIT transmits a "5th paper feed tray upper limit detection error" to the main machine. (The message of resetting the tray is displayed when the both sensors detect the error consecutively 2 times or less.)
		<ul style="list-style-type: none"> ▪ Lift motor error/connector missing ▪ Limit sensor error/connector missing ▪ Harness broken ▪ Bank control board defective ▪ Paper set fault ▪ Timing belt damage/dropout ▪ Timing pulley damage/dropout ▪ Base plate damage/horizontality fault ▪ Paper feed roller missing item ▪ Pickup arm defective ▪ Foreign matter, such as paper scrap, is caught inside the tray

SC No.	Level	Error Name/Error Condition/Major Cause/Solution
		<ul style="list-style-type: none"> ▪ Reset the paper. ▪ Remove the foreign matter. ▪ Replace the motor. ▪ Reset the connector. ▪ Replace the harness. ▪ Replace the sensor. ▪ Replace the control board for the optional side LCT. ▪ Replace the tray. ▪ Replace the paper feed roller. ▪ Replace the pick-up arm. ▪ Replace the timing belt. ▪ Replace the timing pulley. ▪ Replace the base plate.
SC505-42	B	<p data-bbox="509 936 1082 969">Side LCIT Lower Limit Detection Error (D696)</p> <ul style="list-style-type: none"> ▪ Lower limit detection error (during descent) During tray initialization (upper limit not detected /lower limit eject detection), the tray base plate is lowered to check the tray base plate position, but the lower limit sensor is not detected although a predetermined time elapsed. Alternatively, at paper end, the tray base plate is lowered, but the lower limit sensor is not detected although a predetermined time elapsed. ▪ Lower limit detection error (during ascent) During tray initialization (upper limit not detected/lower limit detection), the tray base plate is raised to check the tray base plate position, but the lower limit sensor is detected although a predetermined time elapsed. *If an error occurs for 3 times consecutively: the side LCIT transmits a "5th paper feed tray upper limit detection error" to the main machine. <p data-bbox="509 1776 1283 1854">(The message of resetting the tray is displayed when the both sensors detect the error consecutively 2 times or less.)</p>

SC No.	Level	Error Name/Error Condition/Major Cause/Solution
		<ul style="list-style-type: none"> ▪ Lift motor error/connector missing ▪ Lower limit sensor error/connector missing ▪ Harness broken ▪ Bank control board defective ▪ Paper set fault ▪ Timing belt damage/dropout ▪ Timing pulley damage/dropout ▪ Base plate damage/horizontality fault ▪ Foreign matter, such as paper scrap, is caught inside the tray <hr/> <ul style="list-style-type: none"> ▪ Reset the paper. ▪ Remove the foreign matter. ▪ Replace the motor. ▪ Reset the connector. ▪ Replace the harness. ▪ Replace the sensor. ▪ Replace the control board for the optional side LCT. ▪ Replace the tray. ▪ Replace the timing belt. ▪ Replace the timing pulley. ▪ Replace the base plate.
SC505-43	B	<p data-bbox="507 1339 1007 1375">Side LCIT Paper Overload Error (D696)</p> <hr/> <p data-bbox="507 1413 1299 1494">During tray initialization, both the upper limit and lower limit are detected for 3 times consecutively.</p> <p data-bbox="507 1509 1283 1590">(The message of resetting the tray is displayed when the both sensors detect the error consecutively 2 times or less.)</p> <hr/> <ul style="list-style-type: none"> ▪ Paper overload ▪ Paper set fault ▪ Limit sensor error/connector missing ▪ Lower limit sensor error/connector missing ▪ Harness broken ▪ Bank control board defective ▪ Foreign matter, such as paper scrap, is caught inside the tray

SC Tables: SC5xx (Paper Feed and Fusing)

SC No.	Level	Error Name/Error Condition/Major Cause/Solution
		<ul style="list-style-type: none"> ▪ Reset the paper. ▪ Remove the foreign matter. ▪ Reset the connector. ▪ Replace the harness. ▪ Replace the sensor. ▪ Replace the control board for the optional side LCT.

SC No.	Level	Error Name/Error Condition/Major Cause/Solution
SC520-01	C	Registration Motor: Lock
SC520-02	C	Paper feed Motor: Lock
SC520-03	C	Transport Motor: Lock
		<p>During motor ON, after checking the motor error notification registers (err_velo and err_posi) for 500msec, the error state of either register was detected at least 5 times.</p> <ul style="list-style-type: none"> ▪ Motor defective ▪ Connector disconnected ▪ Harness broken ▪ IOB defective ▪ Encoder defective <ul style="list-style-type: none"> ▪ Replace the motor. ▪ Reset the connector. ▪ Replace the harness. ▪ Replace the IOB.

SC No.	Level	Error Name/Error Condition/Major Cause/Solution
SC521-01	C	Duplex Entrance Motor: Lock
SC521-02	C	Duplex By-pass Motor: Lock
		<p>During motor ON, after checking the motor error notification registers (err_velo and err_posi) for 500msec, the error state of either register was detected at least 5 times.</p> <ul style="list-style-type: none"> ▪ Motor defective ▪ Connector disconnected ▪ Harness broken ▪ IOB defective ▪ Encoder defective <ul style="list-style-type: none"> ▪ Replace the motor. ▪ Reset the connector. ▪ Replace the harness. ▪ Replace the IOB.

SC No.	Level	Error Name/Error Condition/Major Cause/Solution
SC522-00	C	Paper Exit Motor: Lock
		<p>During motor ON, after checking the motor error notification registers (err_velo and err_posi) for 500msec, the error state of either register was detected at least 5 times.</p> <ul style="list-style-type: none"> ▪ Motor defective ▪ Connector disconnected ▪ Harness broken ▪ IOB defective ▪ Encoder defective <ul style="list-style-type: none"> ▪ Replace the motor. ▪ Reset the connector. ▪ Replace the harness. ▪ Replace the IOB.

SC Tables: SC5xx (Paper Feed and Fusing)

SC No.	Level	Error Name/Error Condition/Major Cause/Solution
SC530-00	D	Fusing Fan Lock
		In the motor ON state, the value of the lock sensor is checked every 100msec. If a lock signal is not obtained for 50 times consecutively.
		<ul style="list-style-type: none"> ▪ Motor defective ▪ Connector disconnected ▪ Harness broken ▪ IOB defective
		<ul style="list-style-type: none"> ▪ Replace the fusing fan. ▪ Reset the connector. ▪ Replace the harness. ▪ Replace the IOB.

SC No.	Level	Error Name/Error Condition/Major Cause/Solution
SC531-00	D	Development Bearing Cooling Fan Lock
		In the motor ON state, the value of the lock sensor is checked every 100msec. If a lock signal is not obtained for 50 times consecutively.
		<ul style="list-style-type: none"> ▪ Motor defective ▪ Connector disconnected ▪ Harness broken ▪ IOB defective
		<ul style="list-style-type: none"> ▪ Replace the development bearing cooling fan ▪ Reset the connector. ▪ Replace the harness. ▪ Replace the IOB.

SC No.	Level	Error Name/Error Condition/Major Cause/Solution
SC533-00	D	PSU Cooling Fan Lock
SC533-01	D	Development Bearing Cooling Fan
		<p>In the motor ON state, the value of the lock sensor is checked every 100msec. If a lock signal is not obtained for 50 times consecutively.</p> <ul style="list-style-type: none"> ▪ Motor defective ▪ Connector disconnected ▪ Harness broken ▪ IOB defective <ul style="list-style-type: none"> ▪ Replace the development bearing cooling fan. ▪ Reset the connector. ▪ Replace the harness. ▪ Replace the IOB.

SC No.	Level	Error Name/Error Condition/Major Cause/Solution
SC534-00	D	Development Exhaust Fan
		<p>In the motor ON state, the value of the lock sensor is checked every 100msec. If a lock signal is not obtained for 50 times consecutively.</p> <ul style="list-style-type: none"> ▪ Motor defective ▪ Connector disconnected ▪ Harness broken ▪ IOB defective <ul style="list-style-type: none"> ▪ Replace the development exhaust fan. ▪ Reset the connector. ▪ Replace the harness. ▪ Replace the IOB.

SC No.	Level	Error Name/Error Condition/Major Cause/Solution
SC535-00	D	Paper Exit Cooling Fan Lock
		In the motor ON state, the value of the lock sensor is checked every 100msec. If a lock signal is not obtained for 50 times consecutively.
		<ul style="list-style-type: none"> ▪ Motor defective ▪ Connector disconnected ▪ Harness broken ▪ IOB defective
		<ul style="list-style-type: none"> ▪ Replace the paper exit cooling fan. ▪ Reset the connector. ▪ Replace the harness. ▪ Replace the IOB.

SC No.	Level	Error Name/Error Condition/Major Cause/Solution
SC540-00	D	Fusing/paper Exit Motor: Lock
		During motor ON, after checking lock signals for 2sec, a High level was detected at least 20 times.
		<ul style="list-style-type: none"> ▪ Motor defective ▪ Connector disconnected ▪ Harness broken ▪ IOB defective ▪ Unit torque increased
		<ul style="list-style-type: none"> ▪ Replace the fusing/paper exit motor. ▪ Reset the connector. ▪ Replace the harness. ▪ Replace the IOB.

SC No.	Level	Error Name/Error Condition/Major Cause/Solution
SC541-01	A	Fusing Central Thermopile Disconnection
		Below a predetermined temperature (or below CB) is detected for specified seconds continuously. Detection frequency: 10 times or more.
		<ul style="list-style-type: none"> ▪ Disconnection ▪ Connector disconnected
		<ul style="list-style-type: none"> ▪ Replace the thermopile. ▪ Reset the connector. ▪ Replace the connector.
SC541-02	A	Central NC Sensor Disconnection
		3ED - 3FF (FB voltage: 3.243V-3.300V) is detected for specified seconds continuously (NC sensor center: detection & compensation NC sensor edge: detection & compensation). Detection period: 100 ms, detection frequency: 10 times or more.
		<ul style="list-style-type: none"> ▪ NC sensor disconnection ▪ Connector disconnected
		<ul style="list-style-type: none"> ▪ Reset the NC sensor. ▪ Reset the connector. ▪ Replace the connector.
SC541-03	A	Central NC Sensor Short-circuit
		AD value: 0-13 (FB voltage: 0.000V-0.041V) is detected for specified seconds continuously. Detection period: 100 ms, detection frequency: 10 times or more.
		<ul style="list-style-type: none"> ▪ NC short-circuit ▪ Connector disconnected
		<ul style="list-style-type: none"> ▪ Reset the NC sensor. ▪ Reset the connector. ▪ Replace the connector.

SC No.	Level	Error Name/Error Condition/Major Cause/Solution
SC542-02	A	Fusing Central Thermopile Does Not Reload
		When the fusing central thermopile does not reach a predetermined temperature for 7 seconds consecutively.
SC542-03	A	Fusing Central Thermopile Does Not Reload
		When the fusing central thermopile does not reach the permission temperature of heat central reloading for specified seconds continuously.
SC542-05	D	Fusing Central Thermopile Does Not Reload (Low Voltage)
		When the fusing central thermopile does not reach a predetermined temperature for 7 seconds consecutively.
SC542-06	D	Fusing Central Thermopile Does Not Reload (Low Voltage)
		When the fusing central thermopile does not reach the permission temperature of heat central reloading for specified seconds continuously.
		<ul style="list-style-type: none"> ▪ Thermopile lens dirt ▪ Thermopile modification/float ▪ Outside input voltage guarantee ▪ After excessive temperature rise prevention unit operation
		<ul style="list-style-type: none"> ▪ Replace the thermopile. ▪ Check that the input voltage is within acceptable limits.

SC No.	Level	Error Name/Error Condition/Major Cause/Solution
SC543-00	A	Fusing Central Thermopile High Temperature Detection (Software)
		When the fusing central thermopile detects a predetermined temperature or above for specified seconds consecutively. Detection period 100ms, detection count: 10 times or more.
		<ul style="list-style-type: none"> ▪ Triac short-circuit ▪ IOB board defective ▪ BCU board defective
		<ul style="list-style-type: none"> ▪ Replace the IOB board. ▪ Replace the BCU board. ▪ Replace the fusing unit.

SC No.	Level	Error Name/Error Condition/Major Cause/Solution
SC544-01	A	Fusing High Temperature Detection (hardware) (Central Thermopile High Temperature Error)
		In the event of an error
		<ul style="list-style-type: none"> ▪ Triac defective (short-circuit) ▪ Engine controller defective ▪ Heating central thermopile defective ▪ Fusing control software: out of control
		<ul style="list-style-type: none"> ▪ If the triac is defective, replace the AC power supply board. ▪ If necessary, replace the BCU or the heating central thermopile.

SC No.	Level	Error Name/Error Condition/Major Cause/Solution
SC544-02	A	Fusing High Temperature Detection (hardware) (Non-Contact thermistor High Temperature Error)
		In the event of an error
		<ul style="list-style-type: none"> ▪ Triac defective (short-circuit) ▪ Engine controller defective ▪ Heating central thermopile defective ▪ Fusing control software: out of control
		<ul style="list-style-type: none"> ▪ Attach the new fusing unit, then run SP-5-810-002. ▪ If the triac is defective, replace the AC power supply board. ▪ If necessary, replace the BCU or the Fusing central NC sensor.

SC No.	Level	Error Name/Error Condition/Major Cause/Solution
SC545-01	A	Fusing Central Heater Continuously Heat
		<p>After waiting for full power for more than specified seconds continuously, not detected for specified seconds.</p> <ul style="list-style-type: none"> ▪ Definition of heater full power Continuously heating rate set point (maximum heating rate) ▪ Measurement start point After reload (after heater extinguished, after rotation complete) below the standby temperature (target temperature), measurement starts after a heater heat-up request is issued. ▪ Measurement stop condition Rotation started due to a print signal during measurement or other. ▪ Maximum heat-up Duty (SP interlinked value) 0% is excluded.
		<ul style="list-style-type: none"> ▪ Thermistor deformation/float ▪ Heater disconnection ▪ After excessive temperature rise prevention unit operates

SC No.	Level	Error Name/Error Condition/Major Cause/Solution
		<ul style="list-style-type: none"> ▪ Replace the thermistor. ▪ Replace the fusing lamp. ▪ Replace the fusing unit.
SC545-05	D	Fusing Central Heater Continuously Heat (Low Voltage)

SC No.	Level	Error Name/Error Condition/Major Cause/Solution
SC547-01	D	Zero cross Error (relay-contact soldering)
		In the event of an error
		<ul style="list-style-type: none"> ▪ Fusing relay defective (contact soldering) ▪ Fusing relay drive circuit fault
		<ul style="list-style-type: none"> ▪ Turn the main power supply switch OFF/ON ▪ If the fusing relay is damaged, replace the PSU. ▪ Check the connection between PSU and control board, and replace harness and board if necessary.
SC547-02	D	Zero cross Error (relay contact fault)
		In the event of an error
		<ul style="list-style-type: none"> ▪ Fusing relay damage (contact open) ▪ Fusing relay drive circuit fault ▪ PSU fuse (24VS) blowout
		<ul style="list-style-type: none"> ▪ Turn the main power supply switch OFF/ON. ▪ If the fusing relay is damaged, replace the PSU. ▪ Check the connection between PSU and control board, and replace harness and board if necessary. ▪ If the PSU fuse (24VS) blows out, replace the fuse.

SC547-03	D	Zero cross Error (low-frequency error)
		In the event of an error
		Frequency instability of commercial power line
		<ul style="list-style-type: none"> ▪ Turn the main power supply switch OFF/ON. ▪ Check the power source. ▪ Check the connection between PSU and control board, and replace harness and board if necessary.

SC No.	Level	Error Name/Error Condition/Major Cause/Solution
SC551-01	A	Fusing Edge Thermopile Disconnection
		When the fusing edge thermopile detects a predetermined temperature or less for specified seconds consecutively.
		<ul style="list-style-type: none"> ▪ Thermopile disconnection ▪ Connector disconnected
		<ul style="list-style-type: none"> ▪ Replace the thermopile. ▪ Reset the connector. ▪ Replace the connector. ▪ Replace the fusing unit.
SC551-02	A	Edge NC Sensor Disconnection
		3ED - 3FF (FB voltage: 3.243V-3.300V) is detected for specified seconds continuously (NC sensor center: detection & compensation NC sensor edge: detection & compensation). Detection period: 100 ms, detection frequency: 10 times or more.
		<ul style="list-style-type: none"> ▪ NC sensor disconnection ▪ Connector disconnected
		<ul style="list-style-type: none"> ▪ Replace the NC sensor. ▪ Reset the connector. ▪ Replace the connector. ▪ Replace the fusing unit.

SC No.	Level	Error Name/Error Condition/Major Cause/Solution
SC551-03	A	Edge NC Sensor Short-circuit
		AD value: 0-13 (FB voltage: 0.000V-0.041V) is detected for specified seconds continuously. Detection period: 100 ms, detection frequency: 10 times or more.
		<ul style="list-style-type: none"> ▪ NC sensor short-circuit ▪ Connector disconnected
		<ul style="list-style-type: none"> ▪ Replace the NC sensor. ▪ Reset the connector. ▪ Replace the connector. ▪ Replace the fusing unit.

SC No.	Level	Error Name/Error Condition/Major Cause/Solution
SC552-02	A	Fusing Edge Thermopile Does Not Reload
		When the fusing edge thermopile does not reach a predetermined temperature for specified seconds consecutively.
SC552-03	A	Fusing Edge Thermopile Does Not Reload
		Heating edge reload permission temperature not reached after heater 1 ON for specified seconds.
SC552-05	D	Fusing Edge Thermopile Does Not Reload (Low Voltage)
		When the fusing edge thermopile does not reach a predetermined temperature for specified seconds consecutively.
SC552-06	D	Fusing Edge Thermopile Does Not Reload (Low Voltage)
		When the fusing edge thermopile does not reach the permission temperature of heat edge reloading for specified seconds continuously.

SC Tables: SC5xx (Paper Feed and Fusing)

SC No.	Level	Error Name/Error Condition/Major Cause/Solution
		<ul style="list-style-type: none"> ▪ Thermopile lens dirt ▪ Thermopile modification, float ▪ Outside input voltage guarantee ▪ After excessive temperature rise prevention unit operation
		<ul style="list-style-type: none"> ▪ Replace the thermopile. ▪ Make sure that the input voltage is within acceptable limits. ▪ Replace the fusing unit.

SC No.	Level	Error Name/Error Condition/Major Cause/Solution
SC553-00	A	Fusing End Thermopile High Temperature Detection (software)
		Above a predetermined temperature detected for specified seconds continuously. Detection period: 100ms, detection count: 10 times or more.
		<ul style="list-style-type: none"> ▪ Triac short-circuit ▪ IOB defective ▪ BCU defective
		<ul style="list-style-type: none"> ▪ Replace the IOB. ▪ Replace the BCU. ▪ Replace the fusing unit.

SC No.	Level	Error Name/Error Condition/Major Cause/Solution
SC554-01	A	Fusing End Thermopile High Temperature Detection (hardware)
		In the event of an error
		<ul style="list-style-type: none"> ▪ Triac defective (short-circuit) ▪ Engine controller defective ▪ Heating edge thermopile defective ▪ Fusing control software: out of control
		<ul style="list-style-type: none"> ▪ If the triac is defective, replace the AC power supply board. ▪ If necessary, replace the BCU or heating edge thermopile.
SC554-02	A	Fusing End NC Sensor High Temperature Detection (hardware)
		In the event of an error
		<ul style="list-style-type: none"> ▪ Triac defective (short-circuit) ▪ Engine controller defective ▪ Heating edge thermopile defective ▪ Fusing control software: out of control
		<ul style="list-style-type: none"> ▪ Attach the new fusing unit, then run SP-5-810-002. ▪ If necessary, replace the BCU or Fusing edge NC sensor.

SC No.	Level	Error Name/Error Condition/Major Cause/Solution
SC555-01	A	Fusing Edge Heater Continuously Heat
SC555-05	D	Fusing Edge Heater Continuously Heat (Low Voltage)
		<p>After waiting for full power for more than specified seconds continuously, not detected for specified seconds.</p> <ul style="list-style-type: none"> ▪ Definition of heater full power Continuously heating rate set point (maximum heating rate) ▪ Measurement start point After reload (after heater extinguished, after rotation complete) below the standby temperature (target temperature), measurement starts after a heater heat-up request is issued. ▪ Measurement stop condition Rotation started due to a print signal during measurement or other ▪ Maximum heat-up Duty (SP interlinked value) 0% is excluded
		<ul style="list-style-type: none"> ▪ Thermistor deformation/float ▪ Heater disconnection ▪ After excess temperature rise prevention unit operation
		<ul style="list-style-type: none"> ▪ Replace the thermistor. ▪ Replace the fusing lamp. ▪ Replace the fusing unit.

SC No.	Level	Error Name/Error Condition/Major Cause/Solution
SC557-00	C	Zero Cross Frequency Exceeded
		In the event of an error
		Frequency instability of commercial power line/Noise
		-

SC No.	Level	Error Name/Error Condition/Major Cause/Solution
SC559-00	A	Fusing Jam Detected for 3 Times Consecutively
		<p>Fusing jam (does not reach fusing exit sensor) is detected for 3 times consecutively.</p> <ul style="list-style-type: none"> ▪ Detection conditions Displays the SC559-00 at the time of integrating the counter each time fusing jam occurs, became fusing jam counter value = 3. The counter value is retained without fusing jam also reset by OFF/ON the power supply. ▪ Control ON/OFF And enables ON / OFF is this SC, the default is set to OFF, then ON at the time of customer requirements. SP1-142-001 0: OFF (default), 1: ON (Set at the time of customer requirements) ▪ Counter reset condition occurs fusing jam <ol style="list-style-type: none"> 1. Normal paper exit has been done during this continuous fusing jam, fusing jam counter is reset. 2. When "1" is changed to "0" SP1-142-001, to reset the (SP9-912-001) fusing jam counter. 3. When after displaying SC559, SC release is made, reset the (SP9912-001) fusing jam counter.
		Fusing unit paper jam
		Remove the jam.

SC No.	Level	Error Name/Error Condition/Major Cause/Solution
SC561-00	A	Pressurized Central Thermistor Disconnection
		When the pressurized central thermistor detects a predetermined temperature or less for specified seconds consecutively. Detection period 100ms, detection count: 10 times or more.
		<ul style="list-style-type: none"> ▪ Thermistor disconnection ▪ Connector disconnected
		<ul style="list-style-type: none"> ▪ Replace the thermistor. ▪ Reset the connector. ▪ Replace the connector. ▪ Replace the fusing unit.

SC No.	Level	Error Name/Error Condition/Major Cause/Solution
SC562-02	A	Pressurized Central Thermistor Does Not Reload
SC562-05	D	Pressurized Central Thermistor Does Not Reload (Low Voltage)
		When the pressurized central thermistor does not reach a predetermined temperature for specified seconds consecutively.
		<ul style="list-style-type: none"> ▪ Thermistor dirt ▪ Thermistor deformation, float ▪ Outside input voltage guarantee ▪ After excess temperature rise prevention unit operation
		<ul style="list-style-type: none"> ▪ Replace the thermistor. ▪ Make sure that the input voltage is within acceptable limits. ▪ Replace the fusing unit.

SC No.	Level	Error Name/Error Condition/Major Cause/Solution
SC563-00	A	Pressurized Central Thermistor High Temperature Detection (software)
		Above a predetermined temperature detected for specified seconds continuously. Detection period: 100ms, detection count: 10 times or more.
		<ul style="list-style-type: none"> ▪ Triac short-circuit ▪ IOB defective ▪ BCU defective
		<ul style="list-style-type: none"> ▪ Replace the IOB. ▪ Replace the BCU. ▪ Replace the fusing unit.

SC No.	Level	Error Name/Error Condition/Major Cause/Solution
SC564-00	A	Fusing High Temperature Detection (hardware) (Pressure Roller Thermistor Error)
		In the event of an error
		<ul style="list-style-type: none"> ▪ Triac short-circuit ▪ Pressure roller thermistor defective ▪ BCU controller defective ▪ Fusing control: out of control
		<ul style="list-style-type: none"> ▪ Replace the BCU. ▪ Replace the pressure roller thermistor. ▪ Replace the fusing unit.

SC No.	Level	Error Name/Error Condition/Major Cause/Solution
SC571-00	A	Pressurized Edge Thermistor Disconnection
		When the pressurized edge thermistor detects a predetermined temperature or less for specified seconds consecutively. Detection period: 100 ms, detection counts: 10 times or more.
		<ul style="list-style-type: none"> ▪ Thermistor disconnection ▪ Connector disconnected
		<ul style="list-style-type: none"> ▪ Replace the thermistor. ▪ Reset the connector. ▪ Replace the connector. ▪ Replace the fusing unit.

SC No.	Level	Error Name/Error Condition/Major Cause/Solution
SC572-02	A	Pressurized Edge Thermistor Does Not Reload
		When the temperature does not reach 40 degrees Centigrade for 100 seconds consecutively.
		<ul style="list-style-type: none"> ▪ Thermistor dirt ▪ Thermistor deformation, float ▪ Outside input voltage guarantee ▪ After excess temperature rise prevention unit operation
		<ul style="list-style-type: none"> ▪ Replace the thermistor. ▪ Make sure that the input voltage is within acceptable limits. ▪ Replace the fusing unit.

SC No.	Level	Error Name/Error Condition/Major Cause/Solution
SC573-00	A	Pressurized Edge Thermistor High Temperature Detection (software)
		When the pressurized edge thermistor detects a predetermined temperature or above for specified second consecutively.
		<ul style="list-style-type: none"> ▪ Triac short-circuit ▪ IOB defective ▪ BCU defective
		<ul style="list-style-type: none"> ▪ Replace the IOB. ▪ Replace the BCU. ▪ Replace the fusing unit.

SC No.	Level	Error Name/Error Condition/Major Cause/Solution
SC574-00	A	Pressurized Edge Thermistor High Temperature Detection (hardware)
		Above a predetermined temperature detected
		<ul style="list-style-type: none"> ▪ Triac short-circuit ▪ Pressure roller thermistor defective ▪ BCU defective ▪ Fusing control: out of control
		<ul style="list-style-type: none"> ▪ Replace the BCU. ▪ Replace the pressure roller thermistor. ▪ Replace the fusing unit.

SC No.	Level	Error Name/Error Condition/Major Cause/Solution
SC589-01	D	Fusing center: Low Temperature Detection
		When the fusing center thermopile detects the temperature which is 180 degrees Centigrade lower than target Temperature for 12 seconds consecutively.
		<ul style="list-style-type: none"> ▪ Heater harness disconnected ▪ Connector defective
		<ul style="list-style-type: none"> ▪ Replace the Heater harness. ▪ Replace the connector.
SC589-02	D	Fusing edge: Low Temperature Detection
		When the fusing edge thermopile detects the temperature which is 180 degrees Centigrade lower than target Temperature for 12 seconds consecutively.
		<ul style="list-style-type: none"> ▪ Heater harness disconnected ▪ Connector defective
		<ul style="list-style-type: none"> ▪ Replace the Heater harness. ▪ Replace the connector.

6.7 SC TABLES: SC6XX (COMMUNICATION AND OTHERS)

6.7.1 SC620-01 TO SC687-00

SC No.	Level	Error Name/Error Condition/Major Cause/Solution
SC620-01	D	ADF Communication Error
SC620-02	D	ADF Communication Error
		<p>SC620-01 After ADF connection was recognized on startup, an error is detected. (disconnection detection)</p> <p>SC620-02: After ADF connection was recognized on startup, an error is detected. (Retry out due to communication error)</p> <ul style="list-style-type: none"> ▪ ADF connection fault ▪ ADF defection ▪ IPU board defection ▪ Noise contamination ▪ ADF machine code unmatched <ul style="list-style-type: none"> ▪ Check the ADF cable connection ▪ Replace the ADF ▪ Replace the IPU board ▪ Replace the ADF which matches the machine code

SC Tables: SC6xx (Communication and Others)

SC No.	Level	Error Name/Error Condition/Major Cause/Solution
SC621-00	D	Finisher Communication Error
		<ul style="list-style-type: none"> ▪ Detected an error when connecting the communication line. ▪ Received a communication error notification from the UART.
		<ul style="list-style-type: none"> ▪ Finisher control board defective. ▪ BCU defective ▪ Connection fault between finisher and main machine.
		<ul style="list-style-type: none"> ▪ Turn the power off/on. ▪ Reconnect the Finisher interface cable ▪ Replace the BCU ▪ Replace the finisher

SC No.	Level	Error Name/Error Condition/Major Cause/Solution
SC622	D	Paper Bank Communication Error
SC622-01	D	Paper Bank 1 Communication Error (D694)
SC622-11	D	Paper Bank 1 Communication Error (D787)
SC622-12	D	Paper Bank 1 Communication Error (D787)
SC622-31	D	Paper Bank 1 Communication Error (D695)
		<p>Detected an error when connecting the communication line.</p> <ul style="list-style-type: none"> ▪ Paper bank control board defective ▪ BCU defective ▪ Paper bank-main machine connection fault <ul style="list-style-type: none"> ▪ Turn the power off/on. ▪ Reconnect the optional paper tray connection cable. ▪ Replace the BCU. ▪ Replace the optional paper tray.

SC No.	Level	Error Name/Error Condition/Major Cause/Solution
SC623-00	D	Paper Bank Communication Error (D696)
		When two trays PFU (D787) and side LICT (D696) or LCIT (D695) and side LCIT (D696) are installed, 1. When the upper stream unit (D787 or D695) recognizes the lower stream unit (D696), the break of the lower stream unit is not canceled within predetermined milliseconds. 2. After the upper stream unit (D787 or D695) recognizes the lower stream unit (D696), there is no ACK within predetermined milliseconds after transmission of a data frame to the lower stream unit, and a timeout error occurs for 3 times consecutively even if retransmission is performed.
		<ul style="list-style-type: none"> ▪ Bank control board fault ▪ Connector disconnected
		<ul style="list-style-type: none"> ▪ Turn the power off/on. ▪ Reset the optional paper tray connecting cable. ▪ Replace the BCU. ▪ Replace the optional paper tray.

SC No.	Level	Error Name/Error Condition/Major Cause/Solution
SC632-00	B	Counter Device Error 1
		After 3 attempts to send a data frame to the optional counter device via the serial communication line, no ACK signal was received within 100 ms.
		Serial line between the optional counter device, the relay board and copier control board is disconnected or damaged.
		<ul style="list-style-type: none"> ▪ Turn the main power off/on. ▪ Check the serial communication line.

SC No.	Level	Error Name/Error Condition/Major Cause/Solution
SC633-00	B	Counter Device Error 2
		After communication was established, the controller received the brake signal from the accounting device.
		Serial line between the optional counter device, the relay board and copier control board is disconnected or damaged.
		<ul style="list-style-type: none"> ▪ Turn the main power off/on. ▪ Check the serial communication line.

SC No.	Level	Error Name/Error Condition/Major Cause/Solution
SC634-00	B	Counter Device Error 3
		A backup RAM error was returned by the counter device.
		Counter device control board or the backup battery of counter device defective
		<ul style="list-style-type: none"> ▪ Replace the counter device control board. ▪ Replace the backup battery.

SC No.	Level	Error Name/Error Condition/Major Cause/Solution
SC635-00	B	Counter Device Error 4
		A backup battery error was returned by the counter device.
		Counter device control board or the backup battery of counter device defective
		<ul style="list-style-type: none"> ▪ Replace the counter device control board. ▪ Replace the backup battery.

SC No.	Level	Error Name/Error Condition/Major Cause/Solution
SC636-01	D	IC Card Error (Expanded Authentication Module Error)
		<p>Issued when expanded authentication management is set to "ON" but either of the following occur.</p> <ul style="list-style-type: none"> ▪ There is no expanded authentication module in the machine. ▪ The SD card or the file of the expanded authentication module is broken. ▪ There is no DESS module in the machine.
		<ul style="list-style-type: none"> ▪ There is no DESS module in the machine (models on which the function is optional). ▪ There is no expanded authentication module in the machine. ▪ The SD card or the file of the expanded authentication module is broken.
		<ul style="list-style-type: none"> ▪ Set a working SD card/expanded authentication module file. ▪ Install the DESS module. ▪ In the SSP mode set SP5-401-160 to "0". ▪ In the SSP mode, set SP5-401-161 to "0". ▪ Replace the NVRAM.

SC No.	Level	Error Name/Error Condition/Major Cause/Solution
SC636-02	D	IC Card Error (Version error)
		The version of the expanded authentication module is not correct.
		Incorrect module version
		Install the correct file of the expanded authentication module.

SC No.	Level	Error Name/Error Condition/Major Cause/Solution
SC636-11	D	IC Card Error (OSM user code file error)
		<ul style="list-style-type: none"> ▪ The correct "usercode" file could not be found in the root folder of the SD card. ▪ The "usercode" file on the SD card could not be read.
		<ul style="list-style-type: none"> ▪ The "usercode" file does not exist on the SD card. ▪ The "usercode" file on the SD card is an invalid file. ▪ Data in the "usercode" file on the SD card is invalid. ▪ "usercode" file was not moved when moving the application to another SD card
		Use the user code configuration tool for OSM users (ldissuer.exe) to create the "usercode" and store it in the root folder of the SD card containing the IC card module (eccm.mod).

SC No.	Level	Error Name/Error Condition/Major Cause/Solution
SC637-01	D	Tracking Information Notification Error (Tracking application error)
		Tracking information was lost.
		<ul style="list-style-type: none"> ▪ Tracking SDK application error ▪ Internal notification error
		Turn the main power off/on.

SC No.	Level	Error Name/Error Condition/Major Cause/Solution
SC637-02	D	Tracking Information Notification Error (Management server error)
		Tracking information was lost.
		Communication with tracking management server failed. <ul style="list-style-type: none"> ▪ Network error ▪ tracking management server error ▪ Tracking SDK application error
		Turn the main power off/on.

SC No.	Level	Error Name/Error Condition/Major Cause/Solution
SC641-00	D	Communication Error between Engine and Controller
		Although frame is sent from controller, engine does not reply to it.
		<ul style="list-style-type: none"> ▪ Controller Board soft error ▪ BCU soft error ▪ BCU and controller board connection error
		<ul style="list-style-type: none"> ▪ Turn the main power off/on. ▪ Check the connection between the BCU and controller board.

SC No.	Level	Error Name/Error Condition/Major Cause/Solution
SC650-01	B	Remote Service Modem Communication Error (Dialup authentication failure)
		<ul style="list-style-type: none"> ▪ An error related to communication (dialup connection, modem board etc.) using the RC Gate Type M was detected or an error that prevents RC Gate operation was detected at power on. ▪ Displayed only when an error is detected while RC Gate is operating. ▪ SC is not issued if an error occurs during RC Gate installation (because it can be referenced using SP).
		Dialup authentication failure
		Check the following SPs. <ul style="list-style-type: none"> ▪ SP5-816-156 ▪ SP5-816-157

SC No.	Level	Error Name/Error Condition/Major Cause/Solution
SC650-04	B	Remote Service Modem Communication Error (dialup failing because of incorrect modem configuration)
		<ul style="list-style-type: none"> ▪ An error related to communication (dialup connection, modem board etc.) using the RC Gate Type M was detected or an error that prevents RC Gate operation was detected at power on. ▪ Displayed only when an error is detected while RC Gate is operating. ▪ SC is not issued if an error occurs during RC Gate installation (because it can be referenced using SP).
		Dialup failing because of incorrect modem configuration
		Check if the setting of SP5-816-160 is correct. If it is correct, then there is a software bug.

SC No.	Level	Error Name/Error Condition/Major Cause/Solution
SC650-05	B	Remote Service Modem Communication Error (insufficient current or connection fault)
		<ul style="list-style-type: none"> ▪ An error related to communication (dialup connection, modem board etc.) using the RC Gate Type M was detected or an error that prevents RC Gate operation was detected at power on. ▪ Displayed only when an error is detected while RC Gate is operating. ▪ SC is not issued if an error occurs during RC Gate installation (because it can be referenced using SP).
		Insufficient current or connection fault
		The line is not supported and nothing can be done.

SC No.	Level	Error Name/Error Condition/Major Cause/Solution
SC650-13	B	Remote Service Modem Communication Error (RC Gate Type M was installed but modem is not present (detected during operation))
		<ul style="list-style-type: none"> ▪ An error related to communication (dialup connection, modem board etc.) using the RC Gate Type M was detected or an error that prevents RC Gate operation was detected at power on. ▪ Displayed only when an error is detected while RC Gate is operating. ▪ SC is not issued if an error occurs during RC Gate installation (because this error can be referred by using SP).
		RC Gate Type M was installed but modem is not present (detected during operation).
		<ul style="list-style-type: none"> ▪ If a modem board is not installed, install it. ▪ Check again if the modem driver configurations (SP5-816-160, SP5-816-165 to 171, SP5-816-165 to 171) are correct. ▪ If the problem is not solved, replace the modem.

SC No.	Level	Error Name/Error Condition/Major Cause/Solution
SC650-14	B	Remote Service Modem Communication Error (RC Gate Type N was installed but modem is present or wired/wireless LAN is not working correctly)
		<ul style="list-style-type: none"> ▪ An error related to communication (dialup connection, modem board etc.) using the RC Gate was detected or an error that prevents RC Gate operation was detected at power on. ▪ Displayed only when an error is detected while RC Gate is operating. ▪ SC is not issued if an error occurs during RC Gate installation (because this error can be referred by using SP).
		RC Gate Type N was installed but modem is present or wired/wireless LAN is not working correctly
		<ul style="list-style-type: none"> ▪ If a modem board is attached, remove it. ▪ Check if wired/wireless LAN works.

SC No.	Level	Error Name/Error Condition/Major Cause/Solution
SC651-01	C	Illegal Remote Service Dial-up (Chat program parameter error)
		An unexpected error occurred when RC Gate Type M dialed up the NRS Center.
		Software bug
		Logging only.

SC No.	Level	Error Name/Error Condition/Major Cause/Solution
SC651-02	C	Illegal Remote Service Dial-up (Chat program execution error)
		An unexpected error occurred when RC Gate dialed up the NRS Center.
		Software bug
		Logging only.

SC No.	Level	Error Name/Error Condition/Major Cause/Solution
SC652-00	D	Remote service ID2 mismatching
		There was an authentication mismatch between ID2 for @Remote, the controller board, and NVRAM.
		<ul style="list-style-type: none"> ▪ Used controller board installed ▪ Used NVRAM installed (such action is not allowed.)
		<ul style="list-style-type: none"> ▪ If this occurs during RC Gate installation: Check the validity of the certificate and the NVRAM, check the machine serial number, write the common certificate, and then begin installation again. ▪ If this occurs after RC Gate installation: Clear the RC Gate install status, check the validity of the certificate and the NVRAM, check the machine serial number, write the common certificate, and then begin installation again.

SC No.	Level	Error Name/Error Condition/Major Cause/Solution
SC653-00	D	Incorrect remote service ID2
		ID2 stored in the NVRAM has either of the following problems. <ul style="list-style-type: none"> ▪ Number of characters is not 17. ▪ Includes a character that cannot be printed. ▪ All spaces ▪ NULL
		Replace the NVRAM.
		Clear the RC Gate install status, write the common certificate, and then begin installation again.

SC No.	Level	Error Name/Error Condition/Major Cause/Solution
SC664		ASIC on the BCU SRAM Program Expansion Error
SC664-01	D	Access Permission Error to ASIC on the BCU SRAM (write permission fails)
SC664-02	D	Write Error to ASIC on the BCU SRAM (write result error)
SC664-03	D	ASIC on the BCU Program Startup Error
		<ul style="list-style-type: none"> ▪ Electrical Noise. ▪ Hardware defection.
		<ul style="list-style-type: none"> ▪ Replace the imaging BCU and paper transport BCU. ▪ Check the harness.

FFC set error is detected by port lead and AD value read-out

SC No.	Level	Error Name/Error Condition/Major Cause/Solution
SC665		FFC Set Detection (* See "page 6-189")
SC665-01	D	BCU-IPU Connection Error
		<p>The machine checks the FFC (Flat Flexible Cable) connections at the HORUS module on the BCU to see whether the connections are "H" or "L" to determine whether the connections are correct and secure.</p> <ul style="list-style-type: none"> ▪ The check returns an "H" if the connection is secure, and returns an "L" if the connection is not secure. ▪ This SC is issued if the check returns an "L".
		<ul style="list-style-type: none"> ▪ FFC harness between BCU and IPU broken ▪ FFC harness between BCU and IPU not connected fully ▪ BCU damaged ▪ IPU damaged
		<ul style="list-style-type: none"> ▪ Replace the FFC harness between BCU and IPU. ▪ Reconnect the FFC harness between BCU and IPU. ▪ Replace the BCU board. ▪ Replace the IPU.
SC665-04	D	IO ASIC Does Not Start
		<p>The IO ASIC start-up signal is checked every 10 milliseconds. The SC is issued when the IO ASIC start-up signal is not detected although 3 seconds elapsed.</p>
		BCU defective
		Replace the BCU board.

SC No.	Level	Error Name/Error Condition/Major Cause/Solution
SC669		EEPROM Communication Error
SC669-01	D	EEPROM OPEN: ID error
SC669-02	D	EEPROM OPEN: Channel error
SC669-03	D	EEPROM OPEN: Device error
SC669-04	D	EEPROM OPEN: Communication abort error
SC669-05	D	EEPROM OPEN: Communication timeout error
SC669-06	D	EEPROM OPEN: Operation stopped error
SC669-07	D	EEPROM OPEN: Buffer full
SC669-08	D	EEPROM OPEN: No error code
SC669-09	D	EEPROM CLOSE: ID error
SC669-10	D	EEPROM CLOSE: No error code
SC669-11	D	EEPROM Data write: ID error
SC669-12	D	EEPROM Data write: Channel error
SC669-13	D	EEPROM Data write: Device error
SC669-14	D	EEPROM Data write: Communication abort error
SC669-15	D	EEPROM Data write: Communication timeout error
SC669-16	D	EEPROM Data write: Operation stopped error
SC669-17	D	EEPROM Data write: Buffer full
SC669-18	D	EEPROM Data write: No error code
SC669-19	D	EEPROM Data read: ID error
SC669-20	D	EEPROM Data read: Channel error
SC669-21	D	EEPROM Data read: Device error
SC669-22	D	EEPROM Data read: Communication abort error
SC669-23	D	EEPROM Data read: Communication timeout error

SC No.	Level	Error Name/Error Condition/Major Cause/Solution
SC669-24	D	EEPROM Data read: Operation stopped error
SC669-25	D	EEPROM Data read: Buffer full
SC669-26	D	EEPROM Data read: No error code
		Received an error notification during EEPROM communication and does not resume after 3 retries.
		<ul style="list-style-type: none"> ▪ Electrical noise. ▪ EEPROM damaged.
		<ul style="list-style-type: none"> ▪ Turn the power off/on. ▪ Replace the EEPROM.

SC No.	Level	Error Name/Error Condition/Major Cause/Solution
SC669-36	D	EEPROM: Verify Error
		The machine receives an error notification during EEPROM (BCU) communication and does not resume after 2 retries.
		Electrical noise
		Turn the power off/on.
SC669-37	D	EEPROM: Failure Detection Error
		The machine receives an error notification during EEPROM (BCU) communication and does not resume after 2 retries.
		<ul style="list-style-type: none"> ▪ Electrical noise ▪ EEPROM damaged
		<ul style="list-style-type: none"> ▪ Turn the power off/on. ▪ Replace the EEPROM on the BCU.

SC No.	Level	Error Name/Error Condition/Major Cause/Solution
SC670-00	D	Engine start up error (* See "page 6-189")
		<p>Case 1</p> <ul style="list-style-type: none"> ▪ /ENGRDY signal was not asserted when the machine was turned on or returned from energy saver mode. ▪ /IPURDY signal was not asserted when the machine was turned on or returned from energy saver mode. ▪ EC response was not received within specified time from power on. ▪ PC response was not received within specified time from power on. ▪ SC response was not received within specified time from power on. ▪ Writing to Rapi driver failed (the other party not found through PCI). <p>Case 2</p> <ul style="list-style-type: none"> ▪ Unexpected down status was detected after /ENGRDY assertion.
		<p>Case 1</p> <ul style="list-style-type: none"> ▪ Engine board does not start up. <p>Case 2</p> <ul style="list-style-type: none"> ▪ Engine board reset unexpectedly.
		<p>Check the connection between the engine board and the controller board.</p> <ul style="list-style-type: none"> ▪ If it is always reproduced, replace the engine board. If the problem persists, consider replacing the controller board or other boards between them. ▪ If reproducibility is low, multiple causes are to be considered, such as software, engine board, controller board, and PSU.

SC No.	Level	Error Name/Error Condition/Major Cause/Solution
SC672-10	D	Controller start up error
		After the machine was powered on, communication between the controller and the operation panel was not established.
		<ul style="list-style-type: none"> ▪ Controller stalled ▪ Board installed incorrectly ▪ Controller board defective ▪ Operation panel connector loose, broken, or defective ▪ Controller late
		<ul style="list-style-type: none"> ▪ Turn the main power off/on. ▪ Check the connection of the controller board. ▪ Replace the controller board. ▪ Check the control panel harness.

SC No.	Level	Error Name/Error Condition/Major Cause/Solution
SC672-11	D	Controller start up error
		After the machine was powered on, communication between the controller and the operation panel was not established, or communication with controller was interrupted after a normal startup.
		<ul style="list-style-type: none"> ▪ Controller stalled ▪ Board installed incorrectly ▪ Controller board defective ▪ Operation panel connector loose, broken, or defective ▪ Controller late
		<ul style="list-style-type: none"> ▪ Turn the main power off/on. ▪ Check the connection of the controller board. ▪ Replace the controller board. ▪ Check the control panel harness.

SC No.	Level	Error Name/Error Condition/Major Cause/Solution
SC672-12	D	Controller start up error
		Communication with controller was interrupted after a normal startup.
		<ul style="list-style-type: none"> ▪ Controller stalled ▪ Board installed incorrectly ▪ Controller board defective ▪ Operation panel connector loose, broken, or defective ▪ Controller late
		<ul style="list-style-type: none"> ▪ Turn the main power off/on. ▪ Check the connection of the controller board. ▪ Replace the controller board. ▪ Check the control panel harness.

SC No.	Level	Error Name/Error Condition/Major Cause/Solution
SC672-13	D	Controller start up error
		The operation panel detected that the controller is down.
		<ul style="list-style-type: none"> ▪ Controller stalled ▪ Board installed incorrectly ▪ Controller board defective ▪ Operation panel connector loose, broken, or defective ▪ Controller late
		<ul style="list-style-type: none"> ▪ Turn the main power off/on. ▪ Check the connection of the controller board. ▪ Replace the controller board. ▪ Check the control panel harness.

SC No.	Level	Error Name/Error Condition/Major Cause/Solution
SC672-99	D	Controller start up error
		The operation panel software ended abnormally.
		<ul style="list-style-type: none"> ▪ Controller stalled ▪ Board installed incorrectly ▪ Controller board defective ▪ Operation panel connector loose, broken, or defective ▪ Controller late
		<ul style="list-style-type: none"> ▪ Turn the main power off/on. ▪ Check the connection of the controller board. ▪ Replace the controller board. ▪ Check the control panel harness.

SC Tables: SC6xx (Communication and Others)

SC No.	Level	Error Name/Error Condition/Major Cause/Solution
SC682		PCU: ID Chip Communication Error
SC682-01	D	Invalid Device ID
SC682-06	D	Channel Error
SC682-11	D	Device Error
SC682-16	D	Communication Aborted (error during communication)
SC682-21	D	Communication Timeout
SC682-26	D	Device Stopped (logically stopped)
SC682-31	D	Requested Buffer Full
		Received an error notification during EEPROM communication and does not resume after 3 retries.
		<ul style="list-style-type: none"> ▪ Device ID date error ▪ Mu sesnor / EEPROM defective ▪ Electrical noise ▪ PCU is not set properly.
		<ul style="list-style-type: none"> ▪ Turn the power off/on. ▪ Replace the PCU.

SC No.	Level	Error Name/Error Condition/Major Cause/Solution
SC682-36	D	PCU: Verify Error
		Received a error notification during EEPROM communication and does not resume after 2 retries.
		<ul style="list-style-type: none"> ▪ Device ID date error ▪ Mu sesnsor / EEPROM defective ▪ Electrical noise ▪ PCU is not set properly.
		<ul style="list-style-type: none"> ▪ Turn the power off/on. ▪ Replace the PCU.

SC No.	Level	Error Name/Error Condition/Major Cause/Solution
SC687-00	D	PER Not Received Error
		Unable to receive the PER command from the controller.
		Communication error
		<ul style="list-style-type: none"> ▪ Turn the power off/on.

6.8 SC TABLES: SC7XX (PERIPHERALS)

6.8.1 SC700-01 TO SC792-00

SC No.	Level	Error Name/Error Condition/Major Cause/Solution
SC700		SPDF error
SC700-01	D	Base Plate Lift Motor Error (SPDF)
SC700-02	D	Original Pick-up Error (SPDF)
SC700-04	D	Paper Feed Motor Error (SPDF)
SC700-05	D	Pullout Motor Error (SPDF)
SC700-06	D	Intermediate Motor Error (SPDF)
SC700-07	D	Scanning Motor Error (SPDF)
SC700-09	D	Paper Exit Motor Error (SPDF)
		<p>SC700-01 Even if the base plate motor is rotated in the base plate ascent direction, the base plate paper feed correct position sensor does not detect.</p> <p>Even if the base plate motor is rotated in the base plate descent direction, the base plate home position sensor does not detect.</p> <p>SC700-02 Even if the pick up arm motor is rotated, the pick up arm home position sensor does not detect.</p> <p>SC700-04, 05, 06, 07, 09 When an error notification signal is detected during the motor drive period.</p>

SC No.	Level	Error Name/Error Condition/Major Cause/Solution
		<p>SC700-01</p> <ul style="list-style-type: none"> ▪ Base plate paper feed correct position sensor error (output error) ▪ Base plate home position sensor error (output error) ▪ Base plate motor error (does not rotate) ▪ Controller error <p>SC700-02</p> <ul style="list-style-type: none"> ▪ Pick-up home position sensor error (output error) ▪ Pick-up motor error (does not rotate) ▪ Controller error <p>SC700-04, 05, 06, 07, 09</p> <ul style="list-style-type: none"> ▪ Motor defective ▪ Connector disconnected ▪ Harness broken ▪ Overload
		<p>SC700-01, 02</p> <ul style="list-style-type: none"> ▪ Check the sensor harness and motor harness connection ▪ Replace the sensor harness and motor harness ▪ Replace the sensor ▪ Replace the motor ▪ Replace the controller <p>SC700-04, 05, 06, 07, 09</p> <ul style="list-style-type: none"> ▪ Check the harness connection ▪ Replace the harness ▪ Replace the motor

SC No.	Level	Error Name/Error Condition/Major Cause/Solution
SC701-02	D	Original Pick-up Motor Driver Error (SPDF)
		<p>When the protective function of motor driver IC detects:</p> <ul style="list-style-type: none"> ▪ Over current ▪ Heating <p>and an error is output</p>
		Motor driver IC detects an error

SC No.	Level	Error Name/Error Condition/Major Cause/Solution
		<ul style="list-style-type: none"> ▪ Check the motor harness connection ▪ Check of paper scrap in transport path, and foreign matter contamination in drive unit ▪ Replace the motor harness ▪ Replace the motor ▪ Replace the ADF control board.
SC701-03	D	Paper Feed Motor Driver Error (ARDF)
		Detection of error signal from motor driver
		<ul style="list-style-type: none"> ▪ Encoder disconnection ▪ Encoder connector dropout ▪ Encoder defective ▪ Overload ▪ Motor deterioration
		<ul style="list-style-type: none"> ▪ Replace the encoder harness ▪ Check the harness connection ▪ Replace the motor
SC701-08	D	Paper Exit Motor Driver Error (ARDF)
		Detection of error signal from motor driver.
		<ul style="list-style-type: none"> ▪ Encoder disconnection ▪ Encoder connector dropout ▪ Encoder defective ▪ Overload ▪ Motor deterioration
		<ul style="list-style-type: none"> ▪ Replace the encoder harness ▪ Check the harness connection ▪ Replace the motor

SC No.	Level	Error Name/Error Condition/Major Cause/Solution
SC702-01	D	Protection Device Intercept Error 1 (ARDF)
		When original source 5V power supply is ON, protection device intercept of 24V power supply system is detected.
		Any of feed motor, transport motor, reverse solenoid, paper feed solenoid, paper feed clutch and FAN motor defective, a harness short-circuit occurs, and the protection device of the 24V power supply system intercepts.
		<ul style="list-style-type: none"> ▪ Replace the blown fuse or circuit board ▪ Replace the short-circuited parts
SC702-02	D	Protection Device Intercept Error 2 (ARDF)
		When original source 5V power supply is ON, protection device intercept of 24V OUT power supply system is detected.
		Solenoid defective or harness short-circuit occurs in 24VOUT power supply system.
		<ul style="list-style-type: none"> ▪ Replace the blown fuse or circuit board ▪ Replace the short-circuited parts
SC702-03	D	Protection Device Intercept Error 3 (ARDF)
		When original source 5V power supply is ON, protection device intercept of 5VE power supply system is detected.
		Sensor defective or a harness short-circuit occur in 5VE power supply system.
		<ul style="list-style-type: none"> ▪ Replace the blown fuse or circuit board ▪ Replace the short-circuited parts

SC No.	Level	Error Name/Error Condition/Major Cause/Solution
SC702-04	D	Protection Device Intercept Error 4 (SPDF)
		Motor defective in any of the pickup motor, completion stamp, base plate motor or FAN motor, or a harness short-circuit occurs, and the protection device of the non-interlocking power supply system intercepts.
		Motor defective or a harness short-circuit occurs in the non-interlocking power supply system.
		<ul style="list-style-type: none"> ▪ Replace the blown fuse or circuit board ▪ Replace the short-circuited parts
SC702-05	D	Protection Device Intercept Error 5 (SPDF)
		Motor defective in the paper feed motor, pullout motor, intermediate motor, scanner motor or paper exit motor, or a harness short-circuit occurs, and the protection device of the interlocking power supply system intercepts.
		Motor defective or a harness short-circuit occurs in the interlocking power supply system.
		<ul style="list-style-type: none"> ▪ Replace the blown fuse or circuit board ▪ Replace the short-circuited parts

SC No.	Level	Error Name/Error Condition/Major Cause/Solution
SC720		2K/3K Sheet finisher Error
SC720-03	B	Protection Device Intercept Error 1 (2K/3K sheet finisher)
		Protection device intercept error state (fuse break) is detected.
		<ul style="list-style-type: none"> ▪ Short-circuit defective ▪ Overload defective ▪ Motor defective ▪ Solenoid defective
		<ul style="list-style-type: none"> ▪ Check the harness ▪ Replace the main board of the finisher ▪ Replace the motor ▪ Replace the solenoid

SC No.	Level	Error Name/Error Condition/Major Cause/Solution
SC720		2K/3K Sheet Finisher Error
SC720-10	B	Entrance Transport Motor Error (2K/3K sheet finisher)
SC720-11	B	Horizontal Transport Motor Error (2K/3K sheet finisher)
SC720-12	B	Prestack Transport Motor Error (2K/3K sheet finisher)
SC720-13	B	Intermediate Transport Motor Error (2K/3K sheet finisher)
SC720-16	B	Paper Exit Motor Error (2K/3K sheet finisher)
		Motor driver detects an error state (DC motor control error). (1st time is jam notification, 2nd time is SC notification)
		<ul style="list-style-type: none"> ▪ Motor defective ▪ Connector disconnected ▪ Overload ▪ Encoder defective
		<ul style="list-style-type: none"> ▪ Check the motor connection ▪ Replace the motor ▪ Replace the main board of the finisher

SC No.	Level	Error Name/Error Condition/Major Cause/Solution
SC720		2K/3K Sheet Finisher Error
SC720-20	B	Lower Separation Claw Motor Error (2K/3K sheet finisher)
SC720-24	B	Paper Exit Open/Close Guide Plate Motor Error (2K/3K sheet finisher)
SC720-25	B	Punching Motor Error (2K/3K sheet finisher)
SC720-27	B	Punch Displacement Motor Error (2K/3K sheet finisher)
SC720-28	B	Horizontal Registration Detection Displacement Motor Error (2K/3K sheet finisher)
SC720-30	B	Jogger Motor Error (2K/3K sheet finisher)
SC720-33	B	Strike Roller Drive Motor Error (2K/3K sheet finisher)
SC720-41	B	Release Motor Error (2K/3K sheet finisher)
SC720-42	B	Edge Stapler Displacement Motor Error (2K/3K sheet finisher)
SC720-50	B	Booklet Jogger Motor Error (2K/3K sheet finisher)
SC720-51	B	Booklet Adjustment Claw Displacement Motor Error (2K/3K sheet finisher)
SC720-53	B	Booklet Reference Fence Motor Error (2K/3K sheet finisher)
SC720-65	B	Press Folding Motor Error (2K/3K sheet finisher)
SC720-71	B	Shift Motor Error (2K/3K sheet finisher)
SC720-72	B	Shift Jogger Front Motor Error (2K/3K sheet finisher)
SC720-73	B	Shift Jogger Rear Motor Error (2K/3K sheet finisher)
SC720-74	B	Shift Jogger Retreat Motor Error (2K/3K sheet finisher)
SC720-77	B	Edge Guide Motor Error (2K/3K sheet finisher)

SC No.	Level	Error Name/Error Condition/Major Cause/Solution
		<ul style="list-style-type: none"> ▪ Motor driver detects an error (short-circuit/ overheating) (1st time, SC). ▪ During movement to home, the home position could not be detected within a predetermined pulse (p0 pulse) (1st time is jam notification, 2nd time is SC notification). ▪ During movement from home, the home position was detected for longer than a predetermined pulse (p1 pulse) (1st time is jam notification, 2nd time is SC notification). <p>The return pulse to home and pulse coming from home during normal operation are calculated and measured. The pulses which are 1.5-2 times the normal operation pulse are taken as p0 and p1.</p>
		<ul style="list-style-type: none"> ▪ Motor defective ▪ Connector disconnected ▪ Overload ▪ Encoder defective (*SC720-25 only) ▪ Home position sensor defective
		<ul style="list-style-type: none"> ▪ Check the motor ▪ Check the home position sensor connection ▪ Replace the motor ▪ Replace the home position sensor ▪ Replace the main board of the finisher

SC No.	Level	Error Name/Error Condition/Major Cause/Solution
SC720		2K/3K Sheet Finisher Error
SC720-44	B	Edge Stapler Motor Error (2K/3K sheet finisher)
SC720-60	B	Booklet Stapler Motor Error (2K/3K sheet finisher)
SC720-75	B	Reverse Roller Rocking Motor Error (2K/3K sheet finisher)
SC720-78	B	Rear End Press Motor Error (2K/3K sheet finisher)

SC No.	Level	Error Name/Error Condition/Major Cause/Solution
		<ul style="list-style-type: none"> ▪ Motor driver detects an error (DC motor control error) (1st time is jam notification, 2nd time is SC notification) *SC720-75, 78 only. ▪ During movement to home, the home position could not be detected within a predetermined time (1st time is jam notification, 2nd time is SC notification). ▪ During movement from home, the home position was detected for longer than a predetermined time (t1sec) (1st time is jam notification, 2nd time is SC notification). <p>The time to return to home without fail, the time coming from home, and the time for which the encoder output can be counted during normal operation, are taken as t0, t1 and t2.</p>
		<ul style="list-style-type: none"> ▪ Motor defective ▪ Connector disconnected ▪ Overload ▪ Home position sensor defective
		<ul style="list-style-type: none"> ▪ Check the motor ▪ Check the home position sensor connection ▪ Replace the motor ▪ Replace the home position sensor ▪ Replace the main board of the finisher

SC No.	Level	Error Name/Error Condition/Major Cause/Solution
SC720		2K/3K Sheet Finisher Error
SC720-62	B	Transfer Roller Transport Motor Error (2K/3K sheet finisher)
SC720-63	B	Folding Transport Motor Error (2K/3K sheet finisher)
		<ul style="list-style-type: none"> ▪ SC720-62 Motor driver detects an error (DC motor control error) (1st time is jam notification, 2nd time is SC notification). ▪ SC720-63 Motor driver detects an error (short-circuit/ overheating) (1st time is jam notification, 2nd time is SC notification).

SC No.	Level	Error Name/Error Condition/Major Cause/Solution
		<ul style="list-style-type: none"> ▪ Motor defective ▪ Connector disconnected ▪ Overload ▪ Encoder defective
		<ul style="list-style-type: none"> ▪ Check the motor ▪ Replace the motor ▪ Replace the main board of the finisher

SC No.	Level	Error Name/Error Condition/Major Cause/Solution
SC720-70	B	<p>Tray Lift Motor Error (2K/3K sheet finisher)</p> <ul style="list-style-type: none"> ▪ Motor controller detects an error (overload) (1st time is jam notification, 2nd time is SC notification). ▪ During descent, the paper surface sensor still detects paper even after a predetermined time elapses (1st time is jam notification, 2nd time is SC notification). ▪ During ascent, the paper surface sensor could not detect the paper surface even after a predetermined time elapses (1st time is jam notification, 2nd time is SC notification). <p>The time to return to home without fail, the time coming from home, and the time for which the encoder output can be counted during normal operation, are taken as t0, t1 and t2.</p>
		<ul style="list-style-type: none"> ▪ Motor defective ▪ Connector disconnected ▪ Overload ▪ Home position sensor defective
		<ul style="list-style-type: none"> ▪ Check the motor ▪ Check the home position sensor connection ▪ Replace the motor ▪ Replace the home position sensor ▪ Replace the main board of the finisher

SC No.	Level	Error Name/Error Condition/Major Cause/Solution
SC721-03	B	Protection Device Intercept Error 1 (1K sheet finisher)
		Fuse blowout is detected
		<ul style="list-style-type: none"> ▪ Overload (board defective, harness short-circuit, solenoid defective)
		<ul style="list-style-type: none"> ▪ Replace the main board of the finisher ▪ Replace the harness ▪ Replace the solenoid

SC No.	Level	Error Name/Error Condition/Major Cause/Solution
SC721-10	B	Entrance Transport Motor Error (1K sheet finisher)
		Motor driver detects an error state (DC motor control error). 1st error detection is determined as a jam and 2nd error detection is determined as an SC.
		<ul style="list-style-type: none"> ▪ Motor defective ▪ Connector disconnected ▪ Overload ▪ Encoder error
		<ul style="list-style-type: none"> ▪ Replace the entrance transport motor ▪ Reset the connector ▪ Replace the harness ▪ Replace the main board of the finisher

SC No.	Level	Error Name/Error Condition/Major Cause/Solution
SC721-11	B	Proof Transport Motor Error (1K sheet finisher)
		Motor driver detects an error state (DC motor control error). 1st error detection is determined as a jam and 2nd error detection is determined as an SC.
		<ul style="list-style-type: none"> ▪ Motor defective ▪ Connector disconnected ▪ Overload ▪ Encoder error
		<ul style="list-style-type: none"> ▪ Replace the proof transport motor ▪ Reset the connector ▪ Replace the harness ▪ Replace the main board of the finisher

SC No.	Level	Error Name/Error Condition/Major Cause/Solution
SC721-17	B	Paper Eject Transport Motor Error (1K sheet finisher)
		Motor driver detects an error state (DC motor control error). 1st error detection is determined as a jam and 2nd error detection is determined as an SC.
		<ul style="list-style-type: none"> ▪ Motor defective ▪ Connector disconnected ▪ Overload ▪ Encoder error
		<ul style="list-style-type: none"> ▪ Replace the paper eject transport motor ▪ Reset the connector ▪ Replace the harness ▪ Replace the main board of the finisher

SC No.	Level	Error Name/Error Condition/Major Cause/Solution
SC721-24	B	Paper Eject Cover Open/Close Motor Error (1K sheet finisher)
		<ul style="list-style-type: none"> ▪ During movement to home, the home position could not be detected within a predetermined pulse (p0 pulse) (1st time is jam notification, 2nd time is SC notification). ▪ During movement from home, the home position was detected for longer than a predetermined pulse (p1 pulse) (1st time is jam notification, 2nd time is SC notification). <p>The return pulse to home and pulse coming from home during normal operation are calculated and measured. The pulses which are 1.5-2 times the normal operation pulse are taken as p0 and p1.</p>
		<ul style="list-style-type: none"> ▪ Motor defective ▪ Connector disconnected ▪ Overload ▪ HP sensor defective
		<ul style="list-style-type: none"> ▪ Replace the paper eject cover open/close motor ▪ Reset the connector ▪ Replace the paper guide plate open/close sensor ▪ Replace the harness ▪ Replace the main board of the finisher

SC No.	Level	Error Name/Error Condition/Major Cause/Solution
SC721-25	B	Punch Motor Error (1K sheet finisher)
		<ul style="list-style-type: none"> ▪ During movement to home, the home position could not be detected within a predetermined time (t0 sec) (1st time is jam notification, 2nd time is SC notification). ▪ During movement from home, the home position was detected even after a predetermined time (t1 sec) elapsed (1st time is jam notification, 2nd time is SC notification). ▪ Output from the encoder could not be counted for a predetermined number of times within a predetermined time (t0 sec) (1st time is jam notification, 2nd time is SC notification). <p>The time to return to home without fail, the time coming from home, and the time for which the encoder output can be counted during normal operation, are taken as t0, t1 and t2.</p>
		<ul style="list-style-type: none"> ▪ Motor defective ▪ Connector disconnected ▪ Overload ▪ HP sensor defective ▪ Encoder error
		<ul style="list-style-type: none"> ▪ Replace the punch motor ▪ Reset the connector ▪ Replace the punch rotation pulse sensor ▪ Replace the harness ▪ Replace the main board of the finisher

SC No.	Level	Error Name/Error Condition/Major Cause/Solution
SC721-27	B	Punch Movement Motor Error (1K sheet finisher)
		<ul style="list-style-type: none"> ▪ During movement to home, the home position could not be detected within a predetermined pulse (p0 pulse) (1st time is jam notification, 2nd time is SC notification). ▪ During movement from home, the home position was detected for longer than a predetermined pulse (p1 pulse) (1st time is jam notification, 2nd time is SC notification). <p>The return pulse to home and pulse coming from home during normal operation are calculated and measured. The pulses which are 1.5-2 times the normal operation pulse are taken as p0 and p1.</p>
		<ul style="list-style-type: none"> ▪ Motor defective ▪ Connector disconnected ▪ Overload ▪ HP sensor defective
		<ul style="list-style-type: none"> ▪ Replace the punch movement motor ▪ Reset the connector ▪ Replace the punch movement HP sensor ▪ Replace the harness ▪ Replace the main board of the finisher

SC No.	Level	Error Name/Error Condition/Major Cause/Solution
SC721-28	B	Punch Horizontal Registration Detection Error (1K sheet finisher)
		<ul style="list-style-type: none"> ▪ During movement to home, the home position could not be detected within a predetermined pulse (p0 pulse) (1st time is jam notification, 2nd time is SC notification). ▪ During movement from home, the home position was detected for longer than a predetermined pulse (p1 pulse) (1st time is jam notification, 2nd time is SC notification). <p>The return pulse to home and pulse coming from home during normal operation are calculated and measured. The pulses which are 1.5-2 times the normal operation pulse are taken as p0 and p1.</p>
		<ul style="list-style-type: none"> ▪ Motor defective ▪ Connector disconnected ▪ Overload ▪ HP sensor defective
		<ul style="list-style-type: none"> ▪ Replace the paper position sensor slide motor ▪ Reset the connector ▪ Replace the paper position sensor ▪ Replace the harness ▪ Replace the main board of the finisher

SC No.	Level	Error Name/Error Condition/Major Cause/Solution
SC721-30	B	Jogger Motor 1 Error (1K sheet finisher)
		<ul style="list-style-type: none"> ▪ During movement to home, the home position could not be detected within a predetermined pulse (p0 pulse) (1st time is jam notification, 2nd time is SC notification). ▪ During movement from home, the home position was detected for longer than a predetermined pulse (p1 pulse) (1st time is jam notification, 2nd time is SC notification). <p>The return pulse to home and pulse coming from home during normal operation are calculated and measured. The pulses which are 1.5-2 times the normal operation pulse are taken as p0 and p1.</p>
		<ul style="list-style-type: none"> ▪ Motor defective ▪ Connector disconnected ▪ Overload ▪ HP sensor defective
		<ul style="list-style-type: none"> ▪ Replace the jogger motor ▪ Reset the connector ▪ Replace the jogger HP sensor ▪ Replace the harness ▪ Replace the main board of the finisher

SC No.	Level	Error Name/Error Condition/Major Cause/Solution
SC721-33	B	Positioning Roller Motor Error (1K sheet finisher)
		<ul style="list-style-type: none"> ▪ During movement to home, the home position could not be detected within a predetermined pulse (p0 pulse) (1st time is jam notification, 2nd time is SC notification). ▪ During movement from home, the home position was detected for longer than a predetermined pulse (p1 pulse) (1st time is jam notification, 2nd time is SC notification). <p>The return pulse to home and pulse coming from home during normal operation are calculated and measured. The pulses which are 1.5-2 times the normal operation pulse are taken as p0 and p1.</p>
		<ul style="list-style-type: none"> ▪ Motor defective ▪ Connector disconnected ▪ Overload ▪ HP sensor defective
		<ul style="list-style-type: none"> ▪ Replace the positioning roller motor ▪ Reset the connector ▪ Replace the positioning roller HP sensor ▪ Replace the harness ▪ Replace the main board of the finisher

SC No.	Level	Error Name/Error Condition/Major Cause/Solution
SC721-41	B	Release Claw Motor Error (1K sheet finisher)
		<ul style="list-style-type: none"> ▪ During movement to home, the home position could not be detected within a predetermined pulse (p0 pulse) (1st time is jam notification, 2nd time is SC notification). ▪ During movement from home, the home position was detected even after a predetermined pulse (p1 pulse) elapsed (1st time is jam notification, 2nd time is SC notification). <p>The return pulse to home and pulse coming from home during normal operation are calculated and measured. The pulses which are 1.5-2 times the normal operation pulse are taken as p0 and p1.</p>
		<ul style="list-style-type: none"> ▪ Motor defective ▪ Connector disconnected ▪ Overload ▪ HP sensor defective
		<ul style="list-style-type: none"> ▪ Replace the release claw motor ▪ Reset the connector ▪ Replace release claw HP sensor ▪ Replace the harness ▪ Replace the main board of the finisher

SC No.	Level	Error Name/Error Condition/Major Cause/Solution
SC721-42	B	Stapler Transfer Motor Error (1K sheet finisher)
		<ul style="list-style-type: none"> ▪ During movement to home, the home position could not be detected within a predetermined pulse (p0 pulse) (1st time is jam notification, 2nd time is SC notification). ▪ During movement from home, the home position was detected even after a predetermined pulse (p1 pulse) elapsed (1st time is jam notification, 2nd time is SC notification). ▪ During movement from home, retreat sensor ON could not be detected even after a predetermined pulse (p2 pulse) elapsed (1st time is jam notification, 2nd time is SC notification). ▪ During initialization, retreat sensor ON was detected simultaneously when the home position is detected (1st time is jam notification, 2nd time is SC notification). <p>The return pulse to home and pulse coming from home during normal operation are calculated and measured. The pulses which are 1.5-2 times the normal operation pulse are taken as p0, p1 and p2.</p>
		<ul style="list-style-type: none"> ▪ Motor defective ▪ Connector disconnected ▪ Overload ▪ HP sensor defective ▪ Retreat sensor error
		<ul style="list-style-type: none"> ▪ Replace the stapler transfer motor ▪ Reset the connector ▪ Replace the stapler transfer HP sensor ▪ Replace the harness ▪ Replace the main board of the finisher

SC No.	Level	Error Name/Error Condition/Major Cause/Solution
SC721-44	B	Stapler Error (1K sheet finisher)
		<ul style="list-style-type: none"> ▪ Motor driver detects an error (short-circuit and overheating) (1st time is SC). ▪ During movement to home, the home position could not be detected even after a predetermined time (t0 sec) elapsed (1st time is jam notification, 2nd time is SC notification). ▪ During movement from home, the home position was detected even after a predetermined time (t1 sec) elapsed (1st time is jam notification, 2nd time is SC notification). ▪ During motor drive, the output from the encoder could not be counted for a predetermined number of times within a predetermined time (t0 sec) (1st time is jam notification, 2nd time is SC notification). <p>The time to return to home without fail, the time coming from home, and the time for which the encoder output can be counted during normal operation, are taken as t0, t1 and t2.</p>
		<ul style="list-style-type: none"> ▪ Staple jam ▪ Motor defective ▪ Connector disconnected ▪ Overload ▪ HP sensor defective ▪ Encoder error
<ul style="list-style-type: none"> ▪ Replace the stapler unit ▪ Reset the connector ▪ Replace the harness ▪ Replace the main board of the finisher 		

SC No.	Level	Error Name/Error Condition/Major Cause/Solution
SC721-52	B	Folding Blade Motor Error (1K sheet finisher)
		<ul style="list-style-type: none"> ▪ Motor driver detects an error (short-circuit and overheating) (1st time is SC). ▪ During movement to home, the home position could not be detected within a predetermined pulse (p0 pulse) (1st time is jam notification, 2nd time is SC notification). ▪ During movement from home, the home position was detected for longer than a predetermined pulse (p1 pulse) (1st time is jam notification, 2nd time is SC notification). <p>The return pulse to home and pulse coming from home during normal operation are calculated and measured. The pulses which are 1.5-2 times the normal operation pulse are taken as p0 and p1.</p>
		<ul style="list-style-type: none"> ▪ Motor defective ▪ Connector disconnected ▪ Overload ▪ Center-folding blade HP sensor, or center-folding cam HP sensor defective
<ul style="list-style-type: none"> ▪ Replace the folding blade motor ▪ Reset the connector ▪ Replace the center-folding blade HP sensor ▪ Replace the harness ▪ Replace the main board of the finisher 		

SC No.	Level	Error Name/Error Condition/Major Cause/Solution
SC721-53	B	Trailing Edge Stopper Motor Error (1K sheet finisher)
		<ul style="list-style-type: none"> ▪ During movement to home, the home position could not be detected within a predetermined pulse (p0 pulse) (1st time is jam notification, 2nd time is SC notification). ▪ During movement from home, the home position was detected for longer than a predetermined pulse (p1 pulse) (1st time is jam notification, 2nd time is SC notification). <p>The return pulse to home and pulse coming from home during normal operation are calculated and measured. The pulses which are 1.5-2 times the normal operation pulse are taken as p0 and p1.</p>
		<ul style="list-style-type: none"> ▪ Motor defective ▪ Connector disconnected ▪ Overload ▪ HP sensor defective
		<ul style="list-style-type: none"> ▪ Replace the trailing edge stopper motor ▪ Reset the connector ▪ Replace the trailing edge stopper HP sensor ▪ Replace the harness ▪ Replace the main board of the finisher

SC No.	Level	Error Name/Error Condition/Major Cause/Solution
SC721-58	B	Paper Bundle Transport Upper Pressure Release Motor Error (1K sheet finisher)
		<ul style="list-style-type: none"> ▪ During movement to home, the home position could not be detected within a predetermined pulse (p0 pulse) (1st time is jam notification, 2nd time is SC notification). ▪ During movement from home, the home position was detected for longer than a predetermined pulse (p1 pulse) (1st time is jam notification, 2nd time is SC notification). <p>The return pulse to home and pulse coming from home during normal operation are calculated and measured. The pulses which are 1.5-2 times the normal operation pulse are taken as p0 and p1.</p>
		<ul style="list-style-type: none"> ▪ Motor defective ▪ Connector disconnected ▪ Overload ▪ HP sensor defective
		<ul style="list-style-type: none"> ▪ Replace the paper bundle transport upper pressure release motor ▪ Reset the connector ▪ Replace the stapler tray paper detection sensor ▪ Replace the harness ▪ Replace the main board of the finisher

SC No.	Level	Error Name/Error Condition/Major Cause/Solution
SC721-59	B	Paper Bundle Transport Lower Pressure Release Motor Error (1K sheet finisher)
		<ul style="list-style-type: none"> ▪ During movement to home, the home position could not be detected within a predetermined pulse (p0 pulse) (1st time is jam notification, 2nd time is SC notification). ▪ During movement from home, the home position was detected for longer than a predetermined pulse (p1 pulse) (1st time is jam notification, 2nd time is SC notification). <p>The return pulse to home and pulse coming from home during normal operation are calculated and measured. The pulses which are 1.5-2 times the normal operation pulse are taken as p0 and p1.</p>
		<ul style="list-style-type: none"> ▪ Motor defective ▪ Connector disconnected ▪ Overload ▪ HP sensor defective
		<ul style="list-style-type: none"> ▪ Replace the paper bundle transport lower pressure release motor ▪ Reset the connector ▪ Replace paper bundle transport lower pressure release HP sensor ▪ Replace the harness ▪ Replace the main board of the finisher

SC No.	Level	Error Name/Error Condition/Major Cause/Solution
SC721-70	B	Tray Lift Motor Error (1K sheet finisher)
		<ul style="list-style-type: none"> ▪ Motor driver detects an error (short-circuit or overheating) (1st time is SC). ▪ During descent, the paper surface sensor still detects paper even after a predetermined time (t0sec) elapses (1st time is jam notification, 2nd time is SC notification). ▪ During ascent, the paper surface sensor could not detect the paper surface even after a predetermined time (t0sec) elapses (1st time is jam notification, 2nd time is SC notification). <p>The return pulse to home and pulse coming from home during normal operation are calculated and measured. The pulses which are 1.5-2 times the normal operation pulse are taken as p0 and p1.</p>
		<ul style="list-style-type: none"> ▪ Motor defective ▪ Connector disconnected ▪ Overload ▪ Paper surface sensor defective
		<ul style="list-style-type: none"> ▪ Replace the tray lift motor ▪ Reset the connector ▪ Replace the following sensors: Shift tray paper surface sensor, Shift tray lower limit sensor (upper) or Shift tray upper limit sensor (lower) ▪ Replace the harness ▪ Replace the main board of the finisher

SC No.	Level	Error Name/Error Condition/Major Cause/Solution
SC721-71	B	Shift Motor 1 Error (1K sheet finisher)
		<ul style="list-style-type: none"> ▪ During movement to home, the home position could not be detected within a predetermined pulse (p0 pulse) (1st time is jam notification, 2nd time is SC notification). ▪ During movement from home, the home position was detected for longer than a predetermined pulse (p1 pulse) (1st time is jam notification, 2nd time is SC notification). <p>The return pulse to home and pulse coming from home during normal operation are calculated and measured. The pulses which are 1.5-2 times the normal operation pulse are taken as p0 and p1.</p>
		<ul style="list-style-type: none"> ▪ Motor defective ▪ Connector disconnected ▪ Overload ▪ HP sensor defective
		<ul style="list-style-type: none"> ▪ Replace the shift motor ▪ Reset the connector ▪ Replace the shift HP sensor ▪ Replace the harness ▪ Replace the main board of the finisher

SC No.	Level	Error Name/Error Condition/Major Cause/Solution
SC721-80	B	Folding Transport Motor Error (1K sheet finisher)
		<ul style="list-style-type: none"> ▪ Motor driver detects an error (short-circuit or overheating) (1st time is SC)
		<ul style="list-style-type: none"> ▪ Motor defective ▪ Connector disconnected ▪ Overload
		<ul style="list-style-type: none"> ▪ Replace folding transport motor ▪ Reset the connector ▪ Replace the main board of the finisher

SC No.	Level	Error Name/Error Condition/Major Cause/Solution
SC723-03	B	Power Supply Error (Internal Finisher: Non-Staple Bind)
		When original source 24V power supply is ON, protection device intercept of non-interlock power supply system is detected.
		A motor failure or harness short-circuit occur in the non-interlock power supply system.
		<ul style="list-style-type: none"> ▪ Replace the short-circuited harnesses ▪ Replace the protection devices
SC723-10	B	Transport Motor Error (Internal Finisher: Non-Staple Bind)
		The DCM driver error detection is started after reset, and predetermined milliseconds error signal is detected. This SC will be issued when the above phenomenon repeated 2 times.
		<ul style="list-style-type: none"> ▪ Transport Motor failure ▪ Harness short-circuit ▪ Circuit board failure ▪ Over current ▪ Abnormal temperature
		<ul style="list-style-type: none"> ▪ Replace the motor ▪ Replace the harness ▪ Replace the circuit board.
SC723-20	B	Junction Solenoid Motor Error (Internal Finisher: Non-Staple Bind)
		<p>When the junction claw HP sensor was not turned off while predetermined seconds applied to the solenoid motor with the HP sensor turned on.</p> <p>When the junction claw HP sensor was not turned on while predetermined seconds applied to the solenoid motor with the HP sensor turned off.</p> <p>This SC will be issued when the above phenomenon repeated 2 times.</p>

SC No.	Level	Error Name/Error Condition/Major Cause/Solution
		<ul style="list-style-type: none"> ▪ Junction Solenoid Motor failure ▪ Connector disconnected ▪ Over load ▪ Junction claw HP sensor error
SC723-24	B	<p data-bbox="501 667 1310 752">Exit Paper Pressure Motor Error (Internal Finisher: Non-Staple Bind)</p> <p data-bbox="501 790 1310 920">When the exit paper pressure HP sensor was not turned off while predetermined seconds applied to the exit pressure release motor with the HP sensor turned on.</p> <p data-bbox="501 936 1310 1066">When paper output pressure HP sensor was not turned on while predetermined seconds applied to the exit pressure release motor with the HP sensor turned off.</p> <p data-bbox="501 1081 1310 1167">This SC will be issued when the above phenomenon repeated 2 times.</p> <ul style="list-style-type: none"> ▪ Exit Pressure Release Motor failure ▪ Connector disconnected ▪ Over load ▪ Exit pressure release HP sensor error
		<ul style="list-style-type: none"> ▪ Check the connection ▪ Replace the motor/sensor ▪ Replace the harness

SC No.	Level	Error Name/Error Condition/Major Cause/Solution
SC723-44	B	Stapler Motor Error (Internal Finisher: Non-Staple Bind)
		<p>When the stapler drive HP sensor was not turned off while predetermined seconds applied to the stapler motor with the HP sensor turned on.</p> <p>When stapler drive HP sensor was not turned on while predetermined seconds applied to the stapler motor with the HP sensor turned off.</p> <p>The STM driver error detection is started after reset, and predetermined seconds error signal is detected.</p> <p>This SC will be issued when the above phenomenon repeated 2 times.</p>
		<ul style="list-style-type: none"> ▪ Stapler Motor failure ▪ Connector disconnected ▪ Stapler Motor overload ▪ Stapler HP sensor error ▪ Harness short-circuit ▪ Circuit board failure ▪ Excess current ▪ Abnormal temperature
		<ul style="list-style-type: none"> ▪ Check the connection ▪ Replace the motor/sensor ▪ Replace the harness ▪ Replace the circuit board
SC723-71	B	<p>Shift Motor Error (Internal Finisher: Non-Staple Bind)</p> <p>When the shift HP sensor was not turned off while predetermined seconds applied to the shift motor with the HP sensor turned on.</p> <p>When shift HP sensor was not turned on while predetermined seconds applied to the shift motor with the HP sensor turned off.</p> <p>The STM driver error detection is started after reset, and predetermined seconds error signal is detected.</p> <p>This SC will be issued when the above phenomenon repeated 2 times.</p>

SC No.	Level	Error Name/Error Condition/Major Cause/Solution
		<ul style="list-style-type: none"> ▪ Shift Motor failure ▪ Connector disconnected ▪ Shift Motor overload ▪ Shift HP sensor error ▪ Harness short-circuit ▪ Circuit board failure ▪ Excess current ▪ Abnormal temperature
		<ul style="list-style-type: none"> ▪ Check the connection ▪ Replace the motor/sensor ▪ Replace the harness ▪ Replace the circuit board

SC No.	Level	Error Name/Error Condition/Major Cause/Solution
SC724		Internal Finisher Error
SC724-24	B	<p>Paper Output Open/Close Guide Plate Motor Error (Internal finisher)</p> <ul style="list-style-type: none"> ▪ When Paper Output Open/Close Guide Plate Motor is driven for predetermined seconds after paper exit guide plate HP sensor ON, the HP sensor does not switch OFF (1st time is jam notification, 2nd time is SC notification). ▪ When Paper Output Open/Close Guide Plate Motor is driven for predetermined seconds after paper exit guide plate HP sensor OFF, the HP sensor does not switch ON (1st time is jam notification, 2nd time is SC notification).
SC724-25	B	<p>Punch Motor Error (Internal finisher)</p> <ul style="list-style-type: none"> ▪ When punch motor is driven for predetermined seconds after punch HP sensor ON, the HP sensor does not switch OFF (1st time is jam notification, 2nd time is SC notification). ▪ When punch motor is driven for predetermined seconds after punch HP sensor OFF, the HP sensor does not switch ON (1st time is jam notification, 2nd time is SC notification).

SC No.	Level	Error Name/Error Condition/Major Cause/Solution
SC724-27	B	Horizontal Registration Movement Unit Motor Error (Internal finisher)
		<ul style="list-style-type: none"> ▪ When Horizontal Registration Movement Unit Motor is driven for predetermined seconds when horizontal registration movement HP sensor is ON, the HP sensor does not switch OFF (1st time is jam notification, 2nd time is SC notification). ▪ When Horizontal Registration Movement Unit Motor is driven for predetermined seconds when horizontal registration movement HP sensor is OFF, the HP sensor does not switch ON (1st time is jam notification, 2nd time is SC notification).
SC724-28	B	Punch Horizontal Registration Detection Unit Motor Error (Internal finisher)
		<ul style="list-style-type: none"> ▪ When Punch Horizontal Registration Detection Unit Motor is driven for predetermined seconds when horizontal registration detection HP sensor is ON, the HP sensor does not switch OFF (1st time is jam notification, 2nd time is SC notification). ▪ When Punch Horizontal Registration Detection Unit Motor is driven for predetermined seconds when horizontal registration detection HP sensor is OFF, the HP sensor does not switch ON (1st time is jam notification, 2nd time is SC notification).
SC724-31	B	Jogger Fence Motor (Front) Error (Internal finisher)
		<ul style="list-style-type: none"> ▪ When Jogger Fence Motor (Front) is driven for predetermined seconds when front jogger HP sensor is ON, the HP sensor does not switch OFF (1st time is jam notification, 2nd time is SC notification). ▪ When Jogger Fence Motor (Front) is driven for predetermined seconds when front jogger HP sensor is OFF, the HP sensor does not switch ON (1st time is jam notification, 2nd time is SC notification).

SC No.	Level	Error Name/Error Condition/Major Cause/Solution
SC724-32	B	Jogger Fence Motor (Rear) Error (Internal finisher)
		<ul style="list-style-type: none"> <li data-bbox="497 405 1308 584">▪ When Jogger Fence Motor (Rear) is driven for predetermined seconds when rear jogger HP sensor is ON, the HP sensor does not switch OFF (1st time is jam notification, 2nd time is SC notification). <li data-bbox="497 595 1308 775">▪ When Jogger Fence Motor (Rear) is driven for predetermined seconds when rear jogger HP sensor is OFF, the HP sensor does not switch ON (1st time is jam notification, 2nd time is SC notification).
SC724-33	B	Strike Roller Motor Error (Internal finisher)
		<ul style="list-style-type: none"> <li data-bbox="497 887 1308 1111">▪ During initialization/strike descent, even when the strike roller motor is driven for predetermined seconds when the strike roller HP sensor is ON, the HP sensor does not switch OFF (1st time is jam notification, 2nd time is SC notification). <li data-bbox="497 1122 1308 1301">▪ During initialization, even when the strike roller motor is driven for predetermined seconds when the strike roller HP sensor is OFF, the HP sensor does not switch ON (1st time is jam notification, 2nd time is SC notification). <li data-bbox="497 1312 1308 1491">▪ When the strike roller is lifted from the press position, even when driven for predetermined seconds the HP sensor does not switch ON (1st time is jam notification, 2nd time is SC notification).
SC724-38	B	Paper Bail Motor Error (Internal finisher)
		<ul style="list-style-type: none"> <li data-bbox="497 1606 1308 1785">▪ When the paper press HP sensor is ON and the paper press motor is driven for predetermined seconds, the HP sensor does not switch OFF (1st time is jam notification, 2nd time is SC notification). <li data-bbox="497 1796 1308 1975">▪ When the paper press HP sensor is OFF and the paper press motor is driven for predetermined seconds, the HP sensor does not switch ON (1st time is jam notification, 2nd time is SC notification).

SC No.	Level	Error Name/Error Condition/Major Cause/Solution
SC724-42	B	Stapler Displacement Movable Motor Error (Internal finisher)
		<ul style="list-style-type: none"> <li data-bbox="497 405 1318 584">▪ Sifter stapler displacement HP sensor ON, even when the stapler displacement motor is driven for predetermined seconds, the HP sensor does not switch OFF (1st time is jam notification, 2nd time is SC notification). <li data-bbox="497 595 1318 775">▪ After stapler displacement HP sensor OFF, even when the stapler displacement motor is driven for predetermined seconds, the HP sensor does not switch ON (1st time is jam notification, 2nd time is SC notification).
SC724-70	B	Tray Lift Motor Error (Internal finisher)
		<ul style="list-style-type: none"> <li data-bbox="497 889 1318 1068">▪ During ascent from paper surface sensor ON, even after predetermined seconds elapses, the paper surface sensor does not switch OFF (1st time is jam notification, 2nd time is SC notification). <li data-bbox="497 1079 1318 1258">▪ During descent from paper surface sensor OFF, the paper surface sensor does not switch ON even after predetermined seconds elapses (1st time is jam notification, 2nd time is SC notification). <li data-bbox="497 1270 1318 1359">▪ During descent to the packing position, the full sensor does not switch ON even if predetermined seconds elapses.
SC724-71	B	Shift Motor Error
		If the shift sensor has no response after the shift motor starts moving 1.86 sec.
SC724-80	B	Shift Motor Error (Internal finisher)
		<ul style="list-style-type: none"> <li data-bbox="497 1659 1318 1839">▪ When the shift roller HP sensor is ON, the HP sensor does not switch OFF even when the shift roller motor is driven for predetermined seconds (1st time is jam notification, 2nd time is SC notification) <li data-bbox="497 1850 1318 2029">▪ When the shift roller HP sensor is OFF, the HP sensor does not switch ON even when the shift roller motor is driven for predetermined seconds (1st time is jam notification, 2nd time is SC notification).

SC No.	Level	Error Name/Error Condition/Major Cause/Solution
SC724-86	B	Stapler Motor Error (Internal finisher)
		<ul style="list-style-type: none"> ▪ HP sensor does not switch OFF even when the stapler motor is driven for predetermined seconds after the stapler HP sensor switches ON (1st time is jam notification, 2nd time is SC notification). ▪ HP sensor does not switch ON even when the stapler motor is driven for predetermined seconds after the stapler HP sensor switches OFF (1st time is jam notification, 2nd time is SC notification).
		<ul style="list-style-type: none"> ▪ Motor defective ▪ Connector disconnected ▪ Motor overload ▪ Home position sensor error ▪ Paper surface sensor error (*SC724-38, 70 only) ▪ Staple jam (*SC724-86 only)
		<ul style="list-style-type: none"> ▪ Reset the connector ▪ Replace the motor ▪ Replace the sensor ▪ Replace the harness ▪ Remove the staple jam (*SC724-86 only)

SC No.	Level	Error Name/Error Condition/Major Cause/Solution
SC761		Protection Device Intercept Error *V (Bridge unit or Side Tray)
SC761-03	B	Protection Device Intercept Error 5V
SC761-04	B	Protection Device Intercept Error 24V
		Fuse blowout occurs due to over current during power injection (output detected for longer than 2 seconds).
		<ul style="list-style-type: none"> ▪ Over current of bridge unit motor ▪ Over current due to short-circuit in PCB
		<ul style="list-style-type: none"> ▪ Replace the bridge unit ▪ Replace the PCB.

SC No.	Level	Error Name/Error Condition/Major Cause/Solution
SC780-01	D	Bank 1 (Upper optional paper tray) Protection Device Intercept Error
		When original source of 5V power supply is ON, protection device intercept of 24V power system is detected.
		In 24V power supply system: <ul style="list-style-type: none"> ▪ Motor defective ▪ Solenoid defective ▪ Harness short- circuit
		<ul style="list-style-type: none"> ▪ Replace the PCB ▪ Replace the short-circuited part (harness, motor, solenoid)

SC No.	Level	Error Name/Error Condition/Major Cause/Solution
SC781-01	D	Bank 2 (Lower optional paper tray) Protection Device Intercept Error
		When original source of 5V power supply is ON, protection device intercept of 24V power system is detected.
		In 24V power supply system: <ul style="list-style-type: none"> ▪ Motor defective ▪ Solenoid defective ▪ Harness short- circuit
		<ul style="list-style-type: none"> ▪ Replace the PCB ▪ Replace the short-circuited part (harness, motor, solenoid)

SC No.	Level	Error Name/Error Condition/Major Cause/Solution
SC791-00	D	No Bridge Unit when Finisher is Present
		When power supply is switched on or paper is transported, finisher set is detected but bridge unit set is not detected. (during internal finisher connection, not detected)
		<ul style="list-style-type: none"> ▪ Bridge unit not attached ▪ Bridge unit defective
		<ul style="list-style-type: none"> ▪ Reset the bridge unit ▪ Turn the power off/on

SC No.	Level	Error Name/Error Condition/Major Cause/Solution
SC792-00	B	No Finisher, Bridge Unit Provided
		When a machine which has a bridge unit is powered on, no finisher is detected
		<ul style="list-style-type: none"> ▪ Finisher connector set fault ▪ In a machine which has a bridge unit connected, a finisher is not fitted ▪ Finisher defective
		Connect finisher or disconnect bridge unit, and turn the power off/on

6.9 SC TABLES: SC8XX

6.9.1 SC816 TO SC899

SC No.	Level	Error Name/Error Condition/Major Cause/Solution
SC816	[0x0000]	Energy save I/O subsystem error
SC816-01	D	Subsystem error
SC816-02	D	Sysarch (LPUX_GET_PORT_INFO) error
SC816-03	D	Transition to STR was denied.
SC816-04	D	Interrupt in kernel communication driver
SC816-05	D	Preparation for transition to STR failed.
SC816-07	D	Sysarch (LPUX_GET_PORT_INFO) error
SC816-08	D	Sysarch (LPUX_ENGINE_TIMERCTRL) error
SC816-09	D	Sysarch (LPUX_RETURN_FACTOR_STR) error
SC816-10 to 12	D	Sysarch (LPUX_GET_PORT_INFO) error
SC816-13	D	open() error
SC816-14	D	Memory address error
SC816-15 to 18	D	open() error
SC816-19	D	Double open() error
SC816-20	D	open() error
SC816-22	D	Parameter error
SC816-23, 24	D	read() error
SC816-25	D	write () error
SC816-26 to 28	D	write() communication retry error

SC No.	Level	Error Name/Error Condition/Major Cause/Solution
SC816-29, 30	D	read() communication retry error
SC816-35	D	read() error
SC816-36 to 94	D	Subsystem error
		Energy save I/O subsystem detected some abnormality.
		<ul style="list-style-type: none"> ▪ Energy save I/O subsystem defective ▪ Energy save I/O subsystem detected a controller board error (non-response). ▪ Error was detected during preparation for transition to STR.
		<ul style="list-style-type: none"> ▪ Turn the main power off/on. ▪ Replace the controller board.

SC No.	Level	Error Name/Error Condition/Major Cause/Solution
SC817-00	D	Monitor error: File detection / Digital signature error
		<ul style="list-style-type: none"> ▪ Bootloader cannot read any of diagnostic module, kernel, or root filesystem. ▪ In a bootloader SD card, the digital signature checking for any of diagnostic module, kernel, or root filesystem is failed.
		<ul style="list-style-type: none"> ▪ Any of the following items does not exist or is broken: OS Flash ROM, Diagnostic module in SD card, Kernel, Root filesystem ▪ Any of the following items is revised fraudulently: Diagnostic module in SD card, Kernel, Root filesystem
		<ul style="list-style-type: none"> ▪ ROM update for controller system ▪ Use another booting SD card having a valid digital signature

SC No.	Level	Error Name/Error Condition/Major Cause/Solution
SC818-00	D	Watchdog timer error
		The system program fell into a bus-hold state or an endless loop of the program interruption occurred, causing other process to stop.
		<ul style="list-style-type: none"> ▪ System program defective ▪ Controller board defective ▪ Optional board defective
		<ul style="list-style-type: none"> ▪ Turn the main power off/on. ▪ Replace the controller board.

SC No.	Level	Error Name/Error Condition/Major Cause/Solution
SC819-00	D	Kernel halt error [xxxx]: Detailed error code
		Due to a control error, a RAM overflow occurred during system processing. One of the following messages was displayed on the operation panel.
	[0x5032]	HAIC-P2 error
		HAIC-P2 decompression error (An error occurred in the ASIC compression/decompression module.)
		<ul style="list-style-type: none"> ▪ Turn the main power off/on. ▪ Replace the HDD. ▪ Replace the memory ▪ Replace the controller board. ▪ Fix the software
	[0x6261]	HDD defective
		6261 6420 6469 7200 00 -> "bad dir"
		Replace the HDD.
	[0x696e]	gwinit processing end
		If the SCS process is ended for some reason

SC No.	Level	Error Name/Error Condition/Major Cause/Solution
		<p>If an unexpected error occurs at SCS processing end, gwint processing also halts (this result is judged a kernel stop error, by gwinit specification)</p> <p>"0x69742064" -> "init died"</p> <p>Turn the main power off/on.</p>
	[0x766d]	<p>VM full error</p> <p>Occurs when too much RAM is used during system processing</p> <p>"vm_pageout: VM is full"</p> <p>Turn the main power off/on.</p>
	Console string	<p>Other error (characters on operation panel)</p> <p>System detected internal mismatch error</p> <ul style="list-style-type: none"> ▪ Software defective ▪ Insufficient memory ▪ Hardware driver defective (RAM, FLASH memory) <ul style="list-style-type: none"> ▪ Turn the main power off/on. ▪ Replace the controller board.

SC No.	Level	Error Name/Error Condition/Major Cause/Solution
SC820-00	D	Self-diagnostics error: CPU [xxxx]: Detailed error code
[0001] to [06FF] [0801] to [4005]		CPU error During the self-diagnosis, the controller CPU detects an error. There are 47 types of error code (0001 to 4005) depending on the cause of the error. The CPU detects an error and displays the specific error code with the program address where the error occurs.
		<ul style="list-style-type: none"> ▪ System firmware problem ▪ Defective controller
		<ol style="list-style-type: none"> 1. Turn the main power switch off and on. 2. Reinstall the controller system firmware. 3. Replace the controller. <p>When the problem cannot be fixed with the above procedure, the following information displayed on the screen needs to be reported to the technical support center.</p> <ul style="list-style-type: none"> - SC code - Detailed error code - Program address
[0701] to [070A]		CPU/Memory Error
		<ul style="list-style-type: none"> ▪ System firmware problem ▪ Defective RAM-DIMM ▪ Defective controller
		<ul style="list-style-type: none"> ▪ Reinstall the controller system software. ▪ Replace the RAM-DIMM. ▪ Replace the controller.

SC No.	Level	Error Name/Error Condition/Major Cause/Solution
SC821-00	D	Self-diagnostics error: ASIC [xxxx]: Detailed error code
	[0B00]	ASIC register check error
		The write-&-verify check has occurred in the ASIC.
		Defective ASIC device
		Replace the controller board.
	[0D05]	Comparison error of CPU and ASIC timer
		The CPU checks if the ASIC timer works correctly compared with the CPU timer. If the ASIC timer does not function in the specified range, this SC code is displayed.
		<ul style="list-style-type: none"> ▪ Defective ASIC timer device ▪ Defective CPU device
		Replace the controller board.
	[50A2]	Video bridge device (ASIC) register error
		The CPU detects the video bridge device, but detects error data from the video bridge device.
		Defective I/F between the video bridge device and the controller
		Replace the controller board.

SC No.	Level	Error Name/Error Condition/Major Cause/Solution
SC822-00	B	Self-diagnostic error: HDD [xxxx]: Detailed error code
	[3003]	<p>HDD timeout</p> <p>Check performed only when HDD is installed:</p> <ul style="list-style-type: none"> ▪ HDD device busy for over 31sec. ▪ After a diagnostic command is set for the HDD, but the device remains busy for over 6sec.. <ul style="list-style-type: none"> ▪ HDD defective ▪ HDD harness disconnected, defective ▪ Controller board defective <ul style="list-style-type: none"> ▪ Replace the HDD. ▪ Replace the HDD connector. ▪ Replace the controller board.
	[3004]	<p>Diagnostic command error</p> <p>No response to the self-diagnostic command from the ASIC to the HDD.</p> <p>HDD defective</p> <p>Replace the HDD.</p>

SC No.	Level	Error Name/Error Condition/Major Cause/Solution
SC823-00	B	Self-diagnostics error: NIC [XXXX]: Detailed error code
	[6101]	MAC address check sum error
		The result of the MAC address check sum does not match the check sum stored in ROM.
		<ul style="list-style-type: none"> ▪ Defective SEEP ROM ▪ Defective I2C bus (connection)
		Replace the controller board.
	[6104]	PHY IC error
		The PHY IC on the controller cannot be correctly recognized.
		<ul style="list-style-type: none"> ▪ Defective PHY chip ▪ Defective ASIC MII I/F
		Replace the controller board.
	[6105]	PHY IC loop-back error
		An error occurred during the loop-back test for the PHY IC on the controller.
		<ul style="list-style-type: none"> ▪ PHY chip ▪ Defective MAC of ASIC (SIMAC/COMIC/CELLO) ▪ Defective I/F with the PHY board ▪ Defective solder on the PHY board
		Replace the controller board.

SC No.	Level	Error Name/Error Condition/Major Cause/Solution
SC824-00	D	Self-diagnostics error: NVRAM (resident) [XXXX]: Detailed error code
	[1401]	NVRAM verify error
		NVRAM device is missing or NVRAM device is damaged.
		<ul style="list-style-type: none"> ▪ The NVRAM device is missing. ▪ The NVRAM device is damaged. ▪ NVRAM backup battery exhausted ▪ NVRAM socket damaged
	Replace the NVRAM device.	

SC No.	Level	Error Name/Error Condition/Major Cause/Solution
SC827-00	D	Self-diagnostic error: Standard SDRAM DIMM [XXXX]: Detailed error code
	[0201]	Verification error
		Error detected during a write/verify check for the standard RAM (SDRAM DIMM).
		<ul style="list-style-type: none"> ▪ Loose connection ▪ Defective SDRAM DIMM ▪ Defective controller
	Replace the controller board or RAM DIMM.	
	[0202]	Resident memory error
		The SPD values in all RAM DIMM are incorrect or unreadable.
		<ul style="list-style-type: none"> ▪ Defective RAM DIMM ▪ Defective SPD ROM on RAM DIMM ▪ Defective 12C bus
	Replace the RAM DIMM	

SC No.	Level	Error Name/Error Condition/Major Cause/Solution
SC828-00	D	Self-diagnostic error: ROM [xxxx]: Detailed error code
	[0101]	Check sum error 1
		The boot monitor and OS program stored in the ROM DIMM is checked. If the check sum of the program is incorrect, this SC code is displayed.
		<ul style="list-style-type: none"> ▪ Defective FLASH ROM device ▪ Defective CPU device
	Replace the controller board.	

SC No.	Level	Error Name/Error Condition/Major Cause/Solution
SC835-00	B	Self-diagnostic error: Centronic device [xxxx]: Detailed error code
	[1102]	Verify error
		The loopback connector is connected but check results is an error.
		<ul style="list-style-type: none"> ▪ IEEE1284 connector error ▪ Centronic loopback connector defective
		Replace the controller board.
	[110C]	DMA verify error
		The loopback connector is connected but check results is an error.
		<ul style="list-style-type: none"> ▪ ASIC device error ▪ IEEE1284 connector error ▪ Centronic loopback connector is defective
		Replace the controller board.
	[1120]	Loopback connector undetected
		Centronic loopback connector is not connected for detailed self-diagnostic test.

SC No.	Level	Error Name/Error Condition/Major Cause/Solution
		<ul style="list-style-type: none"> ▪ Centronic loopback connector not connected correctly ▪ Centronic loopback connector is defective ▪ ASIC device is defective
		<ul style="list-style-type: none"> ▪ Connect the centronic loopback connector ▪ Replace the centronic loopback connector ▪ Replace the controller board.

SC No.	Level	Error Name/Error Condition/Major Cause/Solution
SC838-00	D	Self-diagnostic Error: Clock Generator [xxxx]: Detailed error code
	[2701]	Verify error
		A verify error occurred when setting data was read from the clock generator via the I2C bus.
		<ul style="list-style-type: none"> ▪ Defective clock generator ▪ Defective I2C bus ▪ Defective I2C port on the CPU
		Replace the controller board.

SC No.	Level	Error Name/Error Condition/Major Cause/Solution
SC839-00	D	Self-diagnostic Error: Serial Flash [xxxx]: Detailed error code
	[9001]	Serial Flash access error
		USB NAND Flash ROM cannot be read.
		Defective controller board
		Replace the controller board.

SC No.	Level	Error Name/Error Condition/Major Cause/Solution
SC840-00	D	EEPROM access error
		<ul style="list-style-type: none"> ▪ During the I/O processing, a reading error occurred. The 3rd reading failure causes this SC code. ▪ During the I/O processing, a writing error occurred.
		<ul style="list-style-type: none"> ▪ Defective EEPROM
		-

SC No.	Level	Error Name/Error Condition/Major Cause/Solution
SC841-00	D	EEPROM read data error
		Mirrored data of the EEPROM is different from the original data in EEPROM.
		Data in the EEPROM is overwritten for some reason.
		-

SC No.	Level	Error Name/Error Condition/Major Cause/Solution
SC842-01	B	Insufficient Nand-Flash blocks (threshold exceeded)
		At startup, or when machine returned from low power mode, the Nand-Flash status was read and judged that the number of unusable blocks had exceeded threshold, and then SCS generated the SC code.
		Number of unusable blocks exceeded threshold for Nand-Flash
		Replace the controller board.

SC No.	Level	Error Name/Error Condition/Major Cause/Solution
SC842-02	B	Number of Nand-Flash block deletions exceeded
		At startup, or when the machined returned from low power mode, the Nand-Flash was read and judged that the number of deleted blocks had exceeded threshold, and then SCS generated this SC code.
		Number of blocks deleted exceeded threshold for Nand-Flash
		Replace the controller board.

SC No.	Level	Error Name/Error Condition/Major Cause/Solution
SC853-00	B	Bluetooth device connection error
		The Bluetooth hardware (USB type) was connected after the machine was turned on.
		The Bluetooth hardware (USB type) was connected after the machine was turned on.
		Always connect the Bluetooth device (USB type) before the machine is turned on.

SC No.	Level	Error Name/Error Condition/Major Cause/Solution
SC854-00	B	Bluetooth device disconnected
		The Bluetooth hardware (USB type) was disconnected after the machine was turned on.
		The Bluetooth hardware (USB type) was disconnected after the machine was turned on.
		Never remove Bluetooth (USB type) after machine starts

SC No.	Level	Error Name/Error Condition/Major Cause/Solution
SC855-01	B	Wireless LAN board error (driver attachment failure)
		Wireless LAN board error (wireless LAN card: 802.11 is covered)
		<ul style="list-style-type: none"> ▪ Defective wireless LAN board ▪ Loose connection
		<ul style="list-style-type: none"> ▪ Turn the main power off/on. ▪ Replace wireless LAN board

SC No.	Level	Error Name/Error Condition/Major Cause/Solution
SC855-02	B	Wireless LAN board error (driver initialization failure)
		Wireless LAN board error (wireless LAN card: 802.11 is covered)
		<ul style="list-style-type: none"> ▪ Defective wireless LAN board ▪ Loose connection
		<ul style="list-style-type: none"> ▪ Turn the main power off/on. ▪ Replace wireless LAN board

SC No.	Level	Error Name/Error Condition/Major Cause/Solution
SC857-00	B	USB I/F Error
		The USB interface is unusable because of a driver error.
		USB driver error (There are three causes of USB error: RX error/CRC error/STALL. SC is issued only in the case of STALL.)
		<ul style="list-style-type: none"> ▪ Check USB connection. ▪ Replace the controller board.

SC No.	Level	Error Name/Error Condition/Major Cause/Solution
SC858-00	A	Data encryption conversion error (Key Setting Error)
		A serious error occurred during an attempt to update the encryption key.
		<ul style="list-style-type: none"> ▪ USB Flash, other data, corrupted ▪ Communication error caused by electrostatic noise ▪ Controller board defective
		Replace the controller board.

SC No.	Level	Error Name/Error Condition/Major Cause/Solution
SC858-01	A	Data encryption conversion error (HDD Key Setting Error)
		A serious error occurred during an attempt to update the encryption key.
		<ul style="list-style-type: none"> ▪ USB Flash, other data, corrupted ▪ Communication error caused by electrostatic noise ▪ Controller board defective
		Replace the controller board.

SC No.	Level	Error Name/Error Condition/Major Cause/Solution
SC858-02	A	Data encryption conversion error (NVRAM Read/Write Error)
		A serious error occurred after data conversion during an attempt to update the encryption key.
		NVRAM defective
		Replace the controller board.

SC No.	Level	Error Name/Error Condition/Major Cause/Solution
SC858-30	A	Data encryption conversion error (NVRAM Before Replace Error)
		A serious error occurred after data conversion during an attempt to update the encryption key.
		Software error such as conversion parameters being invalid.
		Replace the controller board.

SC No.	Level	Error Name/Error Condition/Major Cause/Solution
SC858-31	A	Data encryption conversion error (Other Error)
		A serious error occurred after data conversion during an attempt to update the encryption key.
		Controller board defective
		Replace the controller board.

SC No.	Level	Error Name/Error Condition/Major Cause/Solution
SC859-00	B	Data encryption conversion HDD conversion error
		When the data encryption key was updated, HDD data was converted, but not correctly. Image displayed at conversion only (this SC is not displayed), but SC is displayed after machine is cycled off/on.
		<ul style="list-style-type: none"> ▪ HDD conversion was set with the data encryption key update function, but the HDD was removed. ▪ Machine lost power during data encryption key update ▪ Electrostatic noise, or an HDD error occurred, during data encryption key update, and data was not encrypted.
		<ul style="list-style-type: none"> ▪ Check HDD connection. ▪ Format the HDD. ▪ If there is a problem with the HDD, it has to be replaced.

SC No.	Level	Error Name/Error Condition/Major Cause/Solution
SC859-01	B	Data encryption conversion HDD conversion error (HDD check error)
		When the data encryption key was updated, HDD data was converted, but not correctly. Image displayed at conversion only (this SC is not displayed), but SC is displayed after machine is cycled off/on.
		<ul style="list-style-type: none"> ▪ HDD conversion was set with the data encryption key update function, but the HDD was removed. ▪ Machine lost power during data encryption key update ▪ Electrostatic noise, or an HDD error occurred, during data encryption key update, and data was not encrypted.
		<ul style="list-style-type: none"> ▪ Check HDD connection. ▪ Format the HDD. ▪ If there is a problem with the HDD, it has to be replaced.

SC No.	Level	Error Name/Error Condition/Major Cause/Solution
SC859-02	B	Data encryption conversion HDD conversion error (Power failure during conversion)
		When the data encryption key was updated, HDD data was converted, but not correctly. Image displayed at conversion only (this SC is not displayed), but SC is displayed after machine is cycled off/on. Details: NVRAM/HDD conversion is incomplete.
		Power failure occurred during encryption key update.
		None The display after restart instructs the user to format the HDD.

SC No.	Level	Error Name/Error Condition/Major Cause/Solution
SC859-10	B	Data encryption conversion HDD conversion error (Data read/write command error)
		<p>When the data encryption key was updated, HDD data was converted, but not correctly. Image displayed at conversion only (this SC is not displayed), but SC is displayed after machine is cycled off/on.</p> <p>Details: Abnormal DMAC return value has been received two or more times (DMAC timeout, serial communication error etc.)</p>
		HDD was not successfully converted during encryption key update due to HDD errors or cable noises.
		<ul style="list-style-type: none"> ▪ Check HDD connection. ▪ Format the HDD. ▪ If there is a problem with the HDD, it has to be replaced.

SC No.	Level	Error Name/Error Condition/Major Cause/Solution
SC860-00	B	HDD startup error at main power on (HDD error)
		<ul style="list-style-type: none"> ▪ The HDD is connected but the driver detected the following errors. <ul style="list-style-type: none"> ▪ SS_NOT_READY:/* (-2)HDD does not become READY*/ ▪ SS_BAD_LABEL:/* (-4)Wrong partition type*/ ▪ SS_READ_ERROR:/* (-5)Error occurred while reading or checking the label*/ ▪ SS_WRITE_ERROR:/* (-6)Error occurred while writing or checking the label*/ ▪ SS_FS_ERROR:/* (-7)Failed to repair the filesystem*/ ▪ SS_MOUNT_ERROR:/* (-8)Failed to mount the filesystem*/ ▪ SS_COMMAND_ERROR:/* (-9)Drive not responding to command*/ ▪ SS_KERNEL_ERROR:/* (-10)Internal kernel error*/ ▪ SS_SIZE_ERROR:/* (-11)Drive size too small*/ ▪ SS_NO_PARTITION:/* (-12)The specified partition does not exist*/ ▪ SS_NO_FILE:/* (-13)Device file does not exist*/ ▪ Attempted to acquire HDD status through the driver but there has been no response for 30 seconds or more.
		<ul style="list-style-type: none"> ▪ Unformatted HDD ▪ Label data corrupted ▪ HDD defective <p>Format the HDD through SP mode.</p>

SC No.	Level	Error Name/Error Condition/Major Cause/Solution
SC863-01	D	HDD data read failure
		The data written to the HDD cannot be read normally.
		Bad sectors were generated during operation. (An error occurred in an area that does not belong to a partition, such as the disklabel area.)
		<p>Guide for when to replace the HDD</p> <ol style="list-style-type: none"> 1. When SC863 has occurred ten times or more <ul style="list-style-type: none"> ▪ The interval is short. ▪ Repeatedly occurs in the same situation (At power-on, etc.). ▪ Startup takes a long time when the main power is turned on. 2. It takes a long time after main power on for the operation panel to become ready. HDD access may be consuming time. Normal HDD access time after main power on is about 5 seconds. If the machine is not waiting for the engine to be ready and it still takes 20 to 30 seconds or more, the HDD may be the cause. If there is a problem with the HDD, HDD-related SCs such as SC860 and SC863 will occur frequently. Print the SC log data and check them.

SC No.	Level	Error Name/Error Condition/Major Cause/Solution
SC863 -02 to 23	D	HDD data read failure
		The data written to the HDD cannot be read normally.
		Bad sectors were generated during operation. (An error occurred in partition "a" (SC863-02) to partition "v" (SC863-23)).
		<p>Guide for when to replace the HDD</p> <ol style="list-style-type: none"> When SC863 has occurred ten times or more <ul style="list-style-type: none"> The interval is short. Repeatedly occurs in the same situation (At power-on, etc.). Startup takes a long time when the main power is turned on. It takes a long time after main power on for the operation panel to become ready. HDD access may be consuming time. Normal HDD access time after main power on is about 5 seconds. If the machine is not waiting for the engine to be ready and it still takes 20 to 30 seconds or more, the HDD may be the cause. If there is a problem with the HDD, HDD-related SCs such as SC860 and SC863 will occur frequently. Print the SC log data and check them.

SC No.	Level	Error Name/Error Condition/Major Cause/Solution
SC864-00	D	HD data CRC error
		During HD operation, the HD cannot respond to a CRC error query. Data transfer did not execute normally while data was being written to the HD.
		HD defective
		-

SC No.	Level	Error Name/Error Condition/Major Cause/Solution
SC864-01	D	HDD data CRC error
		During HDD operation, the HDD cannot respond to a CRC error query. Data transfer did not execute normally while data was being written to the HDD.
		Bad sectors were generated during operation. (An error occurred in an area that does not belong to a partition, such as the disklabel area.)
		<ul style="list-style-type: none"> ▪ Format the HDD. ▪ Replace the HDD.

SC No.	Level	Error Name/Error Condition/Major Cause/Solution
SC864-02 to 23	D	HDD data CRC error
		During HDD operation, the HDD cannot respond to a CRC error query. Data transfer did not execute normally while data was being written to the HDD.
		Bad sectors were generated during operation. (An error occurred in partition "a" (SC864-02) to partition "v" (SC864-23)).
		<ul style="list-style-type: none"> ▪ Format the HDD. ▪ Replace the HDD.

SC No.	Level	Error Name/Error Condition/Major Cause/Solution
SC865-00	D	HD access error
		During HDD operation, the HDD returned an error.
		The HDD returned an error that does not constitute SC863 (bad sector) or SC864 (CRC error).
		Replace the HDD.

SC No.	Level	Error Name/Error Condition/Major Cause/Solution
SC865-01	D	HDD access error
		During HDD operation, the HDD returned an error.
		The HDD returned an error that does not constitute SC863 (bad sector) or SC864 (CRC error). (An error occurred in an area that does not belong to a partition, such as the disklabel area.)
		Replace the HDD.

SC No.	Level	Error Name/Error Condition/Major Cause/Solution
SC865-02 to 23	D	HDD access error
		During HDD operation, the HDD returned an error.
		The HDD returned an error that does not constitute SC863 (bad sector) or SC864 (CRC error). (An error occurred in partition "a" (SC865-02) to partition "v" (SC865-23)).
		Replace the HDD.

SC No.	Level	Error Name/Error Condition/Major Cause/Solution
SC865-50 to 73	D	HDD time-out error
		The machine does not detect a reply from the HDD during the HDD operation.
		The HDD does not respond to the read/ write command from the machine.
		<ul style="list-style-type: none"> ▪ Check the harness connections between the controller board and HDD. ▪ Replace the HDD.

SC No.	Level	Error Name/Error Condition/Major Cause/Solution
SC866-00	B	SD card authentication error
		A license error of an application that is started from the SD card was detected.
		Invalid program data is stored on the SD card.
		Store a valid program data on the SD card.

SC No.	Level	Error Name/Error Condition/Major Cause/Solution
SC867-00	D	SD card removed
		The SD card was removed while the machine is on.
		An application SD card has been removed from the slot (mount point of /mnt/sd0).
		Turn the main power off/on.

SC No.	Level	Error Name/Error Condition/Major Cause/Solution
SC867-01	D	SD card removed
		The SD card was removed while the machine is on.
		An application SD card has been removed from the slot (mount point of /mnt/sd1).
		Turn the main power off/on.

SC No.	Level	Error Name/Error Condition/Major Cause/Solution
SC868-00	D	SD card access error
		The SD controller returned an error during operation. (An error occurred at the mount point of /mnt/sd0)
		<ul style="list-style-type: none"> ▪ SD card defective ▪ SD controller defective
		<ul style="list-style-type: none"> ▪ Reformat the SD card (using the "SD Formatter" made by Panasonic).* ▪ Check the SD card insertion status. ▪ Replace the SD card. ▪ Replace the controller board.

* Do not format an SD card supplied with the main machine or sold as an option. You may only format SD cards used for Firmware Update by a Customer Engineer.

SC No.	Level	Error Name/Error Condition/Major Cause/Solution
SC868-01	D	SD card access error
		The SD controller returned an error during operation. (An error occurred at the mount point of /mnt/sd1)
		<ul style="list-style-type: none"> ▪ SD card defective ▪ SD controller defective

SC No.	Level	Error Name/Error Condition/Major Cause/Solution
		<p>SD card that starts an application</p> <ul style="list-style-type: none"> ▪ Turn the main power off and check the SD card insertion status. <ul style="list-style-type: none"> ▪ If no problem is found, insert the SD card and turn the main power on. ▪ If an error occurs, replace the SD card. ▪ SD card for users <ul style="list-style-type: none"> ▪ In case of a file system error, reformat the SD card (using the "SD Formatter" made by Panasonic).* ▪ In case of a device access error, turn the main power off and check the SD card insertion status. ▪ If no problem is found, insert the SD card and turn the main power on. ▪ If an error occurs, use another SD card. ▪ If the error persists even after replacing the SD card, replace the controller board.

* Do not format an SD card supplied with the main machine or sold as an option. You may only format SD cards used for Firmware Update by a Customer Engineer.

SC No.	Level	Error Name/Error Condition/Major Cause/Solution
SC868-02	D	SD card access error
		The SD controller returned an error during operation. (An error occurred at the mount point of /mnt/sd1)
		<ul style="list-style-type: none"> ▪ SD card defective ▪ SD controller defective

SC No.	Level	Error Name/Error Condition/Major Cause/Solution
		<p>SD card that starts an application</p> <ul style="list-style-type: none"> ▪ Turn the main power off and check the SD card insertion status. <ul style="list-style-type: none"> ▪ If no problem is found, insert the SD card and turn the main power on. ▪ If an error occurs, replace the SD card. ▪ SD card for users <ul style="list-style-type: none"> ▪ In case of a file system error, reformat the SD card (using the "SD Formatter" made by Panasonic).* ▪ In case of a device access error, turn the main power off and check the SD card insertion status. ▪ If no problem is found, insert the SD card and turn the main power on. ▪ If an error occurs, use another SD card. ▪ If the error persists even after replacing the SD card, replace the controller board.

* Do not format an SD card supplied with the main machine or sold as an option. You may only format SD cards used for Firmware Update by a Customer Engineer.

SC No.	Level	Error Name/Error Condition/Major Cause/Solution
SC870-00	B	Address Book data error (Anytime: Address Book Error.)
SC870-01	B	Address Book data error (On startup: Media required for storing the Address Book is missing.)
SC870-02	B	Address Book data error (On startup: encryption is configured but the module required for encryption (DESS) is missing.)
SC870-03	B	Address Book data error (Initialization: Failed to generate a file to store internal Address Book.)
SC870-04	B	Address Book data error (Initialization: Failed to generate a file to store delivery sender.)
SC870-05	B	Address Book data error (Initialization: Failed to generate a file to store delivery destination.)

SC No.	Level	Error Name/Error Condition/Major Cause/Solution
SC870-06	B	Address Book data error (Initialization: Failed to generate a file to store information required for LDAP search.)
SC870-07	B	Address Book data error (Initialization: Failed to initialize entries required for machine operation.)
SC870-08	B	Address Book data error (Machine configuration: HDD is present but the space for storing the Address Book is unusable.)
SC870-09	B	Address Book data error (Machine configuration: Inconsistency in the NVRAM area used for storing settings required for Address Book configuration.)
SC870-10	B	Address Book data error (Machine configuration: Cannot make a directory for storing the Address Book in the SD/USB FlashROM.)
SC870-11	B	Address Book data error (On startup: Inconsistency in Address Book entry number.)
SC870-20	B	Address Book data error (File I/O: Failed to initialize file.)
SC870-21	B	Address Book data error (File I/O: Failed to generate file.)
SC870-22	B	Address Book data error (File I/O: Failed to open file.)
SC870-23	B	Address Book data error (File I/O: Failed to write to file.)
SC870-24	B	Address Book data error (File I/O: Failed to read file.)
SC870-25	B	Address Book data error (File I/O: Failed to check file size.)
SC870-26	B	Address Book data error (File I/O: Failed to delete data.)
SC870-27	B	Address Book data error (File I/O: Failed to add data.)
SC870-30	B	Address Book data error (Search: Failed to obtain data from cache when searching in the machine Address Book. delivery destination/sender.)

SC No.	Level	Error Name/Error Condition/Major Cause/Solution
SC870-31	B	Address Book data error (Search:Failed to obtain data from cache during LDAP search.)
SC870-32	B	Address Book data error (Search:Failed to obtain data from cache while searching the WS-Scanner Address Book.)
SC870-41	B	Address Book data error (Cache: failed to obtain data from cache.)
SC870-50	B	Address Book data error (On startup: Detected abnormality of the Address Book encryption status.)
SC870-51	B	Address Book data error (Encryption settings: Failed to create directory required for conversion between plaintext and encrypted text.)
SC870-52	B	Address Book data error (Encryption settings: Failed to convert from plaintext to encrypted text.)
SC870-53	B	Address Book data error (Encryption settings: Failed to convert from encrypted text to plaintext.)
SC870-54	B	Address Book data error (Encryption settings: Detected data inconsistency when reading the encrypted Address Book.)
SC870-55	B	Address Book data error (Encryption settings: Failed to delete file when changing encryption setting.)
SC870-56	B	Address Book data error (Encryption settings: Failed to erase the file that records the encryption key during an attempt to change the encryption setting.)
SC870-57	B	Address Book data error (Encryption settings: Failed to move a file during an attempt to change the encryption setting.)
SC870-58	B	Address Book data error (Encryption settings: Failed to delete a directory during an attempt to change the encryption setting.)

SC No.	Level	Error Name/Error Condition/Major Cause/Solution
SC870-59	B	Address Book data error (Encryption settings: Detected a resource shortage during an attempt to change the encryption setting.)
SC870-60	B	Address Book data error (Unable to obtain the on/off setting for administrator authentication (06A and later).)
		<p data-bbox="507 622 1310 719">When an error related to the Address Book is detected during startup or operation.</p> <ul style="list-style-type: none"> <li data-bbox="507 741 730 779">▪ Software bug <li data-bbox="507 790 1145 875">▪ Inconsistency of Address Book source location (machine/delivery server/LDAP server) <li data-bbox="507 887 1289 1016">▪ Inconsistency of Address Book encryption setting or encryption key (NVRAM or HDD was replaced individually without formatting the Address Book) <li data-bbox="507 1028 1273 1158">▪ Address Book storage device (SD/HDD) was temporarily removed or hardware configuration does not match the application configuration. <li data-bbox="507 1169 1114 1207">▪ Address Book data corruption was detected. <ul style="list-style-type: none"> <li data-bbox="507 1240 911 1279">▪ Check the HDD connection. <li data-bbox="507 1290 1222 1375">▪ Initialize all UCS settings and address/authentication information (SP5-846-046). <li data-bbox="507 1386 1203 1424">▪ Initialize the Address Book partition (SP5-832-006).

SC No.	Level	Error Name/Error Condition/Major Cause/Solution
SC872-00	B	HDD mail reception error
		An error was detected on the HDD immediately after the machine was turned on.
		<ul style="list-style-type: none"> ▪ HDD defective ▪ Power was turned of while the machine used the HDD.
		<ul style="list-style-type: none"> ▪ Format the HDD (SP5-832-007). ▪ Replace the HDD. <p>When you do the above, the following information will be initialized.</p> <ul style="list-style-type: none"> ▪ Partly received partial mail messages. ▪ Already-read statuses of POP3-received messages (All messages on the mail server are handled as new messages).

SC No.	Level	Error Name/Error Condition/Major Cause/Solution
SC873-00	B	HDD mail reception error
		An error was detected on the HDD immediately after the machine was turned on.
		<ul style="list-style-type: none"> ▪ HDD defective ▪ Power was turned of while the machine used the HDD.
		<ul style="list-style-type: none"> ▪ Format the HDD (SP5-832-007). ▪ Replace the HDD. <p>When you do the above, the following information will be initialized.</p> <ul style="list-style-type: none"> ▪ Default sender name/password (SMB/FTP/NCP) ▪ Administrator mail address ▪ Scanner delivery history

SC No.	Level	Error Name/Error Condition/Major Cause/Solution
SC875-01	D	Delete all error (HDD erasure) (hddchack -i error)
SC875-02	D	Delete all error (HDD erasure) (Data deletion failure)
		An error was detected before HDD/data erasure starts. (Failed to erase data/failed to logically format HDD)
		<ul style="list-style-type: none"> ▪ HDD logical formatting failed. ▪ The modules failed to erase data.
		Turn the main power off/on.

SC No.	Level	Error Name/Error Condition/Major Cause/Solution
		Log Data Error
		An error was detected in the handling of the log data at power on or during machine operation.
		<ul style="list-style-type: none"> ▪ Damaged log data file. ▪ Log encryption is enabled but encryption module is not installed. ▪ Inconsistency of encryption key between NV-RAM and HDD. ▪ Software bug.
SC876-00	D	<p>Try the SC876-01 to -99 solutions listed below. If it is not solved, do the following steps (for when only an HDD is replaced):</p> <ol style="list-style-type: none"> 1. Disconnect the HDD and turn on the main power. 2. Execute SP5-801-019. 3. Turn off the main power. 4. Connect the HDD and turn on the main power. 5. Execute SP5-832-004. 6. Turn off the main power. <p>* The following step is to configure the logging/encryption setting again.</p> <ol style="list-style-type: none"> 7. Turn of the main power. 8. Set SP9-730-002 through -004 to 1. 9. Turn off/on the main power.

SC No.	Level	Error Name/Error Condition/Major Cause/Solution
SC876-01	D	Log Data Error 1
		An error was detected in the handling of the log data at power on or during machine operation.
		Damaged log data file
		Initialize the HDD (SP5-832-004).

SC No.	Level	Error Name/Error Condition/Major Cause/Solution
SC876-02	D	Log Data Error 2
		An error was detected in the handling of the log data at power on or during machine operation.
		Log encryption is enabled but encryption module is not installed.
		<ul style="list-style-type: none"> ▪ Replace or set again the encryption module. ▪ Disable the log encryption setting.

SC No.	Level	Error Name/Error Condition/Major Cause/Solution
SC876-03	D	Log Data Error 3
		An error was detected in the handling of the log data at power on or during machine operation.
		Inconsistency of encryption key between NV-RAM and HDD.
		<ul style="list-style-type: none"> ▪ Disable the log encryption setting. ▪ Initialize LCS memory (SP5801-019). ▪ Initialize the HDD (SP5-832-004).

SC No.	Level	Error Name/Error Condition/Major Cause/Solution
SC876-04	D	Log Data Error 4
		An error was detected in the handling of the log data at power on or during machine operation.
		<ul style="list-style-type: none"> ▪ Log encryption key is disabled but the log data file is encrypted. (NVRAM data corruption) ▪ Log encryption key is enabled but the log data file is not encrypted. (NVRAM data corruption)
		Initialize the HDD (SP5-832-004).

SC No.	Level	Error Name/Error Condition/Major Cause/Solution
SC876-05	D	Log Data Error 5
		An error was detected in the handling of the log data at power on or during machine operation.
		<ul style="list-style-type: none"> ▪ Only the NV-RAM has been replaced with one previously used in another machine. ▪ Only the HDD has been replaced with one previously used in another machine.
		<ul style="list-style-type: none"> ▪ Attach the original NV-RAM. ▪ Attach the original HDD. ▪ With the configuration that caused the SC, initialize the HDD (SP5-832-004).

SC No.	Level	Error Name/Error Condition/Major Cause/Solution
SC876-99	D	Log Data Error 99
		An error was detected in the handling of the log data at power on or during machine operation.
		Other causes
		-

SC No.	Level	Error Name/Error Condition/Major Cause/Solution
SC878-00	D	TPM authentication error
		TPM electronic recognition failure
		<ul style="list-style-type: none"> ▪ Update of system module attempted without correct update path ▪ USB flash memory not operating correctly
		Replace the controller board.

Trusted Platform Module

- In computing, Trusted Platform Module (TPM) is both the name of a published specification detailing a secure crypto processor that can store cryptographic keys that protect information, as well as the general name of implementations of that specification, often called the "TPM chip" or "TPM Security Device" (as designated in certain Dell BIOS settings).

SC No.	Level	Error Name/Error Condition/Major Cause/Solution
SC878-01	D	USB flash error
		There is a problem in the file system of the USB flash memory.
		USB Flash system files corrupted
		Replace the controller board.

SC No.	Level	Error Name/Error Condition/Major Cause/Solution
SC878-02	D	TPM error
		An error occurred in either TPM or the TPM driver
		TPM not operating correctly
		Replace the controller board.

SC No.	Level	Error Name/Error Condition/Major Cause/Solution
SC878-03	D	TCSD dffof
		An error occurred in the TPM software stack.
		<ul style="list-style-type: none"> ▪ TPM, TPM software cannot start ▪ A file required by TPM is missing
		Replace the controller board.

SC No.	Level	Error Name/Error Condition/Major Cause/Solution
SC880-00	D	MLB error
		Reply to MLB access was not returned within a specified time.
		MLB defective
		<ul style="list-style-type: none"> ▪ Replace the MLB. ▪ Remove the MLB.

SC No.	Level	Error Name/Error Condition/Major Cause/Solution
SC881-01	D	Management area error
		<ul style="list-style-type: none"> ▪ A problem was detected in the software ▪ This error may even occur is an IC card option is not installed.
		<ul style="list-style-type: none"> ▪ This is caused by accumulation of abnormal authentication information in the software. (User operation will not directly cause it.) ▪ At login Example: When a job is sent to the printer/when logged on from the operation panel/when logged on from a Web browser
		Turn the main power off/on.

SC No.	Level	Error Name/Error Condition/Major Cause/Solution
SC899-00	D	Software performance error (signal reception end)
		Unknown software error occurred.
		Occurs when an internal program behaves abnormally.
		<p>In case of a hardware defect</p> <ul style="list-style-type: none"> ▪ Replace the hardware. <p>In case of a software error</p> <ul style="list-style-type: none"> ▪ Turn the main power off/on. ▪ Try updating the firmware.

6.10 SC TABLES: SC9XX (OTHERS)

6.10.1 SC900-00 TO SC995-04

SC No.	Level	Error Name/Error Condition/Major Cause/Solution
SC900-00	D	Electrical total counter error
		The total counter contains data that is not a number.
		<ul style="list-style-type: none"> ▪ NVRAM incorrect type ▪ NVRAM defective or corrupted ▪ Unexpected error from external source ▪ When PRT received signals at SRM, the requested count did not complete.
		Replace the NVRAM.

SC No.	Level	Error Name/Error Condition/Major Cause/Solution
SC920-00	B	Printer application error (No response within determined time in Printing)
SC920-01	B	Printer application error (Timeout during Printing)
SC920-02	B	Printer Error 1 (WORK memory not acquired)
SC920-03	B	Printer application error (Filter process not started)
SC920-04	B	Printer Error 1 (Filter processing ended abnormally)
		When an error is detected in the application, which makes continued operation impossible.
		<ul style="list-style-type: none"> ▪ Software bug ▪ Unexpected hardware configuration (such as insufficient memory)
		Turn the main power off/on.

SC No.	Level	Error Name/Error Condition/Major Cause/Solution
SC921-00	B	Printer application error (Resident font not found)
		Resident font was not found at printer startup.
		Preinstalled font files not found.
		Turn the main power off/on.

SC No.	Level	Error Name/Error Condition/Major Cause/Solution
SC925-00	B	NetFile function error
SC925-01	B	NetFile function error
		The NetFile file management on the HDD cannot be used, or a NetFile management file is corrupted and operation cannot continue. The HDDs are defective and they cannot be debugged or partitioned, so the Scan Router functions (delivery of received faxes, document capture, etc.), Web services, and other network functions cannot be used. HDD status codes are displayed below the SC code:
		<ul style="list-style-type: none"> ▪ HDD defective ▪ Power loss while data was writing to HDD ▪ Software bug
		See the table and the procedure below.

Here is a list of HDD status codes:

Display	Meaning
(-1)	HDD not connected
(-2)	HDD not ready
(-3)	No label
(-4)	Partition type incorrect
(-5)	Error returned during label read or check
(-6)	Error returned during label read or check
(-7)	“filesystem” repair failed
(-8)	“filesystem” mount failed
(-9)	Drive does not answer command
(-10)	Internal kernel error
(-11)	Size of drive is too small
(-12)	Specified partition does not exist
(-13)	Device file does not exist

Recovery from SC 925

Procedure 1

1. If the machine shows SC codes for HDD errors (SC860 to SC865) with SC 925, do the recovery procedures for SC860 to SC865.

Procedure 2

1. If the machine does not show one of the five HDD errors (SC860 to SC865), turn the machine power off and on.
2. If this is not the solution for the problem, then initialize the NetFile partition on the HDD with SP5-832-11 (HDD Formatting - Ridoc I/F).

NetFiles: These are jobs printed from the document server using a PC and DeskTopBinder.

Before you initialize the NetFile partition on the HDD, tell the customer:

- Received faxes on the delivery server will be erased
- All captured documents will be erased
- Desk Top Binder/Print Job Manager/Desk Top Editor job history will be erased
- Documents on the document server, and scanned documents, will not be erased.

- The first time that the network gets access to the machine, the management information must be configured again (this will use a lot of time).
3. Before you initialize the Netfile partition with SP5-832-11, do these steps:
 4. In the User Tools mode, do Document Management> Batch Delete Transfer Documents.
 5. Do SP5-832-11, and turn the machine off and on.

Procedure 3

1. If “Procedure 2” is not the solution for the problem, do SP5-832-1 (HDD Formatting - All)
1. Cycle the machine off/on.

Note

- SP5-832-001 erases all document and address book data on the hard disks. Consult with the customer before you do this SP code.

Procedure 4

1. If “Procedure 3” does not solve the problem, replace the HDD.

SC No.	Level	Error Name/Error Condition/Major Cause/Solution
SC994-00	C	Application Item Error
		The numbers of executed application items on the operation panel reach the maximum limit for the operation panel structure.
		Too many executed application items
		Logging only

SC No.	Level	Error Name/Error Condition/Major Cause/Solution
SC995-01	D	CPM setting error 1
		Comparison of machine serial number (11 digits) and machine identification code. Details: <ul style="list-style-type: none"> ▪ Machine serial number cannot be identified because of BICU replacement or malfunctioning. ▪ Machine serial number cannot be identified because of NV-RAM replacement
		Machine serial number (11 digits) or machine identification code does not match.
		<ul style="list-style-type: none"> ▪ Enter the machine serial number using SP5-811, and then turn the power on/off. ▪ Attach the NV-RAM that was installed previously.

SC No.	Level	Error Name/Error Condition/Major Cause/Solution
SC995-02	D	CPM setting error 2
		Comparison of machine serial number (11 digits) and machine identification code. Details: Machine serial number cannot be identified because of NV-RAM replacement or malfunctioning.
		Machine serial number (11 digits) or machine identification code does not match.
		<ul style="list-style-type: none"> ▪ Attach the NV-RAM that was installed previously. ▪ Download data on the NV-RAM using SP5-825.

SC No.	Level	Error Name/Error Condition/Major Cause/Solution
SC995-03	D	CPM setting error 3
		Comparison of machine serial number (11 digits) and machine identification code. Details: Unable to recognize machine identification code because the controller was replaced incorrectly or is malfunctioning.
		Machine serial number (11 digits) or machine identification code does not match.
		Replace it with a specified controller.

SC No.	Level	Error Name/Error Condition/Major Cause/Solution
SC995-04	D	CPM setting error 4
		Comparison of machine serial number (11 digits) and machine identification code.
		Machine serial number (11 digits) or machine identification code does not match.
		Return the parts to the original configuration, and then replace them according to the manual.

6.11 WHEN SC549 IS DISPLAYED

6.11.1 TROUBLESHOOTING FLOWCHART

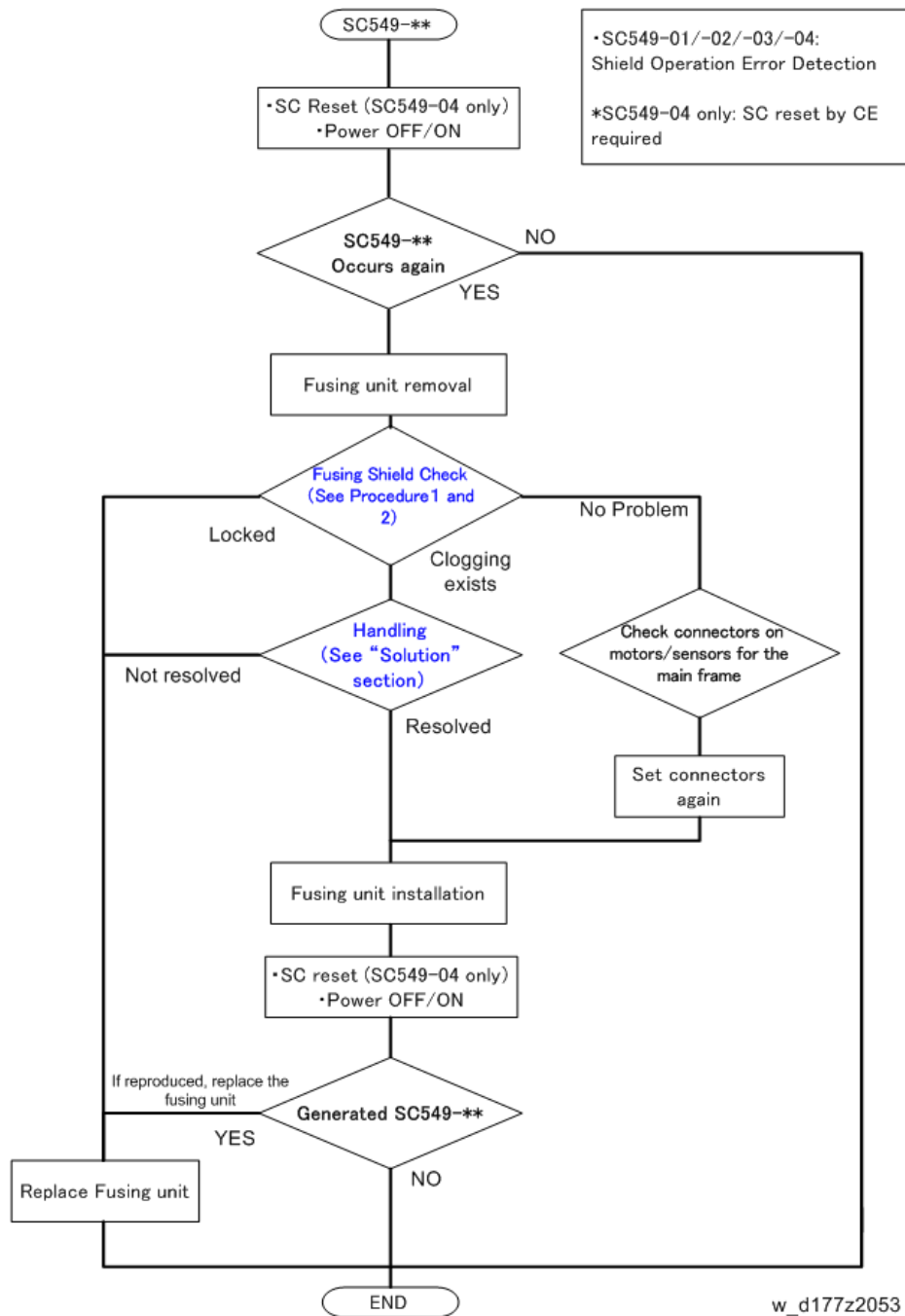

6.11.2 FUSING SHIELD CHECK

<Procedure 1: Operation check for the lower side of the shield detection feeler>

1. Place the fusing unit on a flat place and tilt it towards the drawer connector [A].

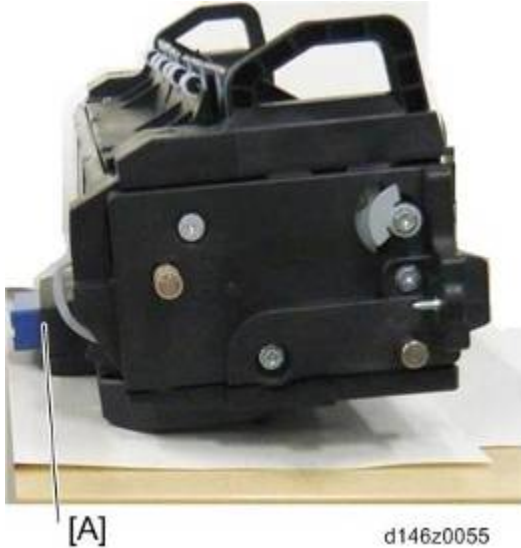

2. Move the shield drive gear with your hands to put the upper surface of the feeler [A] in a horizontal position.



3. Keep your fingers off the shield drive gear.
4. Make sure that the shield detection feeler [A] moves down to the lowest point by its own weight.

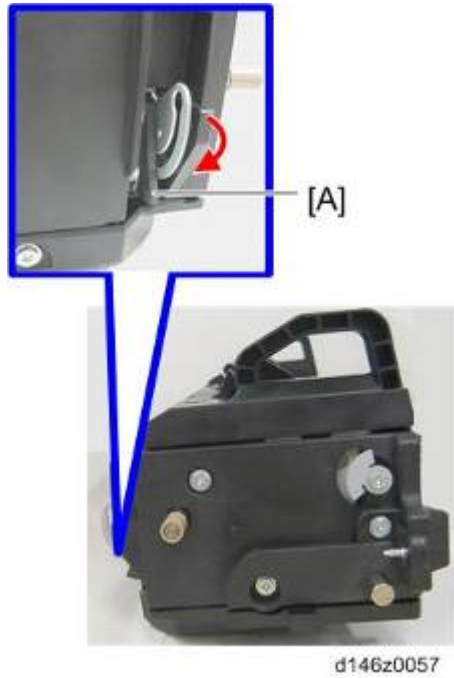

- The feeler moves smoothly: OK
- The feeler does not move / stops during moving / moves but slowly: NG

<Procedure 2: Operation check for the upper side of the shield detection feeler>

1. Place the fusing unit on a flat place with the drawer connector [A] turned up and the handle [B] touching a flat surface.

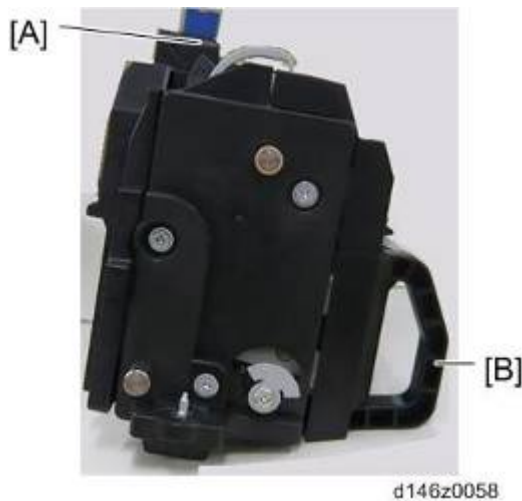

2. Move the shield drive gear with your hands to put the upper surface of the feeler [A] in a vertical position.

When SC549 Is Displayed

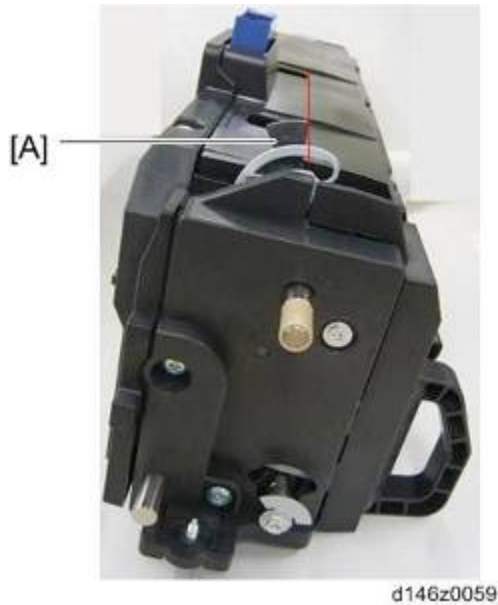

3. Keep your fingers off of the shield drive gear.
4. Make sure that the shield detection feeler [A] moves up to the highest point by its own weight.

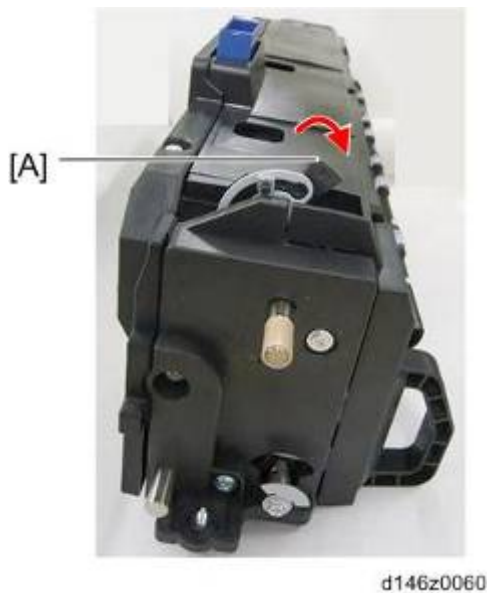

- The feeler moves smoothly: OK
- The feeler does not move / stops during moving / moves but slowly: NG

<Results>

- Both Procedure 1 and 2 are OK: No problem.
- Either Procedure 1 or 2 is NG: The mechanism is blocked.
- The shield detection feeler never moves while moving the shield drive gear by hands or fingers: Locked.

6.11.3 SOLUTION

By tilting the fusing unit, you can check whether the feeler does not move smoothly due to burrs on a part in the unit, and remove the burrs.

1. Tilt the fusing unit [A] approx. 30°.

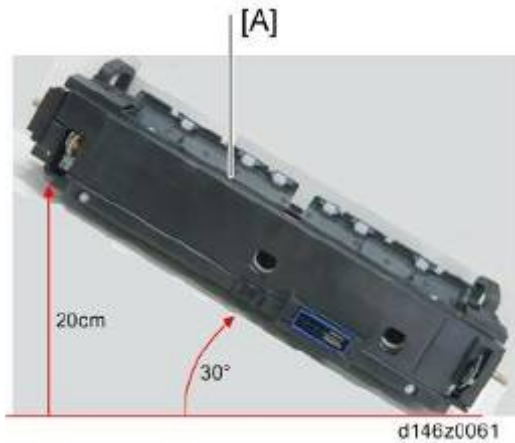

2. Put the fusing unit back to the horizontal position.
3. Perform the checking procedures (page 6-172).

There is no blockage: Resolved

There is some blockage: Not resolved

4. Tilt the fusing unit [A] approx. 30° in the opposite direction from step 1.

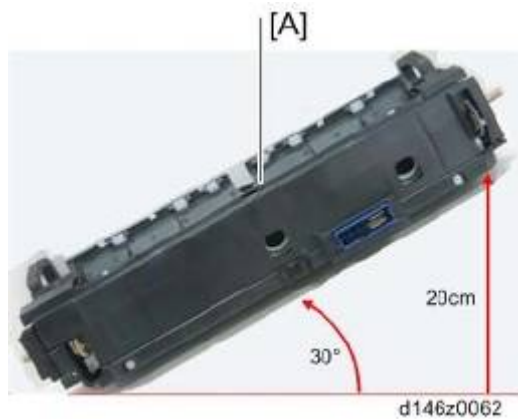

There is no blockage: Resolved

There is some blockage: Not resolved

6.12 JAM DETECTION

6.12.1 PAPER JAM DISPLAY

When a jam occurs, the location is displayed on the operation panel.

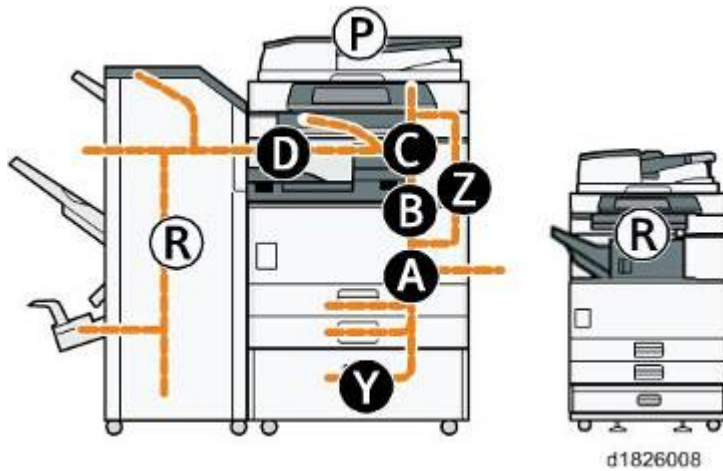

SP7-507 shows the paper jam history.

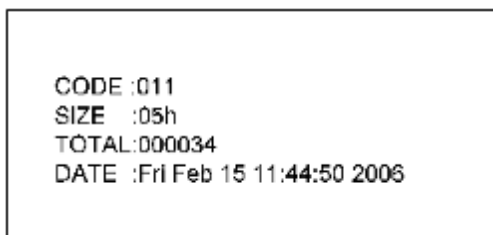

- **CODE:** Indicates the jam code.
- **SIZE:** Indicates the paper Size Code.
- **TOTAL:** Indicates the total counter (SP7-502-001).
- **DATE:** indicates the date when the jam occurred.

↓ Note

- The 10 latest printer jams are displayed.
- Initial jams are not recorded.

6.12.2 JAM CODES AND DISPLAY CODES

Note

- Jam code: Shows the cause of a jam. Appears in the log data.
- Position code: Shows the location of a jam. Appears on the operation panel.

These are lists of jam codes for the main machine and peripheral devices. Please note:

- **Late jam.** The paper has failed to arrive within the prescribed time due to a jam that has occurred upstream of the referenced sensor.
- **Lag jam.** The paper has failed to leave the location of the referenced sensor within the prescribed time due to a jam downstream of the referenced sensor.

Main Machine

Jam code	Jam description	Position code
1	Initial jam	*1
3	Tray 1 No Feed	A1
4	Tray 2 No Feed	A2
5	Tray 3 No Feed	Y1
6	Tray 4 No Feed	Y2
7	LCT No Feed	U1
8	Bypass Paper Feed Sensor	A
9	Duplex No Feed	Z
11	1st Vertical Transport Sensor: Late Jam	A
12	2nd Vertical Transport Sensor: Late Jam	A
13	3rd Vertical Transport Sensor: Late Jam	Y
14	4th Vertical Transport Sensor: Late Jam	Y
15	LCT Transport Sensor: Late Jam	U
17	Registration Sensor: Late Jam	A
18	Fusing entrance Sensor: Late Jam	B
19	Fusing exit Sensor: Late Jam	C

Jam Detection

Jam code	Jam description	Position code
20	Exit Sensor: Late Jam	C
21	Relay Exit Sensor: Late Jam	D
22	Relay Transport Sensor: Late Jam	D
24	Invert Sensor: Late Jam	C
25	Duplex Exit Sensor: Late Jam	Z
27	Duplex Entrance Sensor: Late Jam	Z
51	1st Vertical Transport Sensor: Lag Jam	A
52	2nd Vertical Transport Sensor: Lag Jam	A
53	3rd Vertical Transport Sensor: Lag Jam	Y
54	4th Vertical Transport Sensor: Lag Jam	Y
55	LCT Transport Sensor: Lag Jam	U
57	Registration Sensor: Lag Jam	B
60	Exit Sensor: Lag Jam	C
61	Relay Exit Sensor: Lag Jam	D
62	Relay Transport Sensor: Lag Jam	D
64	Invert Sensor: Lag Jam	C
65	Duplex Exit Sensor: Lag Jam	Z
67	Duplex Entrance Sensor: Lag Jam	Z

***1 Initial Jam**

Jam description	Position code
Main Machine	
1st Vertical Transport Sensor	A
2nd Vertical Transport Sensor	A
3rd Vertical Transport Sensor	Y
4th Vertical Transport Sensor	Y
LCT Transport Sensor	U
Registration Sensor	B
Exit Sensor	C
Relay Exit Sensor	D
Relay Transport Sensor	D
Invert Sensor	C
Duplex Exit Sensor	Z
Duplex Entrance Sensor:	Z
ARDF DF3080	
Initial jam, Overload jam	P
Booklet Finisher SR3170/ Finisher SR3160	
Entrance Sensor	R1-R5
Horizontal Transport Sensor	R1-R5
Switchback Transport Sensor	R1-R5
Proof Tray Paper Exit Sensor	R1-R5
Shift Tray Paper Exit Sensor	R1-R5
Fold Exit Sensor	R6-R11

ARDF DF3090

Jam code	Jam description	Position code
14	Skew Correction Sensor: Late Jam	P
64	Skew Correction Sensor: Lag Jam	P
16	Original Registration Sensor: Late Jam	P
66	Original Registration Sensor: Lag Jam	P
17	Original Exit Sensor: Late Jam	P
67	Original Exit Sensor: Lag Jam	P
239	Misfeed:Original Removed	P

ARDF DF3080

Jam code	Jam description	Position code
13	Separation Sensor: Late Jam	P
63	Separation Sensor: Lag Jam	P
14	Skew Correction Sensor: Late Jam	P
64	Skew Correction Sensor: Lag Jam	P
15	Original Set Sensor: Late Jam	P
65	Original Set Sensor: Lag Jam	P
16	Original Registration Sensor: Late Jam	P
66	Original Registration Sensor: Lag Jam	P
17	Original Exit Sensor: Late Jam	P
67	Original Exit Sensor: Lag Jam	P
239	Misfeed:Original Removed	P

Booklet Finisher SR3170/ Finisher SR3160

Jam code	Jam description	Position code
150	Entrance Sensor: Late Jam	R1-R5
151	Entrance Sensor: Lag Jam	R1-R5
152	Horizontal Transport Sensor: Late Jam	R1-R5
153	Horizontal Transport Sensor: Lag Jam	R1-R5
154	Switchback Transport Sensor: Late Jam	R1-R5
155	Switchback Transport Sensor: Lag Jam	R1-R5
156	Proof Tray Jam	R1-R5
157	Shift Tray Jam	R1-R5

Jam Detection

Jam code	Jam description	Position code
158	Booklet Tray Jam	R6-R11
159	Entrance Transport Motor Jam	R1-R5
160	Horizontal Transport Motor Jam	R1-R5
161	Pre Stack Transport Motor Jam	R1-R5
162	Middle Transport Motor Jam	R1-R5
163	Tray Exit Motor Jam	R1-R5
164	Trailing Edge Pressure Plate Motor Jam	R1-R5
165	Paper Exit Gate Motor Jam	R1-R5
166	Punch Motor Jam	R1-R5
167	Punch Drive Motor Jam	R1-R5
168	Paper Position Sensor Side Motor Jam	R1-R5
169	Lower Junction Gate Motor Jam	R1-R5
170	Jogger Motor	R1-R5
171	Positioning Roller Motor Jam	R1-R5
172	Feed Out Motor Jam	R1-R5
173	Corner Stapler Movement Motor Jam	R1-R5
174	Corner Stapling Motor Jam	R1-R5
175	Booklet Jogger Motor	R6-R11
176	Booklet Guide Motor Jam	R6-R11
177	Booklet Fence Motor Jam	R6-R11
178	Booklet Stapling Motor Jam	R6-R11
179	Movement Roller Transport Motor Jam	R6-R11
180	Folding Transport Motor Jam	R6-R11
181	Booklet Positioning Roller Motor Jam	-
182	Press Folding Motor Jam	R6-R11

Jam code	Jam description	Position code
183	Tray Lift Motor Jam	R1-R5
184	Shift Motor Jam	R1-R5
185	Shift Jogger Front Motor Jam	R1-R5
186	Shift Jogger Rear Motor Jam	R1-R5
187	Shift Jogger Retraction Motor Jam	R1-R5
188	Stacking Roller Motor Jam	R1-R5
189	No Response for Paper Output Complete	R1-R5
190	Main Machine Data Corrupt	R1-R5

Booklet Finisher SR3150/ Finisher SR3140

Jam code	Jam description	Position code
200	Entrance Sensor: Late Jam	R1-R4
201	Entrance Sensor: Lag Jam	R1-R4
202	Proof Tray Paper Exit: Late Jam	R1-R4
203	Proof Tray Paper Exit: Lag Jam	R1-R4
204	Middle Transport (right): Late Jam	R1-R4
205	Middle Transport (left): Late Jam	R1-R4
206	Middle Transport (left): Lag Jam	R1-R4
207	Shift Tray Paper Exit: Late Jam	R1-R4
208	Shift Tray Paper Exit: Lag Jam	R1-R4
209	Stapler Exit: Late Jam	R5-R10
210	Trailing Edge Stopper Transport: Late Jam	R5-R10
211	Trailing Edge Stopper Transport: Lag Jam	R5-R10
212	Fold Exit: Late Jam	R5-R10

Jam Detection

Jam code	Jam description	Position code
213	Fold Exit: Lag Jam	R5-R10
220	Entrance Transport Motor Jam	R1-R4
221	Proof Transport Motor Jam	R1-R4
222	Output Transport/ Positioning, Stacking Roller Motor Jam	R1-R4
223	Shift Motor Jam	R1-R4
224	Jogger Motor Jam	R1-R4
225	Paper Exit Gate Motor Jam	R1-R4
226	Feed Out Motor Jam	R1-R4
227	Tray Lift Motor Jam	R1-R4
228	Positioning Roller Motor Jam	R1-R4
229	Stapler Movement Motor Jam	R1-R4
230	Stapling Motor Jam	R1-R4
231	Punch Motor Jam	R1-R4
232	Stuck Transport Motor Jam	R5-R10
233	Trailing Edge Stopper Motor Jam	R5-R10
234	Folding Blade Motor Jam	R5-R10
248	No Response for Paper Output Complete	R1-R4
249	Main Machine Data Corrupt	R1-R4

Internal Finisher SR3130

Jam code	Jam description	Position code
100	Entrance Sensor: Late Jam	R1-R2
101	Entrance Sensor: Lag Jam	R1-R2
102	Transport Sensor: Late Jam	R1-R2
103	Transport Sensor: Lag Jam	R1-R2
104	Paper Exit Jam	R1-R2
105	Front Jogger Motor Jam	R1-R2
106	Rear Jogger Motor Jam	R1-R2
107	Shift Roller Motor Jam	R1-R2
108	Positioning Roller Motor Jam	R1-R2
109	Paper Exit Gate Motor Jam	R1-R2
110	Stapler Movement Motor Jam	R1-R2
111	Shift Tray Lift Motor Jam	R1-R2
112	Stapling Motor Jam	R1-R2
113	Paper Press Motor Jam	R1-R2
114	Punch Motor Jam	R1-R2
115	Punch Movement Motor Jam	R1-R2
116	Registration Motor Jam	R1-R2
148	No Response for Paper Output Complete	R1-R2
149	Main Machine Data Corrupt	R1-R2

Internal Finisher SR3180

Jam code	Jam description	Position code
300	Entrance Sensor: Late Jam	R1-R2
301	Entrance Sensor: Lag Jam	R1-R2
302	Exit Sensor: Late Jam	R1-R2
303	Exit Sensor: Lag Jam	R1-R2
304	Shift Motor Jam	R1-R2
305	Junction Solenoid Motor Jam	R1-R2
306	Exit Paper Pressure Motor Jam	R1-R2
307	Stapler Motor Jam	R1-R2
308	Exit Lag Jam	R1-R2
348	No Response for Paper Output Complete	R1-R2
349	Main Machine Data Corrupt	R1-R2

6.12.3 SENSOR LOCATIONS

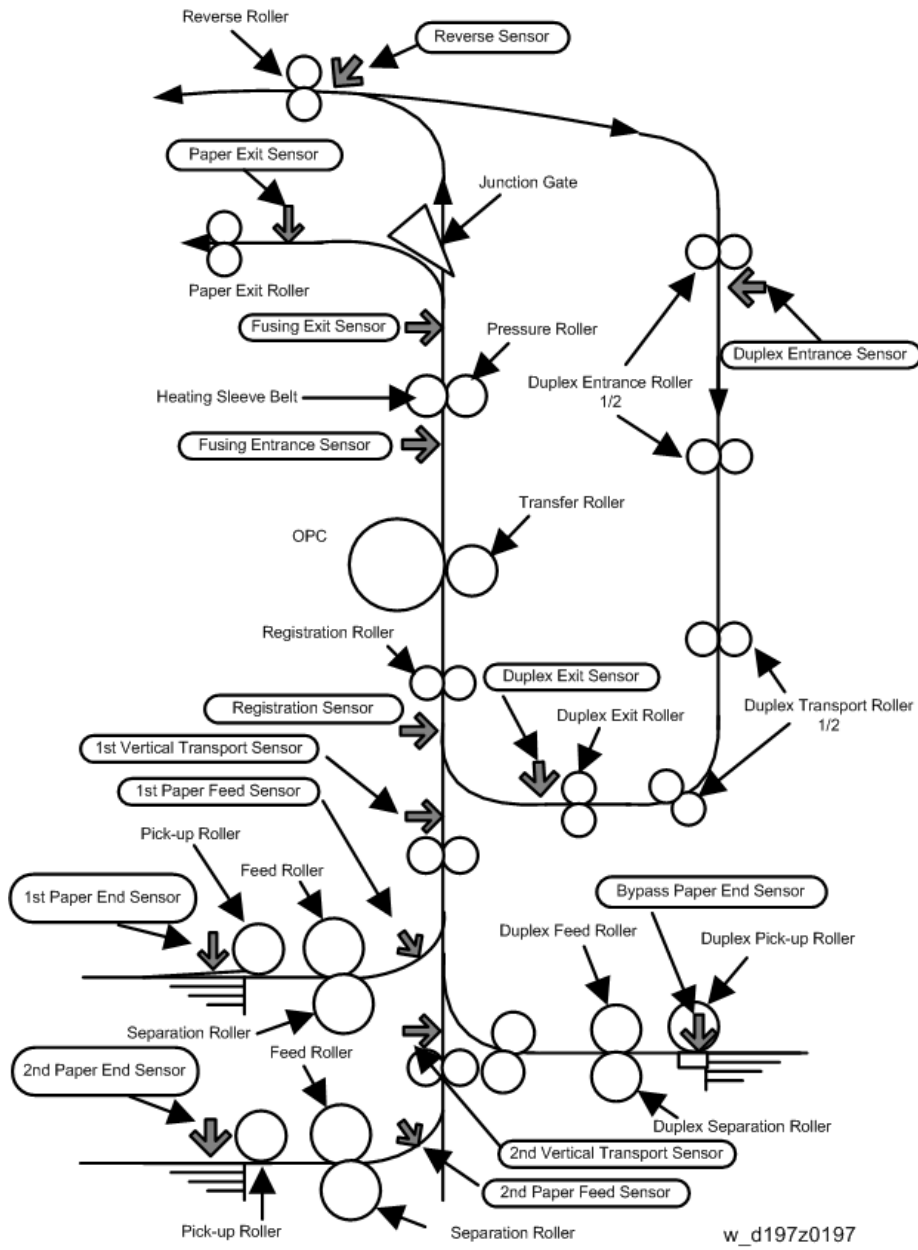

6.12.4 PAPER SIZE CODES

Paper size codes are as follows.

* The unit of Main Scan/Sub Scan Length is 0.1 mm.

Size Code	Paper Size Name	Orientation	Main Scan Length	Sub Scan Length
132(84H)	A3	SEF	2970	4200
005(05H)	A4	LEF	2970	2100
133(85H)	A4	SEF	2100	2970
141(8DH)	B4	SEF	2570	3640
006(06H)	A5	LEF	2100	1480
134(86H)	A5	SEF	1480	2100
014(0EH)	B5	LEF	2570	1820
142(8EH)	B5	SEF	1820	2570
135(87H)	A6	SEF	1050	1480
143(8FH)	B6	SEF	1280	1820
160(A0H)	11"x17"(DLT)	SEF	2794	4318
164(A4H)	8 1/2"x14"(LG)	SEF	2159	3556
166(A6H)	8 1/2"x11"(LT)	SEF	2159	2794
038(26H)	8 1/2"x11"(LT)	LEF	2794	2159
172(ACH)	5 1/2"x8 1/2"(HLT)	SEF	1397	2159
175(AFH)	12" x 18"	SEF	3048	4572

6.13 OTHER PROBLEMS

6.13.1 WHEN SC670 IS DISPLAYED

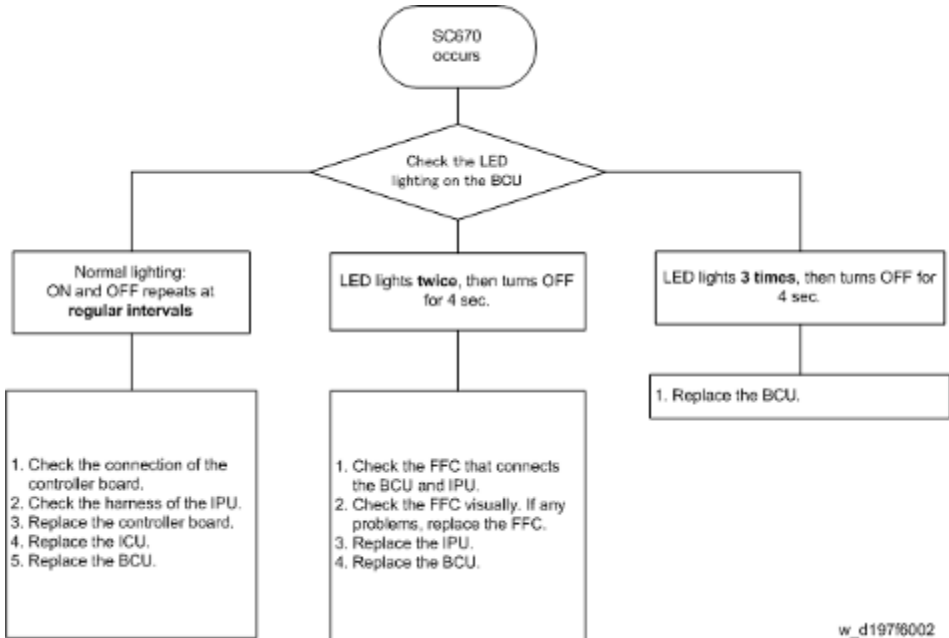

w_d197/6002

6.13.2 MARKS (VERTICAL STREAKS) ON PRINTS AND COPIES DUE TO SCANNING PROBLEMS

Marks on prints and copies are mostly due to dirt on the DF exposure glass [A], generally caused by adhesive contaminants (such as ball point pen ink and correction fluid).

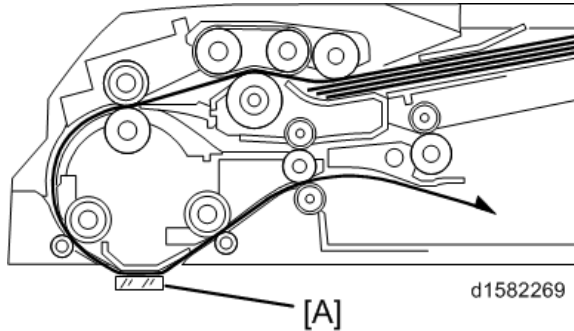

Compared to non-adhesive contaminants (such as paper fragments and eraser dust), adhesive contaminants are more likely to lead to complaints from customers because of the following:

- Vertical streaks caused by adhesive contaminants are more visible in terms of image quality.
- Unless removed by cleaning, adhesive contaminants continue to produce vertical streaks, while non-adhesive contaminants stop producing streaks after they are dislodged.
- Many adhesive contaminants are difficult to remove by cleaning.

The ARDF DF3090 (D779) features a system (non-contact scanning) to reduce vertical streaks caused by adhesive contaminants.

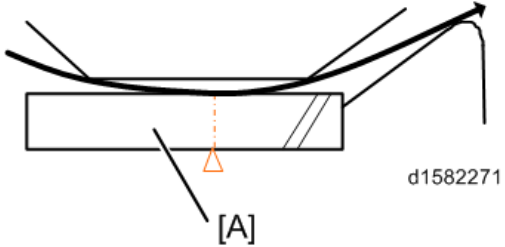
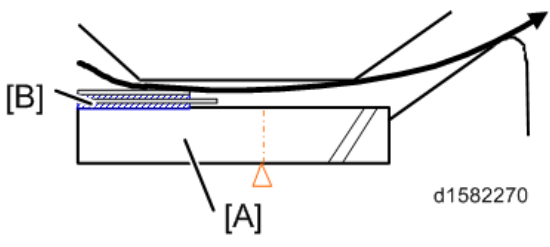
Contact scanning: Other ADFs/ARDFs	Non-contact scanning: DF3090 (D779)
<p>In contact scanning, the whole of the original comes into contact with the DF exposure glass [A] so that non-adhesive contaminants can be removed.</p>  <p>The diagram shows a curved original document touching a rectangular DF exposure glass [A]. A dashed orange triangle points to the contact area. Reference code 'd1582271' is at the bottom right.</p>	<p>By means of the Mylar sheet [B], originals are kept slightly above the DF exposure glass [A], preventing adhesive contaminants from adhering to the glass.</p>  <p>The diagram shows a curved original document held above a rectangular DF exposure glass [A] by a thin Mylar sheet [B]. A dashed orange triangle points to the glass. Reference code 'd1582270' is at the bottom right.</p>

The ARDF DF3090 (D779) can be converted from non-contact scanning to contact scanning for users who wish to reduce vertical streaks caused by non-adhesive contaminants.

SP No.	Contact scanning	Non-contact scanning
SP4-688-001 (DF Density Adjustment ARDF)	97%	102%

6.13.3 FINISHER REGISTRATION ADJUSTMENT

A side-to-side registration error can be produced when the paper is being fed from the mainframe to the finisher.

For SR3170/SR3160

The docking bracket for SR3170/SR3160 [A] (and its screw [B]) can adjust the side-to-side registration.

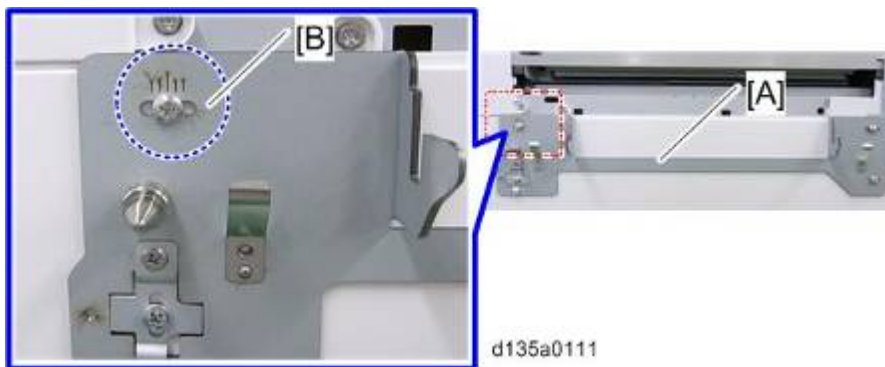

To adjust the side-to-side registration:

Change the position of the standard bracket [B] by rotating it 90 degrees as shown by the arrow.

This makes the docking bracket [A] easier to slide horizontally.

Then reattach the docking bracket [A] to the mainframe.

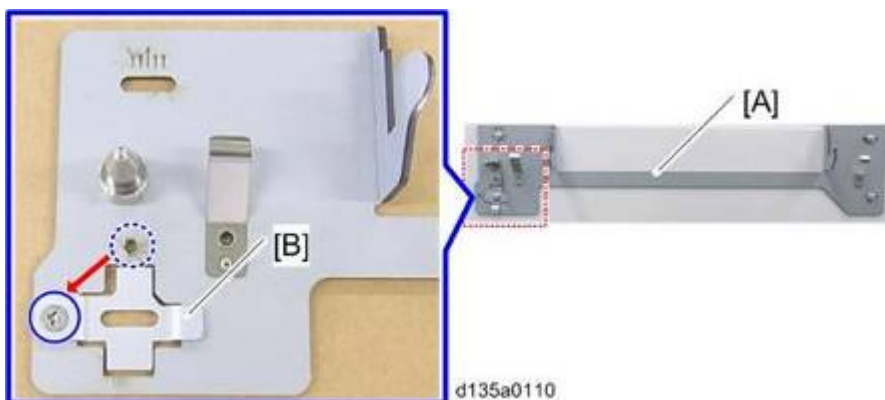

If the paper shifts toward the front

Slide the docking bracket forward by the amount which corresponds to that of the shift, to move the finisher in the same direction.

e.g.: When paper has shifted by 4 mm from the center toward the front (2 mm/division of the scale), move the docking bracket toward the front by 4 mm (2 divisions). The divisions move backward.

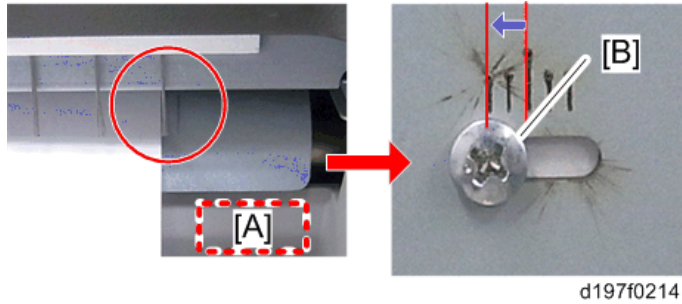

[A]: Proof tray

[B]: Docking Bracket Screw

If the paper shifts toward the rear

Slide the docking bracket backward by the amount which corresponds to that of the shift, to move the finisher in the same direction.

e.g.: When paper has shifted by 4 mm from the center toward the rear (2 mm/division of the scale), move the docking bracket backward by 4 mm (2 divisions). The divisions move forward.

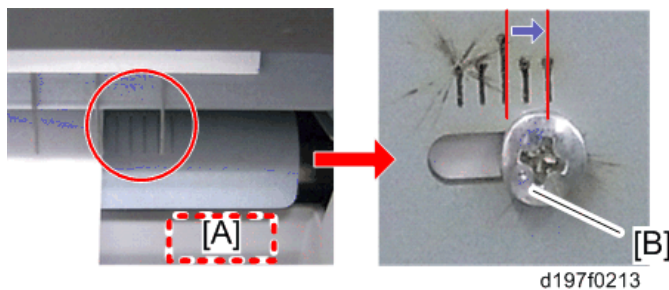

[A]: Proof tray

[B]: Docking Bracket Screw

Note

- After the adjustment, check the side-to-side registration by feeding paper out to the proof tray. If the shift has not been solved, adjust the docking bracket (screw for the docking bracket) slightly again.

For SR3150/SR3140

Side-to-side registration can be adjusted by the docking bracket for SR3150/SR3140 [A] (and the docking bracket screw [B]).

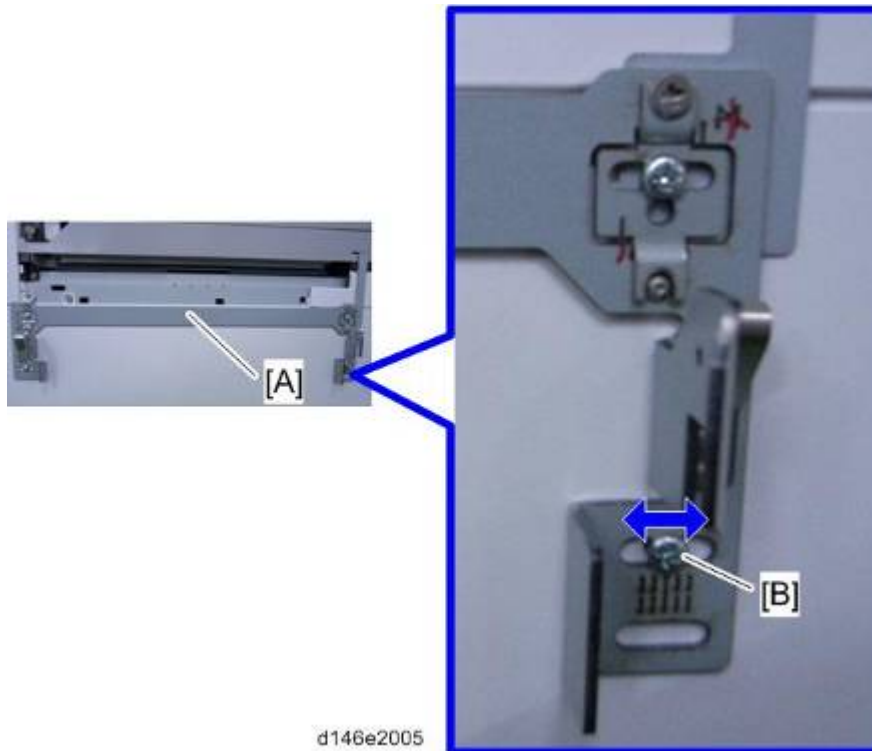

1. Eject a sheet of A4(LEF) or A3 A4(LEF) paper to the proof tray and check for how many divisions of the scale the edge of the paper has shifted from the center.

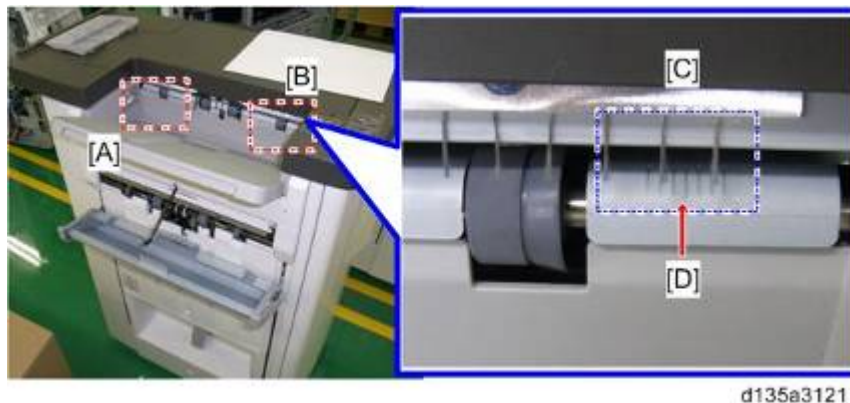

- [A]: Scale marks for DLT
- [B]: Scale marks for A3
- [C]: 7 scale marks in 2mm intervals
- [D]: Center mark

2. Change the position of the standard bracket by rotating it 180 degrees as shown below. This makes the docking bracket easier to slide horizontally. Then reattach the docking bracket to the mainframe.

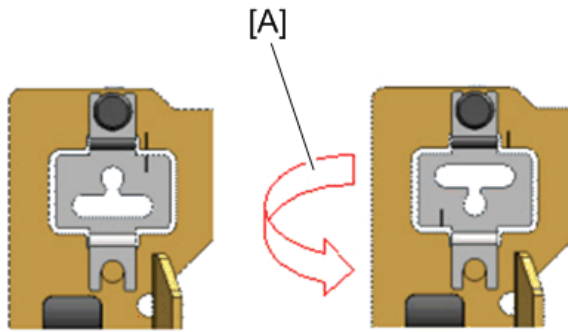

d197f0210

[A]: Reverse

If paper shifts toward the front

Slide the docking bracket backward by the amount which corresponds to that of the shift, in order to move the finisher in the same direction.

e.g.: When paper has shifted by 4 mm from the center toward the rear (2 mm/division of the scale), move the docking bracket backward by 4 mm (2 divisions). The divisions move forward.

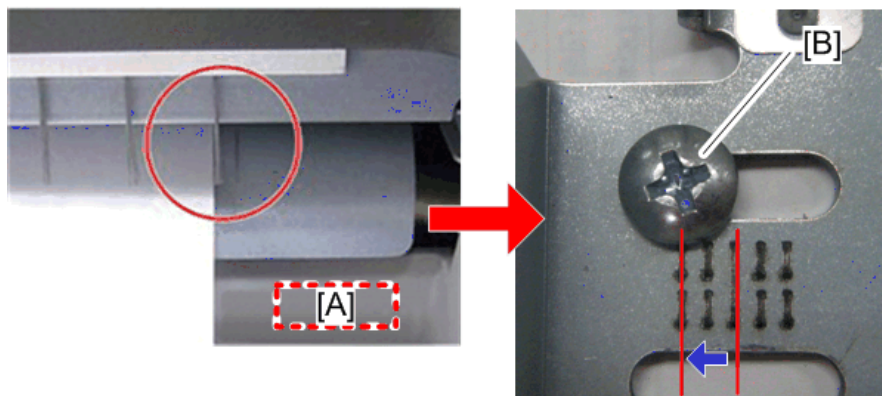

d197f0211

[A]: Proof Tray

[B]: Docking Bracket Screw

If paper shifts toward the rear

Slide the docking bracket backward by the amount which corresponds to that of the shift, in order to move the finisher in the same direction.

e.g.: When paper has shifted by 4mm from the center toward the rear (2 mm/division of the scale), move the docking bracket backward by 4 mm (2 divisions). The divisions move forward.

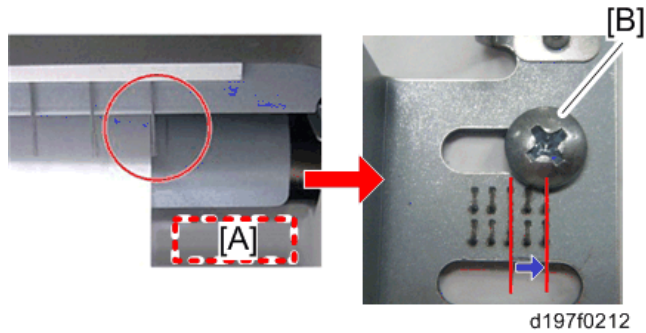

[A]: Proof Tray

[B]: Docking Bracket Screw

ⓘ Note

- After the adjustment, check the side-to-side registration by feeding paper out to the proof tray. If the shift has not been solved, adjust the docking bracket (screw for the docking bracket) slightly again.

6.13.4 STACKING PROBLEM AT THE 1000-SHEET FINISHER

Stacking problem may occur due to paper curl depending on the paper type / size. In this case, it is possible to avoid the problem by attaching the auxiliary tray.



d1826011

Installation procedure for attaching the sheet

1. Clean the back [B] of the auxiliary tray [A] with alcohol

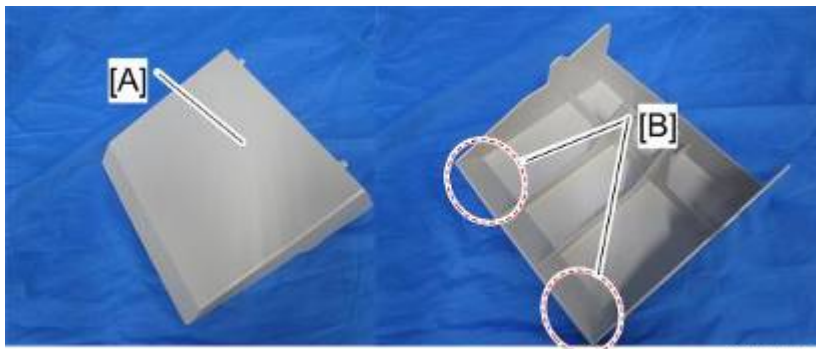

d1826006

2. Attach the fixing sheet [B] to the auxiliary tray [A].

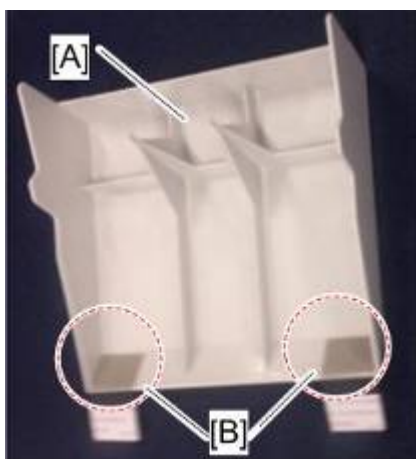

d1826001

↓ Note

- Place the sheet on the outer end [A] of the auxiliary tray and hook the bent portion [B] at the edge of the tray.

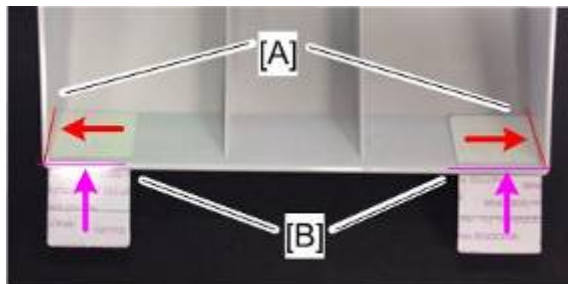

d1826002

Installation procedure for attaching the auxiliary tray to the 1000-sheet finisher

- Turn on the machine.
- Manually lift the paper surface detection feeler [A] to keep the sensor "ON".
Keep lifting the feeler until step 4.

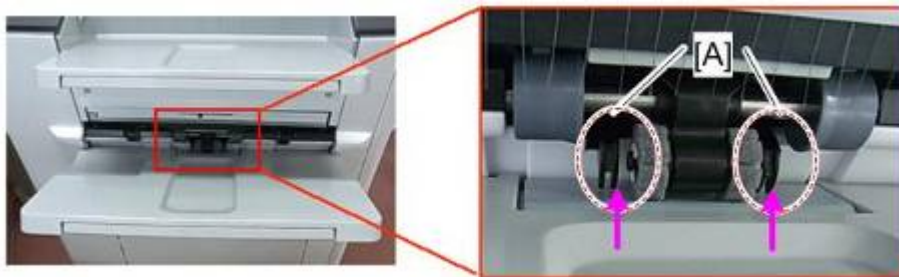

d1826003

- Open and close the upper cover [A] or the front cover [B]. The shift tray [C] starts to descend.



d1826004

- "JAM227" is displayed about 3 seconds later. The shift tray descent is stopped. Release your hand from the feeler.
- Clean the place [A] to attach the fixing sheet with alcohol.

Other Problems

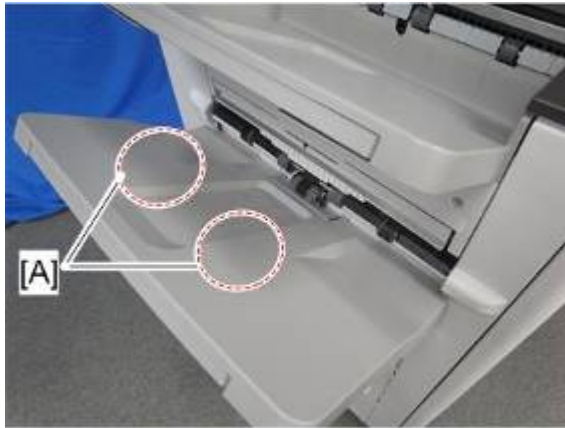

6. Place the auxiliary tray [A] on the shift tray.
7. Attach the fixing sheet [B] on the shift tray and fasten the auxiliary tray.
8. Open and close the front cover or the upper cover. The shift tray starts to rise [C], and "JAM227" is cleared.

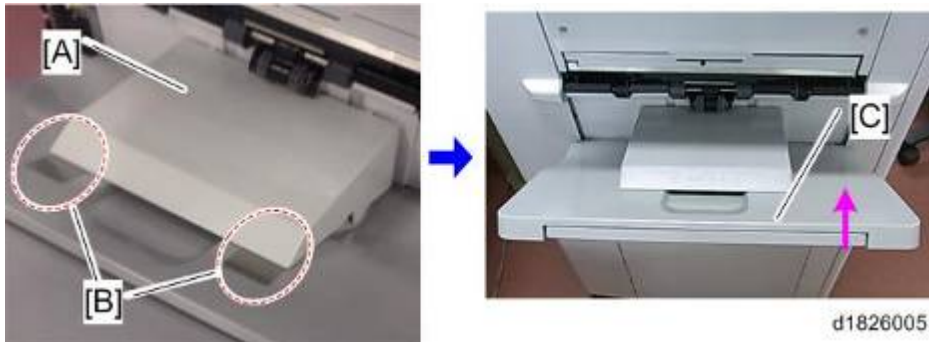

6.13.5 EARLY PAPER FULL DETECTION AT THE 1000-SHEET FINISHER

Early paper full detection may occur due to paper stacking depending on the paper type / size. In this case, it is possible to avoid the early detection by attaching the auxiliary tray



d1826009

Installation procedure

1. Place the auxiliary tray [B] into the dent in the proof tray [A].

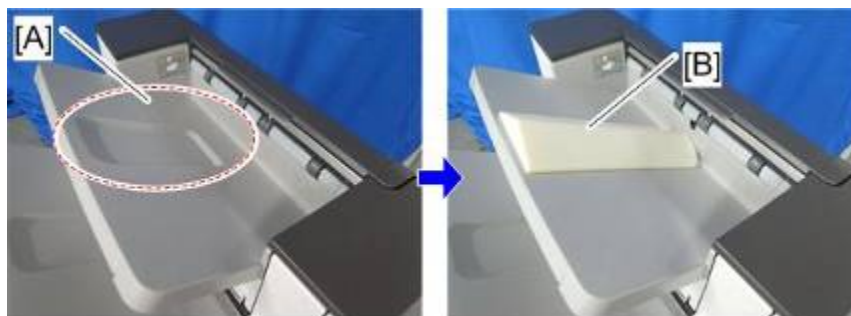

d1826010

6.13.6 FINISHER JOGGER PROBLEM

Jogger Width Adjustment Procedure

If a paper alignment problem occurs as below, do the following procedure to adjust the jogger width.

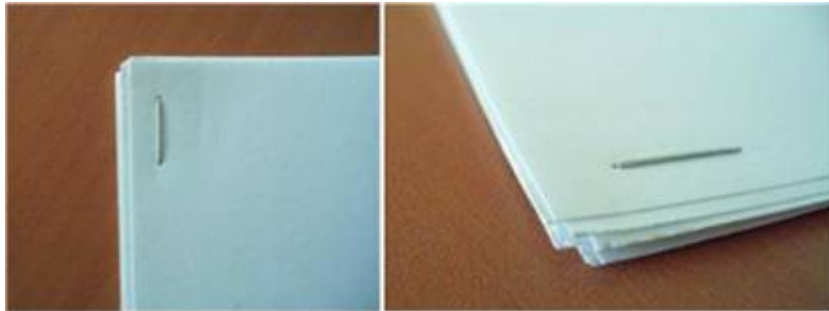

d146z0091

1. Place an A4 original (SEF) on the exposure glass.
2. Select [Staple] on the operation panel (you can select any staple location: top or bottom.)
3. Press [Start].
4. A copy is put out on the staple tray, and is stopped with the jogger not holding the sheet. (Firmware version 01.150.04 and older, a copy is stopped with the jogger holding the sheet.)
5. Check the jogger operation with eyes in the previous step, and then check the position and distance of jogger width and sheet.

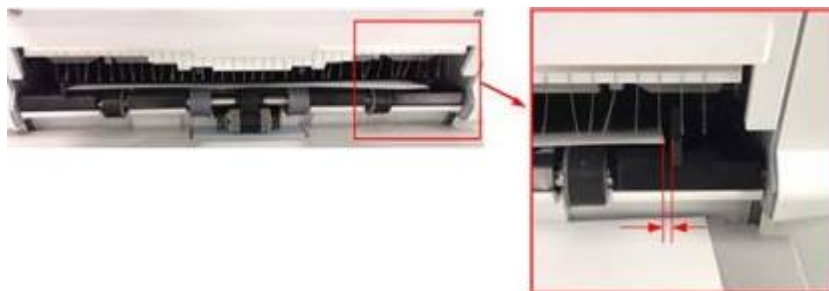

d146z0092

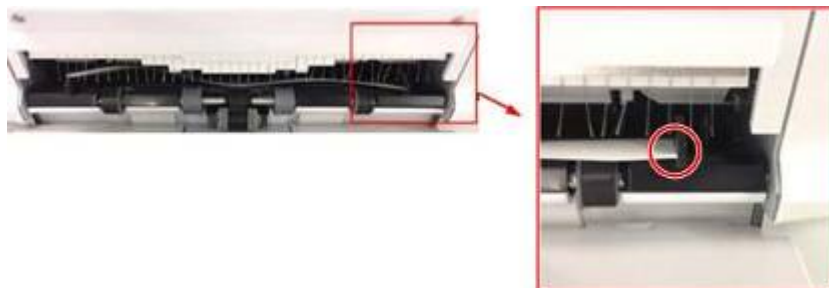

d146z0093

6. Press the [#] button.
7. Adjust the jogger width with SP6-143-004 (adjustable threshold: -1.5 to +1.5 mm for each paper size).

- Repeat step 3 through step 6 to complete the adjustment.

Note

- Adjust the jogger width to be slightly narrower (approximately -0.5 mm) than the paper width.

6.13.7 EARLY PAPER FULL DETECTION MYLAR FOR INTERNAL FINISHER SR3130 (D690)

Paper curl may occur when output gets to near full. Paste the mylar to the full detection feeler to detect paper full early before paper curl occurs.

Pasting Mylar Procedure

- Pull the finisher [A]

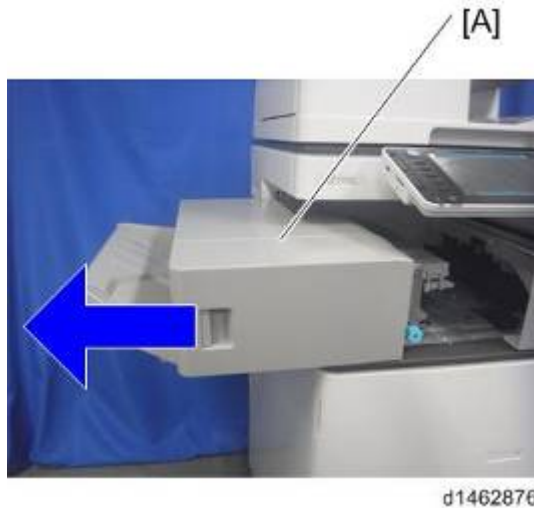

- Finisher front cover (🔧x2)

Other Problems

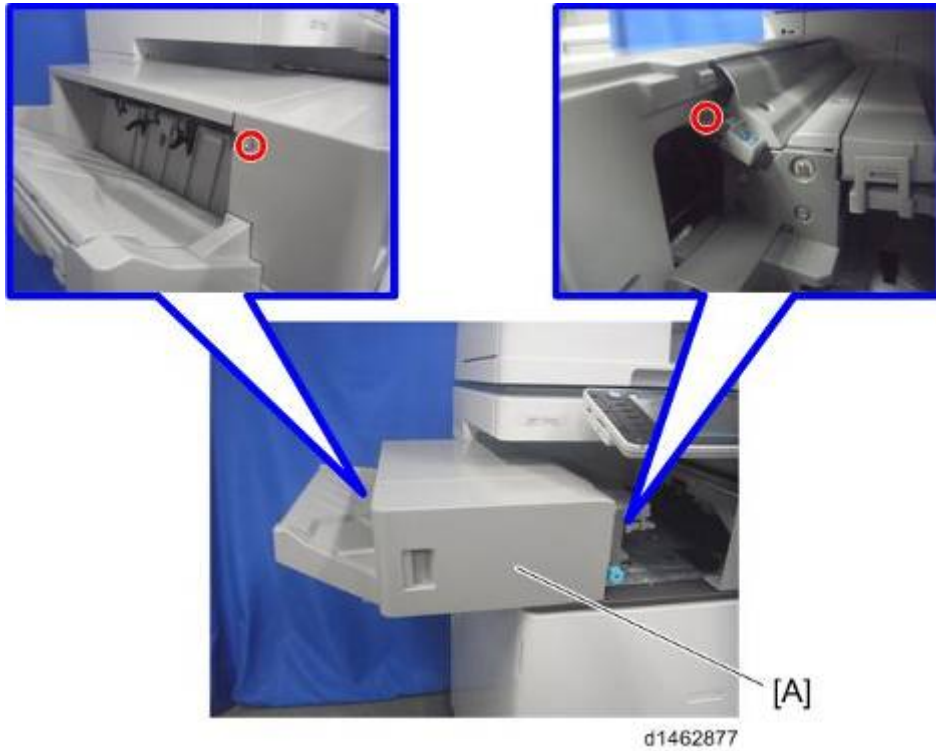

3. Left lower cover [A] (⚙️ x2)



4. Rotate the gear [A] to lift down the movable tray [B].

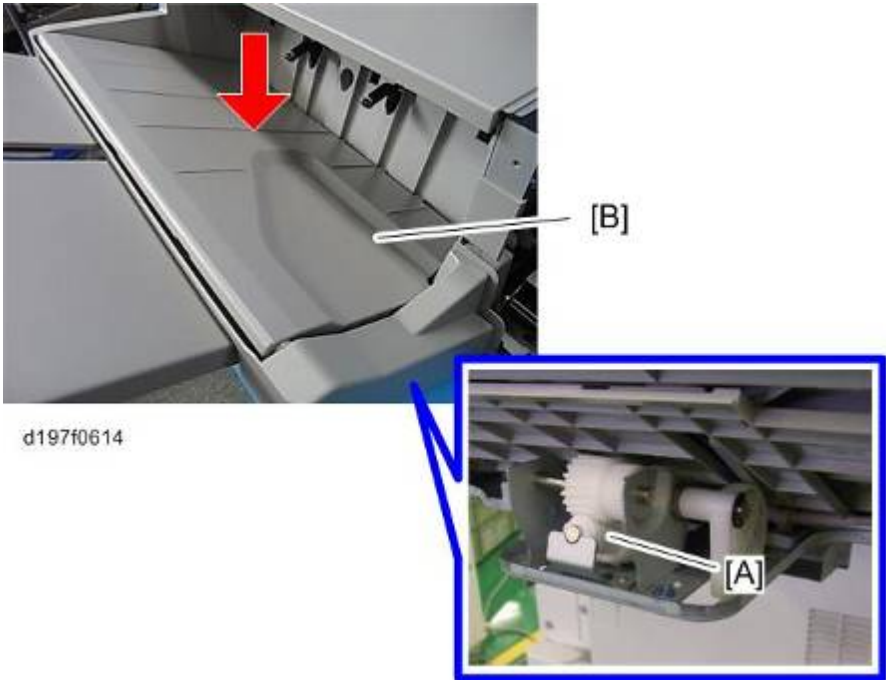

d197f0614

5. Paper output tray [A] (⚙️x2)

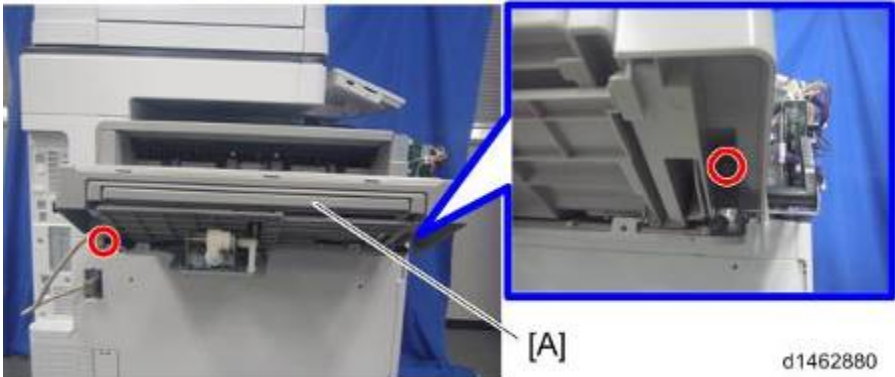

d1462880

6. Paste the mylar [A] on the full detection feeler [B].

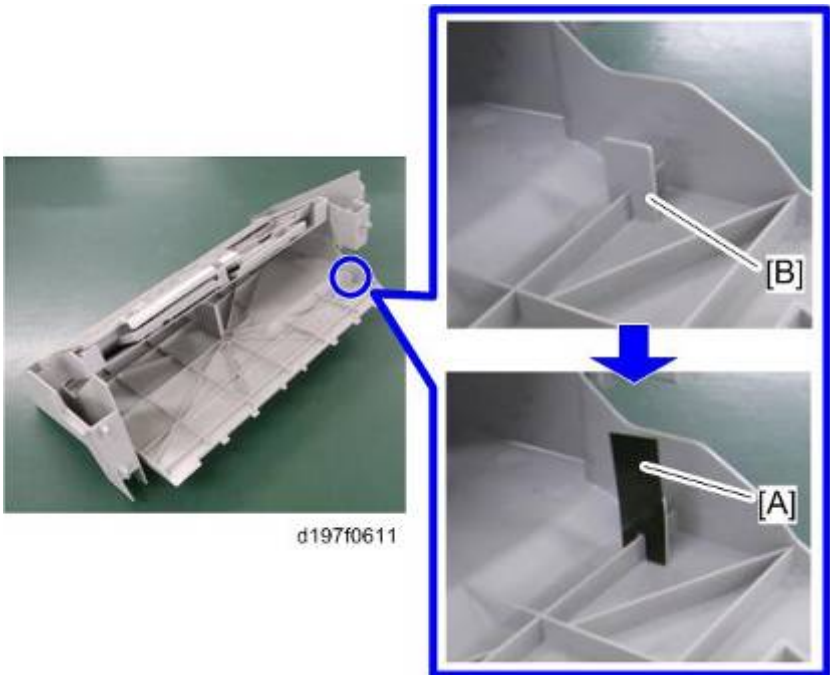

d197f0611

7. Re-assemble the paper output tray (🔩 x2)
8. Move the movable tray [A] up and down to check that the mylar does go through the sensor properly.

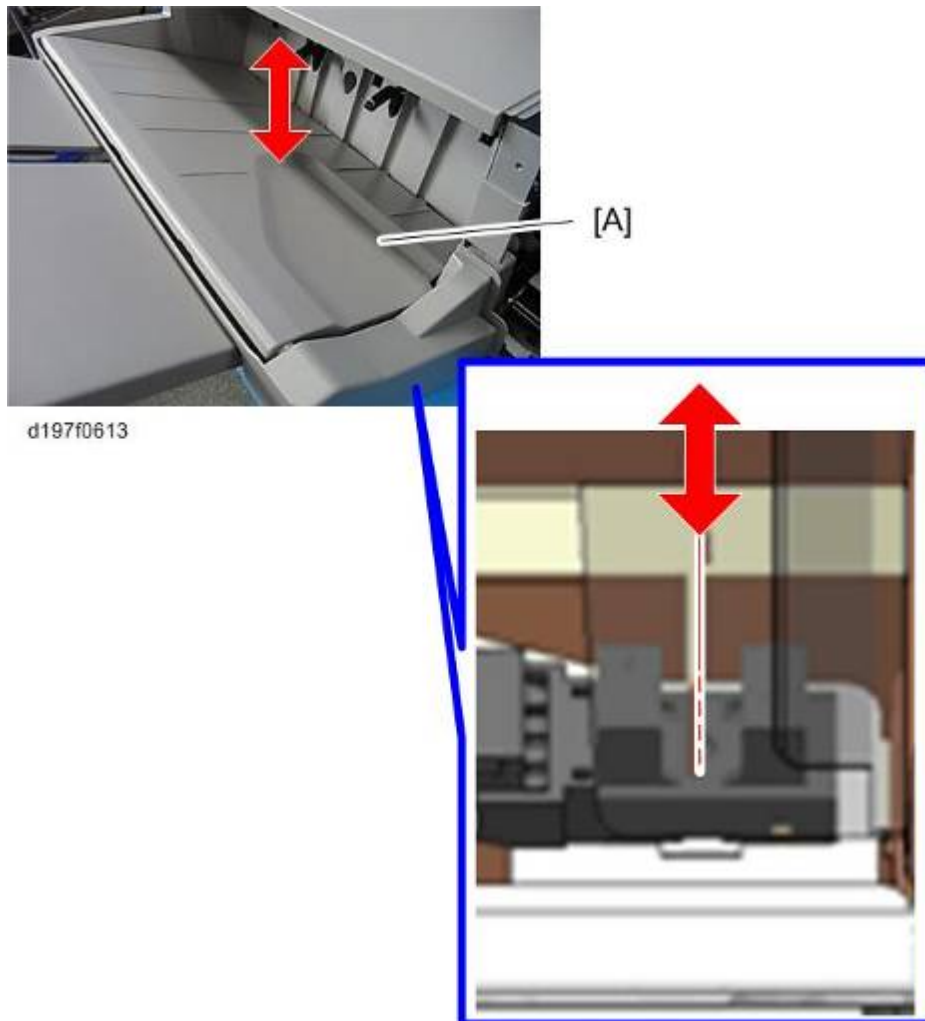

9. Re-assemble the left lower cover (🔩 x2)
10. Re-assemble the finisher front cover (🔩 x2)

6.13.8 HOW TO RE-INSTALL THE OCR UNIT TYPE M2

When the OCR unit is installed, its function is stored in the HDD, and its ID information in the SD card is stored in the NVRAM. So the OCR unit must be installed again when you replace the HDD and/or NVRAM.

If you have the original SD card and when you replaced:

- Only HDD
Re-install the unit with the original SD card.
- Only NVRAM
Re-install with the original SD card if you upload/download of the NVRAM data.
Order a new SD card and Re-install with the new SD card if you do not upload/download of the NVRAM data.
- Both the HDD and NVRAM at the same time
Re-install the original SD card.

If you do not have the original SD card:

Order a new SD card and Re-install with the new SD card.

ⓘ Note

- Re-installation procedure is the same as the installation procedure (page 2-249)

6.13.9 PAPER CURL PROBLEM FOR SR3180

When using the mixing mode, duplex (curl towards the lower) over the simplex (curl towards the upper) and occur paper curl, attach the auxiliary tray (D7667010), disable the paper full detection sensor, and paste the mylar.

1. Paper output cover [A] (🔧 x2)



2. Release the clamp and disconnect the harness of the paper output full sensor 1 [A].

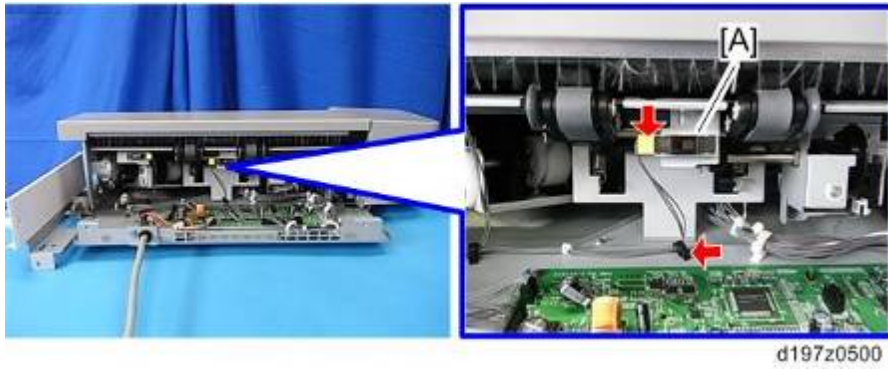

3. Loop and clamp the harness [A] as shown.

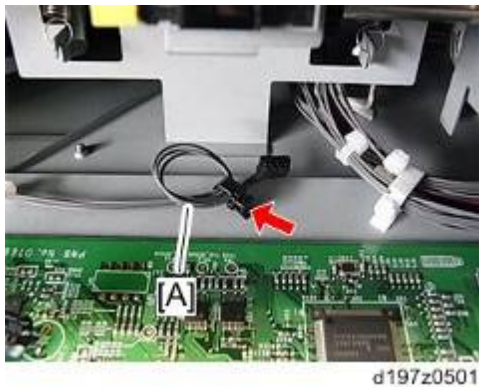

4. Release the clamp and disconnect the harness of the paper output full sensor 2 (Staple) [A].

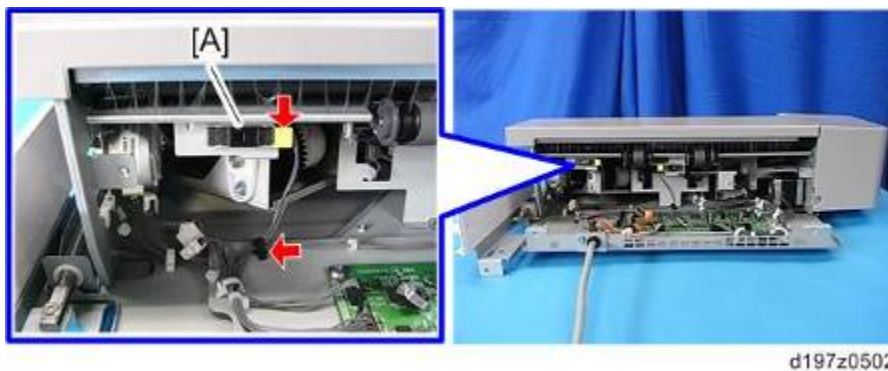

5. Loop and clamp the harness [A] as shown.



Note

- If the harness cable is short to loop, clamp the harness without looping.



- 6. Re-attach the paper output cover (🔩 x2)
- 7. Attach the auxiliary tray (D7667010) [B] to the paper output tray [A]

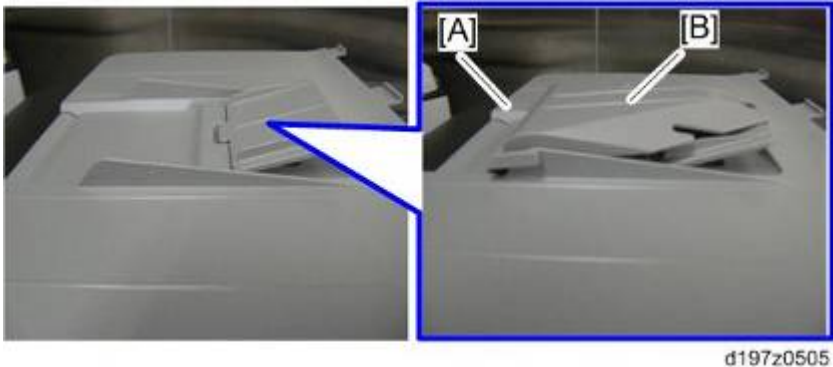

- 8. Paste the mylars [A] on the frame of the finisher.

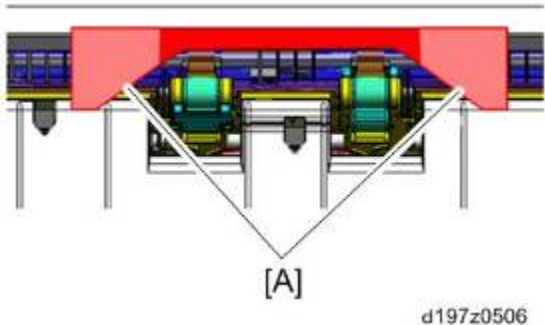

6.14 BLOWN FUSE CONDITION

Fuse: NA

Name	Output connector	Capacity	Part number	Field replacement possible
		Voltage	Part name	Remarks
FU101	CN902 (Fusing Lamp)	15A	11071241	Yes
		AC	TLC-15A-N4	-
FU102	CN904 (DHB)	10A	11071347	Yes
		AC	FIH 250V 10A(EM/CR)	-
FU105	CN913-5, 12 (Zero cross circuit / DH heater)	2A	-	No
		AC	SLT250V2A	-
FU11	CN911-3 (IPU)	5A	-	No
		5V	SLT250V5A	-
FU12	CN912-5, 6 (SIO)	10A	11071216	Yes
		24V	FBT250V10A (EM)	-
FU13	CN912-7 (BCU)	10A	11071216	Yes
		24V	FBT250V10A (EM)	-
FU14	CN912-8 (BCU)	10A	11071216	Yes
		24V	FBT250V10A (EM)	-

Fuse: EU

Name	Output connector	Capacity	Part number	Field replacement possible
		Voltage	Part name	Remarks
FU101	CN902 (Fusing Lamp)	8A	11071346	Yes
		AC	FIH250V8A (EM/CR)	-
FU102	CN904 (DHB)	5A	11071344	Yes
		AC	FIH 250V 5A(TP/CR)	-
FU105	CN913-5, 12 (Zero cross circuit / DH Heater)	2A	-	No
		AC	SCT250V2A	-
FU11	CN911-3 (IPU)	5A	-	No
		5V	SLT250V5A	-
FU12	CN912-5, 6 (SIO)	10A	11071216	Yes
		24V	FBT250V10A (EM)	-
FU13	CN912-7 (BCU)	10A	11071216	Yes
		24V	FBT250V10A (EM)	-
FU14	CN912-8 (BCU)	10A	11071216	Yes
		24V	FBT250V10A (EM)	-

Fuse Location

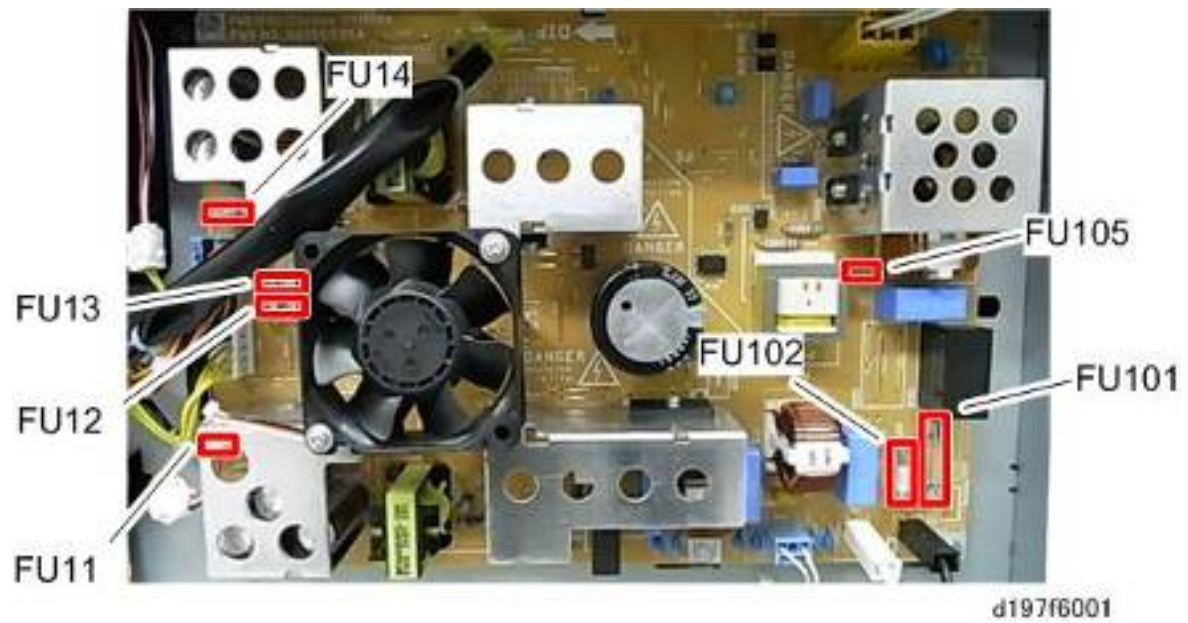

ENERGY SAVING

REVISION HISTORY		
Page	Date	Added/Updated/New
		None

7. ENERGY SAVING

7.1 ENERGY SAVING

7.1.1 ENERGY SAVE

If the Energy Saver Button Is Pressed During Machine Operation

Previous models:

The job in progress is cancelled and the machine switches to Energy Saver mode immediately.

This model:

The following sequence is followed.

1. The [Energy Saver] key lights up and a pop-up message is displayed informing the user that the machine will switch to Energy Saver mode as soon as the current job is completed. The job continues until the end.
2. When the job has been completed, the machine enters Energy Saver mode.

Note

- If the [Energy Saver] key is pressed again during the job, the machine returns to the Ready condition.

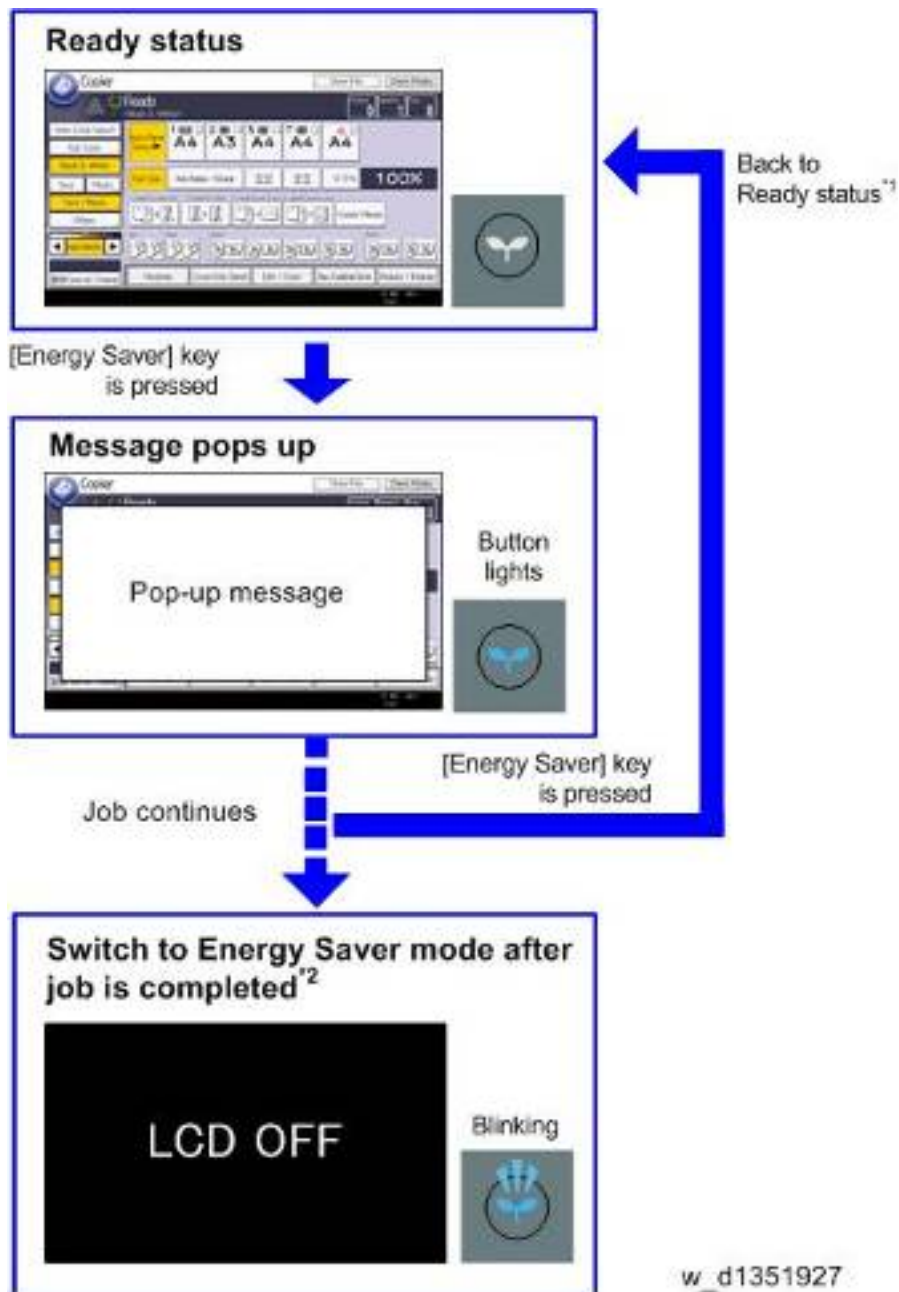

*1: The machine return to ready status by doing one of the following,

- Press the [Energy Saver] key
- Open the platen cover
- Set an original in the ADF

*2: Recovering from the Energy Saver mode is the same as previous models. Do one of the following.

- Press the [Energy Saver] key
- Open the platen cover
- Set an original in the ADF

7.1.2 ENERGY SAVER TIMER

- With this timer, the user can choose when the machine will automatically enter and recover from Energy Saver mode, as well as when it will turn on and off. The user does not need to worry about turning the machine on or off in the morning, during lunchtime, or when leaving the office. As a result, the machine contributes to overall energy saving in the user's office environment, while at the same time helping to improve work efficiency.
- The user is able to control how far the machine will power down, i.e. only to Energy Saver mode or all the way off.
- With auto power ON and OFF, the user need not remember to turn the machine on and off every day.
 - Auto power ON:
Improves work efficiency, as machine warm-up is already completed by the time the user is ready to begin work (the user is not made to wait).
 - Auto power OFF:
Prevents unnecessary power consumption during after-work hours, saving power.

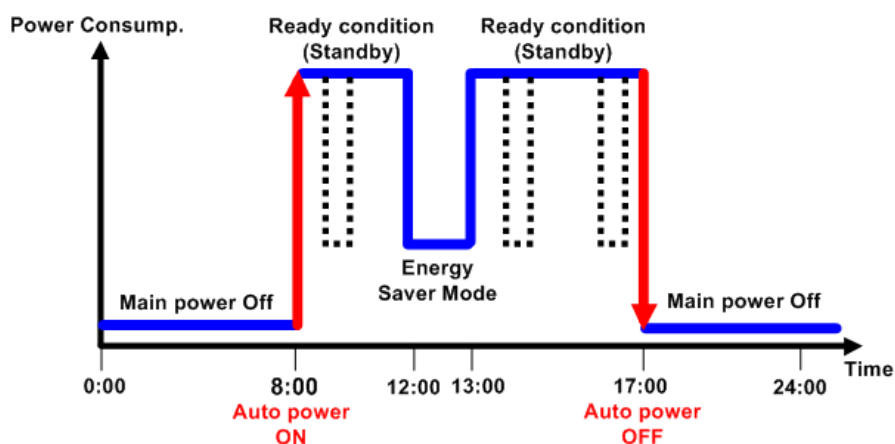

w_d1351928

- The user can disable the Weekly Timer, so that the machine power is not turned on automatically during extended periods of inactivity (Ex. Summer holiday).
- A password can be set so that the machine can be used during this period if necessary, but only by the select group who know this password.

ⓘ Note

- You can set the energy saver timer setting on "Weekly Timer" in "Timer Settings" menu under "System Settings".

7.2 PAPER SAVE

7.2.1 EFFECTIVENESS OF DUPLEX/COMBINE FUNCTION

Duplexing and the combine functions reduce the amount of paper used. This means that less energy overall is used for paper production, which improves the environment.

1. Duplex:

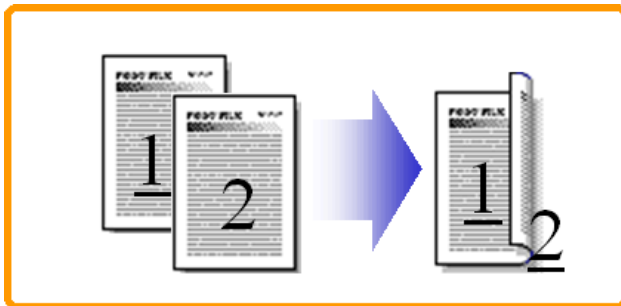

d1351966

Reduce paper volume in half!

2. Combine mode:

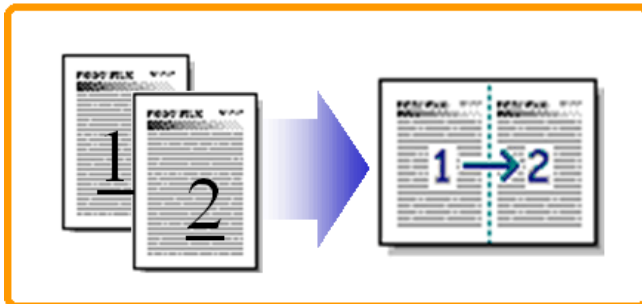

d1351967

Reduce paper volume in half!

3. Duplex + Combine:

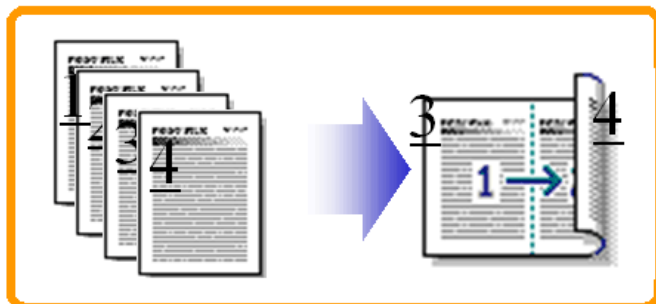

d1351968

Using both features together can further reduce paper volume by 3/4!

To check the paper consumption, look at the total counter and the duplex counter.

The total counter counts all pages printed.

- For one duplex page, the total counter goes up by 2.
- For a duplex job of a three-page original, the total counter goes up by 3.
- The duplex counter counts pages that have images on both sides.
- For one duplex page, the duplex counter goes up by 1.
- For a duplex job of a three-page original, the duplex counter will only increase by 1, even though two sheets are used.

Paper Savings and Counter

- Total counter: SP 8581-001
- Duplex counter: SP 8411-001
- Single-sided with combine mode: SP 8421-004
- Duplex with combine mode: SP 8421-005

The following table shows paper savings and how the counters increase for some simple examples of single-sided and duplex jobs.

Duplex mode:

Originals	Simplex Sheet used	Duplex Sheets used	Paper Saved	Total counter SP8581-001	Duplex counter SP8411-001
1	1	1	0	1	0
2	2	1	1	2	1
3	3	2	1	3	1
4	4	2	2	4	2
5	5	3	2	5	2
10	10	5	5	10	5
20	20	10	10	20	10

If combine mode is used, the total and duplex counters work in the same way as explained previously. The following table shows paper savings and how the counters increase for some simple examples of duplex/combine jobs.

2 in 1 mode:

Originals	Simplex Sheet used	Duplex Sheets used	Paper Saved	Total counter SP8581-001	Duplex counter SP8411-001
1	1	1	0	1	1
2	2	1	1	1	1
3	3	2	1	2	2
4	4	2	2	2	2
5	5	3	2	3	2
10	10	5	5	5	5
20	20	10	10	10	10

Duplex + 2 in 1 mode:

Originals	Simplex Sheet used	Duplex Sheets used	Paper Saved	Total counter SP8581-001	Duplex counter SP8411-001
1	1	1	0	1	0
2	2	1	1	1	0
3	3	1	2	2	1
4	4	1	3	2	1
5	5	2	3	3	1
6	6	2	4	3	1
7	7	2	5	4	2
8	8	2	6	4	2
9	9	3	6	5	2
10	10	3	7	5	2
11	11	3	8	6	3
12	12	3	9	6	3

**D197/D198/D199/D200/D201/D202
SERVICE MANUAL APPENDICES**

D197/D198/D199/D200/D201/D202

APPENDICES

TABLE OF CONTENTS

1. APPENDICES: SPECIFICATIONS	1-1
1.1 GENERAL SPECIFICATIONS	1-1
1.1.1 MAINFRAME	1-1
Copier Specifications.....	1-9
1.1.2 PRINTER SPECIFICATIONS	1-13
1.1.3 SCAN SPECIFICATIONS	1-15
Scan to Email	1-19
Scan to Folder.....	1-21
Network TWAIN Driver	1-23
1.2 SUPPORTED PAPER SIZES	1-24
1.2.1 ORIGINAL SIZE DETECTION.....	1-24
Remarks:.....	1-24
1.2.2 PAPER FEED	1-26
Remarks:.....	1-26
Tray 1 through 3.....	1-27
Bypass Trays	1-29
1.2.3 PAPER EXIT.....	1-31
Main Unit Tray, 1 Bin Tray, Shift Tray, Side Tray	1-31
Remarks:.....	1-33
1.3 SOFTWARE ACCESSORIES.....	1-34
1.3.1 PRINTER DRIVERS	1-34
Windows Environment.....	1-34
Point and Print.....	1-36
Mac OS and UNIX Environment.....	1-38
1.3.2 SCANNER AND LAN FAX DRIVERS	1-39
1.4 OPTIONAL EQUIPMENT.....	1-40
1.4.1 PAPER FEED UNIT PB3210/PB3220 (D787)	1-40
1.4.2 PAPER FEED UNIT PB3150 (D694)	1-40
1.4.3 LCIT PB3170/PB3230 (D695).....	1-41
1.4.4 LCIT RT3030 (D696)	1-41
1.4.5 CASTER TABLE TYPE B (D178)	1-42
1.4.6 PLATEN COVER PN2000 (D700)	1-42
1.4.7 ARDF DF3090 (D779)	1-42

1.4.8 SPDF DF3080 (D683).....	1-43
1.4.9 BRIDGE UNIT BU3070 (D685).....	1-43
1.4.10 1 BIN TRAY BN3110 (D692).....	1-44
1.4.11 INTERNAL SHIFT TRAY SH3070 (D691).....	1-44
1.4.12 SIDE TRAY TYPE M3 (D725).....	1-45
1.4.13 BOOKLET FINISHER SR3170 (D688) / FINISHER SR3160 (D689) 1-46	
1.4.14 PUNCH UNIT PU3060 (D706).....	1-49
1.4.15 BOOKLET FINISHER SR3150 (D686) / FINISHER SR3140 (D687) 1-50	
1.4.16 PUNCH UNIT PU3050 (D717).....	1-53
1.4.17 INTERNAL FINISHER SR3180 (D766).....	1-54
1.4.18 INTERNAL FINISHER SR3130 (D690).....	1-55
1.4.19 PUNCH UNIT PU3040 (D716).....	1-56

2. APPENDICES: PREVENTIVE MAINTENANCE TABLES 2-1

2.1 PREVENTIVE MAINTENANCE	2-1
2.1.1 PREVENTIVE MAINTENANCE ITEMS	2-1
Mainframe: D197/D198/D199.....	2-1
Mainframe: D200/D201/D202.....	2-6
ARDF DF3090.....	2-10
SPDF DF3080.....	2-11
Paper Feed Unit PB3150/PB3210/PB3220.....	2-12
LCIT PB3170/PB3230.....	2-12
LCIT RT3030.....	2-13
1 Bin Tray BN3110.....	2-13
Bridge Unit BU3070.....	2-13
Internal Shift Tray SH3070.....	2-14
Side Tray Type M3.....	2-14
Booklet Finisher SR3150 / Finisher SR3140.....	2-14
Booklet Finisher SR3170 / Finisher SR3160.....	2-15
Internal Finisher SR3130.....	2-16
Internal Finisher SR3180.....	2-16
2.1.2 OTHERS YIELD PARTS.....	2-17
Mainframe:	2-17
ARDF DF3090 (D779):.....	2-17
SPDF DF3080 (D779):.....	2-17

APPENDIX: SPECIFICATIONS

REVISION HISTORY		
Page	Date	Added/Updated/New
		None

1. APPENDICES: SPECIFICATIONS

1.1 GENERAL SPECIFICATIONS

1.1.1 MAINFRAME

Item	Spec.
Configuration:	Desktop
Color Supported:	Black and White
Scanning Element:	One-dimensional solid scanning through CCD
Printing process:	D197/D198/D199: Single Laser beam scanning and electro-photographic printing D200/D201/D202: Twin Laser beam Scanning and electro-photographic printing
Development:	Dry two-component magnetic brush development system
Fusing System:	QSU-DH Fusing System
Max. Imageable Area:	297 x 432 mm (11" x 17")
Target Monthly ACV:	D197: 4K D198: 5K D199: 7K D200: 10K D201: 15K D201: 20K
First Copy Time (LT/A4 LEF, 1st tray):	D197/D198: 4.6 sec D199: 4.3 sec D200: 4.0 sec D201/D202: 2.9 sec

General Specifications

Item	Spec.
Warm-up Time (From main switch):	11.0 sec * If HDD installed: 14.0 sec * If Smart Operation Panel installed: 71.0 sec (Nominal Value)
Power Source:	NA: 120V-127V 60 Hz 12A EU/Asia/China: 220-240V 50-60 Hz 8A TW: 110V 60 Hz 13.6A
Max Power Consumption (Full Configuration):	NA: 1.6 kW or less EU/Asia/China: 1.6 kW or less (D197/D198/D199), 1.78 kW or less (D200/D201/D202)
Dimensions (W x D x H):	<p>Mainframe:</p> <ul style="list-style-type: none"> ▪ 587 x 680 x 788 (23.1" x 26.8" x 31.0") (Mainframe; when Operation panel is at home position) ▪ 668 x 765 x 1035 (26.3" x 30.1" x 40.7") (with 2-Tray Optional Bank, and Fall-Prevention Material) <p>With ARDF:</p> <ul style="list-style-type: none"> ▪ 587 x 680 x 913 (23.1" x 26.8" x 35.9") (Mainframe; when Operation panel is at home position) ▪ 668 x 765 x 1160 (26.3" x 30.1" x 45.7") (with 2-Tray Optional Bank, and Fall-Prevention Material) <p>With SPDF:</p> <ul style="list-style-type: none"> ▪ 587 x 680 x 963 (23.1" x 26.8" x 37.9") (Mainframe; when Operation panel is at home position) ▪ 668 x 765 x 1210 (26.3" x 30.1" x 47.6") (with 2-Tray Optional Bank, and Fall-Prevention Material)

Item	Spec.
Weight:	<p>Mainframe only</p> <ul style="list-style-type: none"> ▪ Less than 60 kg (132.3 lbs) <p>With ARDF</p> <ul style="list-style-type: none"> ▪ Less than 68.5 kg (151.0 lbs) <p>With SPDF</p> <ul style="list-style-type: none"> ▪ Less than 74 kg (163.1 lbs)
CPU:	PMC-Sierra RM7035-533MHz
RAM:	Standard: 2GB
HDD:	<p>320GB</p> <p>* Optional for Basic model. Standard with SP model. Shared with other features (Copy, Fax, and Scanner).</p> <p>Regarding HDD, users can use 206GB only to enhance response rate for storing and loading data.</p>
Max Email Address in HDD:	<p>2,000</p> <p>Without HDD: 1,000</p>
Register Group Address in HDD:	Max. 100 Group (Max. 500 addresses in one group address)
Register client folder address in HDD:	<p>Max. 2,000 folders</p> <p>Without HDD: 1,000</p>
Recommended Paper Size:	<p>Standard Tray:</p> <p>A3 SEF, A4 SEF/LEF, A5 SEF/LEF, A6 SEF, B4 SEF, B5 SEF/LEF, B6 SEF, 11"x 17"(DLT) SEF, 8.5"x 14"(LG) SEF, 8.5"x 13"(Foolscap) SEF, 8.5"x 11"(LT) SEF/LEF, 8.25"x 14"(Government LG) SEF, 8.25"x 13"(Folio) SEF, 8"x 13"(F/GL) SEF, 8"x 10"(Eng Quatro) SEF, 7.25"x 10.5"(Executive) SEF/LEF, 11"x15" SEF, 10"x14" SEF, 8K SEF, 16K SEF/LEF, 5.5"x 8.5" (Half Letter SEF), Com10 SEF/LEF, Monarch SEF, C5 SEF/LEF, C6 SEF/LEF, DL Env SEF/LEF</p> <p><Custom Size Paper></p> <p>Width: 90 mm (3.55 inch) – 297 mm (11.69 inch),</p> <p>Length: 148 mm (5.83 inch) - 431.8 mm (17.00 inch)</p>

General Specifications

Item		Spec.
Recommended Paper Size:	2nd, 3rd & 4th Paper Tray (3rd & 4th Paper Tray optional):	A3 SEF, A4 SEF/LEF, A5 SEF/LEF, A6 SEF, B4 SEF, B5 SEF/LEF, B6 SEF, 11"x 17"(DLT) SEF, 8.5"x 14"(LG) SEF, 8.5"x 13"(Foolscap) SEF, 8.5"x 11"(LT) SEF/LEF, 8.25"x 14"(Government LG) SEF, 8.25"x 13"(Folio) SEF, 8"x 13"(F/GL) SEF, 8"x 10"(Eng Quatro) SEF/LEF, 7.25"x 10.5"(Executive) SEF/LEF, 11"x15" SEF, 10"x14" SEF, 8K SEF, 16K SEF/LEF, 5.5"x 8.5" Half Letter SEF, Com10 SEF/LEF, Monarch SEF, C5 SEF/LEF, C6 SEF/LEF, DL Env SEF/LEF <Custom Size Paper> Width: 90 mm (3.55 inch) – 297 mm (11.69 inch), Length: 148 mm (5.83 inch) - 431.8 mm (17.00 inch)
Recommended Paper Size:	Bypass:	A3 SEF, A4 SEF/LEF, A5 SEF/LEF, A6 SEF, B4 SEF, B5 SEF/LEF, B6 SEF, 11"x 17"(DLT) SEF, 8.5"x 14"(LG) SEF, 8.5"x 13"(Foolscap) SEF, 8.5"x 11"(LT) SEF/LEF, 8.25"x 14"(Government LG) SEF, 8.25"x 13"(Folio) SEF, 8"x 13"(F/GL) SEF, 8"x 10"(Eng Quatro) SEF/LEF, 7.25"x 10.5"(Executive) SEF/LEF, 11"x15" SEF, 12"x18" SEF, 10"x14" SEF, 8K SEF, 16K SEF/LEF, 5.5"x 8.5" (Half Letter SEF), Com10 SEF/LEF, Monarch SEF/LEF, C5 SEF/LEF, C6 SEF/LEF, DL Env SEF/LEF <Custom Size Paper> Width: 90 mm (3.55 inch) - 304.8 mm (12.00 inch), Length: 148 mm (5.83 inch) – 600 mm (23.62 inch) Note <ul style="list-style-type: none"> Image quality is not assured for the length over 432 mm.
	Tandem LCT:	A4 LEF, LT LEF
	Side LCT:	A4 LEF, LT LEF, B5 LEF
Paper Feeding Capacity	Std:	1,200 sheets (550 sheets + 550 sheets + 100 Sheets/ Bypass)

Item		Spec.
(LT/A4: 80gsm paper):	Option:	Paper Feed Unit: 550 sheets x 2 trays Paper Feed Unit: 550 sheets x 1 tray Tandem LCT: 1,000 sheets x 2 Side LCT: 1500 sheets
	Max:	4,700 sheets (550 x 2 + 1000 x 2 + 1500 + 100)
Paper Output Capacity (LT/A4: 80gsm paper):	Std:	Face Down: 500 sheets (A4/LT or smaller) / 250 sheets (B4/LG or larger) *When Bridge Unit or Side Tray is attached: 250 sheets (A4/LT or smaller), 125 sheets (B4/LG or larger)

Appendices:
Specifications

General Specifications

Item		Spec.
Paper Output Capacity (LT/A4: 80gsm paper):	Option:	<p>1 Bin Tray: 125 sheets or Shift Sort Tray: 250 sheets (A4/LT or smaller), 125 sheets(B4/LG or larger)</p> <p><D197/D198/D199> Side Tray: 125 sheets or 1000 sheets Finisher: 1,000 + 250 sheets(A4/LT or smaller), 500 + 50 sheets(B4/LG or larger) or Internal Finisher: 500 sheets, 250 sheets(B4/LG or larger) or Stapleless stapler: 250 sheets(A4/LT or smaller), 125 sheets(B4/LG or larger)</p> <p><D200/D201/D202> Side Tray: 125 sheets or 1000 sheets Finisher: 1,000 + 250 sheets(A4/LT or smaller), 500 + 50 sheets(B4/LG or larger) or 2000 sheets Booklet Finisher: 2,000 + 250 sheets(A4/LT or smaller), 1,500 + 50 sheets(B4/LG or larger) or 3000 sheets Finisher: 3,000 + 250 sheets(A4/LT or smaller), 1,000 + 50 sheets (B4/LG or larger) or Booklet Finisher: 2,000 + 250 sheets, 1000 + 50 sheets(B4/LG or larger) or Internal Finisher: 500 sheets</p>

Item		Spec.
Paper Output Capacity (LT/A4: 80gsm paper):	Max:	3,625 sheets (with 3,000 sheets Finisher (3,250 sheets) + bridge unit (250 sheets) + 1 bin tray (125 sheets))
Paper Type Capacity:	Std Tray:	[Paper Type] Plain Paper (Not Displayed as Paper Type), Recycle Paper, Color Paper, Special Paper, Letterhead, Preprinted Paper, Prepunched Paper, Bond Paper, Cardstock, Plain Paper Backside, Envelope [Thickness] Thin Paper, Plain Paper 1, Plain Paper 2, Middle Thick, Thick Paper 1, Thick Paper 2, Thick Paper 3, Thick Paper 4
	Bypass Tray:	[Paper Type] Plain Paper (Not Displayed as Paper Type), Recycle Paper, Color Paper, Special Paper, Letterhead, Preprinted Paper, Pre-punched Paper, Bond Paper, Cardstock, OHP, Label, Plain Paper Backside, Envelope [Thickness] Thin Paper, Plain Paper 1, Plain Paper 2, Middle Thick, Thick Paper 1, Thick Paper 2, Thick Paper 3, Thick Paper 4
	Option:	[Paper Type] Plain Paper (Not Displayed as Paper Type), Recycle Paper, Color Paper, Special Paper, Letterhead, Preprinted Paper, Pre-punched Paper, Bond Paper, Cardstock, Plain Paper Backside [Thickness] Thin Paper, Plain Paper 1, Plain Paper 2, Middle Thick, Thick Paper 1, Thick Paper 2, Thick Paper 3, Thick Paper 4

General Specifications

Item		Spec.
Paper Weight:	Std Tray:	60 – 300 g/m ² (16 – 80 lb. Bond)
	Bypass:	52 – 300 g/m ² (14 – 80 lb. Bond)
	Duplex Unit:	52 – 256 g/m ² (14 – 68.3 lb. Bond)
	2 tray Paper Feed Unit:	60 – 300 g/m ² (16 – 80 lb. Bond)
	1 tray Paper Feed Unit:	52 – 300 g/m ² (14 – 80 lb. Bond)
	Tandem LCT:	52 – 300 g/m ² (14 – 80 lb. Bond)
	Side LCT:	52 – 300 g/m ² (14 – 80 lb. Bond)
Reliability:	Max Monthly CV (5 years):	D197: 15K, D198: 20K, D199: 30K, D200/D201/D202: 50K
	PM Cycle:	D197/D198/D199: 120K D200/D201/D202: 160K
	MCBC (Mean Copy Between Calls):	D197: 43.1K, D198: 47.8K, D199: 56.0K, D200: 74.8K, D201: 87.6K, D202: 94.5K

Copier Specifications

Item		Spec.
CPM Black:		D197: 25, D198: 30, D199: 35, D200: 40, D201: 50, D202: 60
CPM Color:		-
Copy Resolution:		600 dpi/bit
Multiple Copying:		Up to 999 copies
Reproduction Ratio:	NA:	400%, 200%, 155%, 129%, 121%, 100%, 93%, 85%, 78%, 73%, 65%, 50%, 25%
	EU/Asia:	400%, 200%, 141%, 122%, 115%, 100%, 93%, 82%, 75%, 71%, 65%, 50%, 25%
Zoom:		From 25% to 400% in 1% step
Number of Copy Reservations:		8 jobs
Image Density:		Auto Density Selection Manual: 9 levels
Copy Mode:		Default = Text / Auto Text&Photo Separation (Printed/Glossy/Copied), Photo (Printed/Glossy/Copied), Text, Pale, Generation
Paper Selection:		Default = Auto Paper Selection (APS) Auto Paper Selection (APS) 1st Tray 2nd Tray 3rd Tray (with Paper Bank) 4th Tray (with Paper Bank) 5th Tray LCT Bypass Tray

General Specifications

Item		Spec.
Auto Tray Switch:		Yes
Duplex:		1 sided to 2 sided, 2sided to 2 sided(w/ARDF), Book to 2 sided, Front and Back to 2 sided
Book:	Booklet:	Yes (HDD option is required.)
	Magazine:	
	Layout & Booklet:	
Series:	Book to simplex:	Yes
	2 sided original to simplex:	
Combine (Layout):		The following combinations are supported: 2 into 1 simplex, 4 into 1 simplex, 8 into 1 simplex, 1 duplex into 1 simplex, 2 duplex into 1 simplex, 4 duplex into 1 simplex, 4 into 1 duplex, 8 into 1 duplex, 16 into 1 duplex, 2 duplex into 1 duplex, 4 duplex into 1 duplex, 8 duplex into 1 duplex
Shift/Erase/ Margin Adjustment:	Centering:	Yes
	Cornering:	No
	Margin Adjustment:	1mm step (0-30mm) Default=Front Page:5mm left, Back Page:5mm right
	Scan Position Adjustment:	No
	Creep Adjustment:	No
	Erase Center:	1mm step (2-99mm), Default=10mm

Item		Spec.
	Erase Border:	1mm step (2-99mm) Default = 10mm
Cover Sheet Chapter Slip Sheets:	Front Cover:	Copy or Blank (Default=Copy)
	Front and Back Cover:	
	Chapter:	Yes (Up to 20 chapters)
	Slip Sheets:	Yes
Image Rotation:		Yes (A4, LT, B5)
Electronic Sort:	Without Shift Sort:	With finisher: No Without finisher: Yes
	Rotate Sort:	With finisher: Yes Without finisher: Yes * Not from By-pass
	Shift Sort:	With finisher: Yes Without finisher: No
Electronic Stack:		Yes (with Finisher)
Stapling:		Yes (with Finisher)
Image Creation:	Repeat:	Yes
	Double Copy:	Yes
	Mirror:	No
	Positive/Negative:	Yes
	Erase Inside:	No
	Erase Outside:	No
Stamp/ Numbering:	Preset Stamp:	Yes (8 Stamps / 2 sizes) * Not from By-pass * HDD option is required.
	User Stamp:	Yes (4 Stamps / 1 sizes) * Not from By-pass * HDD option is required.

General Specifications

Item		Spec.
	Date Stamp:	Yes (5 Stamps) * Not from By-pass
	Page Number:	Yes (6 Stamps) * Not from By-pass
	Bates Numbering:	Yes * Not from By-pass
	Printing copy prevention pattern:	Yes * Not from By-pass
Sharp/Soft:		7 levels
Contrast:		9 levels
Background Density Adjustment:		9 levels
Job Programs:		Mode: 25 Program Default: 1 Program
User Code:		8 digits / 1000 user codes
Interrupt Copy:		Yes
Auto Start:		Yes
Job Preset:		Yes(8 jobs) * HDD option is required.
Sample Copy:		Yes

*1 A4 LEF, 1st paper feed tray, with book scanner.

1.1.2 PRINTER SPECIFICATIONS

Item	Spec.
Printer Language:	Standard: PCL 5e/6, PDF Option: PostScript 3, IPDS, XPS
Print Resolution:	Max: 1200 x 1200 dpi (1bit) PCL5c: 300 x 300 dpi (1bit), 600 x 600 dpi (1bit, default) PCL6: 600 x 600 dpi (1bit, default), 1200 x 1200 dpi (1bit) PS3: 600 x 600 dpi (1bit, default), 1200 x 1200 dpi (1bit), 300 x 300 dpi XPS/IPDS: 300 x 300 dpi (1bit), 600 x 600 dpi (1bit, default)
Font:	Standard: PCL: Scalable 45 fonts + international 13 fonts PS3: 136 Roman fonts Option: IPDS: 108 Roman fonts
Host Interfaces:	Standard: Ethernet (1000BASE-T/ 100BASE-TX/ 10BASE-T), USB 2.0 Type A (2 port on back of the machine, 1 port on operational panel), Type B, SD Slot on operational panel Option: IEEE1284/ECP, Wireless LAN (IEEE802.11a/b/g/n), Bluetooth, Additional NIC(2nd port)
Network Protocol:	TCP/IP (IPv4, IPv6), IPX/SPX
MIB:	Standard: MIB-II(RFC1213), Host Resource (RFC1514), Printer MIB (RFC1759), Printer Port Monitor MIB Private: Ricoh Original

General Specifications

Item	Spec.
Network/Operating System:	Windows XP/Vista/7/8/Server 2003/Server 2008/Server2008R2/Server 2012 Netware: 6.5* Unix: Sun Solaris, HP-UX, SCO OpenServer, Red Hat Linux, IBM AIX Mac OS X v.10.26 or later SAP R/3, NDPS Gateway, IBM iSeries, AS/400-using OS/400 Host Print Transform *Netware Option required

1.1.3 SCAN SPECIFICATIONS

Item		Spec.
Color Scan:		Std (SP model or "Printer/ Scanner upgraded" MFP)
Scanning Speed (ARDF):	BW:	80 pages/minute (A4 LEF, 200dpi/300dpi) Push Scan 79 pages/minute (LT LEF, 200dpi/300dpi) Push Scan
	Color:	80pages/minute (A4 LEF, 200dpi/300dpi) Push Scan 79 pages/minute (LT LEF, 200dpi/300dpi) Push Scan
Scanning Speed (SPDF):	BW:	Simplex: 110 pages/minute (A4 LEF/LT LEF, 200 dpi/300 dpi) Push Scan Duplex: 180 pages/minute (A4 LEF/LT LEF, 200 dpi/300 dpi) Push Scan
	Color:	Simplex: 110 pages/minute (A4 LEF/ LT LEF, 200 dpi/ 300 dpi) Push Scan Duplex: 180 pages/minute (A4 LEF/ LT LEF, 200 dpi/ 300 dpi) Push Scan
Scanning Resolution:		100 / 200 (default) / 300 / 400 / 600 dpi
Auto Size Detection (NA):	Exposure Glass:	11"x17"(DLT) SEF, 8 ½"x14"(LG) SEF, 8 ½"x11"(LT) LEF/SEF, 8 1/2"x5 1/2"(HLT) LEF *SP mode adjustment is required : 8 1/2"x5 1/2"(HLT)SEF
	ARDF:	11"x17" (DLT)SEF, 8 ½"x14" (LG)SEF, 8 ½"x11"(LT) LEF/SEF, 5 ½"x8 ½"(HLT) LEF/SEF, 8 1/2"x13"(Foolscap) SEF 10"x14"SEF, 11"x15"SEF (detected the same as DLT SEF, Default = DLT SEF), 8"x10"SEF (detected the same as LT SEF, Default = LT SEF), 7 1/4"x10½" LEF/SEF(detected the same as LEF/SEF, Default=SEF)

General Specifications

Item		Spec.
Auto Size Detection (EU/AS/CHN):	Exposure Glass:	A3 SEF, B4 SEF, A4 LEF/SEF, B5 LEF/SEF, A5 LEF, 8 1/2"x13"(Foolscap) SEF *SP mode adjustment is required: A5 SEF, 8"x13"(F) SEF, 8 1/4"x13"(Folio) SEF, 8K SEF, 16K LEF/SEF
	ARDF:	A3 SEF, B4 SEF, A4 LEF/SEF, B5 LEF/SEF, A5 LEF/SEF, B6 LEF/SEF, DLT SEF, LT SEF/LEF, 8 1/2"x13"(Foolscap) SEF *SP mode adjustment is required: 8"x13"(F) SEF, 8 1/4"x13"(Folio) SEF 8K SEF (detected the same as DLT SEF, Default = DLT SEF), 16K SEF (detected the same as LT SEF, Default = LT SEF), 16K LEF (detected the same as LT LEF, Default = LT LEF)
Scan Area	Main:	297 mm (11.6 inches)
	Sub:	432 mm (17.0 inches)
sRGB Supported:		No
Network Interface:		LAN: Local Area Network Ethernet/ 10base-T, 100base-TX, 1000Base-T Wireless LAN (IEEE 802.11a/b/g/n) *Option
Protocol:		Network: TCP/IP Sending E-mail: SMTP, POP, IMAP4 Scan to Folder: SMB, FTP, NCP* Web Services on Devices for Scanning *Option
Compression Method:		BW: 1 bit (MH, MR, MMR, JBIG2*), Grayscale (JPEG) *PDF format only Color: JPEG
Scan Mode:		BW: BW Text/Line Art, BW Text, BW Text/Photo, BW Photo, BW Grayscale Color: FC Text/Photo, FC Glossy Photo, ACS(Auto Color Selection)

Item		Spec.
Image Density:		Auto Density Selection(Effective in BW/Grayscale and FC scan mode) Manual: 7 levels (Effective in BW/Grayscale and FC scan mode)
Image Rotation:		Yes
SADF/Batch Mode:		Yes
Mixed Size Mode:		Yes
Reduce and Enlarge:		Yes
Split scan from Booklet type Original:		Yes
Digital Signature for PDF:		Yes
Single Page TIFF:	On	BW 1bit / (MH, MR or MMR)
	Off	BW 1bit, BW Grayscale or Full Color
Multi Page TIFF:	On	BW 1bit /(MH, MR or MMR)
	Off	BW 1bit, BW Grayscale or Full Color
Single Page JPEG:	On	BW Grayscale or Full Color / (JPEG)
	Off	-
Single Page PDF:	On	BW 1bit / (MH, MR, MMR or JBIG2), BW Grayscale / (JPEG), Full Color / (JPEG)
	Off	BW 1bit, BW Grayscale or Full Color
Multi PagePDF:	On	BW 1bit / (MH, MR, MMR or JBIG2), BW Grayscale / (JPEG), Full Color / (JPEG)
	Off	BW 1bit, BW Grayscale or Full Color
Single Page High Compression PDF:	On	BW Grayscale / (JPEG or JPEG2000), Full Color / (JPEG or JPEG2000)
	Off	-

General Specifications

Item		Spec.
Multi Page High Compression PDF:	On	BW Grayscale / (JPEG or JPEG2000), Full Color / (JPEG or JPEG2000)
	Off	-
Single Page PDF-A:	On	BW 1bit / (MH, MR, MMR or JBIG2), BW Grayscale / (JPEG), Full Color / (JPEG)
	Off	BW 1bit, BW Grayscale or Full Color
Multi Page PDF-A:	On	BW 1bit / (MH, MR, MMR or JBIG2), BW Grayscale / (JPEG), Full Color / (JPEG)
	Off	BW 1bit, BW Grayscale or Full Color

Scan to Email

Item	Spec.
Requirement (Mail Protocol, Transmission Protocol, Protocol):	SMTP (Mail Server) Gateway, POP, IMAP4
Authorization Function:	SMTP authentication, POP before SMTP authentication
Resolution:	100, 200 (Default), 300, 400, 600
Max Email Address in HDD:	2,000
Register Group Address in HDD:	Max. 100 Group (Max. 500 addresses in one group address)
Input of Destination E-mail Address via Soft Key:	Possible, Max. 100 destinations per job
Search methods of Email Address in HDD:	Direct input on operation panel, Web Image Monitor, Smart Device Monitor for Admin
LDAP Search:	Yes
Max Address Numbers Per Send:	Max. 500 addresses per send
Address Numbers Per Send:	From HDD: Max 500 Direct Print: Max 100* Via LDAP: Max 100*
Simultaneous Transmission:	Max. 550
Attention:	To, cc, bcc
Email Size:	With Restriction: 128 – 102,400 KB Without Restriction: 2,000 MB

General Specifications

Item	Spec.
Input Subject:	<p>Manual: Max. 128 Characters via soft key (1 byte: up to 128 characters, 2 byte: up to 64 characters)</p> <p>User Pre-register: 22 subjects. Max. 20 Characters per a subject (1 byte: up to 20 characters, 2 byte: up to 10 characters)</p>
Input Main body text:	<p>Manual: Max. 80 Characters via soft key (1 byte: up to 80 characters, 2 byte: up to 40 characters)</p> <p>User Pre-register: Max. 400 Characters via soft key (80 characters x 5 lines) (1 byte: up to 400 characters, 2 byte: up to 200 characters)</p> <p>Preset: Yes</p>
Input File Name:	Yes
File Type:	<p>Single Page: TIFF/ JPEG/ PDF/ PDF-A/ High Compression PDF, encryption PDF, OCR*</p> <p>Multi Page: TIFF/ PDF/ PDF-A/ High Compression PDF, encryption PDF, OCR*</p> <p>*Option required</p>
Program User Settings:	Up to 25 programs
Divide and send Email (If the file size exceed the max size.):	<p>Yes (By page or size) / No, Default = Yes(By size)*</p> <p>*If the sent file size exceeded the maximum E-mail size, it would be divided to multiple sending. In addition, the sent files might not be accepted by the receiving side due to the limitation in the receiving capacity at the receiver SMTP server or E-mail software setting.</p>
Resend:	Yes / No, Default = Yes

Scan to Folder

Item	Spec.
Protocol Support:	SMB, FTP, NCP* *Option
Security:	Client folder log-in (log-in name and password), Encryption of log-in name and password during transmission
Resolution:	100 dpi, 200 dpi (default), 300 dpi, 400 dpi, 600 dpi
Register client folder address in HDD:	Max. 2,000 folders
Maintain client folder address in HDD:	Direct input on operation panel, Web Image Monitor, Smart Device Monitor
Direct addressing of destination client folder via soft key:	Yes SMB: Network path -> Client folder -> Password FTP: Server -> Network path -> User account -> Password NCP: Network path -> User account -> Password -> Bindery or NDS
Search client folder:	SMB: Browsing directly to the designated folders FTP: By client folder name NCP: Browsing (*Optional)
Homefolder over LDAP:	Yes
Max. client folder numbers per send:	Max. 50 client folders / PCs per send
Simultaneous Transmission:	Max. 550
Group address:	Max. 500 destinations (Folder destination must be less than 50) e.g. 500 destinations (50 folders included) >OK 500 destinations (51 folders included) >Failure
Input File Name:	Yes

General Specifications

Item	Spec.
Input Subject:	Max. 128 Characters via soft key (1 byte: up to 128 characters, 2 byte: up to 64 characters)
Scan to File size	2,000
File Size when combined Scan to Folder & Scan to E-mail:	128 - 102, 400 KB, Default = 2,048 KB (With restriction) 725MB (Without restriction), (Scan to E-mail file size applied).
File Type:	Single Page TIFF/JPEG/PDF/PDF-A/High Compression PDF, encryption PDF, OCR* Multi Page TIFF/PDF/PDF-A/High Compression PDF, encryption PDF, OCR* *Option required
Program User Settings:	Up to 25 programs
Resend:	Yes (Default) / No

Network TWAIN Driver

Item		Spec.
OS:		32bit/64bit: Windows XP, Vista, 7, 8, Server 2003/ 2008 64bit: Windows Server 2008R2, Server 2012 (Operates in 32-bit compatibility mode on 64-bit operating systems)
Scanning Speed:	BW	ARDF: 72 (A4 200dpi) / 71 (LT 200dpi) SPDF: 104 (A4 200dpi) / 103 (LT 200dpi)
	Color	ARDF: 72 (A4 200dpi) / 71 (LT 200dpi) SPDF: 104 (A4 200dpi) / 103 (LT 200dpi)
Resolution:	BW:	100 – 1200 dpi (Black and White / Grayscale)
	Color:	100 – 1200 dpi (Full Color)
Scan Mode:		Standard / Photo / OCR / Filing
Image Adjustment:		Brightness / Contrast / Threshold /Gamma Adjustment / Halftone Pattern
Endorser:		Supported. Date / Page Number / Text
Stamp:		Supported

1.2 SUPPORTED PAPER SIZES

1.2.1 ORIGINAL SIZE DETECTION

Remarks:

Y	Yes; available
-	Not available

Size (W x L) [mm]	NA		EU/Asia	
	Book	ADF	Book	ADF
A3 SEF (297 x 420)	-	Y	Y ^{*4}	Y
B4 SEF (257 x 364)	-	-	Y ^{*4}	Y
A4 SEF (210 x 297)	Y ^{*5}	Y	Y ^{*4, 5}	Y
A4 LEF (297 x 210)	Y ^{*5}	Y	Y ^{*4, 5}	Y
B5 SEF (182 x 257)	-	-	Y ^{*4}	Y
B5 LEF (257 x 182)	-	-	Y ^{*4}	Y
A5 SEF (148 x 210)	-	-	Y ^{*2, 4}	Y
A5 LEF (210 x 148)	-	-	Y ^{*4}	Y
B6 SEF (128 x 182)	-	-	-	Y
B6 LEF (182 x 128)	-	-	-	Y
DLT SEF (11" x 17")	Y	Y ^{*Db}	-	Y ^{*Df}
LG SEF (8 ¹ / ₂ " x 14")	Y	Y ^{*Dc}	-	-
LT SEF (8 ¹ / ₂ " x 11")	Y ^{*5}	Y ^{*Dd}	Y ^{*5}	Y ^{*Dg}
LT LEF (11" x 8 ¹ / ₂ ")	Y ^{*5}	Y ^{*De}	Y ^{*5}	Y ^{*Dh}
HLT SEF (5 ¹ / ₂ " x 8 ¹ / ₂ ")	Y ^{*2}	Y	-	-
HLT LEF (8 ¹ / ₂ " x 5 ¹ / ₂ ")	Y	Y	-	-
F SEF (8" x 13")	-	-	Y ^{*S3}	Y ^{*S3}

Size (W x L) [mm]	NA		EU/Asia	
	Book	ADF	Book	ADF
Foolscap SEF (8 ¹ / ₂ " x 13")	-	Y ^{*Sc}	Y ^{*D3}	Y ^{*D3}
Folio SEF (8 ¹ / ₄ " x 13")	-	-	Y ^{*S3}	Y ^{*S3}
Folio SEF (11" x 15")	-	Y ^{*Sb}	-	-
Folio SEF (10" x 14")	-	Y	-	-
Folio SEF (8" x 10")	-	Y ^{*Sd}	-	-
US EXE SEF (7 ¹ / ₄ " x 10 ¹ / ₂ ")	-	Y	-	-
US EXE LEF (10 ¹ / ₂ " x 7 ¹ / ₄ ")	-	Y ^{*Se}	-	-
8K SEF (267 x 390)	-	-	Y ^{*4}	Y ^{*Sf}
16K SEF (195 x 267)	-	-	Y ^{*4}	Y ^{*Sg}
16K LEF (267 x 195)	-	-	Y ^{*4v}	Y ^{*Sh}

Sizes with letters (a, b, c) means only either size with the corresponding letter can be selected for size detection. "D" is for default set sizes, and when setting "S" sizes for size detection from SP mode, "D" sizes can no longer be detected.

(*2)For detected originals smaller than A5 size, with SP mode either "detect as A5" or "Detect as Unknown" can be selected. (Default is "Detect as unknown")

(*3)F Sizes (8.5" x 13" SEF, 8.25" x 13" SEF, 8" x 13" SEF) will be available by SP mode settings.

(*4)Switch Book scanner original detection between "K" series and "A/B" series from SP mode.

(Can not set both to detect, but 8K/16K detect can be set from SO mode)

8K SEF -> Switch between A3, B4 SEF

16K SEF -> Switch between A4, A5, B5 SEF

16K LEF -> Switch between A4, A5, B5 LEF *Can not switch only either size.

(*5)Can be selected with switching A4/LT from SP mode:

- Standard detect (default)
- When placing A4/LT size LEF, detect as A4 LEF. When placing SEF, detect as LT SEF.
- When placing A4/LT size LEF, detect as LT LEF. When placing SEF, detect as A4 SEF.

1.2.2 PAPER FEED

Remarks:

A	Auto detectable. Also can be selected with size button of initial setting.
B	Can be selected with size button from initial setting.
C	Select this size by setting the dial.
D	Set dial to “*”, then select with size button from initial setting.
E	Bypass setting Copy window/Bypass/Standard size/Size select or select with the print bypass paper size/size button from initial setting.
F	Select with SP from preset paper sizes. Can not be selected from printer driver.
G	Switches which size to set as auto detect with SP. *Example: The combination of A1-G1. G (When not auto detectable) will be as same as B. Combinations are only made from same region same tray. *Example: The combination of G1 and J1. G (When not auto detectable) will be as same as E. Combinations are only made from same region same tray.
H	Size fixed when shipping.
I	Bypass setting With bypass tray, after 1 st sheet trailing edge goes through, auto detects size, then fixed to size detected from the 2 nd sheet.
J	Bypass setting Auto detect of Copy window/Bypass/Standard size/Select with size button.
K	Select with SP from preset paper sizes. Can be selected from printer driver.
-	Not available
*1	Even the paper size is in the range or available sizes for duplex, envelopes can not be done so.

Tray 1 through 3

Size (W x L) [mm]	Tray 1		Tray 2		Tray 3/4 1 drawer /2 drawers bank	
Region (EU/AA)	NA	EU/AA	NA	EU/AA	NA	EU/AA
A3 SEF	G2	A2	G2	A2	G2	A2
A4 SEF	A	A	A	A	A	A
A4 LEF	G1	A1	G1	A1	G1	A1
A5 SEF	B	B	B	B	B	B
A5 LEF	A	A	A	A	A	A
A6 SEF	B	B	B	B	B	B
B4 SEF	G3	A3	G3	A3	G3	A3
B5 SEF	A	A	A	A	A	A
B5 LEF	G4	A4	G4	A4	G4	A4
B6 SEF	B	B	B	B	B	B
DLT SEF	A2	G2	A2	G2	A2	G2
Legal SEF	A3	G3	A3	G3	A3	G3
Foolscap SEF	B	B	B	B	B	B
Letter SEF	A	A	A	A	A	A
Letter LEF	A1	G1	A1	G1	A1	G1
GovernmentLG SEF	B	B	B	B	B	B
Folio SEF	B	B	B	B	B	B
F/GL SEF	B	B	B	B	B	B
Eng Quatro SEF	B	B	B	B	B	B
Executive SEF	B	B	B	B	B	B
Executive LEF	A4	G4	A4	G4	A4	G4

Supported Paper Sizes

Size (W x L) [mm]	Tray 1		Tray 2		Tray 3/4 1 drawer /2 drawers bank		
	Region (EU/AA)	NA	EU/AA	NA	EU/AA	NA	EU/AA
Half Letter SEF	B	B	B	B	B	B	B
Com10 SEF	B	B	B	B	B	B	B
Com10 LEF	B	B	B	B	B	B	B
Monarch SEF	B	B	B	B	B	B	B
Monarch LEF	-	-	-	-	-	-	-
C5 SEF	B	B	B	B	B	B	B
C5 LEF	B	B	B	B	B	B	B
C6 SEF	B	B	B	B	B	B	B
C6 LEF	B	B	B	B	B	B	B
DL Env SEF	B	B	B	B	B	B	B
DL Env LEF	B	B	B	B	B	B	B
8K SEF	B	B	B	B	B	B	B
16K SEF	B	B	B	B	B	B	B
16K LEF	B	B	B	B	B	B	B
12x18 SEF	-	-	-	-	-	-	-
11x15 SEF	B	B	B	B	B	B	B
10x14 SEF	B	B	B	B	B	B	B

Bypass Trays

Size (W x L) [mm]	Bypass		One Action Bypass	
Region (EU/AA)	NA	EU/AA	NA	EU/AA
A3 SEF	E	J	E	J
A4 SEF	E	J	J	J
A4 LEF	E	J	J	J
A5 SEF	E	J	J	J
A5 LEF	E	J	J	J
A6 SEF	E	J	E	E
B4 SEF	E	J	J	J
B5 SEF	E	J	J	J
B5 LEF	E	J	J	J
B6 SEF	J	E	J	J
DLT SEF	G1	E	G1	E
Legal SEF	E	E	E	E
Foolscap SEF	J1	E	J1	E
Letter SEF	J	E	J	J
Letter LEF	E	E	E	E
Gov. LG SEF	E	E	E	E
Folio SEF	E	E	J	J
F/GL SEF	E	E	E	E
Eng Quatro SEF	E	E	E	E
Executive SEF	E	E	J	J
Executive LEF	J	E	J	J
Half Letter SEF	E ^{*1}	E ^{*1}	E ^{*1}	E ^{*1}

Supported Paper Sizes

Size (W x L) [mm]	Bypass		One Action Bypass	
Region (EU/AA)	NA	EU/AA	NA	EU/AA
Com10 SEF	E ^{*1}	E ^{*1}	J ^{*1}	J ^{*1}
Com10 LEF	E ^{*1}	E ^{*1}	E ^{*1}	E ^{*1}
Monarch SEF	E ^{*1}	E ^{*1}	J ^{*1}	J ^{*1}
Monarch LEF	E ^{*1}	E ^{*1}	E ^{*1}	E ^{*1}
C5 SEF	E ^{*1}	E ^{*1}	J3 ^{*1}	J3 ^{*1}
C5 LEF	E ^{*1}	E ^{*1}	E ^{*1}	E ^{*1}
C6 SEF	E ^{*1}	E ^{*1}	J ^{*1}	J ^{*1}
C6 LEF	E ^{*1}	E ^{*1}	E ^{*1}	E ^{*1}
DL Env SEF	E ^{*1}	E ^{*1}	J ^{*1}	J ^{*1}
DL Env LEF	E	E	J	J
8K SEF	E	E	E	E
16K SEF	E	E	E	E
16K LEF	J	E	J	J
12x18 SEF	E	E	E	E
11x15 SEF	E	E	J	J
10x14 SEF	E	J	E	J

1.2.3 PAPER EXIT

Main Unit Tray, 1 Bin Tray, Shift Tray, Side Tray

Size (W x L) [mm]	Main Unit Tray	1 Bin Tray	Shift Tray		Side Tray	
	Main unit tray	Upper tray	shift	shifting	Bridge upper exit	Side tray
A3 SEF	A	A	A	A	A	A
A4 SEF	A	A	A	A	A	A
A4 LEF	A	A	A	A	A	A
A5 SEF	A	A	A	A	A	A
A5 LEF	A	A	A	A	A	A
A6 SEF	A	B* ¹	A	A	A	A
B4 SEF	A	A	A	A	A	A
B5 SEF	A	A	A	A	A	A
B5 LEF	A	A	A	A	A	A
B6 SEF	A	B* ¹	A	A	A	A
DLT SEF	A	A	A	A	A	A
Legal SEF	A	A	A	A	A	A
Foolscap SEF	A	A	A	A	A	A
Letter SEF	A	A	A	A	A	A
Letter LEF	A	A	A	A	A	A
Gov. LG SEF	A	A	A	A	A	A
Folio SEF	A	A	A	A	A	A
F/GL SEF	A	A	A	A	A	A
Eng Quatro SEF	A	A	A	A	A	A

Supported Paper Sizes

Size (W x L) [mm]	Main Unit Tray	1 Bin Tray	Shift Tray		Side Tray	
	Main unit tray	Upper tray	shift	shifting	Bridge upper exit	Side tray
Executive SEF	A	A	A	A	A	A
Executive LEF	A	A	A	A	A	A
Half Letter SEF	A	A	A	A	A	A
Com10 SEF	A	B* ¹	A	A	A	A
Com10 LEF	A	B* ¹	A	A	A* ^{1,2,3}	-
Monarch SEF	A	B* ¹	A	A	A	A
Monarch LEF	A	B* ¹	A	A	A* ^{1,2,3}	-
C5 SEF	A	B* ¹	A	A	A	A
C5 LEF	A	B* ¹	A	A	A	A
C6 SEF	A	B* ¹	A	A	A	A
C6 LEF	A	B* ¹	A	A	A* ^{1,2,3}	-
DL Env SEF	A	B* ¹	A	A	A	A
DL Env LEF	A	B* ¹	A	A	A* ^{1,2,3}	-
8K SEF	A	A	A	A	A	A
16K SEF	A	A	A	A	A	A
16K LEF	A	A	A	A	A	A
12x18 SEF	A	B* ¹	A	A	A	A
11x15 SEF	A	A	A	A	A	A
10x14 SEF	A	A	A	A	A	A

Remarks:

A	Paper through, paper exit available.
B	Will not guarantee, but paper can go through or exit.
-	Not available.

*1	Out of the true up precision guarantee.
*2	Envelopes can only go through each at a time.
*3	Except envelops with triangle flap.

Appendices:
Specifications

1.3 SOFTWARE ACCESSORIES

The printer drivers and utility software are provided on one CD-ROM. An auto-run installer allows you to select which components to install.

Y = Supported; N = Not Supported

1.3.1 PRINTER DRIVERS

Windows Environment

OS	Type	PCL5e	PCL6	PostScript3	XPS
Windows 2000	Professional	N	N	N	N
	Server	N	N	N	N
	Advanced Server	N	N	N	N
	Datacenter Server	N	N	N	N
Windows XP	Professional	Y	Y*2	Y*2	N
	Home Edition	Y	Y*2	Y*2	N
Windows Vista	Starter	N	N	N	N
	Home Basic	Y	Y*1	Y*1	Y*1
	Home Premium	Y	Y*1	Y*1	Y*1
	Business	Y	Y*1	Y*1	Y*1
	Ultimate	Y	Y*1	Y*1	Y*1
	Enterprise	Y	Y*1	Y*1	Y*1
Windows 7	Starter	N	N	N	N
	Home Basic	N	N	N	N
	Home Premium	Y	Y	Y	Y
	Professional	Y	Y	Y	Y
	Ultimate	Y	Y	Y	Y
	Enterprise	Y	Y	Y	Y

OS	Type	PCL5e	PCL6	PostScript3	XPS
Windows 8	Windows 8	Y	Y	Y	Y
	Pro	Y	Y	Y	Y
	Enterprise	Y	Y	Y	Y
	RT	N	N	N	N
Windows Server 2003	Standard Edition	Y*3	Y	Y	N
	Enterprise Edition	Y*3	Y	Y	N
	Datacenter Edition	N	N	N	N
	Web Edition	N	N	N	N
Windows Server 2003 R2	Standard Edition	Y*3	Y	Y	N
	Enterprise Edition	Y*3	Y	Y	N
	Datacenter Edition	N	N	N	N
Windows Server 2008	Standard Edition	Y	Y	Y	Y
	Enterprise Edition	Y	Y	Y	Y
	Datacenter Edition	N	N	N	N
	Web Edition	N	N	N	N
Windows Server 2008R2	Standard Edition	Y	Y	Y	Y
	Enterprise Edition	Y	Y	Y	Y
	Datacenter Edition	N	N	N	N
	Web Edition	N	N	N	N
Windows Server 2012	Foundation	Y	Y	Y	Y
	Essentials	Y	Y	Y	Y
	Standard	Y	Y	Y	Y
	Datacenter	N	N	N	N

*RPCS driver has been discontinued.

*1:SP1 or later is recommended

*2:SP3 or later (Windows XP Professional x64 Edition recommended to *3)

*3:SP2 or later is recommended

Point and Print

Windows OS		Drivers			
Server	Client(Push to)	PCL5e	PCL6	PostScript3	XPS
Windows Server 2003 /2003 R2	7	Y	Y	Y	N
	8	Y	Y	Y	N
	Vista	Y	Y	Y	N
	XP	Y	Y	Y	N
	W2K Pro	N	N	N	N
Windows Server 2008	7	Y	Y	Y	Y
	8	Y	Y	Y	Y
	Vista	Y	Y	Y	Y
	XP	Y	Y	Y	N
	W2K Pro	N	N	N	N
Windows Server 2008R2	7	Y	Y	Y	Y
	8	Y	Y	Y	Y
	Vista	Y	Y	Y	Y
	XP	Y	Y	Y	N
	W2K Pro	N	N	N	N
Windows 2000 Professional Server & Advanced Server	7	N	N	N	N
	8	N	N	N	N
	Vista	N	N	N	N
	XP	N	N	N	N
	W2K Pro	N	N	N	N
Windows XP	7	Y	Y	Y	N

Windows OS		Drivers			
Server	Client(Push to)	PCL5e	PCL6	PostScript3	XPS
Professional	8	Y	Y	Y	N
	Vista	Y	Y	Y	N
	XP	Y	Y	Y	N
	W2K Pro	N	N	N	N
Windows Vista	7	Y	Y	Y	Y
	8	Y	Y	Y	Y
	Vista	Y	Y	Y	Y
	XP	Y	Y	Y	N
	W2K Pro	N	N	N	N
Windows 7	7	Y	Y	Y	Y
	8	Y	Y	Y	Y
	Vista	Y	Y	Y	Y
	XP	Y	Y	Y	N
	W2K Pro	N	N	N	N
Windows 8	7	Y	Y	Y	Y
	8	Y	Y	Y	Y
	Vista	Y	Y	Y	Y
	XP	Y	Y	Y	N
	W2K Pro	N	N	N	N
Windows Server 2012	7	Y	Y	Y	Y
	8	Y	Y	Y	Y
	Vista	Y	Y	Y	Y
	XP	Y	Y	Y	N

Mac OS and UNIX Environment**Mac OS**

OS	PostScript3	Printer Utility for Mac
Mac OS 8.6 or later, Mac OS X classic	N	N
Mac OS X Native: v.10.6 or later	Y	N

Supported platforms for Unix filter

Platforms	Version
Sun Solaris	9, 10
HP-UX	11.x, 11i v2, 11i v3
Red Hat Linux	Enterprise V4, V5, V6
SCO OpenServer	5.0.7, 6.0
IBM AIX	V 5L, V5.3, V6.1, V7.1

1.3.2 SCANNER AND LAN FAX DRIVERS

Operating System	Driver	
	TWAIN* ⁹	LAN-FAX
Windows XP* ^{1*6}	Y	Y
Windows Vista* ^{2*6}	Y	Y
Windows 7* ^{3*6}	Y	Y
Windows 8* ^{6*7}	Y	Y
Windows 8.1	Y	Y
Windows Server 2003* ^{4*6}	Y	Y
Windows Server 2008* ^{5*6}	Y	Y
Windows Server 2012* ⁸	Y	Y
Macintosh	N	N

*1 Microsoft Windows XP Professional Edition / Home Edition / Media Center Edition / Tablet PC Edition

*2 Microsoft Windows Vista Ultimate / Enterprise / Business / Home Premium / Home Basic

*3 Microsoft Windows 7 Home Premium / Professional / Ultimate / Enterprise

*4 Microsoft Windows Server 2003 Standard Edition / Enterprise Edition / Microsoft Windows Server 2003 R2 Standard Edition / Enterprise Edition

*5 Microsoft Windows Server 2008 Standard / Enterprise / Microsoft Windows Server 2008 R2 Standard / Enterprise

*6 Supports both 32bit, 64bit (Scanner driver works on 32bit compatible mode)

*7 Microsoft Windows 8 (Core Edition) / Pro / Enterprise

*8 Microsoft Windows Server 2012 Standard / Datacenter / Essentials

*9 TWAIN scanner runs on a 64-bit operating system, but is not compatible with 64-bit applications. Use it with 32-bit applications.

Note

- With LAN-FAX driver, sending documents directly from PC will be available.
- Also Address Book Editor and Cover Sheet Editor will installed along.
- Network TWAIN driver will be provided on the scanner driver CD-ROM.

1.4 OPTIONAL EQUIPMENT

1.4.1 PAPER FEED UNIT PB3210/PB3220 (D787)

Item	Description
Number of Trays:	2
Paper Size:	12 x 18 / DLT SEF – A5 LEF
Paper Weight:	60 –300 g/m ² (16 – 80 lb.)
Paper Capacity (80 g/m ² , 20 lb. Bond):	1100 sheets (550 sheets x 2 trays with 80g/m ² paper)
Power Consumption:	Less than 21 W (Average)
Dimension (W x D x H):	587 x 685 x 247 mm (23.2 x 27.0 x 9.8 inches)
Weight:	20.1 kg (44.3 lb.)

1.4.2 PAPER FEED UNIT PB3150 (D694)

Item	Description
Paper Size:	12 x 18 / DLT SEF – A5 LEF
Paper Weight:	52 - 300 g/m ² (14 - 80 lb.) * Complies with specification of the mainframe
Paper Output Capacity:	550 sheets (550 sheets x 1 tray with 80 g/m ² paper)
Power Consumption:	Less than 19 W (Average)
Dimension (W x D x H):	587 x 685 x 120 mm (13.1 x 27.0 x 4.7 inches)
Weight:	10.9 kg (24 lb.)

1.4.3 LCIT PB3170/PB3230 (D695)

Item	Description
Paper Size:	A4/LT LEF
Paper Weight:	52 – 300 g/m ² (14 – 80 lb.) * Complies with specification of the mainframe
Paper Output Capacity:	2000 sheets (1000sheets x 2 trays) * Paper thickness: 0.1 mm. Auto paper detection in the left tray: Minimum 30 sheets.
Power Consumption:	Less than 15 W
Dimension (W x D x H):	587 x 685 x 247 mm (13.1 x 27.0 x 9.7 inches)
Weight:	20 kg (44.1 lb.)

1.4.4 LCIT RT3030 (D696)

Item	Description
Paper Size:	A4/LT LEF, B5 LEF
Paper Weight:	52 – 300 g/m ² (14 – 80 lb.) * Complies with specification of the mainframe
Paper Output Capacity:	1500 sheets * Paper thickness: 0.1 mm.
Power Consumption:	Less than 13 W
Dimension (W x D x H):	340 x 544 x 290 mm (13.4 x 21.4 x 11.7 inches)
Weight:	9.8 kg (21.6 lb.)

1.4.5 CASTER TABLE TYPE B (D178)

Item	Description
Dimension (W x D x H):	565 x 550 x 80 mm (22.2 x 21.7 x 3.2 inches)
Weight:	7.5 kg (16.5 lb.) or less

1.4.6 PLATEN COVER PN2000 (D700)

Item	Description
Dimension (W x D x H):	561 x 497 x 63.8 mm (22.1 x 19.6 x 2.5 inches)
Weight:	2.3 kg (5.1 lb.) or less

1.4.7 ARDF DF3090 (D779)

Item		Description
Original Size:	Simplex:	A3, A4, A5, B4, B5, B6 / DLT, LG, LT, HLT(11"*17" - 5.5"*8.5") Custom Paper: Vertical: 5.1"-11.7" / 128-297 mm Horizontal: 5.1"- 49.6" / 128 - 1, 260 mm *Image quality of custom paper is not guaranteed.
	Duplex:	A3, A4, A5, B4, B5 / LG, LT, HLT, DLT (8.5" x 14" – 5.5"*8.5")
Original Weight:	Simplex:	40 – 128 g/m ² (10.7 – 34.1 lb.)
	Duplex:	52.3 – 128 g/m ² (13.9 – 34.1 lb.)
Stack Capacity:		100 sheets
Power Consumption:		42 W or less
Dimension (W x D x H):		565 x 500 x 125 mm (22.24 x 19.69 x 4.92 inches)
Weight:		8.2 kg (18.08 lb.) or less

1.4.8 SPDF DF3080 (D683)

Item		Description
Original Size:	Simplex:	A3, A4, A5, B4, B5, B6, DLT, LG, LT, HLT
	Duplex:	A3, A4, A5, B4, B5, DLT, LG, LT, HLT
Original Weight:	Simplex:	40 – 128 g/m ² (10.7 – 34.1 lb.)
	Duplex:	52.3 – 128 g/m ² (13.9 – 34.1 lb.)
Stack Capacity:		220 sheets
Power Consumption:		72.2 W or less
Dimension (W x D x H):		587 x 520 x 175 mm (23.11 x 20.47 x 6.89 inches)
Weight:		13.9 kg (30.64 lb.) or less

1.4.9 BRIDGE UNIT BU3070 (D685)

Item	Description
Stack Capacity (80 g/m ² , 20 lb. Bond):	<ul style="list-style-type: none"> ▪ 250 sheets: A4, 8 1/2 x 11 or smaller ▪ 125 sheets: B4 JIS, 8 1/2 x 14 or larger
Power Consumption:	15 W or less
Dimensions (W x D x H):	412 x 466 x 143 mm (16.3 x 18.4 x 5.7 inches)
Weight:	Approx. 4 kg (8.9 lb.)

1.4.10 1 BIN TRAY BN3110 (D692)

Item	Description
Paper Size:	12.6"x17.7" - A5LEF, DLT SEF - HLT SEF
Paper Weight:	52 – 300 g/m ² (14 – 80 lb.)
Paper Output Capacity:	125 sheet with 80 g/m ² paper
Power Consumption:	Max 0.15 W
Dimension (W x D x H):	444 x 450 x 150 mm (17.5 x 17.7 x 5.9 inches)
Weight:	1.4 kg (3.1 lb.)

1.4.11 INTERNAL SHIFT TRAY SH3070 (D691)

Item	Description
Paper Size:	320 x 600 mm or smaller *320 x 1260 mm by using SP mode.
Paper Weight:	52 – 300 g/m ² (14 – 80 lb.)
Paper Output Capacity:	250 sheets with 80 g/m ² paper (A4, LT or smaller) 125 sheets with 80 g/m ² paper (B4, LG or smaller)
Power Consumption:	Max. 4.3 W
Dimension (W x D x H):	420 x 489 x 107 mm (16.5 x 19.3 x 4.2 inches)
Weight:	1.4 kg (3.09 lb.) or less

1.4.12 SIDE TRAY TYPE M3 (D725)

Item	Description
Paper Size:	Internal Tray: 320 x 600 mm or smaller 320 x 1260 mm by using SP mode Left side: 320 x 457.2 mm or smaller
Paper Weight:	52 – 300 g/m ² (14 – 80 lb.)
Paper Output Capacity:	Internal Tray: 250 sheets with 80 g/m ² paper (A4, LT) 125 sheets with 80 g/m ² paper (B4, LG) Left side: 125 sheets with 80 g/m ² paper
Power Consumption:	12 W
Dimension (W x D x H)	800 x 549 x 156 mm (31.5 x 21.7 x 6.2 inches)
Weight:	3.8 kg (8.4 lb.)

1.4.13 BOOKLET FINISHER SR3170 (D688) / FINISHER SR3160 (D689)

Item		Description
Paper Size:		A3 SEF – A5, B6 SEF, A6 SEF, 12" x 18" SEF, HLT – DLT SEF, SRA3 SEF Custom size: 90 x 139.7 – 330.2 x 487.7 mm *Shift supports 125 x 139.7mm - 12" x 18".
Paper Weight:	Proof Tray:	52 – 220 g/m ² (14 – 58.7 lb.)
	Shift Tray:	52 – 300 g/m ² (14 – 80 lb.)
Stack Capacity:	Proof Tray:	250 sheets : A4, LT or smaller 50 sheets: B4, LG or larger
	Shift Tray:	<p>[D688]</p> <p>2000 sheets: A4 LEF, LT LEF</p> <p>1,000 sheets: A3 SEF, A4 SEF, B4 SEF, B5, DLT SEF, LG SEF, LT SEF, 12"x18" SEF, SRA3 SEF</p> <p>500 sheets: A5 LEF</p> <p>100 sheets: A5 SEF, B6 SEF, A6 SEF, HLT SEF</p> <p>*Paper size not listed above:</p> <p>1,000 sheets: Length: 182 – 488 mm</p> <p>500 sheets: Length: 148 – 182 mm</p> <hr/> <p>[D689]</p> <p>3,000 sheets:A4 LEF, LT LEF</p> <p>1,500 sheets:A3 SEF, A4 SEF, B4 SEF, B5, DLT SEF, LG SEF, LT SEF, 12"x18" SEF, SRA3 SEF, 13" x 19.2" SEF</p> <p>500 sheets:A5 LEF</p> <p>100 sheets:A5 SEF, B6 SEF, A6 SEF, HLT SEF</p> <p>*Paper size not listed above:</p> <p>1,500 sheets: Length: 182 – 488 mm</p> <p>500 sheets: Length: 148 – 182 mm</p>

Item		Description
Stack Capacity:	Normal Staple Sort:	<p>[D688]</p> <p>2-12 sheets/set A4/LT LEF: No. of sets: 150 set Max Stack Capacity: 2,000 sheets</p> <p>13-50 sheets/set A4/LT LEF: No. of sets: 150-40 set Max Stack Capacity: 2,000 sheets</p> <p>2-9 sheets/set A4/LT SEF, B5: No. of sets: 100 set Max Stack Capacity: 1,000 sheets</p> <p>10-50 sheets/set A4/LT SEF, B5: No. of sets: 100-20 set Max Stack Capacity: 1,000 sheets</p> <p>2-9 sheets/set Paper size not listed above: No. of sets: 100 set Max Stack Capacity: 1,000sheets</p> <p>10-50 sheets/set Paper size not listed above: No. of sets: 100-20 set Max Stack Capacity: 1,000sheets</p>

Appendices:
Specifications

Optional Equipment

Item		Description
Stack Capacity:	Normal Staple Sort:	<p>[D689]</p> <p>2-9 sheets/set A4/LT LEF: No. of sets: 150 set Max Stack Capacity: 3,000 sheets</p> <p>20-50 sheets/set A4/LT LEF: No. of sets: 150-60 set Max Stack Capacity: 3,000 sheets</p> <p>2-14 sheets/set A4/LT SEF, B5: No. of sets: 100 set Max Stack Capacity: 1,500 sheets</p> <p>15-50 sheets/set A4/LT SEF ,B5: No. of sets: 100-30 set Max Stack Capacity: 1,500 sheets</p> <p>2-14 sheets/set Paper size not listed above: No. of sets: 100 set Max Stack Capacity: 1,500sheets</p> <p>15-50 sheets/set Paper size not listed above: No. of sets: 100-30 set Max Stack Capacity: 1,500sheets</p>
Stack Capacity:	Mixed Size (D689 only):	<p>2-50 sheets: A4 LEF and A3 SEF, B5 LEF and B4 SEF, LT LEF and DLT SEF</p> <p>No. of sets: 30set</p>
	Saddle Stitch Staple Sort (D688 only):	<p>2-5 sheets/set (No. of sets: 30 set)</p> <p>6-10 sheets/set (No. of sets: 15 set)</p> <p>11-15 sheets/set (No. of sets: 10 set)</p> <p>16-20 sheets/set (No. of sets: 6 set)</p>
Staple Capacity (80g/m2):		<p>Normal Staple:</p> <p>Same Paper Size: 50 sheets</p> <p>Mixed Paper Size: 50 sheets (A4 LEF&A3 / B5 LEF&B4 / LT LEF&DLT SEF)</p> <p>Saddle Stitch Staple (D688 only):</p> <p>20 sheets: B5 – A3</p>
Staple Paper Size:		<p>Normal Staple: B5-A3 SEF / LT-DLT SEF</p> <p>Saddle Stitch Staple (D688 only): B5-A3 SEF / LT-DLT SEF / 12" x 18"</p>

Item	Description
Staple Paper Weight:	Normal Staple: 52 – 105 g/m ² (14 – 28 lb.) Saddle Stitch Staple (D688 only): 64 – 105 g/m ² (17 – 28 lb.)
Staple Position:	Top, Bottom, 2 Staple, Top-slant Booklet (D688 only)
Staple Cartridge Capacity:	Normal Staple: 5,000 pins per cartridge Saddle Stitch Staple (D688 only): 2,000 pins per cartridge
Power Consumption:	D688: 59.3 W or less D689: 55.7 W or less
Dimension (W x D x H):	657 x 613 x 960 mm (25.87 x 24.13 x 37.8 inches)
Weight:	[D688] 52.5 kg (115.7 lb.) or less 56.5 kg (124.6 lb.) or less with Punch Unit [D689] 33.5 kg (73.9 lb.) or less 38.0 kg (83.8 lb.) or less with Punch Unit

1.4.14 PUNCH UNIT PU3060 (D706)

Item	Description
Paper Size:	NA/2 Holes: SEF: A5 - A3, HLT - DLT LEF: A5 - A4, HLT, LT
	NA/3 Holes: SEF: B4, A3, DLT LEF: A4, B5, LT
	EU/4 Holes: SEF: A3, B4, DLT LEF: A4, B5, LT
	SC/4 Holes: SEF: A5 - A3, HLT - DLT LEF: A5 - A4, HLT, LT
Paper Weight:	52 – 256 g/m ² (14 – 68 lb.)

1.4.15 BOOKLET FINISHER SR3150 (D686) / FINISHER SR3140 (D687)

Item		Description
Paper Size:		A3 SEF to A5, B6 SEF, A6 SEF, 12" x 18" SEF, HLT – DLT SEF, SRA3 SEF* Custom size: 90 x 139.7 – 330.2 x 600.0 mm
Paper Weight:	Proof Tray:	D686: 52 – 220 g/m ² (14 – 58.7 lb.) D687: 52 – 169 g/m ² (14 – 45 lb.)
	Shift Tray:	52 – 300 g/m ² (14 – 80 lb.)
Stack Capacity:	Proof Tray:	250 sheets: A4, LT or smaller 50 sheets: B4, LG or larger
	Shift Tray:	[D686] 3,000 sheets: A4 LEF, LT LEF 1,500 sheets: A3 SEF, A4 SEF, B4 SEF, B5, DLT SEF, LG SEF, LT SEF, 12"x18" SEF, SRA3 SEF, 13" x 19.2" SEF 500 sheets: A5 LEF 100 sheets: A5 SEF, B6 SEF, A6 SEF, HLT SEF *Paper size not listed above: 1,500 sheets: Length: 182 – 488 mm 500 sheets: Length: 148 – 182 mm
		[D687] 1000 sheets: A4, LT or smaller 500 sheets: B4, LG or larger

Item		Description
Stack Capacity:	Normal Staple Sort:	<p>[D686]</p> <p>2-9 sheets/set A4/B5/LT LEF: No. of sets: 100 set</p> <p>10-50 sheets/set A4/B5/LT LEF: No. of sets: 100-20 set Max Stack Capacity: 1,000 sheets</p> <p>2-9 sheets/set A4/B5/LT SEF: No. of sets: 50set</p> <p>10-50 sheets/set A4/B5/LT SEF: No. of sets: 50-10 set Max Stack Capacity: 500 sheets</p> <p>2-9 sheets/set A3/B4/DLT/LG: No. of sets: 50 set</p> <p>10-30 sheets/set A3/B4/DLT/LG: No. of sets: 50-10 set Max Stack Capacity: 500 sheets</p>
Stack Capacity: Stack Capacity:	Normal Staple Sort:	<p>[D687]</p> <p>2-9 sheets/set A4/B5/LT LEF: No. of sets: 100 set</p> <p>10-50 sheets/set A4/B5/LT LEF: No. of sets: 100-20 set Max Stack Capacity: 1,000 sheets</p> <p>2-9 sheets/set A4/B5/LT SEF: No. of sets: 50 set</p> <p>10-50 sheets/set A4/B5/LT SEF: No. of sets: 50-10 set Max Stack Capacity: 500 sheets</p> <p>2-9 sheets/set A3/B4/DLT/LG: No. of sets: 50 set</p> <p>10-30 sheets/set A3/B4/DLT/LG: No. of sets: 50-10 set Max Stack Capacity: 500 sheets</p>
	Mixed Size (D687 only):	<p>2-22 sheets: A4 LEF and A3 SEF, B5 LEF and B4 SEF, LT LEF and DLT SEF (No. of sets: 22 set)</p>

Optional Equipment

Item		Description
	Saddle Stitch	2-5 sheets/set (No. of sets: 20set)
	Staple Sort	6-10 sheets/set (No. of sets: 10set)
	(D686 only):	11-15 sheets/set (No. of sets: 7set)
Staple Capacity:		<p>Normal Staple: 2 – 50 sheets: A4/LT or smaller 2 – 30 sheets: B4/LG or larger</p> <p>Saddle Stitch Staple (D686 only): 15 sheets</p>
Staple Paper Size:		<p>Normal Staple: A3 - B5, DLT - LT, 12" x 18"</p> <p>Saddle Stitch Staple (D686 only): 12" x 18", A3 SEF, B4 SEF, A4 SEF, B5 SEF, DLT SEF, LG SEF, LT SEF</p>
Staple Paper Weight:		52 – 105 g/m ² (14 – 28 lb.)
Staple Position:		Top, Bottom, 2 Staple Booklet (D686 only)
Staple Cartridge Capacity:		5,000
Power Consumption:		35.4 W or less
Dimension (W x D x H):		646 x 620 x 960 mm (25.4 x 24.4 x 37.8 inches)
Weight:		D686: 39.6 kg (87.3 lb.) D687: 27 kg (60 lb.)

1.4.16 PUNCH UNIT PU3050 (D717)

Item		Description
Paper Size:	NA/2 Holes:	SEF: A5 - A3, HLT - DLT LEF: A5 - A4, HLT, LT
	NA/3 Holes:	SEF: B4, A3, DLT LEF: A4, B5, LT
	EU/4 Holes:	SEF: A3, B4, DLT LEF: A4, B5, LT
	SC/4 Holes:	SEF: A5 - A3, HLT - DLT LEF: A5 - A4, HLT, LT
Paper Weight:		52 – 256 g/m ² (14 – 68 lb.)

1.4.17 INTERNAL FINISHER SR3180 (D766)

Item	Description
Paper Size:	A3 – A6 SEF, DLT-HLT, 12.6" x 17.7", 12"x18" Custom size: 90 – 320 mm x 148 – 1260 mm
Paper Weight:	52 – 300 g/m ² (14 – 80 lb.)
Stack Capacity:	<p>Shift Tray: 250 sheets: A4 LEF / B5 SEF, B5 LEF / LT SEF, LT LEF 125 sheets: A3 SEF – A4 SEF / B4 SEF / LG SEF, DLT SEF</p> <p>Normal Staple Sort: 2-5 sheets/set A4 LEF / LT LEF: No. of sets: 30 set 2-5 sheets/set B5: No. of sets: 20set 2-5 sheets/set A3 SEF – A4 SEF/ B4 SEF / DLT SEF, LT SEF: No. of sets: 15set</p>
Staple Capacity:	2-5 sheets/set
Staple Paper Size:	A3 SEF – B5 SEF / DLT SEF – LT SEF
Staple Paper Weight:	64 – 80 g/m ²
Staple Position:	Top, 1 staple
Power Consumption:	30 W or less
Dimension (W x D x H):	435 x 515 x 150 mm (17.1 x 20.3 x 5.9 inches)
Weight:	9.8 kg (21.6 lb.) or less

1.4.18 INTERNAL FINISHER SR3130 (D690)

Item	Description
Paper Size:	A3 – A6 SEF, DLT – HLT, 12.6" x 17.7", 12"x18" Custom size: 90 – 320 x 148 – 1260 mm
Paper Weight:	52 – 300 g/m ² (14 – 80 lb.)
Stack Capacity:	<p>Shift Tray: 500 sheets: A4/LT or smaller 250 sheets: B4/LG or larger</p> <p>Normal Staple Sort: 2-9 sheets/set:A4/B5/LT LEF (No. of sets:55-46set) 10-50 sheets/set:A4/B5/LT LEF (No. of sets: 45-10set) 2-9 sheets/set:A4/B5/LT SEF (No. of sets: 55-27set) 10-50 sheets/set:A4/B5/LT SEF (No. of sets: 25-8set) 2-9 sheets/set:A3/B4/HLT/LG (No. of sets: 55-27set) 10-30 sheets/set:A3/B4/HLT/LG (No. of sets: 25-8set)</p>
Staple Capacity:	50 sheets 30 sheets: A3, B4, DLT, LG, Foolscap, Government LG, Folio 8K, Mixed size
Staple Paper Size:	A3, B4, A4 SEF/LEF, B5 SEF/LEF, DLT, LG, LT SEF/LEF, Foolscap, Government LG, Folio, Executive SEF/LEF, 8K, 16K SEF/LEF
Staple Paper Weight:	52 – 105 g/m ² (14 – 28 lb.)
Staple Position:	Top, Bottom, 2 staple
Staple Cartridge Capacity:	5,000 pcs. / cartridge
Power Consumption:	47 W or less 60 W or less with Punch Unit
Dimension (W x D x H):	546 x 523 x 170 mm (21.5 x 20.6 x 6.7 inches)
Weight:	12.8 kg (28.2 lb.) or less

1.4.19 PUNCH UNIT PU3040 (D716)

Item		Description
Paper Size:	NA/2 Holes:	SEF: A3, A4, DLT, LG, LT, Foolscap, Executive LEF: A4, LT
	NA/3 Holes:	SEF: A3, DLT LEF: A4, LT
	EU/2 Holes:	SEF: A3, A4, B4, B5, DLT, LG, LT, Foolscap, Executive, 8K, 16K LEF: A4, B5, LT, 16K
	EU/4 Holes:	SEF: A3, DLT LEF: A4, LT
	SC/2 Holes:	SEF: A3, A4, B4, B5, DLT, LG, LT, Foolscap, Executive LEF: A4, B5, LT
Paper Weight:		52 – 163 g/m ² (14 – 43 lb.)

APPENDICES:
PREVENTIVE MAINTENANCE TABLES

REVISION HISTORY		
Page	Date	Added/Updated/New
		None

2. APPENDICES: PREVENTIVE MAINTENANCE TABLES

2.1 PREVENTIVE MAINTENANCE

2.1.1 PREVENTIVE MAINTENANCE ITEMS

Note

- The amounts mentioned as the PM interval indicate the number of prints.

Chart: A4/LT (LEF) / 6%

Mode:

D197/D198: 3 copies/original (prints/job)

D199/D200/D201/D202: 5 copies/original (prints/job)

Environment: Normal temperature and humidity

Yield may change depending on circumstances and print conditions.

Symbol keys: C: Clean, R: Replace, L: Lubricant, I: Inspect

Mainframe: D197/D198/D199

Item	120K	240K	360K	EM	Life	Note
Reflector	-	C//L	-	-	-	Clean with an optics cloth.
1st Mirror	-	C//L	-	-	-	
2nd Mirror	-	C//L	-	-	-	
3rd Mirror	-	C//L	-	-	-	
Exposure Glass	-	C//L	-	-	-	Clean with the RICOH's exposure glass cleaner.
	-	-	-	C//L		
Scanner Guide Rails	-	C//L	-	-	-	Clean with a dry Cloth.
ADF Exposure Glass	-	C//L	-	-	-	Clean with the RICOH's exposure glass cleaner.
	-	-	-	C//L		
Shield Glass	-	-	-	C//L		Clean with an optics Cloth.

Preventive Maintenance

Item	120K	240K	360K	EM	Life	Note
Developer	R	-	-	-	-	Clear PM counter.
Development Roller	C//L	-	-	-	-	
Development Filter	R	-	-	-	-	Clear PM counter.
Development Case	C//L	-	-	-	-	Clean guide plate and spots where toner adheres.
Development Entrance Seal	C//L	-	-	C//L	-	Remove dust.
Development Mixing Auger Bearing		R				Clear PM counter.
Development Side Seal	R	-	-	-	-	
Doctor Blade	C//L	-	-	-	-	Remove adhering developer.
Charge Roller	R	-	-	-	-	Clear PM counter.
Charge Roller Cleaner	R	-	-	-	-	
Cleaning Blade	R	-	-	-	-	
Cleaning Blade Side Seal	C//L	-	-	-	-	
Cleaning Entrance Seal	C//L	-	-	-	-	
OPC Drum	R	-	-	-	-	Clear PM counter.
Pick-off Pawl	R	-	-	-	-	

Item	120K	240K	360K	EM	Life	Note
Waste Toner Bottle	R	-	-	C/I/L	-	Replace when waste toner full is detected. Clear PM counter.
Quenching Lamp	C/I/L	-	-	-	-	
PCL	C/I/L	-	-	-	-	
Transfer Unit	R	-	-	-	-	Clear PM counter.
Fusing Exit Guide	C/I/L	-	-	-	-	
ID Sensor	C/I/L	-	-	C/I/L	-	Use blower brush. Initialize ID sensor after Cleaning.
Heating Sleeve Belt Unit	-	R	-	-	260k	Clear PM counter.
Fusing Entrance Guide Plate	-	-	-	C/I/L	-	Remove adhering toner.
Fusing Exit Guide Plate	-	-	-	C/I/L	-	
Stripper Plate	-	-	-	C/I/L	-	
Pressure Roller	-	R	-		260k	Clear PM counter.
Pressure Roller Bearing	-	R	-		260k	Lubricate (FLUOTRIBO MG GREASE) after replace the bearing.
Thermopile	-	C/I/L	-	C/I/L	-	Clean with a dry cloth.
Pressure Roller Gear	-	-	-	C/I/L	-	Replace when the gear is worn out.
Idler Gear	-	-	-	C/I/L	-	

Preventive Maintenance

Item	120K	240K	360K	EM	Life	Note
Fusing Entrance Sensor	C/I/L	-	-	C/I/L	-	Clean the sensor part with blower brush.
Fusing Exit Sensor	C/I/L	-	-	C/I/L	-	
Registration Roller	-	-	-	C	-	Wipe with a cloth dampened with ethyl alcohol.
Registration Sensor	-	-	-	C	-	Remove dust with dry cloth when sensor failure occurs.
Paper Dust Collection Unit	-	-	-	C	-	Remove dust when paper dust is full.
Vertical Transport Roller	-	-	-	C	-	Wipe with a cloth dampened with ethyl alcohol.
Vertical Transport Sensor	-	-	-	C	-	Remove dust with dry cloth.
Paper Feed Sensor	-	-	-	C	-	Remove dust with dry cloth when sensor failure occurs.
Paper Feed Roller	-	-	-	C	500K	Wipe with a cloth dampened with ethyl alcohol. *Life is just for reference.
Separation Roller	-	-	-	C	500K	
Pickup Roller	-	-	-	C	500K	
Vertical Transport Roller	-	-	-	C	-	Wipe with a cloth dampened with ethyl alcohol.
Vertical Transport Sensor	-	-	-	C	-	Remove dust with dry cloth.

Item	120K	240K	360K	EM	Life	Note
Paper Feed Sensor	-	-	-	C	-	
Paper Feed Roller	-	-	-	C	-	Wipe with a cloth dampened with ethyl alcohol.
Separation Roller	-	-	-	C	-	
Pickup Roller	-	-	-	C	-	
Duplex Transport Roller	-	-	-	C	-	
Duplex Exit Sensor	-	-	-	C	-	Remove dust with dry cloth when sensor failure occurs.
Duplex Exit Roller	-	-	-	C	-	Wipe with a cloth dampened with ethyl alcohol.
Bypass Feed Roller	-	-	-	C	120K	Wipe with a cloth dampened with ethyl alcohol. *Life is just for reference.
Bypass Separation Roller	-	-	-	C	120K	
Bypass Pickup Roller	-	-	-	C	120K	
Bypass Transport Roller	-	-	-	C	-	Wipe with a cloth dampened with ethyl alcohol.
Reverse Roller	-	-	-	C	-	
Reverse Sensor	-	-	-	C	-	Remove dust with dry cloth.
Paper Exit Roller	-	-	-	C	-	Wipe with a cloth dampened with ethyl alcohol.
Paper Exit Sensor	-	-	-	C	-	Remove dust with dry cloth.

Mainframe: D200/D201/D202

Item	160K	320K	480K	EM	Life	Note
Reflector	-	C//L	-	-	-	Clean with an optics cloth.
1st Mirror	-	C//L	-	-	-	
2nd Mirror	-	C//L	-	-	-	
3rd Mirror	-	C//L	-	-	-	
Exposure Glass	-	C//L	-	-	-	Clean with the RICOH's exposure glass cleaner.
	-		-	C//L	-	
Scanner Guide Rails	-	C//L	-	-	-	Clean with a dry Cloth.
ADF Exposure Glass	-	C//L	-	-	-	Clean with the RICOH's exposure glass cleaner.
	-	-	-	C//L	-	
Shield Glass	-	-	-	C//L	-	Clean with an optics Cloth.
Developer	R	-	-	-	-	Clear PM counter.
Development Roller	C//L	-	-	-	-	
Development Filter	R	-	-	-	-	Clear PM counter.
Development Case	C//L	-	-	-	-	
Development Entrance Seal	C//L	-	-	C//L	-	Remove dusts.
Development Mixing Auger Bearing	-	R	-	-	-	Clear PM counter.
Development Side Seal	R	-	-	-	-	
Doctor Blade	C//L	-	-	-	-	Remove adhering developer.

Item	160K	320K	480K	EM	Life	Note
Charge Roller	R	-	-	-	-	Clear PM counter.
Charge Roller Cleaner	R	-	-	-	-	
Cleaning Blade	R	-	-	-	-	
Cleaning Blade Side Seal	C//L	-	-	-	-	
Cleaning Entrance Seal	C//L	-	-	-	-	
OPC Drum	R	-	-	-	-	Clear PM counter.
Pick-off Pawl	R	-	-	-	-	
Waste Toner Bottle	R	-	-	C//L	-	Replace when waste toner full is detected. Clear PM counter.
Quenching Lamp	C//L	-	-	-	-	
PCL	C//L	-	-	-	-	
Transfer Unit	R	-	-	-	-	Clear PM counter.
Fusing Exit Guide	C//L	-	-	-	-	
ID Sensor	C//L	-	-	C//L	-	Use a blower brush. Initialize ID sensor after Cleaning.
Heating Sleeve Belt Unit	-	R	-	-	260k	Clear PM counter.
Fusing Entrance Guide Plate	-	-	-	C//L	-	Remove adhering toner.
Fusing Exit Guide Plate	-	-	-	C//L	-	
Stripper Plate	-	-	-	C//L	-	

Preventive Maintenance

Item	160K	320K	480K	EM	Life	Note
Pressure Roller	-	R	-	-	260k	Clear PM counter.
Pressure Roller Bearing	-	R	-	-	260k	Lubricate (FLUOTRIBO MG GREASE) after replace the bearing.
Thermopile	-	C/I/L	-	C/I/L	-	Clean with a dry cloth.
Pressure Roller Gear	-	-	-	C/I/L	-	Replace if the gear is worn out.
Idler Gear	-	-	-	C/I/L	-	
Fusing Entrance Sensor	C/I/L	-	-	C/I/L	-	Clean the sensor part with blower brush.
Fusing Exit Sensor	C/I/L	-	-	C/I/L	-	
Registration Roller	-	-	-	C	-	Wipe with a cloth dampened with ethyl alcohol.
Registration Sensor	-	-	-	C	-	Remove dust with dry cloth when sensor failure occurs.
Paper Dust Collection Unit	-	-	-	C	-	Remove dust when paper dust is full.
Vertical Transport Roller	-	-	-	C	-	Wipe with a cloth dampened with ethyl alcohol.
Vertical Transport Sensor	-	-	-	C	-	Remove dust with dry cloth.
Paper Feed Sensor	-	-	-	C	-	Remove dust with dry cloth when sensor failure occurs.

Item	160K	320K	480K	EM	Life	Note
Paper Feed Roller	-	-	-	C	500K	Wipe with a cloth dampened with ethyl alcohol. *Life is just for reference.
Separation Roller	-	-	-	C	500K	
Pickup Roller	-	-	-	C	500K	
Vertical Transport Roller	-	-	-	C	-	Wipe with a cloth dampened with ethyl alcohol.
Vertical Transport Sensor	-	-	-	C	-	Remove dust with dry cloth.
Paper Feed Sensor	-	-	-	C	-	
Paper Feed Roller	-	-	-	C	-	Wipe with a cloth dampened with ethyl alcohol.
Separation Roller	-	-	-	C	-	
Pickup Roller	-	-	-	C	-	
Duplex Transport Roller	-	-	-	C	-	
Duplex Entrance Sensor	-	-	-	C	-	Remove dust with dry cloth when sensor failure occurs.
Duplex Exit Sensor	-	-	-	C	-	
Duplex Exit Roller	-	-	-	C	-	Wipe with a cloth dampened with ethyl alcohol.
Duplex Entrance Sensor	-	-	-	C	-	
Bypass Feed Roller	-	-	-	C	120K	Wipe with a cloth dampened with ethyl alcohol. *Life is just for reference.
Bypass Separation Roller	-	-	-	C	120K	
Bypass Pickup Roller	-	-	-	C	120K	
Bypass Transport Roller	-	-	-	C	-	Wipe with a cloth dampened with

Preventive Maintenance

Item	160K	320K	480K	EM	Life	Note
Reverse Roller	-	-	-	C	-	ethyl alcohol.
Reverse Sensor	-	-	-	C	-	Remove dust with dry cloth.
Paper Exit Roller	-	-	-	C	-	Wipe with a cloth dampened with ethyl alcohol.
Paper Exit Sensor	-	-	-	C	-	Remove dust with dry cloth.

ARDF DF3090

Item	EM	120K	240K	360K	Note
Pick-up Roller	C	R	R	R	Wipe with a cloth dampened with ethyl alcohol.
Feed Belt	C	R	R	R	Wipe with a cloth dampened with ethyl alcohol or water.
Separation Roller	C	R	R	R	Wipe with a cloth dampened with ethyl alcohol.
Sensors	C	-	-	-	Clean with a blower brush.
Gears	L	-	-	-	Lubricate, if necessary.
Platen Sheet	C	-	-	-	Wipe with a cloth dampened with ethyl alcohol.
Other Rollers	C	-	-	-	
Scanner Guide Plate	C	-	-	-	

SPDF DF3080

Item	EM	120K	240K	360K	Note
Pick-up Roller	C	R	R	R	Wipe with a cloth dampened with ethyl alcohol.
Feed Belt	C	R	R	R	Wipe with a cloth dampened with ethyl alcohol or water.
Separation Roller	C	R	R	R	Wipe with a cloth dampened with ethyl alcohol.
CIS (Glass area)	-	-	-	-	Clean with the RICOH's glass cleaner.
Sensors	C	-	-	-	Clean with a blower brush.
Gears	L	-	-	-	Lubricate, if necessary.
Platen Sheet	C	-	-	-	Wipe with a cloth dampened with ethyl alcohol.
Other Rollers	C	-	-	-	
Scanner Guide Plate	C	-	-	-	

Paper Feed Unit PB3150/PB3210/PB3220

Item	EM	Note
Paper Feed Roller	C	Wipe with a cloth dampened with ethyl alcohol.
Pick-up Roller	C	
Separation Roller	C	
Relay Rollers	C	
Bottom Plate Pad	C	Remove dust with dry cloth.
Sensors	C	

LCIT PB3170/PB3230

Item	EM	Note
Paper Feed Roller	C	Wipe with a cloth dampened with ethyl alcohol.
Pick-up Roller	C	
Separation Roller	C	
Relay Rollers	C	
Bottom Plate Pad	C	Remove dust with dry cloth.
Sensors	C	

LCIT RT3030

Item	EM	Note
Paper Feed Roller	C	Wipe with a cloth dampened with ethyl alcohol.
Pick-up Roller	C	
Separation Roller	C	
Relay Rollers	C	
Bottom Plate Pad	C	Remove dust with dry cloth.
Sensors	C	

1 Bin Tray BN3110

Item	EM	Note
Rollers	C	Wipe with a cloth dampened with ethyl alcohol.
Copy Tray	C	Clean with a damp cloth, and then wipe with a dry cloth.
Sensors	C	Clean with a blower brush.
Bearings	C	Lubricate with silicone oils when noise occurred.

Bridge Unit BU3070

Item	EM	Note
Rollers	C	Wipe with a cloth dampened with ethyl alcohol.

Internal Shift Tray SH3070

Item	EM	Note
Exit Tray	C	Clean with a damp cloth, and then wipe with a dry cloth.

Side Tray Type M3

Item	EM	Note
Rollers	C	Wipe with a cloth dampened with ethyl alcohol.
Sensors	C	Remove dusts with dry cloth.

Booklet Finisher SR3150 / Finisher SR3140

Item	500K	EM	Note
Rollers	-	C	Wipe with a cloth dampened with ethyl alcohol.
Quenching brush	-	C	Clean with a dry cloth if dirt adheres on it.
Bearings	-	C	Lubricate with silicone oils when noise occurred.
Sensors	-	C	Clean with a blower brush.
Jogger Fence	-	C	Lubricate with silicone oils when noise or malfunction detected.
Stapler	R	C	Replace when staple counter on logging data reached 500 thousand times. Staple some times for test after replacement.

Booklet Finisher SR3170 / Finisher SR3160

tem	300K	3000K	4000K	EM	Note
Rollers	-	-	-	C	Wipe with a cloth dampened with ethyl alcohol.
Quenching brush	-	-	-	C	Clean with a dry cloth if dirt adheres on it.
Bearings	-	-	-	C	Lubricate with silicone oils when noise occurred.
Sensors	-	-	-	C	Clean with a blower brush.
Stapler (Corner)	-	-	R	C	Replace when staple counter on logging data reached 500 thousand times. Staple some times for test after replacement.
Booklet Stapler	-	-	R	C	Replace when staple counter on logging data reached 200 thousand times.
Punch	-	R	-	C	Remove paper dust in the transport unit.
Punch dust	C	-	-	C	Discard paper dust when a full of paper dust is detected.

Internal Finisher SR3130

Item	EM	Note
Rollers	C	Wipe with a cloth dampened with ethyl alcohol.
Sensors	C	Clean with a blower brush.
Stapler	R	Replace when staple counter on logging data reached 200 thousand times.
Bearing	C	Lubricate silicon oil.

Internal Finisher SR3180

Item	EM	Note
Rollers	C	Wipe with a cloth dampened with ethyl alcohol.
Sensors	C	Clean with a blower brush.
Stapler	R	Replace when staple counter on logging data reached 200 thousand times.

2.1.2 OTHERS YIELD PARTS

The parts mentioned in the table below have a target yield. However, the total copy/print volume made by the machine will not reach the target yield within the machine's targeted lifetime if the machine is used under the target usage conditions (ACV, color ratio, P/J, and C/O). So, these parts are categorized not as PM parts but as yield parts (EM parts).

Note

- Symbol keys: U: Unique for this model, C: Common with listed model

Mainframe:

Part Number	Description	Q'ty/Unit	Expected Yield (Pages)	Unique or Common
D8693021	Development Unit	1	D197/D198/D199: 420k D200/D201/D202: 900k	U

ARDF DF3090 (D779):

Part Number	Description	Q'ty/Unit	Expected Yield (Pages)	Unique or Common
D5412121	Paper Feed Belt	1	120k	C (D146)
D6832228	Pick-up Roller	1		
D5412241	Reverse Roller	1		

SPDF DF3080 (D779):

Part Number	Description	Q'ty/Unit	Expected Yield (Pages)	Unique or Common
D5412121	Paper Feed Belt	1	120k	C (D146)
D6832228	Pick-up Roller	1		
D5412241	Reverse Roller	1		

D3A5

FAX OPTION TYPE M12

REVISION HISTORY		
Page	Date	Added/Updated/New
		None

FAX OPTION TYPE M12 (D3A5)

TABLE OF CONTENTS

1. INSTALLATION	1
1.1 FAX OPTION TYPE M12.....	1
1.1.1 COMPONENT CHECK.....	1
1.1.2 INSTALLATION PROCEDURE	2
1.2 G3 INTERFACE UNIT TYPE M12	6
1.2.1 COMPONENT CHECK.....	6
1.2.2 INSTALLATION PROCEDURE	7
For Installing the single G3 Board	7
For Installing the Double G3 Boards	10
1.3 FAX UNIT OPTIONS	16
1.3.1 MEMORY UNIT TYPE M12 64MB.....	16
1.3.2 HANDSET HS3020.....	18
1.4 FAX CONNECTION UNIT TYPE M12	22
1.4.1 INSTALLATION PROCEDURE	22
Installing the application in the Remote Machine and Client-side Machine.....	22
Registering the Client-side Machine(s).....	24
Registering the Remote Machine	26
Configuring the Remote Reception Settings	27
Remote Fax Icon Addition for Remote Machine.....	29
2. REPLACEMENT AND ADJUSTMENT	31
2.1 FCU	31
2.1.1 SRAM DATA TRANSFER PROCEDURE	31
3. TROUBLESHOOTING	35
3.1 ERROR CODES	35
3.2 FAX CONNECTION UNIT ERROR CODES.....	58
3.2.1 FAX CONNECTION UNIT ERROR CODE LIST.....	58
MACHINE_ERR_01	58
MACHINE_ERR_02	58
MACHINE_ERR_03	59
MACHINE_ERR_04	59
MACHINE_ERR_05	60
MACHINE_ERR_06	60
MACHINE_ERR_07	60

MACHINE_ERR_08	61
3.3 IFAX TROUBLESHOOTING	62
3.4 IP-FAX TROUBLESHOOTING	65
3.4.1 IP-FAX TRANSMISSION	65
Cannot send by IP Address/Host Name	65
Cannot send via VoIP Gateway	66
Cannot send by Alias Fax number.	67
3.4.2 IP-FAX RECEPTION	69
Cannot receive via IP Address/Host Name.	69
Cannot receive by VoIP Gateway.....	70
Cannot receive by Alias Fax number.....	71
4. SERVICE TABLES	73
4.1 CAUTIONS	73
4.2 SERVICE PROGRAM TABLES	74
4.2.1 SP1-XXX (BIT SWITCHES).....	74
4.2.2 SP2-XXX (RAM)	75
4.2.3 SP3-XXX (MACHINE SET).....	76
4.2.4 SP4-XXX (ROM VERSIONS)	78
4.2.5 SP5-XXX (RAM CLEAR)	79
4.2.6 SP6-XXX (REPORTS).....	80
4.2.7 SP7-XXX (TESTS).....	82
4.3 BIT SWITCHES - 1	84
4.3.1 SYSTEM SWITCHES	84
4.4 BIT SWITCHES - 2	99
4.4.1 I-FAX SWITCHES.....	99
4.4.2 PRINTER SWITCHES	107
4.5 BIT SWITCHES - 3	115
4.5.1 COMMUNICATION SWITCHES.....	115
4.6 BIT SWITCHES - 4	126
4.6.1 G3 SWITCHES	126
4.7 BIT SWITCHES - 5	137
4.7.1 G3-2 AND G3-3 SWITCHES	137
4.7.2 G4 INTERNAL SWITCHES	145
4.7.3 G4 PARAMETER SWITCHES.....	145
4.8 BIT SWITCHES - 6	146
4.8.1 IP FAX SWITCHES.....	146
4.9 NCU PARAMETERS	155
4.10 DEDICATED TRANSMISSION PARAMETERS.....	170
4.10.1 PROGRAMMING PROCEDURE.....	170

4.10.2	PARAMETERS.....	171
	Fax Parameters.....	171
	E-mail Parameters.....	175
4.11	SERVICE RAM ADDRESSES	179
5.	DETAILED SECTION DESCRIPTIONS.....	191
5.1	OVERVIEW.....	191
5.2	BOARDS.....	192
5.2.1	FCU	192
5.2.2	SG3 BOARD.....	194
5.3	VIDEO DATA PATH.....	196
5.3.1	TRANSMISSION	196
	Memory Transmission and Parallel Memory Transmission	196
	Immediate Transmission	197
	JBIG Transmission.....	197
	Adjustments	197
5.3.2	RECEPTION.....	198
5.4	FAX COMMUNICATION FEATURES.....	199
5.4.1	MULTI-PORT.....	199
5.4.2	DOCUMENT SERVER	199
5.4.3	INTERNET MAIL COMMUNICATION.....	200
	Mail Transmission	200
	Mail Reception	203
	Handling Mail Reception Errors.....	205
	Secure Internet Reception.....	206
	Transfer Request: Request By Mail.....	206
	E-Mail Options (Sub TX Mode)	206
5.5	IP-FAX	211
5.5.1	WHAT IS IP-FAX?	211
5.5.2	T.38 PACKET FORMAT	211
	UDP Related Switches.....	211
5.5.3	SETTINGS.....	212
6.	SPECIFICATIONS	213
6.1	GENERAL SPECIFICATIONS.....	213
6.1.1	FCU	213
6.2	CAPABILITIES OF PROGRAMMABLE ITEMS	215
6.3	IFAX SPECIFICATIONS.....	216
6.4	IP-FAX SPECIFICATIONS.....	218
6.5	FAX UNIT CONFIGURATION.....	219

6.5.1 G3 INTERFACE UNIT TYPE M12219

READ THIS FIRST

Important Safety Notices

WARNING

- Never install telephone wiring during a lightning storm.
- Never install telephone jacks in wet locations unless the jack is specifically designed for wet locations.
- Never touch uninsulated telephone wires or terminals unless the telephone line has been disconnected at the network interface.
- Always use caution when installing or modifying telephone lines.
- Avoid using a telephone (other than a cordless type) during an electrical storm. There may be a remote risk of electric shock from lightning.
- Do not use a telephone or cellular phone to report a gas leak in the vicinity of the leak.

CAUTION

- Before installing the fax unit, switch off the main switch, and disconnect the power cord.
- The fax unit contains a lithium battery. The danger of explosion exists if a battery of this type is incorrectly replaced. Replace only with the same or an equivalent type recommended by the manufacturer.
- Discard batteries in accordance with the manufacturer's instructions and local regulations.





Note

- **Note for Australia:**
- Unit must be connected to Telecommunication Network through a line cord that meets the requirements of ACA Technical Standard TS008.

Symbols and Abbreviations

Conventions Used in this Manual

This manual uses several symbols.

Symbol	What it means
	Screw
	Connector
	Clip ring
	Clamp
SEF	Short Edge Feed
LEF	Long Edge Feed

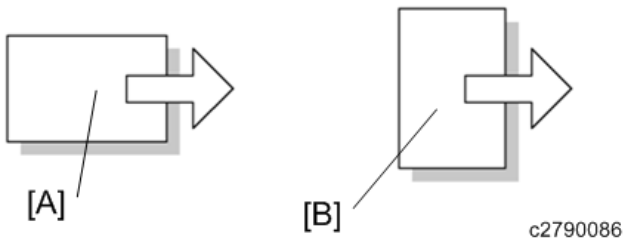

[A] Short Edge Feed (SEF)

[B] Long Edge Feed (LEF)

Cautions, Notes, etc.

The following headings provide special information:

WARNING

- Failure to obey warning information could result in serious injury or death.

CAUTION

- Obey these guidelines to ensure safe operation and prevent minor injuries.

Important

- Obey these guidelines to avoid problems such as misfeeds, damage to originals, loss of valuable data and to prevent damage to the machine.
- Always obey these guidelines to avoid serious problems such as misfeeds, damage to originals, loss of valuable data and to prevent damage to the machine. bold is added for emphasis.

Note

- This document provides tips and advice about how to best service the machine.

1. INSTALLATION

1.1 FAX OPTION TYPE M12

1.1.1 COMPONENT CHECK

Check the quantity and condition of the components against the following list.

No.	Description	Q'ty
1	FCU	1
2	Clamp	2
3	Ferrite Core	2
4	Screw: M3x6	1
5	Fax Key Top Decal	1
6	Serial Number Decal	1
7	Telephone Cord (NA only)	1
-	FCC Decal (NA only)	1
-	EMC Address Decal (EU Only)	1
-	Telephone Jack Cap (TWN only)	1

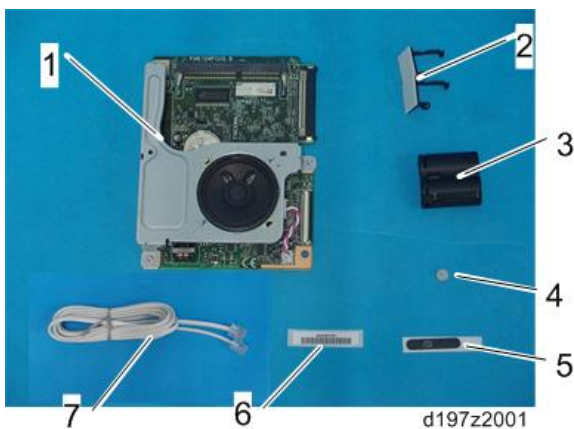

1.1.2 INSTALLATION PROCEDURE

⚠ CAUTION

- **Before installing this fax unit:**

Print out all data in the printer buffer.

Turn off the main power switch and disconnect the power cord and the network cable.

1. Remove the controller box cover [A] (🔩 x 4).

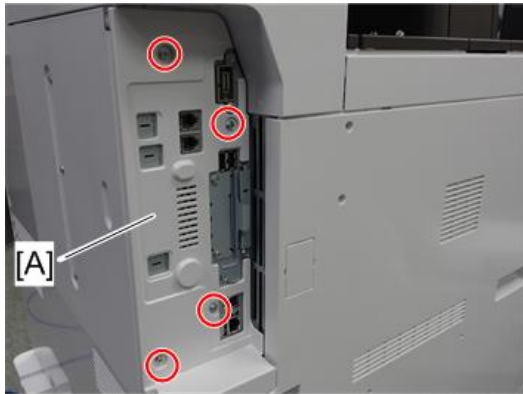

d197z2009

2. Remove the FCU slot cover [A] (🔩 x 2).

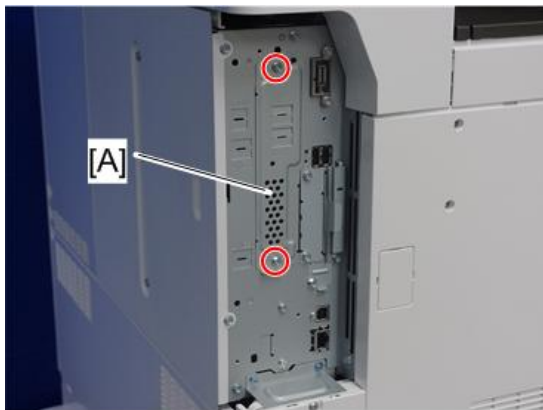

d197z2002

3. Remove the "TEL" [A] and "LINE1" [B] covers on the FCU slot cover with a screw driver.

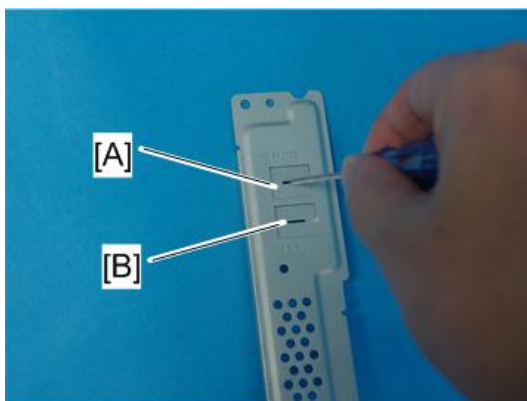

d197z2003

4. Switch the battery jumper switch [A] to the "ON" position.

Note

- SC672 may occur when turning on the machine with the jumper switch "OFF".



5. Insert the SAF memory [A] in the memory slot on the FCU board if the optional memory is to be installed.

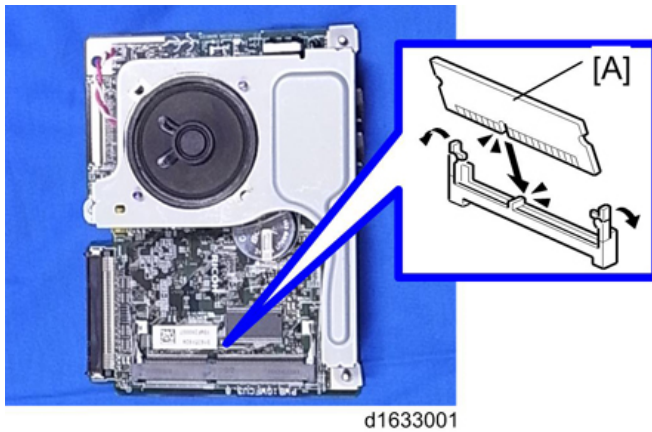

6. Align the FCU board with the rails [A], and then install the FCU [B] fully into the FCU slot.

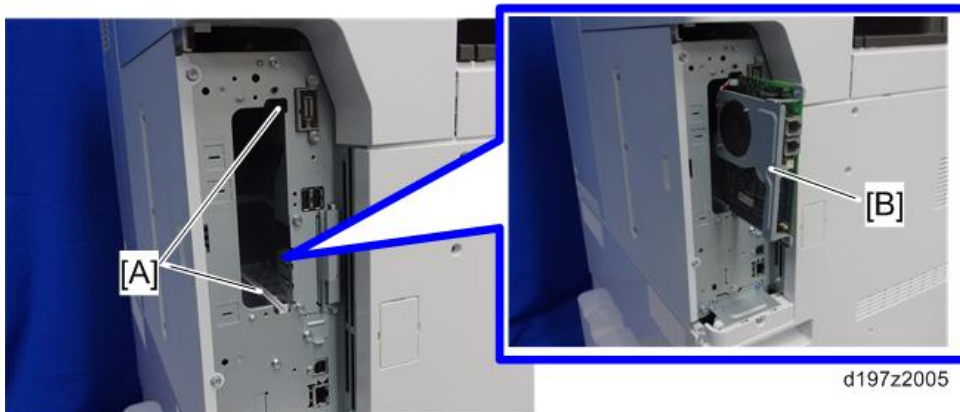

7. Attach the FCU slot cover [A] (🔩 x 3).

Note

- One of the three screws is provided with this option.

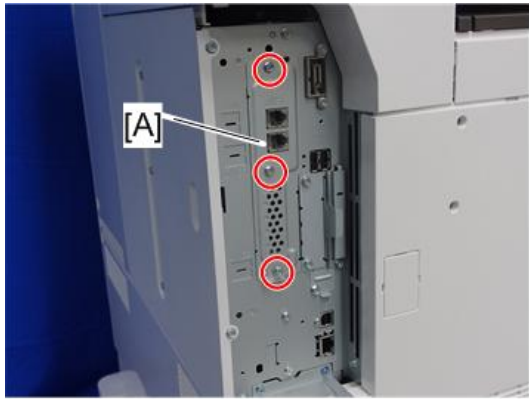

d197z2006

8. If a G3 option is to be installed; See (G3 Interface Unit).
9. Reinstall the controller box cover (🔩 x 4).
10. Attach the handset support bracket and handset bracket to the machine, and then connect the handset cord with the ferrite core to the "TEL" jack if you install the handset to the machine.

⬇ Note

- For details, refer to "Handset Installation" in the Service Manual for the Fax Unit (D3A5).
- Only for the Taiwan model, install the telephone jack cap in the "TEL" jack if the handset is not installed on the machine.

11. Make two loops with the telephone cord, and then attach the ferrite core [A].

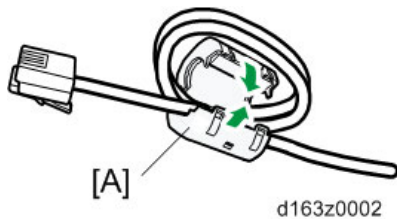

d163z0002

12. Connect the telephone cord to the "LINE 1" jack.
13. Attach the clamps [A] on the rear cover of the optional paper feed unit, and then hold the telephone cord with the clamps as shown below.

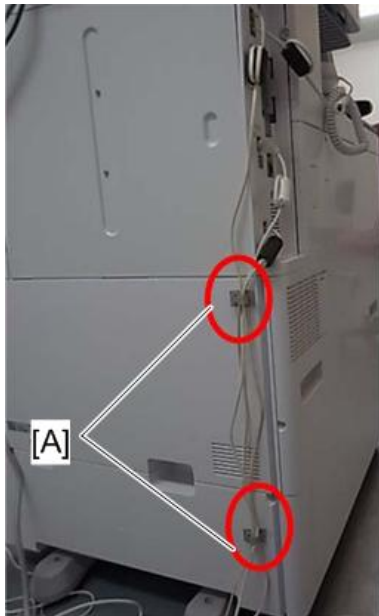

d163z0001

14. Attach the fax key top decal [A] to the second key top from the top.



d197z2007

15. Attach the fax serial number decal [A] to the bottom of the controller cover.



d197z2008

16. Attach the FCC decal on the rear lower cover of the machine (NA only).
17. Put the power plug into the outlet and turn on the main power of the machine.

↓ **Note**

- Make sure that the outlet is grounded.
- "SRAM formatted" shows on the operation panel after you have turned the main switch on. Turn the main switch off and on again for normal use.

18. Make sure that the date and time are correctly set.

1.2 G3 INTERFACE UNIT TYPE M12

This G3 interface unit option is used only for Fax Option Type M12 model.

1.2.1 COMPONENT CHECK

Check the quantity and condition of the components against the following list.

No.	Description	Q'ty
1	SG3 Interface Unit	1
2	Screw: M3x6	4
3	Flat Cable	1
4	Telephone Cable (NA only)	1
-	Ferrite Core	1
-	EMC Address Decal (EU only)	1
-	FCC Decal (NA only)	1
-	NCC Decal (TWN only)	1



1.2.2 INSTALLATION PROCEDURE

⚠ CAUTION

- **Before installing this optional unit:**

Print out all data in the printer buffer.

Turn off the main switch and disconnect the power cord and the network cable.

You can add two more SG3 boards to this model. Follow the procedures for adding the single SG3 board installation or double SG3 board installation as the customer needs.

For Installing the single G3 Board

1. If the FCU is not installed in the machine, install the FCU in the machine first (page 1).
2. Remove the controller cover [A] (🔩 x 4).

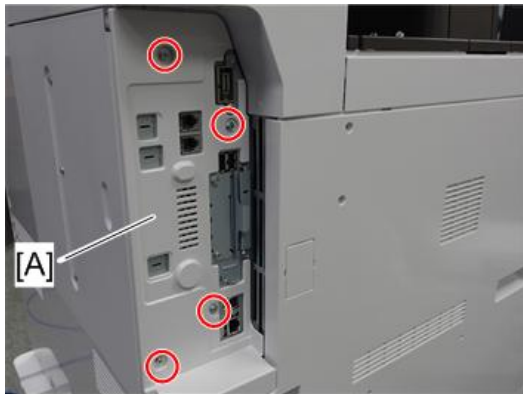

d197z2009

3. Remove the controller rear cover [A] (🔩 x 5).

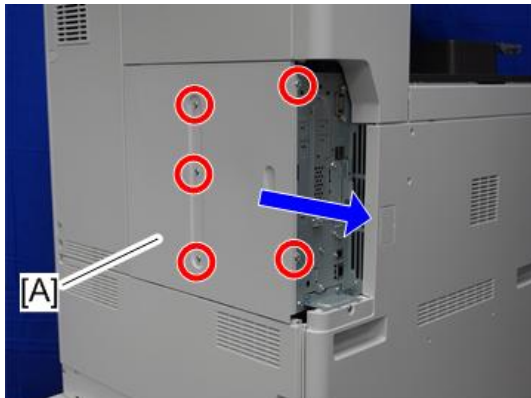

d197f0048

4. Remove the "TEL2" [A] cover with a screw driver.

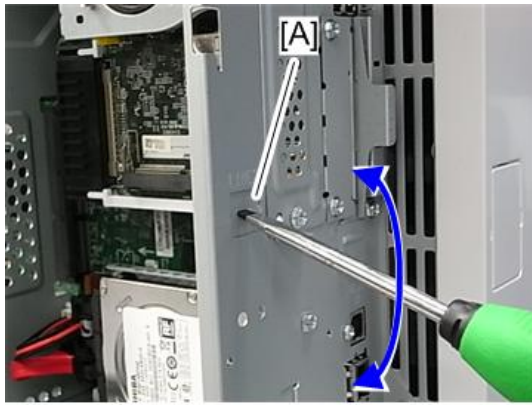

d197z2110

5. Attach one end of the flat cable [B] to CN660 on the CCU I/F board [A] of the SG3 interface unit.

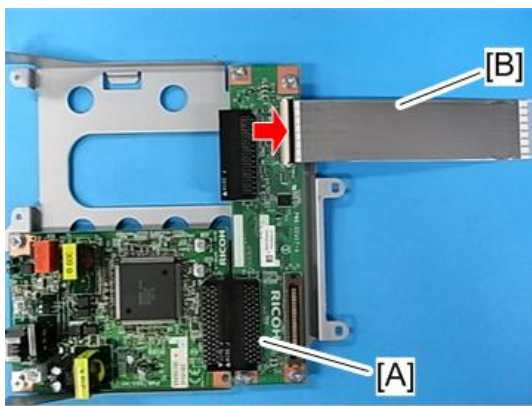

d197z2111

Note

- Make sure that the blue tape of the flat cable faces outward.
- Lock the FFC with the black tab [A].

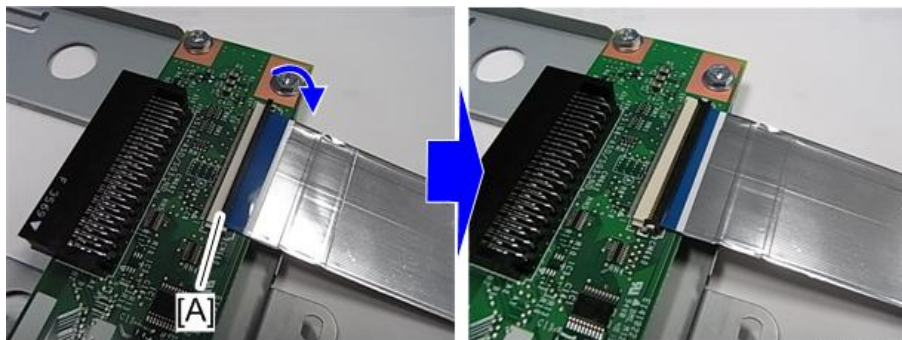

d197z2112

6. Connect the other end [A] of the flat cable to CN603 on the FCU board.



7. Install the SG3 interface unit [A] (Ⓜ x 4).

- Insert the tab of the SG3 interface unit in the cutout of the controller box.
- Push the flat cable [B] inside the machine.

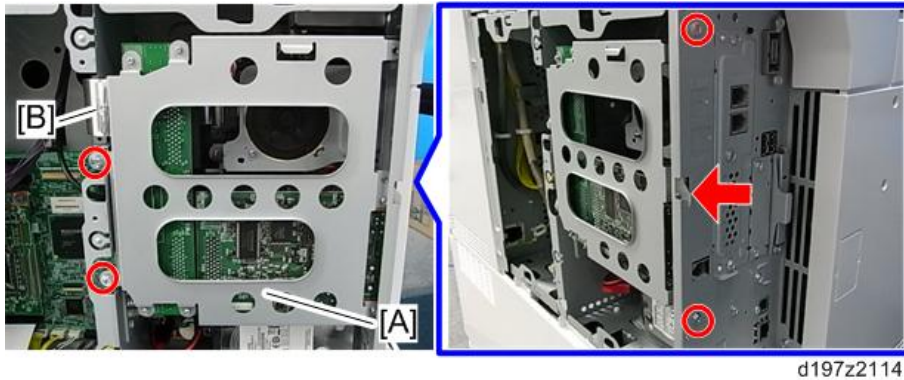

8. Reinstall the controller rear cover and controller cover.

9. Make two loops with the telephone cord, and then attach the ferrite core [A] for single SG3 board installation.

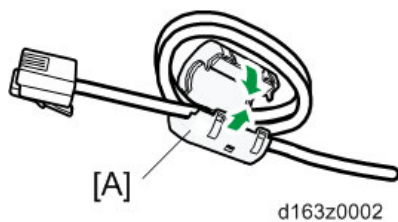

10. Connect the telephone cord to the "LINE 2" jack for single SG3 board installation.

11. Hold the telephone line with the clamps [A] as shown below.

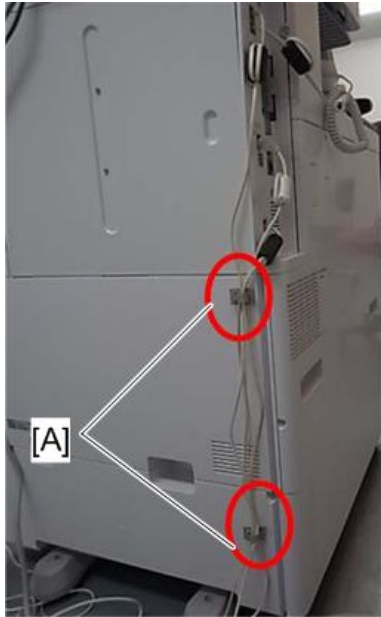

d163z0001

12. Connect the power plug to a power outlet and turn on the main power switch.
13. Enter the service mode. Set bit 1 of communication switch 16 to "1" (SP1-104-023).
14. Exit the service mode.
15. Turn the main power switch off and on.
16. Print out the system parameter list. Then check that "G3" shows as an option.
17. Set up and program the items required for PSTN-2 communications.

For Installing the Double G3 Boards

1. If the FCU is not installed in the machine, install the FCU in the machine first (page 1).
2. Remove the controller cover [A] (🔩 x 4).

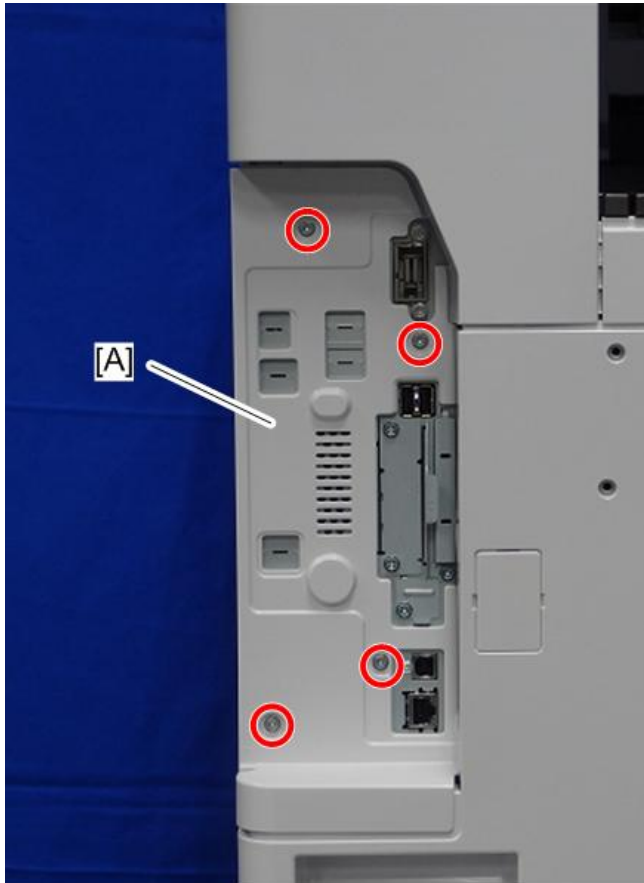

d197f0042

3. Remove the controller rear cover [A] (🔩 x 5).

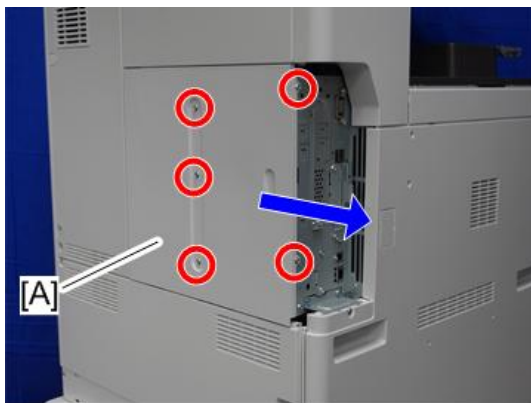

d197f0048

4. Remove the "LINE2" [A] and "LINE3" [B] covers with a screw driver.

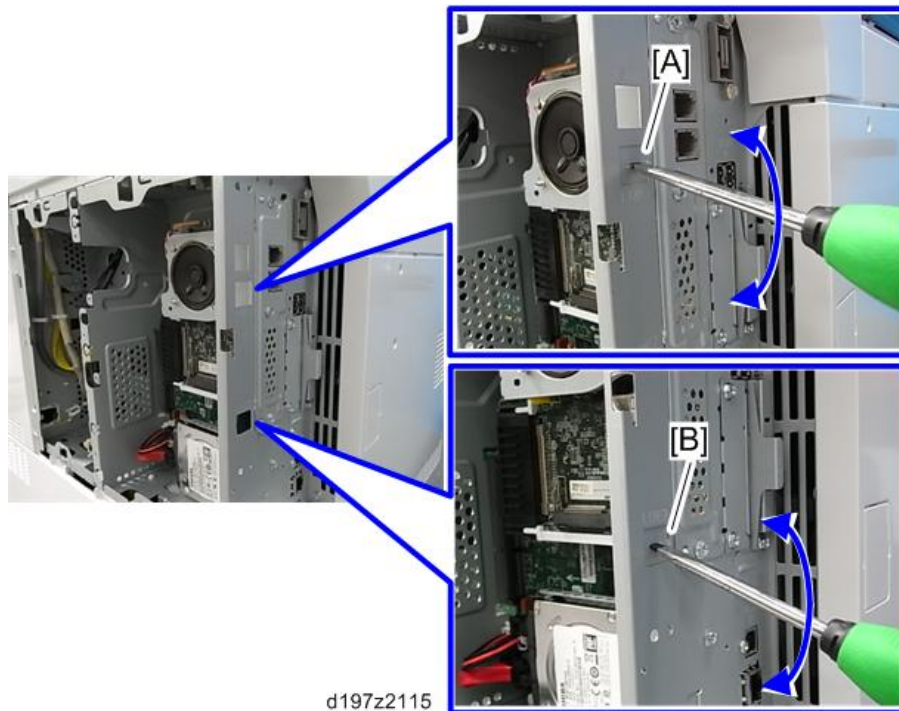

d197z2115

5. Remove the SG3 board [A] from one of the SG3 interface units (🔩 x 2).

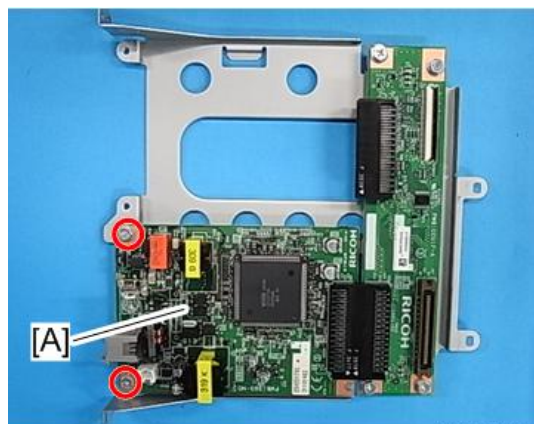

d197z2116

6. Attach the SG3 board [A] removed in step 5 to the CCU I/F of the other SG3 interface unit [B] (🔩 x 2).

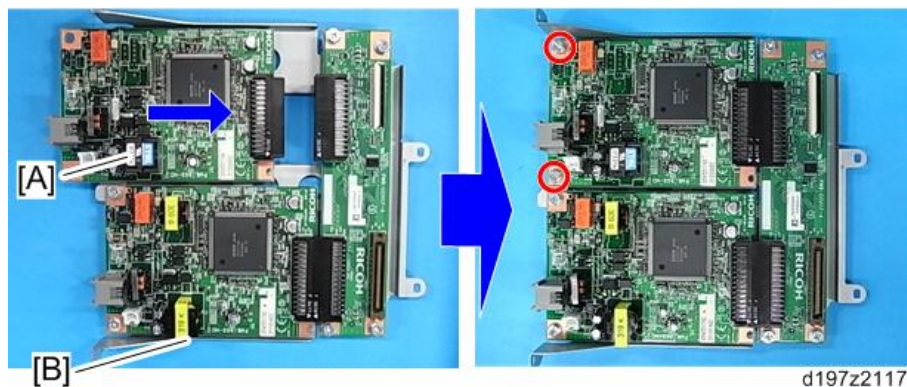

d197z2117

7. Attach one end [A] of the flat cable to CN660 on the CCU I/F board of the SG3 interface unit [B].
- Make sure that the blue tape of the flat cable faces outward.

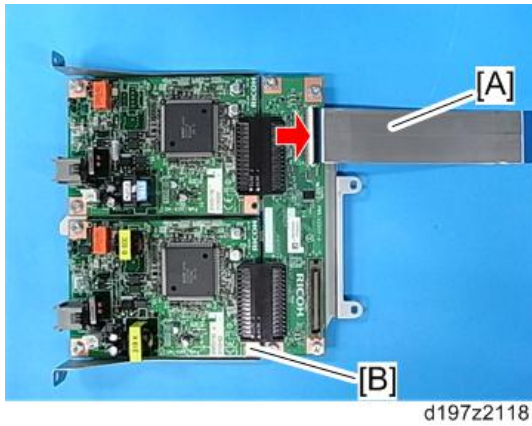

Note

- Make sure that the blue tape of the flat cable faces outward.
- Lock the FFC with the black tab [A].

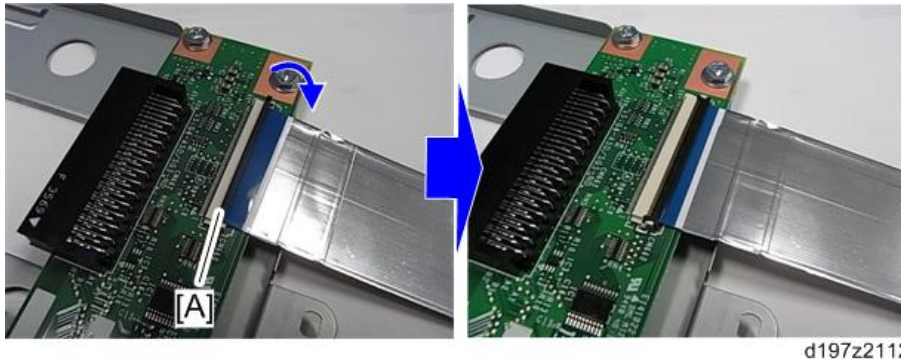

8. Connect the other end [A] of the flat cable to CN603 on the FCU board.

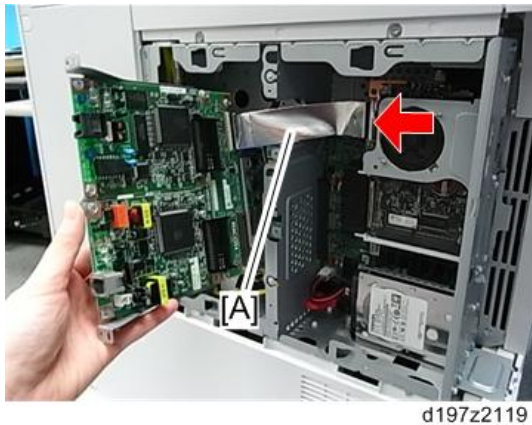

9. Install the SG3 interface unit [A] (🔩 x 3).

- Insert the tab of the SG3 interface unit in the cutout of the controller box.
- Push the flat cable [B] inside the machine.

G3 Interface Unit Type M12

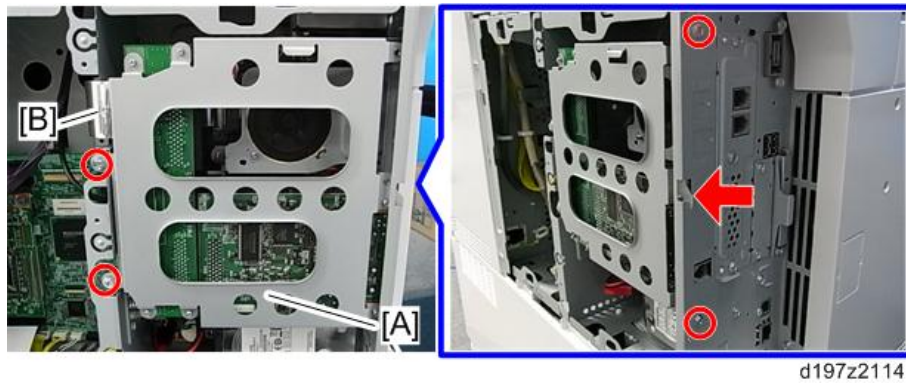

- Only for installing the double SG3 board in Taiwan, attach the NCC decal to the frame [A] of the SG3 interface unit as shown below.

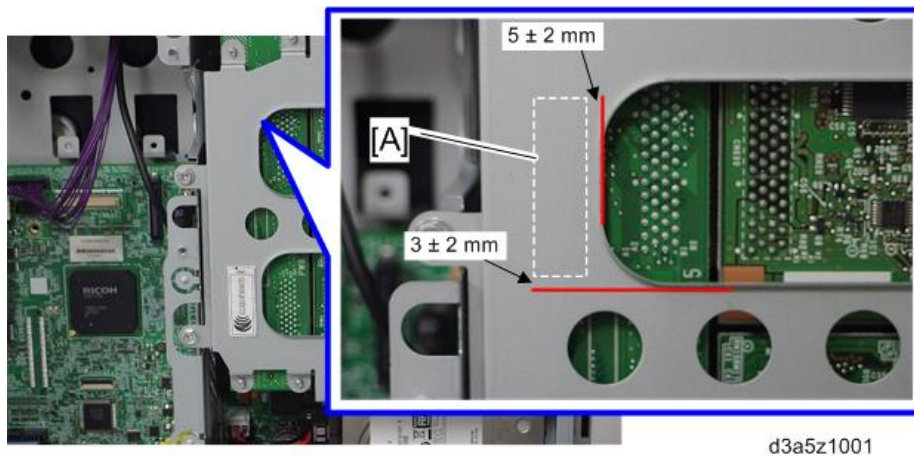

10. Reinstall the controller rear cover and controller cover.
11. Make two loops with the telephone cord for each telephone line (LINE2, LINE3), and then attach the ferrite core [A] to each telephone line for double-SG3 board installation.

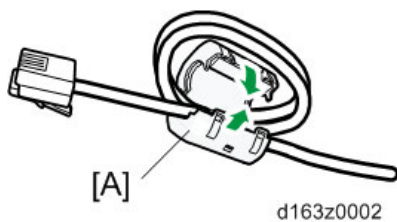

12. Connect the telephone cords to the "LINE2" and "LINE3" jacks.
13. Hold the telephone lines with the clamps [A] as shown below.

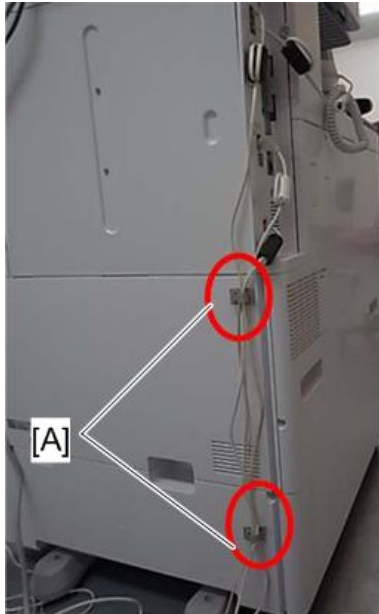

d163z0001

14. Connect the power plug to a power outlet and turn on the main power switch.
15. Enter the service mode. Set bit 1 of communication switch 16 to "1" (SP1-104-023).
16. Set bit 3 of communication switch 16 to "1" (SP1-104-023).
17. Exit the service mode.
18. Turn the main power switch off and on.
19. Print out the system parameter list. Then check that "G3" shows as an option.
20. Set up and program the items required for PSTN-2 communications.

1.3 FAX UNIT OPTIONS

1.3.1 MEMORY UNIT TYPE M12 64MB

1. Remove the controller box cover (🔑 x 4).

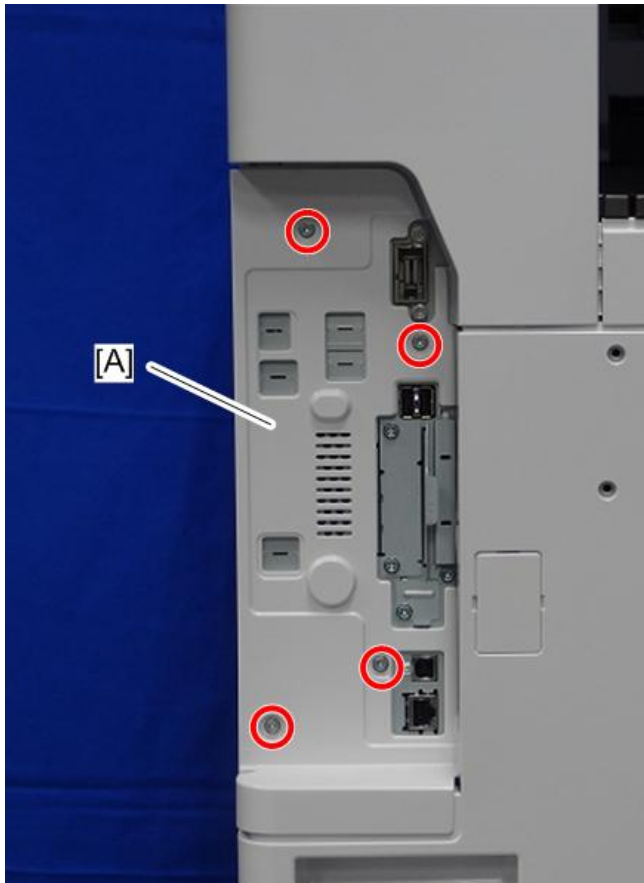

d197f0042

2. Remove the FCU slot cover [A] (🔑 x 3).

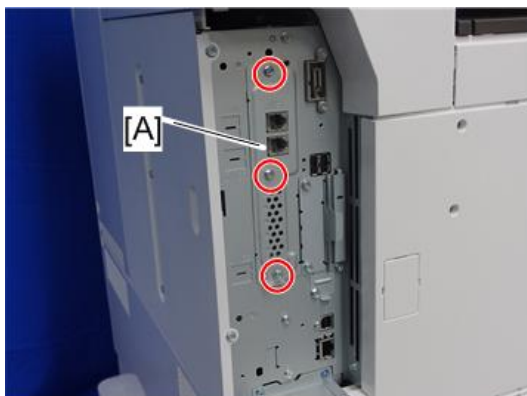

d197z2006

3. Pull out the FCU [A].

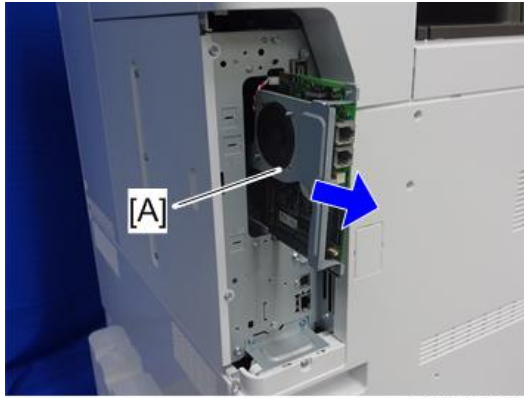

d197z2020

4. Install the memory option [A] on the FCU.

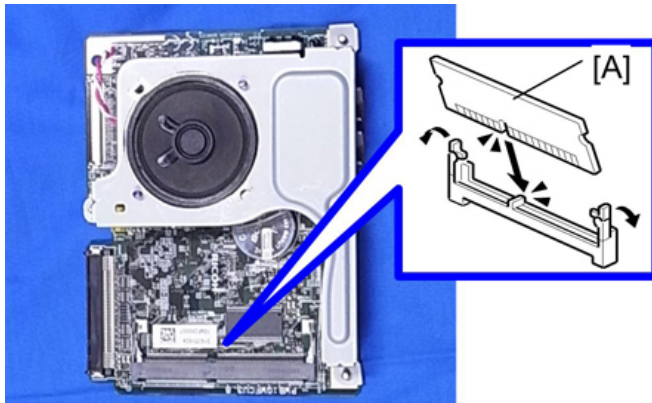

d1633001

5. Reinstall the FCU in the FCU slot.
6. Reassemble the machine.

1.3.2 HANDSET HS3020

Note

- The optional handset is available for the U.S. version only.

1. Open the front cover.



d197f0040

2. Remove the paper exit tray [A].



d1462023

3. Remove the upper left cover [A] (⊖ x1).

- Slide the cover in the direction of the blue arrow.

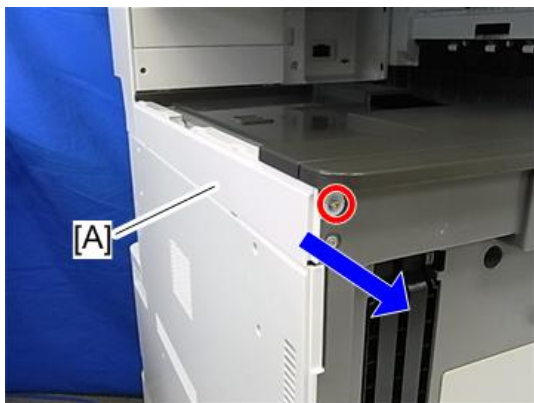

d197z0001

4. Remove the left rear cover [A] (🔧 x2).

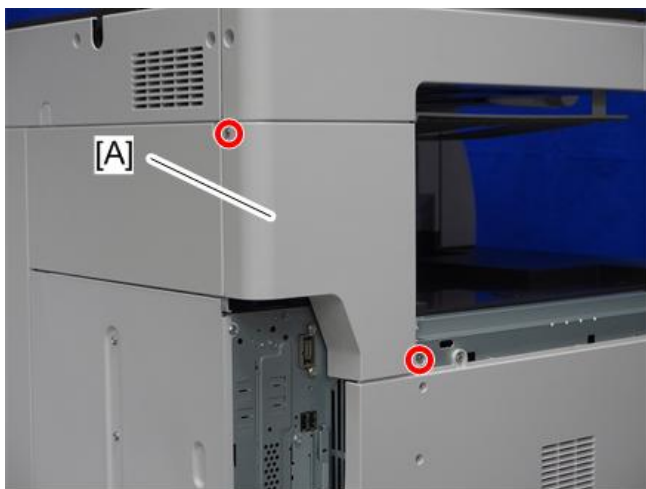

d197f0043

5. Remove the scanner front cover [A] (🔧 x2).

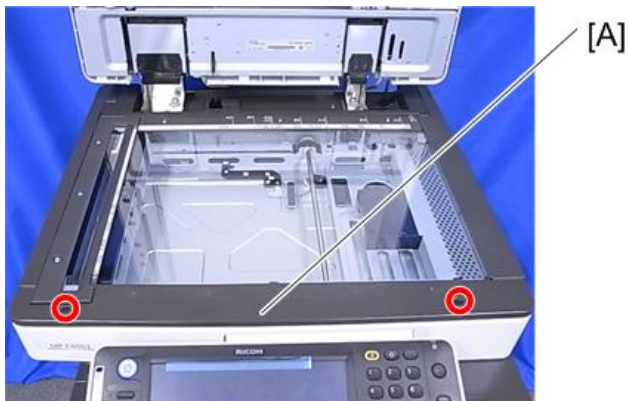

d1462302

6. Remove the scanner left cover [A] (🔧 x3).

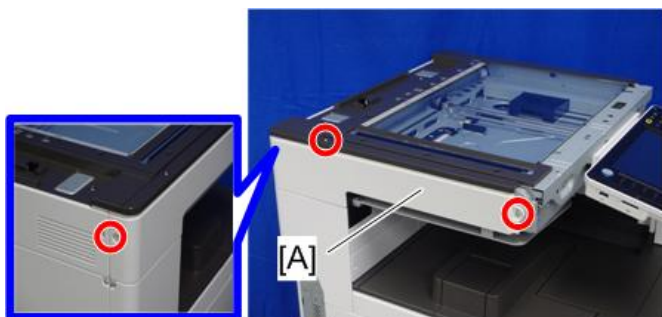

d197f0022

7. Make two holes in the scanner left cover.

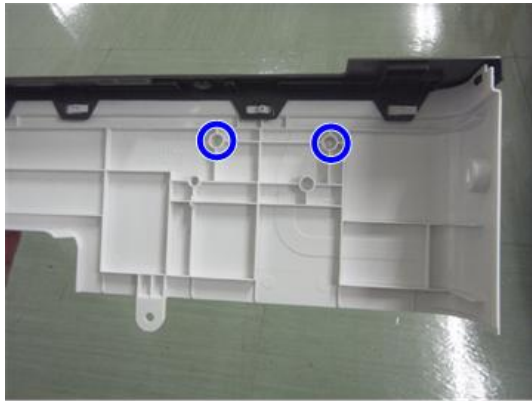

d1463050

8. Reattach the scanner left cover (🔩 x 3).

9. Re-assemble the machine.

10. Attach the bracket [A] enclosed with the fax unit (🔩 x 2: M3 x 12) as shown.

- Only for the machine with the single pass ADF, use the hole [B] to tilt the bracket.

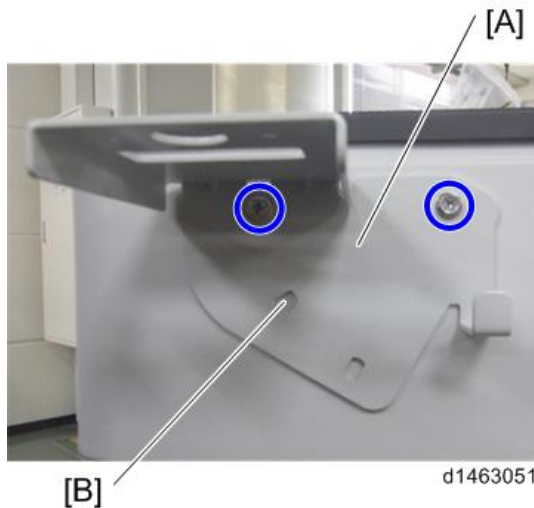

d1463051

11. Attach the cradle [A] to the handset bracket (🔩 x 2).



d1463052

12. Make two loops with the telephone cord, and then attach the ferrite core [A] to the cable.



d1463054

13. Connect the cable to the "TEL" jack on the left side of the controller box.



d1463055

1.4 FAX CONNECTION UNIT TYPE M12

1.4.1 INSTALLATION PROCEDURE

This unit allows a machine without the fax unit installed (“Client-side Machine”) to send and receive faxes via a machine with the fax unit installed (“Remote Machine”).

Requirements:

- Up to six machines can be registered as the Client-side Machines.
- Machines that have the fax unit installed cannot be used as the Client-side Machine.
- Only one machine can be registered as the Remote Machine.
- Firmware for this unit: “aics” (software number: D3A7759)
- Remote Fax transmissions are possible on a G3 line.
- The remote fax function does not support User Code Authentication. Disable the User Code Authentication on the Remote machine.
- Use this function to check the contents of a file that is stored in memory and not yet sent. Also, use this function to cancel a transmission from the Client-side Machine.

Order of Fax Connection Unit installation procedure:

1. Install the Fax Connection Unit in the Remote Machine (fax unit installed).
2. Install the Fax Connection Unit in the Client-side Machine (no fax unit installed).
3. Register the Client-side Machine in the Remote Machine.

★ Important

- Do not register the Remote Machine before the Client-side Machine is registered in the Remote Machine. Otherwise, registering the Remote Machine fails.
4. Register the Remote Machine in the Client-side Machine.

Installing the application in the Remote Machine and Client-side Machine

1. Remove the SD card slot cover from the SD card slots [A] (🔑 x 1).

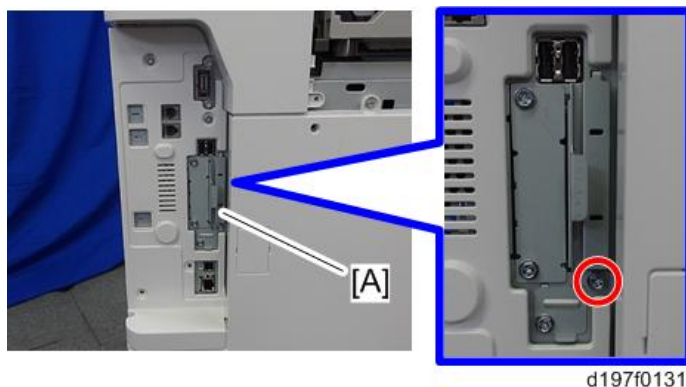

2. Insert the SD card (Fax Connection Unit Type M12) in SD slot 1 (upper) with its label face towards the front of the machine if SD slot 1 is vacant. If not, follow the procedure below.

3. Plug in, and then turn on the machine.
4. Press [Firmware Version] in the [Administrator Tools].
 - [User Tools/Counter] > [System Settings] > [Administrator Tools]
5. Check whether the aics version is displayed.

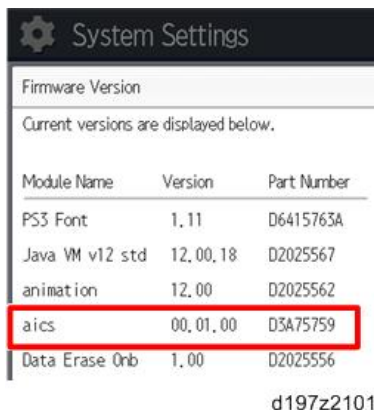

System Settings		
Firmware Version		
Current versions are displayed below.		
Module Name	Version	Part Number
PSS Font	1.11	D6415763A
Java VM v12 std	12.00.18	D2025567
animation	12.00	D2025562
aics	00.01.00	D3A75759
Data Erase Onb	1.00	D2025556

d197z2101

Moving a Fax Communication application into an SD card in SD slot 1

1. Insert the SD card (Fax Connection Unit Type M12) SD slot 2 (lower) with its label face towards the front of the machine. Then push it slowly into SD slot 2 (lower) until you hear a click.
2. Plug in, and then turn on the machine.
3. Move the Fax Connection Unit Type M12 application from the SD card in SD slot 2 (lower) to the SD card in SD slot 1 (upper) with SP5-873-001.
4. Turn off the machine.
5. Remove the SD card from SD slot 2 (lower), and then keep it in a safe place (see “SD Card Appli Move” in the field service manual for the mainframe).
6. Attach the SD-card slot cover, and then turn on the machine (👉 x 1).
7. Turn on the machine.
8. Press [Firmware Version] in the [Administrator Tools].
 - [User Tools/Counter] > [System Settings] > [Administrator Tools]
9. Check whether the aics version is displayed.

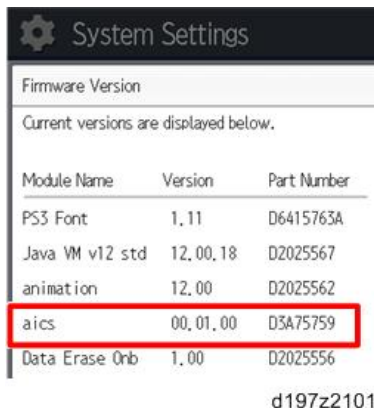

System Settings		
Firmware Version		
Current versions are displayed below.		
Module Name	Version	Part Number
PSS Font	1.11	D6415763A
Java VM v12 std	12.00.18	D2025567
animation	12.00	D2025562
aics	00.01.00	D3A75759
Data Erase Onb	1.00	D2025556

d197z2101

Registering the Client-side Machine(s)

★ Important

- Do not register the Remote Machine in the Client-side machine before the Client-side Machine is registered in the Remote Machine. Otherwise, registering the Remote Machine fails.

On the Remote Machine:

- Press the [User Tools/Counter] key on the operation panel.
- Press [System Settings].
- Press [Administrator Tools].
- Press [Program/Change/Delete Remote Machine].

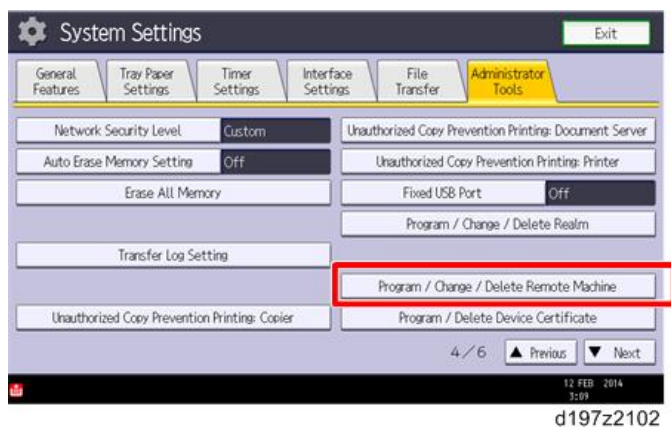

- Press one of the machine registration lines, and then enter the IP address or host name of one of the Client-side Machines.

↓ Note

- Up to six machines can be registered as the Client-side Machines.

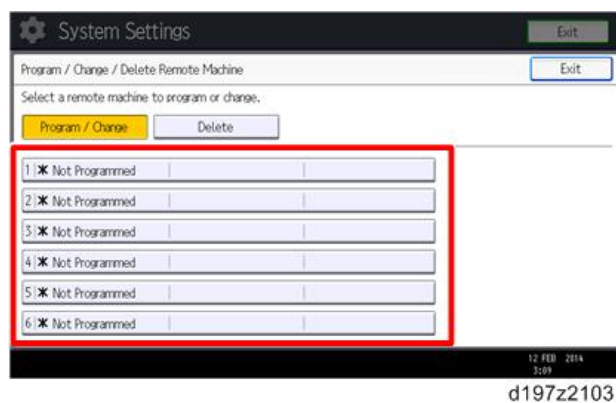

- Press [Connection Test] to check the connection with the client-side machine.

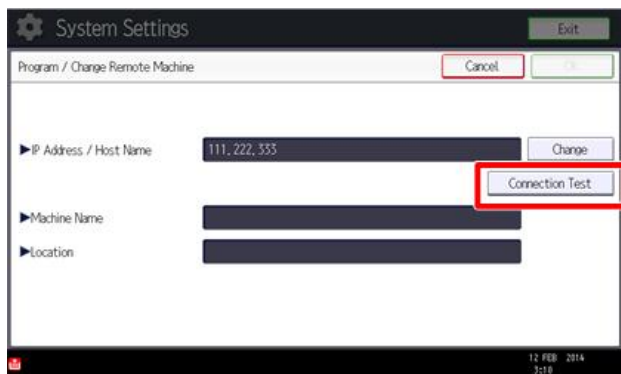

d197z2104

- If an error message is displayed, check the network connection with the client-side machine and make sure that the IP address of the client-side machine is correct.

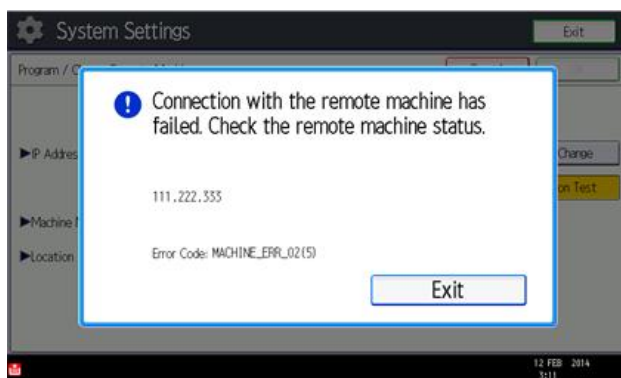

d197z2105

7. Press [OK] after “Connection Test” has been successfully done.

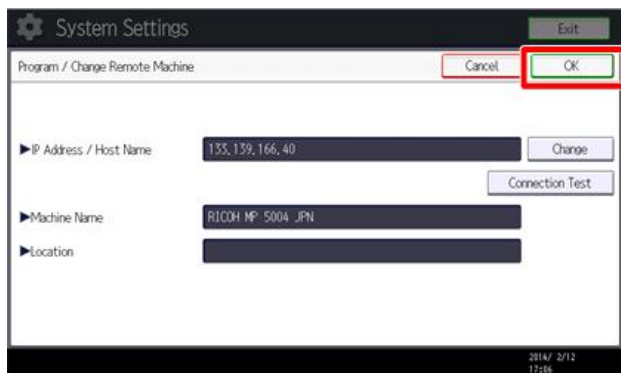

d197z2106

8. Press [User Tools/Counter] key on the operation panel to terminate the System Settings.

Registering the Remote Machine

★ Important

- First register the Client-side Machine in the Remote Machine before proceeding this procedure. Otherwise, registering the Remote Machine fails.

↓ Note

- Only one machine can be registered as the Remote Machine.

On the Client-side Machine(s):

1. Press the [User Tools/Counter] key on the operation panel
2. Press [System Settings].
3. Press [Administrator Tools].
4. Press [Program/Change/Delete Remote Machine].
5. Enter the IP address or host name of the Remote Machine.
6. Press one of the machine registration lines, and then enter the IP address or host name of the Remote Machine

↓ Note

- Only one machine can be registered as the Remote Machine.

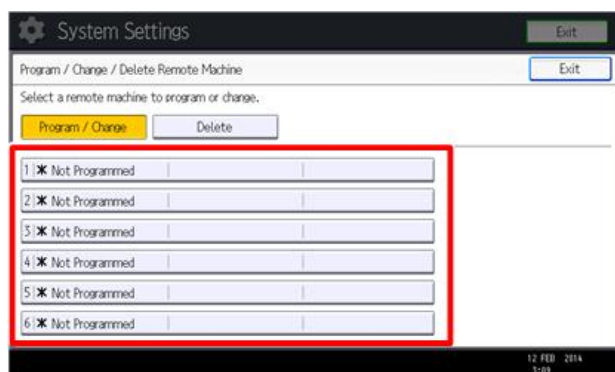

d197z2103

7. Press [Connection Test] to check the connection with the remote machine.

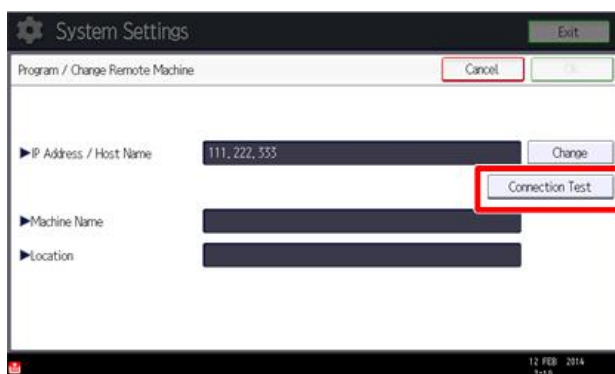

d197z2104

- If an error message is displayed, check the network connection with the remote machine and make sure that the IP address of the remote machine is correct.

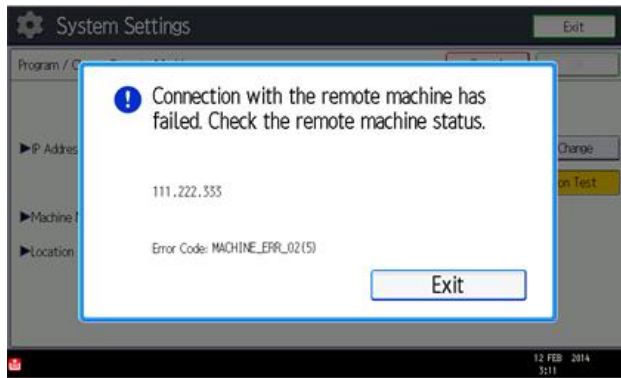

d197z2105

8. Press [OK] after "Connection Test" has been successfully done.

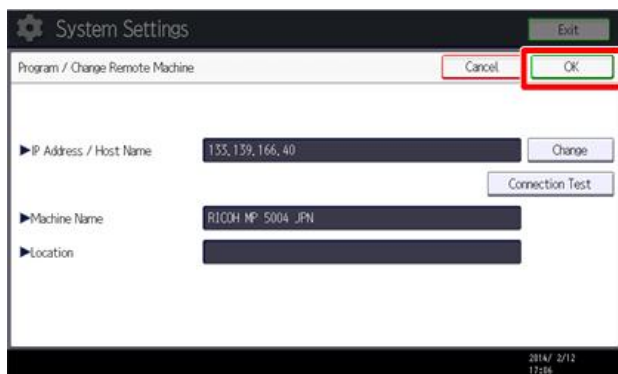

d197z2106

9. Press [User Tools/Counter] key on the operation panel to terminate the System Settings.

Configuring the Remote Reception Settings

Do the following procedure to enable the Client-side Machine(s) to receive faxes via the Remote Machine. You can forward or route received documents per line or special sender.

Note

- By performing procedures described above (Installing the application in the Remote Machine and Client-side Machine, Registering the Client-side Machine(s), Registering the Remote Machine), the Client-side Machines can **send** faxes via the Remote Machine. The procedures shown below are necessary to enable the Client-side Machines to **receive** faxes.

On the Remote Machine:

1) If you use "Remote Reception Setting per Line"

- Press [Facsimile Features].
- Press [Remote Reception Setting per Line] in [Reception Settings].
- Enter an IP address or a host name of the client-side machine to connect.
- Press [Set], and [Exit] to exit from the setting.

2) If you use "Remote Reception per Sender"

- Press [Facsimile Features].

2. Press [Program Special Sender] in [Reception Settings].
3. Select the Special Sender.

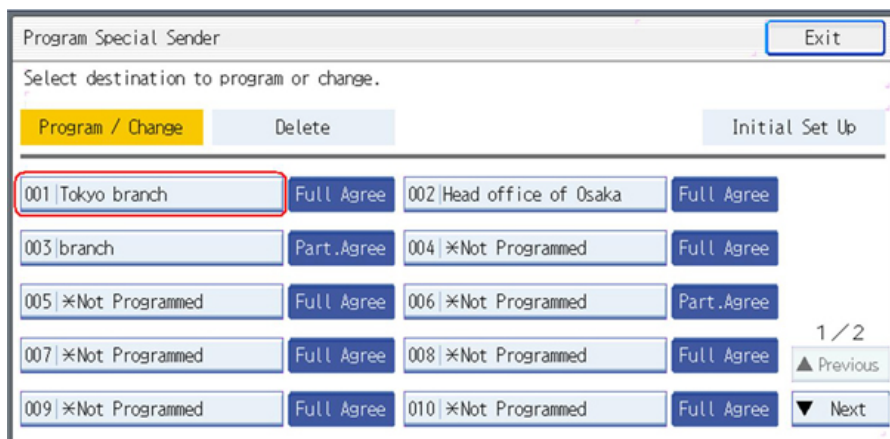

d1661001

4. Press [Remote Reception Setting per Sender].

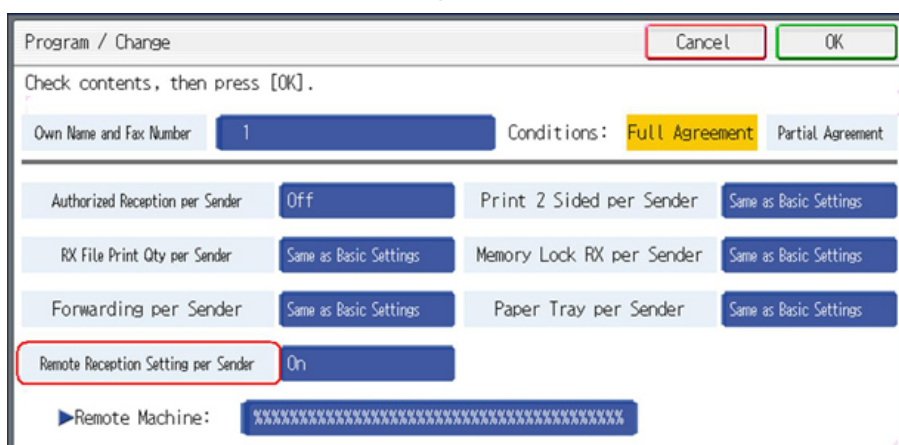

d1661002

5. Press [On] and [Remote Machine].

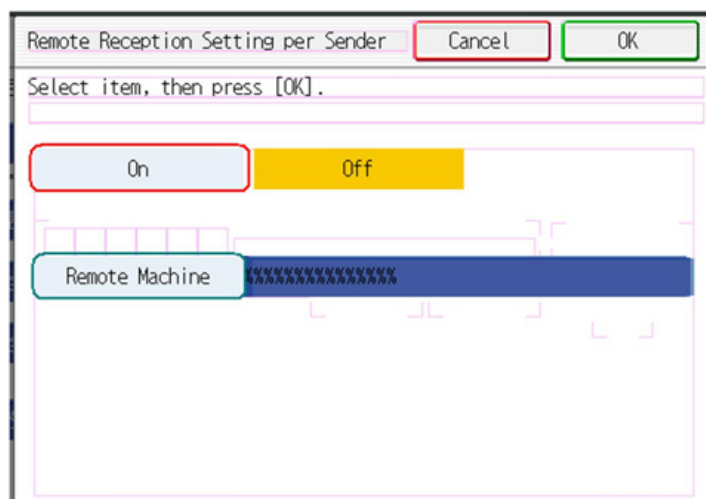

d1661003

6. Enter an IP address or a host name of the client-side machine to connect.
7. Press [OK] to exit from the setting.

Remote Fax Icon Addition for Remote Machine

The icon of the fax communication is supposed to appear automatically on the home screen of the Client-side Machine(s) after installation of the Fax Communication. If the icon of the fax communication does not appear, add the icon manually. This procedure allows the remote fax icon to appear on the home screen of the operation panel.

On both the Remote Machine and the Client-side Machines:

1. Press [User Tools].
2. Press [Edit Home].

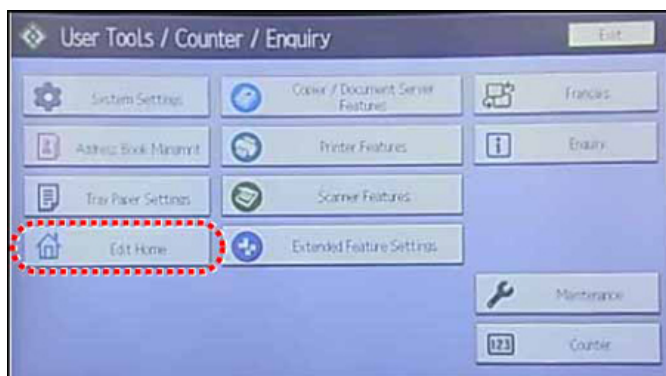

d1440144

3. Press [Add Icon].

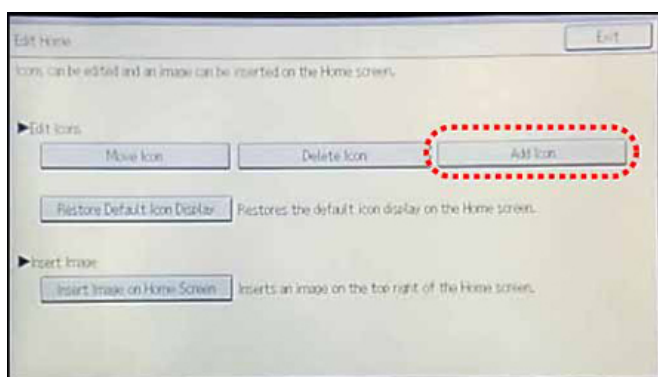

d1440145

4. Press [Remote Fax].

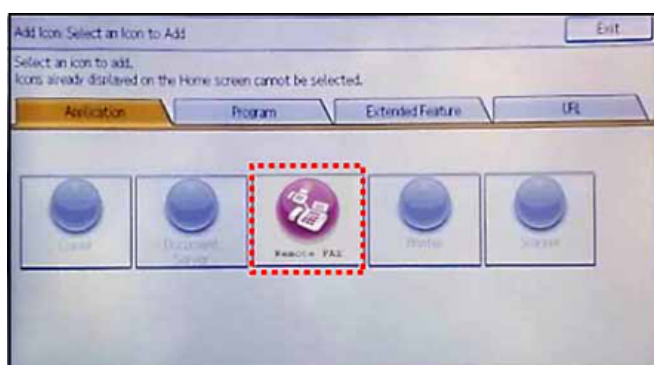

d1440146a

5. Press a [Blank] to set a location for the remote fax icon.

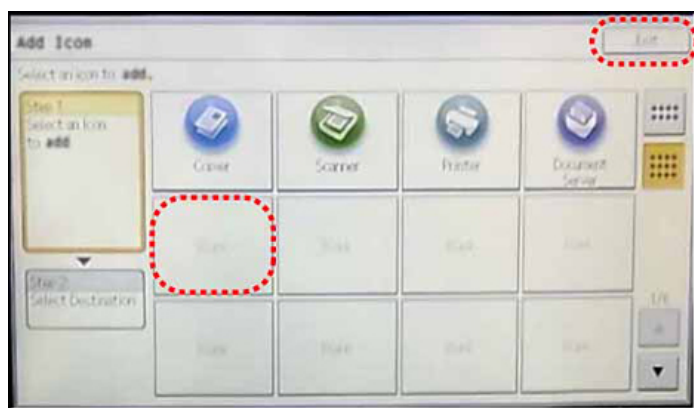

d1440147

6. Press [Exit] to exit from the set-up procedure.

2. REPLACEMENT AND ADJUSTMENT

2.1 FCU

2.1.1 SRAM DATA TRANSFER PROCEDURE

When you replace the FCU board, transfer the SRAM data from the old FCU board to the new FCU board. Do the following procedure to back up the SRAM data.

↓ Note

- The following data can be transferred: TTI, RTI, CSI, Fax bit switch settings, RAM address settings, NCU parameter settings

1. Remove the controller cover [A] (🔩 x 4).

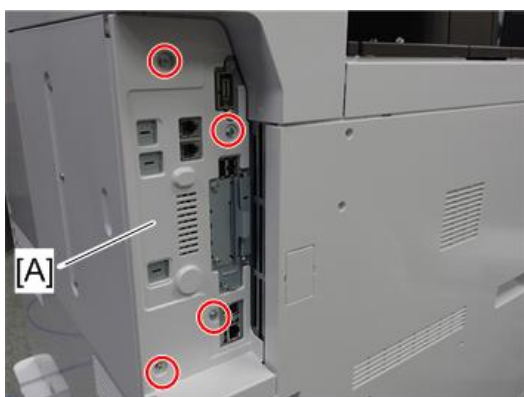

d197z2009

2. Remove the FCU [A] from the FCU slot (🔩 x 3).

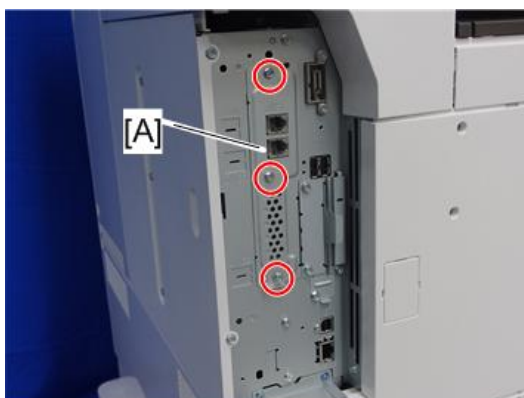

d197z2017

3. Replace the installed FCU board [A] with a new FCU board (🔩 x 3, 📦 x 1).

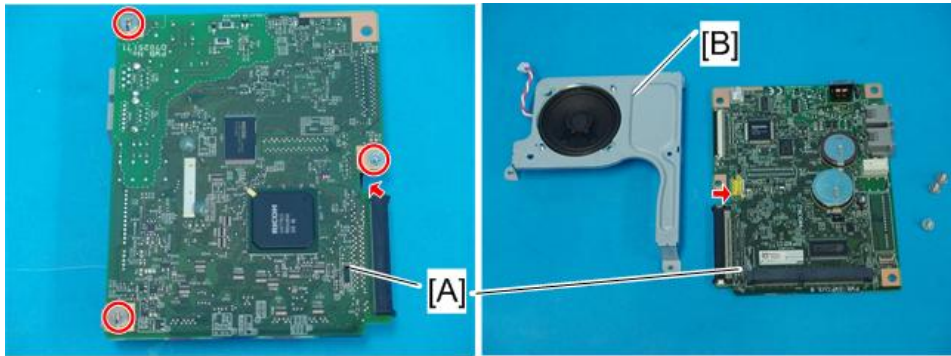

d197z2018

4. **Attach the flat cable [A] to CN603 of the new fax unit.**
 - Use caution to avoid an oblique insertion of the cable.
 - Make sure that the blue tapes of the flat cable face outward.



d197z2019

5. **Switch the battery jumper switch [A] to the "ON" position.**

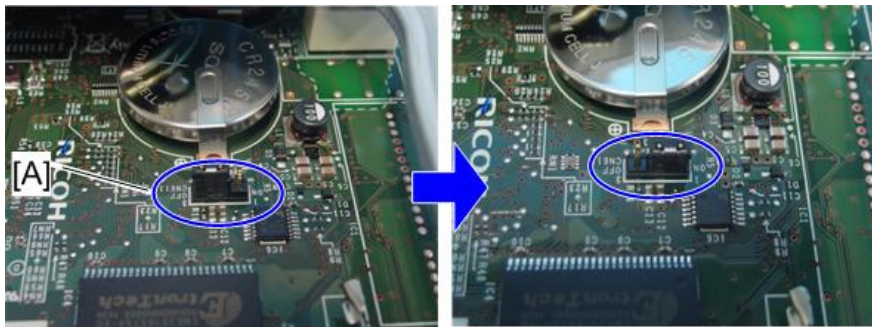

d197z2004

Note

- If you do not switch the battery jumper switch position, SC820 will occur.

6. **Reinstall the new fax unit in the FCU slot (⚙ x 3).**
7. **Remove the controller rear cover [A] (⚙ x 5).**

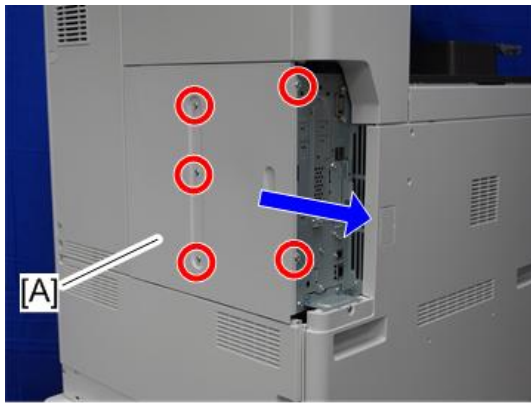

d197f0048

8. Attach the bracket [A] provided with the new fax unit to the center frame of the controller box (🔩 x 1).

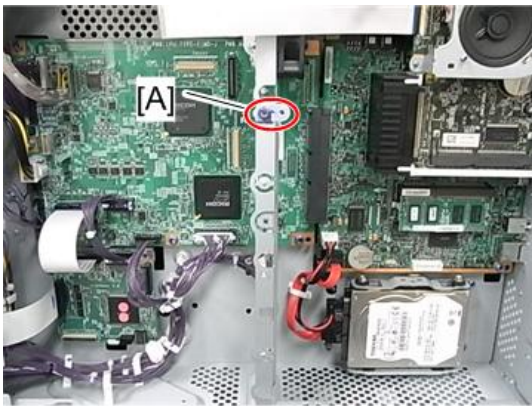

d163z0008

9. Attach the FCU board removed in step 3 to the bracket attached in step 8. Then attach the flat cable attached in step 4 to CN603 of the removed FCU board (🔩 x 1).
- Make sure that the blue tape of the flat cable faces outward.

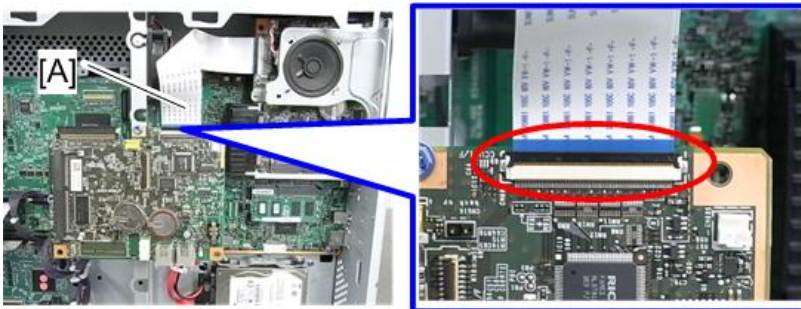

d163z0009

⚠ CAUTION

- The removed FCU board must be away from the metal frames. Otherwise, the removed FCU board may get a short circuit.

10. Install the jumper switch [B] in CN616 on the replaced FCU [A].

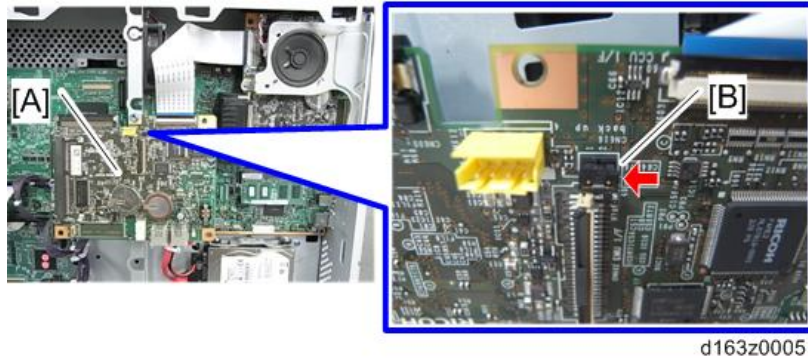

11. Turn on the main power switch.
12. SRAM data transmission starts. When the transmission is completed, you will hear a beeper sound.
 - ⏴ Note
 - The beeper sound is the same volume as the speaker sound.
 - The beeper sounds even if the speaker sound is turned off.
 - If the beeper does not sound, turn the main power switch on and off repeatedly and do the transmission procedure 2 or 3 times.
 - If the beeper does not sound after turning the main switch on and off 3 times, you need to input the settings stored in SRAM memory manually.
13. When “Ready” appears on the copy display, turn off the main power switch, and then disconnect the flat cable from the removed FCU board.
14. Remove the removed FCU board (👉 x 1).
15. Remove the bracket from the center frame of the controller box (👉 x 1).
16. Disconnect the flat cable from the new FCU board.
17. Re-assemble the machine.
18. Turn on the main power switch, then do SP6-101 to print the system parameter list.
19. Check the system parameter list to make sure that the data is transferred correctly.
20. Set the correct date and time with the User Tools: User Tools > System Settings > Timer Setting > Set Date/Time.

3. TROUBLESHOOTING

3.1 ERROR CODES

If an error code occurs, retry the communication. If the same problem occurs, try to fix the problem as suggested below. Note that some error codes appear only in the error code display and on the service report.

Code	Meaning	Suggested Cause/Action
0-00	DIS/NSF not detected within 40 s of Start being pressed	<ul style="list-style-type: none"> ▪ Check the line connection. ▪ The machine at the other end may be incompatible. ▪ Replace the FCU. ▪ Check for DIS/NSF with an oscilloscope. ▪ If the rx signal is weak, there may be a bad line.
0-01	DCN received unexpectedly	<ul style="list-style-type: none"> ▪ The other party is out of paper or has a jammed printer. ▪ The other party pressed Stop during communication.
0-03	Incompatible modem at the other end	The other terminal is incompatible.
0-04	CFR or FTT not received after modem training	<ul style="list-style-type: none"> ▪ Check the line connection. ▪ Try changing the tx level and/or cable equalizer settings. ▪ Replace the FCU. ▪ The other terminal may be faulty; try sending to another machine. ▪ If the rx signal is weak or defective, there may be a bad line. <p>Cross reference</p> <p>Tx level - NCU Parameter 01 (PSTN) Cable equalizer - G3 Switch 07 (PSTN) Dedicated Tx parameters in Service Program Mode</p>

Error Codes

Code	Meaning	Suggested Cause/Action
0-05	Modem training fails even G3 shifts down to 2400 bps.	<ul style="list-style-type: none"> ▪ Check the line connection. ▪ Try adjusting the tx level and/or cable equalizer. ▪ Replace the FCU. ▪ Check for line problems. <p>Cross reference See error code 0-04.</p>
0-06	The other terminal did not reply to DCS	<ul style="list-style-type: none"> ▪ Check the line connection. ▪ Try adjusting the tx level and/or cable equalizer settings. ▪ Replace the FCU. ▪ The other end may be defective or incompatible; try sending to another machine. ▪ Check for line problems. <p>Cross reference See error code 0-04.</p>
0-07	No post-message response from the other end after a page was sent	<ul style="list-style-type: none"> ▪ Check the line connection. ▪ Replace the FCU. ▪ The other end may have jammed or run out of paper. ▪ The other end user may have disconnected the call. ▪ Check for a bad line. ▪ The other end may be defective; try sending to another machine.

Code	Meaning	Suggested Cause/Action
0-08	The other end sent RTN or PIN after receiving a page, because there were too many errors	<ul style="list-style-type: none"> ▪ Check the line connection. ▪ Replace the FCU. ▪ The other end may have jammed, or run out of paper or memory space. ▪ Try adjusting the tx level and/or cable equalizer settings. ▪ The other end may have a defective modem/FCU; try sending to another machine. ▪ Check for line problems and noise. <p>Cross reference</p> <ul style="list-style-type: none"> ▪ Tx level - NCU Parameter 01 (PSTN) ▪ Cable equalizer - G3 Switch 07 (PSTN) ▪ Dedicated Tx parameters in Service Program Mode
0-14	Non-standard post message response code received	<ul style="list-style-type: none"> ▪ Incompatible or defective remote terminal; try sending to another machine. ▪ Noisy line: resend. ▪ Try adjusting the tx level and/or cable equalizer settings. ▪ Replace the FCU. <p>Cross reference</p> <p>See error code 0-08.</p>
0-15	The other terminal is not capable of specific functions.	<p>The other terminal is not capable of accepting the following functions, or the other terminal's memory is full.</p> <ul style="list-style-type: none"> ▪ Confidential rx ▪ Transfer function ▪ SEP/SUB/PWD/SID

Error Codes

Code	Meaning	Suggested Cause/Action
0-16	CFR or FTT not detected after modem training in confidential or transfer mode	<ul style="list-style-type: none"> ▪ Check the line connection. ▪ Replace the FCU. ▪ Try adjusting the tx level and/or cable equalizer settings. ▪ The other end may have disconnected, or it may be defective; try calling another machine. ▪ If the rx signal level is too low, there may be a line problem. <p>Cross reference See error code 0-08.</p>
0-17	Communication was interrupted by pressing the Stop key	If the Stop key was not pressed and this error keeps occurring, replace the operation panel or the operation panel drive board.
0-20	Facsimile data not received within 6 s of retraining	<ul style="list-style-type: none"> ▪ Check the line connection. ▪ Replace the FCU. ▪ Check for line problems. ▪ Try calling another fax machine. ▪ Try adjusting the reconstruction time for the first line and/or rx cable equalizer setting. <p>Cross reference Reconstruction time - G3 Switch 0A, bit 6 Rx cable equalizer - G3 Switch 07 (PSTN)</p>
0-21	EOL signal (end-of-line) from the other end not received within 5 s of the previous EOL signal	<ul style="list-style-type: none"> ▪ Check the connections between the FCU and line. ▪ Check for line noise or other line problems. ▪ Replace the FCU. ▪ The remote machine may be defective or may have disconnected. <p>Cross reference Maximum interval between EOLs and between ECM frames - G3 Bit Switch 0A, bit 4</p>

Code	Meaning	Suggested Cause/Action
0-22	The signal from the other end was interrupted for more than the acceptable modem carrier drop time (default: 200 ms)	<ul style="list-style-type: none"> ▪ Check the line connection. ▪ Replace the FCU. ▪ Defective remote terminal. ▪ Check for line noise or other line problems. ▪ Try adjusting the acceptable modem carrier drop time. <p>Cross reference Acceptable modem carrier drop time - G3 Switch 0A, bits 0 and 1</p>
0-23	Too many errors during reception	<ul style="list-style-type: none"> ▪ Check the line connection. ▪ Replace the FCU. ▪ Defective remote terminal ▪ Check for line noise or other line problems. ▪ Try asking the other end to adjust their tx level. ▪ Try adjusting the rx cable equalizer setting and/or rx error criteria. <p>Cross reference Rx cable equalizer - G3 Switch 07 (PSTN) Rx error criteria - Communication Switch 02, bits 0 and 1</p>
0-29	Data block format failure in ECM reception	<ul style="list-style-type: none"> ▪ Check for line noise or other line problems. ▪ Check the FCU - NCU connectors. ▪ Replace the NCU or FCU.
0-30	The other terminal did not reply to NSS(A) in AI short protocol mode	<ul style="list-style-type: none"> ▪ Check the line connection. ▪ Try adjusting the tx level and/or cable equalizer settings. ▪ The other terminal may not be compatible. <p>Cross reference Dedicated tx parameters - Section 4</p>
0-32	The other terminal sent a DCS, which contained functions that the receiving machine cannot handle.	<ul style="list-style-type: none"> ▪ Check the protocol dump list. ▪ Ask the other party to contact the manufacturer.

Error Codes

Code	Meaning	Suggested Cause/Action
0-33	The data reception (not ECM) is not completed within 10 minutes.	<ul style="list-style-type: none"> ▪ Check the line connection. ▪ The other terminal may have a defective modem/FCU.
0-52	Polarity changed during communication	<ul style="list-style-type: none"> ▪ Check the line connection. ▪ Retry communication.
0-55	FCU does not detect the SG3.	<ul style="list-style-type: none"> ▪ FCU firmware or board defective. ▪ SG3 firmware or board defective.
0-56	The stored message data exceeds the capacity of the mailbox in the SG3.	SG3 firmware or board defective.
0-70	The communication mode specified in CM/JM was not available (V.8 calling and called terminal)	<ul style="list-style-type: none"> ▪ The other terminal did not have a compatible communication mode (e.g., the other terminal was a V.34 data modem and not a fax modem.) ▪ A polling tx file was not ready at the other terminal when polling rx was initiated from the calling terminal.
0-74	The calling terminal fell back to T.30 mode, because it could not detect ANSam after sending CI.	<ul style="list-style-type: none"> ▪ The calling terminal could not detect ANSam due to noise, etc. ▪ ANSam was too short to detect. ▪ Check the line connection and condition. ▪ Try making a call to another V.8/V.34 fax.
0-75	The called terminal fell back to T.30 mode, because it could not detect a CM in response to ANSam (ANSam timeout).	<ul style="list-style-type: none"> ▪ The terminal could not detect ANSam. ▪ Check the line connection and condition. ▪ Try receiving a call from another V.8/V.34 fax.
0-76	The calling terminal fell back to T.30 mode, because it could not detect a JM in response to CM (CM timeout).	<ul style="list-style-type: none"> ▪ The called terminal could not detect a CM due to noise, etc. ▪ Check the line connection and condition. ▪ Try making a call to another V.8/V.34 fax.

Code	Meaning	Suggested Cause/Action
0-77	The called terminal fell back to T.30 mode, because it could not detect a CJ in response to JM (JM timeout).	<ul style="list-style-type: none"> ▪ The calling terminal could not detect a JM due to noise, etc. ▪ A network that has narrow bandwidth cannot pass JM to the other end. ▪ Check the line connection and condition. ▪ Try receiving a call from another V.8/V.34 fax.
0-79	The called terminal detected CI while waiting for a V.21 signal.	<ul style="list-style-type: none"> ▪ Check for line noise or other line problems. ▪ If this error occurs, the called terminal falls back to T.30 mode.
0-80	The line was disconnected due to a timeout in V.34 phase 2 – line probing.	<ul style="list-style-type: none"> ▪ The guard timer expired while starting these phases. Serious noise, narrow bandwidth, or low signal level can cause these errors. <p>If these errors happen at the transmitting terminal:</p> <ul style="list-style-type: none"> ▪ Try making a call at a later time. ▪ Try using V.17 or a slower modem using dedicated tx parameters. ▪ Try increasing the tx level. ▪ Try adjusting the tx cable equalizer setting. <p>If these errors happen at the receiving terminal:</p> <ul style="list-style-type: none"> ▪ Try adjusting the rx cable equalizer setting. ▪ Try increasing the tx level. ▪ Try using V.17 or a slower modem if the same error is frequent when receiving from multiple senders.
0-81	The line was disconnected due to a timeout in V.34 phase 3 – equalizer training.	
0-82	The line was disconnected due to a timeout in the V.34 phase 4 – control channel start-up.	
0-83	The line was disconnected due to a timeout in the V.34 control channel restart sequence.	
0-84	The line was disconnected due to abnormal signaling in V.34 phase 4 – control channel start-up.	
		<ul style="list-style-type: none"> ▪ The signal did not stop within 10 s. ▪ Turn off the main power switch, then turn it back on. ▪ If the same error is frequent, replace the FCU.

Error Codes

Code	Meaning	Suggested Cause/Action
0-85	The line was disconnected due to abnormal signaling in V.34 control channel restart.	<ul style="list-style-type: none"> ▪ The signal did not stop within 10 s. ▪ Turn off the main power switch, then turn it back on. ▪ If the same error is frequent, replace the FCU.
0-86	The line was disconnected because the other terminal requested a data rate using MPh that was not available in the currently selected symbol rate.	<ul style="list-style-type: none"> ▪ The other terminal was incompatible. ▪ Ask the other party to contact the manufacturer.
0-87	The control channel started after an unsuccessful primary channel.	<ul style="list-style-type: none"> ▪ The receiving terminal restarted the control channel because data reception in the primary channel was not successful. ▪ This does not result in an error communication.
0-88	The line was disconnected because PPR was transmitted/received 9 (default) times within the same ECM frame.	<ul style="list-style-type: none"> ▪ Try using a lower data rate at the start. ▪ Try adjusting the cable equalizer setting.
2-11	Only one V.21 connection flag was received	<ul style="list-style-type: none"> ▪ Replace the FCU.
2-12	Modem clock irregularity	<ul style="list-style-type: none"> ▪ Replace the FCU.
2-13	Modem initialization error	<ul style="list-style-type: none"> ▪ Turn off the machine, then turn it back on. ▪ Update the modem ROM. ▪ Replace the FCU.
2-22	Counter overflow error of JBIG chip	If error occurs frequently, change the settings for resolution, paper size, compression type.
2-23	JBIG compression or reconstruction error	Turn off the machine, then turn it back on.
2-24	JBIG ASIC error	<ul style="list-style-type: none"> ▪ Turn off the machine, then turn it back on.

Code	Meaning	Suggested Cause/Action
2-25	JBIG data reconstruction error (BIH error)	<ul style="list-style-type: none"> ▪ JBIG data error ▪ Check the sender's JBIG function. ▪ Update the FCU ROM.
2-26	JBIG data reconstruction error (Float marker error)	
2-27	JBIG data reconstruction error (End marker error)	
2-28	JBIG data reconstruction error (Timeout)	
2-29	JBIG trailing edge maker error	<ul style="list-style-type: none"> ▪ FCU defective ▪ Check the destination device.
2-50	The machine resets itself for a fatal FCU system error	<ul style="list-style-type: none"> ▪ If this is frequent, update the ROM, or replace the FCU.
2-51	The machine resets itself because of a fatal communication error	<ul style="list-style-type: none"> ▪ If this is frequent, update the ROM, or replace the FCU.
2-53	Snd msg() in the manual task is an error because the mailbox for the operation task is full.	<ul style="list-style-type: none"> ▪ The user did the same operation many times, and this gave too much load to the machine.
4-01	Line current was cut	<ul style="list-style-type: none"> ▪ Check the line connector. ▪ Check for line problems. ▪ Replace the FCU.
4-10	Communication failed because of an ID Code mismatch (Closed Network) or Tel. No./CSI mismatch (Protection against Wrong Connections)	<ul style="list-style-type: none"> ▪ Get the ID Codes the same and/or the CSIs programmed correctly, then resend. ▪ The machine at the other end may be defective.
5-00	Data reconstruction not possible	Replace the FCU.
5-10	DCR timer expired	<ul style="list-style-type: none"> ▪ Replace the FCU.

Error Codes

Code	Meaning	Suggested Cause/Action
5-20	Storage impossible because of a lack of memory	<ul style="list-style-type: none"> ▪ Temporary memory shortage. ▪ Test the SAF memory.
5-21	Memory overflow	
5-23	Print data error when printing a substitute rx or confidential rx message	<ul style="list-style-type: none"> ▪ Test the SAF memory. ▪ Ask the other end to resend the message.
5-25	SAF file access error	<ul style="list-style-type: none"> ▪ Replace an SD card or HDD. ▪ Replace the FCU.
6-00	G3 ECM - T1 time out during reception of facsimile data	<ul style="list-style-type: none"> ▪ Try adjusting the rx cable equalizer. ▪ Replace the FCU.
6-01	G3 ECM - no V.21 signal was received	
6-02	G3 ECM - EOR was received	
6-04	G3 ECM - RTC not detected	<ul style="list-style-type: none"> ▪ Check the line connection. ▪ Check for a bad line or defective remote terminal. ▪ Replace the FCU.
6-05	G3 ECM - facsimile data frame not received within 18 s of CFR, but there was no line fail	<ul style="list-style-type: none"> ▪ Check the line connection. ▪ Check for a bad line or defective remote terminal. ▪ Replace the FCU. ▪ Try adjusting the rx cable equalizer <p>Cross reference</p> <ul style="list-style-type: none"> ▪ Rx cable equalizer - G3 Switch 07 (PSTN)
6-06	G3 ECM - coding/decoding error	<ul style="list-style-type: none"> ▪ Defective FCU. ▪ The other terminal may be defective.
6-08	G3 ECM - PIP/PIN received in reply to PPS.NULL	<ul style="list-style-type: none"> ▪ The other end pressed Stop during communication. ▪ The other terminal may be defective.

Code	Meaning	Suggested Cause/Action
6-09	G3 ECM - ERR received	<ul style="list-style-type: none"> ▪ Check for a noisy line. ▪ Adjust the tx levels of the communicating machines. ▪ See code 6-05.
6-10	G3 ECM - error frames still received at the other end after all communication attempts at 2400 bps	<ul style="list-style-type: none"> ▪ Check for line noise. ▪ Adjust the tx level (use NCU parameter 01 or the dedicated tx parameter for that address). ▪ Check the line connection. ▪ Defective remote terminal.
6-21	V.21 flag detected during high speed modem communication	<ul style="list-style-type: none"> ▪ The other terminal may be defective or incompatible.
6-22	The machine resets the sequence because of an abnormal handshake in the V.34 control channel	<ul style="list-style-type: none"> ▪ Check for line noise. ▪ If the same error occurs frequently, replace the FCU. ▪ Defective remote terminal.
6-99	V.21 signal not stopped within 6 s	Replace the FCU.
13-17	SIP user name registration error	<ul style="list-style-type: none"> ▪ Double registration of the SIP user name. ▪ Capacity for user-name registration in the SIP server is not sufficient.
13-18	SIP server access error	<ul style="list-style-type: none"> ▪ Incorrect initial setting for the SIP server. ▪ Defective SIP server.
13-24	SIP authentication error	<ul style="list-style-type: none"> ▪ Registered password in the device does not match the password in the SIP server.
13-25	Network I/F setting error	<ul style="list-style-type: none"> ▪ IPV4 is not active in the active protocol setting. ▪ IP address of the device is not registered.
13-26	Network I/F setting error at power on	<ul style="list-style-type: none"> ▪ Active protocol setting does not match the I/F setting for SIP server. ▪ IP address of the device is not registered.
13-27	IP address setting error	<ul style="list-style-type: none"> ▪ IP address of the device is not registered.

Error Codes

Code	Meaning	Suggested Cause/Action
14-00	SMTP Send Error	<ul style="list-style-type: none"> ▪ Error occurred during sending to the SMTP server. Occurs for any error other than 14-01 to 16. For example, the mail address of the system administrator is not registered.
14-01	SMTP Connection Failed	<ul style="list-style-type: none"> ▪ Failed to connect to the SMTP server (timeout) because the server could not be found. ▪ The PC is not ready to transfer files. ▪ SMTP server not functioning correctly. ▪ The DNS IP address is not registered. ▪ Network not operating correctly. ▪ Destination folder selection not correct.
14-02	No Service by SMTP Service (421)	<ul style="list-style-type: none"> ▪ SMTP server operating incorrectly, or the destination for direct SMTP sending is not correct. ▪ Contact the system administrator and check that the SMTP server has the correct settings and operates correctly. ▪ Contact the system administrator for direct SMTP sending and check the sending destination.

Code	Meaning	Suggested Cause/Action
14-03	Access to SMTP Server Denied (450)	<ul style="list-style-type: none"> ▪ Failed to access the SMTP server because the access is denied. ▪ SMTP server operating incorrectly. Contact the system administrator to determine if there is a problem with the SMTP server and to check that the SMTP server settings are correct. ▪ Folder send destination is incorrect. Contact the system administrator to determine that the SMTP server settings and path to the server are correct. ▪ Device settings incorrect. Confirm that the user name and password settings are correct. ▪ Direct SMTP destination incorrect. Contact the system administrator to determine if there is a problem at the destination at that the settings at the destination are correct.
14-04	Access to SMTP Server Denied (550)	<ul style="list-style-type: none"> ▪ SMTP server operating incorrectly ▪ Direct SMTP sending not operating correctly

Code	Meaning	Suggested Cause/Action
14-05	SMTP Server HDD Full (452)	<ul style="list-style-type: none"> ▪ Failed to access the SMTP server because the HDD on the server is full. ▪ Insufficient free space on the HDD of the SMTP server. Contact the system administrator and check the amount of space remaining on the SMTP server HDD. ▪ Insufficient free space on the HDD where the destination folder is located. Contact the system administrator and check the amount of space remaining on the HDD where the target folder is located. ▪ Insufficient free space on the HDD at the target destination for SMTP direct sending. Contact the system administrator, check the amount of space remaining on the target HDD or check if the mail size setting is the default value (2MB). ▪ Check the size of the original data. For example, if the original has too many pages, the data size can be too big to send.
14-06	User Not Found on SMTP Server (551)	<ul style="list-style-type: none"> ▪ The designated user does not exist. ▪ The designated user does not exist on the SMTP server. ▪ The designated address is not for use with direct SMTP sending.
14-07	Data Send to SMTP Server Failed (4XX)	<ul style="list-style-type: none"> ▪ Failed to access the SMTP server because the transmission failed. ▪ PC not operating correctly. ▪ SMTP server operating incorrectly ▪ Network not operating correctly. ▪ Destination folder setting incorrect. ▪ Direct SMTP sending not operating correctly.

Code	Meaning	Suggested Cause/Action
14-08	Data Send to SMTP Server Failed (5XX)	<ul style="list-style-type: none"> ▪ Failed to access the SMTP server because the transmission failed. ▪ SMTP server operating incorrectly ▪ Destination folder setting incorrect. ▪ Direct SMTP sending not operating correctly. ▪ Software application error.
14-09	Authorization Failed for Sending to SMTP Server	<ul style="list-style-type: none"> ▪ POP-Before-SMTP or SMTP authorization failed. ▪ Incorrect setting for file transfer
14-10	Addresses Exceeded	<ul style="list-style-type: none"> ▪ Number of broadcast addresses exceeded the limit for the SMTP server.
14-11	Buffer Full	<ul style="list-style-type: none"> ▪ The send buffer is full so the transmission could not be completed. Buffer is full due to using Scan-to-Email while the buffer is being used send mail at the same time.
14-12	Data Size Too Large	<ul style="list-style-type: none"> ▪ Transmission was cancelled because the detected size of the file was too large.
14-13	Send Cancelled	<ul style="list-style-type: none"> ▪ Processing is interrupted because the user pressed Stop.
14-14	Security Locked File Error	<ul style="list-style-type: none"> ▪ Update the software because of the defective software.
14-15	Mail Data Error	<ul style="list-style-type: none"> ▪ The transmitting a mail is interrupted via DCS due to the incorrect data. ▪ Update the software because of the defective software.
14-16	Maximum Division Number Error	<ul style="list-style-type: none"> ▪ When a mail is divided for the mail transmission and the division number of a mail are more than the specified number, the mail transmission is interrupted. ▪ Update the software because of the defective software.

Error Codes

Code	Meaning	Suggested Cause/Action
14-17	Incorrect Ticket	<ul style="list-style-type: none"> Update the software because of the defective software.
14-18	Access to MCS File Error	<ul style="list-style-type: none"> The access to MCS file is denied due to the no permission of access. Update the software because of the defective software.
14-20	SMTP Authentication error	Make sure the administrator's e-mail address is same as the SMTP authentication address or POP before SMTP address.
14-21	Transmission error of S/MIME	Register the correct user certificate and device certificate.
14-30	MCS File Creation Failed	<p>Failed to create the MCS file because:</p> <ul style="list-style-type: none"> The number of files created with other applications on the Document Server has exceeded the limit. HDD is full or not operating correctly. Software error.
14-31	UFS File Creation Failed	<p>UFS file could not be created:</p> <ul style="list-style-type: none"> Not enough space in UFS area to handle both Scan-to-Email and IFAX transmission. HDD full or not operating correctly. Software error.
14-32	Cancelled the Mail Due to Error Detected by NFA	<ul style="list-style-type: none"> Error detected with NFA and send was cancelled due to a software error.
14-33	No Mail Address For the Machine	<ul style="list-style-type: none"> Neither the mail address of the machine nor the mail address of the network administrator is registered.
14-34	Address designated in the domain for SMTP sending does not exist	<ul style="list-style-type: none"> Operational error in normal mail sending or direct SMTP sending. Check the address selected in the address book for SMTP sending. Check the domain selection.

Code	Meaning	Suggested Cause/Action
14-50	Mail Job Task Error	<p>Due to an FCU mail job task error, the send was cancelled:</p> <ul style="list-style-type: none"> ▪ Address book was being edited during creation of the notification mail. ▪ Software error.
14-51	UCS Destination Download Error	<p>Not even one return notification can be downloaded:</p> <ul style="list-style-type: none"> ▪ The address book was being edited. ▪ The number for the specified destination does not exist (it was deleted or edited after the job was created).
14-60	Send Cancel Failed	<ul style="list-style-type: none"> ▪ The cancel operation by the user failed to cancel the send operation.
14-61	Notification Mail Send Failed for All Destinations	<ul style="list-style-type: none"> ▪ All addresses for return notification mail failed.
14-62	Transmission Error due to the existence of zero line page	<ul style="list-style-type: none"> ▪ When the 0 line page exists in received pages with G3 communication, the transmission is interrupted.
14-63	Fax Communication Unit: Transmission Error	<p>Check the followings.</p> <ul style="list-style-type: none"> ▪ Name of SMTP server ▪ Port number of SMTP ▪ DNS setting ▪ Server name (FTP) ▪ Path name (computer name and shared folder name at SMTP/ NCP) ▪ Active protocol setting (Netware/ NCP) ▪ NW flame type (NCP) ▪ Log-on mode (NDS tree/ bindery)
-		<p>Check the SMTP server.</p> <ul style="list-style-type: none"> ▪ Check if the SMTP server works normally and is connected to the network. ▪ Check if the settings of the SMTP are correct.

Error Codes

Code	Meaning	Suggested Cause/Action
-		<p>Check the DNS server.</p> <ul style="list-style-type: none"> ▪ Check if the DNS server works normally and is connected to the network. ▪ Check if the settings of the DNS server are correct.
-		<p>Check the network.</p> <ul style="list-style-type: none"> ▪ Check if the LAN works normally. ▪ Check if the no firewall exists.
-		<p>Check the destination folder for the data transfer.</p> <ul style="list-style-type: none"> ▪ Check if the destination folder works normally. ▪ Check if the settings of the destination folder are correct.
-		<p>Ask an administrator of the direct SMTP server in which the data is supposed to be transferred.</p> <ul style="list-style-type: none"> ▪ Check if the destination SMTP server works normally. ▪ Check if the settings of the destination SMTP server are correct.
15-01	POP3/IMAP4 Server Not Registered	<ul style="list-style-type: none"> ▪ At startup, the system detected that the IP address of the POP3/IMAP4 server has not been registered in the machine.
15-02	POP3/IMAP4 Mail Account Information Not Registered	<ul style="list-style-type: none"> ▪ The POP3/IMAP4 mail account has not been registered.
15-03	Mail Address Not Registered	<ul style="list-style-type: none"> ▪ The mail address has not been registered.
15-10	DCS Mail Receive Error	<ul style="list-style-type: none"> ▪ Error other than 15-11 to 15-18.
15-11	Connection Error	<p>The DNS or POP3/IMAP4 server could not be found:</p> <ul style="list-style-type: none"> ▪ The IP address for DNS or POP3/IMAP4 server is not stored in the machine. ▪ The DNS IP address is not registered. ▪ Network not operating correctly.

Code	Meaning	Suggested Cause/Action
15-12	Authorization Error	POP3/IMAP4 send authorization failed: <ul style="list-style-type: none"> Incorrect IFAX user name or password. Access was attempted by another device, such as the PC. POP3/IMAP4 settings incorrect.
15-13	Receive Buffer Full	<ul style="list-style-type: none"> Occurs only during manual reception. Transmission cannot be received due to insufficient buffer space. The buffer is being used for mail send or Scan-to-Email.
15-14	Mail Header Format Error	<ul style="list-style-type: none"> The mail header is not standard format. For example, the Date line description is incorrect.
15-15	Mail Divide Error	<ul style="list-style-type: none"> The e-mail is not in standard format. There is no boundary between parts of the e-mail, including the header.
15-16	Mail Size Receive Error	<ul style="list-style-type: none"> The mail cannot be received because it is too large.
15-17	Receive Timeout	<ul style="list-style-type: none"> May occur during manual receiving only because the network is not operating correctly.
15-18	Incomplete Mail Received	<ul style="list-style-type: none"> Only one portion of the mail was received.
15-31	Final Destination for Transfer Request Reception Format Error	<ul style="list-style-type: none"> The format of the final destination for the transfer request was incorrect.
15-39	Send/Delivery Destination Error	The transmission cannot be delivered to the final destination: <ul style="list-style-type: none"> Destination file format is incorrect. Could not create the destination for the file transmission.
15-41	SMTP Receive Error	<ul style="list-style-type: none"> Reception rejected because the transaction exceeded the limit for the "Auth. E-mail RX" setting.

Error Codes

Code	Meaning	Suggested Cause/Action
15-42	Off Ramp Gateway Error	<ul style="list-style-type: none"> The delivery destination address was specified with Off Ramp Gateway OFF.
15-43	Address Format Error	<ul style="list-style-type: none"> Format error in the address of the Off Ramp Gateway.
15-44	Addresses Over	<ul style="list-style-type: none"> The number of addresses for the Off Ramp Gateway exceeded the limit of 30.
15-61	Attachment File Format Error	<ul style="list-style-type: none"> The attached file is not TIFF format.
15-62	TIFF File Compatibility Error	<p>Could not receive transmission due to:</p> <ul style="list-style-type: none"> Resolution error Image of resolution greater than 200 dpi without extended memory. Resolution is not supported. Page size error The page size was larger than A3. Compression error File was compressed with other than MH, MR, or MMR.
15-63	TIFF Parameter Error	<p>The TIFF file sent as the attachment could not be received because the TIFF header is incorrect:</p> <ul style="list-style-type: none"> The TIFF file attachment is a type not supported. The TIFF file attachment is corrupted. Software error.
15-64	TIFF Decompression Error	<p>The file received as an attachment caused the TIFF decompression error:</p> <ul style="list-style-type: none"> The TIFF format of the attachment is corrupted. Software error.
15-71	Not Binary Image Data	<ul style="list-style-type: none"> The file could not be received because the attachment was not binary image data.

Code	Meaning	Suggested Cause/Action
15-73	MDN Status Error	<ul style="list-style-type: none"> Could not find the Disposition line in the header of the Return Receipt, or there is a problem with the firmware.
15-74	MDN Message ID Error	<ul style="list-style-type: none"> Could not find the Original Message ID line in the header of the Return Receipt, or there is a problem with the firmware.
15-80	Mail Job Task Read Error	<ul style="list-style-type: none"> Could not receive the transmission because the destination buffer is full and the destination could not be created (this error may occur when receiving a transfer request or a request for notification of reception).
15-81	Repeated Destination Registration Error	<ul style="list-style-type: none"> Could not repeat receive the transmission because the destination buffer is full and the destination could not be created (this error may occur when receiving a transfer request or a request for notification of reception).
15-91	Send Registration Error	<p>Could not receive the file for transfer to the final destination:</p> <ul style="list-style-type: none"> The format of the final destination or the transfer destination is incorrect. Destinations are full so the final and transfer destinations could not be created.
15-92	Memory Overflow	<ul style="list-style-type: none"> Transmission could not be received because memory overflowed during the transaction.
15-93	Memory Access Error	<ul style="list-style-type: none"> Transaction could not complete due to a malfunction of SAF memory.
15-94	Incorrect ID Code	<ul style="list-style-type: none"> The machine rejected an incoming e-mail for transfer request, because the ID code in the incoming e-mail did not match the ID code registered in the machine.

Error Codes

Code	Meaning	Suggested Cause/Action
15-95	Transfer Station Function	<ul style="list-style-type: none"> The machine rejected an incoming e-mail for transfer because the transfer function was unavailable.
16-00	No IP address registered	<ul style="list-style-type: none"> The machine does not get an IP address because the DNS server has not been registered for the remote machine or IP address of the remote machine has not been registered. Register the DNS server for the remote machine or configure an IP address of the remote machine.
22-00	Original length exceeded the maximum scan length	<ul style="list-style-type: none"> Divide the original into more than one page. Check the resolution used for scanning. Lower the scan resolution if possible. Add optional page memory.
22-01	Memory overflow while receiving	<ul style="list-style-type: none"> Wait for the files in the queue to be sent. Delete unnecessary files from memory. Transfer the substitute reception files to an another fax machine, if the machine's printer is busy or out of order. Add an optional SAF memory card or hard disk.
22-02	Tx or rx job stalled due to line disconnection at the other end	<ul style="list-style-type: none"> The job started normally but did not finish normally; data may or may not have been received fully. Restart the machine.
22-04	The machine cannot store received data in the SAF	<ul style="list-style-type: none"> Update the ROM Replace the FCU.
22-05	No G3 parameter confirmation answer	<ul style="list-style-type: none"> Defective FCU board or firmware.
23-00	Data read timeout during construction	<ul style="list-style-type: none"> Restart the machine. Replace the FCU.

Code	Meaning	Suggested Cause/Action
25-00	The machine software resets itself after a fatal transmission error occurred	<ul style="list-style-type: none"> ▪ Update the ROM ▪ Replace the FCU.
F0-xx	V.34 modem error	<ul style="list-style-type: none"> ▪ Replace the FCU.
F6-xx	SG3 modem error	<ul style="list-style-type: none"> ▪ Update the SG3 modem ROM. ▪ Replace the SG3 board. ▪ Check for line noise or other line problems. ▪ Try communicating another V.8/V.34 fax.

**FAX OPTION
TYPE M12
(D3A5)**

3.2 FAX CONNECTION UNIT ERROR CODES

3.2.1 FAX CONNECTION UNIT ERROR CODE LIST

MACHINE_ERR_01

Error Code	Suggested Cause	Action
01(1)	IPv4/IPv6 not enabled	Enable IPv4 and IPv6
01(3)	"Cancel" is pressed by user.	-
01(4)	A false connection ID is being used.	Check that the network is established.
01(5)	Network disconnected because of no response within a specified time.	
01(14)	<ul style="list-style-type: none"> ▪ The machine either of destination or of local is entering SP or Initial setting. ▪ An established connection exists. 	<ul style="list-style-type: none"> ▪ Exit SP or initial setting. ▪ Wait until the connection has finished.

MACHINE_ERR_02

Error Code	Suggested Cause	Action
02(5)	<ul style="list-style-type: none"> ▪ Wrong IP address/hostname is used ▪ The machine at destination power off ▪ LAN cable is disconnected ▪ Network is rebooting. 	<ul style="list-style-type: none"> ▪ Enter the correct IP address/Host name ▪ Turn on the main power. ▪ Connect the LAN cable ▪ Wait until the rebooting has finished.

MACHINE_ERR_03

Error Code	Suggested Cause	Action	
03	<ul style="list-style-type: none"> ▪ No user authentication applies for fax application (i.e. Basic/Windows/LDAP/Custom Auth.) ▪ Settings other than user authentication are applied to the fax application. 	Configure the user authentication setting for client-side and Remote Machine as the following table.	
		Client-side Machine	Remote Machine
		OFF	OFF
		ON	OFF
		ON	ON

MACHINE_ERR_04

Error Code	Suggested Cause	Action
04	Although the same user registered to the Remote Machine and Client-side Machine, the user name and password for login are unmatched between the two locations.	<ul style="list-style-type: none"> ▪ Register the same user to both the Remote Machine and Client-side Machine. ▪ Be sure to match the username and password for login between the two locations.

MACHINE_ERR_05

Error Code	Suggested Cause	Action
05	An unauthorized user connects to the fax connection.	Authorize the user to use fax connection.

MACHINE_ERR_06

Error Code	Suggested Cause	Action
06	Timeout error on the node authentication	Adjust the value of SP5-741-001 to prolong the timeout for node authentication.

MACHINE_ERR_07

Error Code	Suggested Cause	Action
07	Multiple destinations are set in the Client-side Machine.	In the Client-side Machine, execute SP5-801-021 to clear AICS memory

MACHINE_ERR_08

Error Code	Suggested Cause	Action
08(1)	<ul style="list-style-type: none"> ▪ A Client-side Machine connects to other Client-side Machine. ▪ The Client-side Machine not registered in the Remote Machine as destinations. 	<ul style="list-style-type: none"> ▪ Connect to the Remote Machine. ▪ Register the Client-side Machine to the Remote Machine as a destination.
08(2)	<ul style="list-style-type: none"> ▪ A Remote Machine connects to other Remote Machine. ▪ Wrong Remote Machine registered in the Client-side Machine. 	<ul style="list-style-type: none"> ▪ Connect to the Client-side Machine. ▪ Check what Remote Machine registered in the Client-side Machine.

3.3 IFAX TROUBLESHOOTING

Use the following procedures to determine whether the machine or another part of the network is causing the problem.

Communication Route	Item	Action [Remarks]
General LAN	1. Connection with the LAN	<ul style="list-style-type: none"> ▪ Check that the LAN cable is connected to the machine. ▪ Check that the LEDs on the hub are lit.
	2. LAN activity	Check that other devices connected to the LAN can communicate through the LAN.
Between IFAX and PC	1. Network settings on the PC	<ul style="list-style-type: none"> ▪ Check the network settings on the PC. [Is the IP address registered in the TCP/IP properties in the network setup correct? Check the IP address with the administrator of the network.]
	2. Check that PC can connect with the machine	<ul style="list-style-type: none"> ▪ Use the “ping” command on the PC to contact the machine. [At the MS-DOS prompt, type ping then the IP address of the machine, then press Enter.]
	3. LAN settings in the machine	<ul style="list-style-type: none"> ▪ Check the LAN parameters ▪ Check if there is an IP address conflict with other PCs. [Use the “Network” function in the User Tools. If there is an IP address conflict, inform the administrator.]

Communication Route	Item	Action [Remarks]
Between machine and e-mail server	1. LAN settings in the machine	<ul style="list-style-type: none"> ▪ Check the LAN parameters ▪ Check if there is an IP address conflict with other PCs. <p>[Use the “Network” function in the User Tools. If there is an IP address conflict, inform the administrator.]</p>
	2. E-mail account on the server	<ul style="list-style-type: none"> ▪ Make sure that the machine can log into the e-mail server. ▪ Check that the account and password stored in the server are the same as in the machine. <p>[Ask the administrator to check.]</p>
	3. E-mail server	<ul style="list-style-type: none"> ▪ Make sure that the client devices which have an account in the server can send/receive e-mail. <p>[Ask the administrator to check. Send a test e-mail with the machine’s own number as the destination. The machine receives the returned e-mail if the communication is performed successfully.]</p>
Between e-mail server and internet	1. E-mail account on the Server	<ul style="list-style-type: none"> ▪ Make sure that the PC can log into the e-mail server. ▪ Check that the account and password stored in the server are the same as in the machine. <p>[Ask the administrator to check.]</p>

Communication Route	Item	Action [Remarks]
	2. E-mail server	<ul style="list-style-type: none"> ▪ Make sure that the client devices which have an account in the server can send/receive e-mail. <p>[Ask the administrator to check. Send a test e-mail with the machine's own number as the destination. The machine receives the returned e-mail if the communication is performed successfully.]</p>
	3. Destination e-mail address	<ul style="list-style-type: none"> ▪ Make sure that the e-mail address is actually used. ▪ Check that the e-mail address contains no incorrect characters such as spaces.
	4. Router settings	<ul style="list-style-type: none"> ▪ Use the "ping" command to contact the router. ▪ Check that other devices connected to the router can sent data over the router. <p>[Ask the administrator of the server to check.]</p>
	5. Error message by e-mail from the network of the destination.	<ul style="list-style-type: none"> ▪ Check whether e-mail can be sent to another address on the same network, using the application e-mail software. ▪ Check the error e-mail message. <p>[Inform the administrator of the LAN.]</p>

3.4 IP-FAX TROUBLESHOOTING

3.4.1 IP-FAX TRANSMISSION

Cannot send by IP Address/Host Name

Check Point		Action
1	LAN cable connected?	Check the LAN cable connection.
2	Specified IP address/hostname correct?	Check the IP address/host name.
3	Firewall/NAT is installed?	Cannot breach the firewall. Send by using another method (Fax, Internet Fax)
4	Transmission sent manually?	Manual sending not supported.
5	IP address of local machine registered?	Register the IP address.
6	Remote terminal port number setting other than 1720 (when using H.323) or 5060 (when using SIP)?	Send by specifying the port number.
7	Specified port number correct?	Confirm the port number of the remote fax.
8	DNS server registered when host name specified?	Contact the network administrator.
9	Remote fax a T.38 terminal?	Check whether the remote fax is a T38 terminal.
10	Remote fax switched off or busy?	Check that the remote fax is switched on.
11	Network bandwidth too narrow?	Request the network administrator to increase the bandwidth.
		Raise the delay level. IPFAX SW 01 Bit 0 to 3

		IP-Fax bandwidth is the same as the DCS speed. Set IP-Fax SW00 Bit 6 to 1.
12	Remote fax cancelled transmission?	Check whether the remote fax cancelled the transmission.

Cannot send via VoIP Gateway

Check Point		Action
1	LAN cable connected?	Check the LAN cable connection.
2	VoIP Gateway T.38 standard?	Contact the network administrator.
3	VoIP Gateway installed correctly?	Contact the network administrator.
4	VoIP Gateway power switched on?	Contact the network administrator.
5	Is the IP address/host name of the specified Gateway correct?	Check the IP address/host name.
6	Number of the specified fax correct?	Check the remote fax number.
7	Firewall/NAT is installed?	Cannot breach the firewall. Send by using another method (Fax, Internet Fax)
8	Transmission sent manually?	Manual sending not supported.
9	IP address of local fax registered?	Register the IP address.
10	DNS registered when host name specified?	Contact the network administrator.
11	Remote fax a G3 fax?	Check that the remote fax is a G3 fax.
12	G3 fax is connected to VoIP gateway?	Check that G3 fax is connected.
13	Remote G3 fax turned on?	Check that G3 fax is switched on.
14	Network bandwidth too narrow?	Request the network administrator to increase the bandwidth.

		Raise the network delay level. IPFAX SW 01 Bit 0 to 3
		IP-Fax bandwidth is the same as the DCS speed. Set IP-Fax SW00 Bit 6 to 1.

Cannot send by Alias Fax number.

	Check Point	Action
1	LAN cable connected?	Check the LAN cable connection.
2	Number of specified Alias fax correct?	Confirm the Alias of the remote fax. Error Code: 13-14
3	Firewall/NAT installed?	Cannot breach the firewall. Send by using another method (Fax, Internet Fax)
4	Transmission sent manually?	Manual sending not supported.
5	Gatekeeper/SIP server installed correctly?	Contact the network administrator.
6	Gatekeeper/SIP server power switched on?	Contact the network administrator.
7	IP address/host name of Gatekeeper/SIP server correct?	Check the IP address/host name.
8	DNS server registered when Gatekeeper/SIP server host name specified?	Contact the network administrator.
9	Enable H.323/Enable SIP SW is set to on?	Check the settings. See User Parameter SW 34 Bit 0/SW 34 Bit 1
10	IP address of local fax registered?	Register the IP address of the local fax.
11	Alias number of local fax registered?	Register the Alias number of the local fax.

IP-Fax Troubleshooting

12	Remote fax registered in Gatekeeper?	Contact the network administrator.
13	Remote fax a T.38 terminal?	Check whether the remote fax is a T38 terminal.
14	Remote fax switched off or busy?	Contact the network administrator.
15	Network bandwidth too narrow?	Request the system administrator to increase the bandwidth.
		Raise the delay level. IPFAX SW 01 Bit 0 to 3
		Lower the modem transmission baud rate. IPFAX SW 05
16	Remote fax cancelled transmission?	Check whether the remote fax cancelled the transmission.

3.4.2 IP-FAX RECEPTION





Cannot receive via IP Address/Host Name.

Check Point		Action
1	LAN cable connected?	Check the LAN cable connection.
2	Firewall/NAT is installed?	Cannot breach the firewall. Send by using another method (Fax, Internet Fax)
3	IP address of local fax registered?	Register the IP address.
4	Port number specified at remote sender fax (if required)?	Request the sender to specify the port number.
5	Specified port number correct (if required)?	Request the sender to check the port number.
6	DNS server registered when host name specified on sender side?	<p>Contact the network administrator.</p> <p> Note</p> <ul style="list-style-type: none"> The sender machine displays this error code if the sender fax is a Ricoh model.
7	Network bandwidth too narrow?	Request the system administrator to increase the bandwidth.
		Lower the start modem reception baud rate on the receiving side. IPFAX SW06
8	Remote fax cancelled transmission?	Check whether the remote fax cancelled the transmission.

Cannot receive by VoIP Gateway.

Check Point		Action
1	LAN cable connected?	Check the LAN cable connection.
2	Firewall/NAT is installed?	Cannot breach the firewall. Request the remote fax to send by using another method (Fax, Internet Fax)
3	VoIP Gateway installed correctly?	Contact the network administrator.
4	VoIP Gateway power switched on?	Contact the network administrator.
5	IP address/host name of specified VoIP Gateway correct on sender's side?	Request the remote fax to check the IP address/host name.
6	DNS server registered when host name specified on sender side?	Contact the network administrator.
7	Network bandwidth too narrow?	Request the network administrator to increase the bandwidth.
8	G3 fax connected?	Check that G3 fax is connected.
9	G3 fax power switched on?	Check that G3 fax is switched on.

Cannot receive by Alias Fax number.

Check Point		Action
1	LAN cable connected?	Check the LAN cable connection.
2	Firewall/NAT is installed?	Cannot the breach firewall. Request the remote fax to send by using another method (Fax, Internet Fax)
3	Gatekeeper/SIP server installed correctly?	Contact the network administrator.  Note <ul style="list-style-type: none"> The sender machine displays this error code when the sender fax is a Ricoh model.
4	Power to Gatekeeper/SIP server switched on?	Contact the network administrator.  Note <ul style="list-style-type: none"> The sender machine displays this error code when the sender fax is a Ricoh model.
5	IP address/host name of Gatekeeper/SIP server correct on the sender's side?	Request the sender to check the IP address/host name.  Note <ul style="list-style-type: none"> The sender machine displays this error code when the sender fax is a Ricoh model.
6	DNS server registered when Gatekeeper/SIP server host name specified on sender's side?	Contact the network administrator.  Note <ul style="list-style-type: none"> The sender machine displays this error code when the sender fax is a Ricoh model.
7	Enable H.323/Enable SIP SW is set to on?	Request the sender to check the settings. User Parameter SW 34 Bit 0/SW 34 Bit 1  Note <ul style="list-style-type: none"> Only if the remote sender fax is a Ricoh fax.

8	Local fax IP address registered?	Register the IP address.
9	Local fax Alias number registered?	Register the Alias number.
10	Network bandwidth too narrow?	Request the system administrator to increase the bandwidth.
		Lower the start modem reception baud rate on the receiving side. IPFAX SW06
11	Remote fax cancelled transmission?	Check whether the remote fax cancelled the transmission.
12	Local fax registered in Gatekeeper/SIP server?	<p>Contact the network administrator.</p> <p>Note</p> <ul style="list-style-type: none"> The sender machine displays this error code when the sender fax is a Ricoh model.

4. SERVICE TABLES

4.1 CAUTIONS

Important

- Never turn off the main power switch when the power LED is lit or flashing. To avoid damaging the hard disk or memory, press the operation power switch to switch the power off, wait for the power LED to go off, and then switch the main power switch off.

Note

- The main power LED lights or flashes while the platen cover or ARDF is open, while the main machine is communicating with a facsimile or the network server, or while the machine is accessing the hard disk or memory for reading or writing data.

4.2 SERVICE PROGRAM TABLES

4.2.1 SP1-XXX (BIT SWITCHES)

page 84

1	Mode No.		Function
101	System Switch		
	001 – 032	00 – 1F	Change the bit switches for system settings for the fax option "page 84" : "System Switches"
102	Ifax Switch		
	001 – 016	00 – 0F	Change the bit switches for internet fax settings for the fax option "page 99" : "I-Fax Switches"
103	Printer Switch		
	001 – 016	00 – 0F	Change the bit switches for printer settings for the fax option "page 99" : "Printer Switches"
104	Communication Switch		
	001 – 032	00 – 1F	Change the bit switches for communication settings for the fax option "page 115" : "Communication Switches"
105	G3-1 Switch		
	001 – 016	00 – 0F	Change the bit switches for the protocol settings of the standard G3 board "page 126" : "G3 Switches"
106	G3-2 Switch		
	001 – 016	00 – 0F	Change the bit switches for the protocol settings of the optional G3 board "page 137" : "G3-2 and G3-3 Switches"

107	G3-3 Switch		
	001 – 016	00 – 0F	Change the bit switches for the protocol settings of the optional G3 board "page 137" : "G3-2 and G3-3 Switches"
108	G4 Internal Switch		
	001 – 032	00 – 1F	Not used (Do not change the bit switches)
109	G4 Parameter Switch		
	001 – 016	00 – 0F	Not used (Do not change the bit switches)
111	IP fax Switch		
	001 – 016	00 – 0F	Change the bit switches for optional IP fax parameters "page 146" : "IP Fax Switches"

4.2.2 SP2-XXX (RAM)

2	Mode No.	Function	
101	RAM Read/Write		
	001		Change RAM data for the fax board directly. page 179
102	Memory Dump		
	001	G3-1 Memory Dump	Print out RAM data for the fax board. page 179
	002	G3-2 Memory Dump	Print out RAM data for the optional SG3 board.
	003	G3-3 Memory Dump	Print out RAM data for the optional SG3 board.
	004	G4 Memory Dump	Not used
103	G3-1 NCU Parameters		

	001 – 023	CC, 01 – 22	NCU parameter settings for the standard G3 board. page 155
104	G3-2 NCU Parameters		
	001 – 023	CC, 01 – 22	NCU parameter settings for the optional G3 board. page 155
105	G3-3 NCU Parameters		
	001 – 023	CC, 01 – 22	NCU parameter settings for the optional G3 board. page 155

4.2.3 SP3-XXX (MACHINE SET)

3	Mode No.		Function
101	Service Station		
	001	Fax Number	Enter the fax number of the service station.
	002	Select Line	Select the line type.
102	Serial Number		
	000		Enter the fax unit's serial number.
103	PSTN-1 Port Settings		
	001	Select Line	Select the line type setting for the G3-1 line. If the machine is installed on a PABX line, select "PABX", "PABX(GND)" or "PABX(FLASH)".
	002	PSTN Access Number	Enter the PSTN access number for the G3-1 line.
	003	Memory Lock Disabled	Not used
104	PSTN-2 Port Settings		
	001	Select Line	Select the line setting for the G3-2 line. If the machine is installed on a PABX line, select "PABX", "PABX(GND)" or "PABX(FLASH)".

FAX OPTION
TYPE M12
(D3A5)

	002	PSTN Access Number	Enter the PSTN access number for the G3-2 line.
	003	Memory Lock Disabled	Not used
	004	Transmission Disabled	If you turn this SP on, the machine does not send any fax messages on the G3-2 line.
105	PSTN-3 Port Settings		
	001	Select Line	Select the line setting for the G3-3 line. If the machine is installed on a PABX line, select "PABX", "PABX(GND)" or "PABX(FLASH)".
	002	PSTN Access Number	Enter the PSTN access number for the G3-3 line.
	003	Memory Lock Disabled	Not used
	004	Transmission Disabled	If you turn this SP on, the machine does not send any fax messages on the G3-3 line.
106	ISDN Port Settings		
	001	Select Line	Not used (Do not change the settings.)
	002	PSTN Access Number	
	003	Memory Lock Disabled	
004	Transmission Disabled		
107	IPFAX Port Settings		
	001	H323 Port	Sets the H323 port number.
	002	SIP Port	Sets the SIP port number.
	003	RAS Port	Sets the RAS port number.
	004	Gatekeeper port	Sets the Gatekeeper port number.

Service Program Tables

	005	T.38 Port	Sets the T.38 port number.
	006	SIP Server Port	Sets the SIP port number.
	007	IPFAX Protocol Priority	Select "H323" or "SIP".
201	FAX SW		
	001 – 032	00 – 1F	

4.2.4 SP4-XXX (ROM VERSIONS)

4	Mode No.		Function
101	001	FCU ROM Version	Displays the FCU ROM version.
102	001	Error Codes	Displays the latest 64 fax error codes.
103	001	G3-1 ROM Version	Displays the G3-1 modem version.
104	001	G3-2 ROM Version	Displays the G3-2 modem version.
105	001	G3-3 ROM Version	Displays the G3-3 modem version.
106	001	G4 ROM Version	Not used (Do not change the settings.)

4.2.5 SP5-XXX (RAM CLEAR)

5	Mode No.	Function
101	Initialize SRAM (except Secure)	
	000	Initializes the bit switches and user parameters, user data in the SRAM, files in the SAF memory, and clock.
102	Erase All Files	
	000	Erases all files stored in the SAF memory.
103	Reset Bit Switches (except Secure)	
	000	Resets the bit switches and user parameters.
104	Factory Setting	
	000	Resets the bit switches and user parameters, user data in the SRAM and files in the SAF memory.
105	Reset All Bit Switches	
	000	Resets all the current bit switch settings.
106	Reset Security Bit Switches	
	000	Resets only the security bit switches. If you select automatic output/display for the user parameter switches, the security settings are initialized.

4.2.6 SP6-XXX (REPORTS)

6	Mode No.		Function
101	System Parameter List		
	000	-	Touch the "ON" button to print the system parameter list.
102	Service Monitor Report		
	000	-	Touch the "ON" button to print the service monitor report.
103	G3 Protocol Dump List		
	001	G3 All Communications	Prints the protocol dump list of all communications for all G3 lines.
	002	G3-1 (All Communications)	Prints the protocol dump list of all communications for the G3-1 line.
	003	G3-1 (1 Communication)	Prints the protocol dump list of the last communication for the G3-1 line.
	004	G3-2 (All Communications)	Prints the protocol dump list of all communications for the G3-2 line.
	005	G3-2 (1 Communication)	Prints the protocol dump list of the last communication for the G3-2 line.
	006	G3-3 (All Communications)	Prints the protocol dump list of all communications for the G3-3 line.
	007	G3-3 (1 Communication)	Prints the protocol dump list of the last communication for the G3-3 line.
104	G4 Protocol Dump List		
	001	Dch + Bch 1	Not used (Do not change the settings.)
	002	Dch	
	003	Bch 1 Link Layer	
	004	Dch Link Layer	

FAX OPTION
TYPE M12
(D3A5)

	005	Dch +Bch 2	
	006	Bch 2 Link Layer	
105	All Files print out		
	000	-	<p>Prints out all the user files in the SAF memory, including confidential messages.</p> <p> Note</p> <ul style="list-style-type: none"> Do not use this function, unless the customer is having trouble printing confidential messages or recovering files stored using the memory lock feature.
106	Journal Print out		
	001	All Journals	The machine prints all the communication records on the report.
	002	Specified Date	The machine prints all communication records after the specified date.
107	Log List Print out		
	001	All log files	These log print out functions are for designer use only.
	002	Printer	
	003	SC/TRAP Stored	
	004	Decompression	
	005	Scanner	
	006	JOB/SAF	
	007	Reconstruction	
	008	JBIG	
	009	Fax Driver	
	010	G3CCU	
	011	Fax Job	
	012	CCU	

Service Program Tables

	013	Scanner Condition	
108	IP Protocol Dump List		
	001	All Communications	Prints the protocol dump list of all communications for the IP fax line.
	002	1 Communication	Prints the protocol dump list of the last communication for the IP fax line.

4.2.7 SP7-XXX (TESTS)

These are the test modes for PTT approval.

7	Function
101	G3-1 Modem Tests
102	G3-1 DTMF Tests
103	Ringer Test
104	G3-1 V34 (S2400baud)
105	G3-1 V34 (S2800baud)
106	G3-1 V34 (S3000baud)
107	G3-1 V34 (S3200baud)
108	G3-1 V34 (S3429baud)
109	Recorded Message Test
110	G3-2 Modem Tests
111	G3-2 DTMF Tests
112	G3-2 V34 (S2400baud)
113	G3-2 V34 (S2800baud)
114	G3-2 V34 (S3000baud)
115	G3-2 V34 (S3200baud)
116	G3-2 V34 (S3429baud)

117	G3-3 Modem Tests
118	G3-3 DTMF Tests
119	G3-3 V34 (S2400baud)
120	G3-3 V34 (S2800baud)
121	G3-3 V34 (S3000baud)
122	G3-3 V34 (S3200baud)
123	G3-3 V34 (S3429baud)
124	IG3-1 Modem Tests - Not used
125	IG3-1 DTMF Tests - Not used
126	IG3-1 V34 (S2400baud) - Not used
127	IG3-1 V34 (S2800baud) - Not used
128	IG3-1 V34 (S3000baud) - Not used
129	IG3-1 V34 (S3200baud) - Not used
130	IG3-1 V34 (S3429baud) - Not used
131	IG3-2 Modem Tests - Not used
132	IG3-2 DTMF Tests - Not used
133	IG3-2 V34 (S2400baud) - Not used
134	IG3-2 V34 (S2800baud) - Not used
135	IG3-2 V34 (S3000baud) - Not used
136	IG3-2 V34 (S3200baud) - Not used
137	IG3-2 V34 (S3429baud) - Not used

FAX OPTION
 TYPE M12
 (D3A5)

4.3 BIT SWITCHES - 1

Note

- Do not adjust a bit switch or use a setting that is described as "Not used", as this may cause the machine to malfunction or to operate in a manner that is not accepted by local regulations. Such bits are for use only in other areas, such as Japan.

Default settings for bit switches are not listed in this manual. Refer to the System Parameter List printed by the machine.

4.3.1 SYSTEM SWITCHES

System Switch 00 (SP No. 1-101-001)		
No	Function	Comments
0	Dedicated transmission parameter programming 0: Disabled 1: Enabled	Set this bit to 1 before changing any dedicated transmission parameters. This setting is automatically reset to "0" after turning off and on.
1	Not used	Do not change this setting.
2	Technical data printout on the Journal 0: Disabled 1: Enabled	1: Instead of the personal name, the following data are listed on the Journal for each G3 communication.

	<p>Example:</p> <p>0000 32V34 288/264 L0100 03 04 (1) (2)(3) (4) (5) (6) (7) (8)</p> <p>(1): EQM value (Line quality data). A larger number means more errors. (2): Symbol rate (V.34 only) (3): Final modem type used (4): Starting data rate (for example, 288 means 28.8 kbps) (5): Final data rate (6): Rx level (see below for how to read the rx level) (7): Total number of error lines that occurred during non-ECM reception. (8): Total number of burst error lines that occurred during non-ECM reception.</p> <p>Note</p> <ul style="list-style-type: none"> ▪ EQM and rx level are fixed at "FFFF" in tx mode. ▪ The seventh and eighth numbers are fixed at "00" for transmission records and ECM reception records. 	
	<p>Rx level calculation</p> <p>Example:</p> <p>0000 32V34 288/264 L0100 03 04 (1) (2)(3) (4) (5) (6) (7) (8)</p> <p>The four-digit hexadecimal value (N) after "L" indicates the rx level. The high byte is given first, followed by the low byte. Divide the decimal value of N by -16 to get the rx level. In the above example, the decimal value of N (= 0100 [H]) is 256. So, the actual rx level is 256/-16 = -16 dB</p>	
3	Not used	Do not change this setting.
4	Line error mark print 0: OFF, 1: ON (print)	When "1" is selected, a line error mark is printed on the printout if a line error occurs during reception. This shows error locations when ECM is turned off.
5	G3 communication parameter display 0: Disabled 1: Enabled	This is a fault-finding aid. The LCD shows the key parameters (see "G3 Communication Parameters" below this table). This is normally disabled because it cancels the CSI display for the user. Be sure to reset this bit to "0" after testing.

6	<p>Protocol dump list output after each communication</p> <p>0: Off</p> <p>1: On</p>	<p>This is only used for communication troubleshooting. It shows the content of the transmitted facsimile protocol signals. Always reset this bit to 0 after finishing testing.</p> <p>If system switch 09 bit 6 is at "1", the list is only printed if there was an error during the communication.</p>
7	Not used	Do not change the setting.

G3 Communication Parameters

Modem rate	<p>336: 33600 bps 168: 16800 bps</p> <p>312: 31200 bps 144: 14400 bps</p> <p>288: 28800 bps 120: 12000 bps</p> <p>264: 26400 bps 96: 9600 bps</p> <p>240: 24000 bps 72: 7200 bps</p> <p>216: 21600 bps 48: 4800 bps</p> <p>192: 19200 bps 24: 2400 bps</p>
Resolution	<p>S: Standard (8 x 3.85 dots/mm)</p> <p>D: Detail (8 x 7.7 dots/mm)</p> <p>F: Fine (8 x 15.4 dots/mm)</p> <p>SF: Superfine (16 x 15.4 dots/mm)</p> <p>21: Standard (200 x 100 dpi)</p> <p>22: Detail (200 x 200 dpi)</p> <p>44: Superfine (400 x 400 dpi)</p>
Compression mode	<p>MMR: MMR compression</p> <p>MR: MR compression</p> <p>MH: MH compression</p> <p>JBO: JBIG compression (Optional mode)</p> <p>JBB: JBIG compression (Basic mode)</p>
Communication mode	<p>ECM: With ECM</p> <p>NML: With no ECM</p>
Width and reduction	<p>A4: A4 (8.3"), no reduction</p> <p>B4: B4 (10.1"), no reduction</p> <p>A3: A3 (11.7"), no reduction</p>

I/O rate	0: 0 ms/line 5: 5 ms/line 10: 10 ms/line 20: 20 ms/line 25: 2.5 ms/line 40: 40 ms/line  Note <ul style="list-style-type: none"> ▪ "40" is displayed while receiving a fax message using AI short protocol.
----------	--

System Switch 01 - Not used (Do not change the factory settings.)

System Switch 02 (SP No. 1-101-003)		
No	Function	Comments
0-1	Not used	Do not change these settings.
2	Forced reset after transmission stalls 0: Off 1: On	With this setting on, the machine resets itself automatically if a transmission stalls and fails to complete the job.
3	Not used	Do not change these settings.
4	File retention time 0: Depends on User Parameter 24 [18(H)] 1: No limit	1: A file that had a communication error will not be erased unless the communication is successful.
5-7	-	Do not change this setting

System Switch 03 - Not used (Do not change the factory settings.)

System Switch 04 (SP No. 1-101-005)		
No	Function	Comments
0-2	Not used	Do not change these settings.

3	Printing dedicated tx parameters on Quick/Speed Dial Lists 0: Disabled 1: Enabled	1: Each Quick/Speed dial number on the list is printed with the dedicated tx parameters (10 bytes each). The first 10 bytes of data are the programmed dedicated tx parameters; 34 bytes of data are printed (the other 24 bytes have no use for service technicians).
4-7	Not used	Do not change these settings.

System Switch 05 - Not used (Do not change the factory settings.)

System Switch 06 - Not used (Do not change the factory settings.)

System Switch 07 - Not used (Do not change the factory settings.)

System Switch 08 - Not used (Do not change the factory settings.)

System Switch 09 (SP No. 1-101-010)

No	Function	Comments
0	Addition of image data from confidential transmissions on the transmission result report 0: Disabled 1: Enabled	If this feature is enabled, the top half of the first page of confidential messages will be printed on transmission result reports.
1	Print timing of communication reports on the Journal when no image data was exchanged. 0: After DCS/NSS communication (default), 1: After polling	0: The Journal is printed only when image data is sent. 1: The Journal is printed when any data is sent.
2	Automatic error report printout 0: Disabled 1: Enabled	0: Error reports will not be printed. 1: Error reports will be printed automatically after failed communications.
3	Printing of the error code on the error report 0: No 1: Yes	1: Error codes are printed on the error reports. This can be used for detecting an error which occurs rarely.

4	Not used	Do not change this setting.
5	Power failure report 0: Disabled 1: Enabled (default)	1: A power failure report will be automatically printed after the power is switched on if a fax message disappeared from the memory when the power was turned off last. NOTE: If "0" is selected, no reports are printed and no one may recognize that fax data is gone due to a power failure.
6	Conditions for printing the protocol dump list 0: Print for all communications 1: Print only when there is a communication error	This switch becomes effective only when system switch 00 bit 6 is set to 1. 1: Set this bit to 1 when you wish to print a protocol dump list only for communications with errors. NOTE: The memory size is limited. Use this bit switch only when some log reports are necessary.
7	Not used	Do not change this setting.

System Switch 0A (SP No. 1-101-011)		
No	Function	Comments
0	Automatic port selection 0: Disabled, 1: Enabled	When "1" is selected, a suitable port is automatically selected if the selected port is not used. NOTE: This bit is useful if all communication lines at a customer site are not the same quality
1-3	Not used	Do not change these settings.
4	Dialing on the ten-key pad when the external telephone is off-hook 0: Disabled 1: Enabled	0: Prevents dialing from the ten-key pad while the external telephone is off-hook. Use this setting when the external telephone is not by the machine, or if a wireless telephone is connected as an external telephone. 1: The user can dial on the machine's ten-key pad when the handset is off-hook.

5	On hook dial 0: Disabled 1: Enabled	0: On hook dial is disabled.
6-7	Not used	Do not change these settings

System Switch 0B - Not used (Do not change the factory settings.)

System Switch 0C - Not used (Do not change the factory settings.)

System Switch 0D - Not used (Do not change the factory settings.)

System Switch 0E (SP No. 1-101-015)

No	Function	Comments
0-1	Not used	Do not change the settings.
2	Enable/disable for direct sending selection 0: Direct sending off 1: Direct sending on	Direct sending cannot operate when the capture function is on during sending. Setting this switch to "1" enables direct sending without capture. Setting this switch to "0" masks the direct sending function on the operation panel so direct sending with ScanRouter cannot be selected.
3	Action when the external handset goes off-hook 0: Manual tx and rx operation 1: Memory tx and rx operation (the display remains the same)	0: Manual tx is possible while the external handset is off-hook. However, manual tx during handset off-hook may not be sent to a correct direction. Manual tx is not possible. 1: The display stays in standby mode even when the external handset is used, so that other people can use the machine for memory tx operation. Note that manual tx and rx are not possible with this setting.
4-7	Not used	Do not change these settings.

FAX OPTION
TYPE M12
(D3A5)

System Switch 0F (SP No. 1-101-016)			
No	Function	Comments	
0 to 7	Country/area code for functional settings (Hex)	This country/area code determines the factory settings of bit switches and RAM addresses. However, it has no effect on the NCU parameter settings and communication parameter RAM addresses. Cross reference NCU country code: SP No. 2-103-001 for G3-1 SP No. 2-104-001 for G3-2 SP No. 2-105-001 for G3-3	
	00: France		12: Asia
	01: Germany		13: Japan
	02: UK		14: Hong Kong
	03: Italy		15: South Africa
	04: Austria		16: Australia
	05: Belgium		17: New Zealand
	06: Denmark		18: Singapore
	07: Finland		19: Malaysia
	08: Ireland		1A: China
	09: Norway		1B: Taiwan
	0A: Sweden		1C: Korea
	0B: Switz.		1D: Brazil
	0C: Portugal		20: Turkey
	0D: Holland		21: Greece
	0E: Spain		22: Hungary
	0F: Israel		23: Czech
10: ---	24: Poland		
11: USA			

System Switch 10 (SP No. 1-101-017)		
No	Function	Comments
0-7	Threshold memory level for parallel memory transmission	Threshold = N x 128 KB + 256 KB N can be between 00 - FF(H) Default setting: 02(H) = 512 KB

System Switch 11 (SP No. 1-101-018)		
No	Function	Comments
0	TTI printing position 0: Superimposed on the page data 1: Printed before the data leading edge	Change this bit to 1 if the TTI overprints information that the customer considers to be important (G3 transmissions). NOTE: If "1" is selected, it is possible that sent data is printed on two sheets of paper.
1-2	Not used	Do not change these settings.
3	TTI used for broadcasting 0: The TTIs selected for each Quick/Speed dial are used 1: The same TTI is used for all destinations	1: The TTI (TTI_1 or TTI_2) which is selected for all destinations during broadcasting.
4-7	Not used	Do not change these settings.

System Switch 12 (SP No. 1-101-019)		
No	Function	Comments
0-7	TTI printing position in the main scan direction	TTI: 08 to 92 (BCD) mm Input even numbers only. This setting determines the print start position for the TTI from the left edge of the paper. If the TTI is moved too far to the right, it may overwrite the file number which is on the top right of the page. On an A4 page, if the TTI is moved over by more than 50 mm, it may overwrite the page number.

System Switch 13 - Not used (do not change these settings)
System Switch 14 - Not used (do not change these settings)

System Switch 15 (SP No. 1-101-022)				
No	Function			Comments
0	Not used			Do not change the settings.
1	Going into the Energy Saver mode automatically 0: Enabled 1: Disabled			1: The machine will restart from the Energy Saver mode quickly, because the +5V power supply is active even in the Energy Saver mode. The LED of the operation switch is flashing instead of entering Energy Saver mode. Use this setting if an external telephone has to be used when the machine is in the Energy Saver mode.
2-3	Not used			Do not change these settings.
4-5	Interval for preventing the machine from entering Energy Saver mode if there is a pending transmission file.			If there is a file waiting for transmission, the machine does not go to Energy Saver mode during the selected period. After transmitting the file, if there is no file waiting for transmission, the machine goes to the Energy Saver mode.
	Bit 5	Bit 4	Setting	
	0	0	1 min	
	0	1	30 min	
	1	0	1 hour	
	1	1	24 hours	
6-7	Not used			Do not change

System Switch 16 (SP No. 1-101-023)		
No	Function	Comments
0	Parallel Broadcasting 0: Disabled 1: Enabled	1: The machine sends messages simultaneously using all available ports during broadcasting. NOTE: If a customer wants to keep a line available for fax reception or other reasons, select "0" (Disable).
1	Priority setting for the G3 line. 0: PSTN-1 > PSTN-2 or 3 1: PSTN-2 or 3 > PSTN-1	This function allows the user to select the default G3 line type. The optional SG3 units are required to use the PSTN-2 or 3 setting.
2-7	Not used	Do not change these settings.

System Switch 17 - Not used (do not change these settings)

System Switch 18 - Not used (do not change these settings)

System Switch 19 (SP No. 1-101-026)		
No	Function	Comments
0-5	Not used	Do not change the settings.
6	Extended scanner page memory after memory option is installed 0: Disabled 1: Enabled	0: After installing the memory expansion option, the scanner page memory is extended to 4 MB from 2 MB. 1: If this bit is set to 1 after installing the memory expansion option, the scanner page memory is extended to 12 MB. But the SAF memory decreases to 18 MB.
7*	Special Original mode 0: Disabled 1: Enabled	1: If the customer frequently wishes to transmit a form or letterhead which has a colored or printed background, change this bit to "1". "Original 1" and "Original 2" can be selected in addition to the "Text", "Text/Photo" and "Photo" modes.

* This setting can be used for the client machine which has no FCU.

System Switch 1A (SP No. 1-101-027)		
No	Function	Comments
0 to 7	LS RX memory capacity threshold setting 00-FF (0-1020 Kbyte: Hex)	Sets the value to x4KB. When the amount of available memory drops below this setting, RX documents are printed to conserve memory. Initial setting 0x80 (512 KB) NOTE: If a customer wants available memory size to be larger, decrease this threshold

System Switch 1B - Not used (do not change these settings)

System Switch 1C - Not used (do not change these settings)

System Switch 1D (SP No. 1-101-030)

No	Function	Comments
0	RTI/CSI/CPS code display 0: Enable 1: Disable	0: RTI, CSI, CPS codes are displayed on the top line of the LCD panel during communication. 1: Codes are switched off (no display)
1-7	Not used	Do not change these settings.

System Switch 1E (SP No. 1-101-031)

No	Function	Comments
0	Communication after the Journal data storage area has become full 0: Impossible 1: Possible	0: When this switch is on and the journal history becomes full, the next report prints. If the journal history is not deleted, the next transmission cannot be received. This prevents overwriting communication records before the machine can print them. 1: If the buffer memory of the communication records for the Journal is full, fax communications are still possible. But the machine will overwrite the oldest communication records. Note <ul style="list-style-type: none"> This setting is effective only when Automatic Journal printout is enabled but the machine cannot print the report (e.g., no paper).

1*	<p>Action when the SAF memory has become full during scanning</p> <p>0: The current page is erased. 1: The entire file is erased.</p>	<p>0: If the SAF memory becomes full during scanning for a memory transmission, the successfully scanned pages are transmitted.</p> <p>1: If the SAF memory becomes full during scanning for a memory transmission, the file is erased and no pages are transmitted.</p> <p> Note</p> <ul style="list-style-type: none"> This setting is effective only when Automatic Journal printout is enabled but the machine cannot print the report (e.g., no paper).
2	<p>RTI/CSI display priority</p> <p>0: RTI 1: CSI</p>	<p>This bit determines which identifier, RTI or CSI, is displayed on the LCD while the machine is communicating in G3 non-standard mode.</p>
3	<p>File No. printing</p> <p>0: Enabled 1: Disabled</p>	<p>1: File numbers are not printed on any reports.</p> <p>NOTE: The file numbers may not be printed in the sequential order. If a customer does not like this numbering, select "0".</p>
4	<p>Action when authorized reception is enabled but authorized RTIs/CSIs are not yet programmed</p> <p>0: All fax reception is disabled 1: Faxes can be received if the sender has an RTI or CSI</p>	<p>0: If the user has stored no acceptable sender RTIs or CSIs, the user can select "ON" in the authorized reception setting but the setting becomes invalid ("OFF"). The machine will not be able to receive any fax messages.</p> <p>If the customer wishes to receive messages from any sender that includes an RTI or CSI, and to block messages from senders that do not include an RTI or CSI, change this bit to "0", then enable Authorized Reception. Otherwise, keep this bit at "1 (default setting)".</p>
5-7	Not used	Do not change the settings

* This setting can be used for the client machine which has no FCU.

System Switch 1F (SP No. 1-101-032)		
No	Function	Comments
0	Not used	Do not change the settings.
1	Report printout after an original jam during SAF storage or if the SAF memory fills up 0: Enabled 1: Disabled	0: When an original jams, or the SAF memory overflows during scanning, a report will be printed. Change this bit to "1" if the customer does not want to have a report in these cases. Memory tx – Memory storage report Parallel memory tx – Transmission result report
2	Not used	Do not change the settings.
3	Received fax print start timing (G3 reception) 0: After receiving each page 1: After receiving all pages	0: The machine prints each page immediately after the machine receives it. 1: The machine prints the complete message after the machine receives all the pages in the memory.
4-6	Not used	Do not change the factory settings.
7	Action when a fax SC has occurred 0: Automatic reset 1: Fax unit stops	0: When the fax unit detects a fax SC code other than SC1201 and SC1207, the fax unit automatically resets itself. 1: When the fax unit detects any fax SC code, the fax unit stops. Cross Reference Fax SC codes - See "Troubleshooting"

4.4 BIT SWITCHES - 2

Note

- Do not adjust a bit switch or use a setting that is described as "Not used", as this may cause the machine to malfunction or to operate in a manner that is not accepted by local regulations. Such bits are for use only in other areas, such as Japan.

Default settings for bit switches are not listed in this manual. Refer to the System Parameter List printed by the machine.

4.4.1 I-FAX SWITCHES

I-fax Switch 00 (SP No. 1-102-001)		
No	Function	Comments
Original Width of TX Attachment File		This setting sets the maximum size of the original that the destination can receive. (Bits 3 to 6 are reserved for future use or not used.)
0	A4	-
1	B4	
2	A3	
3-6	Reserved	
7	Not used	
<p>0: Off (not selected), 1: On (selected)</p> <p>If more than one of these three bits is set to "1", the larger size has priority. For example, if both Bit 2 and Bit 1 are set to "1" then the maximum size is "A3" (Bit 2).</p> <p>When mail is sent, there is no negotiation with the receiving machine at the destination, so the sending machine cannot make a selection for the receiving capabilities (original width setting) of the receiving machine. The original width selected with this switch is used as the RX machine's original width setting, and the original is reduced to this size before sending. The default is A4.</p> <p>If the width selected with this switch is higher than the receiving machine can accept, the machine detects this and this causes an error.</p>		

I-fax Switch 01 (SP No. 1-102-002)		
No	Function	Comments
Original Line Resolution of TX Attachment File		These settings set the maximum resolution of the original that the destination can receive.
0	200x100 Standard	0: Not selected 1: Selected If more than one of these three bits is set to "1", the higher resolution has priority. For example, if both Bit 0 and Bit 2 are set to "1" Then The Resolution is set for "Bit 2 200 x 400.
1	200x200 Detail	
2	200x400 Fine	
3	300 x 300 Reserve	
4	400 x 400 Super Fine	
5	600 x 600 Reserve	
6	Reserve	
7	mm/inch	
		This setting selects mm/inch conversion for mail transmission. 0: Off (No conversion), 1: On (Conversion) When on (set to "1"), the machine converts millimeters to inches for sending mail. There is no switch for converting inches to millimeters. Unlike G3 fax transmissions which can negotiate between sender and receiver to determine the setting, mail cannot negotiate between terminals; the mm/inch selection is determined by the sender fax. When this switch is Off (0): <ul style="list-style-type: none"> ▪ Images scanned in inches are sent in inches. ▪ Images scanned in mm are sent in mm. ▪ Images received in inches are transmitted in inches. ▪ Images received in mm are transmitted in mm. When this switch is On (1): <ul style="list-style-type: none"> ▪ Images scanned in inches are sent in inches. ▪ Images scanned in mm are converted to inches. ▪ Images received in inches are transmitted in inches. ▪ Images received in mm are converted to inches.

I-fax Switch 02 (SP No. 1-102-003)		
No	Function	Comments
0	RX Text Mail Header Processing	
		<p>This setting determines whether the header information is printed with text e-mails when they are received.</p> <p>0: Prints only text mail. 1: Prints mail header information attached to text mail.</p> <p>When a text mail is received with this switch On (1), the "From" address and "Subject" address are printed as header information.</p> <p>When a mail with only binary data is received (a TIFF-F file, for example), this setting is ignored and no header is printed.</p>
1	Output from Attached Document at E-mail TX Error	
		<p>This setting determines whether only the first page or all pages of an e-mail attachment are printed at the sending station when a transmission error occurs.</p> <p>This allows the customer to see which documents have not reached their intended destinations if sent to the wrong e-mail addresses, for example.</p> <p>0: Prints 1st page only. 1: Prints all pages.</p>
2-3	Text String for Return Receipt	
		<p>This setting determines the text string output for the Return Receipt that confirms the transmission was received normally at the destination.</p>

	<p>00: "Dispatched" Sends from PC mail a request for a Return Receipt. Receives the Return Receipt with "dispatched" in the 2nd part: Disposition: Automatic-action/MDN-send automatically; dispatched The "dispatched" string is included in the Subject string.</p> <p>01: "Displayed" Sends from PC mail a request for a Return Receipt. Receives the Return Receipt with "displayed" in the 2nd part: Disposition: Automatic-action/MDN-send automatically; displayed The "displayed" string is included in the Subject string.</p> <p>10: Reserved 11: Reserved</p> <p>A mail requesting a Return Receipt sent from an IFAX with this switch set to "00" (for "dispatched") received by Microsoft Outlook 2000 may cause an error. If any setting other than "displayed" (01) causes a problem, change the setting to "01" to enable normal sending of the Return Receipt.</p>
4	<p>Media accept feature</p> <p>This setting adds or does not add the media accept feature to the answer mail to confirm a reception.</p> <p>0: Does not add the media accept feature to the answer mail 1: Adds the media accept feature to the answer mail.</p> <p>Use this bit switch if a problem occurs when the machine receives an answer mail, which contains the media accept feature field.</p>
5-6	Not Used
7	<p>Image Resolution of RX Text Mail</p> <p>This setting determines the image resolution of the received mail.</p> <p>0: 200 x 200 1: 400 x 400</p> <p>The "1" setting requires installation of the Memory Unit in order to have enough SAF (Store and Forward) memory to receive images at 400 x 400 resolution.</p>

I-fax Switch 03 - Not used (do not change these settings)

I-fax Switch 04 (SP No. 1-102-005)		
No	Function	Comments
0	Subject for Delivery TX/Memory Transfer	
		<p>This setting determines whether the RTI/CSI registered on this machine or the RTI/CSI of the originator is used in the subject lines of transferred documents.</p> <p>0: Puts the RTI/CSI of the originator in the Subject line. If this is used, either the RTI or CSI is used. Only one of these can be received for use in the subject line.</p> <p>1: Puts the RTI/CSI registered on this machine in the Subject line.</p> <p>When this switch is used to transfer and deliver mail to a PC, the information in the Subject line that indicates where the transmission originated can be used to determine automatically the destination folder for each e-mail.</p>
1	<p>Subject corresponding to mail post database</p> <p>0: Standard subject</p> <p>1: Mail post database subject</p> <p>The standard subject is replaced by the mail post database subject in the following three cases:</p> <p>1) When the service technician sets the service (software) switch.</p> <p>2) When memory sending or delivery specified by F code is applied by the SMTP server</p> <p>3) With relay broadcasting (1st stage without the Schmidt 4 function).</p> <p>Note</p> <ul style="list-style-type: none"> This switch does not apply for condition 3) when the RX system is set up for memory sending, delivery by F-code, sending with SMTP RX and when operators are using FOL (to prevent problems when receiving transmissions). 	
2-7	Not Used	

I-fax Switch 05 (SP No. 1-102-006)		
No	Function	Comments
0	Mail Addresses of SMTP Broadcast Recipients	
	Determines whether the e-mail addresses of the destinations that receive transmissions broadcasted using SMTP protocol are recorded in the Journal. For example: "1st destination + Total number of destinations: 9" in the Journal indicates a broadcast to 9 destinations. 0: Not recorded 1: Recorded	
1	IFAXTX Retries	
	Determines whether the machine retries sending IFAX when connection and transmission fails due to errors. 0: Disabled 1: Enabled	
2-7	Not Used	

I-fax Switch 06 - Not used (do not change the settings)

I-fax Switch 07 - Not used (do not change the settings)

I-fax Switch 08 (SP No. 1-102-009)		
No	Function	Comments
0-7	Memory Threshold for POP Mail Reception	
	This setting determines the amount of SAF (Store and Forward) memory. (SAF stores fax messages to send later for transmission to more than one location, and also holds incoming messages if they cannot be printed.) When the amount of SAF memory available falls below this setting, mail can no longer be received; received mail is then stored on the mail server. 00-FF (0 to 1024 KB: HEX) The hexadecimal number you enter is multiplied by 4 KB to determine the amount of memory.	

FAX OPTION
TYPE M12
(D3A5)

I-fax Switch 09 (SP No. 1-102-010)		
No	Function	Comments
0-3	Not used	Do not change the settings
4-7	Restrict TX Retries	This setting determines the number of retries when connection and transmission fails due to errors. 01-F (1-15 Hex)

I-fax Switch 0A - Not used (do not change the settings)
I-fax Switch 0B - Not used (do not change the settings)
I-fax Switch 0C - Not used (do not change the settings)

I-fax Switch 0D (SP No. 1-102-014)				
No	Function			Comments
0-1	Not used			Do not change the settings
2-3	Select the signature when sending mail notification of the send results			In response to IEEE2600.1.
	Bit 2	Bit 3	Setting	
	0	0	No sign	
	0	1	No setting	
	1	0	Individual setting	
4-5	Select the signature when sending mail.			In response to IEEE2600.1.
	Bit 5	Bit 4	Setting	
	0	0	No sign	
	0	1	No setting	
	1	0	Individual setting	

	1	1	Always sign	
6-7	Not used			Do not change the settings.

I-fax Switch 0E - Not used (do not change the settings)

I-fax Switch 0F (SP No. 1-102-016)		
No	Function	Comments
0	Delivery Method for SMTP RX Files	
	This setting determines whether files received with SMTP protocol are delivered or output immediately. 0: Off. Files received via SMTP are output immediately without delivery. 1: On. Files received via SMTP are delivered immediately to their destinations.	
1	Set to select the signature when receiving SMTP mail.	
	0: No sign 1: Always sign	
2	Set to encrypt the data when receiving SMTP mail.	
	0: No encryption 1: Encryption	
3-7	Not used	

4.4.2 PRINTER SWITCHES

Printer Switch 00 (SP No. 1-103-001)		
No	Function	Comments
0	Select page separation marks 0: Off 1: On	<p>0: If a 2 page RX transmission is split, [*] is printed in the bottom right corner of the 1st page and only a [2] is printed in the upper right corner of the 2nd page.</p> <p>1: If a 2 page RX transmission is split into two pages, for example, [*] [2] is printed in the bottom right corner of the 1st page and only a [2] is printed in the upper right corner of the 2nd page.</p> <p>Note</p> <ul style="list-style-type: none"> This helps the user to identify pages that have been split because the size of the paper is smaller than the size of the document received. (When A5 is used to print an A4 size document, for example.)
1	Repetition of data when the received page is longer than the printer paper 0: Off 1: On	<p>1: Default. 10 mm of the trailing edge of the previous page are repeated at the top of the next page.</p> <p>0: The next page continues from where the previous page stopped without any repeated text.</p>
2	Prints the date and time on received fax messages 0: Disabled 1: Enabled	<p>This switch is only effective when user parameter 02 - bit 2 (printing the received date and time on received fax messages) is enabled.</p> <p>1: The machine prints the received and printed date and time at the bottom of each received page.</p>
3-7	Not used	Do not change the settings.

Printer Switch 01 (SP No. 1-103-002)				
No	Function			Comments
0-2	Not used			Do not change the settings.
3-4	Maximum print width used in the setup protocol			These bits are only effective when bit 7 of printer switch 01 is "1".
	Bit 4	Bit 3	Setting	
	0	0	Not used	
	0	1	A3	
	1	0	B4	
	1	1	A4	
5-6	Not used			Do not change the settings.
7	Received message width restriction in the protocol signal to the sender 0: Disabled 1: Enabled			0: The machine informs the transmitting machine of the print width depending on the paper size available from the paper feed stations. Refer to the table on the next page for how the machine chooses the paper width used in the setup protocol (NSF/DIS). 1: The machine informs the transmitting machine of the fixed paper width which is specified by bits 3 and 4 above.

Relationship between available paper sizes and printer width used in the setup protocol

Available Paper Size	Printer width used in the Protocol (NSF/DIS)
A4 or 8.5" x 11"	297 mm width
B5	256 mm width
A5 or 8.5" x 5.5"	216 mm width
No paper available (Paper end)	216 mm width

Printer Switch 02 (SP No. 1-103-003)		
No	Function	Comments
0*	1st paper feed station usage for fax printing 0: Enabled 1: Disabled	<p>0: The paper feed station can be used to print fax messages and reports. 1: The specified paper feed station will not be used for printing fax messages and reports.</p> <p> Note</p> <ul style="list-style-type: none"> Do not disable usage for a paper feed station which has been specified by User Parameter Switch 0F (15), or which is used for the Specified Cassette Selection feature.
1*	2nd paper feed station usage for fax printing 0: Enabled 1: Disabled	
2*	3rd paper feed station usage for fax printing 0: Enabled 1: Disabled	
3*	4th paper feed station usage for fax printing 0: Enabled 1: Disabled	
4*	LCT usage for fax printing 0: Enabled 1: Disabled	
5-7	Not used	Do not change the settings.

* This setting can be used for the client-side machine which has no FCU.

Printer Switch 03 (SP No. 1-103-004)		
No	Function	Comments
0*	Length reduction of received data 0: Disabled 1: Enabled	0: Incoming pages are printed without length reduction. (Page separation threshold: Printer Switch 03, bits 4 to 7) 1: Incoming page length is reduced when printing. (Maximum reducible length: Printer Switches 04, bits 0 to 4)
1-3	Not used	Do not change the settings
4 to 7	Page separation setting when sub scan compression is forbidden 00-0F (0-15 mm: Hex) Default: 6 mm	Page separation threshold (with reduction disabled with switch 03-0 above). For example, if this setting is set to "10", and A4 is the selected paper size: If the received document is 10 mm or less longer than A4, then the 10 mm are cut and only 1 page prints. If the received document is 10 mm longer than A4, then the document is split into 2 pages.

* This setting can be used for the client-side machine which has no FCU.

Printer Switch 04 (SP No. 1-103-005)						
No	Function			Comments		
0 to 4	Maximum reducible length when length reduction is enabled with switch 03-0 above. [Maximum reducible length] = [Paper length] + (N x 5mm) "N" is the decimal value of the binary setting of bits 0 to 4.					
	Bit 4	Bit 3	Bit 2	Bit 1	Bit 0	Setting
	0	0	0	0	0	0 mm
	0	0	0	0	1	5 mm
	0	0	1	0	0	20 mm
	1	1	1	1	1	155 mm
For A5 sideways and B5 sideways paper [Maximum reducible length] = [Paper length] + 0.75 x (N x 5mm)						
5 6	Length of the duplicated image on the next page, when page separation has taken place.					
	Bit 6		Bit 5		Setting	
	0		0		4 mm	
	0		1		10 mm	
	1		0		15 mm	
1		1		Not used		
7	Not used.			Do not change the setting.		

Printer Switch 05 - Not used (do not change the settings)

Printer Switch 06 (SP No. 1-103-007)		
No	Function	Comments
0*	Printing while a paper cassette is pulled out, when the Just Size Printing feature is enabled. 0: Printing will not start 1: Printing will start if another cassette has a suitable size of paper, based on the paper size selection priority tables.	Cross reference Just size printing on/off – User switch 05, bit 5
1-7	Not used.	Do not change the settings.

* This setting can be used for the client-side machine which has no FCU.

Printer Switch 07 (SP No. 1-103-008)		
No	Function	Comments
0-3	Not used.	Do not change the settings.
4	Receiver name printed on the transmission result report	Selects the printing target on the transmission result report. 0: All receivers 1: Printing only receivers which have received fax transmission.
5-7	Not used.	Do not change the settings.

Printer Switch 08 - Not used (do not change the settings)

Printer Switch 09 - Not used (do not change the settings)

Printer Switch 0A - Not used (do not change the settings)

Printer Switch 0B - Not used (do not change the settings)

Printer Switch 0C - Not used (do not change the settings)

Printer Switch 0E (SP No. 1-103-015)				
No	Function		Comments	
0*	Paper size selection priority 0: Width 1: Length		0: A paper size that has the same width as the received data is selected first. 1: A paper size which has enough length to print all the received lines without reduction is selected first.	
1*	Paper size selected for printing A4 width fax data 0: 8.5" x 11" size 1: A4 size		This switch determines which paper size is selected for printing A4 width fax data, when the machine has both A4 and 8.5" x 11" size paper.	
2	Page separation 0: Enabled 1: Disabled		1: If all paper sizes in the machine require page separation to print a received fax message, the machine does not print the message (Substitute Reception is used). After a larger size of paper is set in a cassette, the machine automatically prints the fax message.	
3-4	Printing the sample image on reports			"Same size" means the sample image is printed at 100%, even if page separation occurs. User Parameter Switch 19 (13H) bit 4 must be set to "0" to enable this switch. Refer to Detailed Section Descriptions for more on this feature.
	Bit 4	Bit 3	Setting	
	0	0	The upper half only	
	0	1	50% reduction (sub-scan only)	
	1	0	Same size	
	1	1	Not used	
5-6	Not used		Do not change the settings.	

7	Equalizing the reduction ratio among separated pages (Page Separation) 0: Enabled 1: Disabled	0: When page separation has taken place, all the pages are reduced with the same reduction ratio. 1: Only the last page is reduced to fit the selected paper size when page separation has taken place. Other pages are printed without reduction.
---	--	---

* This setting can be used for the client-side machine which has no FCU.

Printer Switch 0F (SP No. 1-103-016)				
No	Function			Comments
0-1*	Smoothing feature			(0, 0) (0, 1): Disable smoothing if the machine receives halftone images from other manufacturers fax machines frequently.
	Bit 1	Bit 0	Setting	
	0	0	Disabled	
	0	1	Disabled	
	1	0	Enabled	
1	1	Not used		
2*	Duplex printing 0: Disabled 1: Enabled			1: The machine always prints received fax messages in duplex printing mode:
3	Binding direction for Duplex printing 0: Left binding 1: Top binding			0: Sets the binding for the left edge of the stack. 1: Sets the binding for the top of the stack.
4-7	Not used			Do not change the settings.

* This setting can be used for the client-side machine which has no FCU.

4.5 BIT SWITCHES - 3

Note

- Do not adjust a bit switch or use a setting that is described as "Not used", as this may cause the machine to malfunction or to operate in a manner that is not accepted by local regulations. Such bits are for use only in other areas, such as Japan.

Default settings for bit switches are not listed in this manual. Refer to the System Parameter List printed by the machine.

4.5.1 COMMUNICATION SWITCHES

Communication Switch 00 (SP No. 1-104-001)				
No	Function			Comments
0-1	Compression modes available in receive mode			These bits determine the compression capabilities to be declared in phase B (handshaking) of the T.30 protocol.
	Bit 1	Bit 0	Modes	
	0	0	MH only	
	0	1	MH/MR	
	1	0	MH/MR/MMR	
	1	1	MH/MR/MMR/JBIG	
2-3	Compression modes available in transmit mode			These bits determine the compression capabilities to be used in the transmission and to be declared in phase B (handshaking) of the T.30 protocol.
	Bit 3	Bit 2	Modes	
	0	0	MH only	
	0	1	MH/MR	
	1	0	MH/MR/MMR	
	1	1	MH/MR/MMR/JBIG	
4	Not used			Do not change the settings.

5	<p>JBIG compression method: Reception</p> <p>0: Only basic supported</p> <p>1: Basic and optional both supported</p>	<p>Change the setting when communication problems occur using JBIG compression.</p>
6	<p>JBIG compression method: Transmission</p> <p>0: Basic mode priority</p> <p>1: Optional mode priority</p>	<p>Change the setting when communication problems occur using JBIG compression.</p>
7	<p>Closed network (reception)</p> <p>0: Disabled</p> <p>1: Enabled</p>	<p>1: Reception will not go ahead if the polling ID code of the remote terminal does not match the polling ID code of the local terminal. This function is only available in NSF/NSS mode.</p>

Communication Switch 01 (SP No. 1-104-002)				
No	Function			Comments
0	<p>ECM</p> <p>0: Off 1: On</p>			<p>If this bit is set to 0, ECM is switched off for all communications.</p> <p>In addition, V.8 protocol and JBIG compression are switched off automatically.</p>
1	Not used			Do not change the setting.
2-3	Wrong connection prevention method			<p>(0,1): The machine will disconnect the line without sending a fax message, if the last 8 digits of the received CSI do not match the last 8 digits of the dialed telephone number. This does not work when manually dialed.</p> <p>(1,0): The same as above, except that only the last 4 digits are compared.</p> <p>(1,1): The machine will disconnect the line without sending a fax message, if the other end</p>
	Bit 3	Bit 2	Setting	
	0	0	None	
	0	1	8 digit CSI	
	1	0	4 digit CSI	
	1	1	CSI/RTI	

		<p>does not identify itself with an RTI or CSI. (0,0): Nothing is checked; transmission will always go ahead.</p> <p>Note</p> <ul style="list-style-type: none"> This function does not work when dialing is done from the external telephone. 		
4-5	Not used	Do not change the setting.		
6-7	Maximum printable page length available		<p>The setting determined by these bits is informed to the transmitting terminal in the pre-message protocol exchange (in the DIS/NSF frames).</p>	
	Bit 7	Bit 6		Setting
	0	0		No limit
	0	1		B4 (364 mm)
	1	0		A4 (297 mm)
	1	1	Not used	

Communication Switch 02 (SP No. 1-104-003)		
No	Function	Comments
0	G3 Burst error threshold 0: Low 1: High	<p>If there are more consecutive error lines in the received page than the threshold, the machine will send a negative response. The Low and High threshold values depend on the sub-scan resolution, and are as follows.</p>
		100 dpi 6(L) →12(H)
		200 dpi 12(L) →24(H)
		300 dpi 18(L) →36(H)
		400 dpi 24(L) →48(H)
1	Acceptable total error line ratio 0: 5% 1: 10%	If the error line ratio for a page exceeds the acceptable ratio, RTN will be sent to the other end.

2	Treatment of pages received with errors during G3 reception 0: Deleted from memory without printing 1: Printed	0: Pages received with errors are not printed.
3	Hang-up decision when a negative code (RTN or PIN) is received during G3 immediate transmission 0: No hang-up, 1: Hang-up	0: The next page will be sent even if RTN or PIN is received. 1: The machine will send DCN and hang up if it receives RTN or PIN. This bit is ignored for memory transmissions or if ECM is being used.
4-7	Not used	Do not change these settings.

Communication Switch 03 (SP No. 1-104-004)		
No	Function	Comments
0-7	Maximum number of page retransmissions in a G3 memory transmission	00 - FF (Hex) times. This setting is not used if ECM is switched on. Default setting - 03(H)

Communication Switch 04 (SP No. 1-104-005)		
No	Function	Comments
0	Remote mode switch (TEL mode) 0: Disable 1: Enable (Active)	Set this bit to ON when you wish to switch TEL mode to FAX mode remotely.
1	Remote mode switch (FAX mode) 0: Disable 1: Enable (Active)	Set this bit to ON when you wish to turn on the remote mode switch after automatic reception with FAX mode.
2	Remote mode switch (AUTO mode) 0: Disable 1: Enable (Active)	Set this bit to ON when you wish to turn on the remote mode switch after automatic reception with AUTO mode.
3-7	Not used	Do not change the settings.

Communication Switch 05 (SP No. 1-104-006)		
No	Function	Comments
0-3	Remote mode switch number 00-09 (0-9:HEX)	Enter the number to switch between TEL/FAX modes using the external phone.
4-7	Not used	Do not change the settings.

Communication Switch 06 - Not used (do not change the settings)

Communication Switch 07 - Not used (do not change the settings)

Communication Switch 08 - Not used (do not change the settings)

Communication Switch 09 (SP No. 1-104-009)		
No	Function	Comments
0-7	Minimum interval between automatic dialing attempts	This value is the minimum time that the machine waits before it dials the next destination.

Communication Switch 0A (SP No. 1-104-011)		
No	Function	Comments
0	Point of resumption of memory transmission upon redialing 0: From the error page 1: From page 1	0: The transmission begins from the page where transmission failed the previous time. 1: Transmission begins from the first page, using normal memory transmission.
1-7	Not used	Do not change these settings.

Communication Switch 0B (SP No. 1-104-012)		
No	Function	Comments
0-3	Not used	Do not change these settings.
4	Printout of the message when acting as a Transfer Station 0: Disabled, 1: Enabled	When the machine is acting as a Transfer Station, this bit determines whether the machine prints the fax message coming in from the Requesting Terminal.
5-7	Not used	Do not change the settings.

Communication Switch 0C - Not used (do not change the settings)

Communication Switch 0D (SP No. 1-104-014)		
No	Function	Comments
0-7	The available memory threshold, below which ringing detection (and therefore reception into memory) is disabled	00 to FF (Hex), unit = 4 kbytes (e.g., 06(H) = 24 kbytes) One page is about 24 kbytes. The machine refers to this setting before each fax reception. If the amount of remaining memory is below this threshold, the machine cannot receive any fax messages. If this setting is kept at 0, the machine will detect ringing signals and go into receive mode even if there is no memory available. This will result in communication failure.

Communication Switch 0E (SP No. 1-104-015)		
No	Function	Comments
0-7	Minimum interval between automatic dialing attempts	06 to FF (Hex), unit = 2 s (e.g., 06(H) = 12 s) This value is the minimum time that the machine waits before it dials the next destination.

Communication Switch 0F – Not used (do not change the settings.)

Communication Switch 10 (SP No. 1-104-017)		
No	Function	Comments
0-7	Memory transmission: Maximum number of dialing attempts to the same destination	01 – FE (Hex) times

Communication Switch 11 – Not used (do not change the settings.)

Communication Switch 12 (SP No. 1-104-019)		
No	Function	Comments
0-7	Memory transmission: Interval between dialing attempts to the same destination	01 – FF (Hex) minutes

Communication Switch 13 – Not used (do not change the settings.)

Communication Switch 14 (SP No. 1-104-021)				
No	Function			Comments
0	Inch-to-mm conversion during transmission 0: Disabled, 1: Enabled			0: In immediate transmission, data scanned in inch format are transmitted without conversion. In memory transmission, data stored in the SAF memory in mm format are transmitted without conversion. Note: When storing the scanned data into SAF memory, the fax unit always converts the data into mm format. 1: The machine converts the scanned data or stored data in the SAF memory to the format which was specified in the set-up protocol (DIS/NSF) before transmission.
1-5	Not used			Do not change the factory settings.
6-7	Available unit of resolution in which fax messages are received			For the best performance, do not change the factory settings. The setting determined by these bits is informed to the transmitting terminal in the pre-message protocol exchange (in the DIS/NSF frames).
	Bit 7	Bit 6	Unit	
	0	0	mm	
	0	1	inch	
	1	0	mm and inch	
1	1	Not used		

Communication Switch 15 – Not used (do not change the settings)

Communication Switch 16 (SP No. 1-104-023)		
No	Function	Comments
0	Not used	Do not change the settings.
1	Optional G3 unit (G3-2) 0: Not installed 1: Installed	Change this bit to 1 when installing the first optional G3 unit.
2	Not used	
3	Select PSTN connection 0: Off 1: On	This switch enables the G3-2. 0: Off, no connection 1: Recognizes and enables G3-2. This switch can be used only after G3-2 has been installed.
4-7	Not used	Do not change the settings.

Communication Switch 17 (SP No. 1-104-024)		
No	Function	Comments
0	SEP reception 0: Disabled 1: Enabled	0: Polling transmission to another maker's machine using the SEP (Selective Polling) signal is disabled.
1	SUB reception 0: Disabled 1: Enabled	0: Confidential reception to another maker's machine using the SUB (Sub-address) signal is disabled.
2	PWD reception 0: Disabled 1: Enabled	0: Disables features that require PWD (Password) signal reception.
3-4	Not used	Do not change the settings.
5	PSTN dial-in routing setting 0: OFF 1: ON	1: The machine sets multiple PSTN dial-in numbers in the PSTN dial-in line and transfers received data from each PSTN dial-in number to each address.

6	Not used	Do not change the settings.
7	Action when there is no box with an F-code that matches the received SUB code 0: Disconnect the line 1: Receive the message (using normal reception mode)	Change this setting when the customer requires.

Communication Switch 18 (SP No. 1-104-025)		
No	Function	Comments
0-4	Not used	Do not change the settings.
5	IP-Fax dial-in routing selection 0: Off 1: On	1: Transfers received data to each IP-Fax dial-in number. IP-Fax dial-in number is a 4-digit number.
6	PSTN 2 dial-in routing 0: Off 1: On	Enables or disables dial-in routing for the PSTN 2 connection.
7	PSTN 3 dial-in routing 0: Off 1: On	Enables or disables dial-in routing for the PSTN 3 connection.

Communication Switch 19 - Not used (do not change the settings)
Communication Switch 1A - Not used (do not change the settings)

FAX OPTION
TYPE M12
(D3A5)

Communication Switch 1B (SP No. 1-104-028)		
No	Function	Comments
0-7	Extension access code (0 to 7) to turn V.8 protocol On/Off 0: On 1: Off	If the PABX does not support V.8/V.34 protocol procedure, set this bit to "1" to disable V.8. Example: If "0" is the PSTN access code, set bit 0 to 1. When the machine detects "0" as the first dialed number, it automatically disables V.8 protocol. (Alternatively, if "3" is the PSTN access code, set bit 3 to 1.)

Communication Switch 1C (SP No. 1-104-029)		
No	Function	Comments
0-1	Extension access code (8 and 9) to turn V.8 protocol On/Off 0: On 1: Off	Refer to communication switch 1B. Example: If "8" is the PSTN access code, set bit 0 to 1. When the machine detects "8" as the first dialed number, it automatically disables V.8 protocol. (If "9" is the PSTN access code, use bit 1.)
2-7	Not used	Do not change the settings.

Communication Switch 1D - Not used (do not change the settings)
Communication Switch 1E - Not used (do not change the settings)
Communication Switch 1F - Not used (do not change the settings)

4.6 BIT SWITCHES - 4

Note

- Do not adjust a bit switch or use a setting that is described as "Not used", as this may cause the machine to malfunction or to operate in a manner that is not accepted by local regulations. Such bits are for use only in other areas, such as Japan.

Default settings for bit switches are not listed in this manual. Refer to the System Parameter List printed by the machine.

4.6.1 G3 SWITCHES

G3 Switch 00 (SP No. 1-105-001)				
No	Function			Comments
0 1	Monitor speaker during communication (tx and rx)			(0, 0): The monitor speaker is disabled all through the communication. (0, 1): The monitor speaker is on up to phase B in the T.30 protocol. (1, 0): Used for testing. The monitor speaker is on all through the communication. Make sure that you reset these bits after testing.
	Bit 1	Bit 0	Setting	
	0	0	Disabled	
	0	1	Up to Phase B	
	1	0	All the time	
	1	1	Not used	
2	Monitor speaker during memory transmission 0: Disabled 1: Enabled			1: The monitor speaker is enabled during memory transmission.
3-5	Not used			Do not change the settings.
6	Dedicated G3 line mode selection 0: Off 1: On (Dedicated)			Set this bit to 1 when you wish to dedicate a line for G3.
7	Not used			Do not change this setting.

G3 Switch 01 (SP No. 1-105-002)		
No	Function	Comments
0-3	Not used	Do not change the settings.
4	DIS frame length 0: 10 bytes 1: 4 bytes	1: The bytes in the DIS frame after the 4th byte will not be transmitted (set to 1 if there are communication problems with PC-based faxes which cannot receive the extended DIS frames).
5	Not used	Do not change the setting.
6	Forbid CED/ANSam output 0: Off 1: On (Forbid output)	Do not change this setting (Default: 0: Off), unless communication problem is caused by a CED or ANSam transmission.
7	Not used	Do not change this setting.

G3 Switch 02 (SP No. 1-105-003)		
No	Function	Comments
0	G3 protocol mode used 0: Standard and non-standard 1: Standard only	Change this bit to 1 only when the other end can only communicate with machines that send T.30-standard frames only. 1: Disables NSF/NSS signals (these are used in non-standard mode communication)
1-6	Not used	Do not change the settings.
7	Short preamble 0: Disabled 1: Enabled	Refer to Appendix B in the Group 3 Facsimile Manual for details about Short Preamble.

G3 Switch 03 (SP No. 1-105-004)		
No	Function	Comments
0	DIS detection number (Echo countermeasure) 0: 1 1: 2	0: The machine will hang up if it receives the same DIS frame twice. 1: Before sending DCS, the machine will wait for the second DIS which is caused by echo on the line.
1	Not Used	Do not change the settings.
2	Not Used	Do not change the settings.
3	ECM frame size 0: 256 bytes 1: 64 bytes	Keep this bit at "0" in most cases.
4	CTC transmission conditions 0: After one PPR signal received 1: After four PPR signals received (ITU-T standard)	0: When using ECM in non-standard (NSF/NSS) mode, the machine sends a CTC to drop back the modem rate after receiving a PPR, if the following condition is met in communications at 14.4, 12.0, 9.6, and 7.2 kbps. $\sqrt{N_{\text{Transmit}}} \leq N_{\text{Resend}}$ N _{Transmit} - Number of transmitted frames N _{Resend} - Number of frames to be retransmitted 1: When using ECM, the machine sends a CTC to drop back the modem rate after receiving four PPRs. PPR, CTC: These are ECM protocol signals. This bit is not effective in V.34 communications.
5	Modem rate used for the next page after receiving a negative code (RTN or PIN) 0: No change 1: Fallback	1: The machine's tx modem rate will fall back before sending the next page if a negative code is received. This bit is ignored if ECM is being used.
6	Not used	Do not change the settings

7	Select detection of reverse polarity in ringing 0: Off 1: On	This switch is used to prevent reverse polarity in ringing on the phone line (applied to PSTN-G3 ringing). Do not change this setting 0: No detection 1: Detection (Japan and Korea only)
---	--	---

G3 Switch 04 (SP No. 1-105-005)		
No	Function	Comments
0-3	Training error detection threshold	0 - F (Hex); 0 - 15 bits If the number of error bits in the received TCF is below this threshold, the machine informs the sender that training has succeeded.
4-7	Not used	Do not change the settings.

G3 Switch 05 (SP No. 1-105-006)						
No	Function					Comments
0-3	Initial Tx modem rate (kbps)					These bits set the initial starting modem rate for transmission. Use the dedicated transmission parameters if you need to change this for specific receivers. If a modem rate 14.4 kbps or slower is selected, V.8 protocol should be disabled manually. Cross reference V.8 protocol on/off - G3 switch 03, bit 2
	Bit 3	Bit 2	Bit 1	Bit 0	kbps	
	0	0	0	1	2.4	
	0	0	1	0	4.8	
	0	0	1	1	7.2	
	0	1	0	0	9.6	
	0	1	0	1	12.0	
	0	1	1	0	14.4	
	0	1	1	1	16.8	
	1	0	0	0	19.2	
	1	0	0	1	21.6	
1	0	1	0	24.0		

	1	0	1	1	26.4	
	1	1	0	0	28.8	
	1	1	0	1	31.2	
	1	1	1	0	33.6	
	Other settings - Not used					
4-5	Initial modem type for 9.6 k or 7.2 kbps.					These bits set the initial modem type for 9.6 and 7.2 kbps, if the initial modem rate is set at these speeds.
	Bit 5	Bit 4	Setting			
	0	0	V.29			
	0	1	V.17			
	1	0	V.34			
1	1	Not used				
6-7	Not used				Do not change the settings.	

G3 Switch 06 (SP No. 1-105-007)						
No	Function					Comments
0-3	Initial Rx modem rate(kbps)					These bits set the initial starting modem rate for reception. Use a lower setting if high speeds pose problems during reception. If a modem rate 14.4 kbps or slower is selected, V.8 protocol should be disabled manually. Cross reference V.8 protocol on/off - G3 switch 03, bit2
	Bit 3	Bit 2	Bit 1	Bit 0	kbps	
	0	0	0	1	2.4	
	0	0	1	0	4.8	
	0	0	1	1	7.2	
	0	1	0	0	9.6	
	0	1	0	1	12.0	
	0	1	1	0	14.4	
	0	1	1	1	16.8	
	1	0	0	0	19.2	
	1	0	0	1	21.6	

	1	0	1	0	24.0	
	1	0	1	1	26.4	
	1	1	0	0	28.8	
	1	1	0	1	31.2	
	1	1	1	0	33.6	
	Other settings - Not used					
4-7	<p>Modem types available for reception</p> <p>The setting of these bits is used to inform the transmitting terminal of the available modem type for the machine in receive mode.</p> <p>If V.34 is not selected, V.8 protocol must be disabled manually.</p> <p>Cross reference</p> <p>V.8 protocol on/off - G3 switch 03, bit 2</p>					
	Bit 7	Bit 6	Bit 5	Bit 4	Types	
	0	0	0	1	V.27ter	
	0	0	1	0	V.27ter, V.29	
	0	0	1	1	V.27ter, V.29, V.33	
	0	1	0	0	V.27ter, V.29, V.17	
	0	1	0	1	V.27ter, V.29, V.17, V.34	
	Other settings - Not used					

G3 Switch 07 (SP No. 1-105-008)				
No	Function			Comments
0-1	PSTN cable equalizer (tx mode: Internal)			Use a higher setting if there is signal loss at higher frequencies because of the length of wire between the modem and the telephone exchange. Use the dedicated transmission parameters for specific receivers. Also, try using the cable equalizer if one or more of the following symptoms occurs. Communication error Modem rate fallback occurs frequently. Note <ul style="list-style-type: none"> This setting is not effective in V.34 communications.
	Bit 1	Bit 0	Setting	
	0	0	None	
	0	1	Low	
	1	0	Medium	
	1	1	High	
2-3	PSTN cable equalizer (rx mode: Internal)			Use a higher setting if there is signal loss at higher frequencies because of the length of wire between the modem and the telephone exchange. Also, try using the cable equalizer if one or more of the following symptoms occurs. Communication error with error codes such as 0-20, 0-23, etc. Modem rate fallback occurs frequently. Note <ul style="list-style-type: none"> This setting is not effective in V.34 communications.
	Bit 3	Bit 2	Setting	
	0	0	None	
	0	1	Low	
	1	0	Medium	
	1	1	High	
4	PSTN cable equalizer (V.8/V.17 rx mode: External) 0: Disabled 1: Enabled			Keep this bit at "1".

5	Not used	Do not change the settings.
6	Parameter selection for dial tone detection 0: Normal parameter 1: Specific parameter	0: This uses the fixed table in the ROM for dial tone detection. 1: This uses the specific parameter adjusted with SRAM (69ECBEH - 69ECDEH). Select this if the dial tone cannot be detected when the "Normal parameter: 0" is selected.
7	Not used	Do not change the settings.

G3 Switch 08 - Not used (do not change the settings)

G3 Switch 09 - Not used (do not change the settings)

G3 Switch 0A (SP No. 1-105-011)

No	Function			Comments
0-1	Maximum allowable carrier drop during image data reception			These bits set the acceptable modem carrier drop time. Try a longer setting if error code 0-22 is frequent.
	Bit 1	Bit 0	Value (ms)	
	0	0	200	
	0	1	400	
	1	0	800	
	1	1	Not used	
2	Select cancellation of high-speed RX if carrier signal lost while receiving 0: Off 1: On			This switch setting determines if high-speed receiving ends if the carrier signal is lost when receiving during non-ECM mode
3	Not used			Do not change the settings

Bit Switches - 4

4	<p>Maximum allowable frame interval during image data reception. 0: 5 s 1: 13 s</p>	<p>This bit set the maximum interval between EOL (end-of-line) signals and the maximum interval between ECM frames from the other end. Try using a longer setting if error code 0-21 is frequent.</p>
5	Not used	Do not change the settings.
6	<p>Reconstruction time for the first line in receive mode 0: 6 s 1: 12 s</p>	<p>When the sending terminal is controlled by a computer, there may be a delay in receiving page data after the local machine accepts set-up data and sends CFR. This is outside the T.30 recommendation. But, if this delay occurs, set this bit to 1 to give the sending machine more time to send data. Refer to error code 0-20. ITU-T T.30 recommendation: The first line should come within 5 s of CFR.</p>
7	Not used	Do not change the settings.

G3 Switch 0B Not used (do not change the settings).

G3 Switch 0C (SP No. 1-105-013)		
No	Function	Comments
0-1	Not used	Do not change these settings.
4-5	Select detection of DTMF/DP detection when using remote switch. 00: DTMF+PSTN (Simultaneous detection) 01: DTMF 10: DP (10 PPS) 11: DP (20 PPS)	This setting determines how to detect the signals from the handset when remote switch is active.

G3 Switch 0D Not used (do not change the settings).

G3 Switch 0E (SP No. 1-105-015)		
No	Function	Comments
0-7	Set CNG send time interval Some machines on the receiving side may not be able to automatically switch the 3-second CNG interval.	
	High order bit	3000-2250ms: 3000-50xNms 3000 – 50 x Nms 0F (3000 ms) <= N <= FF (2250 ms)
	Low order bit	00-0E(3000-3700ms: 3000+50xNms 3000 – 50 x Nms 0F (3000 ms) <= N <= 0F (3700 ms)

G3 Switch 0F (SP No. 1-105-016)		
No	Function	Comments
0	Alarm when an error occurred in Phase C or later 0: Disabled 1: Enabled	If the customer wants to hear an alarm after each error communication, change this bit to "1".
1	Alarm when the handset is off-hook at the end of communication 0: Disabled 1: Enabled	If the customer wants to hear an alarm if the handset is off-hook at the end of fax communication, change this bit to "1".
2-3	Not used	Do not change these settings.
4	Sidaa manual calibration setting 0: Off 1: On	1: manually calibrates for communication with a line whose current change occurs such as an optical fiber line.
5-7	Not used	Do not change the settings.

4.7 BIT SWITCHES - 5

Note

- Do not adjust a bit switch or use a setting that is described as "Not used", as this may cause the machine to malfunction or to operate in a manner that is not accepted by local regulations. Such bits are for use only in other areas, such as Japan.

Default settings for bit switches are not listed in this manual. Refer to the System Parameter List printed by the machine.

4.7.1 G3-2 AND G3-3 SWITCHES

These switches require an optional G3 interface unit.

G3-3 switches are the same as for G3-2 switches.

G3-2 Switch 00 (SP No. 1-106-001)				
No	Function			Comments
0 1	Monitor speaker during communication (tx and rx)			(0, 0): The monitor speaker is disabled all through the communication. (0, 1): The monitor speaker is on up to phase B in the T.30 protocol. (1, 0): Used for testing. The monitor speaker is on all through the communication. Make sure that you reset these bits after testing.
	Bit 1	Bit 0	Setting	
	0	0	Disable	
	0	1	Up to Phase B	
	1	0	All the time	
	1	1	Not used	
2	Monitor speaker during memory transmission 0: Disabled 1: Enabled			1: The monitor speaker is enabled during memory transmission.
3-7	Not used			Do not change the settings.

G3-2 Switch 01 (SP No. 1-106-002)		
No	Function	Comments
0-3	Not used	Do not change the settings.
4	DIS frame length 0: 10 bytes 1: 4 bytes	1: The bytes in the DIS frame after the 4th byte will not be transmitted (set to 1 if there are communication problems with PC-based faxes which cannot receive the extended DIS frames).
5	Not used	Do not change the setting.
6	Forbid CED/AMsam output 0: Off 1: On (Forbid output)	Do not change this setting (Default: 0: Off), unless communication problem is caused by a CED or ANSam transmission.
7	Not used	Do not change the setting.

G3-2 Switch 02 (SP No. 1-106-003)		
No	Function	Comments
0	G3 protocol mode used 0: Standard and non-standard 1: Standard only	Change this bit to 1 only when the other end can only communicate with machines that send T.30-standard frames only. 1: Disables NSF/NSS signals (these are used in non-standard mode communication)
1-4	Not used	Do not change the settings.
5	AI modem rate selection 0: OFF, 1: ON	Selects if the AI modem rate is ON or OFF.
6	Not used	Do not change the settings.
7	Short preamble 0: Disabled 1: Enabled	Refer to Appendix B in the Group 3 Facsimile Manual for details about Short Preamble.

FAX OPTION
TYPE M12
(D3A5)

G3-2 Switch 03 (SP No. 1-106-004)		
No	Function	Comments
0	DIS detection number (Echo countermeasure) 0: 1 1: 2	0: The machine will hang up if it receives the same DIS frame twice. 1: Before sending DCS, the machine will wait for the second DIS which is caused by echo on the line.
1	Not Used	Do not change the settings.
2	Not Used	Do not change the settings.
3	ECM frame size 0: 256 bytes 1: 64 bytes	Keep this bit at "0" in most cases.
4	CTC transmission conditions 0: After one PPR signal received 1: After four PPR signals received (ITU-T standard)	0: When using ECM in non-standard (NSF/NSS) mode, the machine sends a CTC to drop back the modem rate after receiving a PPR, if the following condition is met in communications at 14.4, 12.0, 9.6, and 7.2 kbps. $\sqrt{N_{\text{transmit}}} \leq N_{\text{resend}}$ N _{transmit} = Number of transmitted frames N _{resend} = Number of frames to be retransmitted 1: When using ECM, the machine sends a CTC to drop back the modem rate after receiving four PPRs. PPR, CTC: These are ECM protocol signals. This bit is not effective in V.34 communications.
5	Modem rate used for the next page after receiving a negative code (RTN or PIN) 0: No change 1: Fallback	1: The machine's tx modem rate will fall back before sending the next page if a negative code is received. This bit is ignored if ECM is being used.
6	Not used	Do not change the settings

7	Select detection of reverse polarity in ringing 0: Off 1: On	This switch is used to prevent reverse polarity in ringing on the phone line (applied to PSTN-G3 ringing). Do not change this setting 0: No detection 1: Detection (Japan and Korea only)
---	--	---

G3-2 Switch 04 (SP No. 1-106-005)		
No	Function	Comments
0-3	Training error detection threshold	0 - F (Hex); 0 - 15 bits If the number of error bits in the received TCF is below this threshold, the machine informs the sender that training has succeeded.
4-7	Not used	Do not change the settings.

G3-2 Switch 05 (SP No. 1-106-006)						
No	Function					Comments
0-3	Initial Tx modem rate (kbps)					These bits set the initial starting modem rate for transmission. Use the dedicated transmission parameters if you need to change this for specific receivers. If a modem rate 14.4 kbps or slower is selected, V.8 protocol should be disabled manually. Cross reference V.8 protocol on/off - G3 switch 03, bit 2
	Bit 3	Bit 2	Bit 1	Bit 0	kbps	
	0	0	0	1	2.4	
	0	0	1	0	4.8	
	0	0	1	1	7.2	
	0	1	0	0	9.6	
	0	1	0	1	12.0	
	0	1	1	0	14.4	
	0	1	1	1	16.8	
	1	0	0	0	19.2	
	1	0	0	1	21.6	
1	0	1	0	24.0		

	1	0	1	1	26.4	
	1	1	0	0	28.8	
	1	1	0	1	31.2	
	Other settings - Not used					
4-5	Initial modem type for 9.6 k or 7.2 kbps.					These bits set the initial modem type for 9.6 and 7.2 kbps, if the initial modem rate is set at these speeds.
	Bit 5	Bit 4	Setting			
	0	0	V.29			
	0	1	V.17			
	1	0	V.34			
1	1	Not used				
6-7	Not used					Do not change the settings.

G3-2 Switch 06 (SP No. 1-106-007)						
No	Function					Comments
0-3	Initial Rx modem rate(kbps)					These bits set the initial starting modem rate for reception. Use a lower setting if high speeds pose problems during reception. If a modem rate 14.4 kbps or slower is selected, V.8 protocol should be disabled manually. Cross reference V.8 protocol on/off - G3 switch 03, bit2
	Bit 3	Bit 2	Bit 1	Bit 0	kbps	
	0	0	0	1	2.4	
	0	0	1	0	4.8	
	0	0	1	1	7.2	
	0	1	0	0	9.6	
	0	1	0	1	12.0	
	0	1	1	0	14.4	
	0	1	1	1	16.8	
	1	0	0	0	19.2	
	1	0	0	1	21.6	
	1	0	1	0	24.0	

Bit Switches - 5

	1	0	1	1	26.4	
	1	1	0	0	28.8	
	1	1	0	1	31.2	
	Other settings - Not used					
4-7	<p>Modem types available for reception</p> <p>The setting of these bits is used to inform the transmitting terminal of the available modem type for the machine in receive mode.</p> <p>If V.34 is not selected, V.8 protocol must be disabled manually.</p> <p>Cross reference</p> <p>V.8 protocol on/off - G3 switch 03, bit 2</p>					
	Bit 7	Bit 6	Bit 5	Bit 4	Types	
	0	0	0	1	V.27ter	
	0	0	1	0	V.27ter	
	0	0	1	1	V.27ter	
	0	1	0	0	V.27ter	
	0	1	0	1	V.27ter	
	Other settings - Not used					

G3-2 Switch 07 (SP No. 1-106-008)				
No	Function			Comments
0-1	PSTN cable equalizer (tx mode: Internal)			Use a higher setting if there is signal loss at higher frequencies because of the length of wire between the modem and the telephone exchange. Use the dedicated transmission parameters for specific receivers. Also, try using the cable equalizer if one or more of the following symptoms occurs. Communication error Modem rate fallback occurs frequently. Note <ul style="list-style-type: none"> ▪ This setting is not effective in V.34 communications.
	Bit 1	Bit 0	Setting	
	0	0	None	
	0	1	Low	
	1	0	Medium	
	1	1	High	
2-3	PSTN cable equalizer (rx mode: Internal)			Use a higher setting if there is signal loss at higher frequencies because of the length of wire between the modem and the telephone exchange. Also, try using the cable equalizer if one or more of the following symptoms occurs. Communication error with error codes such as 0-20, 0-23, etc. Modem rate fallback occurs frequently. Note <ul style="list-style-type: none"> ▪ This setting is not effective in V.34 communications.
	Bit 3	Bit 2	Setting	
	0	0	None	
	0	1	Low	
	1	0	Medium	
	1	1	High	

4	PSTN cable equalizer (V.8/V.17 rx mode: External) 0: Disabled 1: Enabled	Keep this bit at "1".
5-7	Not used	Do not change the settings.

G3-2 Switch 08 - Not used (do not change the settings)

G3-2 Switch 09 - Not used (do not change the settings)

G3-2 Switch 0A (SP No. 1-106-011)

No	Function	Comments		
0-1	Maximum allowable carrier drop during image data reception	These bits set the acceptable modem carrier drop time. Try a longer setting if error code 0-22 is frequent.		
	Bit 1		Bit 0	Value (ms)
	0		0	200
	0		1	400
	1		0	800
	1	1	Not used	
2-3	Not used	Do not change the settings		
4	Maximum allowable frame interval during image data reception. 0: 5 s 1: 13 s	This bit set the maximum interval between EOL (end-of-line) signals and the maximum interval between ECM frames from the other end. Try using a longer setting if error code 0-21 is frequent.		

5	Not used	Do not change the settings.
6	Reconstruction time for the first line in receive mode 0: 6 s 1: 12 s	When the sending terminal is controlled by a computer, there may be a delay in receiving page data after the local machine accepts set-up data and sends CFR. This is outside the T.30 recommendation. But, if this delay occurs, set this bit to 1 to give the sending machine more time to send data. Refer to error code 0-20. ITU-T T.30 recommendation: The first line should come within 5 s of CFR.
7	Not used	Do not change the settings.

G3-2 Switch 0B- Not used (do not change the settings)
G3-2 Switch 0C- Not used (do not change the settings)
G3-2 Switch 0E- Not used (do not change the settings)
G3-2 Switch 0F- Not used (do not change the settings)

4.7.2 G4 INTERNAL SWITCHES

The G4 internal switches (SW00 to 1F) are displayed but do not change these settings.

4.7.3 G4 PARAMETER SWITCHES

The G4 parameter switches (SW00 to 0F) are displayed but do not change these settings.

4.8 BIT SWITCHES - 6

Note

- Do not adjust a bit switch or use a setting that is described as "Not used", as this may cause the machine to malfunction or to operate in a manner that is not accepted by local regulations. Such bits are for use only in other areas, such as Japan.

Default settings for bit switches are not listed in this manual. Refer to the System Parameter List printed by the machine.

4.8.1 IP FAX SWITCHES

IP Fax Switch 00 (SP No. 1-111-001)		
No.	Function	Comments
0	Not used	Do not change this setting.
1	IP Fax Transport 0: TCP, 1: UDP	Selects TCP or UDP protocol for IP-Fax
2	IP Fax single port selection 0: OFF, 1: ON (enable)	Selects single data port.
3	IP Fax double ports (single data port) selection 0: OFF, 1: ON (enable)	Selects whether IP-Fax uses a double port.
4	IP Fax Gatekeeper 0: OFF, 1: ON (enable)	Enables/disables the gatekeeper for IP-Fax.
5	IP Fax T30 bit signal reverse 0: LSB first, 1: MSB first	Reverses the T30 bit signal.
6	IP Fax max bit rate setting 0: Not affected, 1: Affected	When "0" is selected, the max bit rate does not affect the value of the DIS/DCS. When "1" is selected, the max bit rate affects the value of the DIS/DCS.

7	<p>IP Fax received telephone number confirmation 0: No confirmation, 1: Confirmation</p>	<p>When "0" is selected, fax data is received without checking the telephone number. When "1" is selected, fax data is received only when confirming that the telephone number from the sender matches the registered telephone number in this machine. If this confirmation fails, the line is disconnected.</p>
---	--	---

IP Fax Switch 01 (SP No. 1-111-002)					
No.	Function			Comments	
0-3	<p>IP Fax delay level setting Selects the acceptable delay level. Level 0 is the highest quality Default is "0000" (level 0).</p>				
	Bit 3	Bit 2	Bit 1	Bit 0	
	0	0	0	0	Level 0
	0	0	0	1	Level 1
	0	0	1	0	Level 2
0	0	1	1	Level 3	
4-7	<p>IP Fax preamble wait time setting</p>			<p>Selects the preamble wait time. [00 to 0f] There are 16 values in this 4-bit binary switch combination. Waiting time: set value level x 100 ms Max: 0f (1500 ms) Min: 00 (No wait time) The default is "0000" (00H).</p>	

IP Fax Switch 02 (SP No. 1-111-003)		
No.	Function	Comments
0	IP Fax bit signal reverse setting 0: Maker code setting 1: Internal bit switch setting	When "0" is selected, the bit signal reverse method is decided by the maker code. When "1" is selected, the bit signal reverse method is decided by the internal bit switch. (When communicating between IP Fax devices, LSB first is selected.)
1	IP Fax transmission speed setting 0: Modem speed 1: No limitation	Selects the transmit speed for IP Fax communication.
2	SIP transport setting 0: TCP 1: UDP	This bit switch sets the transport that has priority for receiving IP Fax data. This function is activated only when the sender has both TCP and UDP.
3	CCM connection 0: No CCM connection 1: CCM connection	When "1" is selected, only the connection call message with H.323 or no tunneled H.245 is transmitted via CCM.
4	Message reception selection from non-registered SIP server 0: Answer 1: Not answer	0: This answers the INVITE message from the SIP server not registered for the machine. 1: This does not receive the INVITE message from the SIP server not registered for the machine and send a refusal message.
5	ECM communication setting 0: No limit for image compression 1: Limit for image compression	0: This does not limit the type of the image compression with ECM communication. 1: When the other end machine is Cisco, this permits the image compression other than JBIG or MMR with ECM communication.
6-7	Not used	Do not change these settings.

IP Fax Switch 03 (SP No. 1-111-004)		
No.	Function	Comments
0	Effective field limitation for G3 standard function information 0: OFF, 1: 4byte (DIS)	Limits the effective field for standard G3 function information.
1	Switching between G3 standard and G3 non standard 0: Enable switching 1: G3 standard only	Enables/disables switching between G3 standard and G3 non-standard.
2	Not used	Do not change this setting.
3	ECM frame size selection at transmitting 0: 256byte, 1: 64byte	Selects the ECM frame size for sending.
4	DIS detection times for echo prevention 0: 1 time, 1: 2 times	Sets the number of times for DIS to detect echoes.
5	CTC transmission selection 0: PPRx1 1: PPRx4	When "0" is selected, the transmission condition is decided by error frame numbers. When "1" is selected, the transmission condition is based on the ITU-T method.
6	Shift down setting at receiving negative code 0: OFF, 1: ON	Selects whether to shift down when negative codes are received.
7	Not used	Do not change this setting.

IP Fax Switch 04 (SP No. 1-111-005)		
No.	Function	Comments
0-3	TCF error threshold	Sets the TCF error threshold level. [00 to 0f] The default is "1111" (0fH).
4-7	Not used	Do not change these settings.

IP Fax Switch 05 (SP No. 1-111-006)						
No.	Function					Comments
0-3	Modem bit rate setting for transmission (kbps)					Sets the modem bit rate for transmission. The default is "0110" (14.4K bps).
	Bit 3	Bit 2	Bit 1	Bit 0	kbps	
	0	0	0	1	2.4	
	0	0	1	1	4.8	
	0	0	1	1	7.2	
	0	1	0	0	9.6	
	0	1	0	1	12.0	
	0	1	1	0	14.4	
4-5	Modem setting for transmission					Sets the modem type for transmission. The default is "00" (V29).
	Bit 5	Bit 4	Types			
	0	0	V29			
	0	1	V17			
	1	0	Not used			
	1	1	Not used			
6-7	Not used					Do not change these settings.

IP Fax Switch 06 (SP No. 1-111-007)					
No.	Function			Comments	
0-3	Modem bit rate setting for reception Sets the modem bit rate for reception. The default is "0110" (14.4K bps).				
4-7	Modem setting for reception Sets the modem type for reception. The default is "0100" (V27ter, V29, V17).				
	Bit 7	Bit 6	Bit 5	Bit 4	Types
	0	0	0	1	V.27ter
	0	0	1	0	V.27ter, V.29
	0	0	1	1	V.27ter, V.29, V.33
	0	1	0	0	V.27ter, V.29, V.17/V.33
Other settings - Not used					

IP Fax Switch 07 (SP No. 1-111-008)		
No.	Function	Comments
0	TSI information 0: Not added, 1: Added	Adds or does not add TSI information to NSS(S).
1	DCN transmission setting at T1 timeout 0: Not transmitted 1: Transmitted	Transmits or does not transmit DCN at T1 timeout.
2	Not used	Do not change this setting.
3	Hang up setting at DIS reception disabled 0: No hang up 1: Hang up after transmitting DCN	Sets whether the machine disconnects after DIS reception.
4	Number of times for training 0: 1 time, 1: 2 times	Selects the number of times training is done at the same bit rate.

5	Space CSI transmission setting at no CSI registration 0: Not transmitted 1: Transmitted	When "0" is selected, frame data is enabled. When "1" is selected, the transmitted data is all spaces.
6-7	Not used	Do not change these settings.

IP Fax Switch 08 (SP No. 1-111-009)				
No.	Function			Comments
0-1	T1 timer adjustment			Adjusts the T1 timer. The default is "00" (35 seconds).
	Bit 1	Bit 0		
	0	0	35 s	
	0	1	40 s	
	1	0	50 s	
	1	1	60 s	
2-3	T4 timer adjustment			Adjust the T4 timer. The default is "00" (3 seconds).
	Bit 3	Bit 2		
	0	0	3 s	
	0	1	3.5 s	
	1	0	4 s	
	1	1	5 s	
4-5	T0 timer adjustment			Adjusts the fail safe timer. This timer sets the interval between "setup" data transmission and T.38 phase decision. If your destination return is late on the network or G3 fax return is late, adjust the longer interval timer. The default is "00" (75 seconds).
	Bit 5	Bit 4		
	0	0	75 s	
	0	1	120 s	
	1	0	180 s	
	1	1	240 s	

6-7	Not used	Do not change these settings.
-----	----------	-------------------------------

IP Fax Switch 09 (SP No. 1-111-010)				
No.	Function		Comments	
0	Network I/F setting for SIP connection 0: IPv4 1: IPv6.		Selects the connection type (IPV4 or IPV6) to connect to the SIP server.	
1	Network I/F setting for Fax communication 0: Same setting as SIP server connection 1: Automatic setting		0: The I/F setting for fax communication follows the setting for SIP server connection. 1: The negotiation between the SIP server and the device decides whether IPv4 or IPv6 is used for the I/F setting for fax communication.	
2	Record-route setting 0: Disable 1: Enable		0: Disables the record-route function of the SIP server. 1: Enables the record-route function of the SIP server.	
3-4	re-INVITE transmission delay timer setting		This changes the interval for transmit re-INVITE after receiving the ACK message transmitted by T.38 device.	
	Bit 4	Bit 3		
	0	0		No delay
	0	1		1 sec
	1	0		2 sec
	1	1	3 sec	
5	SIP-IPFAX: Adding vender information selection 0: Declare T38VendorInfo=RICOH 1: Not declare T38VendorInfo=RICOH		0: Use this setting normally. 1: This setting is used only when a customer wants to connect the machine with SIP server + VOIP-GW provided by AVAYA Inc.	

6-7	Not used.	Do not change these settings.
-----	-----------	-------------------------------

IP Fax Switch 0A - Not used (do not change the settings)

IP Fax Switch 0B - Not used (do not change the settings)

IP Fax Switch 0C - Not used (do not change the settings)

IP Fax Switch 0D - Not used (do not change the settings)

IP Fax Switch 0E (SP No. 1-111-013)		
No.	Function	Comments
0-1	SIP: IP-FAX port mode (UDP) 00: 3 port mode 01: 2 port mode 10: 1 port mode	Switch the port mode for IP-FAX (T38 transport: UDP) at SIP call control.
2-3	SIP: IP-FAX port mode (TCP) 00: 3 port mode 01: 2 port mode 10: 1 port mode	Switch the port mode for IP-FAX (T38 transport: TCP) at SIP call control.
4-7	Not used.	Do not change these settings.

4.9 NCU PARAMETERS

The following tables give the RAM addresses and the parameter calculation units that the machine uses for ringing signal detection and automatic dialing. The factory settings for each country are also given. Most of these must be changed by RAM read/write (SP2-102), but some can be changed using NCU Parameter programming (SP2-103, 104 and 105); if SP2-103, 104 and 105 can be used, this will be indicated in the Remarks column. The RAM is programmed in hex code unless (BCD) is included in the Unit column.

↓ Note

- The following addresses describe settings for the standard NCU.
- Change the fourth digit from "5" to "6" (e.g. 680500 to 680600) for the settings for the first optional G3 interface unit and from "5" to "7" (e.g. 680700) for the settings for the second optional G3 interface unit.

Address	Function					
680500	Country/Area code for NCU parameters					
	Use the Hex value to program the country/area code directly into this address, or use the decimal value to program it using SP2-103-001					
	Country /Area	Decimal	Hex	Country /Area	Decimal	Hex
	France	00	00	Asia	18	12
	Germany	01	01	Japan	19	13
	UK	02	02	Hong Kong	20	14
	Italy	03	03	South Africa	21	15
	Austria	04	04	Australia	22	16
	Belgium	05	05	New Zealand	26	17
	Denmark	06	06	Singapore	24	18
	Finland	07	07	Malaysia	25	19
	Ireland	08	08	China	26	1A
	Norway	09	09	Taiwan	27	1B

Address	Function					
	Sweden	10	0A	Korea	28	1C
	Switzerland	11	0B	Brazil	29	1D
	Portugal	12	0C	Turkey	32	20
	Holland	13	0D	Greece	33	21
	Spain	14	0E	Hungary	34	22
	Israel	15	0F	Czech	35	23
	USA	17	11	Poland	36	24

Address	Function	Unit	Remarks
680501	Line current detection time	20 ms	Line current detection is disabled. Line current is not detected if 680501 contains FF.
680502	Line current wait time		
680503	Line current drop detect time		
680504	PSTN dial tone frequency upper limit (high byte)	Hz (BCD)	If both addresses contain FF(H), tone detection is disabled.
680505	PSTN dial tone frequency upper limit (low byte)		
680506	PSTN dial tone frequency lower limit (high byte)	Hz (BCD)	If both addresses contain FF(H), tone detection is disabled.
680507	PSTN dial tone frequency lower limit (low byte)		
680508	PSTN dial tone detection time	20 ms	If 680508 contains FF(H), the machine pauses for the pause time (address 68050D / 68050E). Italy: See Note 2.
680509	PSTN dial tone reset time (LOW)		
68050A	PSTN dial tone reset time (HIGH)		
68050B	PSTN dial tone continuous tone time		

Address	Function	Unit	Remarks
68050C	PSTN dial tone permissible drop time		
68050D	PSTN wait interval (LOW)		
68050E	PSTN wait interval (HIGH)		-
68050F	PSTN ring-back tone detection time	20 ms	Detection is disabled if this contains FF.
680510	PSTN ring-back tone off detection time	20 ms	-
680511	PSTN detection time for silent period after ring-back tone detected (LOW)	20 ms	-
680512	PSTN detection time for silent period after ring-back tone detected (HIGH)	20 ms	-
680513	PSTN busy tone frequency upper limit (high byte)		
680514	PSTN busy tone frequency upper limit (low byte)	Hz (BCD)	If both addresses contain FF(H), tone detection is disabled.
680515	PSTN busy tone frequency lower limit (high byte)		
680516	PSTN busy tone frequency lower limit (low byte)	Hz (BCD)	If both addresses contain FF(H), tone detection is disabled.
680517	PABX dial tone frequency upper limit (high byte)		
680518	PABX dial tone frequency upper limit (low byte)	Hz (BCD)	If both addresses contain FF(H), tone detection is disabled.

NCU Parameters

680519	PABX dial tone frequency lower limit (high byte)	Hz (BCD)	If both addresses contain FF(H), tone detection is disabled.
68051A	PABX dial tone frequency lower limit (low byte)		
68051B	PABX dial tone detection time	20 ms	If 68051B contains FF, the machine pauses for the pause time (680520 / 680521).
68051C	PABX dial tone reset time (LOW)		
68051D	PABX dial tone reset time (HIGH)		
68051E	PABX dial tone continuous tone time		
68051F	PABX dial tone permissible drop time		
680520	PABX wait interval (LOW)		
680521	PABX wait interval (HIGH)		
680522	PABX ringback tone detection time	20 ms	If both addresses contain FF(H), tone detection is disabled.
680523	PABX ringback tone off detection time	20 ms	
680524	PABX detection time for silent period after ringback tone detected (LOW)	20 ms	If both addresses contain FF(H), tone detection is disabled.
680525	PABX detection time for silent period after ringback tone detected (HIGH)	20 ms	
680526	PABX busy tone frequency upper limit (high byte)	Hz (BCD)	If both addresses contain FF(H), tone detection is disabled.
680527	PABX busy tone frequency upper limit (low byte)		
680528	PABX busy tone frequency lower limit (high byte)	Hz (BCD)	If both addresses contain FF(H), tone

FAX OPTION
TYPE M12
(D3A5)

680529	PABX busy tone frequency lower limit (low byte)		detection is disabled.
68052A	Busy tone ON time: range 1	20 ms	
68052B	Busy tone OFF time: range 1		
68052C	Busy tone ON time: range 2		
68052D	Busy tone OFF time: range 2		
68052E	Busy tone ON time: range 3		
68052F	Busy tone OFF time: range 3	20 ms	
680530	Busy tone ON time: range 4		
680531	Busy tone OFF time: range 4		
680532	Busy tone continuous tone detection time		
680533	<p>Busy tone signal state time tolerance for all ranges, and number of cycles required for detection (a setting of 4 cycles means that ON-OFF-ON or OFF-ON-OFF must be detected twice).</p> <p>Tolerance (\pm)</p> <p>Bit 1: 0, Bit 0: 0 = 75% Bits 2 and 3 must always be kept at 0.</p> <p>Bit 1: 0, Bit 0: 0 = 50% Bits 2 and 3 must always be kept at 0.</p> <p>Bit 1: 0, Bit 0: 0 = 25%</p> <p>Bit 1: 0, Bit 0: 0 = 12.5%</p> <p>Bits 7, 6, 5, 4 - number of cycles required for cadence detection</p>		
680534	International dial tone frequency upper limit (high byte)	Hz (BCD)	If both addresses contain FF(H), tone detection is disabled.
680535	International dial tone frequency upper limit (low byte)		
680536	International dial tone frequency lower limit (high byte)	Hz (BCD)	If both addresses contain FF(H), tone detection is disabled.
680537	International dial tone frequency lower limit (low byte)		
680538	International dial tone detection time	20 ms	If 680538 contains FF, the machine pauses for

NCU Parameters

680539	International dial tone reset time (LOW)		the pause time (68053D / 68053E). Belgium: See Note 2.
68053A	International dial tone reset time (HIGH)		
68053B	International dial tone continuous tone time		
68053C	International dial tone permissible drop time		
68053D	International dial wait interval (LOW)		
68053E	International dial wait interval (HIGH)		
68053F	Country dial tone upper frequency limit (HIGH)	Hz (BCD)	If both addresses contain FF(H), tone detection is disabled.
680540	Country dial tone upper frequency limit (LOW)		
680541	Country dial tone lower frequency limit (HIGH)		If both addresses contain FF(H), tone detection is disabled.
680542	Country dial tone lower frequency limit (LOW)		
680543	Country dial tone detection time	20 ms	If 680543 contains FF, the machine pauses for the pause time (680548 / 680549).
680544	Country dial tone reset time (LOW)		
680545	Country dial tone reset time (HIGH)		
680546	Country dial tone continuous tone time	-	-

680547	Country dial tone permissible drop time	20 ms	-
680548	Country dial wait interval (LOW)		
680549	Country dial wait interval (HIGH)		
68054A	Time between opening or closing the DO relay and opening the OHDI relay	1 ms	See Notes 3, 6 and 8. SP2-103-012 (parameter 11).
68054B	Break time for pulse dialing	1 ms	See Note 3. SP2-103-013 (parameter 12).
68054C	Make time for pulse dialing	1 ms	See Note 3. SP2-103-014 (parameter 13).
68054D	Time between final OHDI relay closure and DO relay opening or closing	1 ms	See Notes 3, 6 and 8. SP2-103-015 (parameter 14). This parameter is only valid in Europe.
68054E	Minimum pause between dialed digits (pulse dial mode)	20 ms	See Note 3 and 8. SP2-103-016 (parameter 15).
68054F	Time waited when a pause is entered at the operation panel		SP2-103-017 (parameter 16). See Note 3.
680550	DTMF tone on time	1 ms	SP2-103-018 (parameter 17).
680551	DTMF tone off time		SP2-103-019 (parameter 18).

NCU Parameters

680552	Tone attenuation level of DTMF signals while dialing	-N x 0.5 -3.5 dBm	SP2-103-020 (parameter 19). See Note 5.
680553	Tone attenuation value difference between high frequency tone and low frequency tone in DTMF signals	-dBm x 0.5	SP2-103-021 (parameter 20). The setting must be less than -5dBm, and should not exceed the setting at 680552h above. See Note 5.
680554	PSTN: DTMF tone attenuation level after dialling	-N x 0.5 -3.5 dBm	SP2-103-022 (parameter 21). See Note 5.
680555	ISDN: DTMF tone attenuation level after dialling	-dBm x 0.5	See Note 5
680556	Not used	-	Do not change the settings.
680557	Time between 68054Dh (NCU parameter 14) and 68054Eh (NCU parameter 15)	1 ms	This parameter takes effect when the country code is set to France.
680558	Not used	-	Do not change the setting.
680559	Grounding time (ground start mode)	20 ms	The Gs relay is closed for this interval.
68055A	Break time (flash start mode)	1 ms	The OHDI relay is open for this interval.
68055B	International dial access code (High)	BCD	For a code of 100: 68055B - F1 68055C - 00
68055C	International dial access code (Low)		

FAX OPTION
TYPE M12
(D3A5)

68055D	PSTN access pause time	20 ms	This time is waited for each pause input after the PSTN access code. If this address contains FF[H], the pause time stored in address 68054F is used. Do not set a number more than 7 in the UK.
68055E	Progress tone detection level, and cadence detection enable flags	Bit 7: 0, Bit 6: 0, Bit 5: 0 = -25.0 dBm Bit 7: 0, Bit 6: 0, Bit 5: 1 = -35.0 dBm Bit 7: 0, Bit 6: 1, Bit 5: 0 = -30.0 dBm Bit 7: 1, Bit 6: 0, Bit 5: 0 = -40.0 dBm Bit 7: 1, Bit 6: 1, Bit 5: 0 = -49.0 dBm Bits 2, 0 - See Note 2.	
68055F To 680564	Not used	-	Do not change the settings.
680565	Long distance call prefix (HIGH)	BCD	For a code of 0: 680565 – FF 680566 - FF
680566	Long distance call prefix (LOW)	BCD	
680567 to 680571	Not used	-	Do not change the settings.
680572	Acceptable ringing signal frequency: range 1, upper limit	1000/ N (Hz).	SP2-103-003 (parameter 02).
680573	Acceptable ringing signal frequency: range 1, lower limit		SP2-103-004 (parameter 03).
680574	Acceptable ringing signal frequency: range 2, upper limit		SP2-103-005 (parameter 04).

NCU Parameters

680575	Acceptable ringing signal frequency: range 2, lower limit		SP2-103-006 (parameter 05).
680576	Number of rings until a call is detected	1	SP2-103-007 (parameter 06). The setting must not be zero.
680577	Minimum required length of the first ring	20 ms	See Note 4. SP2-103-008 (parameter 07).
680578	Minimum required length of the second and subsequent rings	20 ms	SP2-103-009 (parameter 08).
680579	Ringing signal detection reset time (LOW)	20 ms	SP2-103-010 (parameter 09).
68057A	Ringing signal detection reset time (HIGH)		SP2-103-011 (parameter 10).
68057B to 680580	Not used	-	Do not change the settings.
680581	Interval between dialing the last digit and switching the Oh relay over to the external telephone when dialing from the operation panel in handset mode.	20 ms	Factory setting: 500 ms
680582	<p>Bits 0 and 1 - Handset off-hook detection time Bit 1:0, Bit 0: 0 = 200 ms Bit 1:0, Bit 0: 1 = 800 ms Other Not used</p> <p>Bits 2 and 3 - Handset on-hook detection time Bit 3: 0, Bit 2: 0 = 200 ms Bit 3: 0, Bit 2: 1 = 800 ms Other Not used</p> <p>Bits 4 to 7 - Not used</p>	-	

680583 To 6805A0	Not used	-	Do not change the settings.
6805A1	Acceptable CED detection frequency upper limit (high byte)	BCD (Hz)	If both addresses contain FF(H), tone detection is disabled.
6805A2	Acceptable CED detection frequency upper limit (low byte)		
6805A3	Acceptable CED detection frequency lower limit (high byte)	BCD (Hz)	If both addresses contain FF(H), tone detection is disabled.
6805A4	Acceptable CED detection frequency lower limit (low byte)		
6805A5	CED detection time	20 ms \pm 20 ms	Factory setting: 200 ms
6805A6	Acceptable CNG detection frequency upper limit (high byte)	BCD (Hz)	If both addresses contain FF(H), tone detection is disabled.
6805A7	Acceptable CNG detection frequency upper limit (low byte)		
6805A8	Acceptable CNG detection frequency lower limit (high byte)	BCD (Hz)	If both addresses contain FF(H), tone detection is disabled.
6805A9	Acceptable CNG detection frequency lower limit (low byte)		
6805AA	Not used	-	Do not change the setting.
6805AB	CNG on time	20 ms	Factory setting: 500 ms
6805AC	CNG off time	20 ms	Factory setting: 3000 ms
6805AD	Number of CNG cycles required for detection	-	The data is coded in the same way as address 680533.

NCU Parameters

6805AE	Not used	-	Do not change the settings.
6805AF	Acceptable AI short protocol tone (800Hz) detection frequency upper limit (high byte)	Hz (BCD)	If both addresses contain FF(H), tone detection is disabled.
6805B0	Acceptable AI short protocol tone (800Hz) detection frequency upper limit (low byte)		
6805B1	Acceptable AI short protocol tone (800Hz) detection frequency lower limit (high byte)	Hz(BCD)	If both addresses contain FF(H), tone detection is disabled.
6805B2	Acceptable AI short protocol tone (800Hz) detection frequency lower limit (low byte)		
6805B3	Detection time for 800 Hz AI short protocol tone	20 ms	Factory setting: 360 ms
6805B4	PSTN: Tx level from the modem	-N – 3 dBm	SP2-103-002 (parameter 01).
6805B5	PSTN: 1100 Hz tone transmission level	- N 6805B4 - 0.5N 6805B5 –3.5 (dB) See Note 7.	
6805B6	PSTN: 2100 Hz tone transmission level	- N6805B4 - 0.5N 6805B6 –3 (dB) See Note 7.	
6805B7	PABX: Tx level from the modem	- dBm	
6805B8	PABX: 1100 Hz tone transmission level	- N 6805B7 - 0.5N 6805B8 (dB)	
6805B9	PABX: 2100 Hz tone transmission level	- N 6805B7 - 0.5N 6805B9 (dB)	

FAX OPTION
TYPE M12
(D3A5)

6805BD	Modem turn-on level (incoming signal detection level)	-37-0.5N (dBm)	
6805BE to 6805C6	Not used	-	Do not change the settings.
6805C7	Bits 0 to 3 – Not used Bit 4 = V.34 protocol dump 0: Simple, 1: Detailed (default) Bits 5 to 7 – Not used.		
6805C8 to 6805D9	Not used	-	Do not change the settings.
6805DA	T.30 T1 timer	1 s	
6805E0 bit 3	Maximum wait time for post message	0: 12 s 1: 30 s	1: Maximum wait time for post message (EOP/EOM/MPS) can be changed to 30 s. Change this bit to “1” if communication errors occur frequently during V.17 reception.
6805E3	Bits 0 and 1 – DCV (TIP/RING) Voltage Bit 1:0, Bit 0: 0 = 3.1 V Bit 1:0, Bit 0: 1 = 3.2 V Bit 1:1, Bit 0: 0 = 3.35 V Bit 1:1, Bit 0: 1 = 3.5 V Bits 2 and 3 – MINI (minimum loop electric current) Bit 2:0, Bit 3: 0 = 10 mA Bit 2:0, Bit 2: 1 = 12 mA Bit 2:1, Bit 3: 0 = 14 mA Bit 2:1, Bit 3: 1 = 16 mA Bits 6 and 7 – ACIM (AC impedance) Bit 7:0, Bit 6: 0 Bit 5:0, Bit 4: 0= 600 Bit 7:0, Bit 6: 0 Bit 5:1, Bit 4: 0= TBR21		

6805E4	<p>Bit 0 – OHS (on hook speed) 0: OHS=0 1: OHS=1</p> <p>Bit 1 – SQ (spark quench) 0: SQ=00 1: SQ=11</p> <p>Bit 2 – RZ (call signal Impedance) 0: RZ=0 (high) 1: RZ=1 (low)</p> <p>Bit 3 – RT (call signal detection level) 0: RT=0 (low) 1: RT=1 (high)</p> <p>Bit 4 – ILIM (DC limitation) 0: ILIM=0 (CTR 21) 1: ILIM=1 (other than CTR 21)</p> <p>Bit 5 –FILTER 0: FILTER=0 (around 5Hz) 1: FILTER=1 (around 200Hz)</p> <p>Bits 6 to 7 – Calibration in off hook state Bit 6:0, Bit 7: 0 = off hook to ACAL:128 ms, off hook to MCAL: 1000 ms Bit 6:1, Bit 7: 0 = off hook to ACAL:128 ms, off hook to MCAL: 500 ms Bit 6:0, Bit 7: 1 = off hook to ACAL:128 ms (no MCAL) Bit 6:1, Bit 7: 1 = off hook to ACAL:8 ms (no MCAL)</p>
6805E5	<p>Bits 0 to 6 – Not used</p> <p>Bits 7 – Energy saving for DSP, COMBLK, SiDAA 0: Does not save energy 1: Saves energy</p>

NOTES

1. If a setting is not required, store FF in the address.
2. Italy and Belgium only

RAM address 68055E: the lower four bits have the following meaning.

Bit 2 - 1: International dial tone cadence detection enabled (Belgium)

Bit 1 - Not used

Bit 0 - 1: PSTN dial tone cadence detection enabled (Italy)

If bit 0 or bit 2 is set to 1, the functions of the following RAM addresses are changed.

680508 (if bit 0 = 1) or 680538 (if bit 2 = 1): tolerance for on or off state

- duration (%), and number of cycles required for detection, coded as in address 680533.
 68050B (if bit 0 = 1) or 68053B (if bit 2 = 1): on time, hex code (unit = 20 ms)
 68050C (if bit 0 = 1) or 68053C (if bit 2 = 1): off time, hex code (unit = 20 ms)
3. Pulse dial parameters (addresses 68054A to 68054F) are the values for 10 pps. If 20 pps is used, the machine automatically compensates.
 4. The first ring may not be detected until 1 to 2.5 wavelengths after the time specified by this parameter.
 5. The calculated level must be between 0 and 10.

The attenuation levels calculated from RAM data are:

High frequency tone:

- $-0.5 \times N_{680552/680554} - 3.5$ dBm
- $-0.5 \times N_{680555}$ dBm

Low frequency tone:

- $-0.5 \times (N_{680552/680554} + N_{680553}) - 3.5$ dBm
- $-0.5 \times (N_{680555} + N_{680553})$ dBm

 **Note**

- N_{680552} , for example, means the value stored in address 680552(H)
6. 68054A: Europe - Between Ds opening and Di opening, France - Between Ds closing and Di opening
 68054D: Europe - Between Ds closing and Di closing, France - Between Ds opening and Di closing
 7. Tone signals which frequency is lower than 1500Hz (e.g., 800Hz tone for AI short protocol) refer to the setting at 6805B5h. Tones which frequency is higher than 1500Hz refer to the setting at 6805B6h.
 8. 68054A, 68054D, 68054E: The actual inter-digit pause (pulse dial mode) is the sum of the period specified by the RAM addresses 68054A, 68054D, and 68054E.

4.10 DEDICATED TRANSMISSION PARAMETERS

There are two sets of transmission parameters: Fax and E-mail

Each Quick Dial Key and Speed Dial Code has eight bytes of programmable parameters allocated to it. If transmissions to a particular machine often experience problems, store that terminal's fax number as a Quick Dial or Speed Dial, and adjust the parameters allocated to that number.

The programming procedure will be explained first. Then, the eight bytes will be described.

4.10.1 PROGRAMMING PROCEDURE

1. Set the bit 0 of System Bit Switch 00 to 1.
2. Enter Address Book Management mode ([User Tools]> System Settings> Key Operator> Address Book Management).
3. Select the address book that you want to program.
4. For the fax parameter, select "Fax Dest.", for the E-mail parameter, select "E-mail", then press "Start". Make sure that the LED of the Start button lights green.
5. The settings for the switch 00 are now displayed. Press the bit number that you wish to change.
6. To scroll through the parameter switches, either:
7. Select the next switch: press "Next" or Select the previous switch: "Prev." until the correct switch is displayed. Then go back to step 6.
8. After the setting is changed, press "OK".
9. After finishing, reset bit 0 of System Bit Switch 00 to 0.

4.10.2 PARAMETERS

Fax Parameters

The initial settings of the following fax parameters are all FF(H) - all the parameters are disabled.

Switch 00
FUNCTION AND COMMENTS
<p>ITU-T T1 time (for PSTN G3 mode)</p> <p>If the connection time to a particular terminal is longer than the NCU parameter setting, adjust this byte. The T1 time is the value stored in this byte (in hex code), multiplied by 1 second.</p> <p>Range: 0 to 120 s (00h to 78h)</p> <p>FFh - The local NCU parameter factory setting is used.</p> <p>Do not program a value between 79h and FEh.</p>

Switch 01							
No	FUNCTION					COMMENTS	
0-4	Tx level					<p>If communication with a particular remote terminal often contains errors, the signal level may be inappropriate. Adjust the Tx level for communications with that terminal until the results are better.</p> <p>If the setting is "Disabled", the NCU parameter 01 setting is used.</p> <p>Note</p> <ul style="list-style-type: none"> Do not use settings other than listed on the left. 	
	Bit4	Bit3	Bit2	Bit1	Bit0		
	0	0	0	0	0		0
	0	0	0	0	1		-1
	0	0	0	1	0		-2
	0	0	0	1	1		-3
	0	0	1	0	0		-4
	↓	↓	↓	↓	↓		↓
	0	1	1	1	1		-15
	1	1	1	1	1		Disabled

Dedicated Transmission Parameters

5-7	<p>Cable equalizer</p> <p>Bit 7: 0, Bit 6: 0, Bit 5: 0 = None</p> <p>Bit 7: 0, Bit 6: 0, Bit 5: 1 = Low</p> <p>Bit 7: 0, Bit 6: 1, Bit 5: 0 = Medium</p> <p>Bit 7: 0, Bit 6: 1, Bit 5: 1 = High</p> <p>Bit 7: 1, Bit 6: 1, Bit 5: 1 = Disabled</p>	<p>Use a higher setting if there is signal loss at higher frequencies because of the length of wire between the modem and the telephone exchange when calling the number stored in this Quick/Speed Dial.</p> <p>Also, try using the cable equalizer if one or more of the following symptoms occurs.</p> <p>Communication error with error codes such as 0-20, 0-23, etc.</p> <p>Modem rate fallback occurs frequently.</p> <p>Note</p> <ul style="list-style-type: none"> ▪ Do not use settings other than listed on the left. <p>If the setting is "Disabled", the bit switch setting is used.</p>
-----	--	---

Switch 02						
No	FUNCTION					COMMENTS
0-3	Initial Tx modem rate					<p>If training with a particular remote terminal always takes too long, the initial modem rate may be too high. Reduce the initial Tx modem rate using these bits.</p> <p>For the settings 14.4 or kbps slower, Switch 04 bit 4 must be changed to 0.</p> <p>Note</p> <ul style="list-style-type: none"> ▪ Do not use settings other than listed on the left. If the setting is "Disabled", the bit switch setting is used.
	Bit3	Bit2	Bit1	Bit0	bps	
	0	0	0	0	Not used	
	0	0	0	1	2400	
	0	0	1	0	4800	
	0	0	1	1	7200	
	0	1	0	0	9600	
	0	1	0	1	12000	
	0	1	1	0	14400	
	0	1	1	1	16800	
	1	0	0	0	19200	

	1	0	0	1	21600	
	1	0	1	0	24000	
	1	0	1	1	26400	
	1	1	0	0	28800	
	1	1	0	1	31200	
	1	1	1	0	33600	
	1	1	1	1	Disabled	
	Other settings: Not used					
4-7	Not used				Do not change the settings.	

Switch 03		
No	FUNCTION	COMMENTS
0-1	Inch-mm conversion before tx Bit 1: 0, Bit 0: 0 = Inch-mm conversion available Bit 1: 0, Bit 0: 1 = Inch only Bit 1: 1, Bit 0: 0 = Not used Bit 1: 1, Bit 0: 1 = Disabled	If "inch only" is selected on the machine uses inch-based resolutions for scanning, the printed copy may be slightly distorted at the other end if that machine uses mm-based resolutions. If the setting is "Inch-mm conversion available ", Inch-mm conversion become effective to the special senders. If the setting is "Disabled", the bit switch setting is used.
2-3	DIS/NSF detection method Bit 3: 0, Bit 2: 0 = First DIS or NSF Bit 3: 0, Bit 2: 1 = Second DIS or NSF Bit 3: 1, Bit 2: 0 = Not used Bit 3: 1, Bit 2: 1 = Disabled	(0, 1): Use this setting if echoes on the line are interfering with the set-up protocol at the start of transmission. The machine will then wait for the second DIS or NSF before sending DCS or NSS. If the setting is "Disabled", the bit switch setting is used.

Dedicated Transmission Parameters

4	<p>V.8 protocol</p> <p>0: Off</p> <p>1: Disabled</p>	<p>If transmissions to a specific destination always end at a lower modem rate (14,400 bps or lower), disable V.8 protocol so as not to use V.34 protocol. 0: V.34 communication will not be possible. If the setting is "Disabled", the bit switch setting is used.</p>
5	<p>Compression modes available in transmit mode</p> <p>0: MH only</p> <p>1: Disabled</p>	<p>This bit determines the capabilities that are informed to the other terminal during transmission. If the setting is "Disabled", the bit switch setting is used.</p>
6-7	<p>ECM during transmission</p> <p>Bit 7: 0, Bit 6: 0 = Off</p> <p>Bit 7: 0, Bit 6: 1 = On</p> <p>Bit 7: 1, Bit 6: 0 = Not used</p> <p>Bit 7: 1, Bit 6: 1 = Disabled</p>	<p>For example, if ECM is switched on but is not wanted when sending to a particular terminal, use the (0, 0) setting.</p> <p>Note</p> <ul style="list-style-type: none"> ▪ V.8/V.34 protocol and JBIG compression are automatically disabled if ECM is disabled. ▪ If the setting is "Disabled", the bit switch setting is used.

Switch 04 - Not used (do not change the settings)

Switch 05 - Not used (do not change the settings)

Switch 06 - Not used (do not change the settings)

Switch 07 - Not used (do not change the settings)

Switch 08 - Not used (do not change the settings)

Switch 09 - Not used (do not change the settings)

E-mail Parameters

The initial settings of the following e-mail parameters are all "0" (all parameters disabled).

Switch 00		
No	FUNCTION	COMMENTS
0	MH Compression mode for e-mail attachments 0: Off 1: On	Switches MH compression on and off for files attached to e-mails for sending.
1	MR Compression mode for e-mail attachments 0: Off 1: On	Switches MR compression on and off for files attached to e-mails for sending.
2	MMR Compression mode for e-mail attachments 0: Off 1: On	Switches MMR compression on and off for files attached to e-mails for sending.
3-6	Not used	Do not change these settings.
7	Designates the bits to reference for compression method of e-mail attachments 0: Registered (Bit 0 to 6) 1: No registration.	The "0" selection (default) references the settings for Bits 00, 01, 02 above. The "1" selection ignores the selections of Bits 00, 01, 02.

Dedicated Transmission Parameters

Switch 01		
No	FUNCTION	COMMENTS
0	Original width of e-mail attachment: A4 0: Off 1: On	Sets the original width of the e-mail attachment as A4.
1	Original width of e-mail attachment: B4 0: Off 1: On	Sets the original width of the e-mail attachment as B4.
2	Original width of e-mail attachment: A3 0: Off 1: On	Sets the original width of the e-mail attachment as A3.
3-6	Not used	Do not change these settings.
7	Designates the bits to reference for original size of e-mail attachments 0: Registered (Bit 0 to 6) 1: No registration.	The "0" selection (default) references the settings for Bits 00, 01, 02 above. The "1" selection ignores the selections of Bits 00, 01, 02.

Switch 02		
No	FUNCTION	COMMENTS
0	Line resolution of e-mail attachment: 200 x 100 0: Off 1: On	Sets the line resolution of the e-mail attachment as 200 x100.
1	Line resolution of e-mail attachment: 200 x 200 0: Off 1: On	Sets the line resolution of the e-mail attachment as 200 x 200.

2	Line resolution of e-mail attachment: 200 x 400 0: Off 1: On	Sets the line resolution of the e-mail attachment as 200 x 400.
3	Not used	Do not change these settings.
4	Line resolution of e-mail attachment: 400 x 400 0: Off 1: On	Sets the line resolution of the e-mail attachment as 400 x 400.
5-6	Not used	Do not change these settings.
7	Designates the bits to reference for original size of e-mail attachments 0: Registered (Bit 0 to 6) 1: No registration.	The "0" selection (default) references the settings for Bits 00, 01, 02, 04 above. The "1" selection ignores the selections of Bits 00, 01, 02, 04.

Switch 03 - Not used (do not change the settings)

Switch 04		
No	FUNCTION	COMMENTS
0	Full mode address selection 0: Full mode address 1: No full mode (simple mode)	If the other ends have the addresses, which have the full mode function flag ("0"), this machine determines them as full mode standard machines. <ul style="list-style-type: none"> ▪ This machine attaches the "demand of reception confirmation" to a message when transmitting. ▪ This machine updates the reception capability to the address book when receiving.
1-7	Not used	Do not change these settings.

Dedicated Transmission Parameters

Switch 05		
No	FUNCTION	COMMENTS
0	Directr transmission selection to SMTP server 0: ON 1: OFF	Allows or does not allow the direct transmission to SMTP server.
1-7	Not used	Do not change these settings.

Switch 06 - Not used (do not change the settings)
Switch 07 - Not used (do not change the settings)
Switch 08 - Not used (do not change the settings)
Switch 09 - Not used (do not change the settings)

4.11 SERVICE RAM ADDRESSES

CAUTION

- Do not change the settings which are marked as "Not used" or "Read only."

680001 to 680004(H) - ROM version (Read only)

680001(H) - Revision number (BCD)

680002(H) - Year (BCD)

680003(H) - Month (BCD)

680004(H) - Day (BCD)

680006 to 680015(H) - Machine's serial number (16 digits - ASCII)

680016(H) - Language code

0: Japanese, 1: UK English, 2: US English, 3: French, 4: German, 5: Spanish, 6: Italian, 7: Dutch, 8: Swedish, 9: Norwegian, 10: Danish, 11: Finnish, 12: Czech, 13: Hungarian, 14: Polish, 15: Portuguese, 16: Russian, 17: Traditional Chinese, 18: Simplified Chinese, 19: Korean

680018(H) - Total program checksum (low)

680019(H) - Total program checksum (high)

680020 to 68003F(H) - System bit switches

680050 to 68005F(H) - Printer bit switches

680060 to 68007F(H) - Communication bit switches

680080 to 68008F(H) - G3 bit switches

680090 to 68009F(H) - G3-2 bit switches: Not used

6800A0 to 6800AF(H) - G3-3 bit switches: Not used

6800D0(H) - User parameter switch 00 (SWUER_00) : Not used

6800D1(H) - User parameter switch 01 (SWUSR_01) : Not used

6800D2(H) - User parameter switch 02 (SWUSR_02)

Bit 0: Forwarding mark printing on forwarded messages 0: Disabled, 1: Enabled

Bit 1: Center mark printing on received copies

(This switch is not printed on the user parameter list.)

0: Disabled, 1: Enabled

Bit 2: Reception time printing

(This switch is not printed on the user parameter list.)

0: Disabled, 1: Enabled

Bit 3: TSI print on received messages 0: Disabled, 1: Enabled

Bit 4: Checkered mark printing

(This switch is not printed on the user parameter list.)

0: Disabled, 1: Enabled

Bit 5: Not used

Bit 6: Not used

Bit 7: Not used

6800D3(H) - User parameter switch 03 (SWUSR_03: Automatic report printout)

Bit 0: Transmission result report (memory transmissions) 0: Off, 1: On

Bit 1: Not used

Bit 2: Memory storage report 0: Off, 1: On

Bit 3: Polling reserve report (polling reception) 0: Off, 1: On

Bit 4: Polling result report (polling reception) 0: Off, 1: On

Bit 5: Transmission result report (immediate transmissions) 0: Off, 1: On

Bit 6: Not used

Bit 7: Journal 0: Off, 1: On

6800D4(H) - User parameter switch 04 (SWUSR_04: Automatic report printout)

Bit 0: Not used

Bit 1: Automatic communication failure report and transfer result report output 0: Off, 1: On

Bits 2 to 3: Not used

Bit 4: Indicates the parties 0: Not indicated, 1: Indicated

Bit 5: Include sender's name on reports 0: Off, 1: On

Bit 6: Not used

Bit 7: Inclusion of a sample image on reports 0: Off, 1: On

6800D5(H) - User parameter switch 05 (SWUSR_05)

Bit 0: Substitute reception when the base copier is in an SC condition

0: Enabled, 1: Disabled

Bits 1 and 2: Condition for substitute rx when the machine cannot print messages (Paper end, toner end, jam, and during night mode)

Bit 2: 0, Bit 1: 0 = The machine receives all the fax messages.

Bit 2: 0, Bit 1: 1 = The machine receives the fax messages with RTI or CSI.

Bit 2: 1, Bit 1: 0 = The machine receives the fax messages with the same ID code.

Bit 2: 1, Bit 1: 1 = The machine does not receive anything.

Bit 3: Not used

Bit 4: Not used

Bit 5: Just size printing 0: Off, 1: On

Bit 6: Not used

Bit 7: Add paper display when a cassette is empty 0: Off, 1: On

6800D6(H) - User parameter switch 06 (SWUSR_06)

Bit 0:

Bit 1: V8 protocol (G3-1: Super G3) 0: Off, 1: On

Bit 2: V8 protocol (G3-2: Super G3) 0: Off, 1: On

Bit 3: V8 protocol (G3-3: Super G3) 0: Off, 1: On

6800D7(H) - User parameter switch 07 (SWUSR_07)

Bit 0 Ringing 0: Off, 1: On

Bit 1: Automatic answering message 0: Off, 1: On

Bit 2: Parallel memory transmission 0: Off, 1: On

Bits 3 and 4: Not used

Bit 5: Remote control 0: Off, 1: On

Bits 6 and 7: Not used

6800D8(H) - User parameter switch 08 (SWUSR_08)

Bits 0 and 1: Not used.

Bit 2: Authorized reception

0: Only faxes from senders whose RTIs/CSIs are specified for this feature are accepted.

1: Only faxes from senders whose RTIs/CSIs are not specified for this feature are accepted.

Bits 3 to 7: Not used.

6800D9(H) - User parameter switch 09 (SWUSR_09): Not used**6800DA(H) - User parameter switch 10 (SWUSR_0A)**

Bits 0 to 2: Not used

Bit 3: Page reduction 0: Off, 1: On

Bits 4 and 5: Not used

Bit 6: Use both e-mail notification and printed reports to confirm the transmission results 0: Off, 1: On

Bit 7: Not used

6800DB(H) - User parameter switch 11 (SWUSR_0B)

Bits 0 and 1: Not used

Bit 2: White original detection 0: Off, 1: On (alarm and alert message on the LCD)

Bit 3: Receive rejection for 1300 Hz transmission 0: Off (receive), 1: On (not receive)

Bit 5: Not used

Bit 6: Printout of messages received while acting as a forwarding station 0: Off, 1: On

Bit 7: Not used

6800DC(H) - User parameter switch 12 (SWUSR_0C): Not used**6800DD(H) - User parameter switch 13 (SWUSR_0D): Not used**

6800DE(H) - User parameter switch 14 (SWUSR_0E)

Bit 0: Message printout while the machine is in Night Printing mode 0: On, 1: Off

Bit 1: Maximum document length detection 0: Double letter, 1: Longer than double-letter (well log)
– up to 1,200 mm

Bit 2: Not used

Bit 3: Fax mode settings, such as resolution, before a mode key (Copy/Fax/Printer/Scanner) is pressed 0: Not cleared, 1: Cleared

Bits 4 to 6: Not used

Bit 7: Not used

6800DF(H) - User parameter switch 15 (SWUSR_0F)

(This switch is not printed on the user parameter list.)

Bits 0, 1 and 2: Cassette for fax printout

Bit 2: 0, Bit 1: 0, Bit 0: 1 = 1st paper feed station

Bit 2: 0, Bit 1: 1, Bit 0: 0 = 2nd paper feed station

Bit 2: 0, Bit 1: 1, Bit 0: 1 = 3rd paper feed station

Bit 2: 1, Bit 1: 0, Bit 0: 0 = 4th paper feed station

Bit 2: 1, Bit 1: 0, Bit 0: 1 = LCT

Other settings Not used

Bits 3 and 4: Not used

Bit 5: Using the cassette specified by bits 0, 1 and 2 above only 0: On, 1: Off

Bits 6 and 7: Not used

6800E0(H) – User parameter switch 16 (SWUSR_10)

(This switch is not printed on the user parameter list.)

Bits 0 and 1: Not used

Bit 2: Paper size selection priority for an A4 size fax message when A4/LT size paper is not available. 0: A3 has priority, 1: B4 has priority

Bits 3 to 7: Not used

6800E1(H) – User parameter switch 17 (SWUSR_11)

Bit 0: Not used

Bit 1: Not used

Bit 2: Inclusion of the “Add” button when a sequence of Quick/Speed dials is selected for broadcasting 0:Not needed, 1: Needed

Bits 3 to 6: Not used

Bit 7: Press “Start” key without an original when using the on hook dial or the external telephone, 0: displays “Cannot detect original size”. 1: Receives fax messages.

6800E2(H) - User parameter switch 18 (SWUSR_12)

Bit 0: TTI date 0: Off, 1: On

Bit 1: TTI sender 0: Off, 1: On

Bit 2: TTI file number 0: Off, 1: On

Bit 3: TTI page number 0: Off, 1: On

Bits 4 to 6: Not used

Bit 7: Japan only

6800E3(H) - User parameter switch 19 (SWUSR_13)

Bit 0: Not used

Bit 1: Journal format

0: The Journal is separated into transmissions and receptions

1: The Journal is separated into G3-1, G3-2, and G3-3 communications

Bit 2: Not used

Bit 3: 90° image rotation during B5 portrait Tx (This switch is not printed on the user parameter list.) 0: Off, 1: On

Bit 4: Reduction of sample images on reports to 50% in the main scan and sub-scan directions. (This switch is not printed on the user parameter list.) 0: Technician adjustment (printer switch 0E bits 3 and 4), 1: 50% reduction

Bit 5: Use of A5 size paper for reports (This switch is not printed on the user parameter list.) 0: Off, 1: On

Bits 6 and 7: Not used

6800E4(H) - User parameter switch 20 (SWUSR_14)

Bit 0: Automatic printing of the LAN fax result report 0: Off, 1: On

Bit 1: Not used.

Bits 2 to 5: Store documents in memory which could not be printed from PC fax (LAN fax) driver

Bit 5	Bit 4	Bit 3	Bit 2	Setting
0	0	0	0	0 min.
0	0	0	1	1 min.
↓	↓	↓	↓	↓
1	1	1	0	14 min.
1	1	1	1	15 min.

Bits 6 and 7: Not used.

6800E5(H) - User parameter switch 21 (SWUSR_15)

Bit 0: Print results of sending reception notice request message 0: Disabled (print only when error occurs), 1: Enabled

Bit 1: Respond to e-mail reception acknowledgment request 0: Disabled, 1: Enabled

Bit 2: Not used

Bit 3: File format for forwarded folders 0: TIFF, 1:PDF

Bit 4: Transmit Journal by E-mail 0: Disabled, 1: Enabled

Bit 5: Not used

Bit 6: Network error display 0: Displayed, 1: Not displayed

Bit 7: Transmit error mail notification 0: Enabled, 1: Disabled

6800E6(H) - User parameter switch 22 (SWUSR_16)

(This switch is not printed on the user parameter list.)

Bit 0: Dial tone detection (PSTN 1) 0: Disabled, 1: Enabled

Bits 1 to 7: Not used

6800E7(H) - User parameter switch 23 (SWUSR_17): Not used

6800E8(H) - User parameter switch 24 (SWUSR_18): Not used

6800E9(H) - User parameter switch 25 (SWUSR_19)

Bit 0: Not used

Bit 1: Reception mode switch timer 0: Off, 1: On (switching Fax or Fax/Tel)

Bit 2: Mode priority switch 0: Fax first, 1: Tel first

Bit 3: Dial in function (Japan Only)

Bit 4: **Do not Change this Bit.**

Bits 5 to 7: Not used

6800EA(H) and 6800EB(H) - User parameter switches 26 and 27 (SWUSR_1A and 1B): Not used

6800EC(H) - User parameter switch 28(SWUSR_1C): Not used

6800ED(H) - User parameter switch 29(SWUSR_1D): Not used

6800EE(H) and 6800EF(H) - User parameter switches 30 and 31 (SWUSR_1E and 1F): Not used

6800F0(H) - User parameter switch 32 (SWUSR_20)

Bit 0: Quotation priority for a destination when there is no destination of the specified type

0: Paper output priority = Priority order: 1. IP-fax destination, 2. Fax Number, 3. E-mail address, 4. Folder

1: Electric putout order = Priority order: 1. E-mail address, 2. Folder, 3. IP-fax destination, 4. Fax number

Bits 1 to 7: Not used

6800F1(H) - User parameter switch 33 (SWUSR_21): Not used

6800F2(H) - User parameter switch 34 (SWUSR_22)

Bit 0: Gatekeeper server used with IP-Fax 0: Disabled, 1: Enabled

Bit 1: SIP server used with IP-Fax 0: Disabled, 1: Enabled

Bits 2 to 7: Not used

6800F3(H) - User parameter switch 35 (SWUSR_23)

Redial interval when sending a backup file

6800F4(H) - User parameter switch 36 (SWUSR_24)

Maximum number of redials when sending a backup file

6800F5(H) - User parameter switch 37 (SWUSR_25)

Bit 0: Whether to stop sending a backup file if the destination folder becomes full while the machine is sending or waiting to send a fax or the backup file. 0: No, • 1: Yes

Bit 2 and 3: Backup file is printed along with the TX communication failure report when a backup file transmission failure occurs. 00: Do not print, 01: Print first page only, 10: Print whole file

Bit 4: Display the sender's information in the file name of documents that are forwarded to folder destinations. 0: Disabled, 1: Enabled

Bit 5: Limit the file names of documents that are forwarded to folder destinations to plain characters only. 0: Disabled, 1: Enabled

Bit 6: When using the remote fax function, the sub-machine beeps to let you know when it has printed a received document (If you specify "On", the machine will beep according to the setting of [Panel Key Sound] under [System Settings].) 0: On, 1: Off

Bit 7: Not used

6800F6(H) - User parameter switch 38 (SWUSR_26)

Maximum number of transmissions the machine attempts before determining that a fax cannot be forwarded from a sender (including special senders) to a folder destination

6800F7(H) - User parameter switch 39 (SWUSR_27)

Interval (in minutes) between resend attempts after failing to forward a fax from a sender (including special senders) to a folder destination

6800F8(H) - User parameter switch 40 (SWUSR_28)

Bit 0: When memory space is insufficient, the machine prints and then deletes the oldest faxes, creating memory space for storage of new faxes. 0: Disabled, 1: Enabled

Bit 1 to 7: Not used

6800FD(H) - User parameter switch 45 (SWUSR_2D)

Bit 0 and 1:

Bit 2: File format for files transmitted to e-mail addresses and folders registered as forwarding, destinations of backup file transmission, receivers for Personal Box, or end receivers for Transfer Box. 0: PDF 1: PDF/A

Bit 3:

Bit 4 to 7: Not used

680100 to 68010F(H) - G4 Parameter Switches – Not used

680110 to 68012F(H) - G4 Internal Switches – Not used

680130 to 68016F(H) - Service Switches

680170 to 68017F(H) - IFAX Switches

680180 to 68018F(H) - IP-FAX Switches

680190 to 6801A3(H) - PSTN-1 RTI (Max. 20 characters - ASCII) - See the following note.

6801A4 to 6801B7(H) - PSTN-2 RTI (Max. 20 characters - ASCII)

6801B8 to 6801CB(H) - PSTN-3 RTI (Max. 20 characters - ASCII)

6801CF to 68020E(H) - TTI 1 (Max. 64 characters - ASCII) - See the following note.

68020F to 68024E(H) - TTI 2

68024F to 68028E(H) - TTI 3

68028F to 6802CE(H) - TTI 4

6802CF to 68030E(H) - TTI 5

68030F to 68034E(H) - TTI 6

68034F to 68038E(H) - TTI 7

68038F to 6803CE(H) - TTI 8

6803CF to 68040E(H) - TTI 9

68040F to 68044E(H) - TTI 10

 **Note**

- If the number of characters is less than the maximum (20 for RTI, 32 for TTI), add a stop code (00[H]) after the last character.

68044F(H)

Printing format for TTI 1

0: DOM (Japan), 1:EXP (Export)

680450(H)

Printing format for TTI 2

0: DOM, 1:EXP

680451(H)

Printing format for TTI 3

0: DOM, 1:EXP

680452(H)

Printing format for TTI 4

0: DOM, 1:EXP

680453(H)

Printing format for TTI 5

0: DOM, 1:EXP

680454(H)

Printing format for TTI 6

0: DOM, 1:EXP

680455(H)

Printing format for TTI 7

0: DOM, 1:EXP

680456(H)

Printing format for TTI 8

0: DOM, 1:EXP

680457(H)

Printing format for TTI 9

0: DOM, 1:EXP

680458(H)

Printing format for TTI 10

0: DOM, 1:EXP

680459 to 68046C(H) - PSTN-1 CSI (Max. 20 characters - ASCII)**68046D to 680480(H)** - PSTN-2 CSI (Max.20 characters - ASCII)**680481 to 680494(H)** - PSTN-3 CSI (Max.20 characters - ASCII)**680495(H)** - Number of PSTN-1 CSI characters (Hex)**680496(H)** - Number of PSTN-2 CSI characters (Hex)**680497(H)** - Number of PSTN-3 CSI characters (Hex)**6804C6(H)** - Memory Lock ID (BCD)**6804D2 to 6804D9(H)** - Last power off time (Read only)

6804D2(H) - 01(H) - 24-hour clock, 00(H) - 12-hour clock (AM), 02(H) - 12-hour clock (PM)

6804D3(H) - Year (BCD)

6804D4(H) - Month (BCD)

6804D5(H) - Day (BCD)

6804D6 (H) – Hour

6804D7 (H) – Minute

6804D8(H) – Second

6804D8 (H) - 00: Monday, 01: Tuesday, 02: Wednesday, /// , 06: Sunday

6804E6(H) - Optional equipment (Read only – Do not change the settings)

Bit 0: Page Memory 0: Not installed, 1: Installed

Bit 1: SAF Memory (4M) 0: Not installed, 1: Installed

Bit 2: SAF Memory 0: Not installed, 1: Installed

Bits 3 to 7; Not used

6804E7(H) - Optional equipment (Read only – Do not change the settings)

Bits 0 to 3: Not used

Bit 4: G3-2 0: Not installed, 1: Installed

Bit 5: G3-3 0: Not installed, 1: Installed

Bit 6 and 7: Not used

- 6804EE(H)** - Machine code (Check ram 3)
- 680500(H)** - Start address of G3 table for G3-1
- 680600(H)** - Start address of G3 table for G3-2
- 680700(H)** - Start address of G3 table for G3-3
- 680800 to 68081F(H)** - Service station's fax number (SP3-101)
- 680820 to 680829(H)** - Own fax PABX extension number – Not used
- 68082A to 680833(H)** - Own fax number (PSTN) – Not used
- 680834 to 680847(H)** - Own fax number (ISDN G4) – Not used
- 680848 to 680853(H)** - The first subscriber number (ISDN G3) – Not used
- 680854 to 68085F(H)** - The second subscriber number (ISDN G3) – Not used
- 680860 to 68086B(H)** - The first subscriber number (ISDN G4) – Not used
- 68086C to 680877(H)** - The second subscriber number (ISDN G4) – Not used
- 6808A0 to 6808B7(H)** - G4TID registered information (Max.24 characters - ASCII)
- 6808B8 to 6808CB(H)** - ISDN CSI (Max.20 characters - ASCII)
- 6808CC(H)** - Number of ISDN CSI characters (Hex)
- 6808D1 to 6808D4(H)** - ISDN G3 subaddress registered information
- 6808D5 to 6808D8(H)** - G4 subaddress registered information
- 6808DE to 6808E2** – Option G3 board (G3-2) ROM information (Read only)
 - 6808DE(H) - Suffix (BCD)
 - 6808DF(H) - Version (BCD)
 - 6808E0(H) - Year (BCD)
 - 6808E1(H) - Month (BCD)
 - 6808E2(H) - Day (BCD)
- 6808E3 to 6808E7** – Option G3 board (G3-3) ROM information (Read only)
 - 6808E3(H) - Suffix (BCD)
 - 6808E4(H) - Version (BCD)
 - 6808E5(H) - Year (BCD)
 - 6808E6(H) - Month (BCD)
 - 6808E7(H) - Day (BCD)
- 6808E8(H)** - G3-1 Modem ROM version (Read only)
- 6808EA(H)** - G3-2 Modem ROM version (Read only)
- 6808EC(H)** - G3-3 Modem ROM version (Read only)
- 6808F8(H)** - Number of multiple sets print (Read only)
- 68094E(H)** - Time for economy transmission (Not used)
- 68094F(H)** - Time for economy transmission (Not used)
- 68096A(H)** - Transmission monitor volume 00 - 07(H)
- 68096B(H)** - Reception monitor volume 00 - 07(H)

68096C(H) - On-hook monitor volume 00 - 07(H)
68096D(H) - Dialing monitor volume 00 - 07(H)
68096E(H) - Buzzer volume 00 - 07(H)
68096F(H) - Beeper volume 00 - 07(H)
680980(H) - Machine code (Check ram 4)
680982(H) - Machine serial number (ASCII)
687178 to 68717B(H) - Transmission counter (Max.24 characters - ASCII)
68717C to 68717F(H) - Reception counter (Max.24 characters - ASCII)
6871E8 to 6871EB(H) - Mail transmission counter (Max.24 characters - ASCII)
6871EC to 6871EF(H) - Mail reception counter (Max.24 characters - ASCII)
6A6DEE(H) to 6A70ED(H) - SIP server address (Read only)
 6A6DEE(H) - Proxy server - Main (Max. 128 characters - ASCII)
 6A6E6E(H) - Proxy server - Sub (Max. 128 characters - ASCII)
 6A6EEE(H) - Redirect server - Main (Max. 128 characters - ASCII)
 6A6F6E(H) - Redirect server - Sub (Max. 128 characters - ASCII)
 6A6FEE(H) - Registrar server - Main (Max. 128 characters - ASCII)
 6A706E(H) - Registrar server - Sub (Max. 128 characters - ASCII)
6A70EE(H) - Gatekeeper server address - Main (Max. 128 characters - ASCII)
6A716E(H) - Gatekeeper server address - Sub (Max. 128 characters - ASCII)
6A71EE(H) - Alias Number (Max. 128 characters - ASCII)
6A726E(H) - SIP user name (Max. 128 characters - ASCII)
6A72EE(H) - **SIP digest authentication password** (Max. 128 characters - ASCII)
6A736E(H) - Gateway address information (Max. 7100 characters - ASCII)
6A8F2A(H) - NGN initial setting method 0: Simple, 1: Manual
6A8F2B(H) - SIP digest authentication user name (Max. 128 characters - ASCII)
6A8FAB(H) - NGN-SIP domain name (Max. 64 characters - ASCII)
6A8FEB(H) - NGN-home gateway address (Max. 128 characters - ASCII)
6A906C(H) - Stand-by port number for H.323 connection
6A906E(H) - Stand-by port number for SIP connection
6A9070(H) - RAS port number
6A9072(H) - Gatekeeper port number
6A9074(H) - Port number of data waiting for T.38
6A9076(H) - Port number of SIP server
6A9078(H) - Priority for SIP and H.323 0: H.323, 1: SIP
6A9079(H) - SIP function 0: Disabled, 1: Enabled
6A907A(H) - H.323 function 0: Disabled, 1: Enabled

6A907B(H) - SIP digest authentication function 0: Disabled, 1: Enabled

6B3AE4(H) - 6B3B04 (H) - Dial tone detection parameter (Max. 11 x 3 lines)

This initializes following order. [0x04, 0x40, 0x03, 0x60, 0x64, 0xf4, 0x01,0x64, 0x04, 0xc8, 0x00]

6B3AE4(H) – Dial tone detection frequency – Upper limit (High)

Defaults: NA: 06, EU: 06, ASIA: 06

6B3AE5(H) – Dial tone detection frequency – Upper Limit (Low)

Defaults: NA: 50, EU: 50, ASIA: 50

6B3AE6(H) – Dial tone detection frequency – Lower Limit (High)

Defaults: NA: 03, EU: 02, ASIA: 02

6B3AE7(H) – Dial tone detection frequency – Lower Limit (Low)

Defaults: NA: 60, EU: 90, ASIA: 90

6B3AE8(H) –Dial tone detection waiting time (20 ms)

Defaults: NA: 64, EU 64, ASIA: 64

6B3AE9 to 6B3AEA – Dial tone detection monitoring time (20 ms)

Defaults

Area	6B35A9	6B35AA
NA	F4	01
EU	F4	01
ASIA	F4	01

6B3AEB(H) – Dial tone detect judge time (20 ms)

Defaults: NA: 64, EU: 1B, ASIA: 32

6B3AEC(H) – Dial tone disconnect permission time (20 ms)

Defaults: NA: 11, EU: 0F, ASIA: 11

5. DETAILED SECTION DESCRIPTIONS

5.1 OVERVIEW

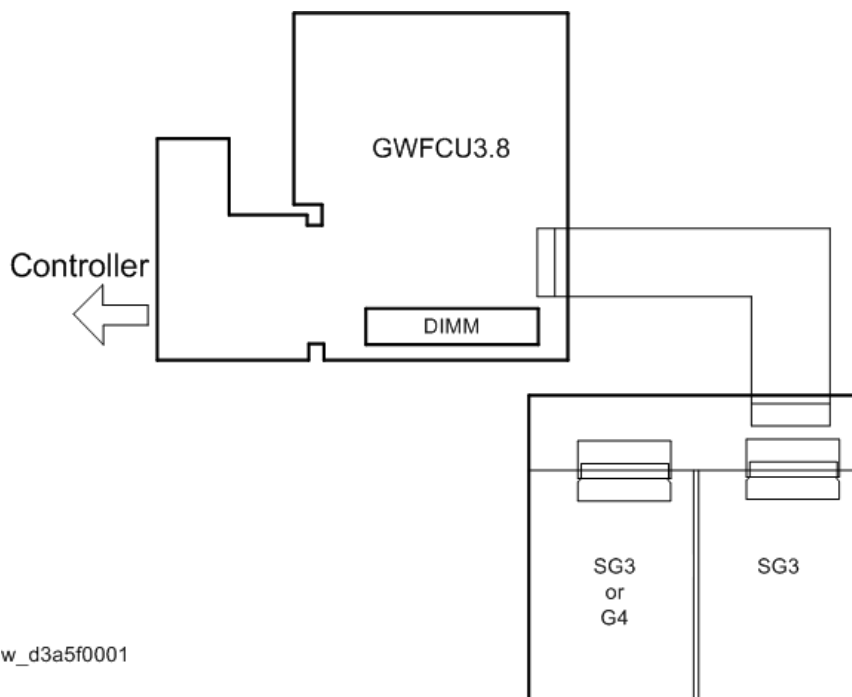

The FCU, which is composed of one PCB, controls all the fax communications and fax features, in cooperation with the controller board.

Fax Options:

- Extra G3 Interface option: This provides one more analog line interface. This allows full dual access. Two extra G3 interface options can be installed.
- Memory Expansion: This expands the SAF memory and the page memory (used for image rotation); without this expansion, the page memory is not big enough for image rotation at 400 dpi, so transmission at 400 dpi is not possible.

5.2 BOARDS

5.2.1 FCU

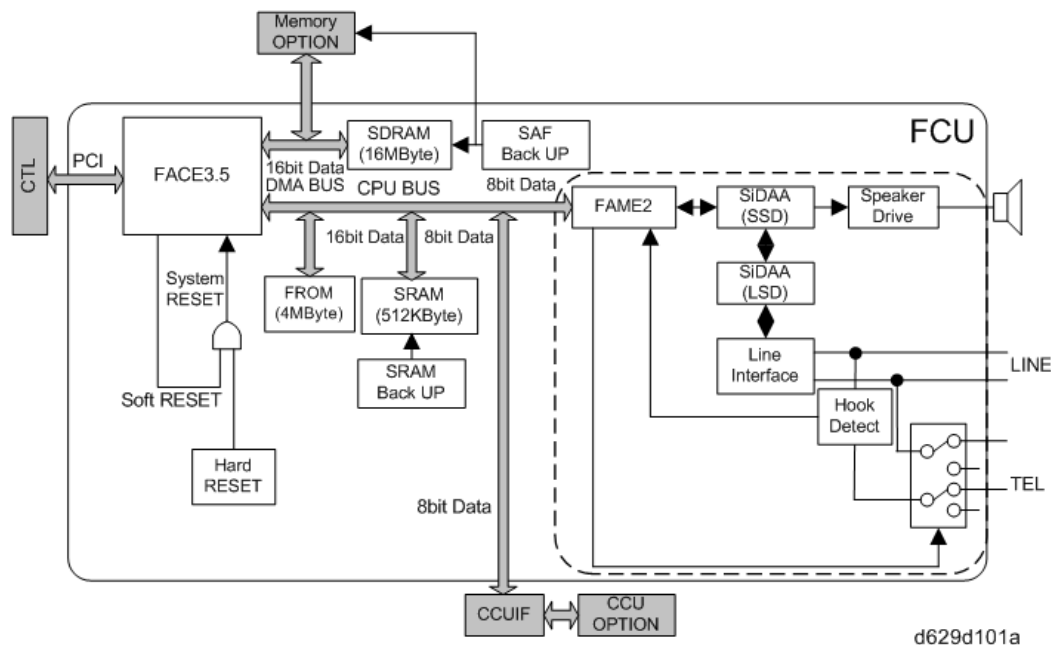

The FCU (Facsimile Control Unit) controls fax communications, the video interface to the base copier's engine, and all the fax options.

FACE3.5 (Fax Application Control Engine)

- CPU
- Data compression and reconstruction (DCR)
- DMA control
- Clock generation
- DRAM backup control

Modem (FAME2)

- V.34, V.33, V.17, V.29, V.27ter, V.21, and V.8

DRAM

- The 16 MB of DRAM is shared as follows.
 - SAF memory: 4MB
 - Working memory: 4MB
 - Page memory: 8MB
 - The SAF memory is backed up by a rechargeable battery.

ROM

- 4MB flash ROMs for system software storage

SRAM

- The 512 KB SRAM for system and user parameter storage is backed up by a lithium battery.

Memory Back-up

- A rechargeable battery backs up the SAF memory (DRAM) for 12 hours.
- A lithium battery backs up the system parameters and programmed items in the SRAM, in case the base copier's main switch is turned off.

Switches

Item	Description
SW1	Switches the SRAM backup battery on/off.

5.2.2 SG3 BOARD

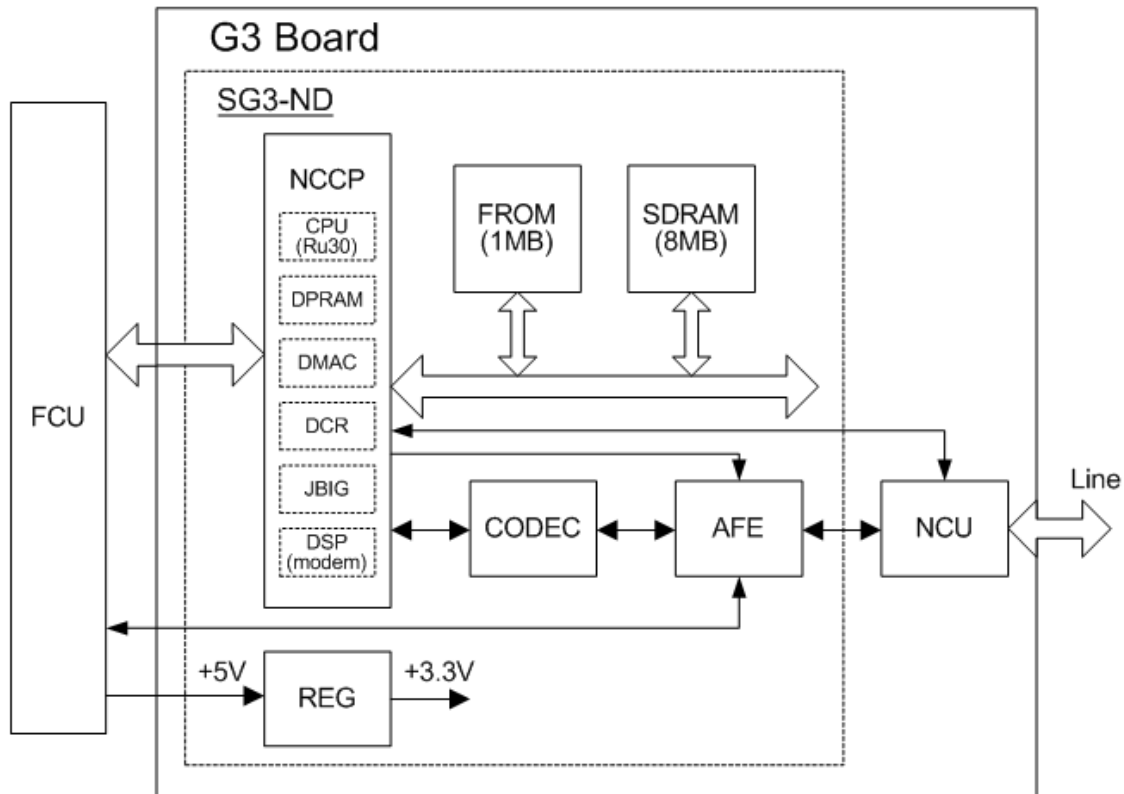

b766d903a

The SG3 board allows up to three simultaneous communications when used in combination with the FCU and optional G3 boards. The NCU is on the same board as the common SG-3 board. This makes the total board structure smaller. But, the specifications of the SG3 board do not change.

NCCP (New Communication Control Processor)

- Controls the SG3 board.
- CPU (RU30)
- DPRAM (Dual Port RAM): Handshaking with the FCU is done through this block.
- DMA controller
- JBIG
- DSP V34 modem (RL5T892): Includes the DTMF Receiver function
- DCR for MH, MR, MMR, and JBIG compression and decompression

FROM

- 1Mbyte flash ROM for SG3 software storage and modem software storage

SDRAM

- 4Mbyte DRAM shared between ECM buffer, line buffer, and working memory

AFE (Analog Front End)

- Analog processing

CODEC (COder-DECoder)

- A/D & D/A conversions for modem

REG

- Generates +3.3 V from the +5V from the FCU

5.3 VIDEO DATA PATH

5.3.1 TRANSMISSION

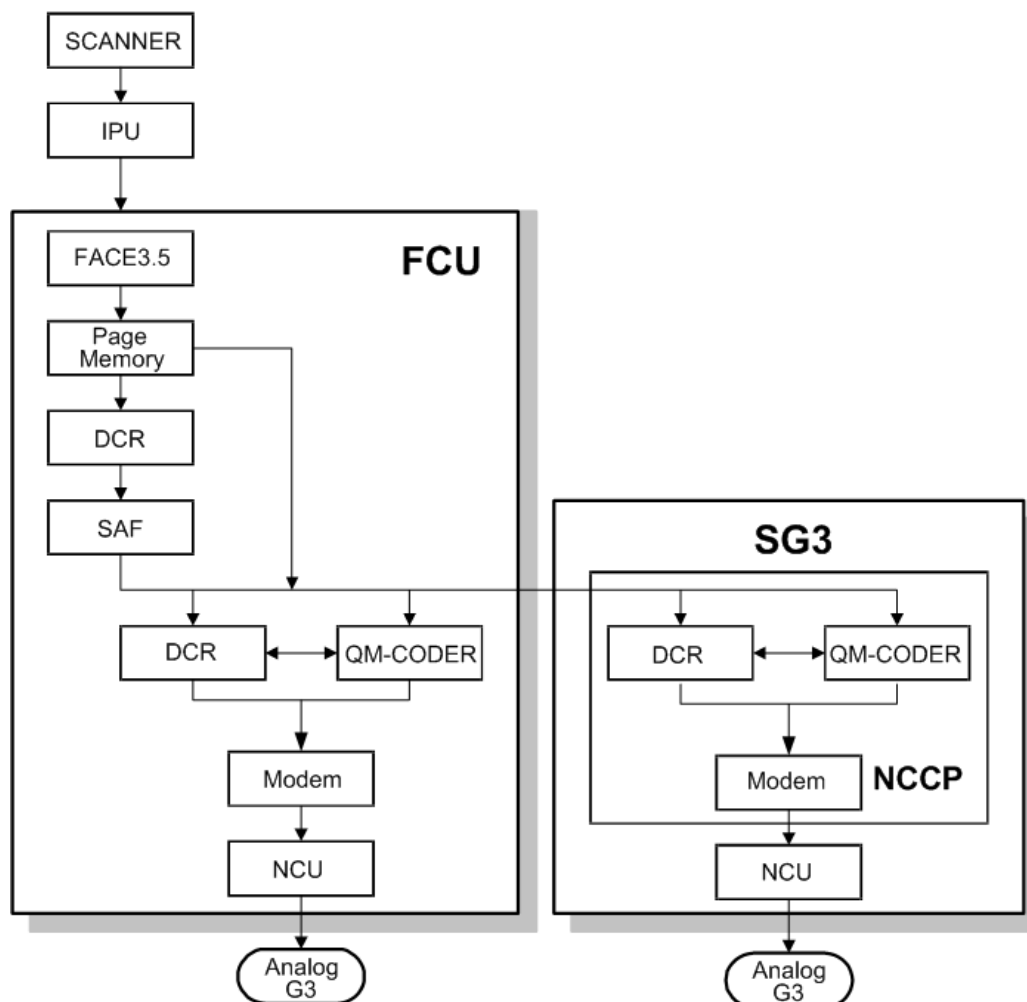

Memory Transmission and Parallel Memory Transmission

The base copier's scanner scans the original at the selected resolution in inch format. The IPU processes the data and transfers it to the FCU.

Note

- When scanning a fax original, the IPU uses the MTF, independent dot erase and thresholding parameter settings programmed in the fax unit's scanner bit switches, not the copier's SP modes.

Then, the FCU converts the data to mm format, and compresses the data in MMR or raw format to store it in the SAF memory. If image rotation will be done, the image is rotated in page memory before compression.

At the time of transmission, the FCU decompresses the stored data, then re-compresses and/or reduces the data if necessary for transmission. The NCU transmits the data to the line.

Immediate Transmission

The base copier's scanner scans the original at the resolution agreed with the receiving terminal. The IPU video processes the data and transfers it to the FCU.

Note

- When scanning a fax original, the IPU uses the MTF, independent dot erase and thresholding parameter settings programmed in the fax unit's scanner bit switches, not the copier's SP modes.

Then the FCU stores the data in page memory, and compresses the data for transmission. The NCU transmits the data to the line.

JBIG Transmission

Memory transmission: If the receiver has JBIG compression, the data goes from the DCR to the QM-Coder. Then the NCU transmits the data to the line. When an optional G3 unit (SG3) is installed and PSTN2 is selected as the line type, JBIG compression is available, but only for the PSTN-2 line.

Immediate transmission: If the receiver has JBIG compression, the data goes from the page memory to the QM-Coder. Then the NCU transmits the data to the line. When an optional G3 unit (SG3) is installed and PSTN2 is selected as the line type, JBIG compression is available, but only for the PSTN-2 line.

Adjustments

- Priority for the line used for G3 transmissions (PSTN 1/PSTN 2 or 3): System switch 16 bit 1

5.3.2 RECEPTION

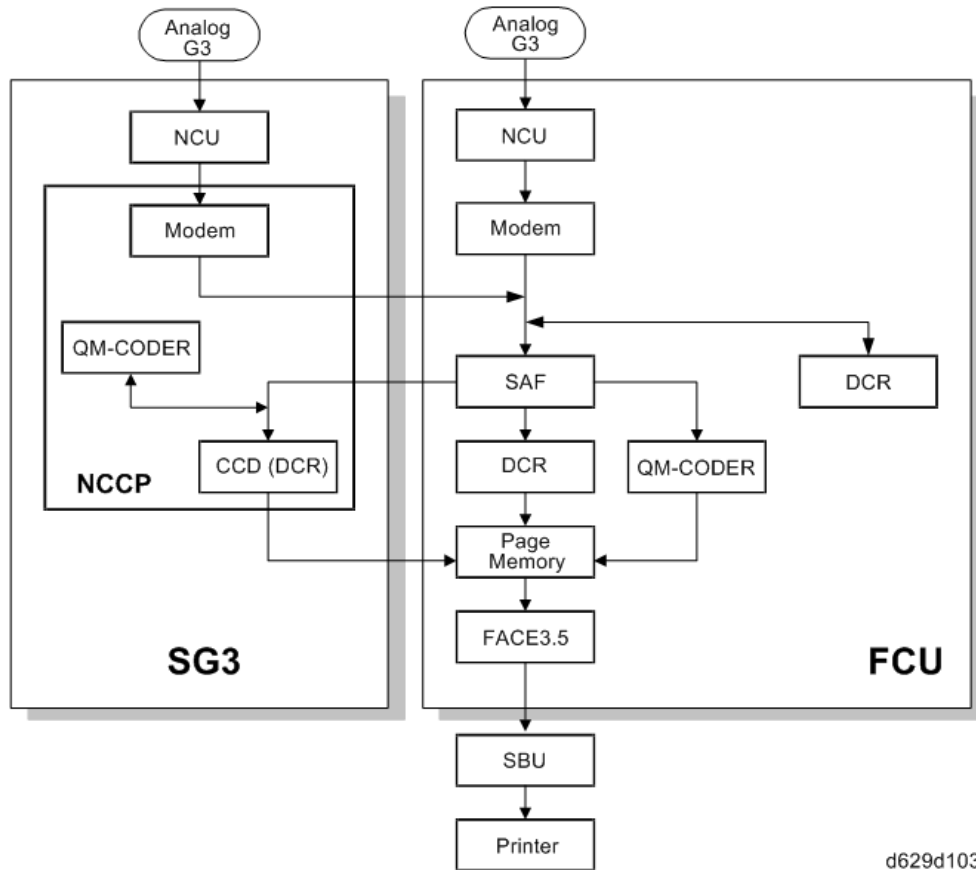

First, the FCU stores the incoming data from either an analog line to the SAF memory. (The data goes to the FACE3 at the same time, and is checked for error lines/frames.)

The FCU then decompresses the data and transfers it to page memory. If image rotation will be done, the image is rotated in the page memory. The data is transferred to the IPU.

If the optional G3 unit is installed, the line that the message comes in on depends on the telephone number dialled by the other party (the optional G3 unit has a different telephone number from the main fax board).

JBIG Reception

When data compressed with JBIG comes in on PSTN-1 (the standard analog line), the data is sent to the QM-CODER for decompression. Then the data is stored in the page memory, and transferred to the IPU.

When data compressed with JBIG comes in on PSTN-2 (optional extra analog line), the data is sent to the QM-CODER on the SG3 board for decompression.

5.4 FAX COMMUNICATION FEATURES

5.4.1 MULTI-PORT

When the optional extra G3 Interface Unit is installed, communication can take place at the same time through the two or three lines at once.

Option	Available Line Type	Available protocol Combinations
Standard only	PSTN	G3
Extra G3 Interface Unit (single)	PSTN + PSTN	G3 + G3
Extra G3 Interface Unit (double)	PSTN + PSTN +PSTN	G3 + G3 +G3

5.4.2 DOCUMENT SERVER

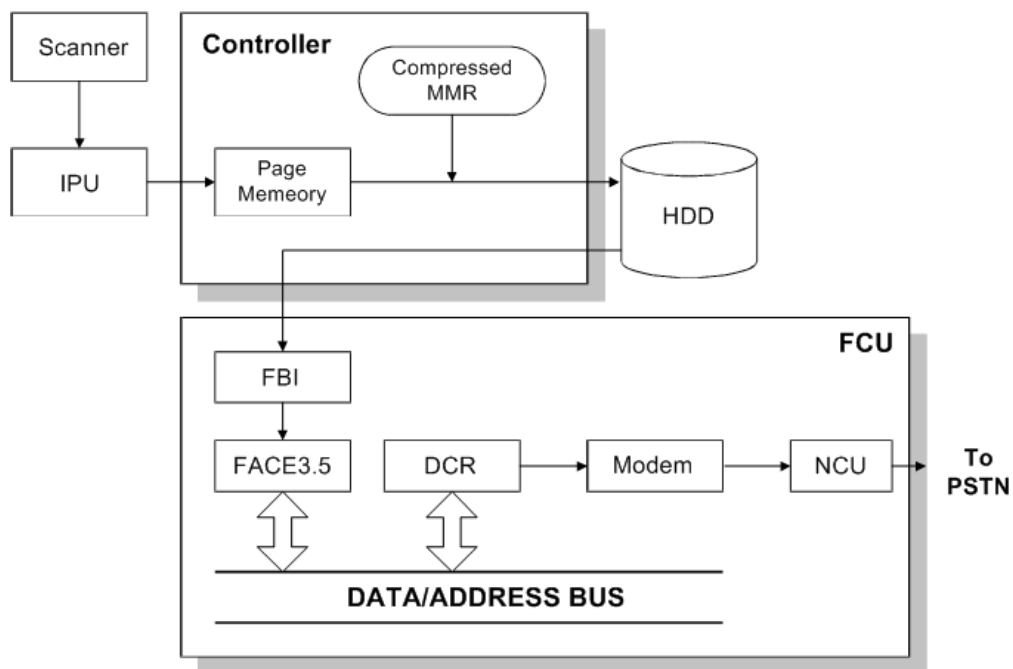

d629d104

The base copier's scanner scans the original at the selected resolution. The IPU video processes the data and transfers it to the controller board.

Then the controller stores the data in the page memory for the copier function, and compresses the data in MMR (by software) to store it in the HDD. If image rotation will be done, the image is rotated in the page memory before compression.

For transmission, the stored image data is transferred to the FCU. The FCU decompresses the image data, then recompresses and/or reduces the data if necessary for transmission. The NCU transmits the data to the line.

The documents can be stored in the HDD (Document Server) from the fax application. The stored documents in the document sever can be used for the fax transmission in many times. More than one document and the scanned document can be combined into one file and then the file can be transmitted.

- When using the document server, the SAF memory is not used.
- The document is compressed with MMR and stored.
- Up to 9,000 pages can be stored (1 file: Up to 1,000 pages) from the fax application.
- Only stored documents from the fax application can be transmitted.
- Scanned documents are given a name automatically, such as "FAX001". But it is possible to change the file name, user name and password.
- Up to 30 files can be selected at once.

Note

- The compression method of the fax application is different from the copy application. The storing time is longer than the copier storing.
- When selecting "Print 1st page", the stored document will be reduced to A4 size.

5.4.3 INTERNET MAIL COMMUNICATION

Mail Transmission

T.37 simple and full modes

This machine supports T.37 full mode. (ITU-T Recommendation, RFC2532). The difference between T.37 simple mode and full mode is as follows.

Function	T.37 Simple Mode	T.37 Full Mode
Resolution	200 x 100 200 x 200	200 x100 200 x 200 200 x 400 400 x 400 (if available)
RX Paper Width	A4	A4, B4, A3
RX Data Compression Method	MH	MH (default), MR, MMR,

Function	T.37 Simple Mode	T.37 Full Mode
Signals	Image data transmission only	Image data transmission, exchange of capability information between the two terminals, and acknowledgement of receipt of fax messages

Data Formats

The scanned data is converted into a TIFF-F formatted file.

The fields of the e-mail and their contents are as follows:

Field	Content
From	Mail address of the sender
Reply To	Destination requested for reply
To	Mail address of the destination
Bcc	Backup mail address
Subject	From CSI or RTI (Fax Message No. xxxx)
Content Type	Multipart/mixed Attached files: image/tiff
Content Transfer Encoding	Base 64, 7-bit, 8-bit, Quoted Printable
Message Body	MIME-converted TIFF-F (MIME standards specify how files are attached to e-mail messages)

Direct SMTP Transmission

Internet Fax documents can be sent directly to their destinations without going through the SMTP server. (Internet Faxes normally transmit via the SMTP server.)

For example:

e-mail address:	gts@ricoh.co.jp
SMTP server address:	gts.abcd.com

In this case, this feature destination e-mail address (gts@ricoh.co.jp) is read as the SMTP server address "gts.abcd.com", and the transmissions bypass the SMTP server. This leads to decrease the server load and to reduce the time lag during transferring the mail.

Requirements for destination server:

- Supports with Internet FAX (as a destination of Internet FAX)
- Can receive mails (as a destination of mail)
- Is installed in the same LAN as this machine
- Supports with the SMTP mail reception, and the reception protocol is set to SMTP

Note

- Set the port number for [SMTP server] to "25" to enable this feature.
- If the sender server sends an Internet FAX or a mail using this feature, the SMTP authentication is disabled even if the server sets it.
- Using this feature, error notification mail will not be sent even if the mail is not properly received.
- Also, error mail will not be sent even if the mail is not sent properly.
- This feature refers to A records (not supported with MX records).

Selectable Options

These options are available for selection:

- With the default settings, the scan resolution can be either standard or detail. Inch-mm conversion before TX depends on IFAX SW01 Bit 7. Detail resolution will be used if Super Fine resolution is selected, unless Fine resolution is enabled with IFAX SW01.
- The requirements for originals (document size, scan width, and memory capacity) are the same as for G3 fax memory TX.
- The default compression is TIFF-F format.
- IFAX SW00: Acceptable paper widths for sending
- IFAX SW09: Maximum number of attempts to the same destination

Secure Internet Transmission

SMTP Authentication:

- User Tools> System Settings> File Transfer> SMTP Authentication

POP Before SMTP:

- User Tools> System Settings> File Transfer> POP Before SMTP

Mail Reception

Three Types

This machine supports three types of e-mail reception:

- POP3 (Post Office Protocol Ver. 3.)
- IMAP4 (Internet Messaging Access Protocol)
- SMTP (Simple Mail Transfer Protocol)

ⓘ Note

- For details: Core Technology Manual – Facsimile Processes – Faxing from a PC – Internet/LAN Fax Boards – Mail Reception

POP3/IMAP4 Mail Reception Procedure

The machine automatically picks up e-mail from the server at an interval which is adjustable in the range 2 to 1440 min. in 1-minute steps:

- User Tools> System Settings> File Transfer> E-mail Reception Interval

SMTP Reception

1. The IFAX must be registered as an SMTP server in the MX record of the DNS server, and the address of the received mail must specify the IFAX.
2. To enable SMTP reception: User Tools> System Settings> File Transfer> Reception Protocol
 - Even if the MX record on the DNS server includes the IFAX, mail cannot be received with SMTP until SMTP reception is enabled:
 - However, if SMTP reception is selected and the machine is not registered in the MX record of the DNS server, then either IMAP4 or POP3 is used, depending on the setting: User Tools> System Settings> File Transfer> Reception Protocol

ⓘ Note

- An error will be issued and error mail will be sent to the mail source when the reception protocol is not set to SMTP even if you configure to enable SMTP reception in the DNS server.
- If the received mail contains error, the reception operation is stopped, the mail is discarded and error report is output. Error mail is also sent to the mail source.
- When a mail is received from SMTP server during sending a mail in the machine, the SMTP server will give a “Busy” response. The SMTP server will usually try to send the mail again later until the time-out is reached.
- This feature cannot be used with the POP server.

Mail Delivery Conditions: Transferring Mail Received With SMTP

1. The machine must be set up for SMTP mail delivery:
 - User Tools> Facsimile Features> Reception Settings> SMTP RX File Delivery Settings
2. If the user wishes to limit this feature so that the machine will only deliver mail from designated senders, the machine's "Auth. E-mail RX" feature must be set (User Tools> Facsimile Features> Reception Settings> SMTP RX File Delivery Settings).
3. If the "SMTP RX File Delivery Setting" is set to "Off" to prohibit SMTP receiving, and if there is mail designated for delivery, then the machine responds with an error. (User Tools> Facsimile Features> Reception Settings> SMTP RX File Delivery Settings)
4. If the quick dial, speed dial, or group dial entry is incorrect, the mail transmission is lost, and the IFAX issues an error to the SMTP server and outputs an error report.

Auth. E-mail RX

In order to limit access to mail delivery with IFAX, the addresses of senders must be limited using the Access Limit Entry. Only one entry can be registered.

1. Access Limit Entry

For example, to limit access to @IFAX.ricoh.co.jp:

gts@IFAX.ricoh.co.jp	Matches and is delivered.
gts@IFAX.abcde.co.jp	Does not match and is not delivered.
IFAX@ricoh.co.jp	Does not match and is not delivered.

1. Conditions
 - The length of the Access Limit Entry is limited to 127 characters.
 - If the Access Limit Entry address and the mail address of the incoming mail do not match, the incoming mail is discarded and not delivered, and the SMTP server responds with an error. However, in this case an error report is not output.
 - If the Access Limit Entry address is not registered, and if the incoming mail specifies a delivery destination, then the mail is delivered unconditionally.

Handling Mail Reception Errors

Abnormal files

When an error of this type occurs, the machine stops receiving and commands the server to erase the message. Then the machine prints an error report and sends information about the error by e-mail to the sender address (specified in the "From" or "Reply-to" field of the message). If there is an incomplete received message in the machine memory, it will be erased.

The machine prints an error message when it fails to send the receive error notification after a certain number of attempts.

The following types of files are judged to be abnormal if one or more of the following are detected:

1. Unsupported MIME headers.

Supported types of MIME header

Header	Supported Types
Content-Type	Multipart/mixed, text/plain, message/rfc822 Image/tiff
Charset	US-ASCII, ISO 8859 X. Other types cannot be handled, and some garbage may appear in the data.
Content-Transfer-Encoding	Base 64, 7-bit, 8-bit, Quoted Printable

2. MIME decoding errors
3. File format not recognized as TIFF-F format
4. Resolution, document size, or compression type cannot be accepted

Remaining SAF capacity error

The machine calls the server but does not receive e-mail if the remaining SAF capacity is less than a certain value (the value depends on IFAX Switch 08. The e-mail will be received when the SAF capacity increases (for example, after substitute reception files have been printed). The error handling method for this type of error is the same as for "Abnormal files".

If the capacity of the SAF memory drops to zero during reception, the machine operates in the same way as when receiving an abnormal file (refer to "Abnormal files" above).

Secure Internet Reception

To enable password encryption and higher level security: User Tools> System Settings> File Transfer> POP3/IMAP4 Settings> Encryption (set to "On")

Transfer Request: Request By Mail

For details: Core Technology Manual – Facsimile Processes – Faxing from a PC – Internet/LAN Fax Boards – Transfer Request

The fields of the e-mail and their contents are as follows:

Field	Content
From	E-mail address of the requesting terminal
To	Destination address (Transfer Station address)
Bcc	Backup mail address
Subject	From TSI (Fax Message No. xxxx)
Content-Type	Multipart/mixed Text/Plain (for a text part), image/tiff (for attached files)
Content-Transfer-Encoding	Base 64, 7-Bit, 8-bit, Quoted Printable
Mail body (text part)	RELAY-ID-: xxxx (xxxx: 4 digits for an ID code) RELAY: #01#*X#**01....
Message body	MIME-converted TIFF-F.

E-Mail Options (Sub TX Mode)

The following features are available as options for mail sending: entering a subject, designating the level of importance, confirming reception of the mail.

Subject and Level of Importance

You can enter a subject message with: TX Mode> Subject

The Subject entry for the mail being sent is limited to 128 characters. The subject can also be prefixed with an "Confidential", "Urgent", "Please phone" or "Copy to corres. Section" notation.

- How the Subject Differs According to Mail Type -

FAX OPTION
TYPE M12
(D3A5)

Mail Type	Item 1	Item 2		Item 3
Subject Entry	---	Entry Condition		Fax Message No. + File No.
No Subject Entry		1. "CSI" ("RTI")		
		2. "RTI"	CSI not registered	
		3. "CSI"	RTI not registered	
		4. None	CSI, RTI not registered	
Confirmation of Reception	From	1. "CSI" ("RTI")		Normal: Return Receipt (dispatched). You can select "displayed" with IFAX SW02 Bits 2 and 3.
		2. "RTI"	CSI not registered	
		3. "CSI"	RTI not registered	Error: Return Receipt (processed/error)
		4. None	CSI, RTI not registered	
Mail delivery, memory transfer, SMTP receiving and delivery	From	RTI or CSI of the station designated for delivery	Mail delivery	Fax Message No. + File Number
		RTI or CSI of sender	Mail sending from G3 memory	
		Mail address of sender	Memory sending	
		Mail address of sender	SMTP receiving and delivery (Off Ramp Gateway)	
Mail error notification	---	Error Message No. xxxx From CSI (RTI)		

Items 1, 2, and 3 in the table above are in the Subject.

- Subjects Displayed on the PC –

Sender	Date	Size	Subject
Substation 2	04/25/2002	1,513	Parts List
Substation 2	04/26/2002	1,147	Specifications
Main Station	05/09/2002	33,551	[Urgent] Memo 2041
		21,624,288	

b766d907

E-mail Messages

After entering the subject, you can enter a message with: TX Mode> Text

An e-mail message (up to 5 lines) can be pre-registered with: User Tools> System Settings> File Transfer> Program/Change/Delete E-mail Message

- Limitations on Entries -

Item	Maximum
Number of Lines	5 lines
Line Length	80 characters
Name Length	20 characters

Message Disposition Notification (MDN)

For details: Core Technology Manual – Facsimile Processes – Faxing from a PC – Internet/LAN Fax Boards – E-mail Options

The network system administrator can confirm whether a sent mail has been received correctly or not. This confirmation is done in four steps.

1. Send request for confirmation of mail reception. To enable or disable this request (known as MDN): TX Mode> Reception Notice
2. Mail reception (receive confirmation request)
3. Send confirmation of mail reception
4. Receive confirmation of mail reception

The other party's machine will not respond to the request unless the two conditions below are met:

- The other party's machine must be set up to respond to the confirmation request.
- The other party's machine must support MDN (Message Disposition Notification).

- Setting up the Receiving Party -

The receiving party will respond to the confirmation request if:

1. The "Disposition Notification To" field is in the received mail header (automatically inserted in the 4th line in the upper table on the previous page, if MDN is enabled), and

2. Sending the disposition notification must be enabled (User Parameter Setting SW21 (15 [H]) Bit 1 for this model). The content of the response is as follows:

Normal reception:	"Return Receipt (dispatched)" in the Subject line
IFAX SW02 (Bit 2, 3)	"Return Receipt (displayed)" in the Subject line
Error:	"Return Receipt (processed/error)" in the Subject line

Handling Reports

- Sending a Request for a Return Receipt by Mail -

After the mail sender transmits a request for a return receipt, the mail sender's journal is annotated with two hyphens (--) in the Result column and a "Q" in the Mode column.

- Mail Receipt (Request for Receipt Confirmation) and Sending Mail Receipt Response -

After the mail receiver sends a response to the request for a return receipt, the mail receiver's journal is annotated with two hyphens (--) in the Result column and an "A" in the Mode column.

- Receiving the Return Receipt Mail -

- After the mail sender receives a return receipt, the information in the mail sender's journal about the receipt request is replaced, i.e. the journal is annotated with "OK" in the Result column.
- When the return receipt reports an error, the journal is annotated with an "E" in the Result column.
- The arrival of the return receipt is not recorded in the journal as a separate communication. Its arrival is only reported by the presence of "OK" or "E" in the Result column.
- If the mail address used by the sender specifies a mailing list (i.e., a Group destination; the machine sends the mail to more than one location. See "How to set up Mail Delivery"), the Result column of the Journal is updated every time a return receipt is received. For example, if the mailing list was to 5 destinations, the Result column indicates the result of the communication with the 5th destination only. The results of the communications to the first 4 destinations are not shown.

Exceptions:

If one of the communications had an error, the Result column will indicate E, even if subsequent communications were OK.

If two of the communications had an error, the Journal will indicate the destination for the first error only.

Fax Communication Features

- Report Sample –

DATE	TIME	ADDRESS	MODE	TIME	PAGE	RESULT
MAY. 5	10:13	fuser 01@domlg. ricoh. co.	Mail SM	0'09"	2	--
	10:16	fuser 01@domlg. ricoh. co.	Mail SMQ	0'05"	1	--
	10:17	s_tadashi@domlg. ricoh. co.	Mail SMQ	0'09"	2	OK
	10:19	m_masataka@domlg. ricoh. co.	Mail SMA	0'05"	1	--

b771d506

5.5 IP-FAX

5.5.1 WHAT IS IP-FAX?

For details: Core Technology Manual – Facsimile Processes – Faxing from a PC – Internet/LAN Fax Boards – IP-FAX

5.5.2 T.38 PACKET FORMAT

TCP is selected by default for this machine, but you can change this to UDP with IPFAX SW 00 Bit 1.

UDP Related Switches

IP-Fax Switch 01						
No.	Function					Comments
0-3	Select IP FAX Delay Level					Raise the level by selecting a higher setting if too many transmission errors are occurring on the network. If TCP/UDP is enabled on the network, raise this setting on the T.30 machine. Increasing the delay time allows the recovery of more lost packets. If only UDP is enabled, increase the number of redundant packets. Level 1~2: 3 Redundant packets Level 3: 4 Redundant packets
	Bit 3	Bit 2	Bit 1	Bit 0	Level	
	0	0	0	0	0	
	0	0	0	1	1	
	0	0	1	0	2	
	0	0	1	1	3	

IP-Fax

5.5.3 SETTINGS

User parameter switch 34 (22[H]), bit 0

IP-Fax Gate Keeper usage, 0: No, 1: Yes

IP Fax Switches: Various IP-FAX settings (see the bit switch table)

6. SPECIFICATIONS

6.1 GENERAL SPECIFICATIONS

6.1.1 FCU

Type:	Desktop type transceiver
Circuit:	PSTN (max. 3ch.) PABX
Connection:	Direct couple
Original Size:	Book (Face down) Maximum Length: 432 mm [17 ins] Maximum Width: 297 mm [11.7 ins] ARDF (Face up) (Single-sided document) Length: 128 - 1200 mm [5.0 - 47.2 ins] Width: 105 - 297 mm [4.1 - 11.7 inch] (Double-sided document) Length: 128 - 432 mm [5.0 - 17 inch] Width: 105 - 297 mm [4.1 - 11.7 inch]
Scanning Method:	Flat bed, with CCD
Resolution:	G3 8 x 3.85 lines/mm (Standard) 8 x 7.7 lines/mm (Detail) 8 x 15.4 line/mm (Fine) See Note1 16 x15.4 line/mm (Super Fine) See Note 1 200 x 100 dpi (Standard) 200 x 200 dpi (Detail) 400 x 400 dpi (Super Fine) See Note 1 ↓ Note <ul style="list-style-type: none"> ▪ Optional Expansion Memory required

General Specifications

Transmission Time:	G3: 3 s at 28800 bps; Measured with G3 ECM using memory for an ITU-T #1 test document (Slerexe letter) at standard resolution
Data Compression:	MH, MR, MMR, JBIG
Protocol:	Group 3 with ECM
Modulation:	V.34, V.33, V.17 (TCM), V.29 (QAM), V.27ter (PHM), V.8, V.21 (FSK)
Data Rate:	G3: 33600/31200/28800/26400/24000/21600/ 19200/16800/14400/12000/9600/7200/4800/2400 bps Automatic fallback
I/O Rate:	With ECM: 0 ms/line Without ECM: 2.5, 5, 10, 20, or 40 ms/line
Memory Capacity:	SAF Standard: 4 MB With optional Expansion Memory: 60 MB (4 MB+ 56 MB) Page Memory Standard: 8 MB (Print: 4 MB + Scanner: 4 MB) With optional Expansion Memory: 16 MB (8 MB + 8 MB) (Print 8 MB + Scanner: 8 MB)

6.2 CAPABILITIES OF PROGRAMMABLE ITEMS

The following table shows the capabilities of each programmable items.

Item	Standard
Quick Dial	2000
Groups	100
Destination per Group	500
Destinations dialed from the ten-key pad overall	500
Programs	100
Auto Document	6
Communication records for Journal stored in the memory	200
Specific Senders	250

The following table shows how the capabilities of the document memory will change after the Expansion Memory are installed.

	Without the Expansion Memory	With the Expansion Memory
Memory Transmission file	800	800
Maximum number of page for memory transmission	1000	1000
Memory capacity for memory transmission (Note1)	320	2240

Note

- Measured using an ITU-T #1 test document (Slerexe letter) at the standard resolution, the auto image density mode and the Text mode.

6.3 IFAX SPECIFICATIONS

Connectivity:	Local area network Ethernet 100base-Tx/10base-T Gigabit Ethernet 1000 Base-T IEEE802.11a/g, g (wireless LAN),
Resolution:	200 × 100 dpi (Standard resolution), 200 × 200 dpi (Detail resolution), 200 × 400 dpi (Fine resolution)*1, 400 × 400 dpi (Super Fine resolution)*1 Note <ul style="list-style-type: none"> ▪ To use 200 × 400 dpi and 400 × 400 dpi, IFAX SW01 Bit 2 and/or bit 4 must be set to “1”.
Transmission Time:	1 s (through a LAN to the server) Condition: ITU-T #1 test document (Selerexe Letter) MTF correction: OFF TTI: None Resolution: 200 x 100 dpi Communication speed: 10 Mbps Correspondent device: E-mail server Line conditions: No terminal access
Document Size:	Maximum Original Size: A3/DLT. Note <ul style="list-style-type: none"> ▪ To use B4 and A3 width, IFAX SW00 Bit 1 (B4) and/or Bit 2 (A3) must be set to “1”.
E-mail File Format:	Single/multi-part MIME conversion Image: TIFF-F (MH, MR, MMR)
Protocol:	Transmission: SMTP, TCP/IP Reception: POP3, SMTP, IMAP4, TCP/IP

Data Rate:	1000 Mbps (1000 Base-T) 100 Mbps (100base-Tx) 10 Mbps (10base-T)
Authentication Method:	SMTP-AUTH POP before SMTP A-POP
Remark:	The machine must be set up as an e-mail client before installation. Any client PCs connected to the machine through a LAN must also be e-mail clients, or some features will not work (e.g. Autorouting).

FAX OPTION
TYPE M12
(D3A5)

6.4 IP-FAX SPECIFICATIONS

Network:	Local Area Network Ethernet/10base-T, 100base-TX Gigabit Ethernet/1000 Base-T IEEE802.11a/b/g/n (wireless LAN)
Scan line density:	8 x 3.85 lines/mm, 200x100 dpi (standard character), 8 x 7.7 lines/mm, 200x200 dpi (detail character), 8 x 15.4 lines/mm (fine character: optional expansion memory required), 16 x 15.4 lines/mm, 400x400 dpi (super fine character: optional expansion memory required)
Maximum Original size:	A3 or 11" x 17" (DLT) Custom: 297 mm x 1200 mm (11.7" x 47.3")
Maximum scanning size:	297 mm x 1200 mm (11.7" x 47.3")
Transmission protocol:	TCP, UDP/IP communication
Compatible machines:	IP-Fax compatible machines
IP-Fax transmission function:	Specify IP address and send faxes to an IP-Fax compatible fax through a network. Also capable of sending faxes from a G3 fax connected to a telephone line via a VoIP gateway.
IP-Fax reception function:	Receive faxes sent from an IP-Fax compatible fax through a network. Also capable of receiving faxes from a G3 fax connected to a telephone line via a VoIP gateway.

6.5 FAX UNIT CONFIGURATION

6.5.1 G3 INTERFACE UNIT TYPE M12

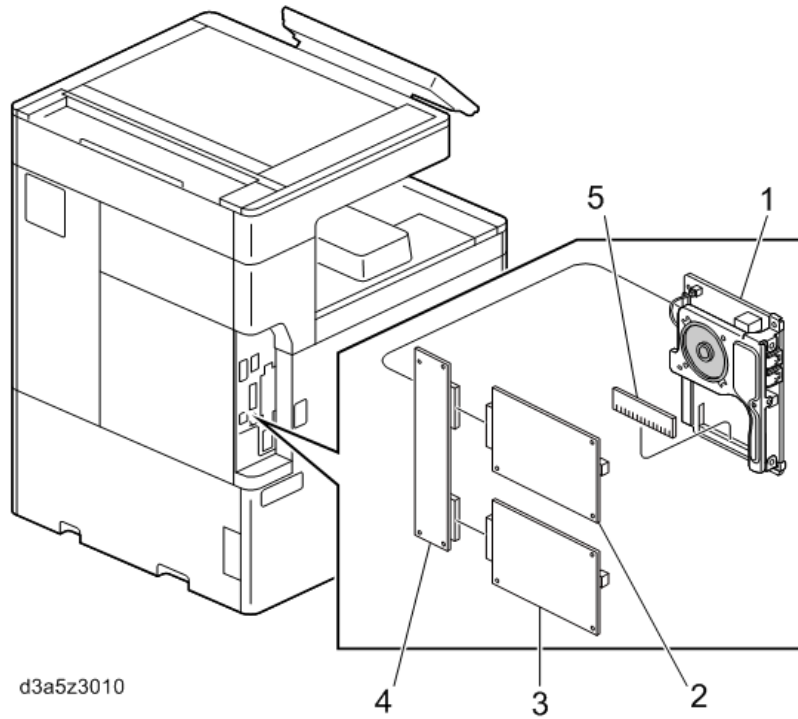

Component	Code	No.	Remarks
FCU	D3A5-01, -02, -03, -11, -12	1	-
SG3 Board	D3A5-05, -06, -07, -13	2	Optional
SG3 Board		3	Optional
CCU I/F Board		4	Included with optional G3 unit
Expansion Memory	D3A5-10	5	Optional

D148-81

SMART OPERATION PANEL TYPE M3

REVISION HISTORY		
Page	Date	Added/Updated/New
		None

SMART OPERATION PANEL TYPE M3 (D148-81)

TABLE OF CONTENTS





1. REPLACEMENT AND ADJUSTMENT	1
1.1 OPERATION PANEL UNIT	1
1.1.1 OPERATION PANEL	1
1.1.2 MICROCOMPUTER BOARD	2
1.1.3 CPU BOARD	4
1.1.4 I/O BOARD	5
1.1.5 SPEAKER	5
1.1.6 LCD	6
1.1.7 MICROPHONE	7
2. MECHANISM	8
2.1 OVERVIEW	8
2.1.1 SYSTEM COMPONENTS	8
Specification	8
Available languages	9
2.1.2 APPEARANCE/SCREEN LAYOUT	10
1. Key specification	11
2. LED specification	11
3. External I/F specification	12
4. Screen layout	12
2.1.3 ELECTRICAL COMPONENTS	13
2.2 POWER SUPPLY CONTROL	14
2.2.1 ENERGY-SAVE RECOVERY OPERATION	14
2.2.2 SCREEN STARTUP MODE	15
2.2.3 SPECIAL SHUTDOWN	16
3. SYSTEM MAINTENANCE	17
3.1 SYSTEM MAINTENANCE	17
3.1.1 BASIC OPERATION	17
Switching the Power OFF before Performing Maintenance (before Disconnecting the Power Supply Plug)	17
Switching the Power OFF before Upgrading the MFP (Controller/Engine) Version	17

Reset Procedure If the Android Screen Freezes	17
3.1.2 MAINTENANCE MODES.....	18
3.1.3 VERSION UPDATE	19
Preparing Version Update SD card	19
Version Update Procedure	19
3.1.4 APPLICATION INSTALLATION/VERSION UPDATE	21
Version update via SD card.....	21
3.1.5 SELF-DIAGNOSIS.....	22
3.2 SP MODE LIST	26
3.2.1 SETTINGS MENU LIST	26
3.3 RECOVERY MENU	28

READ THIS FIRST

Safety and Symbols

This manual uses several symbols and abbreviations. The meaning of those symbols and abbreviations are as follows:

	Clip ring
	Screw
	Connector
	Clamp
SEF	Short Edge Feed
LEF	Long Edge Feed

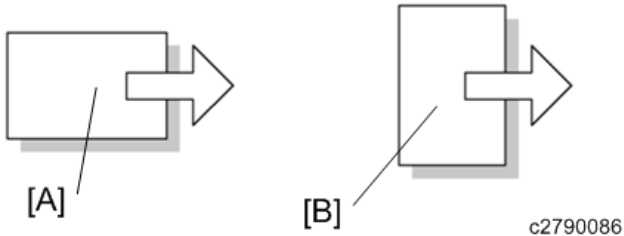

[A] Short Edge Feed (SEF)

[B] Long Edge Feed (LEF)

Trademarks

Microsoft[®], Windows[®], and MS-DOS[®] are registered trademarks of Microsoft Corporation in the United States and /or other countries.

PostScript[®] is a registered trademark of Adobe Systems, Incorporated.

PCL[®] is a registered trademark of Hewlett-Packard Company.

Ethernet[®] is a registered trademark of Xerox Corporation.

PowerPC[®] is a registered trademark of International Business Machines Corporation.

Android is a trademark of Google Inc.

Other product names used herein are for identification purposes only and may be trademarks of their respective companies. We disclaim any and all rights involved with those marks.

1. REPLACEMENT AND ADJUSTMENT

⚠ CAUTION

- Prior to installing the SOP or changing the SP's, the machine **must** be updated with all the firmwares for the Smart Operation Panel version of the machine. (Refer to the Mainframe Firmware History document for more information.)

1.1 OPERATION PANEL UNIT

1.1.1 OPERATION PANEL

1. Scanner front cover (Scanner front cover)
2. Operation panel upper cover [A] (hookx2)

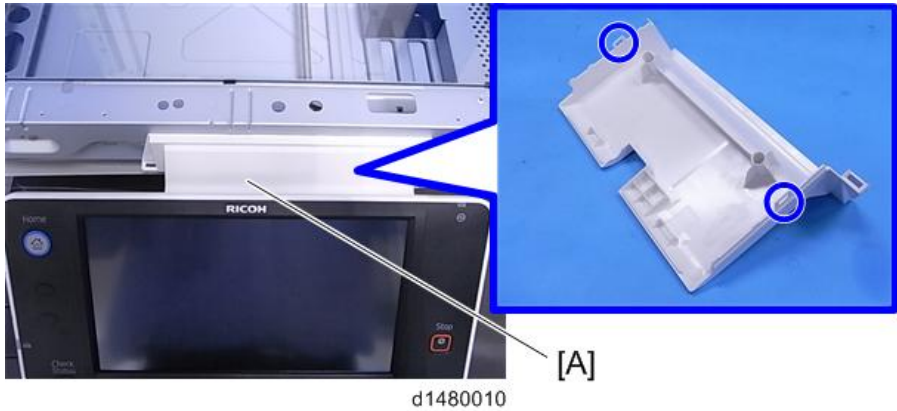

3. Operation panel [A] (🔑 x5, 🛠 x3, 📦 x2)

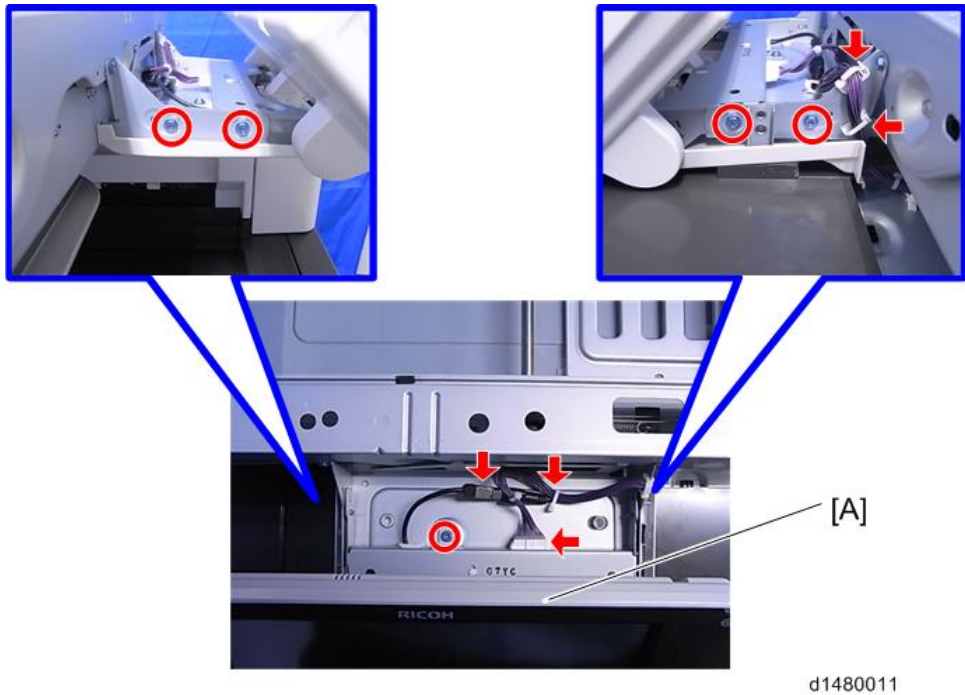

1.1.2 MICROCOMPUTER BOARD

1. Operation panel (page 1)
2. Remove four screw covers.

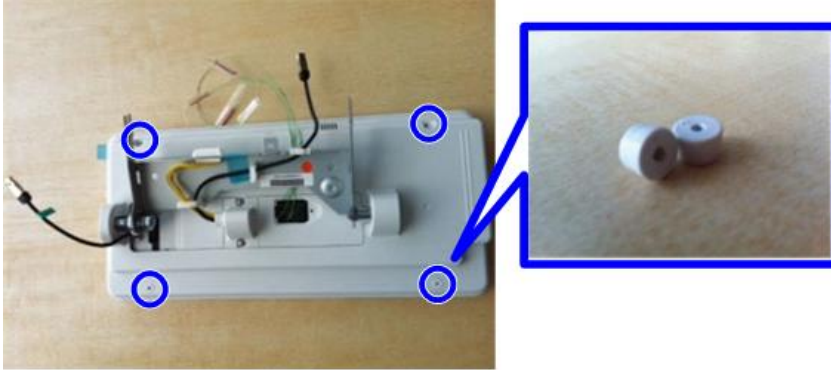

d1464004

3. Operation panel rear cover [A] (hook x4, hookx4)

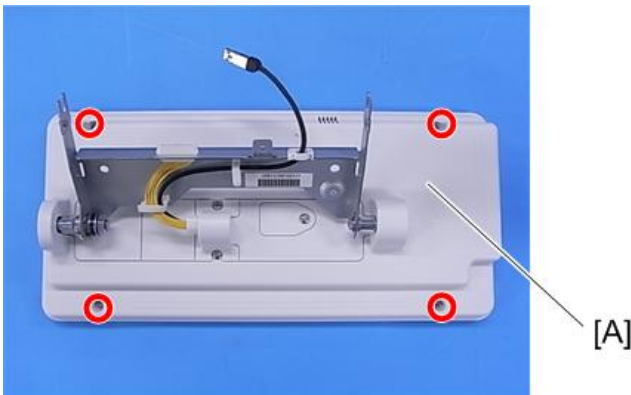

d1480012

Note

- There are 4 hooks inside the operation panel. Before removing the operation panel rear cover, see the photos below.

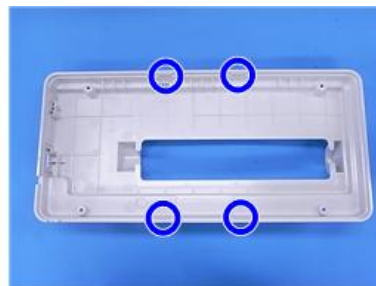

d1480013

4. Operation panel arm bracket [A] ( x7,  x3,  x1)

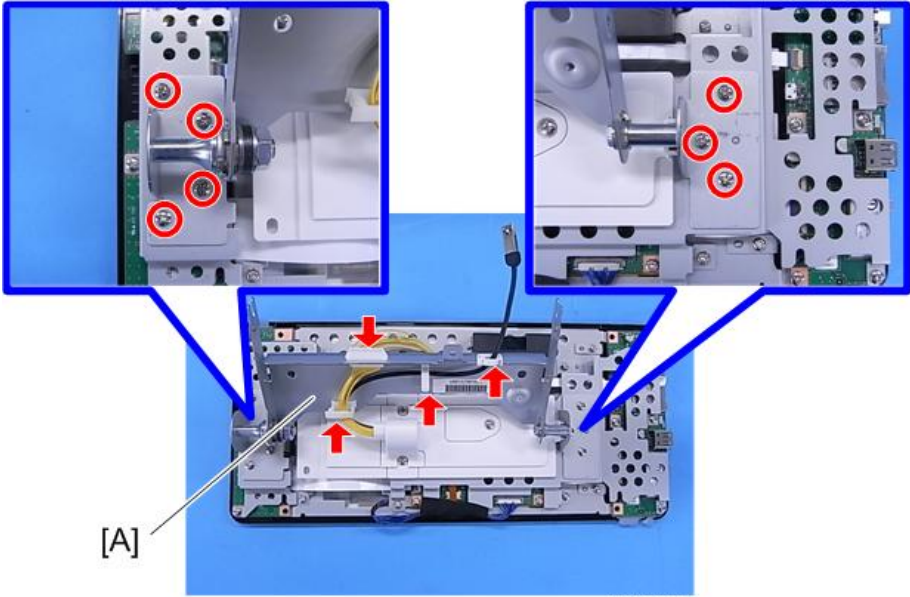

5. Bracket [A] ( x6)

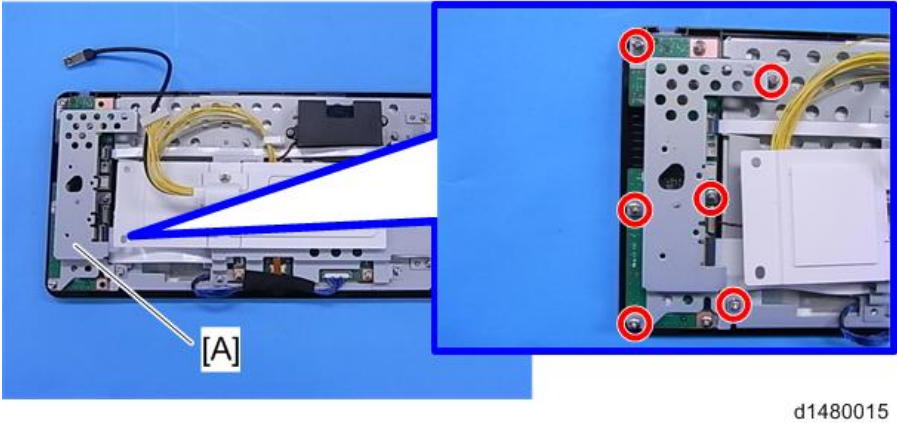

6. Microcomputer Board [A] (FFCx2)

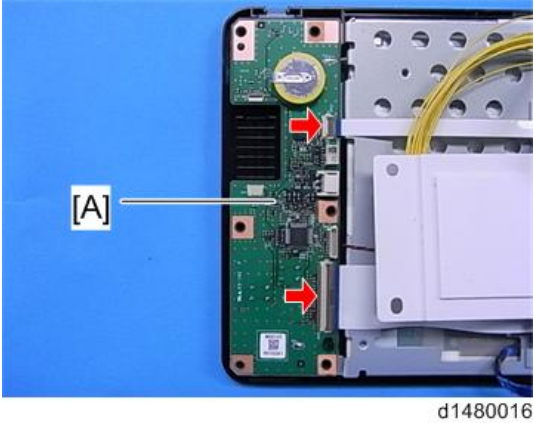

1.1.3 CPU BOARD

1. Operation panel (page 1)
2. Operation panel rear cover (page 2)
3. Operation panel arm bracket (page 2)
4. Harness guide [A] and bracket cover [B] (🔩x2).

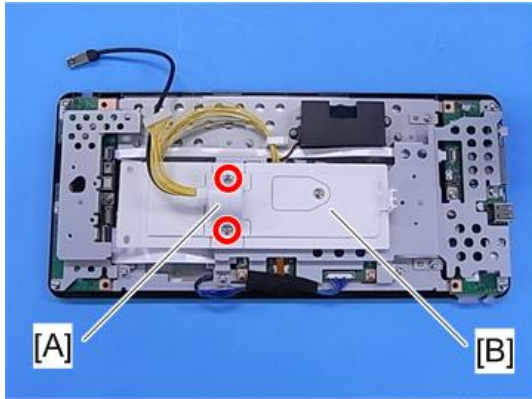

d1480017

5. Bracket [A] (🔩x6, 📏x1, tapex1)

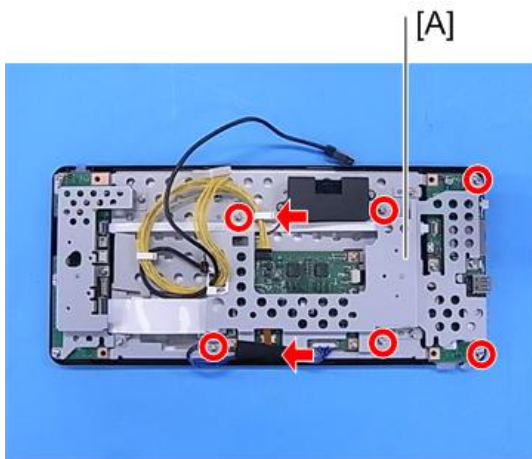

d1480018

6. CPU Board [A] (🔩x4, 📏x6, FFCx3)

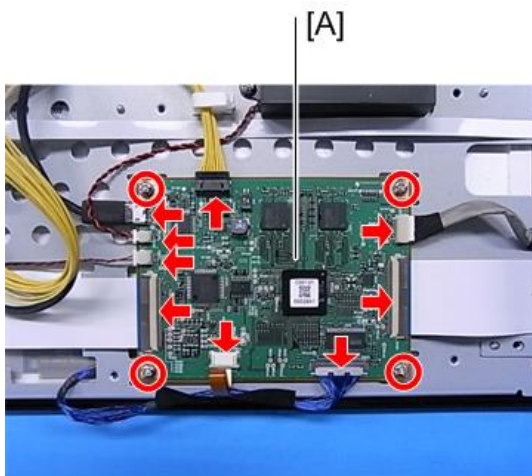

d197z0196



1.1.4 I/O BOARD

1. Operation panel (page 1)
2. Operation panel arm bracket (page 2)
3. Harness guide and bracket cover (page 4)
4. Bracket (page 4)
5. I/O Board [A] ( x1, FFCx2)



d1480020

1.1.5 SPEAKER

1. Operation panel (page 1)
2. Operation panel rear cover (page 2)
3. Operation panel arm bracket (page 2)
4. Harness guide and bracket cover (page 4)
5. Bracket (page 4)
6. Speaker [A] ( x2,  x1)

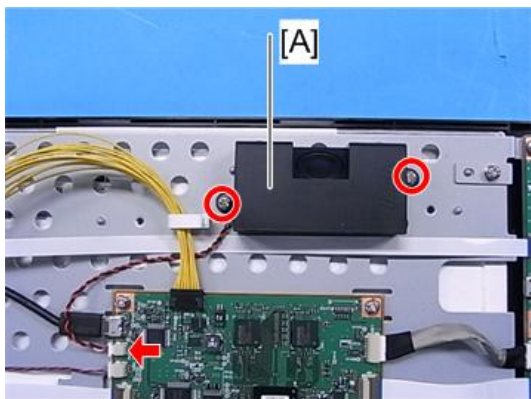

d1480021

1.1.6 LCD

1. Microcomputer Board (page 2)
2. CPU Board (page 4)
3. I/O Board (page 5)
4. Speaker (page 5)
5. Remove the LCD with the bracket [A] (🔩 x2).

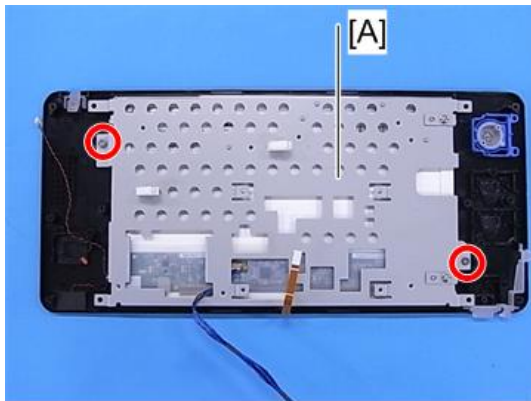

d1480022

6. Remove the bracket [A] from the LCD (🔩 x4).

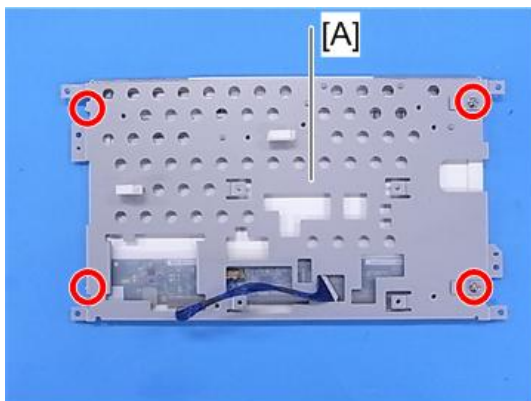

d1480023

7. LCD [A] (📦 x1)



d1480024

1.1.7 MICROPHONE

1. Microcomputer Board (page 2)
2. CPU bracket (page 4)
3. Disconnect a connector. ( x1)

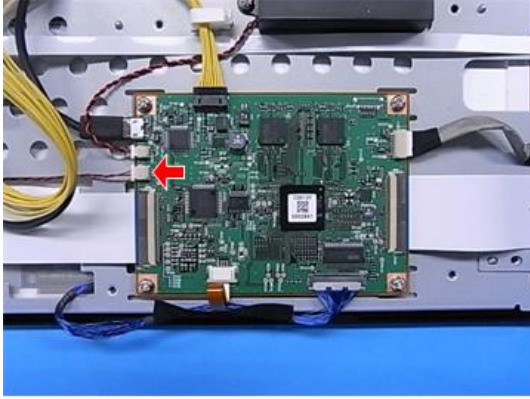

d1480025

4. Microphone [A] (cushioningx1)

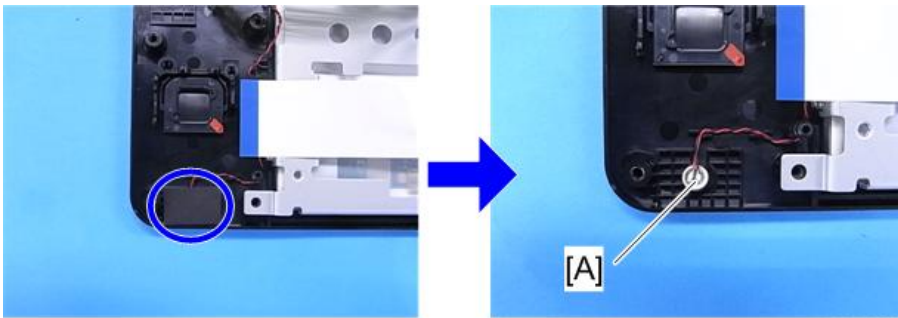

d1480026

2. MECHANISM

2.1 OVERVIEW

2.1.1 SYSTEM COMPONENTS

The Android control unit is a control unit in which the Android OS connected with the MFP by USB, is installed.

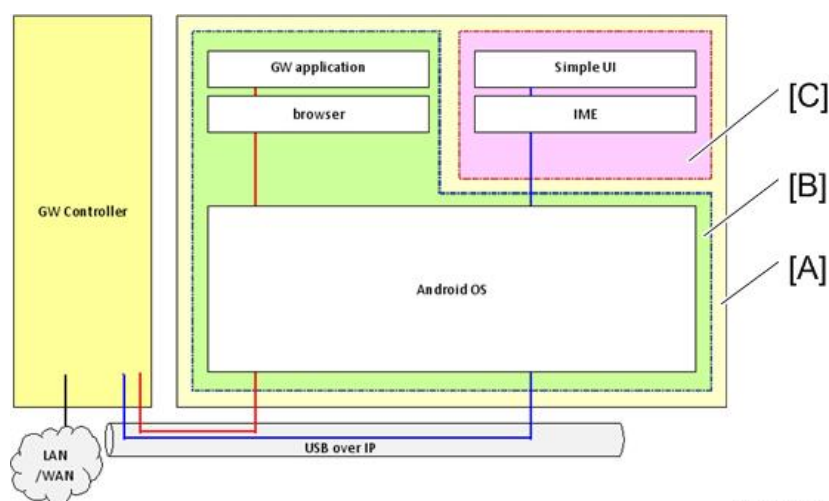

[A]: Android screen

[B]: Android firmware (update from recovery mode)

[C]: Android application (perform installation version update from screen SP mode)

Specification

Category	Item	Contents	Remarks
LCD	Size	10.1 inch panel	
	No. of pixels	WSVGA (1024×600)	
	Bit width	RGB666	18-bit color
	Brightness	200cd/m ² (typ.)	
	Back light	LED rear light (lifetime 15000h)	
Touch panel		Light load touch panel, 2 -point touch detection	
Memory	Volatile memory	RAM: 1GB	

Category	Item	Contents	Remarks
	Non-volatile memory	NAND: 2GB	Program area and data area for the OS and applications
External I/F	USB memory	USB2.0 Host Type-A	
	SD card	SD card slot 1ch (SD/SDHC)	
	USB	USB2.0 Host Type-mini AB	Not available
Network	Wireless LAN	802.11b/g/n	
Audio input/output	Speaker/microphone	Monophonic speaker 1ch (power 1-2W) Microphone	
Power consumption	When active	During regular time: Less than 4W During wireless-LAN high-load operation: Less than 4.6W	Excluding external I/F and internal function expansion.
	During sleep	Less than 350 mW	In sleep mode or while the power is off, do not supply power to an extension USB device connected to an external USB port.

Available languages

Japanese, American English, German, French, Italian, Spanish, Dutch, Russian, Chinese (simplified Chinese characters) and Chinese (traditional Chinese characters)

2.1.2 APPEARANCE/SCREEN LAYOUT

The Android control unit is a control unit in which the Android OS connected with the MFP by USB, is installed.



No.	Description	No.	Description
1	USB slot	9	"Data In" LED
2	USB LED	10	FAX LED
3	SD slot	11	Menu key (Only used for Android Apps)
4	SD LED	12	Back key (Only used for Android Apps)
5	mini USB slot	13	Home key
6	reset key	14	Main power / Energy save LED
7	Check status key	15	Stop key
8	Status LED		

1. Key specification

Key	Description
Home	Change to home screen.
Status check	Change to status display screen.
Stop	Change to stop screen.
Back	Return to previous screen. (The return destination may be the home screen).
Menu	Change to the menu screen of a displayed application. In case of an application without a menu screen, it does not operate.
Reset button	Reboot the control unit.

* The Back and Menu keys are used for operation of Android applications (browser, gallery, etc.).

2. LED specification

LED	Description
Power supply	Shows the OFF/ON status of the power supply.
Home	Shows the HOME screen.
FAX	Displays the fax status. <ul style="list-style-type: none"> ▪ During communication: Blinks ▪ Proxy receive (FAX): Lights ▪ Confidential receipt (FAX): Lights
Data-in	Displays the printer data status.
Status check	Displays the device status.
Main power supply	Shows energy-save and power supply status.
SD access	Shows SD access status.
USB access	Shows USB access status.

3. External I/F specification

External I/F	Description
SD card slot	Available from both GW application/Android application. (to use, change over).
USB slot	Available only from GW application
mini USB slot	Not available

4. Screen layout



d1462657

No.	Part name	Description
[A]	Application screen area	This is the application display area.
[B]	Login banner	Display login information.
[C]	System banner	Perform banner display.
[D]	Energy-save button	Perform energy-save shift and recovery.

2.1.3 ELECTRICAL COMPONENTS

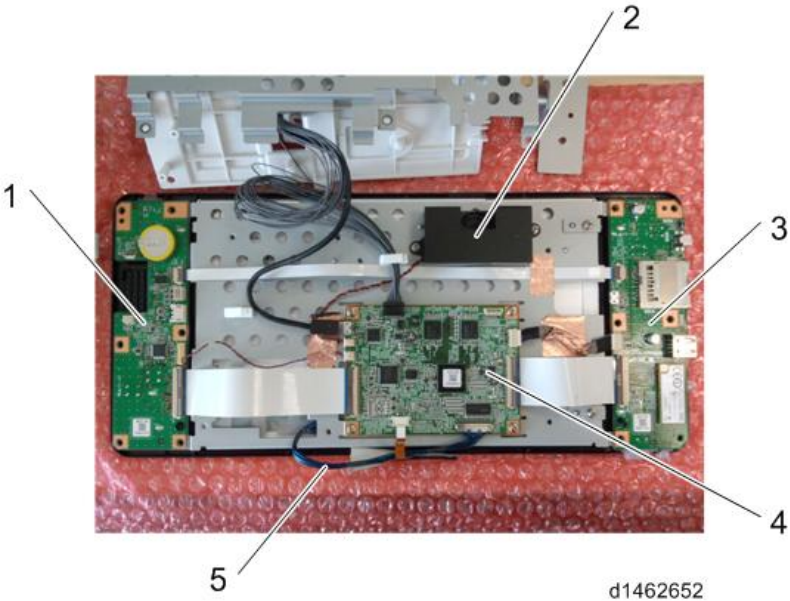

No.	Item	Description
1	Microcomputer board	Board with microcomputer which performs (energy-save) power supply control of the control unit
2	Speaker	-
3	I/O board	Board with external IF connector (also, a WLAN module)
4	CPU board	Main board with main control CPU
5	LCD (liquid crystal) I/F cable	Small gauge coaxial

2.2 POWER SUPPLY CONTROL

2.2.1 ENERGY-SAVE RECOVERY OPERATION

An Android screen is different from a conventional screen (standard screen) in the method of recovery from energy-saving mode.

Key	Android control unit	Standard control unit
HOME	Perform energy-save recovery, and display home screen. (Equivalent to standard control unit [Energy-save] key)	Does not recover.
Status check	Perform energy-save recovery, and display status confirmation screen.	Same left
Energy-save	No key	Perform energy-save recovery, and display priority application screen. * During recovery from low power mode, display application screen before shift.
LCD touch	Perform energy-save recovery, and display status confirmation screen. (Equivalent to standard control unit [Energy-save] key)	Does not recover.
Back	Perform energy-save recovery, and display status confirmation screen. (Equivalent to standard control unit [Energy-save] key)	No corresponding key
MENU	Perform energy-save recovery, and display status confirmation screen. (Equivalent to standard control unit [Energy-save] key)	No corresponding key
STOP	Perform energy-save recovery, and display status confirmation screen. (Equivalent to standard control unit [Energy-save] key).	Does not recover.

Key	Android control unit	Standard control unit
Login/logout	No key	Does not recover.

2.2.2 SCREEN STARTUP MODE

As control unit start-up modes, a Normal Startup Mode (power-saving mode) and Quick Startup Mode are provided. Each mode can be changed over from Screen Features → Screen Device Settings → Screen Startup Mode.

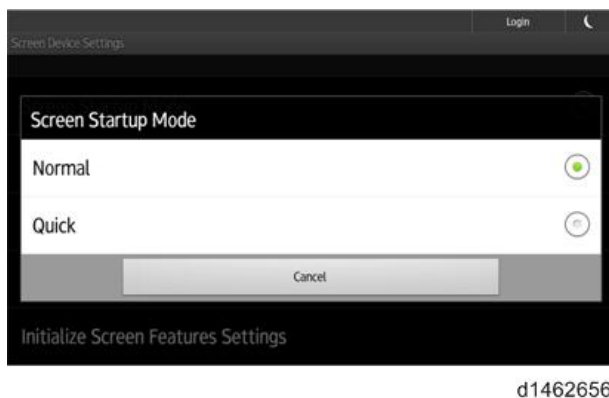

1. Normal Startup Mode (power-saving mode): Default

This is a mode with minimum power. Since the power is reduced to the minimum, normal startup will take time (start-up time guide: 68 seconds).

2. Quick Startup Mode

In this mode, a minute amount of power is supplied to the screen even when the power is OFF, and the home screen is displayed immediately when the power is switched ON. (start-up time guideline: 17 seconds)

In Quick Startup Mode, preparations for the next startup are performed even during shutdown. Therefore, shutdown takes longer than in Normal Startup Mode.

ⓘ Note

- To avoid preparations for the next startup, press the power button while holding the “Stop” key until the shutting down message shows up. This may help you shut down smoothly when you are maintaining the machine.

ⓘ Note

- When shutdown is performed in Quick Startup Mode, the screen changes in the following order:
 1. Displays the shutting down message on the screen.
 2. The screen turns off.
 3. The power LED blinks.
 4. The power LED turns off.

2.2.3 SPECIAL SHUTDOWN

To facilitate maintenance, the following two shutdown procedures are provided:

1. Maintenance shutdown (shortens shutdown time)

When the Quick Startup Mode is set, preparations for the next start-up are performed during shutdown, so shutdown takes more time than in normal start-up mode. If the power is switched OFF by the following steps, even if the Quick Startup Mode is set, the same shutdown is performed as in normal mode (shutdown time is shortened).

Procedure: Press the power button while holding the “Stop“ key until the shutting down message shows up.

2. MFP version update shutdown (screen remains energized)

When the MFP controller or engine firmware version is updated, if shutdown and start-up of the Android screen take time, working efficiency decreases. Therefore, by performing the following procedure, the MFP controller/engine can be powered off alone without completely shutting down the Android screen.

Procedure: Press the power button while holding the “Back“ key until the shutting down message shows up.

 **Note**

- After shutdown is completed by this procedure, when the MFP is left for 5 minutes or longer, it starts up in normal startup mode the next time that the power is switched ON.

3. SYSTEM MAINTENANCE

3.1 SYSTEM MAINTENANCE

3.1.1 BASIC OPERATION

Switching the Power OFF before Performing Maintenance (before Disconnecting the Power Supply Plug)

1. Press the power switch while pressing the [STOP] key.

Continue pressing the [STOP] key until "Shutting Down" is displayed.

Note

- Shutdown can be performed in a short time even when the Quick Startup Mode is set.

Switching the Power OFF before Upgrading the MFP (Controller/Engine) Version

1. Press the power switch while pressing the [STOP] key.

Continue pressing the [STOP] key until "Shutting Down" is displayed.

Note

- When upgrading the Android screen firmware version, switch the power OFF by the normal procedure.

Reset Procedure If the Android Screen Freezes

Note

- If reset is performed when the Android screen is in operation, data stored in the Android screen may be corrupted.

1. Press the reset button on the left side of the control unit in order to reboot the control unit.

3.1.2 MAINTENANCE MODES

The different service modes and their roles are as follows.

* For security reasons, the specific methods for switching between service modes are not given here. Please check according to the usual procedure.

Mode	Application	Remarks
MFP SP mode	MFP (engine) <ul style="list-style-type: none"> ▪ Conventional SP mode 	Since a 10-keypad is used for mode shift, mode shift must be performed from a GW application.
Screen service mode	Android-specific screen service mode <ul style="list-style-type: none"> ▪ Android application installation and version update ▪ Screen self-diagnosis check 	Idem
Recovery mode	Android OS maintenance <ul style="list-style-type: none"> ▪ OS update ▪ Full data format 	-

3.1.3 VERSION UPDATE

Preparing Version Update SD card

1. Download the update module "update_sig.zip".
2. Move the downloaded file to the root directly of the SD card.

ⓘ Note

- Do not unzip the downloaded file.

Version Update Procedure

Android firmware (OS) version update is performed from recovery mode.

ⓘ Note

- If Quick Startup is set, it is not possible to shift to recovery mode. It is necessary to perform either shutdown from Normal Startup Mode, or shutdown by the power OFF procedure prior to maintenance (before disconnecting the power supply plug).

ⓘ Note

- If extended security for firmware update is set to "prohibit", it is not possible to shift to recovery mode. (System Settings>Administrator Tools>Extended Security is displayed in log-on screen for machine administrator)
- If firmware update is required with the above settings, ask customer (machine administrator) to request a change of the setting.

1. Turn off the main power.
2. Insert the SD card in the control unit SD slot, and start the recovery mode.
3. Select "apply update from sdcard.", and press [Home] key.

ⓘ Note

- Screen operations are as follows.
OK: [HOME] key.
UP: [Back] key.
DOWN: [Menu] key.

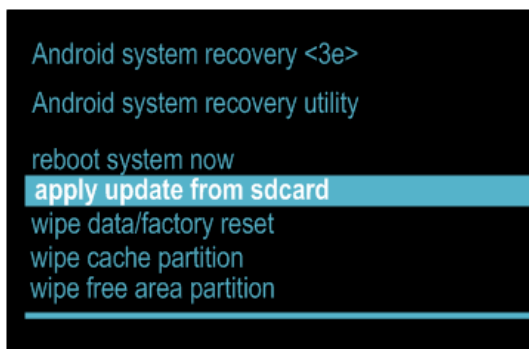

4. Select "update_sig.zip", and press the [HOME] key.

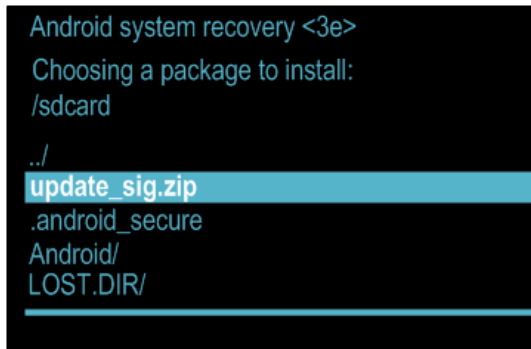

d148f0002

5. The installation screen is displayed.



d1480003

6. The current version of the firmware, and the update version of the firmware in the SD card are displayed. Check that the version is correct.
7. When "Continue Update?" is displayed, press OK ([HOME] key).
8. Version Update is started.
9. When "Install from SD card complete." is displayed, select "reboot system now", press the [HOME] key, and perform a system reboot.



d1480004

3.1.4 APPLICATION INSTALLATION/VERSION UPDATE

Version update via SD card

Preparing the version update SD card

1. Download the update file. (.zip)
2. Create the folder "app" on root directly.
3. Move the downloaded file to the app folder.

Note

- *Do not unzip the downloaded file.*
- *The files with extension ".apk" & ".dalp" must be on the root directory of the SD Card.*

Version Update Procedure

1. Shift to screen service mode.
2. Set a version update SD card in the screen SD slot.
3. Select "Application" → "Install" → "Install from SD card", and start installation.
4. Select the application for which the version is to be updated, and press the "Install Button".
5. The version update result is displayed.
6. Check the version update result, and press down the "Panel reboot" button.

3.1.5 SELF-DIAGNOSIS

The following menus can be performed as self-diagnosis functions of the control unit. Either Japanese or English can be displayed.

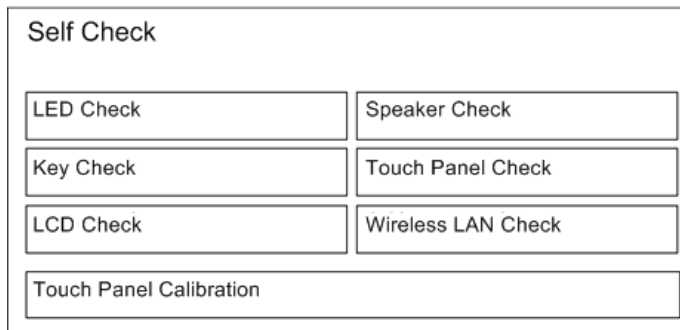

w_d1462660

1. LED Check

The following control unit LED can be changed over between all on/all off.

- Data in
- USB access
- HOME
- Status check (When lit, R->G->B->R->G->B is repeated at 500 ms intervals)
- BACK/MENU
- FAX
- SD access

2. Key check

Check pressing hard keys other than the [HOME] key on the control unit. When a key is depressed, the corresponding key displayed on the control unit is shown highlighted.

If a foot switch is fitted, while the switch is depressed, the "FOOT SW" column is highlighted.

When the [End] key is depressed, the display returns to the self-diagnosis top screen (the Back key works as a key check, so it cannot be used as a key to return to the self-diagnosis top screen).

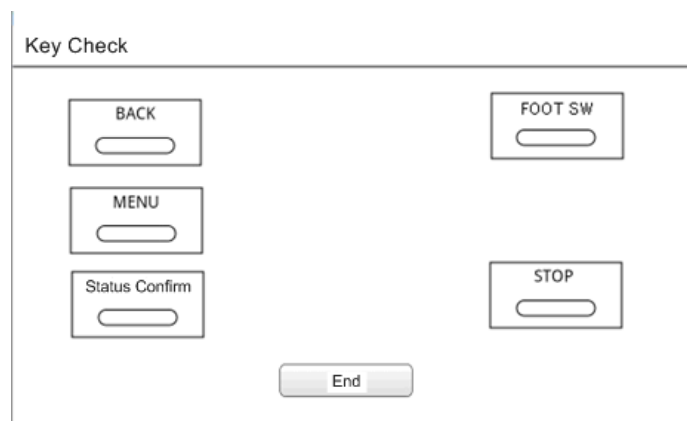

w_d1462661

3. LCD Check

Whenever the screen is touched, the display cycles through All-white -> All-black -> All-green -> All-blue -> End in full screen view, and the display status of each color is visually verified. By cycling through all the colors, the LCD check is completed, and the display returns to the self-diagnosis top screen.



d1462662

4. Speaker check

The following standard sounds are generated according to the button instructions on the screen.

- Frequency: 220 Hz, 440 Hz, 880 Hz, 1760 Hz, 2000 Hz
- Sound volume: 16 levels from minimum to maximum
- Sounds standard sound by START/STOP toggle switch

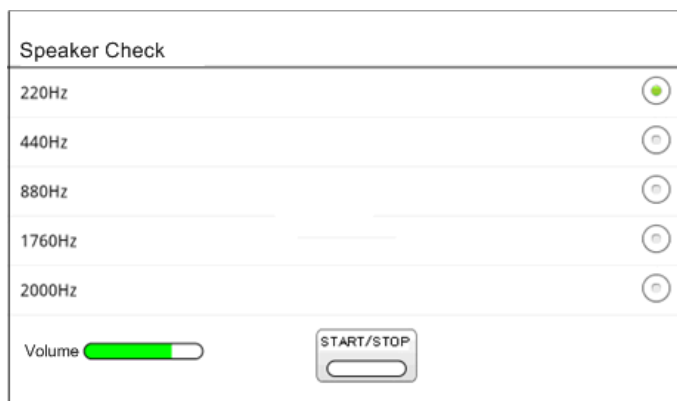

w_d1462663

5. Wireless LAN check

Changes to a screen for searching wireless LAN access points with Android as standard, and a communication status check is displayed.

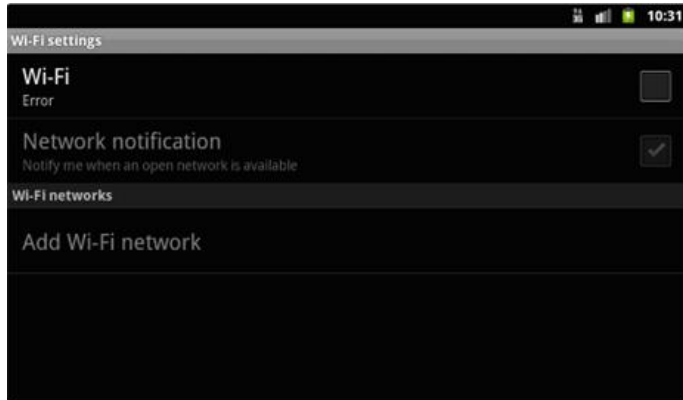

d1462664

6. Touch panel check

Displays the difference of a detection coordinate value from the nearest reference point relative to a standard 9 points on the screen.

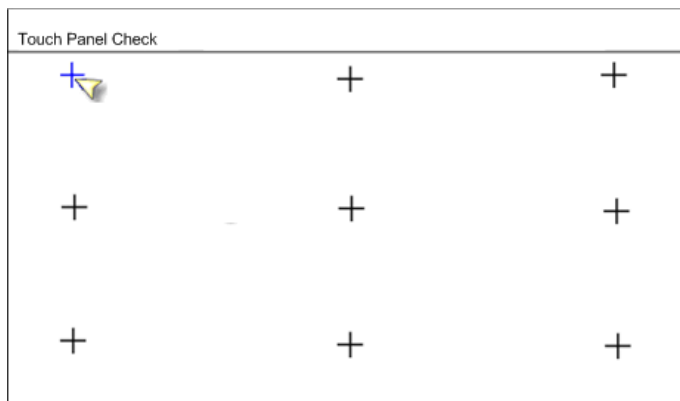

w_d1462665

7. Touch panel calibration

Perform a touch-panel calibration, and set a value.

One + mark after another is displayed at locations (5 points) required for calibration. Press the center point.

When input of 5 points is complete, a display for set/reset appears.

- OK: Press Menu key
- Retry: Press Back key

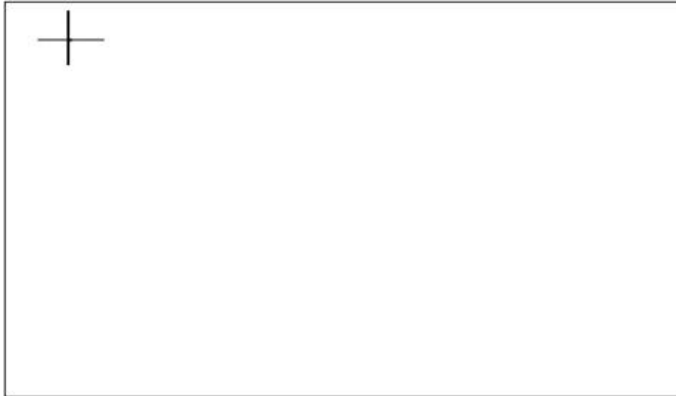

d1462666

When it is desired to set the current value, the operation is completed by pressing the "Menu" key, and the display returns to the self-diagnosis screen.

To repeat the setting, or to stop touch panel calibration, press the Back key.

When the Return key is pressed, a + mark is displayed in the first position for performing calibration. When this display appears, by pressing the Back key again, the display returns to the self-diagnosis screen.

3.2 SP MODE LIST

3.2.1 SETTINGS MENU LIST

Menu level			Description
Level 1	Level 2	Level 3	
Application	Install from SD card (installation of application).		Update by installing application from SD card.
	Installation / update / activation		Activation can be performed using a SD card.
Storage	(SD card) Sum total capacity		When SD card is inserted, display the sum total capacity.
	(SD card) Free space		Display the free space when SD card is inserted.
	Erase the data in the SD card.		Erase the data in the SD card.
	(Internal storage) free space		Display the free space of the internal storage.
Voice input/output	Setting of text read-aloud	Play back a sample	Play back a short sample of speech synthesis with the present setting.
		Always use your own settings (ON/OFF).	When not using the speech synthesis setting of each application and using the setting of this screen, switch ON.
		Default engine (engine: Select)	A dialog for setting the text read-aloud application to be used is displayed (when having installed plural text read-aloud applications).

Menu level			Description
Level 1	Level 2	Level 3	
		Install speech data	Select from the SD card, and install speech synthesis data.
		Audio speed (speed: 5 selection levels)	Select audio speed.
		Language	
		Engine	
Terminal information	Terminal state	wi-fi MAC address (display)	
		Interface setting	
		wi-fi setting	
		Device IP address	
	Legal information (display)		
	Firmware version list		
Device setting	Server setting	Port number (input: 1-65535)	
	Control unit self-diagnosis	-	Perform self-diagnosis of control unit.

3.3 RECOVERY MENU

Menu	Description
Reboot system now	System reboot (used to come out of recovery mode)
apply update from sdcard	Android firmware (OS) version update
wipe data/factory reset	Full format
wipe cache partition	-
wipe free area partition	-

D683

SPDF DF3080

REVISION HISTORY		
Page	Date	Added/Updated/New
		None

SPDF DF3080 (D683)

TABLE OF CONTENTS





1. REPLACEMENT AND ADJUSTMENT	1
1.1 ADF REMOVAL	1
1.2 ADJUSTMENT AFTER REPLACING THE ADF	5
1.2.1 CIS RGB ADJUSTMENT	5
1.2.2 CHECKING THE VERTICAL REGISTRATION	5
1.2.3 CHECKING THE HORIZONTAL REGISTRATION	6
1.2.4 CHECKING THE SKEW	6
1.2.5 CHECKING THE MAGNIFICATION	6
1.3 PLATEN ADJUSTMENT	7
1.4 ADF COVERS.....	8
1.4.1 ADF FRONT COVER.....	8
1.4.2 ADF REAR COVER	9
1.4.3 FEED COVER	10
1.5 DOCUMENT FEED COMPONENTS	11
1.5.1 ORIGINAL FEED UNIT	11
1.5.2 PICK-UP ROLLER / TRANSPORT BELT	12
1.5.3 ADF SEPARATION ROLLER	14
1.5.4 WHITE ROLLER.....	14
1.6 ELECTRICAL COMPONENTS	18
1.6.1 CIS UNIT	18
1.6.2 ADF PICK-UP ROLLER LIFT MOTOR / ADF TRANSPORT MOTOR	20
1.6.3 ADF BOTTOM PLATE LIFT MOTOR	21
1.6.4 ORIGINAL REGISTRATION SENSOR.....	21
1.6.5 ORIGINAL EXIT SENSOR.....	23
1.6.6 ADF CONTROL BOARD	25
1.6.7 SEPARATION SENSOR / SKEW CORRECTION SENSOR	26
1.6.8 ORIGINAL WIDTH SENSOR / INTERVAL SENSOR	27
1.6.9 B5 WIDTH SENSOR / A4 WIDTH SENSOR / LG WIDTH SENSOR ..	28
1.6.10 APS FEELER	29
1.6.11 ADF LIFT-UP INTERLOCK SW / LIFT-UP SENSOR.....	30
1.6.12 ORIGINAL SET SENSOR	31
1.6.13 A4 LEF/LT LEF SENSOR	32
1.6.14 BOTTOM PLATE HP SENSOR.....	33
1.6.15 BOTTOM PLATE POSITION SENSOR	34

1.6.16 ADF FEED COVER INTERLOCK SWITCH / PICK-UP ROLLER HP SENSOR.....	35
1.7 ORIGINAL FEED DRIVE	36
1.7.1 ADF ENTRANCE MOTOR.....	36
1.7.2 ADF SCANNING MOTOR	37
1.7.3 ADF EXIT MOTOR	38
1.7.4 ADF FEED MOTOR.....	38

READ THIS FIRST

Safety and Symbols

This manual uses several symbols and abbreviations. The meaning of those symbols and abbreviations are as follows:

	Clip ring
	Screw
	Connector
	Clamp
SEF	Short Edge Feed
LEF	Long Edge Feed

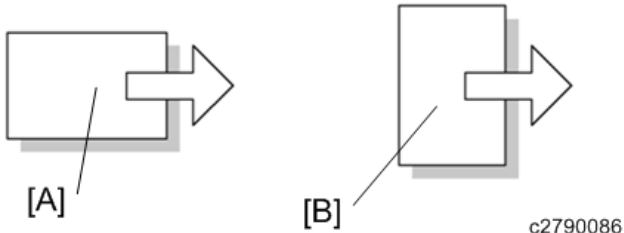

[A] Short Edge Feed (SEF)

[B] Long Edge Feed (LEF)

Trademarks

Microsoft[®], Windows[®], and MS-DOS[®] are registered trademarks of Microsoft Corporation in the United States and /or other countries.

PostScript[®] is a registered trademark of Adobe Systems, Incorporated.

PCL[®] is a registered trademark of Hewlett-Packard Company.

Ethernet[®] is a registered trademark of Xerox Corporation.

PowerPC[®] is a registered trademark of International Business Machines Corporation.

Other product names used herein are for identification purposes only and may be trademarks of their respective companies. We disclaim any and all rights involved with those marks.

1. REPLACEMENT AND ADJUSTMENT

1.1 ADF REMOVAL

1. Controller cover [A] (⊙ x4).

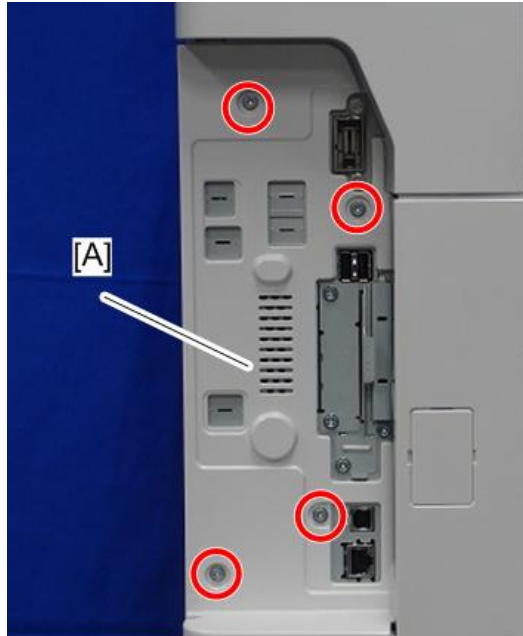

d197f0042

2. Controller rear cover [A] (⊙ x4)

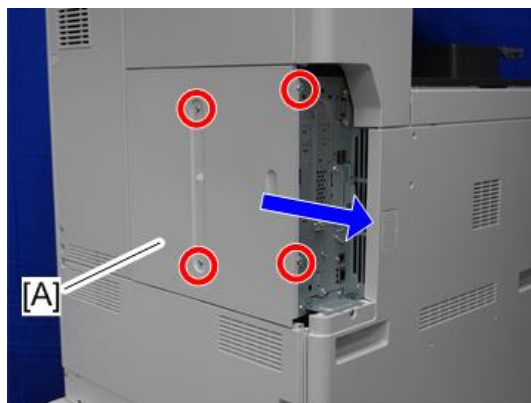

d197f0048

3. Scanner rear cover [A] (⊙ x3)

ADF Removal

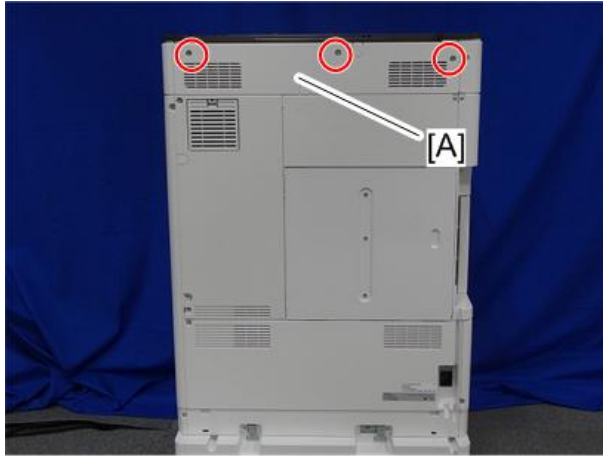

d197f0051

- 4. Rear left cover [A] (🔩 x3)

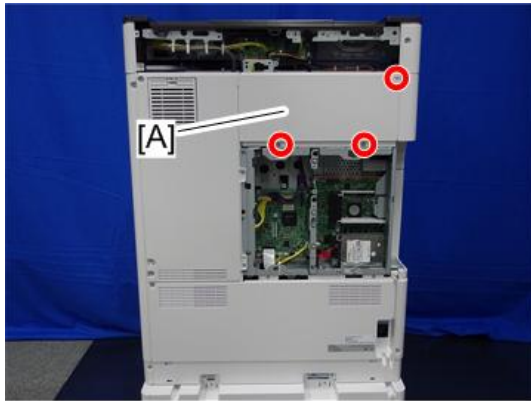

d197f0050_1

- 5. Disconnect the I/F cable [A] along with the bracket [B] (🔩 x2, 📏 x2).

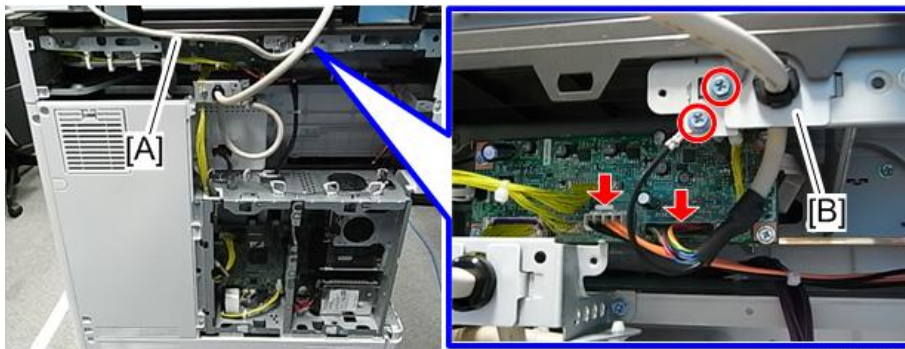

d197z0191

- 6. CIS image cable along with the bracket [A] (🔩 x1, 📏 x1, 📏 x4).

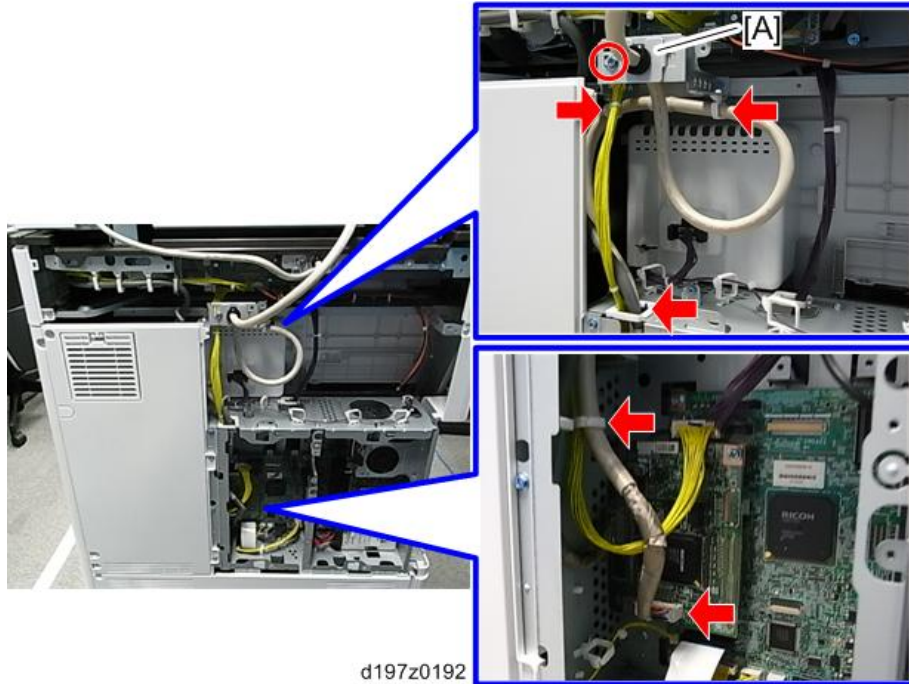

d197z0192

7. Open the ADF [A].



d1463152

8. Remove the fixing screws of the ADF (🔩 x2).

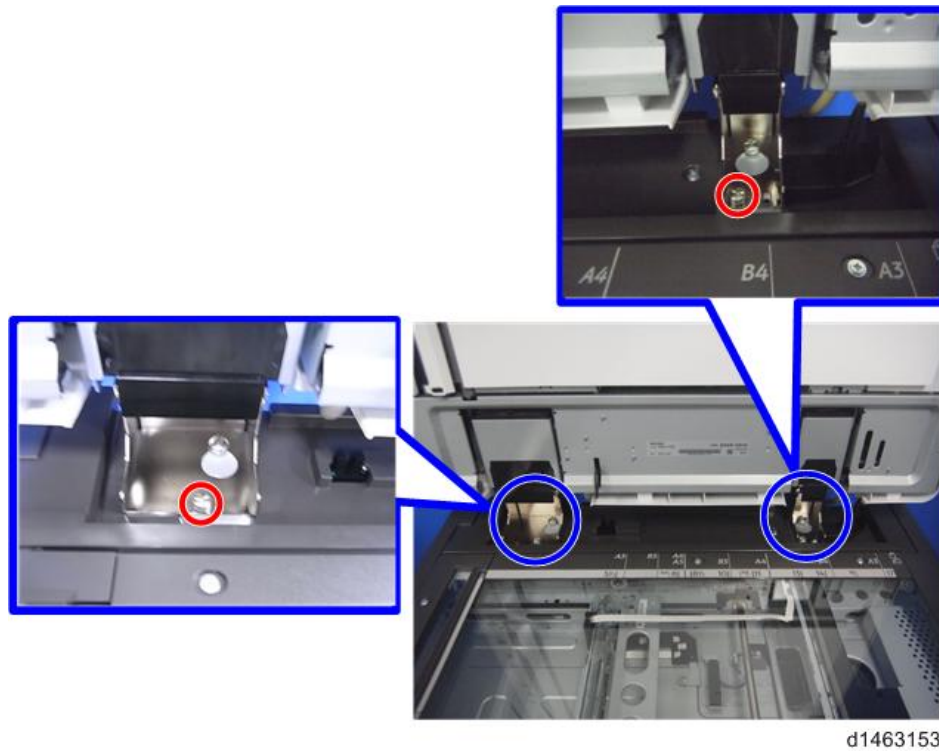

9. While holding the left and right sides of the ADF, lift up to remove it.

Note

- Because of the weight of the ADF, handle with care.

1.2 ADJUSTMENT AFTER REPLACING THE ADF

1.2.1 CIS RGB ADJUSTMENT

Enter the four-digit numeric values for RGB that are listed on the paper that comes with the ADF into the following SP.

R: SP4-712-001 (CIS GB Adj Value: R)

G: SP4-713-001 (CIS GB Adj Value: G)

B: SP4-714-001 (CIS GB Adj Value: B)

1.2.2 CHECKING THE VERTICAL REGISTRATION

SP6-006-001 (ADF Adjustment Side-to-Side Regist: Front)

SP6-006-002 (ADF Adjustment Side-to-Side Regist: Rear)

1. Create an original as shown in the following picture.

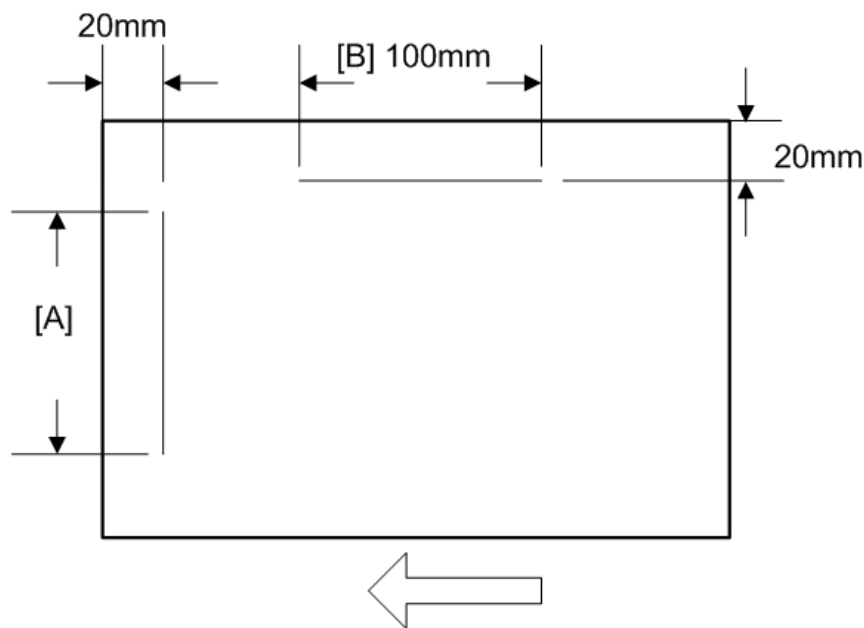

*The arrows indicate the direction of feed.

2. Copy the original and make sure that the position of the line [A] is within $0\pm 1\text{mm}$
3. If not within the standard, adjust with the SP modes.

1.2.3 CHECKING THE HORIZONTAL REGISTRATION

SP6-006-010 (ADF Adjustment L-Edge Regist (1-Pass): Front)

SP6-006-011 (ADF Adjustment L-Edge Regist (1-Pass): Rear)

1. Copy the original and make sure that the position of the line [B] is within $0\pm 2\text{mm}$.
2. If not within the standard, adjust with the SP modes.

1.2.4 CHECKING THE SKEW

SP6-006-012 (ADF Adjustment 1st Buckle (1-Pass))

SP6-006-013 (ADF Adjustment 2nd Buckle (1-Pass))

1. Make sure that the difference between both end positions of the line [A] is within $0\pm 2\text{mm}$.
2. If not within the standard, change the position of the fixing screw [A] to the long hole [B] at the right hinge.

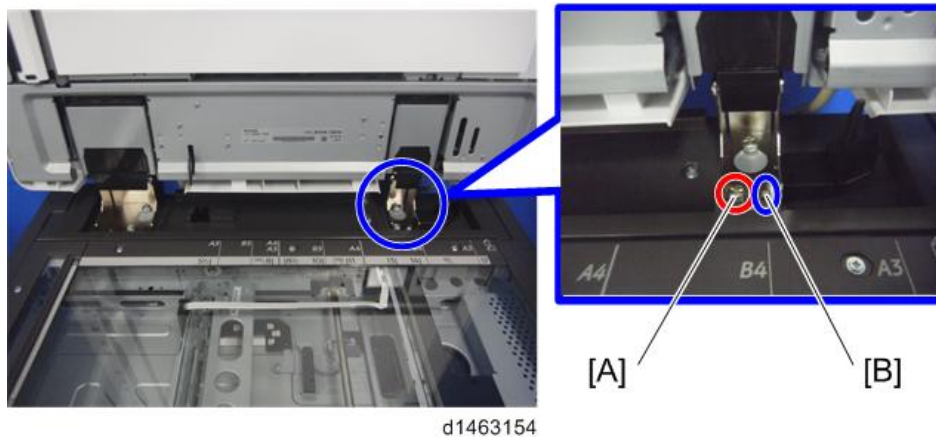

1.2.5 CHECKING THE MAGNIFICATION

SP6-017-001 (DF Magnification Adj.)

1. Copy the original and make sure that the length of the line [B] is within $100\pm 1\text{mm}$.
2. If not within the standard, adjust with the SP mode.

1.3 PLATEN ADJUSTMENT

- 1. Open the ADF and remove the white cover (fabric fastener x 10).

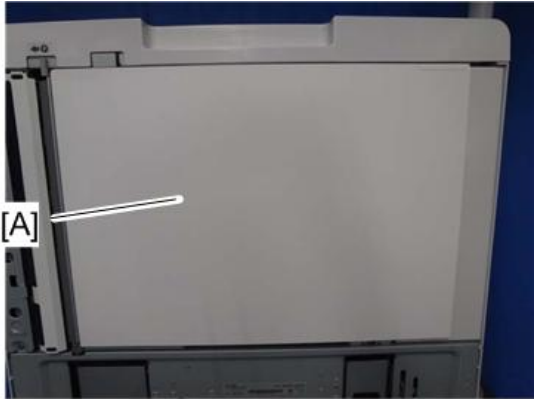

d1352781

- 2. Put the white cover [A] in the correct position on the exposure glass, aligning it with the glass cover [B] and the rear scale [C].

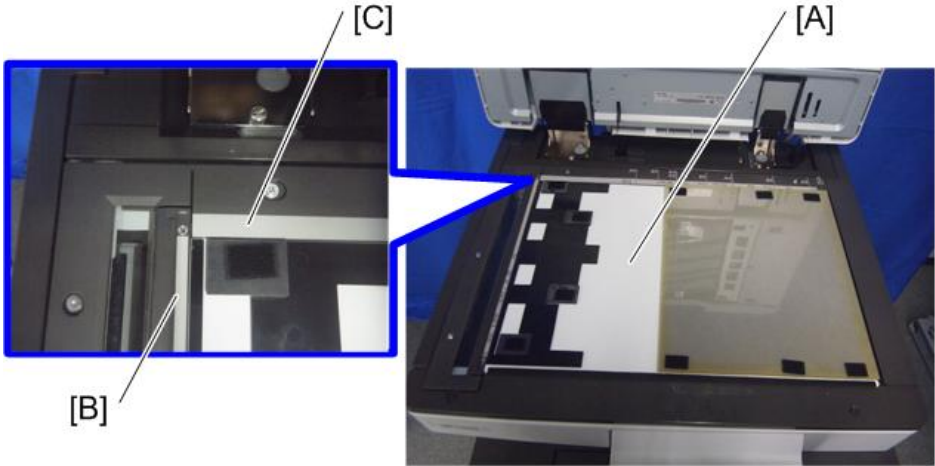

d1463155

- 3. Close the ADF [A] slowly and paste the ADF and the white cover [B] with the fabric fastener.

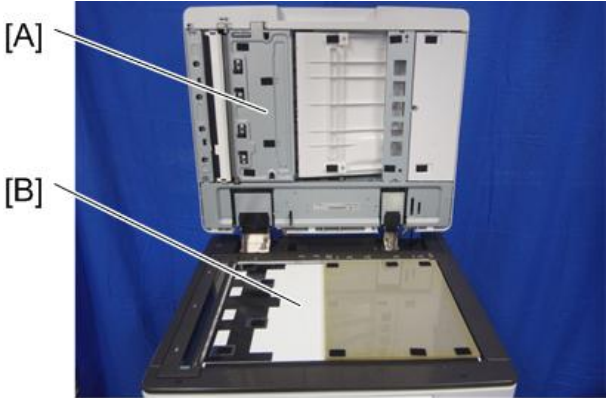

d1463156

1.4 ADF COVERS

1.4.1 ADF FRONT COVER

1. Open the feed cover [A].

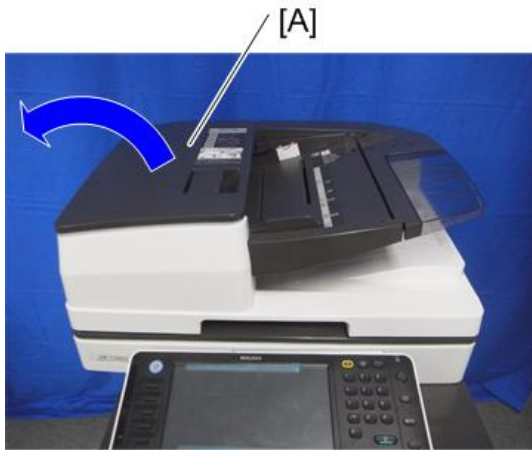

d1463157

2. Slide the ADF front cover [A] to the left (👉x2, hookx4).



d1352048

📌 Note

- Check the position of the hooks in the photo below before removing.

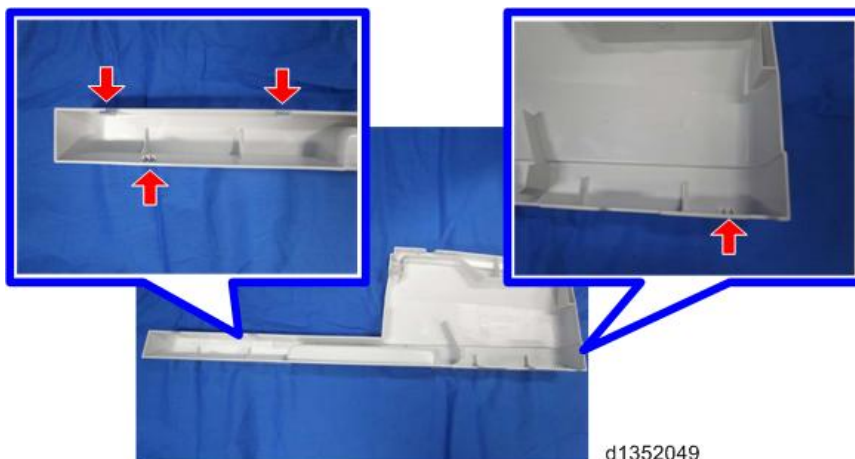

d1352049

1.4.2 ADF REAR COVER

1. Open the feed cover [A].
2. Cover [A] (⊙ x1).



d1352050

3. Lift off the rear cover [A] (⊙ x2, hook x6).

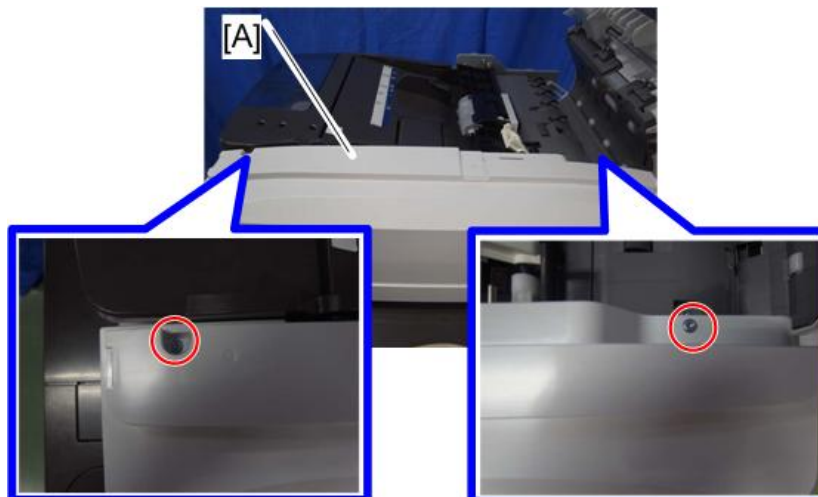

d1352051

ⓘ Note

- Check the position of the hooks in the photo below before removing.

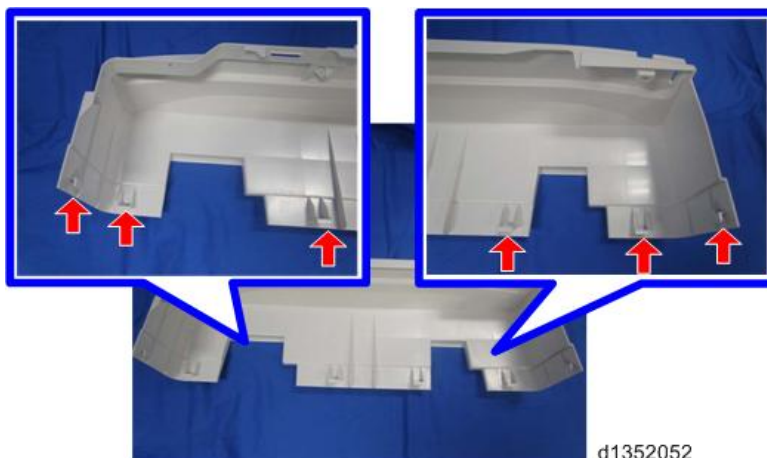

d1352052

1.4.3 FEED COVER

1. ADF front cover (page 8).
2. ADF rear cover (page 9).
3. Feed cover [A] (🔩 x3, 📦 x1, 🛠️ x2).

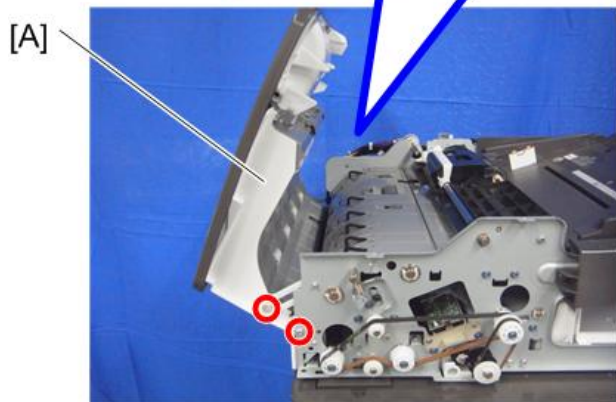
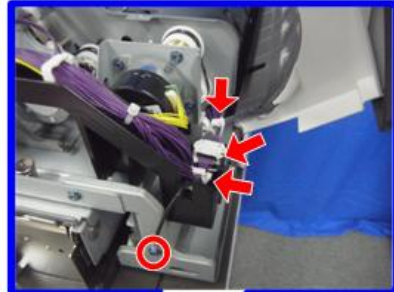

d1463158

1.5 DOCUMENT FEED COMPONENTS

1.5.1 ORIGINAL FEED UNIT

1. Open the feed cover.
2. Remove the snap-fit [A].

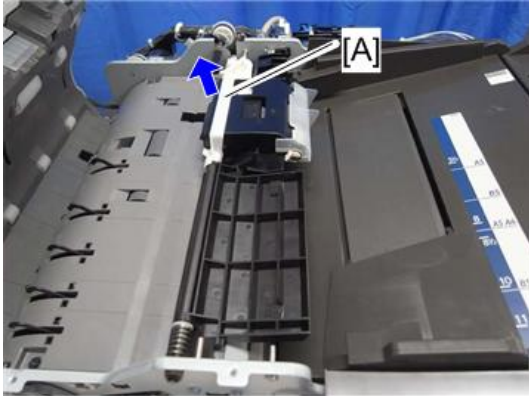

d1352054

3. Pull the original feed unit [A] forward to release the back side of the shaft.
 - Open the original lift plate [B] when pulling the original feed unit forward. This makes it easier to remove the original feed unit.

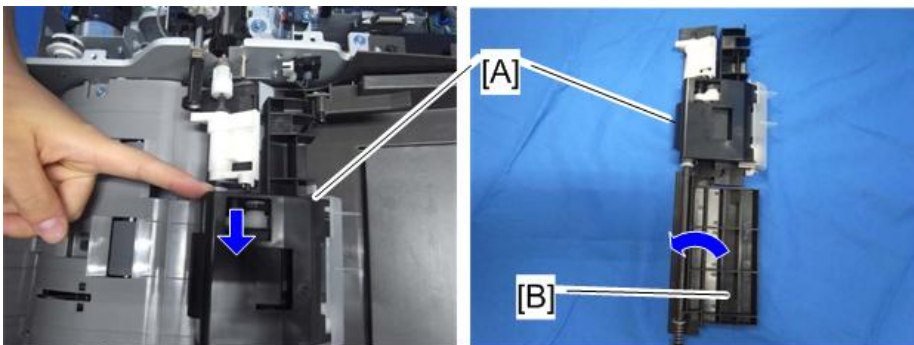

d135z0001

4. Remove the original feed unit.

1.5.2 PICK-UP ROLLER / TRANSPORT BELT

1. Original feed unit (page 11).
2. Slide the resin bushing [A], and then remove the pick-up roller unit [B].

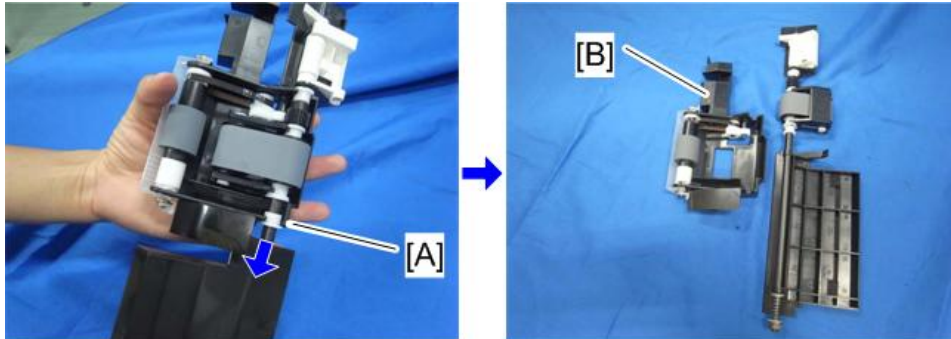

d1352058

↓ Note

- When reassembling this unit, make sure that the boss [B] of the pick-up roller unit is in the hole [A] of the original lift plate.

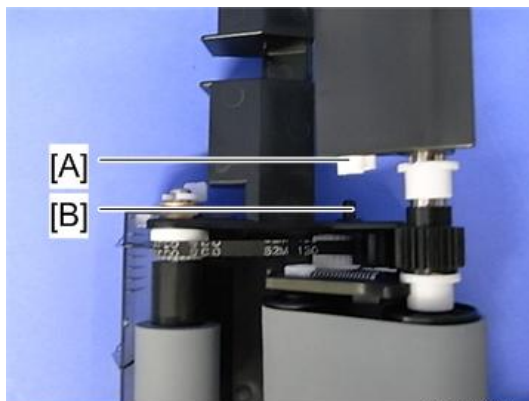

d1774014

↓ Note

- When reassembling this unit, make sure that the tab on the front guide plate [A] is above the pick-up roller [B].

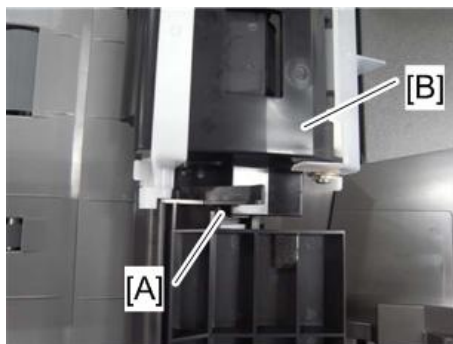

d1352237

3. Pick-up roller cover [A] and pick-up roller [B] (Ⓜx2, bushingx2, one-way clutchx1) .

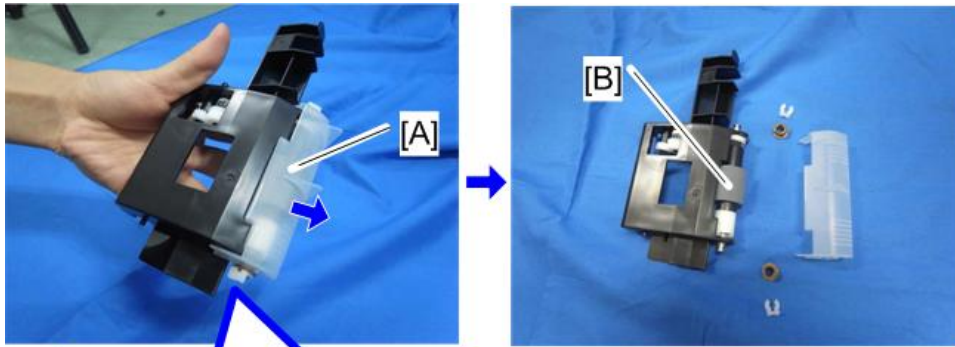

d1352059



4. Lift the left and right sides of the feed belt holder [A], then remove it.

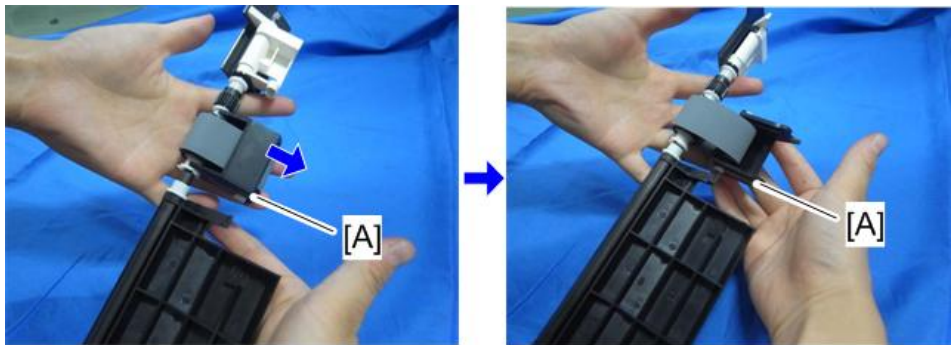

d1352060

5. Remove the feed belt [B] from the feed belt holder [A].

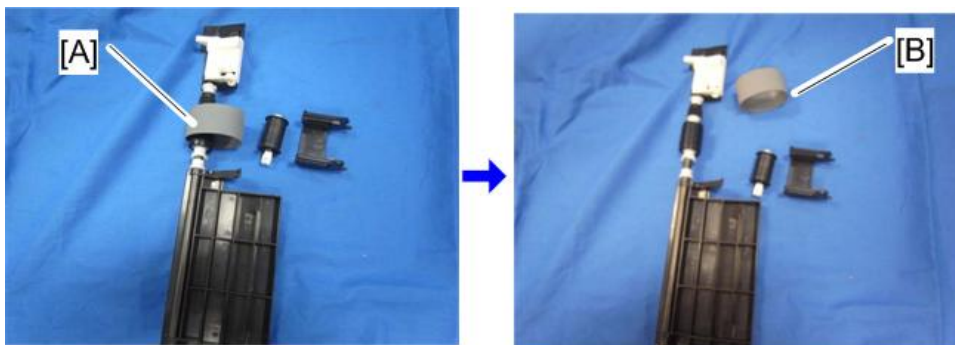

d1352061

1.5.3 ADF SEPARATION ROLLER

1. Open the feed cover.
2. Original feed unit (page 11).
3. ADF separation roller cover [A].

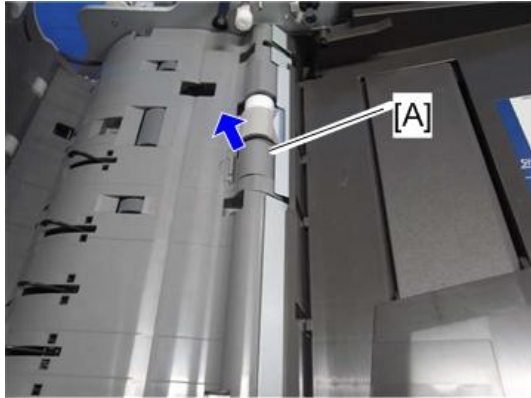

d1352056

4. ADF separation roller [A] and torque limiter clutch [B] (Ⓜx1).

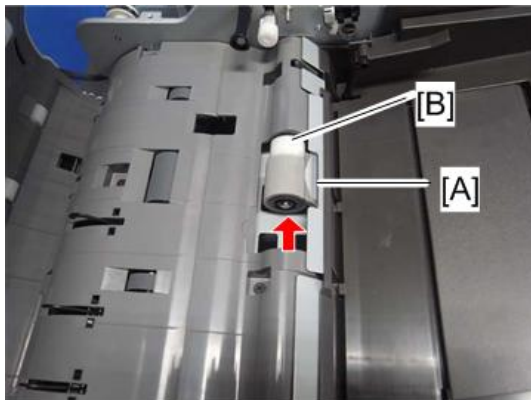

d1352057

1.5.4 WHITE ROLLER

1. ADF Front Cover (page 8).
2. White cover [A].



d197z0488

3. Slide the tab [A], and open the exit unit [B].

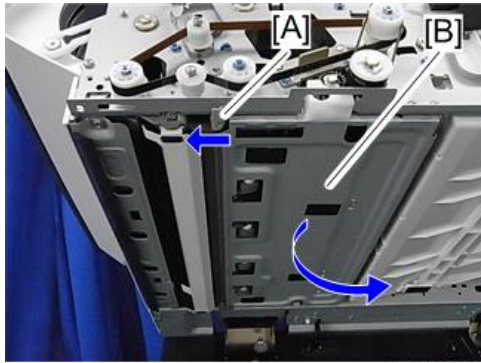

d197z0489

4. Exit unit [A] (🌀 x2).

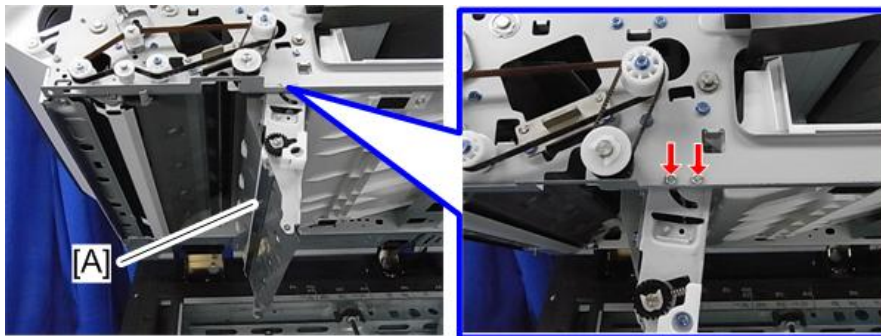

d197z0490

5. Exit lower guide [A], and the CIS exit lower guide unit [B] (🌀 x2 each).

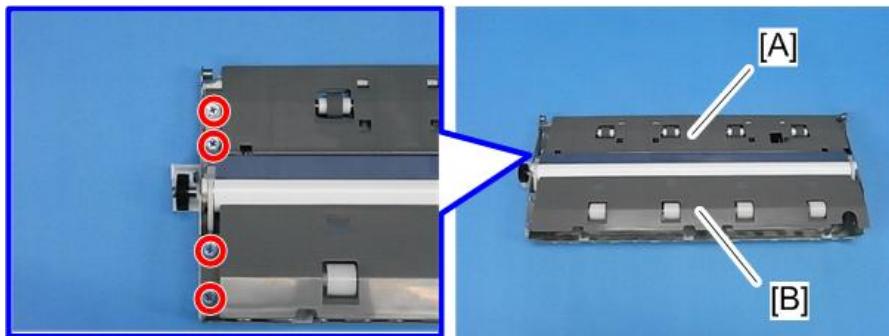

d197z0491

6. Two springs at the both ends of CIS entrance lower guide unit [A] (🌀 x2).

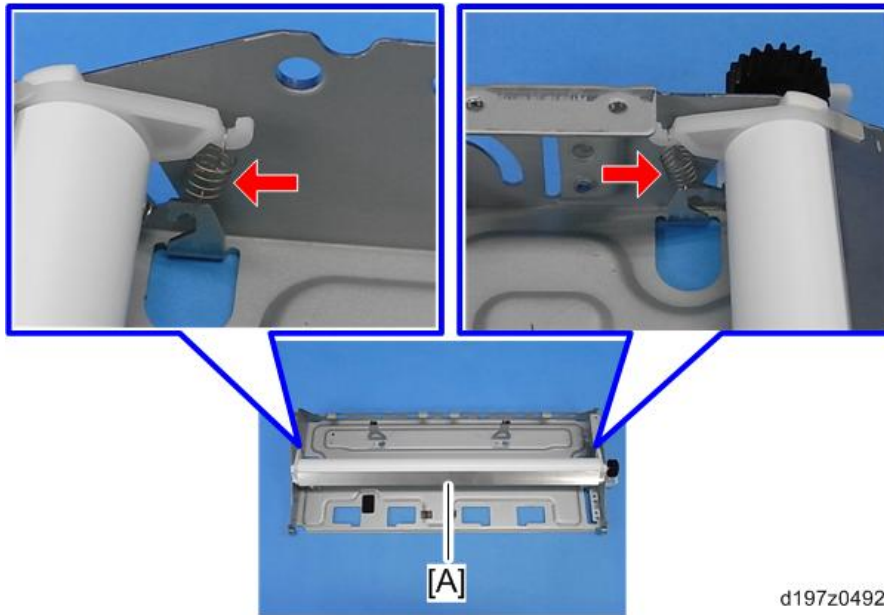

7. CIS entrance lower guide unit [A].

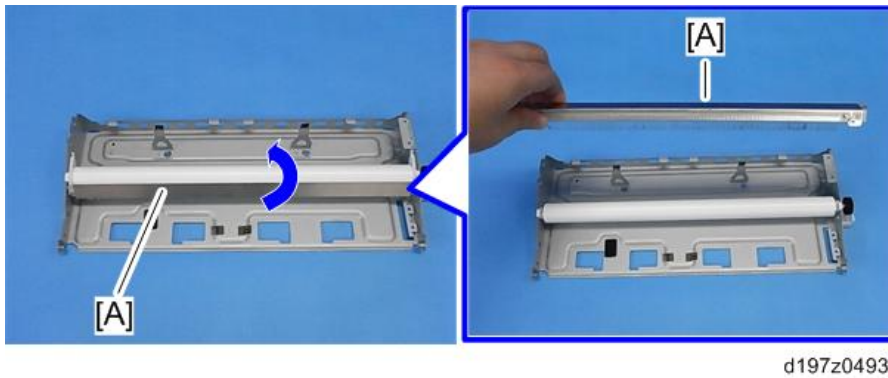

8. Bracket [A] (🔩x1).

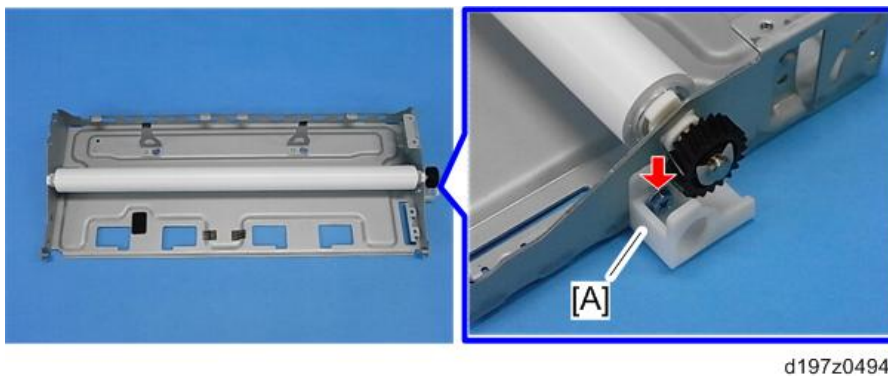

9. Gear [A] (⚙️x1).

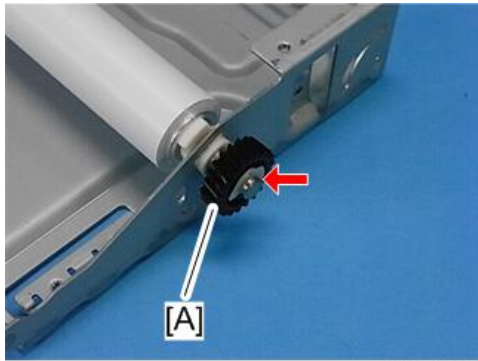

d197z0495

10. Springs on both sides of the white roller [A], and the bearing at the left side of the unit (🌀x1 each, bearing x 1).

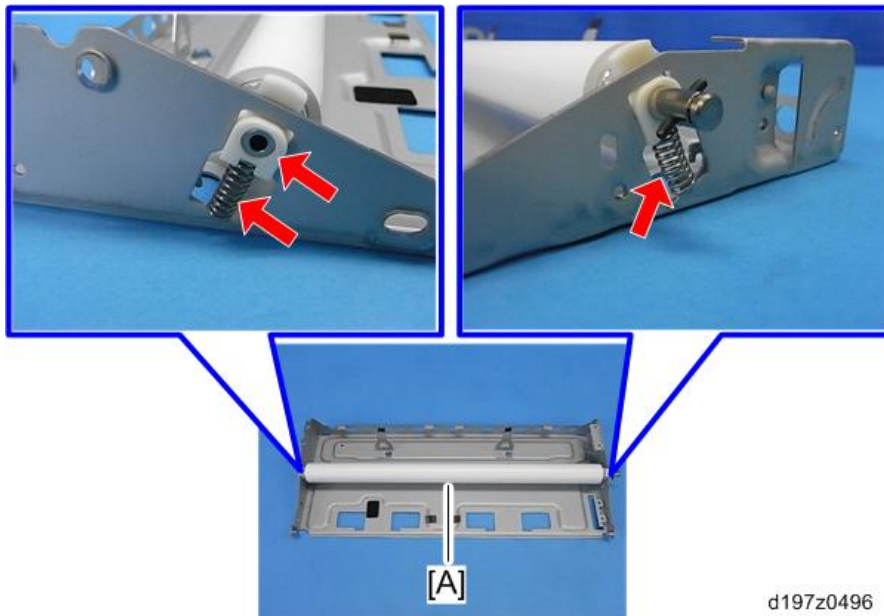

d197z0496

11. White roller [A].

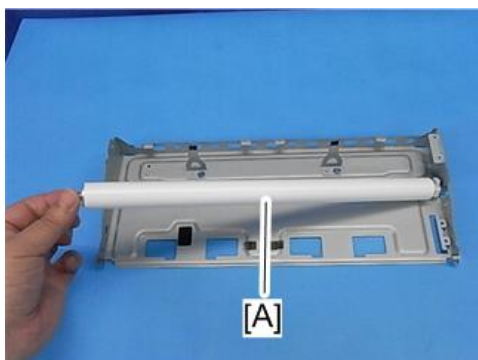

d197z0497

1.6 ELECTRICAL COMPONENTS

1.6.1 CIS UNIT

1. ADF Separation Roller (page 14).
2. ADF front cover (page 8).
3. Guide plate (large) [A] (🔩 x3).

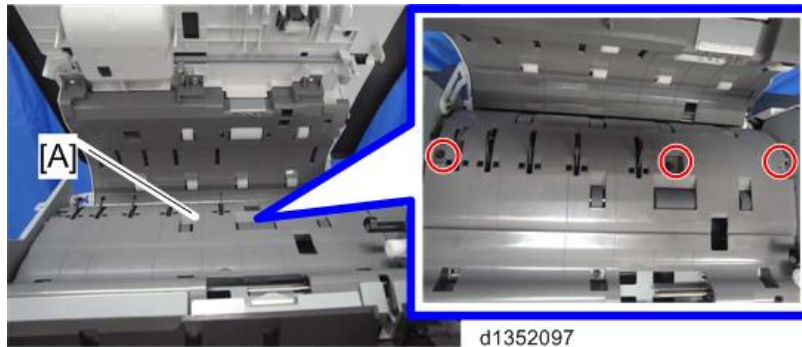

4. Guide plate (small) [A] (🔩 x2).

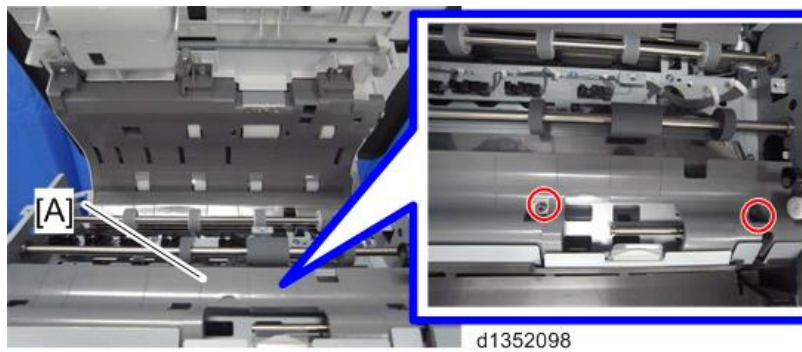

5. Guide plate [A] (🔩 x1).



6. Short timing belt [A] (🌀 x1, pulley x 1)
7. Loosen the screw [B], and then remove the long timing belt [C].

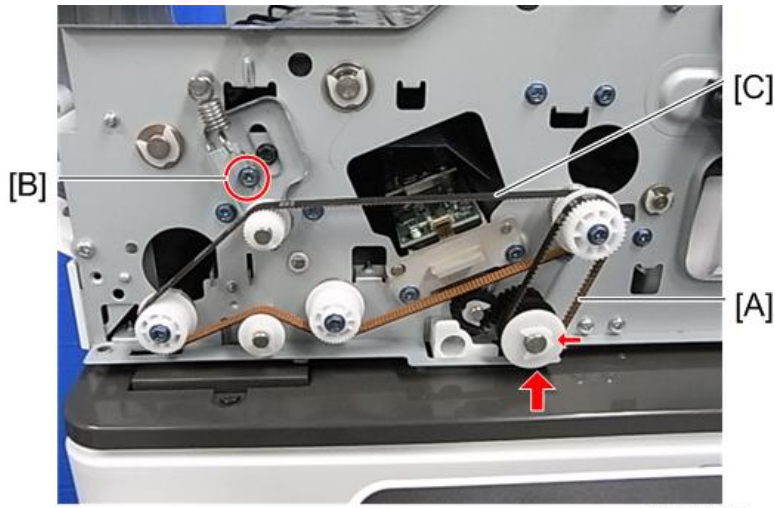

d177z4016

8. CIS unit [A] (⚙️ x2, 📦 x3)

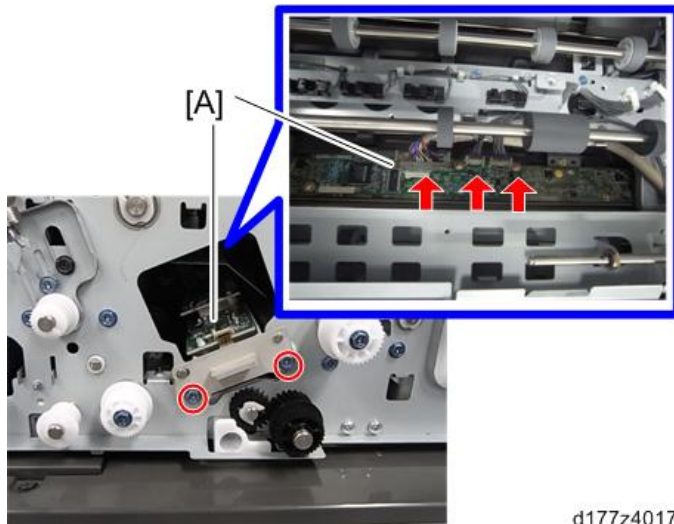

d177z4017

⚠️ Note

- To prevent scratches on the surface of the CIS glass, removal of the CIS unit must be done with the white cover [A] open.

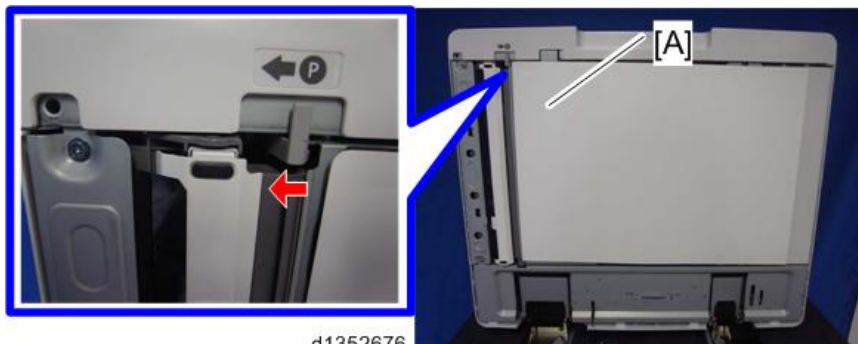

d1352676

1.6.2 ADF PICK-UP ROLLER LIFT MOTOR / ADF TRANSPORT MOTOR

1. ADF rear cover (page 9).
2. Frame (black) [A] (🔩 x3, 📦 x6).

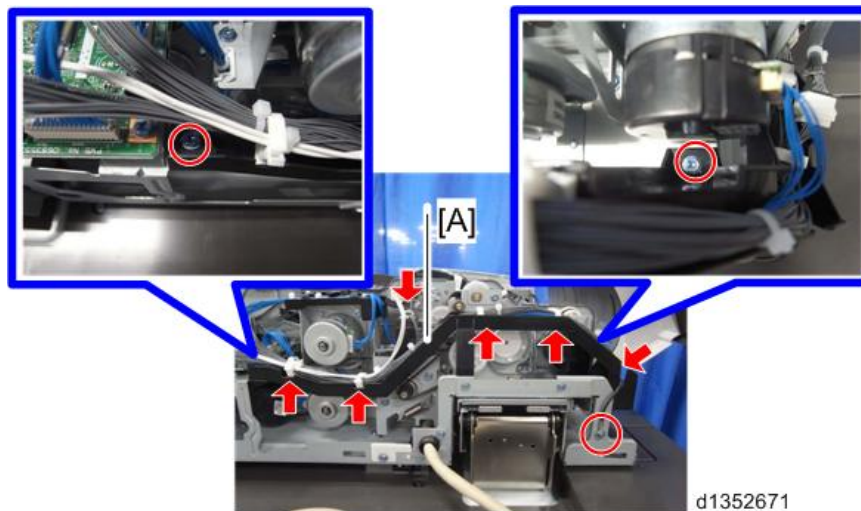

3. ADF pick-up roller lift motor [A] (🔩 x2, 📦 x1, timing belt x1).

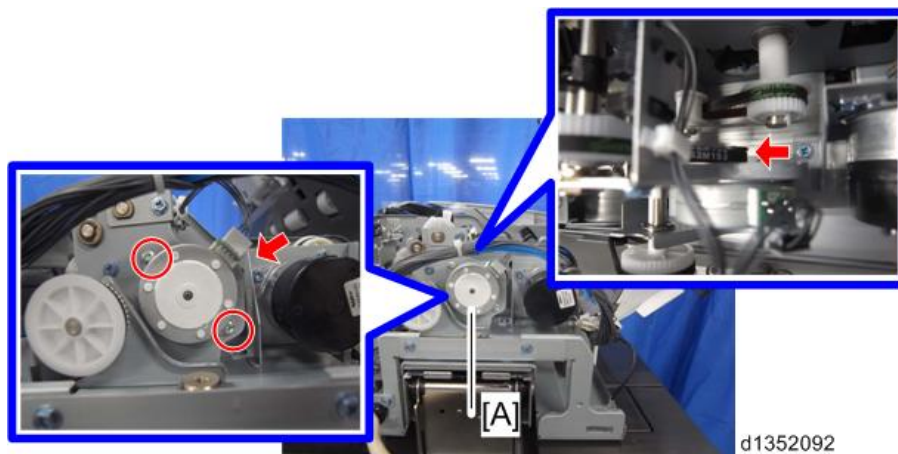

4. ADF transport motor [A] along with the bracket (🔩 x2, 📦 x1, timing belt x1).

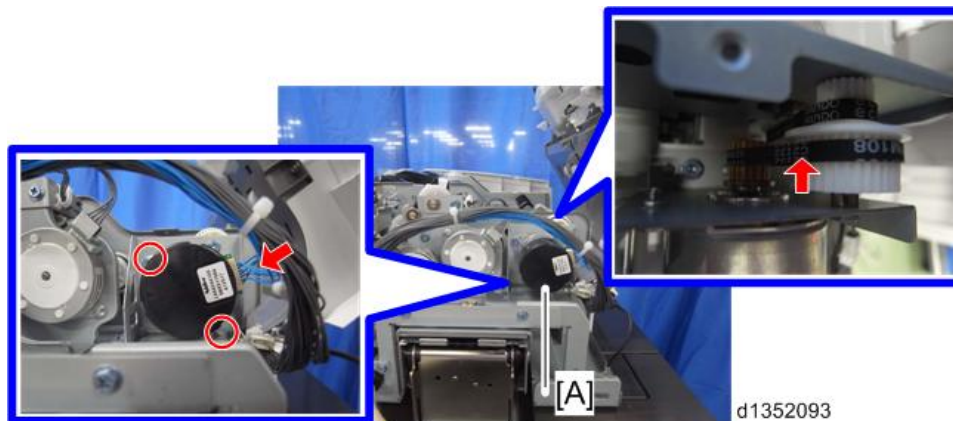

1.6.3 ADF BOTTOM PLATE LIFT MOTOR

1. ADF entrance motor along with the frame (page 36).
2. ADF bottom plate lift motor [A] (⚙️ x2, 📦 x1).

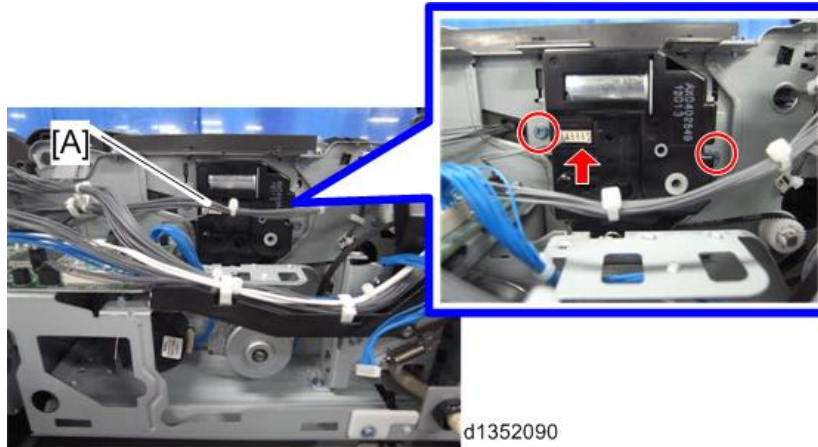

1.6.4 ORIGINAL REGISTRATION SENSOR

1. Entrance lower guide [A] (⚙️ x2).

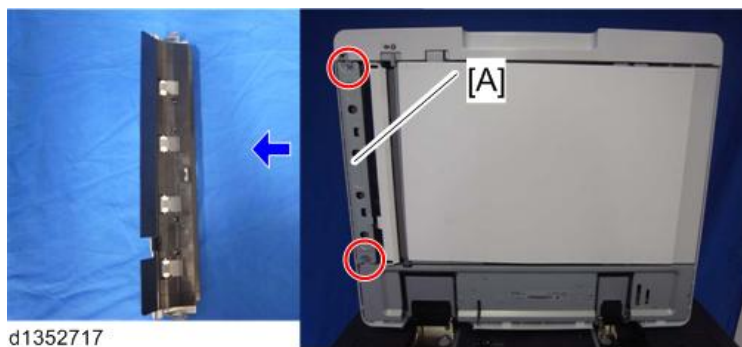

2. Scanning guide plate [A] (hook x1).

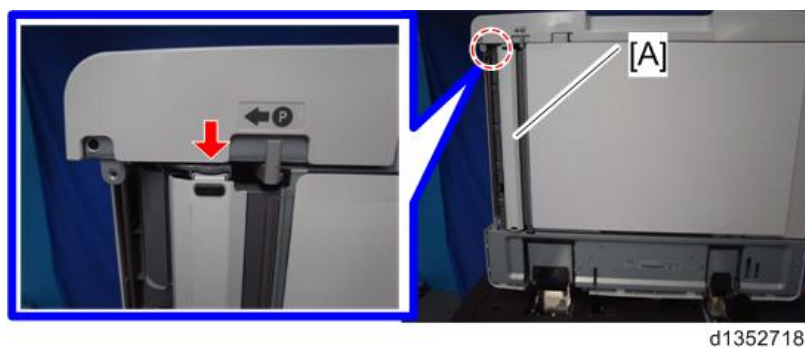

3. Original registration sensor [A] along with the bracket (⚙️ x1, 📦 x1).

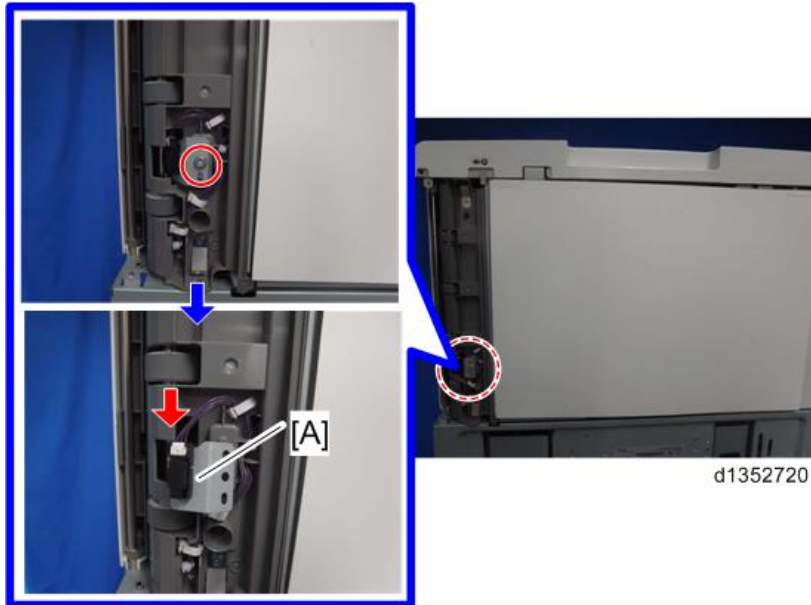

4. Original Registration Sensor [A].

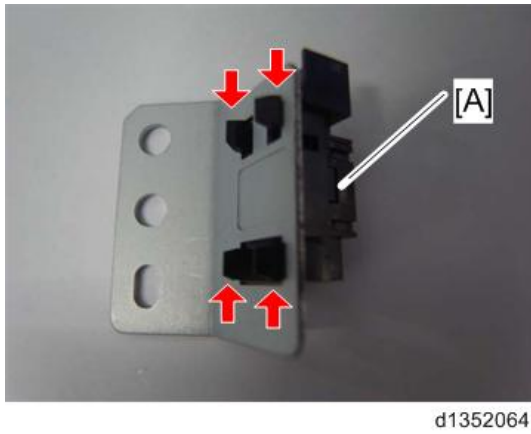

1.6.5 ORIGINAL EXIT SENSOR

1. ADF rear cover (page 9).
2. Disconnect the relay harness [A] (🔌x1, 📦 x1).

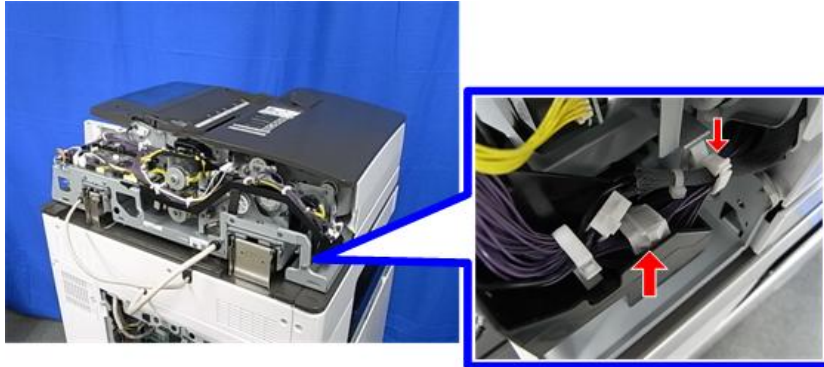

d1774015

3. Entrance lower guide [A] (🔩x2).

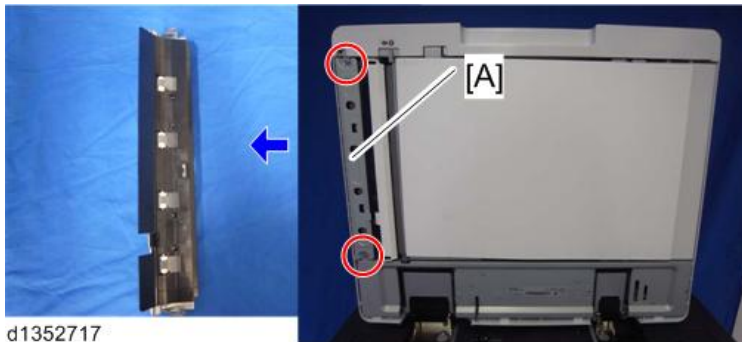

d1352717

4. Scanning guide plate [A] (hookx1).



d1352718

5. Slide the tab to the left and then open the white cover [A].

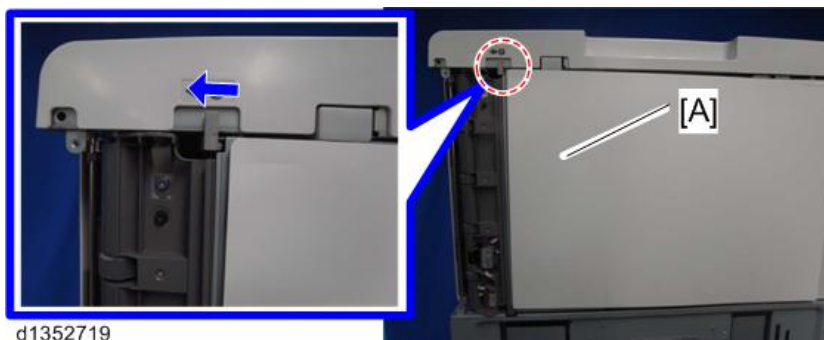

d1352719

6. Remove the original exit sensor [B], which is mounted on the upper guide [A] (⚙️ x6).

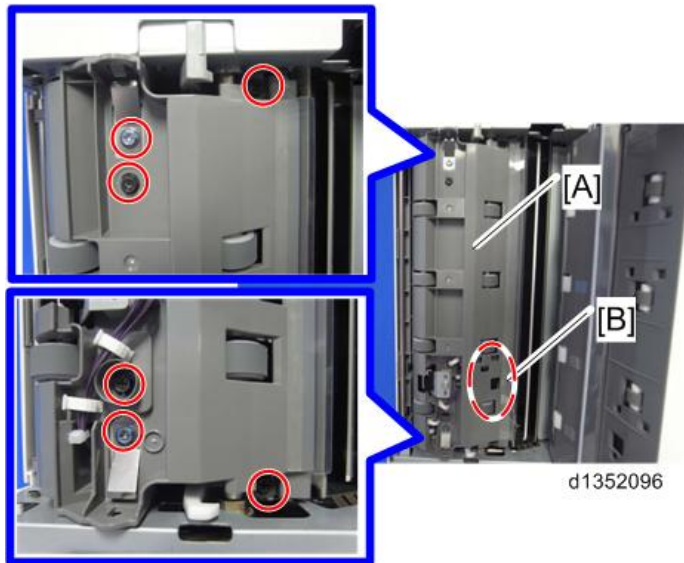

7. Remove the original exit sensor [B] from the upper guide [A] (⚙️ x1, 📦 x1).

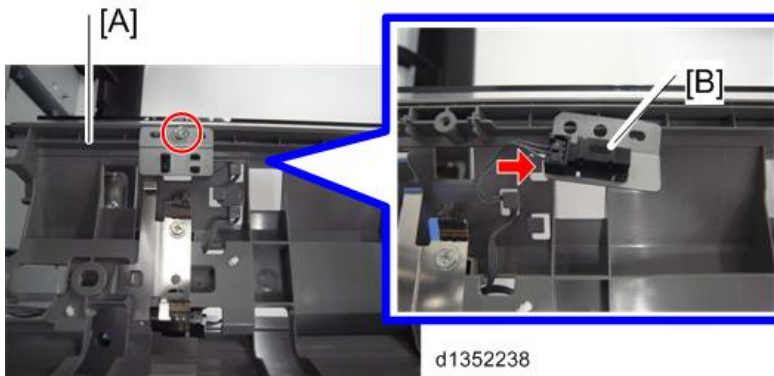

1.6.6 ADF CONTROL BOARD

1. ADF rear cover (page 9).
2. ADF control board [A] (⚙️ x4, 📦 xall).

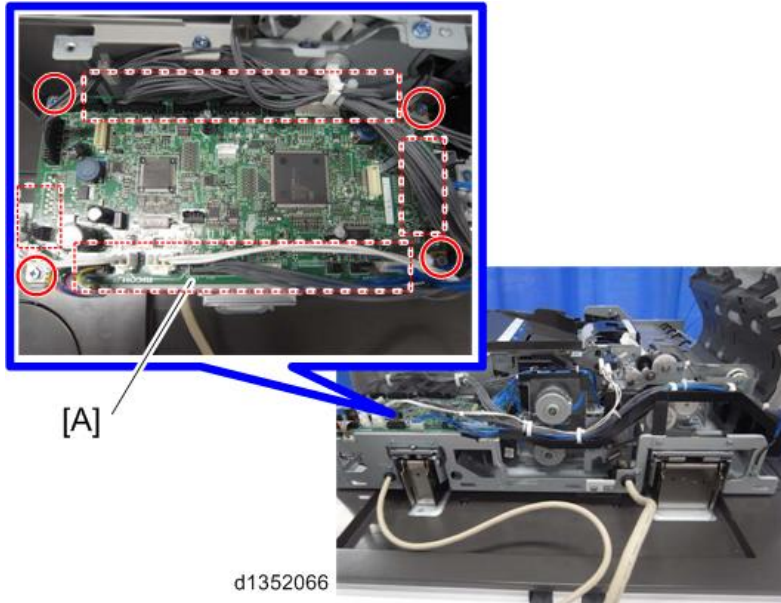

1.6.7 SEPARATION SENSOR / SKEW CORRECTION SENSOR

1. Feed cover (page 10).
2. Feed upper guide [A] in the feed cover (🔑 x3).

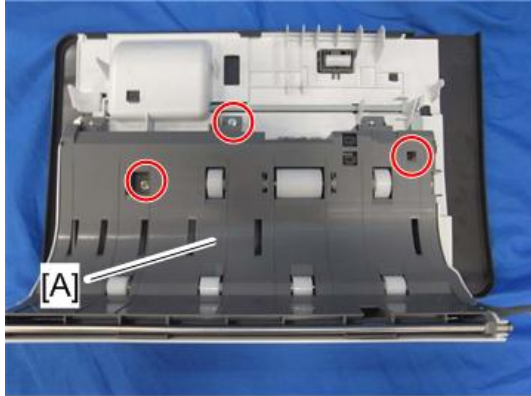

d1352067

3. Remove the sensors along with the bracket [A] (🔑 x1).



d1352068

4. Separation Sensor [A] and Skew Correction Sensor [B] (🔌 x1 each).

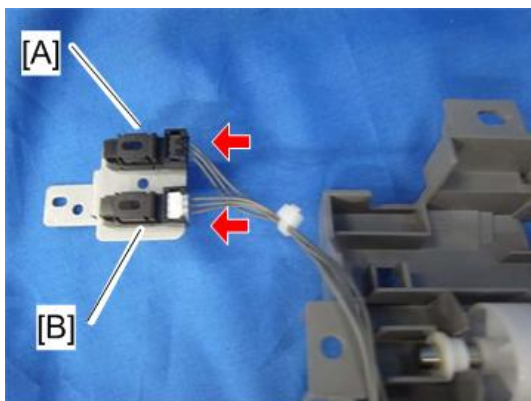

d1352069

1.6.8 ORIGINAL WIDTH SENSOR / INTERVAL SENSOR

1. Feed cover (page 10).
2. Guide plate [A] (🔩 x3).

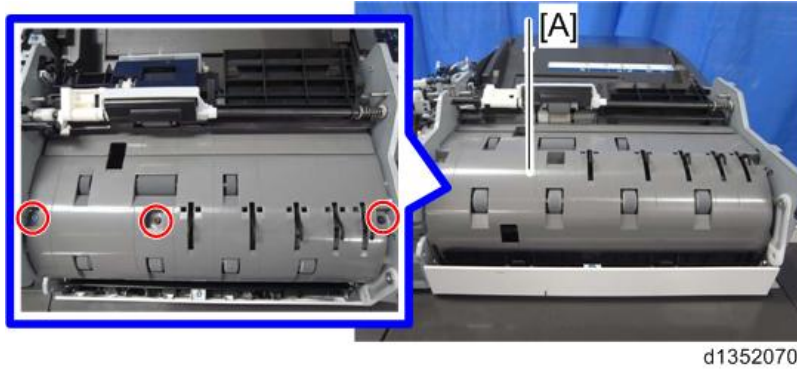

3. Interval sensor [A] (🔩 x1, 📦 x1).

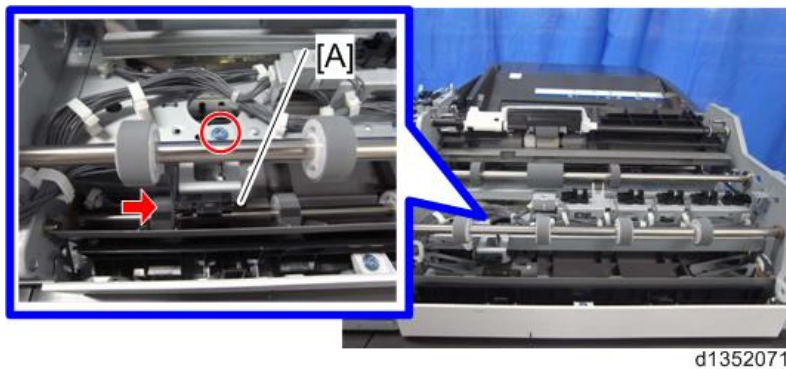

4. Remove the original width sensor guide plate [A] (🔩 x2), then remove the original width sensors [B] (📦 x1 each).

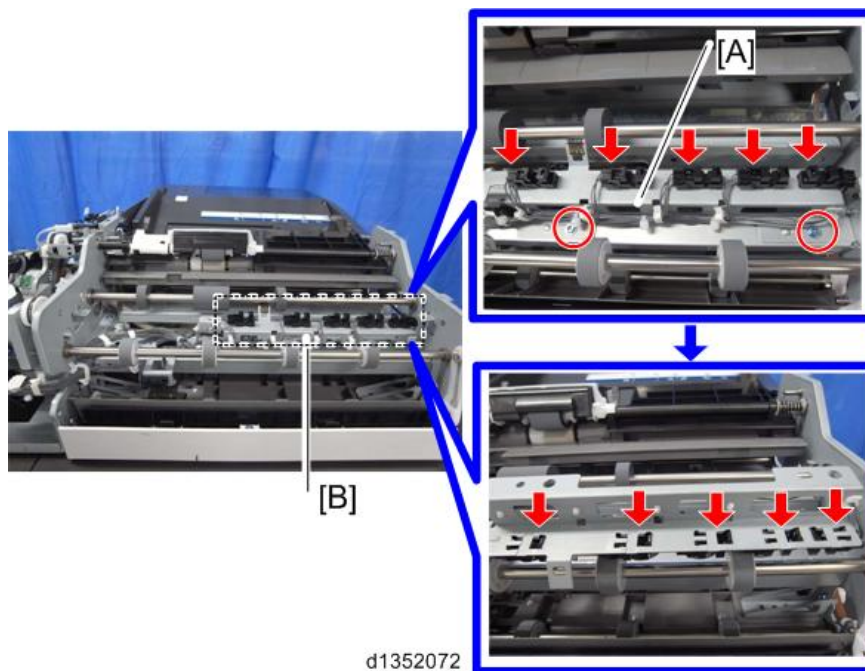

1.6.9 B5 WIDTH SENSOR / A4 WIDTH SENSOR / LG WIDTH SENSOR

1. Raise the document tray [A], then remove the lower cover [B] (🔑 x4).

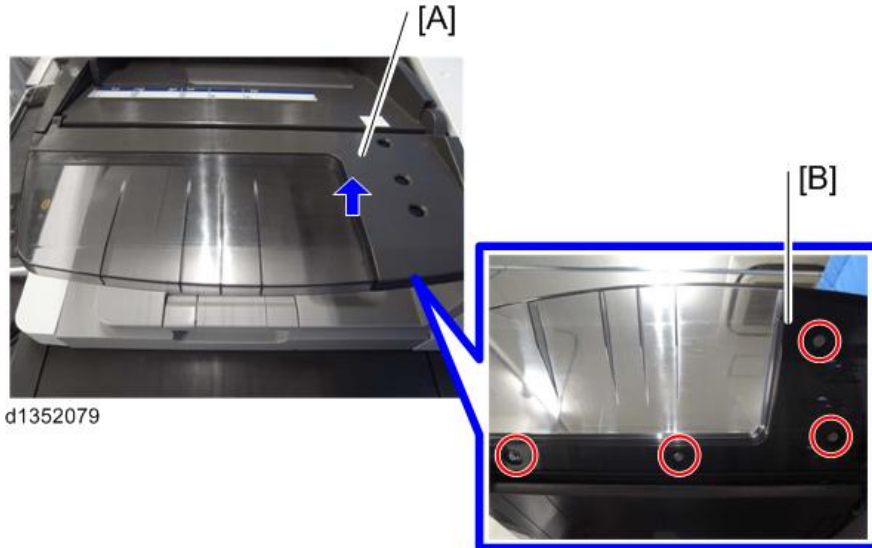

2. B5 Width Sensor [A] (📦 x1).
3. A4 Width Sensor [B] (📦 x1).
4. LG Width Sensor [C] (📦 x1).

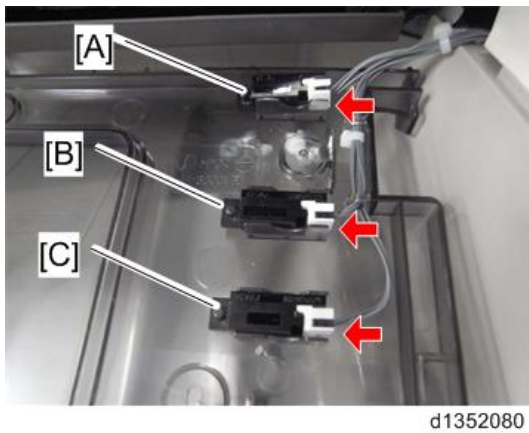

1.6.10 APS FEELER

1. ADF rear cover (page 9).
2. APS Feeler [A] (🔑 x1).

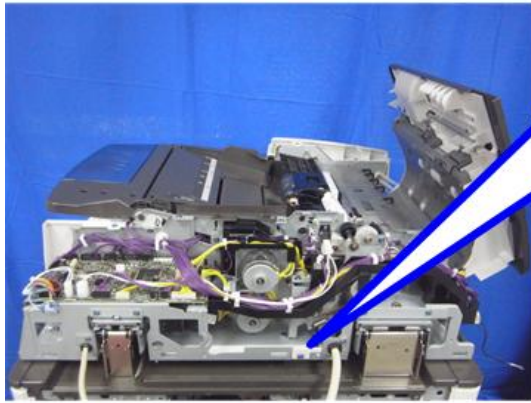

d1463159

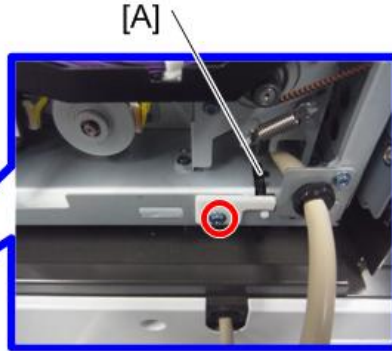

1.6.11 ADF LIFT-UP INTERLOCK SW / LIFT-UP SENSOR

1. ADF Control Board (page 25).
2. ADF lift-up interlock SW [A] along with the bracket (🔩 x3, 📦 x2).

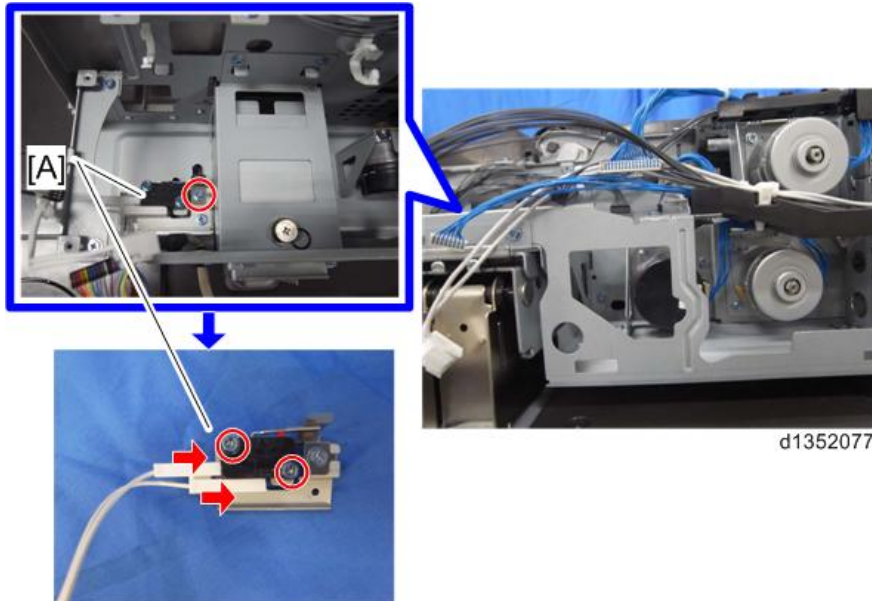

3. Lift-Up Sensor [A] along with the bracket (🔩 x1, 📦 x1).

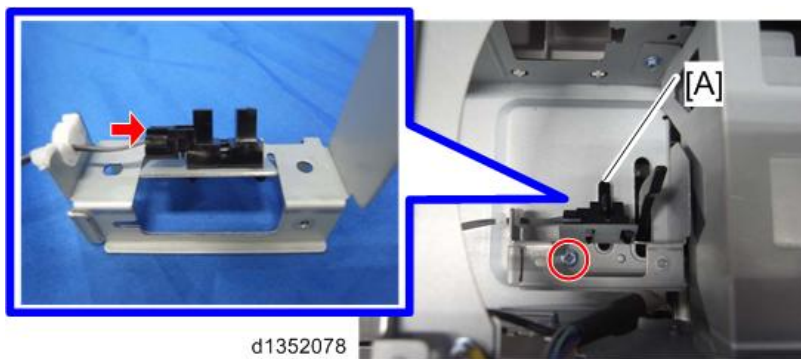

1.6.12 ORIGINAL SET SENSOR

1. ADF front cover (page 8).
2. Original feed unit (page 11).
3. Remove the screw and raise the original tray [A] (🔑 x1).

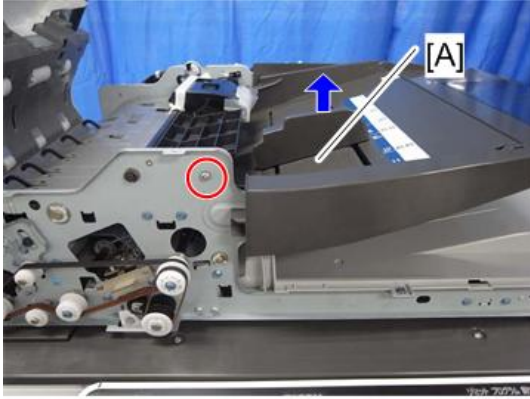

d1352073

4. Original set sensor [A] (🔑 x1, 📦 x1).

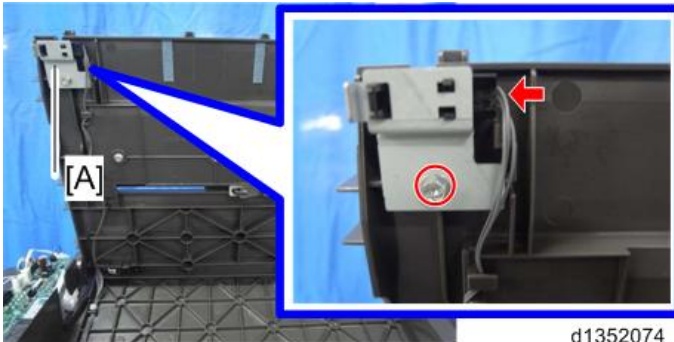

d1352074

1.6.13 A4 LEF/LT LEF SENSOR

1. ADF front cover (page 8).
2. Original feed unit (page 11).
3. Remove the screw and raise the original tray [A] (🔑 x1).

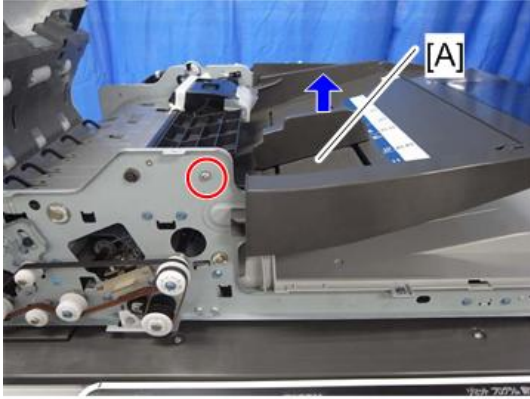

d1352073

4. A4 LEF/LT LEF Sensor [A] (hookx1, 📦 x1).

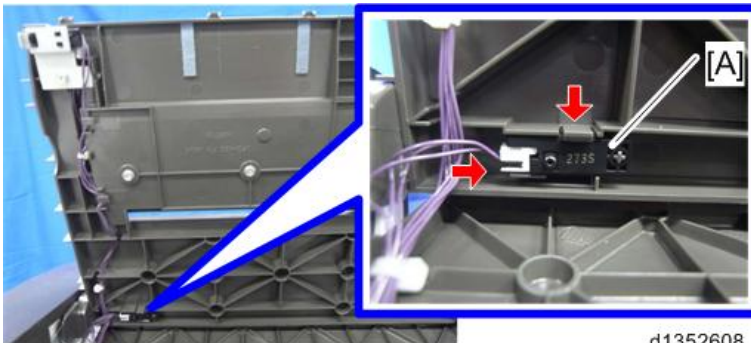

d1352608

1.6.14 BOTTOM PLATE HP SENSOR

1. Original feed unit (page 11).
2. ADF front cover (page 8).
3. Remove the screw and raise the original tray [A] (🔑 x1).

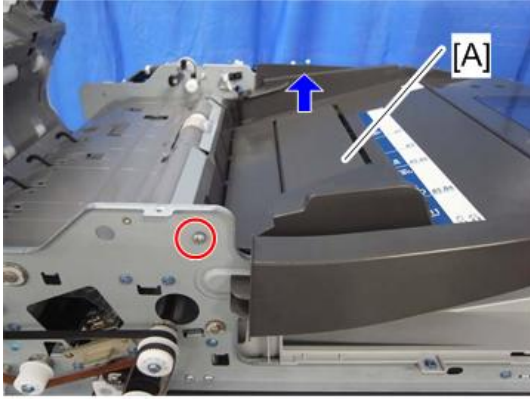

d1352075

4. Bottom plate HP sensor [A] (📦 x1).

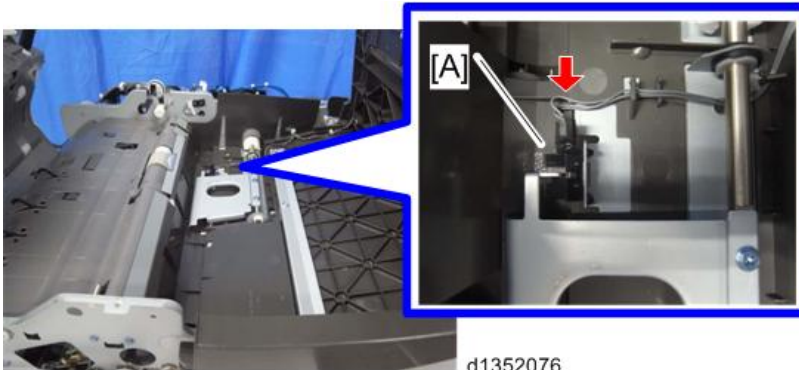

d1352076

1.6.15 BOTTOM PLATE POSITION SENSOR

1. ADF rear cover (page 9).
2. Original feed unit (page 11).
3. Bottom plate position sensor [A] ( x1).

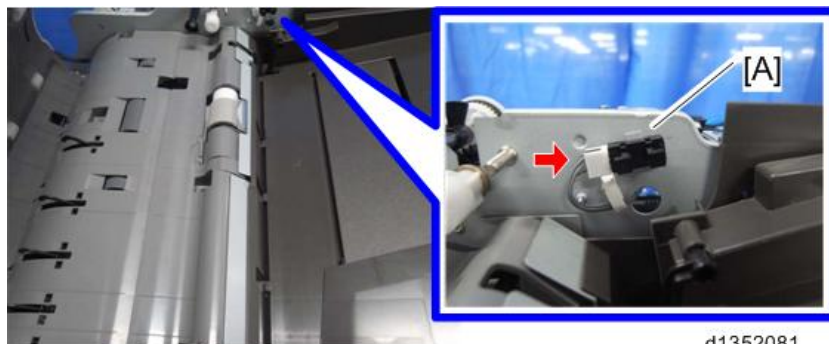

d1352081

1.6.16 ADF FEED COVER INTERLOCK SWITCH / PICK-UP ROLLER HP SENSOR

1. ADF rear cover (page 9).
2. Remove the ADF feed cover interlock switch [A] from the retaining bracket (Ⓜx1, springx1, pinx1).

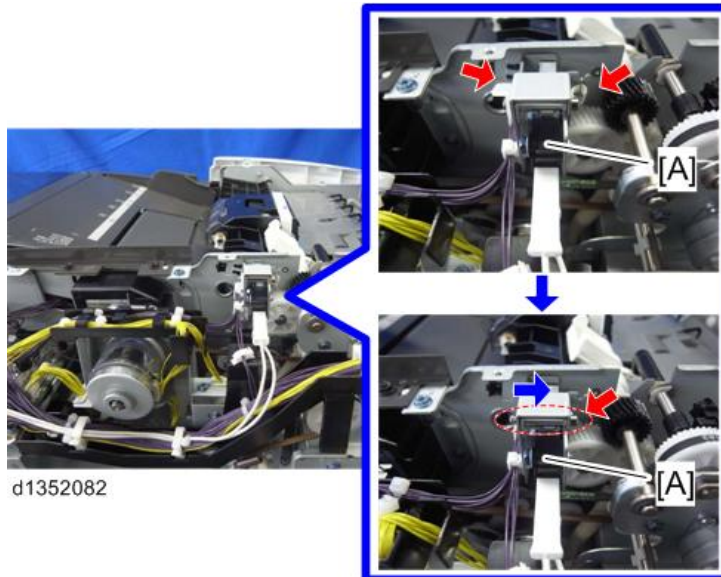

d1352082

3. ADF feed cover interlock switch [A] (Ⓜx2, Ⓜx2).

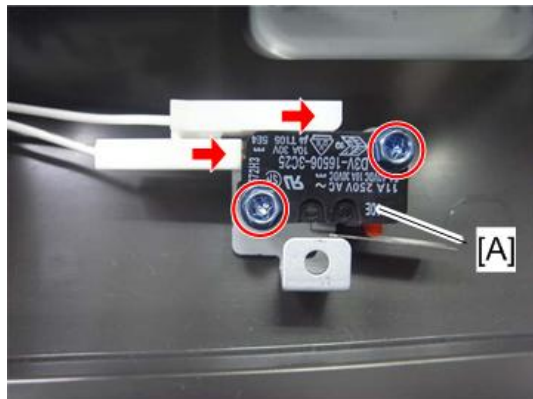

d1352610

4. Pick-up roller HP sensor [A] along with the bracket (Ⓜx1, Ⓜx1, Ⓜx1).

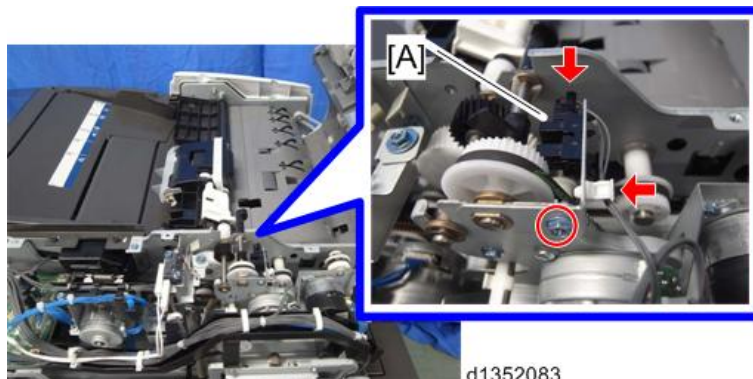

d1352083

1.7 ORIGINAL FEED DRIVE

1.7.1 ADF ENTRANCE MOTOR

1. ADF rear cover (page 9).
2. ADF entrance motor [A] (⊗ x2, ⊞ x1, timing belt x1).

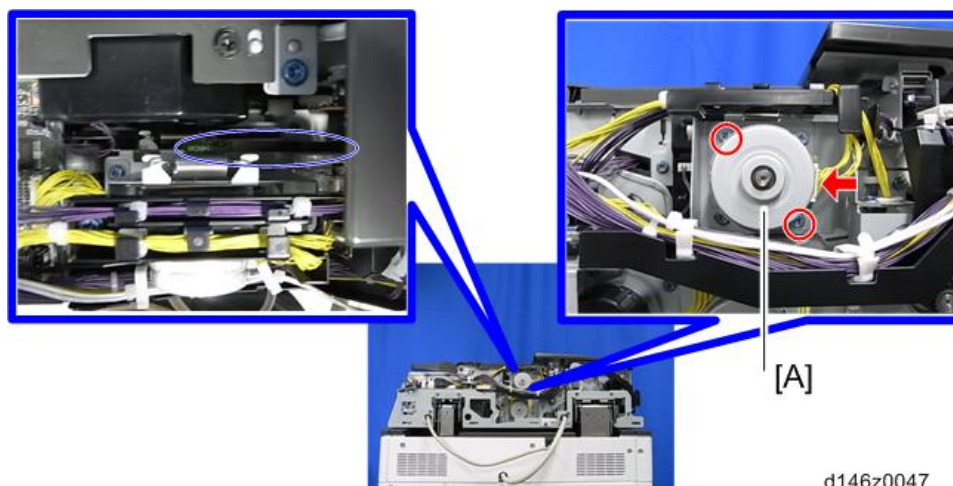

1.7.2 ADF SCANNING MOTOR

- 1. ADF entrance motor along with the frame (page 36).
- 2. ADF read motor [A] along with the bracket (🔩 x2, 📦 x1 , spring x1, timing belt x1)

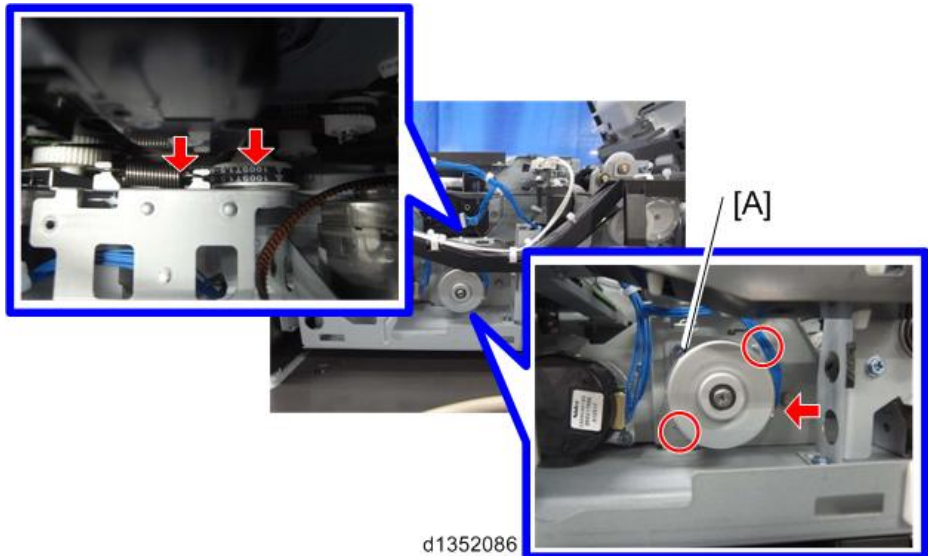

d1352086

- 3. ADF scanning motor [A] (🔩 x2).

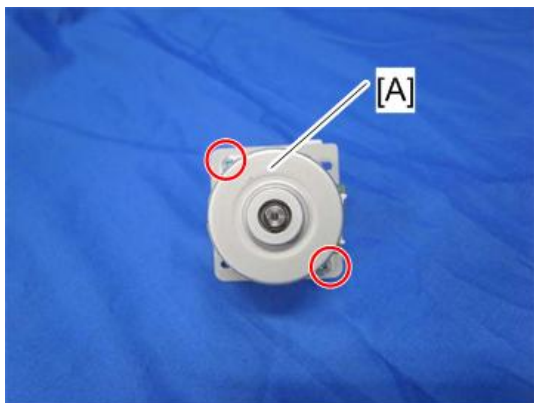

d1352089

1.7.3 ADF EXIT MOTOR

1. ADF Control Board (page 25).
2. ADF exit motor [A] along with the bracket (🔩 x2, 📦 x1, spring x1, timing belt x1).

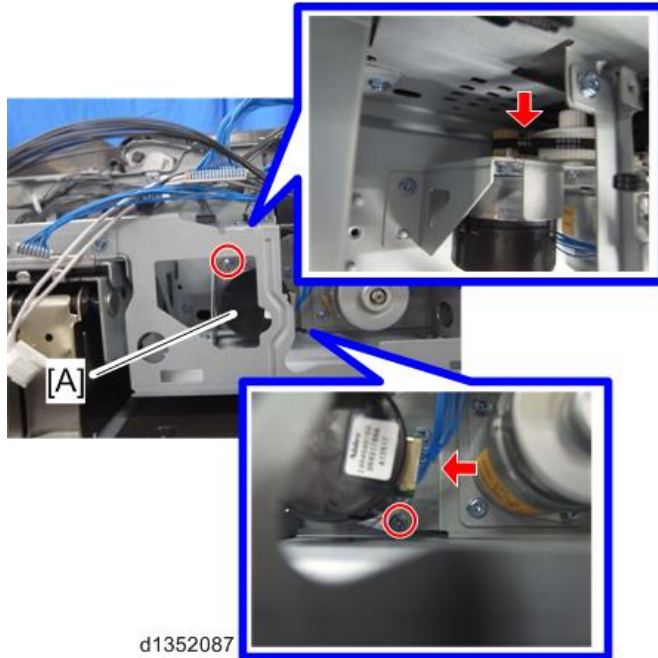

1.7.4 ADF FEED MOTOR

1. ADF rear cover (page 9).
2. Frame (black) [A] (🔩 x3, 📦 x6).

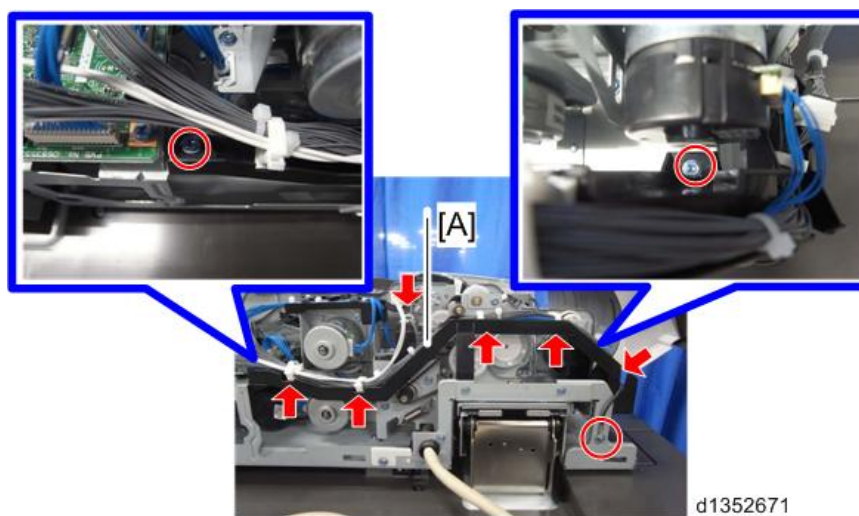

3. ADF entrance motor along with the frame (page 36).
4. ADF feed motor [A] along with the bracket (🔩 x2, 📦 x1, spring x1, timing belt x1).

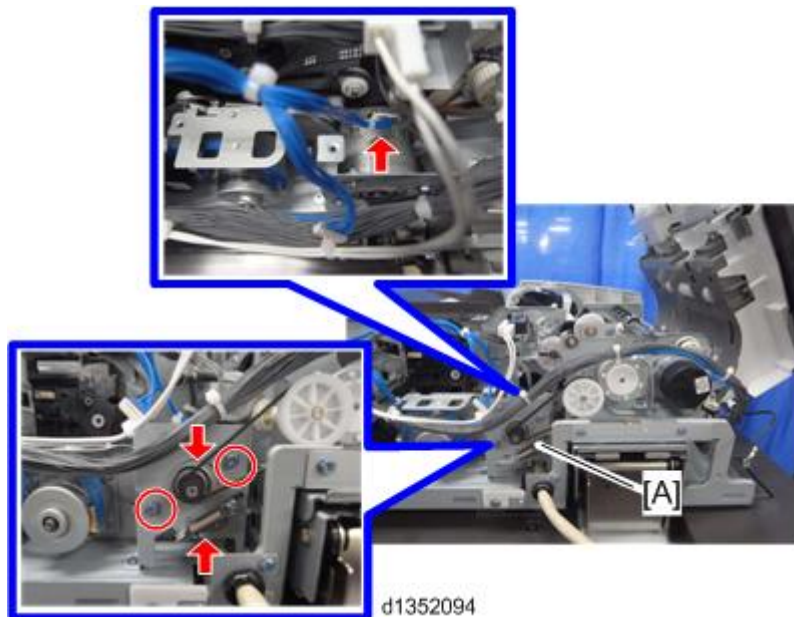

5. ADF feed motor [A] (🔧 x2).

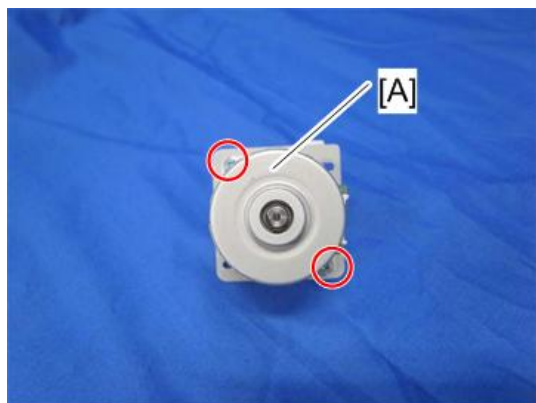

D685
BRIDGE UNIT BU3070

REVISION HISTORY		
Page	Date	Added/Updated/New
		None

BRIDGE UNIT BU3070 (D685)





TABLE OF CONTENTS

1. REPLACEMENT AND ADJUSTMENT	1
1.1 DRIVE MOTOR UNIT	1
1.2 PAPER EXIT SENSOR.....	3
1.3 BRIDGE UNIT TRANSPORT SENSOR.....	6
1.4 PAPER EXIT TRAY SET DETECTION SWITCH.....	7
1.5 PAPER EXIT SWITCHING UNIT SET SWITCH	8

READ THIS FIRST

Safety and Symbols

This manual uses several symbols and abbreviations. The meaning of those symbols and abbreviations are as follows:

	Clip ring
	Screw
	Connector
	Clamp
SEF	Short Edge Feed
LEF	Long Edge Feed

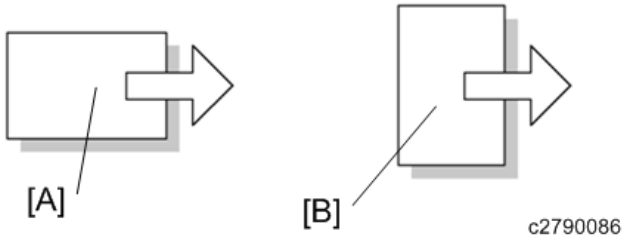

[A] Short Edge Feed (SEF)

[B] Long Edge Feed (LEF)

Trademarks

Microsoft[®], Windows[®], and MS-DOS[®] are registered trademarks of Microsoft Corporation in the United States and /or other countries.

PostScript[®] is a registered trademark of Adobe Systems, Incorporated.

PCL[®] is a registered trademark of Hewlett-Packard Company.

Ethernet[®] is a registered trademark of Xerox Corporation.

PowerPC[®] is a registered trademark of International Business Machines Corporation.

Other product names used herein are for identification purposes only and may be trademarks of their respective companies. We disclaim any and all rights involved with those marks.

1. REPLACEMENT AND ADJUSTMENT

1.1 DRIVE MOTOR UNIT

1. Separate the finisher, and remove the connecting bracket.
2. Bridge unit [A] (🔩 x2).

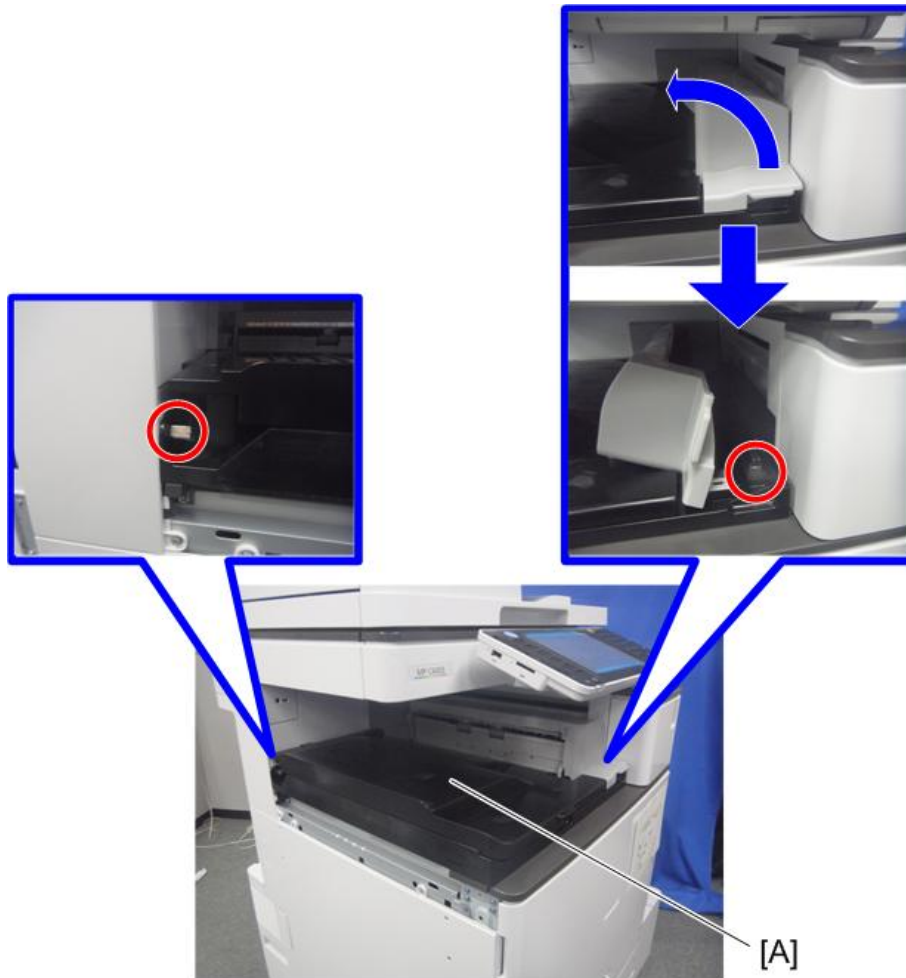

d1462820

3. Drive motor unit cover [A] (🔩 x2).

Drive Motor Unit



d1462821

4. Bridge unit rear cover [A] (🔩 x1).



d1462822

5. Drive motor unit [A] (🔩 x3, 📡 x2).

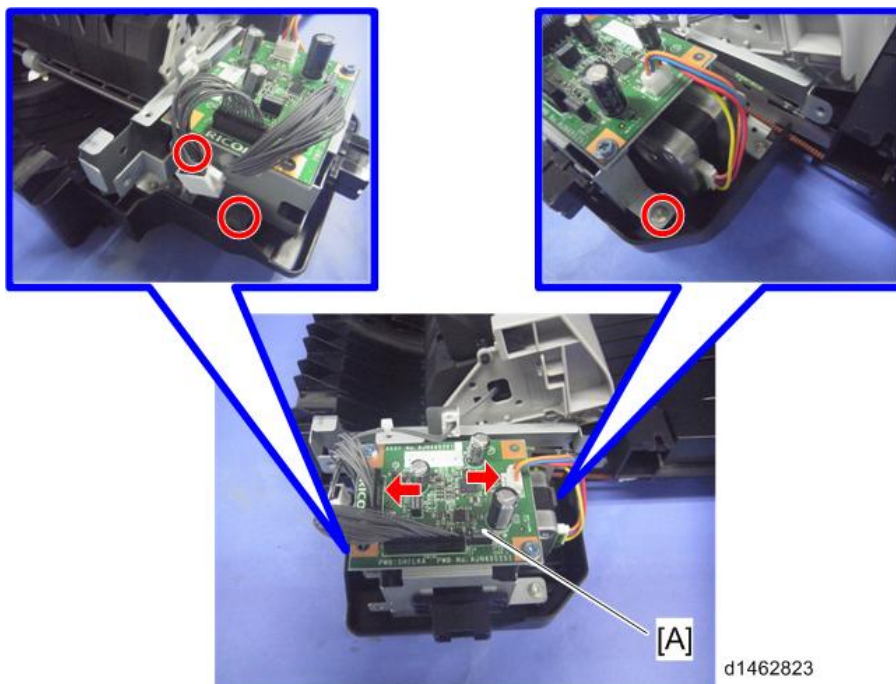

d1462823

1.2 PAPER EXIT SENSOR

1. Bridge unit (page 1).
2. Drive motor unit cover (page 1).
3. Bridge unit rear cover (page 1).
4. Paper exit tray [A].

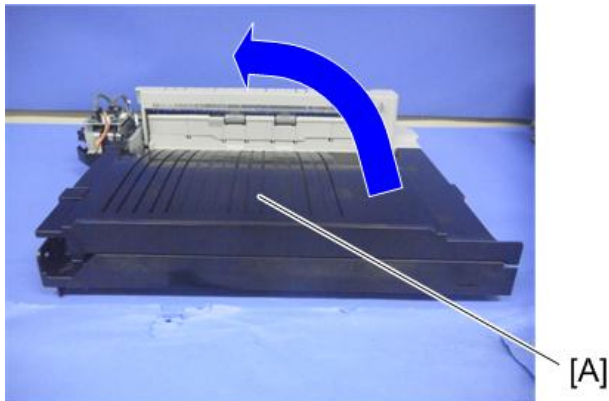

d1462824

5. Paper exit cover [A] (⊙ x1).

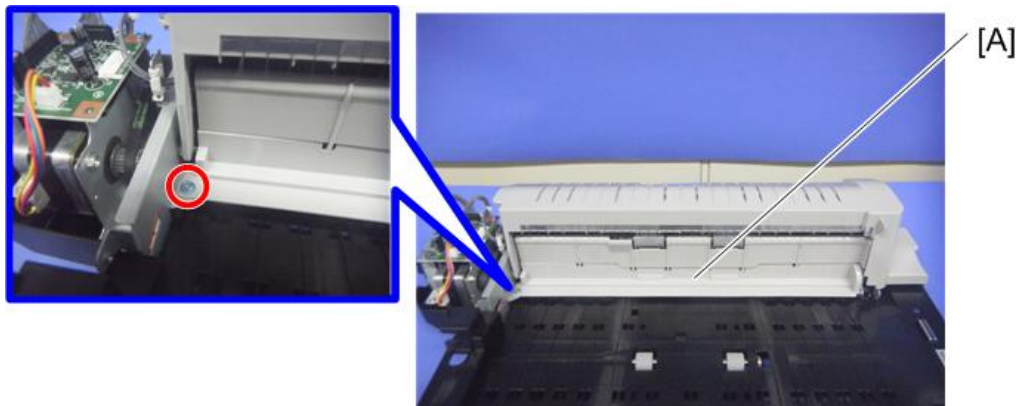

d1462825

Paper Exit Sensor

6. Paper exit switching unit [A] (⚙️x1, 📦x1, 🛠️x1).

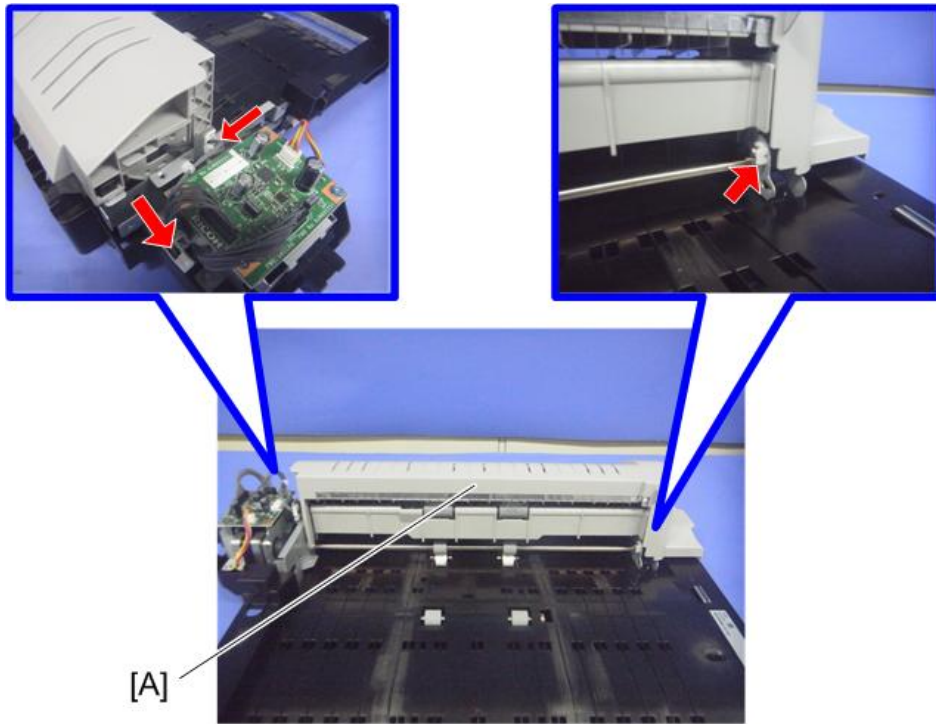

d1462826

7. Paper exit switching unit cover [A] (🔩x4).

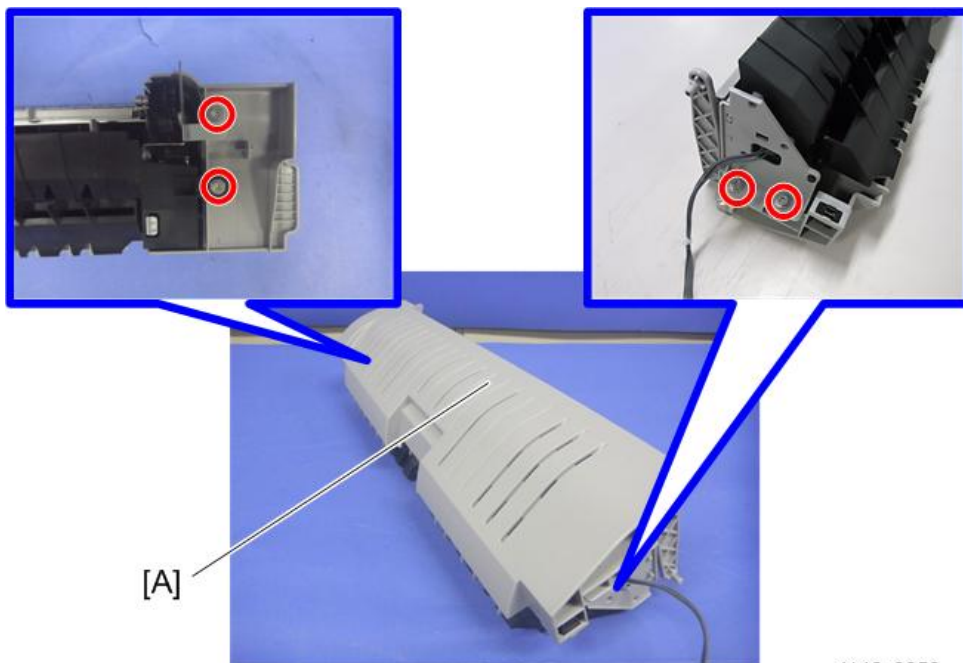

d146z0050

8. Guide plate [A].

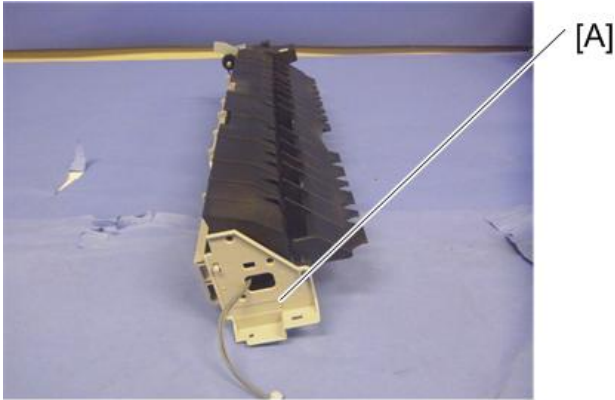

d1462828

9. Guide plate [A] (⚙️ x1).

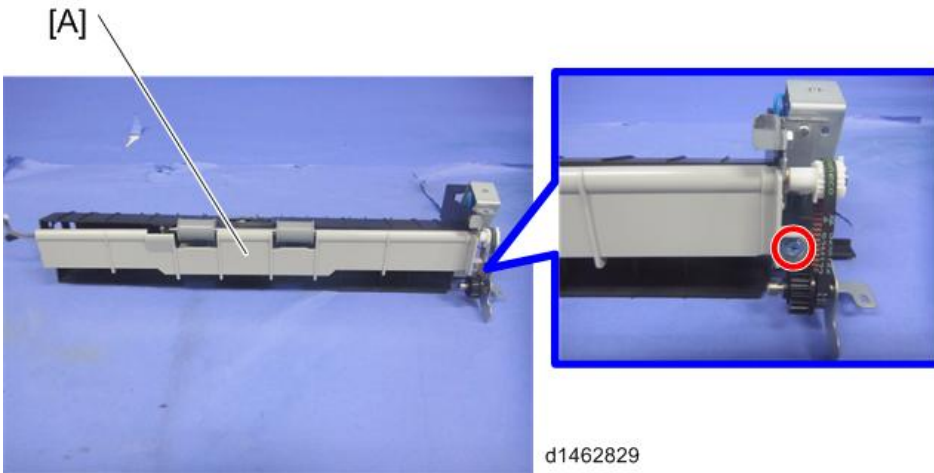

d1462829

10. Paper exit sensor [A] (📏 x1).

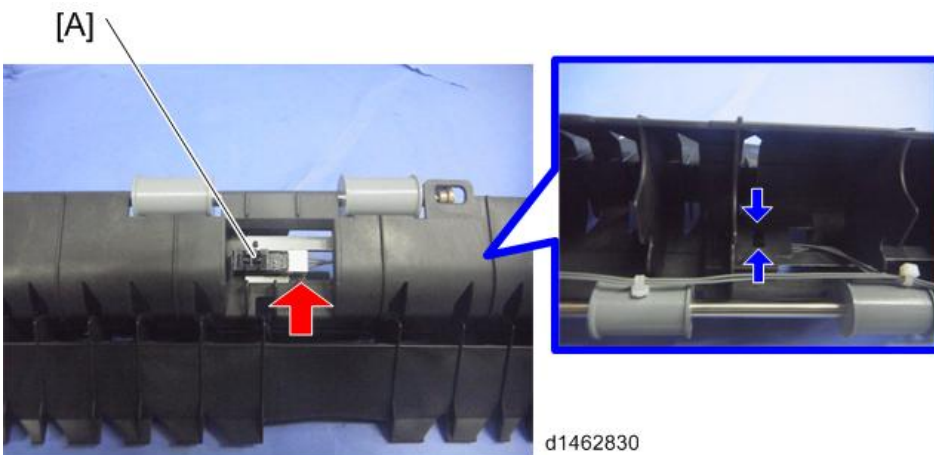

d1462830

1.3 BRIDGE UNIT TRANSPORT SENSOR

1. Bridge unit (page 1).
2. Upside down.

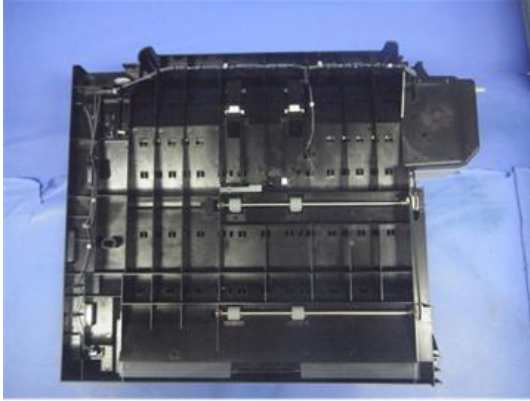

d1462831

3. Bridge unit transport sensor [A] (📦 x1).

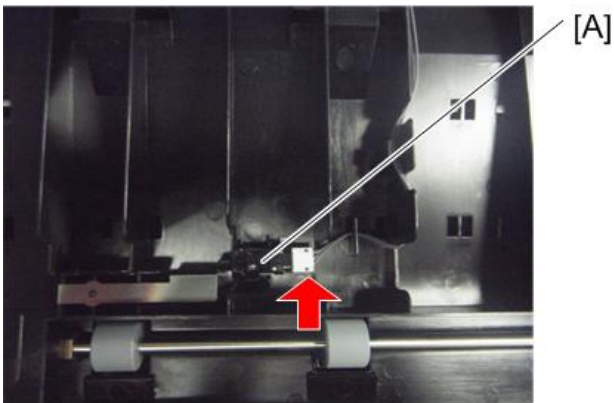

d1462832

1.4 PAPER EXIT TRAY SET DETECTION SWITCH

1. Paper exit tray (page 3).
2. Paper exit tray set switch cover [A].

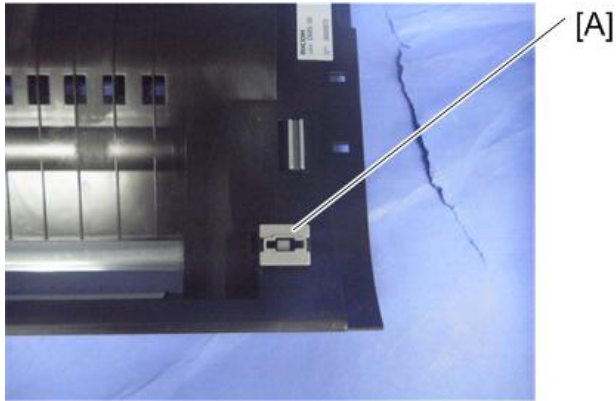

d1462833

3. Paper exit tray set switch [A] (📦 x1).

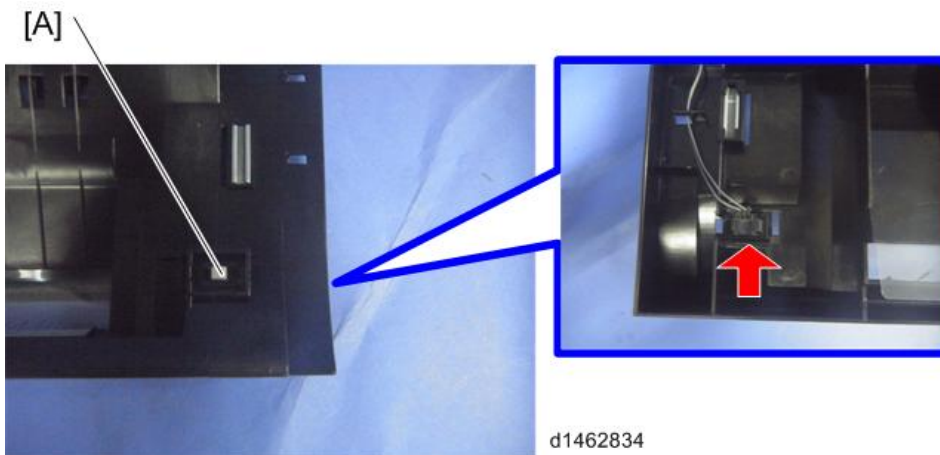

d1462834

1.5 PAPER EXIT SWITCHING UNIT SET SWITCH

1. Bridge Unit (page 1).
2. Open the Paper exit switching unit [A].

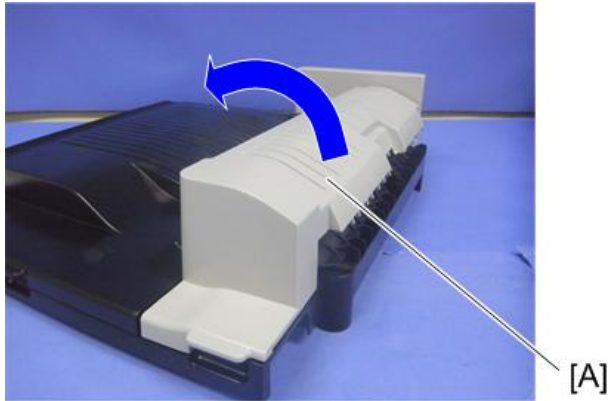

d1462835

3. Paper exit switching unit set switch cover [A].

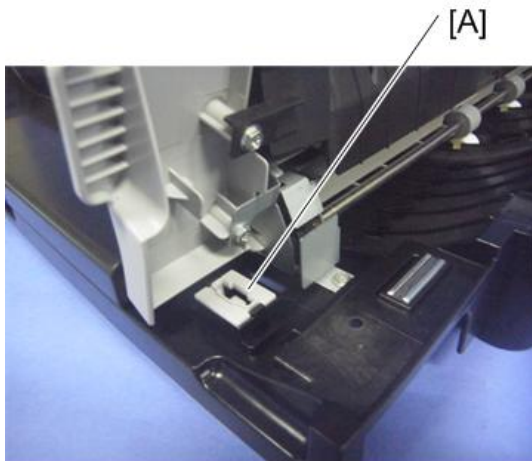

d1462836

4. Paper exit switching unit set switch [A] (📦 x1).

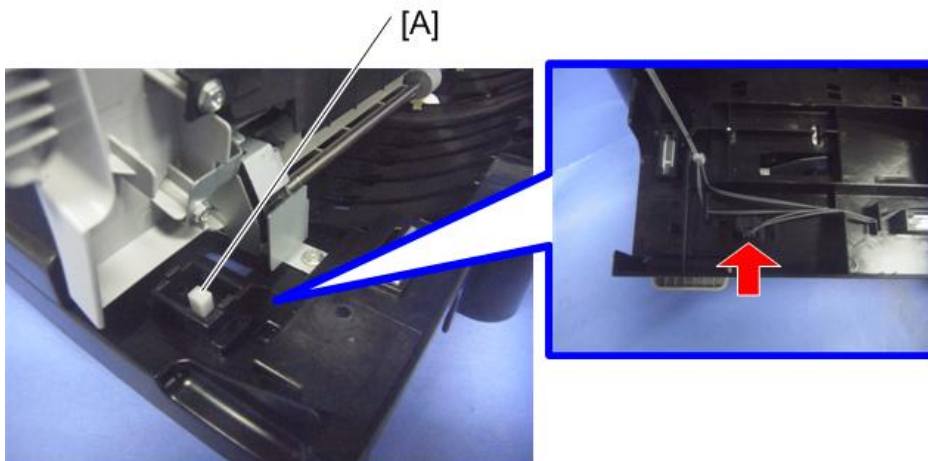

d1462837

D686/D687
Booklet Finisher SR3150/
Finisher SR3140

REVISION HISTORY		
Page	Date	Added/Updated/New
		None

BOOKLET FINISHER SR3150/ FINISHER SR3140 (D686/D687)

TABLE OF CONTENTS





1. REPLACEMENT AND ADJUSTMENT	1
1.1 EXTERIOR PARTS.....	1
1.1.1 FRONT COVER.....	1
1.1.2 INNER COVER.....	2
1.1.3 REAR COVER	3
1.1.4 FRONT LEFT COVER	4
1.1.5 UPPER COVER.....	4
1.1.6 UPPER FRONT COVER	5
1.1.7 UPPER REAR COVER.....	6
1.1.8 PROOF TRAY	7
1.1.9 SHIFT TRAY.....	7
1.1.10 BOOKLET TRAY.....	8
1.1.11 UPPER LEFT COVER	8
1.1.12 LEFT CENTER COVER.....	9
1.1.13 LEFT LOWER COVER.....	10
1.2 MAIN UNIT.....	11
1.2.1 PAPER EJECT COVER OPEN/CLOSE MOTOR	11
1.2.2 PAPER GUIDE PLATE OPEN/CLOSE HP SENSOR.....	11
1.2.3 PROOF TRAY FULL SENSOR.....	12
1.2.4 PROOF TRAY PAPER EJECT SENSOR	12
1.2.5 ENTRANCE SENSOR	13
1.2.6 INTERMEDIATE TRANSPORT SENSOR RIGHT	14
1.2.7 INTERMEDIATE TRANSPORT SENSOR LEFT	15
1.2.8 SHIFT TRAY PAPER SURFACE SENSOR.....	16
1.2.9 SHIFT TRAY UPPER LIMIT SWITCH	17
1.2.10 SHIFT TRAY PAPER EJECT SENSOR.....	17
1.2.11 PROOF TRANSPORT MOTOR	18
1.2.12 POSITIONING ROLLER MOTOR	18
1.2.13 SHIFT MOTOR.....	19
1.2.14 PAPER EJECT TRANSPORT MOTOR	19
1.2.15 PAPER BUNDLE TRANSPORT UPPER MOTOR	20

1.2.16	STAPLER TRAY	21
1.2.17	STAPLER TRAY PAPER DETECTION SENSOR.....	23
1.2.18	PAPER BUNDLE TRANSPORT UPPER PRESSURE RELEASE HP SENSOR.....	24
1.2.19	RELEASE CLAW HP SENSOR	24
1.2.20	JOGGER HP SENSOR	25
1.2.21	JOGGER MOTOR.....	25
1.2.22	PAPER BUNDLE TRANSPORT UPPER PRESSURE RELEASE MOTOR 26	
1.2.23	RELEASE CLAW MOTOR.....	27
1.3	BOARDS.....	28
1.3.1	MAIN CONTROL BOARD.....	28
1.4	BOOKLET STAPLER UNIT	29
1.4.1	STAPLER UNIT	29
1.4.2	BOOKLET STAPLER UNIT	35
1.4.3	CENTER-FOLDING UNIT.....	36
1.4.4	CENTER-FOLDING TRAY PAPER EJECT SENSOR	38
1.4.5	TRAILING EDGE STOPPER TRANSPORT SENSOR	39
1.4.6	TRAILING EDGE STOPPER HP SENSOR	40
1.4.7	CENTER-FOLDING BLADE HP SENSOR	40
1.4.8	CENTER-FOLDING CAM HP SENSOR	41
1.4.9	TRAILING EDGE STOPPER MOTOR.....	42
1.4.10	FOLDING BLADE MOTOR	42
1.4.11	FOLDING TRANSPORT MOTOR.....	43
1.4.12	CENTER-FOLDING TRAY FULL SENSORS 1, 2.....	44
1.4.13	STAPLER TRANSFER MOTOR (MIDDLE)	45
1.4.14	PAPER BUNDLE TRANSPORT LOWER PRESSURE RELEASE HP SENSOR.....	46

READ THIS FIRST

Safety and Symbols

This manual uses several symbols and abbreviations. The meaning of those symbols and abbreviations are as follows:

	Clip ring
	Screw
	Connector
	Clamp
SEF	Short Edge Feed
LEF	Long Edge Feed

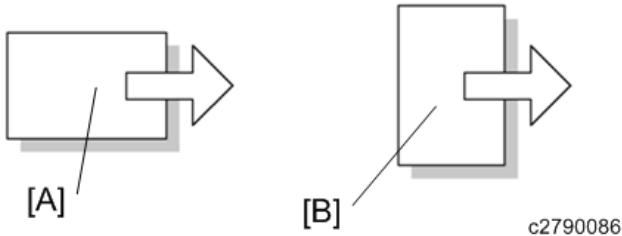

[A] Short Edge Feed (SEF)

[B] Long Edge Feed (LEF)

Trademarks

Microsoft[®], Windows[®], and MS-DOS[®] are registered trademarks of Microsoft Corporation in the United States and /or other countries.

PostScript[®] is a registered trademark of Adobe Systems, Incorporated.

PCL[®] is a registered trademark of Hewlett-Packard Company.

Ethernet[®] is a registered trademark of Xerox Corporation.

PowerPC[®] is a registered trademark of International Business Machines Corporation.

Other product names used herein are for identification purposes only and may be trademarks of their respective companies. We disclaim any and all rights involved with those marks.

The Aim of Anti-tip Components and Precautions

The anti-tip components are necessary for meeting the requirements of IEC60950-1, the international standard for safety.

The aim of these components is to prevent the products, which are heavy in weight, from toppling as a result of people running into or leaning onto the products, which can lead to serious accidents such as persons becoming trapped under the product. (U.S.: UL60950-1, Europe: EN60950-1)

Therefore, removal of such components must always be with the consent of the customer.

Do not remove them at your own judgment.

1. REPLACEMENT AND ADJUSTMENT

1.1 EXTERIOR PARTS

1.1.1 FRONT COVER

1. Open the front cover [A].

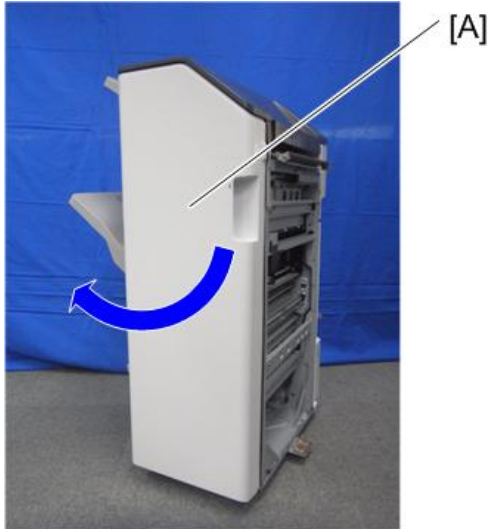

d6873230

2. Front cover (🔩 x1)

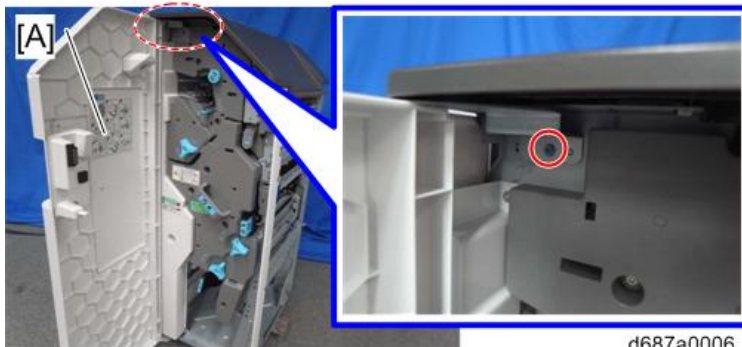

d687a0006

1.1.2 INNER COVER

1. Open the front cover (page 1)
2. Remove the three knobs (hook x1 for each).
 - Use a flathead screwdriver to release the hooks of the knobs if the knobs have the hooks to lock.

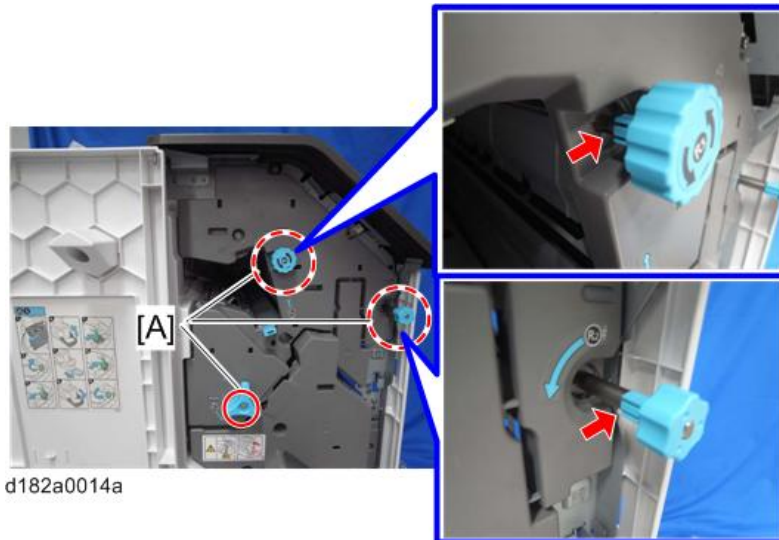

3. Remove the three screws on the inner cover [A] (⌀ x3).



4. Pull the booklet stitch unit [A].
5. Inner cover [B] (x1)

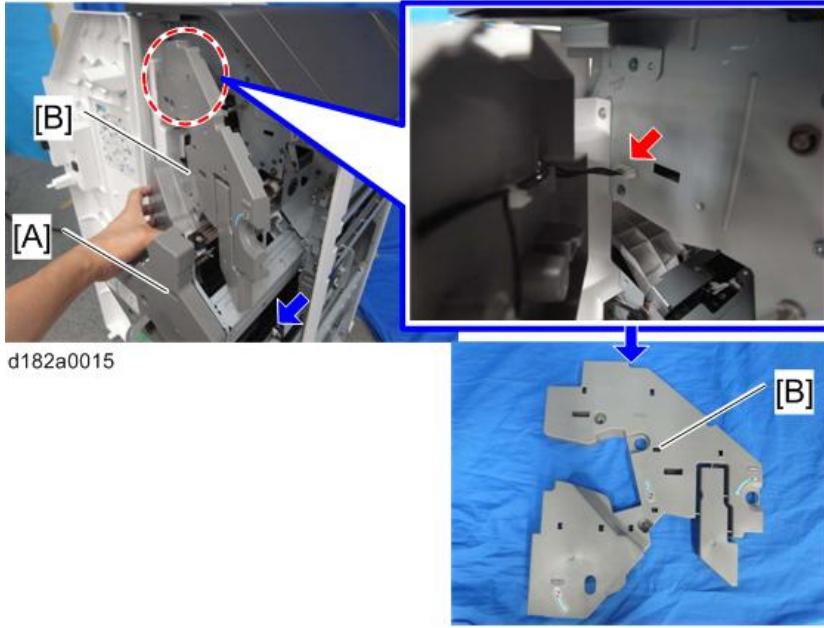

d182a0015

BOOKLET FINISHER
SR3150/ FINISHER
SR3140 (D686/D687)

1.1.3 REAR COVER

1. Rear cover [A] (🔑 x2)



d6873235

1.1.4 FRONT LEFT COVER

1. Front cover (page 1)
2. Inner cover (page 2)
3. Front left cover [A] (🔩 x2)

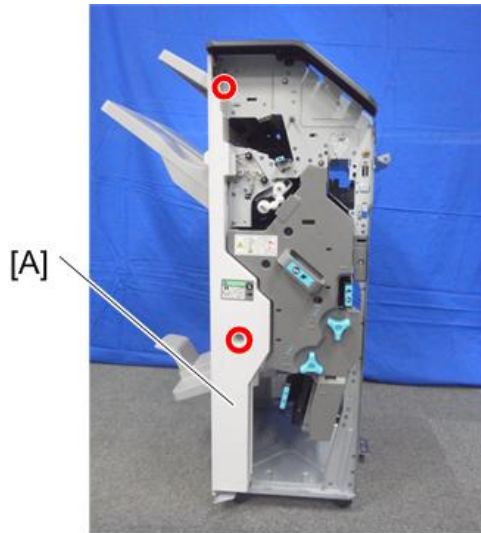

d6873236

1.1.5 UPPER COVER

1. Open the upper cover [A].

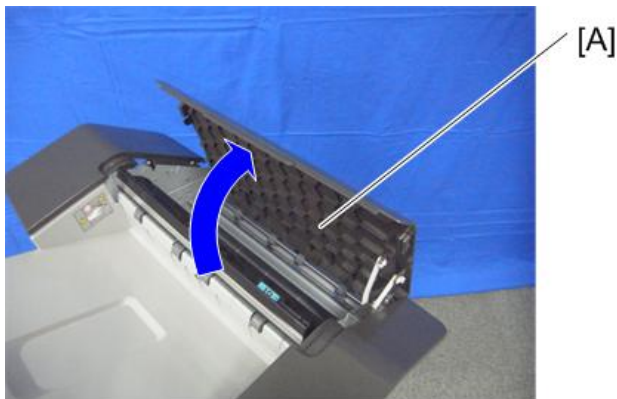

d6873237

2. Upper cover [A] (🔩 x2, hook x 1)

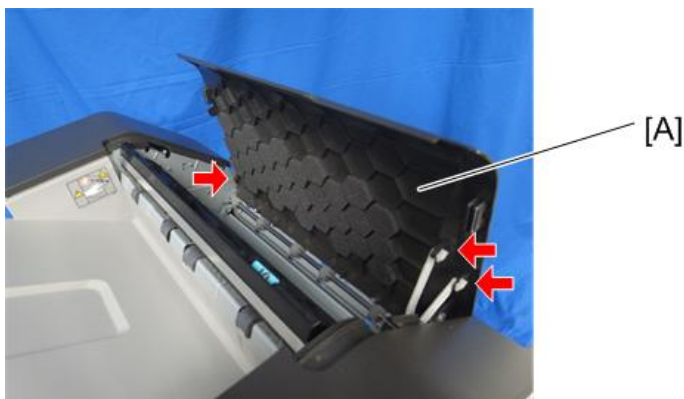

d1822032

Note

- When reattaching the upper cover, attach the clips so that their tabs face forward.

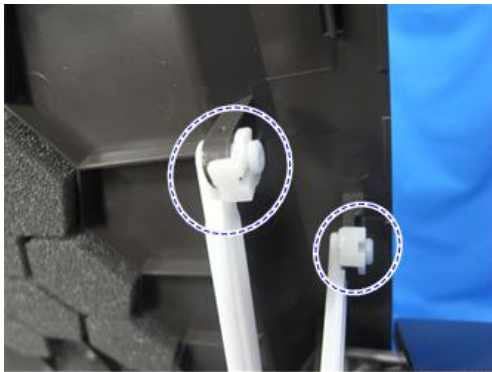

d1822297

BOOKLET FINISHER
SR3150/ FINISHER
SR3140 (D686/D687)

1.1.6 UPPER FRONT COVER

1. Front left cover (page 4)
2. Upper cover (page 4)
3. Upper front cover [A] (⊗ x3)

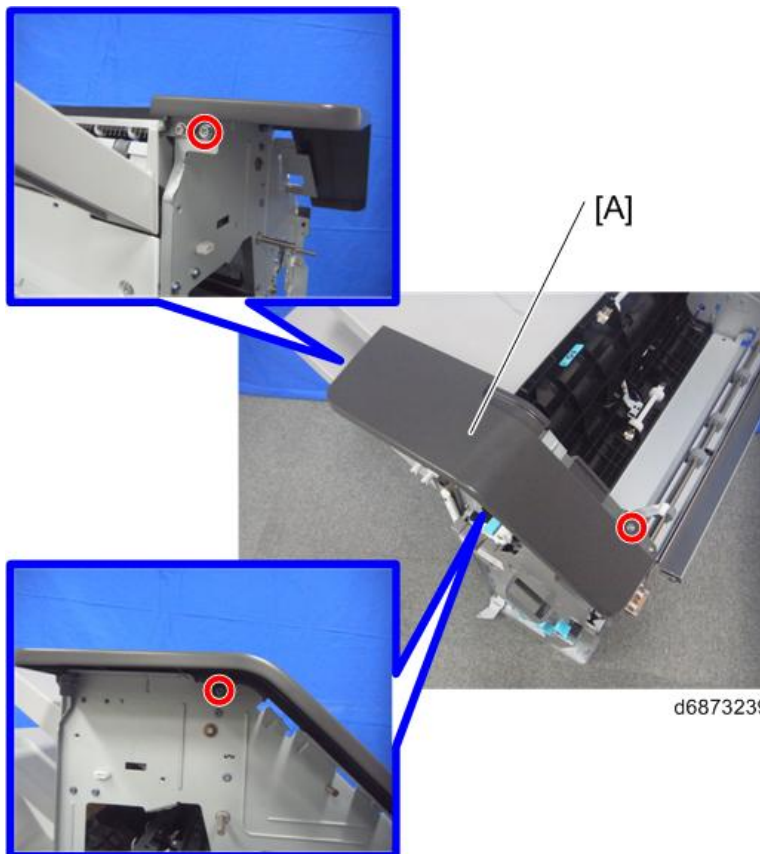

d6873239

1.1.7 UPPER REAR COVER

1. Rear cover (page 3)
2. Upper cover (page 4)
3. Upper rear cover [A] (🔩 x3)

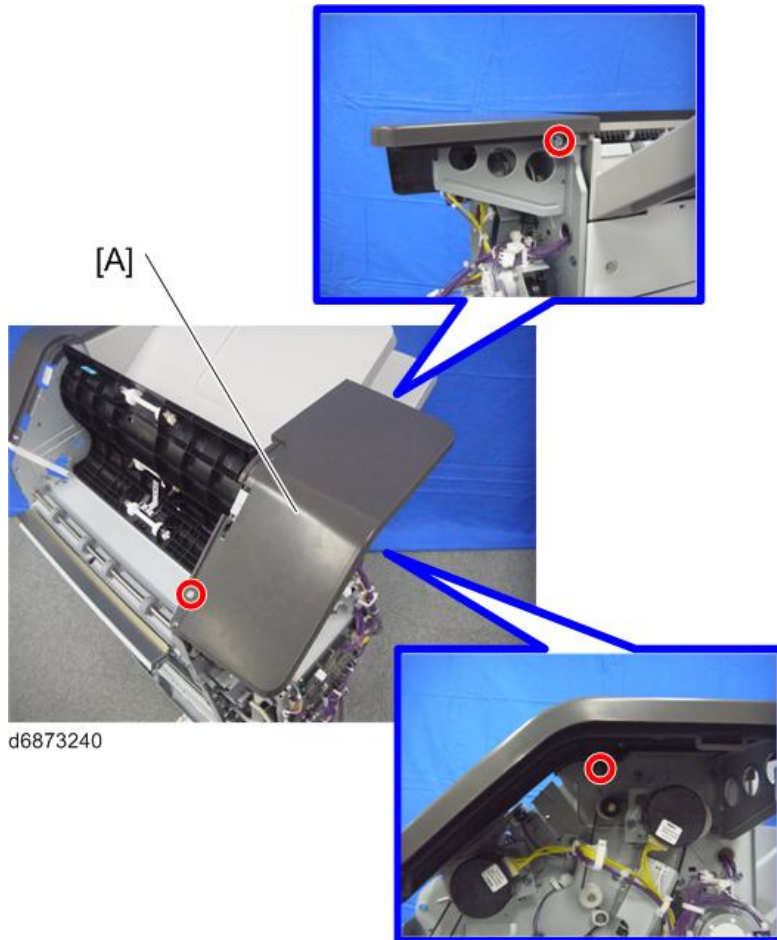

1.1.8 PROOF TRAY

1. Upper front cover (page 5)
2. Upper rear cover (page 6)
3. Proof tray [A] (🔑 x2)

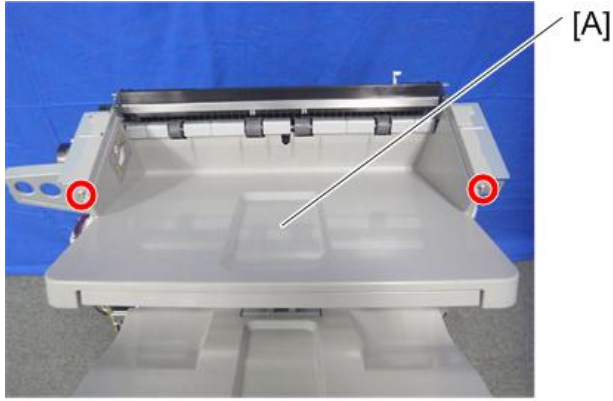

d6873241

1.1.9 SHIFT TRAY

1. Shift tray [A] (🔑 x1)



d6873242

1.1.10 BOOKLET TRAY

1. Booklet tray [A]



1.1.11 UPPER LEFT COVER

1. Upper left cover [A] (🔑 x2)



1.1.12 LEFT CENTER COVER

1. Front cover (page 1)
2. Rear cover (page 3)
3. Shift tray (page 7)
4. Shift tray front bracket [B] (⚙️ x2)
5. Shift tray bracket [A] with the shift tray rear bracket [C]

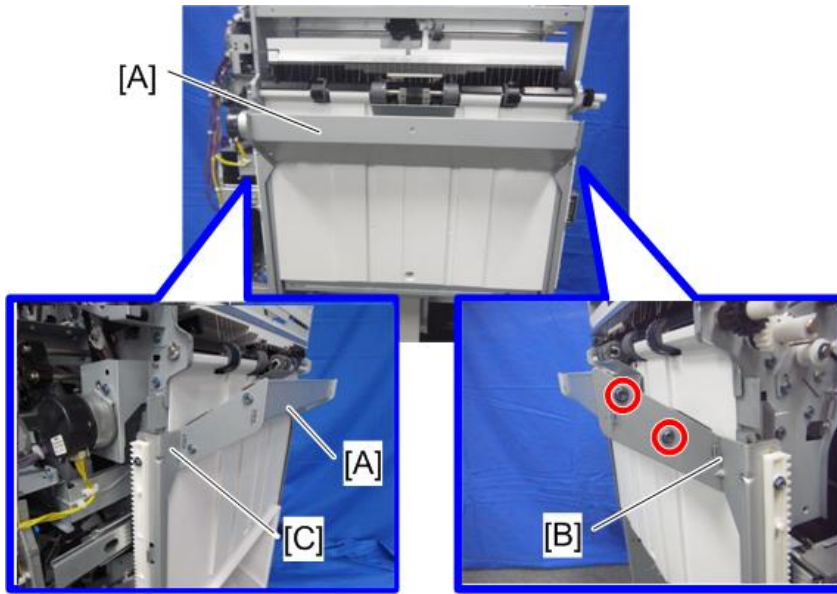

d687z0002a

6. Left center cover [A] (⚙️ x2)

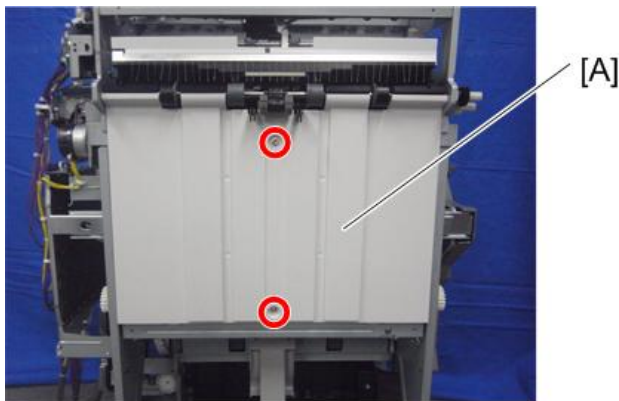

d6873246

1.1.13 LEFT LOWER COVER

1. Front cover (page 1)
2. Rear cover (page 3)
3. Booklet tray (page 8)
4. Left lower cover [A] (🔑 x2)



d6873247

1.2 MAIN UNIT

1.2.1 PAPER EJECT COVER OPEN/CLOSE MOTOR

1. Proof tray (page 7)
2. Paper eject cover open/close motor [A] (⚙️ x2, 📦 x1)

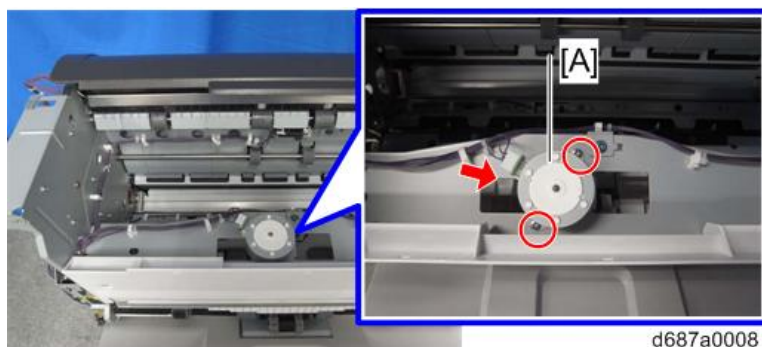

1.2.2 PAPER GUIDE PLATE OPEN/CLOSE HP SENSOR

1. Proof tray (page 7)
2. Paper eject cover HP sensor [A] (⚙️ x1, 📦 x1)

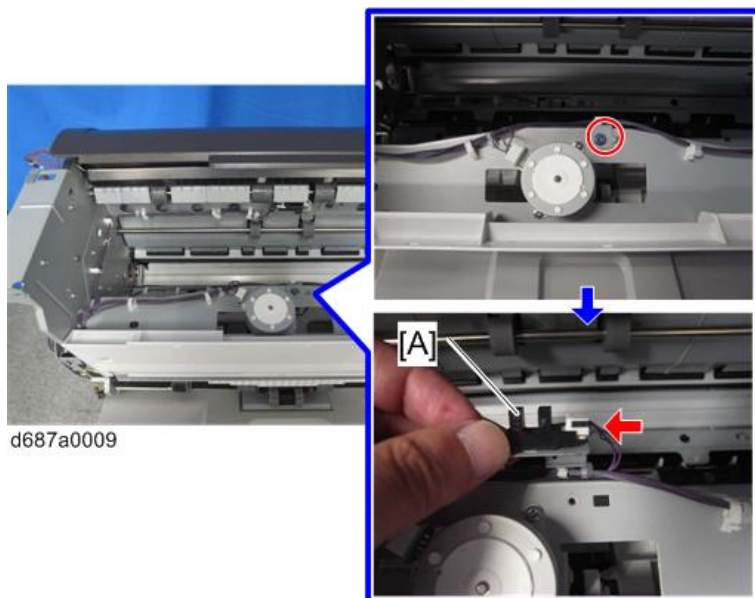

1.2.3 PROOF TRAY FULL SENSOR

1. Proof tray (page 7)
2. Proof tray full sensor [A] (🔩 x1, 📡 x1)

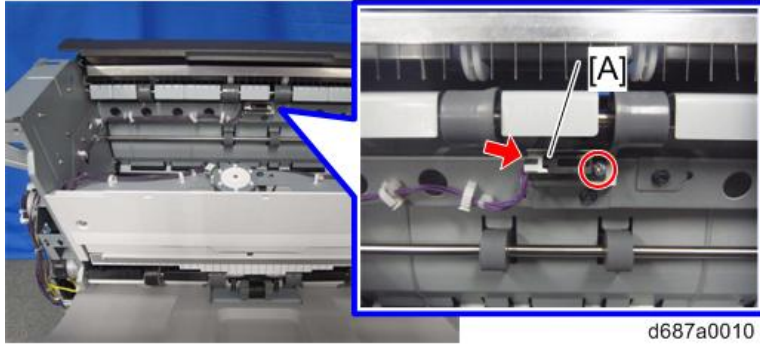

1.2.4 PROOF TRAY PAPER EJECT SENSOR

1. Proof tray (page 7)
2. Proof transport bracket [A] (🔩 x4)

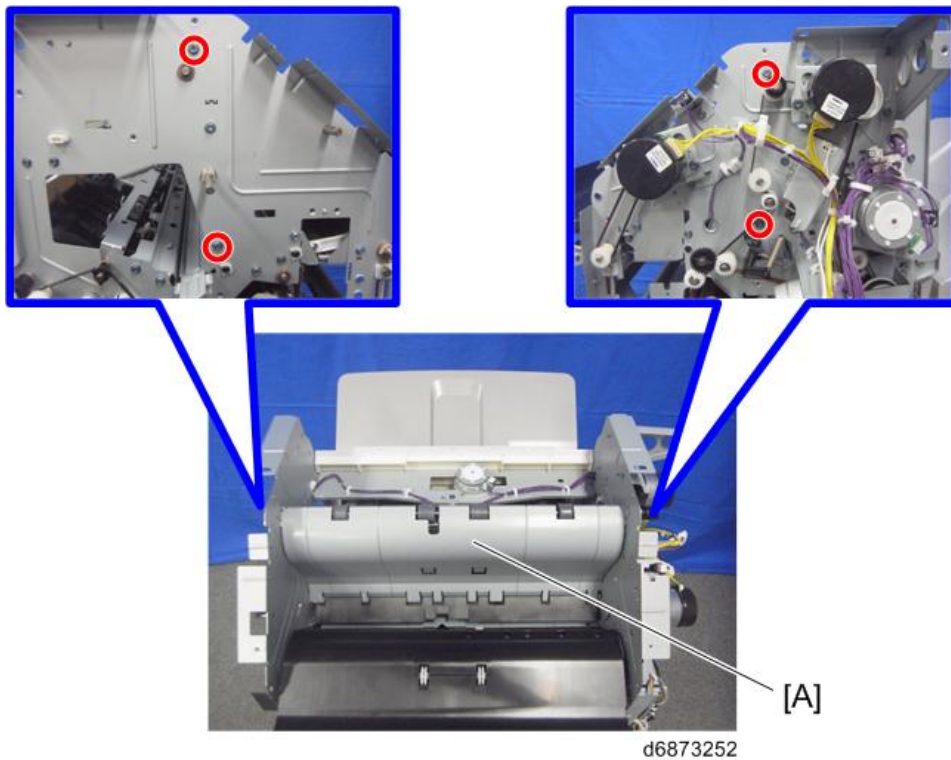

3. Proof paper eject sensor [A] (🔩 x1, 📡 x1)

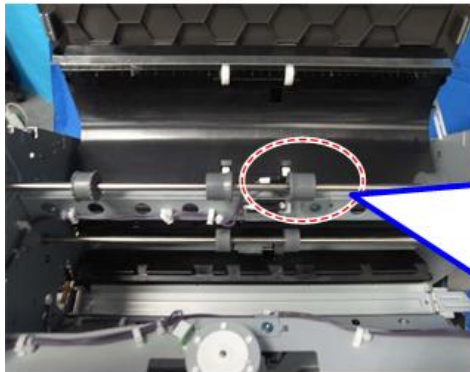

d687a0012

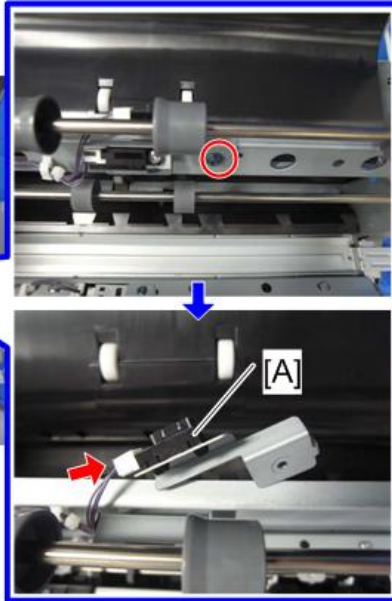

1.2.5 ENTRANCE SENSOR

1. Entrance sensor [A] (⊕ x1, ⊖ x1, ⚡ x1)

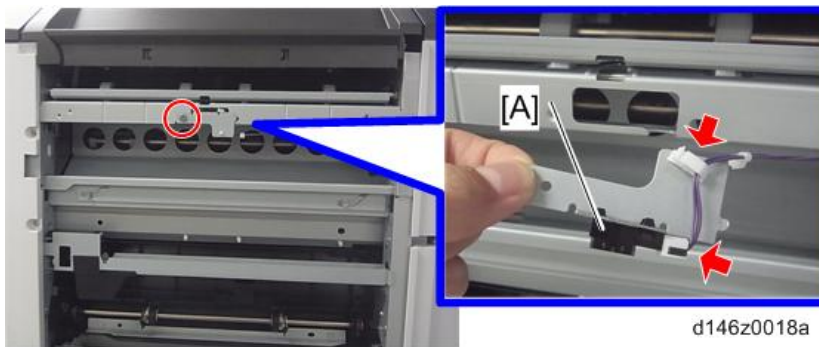

d146z0018a

1.2.6 INTERMEDIATE TRANSPORT SENSOR RIGHT

1. Open the upper cover (page 4).
2. Remove the clip of the upper cover [A].



d1822301

↓ Note

- When reattaching the upper cover, attach the clips so that their tabs face the inside of the unit.



d1822297

3. Intermediate transport sensor right [A] (🔩 x1, 📦 x1,)

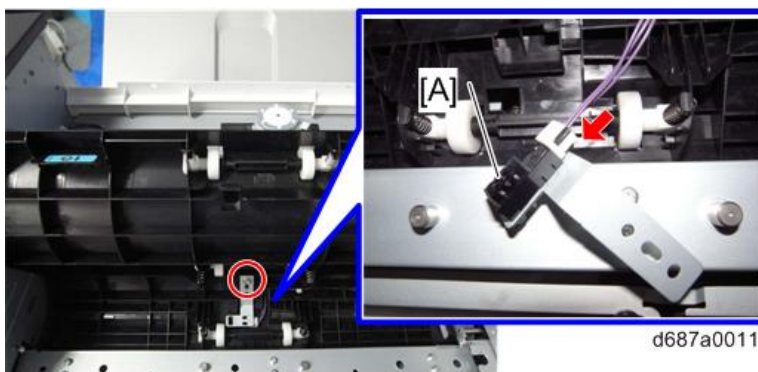

d687a0011

1.2.7 INTERMEDIATE TRANSPORT SENSOR LEFT

1. Proof tray (page 7)
2. Intermediate transport sensor left [A] (🔩 x1, 📦 x1, 🛠️ x1)

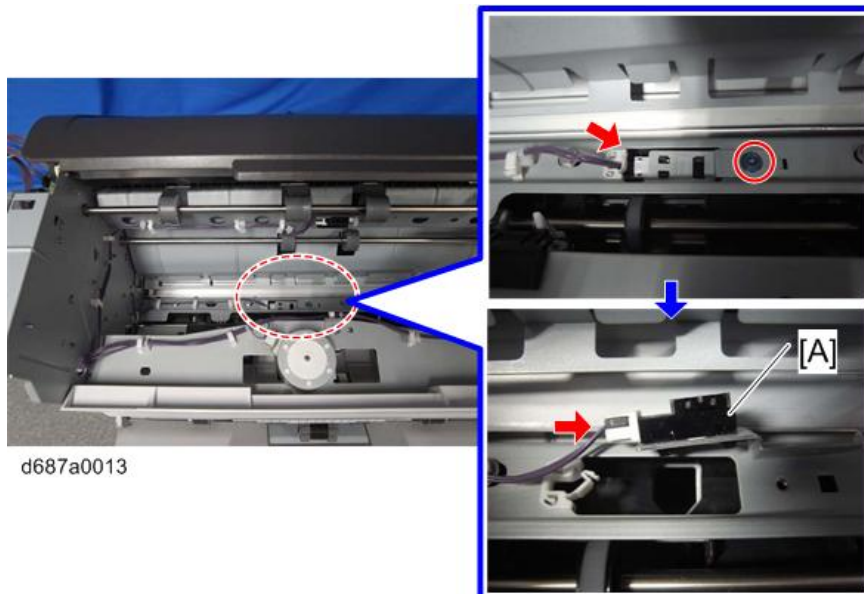

BOOKLET FINISHER
SR3150/ FINISHER
SR3140 (D686/D687)

1.2.8 SHIFT TRAY PAPER SURFACE SENSOR

1. Left center cover (page 9)
2. Bracket [A] (🔩 x4)

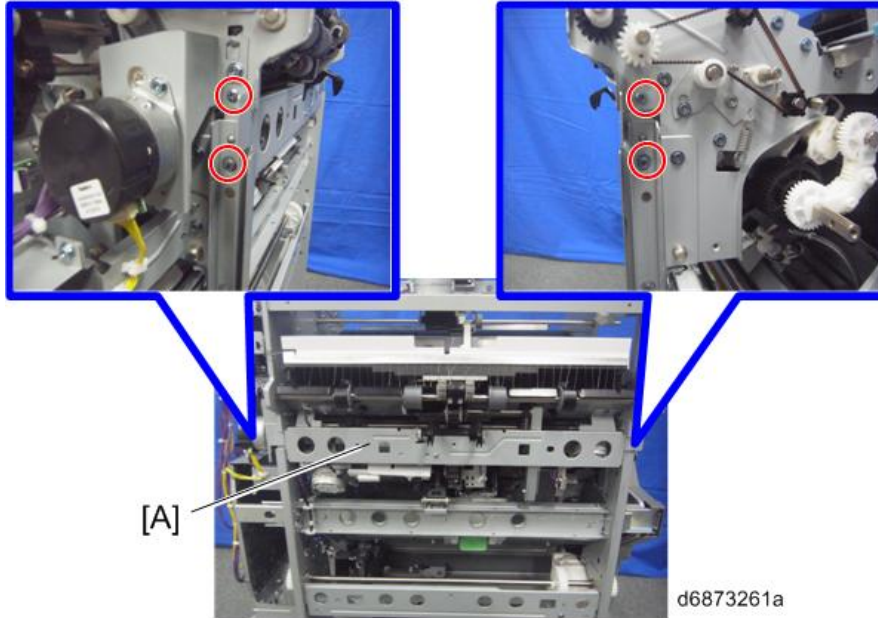

3. Shift tray paper surface sensor [A] (🔩 x1, 📦 x1)

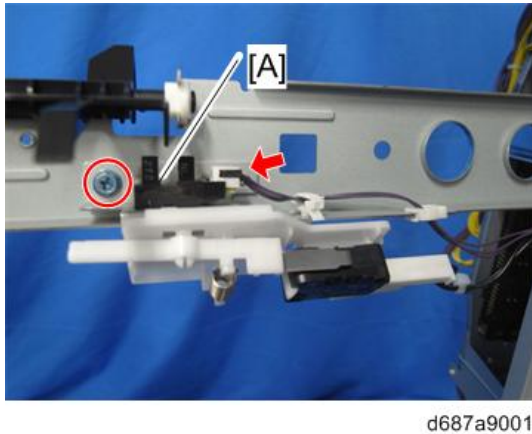

1.2.9 SHIFT TRAY UPPER LIMIT SWITCH

1. Bracket of the shift tray (page 16)
2. Shift tray upper limit switch [A] (📦 x2, hook x 1)

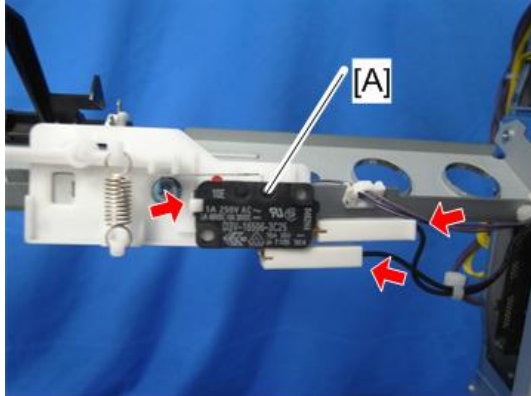

d687a9002

1.2.10 SHIFT TRAY PAPER EJECT SENSOR

1. Left center cover (page 9)
2. Shift tray paper eject sensor [A] (hook x1, 📦 x1, 📦 x1)

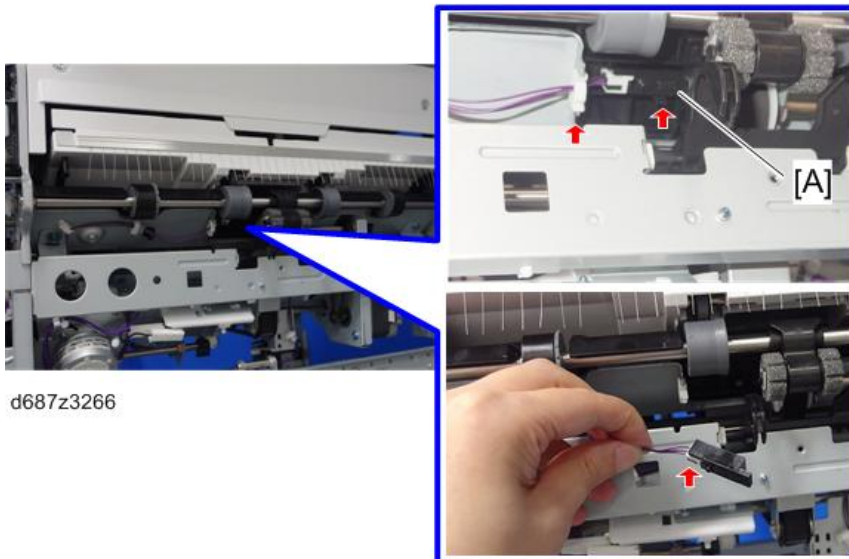

d687z3266

1.2.11 PROOF TRANSPORT MOTOR

1. Rear cover (page 3)
2. Proof transport motor [A] (🔩 x2, 📦 x1)

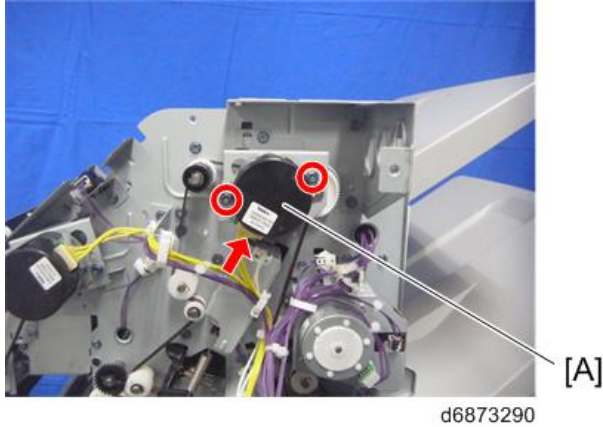

1.2.12 POSITIONING ROLLER MOTOR

1. Rear cover (page 3)
2. Positioning roller motor [A] (🔩 x2, 📦 x1)

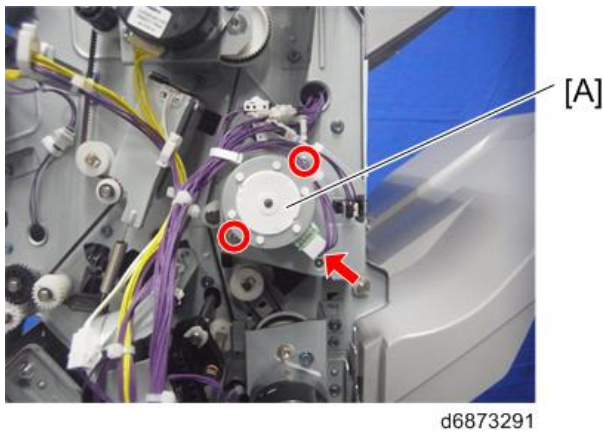

1.2.13 SHIFT MOTOR

1. Rear cover (page 3)
2. Shift motor [A] (⚙️ x2, 📦 x1)

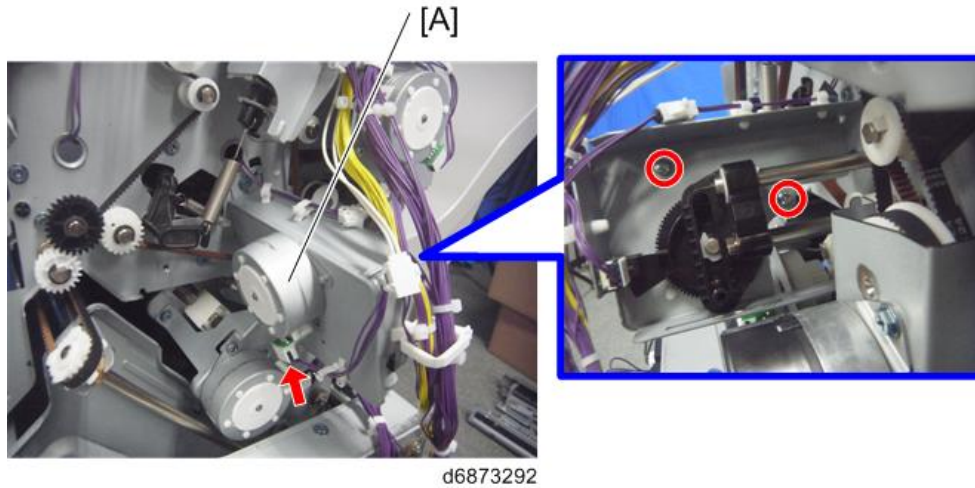

1.2.14 PAPER EJECT TRANSPORT MOTOR

1. Rear cover (page 3)
2. Paper eject transport motor [A] (⚙️ x2, 📦 x1)



1.2.15 PAPER BUNDLE TRANSPORT UPPER MOTOR

1. Rear cover (page 3)

2. Filler [A] (🔩 x1)



3. Control board bracket [A] (🔩 x5, 📦 x21, 🛠️ x17, ground platex1)

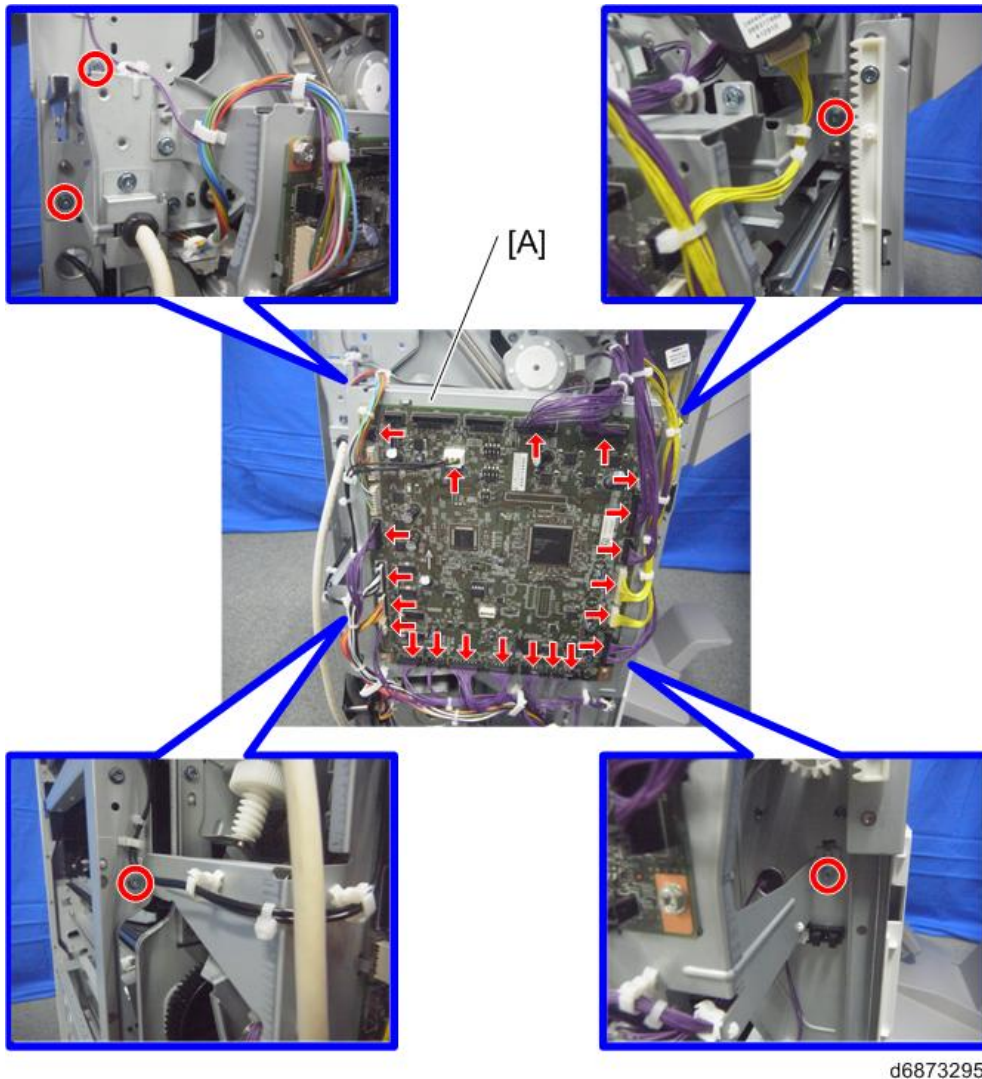

4. Paper bundle transport upper motor [A] (🔩 x2, 📦 x1)

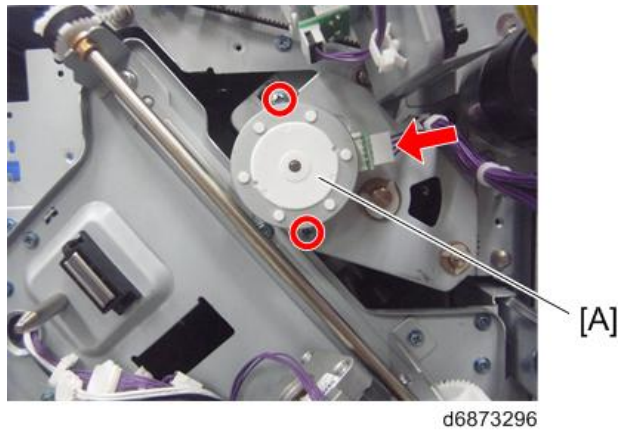

BOOKLET FINISHER
SR3150/ FINISHER
SR3140 (D686/D687)

1.2.16 STAPLER TRAY

1. Inner cover (page 2)
2. Front left cover (page 4)
3. Booklet stapler unit (Booklet Stapler Unit)
4. Paper eject transport motor bracket [A] (🔩 x2, 📦 x1)

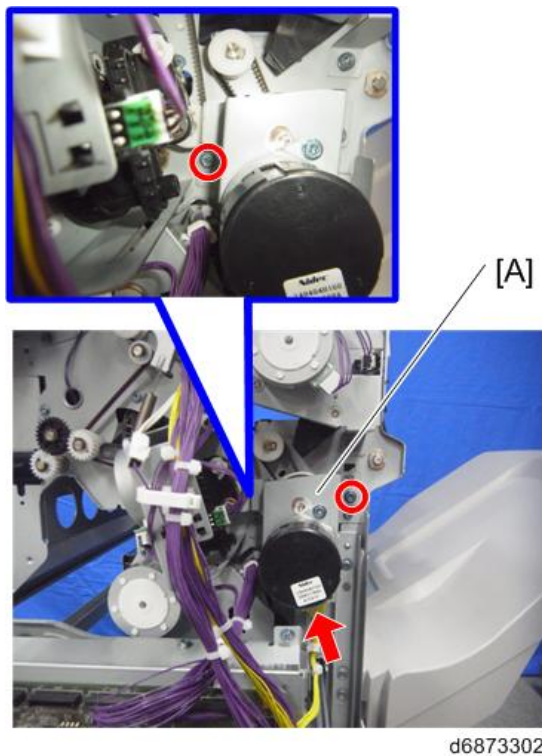

5. Approach roller (front) [A], approach roller (rear) [B]

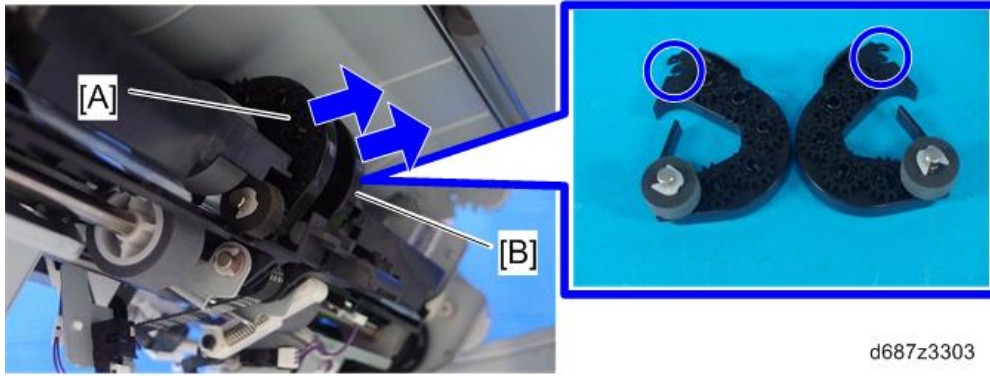

Note

- Be careful not to damage the shape of the claw enclosed by the blue circle when removing the approach rollers.

6. Stapler tray [A] (⚙️ x7, 📦 x2, 🛠️ x1)

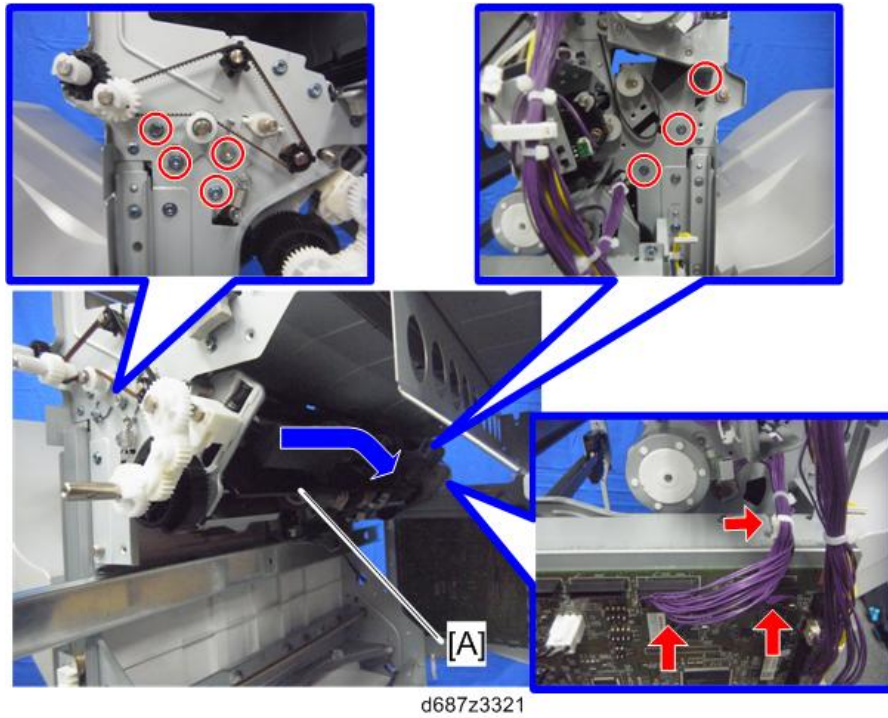

1.2.17 STAPLER TRAY PAPER DETECTION SENSOR

1. Stapler tray (page 21)
2. Stapler tray paper detection sensor bracket [A] (🔑 x1)

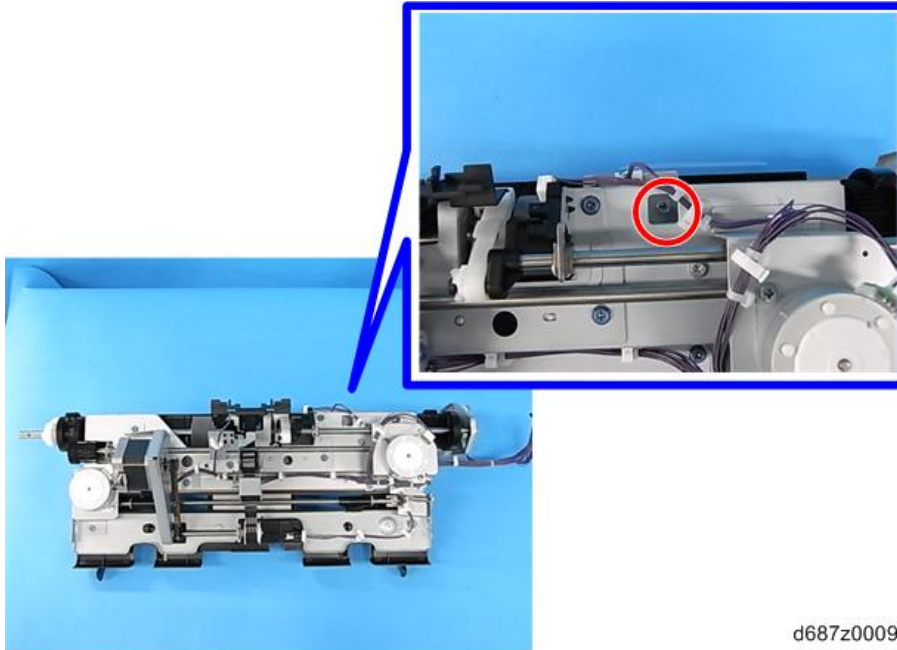

d687z0009

3. Stapler tray paper detection sensor [A] (🔑 x1, 📦 x1, 🌀 x1)

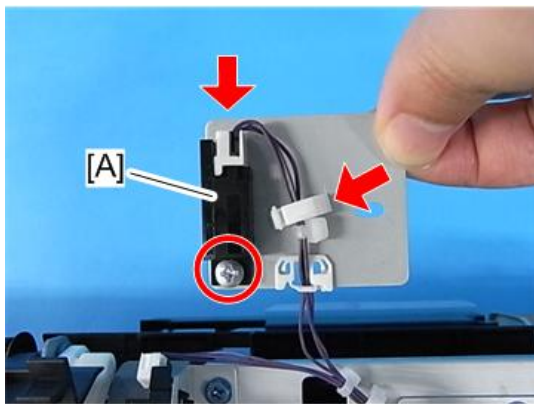

d687z0008

1.2.18 PAPER BUNDLE TRANSPORT UPPER PRESSURE RELEASE HP SENSOR

1. Stapler tray (page 21)
2. Paper bundle transport upper pressure release HP sensor [A] (📦 x1)

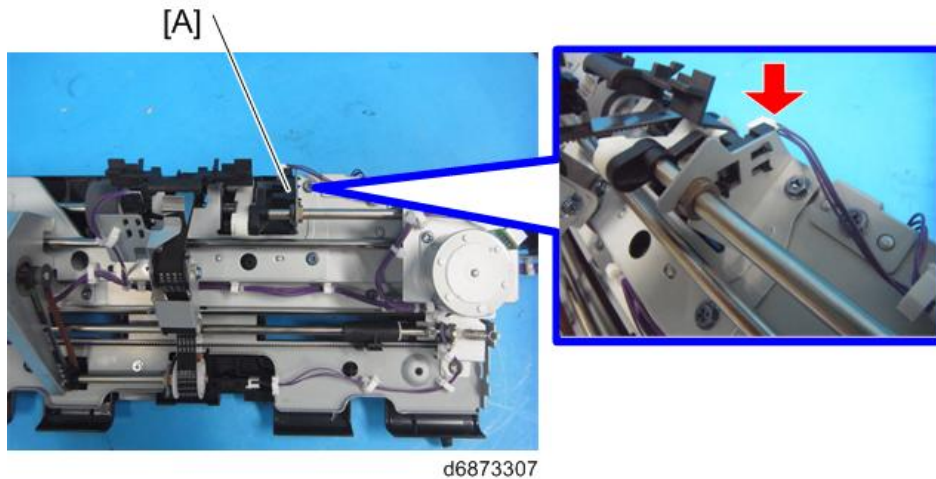

1.2.19 RELEASE CLAW HP SENSOR

1. Stapler tray (page 21)
2. Release claw HP sensor [A] (📦 x1)

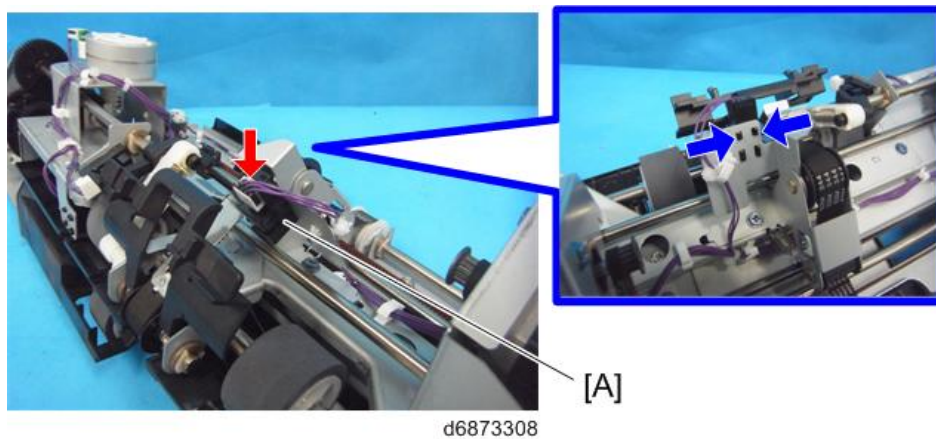

1.2.20 JOGGER HP SENSOR

1. Stapler tray (page 21)
2. Separate the jogger fence [A] from the jogger HP sensor [B].

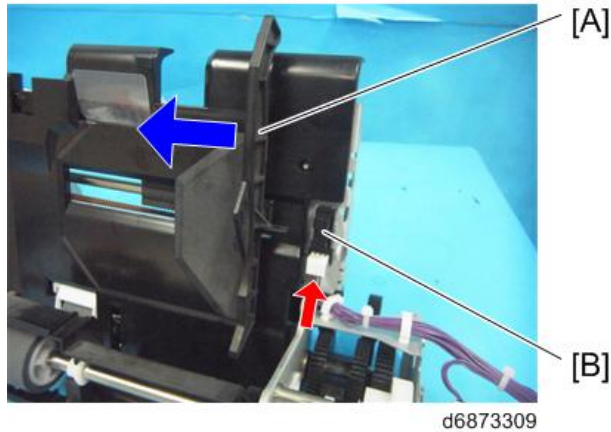

d6873309

3. Jogger HP sensor (📦 x1)

⬇ Note

- Release and remove the claw with a small driver, etc.

1.2.21 JOGGER MOTOR

1. Stapler tray (page 21)
2. Jogger motor [A] (🔩 x2, 📦 x1)

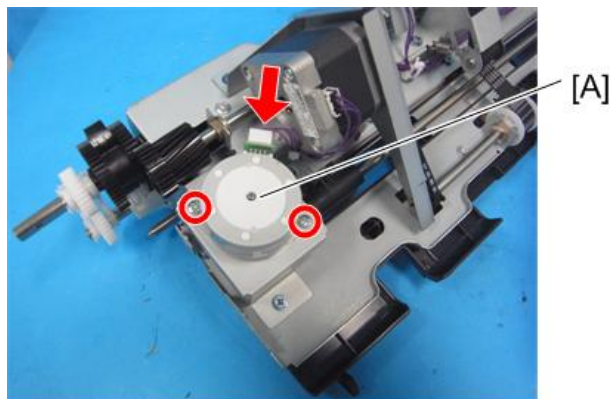

d6873310

1.2.22 PAPER BUNDLE TRANSPORT UPPER PRESSURE RELEASE MOTOR

1. Stapler tray (page 21)
2. Paper bundle transport upper pressure release motor [A] (🔩 x2, 📦 x1)

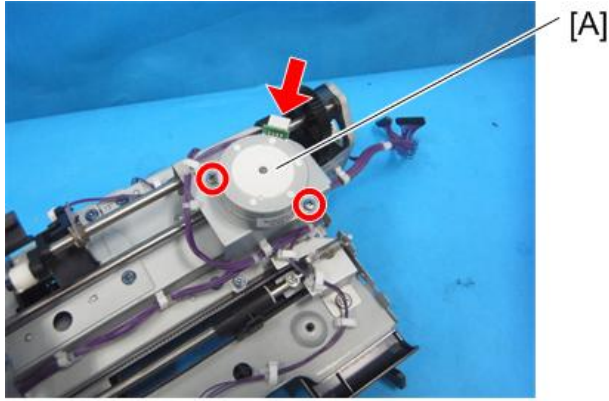

d6873311

1.2.23 RELEASE CLAW MOTOR

1. Stapler tray (page 21)
2. Release claw motor bracket [A] (⚙️ x2, 📦 x1, 🛠️ x2)

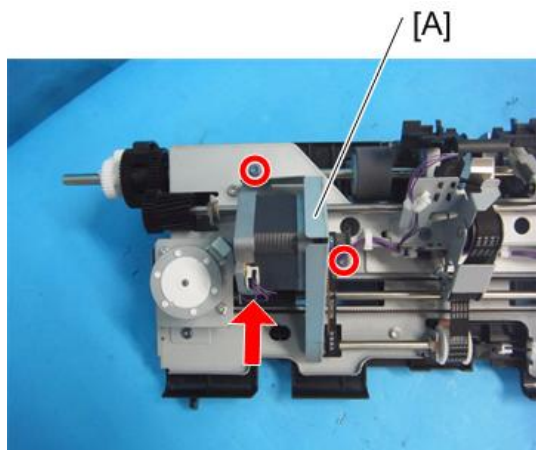

d6873312

3. Release claw motor [A] (⚙️ x2)

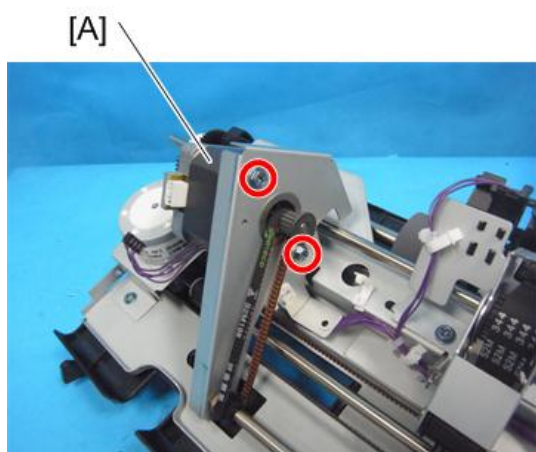

d6873313

1.3 BOARDS

1.3.1 MAIN CONTROL BOARD

Note

- An EEPROM is installed in the control board to record the drive frequency and number of sheets.
- When the control board is replaced, take the EEPROM off the old board and install it on the new one.
- (There is an EEPROM on the new main control board, but this is not needed and can be discarded or kept as a spare part.)

1. Rear cover (page 3)

2. Main control board [A] (⌀ x4, ⓧ x23)

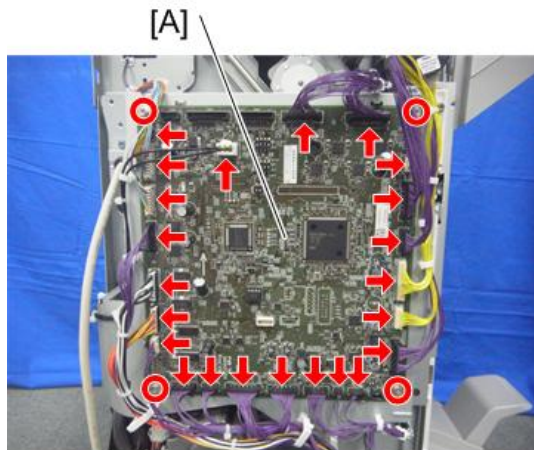

d6873289

BOOKLET FINISHER
SR3150/ FINISHER
SR3140 (D686/D687)

1.4 BOOKLET STAPLER UNIT

1.4.1 STAPLER UNIT

- 1. Open the front cover, and then remove two knobs (🔩 x1 for each)

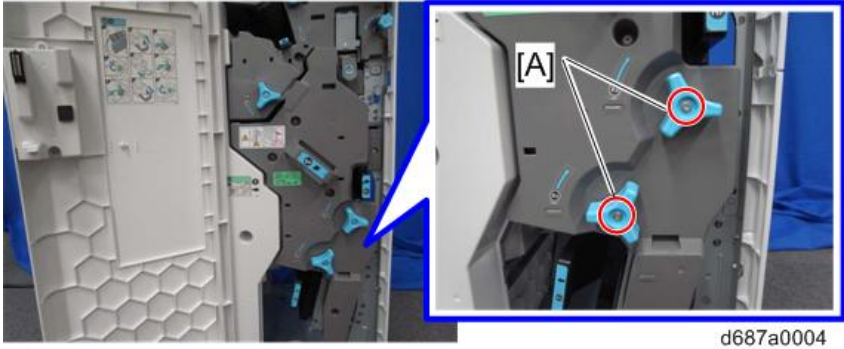

d687a0004

- 2. Booklet stitch unit cover (🔩 x4, 📦 x1)

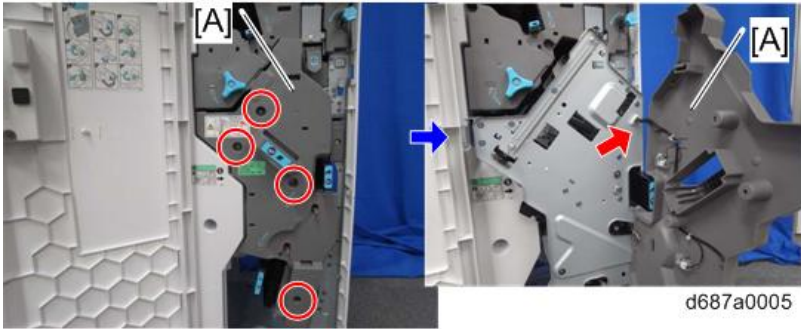

d687a0005

- 3. Pull out the booklet stitch unit, and then disconnect three connectors and release four clamps on the stapler unit.

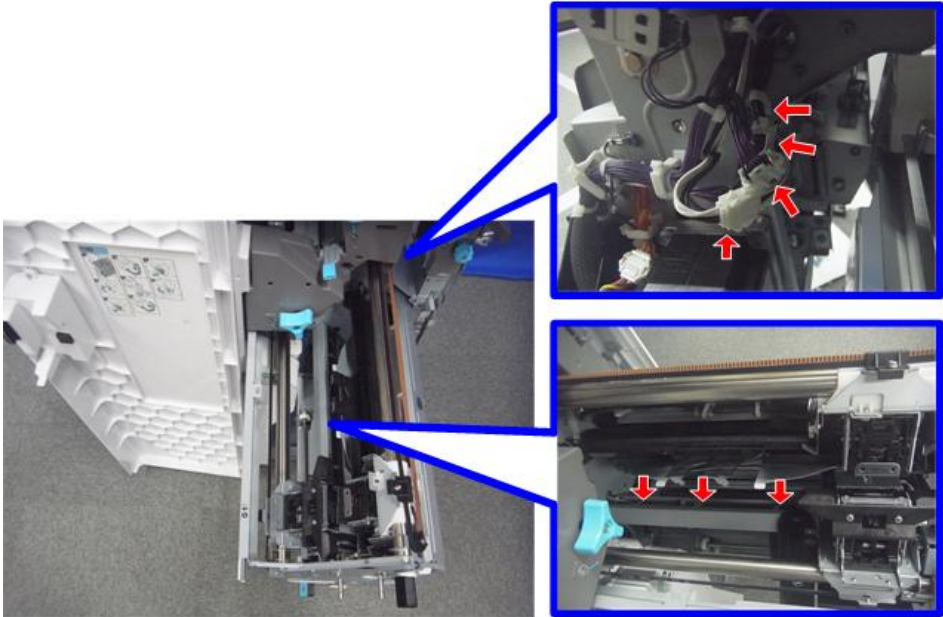

d687z0005

- 4. Bracket [A] (🔩 x4, 📦 x3, 📦 x1)

Booklet Stapler Unit

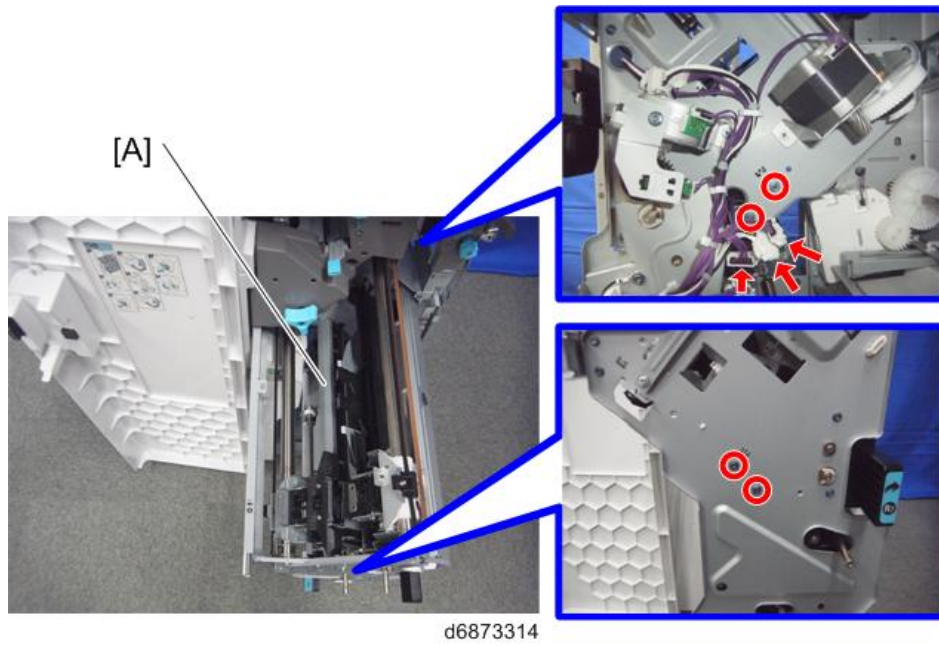

5. Bring the stapler unit [A] near the center.

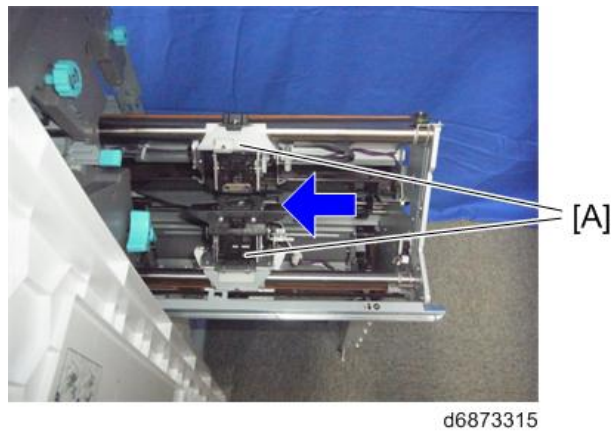

6. Guide plate [A] (Ⓜ x2)

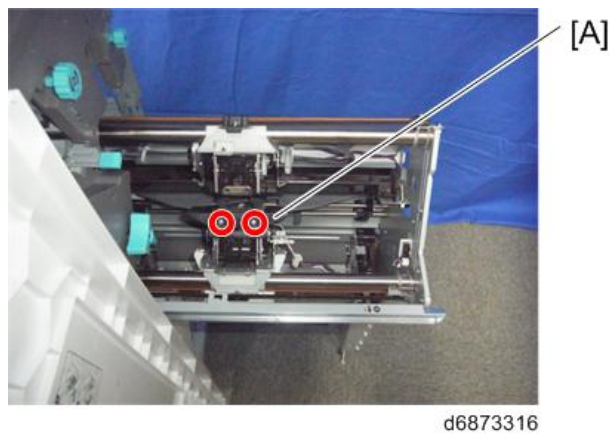

7. Stapler cartridge [A]

BOOKLET FINISHER
SR3150/ FINISHER
SR3140 (D686/D687)

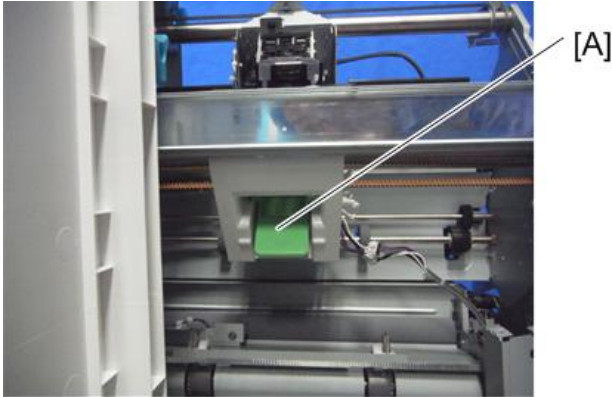

d6873317

8. Cover [A] (🔑 x2)

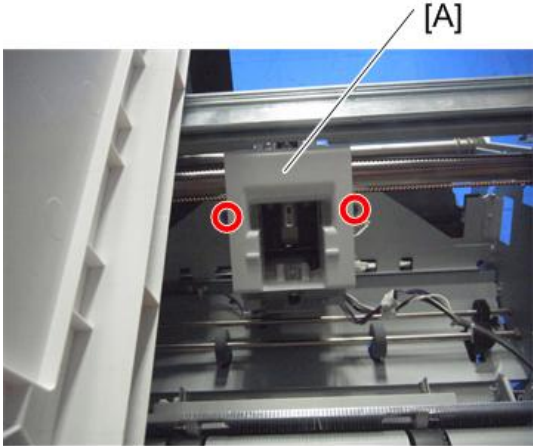

d6873318

9. Stapler unit (clincher side) [A] (🔑 x3, 📦 x2)

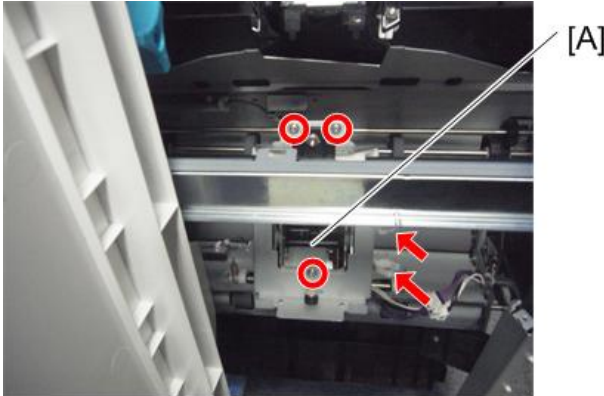

d687z0006

10. Disconnect three connectors and release four clamps on the stapler unit (driver side).

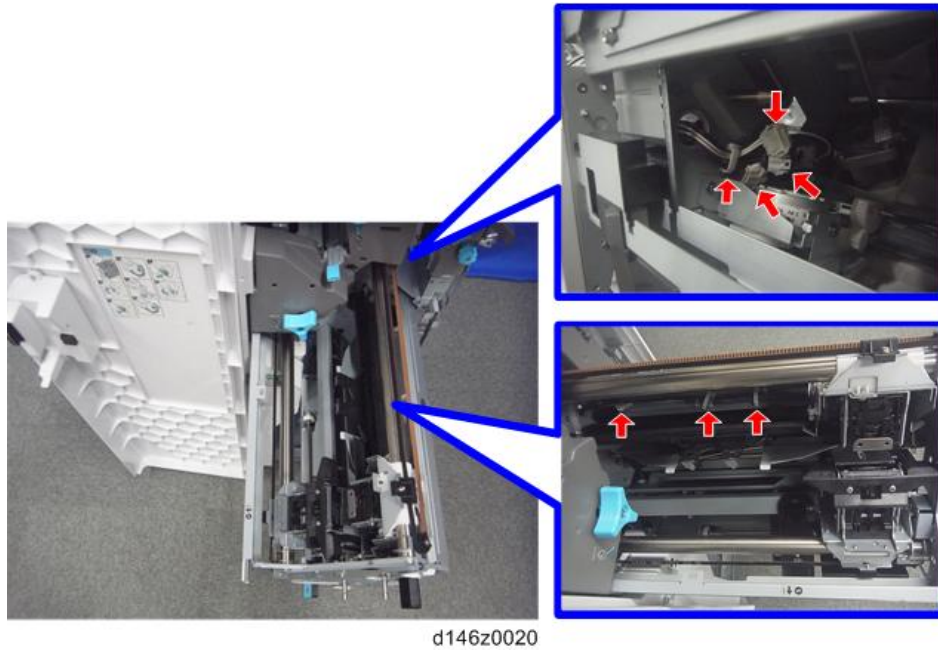

d146z0020

11. Stapler unit (driver side) [A] (🔑 x3, 🛠️ x4)

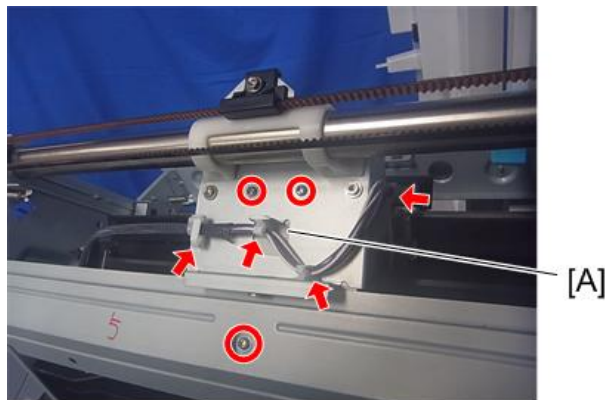

d146z0021

12. Attach the special tool to the stapler unit to adjust the staple position of the stapler unit.

Check that four pins ([A] and [B]) on the special tool are fixed in the slots [C] on the stapler unit as shown below.

[A]: Two pins for driver

[B]: Two pins for clincher

BOOKLET FINISHER
SR3150/ FINISHER
SR3140 (D686/D687)

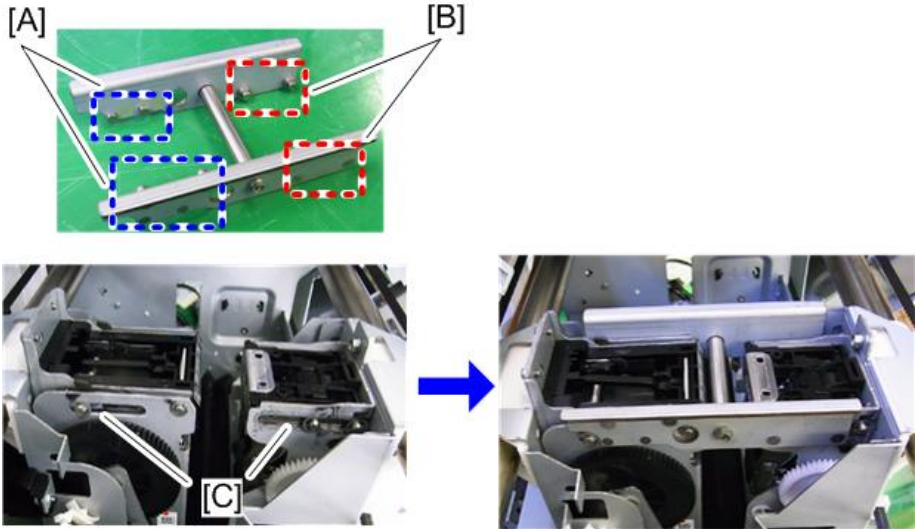

d687z2001

13. Tighten the wing screw [A] on the special tool to secure the stapler and special tool.

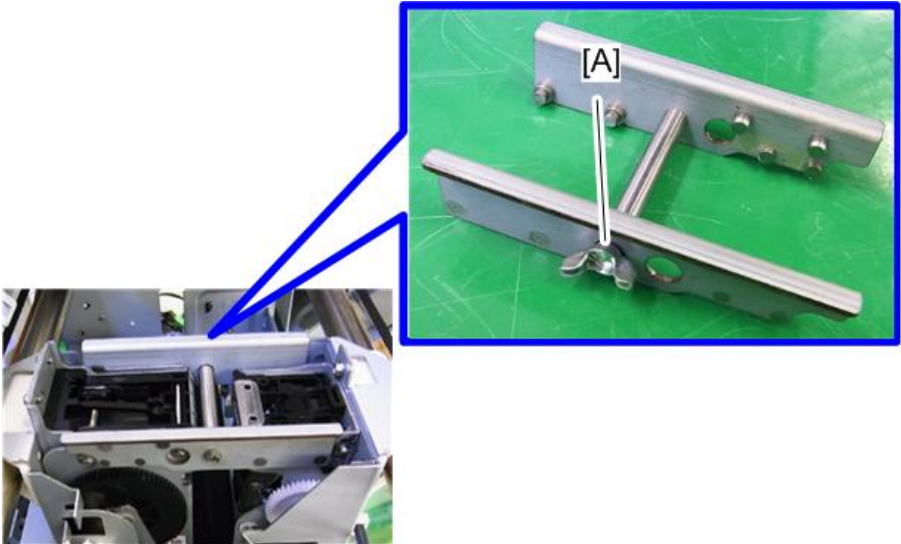

d687z2002

14. Tighten the screws completely to secure the clincher side [A] of the stapler (⚙️ x3).

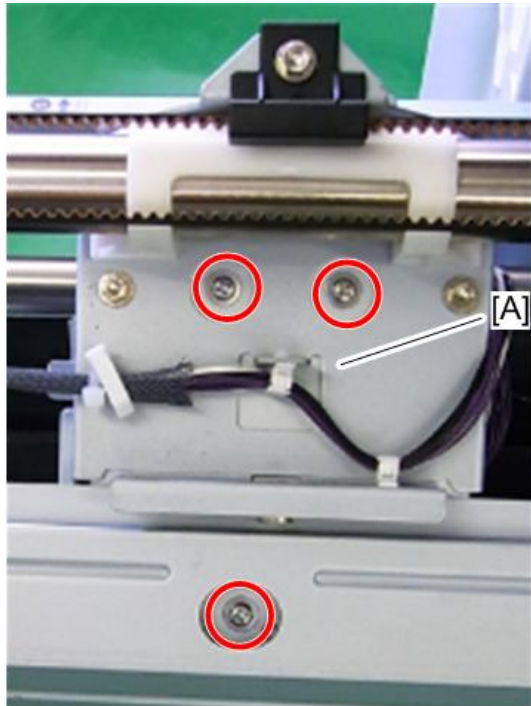

d687z2003

15. Loosen the wing screw to remove the special tool.

16. Reattach all the removed parts.

↓ Note

- Make sure that the harnesses [B] are routed behind the resin part [A]. Otherwise, the harnesses block the route of the stapler, which causes a stapler transfer motor error.

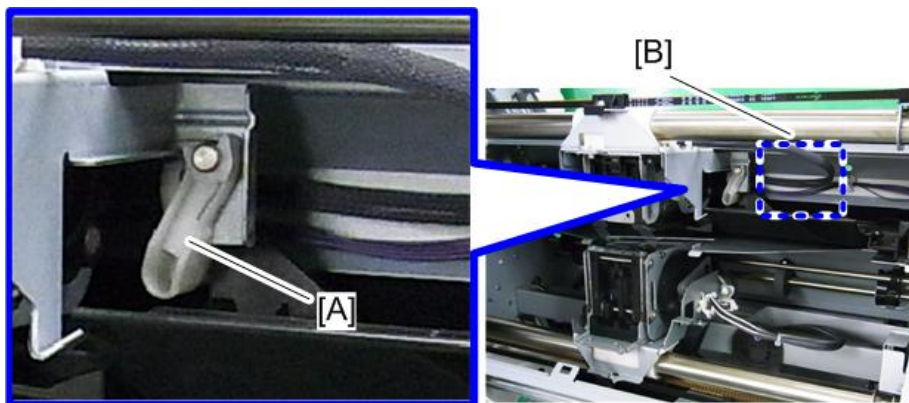

d687z2004

17. Check that the stapler works properly.

↓ Note

- All staple patterns must be checked.
- If there are any problems with the clincher, adjust the staple position with the special tool again.

1.4.2 BOOKLET STAPLER UNIT

1. Rear cover (page 3)
2. Remove connectors (🔌 x9, 🛠️ x2, ground plate x1)

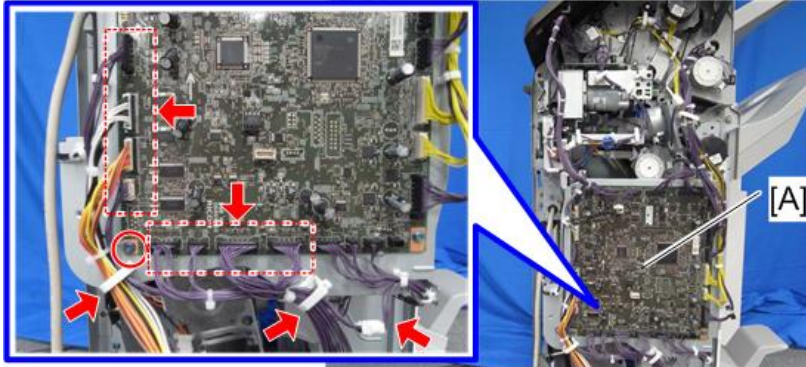

d687a0003

3. Stopper [A] (🛠️ x2)

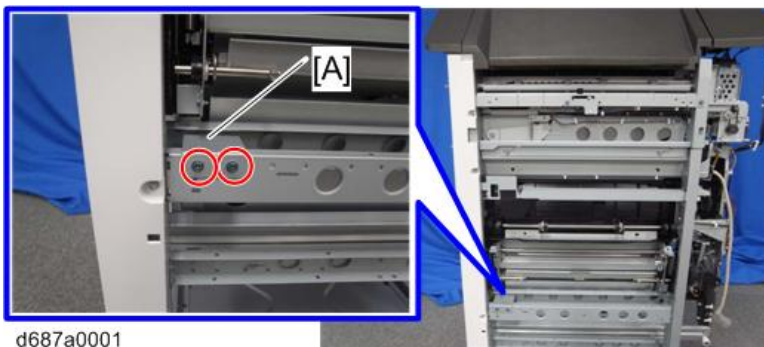

d687a0001

4. Open front cover (page 1)
5. Pull out the booklet stapler unit [A].
6. Booklet stapler unit (🛠️ x2)

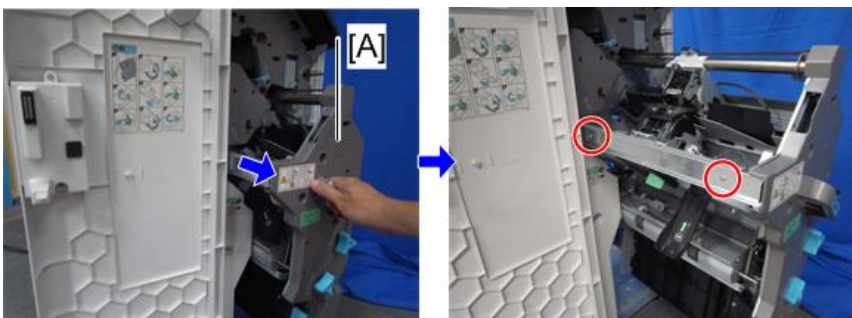

d687a0002

⚠️ Note

- When you remove the booklet stapler unit from the main frame, be careful not to catch the cable on the frame.

1.4.3 CENTER-FOLDING UNIT

1. Booklet stapler unit (page 35)

2. Knobs [A] (🔩 x2)

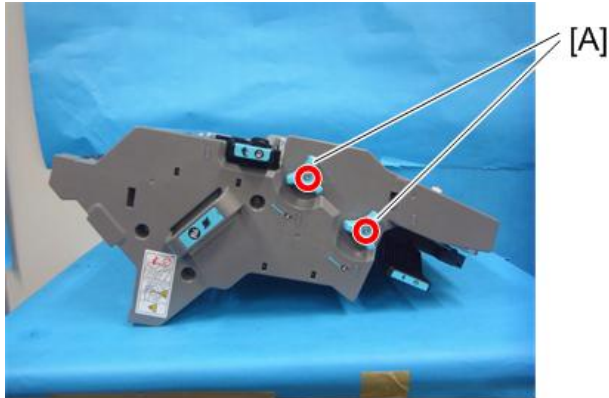

d6873271

3. Booklet stapler unit cover [A] (🔩 x4, 📦 x1)

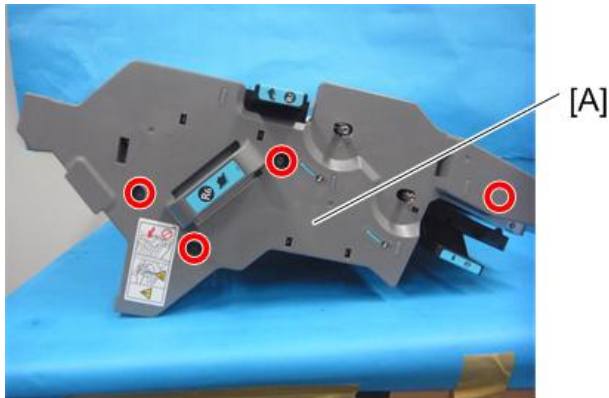

d687z0003

4. Remove connectors (🔩 x1, 📦 x4, 📦 x4, ground plate x1)

BOOKLET FINISHER
SR3150/ FINISHER
SR3140 (D686/D687)

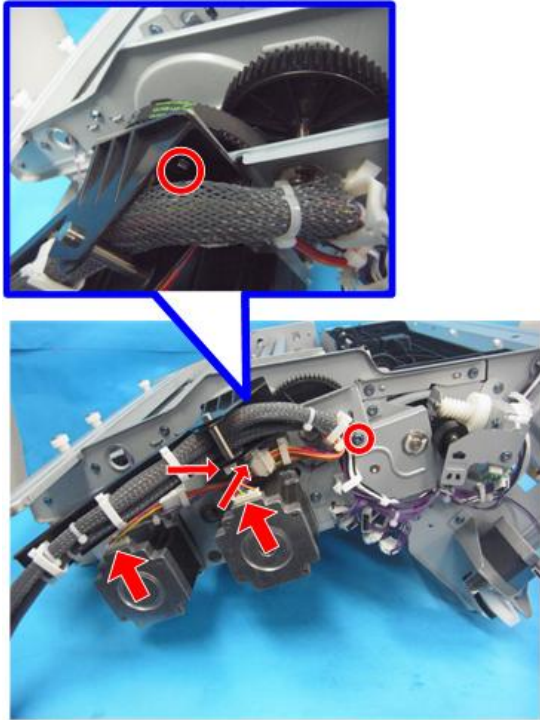

d6873273

5. Bracket [A] (🔩x1, 🛠x3, 🛠x1)

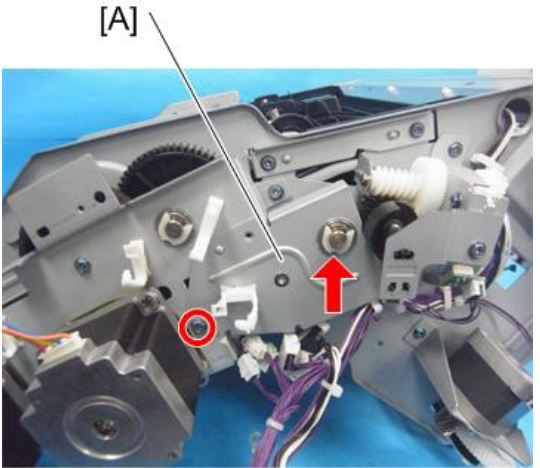

d6873274

6. Center-folding unit [A] (🔩x5)

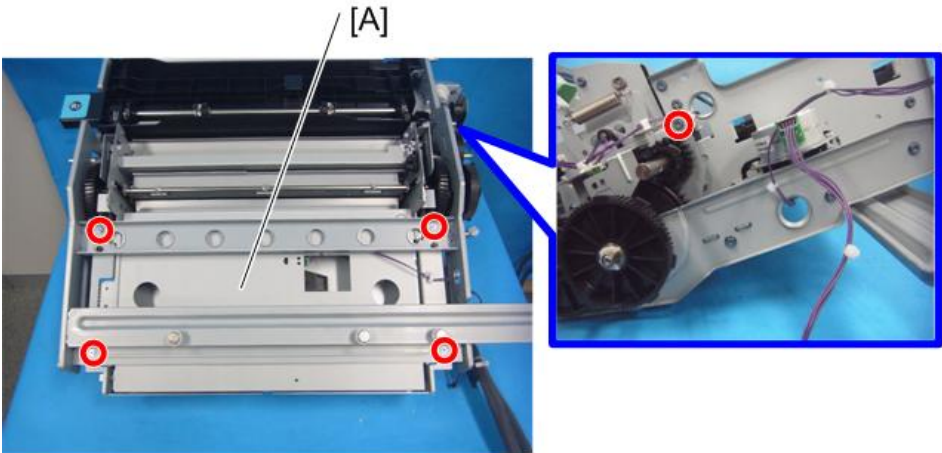

d6873275

1.4.4 CENTER-FOLDING TRAY PAPER EJECT SENSOR

1. Center-folding unit (page 36)
2. Center-folding tray paper eject sensor bracket [A] (🔩 x1, 📦 x1)



3. Center-folding tray paper eject sensor [A]

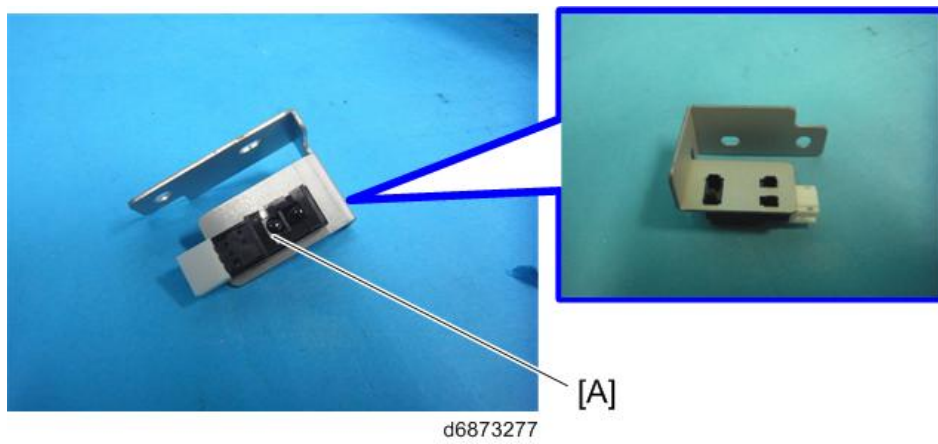

BOOKLET FINISHER
SR3150/ FINISHER
SR3140 (D686/D687)

1.4.5 TRAILING EDGE STOPPER TRANSPORT SENSOR

- 1. Center-folding unit (page 36)
- 2. Trailing edge stopper transport sensor bracket [A] (⚙️ x2, 📦 x1, 🛠️ x4)

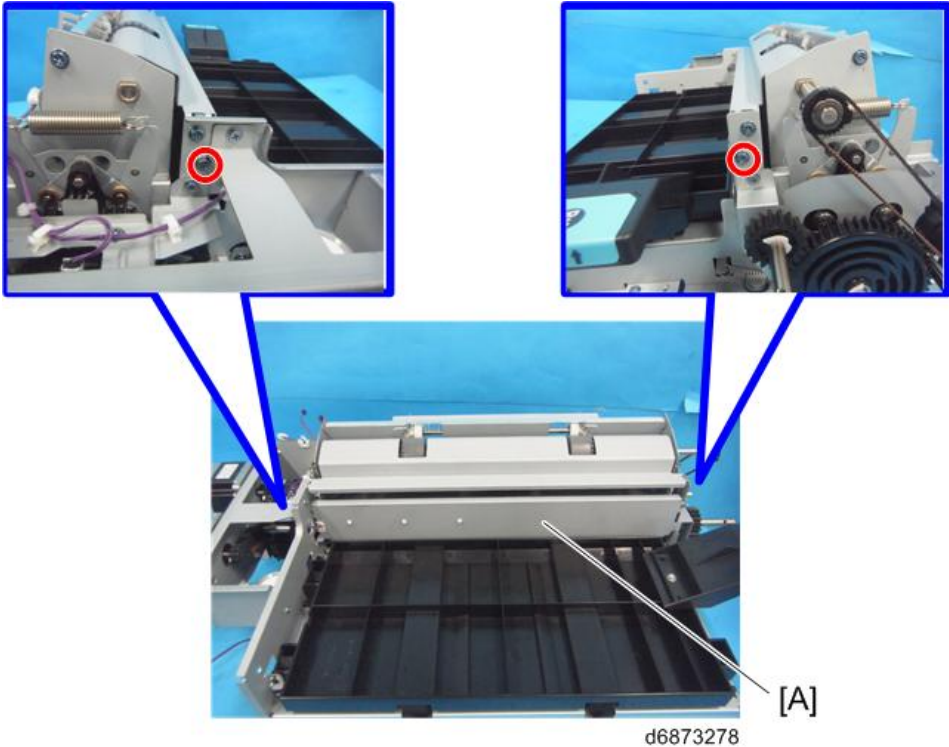

- 3. Trailing edge stopper paper surface sensor [A] (⚙️ x1)

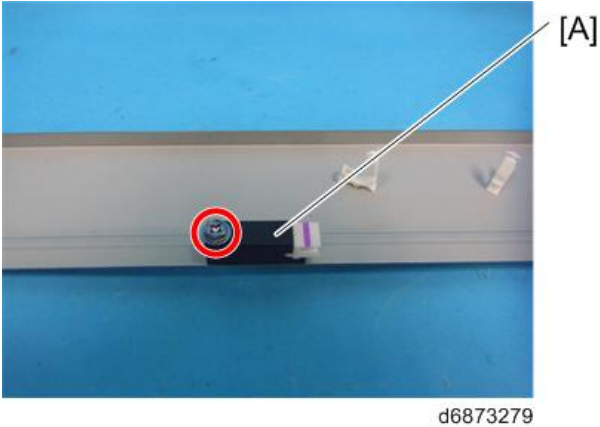

1.4.6 TRAILING EDGE STOPPER HP SENSOR

1. Center-folding unit (page 36)
2. Trailing edge stopper HP sensor [A] (📦 x1)

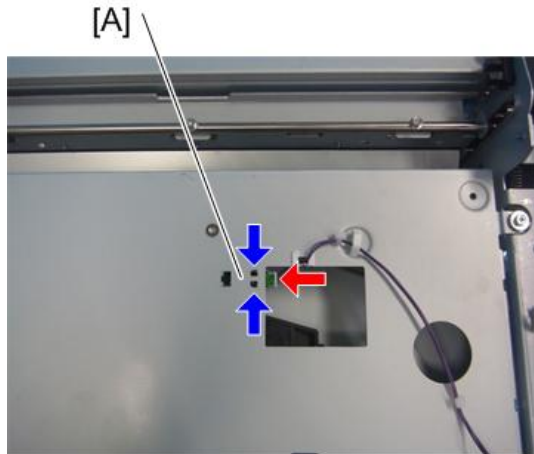

d6873280

1.4.7 CENTER-FOLDING BLADE HP SENSOR

1. Center-folding unit (page 36)
2. Center-folding blade HP sensor [A] (📦 x1)

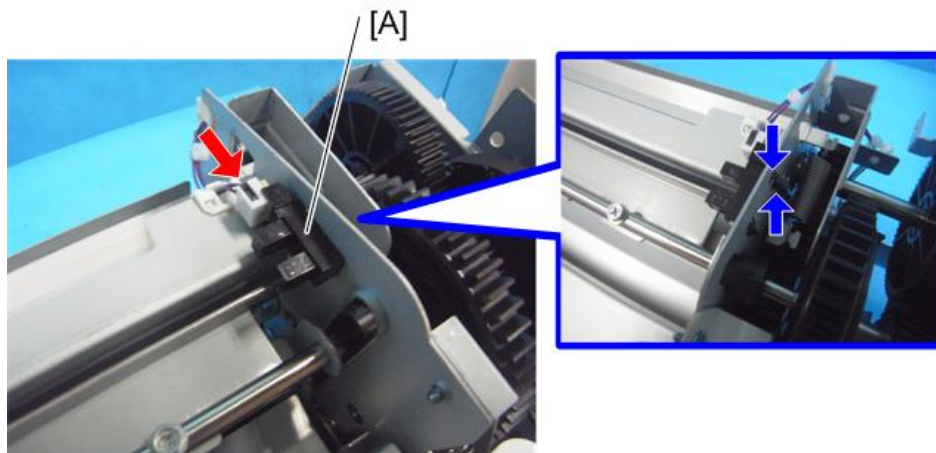

d6873281

BOOKLET FINISHER
SR3150/ FINISHER
SR3140 (D686/D687)

1.4.8 CENTER-FOLDING CAM HP SENSOR

- 1. Center-folding unit (page 36)
- 2. Center-folding cam HP sensor bracket [A] (🔩 x1, 🛠️ x2)

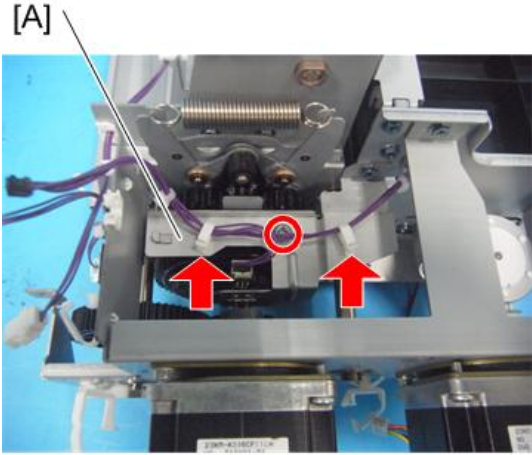

d6873282

- 3. Center-folding cam HP sensor [A] (📦 x1)

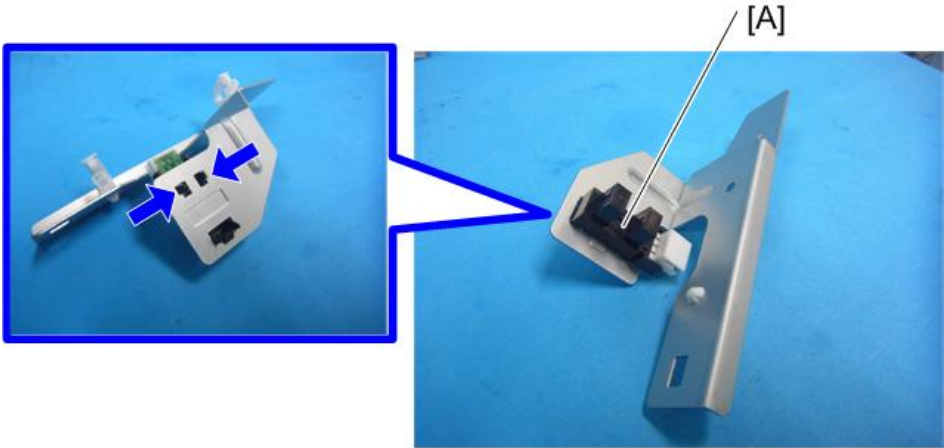

d6873283

1.4.9 TRAILING EDGE STOPPER MOTOR

1. Center-folding unit (page 36)
2. Trailing edge stopper motor [A] (🔩 x2, 📡 x1)

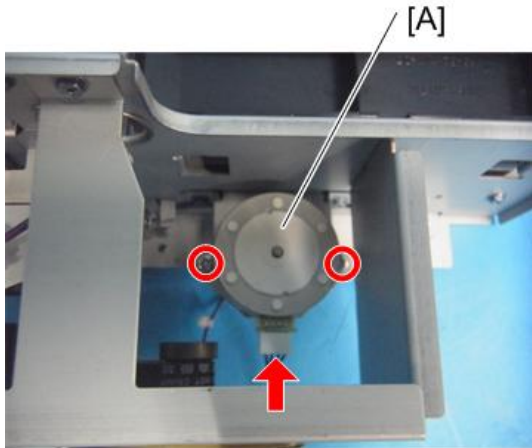

d6873284

1.4.10 FOLDING BLADE MOTOR

1. Center-folding unit (page 36)
2. Folding blade motor [A] (🔩 x2)

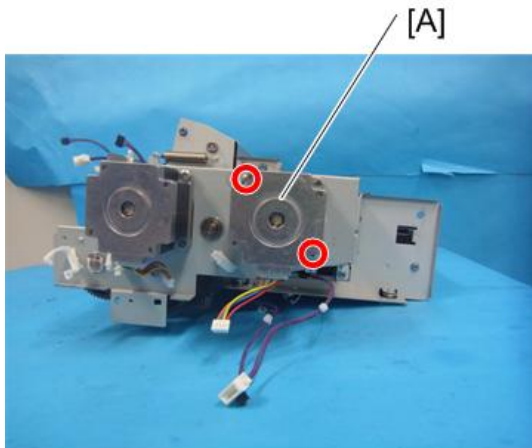

d6873285

1.4.11 FOLDING TRANSPORT MOTOR

1. Center-folding unit (page 36)
2. Folding transport motor [A] (🔩 x2)

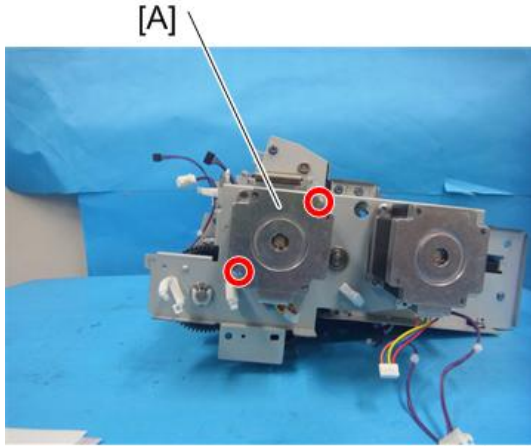

d6873286

BOOKLET FINISHER
SR3150/ FINISHER
SR3140 (D686/D687)

1.4.12 CENTER-FOLDING TRAY FULL SENSORS 1, 2

1. Pull out the booklet stitch unit (page 35)
2. Center-folding tray full sensor bracket [A] (🔩 x2, 📦 x2, 🛠️ x2)

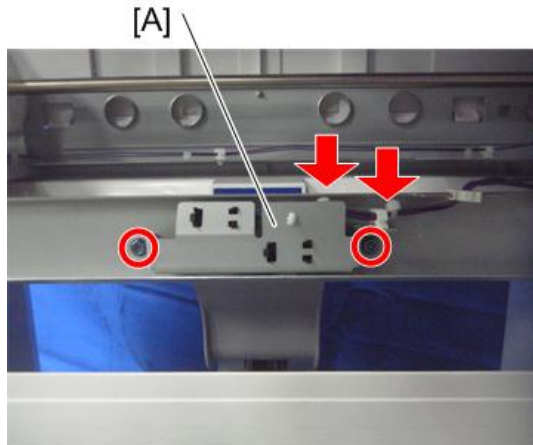

d6873287

3. Center-folding tray full sensor 1 [A], 2 [B]

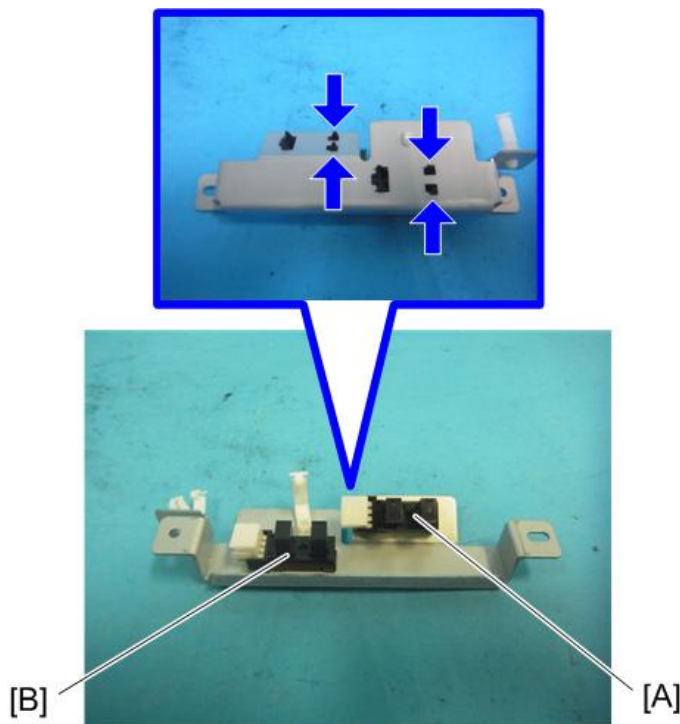

d6873288

1.4.13 STAPLER TRANSFER MOTOR (MIDDLE)

- 1. Control board bracket (page 20)
- 2. Stapler transfer motor (Mid.) [A] (⚙️ x2, 📦 x1)

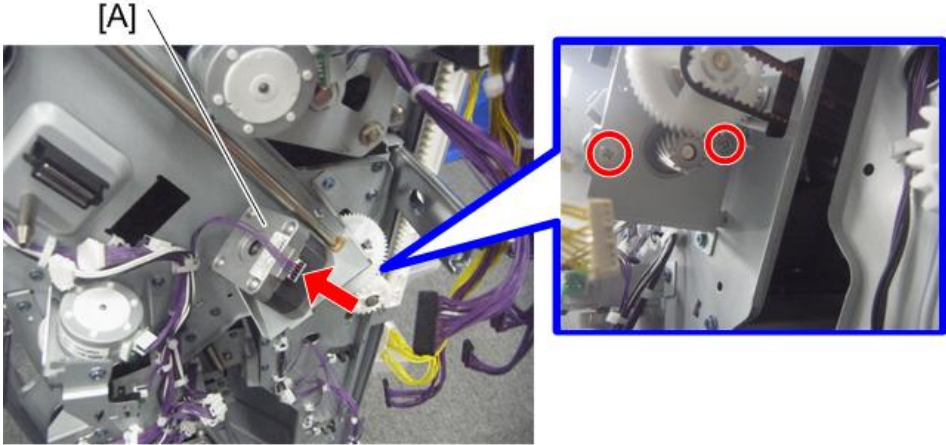

d6873297

BOOKLET FINISHER
SR3150/ FINISHER
SR3140 (D686/D687)

1.4.14 PAPER BUNDLE TRANSPORT LOWER PRESSURE RELEASE HP SENSOR

1. Control board bracket (page 20)
2. Paper bundle transport lower pressure release HP sensor bracket [A] (🔩 x1, 📦 x1)

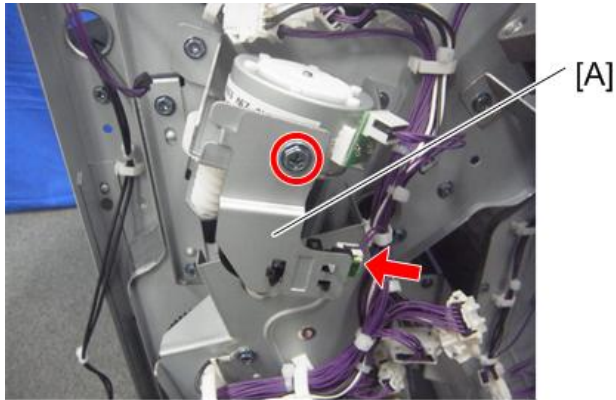

d6873300

3. Paper bundle transport lower pressure release HP sensor [A]

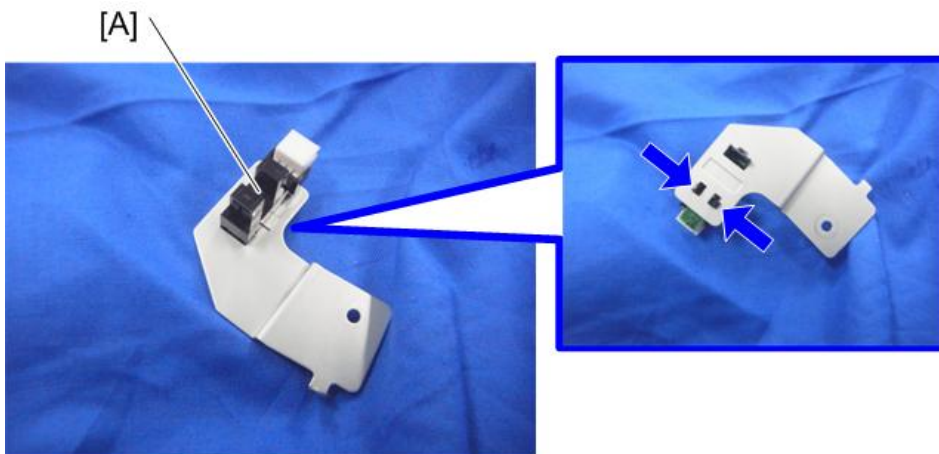

d6873301

D688/D689
Booklet Finisher SR3170 /
Finisher SR3160

REVISION HISTORY		
Page	Date	Added/Updated/New
		None

BOOKLET FINISHER SR3170 / FINISHER SR3160 (D688/D689)

TABLE OF CONTENTS

1. REPLACEMENT AND ADJUSTMENT	1
1.1 EXTERIOR COVERS	1
1.1.1 REAR UPPER COVER, REAR LOWER COVER, UPPER COVER, UPPER RIGHT COVER	1
1.1.2 FRONT COVER, FRONT LEFT SIDE COVER, FRONT INNER COVER	3
1.1.3 PAPER EXIT COVER	4
1.1.4 LOWER TRAY	5
1.1.5 PROOF TRAY	5
1.1.6 UPPER TRAY	6
1.1.7 END FENCE (D688 ONLY)	7
1.1.8 LEFT COVER (D689 ONLY).....	9
1.2 BOARDS.....	11
1.2.1 MAIN BOARD	11
When replacing the main board	11
1.3 CORNER STAPLING UNIT	13
1.3.1 CORNER STAPLING UNIT	13
1.3.2 STACKING ROLLER MOTOR.....	17
1.3.3 STACKING ROLLER HP SENSOR	18
1.3.4 LEADING EDGE GUIDE MOTOR	19
1.3.5 LEADING EDGE GUIDE HP SENSOR.....	20
1.3.6 TRAILING EDGE PRESSURE PLATE MOTOR.....	20
1.3.7 TRAILING EDGE PRESSURE PLATE HP SENSOR	21
1.3.8 SHIFT TRAY PAPER SENSOR.....	22
1.3.9 FEED OUT MOTOR	23
1.3.10 FEED OUT GUIDE HP SENSOR.....	23
1.3.11 JOGGER MOTOR.....	24
1.3.12 JOGGER HP SENSOR	25
1.3.13 SHIFT TRAY EXIT SENSOR	26
1.3.14 STAPLE TRAY PAPER SENSOR.....	27
1.4 MAIN UNIT.....	28







1.4.1 TRAY EXIT MOTOR	28
1.4.2 MIDDLE TRANSPORT MOTOR	28
1.4.3 PRE-STACK TRANSPORT MOTOR	29
1.4.4 ENTRANCE TRANSPORT MOTOR.....	30
1.4.5 HORIZONTAL TRANSPORT MOTOR	31
1.4.6 TRAY LIFT MOTOR.....	31
1.4.7 LOWER JUNCTION GATE MOTOR.....	33
1.4.8 SHIFT MOTOR / LOWER JUNCTION GATE HP SENSOR / SHIFT ROLLER HP SENSOR.....	34
1.4.9 PAPER EXIT GATE MOTOR.....	36
1.4.10 PAPER EXIT GATE HP SENSOR	38
1.4.11 CORNER STAPLING PAPER SENSORS	39
1.4.12 PROOF TRAY FULL SENSOR	40
1.4.13 PROOF TRAY EXIT SENSOR.....	40
1.4.14 POSITIONING ROLLER MOTOR / FEED OUT GUIDE HP SENSOR.....	41
1.4.15 ENTRANCE SENSOR	42
1.4.16 HORIZONTAL TRANSPORT SENSOR	43
1.4.17 SWITCHBACK TRANSPORT SENSOR / PAPER TRANSPORT SENSOR.....	44
1.4.18 SHIFT TRAY LOWER LIMIT SENSORS.....	45
1.4.19 BOOKLET PAPER FULL SENSOR 1, BOOKLET PAPER FULL SENSOR 2 (D688 ONLY)	46
1.5 BOOKLET UNIT (D688 ONLY)	47
1.5.1 BOOKLET UNIT	47
1.5.2 PRESS FOLDING MOTOR	50
1.5.3 BOOKLET JOGGER MOTOR	53
1.5.4 BOOKLET GUIDE MOTOR	53
1.5.5 MOVEMENT ROLLER TRANSPORT MOTOR	54
1.5.6 BOOKLET FENCE MOTOR	54
1.5.7 FOLDING TRANSPORT MOTOR.....	55
1.5.8 BOOKLET STAPLER MOTOR UNIT	55
1.5.9 TRAY UPPER LIMIT SWITCH.....	56
1.5.10 FOLDING BLADE CAM HP SENSOR.....	59
1.5.11 BOTTOM PAPER EXIT SENSOR.....	61
1.5.12 BOOKLET PAPER SENSOR (UPPER)	63
1.5.13 BOOKLET PAPER SENSOR (LOWER).....	64
1.5.14 BOOKLET ADJUSTMENT HP SENSOR	64
1.5.15 BOOKLET JOGGER HP SENSOR	65

1.5.16	BOOKLET GUIDE SENSOR	66
1.5.17	BOOKLET BOTTOM FENCE HP SENSOR	67
1.6	PUNCH UNIT	68
1.7	ADJUSTMENT OF THE FLAT FOLD BOOKLET UNIT	70
1.7.1	ADJUSTING THE ALIGNMENT OF THE FLAT FOLD ROLLERS.....	70
1.7.2	ADJUSTING THE FOLDING SPEED	73
1.8	STAPLER UNIT	74
1.8.1	STAPLER MOVEMENT MOTOR	75
1.8.2	STAPLER MOVEMENT HP SENSOR.....	76

READ THIS FIRST

Safety and Symbols

This manual uses several symbols and abbreviations. The meaning of those symbols and abbreviations are as follows:

	Clip ring
	Screw
	Connector
	Clamp
	E-ring
	Spring
	Timing belt
SEF	Short Edge Feed
LEF	Long Edge Feed



[A]

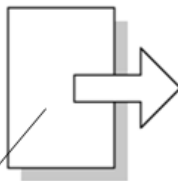

[B]

c2790086

[A] Short Edge Feed (SEF)

[B] Long Edge Feed (LEF)

Trademarks

Microsoft[®], Windows[®], and MS-DOS[®] are registered trademarks of Microsoft Corporation in the United States and /or other countries.

PostScript[®] is a registered trademark of Adobe Systems, Incorporated.

PCL[®] is a registered trademark of Hewlett-Packard Company.

Ethernet[®] is a registered trademark of Xerox Corporation.

PowerPC[®] is a registered trademark of International Business Machines Corporation.

Other product names used herein are for identification purposes only and may be trademarks of their respective companies. We disclaim any and all rights involved with those marks.

The Aim of Anti-tip Components and Precautions

The anti-tip components are necessary for meeting the requirements of IEC60950-1, the international standard for safety.

The aim of these components is to prevent the products, which are heavy in weight, from toppling as a result of people running into or leaning onto the products, which can lead to serious accidents such as persons becoming trapped under the product. (U.S.: UL60950-1, Europe: EN60950-1)

Therefore, removal of such components must always be with the consent of the customer.

Do not remove them at your own judgment.

1. REPLACEMENT AND ADJUSTMENT

1.1 EXTERIOR COVERS

1.1.1 REAR UPPER COVER, REAR LOWER COVER, UPPER COVER, UPPER RIGHT COVER

1. Rear upper cover [A] (🔩 x2)

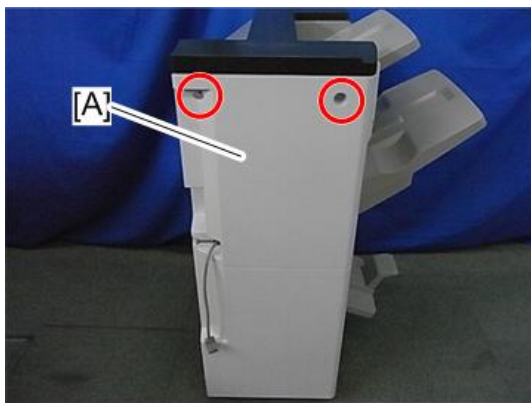

d689z1107

2. Rear lower cover [A] (🔩 x2)

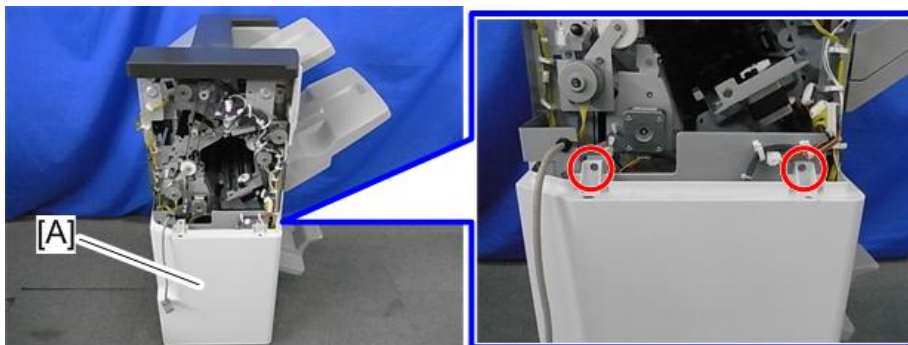

d689z1108

3. Open the front door [A], and remove the screws secured on the front side of the upper cover [B] (🔩 x2)

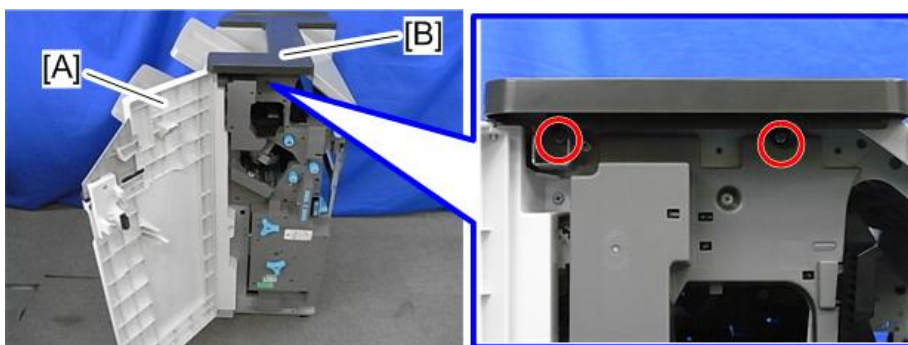

d689z1109

4. Remove the screws secured on the rear side of the upper cover [A] (🔩 x2, hookx2)

Exterior Covers

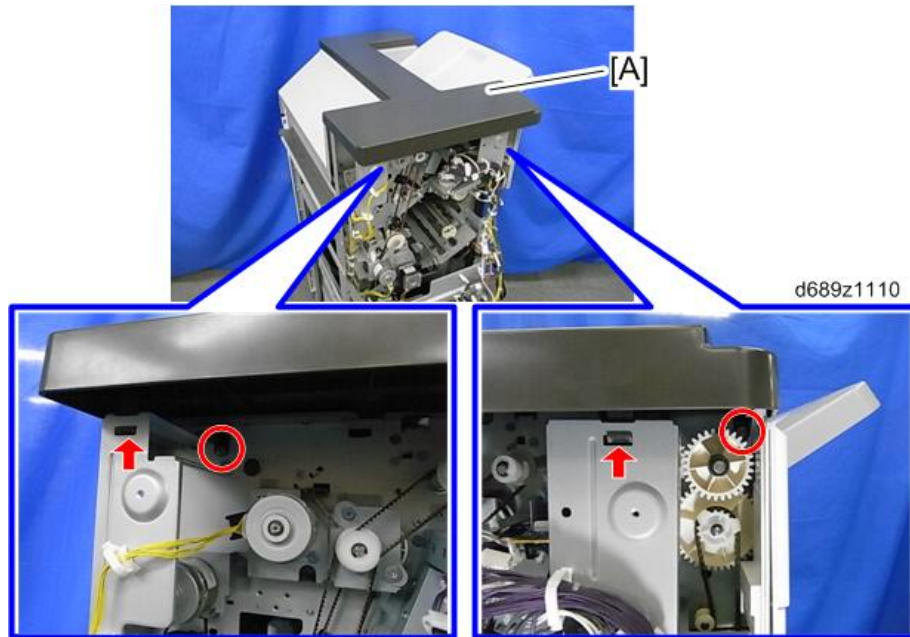

↓ Note

- Check the positions of the bosses and hooks before removing the upper cover.

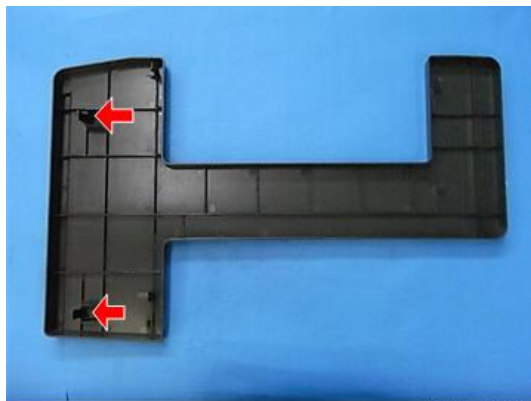

5. Upper right cover [A] (⊙ x2)

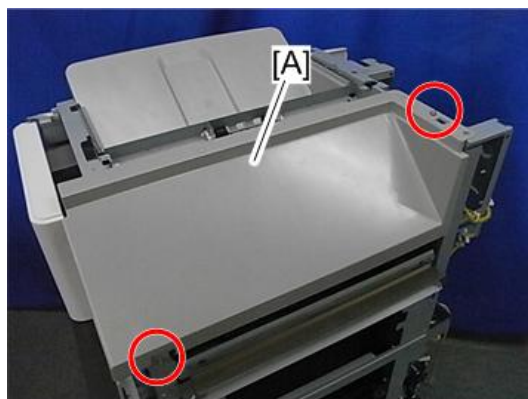

1.1.2 FRONT COVER, FRONT LEFT SIDE COVER, FRONT INNER COVER

1. Open the front cover [A].
2. Release the shaft bracket [B] (upper direction) (🔩 x1).
3. Front cover [A].

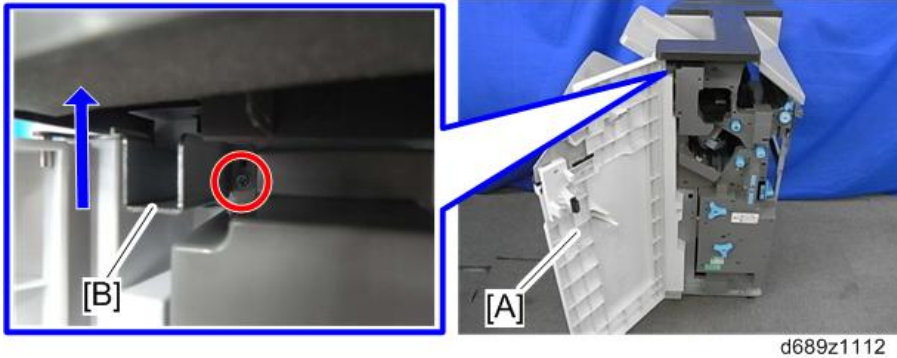

4. Front left side cover [A] (🔩 x2)

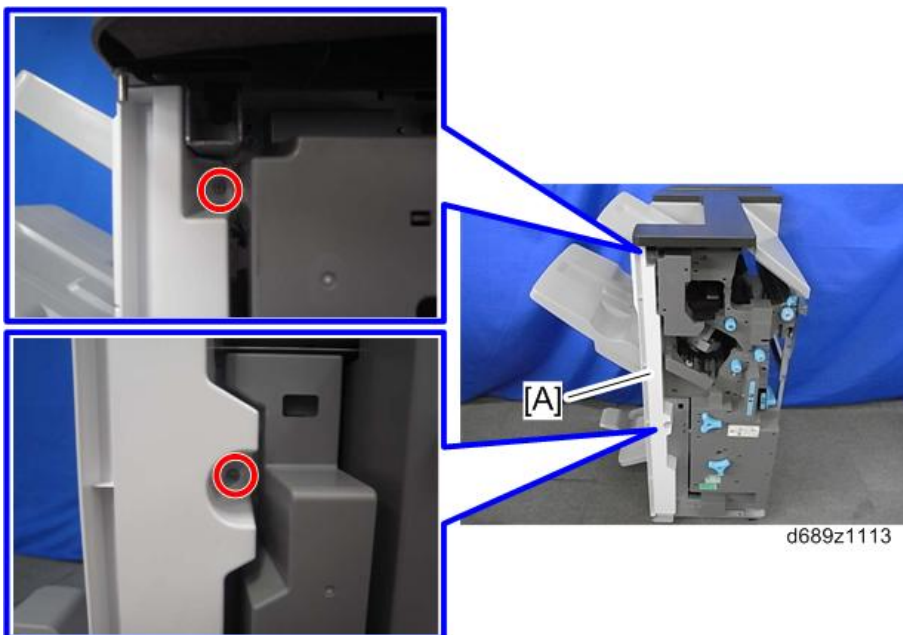

5. D688 only: Slightly pull out the booklet unit [A]
6. Front inner cover [B] (🔩 x1, 🛠️ x2)

📌 Note

- Note that there is a LED connector inside the front inner cover. Be careful when removing the front inner cover.

Exterior Covers

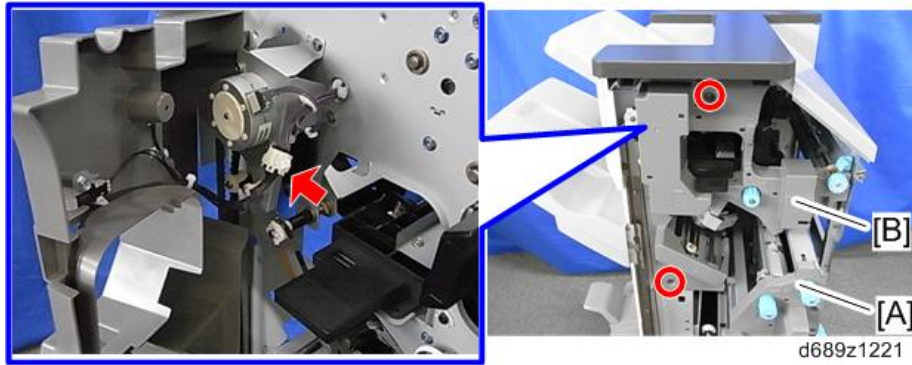

1.1.3 PAPER EXIT COVER

1. Paper exit cover [A] (hookx4)

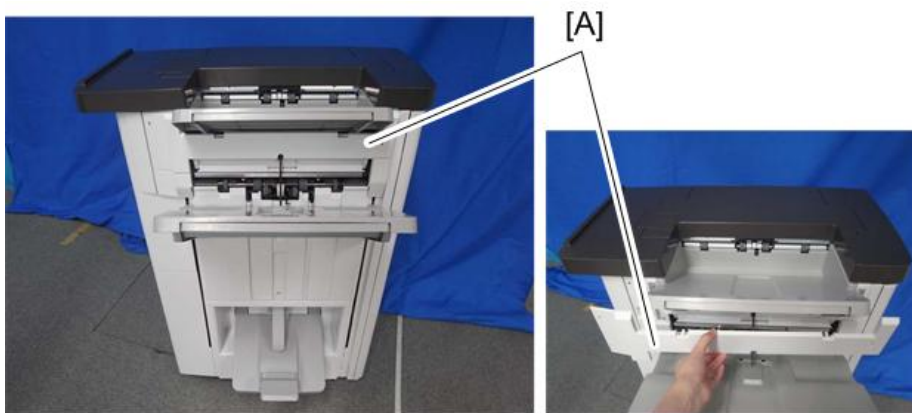

ⓘ Note

- Check the positions of the bosses and hooks before removing the paper exit cover.

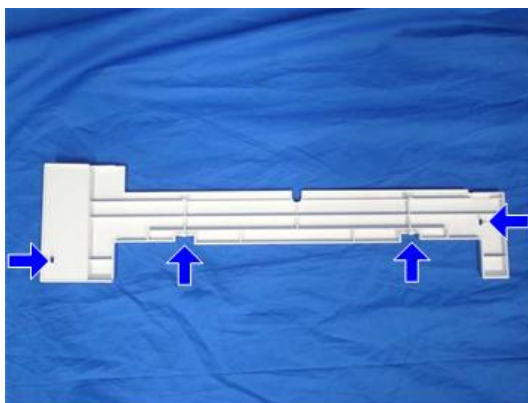

1.1.4 LOWER TRAY

1. Lower tray [A]



1.1.5 PROOF TRAY

1. Remove the following covers (page 1)
 - Rear upper cover
 - Upper cover
2. Proof tray [A] (🔑 x2)

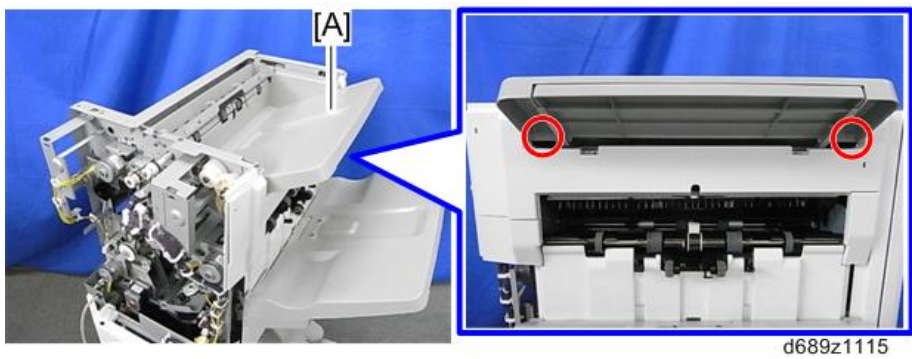

1.1.6 UPPER TRAY

1. Upper tray [A] (🔩 x1)

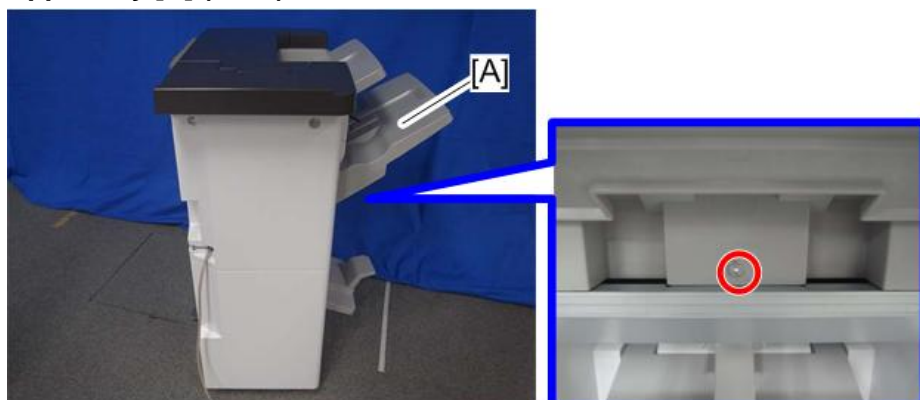

d1351267

1.1.7 END FENCE (D688 ONLY)

1. Remove the following covers.
 - Front cover (page 3)
 - Front left side cover (page 3)
 - Rear upper cover (page 1)
2. Upper tray [A] (🔩 x1)



d6890004

3. Proof lower cover [A] (hook x 5)



d689z0001

4. Left upper cover [A] (🔩 x2)



d6890027

5. Mold bracket (front, rear) [A] (🔩 x2)

Exterior Covers

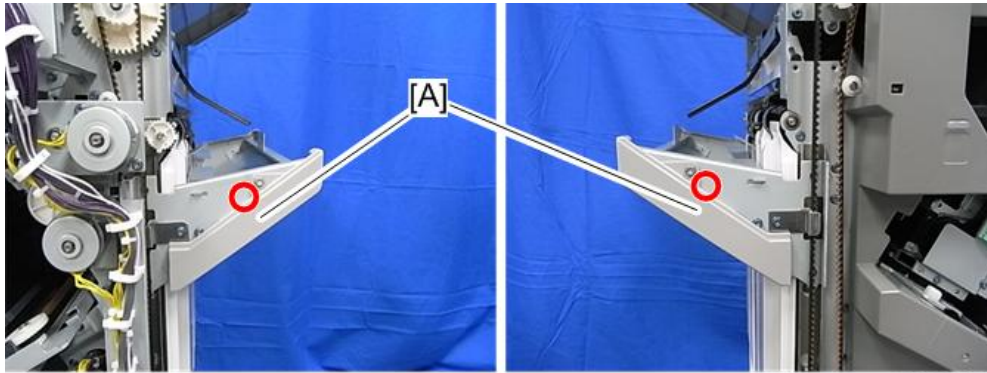

d6890006

6. Shift tray bracket (front, rear) [A] (🔩 x4)

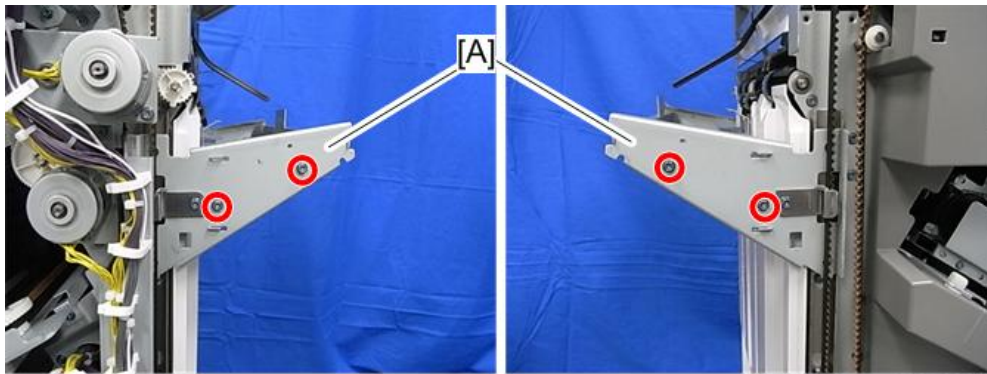

d6890007

7. Shift tray bracket [A].

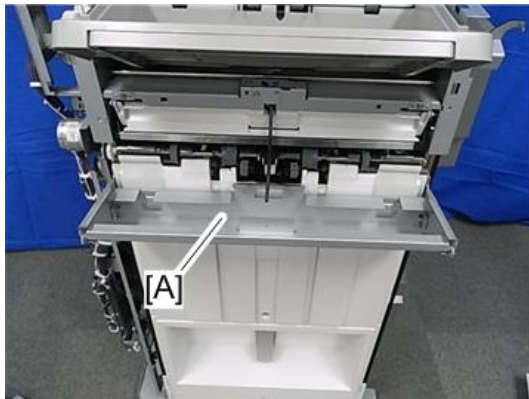

d6890008

8. End fence [A] (🔩 x2)

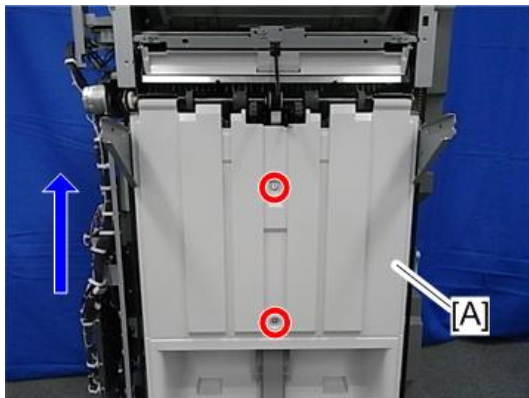

d6890009

1.1.8 LEFT COVER (D689 ONLY)

1. Upper tray [A] (🔩 x1)

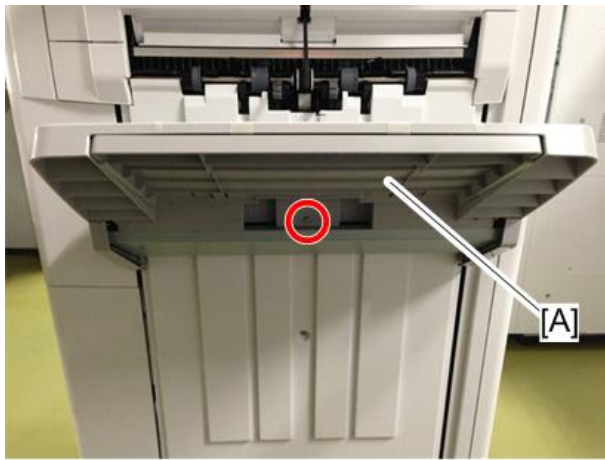

d1351777

2. Rear mold bracket [A] (🔩 x1)

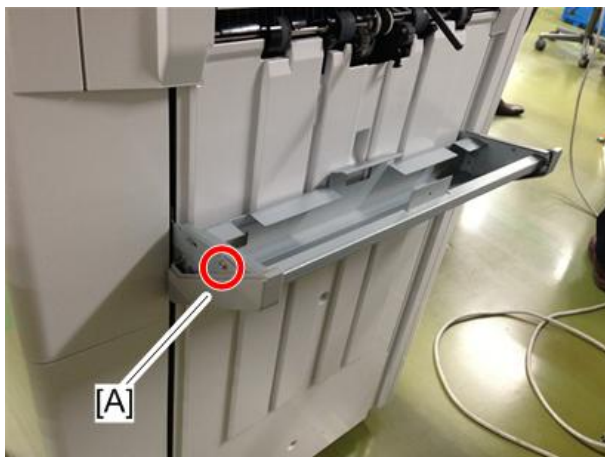

d1351778

3. Front mold bracket [A] (🔩 x1)



d1351779

4. Shift tray bracket [A] (🔩 x4)

Exterior Covers

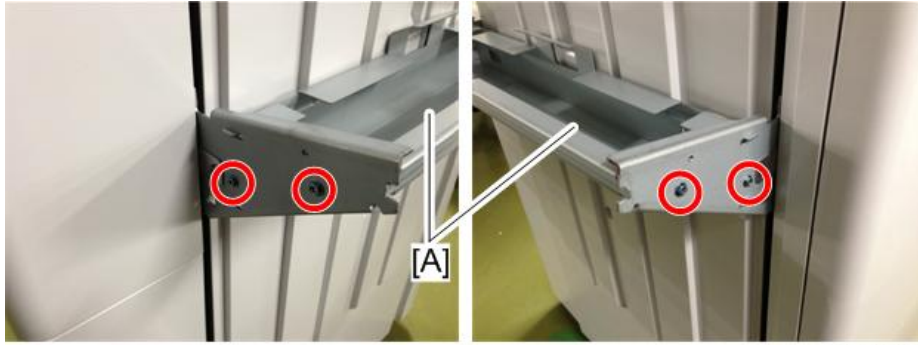

d1351780

5. Left cover [A] (🔑 x3)

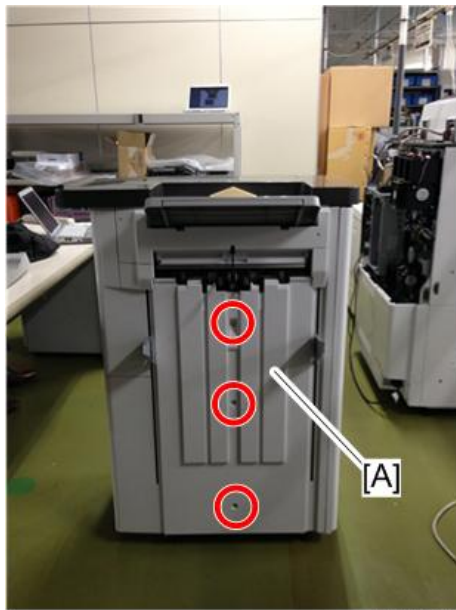

d1351781

1.2 BOARDS

1.2.1 MAIN BOARD

1. Remove the following covers.

- Rear upper cover (page 1)
- Rear lower cover (page 1)

2. Main board [A] (🔑 x8, 🛠️ xall)

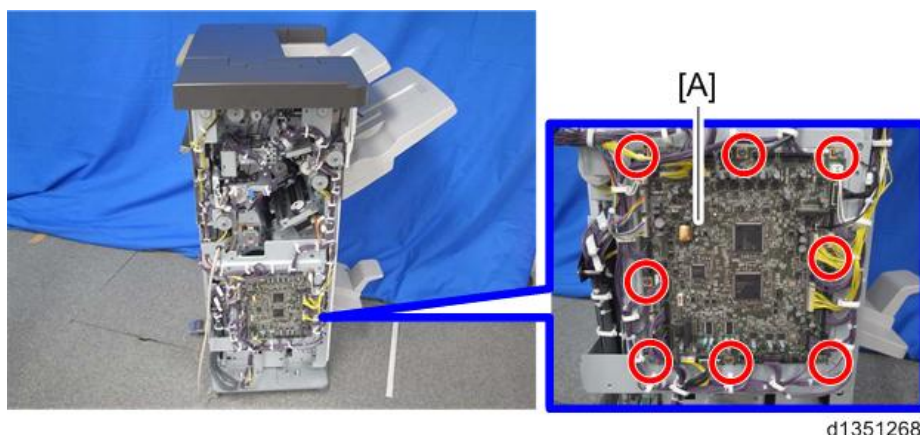

d1351268

When replacing the main board

This board has two blocks of dip switches. When you reinstall the main board, follow the procedure below regarding the dip switch settings.

⚠️ CAUTION

- Keep the EEPROM away from any objects that can cause static electricity. Static electricity can damage EEPROM data.
 - Make sure that the DIP-switch settings on the old main board are the same for the new main board. Do not change the DIP switches on the main board in the field.
1. Check the settings of dip switch [A] on the old main board.
 2. Replace the main board.
 3. Change the settings of dip switch [A] on the new main board to match the settings on the old main board.
 4. Make sure the switches of dip switch [B] on the new main board are all OFF.

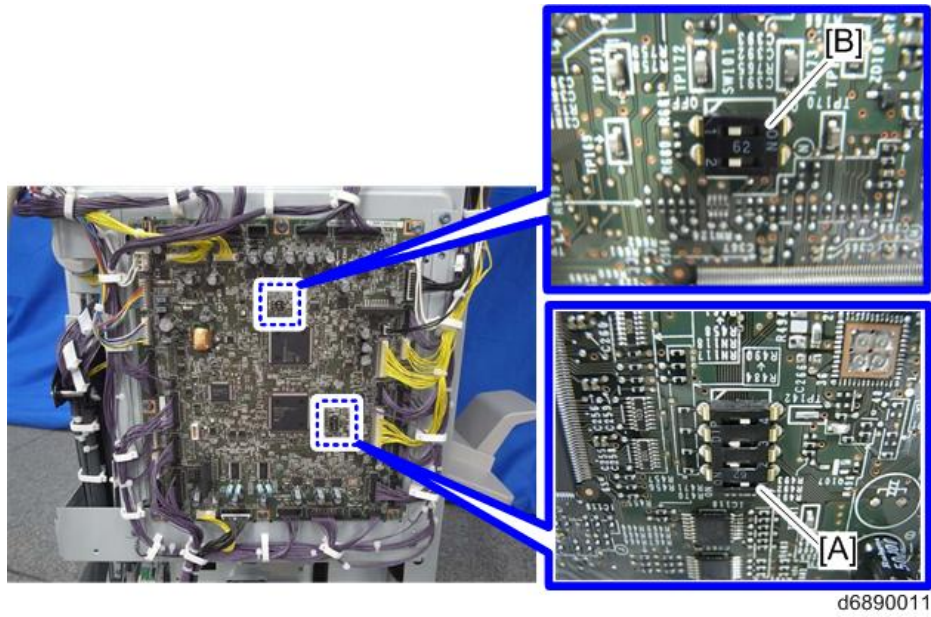

5. Remove the EEPROM [A] from the old main board.
6. Install the EEPROM [A] on the new main board.
 - Make sure the EEPROM is correctly installed on the main board. Insert the EEPROM in the slot with the "half-moon" [B] pointing to the upward side.

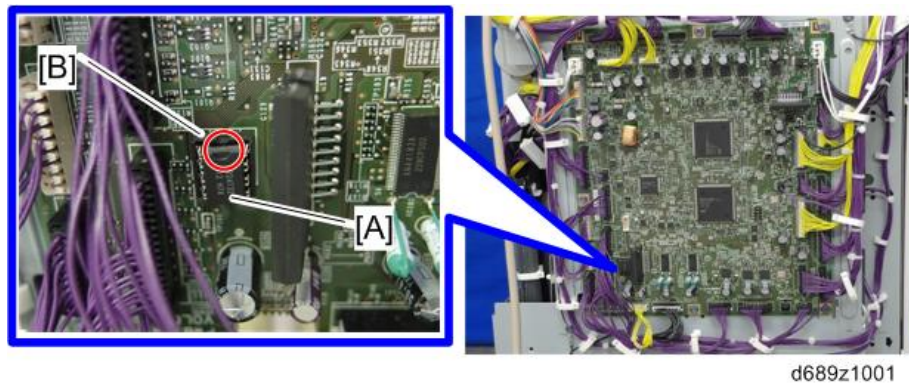

1.3 CORNER STAPLING UNIT

1.3.1 CORNER STAPLING UNIT

1. Remove the following covers.
 - Front cover (page 3)
 - Front left side cover (page 3)
 - Front inner cover (page 3)
 - End fence (page 7)
 - Rear upper cover and Rear lower cover (page 1)
2. Screws (🔩 x7).

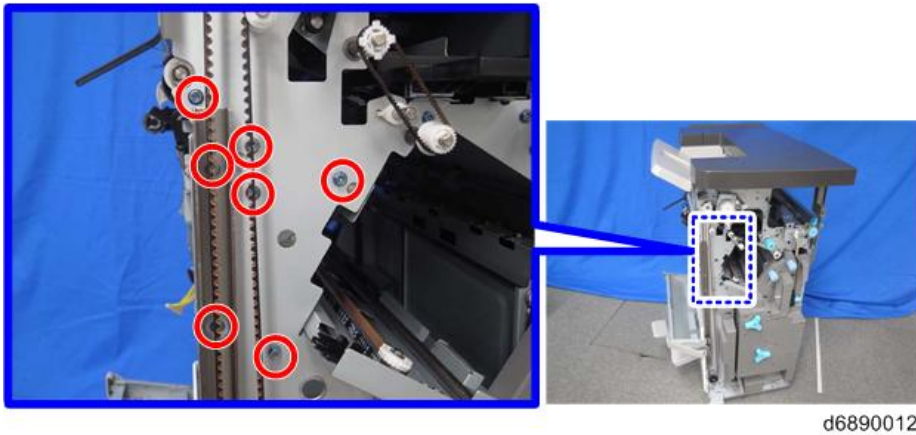

3. Bushing [A] (🔩 x1).

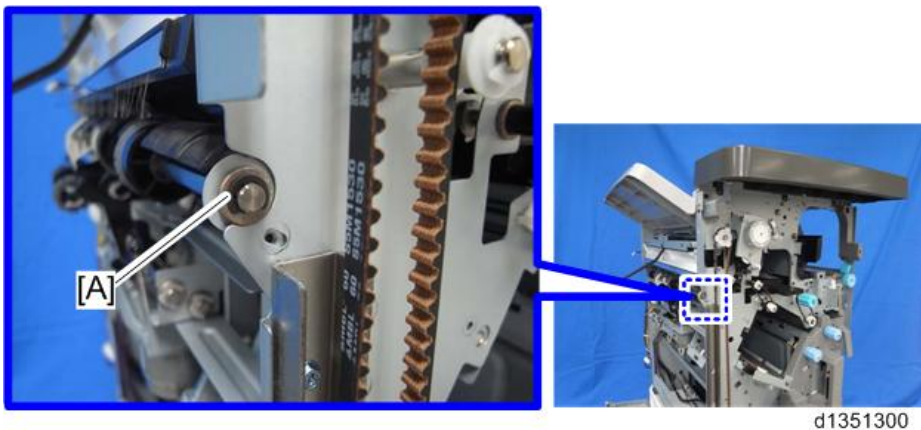

4. Middle transport motor [A] (🔩 x2)

Corner Stapling Unit

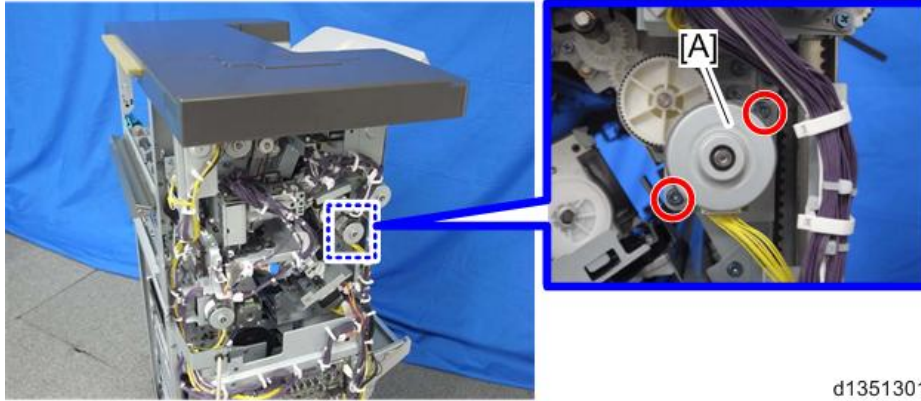

5. Middle transport motor bracket [A] (🔩 x2)

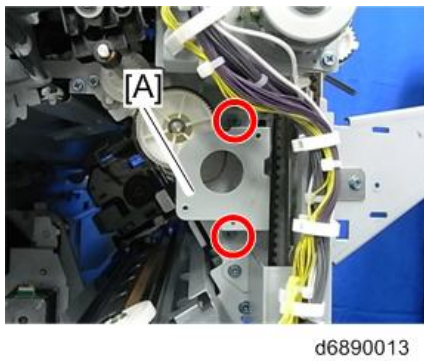

6. Gear [A] (🔩 x1, belt x 1)

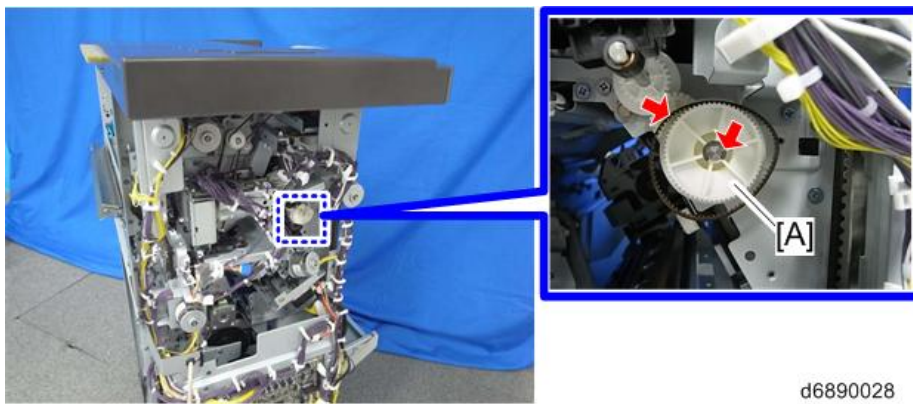

7. Pulley [A] (hook x 1)

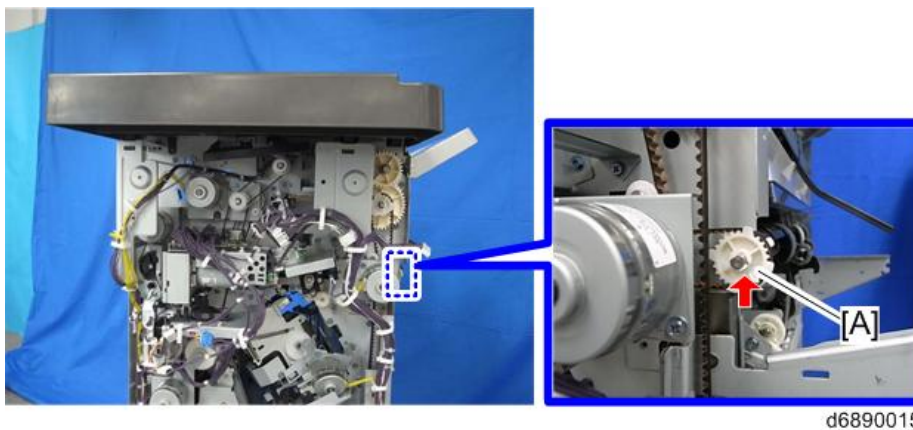

8. Screws from the rear side of the finisher (🔩 x6).

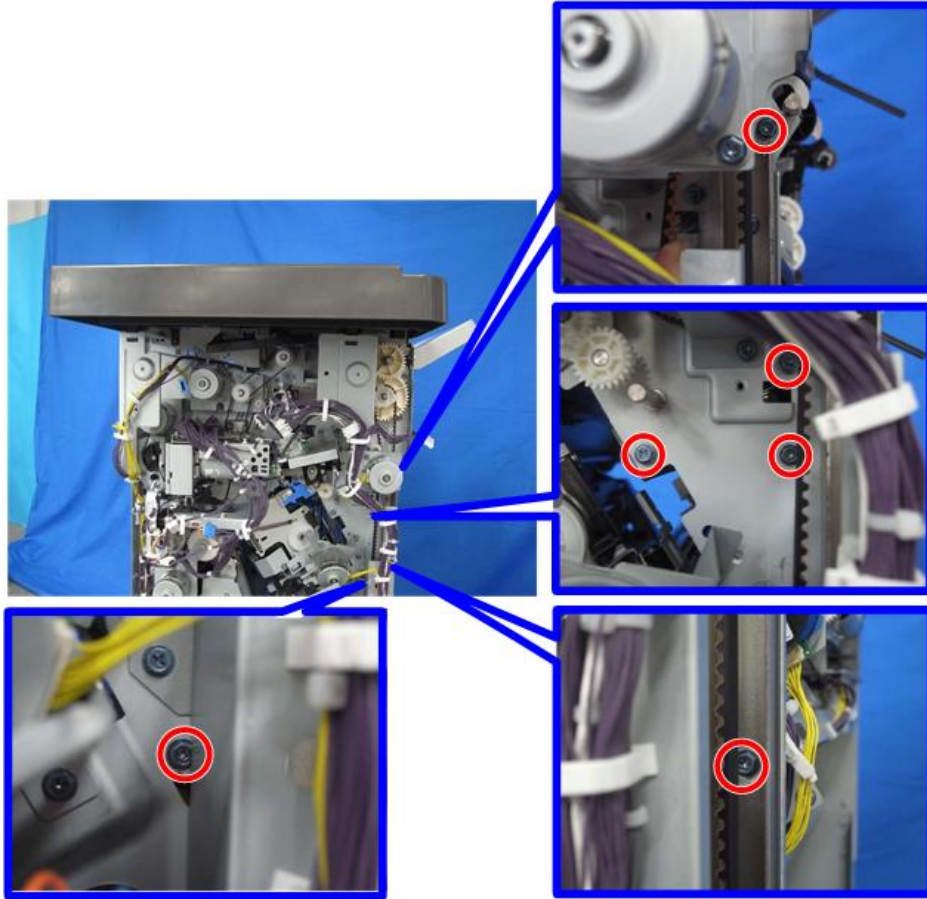

d1351304

9. Release six clamps (🔧x6).

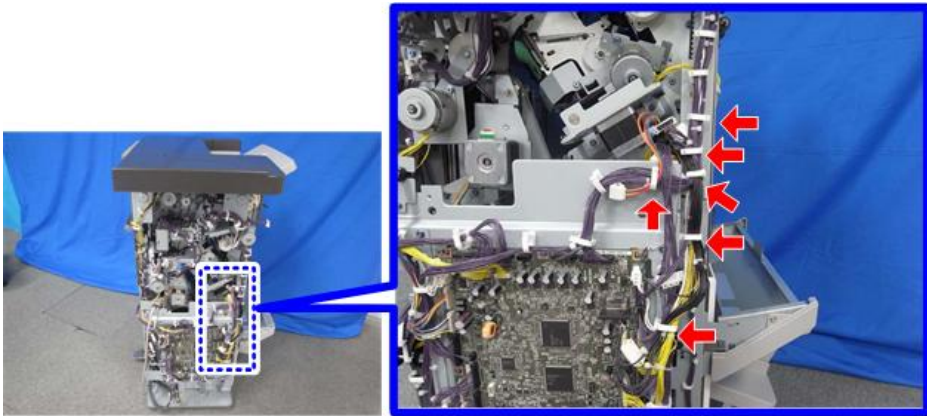

d1351305

10. Ground wire [A] (🔧x1).

Corner Stapling Unit

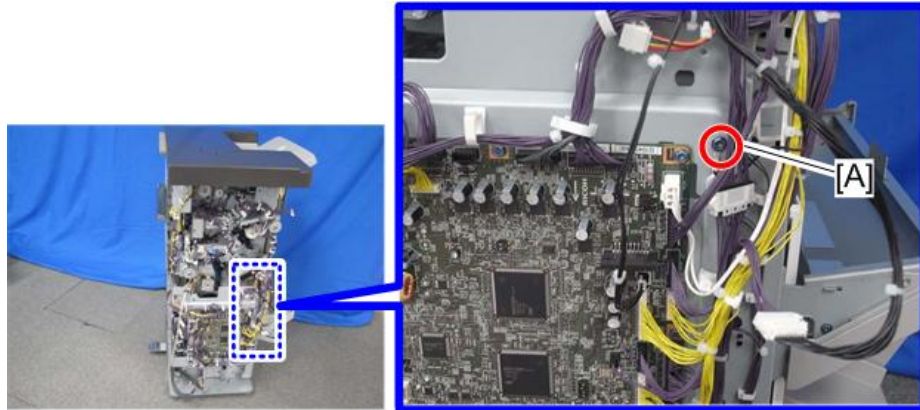

d1351306

11. Disconnect the connectors shown below (🔌 x7).

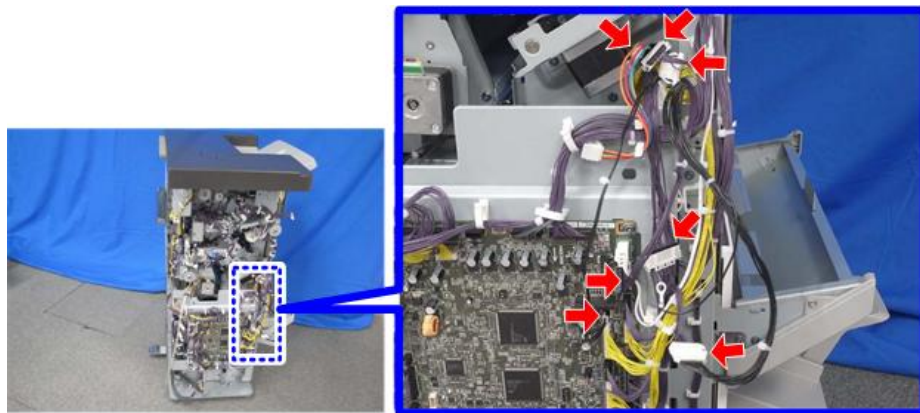

d6890017

12. Pull out the harnesses disconnected in step 13 to the right side of the finisher through the hole [A].

13. Release four clamps (🔧 x4).

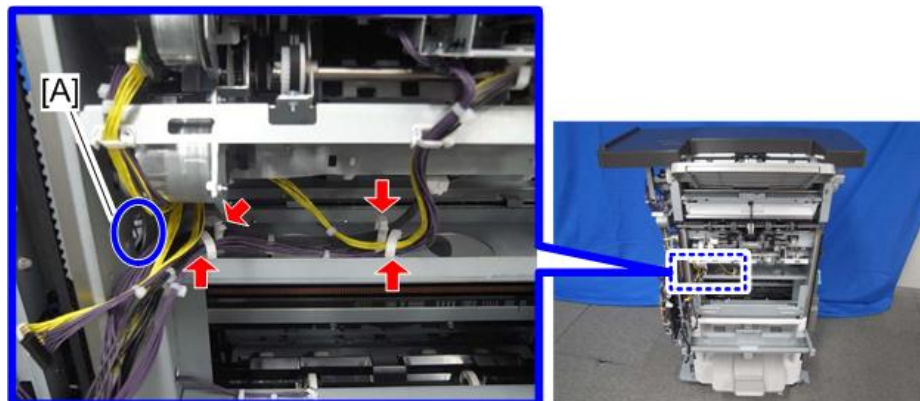

d1351308

14. corner stapling unit [A]

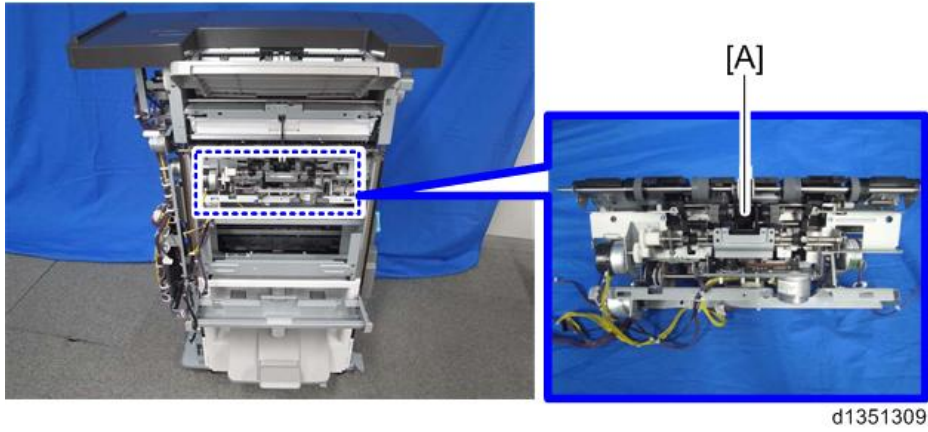

d1351309

1.3.2 STACKING ROLLER MOTOR

1. Corner stapling unit (page 13)
2. Stapler bracket [A] (🔩 x3, 🛠️ x2)

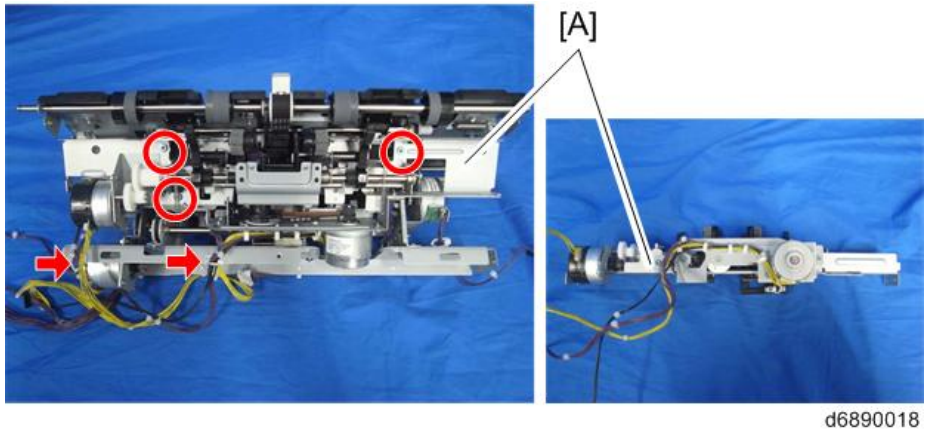

d6890018

3. Stacking roller motor [A] (🔩 x2, 🛠️ x1)

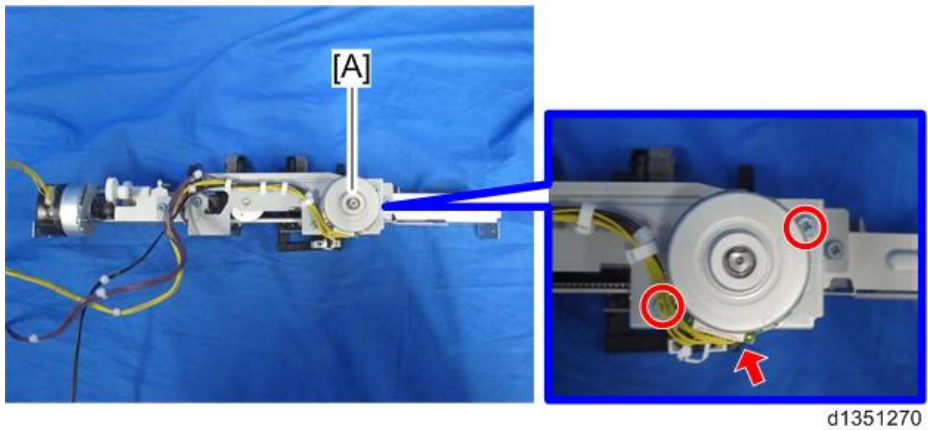

d1351270

1.3.3 STACKING ROLLER HP SENSOR

1. Corner stapling unit (page 13)
2. Stapler bracket [A] (🔩x3, 🛠x1)

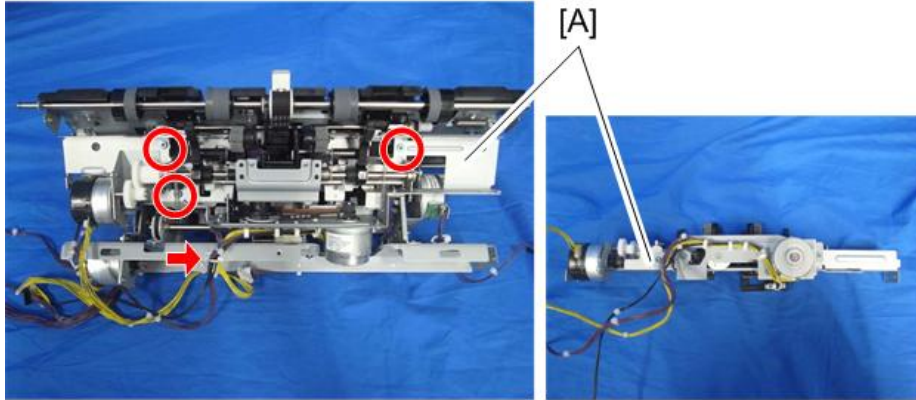

d1351269

3. Stacking roller HP sensor bracket [A] (🔩x1, 🛠x1)

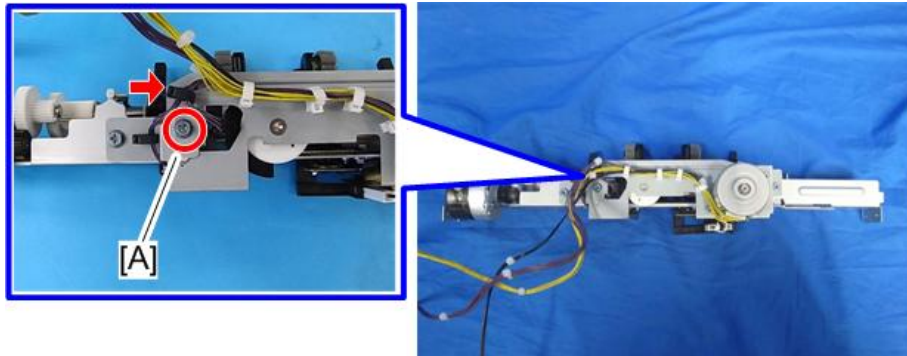

d689z1100

4. Stacking roller HP sensor [A] (📦x1)

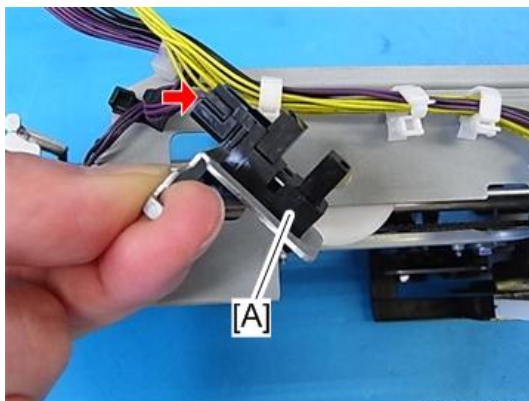

d689z1101

1.3.4 LEADING EDGE GUIDE MOTOR

1. Corner stapling unit (page 13)
2. Stapler bracket [A] (🔩x3, 🛠️x1)

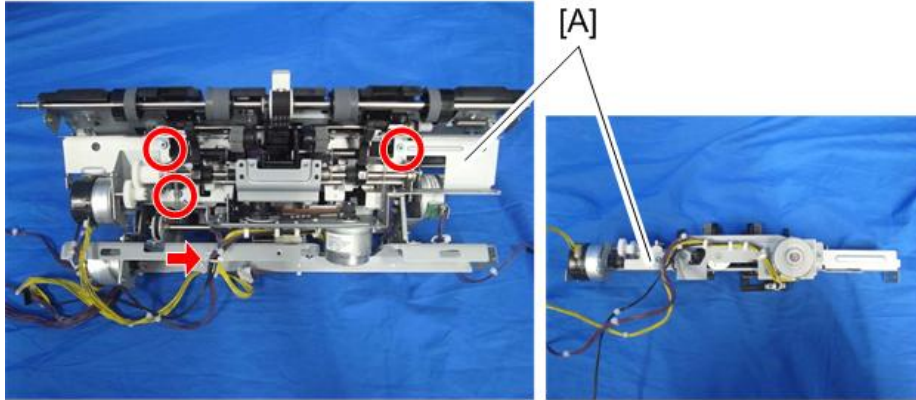

d1351269

3. Leading edge guide motor [A] (🔩x2, 📦x1)

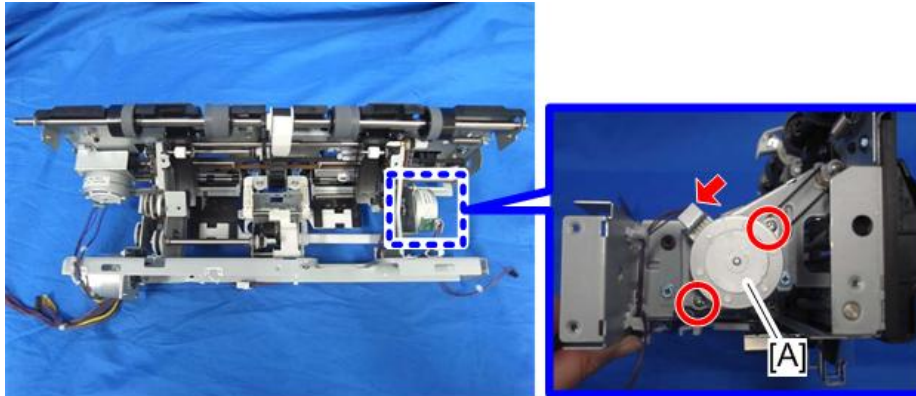

d1351271

1.3.5 LEADING EDGE GUIDE HP SENSOR

1. Corner stapling unit (page 13)
2. Stapler bracket [A] (🔩 x3, 🛠️ x1)

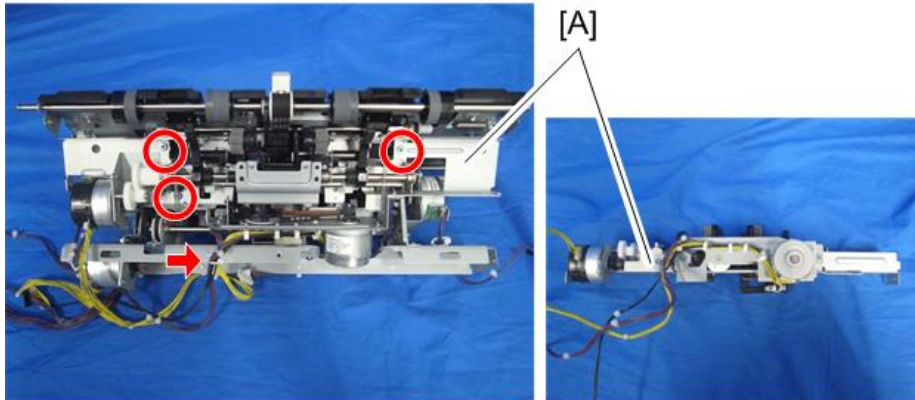

d1351269

3. Leading edge guide HP sensor [A] (📦 x1)

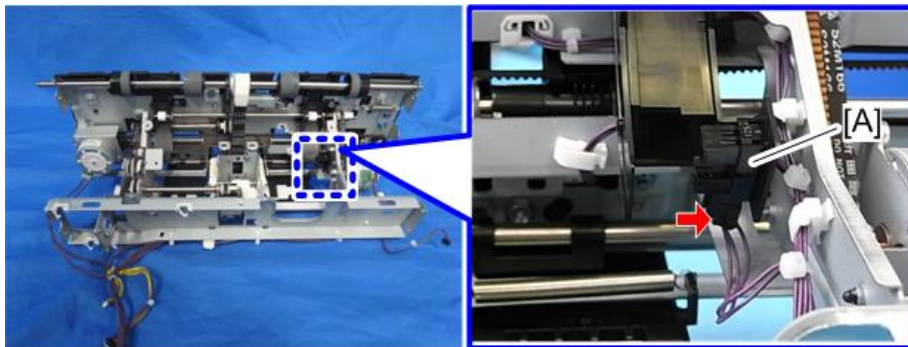

d689z1104

1.3.6 TRAILING EDGE PRESSURE PLATE MOTOR

1. Corner stapling unit (page 13)
2. Trailing edge pressure plate motor [A] (🔩 x2, 📦 x1)

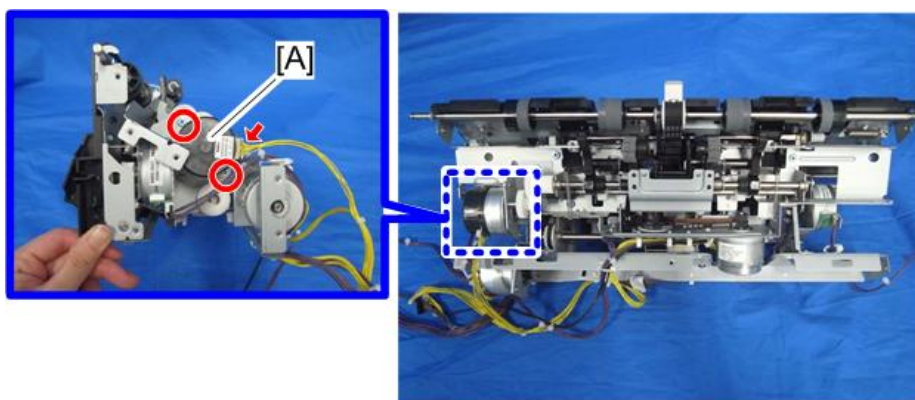

d1351272

1.3.7 TRAILING EDGE PRESSURE PLATE HP SENSOR

1. Corner stapling unit (page 13)
2. Stapler bracket [A] (🔩x3, 🛠️x1)

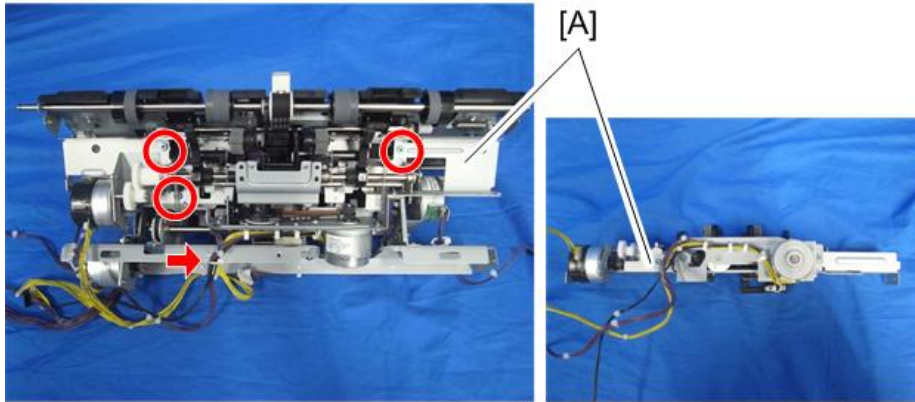

d1351269

3. Turn back the stapler bracket, and remove the trailing edge pressure plate HP sensor bracket [A] (🔩x1)

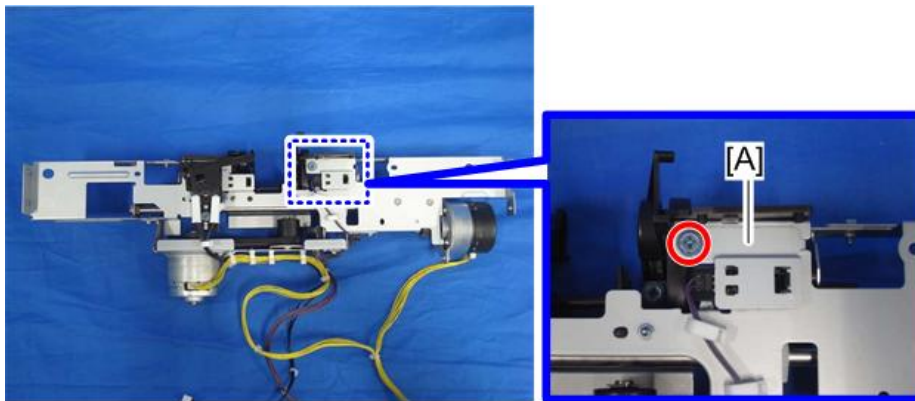

d1351290

4. Trailing edge pressure plate HP sensor [A] (📦x1)

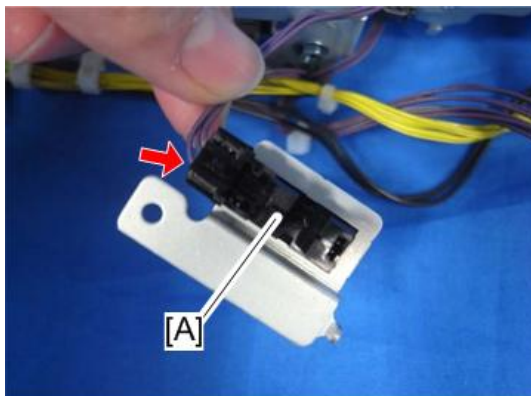

d1351291

1.3.8 SHIFT TRAY PAPER SENSOR

1. Corner stapling unit (page 13)
2. Stapler bracket [A] (🔩x3, 🛠️x1)

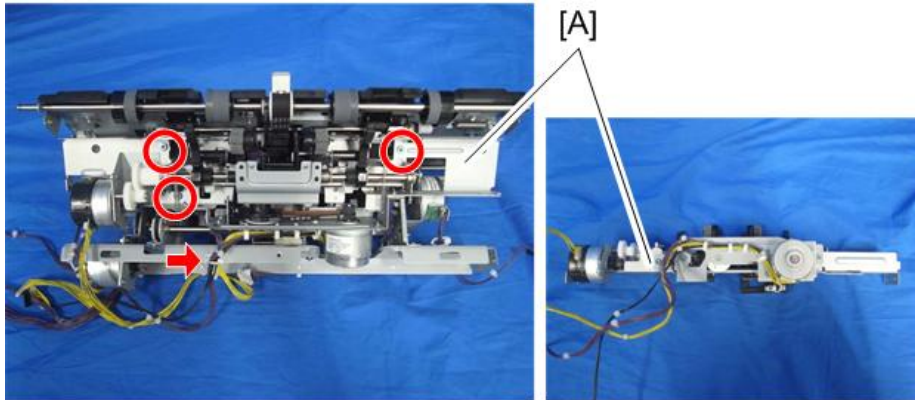

d1351269

3. Turn back the stapler bracket, and remove the tray upper limit switch [A] (🔩x1, 🛠️x1)

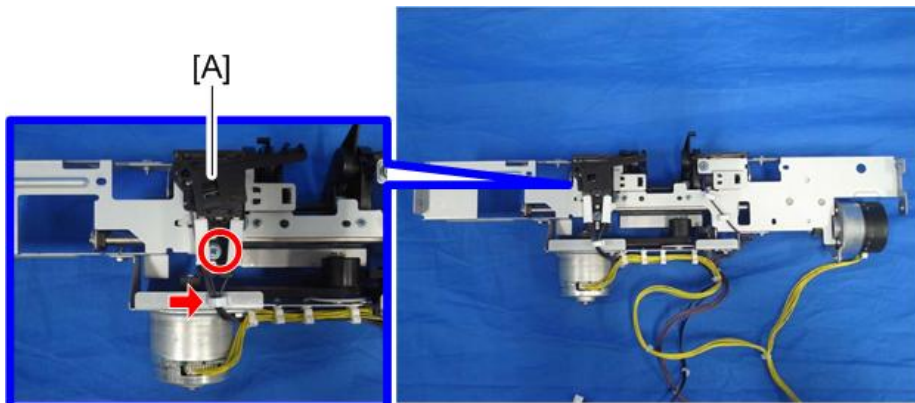

d1351292

4. Shift tray paper sensor bracket [A] (🔩x1)

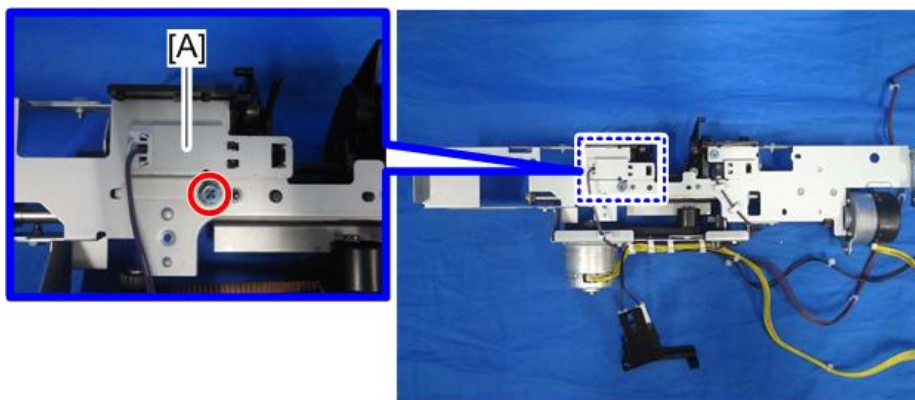

d1351293

5. Shift tray paper sensor [A] (📄x1)

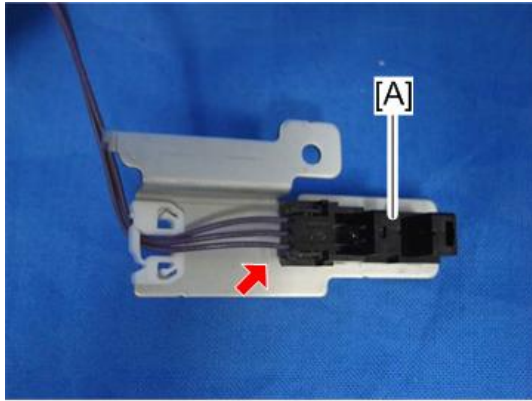

d1351294

1.3.9 FEED OUT MOTOR

1. Corner stapling unit (page 13)
2. Feed out motor [A] (⚙️ x2, 📦 x1, 🔌 x2)

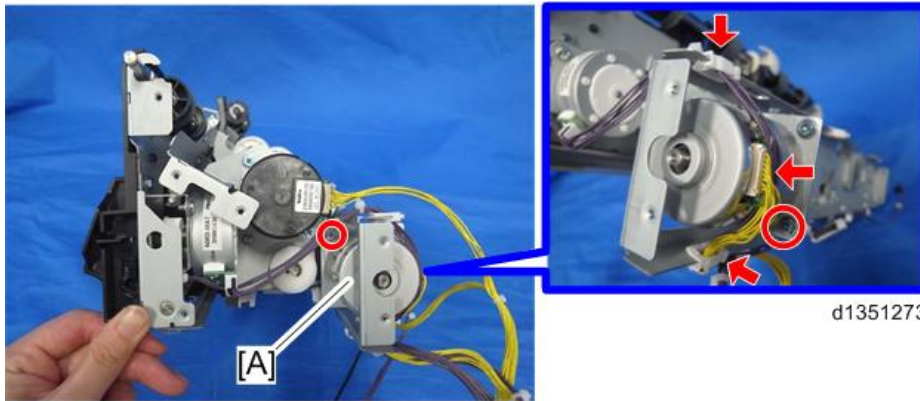

d1351273

1.3.10 FEED OUT GUIDE HP SENSOR

1. Corner stapling unit (page 13)
2. Feed out guide HP sensor [A] (📦 x1)

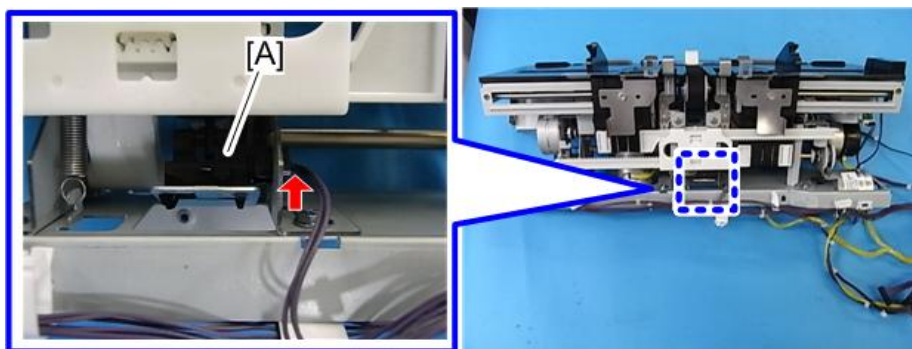

d689z1105

1.3.11 JOGGER MOTOR

1. Corner stapling unit (page 13)
2. Stapler bracket [A] (🔩 x3, 🛠️ x1)

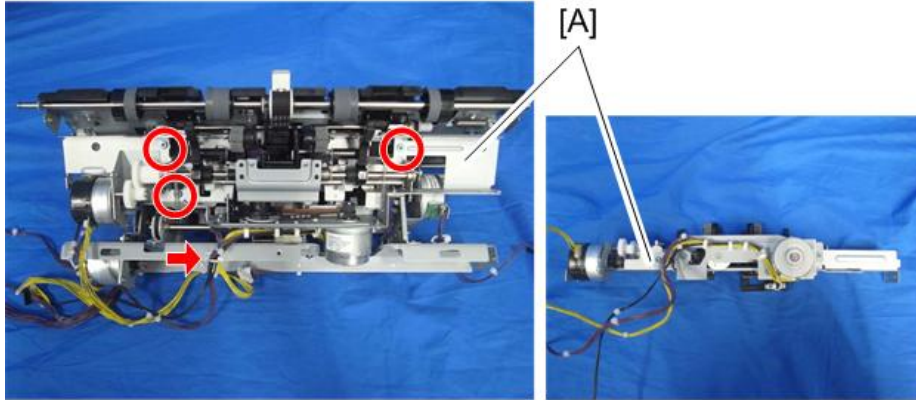

d1351269

3. Feed out motor (page 23)
4. Jogger motor [A] (🔩 x2, 📦 x1)

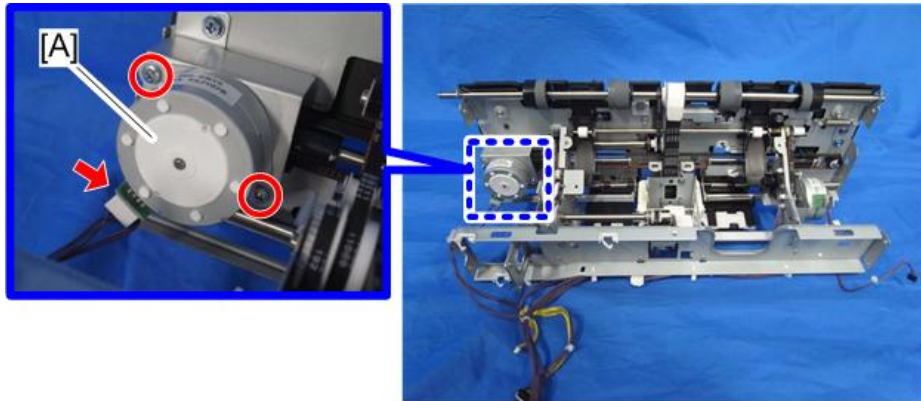

d1351274

1.3.12 JOGGER HP SENSOR

1. Jogger motor (page 24)
2. Screw (🔩 x1)

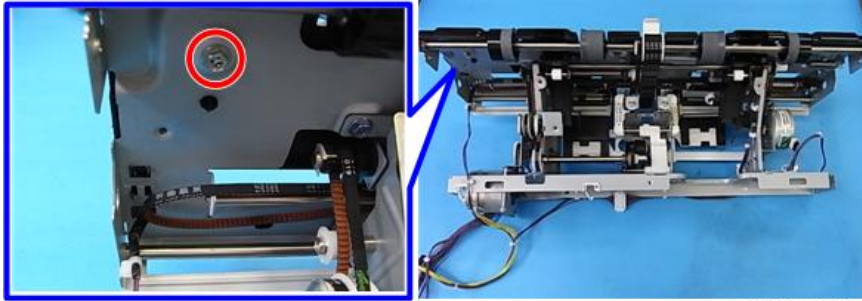

3. Jogger HP sensor [A] (📦 x1)

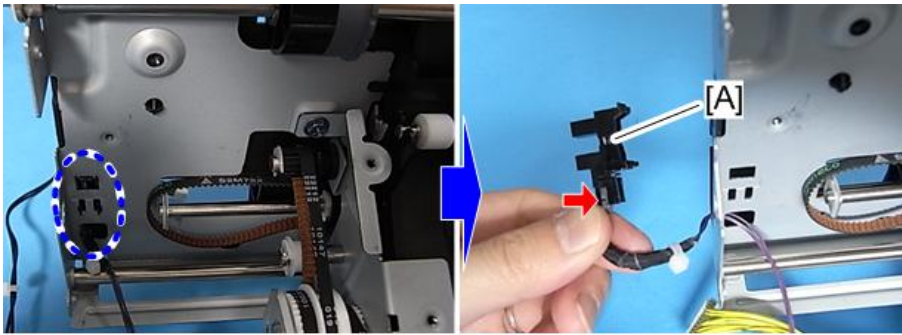

1.3.13 SHIFT TRAY EXIT SENSOR

1. Corner stapling unit (page 13)
2. Stapler bracket [A] (🔩 x3, 🛠️ x1)

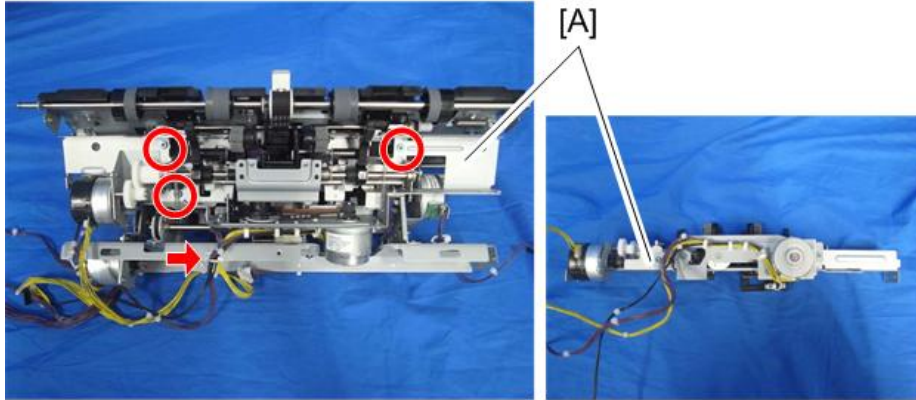

d1351269

3. Shift tray exit sensor bracket [A] (🔩 x1)

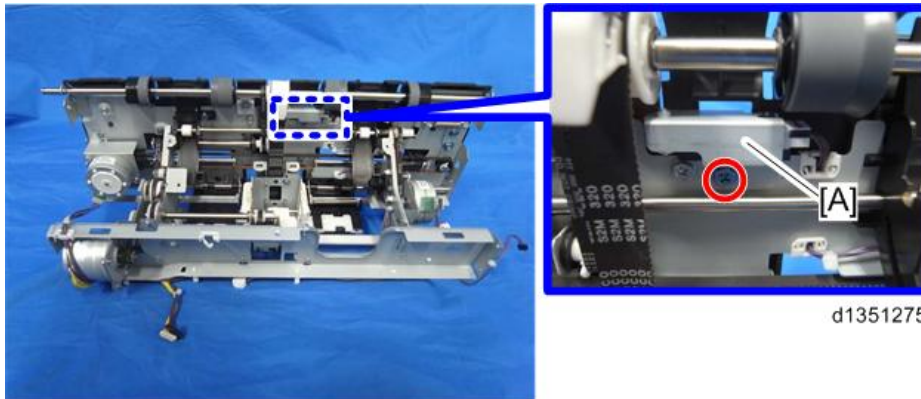

d1351275

4. Shift tray exit sensor [A] (🔩 x1, 📦 x1)

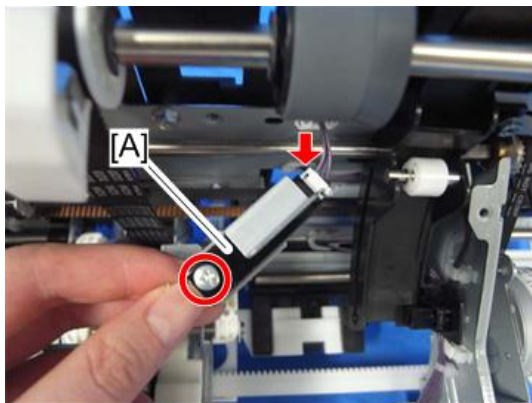

d1351276

1.3.14 STAPLE TRAY PAPER SENSOR

1. Corner stapling unit (page 13)
2. Stapler bracket [A] (🔩x3, 🛠️x1)

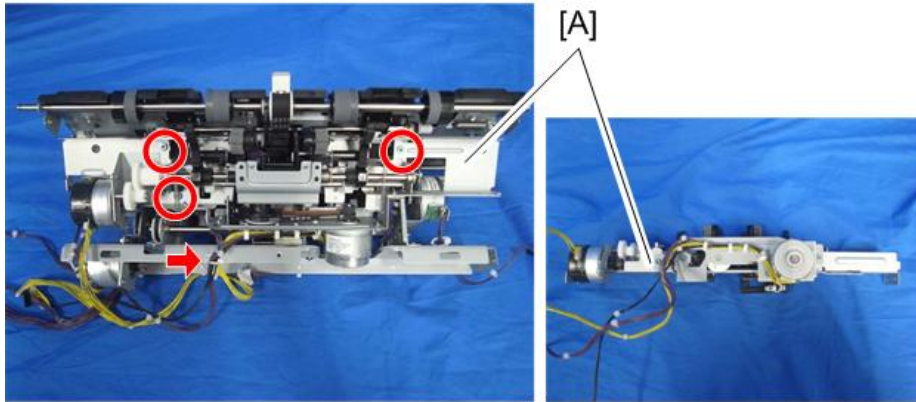

d1351269

3. Staple tray paper sensor bracket [A] (🔩x1, 🛠️x1)

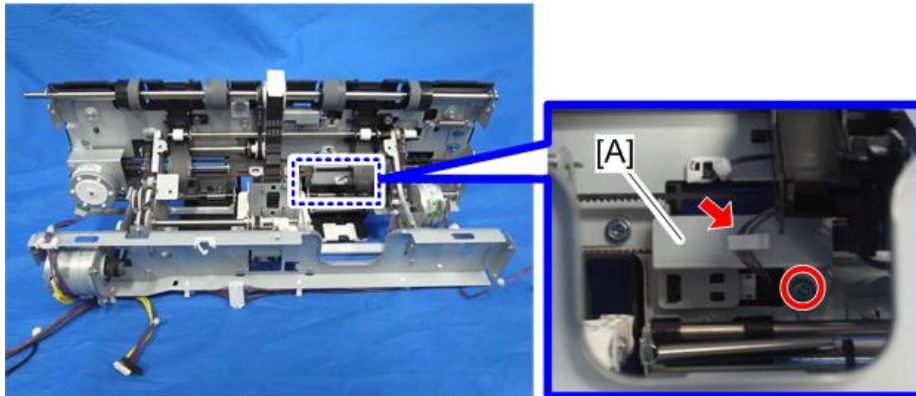

d1351295

4. Staple tray paper sensor [A] (📦x1)

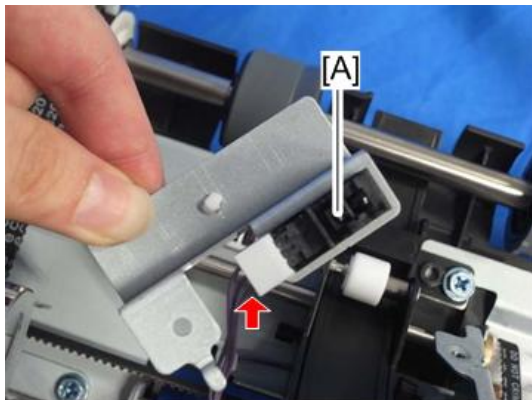

d1351296

1.4 MAIN UNIT

1.4.1 TRAY EXIT MOTOR

1. Rear upper cover (page 1)
2. Tray exit motor [A] (🔩 x2, 📦 x1, 🌀 x1)

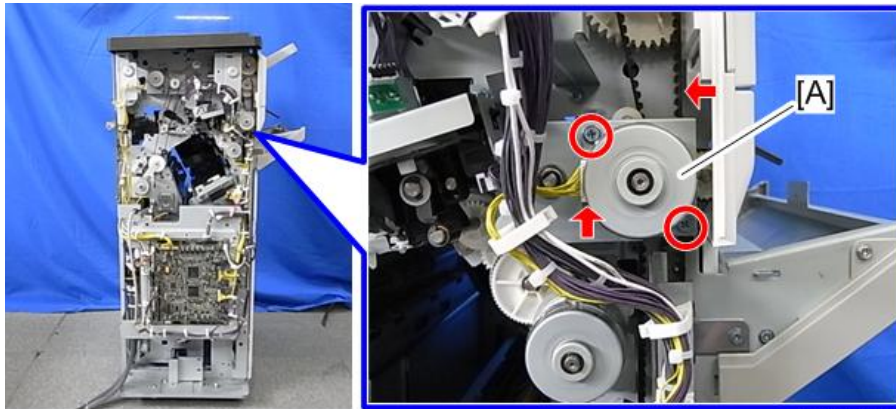

d689z1046

1.4.2 MIDDLE TRANSPORT MOTOR

1. Rear upper cover (page 1)
2. Middle transport motor bracket [A] (🔩 x2, 📦 x1, 🌀 x1)

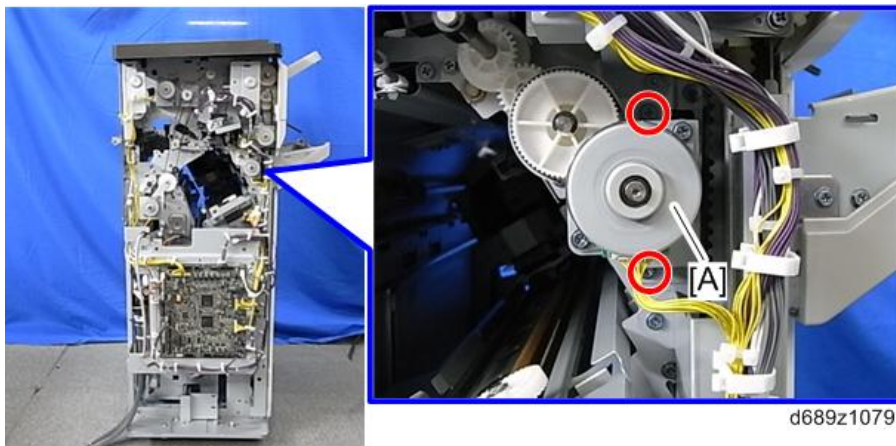

d689z1079

3. Middle transport motor [A] (🔩 x2)

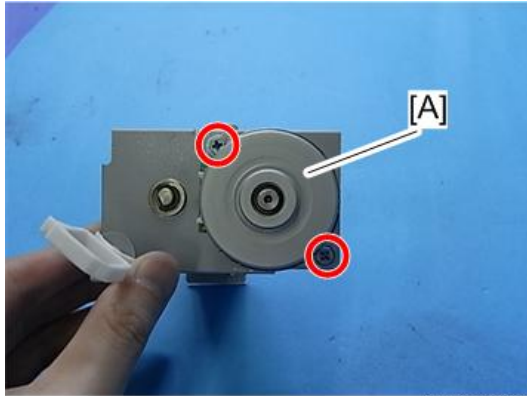

d689z1080

1.4.3 PRE-STACK TRANSPORT MOTOR

1. Rear upper cover (page 1)
2. Pre-stack transport motor [A] (⚙️ x2, 📦 x1, 🌀 x1)

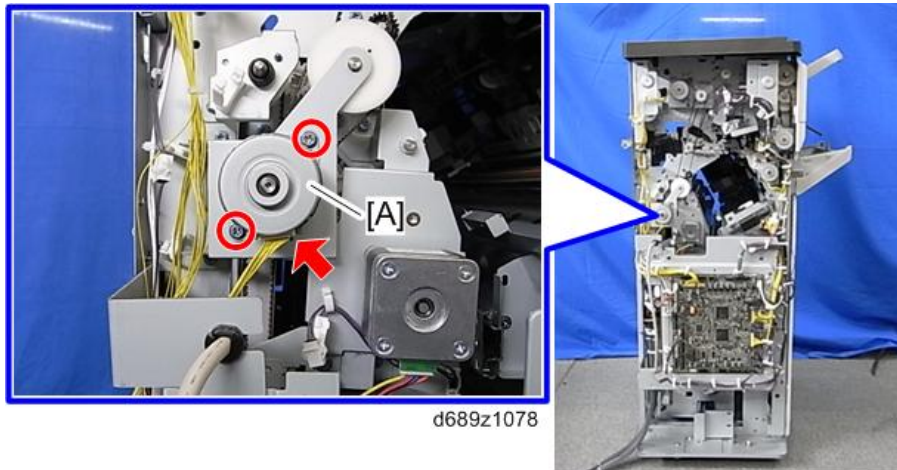

d689z1078

1.4.4 ENTRANCE TRANSPORT MOTOR

1. Rear upper cover (page 1)
2. Entrance transport motor bracket [A] (🔩 x2, 📦 x1, 🌀 x1)

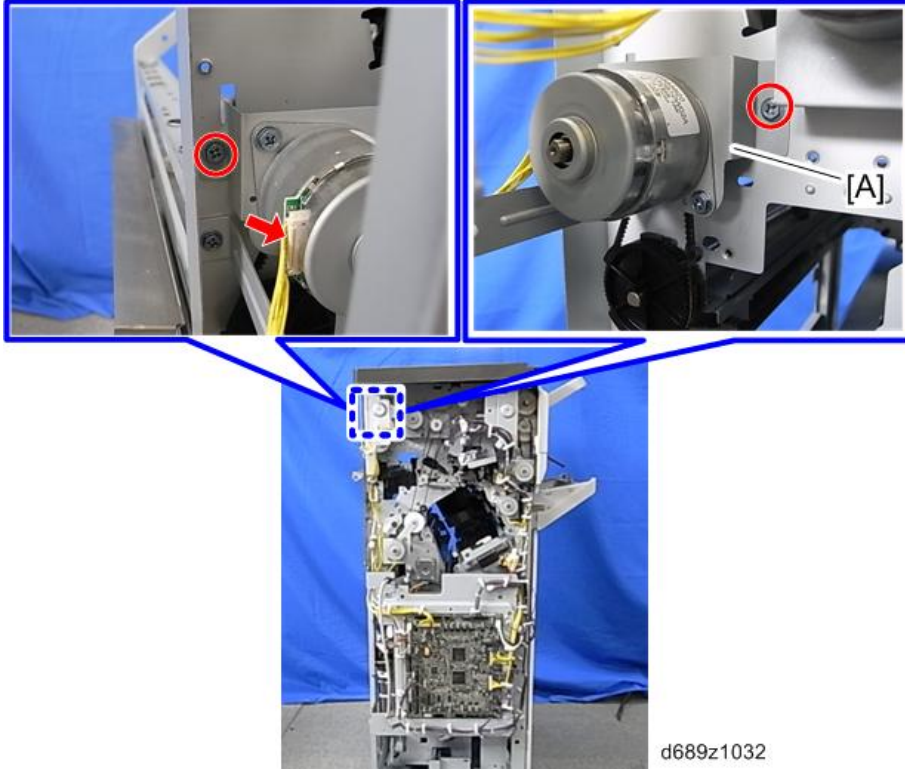

3. Entrance transport motor [A] (🔩 x2)

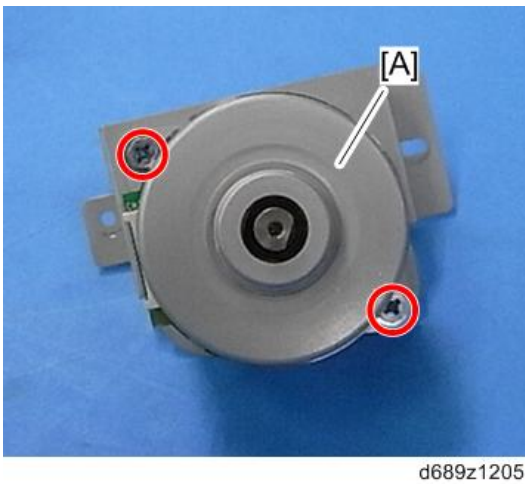

1.4.5 HORIZONTAL TRANSPORT MOTOR

1. Rear upper cover (page 1)
2. Horizontal transport motor [A] (⚙️ x2, 📦 x1, 🌀 x1)

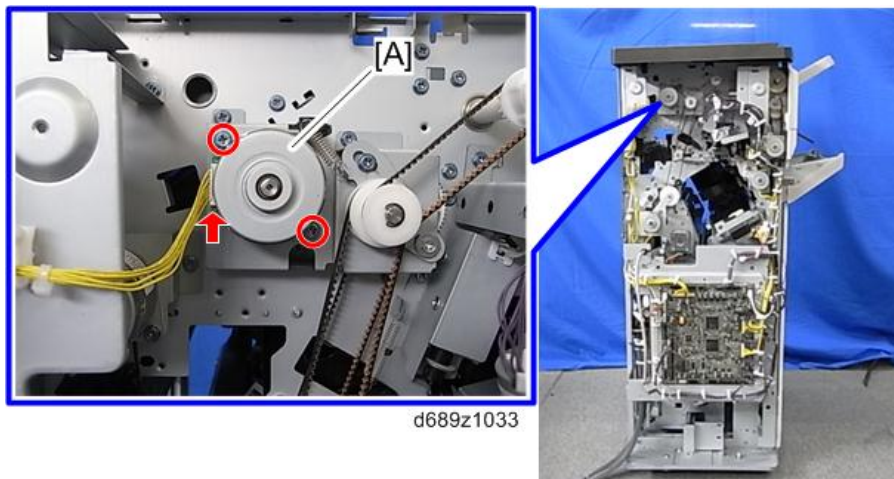

1.4.6 TRAY LIFT MOTOR

1. Rear upper cover (page 1)
2. Upper cover (page 1)
3. Bracket [A] (⚙️ x3, 📦 x2)

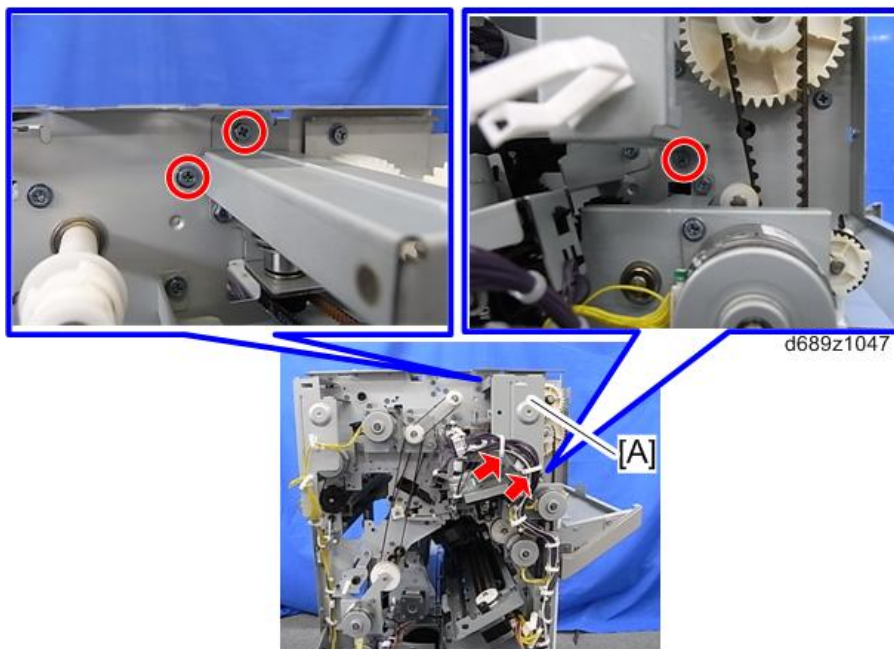

4. Tray lift motor bracket [A] (⚙️ x2)

Main Unit

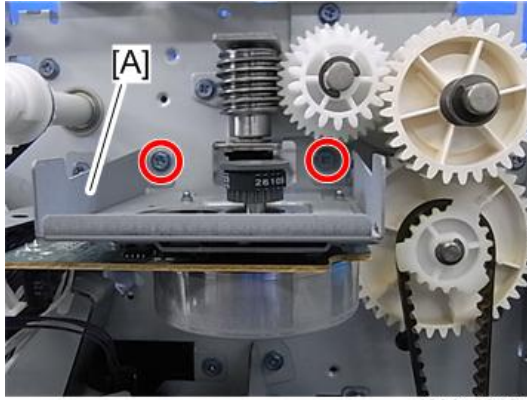

d689z1048

5. Turn back the tray lift motor bracket, and remove the connector and timing belt (🔌 x1, 🌀 x1)

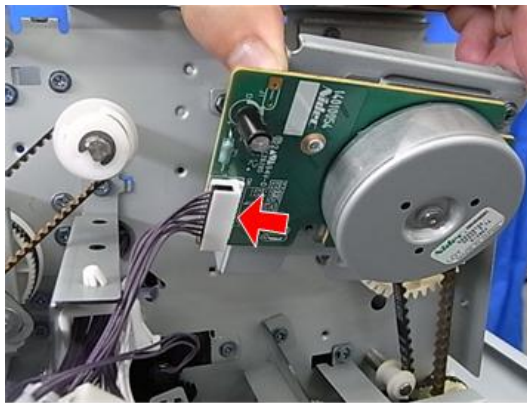

d689z1049

6. Tray lift motor [A] (🌀 x3)

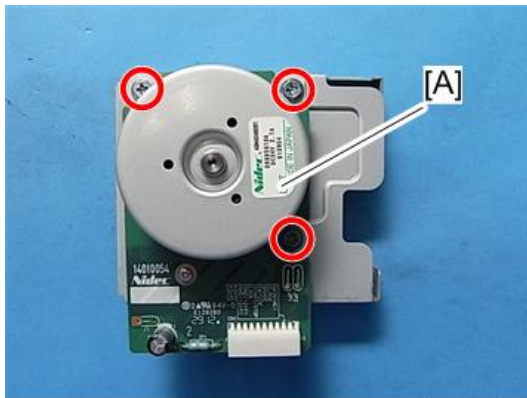

d689z1050

1.4.7 LOWER JUNCTION GATE MOTOR

1. Rear upper cover (page 1)
2. Upper cover (page 1)
3. Proof tray (page 5)
4. Screws (🔩 x2)

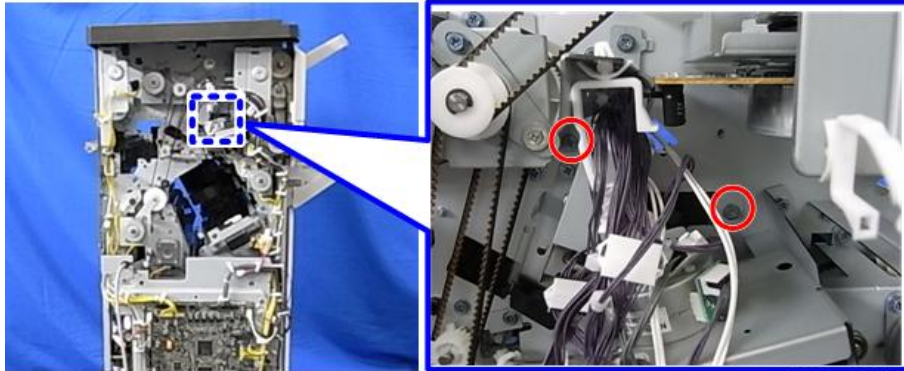

d689z1073

5. Remove the lower junction gate motor bracket [A] while sliding it (📦 x1)

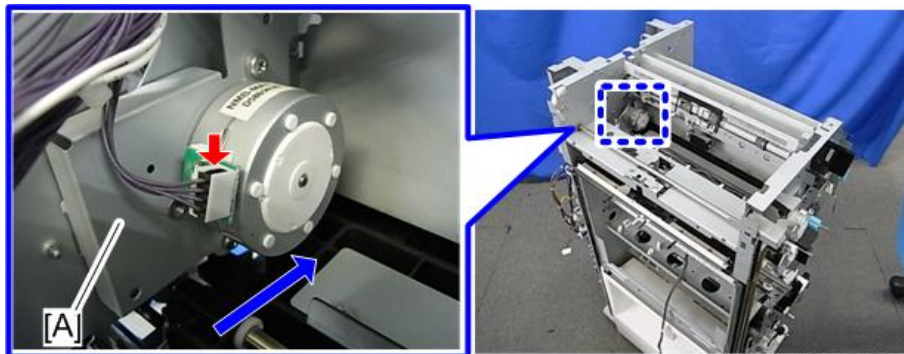

d689z1034

6. Lower junction gate motor [A] (🔩 x2)

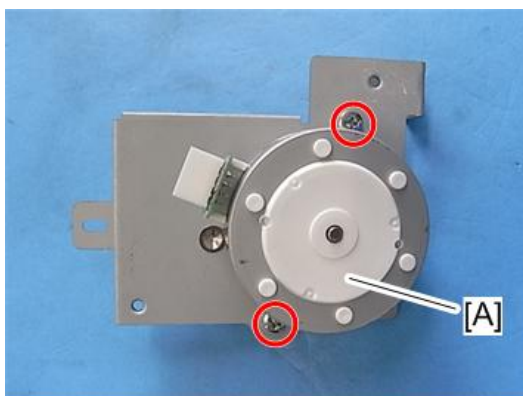

d689z1075

1.4.8 SHIFT MOTOR / LOWER JUNCTION GATE HP SENSOR / SHIFT ROLLER HP SENSOR

1. Rear upper cover (page 1)
2. Upper cover (page 1)
3. Clamps and E-rings (🔧x6, 🌀x2)

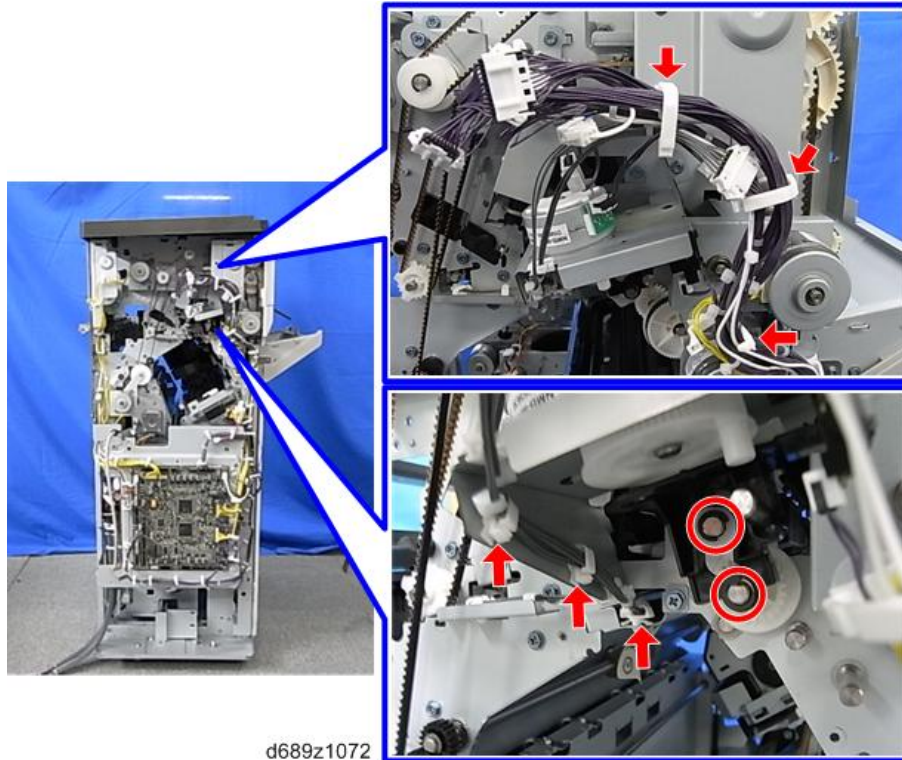

4. Shift motor bracket [A] (🔧x2, 📦x3)

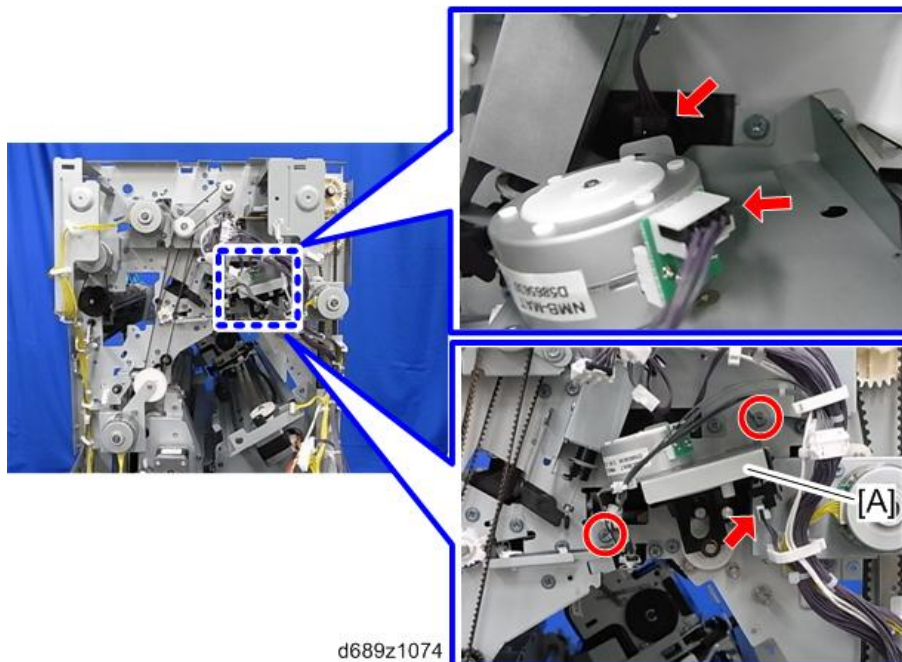

5. Shift motor [A] (🌀x2)
6. Lower junction gate HP sensor [B]

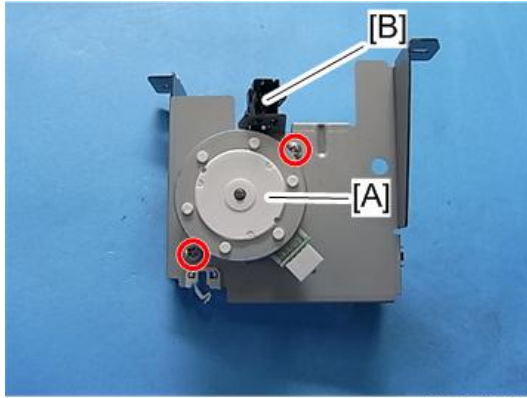

d689z1076

7. Shift roller HP sensor [A]

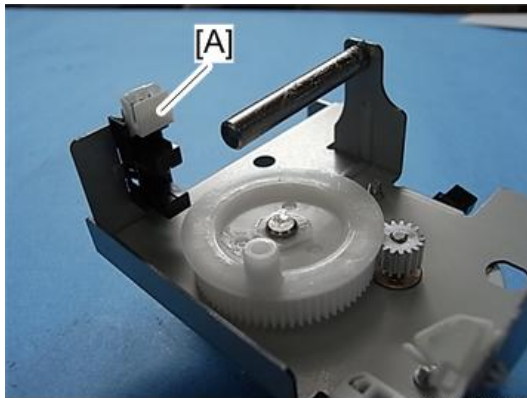

d689z1077

1.4.9 PAPER EXIT GATE MOTOR

1. Rear upper cover (page 1)
2. Upper cover (page 1)
3. Front inner cover (page 1)
4. Proof tray (page 5)
5. Bracket [A] (🔩x3, 🛠️x2)

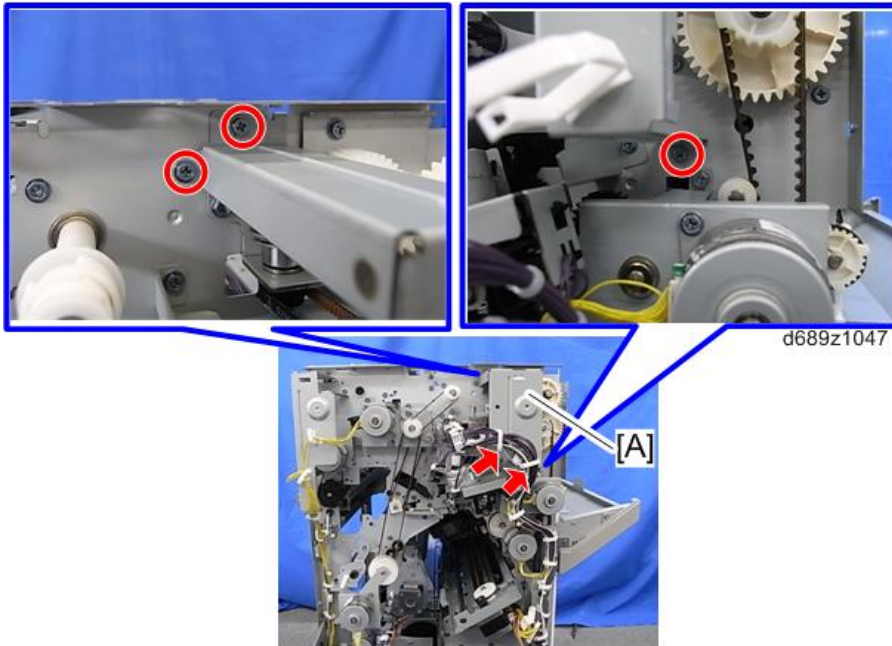

6. Screws on the rear side (🔩x2)

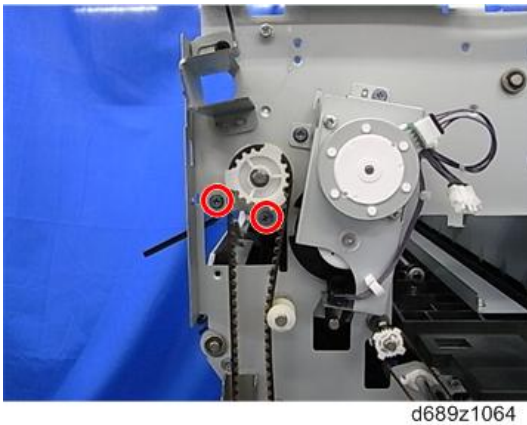

7. Screws on the front side (🔩x2)

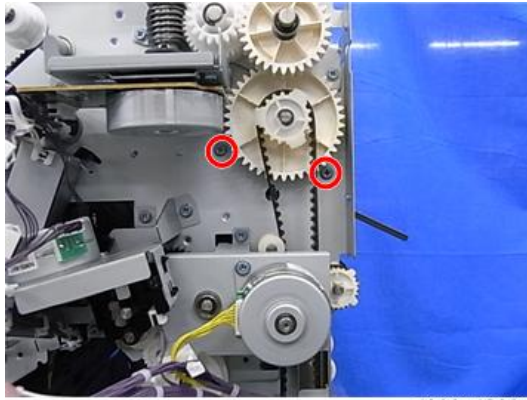

d689z1066

8. Clamps in the proof tray (🔩x6)

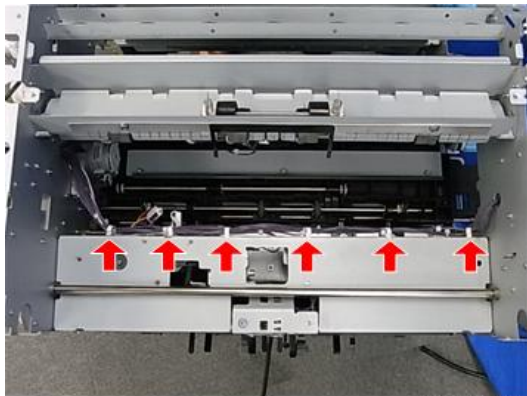

d689z1067

9. Hold up the paper exit guide plate [A] to remove the clip [B] (🔩x1)

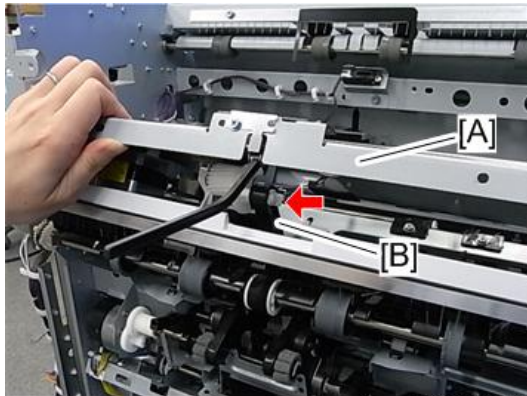

d689z1068

10. Turn back the paper exit guide plate [A] to remove the paper exit gate motor bracket [B]
(🔩x2, 📦x3, 🌀x1)

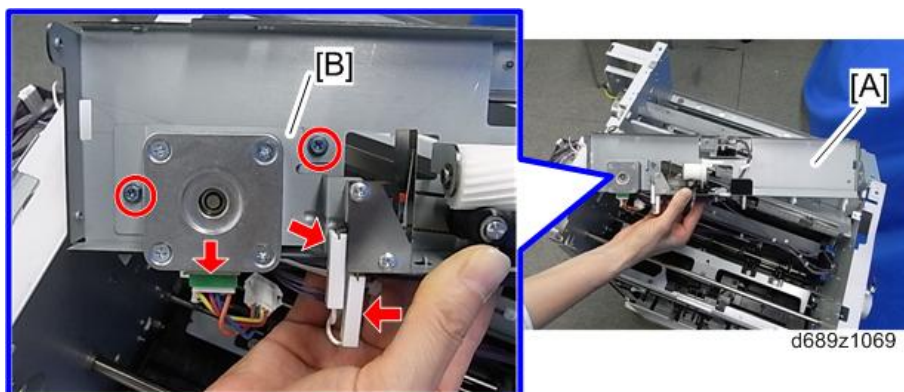

d689z1069

11. Paper exit gate motor [A] (🔩 x2)

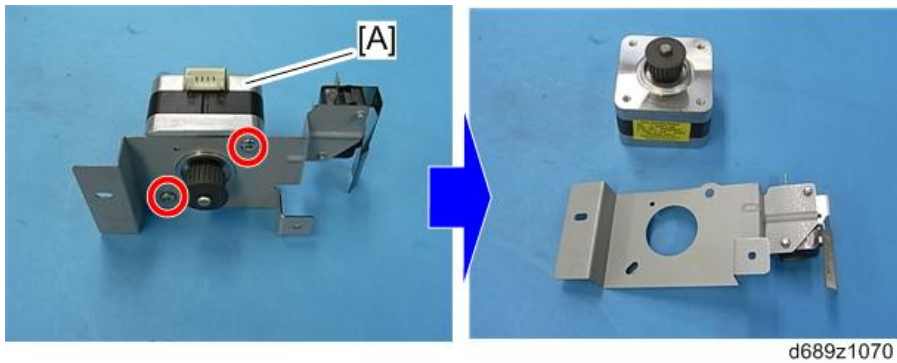

1.4.10 PAPER EXIT GATE HP SENSOR

1. Rear upper cover (page 1)
2. Proof tray (page 5)
3. Paper exit gate HP sensor Bracket [A] (🔩 x1)

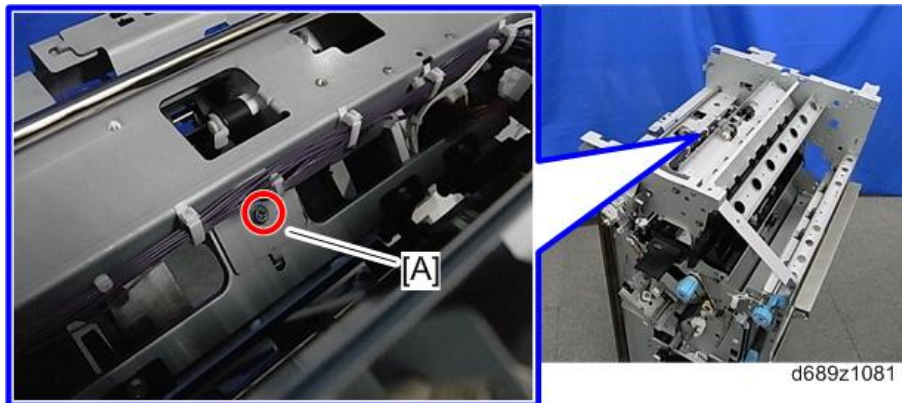

4. Turn back the bracket to remove the connector (🔌 x1)

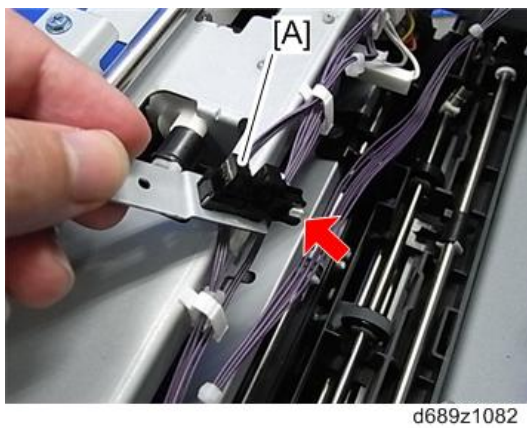

1.4.11 CORNER STAPLING PAPER SENSORS

1. Upper cover (page 1)
2. Proof tray (page 5)
3. Bracket [A] (🔑 x1)

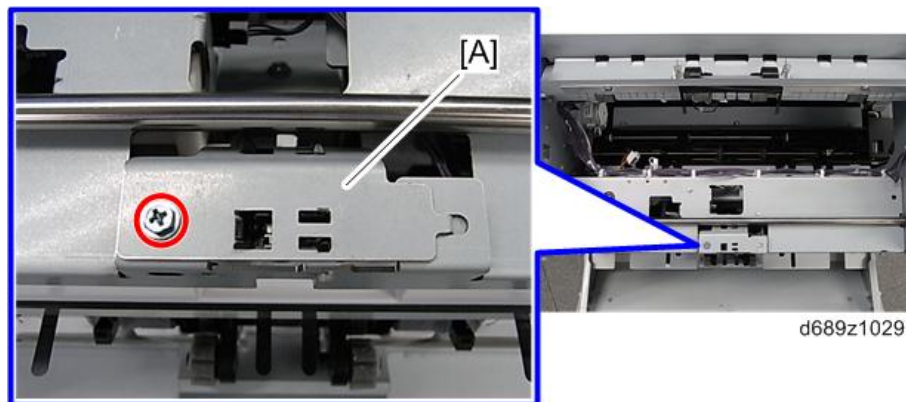

4. Turn the bracket to remove the connector (🔑 x2)

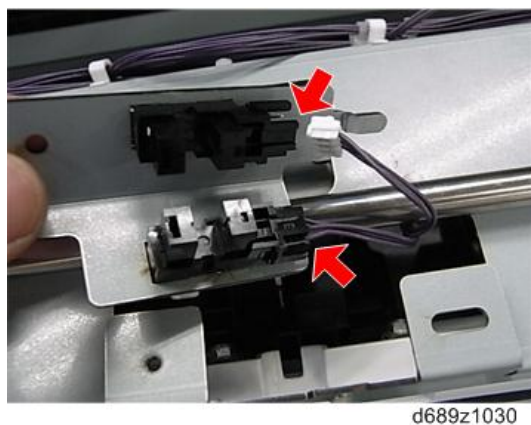

5. Corner stapling paper sensors [A]

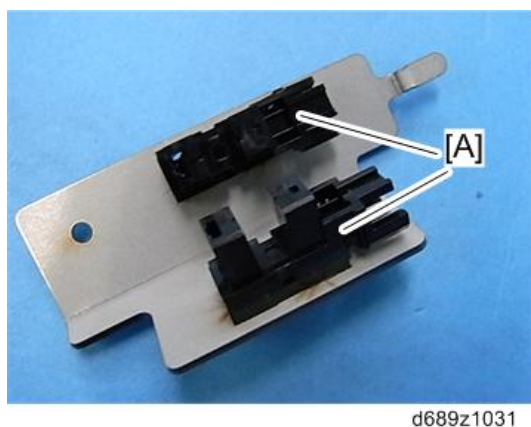

1.4.12 PROOF TRAY FULL SENSOR

1. Upper cover (page 1)
2. Proof tray (page 5)
3. Proof tray full sensor bracket [A] (🔩 x1, 📦 x1)

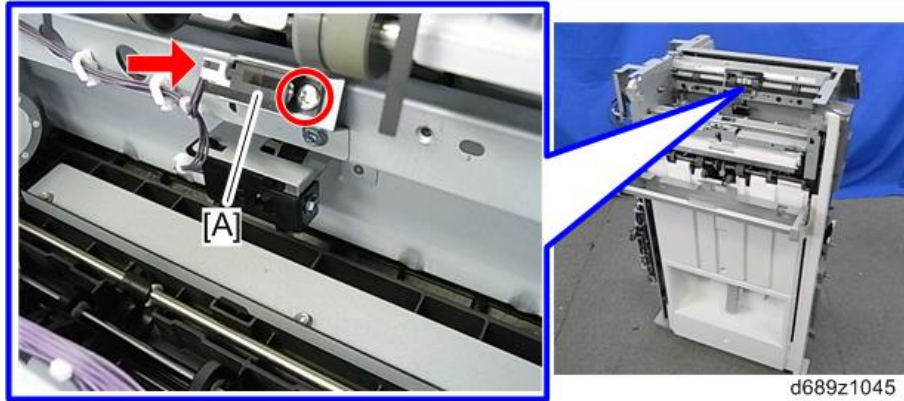

1.4.13 PROOF TRAY EXIT SENSOR

1. Rear upper cover (page 1)
2. Proof tray (page 5)
3. Proof tray exit sensor bracket [A] (🔩 x1)

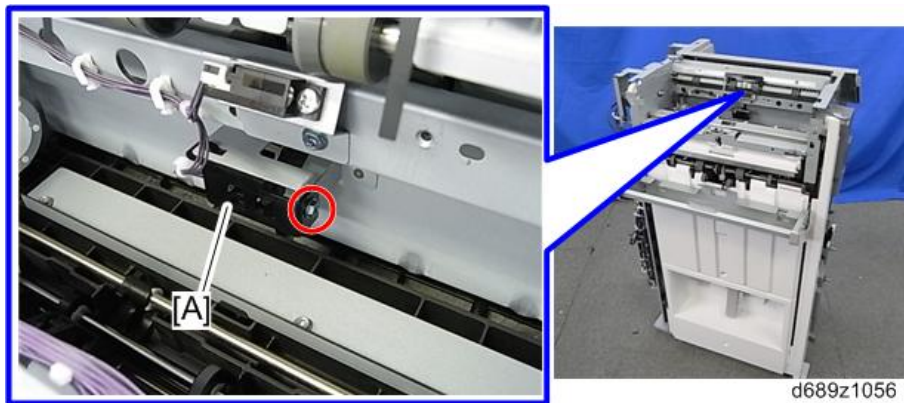

4. Proof tray exit sensor [A] (📦 x1)

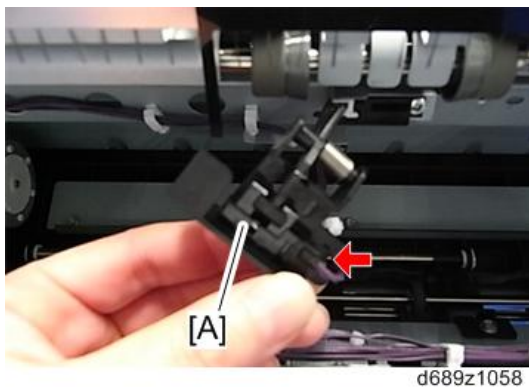

1.4.14 POSITIONING ROLLER MOTOR / FEED OUT GUIDE HP SENSOR

1. Front inner cover (page 3)
2. Positioning roller motor bracket [A] (⚙️ x3, 📦 x2, 🛠️ x2)

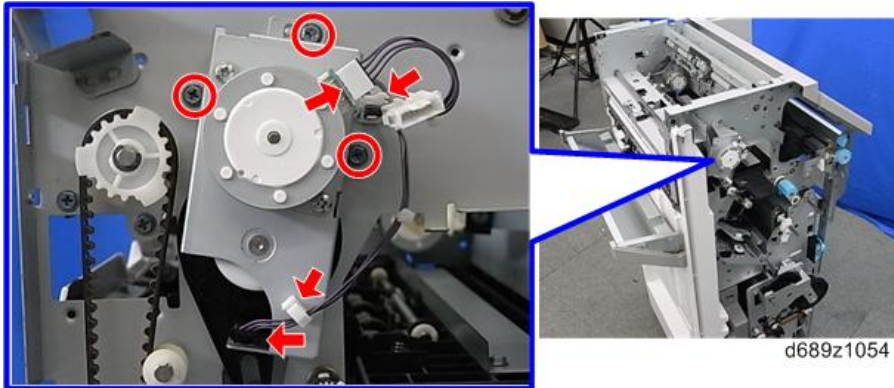

3. Positioning roller motor [A] (⚙️ x2, 🛠️ x1)
4. Feed out guide HP sensor [B]

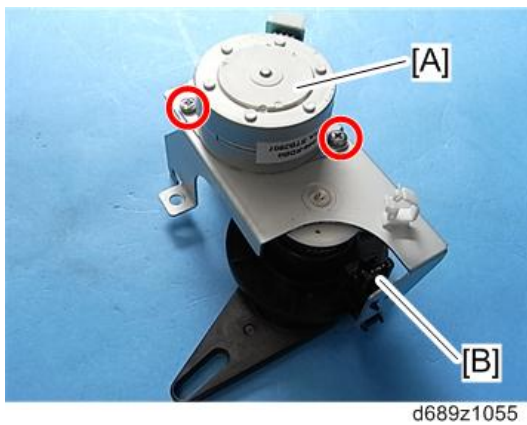

1.4.15 ENTRANCE SENSOR

1. Entrance sensor bracket [A] (🔩 x1)

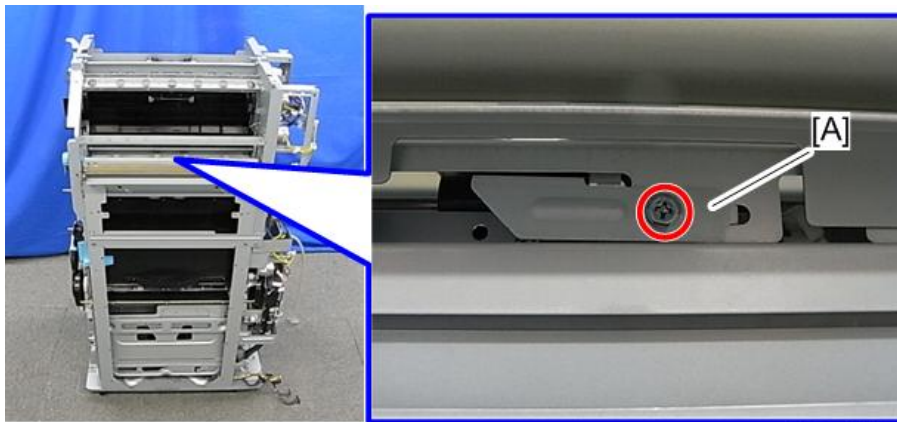

d689z1062

2. Entrance sensor [A] (📦 x1)

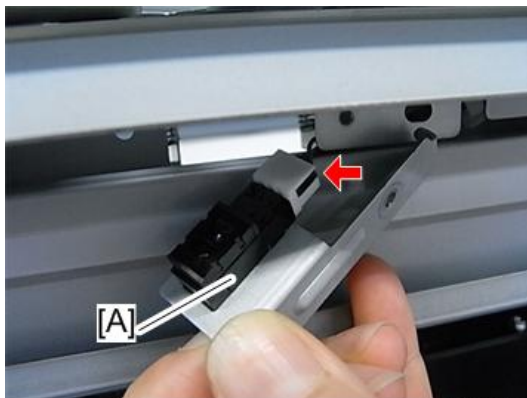

d689z1063

1.4.16 HORIZONTAL TRANSPORT SENSOR

1. Rear upper cover (page 1)
2. Front inner cover (page 3)
3. Screw and clamps (🔩x1, 📎x10)

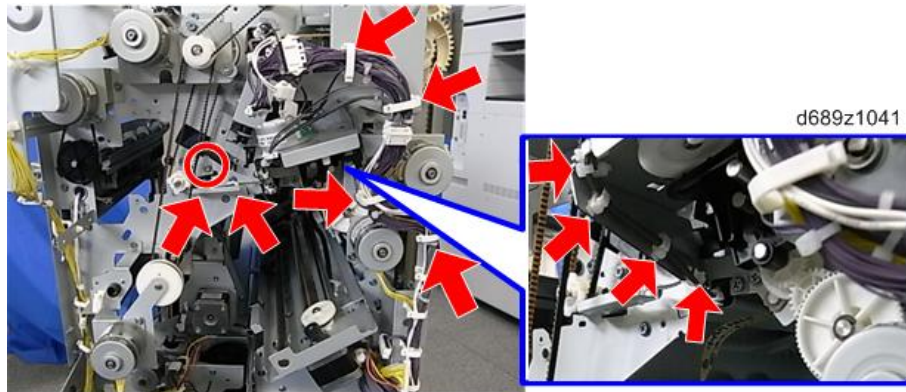

4. Remove the knob [A] and screw (🔩x1, 📎x1)

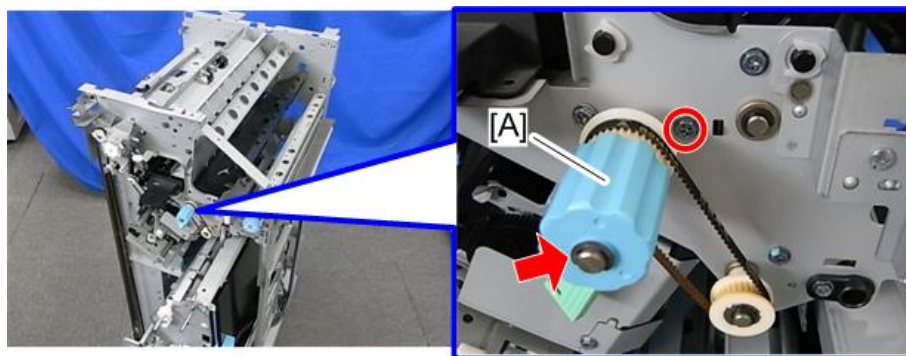

5. Pull out the bracket [A] (📎x3)

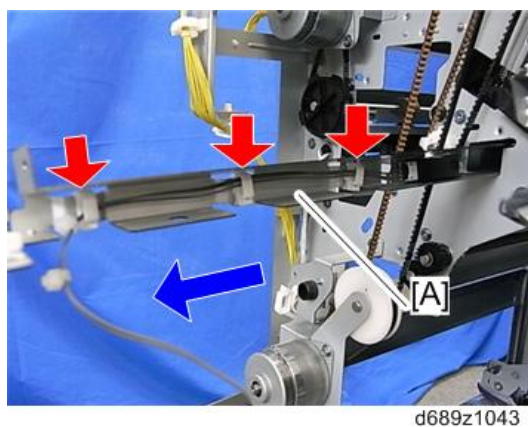

6. Horizontal transport sensor [A] (🔩x1, 📎x1)

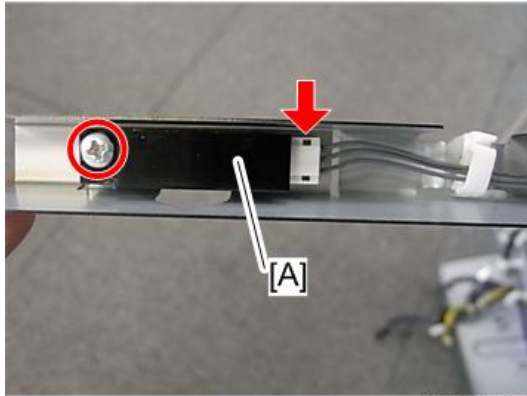

d689z1044

1.4.17 SWITCHBACK TRANSPORT SENSOR / PAPER TRANSPORT SENSOR

1. Rear upper cover (page 1)
2. Screw (🔩 x1)

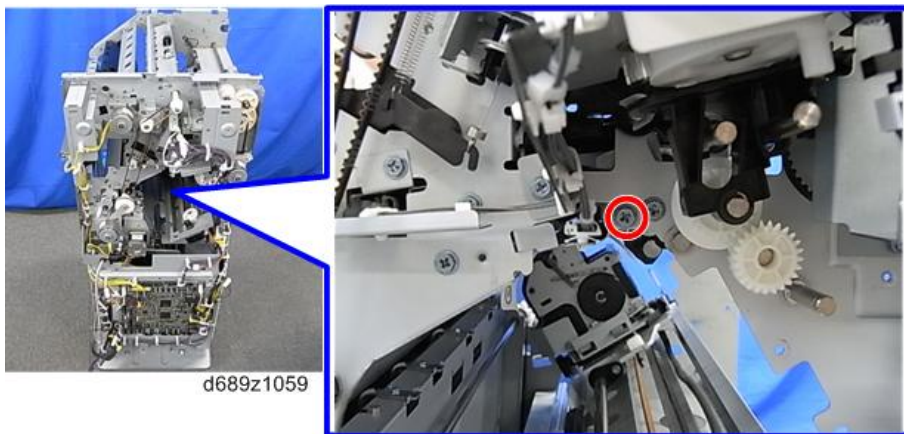

d689z1059

3. Pull out the bracket [A] (📦 x2, 🔩 x4)

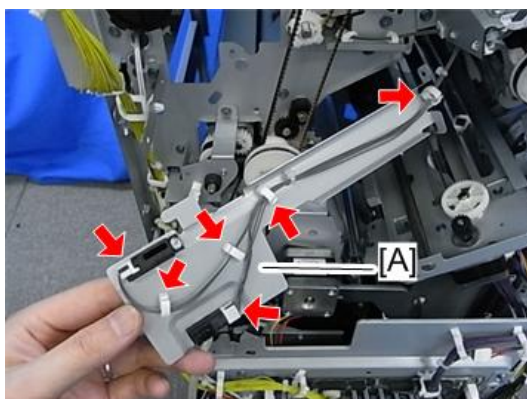

d689z1060

4. Switchback transport sensor [A] (🔩 x1)
5. Paper transport sensor [B]

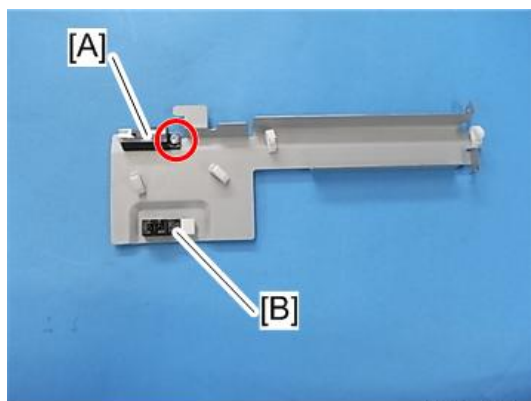

d689z1061

1.4.18 SHIFT TRAY LOWER LIMIT SENSORS

1. Rear upper cover (page 1)
2. Rear lower cover (page 1)
3. Shift tray lower limit sensors [A] (📦 x1 for each sensor)



d689z1057

1.4.19 BOOKLET PAPER FULL SENSOR 1, BOOKLET PAPER FULL SENSOR 2 (D688 ONLY)

1. Booklet unit (page 47)
2. Bracket [A] (🔩 x2, 🛠️ x1)

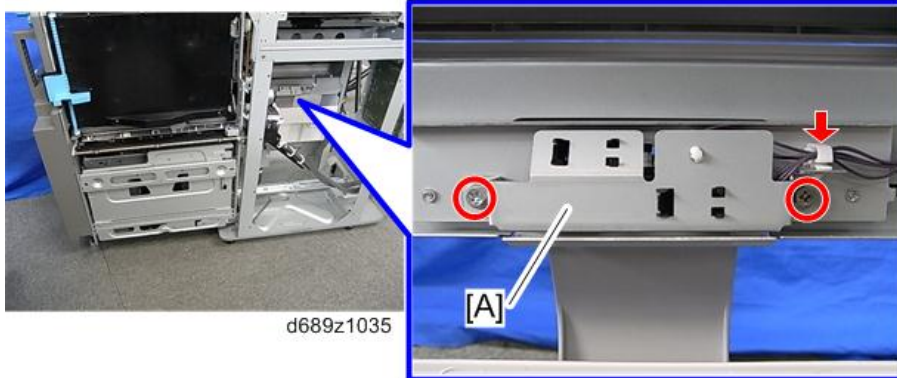

3. Connectors and clamp (📦 x2, 🛠️ x1)



4. Booklet paper full sensor 1 [A], Booklet paper full sensor 2 [B]

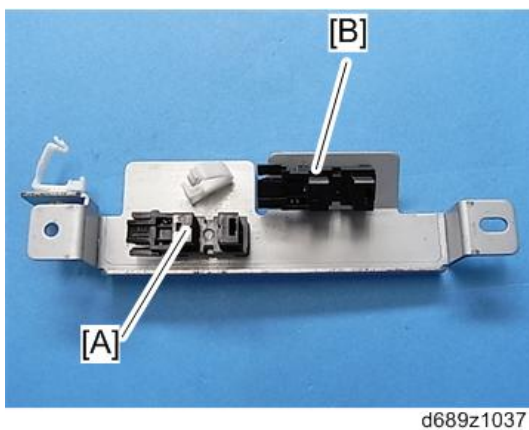

1.5 BOOKLET UNIT (D688 ONLY)

1.5.1 BOOKLET UNIT

1. Remove the following covers (page 1)
 - Rear Upper Cover
 - Rear Lower Cover
2. Remove the ground wire [A] in the left lower side of the main unit (🔪 x1)

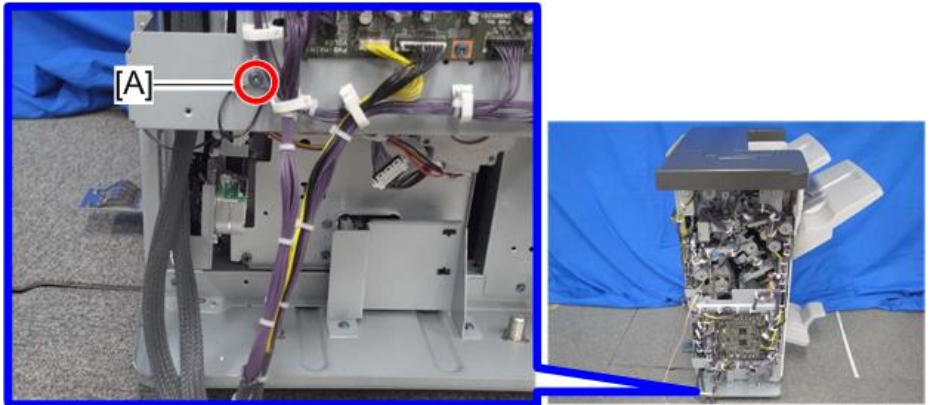

d1351316

3. Release the harness from the 4 clamps shown below (🔪 x4)

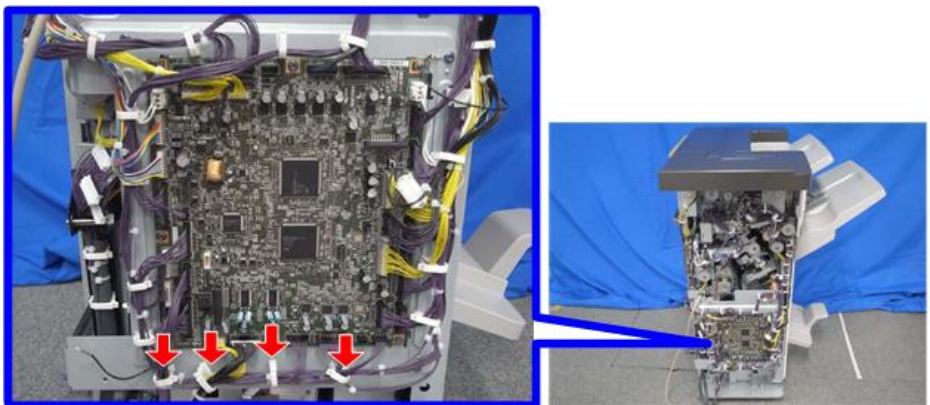

d1351317

4. Disconnect the 7 connectors of the booklet unit from the main board as shown below (🔪 x7)

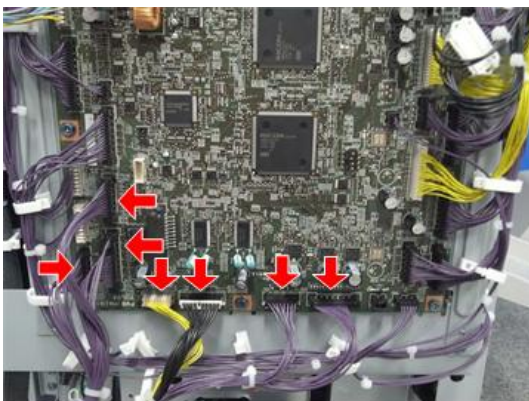

d1351318

5. Open the front door [A] and pull out the booklet unit [B].

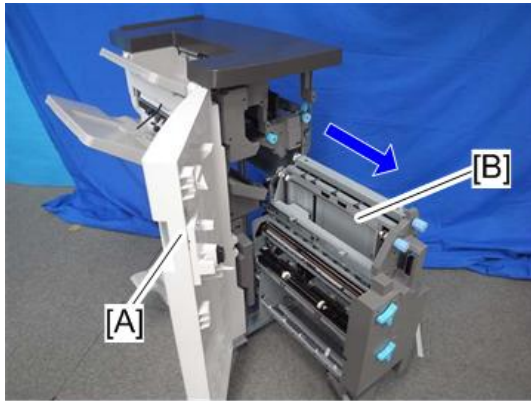

d1351319

6. Remove the screws that hold the finisher and booklet unit. (🔩 x6)

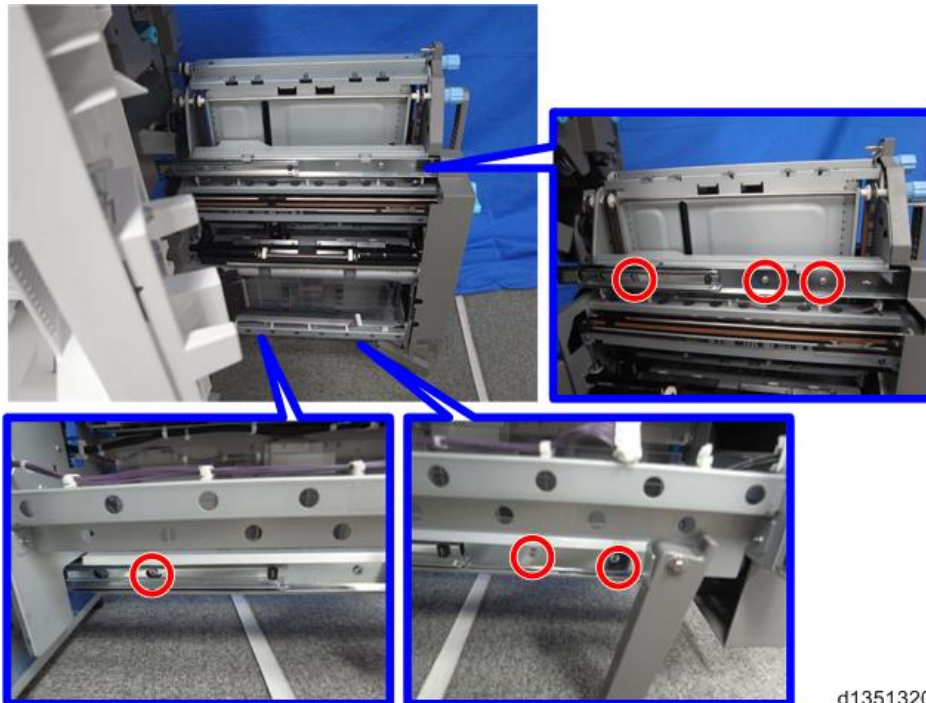

d1351320

7. Lift up the booklet unit [A] and remove it (🔩 x2).

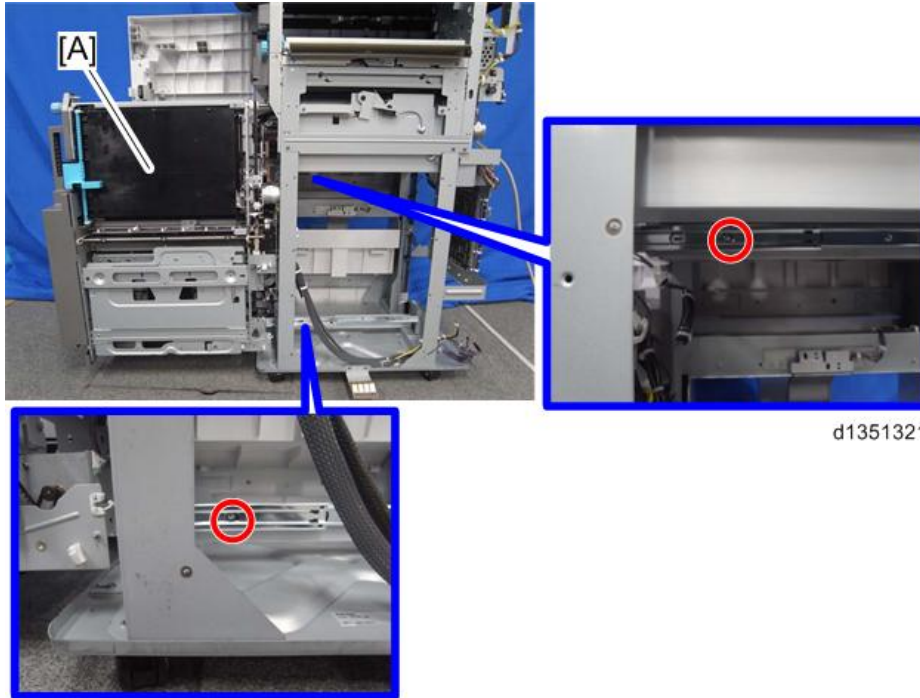

d1351321

**BOOKLET FINISHER
SR3170 /
FINISHER SR3160
(D688/D689)**

1.5.2 PRESS FOLDING MOTOR

1. Booklet unit (page 47)
2. Remove the bracket [A] from the booklet unit (🔩×1, 🌀×1)

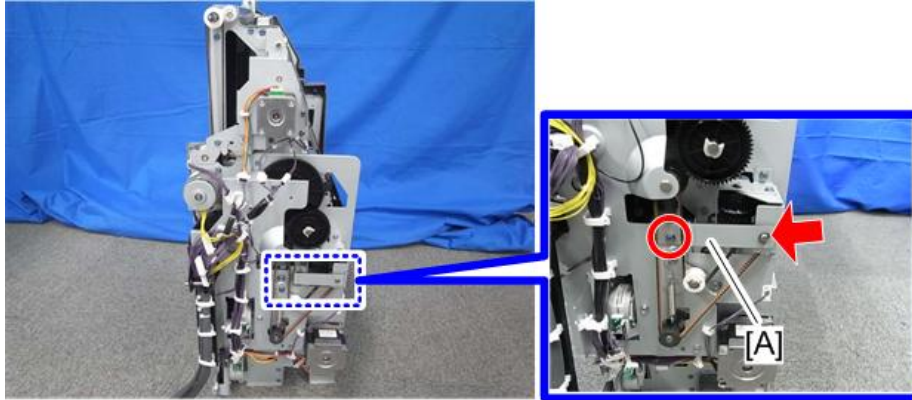

d6890019

3. Remove the screw [A] of the belt holding bracket (🔩×1)
4. Loosen the screw [B] of the belt holding bracket, and then loosen the press folding motor belt [C].

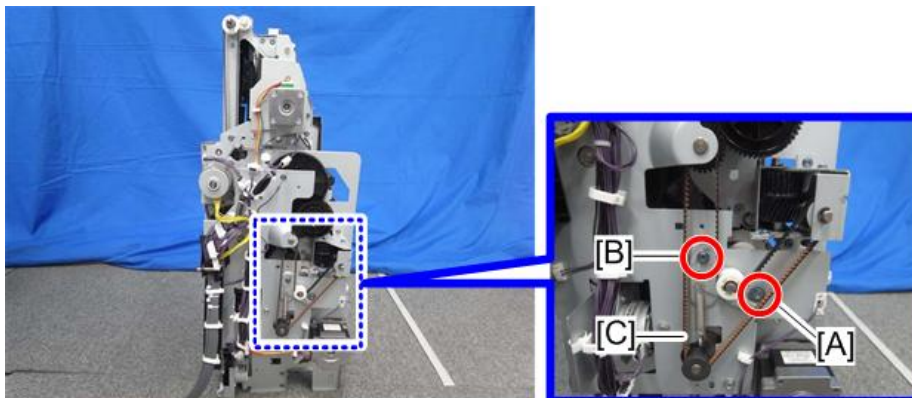

d1351323

5. Release the harness from the clamps shown below (🌀×6)

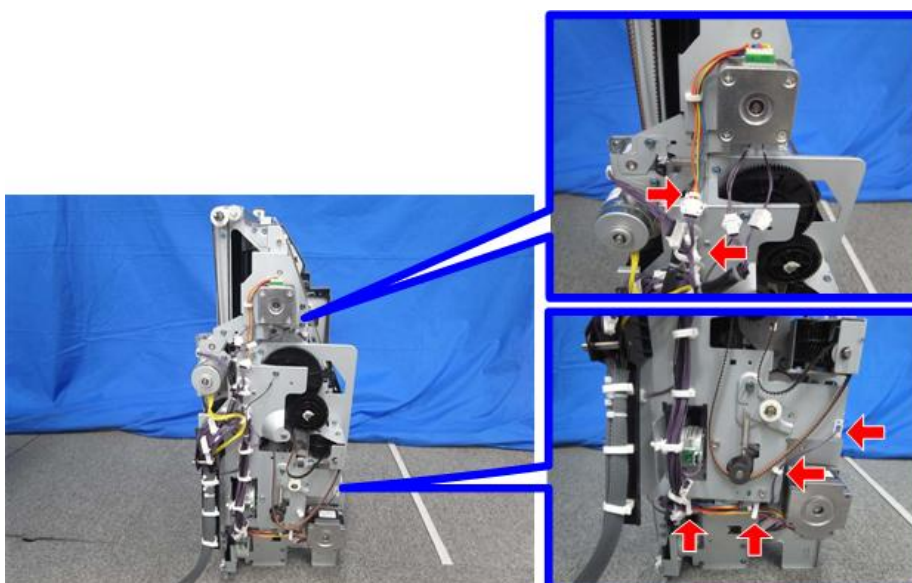

d1351324

BOOKLET FINISHER
SR3170 /
FINISHER SR3160
(D688/D689)

6. Disconnect the connectors shown below (🔌 x11)

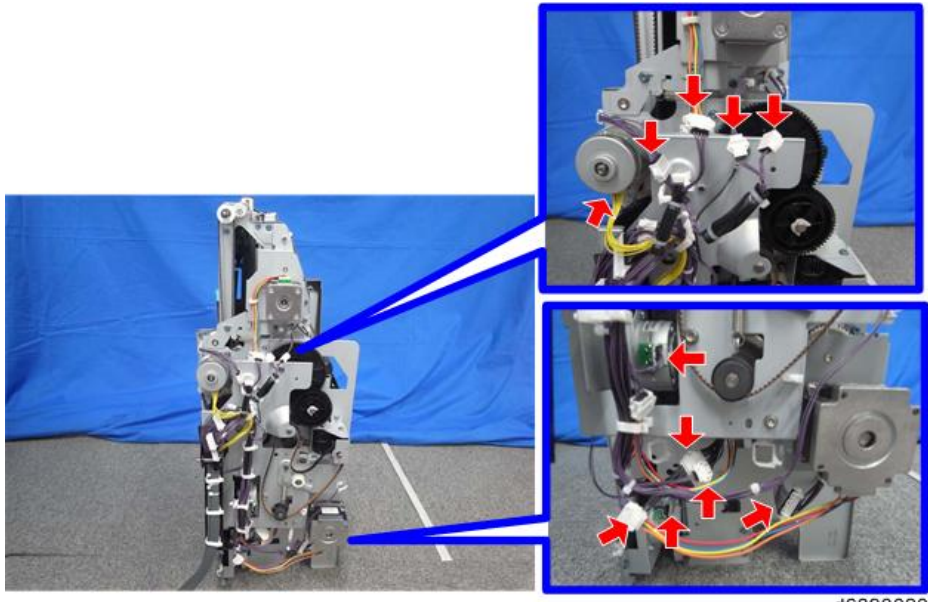

d6890020

7. Disconnect the connectors shown below (🔌 x2)



d1351326

8. Press folding motor bracket [A] (👉 x5)

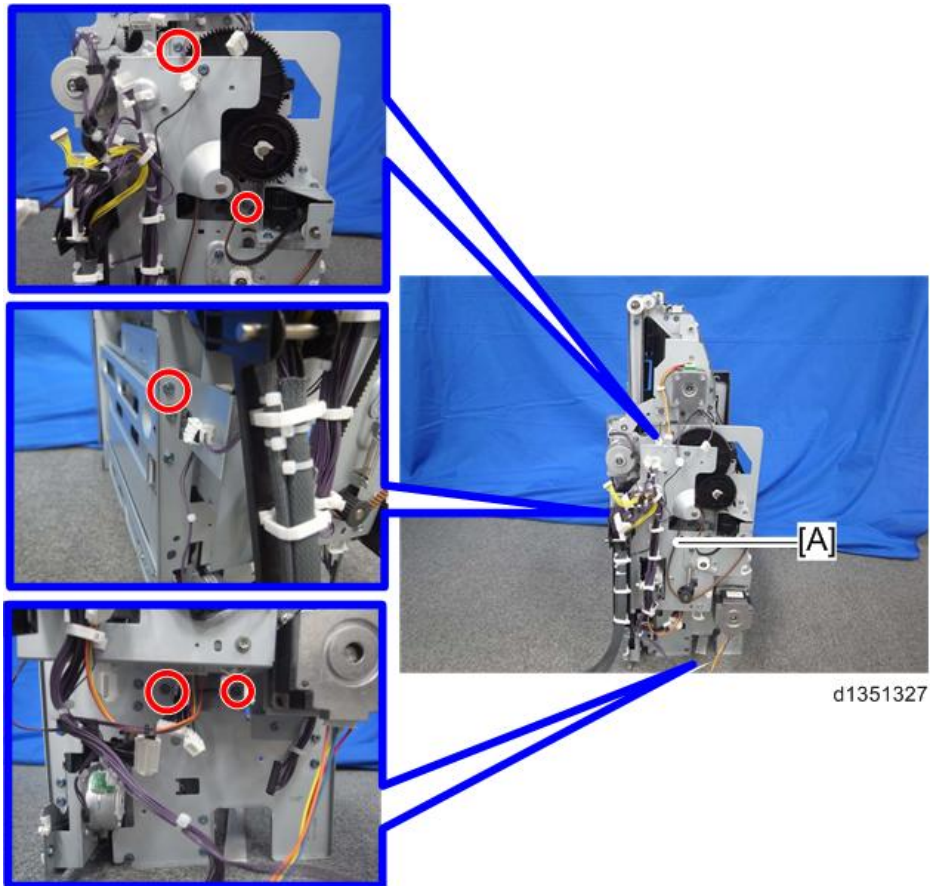

9. Remove the spring [B] from the press folding motor bracket [A] (🔩 x1, 🌀 x1)

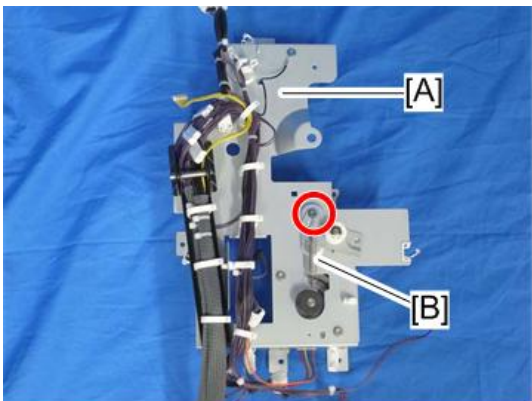

10. Remove the press folding motor [A] (🔩 x2, 📦 x1)

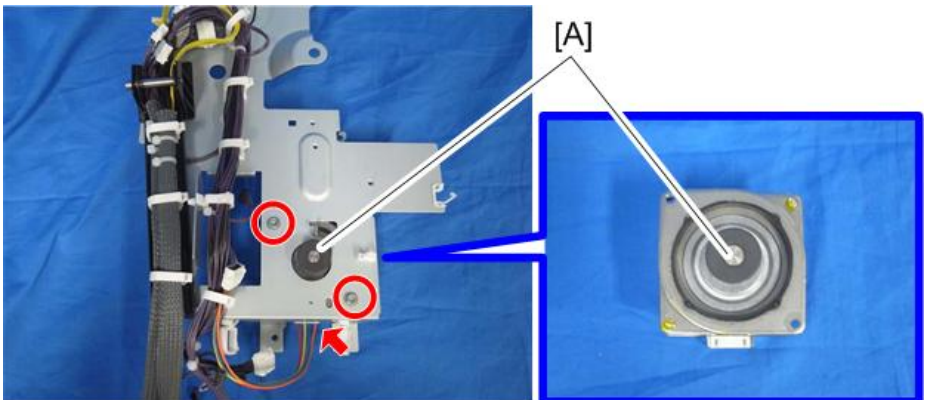

1.5.3 BOOKLET JOGGER MOTOR

1. Booklet unit (page 47)
2. Press folding motor bracket (page 50).
3. Booklet Jogger Motor [A] (🔩 x2)

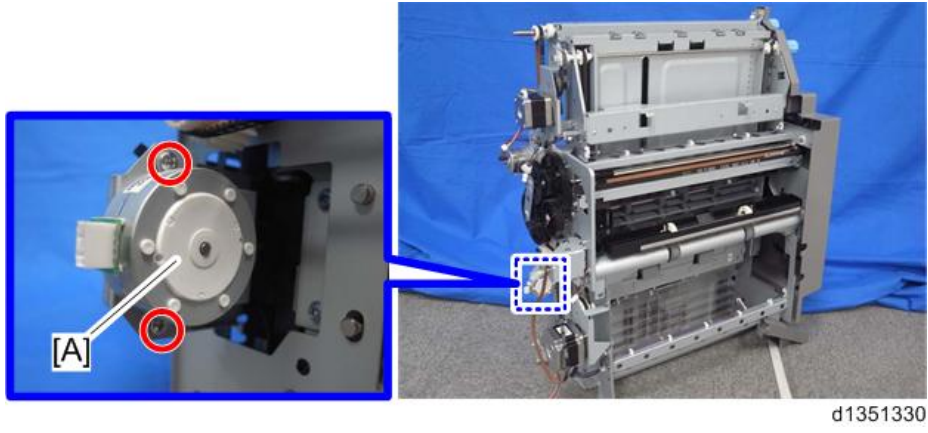

1.5.4 BOOKLET GUIDE MOTOR

1. Booklet unit (page 47)
2. Bracket [A] (🔩 x3, 📦 x1, 🛠️ x2)

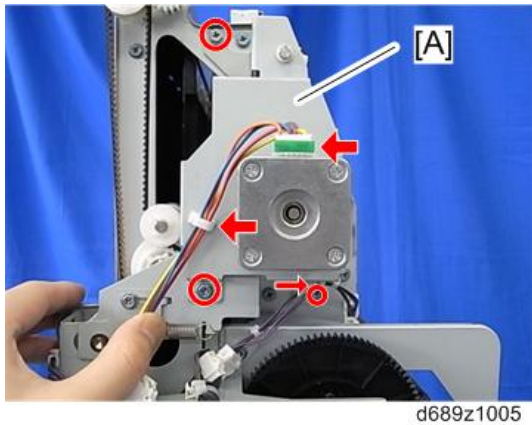

3. Booklet Guide Motor [A] (🔩 x2, 🛠️ x1)

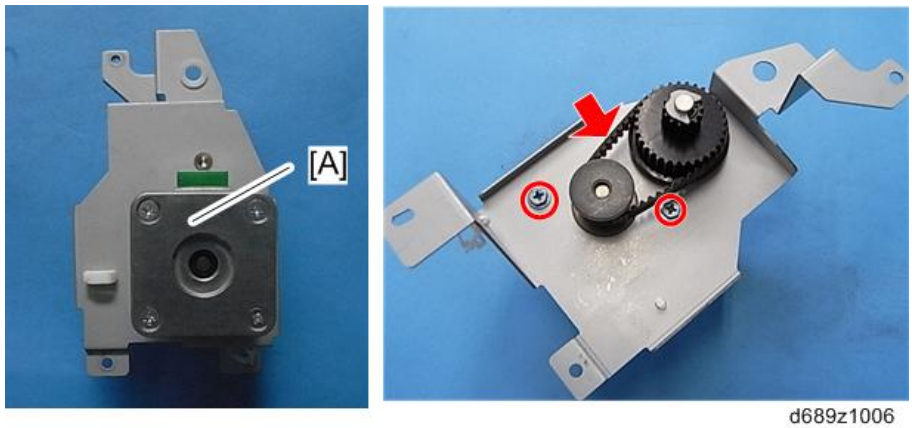

1.5.5 MOVEMENT ROLLER TRANSPORT MOTOR

1. Booklet unit (page 47)
2. Movement Roller Transport Motor [A] (⚙️ x3, 📦 x1, 🌀 x1, 🌀 x1)

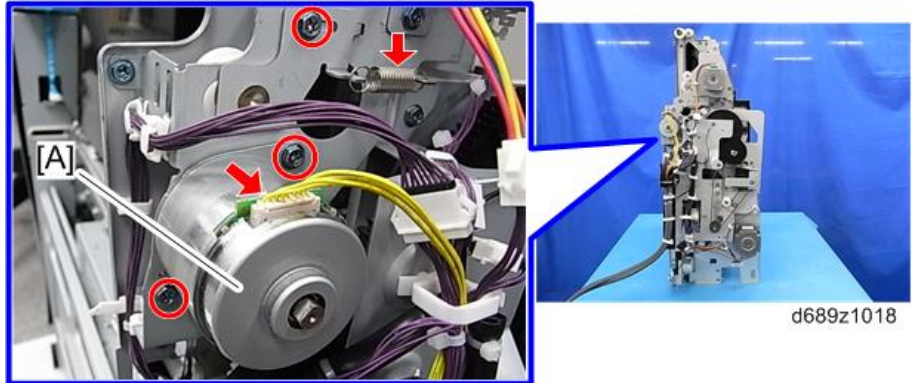

1.5.6 BOOKLET FENCE MOTOR

1. Booklet unit (page 47)
2. Booklet Fence Motor [A] (⚙️ x2, 📦 x1, 🌀 x1)

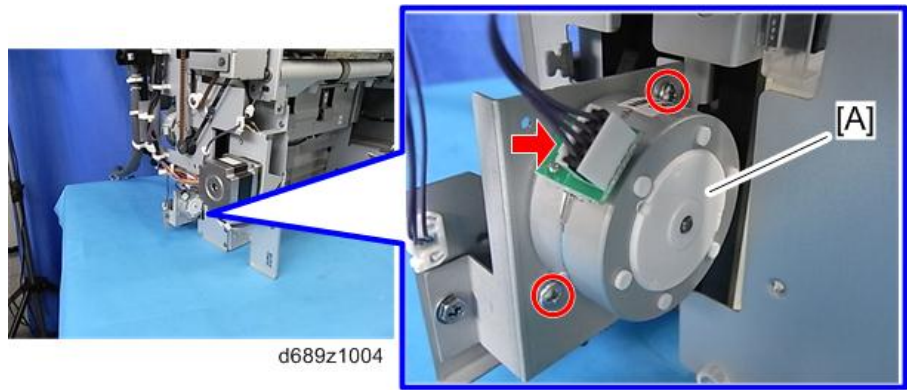

1.5.7 FOLDING TRANSPORT MOTOR

1. Booklet unit (page 47)
2. Folding Transport Motor [A] (🔩 x2, 📦 x1, 🌀 x1)

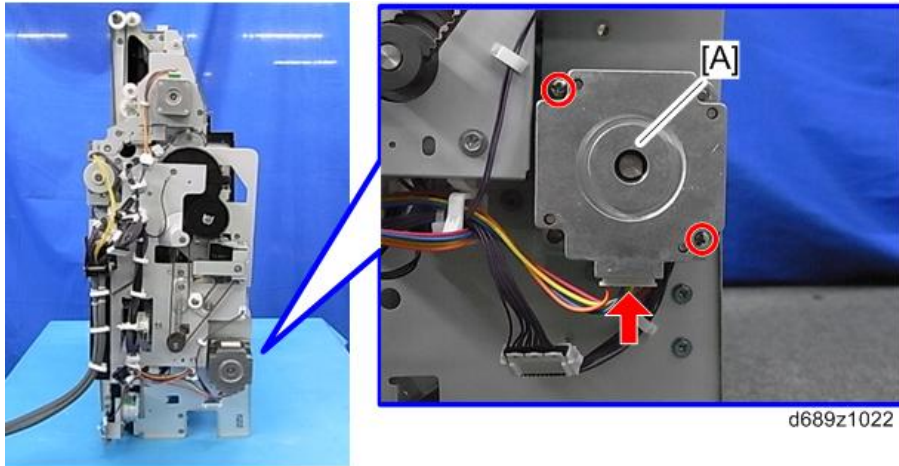

1.5.8 BOOKLET STAPLER MOTOR UNIT

1. Booklet unit (page 47)
2. Release the clamps and remove the screws securing the booklet stapler motor unit and booklet unit. (🔩 x2, 🌀 x3)

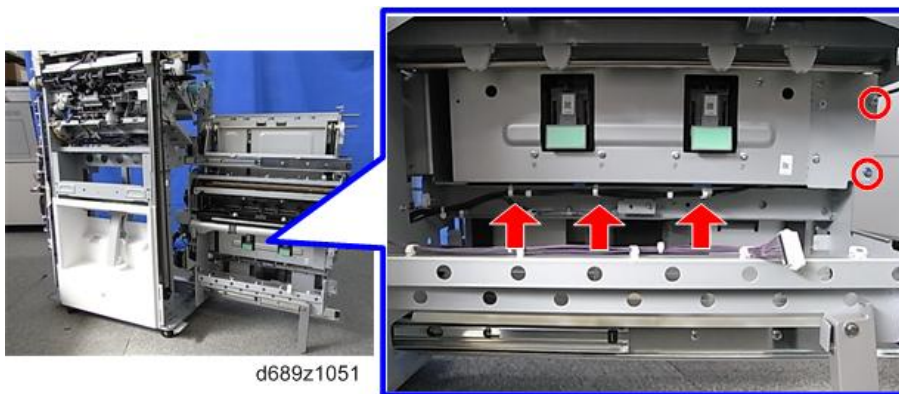

3. Remove Booklet stapler motor unit [A] while sliding it to the front side and then pulling it out from the rear part of the unit. (📦 x1)

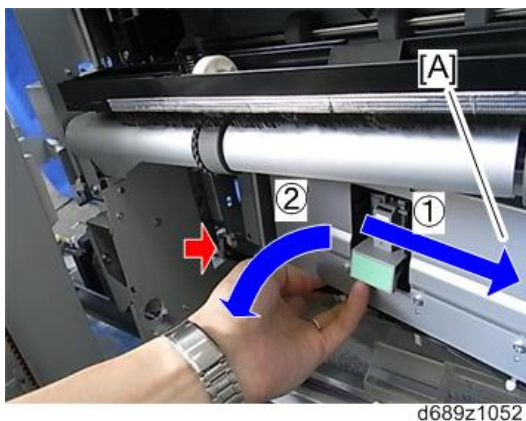

1.5.9 TRAY UPPER LIMIT SWITCH

1. Booklet unit (page 47)
2. Remove the bracket [A] from the booklet unit (🔩x1, 🌀x1)

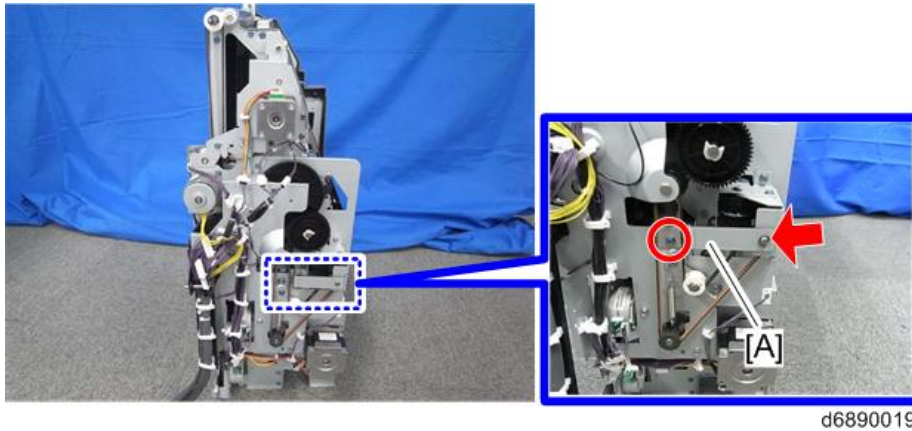

3. Remove the screw [A] of the belt holding bracket (🔩x1)
4. Loosen the screw [B] of the belt holding bracket, and then loosen the press folding motor belt [C].

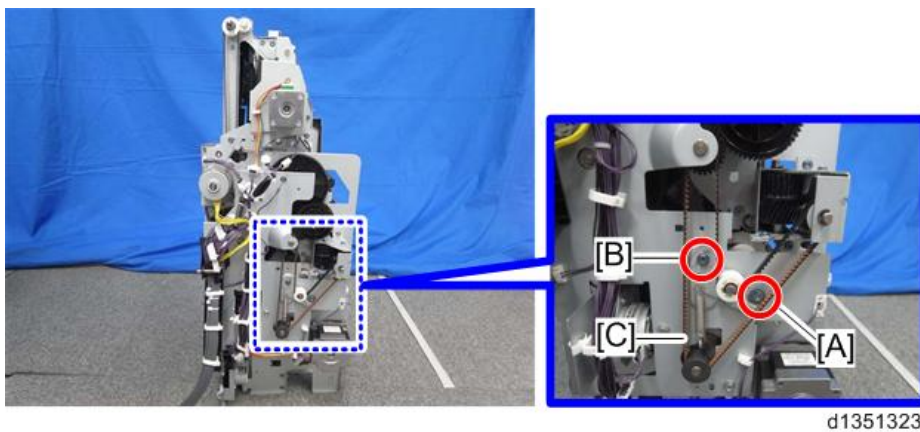

5. Release the harness from the clamps shown below (🌀x6)

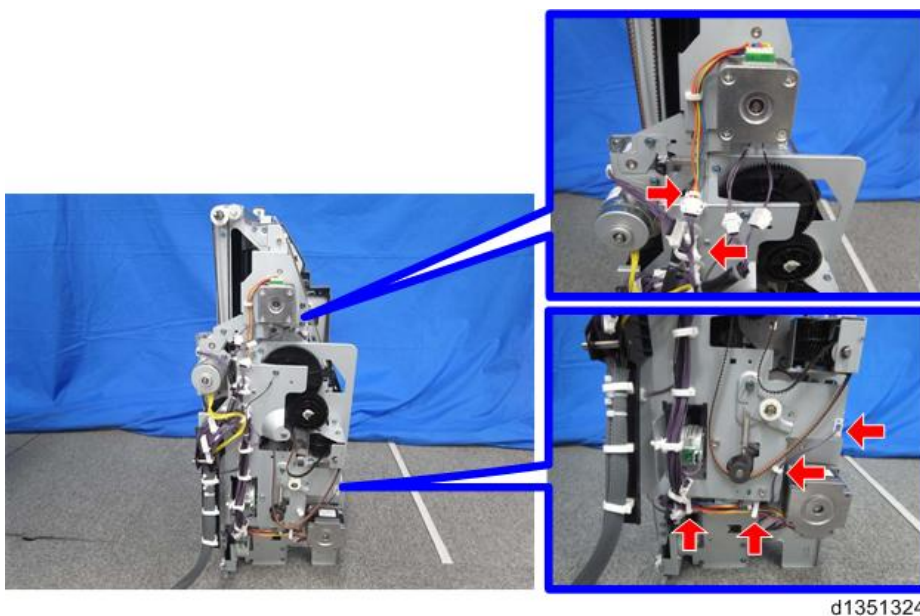

6. Disconnect the connectors shown below (🔌x11)

BOOKLET FINISHER
SR3170 /
FINISHER SR3160
(D688/D689)

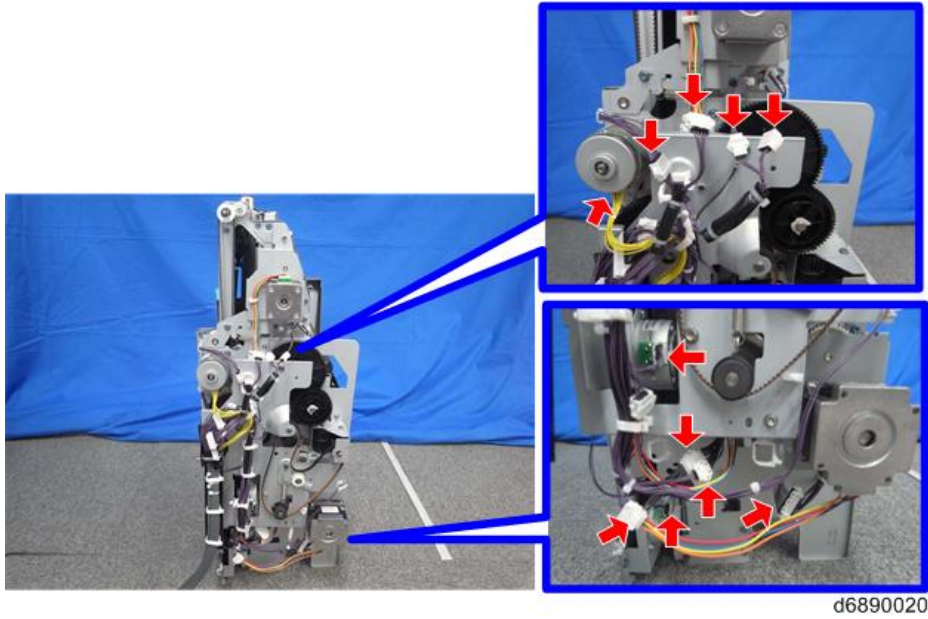

7. Disconnect the connectors shown below (🔌 x2)



8. Press folding motor bracket [A] (👉 x5)

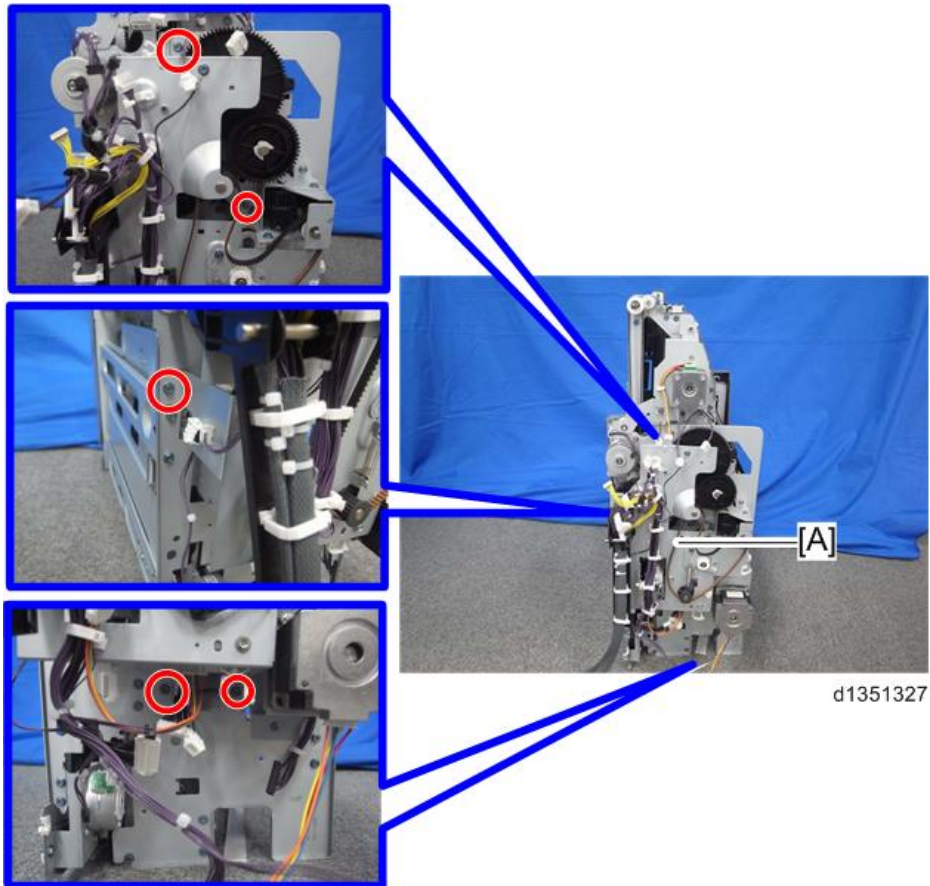

9. Rotate the cam [A] to remove the screw of the tray upper limit switch bracket [B].

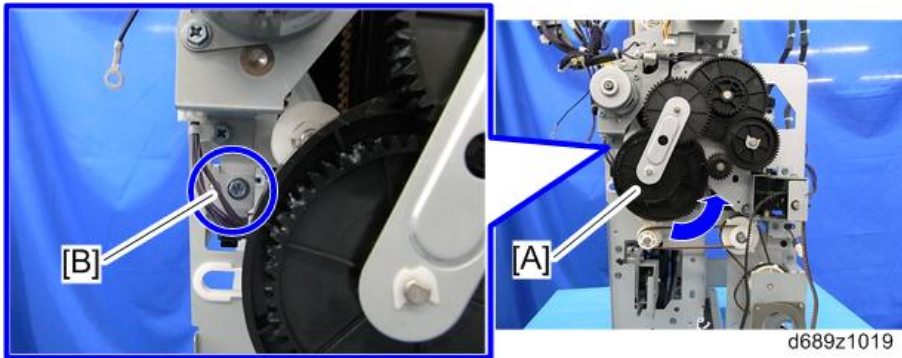

10. Bracket [A] (🔧 x1, 🛠️ x2)

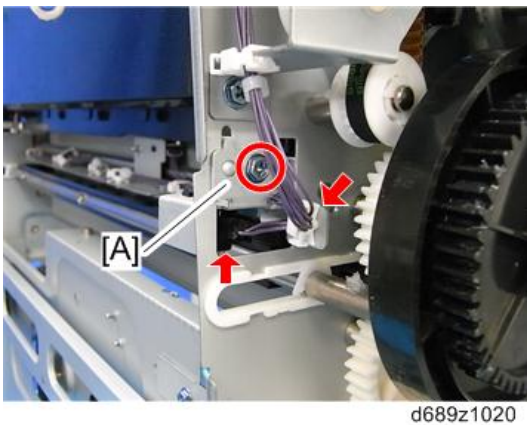

11. Tray upper limit switch [A]

BOOKLET FINISHER
SR3170 /
FINISHER SR3160
(D688/D689)

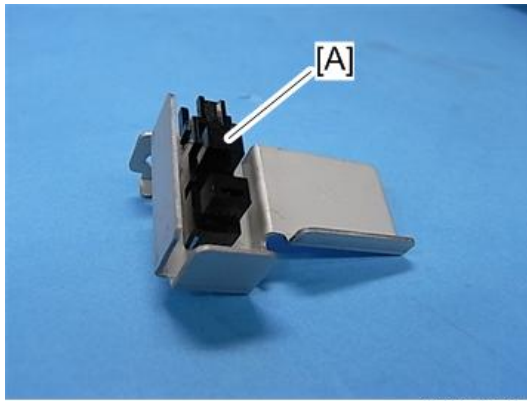

d689z1021

1.5.10 FOLDING BLADE CAM HP SENSOR

1. Booklet unit (page 47)
2. Booklet unit front cover [A] (⚙️ x5, ⚙️ x2, 📦 x1, ⚙️ x2)

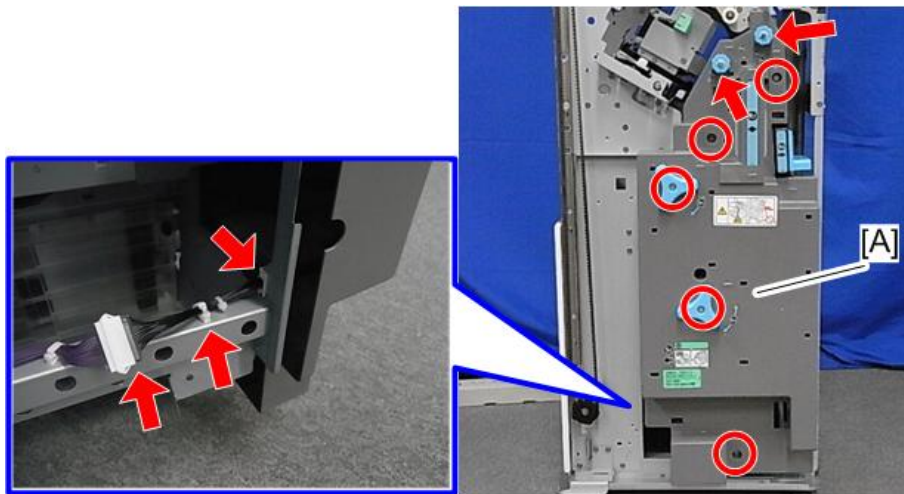

d689z1083

3. Bracket [A] (⚙️ x3, ⚙️ x1)

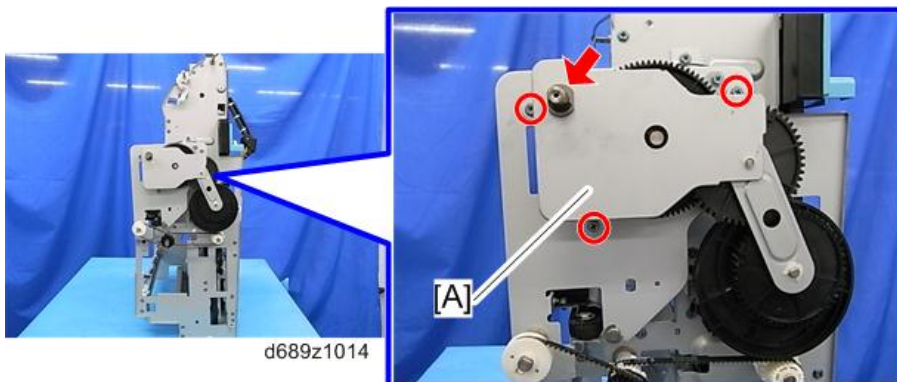

d689z1014

4. Cam bracket [A] (⚙️ x1, 📦 x1)

Booklet Unit (D688 Only)

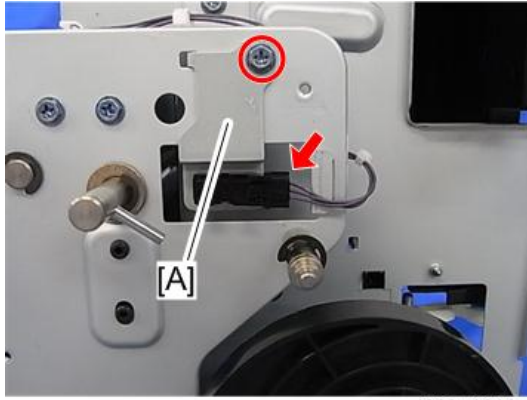

d689z1016

5. Folding blade cam HP sensor [A]

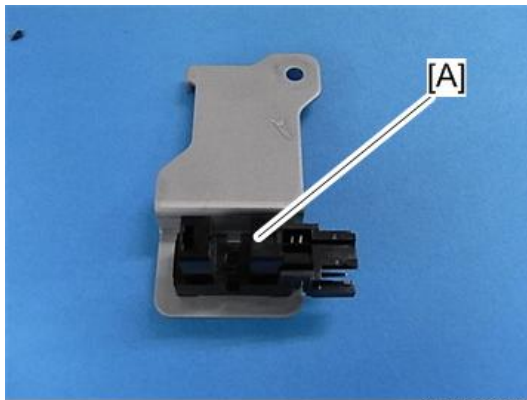

d689z1017

1.5.11 BOTTOM PAPER EXIT SENSOR

1. Booklet unit (page 47)
2. Booklet unit front cover [A] (⊙ x5, ⊙ x2, ⊙ x1, ⊙ x2)

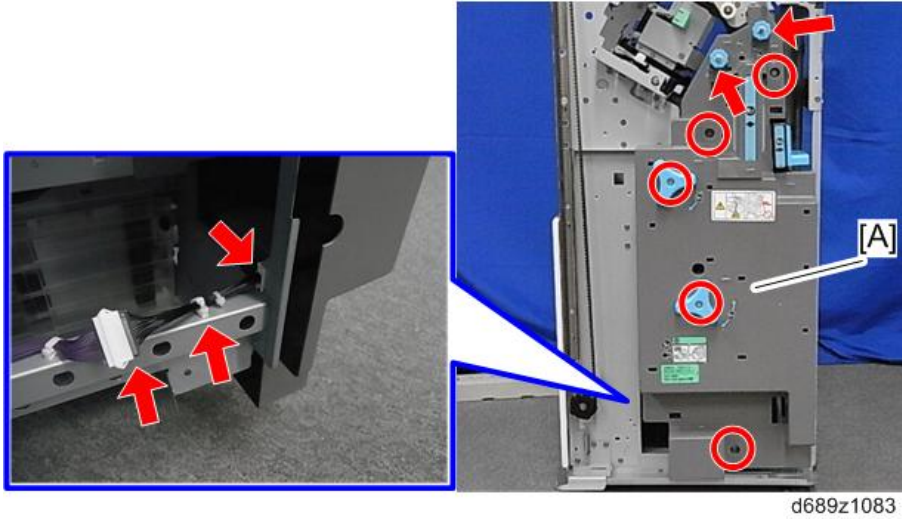

3. Fold plate bracket [A] (⊙ x2)

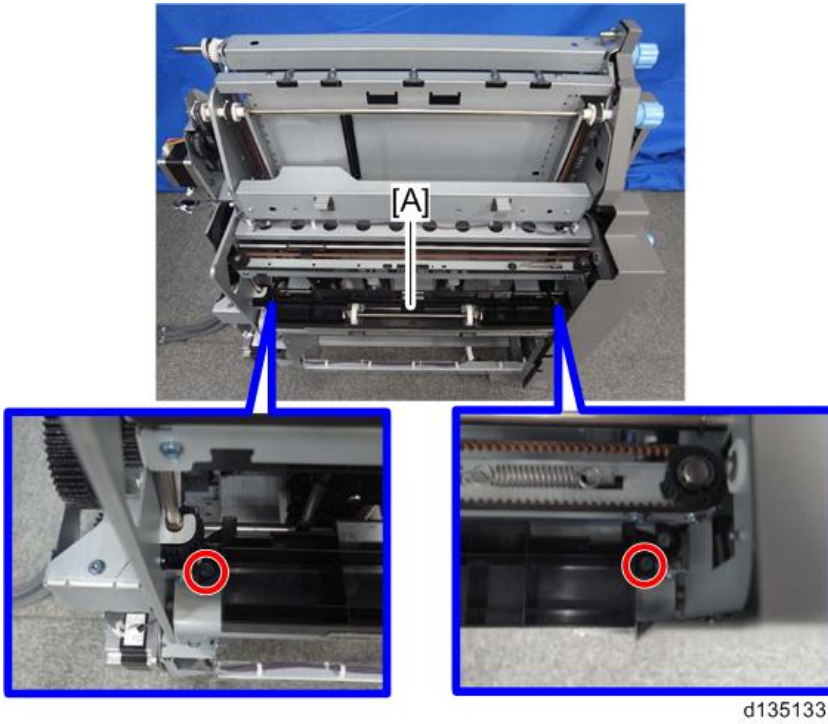

4. Booklet paper exit guide plate [A] (⊙ x4)

Booklet Unit (D688 Only)

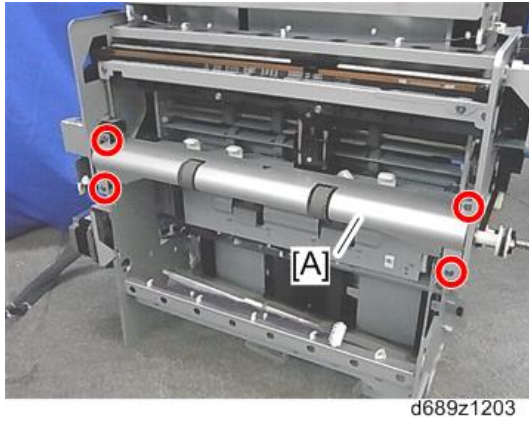

5. Bottom paper exit sensor [A] (🔩 x1, 📦 x1)

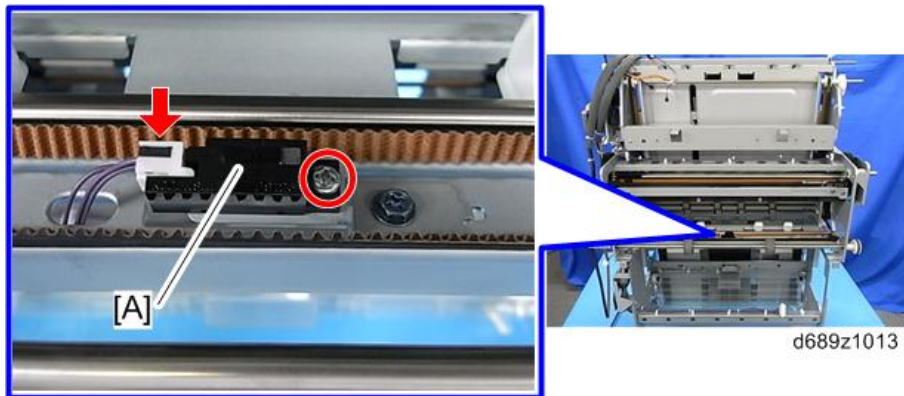

1.5.12 BOOKLET PAPER SENSOR (UPPER)

1. Booklet unit (page 47)
2. Bracket [A] (🔩 x1, 📦 x1, 🛠️ x2)

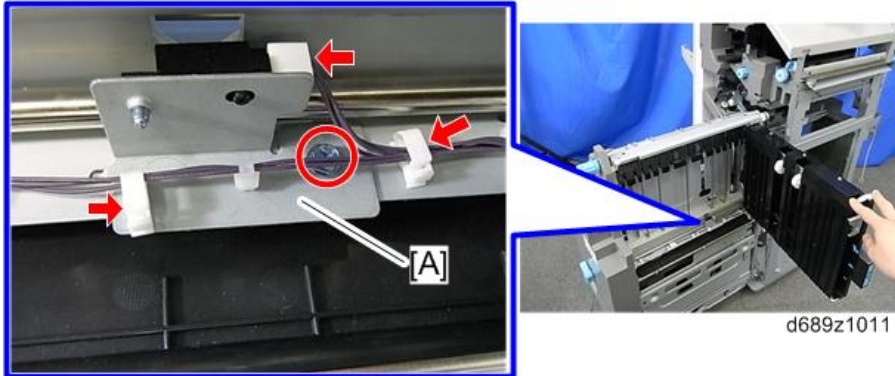

3. Booklet Paper Sensor (Upper) [A] (🔩 x1)

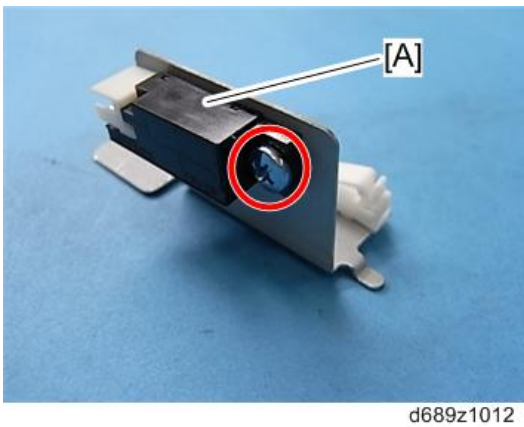

1.5.13 BOOKLET PAPER SENSOR (LOWER)

1. Booklet unit (page 47)
2. Bracket [A] (🔩 x1, 🛠️ x1)

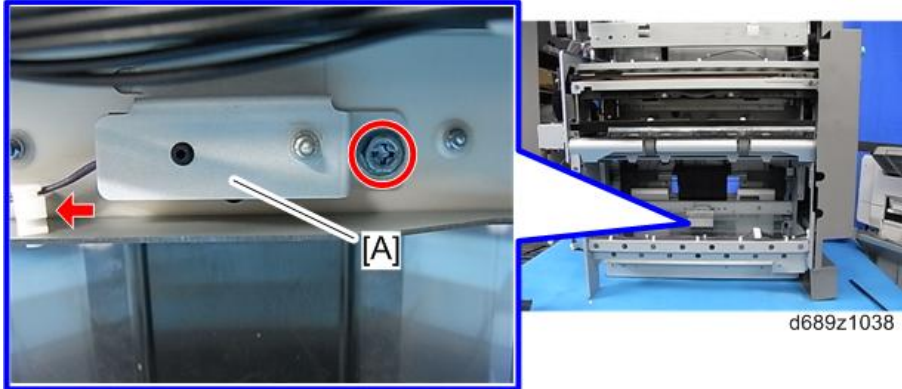

3. Booklet Paper Sensor (Lower) [A] (🔩 x1, 📦 x1)

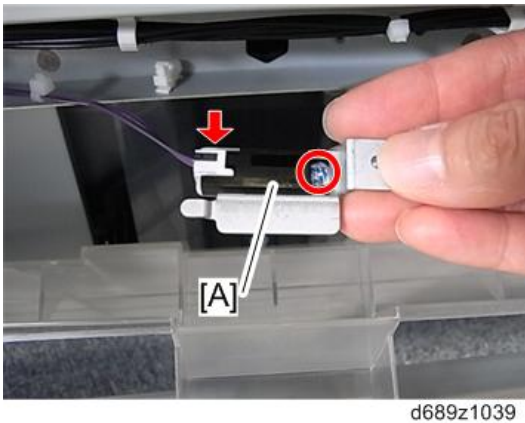

1.5.14 BOOKLET ADJUSTMENT HP SENSOR

1. Pull out the booklet unit.
2. Booklet adjustment HP sensor [A] (📦 x1)

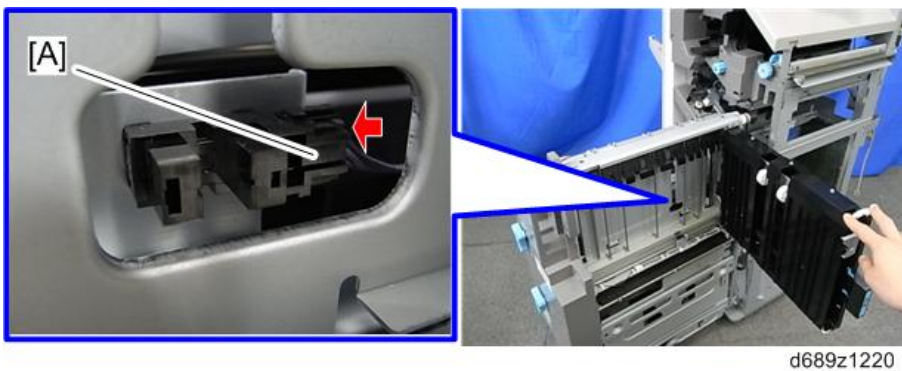

BOOKLET FINISHER
SR3170 /
FINISHER SR3160
(D688/D689)

1.5.15 BOOKLET JOGGER HP SENSOR

1. Pull out the booklet unit.
2. Bracket [A] (🔑 x1)

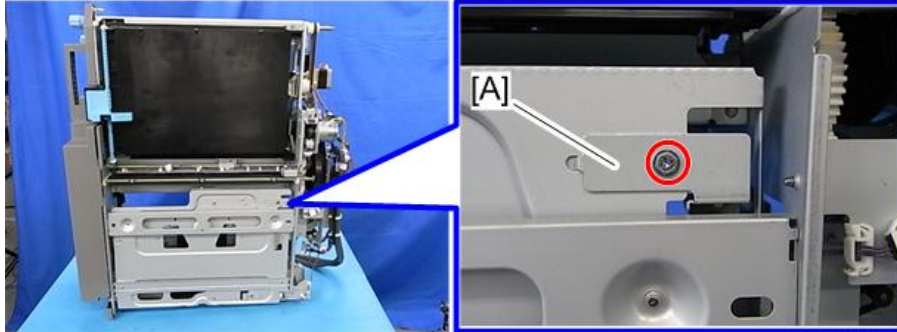

d689z1009

3. Booklet jogger HP sensor [A] (📦 x1, 🔧 x1)

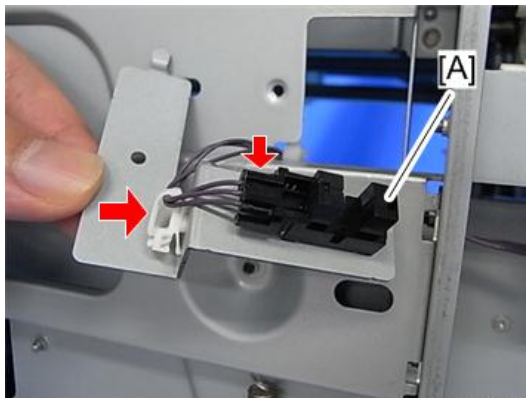

d689z1010

1.5.16 BOOKLET GUIDE SENSOR

1. Pull out the booklet unit.
2. Bracket [A] (🔑 x1)

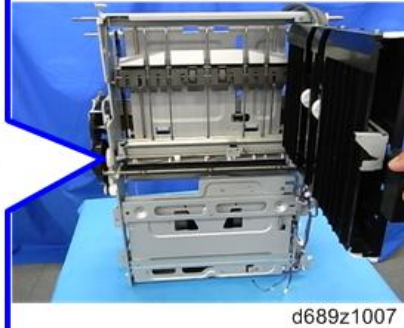
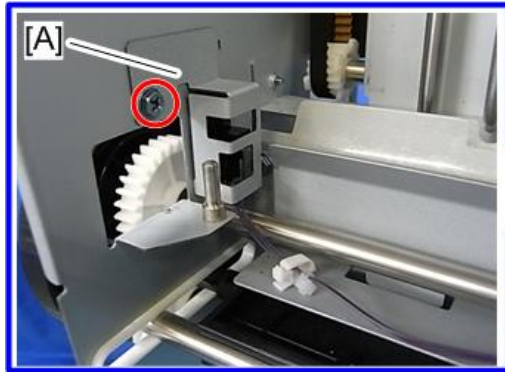

3. Booklet guide sensor [A] (📦 x1)

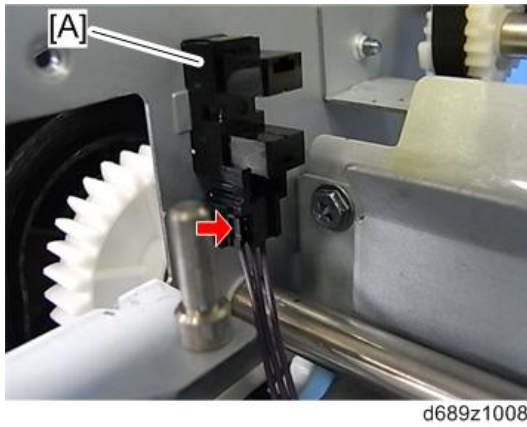

BOOKLET FINISHER
SR3170 /
FINISHER SR3160
(D688/D689)

1.5.17 BOOKLET BOTTOM FENCE HP SENSOR

1. Pull out the booklet unit.
2. Bracket [A] (🔑 x1)

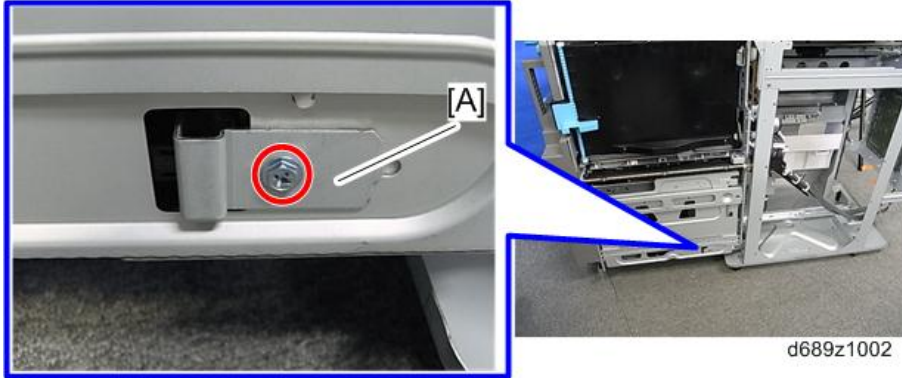

3. Booklet bottom fence HP sensor [A] (📦 x1, 🛠️ x1)

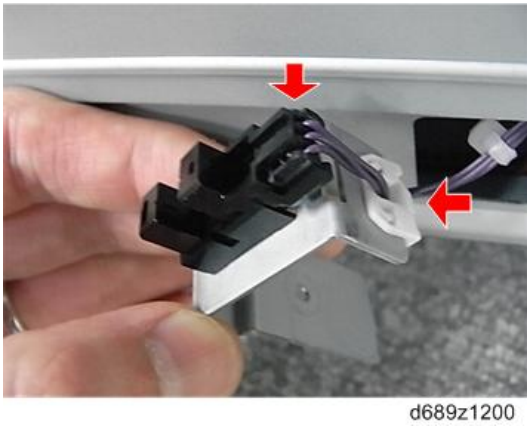

1.6 PUNCH UNIT

The punch unit is already adjusted in the factory, so you don't need to adjust it. When you need to replace the parts of the punch unit, replace the whole unit.

Note

- Do not disassemble the punch unit. This unit is precisely adjusted in the factory.
- Do not drop or give a shock to the unit when you replace it. The unit could be damaged.

1. Remove the following covers.

- Rear upper cover and rear lower cover (page 1)

2. Stepper motor bracket [A] (⚙️ x2, 📦 x2, 🛠️ x2)

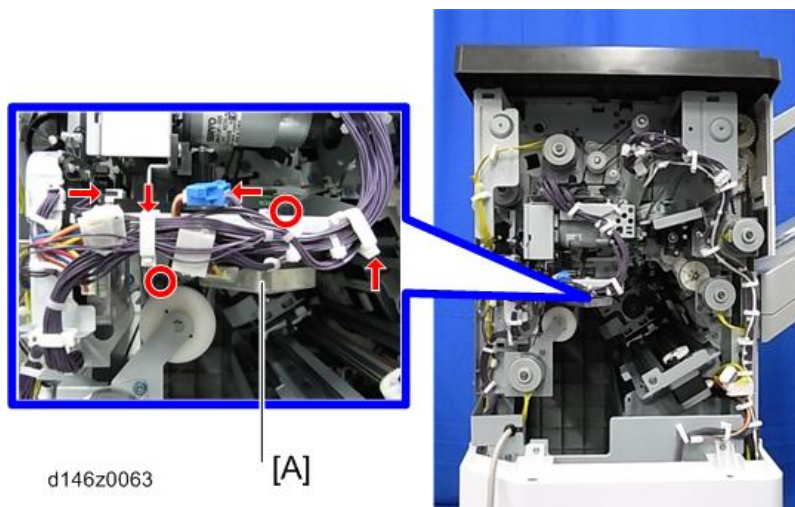

3. Pull out the punch unit [A] (⚙️ x2, 📦 x5, 🛠️ x4)

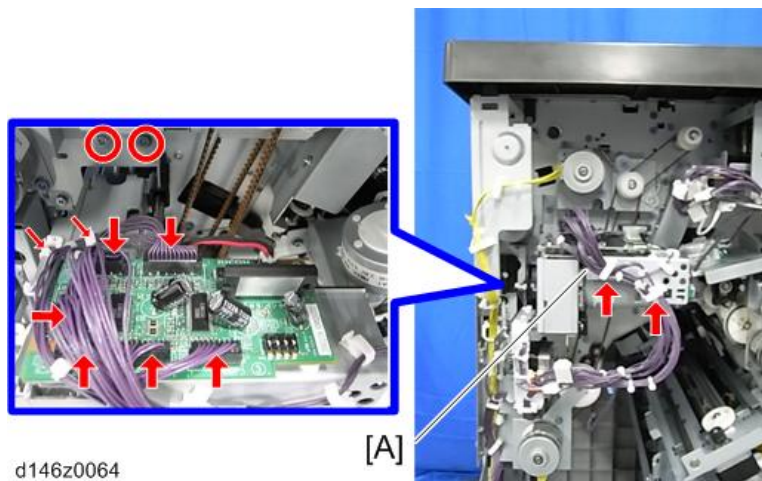

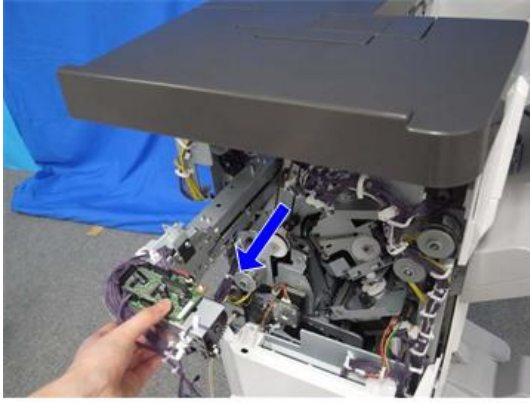

d1351315

**BOOKLET FINISHER
SR3170 /
FINISHER SR3160
(D688/D689)**

1.7 ADJUSTMENT OF THE FLAT FOLD BOOKLET UNIT

1.7.1 ADJUSTING THE ALIGNMENT OF THE FLAT FOLD ROLLERS

To adjust the folding strength, adjust the difference in vertical alignment between the flat fold rollers.

1. Booklet unit (page 47)
2. Fold plate bracket [A] (🔑 x2)

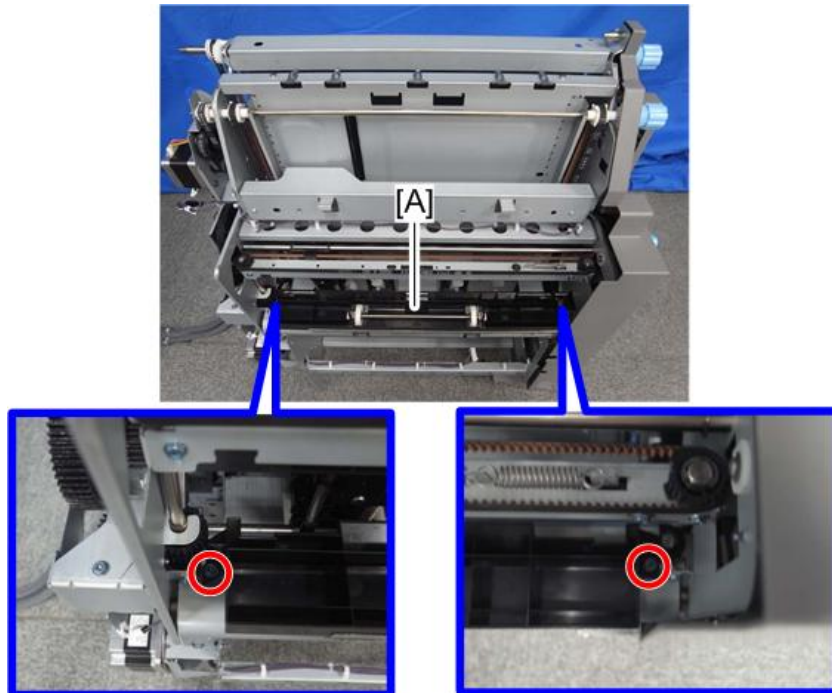

d1351331

3. Open the bracket [A] of the flat fold roller.

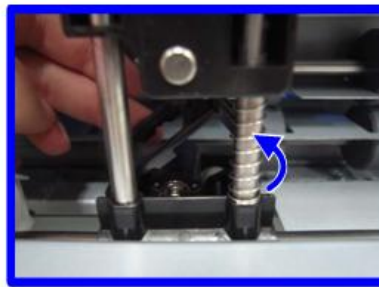
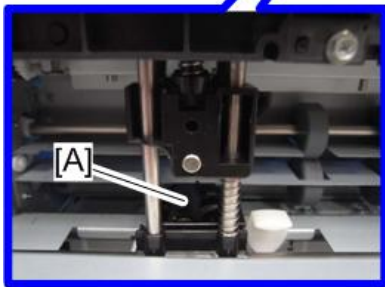
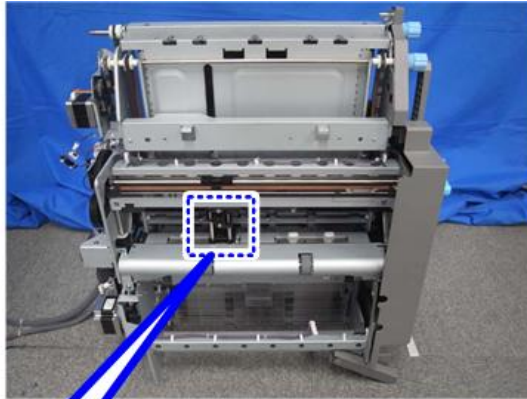

d1351332

4. Adjust the position of the flat fold lower roller [A] to adjust the difference in alignment between the upper and lower rollers of the flat fold booklet unit.

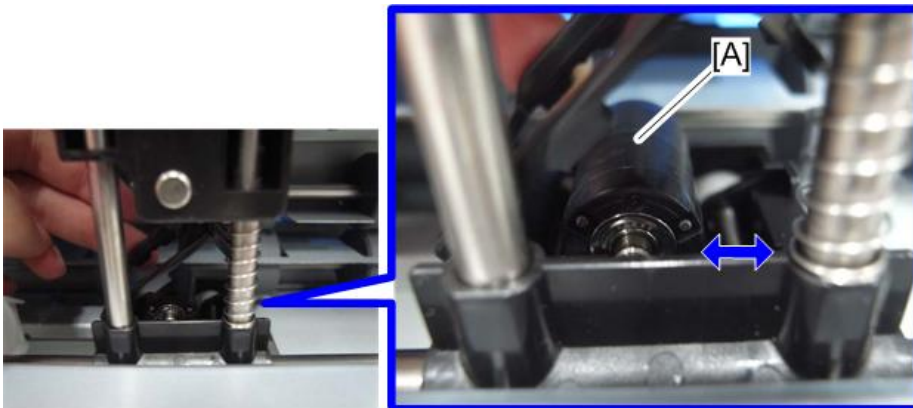

d1351333

⬇ Note

- To lower the booklet fold height (increase folding strength), roller offset is increased. To raise the booklet fold height (decrease folding strength), roller offset is decreased. When the machine is shipped from the factory, the booklet fold height is set low by offsetting the rollers. However, since the folding strength is high, toner cracking may occur at fold lines. In such a case, toner cracking at fold lines may be reduced by adjusting the offset amount to 0 mm.

Difference in Alignment and Folding Strength

Adjustment of the Flat Fold Booklet Unit

Difference in Alignment	Folding Strength	Thickness of the booklet	The amount of toner sticking to the folding line
3mm (default)	Strong	Thin	OK
0mm	Weak	Thick	Good

5. Close the bracket after the adjustment.
6. Reassemble the machine.

1.7.2 ADJUSTING THE FOLDING SPEED

You can adjust the thickness of the booklet by adjusting the moving speed of the flat fold booklet unit.

If you want to make the booklet thinner, set a slower speed. If you want to make the booklet thicker, set a faster speed.

1. Enter the SP mode.
2. Set the moving speed of the flat fold booklet unit for each paper size with SP6-114-001 to 010 (Fold Speed Adj.: 2K/3K FIN).

SP	Setting Items	Selection	Default Value
SP6-114-001	Fold Speed Adj.: 2K/3K FIN: A3 SEF	0: Standard* 1: Middle 2: Low	0: Standard
SP6-114-002	Fold Speed Adj.: 2K/3K FIN: B4 SEF		
SP6-114-003	Fold Speed Adj.: 2K/3K FIN: A4 SEF		
SP6-114-004	Fold Speed Adj.: 2K/3K FIN: B5 SEF		
SP6-114-005	Fold Speed Adj.: 2K/3K FIN: DLT SEF		
SP6-114-006	Fold Speed Adj.: 2K/3K FIN: LG SEF		
SP6-114-007	Fold Speed Adj.: 2K/3K FIN: LT SEF		
SP6-114-008	Fold Speed Adj.: 2K/3K FIN: 12"x18"		
SP6-114-009	Fold Speed Adj.: 2K/3K FIN: 8K SEF		
SP6-114-010	Fold Speed Adj.: 2K/3K FIN: Other		

* [0: Standard] is faster than [1: Middle].

3. Exit the SP mode.

1.8 STAPLER UNIT

1. Remove the following covers.

- Front inner cover (page 3)
- Rear upper cover (page 1)

2. Stapler Unit rear side [A] (⚙️ x2, 📦 x1)

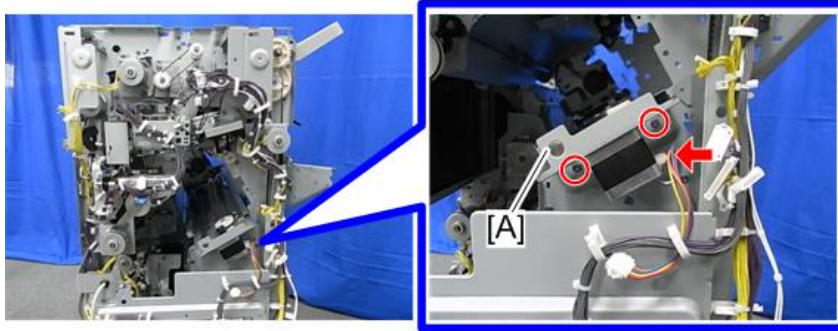

d6890029

3. Stapler Unit front side [A] (⚙️ x2)

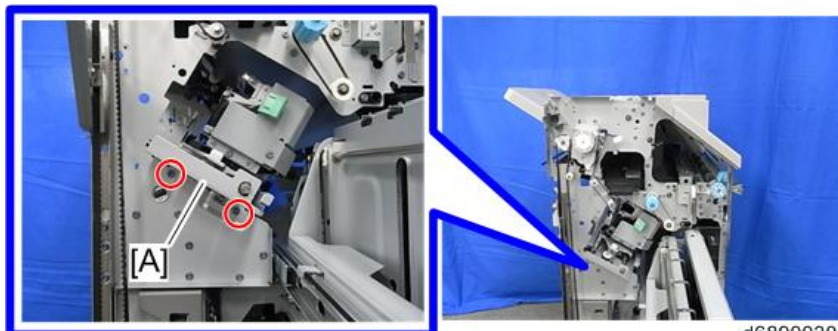

d6890030

4. Stapler Unit [A]

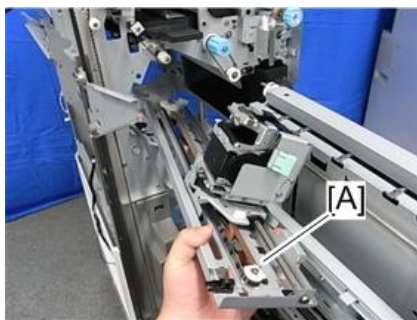

d6890031

1.8.1 STAPLER MOVEMENT MOTOR

1. Remove the following cover.
 - Rear upper cover (page 1)
2. Stapler Movement Motor [A] (🔩 x2, 📦 x1)

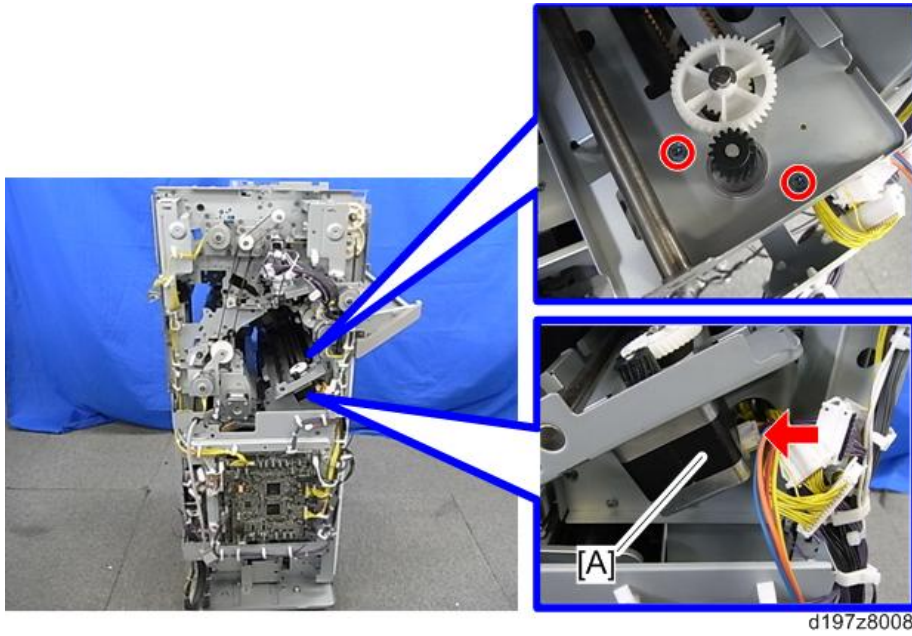

1.8.2 STAPLER MOVEMENT HP SENSOR

1. Remove the following covers.
 - Front inner cover (page 3)
2. Stapler Movement HP Sensor [A] (📦 x1)

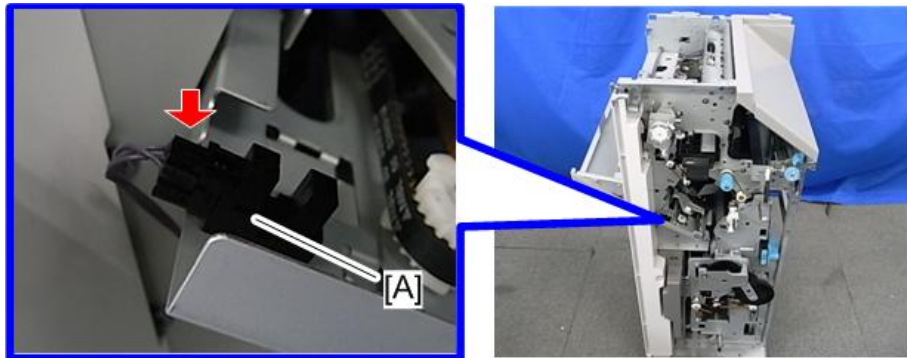

d197z8007

D690

INTERNAL FINISHER SR3130

REVISION HISTORY		
Page	Date	Added/Updated/New
		None

INTERNAL FINISHER SR3130 (D690)

TABLE OF CONTENTS





1. REPLACEMENT AND ADJUSTMENT	1
1.1 INNER FINISHER	1
1.2 COVERS AND TRAYS	3
1.2.1 FINISHER FRONT COVER	3
1.2.2 FINISHER UPPER COVER	4
1.2.3 FINISHER REAR COVER	4
1.2.4 PAPER OUTPUT TRAY	5
1.2.5 PAPER OUTPUT COVER	5
1.3 CONTROL BOARD.....	6
1.4 SENSORS	8
1.4.1 ENTRANCE SENSOR	8
1.4.2 PAPER EXIT FULL SENSOR.....	9
1.4.3 PAPER BAIL HOME POSITION SENSOR	10
1.4.4 PAPER SURFACE DETECTION SENSOR	10
1.4.5 TRANSPORT SENSOR.....	11
1.4.6 STRIKE ROLLER HOME POSITION SENSOR.....	12
1.4.7 PAPER OUTPUT GUIDE PLATE HOME POSITION SENSOR	13
1.4.8 SHIFT ROLLER HOME POSITION SENSOR	14
1.4.9 STAPLER HOME POSITION SENSOR.....	15
1.4.10 JOGGER FENCE HOME POSITION SENSOR (FRONT)	17
1.4.11 JOGGER FENCE HOME POSITION SENSOR (REAR).....	18
1.4.12 STAPLER TRAY JAM DETECTION SENSOR	19
1.4.13 PAPER DETECTION SENSOR	20
1.5 MOTORS	21
1.5.1 ENTRANCE MOTOR.....	21
1.5.2 TRAY LIFT MOTOR.....	22
1.5.3 PAPER BAIL MOTOR.....	23
1.5.4 PAPER OUTPUT GUIDE PLATE MOTOR	23
1.5.5 STRIKE ROLLER MOTOR	24
1.5.6 SHIFT MOTOR	25
1.5.7 STAPLER DISPLACEMENT MOTOR	27
1.5.8 JOGGER FENCE MOTOR (FRONT / REAR).....	28
1.5.9 TRANSPORT MOTOR	29

1.5.10 PAPER OUTPUT MOTOR	30
1.6 STAPLER UNIT	32

READ THIS FIRST

Safety and Symbols

This manual uses several symbols and abbreviations. The meaning of those symbols and abbreviations are as follows:

	Clip ring
	Screw
	Connector
	Clamp
	E-ring
SEF	Short Edge Feed
LEF	Long Edge Feed

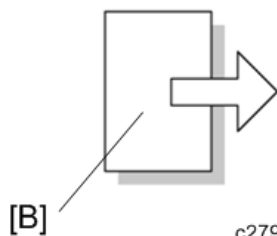
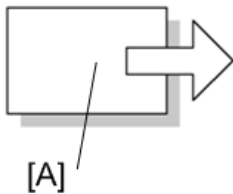

c2790086

[A] Short Edge Feed (SEF)

[B] Long Edge Feed (LEF)

Trademarks

Microsoft[®], Windows[®], and MS-DOS[®] are registered trademarks of Microsoft Corporation in the United States and /or other countries.

PostScript[®] is a registered trademark of Adobe Systems, Incorporated.

PCL[®] is a registered trademark of Hewlett-Packard Company.

Ethernet[®] is a registered trademark of Xerox Corporation.

PowerPC[®] is a registered trademark of International Business Machines Corporation.

Other product names used herein are for identification purposes only and may be trademarks of their respective companies. We disclaim any and all rights involved with those marks.

The Aim of Anti-tip Components and Precautions

The anti-tip components are necessary for meeting the requirements of IEC60950-1, the international standard for safety.

The aim of these components is to prevent the products, which are heavy in weight, from toppling as a result of people running into or leaning onto the products, which can lead to serious accidents such as persons becoming trapped under the product. (U.S.: UL60950-1, Europe: EN60950-1)

Therefore, removal of such components must always be with the consent of the customer.

Do not remove them at your own judgment.

1. REPLACEMENT AND ADJUSTMENT

1.1 INNER FINISHER

1. Interface cable [A].

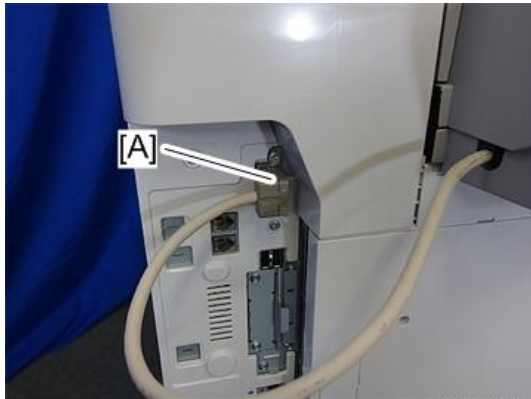

d197f0111

2. Open the front cover [A].



d1462870

3. Left upper cover [A] (⚙️ x1).

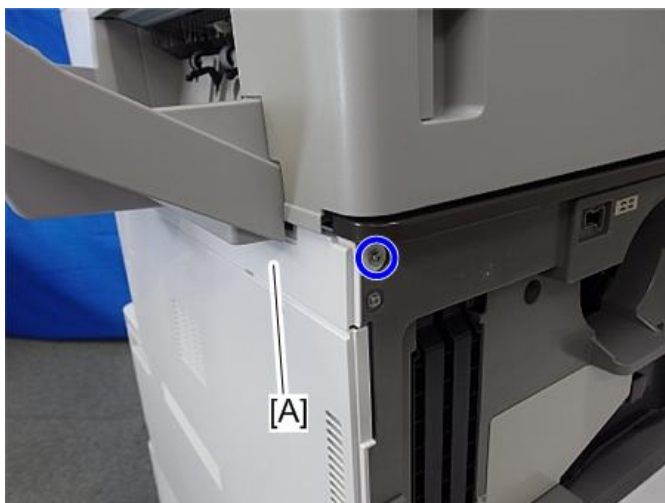

d197f0109

4. Left rear cover [A] (⚙️ x2, hookx1).

Inner Finisher



5. Inner finisher [A] (🔑 x1).



6. Bridge guide plate [A] (🔑 x2).



1.2 COVERS AND TRAYS

1.2.1 FINISHER FRONT COVER

1. Pull the finisher [A].

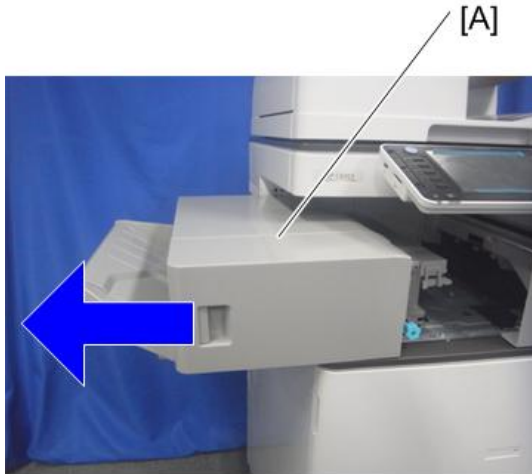

d1462876

2. Finisher front cover [A] (🔑 x2).

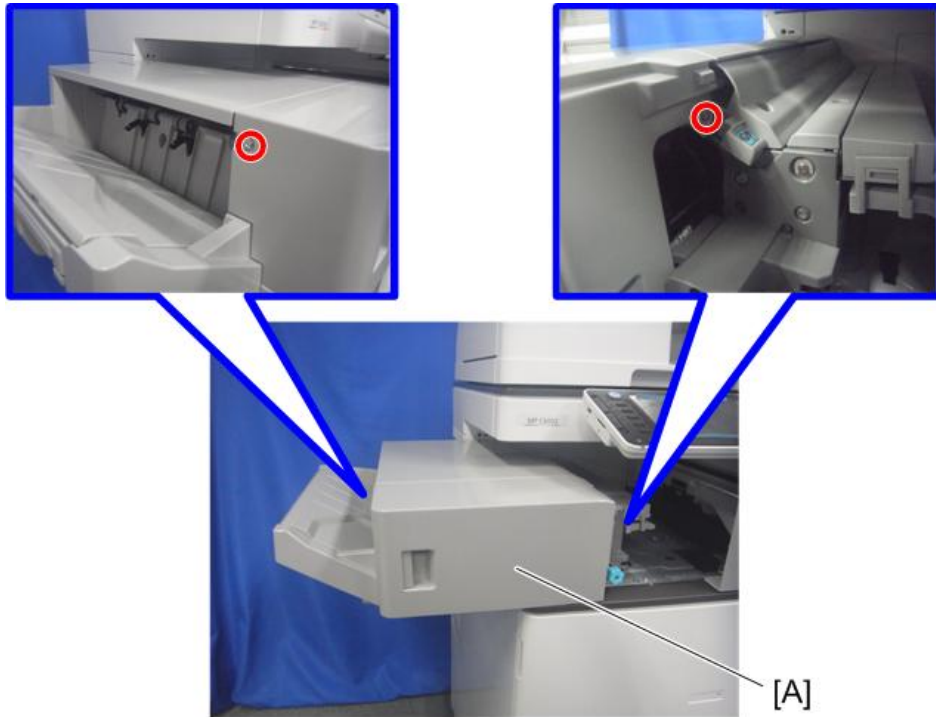

d1462877

1.2.2 FINISHER UPPER COVER

1. Finisher front cover (page 3).
2. Finisher upper cover [A] (🔩 x2).

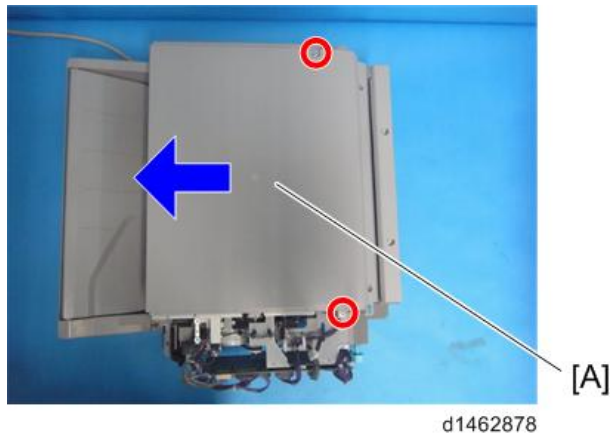

1.2.3 FINISHER REAR COVER

1. Inner finisher (page 1).
2. Finisher rear cover [A] (🔩 x2).

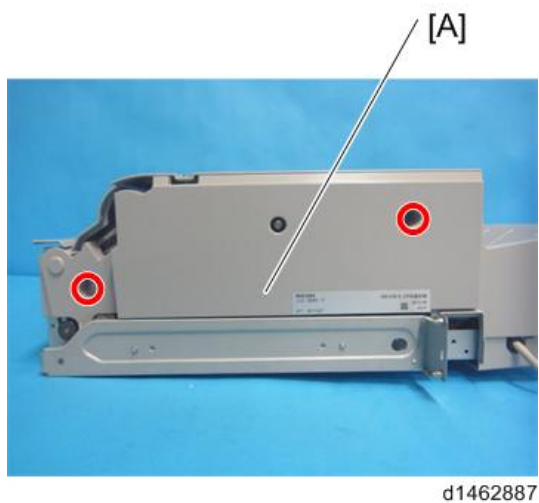

1.2.4 PAPER OUTPUT TRAY

1. Left lower cover [A] (🔑 x2).

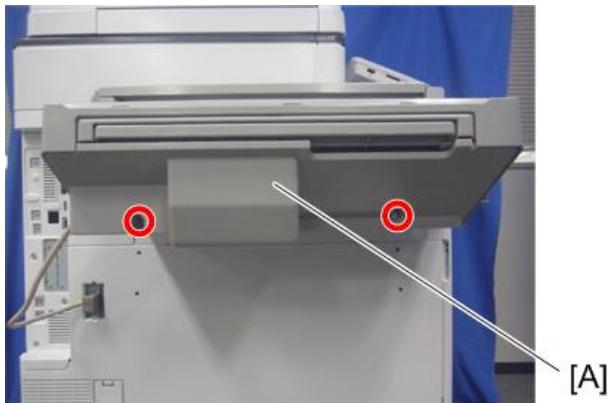

d1462879

2. Paper output tray [A] (🔑 x2).

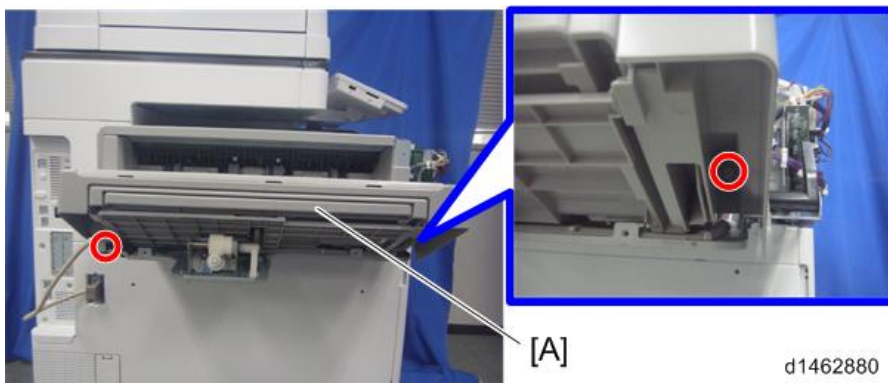

d1462880

1.2.5 PAPER OUTPUT COVER

1. Paper output tray (page 5).
2. Paper output cover [A] (🔑 x3, 📦 x3, 🧰 x2).

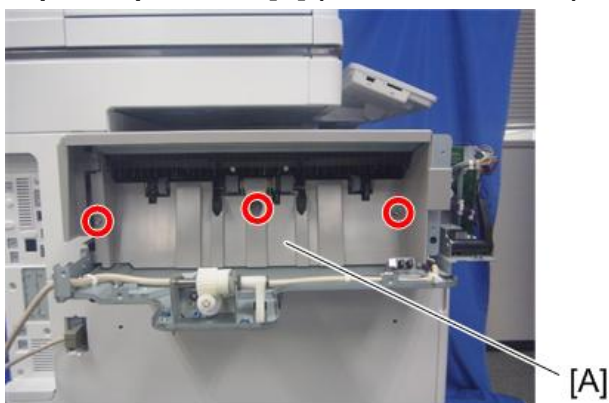

d1462881

1.3 CONTROL BOARD

⚠ CAUTION

- When a control board is replaced, use the same DIP switch settings as those of the control board before replacement.

1. Finisher front cover (page 3).
2. Control board [A] (🔩x3, 🛠xall, plastic rivetx1).

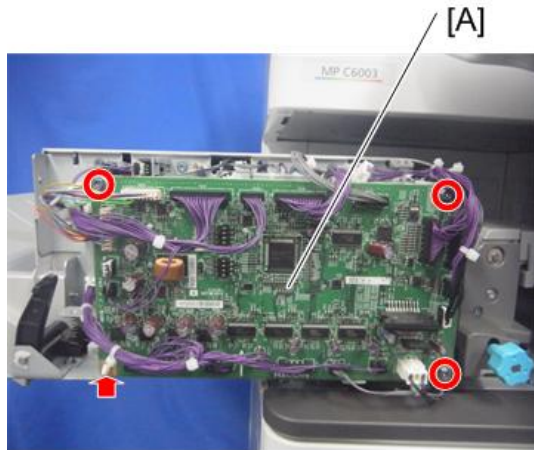

d146z0040

3. Release four clamps and remove the harness bracket [A] on the control board bracket (🛠x4).

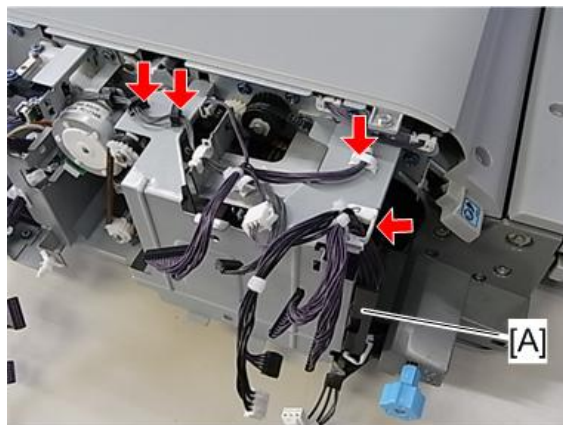

d690z2001

4. Control board bracket [A] (🔩x2).

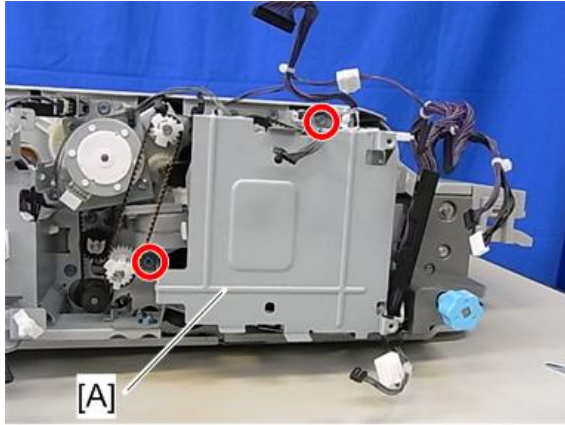

d690z2002

INTERNAL
FINISHER SR3130
(D690)

1.4 SENSORS

1.4.1 ENTRANCE SENSOR

1. Inner finisher (page 1).
2. Open/Close upper cover [A] (🔑 x2).

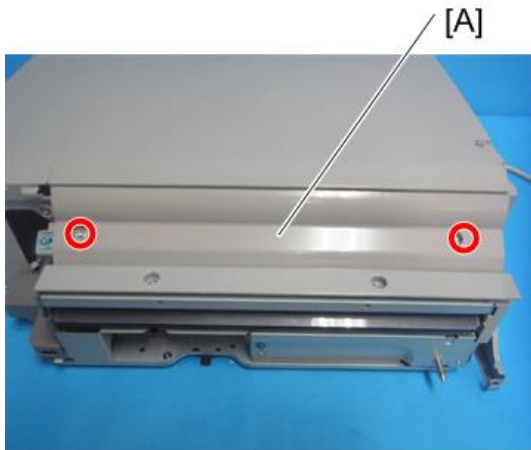

d1462883

3. Entrance sensor unit [A] (🔑 x1, 📦 x1, 🛠️ x1).

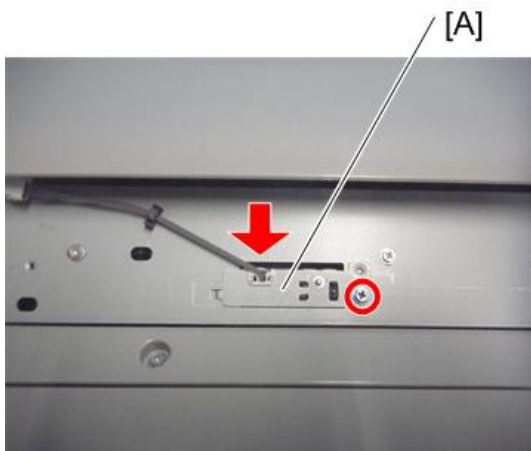

d1462884

4. Entrance sensor [A].

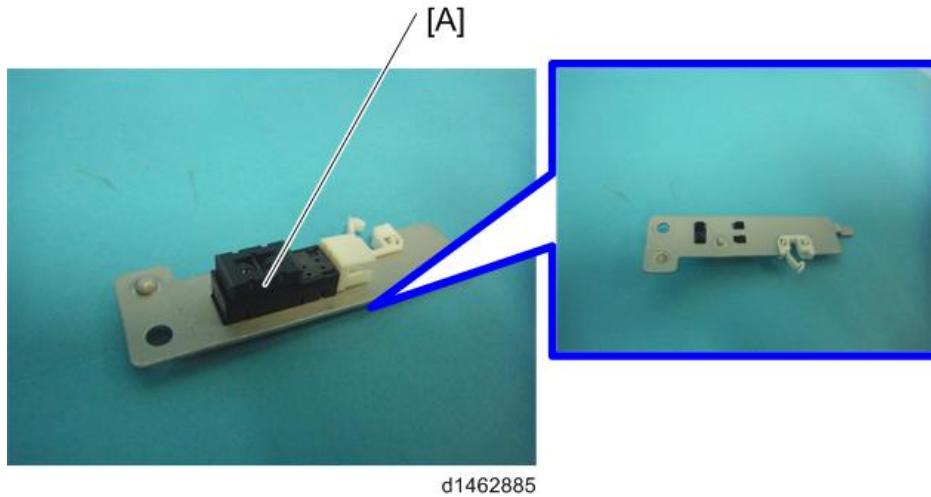

1.4.2 PAPER EXIT FULL SENSOR

1. Paper output tray (page 5).
2. Paper exit full sensor [A] (📄 x1, 🔧 x1).

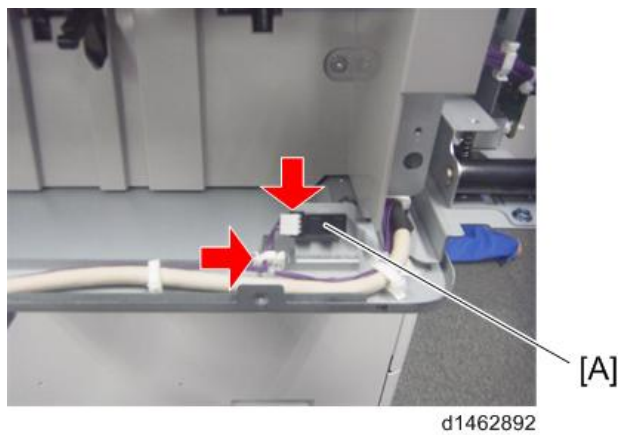

1.4.3 PAPER BAIL HOME POSITION SENSOR

1. Paper output cover (page 5).
2. Paper bail home position sensor [A] (📦 x1).

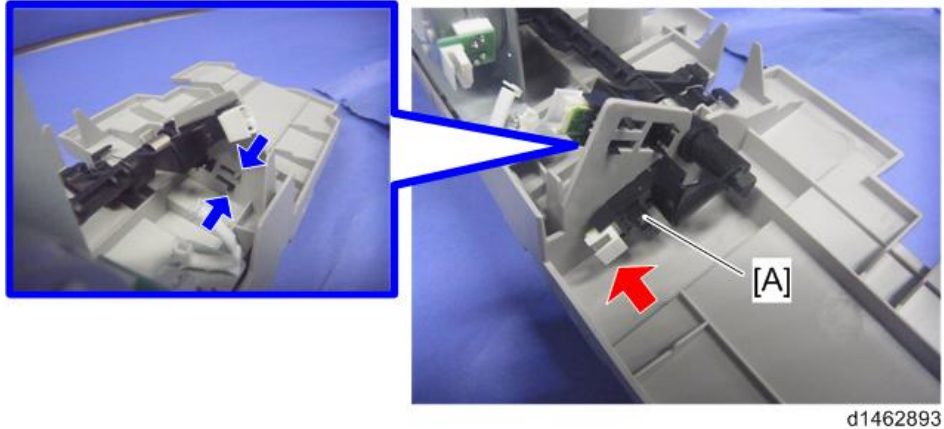

d1462893

1.4.4 PAPER SURFACE DETECTION SENSOR

1. Paper output cover (page 5).
2. Paper surface detection sensor [A] (📦 x1).

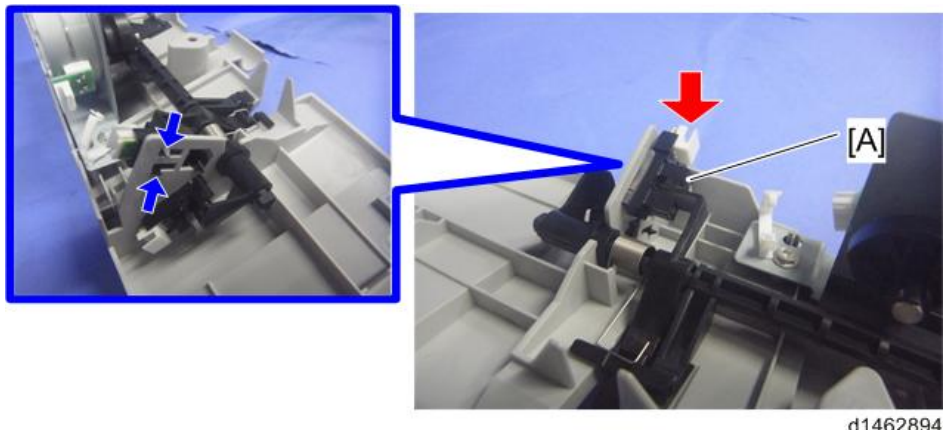

d1462894

1.4.5 TRANSPORT SENSOR

1. Finisher upper cover (page 4).
2. Transport sensor unit [A] (⚙️ x1, 📦 x1, 🛠️ x1).

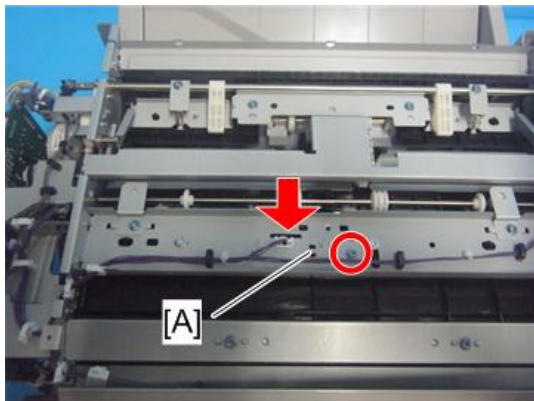

d1462896

3. Transport sensor [A].

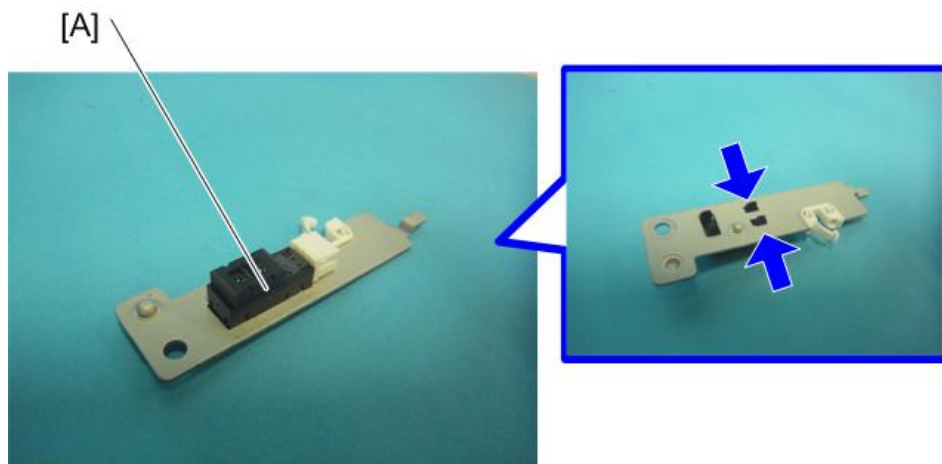

d1462897

1.4.6 STRIKE ROLLER HOME POSITION SENSOR

1. Finisher upper cover (page 4).
2. Finisher rear cover (page 4).
3. Rotate the timing belt [A], and release the strike roller arm unit [B] from the strike roller HP sensor [C].

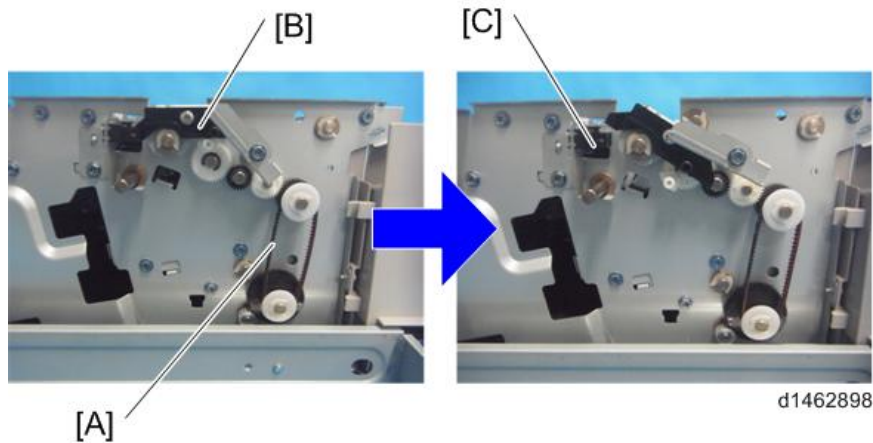

4. Strike roller home position sensor unit [A] (⚙️ x1, 📦 x1, 🛠️ x1).

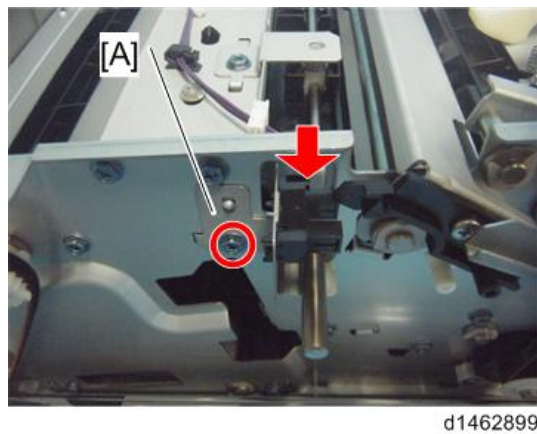

5. Strike roller home position sensor [A].

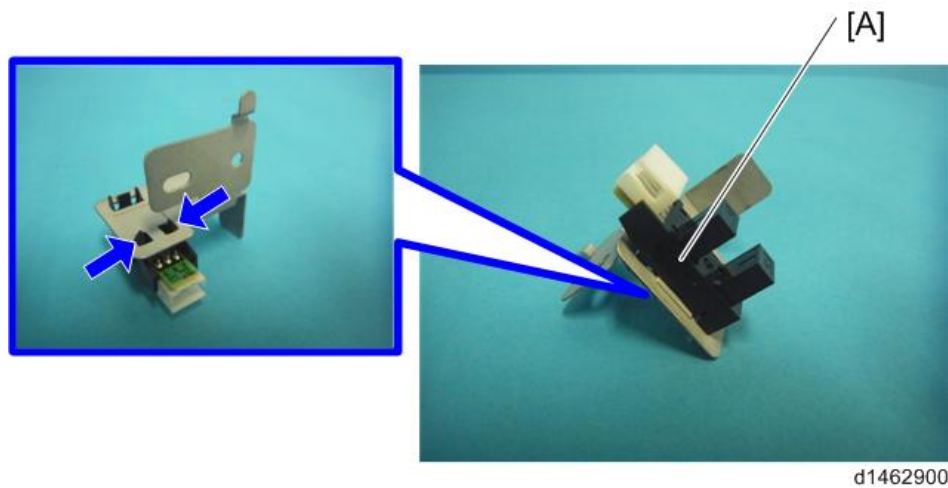

1.4.7 PAPER OUTPUT GUIDE PLATE HOME POSITION SENSOR

1. Control board (page 6).
2. Rotate the paper output guide plate gear [A] counterclockwise, and release the paper output guide plate [B] from the paper output guide plate HP sensor [C].

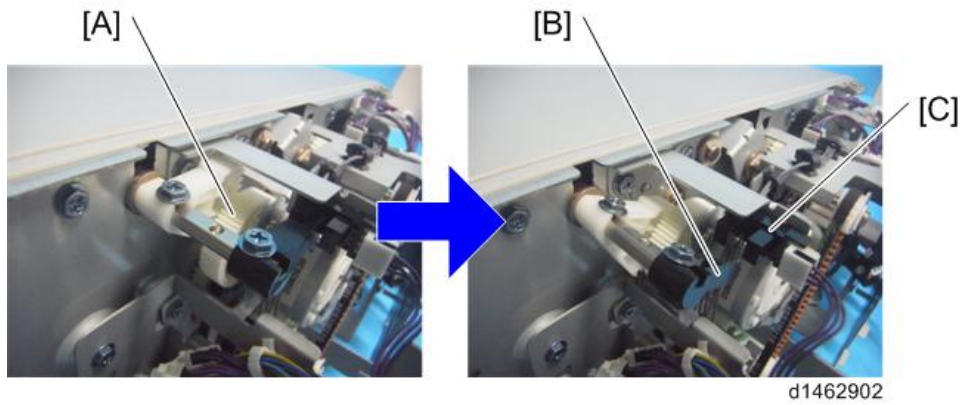

3. Paper Output Guide Plate Home Position Sensor [A] (📦 x1).

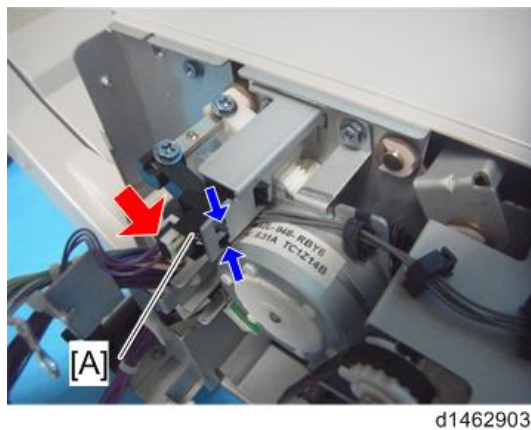

1.4.8 SHIFT ROLLER HOME POSITION SENSOR

1. Control board bracket (page 6).
2. Shift roller home position sensor unit [A] (⚙️ x1, 📦 x1, 🛠️ x2).

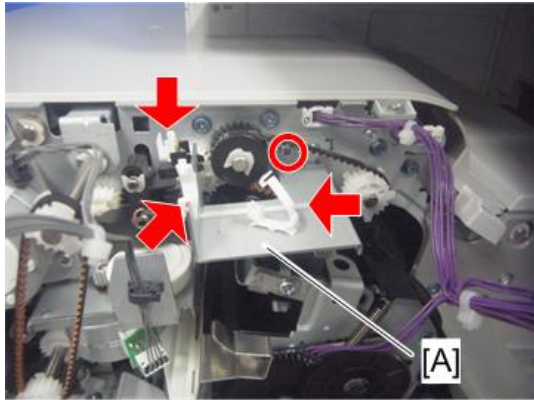

d1462910

3. Shift roller home position sensor [A].

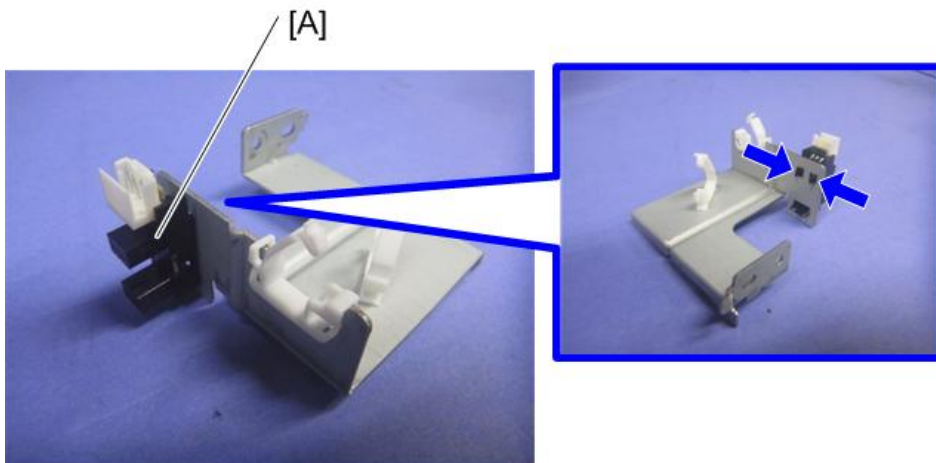

d1462911

1.4.9 STAPLER HOME POSITION SENSOR

1. Control board bracket (page 6).
2. Knob [A].

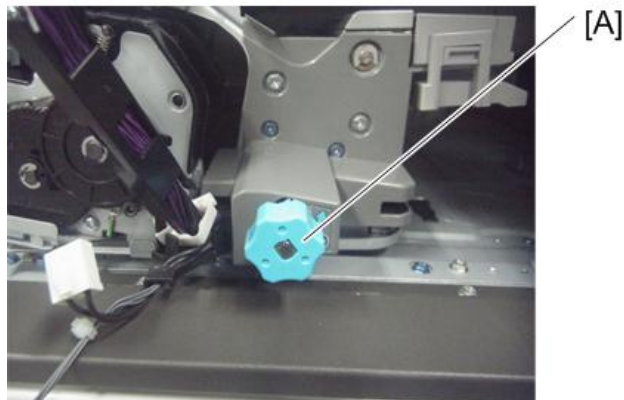

d1462912

3. Entrance cover [A] (🔩 x2).

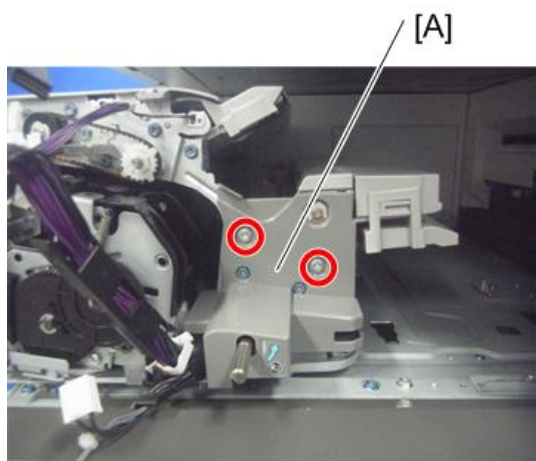

d1462913

4. Stapler home position sensor unit [A] (🔩 x1, 📦 x1).

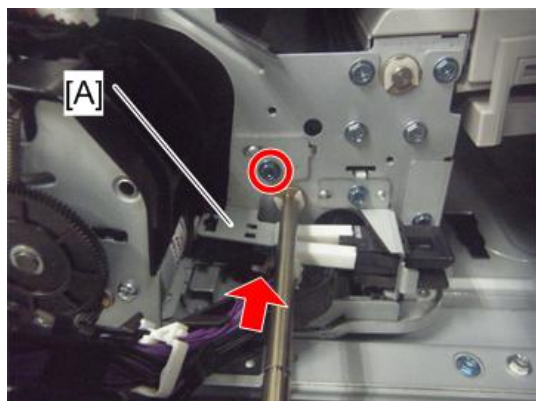

d1462914

5. Stapler home position sensor [A].

Sensors

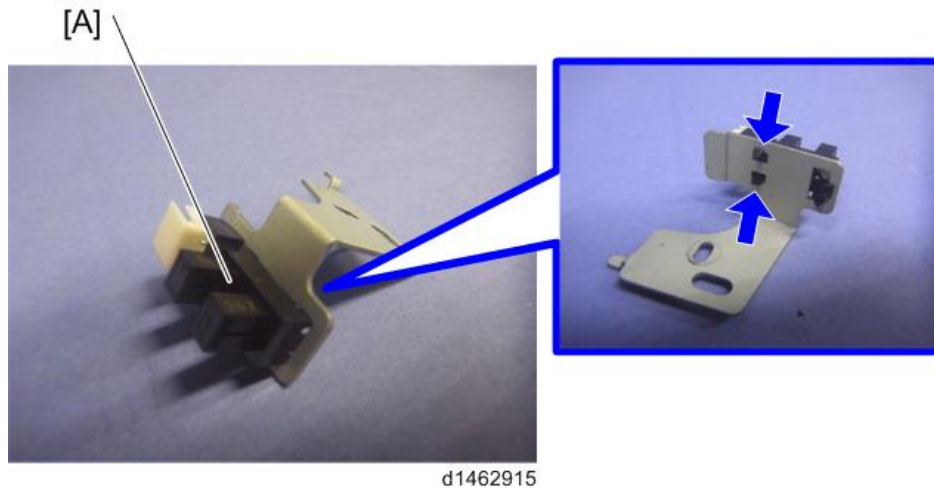

↓ Note

- If it is difficult to remove and attach, push the stapler unit inside.

1.4.10 JOGGER FENCE HOME POSITION SENSOR (FRONT)

1. Paper output cover (page 5).
2. Jogger fence home position sensor (front) unit [A] (⚙️ x1, 📦 x1, 🛠️ x1).

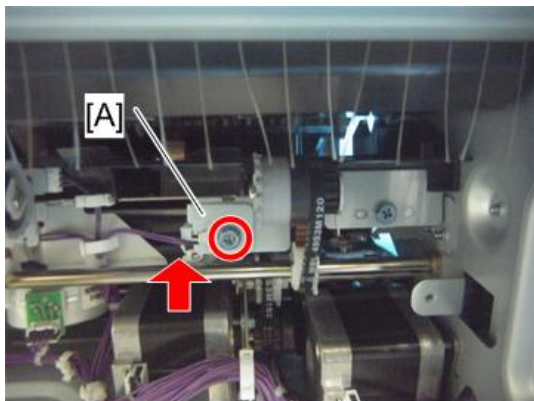

d1462932

3. Jogger fence home position sensor (front) [A].

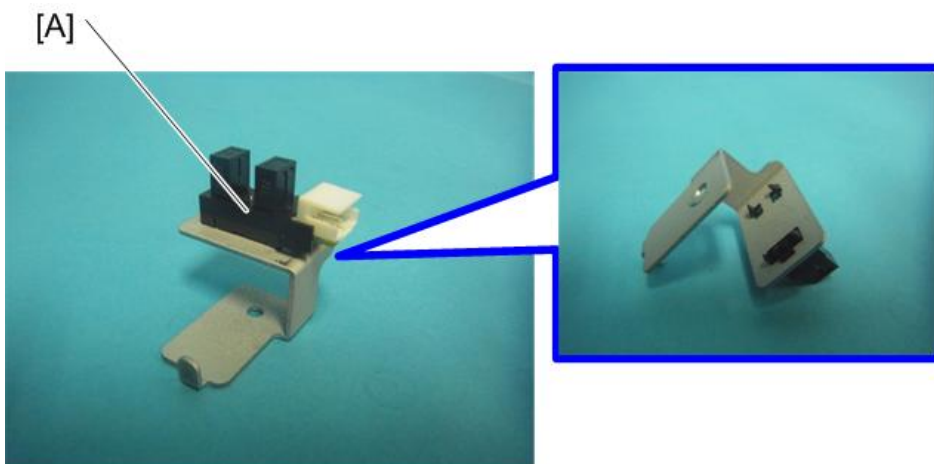

d1462931

1.4.11 JOGGER FENCE HOME POSITION SENSOR (REAR)

1. Paper output cover (page 5).
2. Jogger fence home position sensor (rear) unit [A] (🔩 x1, 📦 x1).

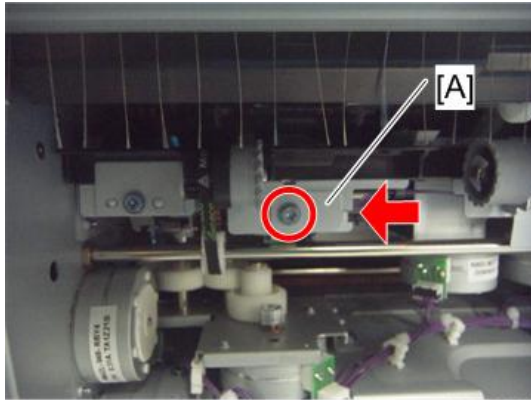

d1462930

3. Jogger fence home position sensor (rear) [A].

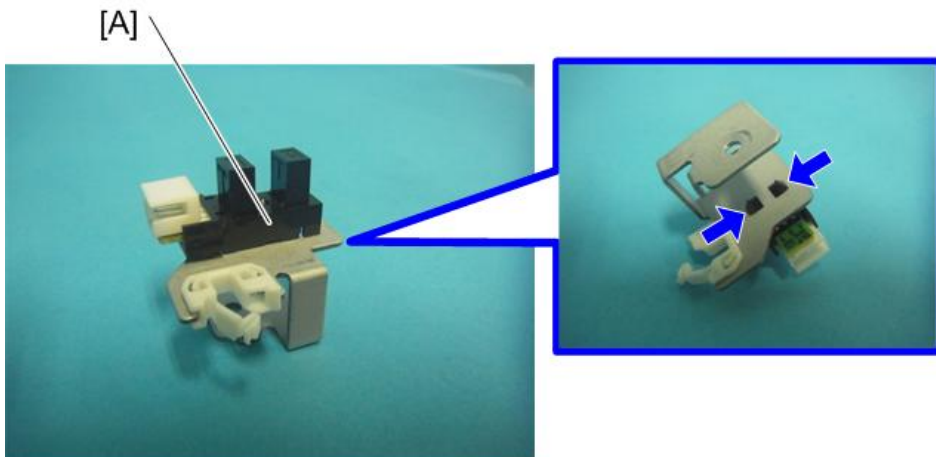

d1462933

1.4.12 STAPLER TRAY JAM DETECTION SENSOR

1. Paper output cover (page 5).
2. Paper exit roller unit [A] (🔩 x1).

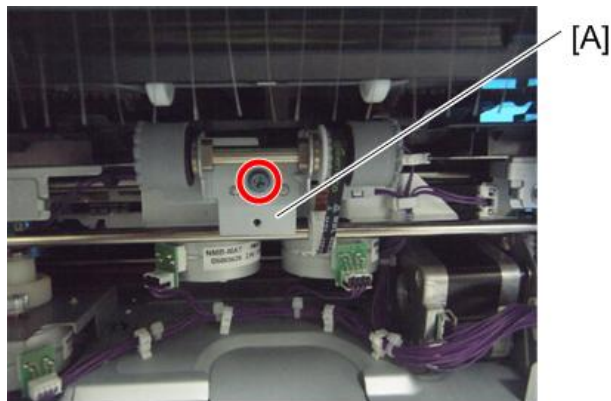

d1462934

3. Stapler tray jam detection sensor unit [A] (🔩 x1, 📦 x1, 🛠️ x1).

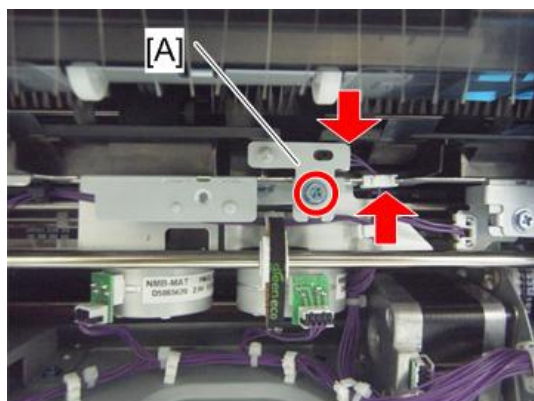

d1462935

4. Stapler tray jam detection sensor [A] (🔩 x1).

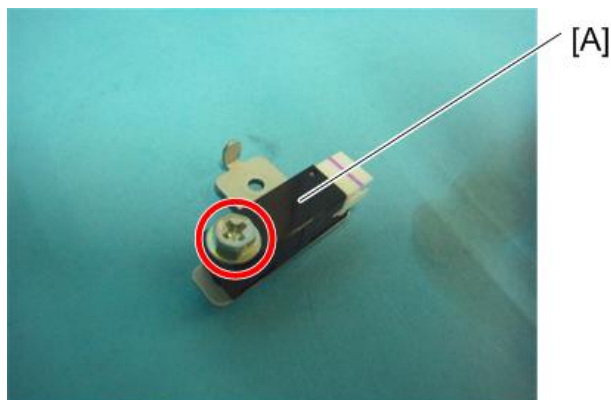

d1462936

1.4.13 PAPER DETECTION SENSOR

1. Jogger fence motor (rear) (page 28).
2. Jogger fence motor (rear) bracket [A] (🔩 x2, 🛠️ x3).

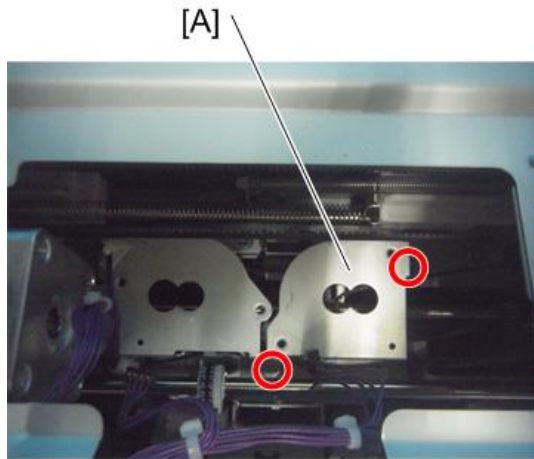

d1462937

3. Paper detection sensor unit [A] (🔩 x1, 📦 x1, 🛠️ x1).

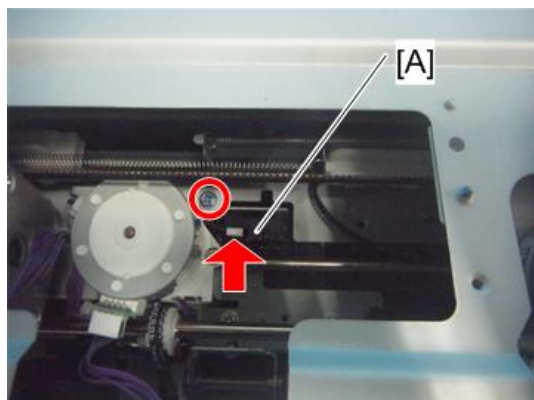

d1462938

4. Paper detection sensor [A].

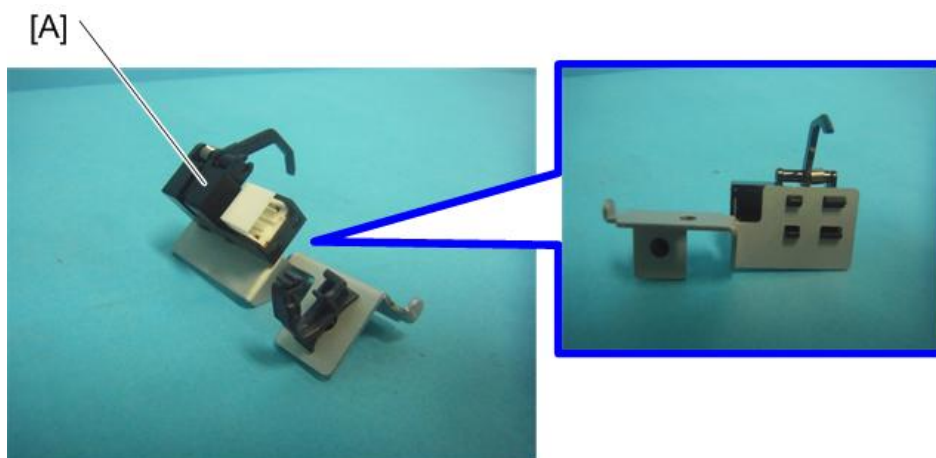

d1462939

Note

- When installing this sensor, be careful not to damage the sensor actuator.

1.5 MOTORS

1.5.1 ENTRANCE MOTOR

1. Finisher rear cover (page 4).
2. Finisher right rear bracket [A] (⊗ x2).

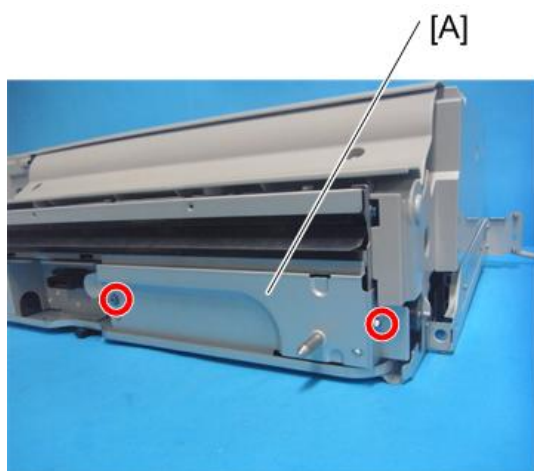

d1462886

3. Entrance motor [A] (⊗ x2, ⊞ x1, Timing belt x1).

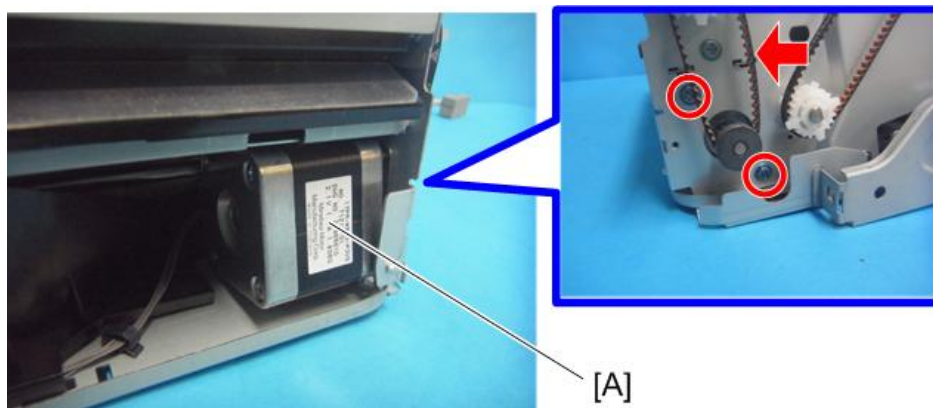

d1462888

1.5.2 TRAY LIFT MOTOR

1. Paper output tray (page 5).
2. Tray lift motor unit [A] (🔩 x2, 📦 x1, 🌀 x1).

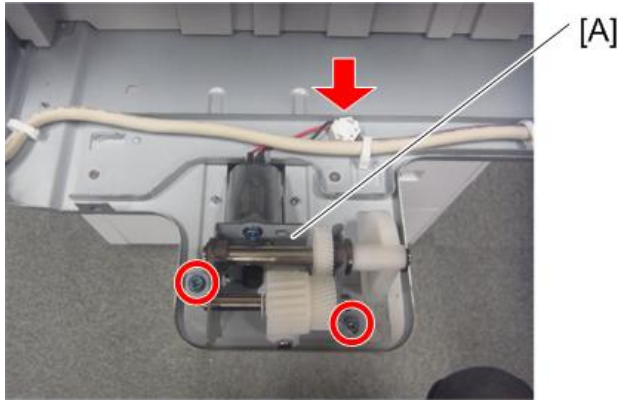

d1462889

3. Cam [A], bearing [B] (🌀 x1).

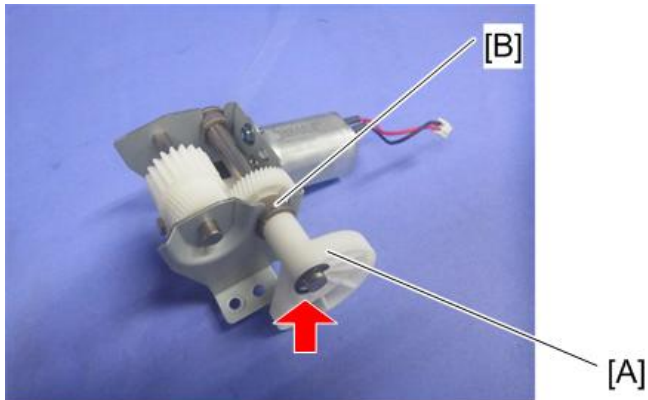

d1462890

4. Tray lift motor [A] (🔩 x2).

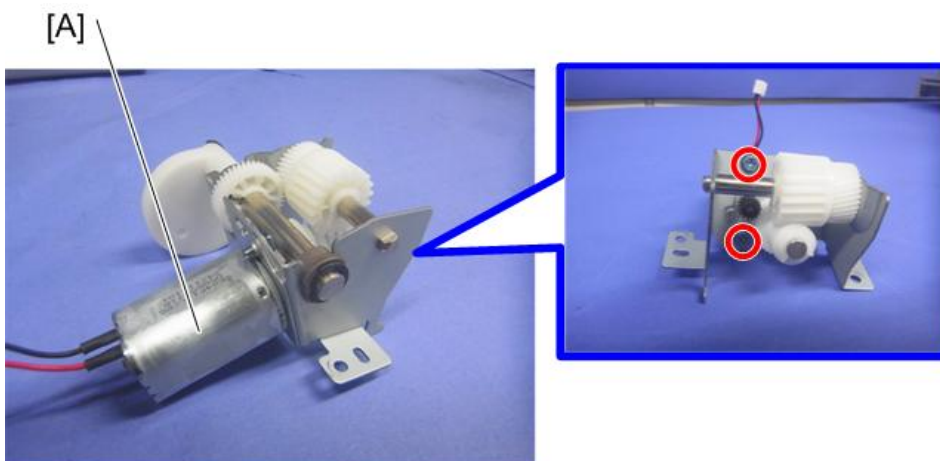

d1462891

1.5.3 PAPER BAIL MOTOR

1. Paper output cover (page 5).
2. Paper bail motor [A] (🔩 x2, 📦 x1).

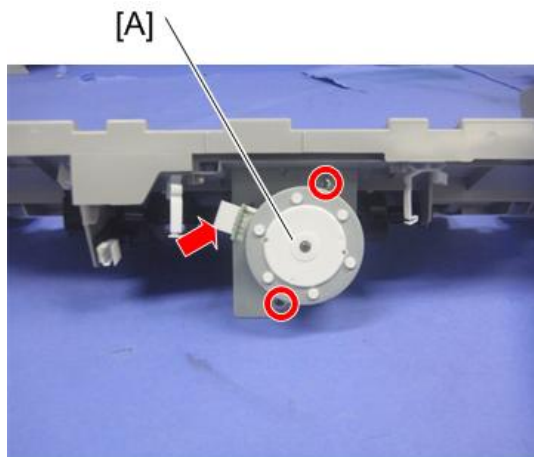

d146z0041

1.5.4 PAPER OUTPUT GUIDE PLATE MOTOR

1. Control board (page 6).
2. Paper output guide plate motor [A] (🔩 x2, 📦 x1, 📦 x1).

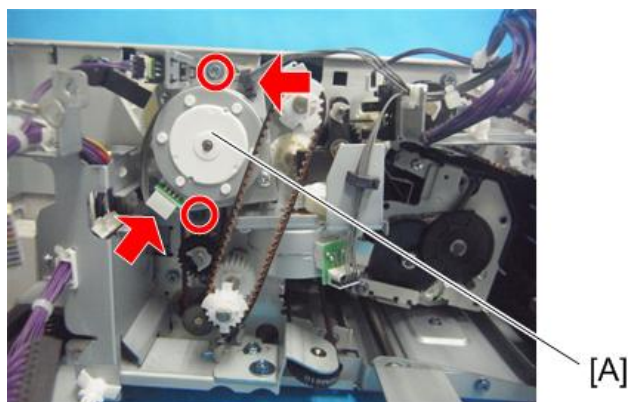

d1462901

1.5.5 STRIKE ROLLER MOTOR

1. Paper output cover (page 5).
2. Finisher rear cover (page 4).
3. Rear rail [A] (🔩 x2).

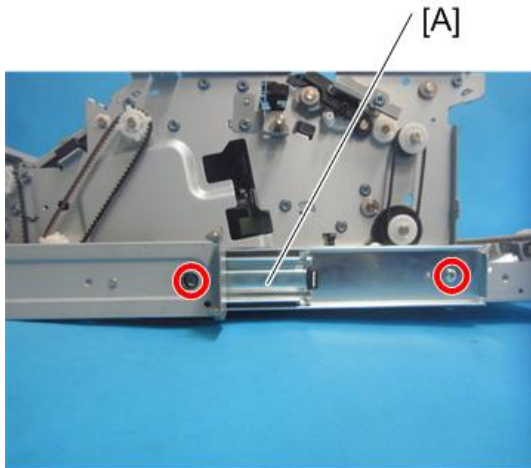

d1462904

4. Strike roller motor [A] (🔩 x2, 📦 x1).

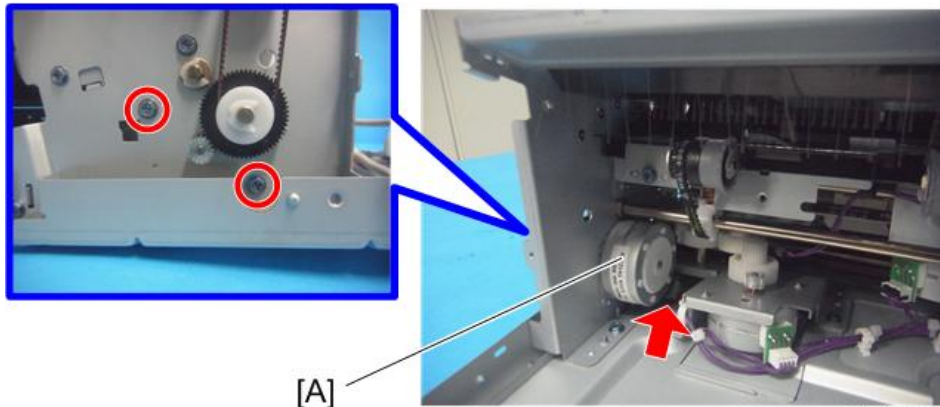

d146z0042

1.5.6 SHIFT MOTOR

⚠ CAUTION

- After attaching, rotate the knob, and check that all gear trains can rotate.
- After attachment, when the cam [A] is rotated, check that the link [B] interlocks.

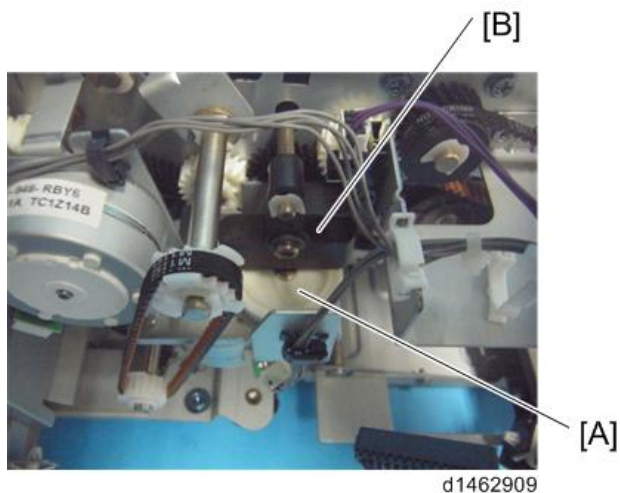

1. Control board bracket (page 6).
2. Pulley [A], Timing belt [B] (Ⓜx1).

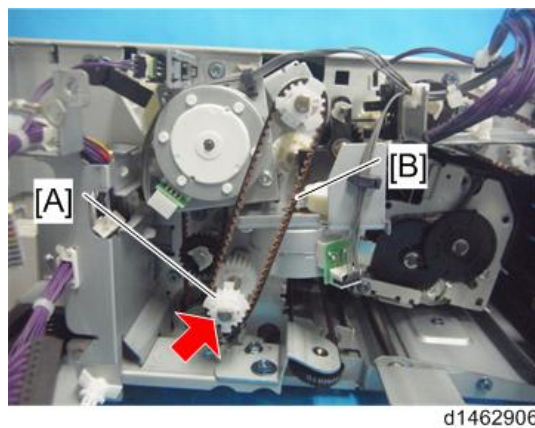

3. Shift motor unit [A] (Ⓜx2, Ⓜx1, Ⓜx1).

Motors

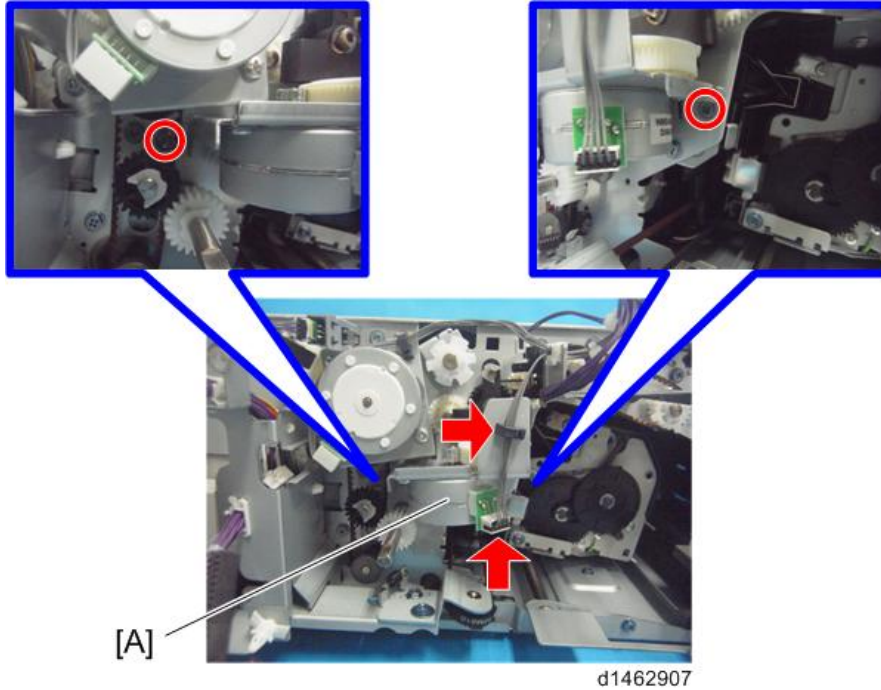

4. Shift motor [A] (🔑 x2).

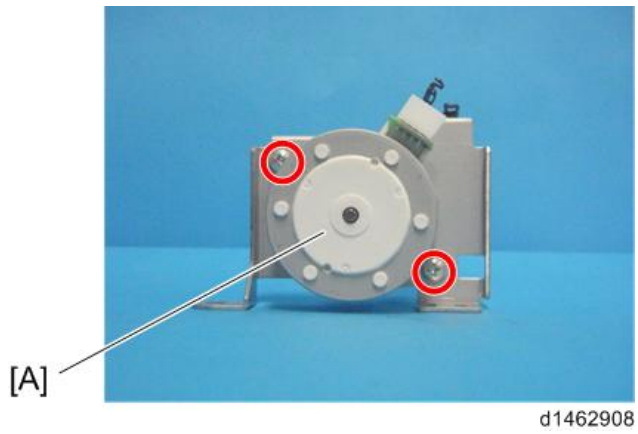

1.5.7 STAPLER DISPLACEMENT MOTOR

⚠ CAUTION

- When the finisher is inverted, be careful not to deform the frame.

- Paper output cover (page 5).
- Remove the four clamps (🔧x4).

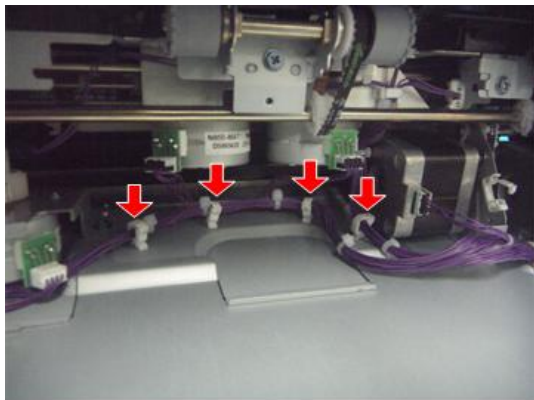

d1462916

- Place the inner finisher upside down on the table with holding the parts below [A].

ⓘ Note

- Hold the parts [A] shown below to lift the inner finisher. Otherwise, other brackets and parts may be deformed.

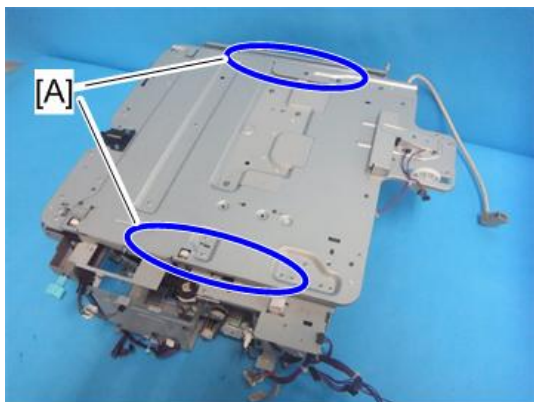

d1462917

- Base cover [A] (🔧x3)



d1462918

- Stapler displacement motor [A] (🔧x2, 📦x1)

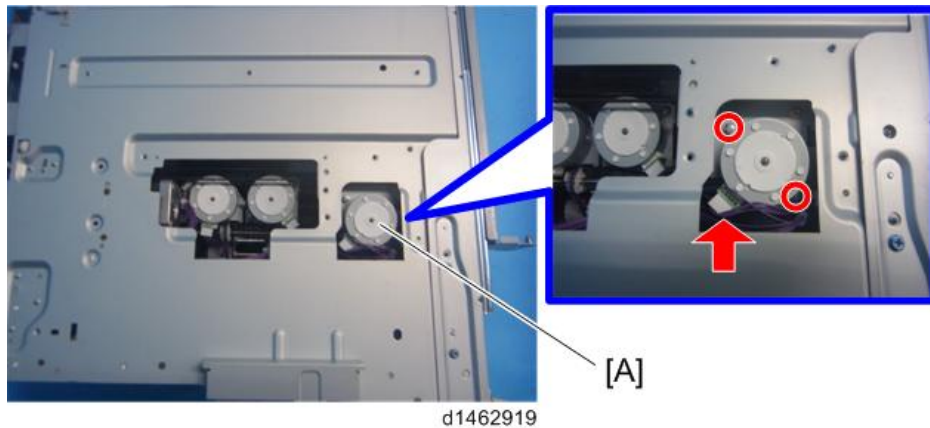

1.5.8 JOGGER FENCE MOTOR (FRONT / REAR)

1. Base cover (page 27)
2. Jogger fence motor (front) [A] (🔩 x2, 📦 x1, Timing belt x1)

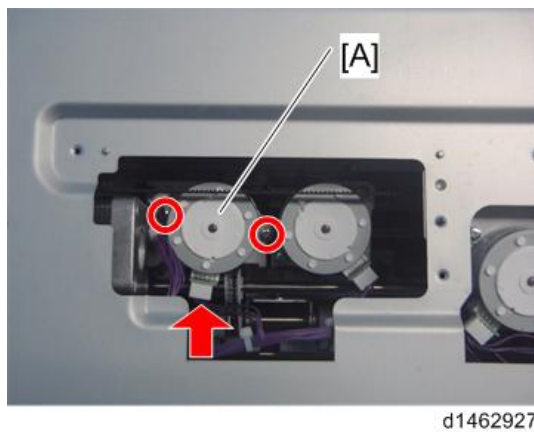

⬇️ **Note**

- During attachment, remove the jogger fence motor (rear) bracket, and check that the motor pulley has not separated from the timing belt.

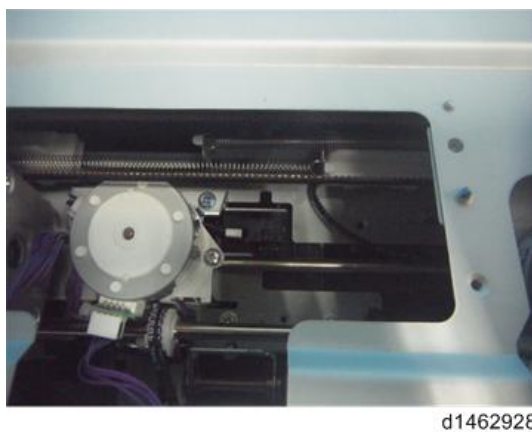

3. Jogger fence motor (rear) [A] (🔩 x2, 📦 x1, Timing belt x1)

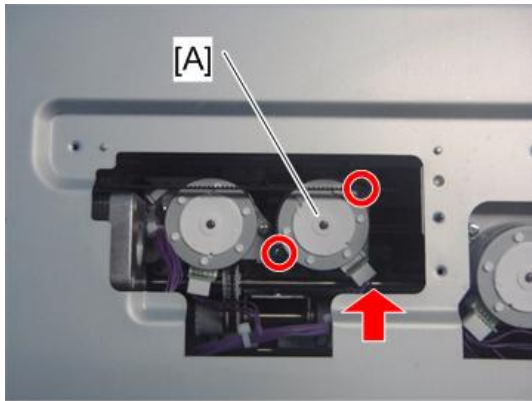

d1462929

Note

- During attachment, check that the motor pulley has not separated from the timing belt.

1.5.9 TRANSPORT MOTOR

- Paper output cover (page 5).
- Control board (page 6)
- Finisher rear cover (page 4)
- Pulley [A], Timing belt [B] (x1).

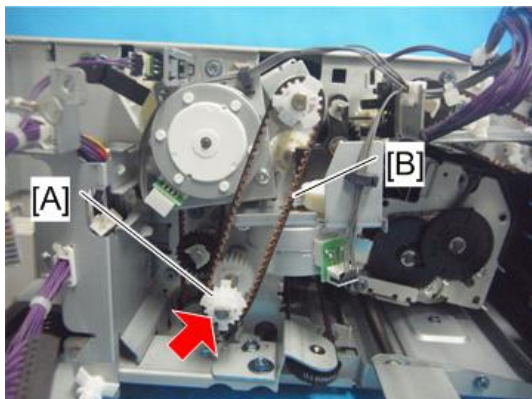

d1462906

- Transport Motor [A] (x2, x1, Timing beltx1)

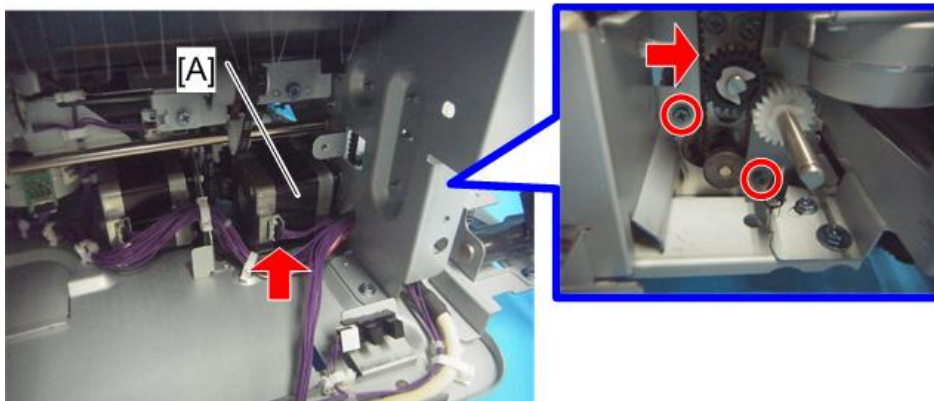

d1462940

1.5.10 PAPER OUTPUT MOTOR

1. Transport motor (page 29)
2. Control board bracket (page 6)
3. Gear [A] (🔩x1)



4. Two clip rings [A] and Shaft bracket [B] (🔩x2).

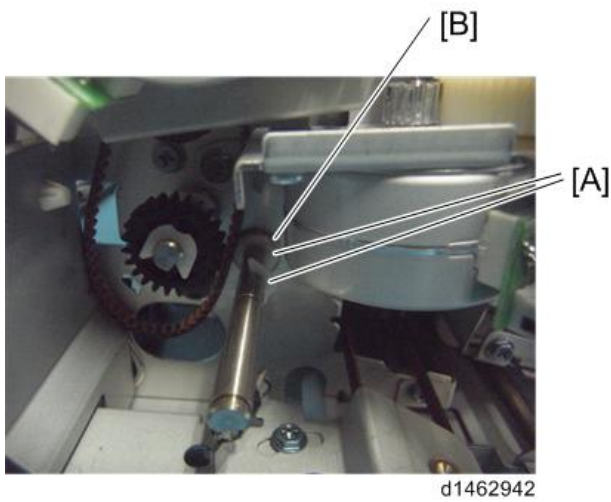

5. Remove the screws of the fan [A] and then lay it down (🔩x2).

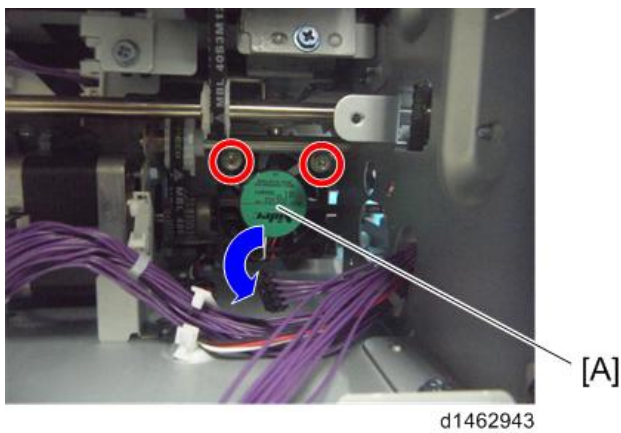

6. Paper Output Motor [A] (🔩x2, 📦x1).

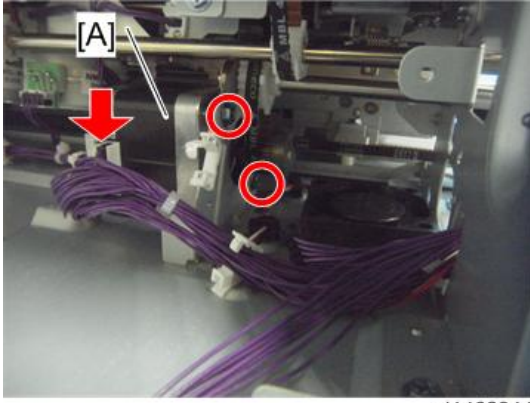

d1462944

INTERNAL
FINISHER SR3130
(D690)

1.6 STAPLER UNIT

1. Control board bracket (page 6).
2. Insert the stapler unit [A] into the rear..

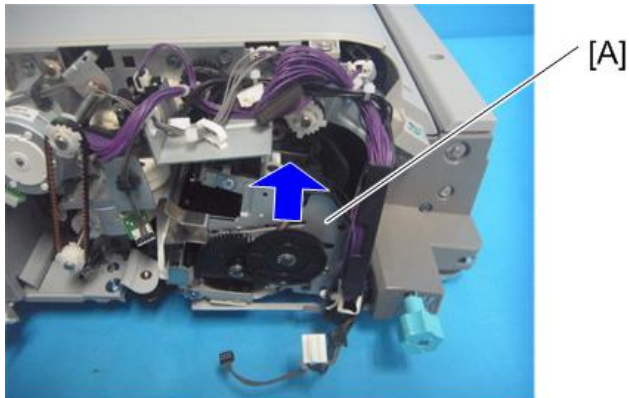

d1462920

3. Rear end reference fence [A] (Ⓜ x2).

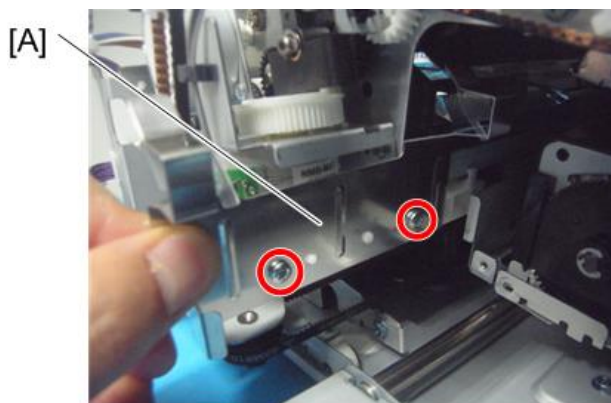

d1462921

4. Stapler home position sensor (page 15).
5. Cover open/close switch unit [A] (Ⓜ x1, Ⓜ x2).

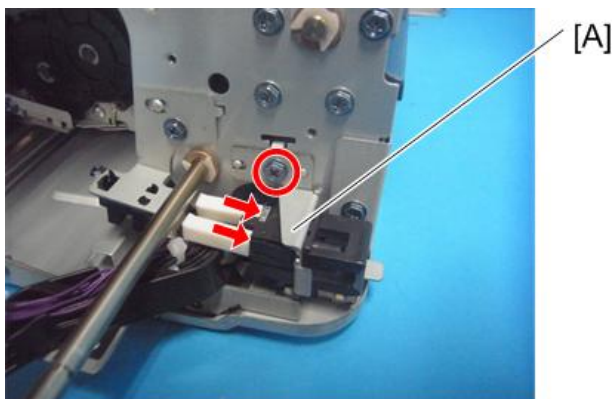

d1462922

6. Harness guide unit [A] (Ⓜ x1).



d1462923

7. Move the stapler unit to the front, and remove the cartridge [A].

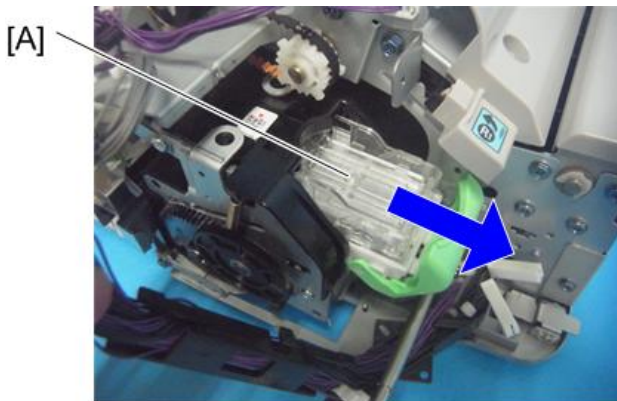

d1462924

Note

- During installation, install the cartridge last.

8. Remove the unit fixing screw of the stapler unit (🔩 x1)

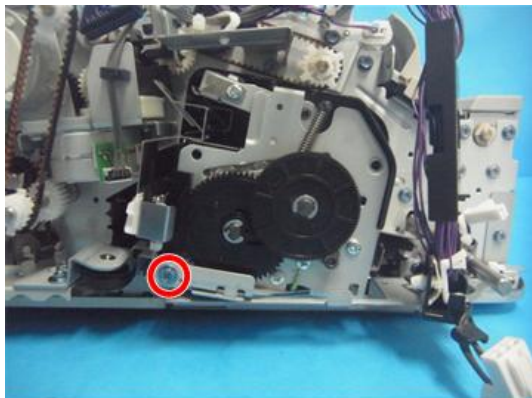

d1462925

9. Stapler unit [A] (🔩 x1, 📦 x2)

Stapler Unit

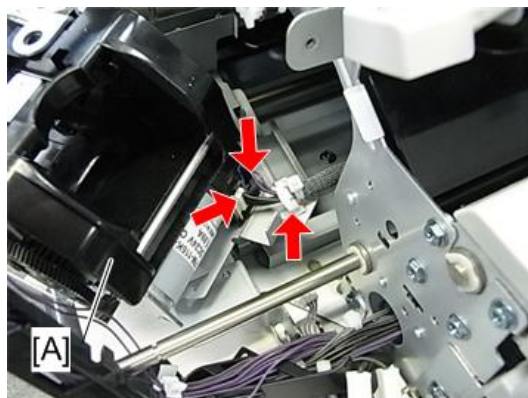

d146z0067

D692

1 BIN TRAY BN3110

REVISION HISTORY		
Page	Date	Added/Updated/New
		None

1 BIN TRAY BN3110 (D692)





TABLE OF CONTENTS

1. REPLACEMENT AND ADJUSTMENT	1
1.1 PAPER SENSOR.....	1
1.2 CONTROLLER BOARD.....	5

READ THIS FIRST

Safety and Symbols

This manual uses several symbols and abbreviations. The meaning of those symbols and abbreviations are as follows:

	Clip ring
	Screw
	Connector
	Clamp
SEF	Short Edge Feed
LEF	Long Edge Feed

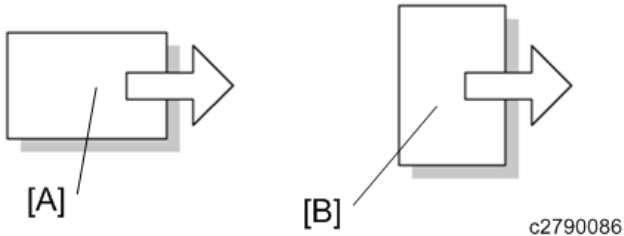

[A] Short Edge Feed (SEF)

[B] Long Edge Feed (LEF)

Trademarks

Microsoft[®], Windows[®], and MS-DOS[®] are registered trademarks of Microsoft Corporation in the United States and /or other countries.

PostScript[®] is a registered trademark of Adobe Systems, Incorporated.

PCL[®] is a registered trademark of Hewlett-Packard Company.

Ethernet[®] is a registered trademark of Xerox Corporation.

PowerPC[®] is a registered trademark of International Business Machines Corporation.

Other product names used herein are for identification purposes only and may be trademarks of their respective companies. We disclaim any and all rights involved with those marks.

1. REPLACEMENT AND ADJUSTMENT

1.1 PAPER SENSOR

1. Open the right cover.
2. Main power switch cover [A] (⊙x1, hookx3).

↓ Note

- The main power switch cover has three tabs: two on the left side (paper exit) and one on the right side (right cover).



d197f0052

3. Paper exit tray [A].



d1462023

4. Left upper cover [A] (⊙x1).

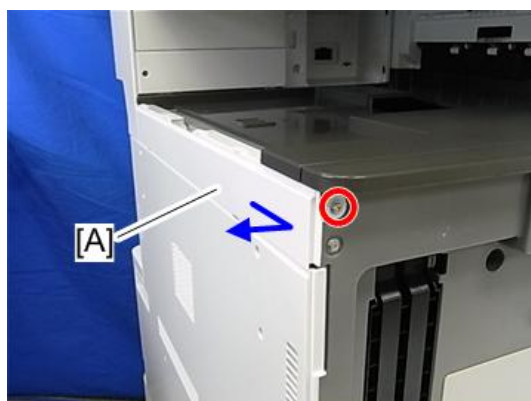

d197z0001

Paper Sensor

5. Left rear cover [A] (🔩x2, hookx1).



d197f0043

6. Cover [A].

↓ Note

- Remove this carefully in accordance with the notes described below.



[A]

d1462800

↓ Note

- Do not twist the cover to remove the cover as shown below. Otherwise, some hooks inside the cover may be broken.



d146z0048

- Lift up the cover vertically to remove the cover as shown below.

1 BIN TRAY
BN3110 (D692)

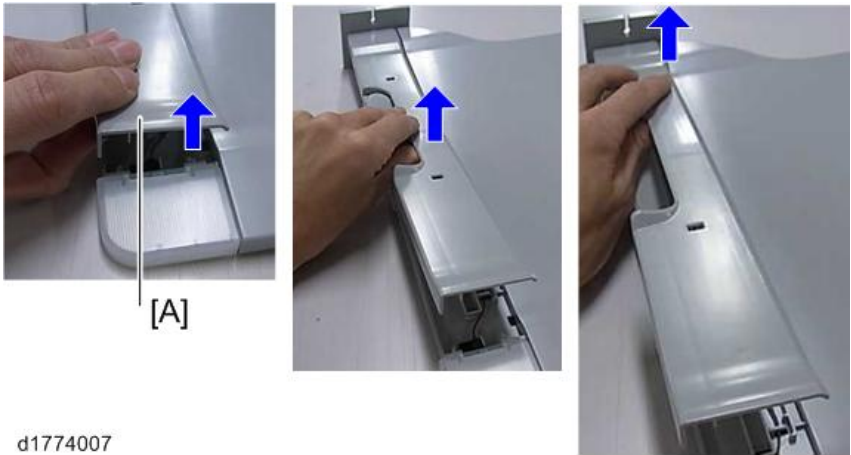

d1774007

7. 1 bin tray [A] (📦 x1).



d1462801

8. 1 bin tray unit [A] (🔩 x1, 📦 x2).

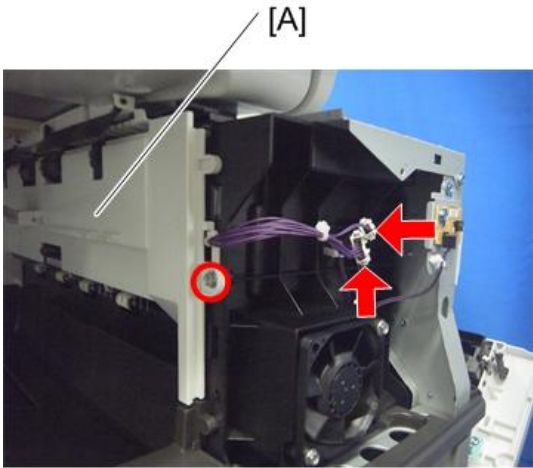

d1462477

9. Paper sensor [A] (📦 x1).

Paper Sensor

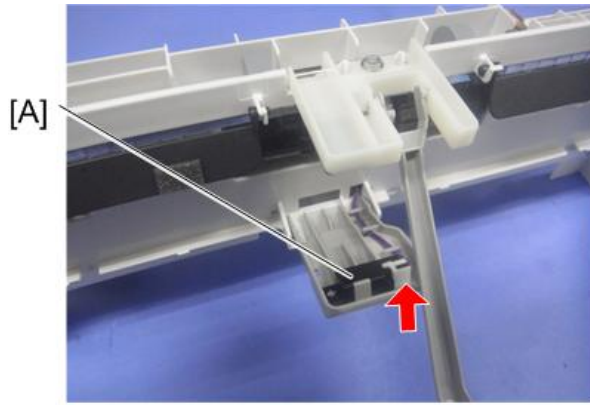

d1462803

1.2 CONTROLLER BOARD

- 1. 1 bin tray unit (page 1).
- 2. Controller board [A] (⚙️ x1, 📦 x3).

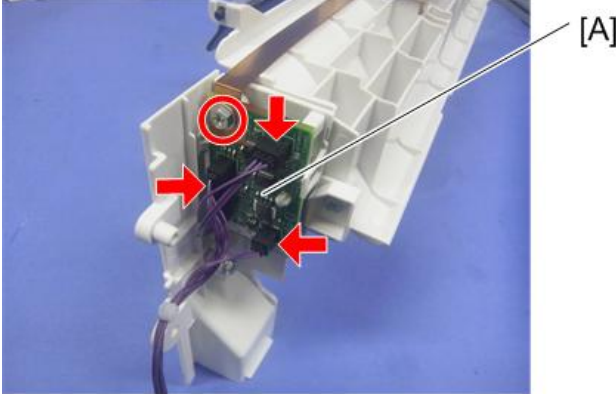

d1462804

D694

PAPER FEED UNIT PB3150

REVISION HISTORY		
Page	Date	Added/Updated/New
		None

PAPER FEED UNIT PB3150 (D694)





TABLE OF CONTENTS

1. REPLACEMENT AND ADJUSTMENT	1
1.1 REAR COVER	1
1.2 TRAY LIFT MOTOR.....	2
1.3 TRANSPORT MOTOR.....	3
1.4 PAPER FEED MOTOR.....	4
1.5 CONTROLLER BOARD.....	5
1.6 TRANSPORT SENSOR, LIMIT SENSOR, PAPER END SENSOR, PAPER FEED SENSOR	6
1.7 PAPER FEED UNIT	8
1.8 PICK-UP ROLLER, FEED ROLLER, FRICTION ROLLER	11

READ THIS FIRST

Safety and Symbols

This manual uses several symbols and abbreviations. The meaning of those symbols and abbreviations are as follows:

	Clip ring
	Screw
	Connector
	Clamp
SEF	Short Edge Feed
LEF	Long Edge Feed

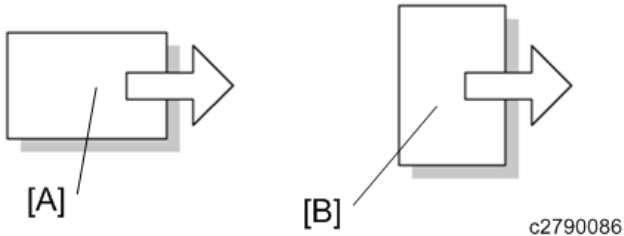

[A] Short Edge Feed (SEF)

[B] Long Edge Feed (LEF)

Trademarks

Microsoft[®], Windows[®], and MS-DOS[®] are registered trademarks of Microsoft Corporation in the United States and /or other countries.

PostScript[®] is a registered trademark of Adobe Systems, Incorporated.

PCL[®] is a registered trademark of Hewlett-Packard Company.

Ethernet[®] is a registered trademark of Xerox Corporation.

PowerPC[®] is a registered trademark of International Business Machines Corporation.

Other product names used herein are for identification purposes only and may be trademarks of their respective companies. We disclaim any and all rights involved with those marks.

The Aim of Anti-tip Components and Precautions

The anti-tip components are necessary for meeting the requirements of IEC60950-1, the international standard for safety.

The aim of these components is to prevent the products, which are heavy in weight, from toppling as a result of people running into or leaning onto the products, which can lead to serious accidents such as persons becoming trapped under the product. (U.S.: UL60950-1, Europe: EN60950-1)

Therefore, removal of such components must always be with the consent of the customer.

Do not remove them at your own judgment.

1. REPLACEMENT AND ADJUSTMENT

1.1 REAR COVER

1. Rear lower gap cover [A] (hookx2).

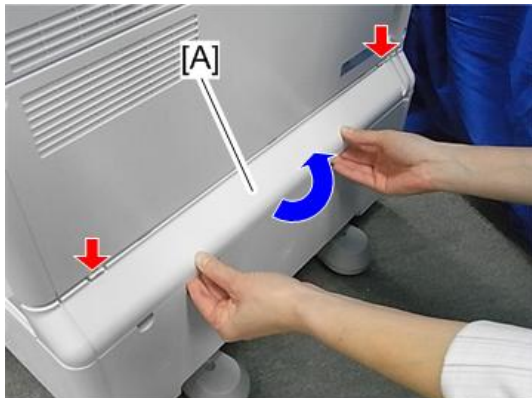

d197z1155

2. Securing brackets [A] (Ⓜ x1 each).

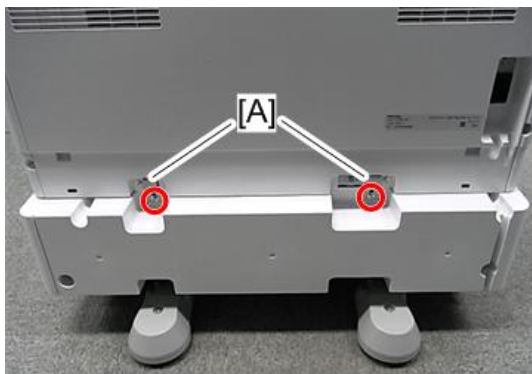

d197z8002

3. Rear cover [A] (Ⓜ x4).

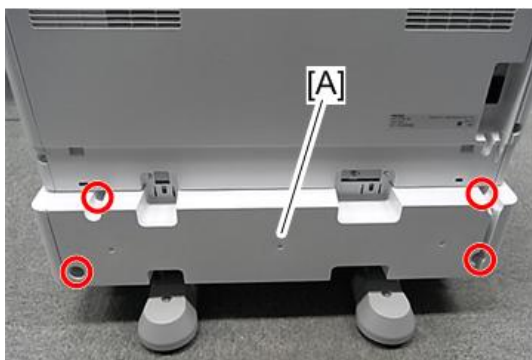

d197z8003

1.2 TRAY LIFT MOTOR

1. Rear cover (page 1).
2. Tray lift motor [A] (⚙️ x2, 📦 x1).

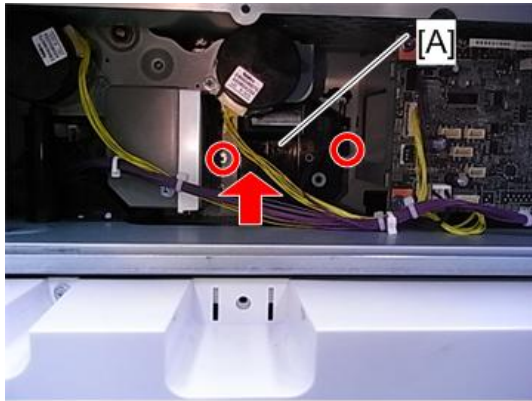

d1462727

1.3 TRANSPORT MOTOR

1. Rear cover (page 1).
2. Transport motor [A] (⚙️ x2, 📦 x1).

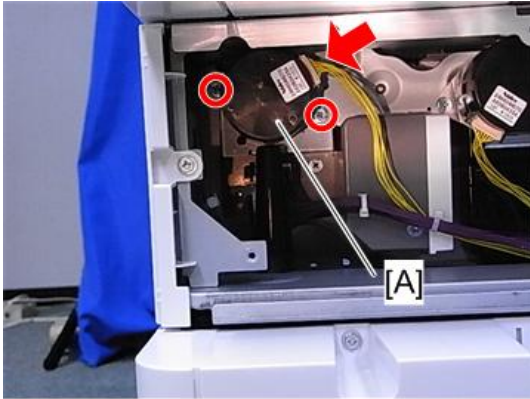

d1462728

1.4 PAPER FEED MOTOR

1. Rear cover (page 1).
2. Paper feed motor [A] (🔩 x2, 📦 x1).

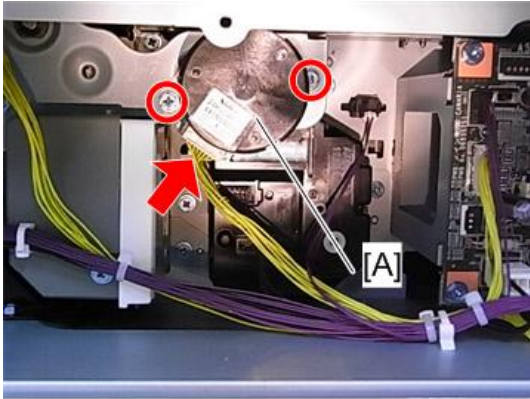

d1462729

1.5 CONTROLLER BOARD

1. Rear cover (page 1).
2. Controller board [A] (⚙️ x4, 📦 x7).

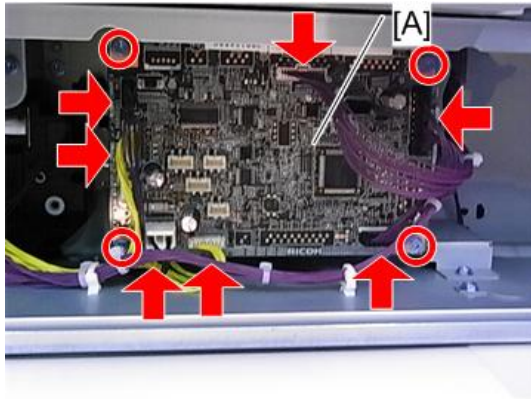

d1462730

1.6 TRANSPORT SENSOR, LIMIT SENSOR, PAPER END SENSOR, PAPER FEED SENSOR

1. Paper feed unit (page 8).
2. Transport sensor bracket [A] (⚙️ x1, 📦 x1).

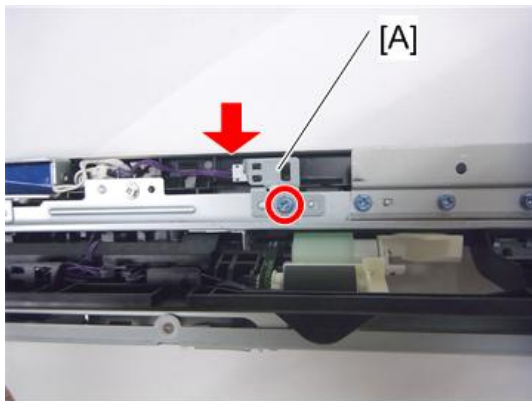

d1462196

3. Transport sensor [A].

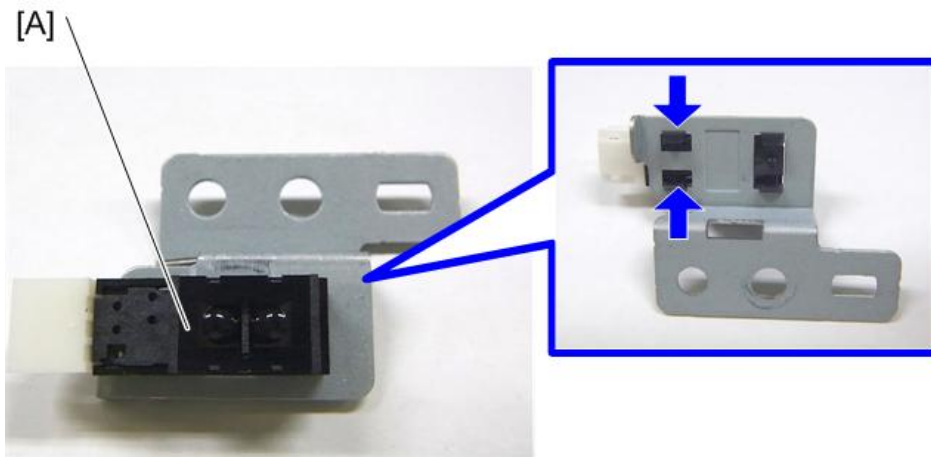

d1462197

4. Paper feed sensor bracket [A] (⚙️ x1, 📦 x1).

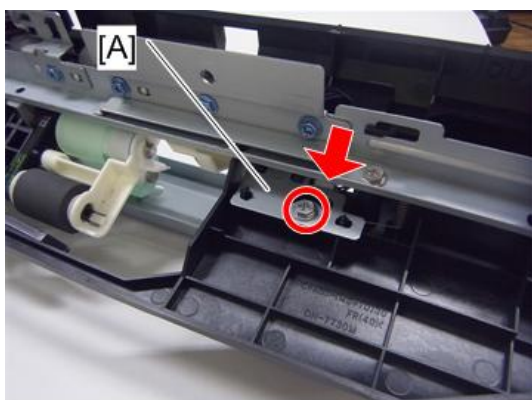

d1462194

5. Paper feed sensor [A].

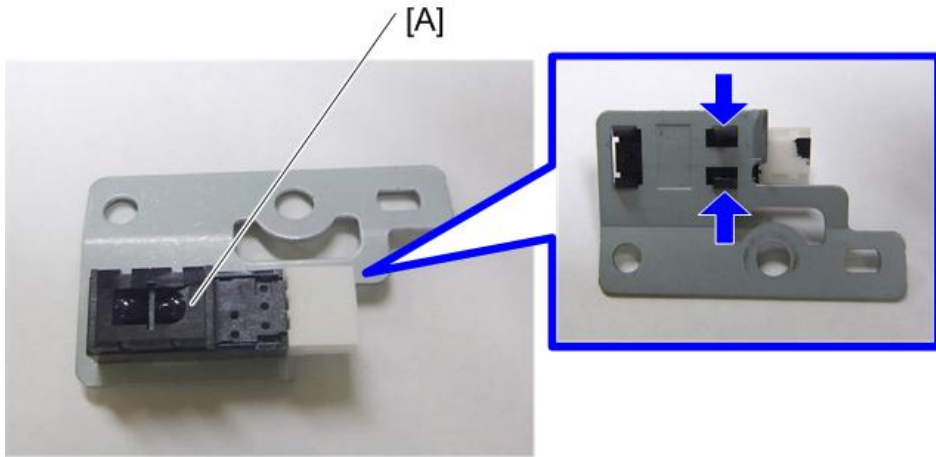

d1462195

6. Paper end sensor [A] (📦 x1).

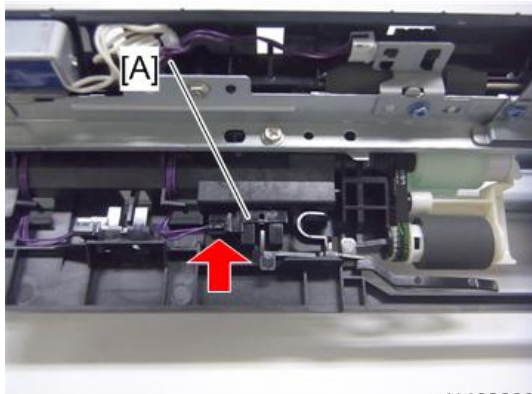

d1462200

7. Limit sensor [A] (📦 x1).

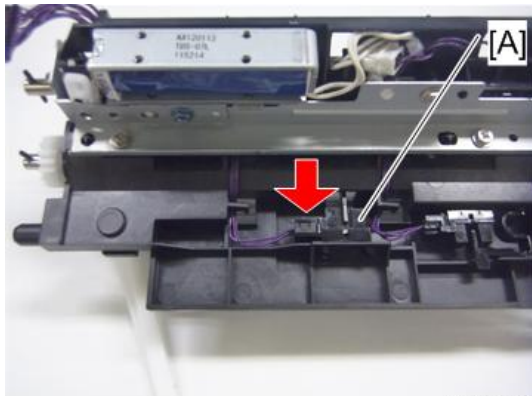

d1462198

1.7 PAPER FEED UNIT

1. Pull out the paper tray.
2. Rear cover (page 1).
3. Right lower cover [A] (hook x1).

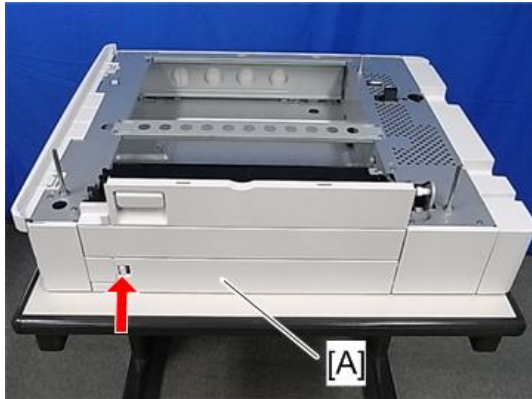

d146z0075

4. Right rear cover [A] (hook x1).

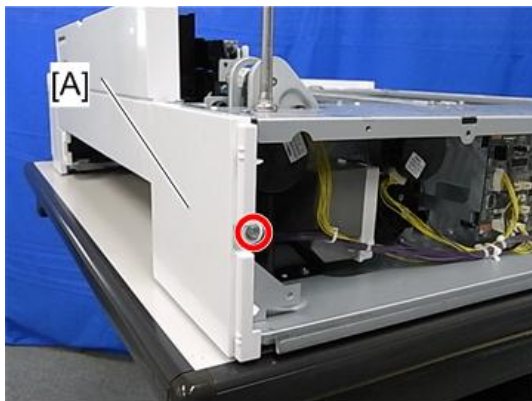

d146z0076

5. Open the transport cover [A].

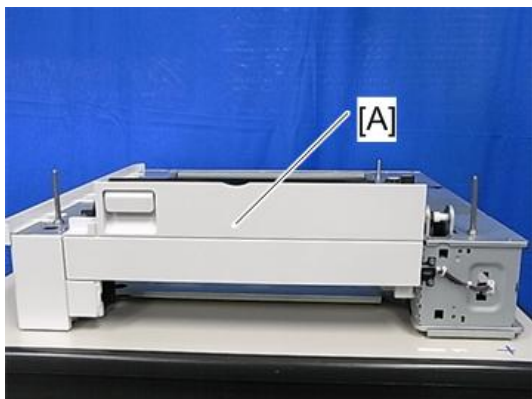

d146z0077

6. Transport guide [A] (tab x1).

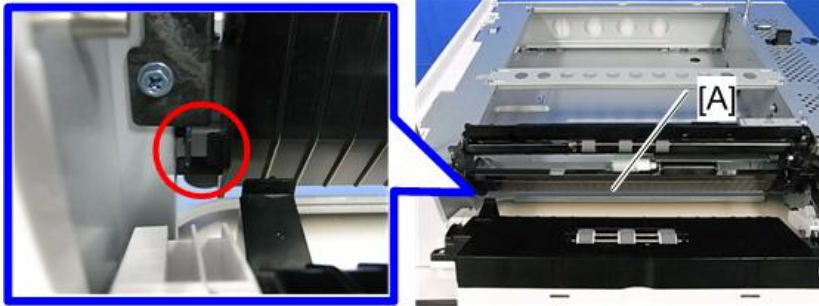

d146z0078

7. Harness guide [A] (🔧 x2).

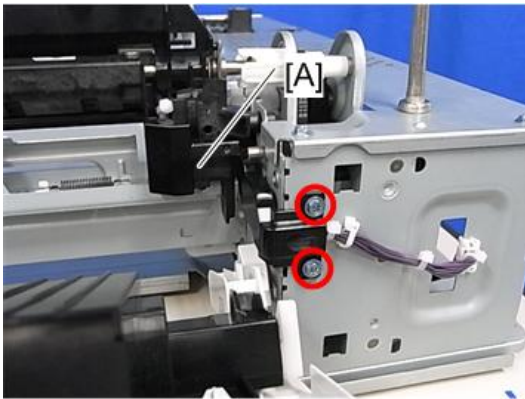

d146z0079

8. Release the clamp, and then disconnect the harness at the right rear of the unit (🔧 x1, 🖱️ x1).

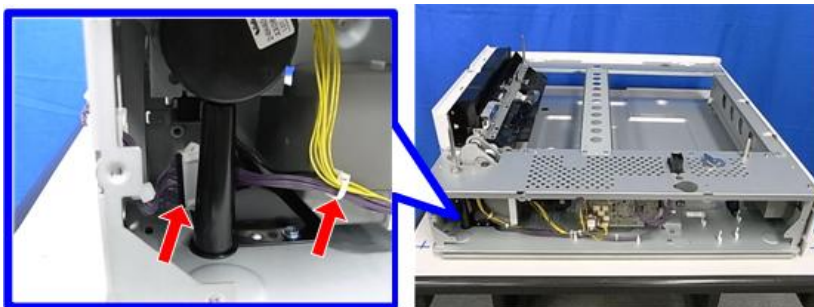

d146z0080

9. Release the four clamps (🔧 x4).

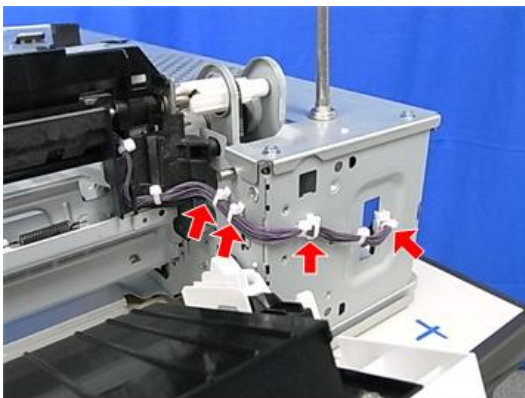

d146z0081

10. Paper feed unit [A] (🔑 x2).

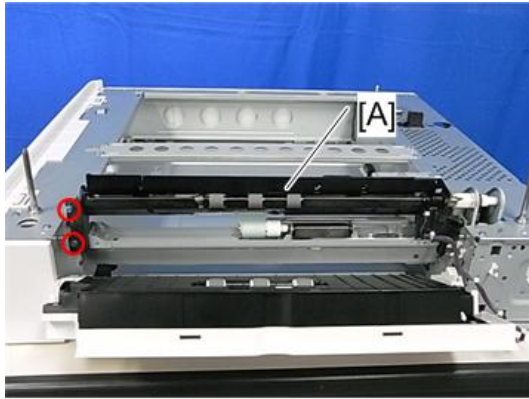

d146z0082

1.8 PICK-UP ROLLER, FEED ROLLER, FRICTION ROLLER

1. Paper feed unit (page 8).
2. Holder [A] (🔧x1).

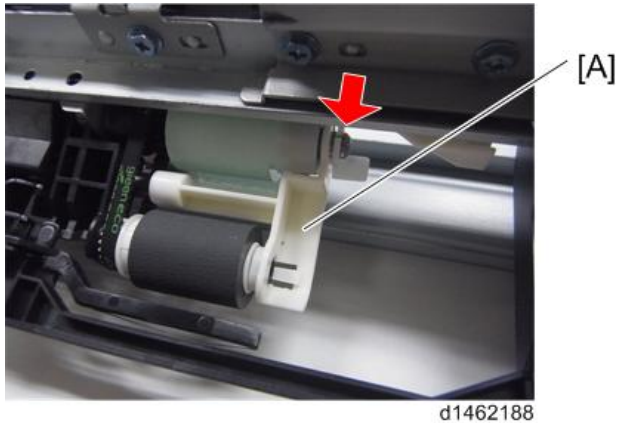

d1462188

3. Pick-up roller [A].

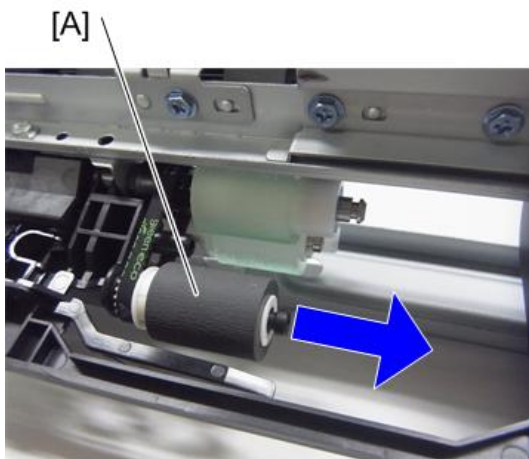

d1462189

4. Feed roller [A].

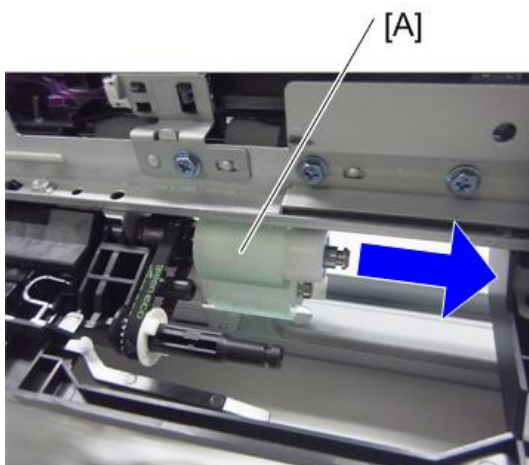

d1462190

5. Friction roller [A] (🔧x1).

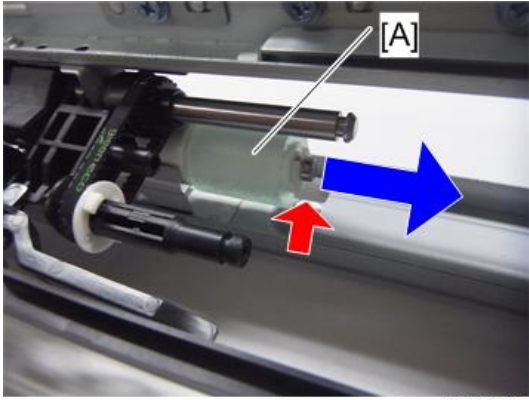

d1462191

D716
PUNCH UNIT PU3040

REVISION HISTORY		
Page	Date	Added/Updated/New
		None

PUNCH UNIT PU3040 (D716)





TABLE OF CONTENTS

1. REPLACEMENT AND ADJUSTMENT	1
1.1 PUNCH UNIT	1
1.2 CONTROLLER BOARD.....	4
1.3 PUNCH UNIT HOME POSITION SENSOR	5
1.4 PUNCH MOTOR.....	6
1.5 PUNCH UNIT PULSE DETECTION SENSOR	7
1.6 HORIZONTAL REGISTRATION MOVEMENT UNIT HOME POSITION SENSOR.....	8
1.7 HORIZONTAL REGISTRATION MOVEMENT UNIT MOTOR.....	9
1.8 PUNCH UNIT	11
1.9 HORIZONTAL REGISTRATION DETECTION UNIT HOME POSITION SENSOR.....	13
1.10 HORIZONTAL REGISTRATION DETECTION UNIT MOTOR	15
1.11 PUNCH HOPPER FULL SENSOR.....	16
1.12 HORIZONTAL REGISTRATION SENSOR	17

READ THIS FIRST

Safety and Symbols

This manual uses several symbols and abbreviations. The meaning of those symbols and abbreviations are as follows:

	Clip ring
	Screw
	Connector
	Clamp
SEF	Short Edge Feed
LEF	Long Edge Feed

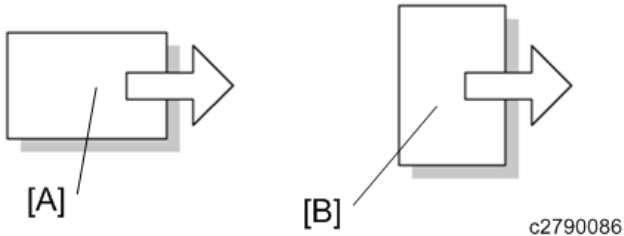

[A] Short Edge Feed (SEF)

[B] Long Edge Feed (LEF)

Trademarks

Microsoft[®], Windows[®], and MS-DOS[®] are registered trademarks of Microsoft Corporation in the United States and /or other countries.

PostScript[®] is a registered trademark of Adobe Systems, Incorporated.

PCL[®] is a registered trademark of Hewlett-Packard Company.

Ethernet[®] is a registered trademark of Xerox Corporation.

PowerPC[®] is a registered trademark of International Business Machines Corporation.

Other product names used herein are for identification purposes only and may be trademarks of their respective companies. We disclaim any and all rights involved with those marks.

1. REPLACEMENT AND ADJUSTMENT

1.1 PUNCH UNIT

1. Open the front cover [A].



d1462960

2. Left upper cover [A] (⊗x1).

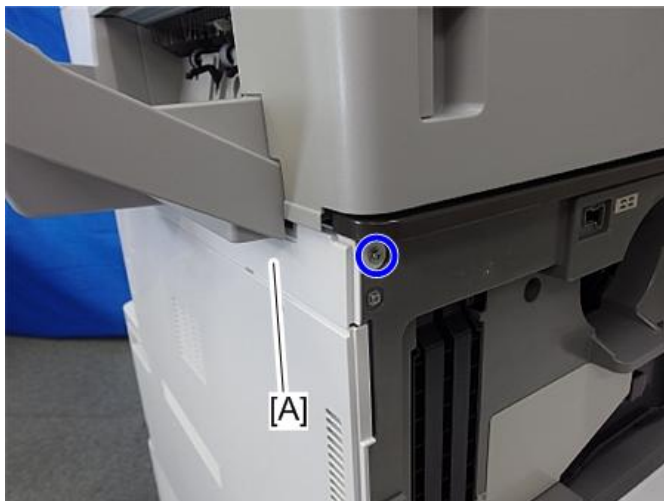

d197f0109

3. Left rear cover [A] (⊗x2, hookx1).



d197f0043

Punch Unit

4. Interface cable [A].

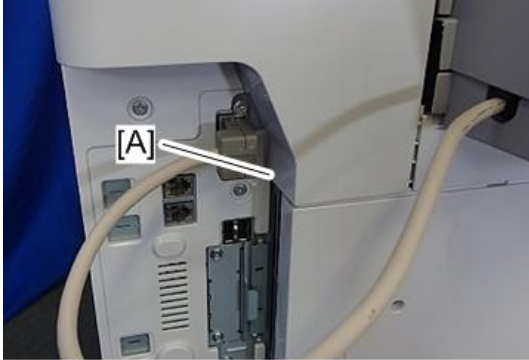

d197f0111

5. Inner finisher [A] (⊙ ×1).



d197z8004

6. Hopper [A].

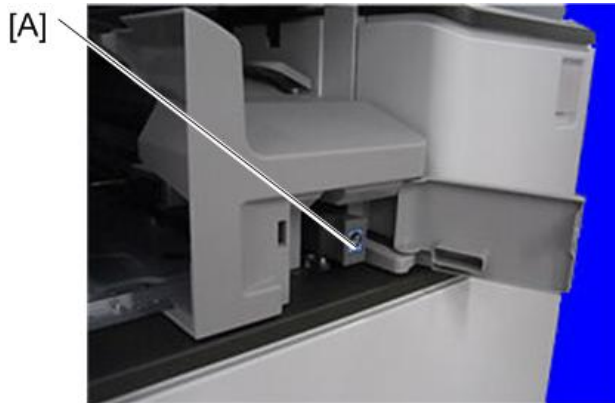

d146z0029

7. Punch unit front cover [A] (⊙ ×1).



8. Punch unit [A] (👉 x1).



1.2 CONTROLLER BOARD

1. Punch unit (page 1).

2. Invert the punch unit, and remove the control plate cover [A].

Release the claw in the blue circle, lift it in the direction of the blue arrow, and remove.

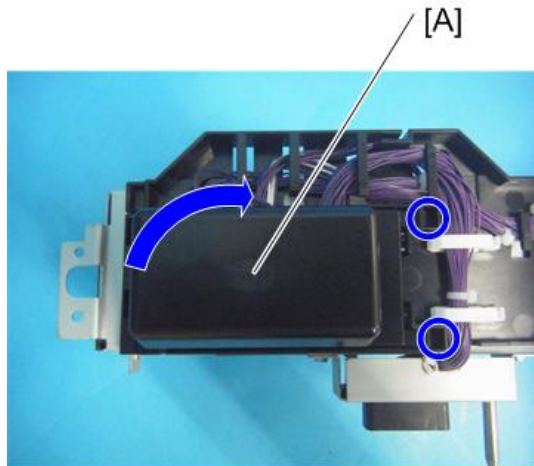

d1462968

3. Controller board [A] (⚙️ x2, 📦 x7).

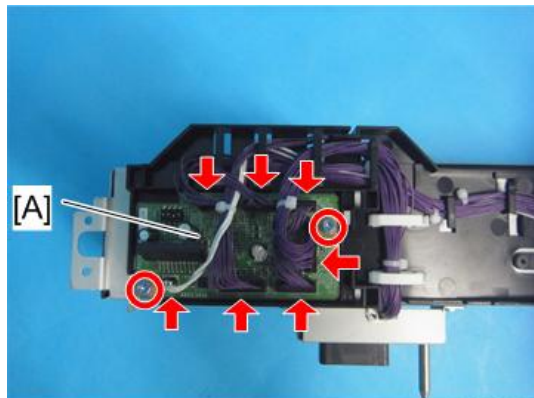

d1462969

1.3 PUNCH UNIT HOME POSITION SENSOR

1. Punch unit (page 1).
2. Upper front cover [A] (🔩 x1).

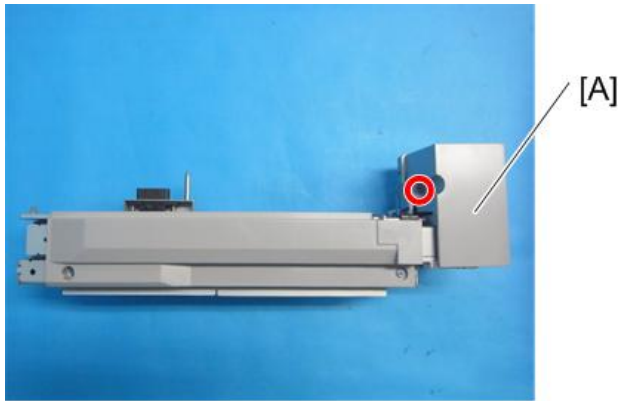

d1462970

3. Push the punch unit [A].

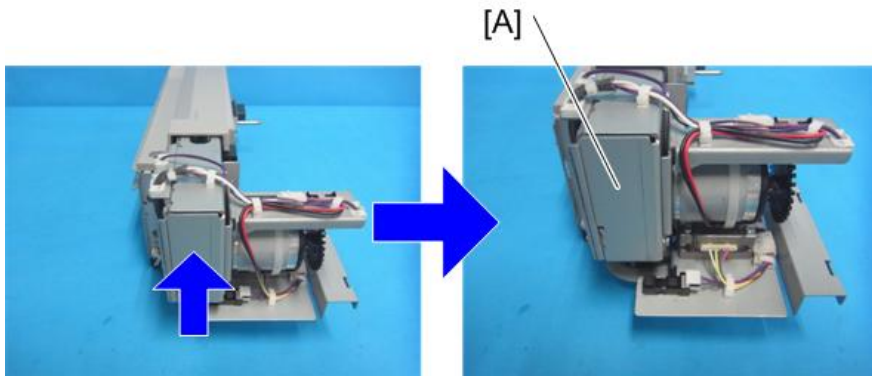

d1462971

4. Punch unit home position sensor [A] (🔩 x1).

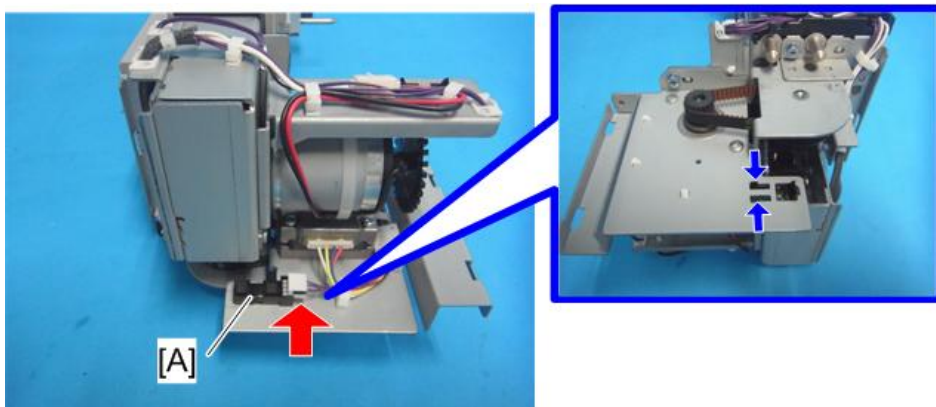

d1462972

1.4 PUNCH MOTOR

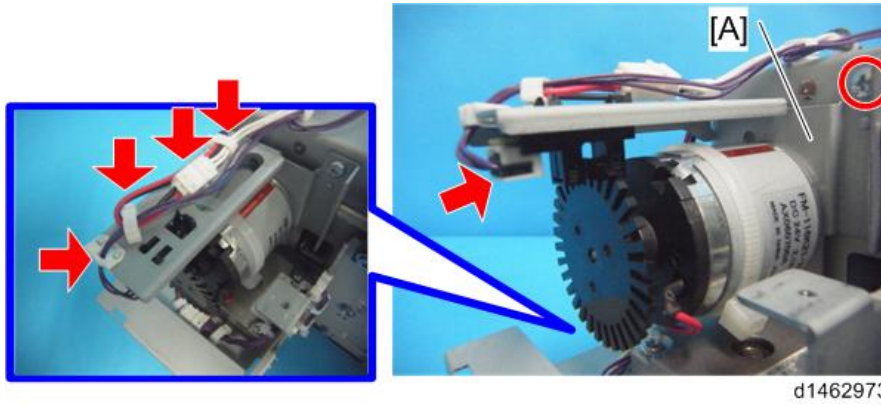

1. Upper front cover (page 5).
2. Punch motor unit [A] (⚙️ x2, 📦 x2, 🛠️ x3).

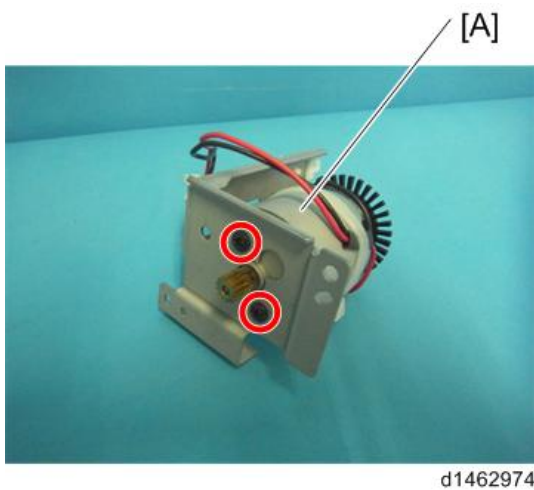

3. Punch motor [A] (⚙️ x2).



1.5 PUNCH UNIT PULSE DETECTION SENSOR

1. Upper front cover (page 5).
2. Punch unit pulse detection sensor [A] ( x1,  x1).

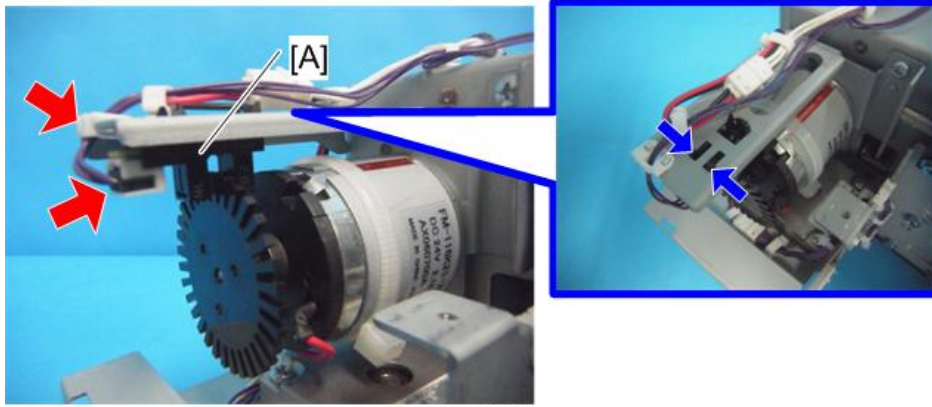

d1462975

1.6 HORIZONTAL REGISTRATION MOVEMENT UNIT HOME POSITION SENSOR

1. Punch Unit (page 1).
2. Horizontal registration movement unit home position sensor unit [A] (🔩 x1, 📦 x1).

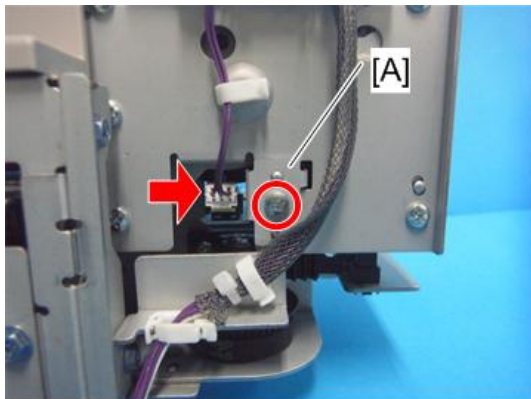

d1462976

3. Horizontal registration movement unit home position sensor [A].

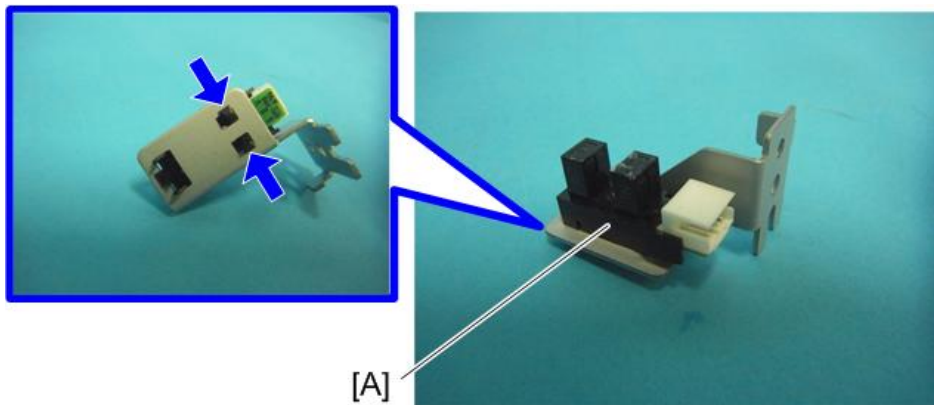

d1462977

1.7 HORIZONTAL REGISTRATION MOVEMENT UNIT MOTOR

1. Upper front cover (page 5).
2. Pull the bracket forward [A] (🔑 x2).

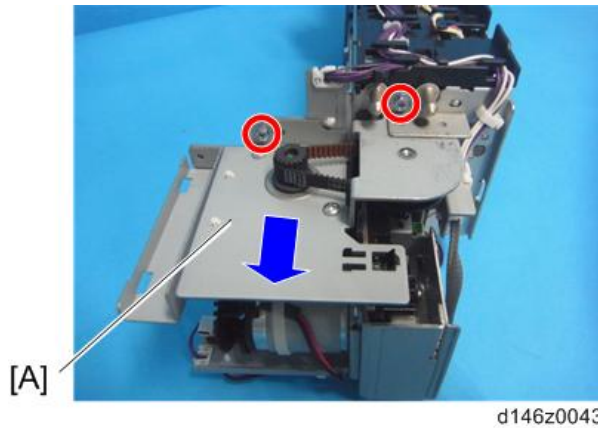

3. Release the two clamps (🔑 x2).

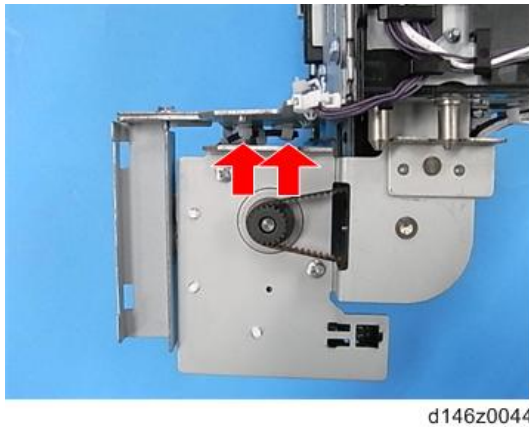

4. Bracket with the horizontal registration movement unit motor (🔑 x3, 📦 x2).

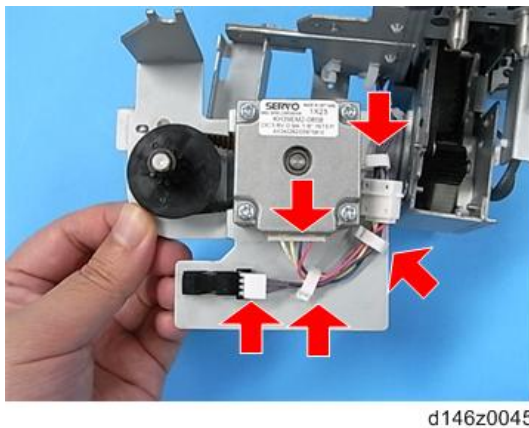

5. Horizontal registration movement unit motor [A] (🔑 x2, Timing belt x1).

Horizontal Registration Movement Unit Motor

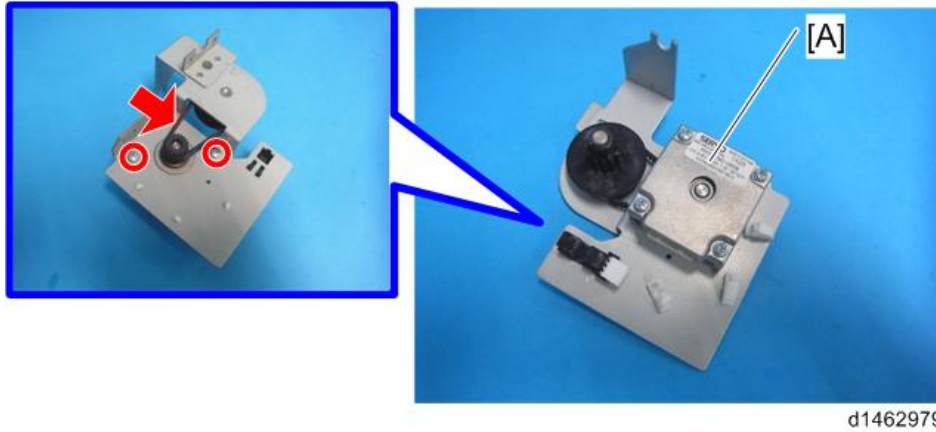

d1462979

1.8 PUNCH UNIT

1. Upper front cover (page 5).
2. Upper cover [A] (🔩 x2).

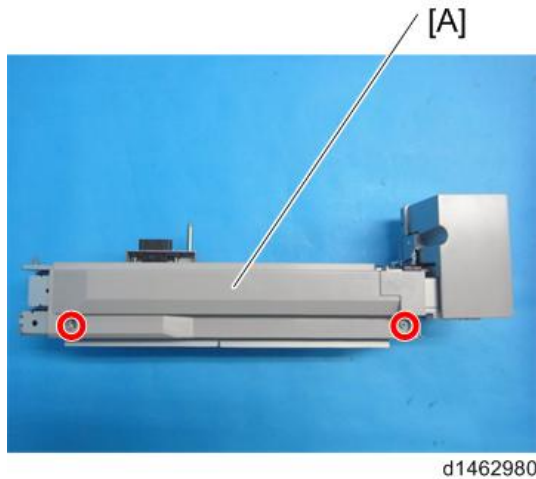

3. Horizontal registration movement unit motor unit (page 9).
4. Upper entrance guide plate [A] (🔩 x3).

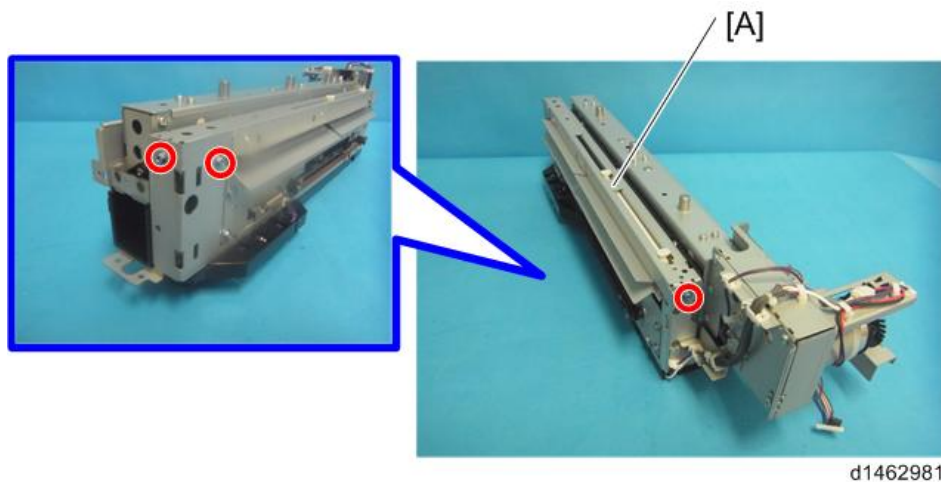

⬇ Note

- To prevent it from falling out, press the moving parts [A] of the detached upper inlet guide plate into the groove in the blue circle.

Punch Unit

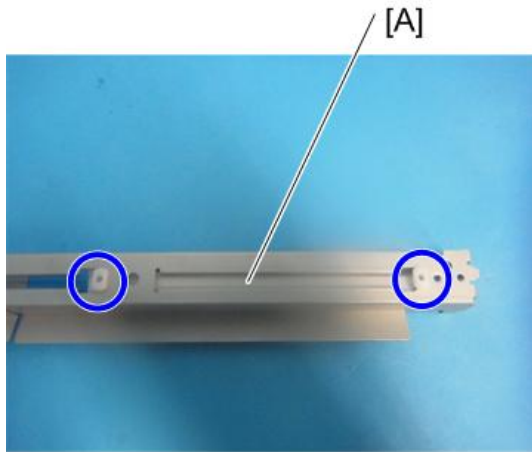

d1462982

↓ Note

- During attachment, attach while bringing moving parts close to the left-hand side.

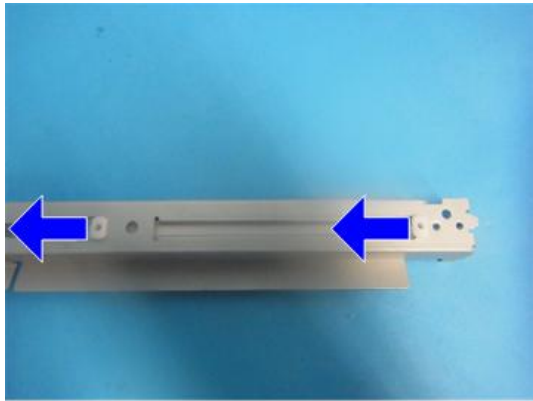

d1462983

5. Punch unit [A] (🔩 x1, 📦 x3, 🛠️ x7).

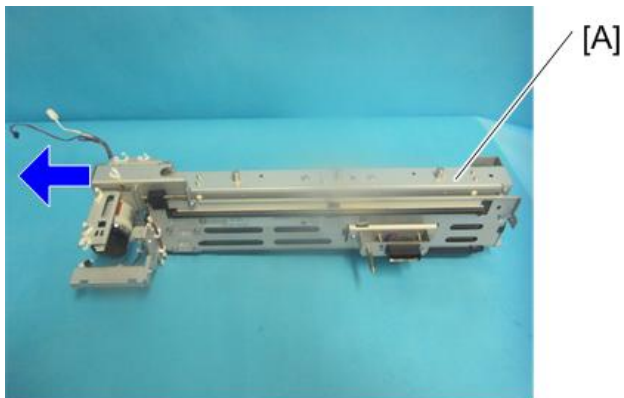

d1462984

1.9 HORIZONTAL REGISTRATION DETECTION UNIT

HOME POSITION SENSOR

1. Upper cover (page 11).
2. Upper entrance guide plate (page 11).
3. Spring [A], Bracket[B] (🔩 x1).

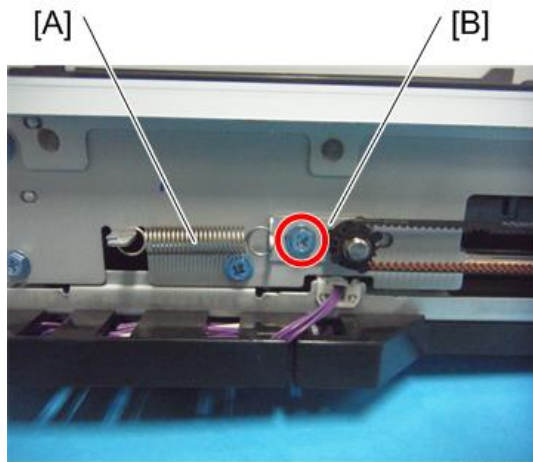

d1462985

4. Horizontal registration detection unit [A] (🔩 x6, 📦 x1).

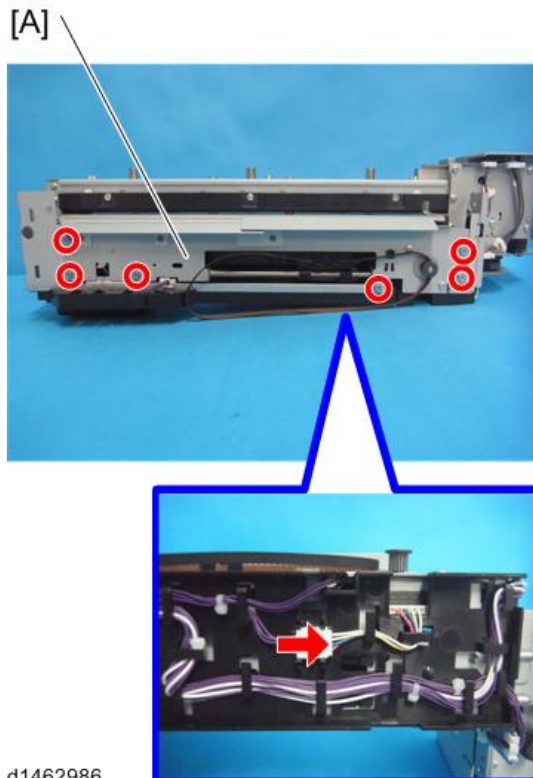

d1462986

Horizontal Registration Detection Unit Home Position Sensor

↓ Note

- When reassembling the horizontal registration detection unit [A], the protrusion of the joint needs to be in the notch of the cam [B].

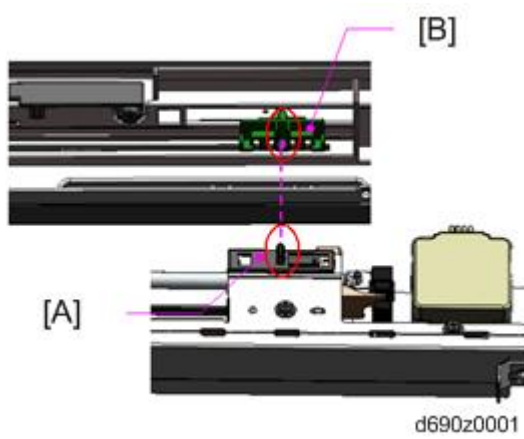

5. Horizontal registration detection unit home position sensor [A] (📦 x1).

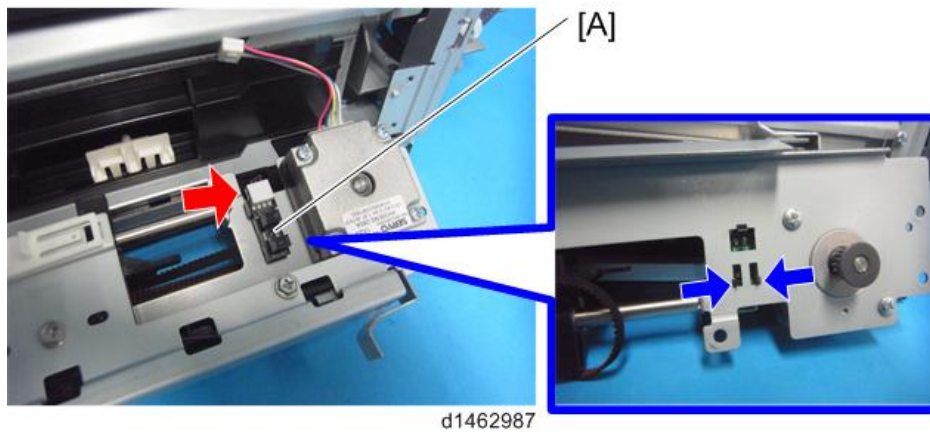

1.10 HORIZONTAL REGISTRATION DETECTION UNIT

MOTOR

1. Horizontal registration detection unit (page 13).
2. Horizontal registration detection unit motor [A] (🔩 x2, 📦 x1).

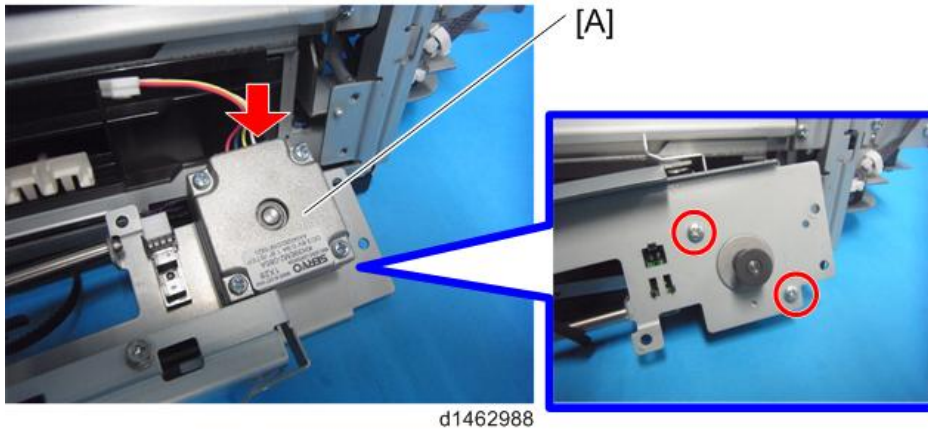

1.11 PUNCH HOPPER FULL SENSOR

1. Horizontal Registration Detection Unit (page 13).
2. Punch hopper full sensor unit [A] (📦 x1).

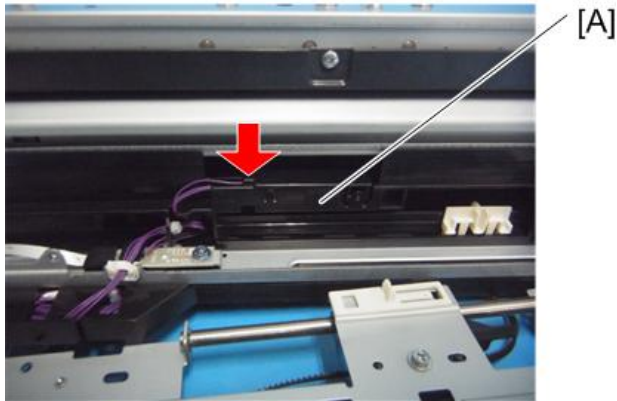

d1462989

3. Punch hopper full sensor [A] (🔧 x1).

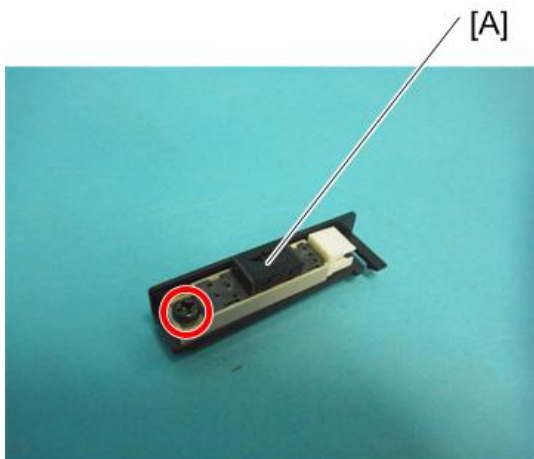

d1462990

1.12 HORIZONTAL REGISTRATION SENSOR

1. Horizontal registration detection unit (page 13).
2. Horizontal registration unit bracket [A] (🔩 x2).

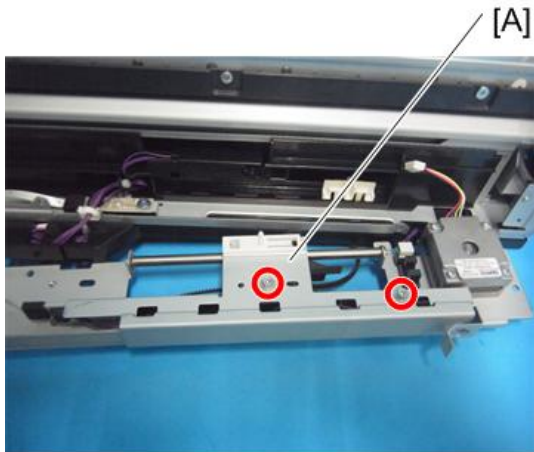

d1462991

3. Horizontal registration sensor [A] (📦 x1).

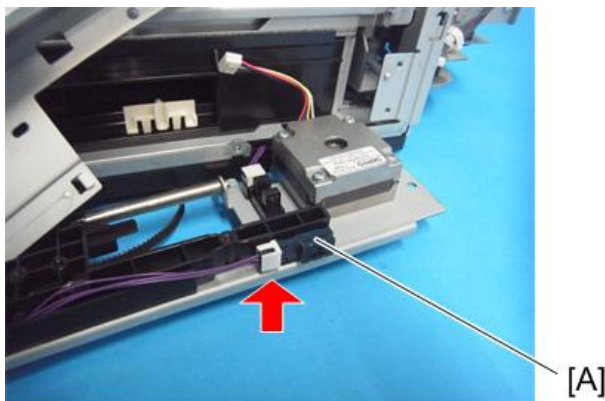

d1462992

D725
SIDE TRAY TYPE M3

REVISION HISTORY		
Page	Date	Added/Updated/New
		None

SIDE TRAY TYPE M3 (D725)





TABLE OF CONTENTS

1. REPLACEMENT AND ADJUSTMENT	1
1.1 DRIVE MOTOR UNIT	1
1.2 UPPER PAPER EXIT SENSOR	4
1.3 LEFT PAPER EXIT SENSOR	7
1.4 UPPER PAPER EXIT TRAY SET SWITCH	8
1.5 PAPER EXIT SWITCHING UNIT SET SWITCH	9

READ THIS FIRST

Safety and Symbols

This manual uses several symbols and abbreviations. The meaning of those symbols and abbreviations are as follows:

	Clip ring
	Screw
	Connector
	Clamp
SEF	Short Edge Feed
LEF	Long Edge Feed

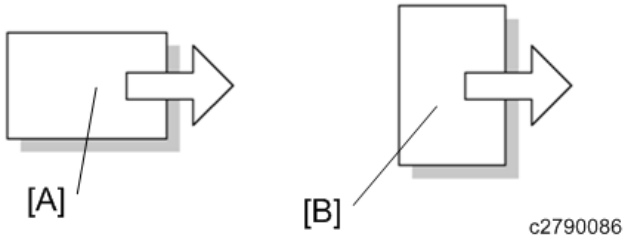

[A] Short Edge Feed (SEF)

[B] Long Edge Feed (LEF)

Trademarks

Microsoft[®], Windows[®], and MS-DOS[®] are registered trademarks of Microsoft Corporation in the United States and /or other countries.

PostScript[®] is a registered trademark of Adobe Systems, Incorporated.

PCL[®] is a registered trademark of Hewlett-Packard Company.

Ethernet[®] is a registered trademark of Xerox Corporation.

PowerPC[®] is a registered trademark of International Business Machines Corporation.

Other product names used herein are for identification purposes only and may be trademarks of their respective companies. We disclaim any and all rights involved with those marks.

1. REPLACEMENT AND ADJUSTMENT

1.1 DRIVE MOTOR UNIT

1. Upper extension tray [A], Left extension tray [B].



d1462840

2. Fixing plate [A] (🔩 x1).



d1462493

3. Side tray [A] (🔩 x1).

Drive Motor Unit

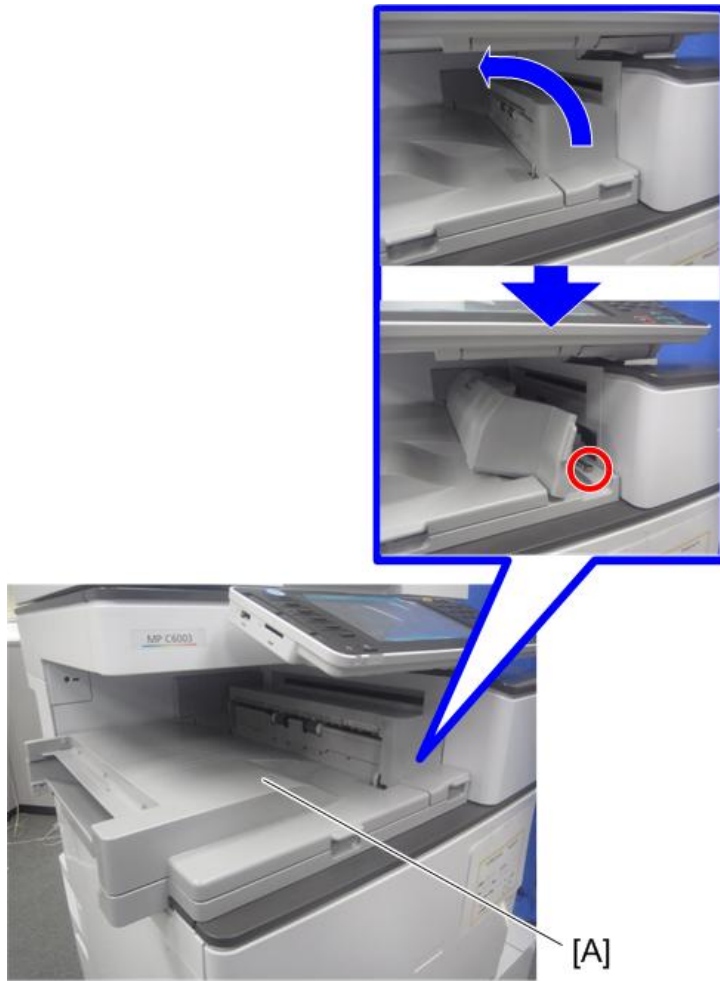

d1462842

4. Drive motor unit cover [A] (🔩 x2).

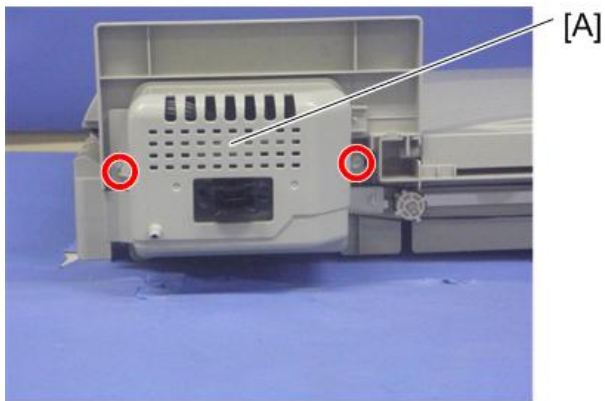

d1462843

5. Side tray rear cover [A] (🔩 x1).

SIDE TRAY TYPE
M3 (D725)

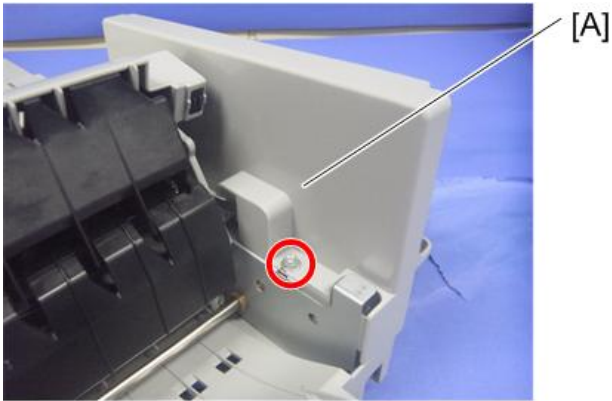

d1462844

6. Drive motor unit [A] (⚙️ x3, 📦 x2).

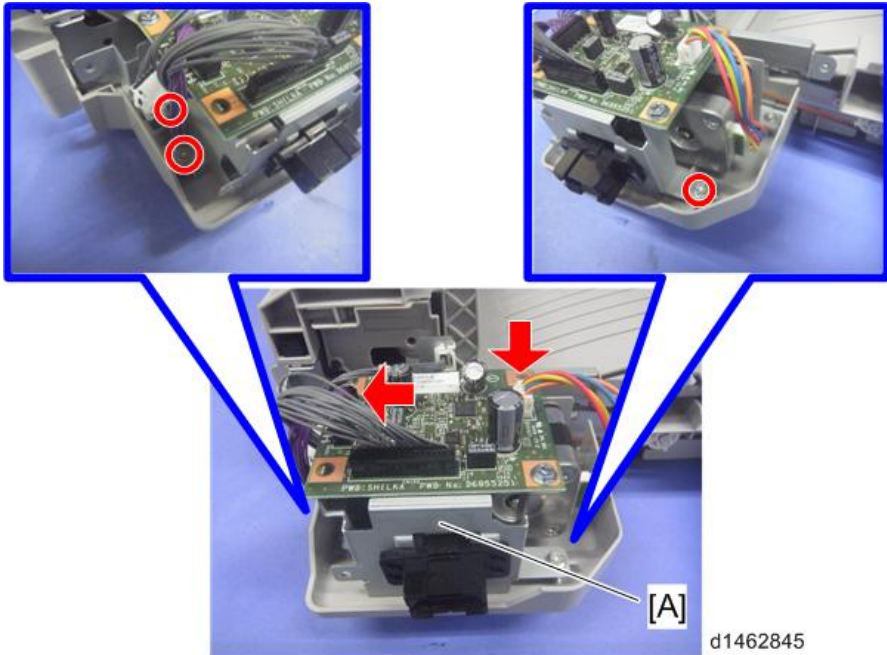

d1462845

1.2 UPPER PAPER EXIT SENSOR

1. Side tray (page 1).
2. Upper paper exit tray [A].

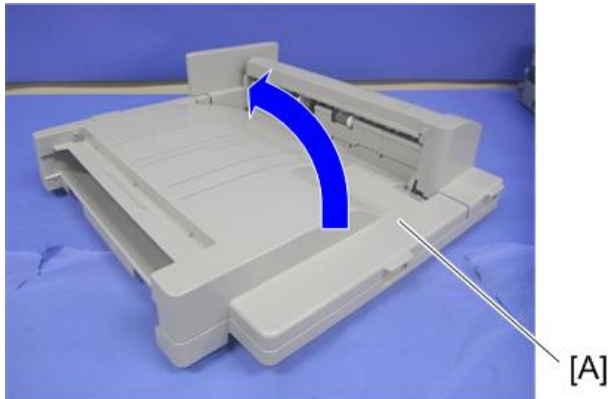

d1462846

3. Drive motor unit cover (page 1).
4. Side tray rear cover (page 1).
5. Left paper exit cover [A] (🔩 x1).



d1462847

6. Paper exit switching unit [A] (🔧 x1, 🛠️ x1, 🔩 x1).

SIDE TRAY TYPE
M3 (D725)

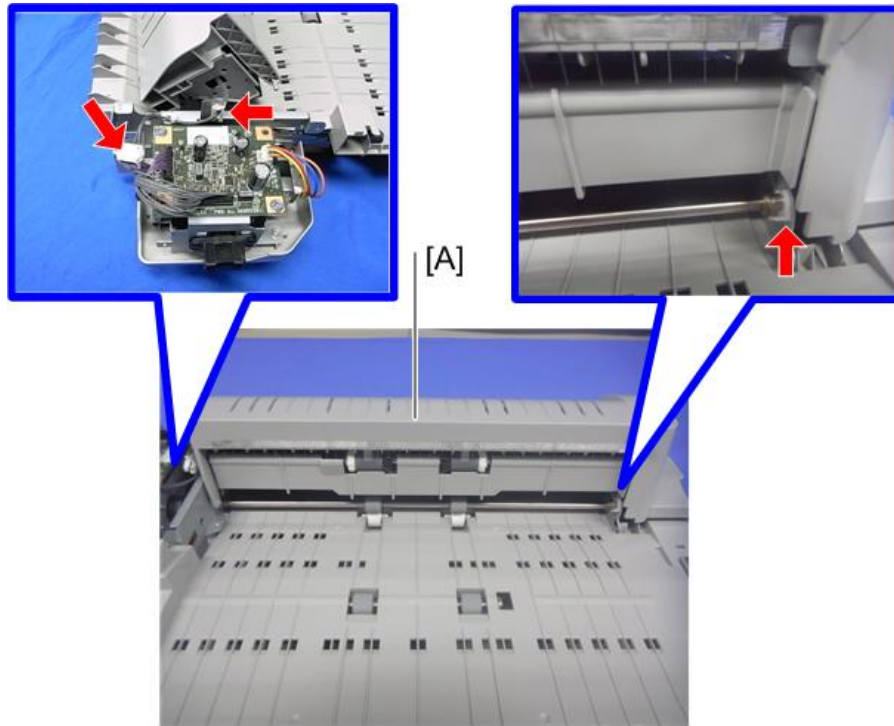

d146z0051

7. Paper exit switching unit cover [A] (⚙️ x4).

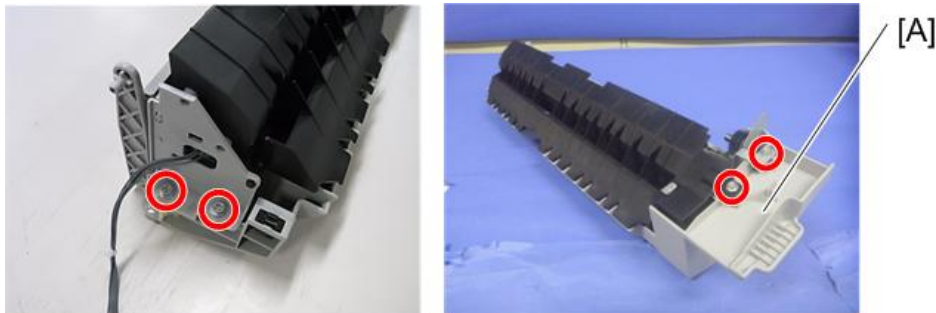

d146z0049

8. Guide plate [A].

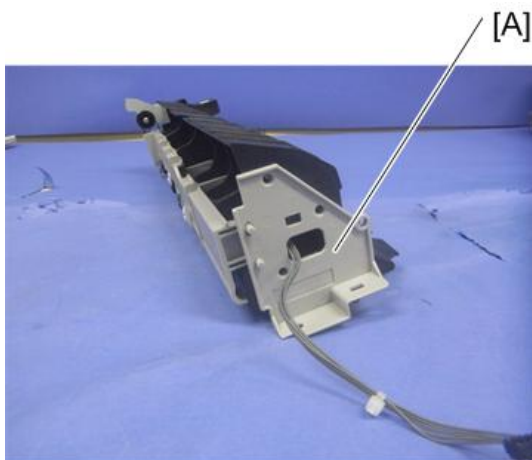

d146z0050

9. Guide plate [A] (⚙️ x1).

Upper Paper Exit Sensor

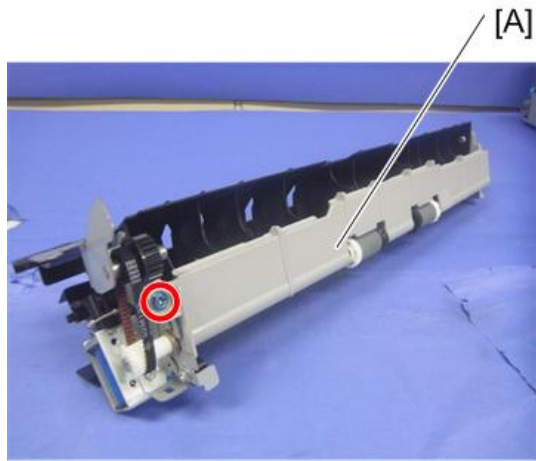

d1462851

10. Upper paper exit sensor [A] (x1).

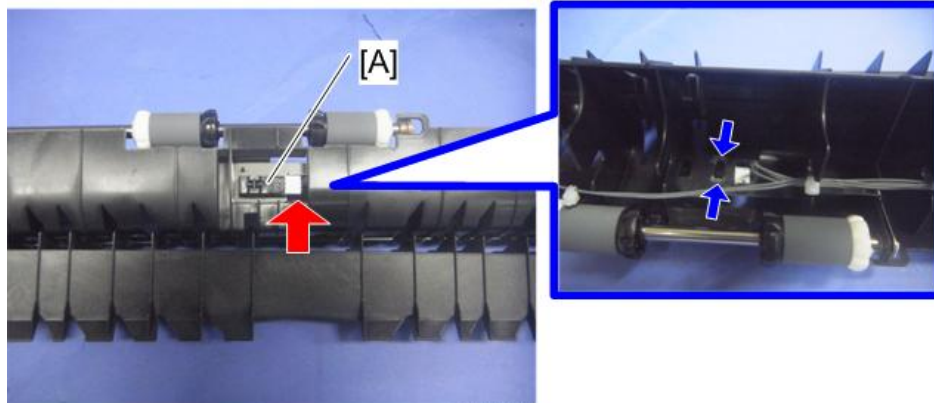

d1462852

1.3 LEFT PAPER EXIT SENSOR

1. Upper paper exit tray (page 4).
2. Turn it upside down.

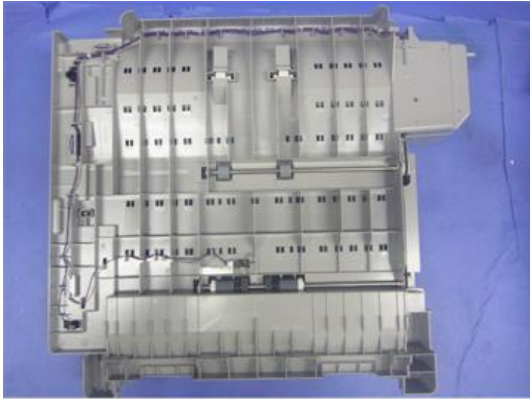

d1462853

3. Left paper exit sensor [A] (📦 x1).

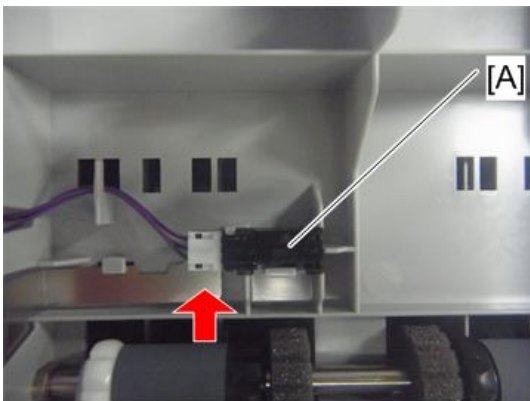

d1462854

1.4 UPPER PAPER EXIT TRAY SET SWITCH

1. Upper paper exit tray (page 4).
2. Upper paper exit tray set switch cover [A].

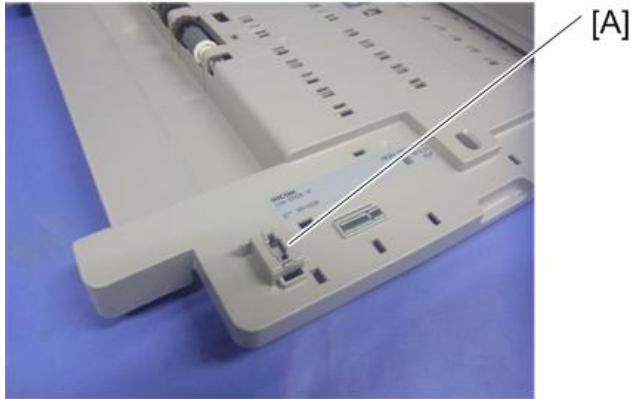

d1462855

3. Upper paper exit tray set switch [A] (📦 x1).

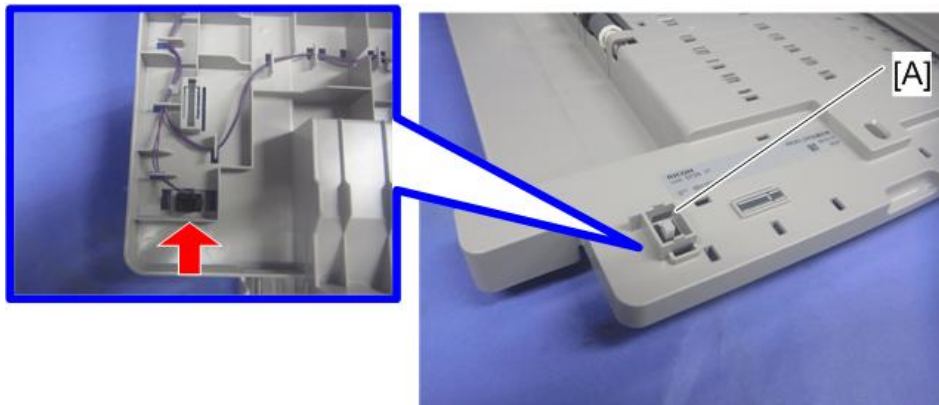

d1462856

1.5 PAPER EXIT SWITCHING UNIT SET SWITCH

1. Open the Paper exit switching unit [A].

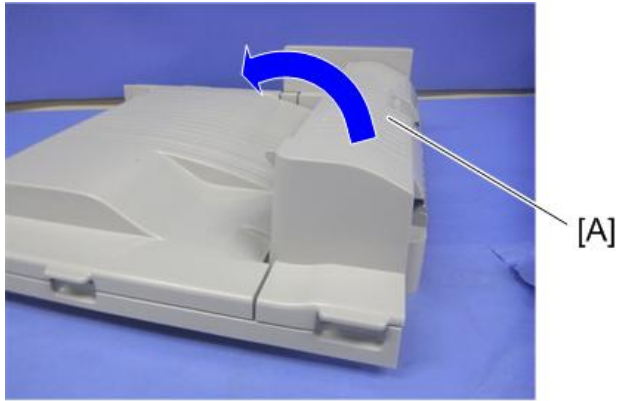

d1462857

2. Paper exit switching unit set switch cover [A].

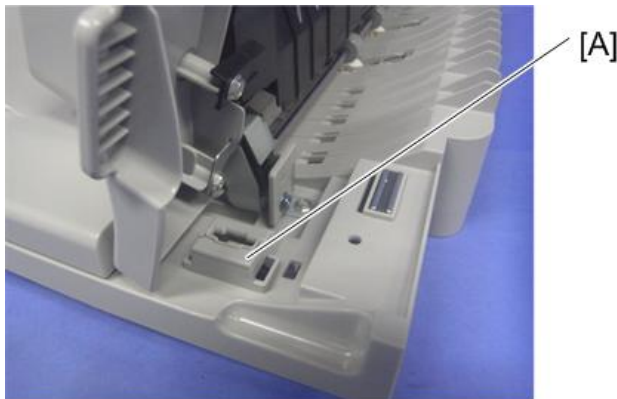

d1462858

3. Paper exit switching unit set switch [A] ( x1).

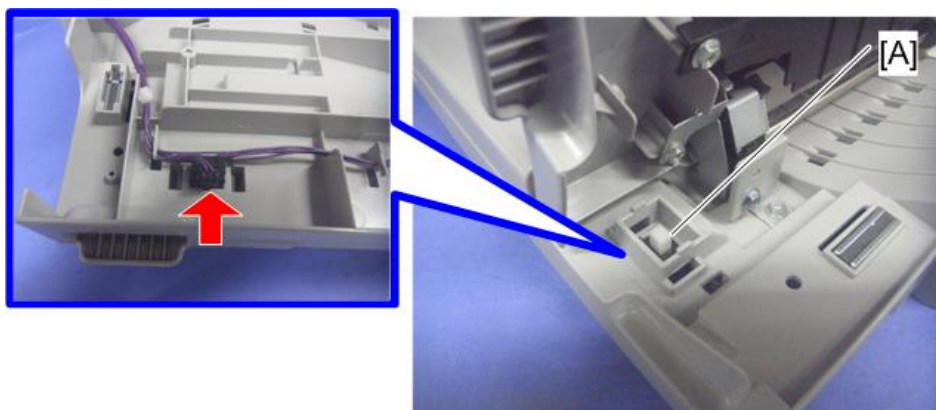

d1462859

D766

INTERNAL FINISHER SR3180

REVISION HISTORY		
Page	Date	Added/Updated/New
		None

INTERNAL FINISHER SR3180 (D766)





TABLE OF CONTENTS

1. REPLACEMENT AND ADJUSTMENT	1
1.1 INTERNAL FINISHER SR3180	1
1.2 FINISHER FRONT COVER	3
1.3 FINISHER UPPER COVER	4
1.4 PAPER OUTPUT TRAY	5
1.5 PAPER OUTPUT COVER	6
1.6 REAR COVER	7
1.7 CONTROL BOARD	8
1.8 ENTRANCE SENSOR	9
1.9 TRANSPORT MOTOR	10
1.10 SHIFT MOTOR	11
1.11 JUNCTION SOLENOID MOTOR	12
1.12 EXIT PAPER PRESSURE MOTOR	13
1.13 SIDE-TO-SIDE REGISTRATION SENSOR	14
1.14 OPEN/CLOSE DOOR SWITCH	15
1.15 SHIFT HOME POSITION SENSOR	16
1.16 PAPER OUTPUT SENSOR	17
1.17 PAPER OUTPUT PRESSURE HP SENSOR	18
1.18 JUNCTION SOLENOID MOTOR HP SENSOR	19
1.19 PAPER OUTPUT FULL SENSOR 1 / PAPER OUTPUT FULL SENSOR 2 (STAPLE)	20
1.20 STAPLER UNIT	21
1.21 STAPLER DRIVE HP SENSOR	23
1.22 STAPLER MOTOR	24

READ THIS FIRST

Safety and Symbols

This manual uses several symbols and abbreviations. The meaning of those symbols and abbreviations are as follows:

	Clip ring
	Screw
	Connector
	Clamp
SEF	Short Edge Feed
LEF	Long Edge Feed

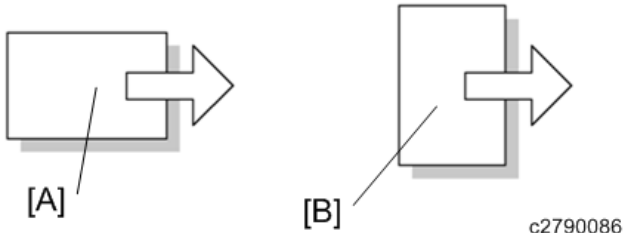

[A] Short Edge Feed (SEF)

[B] Long Edge Feed (LEF)

Trademarks

Microsoft[®], Windows[®], and MS-DOS[®] are registered trademarks of Microsoft Corporation in the United States and /or other countries.

PostScript[®] is a registered trademark of Adobe Systems, Incorporated.

PCL[®] is a registered trademark of Hewlett-Packard Company.

Ethernet[®] is a registered trademark of Xerox Corporation.

PowerPC[®] is a registered trademark of International Business Machines Corporation.

Other product names used herein are for identification purposes only and may be trademarks of their respective companies. We disclaim any and all rights involved with those marks.

1. REPLACEMENT AND ADJUSTMENT

1.1 INTERNAL FINISHER SR3180

1. Interface cable [A].

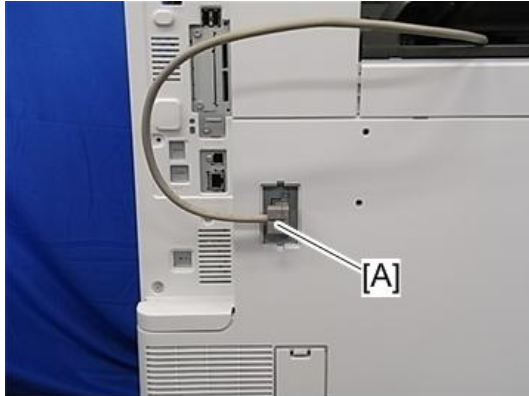

d7662061

2. Paper output tray [A] (⊙ x2).

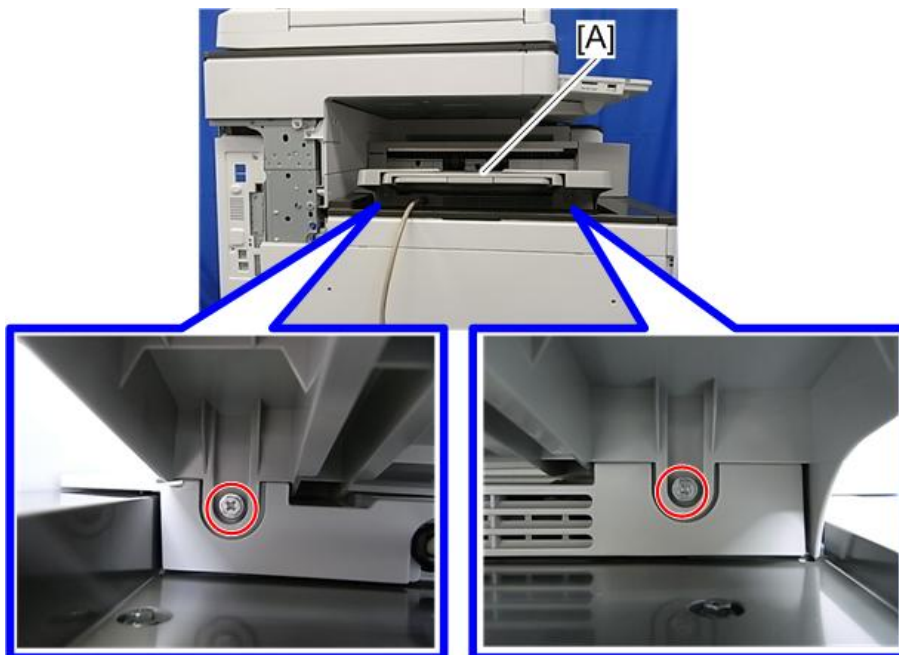

d8662059

3. Cover [A] (⊙ x2).

Internal Finisher SR3180

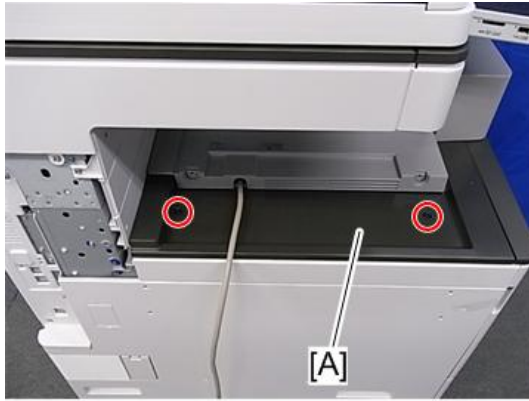

d7662057

4. Screw on the Finisher [A] (🔩 x1).

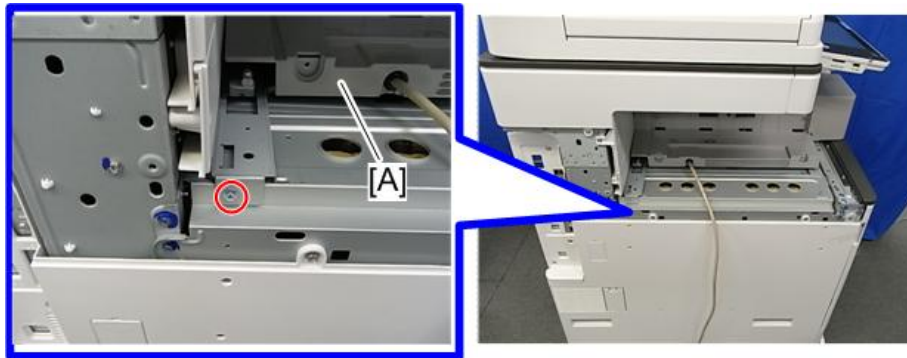

d7662036

5. Finisher [A].

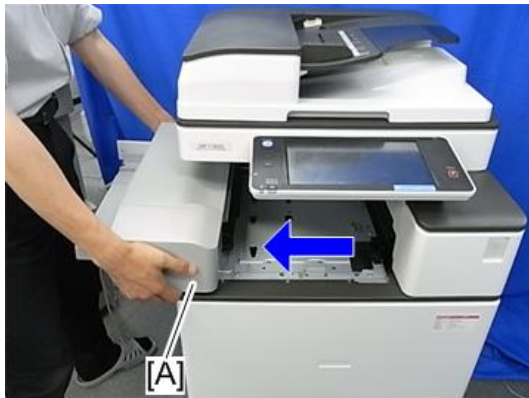

d7662064

1.2 FINISHER FRONT COVER

1. Paper output cover (page 6).
2. Finisher front cover [A] (🔩 x2).

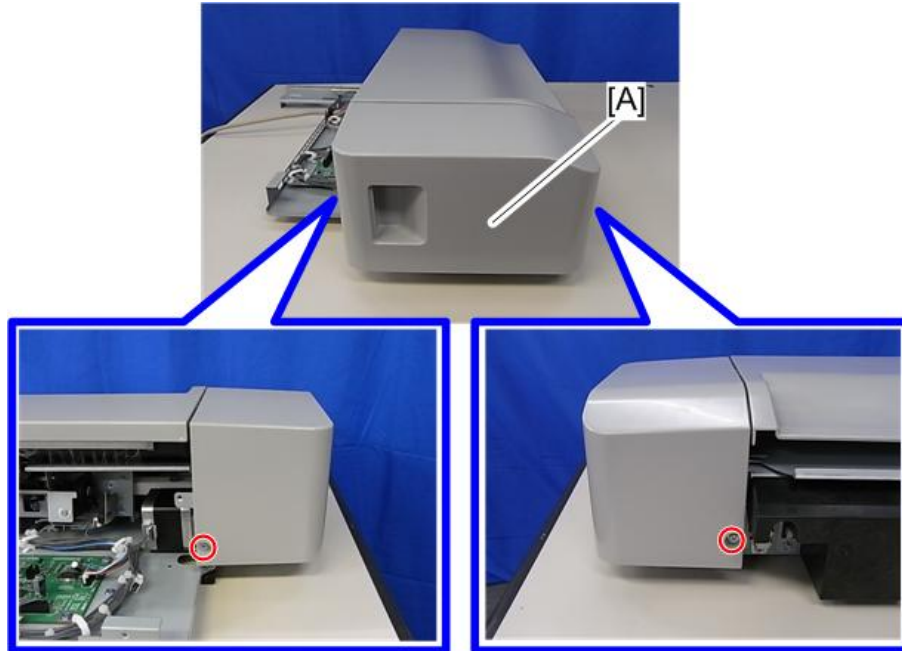

d7662026

1.3 FINISHER UPPER COVER

1. Finisher front cover (page 3).
2. Finisher upper cover [A] (🔑 x1).

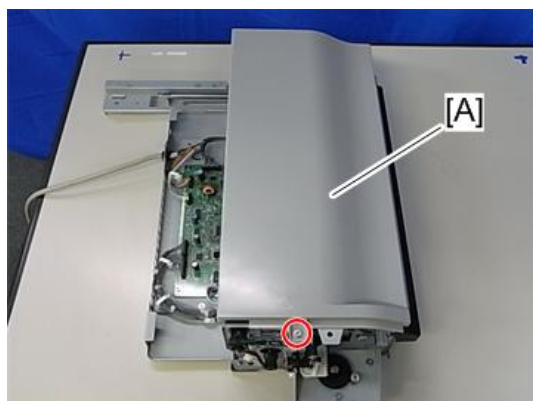

d7662027

1.4 PAPER OUTPUT TRAY

1. Paper output tray [A] (🔑 x2).

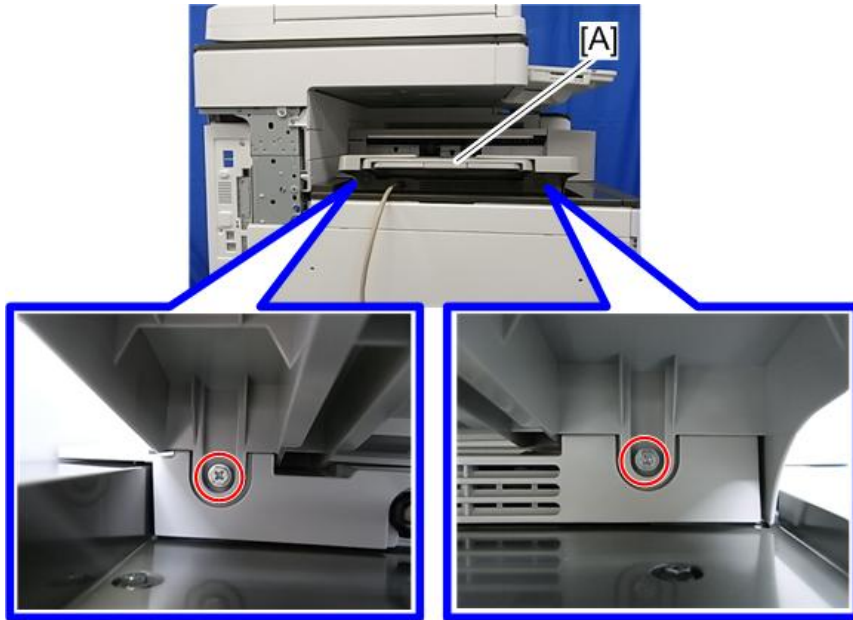

d7662063

1.5 PAPER OUTPUT COVER

1. Internal Finisher (page 1).
2. Paper output cover [A] (🔩 x2).

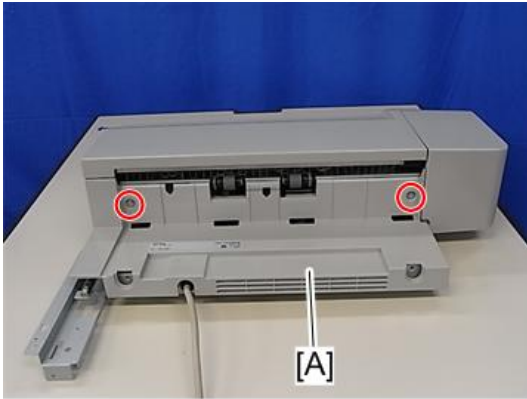

d7662025

1.6 REAR COVER

1. Finisher (page 1).
2. Rear cover [A] (🔑 x2).

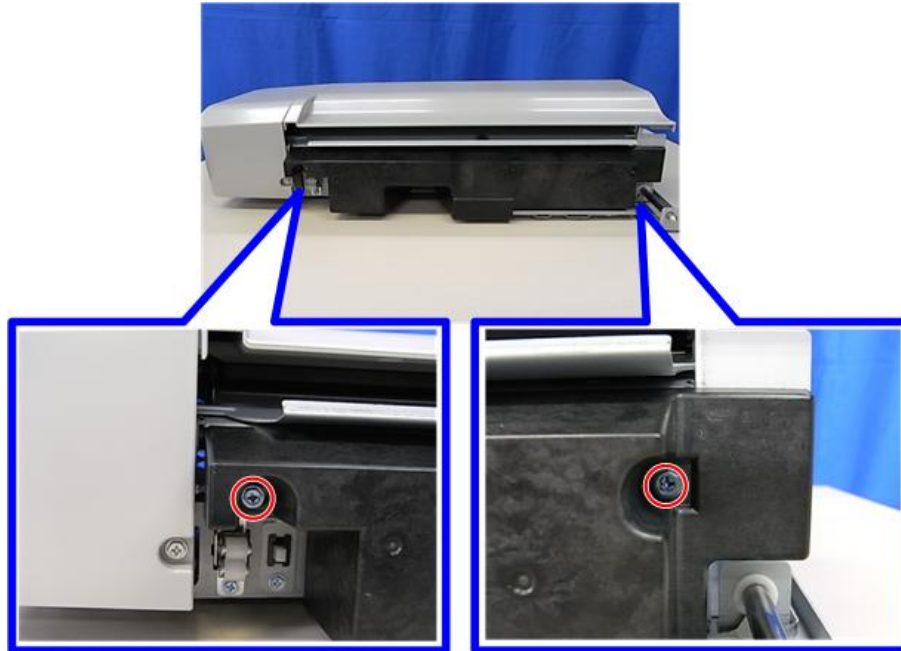

d7662028

↓ Note

- The screw on the right as you face the rear cover [A] is a step screw

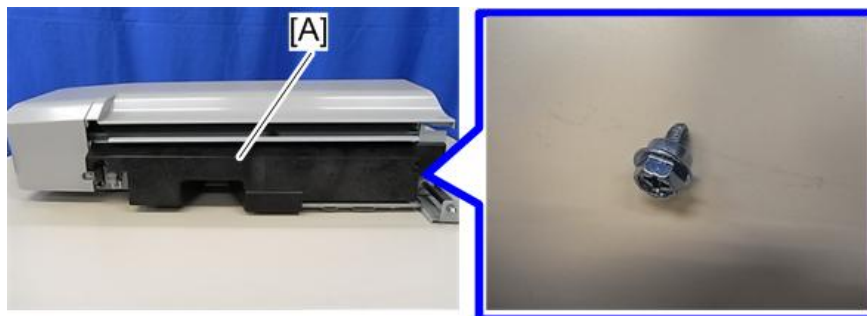

d766z4500

1.7 CONTROL BOARD

1. Paper output cover (page 6).
2. Control board [A] (⚙️ x4, 📡 xall).

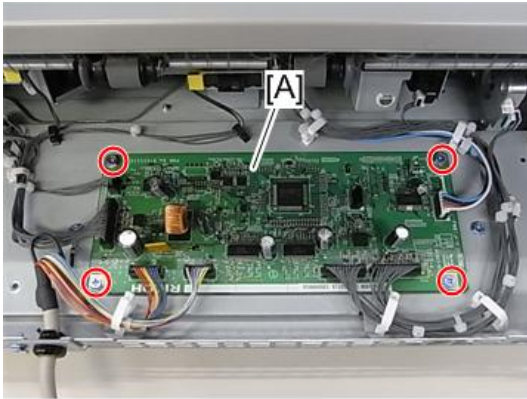

d7662039

1.8 ENTRANCE SENSOR

1. Rear cover (page 7).
2. Remove the entrance sensor [A] together with the bracket (🔩 x1, 🛠️ x1).

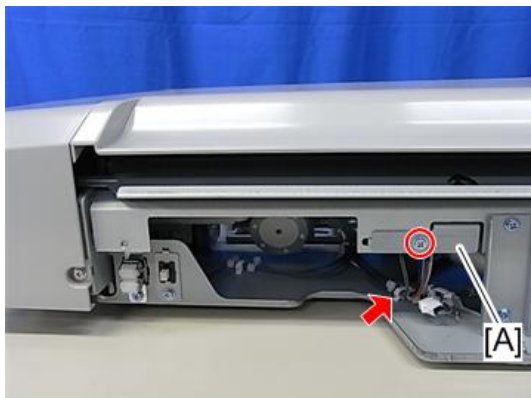

d7662023

3. Entrance sensor [A] (🛠️ x1, 🛠️ x1).

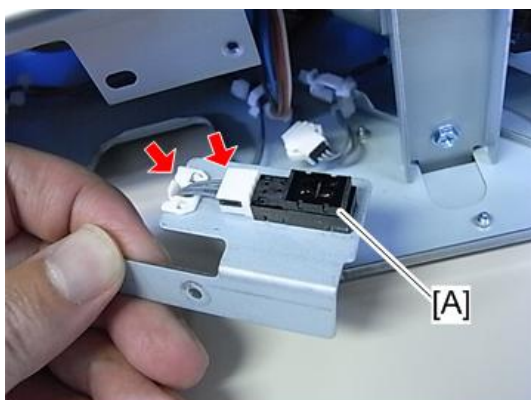

d7662024

1.9 TRANSPORT MOTOR

1. Finisher front cover (page 3).
2. Disconnect the connector attached to the transport motor [A] (🔌 ×1).

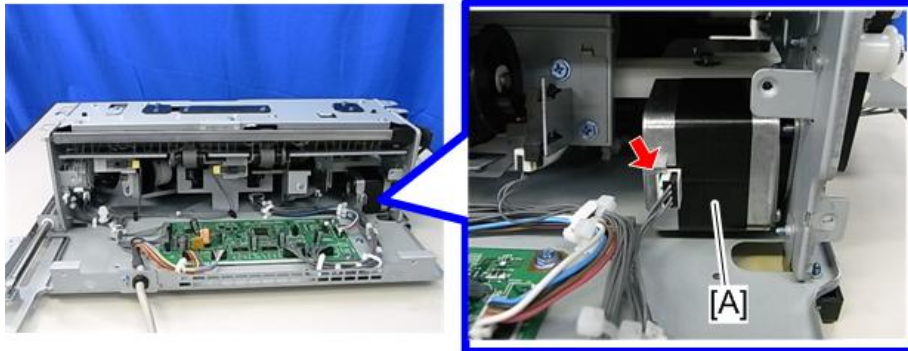

d7662013

3. Loosen the screw securing the spring bracket [A], and then release the belt tension (🔧 ×1).

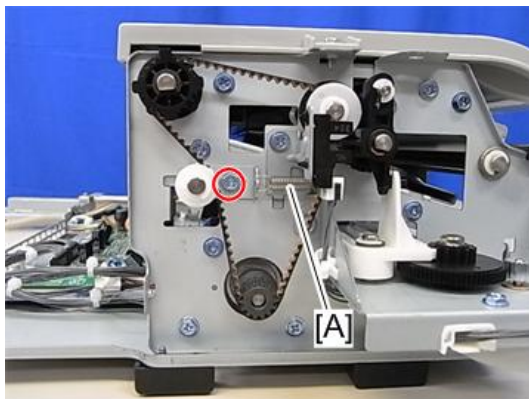

d7662014

4. Transport motor [A] (🔧 ×2).

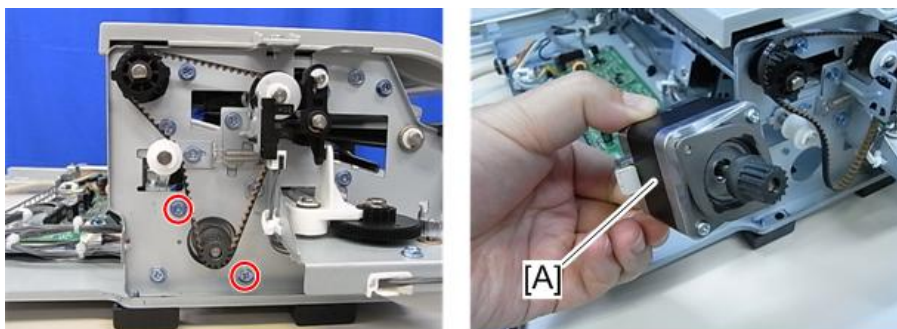

d7662015

1.10 SHIFT MOTOR

1. Finisher front cover (page 3).
2. Shift motor [A] (🔩 x2, 📦 x1, 🛠️ x2).

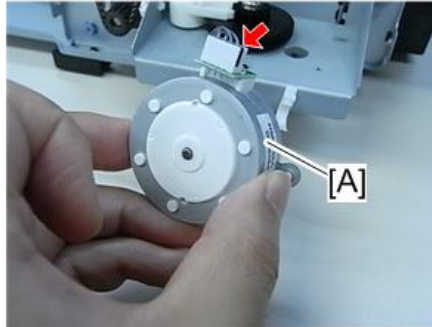
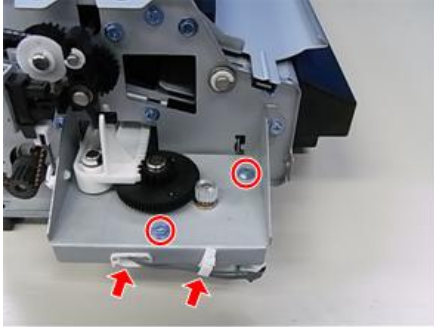

d7662035

1.11 JUNCTION SOLENOID MOTOR

1. Paper output cover (page 6).
2. Release the clamp (🔧x1).



d7662011

3. Junction solenoid motor [A] (🔧x2, 📦x1).

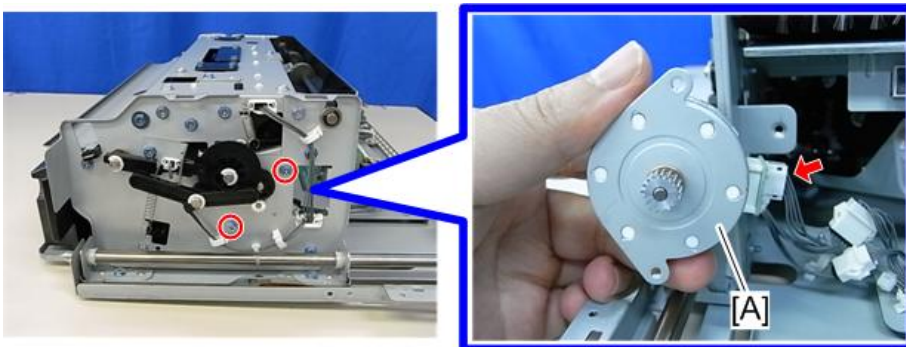

d7662010

1.12 EXIT PAPER PRESSURE MOTOR

1. Paper output cover (page 6).
2. Rear cover (page 7).
3. Release the clamp (🔧x1).



d7662017

4. Remove the screws on the bracket [A] (🔩x2).

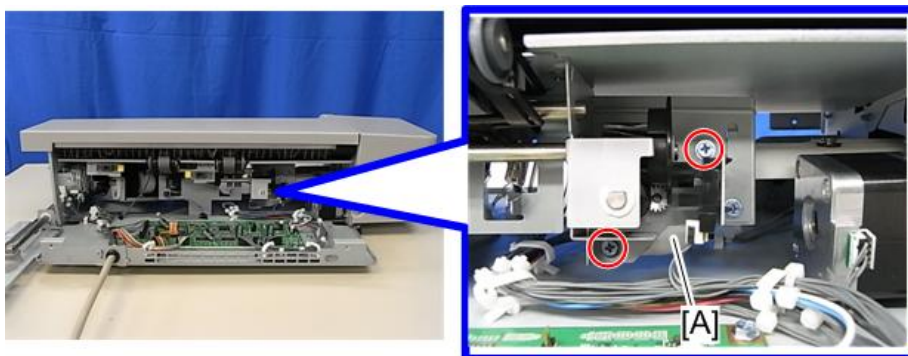

d7662016

5. Exit paper pressure motor [A] (📦x1).

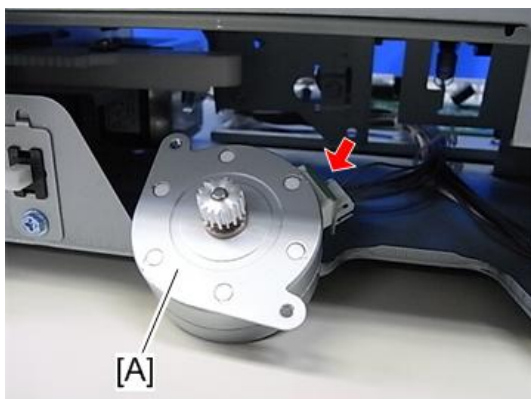

d7662018

1.13 SIDE-TO-SIDE REGISTRATION SENSOR

1. Finisher upper cover (page 4).
2. Remove the screw (🔩 x1).



d7662030

3. Remove the Side-to-Side registration sensor [A] together with the bracket (🔧 x1).

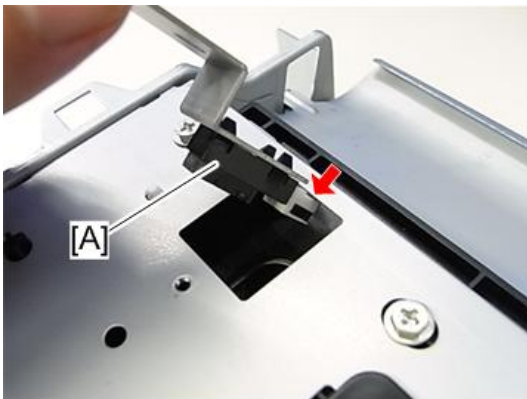

d7662031

4. Side-to-Side registration sensor [A].

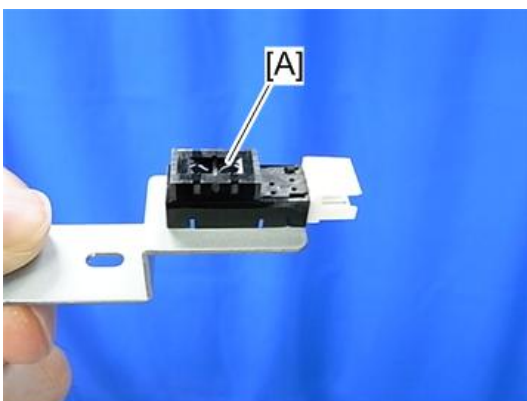

d7662032

1.14 OPEN/CLOSE DOOR SWITCH

1. Rear cover (page 7).
2. Remove the screw (🔩 x1).

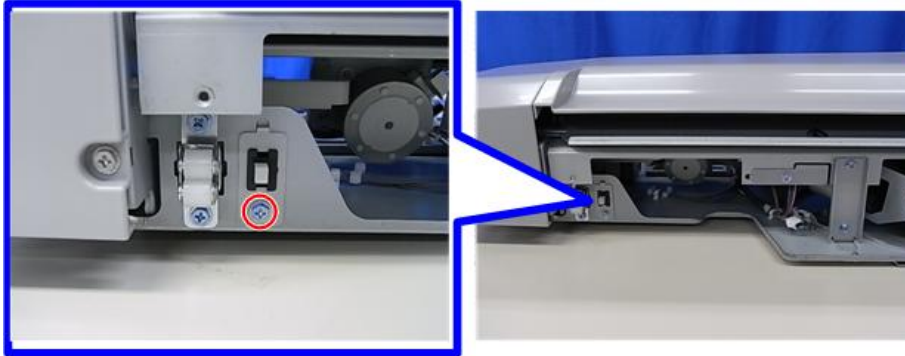

d7662033

3. Open/close door switch [A] (📦 x1).

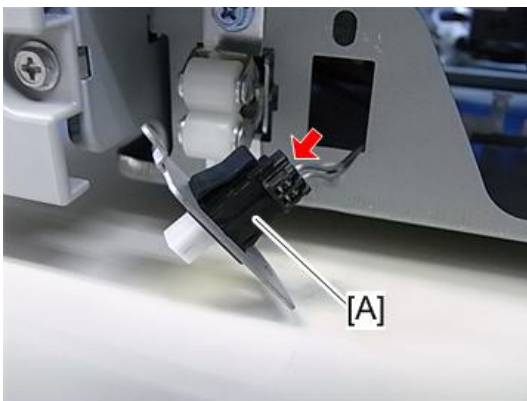

d7662034

1.15 SHIFT HOME POSITION SENSOR

1. Finisher front cover (page 3).
2. Remove the shift home position sensor [A] together with the bracket (⚙️ x1, 🛠️ x1).

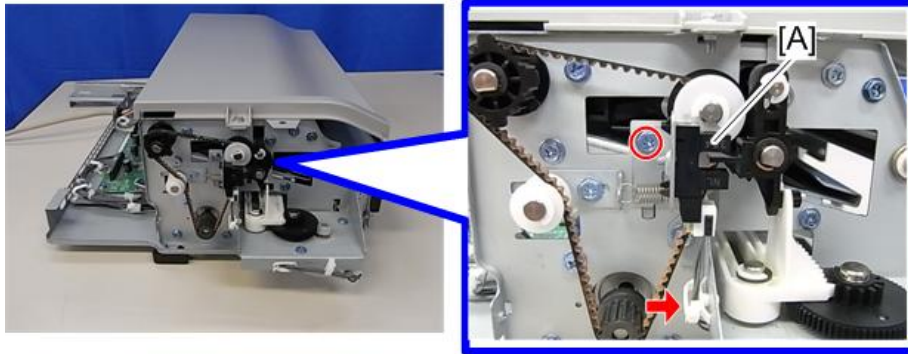

d7662037

3. Shift home position sensor [A] (📦 x1).

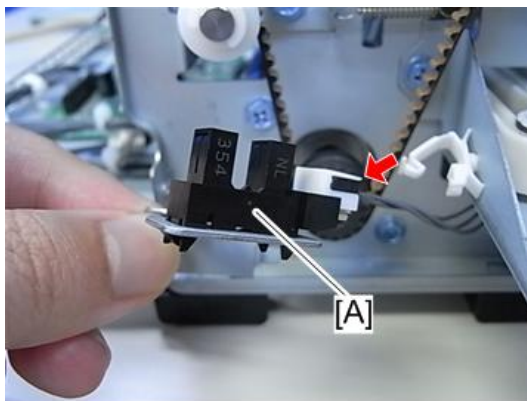

d7662038

1.16 PAPER OUTPUT SENSOR

1. Finisher upper cover (page 4).
2. Remove the screw (🔩 x1).

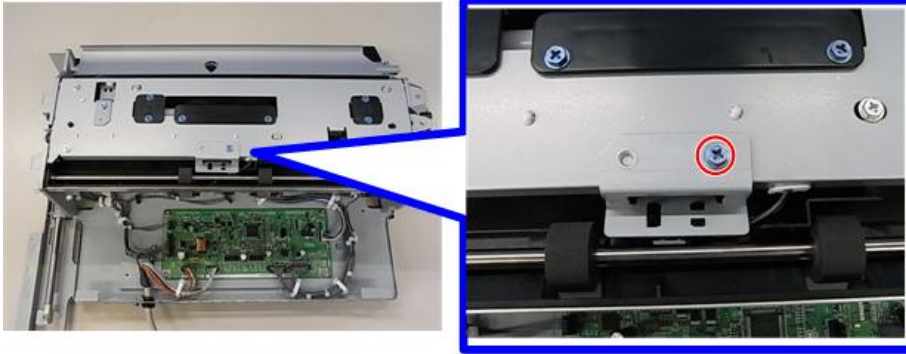

d7662021

3. Paper output sensor [A] (📦 x1).

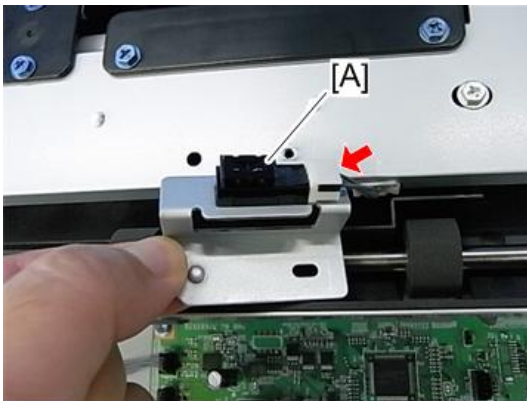

d7662022

1.17 PAPER OUTPUT PRESSURE HP SENSOR

1. Paper output cover (page 6).
2. Remove the screw and release the clamp (🔩 x1, 🗑️ x1).



d7662019

3. Paper output pressure HP sensor [A] (📦 x1).

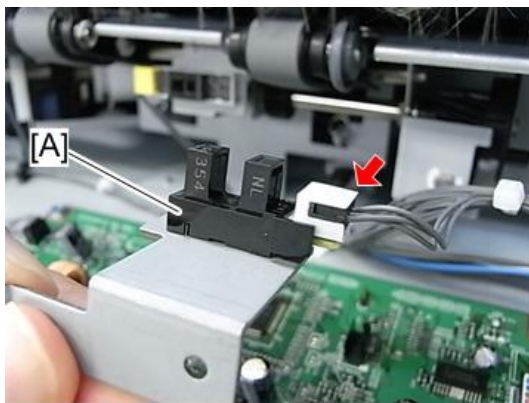

d7662020

1.18 JUNCTION SOLENOID MOTOR HP SENSOR

- 1. Remove the screw (🔩 x1).

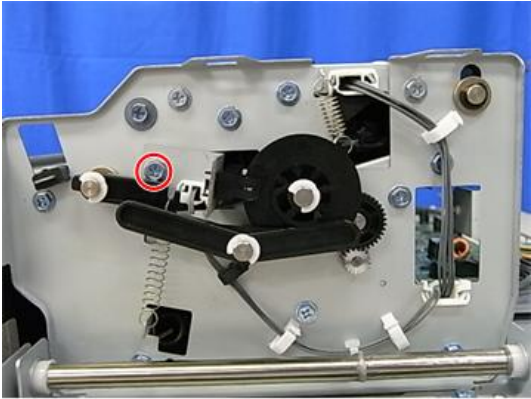

d7662008

- 2. Junction solenoid motor HP sensor [A] (📦 x1, 🛠️ x1)

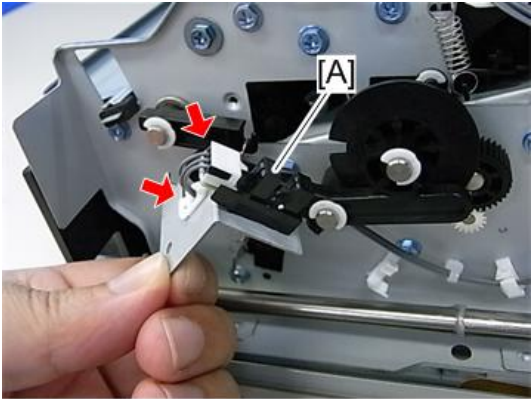

d7662009

1.19 PAPER OUTPUT FULL SENSOR 1 / PAPER OUTPUT FULL SENSOR 2 (STAPLE)

1. Paper output cover (page 6).
2. Paper output full sensor 1 [A], paper output full sensor 2 [B] (🔌 x1, 🛠️ x1, for each).

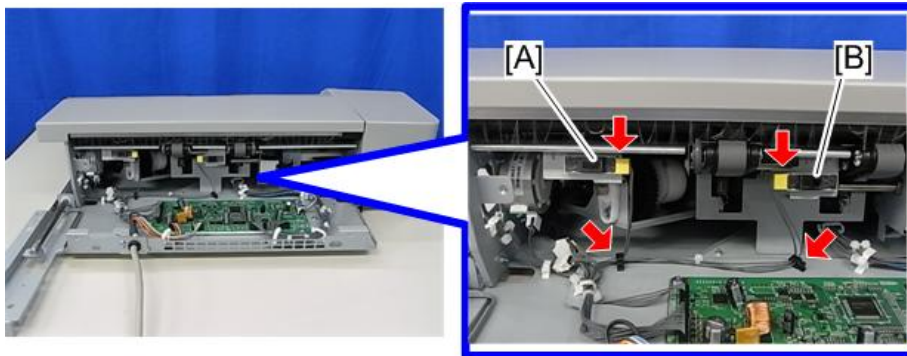

d7662007

1.20 STAPLER UNIT

1. Rear cover (page 7).
2. Disconnect the connector and release the clamps (🔌 x1, 🗉 x2).



d7662000

3. Turn the finisher [A] over.

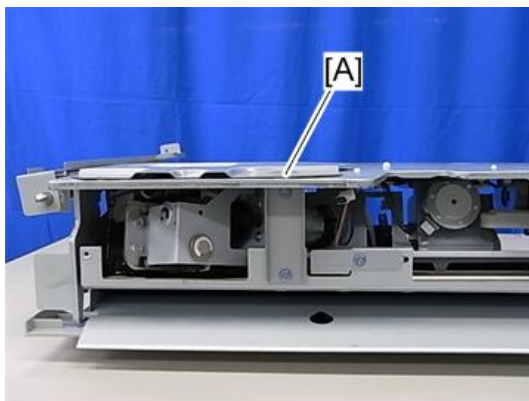

d7662001

4. Remove the screws securing the stapler unit [A] (🔩 x5).

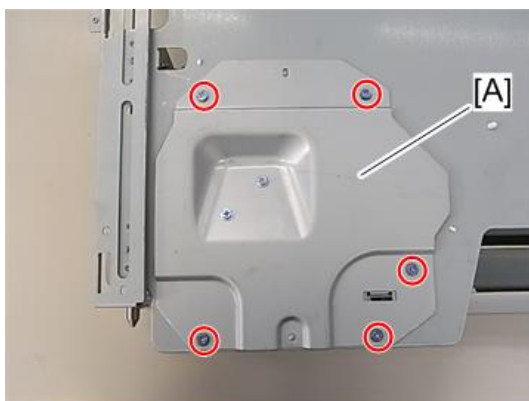

d7662002

5. Stapler unit [A] (🗉 x1).

Stapler Unit

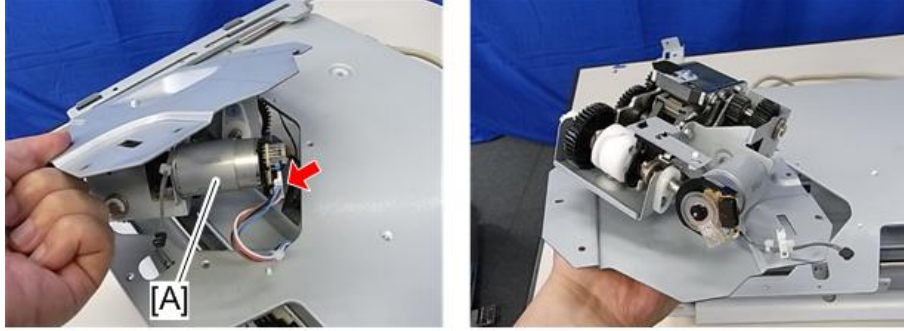

d7662003

6. Bracket [A] from the Stapler unit (🔩 x2).

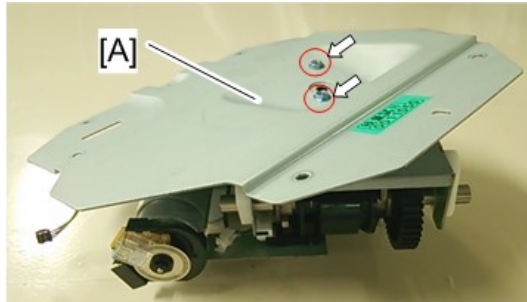

d766e0001

1.21 STAPLER DRIVE HP SENSOR

1. Stapler unit (page 21).
2. Loosen the screw and release the clamp (🔩x1, 🛠️x1).

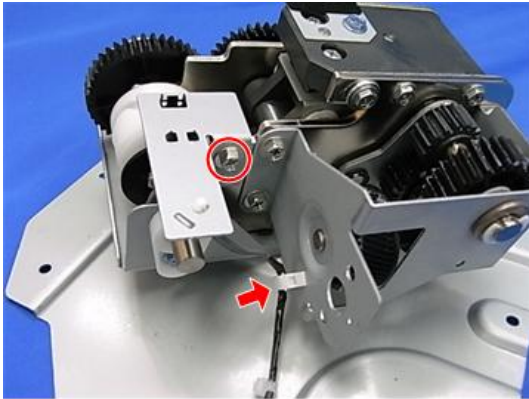

d7662005

3. Stapler drive HP sensor [A] from the bracket (🔩x1, 🛠️x1).

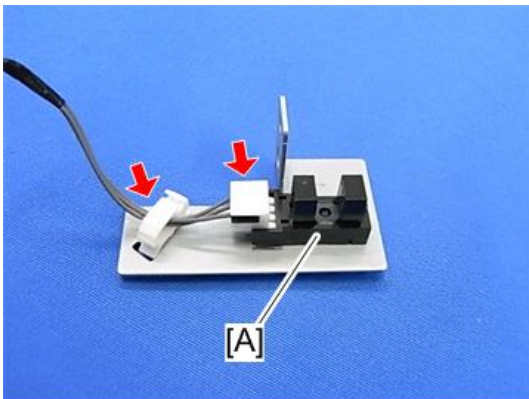

d7662006

1.22 STAPLER MOTOR

1. Stapler unit (page 21).
2. Stapler drive HP sensor (page 23).
3. Stapler motor [A] (🔑 x2).

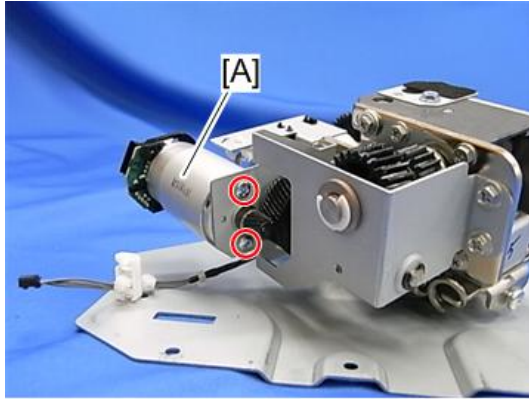

d7662004

D779

ARDF DF3090

REVISION HISTORY		
Page	Date	Added/Updated/New
		None

ARDF DF3090 (D779)





TABLE OF CONTENTS

1. REPLACEMENT AND ADJUSTMENT	1
1.1 COVERS AND ORIGINAL TRAY	1
1.1.1 DF REPLACEMENT	1
1.1.2 REAR COVER	2
1.1.3 FRONT COVER AND ORIGINAL TRAY	3
1.2 ORIGINAL FEED UNIT	4
1.3 PICK-UP ROLLER	5
1.4 FEED BELT	6
1.5 SEPARATION ROLLER	7
1.6 ARDF DRIVE BOARD AND DF POSITION SENSOR	8
1.7 ORIGINAL LENGTH SENSORS AND ORIGINAL SENSOR	9
1.8 ORIGINAL SET SENSOR	10
1.9 ORIGINAL SIZE SENSORS AND SKEW CORRECTION SENSOR	12
1.10 STAMP SOLENOID	13
1.11 ORIGINAL EXIT SENSOR	15
1.12 REGISTRATION SENSOR	16
1.13 LEFT COVER SWITCH	17
1.14 FEED MOTOR	18
1.15 PICK-UP SOLENOID	20
1.16 INVERTER SOLENOID	21
1.17 FEED CLUTCH	22
1.18 TRANSPORT MOTOR	23

READ THIS FIRST

Safety and Symbols

This manual uses several symbols and abbreviations. The meaning of those symbols and abbreviations are as follows:

	Clip ring
	Screw
	Connector
	Clamp
SEF	Short Edge Feed
LEF	Long Edge Feed

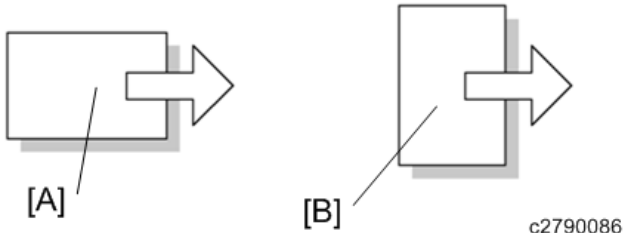

[A] Short Edge Feed (SEF)

[B] Long Edge Feed (LEF)

Trademarks

Microsoft[®], Windows[®], and MS-DOS[®] are registered trademarks of Microsoft Corporation in the United States and /or other countries.

PostScript[®] is a registered trademark of Adobe Systems, Incorporated.

PCL[®] is a registered trademark of Hewlett-Packard Company.

Ethernet[®] is a registered trademark of Xerox Corporation.

PowerPC[®] is a registered trademark of International Business Machines Corporation.

Other product names used herein are for identification purposes only and may be trademarks of their respective companies. We disclaim any and all rights involved with those marks.

1. REPLACEMENT AND ADJUSTMENT

1.1 COVERS AND ORIGINAL TRAY

1.1.1 DF REPLACEMENT

1. Scanner rear cover [A] (🔩 x3).



d197z0182

2. The screw on harness securing bracket, and then the connector and screw on the earth plate (🔩 x2, 📦 x1).

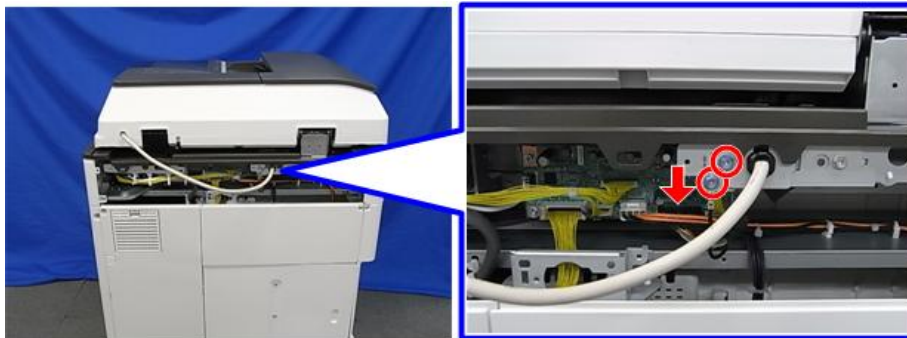

d197z0183

3. Open the DF and remove the screws (🔩 x2).

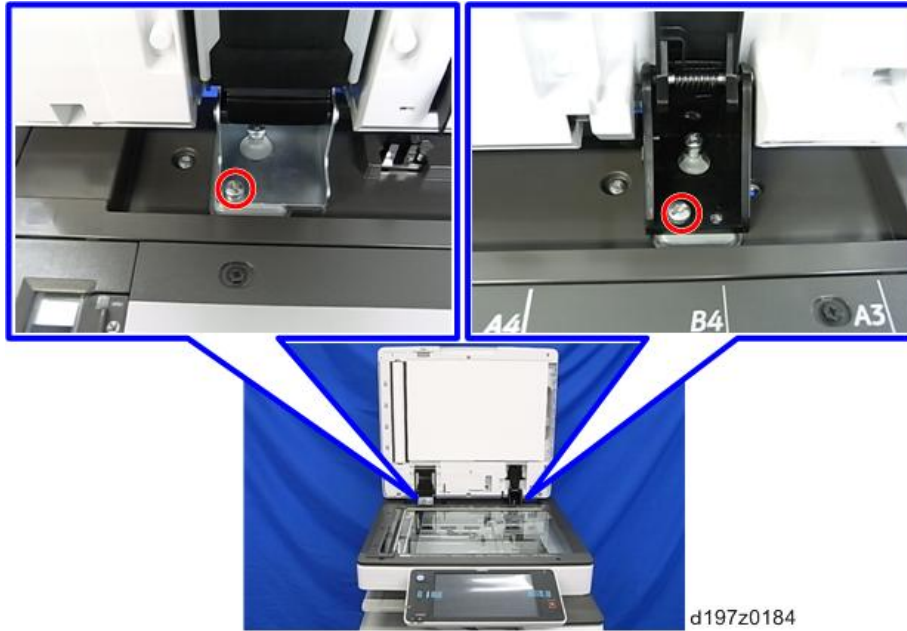

4. Detach the DF while holding the both ends.

Note

- Since DF is heavy, be very careful when you detach it.

1.1.2 REAR COVER

1. Open the left cover [A].
2. Open the original tray [B].
3. Rear cover [C] (⌀ x1, hook x5).

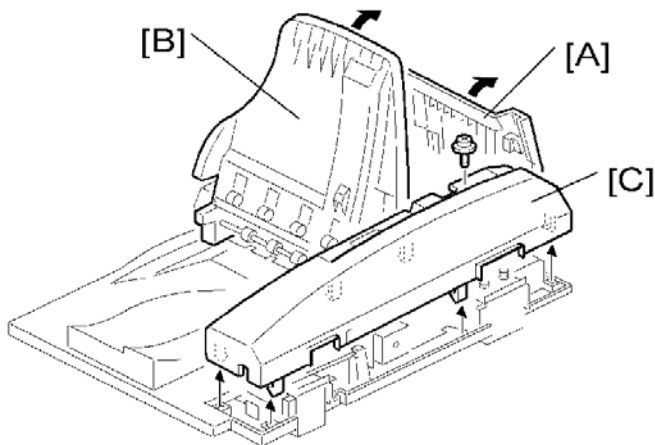

1.1.3 FRONT COVER AND ORIGINAL TRAY

1. Open the left cover.
2. Rear cover (page 2).
3. Front cover [A] (🔩x1).

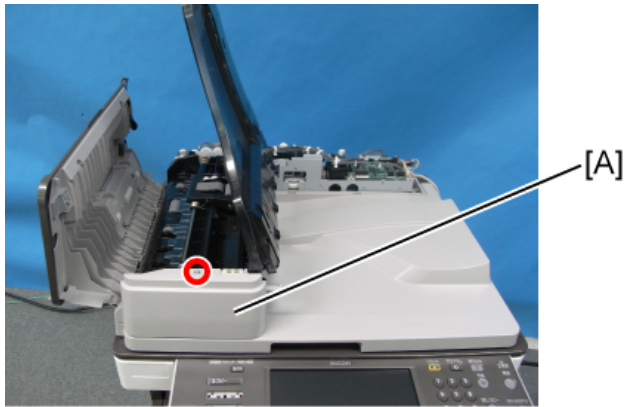

d578r500

⬇️ Note

- Keep the original tray open when you remove the front cover.

4. Original tray [A] (🔩x1, 📦x1, 🛠️x1).

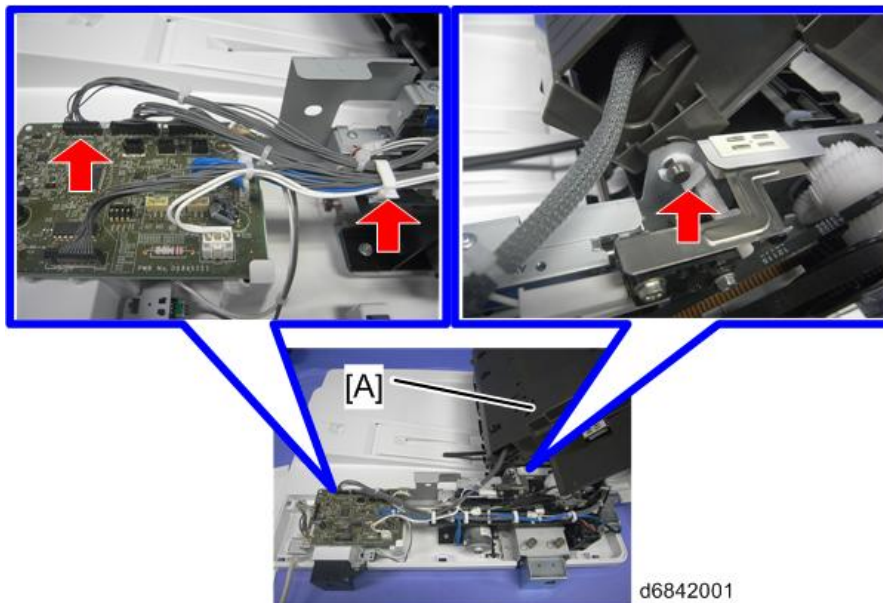

d6842001

1.2 ORIGINAL FEED UNIT

1. Open the left cover.
2. Original feed unit [A].



d578r502

ⓘ Note

- Pull the original feed unit forward to release the back side of the shaft.

1.3 PICK-UP ROLLER

1. Original feed unit (page 4)
2. Pick-up roller [A] (R_x1)

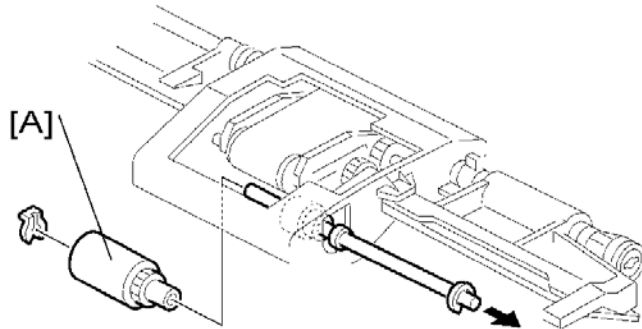

ARDF DF3090
(D779)

1.4 FEED BELT

1. Original feed unit (page 4).
2. Feed belt cover [A] (spring×1).

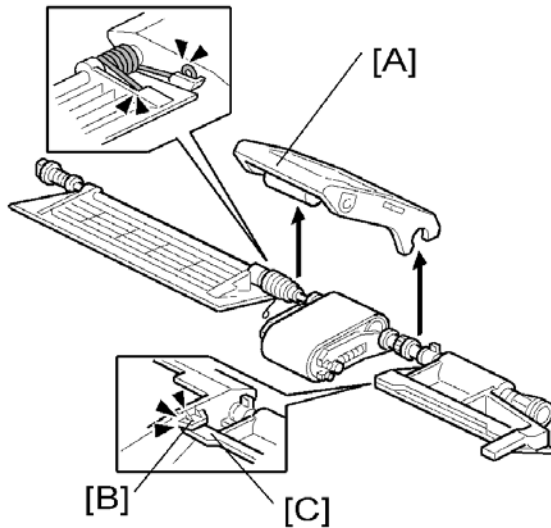

↓ Note

- When reassembling the feed belt cover, make sure that the projection [B] of the feed belt cover is on the guide plate rear [C].

3. Belt tension unit [D]

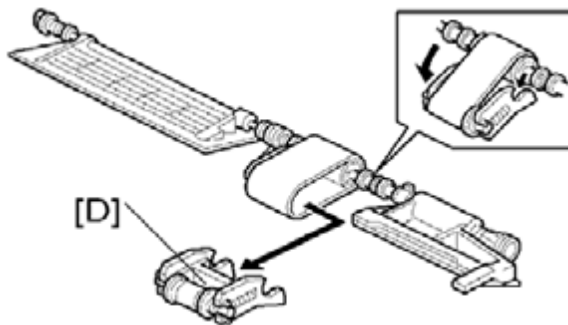

4. Feed belt [E].

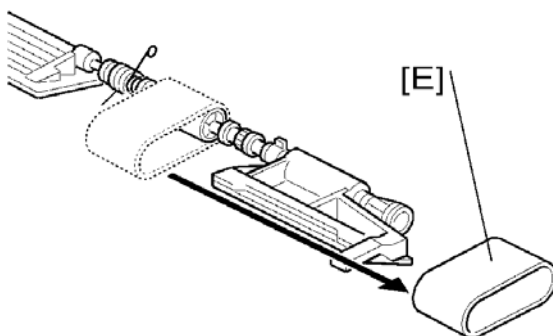

1.5 SEPARATION ROLLER

1. Original Feed Unit (page 4).
2. Separation roller cover [A].

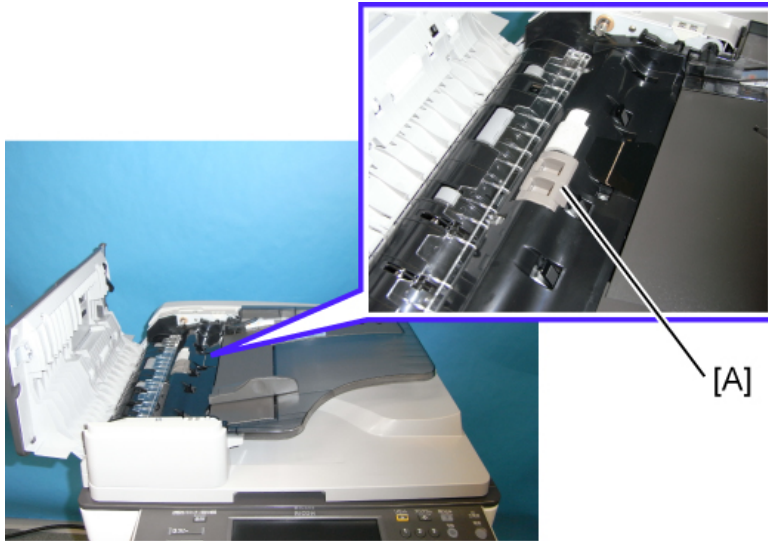

d578r503

3. Separation roller [A] (⌀x1)

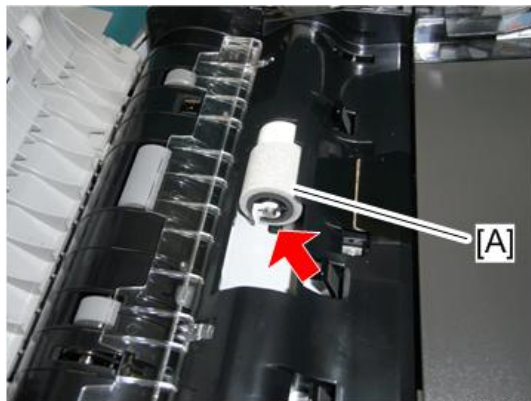

d578r504

1.6 ARDF DRIVE BOARD AND DF POSITION SENSOR

1. Rear cover (page 2).
2. ARDF drive board [A] (🔩 x2, 📦 x7).

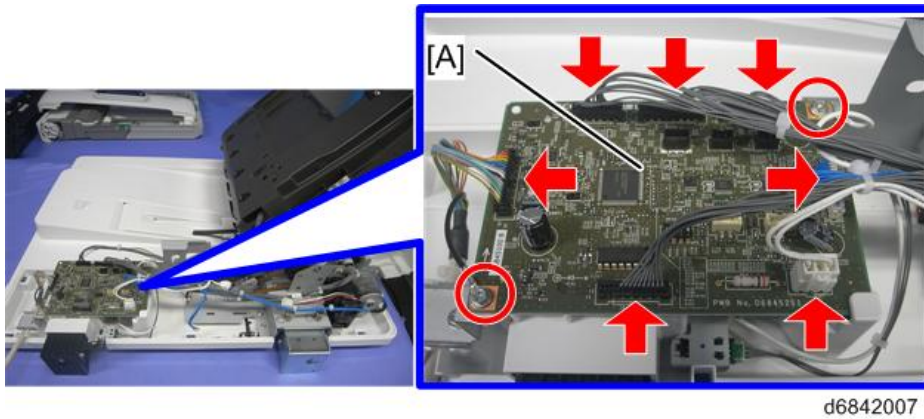

3. DF position sensor with bracket [A] (🔩 x1).

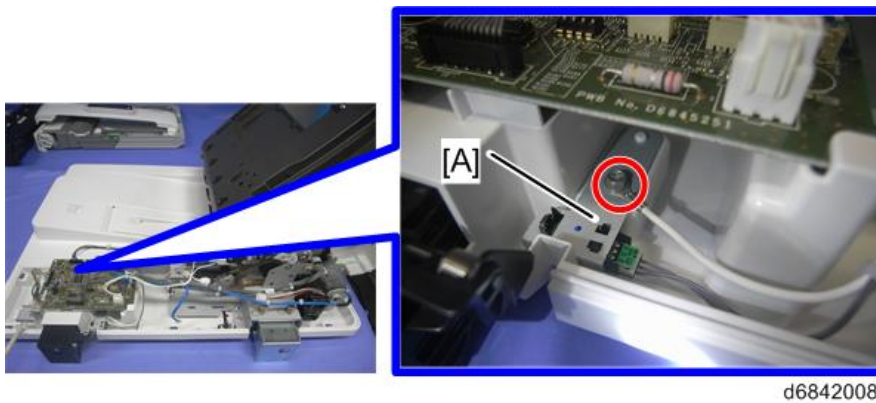

4. DF position sensor [A] (📦 x1).

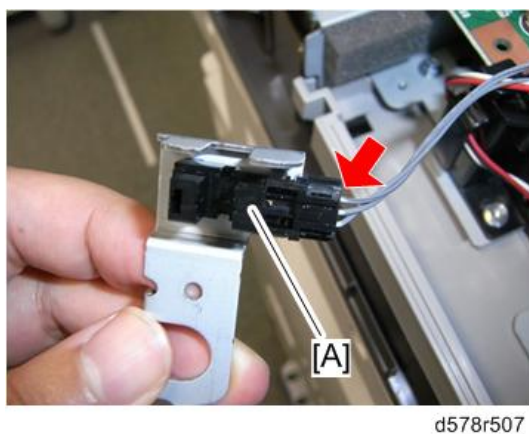

1.7 ORIGINAL LENGTH SENSORS AND ORIGINAL SENSOR

1. Original Tray (page 3).
2. Tray cover [A] (🔩 x3).



d6842009

3. Original sensor [A] (🔧 x1).
4. Original length sensors [B] (🔧 x1 each).

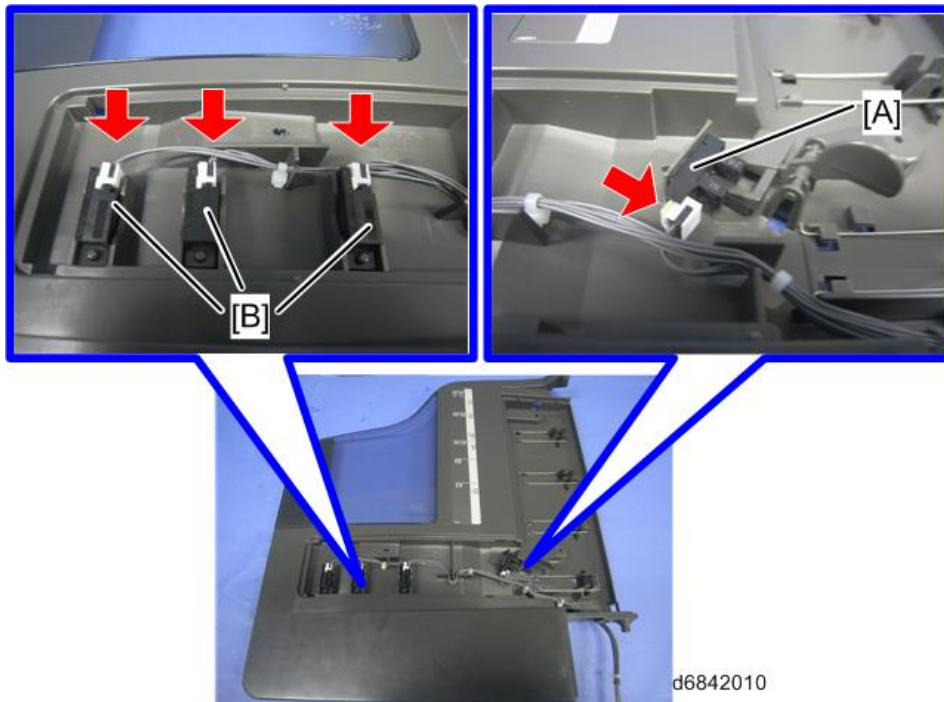

d6842010

1.8 ORIGINAL SET SENSOR

1. Original feed unit (page 4).
2. Original tray (page 3).
3. Original feed-in guide plate [A] (⌀ ×3).

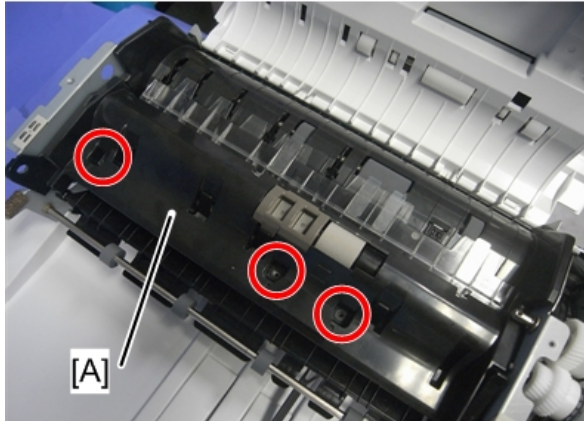

d6842012

4. Feed guide [A].

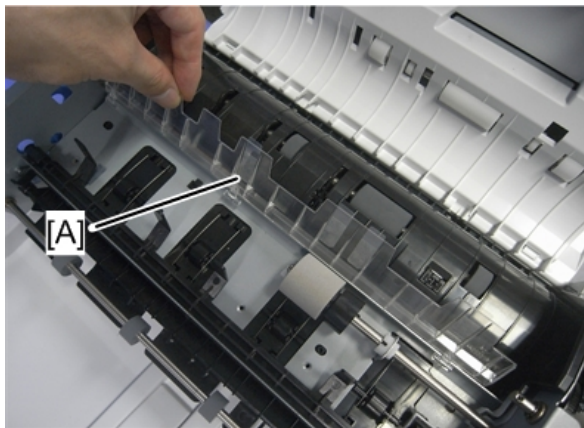

d6842013

5. Original turn guide plate [A] (hook ×2).



d6842014

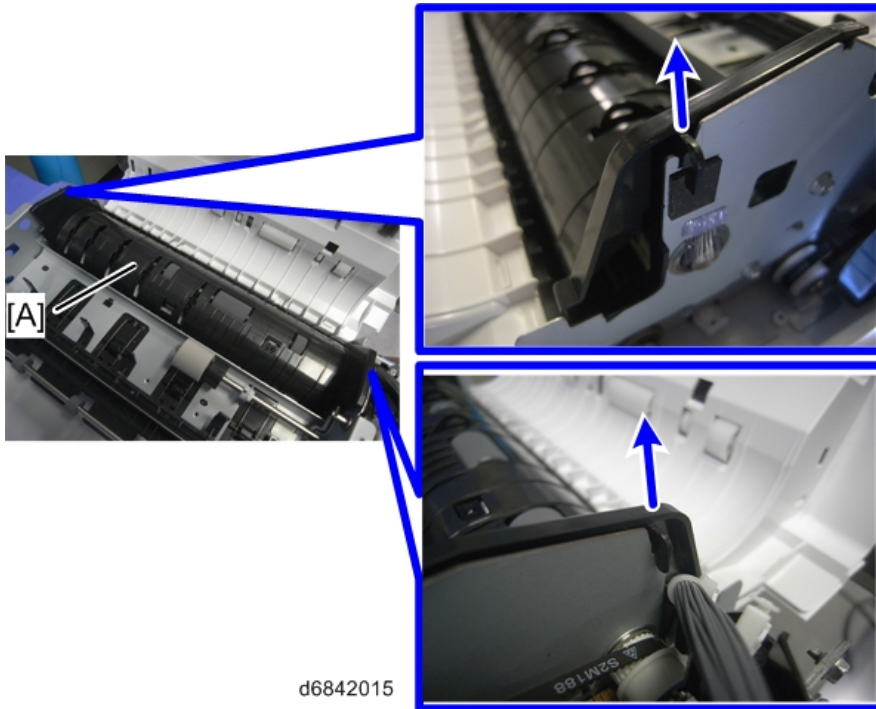

6. Original set sensor bracket [A] (hook x2).

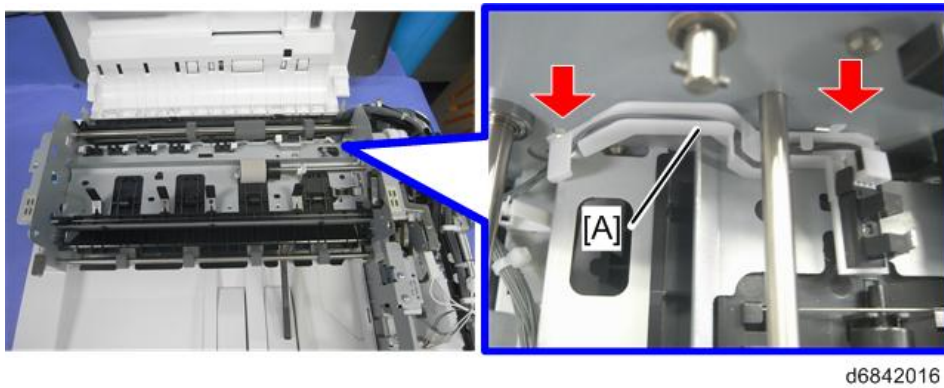

7. Original set sensor [A] (📦 x1).

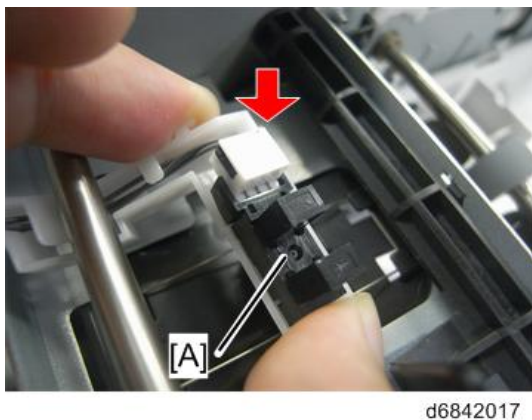

1.9 ORIGINAL SIZE SENSORS AND SKEW CORRECTION SENSOR

SENSOR

1. Original turn guide plate (page 10).
2. Original width sensors [A] (📦 x1 each) and skew correction sensor [B] with bracket (🔩 x1, 📦 x1).

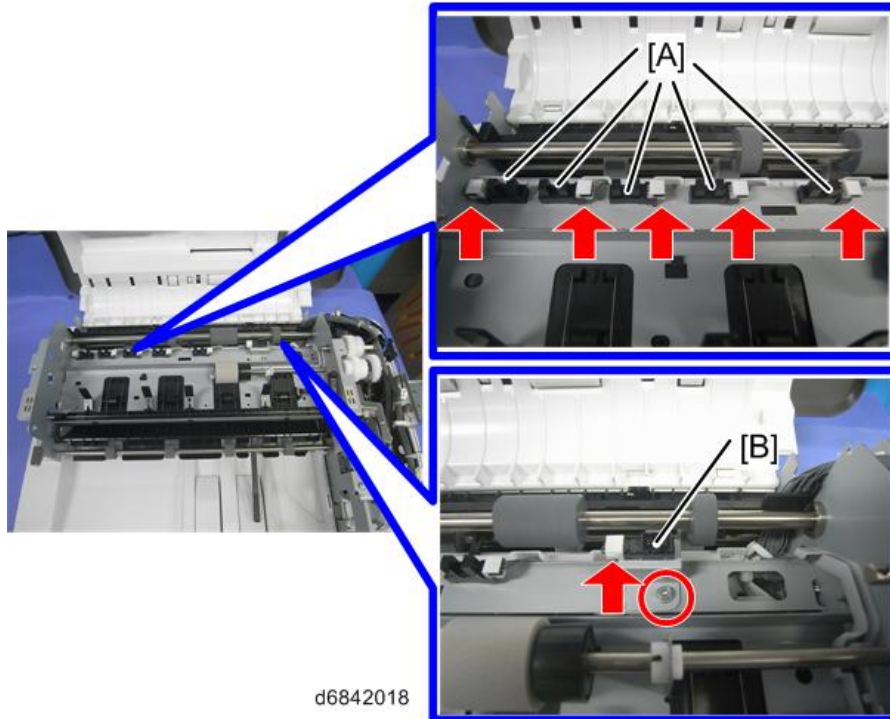

1.10 STAMP SOLENOID

1. Rear cover (page 2).
2. Stamp solenoid harness [A] (🔌 x1, 🛠️ x1).

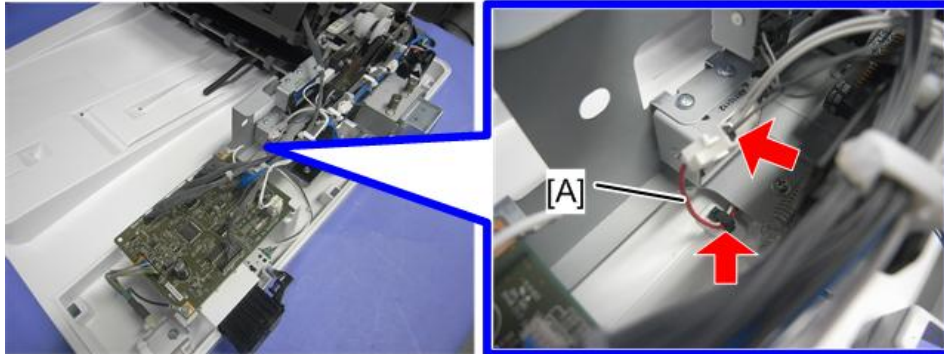

d6842023

3. Open the DF.
4. Remove the platen sheet [A].

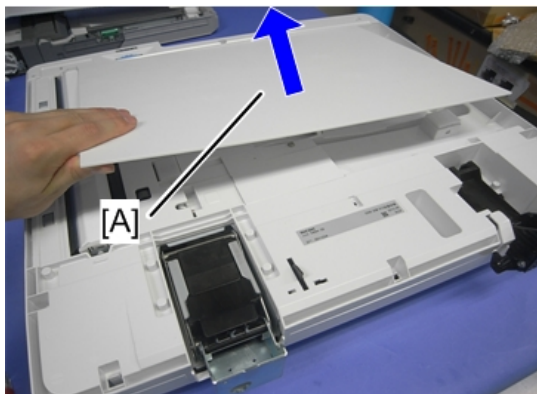

d6842020

5. Stamp solenoid cover [A] (🔩 x1).

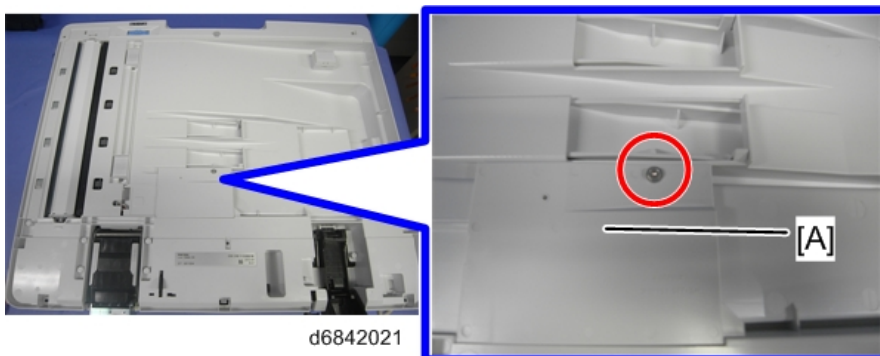

d6842021

6. Stamp solenoid [A] (🔩 x1).

Stamp Solenoid

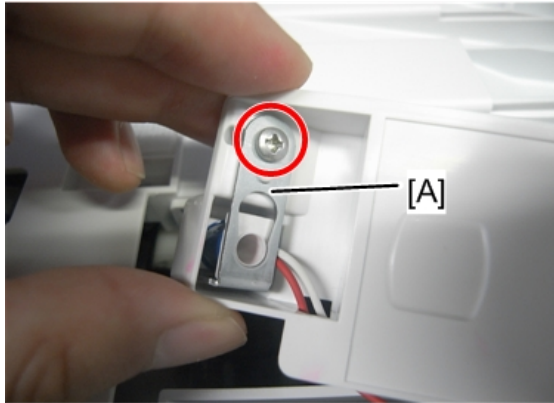

d6842022

7. Pull out the harness [A].

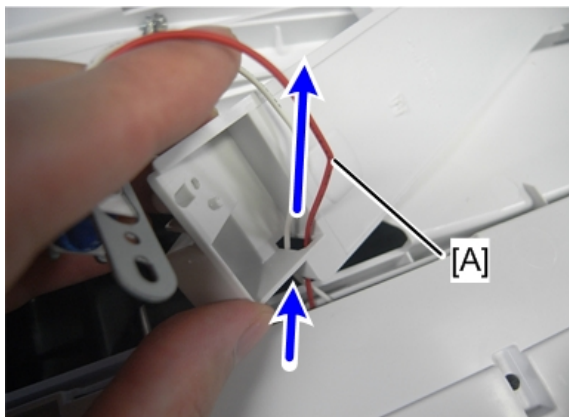

d6842030

1.11 ORIGINAL EXIT SENSOR

- 1. Original feed-in guide plate (page 10).
- 2. The Original Exit Sensor [A] is located in the ARDF mainframe.

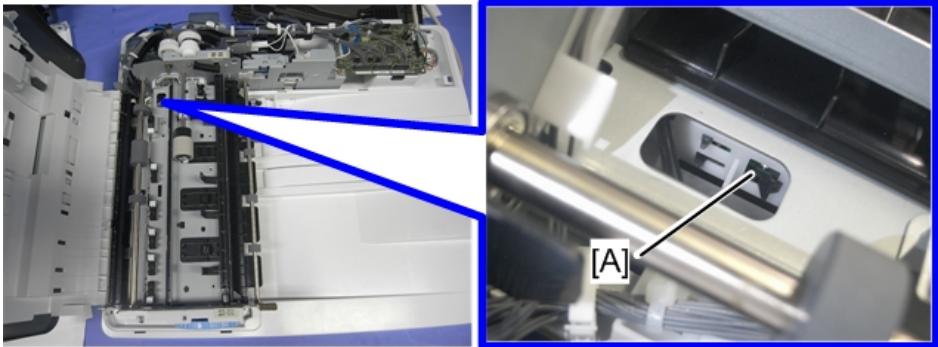

d6842026

- 3. Original exit sensor bracket [A] (🔧x1).

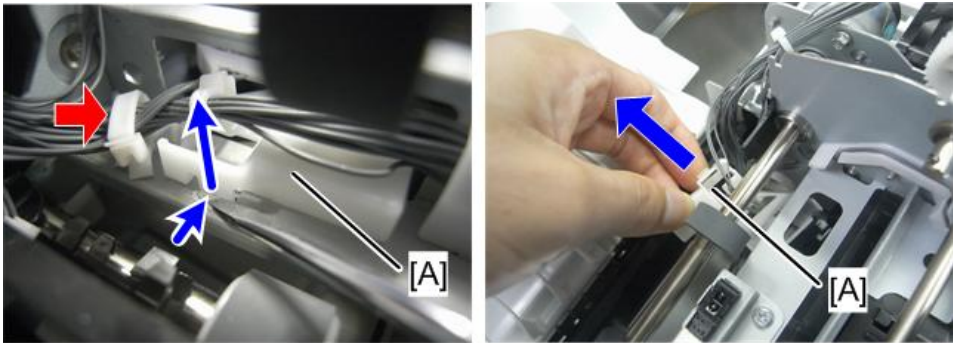

d6842027

- 4. Original exit sensor [A] (🔧 x1).

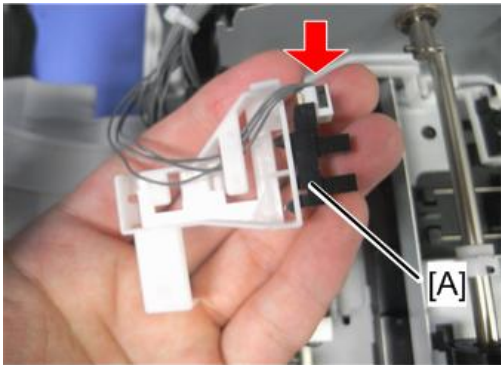

d6842028

1.12 REGISTRATION SENSOR

1. Original feed-in guide plate (page 10).
2. Registration sensor [A] (📦 x1).

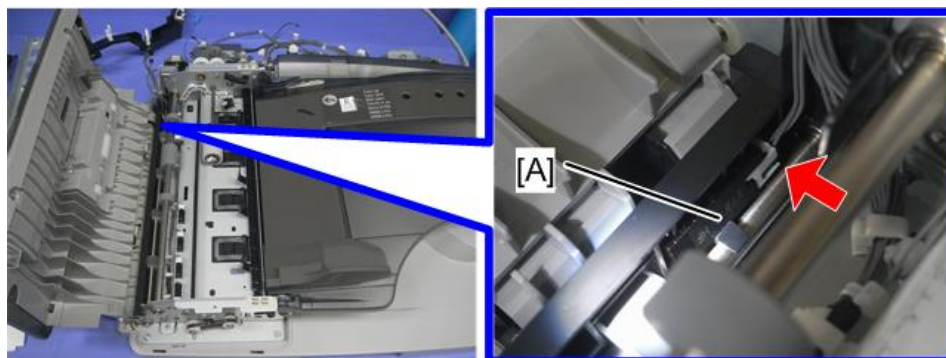

d7242002

1.13 LEFT COVER SWITCH

1. Rear cover (page 2).
2. Left cover switch [A] (🔩 x2, 📡 x2).

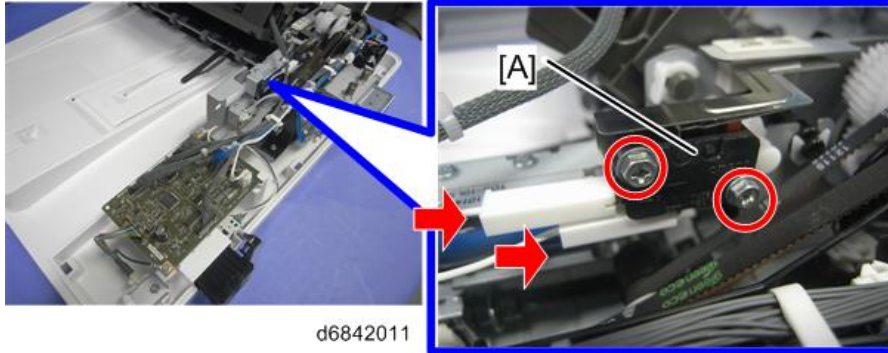

ARDF DF3090
(D779)

1.14 FEED MOTOR

1. Rear cover (page 2).
2. Feed motor harness [A] (🔌 x1).

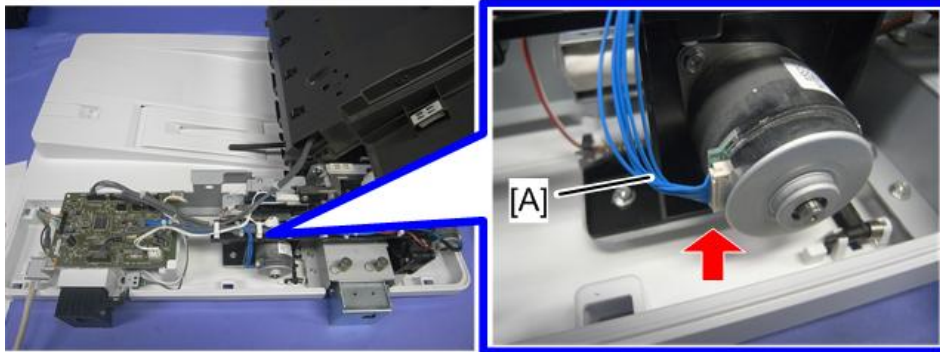

d6842003

3. Harness guide [A] (🔌 x5).

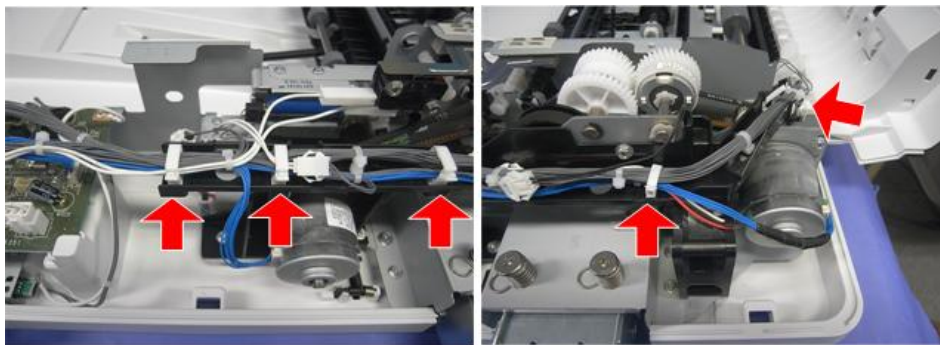

d6842002

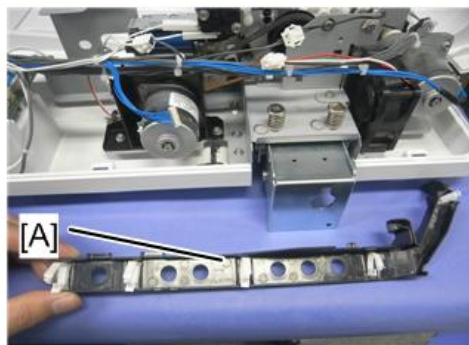

4. Feed motor with bracket [A] (🔌 x2, spring [B] x1, Timing belt x1).

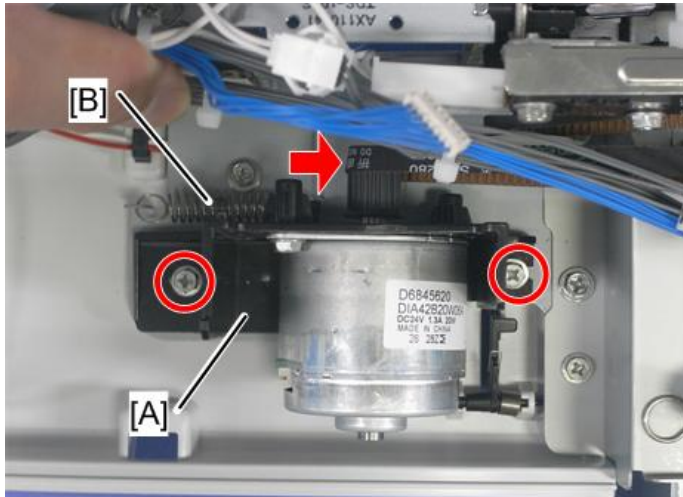

d6842004

5. Feed motor [A] (🔩 x2).

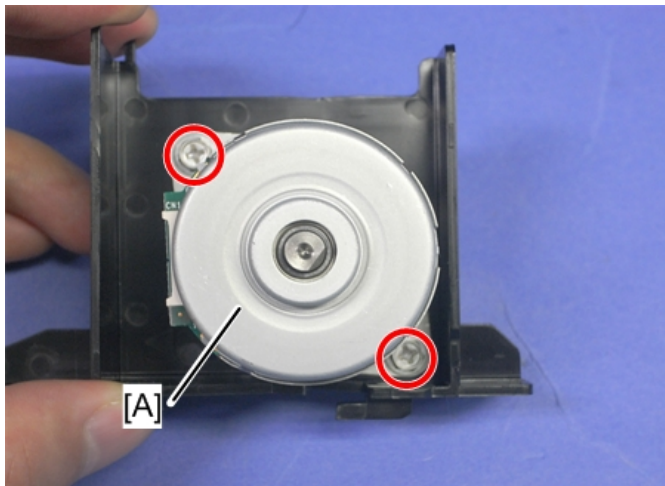

d6842005

1.15 PICK-UP SOLENOID

1. Rear cover (page 2).
2. Harness guide (page 18).
3. Pick-up solenoid [B] (⊙ x2, ⊞ x1).

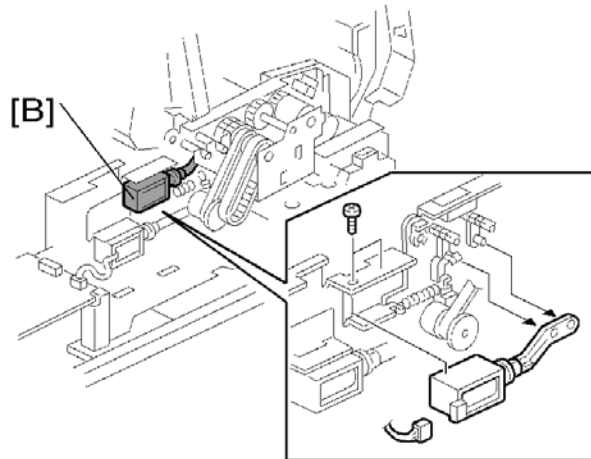

1.16 INVERTER SOLENOID

1. Rear cover (page 2).
2. Harness guide (page 18).
3. Inverter solenoid [A] (⚙️ x2, 📦 x1, 🌀 x1, gear x1, gear cover x1, Timing belt x1).

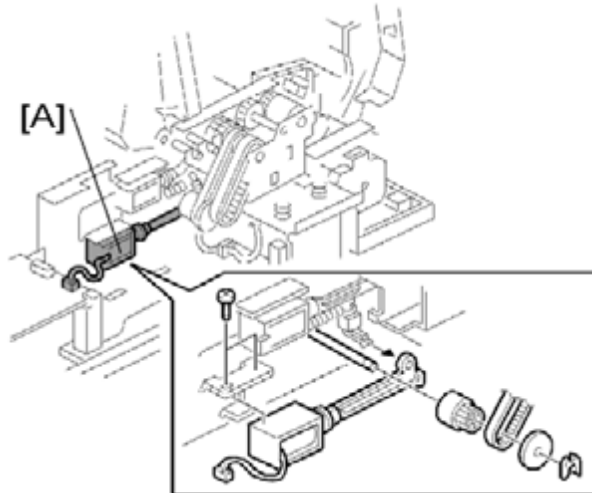

1.17 FEED CLUTCH

1. Rear cover (page 2).
2. Original feed unit (page 4).
3. Feed clutch [A] (⚙️ x2, bushing x1, shaft x1, 📦 x1, 🛠️ x1).

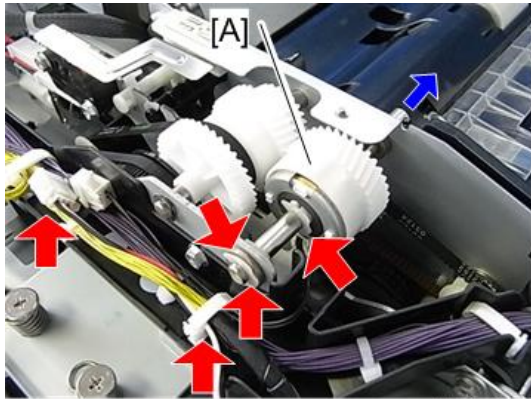

d146z0030

1.18 TRANSPORT MOTOR

- 1. Rear cover (page 2).
- 2. Transport motor bracket [A] (spring x1,  x2,  x1).

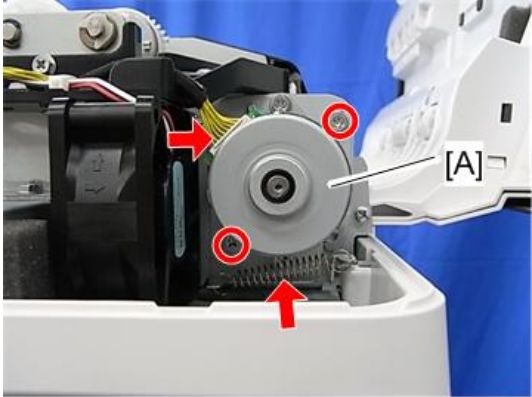

d146z0031

- 3. Transport motor [A] ( x2).

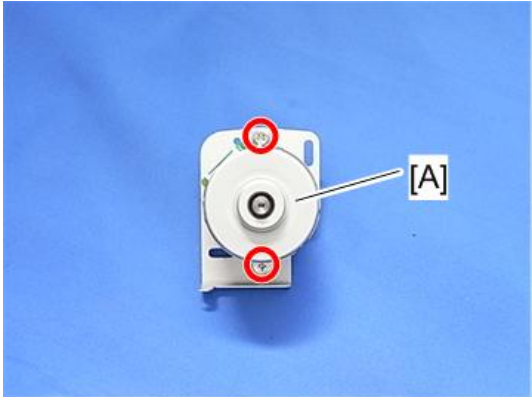

d146z0032

D787

PAPER FEED UNIT PB3220 / PB3210

REVISION HISTORY		
Page	Date	Added/Updated/New
		None

PAPER FEED UNIT PB3220 / PB3210 (D787)





TABLE OF CONTENTS

1. REPLACEMENT AND ADJUSTMENT	1
1.1 REAR COVER	1
1.2 TRAY LIFT MOTOR (UPPER)	2
1.3 TRAY LIFT MOTOR (LOWER)	3
1.4 TRANSPORT MOTOR.....	4
1.5 PAPER FEED MOTOR.....	5
1.6 CONTROLLER BOARD.....	6
1.7 TRANSPORT SENSOR, LIMIT SENSOR, PAPER END SENSOR, PAPER FEED SENSOR	7
1.8 2ND PAPER FEED UNIT	9
1.9 1ST PAPER FEED UNIT	13
1.10 PICK-UP ROLLER, FEED ROLLER, FRICTION ROLLER	14

READ THIS FIRST

Safety and Symbols

This manual uses several symbols and abbreviations. The meaning of those symbols and abbreviations are as follows:

	Clip ring
	Screw
	Connector
	Clamp
SEF	Short Edge Feed
LEF	Long Edge Feed

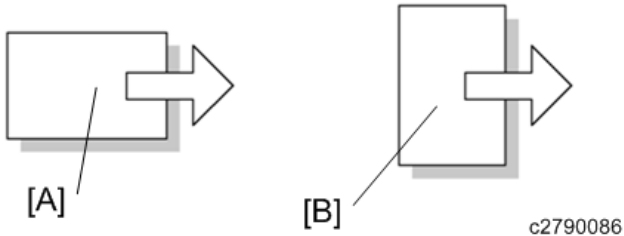

[A] Short Edge Feed (SEF)

[B] Long Edge Feed (LEF)

Trademarks

Microsoft[®], Windows[®], and MS-DOS[®] are registered trademarks of Microsoft Corporation in the United States and /or other countries.

PostScript[®] is a registered trademark of Adobe Systems, Incorporated.

PCL[®] is a registered trademark of Hewlett-Packard Company.

Ethernet[®] is a registered trademark of Xerox Corporation.

PowerPC[®] is a registered trademark of International Business Machines Corporation.

Other product names used herein are for identification purposes only and may be trademarks of their respective companies. We disclaim any and all rights involved with those marks.

The Aim of Anti-tip Components and Precautions

The anti-tip components are necessary for meeting the requirements of IEC60950-1, the international standard for safety.

The aim of these components is to prevent the products, which are heavy in weight, from toppling as a result of people running into or leaning onto the products, which can lead to serious accidents such as persons becoming trapped under the product. (U.S.: UL60950-1, Europe: EN60950-1)

Therefore, removal of such components must always be with the consent of the customer.

Do not remove them at your own judgment.

1. REPLACEMENT AND ADJUSTMENT

1.1 REAR COVER

1. Rear lower gap cover [A] (hookx2).

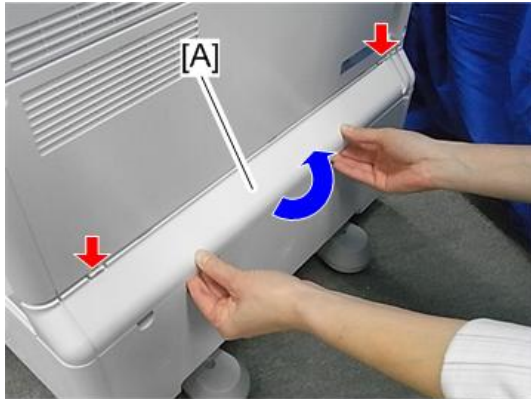

d197z1155

2. Securing brackets [A] (Ⓢx2).

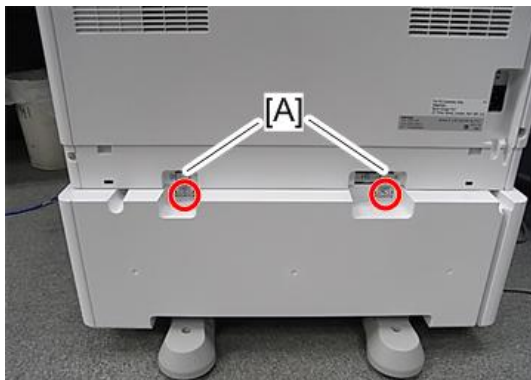

d197z8000

3. Rear cover [A] (Ⓢx2).

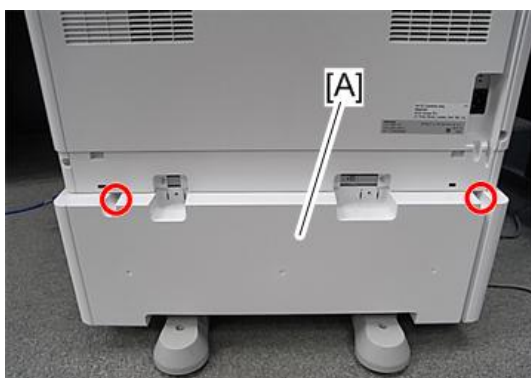

d197z8001

1.2 TRAY LIFT MOTOR (UPPER)

1. Rear cover (page 1).
2. Tray lift motor (upper) [A] (🔩 x2, 📦 x1).

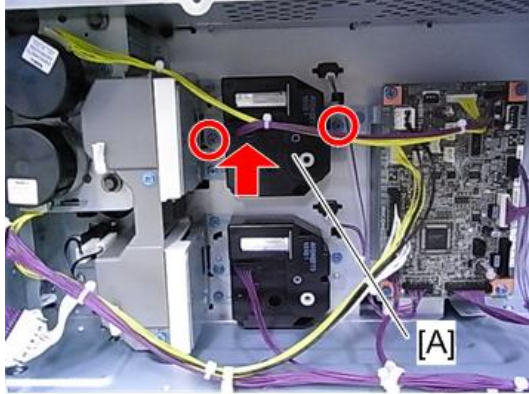

d1462702

1.3 TRAY LIFT MOTOR (LOWER)

1. Rear cover (page 1).
2. Tray lift motor (lower) [A] (🔩 x2, 📦 x1).

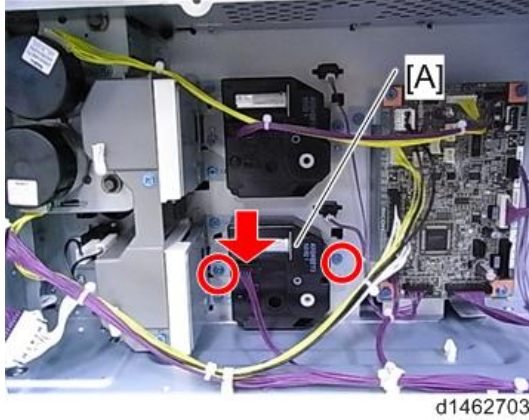

1.4 TRANSPORT MOTOR

1. Rear cover (page 1).
2. Transport motor [A] (⚙️ x2, 📦 x1).

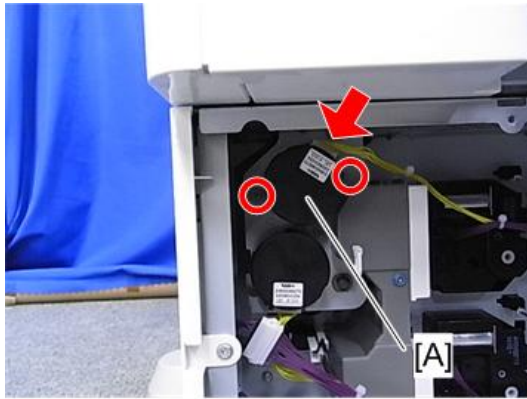

d1462704

1.5 PAPER FEED MOTOR

1. Rear cover (page 1).
2. Paper feed motor [A] (🔩 x2, 📦 x1).

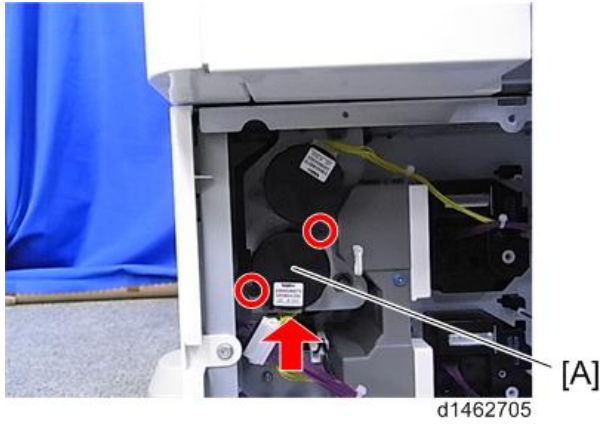

PAPER FEED UNIT
PB3220 / PB3210
(D787)

1.6 CONTROLLER BOARD

1. Rear cover (page 1).
2. Controller board [A] (⊙ x4, ⊞ x10).

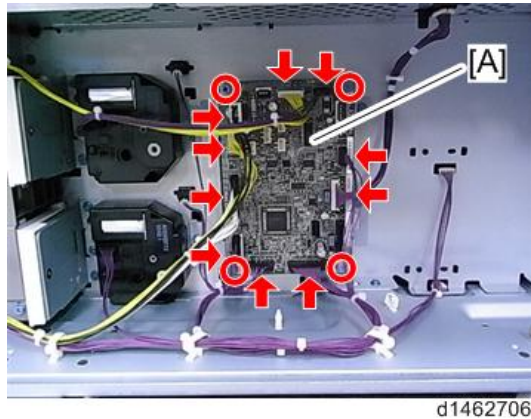

d1462706

1.7 TRANSPORT SENSOR, LIMIT SENSOR, PAPER END SENSOR, PAPER FEED SENSOR

1. Paper feed unit (page 9,page 13).
2. Transport sensor bracket [A] (⚙️ x1, 📦 x1).

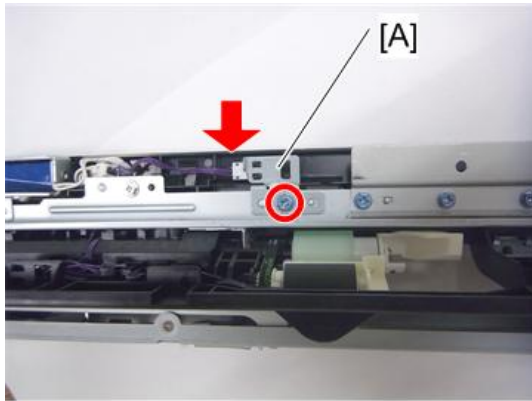

d1462196

3. Transport sensor [A].

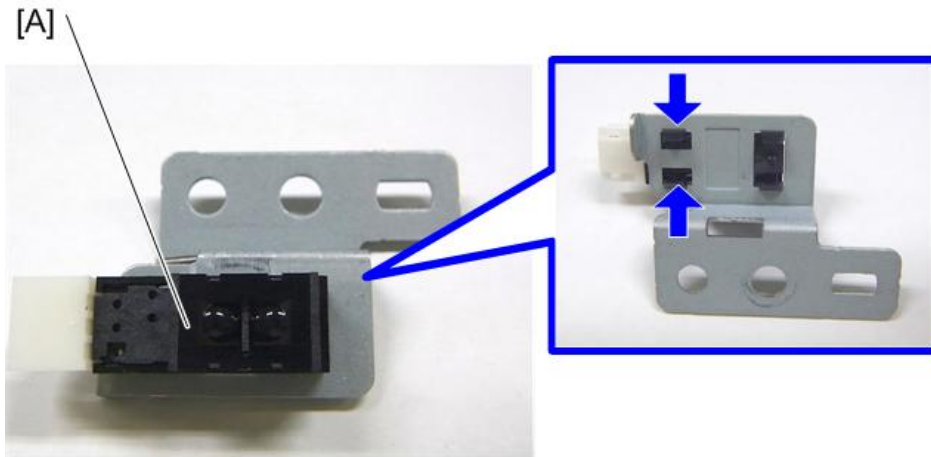

d1462197

4. Paper feed sensor bracket [A] (⚙️ x1, 📦 x1).

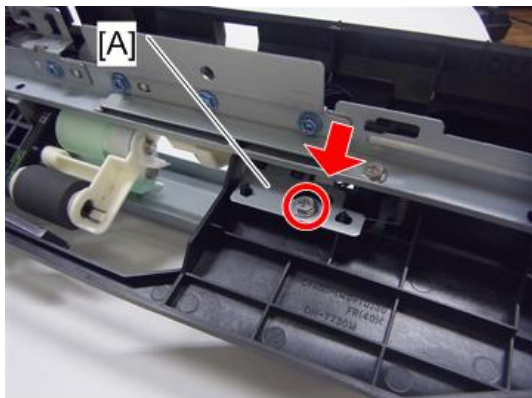

d1462194

5. Paper feed sensor [A].

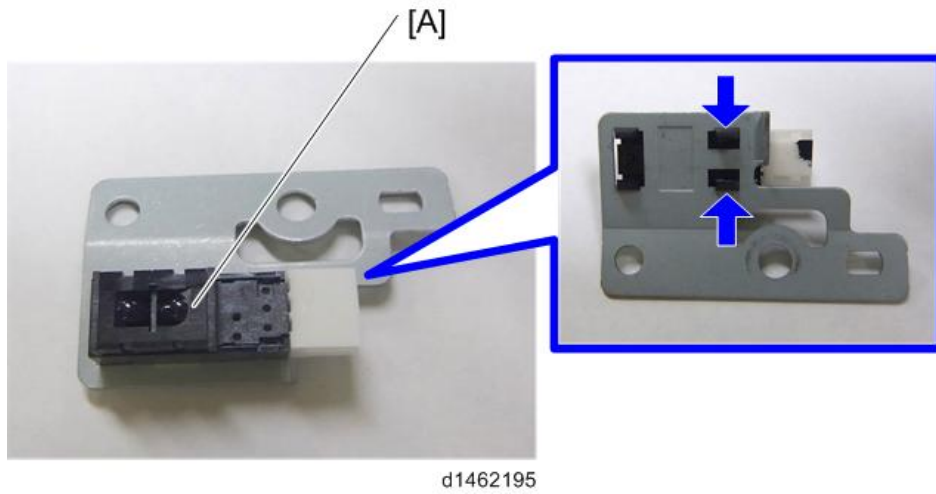

6. Paper end sensor [A] (📦 x1).

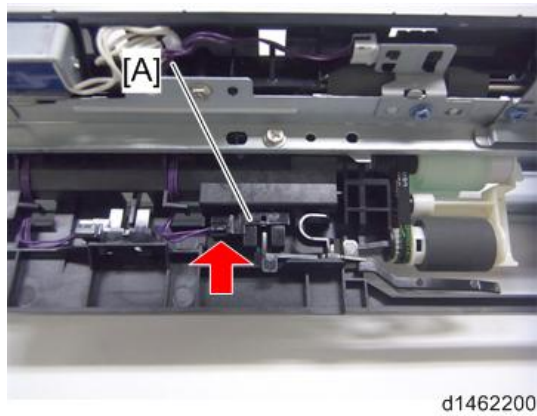

7. Limit sensor [A] (📦 x1).

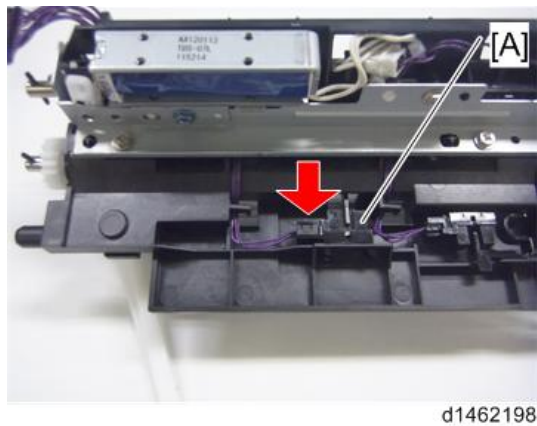

1.8 2ND PAPER FEED UNIT

1. Pull out the paper trays.
2. Rear cover (page 1).
3. Right front cover [A] (🔑 x1).



d1462707

4. Right rear cover [A] (🔑 x1).

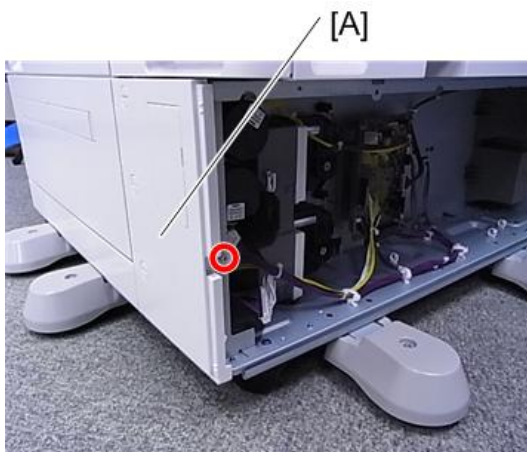

d1462708

5. Anti-tip component covers [A] (🔑 x2).

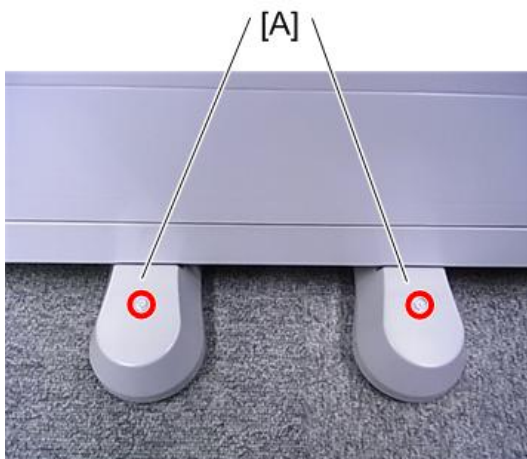

d1462709

2nd Paper Feed Unit

6. Right lower cover [A] (🔩 x2).

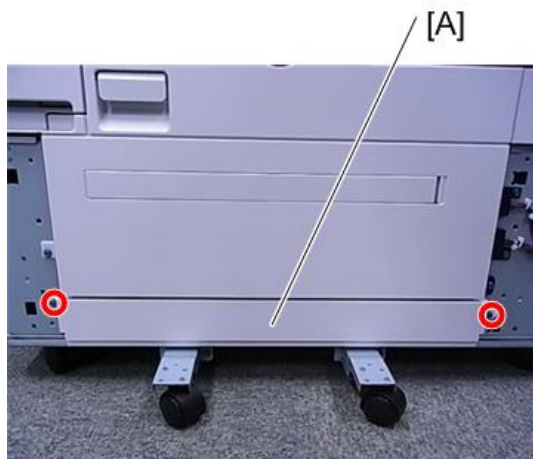

d1462710

7. Open the Transport cover [A].



d1462711

8. Stopper [A] (🔩 x1).

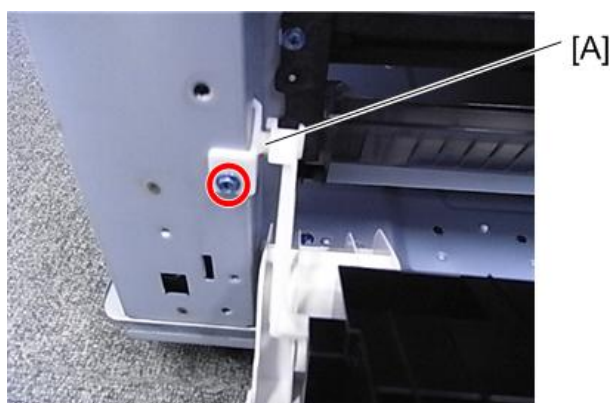

d1462712

9. Interlock switch cover [A] (🔩 x1).

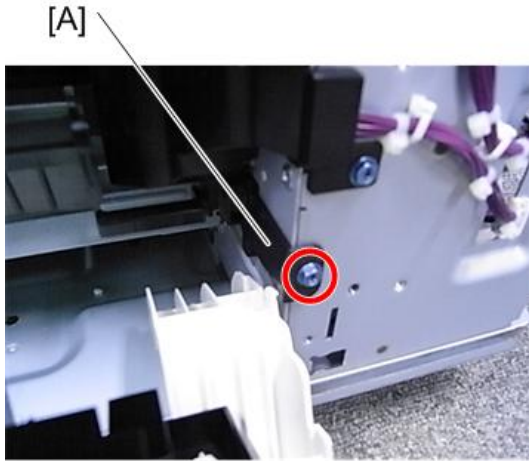

d1462713

10. Paper feed guide plate [A].

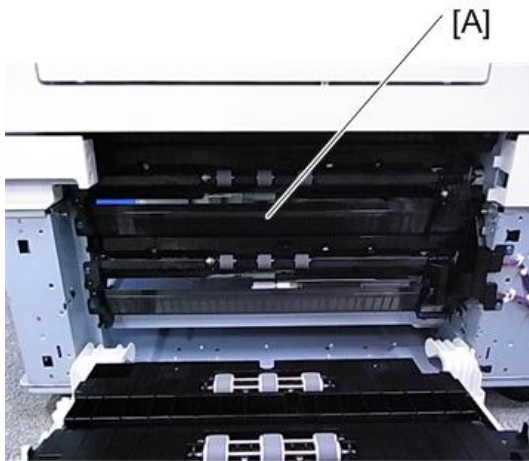

d1462714

11. Harness cover [A] (🔩 x2).

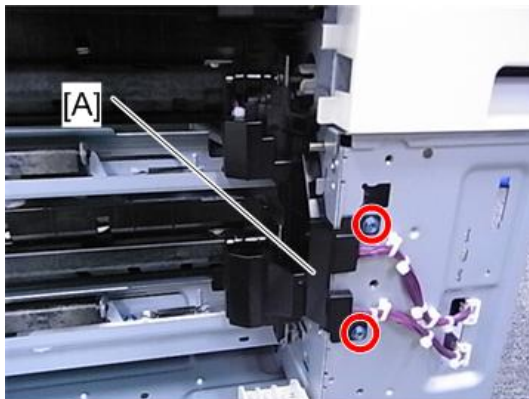

d1462715

2nd Paper Feed Unit

12. Release the clamps, and then disconnect the harness at the right rear of the unit

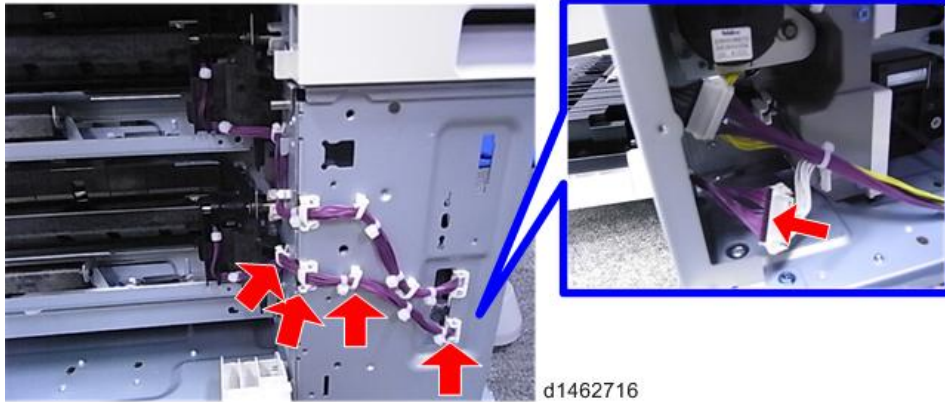

(🔧 x1, 🛠️ x4).

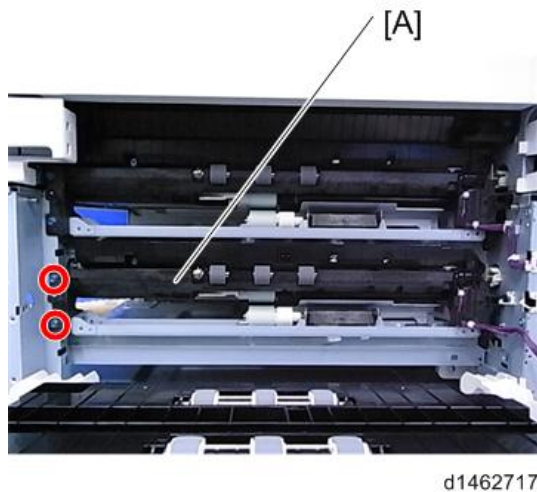

13. 2nd Paper feed unit [A] (🔧 x2).



1.9 1ST PAPER FEED UNIT

1. 2nd Paper feed unit (page 9).
2. Release the clamps, and then disconnect the harness at the right rear of the unit
( x1,  x6).

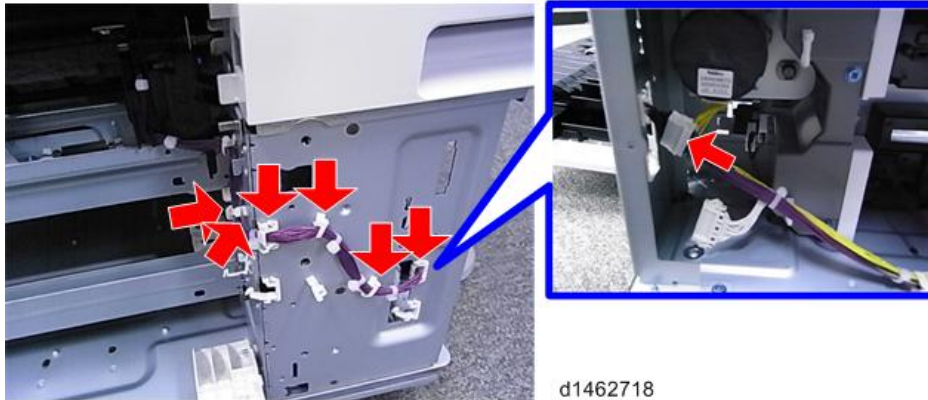

d1462718

3. Guide plate [A] ( x1).

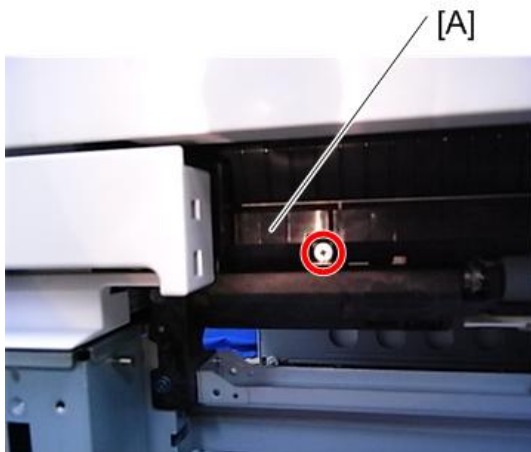

d1462719

4. 1st Paper feed unit [A] ( x2).

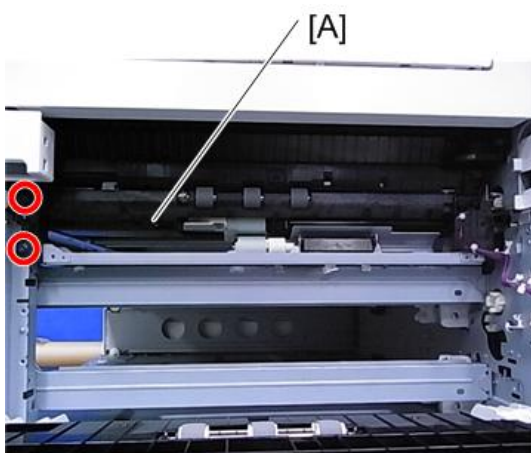

d1462720

1.10 PICK-UP ROLLER, FEED ROLLER, FRICTION ROLLER

1. Paper feed unit (page 9,page 13).
2. Holder [A] (🔩x1).

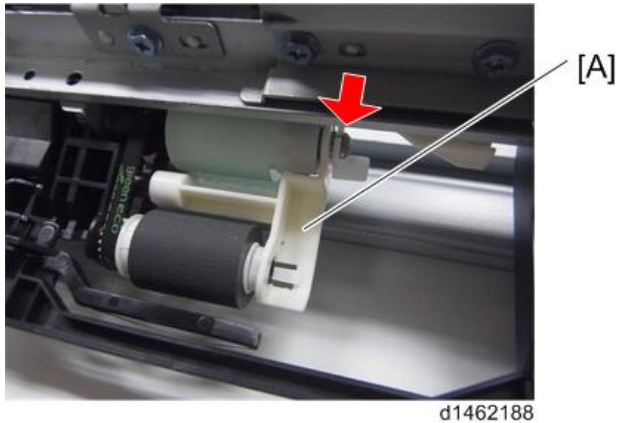

d1462188

3. Pick-up roller [A].

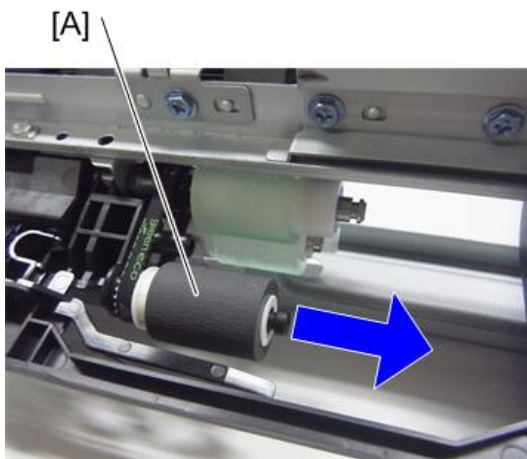

d1462189

4. Feed roller [A].

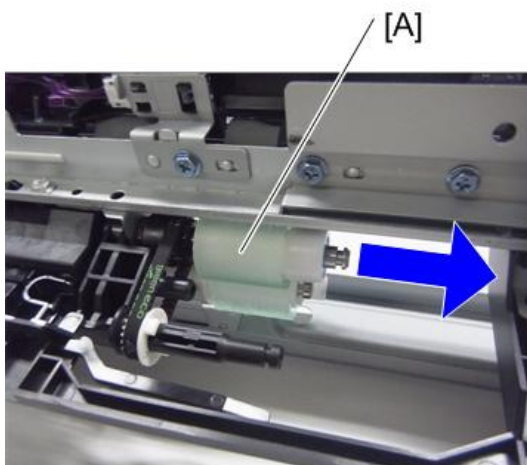

d1462190

5. Friction roller [A] (🔩x1).

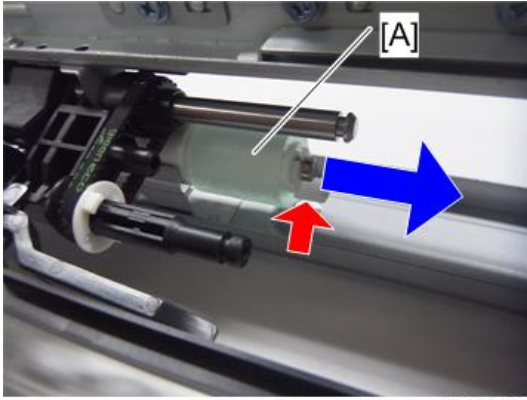

d1462191

PAPER FEED UNIT
PB3220 / PB3210
(D787)