

Model Gim-P1a

**Machine Code:
M171**

Field Service Manual

September, 2014

Important Safety Notices

Important Safety Notices

Prevention of Physical Injury

1. Before disassembling or assembling parts of the main machine and peripherals, make sure that the power cord of the main machine is unplugged.
2. The wall outlet should be near the machine and easily accessible.
3. Note that some components of the machine and the paper tray unit are supplied with electrical voltage even if the main power switch is turned off.
4. If any adjustment or operation check has to be made with exterior covers off or open while the main switch is turned on, keep hands away from electrified or mechanically driven components.
5. The inside and the metal parts of the fusing unit become extremely hot while the machine is operating. Be careful to avoid touching those components with your bare hands.

WARNING

- To prevent a fire or explosion, keep the machine away from flammable liquids, gases, and aerosols.

Health Safety Conditions

1. Toner and developer is non-toxic, but if you get either of them in your eyes by accident, it may cause temporary eye discomfort. Immediately wash eyes with plenty of water. If unsuccessful, get medical attention.
2. This machine, which uses a high voltage power source, can generate ozone gas. High ozone density is harmful to human health. Therefore, the machine must be installed in a well-ventilated room.

Observance of Electrical Safety Standards

1. This machine and its peripherals must be serviced by a customer service representative who has completed the training course on those models.
2. The NVRAM on the system control board has a lithium battery which can explode if replaced incorrectly. Replace the NVRAM only with an identical one. The manufacturer recommends replacing the entire NVRAM. Do not recharge or burn this battery. Used NVRAM must be handled in accordance with local regulations.

Handling Toner

- Work carefully when removing paper jams or replacing toner bottles or cartridges to avoid spilling toner on clothing or the hands.
- If toner is inhaled, immediately gargle with large amounts of cold water and move to a well ventilated location. If there are signs of irritation or other problems, seek medical attention.
- If toner gets on the skin, wash immediately with soap and cold running water.
- If toner gets into the eyes, flush the eyes with cold running water or eye wash. If there are signs of irritation or other problems, seek medical attention.
- If toner is swallowed, drink a large amount of cold water to dilute the ingested toner. If there are signs of any problem, seek medical attention.
- If toner spills on clothing, wash the affected area immediately with soap and cold water. Never use hot water! Hot water can cause toner to set and permanently stain fabric.
- Always store toner and developer supplies such as toner and developer packages, cartridges, and bottles (including used toner and empty bottles and cartridges) out of the reach of children.
- Always store fresh toner supplies or empty bottles or cartridges in a cool, dry location that is not exposed to direct sunlight.

WARNING







- Do not use a vacuum cleaner to remove spilled toner (including used toner). Vacuumed toner may cause a fire or explosion due to sparks or electrical contact inside the cleaner. However, it is possible to use a cleaner designed to be dust explosion-proof. If toner is spilled over the floor, sweep up spilled toner slowly and clean up any remaining toner with a wet cloth.

Safety and Ecological Notes for Disposal

1. Do not incinerate toner bottles or used toner. Toner dust may ignite suddenly when exposed to an open flame.
2. Dispose of used toner, the maintenance unit which includes developer or the organic photoconductor in accordance with local regulations. (These are non-toxic supplies.)
3. Dispose of replaced parts in accordance with local regulations.
4. When keeping used lithium batteries in order to dispose of them later, do not put more than 100 batteries per sealed box. Storing larger numbers or not sealing them apart may lead to chemical reactions and heat build-up.

Symbols, Abbreviations and Trademarks

This manual uses several symbols and abbreviations. The meaning of those symbols and abbreviations are as follows:

	Spring
	Clip ring
	Screw
	Connector
	Clamp
	E-ring
SEF	Short Edge Feed
LEF	Long Edge Feed

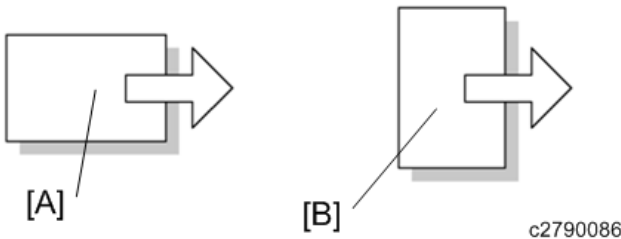

[A] Short Edge Feed (SEF)

[B] Long Edge Feed (LEF)

Trademarks

Adobe, Acrobat, PostScript, PostScript 3, and Reader are either registered trademarks or trademarks of Adobe Systems Incorporated in the United States and/or other countries.

Citrix, Citrix Presentation Server and Citrix XenApp are either registered trademarks or trademarks of Citrix Systems, Inc.

Firefox® is a registered trademark of the Mozilla Foundation.

IPS is a trademark or registered trademark of Zoran Corporation and/or its subsidiaries in the United States or other countries.

Java is a registered trademark of Oracle and/or its affiliates.

JAWS® is a registered trademark of Freedom Scientific, Inc., St. Petersburg, Florida and/or other countries.

Macintosh, Mac OS, OS X, and Safari are trademarks of Apple Inc., registered in the United States and other countries.

Microsoft, Windows, Windows Server, Windows Vista, and Internet Explorer are either registered trademarks or trademarks of Microsoft Corporation in the United States and/or other countries.

Monotype is a registered trademark of Monotype Imaging Inc.

PCL® is a registered trademark of Hewlett-Packard Company.

UNIX is a registered trademark of the Open Group.

UPnP™ is a trademark of the UPnP™ Implementers Corporation.

The proper name of Internet Explorer 6 is Microsoft® Internet Explorer® 6.

The proper name of Internet Explorer 8 is Windows® Internet Explorer® 8.

The proper names of the Windows operating systems are as follows:

- The product names of Windows XP are as follows:
 - Microsoft® Windows® XP Professional Edition
 - Microsoft® Windows® XP Home Edition
 - Microsoft® Windows® XP Media Center Edition
 - Microsoft® Windows® XP Tablet PC Edition
- The product names of Windows Vista are as follows:
 - Microsoft® Windows Vista® Ultimate
 - Microsoft® Windows Vista® Business
 - Microsoft® Windows Vista® Home Premium
 - Microsoft® Windows Vista® Home Basic
 - Microsoft® Windows Vista® Enterprise
- The product names of Windows 7 are as follows:
 - Microsoft® Windows® 7 Home Premium
 - Microsoft® Windows® 7 Professional
 - Microsoft® Windows® 7 Ultimate
 - Microsoft® Windows® 7 Enterprise
- The product names of Windows 8 are as follows:
 - Microsoft® Windows® 8
 - Microsoft® Windows® 8 Pro
 - Microsoft® Windows® 8 Enterprise

-
- The product names of Windows 8.1 are as follows:
 - Microsoft® Windows® 8.1
 - Microsoft® Windows® 8.1 Pro
 - Microsoft® Windows® 8.1 Enterprise
 - The product names of Windows Server 2003 are as follows:
 - Microsoft® Windows Server® 2003 Standard Edition
 - Microsoft® Windows Server® 2003 Enterprise Edition
 - The product names of Windows Server 2003 R2 are as follows:
 - Microsoft® Windows Server® 2003 R2 Standard Edition
 - Microsoft® Windows Server® 2003 R2 Enterprise Edition
 - The product names of Windows Server 2008 are as follows:
 - Microsoft® Windows Server® 2008 Standard
 - Microsoft® Windows Server® 2008 Enterprise
 - The product names of Windows Server 2008 R2 are as follows:
 - Microsoft® Windows Server® 2008 R2 Standard
 - Microsoft® Windows Server® 2008 R2 Enterprise
 - The product names of Windows Server 2012 are as follows:
 - Microsoft® Windows Server® 2012 Foundation
 - Microsoft® Windows Server® 2012 Essentials
 - Microsoft® Windows Server® 2012 Standard
 - The product names of Windows Server 2012 R2 are as follows:
 - Microsoft® Windows Server® 2012 R2 Foundation
 - Microsoft® Windows Server® 2012 R2 Essentials
 - Microsoft® Windows Server® 2012 R2 Standard

Other product names used herein are for identification purposes only and might be trademarks of their respective companies. We disclaim any and all rights to those marks.

Microsoft product screen shots reprinted with permission from Microsoft Corporation.

TABLE OF CONTENTS

- Important Safety Notices..... 1
 - Important Safety Notices..... 1
 - Prevention of Physical Injury..... 1
 - Health Safety Conditions..... 1
 - Observance of Electrical Safety Standards..... 1
 - Handling Toner..... 2
 - Safety and Ecological Notes for Disposal..... 2
- Symbols, Abbreviations and Trademarks..... 3
 - Trademarks..... 3
- 1. Product Information**

- Product Overview..... 13
 - Component Layout..... 13
 - Paper Path..... 14
 - Drive Layout..... 15
- Machine Codes and Peripheral Configuration..... 16
- Specifications..... 18
- 2. Installation**

- Installation Requirements..... 19
 - Environment..... 19
 - Machine Space Requirements..... 20
 - Machine Dimensions..... 20
 - Power Requirements..... 20
- Main Machine Installation..... 22
 - Accessory Check..... 22
 - Instructions for the Customers..... 22
 - Moving the Machine..... 23
 - Security Settings..... 24
 - Changing an Administrator's Password..... 24
 - Configuring SSL/TLS..... 24
- Settings for @Remote Service..... 25
 - Check points before making @Remote settings..... 25
 - Execute the @Remote Settings..... 25

3. Preventive Maintenance

Preventive Maintenance Tables.....	29
Image Quality Standards.....	30
Paper Transfer Quality Standards.....	31

4. Replacement and Adjustment

General Cautions.....	33
Notes on the Main Power Switch.....	33
Characteristics of the Push Switch (DC Switch).....	33
Shutdown Method.....	34
Forced Shutdown.....	34
Exterior Covers.....	35
Front Cover.....	35
Left Cover.....	37
Right Cover.....	39
Rear Cover, Rear Lower Cover.....	41
Upper Cover.....	43
Operation Panel.....	45
LED Optics.....	47
LED Unit.....	47
How to Re-engage Disengaged Springs.....	51
PCDU.....	55
PCDU.....	55
Toner Cartridge.....	56
Toner Cartridge.....	56
Image Transfer.....	58
Image Transfer Roller.....	58
Drive Unit.....	59
Main Motor.....	59
Toner Supply Clutch.....	59
Registration Clutch.....	60
Paper Feed Clutch.....	61
Drive Unit.....	61
Gear Unit.....	62

By-pass Feed Clutch.....	63
Relay Clutch.....	64
By-pass Bottom Plate Clutch.....	65
Duplex Clutch.....	65
Junction Gate Solenoid.....	66
Fusing.....	67
Fusing Unit.....	67
Upper Fusing Unit, Lower Fusing Unit.....	68
Fusing Pressure Roller, Cleaning Roller.....	69
Fusing Lamp, Hot Roller.....	70
Thermostat.....	72
Thermistor.....	73
Hot Roller Stripper.....	76
Paper Feed.....	77
Paper Feed Tray.....	77
Paper Feed Roller.....	77
Friction Pad.....	77
Paper End Sensor.....	78
By-pass Feed Unit.....	79
By-pass Feed Roller.....	80
By-pass Friction Pad.....	82
By-pass Paper End Sensor.....	83
By-pass Bottom Plate HP Sensor.....	84
Paper Size Detection Switch.....	84
Paper Transport.....	86
Exit / Switchback Sensor.....	86
Duplex Entrance Sensor.....	86
Exit / Switchback Roller, Duplex Exit Gear.....	87
Registration Roller (Driven).....	89
Registration Roller (Drive).....	91
Registration Sensor.....	91
Electrical Components.....	93
Controller Box.....	93

PSU.....	93
Controller Board.....	95
BCU.....	96
EEPROM on the BCU.....	97
Toner End Sensor.....	97
HVPS.....	98
HVPS with Bracket.....	98
Fusing Fan.....	99
PCDU Cooling Fan.....	99
PSU Cooling Fan.....	100
DC Switch.....	100
Front Door Interlock Switch.....	101
Rear Door Interlock Switch.....	102
Temp Humid Sensor.....	102
Rear Cover Switch.....	102

5. System Maintenance

Service Program Mode.....	105
SP Tables.....	105
Enabling and Disabling Service Program Mode.....	105
Entering SP Mode.....	105
Exiting SP Mode.....	106
Types of SP Modes.....	106
Updating the Firmware.....	107
Overview.....	107
Environmental Requirements.....	107
Update Precautions.....	107
Items Required for Updating the Firmware.....	108
Update Procedure.....	108
Update Error (Recovery Mode).....	112
Debug Log.....	115
Overview.....	115
Operational procedure (USB connection).....	116
Operational procedure (TCP/IP connection).....	117

6. Troubleshooting

Self-Diagnostic Mode.....	119
Self-Diagnostic Mode at Power On.....	119
Service Call.....	120
Summary.....	120
When a Level “D” SC code occurs.....	120
SC200 (LED Optics).....	121
SC300 (Image Processing – 1).....	123
SC400 (Image Processing – 2).....	124
SC500 (Paper Feed and Fusing).....	125
SC600 (Device Communication).....	133
SC700 (Peripherals).....	138
SC800 (Controller).....	138
SC900 (Others).....	142
Jam Detection.....	146
Jam Displays.....	146
Sensor Position Layout.....	147
Jam Codes and Position Codes.....	147
Main Machine.....	148
Optional Bank.....	148
Troubleshooting.....	150
Test Sheet Printing.....	150
Image Position Adjustment.....	150
Registration Adjustment.....	151
Print Area.....	151
Adjustment Reference Values.....	152
Adjustment Procedure.....	152
Problem at Regular Intervals.....	152
When Vertical Banding is Generated.....	154
When Black Spots are Generated on Print Image.....	154
Paper Feed (Skew).....	155
Recycled or Thin Paper Is Severely Curled after Printing.....	156

7. Energy Save

Energy Save.....	157
Energy Saver Modes.....	157
Sleep Mode Setting.....	157
Return to Stand-by Mode.....	158
Recommendation.....	158
Paper Save.....	160
Effectiveness of Duplex/Combine Function.....	160
1. Duplex:.....	160
2. Combine mode:.....	160
3. Duplex + Combine:.....	161
Recommendation.....	161



1. Product Information

Product Overview

1

Component Layout

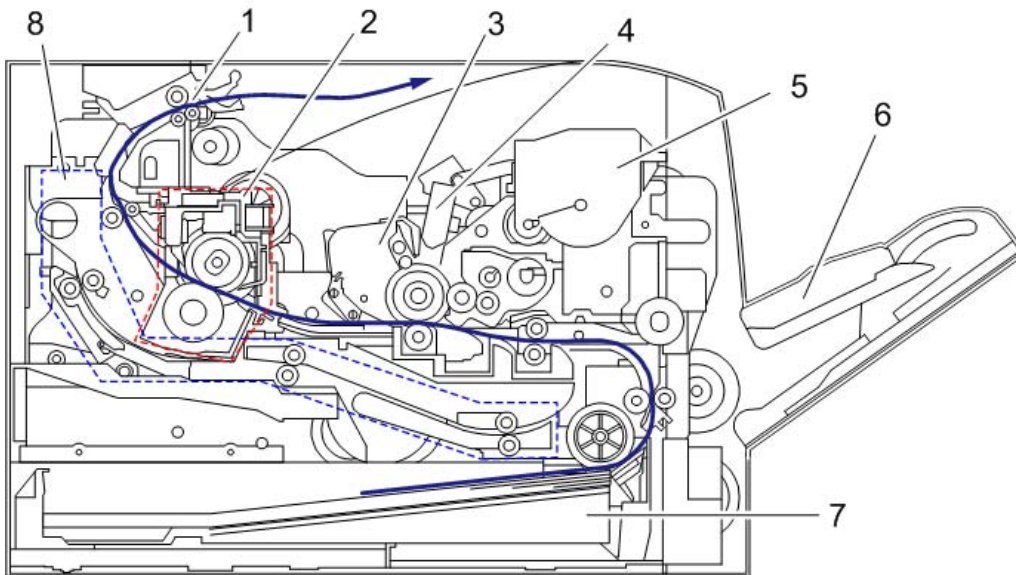

m171m0061

1. Exit / Switchback unit
2. Fusing unit
3. PCDU
4. LED head
5. Toner cartridge
6. By-pass feed tray
7. Paper feed unit
8. Duplex paper path

Paper Path

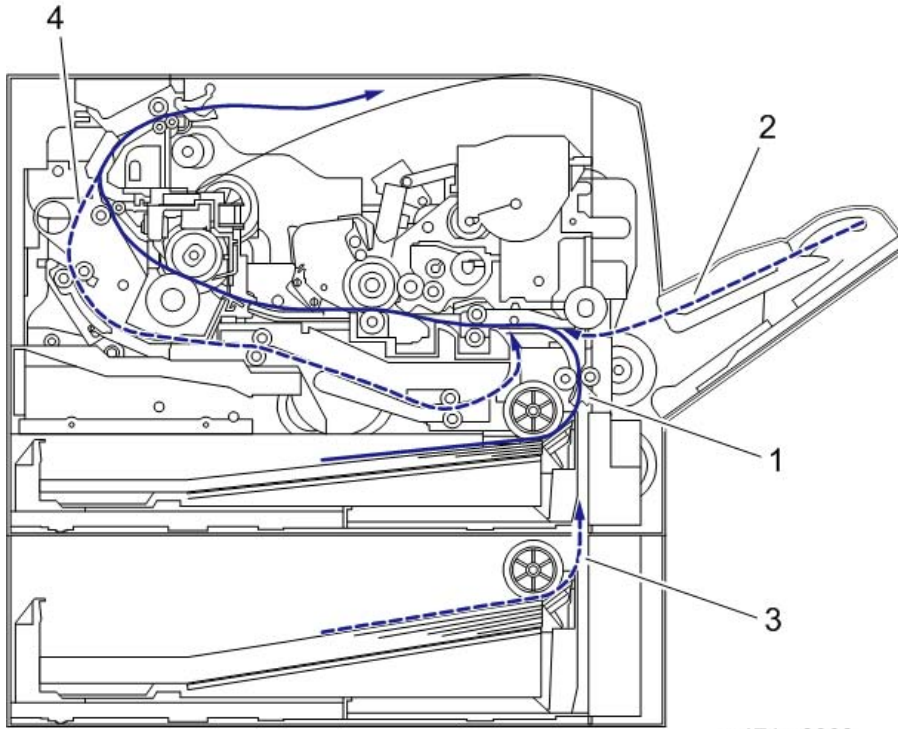

m171m0060

1. Main machine paper feed path
2. By-pass paper feed path
3. Optional tray paper feed path
4. Duplex paper feed path

Drive Layout

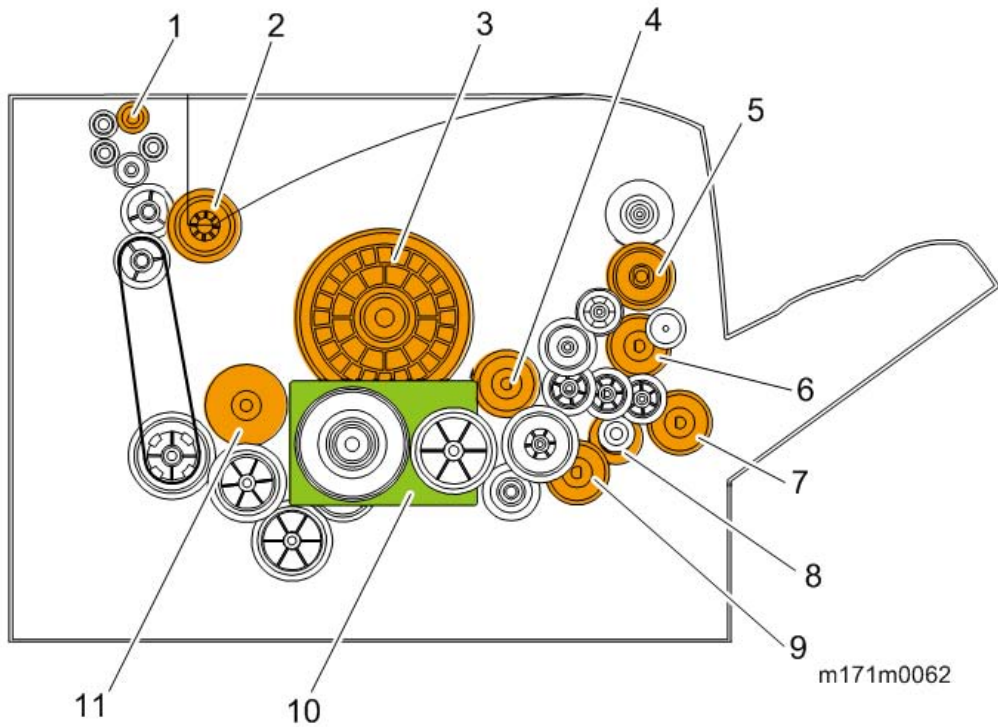

1. Exit / Switchback gear
2. Fusing drive gear
3. Drum gear
4. Registration clutch
5. Toner supply clutch
6. By-pass feed clutch
7. By-pass bottom plate clutch
8. Relay clutch
9. Paper feed clutch
10. Main motor
11. Duplex clutch

Machine Codes and Peripheral Configuration

1

Main Frame

Item	Machine Code	Remarks
M171	M171-17 (NA) M171-27 (EU/AP) M171-21 (CHN)	NEW

External Options

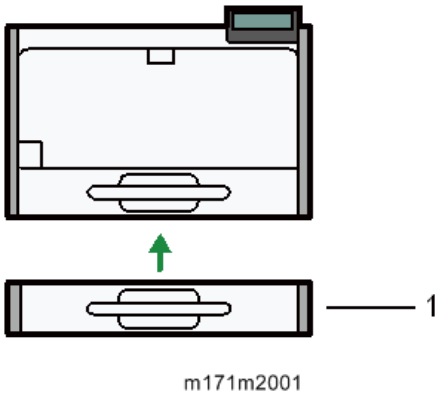

No.	Item	Machine Code	Remarks
1	Paper Feed Unit PB1070	M440-17	NEW
	Paper Feed Unit PB1060	M441-17	NEW

Consumables

Item	Machine Code	Remarks	Yield
Print Cartridge SP 4500A	M902-17	NEW	6,000 pages (ISO)
Print Cartridge SP 4500E	M902-27	NEW	
Print Cartridge SP 4500S	M902-20	NEW	
Print Cartridge SP 4500C	M902-21	NEW	

Item	Machine Code	Remarks	Yield
Print Cartridge SP 4500LA	M903-17	NEW	3,000 pages (ISO)
Print Cartridge SP 4500LE	M903-27	NEW	
Print Cartridge SP 4500LS	M903-20	NEW	
Print Cartridge SP 4500LC	M903-21	NEW	
Photo Conductor Unit SP 4500	M906-17(NA/EU/ AP) M906-21 (CHN)	NEW	20,000 pages (3P/J)
Maintenance Kit SP 3600	M909-17 (NA) M909-27 (EU/AP/ CHN)	NEW	-

Note

- (ISO): The number of printable pages is based on pages that are compliant with ISO/IEC 19752 with the image density set as the factory default. ISO/IEC 19752 is an international standard for measurement of printable pages, set by the International Organization for Standardization.
- (6%, 3P/J): A4/Letter 6% test chart, 3 pages/job
- (3P/J): A4/Letter, 3 pages/job

Specifications

1

See "Appendices" for the following information:

- General Specifications
- Supported Paper Sizes
- Software Accessories
- Optional Equipment

2. Installation

Installation Requirements

Environment

2

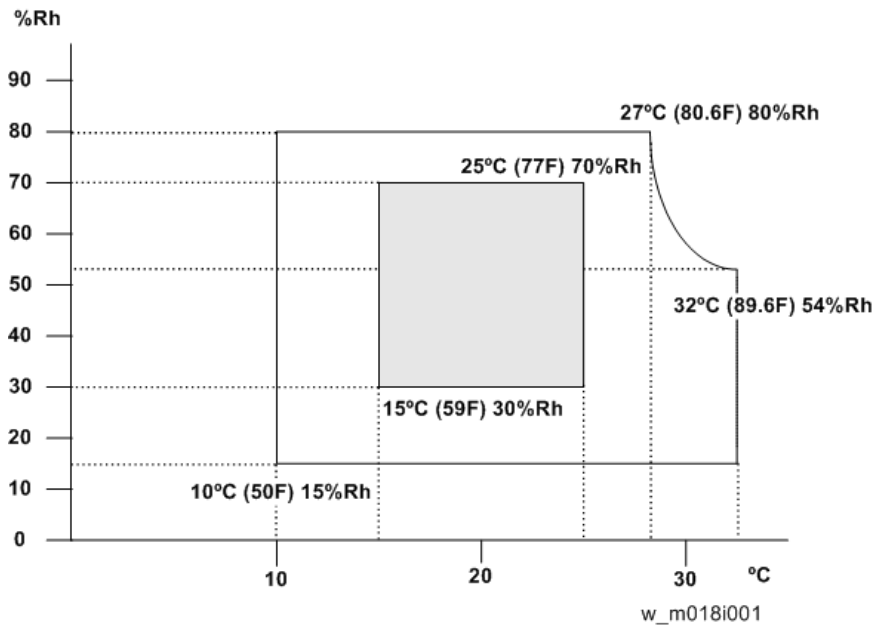

1. Temperature Range: 10°C to 32°C (50°F to 89.6°F)
2. Humidity Range: 15% to 80% RH
3. Ambient Illumination: Less than 1,500 lux (do not expose to direct sunlight)
4. Ventilation: 3 times/hr/person
5. Do not install the machine at locations over 2,000 m (6,562 ft.) above sea level.

Machine Space Requirements

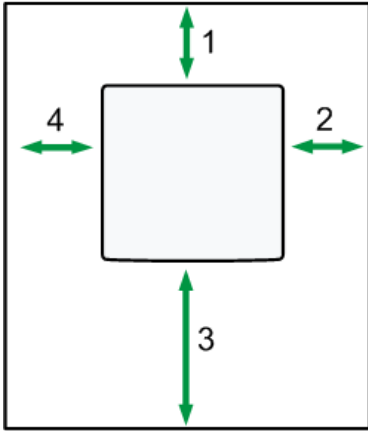

m1600239

1	Rear	Over 20 cm (7.9 inches)
2	Right	Over 10 cm (3.9 inches)
3	Front	Over 35 cm (13.8 inches)
4	Left	Over 10 cm (3.9 inches)

Machine Dimensions

Width	<ul style="list-style-type: none"> Printer only: 370 mm (14.6 inches)
Depth	392 mm (15.4 inches)
Height	<ul style="list-style-type: none"> Printer Only: 258 mm (10.2 inches) With Paper Feed Unit PB1060 attached: 353 mm (13.9 inches): With Paper Feed Unit PB1070 attached: 383 mm (15.1 inches):

Power Requirements

⚠ CAUTION

- Make sure the plug is firmly inserted in the outlet.
- Avoid multi-wiring.
- Be sure to ground the machine.

- Never place anything on the power cord.

1. Input voltage level:

Destination	Power supply voltage	Frequency	Rated current consumption
NA	120 V to 127 V	60 Hz	More than 10 A
EU/AP/CHN	220 V to 240V	50 Hz/60 Hz	5.3 A

2. Permissible voltage fluctuation:

Destination	For printing images	For operating
NA	+8.66 / -10%	+8.66 / -15%
EU/AP/CHN	±10%	±15%

Main Machine Installation

★ Important

- The M171 is for installation by users.

2

Accessory Check

Description	Q'ty		
	-17	-21	-27
Sheet –SEC_NOT_GW_C	1	1	1
Sheet – EULA(End User License Agreement)	1	1	1
Cleaner – Lens:LED Head	1	1	1
Sheet – Security Password	1	1	1
CD-ROM – Driver/OI	1	1	1
Guarantee	1	1	-
Sheet – Control Panel 4L	1	-	1
Manual – Read This First	1	1	1
Sheet – Quick installation Guide	1	1	2
Sheet – PCDU End 4Line	1	1	1
User Registration Sheet	1	-	-
Sheet – Helpdesk	1	-	-
Power Supply Cord	1	1	1
Modular Cord:6pin-6pin	-	1	-

Instructions for the Customers

Provide instructions on the following matters to customers. For detailed procedures, see the user manuals.

- Operating the printer function

- Installing consumables and loading paper
- Operating the main power switch
- Removing jammed paper
- Providing precautions on use
- Connecting to computers (such as configuring the port setting)
- Giving a brief outline of the tabs in the drivers

Moving the Machine

CAUTION

- It is dangerous to handle the power cord plug with wet hands. Doing so could result in electric shock.

CAUTION

- Unplug the power cord from the wall outlet before you move the machine. While moving the machine, take care that the power cord is not damaged under the machine. Failing to take these precautions could result in fire or electric shock.

CAUTION

- When disconnecting the power cord from the wall outlet, always pull the plug, not the cord. Pulling the cord can damage the power cord. Use of damaged power cords could result in fire or electric shock.

CAUTION

- The machine weighs approximately 14.5 kg (32.0 lb.). When moving the machine, use the inset grips on both sides, and lift slowly in pairs. The machine will break or cause injury if dropped.

Important

- **Be careful when moving the machine. Take the following precautions:**
 - Close all covers and trays, including the front cover and by-pass tray.
 - If optional paper feed units are attached, remove them from the machine and move them separately.
 - Keep the machine level and carry it carefully, taking care not to jolt or tip it. Rough handling may cause a malfunction or damage the memory, resulting in loss of stored files.

1. Be sure to check the following:

The main power switch is turned off.

The power cord is unplugged from the wall outlet.

The interface cable is unplugged from the machine.

2. If any external options are attached, remove them.
3. Lift the machine using the inset grips on both sides of the machine, and then move it horizontally to the place where you want to use it.
4. If you removed options, reattach them.

Note

- Be sure to move the machine horizontally. To prevent toner from scattering, move the machine slowly.

Security Settings

Changing an Administrator's Password

This section explains how to change the administrator's password for Web Image Monitor.

Important

- You will be prompted to enter the password when logging in to the printer. No password is set by default.
- We strongly recommend you to change the factory default password immediately to prevent information leakage and unauthorized operations by others.

1. Log in as the administrator from Web Image Monitor.
2. Click [Configuration].
3. Click [Administrator Authentication] under "Administrator Tools".
4. Enter the login password in [New Password].
5. Re-enter the login password in [Confirm Password], and then click [OK].
6. Click [OK].

Note

- For details, see the user manual "Security Guide".

Configuring SSL/TLS

To prevent unauthorized viewing, analysis or modification of the data during its transmission, enable SSL/TLS as required.

Note

- For details, see the user manual "Security Guide".

Settings for @Remote Service

Note

- Prepare and check the following check points before you visit the customer site. For details, ask the @Remote key person.

2

Check points before making @Remote settings

1. The setting of SP5816-201 in the mainframe must be "0".
2. Print the SMC with SP5-990-002 and then check if a device ID2 (SP5811-003) must be correctly programmed.
 - 6 spaces must be put between the 3-digit prefix and the following 8-digit number (e.g. xxx____xxx).
3. The following settings must be correctly programmed.
4. If a proxy server is available, configure the following SP settings.
 - Use Proxy (SP5816-062) Set to "1: Enable".
 - Proxy server IP address (SP5816-063)
 - Proxy server Port number (SP5816-064)
 - Proxy User ID (SP5816-065)
 - Proxy Password (SP5816-066)
5. Reboot the machine.
6. Get a Request Number.

Execute the @Remote Settings

1. Enter the SP mode.
2. Input the Request number which you have obtained from @Remote Center GUI, and then enter [OK] with SP5816-202.
3. Confirm the Request number, and then click [EXECUTE] with SP5816-203.
4. Check the confirmation result with SP5816-204.

Value	Meaning	Solution/ Workaround
0	Succeeded	-
1	Request number error	Check the request number again.

Value	Meaning	Solution/ Workaround
3	Communication error (proxy enabled)	Check the network condition.
4	Communication error (proxy disabled)	Check the network condition.
5	Proxy error (Illegal user name or password)	Check Proxy user name and password.
6	Communication error	Check the network condition.
8	Other error	See "SP5816-208 Error Codes" below this.
9	Request number confirmation executing	Processing... Please wait.
20	Dial-up authentication error	These errors occur only in the modems that support @Remote.
21	Answer tone detection error	
22	Carrier detection error	
23	Invalid setting value (modem)	
24	Low power supply current	
25	unplugged modem	
26	Busy line	

5. Make sure that the screen displays the Location Information with SP5816-205 only when it has been input at the Center GUI.
6. Click [EXECUTE] to execute the registration with SP5816-206.
7. Check the registration result with SP5816-207.

Value	Meaning	Solution/ Workaround
0	Succeeded	-
2	Already registered	Check the registration status.
3	Communication error (proxy enabled)	Check the network condition.
4	Communication error (proxy disabled)	Check the network condition.

Value	Meaning	Solution/ Workaround
5	Proxy error (Illegal user name or password)	Check Proxy user name and password.
8	Other error	See "SP5816-208 Error Codes" below this.
9	Request number confirmation executing	Processing... Please wait.
20	Dial-up authentication error	These errors occur only in the modems that support @Remote.
21	Answer tone detection error	
22	Carrier detection error	
23	Invalid setting value (modem)	
24	Low power supply current	
25	unplugged modem	
26	Busy line	

8. Exit the SP mode.

SP5816-208 Error Codes

Cause	Code	Meaning	Solution/ Workaround
Operation Error, Incorrect Setting	-1200 3	Attempted registration without execution of a confirmation and no previous registration.	Perform Confirmation before attempting the Registration.
	-1200 4	Attempted setting with illegal entries for certification and ID2.	Check ID2 of the mainframe.
	-1200 6	A confirmation request was made after the confirmation had been already completed.	Execute registration.
	-1200 8	Update certification failed because mainframe was in use.	Check the mainframe condition. If the mainframe is in use, try again later.

Cause	Code	Meaning	Solution/ Workaround
Error Caused by Response from GW URL	-2387	Not supported at the Service Center	
	-2389	Database out of service	
	-2390	Program out of service	
	-2391	Two registrations for the same mainframe	Check the registration condition of the mainframe
	-2392	Parameter error	
	-2393	External RCG not managed	
	-2394	Mainframe not managed	
	-2395	Box ID for external RCG is illegal.	
	-2396	Mainframe ID for external RCG is illegal.	
	-2397	Incorrect ID2 format	Check the ID2 of the mainframe.
	-2398	Incorrect request number format	Check the Request No.

3. Preventive Maintenance

Preventive Maintenance Tables

See "Appendices" for the following information:

- Preventive Maintenance Items

Image Quality Standards

Engine

Item	Specification	Remarks
Assured Image Area	Leading edge: 4.3 mm Left/Right: 4.3 mm Trailing edge: 4.3 mm	Envelopes Leading edge: 15 mm Left/Right: 10 mm Trailing edge: 15 mm
Magnification Error	±0.75% or less	Not applicable to the back of the paper when performing duplex printing.
Perpendicularity	±0.7mm/100mm	
Linearity	±0.25mm/100mm	
Parallelism	In an office environment: ±1.0mm or less In other environments: ±1.5mm or less	

Note

- To check whether the problem is with the image or is due to another issue, print the test sheet. (page 150 "Test Sheet Printing")

Paper Transfer Quality Standards

Engines

Item	Specification	Remarks
Margin position	Single Side: Main Scan: 0 ± 2.0 mm Sub Scan: 0 ± 1.5 mm Back of the paper when performing duplex printing: Main Scan: 0 ± 2.0 mm Sub Scan: 0 ± 1.5 mm	
Skew	Single Side: ± 1.2 mm/200 mm or less (B5 SEF or more) ± 1.0 mm/100 mm or less (Less than B5 SEF) Duplex: ± 1.0 mm/100 mm or less (B5 SEF or more) ± 1.5 mm/100 mm or less (Less than B5 SEF)	Not applicable to paper fed from the by-pass tray (Reference value when using the by-pass tray: ± 1.0 mm/100 mm)
Curling after fusing	20 mm or less from the leading and trailing edges with a radius of 40 mm or greater.	In an office environment

These standards are determined using standard paper under standard conditions.

Values may vary depending on environmental conditions such as temperature, humidity, use of used paper, etc.

4. Replacement and Adjustment

General Cautions

Notes on the Main Power Switch

The main power button of this machine has been changed to a push-button switch (push button) from the conventional rocker switch. The push switch has characteristics and specifications different from the rocker switch. Care must be taken when replacing and adjusting parts.

Characteristics of the Push Switch (DC Switch)

Power is supplied to the machine even when the main power switch is turned OFF.

The push switch in this machine uses DC (direct current). Therefore, if the AC power cord is connected to an electrical outlet, power is supplied to the controller board and other modules even when the main power is turned OFF. When replacing the controller board, not only this board, it will damage other electrical components.

So, when performing maintenance work such as replacing parts, in addition to turning off the main power with the push switch, always unplug the AC power cord.

When you disconnect the power cord from the AC wall outlet, inside the machine there is still residual charge.

When you disconnect the power cord from the AC wall outlet, inside the machine for a while there is still residual charge. Therefore, if you remove boards in this state, it can cause a blown fuse or memory failure.

-- How to remove the residual charge inside the machine--

After you unplug the power cord from the AC wall outlet, in order to remove the residual charge from inside the machine, be sure to press the main power switch. Thus, the charge remaining in the machine is released, and it is possible to remove boards.

Shutdown Method

1. Press the main power switch [A] on the left side of the machine.

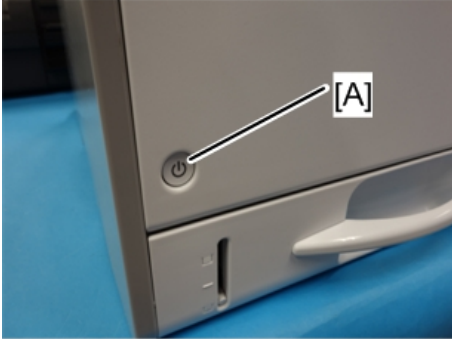

m171m0003

After the shutdown process, the main power is turned off automatically.

When the shutdown is complete

Operation panel LED: Off

2. Take out the power cord.
3. Wait 3 minutes (this is the time required if you will remove the rear cover and access the interior of the machine, to take out the controller board for example).

Note: If some LEDs on any of the boards are blinking or lit, current is still flowing.

How to start from shutdown

To start the machine, press the main power switch. However, if you press the main power switch between the beginning and the end of a shutdown, the machine will not start.

Forced Shutdown

In case normal shutdown does not complete for some reason, the machine has a forced shutdown function.

To make a forced shutdown, press and hold the main power switch for 6 seconds.

In general, do not use the forced shutdown.

★ Important

- Forced shutdown may damage the memory, and can cause damage to the machine. Use a forced shutdown only if it is unavoidable.

Exterior Covers

Front Cover

1. Paper Feed Tray (page 77 "Paper Feed Tray")
2. Open the by-pass tray [A].
3. Release four hinges indicated below to detach the paper guide plate [B].

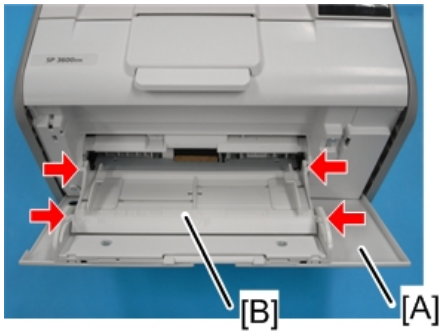

m171m0016

4. Remove the clips on the by-pass tray [A] (Ⓜ x 2).

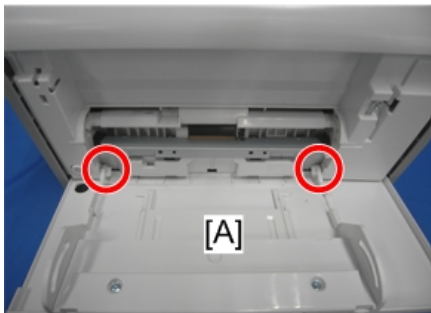

m158m0002

5. Release both the end hinges of the by-pass tray [A] to detach it.



m158m0003

4

↓ Note

- To remove the by-pass tray, lift the left hinge first to release while raising the by-pass tray upwards.
- The left hinge is C-cut.

6. Remove the screw on the front cover [A] in order to remove the strap that ties the front cover to the machine (Ⓜ x 1).

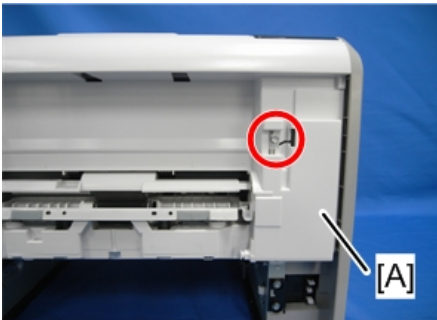

m158m0004

7. Open the front cover [A] and release the strap [B] (Ⓜ x 1).

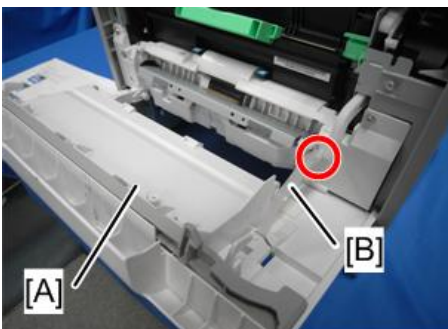

m158m0005

8. Release both the side hinges to detach the front cover [A].

↓ Note

- Release the left hinge [B] first to detach the front cover.

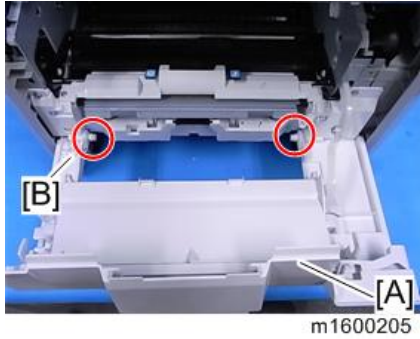

4

Left Cover

↓ Note

- There are 7 tabs on the back of the left cover. Refer to the picture below.

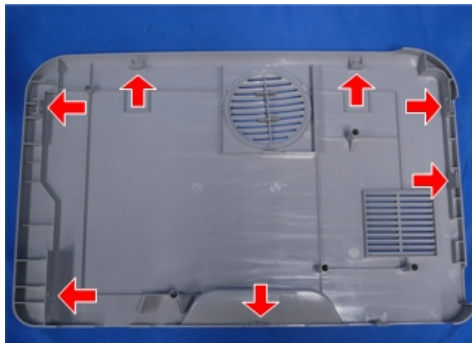

1. Paper Feed Tray (page 77 "Paper Feed Tray")

2. Press the release button and open the front cover [A].

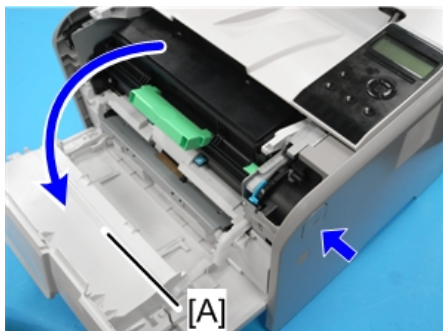

m171m0018

4

3. Open the rear cover [A].

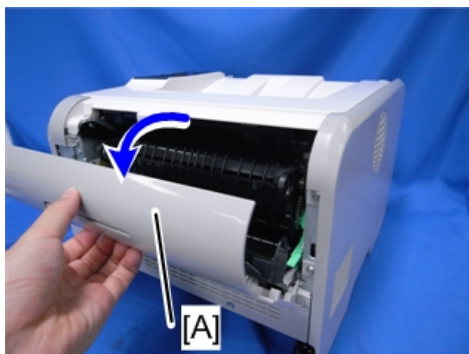

m171m0019

4. Left Cover [A] (Ⓢ x 4, Tab x 7)

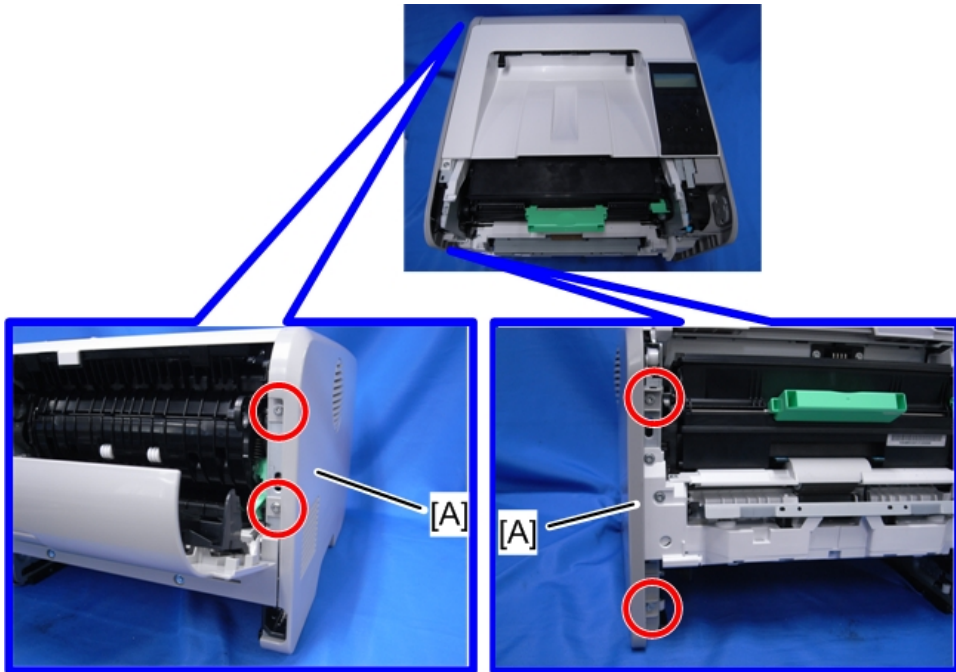

M171m0020

Right Cover

↓ Note

- There are 4 tabs on the back of the right cover. Refer to the picture below.

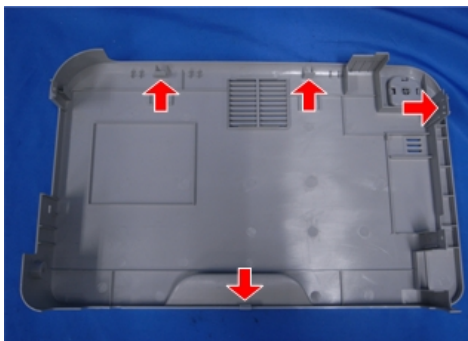

m171m0021

1. Paper Feed Tray (page 77 "Paper Feed Tray")

2. Press the release button and open the front cover [A].

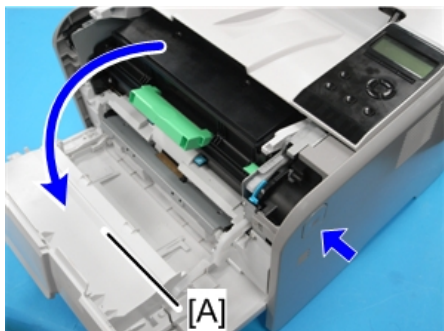

m171m0018

4

3. Open the rear cover [A].

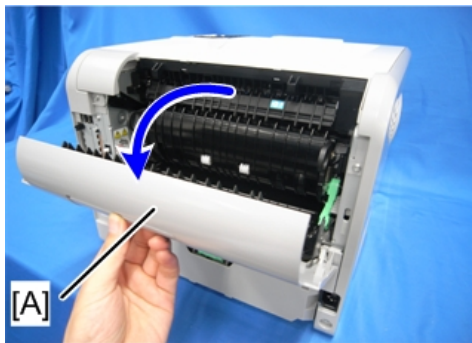

m158m0011

4. Right Cover [A] (🔩 x 4, Tab x 4)

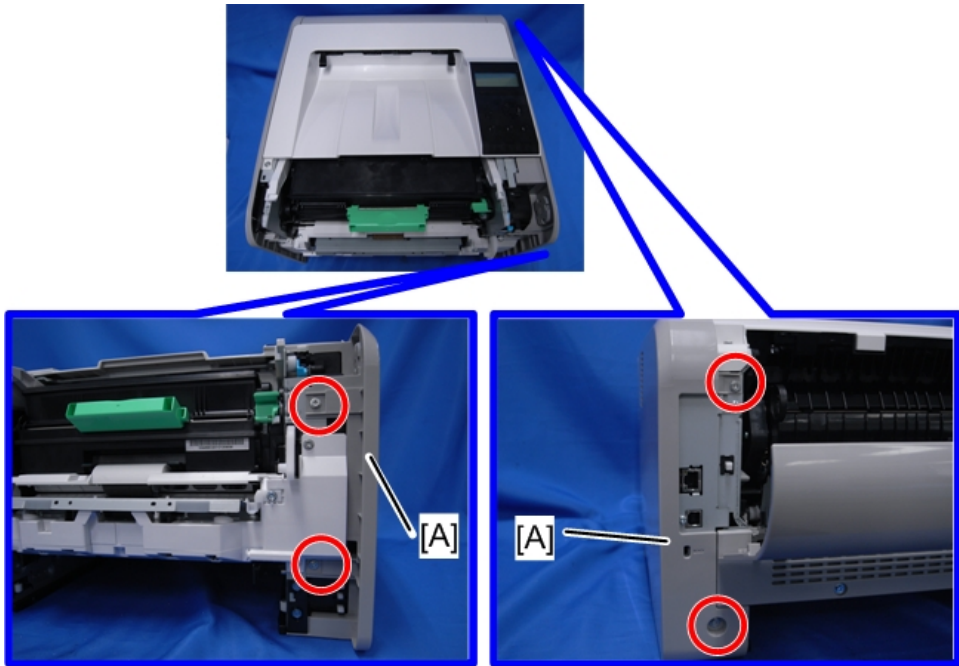

m171m0022

Rear Cover, Rear Lower Cover

1. Two screws on Rear Lower Cover [A] (🔩 x 2)

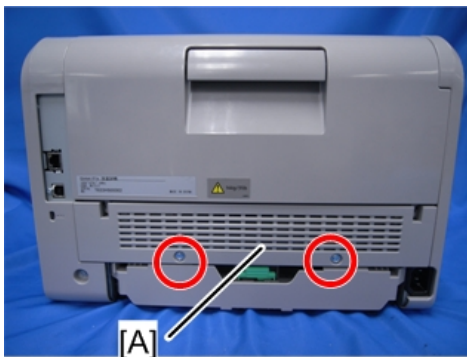

m171m0023

2. Open the rear cover [A].

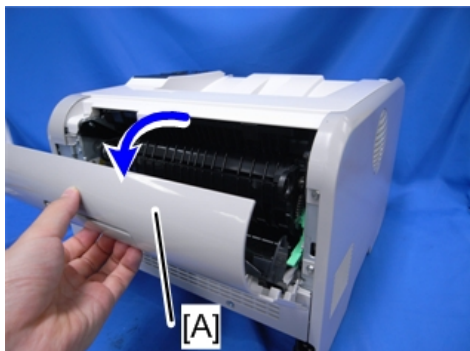

m171m0019

3. Release both side hinges to detach the rear cover [A].

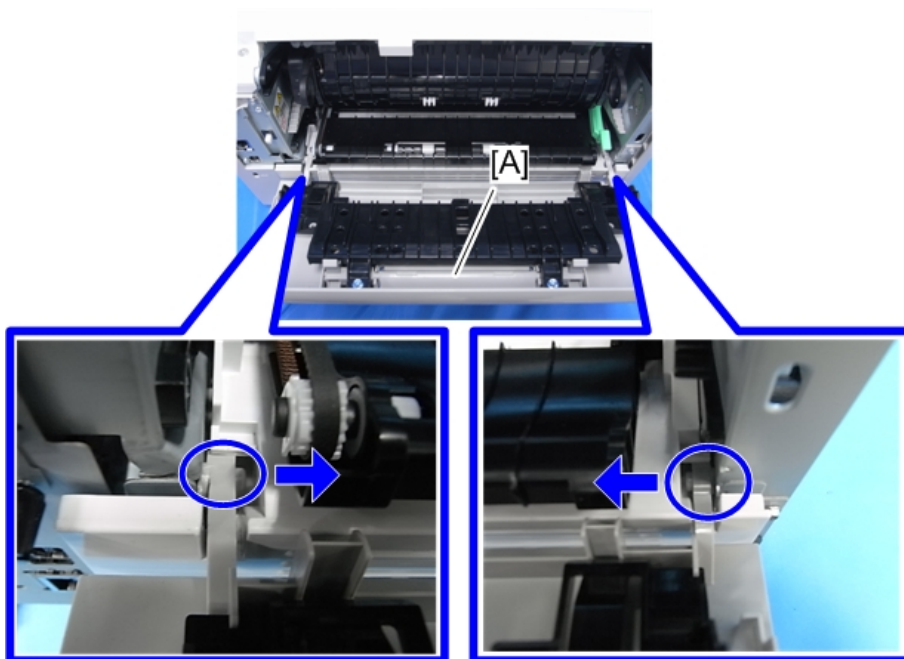

m171m0024

4. Rear Lower Cover [A]

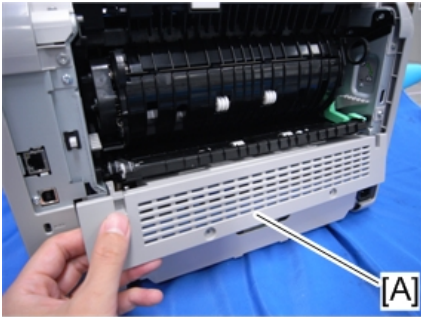

m1710025

Upper Cover

1. Left Cover (page 37 "Left Cover")
2. Right Cover (page 39 "Right Cover")
3. Open the rear cover [A].

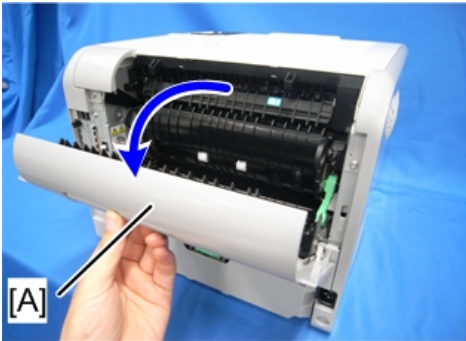

m158m0011

4. Remove the screws at the front side (🔩 x 2).

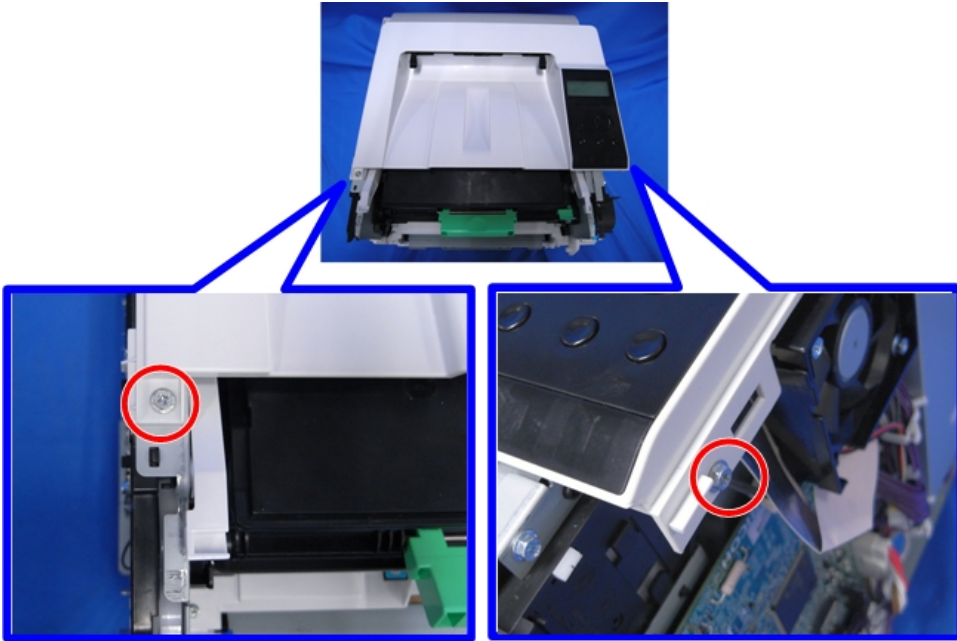

m171m0028

5. Remove the screws at the rear side (🔩 x 2).

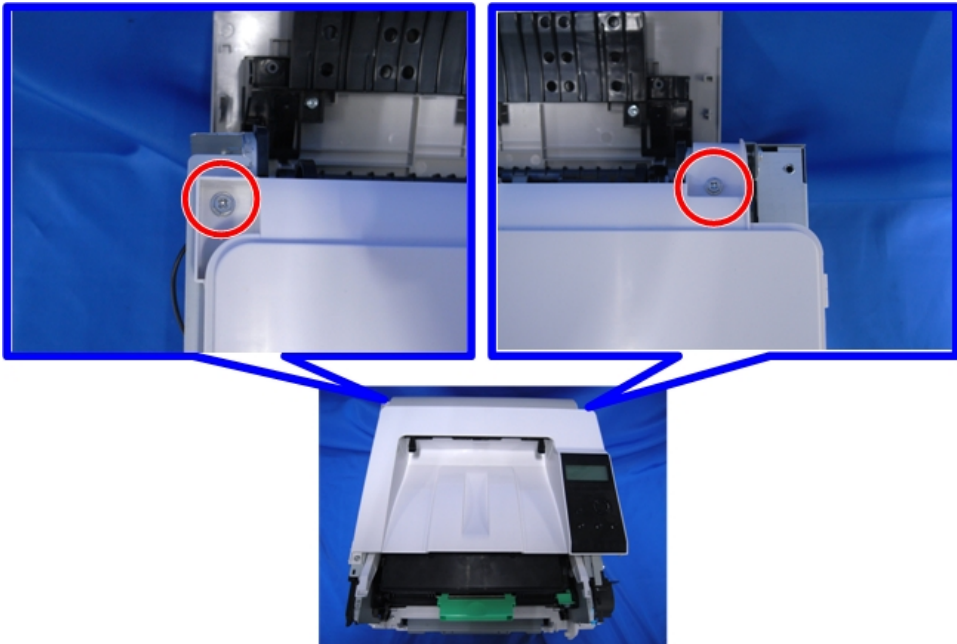

m171m0029

6. Upper Cover [A] (Tab x 1)

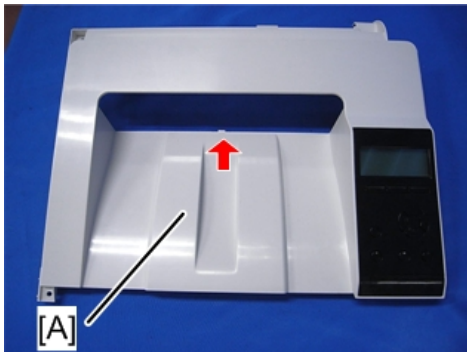

m171m0030

7. Remove the control panel connector. (📦 x 1)



m171m0031

4

Operation Panel

1. Controller Box (page 93 "Controller Box")
2. Upper Cover (page 43 "Upper Cover")

3. OPU Board (🔩 x 7)

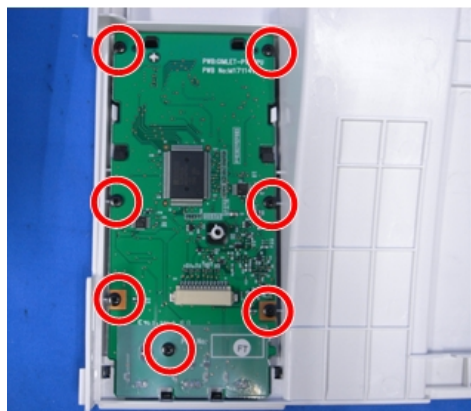

m171m0027

LED Optics

⚠ CAUTION

- Turn off the main power switch and disconnect the power cord before you start any of the procedures in this section. (page 33 "General Cautions")

LED Unit

★ Important

- Be sure to clean the lens of the LED head after replacing the LED unit or if you inadvertently touch the lens when replacing another unit.
1. PCDU (page 55 "PCDU")
 2. Upper Cover (page 43 "Upper Cover")
 3. Upper Inner Cover [A] (⚙ x 2, Hook x 3)

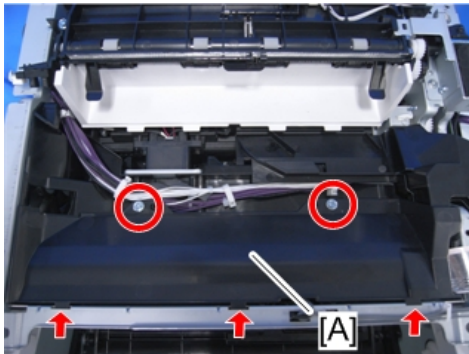

m171m0032

4. Remove the securing screws of the front stay [A] (🔩 x 2).

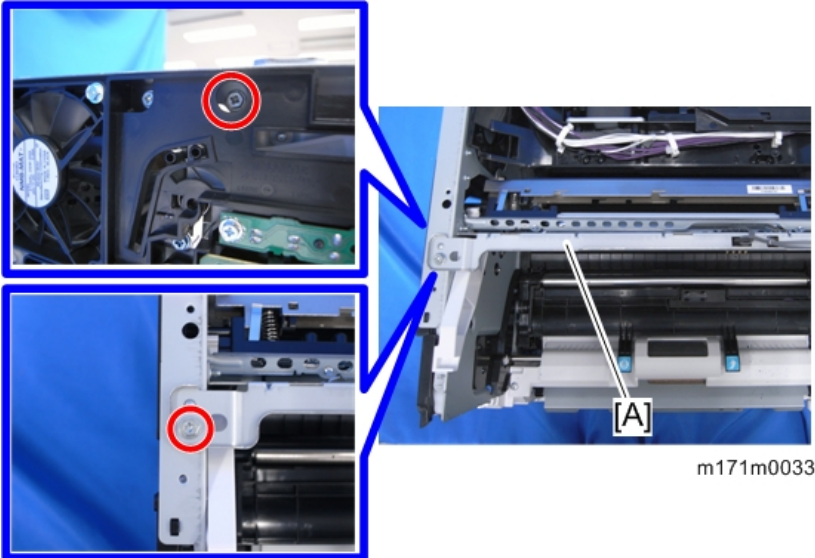

5. Rotate the LED unit [A] in the direction of the arrow until it locks.



6. Remove the spacer [A], ground wire [B], and flat cable [C] from the LED unit.

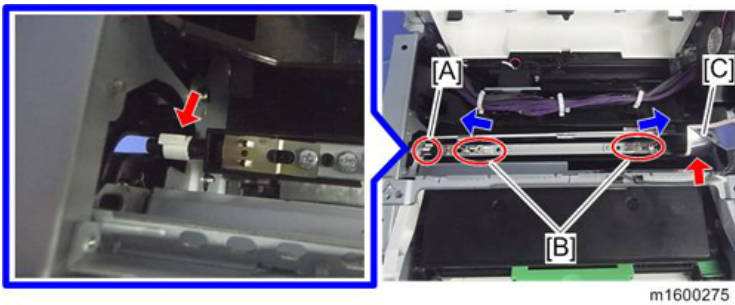

Note

- The spacer [A] has a protruding part that engages with the groove in the shaft to secure the spacer. When you remove the spacer, pull its handle downward as if to rotate the spacer slightly.

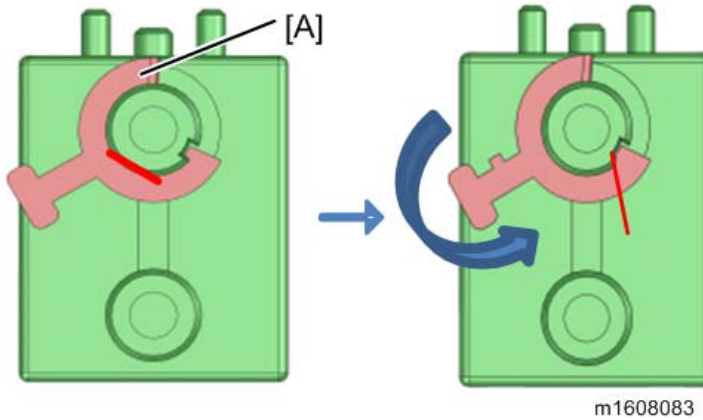

7. Slightly flex the side plates outward and pull the LED unit [A] out of the machine.

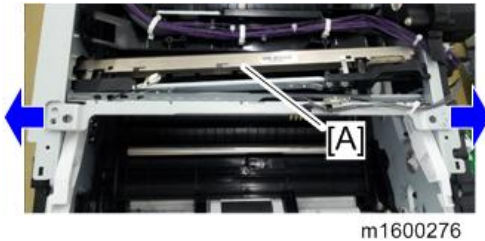

Note

- When you attach the LED unit, engage the LED unit's shaft ends (on the upper part) with the holes in the LED unit holder. Be careful not to force the LED unit in. Doing so may cause the LED unit holder's springs to come off.



4

- 8. Bend the stay [A] to release the left and right tabs, and then separate the stay from the LED head [B].

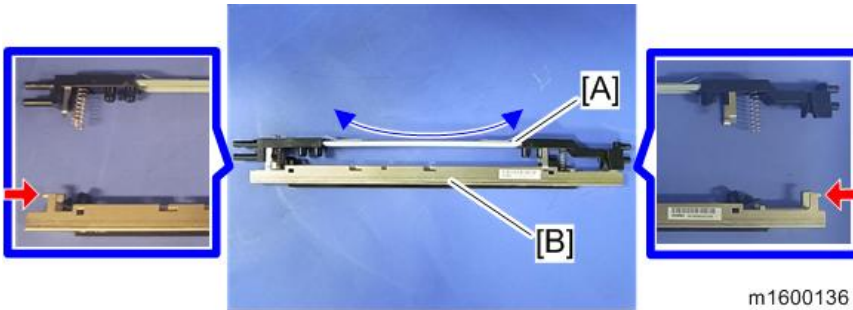

- 9. Remove the two spring holders [B] from the LED head [A].

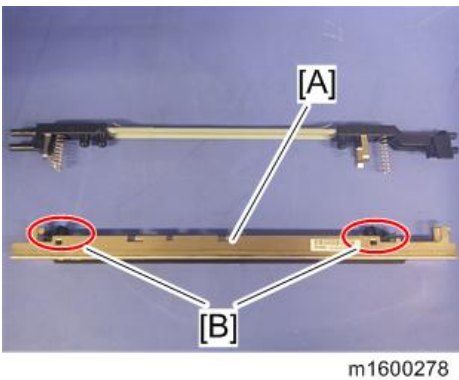

How to Re-engage Disengaged Springs

If the spring hook [A] of the LED unit holder is disengaged, re-engage it according to the following procedure:

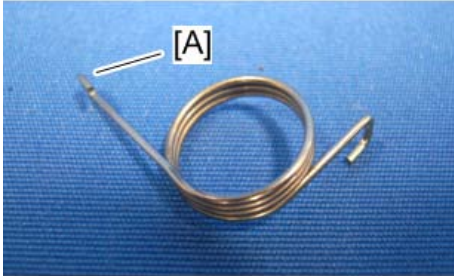

m1608051

Hook disengaged [A]

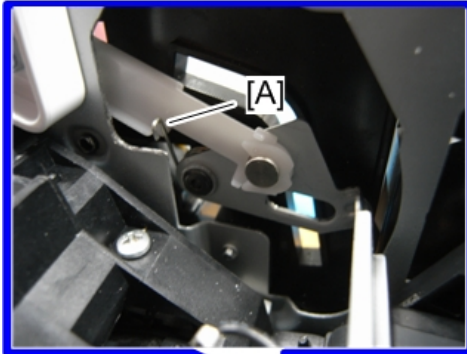

m1608050

Hook correctly engaged [B]

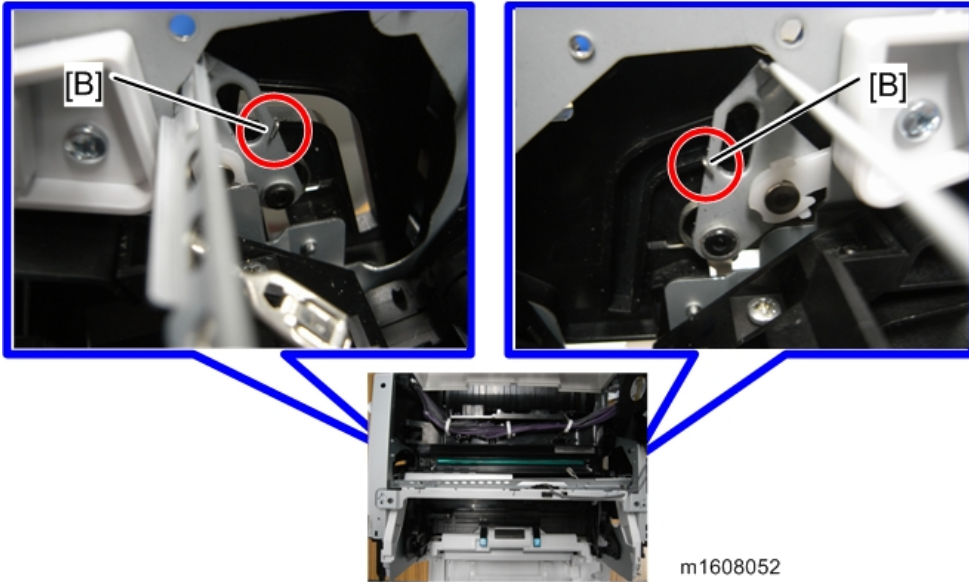

If the hook is engaged correctly, the LED unit holder is raised to the front by the spring.

Right side

1. Remove the right cover, and then remove the gear unit. (page 62 "Gear Unit")
2. Loosen the screws on the cover [A] (⌚ x3).

⬇ Note

- Be sure to loosen the screws holding the cover [A] just enough to insert tweezers or a screwdriver into the gap. Do not actually remove the screws.

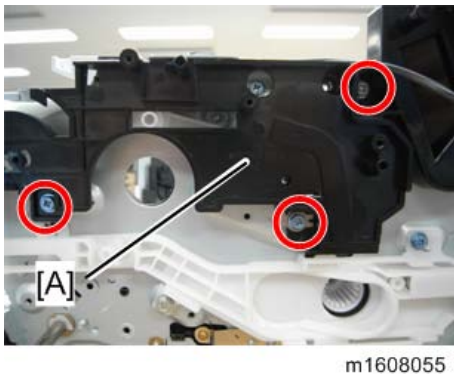

3. Insert tweezers or a screwdriver into the gap between the cover [A] and frame and re-engage the spring hook [B] in the correct position.

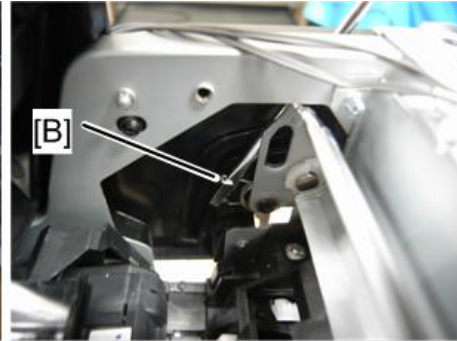
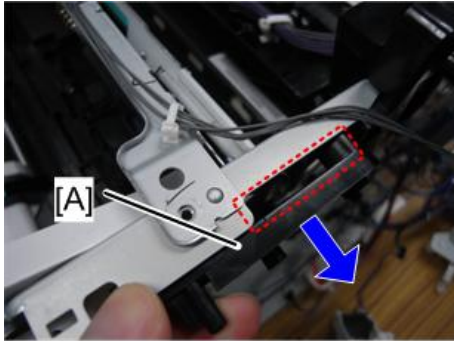

m1608056

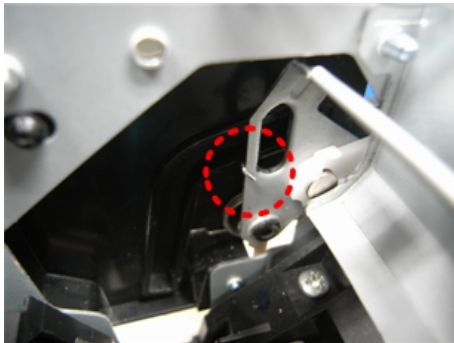

m1608057

Left side

1. Remove the left cover, and then raise the spring using tweezers or a screwdriver inserted through the gap at the lower right of the spring [A].

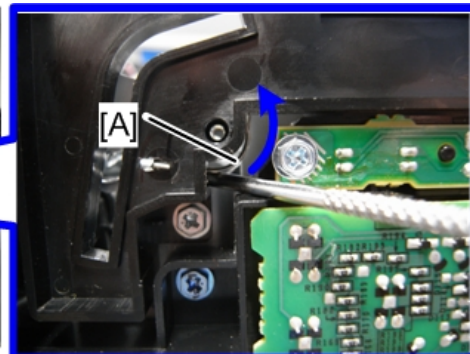
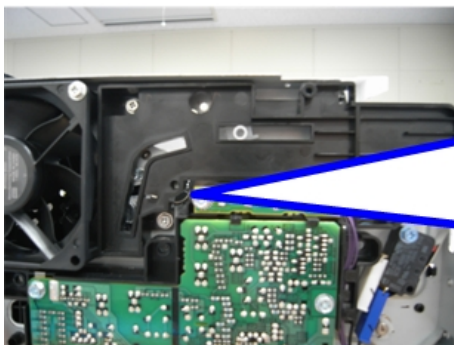

m1608053

2. You can check the position of the hook [A] through the guide of the LED unit. Using tweezers or a screwdriver, re-engage the hook in the correct position.

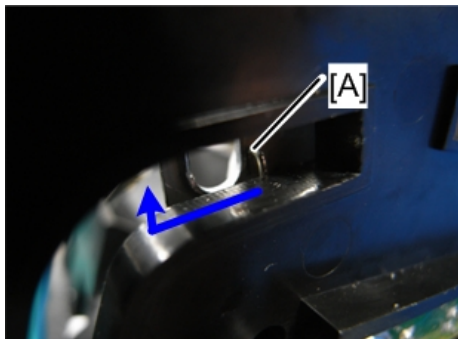

m1608054

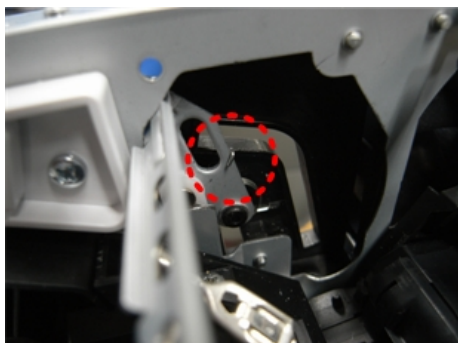

m1608058

PCDU

PCDU

1. Press the release button and open the front cover [A].

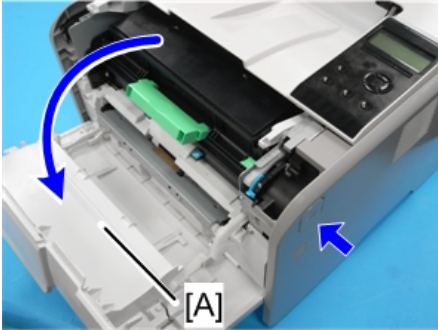

m171m0018

2. Hold the grip to pull the PCDU [A] out.

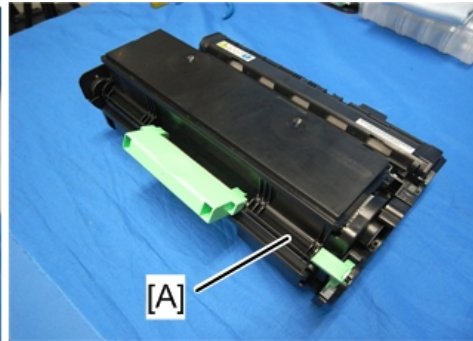

m158m0023

Toner Cartridge

Toner Cartridge

1. Open the front cover [A] and push down the lever [B] of the toner cartridge.

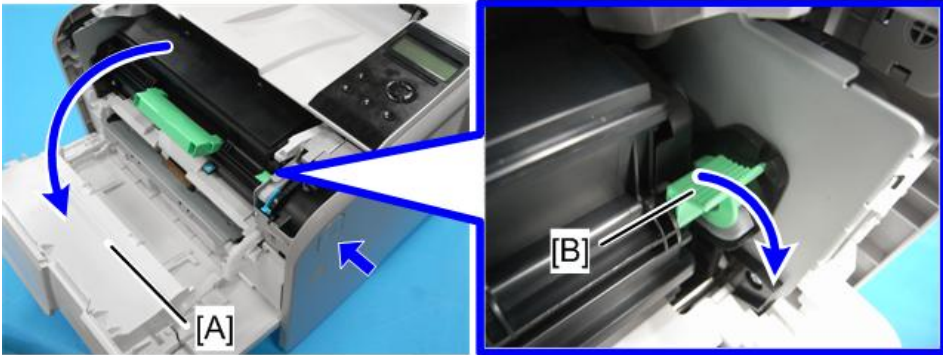

m171m0076

Note

- The release lever works in two steps. To release the lock, push down the release lever to the horizontal position.



m1600280

2. Hold the grip to pull the toner cartridge [A] out.



m158m0025

Image Transfer

Image Transfer Roller

1. PCDU (page 55 "PCDU")
2. Pinch both green ends of the guide [A] and pull it towards you.

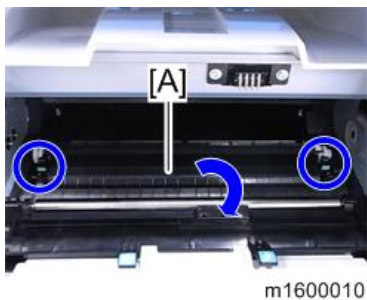

3. Image Transfer Roller [A]



Drive Unit

⚠ CAUTION

- Turn off the main power switch and disconnect the power cord before you start any of the procedures in this section. (page 33 "General Cautions")

Main Motor

The main motor is located behind the drive unit.

1. Drive Unit (page 61 "Drive Unit")
2. Main Motor [A] (⚙ x 4, 📦 x 1)

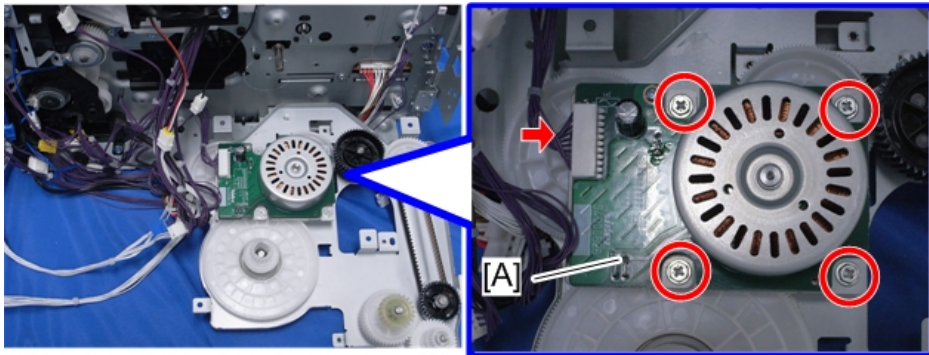

m171m0042

Toner Supply Clutch

1. Drive Unit (page 61 "Drive Unit")
2. Gear Unit (page 62 "Gear Unit")
3. E-ring (🔩 x 1)

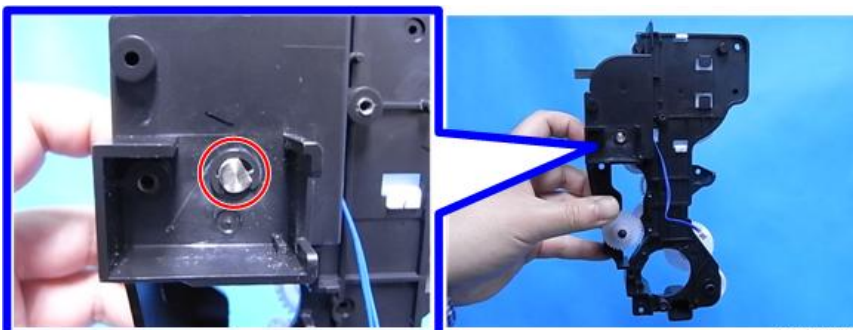

m1600229

4. Toner Supply Clutch [A] with shaft (Gear x 1)



m1600230

5. All things attached to the toner supply clutch [A] (Gear x 1, Shaft x 1).

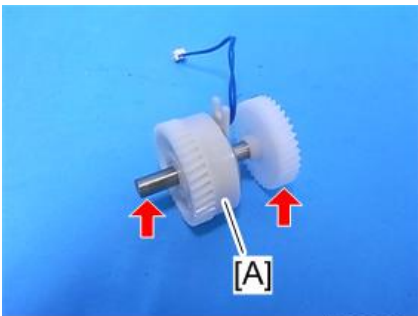

m1600231

4

Registration Clutch

1. BCU (page 96 "BCU")
2. Registration Clutch [A] (📦 x 1, ⚙️ x 1, ⚙️ x 1)

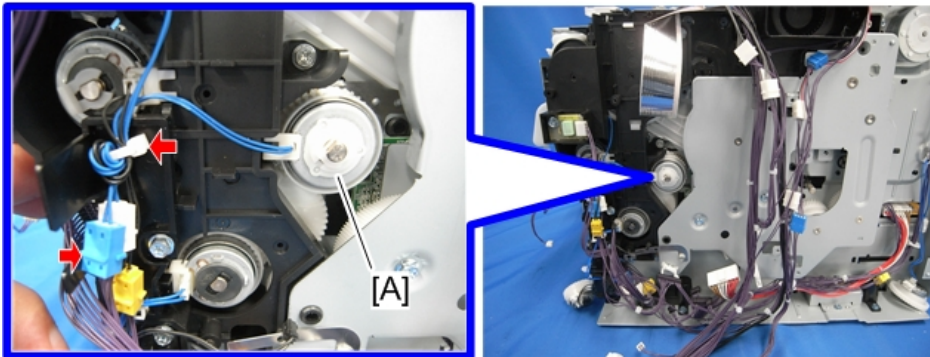

m158m0049

Paper Feed Clutch

1. BCU (page 96 "BCU")
2. Harness Guide [A] (🔧 x 1, 🛠️ x 2)

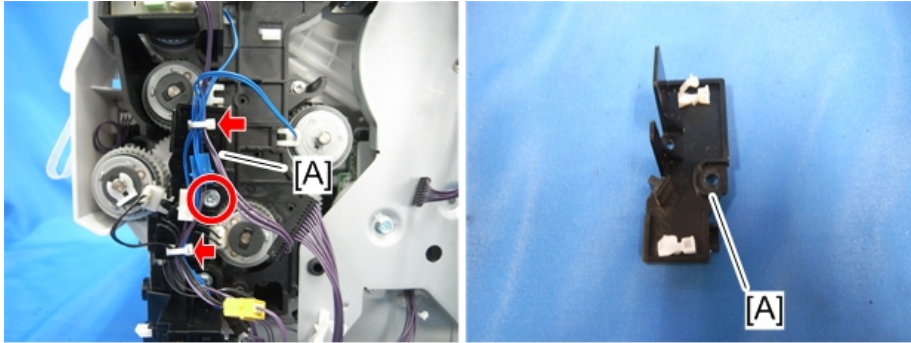

m158m0050

3. Paper Feed Clutch [A] (🔧 x 1)

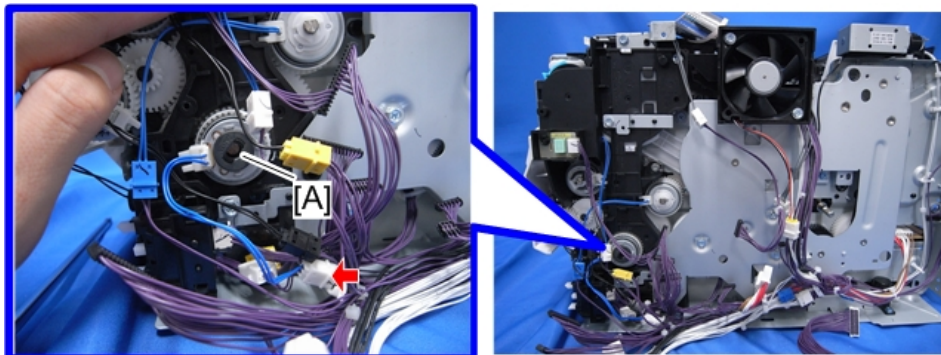

m171m0043

Drive Unit

1. BCU (page 96 "BCU")
2. Duplex Clutch (page 65 "Duplex Clutch")
3. Paper Size Detection Switch (page 84 "Paper Size Detection Switch")
4. Upper Cover (page 43 "Upper Cover")

5. PCDU Cooling Fan with Bracket [A] (🔩 x 2, 📦 x 1, hook x 1)

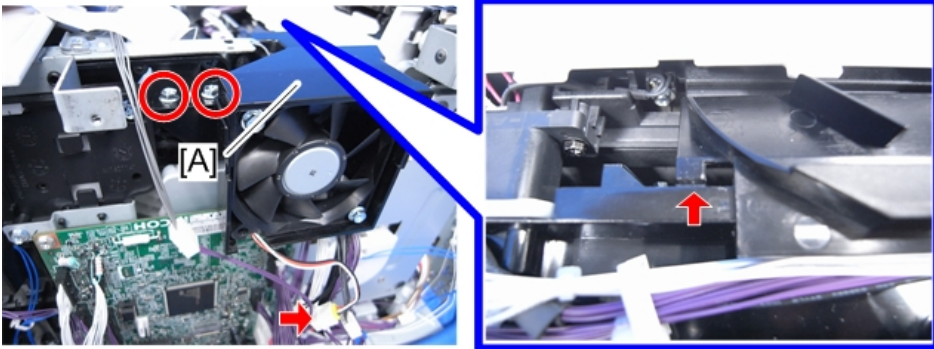

m171m0044

4

6. Drive Unit [A] (🔩 x 7, Grounding Plate x 2, 📦 x 3)

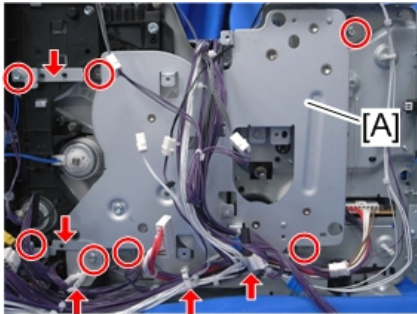

m171m0045

Gear Unit

1. Drive Unit (page 61 "Drive Unit")
2. Registration Clutch (page 60 "Registration Clutch")
3. By-pass Bottom Plate Clutch (page 65 "By-pass Bottom Plate Clutch")
4. Paper Feed Clutch (page 61 "Paper Feed Clutch")
5. By-pass Feed Clutch (page 63 "By-pass Feed Clutch")
6. Temp Humid Sensor (page 102 "Temp Humid Sensor")
7. Paper Size Detection Switch (page 84 "Paper Size Detection Switch")

8. Gear Unit [A] (⊗ x 4, ⊗ x 1, Gear x1)

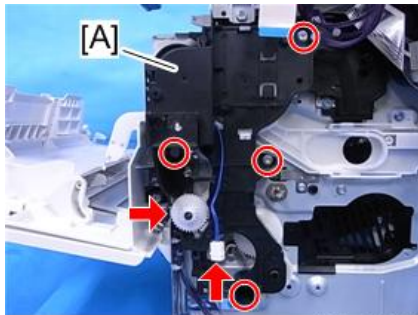

m171m0046

↓ Note

- Before attaching the Gear Unit [A], close the front cover and put the tab [B] on the front cover arm through the link part hole [C] on the Gear Unit back side.

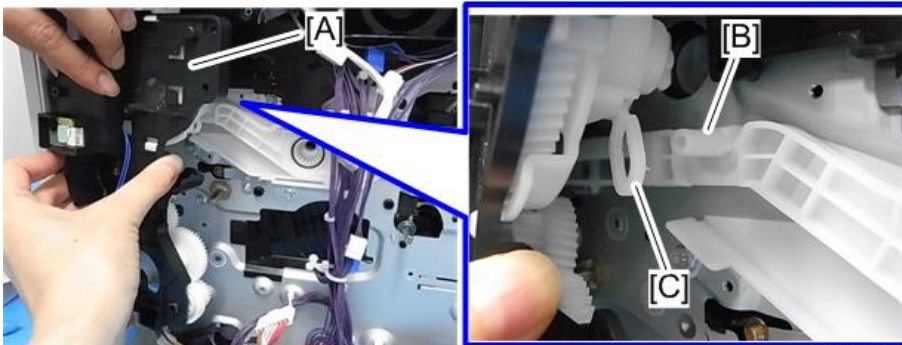

m160z0290

- Note that correct side of the gear is attached when attaching the Gear [D].



m160z0289

By-pass Feed Clutch

1. Right Cover (page 39 "Right Cover")

2. Harness Guide [A] (🔑 x 1, 🛠️ x 1)

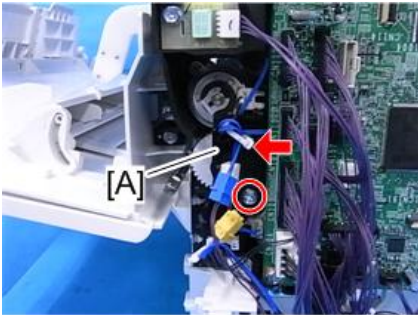

m1600221

3. By-pass Feed Clutch [A] (🔑 x 1, 🛠️ x 1)

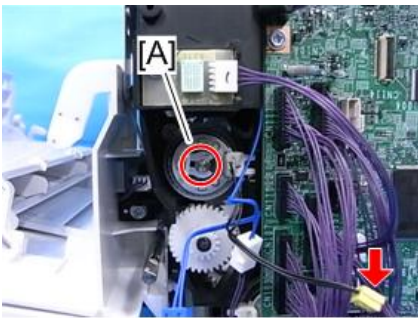

m1600222

4

Relay Clutch

1. By-pass Feed Unit (page 79 "By-pass Feed Unit")
2. Gear Unit (page 62 "Gear Unit")
3. Relay Clutch [A] (🔑 x 1)

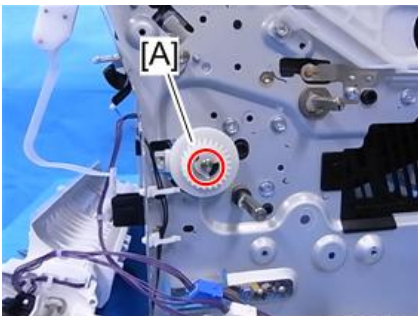

m1600220

By-pass Bottom Plate Clutch

1. Right Cover (page 39 "Right Cover")
2. By-pass Bottom Plate Clutch [A] (⚙️ x 1, ⚙️ x 1, 📦 x 1)

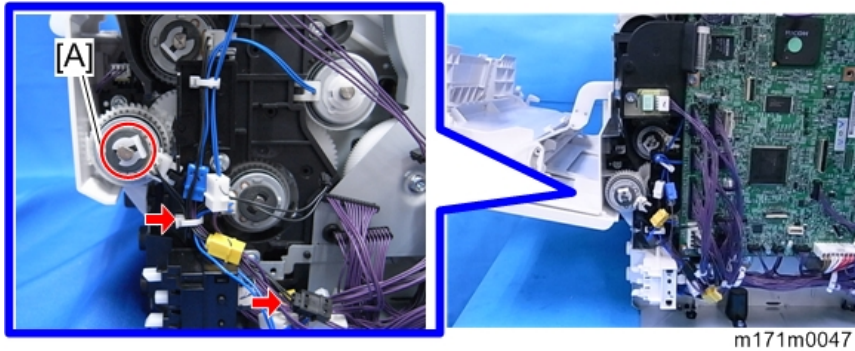

4

Duplex Clutch

1. Controller Board (page 95 "Controller Board")
2. Duplex Clutch Cover [A] (⚙️ x 1, ⚙️ x 1, 📦 x 1)

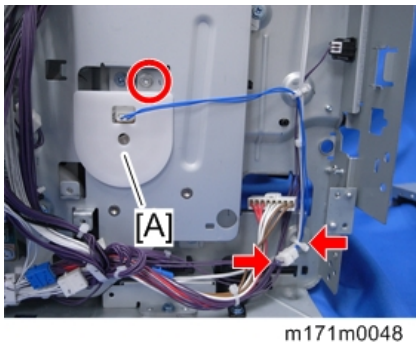

3. Duplex Clutch [A]

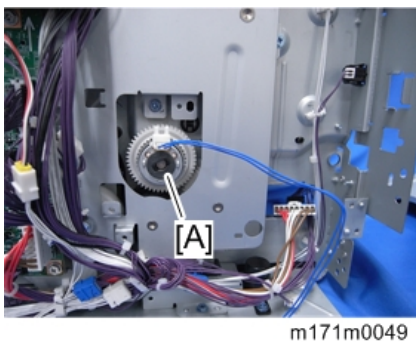

Junction Gate Solenoid

1. Upper Cover (page 43 "Upper Cover")
2. Controller Box (page 93 "Controller Box")
3. One connector of the Junction Gate Solenoid [A] (🔌 x 1)

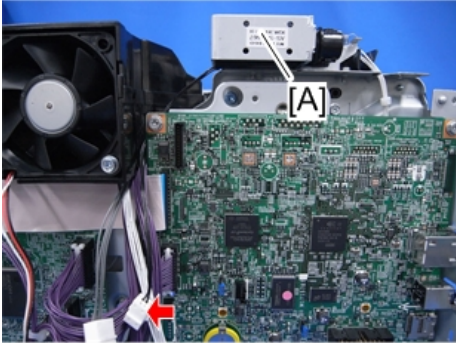

m171m0050

4. Junction Gate Solenoid [A] (🔩 x 2, 🌀 x 1)

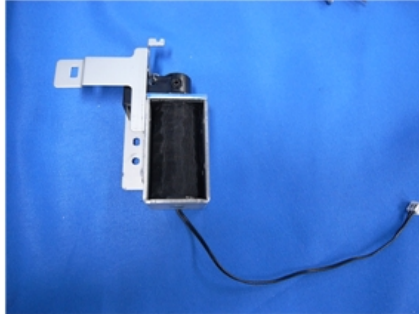
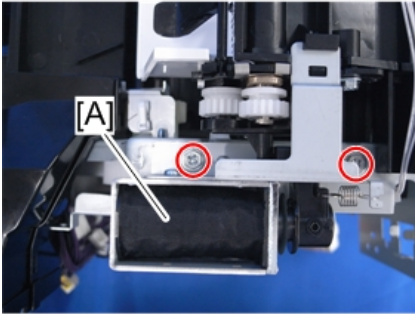

m171m0051

Fusing

⚠ CAUTION

- Because there is a danger of burns on contact with hot parts of the fusing unit, start work when the temperature drops to a low enough temperature.
- Turn off the main power switch and disconnect the power cord before you start any of the procedures in this section. (page 33 "General Cautions")

Fusing Unit

4

1. Open the rear cover [A].
2. Release the lock levers [B].



m158m0055

3. Fusing Unit [A]



m158m0056

↓ Note

- For PM: Replace the fusing unit with new product detection capability from the Maintenance Kit. (User operation)

Upper Fusing Unit, Lower Fusing Unit

1. Fusing Unit (page 67 "Fusing Unit")
2. Remove the screws of the fusing unit (⌀ x5).

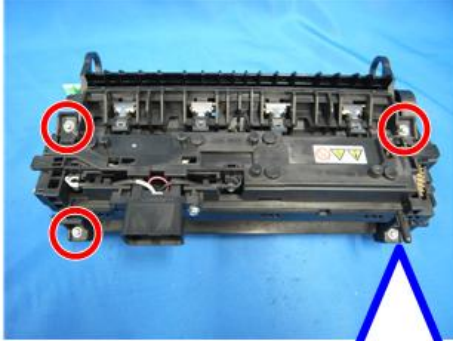

m173m0065

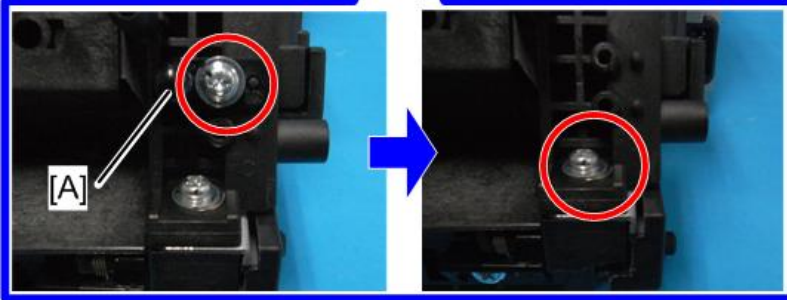

↓ Note

- At the time of installation, be sure to attach the pin [A] to the correct position. If not, the fusing unit cannot be attached to the main body properly.

3. Separate the fusing unit into the upper and lower fusing units.
4. Right cover [A] (⌀ x 2)



m173m0004

5. Left cover [A] (🔩 x 1)

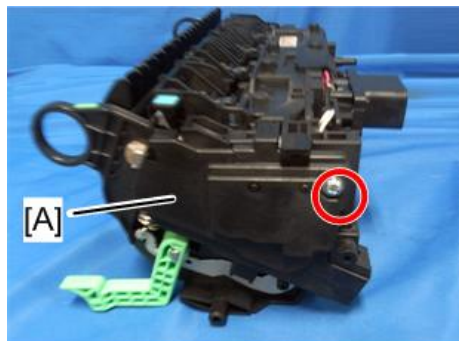

m173m0117

[B]: Lower Fusing Unit

[C]: Upper Fusing Unit

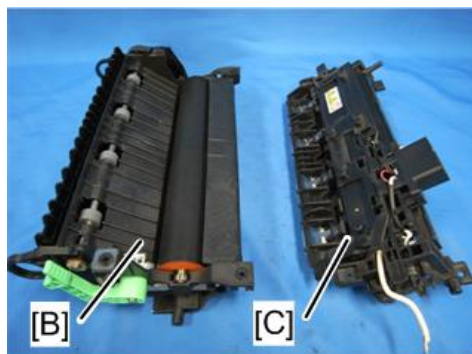

m173m0005

↓ Note

- You can reassemble the upper and lower fusing units with more ease by lowering the envelope lever.

Fusing Pressure Roller, Cleaning Roller

- Separate the fusing unit into the upper and lower fusing units. (page 68 "Upper Fusing Unit, Lower Fusing Unit")

2. Fusing Pressure Roller [A]

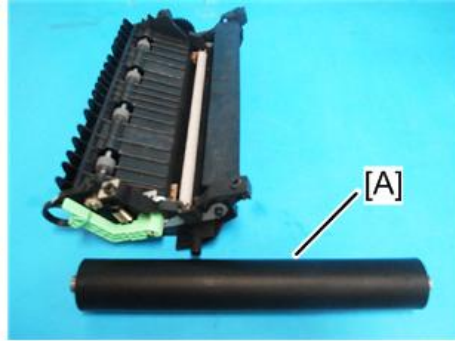
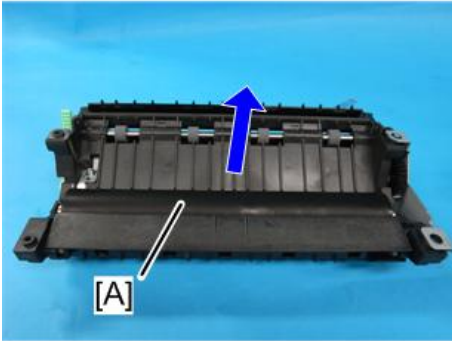

m173m0116

4

3. Cleaning Roller [A]

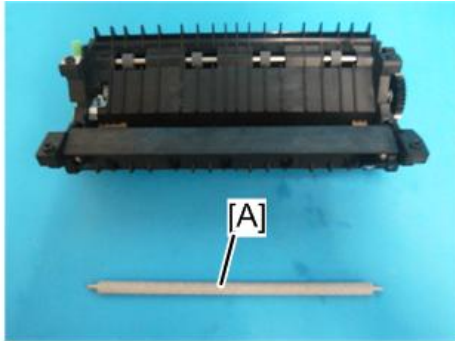
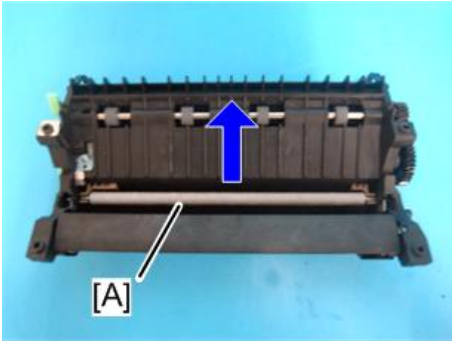

m173m0115

Fusing Lamp, Hot Roller

★ Important

- Be careful not to break the fusing lamp when removing/attaching screws.
- Insert a pin or jeweller's screwdriver into the service hole (see the lower red circle in the photo below), and hold the flat nut with your finger (see the upper red circle in the photo). Otherwise, the lamp secured together with the flat nut moves with rotation of the screw, which causes a lamp breakage.

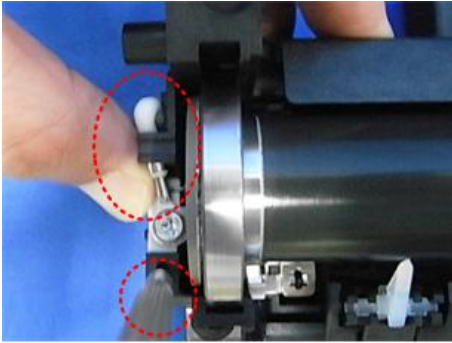

m173m0118

1. Separate the fusing unit into the upper and lower fusing units. (page 68 "Upper Fusing Unit, Lower Fusing Unit")
2. Remove the screws of the fusing lamp (🔩 x3).

4

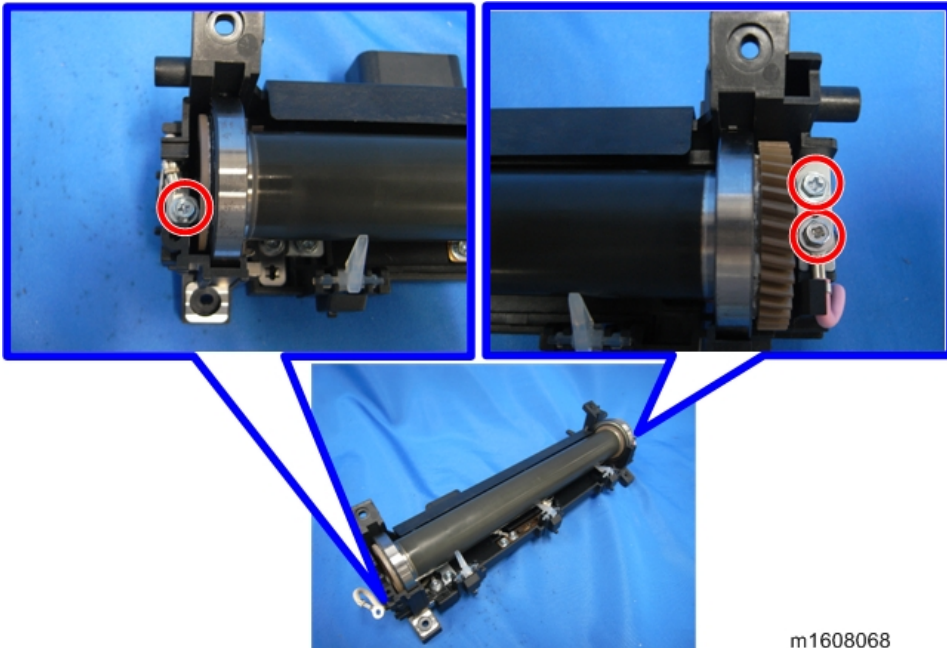

m1608068

3. Two brackets [A]

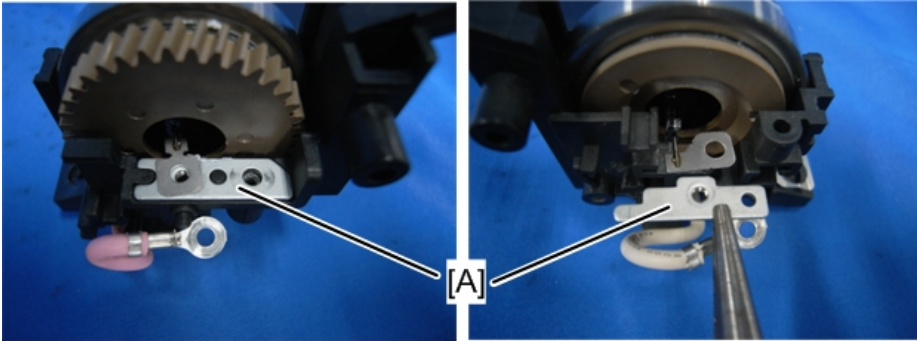

m1608069

4

4. Fusing lamp [A]

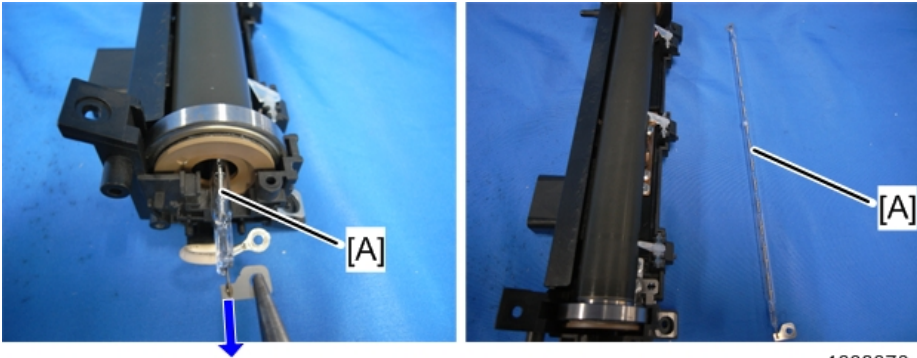

m1608070

5. Hot Roller [A]

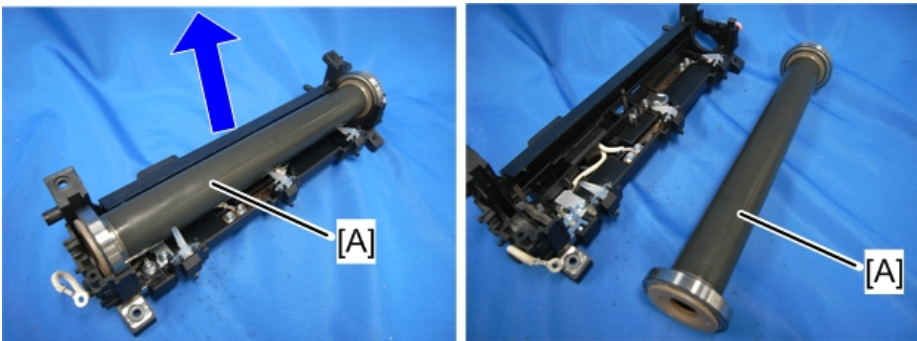

m1608071

Thermostat

1. Separate the fusing unit into the upper and lower fusing units. (page 68 "Upper Fusing Unit, Lower Fusing Unit")

2. Hot Roller (page 70 "Fusing Lamp, Hot Roller")

3. Thermostat [A] (🔩 x2)

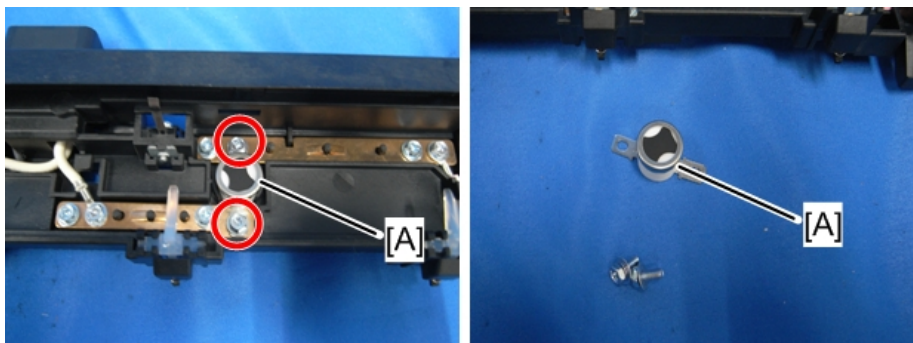

m1608072

4

Thermistor

↓ Note

- The thermistor is integrated with the drawer connector.
1. Separate the fusing unit into the upper and lower fusing units. (page 68 "Upper Fusing Unit, Lower Fusing Unit")
 2. Hot Roller (page 70 "Fusing Lamp, Hot Roller")
 3. Remove the screws of the harness (🔩 x3).

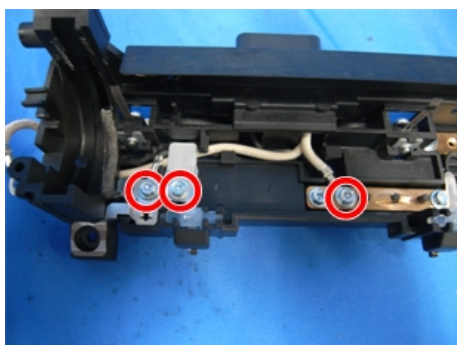

m1608073

4. Remove the bracket of the drawer connector, and then remove the screws of the thermistor (🔩 x3).

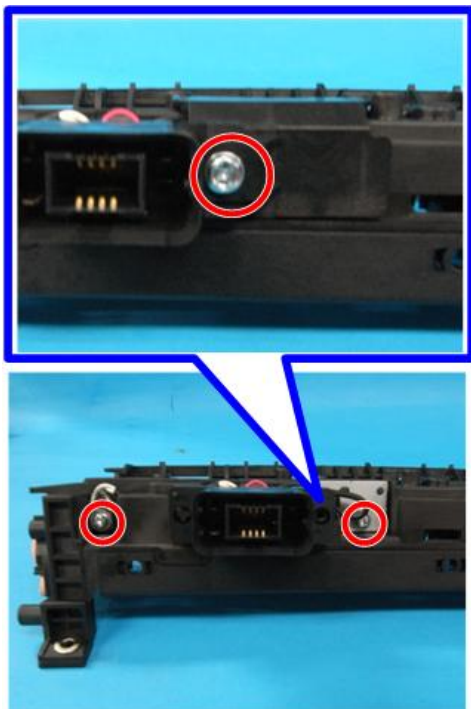

m173m0008

5. Thermistor [A]

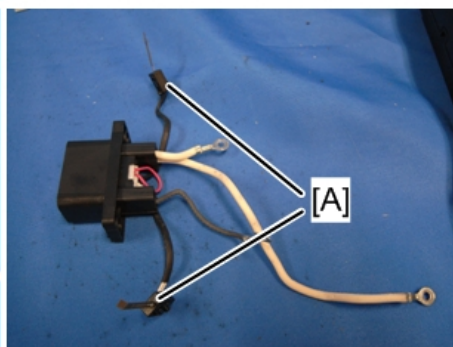
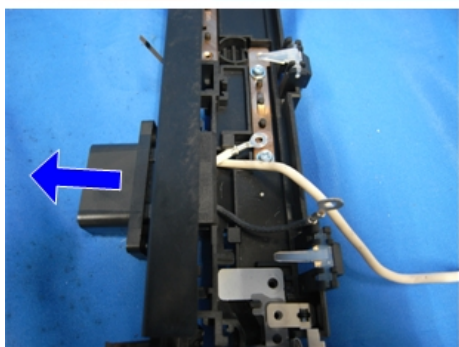
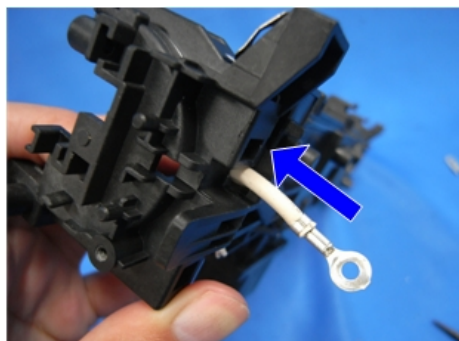

m1608075

Notes on reassembly

Be sure to attach the drawer connector with its protruding part [A] in the position shown below.

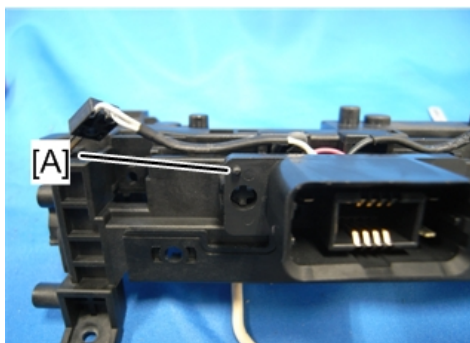

m1608076

Insert the flat nut [A]. Be sure not to drop them during disassembly.

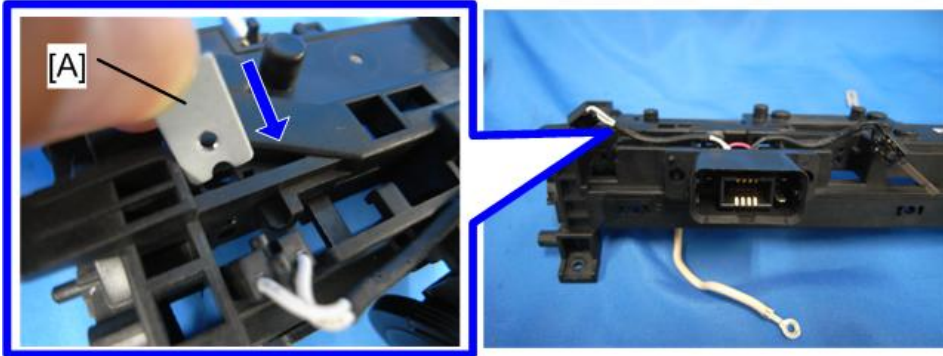

m173m0009

4

Hot Roller Stripper

1. Separate the fusing unit into the upper and lower fusing units. (page 68 "Upper Fusing Unit, Lower Fusing Unit")
2. Spring [A]

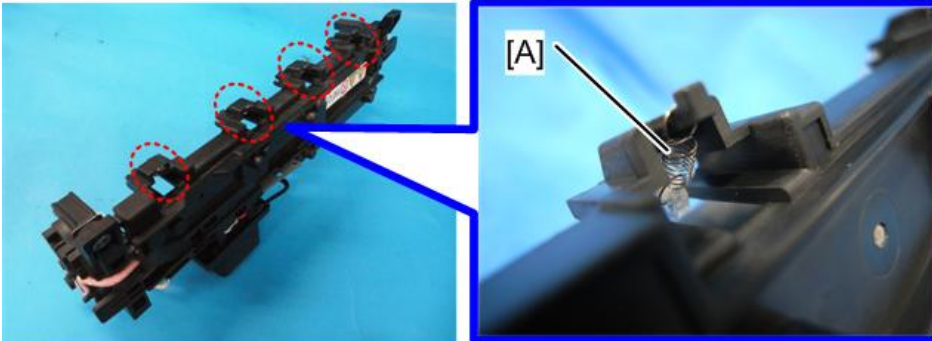

m173m0010

3. Hot Roller Stripper [A]

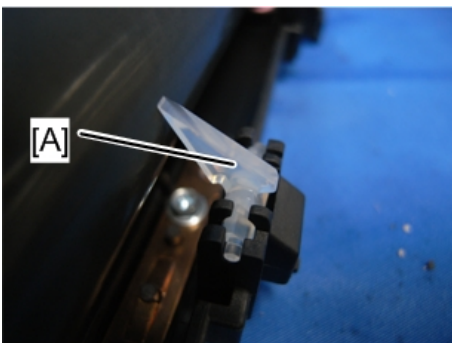

m1608079

Paper Feed

⚠ CAUTION

- Turn off the main power switch and disconnect the power cord before you start any of the procedures in this section. (page 33 "General Cautions")

Paper Feed Tray

1. Pull the paper feed tray [A] out completely to detach it.



m1600081

4

Paper Feed Roller

1. Paper Feed Tray (page 77 "Paper Feed Tray")
2. Slide the lever [B] to the left to detach the paper feed roller [A].

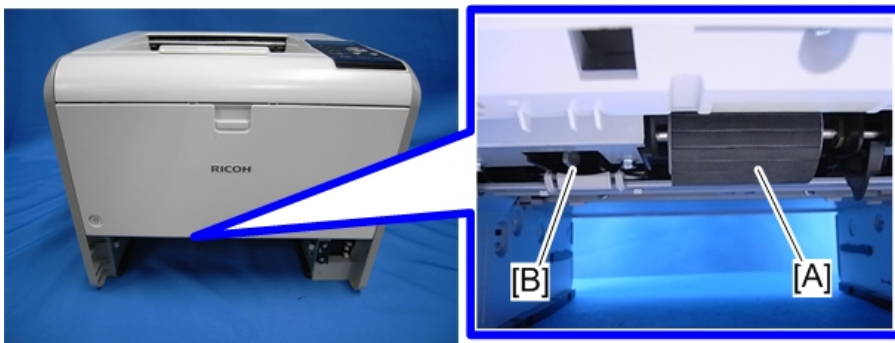

m158m0039

Friction Pad

1. Paper Feed Tray (page 77 "Paper Feed Tray")

2. Release the hooks on the bottom of the paper feed tray to detach the friction pad [A].

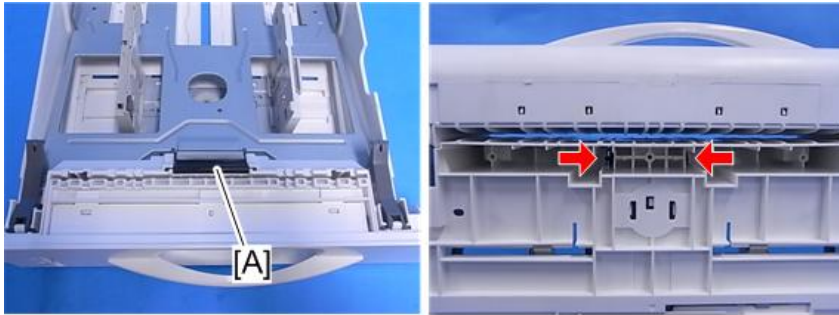

m1600085

4

Paper End Sensor

1. By-pass Feed Unit (page 79 "By-pass Feed Unit")
2. PCDU (page 55 "PCDU")
3. Bracket [A] (🔧 x 6)

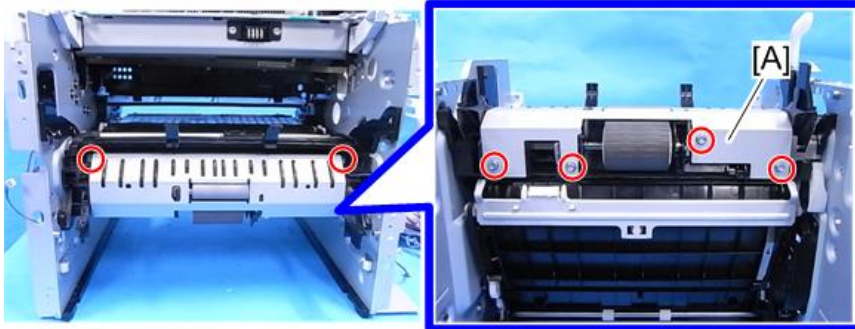

m1600088

4. Paper End Sensor [A] (🔧 x 1, Hook)

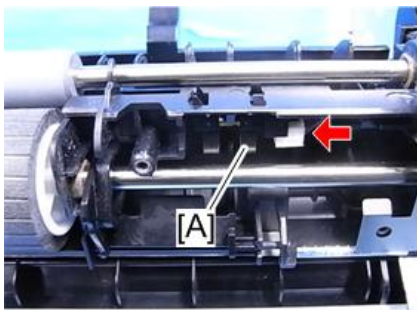

m1600089

By-pass Feed Unit

1. Front Cover (page 35 "Front Cover")
2. Left Cover (page 37 "Left Cover")
3. Gear Unit (page 62 "Gear Unit")
4. By-pass Feed Unit [A] (🔑 x 5, 📦 x 3, 🛠️ x 2)

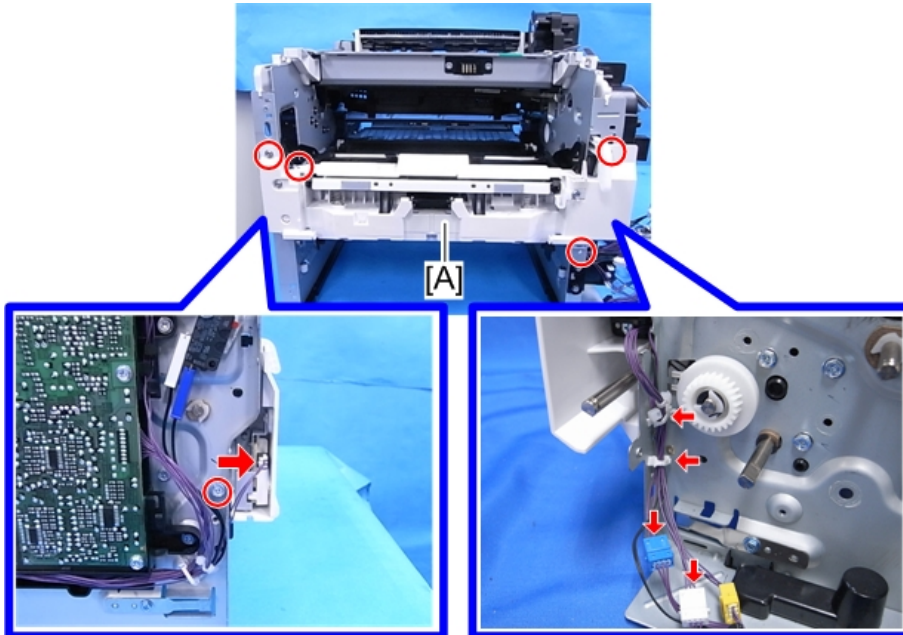

m171m0057



m1600115

↓ Note

- Release the hook [A] and then insert a flat-blade screwdriver into the space [B] to detach the by-pass feed unit from the machine.

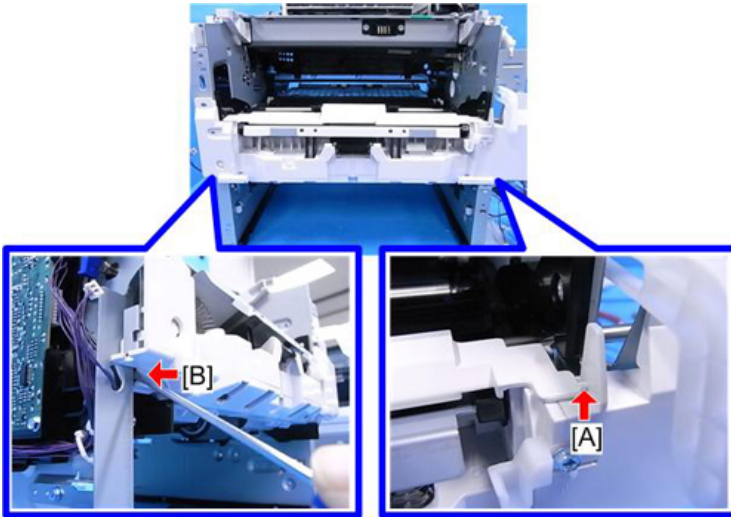

m1600114

By-pass Feed Roller

1. Gear Unit (page 62 "Gear Unit")
2. By-pass Feed Unit (page 79 "By-pass Feed Unit")

Note

- When attaching the By-pass Feed Unit and Gear Unit, secure the harness with clamps to prevent the harness from being caught by gears.

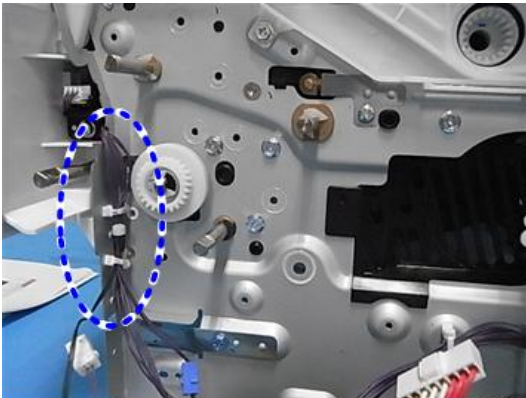

m160z0291

3. Remove the clips and bearings on both sides of the by-pass feed guide [A] (⌀ x 2, Bearing x 2).

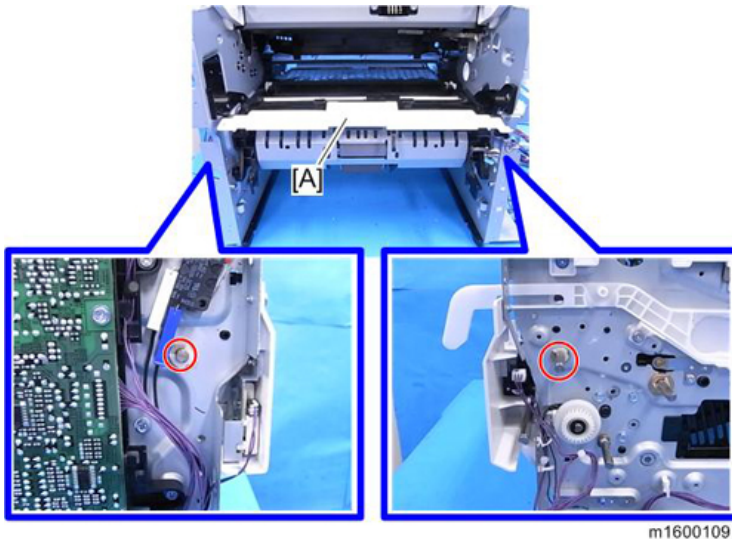

4

4. Slide the by-pass feed guide [A] with the by-pass feed roller to the right to detach it from the machine.

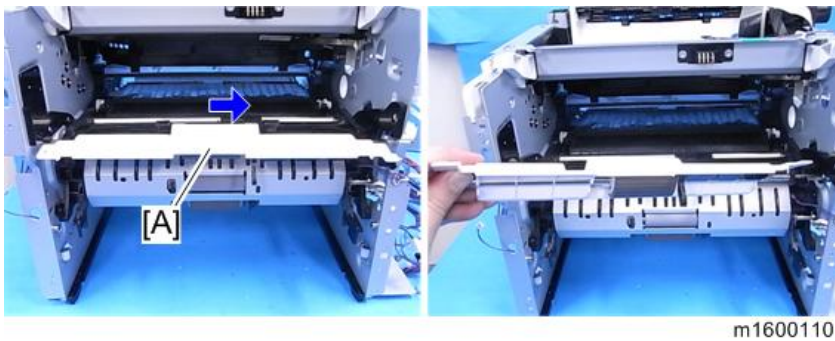

5. Detach the by-pass feed roller with the shaft [B] from the guide [A].

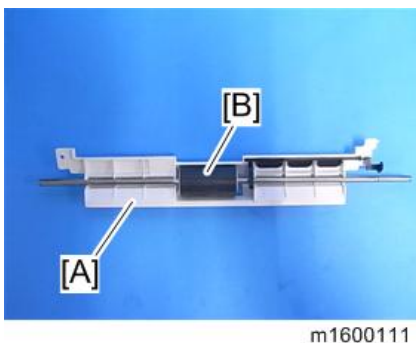

6. Separate the by-pass feed roller [A] from the shaft (Hook x1).

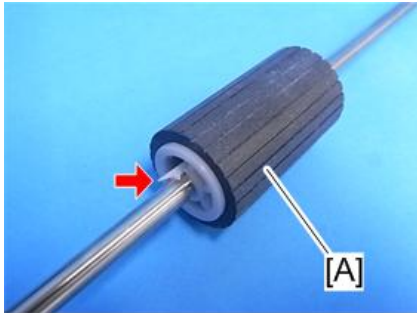

m1600112

4

By-pass Friction Pad

1. By-pass Feed Unit (page 79 "By-pass Feed Unit")
2. Bottom Plate [A]

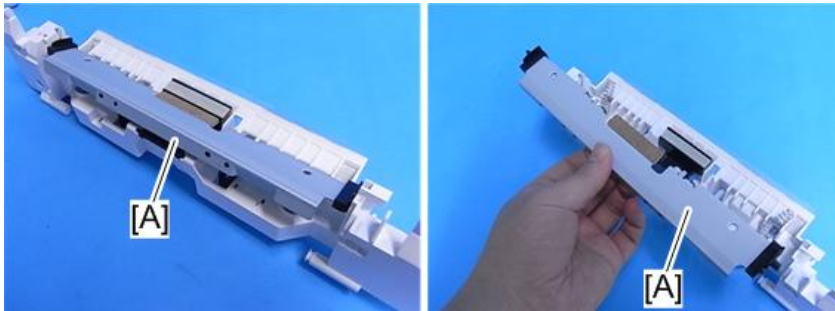

m1600106

Note

- If you cannot remove the bottom plate because the part [A] prevents the cam [B] from releasing, rotate the shaft [C] to let the cam [B] avoid the bottom plate link [A].

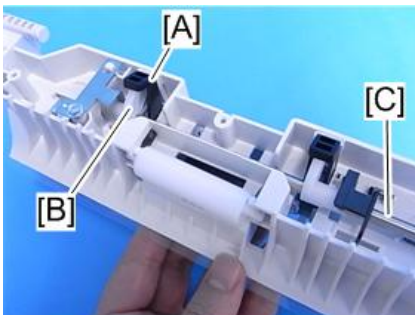

m1600108

3. Remove the friction pad [A] by pressing its hinge downward. (🌀 x 1)

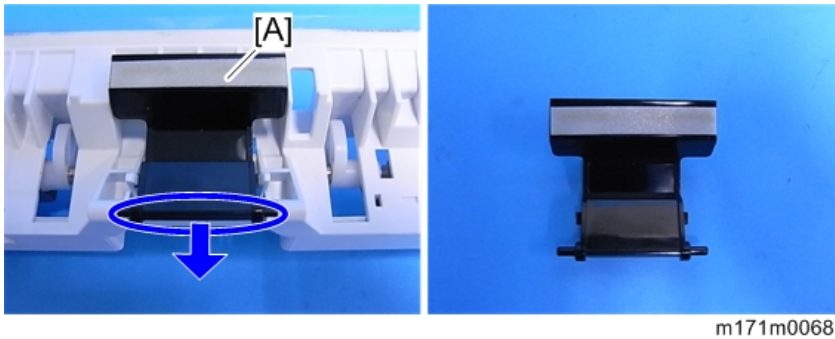

By-pass Paper End Sensor

4

1. By-pass Feed Unit (page 79 "By-pass Feed Unit")
2. Bracket with By-pass Sensor [A] (🌀 x 1)



3. Detach the By-pass Paper End Sensor [A] from the bracket (Hook).

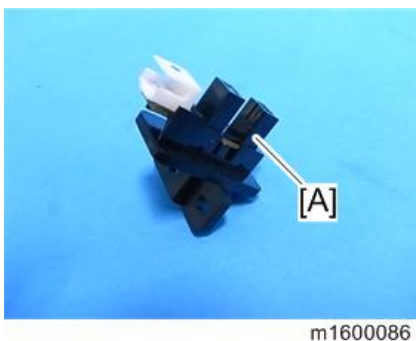

By-pass Bottom Plate HP Sensor

1. By-pass Feed Unit (page 79 "By-pass Feed Unit")
2. By-pass Feed Lower Cover [A] (🔩 x 3)

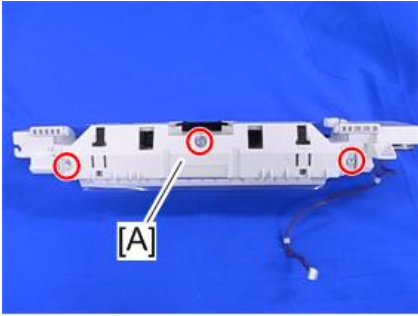

4

3. By-pass Bottom Plate HP Sensor [A] (🔗 x 1, Hook)

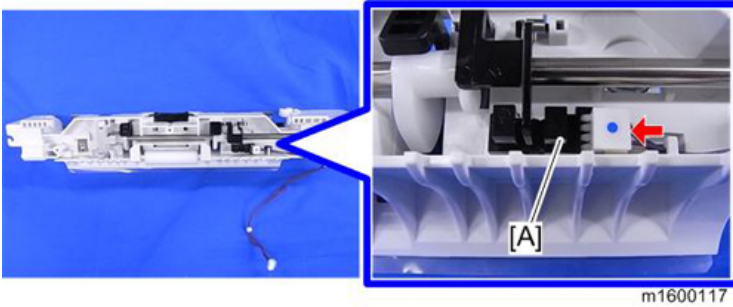

Paper Size Detection Switch

1. Paper Feed Tray (page 77 "Paper Feed Tray")
2. Right Cover (page 39 "Right Cover")

3. Bracket with Paper Size Detection Switch [A] (🔧 x 2)

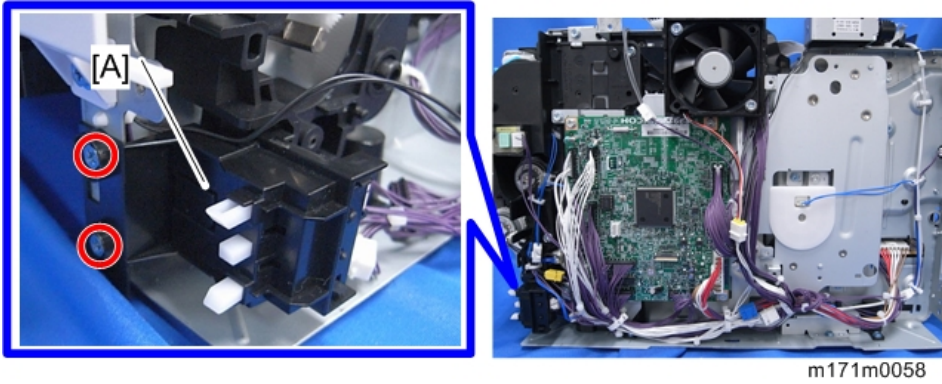

4. Harness for Paper Size Detection Switch (🔌 x 2)

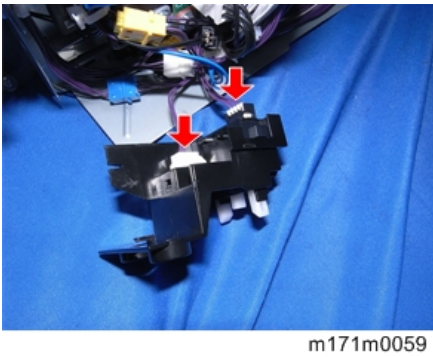

5. Detach the Paper Size Detection Switch [A] from the bracket (Hook x 2).

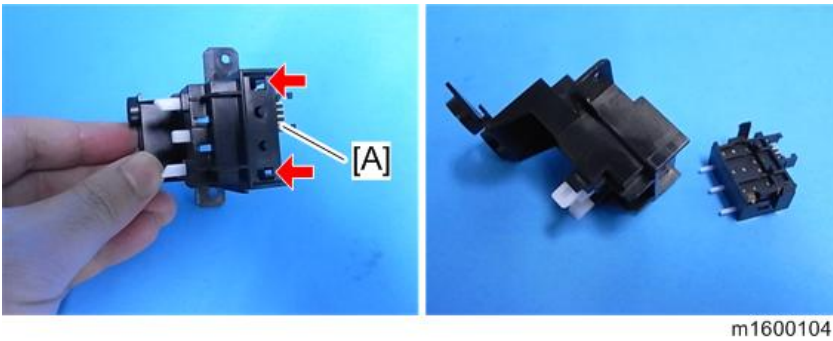

Paper Transport

⚠ CAUTION

- Turn off the main power switch and disconnect the power cord before you start any of the procedures in this section. (page 33 "General Cautions")

Exit / Switchback Sensor

1. Upper Cover (page 43 "Upper Cover")
2. Exit / Switchback Sensor [A] (Hook,  x 1)

4

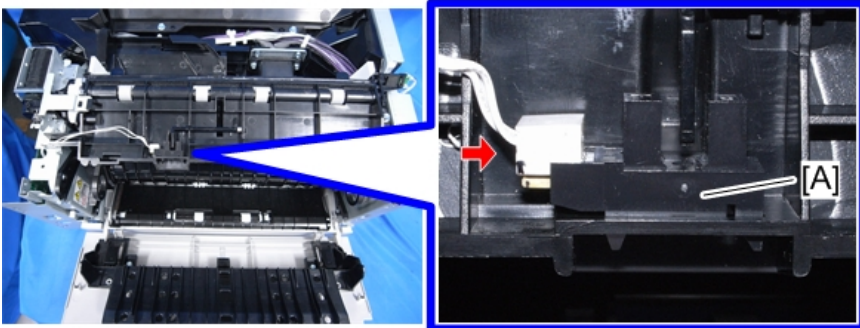

m171m0052

Duplex Entrance Sensor

1. PSU (page 93 "PSU")
2. Duplex Clutch (page 65 "Duplex Clutch")
3. Open the duplex exit guide plate [A].



m1608082

4. Remove screws circled in the picture below ( x 5).
[A] Duplex exit guide unit

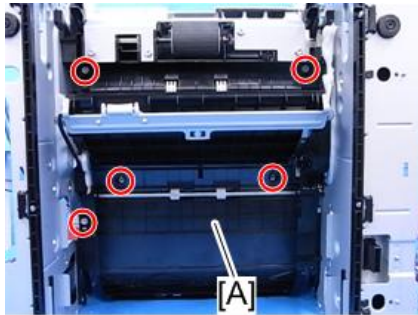

m1600125

5. Release the linking part to remove duplex exit guide unit [A].

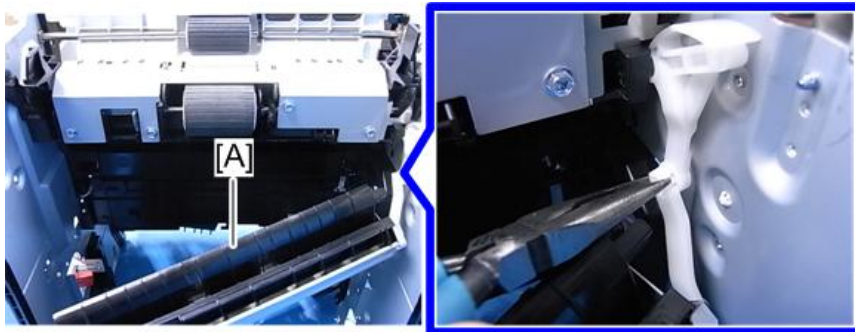

m1600126

Note

- Use pliers to pinch the linking part in order to separate.

6. Duplex Entrance Sensor [A] (📦 x 1, Hook)

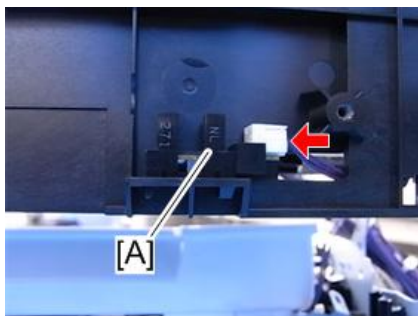

m1600128

Exit / Switchback Roller, Duplex Exit Gear

1. Upper Cover (page 43 "Upper Cover")
2. Junction Gate Solenoid (page 66 "Junction Gate Solenoid")

3. Paper Guide [A] (🌀 x 2, 📦 x 1)

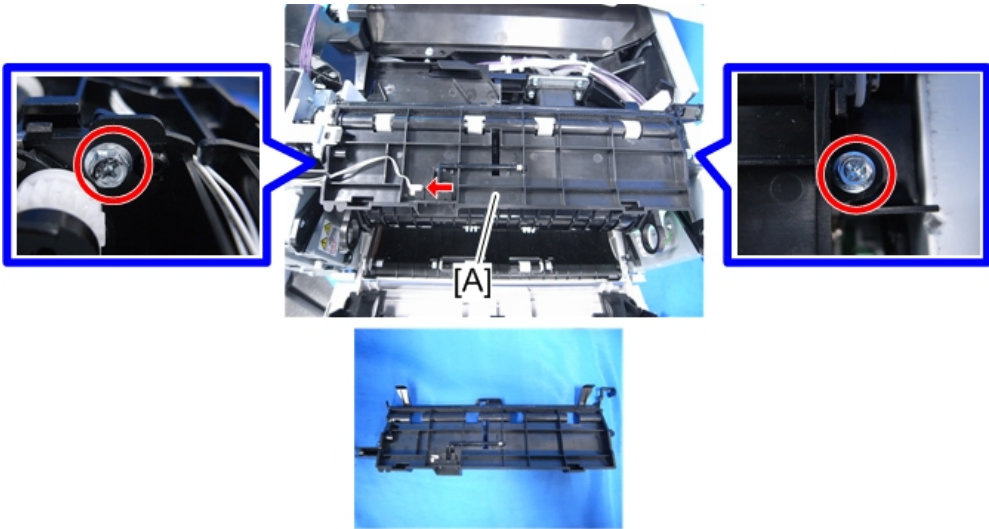

m171m0063

4. Release the bearing at the right end of the exit/switchback roller (🌀 x 1).

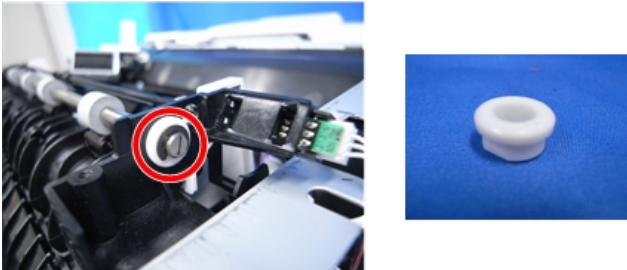

m171m0064

5. Remove the E-ring [A] on the left side of the exit/switchback roller.

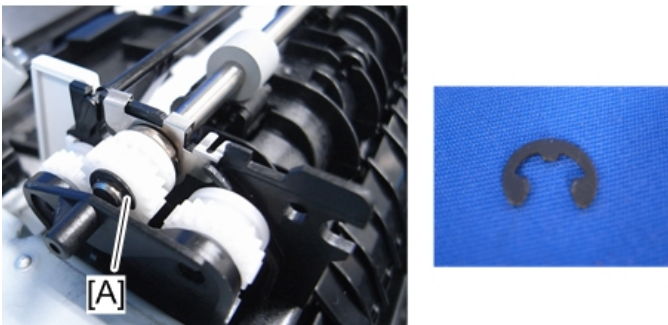

m171m0065

6. Slide the exit/switchback roller [A] to the right to remove it.

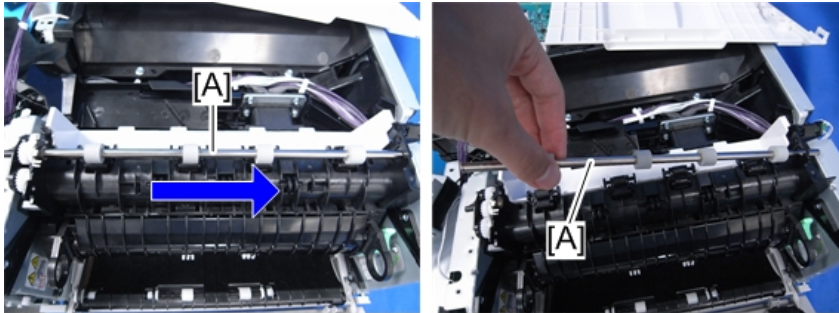

m171m0066

7. Duplex Exit Gear [A]

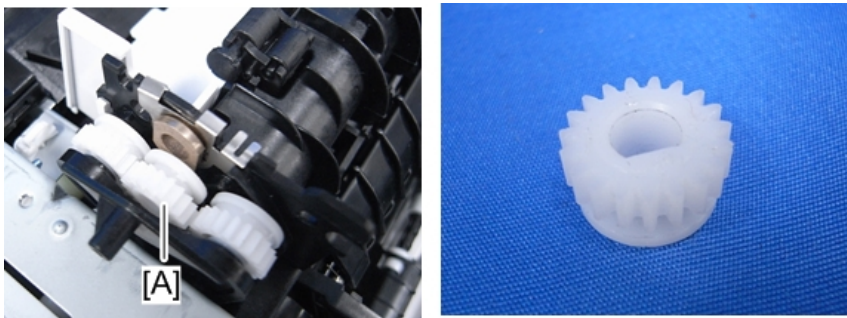

m171m0067

4

Registration Roller (Driven)

1. Gear Unit (page 62 "Gear Unit")
2. Registration Sensor (page 91 "Registration Sensor")
3. HVPS with bracket (page 98 "HVPS with Bracket")
4. Release the bearing [A] at the left end of the registration roller (drive) and fixing plate [B] (⚙ x 1, ⚙ x 2).

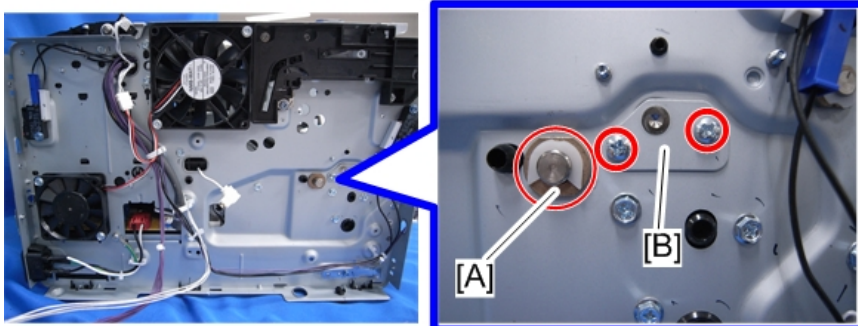

m171m0054

5. Release the bearing at the right end of the registration roller (drive), and remove the grounding plate [A] (⚙ x 1, ⚙ x 1).

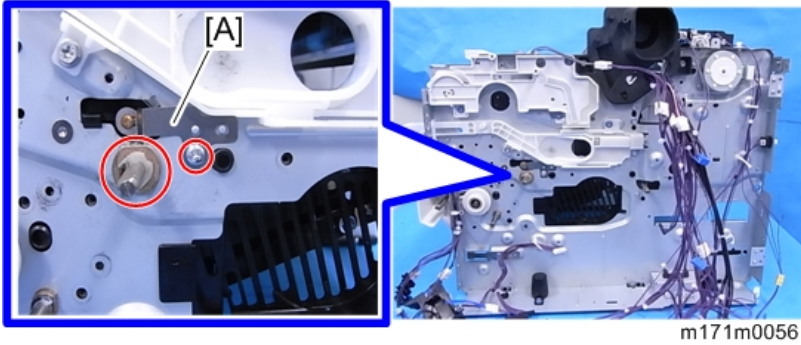

4

6. Insert a flathead screwdriver into the gap on the left of the registration roller guide to release the protruding part.

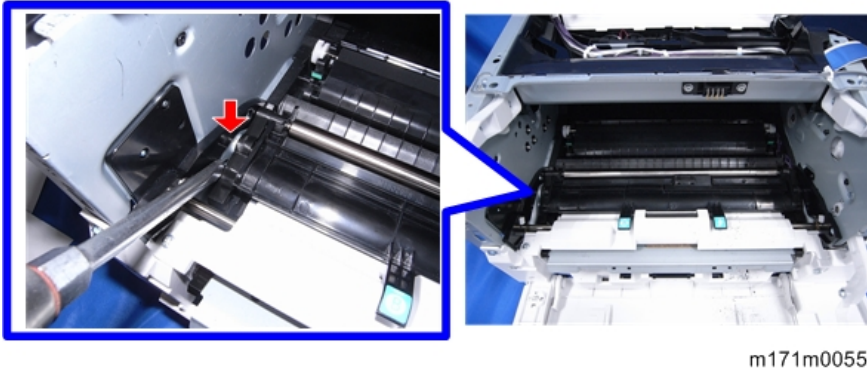

7. Release the harness from the guide [A] to detach the guide [A] with the registration roller (driven).



8. Detach the registration roller (driven) [B] from the guide [A].

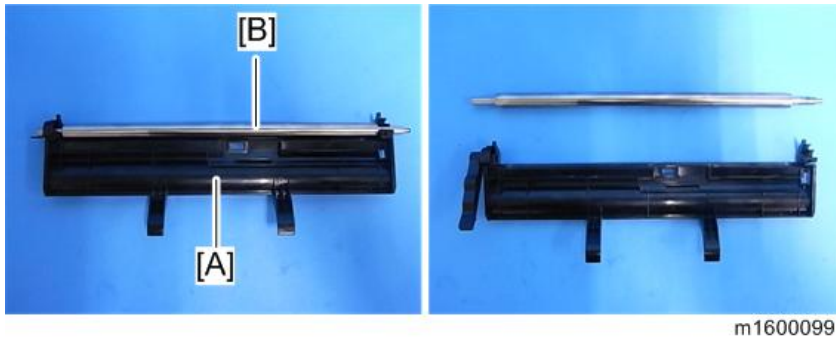

Registration Roller (Drive)

4

1. Registration Roller (Driven) (page 89 "Registration Roller (Driven)")
2. Slide the registration roller (drive) [A] to the right to remove it.

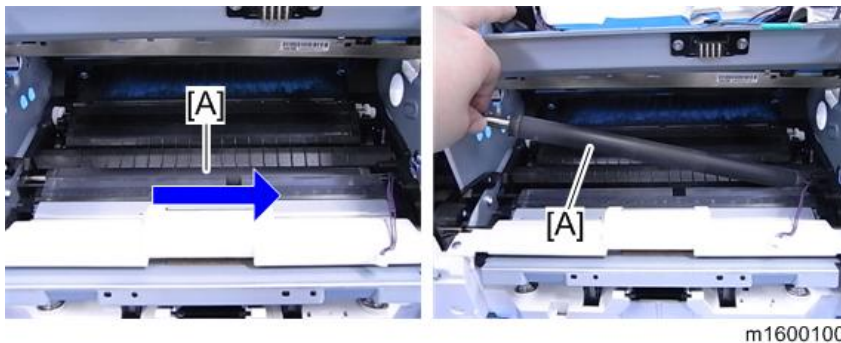

Registration Sensor

1. PCDU (page 55 "PCDU")

2. Sheet [A]

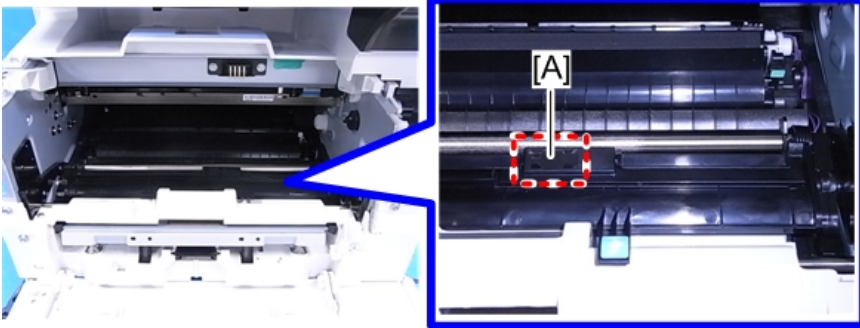

m158m0100

4

3. Release the hooks of the harness cover [A] with a screwdriver to remove it.

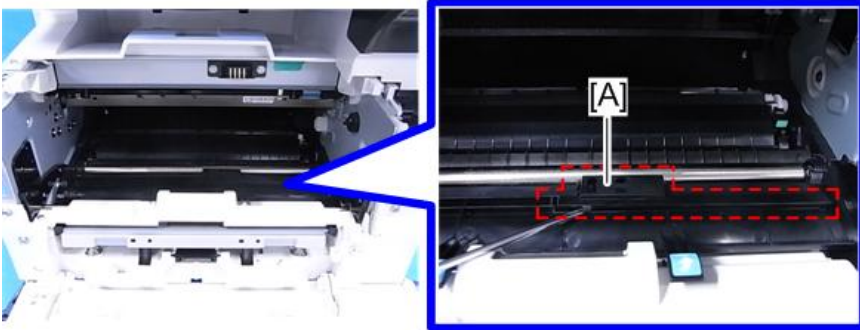

m1600021

4. Registration Sensor [A] (Hook,  x 1)

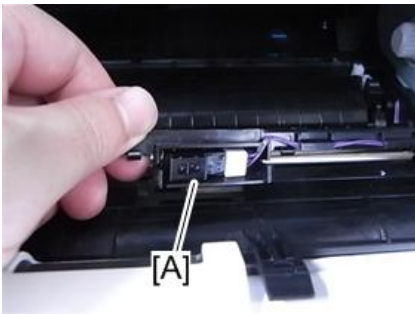

m1600092

Electrical Components

⚠ CAUTION

- Turn off the main power switch and disconnect the power cord before you start any of the procedures in this section. (page 33 "General Cautions")

Controller Box

1. Right Cover (page 39 "Right Cover")
2. Controller Box [A] (⚙ x 7, ⚙ x 2)

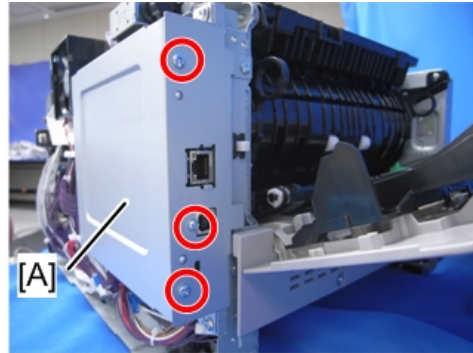
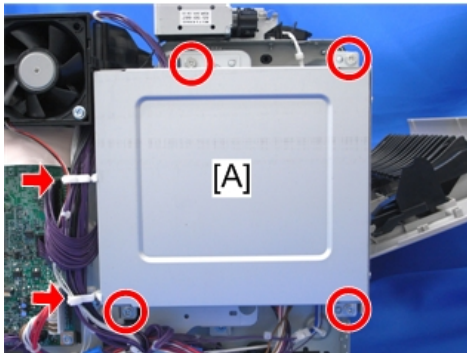

m171m0034

4

PSU

1. Paper Feed Tray (page 77 "Paper Feed Tray")
2. Left Cover (page 37 "Left Cover")
3. Rear Cover, Rear Lower Cover (page 41 "Rear Cover, Rear Lower Cover")
4. Controller Board (page 95 "Controller Board")

5. Remove the screws, clamps and connectors on the left side of the PSU (🔩 x 3, 🗉 x 2, 📡 x 2).

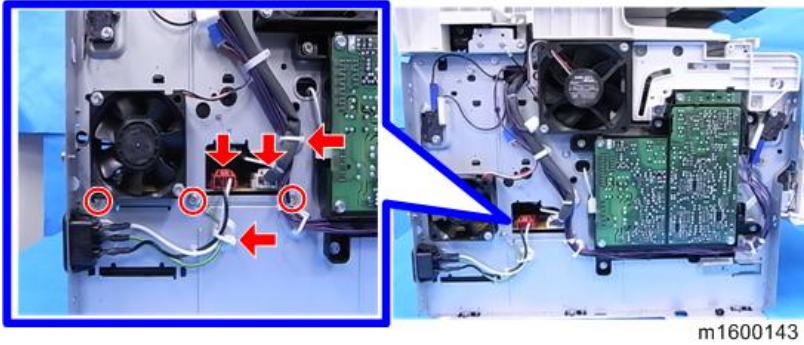

4

6. Remove the screws and connectors on the right side of the PSU (🔩 x 1, 📡 x 1).

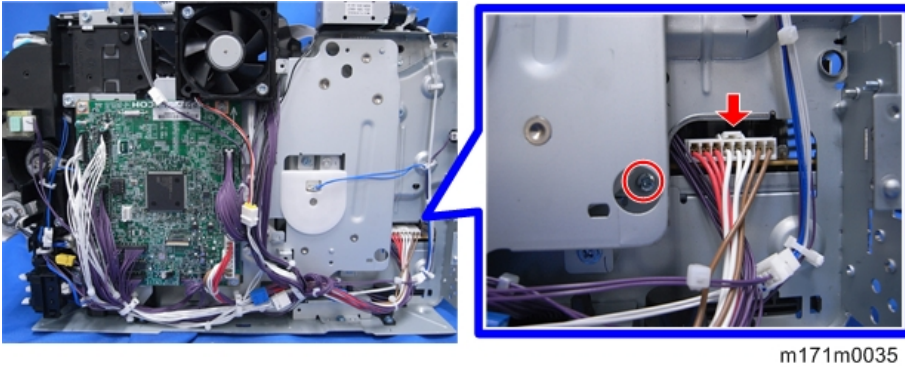

7. Two screws on the rear side of the PSU (🔩 x 2)



8. PSU [A] with Bracket (📦 x 1)



9. Cover [A] (🔩 x 2)

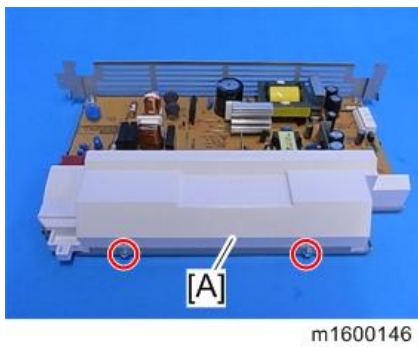

10. Detach the PSU [A] from the bracket (🔩 x 6).

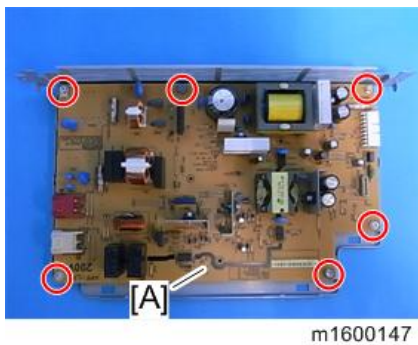

Controller Board

1. Controller Box (page 93 "Controller Box")

2. Controller Board [A] (🔩 x 4, 📦 x 3).

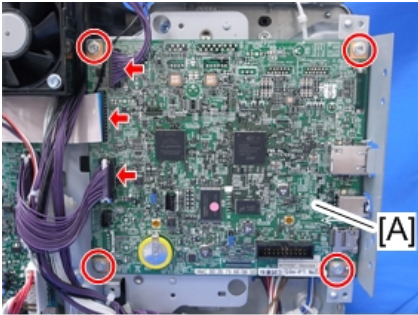

Important note
RTB 6

m171m0036

BCU

1. Controller Board (page 95 "Controller Board")

2. BCU [A] (🔩 x 4, 📦 x all)

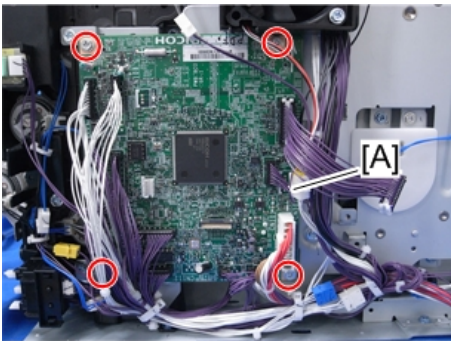

m171m0037

3. Remove the EEPROM [A] from the old board and install it on the new board.

Install so that the indentation [B] on EEPROM is facing the direction of the dent [C] that is printed on the BCU board.

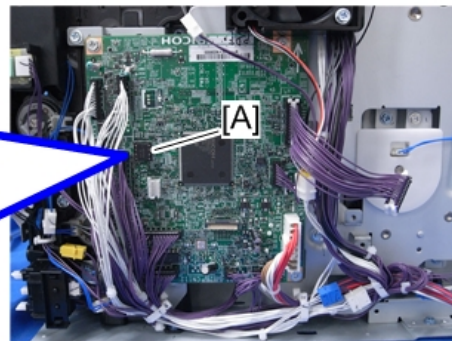
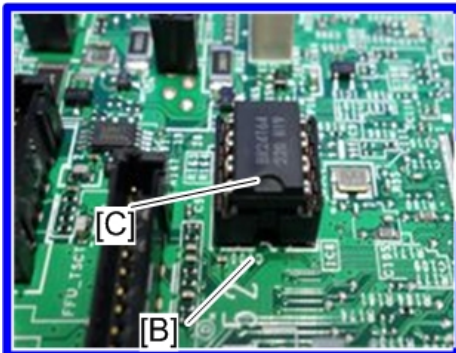

m171m0038

4. Install the new BCU in the machine.
5. Enter the machine's serial number into the BCU (SP5-811-004).

Note

- If the machine's serial number is not entered correctly into the new BCU, SC995-01 (serial number entry error) appears.

6. Turn the main power switch off and on.
7. Set the DIP switches on the new BCU board to the same settings as the old board.

Note

- Make sure the EEPROM is correctly installed on the BCU. Insert the EEPROM in the EEPROM slot with the "half-moon" pointing [C] to the downside.

EEPROM on the BCU

1. Print out the SMC data (SP5-990-002, SP5-990-003).
2. Turn off the main power switch. Then unplug the power cord.
3. Replace the EEPROM on the BCU and reassemble the machine.
4. Plug in the power cord. Then turn the main power switch on.

When you do this, SC995 will be displayed. However, DO NOT turn off the main power switch. Continue with this procedure.

5. Enter the machine serial number (SP5-811-001).

Important

- For information on how to configure SP5-811-001, contact your supervisor or support center.

6. Set the machine state destination (SP5-996-001).

Important

- For information on how to configure SP5-996-001, contact your supervisor or support center.

7. Turn the main power switch off and on.

Note

- If the BCU serial number is not entered correctly, SC995-01 (serial number entry error) appears.

8. In accordance with SMC data, specify the UP and SP mode settings.

Toner End Sensor

1. Left Cover (page 37 "Left Cover")

2. Toner End Sensor [A] (Ⓜ x 1, 📦 x 1, Tab x 1)

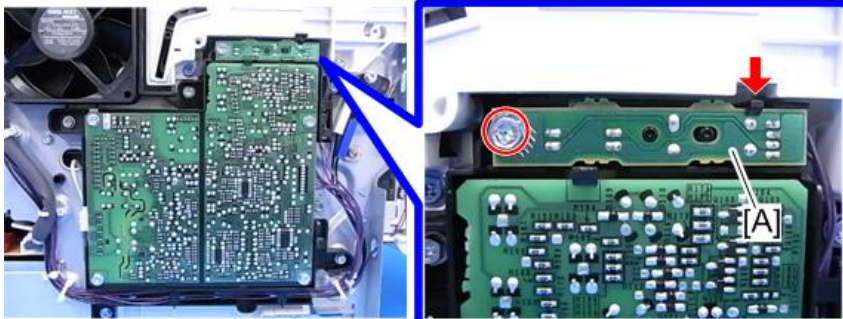

m1600233

4

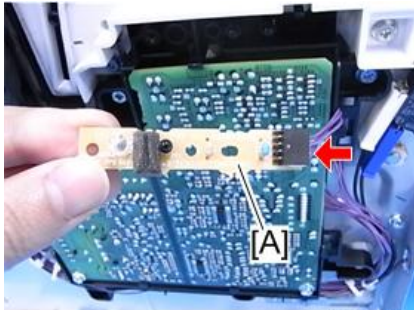

m1600234

HVPS

- 1. Left Cover (page 37 "Left Cover")
- 2. HVPS [A] (Ⓜ x 4, 📦 x 2, Tab x 2)

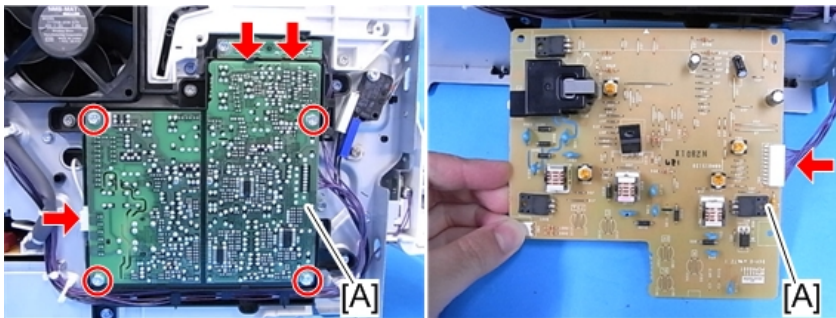

m158m0029

HVPS with Bracket

- 1. Left Cover (page 37 "Left Cover")

2. Toner End Sensor [B] and HVPS [A] with Bracket (🔩 x 5, 📦 x 3, 🛠️ x 2)

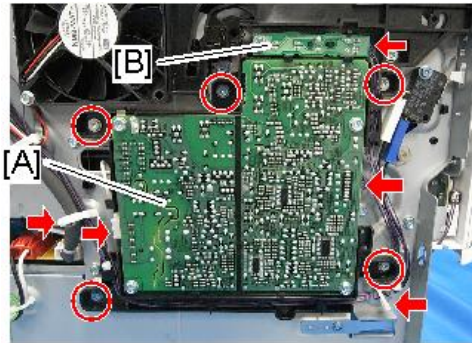

m158m0030

4

Fusing Fan

1. Left Cover (page 37 "Left Cover")
2. Fusing Fan [A] (🔩 x 2, 📦 x 1, 🛠️ x 1)

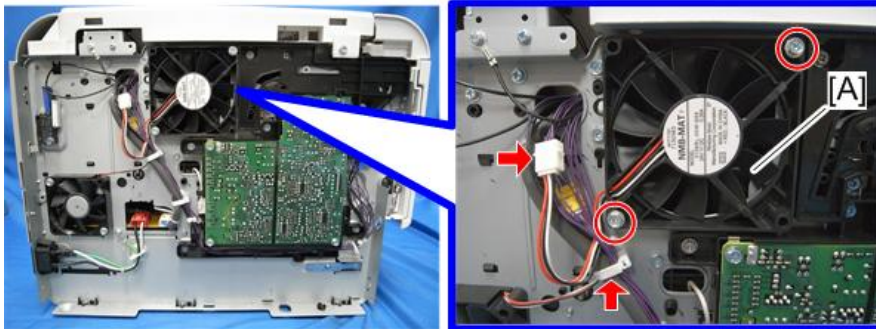

m158m0101

↓ Note

- When you reattach the Fusing Fan, attach it correctly (as shown above, the face of the fan with the sticker is on the outside).

PCDU Cooling Fan

1. Right Cover (page 39 "Right Cover")

2. PCDU Cooling Fan [A] (🔩 x 2, 📦 x 1)

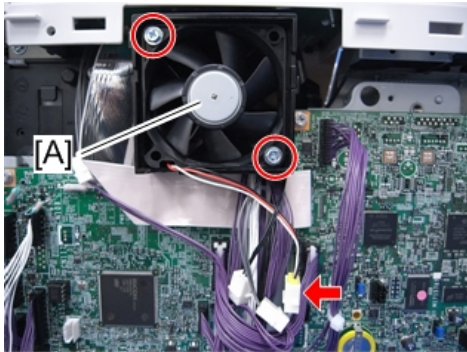

m171m0039

4

↓ Note

- When you reattach the PCDU cooling fan, the face of the fan with the sticker must be on the inside.

PSU Cooling Fan

1. Left Cover (page 37 "Left Cover")
2. PSU Cooling Fan [A] (🔩 x 2, 📦 x 1, 🛠️ x 1)

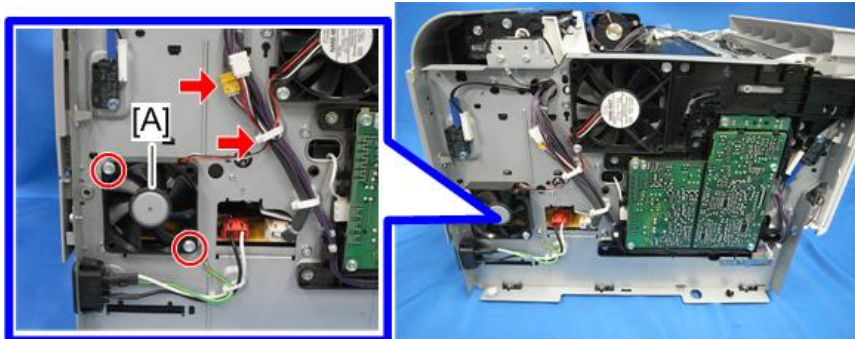

m158m0102

↓ Note

- When you reattach the PSU cooling fan, the face of the fan with the sticker must be on the inside.

DC Switch

1. By-pass Feed Unit (page 79 "By-pass Feed Unit")

2. DC Switch [A] with Bracket (⚙️ x 2)

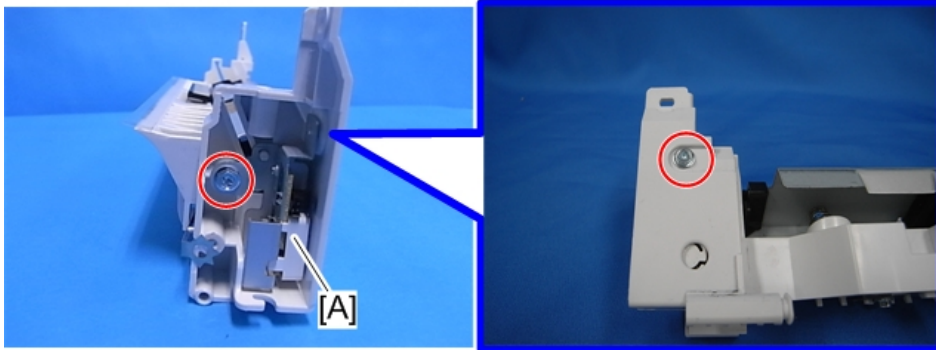

m158m0038

3. Detach the DC Switch from the bracket [A] (⚙️ x 1).

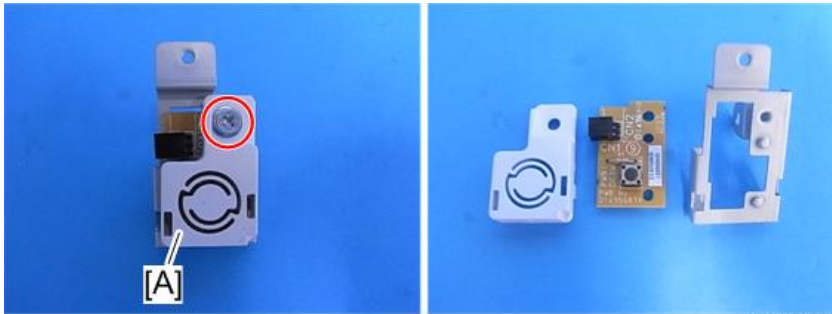

m1600157

Front Door Interlock Switch

1. Left Cover (page 37 "Left Cover")
2. Front Door Interlock Switch [A] (⚙️ x 1, ⚡ x 2)

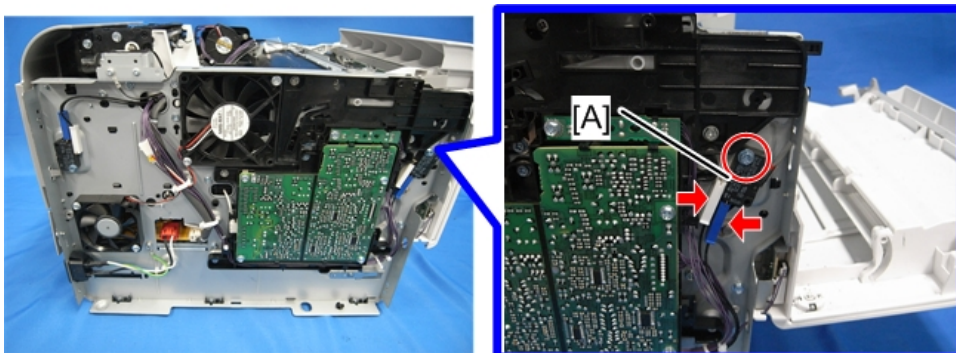

m158m0034

Rear Door Interlock Switch

1. Left Cover (page 37 "Left Cover")
2. Rear Door Interlock Switch [A] (🔩 x 1, 📦 x 2)

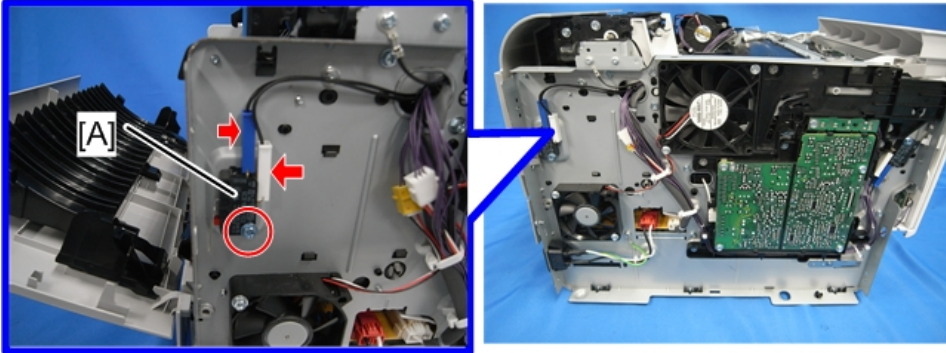

m158m0035

Temp Humid Sensor

1. Right Cover (page 39 "Right Cover")
2. Temp Humid Sensor [A] (🔩 x 1, 📦 x 1)

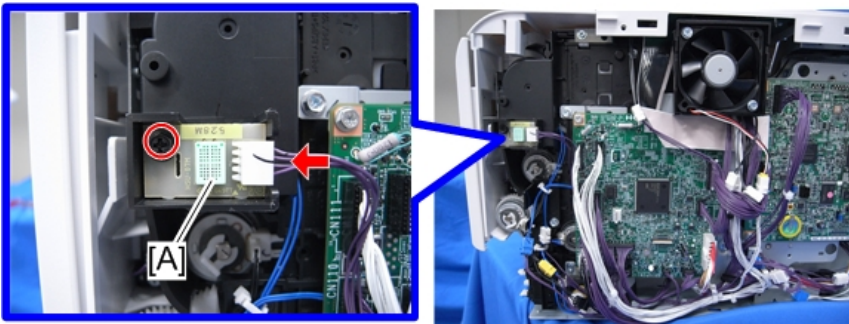

m171m0040

Rear Cover Switch

1. Controller Board (page 95 "Controller Board")

2. Rear Cover Switch [A] (📦 x 1, Hook)

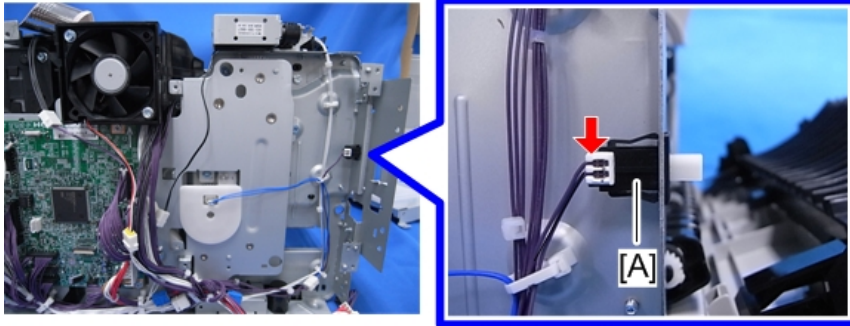

m171m0041

5. System Maintenance

Service Program Mode

CAUTION

- Make sure that the data-in LED is not on before you go into the SP mode. This LED indicates that some data is coming to the machine. When the LED is on, wait for the printer to process the data.

SP Tables

See "Appendices" for the following information:

- Main SP Tables-1
- Main SP Tables-2
- Main SP Tables-3
- Main SP Tables-5
- Main SP Tables-7
- Main SP Tables-8
- Printer SP Tables

Enabling and Disabling Service Program Mode

CAUTION

- Do not let the user access the SP mode. Only service representatives are allowed to access the SP mode. The machine quality or its operation is NOT guaranteed if persons other than service representatives access the SP mode.

Entering SP Mode

For details, ask your supervisor.

Even if the control panel is locked, it is possible to enter the SP mode after the password mismatch message appears. When you exit from the SP mode, the control panel becomes unlocked. To lock the control panel again, turn the main power switch off and then back on.

Note

- Locking the control panel: [Menu] key → System Settings → Administrator Tools → User Restriction → [On]

Exiting SP Mode

Press the [Escape] key on the SP mode screen.



w_m171m0074

5

Note

- To make the settings effective, turn the main power switch off and on after exiting service mode.

Types of SP Modes

Type	Description
1 System SP	SP modes related to the controller/engine functions
2 Printer SP	SP modes related to the printer functions

In the SP mode menu, press the [▲] or [▼] key to select SP No.1 or 2, and then press the [OK] key. Press [◀] or [▶] to select the items in Class 1, Class 2, and then Class 3.



w_m171m0073

Updating the Firmware

Overview

Environmental Requirements

The following Windows operating systems are supported.

You need administrator permission to update the firmware. Log in as an Administrator's group member.

- Windows XP
- Windows XP (x64)
- Windows Vista
- Windows Vista (x64)
- Windows 7
- Windows 7 (x64)
- Windows 8
- Windows 8 (x64)
- Windows 8.1
- Windows 8.1 (x64)
- Windows Server 2003
- Windows Server 2003 (x64)
- Windows Server 2003 R2
- Windows Server 2003 R2 (x64)
- Windows Server 2008
- Windows Server 2008 (x64)
- Windows Server 2008 R2
- Windows Server 2008 R2 (x64)
- Windows Server 2012 (x64)
- Windows Server 2012 R2 (x64)

Update Precautions

- Make sure your computer does not enter sleep mode during the update process. If your computer is running Windows 7, follow the procedure below to check the power options:

1. Click the [Start] menu.

2. Click [Control Panel].

3. Click [Hardware and Sound].

4. Click [Change when the computer sleeps].

5. Make sure [Put the computer to sleep] is set to "Never".

- Follow the procedure below to check that the SNMP status is invalid.

Click [Printer (Driver) Property Setting] > [Port] > [Port Configuration] > uncheck [Enable SNMP Status]

- For procedures to check power options for other operating systems, refer to their respective Help.
- Make sure the printer's power is turned on and the network or USB cable remains connected during updates.
- When operating in the recovery mode, connect the USB cable only and make sure that the printer is not connected to the network.

- Do not print any jobs or run applications that use the printer driver or SmartDeviceMonitor during updates.

- If you want to use the SmartDeviceMonitor port to update the firmware over a network, be sure to clear the [Use Extended Features] check box of SmartDeviceMonitor for Client.

- Check the engine boot version to update.

If an update is executed with wrong boot version, and when a recovery firmware update is executed, the screen freezes with a message "Updating firmware... ". Besides, the update fails.

* The boot version is shown as numbers following the colon of the engine version. For example, the boot version of "1.03:05" is "05".

- When an engine firmware update is executed while the SC670-00 occurs, the screen freezes with a message "Updating firmware... ". Besides, the update fails.

Items Required for Updating the Firmware

- USB cable or Ethernet crossover cable
In the recovery mode, only the USB cable can be used.
- The controller firmware update tool
- The engine firmware update tool ("Engine firmware serial number".exe)

Update Procedure

Before you start updates, ensure the following:

- The printer is connected to the computer with a USB cable or via a peer-to-peer network.
- The printer driver of the printer for which you want to update the firmware is installed properly in the computer.

- The printer is in standby mode.
- No service call message is displayed.
- No applications are running on the computer.

★ Important

- **The printer restarts automatically when the update process is complete. Never turn the printer off during updates.**

1. Launch the controller firmware update tool.
2. Select a language, and then click [OK].

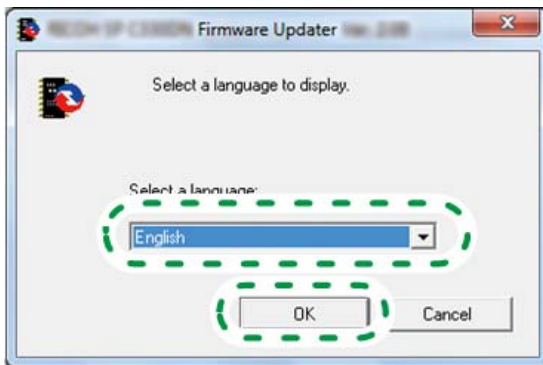

w_m171m0004

3. Check the displayed details, and then click [Next >].

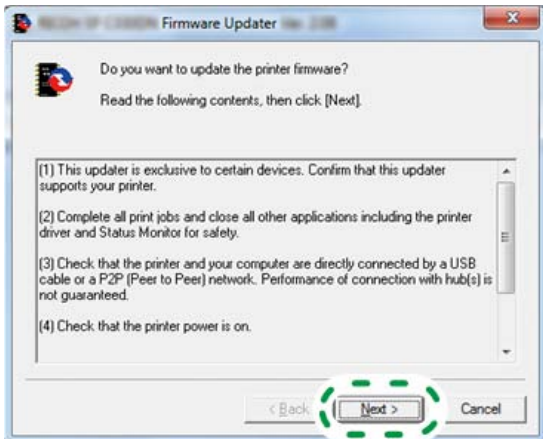

w_m171m0005

4. Select the printer name, and then click [Next >].

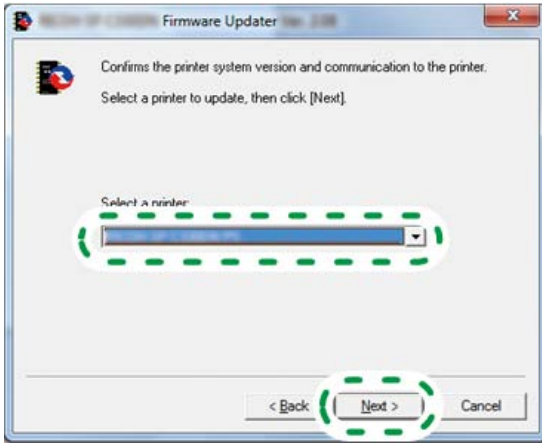

5

5. Check that the system version for [Update data] is later than the system version for [Printer], and then click [Next >].

The following screen is an example. The versions that actually appear may be different.

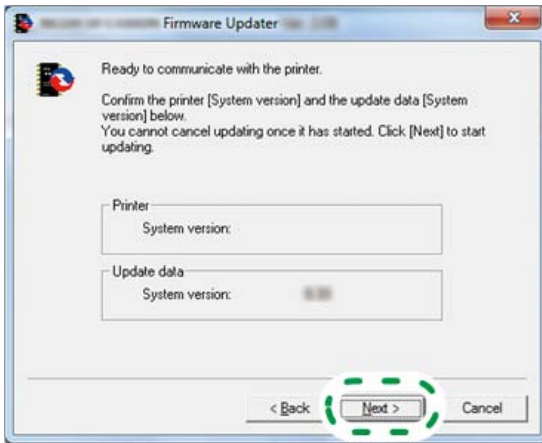

w_m171m0007

6. Click [OK].

Do not turn the printer off during updates.

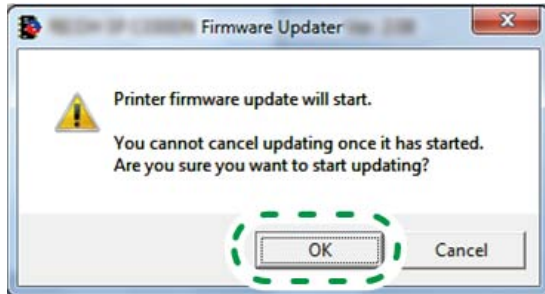

w_m171m0010

7. Updating starts.

"Updating firmware..." appears on the printer's display and the Data in indicator flashes during updates.

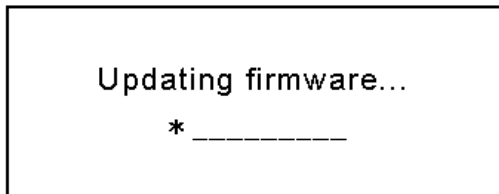

w_m171m0008

When the update is complete, "Firmware update completed" and the new firmware version appear on the display.

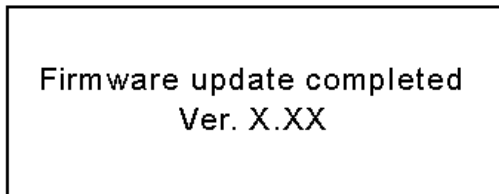

w_m171m0009

8. The printer turns off and on automatically.

9. Check that the new firmware version is displayed using the control panel of the printer.

10. Check the firmware version displayed in the first line.

[Menu] key > System Settings > Administrator Tools > Firmware Version > System

↓ Note

- To also update the engine firmware, follow Steps 1 to 10 using the engine firmware update tool.

Update Progress

You can display the update progress on the control panel, as follows:

No	Progress	Machine Status	Error Message
1	Ready for updating	Ready	Updating firmware...
5	Updater standby	Waiting for the received data	
6	Receiving the image data	Receiving the data	
9	Decompressing the received data	Decompressing the data	
11	Rewriting ROM	Rewriting ROM	
15	Checking ROM	Verifying	
17	Completing the update	Completing the update	Firmware update completed.

Update Error (Recovery Mode)

If the error occurs during the firmware update, the message "Firmware update failed." appears on the display.

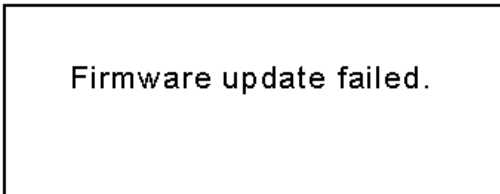

w_m171m0011

Error Status

You can display the error status on the control panel, as follows:

No	Error List	Machine Status	Error Message
2	PJL command error, CRC error	Ready	Firmware update failed.
3	PJL command receive time out		
4	Update data verification error		
7	PJL command data analysis error	Receiving the data	
8	Data receive time out		
10	Data decompression error	Decompressing the data	
12	Error to clear the flag indicating that writing has completed.	Rewriting the data	
13	Error to delete the data in the system ROM area		
14	Error to write in the system ROM area		
16	CRC check error	Verifying	

Recovery Mode

You can launch the recovery mode to update data via USB connection by turning off and then back on the main power under the following conditions:

- If the update is stopped during the update progress No.11 "Rewriting ROM" due to power failure.
- If an error with the error status No.12, 13, or 14 occurs during the "Rewriting the data" status.

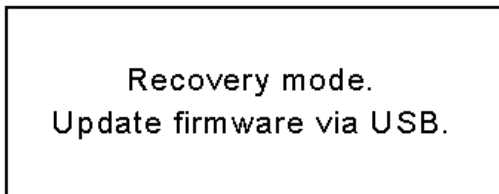

w_m171m0012

If the recovery mode menu appears under TCP/IP connection, change the connection to USB connection and then retry the update.

Notes on Update in the Recovery Mode

Since messages do not appear on the control panel in the recovery mode, check the progress by means of the LEDs as follows:

LED Status		Progress
Data In LED	Flashing	Updating
Data In LED	Lit	Update complete
Alert LED	Lit	Error
Alert LED	Flashing	Recovery mode activates due to the fail of the engine firmware update

Debug Log

Overview

To check the machine's operational status, obtain the following log entries from the machine.

Log entries to obtain

- Log entries on the machine operation and parameters.
- Log entries on the changes to the machine status
- Only log entries for the controller (not including log entries for the engine)

Output format

- Text format

What you need

To obtain log entries from PC

- A laptop PC with a compatible OS [RTB 2](#)
[List was modified](#)
- PC console (dbgmon.exe)
- gawk

Note

- The compatible OSs are shown below.

	Windows XP	Windows Vista	Windows 7	Windows 8
32bit	Yes	Yes	Yes	Yes
64bit	Yes	Yes	Yes	See the note below *

- * Note: Windows certification is necessary for Windows 8 (64 bit), which can be gained by the following procedure;
 1. Shift to test mode
Start the command prompt with administrator authority and execute [bcdedit /set TESTSIGNING ON].
 2. Disable the enforcement of driver signature
The Charms bar > [Settings] > [Change PC Settings] > [General] > [Advanced startup] > [Restart now'] > [Troubleshoot] > [Advanced Options'] > [Windows Startup Settings] > [Restart]
After restart, select [Disable Driver Signature Enforcement].
 3. Install the driver

Install the dbgmon driver.

- 4. Restore the setting

Start the command prompt with administrator authority and execute [bcdedit /set TESTSIGNING OFF].

- 5. Restart the PC

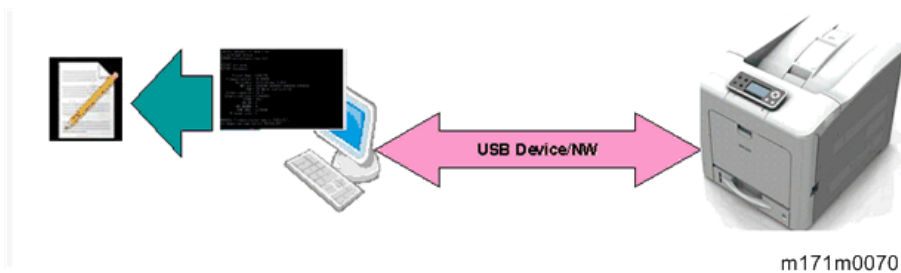

Operational procedure (USB connection)

1. Enable the dbgmon function by setting SP5-844-200 (Debug I/F Setting) to a value other than 1, and then reboot the machine.

The initial factory value is 1 (disabled).

2. The dbgmon driver install wizard is launched. Follow the instruction to install the driver.

↓ Note

- The driver install wizard is not launched if dbgmon has been already installed in the machine and the machine's "Fixed USB Port" is enabled.
[Menu] key > System Settings > Administrator Tools > Fixed USB Port

3. If the PC console (dbgmon) is launched, a CLI-based window appears. Enter "backlog" on the window to start log retrieval.

The log is retrieved into the directory from which the PC console was launched.

↓ Note

- The retrieved log is stored under the name "fw.log". It is the log of all tasks of the firmware (all modules of the controller). From this "fw.log", the log files for each task can be produced.
- To produce the log file for each task, "gawk" must be installed in the computer.
- To stop log retrieval, enter "endlog" on the PC console.
After executing "backlog", be sure to wait at least 30 seconds before executing "endlog". If you do not, the backlog operation may be ended before the log has been completely retrieved.
- If you do not use dbgmon further, disable the dbgmon function using SP5-844-200, and then reboot the machine.

Operational procedure (TCP/IP connection)

The dbgmon function can be used also via TCP/IP.

The computer and the machine must be allowed to establish TCP/IP communication without any firewall (The machine's port number is 7000). It is also necessary to know the machine's IP address.

1. You can connect the machine and computer via TCP/IP by launching dbgmon with the option of "-l<machine's ip address>".
2. You can retrieve the log with the same procedure as that specified in "Operational procedure (USB connection)".

Note

- The dbgmon function via TCP/IP is available only if the dbgmon function is enabled using SP5-844-200.
- If you enable the dbgmon function using SP5-844-200, port number 7000 opens to allow the use of dbgmon via TCP/IP.
- When dbgmon is disabled, port number 7000 cannot be opened.

6. Troubleshooting

Self-Diagnostic Mode

Self-Diagnostic Mode at Power On

As soon as the main machine is powered on, the controller waits for the initial settings of the copy engine to take effect and then starts an independent self-diagnostic test program.

The self-diagnostic test checks the CPU, memory, HDD, and so on. An SC code is displayed if the self-diagnostic program detects any malfunction or abnormal condition. In the case of the error that can start the machine, record it in System Error Log.

Service Call

Summary

Level	Definition	Reset Procedure
A	To prevent damage to the machine, the main machine cannot be operated until the SC has been reset by a service representative (see the note below).	Enter SP mode, go into SP5-810-001, press [Execute], and turn the main power switch off and on.
B	SCs that disable only the features that use the defective item. Although these SCs are not shown to the user under normal conditions, they are displayed on the operation panel only when the defective feature is selected.	Turn the main power switch off and on.
C	The SC history is updated. The machine can be operated as usual.	The SC will not be displayed. Only the SC history is updated.
D	Turning the main power switch off then on resets SCs displayed on the operation panel. These are re-displayed if the error occurs again.	Turn the main power switch off and on.

6

When a Level "D" SC code occurs

When a Level D SC occurs, a screen opens on the operation panel to tell the operator:

- An error occurred
- The job in progress will be erased
- The machine will reboot automatically after approximately 30 seconds.

The operator can wait until the machine reboots automatically or touch "Reset" on the screen to reset the machine immediately and go back to the copy screen.

If the operator does not touch "Reset"

The next message tells the operator that the machine will reset automatically and that the previous job was lost and must be started again. After reading the message, the operator touches "Confirm" on the screen. The next screen shows the number and title of the SC code, and stops until the operator turns the machine off and on.

If the operator touches "Reset"

If the operator touches "Reset" to bypass the 30-second interval for the machine to reboot, the machine reboots immediately and the operation panel displays the copy screen.

★ Important

- Do not try to use the operation panel during an automatic reboot. If the Remote Service System is in use, the SC code is sent immediately to the Service Center.

SC200 (LED Optics)

SC No.	Level	Error Name/Error Condition/Major Cause/Solution
SC230-00	D	FGATE ^{*1} : Does not turn ON.
		GPIO ^{*2} has not been asserted, although the specified time (200 ms) elapsed after setting JOB to be started and reaching the FGAT assert time.
		<ul style="list-style-type: none"> • Engine board defective • ASIC defective • Controller board defective • Harness disconnection
		Turn the main power OFF and then ON

(*1)FGATE: Signals used between the controller and the engine in order to send the information about the sub scan length of the page to be printed.

(*2)GPIO: A type of input/output terminal

SC No.	Level	Error Name/Error Condition/Major Cause/Solution
SC231-00	D	FGATE ^{*1} : Does not turn OFF.
		GPIO ^{*2} has not been negated, although the specified time (200 ms) elapsed after detecting GPIO* assert and then reaching the expected FGATE negate time.
		* This is an I/O pin. Such I/O pins can be used for a variety of applications, depending on the setting.
		<ul style="list-style-type: none"> • Control Board • Engine Board

(*1)FGATE: Signals used between the controller and the engine in order to send the information about the sub scan length of the page to be printed.

(*2)GPIO: A type of input/output terminal

SC No.	Level	Error Name/Error Condition/Major Cause/Solution
SC270-00	D	Write ASIC communication error
		<ul style="list-style-type: none"> When the Engine Board could not read the Unique ID of the Writing ASIC properly when starting this machine. When an Error bit occurred in the communication between the Engine Board and the Writing ASIC.
		The unique ID of the write ASIC was not read normally.
		<ul style="list-style-type: none"> Turn the main power OFF and then ON. Engine Board

SC No.	Level	Error Name/Error Condition/Major Cause/Solution
SC277-00 SC277-10	D	LEDA communication error
		The head type data was read three times in succession
		<p>(277-00)</p> <ul style="list-style-type: none"> Defective ASIC Defective LEDA <p>(277-10)</p> <ul style="list-style-type: none"> LEDA power source error
		<ul style="list-style-type: none"> Turn the main power OFF and then ON. Replace the LED head

SC300 (Image Processing – 1)

SC No.	Level	Error Name/Error Condition/Major Cause/Solution
SC302-00	D	High voltage output error: Charge unit /Development unit
		This SC is issued if the BCU detects a short in the power pack 10 times consecutively.
		Open circuit (+) / Short circuit (-)
		<ul style="list-style-type: none"> • Turn the main power OFF and then ON. • Replace the controller board. • Check the connector connection.

SC No.	Level	Error Name/Error Condition/Major Cause/Solution
SC332-00	D	Toner supply transfer lock
		This SC is issued if the error that the toner is not supplied is detected n times consecutively (n: SP2-931-005) on the condition that the toner cartridge is not in end
		<ul style="list-style-type: none"> • Overload on the toner transferring part (clogging of toner) • Screw for detecting PCDDU does not turn • Detector element (sensor) defective: light leak • Supplying pick does not engage • Defective Supplying clutch • Defective Drive mechanism of screw for supplying toner cartridge
		<ul style="list-style-type: none"> • Turn the main power OFF and then ON.

SC No.	Level	Error Name/Error Condition/Major Cause/Solution
SC364-00	D	TE sensor output count error
		When the average value of the toner end sensor output count is 0 n times consecutively (n: SP2-931-003)
		<ul style="list-style-type: none"> • Connector contact failure/disconnected/broken • Detector element (sensor) does not emit light • Detecting surface inside the developing device is stained
		<ul style="list-style-type: none"> • Turn the main power OFF and then ON.

SC400 (Image Processing – 2)

SC No.	Level	Error Name/Error Condition/Major Cause/Solution
SC440-00	D	High voltage output error: Transfer unit
		This SC is issued if the BCU detects a short in the power pack 10 times consecutively.
		Open circuit (+) / Short circuit (-)
		<ul style="list-style-type: none"> • Turn the main power OFF and then ON. • Replace the controller board. • Check the connector connection.

SC No.	Level	Error Name/Error Condition/Major Cause/Solution
SC498-00	C	Temperature/humidity Sensor error
		<ul style="list-style-type: none"> • Temperature Sensor output error: Out of range between 0.76 V and 2.90 V • Humidity Sensor output error: 2.4 V or more
		<ul style="list-style-type: none"> • Unmounted Sensor (Unset connector or broken wire) • Failed Sensor
		<ul style="list-style-type: none"> • Turn the main power OFF and then ON. • Check that the connector is set. • Set the sensor. • Replace the Sensor. • Replace the connector.

SC500 (Paper Feed and Fusing)

SC No.	Level	Error Name/Error Condition/Major Cause/Solution
SC508-00	B	By-pass bottom plate operation error
		<p>The signal from the by-pass bottom plate position Sensor has not changed (that is, the signal has not changed from ON to OFF or vice versa) for 4 seconds or more after the start of reverse Paper Feed Unit rotation.</p> <p>If the error is detected three times in succession, the appropriate SC number is displayed on the operation panel unit.</p>
		<ul style="list-style-type: none"> • By-pass bottom plate Sensor connector disconnected or other error • By-pass bottom plate Sensor feeler stuck or other error
		<ul style="list-style-type: none"> • Replace the by-pass bottom plate Sensor feeler. • Check and replace the by-pass bottom plate Sensor connector connection. • Replace the Paper Feed Motor. • Replace the harness. • Replace the BCU.

SC No.	Level	Error Name/Error Condition/Major Cause/Solution
SC520-00	D	Main motor error
		When the main motor is driven, the lock (state of rotation) signal is checked every 100 milliseconds. If the machine detects the lock signal in the High status 20 times in succession, it reports this error.
		<ul style="list-style-type: none"> • The main motor incurs too much load from a defective unit. • The main motor is defective.
		Replace the defective unit or the motor

SC No.	Level	Error Name/Error Condition/Major Cause/Solution
SC530-00	D	Fusing fan error
		The fan motor lock (rotating state) signal is sampled at 100 ms intervals and the machine fails to receive the lock signal 50 times in succession.
		<ul style="list-style-type: none"> • Failed fan motor • Disconnected connector
		<ul style="list-style-type: none"> • Replace the fan motor. • Check the connector. • Replace the harness. • Replace the IOB.

SC No.	Level	Error Name/Error Condition/Major Cause/Solution
SC531-00	D	Development Cooling fan error
		The fan motor lock (rotating state) signal is sampled at 100 ms intervals and t the machine fails to receive the lock signal 50 times in succession.
		<ul style="list-style-type: none"> Failed fan motor Disconnected connector Harness disconnection Defective IOB
		<ul style="list-style-type: none"> Replace the fan motor. Check the connector. Replace the harness. Replace the IOB.

SC No.	Level	Error Name/Error Condition/Major Cause/Solution
SC541-00	A	Broken fusing (Center) thermistor wire
		The condition whereby the temperature is -20 deg C or less for 5 seconds has been detected 10 times or more.
		<ul style="list-style-type: none"> Broken thermistor wire Bad connector contact
		<ul style="list-style-type: none"> Clear the SP: fusing SC. Check the connector connection. Replace the fusing (Center) thermistor.

SC No.	Level	Error Name/Error Condition/Major Cause/Solution
SC542-01	A	Fusing lamp (Center) thermistor not reloaded 1
		The heater thermistor has increased by less than 2.0 degrees in 1.5 seconds 5 times in a row.
		<ul style="list-style-type: none"> Deformed or floating thermistor Input voltage out of range
		<ul style="list-style-type: none"> Clear the SP: fusing SC. Replace the thermistor.
SC542-02	A	Fusing lamp (Center) thermistor not reloaded 2
		The heater (Center) thermistor does not reach the reload temperature 50 seconds after the start of motor rotation.
		<ul style="list-style-type: none"> Fusing lamp disconnected The overtemperature prevention mechanism started working
		<ul style="list-style-type: none"> Clear the SP: fusing SC. Replace the thermistor.

SC No.	Level	Error Name/Error Condition/Major Cause/Solution
SC543-00	A	Fusing (Center) thermopile high-temperature detected (software)
		The temperature is detected to stay at 245 deg C or higher for one second.
		<ul style="list-style-type: none"> Shorted triac Failed Engine Board
		<ul style="list-style-type: none"> Clear the SP: fusing SC. Replace the PSU. Replace the Engine Board.

SC No.	Level	Error Name/Error Condition/Major Cause/Solution
SC544-00	A	Fusing (Center) thermopile high-temperature detected (hardware)
		The hardware high-temperature error Sensor flag is detected.
		<ul style="list-style-type: none"> • Damaged triac (shorted) • Failed engine control board • Failed fusing thermopile • Failed fusing thermistor • Abnormal fusing control software behavior • The PWM signal is continuously supplied from the IH inverter (due to a software or temperature Sensor error).
		<ul style="list-style-type: none"> • Clear the SP: fusing SC. • Replace the PSU. • Replace the Engine Board. • Replace the fusing thermopile. • Replace the Fusing Unit.

SC No.	Level	Error Name/Error Condition/Major Cause/Solution
SC545-00	A	Fusing (Center) heater stay ON
		The thermistor (center) has not detected the target temperature, even after the fusing heater stays ON for more than 30 seconds after reloading.
		<ul style="list-style-type: none"> • Deformed or floating thermistor • Broken fusing lamp wire • The overtemperature prevention mechanism started working
		<ul style="list-style-type: none"> • Clear the SP: fusing SC. • Replace the fusing thermistor. • Replace the fusing (Center) lamp.

SC No.	Level	Error Name/Error Condition/Major Cause/Solution
SC547-01	D	Zero-crossing error (adhered relay contact)
		When the fusing relay is in an OFF state, a "zero-crossing interrupt request" occurs in 50 ms.
		Damaged fusing relay (adhered contact)
		<ul style="list-style-type: none"> • Turn the main power OFF and then ON. • Replace the harness. • Replace the PC board. • Replace the PSU.
SC547-02	D	Zero-crossing error (bad relay contact)
		If a "zero-crossing interrupt request" does not occur when the fusing relay is in an ON state, an error results.
		<ul style="list-style-type: none"> • Damaged fusing relay (open contact) • Failed fusing relay drive circuit • PSU fuse (24VS) blown
		<ul style="list-style-type: none"> • Turn the main power OFF and then ON. • Replace the harness. • Replace the Engine Board. • Replace the PSU. • Replace the fuse.
SC547-03	D	Zero-crossing error (low frequency error)
		The number of zero-crossing interrupts does not reach a certain value in 500 ms.
		The frequency of the commercial power supply line is unstable.
		<ul style="list-style-type: none"> • Turn the main power OFF and then ON. • Check the commercial power supply line. • Replace the harness. • Replace the Engine Board. • Replace the PSU.

SC No.	Level	Error Name/Error Condition/Major Cause/Solution
SC551-00	A	Broken fusing (End) thermistor wire
		At least ten times, the temperature is detected to stay at 0 deg C or less for three seconds.
		<ul style="list-style-type: none"> • Broken thermistor wire • Bad connector contact
		<ul style="list-style-type: none"> • Clear the SP: fusing SC. • Check the connector connection. • Replace the fusing (End) thermistor.

SC No.	Level	Error Name/Error Condition/Major Cause/Solution
SC553-01 SC553-02	A	Fusing (End) thermistor high-temperature detected (software)
		<p>(553-01)</p> <p>In a condition of 235 degrees C or higher temperature, the temperature has increased more than 10 degrees C per 1 second, the heater has continuously reached 100% (maximum) duty, and the center thermistor has detected the failure to reach the target temperature by 11 degrees C.</p> <p>(553-02)</p> <p>The temperature is detected to stay at 245 deg C or higher for one second.</p>
		<ul style="list-style-type: none"> • Shorted triac • Failed Engine Board
		<ul style="list-style-type: none"> • Clear the SP: fusing SC. • Replace the PSU. • Replace the Engine Board.

SC No.	Level	Error Name/Error Condition/Major Cause/Solution
SC554-00	A	Fusing (End) thermistor high-temperature detected (software)
		The hardware high-temperature error Sensor flag is detected.
		<ul style="list-style-type: none"> • Damaged triac (shorted) • Failed engine control board • Failed fusing thermopile • Failed fusing thermistor • Abnormal fusing control software behavior • The PWM signal is continuously supplied from the IH inverter (due to a software or temperature Sensor error).
		<ul style="list-style-type: none"> • Clear the SP: fusing SC. • Replace the PSU. • Replace the Engine Board. • Replace the fusing thermopile. • Replace the Fusing Unit.

SC No.	Level	Error Name/Error Condition/Major Cause/Solution
SC557-00	C	Zero-crossing frequency exceeded
		The number of zero-crossing interrupts exceeds a certain value in 500 ms.
		The frequency of the commercial power supply line is unstable or noise occurs.
		None

SC No.	Level	Error Name/Error Condition/Major Cause/Solution
SC559-00	A	Fusing jam detected 3 times in succession
		Fusing jam is detected three times in succession.
		Paper is wrapped around the fusing roller.
		Clear the SP: fusing SC.

SC600 (Device Communication)

SC No.	Level	Error Name/Error Condition/Major Cause/Solution
SC641-00	D	<ul style="list-style-type: none"> • Communication error: Engine (Timeout error) • Communication error: Engine (Retry error)
		<ul style="list-style-type: none"> • There is no response from the engine even after the timeout period specified during the communication has elapsed. • The communication has failed when sending the normal mode (ESIF_LECI_NORMAL) command even after exceeding the maximum number of command transmission retry.
		<ul style="list-style-type: none"> • Controller board/software defective • The connection between the controller board and engine board is faulty. • Engine board/software defective
		<ul style="list-style-type: none"> • Check the connection between the controller board and engine board. • Turn the main power off/on.

SC No.	Level	Error Name/Error Condition/Major Cause/Solution
SC653-00	D	Incorrect remote service ID2
		<p>If the serial number* 1 for producing ID2* 2 has any of the following problems:</p> <ul style="list-style-type: none"> • Blank • Contains control characters • Cannot be read <p>* 1: The serial number refers to "MachineSerial Set" (SP5-811-001). * 2: ID2 refers to "Machine No. Setting" (SP5-811-003).</p>
		<ul style="list-style-type: none"> • The serial number was not specified at the factory. • The NV memory is corrupted and cannot be read. • The NV memory has been corrupted while writing data into it.
		<ul style="list-style-type: none"> • Turn the main power off/on. <p>If the problem persists, the hardware is faulty.</p>

SC No.	Level	Error Name/Error Condition/Major Cause/Solution
SC669- **	D	EEPROM communication error
		An error is notified during EEPROM communication and the printer does not recover after three retries.
		669 - 1 ID error during EEPROM OPEN 669 - 2 Channel error during EEPROM OPEN 669 - 3 Device error during EEPROM OPEN 669 - 4 Communication interrupted error during EEPROM OPEN 669 - 5 Communication timeout error 669 - 6 Not operating error during EEPROM OPEN 669 - 7 Buffer full during EEPROM OPEN 669 - 8 No error code during EEPROM OPEN 669 - 9 ID error 669 - 10 No error code during EEPROM Close
		669 - 11 ID error during EEPROM data write 669 - 12 Channel error during EEPROM data write 669 - 13 Device error during EEPROM data write 669 - 14 Communication interrupted error during EEPROM data write 669 - 15 Communication timeout error 669 - 16 Not operating error during EEPROM data write 669 - 17 Buffer full during EEPROM data write 669 - 18 No error code during EEPROM data write 669 - 19 ID error during EEPROM data read 669 - 20 Channel error EEPROM data read

SC No.	Level	Error Name/Error Condition/Major Cause/Solution
		669 - 21 Device error during EEPROM data read 669 - 22 Communication interrupted error during EEPROM data read 669 - 23 Communication timeout error 669 - 24 Not operating error during EEPROM data read 669 - 25 Buffer full during EEPROM data read 669 - 26 No error code during EEPROM data read
		<ul style="list-style-type: none"> • Electromagnetic noise • EEPROM error
		<ul style="list-style-type: none"> • Turn the main power OFF and then ON. • Replace the BCU

SC No.	Level	Error Name/Error Condition/Major Cause/Solution
SC669-36	D	EEPROM communication error
		The EEPROM data has been transferred to the SRAM twice in succession, but the two sets of transferred data do not match.
		669 - 36 EEPROM SRAM OPEN: Verified error <ul style="list-style-type: none"> • Electromagnetic noise • EEPROM error
		<ul style="list-style-type: none"> • Turn the main power OFF and then ON.

SC No.	Level	Error Name/Error Condition/Major Cause/Solution
SC670-00	D	Engine start up error
		<ul style="list-style-type: none"> • The /ENGRDY signal is not detected even after the specified time has elapsed after turning the main power on or restoring from energy saver mode. • The /ENGRDY signal is detected, but it is negated at an unexpected occasion*. <p>* Expected negation occurs when turning the power off, switching to the energy saver mode (after the engine automatically goes off), and rebooting the machine.</p>
		<ul style="list-style-type: none"> • The engine board does not start up. • The connection between the controller board and engine board is faulty.
		<p>Check the connection between the engine board and the controller board.</p> <ul style="list-style-type: none"> • If this problem always occurs, replace the engine board. If the problem persists, consider replacing the controller board or other boards between them. • If this problem occasionally occurs, multiple causes are to be considered, such as the software, engine board, controller board, and PSU.

SC No.	Level	Error Name/Error Condition/Major Cause/Solution
SC681-**	D	Device ID is not identified (toner cartridge)
		An error is notified during the ID identification after three retries.
		681 - 1 Device ID error (Incorrect ID)
		681 - 6 Channel error
		681 - 11 Device ID error (No ID chip)
		681 - 16 Communication Error
		681 - 21 Communication timeout
		681 - 26 The device has stopped its operation
		681 - 31 The requested buffer is full
681 - 36 EEPROM SRAM OPEN: Verification error		
		<ul style="list-style-type: none"> • Turn the main power OFF and then ON. • Replace the toner cartridge (ID chip)

SC No.	Level	Error Name/Error Condition/Major Cause/Solution
SC682-**	D	Device ID is not identified (PCDU)
		An error is notified during the ID identification after three retries.
		682 - 1 Device ID error (Incorrect ID)
		682 - 6 Channel error
		682 - 11 Device ID error (No ID chip)
		682 - 16 Communication Error
		682 - 21 Communication timeout
		682 - 26 The device has stopped its operation
		682 - 31 The requested buffer is full
682 - 36 EEPROM SRAM OPEN: Verification error		
		<ul style="list-style-type: none"> • Turn the main power OFF and then ON. • Replace the PCDU (ID chip)

SC No.	Level	Error Name/Error Condition/Major Cause/Solution
SC688-00	D	PRREQ signal not asserted
		The print request signal (PRREQ) signal is not asserted within the prescribed time after paper reaches the registration stand-by position,
		<ul style="list-style-type: none"> • Noise • Engine Board error
		<ul style="list-style-type: none"> • Turn the main power OFF and then ON • Replace the Engine Board.

SC700 (Peripherals)

SC No.	Level	Error Name/Error Condition/Major Cause/Solution
SC790-00	D	Maximum number of banks (paper tray units) exceeded error
		When the power is turned ON, the number of mounted paper tray units is detected and the number exceeds three.
		The number of mounted paper tray units exceeds the specifications.
		Reduce the number of mounted paper tray units according to the specifications.

SC800 (Controller)

SC No.	Level	Error Name/Error Condition/Major Cause/Solution
SC816-00	[0x0000]	Energy save I/O subsystem error
SC816-01	D	Subsystem error
SC816-02	D	Sysarch (LPUX_GET_PORT_INFO) error
SC816-03	D	Transition to STR was denied.
SC816-04	D	Interrupt in kernel communication driver
SC816-05	D	Preparation for transition to STR failed.
SC816-06	D	Preparation for transition to STR failed.

SC No.	Level	Error Name/Error Condition/Major Cause/Solution
SC816-07	D	Sysarch (LPUX_GET_PORT_INFO) error
SC816-08	D	Sysarch (LPUX_ENGINE_TIMERCTRL) error
SC816-09	D	Sysarch (LPUX_RETURN_FACTOR_STR) error
SC816-10	D	Sysarch (LPUX_GET_PORT_INFO) error
SC816-11	D	Sysarch (LPUX_GET_PORT_INFO) error
SC816-12	D	Sysarch (LPUX_GET_PORT_INFO) error
SC816-13	D	open() error
SC816-14	D	Memory address error
SC816-15	D	open() error
SC816-16	D	open() error
SC816-17	D	open() error
SC816-18	D	open() error
SC816-19	D	Double open() error
SC816-20	D	open() error
SC816-22	D	Parameter error
SC816-23	D	read() error
SC816-24	D	read() error
SC816-25	D	read() error
SC816-26	D	write() communication retry error
SC816-27	D	write() communication retry error
SC816-28	D	write() communication retry error
SC816-29	D	write() communication retry error
SC816-30	D	write() communication retry error
SC816-35	D	read() error

SC No.	Level	Error Name/Error Condition/Major Cause/Solution
SC816-36 to94	D	Subsystem error
		Energy save I/O subsystem detected some abnormality.
		<ul style="list-style-type: none"> • Energy save I/O subsystem defective • Energy save I/O subsystem detected a controller board error (non-response). • Error was detected during preparation for transition to STR.
		<ul style="list-style-type: none"> • Turn the main power off/on. • Replace the controller board.

SC No.	Level	Error Name/Error Condition/Major Cause/Solution
SC818-00	D	Watchdog timer error
		<ul style="list-style-type: none"> • The system program fell into a bus-hold state or an endless loop of the program interruption occurred, causing other process to stop.
		<ul style="list-style-type: none"> • System program defective • Controller board defective • Optional board defective
		<ul style="list-style-type: none"> • Turn the main power off/on. • Replace the controller board. • Replace the optional devices.

SC No.	Level	Error Name/Error Condition/Major Cause/Solution
SC833-00	D	Self-diagnostic error: Engine I/F ASIC Self-diagnostic error: Video I/F

SC No.	Level	Error Name/Error Condition/Major Cause/Solution
[0F31]		Engine I/F: ASIC register error
		The /CONFIG_DONE signal is not detected even after the specified time has elapsed after turning the power on or restoring from energy saver mode.
		Downloading of the Config data to FPGA has failed.
		Replace the controller board.
[0F10]		Fsync input timeout
		After the /PRREQ signal is detected, the /FSYNC(/FGATE) signal of the first color is not detected even after the specified time has elapsed.
		Connector, harness defective FGATE control error EGB defective
		-

SC No.	Level	Error Name/Error Condition/Major Cause/Solution
SC850-00	B	Network I/F error
		The access to the network work is unavailable due to an error in the printer driver.
		-
		-

SC900 (Others)

SC No.	Level	Error Name/Error Condition/Major Cause/Solution
SC900-00	D	Electronic counter error
		The value provided by the electronic total counter is outside the normal range.
		<ul style="list-style-type: none"> • Unexpected NVRAM installed • Defective NVRAM • NVRAM data corruption • Data is stored in an unexpected area due to external causes. • The count requests made by SRM upon receiving the PRT have not yet been processed.
		Install an NVRAM device designed specifically for the model.

6

SC No.	Level	Error Name/Error Condition/Major Cause/Solution
SC920-**	B	Printer application error
		A serious application error that stops the machine from operating is detected.
		<ul style="list-style-type: none"> • 920-00 At PM startup, no response was returned within the specified period of time. • 920-01 A time-out occurred during PM operation. • 920-02 WORK memory acquisition failed. • 920-03 The filter process cannot be started. • 920-04 The filter process was aborted.
		Turn the main power switch off and on.

SC No.	Level	Error Name/Error Condition/Major Cause/Solution
SC990-00	D	Software performance error
		The software attempted to make an unexpected operation.
		<ul style="list-style-type: none"> • Incorrect argument • Incorrect internal parameter • Insufficient working memory • Abnormal performance caused by an error that cannot be detected in normal SC detection due to hardware specifications.
		<ul style="list-style-type: none"> • Turn the main power switch off and on. • Reinstall the software of the controller board. • Reinstall the software of the engine board.

SC No.	Level	Error Name/Error Condition/Major Cause/Solution
SC991-00	C	Software continuity error
		The software has attempted to perform an unexpected operation. (However, the process can continue running if recovery processing is carried out.)
		<ul style="list-style-type: none"> • Incorrect argument • Incorrect internal parameter • Insufficient working memory • May have resulted from an error that cannot be detected by the hardware using normal SC detection.
		Not required

SC No.	Level	Error Name/Error Condition/Major Cause/Solution
SC992-00	D	Undefined SC error
		An error that is not controlled by the system occurred (the error does not come under any other SC code).
		A SC code used in the previous machine was applied erroneously.
		Turn the main power switch off and on.

SC No.	Level	Error Name/Error Condition/Major Cause/Solution
SC995-**	D	CPM setting error
		Comparison of machine serial number (11 digits) and machine identification code. Details: <ul style="list-style-type: none"> Machine serial number cannot be identified because of BCU replacement or malfunctioning. Machine serial number cannot be identified because of NV-RAM replacement
		Machine serial number (11 digits) or machine identification code does not match.
		<ul style="list-style-type: none"> Replace the board(s) to match the CPM of the controller and BCU boards. Turn the main power switch off and on.

SC No.	Level	Error Name/Error Condition/Major Cause/Solution
SC997-00	B	Application function selection error <ul style="list-style-type: none"> The application has not responded to the set command created by SCS within a certain period of time. The application selected ended abnormally.
		Software bug
		<ul style="list-style-type: none"> Check whether an option required by the application (RAM, DIMM, board) is installed properly. Check whether downloaded applications are correctly configured. (Take necessary countermeasures specific to the application in which the error occurs. In some applications, the logs can be taken from the monitor. If this option is available, analyze the logs.)

SC No.	Level	Error Name/Error Condition/Major Cause/Solution
SC998-00	D	Application start error
		<ul style="list-style-type: none"> • After power on, no application program is registered to the system within a predetermined period of time. (No application starts or ends normally.) • Even if they are started, all applications have become unable to be rendered due to an unknown defect.
		<ul style="list-style-type: none"> • Software bug • An option required by the application (RAM, DIMM, board) is not installed properly
		<ul style="list-style-type: none"> • Turn the main power switch off and on. • Check whether an option required by the application (RAM, DIMM, board) is installed properly. • Check whether downloaded applications are correctly configured. • Replace the Controller Board.

Jam Detection

Jam Displays

The operation panel of this model has a four-line display which shows only the message indicating the paper jam location. (e.g. "%r (A1)", "%r (B)")

Position Code

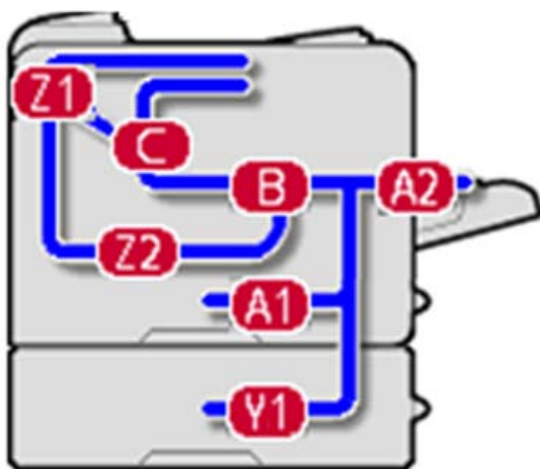

m171m0002

Sensor Position Layout

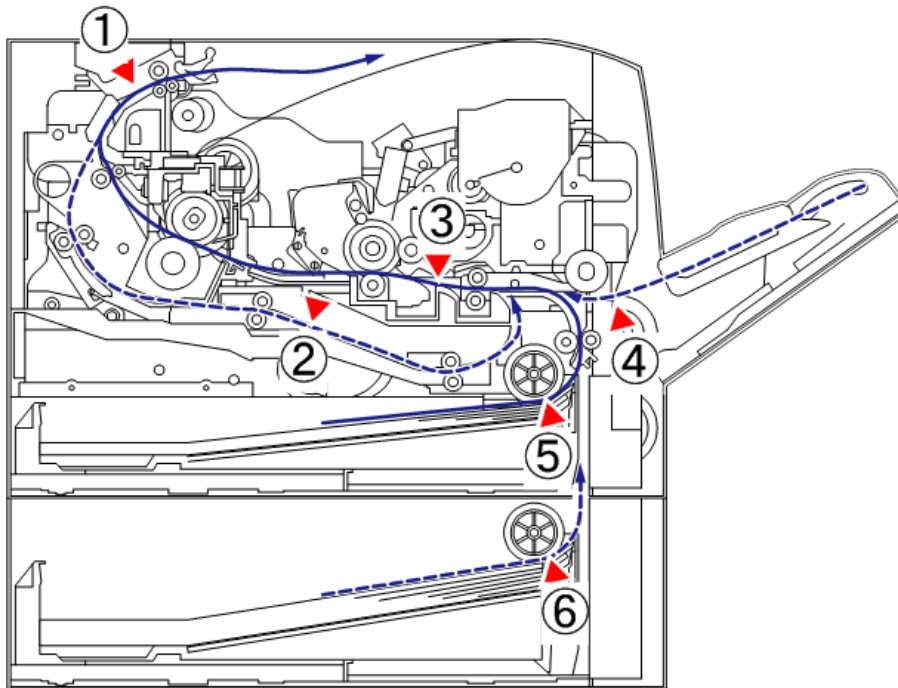

m171m0071

1. Exit / Switchback Sensor
2. Duplex Entrance Sensor
3. Registration Sensor
4. By-pass Paper End Sensor
5. Paper End Sensor (Main Machine)
6. Paper End Sensor (Optional Bank)

Jam Codes and Position Codes

↓ Note

- Jam code: Shows the cause of a jam. Appears in the log data.
- Position code: Shows the location of a jam. Appears on the operation panel.

These are lists of jam codes for the main machine and peripheral devices. Please note:

- **Late jam.** The paper has failed to arrive within the prescribed time due to a jam that has occurred upstream of the referenced sensor.

- **Lag jam.** The paper has failed to leave the location of the referenced sensor within the prescribed time due to a jam downstream of the referenced sensor.

Main Machine

Jam Code	Jam Type	Position Code
1	Registration Sensor Jam	B
1	Exit / Switchback Sensor Jam	B Z1
1	Duplex Entrance Sensor Jam	Z1 Z2
3	Tray 1 : No Paper Feeding	A1
8	By-pass Tray : No Paper Feeding	A2
9	Duplex : No Paper Feeding	Z2
17	Registration Sensor: Late Jam	A1
20	Exit / Switchback Sensor: Late Jam	B C
57	Registration Sensor: Lag Jam	B
60	Exit / Switchback Sensor: Lag Jam	B Z1
26	Duplex Entrance Sensor: Late Jam	Z1
66	Duplex Entrance Sensor: Lag Jam	Z1 Z2

Optional Bank

Jam Code	Jam Type	Position Code
4	Tray 2 : No Paper Feeding	Y1

Jam Code	Jam Type	Position Code
53	Tray 2 Relay Sensor(VERTICAL Transport Sensor) : Lag Jam	A1 Y1
1	Tray 2 Relay Sensor(VERTICAL Transport Sensor) Jam	Y1

Troubleshooting

Test Sheet Printing

Press the [Menu] key, and then select the setting items using the [▼] or [▲] key.

1. Select [System Settings] ▶ Press [OK]
2. Select [Maintenance] ▶ Press [OK]
3. Select [Registration] ▶ Press [OK]
4. Select [Print Test Sheet] ▶ Press [OK]
5. Select the tray you want to adjust ▶ Press [OK]
6. Print the test sheet to preview the settings.

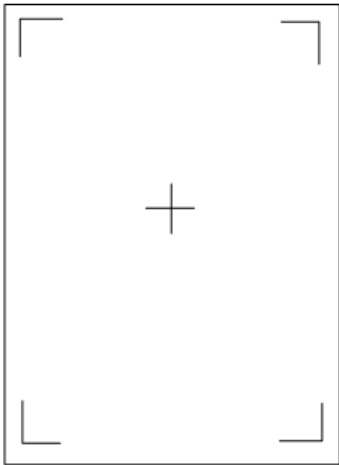

m171m0077

Use this sheet to check the current print position.

Image Position Adjustment

Note

- Adjust the blank margin width only if it cannot be adjusted by registration (leading edge/side-to-side). First adjust C and D; then A and B.

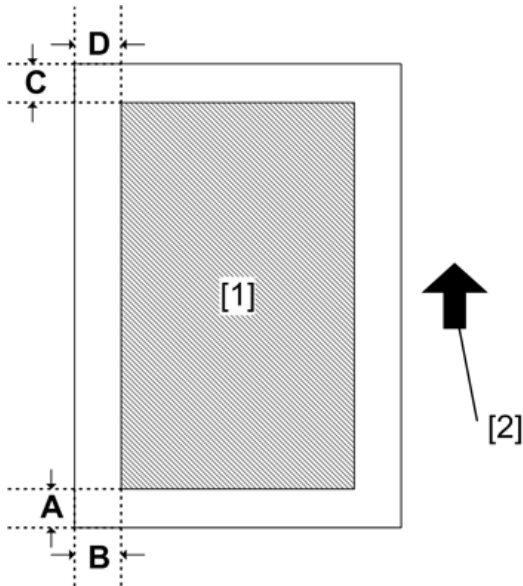

- [1]: Print area
- [2]: Paper feed direction

1. Print the test sheet. (page 150 "Test Sheet Printing")

2. Adjust the blank margin width of the image with SP2-103-(001-004).

- Leading edge: 2.7 to 9.9 mm (Default: 3.0 mm)
- Trailing edge: 0.0 to 9.9 mm (Default: 2.0 mm)
- Left: 0.0 to 9.9 mm (Default: 2.0 mm)
- Right: 0.0 to 9.9 mm (Default: 2.0 mm)

Registration Adjustment

Print Area

Check that the adjustment meets the product specification.

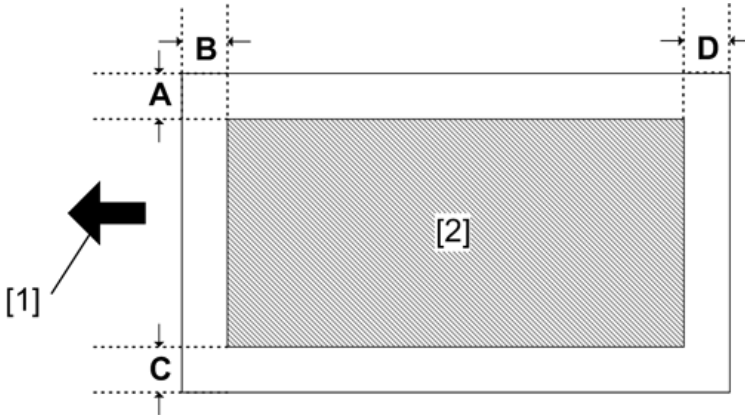

- [1]: Paper feed direction
- [2]: Print area

Adjustment Reference Values

- B: Leading edge (Sub scanning direction): 3.0 ± 1.5 mm
- D: Trailing edge (Sub scanning direction): 3.0 mm
- C: Left (Main scanning direction): 2.0 ± 1.5 mm
- A: Right (Main scanning direction): 2.0 mm

Adjustment Procedure

1. Print the test sheet. (page 150 "Test Sheet Printing")

↓ Note

- Print the test sheet, and then adjust the leading edge registration in the SP mode to the optimum value.

2. Do SP1-002-(001,002,003,006) to check and adjust the registration.

3. Check the side-to-side registration for each paper feed trays.

Problem at Regular Intervals

Image problems may appear at regular intervals that depend on the circumference of certain components.

The following diagram shows the possible symptoms (black or white dots at regular intervals or other problems).

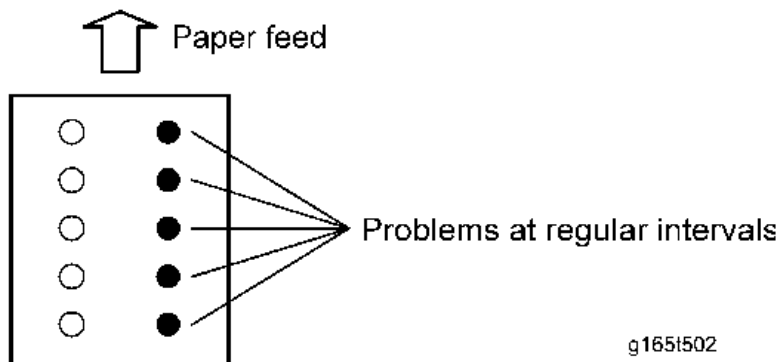

Problems	Intervals	Defective parts
Problems with the printed result (other than black or white dots)	29.9mm	Charge roller
	37.7mm	Registration roller
	45.8mm	Image transfer roller
	112mm	Fusing pressure roller
	94mm	Fusing roller
	100.5mm	Paper feed roller
Black or white dots	35.6mm	Development roller
	94.4mm	Drum

The LED head contains 26 LED chips, each covering a line 8 mm wide. If a line 8 mm wide extending in the paper feed direction appears, an LED chip may be damaged. If so, replace the LED head.

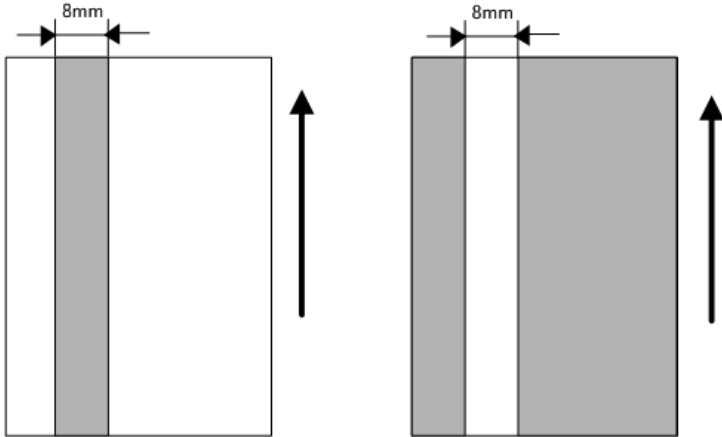

w_m1093070

When Vertical Banding is Generated

6

The vertical banding on a print image may be improved by the [Drum Rotation] function.

1. Select a drum rotation level.

[Menu] key > System Settings > Maintenance > Drum Rotation

2. Select a drum rotation level from the following 2 levels: Level 1 (Normal) and Level 2 (Strong).

<Operation>

- Level1 : Photo conductor idles for 55 seconds
- Level2 : Photo conductor idles for 30 seconds (for black and white vertical banding)

<Effectively Prevented Phenomena>

- Level1 : Pieces of white banding (for half tone or continuous printing)
- Level2 : White vertical banding (for half tone), black vertical banding, and black horizontal banding

Note

- If the [Drum Rotation] function is performed many times, the life of the drum unit may be shortened.

When Black Spots are Generated on Print Image

The black spots on a print image may be improved by the [Fusing Roller Cleaning].

1. Load a paper (A4 or LT size plain paper) to the by-pass tray.

2. Perform the [Fusing Roller Cleaning] (toners are consumed).

[Menu] key > System Settings > Maintenance > Fusing Roller Cleaning

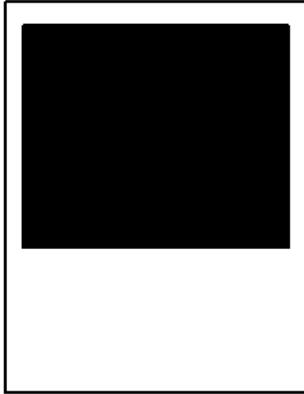
3. A paper is fed and images are printed on both sides of the paper.

m1608086

4. Check that the black spots do not appear any more.**Note**

- The effectiveness of the fusing cleaning varies depending on the types of images printed or papers used until now. Therefore, the problem may be improved by performing the [Fusing Roller Cleaning] several times, which consumes the toners.

Paper Feed (Skew)

Use the following flowchart to determine the cause and deal with the problem.

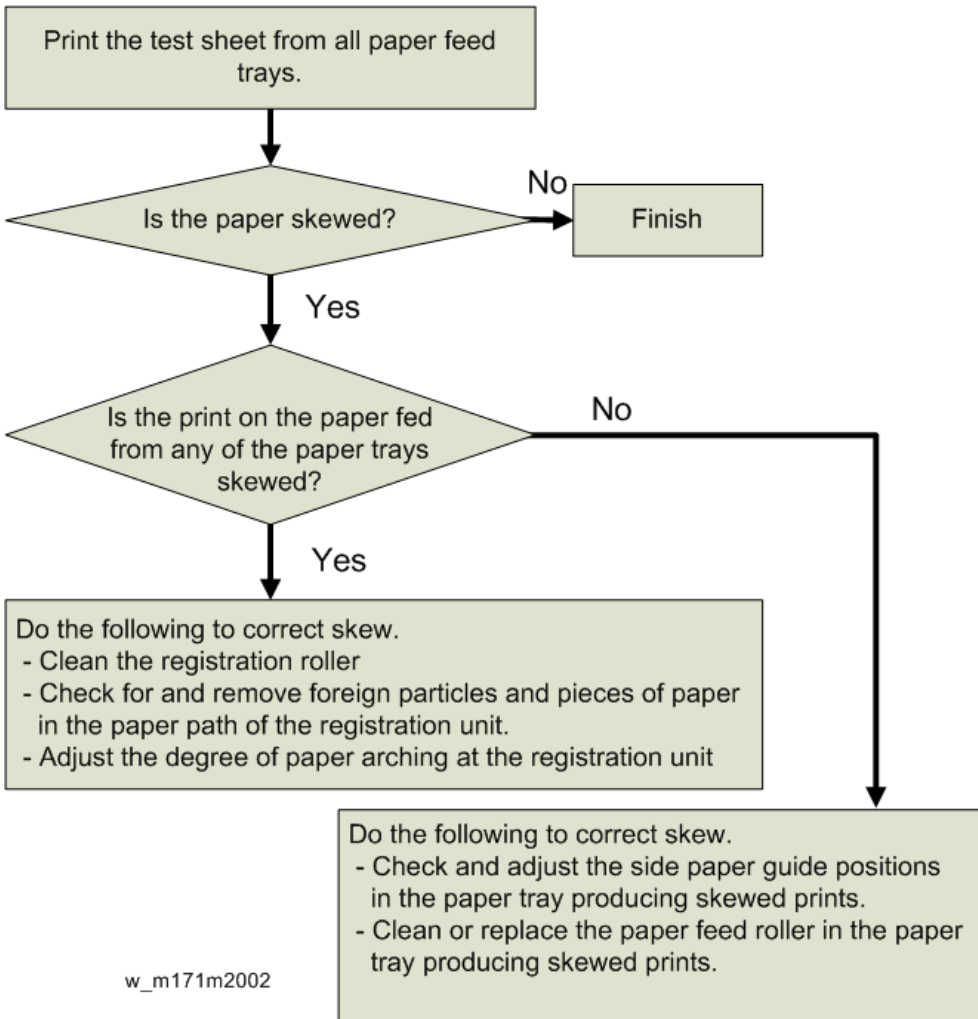

Recycled or Thin Paper Is Severely Curled after Printing

If the delivered paper is curled, it cannot be stacked properly. In such a case, raise the paper stop on the output tray and remove the delivered paper frequently. You can also configure [Curl Prevention] in the UP mode

- [Menu] key > System Settings > Maintenance > Curl Prevention

If you set [Curl Prevention] to [Active], the machine idles for 20 seconds before it starts printing. By adding the idle time before printing, it takes longer to print, but paper curling can be reduced. To stop the 20-second idling, set [Curl Prevention] to [Inactive].

7. Energy Save

Energy Save

Energy Saver Modes

Customers should use energy saver modes properly, to save energy and protect the environment.

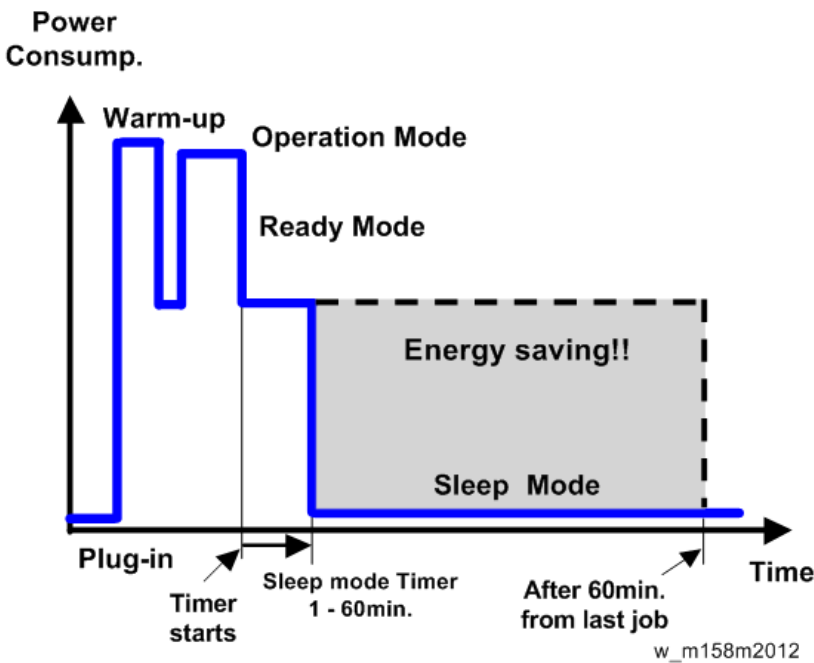

The area shaded grey in this diagram represents the amount of energy that is saved when the timers are at the default settings. If the timers are changed, then the energy saved will be different. For example, if the timers are all set to 60 min., the grey area will disappear, and no energy is saved before 60 min. expires.

Sleep Mode Setting

Sleep Mode

(Menu > System Settings > Timer Settings > Sleep Mode)

The user can specify the duration the printer waits before entering Sleep mode. The printer enters Sleep mode if no user input has been made during the specified duration. When the printer is in Sleep mode, it takes longer to start printing.

Specify a wait time of between 1 to 60 minutes.

Default: [1 minute]

Ready State After Printing

(Menu > System Settings > Administrator Tools > Ready State After Printing)

The user can specify how the printer operates when it receives print jobs in Sleep mode.

Default: [Cntrl Panel Off (EngySavg)]

- Control Panel On
The printer turns on the control panel and prints received jobs.
- Cntrl Panel Off (EngySavg)
The printer prints received jobs but the control panel remains off.

Slp Tmr after Engy Sv Prt

(Menu > System Settings > Administrator Tools > Slp Tmr after Engy Sv Prt)

When [Ready State After Printing] is set to [Cntrl Panel Off (EngySavg)], the user can specify whether or not the printer resumes Sleep mode immediately after exiting Energy Saver mode.

Default: [Immediate]

- Immediate
The printer resumes Sleep mode immediately after printing, regardless of the Sleep Mode Timer settings.
- After Time Set by Tmr Ends
The printer resumes Sleep mode after the time specified in Sleep mode elapses.

Return to Stand-by Mode

Sleep Mode

Recovery time: 9 sec.

Recommendation

We recommend that the default settings should be kept.

- If the customer requests that these settings should be changed, please explain that their energy costs could increase, and that they should consider the effects on the environment of extra energy use.
- If it is necessary to change the settings, please try to make sure that the Sleep Mode timer is not too long. Try with a shorter setting first, such as 5 min., then go to a longer one (such as 15 min.) if the customer is not satisfied.

- If the Sleep Mode timer is all set to the maximum value, the machine will not begin saving energy until 60 minutes has expired after the last job. This means that after the customer has finished using the machine for the day, energy will be consumed that could otherwise be saved.

Paper Save

Effectiveness of Duplex/Combine Function

Duplexing and the combine functions reduce the amount of paper used.

1. Duplex:

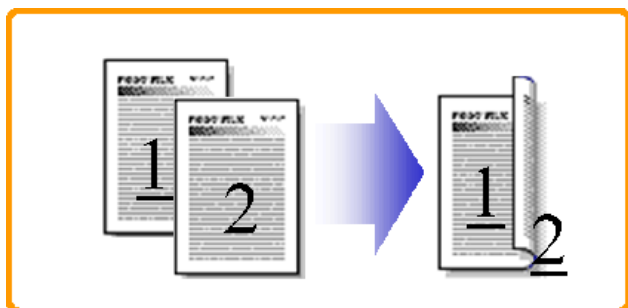

d062d102

7

Reduce paper volume in half!

2. Combine mode:

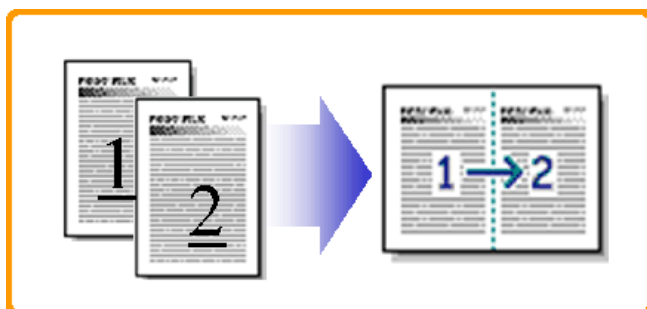

d062d100

Reduce paper volume in half!

3. Duplex + Combine:

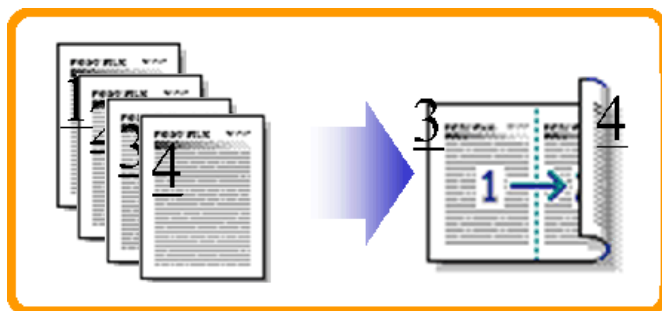

d062d101

Using both features together can further reduce paper volume by 1/4!

To check the paper consumption, look at the total counter and the duplex counter.

The total counter counts all pages printed.

- For one duplex page, the total counter goes up by 2.
- For a duplex job of a three-page original, the total counter goes up by 3.
- The duplex counter counts pages that have images on both sides.
- For one duplex page, the duplex counter goes up by 1.
- For a duplex job of a three-page original, the duplex counter will only increase by 1, even though two sheets are used.

7

Recommendation

Please explain the above features to the customers, so that they can reduce their paper usage.

- Total counter: SP8-581-001
- Duplex counter: SP8-411-001

The following table shows paper savings and how the counters increase for some simple examples of single-sided and duplex jobs

Duplex mode:

Originals	Simplex Sheet used	Duplex Sheets used	Paper Saved	Total counter SP8-581-001	Duplex counter SP8-411-001
1	1	1	0	1	0
2	2	1	1	2	1
3	3	2	1	3	1

Originals	Simplex Sheet used	Duplex Sheets used	Paper Saved	Total counter SP8-581-001	Duplex counter SP8-411-001
4	4	2	2	4	2
5	5	3	2	5	2
10	10	5	5	10	5
20	20	10	10	20	10

If combine mode is used, the total and duplex counters work in the same way as explained previously. The following table shows paper savings and how the counters increase for some simple examples of duplex/combine jobs.

2 in 1 mode:

Originals	Simplex Sheet used	Duplex Sheets used	Paper Saved	Total counter SP8-581-001
1	1	1	0	1
2	2	1	1	1
3	3	2	1	2
4	4	2	2	2
5	5	3	2	3
10	10	5	5	5
20	20	10	10	10

Duplex + 2 in 1 mode:

Originals	Simplex Sheet used	Duplex Sheets used	Paper Saved	Total counter SP8-581-001
1	1	1	0	1
2	2	1	1	1
3	3	1	2	2
4	4	1	3	2

Originals	Simplex Sheet used	Duplex Sheets used	Paper Saved	Total counter SP8-581-001
5	5	2	3	3
6	6	2	4	3
7	7	2	5	4
8	8	2	6	4
9	9	3	6	5
10	10	3	7	5
11	11	3	8	6
12	12	3	9	6

MEMO

Model Gim-P1a

**Machine Code:
M171**

Appendices

September, 2014

TABLE OF CONTENTS

1. Appendices: Specifications

- General Specifications..... 3
 - Mainframe..... 3
 - Printer..... 5
- Supported Paper Sizes..... 6
 - Paper Feed..... 6
 - Paper Exit..... 9
 - Mainframe..... 9
- Software Accessories..... 12
 - Printer Drivers..... 12
 - Utility Software..... 12
- Optional Equipment..... 13
 - Paper Feed Unit PB1060..... 13
 - Paper Feed Unit PB1070..... 13

2. Appendices: Preventive Maintenance Tables

- Preventive Maintenance Tables..... 15
 - Maintenance Tables..... 15
 - Mainframe..... 15
 - Paper Feed Tray PB1060 / Paper Feed Tray PB1070..... 17
 - Other Yield Parts..... 17

3. Appendices: SP Mode Tables

- Service Program Mode..... 19
 - Service Table Key..... 19
- Main SP Tables-1..... 20
 - SP1-XXX (Feed)..... 20
- Main SP Tables-2 27
 - SP2-XXX (Drum)..... 27
- Main SP Tables-3 40
 - SP3-XXX (Process)..... 40
- Main SP Tables-5..... 41
 - SP5-XXX (Mode)..... 41
- Main SP Tables-7..... 67
 - SP7-XXX (Data Log)..... 67

Main SP Tables-8.....	73
SP8-XXX (Data Log 2).....	73
Keys and abbreviations in Data Log 2.....	73
Input and Output Check.....	79
Input Check Table.....	79
Output Check Table.....	80
Printer Service Mode.....	82
SP1-XXX (Service Mode).....	82

1. Appendices: Specifications

General Specifications

1

Mainframe

Items	Specification
Type	Desktop
CPU	ARM Cortex A8 500MHz
Memory	256MB
Photosensitivity Type	OPC Drum
Development System	Non-magnetic one-component development system
Fusing System	Thin, hard heating roller fusing system
Warm-up Time	19 seconds or less (23°C, rated voltage)
First Print Time	6.5 seconds or less

Items	Specification	
Paper Size	Std. Tray	A4 (SEF), B5 (SEF), A5, B6 (SEF), A6 (SEF), LG (SEF), Government LG (SEF), G LT (SEF), LT (SEF), HLT (SEF), Executive (SEF), F (SEF), Foolscap (SEF), Folio (SEF), 16K (SEF), Com10 (SEF), Monarch (SEF), C5 (SEF), C6 (SEF), DL Env (SEF) Custom size: Min. 100mm x 148mm (4.0"x5.9"), Max. 216mm x 356mm (8.5"x14.0")
	Bypass Tray	A4 (SEF), B5 (SEF), A5, B6, A6 (SEF), LG (SEF), Government LG (SEF), G LT (SEF), LT (SEF), HLT, Executive (SEF), F (SEF), Foolscap (SEF), Folio (SEF), 16K (SEF)), Com10 (SEF), Monarch (SEF), C5 (SEF), C6 (SEF), DL Env (SEF) Custom size: Min. 60mm x 127mm (2.4" x 5.0"), Max. 216mm x 900mm (8.5" x 35.4")
	Op. Paper Tray	A4 (SEF), B5 (SEF), A5, B6 (SEF), A6 (SEF), LG (SEF), Government LG (SEF), G LT (SEF), LT (SEF), HLT (SEF), Executive (SEF), F (SEF), Foolscap (SEF), Folio (SEF), 16K (SEF) Custom size: Min. 100mm x 148mm (4.0"x5.9"), Max. 216mm x 356mm (8.5" x 14.0")
Paper Thickness	<ul style="list-style-type: none"> • Tray1: 52 - 162g/m2(45 - 139kg) • Bypass: 52 - 162g/m2(45 - 139kg) • Duplex: 52 - 162g/m2(45 - 139kg) 	
Resolution (Print)	1200dpi	
Tone	256 tones	
Paper Feed Capacity	Max. 850 sheets Standard: 250 sheets (Main) + 100 sheets (Bypass tray) Option: 500 sheet tray x 1	
Power Source	NA	120 – 127V, 60 Hz
	EU/AP/CHN	220 – 240V, 50 – 60 Hz
Max Power Consumption	NA	1,030 W or less
	EU/AP/CHN	990 W or less

Items	Specification
Dimensions	W × D × H(up to the control panel): 370 × 392 × 268 mm (14.6 × 15.4 × 10.6 inches)
Space for Main Unit	W×D: 370 × 594 mm (14.6 × 23.4 inches): Including the bypass tray
Weight	Approx. 14.5 kg (32.0 lb.)

Printer

Items	Specification
Print Size	<ul style="list-style-type: none"> Fixed: Max. A4(SEF)(210×297mm), 8 1/2×14(SEF)(215.9×355.6mm) Custom: Max.216.0 × 900.0mm (Bypass tray)
Continuous Printing Speed	<p>One-side printing: 30 ppm (A4 SEF), 31 ppm (LT SEF)</p> <p>Two-side printing: 15 ppm (A4 SEF), 16 ppm (LT SEF)</p>
Resolution	<p>600 × 600 dpi</p> <p>1,200 × 1,200 dpi</p>
Printer Language	<ul style="list-style-type: none"> Standard: PCL5e/6, Postscript3
Interface	<ul style="list-style-type: none"> Standard: Ethernet(100BASE-TX, 10BASE-T), USB2.0
Protocol	TCP/IP (IPv4, IPv6), SNMP, MIB, WSM
Compatible OS	<ul style="list-style-type: none"> Standard: Windows XP/Vista/7/8/8.1, Windows Server 2003/2003 R2/2008/2008 R2/2012/2012 R2, Mac OS X 10.6.8 or later
Resident Fonts	<p>PCL: 45 fonts + International fonts 13 fonts</p> <p>PS: 136 fonts</p>
Reproduction Ratio	25 - 400%

Supported Paper Sizes

1

Paper Feed

Paper	Size (W x L)	Standard Tray	Optional Tray	Bypass Tray	Duplex Tray
12 x 18inch (SEF)	305×458	N	N	N	N
A3 (SEF)	297×420	N	N	N	N
A3 (LEF)	420×297	N	N	N	N
B4 (SEF)	257×364	N	N	N	N
B4 (LEF)	364×257	N	N	N	N
A4 (SEF)	210×297	A	A	D	C
A4 (LEF)	297×210	N	N	N	N
B5 (SEF)	182×257	B	B	D	N
B5 (LEF)	257×182	N	N	N	N
A5 (SEF)	148×210	A	A	D	N
A5 (LEF)	210×148	B	B	D	N
B6 (SEF)	128×182	B	B	D	N
B6 (LEF)	182×128	N	N	D	N
A6 (SEF)	105×148	A	A	D	N
A6 (LEF)	148×105	N	N	N	N
DLT (SEF)	11"×17"	N	N	N	N
DLT (LEF)	17"×11"	N	N	N	N
LG (SEF)	8 1/2"×14"	A	A	D	C
LG (LEF)	14"×8 1/2"	N	N	N	N
LT (SEF)	8 1/2"×11"	A	A	D	C
LT (LEF)	11"×8 1/2"	N	N	N	N

Paper	Size (W x L)	Standard Tray	Optional Tray	Bypass Tray	Duplex Tray
GovernmentLG (SEF)	8 1/4"x14"	B	B	D	C
G LT (SEF)	8"x10 1/2"	B	B	D	N
G LT (LEF)	10 1/2"x8"	N	N	N	N
Eng Quatro (SEF)	8"x10"	B	B	D	N
Eng Quatro (LEF)	10"x8"	N	N	N	N
HLT (SEF)	5 1/2"x8 1/2"	A	A	D	N
HLT (LEF)	8 1/2"x5 1/2"	N	N	D	N
Executive (SEF)	7 1/4"x10 1/2"	B	B	D	N
Executive (LEF)	10 1/2"x7 1/4"	N	N	N	N
F (SEF)	8"x13"	B	B	D	C
F (LEF)	13"x8"	N	N	N	N
Foolscap (SEF)	8 1/2"x13"	B	B	D	C
Foolscap (LEF)	13"x8 1/2"	N	N	N	N
Folio (SEF)	8 1/4"x13"	B	B	D	C
Folio (LEF)	13"x8 1/4"	N	N	N	N
Com10 (SEF)	4 1/8"x9 1/2"	B	N	D	N
Com10 (LEF)	9 1/2"x4 1/8"	N	N	N	N
Monarch (SEF)	3 7/8"x7 1/2"	B	N	D	N
Monarch (LEF)	7 1/2"x3 7/8"	N	N	N	N
C5 (SEF)	162x229	B	N	D	N
C5 (LEF)	229x162	N	N	N	N
C6 (SEF)	114x162	B	N	D	N
C6 (LEF)	162x114	N	N	N	N

Paper	Size (W x L)	Standard Tray	Optional Tray	Bypass Tray	Duplex Tray
DL Env (SEF)	110×220	B	N	D	N
DL Env (LEF)	220×110	N	N	N	N
8K (SEF)	267×390	N	N	N	N
16K (SEF)	195×267	B	B	D	N
16K (LEF)	267×195	N	N	N	N
Custom Size (Width)	mm	100 – 216	100 – 216	60 – 216	100 – 216
Custom Size (Length)	mm	148 - 356	148 – 356	127 – 900	279 – 356
Postcard (SEF)	100×148	N	N	N	N
Postcard (LEF)	148×100	N	N	N	N
Double postcard (SEF)	200×148	N	N	N	N
Double postcard (LEF)	148×200	N	N	N	N

Remarks: Standard Tray, Optional Tray

A	Supported size. Need to set the dial to the paper size.
B	Supported size. Need to set the dial “*” and select the paper size by operation panel.
N	Not supported.

Remarks: Bypass Tray

C	Supported.
D	Supported. Need to select the Bypass Tray and the paper size on operation panel.
N	Not supported.

Remarks: Duplex

C	Supported.
---	------------

N	Not supported.
---	----------------

Paper Exit

1

Mainframe

Paper	Size (W x L)	Paper Exit Tray
12 x 18inch (SEF)	305×458	N
A3 (SEF)	297×420	N
A3 (LEF)	420×297	N
B4 (SEF)	257×364	N
B4 (LEF)	364×257	N
A4 (SEF)	210×297	C
A4 (LEF)	297×210	N
B5 (SEF)	182×257	C
B5 (LEF)	257×182	N
A5 (SEF)	148×210	C
A5 (LEF)	210×148	C
B6 (SEF)	128×182	C
B6 (LEF)	182×128	N
A6 (SEF)	105×148	C
A6 (LEF)	148×105	N
DLT (SEF)	11"×17"	N
DLT (LEF)	17"×11"	N
LG (SEF)	8 1/2"×14"	C
LG (LEF)	14"×8 1/2"	N
LT (SEF)	8 1/2"×11"	C

Paper	Size (W x L)	Paper Exit Tray
LT (LEF)	11"×8 1/2"	N
GovernmentLG (SEF)	8 1/4"×14"	C
G LT (SEF)	8"×10 1/2"	C
G LT (LEF)	10 1/2"×8"	N
Eng Quatro (SEF)	8"×10"	C
Eng Quatro (LEF)	10"×8"	N
HLT (SEF)	5 1/2"×8 1/2"	C
HLT (LEF)	8 1/2"×5 1/2"	N
Executive (SEF)	7 1/4"×10 1/2"	C
Executive (LEF)	10 1/2"×7 1/4"	N
F (SEF)	8"×13"	C
F (LEF)	13"×8"	N
Foolscap (SEF)	8 1/2"×13"	C
Foolscap (LEF)	13"×8 1/2"	N
Folio (SEF)	8 1/4"×13"	C
Folio (LEF)	13"×8 1/4"	N
Com10 (SEF)	4 1/8"×9 1/2"	C
Com10 (LEF)	9 1/2"×4 1/8"	N
Monarch (SEF)	3 7/8"×7 1/2"	C
Monarch (LEF)	7 1/2"×3 7/8"	N
C5 (SEF)	162×229	C
C5 (LEF)	229×162	N
C6 (SEF)	114×162	C
C6 (LEF)	162×114	N
DL Env (SEF)	110×220	C

Paper	Size (W x L)	Paper Exit Tray
DL Env (LEF)	220×110	N
8K (SEF)	267×390	N
16K (SEF)	195×267	C
16K (LEF)	267×195	N
Custom Size (Width)	mm	60 – 216
Custom Size (Length)	mm	127 – 900
Postcard (SEF)	100×148	C
Postcard (LEF)	148×100	N
Double postcard (SEF)	200×148	C
Double postcard (LEF)	148×200	C

Remarks: Output Tray

C	Supported.
N	Not supported.

Software Accessories

The printer drivers and utility software are provided on one CD-ROM. An auto-run installer lets you select the components you want to install.

Printer Drivers

Printer Language	Windows XP	Windows Vista	Windows 7	Windows 8 / 8.1
PCL 5e / 6	Yes	Yes	Yes	Yes
PostScript3	Yes	Yes	Yes	Yes

Printer Language	Windows Server 2003	Windows Server 2008 / 2008 R2	Windows Server 2012 / 2012 R2	Mac OSX 10.6.8 or later
PCL 5e / 6	Yes	Yes	Yes	No
PostScript3	Yes	Yes	Yes	Yes

Utility Software

The following utilities are available.

Software	Description
Device Manager NX Lite	A PC Client based application program that monitors and manages up to 250 networked print devices.
Device Manager NX Accounting	
DeskTopBinder-SmartDeviceMonitor for Client	A printer management utility for client users. A utility for peer-to-peer printing over a NetBEUI or TCP/IP network. A peer-to-peer print utility over a TCP/IP network. This provides the parallel printing and recovery printing features. This is provided on the printer drivers CD-ROM.
Remote Communication Gate A	A communication device that enables digital MFPs and printers to be connected to the communication server in the maintenance center.

Optional Equipment

Paper Feed Unit PB1060

Category	Item	Unit
Paper Size	A4, B5, A5, B6, A6, Legal, Letter, GovernmentLG, GLT, Eng Quatro, HLT, Executive, F, Foolscap, Folio, 16K, Custom size: Min. 100mm x 216mm (3.93" x 8.46"), Max. 148mm x 356mm (5.83" x 14.0")	
Paper Weight	52-162	g/m2
	14-43	lbs
Paper Output Capacity	250	sheet
Power Consumption	15.0	W
Dimension (W x D x H)	W370xD392xH95	mm
	W14.6xD15.4xH3.7	inch
Weight	4.1	kg
	9.0	lbs.

Paper Feed Unit PB1070

Category	Item	Unit
Paper Size	A4, B5, A5, B6, A6, Legal, Letter, HLT, GovernmentLG, GLT, Eng Quatro, Executive, F, Foolscap, Folio, 16K, Custom size: Min. 100mm x 216mm (3.93" x 8.46"), Max. 148mm x 356mm (5.83" x 14.0")	
Paper Weight	52-162	g/m2
	14-43	lbs
Paper Output Capacity	500	sheet
Power Consumption	15.0	W

Category	Item	Unit
Dimension (W x D x H)	W370×D392×H125	mm
	W14.6×D15.4×H4.9	inch
Weight	4.5	kg
	9.9	lbs.

2. Appendices: Preventive Maintenance Tables

Preventive Maintenance Tables

Maintenance Tables

Chart: A4 (LT)/5%

Mode: 3 prints/job

Ratio: 50%

Environment: Normal temperature and humidity

Yield may change depending on circumstances and print conditions.

Symbol keys: C: Clean, R: Replace

Mainframe

Paper Feed

Item	20K	120K	600K	EM	Remarks
Registration Roller				C	<ul style="list-style-type: none">Wipe with a damp cloth
Registration Sensor				C	<ul style="list-style-type: none">Remove dust with a dry cloth when sensor failure occurs
Vertical Transport Roller				C	<ul style="list-style-type: none">Wipe with a damp cloth
Paper Feed Roller (Tray)		R		C	<ul style="list-style-type: none">Replace when a feeding failure occursWipe with a damp cloth when cleaning
Friction Pad (Tray)		R		C	<ul style="list-style-type: none">Replace when a double feed occursWipe with a dry cloth when cleaning

Item	20K	120K	600K	EM	Remarks
By-pass Feed Roller				C	<ul style="list-style-type: none"> Wipe with a damp cloth when cleaning
By-pass Friction Pad				C	<ul style="list-style-type: none"> Wipe with a dry cloth when cleaning

PCDU

Item	20K	120K	600K	EM	Remarks
PCDU	R				

LED Optics

Item	20K	120K	600K	EM	Remarks
LED Lens				C	<ul style="list-style-type: none"> Customers perform this concurrently with PCDU replacement Use the LED lens cleaner packed with the unit or mainframe

Transfer

Item	20K	120K	600K	EM	Remarks
Image Transfer Roller		R		C	<ul style="list-style-type: none"> Wipe with a damp cloth, then dry cloth when cleaning

Fusing

Item	20K	120K	600K	EM	Remarks
Fusing Unit		R		C	<ul style="list-style-type: none"> Wipe with a damp cloth, then dry cloth when cleaning

Duplex

Item	20K	120K	600K	EM	Remarks
Duplex Transport Roller				C	<ul style="list-style-type: none"> Wipe with a damp cloth

Paper Exit

Item	20K	120K	600K	EM	Remarks
Paper Exit Roller				C	<ul style="list-style-type: none"> Wipe with a damp cloth, then dry cloth when cleaning
Exit / Switchback Sensor				C	<ul style="list-style-type: none"> Remove dust with a dry cloth when sensor failure occurs

Paper Feed Tray PB1060 / Paper Feed Tray PB1070

Item	20K	120K	600K	EM	Remarks
Grip Roller				C	<ul style="list-style-type: none"> Wipe with a damp cloth when cleaning
Paper Feed Roller (Tray)		R		C	<ul style="list-style-type: none"> Replace when a feeding failure occurs Wipe with a damp cloth when cleaning
Friction Pad (Tray)		R		C	<ul style="list-style-type: none"> Replace when a double feed occurs Wipe with a dry cloth when cleaning

Other Yield Parts

The parts mentioned in these tables have a target yield. However, the total copy/print volume made by the machine will not reach the target yield within the machine's targeted lifetime if the machine is used under the target usage conditions (ACV, color ratio, P/J, and C/O). So, these parts are categorized not as PM parts but as yield parts (EM parts).

	Yield – Condition		Compatibility
	Yield (Page)	Condition	M171
High Yield Toner	6,000	ISO	Available
Low Yield Toner	3,000	ISO	Available
Standard PCDU	20,000	3P/J	Available

3. Appendices: SP Mode Tables

Service Program Mode

Service Table Key

Notation	What it means
[range / default / step]	Example: [-9 to +9 / 0 / 0.1 mm step]. The setting can be adjusted in the range ± 9 , value reset to +3.0 after an NVRAM reset, and the value can be changed in 0.1 mm steps with each key press.
DFU	Denotes "Design or Factory Use". Do not change this value.
Japan only	The feature or item is for Japan only. Do not change this value.
FSP	This denotes a "Factory Service Program" mode.

Main SP Tables-1

SP1-XXX (Feed)

3

1001	[User Lead Edge Reg]		
	Adjusts the leading edge registration by changing the registration motor operation timing for each mode.		
	<ul style="list-style-type: none"> Increasing a value: an image is moved to the trailing edge of paper. Decreasing a value: an image is moved to the leading edge of paper. 		
	1-001-001	By-pass	E
	1-001-002	Tray 1	E
1-001-003	Tray 2	E	
1-001-006	Duplex	E	
[-4.0 to 4.0 / 0.0 / 0.1 mm/step]			

1002	[User S-to-S Reg]		
	Adjusts the printing side-to-side registration from each paper feed station, using the Trimming Area Pattern.		
	<ul style="list-style-type: none"> To move the start position to the right, increase the value (+). To move the start position to the left, decrease the value (-). 		
	1-002-001	By-pass	E
	1-002-002	Tray 1	E
1-002-003	Tray 2	E	
1-002-006	Duplex	E	
[-4.0 to 4.0 / 0.0 / 0.1 mm/step]			

1003	[Paper Buckle]		
	This SP eliminates the amount of buckle at the registration roller.		
	<ul style="list-style-type: none"> When paper is fed from the paper cassette, before the registration rollers start to rotate the leading edge of the paper stops and hits the nip of the registration rollers and stops. The registration rollers remain idle long enough to stop the paper from skewing in the paper path. This SP adjusts the amount of time that the registration rollers remain idle to reduce paper buckle. Raise this setting to lengthen the amount of time that the paper pauses at the nip of the registration rollers if you notice a large amount of skew in printouts. 		
	1-003-011	By-pass: Plain	E
	1-003-012	By-pass: Thick	E
	1-003-013	By-pass: Envelope	E
	1-003-021	Tray1: Plain	E
	1-003-022	Tray1: Thick	E
	1-003-023	Tray1: Envelope	E
	1-003-031	Tray2: Plain	E
1-003-032	Tray2: Thick	E	
1-003-061	Duplex: Plain	E	
1-003-062	Duplex: Thick	E	
[-5 to 5 / 0 / 1 mm/step]			
[-5 to 5 / 0 / 1 mm/step]			
1101	[Flicker Control]		
Sets the flicker control (0: Disable, 1: Enable).			
1-101-001	Flicker Control	E	[0 or 1 / 0 / 1 /step] 0: Disabled 1: Enabled
1105	[Print Target Temp]		
Adjusts the target fusing temperature for each paper type. "C" indicates the center of the roller.			

1-105-001	C: Plain 1	E	[140 to 205 / 167 / 1 deg/step]
1-105-003	C: Plain2	E	[140 to 205 / 174 / 1 deg/step]
1-105-005	C: Thick 1	E	[140 to 205 / 180 / 1 deg/step]
1-105-007	C: Thick2	E	[140 to 205 / 190 / 1 deg/step]
1-105-011	C: Thin	E	[140 to 205 / 160 / 1 deg/step]
1-105-013	C: Envelope	E	[140 to 205 / 205 / 1 deg/step]
1-105-015	C: Card	E	[140 to 205 / 190 / 1 deg/step]
1-105-017	C: Transparency	E	[140 to 205 / 165 / 1 deg/step]
1-105-019	C: Special	E	[140 to 205 / 180 / 1 deg/step]
1-105-023	C: Middle Thick	E	[140 to 205 / 177 / 1 deg/step]
1-105-025	C: Thick 1 (LowTemp)	E	[140 to 205 / 185 / 1 deg/step]
1-105-031	FuserOffMode	E	[0 or 1 / 1 / 1/step] The switch that turns the fuser off after the idle process runs over 30 minutes.

1105	[Curl Dec Mode]		
1-105-021	Mode Display	E	[0 or 1 / 0 / 1 /step] Enables or disables the CurlDecMode (0: Disabled, 1: Enabled)
1-105-022	PreprtRotTime	E	[500 to 60000 / 20000 / 500msec/step] Sets the pre-print rotation time for reducing curls.

1106	[Fusing Temp Disp] This SP displays the hot roller and pressure roller temperatures.		
1-106-001	RollerCenter	E	[-20 to 250 / 0 / 1 deg/step] Displays the current fusing thermistor temperature (Center).

1-106-002	RollerEnds	E	[-20 to 250 / 0 / 1 deg/step] Displays the current fusing thermistor temperature (Ends).
1-106-003	MachinePowerOn	E	[-20 to 250 / 0 / 1 deg/step] Displays the external temperature measured at power On, which is detected with the temperature and humidity sensor.

1109	[Micro Ptcl SW] The switch that turns ON/OFF the micro particle countermeasure mode.		
1-109-001	0:Off 1:On	E	[0 or 1 / 0 / 1 / -]

1113	[Env Fus Cond]		
1-113-001	PrePrtRotTime	E	[500 to 60000 / 7000 / 500msec/step]

1135	[Inrush Control] Enables or disables the setting of Inrush control (0: Disabled, 1: Enabled)		
1-135-001	Inrush control	E	[0 or 1 / 0 / 1 /step]

1152	[Nip Width Measuring] Checks the fusing nip band.		
1-152-001	0:Off 1:On	E	[0 or 1 / 0 / 1 /step]

1159	[Fusing Jam Detect] Disables or enables the consecutive jam error for the fusing unit. When set to "1" (on) this SC code is issued after the 3rd consecutive jam in the fusing unit.		
1-152-001	SCdisplay	E	[0 or 1 / 0 / 1 /step] 0: Not detects SC 1: Detects SC

1801	[Motor Speed Adj]		
	<p>This SP adjusts the speed of the motor. The motor speed can be adjusted to correct images that appear scratchy or of uneven density. This can occur when:</p> <ul style="list-style-type: none"> • Copying originals with large quantities of black. • Copying originals with a large quantity of black near the trailing edge. • Printing multiple copies of positive/negative (reverse) images. 		
1-801-011	Exit Reverse	E	[-4.0 to 4.0 / 0.0 / 0.1%/step]

1907	[Paper Timing Adj]		
	<p>Adjusts the timing of paper feed. (A "+" setting broadens paper feed interval, a "-" setting narrows paper feed interval.)</p>		
	1-907-005	Reverse Stop Posi	<p>E</p> <p>[-10 to 10 / 0 / 1mm/step]</p> <p>Adjusts the reverse stop timing of the range from the Registration Sensor Off to the Paper Exit Inverter motor.</p> <p>Makes it slower (+) or faster (-) than the default.</p>
1-907-015	Re-Feed Stop Posi	<p>E</p> <p>[-10 to 10 / 0 / 1mm/step]</p> <p>Adjusts the reverse stop timing of the range from the duplex entrance sensor On to the duplex clutch.</p> <p>Makes it slower (+) or faster (-) than the default.</p>	

1908	[Paper Timing Adj]		
	<p>Adjusts the timing of paper feed. (A "+" setting broadens paper feed interval, a "-" setting narrows paper feed interval.)</p>		
	1-908-015	Junc Gate SOL:On	E
1-908-017	Junc Gate SOL:Off	E	[-10 to 10 / 0 / 1mm/step]

1921	[Fact Lead Edge Reg]		
	<ul style="list-style-type: none"> • Increasing a value: an image is moved to the trailing edge of paper. • Decreasing a value: an image is moved to the leading edge of paper. 		

1-921-011	By-Pass: Plain	E	[-4.0 to 4.0 / 0.0 / 0.1mm/step] Reflects adjustment values with no change.
1-921-012	By-Pass: Thick	E	[-4.0 to 4.0 / 0.0 / 0.1mm/step] Adds on to the adjusted values of the Plain paper.
1-921-013	By-Pass: Envelope	E	[-4.0 to 4.0 / 0.0 / 0.1mm/step] Adds on to the adjusted values of the Plain paper.
1-921-021	Tray1: Plain	E	[-4.0 to 4.0 / 0.0 / 0.1mm/step] Reflects adjustment values with no change.
1-921-022	Tray1: Thick	E	[-4.0 to 4.0 / 0.0 / 0.1mm/step] Adds on to the adjusted values of the Plain paper.
1-921-023	Tray1: Envelope	E	[-4.0 to 4.0 / 0.0 / 0.1mm/step] Adds on to the adjusted values of the Plain paper.
1-921-031	Tray2: Plain	E	[-4.0 to 4.0 / 0.0 / 0.1mm/step] Reflects adjustment values with no change.
1-921-032	Tray2: Thick	E	[-4.0 to 4.0 / 0.0 / 0.1mm/step] Adds on to the adjusted values of the Plain paper.
1-921-061	Duplex: Plain	E	[-4.0 to 4.0 / 0.0 / 0.1mm/step] Reflects adjustment values with no change.
1-921-062	Duplex: Thick	E	[-4.0 to 4.0 / 0.0 / 0.1mm/step] Adds on to the adjusted values of the Plain paper.

1922	[Fact S-to-S Reg]
	Reflects adjustment values with no change. <ul style="list-style-type: none"> To move the start position to the right, increase the value (+). To move the start position to the left, decrease the value (-).

1-922-001	By-pass	E	[-4.0 to 4.0 / 0.0 / 0.1mm/step]
1-922-002	Tray 1	E	
1-922-003	Tray 2	E	
1-922-006	Duplex	E	[-4.0 to 4.0 / 0.0 / 0.1mm/step] The value of this SP adds on to the adjusted values of the front page of each tray.





1952	[Fan Off Mode Time]		
	-		
1-952-001	-	E	[0 to 60 / 13 / 1min/step]

1998	[Print Target Temp]		
	-		
1-998-001	Fusing Clean Temp	E	[140 to 205 / 165 / 1 deg/step]

1998	[Reserve SP]		
1-998-002	reserve02	E	[0 to 255 / 0 / 1/step]
1-998-003	reserve03	E	
1-998-004	reserve04	E	
1-998-005	reserve05	E	
1-998-006	reserve06	E	[0 to 65535 / 0 / 1/step]
1-998-007	reserve07	E	
1-998-008	reserve08	E	
1-998-009	reserve09	E	
1-998-010	reserve10	E	

Main SP Tables-2

SP2-XXX (Drum)

2001	[C biasControl]		
2-001-001	C setting	E	[-1350 to -900 / -1020 / 1V/step] C: bias value.  Note <ul style="list-style-type: none"> This setting is available when the bias control is Off.
2-001-002	C(low) setting	E	[-400 to -200 / -350 / 50V/step] C(low): The value of C(low) output.
2-001-011	Vd_ref_lowhumi	E	[-700 to -400 / -420 / 10V/step] Displays or adjusts the target dark potential (Vd) in the Env Division, low humidity.  Note <ul style="list-style-type: none"> This setting is available when the bias control is On.
2-001-012	Vd_ref_midhumi	E	[-700 to -400 / -470 / 10V/step] Displays or adjusts the target dark potential (Vd) in the Env Division, mid humidity.  Note <ul style="list-style-type: none"> This setting is available when the bias control is On.
2-001-013	Vd_ref_highhumi	E	[-700 to -400 / -490 / 10V/step] Displays and adjusts the target dark potential (Vd) in the Env Division, high humidity.  Note <ul style="list-style-type: none"> This setting is available when the bias control is On.

2-001-100	F:Coefficient:a0	E	<p>[-500 to -350 / -350 / 1/step]</p> <p>Displays and adjusts the coefficient a0 used for the C-calculated function F (Vd, AH, D).</p> <p>Note</p> <ul style="list-style-type: none"> This setting is available when the bias control is On.
2-001-101	F:Coefficient:a1	E	<p>[0.80 to 1.20 / 1.00 / 0.01/step]</p> <p>Displays and adjusts the coefficient a1 used for the C-calculated function F (Vd, AH, D).</p> <p>Note</p> <ul style="list-style-type: none"> This setting is available when the bias control is On.
2-001-102	F:Coefficient:a2	E	<p>[0.0 to 10.0 / 5.0 / 0.1/step]</p> <p>Displays and adjusts the coefficient a2 that is of the C-calculated function F (Vd, AH, D).</p> <p>Note</p> <ul style="list-style-type: none"> This setting is available when the bias control is On.
2-001-103	F:Coefficient:a3	E	<p>[-20 to 0 / -9.9 / 0.1/step]</p> <p>Displays and adjusts the coefficient a3 that is of the C-calculated function F (Vd, AH, D).</p> <p>Note</p> <ul style="list-style-type: none"> This setting is available when the bias control is On.

2101	[Reg Correct]		
	The amount of the correction for the main scan position.		
2-101-001	Main Dot	E	[-300 to 300 / 0 / 1 dot/step]

2102	[Magnification Adj]		
	Sub Scan Magnification Adjustment		
2-102-002	Sub Mag.:N	E	[-1.0 to 1.0 / 0.0 / 0.1%/step]

2103	[Erase Margin Adj] Image Erase Margin Adjustment Adjusts the erase margin by deleting image data at the margins.		
2-103-001	Lead Edge Width	E	[2.7 to 9.9 / 3.0 / 0.1 mm/step]
2-103-002	Trail. Edge Width	E	[0.0 to 9.9 / 2.0 / 0.1 mm/step]
2-103-003	Left	E	
2-103-004	Right	E	
2103	[Erase Margin Adj] Image Erase Margin Adjustment: Back side		
2-103-005	Duplex:Lead	E	[0.0 to 4.0 / 0.0 / 0.1 mm/step]
2-103-006	Duplex:Trail.	E	
2-103-007	Duplex:Left Width	E	
2-103-008	Duplex:RightWidth	E	

2104	[Exposure energy]		
2-104-010	Normal Print	E	[0.23 to 0.98 / 0.50 / 0.01 uJ/cm ² /step] LEDA light emission energy: Normal printing Bk: Display/Setting
2-104-011	Normal Discharge	E	[0.23 to 0.98 / 0.70 / 0.01 uJ/cm ² /step] LEDA light emission energy: Quenching pattern Normal speed: Display/Setting
2-104-012	Low Discharge	E	[0.23 to 0.98 / 0.70 / 0.01uJ/cm ² /step] LEDA light emission energy: Quenching pattern Low speed: Display/Setting

2105	[LED Emit Time Adj] Adjusts the LEDA Light emission time.		
2-105-001	Normal Speed	E	[50 to 200 / 100 / 1%/step]

2106	[LEDA Emit Time] LEDA Light emission time.		
-------------	--	--	--

2-106-021	Print:Normal	E	[1000 to 12000 / 3000 / 1ns/step]
2-106-023	Quenching:Normal	E	

2201	[DV bias Control]		
2-201-001	DV(-)_setting	E	[-350 to -10 / -150 / 1v/step]
2-201-002	DV(+)_offset	E	[-100 to 0 / 0 / 25v/step]
2-201-003	DV(-)_offset	E	[-75 to 75 / 0 / 25v/step]
2-201-011	Line1:L1	E	[500000 to 950000 / 500000 / 50000mm/step]
2-201-012	Line2:L2	E	[1000000 to 1950000 / 1000000 / 50000mm/step]
2-201-013	Line3:L3	E	[2000000 to 2950000 / 3000000 / 50000mm/step]
2-201-014	Line4:L4	E	[3000000 to 7950000 / 5000000 / 50000mm/step]
2-201-015	Line5:L5	E	[8000000 to 19950000 / 8000000 / 50000mm/step]
2-201-016	Line6:L6	E	[20000000 to 29950000 / 20000000 / 50000mm/step]
2-201-017	Line7:L7	E	[30000000 to 39950000 / 33000000 / 50000mm/step]
2-201-204	Coefficient:a4	E	[0.00 to 0.50 / 0.13 / 0.01/step]
2-201-205	Coefficient:a5	E	[0.0 to 5.0 / 0.0 / 0.1/step]
2-201-206	Coefficient:a6	E	[-200 to 0 / 0 / 1/step]

2211	[PcuReverse] Switches the PCU reverse on / off.		
-------------	---	--	--

2-211-001	On/Off	E	[0 to 1 / 1 / 1/step] 0: Switch Off 1: Switch On with the reverse rotation sheet counts for normal time
-----------	--------	---	---

2212	[ExeSheets]		
2-212-001	Normal	E	[101 to 999 / 300 / 1 page/step] Cumulative sheets threshold after the last reverse.
2-212-002	LowPrinting	E	[1 to 500 / 50 / 1 page/step] This SP is not used and disabled. Changing this SP does not affect the control. Stops printing and executing reversing PCU every sheets that has been set for low printing.

2221	[LEDA Data:Display] Displays LEDA data.		
2-221-005	Serial No.	E	[- / - / -]
2-221-009	Power Error	E	[0 or 1 / 0 / 1/step]

2301	[T bias Control] Transfer Bias Control Use these SP's to adjust the power output and power coefficient used to transfer the toner image from drum to paper. Four separate voltages are applied before the leading edge, at the leading edge of the paper, across the image area and at the trailing edge of the paper. Notes: <ul style="list-style-type: none"> The coefficient adjustment should be done before the power output. The amount of voltage applied to each area can be set independently in each area for the type of paper in use. 		
2-301-002	T(+)_2_FaceOffset	E	[-15 to 15 / 0 / 1uA/step] Displays the setting of the offset amount of transfer constant current level during creating an image on the face page.

2-301-003	T(+)_2_BackOffset	E	[-15 to 15 / 0 / 1uA/step] Displays the setting of the offset amount of transfer constant current level during creating an image on the back page.
2-301-101	Used Adjust A2	E	[0 to 100 / 80 / 1%/step] Output adjustment for the value of the transfer output table which is to be a basis when the transfer paper count is in the range of 15K and 30K.
2-301-102	Used Adjust A3	E	[0 to 100 / 70 / 1%/step] Output adjustment for the value of the transfer output table which is to be a basis when the transfer paper count is in the range of 30K and 60K.
2-301-103	Used Adjust A4	E	[0 to 100 / 65 / 1%/step] Output adjustment for the value of the transfer output table which is to be a basis when the transfer paper count is in the range of 60K and 90K.
2-301-104	Used Adjust A5	E	[0 to 100 / 60 / 1%/step] Output adjustment for the value of the transfer output table which is to be a basis when the transfer paper count is over 90K.

2401	[Timing Control]		
2-401-003	T[rotation print]	E	[600 to 9900 / 600 / 100msec/step]
2-401-004	T[rotation WU]	E	[600 to 9900 / 5000 / 100msec/step]

2411	[envi_section]		
2-411-001	AH_LM	E	[0.0 to 10.0 / 5.5 / 0.5g/m ³ /step] Displays and adjusts the threshold under low/mid humidity on environment section in regard to control the Environment Correction.

2-411-002	AH_MH	E	[11.0 to 30.0 / 15.0 / 0.5g/m ³ /step] Displays and adjusts the threshold under mid/high humidity on environment section in regard to control the Environment Correction.
-----------	-------	---	--

2924	[Supply Speed] For circulating the time to supply certain amount		
2-924-001	Remaining H:240	E	[0.01 to 1.00 / 0.35 / 0.01g/sec/step]
2-924-002	Remaining M:240	E	[0.01 to 1.00 / 0.29 / 0.01g/sec/step]
2-924-003	Remaining L:240	E	[0.01 to 1.00 / 0.22 / 0.01g/sec/step]
2-924-004	Remaining H:182	E	[0.01 to 1.00 / 0.25 / 0.01g/sec/step]
2-924-005	Remaining M:182	E	[0.01 to 1.00 / 0.21 / 0.01g/sec/step]
2-924-006	Remaining L:182	E	[0.01 to 1.00 / 0.17 / 0.01g/sec/step]

2925	[Toner Supply]		
2-925-001	consumed amount	E	[0.0 to 100000.0 / 0.0 / 0.1mg/step] Counter for judging to supply toner during printing.
2-925-002	Supply Threshold	E	[1.0 to 100000.0 / 300.0 / 0.1mg/step] Threshold for judging to supply toner during printing.
2-925-003	Sup- Coefficient	E	[0.0 to 5.0 / 0.7 / 0.1/step] Coefficient for calculating toner amount to supply during printing.

2926	[Recovery Supply]		
2-926-001	Recovery Amount	E	[0 to 300 / 5 / 1g/step] Amount for Recovery Supply.
2-926-002	Mixing Time	E	[0 to 300 / 10 / 1sec/step] Idle time to mix for Recovery Supply.

2-926-003	Recovery Count	E	[0 to 10000 / 0 / 1count/step] Total count of executed Recovery Supply
2-926-004	Self-Recovery	E	[- / - / -] [Execute] Forcibly executes one time Recovery Supply.

2927	[Initial Supply]		
2-927-001	Initial Amount	E	[1 to 50 / 10 / 1g/step] Target toner amount for supplying fixed amount of toner when replacing.
2-927-002	Initial Mixing T	E	[0 to 300 / 10 / 1sec/step] Idle time to mix for supplying fixed amount of toner when replacing.
2-927-003	Ini-Coefficient	E	[0.0 to 5.0 / 1.5 / 0.1/step] Coefficient for calculating the amount of toner supplying during printing after toner cartridge is replaced.
2-927-004	Initial Flag	E	[0 or 1 / 0 / 1/step] Information used to detect the replacements and judge the upper limit.
2-927-005	Exchange Count	E	[0 to 1000 / 0 / 1count/step] Counter for new toner detection.

2930	[Detection]		
2-930-001	Cleaner Count	E	[1 to 20 / 5 / 1cycle/step] Counter to rotate the cleaner parts when remaining toner in the developer detected.
2-930-002	stabilization T	E	[0.0 to 3.0 / 0.0 / 0.1sec/step] Stability time of the sensor used for detecting remaining toner in the developer.

2-930-003	Upper n cycle	E	[0 to 20 / 1 / 1/step] Upper counter to exclude from the obtained result when toner remaining in the developer detected.
2-930-004	Lower m cycle	E	[0 to 20 / 1 / 1/step] Lower counter to set it aside from the obtained result if toner remaining in the developer detected.
2-930-005	HH:240 Upper	E	[0 to 70 / 25 / 1 count/step] Counter for judging the upper limit when toner remaining in the developer detected.
2-930-006	HH:240 Lower	E	[0 to 70 / 38 / 1 count/step] Counter for judging the lower limit when toner remaining in the developer detected.
2-930-007	MM:240 Upper	E	[0 to 70 / 18 / 1 count/step] Counter for judging the upper limit when toner remaining in the developer detected.
2-930-008	MM:240 Lower	E	[0 to 70 / 34 / 1 count/step] Counter for judging the lower limit when toner remaining in the developer detected.
2-930-009	LL:240 Upper	E	[0 to 70 / 18 / 1 count/step] Counter for judging the upper limit when toner remaining in the developer detected.
2-930-010	LL:240 Lower	E	[0 to 70 / 36 / 1 count/step] Counter for judging the lower limit when toner remaining in the developer detected.
2-930-011	HH:182 Upper	E	[0 to 70 / 38 / 1 count/step] Counter for judging the upper limit when toner remaining in the developer detected.
2-930-012	HH:182 Lower	E	[0 to 70 / 52 / 1 count/step] Counter for judging the lower limit when toner remaining in the developer detected.

2-930-013	MM:182 Upper	E	[0 to 70 / 33 / 1 count/step] Counter for judging the upper limit when toner remaining in the developer detected.
2-930-014	MM:182 Lower	E	[0 to 70 / 48 / 1 count/step] Counter for judging the lower limit when toner remaining in the developer detected.
2-930-015	LL:182 Upper	E	[0 to 70 / 34 / 1 count/step] Counter for judging the upper limit when toner remaining in the developer detected.
2-930-016	LL:182 Lower	E	[0 to 70 / 46 / 1 count/step] Counter for judging the lower limit when toner remaining in the developer detected.
2-930-017	Sensor Standard V	E	[0.0 to 3.3 / 2.0 / 0.1V/step] Threshold for judging the detection result of toner end sensor.
2-930-018	Average Count	E	[0 to 255 / 0 / 1 count/step] Result of remaining detection in the developer.
2-930-019	Self- Detection	E	[- / - / -] [Execute] Detects forcibly the toner remaining in the developer.
2-930-020	Self-Mixing Time	E	[0 to 300 / 10 / 1sec/step] Required time for mixing prior to forcibly execute remaining detection.

2931	[Supply Error]		
2-931-002	0 count	E	[0 to 10000 / 0 / 1 count/step] Counter for detecting the SC364.
2-931-003	0 count Threshold	E	[1 to 50 / 30 / 1 count/step] Threshold for detecting the SC364.

2-931-004	Lower Count	E	[0 to 10000 / 0 / 1count/step] Counter for detecting the SC332.
2-931-005	Lower Threshold	E	[1 to 10 / 5 / 1count/step] Threshold for detecting the SC332.
2-931-006	SC332 Count	E	[0 to 10 / 0 / 1count/step] Counts that continuously detected the SC332.

2932	[End Detection]		
2-932-001	End Count	E	[0 to 10000 / 0 / 1count/step]
2-932-002	End Threshold	E	[1 to 10 / 3 / 1count/step]

2940	[Remain Control]		
2-940-001	Remaining Amount	E	[0.0 to 30.0 / 0.0 / 0.1g/step] Counter for detecting toner end.
2-940-002	Remaining Time	E	[0 to 300 / 0 / 1sec/step] Threshold for detecting toner end.

2941	[Remain Control] Counter for supplying triggered by the front cover open/close during Power ON.		
2-941-001	closing count	E	[0 to 65535 / 0 / 1count/step]

2952	[S_PaperRefresh] Correction coefficients of the toner refresh control when printing the small sized paper.		
2-952-001	Input Coefficient	E	[1000 to 3000 / 1884 / 1 / step]
2-952-002	Threshold Dist	E	[2010 to 7500 / 2100 / 1mm / step]
2-952-003	W.T.Coefficient	E	[1800 to 7100 / 2280 / 10 / step]

2961	[Cleaning Operation]		
2-961-001	Level 1	E	[0 to 1 / 0 / 1 / step]

2-961-002	Level 2	E	[0 to 1 / 0 / 1 / step]
-----------	---------	---	--------------------------------

2990	[Duty Control] Correction values of printing interval control in order to avoid the increasing temperature from continuous printing.		
2-990-001	Counter	E	[0 to 65535 / 0 / 1 count / step]
2-990-002	Lower	E	[2000 to 60000 / 14400 / 1 count / step]
2-990-003	Upper	E	[2000 to 60000 / 158400 / 1 count / step]
2-990-004	OFF/ON	E	[0 to 1 / 0 / 1 / step]
2-990-005	Accumulation	E	[0 to 65535 / 0 / 1 count / step]

2997	[PCDU STOP]		
2-997-001	End Mgn Distance	E	[100000 to 960000000 / 10490000 / 10000mm/ step] The parameter which is used to calculate the print stop end threshold [mm]. "Print stop end threshold [mm]" = "End threshold (distance) [mm]" + "End margin (distance) [mm]" * "+1 [kp]" = "+650000 [mm]" (Add approximately 650000 [mm] to increase the end distance by 1 [kp])

2998	[Timing Control]		
2-998-001	T:ReverseRotation	E	[1 to 100 / 32 / 1msec/step] Adjusts the reverse rotation time of PCU reverse rotation.
2-998-002	T:MotorStop	E	[550 to 1000 / 550 / 50msec/step] Adjusts the stop rotation time of PCU reverse rotation.
2-998-003	T:NormalRotation	E	[1 to 100 / 29 / 1msec/step] Adjusts the normal rotation time of PCU reverse rotation.

2-998-004	T:NormalRotation2	E	[1 to 100 / 120 / 1msec/step] Adjusts the normal rotation time of PCU reverse rotation.
-----------	-------------------	---	---

Main SP Tables-3

SP3-XXX (Process)

3

3098	[Days Before End] Switches the near end timing: days before end toner		
3-098-001	Toner	E	[0 to 2 / 1 / 1/step] 0: Earlier 1: Normal 2: Later
3501	[Dev Bias Control] Development Bias Control: On/Off designation.		
3-501-001	On/Off	E	[0 or 1 / 1 / 1-/step] 0: Off 1: On
3502	[C Bias Control] C bias Control: On/Off designation		
3-502-001	On/Off	E	[0 or 1 / 1 / 1/step] 0: Off 1: On
3800	[Days Before End] Switches the near end timing: days before end toner		
3-800-001	Waste Toner	E	[0 to 2 / 1 / 1/step] 0: Earlier 1: Normal 2: Later

Main SP Tables-5

SP5-XXX (Mode)

5024	[mm/inch Selection] Selects whether mm or inches are used in the display. Note: After selecting the number, you must turn the main power switch off and on.		
5-024-001	0:mm 1:inch	C	[0 or 1 / 1 / 1/step] 0: mm (Europe/Asia) 1: inch (USA)
5045	[Accounting counter] Selects whether the accounting counter is displayed on the LCD or not. SP5-801-001/003 will not clear this SP. The value will be under an exclusive control because the value varies in segments.		
5-045-001	Counter Method	C	[0 or 1 / 0 / 1/step] 0: Pattern 1 1: Pattern 2
5051	[Refill Toner Disp] Enables or disables the toner refill detection display.		
5-051-001	-	C	[0 or 1 / 0 / 1/step] 0: On 1: Off
5055	[Display IP Address] Display or does not display the IP address on the operation panel.		
5-055-001	-	C	[0 or 1 / 0 / 1/step] 0: Off 1: On

5067	[Parts PM System]		
	Selects the whether to perform the service management or user management as the PM management. The system banner and the message in which the system warning screen appears varies according to this setting.		
	5-067-001	PCDU	C [0 or 1 / 0 / 1/step]
5-067-009	Fusing Unit	C	0: Service management 1: User management

5083	[Led Switch]		
	Specifies whether the alert LED is lit or not when toner near end condition is detected. (This does not change the toner near end condition indication in the operation panel LCD.)		
5-083-001	Toner Near End	C	[0 or 1 / 0 / 1/step] 0: Off 1: On

5302	[Set Time]		
	Adjusts the RTC (real time clock) time setting for the local time zone. Examples: For Japan (+9 GMT), enter 540 (9 hours x 60 min.) JP: +540 (Tokyo) NA: -300 (New York) EU: + 60 (Paris) CH: +480 (Peking) TW: +480 (Taipei) AS: +480 (Hong Kong) KO: +540 (Korea)		
5-302-002	Time Difference	C	[-1440 to 1440 / -300 / 1min./step]

5305	[Auto Off Set]		
	Auto Off Limit Set		
5-305-101	Set Disp	C	[0 or 1 / 1 / 1/step] 0:Off, 1:On

5507	[Supply Alarm] Enables or disables the notifying a supply call via the @Remote.		
5-507-003	Toner	C	[0 or 1 / 1 / 1/step] Switches the control call on/off for the stapler installed in the finisher. DFU If you select "1" the alarm will sound when the copier detects toner end. 0: Off 1: On
5-507-006	WasteTonerBottle	C	[0 or 1 / 1 / 1/step] 0: Off 1: On
5-507-080	Toner Call Timing	C	[0 or 1 / 0 / 1/step] 0: At replacement 1: AtLessThanThresh Changes the timing of the "Toner Supply Call" via the @Remote, when the following conditions occur.
5-507-081	Toner Call Thresh	C	[10 or 90 / 10 / 10%/step]

5515	[SC/Alarm Setting] With NRS (New Remote Service) in use, these SP codes can be set to issue an SC call when an SC error occurs. If this SP is switched off, the SC call is not issued when an SC error occurs.		
5-515-001	SC Call	C	[0 or 1 / 1 / 1/step] 0: Off 1: On
5-515-004	User Call	C	
5-515-006	Communication Test Call	C	
5-515-007	Machine Information Notice	C	
5-515-010	Supply Automatic Ordering Call	C	

5801	[Memory Clear]		
-------------	-----------------------	--	--

5-801-001	All Clear	C	<p>[- / - / -] [Execute]</p> <p>Restores the set value which the controller keeps to the initial value (with certain exceptions).</p> <p>* The engine SP clear (SP5-801-002) is not executed.</p>
5-801-002	Engine	E	<p>[0 or 1 / 0 / 1/step]</p> <p>Initializes all registration settings for the engine and copy process settings.</p>

5803	<p>[INPUT Check] See "page 79 "Input Check Table"</p>		
-------------	--	--	--

5804	<p>[OUTPUT Check] See "page 80 "Output Check Table"</p>		
-------------	--	--	--

5810	<p>[SC Reset] Cancel SC of the CE cancellation.</p>		
5-810-001	Fusing SC Reset	E	<p>[0 or 1 / 0 / 1/step]</p> <p>[Execute]</p>

5811	<p>[MachineSerial]</p>		
5-811-002	Display	E	<p>[0 to 255 / 0 / 1/step]</p> <p>Displays the machine serial number.</p>
5-811-004	BCU	E	<p>[0 to 255 / 0 / 1/step]</p> <p>Inputs the machine's serial number.</p>

5811	<p>[Machine No. Setting]</p>		
5-811-003	ID2 Code Display	C	<p>[- / - / -] [17digit characters]</p> <p>Sets the ID-2 code for recognizing equipment when setting CSS. (for remote access only)</p>

5816	[Remote Service]		
5-816-002	CE Call	C	<p>[0 or 1 / 0 / 1/step]</p> <p>0: Start of the service</p> <p>1: End of the service</p> <p>Performs the CE Call at the start or end of the service.</p> <p>Note: This SP is activated only when SP5816-001 is set to "1".</p>
5-816-003	Function Flag	C	<p>[0 or 1 / 0 / 1/step]</p> <p>0: Disabled</p> <p>1: Enabled</p> <p>Enables or disables the remote service function.</p> <p>NOTE: This SP setting is changed to "1" after @Remote register has been completed.</p>
5-816-004	Communication Test	C	<p>[- / - / -]</p> <p>[Execute]</p> <p>Judges whether or not to communicate with the center correctly after the NRS equipment is set.</p> <p>The communication test call is executed in remote service.</p> <p>A return value of the execution is 0 to 99.</p> <p>0: Normally finished (during the center in operation)</p> <p>1: Normally finished (during the center out of operation)</p> <p>Other number: Abnormally finished</p> <p>Communication can not be performed If SP5-515-006 is disabled.</p>

5-816-005	Device Info	C	<p>[- / - / -] [Execute] Performs a call for notifying equipment internal information to the call center. The call for checking equipment status is executed in remote service. A return value of the execution is 0 to 99. 0: Normally finished (during the center in operation) 1: Normally finished (during the center out of operation) Other number: Abnormally finished</p>
5-816-022	RCG Reg. State	C	<p>[0 to 2 / 0 / 1/step] 0: RC Gate not registered, 1:RC Gate registered, 2: Equipment registered</p>
5-816-025	GW URL	C	DFU
5-816-026	Polling Interval	C	<p>[60 to 99999 / 60 / 1 sec/step] Displays and sets the polling interval to NRS G/W. If 0 is designated, the polling with 0x7ffffff interval is designated actually.</p>
5-816-027	HTTP Con Timeout	C	<p>[1 to 90 / 30 / 1 sec/step] Timeout time for connecting to G/W. This is enabled only when @Remote is in operation.</p>
5-816-028	HTTP Sen Timeout	C	[0 to 100 / 30 / 1/step]
5-816-029	HTTP Rec Timeout	C	[0 to 100 / 30 / 1/step]
5-816-030	HTTP Retry Timeout	C	<p>[0 to 65535 / 3 / 1 sec/step] Interval of retrying connection when the connection to the G/W failed.</p>

5-816-031	HTTP Retry #	C	[0 to 255 / 3 / 1/step] The number of times of retrying connection when the connection to the G/W failed. When the connection fails for this number of times, it processes the connection as failure.
5-816-032	HTTP Con Delay	C	[0 to 255 / 5 / 1/step] Waiting time until the notification is executed actually after a notification demand is sent.
5-816-033	Max Multipart	C	[1 to 10 / 10 / 1/step] The maximum number of sending/receiving multipart messages to/from G/W. 10 is the maximum in accordance with G/W.
5-816-039	Rescue G/W URL	C	[Up to 81 / http://210.173.216.60/Rescue/AS / - / -] Sets and checks the URL of the rescue G/W.
5-816-040	Per Notice Mode	C	[0 to 5/ 0 / 1/step]
5-816-041	Cnt Notice Mode	C	Displays the notifying timing specified by G/W. 0: Not notify, 1: Notify immediately, 2: Monthly, 3: Weekly, 4: Daily, 5: At specified interval
5-816-042	Per Notice Time	C	[0 to 0xffffffff / 0 / 1/step] Displays the notifying timing specified by G/W. 0: Not notify, 1: Notify immediately, 2: Monthly, 3: Weekly, 4: Daily, 5: At specified interval
5-816-043	Cnt Notice Time	C	[0 to 0xffffffff / 0 / 1/step] Displays the notifying date specified by G/W. The notifying date is displayed as elapsed time in seconds from 00:00:00 January 1, 1970.

5-816-044	Cnt End Time	C	<p>[0 to 0xffffffff / 0 / 1/step]</p> <p>Displays the ending date specified by G/W. The ending date is displayed as elapsed time in seconds from 00:00:00 January 1, 1970.</p>
5-816-045	Next Per NotiTime	C	<p>[0 to 0xffffffff / 0 / 1/step]</p> <p>Displays the notifying type and date specified by G/W, and actual next notifying date based on the notifying date and time when setting. The notifying date is displayed as elapsed time in seconds from 00:00:00 January 1, 1970.</p>
5-816-046	Next Cnt NotiTime	C	<p>[0 to 0xffffffff / 0 / 1/step]</p> <p>Displays the notifying type and date specified by G/W, and actual next notifying date based on the notifying date and time on setting. The notifying date is displayed as elapsed time in seconds from 00:00:00 January 1, 1970.</p>
5-816-047	Next Cnt End Time	C	<p>[0 to 0xffffffff / 0 / 1/step]</p> <p>Displays the notifying type and date specified by G/W, and actual next notifying date based on the notifying date and time on setting. The notifying date is displayed as elapsed time in seconds from 00:00:00 January 1, 1970.</p>
5-816-048	Fix CntPol Time	C	<p>[0 to 0xffffffff / 0 / 1/step]</p> <p>Displays the specified date when executing the center polling specified by G/W. The notifying date is displayed as elapsed time in seconds from 00:00:00 January 1, 1970. After executing the date-specified center polling, it comes back to the initial value.</p>

5-816-052	Test Flag	C	<p>[0 to 255 / 0 / 1/step]</p> <p>Displays whether or not to execute a test call when executing change of time-specified setting value by G/W.</p> <p>Displays the specified date when executing the center polling to which the test call is executed.</p> <p>0: Does not execute a test call 1: Execute a test call</p>
5-816-053	Update Result	C	[0 to 255 / 0 / 1/step]
5-816-060	Mgn Expir Time	C	<p>[2592000 to 15552000 / 2592000 / 1 sec/step]</p> <p>A reference value (second) for determining that the certification is expiring during RC Gate operation.</p> <p>During RC Gate operation, when it reaches the date when the period set by this SP before expiration date written on the certificate is left, it detects that validity is close to expiration and notifies that to Gateway.</p> <p>If notification failed, it notifies again at the date when the 1/4 and 1/10 of the set period is left.</p>
5-816-061	NotiTime ExpTime	C	<p>[- / 0 / -]</p> <p>Proximity of the expiration of the certification.</p>
5-816-062	HTTP Proxy use	C	<p>[- / - / -]</p> <p>Determines if the proxy server is used when the machine communicates with the service center.</p>

5-816-063	HTTP Proxy Host	C	<p>[up to 127 / - / 1/step]</p> <p>This SP sets the address of the proxy server used for communication between the RCG device and the gateway. Use this SP to set up or display the customer proxy server address.</p> <p>The address is necessary to set up the embedded RCG-N.</p> <p>Note</p> <ul style="list-style-type: none"> The address display is limited to 128 characters. Characters beyond the 128 character are ignored. This address is customer information and is not printed in the SMC report.
5-816-064	HTTP Proxy Port	C	<p>[0 to 65535 / 8080 / 1/step]</p> <p>This SP sets the port number of the proxy server used for communication between the embedded RCG-N and the gateway. This setting is necessary to set up the embedded RC Gate-N.</p> <p>Note</p> <ul style="list-style-type: none"> This port number is customer information and is not printed in the SMC report.
5-816-065	HTTP Prox AutUsr	C	<p>[up to 31 / - / 1/step]</p> <p>This SP sets the HTTP proxy certification user name.</p> <p>Note</p> <ul style="list-style-type: none"> The length of the name is limited to 31 characters. Any character beyond the 31st character is ignored. This name is customer information and is not printed in the SMC report.

5-816-066	HTTP Prox AutPass	C	<p>[up to 31 / - / 1/step]</p> <p>This SP sets the HTTP proxy certification password.</p> <p>Note</p> <ul style="list-style-type: none">• The length of the password is limited to 31 characters. Any character beyond the 31st character is ignored.• This name is customer information and is not printed in the SMC report.
-----------	-------------------	---	--

5-816-067	Cer Updt Cond		C	[- / - / -] Displays the status of the certification update.
	0	The certification used by Embedded RC Gate is set correctly.		
1	The certification request (setAuthKey) for update has been received from the GW URL and certification is presently being updated.			
2	The certification update is completed and the GW URL is being notified of the successful update.			
3	The certification update failed, and the GW URL is being notified of the failed update.			
4	The period of the certification has expired and new request for an update is being sent to the GW URL.			
11	A rescue update for certification has been issued and a rescue certification setting is in progress for the rescue GW connection.			
12	The rescue certification setting is completed and the GW URL is being notified of the certification update request.			
13	The notification of the request for certification update has completed successfully, and the system is waiting for the certification update request from the rescue GW URL.			
14	The notification of the certification request has been received from the rescue GW controller, and the certification is being stored.			
15	The certification has been stored, and the GW URL is being notified of the successful completion of this event.			
16	The storing of the certification has failed, and the GW URL is being notified of the failure of this event.			
17	The certification update request has been received from the GW URL, the GW URL was notified of the results of the update after it was completed, but a certification error has been received, and the rescue certification is being recorded.			
18	The rescue certification of No. 17 has been recorded, and the GW URL is being notified of the failure of the certification update.			

5-816-068	Cer Abnml Cause		C	[- / - / -] Displays a number code that describes the reason for the request for update of the certification.
	0	Normal. There is no request for certification update in progress.		
	1	Request for certification update in progress. The current certification has expired.		
	2	An SSL error notification has been issued. Issued after the certification has expired.		
	3	Notification of shift from a common authentication to an individual certification.		
	4	Notification of a common certification without ID2.		
	5	Notification that no certification was issued.		
	6	Notification that GW URL does not exist.		
5-816-069	Cer Updt ReqID		C	[- / - / -] The ID of the request for certification.
5-816-071	HTTP ConRty IntBU		C	[0 to 65535 / 3 / 1sec/step]
5-816-072	HTTP ConRty # BU		C	[0 to 255 / 3 / 1/step]
5-816-073	HTTP ConReqDelBU		C	[0 to 255 / 5 / 1sec /step]
5-816-074	HTTP ConTimOut BU		C	[0 to 90 / 30 / 1sec /step]
5-816-075	Multipart Max BU		C	[0 to 10 / 10 / 1/step]
5-816-078	Center URL Backup		C	[Up to 81 char / - / -]
5-816-079	RescueURL Backup		C	[Up to 81 char / - / -]
5-816-080	ExpTme Notifn BU		C	[2592000 to 15552000 / 2592000 / 1sec /step]
5-816-081	Pol Intvl Backup		C	[60 to 99999 / 60 / 1sec /step]
5-816-087	CERT:Macro Ver.		C	[- / - / -] Displays the macro version of the @Remote certification.

5-816-088	CERT:PAC Ver.	C	[- / - / -] Displays the PAC version of the @Remote certification.
5-816-095	Svr CNCheck	C	[0 or 1 / 0 / 1/step] 0: Certification CN strict check 1: Certification CN loose check
5-816-121	CERT: GW URL	C	[Up to 81 char / - / -]
5-816-122	CERT: Use Pass	C	[0 or 1 / 0 / 1/step] 0:Not available 1:Avilable
5-816-123	CERT: Pass Phrase	C	[Up to 31 char / - / -]
5-816-124	CERT: Use MAC	C	[0 or 1 / 0 / 1/step] 0:Not available 1:Avilable
5-816-125	CERT: MAC Pass	C	[Up to 31 char / - / -]
5-816-131	CERT: Pass Phrase BU	C	[Up to 31 char / - / -]
5-816-132	CERT: Use MAC BU	C	[0 or 1 / 0 / 1/step] 0:Not available 1:Avilable
5-816-133	CERT: MAC Pass BU	C	[Up to 31 char / - / -]
5-816-135	Reg Notify Int	C	[0 to 4294967295 / 0 / 1/step]
5-816-136	Reg Notify Week	C	[0 to 6 / 0 / 1/step] 0:Sunday, 1:Monday, 2:Tuesday, 3:Wednesday, 4:Tursday, 5:Friday, 6:Saturday
5-816-137	Count Notify Int	C	[0 to 4294967295 / 0 / 1/step]
5-816-138	Count Notify Week	C	[0 to 6 / 0 / 1/step] 0:Sunday, 1:Monday, 2:Tuesday, 3:Wednesday, 4:Tursday, 5:Friday, 6:Saturday

5-816-139	SSL port	C	[0 to 65535 / 443 / 1/step]
5-816-200	Poling Man Exc	C	[- / - / -] [Execute] Executes the center polling manually.
5-816-201	Instl:Condition	C	[0 to 4 / 0 / 1/step] Displays a number that indicates the status of the @Remote service device. 0: Neither the @Remote device nor Embedded RCG Gate is set. 1: The Embedded RCG Gate is being set. Only Box registration is completed. In this status, @Remote device cannot communicate with this device. 2: The Embedded RCG Gate is set. In this status, the @Remote device cannot communicate with this device. 3: The @Remote device is being set. In this status the Embedded RCG Gate cannot be set. 4: The @Remote module has not started.
5-816-202	Instl:ID #	C	[- / - / -] Allows entry of the request number needed for the Embedded RCG Gate.
5-816-203	Instl:Reference	C	[- / - / -] [Execute] Executes the confirmation request to the @Remote Gateway.

5-816-204	Instl:Ref Rslt	C	<p>[0 to 255 / 0 / 1/step]</p> <p>Displays a number that indicates the result of the inquiry executed with SP5816-203.</p> <p>0: Succeeded</p> <p>1: Inquiry number error</p> <p>3: Proxy error (proxy enabled)</p> <p>4: Proxy error (proxy disabled)</p> <p>5: Proxy error (Illegal user name or password)</p> <p>6: Communication error</p> <p>8: Other error</p> <p>9: Inquiry executing</p> <p>20: Dial-up authentication error</p> <p>21: Answer tone detection error</p> <p>22: Carrier detection error</p> <p>23: Invalid setting value (modem)</p> <p>24: Low power supply current</p> <p>25: Unplugged modem</p> <p>26: Busy line</p>
5-816-205	Instl:Ref Section	C	<p>[- / - / -]</p> <p>Displays the result of the notification sent to the device from the GW URL in answer to the inquiry request. Displayed only when the result is registered at the GW URL.</p>
5-816-206	Instl:Rgstltn	C	<p>[- / - / -]</p> <p>[Execute]</p> <p>Executes "Embedded RCG Registration".</p>

5-816-207	Instl:Rgstltn Rst	C	<p>[0 to 255 / 0 / 1/step]</p> <p>Displays a number that indicates the registration result.</p> <p>0: Succeeded</p> <p>2: Registration in progress</p> <p>3: Proxy error (proxy enabled)</p> <p>4: Proxy error (proxy disabled)</p> <p>5: Proxy error (Illegal user name or password)</p> <p>8: Other error</p> <p>9: Registration executing</p> <p>20: Dial-up authentication error</p> <p>21: Answer tone detection error</p> <p>22: Carrier detection error</p> <p>23: Invalid setting value (modem)</p> <p>24: Low power supply current</p> <p>25: Unplugged modem</p> <p>26: Busy line</p>
5-816-208	Instl:ErrorCode	C	[-2147483647 to 2147483647 / - / -]
	Cause	Code	Meaning
	Illegal Modem Parameter	-11001	Chat parameter error
		-11002	Chat execution error
		-11003	Unexpected error
		-11004	Cutting process occurred during modem communication.
		-11005	NCS reboot occurred during modem communication.

	Operation Error, Incorrect Setting	-12003	Attempted registration without execution of an inquiry and no previous registration.
		-12004	Attempted setting with illegal entries for certification and ID2.
		-12006	A confirmation request was made after the confirmation had been already completed.
		-12008	Update certification failed because mainframe was in use.
	Error Caused by Response from GW URL	-2387	Not supported at the Service Center
		-2389	Database out of service
		-2390	Program out of service
		-2391	Two registrations for same device
		-2392	Parameter error
		-2393	Basil not managed
		-2394	Device not managed
		-2395	Box ID for Basil is illegal
		-2396	Device ID for Basil is illegal
		-2397	Incorrect ID2 format
	-2398	Incorrect request number format	
5-816-209	Instl Clear	C	[- / - / -] [Execute] Releases the machine from its embedded RCG setup.

5818	[Network Setting]		
	-		
5-818-010	Print Time Out	C	[5 to 300 / 15 / 1/step] Sets timeout time for DIPRINT or LPR printing.

5-818-059	ICMPv6 Redirect Enable / Disable	C	[0 or 1 / 0 / 1/step] Sets Enable/Disable for ICMPv6 redirection. 0: Disable 1: Enable
5-818-074	Fixed USB Port		[0 or 1 / 0 / 1/step] Sets On/Off for USB port fixed function. 0: Off 1: On
5-818-075	USB Host	C	[0 or 1 / 1 / 1/step] Refers to Enable/Disable for USB host function. 0: USB host function OFF 1: USB host function ON

5828	[Network Setting] Interface selection for Ethernet		
5-828-001	IPv4 Address (Ethernet/IEEE 802.11)	C	[00000000h to ffffffffh / 0B16212Ch / -] Refers to / Sets IPv4 address used in Ethernet. Data is handled in 8 bits when displaying current value, or on operating part, or printing with summary print.
5-828-002	IPv4 Subnet Mask(Ethernet/IEEE 802.11)	C	[00000000h to ffffffffh / 00000000h / 1/step] Refers to / Sets IPv4 address used in Ethernet. Data is handled in 8 bits when displaying current value, or on operating part, or printing with summary print.

5-828-003	IPv4 Default Gateway (Ethernet/IEEE 802.11)	C	<p>[00000000h to ffffffffh / 00000000h / 1/step]</p> <p>Refers to / Sets IPv4 address used in Ethernet.</p> <p>Data is handled in 8 bits when displaying current value, or on operating part, or printing with summary print.</p>
5-828-006	DHCP (Ethernet/IEEE 802.11)	C	<p>[0 or 1 / 1 / 1/step]</p> <p>0: Not used (manual setting) 1: Use</p> <p>Refers to / Sets whether or not to set IP address using DHCP in Ethernet.</p>
5-828-008	Enabled Protocol	C	<p>[0 to 255 / 1 / 1/step]</p> <p>0:off, 1:on</p> <p>Refers to / Sets enabled protocol used in network.</p> <p>bit0: IPv4 0: off, 1: on (0x01) bit1: Reserved 0: off, 1: on (0x02) bit2: Reserved 0: off, 1: on (0x04) bit3: Reserved 0: off, 1: on (0x08) bit7: IPv6 0: off, 1: on (0x80)</p>

5-828-026	Action Mode (IPv4)	C	<p>[00000000h to ffffffffh / 0x0000007f / 1/step]</p> <p>1:on, 0:off</p> <p>Refers to / Sets network protocol operation mode.</p> <p>bit0: DIPRINT</p> <p>bit1: LPR</p> <p>bit2: HTTP</p> <p>bit3: SNMP</p> <p>bit4: Bonjour</p> <p>bit5: SSL/TLS</p> <p>bit6: NBT</p> <p>bit7 to 30: reserved</p> <p>bit31: TELNET</p>
5-828-071	Priority Boot I/F (Setting)	C	<p>[0 or 1 / 0 / 1/step]</p> <p>0: Ethernet, 1: Reserved</p>
5-828-091	Web (0:Off 1:On)	C	<p>[0 or 1 / 1 / 1/step]</p> <p>Enables or disables the Web operation.</p> <p>0: Disable, 1: Enable</p>
5-828-123	Active SSL/TLS Encryption Mode	C	<p>[0 to 2 / 2 / 1/step]</p> <p>0: Only ciphertext</p> <p>1: Ciphertext in preference</p> <p>2: Ciphertext/plaintext</p> <p>Specifies communication allowed in SSL/TLS.</p>
5-828-156	IPv6 Manual Address	C	<p>[- / - / -]</p> <p>This SP is the IPv6 manually set address referenced on the Ethernet in the format: "Manual Set Address" + "Prefix Length"</p> <p>The IPv6 address consists of a total 128 bits configured in 8 blocks of 16 bits each.</p>

5-828-158	IPv6 Gateway Address	C	<p>[- / - / -]</p> <p>This SP is the IPv6 gateway address referenced on the Ethernet. The IPv6 address consists of a total 128 bits configured in 8 blocks of 16 bits each.</p>
5-828-160	Action Mode (IPv6)	C	<p>[00000000h to ffffffffh / 0x00000003f / 1/step]</p> <p>1:on, 0:off</p> <p>Refers to / Sets network protocol operation mode.</p> <p>bit0: DIPRINT</p> <p>bit1: LPR</p> <p>bit2: HTTP</p> <p>bit3: SNMP</p> <p>bit4: Bonjour</p> <p>bit5: SSL/TLS</p> <p>bit6 to 30: reserved</p> <p>bit31: TELNET</p>
5-828-161	IPv6 Stateless Auto Setting	C	<p>[0 or 1 / 1 / 1 /step]</p> <p>Enables or disables the automatic setting for IPv6 stateless.</p> <p>0: Disable, 1: Enable</p>
5-828-217	IPsec Mode Setting	C	<p>[0 or 1 / 0 / 1/step]</p> <p>Sets Enable/Disable for IPsec.</p> <p>0: Disable</p> <p>1: Enable</p>
5-828-249	DUID	C	<p>[- / 0000000000000000 / - /]</p> <p>Sets DU-ID value of DHCPv6 in hexadecimal, 14 bytes.</p>
5831	<p>[Initial Setting Mode Clear]</p> <p>Initializes SP5-201-002 (panel lock ON/OFF setting) and SP5-201-003 (panel lock password) by executing this SP.</p>		

5-831-092	Panel Lock Clear	C	[- / - / -] [Execute]
-----------	------------------	---	--------------------------

5840	[IEEE 802.11/step] DFU		
5-840-011	WEP Key Select	C	[- / 00000000 / -] Reserved
5-840-101	WLAN Destination Setting	C	[0 to 2 / 2 / 1/step] Reserved

5844	[USB]		
5-844-001	Transfer Rate	C	[- / 0x04 / -] Sets the speed for USB data transmission. 0x01: Full Speed 0x04: Auto Change
5-844-002	Vendor ID	C	[0x0000 to 0xffff / 0x05ca / -] DFU
5-844-003	Product ID	C	[0x0000 to 0xffff / 0x0443 / -] DFU
5-844-004	Device Release Number	C	[0 to 9999 / 256 / -] DFU
5-844-005	Fixed USB Port	C	[0 or 1 / 0 / 1/step] Sets On/Off for USB port fixed function. 0: Off 1: On
5-844-200	Debug I/F Setting	C	[0x00 to 0xff / 0x00 / 1/step] Sets Enable/Disable for dbgmon connection. 1: Disabled, Other than 1: Enabled

5849	[Installation Date] Displays or prints the installation date of the machine.		
-------------	--	--	--

5-849-001	Display	C	[- / - / -] Displays the installation date. The installation date is set automatically after test copies are done at the installation site.
5-849-002	Print	C	[0 or 1 / 1 / 1 / step] 0: Off (No Print) 1: On (Print) Determines whether the installation date is printed on the printout for the total counter.
5-849-003	Total Counter	C	[0 to 99999999 / 0 / 1 / step] Displays the total counts at the installed date (SP5-849-001).

5870	[Common KeyInfo Initialize] Writes to flash ROM the common proof for validating the device for NRS specifications.		
5-870-003	-	C	[- / - / -] [Execute]

5875	[SC Auto Reboot] Determines whether the machine reboots automatically when an SC error occurs.		
5-875-001	Reboot Mode	C	[0 or 1 / 0 / 1 / step] Enables or disables the automatic reboot function when an SC error occurs. The reboot is not executed for Type A or C SC codes. 0: The machine reboots automatically when the machine issues an SC error and logs the SC error code. If the same SC occurs again, the machine does not reboot. 1: The machine does not reboot when an SC error occurs.

5-875-002	Reboot Method	C	[0 or 1 / 0 / 1/step] 0: Manual reboot 1: Automatic reboot Selects the reboot method for SC.
-----------	---------------	---	---

5894	[ExternalCountSet] Switch the Charge Mode of External Mech Count		
5-894-001	SW Change Mode	E	[0 to 2 / 0 / 1/step]

5907	[Plug & Play] Selects the brand name and the production name for Windows Plug & Play. This information is stored in the NVRAM. If the NVRAM is defective, these names should be registered again. After selecting, press the "Original Type" key and "#" key at the same time. When the setting is completed, the beeper sounds five times.		
5-907-001	-	C	[- / - / -]
5-907-002	Maker Name	C	[- / - / -]
5-907-003	Model Name	C	[- / - / -]

5930	[MeterClick Charge]		
5-930-001	Setting	E	[0 or 1 / 0 / 1/step]

5931	[Life Alert Disp.]		
5-931-001	Mentenance Kit	E	[0 or 1 / 0 / 1/step]
5-931-002	PCDU	E	
5-931-003	PCDU STOP	E	

5981	[Remote Service]		
5-981-002	Remote diagnostics	C	[- / - / -] [Execute]
5-981-004	CE Working Start	C	[0 to 0xffffffff / 0 / 1/step]

5-981-005	CE Working Total	C	[0 to 0xffffffff / 0 / 1sec/step] It is counted only during CE operating.
-----------	------------------	---	--

5987	[Mech. Counter] This SP detects that a mechanical counter device is removed. If it is detected, SC610 occurs.		
-------------	---	--	--

5-987-001	0:Off / 1:On	E	[0 or 1 / 0 / 1/step] 0: Off. 1: On
-----------	--------------	---	--

5990	[SP Print Mode] Prints out the SMC sheets.		
-------------	--	--	--

5-990-002	SP	C	[- / - / -] [Execute] Press "Execute" key to start printing the SMC sheets.
5-990-003	User Program	C	
5-990-006	Non-Default	C	
5-990-231	Printer Service Summary	C	

Main SP Tables-7

SP7-XXX (Data Log)

7401	[Total SC Counter]		
	Stores total SC occurring count. If the same SC codes are detected continuously and total counter is not increasing, it only logs once in case of deleting other SC code logs.		
7-401-001	-	C	[0 to 9999 / - / 1/step]

7403	[SC History]			
	Logs and displays the SC codes detected. The 10 most recently detected SC Codes are displayed on the screen, and also can be seen on the SMC (logging) outputs.			
	<div style="border: 1px solid blue; border-radius: 10px; padding: 2px; display: inline-block;"> ↓ Note </div> <ul style="list-style-type: none"> If the same SC codes are detected continuously and total counter is not increasing, it only logs once in case of deleting other SC code logs. 			
	7-403-001	Latest	C	[0 to 65535 / - / 1/step]
	7-403-002	Latest 1	C	
	7-403-003	Latest 2	C	
	7-403-004	Latest 3	C	
	7-403-005	Latest 4	C	
	7-403-006	Latest 5	C	[0 to 65535 / - / 1/step]
	7-403-007	Latest 6	C	
	7-403-008	Latest 7	C	
7-403-009	Latest 8	C		
7-403-010	Latest 9	C		

7803	[Disp. PM Counter]		
	Displays and sets the Sheets/Distance/Usage counter		

7-803-002	Sheets PCDU	E	[0 to 9999999 / 0 / 1 sheet/step]
7-803-003	Sheets Fuser	E	
7-803-004	Sheets Trans.	E	
7-803-005	Sheets Feed	E	
7-803-006	Sheets Fric. Pad	E	
7-803-012	Distance PCDU	E	
7-803-013	Distance Fuser	E	
7-803-014	Distance Trans.	E	
7-803-022	Usage PCDU	E	[0 to 255 / 0 / 1%/step]
7-803-023	Usage Fuser	E	
7-803-024	Usage Trans.	E	
7-803-025	Usage Feed	E	
7-803-026	Usage Fric. Pad	E	

7804	[Reset PM Counter] Counter reset by execution SP.		
7-804-002	PCDU	E	[- / - / -] [Execute]
7-804-003	Fuser	E	
7-804-004	Trans.	E	
7-804-005	Feed	E	
7-804-006	Fric. Pad	E	
7-804-010	Maintenance Kit	E	
7-804-011	All	E	

7805	[Counter Continue]		
7-805-001	Setting	E	[- / - / -] [Execute]

7-805-002	Distance PCDU	E	[0 to 99999999 / - / -]
-----------	---------------	---	-------------------------

7850	[Toner Counter] Counter resetting by execution SP.		
7-850-001	PCDU Distance	E	[0 to 999999999 / 0 / 1mm/step]
7-850-002	Total Consump	E	[0.0 to 10000000.0 / 0.0 / 0.1mg/step]

7931	[Toner Info.] Displays the ID chip information in the toner cartridge. Returns "0", if it could not access to the ID chip.		
7-931-001	Machine ID	E	[0 to 255 / 0 / 1/step]
7-931-002	Version	E	
7-931-003	Brand ID	E	
7-931-004	Area ID	E	
7-931-005	Class ID	E	
7-931-006	Color ID	E	
7-931-007	Maintenance ID	E	
7-931-008	New AIO	E	
7-931-009	Recycle Count	E	
7-931-010	EDP Code	E	
7-931-011	Serial No.	E	
7-931-012	Remaining Toner	E	[0 to 100 / 0 / 20%/step]
7-931-013	Toner End	E	[- / - / -]
7-931-014	Refill Flag	E	
7-931-015	R:Total Cnt.	E	[0 to 99999999 / 0 / 1sheet/step]
7-931-016	E:Total Cnt.	E	
7-931-017	Unit Output Cnt.	E	

7-931-018	Install Date	E	[- / - / -]
7-931-019	Toner End Date	E	
7-931-020	Total Consump	E	[0.0 to 10000000.0 / 0.0 / 0.1mg/step]
7-931-021	PCDU Distance	E	[0 to 999999999 / 0 / 1mm/step]
7-931-022	Initial Amount	E	[0 to 65535 / 0 / 1g/step]

3

7932	[PCDU Info.] Displays the ID chip information in the PCDU. Returns "0", if it could not access to the ID chip.		
7-932-001	Machine ID	E	[0 to 255 / 0 / 1/step]
7-932-002	Class ID	E	
7-932-003	Maintenance ID	E	
7-932-004	New AIO	E	
7-932-005	Serial No.	E	[- / - / -]
7-932-006	Install Date	E	
7-932-007	Sheets	E	[0 to 999999 / 0 / 1sheet/step]
7-932-008	Distance	E	[0 to 999999999 / 0 / 1mm/step]
7-932-010	Control Distance	E	
7-932-011	PM Chg Sheets	E	
7-932-012	PM Chg Distance	E	
7-932-013	Cleaning 1 Count	E	[0 to 65535 / 0 / 1count/step]
7-932-014	Cleaning 2 Count	E	

7935	[Toner Info. Log] Displays the ID chip log data in the toner cartridge.		
7-935-001	1:Serial No.	E	[- / - / -]
7-935-002	1:Install Date	E	

7-935-003	1:R:Total Cnt.	E	[0 to 999999999 / 0 / 1/step]
7-935-004	1:Refill Flag	E	[- / - / -]
7-935-005	2:Serial No.	E	
7-935-006	2:Install Date	E	
7-935-007	2:R:Total Cnt.	E	[0 to 999999999 / 0 / 1/step]
7-935-008	2:Refill Flag	E	[- / - / -]
7-935-009	3:Serial No.	E	
7-935-010	3:Install Date	E	
7-935-011	3:R:Total Cnt.	E	[0 to 999999999 / 0 / 1/step]
7-935-012	3:Refill Flag	E	[- / - / -]
7-935-013	4:Serial No.	E	
7-935-014	4:Install Date	E	
7-935-015	4:R:Total Cnt.	E	[0 to 999999999 / 0 / 1/step]
7-935-016	4:Refill Flag	E	[- / - / -]
7-935-017	5:Serial No.	E	
7-935-018	5:Install Date	E	
7-935-019	5:R:Total Cnt.	E	[0 to 999999999 / 0 / 1/step]
7-935-020	5:Refill Flag	E	[- / - / -]
7-935-021	1:Toner End	E	
7-935-022	2:Toner End	E	
7-935-023	3:Toner End	E	
7-935-024	4:Toner End	E	
7-935-025	5:Toner End	E	

7936

[PCDU Log]

Displays the ID chip log data in the toner cartridge.

7-936-001	1:Serial No	E	[0 / 0 / 1/step]
7-936-002	1:Install Date	E	[0 / 0 / 0/step]
7-936-003	2:Serial No	E	[0 / 0 / 1/step]
7-936-004	2:Install Date	E	[0 / 0 / 0/step]
7-936-005	3:Serial No	E	[0 / 0 / 1/step]
7-936-006	3:Install Date	E	[0 / 0 / 0/step]
7-936-007	4:Serial No	E	[0 / 0 / 1/step]
7-936-008	4:Install Date	E	[0 / 0 / 0/step]
7-936-009	5:Serial No	E	[0 / 0 / 1/step]
7-936-010	5:Install Date	E	[0 / 0 / 0/step]

7952	[Days Before End] Switch the timing of the near end: Days until the end.		
7-952-001	Maintenance Kit	E	[0 to 2 / 1 / 1/step] 0: Earlier 1: Normal 2: Later
7-952-002	PCDU	E	[0 to 2 / 1 / 1/step] 0: Earlier 1: Normal 2: Later

7993	[Total Counter] Sheet number counter: Engine: Total		
7-993-001	-	E	[0 to 999999999 / 0 / 1/step]

Main SP Tables-8

SP8-XXX (Data Log 2)

Most of the SPs in this group are prefixed with a letter that indicates the mode of operation (the mode of operation is referred to as an "application"). Before reading the Group 8 Service Table, make sure that you understand what these prefixes mean.

Prefixes	What it means	
T:	Total: (Grand Total).	Grand total of the items counted for all applications (C, F, P, etc.).
C:	Copy application.	Totals (pages, jobs, etc.) executed for each application when the job was not stored on the document server.
F:	Fax application.	
P:	Print application.	
S:	Scan application.	
O:	Other applications (external network applications, for example)	Refers to network applications such as Web Image Monitor. Utilities developed with the SDK (Software Development Kit) will also be counted with this group in the future.

The Group 8 SP codes are limited to 17 characters, forced by the necessity of displaying them on the small LCDs of printers and faxes that also use these SPs. Read over the list of abbreviations below and refer to it again if you see the name of an SP that you do not understand.

Keys and abbreviations in Data Log 2

Abbreviation	What it means
/	"By", e.g. "T:Jobs/Apl" = Total Jobs "by" Application
>	More (2> "2 or more", 4> "4 or more")
AddBook	Address Book
Apl	Application
B/W	Black & White

Abbreviation	What it means
Bk	Black
ColCr	Color Create
ColMode	Color Mode
Comb	Combine
Comp	Compression
Deliv	Delivery
DesApl	Designated Application. The application (Copy, Fax, Scan, Print) used to store the job on the document server, for example.
Dev Counter	Development Count, no. of pages developed.
Dup, Duplex	Duplex, printing on both sides
Emul	Emulation
FIN	Post-print processing, i.e. finishing (punching, stapling, etc.)
Full Bleed	No Margins
GenCopy	Generation Copy Mode
GPC	Get Print Counter. For jobs 10 pages or less, this counter does not count up. For jobs larger than 10 pages, this counter counts up by the number that is in excess of 10 (e.g., for an 11-page job, the counter counts up $11 - 10 = 1$)
ImgEdt	Image Edit performed on the original with the copier GUI, e.g. border removal, adding stamps, page numbers, etc.
K	Black (YMCK)
LSize	Large (paper) Size
Mag	Magnification
MC	One color (monochrome)
NRS	New Remote Service, which allows a service center to monitor machines remotely. "NRS" is used overseas, "CSS" is used in Japan.
Org	Original for scanning

Abbreviation	What it means
OrgJam	Original Jam
Palm 2	Print Job Manager/Desk Top Editor: A pair of utilities that allows print jobs to be distributed evenly among the printers on the network, and allows files to move around, combined, and converted to different formats.
PC	Personal Computer
PGS	Pages. A page is the total scanned surface of the original. Duplex pages count as two pages, and A3 simplex count as two pages if the A3/DLT counter SP is switched ON.
PJob	Print Jobs
Ppr	Paper
PrtJam	Printer (plotter) Jam
PrtPGS	Print Pages
R	Red (Toner Remaining). Applies to the wide format model A2 only. This machine is under development and currently not available.
Rez	Resolution
SC	Service Code (Error SC code displayed)
Scn	Scan
Sim, Simplex	Simplex, printing on 1 side.
S-to-Email	Scan-to-E-mail
SMC	SMC report printed with SP5990. All of the Group 8 counters are recorded in the SMC report.
Svr	Server
TonEnd	Toner End
TonSave	Toner Save
TXJob	Send, Transmission

Note

- All of the Group 8 SPs are able to reset by “SP5-801-001 Memory All Clear”.

8071	[T:Jobs/PGS]		
	These SPs count the number of jobs broken down by the number of pages in the job, regardless of which application was used.		
	8-071-001	1 Page	C
	8-071-002	2 Pages	C
	8-071-003	3 Pages	C
	8-071-004	4 Pages	C
	8-071-005	5 Pages	C
	8-071-006	6~10 Pages	C
	8-071-007	11~20 Pages	C
	8-071-008	21~50 Pages	C
	8-071-009	51~100 Pages	C
	8-071-010	101~300 Pages	C
	8-071-011	301~500 Pages	C
	8-071-012	501~700 Pages	C
8-071-013	701~1000 Pages	C	
8-071-014	1001~Pages	C	

[0 to 99999999 / 0 / 1/step]

[0 to 99999999 / 0 / 1/step]

[0 to 99999999 / 0 / 1/step]

- Interrupted jobs (paper jam, etc.) are counted, even though they do not finish.
- If a job is paused and re-started, it counts as one job.
- If the finisher runs out of staples during a print and staple job, then the job is counted at the time the error occurs.
- When printing the first page of a job from within the document server screen, the page is counted.

8381	[T:Total PrtPGS]	C	[0 to 99999999 / 0 / 1/step]
8382	[C:Total PrtPGS]	C	These SPs count the number of pages printed by the customer. The counter for the application used for storing the pages increments.
8383	[F:Total PrtPGS]	C	
8384	[P:Total PrtPGS]	C	

- When several documents are merged for a print job, the number of pages stored is counted for the application that stored them.
- These counters are used primarily to calculate charges on use of the machine, so the following pages are not counted as printed pages:
 - Blank pages in a duplex printing job.
 - Blank pages inserted as document covers, chapter title sheets, and slip sheets.
 - Reports printed to confirm counts.
 - All reports done in the service mode (service summaries, engine maintenance reports, etc.)
 - Test prints for machine image adjustment.
 - Error notification reports.
 - Partially printed pages as the result of a copier jam.

8411	[Prints/Duplex]		This SP counts the amount of paper (front/back counted as 1 page) used for duplex printing. Last pages printed only on one side are not counted.
8-411-001	-	C	[0 to 99999999 / 0 / 1/step]

8581	[T:Counter]		These SPs count the total output broken down by color output, regardless of the application used. In addition to being displayed in the SMC Report, these counters are also displayed in the User Tools display on the copy machine.
8-581-001	Total	C	[0 to 99999999 / 0 / 1/step]

8591	[O:Counter]		This SP count the number of duplex pages printed. This total is for Other (O:) applications only.
8-591-002	Duplex	C	[0 to 99999999 / 0 / 1/step]

8921	[Cvr Cnt/Total] This SP displays the total coverage and total printout number for each color.		
8-921-001	Coverage (%):Bk	C	[0 to 2147483647 / 0 / 1%/step]
8-921-011	Coverage /P: Bk	C	[0 to 99999999 / 0 / 1/step]

8999	[AdminCounter]		
8-999-001	Total	C	[0 to 99999999 / 0 / 1/step]
8-999-007	Printer:BW	C	
8-999-013	Duplex	C	

Input and Output Check

When entering the Input Check mode, 8 digits display the result for a section. Each digit corresponds to a different device as shown in the table.

Bit No.	7	6	5	4	3	2	1	0
Result	0 or 1	0 or 1	0 or 1	0 or 1	0 or 1	0 or 1	0 or 1	0 or 1

Input Check Table

5803	[INPUT Check]		
5-803-001	Paper Size	E	[0 to 15 / 0 / 1/step]
5-803-002	Paper End	E	[0 or 1 / 0 / 1/step]
5-803-003	Bypass:Paper End	E	
5-803-004	Bypass:Tray	E	
5-803-005	Paper Exit Full	E	
5-803-006	Paper Exit	E	
5-803-008	Registration	E	
5-803-010	Duplex:Entrance	E	[0 or 1 / 0 / 1/step]
5-803-012	Rear Interlock	E	
5-803-013	Front Interlock	E	
5-803-017	Fusing Unit New	E	
5-803-018	Fusing Unit Set	E	[0 or 1 / 0 / 1/step]
5-803-019	HVP: SC_C_DV	E	
5-803-020	HVP: SC_T	E	
5-803-022	PSU Fan Lock	E	
5-803-023	Fusing Fan Lock	E	
5-803-024	Drum Fan Lock	E	

5-803-025	Main Motor Lock	E	[0 or 1 / 0 / 1/step]
5-803-027	BiCU Ver	E	[0 to 7 / 0 / 1/step]
5-803-083	BANK1: 500 / 250	E	[0 or 1 / 0 / 1/step]
5-803-087	BANK1:Relay SN	E	
5-803-092	BANK1:Paper End	E	
5-803-094	BANK1:Paper Size	E	[0 to 7 / 0 / 1/step]

Output Check Table

5804	[OUTPUT Check]		
5-804-001	All Off	E	[0 or 1 / 0 / 1/step]
5-804-002	MainMT:CW:High	E	
5-804-003	MainMT:CW:Mid	E	
5-804-004	MainMT:CW:Low	E	
5-804-005	MainMT:CCW:High	E	[0 or 1 / 0 / 1/step]
5-804-006	MainMT:CCW:Mid	E	
5-804-007	MainMT:CCW:Low	E	
5-804-009	PSU Fan	E	
5-804-010	Fusing Fan: High	E	
5-804-011	Fusing Fan: Low	E	
5-804-012	Drum Fan: High	E	[0 or 1 / 0 / 1/step]
5-804-013	Drum Fan: Low	E	
5-804-014	Registration CL	E	
5-804-015	Paper Feed CL	E	
5-804-016	Feed Connect CL	E	

5-804-017	Duplex CL	E	[0 or 1 / 0 / 1/step]
5-804-018	Bypass:Feed CL	E	
5-804-019	Bypass:Tray CL	E	
5-804-020	Toner Supply CL	E	
5-804-022	Duplex Rev SOL	E	
5-804-023	HVP: Charge	E	[0 or 1 / 0 / 1/step]
5-804-024	HVP: Development	E	
5-804-025	HVP: Transfer: -	E	
5-804-026	HVP: Transfer: +	E	
5-804-027	BICTL	E	
5-804-029	Toner End Sensor	E	[0 or 1 / 0 / 1/step]
5-804-163	BANK1:Motor:High	E	[0 or 1 / 0 / 1/step]
5-804-164	BANK1:Motor:Mid	E	
5-804-169	BANK1:Feed CL	E	
5-804-171	BANK1:Motor:Low	E	

Printer Service Mode

SP1-XXX (Service Mode)

3

1001	[Bit Switch]			
001	Bit Switch 1 Settings		0	1
	bit 0	DFU	-	-
	bit 1	DFU	-	-
	bit 2	DFU	-	-
	bit 3	DFU	-	-
	bit 4	DFU	-	-
	bit 5	DFU	-	-
	bit 6	DFU	-	-
	bit 7	DFU	-	-
1001	[Bit Switch]			

002	Bit Switch 2 Settings		0	1
	bit 0	DFU	-	-
	bit 1	DFU	-	-
	bit 2	DFU	-	-
	bit 3	[PCL,PS]: PDL Auto Switching	Enabled	Disabled
		Enables/Disables the MFPs ability to change the PDL processor mid-job. Some host systems submit jobs that contain both PS and PCL. If Auto PDL switching is disabled, these jobs will not be printed properly.		
	bit 4	DFU	-	-
	bit 5	DFU	-	-
	bit 6	DFU	-	-
bit 7	DFU	-	-	

1001	[Bit Switch]			
003	Bit Switch 3 Settings		0	1
	bit 0	DFU	-	-
	bit 1	DFU	-	-
	bit 2	DFU	-	-
	bit 3	DFU	-	-
	bit 4	DFU	-	-
	bit 5	DFU	-	-
	bit 6	DFU	-	-
	bit 7	DFU	-	-

1001	[Bit Switch]		
-------------	---------------------	--	--

004	Bit Switch 4 Settings		0	1
	bit 0	DFU	-	-
	bit 1	DFU	-	-
	bit 2	DFU	-	-
	bit 3	DFU	-	-
	bit 4	DFU	-	-
	bit 5	DFU	-	-
	bit 6	<p>[PCL, PS, PDF]: Changes the paper direction used with the settings "Any Size/Type" or "Any Custom Size/Type".</p> <p>By default "Any Size/Type" and "Any Custom Size/Type" treat all paper in the bypass tray as if it were loaded in the SEF direction. This bitswitch changes the assumed direction to LEF.</p>	LEF	SEF
	bit 7	DFU	-	-
1001	[Bit Switch]			

005	Bit Switch 5 Settings		0	1
	bit 0	DFU	-	-
	bit 1	DFU	-	-
	bit 2	DFU	-	-
	bit 3	DFU	-	-
	bit 4	DFU	-	-
	bit 5	DFU	-	-
	bit 6	Method for determining the image rotation for the edge to bind on	Disabled	Enabled
<p>If enabled, the image rotation will be performed as they were in the specifications of older models for the binding of pages of mixed orientation jobs.</p> <p>The old models are below:</p> <ul style="list-style-type: none"> - PCL: Pre-04A models - PS/PDF/RPCS:Pre-05S models 				
bit 7	DFU	-	-	

1001	[Bit Switch]		
006	Bit Switch 6 Settings	-	-

1001	[Bit Switch]		
------	---------------------	--	--

007	Bit Switch 7 Settings		0	1
		Print path	Disabled	Enabled
	bit 0	If enabled, simplex pages (in mixed simplex/duplex PS/PCL5 jobs only) and the last page of an odd paged duplex job (PS, PCL5, PCL6), are always routed through the duplex unit. Not having to switch paper paths increases the print speed slightly.		
	bit 1	DFU	-	-
	bit 2	DFU	-	-
	bit 3	DFU	-	-
	bit 4	DFU	-	-
	bit 5	DFU	-	-
	bit 6	DFU	-	-
bit 7	DFU	-	-	
1001	[Bit Switch]			

008	Bit Switch 8 Settings		0	1
	bit 0	DFU	-	-
	bit 1	DFU	-	-
	bit 2	DFU	-	-
	bit 3	[PCL,PS]: Allow BW jobs to print without requiring User Code	Disabled	Enabled (allow BW jobs to print without a user code)
	BW jobs submitted without a user code will be printed even if usercode authentication is enabled. Note: Color jobs will not be printed without a valid user code.			
	bit 4	PCL5: Switching Edge to Edge for special order (for BMS company)	Disabled (Normal Edge to Edge)	Enabled (Special Edge to Edge)
	bit 5	DFU	-	-
	bit 6	PCL, PS3: Forced BW print	Enabled	Disabled
Switches whether to ignore PDL color command.				
bit 7	DFU	-	-	
1001	[Bit Switch]			

009	Bit Switch 9 Settings		0	1
	bit 0	DFU	-	-
	bit 1	DFU	-	-
	bit 2	DFU	-	-
	bit 3	DFU	-	-
	bit 4	DFU	-	-
	bit 5	DFU	-	-
	bit 6	DFU	-	-
	bit 7	DFU	-	-

1001	[Bit Switch]			
010	Bit Switch A Settings		0	1
	bit 0	DFU	-	-
	bit 1	DFU	-	-
	bit 2	DFU	-	-
	bit 3	DFU	-	-
	bit 4	DFU	-	-
	bit 5	DFU	-	-
	bit 6	DFU	-	-
	bit 7	DFU	-	-

1001	[Bit Switch]		
-------------	---------------------	--	--

011	Bit Switch B Settings		0	1
	bit 0	DFU	-	-
	bit 1	DFU	-	-
	bit 2	DFU	-	-
	bit 3	DFU	-	-
	bit 4	DFU	-	-
	bit 5	DFU	-	-
	bit 6	DFU	-	-
	bit 7	DFU	-	-

1001	[Bit Switch]			
012	Bit Switch C Settings		0	1
	bit 0	DFU	-	-
	bit 1	DFU	-	-
	bit 2	DFU	-	-
	bit 3	DFU	-	-
	bit 4	DFU	-	-
	bit 5	DFU	-	-
	bit 6	DFU	-	-
	bit 7	DFU	-	-

1007	[Supply Display]		
	Sets displaying remaining supply amount information or not. 0: Displays remaining supply amount information 1: Does not display remaining supply amount information		

001	-	C	[0 or 1 / 1 / 1 /step] *The Default setting is 1 but the Factory setting is 0
002		C	
004		C	
006		C	

1109	[Economy Color]		
	Sets the toner concentration (%) for each of text, image, line, and paint when the Economy Color setting is enabled (ON).		
	001	Text	C [0 to100 / 100 / 1 / -]
	002	Image	C [0 to75 / 50 / 1 / -]
	003	Line	C [0 to 75 / 30 / 1 / -]
004	Paint	C [0 to 75 / 30 / 1 / -]	

3

MEMO

MEMO