

CÓPIA NÃO CONTROLADA



RICOH UNIVERSITY

Learning ♦ Knowledge ♦ Performance



M001
SERVICE MANUAL

004224MIU

LANIER RICOH SAVIN

CÓPIA NÃO CONTROLADA

CÓPIA NÃO CONTROLADA

CÓPIA NÃO CONTROLADA

CÓPIA NÃO CONTROLADA



M001
SERVICE MANUAL

LANIER
RICOH
SAVIN®

CÓPIA NÃO CONTROLADA

CÓPIA NÃO CONTROLADA

CÓPIA NÃO CONTROLADA

CÓPIA NÃO CONTROLADA



RICOH UNIVERSITY

Learning ♦ Knowledge ♦ Performance

M001

SERVICE MANUAL

004224MIU

LANIER RICOH SAVIN

CÓPIA NÃO CONTROLADA

CÓPIA NÃO CONTROLADA

CÓPIA NÃO CONTROLADA

It is the reader's responsibility when discussing the information contained within this document to maintain a level of confidentiality that is in the best interest of Ricoh Americas Corporation and its member companies.

NO PART OF THIS DOCUMENT MAY BE REPRODUCED IN ANY FASHION AND DISTRIBUTED WITHOUT THE PRIOR PERMISSION OF RICOH AMERICAS CORPORATION.

All product names, domain names or product illustrations, including desktop images, used in this document are trademarks, registered trademarks or the property of their respective companies.

They are used throughout this book in an informational or editorial fashion only and for the benefit of such companies. No such use, or the use of any trade name, or web site is intended to convey endorsement or other affiliation with Ricoh products.

© 2009 RICOH Americas Corporation. All rights reserved.

CÓPIA NÃO CONTROLADA

CÓPIA NÃO CONTROLADA

WARNING

The Service Manual contains information regarding service techniques, procedures, processes and spare parts of office equipment distributed by Ricoh Americas Corporation. Users of this manual should be either service trained or certified by successfully completing a Ricoh Technical Training Program.

Untrained and uncertified users utilizing information contained in this service manual to repair or modify Ricoh equipment risk personal injury, damage to property or loss of warranty protection.

Ricoh Americas Corporation

CÓPIA NÃO CONTROLADA

CÓPIA NÃO CONTROLADA

LEGEND

PRODUCT CODE	COMPANY			
	GESTETNER	LANIER	RICOH	SAVIN
M001	SP 4210N	LP37N	Aficio SP 4210N	MLP37N

DOCUMENTATION HISTORY

REV. NO.	DATE	COMMENTS
*	01/2009	Original Printing

CÓPIA NÃO CONTROLADA

CÓPIA NÃO CONTROLADA

M001

TABLE OF CONTENTS

INSTALLATION

1. INSTALLATION	1-1
1.1 INSTALLATION REQUIREMENTS.....	1-1
1.1.1 ENVIRONMENT	1-1
1.1.2 MACHINE LEVEL	1-2
1.1.3 REQUIRED SPACE	1-2
1.1.4 POWER SUPPLY	1-3
1.2 MACHINE INSTALLATION	1-4
1.3 DATA OVERWRITE SECURITY UNIT INSTALLATION	1-5
1.3.1 INSTALLATION	1-5
1.3.2 CHECKING AND COMPLETING THE INSTALLATION	1-6

PREVENTIVE MAINTENANCE

2. PREVENTIVE MAINTENANCE	2-1
2.1 USER MAINTENANCE	2-1
2.2 SERVICE MAINTENANCE	2-2

REPLACEMENT AND ADJUSTMENT

3. REPLACEMENT & ADJUSTMENT	3-1
3.1 GENERAL.....	3-1
3.1.1 PRECAUTIONS ON DISASSEMBLY	3-1
3.1.2 RELEASING PLASTIC LATCHES	3-2
3.1.3 AFTER SERVICING THE MACHINE.....	3-2
3.2 SPECIAL TOOLS.....	3-3
3.3 COVERS.....	3-4
3.3.1 UPPER COVER.....	3-4
3.3.2 LEFT COVER	3-5
3.3.3 BY-PASS TRAY UNIT	3-6

3.3.4 FRONT COVER.....	3-6
3.3.5 RIGHT COVER	3-7
3.4 LASER UNIT	3-8
3.4.1 CAUTION DECAL LOCATIONS	3-8
3.4.2 POLYGON MIRROR MOTOR	3-9
3.4.3 LASER SYNCHRONIZATION DETECTOR	3-10
3.4.4 LASER UNIT	3-11
3.4.5 LASER DIODE UNIT	3-12
3.4.6 LASER BEAM PITCH ADJUSTMENT	3-12
3.5 TRANSFER ROLLER	3-14
3.6 TONER END SENSOR.....	3-15
3.7 FUSING	3-16
3.7.1 FUSING UNIT	3-16
3.7.2 HOT ROLLER AND FUSING LAMP	3-17
3.7.3 PRESSURE ROLLER.....	3-19
3.7.4 THERMISTOR AND THERMOSTAT	3-20
3.7.5 HOT ROLLER STRIPPERS.....	3-21
3.8 PAPER FEED	3-22
3.8.1 PAPER FEED ROLLER.....	3-22
3.8.2 FRICTION PAD.....	3-23
3.9 BY-PASS TRAY	3-24
3.10 PRINTER CONTROLLER BOARD	3-25
3.11 ENGINE BOARD.....	3-26
3.12 MAIN MOTOR	3-27
3.13 CLUTCHES	3-28
3.13.1 BY-PASS FEED CLUTCH AND RELAY CLUTCH	3-29
3.13.2 PAPER FEED CLUTCH AND REGISTRATION CLUTCH	3-30
3.14 PSU, HVPS	3-31
3.15 FANS.....	3-33
3.15.1 COOLING FAN.....	3-33
3.15.2 PSU FAN.....	3-34

TROUBLESHOOTING

4. TROUBLESHOOTING	4-1
4.1 SERVICE CALL CONDITIONS	4-1
4.1.1 SUMMARY	4-1
4.1.2 SC CODE DESCRIPTIONS	4-2
4.2 ERROR MESSAGES	4-19
4.3 GENERAL TROUBLESHOOTING	4-26
4.3.1 IMAGE ADJUSTMENT	4-26
Registration Adjustment	4-26
Parallelogram Image Adjustment	4-26
4.3.2 ELECTRICAL DEFECTS	4-27
4.3.3 SKEW ADJUSTMENT	4-31
4.3.4 STREAKS IN THE SUB SCAN DIRECTION.....	4-32
4.3.5 MISCELLANEOUS PROBLEMS.....	4-33

SERVICE TABLES

5. SERVICE TABLES.....	5-1
5.1 SERVICE PROGRAM MODE	5-1
5.1.1 SERVICE PROGRAM MODE: OVERVIEW	5-1
Entering the Service Mode	5-1
Setting a Service Program.....	5-2
Exiting Service Mode.....	5-2
5.2 PRINTER CONTROLLER SERVICE MODE	5-3
5.2.1 BIT SWITCH PROGRAMMING	5-3
5.2.2 SERVICE MODE MENU ("1. SERVICE MENU").....	5-4
5.3 PRINTER ENGINE SERVICE MODE	5-8
5.3.1 SERVICE MODE TABLE	5-8
SP1-xxx: Feed.....	5-8
SP2-xxx: Drum	5-12
SP3-xxx: Process	5-14
SP5-xxx: Mode	5-16
SP7-xxx: Data Log	5-59
SP8XXX: Data Log 2.....	5-74
5.4 FIRMWARE UPDATE	5-86
5.4.1 TYPE OF FIRMWARE	5-86

5.4.2 PRECAUTIONS	5-87
Handling SD Cards.....	5-87
Upload/Download	5-87
Network Connection	5-87
5.4.3 MACHINE FIRMWARE UPDATE	5-88
5.5 NVRAM DATA UPLOAD/DOWNLOAD	5-90
5.5.1 UPLOADED NVRAM DATA	5-90
5.5.2 DOWNLOADING NVRAM DATA	5-92
5.6 SD CARD APPLICATION MOVE.....	5-94
5.6.1 OVERVIEW.....	5-94
5.6.2 MOVE EXEC.....	5-95
5.6.3 UNDO EXEC.....	5-96
5.7 CONTROLLER SELF TEST AT POWER-ON.....	5-97
5.8 MENU MODE.....	5-98
5.9 CONTROLLER BOARD DIP SWITCHES	5-104
5.10 CARD SAVE FUNCTION	5-105
5.10.1 OVERVIEW	5-105
Card Save:	5-105
5.10.2 PROCEDURE	5-106
Error Messages	5-107
5.10.3 ERROR MESSAGES	5-108

DETAILED DESCRIPTIONS

6. DETAILED DESCRIPTIONS.....	6-1
6.1 OVERVIEW.....	6-1
6.1.1 MECHANICAL COMPONENT LAYOUT	6-1
6.1.2 PAPER PATH	6-2
6.2 BOARD STRUCTURE	6-3
6.2.1 BLOCK DIAGRAM	6-3
6.2.2 CONTROLLER BOARD.....	6-4
6.3 PRINTING PROCESS	6-5
6.3.1 OVERVIEW.....	6-5
6.3.2 LASER EXPOSURE	6-6
Overview	6-6
Automatic Power Control (APC).....	6-7

LD Safety Mechanisms	6-8
6.3.3 CARTRIDGE OVERVIEW.....	6-10
6.3.4 DRUM CHARGE	6-11
6.3.5 DEVELOPMENT	6-12
Toner Supply and Development.....	6-12
Toner Density Control	6-13
6.3.6 TONER END DETECTION	6-15
Overview	6-15
Toner End Sensor	6-15
Main Motor Rotation Count.....	6-16
Toner Overflow Prevention.....	6-16
Summary.....	6-18
6.4 PAPER FEED	6-20
6.4.1 OVERVIEW.....	6-20
6.4.2 PAPER TRAY	6-22
Tray Extension	6-22
Paper Lift.....	6-23
Paper Feed and Registration.....	6-24
Paper Size Detection.....	6-25
Paper End Detection	6-26
Remaining Paper Detection.....	6-27
6.4.3 BY-PASS TRAY.....	6-28
6.5 IMAGE FUSING AND PAPER EXIT	6-29
6.5.1 OVERVIEW.....	6-29
6.5.2 FUSING DRIVE	6-30
6.5.3 FUSING ENTRANCE AND GUIDE SHAFT	6-30
6.5.4 PRESSURE ROLLER.....	6-31
6.5.5 NEW FUSING UNIT DETECTION	6-32
6.5.6 FUSING TEMPERATURE CONTROL.....	6-33
Overheat Protection	6-34
6.5.7 PAPER EXIT.....	6-35
6.5.8 ENERGY SAVER MODE	6-36
6.6 CONTROLLER FUNCTIONS.....	6-37

SPECIFICATIONS

7. SPECIFICATIONS.....	7-1
7.1 BASIC SPECIFICATIONS	7-1
7.1.1 GENERAL SPECIFICATIONS	7-1
7.1.2 EXTERNAL OPTIONS	7-4
7.1.3 PAPER SIZES	7-5
Envelopes.....	7-8
7.1.4 OPERATING ENVIRONMENT	7-9
7.1.5 OPERATION PANEL LED SPECIFICATIONS	7-10
7.2 CONTROLLER SPECIFICATIONS.....	7-11
7.2.1 CONTROLLER BOARD.....	7-11
7.2.2 PRINTING FUNCTIONS.....	7-12
7.2.3 PRINTER DRIVERS	7-13
7.2.4 SUPPORTED ENVIRONMENTS.....	7-16
Windows Environments.....	7-16
Mac OS Environments	7-17
UNIX Environment.....	7-18
Novell Netware	7-18
SAP R/3 Environment	7-19
7.2.5 CONTROLLER INTERFACE SPECIFICATIONS	7-20
7.2.6 SUPPORTED UTILITIES.....	7-22
Bundled Utilities.....	7-22
Optional Utilities	7-22
7.3 MACHINE CONFIGURATION	7-23
7.3.1 SYSTEM COMPONENTS.....	7-23

INSTALLATION

TAB
POSITION 1

PREVENTIVE MAINTENANCE

TAB
POSITION 2

REPLACEMENT AND ADJUSTMENT

TAB
POSITION 3

TROUBLESHOOTING

TAB
POSITION 4

SERVICE TABLES

TAB
POSITION 5

DETAILED DESCRIPTIONS

TAB
POSITION 6

SPECIFICATIONS

TAB
POSITION 7

TAB
POSITION 8

CÓPIA NÃO CONTROLADA

CÓPIA NÃO CONTROLADA

Read This First

Safety, Conventions, Trademarks

Safety

Prevention of Physical Injury

1. Before disassembling or assembling parts of the printer and peripherals, make sure that the printer power cord is unplugged.
2. The wall outlet should be near the printer and easily accessible.
3. Note that some components of the printer and the paper tray unit are supplied with electrical voltage even if the main power switch is turned off.
4. If any adjustment or operation check has to be made with exterior covers off or open while the main switch is turned on, keep hands away from electrified or mechanically driven components.
5. The inside and the metal parts of the fusing unit become extremely hot while the printer is operating. Be careful to avoid touching those components with your bare hands.
6. To prevent a fire or explosion, keep the machine away from flammable liquids, gases, and aerosols.

Health Safety Conditions

Toner and developer are non-toxic, but if you get either of them in your eyes by accident, it may cause temporary eye discomfort. Try to remove with eye drops or flush with water as first aid. If unsuccessful, get medical attention.

Observance of Electrical Safety Standards

The printer and its peripherals must be installed and maintained by a customer service representative who has completed the training course on those models.

Safety and Ecological Notes For Disposal

1. Do not incinerate toner bottles or used toner. Toner dust may ignite suddenly when exposed to an open flame.
2. Dispose of used toner, developer, and organic photoconductors in accordance with local regulations. (These are non-toxic supplies.)
3. Dispose of replaced parts in accordance with local regulations.
4. When keeping used lithium batteries in order to dispose of them later, do not put more than 100 batteries per sealed box. Storing larger numbers or not sealing them apart may lead to chemical reactions and heat build-up.

CAUTION

- The controller board in this machine contains a lithium battery.
- The danger of explosion exists if a battery of this type is incorrectly replaced. Replace only with the same or an equivalent type of battery recommended by the manufacturer.
- Dispose of batteries in accordance with the manufacturer's instructions and local laws and regulations.

LASER SAFETY

The Center for Devices and Radiological Health (CDRH) prohibits the repair of laser-based optical units in the field. The optical housing unit can only be repaired in a factory or at a location with the requisite equipment. The laser subsystem is replaceable in the field by a qualified Customer Engineer. The laser chassis is not repairable in the field. Customer engineers are therefore directed to return all chassis and laser subsystems to the factory or service depot when replacement of the optical subsystem is required.

WARNING

- Use of controls, or adjustment, or performance of procedures other than those specified in this manual may result in hazardous radiation exposure.

WARNING

- Turn off the main switch before attempting any of the procedures in the Laser Unit section. Laser beams can seriously damage your eyes.



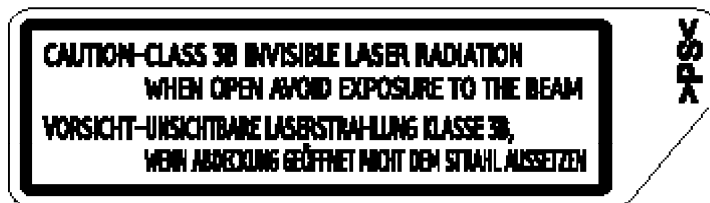
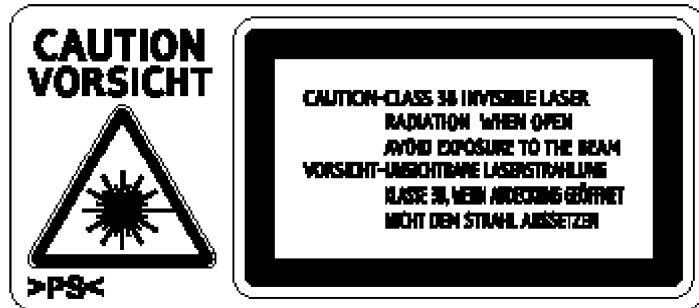



Caution Labels



g176_labels

Conventions and Trademarks

Conventions

Symbol	What it means
	Refer to section number
	See Core Tech Manual for details
	Screw
	Connector
	E-ring
	C-ring

The following notations are used in text to describe the direction of paper feed: lengthwise and sideways. The annotations “SEF” and “LEF” denote “Short Edge Feed” and “Long Edge Feed”. (The arrows indicate the direction of paper feed.)

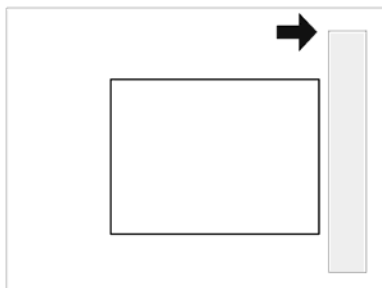

SEF (Short Edge Feed)

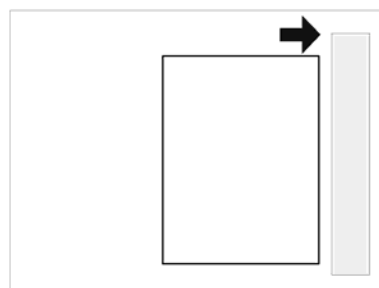

LEF (Long Edge Feed)

Trademarks

Microsoft[®], Windows[®], and MS-DOS[®] are registered trademarks of Microsoft Corporation in the United States and /or other countries.

PostScript[®] is a registered trademark of Adobe Systems, Incorporated.

PCL[®] is a registered trademark of Hewlett-Packard Company.

Ethernet[®] is a registered trademark of Xerox Corporation.

PowerPC[®] is a registered trademark of International Business Machines Corporation.

Other product names used herein are for identification purposes only and may be trademarks of their respective companies. We disclaim any and all rights involved with those marks.

This manual uses several symbols and some simple abbreviations.

CÓPIA NÃO CONTROLADA

CÓPIA NÃO CONTROLADA

CÓPIA NÃO CONTROLADA

INSTALLATION

CÓPIA NÃO CONTROLADA

CÓPIA NÃO CONTROLADA

CÓPIA NÃO CONTROLADA

1. INSTALLATION

1.1 INSTALLATION REQUIREMENTS

1.1.1 ENVIRONMENT

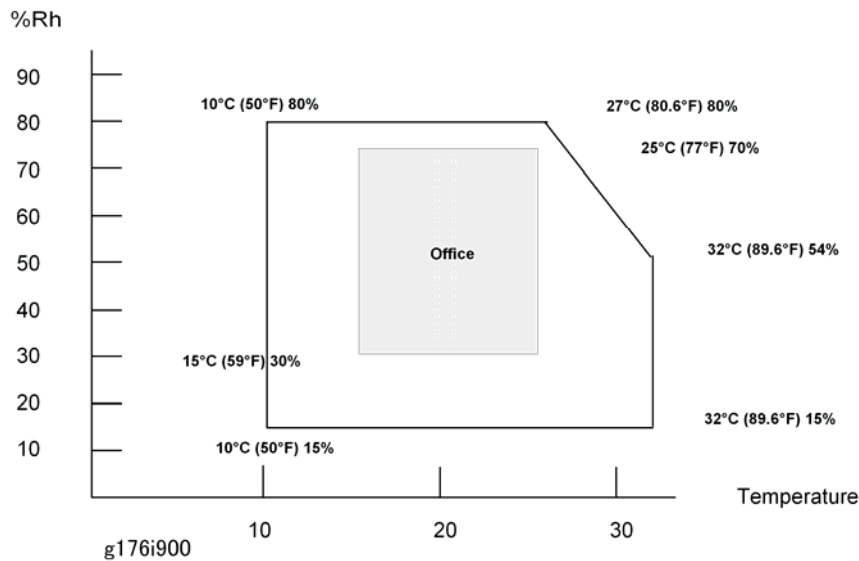

Temperature/Humidity Ranges:	Acceptable: 10C (50F) 15% to 27C (80.6F) 80% Recommended (Office): 15C (59F) 30% to 25C (77F) 70%
Ambient Illumination:	Less than 2000 lux (do not expose to direct sunlight).
Ventilation:	3 times/hr/person

1. Avoid areas that are exposed to sudden temperature changes. This includes:
 - Areas directly exposed to cool air from an air conditioner.
 - Areas directly exposed to heat from a heater.
2. Do not install this machine in an area where it will be exposed to corrosive gases.
3. Do not install the machine at locations over 2,500 m (8,125 ft.) above sea level.
4. Put the machine on a strong and level base. Inclination on any side should not exceed 5 mm.
5. Do not put the machine where it may be subjected to strong vibrations.

Installation Requirements

1.1.2 MACHINE LEVEL

Front to back:	Within 5 mm. (0.2 inches) of level.
Right to left:	Within 5 mm. (0.2 inches) of level.

1.1.3 REQUIRED SPACE

Place the machine near the power source, providing the clearance as shown below:

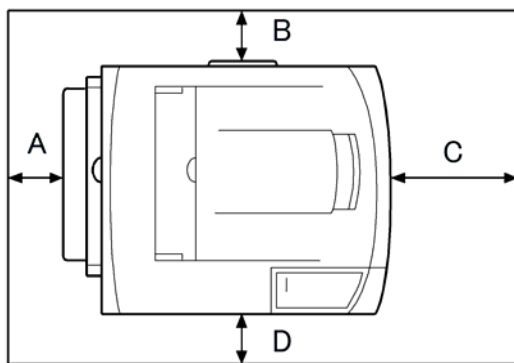

g176i500

- A:** Over 10 cm (4 inches)
- B:** Over 10 cm (4 inches)
- C:** Over 40 cm (15.8 inches)
- D:** Over 10 cm (4 inches)

1.1.4 POWER SUPPLY

CAUTION

- Make sure the plug is firmly inserted in the outlet.
- Avoid multi-wiring.
- Be sure to ground the machine.

Input voltage level	NA: 120 volts, 60 Hz
	EU: 220-240 volts, 50 Hz/60 Hz
Permitted voltage	Fluctuation: $\pm 10\%$

CAUTION

- Never place anything on the power cord.

Machine Installation

1.2 MACHINE INSTALLATION

Refer to the following sections of the “Operating Instructions” for installation details for all models.

Main unit	-	Quick Installation Guide
Options	Paper Feed Unit G894	Paper Feed Unit TK1030
	Envelope Feeder G362	Envelope Feeder Type400
	Duplex Unit G893	AD1000 (Duplex Unit)
	Memory Unit Type G 128 MB M354	Hardware Guide, Section 2
	Memory Unit Type G 256 MB D362	
	Hard Disk Drive Type 2670 M352	
	IEEE 802.11a/g interface Unit Type L M344 (NA) *1	
	IEEE 802.11a/g interface Unit Type M M344 (EU) *1	
	IEEE 1284 Interface Board Type A B679	
	Gigabit Ethernet Board Type A G874 *1	
	VM Card Type K M354	
	Data Storage Card Type A G874	
	Data Overwrite Security Unit Type L M352	
	SD Card for Netware Printing Type B M352	Software Guide, Section 6
Drivers	-	Section 1 of the Software Guide

*1: These units cannot be installed at the same time.

1.3 DATA OVERWRITE SECURITY UNIT

INSTALLATION

1.3.1 INSTALLATION

★ Important

- The correct number and type for this installation is Type L. Do not attempt to install any other type (Type C, Type D, for example).
- The SD card that holds the DOS application must always reside in SD card slot 1. (This can be the original SD or another SD card where the DOS application has been moved with SP5873.)

1. If the machine is on, turn off the main power switch.
2. Disconnect the network cable.
3. Turn the main power switch on.
4. Turn the operation switch and main power switch off.

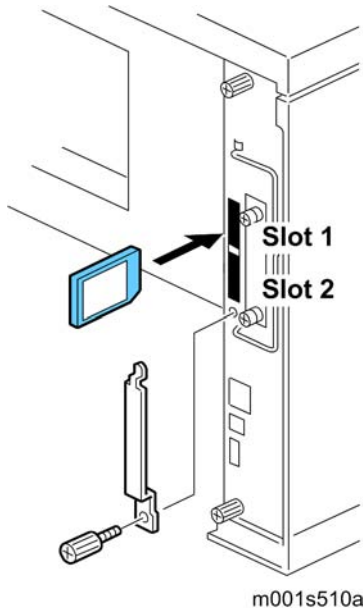

5. Remove the SD card slot cover (⚙️x1).
6. Insert the DOS SD card into Slot 1.
7. Reconnect the network cable, if the network is connected to the copier.
8. Turn the main power switch on.
9. Enter the SP mode and do SP5878 and push [#Enter] to enable the DOS application.
10. Go out of the SP mode, turn the operation switch off, then turn the main power switch off.

Data Overwrite Security Unit Installation

1.3.2 CHECKING AND COMPLETING THE INSTALLATION

Do this procedure to confirm that the data overwrite security feature is enabled and operating.

1. Turn the machine power on.
2. Do SP5990 005 (Diagnostic Report) to print the diagnostic report
3. Check the diagnostic report.
 - Under [ROM No./Firmware Version] you should see "M3525814" displayed for "HDD Format Option".
 - Under [Loading Program] you should see "GW1a_zoffy: M3525814"

Important

- The numbers in the diagnostic report must match. (The ROM number and firmware version number change after the firmware has been upgraded.)
 - If the ROM numbers or version numbers do not match, this means that the DOS unit type was incorrect (not "Type L"),
 - If this occurs:
 - (1) Obtain the Type L DOS unit card or confirm that the DOS unit is Type L.
 - (2) Replace the NVRAM on the controller board.
 - (3) Insert the Type L DOS unit SD card in Slot 2.
 - (4) Do the DOS unit installation procedure again.
4. Push and release in this order: [#Enter]> [Escape]> [Menu].
 5. Push [▼] or [▲] to display "Maintenance" then push [#Enter].
 6. Push [▼] or [▲] to display "Memory Erase" and "Erase All Mem."
 7. If you see "Memory Erase" and "Erase All Mem." in the selections, then the DOS application has been enabled and is operating.

CÓPIA NÃO CONTROLADA

PREVENTIVE MAINTENANCE

CÓPIA NÃO CONTROLADA

CÓPIA NÃO CONTROLADA

CÓPIA NÃO CONTROLADA

2. PREVENTIVE MAINTENANCE

2.1 USER MAINTENANCE

The customer can replace all PM items with the Maintenance Kit.

The user can maintain this machine. For more see "Printer Engine Service Mode".

The operation panel shows "Replace Maintenance Kit" when the PM counter reaches 90K.

After the user replaces the fusing unit in the maintenance kit, the machine automatically resets the PM counter.

Item	Quantity	Remarks
Fusing unit	1	-
Transfer roller	1	-
Paper feed roller	3	For standard and optional tray(s)
Friction pad	3	For standard and optional tray(s)

Service Maintenance

2.2 SERVICE MAINTENANCE

To enable the machine for maintenance by the service technician, the meter-charge mode must be set to “enabled” with SP5930.

The table below shows the PM items serviced by the service technician.

After completing a PM procedure, reset the PM counter for the replaced part with SP7-804.

Symbol key:

- C: Clean
- R: Replace
- L: Lubricate
- I: Inspect

Main unit

Item	90K	EM	Quantity	Remarks
Paper Feed				
Paper Feed Roller	R	C	1	Clean with water
Friction Pad	R	C	1	Clean with water
Registration Roller	C	C	1	Clean with water
Bottom Plate Pad	C	C	1	Clean with water
Around the Drum				
Transfer Roller	R		1	
Fusing Unit and Paper Exit				
Hot Roller	R		1	
Pressure Roller	R		1	
Hot Roller Strippers	R		3	
Fusing Thermistor	R	C	1	Clean with alcohol if necessary.
Bushings - Hot Roller	R		2	

Item	90K	EM	Quantity	Remarks
Bushings - Pressure Roller	R		2	
Fusing Entrance and Exit Guide Plates	C		1 each	Clean with water or alcohol
Fusing Unit Ass'y 110V/220 V	R		1	

Preventive
Maintenance

Paper Tray Unit

	90K	EM	Quantity	NOTE
Paper Feed Roller	R	C	1	Clean with water
Friction Pad	R	C	1	Clean with water
Bottom Plate Pad	C	C	1	Clean with water

CÓPIA NÃO CONTROLADA

CÓPIA NÃO CONTROLADA

CÓPIA NÃO CONTROLADA

REPLACEMENT & ADJUSTMENT

CÓPIA NÃO CONTROLADA

CÓPIA NÃO CONTROLADA

CÓPIA NÃO CONTROLADA

3. REPLACEMENT & ADJUSTMENT

3.1 GENERAL

3.1.1 PRECAUTIONS ON DISASSEMBLY

CAUTION

- Always turn off the main power switch and unplug the machine before attempting any of the procedures in this section.

Use extreme caution when removing and replacing components. The cables in the machine are located very close to moving parts; proper routing is a must.

After components have been removed, any cables that have been displaced during the procedure must be restored as close as possible to their original positions. Before removing any component from the machine, note any cable routings that may be affected.

Before servicing the machine:

1. Verify that documents are not stored in memory.
2. Remove the print cartridge before you remove parts.
3. Unplug the power cord.
4. Work on a flat and clean surface.
5. Replace with authorized components only.
6. Do not force plastic material components.

Make sure all components are returned to their original positions.

Laser Unit

1. Do not loosen or adjust the screws securing the LD drive board on the LD unit. Doing so will throw the LD unit out of adjustment.
2. Do not adjust the variable resistors on the LD unit, as these are permanently adjusted at the factory. If replacement of the LD drive board is necessary, replace the entire LD unit.
3. Keep the polygon mirror and toroidal lens free of dust. Laser performance is very sensitive to dust on these components.
4. Do not touch the shield glass or the surface of the polygon mirror with bare hands.
5. Do not adjust the Laser Synchronization detector on the LD unit, as these are permanently adjusted at the factory. If the position of the Laser Synchronization detector has changed from the factory set position, SC 322 will be shown.

Transfer Roller

General

1. Never touch the surface of the transfer roller with bare hands.
2. Be careful not to scratch the transfer roller, as the surface is easily damaged.

Fusing

1. After installing the fusing thermistor, make sure that it is in contact with the hot roller and that the roller can rotate freely.
2. Be careful to avoid damage to the hot roller stripper pawls and their tension springs.
3. Do not touch the fusing lamp and rollers with bare hands.
4. Make sure that the fusing lamp is positioned correctly and that it does not touch the inner surface of the hot roller.

Paper Feed

1. Do not touch the surface of paper feed rollers.
2. To avoid misfeeds, the side and end fences in each paper tray must be positioned correctly so as to align with loaded paper size.

3.1.2 RELEASING PLASTIC LATCHES

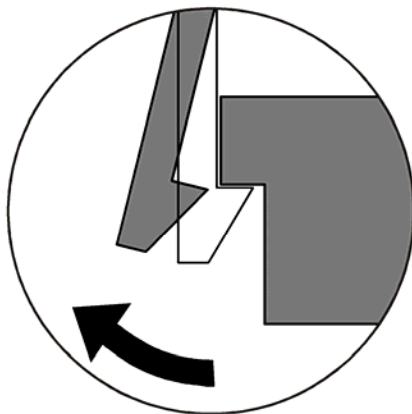

g094r513

Many of the parts are held in place with plastic latches. The latches break easily, so release them carefully. To release a latch, press the hook end of the latch away from the part to which it is latched.

3.1.3 AFTER SERVICING THE MACHINE

1. Make sure all parts that require grounding are properly grounded.
2. Make sure the interlock switch is functioning.
3. Do not leave unused solder or parts inside the machine.
4. Do not leave any tools inside the machine.
5. Make sure all wires are properly connected and routed.
6. Make sure wires are not jammed between parts of the machine.

3.2 SPECIAL TOOLS

	Part No.	Description	Q'ty	Remarks
1	B6455010	SD Card	1	Common
2	B6456700	PCMCIA Card Adapter	1	Common
3	B6456800	USB Reader/Writer	1	Common
4	VSSM9000	Digital Multimeter – FLUKE 187	1	Common
5	A0069104	Scanner Positioning Pin	1	Common
6	---	Ricoh System Information Tool (Support Tool Ver. 2)		
		▪ Basic version	1	
		▪ Mail version	1	

Replacement
Adjustment

Covers

3.3 COVERS

3.3.1 UPPER COVER

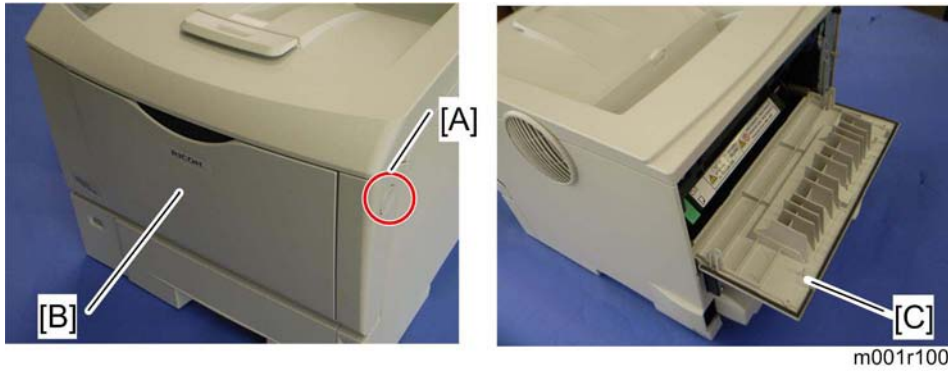

1. Gently push the front cover release button [A], and open the front cover [B].
2. Open the rear cover [C].

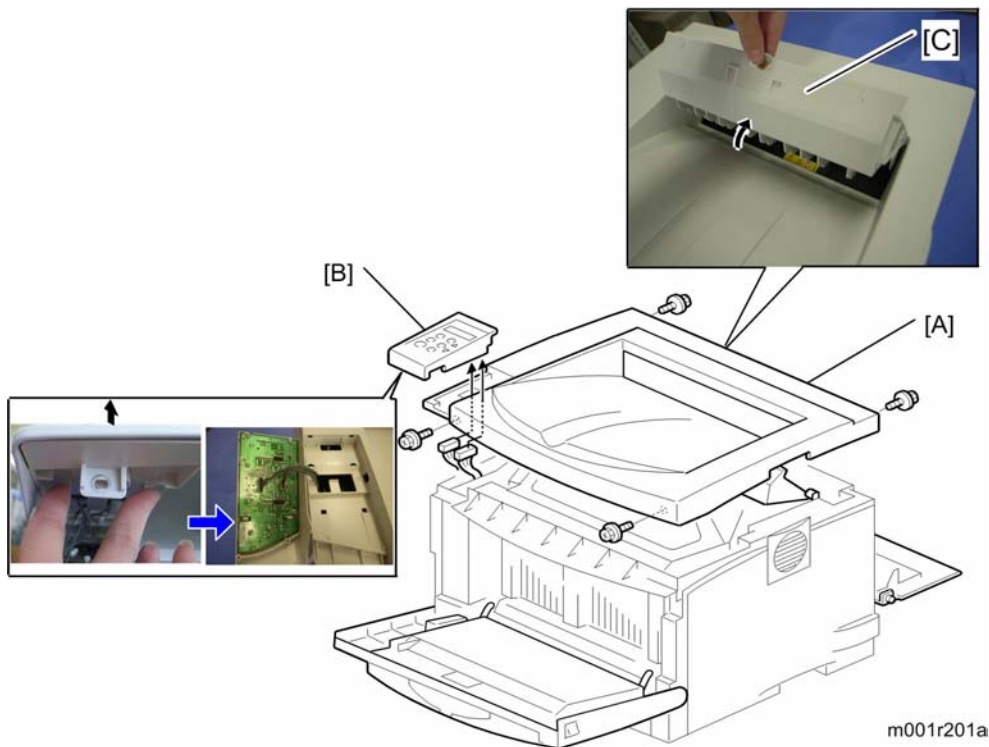

3. Remove four screws of the upper cover [A].
4. Operation panel [B] (2 hooks, 𠄎 x 2)
5. Open the exit guide plate [C], and then remove the upper cover [A].

↓ Note

- Remove the exit guide plate after you have removed the upper cover.

3.3.2 LEFT COVER

1. Upper cover (➡ Upper Cover)

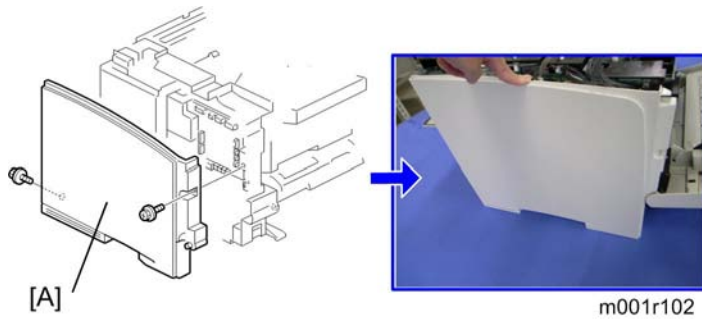

1. Left cover [A] (⚙ x 2)
2. Push down the left cover as shown above.

⚠ Note

- Make sure that the harness band [A] is placed at clamp [B] the under, when reinstalling the left cover.

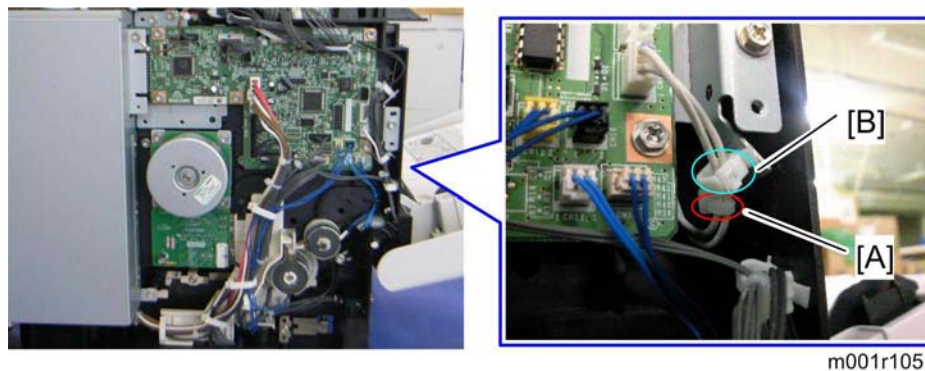

Covers

3.3.3 BY-PASS TRAY UNIT

1. Standard paper tray

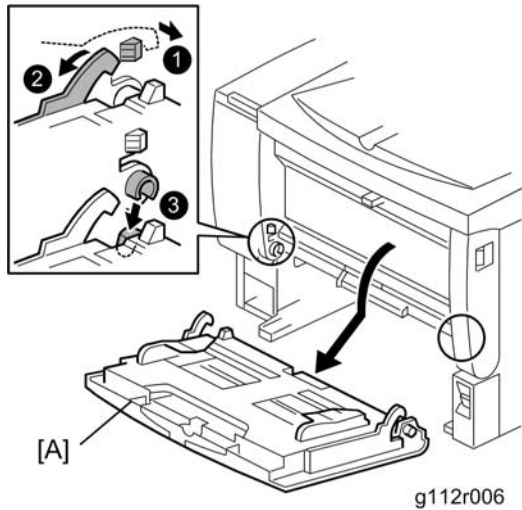

2. By-pass tray unit [A] (hooks x 2)

3.3.4 FRONT COVER

1. Standard paper tray
2. By-pass tray unit (↔ By-pass Tray Unit)
3. Upper cover (↔ Upper Cover)
4. Left cover (↔ Left Cover)

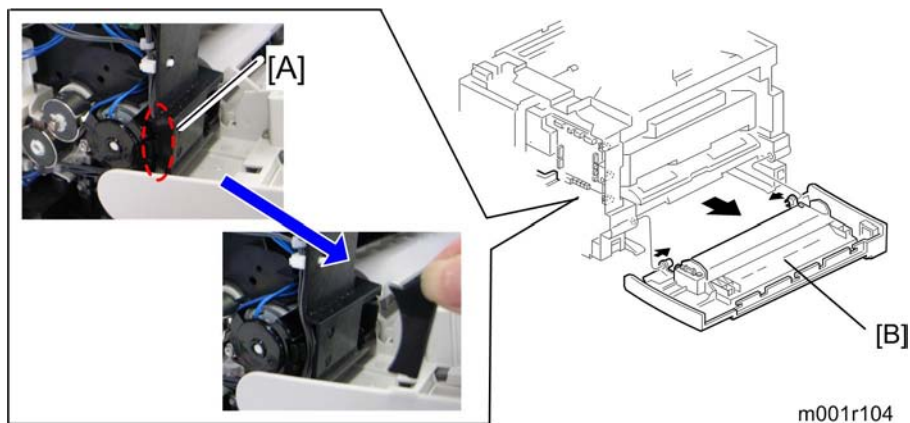

5. Holder [A] (hook)
6. Front cover [B] (↔ x 3, ↔ x 2)

★ Important

- Remove the by-pass tray unit before removing the front cover.

3.3.5 RIGHT COVER

1. Upper cover (☛ Upper Cover)
2. Left cover (☛ Left Cover)
3. Front cover (☛ Front Cover)

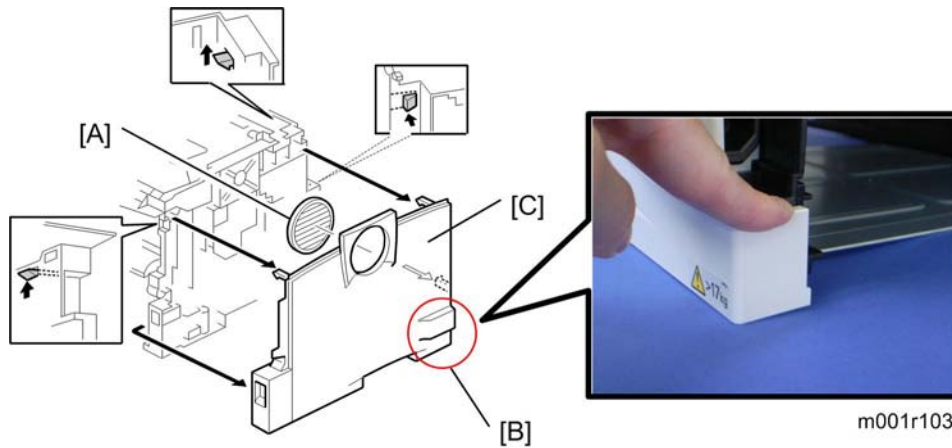

4. Fan cover [A]
5. Release the three hooks, and push down the place [B] as shown above.
6. Right cover [C]

Laser Unit

3.4 LASER UNIT

CAUTION

- Turn off the main power switch and unplug the machine before attempting any of the procedures in this section. Laser beams can seriously damage your eyes.

3.4.1 CAUTION DECAL LOCATIONS

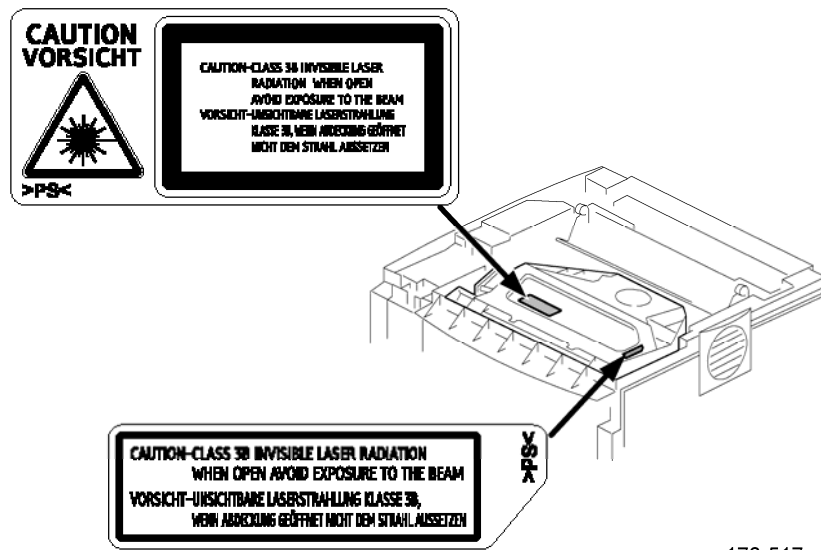

3.4.2 POLYGON MIRROR MOTOR

CAUTION

- Turn off the main switch and unplug the machine before attempting any of the procedures in this section. Laser beams can seriously damage your eyes.

- Upper cover ( Upper Cover)

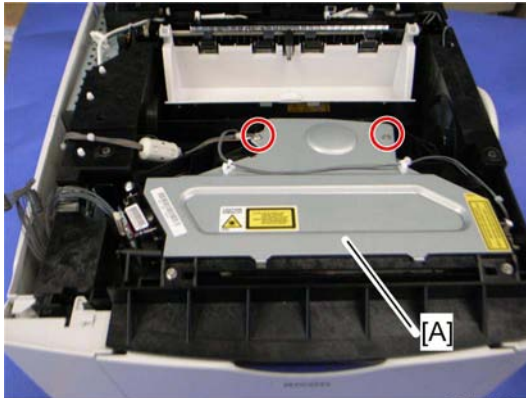

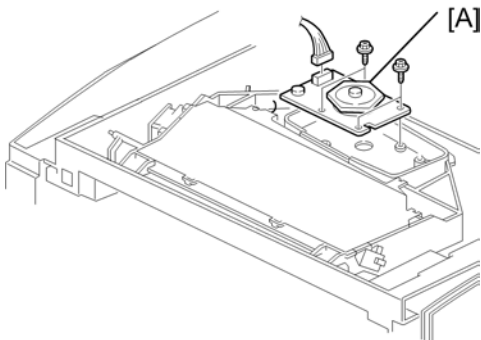

m001r113

- Polygon mirror cover (Ground screw x 1,  x 1,  x 2)



m001r112

- Polygon mirror motor [A] ( x 4,  x 1)

Note

- Never touch the surface of the mirror with bare hands.

Laser Unit

3.4.3 LASER SYNCHRONIZATION DETECTOR

1. Upper cover (☛ Upper Cover)
2. By-pass tray unit (☛ Bypass Tray Unit)
3. Left cover (☛ Left Cover)
4. Front cover (☛ Front Cover)
5. Right cover (☛ Right Cover)

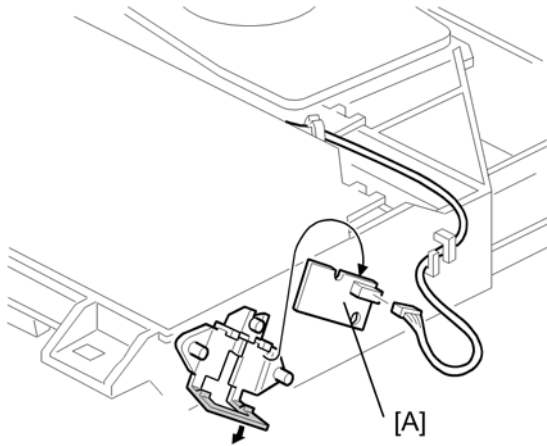

g094r519

6. Laser synchronization detector [A] (☛ x 1)

3.4.4 LASER UNIT

1. Upper cover (➡ Upper Cover)
2. Left cover (➡ Left Cover)
3. Front cover (➡ Front Cover)
4. Right cover (➡ Right Cover)

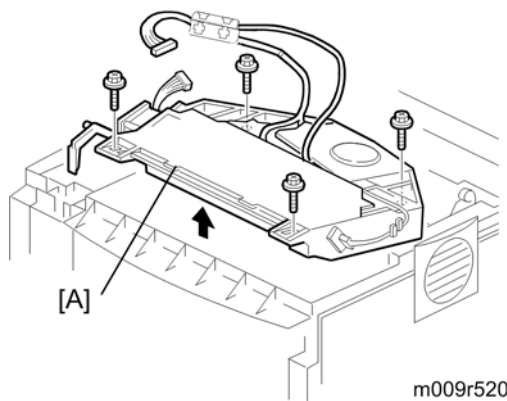

5. Laser unit [A] (⚙ x 4, ⚙ x 2)

When reinstalling the laser unit.

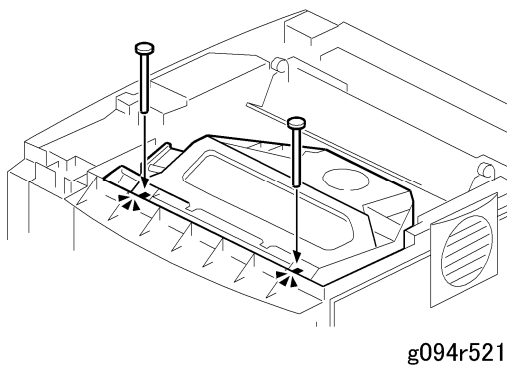

- Use the scanner positioning pins (P/N: A0069104) to reinstall the unit.
- Set the positioning pins as shown above. Then secure the laser unit.

Laser Unit

3.4.5 LASER DIODE UNIT

1. Laser Unit (↔ Laser Unit)

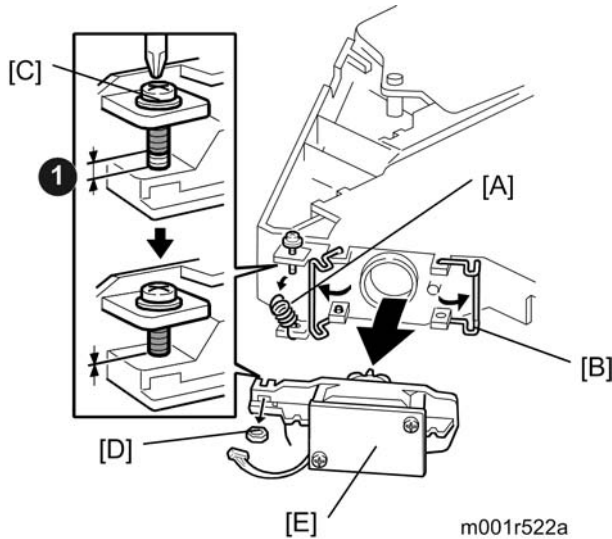

2. Spring [A]
3. LD unit holders [B] (x 2)
4. Loosen the screw [C]
5. Nut [D]
6. LD Unit [E]

Note

- Do not remove the screws that secure the LD board.
- Do not touch any variable resistors on the LD board.

When Reinstalling the Laser Diode Unit:

- Tighten the screw [C] until the unpainted portion of the screw ❶ is not visible.
- After installing the LD unit, check the test pattern for the final adjustment (see the following procedure).

3.4.6 LASER BEAM PITCH ADJUSTMENT

1. Print out the following test patterns.
 - Select the test pattern with SP 5902-3.
 - Use SP 5902-1 to print one test pattern.
2. Check this test pattern.
3. Adjust the LD unit holder position: Tighten or loosen the screw [C] (see the previous page) until the printout appears as the sample test pattern below.

Sample test pattern

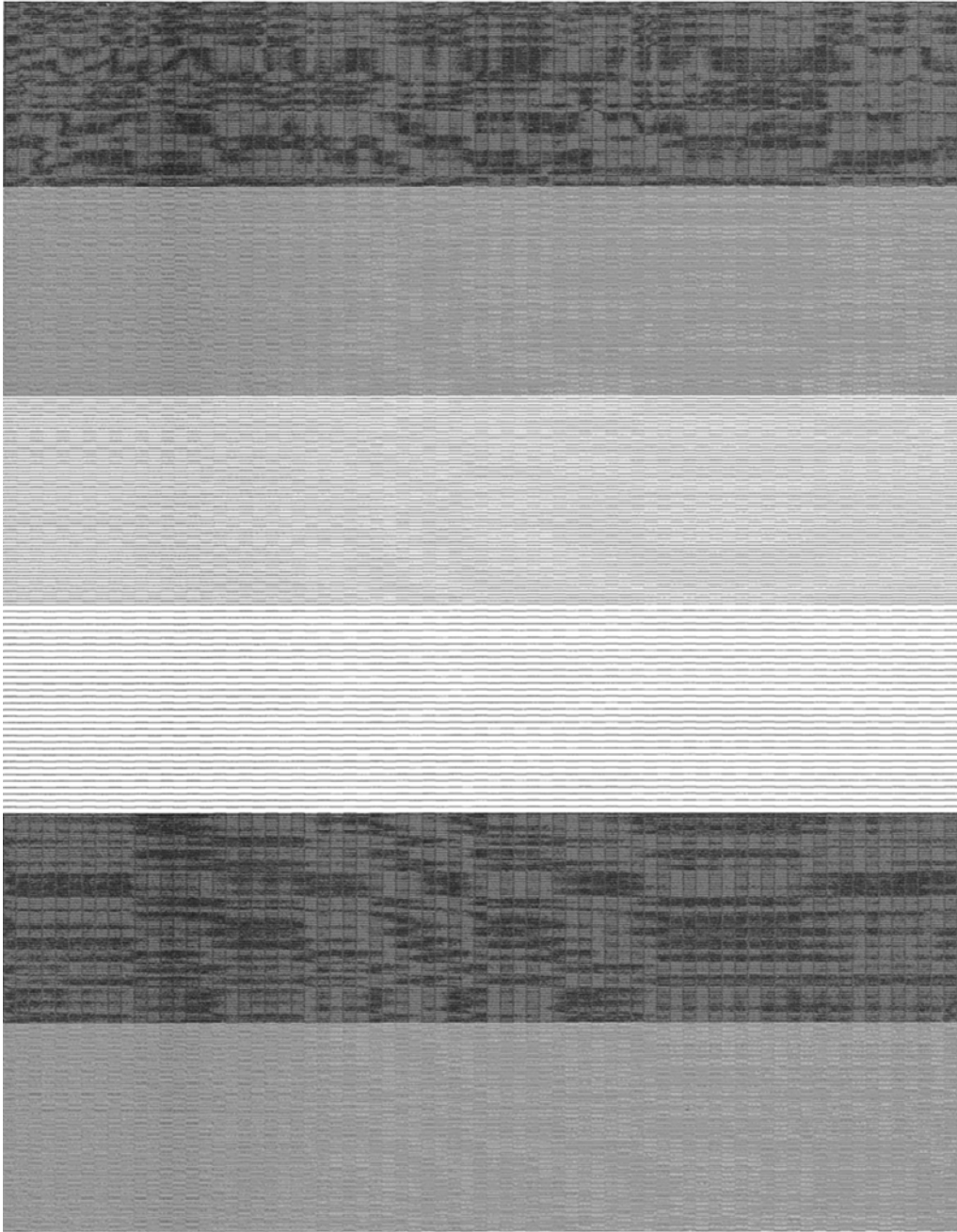

m001r523

Replacement
Adjustment

Transfer Roller

3.5 TRANSFER ROLLER

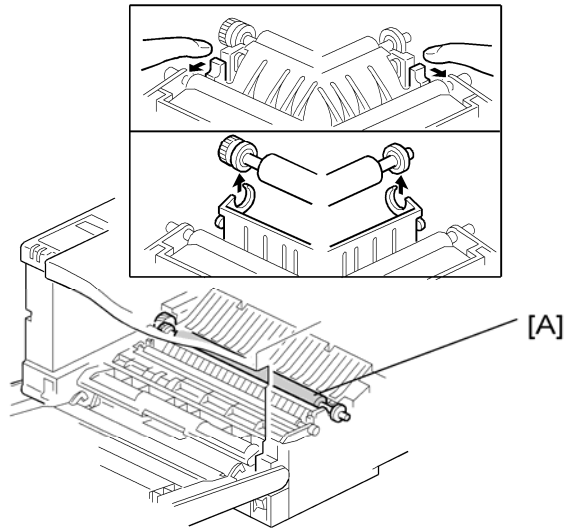

g094r524

1. Remove the AIO.
2. Remove the transfer roller [A] as shown above.

↓ Note

- Do not touch the transfer roller surface.

3.6 TONER END SENSOR

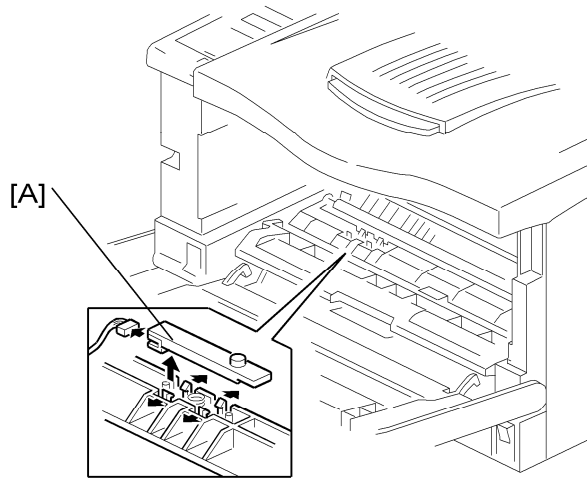

g094r525

1. Remove the AIO.
2. Toner end sensor [A] (hooks x 4,  x 1)

Fusing

3.7 FUSING

CAUTION

- Allow time for the unit to cool before doing the following procedure.

3.7.1 FUSING UNIT

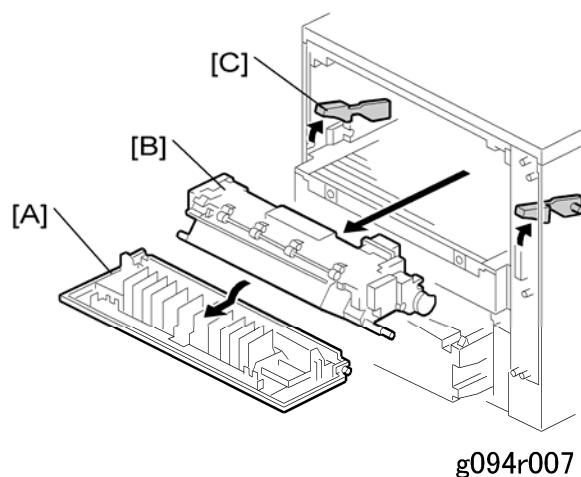

1. Rear cover [A]
2. Fusing unit [B] (hooks [C] x 2).

Note

- Lift both hooks before attempting to remove the fusing unit from the machine.

3.7.2 HOT ROLLER AND FUSING LAMP

1. Fusing Unit (↔ Fusing Unit)

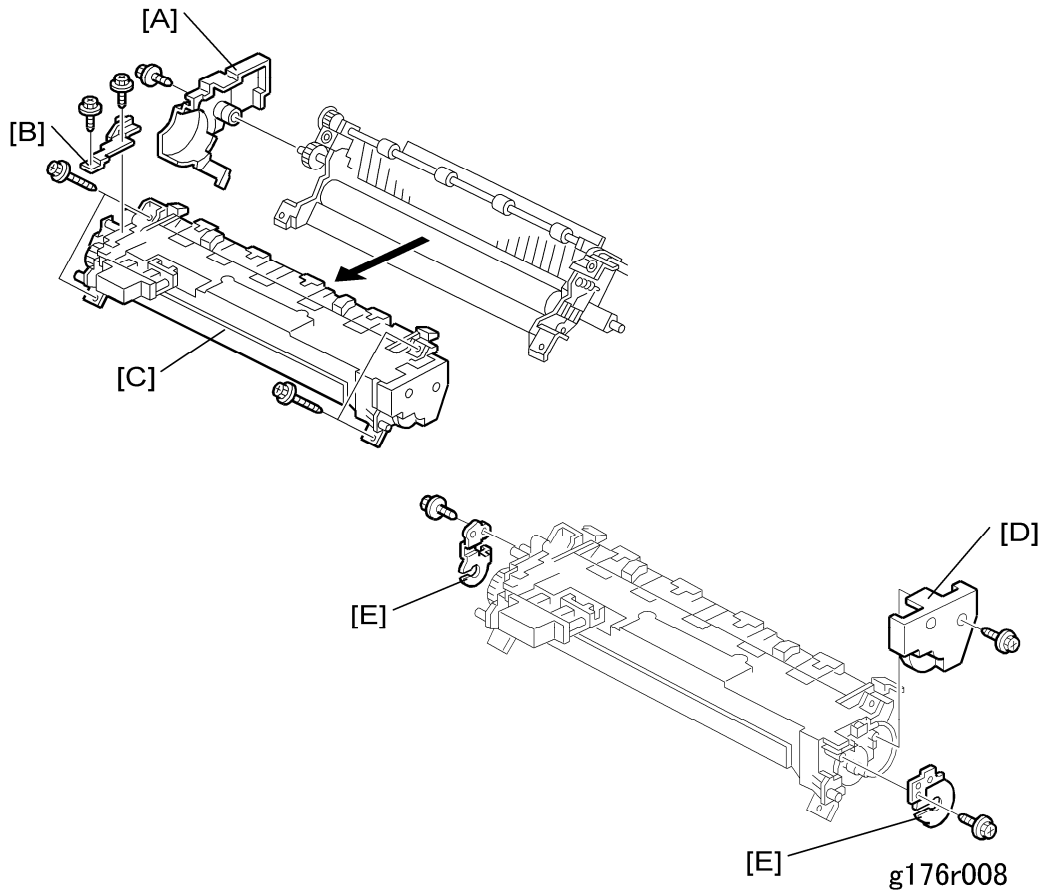

2. Left cover [A] (⌀ x 1)
3. Plate [B] (⌀ x 2)
4. Upper fusing unit assembly [C] (⌀ x 4, springs x 2)
5. Right cover [D] (⌀ x 1)
6. Lamp holders [E] (⌀ x 1 each)

↓ Note

- Remove both springs before taking apart the fusing unit assembly. The reason for this is to relieve pressure on the unit.
- When reinstalling the fusing unit assembly, install both springs last. The reason for this is to reset the springs back to their default position.

Fusing

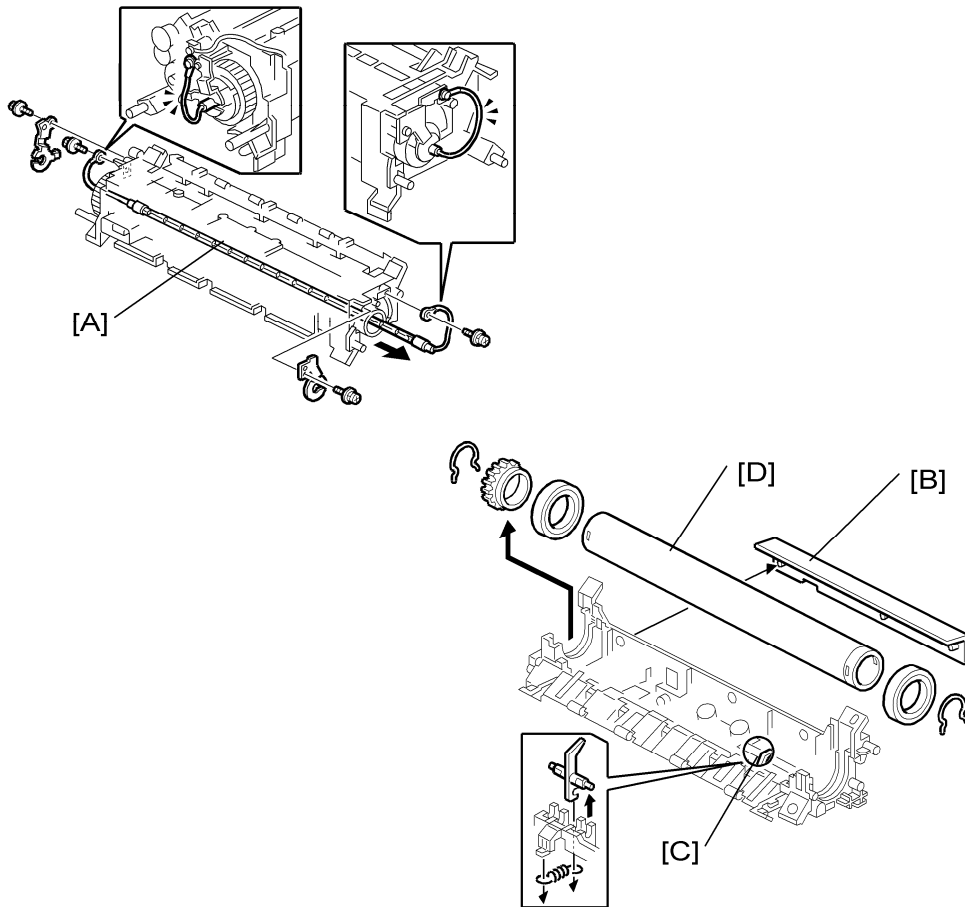

g094r526

1. Fusing Lamp [A] (2 x)

Note

- The colored cable must be at the hot roller gear side.

2. Guide plate [B] (3 hooks)
3. Hot roller strippers [C] (1 spring x each)
4. Hot roller [D] (2 x C-rings, 1 x gear, 2 x bushings)

Important

- Before removing the hot roller from the unit, remove the gear and the pin first,
- Use a small screwdriver to separate the guide plate from the unit.
- Before installing the new hot roller, peel off 3 cm (1 inch) from both ends of the protective sheet on the new hot roller. Be sure to remove the remaining paper before starting the machine.

3.7.3 PRESSURE ROLLER

1. Fusing Unit (☛ Fusing Unit)
2. Hot roller and fusing lamp (☛ Hot Roller and Fusing Lamp)

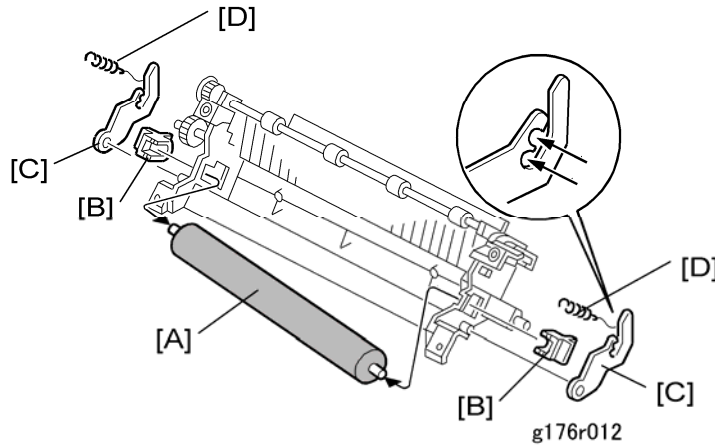

3. Pressure roller [A]
4. Bushing [B]
5. Pressure roller lever [C]
6. Spring [D]

Fusing

3.7.4 THERMISTOR AND THERMOSTAT

1. Hot roller and fusing lamp (→ Hot Roller and Fusing Lamp)

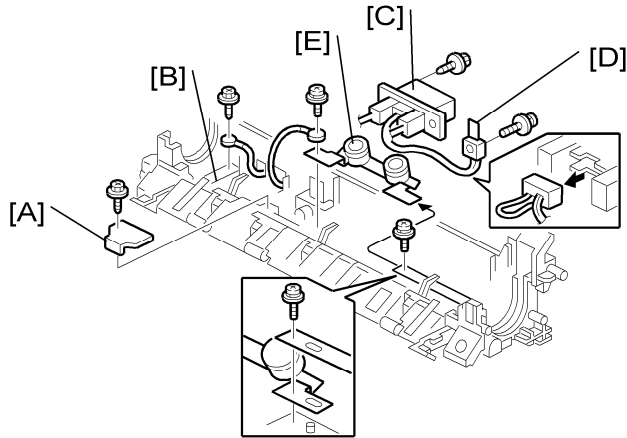

g094r011

1. Wire cover [A] (🔩 x 1)
2. Grounding plate [B] (🔩 x 2, 1 x wire)
3. Fusing unit connector [C] (🔩 x 6, 📌 x 1, 2 hooks)
4. Thermistor [D] (🔩 x 1, 📌 x 1)
5. Thermostat [E] (🔩 x 1)

★ Important

- When removing the thermistor, remove the entire unit first and then separate it into two parts.
- Do not touch the thermostat with your hands.

3.7.5 HOT ROLLER STRIPPERS

1. Hot roller and fusing lamp (↔ Hot Roller and Fusing Lamp)

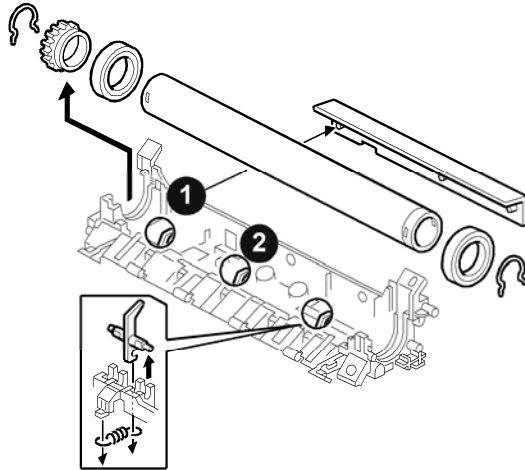

g094r003

↓ Note

- Two extra hot roller strippers ①, ② are installed for a better grip on narrow paper. This prevents paper from curling around the hot roller. When installing the extra hot roller strippers, insert them in the two slots using a small pair of pliers until they snap into place.

Paper Feed

3.8 PAPER FEED

3.8.1 PAPER FEED ROLLER

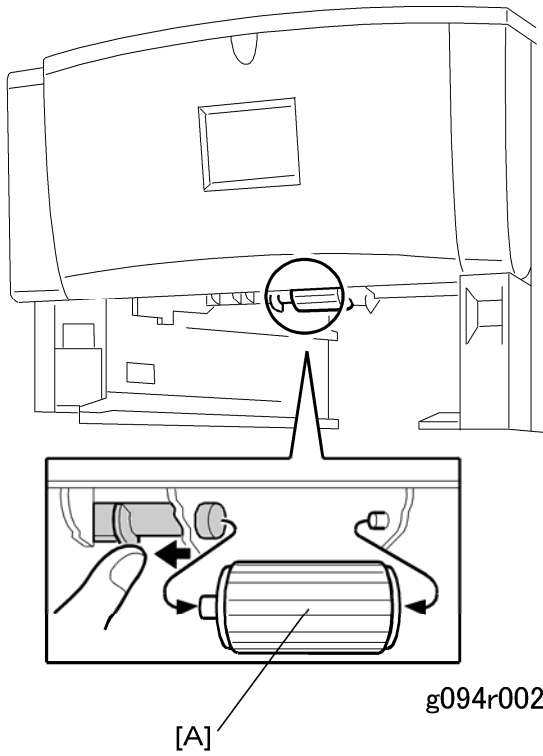

1. Pull out the paper tray before removing the paper feed roller.
2. Paper feed roller [A]

3.8.2 FRICTION PAD

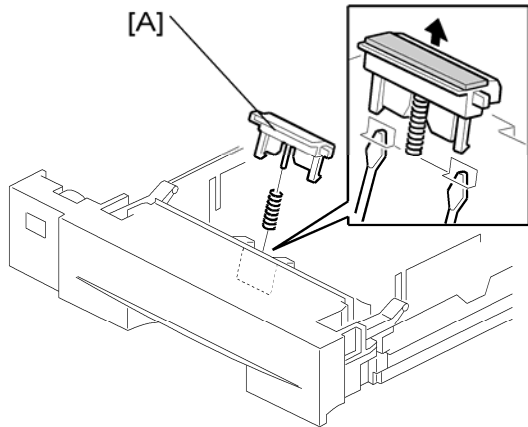

g094r010

1. Remove the paper tray unit from the machine before removing the friction pad.
2. Friction pad [A] (2 hooks, 1 spring)

When reinstalling the friction pad follow this order:

1. Replace the spring.
2. Insert the right side of the friction pad first followed by the left side.
3. Gently push the friction pad down into the slot and then pull forward very slightly.

By-pass Tray

3.9 BY-PASS TRAY

1. Left Cover (↔ Left Cover)
2. Front Cover (↔ Front Cover)

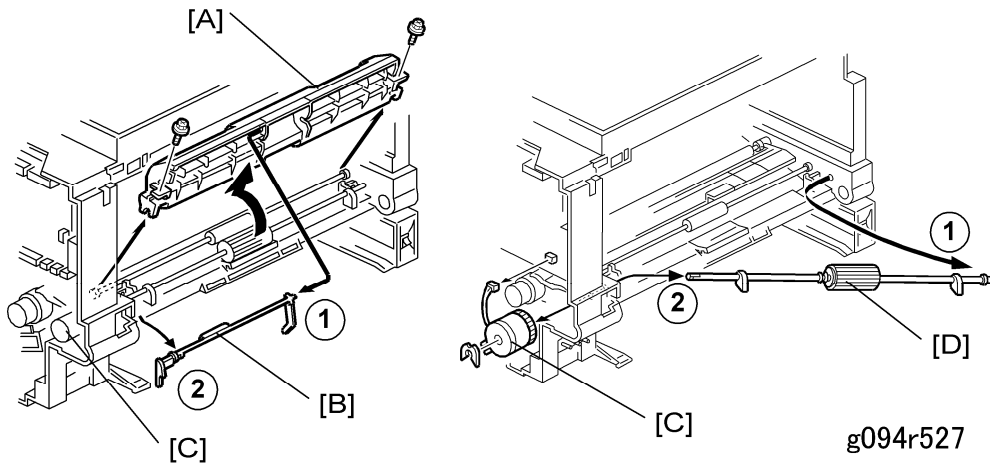

3. Remove the AIO
4. Paper guide [A] (↔ x 2)
5. Actuator [B]
6. Clutch (↔ x1) [C]
7. By-pass feed roller [D]

When reinstalling the paper guide.

1. Set the paper guide on the bushing.
2. Install the right part of the actuator on the paper guide.
3. Install the left part of the actuator in the machine.
4. Install the paper guide.
5. Check that the actuator moves smoothly and swings freely.

3.10 PRINTER CONTROLLER BOARD

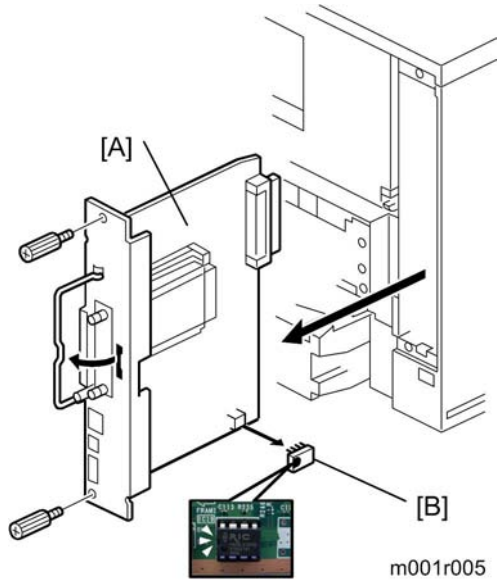

1. Printer controller board [A] (⚙️ x 2)
2. NVRAM [B]

↓ Note

- Remove the NVRAM from the old printer controller board and insert it on the new board.
- The screws on the printer controller board are hand screws. Gently turn these screws when removing the printer control board.
- Pull on the handle to remove the printer controller board from the machine.

Engine Board

3.11 ENGINE BOARD

1. Left cover (➡ "Left Cover")
2. Printer controller board (➡ "Printer Controller Board")

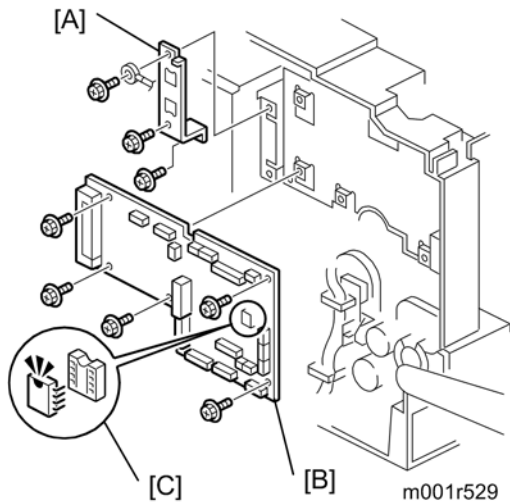

3. Bracket [A] (⚙ x 2, 1 grounding wire)
4. Engine board [B] (⚙ x 5, all connectors)

★ Important

- Remove the NVRAM [C] from the old engine board and install it on the new board.

3.12 MAIN MOTOR

1. Left cover (↗ Left Cover)

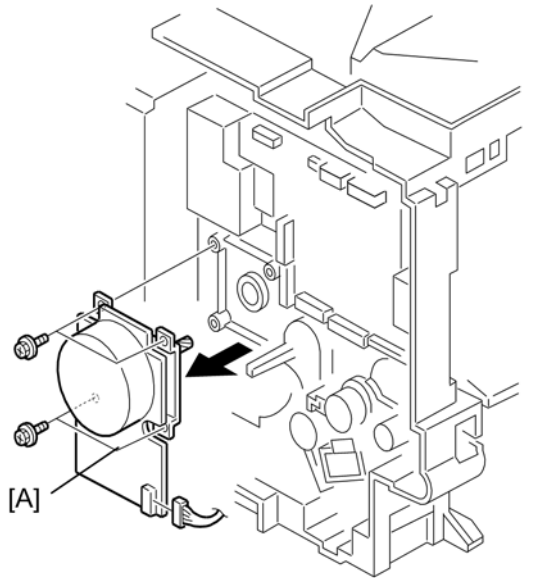

2. Main motor [A] (⚙ x 4, ⚙ x 1)

Clutches

3.13 CLUTCHES

There are four clutches on the machine as shown below.

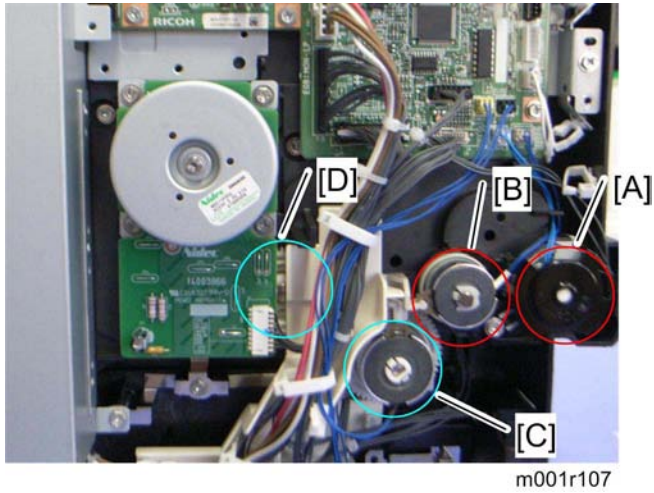

[A]: By-pass feed clutch

[B]: Relay clutch

[C]: Paper feed clutch

[D]: Registration clutch

3.13.1 BY-PASS FEED CLUTCH AND RELAY CLUTCH

1. Left cover (☛ Left Cover)

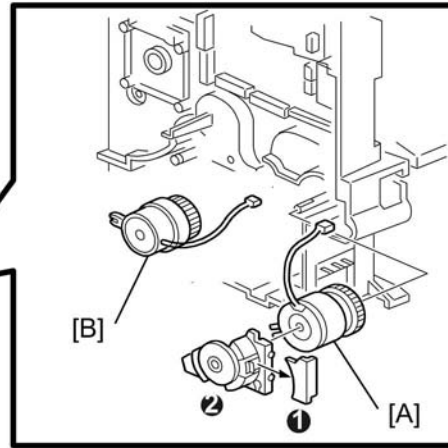
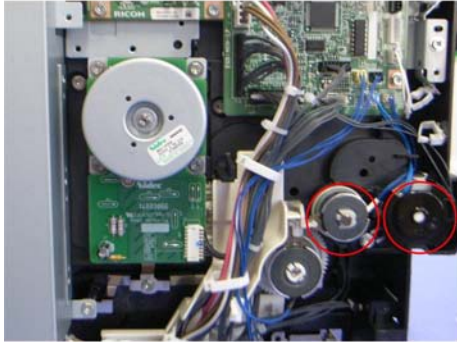

m001r108

2. Holder ❶
3. Clutch bracket ❷ (☞ x 1)
4. By-pass feed clutch [A] (☞ x 1)
5. Relay clutch (☞ x 1, ☞ x 1)

↓ Note

- Route the harness [A] as shown below, when reinstalling the holder ❶.

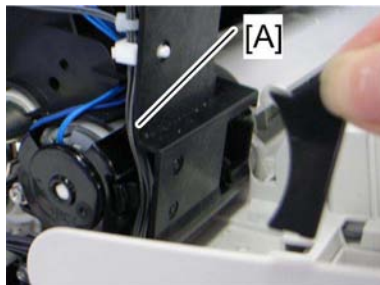

m001r111

Clutches

3.13.2 PAPER FEED CLUTCH AND REGISTRATION CLUTCH

1. Left cover (☛ Left Cover)

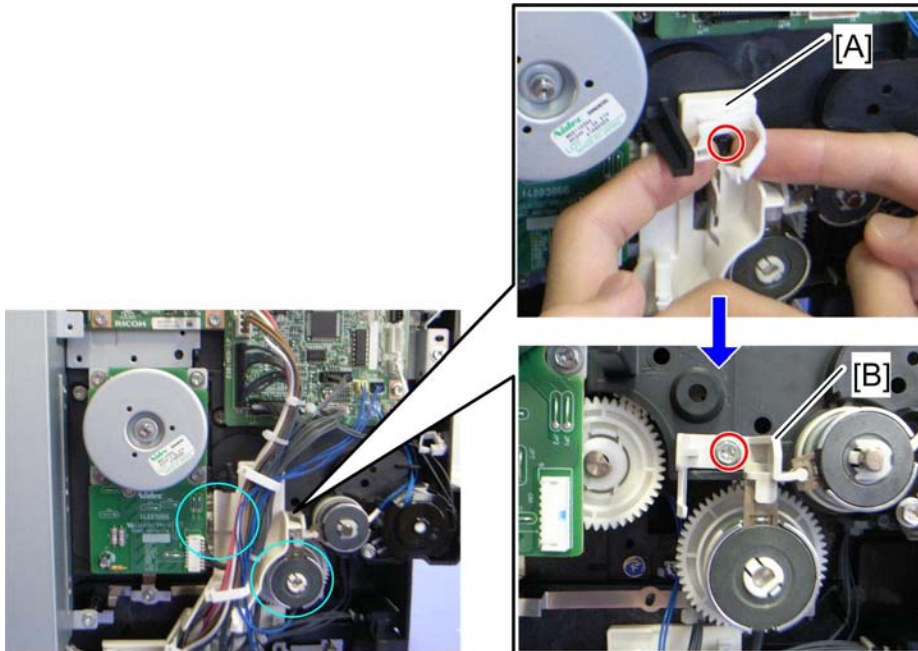

m001r109

2. Harness guide [A] (Rivet screw x 1, ☛ x 3, ☛ x all)
3. Magnetic clutch stopper [B] (☛ x 1)

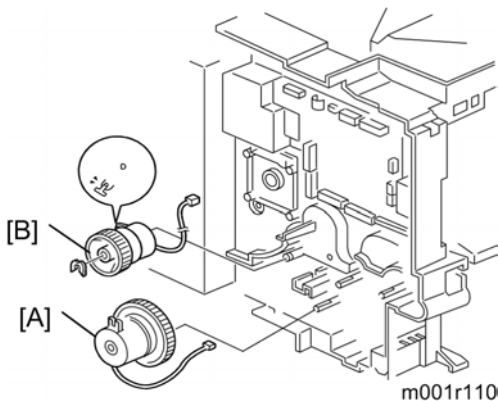

m001r110

4. Paper feed clutch [A] (☛ x 1)
5. Main motor (☛ Main Motor)
6. Registration clutch [B] (☛ x 1, ☛ x 1)

3.14 PSU, HVPS

1. Right cover (➔ Right Cover)
2. Fusing unit (➔ Fusing Unit)

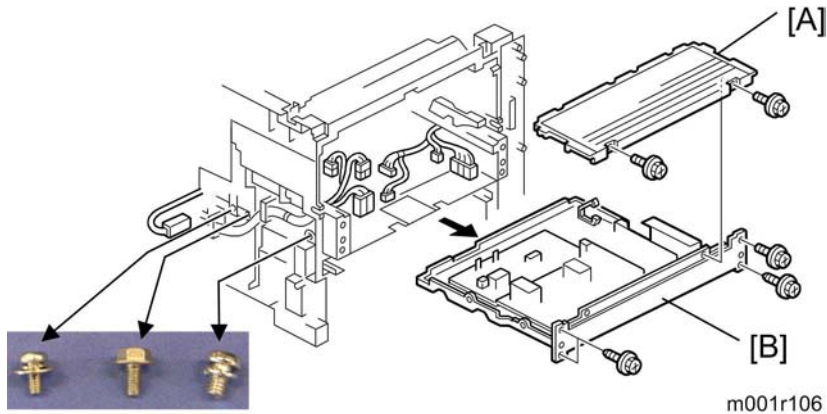

3. PSU cover [A] (⚙ x 2)
4. PSU assembly [B] (⚙ x 7, all connectors)

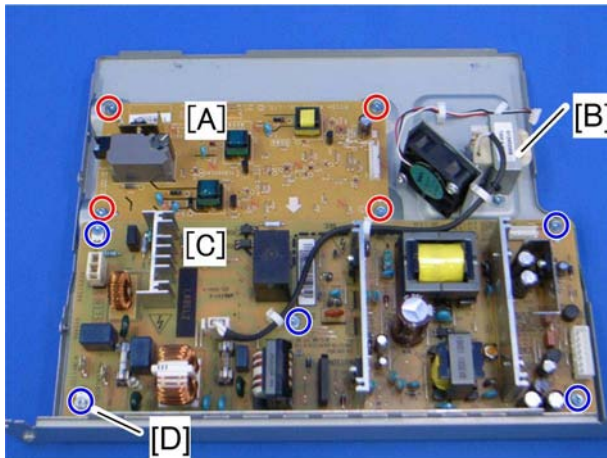

5. High voltage supply board [A] (⚙ x 4)
6. **230-volt machine only:** Choke coil [B] (⚙ x 2, ⚙ x 1, ⚙ x 3)
7. PSU [C] (⚙ x 5)

Replacement Adjustment

PSU, HVPS

↓ Note

- The screw [D] is different from other four screws.

↓ Note

- Route the PSU fan harness as shown the picture below, when reinstalling the PSU assembly.

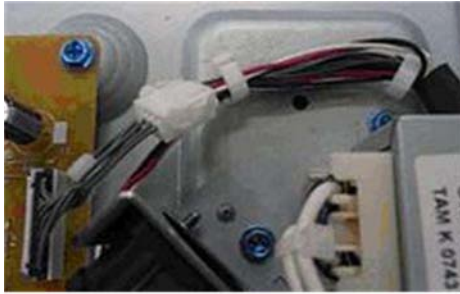

m001r114

3.15 FANS

3.15.1 COOLING FAN

1. Right cover (→ Right Cover)

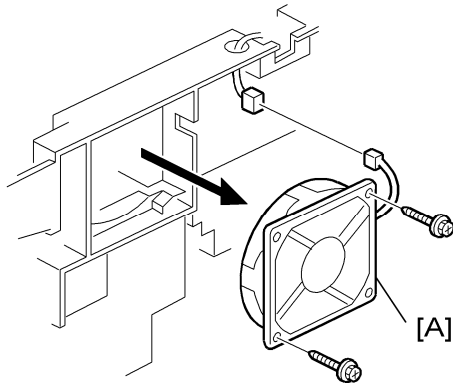

g176r501

1. Cooling fan [A] (⚙ x 2, 📏 x1)

↓ Note

- Make sure that the cooling fan is reinstalled in the correct mounting position. If it is not in the correct mounting position, incorrect air circulation will result.

Fans

3.15.2 PSU FAN

1. Right cover (➡ Right Cover)
2. Fusing unit (➡ Fusing Unit)
3. PSU assembly (➡ PSU, HVPS)

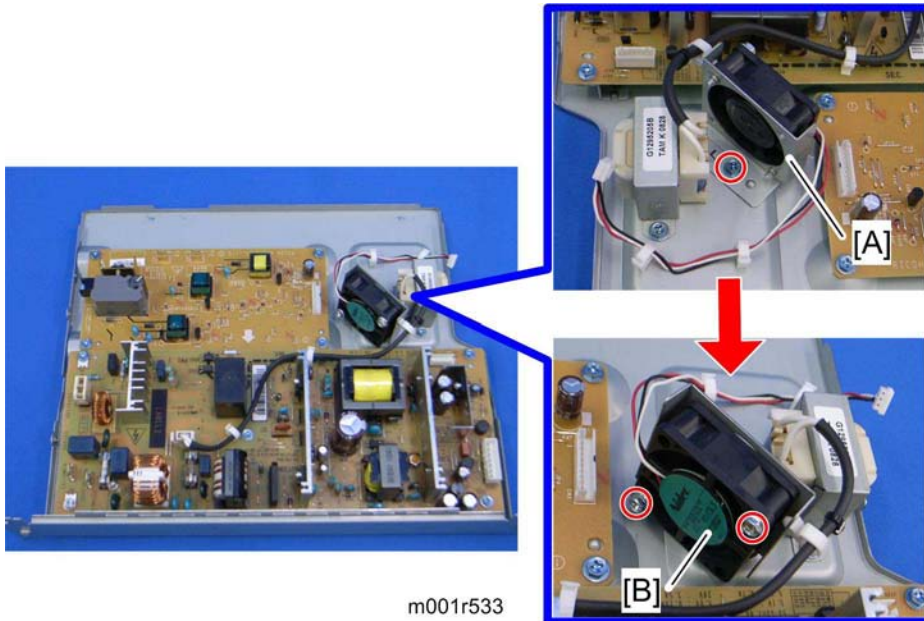

4. PSU fan with the bracket [A] (⚙ x 1, 🔩 x 2)
5. PSU fan [B] (⚙ x 2)

CÓPIA NÃO CONTROLADA

TROUBLESHOOTING

CÓPIA NÃO CONTROLADA

CÓPIA NÃO CONTROLADA

CÓPIA NÃO CONTROLADA

4. TROUBLESHOOTING

4.1 SERVICE CALL CONDITIONS

4.1.1 SUMMARY

There are 4 levels of service call conditions

Level	Definition	Reset Procedure
A	Fusing unit SCs shown on the operation panel. The machine is disabled. The user cannot reset the SC.	<ol style="list-style-type: none"> 1. Do SP5810 and press [#Enter]. 2. When "execute" is displayed, press [#Enter] again. 3. Press [Escape]. 4. Turn the machine power off/on.
B	These SCs disable only the features that use the defective item. The user does not see these SCs in usual conditions. But, they are shown on the operation panel when the defective feature is used.	Set the main power switch to "off" then to "on".
C	SCs that are not shown on the operation panel. They are recorded internally.	Recorded only.
D	These SCs are shown on the operation panel. To reset these SCs, turn the operation switch or main power switch off and on. These SCs are shown again if the error occurs again.	Set the operation switch or the main power switch to "off" then to "on".

Service Call Conditions

 Note

- If the problem is with electrical circuit boards, disconnect the connectors first. Then reconnect the connectors before you replace the PCBs.
- If the problem is with a motor lock, first examine the mechanical load. Then replace motors or sensors.

4.1.2 SC CODE DESCRIPTIONS

230	B	FGATE error	<ul style="list-style-type: none"> ▪ Defective engine board ▪ Defective controller board ▪ Disconnect harness
		<p>The PFGATE ON signal does not assert within 1 second.</p> <p>The PFGATE ON signal still assert within 7 seconds, after processing the image in a normal job</p>	

302	B	Charge roller current leak	<ul style="list-style-type: none"> ▪ Cartridge (charge roller) defective ▪ High voltage supply board defective ▪ Defective cartridge connection
		<p>The PWM duty output exceeded 60% for longer than 200 ms, indicating a leak in the charge roller current.</p>	

320	B	Polygon motor error	<ul style="list-style-type: none"> ▪ Polygon motor ▪ Polygon motor cable
		<p>The polygon motor did not enter the lock state within 10 sec. after it switched on.</p> <p>-or-</p> <p>Once the polygon motor was detected in the lock state after started to rotate, within 0.2 sec. it entered the unlock state.</p> <p>-or-</p> <p>After the polygon motor switched off, it did not enter unlock state within 3 sec.</p>	

322	B	1st beam laser synchronization error	<ul style="list-style-type: none"> ▪ Laser synchronization detector board out of position ▪ Laser synchronization detector board or cable defective ▪ Laser synchronization mirror out of position ▪ LD unit defective ▪ Engine board defective
		With all doors closed the polygon motor is locked and not rotating, or the laser synchronization detector could not detect 1st beam laser detection signal within 500 ms.	
323	C	LD drive current exceeded	<ul style="list-style-type: none"> ▪ LD unit defective
		The LD driver detected an error for 50 ms.	
326	B	2nd beam laser synchronization error	<ul style="list-style-type: none"> ▪ Laser synchronization detector board out of position ▪ LD unit defective ▪ Engine board defective
		With all doors closed the polygon motor is locked and not rotating, or the laser synchronization detector could not detect 2nd beam laser detection signal within 500 ms.	
391	B	Development bias leak	<ul style="list-style-type: none"> ▪ High voltage supply board defective ▪ Defective cartridge connection
		A development bias leak signal was detected for 200 ms.	

Trouble-shooting

Service Call Conditions

500	B	Main motor error	<ul style="list-style-type: none"> ▪ Main motor defective ▪ Mechanical overload on the drive mechanism
		<p>The machine does not detect a main motor lock signal within 700 ms after the main motor started to rotate.</p> <p>-or-</p> <p>The machine detects a main motor lock signal within 500 ms after the main motor started to rotate, after that, the main motor lock signal does not detect within 200ms.</p> <p>-or-</p> <p>The machine does not detect a main motor lock signal within 200 ms after the main motor switched off.</p>	

541	A	Fusing thermistor error	<ul style="list-style-type: none"> ▪ Thermistor disconnected, defective ▪ Fusing lamp disconnected, defective ▪ Fuse blown ▪ Power supply board defective ▪ Fusing unit connected improperly
		<p>The fusing temperature did not rise higher than 20°C within 10 sec. after the main motor switched off.</p> <p>-or-</p> <p>The fusing temperature was detected lower than 0°C for over 1 sec. after the power relay switched on.</p>	

542	A	Fusing temperature warm-up error	<ul style="list-style-type: none"> ▪ Thermistor defective ▪ Fusing lamp open ▪ Fusing thermostat open ▪ Power supply board Defective ▪ Defective connection of the fusing unit
		<p>Just before reaching warm-up temperature, the fusing temperature did not rise above 80°C within 15.5 sec. after the power relay switched on.</p>	

543	A	Fusing overheat error – software	<ul style="list-style-type: none"> ▪ Fusing thermistor defective ▪ Power supply board defective
		The fusing temperature was detected higher than 235°C for longer than 200 ms.	

544	A	High temperature detection: Hard	<ul style="list-style-type: none"> ▪ Defective thermister ▪ Defective fusing unit, PSU, engine board
		The thermister detects a high temperature signal.	

545	A	Fusing lamp remains on	<ul style="list-style-type: none"> ▪ Fusing thermistor defective ▪ Power supply board defective ▪ Defective connection of the fusing unit
		The fusing lamp remained on longer than 12 sec. after the fusing unit reached optimum temperature and the main motor switched off.	

546	A	Unstable fusing temperature	<ul style="list-style-type: none"> ▪ Fusing thermistor defective ▪ Power supply board defective ▪ Defective connection of the fusing unit
		During standby, the fusing temperature went below 60 °C twice or went above 60 °C three times within 500 ms.	
		A 60°C increase in fusing temperature was detected at five 1-sec. intervals within 60 sec. before reaching fusing temperature.	

Trouble-shooting

Service Call Conditions

547	B	Zero cross signal error	<ul style="list-style-type: none"> ▪ Power supply board defective ▪ Defective mains power supply condition
		<p>Zero cross signals of wavelength 50-60 Hz were not detected within 5 sec after the fusing relay switched on.</p> <p>-or-</p> <p>Zero cross interrupts did not issue at the prescribed 3 sec. intervals.</p>	

559	A	Fusing unit jam	<ul style="list-style-type: none"> ▪ Fusing unit installed incorrectly ▪ Fusing unit defective
		<p>Three consecutive paper lag jams (paper failed to arrive) were detected in the fusing unit.</p> <p>-or-</p> <p>During printing of the 1st side during duplexing, the paper did not arrive at the duplex entrance sensor three times.</p>	
		<p>Note: SP1913 determines whether SC559 is issued. The default is off. SC559 is not issued after three consecutive jams in the paper unit. If SP1913 is set to on, turning the machine power off/on does not reset the jam counter.</p>	

590	B	Fan motor error	<ul style="list-style-type: none"> ▪ Fan motor disconnected, defective ▪ Fan motor harness loose, broken, defective
		The machine does not lock for 3sec during rotating the fusing fan motor.	

591	B	PSU fan error	<ul style="list-style-type: none"> ▪ Defective PSU fan
		The machine does not lock for 3sec during rotating the PSU fan motor.	

Service Call Conditions

620	B	GAVD communication error	<ul style="list-style-type: none"> ▪ Defective engine board ▪ Defective ASIC
		The machine detects an error data of the ASIC.	

622		Paper tray unit communication error	<ul style="list-style-type: none"> ▪ Disconnect harnesses
		Three consecutive errors occur during polling, after the paper tray unit is successful I2C communication.	

669	B	EEPROM Error	
		The EEPROM was not connected at power on, or read/write operations on the EEPROM failed.	<ul style="list-style-type: none"> ▪ EEPROM connected improperly ▪ EEPROM missing

670	D	Engine startup error	
		The BCU failed to respond within the prescribed time when the machine is turn on.	<ul style="list-style-type: none"> ▪ Connections between BCU and controller board are loose, disconnected, or damaged ▪ Replace the BCU ▪ Replace the controller board

Trouble-shooting

Service Call Conditions

672	D	Controller startup error	
		<p>After power on, the line between the controller and the operation panel did not open for normal operation.</p> <p>After normal startup, communication with the controller stopped.</p>	<ul style="list-style-type: none"> ▪ Controller stalled ▪ Controller installed incorrectly ▪ Controller board defective ▪ Operation panel harness disconnected or defective

687	B	PER-command error	
		<p>The machine does not receive PAPI-PER command for specific time, after PAPI-PES was issued.</p>	<ul style="list-style-type: none"> ▪ Defective controller

688	B	PAPI-PES error	
		<p>The machine does not receive PAPI-PES command after paper is in registration.</p>	<ul style="list-style-type: none"> ▪ Defective controller ▪ Poor communication

817	D	Monitor error	
		<p>This is a file detection and electronic file signature check error when the boot loader attempts to read the self-diagnostic module, system kernel, or root system files from the OS Flash ROM, or the items on the SD card in the controller slot are false or corrupted.</p>	<ul style="list-style-type: none"> ▪ OS Flash ROM data defective; change the controller firmware ▪ SD card data defective; use another SD card

819	C	Fatal kernel error	
		Due to a control error, a RAM overflow occurred during system processing. One of the following messages was displayed on the operation panel.	<ul style="list-style-type: none"> ▪ System program defective ▪ Controller board defective ▪ Optional board defective ▪ Replace controller firmware
		0x696e	init died
		0x766d	vm_pageout: VM is full
		4361	Cache Error
		Other	

For more details about this SC code error, execute SP5990 to print an SMC report so you can read the error code. The error code is not displayed on the operation panel.

820	D	Self-Diagnostic Error: CPU	<ul style="list-style-type: none"> ▪ Controller board defective ▪ Software defective
		The central processing unit returned an error during the self-diagnostic test.	

821	D	Self-diagnostic error 2: ASIC	
		The ASIC provides the central point for the control of bus arbitration for CPU access, for option bus and SDRAM access, for SDRAM refresh, and for management of the internal bus gate.	<ul style="list-style-type: none"> ▪ ASIC (controller board defective)

For more details about this SC code error, execute SP5990 to print an SMC report so you can read the error code. The error code is not displayed on the operation panel.

Trouble-shooting

CÓPIA NÃO CONTROLADA

Service Call Conditions

822	B	Self-diagnostic error 3: HDD	
		3003	<p>Check performed when HDD is installed: HDD device busy for over 31 s. After a diagnostic command is set for the HDD, but the device remains busy for over 6 s. A diagnostic command is issued to the HDD device but the result is an error</p> <ul style="list-style-type: none"> ▪ HDD defective ▪ HDD harness disconnected, defective ▪ Controller board defective
		3004	<p>No response to the self-diagnostic command from the ASIC to the HDDs</p> <ul style="list-style-type: none"> ▪ HDD defective

823	B	Self-diagnostic Error: NIC	<ul style="list-style-type: none"> ▪ Network interface board defective ▪ Controller board defective
		The network interface board returned an error during the self-diagnostic test.	

824	D	Self-diagnostic error 4: NVRAM	
		NVRAM device does not exist, NVRAM device is damaged, NVRAM socket damaged	<ul style="list-style-type: none"> ▪ NVRAM defective ▪ Controller board defective ▪ NVRAM backup battery exhausted ▪ NVRAM socket damaged

826	D	Self-diagnostic Error: NVRAM/Optional NVRAM	<ul style="list-style-type: none"> ▪ Make sure NVRAM is seated correctly in its socket ▪ Replace the NVRAM on the controller board
		The NVRAM or optional NVRAM returned an error during the self-diagnostic test.	

827	D	Self-diagnostic Error: RAM	<ul style="list-style-type: none"> ▪ Update controller firmware again ▪ Replace RAM DIMM
		The resident RAM returned a verify error during the self-diagnostic test.	

828	D	Self-diagnostic error 7: ROM	
		Measuring the CRC for the boot monitor and operating system program results in an error. A check of the CRC value for ROMFS of the entire ROM area results in an error.	<ul style="list-style-type: none"> ▪ Software defective ▪ Controller board defective ▪ ROM defective

829	B	Self-diagnostic Error: Optional RAM	<ul style="list-style-type: none"> ▪ Replace the optional memory board ▪ Controller board defective
		The optional RAM returned an error during the self-diagnostic test.	

833/834	C	For more details about SC 833, SC834 error.	
		Execute SP5990 to print an SMC report so you can read the error code. The error code is not displayed on the operation panel. The additional error codes (0F30, 0F31, etc. are listed in the SMC report).	

Trouble-shooting

CÓPIA NÃO CONTROLADA

Service Call Conditions

838	D	Self-diagnostic Error: Clock Generator	<ul style="list-style-type: none"> ▪ Replace the controller board
		A verify error occurred when setting data was read from the clock generator via the I2C bus.	

851	B	IEEE 1394 I/F error	<ul style="list-style-type: none"> ▪ NIB (PHY), LINK module defective; change the Interface Board ▪ Controller board defective
		Driver setting incorrect and cannot be used by the 1394 I/F.	

853	B	Wireless LAN Error 1	<ul style="list-style-type: none"> ▪ Wireless LAN card missing (was removed)
		During machine start-up, the machine can get access to the board that holds the wireless LAN, but not to the wireless LAN card (802.11b or Bluetooth).	

854	B	Wireless LAN Error 2	<ul style="list-style-type: none"> ▪ Wireless LAN card missing (was removed)
		During machine operation, the machine can get access to the board that holds the wireless LAN, but not to the wireless LAN card (802.11b or Bluetooth).	

855	B	Wireless LAN error 3	<ul style="list-style-type: none"> ▪ Wireless LAN card defective ▪ Wireless LAN card connection incorrect
		An error was detected on the wireless LAN card (802.11b or Bluetooth).	

856	B	Wireless LAN error 4	
		An error was detected on the wireless LAN card (802.11b or Bluetooth).	<ul style="list-style-type: none"> ▪ Wireless LAN card defective ▪ PCI connector (to the mother board) loose

857	B	USB I/F Error	
		The USB driver is not stable and caused an error.	<ul style="list-style-type: none"> ▪ Bad USB card connection ▪ Replace the controller board

860	B	HDD startup error at main power on	
		<p>HDD is connected but a driver error is detected.</p> <p>The driver does not respond with the status of the HDD within 30 s.</p>	<ul style="list-style-type: none"> ▪ HDD is not initialized ▪ Level data is corrupted ▪ HDD is defective

861	D	HDD re-try failure	
		At power on the HDD was detected. Power supply to the HDD was interrupted after the system entered the energy save mode, but after the HDD was awakened from the energy save mode it did not return to the ready status within 30 sec.	<ul style="list-style-type: none"> ▪ Harness between HDD and controller board disconnected, defective ▪ HDD power connector disconnected ▪ HDD defective ▪ Controller board defective

Trouble-shooting

CÓPIA NÃO CONTROLADA

Service Call Conditions

863	D	HDD data read failure	
		<p>The data written to the HDD cannot be read normally, due to bad sectors generated during operation.</p>	<ul style="list-style-type: none"> ▪ HDD defective <p>Note: If the bad sectors are generated at the image partition, the bad sector information is written to NVRAM, and the next time the HDD is accessed, these bad sectors will not be accessed for read/write operation.</p>

864	D	HDD data CRC error	
		<p>During HDD operation, the HDD cannot respond to an CRC error query. Data transfer did not execute normally while data was being written to the HDD.</p>	<ul style="list-style-type: none"> ▪ HDD defective

865	D	HDD access error	
		<p>HDD responded to an error during operation for a condition other than those for SC863, 864.</p>	<ul style="list-style-type: none"> ▪ HDD defective.

866	B	SD card error 1: Confirmation	
		<p>The machine detects an electronic license error in the application on the SD card in the controller slot immediately after the machine is turned on. The program on the SD card contains electronic confirmation license data. If the program does not contain this license data, or if the result of the check shows that the license data in the program on the SD card is incorrect, then the checked program cannot execute and this SC code is displayed.</p>	
		<ul style="list-style-type: none"> ▪ Program missing from the SD card ▪ Download the correct program for the machine to the SD card 	

867	D	SD card error 2: SD card removed	
		The SD card in the boot slot when the machine was turned on was removed while the machine was on.	<ul style="list-style-type: none"> ▪ Insert the SD card, then turn the machine off and on.

868	D	SD card error 3: SC card access	
		An error occurred while an SD card was used.	<ul style="list-style-type: none"> ▪ SD card not inserted correctly ▪ SD card defective ▪ Controller board defective ▪ Note: If you want to try to reformat the SC card, use SD Formatter Ver 1.1.

870	B	Address book data error	
		Address book data on the hard disk was detected as abnormal when it was accessed from either the operation panel or the network. The address book data cannot be read from the HDD or SD card where it is stored, or the data read from the media is defective.	<ul style="list-style-type: none"> ▪ HDD defective. ▪ Initialize the HDD with SP5832. If this does not solve the problem, replace the HDD and initialize with SP5832. <p>Note: If you turn off the machine while the HDD is being accessed, this can damage the HDD.</p>

872	B	HDD mail receive data error	
		The machine detected that the HDD was not operating correctly at power on. The machine detected that the HDD was not operating correctly (could neither read nor write) while processing incoming email	<ul style="list-style-type: none"> ▪ HDD defective. ▪ Initialize the HDD with SP5832. If this does not solve the problem, replace the HDD and initialize with SP5832. <p>Note: If you turn off the machine while the HDD is being accessed, this can damage the HDD.</p>

Trouble-shooting

Service Call Conditions

873	B	HDD mail send data error	
		<p>An error was detected on the HDD immediately after the machine was turned on, or power was turned off while the machine used the HDD.</p>	<ul style="list-style-type: none"> ▪ HDD defective. ▪ Initialize the HDD with SP5832. If this does not solve the problem, replace the HDD and initialize with SP5832. <p>Note: If you turn off the machine while the HDD is being accessed, this can damage the HDD.</p>

874	D	Delete All error 1: HDD	
		<p>A data error was detected for the HDD/NVRAM after the Delete All option was used.</p> <p>Note: The source of this error is the Data Overwrite Security Unit B660 running from an SD card.</p>	<ul style="list-style-type: none"> ▪ Turn the main switch off/on and try the operation again. ▪ Install the Data Overwrite Security Unit again. For more, see section “1. Installation”. ▪ HDD defective

875	D	Delete All error 2: Data area	
		<p>An error occurred while the machine deleted data from the HDD.</p> <p>Note: The source of this error is the Data Overwrite Security Unit B660 running from an SD card.</p>	<ul style="list-style-type: none"> ▪ Turn the main switch off/on and try the operation again.

876	D	Log data abnormal	
		An error was detected in the handling of the log data at power on or during machine operation. This can be caused by switching the machine off while it is operating.	<ul style="list-style-type: none"> ▪ Software error. Update the firmware ▪ NVRAM defective ▪ HDD defective

		File Format Converter (MLB) error	
880	B	A request to get access to the MLB was not answered within the specified time.	<ul style="list-style-type: none"> ▪ MLB defective, replace the MLB

		Electrical total counter error	
900	D	The total counter contains something that is not a number.	<ul style="list-style-type: none"> ▪ NVRAM incorrect type ▪ NVRAM defective ▪ NVRAM data scrambled ▪ Unexpected error from external source

		Printer error 1	
920	B	An internal application error was detected and operation cannot continue.	<ul style="list-style-type: none"> ▪ Software defective; turn the machine off/on, or change the controller firmware ▪ Insufficient memory

		Software error 1	
990	D	The software performs an unexpected function and the program cannot continue.	Software defective, re-boot*1

Trouble-shooting

Service Call Conditions

991	C	Software error 2	
		The software performs an unexpected function. However, unlike SC990, recovery processing allows the program to continue.	Software defective, re-boot*1

*1: In order to get more details about SC990 and SC991:

1. Execute SP7403 or print an SMC Report (SP5990) to read the history of the 10 most recent logged errors.
2. If you press the zero key on the operation panel with the SP selection menu displayed, you will see detailed information about the recently logged SC990 or SC991, including the software file name, line number, and so on. 1) is the recommended method, because another SC could write over the information for the previous SC.

995	A	Model information error	<ul style="list-style-type: none"> ▪ Engine firmware not installed correctly
		The CPM information sent from the controller to the engine immediately after power on did not match the DIP SW settings.	

4.2 ERROR MESSAGES

Here is a list of common error messages, a description of the problems, and their solutions. This is just a reference information.

1st/2nd Message	Problem/Solution
Cannot check, Signal in Ad hoc	Disable Ad hoc in the Comm. Mode settings.
Cannot duplex Tray #/ Press Form Feed or reset the Job	Duplexing prohibited from specified tray. Cancel duplex mode Press [Form Feed] or [Job Reset].
Cannot install from this SD card	SD card contains a DOS (Data Overwrite Security) program that has already been installed for another machine. <ul style="list-style-type: none"> Contact system administrator.
Certificate auto renewal failed	Automatic certificate renewal has failed. <ul style="list-style-type: none"> Call your service provider.
Change Setting Tray #/Paper Size:, Paper Type:	The paper size/paper type settings in the application program and printer driver do not match. <ul style="list-style-type: none"> Change the paper type on the paper type setting menu on the machine operation panel Push [Form Feed] Cancel the print job.
Change Setting Tray #/ Paper Size:, Paper Type:	The paper size/paper type settings in the application program and printer driver do not match. Do one of the following: <ul style="list-style-type: none"> Load the tray with the correct paper Change the paper size using the dial or the special paper size setting menu on the operation panel. Push [Form Feed] Cancel the print job.

Error Messages

1st/2nd Message	Problem/Solution
Close Duplex Unit Cover	The duplex unit cover is open. <ul style="list-style-type: none"> ▪ Close the duplex unit cover.
Close Front Cover	The front cover is open. <ul style="list-style-type: none"> ▪ Close the front cover.
Close Rear/Paper Exit Cover	The paper output tray cover or the rear cover is open, or both covers are open. <ul style="list-style-type: none"> ▪ Check the covers, make sure they are closed.
DHCP assigned, Cannot change	DHCP has been enabled to assign network addresses of: IP address, subnet mask, gateway address. <ul style="list-style-type: none"> ▪ Disable DHCP in host interface network setup to change any of these addresses.
Error: Enter 10, or 26 Characters	Number of hex characters entered for the WEP key is incorrect. <ul style="list-style-type: none"> ▪ Enter correct number of characters.
Error: Enter 5, or 13 Characters	Number of ASCII characters entered for the WEP key is incorrect. <ul style="list-style-type: none"> ▪ Enter correct number of characters.
Hardware Problem, Ethernet	Machine detected an Ethernet error. <ul style="list-style-type: none"> ▪ Replace controller board.
Hardware Problem, HDD	Machine identified a HDD Board error. <ul style="list-style-type: none"> ▪ Replace HDD board.
Hardware Problem, Option RAM	Machine detected an optional RAM error. <ul style="list-style-type: none"> ▪ Replace optional RAM.
Hardware Problem, Parallel I/F	Machine failed self-diagnostic test due to a loop back error. <ul style="list-style-type: none"> ▪ If parallel I/F is in use, replace the IEEE1284 interface board.

1st/2nd Message	Problem/Solution
Hardware Problem, Printer Font	Problem with machine font file. <ul style="list-style-type: none"> ▪ Replace print module.
Hardware Problem, USB	Machine detected a USB I/F board error. <ul style="list-style-type: none"> ▪ Replace the USB I/F board.
Hardware Problem, Wireless Board	Access to the IEEE 802.11 a/g board was possible, but an error has been detected. Machine can access IEEE802.11 a/g board but an error was detected. <ul style="list-style-type: none"> ▪ Confirm that the board is installed correctly.
Hardware Problem, Wireless Card	Machine failed to access IEEE 802.11a/g board. <ul style="list-style-type: none"> ▪ Confirm that the board is installed correctly.
Invalid Data, Power Off On	Machine has received spurious data. <ul style="list-style-type: none"> ▪ Turn the printer off/on.
Invalid Password, Try again	The invalid password was entered and Locked Print or Saved File Print is not applicable. Invalid password entered, Locked Print or Saved File Print cannot apply. Printer displays this message for 4 sec., then returns to previous display. <ul style="list-style-type: none"> ▪ Enter correct password.
Load Correct Size Paper/ Paper Size:, Paper Type:	Size of paper selected does not match size selected with dial on paper tray. <ul style="list-style-type: none"> ▪ Use the dial to select the correct paper size. -or- <ul style="list-style-type: none"> ▪ Press [Form Feed].
Load Paper: Tray# or Form Feed	The specified tray is out of paper. <ul style="list-style-type: none"> ▪ Load paper in the specified tray.

CÓPIA NÃO CONTROLADA

Error Messages

1st/2nd Message	Problem/Solution
Menu Protected, Cannot change	The operation panel has been digitally locked, settings cannot be changed. Message displays for 5 sec., returns to previous display.
Misfeed: Duplex Check paper size/ Open Duplex Unit cover	Paper fed from bypass tray jammed in duplex unit.
Misfeed: Internal, Check paper size/ Open Front Cover	Paper fed from bypass tray jammed in duplex unit.
Misfeed: Ppr, Exit Check paper size/ Open Paper Exit Cover	Paper fed from bypass tray jammed in duplex unit.
Misfeed: Ppr. Tray, Check paper size/ Pull out Tray	Paper is jammed in the duplex unit.
No Files exist	No files available for deleting or printing. This error displays for 3 sec., then machine returns to previous display.
Press # to continue/ Paper Size:, Paper Type:	Requested paper size does not match dial setting on the paper tray. <ul style="list-style-type: none"> ▪ Press [#] to start printing.
Proxy User Name, Password error	Proxy user name and password are incorrect. <ul style="list-style-type: none"> ▪ Change current user name and password to the correct user name and password.
Proxy setting or connection error	1) Proxy address port No. is invalid, 2) proxy is not active, 3) invalid center URL is set, 4) center is not active, 5) proxy is not set. <ul style="list-style-type: none"> ▪ Check all proxy settings.

1st/2nd Message	Problem/Solution
RC Gate, Connection error	<p>Cannot communicate with remote communication gate.</p> <ul style="list-style-type: none"> ▪ Check printer connection. ▪ Check remote communication gate.
ROM Update, Waiting for Data	<p>The printer is waiting for updated data. The image file will be downloaded from an Internet Web site. The image data will overwrite previous ROM , engine firmware, PS DIMM, and other data on the machine.</p> <ul style="list-style-type: none"> ▪ No action required.
ROM Update:, Waiting for Data	<p>The printer is receiving updated data.</p> <ul style="list-style-type: none"> ▪ No action required.
Remove Misfeed Duplex Unit/ Open Duplex Unit cover	<p>Paper is jammed under the paper exit cover.</p> <ul style="list-style-type: none"> ▪ Remove and re-install the duplex unit. ▪ Remove any jammed paper from the duplex unit and under the rear cover.
Remove Misfeed Internal Path/ Open Front Cover	<p>Paper is jammed in the specified input paper feed tray.</p> <ul style="list-style-type: none"> ▪ Open the front and rear cover. ▪ Remove jammed paper.
Remove Misfeed Paper Exit Cover/ Open Paper Exit Cover	<p>Paper is jammed in the specified input paper tray.</p> <ul style="list-style-type: none"> ▪ Open the front and rear cover ▪ Remove jammed paper.
Remove Misfeed Paper Tray/ Pull out Tray	<p>Paper is jammed in the specified input paper tray.</p> <ul style="list-style-type: none"> ▪ Remove paper from the input paper tray. ▪ Reload paper. ▪ Open and close front cover to extinguish message.
Remove Paper Standard Tray	<p>The standard output tray is full.</p> <ul style="list-style-type: none"> ▪ Remove paper from output tray.

Trouble-shooting

CÓPIA NÃO CONTROLADA

Error Messages

1st/2nd Message	Problem/Solution
Replace Maintenance Kit	It is time to replace: feed roller, transfer unit, fusing unit, development unit.
Replace Print Cartridge	Print cartridge requires replacement.
Replace Print Cartridge	Print cartridge requires replacement (out of toner).
Replace Print Cartridge	Print cartridge requires replacement (used toner tank full).
Replace Print Cartridge soon	The print cartridge is out of toner or has reached the end of its service life. Print cartridge requires replacement.
Reset Fusing Unit correctly	<p>Fusing unit not set correctly, or incorrect type installed.</p> <ul style="list-style-type: none"> ▪ Check the type of fusing unit installed. ▪ Confirm that unit is installed correctly.
Reset Print Cartridge	<p>AIO unit not installed or is not installed correctly.</p> <ul style="list-style-type: none"> ▪ Insert AIO. ▪ Check that it is inserted properly.
Reset Tray # or Form Feed	<p>Specified paper input tray is not set correctly. (Current resident printer languages only).</p> <ul style="list-style-type: none"> ▪ Set input tray correctly.
Reset the Job or Form Feed/ Paper Size:, Paper Type:	<p>Actual paper type and size do not match the paper tray size and type setting.</p> <ul style="list-style-type: none"> ▪ Load the indicated tray with the correct paper. ▪ Or, change the paper size using tray dial or operation panel. ▪ Or, push [Form Feed] to print on current paper. ▪ Or, cancel job.
SD authentication failed	<p>Authentication from the SD card failed.</p> <ul style="list-style-type: none"> ▪ Turn the machine off/on.

1st/2nd Message	Problem/Solution
SD card not set, Contact admin.	The SD card for DOS is not set.
SSID not entered	This message confirms that no ID has been entered. Enter correct ID
Supply order failed.	Call for supply order has failed. <ul style="list-style-type: none"><li data-bbox="683 651 1145 685">▪ Confirm the setting of @Remote.
Update Mode Err, Power Off On	The printer has failed to restart the update. <ul style="list-style-type: none"><li data-bbox="683 772 1038 806">▪ Turn the machine off/on.

General Troubleshooting

4.3 GENERAL TROUBLESHOOTING**4.3.1 IMAGE ADJUSTMENT*****Registration Adjustment***

The registration is adjusted in the user mode ("Maintenance-Registration"). For details, see the Printer Reference operation manual.

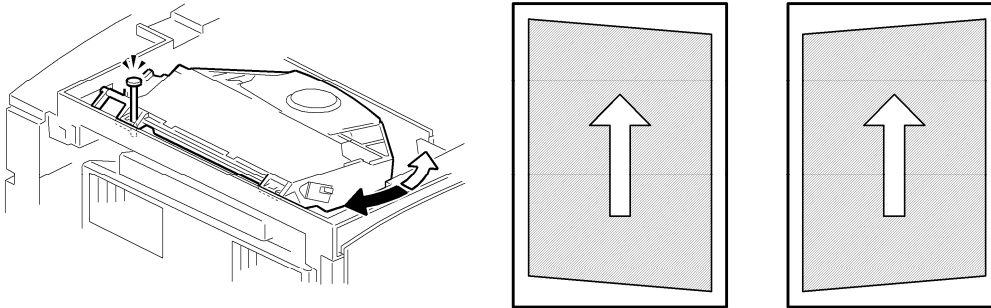
Parallelogram Image Adjustment

g094r533

Do the following procedure if a parallelogram is printed while adjusting the printing registration using a trimming pattern.

↓ **Note**

- Use the scanner positioning pin (P/N: A0069104) for this adjustment.
1. Remove the upper cover (See "Upper Cover")
 2. Put a positioning pin in one of the holes
 3. Loosen four screws and move the laser unit.
 4. Tighten the laser unit.
 5. Print the trimming area pattern to check the image. If it is still the same, repeat steps 3 to 5.

4.3.2 ELECTRICAL DEFECTS

Sensors



- The "CN" numbers describe the connector number on the engine board.

CN	Component	Condition	Symptom
5-25	Paper Exit	Open	The Paper Jam indicator will light whenever a print is made.
		Shorted	The Paper Jam indicator lights even if there is no paper.
5-30	Paper Overflow	Open	The paper overflow message is not displayed even when a paper overflow condition exists.
		Shorted	The paper overflow message is displayed.
14-29	Registration	Open	The Paper Jam indicator will light whenever a print is made.
		Shorted	The Paper Jam indicator lights even if there is no paper.
14-14	Mlt Paper end sensor	Open	The Paper End indicator lights even if paper is placed in the Mlt paper tray.
		Shorted	The Paper End indicator does not light even if there is no paper in the 1st paper tray.

General Troubleshooting

CN	Component	Condition	Symptom
14-17	Tray1 Paper end sensor	Open	The Paper End indicator lights even if paper is placed in the 1st paper tray.
		Shorted	The Paper End indicator does not light even if there is no paper in the 1st paper tray.
14-20	Remaining paper sensor 1	Open	The machine cannot determine the paper near-end condition properly.
		Shorted	
14-23	Remaining paper sensor 2	Open	The machine cannot determine the paper near-end condition properly.
		Shorted	
14-27	Toner End	Shorted	Toner near-end (toner end) is not detected.
		Low	The add toner message is displayed.

Switches

- The "CN" numbers describe the connector number on the engine board (except for the main switch).

CN	Component	Condition	Symptom
103-1.3 (PSU 120V) TAB1, TAB2 (PSU 230V)	Main	Open	The machine does not turn on.
		Shorted	The machine does not turn off.
8-1	Front Cover Safety	Open	The Front Cover Open message is not displayed even if the front cover is opened.
		Shorted	The Front Cover Open message is displayed even if the front cover is closed.
4-3	Rear Cover Safety	Open	The Rear Cover Open message is not displayed even if the rear cover or paper exit cover is opened.
		Shorted	The Rear Cover Open message is displayed even if the rear cover or paper exit cover is closed.

General Troubleshooting

Fuses

North America

Fuse	Current	Voltage
FU1	15.0 A	AC 100V/120V
FU2	5.0 A	AC 100V/120V
FU3	4.0 A	DC 5V
FU4	5.0 A	DC 5V
FU5	6.3A	DC24V

Europe

Fuse	Current	Voltage
FU1	8.0 A	AC 220V-240V
FU2	3.15 A	AC 220V-240V
FU3	4.0 A	DC 5V
FU4	5.0 A	DC 5V
FU5	6.3A	DC24V

4.3.3 SKEW ADJUSTMENT

Follow the instructions in this flowchart to correct image skew.

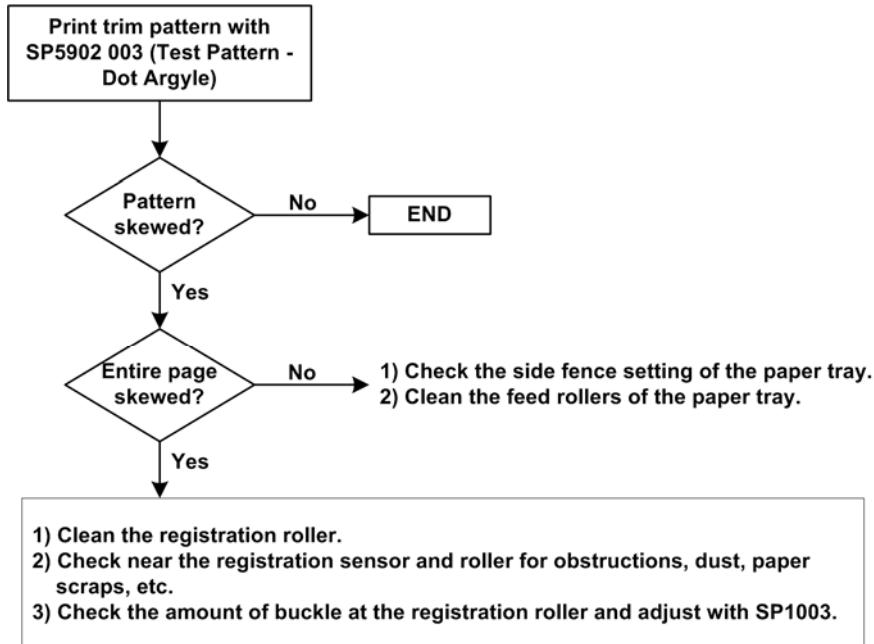

m001r901

General Troubleshooting

4.3.4 STREAKS IN THE SUB SCAN DIRECTION

If you see streaks or lines at a regular interval in the sub scan direction:

1. Measure the width of the interval between the streaks.
2. Identify the component in the table below that is causing the problem (based on the size of the measured interval), then inspect that component.

Interval Width (approx.)	Check:
94 mm	OPC Drum (diameter 30 mm)
50 mm	Transfer Roller (diameter 16 mm)
105 mm	Fusing Roller (diameter 33 mm)
100 mm	Pressure Roller(diameter 32 mm)

4.3.5 MISCELLANEOUS PROBLEMS

Here is a summary of some problems, what causes them, and how they can be solved.

Problem	Probable Cause/Solution
Black spots at approximately 94 mm intervals.	AIO is defective, transfer roller is dirty. <ul style="list-style-type: none"> ▪ Replace AIO ▪ Clean the transfer roller
Spurious noise during printing	Relay clutch defective. <ul style="list-style-type: none"> ▪ Replace relay clutch
Vertical positioning of printed image is not consistent (sub scan direction)	Registration clutch defective <ul style="list-style-type: none"> ▪ Replace registration clutch
Multiple vertical stripes appear in areas of black coverage	NIC defective <ul style="list-style-type: none"> ▪ Replace NIC
Entire page appears gray, text appears light and enlarged	Synchronization defective. <ul style="list-style-type: none"> ▪ Replace main (engine) board
Frequent paper jams, or message prompts to load correct paper size and type.	Registration sensor defective, registration sensor actuator defective. (High usage can foul the actuator with paper dust.) <ul style="list-style-type: none"> ▪ Replace registration sensor ▪ Replace registration sensor actuator
HDD unit not recognized	The HDD unit of another machine cannot be used. <ul style="list-style-type: none"> ▪ Replace the HDD unit with the new HDD.

CÓPIA NÃO CONTROLADA

CÓPIA NÃO CONTROLADA

CÓPIA NÃO CONTROLADA

SERVICE TABLES

CÓPIA NÃO CONTROLADA

CÓPIA NÃO CONTROLADA

CÓPIA NÃO CONTROLADA

5. SERVICE TABLES

5.1 SERVICE PROGRAM MODE

★ Important

- Before calling for service, first, confirm that there is no print data in the printer buffer (the Data-in LED should not be lit or blinking). If the LED is blinking, this means there is data in the buffer. Wait until all data has been printed.

5.1.1 SERVICE PROGRAM MODE: OVERVIEW

Entering the Service Mode



m001s509

There are two ways to enter the service mode.

Method 1: Fast Start (Power Off)

Use this method to open the SP mode when you are turning the machine's power on. This method bypasses the warm-up time.

1. Hold down [Suspend/Resume] and [Escape] together, then turn the machine on.
2. Hold down both keys until "1. Service Menu" appears on the display.

Method 2: Normal Start (Power On)

Use this method to enter the SP mode with the machine on.

1. With the machine on, press [▼] [▲] together and hold them down for about 5 sec.
2. Press [Enter]. "1. Service Menu" appears on the screen.

Service Program Mode

Setting a Service Program

1. Enter the service program mode as explained above.
2. The setting that appears on the display is the current setting.
Select the required setting using the “Up/Down arrow” keys,
3. Press the [Enter] key. The previous value remains if the [Enter] key is not pressed.

Exiting Service Mode

Select “3. End” from the service mode main menu, then press the “Enter” key.

5.2 PRINTER CONTROLLER SERVICE MODE

5.2.1 BIT SWITCH PROGRAMMING

1. Enter the sp mode, select “Service Menu”, then press [Enter] twice.
2. Select #1, #2, #3, or #4 for the desired bit switch, then press [Enter].
 - [▲] [▼]: Move to the next switch.
3. Adjust the bit switch using the following keys.
 - [▲] [▼]: Move to the next bit.
 - [Escape]: Exit without saving changes.
 - [Enter]: Exit and save changes.
 - The left digit on the display is bit 7 and the right digit is bit 0.
4. Press [Enter] to save changes and exit.

Printer Controller Service Mode

5.2.2 SERVICE MODE MENU ("1. SERVICE MENU")

1001	Bit Switch			
001	Bit Switch 1		0	1
	bit 0	DFU	-	-
	bit 1	DFU	-	-
	bit 2	DFU	-	-
	bit 3	No I/O Timeout	0: Disable	1: Enable
		Enables/Disables MFP I/O Timeouts. Enabled: The MFP I/O Timeout setting will have no affect. I/O Timeouts will never occur.		
	bit 4	SD Card Save Mode	0: Disable	1: Enable
		Enabled: Print jobs will be saved to an SD Card in the GW SD slot (➡ "Card Save Function" in the service tables of Field Service Manual).		
	bit 5	DFU	-	-
	bit 6	DFU	-	-
bit 7	[RPCS,PCL]: Printable area frame border	0: Disable	1: Enable	
	Enable: The machine prints all RPCS and PCL jobs with a border on the edges of the printable area.			

1001	Bit Switch			
002	Bit Switch 2		0	1
	bit 0	DFU	-	-
	bit 1	DFU	-	-
	bit 2	DFU	-	-
	bit 3	[PCL5e/c,PS]: PDL Auto Switching	0: Enable	1: Disable
		Disabled: The MFPs ability to change the PDL processor mid-job. Some host systems submit jobs that contain both PS and PCL5e/c. If Auto PDL switching is disabled, these jobs will not be printed properly.		
	bit 4	DFU	-	-
	bit 5	DFU	-	-
	bit 6	DFU	-	-
bit 7	DFU	-	-	

Printer Controller Service Mode

1001	Bit Switch			
003	Bit Switch 3		0	1
	bit 0	DFU	-	-
	bit 1	DFU	-	-
	bit 2	[PCL5e/c]: Legacy HP compatibility	0: Disable	1: Enable
		Enabled: Uses the same left margin as older HP models such as HP4000/HP8000. In other words, the left margin defined in the job (usually "<ESC>*r0A") will be changed to "<ESC>*r1A"		
	bit 3	DFU	-	-
	bit 4	DFU	-	-
	bit 5	DFU	-	-
	bit 6	DFU	-	-
bit 7	DFU	-	-	

1001	Bit Switch		
004	Bit Switch 4 DFU	-	-

1001	Bit Switch			
005	Bit Switch 5		0	1
	bit 0	DFU	-	-
	bit 1	DFU	-	-
	bit 2	DFU	-	-
	bit 3	[PS] PS Criteria	Pattern3	Pattern1
		Change the number of PS criterion used by the PS interpreter to determine whether a job is PS data or not. Pattern3: includes most PS commands. Pattern1: A small number of PS tags and headers		
	bit 4	Increase max number of the stored jobs to 1000 jobs.	Disable (100)	Enable (1000)
		Enabled: Changes the maximum number of jobs that can be stored on the HDD via Job Type settings to 1000. The default is 100.		
	bit 5	DFU	-	-
bit 6	Method for determining the image rotation for the edge to bring on	Disable	Enable	
	Enabled: The image rotation will be performed as they were in the specifications of older models for the binding of pages of mixed orientation jobs. The old models are below: -PCL-: Pre-04A models			
bit 7	DFU	-	-	
1003	Clear Setting	Initializes settings in the "System" menu of the user mode.		
1004	Print summary	Prints the service summary sheet (a summary of all the controller settings).		
1005	Disp Version	Displays the version of the controller firmware.		

Service Tables

Printer Engine Service Mode

5.3 PRINTER ENGINE SERVICE MODE

5.3.1 SERVICE MODE TABLE

Notation	What it means
[range/default/step]	Example: [-9 to +9/+3.0/0.1 mm step]. The setting can be adjusted in the range ± 9 , value reset to +3.0 after an NVRAM reset, and the value can be changed in 0.1 mm steps with each key press.
DFU	Denotes "Design or Factory Use". Do not change this value.

SP1-xxx: Feed

	Lead Edge Regist	Leading Edge Registration
1001	Adjusts the printing leading edge registration for feeding from the trays and duplex tray using the trimming area pattern (SP5-902-003 No.9). Push [▲] or [▼] to select the settings (plus or minus). The specification is 4 ± 2 mm	
1001 001	Bypass Tray Plain	[-40 to +40/0/1]
1001 002	Bypass Tray Thick	
1001 003	Main Tray Plain	
1001 004	Main Tray Thick	
1001 005	Optional Tray	
1001 006	Duplex	

1002	Side to Side Reg	Side-to-Side Registration
	Adjusts the printing side-to-side registration from the 1st paper feed station using the trimming area pattern (SP2-902 No.12). Push [▲] or [▼] to select the settings (plus or minus). Specification: 0 ±2.0 mm.	
1002 001	1st Tray	[-40 to +40/ 0 /1]
1002 002	2nd Tray	
1002 003	3rd Tray	
1002 004	Bypass Tray	
1002 005	Duplex	

1003	Regist sag	Registration Buckle Adjustment
	Adjusts the relay clutch timing at registration. Relay clutch timing determines the amount of paper buckle at registration. (A "+" setting causes more buckling.)	
1003 001	Cassette	[-8 mm to+8 mm/ 0 /2 mm step]
1003 002	Multi Tray	[-8 mm to+8 mm/ 0 /2 mm step]
1003 003	Duplex Tray	[-8 mm to+8 mm/ 0 /2 mm step]

1104	Fusing control	Normal, Phase control
	Use phase control if the room lights flicker when the fusing lamp starts. Off: Normal On: Phase Control Defaults: NA Off (Normal), EU On (Phase Control)	

Service Tables

CÓPIA NÃO CONTROLADA

Printer Engine Service Mode

1105	Fusing Temp DFU	
	Adjusts the fusing temperatures for printing and standby mode.	
1105 001	Fusing Temp	Adjusts the fusing temperature for printing on normal paper. [150 to 195/ 180 /5 deg.]
1105 002	Fusing T Stand	Adjusts the fusing temperature for standby mode. [140 to 185/ 168 /1 deg.]

1106	Fusing T Disp(lay)
	Displays the current fusing temperature.

1902	OHP Clutch Rt	OHP Clutch Rotations
	Selects the number of rotations for the bypass feed roller when the paper type is set for "Transparencies". Change this setting to "2" if jams occur frequently when feeding transparencies from the bypass tray. 1 = 1 rotation , 2 = 2 rotations	

1910	Fusing Start DFU
	[Roller Turn / Normal] Roller Turn: Warms up the fusing unit for 20 sec. just after the power switch has been turned on or when the machine warms up from energy saver mode. Normal: There is no 20 sec. warm-up period. However, just after the main power switch is turned on, the motor rotates to clean the drum. Normal, Roller Turn

1911	Curl Control	
	<p>Thin paper has a tendency to jam or wrinkle, especially during duplex printing. When this SP code is switched on:</p> <ul style="list-style-type: none"> ▪ The machine ignores the fusing temperature set for SP1105. ▪ When the machine is powered on or recovers from the low power mode the machine requires about 20 sec. to warm up (this is longer than normal). <p>[0 to 1/0/1] 0: Normal 1: Curl Control</p>	

1913	SC559 Detect	Fusing Jam SC Setting
	<p>This SP setting determines whether SC559 is issued after three paper late jams occur in the fusing unit. After this SP code is turned on, a counter monitors the number of paper late jams that occur in the fusing unit. After the 3rd occurrence of a fusing jam, SC559 is issued and the machine cannot be used until the service technician releases the error.</p> <p>Note: Switching the machine off/on does not reset this jam counter. The counter is reset after the cause of the jam has been removed and a sheet of paper successfully passes the fusing exit sensor.</p> <p>[0 to 1/0/1] 0: No 1: Yes</p>	

1914	[Nip Measure] Fusing Nip Width Measurement	
1914 001	Measure Exe.	<p>[0 or 1 / 0 /-] 0: Not execute, 1: Execute</p>
	<p>Performs the nip width measurement. This is for by-pass tray and used OHP type.</p>	

Service Tables

CÓPIA NÃO CONTROLADA

Printer Engine Service Mode

SP2-xxx: Drum

2001	Charge Rol Bias DFU	
	Adjusts the voltage applied to the charge roller for printing. [-2000 to 1000/ -1670 /10V step]	

2112	Mainscan Mag	Main Scan Magnification
	Adjusts the main scan magnification. [-0.5% to 0.5%/0/0.1% step]	

2113	Subscan Mag	Sub Scan Magnification
	Adjusts the sub scan magnification. [-0.5% to 0.5%/0/0.1% step]	

2201	Developer Bias	
	Adjusts the development bias for printing. [200 to 800/ 750V /10V step] DFU	

2213	Toner End Count	
	Adjusts the number of prints the machine can make after it detects toner near-end. [50 to 200/ 200 /50 sheets/step]	

2301	Transfer Curr	Transfer Current
	Adjusts the correction current applied to the transfer roller. [-4 to +8/ 0 /2 uA /step]	

2910	Thermistor Adj DFU	Thermistor Adjustment
	If this is "Yes", the machine automatically adjusts the charge roller voltage and transfer current in response to the temperature in the machine. [Yes/ No]	

2980	Waste Toner Cnt	Used Toner Count
	Displays the waste toner count.	

Printer Engine Service Mode

SP3-xxx: Process

3923	Cartridge Stop	
	<p>Determines whether the machine stops printing after the cartridge counter reaches a set number of main motor rotations.</p> <p>[0 or 1 / 1 /-]</p> <p>0: No: Does not stop after the number of rotations is exceeded.</p> <p>1: Yes: Stops after the number of rotations is exceeded.</p>	

3924	Toner End Sensor	
3924 001	Toner Near-end	Threshold adjustment for toner near-end detection. [100 to 1000/ 200 /100 ms step]
3924 002	Toner End	Threshold adjustment for toner end detection. [100 to 1000/ 550 /100 ms step]

3926	Prevention of fi	Prevention of Filming
	<p>No, Yes</p> <p>If set to "Yes": This is done every 50 prints, for 0.2 s, to lubricate the cleaning blade. The charge roller voltage is cut, and toner is transferred to the cleaning blade. If the 50-print interval is reached during a job, printing stops and this process is done.</p> <p>Set this to yes to prevent the following:</p> <ul style="list-style-type: none"> ▪ Grey banding parallel to the paper feed direction ▪ Cleaning blade flipping due to friction between blade and drum ▪ Noise due to friction between blade and drum 	

3927	TonerEndJudg
	<p>This SP code determines whether the machine disables printing when the machine detects toner end.</p> <ul style="list-style-type: none">▪ Even when toner end is detected, there is a small amount of toner left in the AIO. If a user wants to print with the AIO until all toner is used up, then set this SP to 1. But then, there is no toner end detection, and the user must watch the print quality and change the AIO when prints become too pale. <p>[0 to 1/0/1] 0: Yes (Printing stops when toner end is detected.) 1: No (Printing can continue even after toner end is detected.)</p>

Printer Engine Service Mode

SP5-xxx: Mode

5024	mm/inch Display Selection	
	Selects the unit of measurement. After selection, turn the main power switch off and on. 0: Europe/Asia (mm), 1: North America (inch)	

5051	Toner Refill Displ	Toner Refill Detect Display
	This SP switches on/off the message that prompts the operator when it is necessary to replenish toner in the machine. 0: enable (Message displayed (Default)) 1: disable (Message not displayed)	

5055	Display IP add	Display IP Address
	Switches the banner display of the IP address off and on. [0 to 1/0/1] 0= No, 1= Yes For example, if this SP is switched on, the IP address will be displayed below "Ready" while the printer is in standby mode: Ready 169.254.187.055	

5302	Set Time
002	<p>Time Difference</p> <p>Sets the time clock for the local time. This setting is done at the factory before delivery. The setting is GMT expressed in minutes.</p> <p>[-1440 to 1440 / - / 1 min.]</p> <p>Japan: +540 (Tokyo)</p> <p>NA: -300 (NY)</p> <p>EU: +60 (Paris)</p> <p>CH: +480 (Peking)</p> <p>TW: +480 (Taipei)</p> <p>AS: +480 (Hong Kong)</p> <p>KO: +540 (Korea)</p>

5307	Summer Time	
	<p>Lets you set the machine to adjust its date and time automatically with the change to Daylight Savings time in the spring and back to normal time in the fall. This SP lets you set these items:</p> <p>Day and time to go forward automatically in April.</p> <p>Day and time to go back automatically in October.</p> <p>Set the length of time to go forward and back automatically.</p> <p>The settings for 002 and 003 are done with 8-digit numbers:</p>	
	Digits	Meaning
	1st, 2nd	Month. 4: April, 10: October (for months 1 to 9, the first digit of 0 cannot be input, so the eight-digit setting for 002 or 003 becomes a seven-digit setting)
	3rd	Day of the week. 0: Sunday, 1: Monday
	4th	The number of the week for the day selected at the 3rd digit. If "0" is selected for "Sunday", for example, and the selected Sunday is the start of the 2nd week, then input a "2" for this digit.
	5th, 6th	The time when the change occurs (24-hour as hex code).

Service Tables

CÓPIA NÃO CONTROLADA

Printer Engine Service Mode

		Example: 00:00 (Midnight) = 00, 01:00 (1 a.m.) = 01, and so on.	
	7th	The number of hours to change the time. 1 hour: 1	
	8th	If the time change is not a whole number (1.5 hours for example), digit 8 should be 3 (30 minutes).	
	001	Setting	Enables/disables the settings for 002 and 003. [0 to 1/1] 0: Disable 1: Enable
	003	Rule Set (Start)	The start of summer time.
	004	Rule Set (End)	The end of summer time.

5404	UCodeCtrClr	User Code Count Clear
	Clears the counts for the user codes assigned by the key operator to restrict the use of the machine. Press [#Enter] to clear.	

5501	PM Alarm
	[0 to 9999/0/1 step] 0: Alarm off 1 to 9999: Alarm goes off when Value (1 to 9999) ≥ PM counter

5504	Jam Alarm
	Sets the alarm to sound for the specified jam level (document misfeeds are not included). [0 to 3/3/1 step] 0: Zero (Off) 1: Low (2.5K jams) 2: Medium (3K jams) 3: High (6K jams)

5505	Error Alarm DFU	
	Sets the error alarm level. [0 to 255/ 30 /100 copies per step]	

5507	Supply Alarm	
5507 001	Paper Supply Ala(rm)	Switches the control call on/off for the paper supply. DFU 0: Off, 1: On 0: No alarm. 1: Sets the alarm to sound for the specified number transfer sheets for each paper size (A3, A4, B4, B5, DLT, LG, LT, HLT)
5507 004	MaintenanceKit A	When switched on this function informs the @Remote supply center that the maintenance kit requires servicing. [OFF/ ON]
5507 009	Cartridge Alarm	When switched on this function informs the @Remote supply center that the toner cartridge is almost empty (near-end). [OFF/ ON]
5507 128	Interval: Others	The "Paper Supply Call Level: nn" SPs specify the paper control call interval for the referenced paper sizes. DFU [00250 to 10000/1000/1 Step]
5507 132	Interval: A3	
5507 133	Interval: A4	
5507 134	Interval: A5	
5507 141	Interval: B4	
5507 142	Interval: B5	
5507 160	Interval: DLT	

Service Tables

CÓPIA NÃO CONTROLADA

Printer Engine Service Mode

5507 164	Interval: LG	
5507 166	Interval: LT	
5507 172	Interval: HLT	

5515*	SC/Alarm Setting	
	With @Remote in use, these SP codes can be set to issue an SC call when an SC error occurs. If this SP is switched off, the SC call is not issued when an SC error occurs.	
001	SC Call	[0 or 1 / 1 / 1] 0: OFF 1: ON
002	Service Parts Near End Call	[0 or 1 / 0 / 1] 0: OFF 1: ON
003	Service Parts End Call	
004	User Call	[0 or 1 / 1 / 1] 0: OFF 1: ON
006	Communication Information Test Call	
007	Machine Information Notice	
008	Alarm Notice	[0 or 1 / 0 / 1] 0: OFF 1: ON
009	Non Genuine Toner	[0 or 1 / 1 / 1] 0: OFF 1: ON
010	Supply Automatic Ordering Call	
011	Supply Management Report Call	

5801	Memory Clear	
	Resets NVRAM data to the default settings. Before executing any of these SP codes, print an SMC Report.	
5801 001	All	Initializes items 2 to 15 below.
5801 002	Eng Memory Clr	Initializes all registration settings for the engine and process settings.
5801 003	SCS	Initializes default system settings, SCS (System Control Service) settings, operation display coordinates, and ROM update information.
5801 004	IMH	Initializes the image file system. (IMH: Image Memory Handler)
5801 005	MCS	Initializes the automatic delete time setting for stored documents. (MCS: Memory Control Service)
5801 008	PRT	Initializes the printer defaults, programs registered, the printer SP bit switches, and the printer CSS counter.
5801 010	WebService	Deletes the Netfile (NFA) management files and thumbnails, and initializes the Job login ID. Netfiles: Jobs to be printed from the document server using a PC and the DeskTopBinder software
5801 011	NCS	Initializes the system defaults and interface settings (IP addresses also), the SmartNetMonitor for Admin settings, WebStatusMonitor settings, and the TELNET settings. (NCS: Network Control Service)
5801 014	DCS Setting	Initializes the DCS (Delivery Control Service) settings.

CÓPIA NÃO CONTROLADA

Printer Engine Service Mode

5801 015	Clr UCS Setting	Initializes the UCS (User Information Control Service) settings.
5801 016	MIRS Setting	Initializes the MIRS (Machine Information Report Service) settings.
5801 017	CCS	Initializes the CCS (Certification and Charge-control Service) settings.
5801 018	SRM	Initializes information in non-volatile RAM.
5801 019	LCS Setting	Initializes information in non-volatile RAM.

5802	Free Run
	The machine performs a free run. Press [#Enter] to start. Press [#Enter] to stop. Please note that the machine will not stop immediately after the [#Enter] key is pressed.

5803	Input check	
	Displays signals received from sensors and switches. SP Modes other than those listed in this table, are not used in the machine.	
	Operation Panel	Component Name
5803 001	Cover Info	Cover sensors
5803 002	Main Moter CLK	Main Motor Lock
5803 003	PollyMoter CLK	Polygon Motor Lock
5803 004	Fan High	Exhaust fan
5803 005	Fan Lock	Exhaust fan

5803 006	PSU Fan Lock	PSU fan
5803 007	Destination	-
5803 008	AIO UnitSet	AIO Unit
5803 009	Fuser Temp Error	Fuser Temperature Error
5803 010	Toner End Sens	Toner end sensor
5803 011	Paper Full Sens	Paper Overflow Sensor
5803 013	Regist Sens	Registration Sensor
5803 014	Exit Sens	Paper Exit Sensor
5803 016	Mlt PaperEnd	Bypass paper sensor
5803 017	Tray1 PaperEnd	Paper end sensor, Standard Tray
5803 018	Remaining paper sensor	Standard Tray
5803 020	Tray1 PSize	Paper size switch, Standard tray
5803 022	Test Mode	-
5803 023	Test Print	-
5803 024	Trans Thermistor	Transfer Thermistor
5803 025	Fuser Thermistor	Fuser Thermistor
5803 026	Fuser UnitSet	Fusing Unit
5803 027	Trans FeedBack	Transfer Roller
5803 028	Charge FeedBack	-
5803 029	Develop FeedBack	
5803 030	No2 Carry Sens	Paper feed sensor, 1st Opt. Paper Tray

CÓPIA NÃO CONTROLADA

Printer Engine Service Mode

5803 031	Tray2 PaperEnd	Paper end sensor, 1st Opt. Paper Tray
5803 032	Tray2 RestSens	Remaining paper sensor, 1st Opt. Paper Tray
5803 033	Tray2 PSize	Paper size switch, 1st Opt. Paper Tray
5803 034	No3 Carry Sens	Paper feed sensor, 2nd Opt. Paper Tray
5803 035	Tray3 PaperEnd	Paper end sensor, 2nd Opt. Paper Tray
5803 036	Tray3 RestSens	Remaining paper sensor, 2nd Opt. Paper Tray
5803 037	Tray3 PSize	Paper size switch, 2nd Opt. Paper Tray
5803 038	Duplex Cover	Duplex Unit cover switch
5803 039	Duplex UnitSet	Duplex Unit
5803 040	Dplx Ent Sens	Duplex Entrance Sensor
5803 041	Dplx Exit Sens	Duplex Exit Sensor
5803 042	Dplx Turn Sens	Duplex Inverter Sensor

5804	Output check	
	Turns on electrical components individually for test purposes. SP Modes other than those listed in this table, are not used in the machine.	
	Operation Panel	Component Name
5804 001	Main Motor	Main Motor
5804 003	Middle CL	Relay Clutch
5804 004	No1 CL	Paper Feed Clutch
5804 005	Multi SOL	Bypass Feed Clutch
5804 006	Regist CL	Registration Clutch

5804 008	Fan High/PSU fan	Exhaust fan/PSU fan
5804 009	LD1 Compulsion	Force Test LD 1
5804 010	LD2 Compulsion	Force Test LD 2
5804 011	LD1+2 Compulsion	Force Test LD 1 + LD 2
5804 012	Polygon Motor	Polygon Motor
5804 016	Fuser Fuse Cut	-
5804 017	QL	-
5804 018	Charge Bias	-
5804 019	Developer Bias	-
5804 020	Transfer Plus	-
5804 021	Transfer minus	-
5804 022	Bank1 Motor	Paper Tray Motor-1st Opt. Paper Tray
5804 024	Bank2 Motor	Paper Tray Motor-2nd Opt. Paper Tray
5804 026	No2 CL	Paper Feed Clutch-2nd Opt. Paper Tray
5804 027	No3 CL	Paper Feed Clutch-3rd
5804 028	Dplx Mt Normal	Duplex Inverter Motor-forward
5804 030	Dplx Mt Revers(e)	Duplex Inverter Motor-reverse
5804 032	Dplx Mt Long	Duplex Transport Motor
5804 034	Dplx Split SOL	Inverter Gate Solenoid

CÓPIA NÃO CONTROLADA

Printer Engine Service Mode

5810	Fusing Err Clr	
	Resets an SC code for a fusing unit error. After using this SP mode, turn the main switch off and on.	

5811	Machine No. Sett DFU	
	Used to input the machine serial number. This is normally done at the factory.	

5812	Tel. No. Setting	
	Use these SP modes to input service and support telephone numbers. Enter the number and press [#Enter].	
5812 1	Service	Use this to input the telephone number of the CE printed on the SP print mode printout.
5812 2	Fax Tel No.	Use this to input the fax number of the CE printed on the SP print mode printout.

5816	Remote Service
5816 001	I/F Setting
	Selects the remote service setting. [0 or 2 / 2 / 1 /step] 0: OFF (Remote service off) 2: Network (@Remote remote service on)
5816 002	CE Call
	Performs the CE Call at the start or end of the service. [0 or 1 / 0 / 1 /step] 0: Start of the service 1: End of the service NOTE: This SP is activated only when SP 5816-001 is set to "2".
5816 003	Function Flag
	Enables or disables the remote service function. [0 to 1 / 0 / 1 /step] 0: Disabled 1: Enabled
5816 007	SSL Disable
	Uses or does not use the RCG certification by SSL when calling the RCG. [0 to 1 / 0 / 1 /step] 0: Uses the RCG certification 1: Does no use the RCG certification
5816 008	RCG Connect Timeout
	Specifies the connect timeout interval when calling the RCG. [1 to 90 / 10 / 1 second /step]
5816 009	RCG Write Timeout
	Specifies the write timeout interval when calling the RCG. [1 to 100 / 60 / 1 second /step]

Printer Engine Service Mode

5816 010	RCG Read Timeout	
	Specifies the read timeout interval when calling the RCG. [1 to 100 / 60 / 1 second /step]	
5816 011	Port 80 Enable	-
	Enables/disables access via port 80 to the SOAP method. [0 or 1 / 0 / -] 0: Disabled 1: Enabled	
5816 012	@Remote Service 1	
	Enables/disables @Remote service. [0 or 1 / 1 / -] 0: Disabled, 1: Enabled	
5816 021	RCG-C Registred	
	This SP displays the embedded RCG installation end flag. 0: Installation not completed 1: Installation completed	
5816 022	RCG-C Regist Det	
	This SP displays the external RCG installation status. 0: External RCG not registered 1: External RCG registered 2: Device registered	
5816 023	Connect Type (N/M)	
	This SP displays and selects the embedded RCG connection method. [0 or 1 / 0 / 1 /step] 0: Internet connection 1: Dial-up connection	
5816 061	Cert Expire Tim(ing) DFU	Proximity of the expiration of the certification.

5816 062	HTTP Proxy
	<p>This SP setting determines if the proxy server is used when the machine communicates with the service center.</p> <p>[0 or 1 / 0 / 1 /step]</p> <p>0: HTTP Proxy not used 1: HTTP Proxy used</p>
5816 063	HTTP Proxy (Host)
	<p>This SP sets the address of the proxy server used for communication between embedded RCG-N and the gateway. Use this SP to set up or display the customer proxy server address. The address is necessary to set up embedded RCG-N.</p> <p>Note: The address display is limited to 128 characters. Characters beyond the 128 character are ignored.</p> <p>This address is customer information and is not printed in the SMC report.</p>
5816 064	Proxy Port Number
	<p>This SP sets the port number of the proxy server used for communication between embedded RCG-N and the gateway. This setting is necessary to set up embedded RCG-N.</p> <p>Note: This port number is customer information and is not printed in the SMC report.</p>
5816 065	Proxy/User Name
	<p>This SP sets the HTTP proxy certification user name.</p> <p>Note:</p> <ul style="list-style-type: none"> ▪ The length of the name is limited to 31 characters. Any character beyond the 31st character is ignored. ▪ This name is customer information and is not printed in the SMC report.
5816 066	Proxy Password
	<p>This SP sets the HTTP proxy certification password.</p> <ul style="list-style-type: none"> ▪ The length of the name is limited to 31 characters. Any character beyond the 31st character is ignored.

Printer Engine Service Mode

	<ul style="list-style-type: none"> ▪ This name is customer information and is not printed in the SMC report. 	
5816 067	Cert: Up State	
	Displays the status of the certification update.	
	0	The certification used by embedded RCG is set correctly.
	1	The certification request (setAuthKey) for update has been received from the GW URL and certification is presently being updated.
	2	The certification update is completed and the GW URL is being notified of the successful update.
	3	The certification update failed, and the GW URL is being notified of the failed update.
	4	The period of the certification has expired and new request for an update is being sent to the GW URL.
	11	A rescue update for certification has been issued and a rescue certification setting is in progress for the rescue GW connection.
	12	The rescue certification setting is completed and the GW URL is being notified of the certification update request.
	13	The notification of the request for certification update has completed successfully, and the system is waiting for the certification update request from the rescue GW URL.
	14	The notification of the certification request has been received from the rescue GW controller, and the certification is being stored.
	15	The certification has been stored, and the GW URL is being notified of the successful completion of this event.
	16	The storing of the certification has failed, and the GW URL is being notified of the failure of this event.

	17	The certification update request has been received from the GW URL, the GW URL was notified of the results of the update after it was completed, but an certification error has been received, and the rescue certification is being recorded.
	18	The rescue certification of No. 17 has been recorded, and the GW URL is being notified of the failure of the certification update.
5816 068	CERT:Error	
	Displays a number code that describes the reason for the request for update of the certification.	
	0	Normal. There is no request for certification update in progress.
	1	Request for certification update in progress. The current certification has expired.
	2	An SSL error notification has been issued. Issued after the certification has expired.
	3	Notification of shift from a common authentication to an individual certification.
	4	Notification of a common certification without ID2.
	5	Notification that no certification was issued.
	6	Notification that GW URL does not exist.
5816 069	CERT Up ID	The ID of the request for certification.
5816 083	Firm Up Status	Displays the status of the firmware update.
5816 084	Non-HDD Firm Up	This setting determines if the firmware can be updated, even without the HDD installed. 0: Not allowed update 1: Allowed update

Service Tables

Printer Engine Service Mode

5816 085	Firm Up User Che(ck)	This SP setting determines if the operator can confirm the previous version of the firmware before the firmware update execution. If the option to confirm the previous version is selected, a notification is sent to the system manager and the firmware update is done with the firmware files from the URL.
5816 086	Firmware Size	Allows the service technician to confirm the size of the firmware data files during the firmware update execution.
5816 087	CERT: Macro Ver.	Displays the macro version of the @Remote certification.
5816 088	CERT: PAC Ver.	Displays the PAC version of the @Remote certification.
5816 089	CERT: ID2Code	Displays ID2 for the @Remote certification. Spaces are displayed as underscores (_). Asterisks (***) indicate that no @Remote certification exists.
5816 090	CERT: Subject	Displays the common name of the @Remote certification subject. CN = the following 17 bytes. Spaces are displayed as underscores (_). Asterisks (***) indicate that no DESS exists.
5816 091	CERT: SerialNo.	Displays serial number for the @Remote certification. Asterisks (***) indicate that no DESS exists.
5816 092	CERT: Issuer	Displays the common name of the issuer of the @Remote certification. CN = the following 30 bytes. Asterisks (***) indicate that no DESS exists.

5816 093	CERT: Valid Start	Displays the start time of the period for which the current @Remote certification is enabled.
5816 094	CERT: Valid End	Displays the end time of the period for which the current @Remote certification is enabled.
5816 200	Manual Polling	
	Executes manual polling. Cumin periodically polls the @Remote Gateway by HTTPS. This is called "center polling". Use this SP at any time to poll the @Remote supply center.	
5816 201	Regist Status	
	<p>Displays a number that indicates the status of the @Remote service device.</p> <p>0: Neither the registered device by the embedded RCG nor embedded RCG device is set.</p> <p>1: The embedded RCG device is being set. Only Box registration is completed. In this status the external RCG unit cannot answer a polling request.</p> <p>2: The embedded RCG device is set. In this status the external RCG unit cannot answer a polling request.</p> <p>3: The registered device by the embedded RCG is being set. In this status the embedded RCG device cannot be set.</p> <p>4: The registered module by the embedded RCG has not started.</p>	
5816 202	Letter Number	Allows entry of the number of the request needed for the embedded RCG device.
5816 203	Confirm Execute	Executes the inquiry request to the @Remote GateWay URL.

Printer Engine Service Mode

5816 204	Confirm Result	
	<p>Displays a number that indicates the result of the inquiry executed with SP5816 203.</p> <p>0: Succeeded 1: Inquiry number error 2: Registration in progress 3: Proxy error (proxy enabled) 4: Proxy error (proxy disabled) 5: Proxy error (Illegal user name or password) 6: Communication error 7: Certification update error 8: Other error 9: Inquiry executing</p>	
5816 205	Confirm Place	
	<p>Displays the result of the notification sent to the device from the GW URL in answer to the inquiry request. Displayed only when the result is registered at the GW URL.</p>	
5816 206	Register Execute	Executes Embedded RCG Registration.
5816 207	Register Result	
	<p>Displays a number that indicates the registration result.</p> <p>0: Succeeded 2: Registration in progress 3: Proxy error (proxy enabled) 4: Proxy error (proxy disabled) 5: Proxy error (Illegal user name or password) 6: Communication error 7: Certification update error 8: Other error 9: Registration executing</p>	

5816 208	Error Code		
	Displays a number that describes the error code that was issued when either SP5816-204 or SP5816-207 was executed.		
	Cause	Code	Meaning
	Illegal Modem Parameter	-11001	Chat parameter error
		-11002	Chat execution error
		-11003	Unexpected error
	Operation Error, Incorrect Setting	-12002	Inquiry, registration attempted without acquiring device status.
		-12003	Attempted registration without execution of an inquiry and no previous registration.
		-12004	Attempted setting with illegal entries for certification and ID2.
	Error Caused by Response from GW URL	-2385	Attempted dial up overseas without the correct international prefix for the telephone number.
		-2387	Not supported at the Service Center
		-2389	Database out of service
		-2390	Program out of service
		-2391	Two registrations for same device
		-2392	Parameter error
-2393		External RCG not managed	
-2394	Device not managed		

Service Tables

CÓPIA NÃO CONTROLADA

Printer Engine Service Mode

		-2395	Box ID for External RCG is illegal
		-2396	Device ID for External RCG is illegal
		-2397	Incorrect ID2 format
		-2398	Incorrect request number format
5816 209	Instl Clear	Releases the machine from its embedded RCG setup.	
5816 250	Comm Log Print	Prints the communication log.	

Note: The proxy number, user name, and password comprise proprietary customer information required by the service technician to do the necessary settings for Cumin-N. To prevent unauthorized access this information, these SP settings do not appear in the SMC report.

5821	Remote Service A(ddress)	
5821 1	CSS-PI Device Co(de)	Sets the PI device code. After changing this setting, you must switch the machine off and on.
5821 2	RCG IP Address	Sets the IP address of the RCG (Remote Communication Gate) destination for call processing at the remote service center. [00000000h to FFFFFFFFh/00000000h/

5823	Paper Supply for DFU	
	An @Remote setting. Not required for service technician.	

5824	NVRAMUpload	
	Uploads the UP and SP mode data (except for counters and the serial number) from NVRAM on the control board to a flash memory card. While using this SP mode, always keep the front cover open. This prevents a software module accessing the NVRAM during the upload.	

5825	NVRAMDownload	
	Downloads the content of a flash memory card to the NVRAM on the control board.	

5828	Network	
	This machine supports both Internet Protocols IPv4 and IPv6. IPv6 is the next generation protocol designed by the IETF to replace IPV4. IPv6 adds many improvements such as routing and network auto-configuration.	

5828 022	ActIPv4 SbNet	This SP allows you to confirm the IPv4 subnet mask setting that was used when the machine started up with DHCP. For example, if the setting for the IPv4 subnet mask is "FFFFFF00H" this is displayed as "255.255.255.000"
----------	---------------	--

5828 023	ActIPv4Gatew	This SP allows you to confirm the IPv4 default gateway setting that was used when the machine started up with DHCP. For example, if the setting for the IPv4 gateway is "0C0A80001h" this is displayed as "192.168.000.001".
----------	--------------	--

5828 045	Bi Direct Centro	Enables and disables the Centro communication. [0to1/1] 0:Off, 1: On
----------	------------------	--

Service Tables

CÓPIA NÃO CONTROLADA

Printer Engine Service Mode

5828 050	1284 Compatible	Enables and disables bi-directional communication on the parallel connection between the machine and a computer. [0to1/1] 0:Off, 1: On
5828 052	ECP	Disables and enables the ECP feature (1284 Mode) for data transfer. [0to1/1] 0: Disabled 1: Enabled
5828 065	Job Spool	Switches job spooling spooling on and off. 0: No spooling , 1: Spooling enabled
5828 066	HD job Clear	This SP determines whether the job interrupted at power off is resumed at the next power on. This SP operates only when SP5828 065 is set to 1. 1: OFF (Resumes printing spooled jog.) 0: ON (Clears spooled job.)
5828 069	JobSpool Protocl	
		This SP determines whether job spooling is enabled or disabled for each protocol. This is a 8-bit setting. 0: LPR/ 1: FTP (Not Used)/ 2: IPP/ 3: SMB/ 4: BMLinks (Japan Only)/ 5: DIPRINT/ 6: Reserved (Not Used)/ 7: Reserved (Not Used)
5828 090	TELNET	Disables or enables Telnet operation. If this SP is disabled, the Telnet port is closed. [0to1/1] 0: Disable 1: Enable

5828 091	Web	Disables or enables the Web operation. [0to1/1] 0: Disable 1: Enable
5828 145	ActIPv6LinkLocal	This is the IPv6 local address referenced on the Ethernet or wireless LAN (802.11b) in the format: "Link-Local address" + "Prefix Length" The IPv6 address consists of a total 128 bits configured in 8 blocks of 16 bits each. These notations can be abbreviated. See "Note: IPV6 Addresses " below this table.
5828 147	ActIPv6Sttles1	These SPs are the IPv6 stateless addresses (1 to 5) referenced on the Ethernet or wireless LAN (802.11b) in the format: "Stateless Address" + "Prefix Length" The IPv6 address consists of a total 128 bits configured in 8 blocks of 16 bits each.
5828 149	ActIPv6Sttles2	
5828 151	ActIPv6Sttles3	
5828 153	ActIPv6Sttles4	
5828 155	ActIPv6Sttles5	
5828 156	IPv6Manual Address	This SP is the IPv6 manually set address referenced on the Ethernet or wireless LAN (802.11b) in the format: "Manual Set Address" + "Prefix Length" The IPv6 address consists of a total 128 bits configured in 8 blocks of 16 bits each. These notations can be abbreviated. See "Note: IPV6 Addresses" below this table.
5828 158	IPv6 Gateway	This SP is the IPv6 gateway address referenced on the Ethernet or wireless LAN (802.11b). The IPv6 address consists of a total 128 bits configured in 8 blocks of 16 bits each. These notations can be abbreviated. See "Note: IPV6 Addresses " below this table.

Service Tables

Printer Engine Service Mode

5828 161	IPv6 Stateless Auto	Enables or disables the IPv6 Stateless Auto setting on the Ethernet or wireless LAN (802.11b). 0: Off, 1: On
----------	---------------------	---

Note: IPV6 Addresses

Ethernet and the Wireless LAN (802.11b) reference the IPV6 "Link-Local address + Prefix Length". The IPV6 address consists of 128 bits divided into 8 blocks of 16 bits:

aaaa:bbbb:cccc:dddd:eeee:ffff:gggg:hhhh:

The prefix length is inserted at the 17th byte (Prefix Range: 0x0to0x80). The initial setting is 0x40(64).

For example, the data:

2001123456789012abcdef012345678940h

is expressed:

2001:1234:5678:9012:abcd:ef01:2345:6789: prefixlen 64

However, the actual IPV6 address display is abbreviated according to the following rules.

Rules for Abbreviating IPV6 Addresses

1. The IPV6 address is expressed in hexadecimal delimited by colons (:) with the following characters:
0123456789abcdefABCDEF
2. A colon is inserted as a delimiter every 4th hexadecimal character.
fe80:0000:0000:0000:0207:40ff:0000:340e
3. The notations can be abbreviated by eliminating zeros where the MSB and digits following the MSB are zero. The example in "2" above, then, becomes:
fe80:0:0:0207:40ff:0:340e
4. Sections where only zeros exist can be abbreviated with double colons (::). This abbreviation can be done also where succeeding sections contain only zeros (but this can be done only at one point in the address). The example in "2" and "3" above then becomes: fe80::207:40ff:0:340e (only the first null sets zero digits are abbreviated as "::")
-or-
fe80:0:0:0:207:40ff::340e (only the last null set before "340e" is abbreviated as "::")

5832	HDD Init.
	Initializes the hard disk and clears all data. Use this only if there is a hard disk error.

5837	Prog Checksum
	Displays the checksum for the engine firmware.

5840	IEEE 802.11b
5840 006	Channel Max
	Sets the maximum range of the bandwidth for the wireless LAN. This bandwidth setting varies for different countries. [1 to 11(NA) or 13 (EU)/ 11 (NA) or 13 (EU)]
5840 007	Channel Min
	Sets the minimum range of the bandwidth for operation of the wireless LAN. This bandwidth setting varies for different countries. [1 to 11(NA) or 13 (EU)/ 1 (NA) or 1 (EU)]
5840 011	WEP key number
	Determines how the initiator (SBP-2) handles subsequent login requests. [00 to 11/00/1] Note: There are four settings (binary numbers): 00, 01, 10, 11. These settings are possible only after the wireless LAN card has been installed. 00: 1st key. If the initiator receives another login request while logging in, the request is refused. 01, 10, 11: 2nd, 3rd, 4th keys are "Reserved".

Service
Tables

Printer Engine Service Mode

5842	NFA analysis DFU	Netfile Analysis	
	This is a debugging tool. It sets the debugging output mode of each Net File process. Bit SW 0011 1111	Bit	Groups
		0	System & other groups (LSB)
		1	Capture related
		2	Certification related
		3	Address book related
		4	Machine management related
		5	Output related (printing, delivery)
		6	Repository related

5844	USB
001	Transfer Rate
	Sets the speed for USB data transmission. [Full Speed or Auto Change]
002	Vendor ID
	Sets the vendor ID: Initial Setting: 0x05A Ricoh Company [0x0000 to 0xFFFF/1] (DFU)
003	Product ID
	Sets the product ID. [0x0000 to 0xFFFF/1] (DFU)

004	Device Release No.
	<p>Sets the device release number of the BCD (binary coded decimal) display. [0000 to 9999/1] (DFU)</p> <p>Enter as a decimal number. NCS converts the number to hexadecimal number recognized as the BCD.</p>

5845	Delivery Srv		
	Provides items for delivery server settings.		
5845 003	<table border="1"> <tr> <td>Retry Interval</td> <td> <p>Determines the time interval between retries before the machine returns to standby after an error occurs during an image transfer with the delivery scanner or SMTP server. [60 to 900/300/1]</p> </td> </tr> </table>	Retry Interval	<p>Determines the time interval between retries before the machine returns to standby after an error occurs during an image transfer with the delivery scanner or SMTP server. [60 to 900/300/1]</p>
Retry Interval	<p>Determines the time interval between retries before the machine returns to standby after an error occurs during an image transfer with the delivery scanner or SMTP server. [60 to 900/300/1]</p>		
5845 004	<table border="1"> <tr> <td>No. of Retries</td> <td> <p>Determines the number of retries before the machine returns to standby after an error occurs during an image transfer with the delivery or SMTP server. [0 to 99/3/1]</p> </td> </tr> </table>	No. of Retries	<p>Determines the number of retries before the machine returns to standby after an error occurs during an image transfer with the delivery or SMTP server. [0 to 99/3/1]</p>
No. of Retries	<p>Determines the number of retries before the machine returns to standby after an error occurs during an image transfer with the delivery or SMTP server. [0 to 99/3/1]</p>		
5845 022	InstantTrans Off		
	<p>Switches instant transmission off/on. [0 to 1/1/1]</p> <p>0: Off. Instant transmission not possible with network setting errors. 1: On. Instant transmission possible with network setting errors.</p> <p>Note:</p> <ul style="list-style-type: none"> ▪ The machine will continue to transmit over the network, even if the network settings are incorrect. (This causes multiple errors, of course.) ▪ With this SP off, the machine will stop communicating with the network if the settings are wrong. This reduces the amount of spurious network traffic caused by errors due to incorrect settings. 		

Service Tables

Printer Engine Service Mode

5846	UCS Setting
5846 043	<p>AddB Media</p> <p>Displays the location of the address book currently in use.</p> <p>0: Not specified 1: SD Card Slot 1 2: SD Card Slot 2 20: HDD 30: None</p>
5846 047	<p>Init Local Add B</p> <p>Clears all of the address information from the local address book of a machine managed with UCS.</p>
5846 050	<p>Init All Dir</p> <p>Clears everything (including users codes) in the directory information managed by UCS. However, the accounts and passwords of the system administrators are not deleted.</p>

5846 060	Search Option	
	This SP uses bit switches to set up the fuzzy search options for the UCS local address book.	
	Bit	Meaning
	0	Checks both upper/lower case characters
	1	Japan Only
	2	
	3	
	4	--- Not Used ---
	5	--- Not Used ---
	6	--- Not Used ---
7	--- Not Used ---	
5846 062	Complexity Opt1	
	<p>Use this SP to set the conditions for password entry to access the local address book. Specifically, this SP limits the password entry to upper case and sets the length of the password. [0 to 32/0]</p> <p>Note:</p> <ul style="list-style-type: none"> ▪ This SP does not normally require adjustment. ▪ This SP is enabled only after the system administrator has set up a group password policy to control access to the address book. 	

Service Tables

Printer Engine Service Mode

5846 063	<p>Complexity Opt 2</p> <p>Use this SP to set the conditions for password entry to access the local address book. Specifically, this SP limits the password entry to lower case and defines the length of the password. [0 to 32/0]</p> <p>Note:</p> <ul style="list-style-type: none"> ▪ This SP does not normally require adjustment. ▪ This SP is enabled only after the system administrator has set up a group password policy to control access to the address book.
5846 064	<p>Complexity Opt 3</p> <p>Use this SP to set the conditions for password entry to access the local address book. Specifically, this SP limits the password entry to numbers and defines the length of the password. [0 to 32/0]</p> <p>Note: This SP does not normally require adjustment. It is enabled only after the system administrator has set up a group password policy to control access to the address book.</p>
5846 065	<p>Complexity Opt 4</p> <p>Use this SP to set the conditions for password entry to access the local address book. Specifically, this SP limits the password entry to symbols and defines the length of the password. [0to32/0]</p> <p>Note: This SP does not normally require adjustment. It is enabled only after the system administrator has set up a group password policy to control access to the address book.</p>

5848	WebService		
5848 004	ac:ud	Switches access control on and off. 0000: OFF, 0001: ON	
5848 009	ac:jc		
5848 011	ac:dm		
5848 210	Log Type:Job 1 DFU		
	[0 to 0xFFFFFFFF/0/1]	Note: These SP codes are for display only; they cannot be changed.	
5848 211	Log Type:Job 2 DFU		
	[0 to 0xFFFFFFFF/0/1]		
5848 212	Log Type Access DFU		
	[0 to 0xFFFFFFFF/0/1]		
5848 213	PrimarySrv DFU		
5848 214	Secondary Srv DFU		
5848 215	StartTime DFU		
	[0 to 0xFFFFFFFF/0/1]		
5848 216	IntervalTime DFU		
	[1 to 100/1/1]		
5848 217	Timing DFU		
	[0 to 2/0/1]		
	0: Transmission off 1: Transmission 1 by 1 2: Periodic transmission		

Service Tables

CÓPIA NÃO CONTROLADA

Printer Engine Service Mode

5849	Installation Date	
	Displays or prints the installation date of the machine.	
5849 002	Switch to Print	Determines whether the installation date is printed on the printout for the total counter. [0 to 1/1] 0: OFF (No Print) 1: ON (Print)
5849 003	Total Counter	Displays the total counter of the machine installation's day.

5856	Remote Update	
	Allow ROM Update from Remote Source	
	When set to "1" allows reception of firmware data via the local port (IEEE 1284) during a remote ROM update. This setting is reset to zero after the machine is cycled off and on. [0to1 / 0 / 1] 0: Not allowed 1: Allowed	

5857	Save Debug Log	
5857 001	On/Off	
	Switches on the debug log feature. The debug log cannot be captured until this feature is switched on. [0 to 1/0] 0: OFF 1: ON	
5857 006	Save to SD	
	Saves the debug log of the input SC number in memory to SD card.	

5857 012	Erase SD Log	
	Erases all debug logs on the SD Card. If the card contains only debugging files generated by an event specified by SP5858, the files are erased when SP5857 010 or 011 is executed. To enable this SP, the machine must be cycled off and on.	
5857 013	FreeSpaceonSD	
	Displays the amount of space available on the SD card.	
5857 014	SD to SD (4MB)	
	Copies the last 4MB of the log (written directly to the card from shared memory) onto an SD card.	
5857 015	SD to SD (Any)	
	This SP copies the log on an SD card (the file that contains the information written directly from shared memory) to a log specified by key number.	
5857 017	Make SD LogFile	
	This SP creates a 4 MB file to store a log on an SD card.	

5858	Debug Save When	
	These SPs select the content of the debugging information to be saved to the destination. Refer to Section 4 for a list of SC error codes.	
5858 001	EngineSC Error	Stores SC codes generated by copier engine errors.
5858 002	SystemSC Error	Stores SC codes generated by GW controller errors.
5858 003	Any SC Error	[0 to 65535/0/1]
5858 004	Jam	Stores jam errors.

Service Tables

CÓPIA NÃO CONTROLADA

Printer Engine Service Mode

5859	LogSaveKey No.	
5859 001	Key 1	<p>These SPs allow you to set up to 10 keys for log files for functions that use common memory on the controller board. [-9999999 to 9999999/0/1]</p>
5859 002	Key 2	
5859 003	Key 3	
5859 004	Key 4	
5859 005	Key 5	
5859 006	Key 6	
5859 007	Key 7	
5859 008	Key 8	
5859 009	Key 9	
5859 010	Key 10	

5860	SMTP/POP3/IMAP	
5860 002	SMTP SW Port No.	Input the SMTP server port number
5860 003	SMTP Auth Encryp	<p>SMTP authentication enable/disable. [0-1/0/2] 0: Disable 1: Enable</p>
5860 006	SMTP Auth encryp	<p>Encryption mode for SMTP authentication enable/disable (Only valid if 5860 3 is set to "enable") [0-2/0/1] 0: Automatic 1: No encryption 2: Encrypt</p>

5860 007	POP Before SMTP	Enable/disable POP before SMTP. If the SMTP server does not have authentication, you can enable POP before SMTP, then POP authentication is available (SP 5860 13) [0-1/0/1] 0: Disable 1: Enable
5860 008	POP to SMTP Wait	When using POP before SMTP, this SP mode determines the maximum wait time between POP authentication and connection with SMTP. Communication stops if this time is exceeded. [0-3000/300]
5860 009	Rcv Protocol	This SP specifies POP3 protocol or switches off receiving. 1: POP3 2: IMAP4 3: SMTP
5860 013	POP Auth Encrypt	If POP before SMTP is enabled, then you can use this SP to enable or disable encryption mode for POP authentication. [0-2/0/1] 0: Automatic 1: No encryption 2: Encrypt
5860 014	POP Srv Port No.	Input the POP server port number
5860 015	IMAP Srv Port No	This SP sets the number of the IMAP4 server port. [1 to 65535/143/1]
5860 016	SMTP Rcv Port No	This SP sets the number of the port that receives SMTP mail. [1 to 65535/25/1]

CÓPIA NÃO CONTROLADA

Printer Engine Service Mode

5860 017	Receive Interval	<p>This SP sets the timing for mail received at regular intervals. [2 to 1440/3/1 min.]</p> <p>Note: Setting this SP to "0" switches off receiving mail at timed intervals.</p>
5860 019	Mail Keep Sett.	<p>This SP setting determines whether received mail is stored on the server.</p> <p>0: Received mail not stored 1: All received mail stored 2: Stores only mail that generated errors during receiving</p>
5860 020	ParMail RectOut	
	<p>[1 to 168/72/1]</p> <p>Sets the amount of time to wait before saving a mail that breaks up during reception. The received mail is discarded if the remaining portion of the mail is not received during this prescribed time.</p>	
5860 021	MDN Res RFC2298	
	<p>Determines whether RFC2298 compliance is switched on for MDN reply mail. [0 to 1/1]</p> <p>0: No 1: Yes</p>	
5860 022	SMTPAut FieldRep	
	<p>Determines whether the FROM item of the mail header is switched to the validated account after the SMTP server is validated. [0 to 1/0]</p> <p>0: No. "From" item not switched. 1: Yes. "From" item switched.</p>	

5860 025	SMTP Auth Direct	
	<p>Occasionally, all SMTP certifications may fail with SP5860 006 set to "2" to enable encryption during SMTP certification for the SMTP server. This can occur if the SMTP server does not meet RFC standards. In such cases you can use this SP to set the SMTP certification method directly. However, this SP can be used only after SP5860 003 has been set to "1" (On).</p> <p>Bit0: LOGIN Bit1: PLAIN Bit2: CRAM_MD5 Bit3: DIGEST_MD5 Bit4 to Bit 7: Not Used</p>	

5866	E-Mail Report	
	This SP controls operation of the email notification function.	
5866 001	E-Mail Validity	Disables and re-enables the email notification feature. [0to1/0/1] 0: Enable 1: Disable
5866 005	ForceDateField	Disables and re-enables the addition of a date field to the email notification. [0to1/0/1]

5869	RAM Disk Setting	
5869 001	This SP enables and disables email sending and receiving. This setting determines the size of the RAM disk (MB) that the machine uses to manage email sending and receiving. [0 to 1/0/1] 0: Use. Allocates 46 MB for sending and 8 MB for receiving. 1: Do not use	

Service Tables

Printer Engine Service Mode

5869 002	Adjusts the RAM Disk size for the PDL storage. [0 to 255 / 4 / 1]
----------	--

5870	Common KeyInfo W(riting)	
	Writes to flash ROM the common proof for validating the device for @Remote specifications. Note: <ul style="list-style-type: none"> ▪ These SP settings are required to connect @Remote or must also be set after the board is replaced. ▪ Even if @Remote is not connected, these settings are used for Web validation, so at least SP5870 003 must be enabled. 	
5870 001	Writing	Writes the authentication data (used for NRS) in the memory.
5870 003	Initialize	Initializes the authentication data in the memory.

5873	SDCardAppliMove	
	Allows you to move applications from one SD card another. For more, please refer to the "SD Card Application Move" section.	
5873 001	MoveExec	Executes the move from one SD card to another.
5873 002	UndoExec	This is an undo function. It cancels the previous execution.

5878	Option Setup	Data Overwrite Security (DOS) Setup
	Press [#Enter] to initialize the Data Overwrite Security option.	

5886	ROM update	
	The setting of this SP allows or prohibits updating the ROM. 0:Yes, 1:No	

5887	SD GetCounter
	This SP outputs a text file (.txt) that lists the counts for the application SD card inserted into the SD service slot. Before executing this SP, you must first create a folder entitled "SD_COUNTER" in the root directory of the SD card.

5902	Test Print
	Prints the test pattern that you selected with SP 5902-003.
5902 001	1 Sheet Test
	Prints one test pattern
5902 002	Cont Test
	Prints consecutive copies of the test pattern
5902 003	Test Pattern
	Selects a printer test pattern. Use SP 5902 to print either one test pattern (5902-1) or more than one pattern. (5902-2).
	Pattern:
	0: Not Specified
	1: Vertical Line (1dot)
	2: Vertical Line (2dot)
	3: Horizontal (1dot)
	4: Horizontal (2dot)
	5: Grid pattern Small
	6: Grid pattern Large

Service Tables

Printer Engine Service Mode

	7: Argyle Pattern Small
	8: Argyle Pattern Large
	9: Trimming Area
	10: Horizontal Stitch
	11: Checker Flag

	Plug / Play
5907	<p>Sets the brand name and the production name for Windows Plug & Play. This information is stored in NVRAM. If the NVRAM is defective or has been replaced, these names should be registered again.</p> <p>To set the plug and play model name, enter the model number, and then press [#Enter].</p>

5930	Meter Charge
5930 001	<p>Meter Charge</p> <p>Switches the meter-click charge mode on and off. [No], [Yes]</p> <p>Important: Turn the main switch off/on after changing this setting.</p> <p>No: Meter charge mode disabled (default). This setting is for machines where the operator is responsible for replacing the AIO and the Maintenance Kit.</p> <ul style="list-style-type: none"> ▪ Alert messages are displayed on the operation panel when the AIO or PM parts reach the limit of their yield. ▪ The PM counter resets automatically after the user replaces the fusing unit. <p>Yes: Meter charge mode enabled. This setting is for machines where the service technician has responsibility for servicing the machine.</p> <ul style="list-style-type: none"> ▪ Alert messages are not displayed when the AIO or PM parts reach the limits of their yield. ▪ Pressing the [Menu] button displays the meter charge count. ▪ The service technician must reset the PM counter after completing machine maintenance.
5930 002	<p>M C Display</p> <p>Switches the PM alerts on and off. [No], [Yes]</p> <p>No: Maintenance Kit alerts will not display. Yes: Maintenance Kit alerts will display.</p> <p>Important:</p> <ul style="list-style-type: none"> ▪ The setting of SP5930 002 is ignored unless SP5930 001 is set to "Yes". ▪ In order for the PM alerts to display both SP5930 001 and SP5930 002 must be set to "Yes".

Service Tables

Printer Engine Service Mode

5930 003	Pcon. Life Alert
	<p>This SP switches the near-end and end alerts on/off for the service life of the OPC (not toner), based on the accumulated operation time of the main motor.</p> <p>Note: "Pcon" (photoconductor) means OPC drum.</p> <p>[No], [Yes]</p> <p>No: Near-end and end alerts will not display.</p> <p>Yes: Near-end and end alerts will display.</p> <p>Important:</p> <ul style="list-style-type: none"> ▪ The setting of SP5930 003 is ignored unless SP5930 001 is set to "Yes". ▪ In order for the OPC alerts to display (near-end, end of service life) for the AIO, both SP5930 001 and SP5930 003 must be set to "Yes".

5990	SP Print Mode	
5990 001	All (Data List)	Prints the summary sheet for the item selected.
5990 002	SP (Mode Data Li(st)	
5990 004	Logging Data	
5990 005	Diagnostic Repor(t)	
5990 006	Non-Default	
5990 007	NIB Summary	

SP7-xxx: Data Log

7001	Operation Time	
	Displays the total number of engine rotation cycles made so far. Note: <ul style="list-style-type: none"> ▪ One cycle is calculated as 2.4 sec. of drum rotation. ▪ However, this counter also includes idle rotations. ▪ This counter is not reset at PM. 	

7401	SC Counter	Displays the total number of service calls that have occurred. Display range: 0000 to 9999
-------------	------------	---

7403	Latest10SCLog	
7403 001	Latest	Displays the most recent service calls successive groups of 10.
7403 002	Latest 1	
7403 003	Latest 2	
7403 004	Latest 3	
7403 005	Latest 4	
7403 006	Latest 5	
7403 007	Latest 6	
7403 008	Latest 7	
7403 009	Latest 8	
7403 010	Latest 9	

7502	Total Jam	Displays the total number of jams. Display range: 0000 to 9999
-------------	-----------	---

Service Tables

Printer Engine Service Mode

7504	Jam Location	
	<p>Displays the total number of jams by location. A "Paper Late" error occurs when the paper fails to activate the sensor at the precise time. A "Paper Lag" paper jam occurs when the paper remains at the sensor for longer than the prescribed time. Display range: 0000 to 9999</p>	
	Error No.	Error
	1	At Power On
	17	Off-1 VerticalSN
	18	Off-2 VerticalSN
	19	Off-RegistBypass
	20	Off-Regist Tray1
	21	Off-Regist Tray2
	22	Off-Regist Tray3
	23	Off-RegistDuplex
	24	On-Regist SN
	25	Off-Exit SN
	32	On-Exit SN
	49	Off-Duplx Exit
	50	On- Duplx Exit
	51	Off-Dup Inverter
	52	On- Dup Inverter
	53	Off-Duplex Exit
	54	On- Duplex Exit

7506	Paper Size	
7506 006	A5 LEF	Displays the total number of jams by paper size
7506 044	HLT LEF	
7506 133	A4 SEF	
7506 134	A5 SEF	
7506 142	B5 SEF	
7506 164	LG SEF	
7506 166	LT SEF	
7506 172	HLT SEF	
7506 255	Others	

Printer Engine Service Mode

7507	Jam History	
	<p>Displays the copy jam history in groups of 10, starting with the most recent 10 jams. Display contents are as follows:</p> <p>CODE is the SP7-504-nnn number.</p> <p>SIZE is the ASAP paper size (hexadecimal).</p> <p>TOTAL is the total jam error count (SP7-003)</p> <p>DATE is the date the jams occurred.</p>	
7507 001	Latest	<p>Sample Display:</p> <p>CODE: 007</p> <p>TOTAL: 0000334</p>
7507 002	Latest 1	
7507 003	Latest 2	
7507 004	Latest 3	
7507 005	Latest 4	
7507 006	Latest 5	
7507 007	Latest 6	
7507 008	Latest 7	
7507 009	Latest 8	
7507 010	Latest 9	

Paper Size	Code (hex)	Paper Size	Code (hex)
A4 LEF	05	B4 SEF	8D
A5 LEF	06	B5 SEF	8E
B5 LEF	0E	DLT SEF	A0
LT LEF	26	LG SEF	A4
HLT LEF	2C	LT SEF	A6
A3 SEF	84	HLT SEF	AC
A4 SEF	85	Others	FF
A5 SEF	86		

7803	PM Counter
	Displays the PM counter. This is not a page counter. It estimates the page count using the engine rotation cycle count. It counts up one page when the engine has made the average number of rotations that is required for one page of a three-page job.
7803 001	Paper
7803 002	Transfer Rol(ler)
7803 003	Paper Feed Rol(ler)
7803 004	Fusing Unit

Printer Engine Service Mode

7804	PM Counter Reset
	Resets the PM counter. To reset, press [#Enter].
7804 001	Paper
7804 002	Transfer Rol(ler)
7804 003	Paper Feed Rol(ler)
7804 004	Fusing Unit

7807	SC/Jam Clear
	Resets the SC and jam counters. To reset, press [#Enter]. Note: This SP does not reset the jam history counter: SP7-507

7832	DiagResult
	Press [#Enter] to display a list of error codes. Nothing is displayed if no errors have occurred.

7836	TotalMemorySize
	Displays the memory capacity of the controller system.

7901	Assert Info	
7901 001	File Name	Records the location where a problem is detected in the program. The data stored in this SP is used for problem analysis.
7901 002	# of Lines	
7901 003	Location	

7910	ROM No.	
7910 001	System	
7910 002	Engine	
7910 013	Duplex	
7910 018	NIB	
7910 132	Netware Opt.	
7910 150	RPCS	
7910 151	PS	
7910 158	PCL	
7910 159	PCLXL	
7910 180	FONT	
7910 181	FONT1	
7910 182	FONT2	
7910 183	FONT3	
7910 200	Factory	
7910 202	Net File	
7910 204	Printer	
7910 209	Test Suite	
7910 210	MIB	
7910 211	Web System	
7910 213	SDK1	
7910 214	SDK2	
7910 215	SDK3	

CÓPIA NÃO CONTROLADA

Printer Engine Service Mode

7911	Firmware Ver.	
7910 001	System	
7910 002	Engine	
7910 013	Duplex	
7910 018	NIB	
7910 132	Netware Opt.	
7910 150	RPCS	
7910 151	PS	
7910 158	PCL	
7910 159	PCLXL	
7910 180	FONT	
7910 181	FONT1	
7910 182	FONT2	
7910 183	FONT3	
7910 200	Factory	
7910 202	Net File	
7910 204	Printer	
7910 209	Test Suite	
7910 210	MIB	
7910 211	WebSystem	
7910 213	SDK1	
7910 214	SDK2	
7910 215	SDK3	

7931	Cartridge info	
	<p>Displays information about the cartridge.</p> <ul style="list-style-type: none"> ▪ Returns a value of "0" if the number stored in the cartridge is not recognized. ▪ This is information on the AIO ID Chip so if the cartridge is not installed, if the AIO is not set properly, or if the front door is open, no value will be displayed because the machine cannot communicate with the AIO. 	
7931 001	Machine ID	Identification number of the machine (Model Name)
7931 002	Version	Cartridge version number
7931 003	Brand ID	Displays the OEM brand 1: Ricoh
7931 004	Area ID	Displays the area ID 1: DOM (Japan 2: NA (North America) 3: EU (Europe) 4: Asia
7931 005	Kind ID	Displays the part code number 1: 6K 3: 15K
7931 006	Color ID	Displays "1" for the color of the toner (Black), this is the only setting for this machine.
7931 007	Maintenance ID	Displays the maintenance ID 1: Printer (no maintenance contract) 3: Accessories
7931 008	New AIO	Displays the conditions of AIO 0: Normal 64: New AIO

CÓPIA NÃO CONTROLADA

Printer Engine Service Mode

7931 009	Recycle Count	0 to 3
7931 010	EDP Code	Displays the toner order code, the code is a string of ASCII characters.
7931 011	Serial No	Displays an ASCII string that identifies the manufacturer Note: <ul style="list-style-type: none"> ▪ This data is originally entered as BCD and changes into a 16-character string in order to convert it to ASCII. ▪ However, only 10 bytes can be used to communicate with the controller, so the 16 bytes are truncated to 10 bytes.
7931 012	Remaining Toner	Displays "0" to "100" (the percentage of toner remaining in the cartridge)
7931 013	Toner End	N: Toner near end E: Toner end
7931 014	Refill Flag	Displays "RF" when the cartridge requires refilling
7931 015	R:Total Counter	Displays a number in the range "0" to "99999999", this is the total count at time of installation.
7931 016	E:Total Counter	Displays a number in the range "0" to "99999999", this is the total count at toner end.
7931 017	Unit Counter	Displays a number in the range "0" to "99999999", this is the total number of pages output by the AIO unit. Counter adds once for each sheet output.

7931 018	Install Date	Displays Year-Month-Date of installation for the AIO unit, this setting updates automatically through a serial interface with the machine when the new unit is installed.
7931 019	Toner End Date	Displays Year-Month-Date when toner end occurred
7931 020	Conductor Time1	<p>Displays a number in the range "0" to "00000000", this is the count for OPC.</p> <p>Note:</p> <ul style="list-style-type: none"> ▪ This information resides at four locations (020, 021, 022, 023). The recycle count determines where the value is written. ▪ The counter increments by "1" for every 6 sec. of drum rotation time. ▪ To calculate the actual time in sec., multiply the displayed value by 6.
7931 021	Conductor Time2	
7931 022	Conductor Time3	
7931 023	Conductor Time4	

7932	CartRidge Life
	<p>Displays information about the cartridge service life.</p> <ul style="list-style-type: none"> ▪ Returns a value of "0" if the number stored in the cartridge is not recognized. ▪ This is information on the AIO ID Chip so if the cartridge is not installed, if the AIO is not set properly, or if the front door is open, no value will be displayed because the machine cannot communicate with the AIO.

Service Tables

Printer Engine Service Mode

7932 001	ConductorTime	The is the same information retrieved with SP7931 (see 7931 020to023 above), but the value displayed here calculated with the rotation time numbers of the EEPROM (sec.)														
7932 002	PreConductTime	<ul style="list-style-type: none"> ▪ Conductor Time. Rotation count of the OPC presently installed. ▪ PreConduct Time. Rotation count of the previous OPC. <p>Note:</p> <ul style="list-style-type: none"> ▪ The counter increments by "1" for every 6 sec. of drum rotation time. ▪ To calculate the actual time in sec., multiply the displayed value by 6. 														
7932 003	Cart Alert	Displays a 6-bit array that provides information about toner, used toner, and OPC service life of the cartridge presently installed in the machine. Note: "000000" indicates "Normal". A "1" indicates that a change has occurred for the in the alert status at one or more of the bit positions below.														
		<table border="1"> <thead> <tr> <th>Bit</th> <th>What It Means</th> </tr> </thead> <tbody> <tr> <td>0</td> <td>Toner near-end</td> </tr> <tr> <td>1</td> <td>Toner end</td> </tr> <tr> <td>2</td> <td>-</td> </tr> <tr> <td>3</td> <td>Used toner end</td> </tr> <tr> <td>4</td> <td>OPC service life near-end</td> </tr> <tr> <td>5</td> <td>OPC service life end</td> </tr> </tbody> </table>	Bit	What It Means	0	Toner near-end	1	Toner end	2	-	3	Used toner end	4	OPC service life near-end	5	OPC service life end
		Bit	What It Means													
		0	Toner near-end													
		1	Toner end													
		2	-													
		3	Used toner end													
		4	OPC service life near-end													
5	OPC service life end															

7932 04	Pre Cart Alert	<p>Displays a 6-bit array that provides information about toner, used toner, and OPC service life of the cartridge previously installed in the machine.</p> <p>Note: "000000" indicates "Normal". A "1" indicates that a change has occurred for the in the alert status at one or more of the bit positions below.</p>	
		Bit	What It Means
		0	Toner near-end
		1	Toner end
		2	-
		3	Used toner end
		4	OPC service life near-end
		5	OPC service life end
7932 005	VarietyID	<p>This is the same type of information read with SP7931 005 from the AIO ID Chip for the cartridge presently installed in the machine. However, this SP displays the value read from the EEPROM.</p> <p>1: 6K 3: 15K</p>	
7932 006	Pre VarietyID	<p>This is the same type of information read with SP7931 005 for the cartridge presently installed in the machine, but this SP displays the value read from the EEPROM for the previously installed cartridge.</p> <p>1: 6K 3: 15K</p>	

Printer Engine Service Mode

7932 007	RFConductTime	<p>This SP saves the rotation count (sec.) for the OPC when a re-filled cartridge is detected. When a re-filled cartridge is detected, the value for the OPC rotation count is copied from the AIO ID Chip and saved this SP.</p> <p>Note:</p> <ul style="list-style-type: none"> ▪ If the cartridge is not installed, if the AIO is not set properly, or if the front door is open, no value will be displayed because the machine cannot communicate with the AIO. ▪ The counter increments by "1" for every 6 sec. of drum rotation time. ▪ To calculate the actual time in sec., multiply the displayed value by 6.
7932 008	RemainingCart	<p>This SP displays the length of the service life that remains for the OPC.</p> <ul style="list-style-type: none"> ▪ The value is read from the AIO ID Chip. ▪ The number displayed indicates as a percentage the amount of time remaining for the OPC based on the number of drum rotations. ▪ If the cartridge is not installed, if the AIO is not set properly, or if the front door is open, no value will be displayed because the machine cannot communicate with the AIO. <p>Important Note: This SP reads only the engine information. This information is not sent to the controller.</p>

7993	Total counter
	Displays the engine total counter. It counts up for all prints, including service reports.

Printer Engine Service Mode

SP8XXX: Data Log 2

The SPs in this group are prefixed with a letter that indicates the mode of operation. The mode of operation is referred to as an 'application'. Before reading the Group 8 Service Tables, make sure that you understand what these prefixes mean.

Prefix	Application	What It Means
T:	Total	Grand total of the items counted for all applications (C, F, P, etc.).
P:	Print	Totals (pages, jobs, etc.) executed for each application when the job was not stored on the document server.
O:	Other	Other applications (external network applications, etc.). Refers to network applications such as Web Image Monitor. Utilities developed with the SDK (Software Development Kit) are also counted.

Group 8 SP codes are limited to 17 characters, forced by the necessity of displaying them on the small LCDs of printers and faxes that also use these SPs.

 Note

- All of the Group 8 SPs are reset with SP5 801 1 Memory All Clear.

8381	T:2-2-01	These SPs count the number of pages printed by the customer.
8384	P:2-2-01	The counter for the application used for storing the pages increments.
8387	O:2-2-01	[0 to 9999999/0/1]

- When the A3/DLT double count function is switched on with SP5104, 1 A3/DLT page is counted as 2.
- When several documents are merged for a print job, the number of pages stored are counted for the application that stored them.
- These counters are used primarily to calculate charges on use of the machine, so the following pages are not counted as printed pages:
- Blank pages in a duplex printing job.

- Reports printed to confirm counts.
- All reports done in the service mode (service summaries, engine maintenance reports, etc.)
- Test prints for machine image adjustment.
- Error notification reports.
- Partially printed pages as the result of a jam.

8391	T:2-2-02	Large Size Pages Printed
	These SPs count pages printed on paper sizes A3/DLT and larger. [0 to 9999999/0/1]	

8411	T:2-2-04	Total Duplex Pages Printed
	This SP counts the amount of paper (front/back counted as 1 page) used for duplex printing. Last pages printed only on one side are not counted. [0 to 9999999/0/1]	

8421	T:2-2-05	Total Simplex/Duplex Pages
	These SPs count by binding and combine, and n-Up settings the number of pages processed for printing. This is the total for all applications. [0 to 9999999/0/1]	

8424	P: 2-2-05	Total Simplex/Duplex Pages
	These SPs count by binding and combine, and n-Up settings the number of pages processed for printing by the printer application. [0 to 9999999/0/1]	

8427	O: 2-2-05	Total Simplex/Duplex Pages
	These SPs count by binding and combine, and n-Up settings the number of pages processed for printing by Other applications [0 to 9999999/0/1]	

842x 1	Simplex> Duplex	
--------	-----------------	--

Service Tables

CÓPIA NÃO CONTROLADA

Printer Engine Service Mode

842x 4	Simplex Combine	
842x 5	Duplex Combine	
842x 6	2>	2 pages on 1 side (2-Up)
842x 7	4>	4 pages on 1 side (4-Up)
842x 8	6>	6 pages on 1 side (6-Up)
842x 9	8>	8 pages on 1 side (8-Up)
842x 10	9>	9 pages on 1 side (9-Up)
842x 11	16>	16 pages on 1 side (16-Up)
842x 12	Booklet	
842x 13	Magazine	

- These counts are especially useful for customers who need to improve their compliance with ISO standards for the reduction of paper consumption.
- Pages that are only partially printed with the n-Up functions are counted as 1 page.

8441	T:2-2-07	Total Printed/Paper Size: All Applications
	These SPs count by print paper size the number of pages printed by all applications. [0 to 9999999/0/1]	
8444	P: 2-2-07	Total Printed/Paper Size: Printer Application
	These SPs count by print paper size the number of pages printed by the printer application. [0 to 9999999/0/1]	

	O: 2-2-07	Total Printed/Paper Size: Other
8447	These SPs count by print paper size the number of pages printed by Other applications. [0 to 99999999/0/1]	
844x 1	A3	
844x 2	A4	
844x 3	A5	
844x 4	B4	
844x 5	B5	
844x 6	DLT	
844x 7	LG	
844x 8	LT	
844x 9	HLT	
844x 10	Full Bleed	
844x 254	Other (Standard)	
844x 255	Other (Custom)	

- These counters do not distinguish between LEF and SEF.

CÓPIA NÃO CONTROLADA

Printer Engine Service Mode

8451	2-2-08	Printed Pages/Paper Tray
	These SPs count the number of sheets fed from each paper feed station. [0 to 9999999/0/1]	
001	Bypass Tray	Bypass Tray
002	Tray 1	Main Machine
003	Tray 2	Main Machine
004	Tray 3	Paper Tray Unit (Option)
005	Tray 4	Paper Tray Unit (Option)
006	Tray 5	LCT (Option)
007	Tray 6	Currently not used.
008	Tray 7	
009	Tray 8	
010	Tray 9	

8461	T:2-2-09	Printed Pages/Paper Type
	<p>[0 to 9999999/0/1]</p> <p>These SPs count by paper type the number pages printed by all applications.</p> <ul style="list-style-type: none"> ▪ These counters are not the same as the PM counter. The PM counter is based on feed timing to accurately measure the service life of the feed rollers. These counts are based on output timing. ▪ Blank sheets (covers, chapter covers, slip sheets) are also counted. ▪ During duplex printing, pages printed on both sides count as 1, and a page printed on one side counts as 1. 	
8464	P: 2-2-09	[0 to 9999999/0/1]
	<p>These SPs count by paper type the number pages printed by the printer application.</p>	
846x 1	Normal	
846x 2	Recycled	
846x 3	Special	
846x 4	Thick	
846x 5	Normal (Back)	
846x 6	Thick (Back)	
846x 7	OHP	
846x 8	Other	

Service Tables

CÓPIA NÃO CONTROLADA

Printer Engine Service Mode

8521	T:2-2-15	Total Pages/Finish
	[0 to 99999999/0/1] These SPs count by finishing mode the total number of pages printed by all applications.	
8524	P: 2-2-15	Total Pages/Finish
	These SPs count by finishing mode the total number of pages printed by the Print application. [0 to 99999999/0/1]	
852x 1	Sort	
852x 2	Stack	
852x 3	Staple	
852x 4	Booklet	
852x 5	Z-Fold	
852x 6	Punch	
852x 7	Other	

- If stapling is selected for finishing and the stack is too large for stapling, the unstapled pages are still counted.
- The counts for staple finishing are based on output to the staple tray, so jam recoveries are counted.

8581	T:2-2-26	Total Counter: Breakdown
	These SPs count the total output broken down by color output, regardless of the application used. In addition to being displayed in the SMC Report, these counters are also displayed [0 to 9999999/0/1]	

8591	O: 2-2-26	Total Counter: Other
	These SPs count the totals for A3/DLT paper used, number of duplex pages printed, and the number of staples used. These totals are for Other (O:) applications only. [0 to 9999999/0/1]	
8591 001	A3/DLT	
8591 002	Duplex	

8601	T:2-2-28	Coverage Counter
	These counts correspond to the total counts recorded with the mechanical counter.	
8601 001	Cvg: BW %	Coverage: BW Pages
8601 011	Cvg: BW Pages	Coverage: BW Percent

8771	3-0-01	Dev Counter
	This SP counts the number of development roller rotations for development. [0 to 9999999/0/1]	

Service Tables

CÓPIA NÃO CONTROLADA

Printer Engine Service Mode

8781	3-0-03	Pixel Coverage Ratio
	This SP displays the count for the number of toner bottles used. The count is done based on the assumption that one toner bottle yields about 1,000 printed pages.	

8801	3-0-05	Toner Remain
	This SP displays (as a percentage) the amount of toner remaining. This precise method of measuring remaining toner supply (1% steps) is better than other machines in the market that can only measure in increments of 10 (10% steps). [0 to 100/0/1]	

8851	3-2-03	Toner Coverage 0-10%
	These SPs count the percentage of dot coverage for K toner. [0 to 9999999]	
8851 011	0 to 2%:BK	
8851 021	3 to 4%:BK	
8851 031	5 to 7%:BK	
8851 041	8 to 10%:BK	

8861	3-2-04	Toner Coverage 11-20%
	This SP counts the number of prints that had a percentage of black dot coverage in the range 11-20%. [0 to 9999999]	

8871	3-2-05	Toner Coverage 21-30%
	This SP counts the number of prints that had a percentage of black dot coverage in the range 21-30%. [0 to 9999999]	

8881	3-3-06	Toner Coverage 31 -%
	This SP counts the number of prints that had a percentage of black dot coverage in the range above 31%. [0 to 9999999]	

8891	3-2-07	Coverage Display (Current)
8901	3-2-08	Coverage Display (Previous)
8911	3-2-09	Coverage Display (Before Previous)

8921	3-2-10	Dot Coverage Count Total
	These counters count the percentage of dot coverage for K toner. (This machine uses only black toner)	
8921 001	Coverage (%):BK	
8921 011	Coverage/P:BK	

Service
Tables

CÓPIA NÃO CONTROLADA

Printer Engine Service Mode

8941	3-6-01	Machine Status
	<p>These SPs count the amount of time the machine spends in each operation mode. These SPs are useful for customers who need to investigate machine operation for improvement in their compliance with ISO Standards. [0 to 9999999/0/1]</p>	
8941 001	Operation Time	Engine operation time. Does not include time while controller is saving data to HDD (while engine is not operating).
8941 002	Standby Time	Engine not operating. Includes time while controller saves data to HDD. Does not include time spent in Energy Save mode.
8941 003	Energy Save Time	Includes time while the machine is performing background printing.
8941 004	Low Power Time	Includes time in Energy Save mode with Engine on. Includes time while machine is performing background printing.
8941 005	Off Mode Time	Includes time while machine is performing background printing. Does not include time machine remains powered off with the power switches.
8941 006	SC	Total down time due to SC errors.
8941 007	PrtJam	Total down time due to paper jams during printing.
8941 008	OrgJam	Total down time due to original paper jams.
8941 009	PM Unit End	Total down time due to toner end.

	AdminCounter	Machine Administration Counter
8999	<p>This SP displays the counts for the items listed below. Use this SP as a quick reference to see the total counts of the corresponding SP codes listed below.</p> <p>Note: This machine supports K printing only, so the counts for 015 and 017 are identical.</p>	
8999 001	Total (SP8381 001)	Total output (sheets fed out)
8999 007	Printer: BW	Total output for black & white
8999 013	Duplex (SP8411 001)	Total output of duplexed sheets
8999 015	Cvg:BW% (SP8601 001)	Total output of K pages
8999 017	Cvg:BW Pages (SP8601 011)	Total output of K pages

Firmware Update

5.4 FIRMWARE UPDATE



- Never turn off the machine while downloading the firmware.

5.4.1 TYPE OF FIRMWARE

The table lists the firmware programs used by the machine. All programs can fit on one SD card.

Program	What It Updates
Engine	Printer engine control
Network DocBox	Document server firmware
Printer	Printer feature applications
System	Printer management
Network Support	Network application
Update Mode Err.	Displays if an error occurs.
Verify Data	Verifies that the update executed successfully.

5.4.2 PRECAUTIONS

Handling SD Cards

Observe these precautions when handling SD cards:

- Always turn off the main power switch before you insert or remove an SD card. Data on an SD card can be corrupted if you insert or remove an SD card while the main power switch is on.
- Never turn off the main power switch during downloading.
- Keep SD cards in a safe location. Never store SD cards in locations where they will be exposed to:
 - High temperature, high humidity
 - Direct sunlight
 - Strong vibrations
 - Magnetic fields generated by machines or electronic devices
- Handle SD cards carefully to avoid dropping them, bending, scratching, etc.

Upload/Download

In this service manual, "upload" and "download" have these meanings:

- Upload: Copying data from the printer to the SD card
- Download: Copying data from the SD card to the printer

Network Connection

A print job sent to the machine during firmware update will interrupt the procedure. Before you start the firmware update procedure tell the operator:

- The machine must be disconnected from the network.
- The machine cannot be used during firmware update.

Firmware Update

5.4.3 MACHINE FIRMWARE UPDATE

Each program must be updated one a time. Follow the procedure below to update one program.

1. Prepare a card that contains the required program.
2. If the machine is on, switch it off.

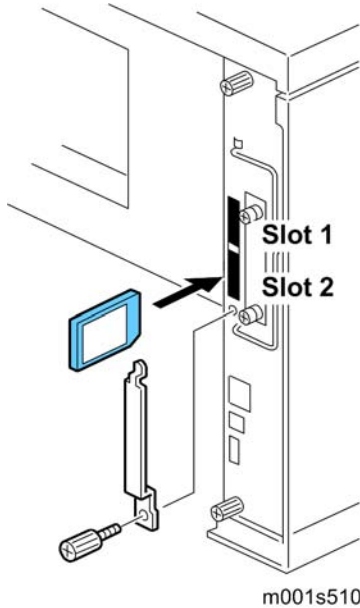

3. Remove the SD card cover (⚙️x1).
4. Insert the SD card into Slot 2.
5. Turn on the power. The screen remains blank for about 20 to 30 sec., "Please Wait" appears, then you will see "Engine", the first item available for selection.

↓ Note

- The first selection "Engine" will appear about 1 min. after switching the power on.
6. Scroll to the program to upgrade, then press [#Enter].
 7. Press the [Online] to start the upgrade. You will see a series of messages. If you selected "Engine", for example, you would see:

ROM Update

Updating

Updated
Power Off On

The "Power Off On" message appears after about 90 sec.

8. Turn off the power, remove the SD card from Slot 2, and turn on the power.

-or-

If you intend to update another program, leave the SD card in Slot 2 and turn on the power.

↓ Note

- The firmware has not updated successfully if the "Power Off On" message does not appear. If this occurs, turn the machine power off/on and repeat the procedure.

NVRAM Data Upload/Download

5.5 NVRAM DATA UPLOAD/DOWNLOAD

5.5.1 UPLOADING NVRAM DATA

Follow this procedure to upload the NVRAM data to an SD card.

 **Note**

- If the NVRAM data cannot be uploaded successfully before NVRAM replacement, you must manually input the required settings after the NVRAM has been replaced. For this reason, you should always print an SMC report before NVRAM replacement.

1. Enter the SP mode and do SP5990 1 (All) to print the SMC Report.
2. Exit the SP mode.
3. Turn off the main power switch.

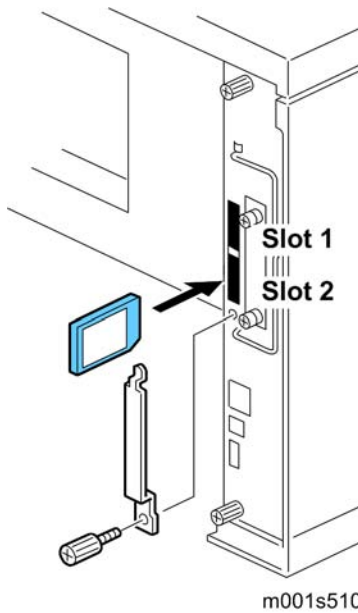

4. Remove the SD card slot cover.
5. Insert an SD card into Slot 2.
6. Turn on the main power switch.
7. Enter the SP mode and do SP5824 (NVRAM Upload).
8. Push [#Enter].

<NVRAM Upload>
execute?

9. Push [#Enter].
10. You will see "Processing". Then when you see "result=OK" the NVRAM data has been uploaded successfully.

This procedure creates an NVRAM folder on the SD card with one file that holds the NVRAM data. The file name is the serial number and the file extension is *.nv.

Example: G1772700016.nv,

11. Exit the SP mode.
12. Turn off the main power switch.
13. Remove the SD card.
14. Mark the SD card with the machine code for later reference. You will need this SD card to download NVRAM to the new NVRAM.

 Note

- One SD card can store the NVRAM data of two or more machines.

NVRAM Data Upload/Download

5.5.2 DOWNLOADING NVRAM DATA

Follow this procedure to download the data from the SD card to the NVRAM, after the NVRAM has been replaced.

 Note

- If the NVRAM data file cannot be downloaded successfully, the settings must be restored manually using the SMC report that was printed before NVRAM uploading.
1. Confirm that the main power switch is off.
 2. Confirm that you have the SD card that contains the proper NVRAM data for the machine.

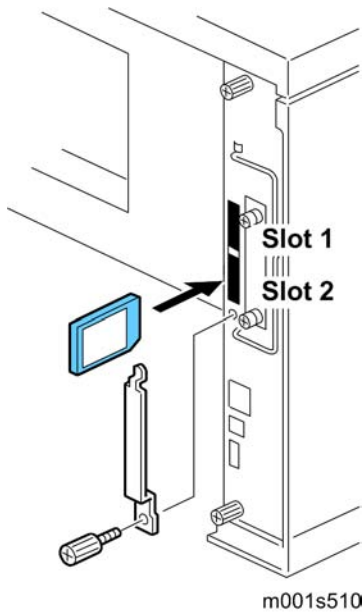

3. Remove the SD card slot cover.
4. Insert the SD card into Slot 2.
5. Turn on the main power switch.
6. Enter the SP mode and do SP5825 (NVRAM Download).
7. Push [#Enter].

```
<NVRAM Download>
execute?
```

8. Push [#Enter].

You will see "Processing". Then when you see "result=OK", the NVRAM data has been downloaded successfully.

↓ Note

- The machine cannot do the download if the file name SD card name is different from the printer serial number.
9. Exit the SP mode.
 10. Turn off the main power switch.
 11. Remove the SD card.
 12. Turn on the main power switch.

SD Card Application Move

5.6 SD CARD APPLICATION MOVE

5.6.1 OVERVIEW

The service program "SD Card Appli Move" (SP5873) moves application programs from one SD card to another.

Obey these precautions during the SD Card Appli move procedure:

- The authentication data is moved with the application program from an SD card to the other SD card. Authentication fails if you try to use the SD card after you move the application program from this card to another SD card.
- Do not use an SD card if it has been used for some other work, for example, on a computer. Normal operation is not guaranteed when such SD card is used.
- Store the original SD card in a safe location after the procedure. The original SD card cannot be used but it must be saved because (1) the original card is the only proof that the user is licensed to use the application program, and (2) you may need to check the SD card and its data to solve a problem in the future.

5.6.2 MOVE EXEC

"Move Exec" (SP5873 1) moves application programs from the original SD card to another SD card. The application programs are moved from Slot 2 to Slot 1.

1. Turn off the main power switch.

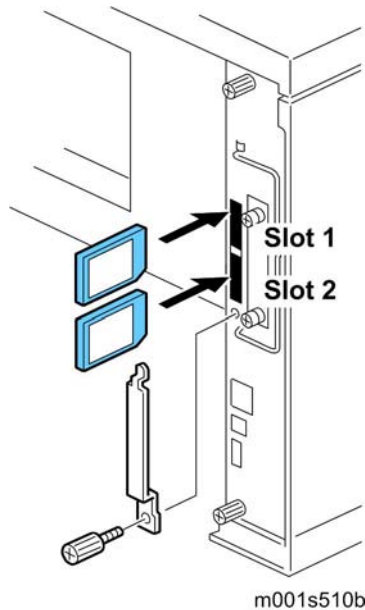

2. Remove the SD card slot cover.
3. Insert the original SD card with the application in Slot 2.
4. Insert the SD card to receive the application in Slot 1.
5. Turn on the main power switch.
6. Enter the SP mode and do SP5873 1 "Move Exec."
7. Follow the messages on the operation panel to complete the procedure.
8. Exit the SP mode.
9. Turn off the main power switch.
10. Remove the original SD card from Slot 2.
11. Leave the other SD card in Slot 1.
12. Turn on the main power switch.
13. Confirm that the application program runs normally.
14. Tell the customer to store the original SD card in a safe place.

SD Card Application Move

5.6.3 UNDO EXEC

"Undo Exec" (SP5873 2) restores an application to its original SD card. The application is moved from Slot 1 to Slot 2.

1. Turn off the main power switch.

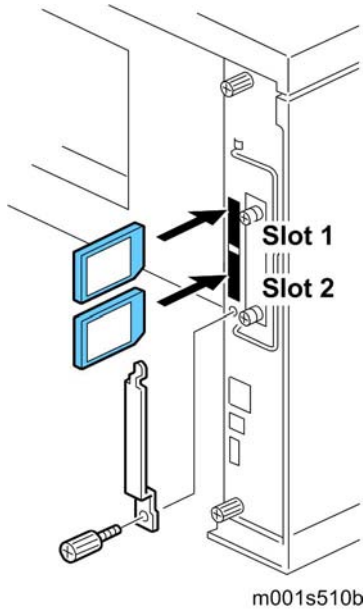

2. Remove the SD card slot cover.
3. Insert the SD card that currently holds the application in Slot 1.
4. Insert the original SD card to receive the restored application in Slot 2.
5. Turn on the main power switch.
6. Enter the SP mode and do SP5873 "Undo Exec."
7. Follow the messages on the operation panel to complete the procedure.
8. Exit the SP mode.
9. Turn off the main power switch.
10. Remove both SD cards.
11. Insert the SD card with the restored application in Slot 1.
12. Turn on the main power switch.
13. Confirm that the application operates normally.

5.7 CONTROLLER SELF TEST AT POWER-ON

There are two types of self-diagnostics for the controller:

- Power-on self-diagnostics: The machine automatically starts the self-diagnostics just after the power has been turned on.
- SC detection: The machine automatically detects SC conditions at power-on or during operation.

The following flowchart shows flow of the power-on self-diagnostic test.

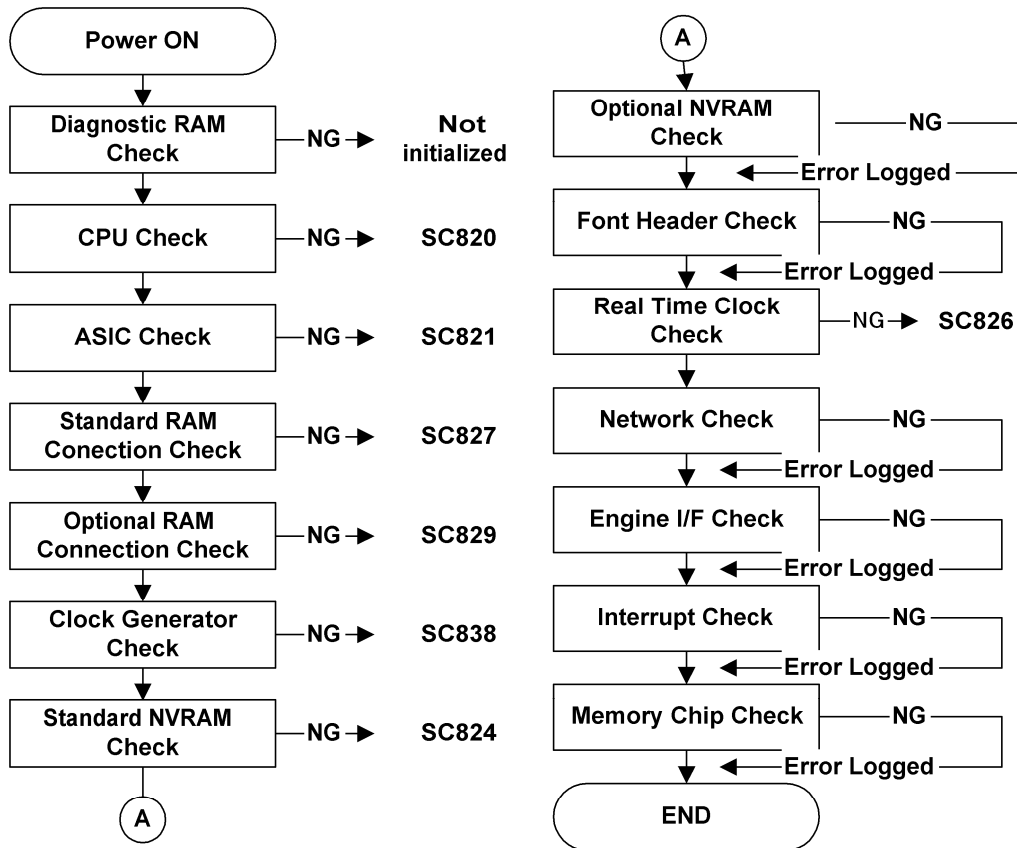

g176s904

Service Tables

Menu Mode

5.8 MENU MODE

There are two menu modes:

- User menu mode
- System administrator menu mode

To enter and use the user menu mode:

1. Press [Menu]
2. Press [▼] or [▲] to scroll through the menu listing.
3. To return to the previous level, press [Escape].
4. After changing the settings, press [On Line] to return to standby mode

To enter and use the system administrator menu mode:

1. Push and release in order: [#Enter]> [Escape]> [Menu]
2. Press [▼] or [▲] to scroll through the menu listing.
3. To return to the previous level, press [Escape].
4. After changing the settings, press [Suspend/Resume] to return to standby mode



- The user menu list shown below can be printed: [Menu]> "List/Test Print"> [▼] 4 times> "Menu List"> [#Enter].
- The first four items (Sample, Locked, Hold, Stored Print) are not included in the printed list.

Menu Mode Tree

Here is quick summary of the menus. The system administrator mode menus have some additional items that are not displayed in the user menu mode.



- The items that are displayed only in the system administrator menu mode are enclosed in square brackets in the table below.

1st Level	2nd Level
Sample Print	Print One File
	Print All Files
	Delete One File
	Del. All Files
	Error File(s)
Locked Print	Print One File
	Print All Files
	Delete One File
	Del. All Files
	Error File(s)
Hold Print	Print One File
	Print All Files
	Delete One File
	Del. All Files
	Error File(s)
Stored Print	Print One File
	Print All Files
	Delete One File
	Del. All Files
	Error File(s)

CÓPIA NÃO CONTROLADA

Menu Mode

1st Level	2nd Level
Paper Input	Bypass Size
	Tray Paper Size
	Paper Type
	Aut. Tray Select
	Tray Priority
List/Test Print	Multiple Lists
	Config. Page
	Error Log
	Network Summary
	Menu List
	PCL Config. Page
	PS Config. Page
	PDF Config. Page
	Hex Dump
Maintenance	Image Density
	Registration
	Curl Prevention
	Del. All Temp
	Del. All Stored
	HD Format
	Date/Time

1st Level	2nd Level
	[Network Security]
	Key Repeat
	Panel Key Sound
	Warm-Up Beeper
	[Menu Protect]
	[List Print Lock]
	[Ppr. Size Err.]
	[File Locking]
	[Memory Erase]
	[Erase All Memory]
	[Log Transfer]
	[@Remote Service]
System	Print Err. Report
	Auto Continue
	Memory Overflow
	Copies
	Printer Lang
	Sub Paper Size
	Page Size
	Edge-Edge Print
	Def. Print Lang.

Menu Mode

1st Level	2nd Level
	Blank Pages
	Rotate 180 Deg.
	Energy Saver
	Auto Reset Time
	Auto Del. Temp
	Auto Del. Stored
	Memory Usage
	Unit of Measure
	Edge Smoothing
	Toner Saving
	Spool Printing
	Letterhead Mode
	Bypass Priority
	Auto Tray SW
	Auto Email Ntfy
Host Interface	I/O Buffer
	I/O Timeout
	Network Setup
	[USB Speed]
	Fixed USB Port

1st Level	2nd Level	
PCL Menu	Orientation	
	Form Lines	
	Font Source	
	Font Number	
	Point Size	
	Font Pitch	
	Symbol Set	
	Courier Font	
	Ext. A4 Width	
	Append CR to LF	
	Resolution	
	PS Menu	Data Format
		Resolution
PDF Menu	PDF: Change PW	
	PDF Group PW	
	Resolution	
Language	(Select 1 of 14 available languages)	

Controller Board DIP Switches

5.9 CONTROLLER BOARD DIP SWITCHES

The controller board DIP switches must always be set as shown below.

Controller Board Default DIP SW Settings

DIP SW	Setting
1	ON
2	OFF
3	OFF
4	OFF

★ Important

- Do not change these settings.

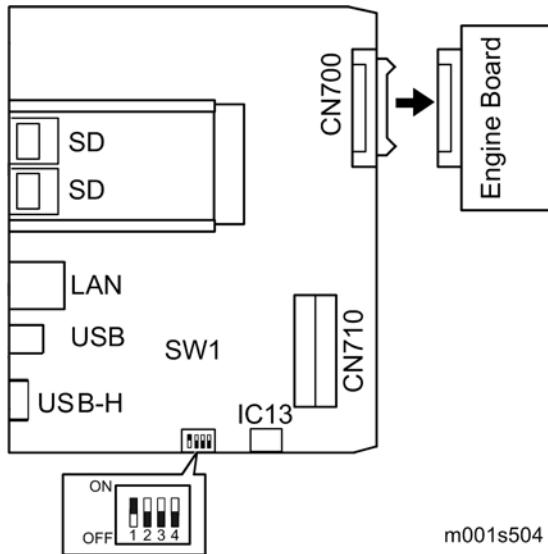

5.10 CARD SAVE FUNCTION

5.10.1 OVERVIEW

Card Save:

- The Card Save function is used to save print jobs received by the printer on an SD card with no print output. Card Save mode is toggled using printer Bit Switch #1 bit number 4. Card Save will remain enabled until the SD card becomes full, or until all file names have been used.
- Captures are stored on the SD card in the folder /prt/cardsave. File names are assigned sequentially from PRT00000.prn to PRT99999.prn. An additional file PRT.CTL will be created. This file contains a list of all files created on the card by the card save function.
- Previously stored files on the SD card can be overwritten or left intact. Card Save SD has “Add” and “New” menu items.
 - **Card Save (Add):** Appends files to the SD Card. Does not overwrite existing files. If the card becomes full or if all file names are used, an error will be displayed on the operation panel. Subsequent jobs will not be stored.
 - **Card Save (New):** Overwrites files in the card's /prt/cardsave directory.

Limitation:

- Card Save cannot be used with PjL Status Readback commands. PjL Status Readbacks will not work. In addition they will cause the Card Save to fail.

Card Save Function

5.10.2 PROCEDURE

1. Turn the main power switch OFF.



m001r115

2. Insert the SD card into the service slot (lower) of the controller board. Then turn the power ON.



- To determine which slot is the service slot, please see the service manual.

3. Enter SP mode.
4. Select "Service" and press "#Enter" button twice.
5. Select "Bit Switch 1" and press "#Enter" button.

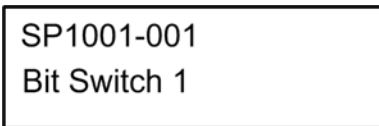

m001t100

6. Use the arrow key to turn "Bit Switch 4" and press "Enter" and use the arrow key to turn bit 4 ON. The result should look like: **00010000**. By doing this Card Save option will appear in "List/Test Print".

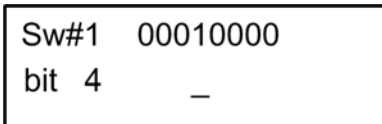

m001t101

7. Press the “Escape” button several times, and use arrow key to select “3 End” to exit SP Mode.
8. Press the “Menu” button.
9. Use the arrow key and select “List/Test Print”.



m001t102

10. Use the arrow key and select “Cardsave (ADD) or Cardsave (New).

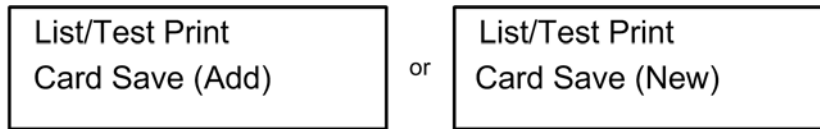

m001t103

11. To enable the newly configured settings, select “#” button and then press the “Escape” button to exit the “List/Test Print” menu.
12. Send a job to the printer.
13. As soon as the printer receives the data, it will be stored on the SD card automatically with no print output. Nothing is displayed on the screen indicating that a Card Save operation was successful.
14. Press the “Suspend/Resume” button and then the “Escape” button to exit Card Save mode.
15. Change the Bit Switch Settings back to the default **00000000**.
16. Remove the SD card after main power switch is turned off.

Error Messages

Card Save error messages:

- **Init error:** A card save process (i.e. card detection, change to kernel mode) failed to initialize.
- **Card not found:** Card cannot be detected in the slot.
- **No memory:** Insufficient working memory to process the job.
- **Write error:** Failed to write to the card.
- **Other error:** An unknown error occurred.

If an error occurs, pressing “#Enter” will cause the device to discard the job and return to the ready state.

Card Save Function

5.10.3 ERROR MESSAGES

Card Save error messages:

- **Init error:** A card save process (e.g. card detection, change to kernel mode) failed to initialize.
- **Card not found:** Card cannot be detected in the slot.
- **No memory:** Insufficient working memory to process the job.
- **Write error:** Failed to write to the card.
- **Other error:** An unknown error occurred.

If an error occurs, pressing “#Enter” will cause the device to discard the job and return to the ready state.

CÓPIA NÃO CONTROLADA

DETAILED DESCRIPTIONS

CÓPIA NÃO CONTROLADA

CÓPIA NÃO CONTROLADA

CÓPIA NÃO CONTROLADA

6. DETAILED DESCRIPTIONS

6.1 OVERVIEW

6.1.1 MECHANICAL COMPONENT LAYOUT

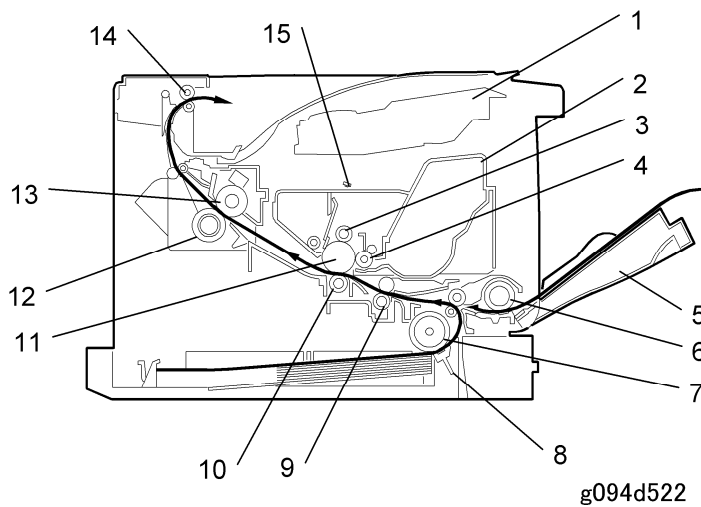

1. Laser unit
2. Cartridge (AIO-type)
3. Charge roller
4. Development roller
5. By-pass feed tray
6. By-pass feed roller
7. Paper feed roller
8. Friction pad
9. Registration roller
10. Transfer roller
11. Drum
12. Pressure roller
13. Hot roller
14. Paper exit roller
15. Quenching lamp

Overview

6.1.2 PAPER PATH

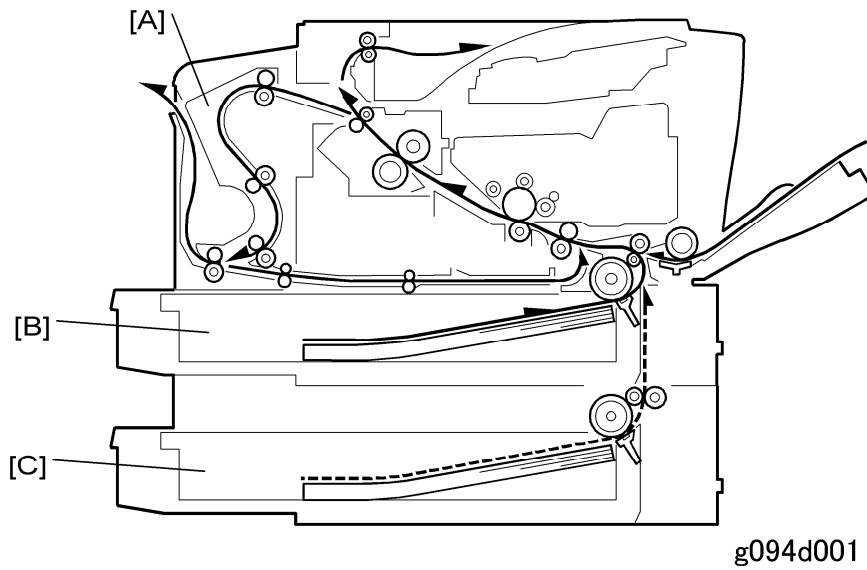

- [A] Optional duplex unit
- [B] Standard paper tray unit
- [C] Optional paper tray unit

6.2 BOARD STRUCTURE

6.2.1 BLOCK DIAGRAM

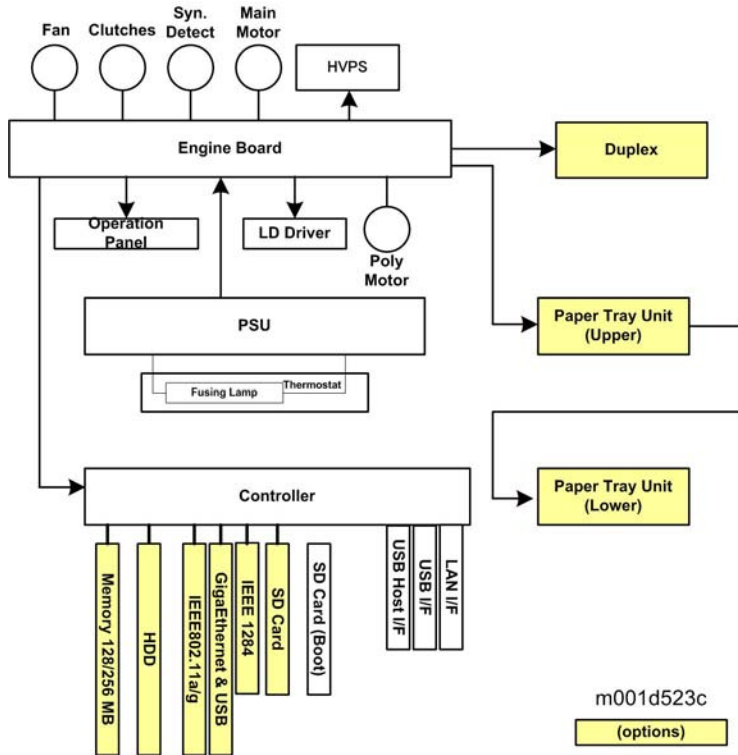

The engine board controls all the mechanical components.

The printer controller board connects to the engine board through a PCI bus.

Note

- The IEEE 802.11a/g Interface Unit (M344) and Gigabit Ethernet Board (G874) cannot be installed at the same time.

Board Structure

6.2.2 CONTROLLER BOARD



The controller controls all applications. Optional features can be added by inserting application an SD card into the controller SD slot.

ASIC. Contains the dedicated GW controller chips of the shared resources (the CPU, memory, and HDD hardware) for the copying and printing functions.

- **CPU.** The central processing unit that controls the operation of the controller board.
- **SD Card Slot.** Service slot for firmware version updates, moving applications to other SD cards, and downloading/uploading NVRAM contents.
- **SDR SDRAM.** The image memory for the printer functions where image compression, image rotation and other operations are done.
- **Board Option Slots.** One slot (CN710) is available for the optional HDD unit and another slot (CN703) is available for either the IEEE 802.11a/g, IEEE 1284 Interface Unit or Gigabit Ethernet Board.
- **Flash ROM.** Stores the program. Maximum capacity: 32 MB.
- **USB.** The interface for USB 2.0. Supports both low-speed and high-speed modes. USB support is built into the controller. No installation is required for the USB function.
- **NIB.** The Ethernet interface connection. Ethernet support is built into the controller. No installation is required for the Ethernet function.
- **EEPROM.** Stores the data for the SP code settings.
- **NVRAM.** The memory that stores the system configuration and other information.

6.3 PRINTING PROCESS

6.3.1 OVERVIEW

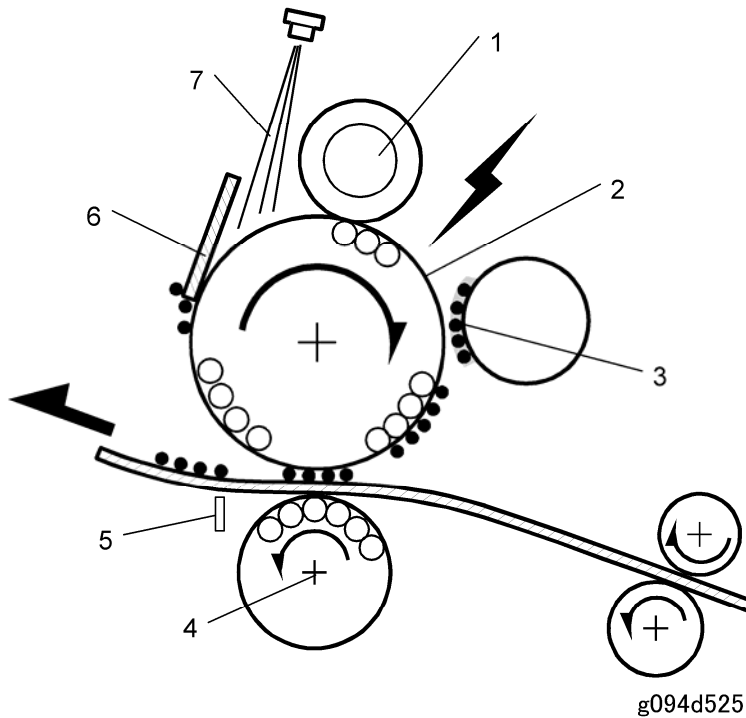

1. **Drum Charge:** The charge roller gives the drum a negative charge.
2. **Laser Exposure:** A laser beam writes the print data on the drum.
3. **Development:** The development roller moves toner to the latent image on the drum surface.
4. **Image Transfer:** The transfer roller moves the toner from the drum to the paper.
5. **Separation:** The separation plate helps to remove the paper from the drum.
6. **Cleaning:** The cleaning blade removes remaining toner on the drum surface after the image moved to the paper.
7. **Quenching:** The light from the quenching lamp cancels the charge that stays on the drum.

Printing Process

6.3.2 LASER EXPOSURE

Overview

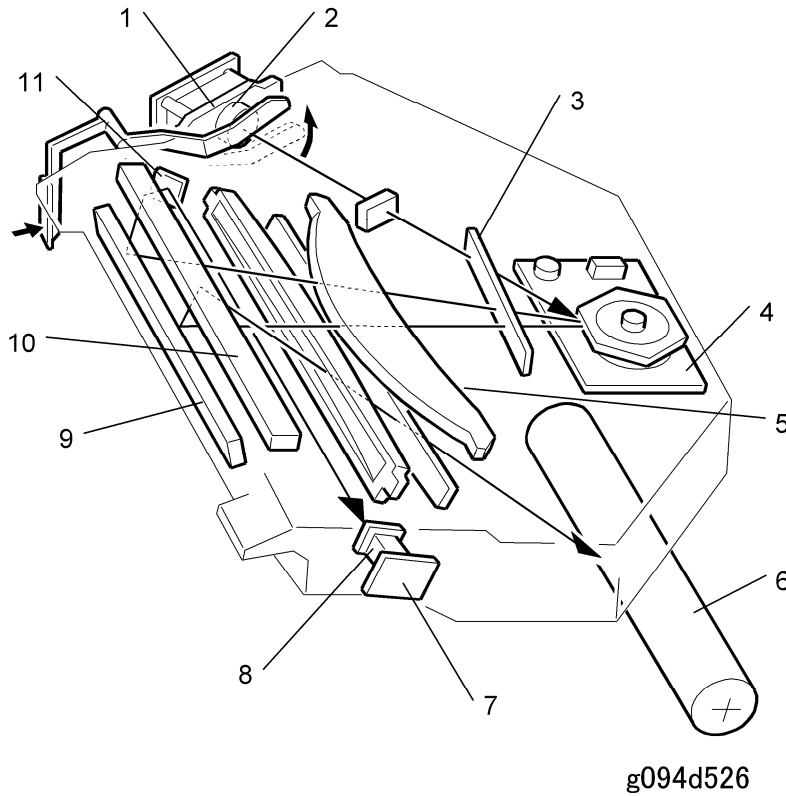

- | | |
|-------------------|-----------------------------|
| 1. LD unit | 7. Synchronization detector |
| 2. Laser shutter | 8. Toroidal lens |
| 3. Shield glass | 9. 1st mirror |
| 4. Polygon mirror | 10. 2nd mirror |
| 5. F-Theta lens | 11. Detector mirror |
| 6. Drum | |

- **Synchronization detector:** The 1st mirror, 2nd mirror, and the detector mirror reflect the beam from the LD unit to the synchronization detector.
- **Two laser beams:** The LD unit writes two lines at the same time.
- **LD safety shutter:** When the user opens the front cover, the shutter closes and blocks the laser beam path.

After you replace the LD unit, adjust its position (see Replacement and Adjustment).
The thermistor next to the laser unit (not shown) checks the temperature inside the machine. The machine automatically corrects the charge roller and transfer voltages for this temperature.

Automatic Power Control (APC)

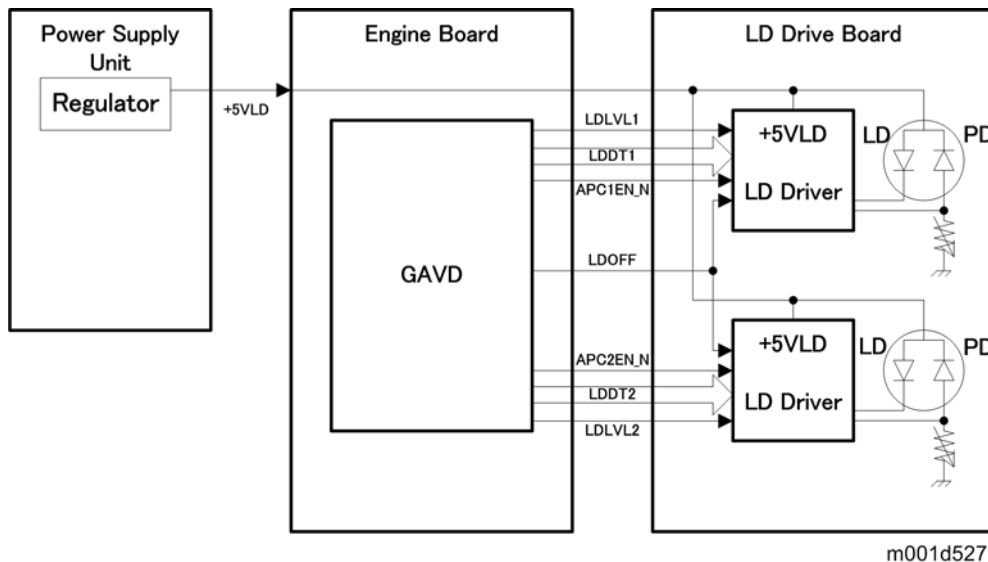

The LD driver on the LD drive board automatically controls power for the laser diodes. The laser diode power is adjusted in the factory.

↓ Note

- Never touch the variable resistors on the LD unit in the field.

Printing Process

LD Safety Mechanisms

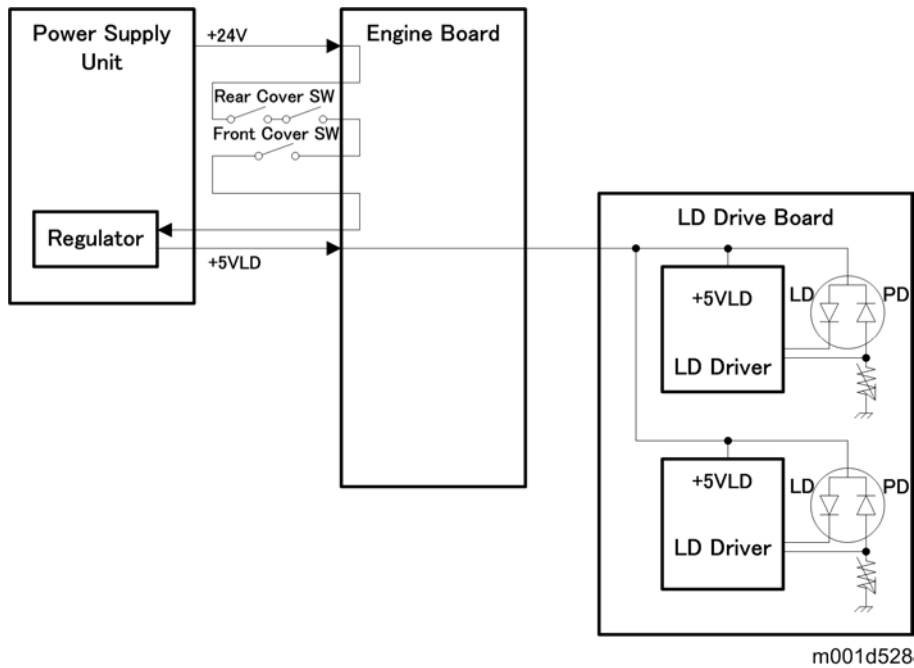

Laser Safety Switch

There are safety switches on the front and rear covers. These switches stop the laser while the cover is open. If the user opens one of these covers, the +5VLD power to the laser diodes is stopped.

Laser Shutter

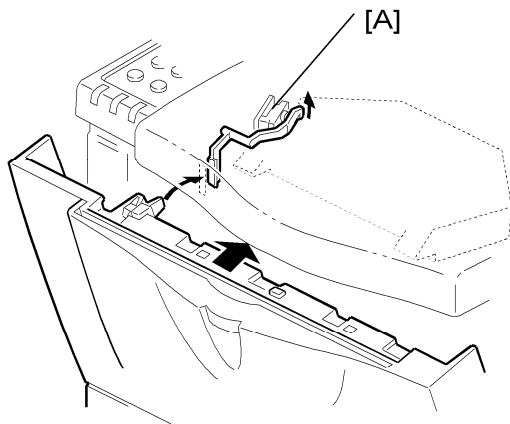

g094d529

The laser shutter [A] is for back-up safety. If the switches do not work, the +5VLD power gets to the laser diodes if the cover is open.

The laser shutter cuts the laser beam when the front cover is open.

Printing Process

6.3.3 CARTRIDGE OVERVIEW

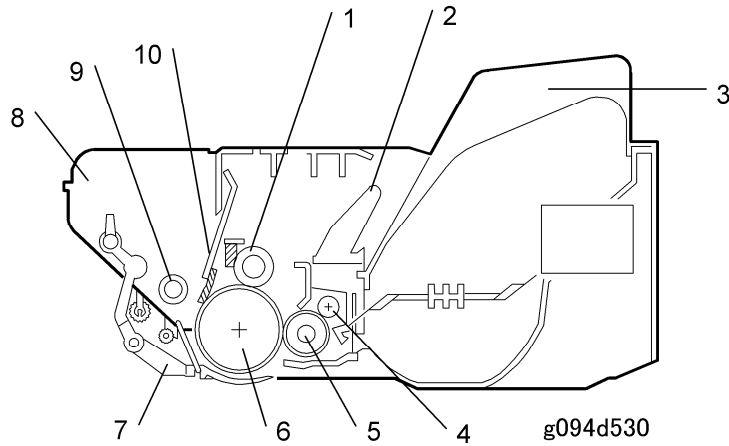

- | | |
|-----------------------|----------------------------|
| 1. Charge roller | 6. Drum |
| 2. Developer tank | 7. Drum shutter |
| 3. Toner tank | 8. Waste toner tank |
| 4. Reverse roller | 9. Toner collection roller |
| 5. Development roller | 10. Cleaning blade |

This type of cartridge is known as the “All-in One” (AIO) cartridge.

6.3.4 DRUM CHARGE

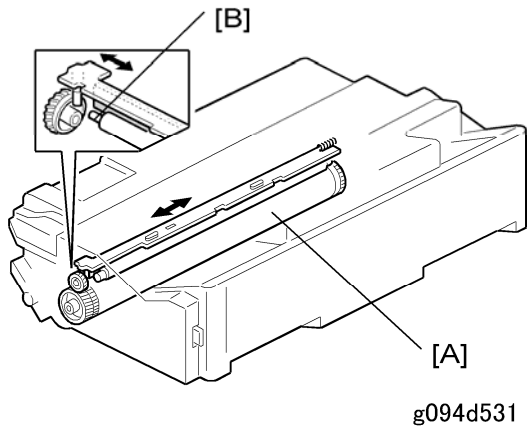

[A] Charge roller

[B] Cleaning pad

The charge roller [A] gives the drum surface a negative charge of approximately -900 V.

The cleaning pad [B] touches the charge roller to clean the surface.

Printing Process

6.3.5 DEVELOPMENT

Toner Supply and Development

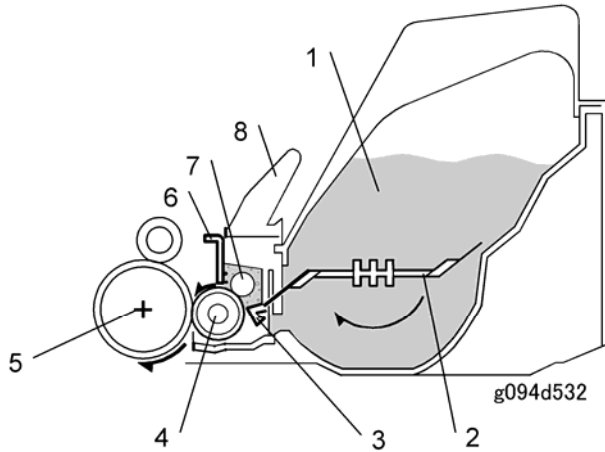

- | | |
|-----------------------|-------------------|
| 1. Toner tank | 5. Drum |
| 2. Agitator | 6. Doctor blade |
| 3. Pre-doctor blade | 7. Reverse roller |
| 4. Development roller | 8. Developer tank |

Toner Supply

The agitator [2] mixes toner and sends it to the development roller.

Development Unit

This machine uses a one-roller development system. The high voltage supply applies -700V to the development roller.

When the user removes the developer seal, the developer falls and the magnetic reverse roller [7] mixes the developer.

This machine does not use a TD sensor or ID sensor to control toner density. The pre-doctor blade [3] and the doctor blade [6] control the toner density.

Toner Density Control

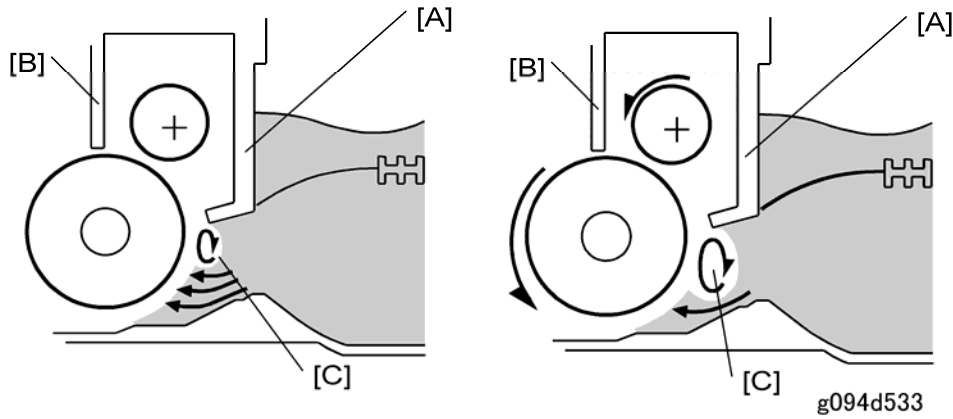

More toner is fed when the toner coating on the development roller is thin

Less toner is fed when the toner coating on the development roller is thick

[A]: Pre-doctor blade

[B]: Doctor blade

[C]: Circulation of developer

A mixture of toner and developer circulates at the pre-doctor blade [A].

When the toner on the development roller decreases, the circulating region [C] gets smaller to let more toner get to the development roller.

When the toner on the development roller increases, the circulating region [C] gets bigger to let less toner get to the development roller.

Printing Process

Development Bias

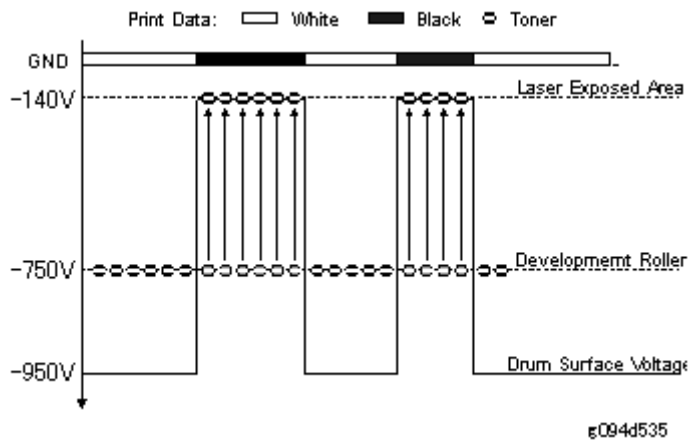

Toner transfers from the development roller to the areas on the drum that were exposed to the laser.

6.3.6 TONER END DETECTION

Overview

This machine uses two methods to detect toner near-end and toner end:

- A toner-end sensor, mounted below the print cartridge, monitors the level of the toner in the cartridge.
- The machine monitors the length of time the main motor has been running with the same AIO cartridge.

Note that print quality between toner near-end and toner end cannot be guaranteed. This is because toner end is not detected directly; it is automatically detected 200 pages after near-end (or, in the case of main motor rotation count, after the motor rotates enough to print an additional 200 A4 pages at 2 pages/job). Toner can run out more quickly than this, if the coverage ratio is high.

Toner End Sensor

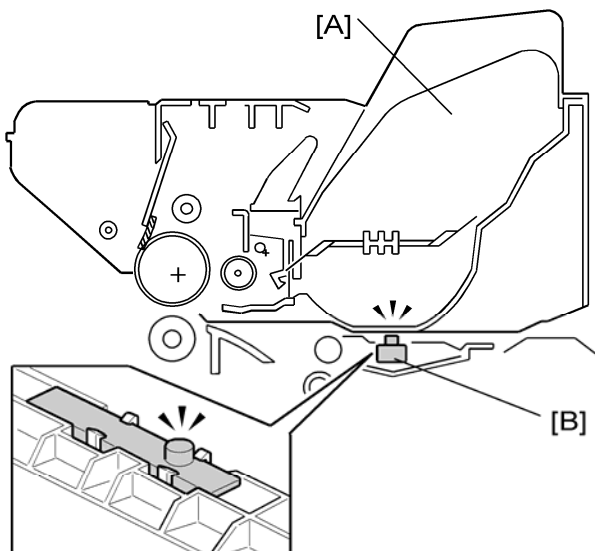

g094d536

[A] Toner tank

[B] Toner end sensor

The toner end sensor detects toner near-end by the voltage output. When the output from the toner end sensor is below a given level, the machine displays “Low on Toner”.

After toner near-end, the machine can print approximately 200 additional pages. At this time, the “Replace Printer Cartridge Soon” message appears.

Printing Process

After the additional pages have printed, printing stops and then the “Replace Printer Cartridge” message remains in the display.



- The 200 page limit for after the near-end alert appears can be adjusted with SP2213. However, the print quality of these pages cannot be completely guaranteed. This is because the 200-page limit is calculated for A4, with a 5% coverage ratio (depending on the coverage ratio of these 200 pages, toner could run out before the 200 pages are made).

Main Motor Rotation Count

The time to replace the AIO cartridge can also be determined by the length of time the main motor has been rotating.

When toner end is detected, ‘Replace Print Cartridge’ is displayed alternately with ‘Ready’.



- The servicing alert messages are not displayed when SP5930 001 (meter click charge) is set to "Yes". The default setting of SP 5930 001 is "No". For more, please refer to "5. Service Tables".

At about 200 pages before this (based on A4 prints at 2 pages/job), the machine detects toner near-end. At this time, ‘Replace Print Cartridge Soon’ is displayed.

- Note that toner can run out more quickly 200 pages after near-end, if the coverage ratio is high. Because of this, after toner near-end, printing quality cannot be guaranteed.

Toner Overflow Prevention

With the main motor rotation count feature, the machine can be set to stop printing after the print total exceeds a certain set value. If the print count exceeds this value, then ‘Replace Print Cartridge’ remains in the display. Then a new AIO cartridge must be installed.

This feature is a safety measure to prevent the used toner tank from becoming full (there is no toner overflow detection mechanism).

To enable this feature, you must set SP3923 (Cartridge Stop) to "Yes".

Why do we need this feature?

Normally, the AIO is replaced by the user at about 15k. But some users will refill the old AIO with toner, and use the same AIO again. If this occurs, the used toner tank will not be emptied. So there must be a way to stop users from repeatedly filling the old AIO with fresh toner.

If you enable SP 3923, then after a certain number of prints are made with the same AIO, the machine prevents printing, and a completely new AIO must be installed. If you try to print again by removing/replacing the old AIO or adding new toner, there will be no printing.

How does the machine know if the AIO is a new one?

The AIO has serial number information on a chip. The machine checks this number when the AIO is placed in the machine.

Why is this feature disabled?

Ricoh does not support the practice of refilling old AIOs with fresh toner, so the feature is disabled by default. But if field service stations know that this practice occurs in their region, or they know a customer who is doing this, then they can enable the feature.

Printing Process

Summary

In the illustration below [A], [B], and [C] have these meanings:

[A] Heavy usage (jobs that require large amounts of toner)

Toner coverage is 5% more than normal. The machine detects toner near end

[B] based on main motor rotation before the toner end sensor detects that toner is low.

Toner coverage is 5% lower than normal. The machine detects toner near end

[C] low. The toner overflow prevention mechanism is triggered before toner is completely exhausted.

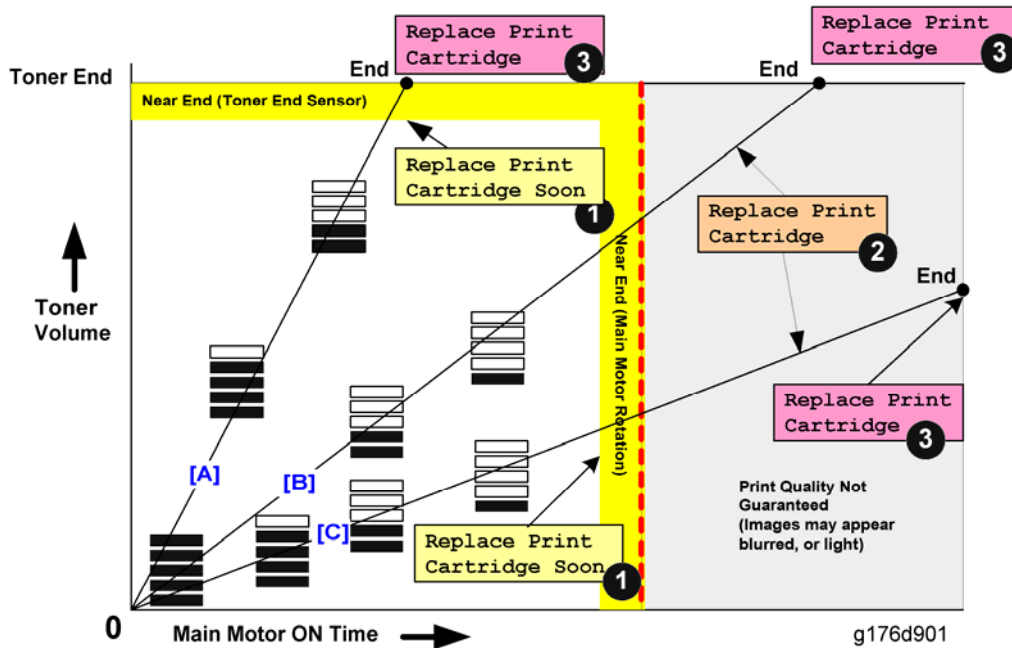

<p>❶</p>	<p>"Replace Print Cartridge Soon"</p>	<p>Displays at toner near-end (based on the toner end sensor), or when the print cartridge is near the end of its service life (based on main motor rotation). Printing can continue but print quality is not guaranteed.</p>
<p>❷</p>	<p>"Replace Print Cartridge" flashes and alternates with "Ready".</p>	<p>The print cartridge is at the end of its service life (about 200 pages or more after near end is detected by main motor rotation) but some toner still remains (toner end sensor did not detect toner end). Printing can continue but print quality is not guaranteed. This condition will occur if an old AIO is refilled with toner. The grey area in the diagram is marked 'out of guaranteed range' because Ricoh cannot guarantee the operation of the machine if an old AIO is refilled with toner.</p>
<p>❸</p>	<p>"Replace Print Cartridge" remains in the display</p>	<p>Toner is exhausted (200 pages after the toner end sensor detects near end), or the toner overflow prevention mechanism is triggered (based on main motor rotation). Printing cannot continue and "Replace Print Cartridge" will remain in the display until the AIO unit is replaced.</p>

The following items have been added to the SMC Report (printed with SP5990).

1. Previous Running Time
2. Previous Number of Alerts
3. Previous AIO Type (Accessory or 15 K)
4. Present Running Time
5. Present Number of Alerts
6. Present AIO Type (Accessory or 15 K)
7. Running Time When AIO Replaced
8. Current Running Time Remaining (%)

Paper Feed

6.4 PAPER FEED

6.4.1 OVERVIEW

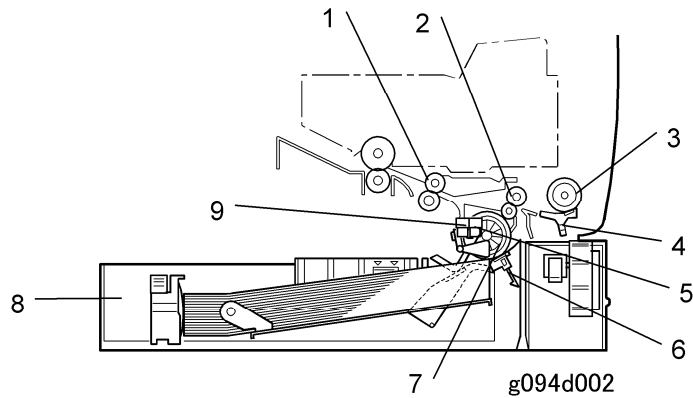

1. Registration Roller
2. Relay Roller
3. By-pass feed roller
4. By-pass friction pad
5. Paper end sensor
6. Friction pad
7. Feed roller
8. Paper tray
9. Remaining paper sensors (1 and 2)

Paper Tray

Paper Feed System:	Feed roller and friction pad
Paper Lift Mechanism:	Tray arm and spring
Paper End Detection:	Remaining paper sensors Paper end sensor
Paper Size Detection:	Paper size switch
Tray Capacity:	500 sheets
Tray Extension:	Available

By-pass Tray

Paper Feed System:	Feed roller and friction pad
Paper Lift Mechanism:	Cams and springs
Paper Detection:	By-pass tray paper sensor
Paper Size Detection:	None
Tray Capacity:	100 sheets

Paper Feed

6.4.2 PAPER TRAY

Tray Extension

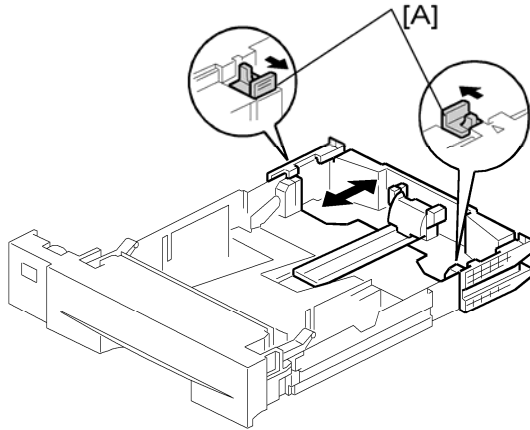

g094d003

The user can extend the tray manually to hold paper longer than A4/Letter size.

To use longer paper:

- Release the two locks [A]
- Extend the tray and close the locks.

These paper sizes can be used:

Paper Sizes

Tray Mode	Possible Paper Sizes
Short (default)	A5 (LEF/SEF), B5 (SEF), A4 (SEF), LT (SEF)
Long	LG (SEF), 8.5" x 13" (SEF), 8" x 13" (SEF), 8.25" x 13" (SEF)

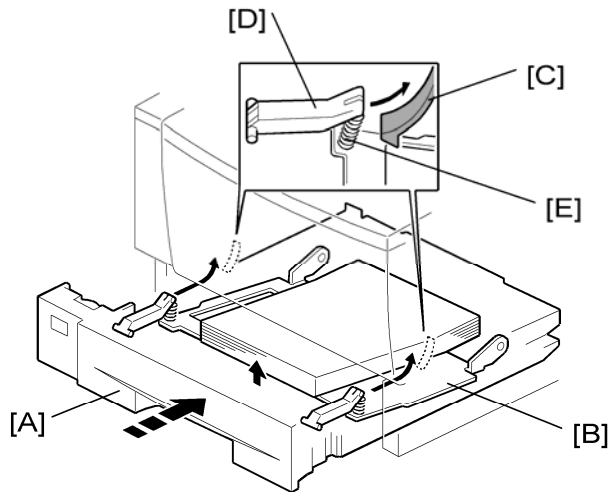
Paper Lift

g094d004

When the user puts the tray [A] in the machine, the bottom plate [B] lifts as follows.

- The slopes on the guide blocks [C] on the machine lift the tray arms [D] up.
- The springs [E] between the tray arms and bottom plates lift the plate.
- The springs [E] keep the top sheet of the paper at the correct height.

Paper Feed

Paper Feed and Registration

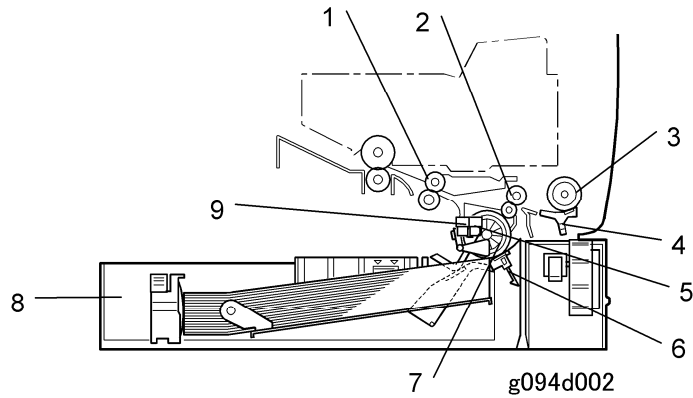

1. Registration Roller
2. Relay Roller
3. By-pass feed roller
4. By-pass friction pad
5. Paper end sensor
6. Friction pad
7. Feed roller
8. Paper tray
9. Remaining paper sensors (1 and 2)

The friction pad cannot be adjusted.

The machine makes a paper buckle at the registration roller to correct paper skew.

The paper buckle can be adjusted with engine SP 1003.

Paper Size Detection

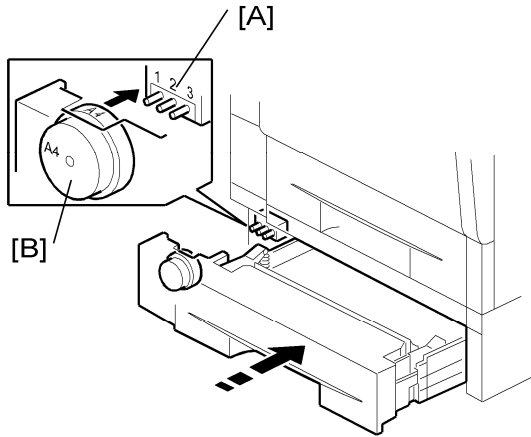

g094d542

[A] Paper size switch

[B] Paper size dial

Paper Size Detection Table

Size	SW1	SW2	SW3
A4 SEF	ON	ON	OFF
A5 SEF	ON	OFF	ON
B5 SEF	OFF	ON	OFF
Custom Size	ON	OFF	OFF
LG SEF	OFF	OFF	OFF
LT SEF	OFF	OFF	ON
HLT SEF	OFF	ON	ON

Detailed Descriptions

Paper Feed

Paper End Detection

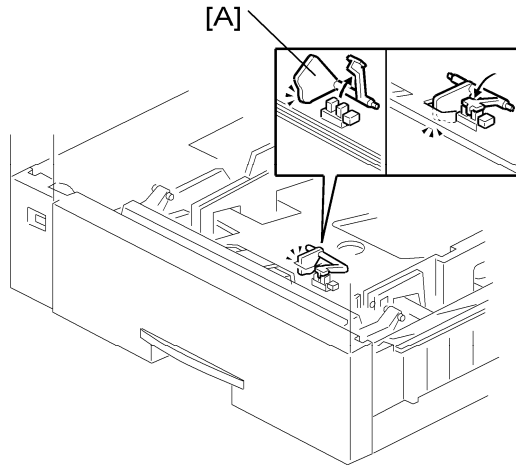

g094d543

When there is no paper in the tray, the feeler [A] falls into the cutout in the bottom plate, and the paper end sensor comes on.

Remaining Paper Detection

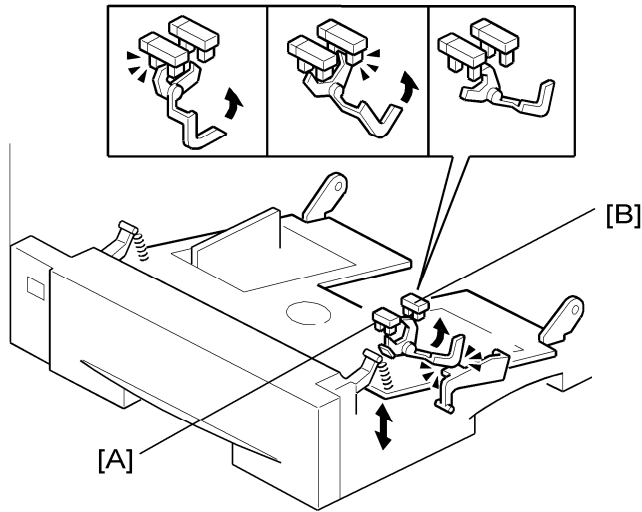

g094d002

Remaining paper is detected by the combination of the remaining paper sensor signals. The signals from the sensors indicate whether there are 500, 450, 250, or 50 sheets remaining.

[A] Remaining paper sensor 1

[B] Remaining paper sensor 2

Amount of paper	Rem. paper sensor 1	Rem. paper sensor 2
1-50 sheets (10%)	OFF	OFF
51-250 sheets (50%)	OFF	ON
251-450 sheets (90%)	ON	ON
451-500 sheets (100%)	ON	OFF

Paper Feed

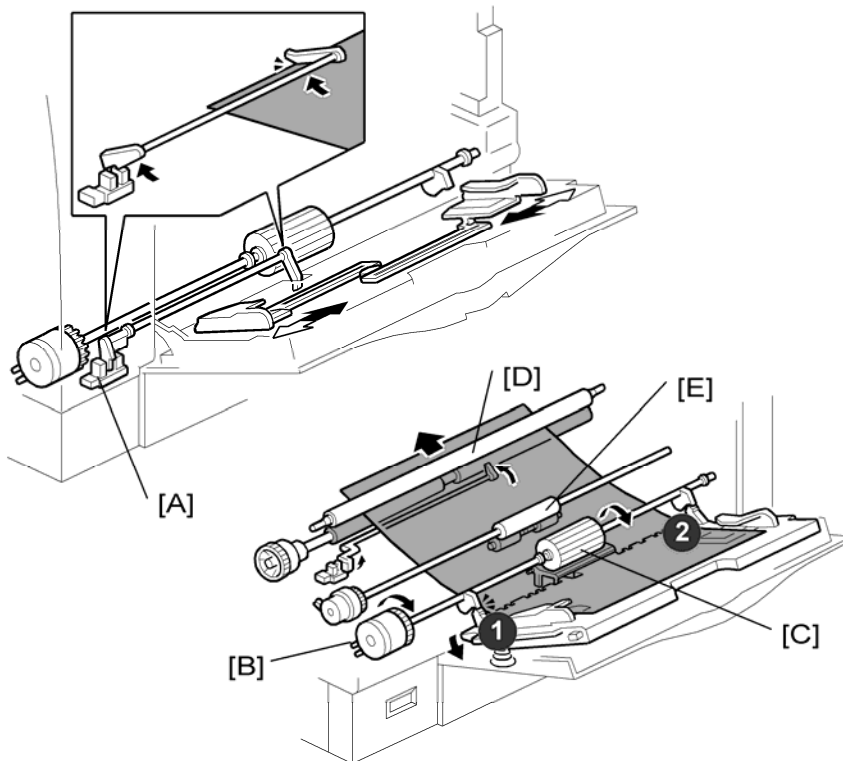
6.4.3 BY-PASS TRAY

g176d103

The by-pass paper sensor [A] detects when paper is placed on the tray.

The CPU energizes the by-pass clutch [B]. Then the by-pass feed roller [C] starts to feed paper to the registration roller [D] through the relay roller [E].

The by-pass feed roller shaft has two cams ❶, ❷. These cams release the bottom plate to press the stack of paper against the feed roller. There is no width sensor.

↓ Note

- To prevent bad effects from too much friction between the feed roller and friction pad, the feed roller contains a metal plate.

6.5 IMAGE FUSING AND PAPER EXIT

6.5.1 OVERVIEW

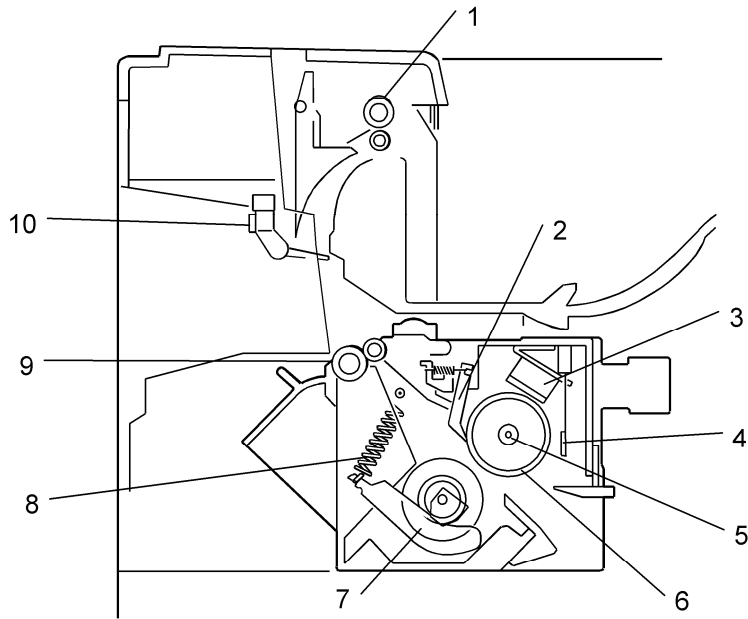

g094d503

1. Paper exit roller
2. Hot roller strippers
3. Thermostat
4. Thermistor
5. Fusing lamp
6. Hot roller
7. Fusing pressure roller
8. Pressure spring
9. Fusing exit roller
10. Paper exit sensor

Image Fusing and Paper Exit

6.5.2 FUSING DRIVE

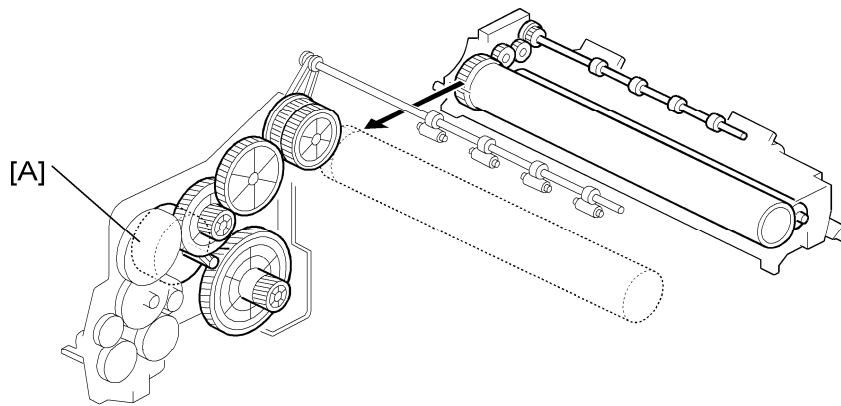

g094d504

The main motor [A] drives the fusing unit through a gear train.

6.5.3 FUSING ENTRANCE AND GUIDE SHAFT

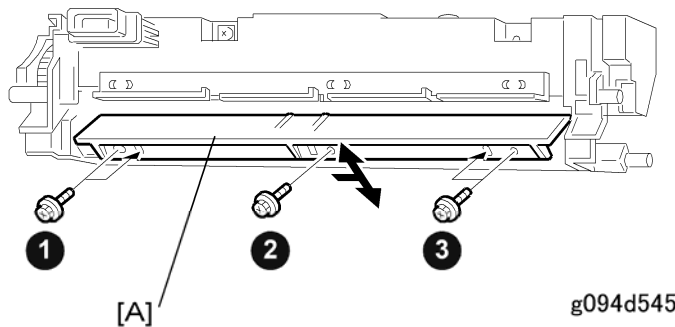

g094d545

The entrance guide [A] is adjustable for paper thickness to prevent creasing.

If creasing occurs frequently in the fusing unit, remove all screws (1 2 3) and slide the entrance guide to the right. Replace the two end screws only. Do not replace the middle screw. This procedure allows paper to have more direct access to the gap between the hot roller and the pressure roller.

6.5.4 PRESSURE ROLLER

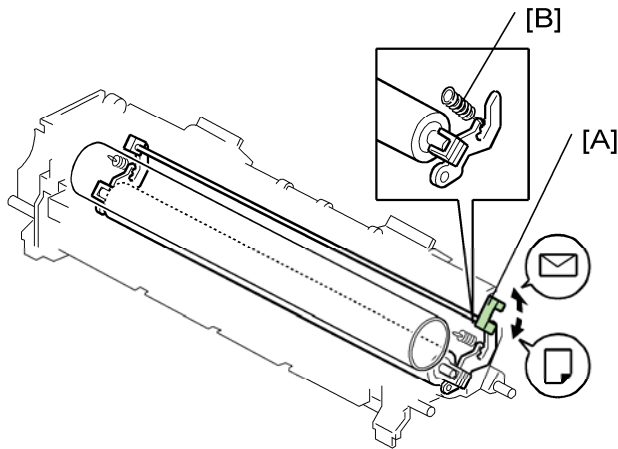

g176d505

To change the applied pressure (for example, if the customer complains of insufficient fusing), adjust the position of the pressure springs [B]. The factory setting for the spring position is at the top (minimum pressure).

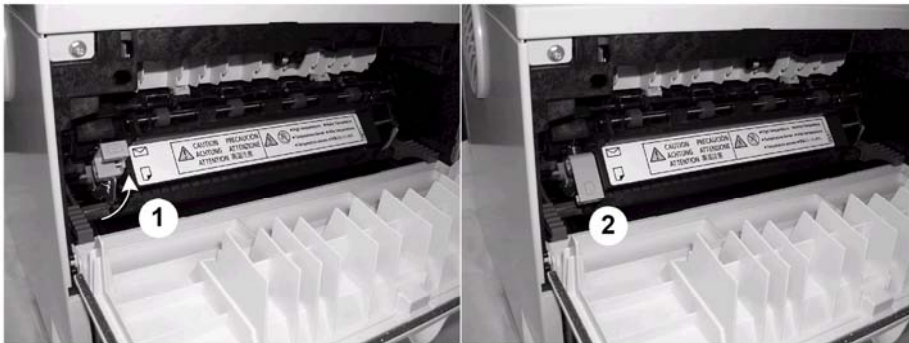

g176r900

The envelope lever [A] is used by the operator to adjust the size of the gap between the pressure roller and hot roller. A larger gap is needed for envelopes, which are thicker than paper.

- Raise the lever ❶ to increase the size of the gap between the hot roller and pressure roller. This prevents jams and wrinkling when printing on envelopes.
- Lower the lever ❷ to reduce the gap for all other print jobs. Normally this lever should be down.

Image Fusing and Paper Exit

6.5.5 NEW FUSING UNIT DETECTION

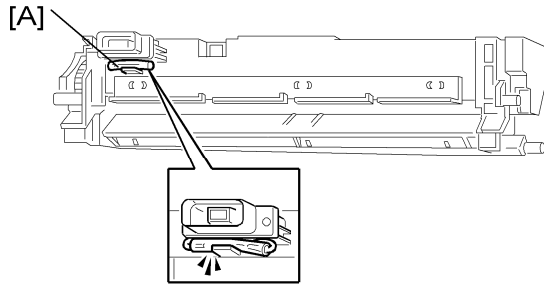

g094d546

There are two types of fusing unit: Service part, and Maintenance Kit part.

Only the fusing unit in the maintenance kit has the detection mechanism.

In the maintenance kit fusing unit, the looped wire on the fusing unit connector contains a fuse [A]. When power is switched on after installing a new fusing unit, the engine board detects the fusing unit through the looped wire. However, the fuse opens very shortly afterwards.

What happens next depends on the setting of engine SP mode 5930 (Meter Charge):

- If Meter Charge Mode is enabled, after the technician replaces the fusing unit, the maintenance counter must be reset with SP mode 7804.
- If Meter Charge Mode is disabled (default), after the fusing unit has been replaced: (1) the CPU detects the new unit, (2) the “Replace Maintenance Kit” message disappears automatically, and (3) the maintenance counter resets automatically.

6.5.6 FUSING TEMPERATURE CONTROL

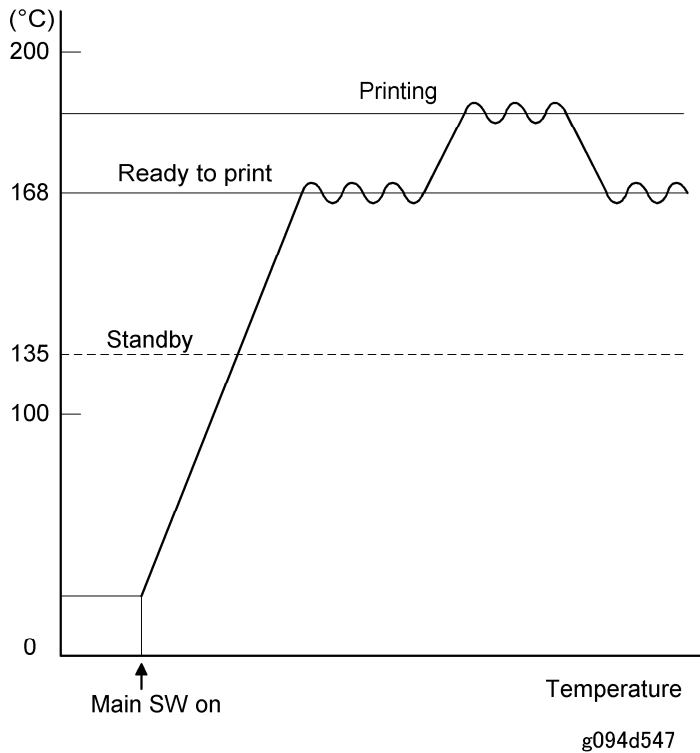

When the main switch turns on, the CPU turns on the fusing lamp using the soft start process. (The soft start process prevents the room lights from flickering.) The lamp stays on until the thermistor detects the standby temperature. Then the CPU maintains this temperature using on-off control. To start printing, the CPU raises the temperature to the printing temperature.

The fusing temperature for each mode is as follows:

Image Fusing and Paper Exit

Condition			Temperature (°C)				
Standby Mode			135				
Ready to Print			168				
Printing							
Charge Thermistor	Paper	Feed	Start-30s	0.5-2min.	2-4min	4-6min.	6min.-
<15°C	Plain, OHP	Bypass	190	185	180	175	170
	Env.	Bypass, Env. Feeder	195	195	190	190	190
	Postcard	Bypass	195	195	190	190	190
	Thick	Bypass	195	195	190	190	190
>15°C	Plain, OHP	Bypass	180	180	175	170	170
	Env.	Bypass, Env. Feeder	190	190	190	190	190
	Postcard	Bypass	190	190	190	190	190
	Thick	Bypass	190	190	190	190	190

Overheat Protection

If the hot roller temperature becomes greater than 245 °C, the CPU cuts off the power to the fusing lamp. At this time, SC543 will be generated.

If the thermistor overheat protection fails, there is a thermostat in series with the common ground line of the fusing lamp. If the temperature of the thermostat becomes greater than 210 °C, the thermostat opens, removing power from the fusing lamp. At this time, the machine stops operation.

6.5.7 PAPER EXIT

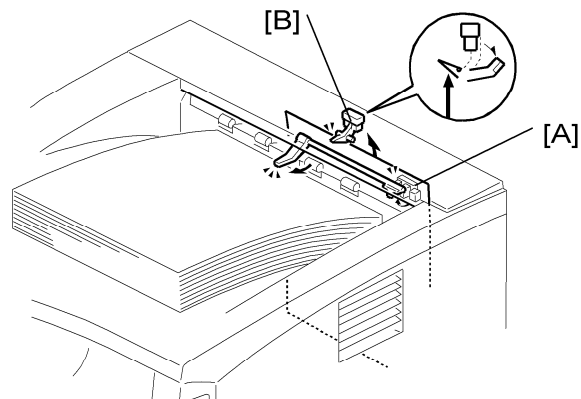

g094d601

[A] Paper overflow detection
sensor

[B] Paper exit sensor

When the paper overflow detection sensor [A] is activated, the machine detects that the paper stack height has exceeded a certain limit and stops printing.

The paper exit sensor [B] detects paper misfeeds.

Detailed
Descriptions

Image Fusing and Paper Exit

6.5.8 ENERGY SAVER MODE

When the machine is not being used, the energy saver feature reduces power consumption by switching off the fusing lamp.

Entering Energy Saver Mode

Energy saver mode starts after the machine has been idle for a specified time. The operator can set the time on the System menu. ([Menu] > "System"). Several settings are available: Off, 1, 5, 15, 30, 45, 60 min (Default: 5 min.)

When the machine is in energy saver mode, the CPU turns off the fusing lamp. The +5VE (power enabled in energy saver mode) line is active in energy saver mode; however, the +24V and +5V lines are not active.

Leaving Energy Saver Mode

The machine leaves energy saver mode when one of the following events occur:

- Print command received from the PC
- Any cover opened and closed
- Any operation panel keys pressed

6.6 CONTROLLER FUNCTIONS

Meter-charge Counter Display

When meter charge mode is switched on with SP5930-001, the meter-charge counter menu is the first item shown on the user menu:

Menu: Counter

(The “Sample Print” menu appears first when the meter-charge mode is switched off.)

PM Warning Display

When meter charge mode is switched on with SP5930, “Replace Maintenance Kit” will not be displayed at 90k prints. The default setting for this machine is meter-charge mode off.

Item	Meter-charge On	Meter-charge Off	Remarks
Meter-charge counter	Shown as the first item in the user menu	Not shown	User menu
PM Warning	Not shown	“Replace Maintenance Kit” displayed at 90k prints	
PM	Service	Customer	
PM Counter	Reset manually	Automatically reset when the fusing unit is replaced using the maintenance kit	Printer engine service mode “PM counter”

Controller Functions

The meter-charge counter is not the same as the PM counter because the meter-charge counter does not count up in the following cases:

- Blank rear side during duplex printing
- Blank page when using the “Cover Page” or “Two in One” features
- Service reports

 **Important**

- The meter-charge counter cannot be reset.

CÓPIA NÃO CONTROLADA

SPECIFICATIONS

CÓPIA NÃO CONTROLADA

CÓPIA NÃO CONTROLADA

CÓPIA NÃO CONTROLADA

7. SPECIFICATIONS

7.1 BASIC SPECIFICATIONS

7.1.1 GENERAL SPECIFICATIONS

Type	Desktop	
Technology	Laser beam scanning & Electro photographic printing and Dual-component toner development	
Operation Panel	<ul style="list-style-type: none"> ▪ 8 keys, 4 LEDs ▪ 2-line display (2 lines x 16 characters/line) 	
Resolution (dpi)	1,200 x 600 dpi, 600 x 600 dpi, 300 x 300 dpi	
Printing Speed	36 ppm (A4 - SEF), 37 ppm (LT - SEF) Note: 36 ppm/37 ppm applies to both simplex and duplex printing.	
First Print	6.9 sec or less (A4/LT, SEF, Std. Tray)	
Duplex Printing	A4/LT Approx. 100% productivity (from the standard tray)	
Dimensions (WxDxH)	Standard	388 x 450 x 345 mm 15.3 x 17.7 x 13.6 in.
	With back cover	388 x 455 x 345 mm 15.3 x 18.0 x 13.6 in.
	LG Mode	388 x 509 x 345 mm 15.3 x 20.0 x 13.6 in.
	With duplex attached	388 x 543 x 345 mm 15.3 x 21.4 x 13.6 in.
	With Opt. Tray (x1 500)	388 x 450 x 477 mm 15.3 x 17.7 x 18.8 in.

CÓPIA NÃO CONTROLADA

Basic Specifications

	With Opt. Trays (x2)	388 x 450 x 609 mm 15.3 x 17.7 x 24.0 in.	
Weight	17.5 kg / 38.6 lb. (with std. tray and AIO) 15.5 kg / 34.2 lb. (without AIO)		
Input capacity	Standard	Std Tray	500 sheets (80g/m ² , 20lb)
		Bypass tray	100 sheets (80g/m ² , 20lb)
	Op. Paper Tray	PFU	500 sheets x 2 (80g/m ² , 20lb)
	Max	1600 sheets (80g/m ² , 20lb)	
Output capacity	Standard Tray Face down	250 sheets (A4/LT, 80g/m ² , 20lb)	
Input Paper Size	Std. Tray	A4 SEF-A5 SEF, LG SEF-A5 SEFB, Width 98 to 216 mm - Length 140 to 356 mm (Width 3.9 to 8.5 in - Length 5.6 to 14 in.)	
	Bypass Tray	A4 SEF-A6 SEF, LG SEF-A6 SEF, Width 64 to 216 mm - Length 140 to 356 mm (Width 2.6 to 8.5 in - Length 5.6 to 14 in.)	
	Opt. Tray	A4 SEF-A5 SEF, LG SEF-A5 SEF, Width 98 to 216 mm - Length 160 to 356 mm (Width 3.9 to 8.5 in - Length 6.3 to 14 in.)	
Media Type	Std./Opt. Tray, Duplex Unit	Plain Paper, Thick Paper, Recycled Paper	
	Bypass tray	Plain Paper, Thick Paper, Transparency, Recycled Paper, Envelope	
	Env. Feeder	Envelope	
Paper Weight	Standard Tray	60-105g/m ² , 16-34 lb.	
	Op. Paper Tray	60-105g/m ² , 16-34 lb.	
	Bypass tray	60-162g/m ² , 16-43 lb.	

Warm-up Time	19 sec or less	
Target Yield	Toner (AIO)	15K prints. Starter: 6K prints
	Maint. Kit	90K prints
	<p>Note:</p> <p>1) A4 (8.5"x11")/ 5% Chart is used to measure the above yield.</p> <p>2) The condition is standard temperature and humidity.</p> <p>3) This yield number may change depending on the circumstances and printing conditions.</p>	
Environment	Energy Star Mode	<p>5 min (default)</p> <p>Selectable: 1, 5, 15, 30, 45, 60, Off</p>
Safety Standard		<p>US: UL60950, CUL</p> <p>EU: CE Marking, TUV(EN60950)</p>
Environmental Standard		<p>US: Energy Star</p> <p>EU: BAM specifications</p>
Total counter		Electric Counter
NRS		Supported
DESS		Supported
HDD		80 GB
RAM	Standard	256 MB
	Maximum	512 MB

Basic Specifications

7.1.2 EXTERNAL OPTIONS

Paper Tray (500 x1)	
Paper Size	A4 SEF-A5 SEF, LG SEF-A5 SEF
Paper Weight	60-130g/m ² , 16-34 lb.
Paper capacity	500 sheets x 2 tray (2 unit installable)
Dimensions(w x d x h)	388 x 486 x 135 mm (15.3 x 19.1 x 5.4 in.)
Weight	6.0 kg or less, 13.3 lb. or less
Envelope Feeder	
Paper Size	Crane Crest Com#10, Strathmore Writing Com#10, Neenah Classic Crest Com#10, C5,C6, DL
Paper capacity	60 Envelopes
Dimensions (w x d x h)	359.4 x 427 x 101 mm, 14.15 x 16.8 x 3.98 in.
Weight	1.7 kg or less, 3.75 lb or less
Duplex Unit (G893)	
Paper Size	A4 SEF-A5 SEF, LG SEF-A5 SEF
Paper Weight	60-105g/m ² , 16-28 lb.
Dimensions (w x d x h)	305.5 x 336.6 x 216.4 mm, 12.0 x 13.3 x 8.5 in.
Weight	5.0 kg or less, 13.2 lb or less
Printing Speed	P2: 36 (A4-SEF) / 37 (LT-SEF) ppm

7.1.3 PAPER SIZES**Plain Paper**

Type	Orient	Size	Std. Tray	Opt. Tray	Bypass	Env. Feed	Dup.
A4	SEF	210x297 mm	D	D	C	N	A
B5	SEF	182x257 mm	D	D	C	N	A
A5	SEF	148x210 mm	D	D	C	N	A
	LEF	210x148 mm	B	N	C	N	A
B6	SEF	128x182 mm	N	N	N	N	N
A6	SEF	105x148 mm	N	N	C	N	N
Legal	SEF	8 1/2"x14" mm	D	D	C	N	A
Letter	SEF	8 1/2"x11" mm	D	D	C	N	A
HLT	SEF	5 1/2" x 8 1/2"	D	D	C	N	A
	LEF	5 1/2" x 8 1/2"	B	N	C	N	A
Exec	SEF	7 1/4"x10 1/2"	N	B	C	N	A
F	SEF	8" x 13"	B	B	C	N	A
Foolscap	SEF	8 1/2" x 13"	B	B	C	N	A
Folio	SEF	8 1/4" x 13"	B	B	C	N	A

Basic Specifications

Envelope

Type	Orient	Size	Std. Tray	Opt. Tray	Bypass	Env. Feed	Dup.
Com10	SEF	4 1/8" x 9 1/2"	N	N	C	C	N
Monarch	SEF	3 7/8" x 7 1/2"	N	N	C	C	N
C6	SEF	114 x 162 mm	N	N	C	C	N
C5	SEF	162 x 229 mm	N	N	C	C	N
DL Env	SEF	110 x 220 mm	N	N	C	C	N

Custom

		Std. Tray	Opt. Tray	Bypass	Env. Feed	Dup.
Width	98-216 mm (3.9-8.5 in.)	B	B	/	N	N
Length	140-356 mm (5.5-14 in.) 160-356 mm (6.3-14 in.) Opt. Tray	B	B	/	N	N
Width	64-216 mm (2.5-8.5 in.)	/	/	C	N	N
Length	140-356 mm (5.5-14 in. in.)	/	/	C	N	N

A	Supported and the size is automatically detected.
B	Need to select paper size by operation panel after the dial is set to
C	Need to input paper size by operation panel and driver.
D	Need to specify paper size by using dial.
N	Not supported.
/	Does not apply

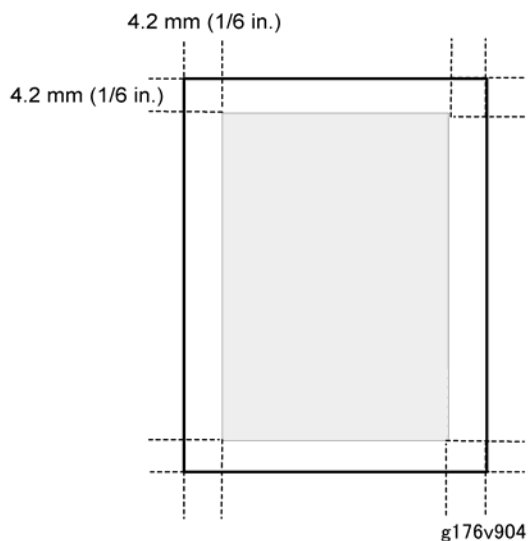

Note

- The printable area may vary depending on paper size, printer language and printer driver settings.

Basic Specifications

Envelopes

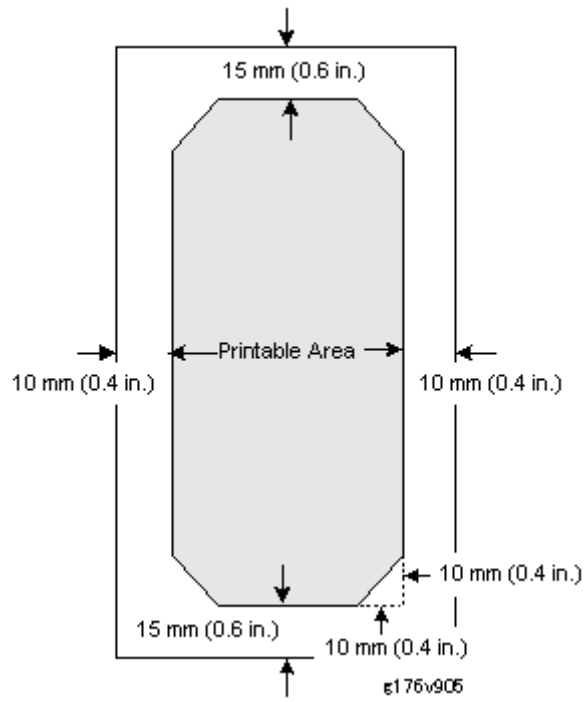

7.1.4 OPERATING ENVIRONMENT

Power Source	North America: 120 V, 60 Hz		
	Europe: 220-240 V, 50/60 Hz		
Power Consumption (North America)	North America	Main Unit	Full System
	Maximum	930 W or less	960 W or less
	Printing	630 W or less	630 W or less
	Energy Saver	4.5 W or less	10 W or less
Power Consumption (Europe)	Europe	Main Unit	Full System
	Maximum	970 W or less	990 W or less
	Printing	630 W or less	630 W or less
	Energy Saver	4.5 W or less	10 W or less
Noise Emission	Printing	67 dB or less	71 dB or less
	Standby	42 dB or less	42 dB or less
Sound Pressure Level (All Models) (Operating Position)	Printing	61 dB or less	65 dB or less
	Standby	36 dB or less	36 dB or less

Basic Specifications

7.1.5 OPERATION PANEL LED SPECIFICATIONS

LED	Color	Appearance	Meaning
Power	Green	Off	Power off or in Energy Saver mode
		Flashing	Warming up
		On	Power on and not in Energy Saver mode
Data In	Green	Off	No data
		Flashing	Data being received or processed or the printer is spooling
		On	Data being received or processed; more data coming
Suspend/Resume	Green	Off	Ready to print
		On	Suspend
Error	Red	Off	No messages or error conditions requiring attention
		On	Printer requires service

7.2 CONTROLLER SPECIFICATIONS

7.2.1 CONTROLLER BOARD

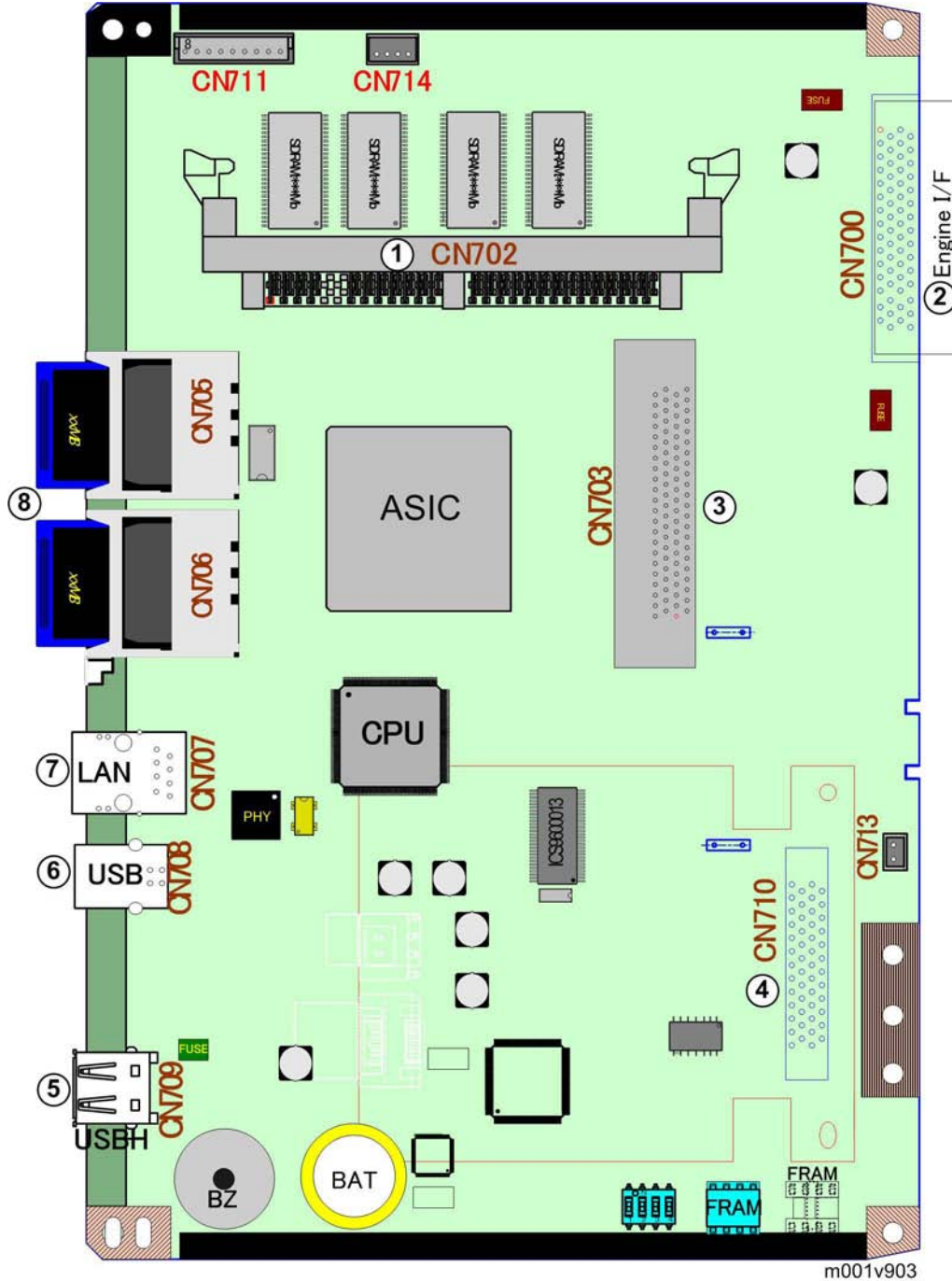

Specifications

Controller Specifications

1. DDR DIMM I/F
2. Engine I/F
3. PCI Option
4. HDD I/F
5. USB Host I/F
6. USB I/F
7. LAN I/F
8. SD Card I/F (Slots x2)

7.2.2 PRINTING FUNCTIONS

Job Spool	Y*
Adjustment Registration	Y
Adjustment Image Density	Y
* With HDD	

7.2.3 PRINTER DRIVERS

Item	PCL5e/6	RPCS	PostScript3		
			Windows	Mac	
			2000/XP/ Vista /Server2003 /2008	OS 8.6-9.2	OSX
Job Binding	N	Y	N	N	N
Send to Document Server	N	N	N	N	N
Sample Print	Y	Y	Y	Y	Y*3
Locked Print	Y	Y	Y	Y	Y*3
Reduce/Enlarge (Scaling)	N	Y	Y	Y	Y
Reduce/Enlarge Centering	Y	Y	N	N	N
Collate	Y	Y	Y	Y	Y
Layout (N-up)	Y	Y	Y	Y	Y
Poster	N	Y	N	Y	N
Duplex	Y	Y	Y	Y	Y
Booklet1	N	Y	N	N	N
Booklet2 (Magazine)	Y	Y	N	N	N
Non-Reduction Booklet	N	Y	N	N	N

CÓPIA NÃO CONTROLADA

Controller Specifications

Punch	N	N	N	N	N
Staple	N	N	N	N	N
Front Cover Sheet	Y	Y	N	Y*1	Y*1
Front and Back Cover Sheets	N	N	N	N	N
Slip Sheet	Y	Y	N	N	N
Chaptering (Page Layout)	N	N	N	N	N
Chaptering (Single Page Insert)	N	N	N	N	N
Chaptering (Page Block Insert)	N	N	N	N	N
User Defined Pages	Y	N	N	N	N
Tab Stock Printing	N	N	N	N	N
Mirror Image Print	N	N	Y	Y	N
Negative Image Print	N	N	Y	Y	N
Dithering	Y	Y	Y	Y	Y
Image Smoothing	/	/	Y	Y	Y
Edge Smoothing	Y	Y	Y	Y	Y
Toner Saving	Y	Y	Y	Y	Y
Watermark	Y	Y	Y*2	Y	Y*2
Form Overlay	N	Y	N	N	N

Header/Footer	N	Y	N	N	N
Adjust image position	N	Y	N	N	N
Binding Margins	N	Y	N	N	N
User ID	Y	Y	Y	Y	Y*3
User Code	Y	Y	Y	Y	Y*3
Rotate Print	Y	Y	Y	N	N
Reverse Order Print	N	Y	Y	Y	Y
Do not print Blank pages	N	Y	N	N	N
Edge to Edge Print	Y	Y	Y	Y	Y
Y*3: After Mac OSX10.2					

Controller Specifications

7.2.4 SUPPORTED ENVIRONMENTS

Windows Environments

Windows OS	Type	PCL5e	PCL6	RPCS	PS3
Win 2000	Professional	Yes	Yes	Yes	Yes * ¹
	Server (*1)	Yes	Yes	Yes	Yes * ¹
	Advanced Server (*1)	Yes	Yes	Yes	Yes * ¹
	Datacenter Server	No	No	No	No
Win XP	Professional	Yes	Yes	Yes * ²	Yes * ¹
	Professional x64 Ed.	Yes * ²	Yes * ²	Yes * ²⁺⁴	Yes * ¹⁺³
	Home Ed.	Yes	Yes	Yes * ²	Yes * ¹
Win Server 2003/2003R2	Standard Ed.	Yes	Yes	Yes	Yes * ¹
	Enterprise Ed.	Yes	Yes	Yes	Yes * ¹
	Datacenter Ed.	No	No	No	No
	Standard x64 Ed.	Yes* ³	Yes* ³	Yes* ⁴	Yes * ¹⁺³
	Enterprise x64 Ed.	Yes* ³	Yes* ³	Yes* ⁴	Yes * ¹⁺³
	Datacenter x64 Ed.	No* ³	No* ³	No* ⁴	No* ³
	Web Ed.	No	No	No	No
Vista	Ultimate Ed.	Yes	Yes	Yes	Yes
	Enterprise Ed.	Yes	Yes	Yes	Yes
	Business Ed.	Yes	Yes	Yes	Yes
	Premium Ed.	Yes	Yes	Yes	Yes
	Home Ed.	Yes	Yes	Yes	Yes

Notes

*1	Adobe does not release PS driver for Windows 2000 and XP. Only MS-PostScript driver is available and PPD file for MS-PS is included in the Driver CD.
*2	RPCS driver does not support "Fast User Switching" function of Windows XP.
*3	64bit drivers are not included in driver CD-ROM and are provided by web site(English only)
*4	RPCS64bit driver is in the progress of release schedule.

Mac OS Environments

Mac OS	PS3	Printer Utility for MAC
Mac OS 8.6 - 9.2.X (OS X Classic)	Y	Y
Mac OS X Native (v. 10.1 or Later) *1	Y	Y*2

Notes

*1 Mac OS X v.10.0.X is not supported. Plug-in function for "Sample Print", "Locked Print" and "User Code" is supported from Mac OS X 10.2 and later.

*2 Mac OS X v.10.2.0 is not supported.

Controller Specifications

UNIX Environment

Supported Platforms	Network Installation	Device Option Support*
Sun Solaris	2.6 / 7 / 8/ 9 /10	2.6 / 7 / 8/ 9 / 10
HP-UX	10.X / 11.X / 11iv2	10.X / 11.X / 11iv2
SCO OpenServer	5.07 , 6.0	5.07 , 6.0
RedHat Linux	6.X / 7.X / 8.X / 9.X / Enterprise	6.X / 7.X / 8.X / 9.X / Enterprise
IBM AIX	V4.3 / 5L V5.1 / 5L V5.2 / 5L V5.3	V4.3 / 5L V5.1 /5L V5.2 / 5L V5.3
Data Stream	PostScript, PCL, ASCII	
Localization	English only	
* Device Option feature is not supported in PCL.		

Novell Netware

Netware Server	Supported Version	Netware 3.12, 3.2, 4.1, 4.11, 5.0, 5.1, 6 , 6.5
	Client OS	Windows 2000 / XP(professional) /Vista
NDPS Gateway (V4 Release)	Supported Server OS	NetWare 5.1 with SP7 or later, 6.0 with SP4 or later, 6.5
	Supported Client OS	Microsoft Windows 2000/XP Professional with Novell Client 4.83 or later *Windows XP Home Edition is not supported since Novell Client does not support this OS.
	Localization	English, German, French, Italian, Spanish

SAP R/3 Environment

Supported environment	R/3 version	3.x or later (4.x = Supported, 3.x, 6.x = Compatible)
	Platform	Independent
	PDL	PCL5e
	Character Set	Latin 1(Western European), Latin 2 (Eastern European)
	Localization	English only
Supported features	i.e: Input/Output Bin, Duplex, Stapling, Punching, Resolution, Collation, EconoMode/TonerSaving, Smoothing, Page Protect, Auto Tray Change/Opt Tray select	
Supported Barcode & OCR Fonts*	Barcode Fonts (Support Latin 1 only)	Code 128, Code 39, Code 93, Codebar, 2 of 5 interleaved/Industrial/Matrix, MSI, USPS, UPC/EAN
	OCR Fonts	OCR A, OCR B
* Need to purchase Barcode & OCR Package		

Controller Specifications

7.2.5 CONTROLLER INTERFACE SPECIFICATIONS

Network Interface (Standard)	
Data Transmission Speed	10M bps, 100 Mbps
Protocol	TCP/IP, IPX/SPX, SMB, AppleTalk
Supported OS	Windows 2000/XP/Vista, Windows Server2003/2003R2/2008, Mac OS
Distance between devices	100m
USB 2.0 Interface (Standard)	
Data Transmission Speed	480 Mbps (High Speed:USB 2.0), 12 Mbps (Full Speed)
Supported OS	Windows 2000/XP (USB 1.1), Windows 2000/XP (USB 2.0)
IEEE 1284 Interface (Option)	
Data Transmission Speed	Compatible/Nibble/Byte/ECP mode
Supported OS	Windows 2000 /XP /Server2003, Mac OS
Distance between devices	2.5m

Wireless LAN Interface (Option)	
Data Transmission Speed	11 Mbps, 5.5 Mbps, 2 Mbps, 1 Mbps
Protocol	TCP/IP, IPX/SPX, SMB, AppleTalk
Supported OS	Windows 2000/XP/Vista, Windows Server2003/2003R2/2008, Mac OS
Distance between devices	140m (11M bps), 200m (5.5 Mbps), 270 m (2 Mbps), 400 m (1 Mbps)
Frequency	From 2,400 MHz to 2,497 MHz
Channel	1-11 ch (US model), 1-13 ch (EU model)
Type of connection	Ad hoc mode, 802.11b Ad hoc mode, Infrastructure mode, WPA
Gigabit Ethernet (Option)	
Data Transmission Speed	10M bps, 100 Mbps, 1000 Mbps
Protocol	TCP/IP, IPX/SPX, SMB, AppleTalk
Supported OS	Windows 2000/XP/Vista, Windows Server2003/2003R2/2008, Mac OS
Distance between devices	100m

Controller Specifications

7.2.6 SUPPORTED UTILITIES***Bundled Utilities***

No.	Utility Name	Supported?
1	SmartDeviceMonitor for Admin	YES
2	Printer Utility for Mac	YES ^{*1, *2}
3	DeskTopBinderLite –SmartDeviceMonitor for Client	YES
4	Font Manager 2000	YES
5	WebImageMonitor (embedded web server)	YES

*1Mac OS X v.10.0.x is not supported.

*2Mac OS X v.10.2.0 is not supported

Optional Utilities

No.	Utility Name	Supported?
1	DeskTopBinder Professional	YES
2	Web Smart Device Monitor	YES

7.3 MACHINE CONFIGURATION

7.3.1 SYSTEM COMPONENTS

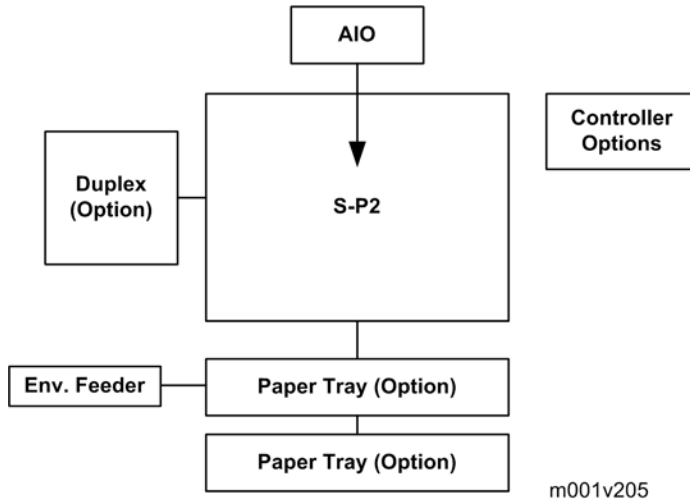

All the options listed below can be installed by the customer, except the Data Overwrite Security Unit.

Main		
Mainframe (36 / 37 ppm)	M001	36 ppm (A4 - SEF) 37 ppm (LT - SEF)
Options		
Paper Feed Unit TK1030	G894	1 or 2 trays can be installed.
Duplex Unit AD1000	G893	
Envelope Feeder Type 400	G362	If 2 PFUs are installed, the envelope feeder must go in the top tray.

Machine Configuration

Internal Options		
Memory Unit Type G 128 MB	M345	
Memory Unit Type G 256 MB	D362	
Hard Disk Drive Type 2670	M352	
IEEE 1284 Interface Board Type A	B679	
IEEE 802.11a/g interface Unit Type L	M344	For NA
IEEE 802.11a/g Interface Unit Type M	M344	For EU
Gigabit Ethernet Board Type A	G874	
VM Card Type K	D354	
Data Storage Card Type A	G874	
Data Overwrite Security Unit Type L	M352	Must be installed by a technician.

CÓPIA NÃO CONTROLADA

G893

DUPLEX UNIT AD1000

CÓPIA NÃO CONTROLADA

CÓPIA NÃO CONTROLADA

CÓPIA NÃO CONTROLADA

G893

TABLE OF CONTENTS

1. REPLACEMENT AND ADJUSTMENT	1
1.1 COVERS	1
1.2 DUPLEX BOARD AND SENSORS	2
1.3 INVERTER MOTOR.....	3
2. DETAILED DESCRIPTIONS	4
2.1 OVERVIEW.....	4
2.1.1 MECHANICAL COMPONENTS	4
2.1.2 DRIVE COMPONENTS	5
2.1.3 ELECTRICAL COMPONENTS	5
2.2 DUPLEXING	7
2.2.1 A4 LEF/LT LEF AND LONGER PAPER.....	7
2.2.2 PAPER SMALLER THAN A4 LEF/LT LEF.....	7
2.2.3 FEED IN AND EXIT MECHANISM	9
2.3 SAFETY FUSE.....	10

CÓPIA NÃO CONTROLADA

CÓPIA NÃO CONTROLADA

1. REPLACEMENT AND ADJUSTMENT

1.1 COVERS

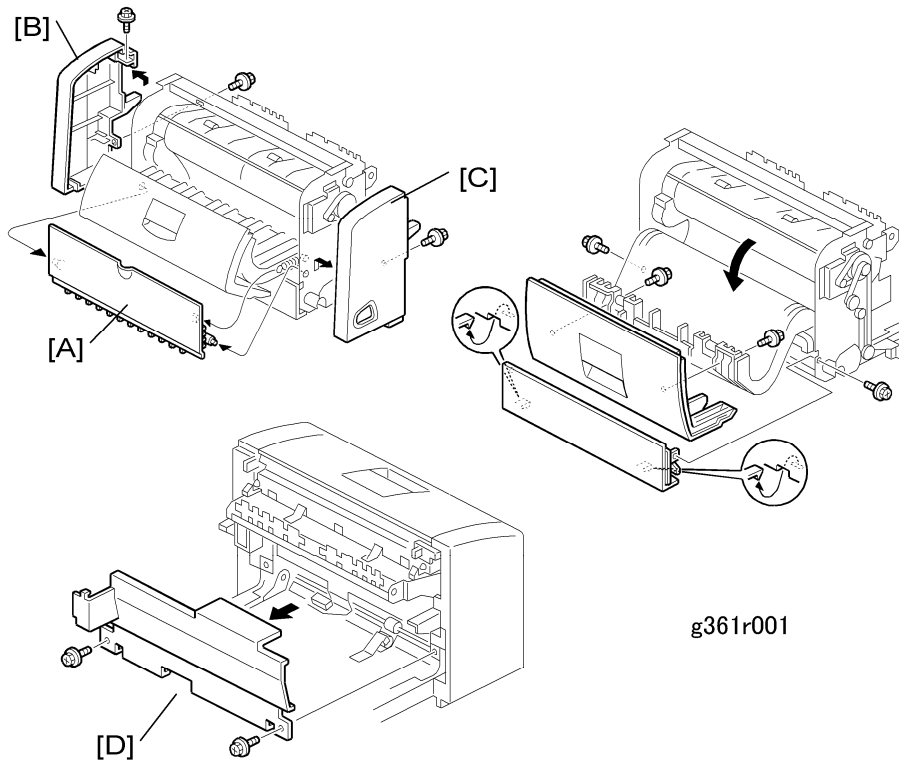

CAUTION

- Turn off the main power switch and unplug the machine before attempting any of the procedures in this section.
- Remove the duplex unit from the main unit.
- Open the upper cover [A]

[A] Upper cover (⚙️ x 2)

[B] Right cover (⚙️ x 2)

[C] Left cover (⚙️ x 1)

[D] Front cover (⚙️ x 2)

1.2 DUPLEX BOARD AND SENSORS

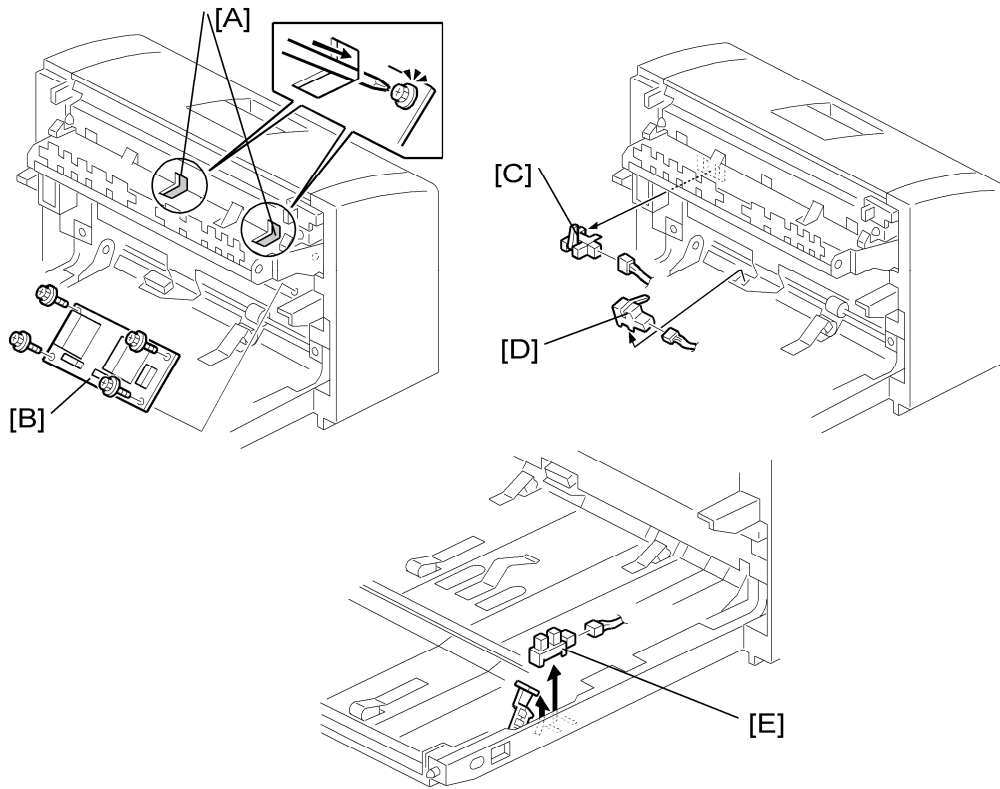

g361r102

- Remove front cover (see previous section).

[A] Duplex board bracket (🔩 x2)

[B] Duplex board (🔩 x4)

[C] Inverter sensor (🔩 x1)

[D] Entrance sensor (🔩 x1)

[E] Exit sensor (🔩 x1)

Inverter Motor

1.3 INVERTER MOTOR

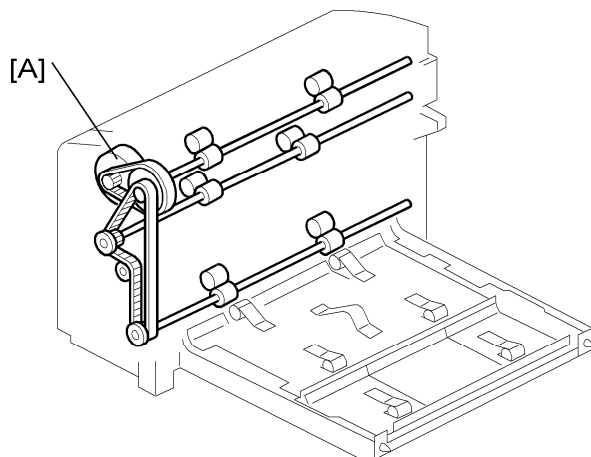

g361d002

★ Important

- Remove the motor bracket before removing the inverter motor.

[A] Inverter motor (Timing belts x2, C x1, Gear x1)

G893
Duplex Unit
AD1000

2. DETAILED DESCRIPTIONS

2.1 OVERVIEW

2.1.1 MECHANICAL COMPONENTS

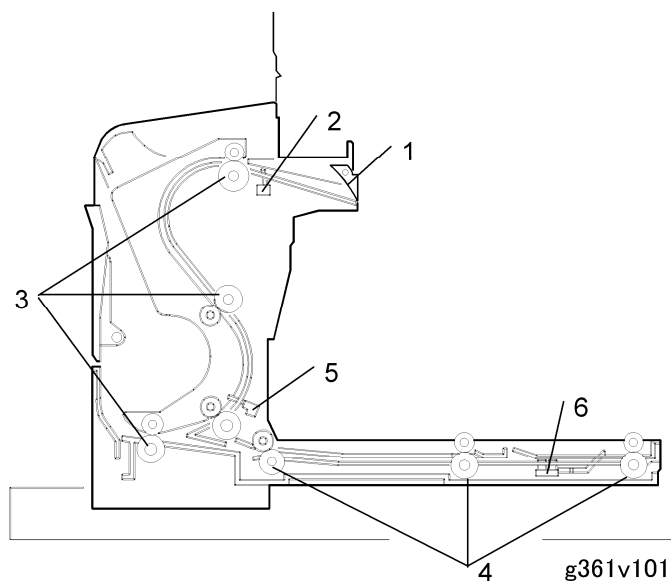

1. Junction gate
2. Entrance sensor
3. Inverter rollers
4. Transport rollers
5. Transport sensor
6. Exit sensor

Overview

2.1.2 DRIVE COMPONENTS

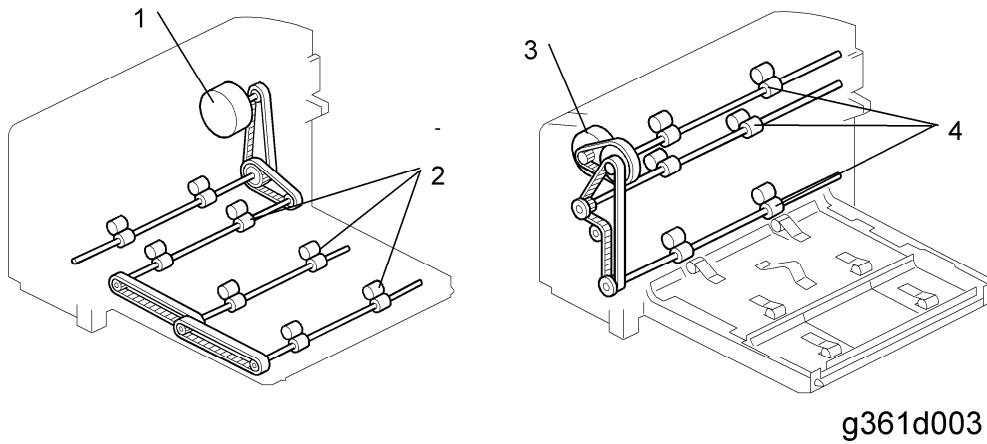

1. Transport motor
2. Transport rollers
3. Inverter motor
4. Inverter rollers

2.1.3 ELECTRICAL COMPONENTS

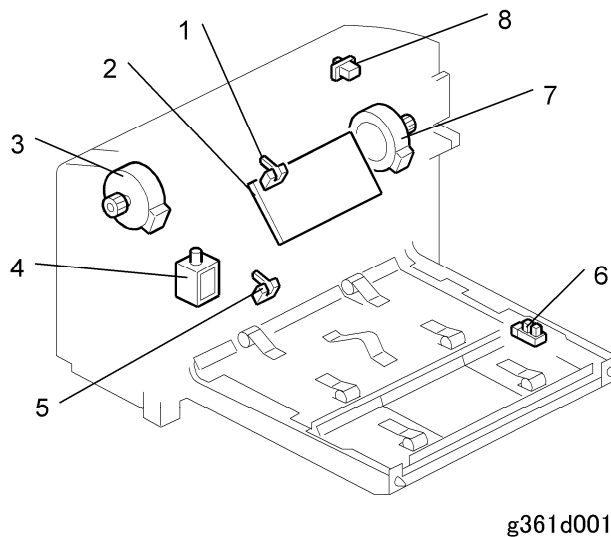

1. Entrance sensor
2. Duplex board
3. Inverter motor

G893
Duplex Unit
AD1000

4. Junction gate solenoid
5. Inverter sensor
6. Exit sensor
7. Transport motor
8. Cover switch

Duplexing

2.2 DUPLEXING

2.2.1 A4 LEF/LT LEF AND LONGER PAPER

The duplex unit can store only one sheet of paper.

Example: 8 pages. The center number (not circled) in the illustration shows the page order in the job. The circled numbers show the printing order (white circles: 1st side, black circles: 2nd side).

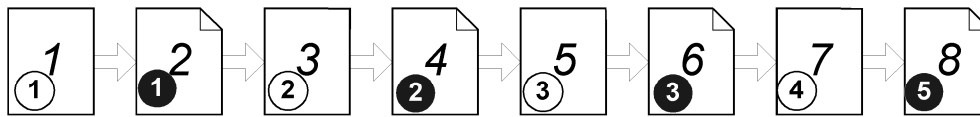

g361i500

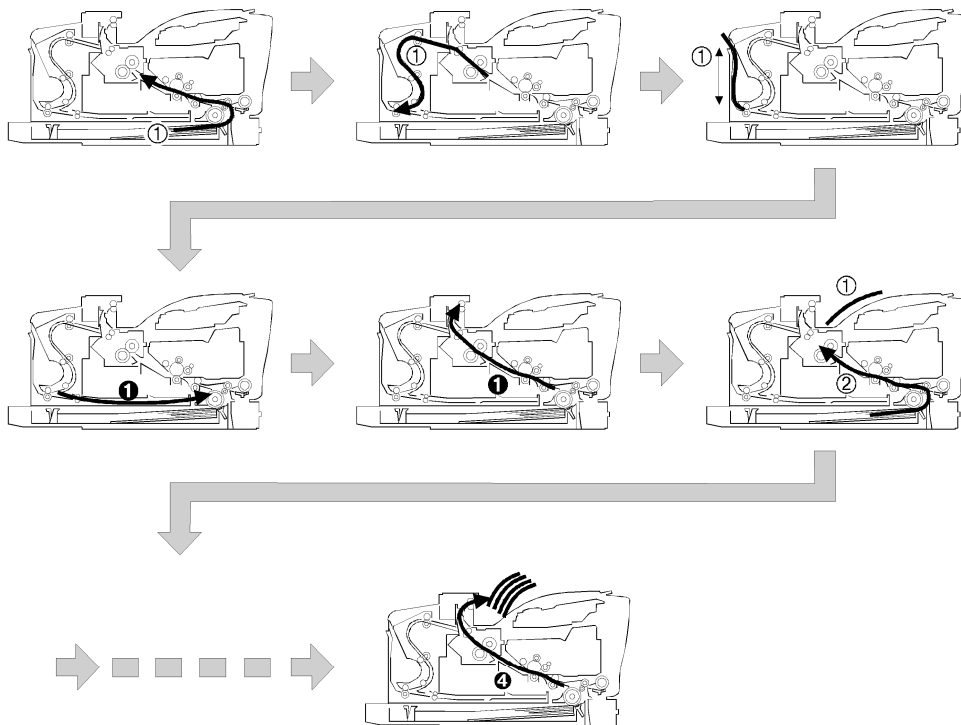

g361d106

2.2.2 PAPER SMALLER THAN A4 LEF/LT LEF

The duplex unit can store three sheets of paper.

Example: 8 pages. The center number (not circled) in the illustration shows the page order in the job. The circled numbers show the printing order (white circles: 1st side, black circles: 2nd side).

G893
Duplex Unit
AD1000

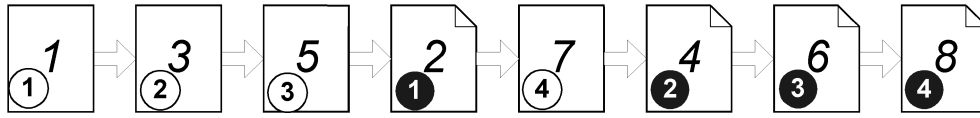

g361i501

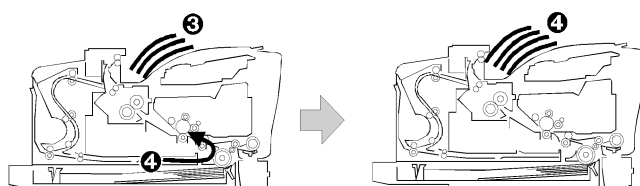
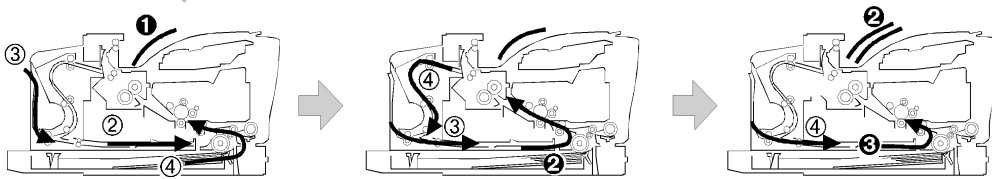
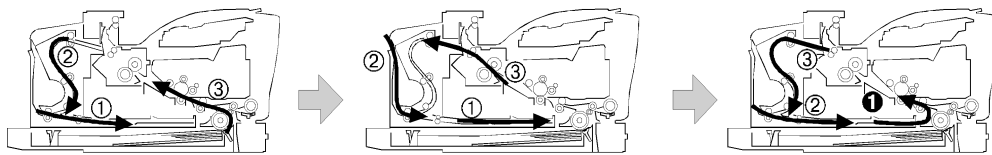
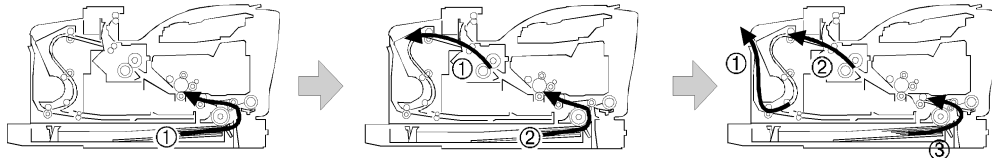

g361d107

Duplexing

2.2.3 FEED IN AND EXIT MECHANISM

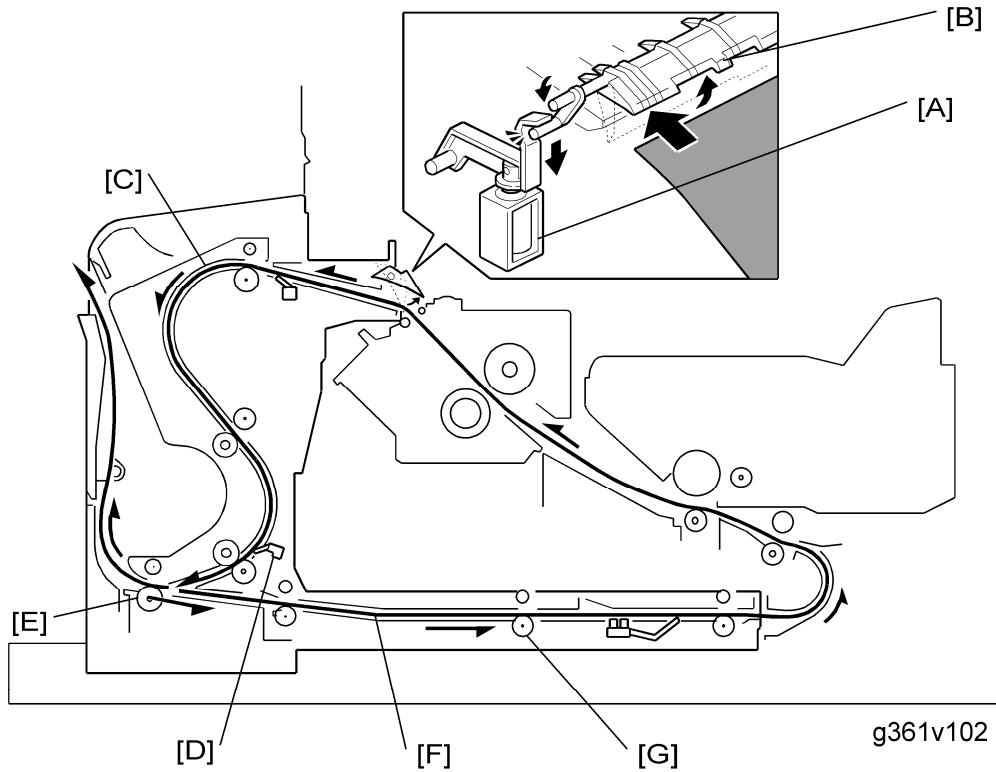

Feed:

The junction gate solenoid [A] turns on to open the junction gate [B]. The paper fed from the main frame is sent to the inverter section [C].

Inversion and Exit:

After the trailing edge of the paper passes the inverter sensor [D], the inverter roller [E] changes its rotation direction and the paper goes to the transport area [F].

The transport rollers [G] send the paper to the registration rollers in the main frame.

G893
Duplex Unit
AD1000

2.3 SAFETY FUSE

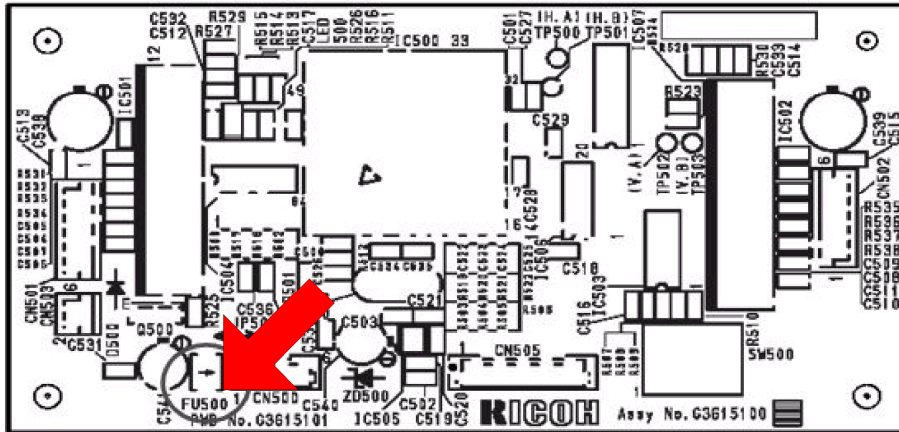

g361d901a

Name	Rating	Manufacturer	Type No.
FU500	DC50V/1.5A	ROHM CO.,LTD	ICP-N38

CÓPIA NÃO CONTROLADA

**G894 PAPER FEED UNIT TK1030
&
G362 ENVELOPE FEEDER TYPE 400**

CÓPIA NÃO CONTROLADA

CÓPIA NÃO CONTROLADA

CÓPIA NÃO CONTROLADA

G894/G362

TABLE OF CONTENTS

1. REPLACEMENT AND ADJUSTMENT	1
1.1 PAPER FEED UNIT	1
1.2 PAPER FEED ROLLER	2
1.3 FRICTION PAD	3
1.4 PAPER FEED CLUTCH, MOTOR	4
1.5 PAPER TRAY BOARD	5
1.6 PAPER SIZE SWITCH	6
2. DETAILED DESCRIPTIONS	7
2.1 OVERVIEW	7
2.1.1 MECHANICAL COMPONENTS	7
2.1.2 ELECTRICAL COMPONENTS	7
2.2 PAPER FEED AND SEPARATION	8
2.3 PAPER LIFT	9
2.4 PAPER END DETECTION	10
2.5 REMAINING PAPER DETECTION	11
2.6 PAPER SIZE DETECTION	12
2.7 SAFETY FUSE	13
3. ENVELOPE FEEDER	14
3.1 ENVELOPE FEEDER (G362)	14

CÓPIA NÃO CONTROLADA

CÓPIA NÃO CONTROLADA

1. REPLACEMENT AND ADJUSTMENT

1.1 PAPER FEED UNIT

CAUTION

- Turn off the main power switch and unplug the machine before attempting any of the procedures in this section.

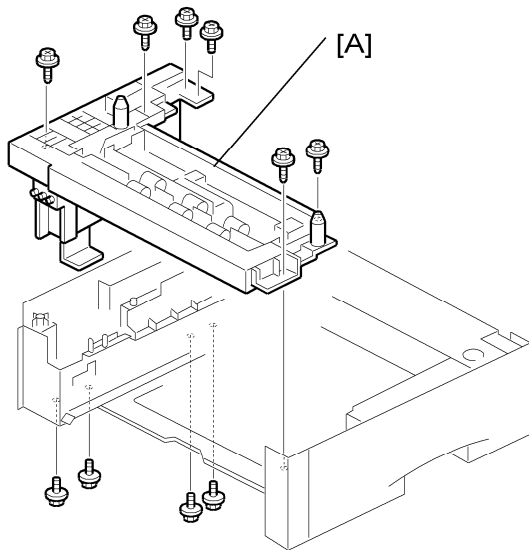

g360r001

1. Remove the paper tray unit from the main unit.
2. Pull out the paper tray.
3. Before removing the paper feed unit, turn the main unit over.
4. Remove the paper feed unit [A] ( x10)

1.2 PAPER FEED ROLLER

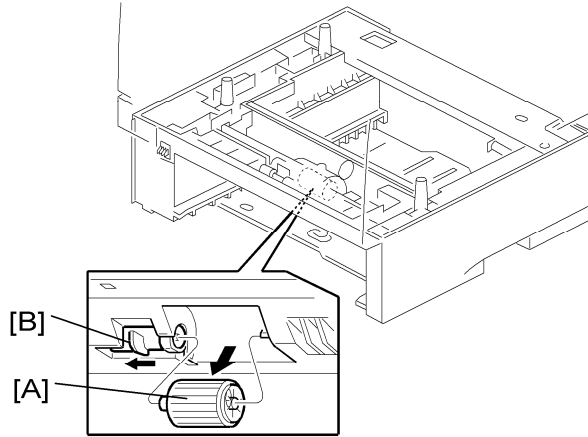

g360r103

1. Pull out the paper tray.
2. Pull lever [B] to remove the paper feed roller [A].

Friction Pad

1.3 FRICTION PAD

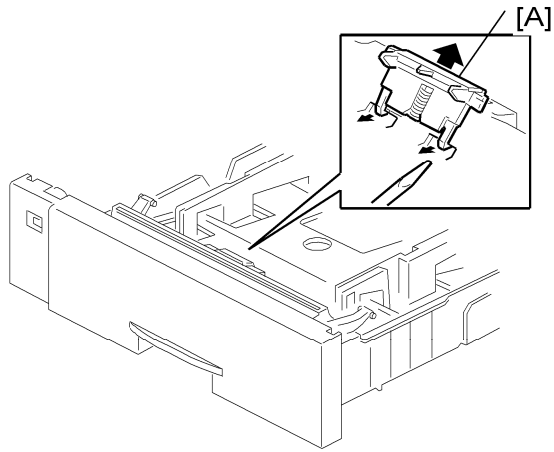

g360r102

1. Pull out the paper tray
2. Remove friction pad [A].

G894 Paper
Feed Unit
&
G362
Envelope
Feeder

1.4 PAPER FEED CLUTCH, MOTOR

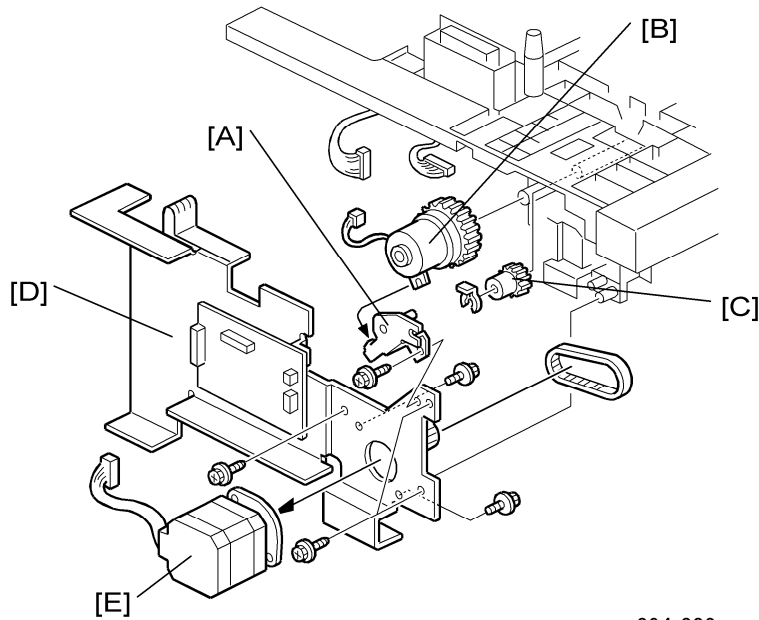



g894r003

- [A] Bracket (🔩 x1)
- [B] Paper feed clutch (🔩 x1, gear x1)
- [C] Paper feed gear (🔩 x1)
- [D] Feed motor bracket (🔩 x3, 📏 x2)
- [E] Feed motor (🔩 x2, Timing belt x1, 📏 x1)

Paper Tray Board

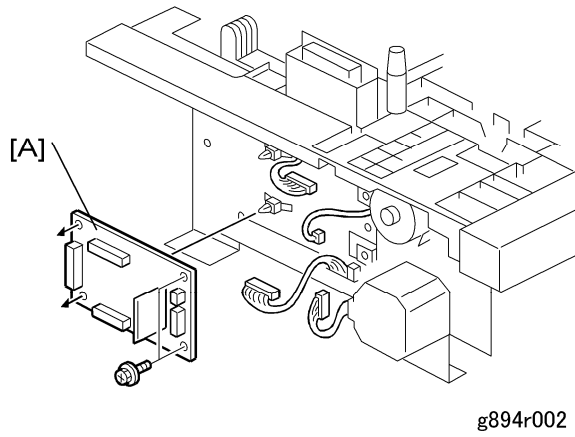
1.5 PAPER TRAY BOARD



[A] Paper tray board (Hooks x3,  x2)

G894 Paper
Feed Unit
&
G362
Envelope
Feeder

1.6 PAPER SIZE SWITCH

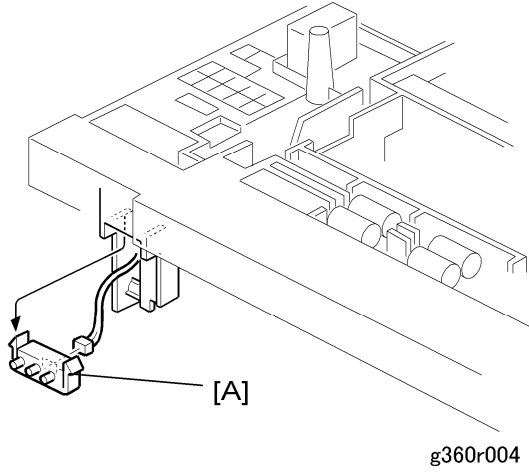

[A] Paper size switch (Hook x1,  x1)

2. DETAILED DESCRIPTIONS

2.1 OVERVIEW

2.1.1 MECHANICAL COMPONENTS

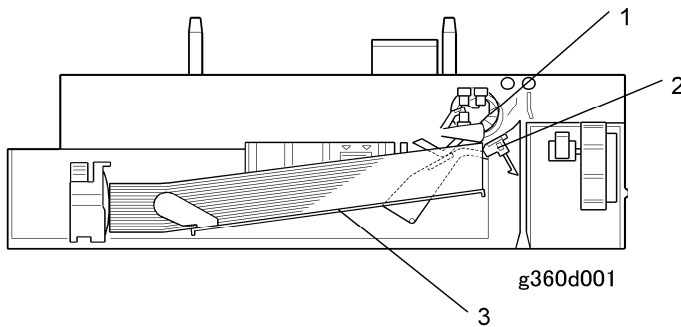

1. Paper feed roller
2. Friction pad
3. Bottom plate

2.1.2 ELECTRICAL COMPONENTS

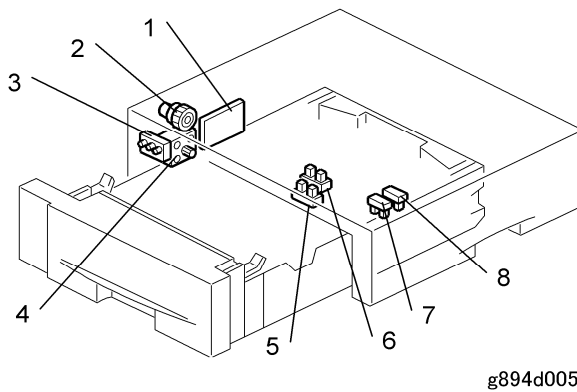

- | | |
|----------------------|-----------------------------|
| 1. Paper tray board | 5. Paper end sensor |
| 2. Paper feed clutch | 6. Paper feed sensor |
| 3. Paper size switch | 7. Remaining paper sensor 1 |
| 4. Paper feed motor | 8. Remaining paper sensor 2 |

2.2 PAPER FEED AND SEPARATION

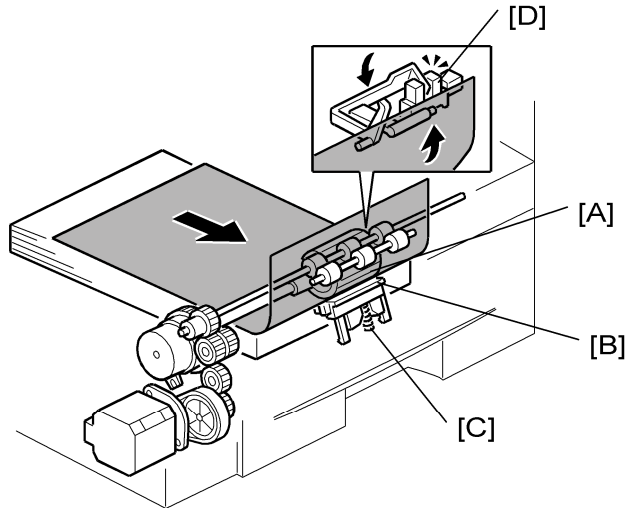

g894d004

The paper tray holds 500 sheets of paper

The paper feed unit uses the feed roller and friction pad method to separate paper.

[A] Paper feed roller

[B] Friction pad

[C] Pressure spring

[D] Paper feed sensor

2.3 PAPER LIFT

Paper lift is the same as for the main unit.

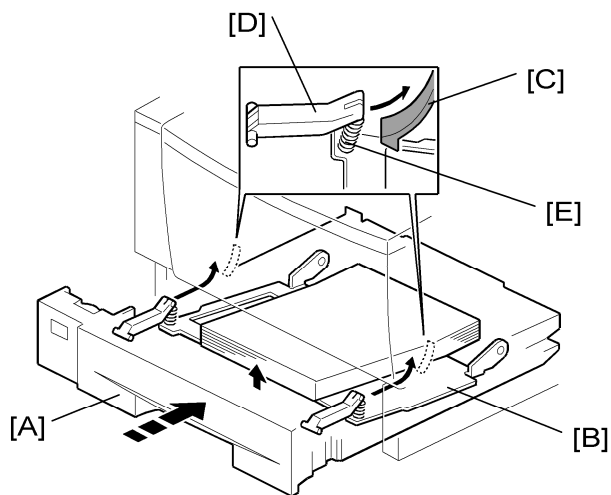

g094d004

When the user puts the tray [A] in the machine, the bottom plate [B] lifts as follows.

- The slopes on the guide blocks [C] on the machine lift the tray arms [D] up.
- The springs [E] between the tray arms and bottom plates lift the plate.
- The springs [E] keep the top sheet of the paper at the correct height.

2.4 PAPER END DETECTION

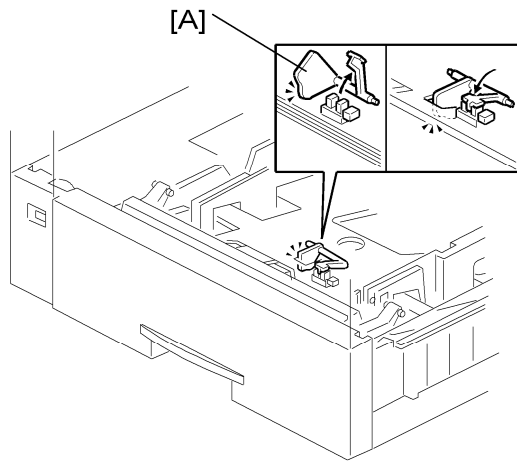

g360d103

When the paper tray runs out of paper, the feeler [A] drops into the cutout in the bottom plate to actuate the remaining paper sensor.

2.5 REMAINING PAPER DETECTION

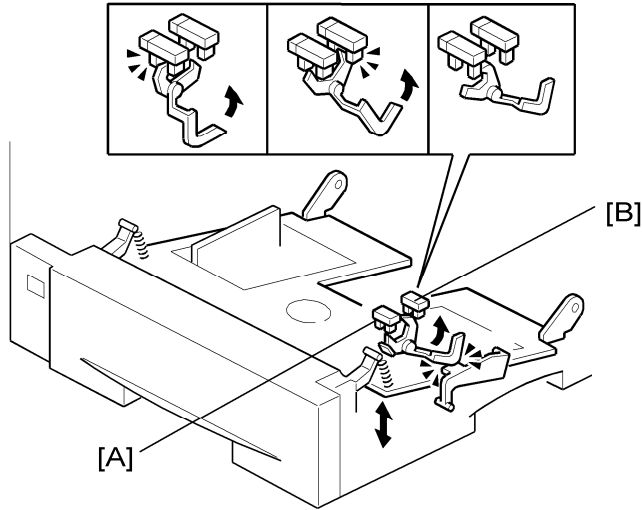

g094d002

[A] Remaining paper sensor 1

[B] Remaining paper sensor 2

Amount of paper	Remaining Paper Sensor 1	Remaining Paper Sensor 2
0 sheets (0%)	On	On
50 sheets (10%)	On	On
250 sheets (50%)	On	Off
450 sheets (90%)	Off	Off
500 sheets (100%)	Off	On

OFF: Actuator Out, ON: Actuator In

2.6 PAPER SIZE DETECTION

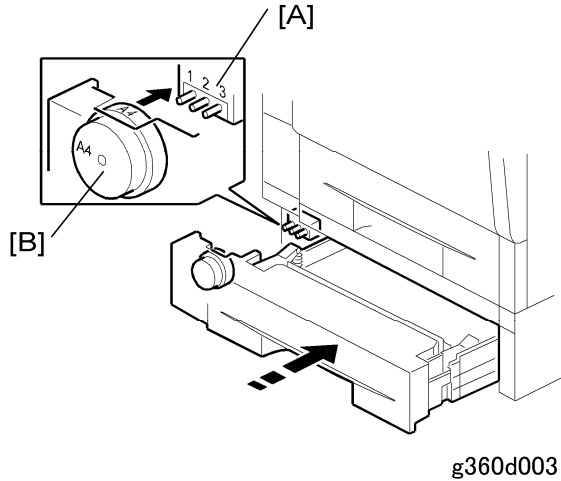

[A] Paper size switch

[B] Paper size dial

g360d003

Paper Size	SW1	SW2	SW3
A4 SEF	ON	ON	OFF
A5 SEF	ON	OFF	ON
B5 SEF	OFF	ON	OFF
Custom Size	ON	OFF	OFF
LG SEF	OFF	OFF	OFF
LT SEF	OFF	OFF	ON
HLT SEF	OFF	ON	ON

ON (Not pushed)

OFF (Pushed)

The machine disables paper feed from a tray if the paper size cannot be detected (if the paper size actuator is broken or no tray is installed)

When the paper size dial is at the “*” mark, the paper tray can be set up to accommodate one of a wider range of paper sizes by using a User Tool at the machine’s operation panel (Paper Input menu – Tray Paper Size).

2.7 SAFETY FUSE

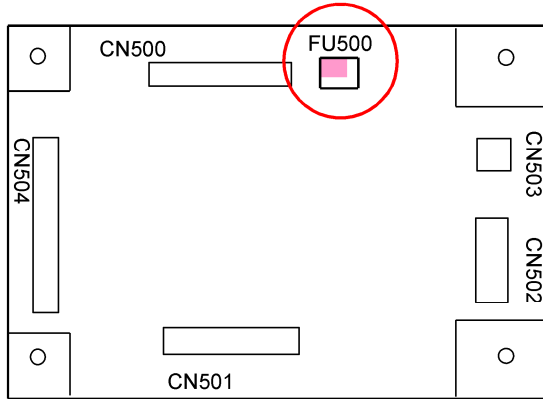

g894d901b

Name	Rating	Manufacturer	Type No.
FU500	DC50V/1.5A	ROHM CO.,LTD	ICP-N38

3. ENVELOPE FEEDER

3.1 ENVELOPE FEEDER (G362)

This envelope feeder is a tray that slides into the optional paper feed unit, replacing the paper tray. If two optional trays have been installed, the envelope feeder must go into the top tray.

The layout is the same as the paper tray:

- The tray pushes down and locks the mechanism in place
- The paper size can be fixed using the end fence.
- The end fence prevents the envelopes from overflowing and spilling out of the envelope unit.