

Model N-C3
Machine Code: D093/D094
Field Service Manual

30 November, 2010

Safety, Symbols, Trademarks

Safety

PREVENTION OF PHYSICAL INJURY

1. Before disassembling or assembling parts of the machine and peripherals, make sure that they are unplugged.
2. The plug should be near the machine and easily accessible.
3. Note that some components of the machine and the paper tray unit are supplied with electrical voltage even if the main power switch is turned off.
4. If any adjustment or operation check has to be made with exterior covers off or open while the main switch is turned on, keep hands away from electrified or mechanically driven components.
5. If the [Start] key is pressed before the machine completes the warm-up period (the [Start] key starts blinking red and green), keep hands away from the mechanical and the electrical components as the machine starts making copies as soon as the warm-up period is completed.
6. The inside and the metal parts of the fusing unit become extremely hot while the machine is operating. Be careful to avoid touching those components with your bare hands.
7. To prevent a fire or explosion, keep the machine away from flammable liquids, gases, and aerosols.

HEALTH SAFETY CONDITIONS

1. Never operate the machine without the ozone filters installed.
2. Always replace the ozone filters with the specified types at the proper intervals.
3. Toner and developer are non-toxic, but if you get either of them in your eyes by accident, it may cause temporary eye discomfort. Try to remove with eye drops or flush with water as first aid. If unsuccessful, get medical attention.

OBSERVANCE OF ELECTRICAL SAFETY STANDARDS

1. The machine and its peripherals must be installed and maintained by a customer service representative who has completed the training course on those models.

SAFETY AND ECOLOGICAL NOTES FOR DISPOSAL

1. Do not incinerate toner bottles or used toner. Toner dust may ignite suddenly when exposed to an open flame.

2. Dispose of used toner, developer, and organic photoconductors in accordance with local regulations. (These are non-toxic supplies.)
3. Dispose of replaced parts in accordance with local regulations.
4. When keeping used lithium batteries in order to dispose of them later, do not put more than 100 batteries per sealed box. Storing larger numbers or not sealing them apart may lead to chemical reactions and heat build-up.

⚠ CAUTION

- The danger of explosion exists if a battery of this type is incorrectly replaced. Replace only with the same or an equivalent type recommended by the manufacturer. Discard used batteries in accordance with the manufacturer's instructions.







LED SAFETY













⚠ WARNING

- Use of controls, or adjustment, or performance of procedures other than those specified in this manual may result in hazardous radiation exposure.
- Turn off the main switch before attempting any of the procedures in the scanner section. LED (CIS) radiations can seriously damage your eyes.
- Do not actuate the safety switches, when the original feed unit is open. (This will turn on the main power.)

Conventions and Trademarks

Conventions

Symbol	What it means
	For more refer to Core Tech Manual
	Bushing
	C-ring
	Connector
	E-ring
	FFC (Flat Film Connector)
	Gear

Symbol	What it means
	Harness clamp
	Hook (or tab release)
	Knob screw (black)
	Knob screw (sliver)
	Pivot screw
	Screw (common screw)
	Shoulder screw
	Spring  x2
	Standoff
	Stud screw
	Timing belt

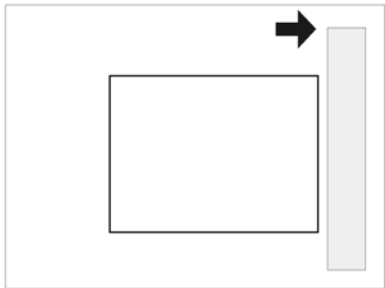

SEF (Short Edge Feed)

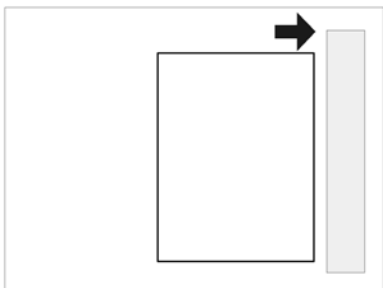

LEF (Long Edge Feed)

The notations "SEF" and "LEF" describe the direction of paper feed. The arrows indicate the direction of paper feed.

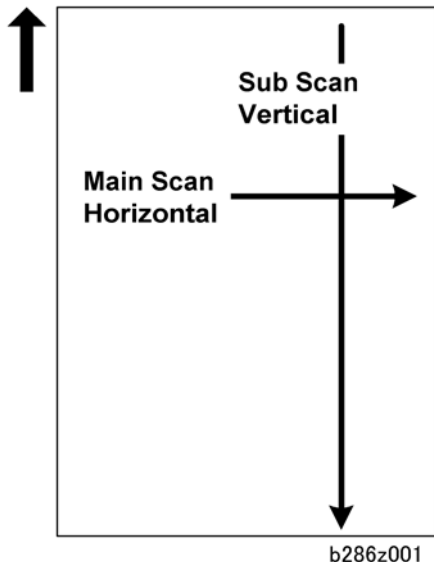

In this manual "Horizontal" means the "Main Scan Direction" and "Vertical" means the "Sub Scan Direction" relative to the paper feed direction.

Warnings, Cautions, Notes

In this manual, the following important symbols and notations are used.

WARNING

- A Warning indicates a potentially hazardous situation. Failure to obey a Warning could result in death or serious injury.

CAUTION

- A Caution indicates a potentially hazardous situation. Failure to obey a Caution could result in minor or moderate injury or damage to the machine or other property.

Important

- Obey these guidelines to avoid problems such as misfeeds, damage to originals, loss of valuable data and to prevent damage to the machine

Note

- This information provides tips and advice about how to best service the machine.

Trademarks

- Microsoft[®], Windows[®], and MS-DOS[®] are registered trademarks of Microsoft Corporation in the United States and /or other countries.
- PostScript[®] is a registered trademark of Adobe Systems, Incorporated.
- PCL[®] is a registered trademark of Hewlett-Packard Company.
- Ethernet[®] is a registered trademark of Xerox Corporation.
- PowerPC[®] is a registered trademark of International Business Machines Corporation.
- Other product names used herein are for identification purposes only and may be trademarks of their respective companies. We disclaim any and all rights involved with those marks.

New Features of D093/D094

Main Machine

Model Numbers/Names

Production No.	Model Name
D093-21	Ricoh Aficio MP W2401
D093-27	Ricoh Aficio MP W2401
	NRG MP W2401
D094-17	Ricoh Aficio MPW3601
	Gestetner GWD 3006
	Savin 3406WD
	Lanier LW246
D094-21	Ricoh Aficio MPW3601
D094-27	Ricoh Aficio MPW3601
	NRG MP W3601

External

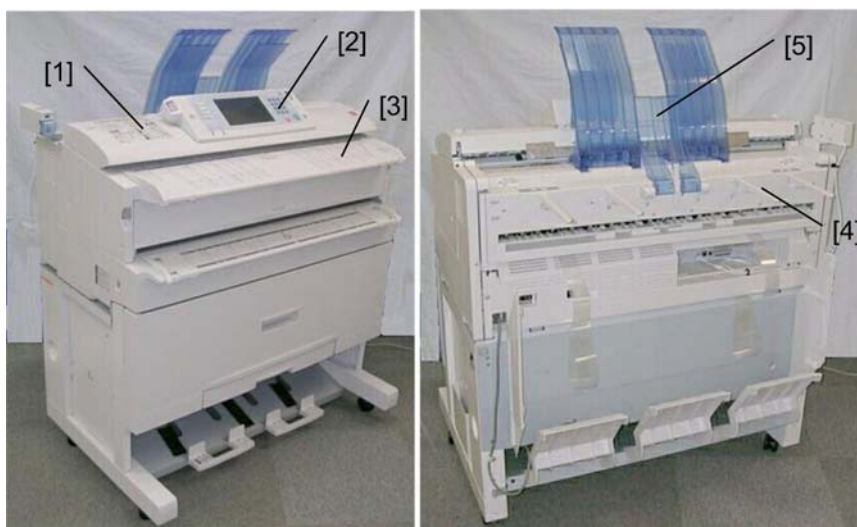

d093f901

[1]	Color scanner. Equipped with a color scanner so color drawings or drawings marked with color can be scanned in color and distributed with scan-to-email or scan-to-folder. (The Scanner option is required for color scanning.)
[2]	Operation panel. The new operation panel provides better usability and many new features (described below).
[3]	Original table. The original table is longer by 40 mm (1.8"). The extra length provides more surface to hold stabilize originals while they are being scanned.
[4]	Output Guides. The number of output guides has been reduced from six to four.
[5]	Upper output guide. Remains up for output to the upper trays and can be lowered for output to the rear.

Rear Switches

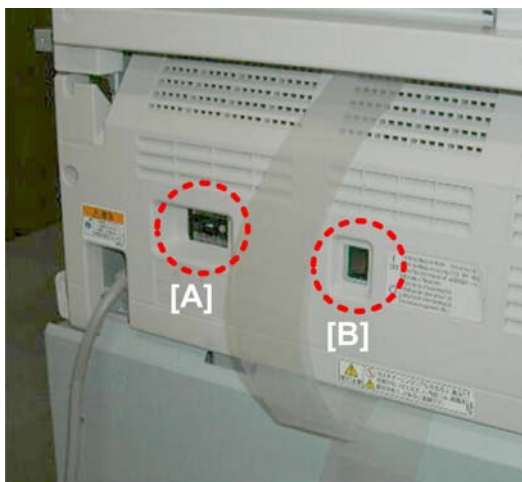

d093i918

There are two new switches on the back of the machine.

- The breaker switch [A] is at the same location. However, removal of the rear cover is no longer required for breaker switch testing.
- A new anti-condensation heater switch is provided. The anti-condensation heater does not require connection at installation. The anti-condensation heaters can be easily switched on and off.

Operation Panel

B286/B289



D093/D094



d093f902

The new operation panel has a centered WVGA touch panel, new status LEDs that can be seen from a distance, new login/logout key allows easier operation during authentication, and better overall accessibility. New firmware has also added more features for use on the operation panel:

- **Thumbnail view.** Documents can be viewed as thumbnails in full color. Zoom in/out feature also provided.
- **Simplified display.** Allows selecting enlarged display with minimum number of keys with large fonts.
- **Job management.** Job list function allows management of copy and print jobs (holding back jobs, changing order of the job queue, deleting jobs, etc.)
- **Animated guidance.** Animated help gives step-by-step instructions that guide you through problems such as paper jams, open covers, etc.

Paper Exit Selection

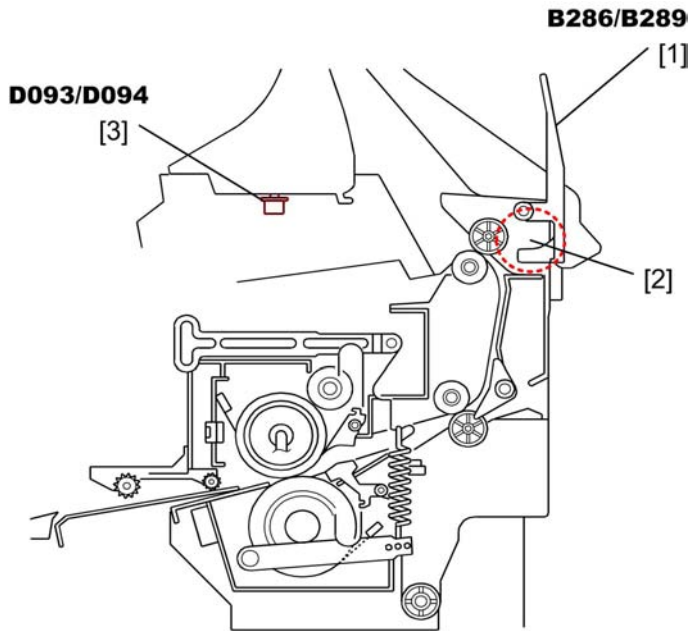

d093d601

The previous model (B286/B289) has a selection lever [1] that can be raised and lowered to select the exit path. A paper exit selection sensor [2] below the lever detects the position of the lever and tells the machine whether the upper or lower path can be selected on the operation panel, or whether output is restricted to the lower path.

The D093/D094 also has the lever, but no sensor. The paper exit selection switch [3] tells the machine whether the upper or lower path can be selected on the operation panel. This mechanism is described in a later section of this manual. (p.33 "Original/Copy Paper Paths")

★ Important

- When the optional Rear Stacker (D312) is installed, the standard lower stacker cannot be used.

Security and Encryption Unit

The Security & Encryption applications (Data Overwrite Security and HDD Encryption) are provided on one SD card that is inserted into SD card Slot 1 before the machine is shipped. The applications must be moved to the Printer Option SD card (D506) before installation.

Options

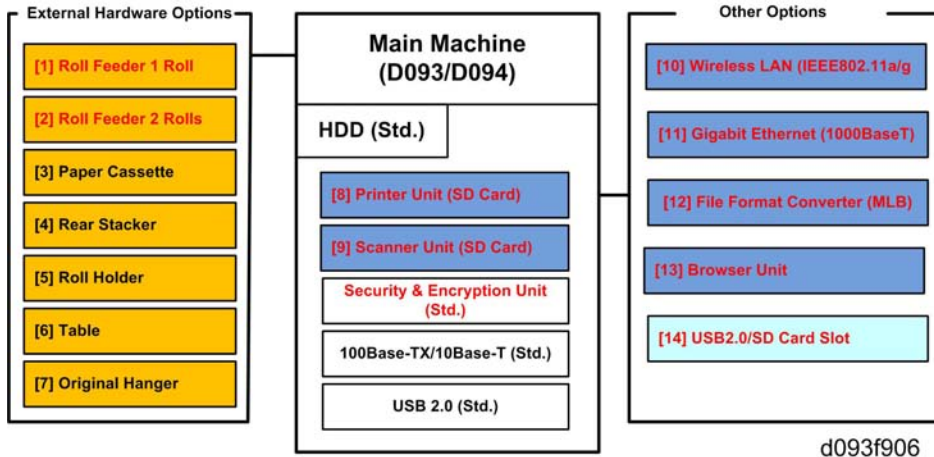

Note

- Red text in the diagram above denotes new options.

No.	Option	Comments
[01]	Roll Feeder Type 3601A/B (D503)	One-roll. *1
[02]	Roll Feeder Type 3601A/B (D504)	Two-rolls. *1
[03]	Paper Cassette Type 240 (B853)	Same as previous.
[04]	Rear Stacker (D312)	Same as previous.
[05]	Roll Holder Unit Type A (B394)	Same as previous.
[06]	Table Type 240 (B854)	Same as previous.
[07]	Original Hanger (D311)	Same as previous.
[08]	Printer Option Type W3601 (D506)	SD card (x2). *2
	Printer Option TIFF/GL Filter	Provided with [08].
[09]	Scanner Option Type W3601 (D507)	SD card. *3
[10]	IEEE802.11a/g Interface Unit Type J (D377-01, -02) /K (D377-19)	Board. Antennas attached.
[11]	GigaBit Ethernet Type B (D377-21)	Board.
[12]	File Format Converter Type F (D533)	Board.

No.	Option	Comments
[13]	Browser Unit Type E (D430-05, -06, -07)	SD card.
[14]	USB 2.0/SD Slot Type E (D534)	Mounted on main machine.*4

Notes

- *1 The mechanical and electrical components of the new Roll Feeder (D503/D504) are nearly identical to the previous Roll Feeder (B851/B852).
- *2
 - A roller feeder must be installed with this printer option.
 - The TIFF/GL filter application is provided on a separate printer option SD card. VMware is also provided on this SD card. VMware is required for the SDK application.
- *3 The File Format Converter [12] must be installed for the Scanner option.
- *4 This a new option that provides easier access to USB and SD card slots at the front of the machine. Operators can scan documents to either an SD card or a USB memory device inserted into this unit.



d093f908

TABLE OF CONTENTS

- Safety, Symbols, Trademarks..... 1
 - Safety..... 1
 - Conventions and Trademarks..... 2
 - Warnings, Cautions, Notes..... 4
- New Features of D093/D094..... 6
 - Main Machine..... 6
 - Options..... 11
- 1. Product Information**

- Specifications..... 21
- Main Machine and Peripherals..... 22
- Guidance for Those Who Are Familiar with Predecessor Products..... 24
 - Feature Comparison..... 24
 - Option Comparison..... 25
- Overview..... 28
 - Machine General Layout..... 28
 - Mechanical Component Layout..... 30
 - Drive Layout..... 32
 - Original/Copy Paper Paths..... 33
 - Electrical Components..... 36
- 2. Installation**

- Preparation..... 51
 - Environment..... 51
 - Minimum Space Requirements..... 52
 - Machine Level..... 53
 - Power Source..... 53
 - Installation Overview..... 53
- Main Machine Installation (D093/D094)..... 57
 - Accessory Check..... 57
 - Machine Installation Procedure..... 58
 - Main Machine Final Installation..... 73
 - Anti-Condensation Heater..... 79
 - Moving the Machine..... 80
- Original Hanger (D311)..... 82

Accessory Check.....	82
Installation.....	82
Roll Feeder (D503/D504).....	83
Accessory Check.....	83
Roll Feeder Installation Procedure.....	84
Paper Cassette (B853).....	102
Accessory Check.....	102
Paper Cassette Installation Procedure.....	102
Table (B854).....	105
Accessory Check.....	105
Installation Procedure.....	106
Rear Stacker (D312).....	114
Accessories.....	114
Installation.....	115
USB 2.0/SD Slot Type E (D534).....	116
Accessory Check.....	116
USB 2.0/SD Slot Installation.....	117
Installation of MFP Options.....	122
Overview.....	122
Enabling the Onboard Features.....	123
Using SD Cards.....	124
Printer Option Type W3601 (D506).....	127
Scanner Option Type W3601 (D507).....	128
File Format Converter Type F (D533).....	131
IEEE802.11 a/g Interface Unit Type J (D377-01, -02), Type K (D377-19).....	132
GigaBit Ethernet Type B (D377-21).....	135
Browser Unit Type E (D430-05, -06, -07).....	138

3. Preventive Maintenance

PM Tables.....	141
Main Machine (D093/D094).....	141
Roll Feeder (D503/D504).....	144
Paper Cassette (B853).....	145
Cleaning Points.....	146

Entrance Spurs.....	146
Corona Wire Cleaning.....	146
LPH Cleaning.....	148
Idle Registration Roller Panel.....	149
Lubrication Points.....	150
Development Gears.....	150
Fusing Gears.....	151

4. Replacement and Adjustment

Common Procedures.....	153
Before Working On the Main Machine.....	153
Side Covers.....	154
Rear Cover, Controller Cover.....	155
Paper Exit Unit.....	156
Unlocking, Opening the Original Unit.....	157
Removing the Original Feed Unit.....	157
Raising and Locking the Scanner Unit.....	158
Toner Hopper Cover.....	159
Idle Registration Roller Panel.....	160
Original Feed Table, Original Feed Sensor Cover.....	161
Drawer Front Cover.....	162
Scanner.....	163
LED Safety Switches.....	164
Original Width Sensors, Original Set Sensor, Scanner Switch.....	165
Original Exit Sensor.....	165
Original Feed Unit Rollers.....	166
Exposure Glass.....	168
CIS.....	169
VDB, SIF, CGB Power Pack.....	172
Operation Panel Boards.....	174
Around the Drum.....	180
Charge Corona Unit.....	180
Quenching Lamp Unit, Quenching Lamps.....	182
Wire Cleaner Motor, Wire Cleaner Sensor.....	183

LPH.....	184
Transfer Corona, Separation Corona Wires.....	186
Development.....	188
Development Unit.....	188
Developer.....	189
Paper Set Sensor, Registration Sensor.....	191
Toner Supply Clutch.....	192
Development Filter.....	193
Used Toner Collection Bottle, Toner Overflow Sensor.....	193
Drum.....	195
Drum Unit.....	195
Cleaning Blade.....	198
ID Sensor, Pick-Off Pawls, Pick-Off Pawl Solenoid.....	199
Paper Feed.....	200
Registration Clutch, Registration Roller.....	200
Roll 1 Paper Feed Clutch, Feed Roller.....	203
Roll 2 Paper Clutch, Feed Roller.....	204
RF Exit Sensor.....	205
Roll Feed Motor.....	206
Cutter Motor, HP Sensors.....	207
Roll Paper End Sensors.....	208
Cassette Feed Roller.....	209
Cassette Relay Sensor, Cassette End Sensor.....	210
Cassette Feed Motor, Cassette Open Sensor.....	212
Cassette Feed Clutch.....	213
Fusing.....	214
Pressure Spring Adjustment.....	214
Hot Roller Strippers.....	215
Fusing Exit Sensor.....	215
Pressure Roller Thermistors.....	216
Pressure Roller Strippers.....	217
Exit Unit Switch.....	218
Fusing Unit.....	218

Fusing Cleaning Roller.....	221
Fusing Lamp.....	222
Hot Roller.....	223
Pressure Roller.....	223
Hot Roller Thermistor, Thermostats.....	224
Motors.....	225
Scanner Motor.....	225
Drum Motor.....	226
Fusing Motor, Main Motor.....	227
Used Toner Bottle Motor.....	229
Boards.....	230
MCU, SIPU, MB.....	230
Circuit Breaker/PSU.....	236
Controller Board.....	239
NVRAM.....	241
T&S Power Pack.....	243
RFDB (Roll Feeder Drive Board).....	244
SFDB (Sheet Feed Drive Board).....	245
HDD.....	247
Cooling Fan, Ozone Filter, Paper Exit Selection Switch.....	249
Special Adjustments.....	251
Image Adjustment with SP Modes.....	251
CIS Adjustment with SP Modes.....	259
LPH Adjustment with SP Modes.....	262
LPH Density Adjustment with SP Modes.....	265
Firmware Update.....	267
Overview.....	267
Updating Firmware.....	267

5. System Maintenance Reference

Service Program Mode.....	271
Main SP Modes.....	272
System.....	272
Printer.....	362

Scanner.....	365
6. Troubleshooting	
Image Problem Troubleshooting.....	367
Flow Chart.....	367
Scanning.....	369
Image Writing.....	373
Printing.....	375
Other Problems.....	377
Service Call Conditions.....	379
Service Call Tables.....	380
SC100.....	380
SC200.....	382
SC300.....	382
SC400.....	382
SC500.....	384
SC600.....	389
SC700.....	393
SC800.....	393
SC900.....	404
Jam Code Tables, Cover Open.....	410
Overview.....	410
Scanner Jams.....	411
Plotter (Printer) Jams.....	412
Cover Open.....	414
Electrical Component Diagrams.....	415
Fuses.....	423
PSU.....	423
Board LEDs, DIP Switches.....	425
PSU.....	425
MCU.....	426
SIPU.....	427
VDB, SIF.....	429
GW Controller Board.....	430

7. Energy Saving

Energy Save.....	435
Energy Saver Modes.....	435
Paper Save.....	437
INDEX	439



1. Product Information

Specifications

See "Appendices" for the following information:

- Specifications

Main Machine and Peripherals

1

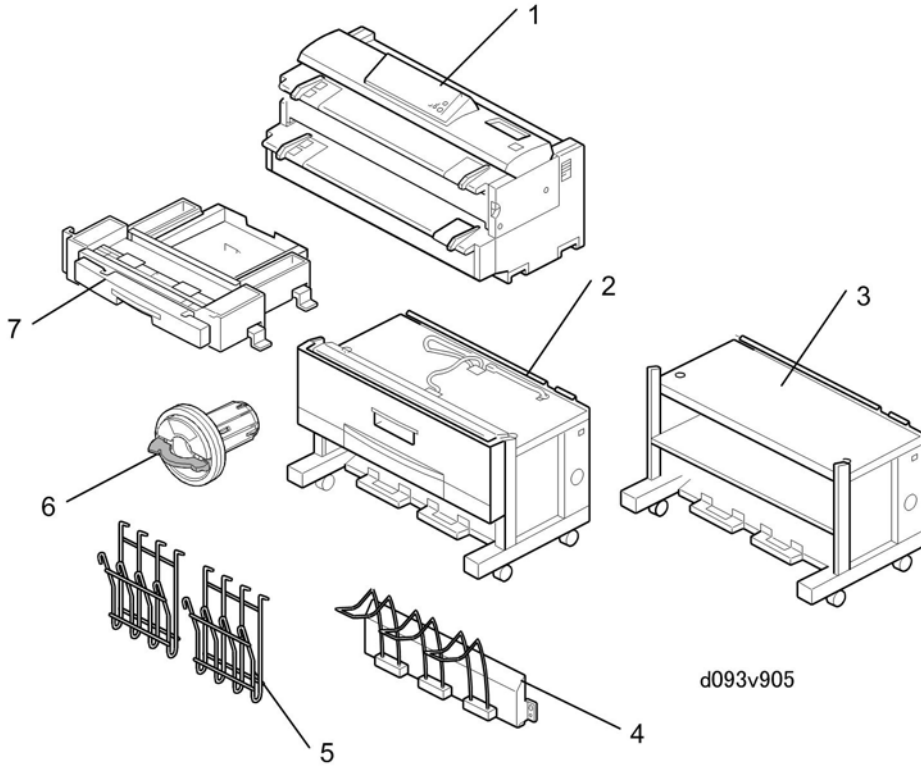

Main Peripherals

No.	Item	Machine Code
1	Main Machine	D093/D094
2	Roll Feeder Type 3601A/B (D504/D504)	D503/D504
3	Table Type 240	B854
4	Rear Stacker (Option for copies)	D312
5	Original Hanger (Option for originals)	D311
6	Roll Holder Type A	B394
7	Paper Cassette Type 240	B853

Options (Not Shown Above)

Name	Comments
Printer Option Type W3601 (D506)	SD cards (x2)
Scanner Option Type W3601 (D507)	SD card
IEEE802.11a/g Interface Unit Type J (D377-01, -02) /K (D377-19)	Board
GigaBit Ethernet Type B (D377-21)	Board
File Format Converter Type F (D533)	Board
Browser Unit Type E (D430-05, -06, -07)	SD card
USB 2.0/SD Slot Type E (D534)	Mounted on main machine

Guidance for Those Who Are Familiar with Predecessor Products

This section describes similarities and minor differences. The D093/D094 is based on the engine of the B286/B289. The target reliability specifications are the same for both models.

Feature Comparison

Target Reliability: D093/D094 vs. B286/B289

Item	D093/D094		B286/B289	
	D093	D094	B286	B289
ACV	360 m (1180 ft.)	540 m (1782 ft.)	360 m (1180 ft.)	540 m (1782 ft.)
Estimated service life	180,000 m (590,400 ft.) or 5 years			
Max. CV	3,000 m (9,840 ft.)			
PM Cycle (A1/D)	5,500 m (18,150 ft.)			

Feature Comparison Table

Item	D093/D094	B286/B289
Operation panel	Wide Color VGA	Wide Monochrome VGA
Upper Stack Capacity	50 sheets A1/D size LEF	50 sheets A1/D size SEF
External controller (P/S)*1	No	Yes (RATIO CTL)
Color scanning*2	Yes	No
SDK*3	Yes	No
PDF batch scanning	Yes*4	
Print and scan tools	TBA	No
Memory	1 GB (Std.) + 160GB HDD (Std.) *5	1 GB + 80 GB HDD (Std.)

Item	D093/D094	B286/B289
Scanning speed	80.0 mm/sec (B/W) 26.7 mm/sec (FC)	80.0 mm/sec (B/W)
Languages* 6	18 languages	9 languages
Board/slot arrangement* 7	SD cards x 2	SD card slots x 3

- *1** Both models have an embedded Ricoh controller.
- *2** Color scanning is limited to scanning to a file (printing limited to B&W). (The Scanner option is required for color scanning.)
- *3** SDK (Software Development Kit). A set of development tools that allows for the creation of applications. These tools require installation of Printer Option Type W3601 (D506).
- *4** On the B286/B289 batch scanning is possible only with a firmware update on the main machine
- *5** An additional 1 GB memory unit is required for the Scanner Option Type W3601 (D507). (Memory is provided with the scanner option.)
- *6** These languages are available for the D093/D094 user interface: 1. English, 2. German, 3. French, 4. Italian, 5. Spanish, 6. Dutch, 7. Swedish, 8. Norwegian, 9. Danish, 10. Finnish, 11. Hungarian, 12. Czech, 13. Polish, 14. Portuguese, 15. Russian, 16. Catalan, 17. Turkish, 18. Simplified Chinese
- *7** The arrangement of the board slots and SD cards on the controller box has changed. The D093/D094 has only two SD card slots..

Option Comparison

Identical Options

These options are identical for the D094/D094 and B286/B289.

- Roll Holder Unit Type A (B394)
- Paper Cassette Type 240 (B853)
- Table Type 240 (B854)
- Original Hanger (D311)
- Rear Stacker (D312)

Discarded Options

These B286/B289 options have been discarded for D093/D094.

- Folder FD 6500A (B889)
- Manual Feeder (D333)
- VM Card Type E (D338)

Note

- VMware for this machine resides on the new printer SD card (Printer Option TIFF/GL Filter).
- Printer Controller RW-3600/Interface PCB Type 3600 (D344/D329)
- USB Host Interface Unit Type 7300 (G819)

New Options

These are new options for the D093/D094.

- USB 2.0/SD Card Slot Type E (D534)
- Roll Feeder (D503/D504).

Important

- **The roll feeder is new, but the mechanical and electrical components are the same as those of the previous Roller Feeder (B851/B852). However, the Roll Feeder B851/B852 cannot be used with this machine.**

Changed Options

The following options are available for both the B286/B289 and D093/D094, but note that the "Type" and number designations for these options have changed.

Item	B286/B289	D093/D094
Roll Feeder	Type 3600 A/B (B852/B853)	Type 3601 A/B (D503/D504)
Printer Option	Type 3600 (D320)	Type 3601 (D506)
Scanner Option	Type 3600 (D321)	Type 3601 (D507)
Browser Unit	Type C (B828)	Type E (D430-05, -06, -07)
File Format Converter (MLB)	Type C (B609)	Type F (D533)
Gigabit Ethernet Board	Type A (G874)	Type B (D377-21)

Item	B286/B289	D093/D094
IEEE802.11b	Type H (G813)	Type J (D377-01) Type K (D377-19)
Data Overwrite Security Unit	Type D (B735)	Standard with main machine



Overview

1

Machine General Layout

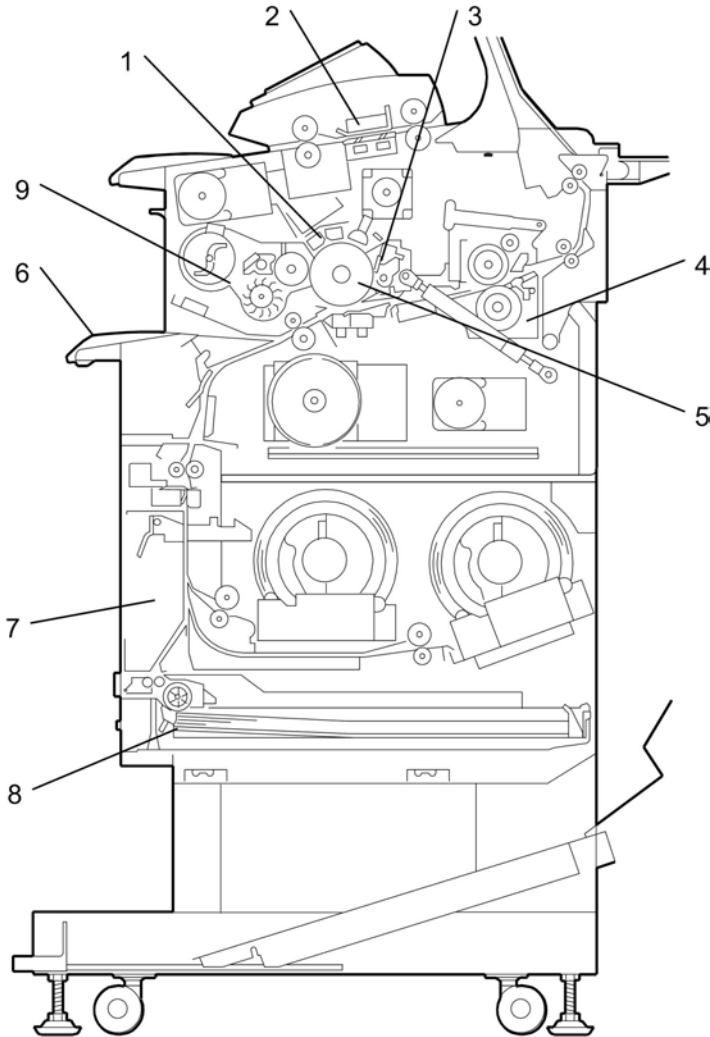

d093d969

1.	Image Writing Unit	Uses an LPH (LED Print Head)
2.	Scanner Unit	Uses a CIS (Contact Image Sensor) unit for scanning. The CIS is made of 5 sensor arrays connected at four joints. The CIS scans the face-down original from below.

3.	Cleaning Unit	A counter blade cleans the drum.
4.	Fusing Unit	The hot roller contains one halogen lamp. The machine uses the applicable fusing temperature for the paper size and paper type that the user input at the operation panel.
5.	OPC Drum	The components around the OPC drum do the charging, image writing, development, transfer, separation, cleaning, and quenching.
6.	Manual Feed Table	The user can feed paper from the manual feed table (this is also referred to as the bypass tray).
7.	Roll Feeder	Paper also feeds from the optional roll feeder with one or two paper rolls installed.
8.	Paper Cassette	Cut sheets are also supplied from the optional paper cassette.
9.	Development Unit	Toner transfers from a magnetic roller to the OPC drum. An ID sensor controls the toner concentration.

Mechanical Component Layout

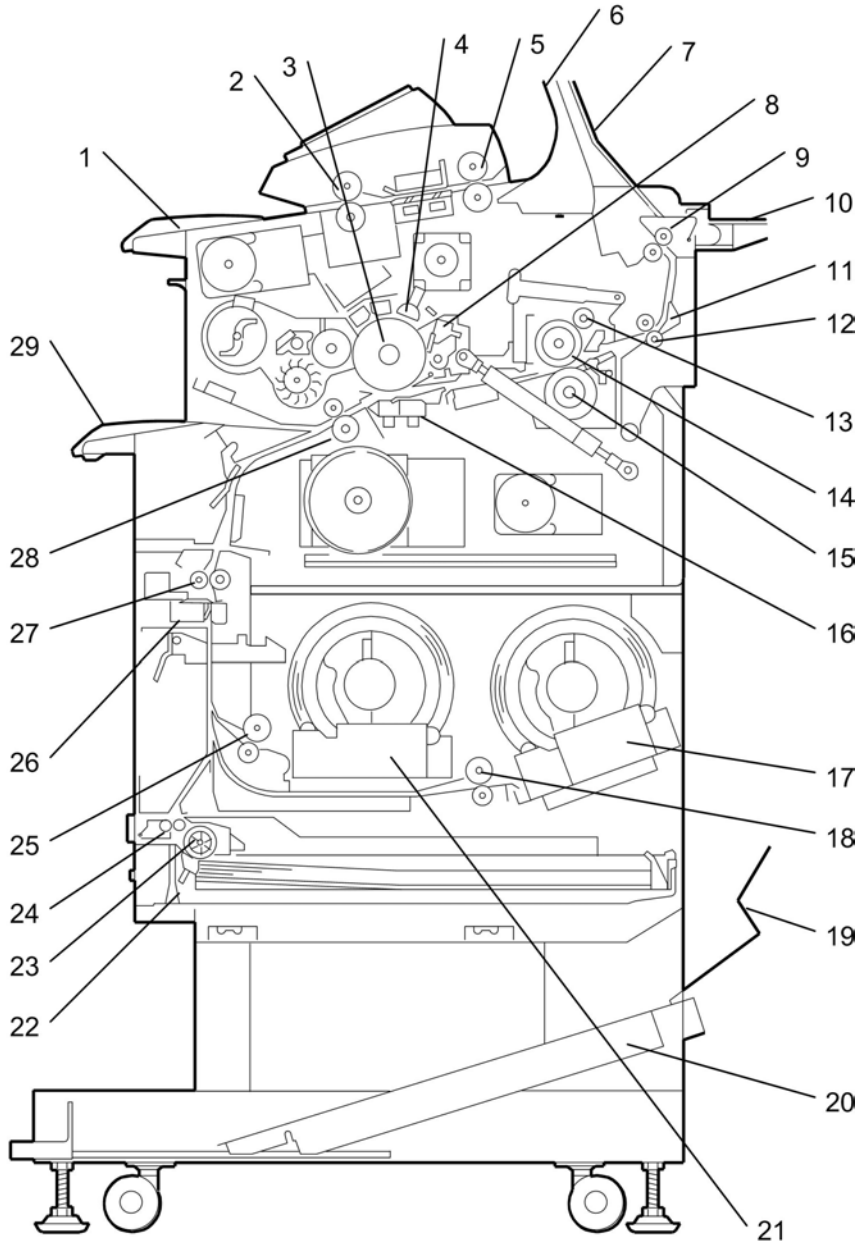

d093d969a

1. Original Table

16. T&S Corona Unit

2. Original Feed Rollers

17. Roll 2 Holders

3. OPC Drum
4. Charge Corona Unit
5. Original Exit Roller
6. Upper Output Stacker
7. Original Upper Exit Guides
8. Cleaning Unit
9. Upper Exit Rollers
10. Original Exit Guides (Straight-Through)
11. Paper Exit Junction Gate
12. Fusing Exit Rollers
13. Fusing Cleaning Roller
14. Hot Roller
15. Pressure Roller
18. Roll 2 Paper Feed Rollers
19. Lower Output Guide
20. Lower Output Stacker
21. Roll 1 Holder
22. Paper Cassette
23. Paper Cassette Feed Roller
24. Paper Cassette Grip Rollers
25. Roll 1 Paper Feed Rollers
26. Cutter
27. Roll/Cassette Exit Rollers
28. Registration Rollers
29. Manual Feed Table (Bypass)

Drive Layout

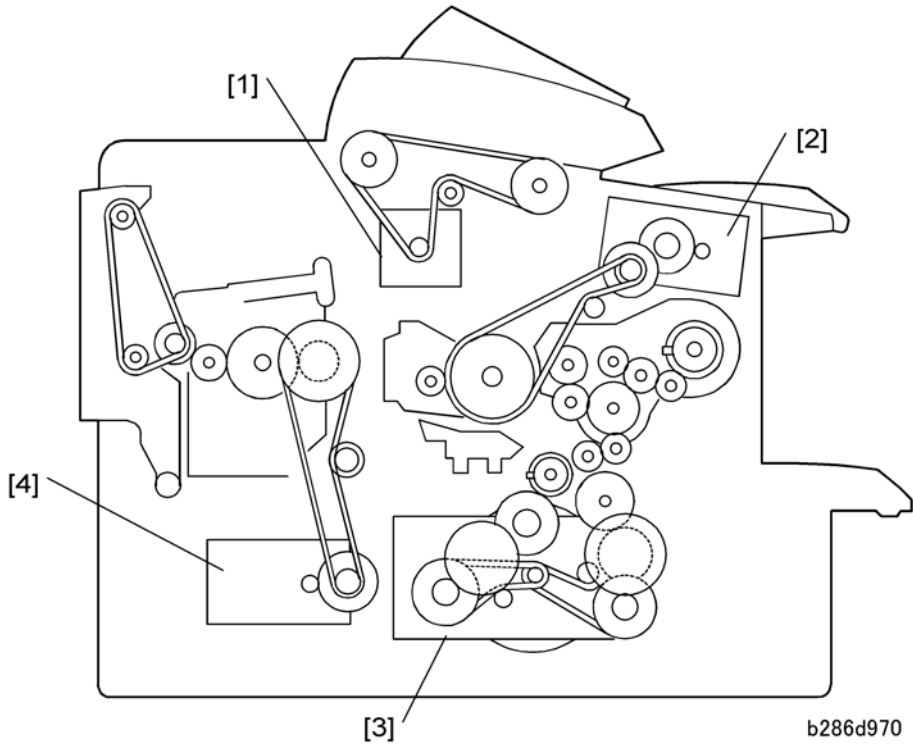

1. Scanner Motor
2. Drum Motor
3. Main Motor
4. Fusing Motor

Original/Copy Paper Paths

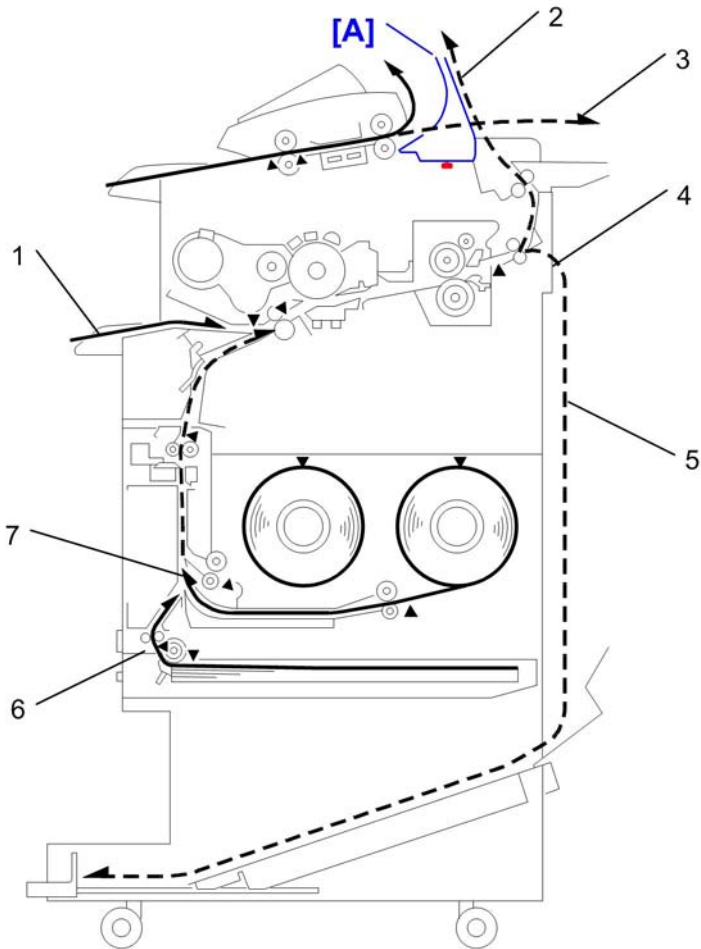

d093d971

1.	Manual Feed (Bypass) Path	
2.	Original Path (Upper)	Upper output stacker installed.
3.	Original Path (Straight-Through)	Upper output stacker removed.
4.	Paper Path (Upper)	Normal (Default)
5.	Paper Path (Rear)	Selectable (See below)
6.	Paper Path (Paper Cassette)	

7.	Paper Path (Rolls)	D503 (1 Roll),D504 (2 Rolls)
----	--------------------	------------------------------

1

With the left upper output stackers [A] installed on the machine, the operator can select either the upper path or the lower path on the operation panel.

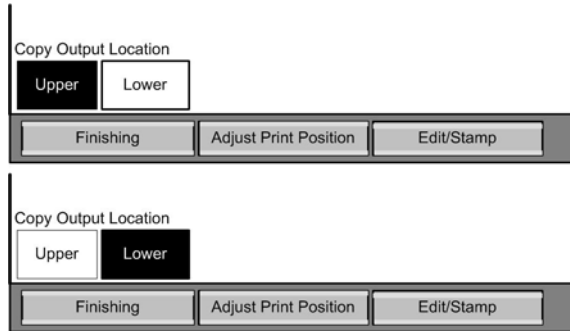

d093f905

Either "Upper" or "Lower" (Copy Output Location) can be selected on the operation panel. The operator touches "Upper" or "Lower" under "Copy Output Location" on the display to select the exit :

- "Upper": Copy feeds out to the top of the machine.
- "Lower": Copy feeds out the rear.

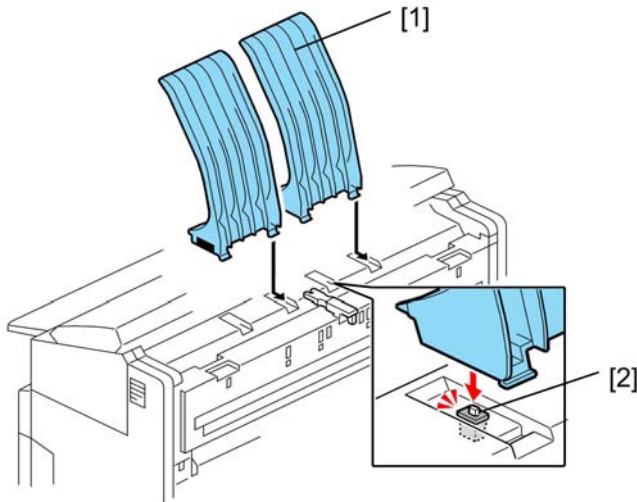

d093d609

If the upper output stackers [1] are removed:

- The paper exit selection switch [2] under the left output stacker comes up.
- "Lower" is selected for the "Copy Output Location" on the operation panel, so the copy always feeds out the rear. "Upper" cannot be selected.

- If the operator touches “Upper” a message will prompt the operator that the output destination cannot be selected.

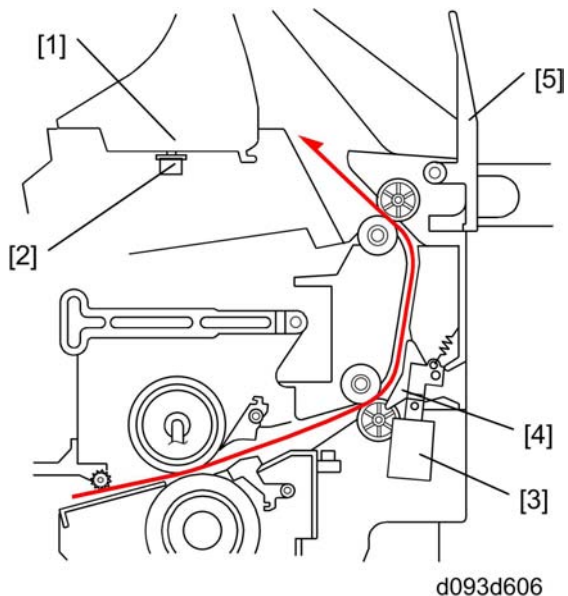

When the upper output stackers are installed:

- The bottom of the left output stacker [1] depresses paper exit selection switch [2] and keeps it closed. This de-activates the paper junction gate solenoid [3].
- The closed junction gate [4] guides paper to the top of the machine.
- The lever [5] should be up.

Note

- For normal operation, the left upper output stacker must be installed, so the operator has the option of selecting either “Upper” or “Lower” for paper exit.

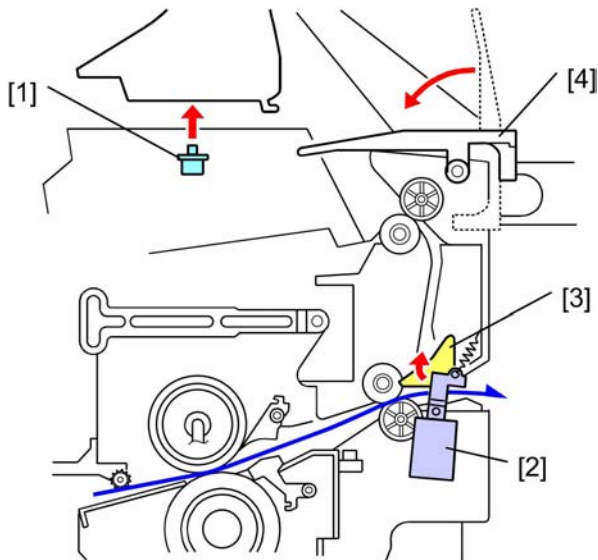

d093d607

When the left and right upper output stackers are removed:

- The paper exit selection switch [1] under the left output stacker comes up and opens the switch.
- This activates the [2] paper junction gate solenoid which opens the paper junction gate [3]. The open junction gate guides paper out the back of the machine.
- With both the upper output stackers removed, the lever [4] must be lowered so the original can pass over it. (With both left and right output stackers removed, the original must exit to the rear.)

Electrical Components

Overview

Overall System

The illustration below shows the basic layout of the main machine circuit boards. For more details, please refer to the point-to-point diagram provided with the machine.

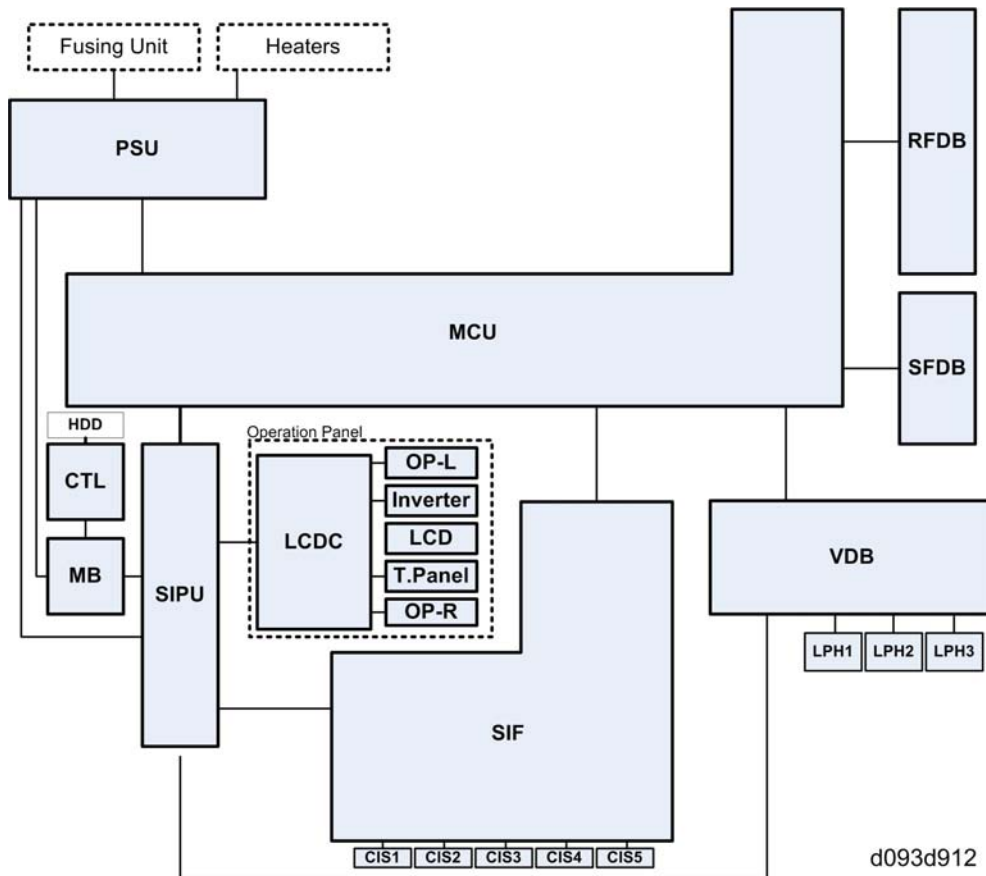

Here is a brief description of functions of the important boards:

PSU (Power Supply Unit). Supplies AC/DC current to the machine. Also contains the AC drive board that supplies AC power to the fusing lamp.

MCU (Main Control Unit). This is the engine control board. The MCU manages:

- Base engine control, scanning control, image processing control, image writing control.
- Basic I/O function control for the power packs, motors, sensors, solenoids, clutches, and fusing.
- Power supply to scanner components (sensors, motors).

RFDB. Drives and controls the components of the optional roll feeder (the motor, clutch, sensors, and switches).

SFDB (Sheet Feed Driver Board). Controls the operation of the optional paper cassette that feeds cut sheets.

VDB (Video Drive Board). Controls operation of the LPH (LED Print Head), including the conversion of video sent to the LPH.

SIF (Scanner Interface). Interfaces with operation of the CIS elements (x5) and corrects sub scanning. Also manages the A/D conversion of the scanned image data. Image data scanned by the CIS elements is converted from analog to digital data by the SIF and then sent to the SIPU for processing.

Operation Panel Boards. Four boards: LCDC, OP-L, Inverter, Touch Panel, OP-R.

- **LCDC** (LCD Controller). Controls the operation panel.
- **OP-L.** (Operation Panel-Left). Relays key presses from keys located on the left side of the panel. Also contains the LEDs for the left side keys.
- **Inverter.** Mounted under the LCDC, provides the light for the LCD touch panel.
- **OP-R.** (Operation Panel-Left). Relays key presses from keys located on the right side of the panel. Also contains the LEDs for the right side keys.

SIPU (Scanned Image Processing Unit). Provided with five RI1001A_BGA components that do every type of processing of the image data received from the SIF. LUPUS contains the Rapi I/F functions. Also manages sending and receiving image data between itself and the GW controller board.

MB (Mother Board). Provides important relay functions 1) for the Rapi Bus I/F between the SIPU, GW controller, file format converter, and VLB, and 2) for machine power supply.

CTL (GW Controller). Performs overall control of all multi-function peripheral (MFP) devices.

Description of Electrical Components

NUMBER	NAME	DESCRIPTION
CIS		
CIS1 - 5	CIS 1 - 5 (Contact Image Sensor)	Transfer the image signals from the CIS LEDs to the SIF.
Lamp		
L1	Fusing Lamp	One fusing lamp (1100 W) in the hot roller.
LPH		
LPH1-3	LPH1-3 (LED Print Head)	Each section writes a part of the image on the PCB drum. The VDB controls the LPH units.
Magnetic Clutches		
MC1	Cassette Feed Clutch	This transfers power from the cassette feed motor to the feed and grip rollers in the cassette.
MC2	Paper Registration Clutch	This controls the registration roller. It switches off for a short time to stop the registration roller to correct skew in the paper feed path.
MC3	Roll Feed Clutch 1	This transfers power from the roll feed motor to roll 1 in the roll feeder.

NUMBER	NAME	DESCRIPTION
MC4	Roll Feed Clutch 2	This transfers power from the roll feed motor to roll 2 in the roll feeder.
MC5	Toner Supply Clutch	This controls the toner supply mechanism.
Motors		
M1	Cassette Feed Motor	This stepper motor controls the paper feed roller in the paper cassette.
M2	Cooling Fan Motor	This is an exhaust fan for the area around the drum.
M3	Cutter Motor	This controls the cutter in the roll feeder.
M4	Drum Motor	This controls the OPC drum.
M5	Fusing Motor	This controls the hot roller, fusing exit rollers, and upper exit rollers.
M6	Main Motor	This controls the registration roller, development unit, and the agitator in the toner cartridge.
M7	PCB Cooling Fan Motor 1	Cools the SIPU, MCU and controller board.
M8	PCB Cooling Fan Motor 2	Cools the SIPU, MCU and controller board.
M9	Roll Feed Motor	This controls the feed rollers for roll 1 and roll 2 in the roll feeder.
M10	Scanner Motor	This controls the original feed rollers and original exit rollers.
M11	Used Toner Bottle Motor	This controls the mechanism that keeps the level of used toner in the bottle flat.
M12	Wire Cleaner Motor	This moves the corona wire cleaner to the left and right to clean the charge corona wire.
PCBs		
PCB1	SIPU	Scanner Image Processing Unit . This processes image data from the CIS (Contact Image Sensor), and sends it to the VDB (Video Drive Board) and LPH (LED Print Heads). The SIPU also controls the HDD unit and the PC interfaces.

NUMBER	NAME	DESCRIPTION
PCB2	MCU	Main Control Unit. This is the machine's main board. It contains the SCU (Scanner Control Unit) and ECU (Engine Control Unit). These units control all parts of the machine, and this includes the print engine, scanner, and image processing.
PCB3	PSU (Power Supply Unit)	This supplies dc power for the machine, heaters, and dehumidifiers in the roll feeder.
PCB4	RFDB (Roll Feed Drive Board)	This is attached to the optional roll feeder. It controls the components of the roll feeder (motor, clutches, sensors, and switches).
PCB5	SFDB (Sheet Feed Drive Board)	This is attached to the optional paper cassette. It controls the components of the paper cassette (motor, clutches, sensors, and switches).
PCB6	SIF (Scanner Interface Board)	Interfaces between the SIPU and CIS.
PCB7	Mother Board	Interfaces with the controller, SIPU, and optional devices such as interface board for the printer controller.
PCB8	VDB (Video Drive Board)	This controls the image signals that are sent to the LPH (LED Print Head).
PCB9	Controller Board	Controls the memory and all peripheral devices. The GW architecture allows the board to control all applications (copying, printing, and scanning).
PCB10	Interface Board	Option. This relay board must be installed with the external printer controller for interface between the server PC and the copier.
PCB11	LCDC	LCD control Board. Controls operation of the operation panel and interfaces with the MCU.
PCB12	Inverter	Provides the background lighting of the LCD screen on the operation panel.
PCB13	OP-R	Relays the key presses from keys on the right side of the operation panel to the LCDC

NUMBER	NAME	DESCRIPTION
PCB14	OP-L	Relays the key presses from keys on the left side of the operation panel to the LCDC
PCB15	File Format Converter (MLB)	Option.
Power Packs		
PP1	CGB Power Pack	High voltage power supply for the charge corona wire (C), development bias (B), and charge corona grid (G).
PP2	T&S Power Pack	High voltage power supply for the transfer corona wire (T) and the separation corona wire (S) in the T&S (Transfer and Separation) unit.
QL		
QL1 - 3	Quenching Lamps: 1: Left, 2: Center, 3: Right	This removes remaining electrical charge on the left part of the drum immediately after cleaning.
Sensors		
S1	Cassette End Sensor	This sensor is above the paper cassette. It detects paper end after the last sheet feeds.
S2	Cassette Set Sensor	This detects when the cassette is set and locked in its place.
S3	Exit Cover Sensor	This detects if the exit cover on the rear of the machine is open or closed.
S4	Fusing Exit Sensor	This sensor is in front of the fusing exit rollers. It switches on when the leading edge of the copy leaves the fusing unit.
S5	ID Sensor	The machine uses this sensor to control toner supply, toner near-end, and toner end. There is no toner density sensor in this machine.
S6	Original Exit Sensor	This detects the original when it feeds out of the scanner.

NUMBER	NAME	DESCRIPTION
S7	Original Registration Sensor	(1) Detects the leading edge of the original and stops the original feed roller. The user can then manually make the original straight. (2) Detects the trailing edge of the original, or detects a jam if it does not detect the trailing edge.
S8	Original Set Sensor (A4/8.5")	Detects the leading edge of the original. This starts the scanner motor. This sensor also detects A4 or 8.5" width paper.
S9	Original Width Sensor (A0/8.5")	Detects A0/8.5"-width paper.
S10	Original Width Sensor (A1/34")	Detects A1/34"-width paper.
S11	Original Width Sensor (A2/22")	Detects A2/22"-width paper.
S12	Original Width Sensor (A3/17")	Detects A2/22"-width paper.
S13	Original Width Sensor (914mm/36")	Detects 914mm/36"-width paper.
S14	Original Width Sensor (30")	Detects 30"-width paper. (-17 version only)
S15	Original Width Sensor (B1/24")	Detects B1/24"-width paper.
S16	Original Width Sensor (B2/18")	Detects B2/18"-width paper.
S17	Original Width Sensor (B3/12")	Detects B3/12"-width paper.
S18	Original Width Sensor (B4/9")	Detects B4/9"-width paper.
S19	Paper Registration Sensor	This detects paper at the registration rollers.
S20	Paper Set Sensor	This detects when a cut sheet is placed on the manual feed table (by-pass).

NUMBER	NAME	DESCRIPTION
S21	Relay Sensor	This sensor is near the grip rollers, and (1) Detects the leading edge of every cut sheet, switches off the cassette paper feed clutch, and switches on the grip rollers, (2) Detects paper jams where the paper feeds out of the paper cassette.
S22	RF Exit Sensor	(1) Detects the leading edge of the paper from the rolls. (2) Detects the trailing edge of cut sheets from the paper cassette and trailing edges of sheets cut from the paper rolls for paper feed timing and jam detection. (3) If this sensor does not detect a leading edge after feeding from Roll 1 or Roll 2, it also signals paper end for the roll.
S23	RF Set Sensor	This detects if the spring-loaded lock lever of the roll feeder drawer is locked.
S24	Roll End Sensor 1	This reflective photosensor above Roll 1 detects the core of the roll (which is black), after there is no more paper on Roll 1.
S25	Roll End Sensor 2	This reflective photosensor above Roll 2 detects the core of the roll (which is black), after there is no more paper on Roll 2.
S26	Roll End Sensor 3	Detects the trailing edge of the roll after there is no more paper on Roll 1. This sensor is included because if the color of the roll core is not black, Roll End Sensor 1 cannot always detect roll end.
S27	Roll End Sensor 4	Detects the trailing edge of the roll after there is no more paper on Roll 2. This sensor is included because if the color of the roll core is not black, Roll End Sensor 2 cannot always detect roll end.
S28	Toner Overflow Sensor	Detects toner overflow in the used toner collection bottle.
S29	Upper Unit Sensor	Detects when the upper unit is open.
S30	Wire Cleaner Sensor	The actuator of this sensor is attached to the wire that moves the transfer cleaner from left to right. This tells the machine when the wire cleaner moves.

NUMBER	NAME	DESCRIPTION
Solenoids		
SOL1	Paper Junction Gate Solenoid	This controls the paper junction gate in front of the rear paper exit and below the upper exit. When closed, paper feeds out at the top. When open, paper feeds out at the back.
SOL2	Pick-Off Pawl Solenoid	This moves the pick-off pawls until they touch the drum.
Switches		
SW1	Dehumidifier Switch	Switches the dehumidifiers (x4) in the roll feeder on/off.
SW2	Exit Cover Switch	This detects if the exit cover on the rear of the machine is closed.
SW3	Main Power Switch	This switches the copier on and off.
SW4	Scanner Stop Switch	This is on the operation panel. The user pushes this to stop original feed if there is a problem during scanning.
SW5	Scanner Switch	This interlock switch stops power to the original feed unit when the original feed unit cover is lifted.
SW6	Toner Hopper Cover Switch	This detects if the toner supply cover is open or closed.
SW7	Upper Unit Switch 1	This detects if the upper unit is open on the left side.
SW8	Upper Unit Switch 2	This detects if the upper unit is open on the right side.
SW9	Left Cutter HP Switch	This detects if the cutter in the roller feeder is at the home position at the left side. In this condition, the paper holder of the cutter is locked open (the paper feed path is open).
SW10	Right Cutter HP Switch	This detects if the cutter in the roller feeder is at the home position at the right side. In this condition, the paper holder of the cutter is locked open (the paper feed path is open).

NUMBER	NAME	DESCRIPTION
SW11	Exit Unit Switch	<p>Detects whether the fusing unit cover is open or closed. SC559 is issued after 3 consecutive jams occur in the fusing unit.</p> <p>Note:</p> <ul style="list-style-type: none"> SC559 is not issued unless SP1159 is switched on (Default: "0" off). The fusing unit cover must always be opened and closed after this SC occurs to restore the machine to full operation. This ensures that the operator has opened and closed the cover to check for paper and/or paper scraps around the hot roller. Loose paper around the hot roller is a fire hazard.
SW12	Paper Exit Selection Switch	<p>The upper output stacker depresses this switch and closes. This sets normal operation. The operator can select "Upper" or "Lower" on the operation panel. When the upper output stacker is removed, this opens the switch and sets the machine for paper exit to the lower path only. ("Upper" cannot be selected on the operation panel.)</p>
SW13	Anti-condensation Heater Switch	<p>Switches the anti-condensation heaters on/off in the main machine. There are two 13W heaters, one located at either end of the OPC drum. These heaters operate only when the main switch is switched off.</p>
Others		
CO1	Recycle Counter	<p>A mechanical counter that measures the total length in meters of paper that the machine feeds. It starts from the first copy.</p>
H1	Dehumidifier 1 (Front/Right)	<p>One of four dehumidifiers that keeps the roll feeder drawer free of moisture.</p>
H2	Dehumidifier 2 (Front/Left)	
H3	Dehumidifier 3 (Rear/Right)	
H4	Dehumidifier 4 (Rear/Left)	

NUMBER	NAME	DESCRIPTION
H5	Anti-Condensation Heater (Left)	These are below the OPC drum. They keep the copier free of moisture, which could cause problems with paper feed and fusing.
H6	Anti-Condensation Heater (Right)	
HDD1	HDD	Hard Disk Drive. One unit: 160 GB
TH1	Hot Roller Thermistor	The CPU uses this thermistor to monitor the temperature of the hot roller.
TH2	Pressure Roller Thermistor 1 (Edge)	The CPU uses these thermistors to monitor the temperature of the pressure roller.
TH3	Pressure Roller Thermistor 2 (Center)	
TS1	Thermostat 1 (Center)	199°C. This safety device prevents overheating if the temperature control circuit fails.
TS2	Thermostat 2 (End)	200°C. This safety device prevents overheating if the temperature control circuit fails.
CB1	Circuit Breaker	Breaks the main power supply to the machine if there is an overload or short circuit. Located on the back of the machine, this switch is set manually. This breaker switch must be at the down position for the machine to operate.

MCU, SIPU

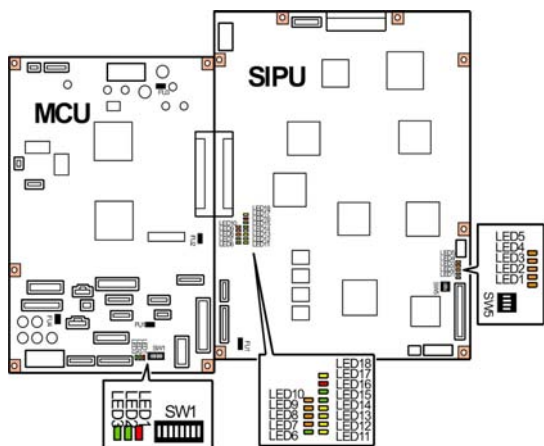

d093t981a

MCU (Main Control Unit)

This is the main control board of the machine. It does the following:

- System control
- Base engine control
- Scanner control
- Image processing

The MCU also sends load signals and supplies power to:

- Base engine (high voltage power pack, motors, sensors, solenoid, clutches, fusing unit, RSS, etc.)
- Scanner (sensors, motors, etc.)

The MCU contains two large blocks, connected by a UART: SCU and ECU.

- **SCU:** (System & Scanner Control Unit). Does overall system and scanner control.
- **ECU:** (Engine Control Unit). Does print engine and image processing control.

↓ Note

- The MCU DIP switches must always be OFF (default) and they must not be changed in the field.

SIPU (Image Processing Unit)

The SIPU (Scanned Image Processing Unit) processes image data from the CIS (Contact Image Sensors), sends the data to the VDB (Video Drive Board). The VDB sends the data the LPH (LED Print Heads) which writes the image on the surface of the drum. The SIPU also controls the HDD and the printer/scanner interface.

↓ Note

- The SIPU DIP switches must always be OFF (default) and they must not be changed in the field.

PSU

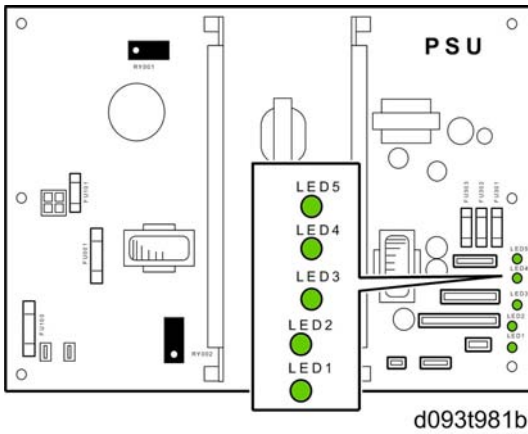

The PSU (Power Supply Unit) supplies DC power for all electrical components in the machine, and controls AC input to the fusing lamps and anti-condensation lamps.

VDB, SIF

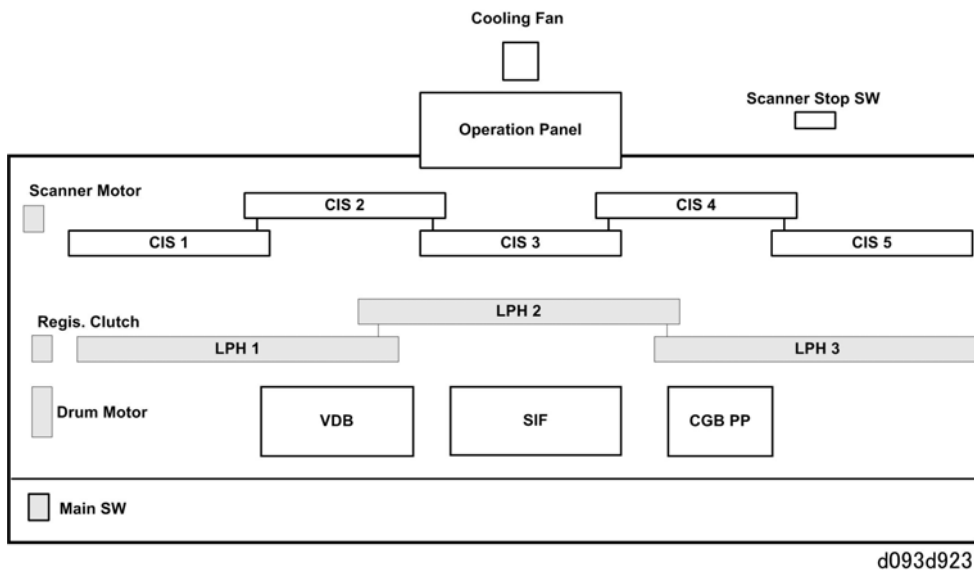

VDB (Video Drive Board)

The VDB controls the LPH and the algorithms to convert video data.

SIF (Scanner Interface Board)

The SIF controls the CIS (Contact Image Sensor) and changes analog data to digital data (A/D) for scanned images.

CGB PP (Charge, Grid Bias Power Pack)

Supplies the high voltage power for the charge corona wire (C), development bias (B), and charge corona grid (G).

1

RFDB, SFDB

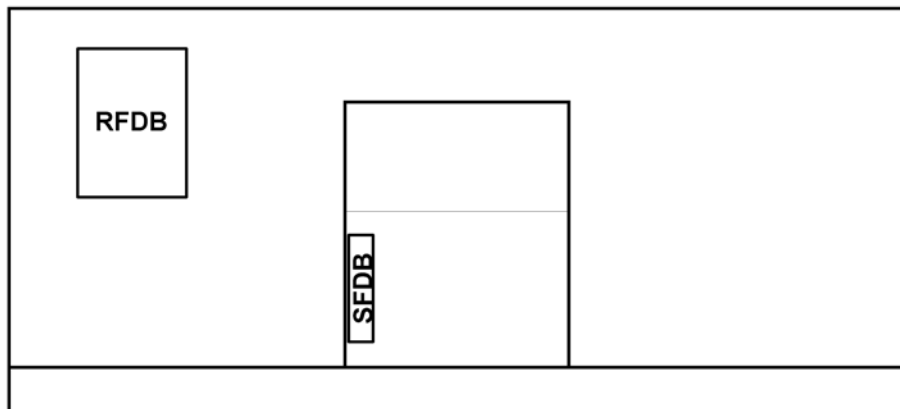

b286d924

The RFDB and SFDB are on the bottom plate of the drawer in the optional roll sheet feeder.

RFDB (Roll Feed Drive Board)

The RFDB, on the bottom panel of the roll feeder, controls the motors, solenoids, and clutches for the two paper rolls in the roll sheet feeder.

SFDB (Sheet Feed Drive Board)

The SFDB, on the left side of the paper cassette unit, controls the paper feed mechanisms for the optional paper cassette.

GW Controller Board

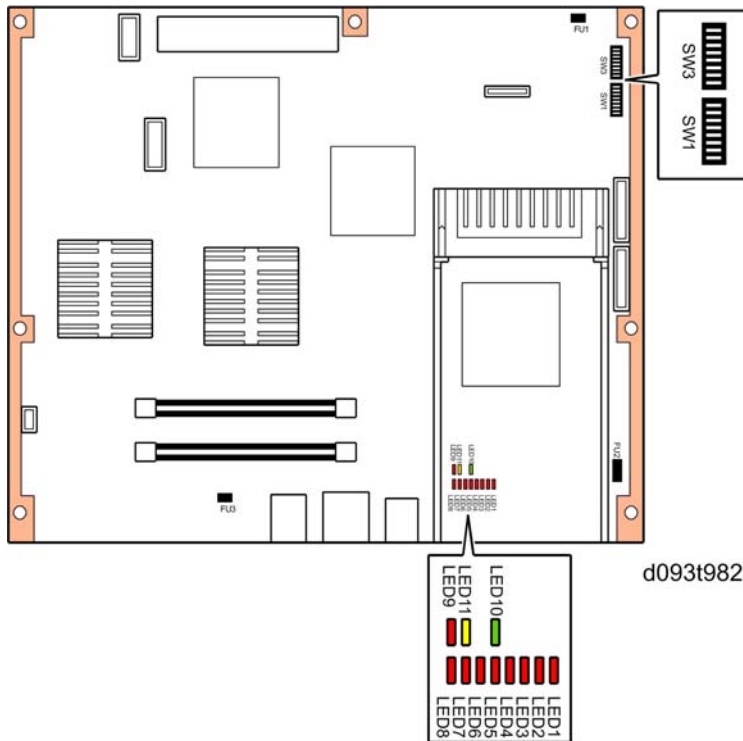

The controller board controls the memory and all peripheral devices. The GW architecture control all applications, i.e. copying, printing, and scanning. The controller board has board slots and SD card slots that allow installation of the MFP options.

2. Installation

Preparation

Environment

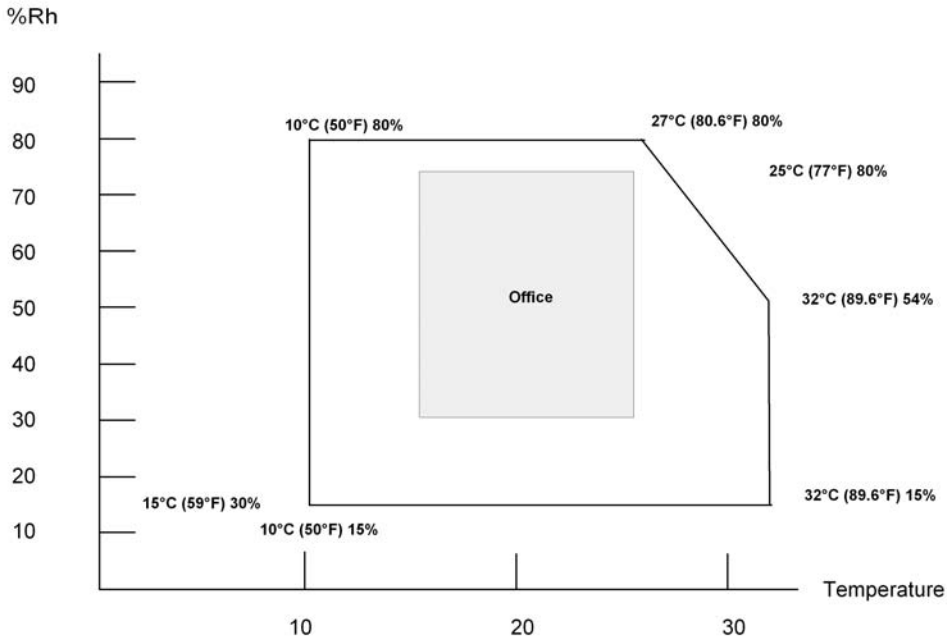

b286i900

1. Temperature Range: 10 °C to 30 °C (50 °F to 86 °F)
2. Humidity Range: 15% to 90% RH
3. Ambient Illumination: Less than 1,500 Lux.

★ Important

- Never expose the machine to direct sunlight.
 - If the scanning unit on top of the machine is exposed to direct sunlight, this could cause vertical black and white lines in scanned images.
 - If the machine is near a window, turn it around so the back of the machine is not facing the window and install blinds to block sunlight.
4. Ventilation: More than 30 m³/hr/person in the work area
 5. Ambient Dust: Less than 0.075 mg/m³
 6. If the installation area has air-conditioners or heaters, put the machine in a location where:

- There are no sudden temperature changes from low to high, or high to low.
 - The machine will not be directly exposed to cool air from an air conditioner in the summer.
 - The machine will not be directly exposed to reflected heat from a space heater in the winter.
7. Do not install the machine in an area filled with gases that can cause corrosion.

★ Important

- Never set up the machine where it will be exposed to ammonia fumes.
 - Ammonia in the surrounding area can cause poor reproduction of filled areas in images.
 - If exposing the machine to ammonia in the air cannot be avoided, and if poor reproduction in filled areas of the images is visible, do SP2201-2 and enter a setting 50 steps lower than the current setting.
8. Do not install the machine in areas higher than 2,000 m (6,600 ft) above sea level.
9. Put the machine on a strong and level surface.

★ Important

- The floor must be able to support a load of more than 2.94 kPa (300 kgf/m²).
10. Do not install the machine in an area where there are frequent strong vibrations.

Minimum Space Requirements

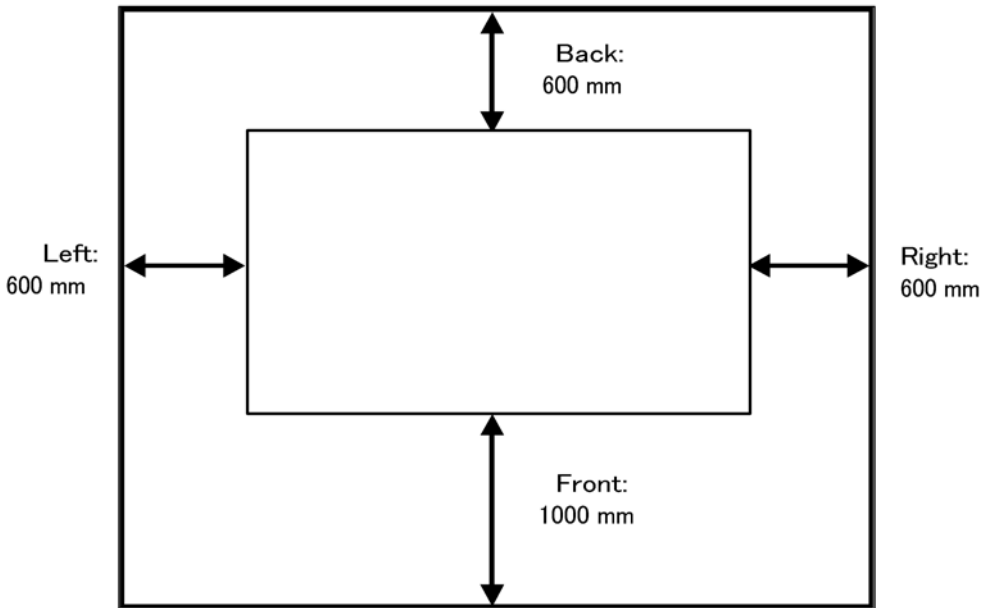

b286i520

1. Front: 1000 mm (40")

2. Back: 600 mm (23")
3. Right: 600 mm (23")
4. Left: 600 mm (23")

Machine Level

1. Front to back: Not more than 5 mm from level
2. Right to left: Not more than 0.15/1000 mm from level.

Power Source

WARNING

- This machine is provided with a circuit breaker that cuts the power supply to the main machine in case of a current overload or short circuit. The machine must be installed in a building where circuit breakers (and equivalent devices) can operate properly.
1. Input Voltage Level:
 - 120V, 60 Hz, 15A or more
 - 220-240V, 50/60 Hz, 10A or more
 2. Permissible Voltage Fluctuation: $\pm 10\%$
 3. Do not set objects on the power cord.

Important

- Make sure the plug is firmly inserted in the outlet.
- Do not connect the machine to a power source that is shared with other equipment.
- To prevent damage to the breaker switch, installation of a voltage stabilizer (constant voltage transformer) is recommended for work sites where there is fluctuation in the AC power source.
- To protect the HDD, always switch the machine off with the operation switch on the operation panel, wait for the power switch LED to stop flashing, then switch off the main switch on the side of the machine.

Installation Overview

Installation Flow

The machine can be installed on either a roll feeder or a table.

- **Roll feeder.** You can install a roll feeder with one roll or two rolls. You can also install a universal paper cassette inside the roll feeder. You cannot install the paper cassette without the roll feeder.

- **Table.** Used as an alternative to the roll feeder, it contains only the lower stacker.

Here is a summary of the sequence recommended for installation of all options at installation.

Installation Flow Diagram

Machine Pre-Installation

Remove the machine from its box. Remove all packing material and tape. Put the machine on the roll feeder or the table.



Roll Feeder (or Table) Installation



Install Paper Cassette



SP and User Tool Settings for Installation

Do all the SP and User Tool settings for the machine and the installed options.



Machine Final Installation

Complete the installation of the machine after you put it on the roll feeder or table, and after you install all options. Do some sample copies to check the operation of the machine and the installed options.



MFP Options, Other Options

Install the MFP options and any other options, such as the USB2.0/SD Slot Type E (D354).

SP and User Tool Settings Required for Installation

This is a summary of the important SP and User Tool settings that are necessary for this installation.

Main Machine Installation

2801-2	Lot Number 1	Enter the developer lot numbers at installation before doing SP2801-1
2801-3	Lot Number 2	
2801-1	Initialize Developer	Mixes developer and supplies toner.

2923-1	Execute Cleaning Blade Replace Mode	Applies a thin layer of toner to the drum. This prevents scratches on the drum when the machine power comes on for the first time.
3001-2	Initialize ID Sensor	Initializes the ID sensor after toner has been applied to the drum.
User Tool	System Settings > Tray Paper Setting > Next > Paper Type: Tray n	Sets the paper type for each tray: <ul style="list-style-type: none"> • Tray 1: Roll 1 • Tray 2: Roll 2 • Tray 3: Cassette • Bypass
User Tool	System Settings > Timer Settings > Set Date, Set Time	Check the date and time setting. If they are not correct, set the correct date and time.

Roll Feeder Installation

SP	Adjustment	
1920	Cut Length Adjustment	
	Sets the cut length settings for the rolls installed in the roll feeder. These settings are different for each machine. The settings are on a label attached to the right side of the roll feeder drawer.	
1920-22	Cut Length Adjustment: 1st Roll: 297 mm: Plain Paper	Adjust for D503/D504, 1st Roll
1920-26	Cut Length Adjustment: 1st Roll: 1189 mm: Plain Paper	Adjust for D503/D504, 1st Roll
1920-82	Cut Length Adjustment: 2nd Roll: 297 mm: Plain Paper	Adjust for D504, 2nd Roll
1920-86	Cut Length Adjustment: 2nd Roll: 1189 mm: Plain Paper	Adjust for D504, 2nd Roll
1001-1	Leading Edge Registration – 1st Roll	Adjust D503/D504, 1st roll.
1001-2	Leading Edge Registration – 2nd Roll	Adjust for D504, 2nd roll.
1002-1	Side-to-Side Registration – 1st Roll	Adjust for D503/D504, 1st roll

SP	Adjustment	
1002-2	Side-to-Side Registration – 2nd Roll	Adjust for D504, 2nd roll.

Paper Cassette

1001-3	Leading Edge Registration – Cassette	Adjust for Paper Cassette B853.
1002-3	Side-to-Side Registration – Cassette	

MFP Options: Onboard Device Settings

5985-1	On Board NIC	Both SP codes must be set to "1" to enable these built-in features. (The default is "0" OFF).
5985-2	On Board USB	

Main Machine Installation (D093/D094)

Note

- Always have this Service Manual with you. The installation procedures are not shipped with the main machine.

CAUTION

- Never turn the main machine off when the main power LED is lit or flashing.
- To protect the HDD, always switch the machine off with the operation switch on the operation panel, wait for the power switch LED to stop flashing, then switch off the main switch on the side of the machine.

2

Accessory Check

Check the accessories and their quantities against the table below.

No.	Description	Q'ty
1	Flat Brush (Fusing Unit Guide Spurs)	1
2	Original Output Guides	4
3	Upper Output Stacker (Left)	1
4	Upper Output Stacker (Right)	1
5	Original Tray	1
6	Operating Instructions (-17, -21)	3
7	CD-ROM (-17, -21)	1
8	Studs	2
9	Panel: Logo	1
10	Cloth – Exposure Glass	1
11	Guide Lever	1
12	Operation Panel Anchor Screws	3
13	Operating Instruction Holder	1
14	Cloth Pocket	1
15	Ferrite Core (For Network Cable)	1

No.	Description	Q'ty
16	Hinges: Upper Output Guide	2
17	Upper Output Guide	1

2

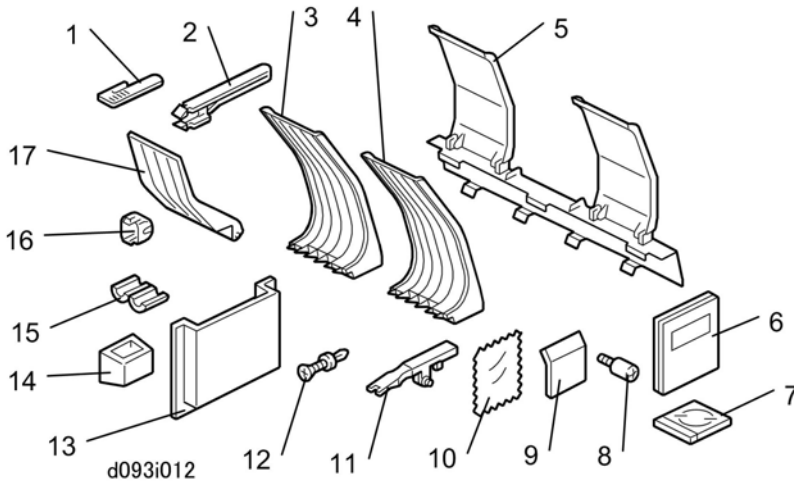

Machine Installation Procedure

Before You Begin...

Condensation can occur on the drum the first time the machine is started up in a cold environment, or if the machine has been stored for a long period in a cold location and moved to a warm room.

- If time permits, delay installation and allow the machine to set for at least 24 hours at room temperature after moving it from a cold environment to a warm environment.
- If the machine has already been installed elsewhere, connect the machine and allow it to set overnight so the anti-condensation heaters can eliminate the moisture. (Main power switch should be on and operation power switch off.)
- Use a hand dryer to dry the area around the drum, or you can remove the drum and dry it with a clean, dry cloth.

Removing the Shipping Material

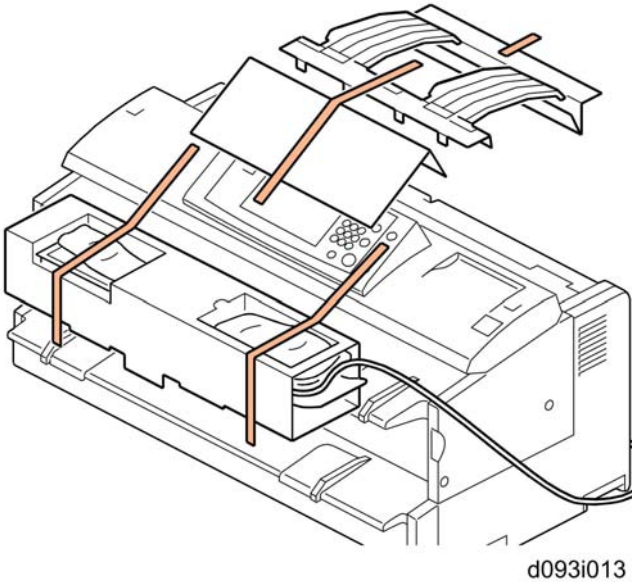

2

⚠ CAUTION

- Do not connect the power cord to the power source during these installation procedures until the procedure tells you to do this.
1. Remove all the orange filament tape and packing materials from the main machine.

↓ Note

- Use a clean cloth moistened with alcohol to remove any tape adhesive that remains on the main machine after tape removal.

Setting the Main Machine on the Roll Feeder (D503/D504) or Table (B854)

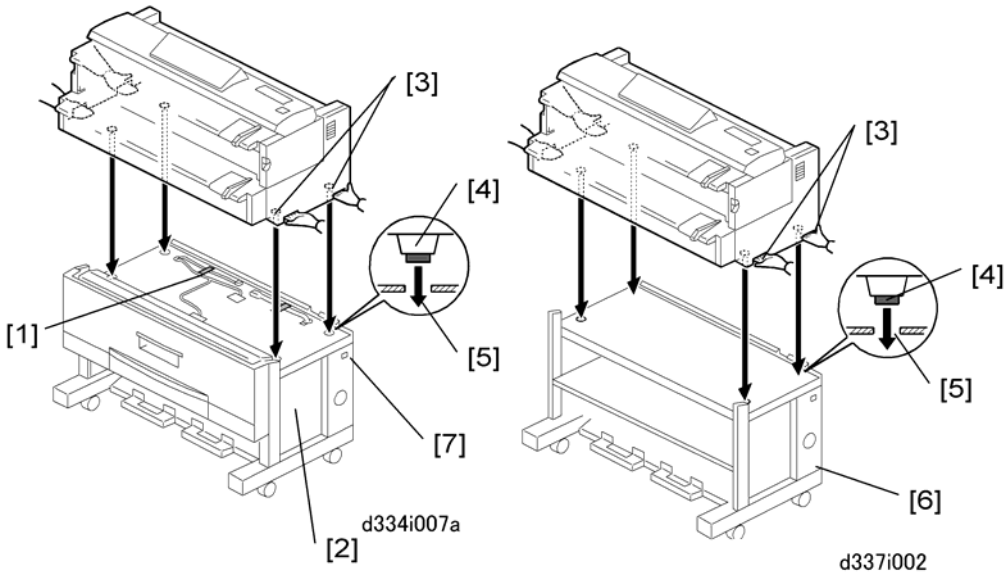

1. Do not remove the shipping tape from the connectors [1] of the roll feeder [2]. This prevents damage to the connectors when the main machine is put on top of the roll feeder.

⚠ CAUTION

- The main machine weighs 107 kg (235 lb.).
 - There are two handles in recesses on each side of the main machine. To prevent injury or damage to the main machine, always use these handles [3] to lift the main machine.
 - Two or more service technicians are necessary to lift the main machine and set it on the roll feeder or table.
2. Lift the main machine, and set its rubber feet [4] into the holes [5] on the top of the roll feeder or table [6].

↓ Note

- With one person at each end of the main machine, use the two handles on each end of the main machine to lift it.
3. Make sure that you put the rubber feet of the main machine into the holes on top of the roll feeder or table.
 4. Check the dehumidifier switch [7] of the roll feeder. Make sure that it is OFF. If it is ON, set it to OFF.

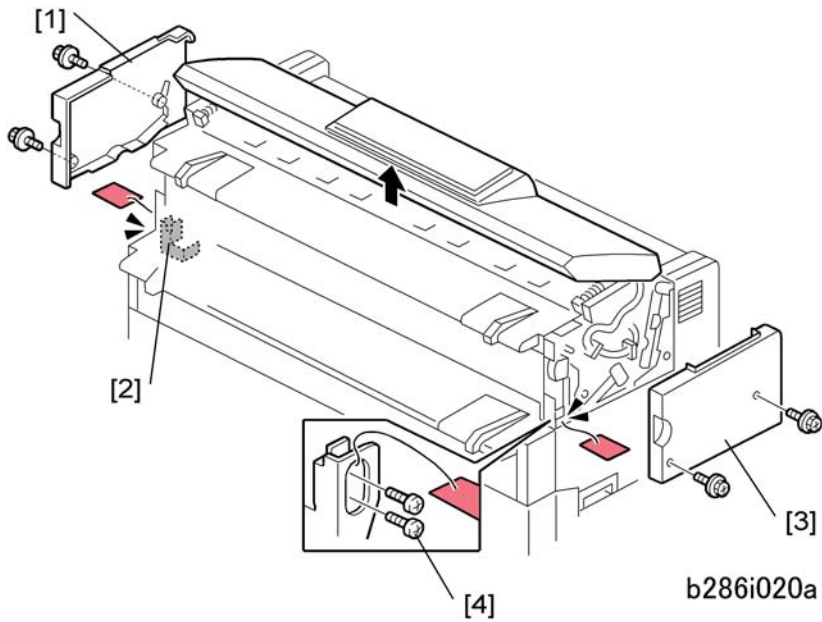

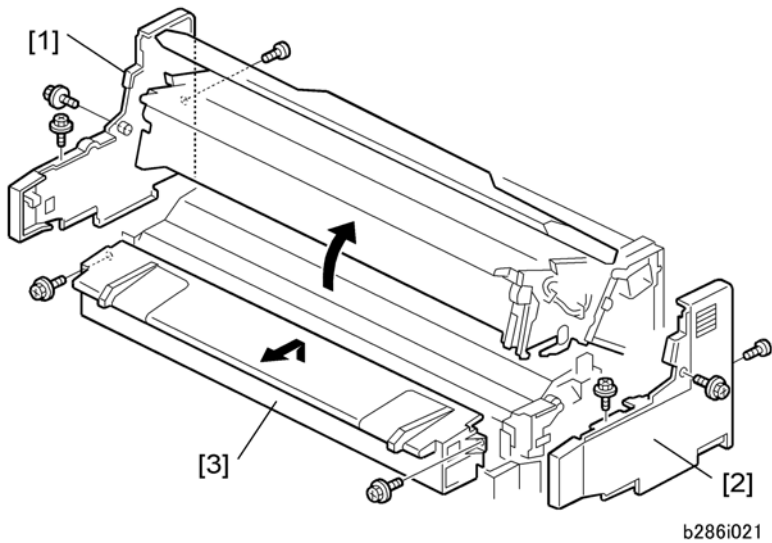

5. Remove the covers and screws:

- [1] Left upper cover (2 x 2)
- [2] Left screws (2 x 2)
- [3] Right upper cover (2 x 2)
- [4] Right screws (2 x 2)





6. Open the upper unit.

7. Remove:

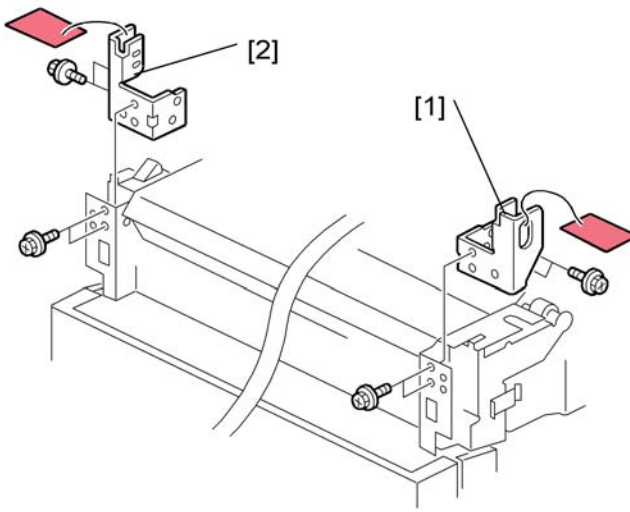
- [1] Left cover ( x 3)
- [2] Right cover ( x 3)
- [3] Manual feed table ( x 2). Open the drawer of the roll feeder before removing if the roll feeder is installed.



b286i022

8. Remove the right transport lock plate [1] ( x 4).
9. Remove the left transport lock plate [2] ( x 4).

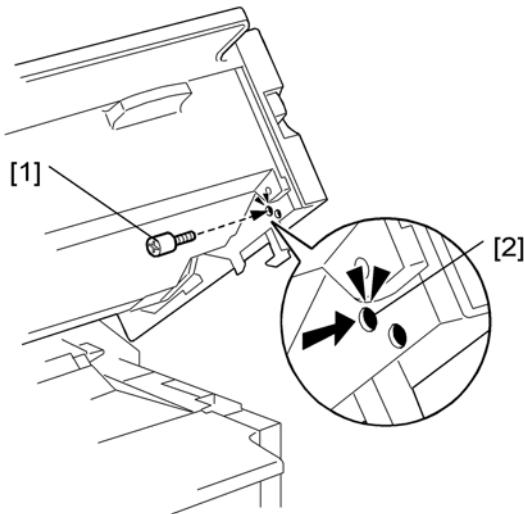

b286i016

10. Install the studs [1] on the right side and the left side.

↓ **Note**

- You must fasten each stud in the upper hole [2] on both sides.

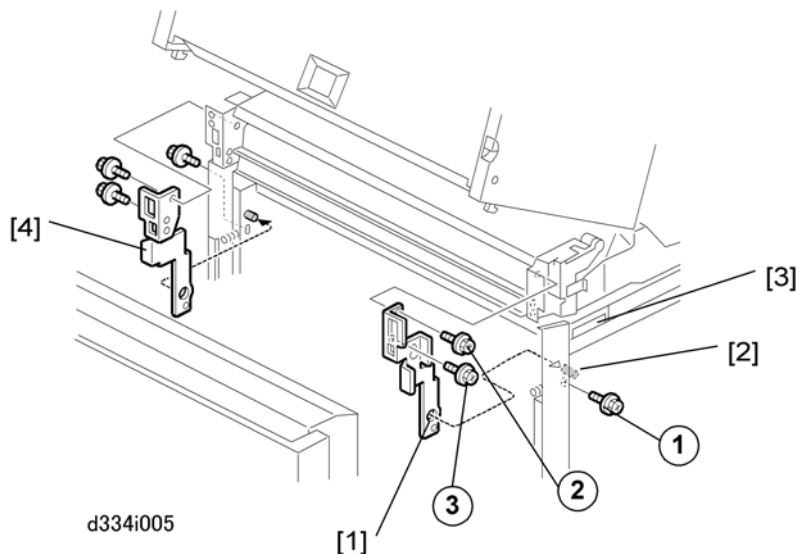

- Attach the right joint bracket [1] (the spindle [2] must go through the hole). At the same time, align the plate with the holes for the three screws (blue).

↓ **Note**

- The joint brackets and screws are provided as accessories with either the Roll Feeder (D503/D504) or Table (B854).
- Attach screws but do not tighten them.
 - While you lift the main machine by its handle [3], set screw ③ in the lower hole of the keyhole cutout and tighten it.
 - Tighten screws ① and ②.
 - Do the above procedure again for the left joint bracket [4].

⚠ CAUTION

- When you attach the left bracket make sure that the bracket does not pinch or interfere with the harness of the main switch.

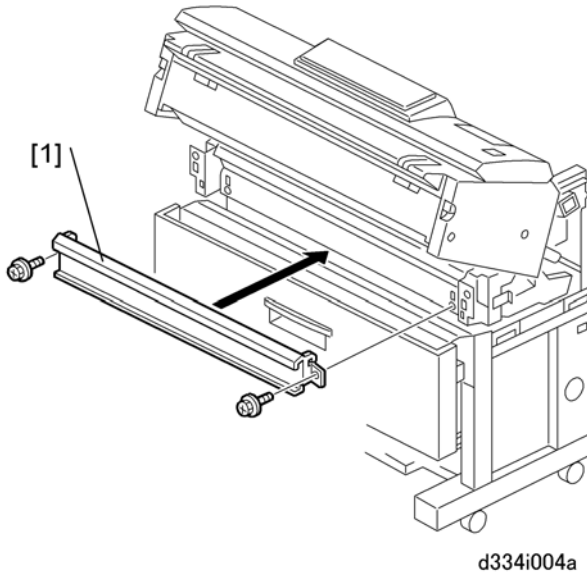

↓ **Note**

- The guide plate and screws are provided as accessories with either the Roll Feeder (D503/D504) or Table (B854).

16. Install the guide plate [1] ( x 2 Blue). Hang the hooks on each end; this puts the plate in the correct position to be installed.

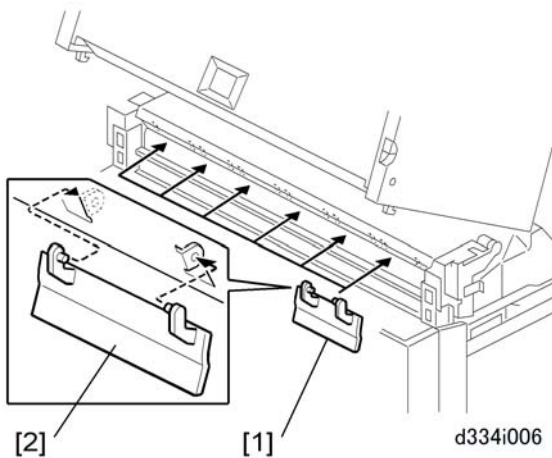

↓ **Note**

- The movable guide plates are provided as accessories with either the Roll Feeder (D503/D504) or Table (B854).

17. Attach the movable guide plates [1] (x6).

- Each plate is the same. It is not possible to install a plate in the incorrect position.

- Attach each plate with the ribbed side down.
- Move the hinges [2] a small distance apart. This allows the tabs to attach easily into the holes.

18. Lift each plate and let it fall, to make sure that they move smoothly on the hinges.

19. Reattach the manual feed table.

20. Reattach the left and right covers.

Note

- The flat-head screw must be attached at the rear side of each cover.

21. Close the upper unit.

2

Leveling the Main Machine and Attaching Leg Covers

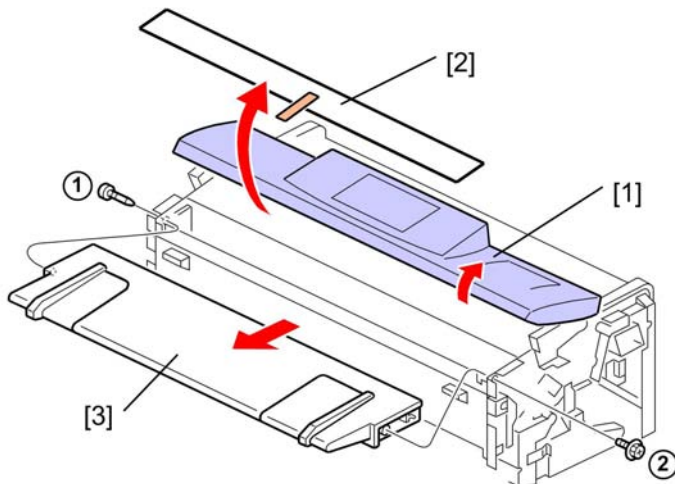

d093i017b

1. Raise the original feed unit [1].
2. Remove the protective sheet and tape [2].
3. Remove the original table [3] (⚒ x1, 🔩 x1).

★ Important

- Be sure to re-attach the pivot screw ① and tapping screw ② at the correct positions.

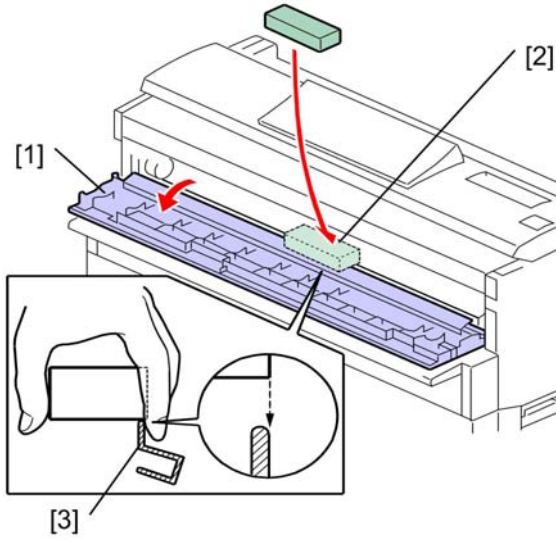

d093i017

4. Open the toner hopper cover [1].
5. Set a level [2] on the plate [3] of the development unit as shown.

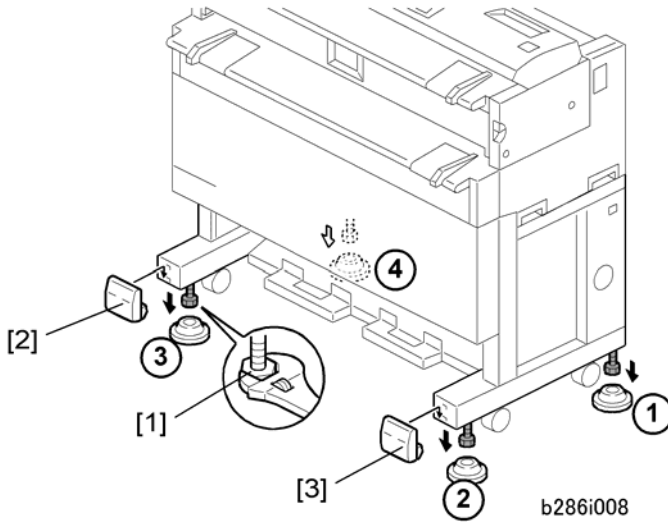

b286i008

6. Set the shoes ①, ②, ③, ④, under the main machine.
7. Use a wrench to adjust the nuts [1] on each foot to raise or lower the main machine at each corner.

Note

- The main machine must be level side-to-side within $\pm 0.15/m$.

8. Attach the left leg cover [2] and the right leg cover [3].

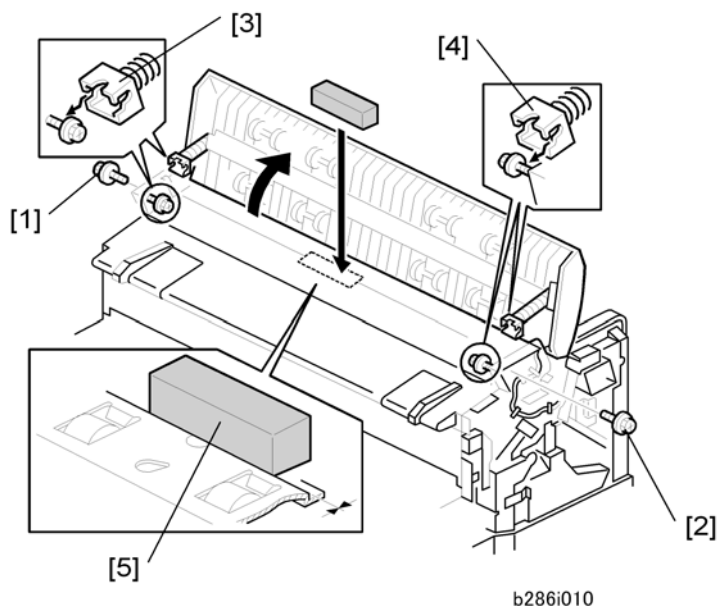

9. Remove the lock screws [1], [2] ( x 2).
10. Lift the left hinge [3] and right hinge [4] off their support screws then lift the unit to the vertical position. (Do not remove the support screws.)
11. Put the level [5] on the exposure glass.
12. If the machine is level, you are finished. Be sure to re-attach the lock screws and hinges removed in Steps 9 and 10.

-or-

If the machine is not level, use a wrench to adjust the nuts on each foot to raise or lower the main machine at each corner.

Note

- The main machine must be level side-to-side within $\pm 0.15/m$.
- Normally, the adjustment with the level on the exposure glass is not required. However, if you have to do the adjustment with the level on the exposure glass, go back to Step 5 and do the adjustment again with the level on the development unit.

Developer

2

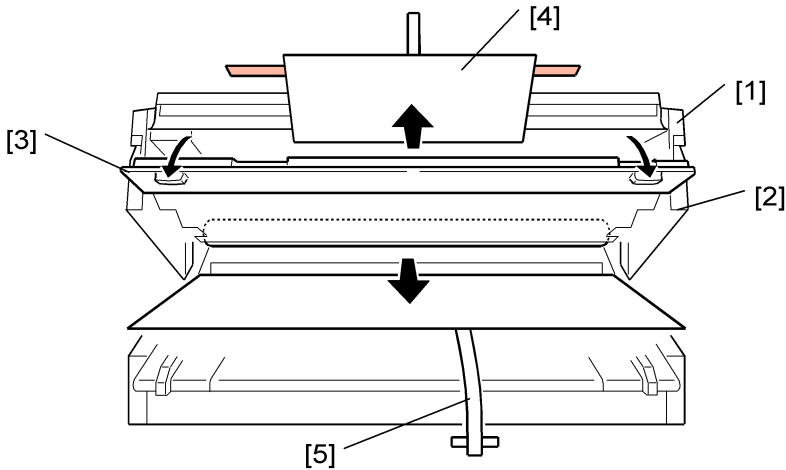

b286i002

1. Push up the buttons [1] to release the upper unit. Then open the upper unit [2].
2. Open the toner hopper cover [3].
3. Remove all tape and packing materials [4] in the upper unit.
4. Slowly pull out the drum protection sheet [5].

★ Important

- A developer lot number is embossed on the top edge of each package. Save these top edges after you open each developer package. You will need these numbers when you enter them later with SP2801-2 and -3.

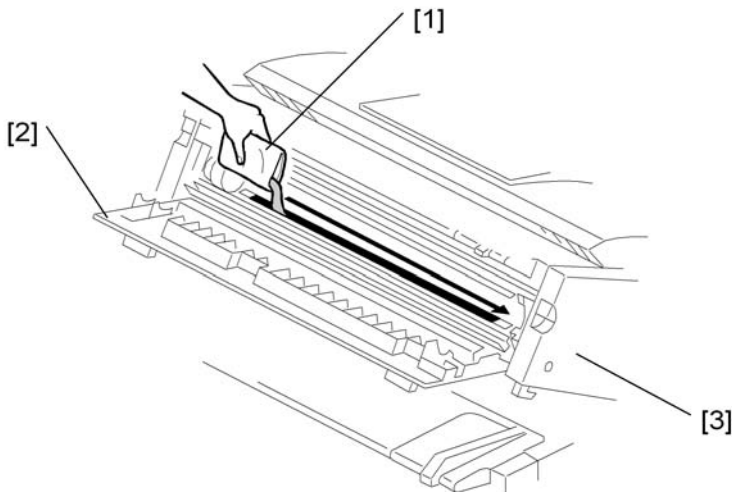

b286i005

5. Open a 1 kg pack of developer and pour it into the development unit.

★ Important

- **Do not add the second pack at this time.**
- Open the first pack of developer [1].
- Slowly add the developer from the first pack into the development unit, as you move the pack from left to right until the pack is empty.
- An equal amount of developer must be spread along the entire open slot of the development unit.

6. Close the toner hopper cover [2].

7. Close the upper unit [3].

8. Connect the power supply cord.

⚠ WARNING

- To ensure safe operation of the machine, always make sure that the machine is grounded at the power source.

9. Switch the main power switch on.

If the development motor starts, wait 50 sec. for it to stop. Go to Step 13.

-or-

If the development motor does not start, go to the next step.

10. Open SP2924-1. Change the "1" setting to "3".

11. Switch the main power switch off/on. The development motor starts. Wait 50 sec. for it to go off.

12. Open SP2924-1. Change the "3" setting to "1".

13. Turn the main power switch off.

14. Disconnect the power cord.

15. Open the upper unit.

16. Open the toner hopper cover.

17. Open the second 1 kg pack of developer, then slowly add it to the development unit. Move the pack from left to right until it is empty.

18. Use a clean cloth to clean the edges around the slot of the development unit.

19. Close the upper unit.

Toner Cartridge Installation

To prepare a toner cartridge for installation

★ Important

- Please install and use the toner cartridge that is designed for this machine.

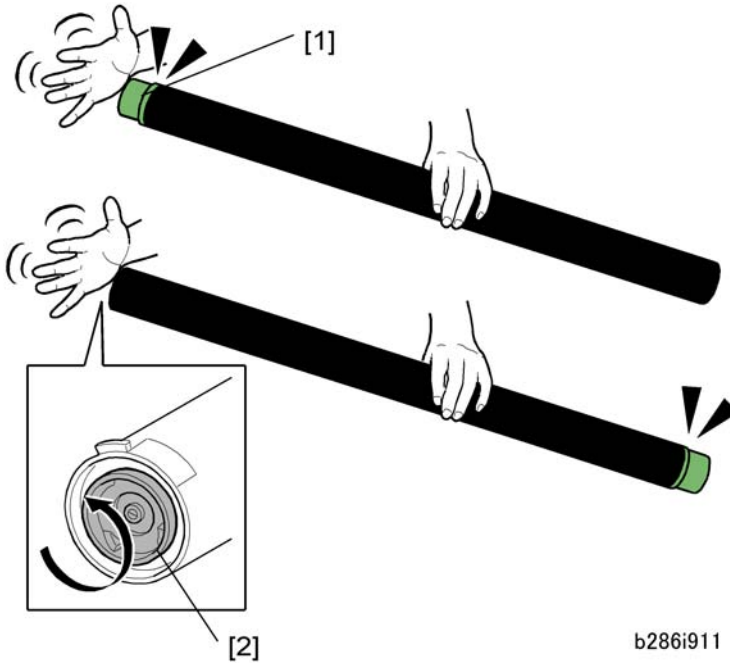

b286i911

1. Remove the cartridge from its package.
2. Gently tap the capped end of the cartridge [1] 4 or 5 times.
3. Tap the other end of the cartridge 4 or 5 times.
4. Shake the cartridge from side to side 4 or 5 times so the toner moves freely inside the cartridge.
5. Rotate the joint [2] to confirm that it rotates easily. If the joint does not rotate easily, tap the ends of the cartridge and shake it again.

★ Important

- Show the operators this procedure so that they know how to load the cartridge properly.
- If the toner is not loosened inside the cartridge before it is installed, the operator may hear a rattling noise when the main machine is switched on. (The noise is caused by agitators inside the cartridge that disengage if compacted toner prevents them from rotating.)

Toner Cartridge Storage

Show the operators how to store unused toner cartridges properly.

- Cartridges must be stored horizontally on a flat surface to prevent toner from clumping together at one end of the cartridge.
- A toner cartridge should never be stored standing on one end.
- Toner cartridges should never be stored in a location exposed to direct sunlight.

- Never break the seal of a toner cartridge until it is to be installed.
- The room temperature where toner cartridges are stored should be less than 40°C (104°F).
- To prevent fire hazards and personal injury, never incinerate used toner cartridges. Obey the local laws and regulations that apply to such materials.

To install a toner cartridge

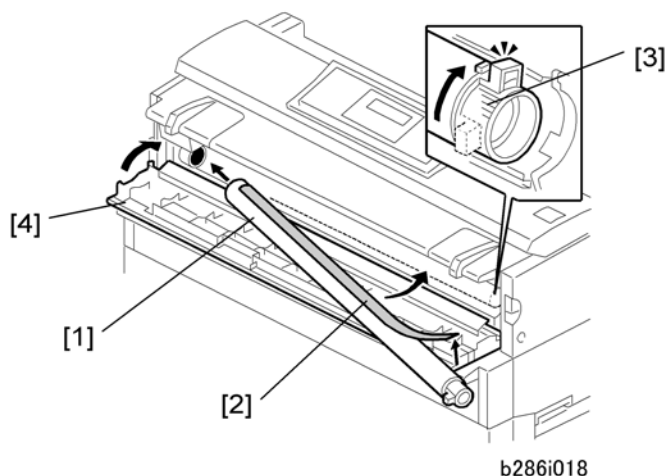

1. Set the toner cartridge [1] in the main machine.
2. Pull up the tape [2] then pull it across the toner cartridge from right to left to remove the tape.
3. On the right end of the toner cartridge, push the knob [3] up until it stops.
4. Close the toner hopper cover [4].
5. Switch the main power switch on.

Enter Developer Lot Numbers

1. Go into the SP mode.
2. Do SP2801-2 and 3 to enter the lot numbers.

↓ Note

- Use the soft keyboard on the display panel to enter the lot numbers. (The lot numbers are embossed on the top edge of each developer pack.) If the numbers are the same, enter the same number twice.

★ Important

- You must enter the lot numbers with SP2801-2 and -3 before doing SP2801-1. The main machine will return an error ("Failed") if you attempt to do SP2801-1 before SP2801-2 and -3.

Mix Developer, Supply Toner

1. First, make sure that the toner cartridge has been installed in the machine. (See previous section.)
2. Next, do SP2801-1 to mix the developer and supply toner. This takes about 5 minutes.
3. Do SP2923. This applies a thin layer of toner to the bare drum.

2

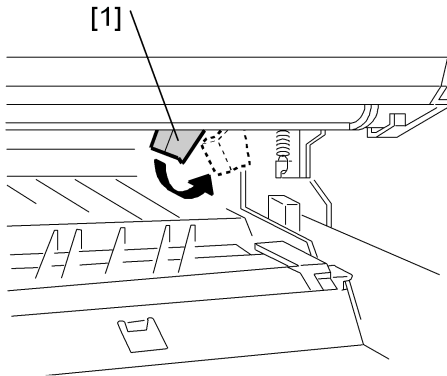

b286i020

4. Open the upper unit.
5. Push the cleaning-blade release lever [1] to the right.

↓ Note

- The cleaning-blade release lever keeps the cleaning blade away from the drum during transportation. To prevent damage to the drum, before you move the main machine to a different location, be sure to push this lever to the left.

6. Close the upper unit.
7. Do SP3001-2 to initialize the ID sensor. Initialization takes about 15 sec.
8. Exit the SP mode and turn off the main power switch.
9. If you will install one or more of the following options, do these installations at this time:
 - **Roll Feeder, Paper Cassette** See Roll Feeder (D503/D504), Paper Cassette (B853).
 - **Table.** See Table (B854).
 - **MFP Options.** See Installation of MFP Options.
 - After installing all options, complete main machine installation. See Main Machine Final Installation.

Main Machine Final Installation

Set the Operation Panel Position

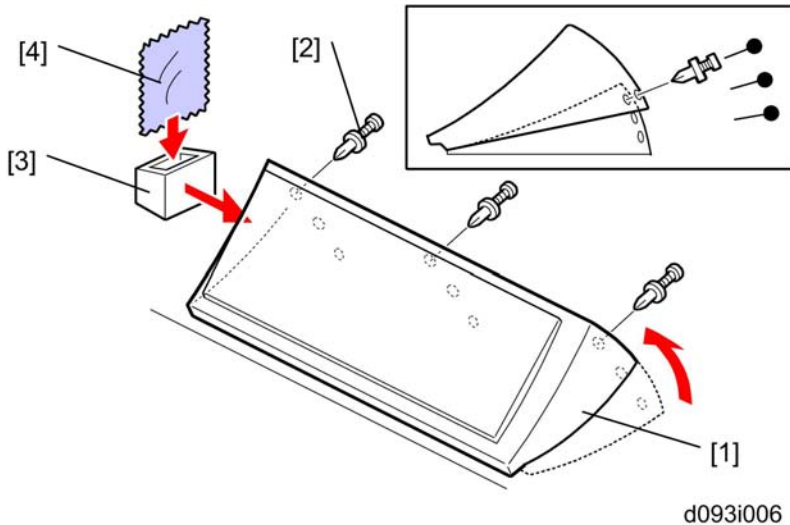

2

You can adjust the position of the operation panel to reduce glare from overhead lighting hitting the operation panel display.

1. Lift or lower the operation panel [1] to one set of the three sets of holes to set the panel at the desired angle to reduce glare on the operation panel.
2. Push each anchor screw [2] into its hole ( x 3).

↓ Note

- It is not necessary to tighten the screws.
3. Attach the exposure glass cloth pocket [3].
 4. Put the exposure glass cloth in the pocket [4].

Select the Tray Paper Size and Type

1. Push [User Tools] > "System Settings" > "Tray Paper Settings".

↓ Note

- Selections are shown only for installed options. If you installed all the options, you will see "Tray Paper Size: Tray 1" (1st Roll), "Tray Paper Size: Tray 2" (2nd Roll), and "Tray Paper Size: Tray 3" (Cassette).
2. Select the paper size for each tray and bypass tray.
 3. Select the paper type for each tray and bypass tray.

Testing the Main Machine Circuit Breaker

★ Important

- Follow the procedure below to test the operation of the circuit breaker. This must be done at installation and at least once a year after installation.
1. Plug the main machine power cord into its power source and make sure that the main machine power is off.

★ Important

- Do not turn on the main machine. The main machine must be off.



d093r151

2. At the back of the machine, use the tip of a small screwdriver to depress the breaker test button [A].
 - The breaker switch should flip from "—" to "O". This indicates that the breaker switch is operating normally.
 - If the breaker switch does not flip to "O", the breaker switch must be replaced.
3. Push the breaker button to display "—" again. This resets the main machine for normal operation.

★ Important

- The main machine power will not turn on if the breaker switch remains at "O".

Main Machine Accessories

2



d093i007c

1. Make sure the blinders [A] are straight and not separated from the back of the machine.

★ Important

- These blinders prevent light from entering the scanner unit.
- Strong light or direct sunlight can interfere with the operation of the CIS unit and cause vertical white and black lines to appear in copy images.
- Never remove these blinders.

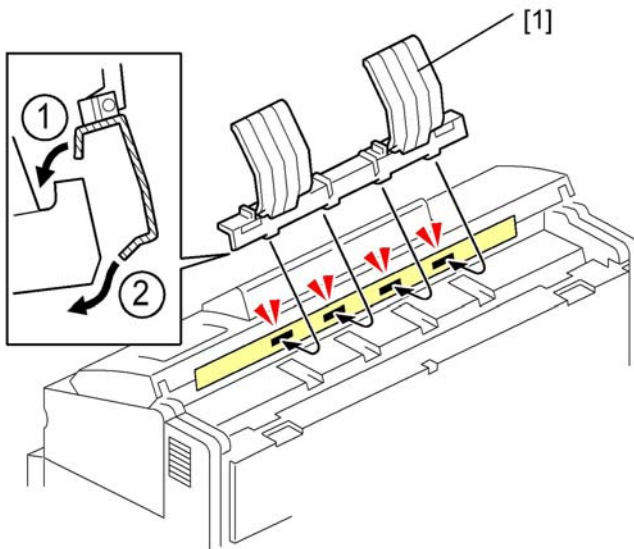

d093i007a

2. To attach the original tray [1], attach the top ① first, then the bottom ② as shown.
3. Make sure the four tabs ② (x4) are completely engaged.

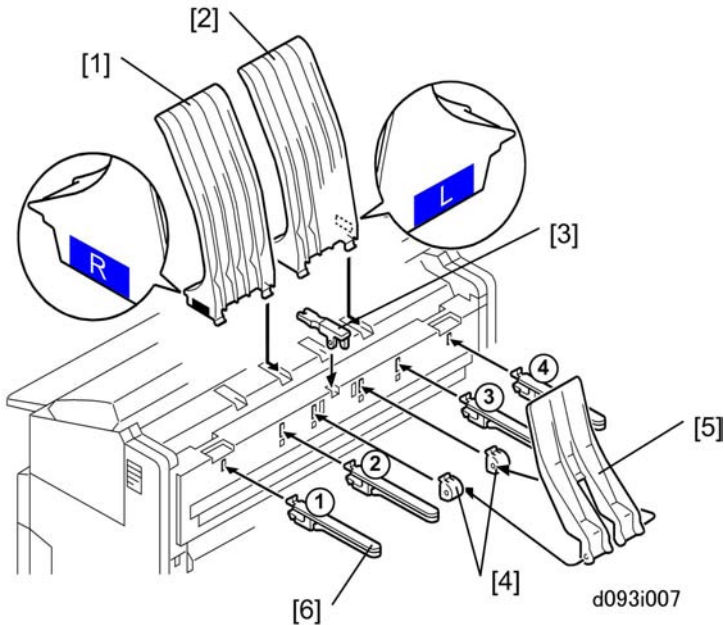

4. Attach upper output stacker (R) [1].
5. Attach upper output stacker (L) [2].
6. Attach the guide lever [2].

This guide lever should be up or down, depending on whether "Upper" or "Lower" is selected for "Copy Output" on the operation panel:

- The guide lever should be up for "Upper" output.
- The guide lever should be down for "Lower" output so the original can pass over it.

7. Attach the upper output guide hinges [4].
8. Attach the upper output guide [5].
9. Attach the original output guides [6] ①,②,③,④.

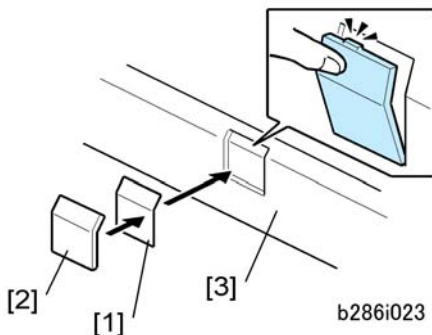

10. Attach the emblem [1] and panel [2] to the toner hopper cover [3].

Note

- Push the panel in until the emblem and panel move into their positions with an audible click.

Roll Feeder, Table Accessories

2

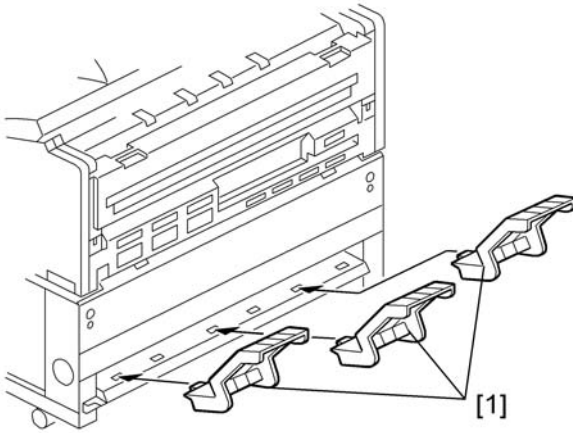

d334i011

1. Attach the lower output trays [1] to the lower rear of the roller feeder or table (x 3).

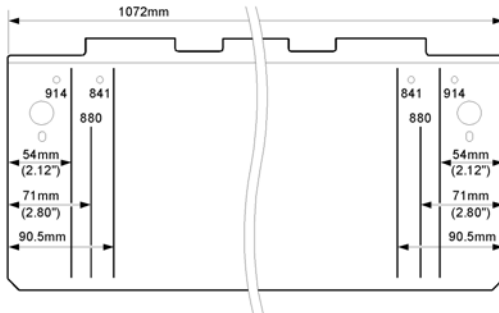

d334i031a

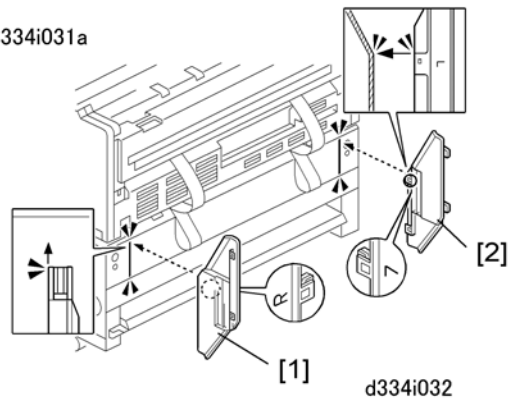

d334i032

↓ Note

- The lines and numbers embossed on the back of the main machine (see the upper left of the above diagrams) show where to position the exit guide plates for different paper widths.
2. Position the right exit guide plate [1] as shown, then attach it with its magnet.
 3. Position the left exit guide plate [2] as shown, then attach it with its magnet.

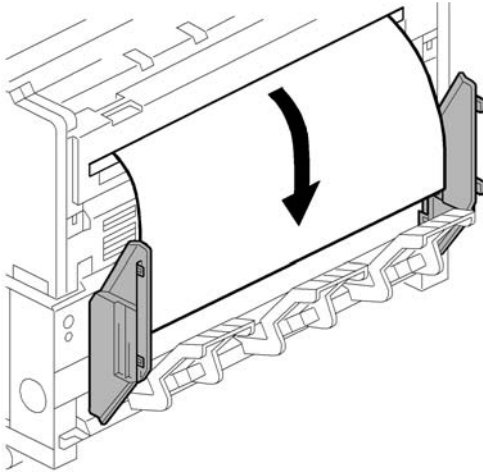

d334i033

4. Do a test print to confirm that the paper exits the main machine straightly and smoothly between the guide plates.

Copy Check

Scan an original to confirm that the main machine operates correctly.

1. Set an original or test pattern face down on the original feed tray.
2. After about 1 second, the main machine pulls the original, stops for 1 second, then starts to feed it.
3. Do a sample copy from the roller feeder and paper cassette if these options are installed.
4. If the copied image is not in the correct position, do SP4417 Pattern 28. For instructions on leading edge and side-to-side adjustments, see SP Adjustments.

Paper Roll Adjustments

SP No.	Name	Comment
1001-1	Leading Edge Registration – 1st Roll	D503/D504
1001-2	Leading Edge Registration – 2nd Roll	D504
1002-1	Side-to-Side Registration – 1st Roll	D503/D504

SP No.	Name	Comment
1002-2	Side-to-Side Registration – 2nd Roll	D504

Paper Cassette Adjustments

SP No.	Name
1001-3	Leading Edge Registration – Cassette (B853)
1002-3	Side-to-Side Registration – Cassette (B853)

2

Anti-Condensation Heater

Before You Begin...



d093i917

The anti-condensation heater has an ON/OFF switch on the back of the machine. When this switch is on, the heaters prevent condensation from forming inside the machine when the main machine is switched off with the main power switch or operation switch.

★ Important

- Always ask permission from the customer before you switch on the anti-condensation heater.

In order to comply with new International Energy Star Standards, the anti-condensation heater is switched off when the machine leaves the factory. Before you switch the anti-condensation heater on, discuss these points with the customer:

- The anti-condensation heater should be switched on to prevent condensation from forming on the drum if the humidity at the work site is very high. Drum condensation can cause image smearing and other problems.
- If the machine remains off with the heater off for long periods under low-temperature conditions (10° C (50°F) or lower), condensation can form on the drum surface after the machine is turned on. This is especially true if the machine has been off overnight during the winter.
- Please remind the customer that the anti-condensation heater consumes an additional 26W when it is switched on.
- The heaters operate after the machine is switched off with both the operation power switch and main power switch. However, in order for the heaters to function, the machine must remain plugged into the power mains.

Moving the Machine

- If you will move the main machine to a different building, open the paper feed section and push the cleaning blade lever to the left. This keeps the cleaning blade away from the drum while you move the main machine.
- If you will move the main machine to a different location in the same building, it is not necessary to set the lever to the left, and it is not necessary to disconnect the main machine from the roll feeder or table.

★ Important

- **Always push low on the roll feeder or table to move the main machine.**
- **If you push on the main machine, you could twist and possibly damage the bottom of the main machine.**
- **Never push on the main machine while it is installed on top of the roll feeder or table.**
- To prepare the main machine for transport to a different building, disconnect the main machine and the roller feeder (or table). Attach the drawer to the frame with tape, or the roll feeder drawer will fall out of the table frame.
- Lift the main machine with one person on each end of the main machine. Be sure to use the handles in recesses on the sides of the main machine.
- To prevent developer and toner spill, never tilt the main machine more than 30° from the horizontal.
- If the machine must be tilted more than 30° remove the development unit and toner cartridge before moving the machine.

⚠ CAUTION

- Never tilt the machine more than 45° from the horizontal.
- When the machine is moved, never expose the machine to temperatures above 40°C (104°F).

- If the machine needs to be stored temporarily it should be stored where the temperature is within the range 30° to 40°C (86° to 104°F).
- The machine should not be stored longer than one month with developer/toner inside the machine.

Original Hanger (D311)

The optional original hanger is attached to the bypass feed table on the front of the main machine.

Accessory Check

2

Check the accessories and their quantities against the table below.

No.	Description	Q'ty
1	Original Hangers	2

Installation

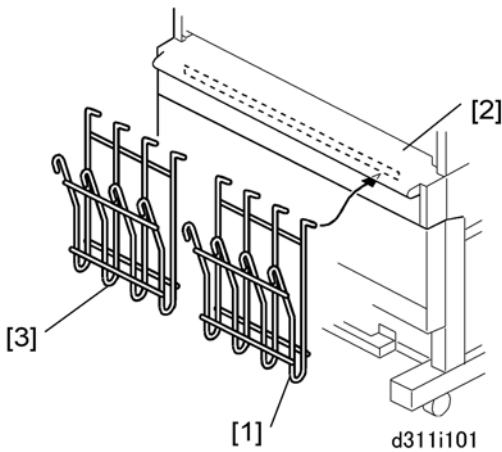

1. Attach one original hanger [1] to the bypass feed table [2].
2. Attach the other original hanger [3] to the bypass feed table.

Roll Feeder (D503/D504)

★ Important

- The Roll Feeder (D503/D504) is required for the Printer Option (D506).

Accessory Check

2

Check the accessories and their quantities against the table below.

No.	Description	Q'ty
1	Lower Output Trays	3
2	Leg Covers	2
3	Movable Guides	6
4	Shoes	4
5	Joint Brackets (Left, Right)	2
6	Exit Guide Plates	2
7	Screws (Cosmetic Silver)	4
8	Screws (Blue)	9
9	Harness Brackets	2
10	Mylars – Wide	2
11	Mylars – Narrow	2
12	Nylon clamp	1
13	Harness clamp	1
14	Ferrite Core	1
15	Guide Plate	1
16	Decal: Cutter: Caution (16 Languages)	1

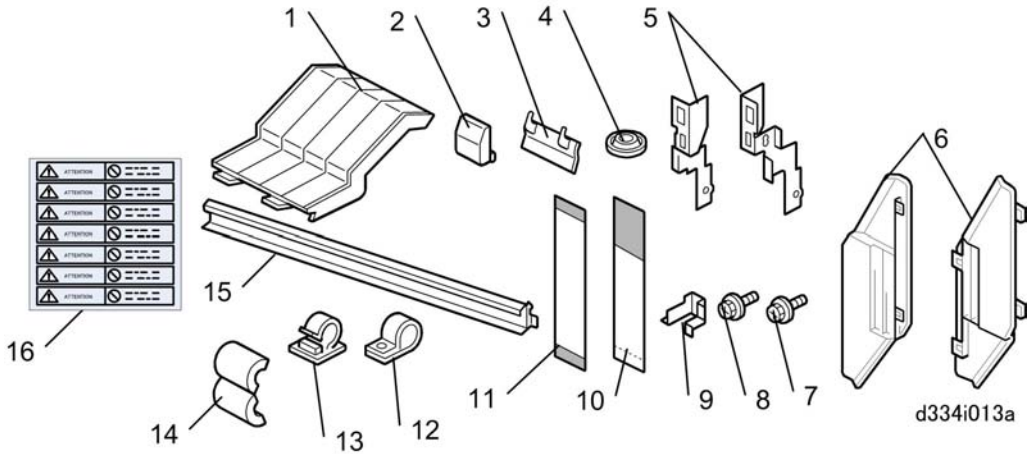

Roll Feeder Installation Procedure

Setting the Main Machine on the Roll Feeder

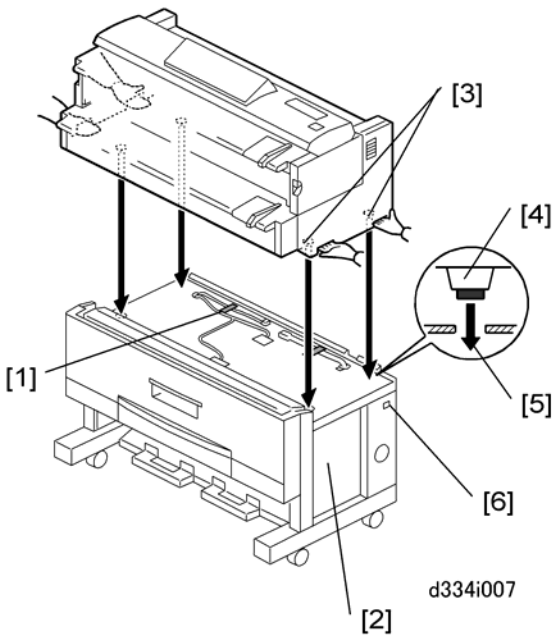

1. Do not remove the shipping tape from the connectors [1] of the roll feeder [2]. This prevents damage to the connectors when the main machine is put on top of the roll feeder.

⚠ CAUTION

- The main machine weighs 107 kg (235 lb.).

- There are two handles in recesses on each side of the main machine. To prevent injury or damage to the main machine, always use these handles [3] to lift the main machine.
 - Two or more service technicians are needed to lift the main machine and set it on the roll feeder.
2. Lift the main machine, and set its rubber feet [4] into the holes [5] on the top of the roll feeder.

Note

- With one person at each end of the main machine, use the two handles on each end of the main machine to lift it.
3. Make sure that you put the rubber feet of the main machine into the holes on top of the roll feeder.
 4. Check the dehumidifier switch [6] of the roll feeder. Make sure that it is OFF. If it is ON, set it to OFF.

2

Opening the Roll Feeder and Removing Shipping Material

Important

- The drawer of the roll feeder is locked and cannot be opened until the main machine is set on top of the roll feeder.
- Do not try to open the drawer of the roll feeder until after you set the main machine on top of the roll feeder.

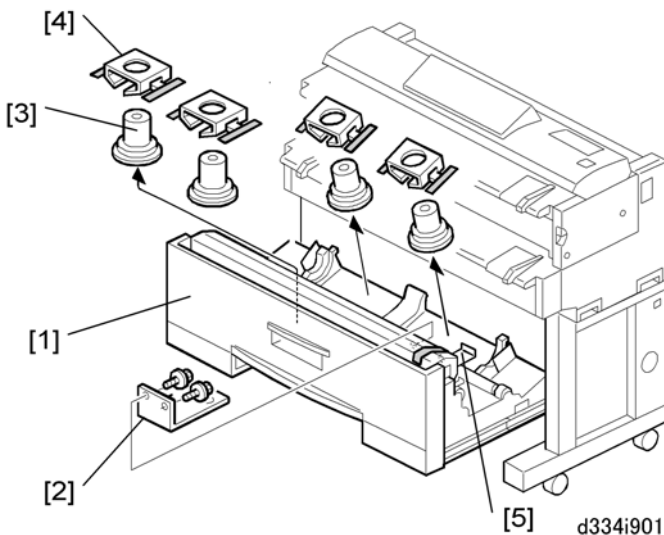





1. Open the drawer [1] of the roll feeder.
2. Remove the spring lock plate [2] ( x 2).
3. Remove the roll paper holders [3] and cardboard packing [4].

Note

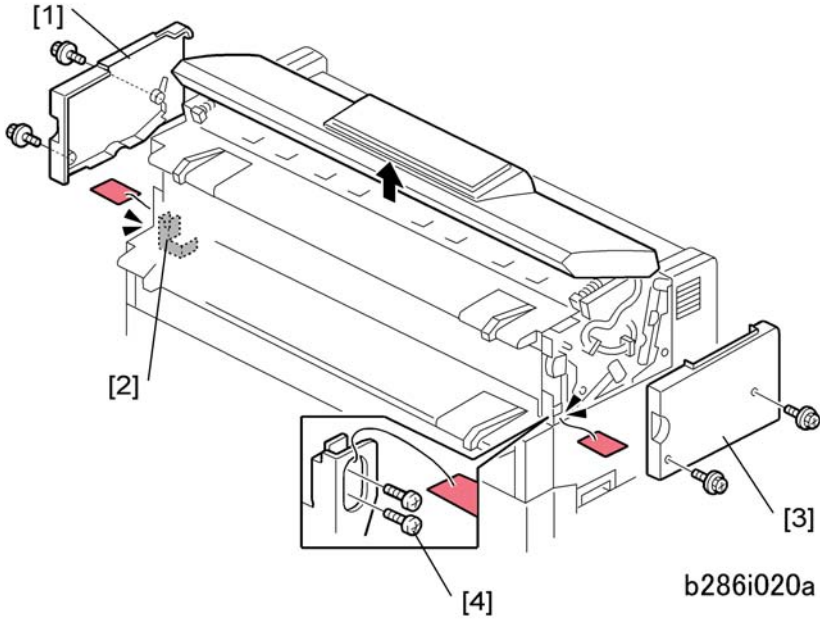
- Roll Feeder D503 has 2 holders, and Roll Feeder D504 has 4 holders (shown above).

4. Remove other tape or packing material in the roll feeder.
5. Remove the shipping lock plate [5] ( x 2).



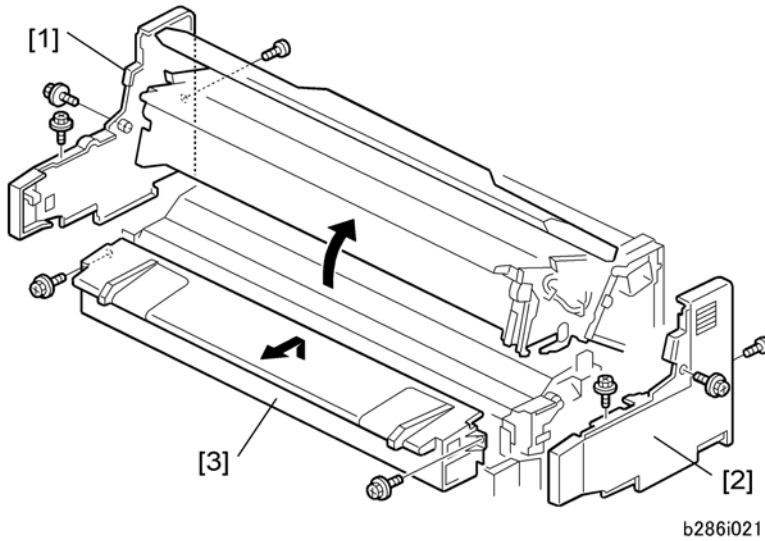

6. Remove the covers and screws:
 - [1] Left upper cover ( x 2)
 - [2] Left screws ( x 2)
 - [3] Right upper cover ( x 2)
 - [4] Right screws ( x 2)



7. Open the upper unit.

8. Remove:

- [1] Left cover ( x 3)
- [2] Right cover ( x 3)
- [3] Manual feed table ( x 2)

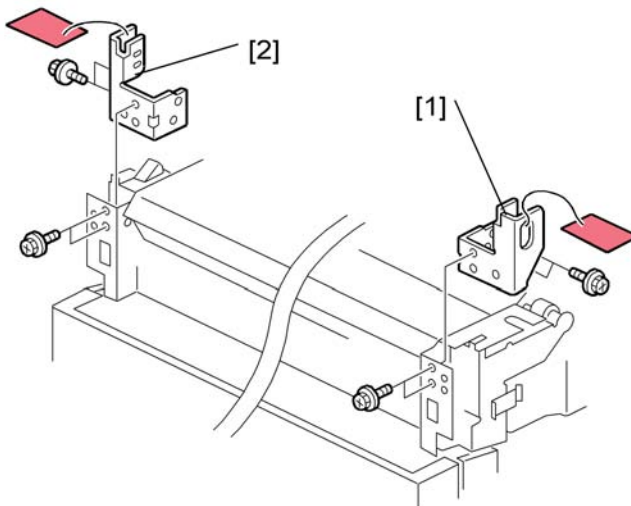

9. Remove the right transport lock plate [1] ( x 4).

10. Remove the left transport lock plate [2] ( x 4).

2

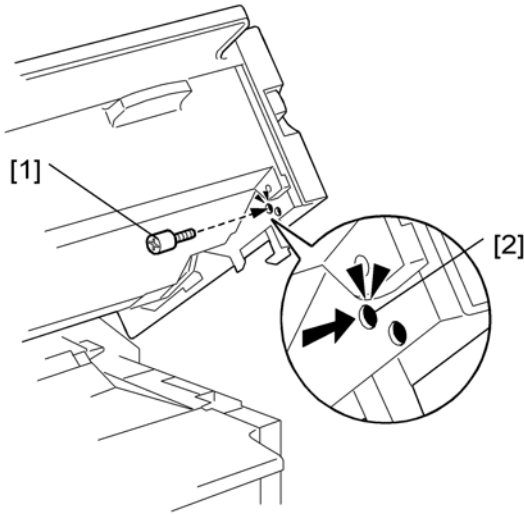

b286i016

11. Install the studs [1] on the right side and the left side.

Note

- You must fasten each stud in the upper hole [2] on both sides.

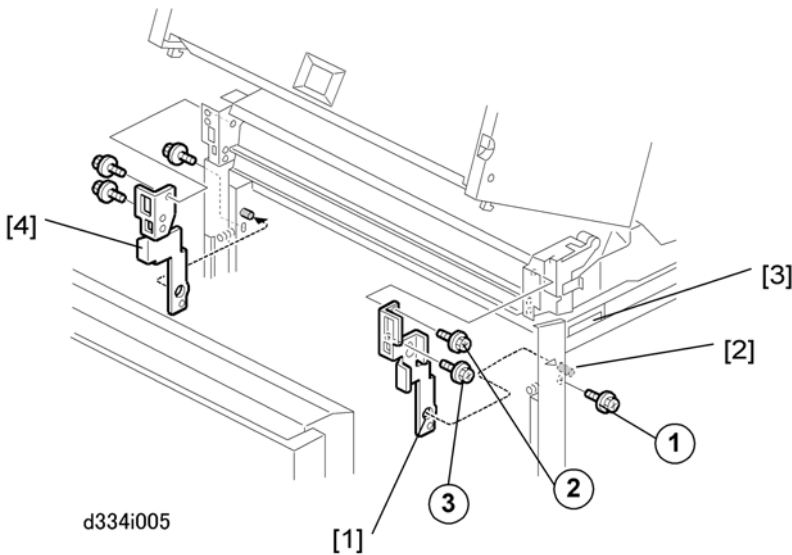

d334i005

12. Attach the right joint bracket [1] (the spindle [2] must go through the hole). At the same time, align the plate with the holes for the three screws (blue).

Note

- The joint brackets and screws are provided as accessories with the roll feeder.

13. Attach screws ①, ② but do not tighten them.

14. While you lift the main machine by its handle [3], set screw ③ in the lower hole of the keyhole cutout and tighten it.
15. Tighten screws ① and ②.
16. Do the above procedure again for the left joint bracket [4].

CAUTION

- When you attach the left bracket make sure that the bracket does not pinch or interfere with the harness of the main switch.

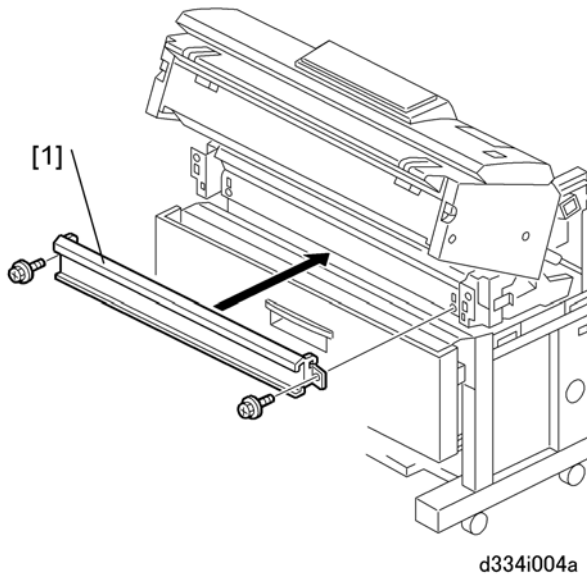

Note

- The guide plate and screws are provided as accessories with the roll feeder.
17. Install the guide plate [1] ( x 2 Blue). Hang the hooks on each end (this positions the plate for installation).

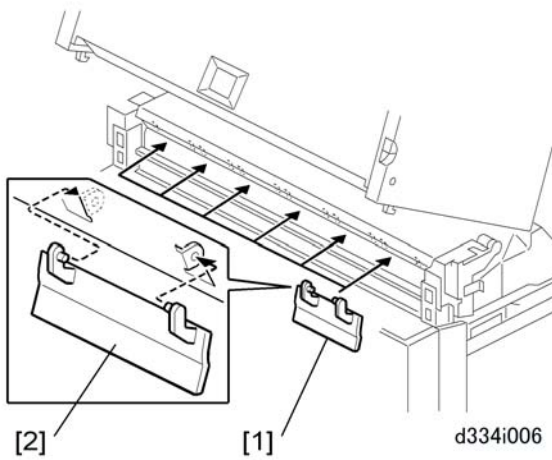

Note

- The movable guide plates are provided as accessories with the roll feeder.

18. Attach the movable guide plates [1] (x6).

- Each plate is the same. It is not possible to install a plate in the incorrect position.
- Attach each plate with the ribbed side down.
- Move the hinges [2] a small distance apart. This allows the tabs attach easily into the holes.

19. Lift each plate and let it fall, to make sure that they move smoothly on the hinges.

20. Reattach the manual feed table.

21. Reattach the left and right covers.

Note

- The flat-head screw must be attached at the rear side of each cover.

22. Close the upper unit.

Leveling the Main Machine and Attaching Leg Covers

2

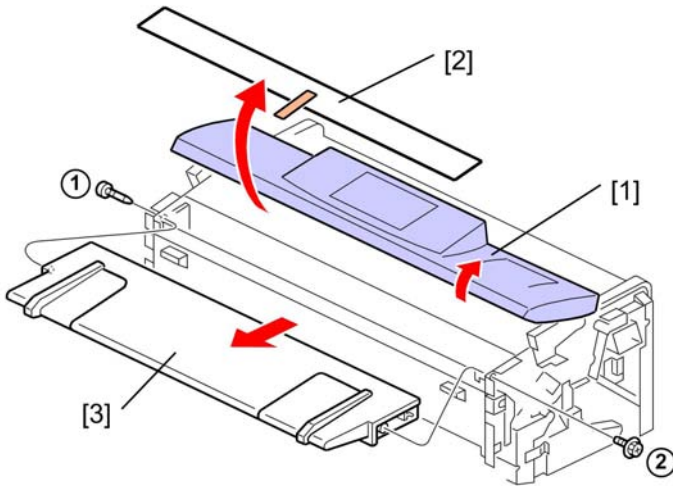

d093i017b

1. Raise the original feed unit [1].
2. Remove the protective sheet and tape [2].
3. Remove the original table (🔧 x1, 🔧 x1).

★ Important

- Be sure to re-attach the pivot screw ① and tapping screw ② at the correct positions.

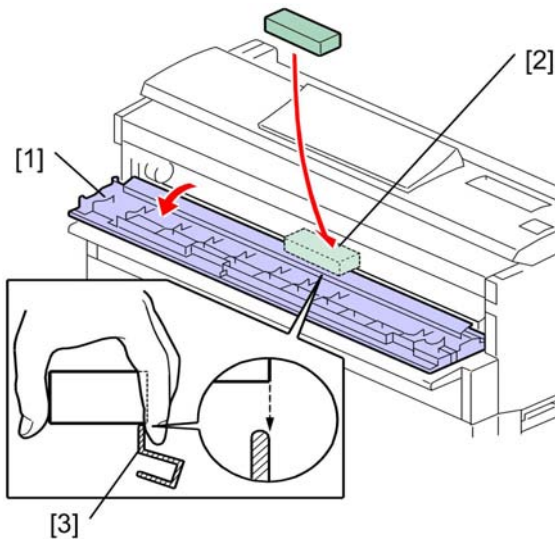

d093i017

4. Open the toner hopper cover [1].

5. Set a level [2] on the plate [3] of the development unit as shown.

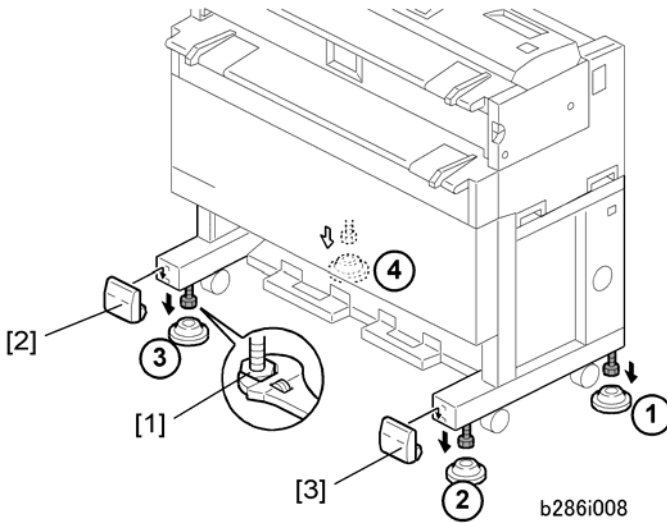

6. Set the shoes ①, ②, ③, ④, under the main machine.

7. Use a wrench to adjust the nuts [1] on each foot to raise or lower the main machine at each corner.

Note

- The main machine must be level side-to-side within $\pm 0.15/m$.

8. Attach the left leg cover [2] and the right leg cover [3].

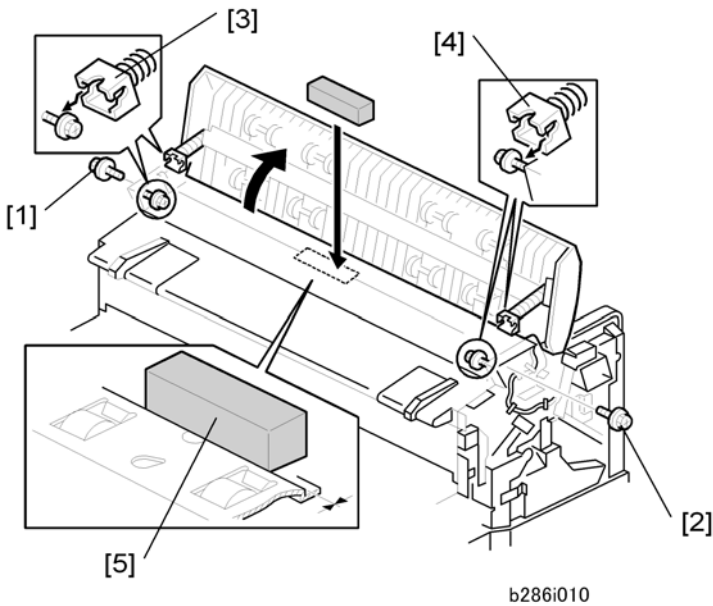

9. Remove the lock screws [1], [2] ( x 2).

10. Lift the left hinge [3] and right hinge [4] off their support screws then lift the unit to the vertical position. (Do not remove the support screws.)
11. Put the level [5] on the exposure glass.
12. If the machine is level, you are finished. Be sure to re-attach the lock screws and hinges removed in Steps 9 and 10.

-or-

If the machine is not level, use a wrench to adjust the nuts on each foot to raise or lower the main machine at each corner.



Note

- The main machine must be level side-to-side within $\pm 0.15/m$.
- Normally, the adjustment with the level on the exposure glass is not required. However, if you have to do the adjustment with the level on the exposure glass, go back to Step 5 and do the adjustment again with the level on the development unit.

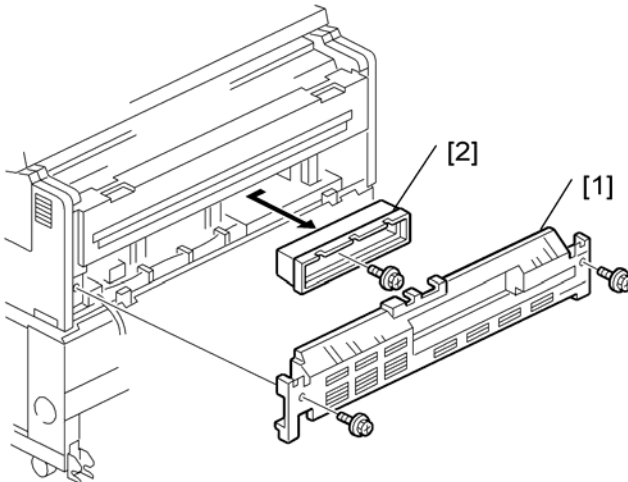
Connecting the Main Machine and Roll Feeder



b286i914a

1. Remove the rear cover [1] of the main machine ( x2).
2. Remove the cover of the controller unit [2] ( x1).

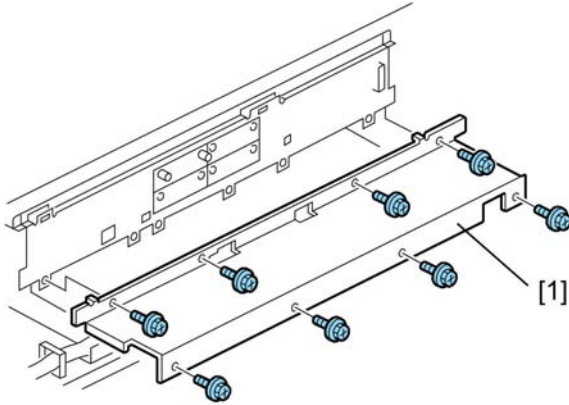





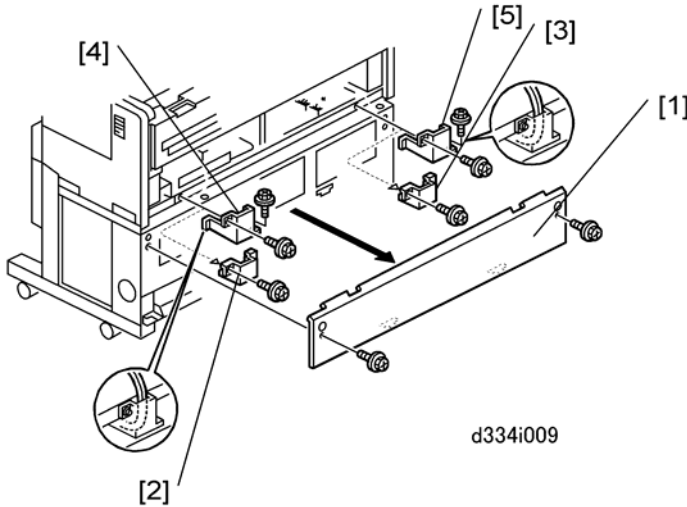

d093i105a

3. Remove the shield cover [1] ( x 8).



d334i009

4. Remove the rear plate [1] of the roll feeder ( x 2).
5. Remove the metal brackets [2], [3] ( x 1 each). Discard these brackets and screws.
6. Remove the shipping tape from the roll feeder harnesses between the bottom of the main machine and top of the roll feeder.
7. Route the harness ( x 1) through bracket [4] then attach the bracket ( x 2). (Use one screw from the accessories.)
8. Route the harness ( x 2) through bracket [5] and then attach the bracket ( x 2). (Use one screw from the accessories).

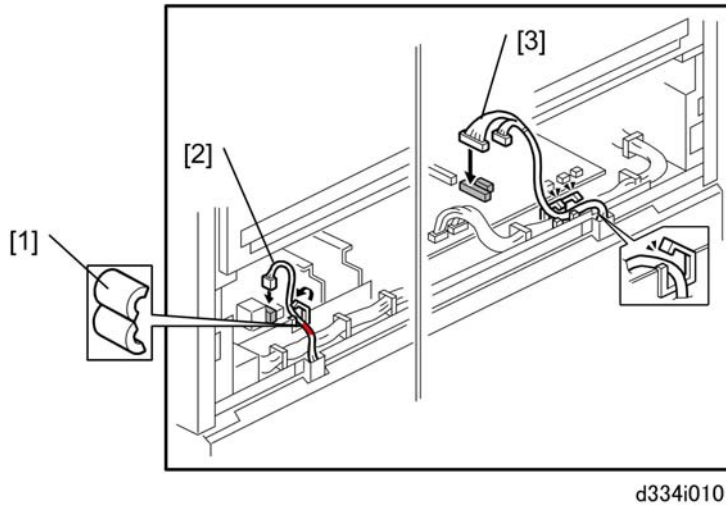

9. Attach ferrite core [1].
10. Connect the left harness [2] to **CN103** on the PSU (🔌 x 1, 📡 x 1).
11. Connect the right harness [3] to **CN220** and **CN221** on the MCU (🔌 x 2, 📡 x 3).
12. Reattach:
 - Shield cover
 - Controller box cover
 - Rear cover

★ Important

- Open and close the paper exit cover C1 and paper exit unit C2 together to confirm that the rear cover is installed correctly. If the paper exit cover does not open properly, remove the rear cover and install it again.

Attaching the Narrow Mylars to the Main Machine

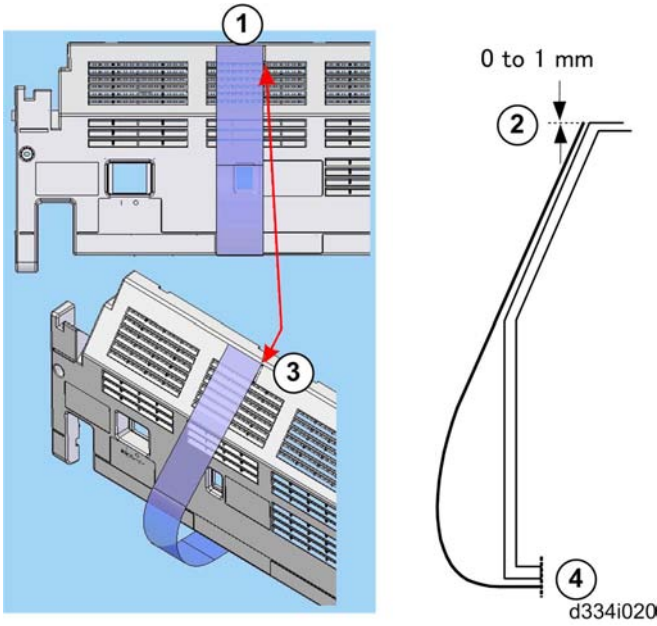



1. Use a clean cloth, moistened with a small amount of alcohol, to clean the area around the rib ①.
2. Remove the tape from each end of one of the narrow mylars.
3. Attach one end to the top edge of the cover ②.

↓ **Note**

- The top edge must be flat and parallel to the edge of the cover. The right edge of the mylar must be parallel to rib ③.
4. Attach the other end of the mylar to the bottom edge of the cover ④.
 5. Do this procedure again to attach the other narrow mylar to the right side of the cover.

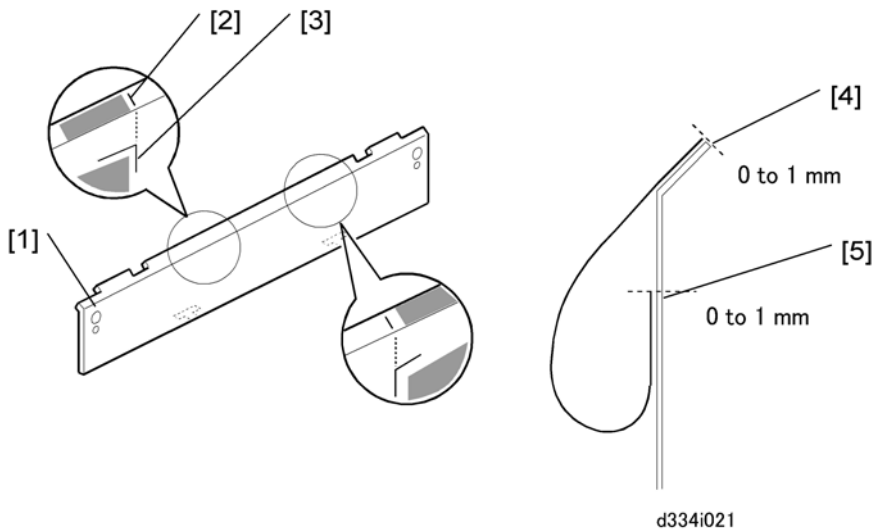
Attaching the Wide Mylars to the Back of the Roll Feeder



1. On the left side of the rear plate [1], find the straight line [2] and \lrcorner , \llcorner patterns [3].
2. Use a clean cloth, moistened with a small amount of alcohol, to clean this area and the bottom edge of the cover.
3. Remove the tape from each end of one of the wide mylars.
4. Align the end with the narrow tape with the top edge [4] of the rear plate. Make sure that the right edge is parallel to the vertical lines on the plate, then push down.
5. Turn the end with the wide tape against the plate, and align its corner [5] with the inverted "L" pattern embossed on the plate, then push it against the rear plate.
6. Make sure that the tape surfaces are pushed fully against the rear plate.
7. Reattach the rear cover of the main machine ( x 2).

Securing the Power Cord

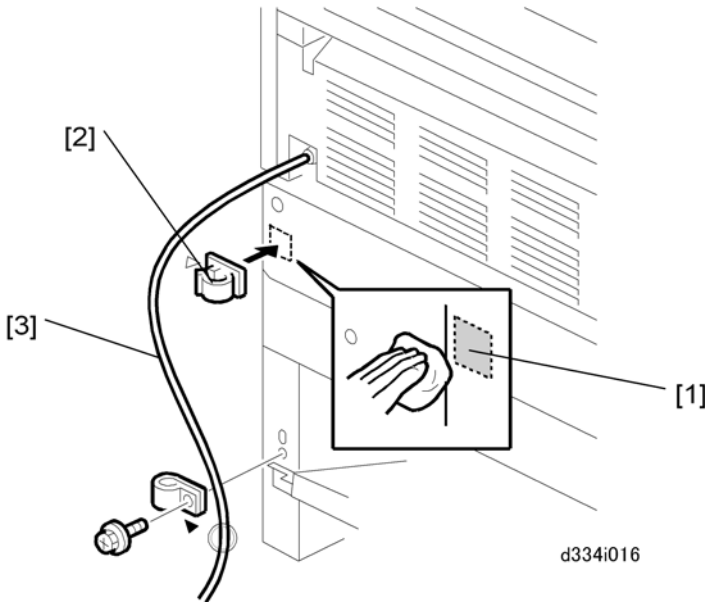

1. Clean the rear plate [1] with alcohol.
2. Attach the harness clamp [2].
3. Clamp the power cord [3] to the roll feeder ( x 1).

Installing the Paper Rolls

★ Important

- If you will install the optional paper cassette, install it before you install the paper rolls. ( p.102 "Paper Cassette (B853)". (If you do not install the paper cassette first, you must remove Roll 2 before you can install the optional paper cassette.)

↓ Note

- To install the paper rolls, follow the instructions on the decal on the top edge of the roll feeder drawer.

Attaching the Lower Output Tray, Exit Guide Plates

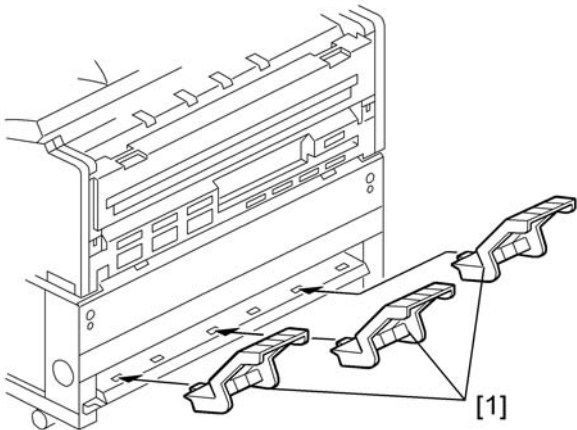

[1]

d334i011

- 1. Attach the lower output trays [1] to the lower rear of the roll feeder (x 3).

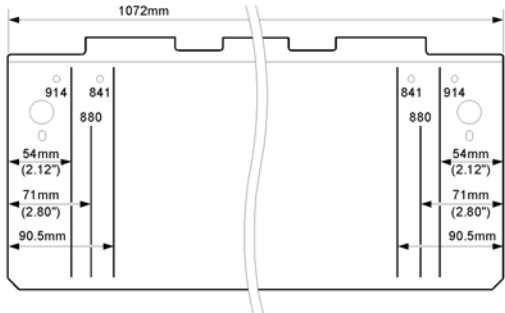

d334i031a

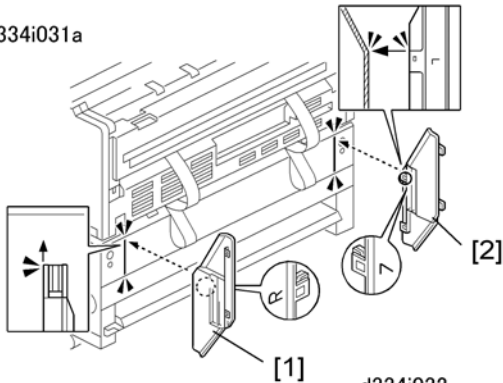

[1]

d334i032

Note

- The lines and numbers embossed on the back of the main machine (see the upper left of the above diagrams) show where to position the exit guide plates for different paper widths.

- 2. Position the right exit guide plate [1] as shown then attach it with its magnet.

3. Position the left exit guide plate [2] as shown then attach it with its magnet.

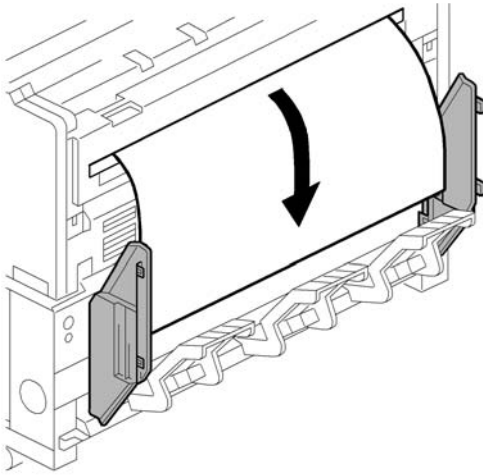

d334i033

4. Do a test print to confirm that the paper exits the main machine straightly and smoothly between the guide plates.

Entering the Cut Length Adjustment

1. Do the settings for SP1920. These are the cut length SP settings for the rolls (there are two settings for each roll).
2. Check the label on the right side of the roll feeder drawer. Do the settings written on the label.

Roll	SP No.	Name
Roll 1	1920-22	Cut Length Adjustment: 1st Roll:297 mm:Plain Paper
Roll 1	1920-26	Cut Length Adjustment: 1st Roll:1 189 mm:Plain Paper
Roll 2	1920-82	Cut Length Adjustment: 2nd Roll:297 mm:Plain Paper
Roll 2	1920-86	Cut Length Adjustment: 2nd Roll:1 189 mm:Plain Paper

1. Switch the main power switch off, then switch it on again.

Setting Paper Sizes/Types for the Tray 1 (1st Roll), Tray 2 (2nd Roll)

1. Push [User Tools]> "System Settings"> "Tray Paper Settings"> "Tray Paper Size: Tray 1", "Tray Paper Size: Tray 2".
2. Select the paper size for Tray 1 and Tray 2.

3. Push "Next"> "Paper Type: Tray 1", "Paper Type: Tray2"
4. Select the paper type for Tray 1 and Tray 2.

Cutter Caution Decal

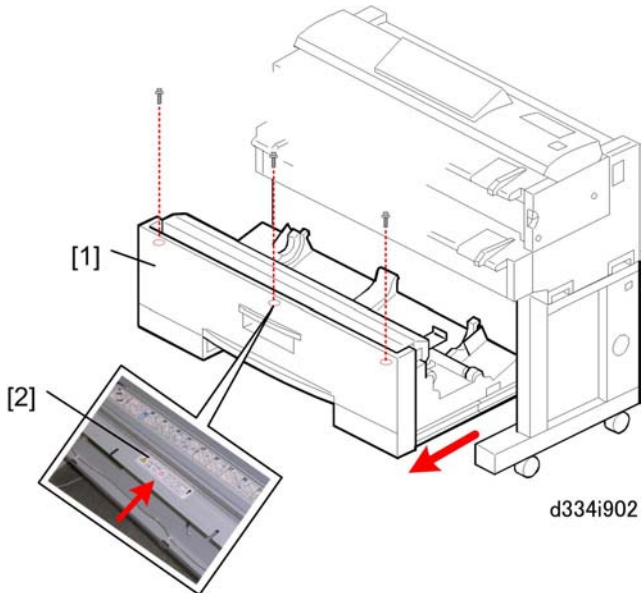

Note

- An caution decal printed in English is already attached. Do this procedure only if you need to attach a decal for another language.
1. Pull the roll feeder out of the machine.
 2. Remove the front cover of the roll feeder [1] ( x3).
 3. Select one cutter caution decal [2] (for your language) and attach it to the top of the roll feeder frame.

Paper Cassette (B853)

★ Important

- The Paper Cassette (B853) is installed inside the Roll Feeder (D503/D504).

2

Accessory Check

Check the accessories and their quantities the table below.

No.	Description	Q'ty
1	Paper Cassette Unit	1
2	Screws	4
3	Harness Clamps	4
4	Paper Cassette (Universal Type)	1

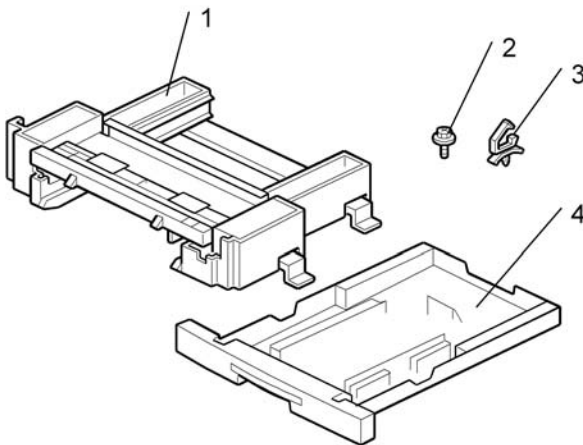



d336i003

Paper Cassette Installation Procedure

⚠ CAUTION

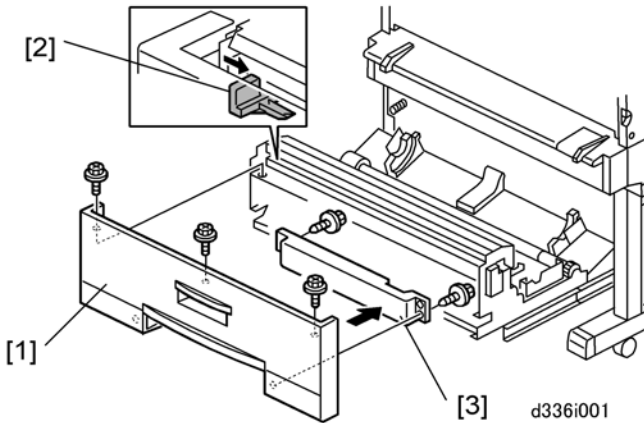
- Confirm that the machine is switched off and that the power cord is disconnected from the power source before doing this procedure.





1. Open the drawer of the roll feeder.
2. Remove the front cover [1] of the roll feeder ( x 3).

Note

- If you cannot see the screw on the left or right side of the front cover, push the cutter [2] away from the top of the screw.

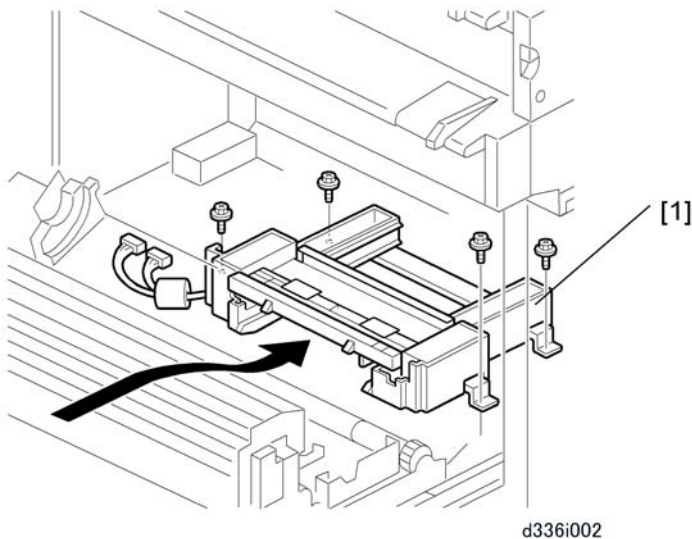
3. Remove the knockout [3] ( x 2).
4. If Roll 2 is installed, remove it.
5. Remove the paper cassette from the paper cassette unit.



6. Remove the rear plate of the roll feeder ( x 2).
7. Put the cassette unit [1] in the roll feeder. The bosses must go through the holes in the flanges of the cassette unit. Then, attach the cassette unit ( x 4).

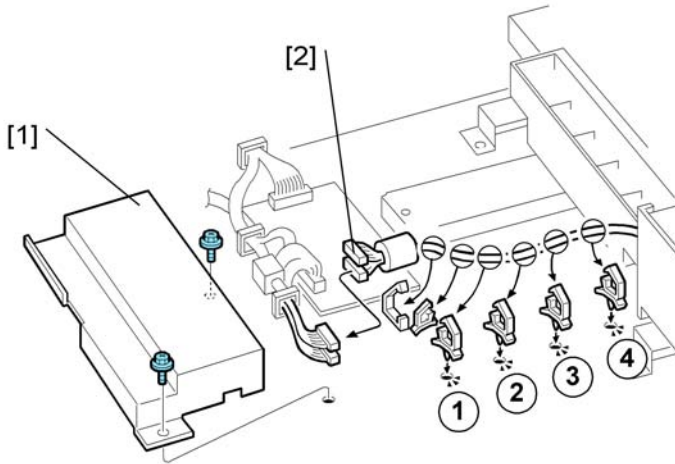

d336i004



8. From the front, remove the board cover [1] ( x 2).
9. Connect the paper-cassette-unit connectors [2] ( x 2) to the roll feeder.
10. From the front, attach the harness clamps ①, ②, ③, ④,
11. Route the connector cable through the open clamps, then close the clamps ( x6).
12. Reattach the board cover, front cover, and rear plate of the roll feeder.
13. Reinstall the paper rolls, and close the drawer of the roll feeder.
14. Put the paper cassette in the paper cassette unit.
15. Set the Paper Size and Type for the Paper Cassette
 - Push [User Tools]> "System Settings"> "Tray Paper Settings"> "Tray Paper Size: Tray 3"
 - Select the paper size for the paper cassette> [OK].
 - Push "Next"> "Paper Type: Tray 3"
 - Select the paper type for the paper cassette.

Table (B854)

Accessory Check

Check the accessories and their quantities in the table below.

2

No.	Description	Q'ty
1	Lower Output Trays	3
2	Leg Covers	2
3	Shoes	4
4	Joint Brackets (Left, Right)	2
5	Exit Guide Plates	2
6	Screws	9
7	Mylars – Wide	2
8	Mylars – Narrow	2
9	Guide Plate	1
10	Nylon Clamp	1
11	Harness Clamp	1
12	Stopper Bracket (for inch paper sizes)	1

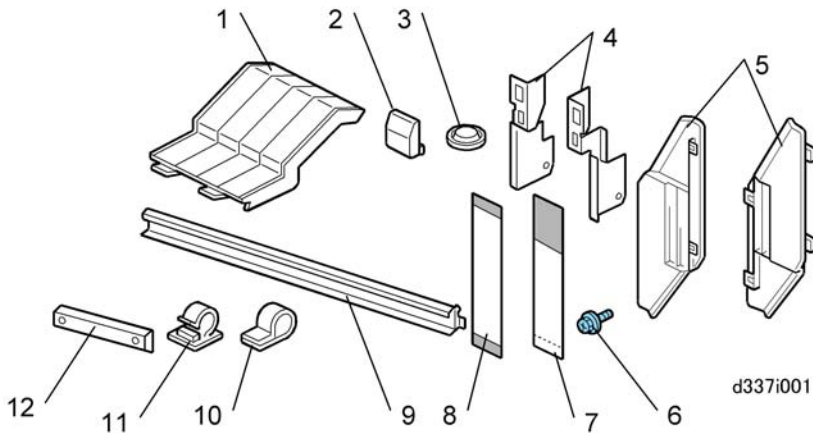

Installation Procedure

⚠ CAUTION

- Confirm that the machine is switched off and that the power cord is disconnected from the power source before doing this procedure.

2

Setting the Main Machine on the Table

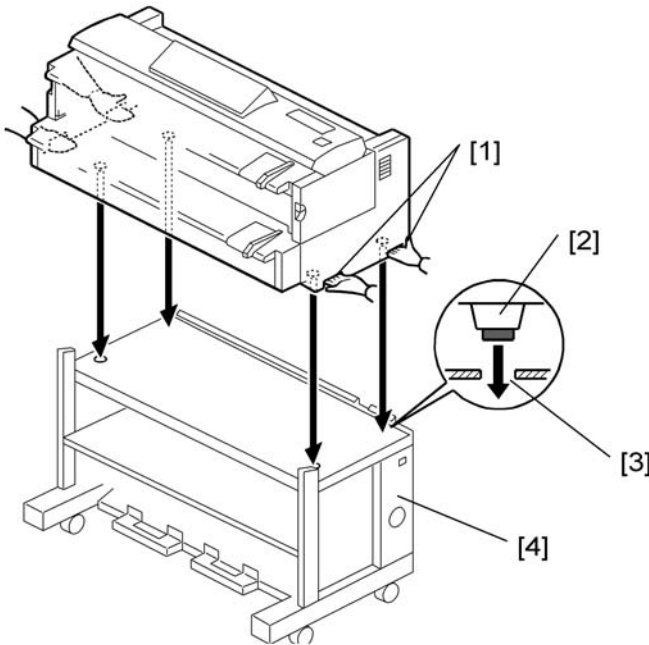

d337i002

⚠ CAUTION

- The main machine weighs 107 kg (235 lb.).
- There are two handles in recesses on each side of the main machine. To prevent injury or damage to the main machine, always use these handles [1] to lift the main machine.
- Two or more service technicians are necessary to lift the main machine and set it on the table.

1. Lift the main machine, and set its rubber feet [2] into the holes [3] on the top of the table [4].

↓ Note

- With one person at each end of the main machine, use the two handles on each end of the main machine to lift it.
2. Make sure that you put the rubber feet of the main machine into the holes on top of the table.

Leveling the Main Machine and Attaching Leg Covers

Make the main machine level. Attach the leg covers. (See p.65 "Leveling the Main Machine and Attaching Leg Covers").

Attaching the Guide Plate

⚠ CAUTION

- Keep the power cord disconnected while you do this procedure.

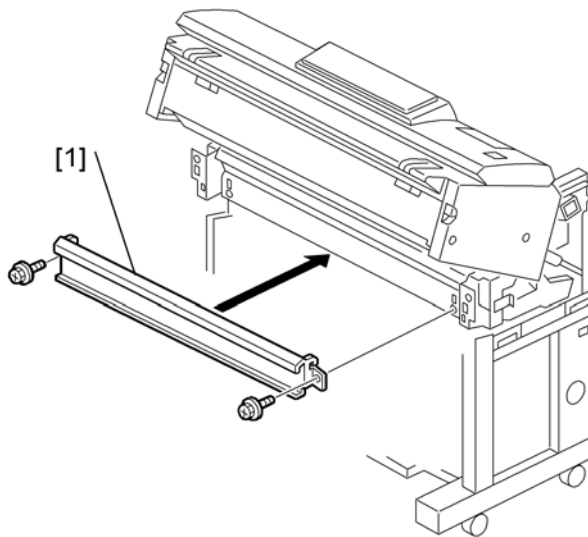

d337i004

1. Install the guide plate [1] ( x 2 Blue). Hang the hooks on each ends; this puts the plate in the correct position to be installed.

Connecting the Main Machine and Table

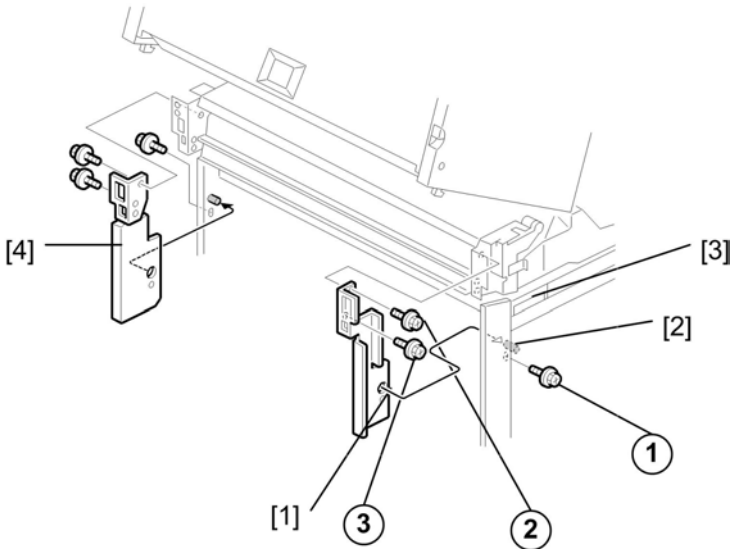



d337i003

1. Attach the right joint bracket [1] (the spindle [2] must go through the hole). At the same time, align the plate with the holes for the three screws (blue).
2. Attach screws ①, ② but do not tighten them.
3. While you lift the main machine by its handle [3], set screw ③ in the lower hole of the keyhole cutout and tighten it.
4. Tighten screws ①, ②.
5. Do the above procedure again for the left joint bracket [4].

⚠ CAUTION

- When you attach the left bracket make sure that the bracket does not pinch or interfere with the harness of the main switch.

6. Reattach the manual feed table ( x 2).
7. Reattach the left and right covers ( x 3 ea.).

↓ Note

- Make sure that you attach the longer screws with the fine threads at the rear sides of the covers.

8. Close the upper unit.

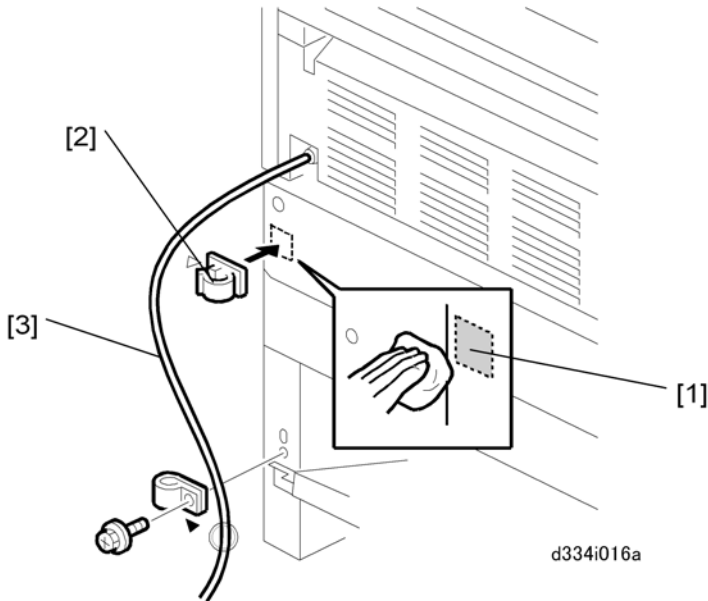

9. Clean the rear plate [1] of the table with alcohol.
10. Attach the harness clamp [2].
11. Clamp the power cord [3] to the table ( x 1).

Attach the Narrow Mylars to the Main Machine

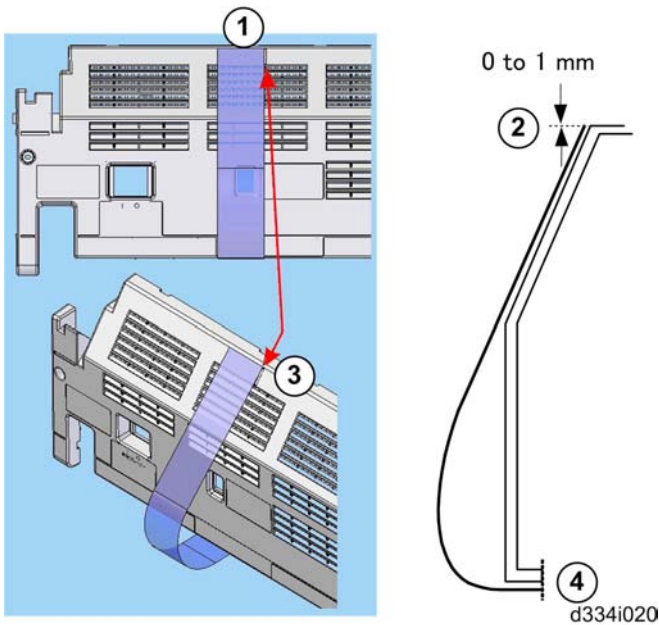

1. If the rear cover is attached to the main machine, remove it ( x 2).

1. Use a clean cloth, moistened with a small amount of alcohol, to clean the area around the rib ①.
2. Remove the tape from each end of one of the narrow mylars.
3. Attach one end to the top edge of the cover ②.

Note

- The top edge must be flat and parallel to the edge of the cover. The right edge of the mylar must be parallel to rib ③.

4. Attach the other end of the mylar to the bottom edge of the cover ④.
5. Do this procedure again to attach the other narrow mylar to the right side of the cover.
6. Reattach the cover to the back of the main machine ( x 2).

Attach the Wide Mylars to the Back of the Table

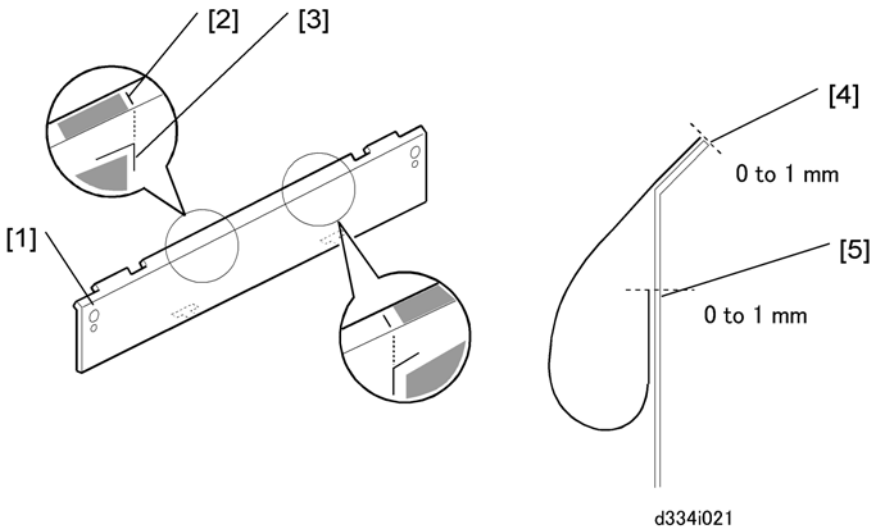

1. On the left side of the rear plate [1], find the straight line [2] and,  patterns [3].
2. Use a clean cloth, moistened with a small amount of alcohol, to clean this area and the bottom edge of the cover.
3. Remove the tape from each end of one of the wide mylars.
4. Align the end with the narrow tape with the top edge [4] of the rear plate. Make sure that the right edge is parallel to the vertical lines on the plate, then push down.
5. Turn the end with the wide tape against the plate, and align its corner [5] with the inverted “L” pattern embossed on the plate, then push it against the rear plate.
6. Make sure that the tape surfaces are pushed fully against the rear plate.

Attaching the Stopper Brackets

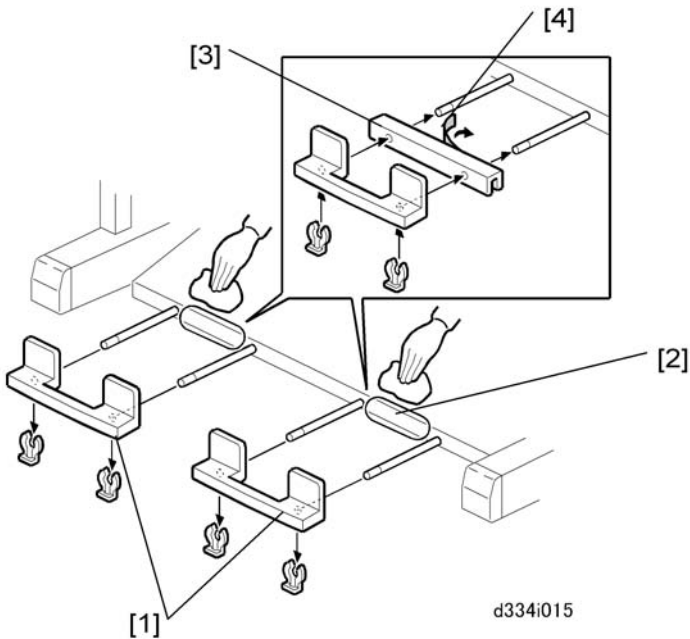

↓ Note

- This stopper bracket is only for machines in North America that use inch paper sizes.
1. Remove the stoppers [1] (☞x 2 ea.).
 2. Use a clean cloth soaked in alcohol to clean the surfaces [2] where the stopper brackets [3] will be attached.
 3. Remove the double-sided tape [4] from the rear of each bracket.
 4. Install each bracket and stopper on the arms.
 5. Lock each stopper in the correct position (☞x 2 ea.).

Table Accessories

2

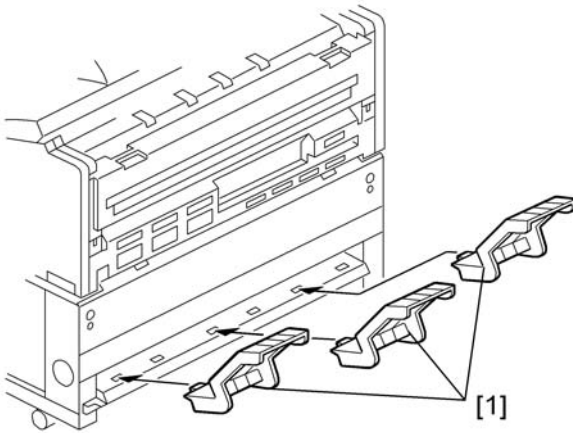

[1]

d334i011

1. Attach the lower output trays [1] to the bottom rear of the table (x 3).

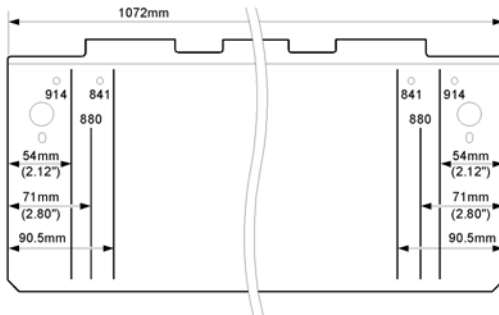

d334i031a

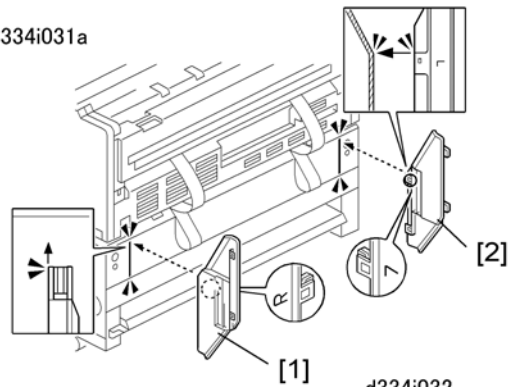

[1]

d334i032

Note

- The lines and numbers embossed on the back of the main machine (see the upper left of the above diagram) show where to position the exit guide plates for different paper widths.

2. Position the right exit guide plate [1] as shown then attach it with its magnet.

3. Position the left exit guide plate [2] as shown then attach it with its magnet.

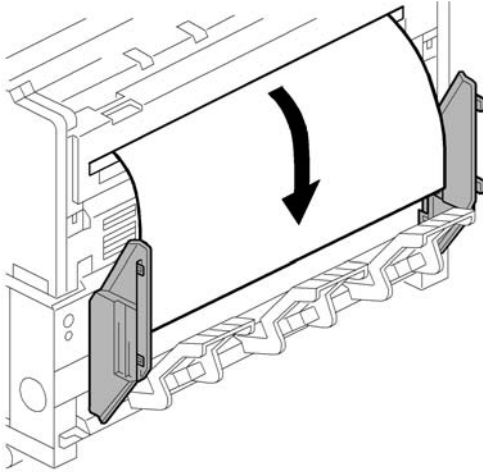

d334i033

4. Do a test print to confirm that the paper exits the main machine straightly and smoothly between the guide plates.

Rear Stacker (D312)

The rear stacker is an option installed on the back of the Roll Feeder (D503/D504).

Accessories

2

Check the accessories and their quantities against the table below.

No.	Description	Qty
1.	Copy Tray Holder	1
2.	Guide Mylar	1
3.	Rear Copy Tray	3
4.	Screws (M4x8)	4

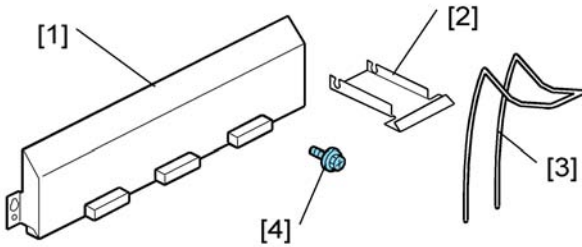

d312i100

Installation

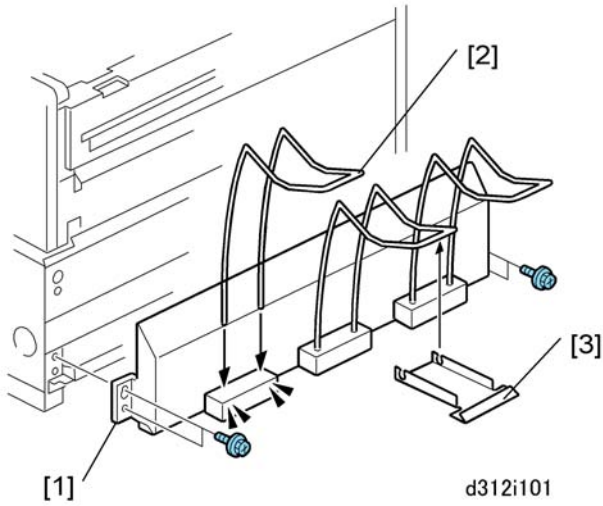

1. Attach:

- [1] Copy tray holder ( x4)
- [2] Rear copy tray (x3)
- [3] Guide mylar (x1)] to center of copy tray

USB 2.0/SD Slot Type E (D534)

Accessory Check

Check the accessories and their quantities against the table below.

2

No.	Description	Q'ty
1	Screw (M3x6)	1
2	Screw (M3x8: Wide Pitch)	4
3	Screw (M3x8: Narrow Pitch)	2
4	Clamp	3
5	Plate Spring	1
6	USB Cable	1
7	Slot Unit	1
8	Bracket	1
9	Device Access Decal Sheet (x16 Languages)	1
10	Close Cover Decal Sheet (x16 Languages)	1

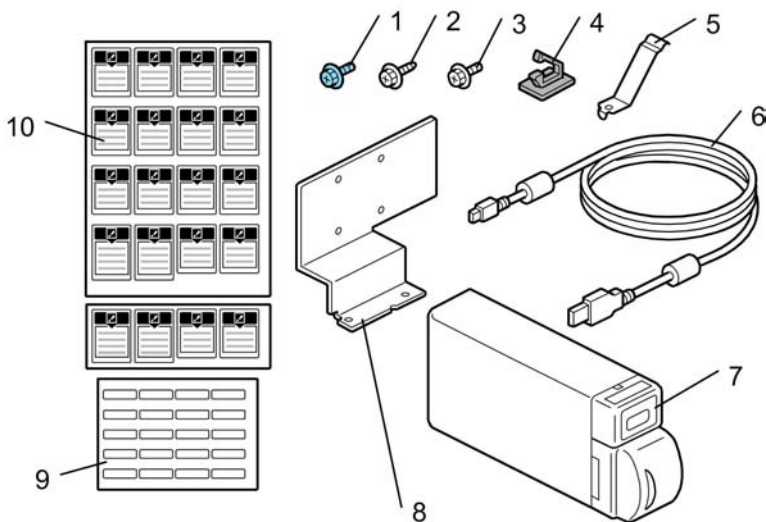

d534i100

USB 2.0/SD Slot Installation

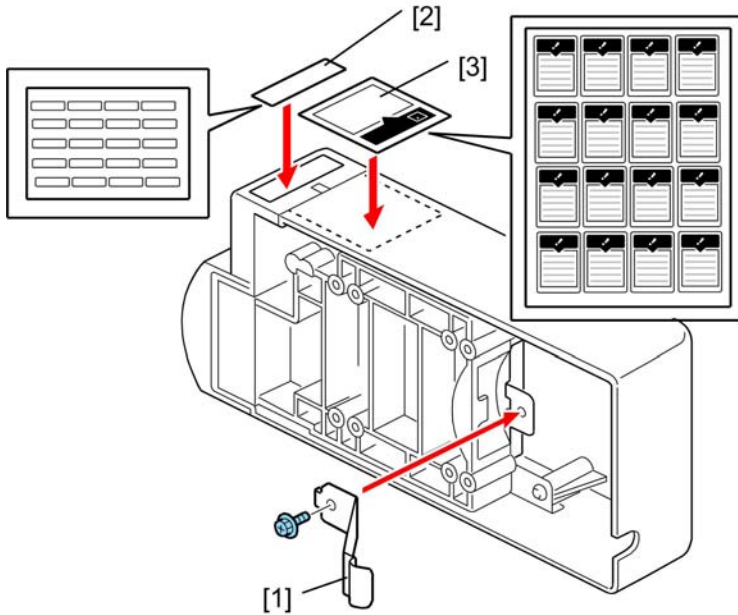

d534i101

1. Attach plate spring [1] (🔩 x1).
2. Select the "device access" decal [2] for the local language and attach it to the top of the unit.
3. Select the "close cover" decal [3] for the local language and attach it to the top of the unit.

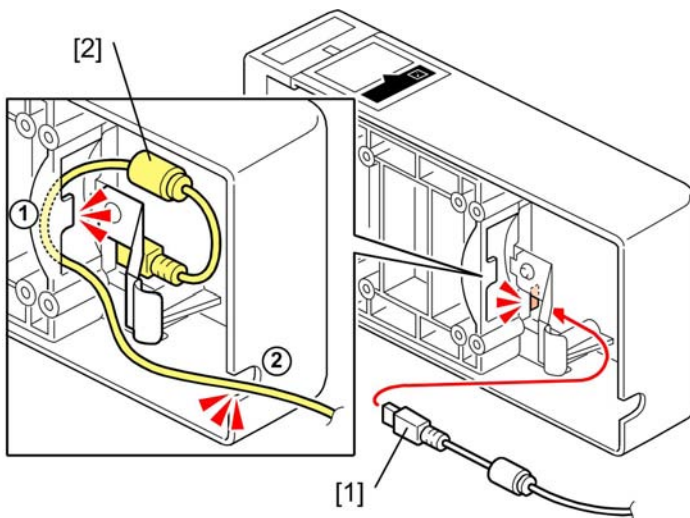

d534i102

4. Connect the smaller end of the connector [1] (🔌 x1).

5. Raise ferrite core [2] above the plate.
6. Route the cable at ① and ② as shown.

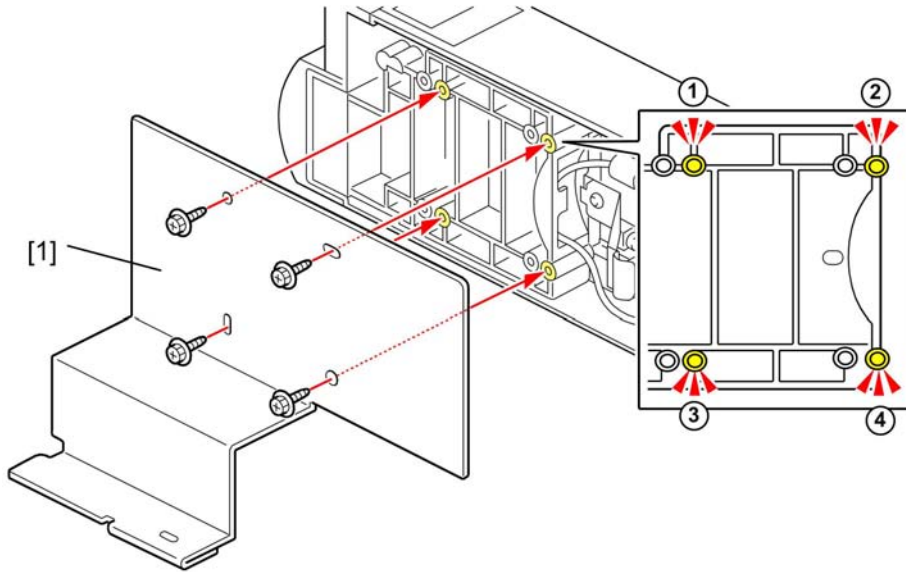



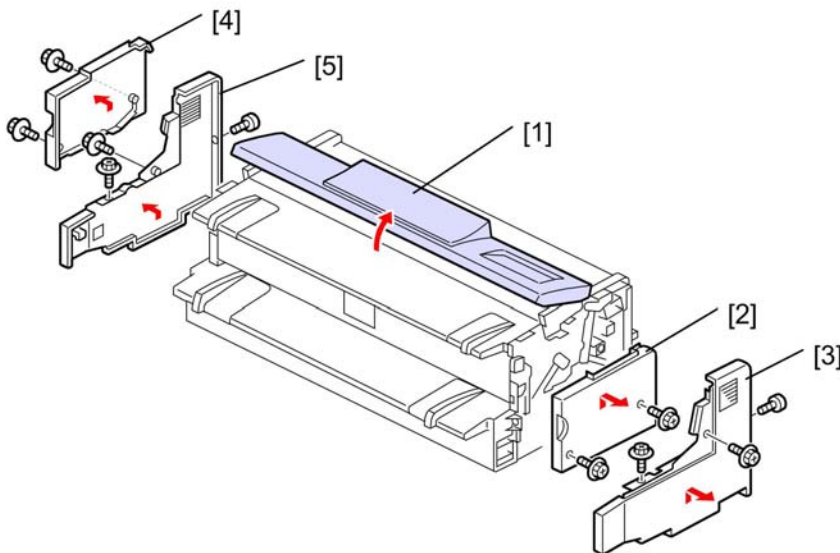

d534i103

7. Fasten the bracket [1] to the side of the slot unit ( x4).





d534i104

8. Open the original feed unit [1].
9. Remove the right upper cover [2] ( x 2).
10. Remove the right cover [3] ( x 3).

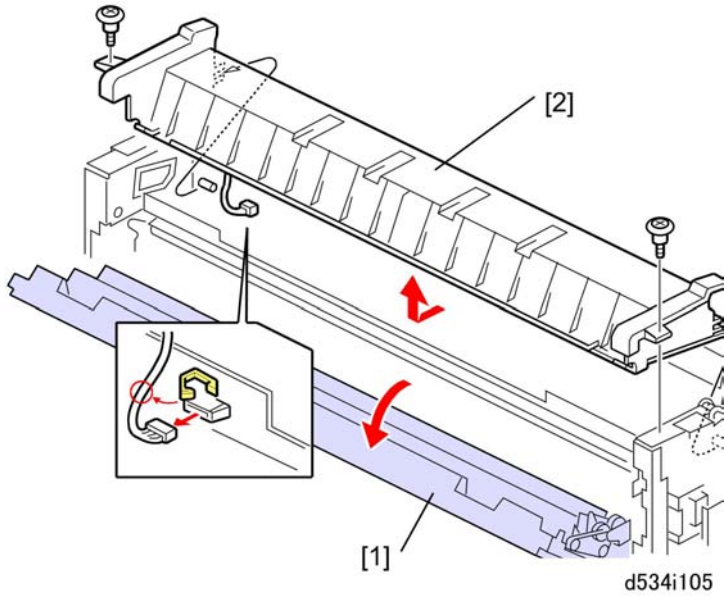
11. Remove the left upper cover [4] ( x 2).
12. Remove the left cover [5] ( x 3).



13. Open the rear exit cover [1].
14. Remove rear top cover [2] ( x 1,  x 1,  x 2).

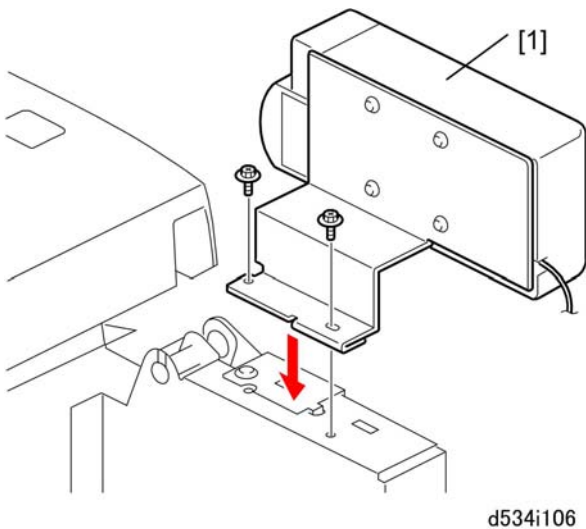

15. Attach the unit [1] to the left rear corner of the machine ( x 2).

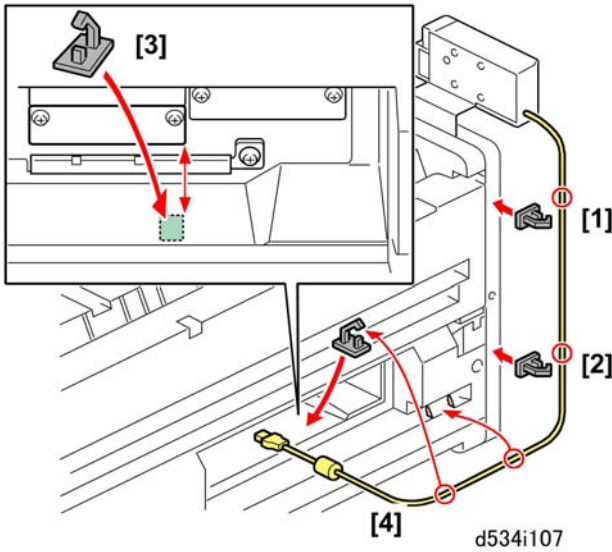

16. Use a clean cloth moistened with alcohol to wipe and clean the points where the clamps will be attached at [1], [2], [3].
17. Attach clamps [1] and [2].
18. Attach clamp [3] so it is aligned with the edges of the slot covers above.
19. Route the cable and close the clamps (🔧x3).

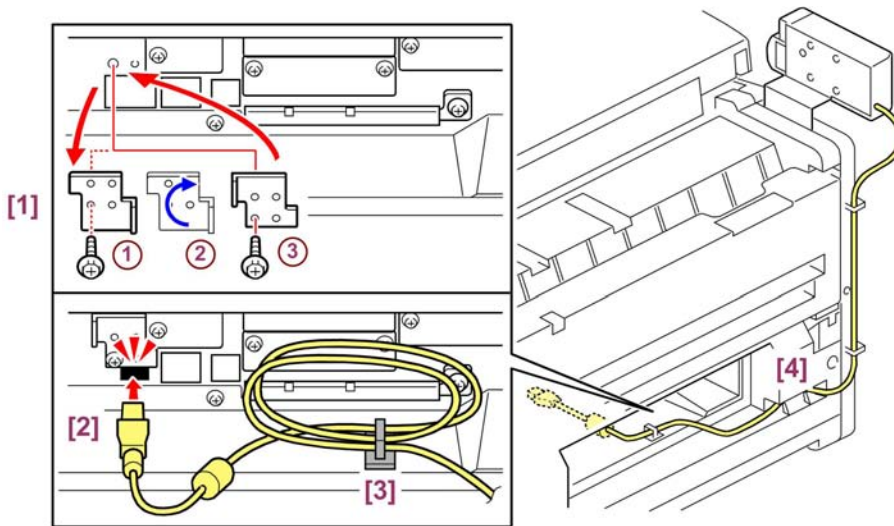

20. Re-set plate [1].
 - ① Remove the plate (🔧 x1).
 - ② Rotate it clockwise 180 degrees.
 - ③ Re-attach the plate (🔧 x1).

d534i108

21. Connect the USB cable [2].
22. Coil and secure the loose cable at [3] (🔒 x1).
23. Confirm that the coiled cable is not visible at [4].
24. Plug in the machine and turn it on.
25. Do SP1013 (Multi Media Function). Set "0" to "1" to enable the unit.

⬇ **Note**

- SP1013 is a Scanner SP code. To open the Scanner SP list, enter the SP mode and select "Scanner SP" (not "System SP").

26. Exit SP mode and test operation of the installed unit.

Installation of MFP Options

Overview

2

Four slots for boards (A, B, C, D) and two slots for SD cards (1,2) are on the controller box. Each board or SD card must be inserted into its assigned slot. The slot assignments of boards and SD cards are written on a decal on the controller box cover.

★ Important

- Always touch a grounded surface to discharge static electricity from your hands before you handle SD cards, printed circuit boards, or memory boards.

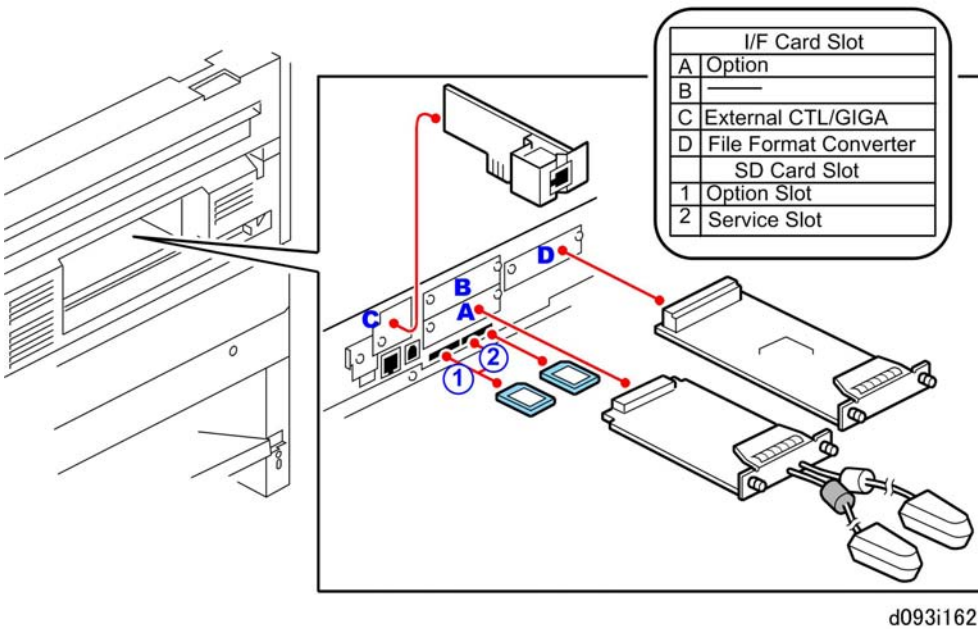

d093i162

MFP Option Board Slot/SD Card Assignments

Slot	Option Name
A	IEEE802.11a/g Interface Unit Type J (D377-01, -02), Type K (D377-19)
B	Not used
C	GigaBit Ethernet Type B (D377-21)
D	File Format Converter Type F (D533)

Slot	Option Name
2	Service Slot: <ul style="list-style-type: none"> • Firmware update • NVRAM data download/upload • Application move/undo • Printer Option TIFF/GL Filter*¹
1	Option Slot <ul style="list-style-type: none"> • Printer Option Type W3601 (D506) • Security & Encryption Unit*² • Scanner Option Type W3601 (D507) *³ • Browser Unit Type E (D430-05, -06, -07)*⁴

- *1 Printer Option TIFF/GL Filter SD card also holds the VMware.
- *2 The Security & Encryption SD card contains the HDD Encryption and Data Overwrite Security applications. This SD card is provided with the machine inserted into SD card Slot 1. Before installation, these applications must be moved to the Printer Option SD card. These three applications are then installed together. (p. 127 "Printer Option Type W3601 (D506)")
- *3 The scanner option requires the File Format Converter.
- *4 The Browser Unit SD card can be removed from the SD card slot after installation.

The machine has two SD card slots:

- SD card Slot 1 is for application programs. The machine is shipped with the Security & Encryption SD card in SD card Slot 1.
- Slot 2 is used for machine servicing and application program installation (firmware updates, NVRAM upload and download, application move and undo).
- If the customer needs more than two applications, one or more application must be moved to one SD card with SP5873-1.

Enabling the Onboard Features

The network and USB support features are built into the GW controller board. However, these features cannot be used until they have been enabled with SP5985 (Device Setting). Before installing any other options in this section, do SP5985 and make sure each item is set to "1".

- SP5985-001. Must be set to "1" to enable the network functions.

- SP5985-002. Must be set to "1" to enable the USB function.

Using SD Cards

2

Removing the SD Card Slot Cover

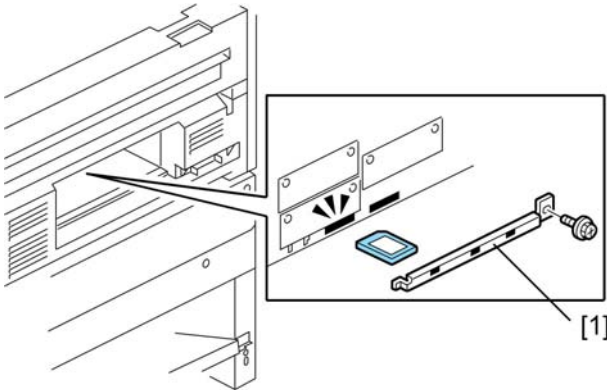

d093i161

The SD card slot cover [1] is fastened by one screw. Remove this cover to insert SD cards. Always reattach this cover after removing or inserting SD Cards.

Restrictions and Precautions on the Use of SD Cards

- Always touch a grounded surface to discharge static electricity from your hands before you handle SD cards.
- When an application is moved from one SD card to another SD card, the authentication data is moved with the application program to the target SD card.
- Do not use an SD card if it has been used with a computer or other device. (The SD card may not operate correctly.)
- The original SD card received with purchase of the application program is the only evidence that the customer is licensed to use the application. For this reason, the original SD card should be stored at the work site as proof of purchase by the customer. Also, the service technician may occasionally need to check the dates and version numbers SD cards during troubleshooting.
- After an SD card has been used to combine applications on one card, it cannot be used for any other purpose.
- Always make sure that the write-protect switch is OFF before uploading data to an SD card. It is very easy to accidentally turn on the write-protect switch when inserting and removing an SD card.
- To remove an SD card from its slot, push it in gently to release it then pull it out of its slot.

Move/Undo Restrictions

Copyright restrictions prevent some applications from being moved.

Application	SD Card Slot Assignment	Can Move?
Printer Option Type W3601 (D506)	1	--- No ---
Scanner Option Type W3601 (D507)	1	Yes → D506, or Security & Encrypt. Unit
Printer Option TIFF/GL Filter	2	--- No ---

2

★ Important

- The Data Overwrite Security and HDD Encryption applications are on one the Security & Encryption SD card that is inserted into SD card Slot 1 before the machine is shipped.
- These applications must be moved to the Printer Option SD card (D506) so these three options can be installed together.

Application Move

“Move Exec” (SP5873-1) moves one application program from the original SD card to another SD card. The application program is moved from Slot 2 to Slot 1.

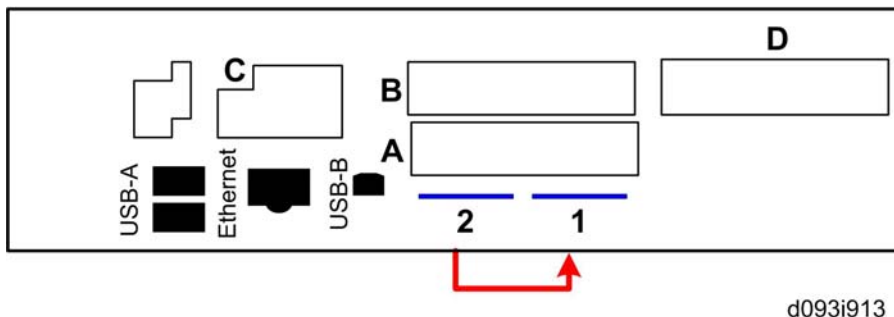

1. Turn off the main power switch.
2. Remove the SD card slot cover (1 x1). (p.124 "Removing the SD Card Slot Cover")
3. Insert the original SD card with the application in Slot 2.
4. Insert the SD card to receive the application in Slot 1.
5. Turn on the main power switch.
6. Enter the SP mode and do SP5873-1 “Move Exec.”
7. Follow the messages on the operation panel to complete the procedure.

8. Exit the SP mode.
9. Turn off the main power switch.
10. Remove the original SD card from Slot 2.
11. Leave the other SD card in Slot 1.
12. Turn on the main power switch.
13. Check that the application program runs normally.
14. Tell the customer to store the original SD card in a safe place.

Undo Exec

“Undo Exec” (SP5873-2) restores an application to its original SD card. The application is moved from Slot 2 to Slot 1.

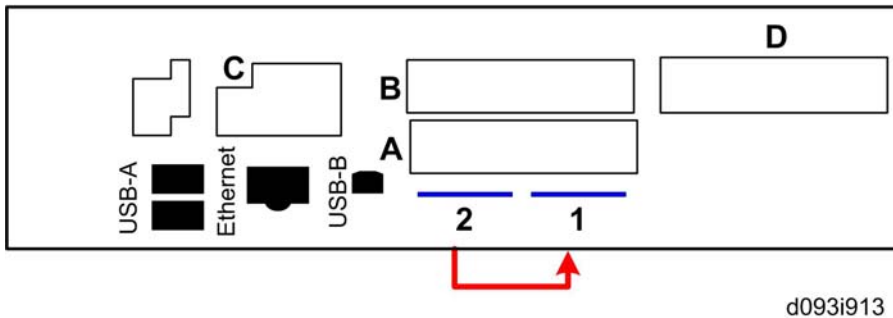

d093i913

1. Turn off the main power switch.
2. Remove the SD card slot cover (1 x1). (p.124 "Removing the SD Card Slot Cover")
3. Insert the SD card that currently holds the application in Slot 2.
4. Insert the original SD card to receive the restored application in Slot 1.
5. Turn on the main power switch.
6. Enter the SP mode and do SP5873-2 “Undo Exec.”
7. Follow the messages on the operation panel to complete the procedure.
8. Exit the SP mode.
9. Turn off the main power switch.
10. Remove both SD cards.
11. Insert the SD card with the restored application in Slot 1.
12. Turn on the main power switch.
13. Check that the application operates normally.

Printer Option Type W3601 (D506)

★ Important

- The Roll Feeder (D503/D504) is required for Printer Option Type W3601 (D506).

Accessories

2

Check the accessories and their quantities against the table below.

No.	Description	Qty
1.	SD Card: Printer	1
2.	SD Card: TIFF/GL Filter (also contains VMware)	1
3.	Keytop	1
4.	Decal: PS3	1
5.	Decal: Enabled Software Architecture	1



Installation

★ Important

- The machine is shipped from the factory with Data Overwrite Security and HDD Encryption applications on the Security & Encryption SD card in Slot 1.

Before installation of the printer application, you must first move the Data Overwrite Security and HDD Encryption applications to the Printer SD card.

⚠ CAUTION

- Make sure that the machine is switched off and disconnected from its power source.
1. Remove the SD card slot cover ( x1). ( p.124 "Removing the SD Card Slot Cover")
 2. Remove the Security & Encryption SD card from Slot 1.
 3. Move Data Overwrite Security and HDD Encryption applications to the Printer SD card (Printer). ( p.125 "Application Move")
 4. Make sure that the machine is switched off.
 5. If a network cable is connected, disconnect it.
 6. Insert the SD Card (Printer) in Slot 1.
 7. Insert the SD Card (TIFF/GL Filter) in Slot 2.
 8. Turn on the machine.

9. Follow the prompts on screen to complete the installation of the printer option.
10. Reattach the SD card slot cover.

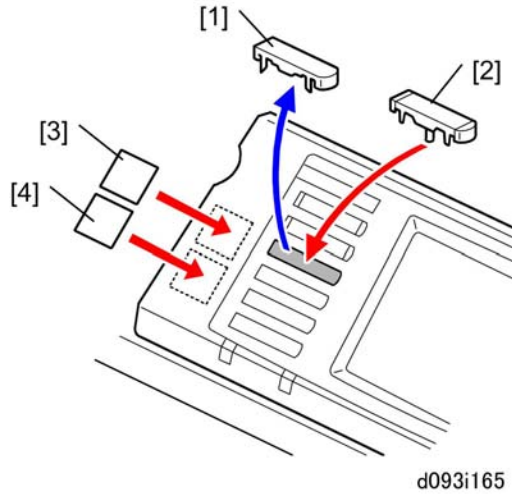

11. On the operation panel, remove the dummy keytop [1] and replace it with the "Printer" keytop [2].
12. Attach the "PS3" decal [3].
13. Attach the "Enable Software Architecture" decal [4].

Scanner Option Type W3601 (D507)

Accessories

Check the accessories and their quantities against the table below.

	Description	Qty
1.	SD Card: Scanner	1
2.	Keytop	1
3.	1 GB Memory	1

★ Important

- Installation of the File Format Converter (D533) is required for this scanner option.

Installation

★ Important

- The machine is shipped from the factory with Data Overwrite Security and HDD Encryption applications on the Security & Encryption SD card in Slot 1.

Before installation of the printer application, you must first move the Data Overwrite Security and HDD Encryption applications to the Printer SD card.

⚠ CAUTION



- Make sure that the machine is switched off and disconnected from its power source.
1. If the Scanner option is to be used with the Printer option, you must first move the Scanner application to the Printer SD card. (p. 125 "Application Move")

-or-

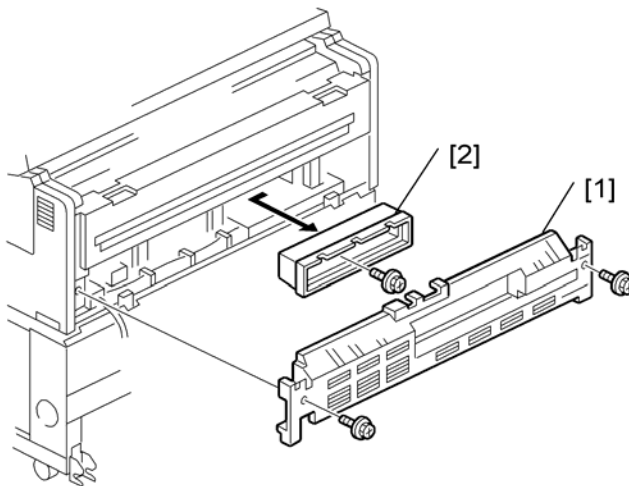
If the printer option is not to be installed, you must first move the Scanner application to the Security & Encryption Unit SD card.



b286i914a

2. Remove the rear cover [1] of the main machine ( x2).
3. Remove the cover of the controller unit [2] ( x1).

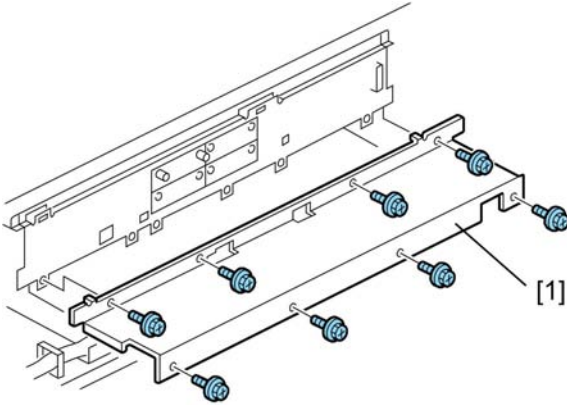

d093i105a

4. Remove the shield cover [1] ( x 8).

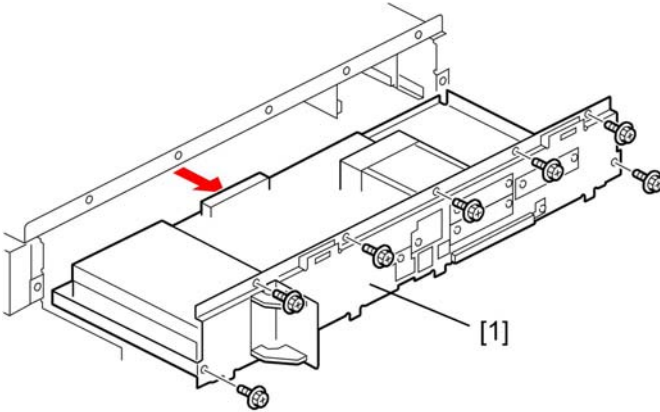

d377i111

5. Remove controller board unit [1] ( x7).

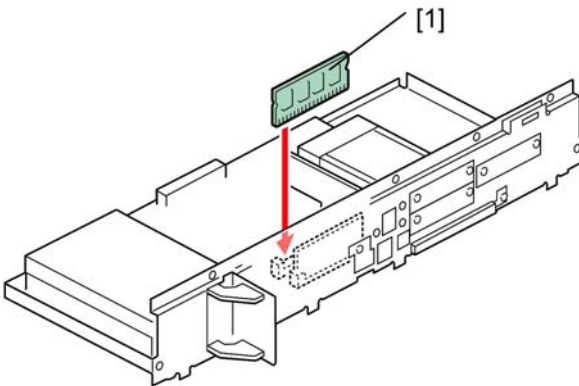

d377i113

6. Insert the expansion memory [1], then re-assemble the machine.

7. Remove the SD card slot cover ( x1).

- 8. Insert the application SD card into Slot 1.
- 9. Reattach the SD card slot cover ( x1).

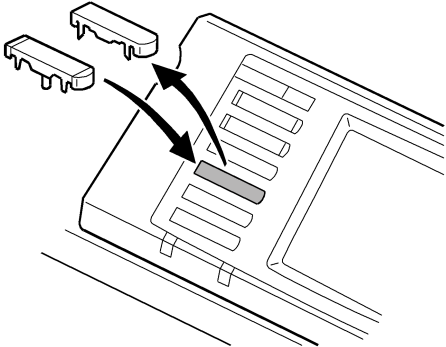

b286i166

- 10. On the operation panel, remove the dummy keytop and replace it with the "Scanner" keytop.
- 11. Reconnect the machine to its power source and turn the main power switch on.
- 12. Enter the SP mode and make sure that SP5985-1 and SP5985-2 are both set to "1" (enabled).
- 13. Turn the machine power off/on.
- 14. Print a Configuration Page to make sure that the machine recognizes the installed option:
 User Tools> Printer Features> List/Test Print> Configuration Page

File Format Converter Type F (D533)

Accessories

Check the accessories and their quantities against the table below.

Description	Q'ty
1. File Format Converter PCB	1

★ Important

- Installation of the File Format Converter is required for the scanner option.

Installation

⚠ CAUTION

- Before doing the procedure, turn off the main power switch and unplug the machine from its power source.

2

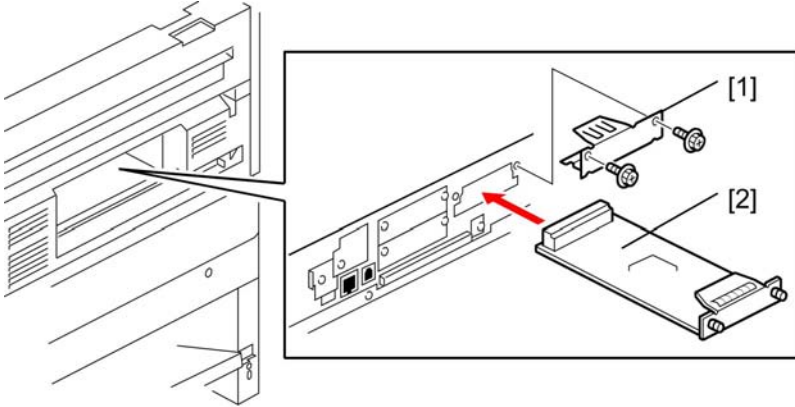

d533i100

1. Remove the cover [1] from Slot D (⚙ x2).
2. Insert and attach the File Format Converter board [2] (⚙ x2).

IEEE802.11 a/g Interface Unit Type J (D377-01, -02), Type K (D377-19)

Accessories

Check the accessories and their quantities against the table below.

	Description	Qty
1.	LAN board (with antennas)	1
2.	Tape	2
3.	Clamp	8

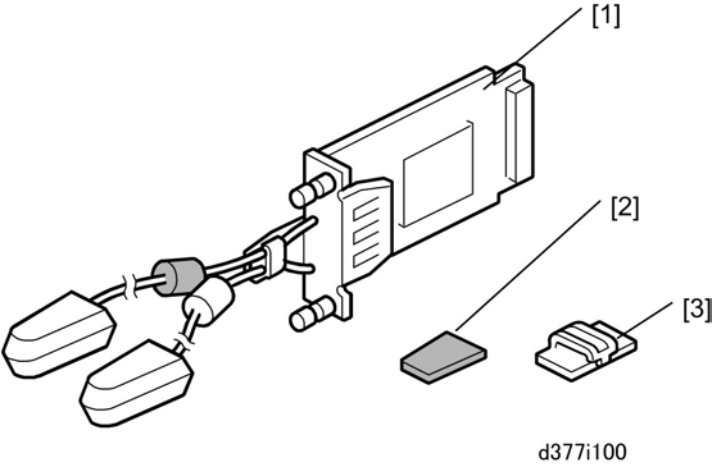



Installation

CAUTION

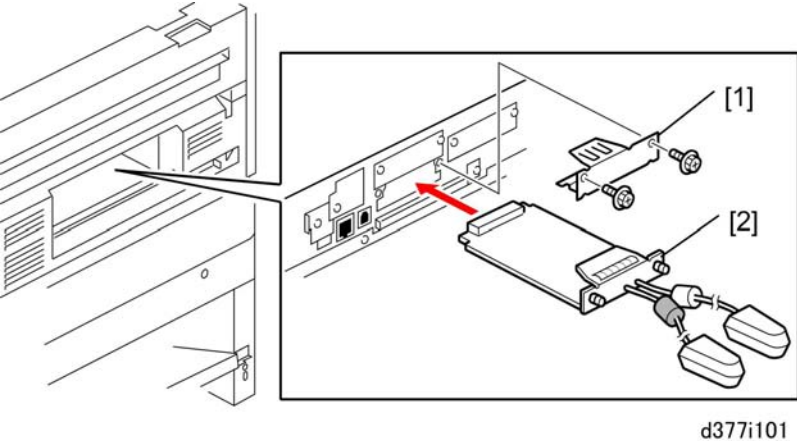
- Before doing the procedure, turn off the main power switch and unplug the machine from its power source.



1. Remove the cover [1] of Slot A ( x 2).
2. Insert the LAN board [2] into Slot A ( x 2).

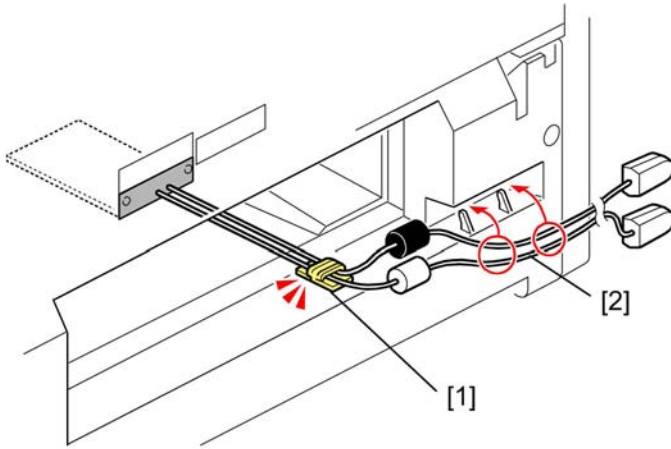

d377i102

3. Use a clean cloth moistened with alcohol to clean where clamp [1] will be attached.
4. Attach clamp [1] (🔧x1).
5. Set the cables [2] in the notch clamps as shown.
6. Make sure the cables are arranged as shown and not twisted.

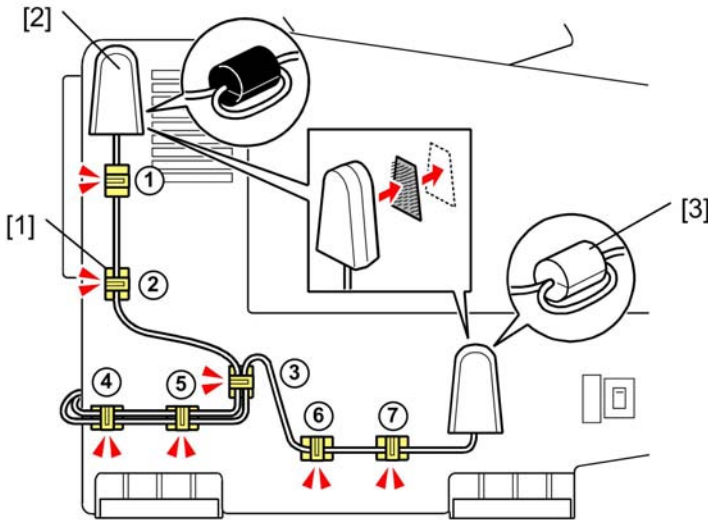

d377i103

7. Use a clean cloth moistened with alcohol to clean where the 7 clamps will be attached.
8. Attach clamps [1] to the left side of the main machine (🔧x7).
9. Use one tape to attach the antenna with the black ferrite core at [2].
10. Use one tape to attach the antenna with the white ferrite core at [3].

★ Important

- Make sure that Antenna 1 [2] with the black ferrite core is high and that Antenna 2 [3] with the white ferrite core is low as shown above.
- Antenna 2 receives and Antenna 1 transmits as well as receives so it must always be placed higher for signal transmission.

11. Route the cables through the clamps as shown and close the clamps.
12. Reconnect the machine to the power source and turn the main power switch on.
13. Print a Configuration Page to confirm correct installation:
User Tools> Printer Features> List/Test Print> Configuration Page
14. Do SP5840-001 (WEP Key Select).

2

GigaBit Ethernet Type B (D377-21)**Accessories**

Check the accessories and their quantities against the table below.

	Description	Qty
1.	Gigabit Ethernet Board	1
2.	Ferrite Core	1
3.	Standard LAN Connector Cap	1

★ Important



- When the Gigabit Ethernet Board is installed, the standard Ethernet board can no longer be used. A cap is provided to cover the standard Ethernet connector. This prevents accidental reconnection of the cable while the Gigabit Ethernet board is installed in the machine.
- Touch a metal surface to discharge any static electricity from your hands before you handle the board.

Installation**⚠ CAUTION**

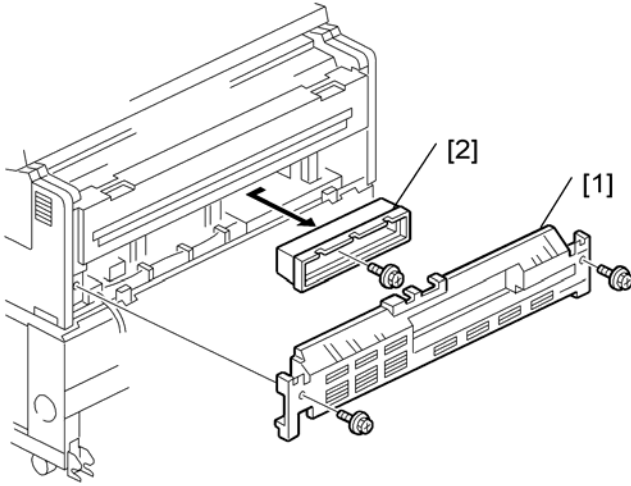
- Before doing the procedure, turn off the main power switch and unplug the machine from its power source.



b286i914a

1. Remove the rear cover [1] of the main machine ( x2).
2. Remove the cover of the controller unit [2] ( x1).

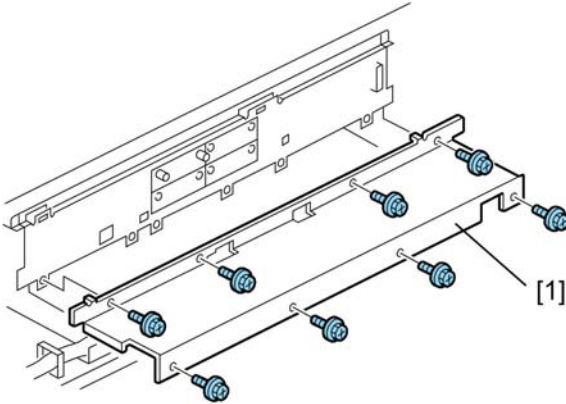

d093i105a

3. Remove the shield cover [1] ( x 8).

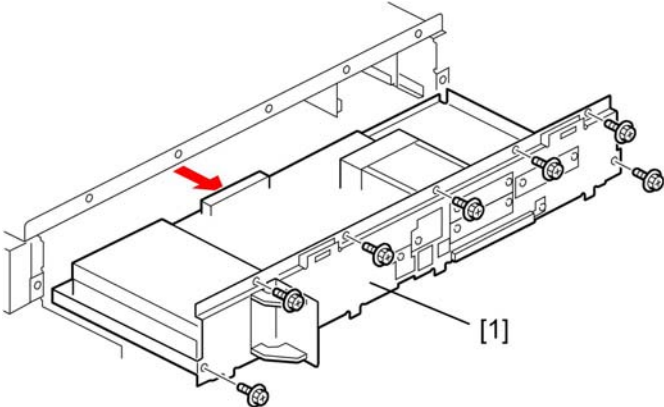

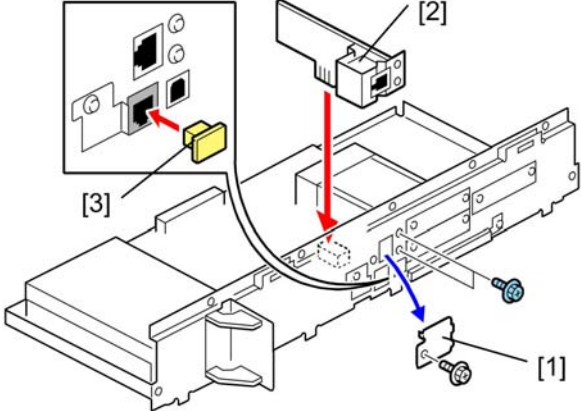

d377i111

4. Remove controller board unit [1] ( x7).



d377i112

- 5. Remove the cover of Slot C ( x1).
- 6. Install the Gigabit Ethernet board ( x2).
- 7. Insert the LAN connector cap [3] into the open "Ethernet" connection point.

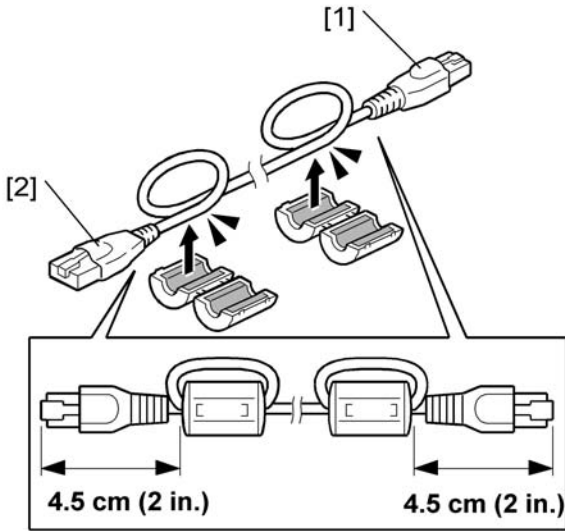

g874i151

8. Attach the ferrite core provided with the Gigabit Ethernet Board to the end of the cable [1] to be attached to the network.
9. Attach the ferrite core provided with the main machine to the end of the cable [2] to be attached to the main machine.

Note

- Attach both cores 4.5 cm (about 2 in.) from each end of the cord.

10. Reconnect the machine to its power source and turn the main power switch on.
11. Do SP5985-1, SP5985-2 and make sure that both are set to "1" (enable).
12. Turn the machine's power off/on.
13. Print a Configuration Page to make sure that the machine recognizes the installed board for USB2.0:
User Tools > Printer Features > List/Test Print > Configuration Page

Browser Unit Type E (D430-05, -06, -07)

Accessories



Check the accessories and their quantities against the table below.

No.	Description	Qty
1.	Browser Unit Type E (SD Card)	1

No.	Description	Qty
2.	Keytops (EU/NA)	2

Installation

CAUTION

- Before doing the procedure, turn off the main power switch and unplug the machine from its power source.
1. Remove the SD card slot cover ( x1). ( p.124 "Removing the SD Card Slot Cover")
 2. Insert the SD card into Slot 1.
 3. Reconnect the machine and turn it on.
 4. Push [User Tools].
 5. Push [Login/Logout] on the operation panel
 6. Login with the administrator user name and password.
 7. Touch [Extended Feature Settings].
 8. Touch [Extended Feature Settings] again.
 9. Touch [SD Card].
 10. Touch the [Browser] line.
 11. Under "Install to:" touch [Machine HDD] then touch [Next]
 12. When you see "Ready to Install", check the information on the screen to confirm the previous selection.
 13. Touch [OK]. You will see "Installing..." then "Completed".
 14. Touch [Exit] twice to return to the copy screen.
 15. Turn the machine off.
 16. Remove the SD card for the Browser unit from Slot 1, then reattach the SD card slot cover.
 17. Turn the machine power on.
 18. Open the Browser screen from the "Extended Feature Settings" in User Tools. A message appears if the installation was successful:

"The MFP Browser was successfully installed."

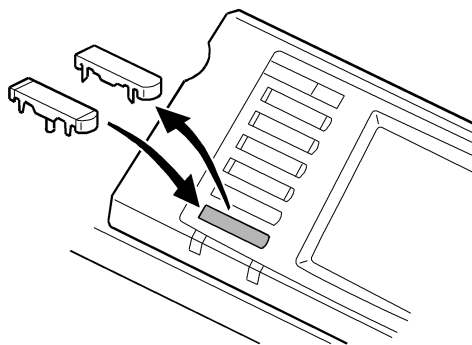

b286i163

2

19. On the operation panel remove the dummy keytop and replace it with the "Others" keytop.

3. Preventive Maintenance

PM Tables

Key for the PM Table

A = Adjust, C = Clean, I = Inspect, L = Lubricate, R = Replace

Note

- Units of measure in the PM Interval column: Metric: 1,000 meters, Feet: 1,000 feet

Main Machine (D093/D094)

Description	Q'ty	PM Interval		PM	Comments
		Metric	Feet		
Scanner					
Original Feed Rollers		5.5	18.0	C	Damp cloth
Original Exit Rollers		5.5	18.0	C	
Platen White Plate		5.5	18.0	C	
Original Width, Set, Registration, Exit Sensors		33.0	108.0	C	Blower brush
Exposure Glass		5.5	18.0	C	Damp cloth or glass cleaner
CIS Surfaces		5.5	18.0	C	Alcohol or lens paper
Development					
Developer (1000 g)	2	27.5	90.0	R	Replace if necessary. (p.189)
Development Filter		5.5	18.0	C	Dry cloth or vacuum cleaner
Development Roller Gear		5.5	18.0	I	
Development Lower Casing		5.5	18.0	C	Dry

Description	Q'ty	PM Interval		PM	Comments
		Metric	Feet		
Magnets (Idle Registration Roller Panel)		5.5	18.0	C	Vacuum cleaner (p.149)
Cleaning					
Cleaning Blade	1	11.0	36.0	I/R	Replace if necessary. (p.198)
Cleaning Entrance Seal		11.0	36.0	C	Lens paper or dry cloth.
Side Seals		11.0	36.0	C	
Inside Cleaning Unit		11.0	36.0	I	Dry cloth or vacuum cleaner
Used Toner Bottle		5.5	18.0	C	Empty used toner
Registration					
Registration Rollers		5.5	18.0	C	Damp cloth
Paper Registration Sensor		5.5	18.0	C	Blower brush
Around the Drum					
Charge Corona Wire		5.5	18.0	C	Lens paper (p.147)
	1	11.0	36.0	R	
Corona Wire Cleaner	1	5.5	18.0	R	(p.180)
Charge Corona Casing		5.5	18.0	C	Damp cloth(p.147)
Grid Wires		5.5	18.0	C	Lens paper (p.147)
Transfer Corona Wire		5.5	18.0	C	Lens paper (p.146)
	1	11.0	36.0	R	
Separation Corona Wire		5.5	18.0	C	
	1	11.0	36.0	R	
T&S Unit Casing, Guides		5.5	18.0	C	Lens paper or dry cloth.
Quenching Lamp		5.5	18.0	C	Lens paper or dry cloth

Description	Q'ty	PM Interval		PM	Comments
		Metric	Feet		
ID Sensor		5.5	18.0	C	Dry cloth; do SP3001 2 to initialize the sensor after you clean it.
Pick-off Pawl		5.5	18.0	C	
LPH (LED Print Heads)		5.5	18.0	C	Lens paper or clean cloth and alcohol. (p.148) After cleaning, touch to discharge static. Important: Use no other chemical cleaners.
Fusing Unit					
Hot Roller	1	27.5	90.0	R	Replace if necessary. (p.223)
Fusing Cleaning Roller	1	27.5	90.0	R	Always replace with hot roller. (p.221)
Hot Roller Bushings	1	27.5	90.0	R	Always replace with hot roller. Lubricate with Barrierta – S552R (p.223)
Pressure Roller	1	33.0	108.0	R	Replace if necessary. (p.223)
Hot Roller Strippers		5.5	18.0	C	Dry cloth.
Pressure Roller Strippers		5.5	18.0	C	
Hot Roller Thermistor		11.0	36.0	C	
Pressure Roller Thermistor		11.0	36.0	C	
Fusing Exit Guide Plate		5.5	18.0	C	
Paper Junction Gate		5.5	18.0	C	
Fusing Entrance Guide Spurs		5.5	18.0	C	Cleaner brush Alcohol, dry cloth at every visit. (p.146)
Fusing Exit Rollers		11.0	36.0	C	Damp cloth

Description	Q'ty	PM Interval		PM	Comments
		Metric	Feet		
Fusing Exit Sensor		5.5	18.0	C	Blower brush
Fusing Gears		5.5	18.0	L	Lubricate with Barrierta – S552R (p.151)
Mechanical Drive Section					
Drum Drive Gears		5.5	18.0	L	Lubricate with Silicone Grease G501. (p.150)
Development Drive Gears		5.5	18.0	L	
Fusing Drive Gears		5.5	18.0	L	
Others					
Ozone Filter	1	5.5	18.0	R	(p.249)
Line Speed & Magnification Adjustments				A	Adjust after replacing rollers. For details, see SP Adjustments.
Circuit Breaker		The circuit breaker should be tested once a year. See Main Machine Final Installation.			

Roll Feeder (D503/D504)

Description	Q'ty	PM Interval		PM	Comments
		Metric	Feet		
Cutter unit		5.5	18.0	C	Blower brush, dry cloth. (Estimated service life: 127 K cuts)
Feed Rollers		5.5	18.0	C	Damp cloth
Exit Rollers		5.5	18.0	C	
Exit Sensor		11.0	36.0	C	Blower brush or dry cloth
Roll End Sensors 3, 4 (EXP)		11.0	36.0	C	

Paper Cassette (B853)

Description	Q'ty	PM Interval	PM	Comments
		K Prints		
Feed Roller	1	40	C/R	Replace if necessary. (p.209)
Friction Pad	1		C/R	
Grip Rollers			C	Blower brush or dry cloth
Relay Sensor			C	

Cleaning Points

Entrance Spurs

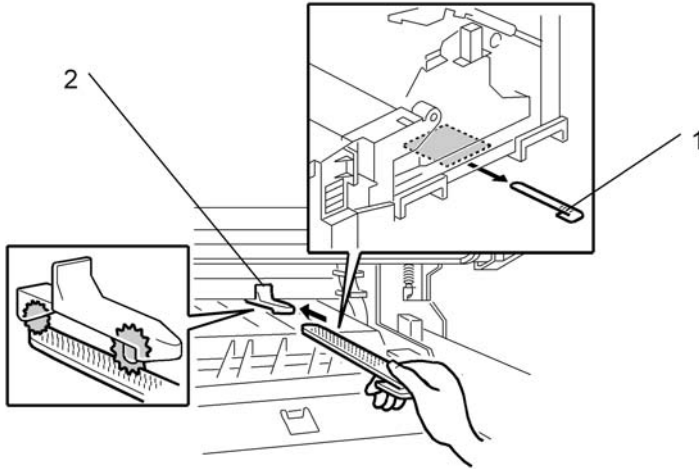

b286p901

1. Open the upper unit.
2. Retrieve the flat brush from [1] from its storage location.
3. Use the flat brush to clean the 5 entrance spurs [2].

★ Important

- Be sure to return the flat brush to its storage location when you are finished.

Corona Wire Cleaning

Transfer/Separation Corona Unit

1. Remove the transfer/separation corona unit. (p. 186 "Transfer Corona, Separation Corona Wires")

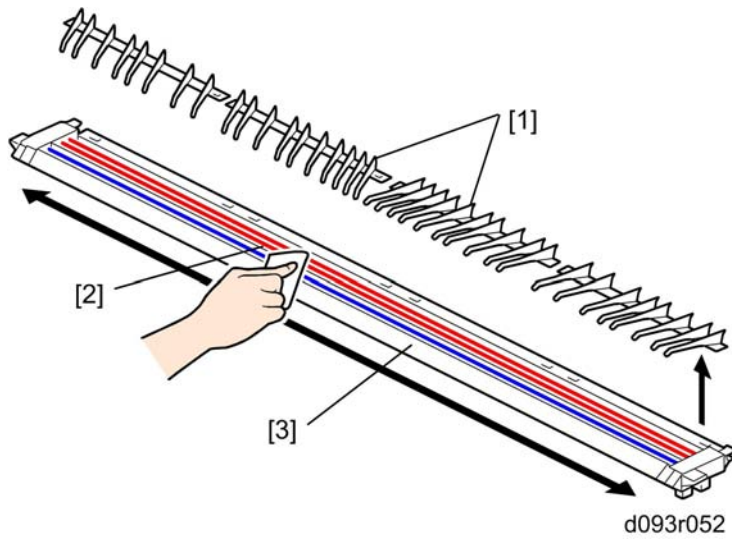

2. Remove the paper guides [1].
3. Use lens paper to clean the transfer/separation wires [2].
4. Use a dry or water damp cloth to clean the paper guide and frame [3].

★ Important

- If you use a damp cloth, use the damp cloth first. Then be sure to wipe the cleaned area dry with a clean dry cloth.

Charge Corona Unit

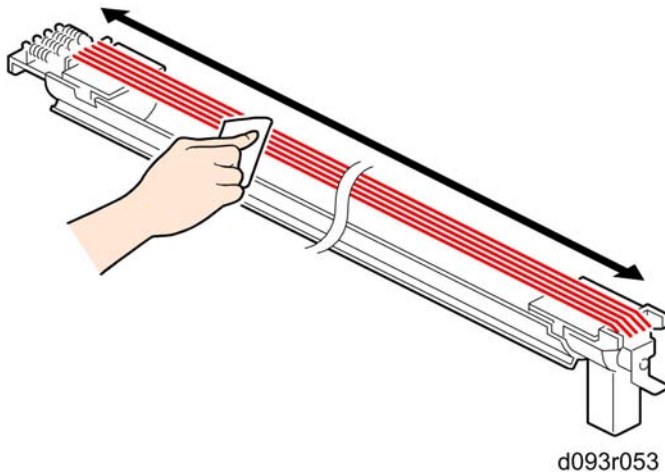

1. Remove the charge corona unit (▶ p.180 "Charge Corona Unit")
2. Use lens paper to clean the grid wires.

3

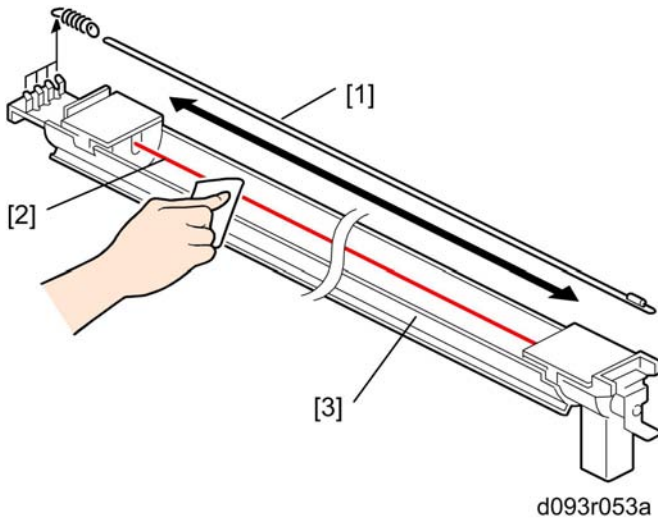

3. Remove the grid wires [1].
4. Use lens paper to clean the charge corona wire [2].
5. Remove the wire and clean the casing [3] with dry or water damp cloth.

★ Important

- If you use a damp cloth, use the damp cloth first. Then be sure to wipe the cleaned area dry with a clean dry cloth.

LPH Cleaning

1. Remove the LPH. (See p.184 "LPH")

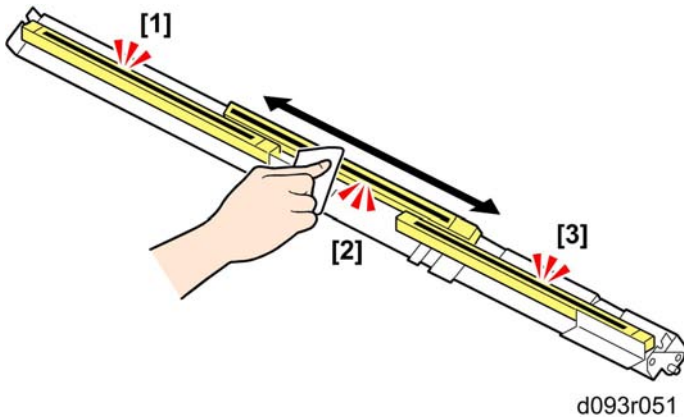

2. Use lens paper (or clean cloth dampened with alcohol) to clean the surfaces of the LPH unit lenses.
3. After cleaning, touch a grounded surface to discharge static electricity from your hands.

★ Important

- If you use a cloth dampened with alcohol, be sure there is no residue remaining around the cleaned area.
- If you use a damp cloth, use the damp cloth first. Then be sure to wipe the cleaned area dry with a clean dry cloth.

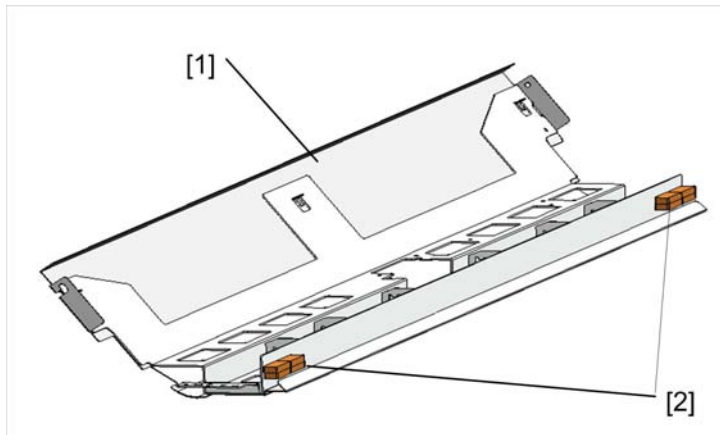
Idle Registration Roller Panel

d093r922

1. Remove idle registration roller panel [1]. (p. 160)
2. Use a vacuum cleaner to remove developer from the magnets [2].

Lubrication Points

Development Gears

3

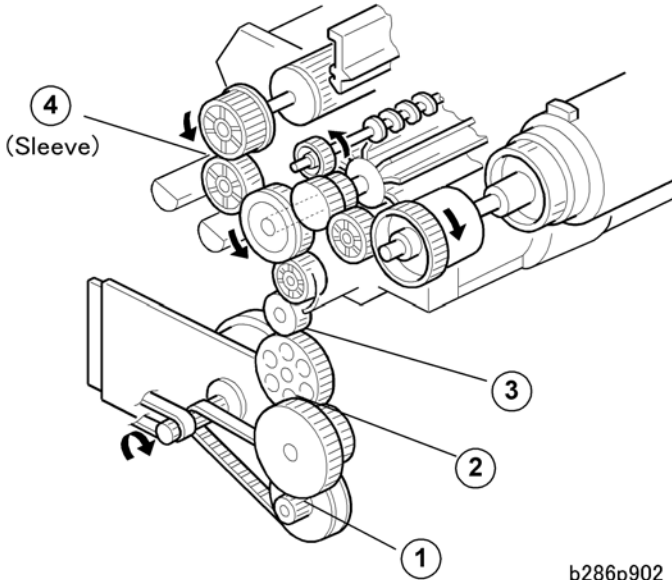

b286p902

1. Remove the development unit. (p.188 "Development Unit")
2. Lubricate the development unit gears with Silicone Grease G501). Apply at the points shown by the numbers in the drawing.

Fusing Gears

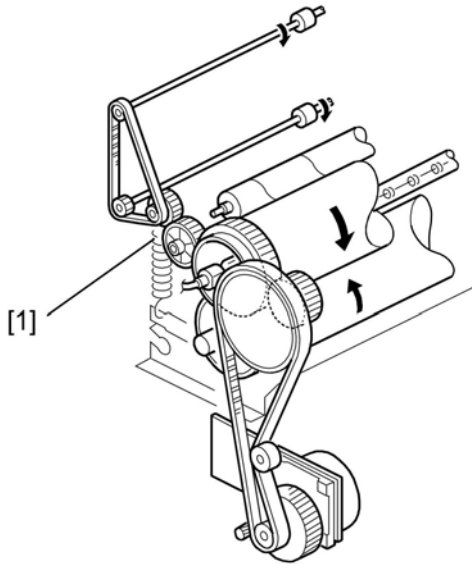

b286d603a

1. Remove the fusing unit (p.218)

[1]: Fusing Gears (Barrierta S552R). Apply to the surface of the rim.

4. Replacement and Adjustment

Common Procedures

⚠ CAUTION

- Before doing any procedure, turn off the main power switch and unplug the machine from its power source.

Before Working On the Main Machine

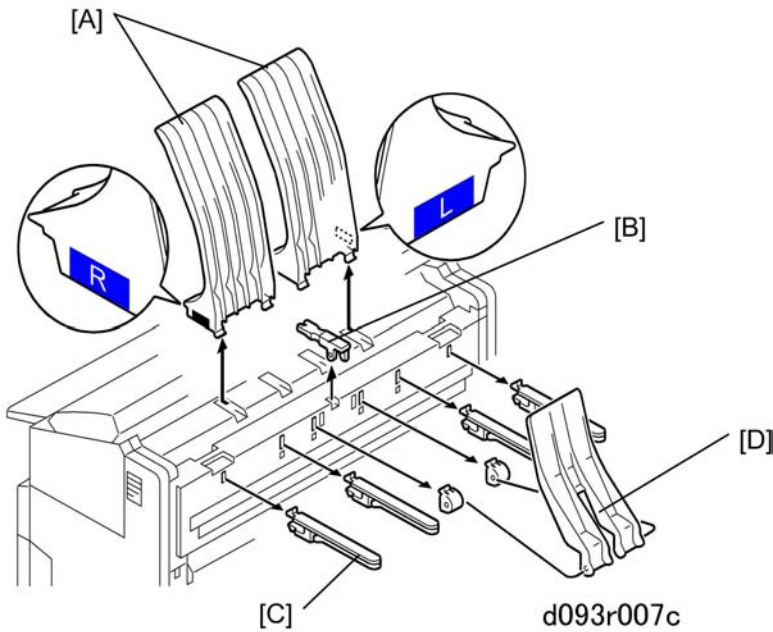

Always remove these items before you start work on the machine:

1. Remove:
 - [A]: Upper output stackers (x 2)
 - [B]: Guide lever
 - [C]: Original output guides (x 4)
 - [D]: Upper output guide (x 1)
 - Lower output trays (x 3) (not shown)

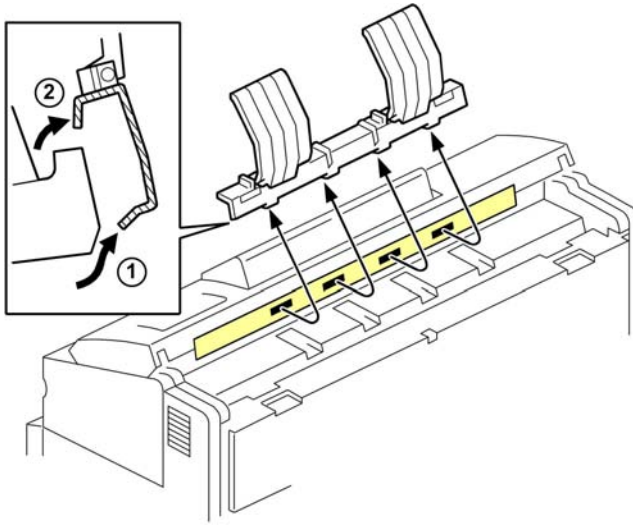

d093r007b

2. To remove the original tray, detach the bottom first ① then the top ②.

Side Covers

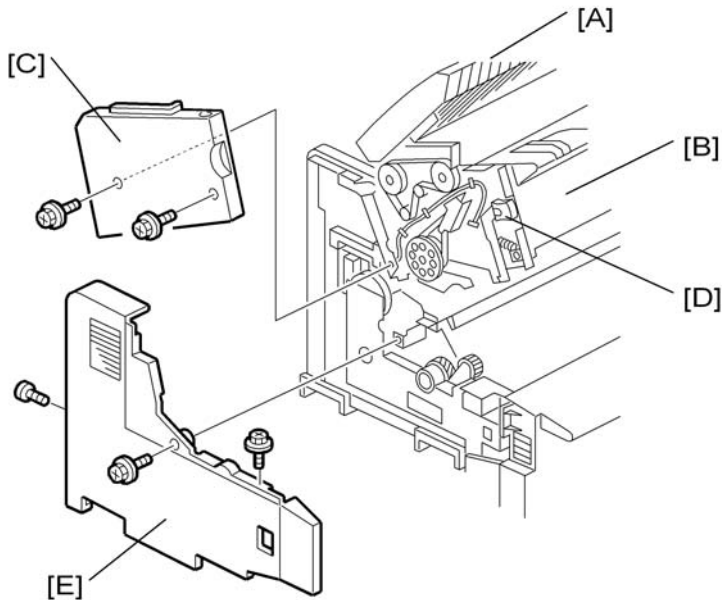

b286r502

1. Open the original feed unit [A].
2. Open the upper unit [B].

3. Remove the left upper cover [C] ( x 2).

 **Note**

- If necessary, push in the release button [D] to remove the cover.

4. Remove the left cover [E] ( x 3).
5. Do Steps 3 and 4 to remove the right upper cover and right cover.



Reinstallation

- Make sure the original feed unit and upper unit are open.
- Always install the lower covers before the upper covers.
- If necessary, push in the upper unit release buttons [D] when you attach the upper covers.

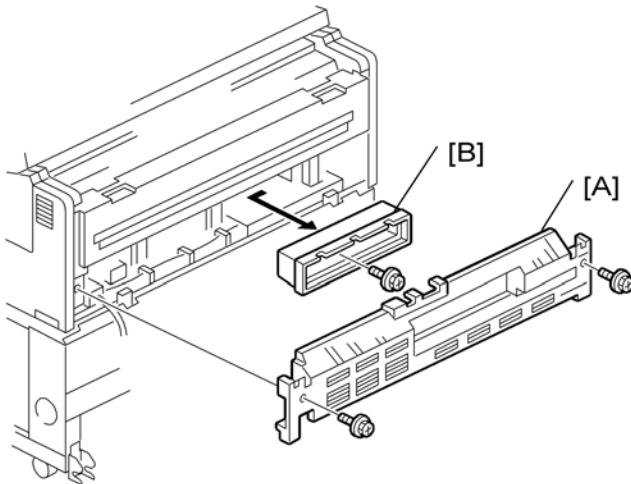
Rear Cover, Controller Cover









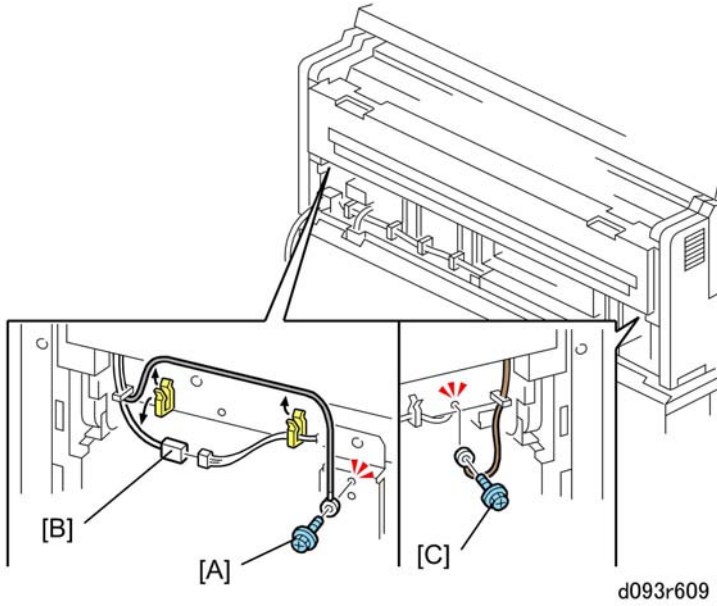

b286r914

1. Rear cover ( x 2) [A]
2. Controller cover [B] ( x 1)

Paper Exit Unit

4



1. Remove the rear cover and controller cover ( x 2). ( p.155 "Rear Cover, Controller Cover")
2. Disconnect the ground wire [A] and connector [B] on the left ( x 2,  x 1,  x 1).
3. Disconnect the ground wire [C] on the right ( x 1,  x 1).

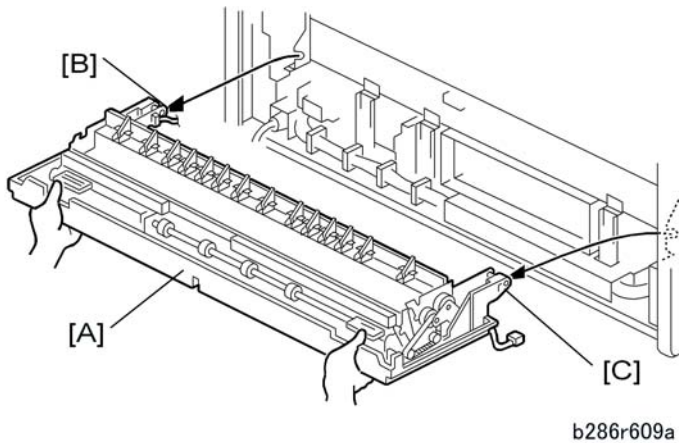

4. Open the paper exit unit [A] and cover.
5. Raise the paper exit unit approximately 30° from horizontal, and pull the unit away from the left and right hinges [B] and [C].

Unlocking, Opening the Original Unit

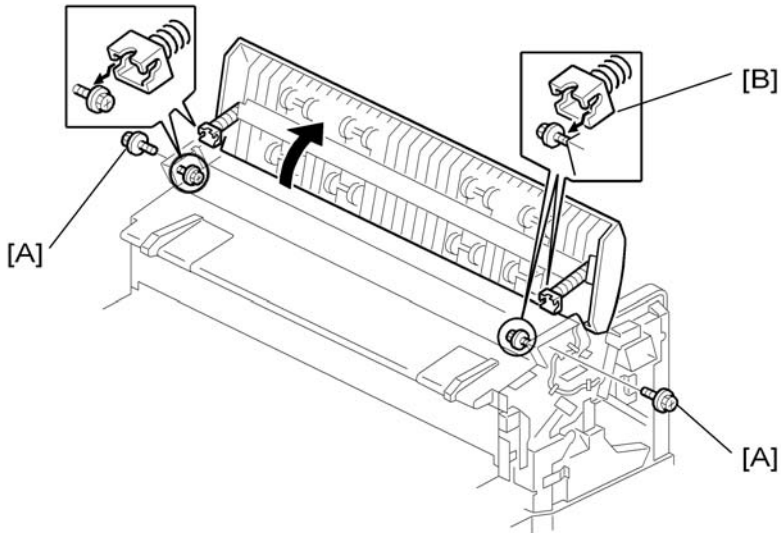

b286r105

1. Open the upper unit.
2. Remove the lock screws [A] ($\times 2$).
3. On the left and right sides, lift the hinges [B] off the support screws and lift the unit to the vertical position. (Do not remove the support screws.)

Removing the Original Feed Unit

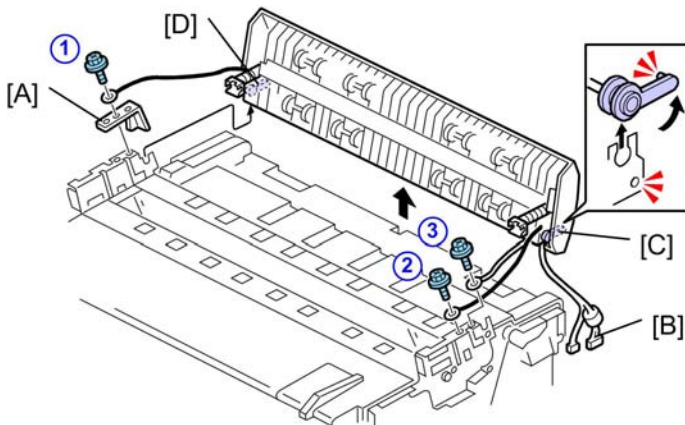

d093r106

1. Remove:

- Left upper cover (☛ p.154 "Side Covers")
 - Right upper cover (☛ p.154 "Side Covers")
2. Unlock the original unit and raise it. (☛ p.157 "Unlocking, Opening the Original Unit")
 3. Remove the plate [A] and disconnect the ground wire ① (🔩 x 1).
 4. On the right side, disconnect the ground wires ②, ③ (🔩 x 2).
 5. Disconnect the connectors [B] (🔌 x 2).
 6. On the ends of the original unit shaft, move the Teflon arms [C] and [D] out of the holes and lift them until they are horizontal.
 7. Hold the Teflon arms up. At the same time, lower the original feed unit in your direction. When it is approximately 70° from the vertical, lift it off the top of the machine.
 8. Be sure to remove the Teflon arms from the ends of the shaft so they do not fall off.

Raising and Locking the Scanner Unit

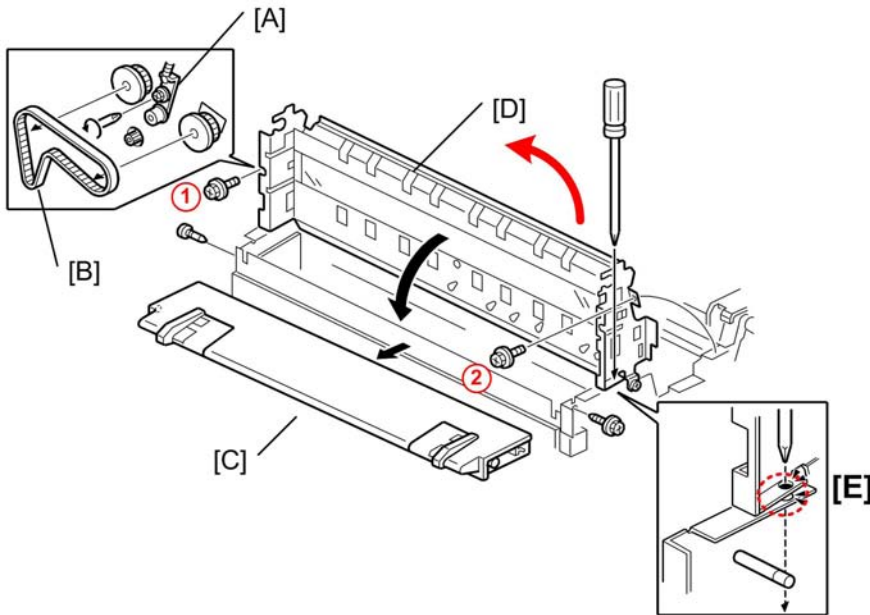

d093r107a

1. Remove the original feed unit. (☛ p.157 "Removing the Original Feed Unit")
2. Loosen spring [A] and remove the scanner motor belt [B].
3. Tighten the screw again to make sure that the screw and spring do not fall off.
4. Remove the original table ([C] (🔩 x2)).

5. Remove screws ①, ② and raise the scanner unit [D]
6. Put a long screwdriver [E] through the holes to lock the scanner unit in the up position.

★ Important

- Always lock the scanner with a screwdriver when it is in the up position.

Toner Hopper Cover

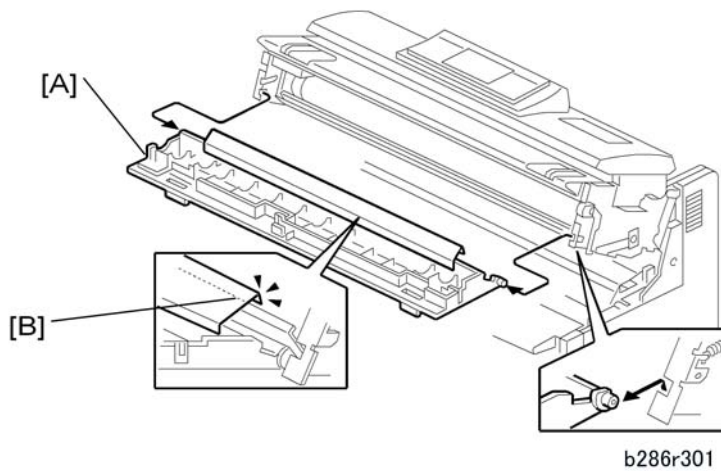

1. Side covers. (p. 154 "Side Covers")
2. Open the toner hopper cover [A].

Reinstallation

- Make sure that the bent edge of the mylar [B] is attached around the edge of the plate.

Idle Registration Roller Panel

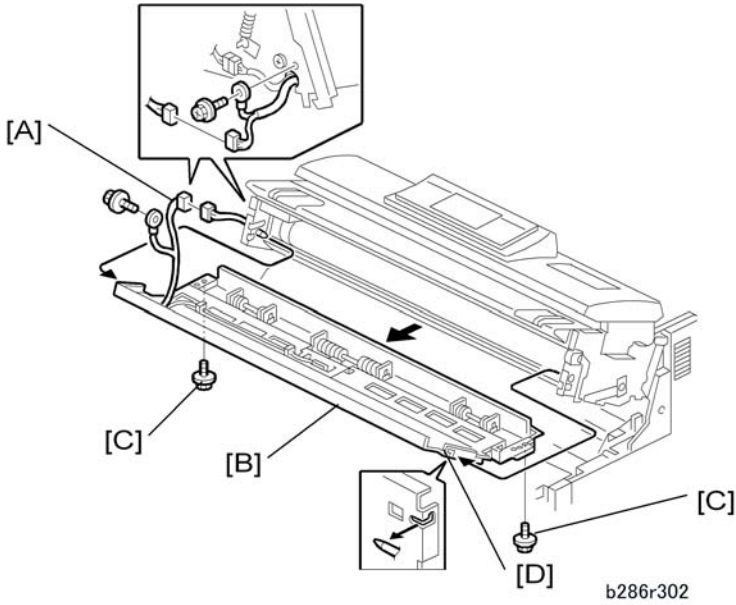

4

1. Open the upper unit.
2. Side covers. (p. 154 "Side Covers")
3. Toner hopper cover (p. 159 "Toner Hopper Cover")
4. Disconnect the connector and ground wire [A] (x 1, x 1).
5. Idle registration roller panel [B] (x 2)
 - Remove the two rear screws [C] first and let the panel come down. Use a very short screwdriver to remove the rear screws.
 - Disconnect the panel from the stud screw on the right side first [D], then the left side. Do not remove the stud screws.

Original Feed Table, Original Feed Sensor Cover

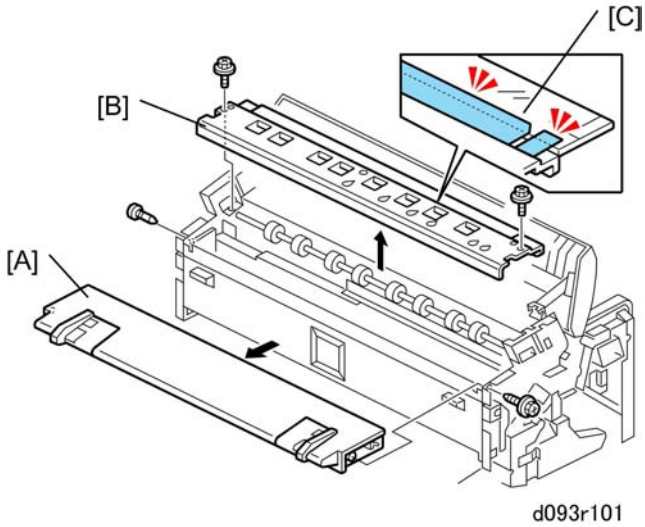

1. Unlock and lift the original feed unit. (➡ p.157 "Unlocking, Opening the Original Unit")
2. Open the upper unit.
3. Side covers (➡ p.154 "Side Covers")
4. Original feed table [A] (🔧 x1, 🛠️ x1)
5. Original feed sensor cover [B] (🛠️ x2)

Re-installation

- Make sure both mylars [C] are on the top of the front edge of the exposure glass.

Drawer Front Cover

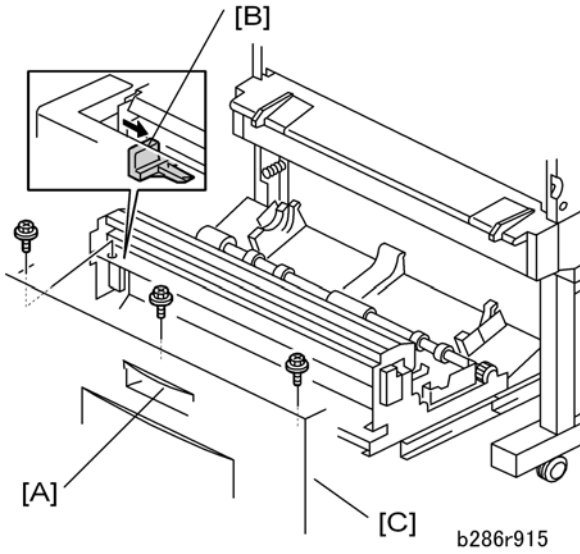

4

1. Open the front drawer of the roll feeder [A].
2. Push the cutter [B] to the right.
3. Front cover [C] ( x 3)

Scanner

CAUTION

- CLASS 1 M LED RADIATION WHEN OPEN DO NOT VIEW DIRECTLY WITH OPTICAL INSTRUMENTS

WARNING

- Be sure to turn off the main switch and disconnected the power plug from the power outlet before beginning any disassembly or adjustment of the scanner unit. This copier uses a class 1 M LED radiation.
- LED radiations can seriously damage your eyes.
- Blue: Wavelength 452-463 nm and an output 6.9 mW
- Green: Wavelength 520-531 nm and an output 3.9 mW
- Red: Wavelength 629-634 nm and an output 4.8 mW
- Do not actuate the safety switches, when the original feed unit is open. (This will turn on the main power.)
- Make sure that the safety switches work correctly after finishing any disassembly or adjustment of the scanner unit.
- Make sure that the original feed unit closes correctly after finishing any disassembly or adjustment of the scanner unit.

LED Safety Switches

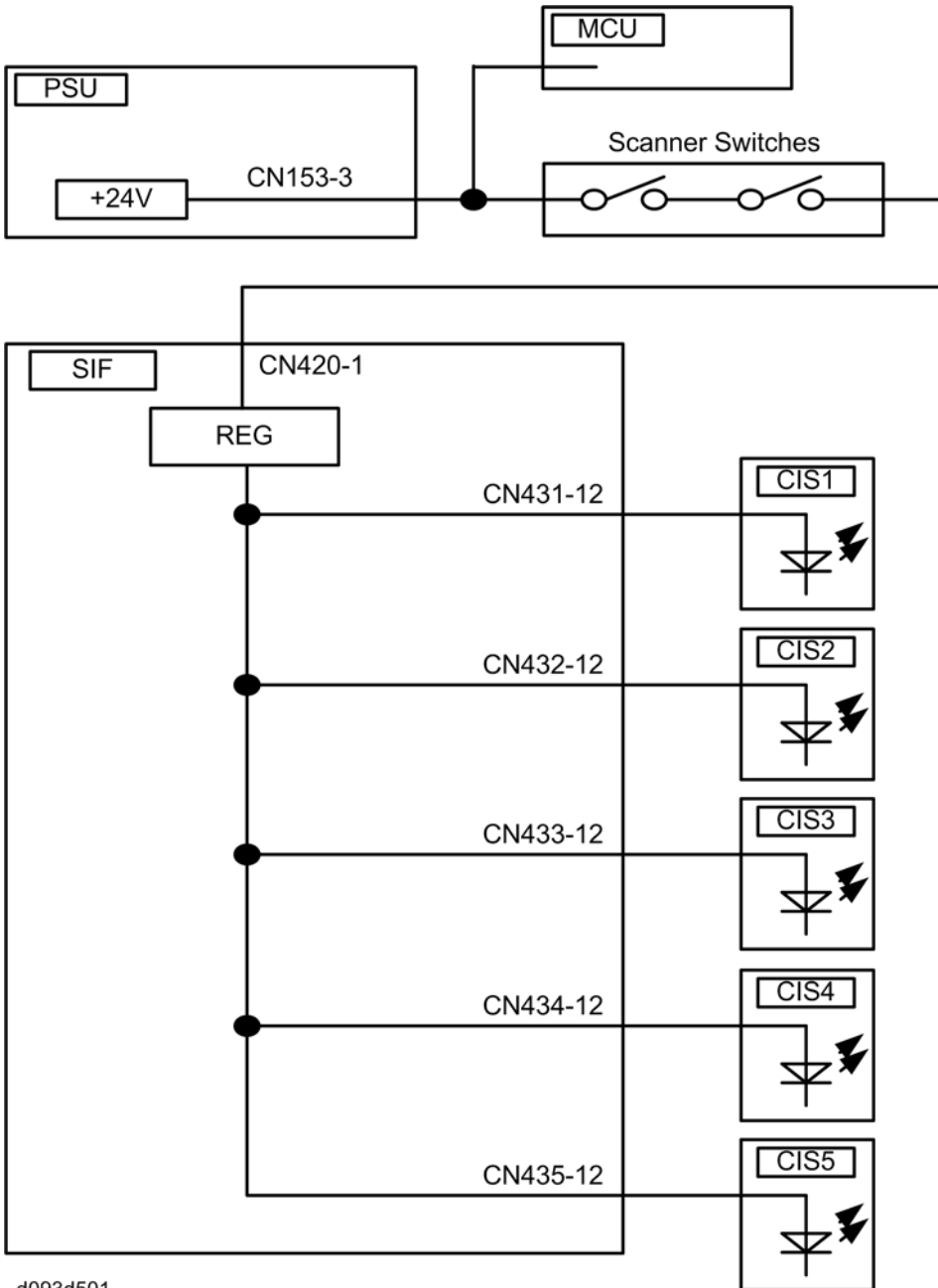

To ensure the safety of customers and customer engineers, two switches inside the scanner section prevent the LED radiation from switching on accidentally. When the original feed unit is open, the +24V line connecting each LED driver on the SIF board is disconnected.

Original Width Sensors, Original Set Sensor, Scanner Switch

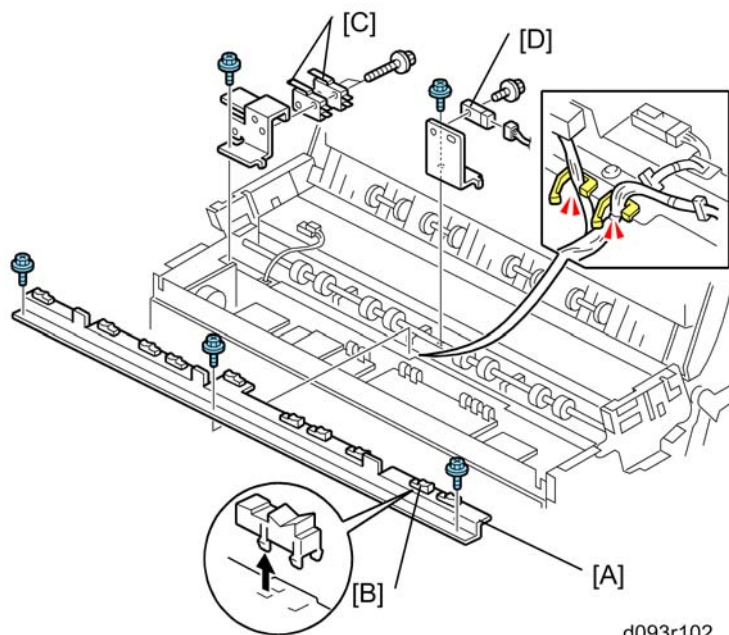

4

1. Original feed table, original feed sensor cover (➤ p.161 "Original Feed Table, Original Feed Sensor Cover").
2. Original width sensor bracket [A] (📏 x 3, 🛠️ x2, 🔩 x3)
3. Original width sensors [B] (📏 x 1 ea.)
4. Scanner switches [C] (📏 x 2, 🔩 x 3)
5. Registration sensor [D] (📏 x 1, 🔩 x 2)

Original Exit Sensor

1. Raise and lock the scanner unit (➤ p.158 "Raising and Locking the Scanner Unit")

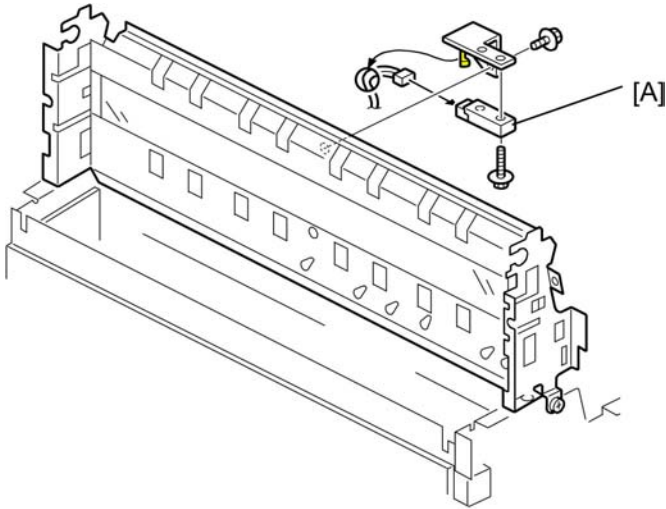

d093r102a

2. Remove original exit sensor [A] (🔧 x1, 🔪 x2, 🛠️ x1)

Original Feed Unit Rollers

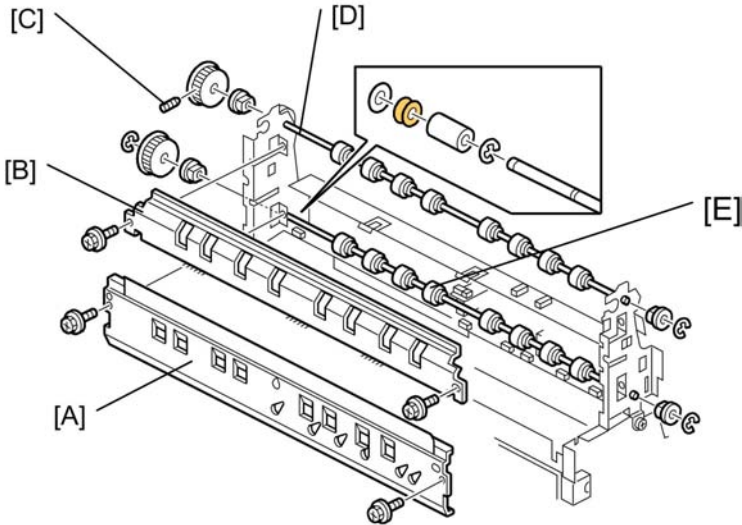

d093r108

1. Raise and lock the scanner unit. (📖 p.158 "Raising and Locking the Scanner Unit")
2. Remove:
 - [A] Original width sensor cover (🔧 x 2)
 - [B] Original exit roller cover (🔧 x 2)
3. Use an Allen key to loosen the screw [C] that fastens the left end of the exit roller shaft.

4. Remove:

[D] Original exit rollers (Ⓒ x 1, ■ x 2)

[E] Original feed rollers (Ⓒ x 2, Steel washer x 1, Rubber spacer x1, Plastic sleeve x1, ■ x 2)

★ Important

- The control timing of the scanner motor has modified to operate the new original feed and original exit rollers because the composition of these rollers has changed.
- The drive and idle rollers of the scanner unit (original feed and original exit rollers) must be replaced with the rollers designed for use with this machine.
- If the rollers of the previous model are installed in this machine, this could cause undesirable vibration.

Reinstallation

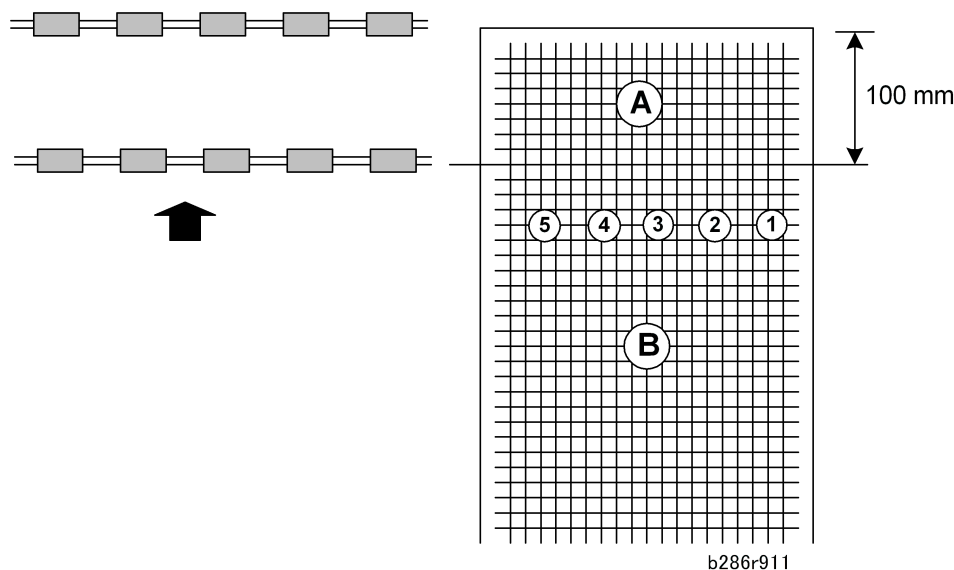

- After you replace the original feed roller or the original exit roller, do the CIS sub scan test and adjustment as follows.
 1. Do **SP4417** Pattern 28.
 2. Make a copy of the Pattern 28 output that you made in step 1.
 3. On the copy, first, check Area "B".
 - If the lines at all the joints are correct (not broken), go to the next step. The joints are labeled 1 to 5 in the diagram; these joints are at the same locations as the joints between segments of the CIS.
 - If the lines are broken at a joint, do SP4972 to adjust them. Then go to the next step.
 4. Next, check Area "A".

Note

- Area A (100 mm) is the distance that the original is fed by only the feed roller, until the original exit roller gets and feeds the original.
- If the lines at the joints in Area A are correct (not broken), the procedure is completed.
- If the lines are broken at a joint, do SP4965 to adjust them (adjust by trial and error). Then go back to step 3 and check again.

Exposure Glass

4

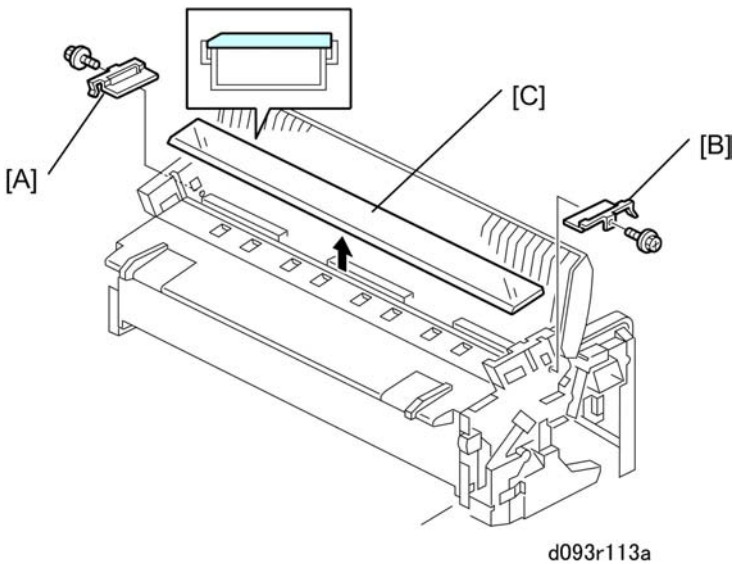

1. Unlock and lift the original feed unit. (p.157 "Removing the Original Feed Unit")
2. Side covers (p.154 "Side Covers")
3. Left exposure glass plate [A] (x 1 with washer)
4. Right exposure glass plate [B] (x 1 with washer)
5. Exposure glass [C]

Important

- The exposure glass is very long and thin. It is very easy to break.

Re-installation

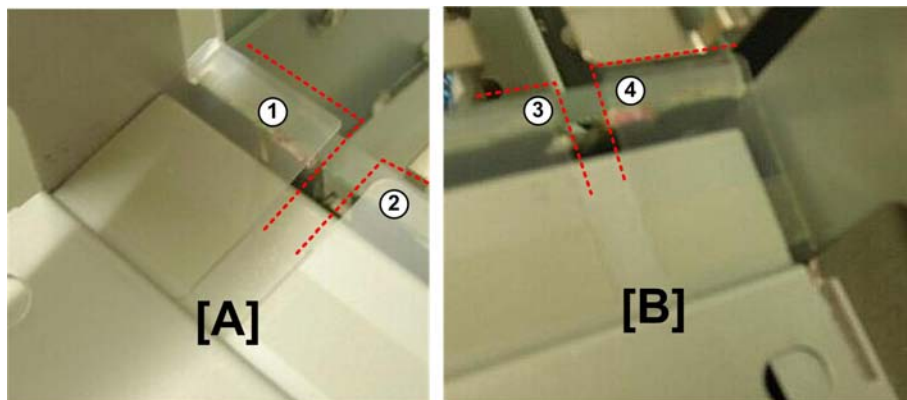

d093r916a

4

Make sure that the edges of the mylars are top of the beveled edge of the exposure plate.

- On the left [A] the top edge of the small mylar ① and left corner and edge of the large mylar ② must both be on to of the exposure glass edge.
- On the right [B] the top edge of the small mylar ③ and left corner and edge of the large mylar ④ must both be on to of the exposure glass edge.

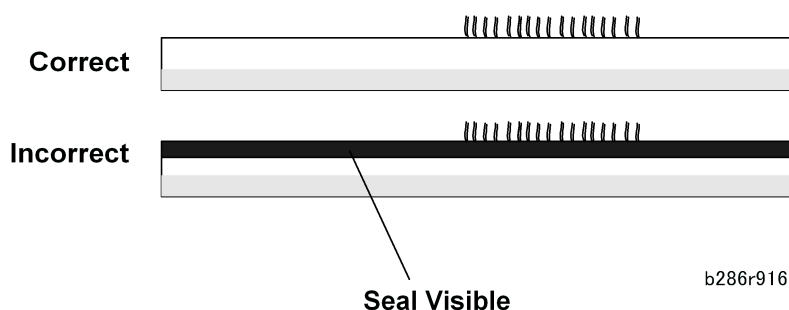

b286r916

Make sure that the black seal is below the rear edge of the exposure glass. The rear edge of the exposure glass must be on its metal supports and not in front of them.

CIS

Before You Begin...

- To preserve the alignment of its components and to prevent other damage, always handle the CIS unit carefully to protect it from sudden shock and vibration.
- To prevent finger prints and smudges, never touch the CIS lens cover with bare hands.
- Clean the CIS lens cover with lens paper only. Never use tissue paper or cloth that could leave lint or other particles on the glass.

- To preserve the alignment of its components, always disconnect and re-connect the CIS unit at the SIF. Never disconnect the signal or power supply harnesses from the CIS unit.

Preparation

- Remove the left and right upper side covers. (p.154 "Side Covers")
- Unlock and raise the original unit. (p.157 "Unlocking, Opening the Original Unit")
- Raise and lock the scanner unit and remove the original table. (p.158 "Raising and Locking the Scanner Unit")

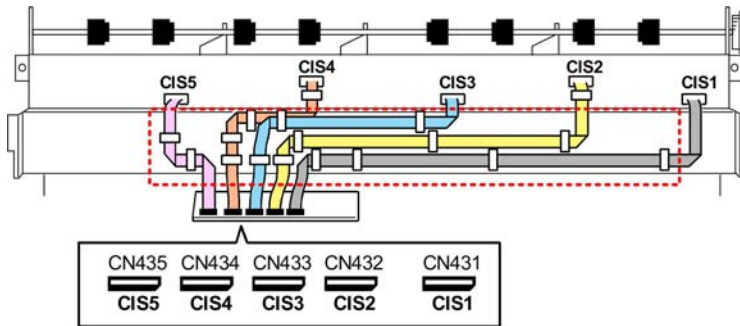

d093r110

1. At the rear, open the clamps on the lower plate (x16).

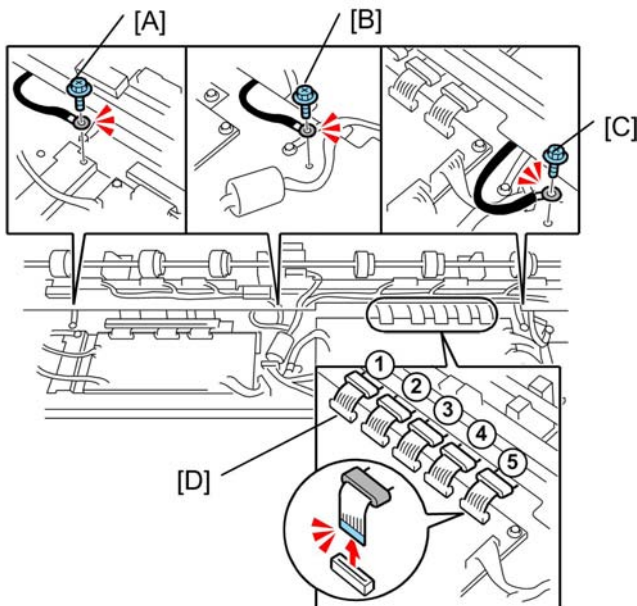

d093r109a

2. At the front, disconnect the ground wires:



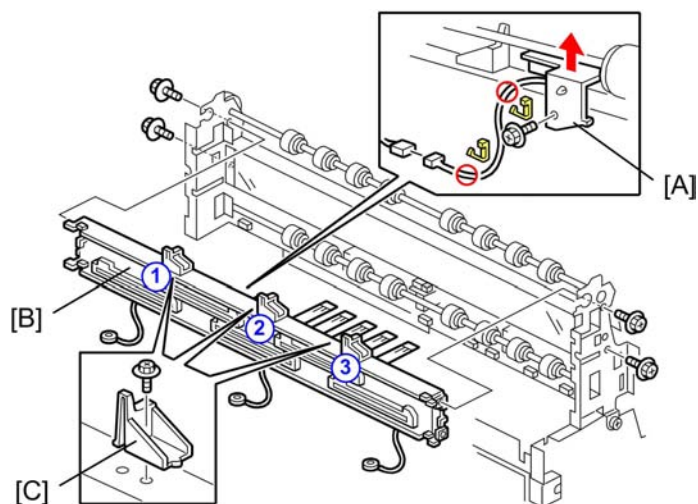

- [A] Left (x1)
- [B] Center (x1)

[C] Right ( x1)

3. Disconnect the CIS from the SIF ( x5).



d093r109

1. Remove the original exit sensor [A] ( x1,  x2,  x1)
2. Remove the CIS unit [B] ( x4).
3. Remove the three brackets [C] ( x3)

★ Important

- The three brackets must be removed and re-attached to the new CIS unit. These brackets are not provided with a new CIS unit.

Re-installation

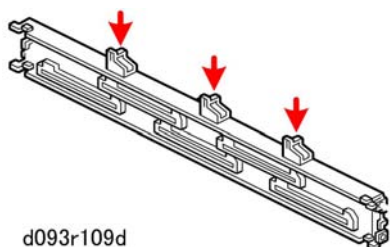

d093r109d

1. Attach the three brackets removed from the old CIS unit to the new CIS unit.
2. Install the new CIS in the machine.
3. Remove the SD card slot cover ( x1).
4. Insert the SD card (provided with CIS unit) in Slot 1.
5. Re-connect the machine power plug and switch the machine on.
6. Wait for the "Ready" screen to display.

7. Press the [Program] key on the right side of the operation panel.

```
SPC DATA SET MODE Application (Ver. 0.01 SPC
OK 01.SPC DATA SET MODE
d093r113
```

8. On the operation panel, press [0]> [1]> [Start].

```
SPC DATA SET MODE Application (Ver. 0.01 SPC
Finished!!
d093r114
```

4

9. Press the [Program] key then touch [Exit] to return to standby mode.
10. Press the operation power switch to switch the machine off, then switch off the main power switch.
11. Remove the SD card from Slot 1, replace the SD card slot cover, then turn the machine on.
12. Do SP4417 and print Pattern 28 to check the CIS.
13. Do a test copy and check the quality.

★ Important

- After replacing the CIS, store the SD card and the data sheet with the flat brush stored on the right bottom edge of the main machine.



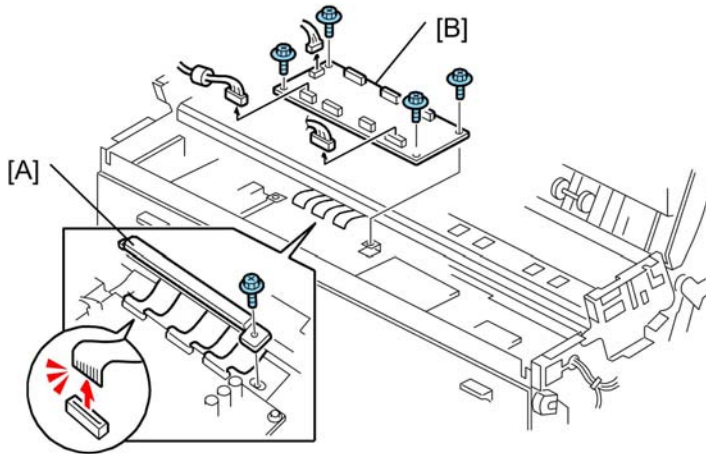

VDB, SIF, CGB Power Pack

Preparation

- Side covers (p. 154 "Side Covers")
- Manual feed table, original feed sensor cover (p. 161 "Original Feed Table, Original Feed Sensor Cover")



d094r104b

1. Remove the LPH harness plate [A] ( x1).
2. Remove the VDB [B] ( x3,  x3,  x4)

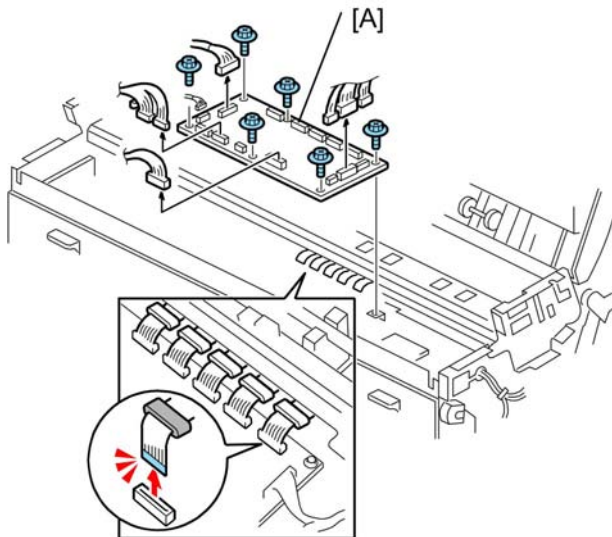

d093r104

3. Remove SIF [A] ( x5,  x9,  x6)

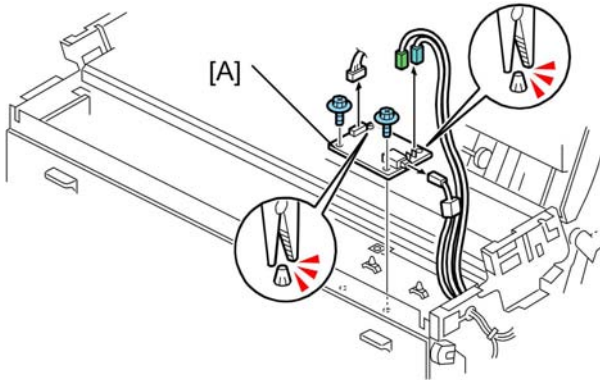

d093r103

4

4. Remove CGB power pack [A] (🔧 x 4, 🔩 x 2, 🛠️ x 2)

Operation Panel Boards

Preparation

Remove: (📖 p.153 "Before Working On the Main Machine")

- Upper output stackers (x 2)
- Original output guides (x 4)
- Upper output guide (x 1)
- Original tray (x1)

Removing the Operation Panel

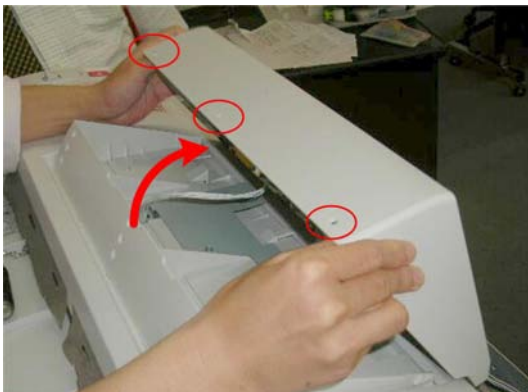

d093r120

1. Open and raise the operation panel cover. (🔩 x3)



d093r121

2. Disconnect the operation panel (🔌 x1).

4

LCDC, Inverter, LCD Display Window, LCD Unit

1. Remove the operation panel (🔌 p.174).

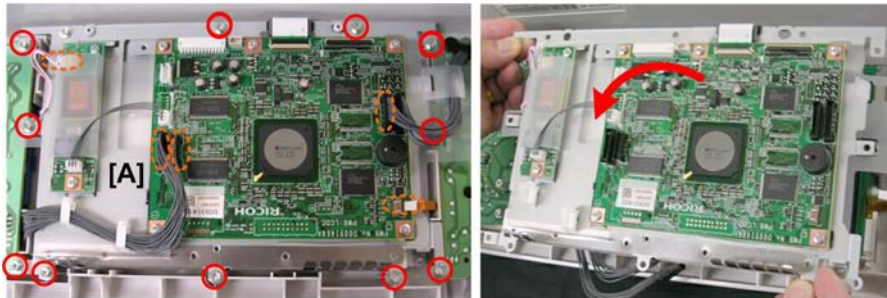

d093r670

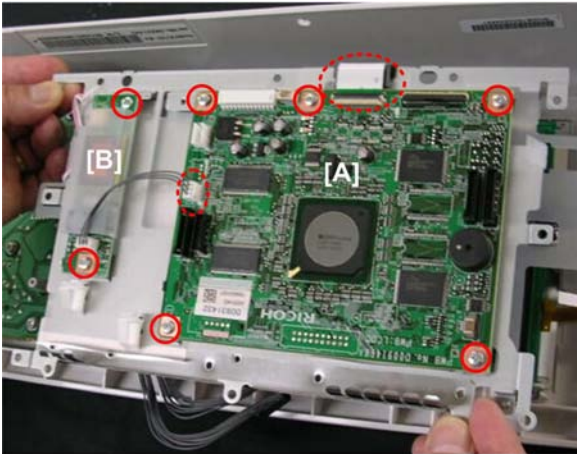

2. Remove LCDC bracket with the LCDC attached (🔌 x4, 🛠️ x12)

4



d093r671

3. Remove:

[A] LCDC ( x1,  x1,  x5)

[B] Inverter ( x2)

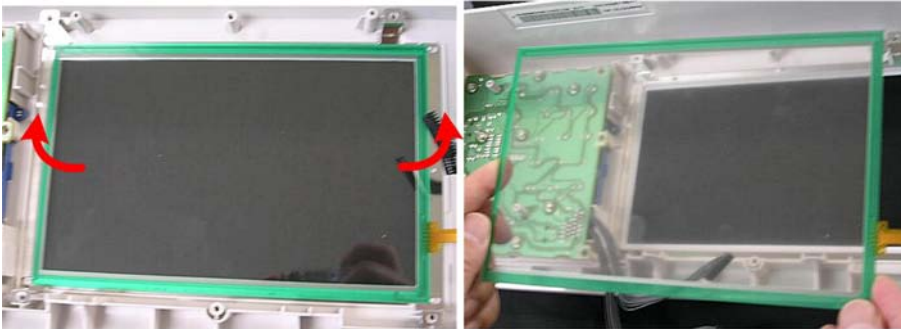

d093r672

4. Lift the touch panel out of its frame.

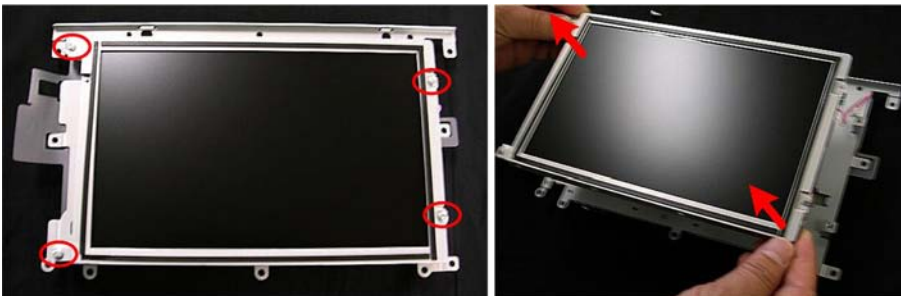

d093r673

5. Remove the LCD from its frame ( x4).

OP-R Board

1. Remove the operation panel (p.174 "Removing the Operation Panel")
2. Remove the LCDC (p.175 "LCDC, Inverter, LCD Display Window, LCD Unit")

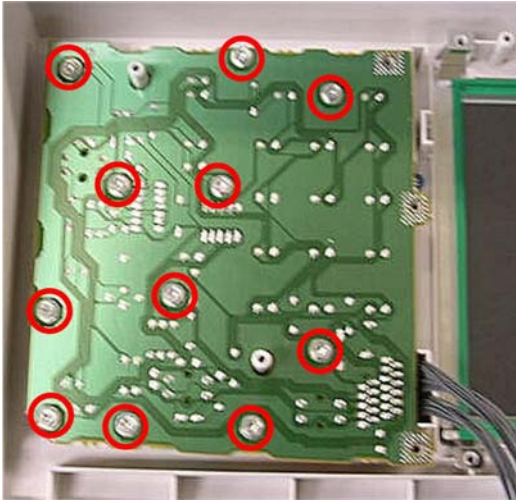

d093r674

3. Remove the OP-R board (x11).

OP-L Board

1. Remove the operation panel (p.174 "Removing the Operation Panel")
2. Remove the LCDC (p.175 "LCDC, Inverter, LCD Display Window, LCD Unit")

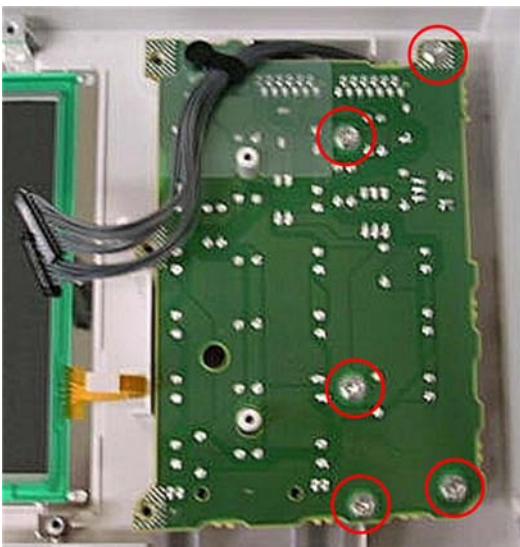

d093r675

3. Remove the OP-L board ( x5).

Touch Screen Calibration

Always re-calibrate the screen after replacing the LCDC.

Important

- Do not attempt to use other items on these menu. Items other than "Touch Screen Adjust" are for design use only.
- To avoid errors, do not touch the [Reset] key on the operation panel during this procedure.

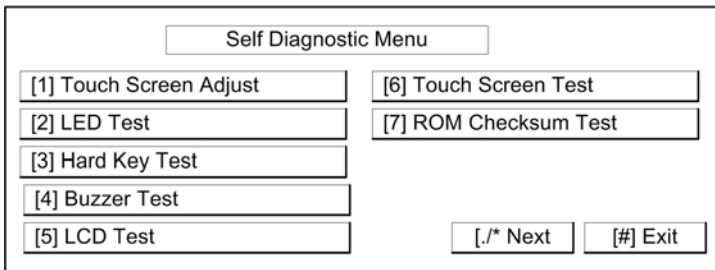

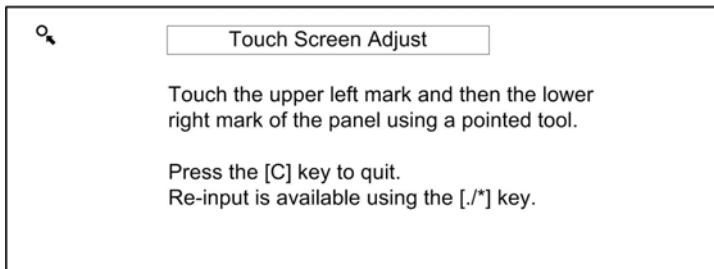

d093r892

1. Push [Clear], push [1] [9] [9] [3], and then press [Clear/Stop] 5 times.
2. Touch "[1] Touch Screen Adjust" on the touch-panel or push [1] on the operation panel.



d093r893

3. Use a soft point (not sharp!) to press  in the upper left corner.
4. Press the  in the lower left corner after it appears.

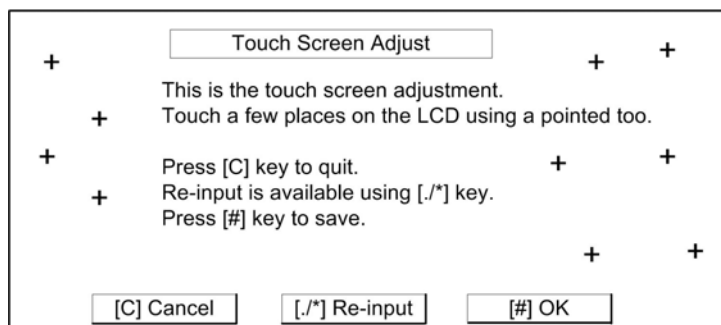

d093r893

5. Touch a few random spots on the touch screen to confirm that the marker (+) appears exactly where the screen is touched.
6. If the (+) mark does not appear where the screen is touched, push [./* Re-input] and repeat the procedure.
7. When you are finished, touch "[#] OK" on the screen (or push [#] on the operation panel).
8. Touch [#] Exit on the screen to close the menu and save the settings.

Around the Drum

Charge Corona Unit

Charge Corona Wire, Grid Wire, Wire Cleaner

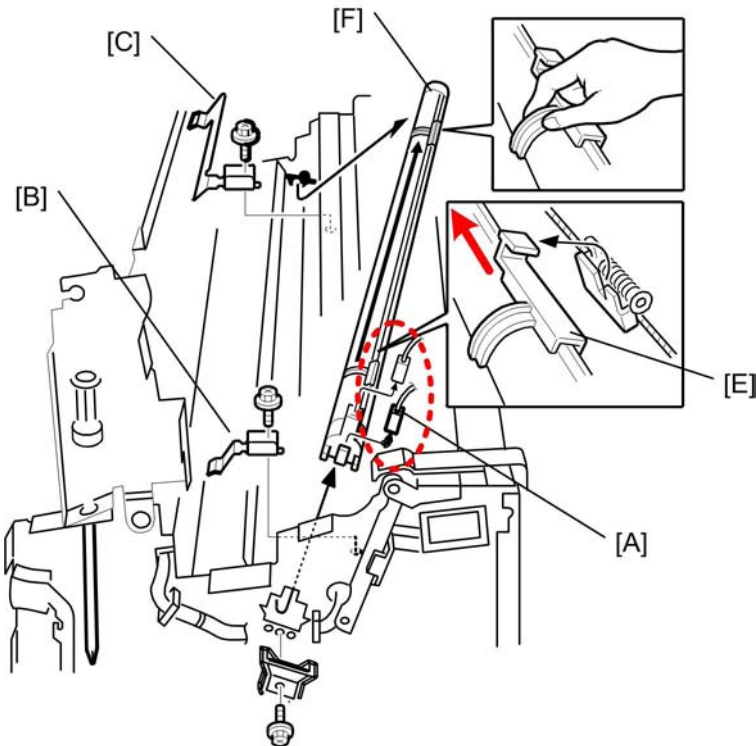

b286r307

1. Lift and lock the scanner unit (p.158 "Raising and Locking the Scanner Unit")
2. Remove the LPH (p.184 "LPH")
3. Disconnect the charge corona unit at [A] (x2).
4. Remove:
 - [B] Leaf spring (x 1)
 - [C] Leaf spring (x 1)
 - [D] End plate (x 1)
5. Disconnect the cleaning pad [E] and then move it to the left.

Note

- You must move the cleaning pad to the left so you can use it as a handle to lift the unit out of the machine.

6. Remove the charge corona unit [F].

Cleaning

- To prevent voltage leak, remove the cap of the end block and clean the charge wire thoroughly with lens paper (never a damp cloth).
- To ensure an even charge along the length of the wire, use a damp cloth to clean the inside surface of the casing. Next, use a clean, dry cloth to wipe the area dry.
- Before installing a new wire, wipe it clean with lens paper to remove dust and other foreign matter that may have collected on the wire at the factory where it was manufactured.

Reinstallation

- Put the left end into the hole on the left first (viewed from the rear of the machine). Then, put the right end into the hole on the right.
- Attach the right plate, then the left plate. Make sure the T-bar of the cleaning pad [D] is connected to the guide wire.
- After you replace the charge corona wire, do SP2803 (Corona Wire Cleaning) to clean the new corona wire.

Disassembling the Charge Corona Unit

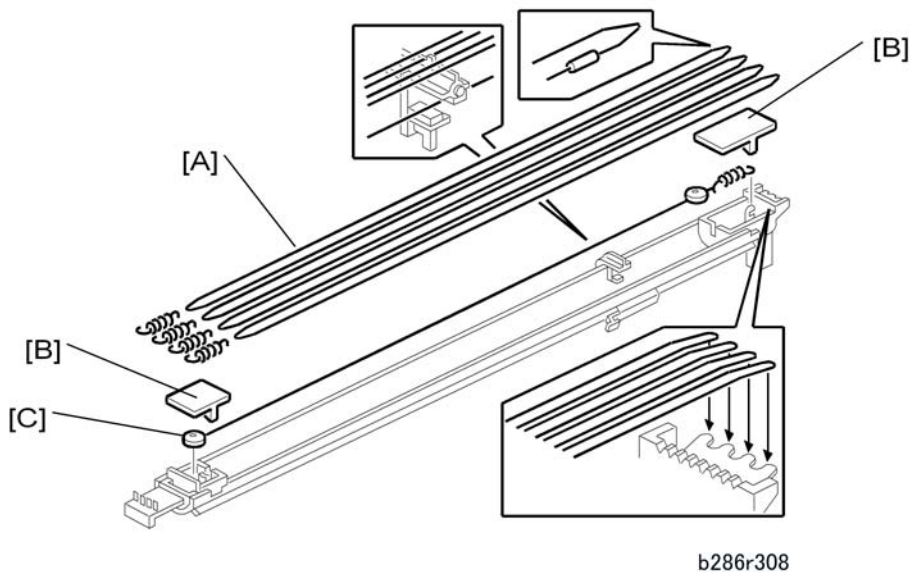

1. Grid wires [A] (x4) ( x 1 ea.)

2. Two cover plates [B] (pressure release)
3. Charge corona wire [C] (🔧 x1)

Quenching Lamp Unit, Quenching Lamps

1. Remove:

- OPC drum unit (🔧 p.195 "Drum Unit")
- LPH (🔧 p.184 "LPH")
- Scanner motor (🔧 p.225 "Scanner Motor")
- Charge corona unit (🔧 p.180 "Charge Corona Wire, Grid Wire, Wire Cleaner")

4

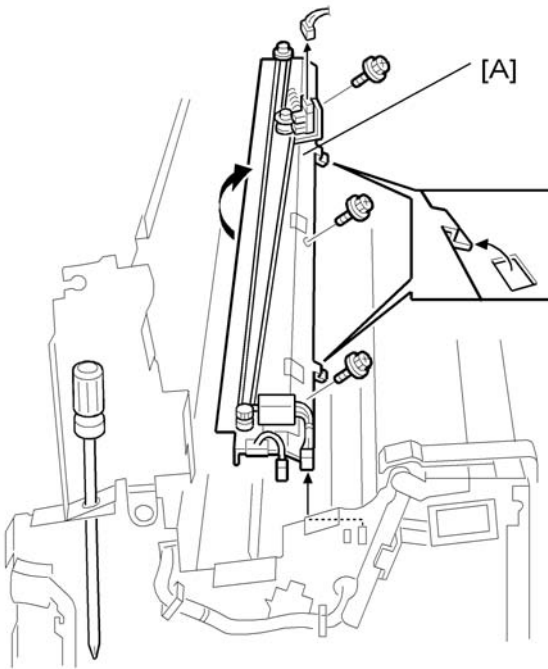

b286r115

2. Quenching lamp unit [A] (🔧 x 3, 🔧 x 3)

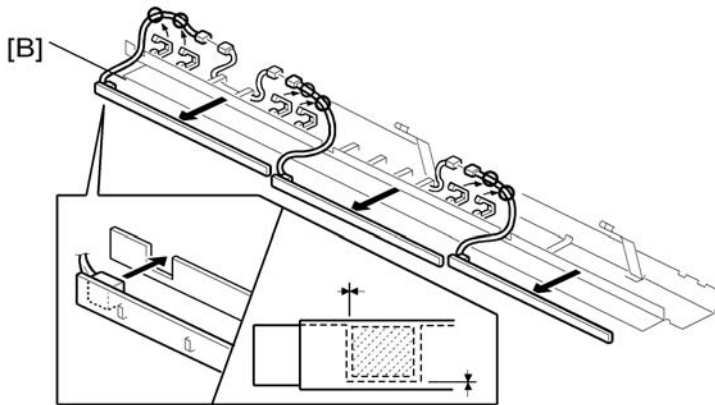

b286r116

3. Quenching lamps (x3) [B] (🔧 x all, 🛠️ x 3)

Note

- The quenching lamps are attached to the plate with double-sided tape.

Wire Cleaner Motor, Wire Cleaner Sensor

1. Remove the quenching lamp unit (🔧 p.182 "Quenching Lamp Unit, Quenching Lamps")
2. Place the quenching lamp unit on a flat surface.

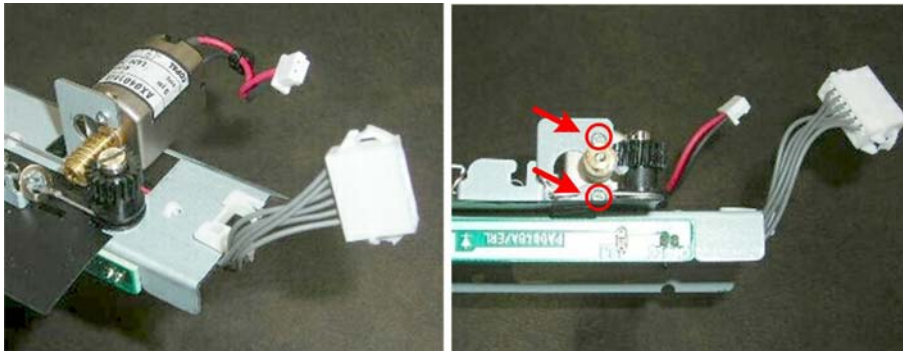

d093r309

3. Remove the wire cleaner motor (🔧 x2).

4

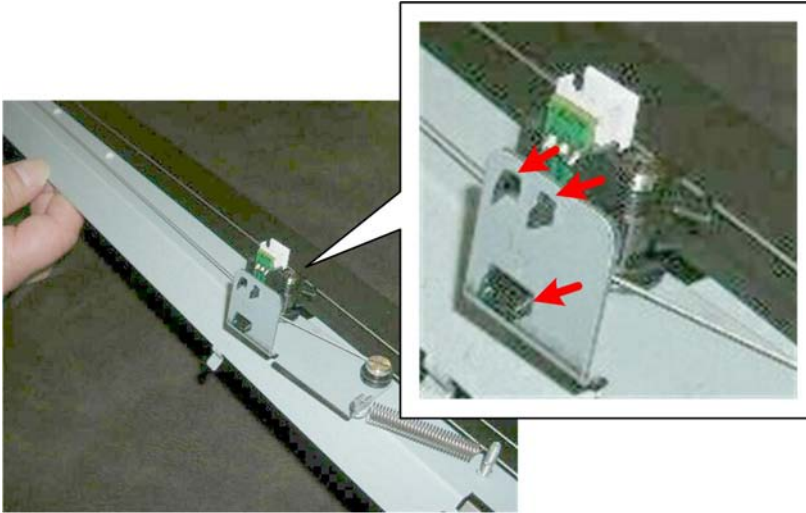

d093r910

- 4. Remove the wire cleaner sensor (🔧 x3).

LPH

Before You Begin...



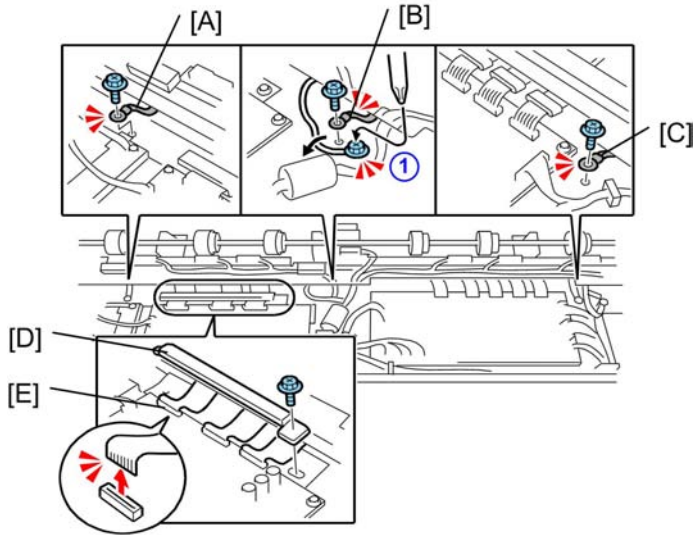

- To preserve the alignment of the LPH components, always handle the LPH unit carefully to protect it from sudden shock or vibration.
- Never touch the LPH lens cover with bare hands to prevent finger prints and smudges that can cause poor image reproduction.
- Clean the LPH lens cover with lens paper only. Never use tissue paper or cloth that could leave lint or other particles on the glass.

Preparation

- Remove upper side covers on both sides of the machine. (🔧 p.154 "Side Covers")
- Raise the original unit (🔧 p.157 "Unlocking, Opening the Original Unit")
- Remove the original table (🔧 x2).



d093r109b

1. Remove
 - [A] Left ground wire ( x1)
 - [B] Center ground wire ( x1) You may need to loosen screw ①.
 - [C] Right ground wire ( x1)
 - [D] LPH harness plate ( x1)
2. Disconnect the LPH at [E] ( x3).

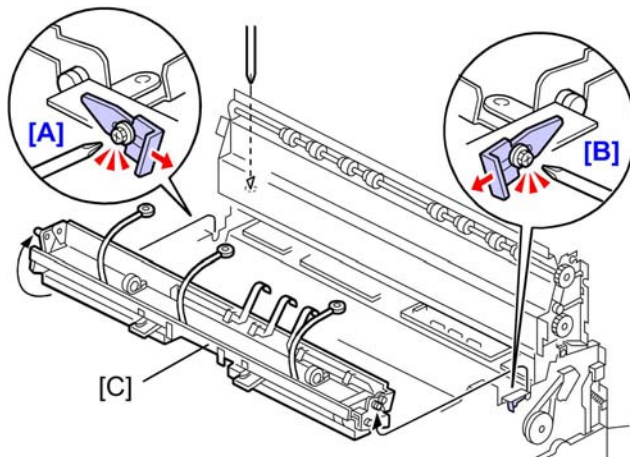

d093r112

3. Loosen screws [A] and [B] and slide the plates to the rear.
4. Remove the LPH [C].

Re-installation

1. New silver ground wires are provided with the new LPH unit.
2. After re-installing the LPH do SP2943, input the values that are printed on the label attached to the replacement unit. (📄 p.262 "LPH Adjustment with SP Modes")
3. Do SP2952 and input the values that are printed on the label attached to the replacement unit. (📄 p.262 "LPH Adjustment with SP Modes")
4. Make a test print and adjust if necessary. (📄 p.262 "LPH Adjustment with SP Modes")

Transfer Corona, Separation Corona Wires

4

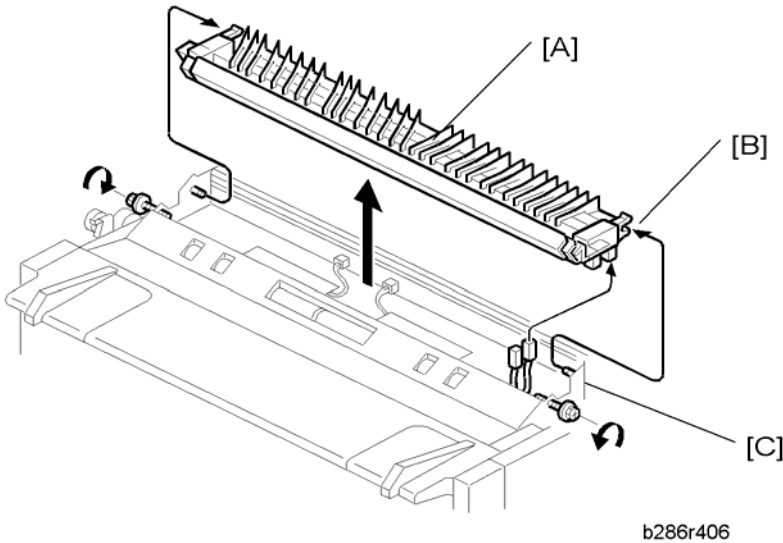

1. Open the upper unit.
2. Side covers (📄 p.154 "Side Covers")
3. Transfer unit [A] (📄 x 2, 📄 x 2)

Reinstallation

- At each end of the unit, make sure that the tabs [B] are fully engaged with the studs [C].
- When the tabs are engaged correctly, the caps on the end are fully level.

Disassembling the Transfer Unit

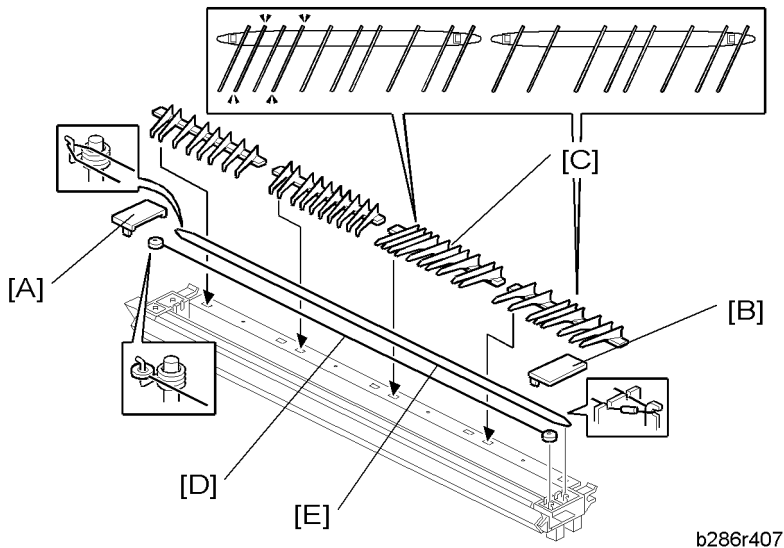

1. Left cap [A] (▼ x1)
2. Right cap [B] (▼ x1)

↓ Note

- To remove a paper guide, lift it a small distance and move it in the direction of the center. Make a note of the position of each guide. Each guide must be installed at its original position.

3. Paper guides [C] (x4)
4. Transfer wire [D]
5. Separation wires [E]

Reinstallation

- Each paper guide pair must be installed at its original position.
- For each pair, the high guide is set on the outer side and the low guide is set on the inner side.
- If each guide is not installed at its original position, this will cause paper to wrinkle.

Development

Development Unit

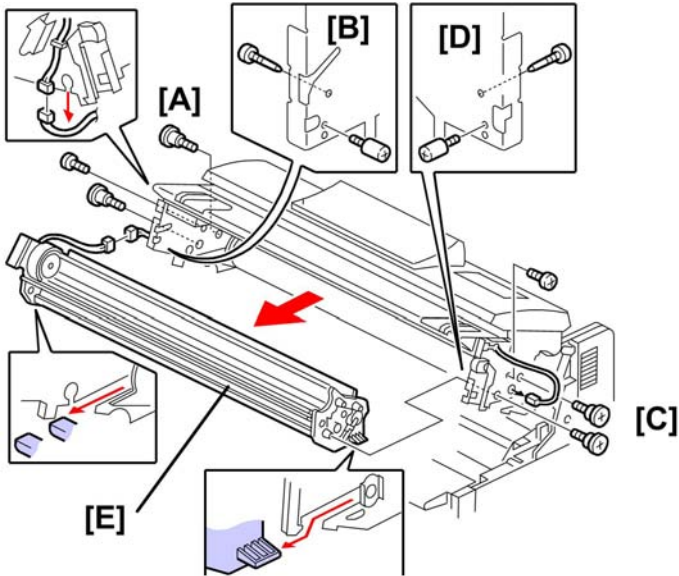

d093r304

Preparation

- Raise the upper unit. (▶ p.158 "Raising and Locking the Scanner Unit")
- Remove:
 - Side covers (▶ p.154 "Side Covers")
 - Toner hopper cover (▶ p.159 "Toner Hopper Cover")
 - Idle registration roller panel (▶ p.160 "Idle Registration Roller Panel")
 - Toner cartridge

1. On the left side:

- Disconnect the left end of the development unit [A] (⚙️ x2, 🔧 x1, 📦 x1).
- Remove the screws [B] (🔧 x1, 🔩 x1).

2. On the right side:

- Disconnect the right end of the development unit [C] (⚙️ x2, 🔧 x1, 📦 x1).
- Remove the screws [D] (🔧 x1, 🔩 x1).

3. Remove the development unit [E].

⚠ CAUTION

- The development unit is very heavy. Pull it out slowly.

Re-installation

- Re-attach the large shoulder screws on each side first, then re-attach the other screws.

Developer

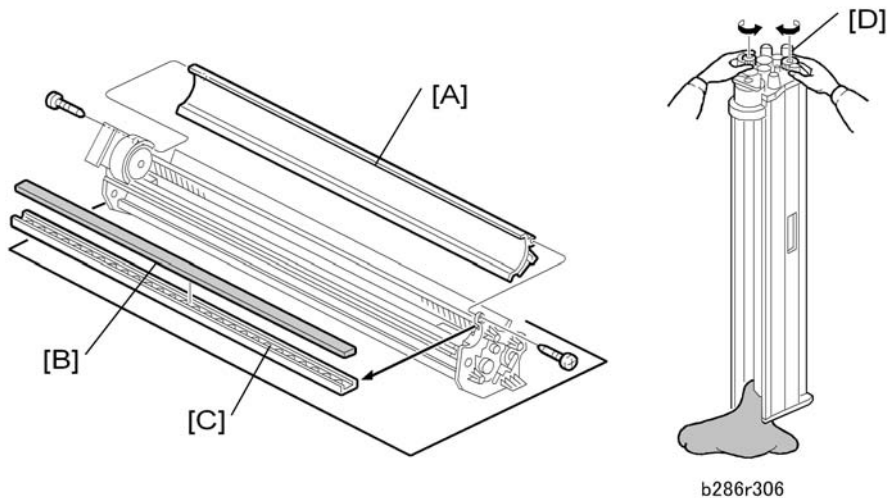

1. Remove the development unit (🔧 p.188 "Development Unit")

⬇ Note

- Do not bend the bias terminal.

2. Put the development unit on a large sheet of paper.
3. Remove the casing [A] for the toner supply unit (🔧 x 2)
4. Remove the development filter [B] and bracket [C].
5. Hold the development unit above the paper with the gears up.
6. Turn the paddle roller knob [D] clockwise until all developer is out of the unit.

★ Important

- When disposing of used developer, always obey local laws and regulations regarding the disposal of such items.

7. Clean the development unit (especially the right end), the development filter, and development filter bracket.

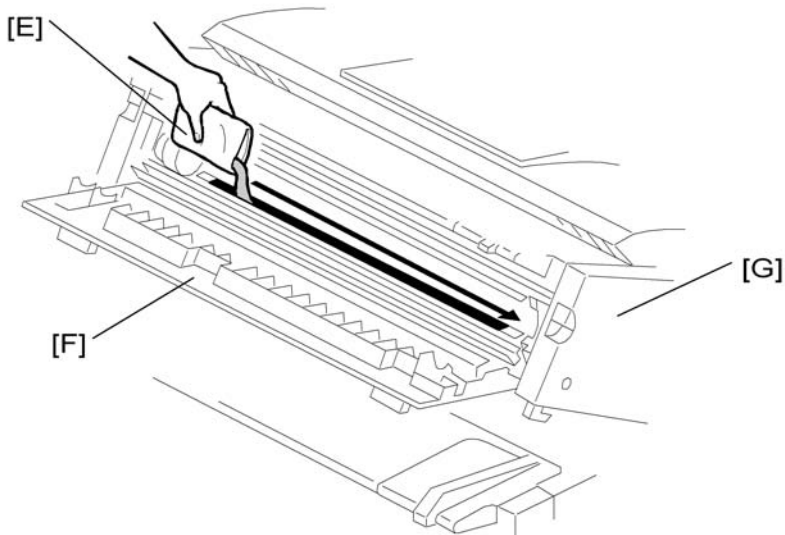

b286r917

8. Add one (1 kg) pack of developer. Do not add the second pack at this time.

- Open the first developer pack [E].

Note

- Save the top of the pack. You will need the number to enter the lot number with SP2801.
- Slowly add the first pack of developer to the development unit. Move the pack from left to right until it is empty.
- Make sure that the developer is applied equally across the slot of the development unit.

9. Close the toner hopper cover [F].

10. Close the upper unit [G].

11. Connect the power supply cord.

12. Switch the main power switch on.

If the development motor starts, wait 50 sec. for it to stop. Go to Step 16.

-or-

If the development motor does not start, go to the next step.

13. Open SP2924-1. Change the "1" setting to "3".

14. Switch the main power switch off/on. The development motor starts. Wait 50 sec. for it to go off.

15. Open SP2924-1. Change the "3" setting to "1".

16. Switch the main power switch off.

17. Open the upper unit.

18. Open the toner hopper cover.

19. Open the second 1 kg pack of developer and slowly add it to the development unit. Move the pack from left to right until it is empty.

Note

- Save the top of the pack. You will need the number to enter the lot number with SP2801.
20. Use a clean cloth to clean the edges around the slot of the development unit.
 21. Install the development unit in the machine and close the toner hopper cover.
 22. Close the upper unit. Make sure that the upper unit locks on each side.
 23. Switch the main power switch on.
 24. Go into the SP mode, enter the developer lot numbers, then mix the developer and initialize the ID sensor.
 - First, do SP2801-2 and -3 and use the soft keyboard on the display panel to enter the lot numbers to enter the lot numbers of both developer packs.



Important

- You must enter the lot numbers with SP2801-2 and -3 before doing SP2801-1. The machine will return an error ("Failed") if you attempt to do SP2801-1 before SP2801-2 and -3.
- If the lot numbers are the same, just enter the same number twice.
- Do SP2801-1 to mix the developer and initialize the ID sensor.

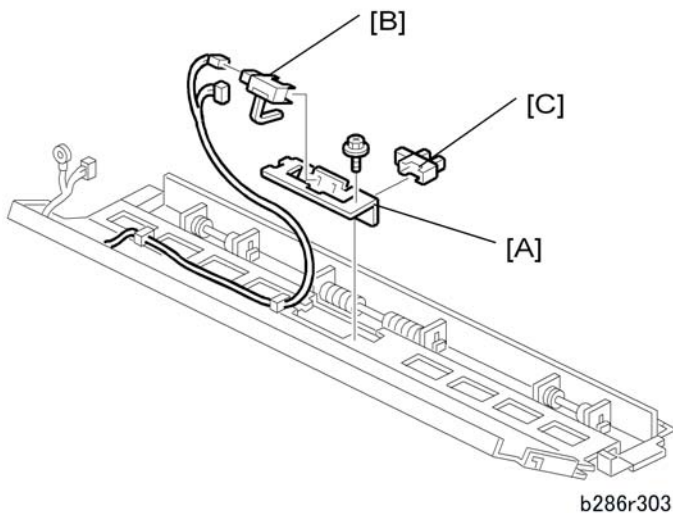
Paper Set Sensor, Registration Sensor





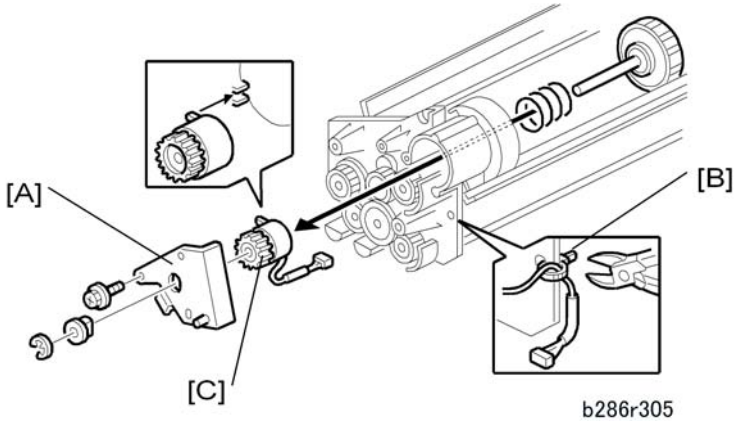

1. Idle registration roller panel (p. 160 "Idle Registration Roller Panel")

2. Sensor bracket [A] ( x 1)
3. Paper set sensor [B] ( x 1)
4. Registration sensor [C] ( x 1)

Toner Supply Clutch



1. Remove the development unit ( p.188 "Development Unit")
2. Plate [A] ( x 1,  x 1)
3. Cut the harness clamp [B].
4. Toner supply clutch [C] ( x 1)

 **Note**

- The stopper is spring-loaded and will come out suddenly after you remove the e-ring.

Development Filter

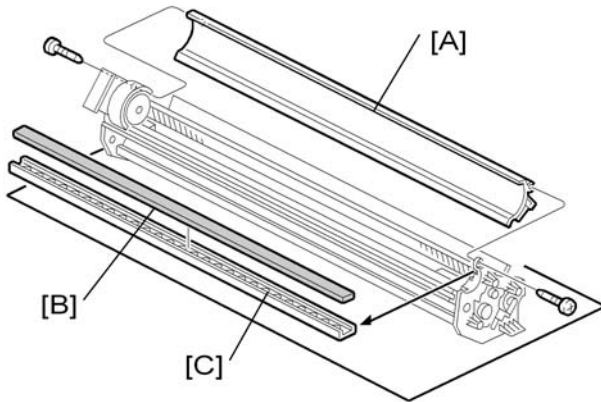

b286r309



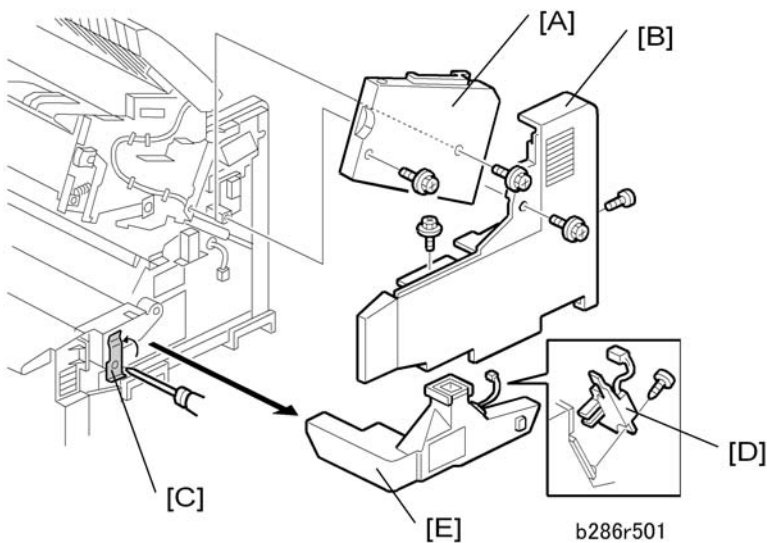

1. Remove the development unit (p.188 "Development Unit")
2. Development unit casing [A] ( x 2)
3. Filter rack [B]
4. Filter [C]

Used Toner Collection Bottle, Toner Overflow Sensor



b286r501

1. Lift the original feed unit.

2. Lift the upper unit.
3. Right upper cover [A] ( x 2)
4. Right cover [B] ( x 3)
5. Loosen the leaf spring [C] and lift it.
6. Toner overflow sensor [D] ( x 1,  x 1)
7. Toner collection bottle [E]

Drum

Drum Unit

★ Important

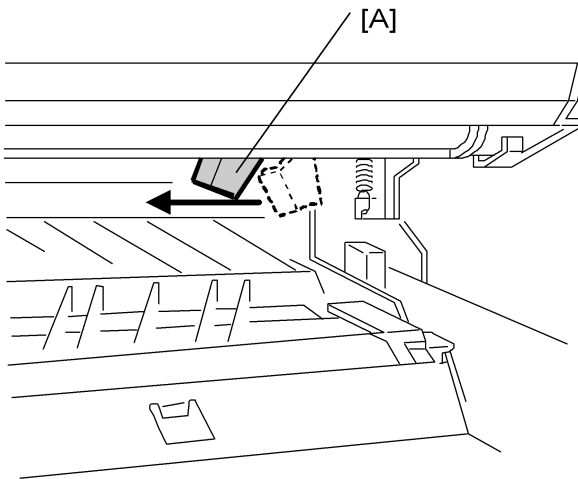

- To prevent smudging and fingerprints from appearing in images, never touch the surface of the drum with bare hands.
- To prevent damaging the drum surface, never clean the drum with alcohol.
- To prevent deterioration of the drum surface, never expose the surface of the drum to strong light, especially direct sunlight.
- When the drum is removed during machine servicing, place the drum inside the black vinyl back it was shipped in, or cover it with paper, immediately after it is removed from the machine and store it in a dark location.



b286r901

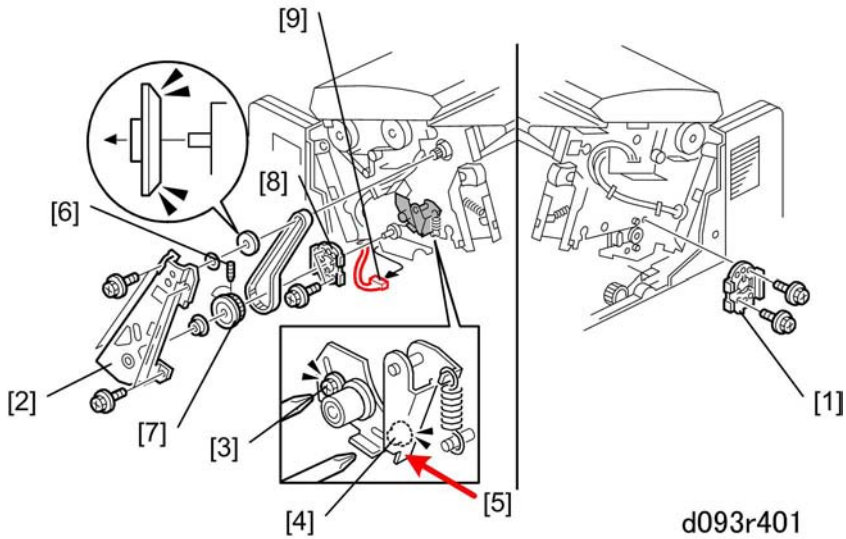

1. Open the upper unit and set the cleaning blade release lever [A] to the left.
2. Remove the development unit (see p. 188 "Development Unit").



3. On the right, remove hub [1] ( x 2)
4. Remove drive belt plate [2] with washer, spacer ( x 4).
5. Loosen screw [3] and remove screw [4] ( x 1).
6. Press swivel plate [5] to release pressure on the drive belt and remove the belt.
7. Use the long end of Allen key to loosen the two Allen screws [6].
8. Remove drum gear [7].

★ Important

- Handle the drum gear carefully to avoid dropping and losing the two Allen screws inside the gear.

9. Remove left hub [8] of drum shaft ( x 2).
10. Disconnect the drum at [9] ( x 1,  x 1).

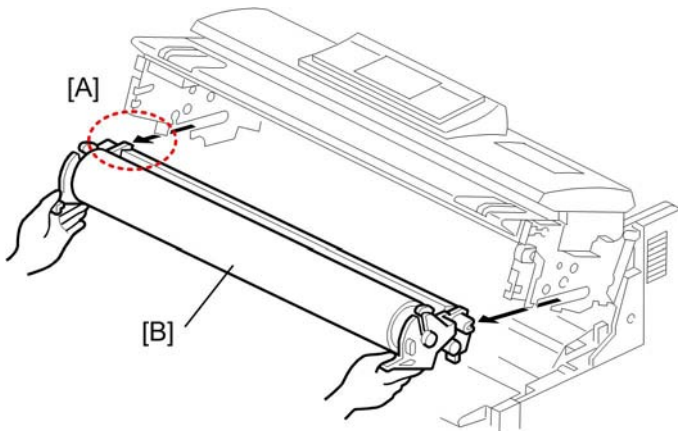

b286r402

11. Confirm that the drum is disconnected at the left rear corner [A].
12. Remove drum unit [A].



⚠ CAUTION

- The drum unit is very heavy. Pull it out slowly.
- Never touch the surface of the drum.
- Cover the drum with some clean paper to protect the drum surface from light.

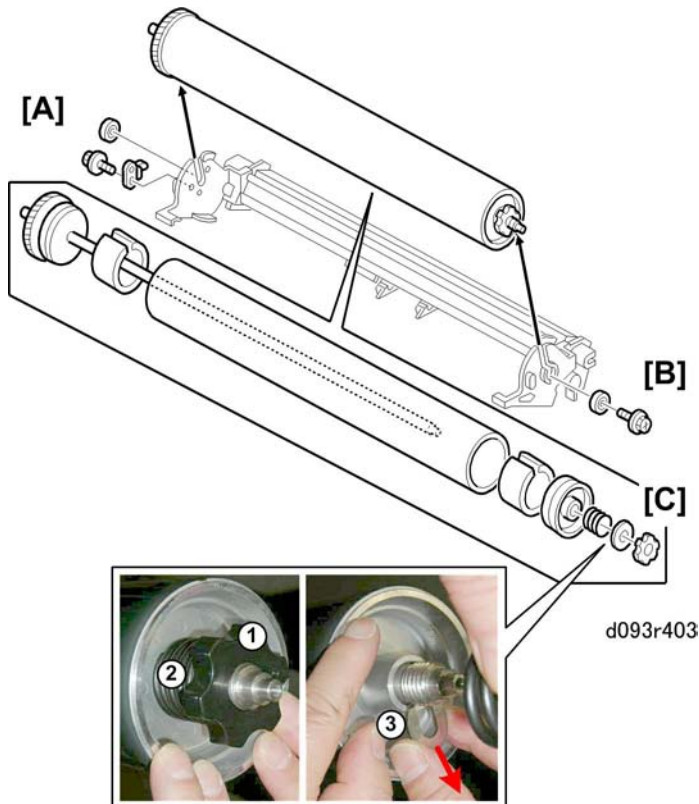
13. Place the drum on a flat, clean surface.



14. To disassemble the drum unit:

- Disconnect the left end [A] ( x1, Plate x1, Bearing x1).
- Disconnect the right end [B] ( x1, Bearing x1).
- Turn knob ① counter-clockwise and remove it.
- At [C] remove spring ② and slide plate ③.

Reinstallation

After you replace the drum:

1. After re-attaching the drum drive gear, be sure to tighten both Allen screws.

2. Do SP2923 (Execute Cleaning Blade Replace Mode). This applies toner to the drum and blade to decrease friction between the drum and the cleaning blade. If you do this, scratches on the drum or a bent cleaning blade are less possible to occur.
3. Re-set the cleaning-blade release lever to the right.
4. Do SP3001-2 to initialize the ID sensor.

Cleaning Blade

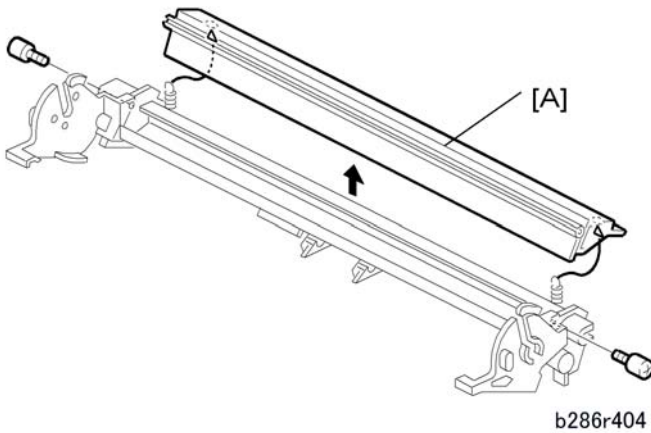

1. Drum (p.195 "Drum Unit")
2. Cleaning blade [A] (x 2, x 2)

Reinstallation

After you replace the cleaning blade:

- Do SP2923 (Execute Cleaning Blade Replace Mode) to apply toner to the drum and blade. The coating of toner reduces friction between the drum and the cleaning blade and prevents scratching the drum surface or bending the blade.

ID Sensor, Pick-Off Pawls, Pick-Off Pawl Solenoid

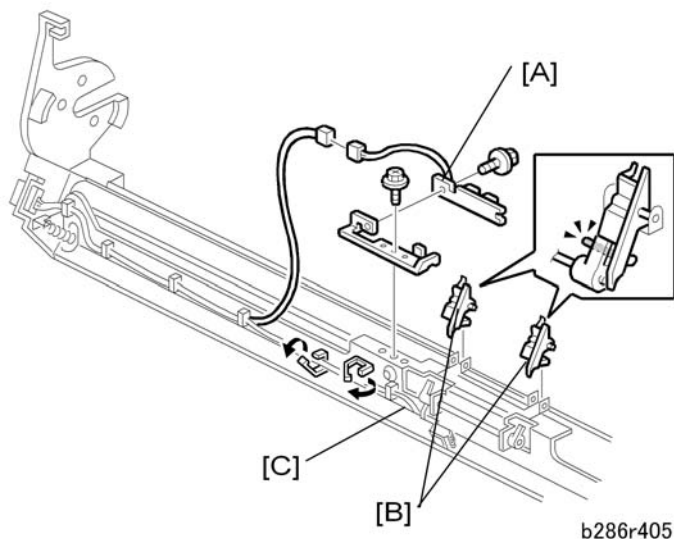

1. Drum (p.195 "Drum Unit")
2. Cleaning blade (p.198 "Cleaning Blade")
3. ID sensor [A] (x 3, x 1, x 1)
4. Pick-off pawls (x2) [B] (pressure release).
5. Pick-off pawl solenoid [C] (x 2, x 1)

Re-installation

- After replacing or cleaning the ID sensor, do SP3001-2 to initialize the new ID sensor.
- If the ID sensor is damaged and cannot be replaced immediately, set SP2208-3 (Toner Supply Setting: Toner Supply Mode) to "1". Then the customer can continue to use the machine until a new ID sensor is available. After you install a new ID sensor, reset this SP to 0.

Paper Feed

Registration Clutch, Registration Roller

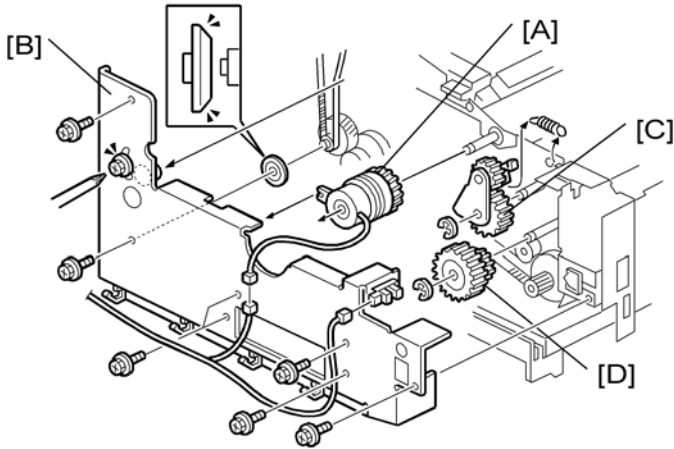

b286r507

1. Side covers (☞ p.154 "Side Covers")
2. Registration clutch [A] (☞ x 1, ☞ x 1)
3. Gear cover plate [B] (☞ x 7, cap x 1, ☞ x 1)
4. Gear [C] (☞ x 1, ☞ x 1)
5. Gear [D] (☞ x 1)
6. Remove the used toner collection bottle (☞ p.193 "Used Toner Collection Bottle, Toner Overflow Sensor")

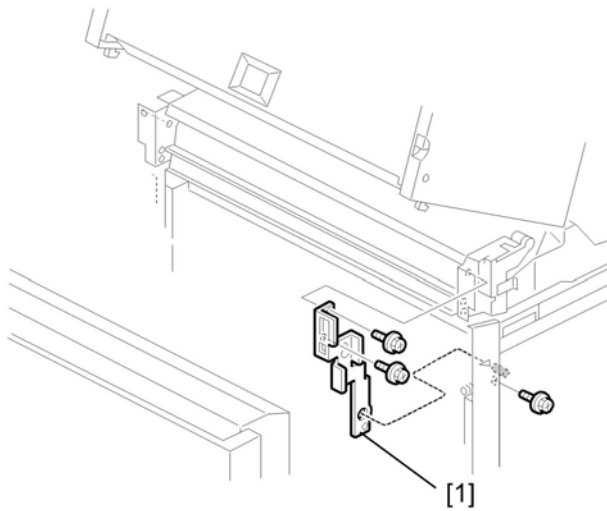

d334i005a

7. Remove the right roller feeder joint bracket ( x3).

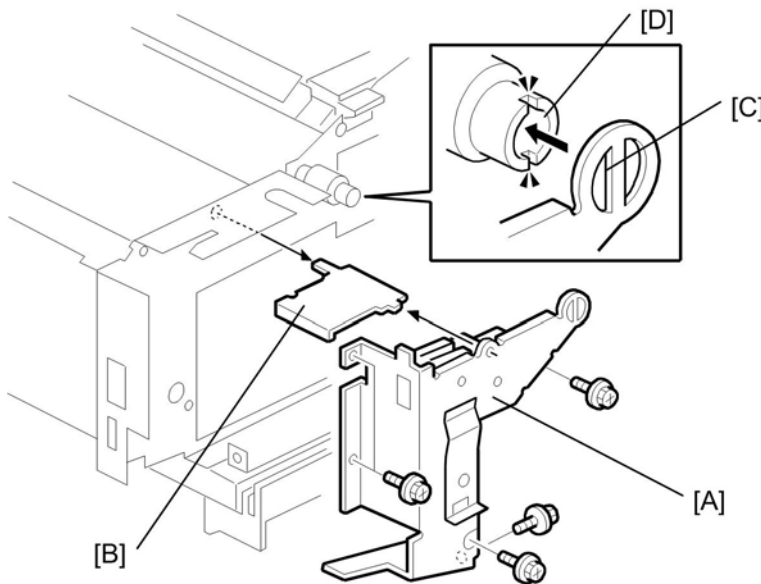

b286r506



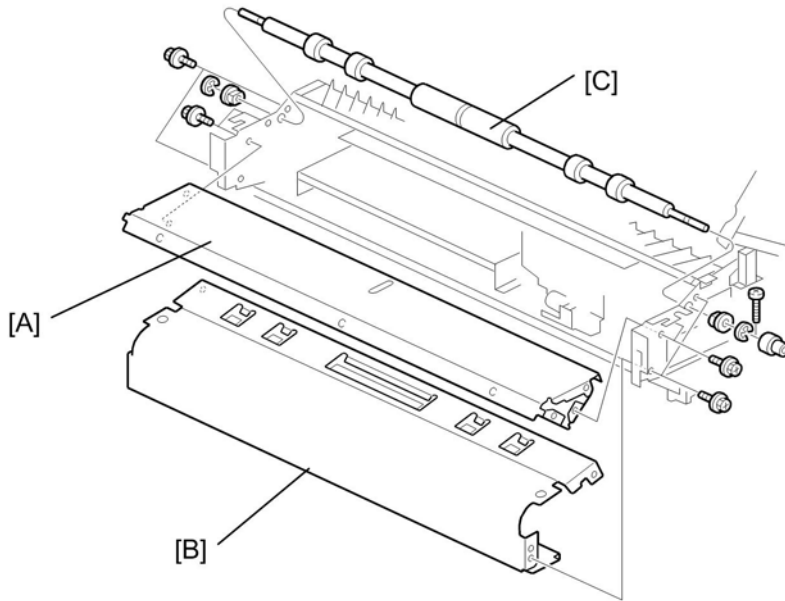

8. Remove cover plate [A] ( x 5)
9. Switch pressure plate [B]

 **Note**

- At reinstallation, make sure that the vertical brace [C] is locked in the cutouts in the ceramic clutch [D].



b286r508

10. Front plate [A] ( x 6)
11. Transport roller dust cover [B] ( x 4)
12. Registration roller [C] ( x 2,  x 2, Torque limiter x 1,  x1)

Roll 1 Paper Feed Clutch, Feed Roller

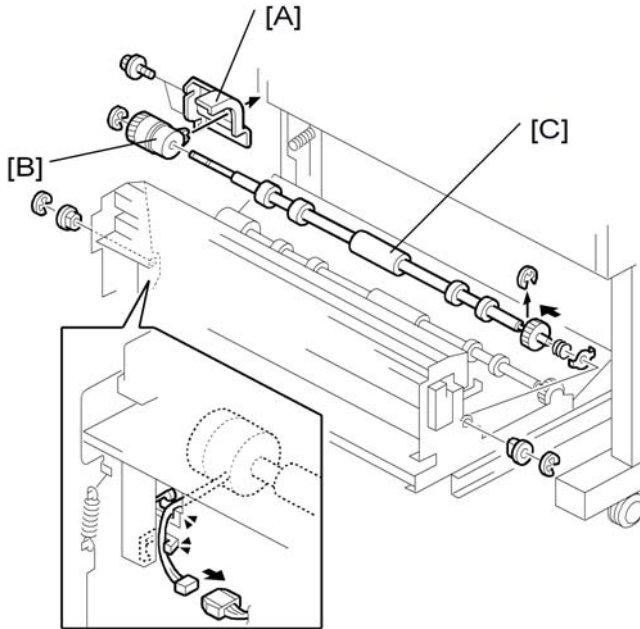

b286r918

1. Open the roll feeder drawer.
2. Remove the paper rolls.
3. Roll 1 feed clutch cover [A] (🔧 x 2)
4. Roll 1 feed clutch [B] (🔧 x 1, ⚙️ x 1)
5. Roll 1 feed rollers [C] (⚙️ x 3, 🟫 x 2)
6. After you replace the roller or the clutch, adjust the cut length with SP1920-111 and SP 1920-115.
(📖 p.251 "Image Adjustment with SP Modes")

Roll 2 Paper Clutch, Feed Roller

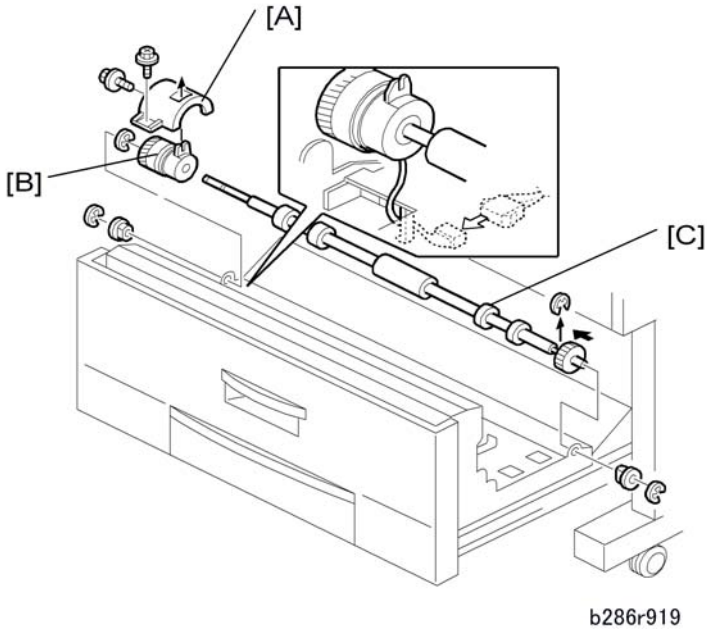





4

↓ Note

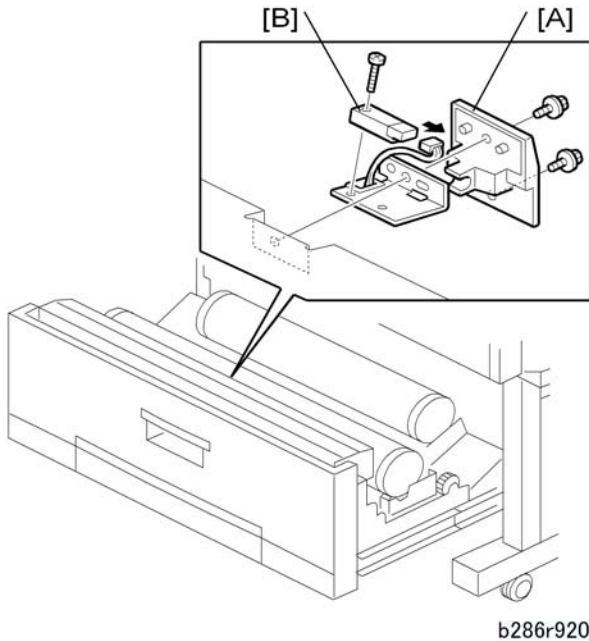
- The procedure is for the B642 only.
1. Open the roll feeder drawer.
 2. Remove paper roll 2 (at the rear).
 3. Roll 2 feed clutch cover [A] (🔧 x 2)
 4. Roll 2 feed clutch [B] (🔧 x 1, ⚙️ x 1)
 5. Roll 2 feed rollers [C] (⚙️ x 3, 🟫 x 2)
 6. After you replace the roller or the clutch, adjust the cut length with SP 1920-211 and SP 1920-215. (📄 p.251 "Image Adjustment with SP Modes")

RF Exit Sensor



1. Open the drawer of the roll feeder.
2. Plate [A] ( x 2)
3. RF exit sensor [B] ( x 1,  x 1)

Roll Feed Motor

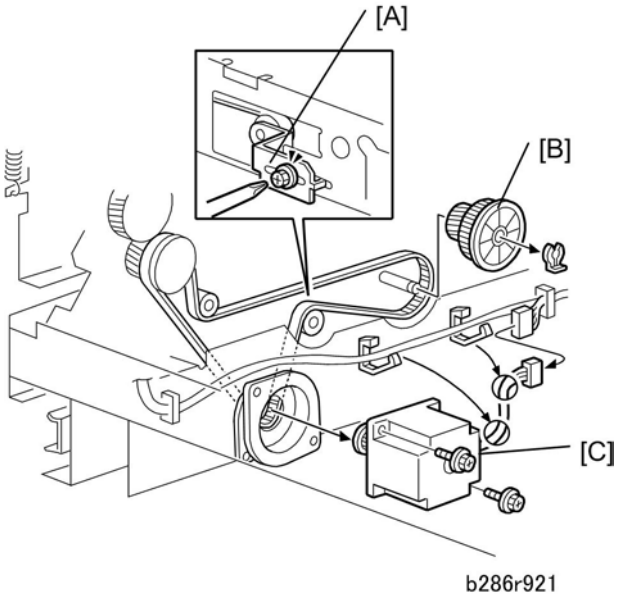

1. Open the roll feeder drawer.
2. Drawer front cover (p.162 "Drawer Front Cover")
3. Below the front, left corner of the roll feeder unit, loosen belt tension bracket [A].
4. Gear [B] (x1)
5. Roll feeder motor [C] (x 2, x 1, x 2)

Cutter Motor, HP Sensors

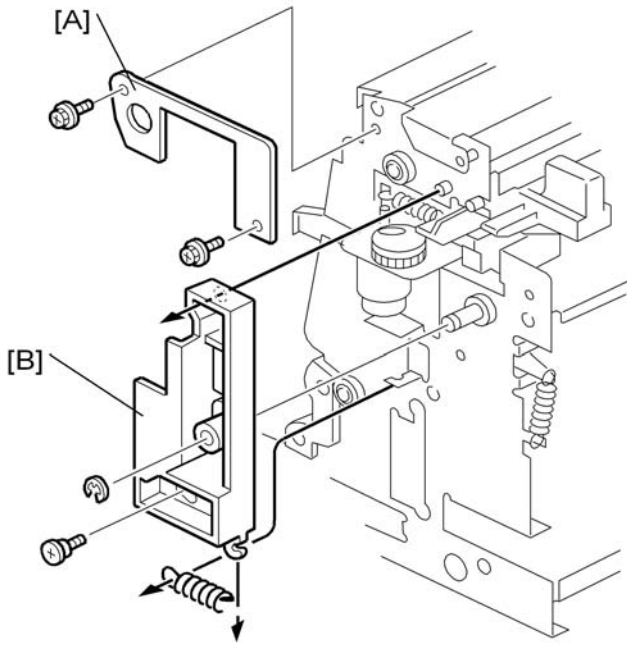

b286r922

1. Open the roller feeder drawer.
2. Drawer front cover (p.162 "Drawer Front Cover")
3. Upper bracket [A] (x 2)
4. Lower bracket [B] (x 1, x 1, x 1)

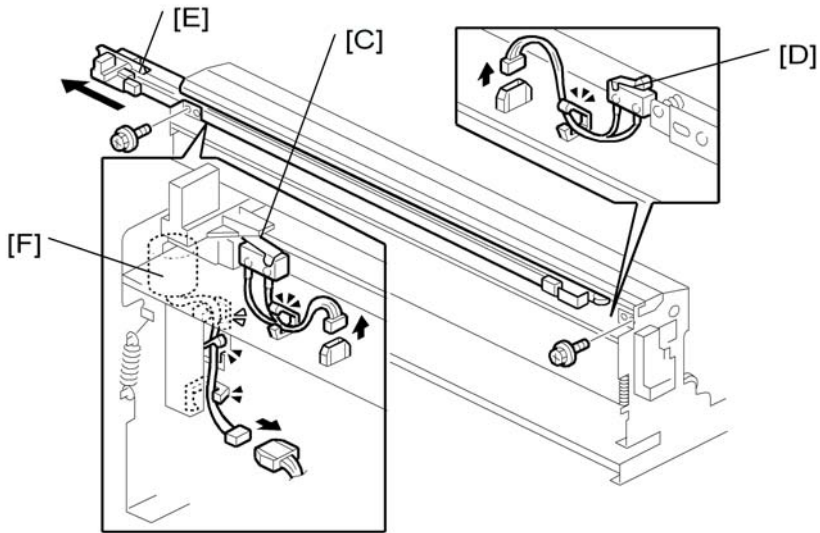

b286r923

4

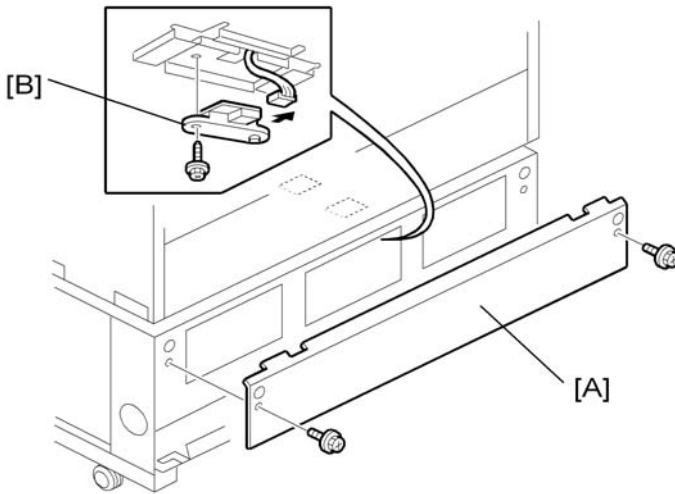

5. Right cutter HP switch [C] (🔌 x 1, 📦 x 1)
6. Left cutter HP switch [D] (🔌 x 1, 📦 x 1)
7. Cutter, race, and motor assembly [E] (🔌 x 3, 📦 x 1, 🛠️ x 2)
8. Cutter motor [F] (🛠️ x 2)

Roll Paper End Sensors



b286r924

1. Open the roll feeder drawer.

2. Roll feeder back plate [A] ( x 2)
3. Roll end sensors [B] ( x 1,  x 1 each)

Note

- The Roll Feeder B641 has one roll end sensor, and the Roll Feeder B642 has two roll end sensors.



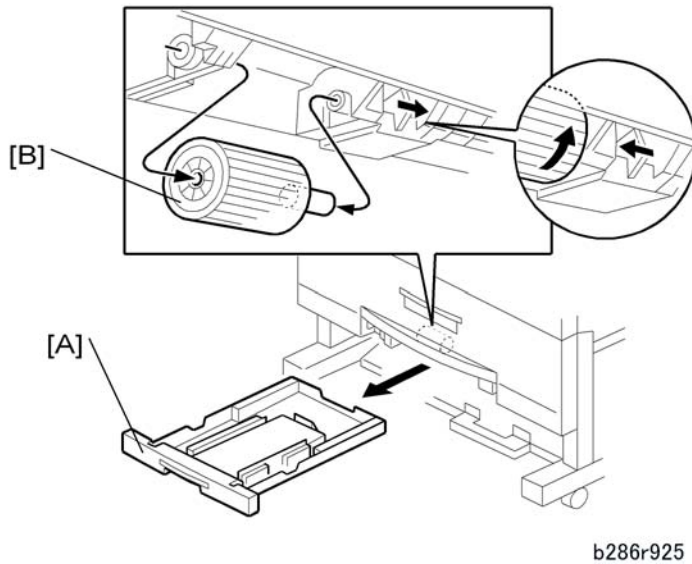

Cassette Feed Roller

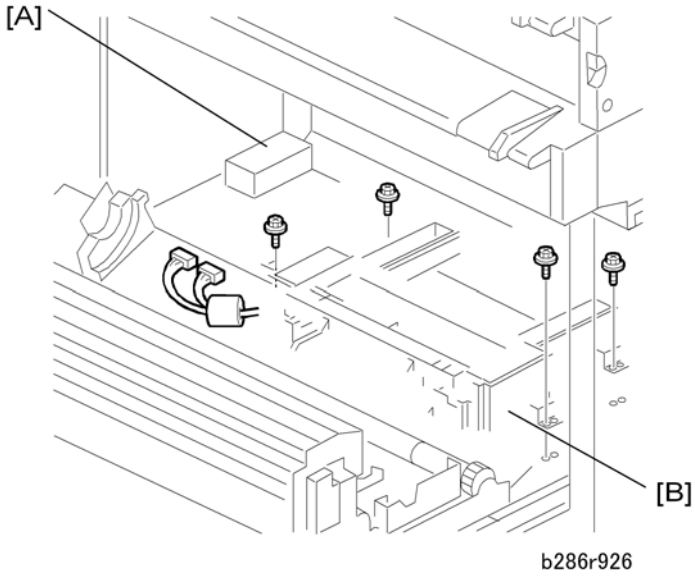

1. Paper cassette [A]
2. Cassette feed roller [B]

Cassette Relay Sensor, Cassette End Sensor







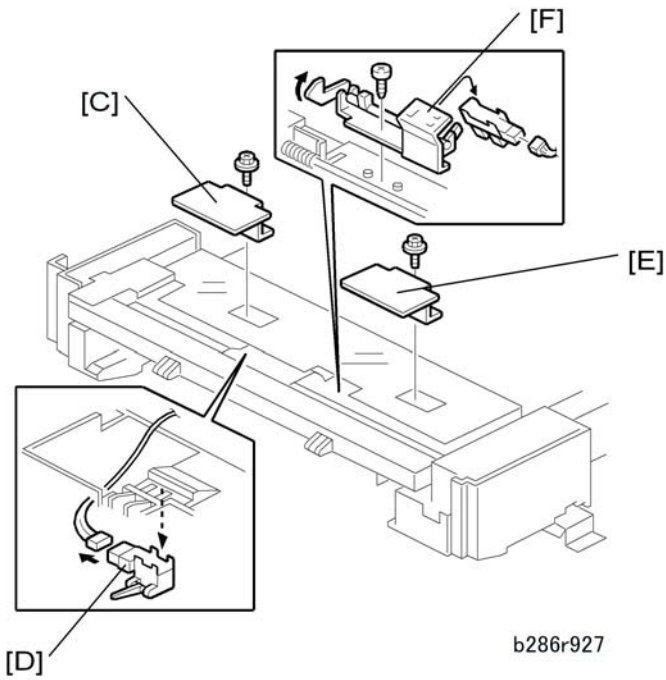

1. Open the roll feeder drawer and remove the paper cassette.
2. Roll feeder rear plate ( x 2 Blue)
3. RFDB shield plate [A] ( x 2 Blue).
4. Paper cassette unit [B] ( x 6,  x 2,  x 4 Blue)

 **Note**

- Pull the unit to the rear, then remove it from the front.



5. Relay sensor plate [C] ( x 1 Blue)
6. Relay sensor [D] ( x 1,  x 2)
7. Cassette end sensor plate [E] ( x 1 Blue)
8. Cassette end sensor [F] ( x 1,  x 1,  x 3)

Cassette Feed Motor, Cassette Open Sensor

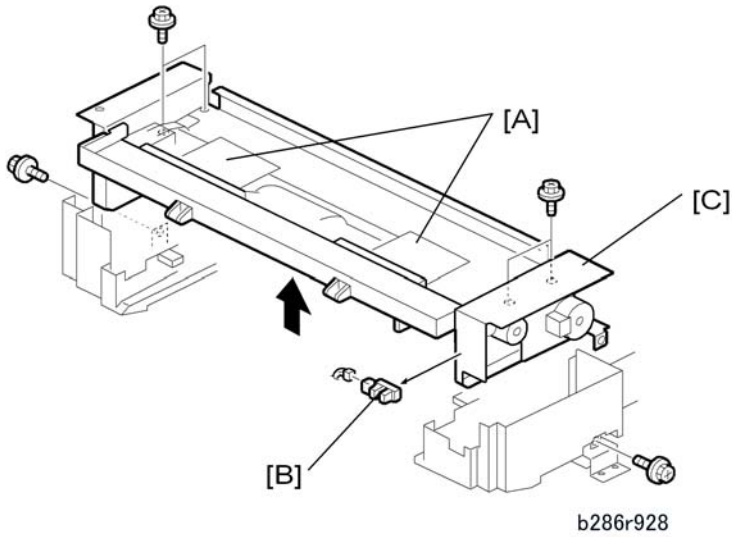

1. Open the roll feeder drawer and remove the paper cassette unit (p.210).
2. Relay sensor plate, cassette end sensor plate [A] (x 1 each)
3. Cassette open sensor [B] (x 1, x 2)
4. Paper cassette feed assembly [C] (x 6)

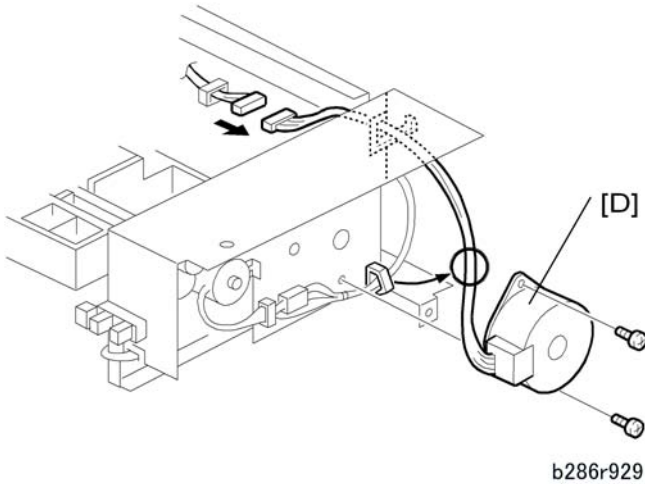

5. Paper cassette motor [D] (x 2, x 1, x 2)

Cassette Feed Clutch

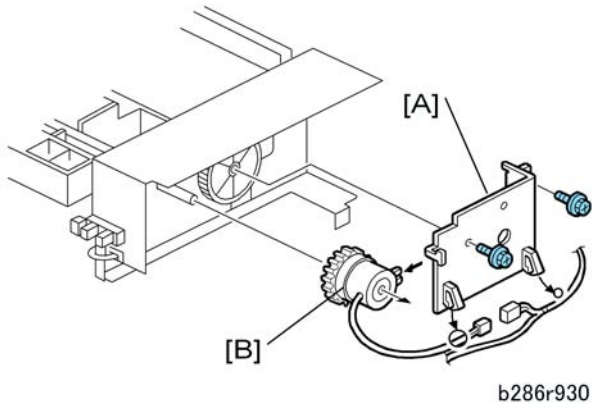

1. Cassette feed motor (p.212 "Cassette Feed Motor, Cassette Open Sensor")
2. Motor mount plate [A] (x 2)
3. Cassette feed clutch [B] (x 1, x 1)

Fusing

Pressure Spring Adjustment

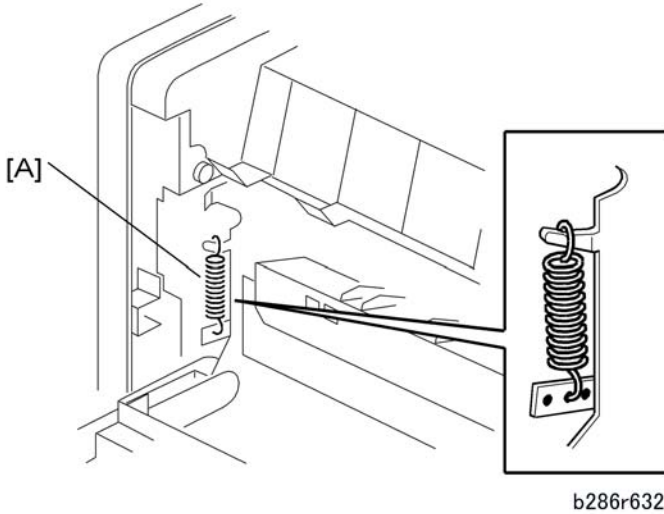

4

1. Open the exit cover and exit unit together.
2. To adjust the pressure, disconnect the spring [A] and connect it to a different hole.
 - Center: Standard tension, standard pressure.
 - Left: Less tension, less pressure. Set to this position to decrease wrinkling
 - Right: More tension, more pressure. Can give better fusing with thick paper.

Note

- Wrinkling occurs more frequently with some types of paper or film. Adjust the tension of the spring only when necessary.

Hot Roller Strippers

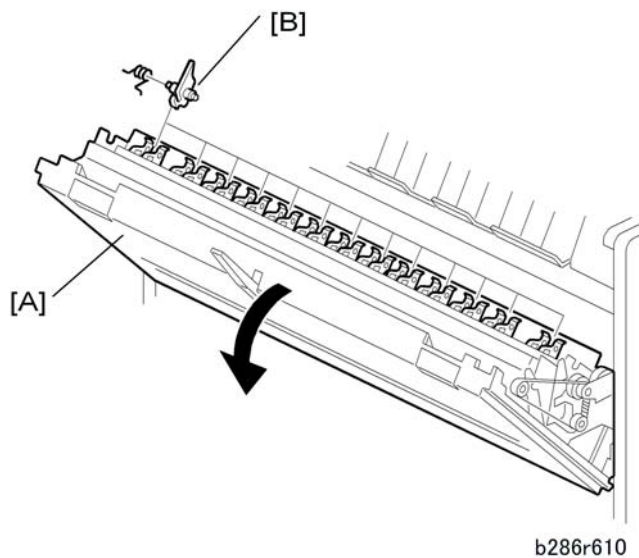

1. Open the paper exit cover and paper exit unit together [A].
2. Hot roller strippers [B] (pressure release, spring x 1 each)

Fusing Exit Sensor

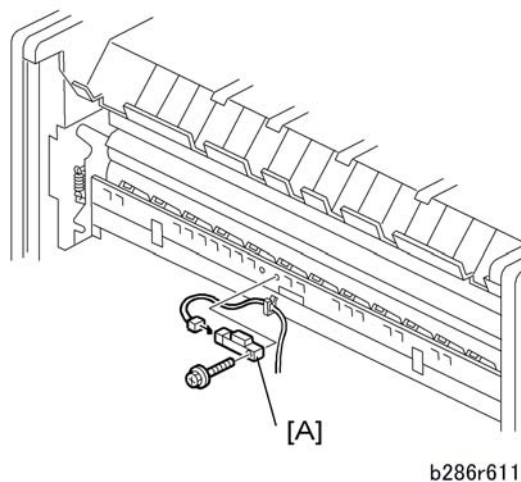

1. Remove:
 - Rear cover (p.154 "Side Covers")
 - Paper exit unit (p.156 "Paper Exit Unit")

2. Remove fusing exit sensor [A] (🔌 x 1 white, 🔧 x 1)

Pressure Roller Thermistors

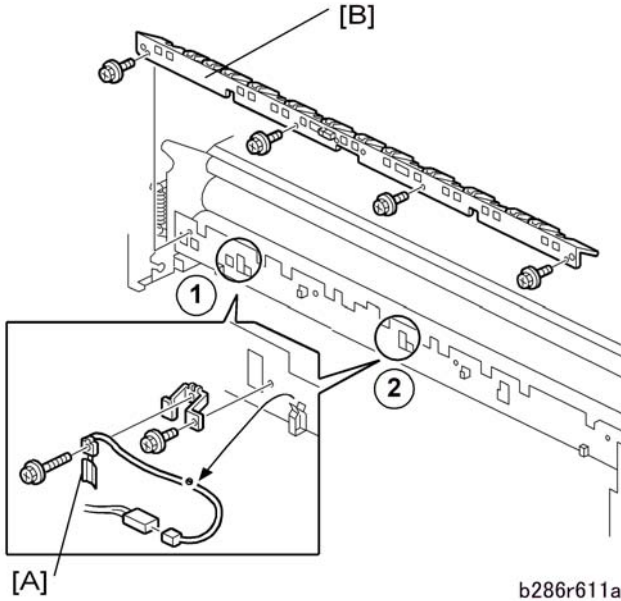

1. Remove:
- Rear cover (🔧 p.155 "Rear Cover, Controller Cover")
 - Paper exit unit (🔧 p.156 "Paper Exit Unit")
2. Remove pressure roller thermistors [A] (🔌 x 1, 🔧 x 2, 🛠️ x 1).
- The end roller thermistor is at ①.
 - The center roller thermistor is at ②.

↓ **Note**



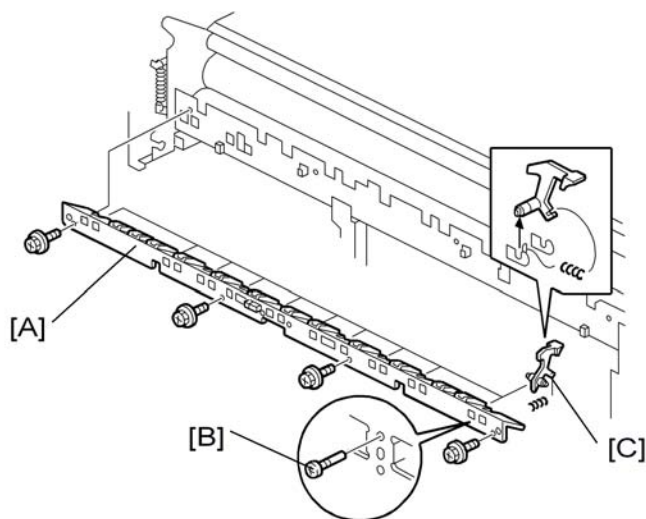

- You must first remove the stripper unit [B] in order to remove the center thermistor ②.

Pressure Roller Strippers





b286r612

1. Remove:

- Rear cover ( x 2). ( p.155 "Rear Cover, Controller Cover")
- Paper exit unit and exit cover ( x 4,  x 1) ( p.156 "Paper Exit Unit")

2. Remove:

- Pressure roller stripper unit [A] ( x 4)
- Stopper screw [B] ( x 1 ea.)
- Pressure roller strippers [C] ( x 1 each)

Note

- There are 11 pressure roller strippers. To remove them, push back and pull out.

Exit Unit Switch

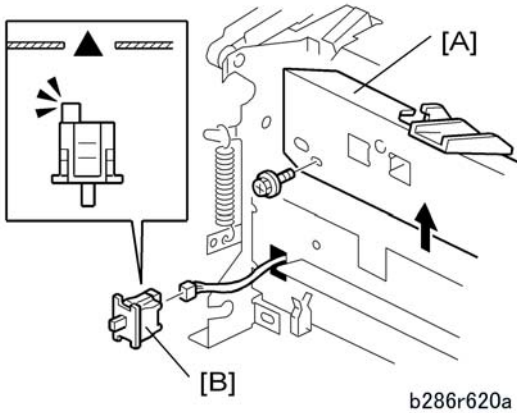

4

1. Remove the pressure roller stripper unit [A]. (p.217 "Pressure Roller Strippers")
2. Remove the exit unit switch [B].

Note

- Use tips of two small flat-head screwdrivers to release the tabs at the top and bottom of the switch to release it, then pull it out.

Fusing Unit

CAUTION

- Switch the main power switch off. Then disconnect the machine from its power source. Let the fusing unit become cool for 10 minutes or more before you remove it.

Preparation

- Rear cover, controller cover (p.155 "Rear Cover, Controller Cover")
- Remove the left and right side covers. (p.154 "Side Covers")
- Remove paper exit unit (p.156 "Paper Exit Unit")

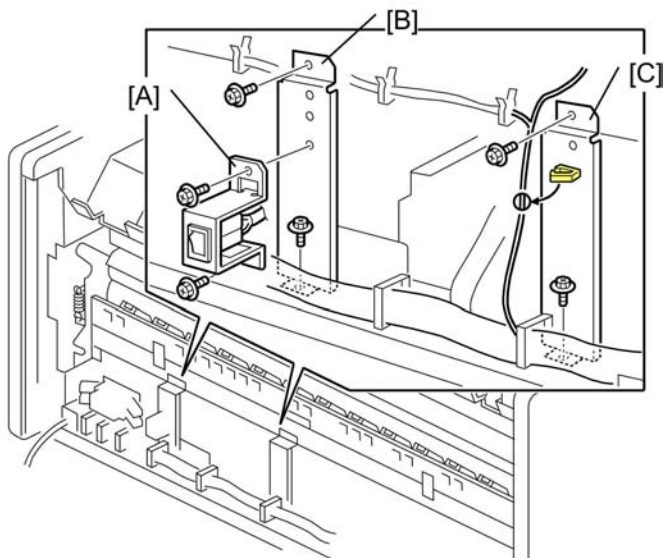

d093r611a

1. Remove:

[A] Anti-condensation heater switch bracket ( x2)

[B] Left vertical ground plate ( x2)

[C] Right vertical ground plate ( x2,  x1)

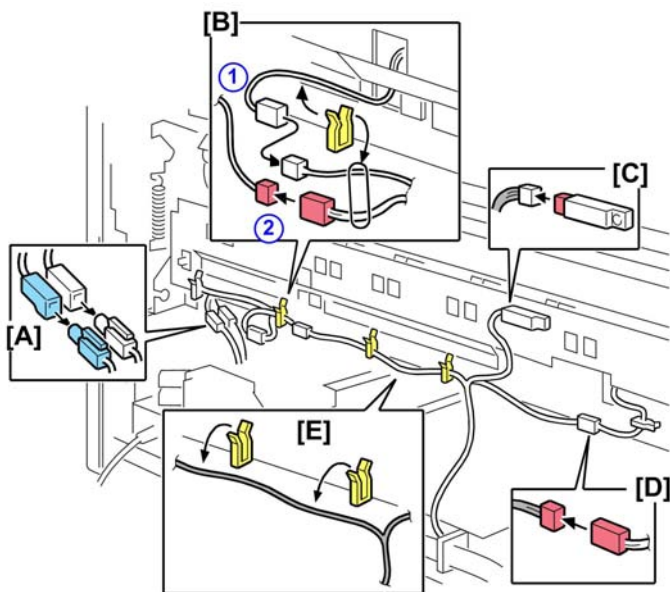

d093r611b

2. Disconnect:

[A] Fusing lamps ( x2)

[B] Pressure roller thermistor ① (🔧 x1, 🛠️ x1)

Exit unit set switch ② (🔧 x1)

[C] Fusing exit sensor (🔧 x1)

[D] Pressure roller thermistor (🔧 x1)

3. Open clamps [E] (🛠️ x2).

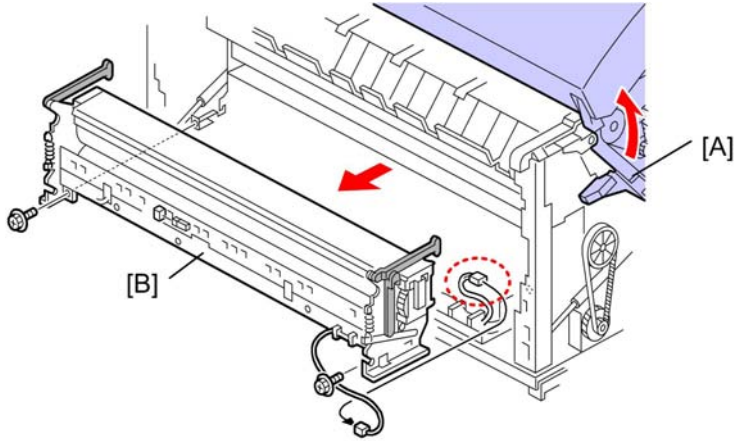

d093r613

4. Release the arms of the fusing unit [A] on both sides.

⚠️ CAUTION

- The fusing unit is very heavy. Pull it out slowly.

5. Remove the fusing unit [B] (🔧 x1, 🛠️ x2)

Reinstallation

- Make sure that the upper unit is open when you install the fusing unit.

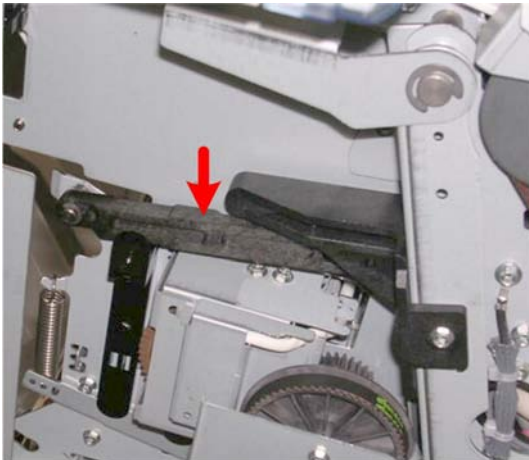

d093r623

- Close the top cover and push down on the levers on both ends of the fusing unit when you set the fusing unit in the machine.

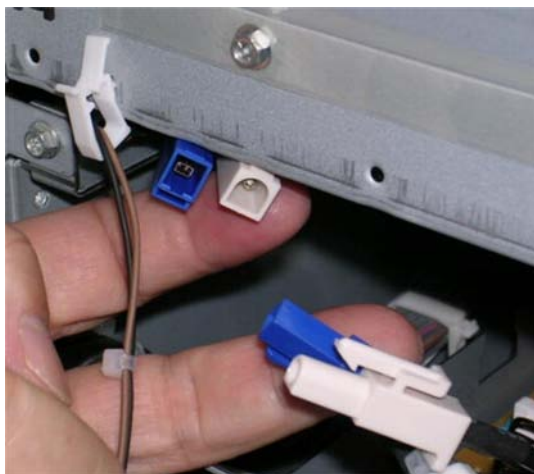

d093r617



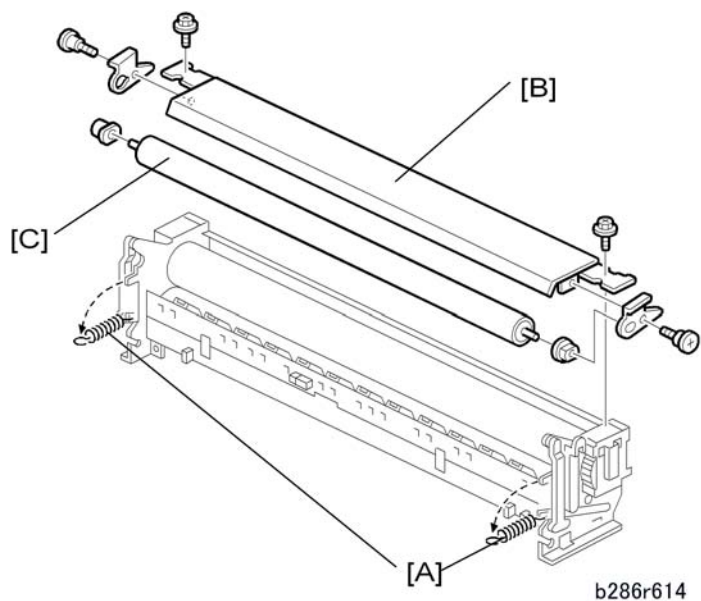

- Be sure to match and connect the color coded fusing lamp connectors correctly:
Europe: Blue-to-Blue, White to White (as shown above)
North America: Red-to-Red, White-to-White

Fusing Cleaning Roller



b286r614

1. Fusing unit (p.218 "Fusing Unit")

2. Springs [A] ( x 2)
3. Felt plate [B] ( x 2)
4. Fusing cleaning roller [C] ( x 2,  x 2)

Note



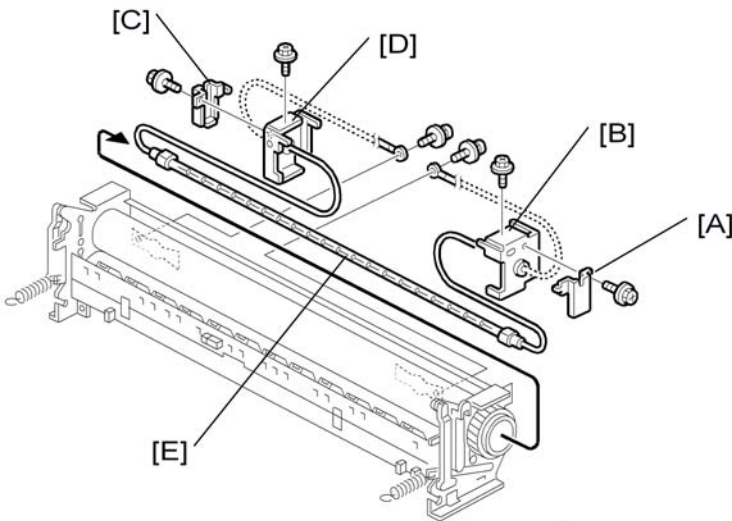

- The brown bushing is on the right; the white bushing is on the left.

Fusing Lamp

4



b286r615

1. Fusing cleaning roller ( p.221 "Fusing Cleaning Roller")
2. Right plate [A] ( x 1)
3. Right support [B] ( x 1)
4. Left plate [C] ( x 1)
5. Left support [D] ( x 1)

Note

- This is the support with the anti-static brush.
6. Fusing lamp [E] ( x 2, Metal harness clamps x 2)

Reinstallation

- Make sure that the ends of the fusing lamp are given support by the rubber grommets of the right support [B] and left support [D].

Hot Roller

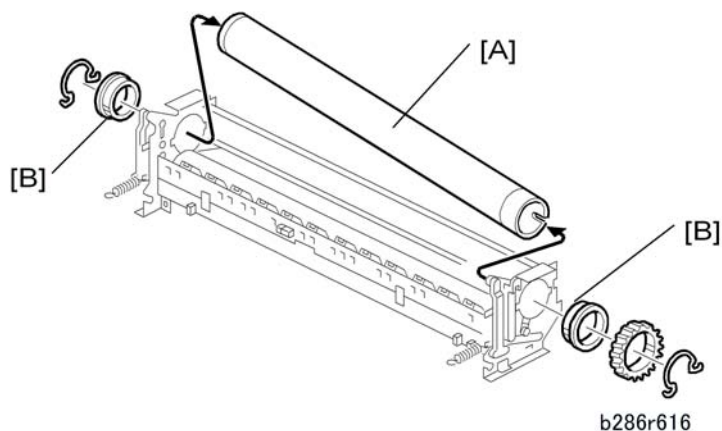

1. Fusing lamp (p.222 "Fusing Lamp")
2. Hot roller [A] (Clip springs x 2, Sleeve bearings x 2, Gear x 1)
3. Lubricate [B] with Barrierta – S552R (x 2)

Pressure Roller

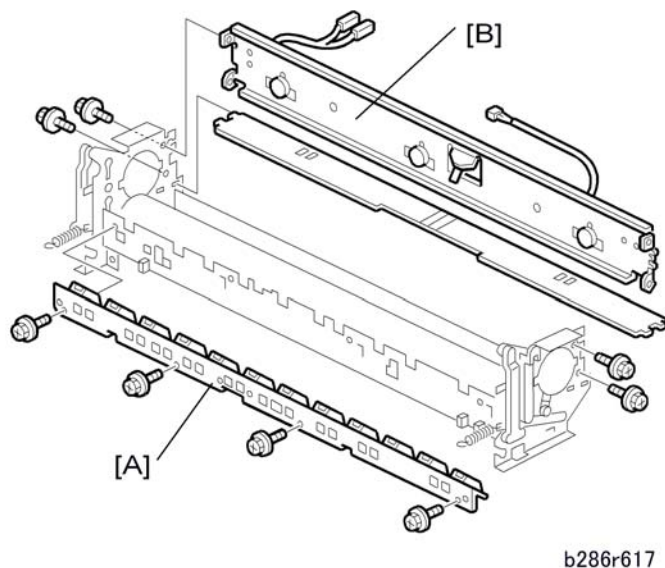

1. Hot roller (p.223 "Hot Roller")
2. Pressure roller plate [A] (x 4)
3. Thermistor/Thermostat plate [B] (x 4)

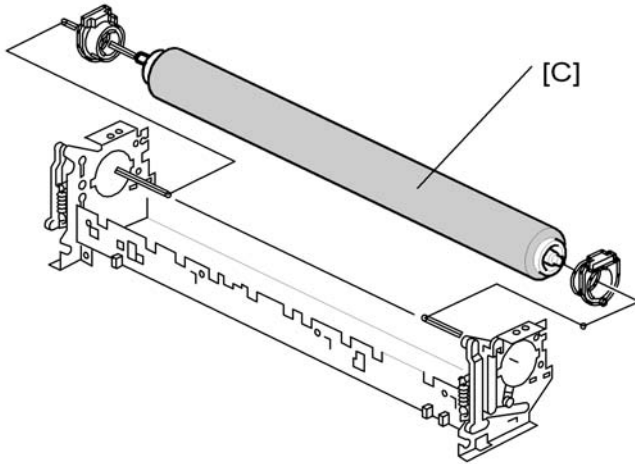

b286r618

4. Pressure roller [C] (Sleeve bearings x 2)

Hot Roller Thermistor, Thermostats

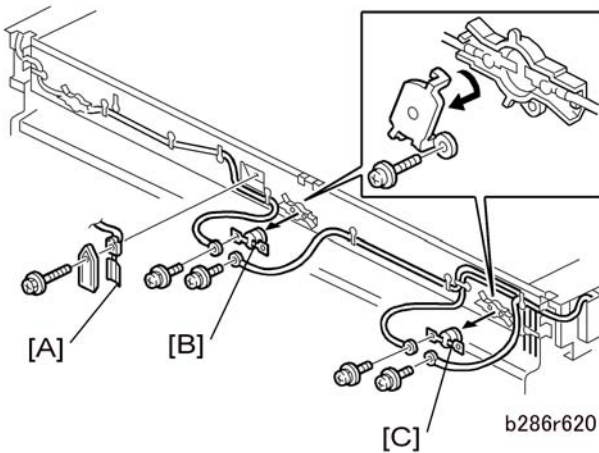

b286r620

1. Fusing unit (p.218 "Fusing Unit")
2. Hot roller thermistor [A] (x1) (x 1)
3. Thermostat 2 – 199 °C [B] (M3x6 x 2)
4. Thermostat 1 – 200 °C [C] (M3x6 x 2)

Reinstallation

- The thermostats (199 °C and 200 °C) must be installed at [B] and [C]. "199" and "200" are clearly shown on the edge of each thermostat.

Motors

Scanner Motor

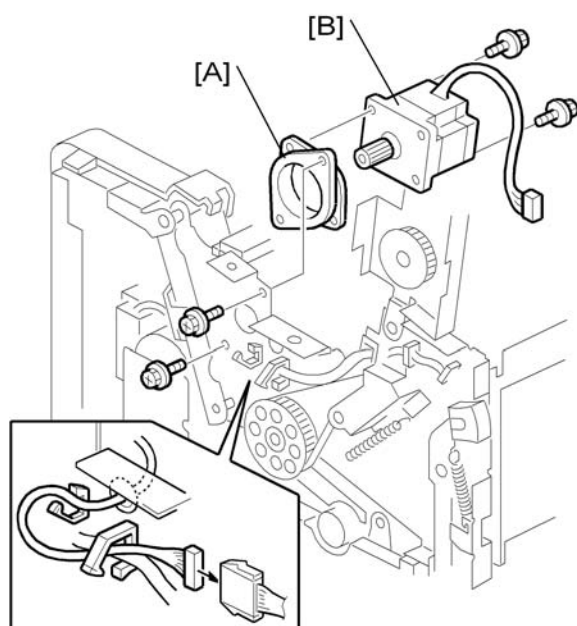





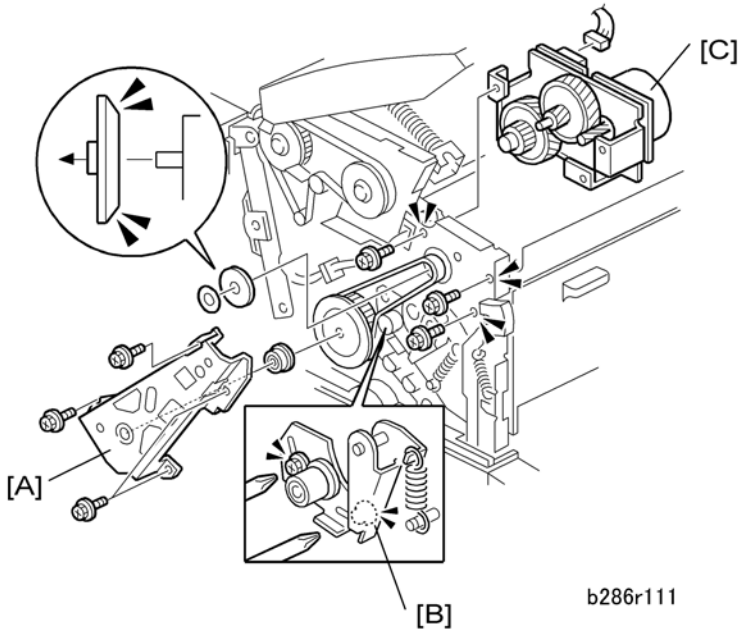

b286r114

1. Original feed unit (🔧 p.157 "Removing the Original Feed Unit")
2. Lift and lock the scanning unit (🔧 p.158 "Raising and Locking the Scanner Unit")
3. Scanner motor assembly [A] (🔧 x 2, 📄 x 1, 🔧 x 2)
4. Scanner motor [B] (🔧 x 2)

Drum Motor



b286r111

1. Open the original feed unit.
2. Drive belt plate [A] ( x4)
3. Loosen belt tension plate [B] ( x 2,  x 1).
4. Remove drive belt ( x1).
5. Drum motor unit [C] ( x 1,  x 3)

Fusing Motor, Main Motor

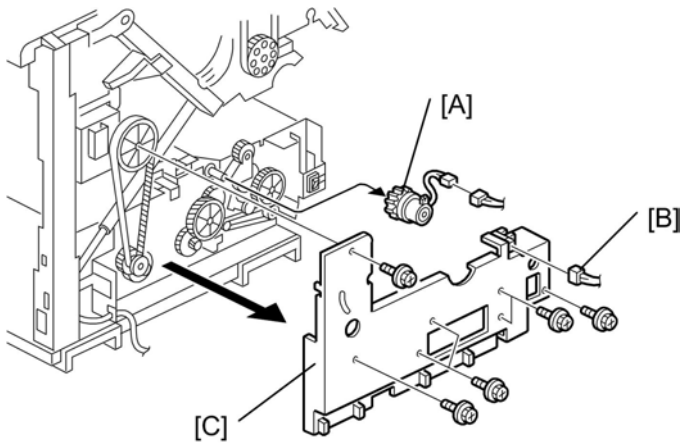

d093r503

1. Open the upper unit.
2. Side covers (▶ p.154 "Side Covers")
3. Registration clutch [A] (🔧 x 1, 📦 x 1)
4. Disconnect upper unit sensor harness [B] (📦 x 1, 🗑️ x 3)
5. Gear cover plate [C] (🔧 x 7)

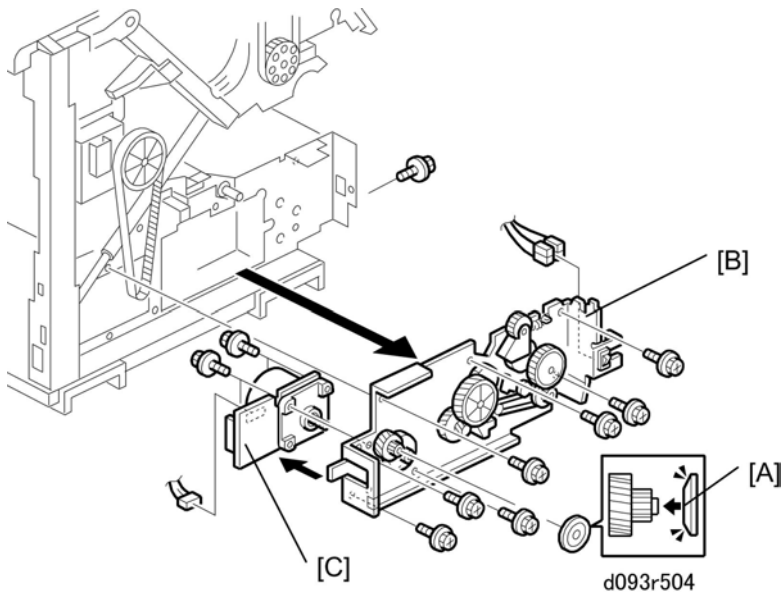

d093r504

6. Timing belt and cap [A]
7. Motor mount plate [B] (🔧 x 8, 📦 x 4, 🗑️ x 1)
8. Fusing motor [C] (📦 x 1, 🔧 x 4)

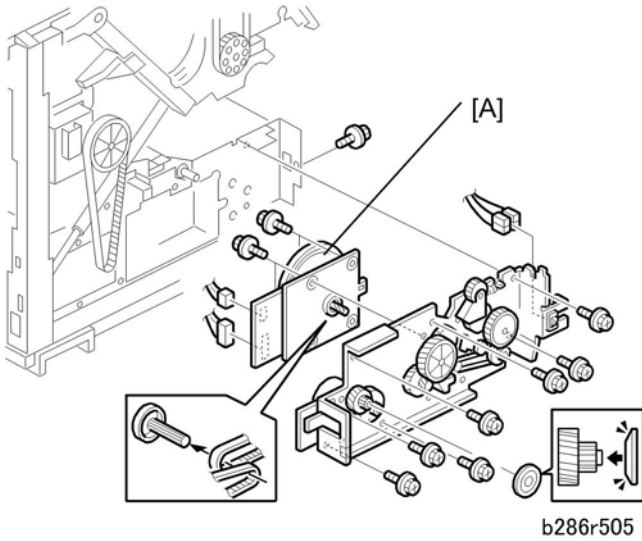

b286r505

4

9. Main motor [A] (E x 2, O x 2, S x 4)

Reinstallation

Refer to Steps 6 to 9 above. If it is not easy to connect the connector at the rear of the motor when you install the motor mount plate:

- Remove the rear cover.
- At the left rear corner of the main machine, open two or three harness clamps to release the motor harnesses. This will decrease the tension in the harnesses.

Used Toner Bottle Motor

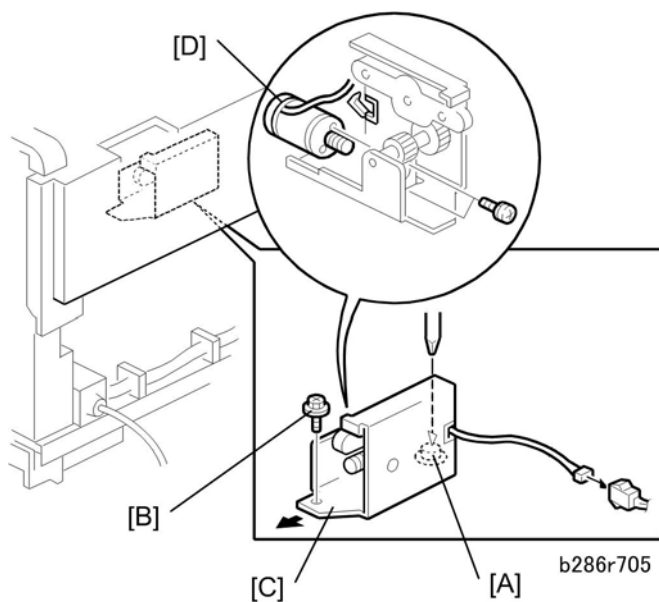

4

Preparation

↓ Note

- You will need a stubby driver for this procedure.
- PSU (p.236 "Circuit Breaker/PSU")
- Toner collection bottle (p.193 "Used Toner Collection Bottle, Toner Overflow Sensor")
- T&S power pack (p.243 "T&S Power Pack")

↓ Note

- Removal of the fusing unit is recommended.

1. Loosen screw [A] (x1).
2. Remove screw [B] (x1)
3. Disconnect motor and slide it out of the machine [C] (x 1).
4. Motor [D] (x1, x 2)

Boards

★ Important

- Always touch a grounded surface to discharge static electricity from your hands before you handle printed circuit boards or memory boards.

MCU, SIPU, MB

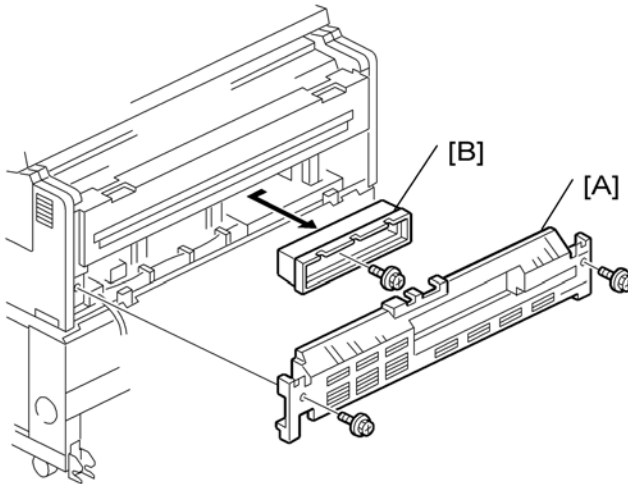

1. If you need to replace the MCU, before disassembling the machine do SP5824 to upload the UP and SP mode data from NVRAM to an SD card.

4



b286r914

2. Remove:

- [A] Rear cover ( x2)
- [B] Controller cover ( x1)

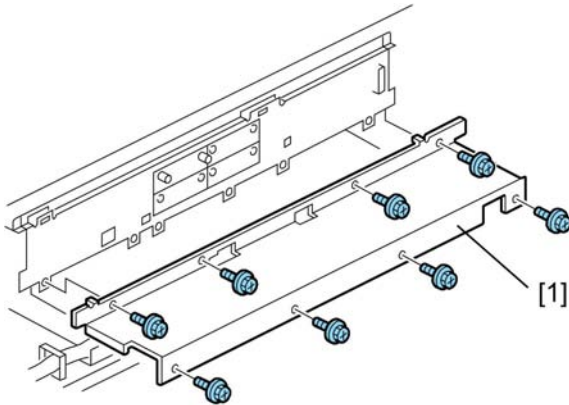



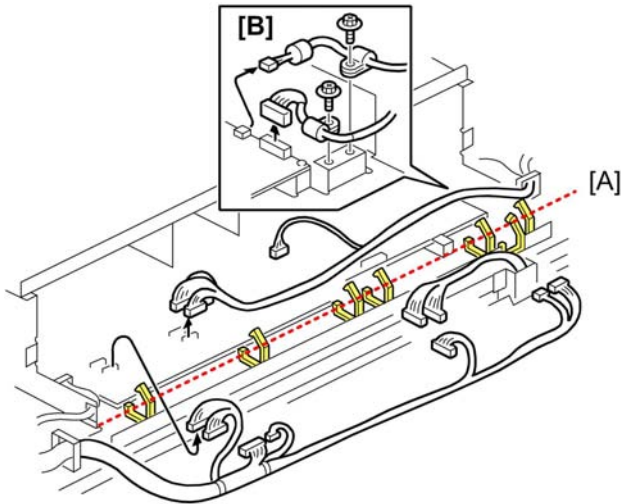

d093i105a

3. Remove PCB shield cover [1] ( x8)



d093r701

4. Open all the clamps at [A] in front of the board tray ( x7).
5. Disconnect both harnesses [B] ( x2,  x2).
6. Disconnect the board ( x13,

4

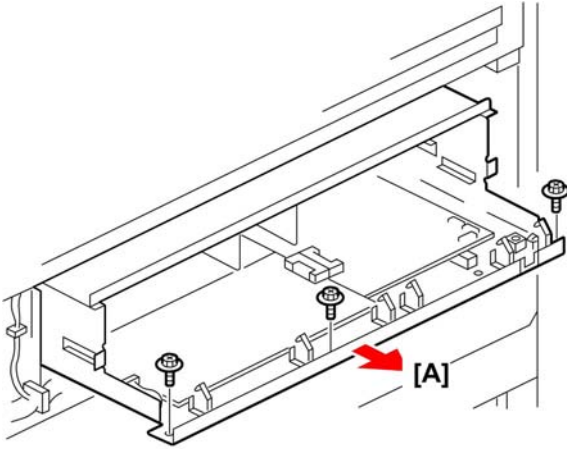

d093r701a

- 7. Disconnect the board tray [A] and remove it ( x3)
- 8. Set the board tray on a flat surface.

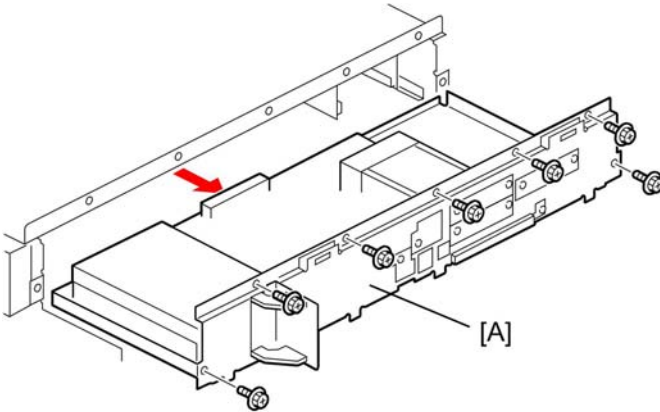

d377i111a

- 9. Remove the controller box [A] ( x7).

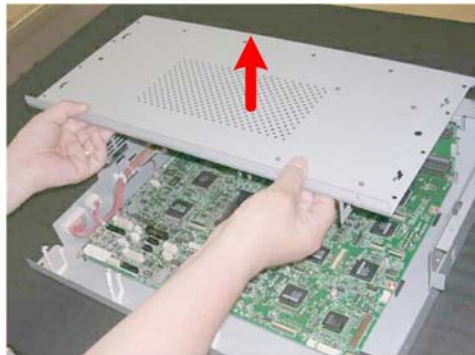
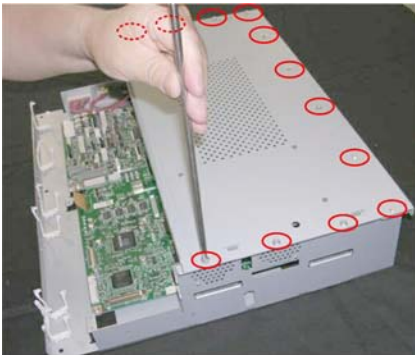

d093r635

10. Remove the PCB cover ( x12)

★ Important

- The boards must be removed in this order: MCU> SIPU> Motherboard.

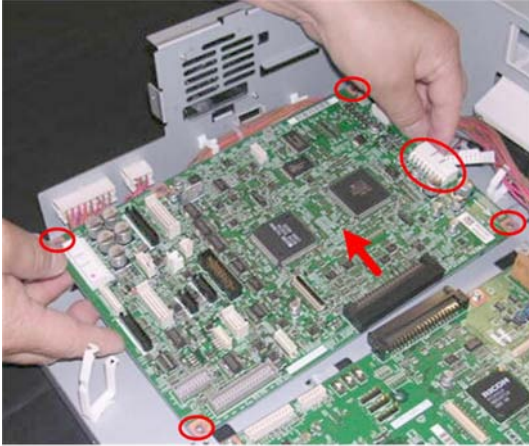

d093r636

11. Remove the MCU ( x4,  x1)

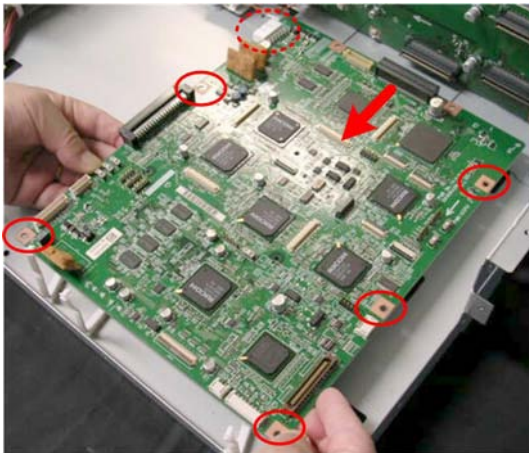

d093r637

12. Remove the SIPU ( x5,  x1)

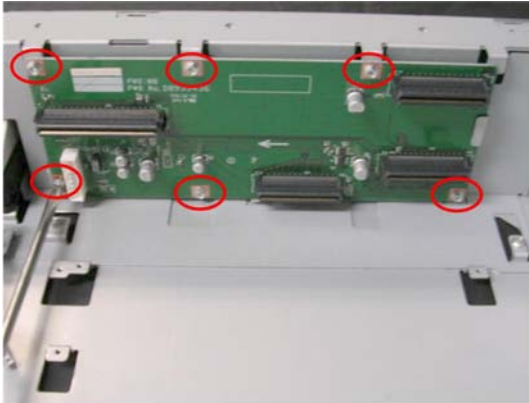

d093r638

4

13. Remove the motherboard ( x6).

Re-installation

- After replacing the MCU and re-assembling the machine do SP5825 to download the NVRAM data from the SD card.
- If the NVRAM has been corrupted, or if the NVRAM download fails, do the following SP codes settings manually.

SP		Name
4008	001	Scanner Sub Scan Magnification
4010	001	Scanner Sub Scan Registration
4961	001	Original Adjustment - Synchro-cut 210mm
	002	Original Adjustment - Synchro-cut 1000mm
4965	001	Scan Speed Switch Correction
4709	001 to 015	Gray Balance Adj Value – CIS1,2,3 (R,G,B)
4972	001	Scan Correction - CIS1-2 Main Scan
	003 to 005	Scan Correction – CIS2-3 Main Scan ...
	006	Scan Correction - CIS1-2 Sub Scan
	008 to 010	Scan Correction - CIS2-3 Sub Scan ...
4979	001 to 060	Scan Correction

- Check the DIP switch settings on the MCU board before you replace it.

No.	Setting		
	NA	EU	CHN
0	OFF	ON	ON
1	ON	OFF	ON
2	OFF	OFF	OFF
3	OFF	OFF	OFF
4	OFF	OFF	OFF
5	OFF	OFF	OFF
6	OFF	OFF	OFF
7	OFF	OFF	OFF

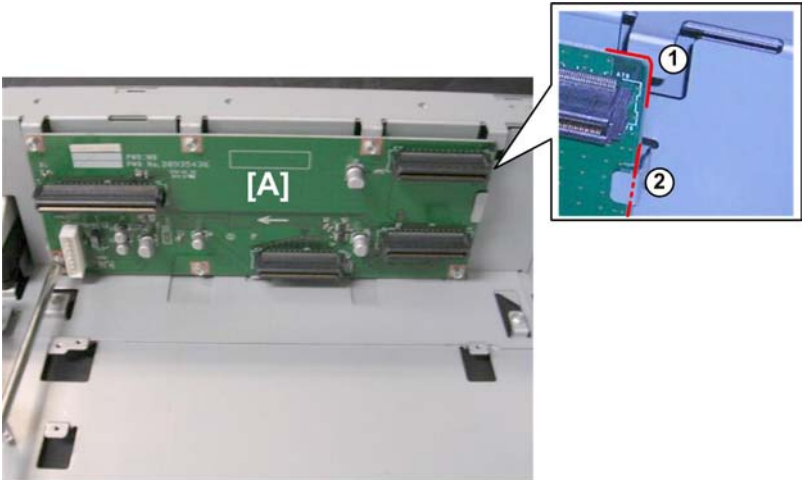

d093r702c



- When you re-install the motherboard [A], check the right upper corner and make sure that the board lies flat on top of the metal tab at ① and is behind the metal tab at ②.

Circuit Breaker/PSU

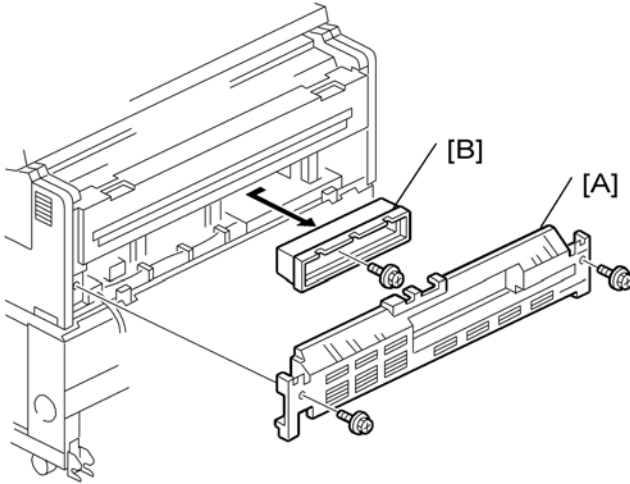
4





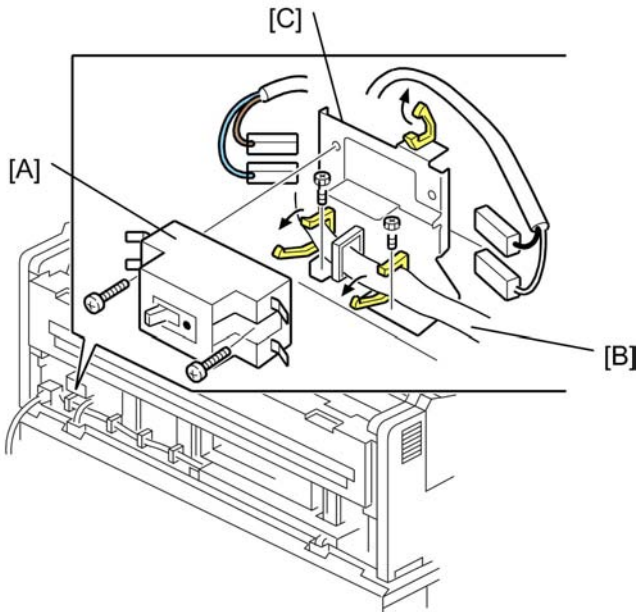

b286r914

1. Remove the rear cover [A] ( x2).
2. Remove the controller box cover [B] ( x1).





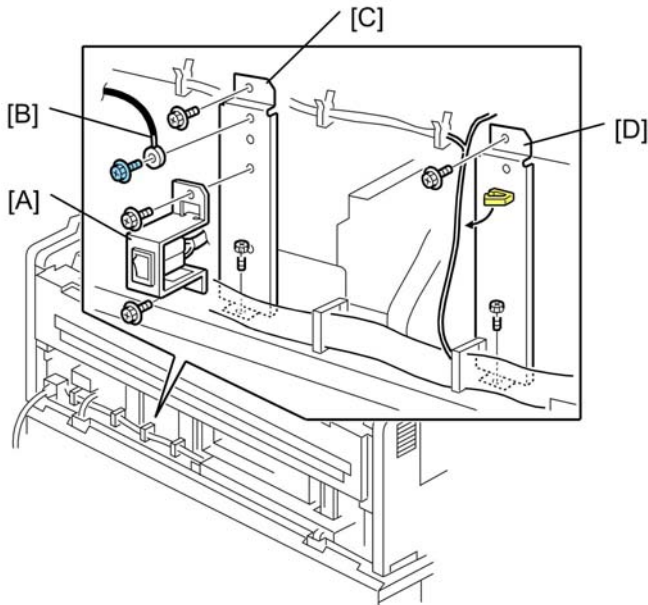

d093r640

3. Remove breaker switch [A] ( x2,  x4,  x1).
4. Open the clamps to free harness [B] ( x2).

5. Remove the breaker switch bracket [C] ( x2).



d093r641

6. Open the paper exit guide unit.
7. Remove:
- [A] Anti-condensation heater switch bracket ( x2)
 - [B] Ground wire ( x1)
 - [C] Left vertical ground plate ( x2)
 - [D] Right vertical ground plate ( x1,  x2)
8. Close the paper exit guide unit.

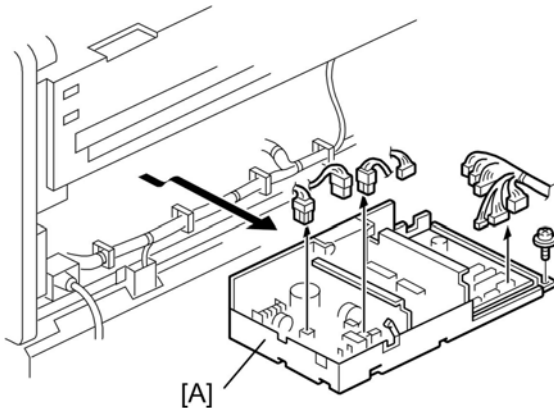

d093r703a

9. Remove PSU [A] ( x12,  x1)

10. Lay the PSU tray on a flat surface.

11. Remove the PSU from the tray ( x9,  x1,  x2).

★ Important

- If the breaker switch is covered with soot, this could indicate that the breaker switch has been damaged.
- To prevent damage to the breaker switch, installation of a voltage stabilizer (constant voltage transformer) is recommended for work sites where there is significant fluctuation in the AC power source.

Re-installation



d093r650

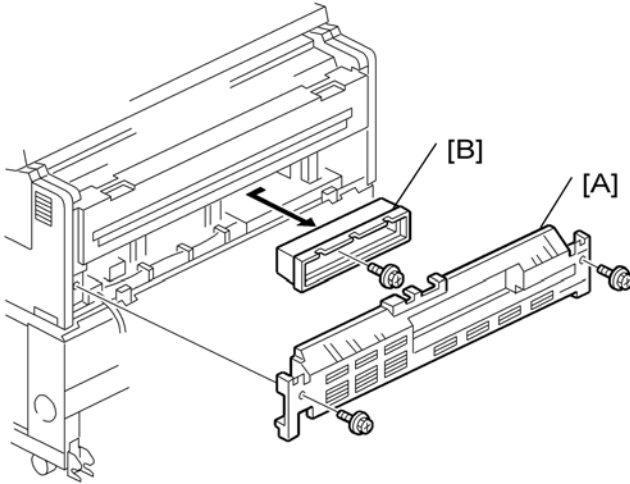

- Be sure to re-connect the breaker switch correctly.
- The harnesses are color coded: ① Brown, ② Blue, ③ Black, ④ White.
- The machine will not operate if these connectors are re-connected incorrectly.

Controller Board



b286r914

1. Remove:

- [A] Rear cover ( x2)
- [B] Controller cover ( x1)

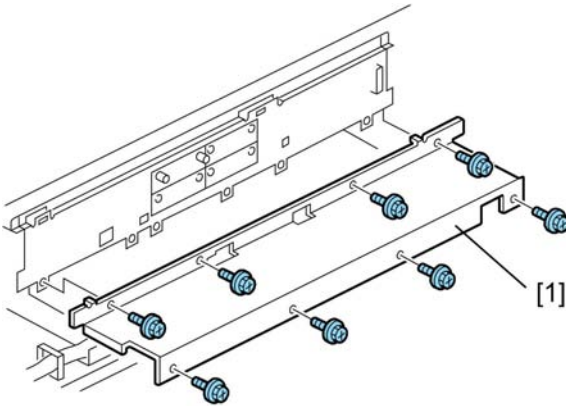

d093i105a

2. Remove the PCB shield cover [1] (x8).

 1324 660

3. Remove the slot covers of Slots A, B, D (or installed boards) (x6).



d093r661

4

4. Remove the controller box [A] ( x7).
5. Lay the controller box on a flat surface.

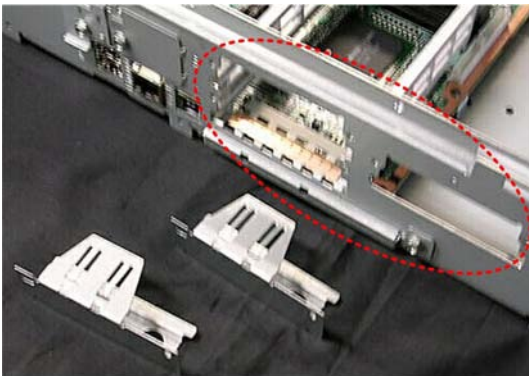

d093r662

6. Confirm that all slot covers or boards have been removed from Slots A, B, and D.

★ Important

- Boards or slot covers must be removed from Slots A, B, D, before you can remove the controller board.

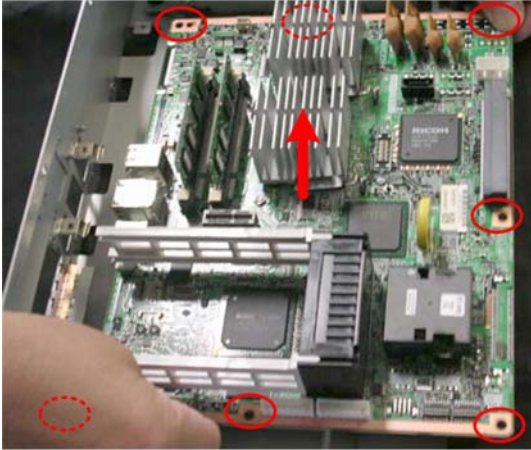

d093r663

7. Remove the controller board (🔧 x7).
8. Remove the NVRAM for the old controller board and then mount it on the new controller board.

NVRAM

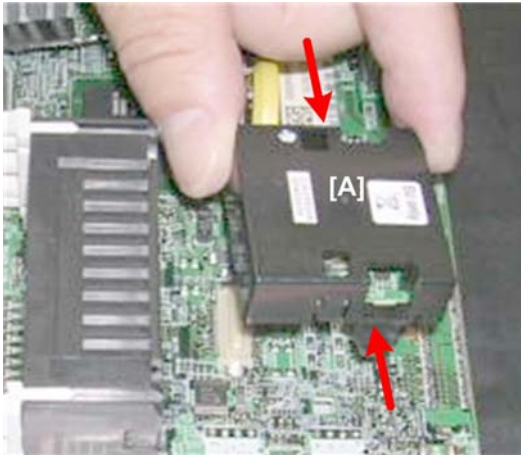

d093r664

1. Remove the controller board (🔧 p.239 "Controller Board")
2. Press in on the sides of the NVRAM [A] this lift it off the controller board.

★ Important

- If you change the controller board, put the old NVRAM on the new board.

NVRAM Upload

Do this procedure to upload the NVRAM data from NVRAM to an SD card. Do this procedure before replacing the NVRAM.

1. Switch the machine off.
2. Insert an SD card in SD card Slot 2.
3. Switch the machine on.
4. Go into the SP mode and do SP5824 (Upload NVRAM Data).
5. When you see "Completed!", switch the machine off.

4

NVRAM Download

Do this procedure to download the NVRAM data from an SD card to the NVRAM in the machine.

1. Switch the main power switch off.
2. If a new NVRAM is to be installed, do SP5801-2 to make sure that the new NVRAM is clear.

★ Important

- **After replacing the NVRAM, the total counter should be reset to 0: [User Tools]> [Counter].**

3. Do SP5811 (Machine Serial Number) to set the serial number.
4. Insert the SD card with the NVRAM data in SD card Slot 2.
5. Switch the main power switch on.
6. Go into SP mode and do SP5825 (Download NVRAM Data).
7. Follow the instructions on the operating panel display to execute the download.
8. Switch the main power switch off.
9. Switch the main power switch on.
10. If the Data Overwrite Security Unit has been installed, it must be installed again.
11. Do SP3001-2 to initialize the ID sensor.

T&S Power Pack

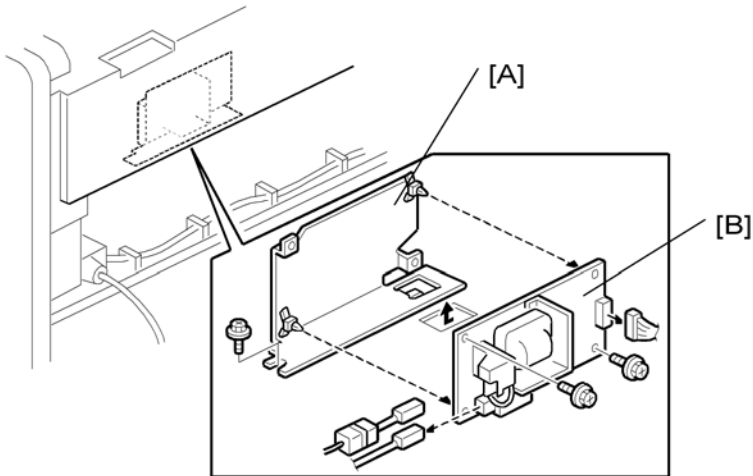

b286r704

4

Preparation

Remove:

- Fusing Unit (Fusing Unit)
- PSU (p.236 "Circuit Breaker/PSU")

⬇ Note

- Removal of the fusing unit is not absolutely required but is recommended to make this procedure easier.

1. Remove T&S power pack mount [A] (⚙ x 3, 🔩 x 1)
2. Remove T&S power pack (🔩 x 2, 🛠 x 2)



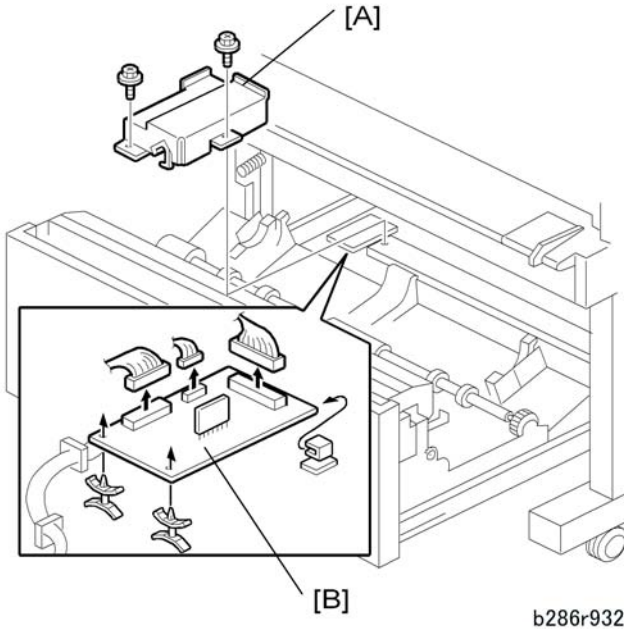



RFDB (Roll Feeder Drive Board)

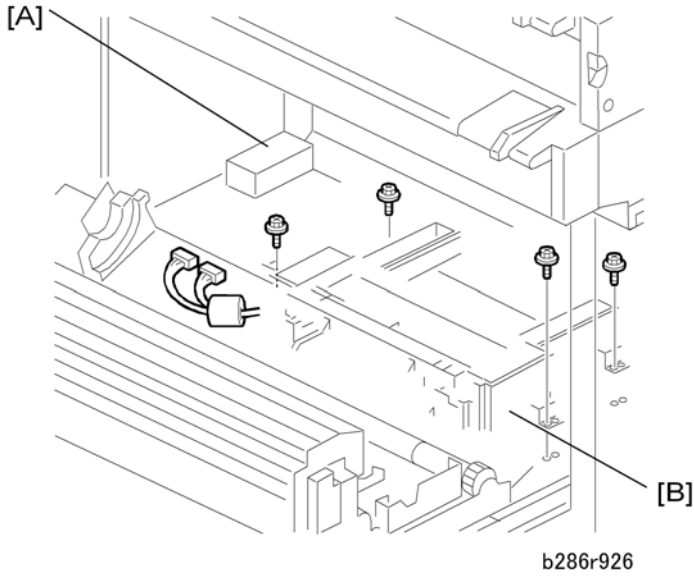

1. Open the roll feeder drawer.
2. Remove the rear plate of the roll feeder (📦 x 2 blue)
 - [A] Shield plate (📦 x 2)
 - [B] RFDB (📦 x 3, 📦 x 2)

SFDB (Sheet Feed Drive Board)





1. Open the roll feeder drawer and remove the paper cassette.
2. Remove
 - Roll feeder rear plate ( x 2 Blue) ( p.208 "Roll Paper End Sensors")
 - [A] RFDB shield plate [A] ( x 2).
 - [B] Paper cassette unit [B] ( x 4,  x 2,  x 4)

Note

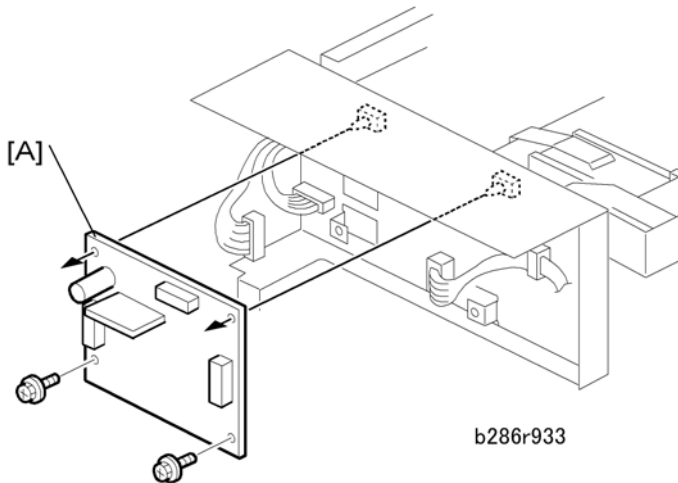
- Pull the unit to the rear, remove it from the front.



3. Remove the SFDB [A] ( x 2,  x 2,  x 2)

HDD

1. Remove the controller box (▶ p.239 "Controller Board")

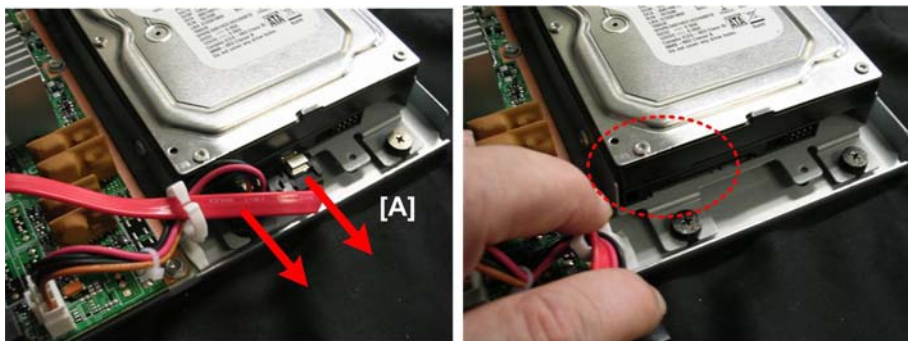

d093r665

2. Disconnect the HDD at [A] (🔧 x2).

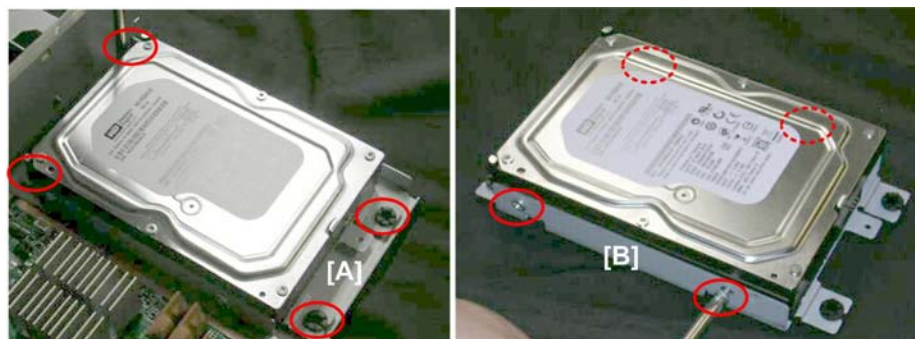

d093r666

3. Remove the HDD bracket [A] (with HDD attached) (🔧 x4).
4. Lay the HDD unit on a flat surface.
5. Remove the screws from sides of the HDD bracket [B] (🔧 x4).



d093r667

4

6. Separate the HDD and the bracket.

Re-installation

- Do SP5832-1 (HDD Formatting - All) to format the new HDD.
- Do SP5853 (Stamp Data Download) to download the fixed stamp data from ROM to the hard disk.

★ Important

- A new hard disk should always be formatted with SP5832-1, even if it has already been formatted.
- The fixed stamp data, the files for fixed stamps such as "Confidential", "Urgent", etc. should always be downloaded from ROM with SP5853 after the HDD is replaced or reformatted.

Cooling Fan, Ozone Filter, Paper Exit Selection Switch

Preparation

- Side covers off (p. 154 "Side Covers")
- Trays, guides on top of the machine off (p. 153 "Before Working On the Main Machine")

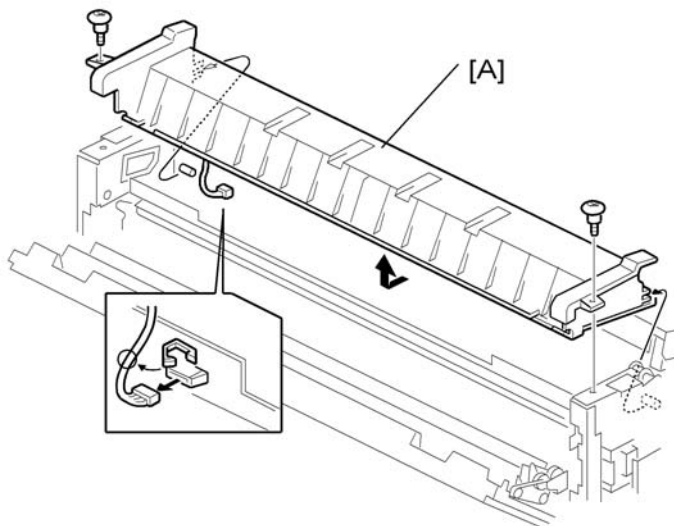

b286r310

1. Remove rear top cover [A] (🔩 x 1, 📦 x 1, 🔧 x 2).

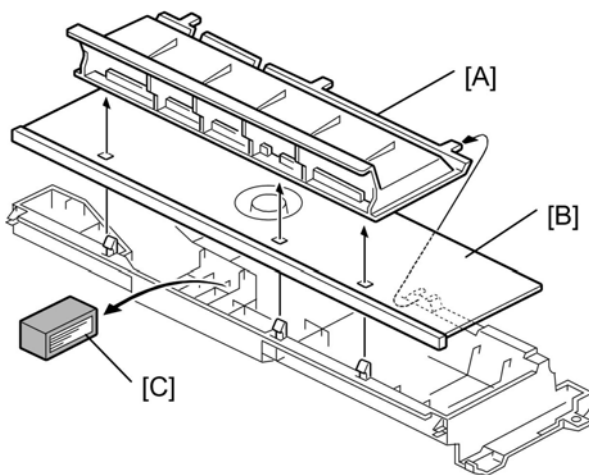

d093r311

2. Remove the plate [A] (press release).
3. Lift plate [B].

4. Remove the ozone filter [B].

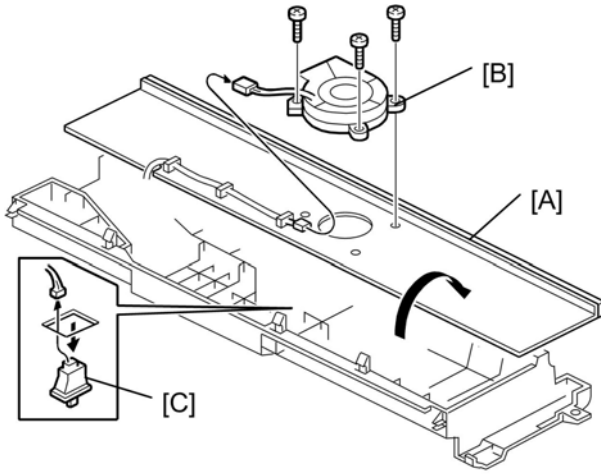

d093r312

5. Turn over plate [A].

6. Remove the cooling fan [B] (⚙️ x1, 📏 x1, 🔧 x3)

7. Disconnect the paper exit selection switch [C] (📏 x1).

8. Press in the sides of the switch and push it down to remove it.

Special Adjustments

Image Adjustment with SP Modes

Do these adjustments if output is unsatisfactory. Before you start measurements and adjustments, let the test print output cool for five minutes.

↓ Note

- Do each adjustment in the order described below. Be sure to turn the main machine's power off/on after each SP adjustment to enable the new setting.

Step 1: Magnification for Paper Type: Plain

1. Go into the SP mode.
2. Do SP4417, select pattern 28 (Grid Pattern), then touch [OK].
3. Touch "COPY Window".
4. Select the paper size.
5. Set a blank sheet of A1 SEF paper in the original tray.
6. Press [Start] to print a test pattern.
7. Print two more test patterns (you need three grid pattern prints).
8. Refer to the diagram and instruction table below to do the SP magnification corrections (if needed).

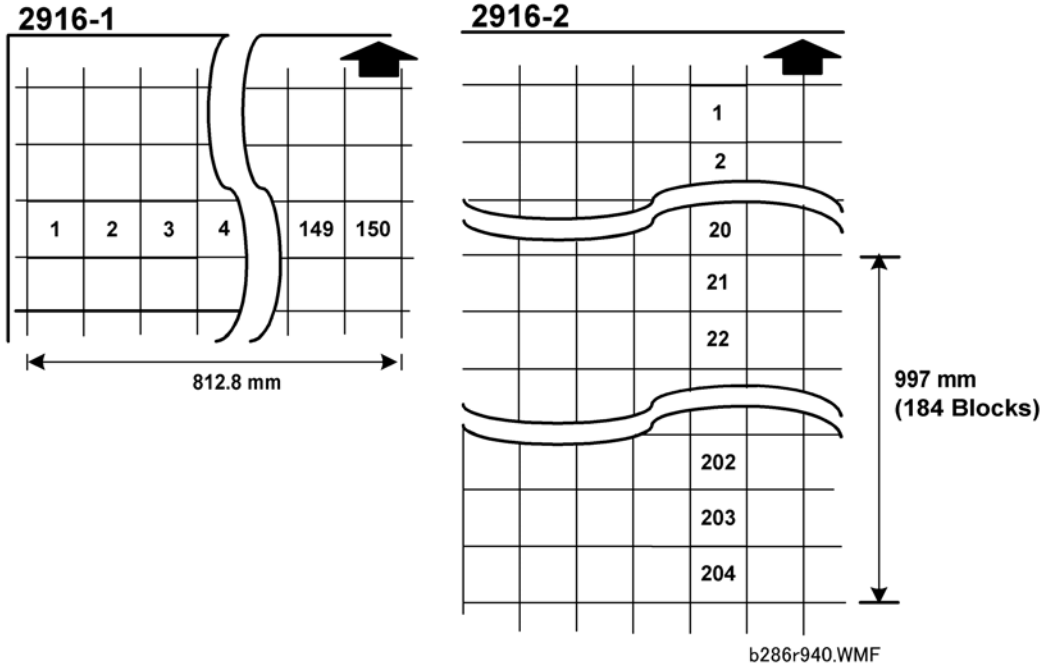

4

SP	Comments
2916-1	On each grid pattern measure the width from block 1 to block 150 (150 blocks) then average the three measurements. The width must be 812.8 mm. If the average measured width is not 812.8 mm, adjust this SP until the width is 812.8 mm.
2916-2	On each grid pattern measure the length from block 21 to block 204 (184 blocks) then average the three measurements. The length must be 997 mm. If the measured length is not 997 mm, adjust this SP until the length is 997 mm.

Step 2: Scanning Magnification

1. Make a 1:1 copy of the A0 SEF Magnification Chart with plain roll paper.

Note

- You can use a different test chart, if it has lines 1000 mm long in the sub-scan direction and 700 mm long in the main-scan direction.
2. Measure the length and width of the images on the original and the copy.
 3. Do these SPs in the sequence shown in this table, if the measurements are not in the standard range:

SP	Standard	Comments
4008	Less than ± 0.5	Scanner Sub Scan Magnification
4101	Less than ± 0.5	Scanner Main Scan Magnification

Step 3: Magnification for Paper Type: Translucent

1. Make a 1:1 copy of the A0 SEF Magnification Chart with translucent (tracing) paper.

↓ Note

- You can use a different test chart, if it has lines 1000 mm long in the sub-scan direction and 700 mm long in the main-scan direction.
2. Measure the length and width of the images on the original and the copy.
 3. Do the same measurements that you did for "Step 1: Magnification for Paper Type: Plain".
 4. Do these SPs in the sequence shown in this table, if the measurements are not in the standard range:

SP	Standard	Fine Magnification
2916-3	Less than ± 0.5	Translucent: Mode 1-4: Main Scan
2916-4	Less than ± 0.5	Translucent: Mode 1-4: Sub Scan

Step 4: Magnification for Paper Type: Film

1. Make a 1:1 copy of the A0 SEF Magnification Chart with film.

↓ Note

- You can use a different test chart if it has lines 1000 mm long in the sub-scan direction and 700 mm long in the main-scan direction.
2. Measure the length and width of the images on the original and the copy.
 3. Do the same measurements for "Magnification for Paper Type: Plain".
 4. Do these SPs in the sequence shown in this table, if the measurements are not in the standard range:

SP	Standard	Fine Magnification
2916-5	Less than ± 0.5	Film: Mode 1-4: Main Scan
2916-6	Less than ± 0.5	Film: Mode 1-4: Sub Scan

Step 5: Scanner Mask Setting

SP	Set To:	Comments
4012-5	0	Scanner Erase Margin DF – LEdge
4012-6	0	Scanner Erase Margin DF – TEdge
4012-7	0	Scanner Erase Margin DF – Left
4012-8	0	Scanner Erase Margin DF – Right

4

Step 6: Erase Margins

Set these SPs to "5" to make measurement easier:

SP	Set To:	Comments
2101-1	5	Print Erase Margin – Leading Edge
2101-2	5	Print Erase Margin – Trailing Edge
2101-3	5	Print Erase Margin – Left Edge
2101-4	5	Print Erase Margin – Right Edge

Step 7: Printer: Leading Edge, Side-to-Side Registration

- Use a sheet of blank plain paper to print the IPU Printing test pattern (SP4417 Pattern 28) for each paper feed station installed on the machine:
 - Manual feed (bypass)
 - Roll Feeder Roll 1
 - Roll Feeder Roll 2
 - Paper Cassette
- Measure the gaps for the leading edge and side-to-side registration.

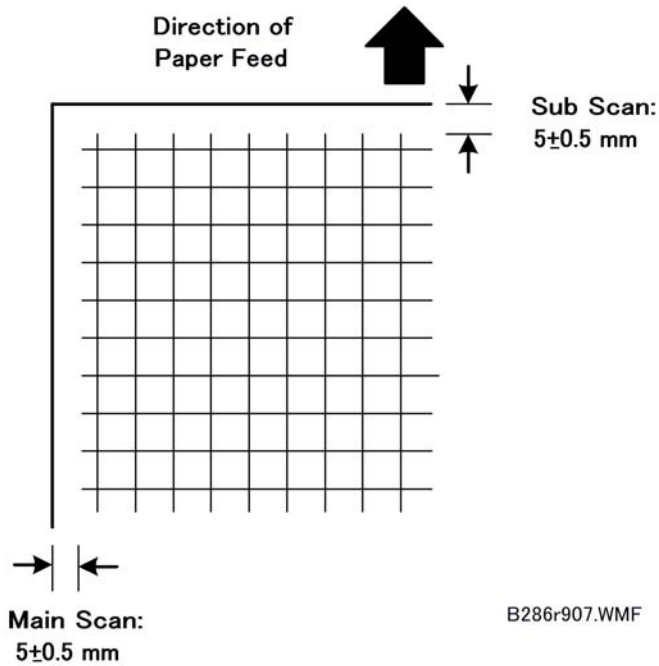

3. Touch "SP Mode" and adjust these SPs if a measurement is not in the standard range.

SP	Standard:	Comments
1001-1	5 ±0.5 mm	Leading Edge Registration – 1 st Roll
1001-2		Leading Edge Registration – 2nd Roll
1001-3		Leading Edge Registration –Cassette
1001-5		Leading Edge Registration – By-pass Feed
1002-1		Side-to-Side Registration – 1 st Roll
1002-2		Side-to-Side Registration – 2nd Roll
1002-3		Side-to-Side Registration –Cassette
1002-5		Side-to-Side Registration – By-pass Feed

Step 8: Scanner Mask Setting

Do these SPs to replace the "0" settings done in Step 5.

SP	Set To:	Comments
4012-5	1.5	Scanner Erase Margin DF – LEdge
4012-6		Scanner Erase Margin DF – TEdge
4012-7		Scanner Erase Margin DF – Left
4012-8	0.5	Scanner Erase Margin DF – Right

Step 9: Erase Margins

Do these SPs to replace the settings done in Step 6.

4

SP	Set To:	Comments
2101-1	2	Print Erase Margin – Leading Edge
2101-2		Print Erase Margin – Trailing Edge
2101-3		Print Erase Margin – Left Edge
2101-4	0.5	Print Erase Margin – Right Edge

Step 10: Scanner Registration

1. Use the A1 LEF Test Chart to make a 1:1 copy on plain A1 LEF paper.
2. On the copy, measure the gap between the chart image and the leading edge and left edge.
3. Adjust these SPs if necessary:

SP	Standard	Comments
4010-1	±3 mm	Scanner Sub Scan Reg – Leading Edge
4011	±2.8 mm	Scanner Main Scan Reg

Step 11: Printer: Cut Length

The following SPs are necessary for this step:

SP	Comments
1920-22	Cut Length Adjustment-1st Roll:297 mm (11" or 12"):Plain Paper

SP	Comments
1920-26	Cut Length Adjustment-1st Roll:1 189 mm (44" or 48"):Plain Paper
1920-82	Cut Length Adjustment-2nd Roll:297 mm (11" or 12"):Plain Paper
1920-86	Cut Length Adjustment-2nd Roll:1 189 mm (44" or 48"):Plain Paper

Note

- The cut length adjustment is done for all paper sizes after these settings are done.
 - After these settings are done you may still need to do fine adjustments for each paper size.
1. Use the Preset Cut feature to make standard cuts of plain paper for these sizes:

Size	Orientation
A3	Sideways
A1	Lengthways
A0	Lengthways
A	Sideways (Eng. 11")
B	Sideways (Eng. 17")
D	Lengthways (Eng. 34")
E	Lengthways (Eng. 44")

2. Measure the cuts and check them against the standards of this table.

Cut Length (mm)	Cut Tolerance (mm)
Less than 297	±3
420 to 1 189	±5
to 2000	±6
=3000	±11
to 4000	±14

3. If a measurement is not in the standard range of the "Cut Tolerance" in the table above, adjust SP1920-22 to -130 for each roll, paper width, and paper type.

Step 12: Synchro Cut (Trailing Edge Registration)

The following SPs are necessary for this step:

- SP4961-1 (Original Adjustment – Synchro Cut Adjustment 210 mm)
- SP4961-2 (Original Adjustment – Synchro Cut Adjustment 1000 mm)
- SP4961-3 (Original Adjustment – Original Length Display)

1. Prepare two originals
 - 1 original 210 mm long (A4 LEF)
 - 1 original 1000 mm long (measure and cut)
2. Go into the SP mode and do SP4961-1.
3. Touch "COPY Window" and copy the 210 mm sheet that you prepared in Step 1.
4. Touch "SP Mode" to go back to the SP mode.
5. Do SP4961-3 to check the original scan length.
6. If the display is different, adjust with SP4961-1.
7. Do SP4961-2.
8. Touch "COPY Window" and scan the 1000 mm sheet that you prepared in Step 1.
9. Touch "SP Mode" to go back to the SP mode.
10. Do SP4961-3 to check the scan length.
11. If the display is different, adjust with SP4961-2.

Cut Length (mm)	Cut Tolerance (mm)
Less than 297	±4.50
to 594	±5.00
to 841	±6.00
to 1189	±8.50
to 2000	±18.0
to 3000	±27.0
to 3600	±33.0

CIS Adjustment with SP Modes

To Print the CIS Adjustment Pattern

1. Open the roll feeder drawer and cut off a sheet of paper from the widest roll. (Turn the manual feed knob to feed the paper, then push the cutter from side to side to cut.)
2. Close the roll feeder drawer.
3. Enter the SP mode.
4. Open SP4417 Pattern 28, and touch [OK].
5. Touch "COPY Window" to go to the main screen.
6. On the operation panel, select one of the rolls for paper feed.
7. Put the blank sheet of paper on the original feed tray and feed it into the original feed unit. Pattern 28 (grid pattern) prints.
8. Touch "SP Mode" to return to the SP mode.
9. Open SP4973, push [0] on the operation panel to change the setting from "2" to "0", then push [#]
10. Touch "Exit" twice to leave the SP mode.
11. Select the paper roll size, then copy the grid pattern that you printed in Step 7 above.

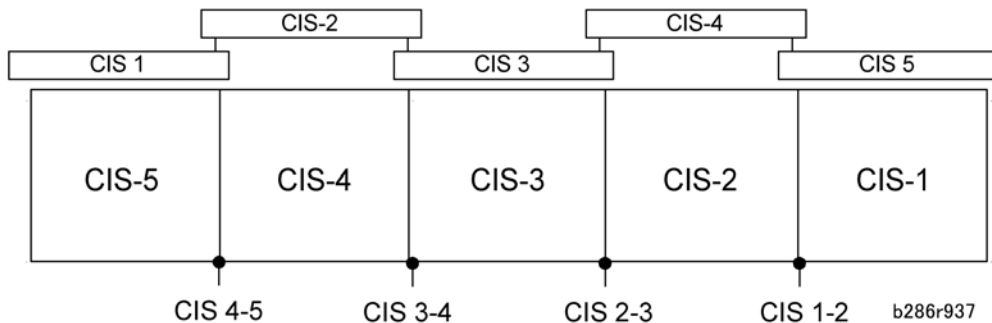

Note

- When you look at the printed pattern, the number sequence of the CIS joints is opposite, with CIS-5 on the left through CIS-1 on the right as shown in the diagram above.

Important

- After completing the CIS adjustments, be sure to reset SP4973 to "2".

To Adjust the Image at the CIS Joints

1. Check the printed pattern to find if the dots are aligned at CIS 1-2.
2. If they are aligned correctly, no adjustment is necessary.

-or-

If they are not aligned correctly, do the next step.

Here are two samples where the outputs are not aligned correctly.

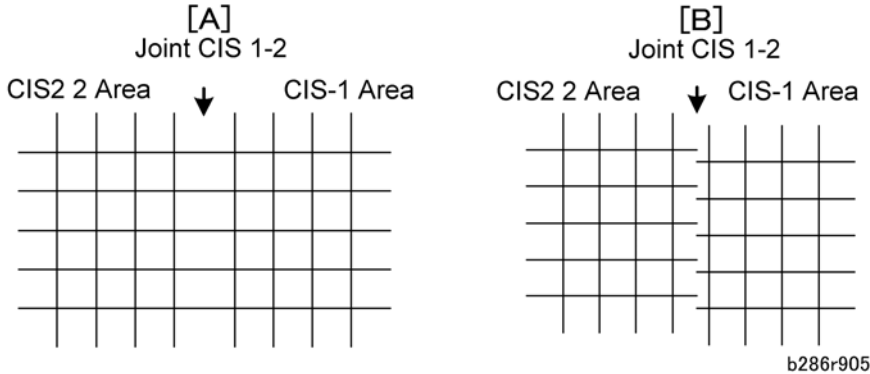

- [A]: Distance between the lines at CIS 1-2 is wider than usual (as shown above). If the distance between these lines is wider or narrower than the other lines, adjust the main scan offset at CIS 1-2 with SP4972-1 (CIS Joint Adjustment – CIS 1-2 Main Scan) as described below.
- [B]: The lines at CIS 1-2 are broken. If the output from CIS 1 is lower (as shown above) or higher, adjust the sub scan offset at CIS 1-2 with SP4972-6 (CIS Joint Adjustment – CIS 1-2 Sub Scan) as described below.

To adjust the main scan offset for Example [A]

Problem: Output from CIS 1 is too far to the right.

1. Do SP4972-1 and adjust the setting.
 - Adjust the position of CIS 1. The position of CIS 2 does not move.
 - If the area at the joint is too wide, set a smaller value.
 - If the area at the joint is too narrow, set a larger value.
 - In the example [A], you must set a smaller value.

To adjust the sub scan offset for Example [B]

Problem: Output from CIS 1 is lower than the output from CIS 2.

1. Do SP4972-6 and adjust the setting.
 - Adjust the position of CIS 1. The position of CIS 2 does not move.
 - If the CIS 1 area is higher than the CIS 2 area, set a larger value.
 - If the CIS 1 area is lower than the CIS 2 area, set a smaller value.
 - In the example shown [B], you must decrease the value for CIS 1.

After adjusting

1. Print one more pattern and check CIS 1-2.
2. Repeat these procedures until the image at CIS 1-2 is correct.
3. Do these procedures for the other joints (CIS 2-3, CIS 3-4, CIS 4-5)

Note

- The "Effect" column in the table below tells you which area moves with the adjustment, and which area does not move.

SP4972	CIS Main/Sub Scan Offset Adjustment [0 to 2047/638/1]		
	Problem	Joint	Effect
1	Main Scan Offset: Interval 1-2	CIS 1-2	CIS 1 moves. CIS 2 does not move.
3	Main Scan Offset: Interval 2-3	CIS 2-3	CIS 3 moves. CIS 2 does not move.
4	Main Scan Offset :Interval 3-4	CIS 3-4	CIS 4 moves. CIS 3 does not move.
5	Main Scan Offset: Interval 4-5	CIS 4-5	CIS 5 moves. CIS 4 does not move.
6	Sub Scan Offset: Interval 1-2	CIS 1-2	CIS 1 moves. CIS 2 does not move.
8	Sub Scan Offset: Interval 2-3	CIS 2-3	CIS 3 moves. CIS 2 does not move.
9	Sub Scan Offset: Interval 3-4	CIS 3-4	CIS 4 moves. CIS 3 does not move.
10	Sub Scan Offset: Interval 4-5	CIS 4-5	CIS 5 moves. CIS 4 does not move.

Important

- After completing the CIS adjustments, be sure to reset SP4973 to "2."

LPH Adjustment with SP Modes

Doing SP Adjustment Settings for a Replacement LPH

1. Remove the replacement LPH from its box.
2. Read the label attached to the replacement LPH and note of the settings for SP2952 and SP2943.

 **Note**

- This label is attached to the replacement LPH only.
3. Remove the old LPH and install the new LPH unit. (p. 184 "LPH")
 4. Do SP2952-1, -2 and enter the settings you read from the label attached to the LPH replacement unit.
 5. Do SP2943-1, -2, -3 and enter the settings you read from the label attached to the replacement unit.
 6. Print a test print in the IPU Test Pattern mode to make sure that the LPH joints are aligned correctly. (See below.)
 7. Do SP4417 Pattern 27 (Horizontal Grayscale) to print IPU Test Pattern 10 to confirm that the LPH is functioning normally (see the procedure below).

4

To Print Pattern IPU Test Pattern 27

1. Open the roll feeder drawer. Cut off a sheet manually from a roll.
2. Close the roll feeder drawer.
3. Go into the SP mode.
4. Do SP4417, select Pattern 27, then touch [OK].
5. Touch "COPY Window" to go to the copy display.
6. Select one of the rolls for paper feed.
7. Feed a blank sheet of paper into the machine then press [Start] to print Pattern 27.
8. Check the printed pattern:
 - If you see vertical white or black lines, do the vertical line adjustments (See the next section, "Main Scan Adjustment: White, Black Vertical Lines").
 - If you see the areas are not aligned, do the misalignment adjustments (See below, "To Adjust the LPH for Misalignment").
 - If you see vertical white/black lines and misalignment, do the vertical line adjustment first.

Main Scan Adjustment: White, Black Vertical Lines

1. Check the printed pattern at LPH 1-2 for white or black lines.
2. If there are no lines, no adjustment is necessary.

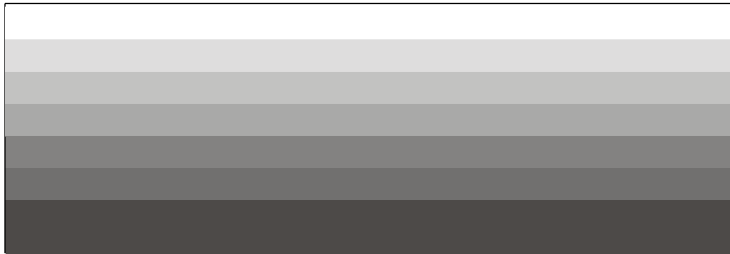

Normal Pattern

b286r561

If you see white or black lines at LPH 1-2, go to the next step.

- White lines occur if too few LEDs come on at the joint.
- Black lines occur if too many LEDs come on at the joint.

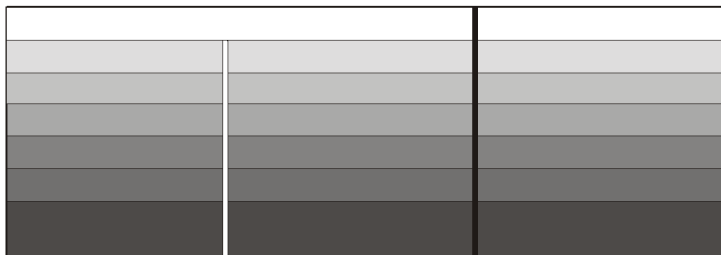

Abnormal Pattern

b286r562

3. Left line:
 - If the left line is **white**, adjust SP2952-1 to a smaller value.
 - If the left line is **black**, adjust SP2952-1 to a larger value.
4. Right line:
 - If the right line is **white**, adjust SP2952-2 to a smaller value.
 - If the right line is **black**, adjust SP2952-2 to a larger value.
5. After the adjustment, feed the blank sheet again to print one more pattern.
6. Check the results of the adjustment.
7. Do the adjustment again until the lines appear faint.

Note

- The lines cannot be completely erased.

Main Scan Adjustment: LED Light Level at LPH Joints

After you do the previous procedure to adjust the main scan at the LPH joints, you can do a fine adjustment on this area. To do this, you increase or decrease the intensity of the light from the four LEDs at the joints.

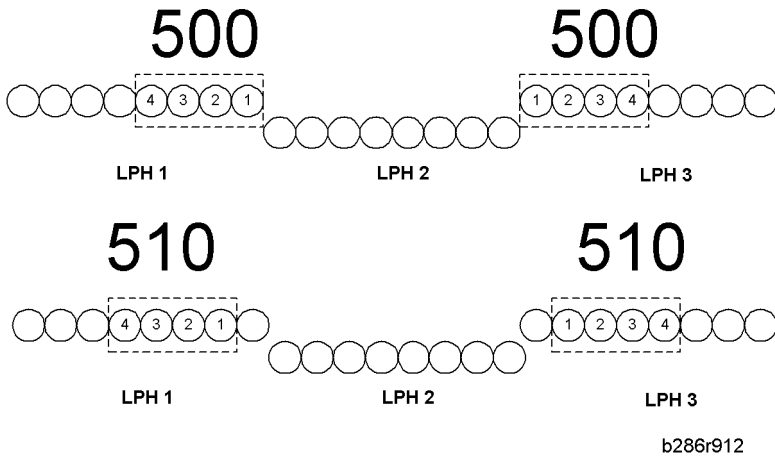

4

“500” is the default setting for LPH 1-2 and LPH 2-3.

- If you change the 2nd digit of the value for LPH 1-2 (500 to **510**) with SP2952-1, this moves the four LEDs by one position to the **left**.
- If you change the 2nd digit of the value for LPH 2-3 (500 to **510**) with SP2952-2, this moves the four LEDs by one position to the **right**.
- If you change the 3rd digit of LPH 1-2 or LPH 2-3 (510 to **512**, for example), this increases the quantity of light from LEDs 1, 2, 3, 4 in the illustration.

The quantity of light can be adjusted for each LED independently with SP2953 (Power Correction). But, this fine adjustment is usually not necessary in the field.

Adjusting LPH Alignment

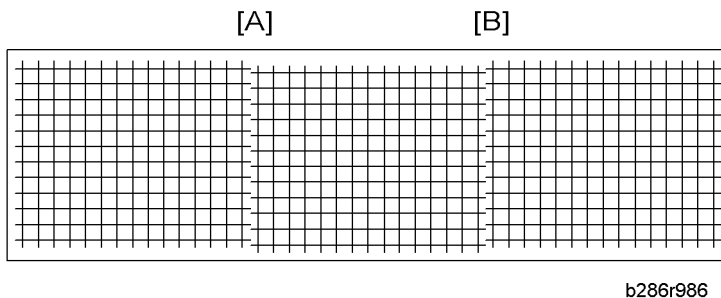

b286r986

Broken lines [A] or [B] in the IPU Test Pattern (SP4417 Pattern 28) indicate incorrect sub scan timing at one or both joints.

1. Go into the SP mode, and do SP2952-11 for LPH 1-2
 - Adjust the position of LPH 2 (LPH 1 does not move).
 - If LPH 2 is higher than LPH 1, set a larger value.

- If LPH 2 is lower than LPH 1, set a smaller value.
2. Print one more pattern with SP2952-11) and check the alignment at the joints.
 3. Do this procedure again until the pattern at the joint is correct.
 4. Do SP2952-12 for LPH 2-3
 - Adjust the position of LPH 3 to LPH 2 (LPH 2 is the standard).
 - If LPH 3 is higher than LPH 2, set a larger value.
 - If LPH 3 is lower than LPH 2, set a smaller value.
 5. Do this procedure again until the pattern at the joint is correct.

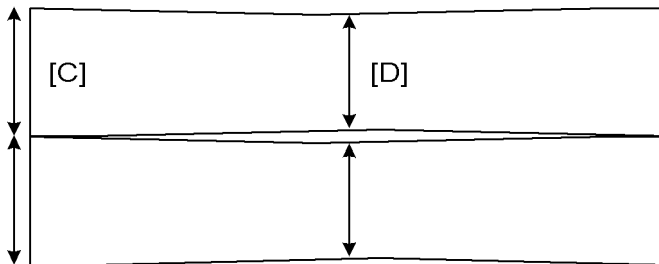

b286r939

The hot roller and pressure roller have a slight spindle shape. The circumference at the ends of the rollers [C] is slightly larger than the circumference at the centers [D]. This arrangement ensures that there is always sufficient pressure on the paper between the roller ends.

However, this difference in circumference also causes a small difference in the speed of paper feed. The paper transport speed at the ends is slightly faster than at the center. Because the centers of the rollers bend in slightly, this also increases the risk of slippage at the center with paper narrower than 420 mm.

- For operators who frequently use paper wider than 420 mm, do the sub scan adjustments for the LPH joints with SP2952-11, -12.
- For operators who frequently use paper that is less than 420 mm wide, do the sub scan adjustments for the LPH joints with SP2952-51, -52 after you input the values of SP 2952-11 and -12 from the decal.

LPH Density Adjustment with SP Modes

To Print the IPU Test Pattern 19

1. Open the roll feeder drawer. Cut off a sheet manually from a roll.
2. Close the roll feeder drawer.
3. Go into the SP mode.

4. Do SP4417, select Pattern "19" (Horizontal Grayscale: 16-Lvl: PRN), then touch "OK".
5. Touch "COPY Window" to show the main screen.
6. On the operation panel, select one of the rolls for paper feed.

Note

- You must select Tray 1 (1st Roll) or Tray 2 (2nd Roll). You cannot use "Auto Paper Select". If you select "Auto Paper Select" the pattern will not print.
7. Set the blank sheet of paper on the original feed tray.
 8. Press [Start]. The pattern prints.
 9. Touch "SP Mode" to return to the SP mode.
 10. Check the density of the patterns in LPH 1, LPH 2, and LPH 3.
If density is equal for all areas, no adjustment is necessary. If the density is not equal, do the next procedure.



B286r906

To Correct Pattern Density

1. Do SP2943-1, -2, and -3
 - This SP makes the output of each LPH block brighter or darker.
2. Adjust the density for LPH 1 with SP2943-1.
 - If the density is too dark, set a smaller value.
 - If the density is too light, set a larger value.
3. Do SP2902-2, select Pattern #10, touch [OK], then print the pattern by feeding the blank sheet and check the density.
4. Do this procedure for LPH2 and LPH3 until the density is the same in each of the three sections.
 - LPH2: SP2943-2
 - LPH3: SP2943-3

Firmware Update

Overview

The MCU (Main Control Unit) board flash-memory contains the software for this machine. To upgrade the software, .SD cards are necessary. The SD cards contain the SCU and ECU firmware.

★ Important

- Always turn the main power switch off before you insert or remove an SD card.
- Keep the main switch on during software installation.
- Store and handle SD cards carefully to protect them from heat, humidity, and sunlight.
- Before you handle SD cards, touch a grounded surface to discharge static electricity from your hands.

4

Updating Firmware

1. Turn the operation power switch off.
2. Wait for the power LED to go off, then switch the main power switch off.

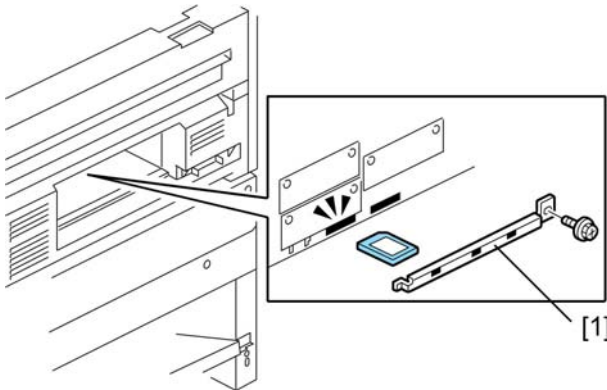

d093i161

3. Remove the SD slot cover [1] ( x1).
4. Insert the SD card [2] with the firmware in SD card Slot 2. (If there is an SD card in Slot 2, remove it.)
5. Turn on the main power switch. "Program to start firmware update" appears on the operation panel display.

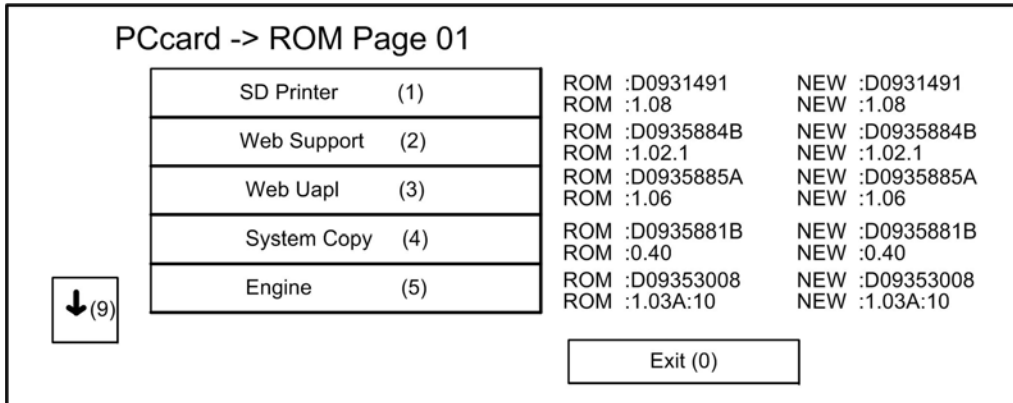

D093s941

4

After approximately 90 sec. the initial firmware update screen appears.

Note

- Only the firmware update applications on the SD card are displayed in the menu. If more than one update is to be done, the System Copy and Engine updates should always be done first.
6. Look at the numbers in the right (ROM) and left (NEW) columns.
 - If the NEW number is higher than the ROM number the application needs to be updated.
 - If the numbers are the same, the application does not need to be updated.
 7. Press the down arrow to see the next screen.

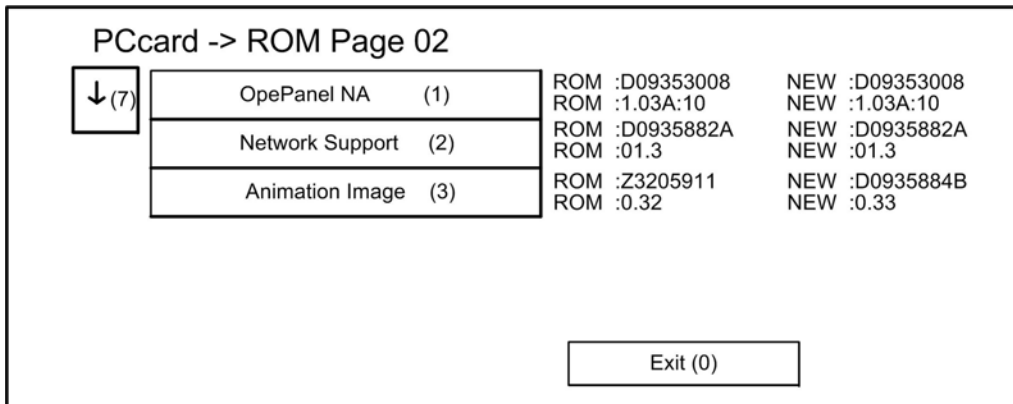

D093s942

8. If no application needs to be updated, touch [Exit].
9. To update an application:
 - Touch the name of the application that needs to be updated. The name of the application changes to reverse black and the [Update#] key appears at the lower right corner of the screen.
 - Touch [Update#] to start the update procedure.

- Follow the instructions on the operation panel to complete the procedure.

CAUTION

- Never switch the machine off while a firmware update is in progress.

10. When the update is finished:

- Switch the machine off.
- Remove the SD card from Slot 2.
- Reattach the SD card slot cover.

Note:

- More than one application can be selected for update, but there are restrictions.
- Controller applications and the operation panel update must be done separately.
- If you select a controller application and the operation panel for update, the machine will display a message:

Caution!

Controller applications and Op Panel must be installed separately.

5. System Maintenance Reference

Service Program Mode

See "Appendices" for Service Program Mode.

Main SP Modes

This is a collection of the most commonly used SP codes.

System

SP1-xxx Feed

1001	Leading Edge Registration	
1	1st Roll	Adjusts the leading edge registration for printing. To move the image down the page, increase the value. [-10.0 to +10.0/ 0 /0.1 mm step]
2	2nd Roll	
3	Cassette	
5	By-pass Feed	

1002	Side-to-Side Registration	
1	1st Roll	Adjusts the side-to-side registration for printing. [-10.0 to +10.0/ 0 /0.1 mm step] <ul style="list-style-type: none"> To move the start position to the right, increase the value (+). To move the start position to the left, decrease the value (-). Note: If you use paper 914 mm wide, adjust within the range of ± 2 mm. If you set the adjustment outside this range, part of the image will be cut off.
2	2nd Roll	
3	Cassette	
5	By-pass Feed	

1003	Registration Buckle Adjustment – Cassette Feed	
------	--	--

	<p>This SP eliminates the amount of buckle at the registration roller.</p> <ul style="list-style-type: none"> • When paper is fed from the paper cassette, before the registration rollers start to rotate the leading edge of the paper stops and hits the nip of the registration rollers and stops. • The registration rollers remain idle long enough to stop the paper from skewing in the paper path. • This SP adjusts the amount of time that the registration rollers remain idle to reduce paper buckle. • Raise this setting to lengthen the amount of time that the paper pauses at the nip of the registration rollers if you notice a large amount of skew in printouts. <p>[-20 to +20 / 5 / 1]</p>
--	--

1105	Fusing Temperature Adjustment
	Be sure to switch the main power switch off and on after adjustment.
1	Copy Ready Temperature
	<p>Sets the copy ready fusing temperature. The setting is the difference from the target fusing temperature that is set with SP1931.</p> <p>[0 to 50/10/1°C]</p> <p>Copying can start at this temperature before the hot roller reaches its target temperature (SP1931).</p>
3	Low Power Mode
	<p>Sets the copy ready temperature for low power mode.</p> <p>[80 to 150/90/1°C step]</p>

1106	Fusing Temperature Display
	This SP displays the hot roller and pressure roller temperatures.
1	Hot Roller Temperature
2	Pressure Roller Temperature: Center
3	Pressure Roller Temperature: Edge

1159	Fusing Jam SC Setting
------	-----------------------

	<p>The setting of this SP determines whether the machine issues SC559 after three successive jams occur in the fusing unit.</p> <p>[0-1/0/1]</p> <p>0: Disabled. SC559 not issued after 3 successive jams in the fusing unit.</p> <p>1: Enabled. SC559 issued after 3 successive jams in the fusing unit. The operator cannot restore operation of the machine by cycling the machine off/on. SC559 is a Class "A" SC error. The service technician must restore operation of the machine.</p>
1911	<p>By-pass Feed Start Timing</p> <p>Adjusts the time that the operator has to adjust the paper skew manually when feeding paper manually from the bypass tray..</p> <p>[1.0 to 8.0/2.0/0.1 sec.]</p>
1912	<p>Registration (Main Motor) Motor Speed-up</p> <p>This SP can increase the speed of the main motor just before the trailing edge of the paper leaves the nip of the registration rollers.</p> <ul style="list-style-type: none"> • Normally, the speed of the fusing roller is slightly faster than the speed of the registration roller in order to pull the paper taut and stabilize paper feed. • However, this small difference in speed between the rollers can cause jitter when the trailing edge of the paper leaves the nip of the registration rollers. • In order to prevent this jitter, just before the paper leaves the registration roller the speed of the registration roller can be increased slightly to match the speed of the fusing roller. <p>[0 to 125 / 0 / 1]</p>
1915	<p>Motor Speed Adjustment</p> <p>The fusing roller rotates slightly faster than the registration roller in order to keep the paper taut in the paper path. In some cases, this can cause "jitter" when the trailing edge is released by the registration roller. To correct this problem, this SP can be set to reduce the speed of the fusing roller just before the trailing edge of the paper is released by the registration roller in order to reduce the effect of the trailing edge snapping away from the registration roller.</p> <p>[-5 to 0 / 0 / 0.02 %]</p>
1920	<p>Cut Length Adjustment</p> <p>These SP's adjust the cut length of the paper sizes below.</p>

22	1st Roll: 297mm: Plain Paper	[-10 to +10/0/0.1 mm]
23	1st Roll: 420mm: Plain Paper	
24	1st Roll: 594mm: Plain Paper	
25	1st Roll: 841 mm: Plain Paper	[-20 to +20/0/0.1 mm]
26	1st Roll: 1 189mm: Plain Paper	[-20.0 to +20.0/0/0.1 mm]
27	1st Roll: 2000mm: Plain Paper	[-30 to +30/0/1 mm]
28	1st Roll: 3600mm: Plain Paper	[-30 to +30/0/1 mm]
29	1st Roll: 6000mm: Plain Paper	
30	1st Roll: 15000mm: Plain Paper	[-100 to +100/0/ 1 mm]
42	1st Roll: 297mm: Translucent Paper	[-10.0 to +10.0/0/0.1 mm]
43	1st Roll: 420mm: Translucent Paper	
44	1st Roll: 594mm: Translucent Paper	
45	1st Roll: 841 mm: Translucent Paper	[-20 to +20/0/0.1 mm]
46	1st Roll: 1 189mm: Translucent Paper	
47	1st Roll: 2000mm: Translucent Paper	[-30 to +30/0/1 mm]
48	1st Roll: 3600mm: Translucent Paper	
49	1st Roll: 6000mm: Translucent Paper	
50	1st Roll: 15000mm: Translucent Paper	[-100 to +100/0/ 1 mm]
62	1st Roll: 297mm: Film	
63	1st Roll: 420mm: Film	
64	1st Roll: 594mm: Film	[-10 to +10/0/0.1 mm]
65	1st Roll: 841 mm: Film	[-20 to +20/0/0.1 mm]
66	1st Roll: 1 189mm: Film	
67	1st Roll: 2000mm: Film	[-30 to +30/0.0/1 mm]
68	1st Roll: 3600mm: Film	
69	1st Roll: 6000mm: Film	

70	1st Roll: 15000mm: Film	[-100 to +100/0/ 1 mm]
82	2nd Roll: 297mm: Plain Paper	[-10 to +10/0/0.1 mm]
83	2nd Roll: 420mm: Plain Paper	
84	2nd Roll: 594mm: Plain Paper	
85	2nd Roll: 841mm: Plain Paper	[-20 to +20/0/0.1 mm]
86	2nd Roll: 1189mm: Plain Paper	
87	2nd Roll: 2000mm: Plain Paper	[-30 to +30/0/1 mm]
88	2nd Roll: 3600mm: Plain Paper	
89	2nd Roll: 6000mm: Plain Paper	
90	2nd Roll: 15000mm: Plain Paper	[-100 to +100/0/ 1 mm]
102	2nd Roll: 297mm: Translucent Paper	[-10 to +10/0/0.1 mm]
103	2nd Roll: 420mm: Translucent Paper	
104	2nd Roll: 594mm: Translucent Paper	
105	2nd Roll: 841mm: Translucent Paper	[-20 to +20/0/0.1 mm]
106	2nd Roll: 1189mm: Translucent Paper	
107	2nd Roll: 2000mm: Translucent Paper	[-30 to +30/0/1 mm]
108	2nd Roll: 3600mm: Translucent Paper	
109	2nd Roll: 6000mm: Translucent Paper	
110	2nd Roll: 15000mm: Translucent Paper	[-100 to +100/0/ 1 mm]
122	2nd Roll: 297mm: Film	[-10 to +10/0/0.1 mm]
123	2nd Roll: 420mm: Film	
124	2nd Roll: 594mm: Film	
125	2nd Roll: 841mm: Film	[-20 to +20/0/1 mm]
126	2nd Roll: 1189mm: Film	

127	2nd Roll: 2000mm: Film	[-30 to +30/0/1 mm]
128	2nd Roll: 3600mm: Film	
129	2nd Roll: 6000mm: Film	
130	2nd Roll: 15000mm: Film	[-100 to +100/0/ 1 mm]

1923	Paper Interval Adjustment
	<p>This SP slightly increases the gap between sheets in the paper path. When the machine shifts to the CPM down mode, the paper is fed by whichever interval between sheets is longer, the gap set with this SP or the gap determined by CPM down.</p> <p>[0 to 500/0/1 mm]</p> <p>Note:</p> <ul style="list-style-type: none"> • The "0" (default) setting does not mean that the gap is eliminated. • When set to "0" the standard gap between sheets is maintained (480 mm for the D093 and 168 mm for the D094.)

1931	Target Temp: Hot Roller	
	<p>Sets the target fusing temperature of the hot roller. After you adjust these SP's, you must switch the main power switch off and on.</p> <p>Important: Modes "1" to "5" below refer to the paper type and thickness settings selected in User Tools (see "Paper Thickness Default Selection" in this section).</p>	
1	Plain: Mode1	[120 to 220/195/5°C]
2	Plain: Mode2	
3	Plain: Mode3	
4	Plain: Mode4	[120 to 220/185/5°C]
5	Plain: Mode5	[120 to 220/175/5°C]
6	Trans.: Mode1	[120 to 220/205/5°C]
7	Trans.: Mode2	[120 to 220/195/5°C]
8	Trans.: Mode3	
9	Trans.: Mode4	[120 to 220/165/5°C]
10	Trans.: Mode5	[120 to 220/165/5°C]

11	Film: Mode1	[120 to 220/195/5°C]
12	Film: Mode2	[120 to 220/190/5°C]
13	Film: Mode3	[120 to 220/185/5°C]
14	Film: Mode4	
15	Film: Mode5	[120 to 220/175/5°C]
16	Plain: Low Temp Mode	[120 to 220/195/5°C]

5

1932	Target Temp: Press. Roller	
	<p>Sets the target fusing temperature of the pressure roller for plain paper, translucent paper, and film. These temperatures are used for pressure roller feedback. Turn the machine power off/on after changing the settings.</p> <p>Important:</p> <ul style="list-style-type: none"> • Modes "1" to "5" below refer to the paper type and thickness settings selected in User Tools (see "Paper Thickness Default Selection" in this section). • After adjusting these SP's, you must turn the machine power off/on. 	
1	Plain: Mode1	[60 to 180 /100/5°C]
2	Plain: Mode2	[60 to 180 /85/5°C]
3	Plain: Mode3	[60 to 180 /60/5°C]
4	Plain: Mode4	
5	Plain: Mode5	
6	Trans.: Mode1	[60 to 180 /130/5°C]
7	Trans.: Mode2	[60 to 180 /100/5°C]

8	Trans.: Mode3	[60 to 180 /60/5°C]
9	Trans.: Mode4	
10	Trans.: Mode5	
11	Film: Mode1	
12	Film: Mode2	
13	Film: Mode3	
14	Film: Mode4	
15	Film: Mode5	
16	Plain: Low Temp Mode	[60 to 180 /120/5°C]

1934	Lower Limit Temp: Hot Roller	
	<p>This SP sets the minimum difference in temperature allowed between the actual temperature and the target temperature of the hot roller.</p> <p>Important: Modes "1" to "5" below refer to the paper and thickness settings selected in User Tools (see "Paper Thickness Default Selection" in this section).</p>	
1	Plain: Mode1	[0 to 50/20/5]
2	Plain: Mode2	[0 to 50/15/5]
3	Plain: Mode3	[0 to 50/25/5]

4	Plain: Mode4	[0 to 50/20/5]
5	Plain: Mode5	
6	Trans.: Mode1	
7	Trans.: Mode2	
8	Trans.: Mode3	
9	Trans.: Mode4	
10	Trans.: Mode5	
11	Film: Mode1	
12	Film: Mode2	
13	Film: Mode3	
14	Film: Mode4	
15	Film: Mode5	
16	Plain: Low Temp Mode	

1935	Upper Limit Temperature: Press Roller	
	<p>This SP changes the stepped adjustments of SP1932 (Target Temp: Pressure Roller) by using the sum of the settings of SP1932 (Target Temp: Pressure Roller) +SP1935 (Press FB Control Steps) as the steps.</p> <p>Example</p> <ul style="list-style-type: none"> • If the pressure roller temperature for SP1935-1 is 100oC, the target hot roller temperature is 195oC ("100" is SP1932, "195" is SP1931). • If the pressure roller temperature 120oC (= "100"+"20", this is SP1932+SP1935), the target hot roller temperature is 175oC (= "195"-"20", this is SP1931 – SP1934) • If the setting is "0", the temperature settings of SP1931 do not change. 	
1	Plain: Mode1	[0 to 50/20/5]
2	Plain: Mode2	[0 to 50/25/5]
3	Plain: Mode3	[0 to 50/30/5]

4	Plain: Mode4	[0 to 50/20/5]	
5	Plain: Mode5		
6	Trans.: Mode1		
7	Trans.: Mode2		
8	Trans.: Mode3		
9	Trans.: Mode4		
10	Trans.: Mode5		
11	Film: Mode1		
12	Film: Mode2		
13	Film: Mode3		
14	Film: Mode4		
15	Film: Mode5		
16	Plain: Low temp. Mode		[0 to 50/0/5]

1936	Lower Limit Temp: Press Roller
	<p>This SP sets the minimum difference allowed between the actual temperature and the target temperature of the pressure roller.</p> <ul style="list-style-type: none"> • If the setting for the target temperature of the pressure roller is high (SP1932), the temperature of the pressure roller is lowered for continuous printing on plain paper. • At this time, if the temperature is below the temperature set for the pressure roller, paper feed will stop during a long job to perform inching to allow enough time for the pressure roller temperature to rise to the level of the prescribed setting, and then the job will continue. <p>Important: Modes "1" to "5" below refer to the paper and thickness settings selected in User Tools (see "Paper Thickness Default Selection" in this section).</p>

1	Plain: Mode1	[0 to 50/0/5°C]
2	Plain: Mode2	
3	Plain: Mode3	
4	Plain: Mode4	
5	Plain: Mode5	
6	Trans.: Mode1	[0 to 50/20/5°C]
7	Trans.: Mode2	[0 to 50/0/5°C]
8	Trans.: Mode3	
9	Trans.: Mode4	
10	Trans.: Mode5	
11	Film: Mode1	
12	Film: Mode2	[0 to 50/0/5°C]
13	Film: Mode3	
14	Film: Mode4	
15	Film: Mode5	

SP2-xxx Drum

2001	Charge Corona Adjustment
	This SP adjusts the charge corona outputs.
2	Grid Voltage: Image Area
	Adjusts the charge grid output. [160 to 1080/800/1 μA step]
2101	Print Erase Margin
	Adjusts the quantity of erase for copy mode (quantity of white space).

1	Leading Edge	[0 to 10 / 2 /0.1 mm step]
2	Trailing Edge	
3	Left edge	
4	Right edge	[0 to 10/ 0.5 / 0.5 mm step]

2201	Development Bias Adjustment	
	<p>This SP sets the development bias to adjust the amount of toner used in the image area.</p> <ul style="list-style-type: none"> • The amount charge applied by the CGB power pack for image transfer varies depending on whether CV is high or low. • Toner density is controlled to raise toner density in Low Duty mode when copy volume is high. • For this reason, SP2201-4 can be used to switch between High Duty Mode (> 400 m/day) and Low Duty Mode (< 400 m/day). • The default setting is Low Duty Mode. 	
1	Image Area	
	<p>This SP sets the bias voltage applied to the image area in the development unit (adjusted at the factory).</p> <p>[100 to 1000 / 600 /1 V step]</p>	
4	Copy Jobs	
	<p>This SP is used to switch between Low Duty Mode and High Duty Mode.</p> <p>Note: The Low Duty Mode is set as the default because wide format copiers are generally used for low volume copying and printing.</p> <p>[0 to 1/0/1]</p> <p>0: Low Duty Mode Copy Jobs (< 400 meters/day)</p> <p>1: High Duty Mode Copy Jobs (> 400 meters/day)</p>	

2207	Forced Toner Supply	
------	---------------------	--

	<p>Push [Execute] to force toner supply. Make a copy and check the image density. This SP supplies more toner to make light copies darker. Each time this SP is done, toner is supplied one time.</p> <ul style="list-style-type: none"> • After [Execute] is pressed the main motor, charge unit, and other components turn on, then the machine supplies a prescribed amount of toner to the development unit. • If image density is light, use this SP to recover from a low toner supply problem. • After executing forced toner supply, the Vsp value displays in the range 0.1 to 0.4 V, and thereafter, the value is stabilized (near 0.4 V) for subsequent printouts.
--	--

5

2208	Toner Supply Setting
1	Gain
	<p>This SP setting determines the supply GAIN for toner supply based on the readings of the ID sensor (Vsp/Vsg). This value is the threshold setting used calculate toner supply with the toner supply coefficient set with SP2208-2.</p> <ul style="list-style-type: none"> • The Vsp/Vsg value is used to fetch the corresponding value from the GAIN lookup table. • Increasing the value of this setting raises GAIN for image density control. <p>[0 to 9/1/1] 0: Lowest, 5: Medium, 9: Very High</p>
2	Supply Capacity
	<p>This SP sets the coefficient for toner supply control.</p> <ul style="list-style-type: none"> • This coefficient is used in a calculation with GAIN value, and width of the paper to determine the amount of toner supply. • Increasing the value of this setting raises the amount of toner applied to control image density. <p>[0 to 3.5 / 1.7 / /0.1 Steps]</p>
3	Toner Supply Mode

	<p>Sets the toner supply mode.</p> <ul style="list-style-type: none"> • This SP sets the toner supply mode for toner supply control. This determines the supply GAIN based on the ID sensor reading of the ID sensor pattern. This determines the supply GAIN for the fixed toner supply mode for 3% coverage and 6% coverage. • When fixed toner supply is selected, the image density is determined by the rate of coverage in the image passing through the machine. • If the density of the image on the paper passing through is higher than the rate set for the fixed toner supply mode, the image will be lighter. <p>[0 to 2 / 0 / 1]</p> <p>0: Detect Mode (uses ID sensor)</p> <p>1: Fixed Mode (3%). Coverage fixed at 3% (medium)</p> <p>2: Fixed Mode (6%). Coverage fixed at 6% (darker)</p> <ul style="list-style-type: none"> • If the ID sensor is damaged and cannot be replaced immediately, set either SP to "1". The operator can continue to use the machine until a new ID sensor becomes available. • After the ID sensor has been replaced, reset the SP to 0.
5	Long Print: Drawing
	<p>The machine switches to the Long Print mode (fixed toner supply mode) for any original longer than 1189 mm (46.8 in.).</p> <ul style="list-style-type: none"> • There are two Long Print modes (Long Print/Drawing and Long Print Graphic). • If the operator is frequently running jobs that contain either a lot of lines or graphics then SP2208-7 (Long Print Mode Setting) should be set accordingly. • The values set for this SP are reflected in the printed images after Long Print/Graphic has been selected. <p>[1 to 40 / 3 / 1%]</p>
6	Long Print: Graphic
	<p>The machine switches to the Long Print mode (fixed toner supply mode) for any original longer than 1189 mm (46.8 in.).</p> <ul style="list-style-type: none"> • There are two Long Print modes (Long Print/Drawing and Long Print Graphic). • If the operator is frequently running jobs that contain either a lot of lines or graphics then SP2208-7 (Long Print Mode Setting) should be set accordingly. • The values set for this SP are reflected in the printed images after Long Print/Graphic has been selected. <p>[1 to 40 / 6 / 1%]</p>
7	Long Print: Mode Setting

	<p>The machine switches to the Long Print mode (fixed toner supply mode) for any original longer than 1189 mm (46.8 in.).</p> <p>[0 to 1/0/1]</p> <p>*0: Drawing</p> <p>1: Graphic</p> <ul style="list-style-type: none"> This SP can be set for the graphic or line mode, depending on which type of job is most frequently required for printing. For a Long Print mode job the setting of SP2208-5 is reflected when the operator selects graphic mode, and the setting of SP2208-6 is reflected when the operator selects line mode.
--	--

5

2301	Transfer Current Adjustment
	<p>Use these SP's to adjust the power output and power coefficient used to transfer the toner image from drum to paper. Four separate voltages are applied before the leading edge, at the leading edge of the paper, across the image area and at the trailing edge of the paper..</p> <p>Notes:</p> <ul style="list-style-type: none"> The coefficient adjustment should be done before the power output. The amount of voltage applied to each area can be set independently in each area for the type of paper in use.

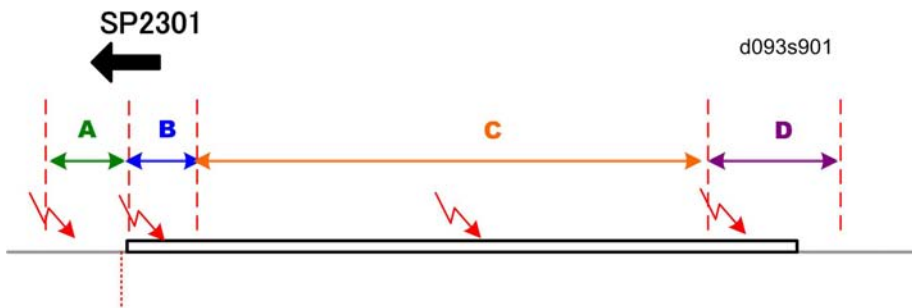

Transfer Current Adjustment Table

The four separate voltages for image transfer to paper are applied:

- A: Before paper leading edge
- B: Leading edge
- C: Image area
- D: Trailing edge

Default Voltages for Different Media

Paper	A		B		C		D	
	2301	uA	2301	uA	2301	uA	2301	uA
Plain: Roll	-001	60	-002	60	-003	60	-004	60
Translucent: Roll	-006	60	-007	60	-008	60	-009	60
Film: Roll	-011	80	-012	80	-013	80	-014	80
Plain: Cut Sheet	-021	60	-022	60	-023	60	-024	60
Translucent: Cut Sheet	-026	60	-027	60	-028	60	-029	60
Film: Cut Sheet	-031	80	-032	80	-033	80	-034	80

- The four voltages applied to the paper for image transfer can be adjusted at each area, depending on what type of paper is used.
- Note that the default voltages are slightly higher for Roll Film and Cut-Sheet Film.
- SP2301 sets the voltage levels. The timing for the application of the voltages is controlled by SP2925.

5

1	Roll Paper: Plain Paper: Before Leading Edge [0 to 230/60/1 μ A]
2	Roll Paper: Plain Paper: Leading Edge [0 to 230/60/1 μ A]
3	Roll Paper: Plain Paper: Image Area [0 to 230/60/1 μ A]
4	Roll Paper: Plain Paper: Trailing Edge [0 to 230/60/1 μ A]
5	Roll Paper: Plain Paper: Coefficient DFU
	Adjusts the transfer output coefficient for the image at the center, leading edge, and trailing edge on plain roll paper. [1 to 2 / 1/ 0.1]
6	Roll Paper: Translucent: Before Leading Edge [0 to 230/60/1 μ A]
7	Roll Paper: Translucent: Leading Edge [0 to 230/60/1 μ A]

8	Roll Paper: Translucent: Image Area [0 to 230/60/1 μ A]
9	Roll Paper: Translucent Paper: Trailing Edge [0 to 230/60/1 μ A]
10	Roll Paper: Translucent Paper: Coefficient DFU
	Adjusts the transfer output coefficient for the image at the center, leading edge, and trailing edge on translucent roll paper. [1 to 2 / 1 / 0.1]
11	Roll Paper: Film: Before Leading Edge [0 to 230/80/1 μ A]
12	Roll Paper: Film: Leading Edge [0 to 230/80/1 μ A]
13	Roll Paper: Film: Image Area [0 to 230/80/1 μ A]
14	Roll Paper: Film: Trailing Edge [0 to 230/80/1 μ A]
15	Roll Paper: Film: Coefficient DFU
	Adjusts the transfer output coefficient for the image at the center, leading edge, and trailing edge on film roll paper. [1 to 2 / 1 / 0.1]
21	Cut Paper: Plain Paper: Before Leading Edge [0 to 230/60/1 μ A]
22	Cut Paper: Plain Paper: Leading Edge [0 to 230/60/1 μ A]
23	Cut Paper: Plain Paper: Image Area [0 to 230/60/1 μ A]
24	Cut Paper: Plain Paper: Trailing Edge [0 to 230/60/1 μ A]

25	Cut Paper: Plain Paper: Coefficient DFU
	Adjusts the transfer output coefficient for the image at the center, leading edge, and trailing edge on plain cut-sheet paper. [1 to 2 / 1 / 0.1]
26	Cut Paper: Translucent: Before Leading Edge [0 to 230/60/1 μ A]
27	Cut Paper: Translucent: Leading Edge [0 to 230/60/1 μ A]
28	Cut Paper: Translucent: Image Area [0 to 230/60/1 μ A]
29	Cut Paper: Translucent: Trailing Edge [0 to 230/60/1 μ A]
30	Cut Paper: Translucent: Coefficient DFU
	Adjusts the transfer output coefficient for the image at the center, leading edge, and trailing edge on translucent cut-sheet paper. [1 to 2 / 1 / 0.1]
31	Cut Paper: Film: Before Leading Edge [0 to 230/80/1 μ A]
32	Cut Paper: Film: Leading Edge [0 to 230/80/1 μ A]
33	Cut Paper: Film: Image Area [0 to 230/80/1 μ A]
34	Cut Paper: Film: Trailing Edge [0 to 230/80/1 μ A]
35	Cut Paper: Film: Coefficient DFU
	Adjusts the transfer output coefficient for the image at the center, leading edge, and trailing edge on film cut-sheet paper. [1 to 2 / 1 / 0.1]
2801	Developer Initial Setting

	<p>This SP supplies some toner to the development unit, mixes the developer and toner, and initializes the ID sensor. Execute this SP to mix the developer during machine installation or after the developer has been replaced. The machine requires two packs of developer. Two SP codes are provided for entering the lot numbers of both packages.</p> <p>Note:</p> <ul style="list-style-type: none"> • Always enter the lot numbers with SP2801-2 and -3 before doing SP2801-1. • Execution of this SP requires that 2 kg of developer be loaded in the development unit and that the toner cartridge be set. • If the lot numbers are not entered, then the developer cannot be initialized (complete failure with no operation). • The Lot Numbers are stored in NVRAM. • Even if the Lot Numbers are the same, the number must be entered twice, once for each packet. • Enter the Lot Numbers with the soft keyboard.
1	Initialize Developer
	Touch [EXECUTE] to mix developer and initialize the ID sensor
2	Lot Number 1
	This is the lot number of the 1st packet.
3	Lot Number 2
	This is the lot number of the 2nd packet.
2803	Corona Wire Cleaning
	Do this SP to clean the charge corona wire. This SP also moves the cleaning pad to the home position. The cleaning requires about 20 sec. to complete.
2804	Corona Wire Cleaning Interval

	<p>Sets the interval for charge corona wire cleaning.</p> <p>Note: The wire is cleaned only when the hot roller temperature is below 50 °C (122°F).</p> <p>[0 to 6/3/1 step]</p> <p>0: None (no cleaning)</p> <p>1: After the main switch is turned on.</p> <p>2: After 300 m of copies</p> <p>3: After 600 m of copies</p> <p>4: After 900 m of copies</p> <p>5: After 1200 m of copies</p> <p>6: After 1500 m of copies</p>
--	--

2902	Test Pattern	
	Use these SP's to select and print test patterns. Select one of 25 available test patterns (1-25). [0 to 25/0/1] 0: None (default)	
	0: None	13: 1-dot Vertical Line
	1: 1-dot Grid Pattern	14: 2-dot Vertical Line
	2: 2-dot Grid Pattern	15: 1-dot Horizontal Line
	3: 3-dot Grid Pattern	16: 2-dot Horizontal Line
	4: 4-dot Grid Pattern	17: Checkered Flag
	5: 5-dot Grid Pattern	18: 1-dot Alternating Dot Pattern
	6: 6-dot Grid Pattern	19: 2-dot Alternating Dot Pattern
	7: 1-dot Argyle Pattern	20: 4-dot Alternating Dot Pattern
	8: 2-dot Argyle Pattern	21: Trimming Area
	9: 3-dot Argyle Pattern	22: Full Dot Pattern
	10: 4-dot Argyle Pattern	23: Vertical Black Band
	11: 5-dot Argyle Pattern	24: Horizontal Black Band
	12: 6-dot Argyle Pattern	25: Blank Image

2916	Fine Magnification
	<p>Adjusts the magnification for each paper type. These settings are enabled automatically for the paper type when the operator selects a magnification ratio for the copy job. These corrections are done during image processing after the original is scanned. Adjust the setting for a paper type if you consistently notice distortion in magnified images for a particular type.</p> <p>[-10 to +10/0/0.1%]</p> <p>Notes</p> <ul style="list-style-type: none"> • SP2916-1, SP2916-2 should be adjusted at installation of the main machine. In "1. Installation" see SP Adjustments.
1	Plain Paper: Mode1-4: Main Scan
2	Plain Paper: Mode1-4: Sub Scan
3	Translucent: Mode1-4: Main Scan
4	Translucent: Mode1-4: Sub Scan
5	Film: Mode1-4: Main Scan
6	Film: Mode1-4: Sub Scan
7	Recycled Paper: Mode1-4: Main Scan
8	Recycled Paper: Mode1-4: Sub Scan
9	Plain Paper: Mode5: Main Scan
10	Plain Paper: Mode5: Sub Scan
11	Translucent: Mode5: Main Scan
12	Translucent: Mode5: Sub Scan
13	Film: Mode5: Main Scan
14	Film: Mode5: Sub Scan
15	Recycled Paper: Mode5: Main Scan
16	Recycled Paper: Mode5: Sub Scan
2923	Execute Cleaning Blade Replace Mode

	<p>Always do this SP after replacing the OPC or cleaning blade.</p> <p>This SP applies a small amount of toner to the drum and blade to reduce friction between the new drum and/or new blade. This prevents scratching the drum or bending the blade.</p>
--	--

2924	Developer Mixing
1	Warmup
	<p>Prevents the occurrence of dirty background on the first copy after the machine is switched on, or returns from the auto off mode or sleep mode.</p> <p>[0 to 3/1/1]</p> <p>0: Off</p> <p>1: On (50 sec.). Development motor rotates 50 sec. after the machine is switched on when fusing temperature is less than 50°C (122°F).</p> <p>2: On (30 sec.). Development motor rotates 30 sec. after the machine is switched on when fusing temperature is less than 50°C (122°F).</p> <p>3: Development motor rotates 50 sec., regardless of the current fusing temperature.</p>
2	Enable
	<p>If the upper unit remains open for a long time, external light can sometimes temporarily fatigue the drum and cause horizontal banding in prints. To solve this problem, set this SP to "1" so as soon as the upper unit is closed, the charge corona can apply a charge to the drum to correct the problem.</p> <p>[0 to 1/1/1]</p> <p>0: OFF</p> <p>1: ON</p>

2926	Used Toner Overflow Detect
	The used toner bottle motor operates a cam which vibrates against the side of the used toner bottle. This vibration settles and evens the level of the used toner inside the bottle.
1	Used Tnr M (Sensor Detection)

	<p>Sets the length of time that the used toner bottle motor operates. The motor starts 10 sec. after the main power switch is switched on and if the fusing temperature is less than 50°C (122°F).</p> <p>[0 to 30/30/5]</p> <p>Note: Ten seconds after the machine is switched on if the machine detects that the toner collection bottle is full, the used toner bottle motor does not operate.</p>
2	Used Tnr M (TE Recovery)
	<p>Sets the length of time that the used toner bottle motor operates after TE (toner end).</p> <p>[0 to 80/30/5 sec.]</p>
3	Used Toner Bottle Full Detect
	<p>Sets the length of paper that can be printed from the time the toner bottle is detected near full until the used toner bottle is detected completely full.</p> <p>[1 to 50/30/1 m]</p>

2927	Toner (Near) End Detection DFU
	These SP's set the levels for the toner near-end and toner end levels.
1	Near End Level
	<p>Sets the level for toner near end detection. ($V_{sp}/V_{sg} = V_{end}$).</p> <p>[0.140 to 0.275/0.145/0.005 V]</p>
2	Toner End Level
	<p>Sets the V_{sp}/V_{sg} level for toner end detection. The ID sensor must detect this value three times in succession to detect toner end. The machine stops when toner end is detected.</p> <p>[0.150 to 300/0.165/0.005 V]</p>

2928	Toner End Recovery
------	--------------------

	<p>Recovery starts after the toner cartridge is replaced when a toner-end condition exists. [0.130 to 0.215/0.145/0.005 V]</p> <p>In the toner-end recovery process:</p> <ul style="list-style-type: none"> • The machine writes an ID sensor pattern on the surface of the drum. • The ID sensor reads the density of the ID sensor pattern and converts it to an electrical signal (Vsp). • The machine compares the Vsp value with Vsg, which is read from the bare surface of the drum (Vsg/Vsg=Vref) • If $V_{sp}/V_{sg} < V_{ref}$ (the value of this SP setting), recovery is completed and the machine goes back to normal operation.
--	---

2943	LED Duty Adjustment	
	Adjusts the on timing (the "width" or "duty") of the LEDs in the LPH units to change image exposure. Use this SP if it is necessary to make the output of one LPH block brighter or darker. Raising the setting creates darker pixels, lowering the setting creates lighter pixels.	
1	LPH1	[1.0 to 20.0/12.0/0.1%]
2	LPH2	The optimum LPH settings are printed on the label that is attached to LPH replacement units. Always input these settings immediately after the LPH unit has been replaced.
3	LPH3	

2952	LPH Joint Adjustment	
	Adjust these settings only after you replace the LPH. For more, refer to "Replacement and Adjustment".	
1	LPH1-2 Main Scan	
	Adjusts the LPH joint for main scan between LPH1 and LPH2. [0 to 999/500/1]	
2	LPH2-3 Main Scan	
	Adjusts the LPH joint for main scan between LPH2 and LPH3. [0 to 999/500/1]	
11	LPH1-2 Sub Scan	
	Adjusts sub scanning at LPH 1-2 for paper more than 420 mm wide. [300 to 500/412/1]	

12	LPH2-3 Sub Scan
	Adjusts sub scanning at LPH 2-3 for paper more than 420 mm wide. [2 to 100/16/1]
51	LPH1-2 Sub Scan: < 420mm
	Adjusts sub scanning at LPH 1-2 for paper less than 420 mm wide. This value is calculated automatically. [-50 to +50/0/1]
52	LPH2-3 Sub Scan: < 420mm
	Adjusts sub scanning at LPH 2-3 for paper less than 420 mm wide. This value is calculated automatically. [-50 to +50/0/1]

295 3	LPH Joint Power Correction		
	Adjusts the four LEDs at each end of LPH 2. This fine adjustment is not usually necessary in the field. [-63 to +63 / 0 / 1]		
1	1-Dot: Left	11	1-Dot: Right
2	2-Dot: Left	12	2-Dot: Right
3	3-Dot: Left	13	3-Dot: Right
4	4-Dot: Left	14	4-Dot: Right

2954	Print Image Priority
------	----------------------

Sets level for line thickness processing for vertical lines wider than 2-dots. This SP is provided to adjust the settings if the desired image quality cannot be obtained with the default settings. However, with the content of some settings some scratchiness or other problems may occur in the images, so use this adjustment with caution.

[0 to 3/1/1]

0: Strongest processing (thinnest)

1: Normal processing

2: Weaker processing

3: Weakest processing (thickest)

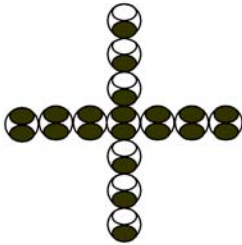

b286s931

The illustration above shows how two elements comprise each dot. This example shows vertical and horizontal 1-dot lines.

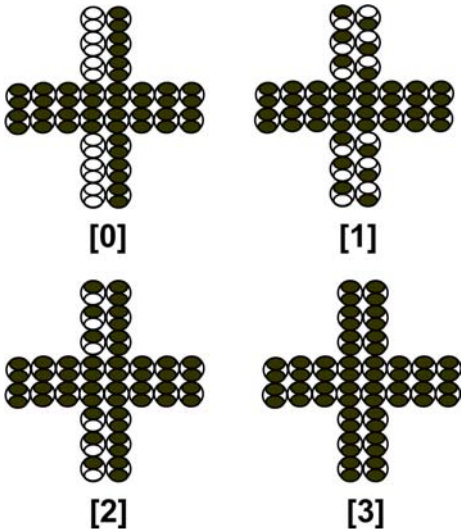

b286s932

The diagram above illustrates the patterns for the settings SP2954-10 (0 to 3) on a 2-dot vertical line. The settings have no effect on the horizontal line.

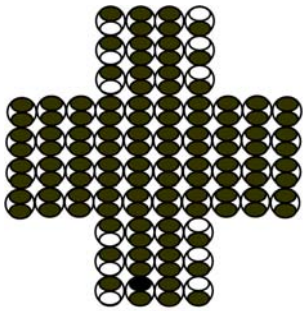

[1] b286s933

When line thickness more than 2 dots the value selected for SP2954-10 affects only the outer lines. The diagram above shows "1" selected for SP2954-10. The setting does not affect the horizontal line.

5

SP3-xxx Process Control

3001	ID Sensor Initial Setting
	These SP's do the settings for the ID sensor LED.
1	PWM Setting: ID Sensor LED DFU
	Sets the level of the PWM (Pulse Width Modulation) of the ID sensor LED. [0 to 100/20/0.1%]
2	Initialize ID Sensor: Execute
	Automatically adjusts the ID sensor with a sensor reading of the bare drum. The initial setting is 4.0V ±0.2. This SP requires about 4 sec. to execute. Always do this SP at installation, and after you replace these components: <ul style="list-style-type: none"> • OPC Drum • ID Sensor • NVRAM • MCU

310	ID Sensor Output Display	
3	This SP displays the current readings of the bare drum surface (Vsg) and the ID sensor pattern (Vsp)	
1	Vsg	Bare drum reflection

2	Vsp	ID sensor pattern reflection
3920	ID Sensor Pattern Interval	
1	Job End	
	This SP sets the distance between the readings of the previous and next ID sensor pattern. [20 to 1000 / 100 / 100 cm]	
2	During Job ON/OFF	
	This setting is for ID sensor pattern reading during print jobs. [0 to 1 / 1 / 1] <ul style="list-style-type: none"> • If "0" (OFF) is selected the ID sensor pattern will not be read until the job ends (this means that the most recent Vsp/Vsg reading at the end of the previous job is used). • If "On" is selected the ID sensor will read the ID sensor patterns at the prescribed interval to stabilize toner supply control. 	
3	During Job	
	This SP sets the time interval between the readings of the previous and next ID sensor pattern during a job. [20 to 2000 / 100 / 10 cm]	

SP4-xxx Scanner

4008	Scanner Sub Scan Magnification	
	Adjusts magnification in the sub scan direction by changing the speed of the main motor. [-0.9 to +0.9/0/0.1% step]	
4010	Scanner Sub Scan Registration	
1	Leading Edge	
	This SP shifts the leading edge of the scanned image relative to the sub scan direction. [-10 to 10/0/ 0.1 mm step] <ul style="list-style-type: none"> • A higher setting "+" shifts the image down (opposite the sub scan direction). • A lower setting "-" shifts the image up (in the same direction as the sub scan direction). 	
2	Trailing Edge	

	<p>This SP shifts the trailing edge of the scanned image relative to the sub scan direction. [-10 to 10/0.0/0.1 mm step]</p> <ul style="list-style-type: none"> • A higher setting "+" shifts the image down (opposite the sub scan direction). • A lower setting "-" shifts the image up (in the same direction as the sub scan direction).
--	--

4011	Scanner Main Scan Registration
	<p>This SP shifts the scanned image relative to the main scan direction. [-4 to 4/0.0/0.1 mm]</p> <ul style="list-style-type: none"> • A higher setting "+" shifts the image to the right (in the main scan direction). • A lower setting "-" shifts the image to the left (against the main scan direction).

5

4012	Scanner Erase Margin	
	<p>These SP's define borders around the image area output by the scanner. Each edge can be set independent of the others.</p>	
5	DF: LEdge	[0 to 9 / 1.5 / 0.1 mm]
6	DF: TEdge	
7	DF: Left	
8	DF: Right	[0 to 9 / 0.5 / 0.1 mm]

4013	Scanner Free Run
	<p>These SP's set up and start the scanner free run operation for testing.</p>
1	Start
	<p>This SP uses the most recent settings for the original length and interval between sheets to print virtual pages for a scanner free run. [ON] Start [OFF] Stop</p>
2	Page Interval Setting
	<p>Sets the interval between virtual prints for the scanner free run. [0 to 25/ 0.9 / 0.1 s]</p>
3	Original Length Setting

	Sets the interval between multiple feeds for the DF free run. [0.2 to 15 / 0.6 / 0.1 m]
--	--

4101	Scanner Main Scan Magnification
	Adjusts the side-to-side scan magnification. [-0.9 to +0.9/0.0/0.1 %]

4417	IPU Test Pattern
	Enter the number for the desired test pattern, switch the display to the "Copy Window" then press the [Start] button. [0 to 28 / 0 / 1]
	Scan Text Patterns
0	*0: Scanner Data
1	1-dot Vertical Line: SCN
2	2-dot Vertical Line: SCN
3	1-dot Horizontal Line: SCN
4	2-dot Horizontal Line: SCN
5	1-dot Alternating Dot Pattern: SCN
6	1-dot Grid Pattern: SCN
7	Vertical Stripes: SCN
8	Horizontal Grayscale: 16-Lvl:SCN
9	Vertical Grayscale: 16-Lvl:SCN
10	Density Patch: 16-Lvl: SCN
11	Cross Pattern: SCN
12	Argyle Pattern: SCN
13	Density Patch: 256-Lvl: SCN
14	Density Patch: 64-Lvl: SCN
15	Trim Area: SCN

	16	Vert. Frequency Characteristics: SCN
	17	Horiz. Frequency Characteristics: SCN
Print Text Patterns		
	18	1to4-dot Ind. Dot & Coverage: PRN
	19	Horizontal Grayscale: 16-Lvl: PRN
	20	Vertical Grayscale: 16-Lvl: PRN
	21	16-Lvl Grayscale: PRN
	22	Density Patch (256-Lvl): PRN
	23	Density Patch (64-Lvl): PRN
	24	Cross Pattern: PRN
	25	Grid Pattern (96-dot Width)
	26	Argyle Pattern
	27	Horizontal Grayscale (8-Lvl) & Line
	28	Grid Pattern (128-dot Width)

4903	Image Quality Adjustment
	<p>Use this if density is not equal in shaded areas of the copy. The change from high to low density areas in shaded areas must be smooth. Do these SP adjustments if you see "false outlines" in shaded areas of the copy.</p> <ul style="list-style-type: none"> • To increase the effect, use a higher setting. • To decrease the effect, use a lower setting. • The higher settings can make text look better, but can also decrease the quality of the image.
1	<p>Independent Dot Erase: Text</p> <p>Sets the independent dot erase mode for scanning Text Mode.</p> <p>[0 to 7 / 4 / 1]</p> <p>0 (Weakest), 4 (Medium: Default), 7 (Strongest)</p>

2	<p>Independent Dot Erase : Generation</p> <p>Sets the independent dot erase mode for scanning Generation Mode.</p> <p>[0 to 7 / 4 / 1]</p> <p>0 (Weakest), 4 (Medium: Default), 7 (Strongest)</p>
3	<p>Independent Dot Erase : Drawing</p> <p>Sets the independent dot erase mode for scanning independent dot erase in Line Drawing Mode.</p> <p>[0 to 7 / 0 / 1]</p> <p>0 (Weakest), 4 (Medium: Default), 7 (Strongest)</p>
11	<p>Line Width Corr : Text: Mode Select</p> <p>Sets the strength of line correction effect for Text Mode.</p> <p>[0 to 8 / 3 / 1]</p> <p>0 (Weakest)</p> <p>3: Default</p> <p>4 (Medium)</p> <p>8 (Strongest)</p>
12	<p>Line Width Corr : Text: Main Scan</p> <p>Sets the strength of line correction in the main scan direction for Text Mode</p> <p>[0 to 2 / 1 / 1]</p> <p>0: No line width correction</p> <p>1: Line width and shaded area correction</p> <p>2: Line width correction only</p>
13	<p>Line Width Corr : Text: Sub Scan</p> <p>Sets the strength of line correction effect for Text Mode in the sub scan direction.</p> <p>[0 to 1 / 1 / 1]</p> <p>0: No line width correction</p> <p>1: Line width correction</p>

14	<p>Line Width Corr : Generation: Mode Select</p> <p>Sets the strength of line correction effect for Generation Mode</p> <p>[0 to 8 / 3 / 1]</p> <p>0 (Weakest)</p> <p>3: Default</p> <p>4 (Medium)</p> <p>8 (Strongest)</p>
15	<p>Line Width Corr : Generation: Main Scan</p> <p>Sets the strength of line correction in the main scan direction for Generation Mode.</p> <p>[0 to 2 / 1 / 1]</p> <p>0: No line width correction</p> <p>1: Line width and shaded area correction</p> <p>2: Line width correction</p>
16	<p>Line Width Corr : Generation: Sub Scan</p> <p>Sets the strength of line correction effect for Generation Mode.</p> <p>[0 to 1 / 1 / 1]</p> <p>0: No line width correction</p> <p>1: Line width correction</p>
4905	<p>Gray Scale Processing</p> <p>Selects the type of dithering done in Photo mode.</p> <p>[0 to 255/0/1]</p> <p>0: 2-value dithering 8x8</p> <p>1: 2-value dithering 16x16</p> <p>2: 2-value dithering 16x16</p>
4961	<p>Original Adjustment</p> <p>1 Synchro-cut Adjustment 210mm</p> <p>Adjusts the synchro-cut position.</p> <p>[-9.9 to +9.9/0.0/0.1 mm]</p> <p>Use the 210-mm position in the sample to check the difference. This setting is used to calculate the motor clock count for adjusting the difference.</p>

2	Synchro-cut Adjustment 1000mm
	<p>Adjusts the synchro-cut position. [-9.9 to +9.9/0.0/0.1 mm step]</p> <p>Use the 1000-mm position in the sample to check the difference. This setting is used to calculate the motor clock count for adjusting the difference.</p>
3	Original Length Display
	Displays the original length.

4965	Scan Speed Switch Correction
	<p>The original feed roller tries to adjust for slippage of the feed rollers to allow the machine measure the length of the original accurately. The diameter of the feed roller (32 ± 0.05) differs slightly from the diameter of the exit roller (32 ± 0.05). The slightly higher speed of the exit roller could cause the original to feed faster than usual, and cause distortion of the image at the joints of the CIS. Use this SP to lower the speed of the original to correct this problem if image distortion at the CIS joints occurs.</p> <p>When to Use This SP</p> <ul style="list-style-type: none"> Adjust this SP if you see image distortion after replacing the original feed roller or exit roller. You may also need to adjust this SP if you see image distortion after CIS adjustments with SP4972. <p>For more about how to use SP4965, please refer to "Replacements and Adjustments" > "Scanner", "Original Feed Unit Rollers".</p> <p>[-1.0 to 0.0/ -0.2 /0.1]</p>
1	Leading Edge

	<p>The original feed roller tries to adjust for slippage of the feed rollers to allow the machine measure the length of the original accurately. The diameter of the feed roller (32 ± 0.05) differs slightly from the diameter of the exit roller (32 ± 0.05). The slightly higher speed of the exit roller could cause the original to feed faster than usual, and cause distortion of the image at the joints of the CIS. Use this SP to lower the speed of the original to correct this problem if image distortion at the CIS joints occurs.</p> <p>When to Use This SP</p> <ul style="list-style-type: none"> Adjust this SP if you see image distortion after replacing the original feed roller or exit roller. You may also need to adjust this SP if you see image distortion after CIS adjustments with SP4972. <p>[-1 to 0 / -0.2 / 0.1%]</p>
2	Position to Switch
	<p>Sets the original position where the motor speed adjustment for SP4965-1 starts.</p> <p>[0 to 200 / 112 / 1 mm]</p>
3	Trailing Edge
	<p>Specifies the point 14.5 mm past the original set sensor where the speed of the original exit motor should be adjusted.</p> <p>[-1 to 1 / 0 / 0.1%]</p>

4972	Scan Correction	
	These SP's correct the alignment the image scanned by the CIS. For more, see SP Adjustments.	
1	CIS1-2 Main Scan	[0 to 656 / 358 / 0]
2	CIS2 Main Scan	DFU
3	CIS2-3 Main Scan	[0 to 656 / 424 / 0]
4	CIS3-4 Main Scan	[0 to 656 / 425 / 0]
5	CIS4-5 Main Scan	[0 to 656 / 426 / 0]
6	CIS1-2 Sub Scan	[0 to 2815 / 620 / 1]
7	CIS2 Sub Scan	DFU
8	CIS2-3 Sub Scan	[0 to 2815 / 645 / 1]
9	CIS3-4 Sub Scan	[0 to 255 / 26 / 1]

10	CIS4-5 Sub Scan	[0 to 2815 / 643 / 1]
4973	Scan Correction	
	<p>This SP turns on image adjustment feature that corrects slight misalignment of the image at the joints of the CIS elements.</p> <p>[0 to 2 / 2 / 1]</p> <p>0: No adjustment</p> <p>1: Simple adjustment at joints</p> <p>2: Gradation adjustment at joint</p>	
4975	Prevent Original Falling	
	<p>This SP determines whether the machine stops and holds the edge of the original after the original is fed so that it does not fall.</p> <p>[0 to 1/0/1]</p> <p>*0: Disable, 1: Enable</p>	

SP5-xxx Mode

5045	Accounting Counter		CTL
	These SP codes setting the method and units for counting.		
1	Counter Method		
	<p>Selects the counting method</p> <p>[0 to 1/0/1]</p> <p>0: Development counter (black prints)</p> <p>1: Paper counter. Shows the total page counts</p>		
2	Counter Unit		
	<p>[0 to 8/ 0 / 1]</p> <p>0: Models -21/-27, 2: Model -17</p>		
	0	Meters	
	1	Yards	

	2	Feet	
	3	Meters ²	
	4	Yards ²	
	5	Feet ²	
	6	A3=1	Surface area count
	7	0.1 meters	Only for counting devices by user.
	8	01. yards	

5

5055	Display IP Address	CTL
	<p>Switches the banner display of the IP address off and on. (Default: * Off) [OFF] ON For example, if this SP is switched on, the IP address will be displayed below "Ready" while the printer is in standby mode: Ready 169.254.187.055</p>	

5056	Coverage Counter Display	CTL
	<p>This SP switches the counter list for the system administrator on/off. [0 to 1/1/1] 0: On, 1: Off</p>	

5071	Set Bypass Paper Size Display	CTL
	<p>This SP determines whether long paper can be fed from the bypass tray. Note: Even if "1" is selected only paper up to 432 mm can be used. [0 to 1 / 0 / 1] 0: Disable 1: Enable</p>	

5113	Optional Counter Type	CTL
------	-----------------------	-----

1	Default Optional Counter Type
	<p>[0 to 12/0/1]</p> <p>Selects the type of counter:</p> <p>0: None</p> <p>1: Key Card (RK3, 4) Japan Only</p> <p>2: Key Card Down</p> <p>3: Pre-paid Card</p> <p>4: Coin Rack</p> <p>5: MF Key Card</p> <p>11: Exp Key Card (Add)</p> <p>12: Exp Key Card (Deduct)</p>
2	External Optional Counter Type
	<p>Enables the SDK application. This lets you select a number for the external device for user access control.</p> <p>[0 to 3/0/1]</p> <p>Note: "SDK" refers to software on an SD card.</p> <p>[0 to 3/1]</p> <p>0: None</p> <p>1: Expansion Device 1</p> <p>2: Expansion Device 2</p> <p>3: Expansion Device 3</p>

5114	Optional Counter I/F	CTL
	<p>This SP code enables the interface for an optional counting device.</p> <p>[0 to 8/0/1]</p> <p>Important Note: Only settings that can be enabled for machines outside Japan are listed here.</p> <p>0: Disabled</p> <p>1: Key Cards (RK2, 3, 4)</p> <p>2: Decrementing keycard</p> <p>11: Incrementing key cards for use outside Japan</p> <p>12: Decrementing key cards for use outside Japan</p>	

5118	Disable Copying	CTL
	<p>Temporarily denies access to the machine.</p> <p>[0 to 1/0/1]</p> <p>0: Release for normal operation</p> <p>1: Prohibit access to machine</p>	
5120	Mode Clear Count Removal	CTL
<p>For a machine that has a counting device, this SP sets the next action when a copy job stops because the card is removed, the card is expired, or if the paper supply runs out. Japan Only</p> <p>[0 to 2/0/1 step]</p> <p>0: Yes</p> <p>1: Stand-by</p> <p>2: No</p>		
5121	Counter Up Timing	CTL
<p>Determines whether the optional key counter counts up at paper feed-in or at paper exit.</p> <p>[0 to 1/1/1]</p> <p>0: Feed count</p> <p>1: No feed count</p>		
5127	APS Off Mode	CTL
<p>This SP can be used to switch APS (Auto Paper Select) off while a coin lock or pre-paid key card device is connected to the machine.</p> <p>[0 to 1/0/1]</p> <p>0: On</p> <p>1: Off</p>		
5162	App. Switch Method	CTL
<p>Determines if the application screen changes with a hardware switch or a software switch.</p> <p>[0 to 1/0/1]</p> <p>0: Soft Key Set</p> <p>1: Hard Key Set</p>		

5169	CE Login	CTL
<p>This SP enables and disables the CE log in mode. With this SP enabled, the machine is in the CE (Customer Engineer/Service Technician) login mode.</p> <p>In the CE login mode:</p> <ul style="list-style-type: none"> • The machine power can be turned off and on in the SP mode, and it will remain in the SP mode after power is restored. • This SP is automatically reset to "0" (disabled) after the service technician closes the SP mode with the [Exit] soft button or after the log out timer expires. <p>Note: The Auto Logout Timer is in the "System Settings" of UserTools.</p> <p>[0 to 1/0/1]</p> <p>0: Disable, 1: Enable</p> <p>0: CE login mode disabled.</p> <p>1: CE login mode enabled.</p>		
5180	Charge Counter Method Japan Only	CTL
<p>This SP codes sets the charge counter method.</p> <p>[0 to 1/0/1]</p> <p>0: Count number of sheets by paper size</p> <p>1: Count frequency by paper size</p>		
5195	Limitless Switch	CTL
<p>This SP selects the paper feed mode by switching between "productivity priority" (0) and "tray priority" (1). This SP operates only if the operator has selected "Auto Paper Select".</p> <p>[0 to 1 / 0 / 1]</p> <p>0: Productivity priority. Switches from the current feed tray to the priority tray as soon as the machine detects the priority tray, even if paper still remains in the current feed tray.</p> <p>1: Tray priority. Switches the feed tray only after the paper in the tray current tray runs out of paper.</p>		

5302	Set Time	CTL
	<p>Sets the time clock for the local time. This setting is done at the factory before delivery. The setting is GMT expressed in minutes.</p> <p>[-1440 to 1440/1 min.]</p> <p>AS: +480 (Hong Kong)</p> <p>CH: +480 (Peking)</p> <p>EU: +60 (Paris)</p> <p>JA: +540 (Tokyo)</p> <p>KO: +540 (Korea)</p> <p>NA: -300 (NY)</p> <p>TW: +480 (Taipei)</p>	

5404	User Code Count Clear	CTL
	<p>Clears the counts for the user codes assigned by the key operator to restrict the use of the machine. Press [Execute] to clear.</p>	

5490	MF Keycard Japan Only	CTL
	<p>Sets up operation of the machine with a keycard.</p> <p>[0 to 1/0/1]</p> <p>0: Disabled. Cancels operation if no code is input.</p> <p>1: Enabled. Allows operation if another code is input and decrements the counter once for use of the entered code.</p>	

5501	PM Alarm	CTL
1	PM Alarm Level	
	<p>[0 to 9999 / 0 / 1 step]</p> <p>0: Alarm off</p> <p>1 to 9999: Alarm goes off when Value (1 to 9999) > PM counter</p>	
2	Original Count Alarm	
	<p>[0 to 1/0/1]</p> <p>0: No alarm sounds</p> <p>1: Alarm sounds after the number of originals passing through the ARDF > 10,000</p>	

5504	Jam Alarm	CTL
	Sets the alarm to sound for the specified jam level (document misfeeds are not included). [0 to 3 / 3 / 1 step] 0: Zero (Off) 1: Low (2.5K jams) 2: Medium (3K jams) 3: High (6K jams)	
5505	Error Alarm	CTL
	Sets the error alarm level. [0 to 255 / 1 / 1 Step] Note: 1 Step is 100 mm.	
5507	Supply Alarm	CTL
1	Paper Supply Alarm	
	Switches the control call on/off for the paper supply. [0 to 1/0/1] 0: Off, 1: On 0: No alarm. 1: Sets the alarm to sound for the specified number transfer sheets for each paper size (A3, A4, B4, B5, DLT, LG, LT, HLT)	
3	Toner Supply Alarm	
	Switches the control call on/off for the toner end. [0 to 1/0/1] 0: Off, 1: On If you select "1" the alarm will sound when the main machine detects toner end.	
80	Toner Call Timing	
	This SP switches the toner supply call for @Remote. [0 to 1 / 0 / 1] 0: Toner replacement. Triggers the alarm when toner should be replaced with new toner. 1: Toner near-end. The alarm triggers at toner-end or toner near-end.	

	<p>Note: The "Interval nn" SP's below specify the paper control call interval for the referenced paper sizes. [00250 to 10000 / 1000 / 1 Step]</p>
--	---

5508	CC Call	CTL
1	Jam Remains	Enables/disables initiating a call. [0 to 1/1/1] 0: Disable 1: Enable
2	Continuous Jams	
3	Continuous Door Open	
11	Jam Detection: Time Length	
	Sets the length of time to determine the length of an unattended paper jam. [3 to 30/10/1] This setting is enabled only when SP5508-4 is enabled (set to 1).	
12	Jam Detection Continuous Count	
	Sets the number of continuous paper jams required to initiate a call. [2 to 10/5/1] This setting is enabled only when SP5508-4 is enabled (set to 1).	
13	Door Open: Time Length	
	Sets the length of time the remains opens to determine when to initiate a call. [3 to 30/10/1] This setting is enabled only when SP5508-4 is enabled (set to 1).	

	SC/Alarm Setting	CTL
5515	<p>Determines whether an SC call is issued when an SC error occurs while either CSS (Japan) or @Remote is enabled: [0 to 1/1/1] 1: An SC call is issued when an SC error occurs. 0: An SC call is not issued when an SC error occurs.</p>	
1	SC Call	

	<p>Determines whether an SC call is issued when an SC error occurs while either CSS or @Remote is enabled:</p> <p>[0 to 1/1/1]</p> <p>1: An SC call is issued when an SC error occurs.</p> <p>0: An SC call is not issued when an SC error occurs.</p>
2	Service Parts Near End Call
3	Service Parts End Call
4	User Call
6	Communication Test Call
7	Machine Information Notice
8	Alarm Notice
10	Supply Automatic Ordering Call
11	Supply Management Report Call
12	Jam/Door Open Call

5801	Memory Clear
	Resets NVRAM data to the default settings. Before executing any of these SP's, print an SMC Report.
1	All Clear
	Initializes items 2 to 22 below.
2	Engine
	Initializes all registration settings for the engine and copy process settings.
3	SCS
	Initializes default system settings, SCS (System Control Service) settings, operation display coordinates, and ROM update information.
4	IMH Memory Clr
	Initializes the image file system. (IMH: Image Memory Handler)
5	MCS

	Initializes the automatic delete time setting for stored documents. (MCS: Memory Control Service)
6	Copier Application
	Initializes all main machine application settings.
8	Printer Application
	Initializes the printer defaults, programs registered, the printer SP bit switches, and the printer CSS counter.
9	Scanner Application
	Initializes the defaults for the scanner and all the scanner SP modes.
10	Web Service
	Deletes the Netfile (NFA) management files and thumbnails, and initializes the Job login ID. Netfiles: Jobs to be printed from the document server using a PC and the Desk Top Binder software
11	NCS
	Initializes the system defaults and intersection settings (IP addresses also), the Smart Net Monitor for Admin settings, Web Status Monitor settings, and the TELNET settings. (NCS: Network Control Service)
14	Clear DCS Setting
	Initializes the DCS (Delivery Control Service) settings.
15	Clear UCS Setting
	Initializes the UCS (User Information Control Service) settings.
16	MIRS Setting
	Initializes the MIRS (Machine Information Report Service) settings.
17	CCS
	Initializes the CCS (Certification and Charge-control Service) settings.
18	SRM Memory Clr
	Initializes information in non-volatile RAM.

19	LCS Memory Clr
	Initializes information in non-volatile RAM.
20	Web Uapli
	Initializes the web user application settings.
21	ECS
	Initializes the ECS settings.
22	Folder
	Initializes the folder settings.

5802	Printer Free Run
	Does a free run in the mode specified on the operation panel. Push On or Off to switch on or off.

5803	Input Check
	Displays the signals received from switches and sensors.
1	Roll Unit Open Sensor
2	Cutter Sensor
3	Roll Leading Edge Sensor
4	Roll Unit Sensor 1
5	Roll End Sensor 1
6	Roll End Sensor 1: White
7	Roll Unit: Sensor 2
8	Roll End Sensor 2
9	Roll End Sensor 2: White
10	Cassette Unit Sensor
11	Cassette Tray Set Sensor 1
12	Cassette 1 Feed Sensor

13	Paper End Sensor 1
14	Exit Fan Lock Sensor
15	Paper Set Sensor
16	Paper Registration Sensor
17	Paper Exit Sensor
18	Total Counter Set
19	Toner Overflow Sensor
20	Charge Corona Cleaner Motor Rotation Sensor
21	Clam Shell Open Sensor (Right) 24V
22	Clam Shell Open Sensor (Left) 5V
23	Exit Cover Open Sensor (Right) 24V
24	Exit Cover Open Sensor (Left) 5V
25	Fusing Unit Sensor
26	Toner Cover Open Sensor
27	Main Motor Lock Sensor
28	Drum Motor Lock Sensor
29	Fusing Motor Lock Sensor
30	Overheat Sensor
31	Zero Cross
32	DIP SW1
33	Key Card Set
34	Key Counter Set
35	Folder Connect Sensor
36	Model Detect
37	Copy Exit Switch
201	Original Width Sensor: A0

202	Original Width Sensor: A1
203	Original Width Sensor: A2
204	Original Width Sensor: A3
205	Original Width Sensor: B1
206	Original Width Sensor: B2
207	Original Width Sensor: B3
208	Original Width Sensor: B4
209	Original Width Sensor: 914 mm
210	Original Width Sensor: 30"
211	Original Set Sensor
212	Original Registration Sensor
213	Original Exit Sensor
214	Original Emergency Stop Sensor
215	Original Feed Unit Open Sensor

5804	Output Check
	Switches each electrical component to test its operation.
11	Roll Feed Motor: Forward
12	Roll Feed Motor: Reverse
15	1st Roll Feed Clutch
16	2nd Roll Feed Clutch
19	Cutter Motor
21	Cassette Feed Motor
25	Cassette Feed Clutch
32	Main Motor
33	Fusing Motor

34	Drum Motor	
35	Registration Clutch	
36	Paper Junction Gate Solenoid	
37	Used Toner Motor	
41	Charge Corona	
42	Charge Grid: Image Area	
43	Charge Grid: ID Sensor Pattern	
44	Charge Corona/Grid: Image Area	
45	Development Bias: Image Area	
46	Development Bias: ID Sensor Pattern	
49	Separation Corona: Leading Edge	
50	Separation Corona	
52	Toner Supply Clutch	
53	Quenching Lamp	
54	Pick-off Pawl Solenoid	
55	ID Sensor LED	
66	Charge Corona Wire Cleaner Motor	
67	Recycle Counter	
68	Dehumidifier	
70	Transfer Corona: Leading Edge	
71	Transfer Corona: Pre-Leading Edge	
72	Transfer Corona	
73	Transfer Corona: Rear Edge	
74	Exit Fan	
201	Scanner Motor Off/On	
211	CIS LED R	

212	CIS LED G	
213	CIS LED B	

5810	SC Reset	
	<p>Touch [EXECUTE] to release the machine for servicing.</p> <ul style="list-style-type: none"> • When the machine issues a "Level A" SC code, this indicates a serious problem in the fusing unit (SC542 to SC546, for example). • As soon as the Level A SC code is issued, the machine is disabled immediately. • The operator cannot reset the SC because the machine requires servicing immediately. • The machine cannot be used until the machine has been service. 	

5811	Machine No. Setting DFU	CTL
	<p>This SP presents the screen used to enter the 11-digit number of the machine. The allowed entries are "A" to "Z" and "0" to "9". The setting is done at the factory, and should not be changed in the field.</p>	

	Service Tel. No. Setting	CTL
5812	<p>Use these SP modes to input service and support telephone numbers. Enter the number and press</p> <p>Press the [./*] key to input a pause. Press the "Clear modes" key to delete the telephone number.</p>	
1	Service	Service representative telephone number.
2	Facsimile	Fax number of service representative
3	Supply	Supplier of consumables
4	Operation	Operation support

5816	Remote Service	CTL
------	----------------	-----

1	I/F Setting
	<p>Turns the remote diagnostics off and on.</p> <p>[0 to 2/2/1]</p> <p>0: Remote diagnostics off.</p> <p>1: Serial (CSS or @Remote) remote diagnostics on.</p> <p>2: Network remote diagnostics on for @Remote</p>
2	CE Call
	<p>Lets the operator engineer start or end of the remote machine check with CSS or @Remote; to do this, push the center report key</p>
3	Function Flag
	<p>Enables and disables remote diagnosis over the @Remote network.</p> <p>[0 to 1/0/1]</p> <p>0: Disables remote diagnosis over the network.</p> <p>1: Enables remote diagnosis over the network.</p>
7	SSL Disable
	<p>Controls if RCG (Remote Communication Gate) confirmation is done by SSL during an RCG send for the @Remote over a network intersection.</p> <p>[0 to 1/0/1]</p> <p>0: Yes. SSL not used.</p> <p>1: No. SSL used.</p>
8	RCG Connect Timeout
	<p>Sets the length of time (seconds) for the time-out when the RCG (Remote Communication Gate) connects during a call via the @Remote network.</p> <p>[1 to 90/30/1 sec.]</p>
9	RCG Write to Timeout
	<p>Sets the length of time (seconds) for the time-out when sent data is written to the RCG during a call over the @Remote network.</p> <p>[0 to 100/60/1 sec.]</p>

10	RCG Read Timeout
	Sets the length of time (seconds) for the timeout when sent data is written from the RCG during a call over the @Remote network. [0 to 100/60/1 sec.]
11	Port 80 Enable
	Controls if permission is given to get access to the SOAP method over Port 80 on the @Remote network. [0 to 1/0/1] 0: No. Access denied 1: Yes. Access granted.
13	RFU Timing
	This SP determines how the machine receives forum (RFU: @Remote Forum Updates) updates. [0 to 1 / 1/ 1] 0: All forum updates 1: Energy status update only
21	RCG – C Registered
	This SP displays the Embedded RC Gate installation end flag. 1: Installation completed 2: Installation not completed
23	Connect Type (N/M)
	This SP displays and selects the Embedded RC Gate connection method. 0: Internet connection 1: Dial-up connection
61	Cert. Expire Timing DFU
	Proximity of the expiration of the certification.
62	Use Proxy
	This SP setting determines if the proxy server is used when the machine communicates with the service center.

63	Proxy Host
	This is the address of the HTTP proxy server used to effect communication between Embedded RC Gate-M and the Gateway. The length of the address is limited to 127 characters (characters beyond the 127th character are ignored).
64	Proxy Port Number
	This is the port number of the HTTP proxy used to effect communication between Embedded RC Gate-N and the Gateway. [0 to 0xffff/0/1]
65	Proxy User name
	This is the user name used for certification of the HTTP proxy. The length of the name is limited to 31 characters (characters beyond the 31st character are ignored).
66	Proxy Password
	This is the certification password of the HTTP proxy. The length of the password is limited to 31 characters (characters beyond the 31st character are ignored).

Note: The proxy number, user name, and password comprise proprietary operator information required by the service technician to do the necessary settings for Embedded RC Gate-N. To prevent unauthorized access this information, these SP settings do not appear in the SMC report.

	CERT: Up State
	Displays the state of the certification update used for Embedded RC Gate. If Embedded RC Gate has not been set up, These SP settings are done automatically as soon as Embedded RC Gate is set up.
	0 The certification used by Embedded RC Gate is set correctly.
	1 The certification request (SetAuthKey) for update has been received from the CTL URL and certification is presently being updated.
	2 The certification update is completed and the CTL URL is being notified of the successful update.
	3 The certification update failed, and the CTL URL is being notified of the failed update.
	4 The period of the certification has expired and new request for an update is being sent to the CTL URL.
67	11 A rescue update for certification has been issued and a rescue certification setting is in progress for the rescue CTL connection.
	12 The rescue certification setting is completed and the CTL URL is being notified of the certification update request.
	13 The notification of the request for certification update has completed successfully, and the system is waiting for the certification update request from the rescue CTL URL.
	14 The notification of the certification request has been received from the rescue CTL URL, and the certification is being stored.
	15 The certification has been stored, and the CTL URL is being notified of the successful completion of this event.
	16 The storing of the certification has failed, and the CTL URL is being notified of the failure of this event.
	17 The certification update request has been received from the CTL URL, the CTL URL was notified of the results of the update after it was completed, but a certification error has been received, and the rescue certification is being recorded.
	18 The rescue certification of No. 17 has been recorded, and the CTL URL is being notified of the failure of the certification update.

68	CERT: Error	
	Displays a number code that describes the reason for the notification requesting the certification update.	
	0	Normal. No request for certification update in progress.
	1	Certification update in progress due to expiration of certification.
	2	SSL error has been issued after the certification has expired.
	3	There has been a shift from a common to individual certification.
	4	There has been a common certification without ID2.
	5	No certification has been issued.
69	CERT: Up ID	
	The ID of the request for certification.	
83	Firm Up Status	
	Displays the status of the firmware update.	
85	Firm Up User Check	
	This SP setting determines if the operator can check the previous version of the firmware before the firmware update execution. If the option to check the previous version is selected, a notification is sent to the system manager and the firmware update is done with the firmware files from the URL.	
86	Firmware Size	
	Allows the service technician to check the size of the firmware data files during the firmware update execution.	
87	CERT: Macro Version	
	Displays the macro version of the @Remote certification	
88	CERT: PAC Version	
	Displays the PAC version of the @Remote certification.	

89	<p>CERT: ID2 Code</p> <p>Displays ID2 for the @Remote certification. Spaces are displayed as underscores (_). Asterisks (****) indicate that no @Remote certification exists.</p>
90	<p>CERT: Subject</p> <p>Displays the common name of the @Remote certification subject. CN = the following 17 bytes. Spaces are displayed as underscores (_). Asterisks (****) indicate that no DESS exists.</p>
91	<p>CERT: Serial Number</p> <p>Displays serial number for the @Remote certification. Asterisks (****) indicate that no DESS exists.</p>
92	<p>CERT: Issuer</p> <p>Displays the common name of the issuer of the @Remote certification. CN = the following 30 bytes. Asterisks (****) indicate that no DESS exists.</p>
93	<p>CERT: Valid Start</p> <p>Displays the start time of the period for which the current @Remote certification is enabled.</p>
94	<p>CERT: Valid End</p> <p>Displays the end time of the period for which the current @Remote certification is enabled.</p>
150	<p>Selection Country DFU</p> <p>Used only for Embedded RC Gate-M to select a country name. Once the number/country is selected, the following settings are checked:</p> <ul style="list-style-type: none"> • Access point telephone number • Dial-up user name • Modem parameters set for the country <p>[0 to 10/*/1]</p> <p>*: 0: Japan, 1: USA, 3:UK</p> <p>0:Japan, 1:USA, 2:Canada, 3:UK, 4:Germany, 5:France, 6:Italy, 7:Netherlands, 8:Belgium, 9:Luxembourg, 10:Spain</p>

151	Line Type Automatic Judgment DFU	
	Used only for Embedded RC Gate-M to determine whether the dial-up line is for manual rotary or push-button tone dialing. <ul style="list-style-type: none"> • The status of the execution of this SP (dialing in progress, success, failure) is written to SP5816-152. • If the check succeeds, the number (dial or push number) written to SP5816-153 can be used • If the check succeeds, the number of the carrier line written to SP816-154 can be used. 	
152	Line Type Judgment Result DFU	
	Used only for Embedded RC Gate-M to display the status of the execution of SP5816-151 identify the type of line.	
	0	Success
	1	Currently dialing
	2	Line abnormal
	3	Could not confirm external line carrier with automatic detection.
	4	Line disconnected
	5	Power supply insufficient
	6	Line determination not supported
	7	Error due to fax transmission in progress.
	8	Other error
	9	Line type identification still in progress. Please wait.
153	Selection Dial/Push DFU	
	Used only for Embedded RC Gate-M to set the telephone number of the dial-up access point of the line checked with SP5816-151. If a number is entered, use that number. If a number is not displayed, use the pre-set value for that country.	
154	Outside Line Outgoing Number DFU	
	Used only for Embedded RC Gate-M to set the number of the PSTN number to dial out where Embedded RC Gate-M is used with a PBX system. If a number is set here, the number will be replaced by the number returned by the successful execution of SP5816-151.	

156	Dial Up User Name DFU
	This is the user name for dialing at the access point where Embedded RC Gate-M is used. Note: Numbers with spaces or # marks appear enclosed with quotation marks in the user name.
157	Dial Up Password DFU
	This is the password for dialing at the access point where Embedded RC Gate-M is used. Note: Numbers with spaces or # marks appear enclosed with quotation marks in the user name.
161	Local Phone Number DFU
	This is the number of the local line where Embedded RC Gate-M is connected. This is the line used to communicate with the Call Center.
162	Connection Timing Adjustment Incoming DFU
	When the Call Center calls out to the access point where Embedded RC Gate-M is used, the ID tone (*#1#) is sent repeatedly. This SP sets the amount of time to elapse for ID tone output. [0 to 24/1/1 pause count] 1 pause count = 2 sec.
163	Access Point DFU
	This is the dial-up telephone line number of the access point connected to Embedded RC Gate-M. If a number is entered here that number is used. If no number is entered here then the pre-set country setting is used.
164	Line Connecting DFU
	This SP code should be set for the customer using Embedded RC Gate-M, depending on the line usage (whether line is shared with a fax or not). [0 to 1/0/1] 0: Line shared with facsimile 1: Line not shared with facsimile
173	Modem Serial No. DFU
	This SP code displays the serial number of the Embedded RC Gate-M (modem).

174	Retransmission Limit DFU	
	Use this SP to manually send a registration update request to Embedded RC Gate-M.	
187	FAX TX Priority DFU	
	<p>This SP is used with SP5816-164 for users who are using a line shared with a facsimile unit.</p> <p>[0 to 1/0/1]</p> <p>0: Disabled. Embedded RC Gate-M continues to operate if a fax transmission starts on the same line.</p> <p>1: Enabled. Fax transmissions have priority. Embedded RC Gate-M will shut down when a fax transmission begins.</p>	
200	Manual Polling	
	Executes manual polling. Embedded RC Gate periodically polls the @Remote Gateway by HTTPS. This is called "center polling". Use this SP at any time to poll the @Remote supply center.	
201	Regist: Status	
	Displays a number that indicates the status of the @Remote service device.	
	0	Neither the @Remote device nor Embedded RC Gate device are set.
	1	The Embedded RC Gate device is being set. Only Box registration is completed. In this status the Basil unit cannot answer a polling request.
	2	The Embedded RC Gate device is set. In this status the Basil unit cannot answer a polling request.
	3	The @Remote device is being set. In this status the Embedded RC Gate device cannot be set.
	4	The @Remote module has not started.
202	Letter Number	
	Allows entry of the number of the request needed for the Embedded RC Gate device.	
203	Confirm Execute	
	Executes the inquiry request to the @Remote CTL URL.	

204	Confirm Result	
	Displays a number that indicates the result of the inquiry executed with SP5816203.	
	0	Succeeded
	1	Inquiry number error
	2	Registration in progress
	3	Proxy error (proxy enabled)
	4	Proxy error (proxy disabled)
	5	Proxy error (Illegal user name or password)
	6	Communication error
	7	Certification update error
	8	Other error
9	Inquiry executing	
205	Confirm Place	
	Displays the result of the notification sent to the device from the CTL URL in answer to the inquiry request. Displayed only when the result is registered at the CTL URL.	
206	Register Execute	
	Executes Embedded RC Gate Registration.	

207	Register Result	
	Displays a number that indicates the registration result.	
	0	Succeeded
	2	Registration in progress
	3	Proxy error (proxy enabled)
	4	Proxy error (proxy disabled)
	5	Proxy error (Illegal user name or password)
	6	Communication error
	7	Certification update error
	8	Other error
	9	Registration executing

	Error Code		
	Displays a number that describes the error code that was issued when either SP5816 204 or SP5816 207 was executed.		
	Cause	Code	Meaning
208	Illegal Modem Parameter	-11001	Chat parameter error
		-11002	Chat execution error
		-11003	Unexpected error
	Operation Error, Incorrect Setting	-12002	Inquiry, registration attempted without acquiring device status.
		-12003	Attempted registration without execution of an inquiry and no previous registration.
		-12004	Attempted setting with illegal entries for certification and ID2.
	Error Caused by Response from CTL URL	-2385	Attempted dial up overseas without the correct international prefix for the telephone number.
		-2387	Not supported at the Service Center
		-2389	Database out of service
		-2390	Program out of service
		-2391	Two registrations for same device
		-2392	Parameter error
		-2393	Basil not managed
		-2394	Device not managed
-2395		Box ID for Basil is illegal	
-2396		Device ID for Basil is illegal	
-2397		Incorrect ID2 format	
-2398	Incorrect request number format		
209	Instl Clear		
	Releases a machine from its embedded RCG setup.		

250	CommLog Print
	Prints the communication log.

5821	Remote Service Address	CTL
	This SP sets the IP address for RCG (Remote Communication Gate) for processing calls to the @Remote service center.	

5824	NVRAM Data Upload	CTL
	<p>Uploads the UP and SP mode data (except for counters and the serial number) from NVRAM on the control board to an SD card inserted in Slot 2.</p> <ul style="list-style-type: none"> • Remove the SD card slot cover on the back of the machine. • Insert a blank SD card in Slot 2. • Open this SP and touch [EXECUTE]. • When you see "Completed", remove the SD card from Slot 2. 	

5825	NVRAM Data Download	CTL
	<p>Downloads the content of an SD card in Slot 2 to the NVRAM on the control board.</p> <ul style="list-style-type: none"> • Remove the SD card slot cover on the back of the machine. • Insert a blank SD card in Slot 2. • Open this SP and touch [EXECUTE]. • When you see "Completed", remove the SD card from Slot 2. 	

5828	Network Setting	CTL
50	1284 Compatibility (Centro)	
	<p>Enables and disables bi-directional communication on the parallel connection between the machine and a computer.</p> <p>[0 to 1 / 1 / 1] 0:Off, 1: On</p>	
52	ECP (Centro)	

	Disables and enables the ECP feature (1284 Mode) for data transfer. [0 to 1 / 1 / 1] 0: Disabled, 1: Enabled			
65	Job Spool			
	Switches job spooling on and off. [0 to 1/0/1] 0: No spooling 1: Spooling enabled			
66	Job Spool Clear: Start Time			
	This SP determines whether the job interrupted at power off is resumed at the next power on. This SP operates only when SP5828065 is set to 1. [0 to 1/1/1] 1: Resumes printing spooled job. 0: Clears spooled job.			
69	Spooling (Protocol)			
	This SP determines whether job spooling is enabled or disabled for each protocol. This is a 8-bit setting.			
	0	LPR	4	BMLinks (Japan Only)
	1	FTP (Not Used)	5	DIPRINT
	2	IPP	6	Reserved (Not Used)
	3	SMB	7	Reserved (Not Used)
90	TELNET (0:OFF 1:ON)			
	Disables or enables Telnet operation. If this SP is disabled, the Telnet port is closed. [0 to 1/1/1] 0: Disable 1: Enable			
91	Web (0:OFF 1:ON)			

	<p>Disables or enables the Web operation.</p> <p>[0 to 1/1/1]</p> <p>0: Disable</p> <p>1: Enable</p>
145	Active IPv6 Link Local Address
	<p>This is the IPv6 local address referenced on the Ethernet or wireless LAN (802.11b) in the format:</p> <p>"Link-Local address" + "Prefix Length"</p> <p>The IPv6 address consists of a total 128 bits configured in 8 blocks of 16 bits each. These notations can be abbreviated. See "</p> <p>Note: IPv6 Addresses" below this table.</p>
147	Active IPv6 Stateless Address 1
149	Active IPv6 Stateless Address 2
151	Active IPv6 Stateless Address 3
153	Active IPv6 Stateless Address 4
155	Active IPv6 Stateless Address 5
	<p>SP codes 147 to 155 are the IPv6 stateless addresses (1 to 5) referenced on the Ethernet or wireless LAN (802.11b) in the format:</p> <p>"Stateless Address" + "Prefix Length"</p> <p>The IPv6 address consists of a total 128 bits configured in 8 blocks of 16 bits each.</p>
156	IPv6 Manual Address
	<p>This SP is the IPv6 manually set address referenced on the Ethernet or wireless LAN (802.11b) in the format:</p> <p>"Manual Set Address" + "Prefix Length"</p> <p>The IPv6 address consists of a total 128 bits configured in 8 blocks of 16 bits each. These notations can be abbreviated. See "</p> <p>Note: IPv6 Addresses" below this table.</p>
158	IPv6 Gateway Address

	<p>This SP is the IPv6 gateway address referenced on the Ethernet or wireless LAN (802.11b). The IPv6 address consists of a total 128 bits configured in 8 blocks of 16 bits each. These notations can be abbreviated. See "</p> <p>Note: IPV6 Addresses " below this table.</p>
161	IPv6 Stateless Auto Setting
	<p>Sets the machine to reference the stateless auto setting for Ethernet and wireless LAN operation.</p> <p>[0 to 1 / 1 / 1]</p> <p>0: Disable</p> <p>1: Enable</p>

5832	HDD	CTL
	Enter the SP number for the partition to initialize, then press #. When the execution ends, turn the machine power off and on.	
1	HDD Formatting (All)	
2	HDD Formatting (IMH)	
3	HDD Formatting (Thumbnail)	
4	HDD Formatting (Job Log)	
5	HDD Formatting (Printer Fonts)	
6	HDD Formatting (User Info)	
7	Mail RX Data	
8	Mail TX Data	
9	HDD Formatting (Data for Design)	
10	HDD Formatting (Log)	
11	HDD Formatting (Ridoc I/F) (for Ridoc DesktopBinder)	

5840	IEEE 802.11	CTL
------	-------------	-----

6	Channel MAX	
	Sets the maximum range of the bandwidth for the wireless LAN. This bandwidth setting varies for different countries. [1 to 14/14/1]	
7	Channel MIN	
	Sets the minimum range of the bandwidth for operation of the wireless LAN. This bandwidth setting varies for different countries. [1 to 14/1/1]	
8	Transmission Speed	
	0 x FF to Auto [Default] 0 x 11 – 55M Fix 0 x 10 – 48M Fix 0 x 0F – 36M Fix 0 x 0E – 18M Fix 0 x 0D – 12M Fix 0 x 0B – 9M Fix	0 x 0A – 6M Fix 0 x 07 – 11M Fix 0 x 05 – 5.5M Fix 0 x 08 – 1M Fix 0 x 13 – 0 x FE (reserved) 0 x 12 – 72M (reserved) 0 x 09 – 22M (reserved)
11	WEP Key Select	
	Determines how the initiator (SBP-2) handles subsequent login requests. [00 to 11/00/1] Note: There are four settings (binary numbers): 00, 01, 10, 11. These settings are possible only after the wireless LAN card has been installed. 00: 1st key. If the initiator receives another login request while logging in, the request is refused. 01, 10, 11: 2nd, 3rd, 4th keys are "Reserved".	
42	Fragment Thresh	
	Adjusts the fragment threshold for the IEEE802.11 card. [256 to 2346 / 2346 / 1] This SP is displayed only when the IEEE802.11 card is installed.	
43	11g CTS to Self	

	<p>Determines whether the CTS self function is turned on or off. [0 to 1 / 1 / 1] 0: Off, 1: On This SP is displayed only when the IEEE802.11 card is installed.</p>
44	11g Slot Time
	<p>Selects the slot time for IEEE802.11. [0 to 1 / 0 / 1] 0: 20 μm, 1: 9 μm This SP is displayed only when the IEEE802.11 card is installed.</p>
45	WPA Debug Lvl
	<p>Selects the debug level for WPA authentication application. [1 to 3 / 3 / 1] 1: Info, 2: warning, 3: error This SP is displayed only when the IEEE802.11 card is installed.</p>

5841	Supply Name Setting	CTL
	Use the soft keyboard of this SP to enter the names and numbers of consumables. These are the names that appear on the display when [Inquiry] is pressed on the User Tools screen.	

5844	USB	CTL
1	Transfer Rate	
	Sets the speed for USB data transmission. [Full Speed], [Auto Change]	
2	Vendor ID DFU	
	Sets the vendor ID: Initial Setting: 0x05A Ricoh Company [0x0000 to 0xFFFF/1]	
3	Product ID DFU	
	Sets the product ID. [0x0000 to 0xFFFF/1]	
4	Device Release Number DFU	

	<p>Sets the device release number of the BCD (binary coded decimal) display. [0000 to 9999/100/1]</p> <p>Enter as a decimal number. NCS converts the number to hexadecimal number recognized as the BCD.</p>
5	Fixed USB Port
	<p>This SP standardizes for common use the model name and serial number for USB PnP (Plug & Play). It determines whether the driver requires re-installation. [0 to 2 / 0 / 4]</p> <p>0: Off 1: Level 1 2: Level 2</p>
6	PnP Model Name
	<p>This SP sets the model name to be used by the USB PnP when "Function Enable (Level 2) is set so the USB Serial No. can have a common name (SP5844-5). Default: Laser Printer (up to 20 characters allowed).</p>
7	PnP Serial Number
	<p>This SP sets the serial number to be used by the USB PnP when "Function Enable (Level 2) is set so the USB Serial No. can have a common name (SP5844-5). Default: None (up to 12 characters allowed for entry).</p> <ul style="list-style-type: none"> • Make sure that this entry is the same as the serial number in use. • At initialization the serial number generated from the model name is used, not the setting of this SP code. • At times other than initialization, the value set for this SP code is used.
100	Notify Unsupport

	<p>This SP determines whether an alert message appears on the control panel when a a USB device (unsupported device) that cannot use an A-connector is connected.</p> <p>[0 to 1/1/1]</p> <p>0: Function enable</p> <p>1: Function disable</p> <ul style="list-style-type: none"> • An unsupported device is a device that cannot use the functions of the USB device. For example, a USB mouse cannot be used even if it connected. • If the PictBridge option is not mounted, even if a digital camera is connected it cannot be used because it is an unsupported device.
--	--

5846	UCS Setting	CTL
	UCS (User Control Service) is the software that manages user codes and the address books for scan-to-email and scan-to-folder.	
	Machine ID (for Delivery Server)	
	Displays the unique device ID in use by the delivery server directory. The value is only displayed and cannot be changed.	
	This ID is created from the NIC MAC or IEEE 1394 EUI.	
1	The ID is displayed as either 6-byte or 8-byte binary.	
	6-byte	
	%02X.%02X.%02X.%02X.%02X.%02X	
	8-byte	
	%02X.%02X.%02X.%02X.%02X.%02X.%02X.%02X	
	Machine ID Clear (Delivery Server)	
2	Clears the unique ID of the device used as the name in the file transfer directory. Execute this SP if the connection of the device to the delivery server is unstable. After clearing the ID, the ID will be established again automatically by cycling the machine off and on.	
	Maximum Entries	
3	Changes the maximum number of entries that UCS can handle.	
	[2000 to 20000/2000/1]	
	If a value smaller than the present value is set, the UCS managed data is cleared, and the data (excluding user code information) is displayed.	

6	Delivery Server Retry Timer
	<p>Sets the interval for retry attempts when the delivery server fails to acquire the delivery server address book.</p> <p>[0 to 255/0/1 sec.]</p> <p>0: No retries</p>
7	Delivery Server Retry Times
	<p>Sets the number of retry attempts when the delivery server fails to acquire the delivery server address book.</p> <p>[0 to 255/0/1]</p>
8	Delivery Server Maximum Entries
	<p>Lets you set the maximum number of account entries and information about the users of the delivery server controlled by UCS.</p> <p>[2000 to 20000/2000/1]</p>
10	LDAP Search Timeout
	<p>Sets the length of the time-out for the search of the LDAP server.</p> <p>[1 to 255/60/1]</p>
20	WSD Maximum Entries
	<p>WSD (Web Services on Devices) is the Microsoft standard for connectivity to web-service enabled devices.</p> <p>[50 to 250/250/1]</p> <p>Default: 250</p>
21	Folder Auth Change
	<p>This SP determines whether the user login information (Login User name and Password) or address (destination setting in the address book for Scan-to-SMB) is used to permit folder access. The machine must be cycled off/on for this setting to take effect if it is changed.</p> <p>[0 to 1 / 0 / 1]</p> <p>0: Uses operator login information (initial value of main machine)</p> <p>1: Uses address authorization information</p>

40	<p>Addr Book Migration (SD -> HDD)</p> <p>This SP moves the address book data from an SD card to the HDD. You must turn the machine power off and on after executing this SP.</p> <ol style="list-style-type: none"> 1. Turn the machine off. 2. Install the HDD. 3. Insert the SD card with the address book data in SD card Slot C3. 4. Turn the machine on. 5. Do SP5846-40. 6. Turn the machine off. 7. Remove the SD card from SD card Slot C3. 8. Turn the machine on. <p>Notes:</p> <ul style="list-style-type: none"> • Executing this SP overwrites any address book data already on the HDD with the data from the SD card. • We recommend that you back up all directory information to an SD card with SP5846-51 before you execute this SP. • After the address book data is copied to HDD, all the address book data is deleted from the source SD card. If the operation fails, the data is not erased from the SD card.
41	<p>Fill Addr Acl Info.</p> <p>This SP must be executed immediately after installation of an HDD unit in a basic machine that previously had no HDD. The first time the machine is powered on with the new HDD installed, the system automatically takes the address book from the NVRAM and writes it to the new HDD. However, the new address book on the HDD can be accessed only by the system administrator at this stage. Executing this SP by the service technician immediately after power on grants full address book access to all users.</p> <p>Procedure</p> <ol style="list-style-type: none"> 1. Turn the machine off. 2. Install the new HDD. 3. Turn the machine on. 4. The address book and its initial data are created on the HDD automatically. However, at this point the address book can be accessed by only the system administrator or key operator. 5. Enter the SP mode and do SP5846-41. After this SP executes successfully, any user can access the address book.

43	Addr Book Media
	<p>This SP displays the media where the address book currently in use is stored.</p> <p>[0 to 30 / 0 / 1]</p> <p>0: Unconfirmed</p> <p>1: SD Slot 1</p> <p>2: SD Slot 2</p> <p>4: USB Flash ROM</p> <p>20: HDD</p> <p>30: Nothing</p>
47	Initialize Local Addr Book
	Clears all of the address information from the local address book of a machine managed with UCS.
48	Initialize Delivery Addr Book
	Push [Execute] to delete all items (this does not include user codes) in the delivery address book that is controlled by UCS.
49	Initialize LDAP Addr Book
	Push [Execute] to delete all items (this does not include user codes) in the LDAP address book that is controlled by UCS.
50	Initialize All Addr Book
	Clears everything (including user codes) in the directory information managed by UCS. However, the accounts and passwords of the system administrators are not deleted.
51	Backup All Addr Book
	Uploads all directory information to the SD card.
52	Restore All Addr Book
	Downloads all directory information from the SD card.
53	Clear Backup Info.
	<p>Deletes the address book uploaded from the SD card in the slot. Deletes only the files uploaded for that machine. This feature does not work if the card is write-protected.</p> <p>Note: After you do this SP, go out of the SP mode, turn the power off. Do not remove the SD card until the Power LED stops flashing.</p>

	Search Option																	
	This SP uses bit switches to set up the fuzzy search options for the UCS local address book.																	
	<table border="1"> <thead> <tr> <th>Bit</th> <th>Meaning</th> </tr> </thead> <tbody> <tr> <td>0</td> <td>Checks both upper/lower case characters</td> </tr> <tr> <td>1</td> <td rowspan="2">Japan Only</td> </tr> <tr> <td>2</td> </tr> <tr> <td>3</td> <td></td> </tr> <tr> <td>4</td> <td>--- Not Used ---</td> </tr> <tr> <td>5</td> <td>--- Not Used ---</td> </tr> <tr> <td>6</td> <td>--- Not Used ---</td> </tr> <tr> <td>7</td> <td>--- Not Used ---</td> </tr> </tbody> </table>	Bit	Meaning	0	Checks both upper/lower case characters	1	Japan Only	2	3		4	--- Not Used ---	5	--- Not Used ---	6	--- Not Used ---	7	--- Not Used ---
Bit	Meaning																	
0	Checks both upper/lower case characters																	
1	Japan Only																	
2																		
3																		
4	--- Not Used ---																	
5	--- Not Used ---																	
6	--- Not Used ---																	
7	--- Not Used ---																	
60																		
	Complexity Option 1																	
	Use this SP to set the conditions for password entry to access the local address book. Specifically, this SP limits the password entry to upper case and sets the length of the password. [0 to 32/0/1]																	
62	<p>Note:</p> <p>This SP does not normally require adjustment.</p> <p>This SP is enabled only after the system administrator has set up a group password policy to control access to the address book.</p>																	
	Complexity Option 2																	
	Use this SP to set the conditions for password entry to access the local address book. Specifically, this SP limits the password entry to lower case and defines the length of the password. [0 to 32/0/1]																	
63	<p>Note:</p> <p>This SP does not normally require adjustment.</p> <p>This SP is enabled only after the system administrator has set up a group password policy to control access to the address book.</p>																	

64	Complexity Option 3
	<p>Use this SP to set the conditions for password entry to access the local address book. Specifically, this SP limits the password entry to numbers and defines the length of the password. [0 to 32/0/1]</p> <p>Note: This SP does not normally require adjustment. This SP is enabled only after the system administrator has set up a group password policy to control access to the address book.</p>
65	Complexity Option 4
	<p>Use this SP to set the conditions for password entry to access the local address book. Specifically, this SP limits the password entry to symbols and defines the length of the password. [0 to 32/0/1]</p> <p>Note: This SP does not normally require adjustment. This SP is enabled only after the system administrator has set up a group password policy to control access to the address book.</p>
91	FTP Auth. Port Settings
	<p>Sets the FTP port to get the delivery server address book that is used in the individual authorization mode. [0 to 65535/3671/1]</p>
94	Encryption Stat
	Shows the status of the encryption function of the address book on the LDAP server.

5849	Installation Date	CTL
	Displays or prints the installation date of the machine.	
1	Display	
	Displays the installation date. The installation date is set automatically after test copies are done at the installation site.	
2	Switch to Print	

	Determines whether the installation date or total count is printed on the total counter printout. [0 to 1/0/1] 0: Off. No Print 1: On. Print
3	Total Counter
	Displays the total count starting from the installation date (SP5849-1).

5853	Stamp Data Download	CTL
	<p>Push [Execute] to download the fixed stamp data from the machine ROM onto the hard disk so that these stamps can be used by the system. The customer will not be able to use these stamps ("Confidential", "Secret", etc.) until this SP has been executed.</p> <p>Note:</p> <ul style="list-style-type: none"> • This SP must always be executed after the HDD has been reformatted or replaced. • Always switch the machine off and on after executing this SP. 	

5856	Remote ROM Update	CTL
	<p>When set to "1" allows reception of firmware data via the local port (IEEE 1284) during a remote ROM update. This setting is reset to zero after the machine is cycled off and on. [0 to 1 / 0 / 1] 0: Not allowed 1: Allowed</p>	

5860	SMTP/POP3/IMAP4	CTL
	MDN Response RFC2298Compliance	
21	<p>Determines whether RFC2298 compliance is switched on for MDN reply mail. [0 to 1/1/1] 0: No 1: Yes</p>	

22	SMTP Auth. From Field Replacement
	<p>Determines whether the FROM item of the mail header is switched to the validated account after the SMTP server is validated.</p> <p>[0 to 1/0/1]</p> <p>0: No. "From" item not switched.</p> <p>1: Yes. "From" item switched.</p>
26	S/MIME:MIME Header Specification
	<p>This SP determines the standard type of header for e-mails sent with S/MIME.</p> <p>[0 to 1 / 0 / 1]</p> <p>0: Microsoft Outlook Express</p> <p>1: Internet Draft</p> <p>2: RFC</p>

5870	Common Key Info Writing	CTL
	Writes to flash ROM the common proof for validating the device for @Remote specifications.	
1	Writing	Note: These SP's are for future use and currently are not used.
3	Initialize	

5873	SD Card Appli Move	CTL
	Moves an application from one SD card to another..	
1	Move Exec	Executes the move from one SD card to another.
2	Undo Exec	This is an undo function. It cancels the previous execution.

5875	SC Auto Reboot	CTL
1	Reboot Setting	

	<p>Determines whether the machine reboots automatically when an SC error occurs.</p> <p>[0 to 1/0/1]</p> <p>1: The machine does not reboot when an SC error occurs. However, the reboot does not occur for Type "A" SC codes.</p> <p>0: The machine reboots automatically when the machine issues an SC error and logs the SC error code. If the same SC occurs again, the machine does not reboot.</p>
2	Reboot Type
	<p>Selects the reboot method after an SC error occurs.</p> <p>[0 to 1/0/1]</p> <p>0: Manual reboot by operator or technician</p> <p>1: Automatic reboot</p>

5878	Option Setup	CTL
	Press [Execute] to initialize the Data Overwrite Security and HDD Encryption option. Both options are available on SD cards.	
1	Data Overwrite Security	
	<p>This SP enables the Data Overwrite Security option.</p> <p>Note:</p> <ul style="list-style-type: none"> • Before execution the SD card must be in SD Card Slot 1 (option slot). • The SD card must reside in Slot 1 after execution. 	
2	HDD Encryption	
	<p>This SP enables the HDD Encryption option.</p> <p>Note:</p> <ul style="list-style-type: none"> • Before execution the SD card must be in SD Card Slot 1 (option slot). • The SD card can be removed after execution. 	

5885	Set WIM Function	CTL
	This SP determines how access to the Web Image Monitor document server is controlled. These are bit settings where "1" enables and "0" disables.	
20	DocSvr Acc Ctrl	

	Allows or disallows the functions of web image monitor. 0: OFF, 1: ON		
		(7) 0000 0000 (0)	
	LSB	0bit	Denies all access to document server
		1 bit	Denies all access to User Tools
		2bit	Denies access to printing
		3bit	Denies access to fax
		4bit	Denies access to scan-to-email
		5bit	Denies access data downloading functions
		6bit	Denies access to data delete functions
	MSB	7bit	Forbid guest user
50	DocSvr Format		
	Selects the display type for the document box list. [0 to 2 / 0 / 1] 0: Thumbnail, 1: Icon, 2: Details		
51	DocSvr Trans		
	Sets the number of documents to be displayed in the document box list. [5 to 20 / 10 / 1]		
100	Set Signature		
	This SP determines whether a signature is attached to scanned documents queued for sending with Web Image Monitor. [0 to 2 / 0 / 1] 0: Set individually Operator selects signature on the send screen when documents are sent via email. Operator has the option of selecting or not selecting a signature. 1: Signature required. A signature must be selected for sending. 2: No signature. No signature required.		
101	Set Encryption		

	Determines whether the scanned documents with the WIM are encrypted when they are transmitted by an e-mail. [0 to 1 / 0 / 1] 0: Not encrypted, 1:Encryption	
200	Detect Mem Leak	
	This SP determines how Web Image Monitor memory leaks are handled. A "1" setting enables the function.	
	(7) 0000 0000 (0)	
	Bit 0	Displays memory status at session timeouts.
	Bit 1	Displays memory status at the start/end of PF handler only.
	Bit2-7	Not used
201	DocSvr Timeout	
	This SP sets the length of time for session timeout. The default is 30 min. The time can be reduced to shorten the time between memory leak detections. [1 to 255 / 30 / 1 min.]	

5887	SD Get Counter	CTL
	<p>After you touch [EXECUTE] this SP sends a text file to an SD card inserted in SD card Slot 2. The file is stored in a folder created in the root directory of the SD card called SD_COUNTER. The file is saved as a text file (*.txt) prefixed with the number of the machine.</p> <ul style="list-style-type: none"> • Insert the SD card in SD card Slot 1 (lower slot). • Select SP5887 then touch [EXECUTE]. • Touch [EXECUTE] in the message when you are prompted. 	

	SDK Application Counter	CTL
5893	<p>The machine stores up to six registered names in the SDK application.</p> <ul style="list-style-type: none"> • This SP has been implemented for all machines using Engine 08S and later. • This SP is not needed if there are no SDK applications loaded. 	
1 to 6	SDK1 to SDK-6	

5967	Copy Server: Set Function	CTL
------	---------------------------	-----

	<p>Disables and enables the document server. This is a security measure that prevents image data from being left in the temporary file sector of the HDD. After changing this setting, switch the main switch off and on to enable the new setting.</p> <p>[0 to 1/0/1]</p> <p>0: Enable</p> <p>1: Disable</p>
--	--

5974	Cherry Server	CTL
	<p>Selects which version of the Scan Router application program, "Light" or "Full (Professional)", is installed.</p> <p>[0 to 1 / 0 / 1 /step]</p> <p>0: Light version (supplied with this machine)</p> <p>1: Full version (optional)</p>	

5

5985	Device Setting	CTL
	<p>The NIC and USB support features are built into the CTL controller. Use this SP to enable and disable these features. In order to use the NIC and USB functions built into the controller board, these SP's must be set to "1".</p> <p>[0 to 2/0/1]</p> <p>0: Disable 1: Enable 2: Enable for @Remote</p>	
1	On Board NIC	
2	On Board USB	

5990	SP Print Mode (SMC Printout)	CTL
------	------------------------------	-----

1	All (Data List)	<p>Prints all of the system parameter lists for the item selected.</p> <p>Input the number for the item that you want to print, and then press [1]: "Execute" on the touch panel.</p>
2	SP (Mode Data List)	
3	User Program	
4	Logging Data	
5	Diagnostic Report	
6	Non-Default	
7	NIB Summary	
8	Capture Log	
21	Copier User Program	
22	Scanner SP	
23	Scanner User Program	
24	SDK/J Summary	
25	SDK/J Application Info.	

SP7-xxx Data Log

7001	Operation Time	
1	Main Motor	
	Shows the total operation time of the main motor that drives the OPC drum.	
2	Scanner Motor	
	Shows the total operation time of the scanner motor that drives the scanner unit rollers that feed originals.	
7401	Total SC Counter	CTL
	Shows the total SC count as a 4-digit number.	
7403	SC History	CTL

5

1	Latest	Display the most recent service calls in their order of occurrence.
2	Latest 1	
3	Latest 2	
4	Latest 3	
5	Latest 4	
6	Latest 5	
7	Latest 6	
8	Latest 7	
9	Latest 8	
10	Latest 9	

7404	SC991 History	CTL
	<p>This SP determines whether up to the last 10 occurrences of SC991 (Software Error 2) are recorded in the log information.</p> <p>Execute SP7403 or print an SMC Report (SP5990) to read the history of the 10 most recent logged errors.</p> <p>If you press [0] on the operation panel with the SP selection menu displayed, you will see detailed information about the recently logged SC991 errors, including the software file name, line number, and so on.</p>	

1	Latest	Display the occurrences of SC991 in order of occurrence.
2	Latest 1	
3	Latest 2	
4	Latest 3	
5	Latest 4	
6	Latest 5	
7	Latest 6	
8	Latest 7	
9	Latest 8	
10	Latest 9	

7502	Total Paper Jam Counter	CTL
	Displays the total number of copy jams. Display range: 0000 to 9999	

7503	Total Original Jam Counter	CTL
	Displays the total number of original jams. Display range: 0000 to 9999	

7504	Paper Jam Loc(ation)	CTL
	<p>Displays the total number of copy jams by location.</p> <p>A "Paper Late" error occurs when the paper fails to activate the sensor at the precise time. A "Paper Lag" paper jam occurs when the paper remains at the sensor for longer than the prescribed time.</p> <p>Display range: 0000 to 9999</p>	
	Main Machine (D093/D094)	
	1: At Power On	
	3: Tray 1: No Feed	
	4: Tray 2: No Feed	
	5: Tray 3: No Feed	
	8: RF Exit Sn: Not On	
	13: Reg Sn: Not On	
	16: Exit Sn: Not On	
	34: Bypass: No Feed	
	53: Tray 1: Paper Lag	
	54: Tray 2: Paper Lag	
	55: Tray 3: Paper Lag	
	58: RF Exit Sn: Not Off	
	63: Reg Sn: Not Off	
	66: Exit Sn: Not Off	
	84: Bypass Sn: Not Off	
	Folder FD Unit (B889)	
	100 to 146	Not used for this machine

	Original Jam Det	CTL
	<p>Displays the total number of original jams by location. These jams occur when the original does not activate the sensors.</p> <p>Display range: 0000 to 9999</p> <p>Note:</p> <p>A "Check In" failure occurs when the paper fails to activate the sensor at the precise time.</p> <p>A "Check Out" failure occurs when the paper remains at the sensor for longer than the prescribed time and causes a jam.</p> <p>The 3rd column in the table below tells you the correct component name used in the service manual.</p>	
7505	Operation Panel Display	
	1	Org at Power On
	2	Org Reg Sn: Not On
	3	Org Reg Sn/Exit Sn: Both Off
	4	Org Reg Sn: Not Off
	5	Org Exit Sn: Not Off
	6	Org Stop
	7	Org Exit Sn: Not On
	8	Org Interval Error

7506	Jam Count by Paper Size	CTL
	<p>This SP displays the counts for the number of jams by paper size.</p> <p>Note: In the paper size notations below, "T" means "SEF" (Short Edge Feed).</p>	
97	A0T/A1	
98	A1T/A2	
99	A2T/A3	
100	A3T/A4	
101	A4T	
106	B1T/B2	

107	B2T/B3
108	B3T/B4
109	B4T
225	36x48T/24x36
226	24x36T/18x24
227	18x24T/12x18
228	12x18T/9x12
229	9x12T
234	34x44T/22x34
235	22x34T/17x22
236	17x22T/11x17
237	11x17T/8.5x11
238	8.5x11T
255	Others

	Plotter Jam History	CTL
7507	<p>Displays the copy jam history in groups of 10, starting with the most recent 10 jams. Display contents are as follows:</p> <p>CODE: SP7-504-*** number.</p> <p>SIZE: Paper size code in hex. (See the table below.)</p> <p>TOTAL :Total jam error count (SP7003)</p> <p>DATE: Previous jam occurred</p>	

1	Latest	Sample Display: CODE: 007 SIZE: 05h TOTAL: 0000334 DATE: Mon Mar 15 11:44:50 2000
2	Latest 1	
3	Latest 2	
4	Latest 3	
5	Latest 4	
6	Latest 5	
7	Latest 6	
8	Latest 7	
9	Latest 8	
10	Latest 9	

5

	Original Jam History	CTL
7508	Displays the original jam history in groups of 10, starting with the most recent 10 jams. Display contents are as follows: CODE: SP7505-*** number. SIZE: Paper size code in hex. (See table below.) TOTAL: Total jam error count (SP7003) DATE: Date the previous jam occurred	

5

1	Latest	Sample Display: CODE: 007 SIZE: 05h TOTAL: 0000334 DATE: Mon Mar 15 11:44:50 2000
2	Latest 1	
3	Latest 2	
4	Latest 3	
5	Latest 4	
6	Latest 5	
7	Latest 6	
8	Latest 7	
9	Latest 8	
10	Latest 9	

Paper Size Hex Codes

These codes are displayed by SP7507 and SP7508.

Paper Size	Code (hex)	Paper Size	Code (hex)
A4 LEF	05	B4 SEF	8D
A5 LEF	06	B5 SEF	8E
LT LEF	26	DLT SEF	A0
A3 SEF	84	LG SEF	A4
A4 SEF	85	LT SEF	A6
A5 SEF	86	Others	FF

7801	ROM No./Firmware Version	CTL
	Displays the ROM number, firmware version numbers, and other important information about the machine. Press ▲ or ▼ to see more information.	

7803	PM Counter Display	CTL
	Displays the PM counter since the last PM.	

7804	PM Counter Reset	CTL
	Resets the PM counter. To reset, press [Execute]	
7807	SC/Jam Counter Reset	CTL
	Resets the SC and jam counters. To reset, press [Execute]. This SP does not reset the jam history counters: SP7507, SP7508.	
7826	MF Error Counter Japan Only	CTL
	Displays the number of counts requested of the card/key counter.	
1	Error Total	
	A request for the count total failed at power on. This error will occur if the device is installed but disconnected.	
2	Error Staple	
	The request for a staple count failed at power on. This error will occur if the device is installed but disconnected.	
7827	MF Error Counter Clear	CTL
	Press [Execute] to reset the values of SP7826 to "0". Japan Only	
7832	Self-Diagnosis Result Display	CTL
	Opens the "Self-Diagnose Result Display" to view details about errors. Use the keys on in the display to scroll through all the information. If no errors have occurred, you will see "No Error".	
7836	Total Memory Size	CTL
	Displays the memory capacity of the controller system: "1024 MB".	
7901	Assert Info.	
	This SP displays the results of the last occurrence of SC990. SC990 is issued when unexpected branching and decision data is generated by the program, and the module name, line number, and values for the error are displayed for analysis. This data should be reported after SC990 occurs.	

1	File Name	Module name
2	Number of Lines	Lines where error occurred.
3	Location	Component affected by error

Printer

1001	Bit Switch			
001	Bit Switch 1 Settings		0	1
	bit 0	DFU	-	-
	bit 1	DFU	-	-
	bit 2	DFU	-	-
	bit 3	No I/O Timeout	Disabled	Enabled
		Enables/disables MFP I/O timeouts. If enabled, the MFP I/O timeout setting will have no effect (I/O timeouts never occur.)		
	bit 4	SD Card Save Mode	Disabled	Enabled
		If enabled, print jobs will be output to the SD card slot (not to paper).		
	bit 5	DFU		
bit 6	DFU			
bit 7	[RPCS,PCL]: Printable area frame border	Disabled	Enabled	
	If enabled, prints all RPCS and PCL jobs with a border around the printable area.			
002	Bit Switch 2 Settings DFU			
003	Bit Switch 3 Settings DFU			
004	Bit Switch 4 Settings DFU			
005	Bit Switch 5 Settings	0	1	

		Show "Collate Type", "Staple Type" and "Punch Type" buttons on the operation panel.	Disabled	Enabled
	bit 0	If enabled, users will be able to configure a Collate Type, Staple Type, and Punch Type from the operation panel. The available types will depend on the device and configured options. After enabling the function, the settings will appear under: "User Tools > Printer Features > System"		
	bit 1	DFU		
	bit 2	If enabled, SDK applications will not be able to alter print data. This is achieved by preventing SDK applications from accessing a module called the "GPS Filter". Note: The main purpose of this bit switch is for troubleshooting the effects of SDK applications on data.		
		[PS] PS Criteria	Pattern3	Pattern1
	bit 3	Changes the number of PS criterion used by the PS interpreter to determine whether a job is PS data or not. Pattern 3: Includes most PS commands. Pattern 1: A small number of PS tags and headers		
		Increase max number of the stored jobs to 1000 jobs.	Disable (100)	Enable (1000)
	bit 4	If enabled, changes the maximum number of jobs that can be stored on the HDD (via Job Type settings) to 1000. The default is 100.		
	bit 5	DFU		
	bit 6	If enabled, the image rotation will be performed according to specifications of older models (PCL: Pre-04A Models) for binding pages in mixed orientation jobs.		
	bit 7	DFU		
006	Bit Switch 6 Settings DFU			
007	Bit Switch 7 Settings DFU		-	-
008	Bit Switch 8 Settings DFU			
009	bit 0	PDL Auto Detection of Jobs Submitted via USB/IEEE1284		
		To be used if PDL auto detection fails. A failure of PDL auto detection does not necessarily mean that the job cannot be printed. This bit switch tells the device whether to execute a time out immediately (default) upon failure or to wait 10 sec.		

	bit 1	Forced Printing
		If enabled, the image will be printed regardless of whether the specified roller for the correct size paper or not. This is similar to "Form Feed" on a standard printer. Default: Enabled
	bit 2	Job Cancel
		If enabled, all jobs will be cancelled after a jam occurs. Note: If this bit switch is enabled, printing under the following conditions could cause problems: <ul style="list-style-type: none"> • Job submission via USB port or parallel port. • Spool printing: WIM> Configuration> Device Settings> System

5

1003	Clear Setting
1	Initialize Printer System
	Initializes settings in the "System" menu of the user mode.
3	Delete Program
	*This SP is for Japan model only.

1004	Print Summary
	Prints the service summary sheet (a summary of all the controller settings).

1005	Display Version
	Displays the version of the printer application.

1006	Sample/Locked Print
	Enables and disables the document server. When you select "0", the document server is enabled or disabled in accordance with Copy Service Mode SP5-967. When you select "1", the document server is enabled regardless of Copy Service Mode SP5-967. 0: Linked, 1: On

Scanner

100 1	Scan Nv Version
	Displays the scanner firmware version stored in NVRAM in a 9-digit format: Func. Name_Model Name_History No.
100 4	Compression Type Selects the compression type for binary picture processing. [1-3/1/1] 1: MH, 2: MR, 3: MMR
100 5	Erase Margin (Remote Scan) Creates an erase margin for all edges of the scanned image. If the machine has scanned the edge of the original, create a margin. [0 to 5/0/1 mm]
1009	Remote Scan Disable This SP switches the TWAIN scanner function on/off. This is one of the scanner application functions. [0 to 1 / 0 / 1] 0: ON (enabled- 1: OFF (disabled)
1011	Org Count Display This SP codes switches the original count display on/off. [0 to 1 / 0 / 1] 0: OFF (no display) 1: ON (count displays)

1012	User Info Release
	<p>This SP code sets the machine to release or not release the following items at job end]</p> <ul style="list-style-type: none"> • Destination (E-mail/Folder/CS) • Sender name • Mail Text • Subject line • File name <p>[0 to 1 / 1 / 1] 1: Release 0: Do not release</p>

1013	Multi Media Func
	<p>This SP code enables/disables the multi-media function option (USB 2.0/SD Slot) mounted on the left rear corner of the machine. Operators can scan documents to either an SD card or a USB memory device inserted into this unit. This SP must be enabled (set to "1") in order for the device to function.</p> <p>[0 to 1 / 0 / 1] 0: Disable 1: Enable</p>

2021	Summary Image Quality - Compression Level (Gray-scale)	
	Selects the compression ratio for grayscale processing mode (JPEG) for the three settings that can be selected at the operation panel.	
1	Comp1: 5-95	[5 to 95 / 40 / 1 /step]
2	Comp2: 5-95	[5 to 95 / 50 / 1 /step]
3	Comp3: 5-95	[5 to 95 / 30 / 1 /step]
4	Comp4: 5-95	[5 to 95 / 60 / 1 /step]
5	Comp5: 5-95	[5 to 95 / 20 / 1 /step]

6. Troubleshooting

Image Problem Troubleshooting

Flow Chart

Follow this flow chart to determine the cause of an image problem. Use SP2902 to print the VDB/SIPU test patterns.

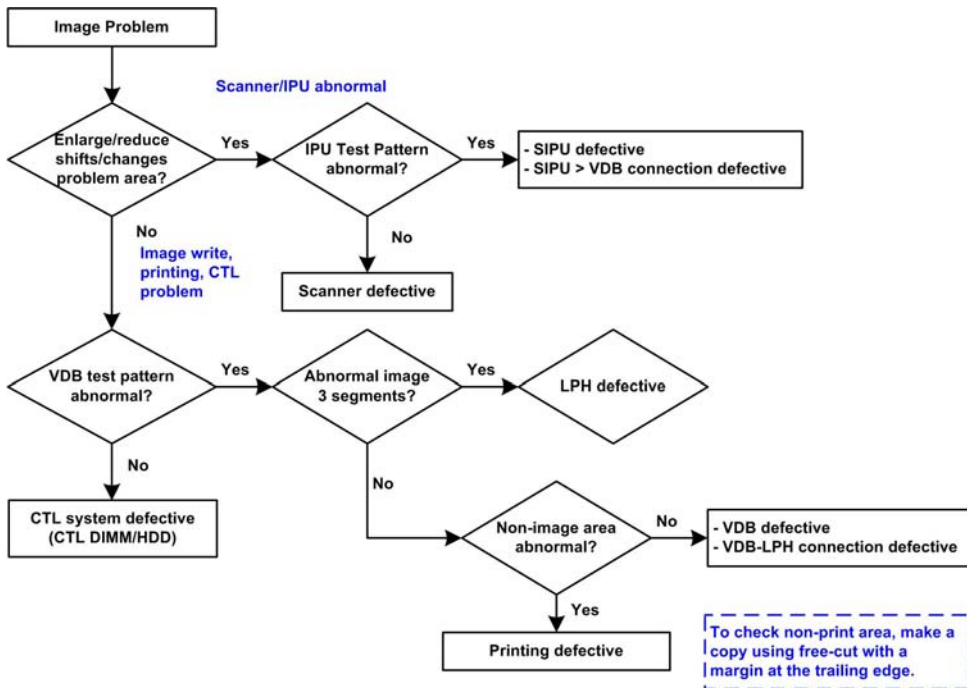

d093t540

SP2902 Test Patterns

* 0: None	13: 1-dot Vertical Line
1: 1-dot Grid Pattern	14: 2-dot Vertical Line
2: 2-dot Grid Pattern	15: 1-dot Horizontal Line
3: 3-dot Grid Pattern	16: 2-dot Horizontal Line
4: 4-dot Grid Pattern	17: Checkered Flag
5: 5-dot Grid Pattern	18: 1-dot Alternating Dot Pattern

6: 6-dot Grid Pattern	19: 2-dot Alternating Dot Pattern
7: 1-dot Argyle Pattern	20: 4-dot Alternating Dot Pattern
8: 2-dot Argyle Pattern	21: Trimming Area
9: 3-dot Argyle Pattern	22: Full Dot Pattern
10: 4-dot Argyle Pattern	23: Vertical Black Band
11: 5-dot Argyle Pattern	24: Horizontal Black Band
12: 6-dot Argyle Pattern	25: Blank Image

SP4417 IPU Test Patterns:

Scan Test Patterns	Print Text Patterns
0: *0: Scanner Data	18: 1 to 4-dot Ind. Dot & Coverage: PRN
1: 1-dot Vertical Line: SCN	19: Horizontal Grayscale: 16-Lvl: PRN
2: 2-dot Vertical Line: SCN	20: Vertical Grayscale: 16-Lvl: PRN
3: 1-dot Horizontal Line: SCN	21: 16-Lvl Grayscale: PRN
4: 2-dot Horizontal Line: SCN	22: Density Patch (256-Lvl): PRN
5: 1-dot Alternating Dot Pattern: SCN	23: Density Patch (64-Lvl): PRN
6: 1-dot Grid Pattern: SCN	24: Cross Pattern: PRN
7: Vertical Stripes: SCN	25: Grid Pattern (96-dot Width)
8: Horizontal Grayscale: 16-Lvl: SCN	26: Argyle Pattern
9: Vertical Grayscale: 16-Lvl: SCN	27: Horizontal Grayscale (8-Lvl) & Line
10: Density Patch: 16-Lvl: SCN	28: Grid Pattern (128-dot Width)
11: Cross Pattern: SCN	
12: Argyle Pattern: SCN	
13: Density Patch: 256-Lvl: SCN	
14: Density Patch: 64-Lvl: SCN	
15: Trim Area: SCN	

16: Vert. Frequency Characteristics: SCN	
17: Horiz. Frequency Characteristics: SCN	

Scanning

1. No image



d093t541

Possible causes:

- Connection problem between CIS and SIPU.
- CIS defective

2. No image (solid black copy/print, or no image with only vertical white lines on the output)



b286t542

Possible causes:

- Connection problem between CIS and SIPU.
- CIS defective

3. Light image

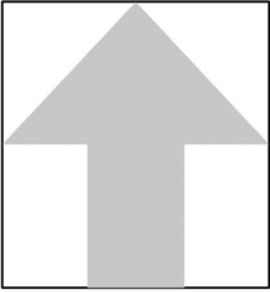

b286t543

Possible causes:

- Low CIS output
- SPU board defective

4. Vertical black lines

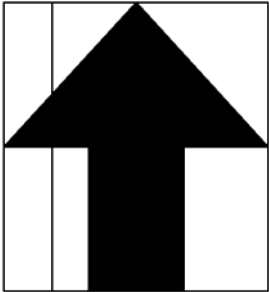

b286t544

Possible causes:

- Dirty exposure glass
- CIS defective

5. Vertical white lines

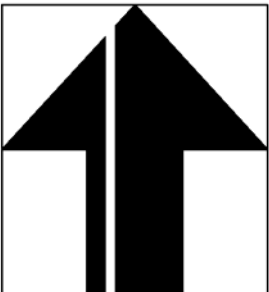

b286t545

Possible causes:

- Dirty exposure glass

- Dirt or scratches on the white plate above the CIS
- CIS defective

6. Black or white bands with no image-width 1/5 A0 (E) size

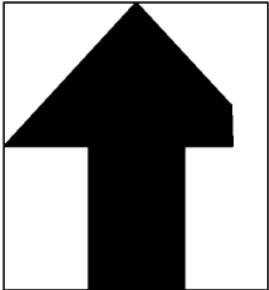

b286t546

Possible causes:

- Connection problem between CIS and SIPU
- CIS output error
- SIPU board adjustment error

7. White lines every 1mm pitch in halftone areas



b286t547

Possible causes:

- CIS defective

Case 8: Dark image density at CIS1, CIS3, and CIS5.

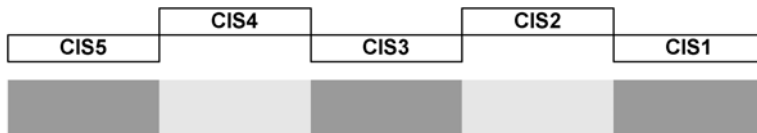

b286t574

Possible cause:

- The machine is near a window and sunlight is hitting the CIS unit

- The blinders have been removed from the machine.

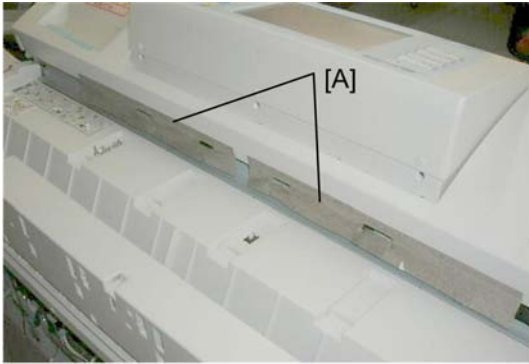

d093i007c

1. Make sure that the blinders [A] have not been removed. These protect the CIS unit from light.
2. Move the machine away from the window.

6

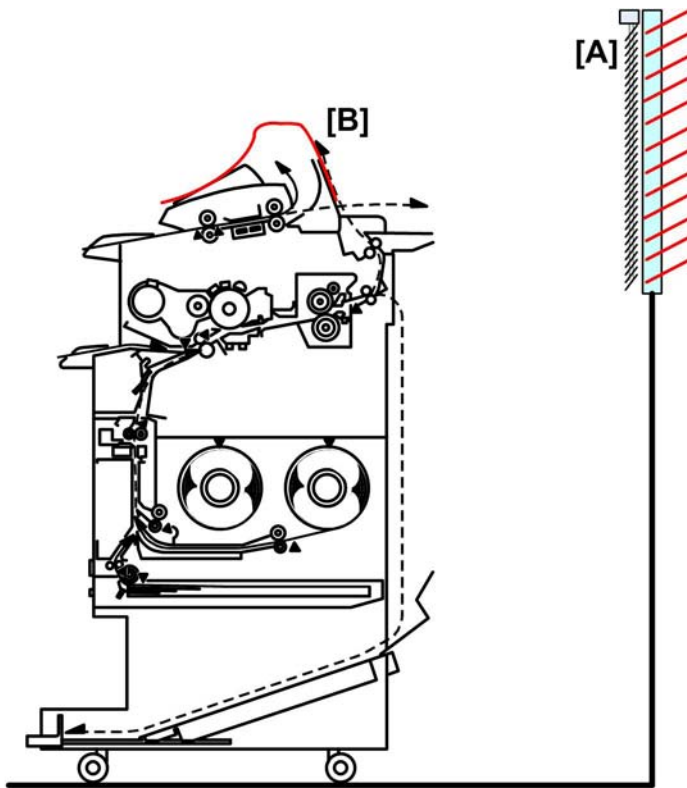

d093t971

3. Close the window blinds [A] to block the sunlight.

- If closing the blinds or moving the machine is not possible (or if the blinders have been removed or damaged), cover the top of the machine with one wide sheet of paper [B] (at least 840 mm wide) to block the sunlight.

Case 2: Dark image density at CIS2 and CIS4.

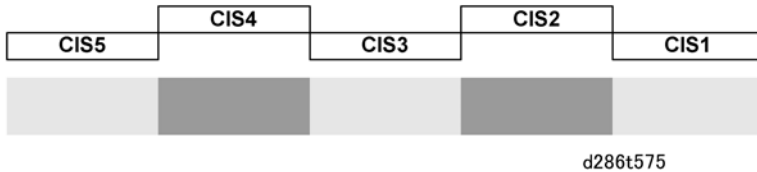

Possible causes:

- The white plate is not flat against the original.
- The original is wrinkled.

Image Writing

1. No Image (blank copy/print)



Possible causes:

- VDB board defective
- SIPU board defective
- LPH (LED head) defective

2. Band with no image-width 1/3 of image

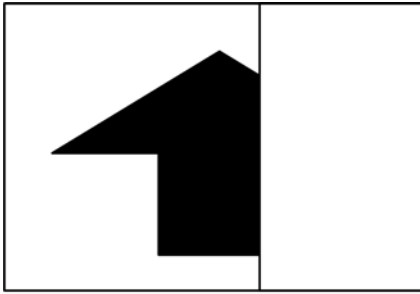

b286t550

Possible causes:

- Connection problem between VDB and LPH
- LPH head defective

3. Vertical white and black line at 150 mm from center.

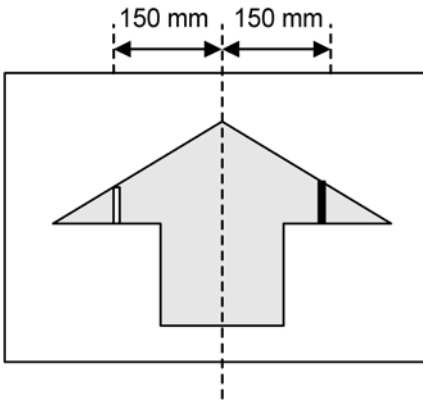

b286t572

Possible causes:

- LPH Joints adjustment error

4. Horizontal line broken at 150 mm from center.

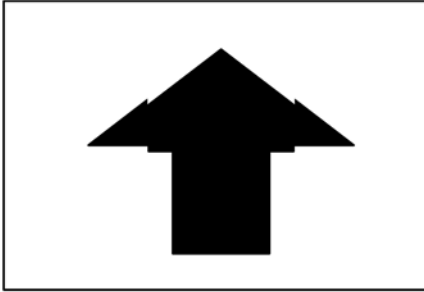

b286t573

Possible causes:

- LPH subscan timing error at joint position

5. Bands/lines every 20 mm pitch in halftone areas

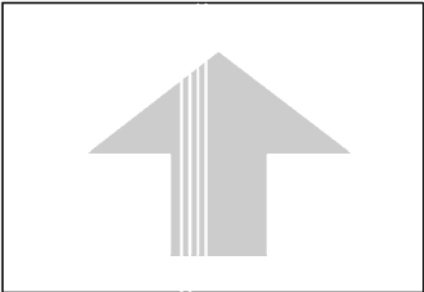

b286t548

Possible causes:

- LPH defective

Printing

1. Dirty Background

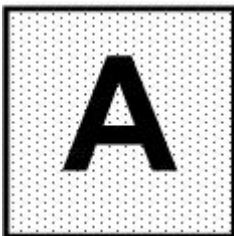

d093t991

Possible causes:

- Dirty ID sensor

- Deteriorated developer
- Deteriorated OPC drum
- Excessive toner due to toner over supply

2. Black Spots at Regular Intervals (Pitch)

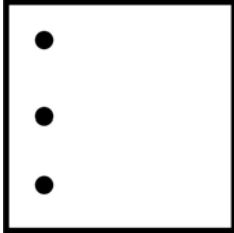

d093t992

Possible causes:

- Scratched OPC drum (250 mm pitch)
- Scratched hot roller (157 mm pitch)
- Scratched pressure roller (173 mm pitch)

6

3. Random Black Spots

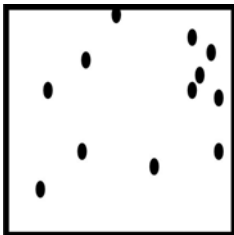

d093t993

Possible causes:

- Toner scattering caused by bent entrance seal in cleaning unit
- Developer scattering caused by defective seals in development unit
- Deteriorated OPC drum
- Hot roller cleaning roller dirty

4. Vertical Black Lines or Bands

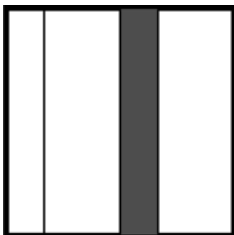

d093t994

Possible causes:

- Line caused by defective cleaning blade
- Band caused by bent cleaning blade
- Line caused by dirty corona wire
- Band caused by dirty OPC drum
- Line caused by scratched OPC drum

5. Horizontal Black Lines or Bands



d093t995

Possible causes:

- Line caused by scratched OPC drum
- Line caused by discharge at trailing edge of paper
- Band caused by development bias leakage

6. Light Images



d093t996

Possible causes:

- Damp paper
- Corona leakage
- Defective T&S power pack

Other Problems

1. Excessive curl

Possible causes:

- When a paper roll reaches its end, the paper closest to the core tends to have excessive curl.
- There is no way to correct this. Operators should be instructed to use cut sheets if possible.

2. Shrinkage of areas in incomplete images

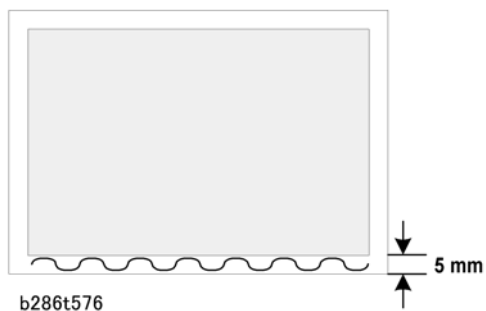

Possible causes:

- Some customers complained about loss of borderlines at the trailing edge of copies when an A1 original is reduced to A3.
- This problem has not been corrected.

Service Call Conditions

There are 4 levels of service call conditions

Level	Definition	Reset Procedure
A	Fusing unit SC codes shown on the operation panel. The machine is disabled. The operator cannot reset the machine.	The machine requires immediate servicing by a service technician.
B	These SC codes disable only the features that use the defective item. The user does not see these SC codes in usual conditions. But, they are shown on the operation panel when the defective feature is used.	Cycle the machine off/on with the main power switch..
C	SC codes that are not shown on the operation panel. They are recorded internally.	Recorded only.
D	These SC codes are shown on the operation panel. To reset these SC codes, turn the operation switch or main power switch off and on. These SC codes are shown again if the error occurs again.	Set the operation switch or the main power switch to "off" then to "on".

6

Preliminary Instructions

- After a Level A SC code is issued, the machine is disabled and cannot be used until it has been serviced by a qualified technician. SP5810, executed by the service technician, releases the machine for servicing.
- If the problem is in an electrical circuit board, disconnect then connect the board connectors again before you replace the PCB.
- If the problem is a motor lock, check the mechanical load before you replace a motor or sensor.
- When a Level A or Level B SC occurs while the machine is in the SP mode, the SC number will not be shown. If this occurs, check the SC number after the machine goes out from the SP mode. This does not include Level B codes.
- Many SC codes contain more than one level (SC303-1, SC303-2, SC303-3, and others). Some SC codes can show a "-1", even if there is only one level.

The following abbreviations are used in these SC tables:

- (F) means "Front"
- (R) means "Rear"
- "CTL" means "Controller", a problem with the controller.

Service Call Tables

SC100

101	D	Scanner Lamp Error
		At power on the scan lamp trigger remained off.
		<ul style="list-style-type: none"> • CIS-to-SIPU harness loose, disconnected, or defective • CIS-to-SIF-to-SIPU harness loose, disconnected, or defective • CIS, SIPU defective
143	C	Scanner Automatic Adjustment Error
		Automatic adjustment of the CIS failed at power on.
		<ul style="list-style-type: none"> • Standard white strips dirty or not platen white plate installed improperly • CIS LED defective and not lighting • CIS-to-PSU harness connector loose, disconnected, or defective • CIS-to-SIPU harness connector loose, disconnected, or defective • CIS defective • MCU defective • SIF defective • SIPU defective
144	D	SIF Communication Error
		SIF serial transmission did not begin within 1 sec. after power on. No communication with SIF.
		<ul style="list-style-type: none"> • MCU defective • SIF defective • SIF-to-MCU harness connector loose, disconnected, or defective • SIPU defective
161-1	D	SIPU Error 1: FPGA Configuration Error

		At power on, or when the machine returned from energy save mode, the FPGA Flash Program did not configure correctly. -or- An SIPU error occurred during the FPGA check after three attempts.
		<ul style="list-style-type: none"> • SIPU defective

161-2	D	SIPU Error 2: Ri2005 Chip Failure
		At power on, or when the machine returned from energy save mode, an SIPU error occurred during Ri2500 access (Ri2500 did not respond within 5 ms).
		<ul style="list-style-type: none"> • SIPU defective

161-3	D	SIPU Error 3: Ri2001A Chip Failure
		At power on, or when the machine returned from energy save mode, the Ri2001A chip on the SIPU failed (Ri2001A did not respond within 5 ms).
		<ul style="list-style-type: none"> • SIPU defective

161-4	D	SIPU Error 4: Cetus Configuration Error
		At power on, or when the machine returned from energy save mode, Cetus configuration failed after three attempts within 810 ms
		<ul style="list-style-type: none"> • SIPU defective

186	B	Gray Balance Adjustment Error
		The value for gray balance was detected out of range after gray adjustment.
		<p>If cycling the machine power off/on does not solve the problem:</p> <ul style="list-style-type: none"> • Clean the platen white plate • Clean the exposure glass • CIS-SIF harnesses loose, broken, defective • SIF-SIPU harnesses loose, broken, defective • SIF defective • CIS defective • SIPU defective

SC200

There are no Group 2 SC codes for this machine

SC300

Group 3 SC codes are related to image making.

300	D	Charge Corona Output Error
		After sampling at 10 ms intervals, the charge-corona feedback voltage remained less than 0.5 V for more than 200 ms.
		<ul style="list-style-type: none"> • Charge corona unit leakage • High voltage cable defective • Corona wire dirty or broken • CGB power pack fuse, connections loose, broken, or defective

6

305	D	Charge Corona Wire Cleaner Error
		The charge wire cleaner did not: (1) come from the home position within 5 s, or (2) did return to the home position within 3.75 s due to wire cleaner overload.
		<ul style="list-style-type: none"> • Cleaner unit blocked or damaged • Until replacement parts become available, set SP2804 to "0" to disable the charge-corona cleaning function so the machine can operate.

392	D	Development Bias Error
		The development bias feedback voltage was less than 0.3 V for longer than 200 ms while the PWM duty value was more than 5% (indicating a development bias leak).
		<ul style="list-style-type: none"> • Bias terminal damaged • High voltage cable damaged, defective • CGB power pack defective

SC400

Group 4 SC codes are also related to image making.

400	D	ID Sensor Auto Adjustment Error
		Vsg did not reach 4 ± 0.2 V when the ID sensor was initialized with SP3001-2.
		<ul style="list-style-type: none"> • ID sensor dirty • ID sensor harness, connector loose, disconnected, damaged, defective • ID sensor defective • MCU defective • Development unit defective • CGB power pack defective

401	D	ID Sensor Vsg Error
		The Vsg level was twice detected lower than 2.5 V. -or- The Vsg level was once detected higher than 4.8V.
		<ul style="list-style-type: none"> • ID sensor dirty • ID sensor harness, connector loose, disconnected, damaged, defective • ID sensor defective • MCU defective • CGB power pack defective

402	D	ID Sensor Vsp Error
		The Vsp level was twice detected at 0V or at more than 2.5 V.
		<ul style="list-style-type: none"> • Under the left upper cover, make sure that the Allen screw of the main drum drive gear is tight • ID sensor dirty • ID sensor harness, connector loose, disconnected, damaged, defective • ID sensor defective • MCU defective • Development unit defective • CGB power pack defective

406	D	ID Sensor Pattern Edge Detection Error
		The ID sensor pattern check could not detect the correct voltage on the ID sensor pattern (below 2.5V) within 0.6 sec.
		<ul style="list-style-type: none"> • ID sensor dirty • ID sensor harness loose, damaged, defective • ID sensor connector defective • ID sensor defective • MCU defective • CGB power pack defective

440	D	Transfer Output Error
		A high voltage feedback voltage of less than 0.5 V was detected for 200 ms.
		<ul style="list-style-type: none"> • High voltage cable disconnected, damaged • T/S power pack defective

460	D	DC Separation Corona Output Error
		A dc separation feedback voltage of less than 0.5 V was detected after more than 200 ms.
		<ul style="list-style-type: none"> • High voltage cable disconnected, damaged • T/S power pack defective

SC500

508	B	Cutter Error
		The left and right cutter HP sensors remained on or off more than 2 sec.
		<ul style="list-style-type: none"> • HP sensors on the left and right side loose, disconnected, defective • Cutter motor harness damaged, defective • Cutter motor defective <p>Note: Paper can be fed from the bypass table if the roll feeder or paper cassette is not operating.</p>

520	D	Main Motor Error
		After the motor started, the main motor lock signal remained HIGH for 5 sec.
		<ul style="list-style-type: none"> • Physical obstruction blocking motor • Motor harness damaged, defective • Motor defective

521	D	Drum Motor Error
		After the motor started, the drum motor lock signal remained HIGH for 5 sec.
		<ul style="list-style-type: none"> • Physical obstruction blocking motor • Motor harness damaged, defective • Motor defective

522	D	Fusing Unit Drive Motor Error
		After the motor started, the fusing motor lock signal remained HIGH for 5 sec.
		<ul style="list-style-type: none"> • Physical obstruction blocking motor • Motor harness damaged, defective • Motor defective

530	D	Fusing Unit Ventilation Fan Error
		After the motor started, the fan motor lock signal remained HIGH for 5 sec.
		<ul style="list-style-type: none"> • Physical obstruction blocking motor • Motor harness damaged, defective • Motor defective

541	A	Fusing Thermistor Errors
		The thermistor measured the hot roller temperature every 1 sec. for 30 sec. and the temperature remained below 5°C (54°F).

		<ul style="list-style-type: none"> • Thermistor positioned incorrectly • Thermistor cable loose, disconnected, damaged • Thermistor defective
--	--	--

542	A	Fusing Temperature Warm-up Error
		The hot roller did not reach the ready temperature within 4 min. 30 sec. after power on. -or- The hot roller did not reach 100°C within 130 sec. after power on.
		<ul style="list-style-type: none"> • Fusing lamp connections loose, broken, defective • Fusing lamp defective • Thermistor not touching the hot roller • Thermistor defective • MCU defective
		The ready temperature is determined by the state of the machine at recovery:
		<ul style="list-style-type: none"> • Ready Temp. = Target Fusing Temp. (if power on or recovery starts when the hot roller is 80°C or higher). • Ready Temp. = Target Fusing Temp. – 10°C (SP1105-1 default) if power on or recovery starts when the hot roller is less than 80°C. • Ready Temp. = Target Fusing Temp. – 20°C (SP1937-3 default) if power on or recovery starts with pressure roller inching control on.

543	A	Fusing Temperature: Error 1
		The circuit on the MCU that monitors the temperature of the board detected a fusing temperature of 230°C (446°F) for longer than 2 sec.
		<ul style="list-style-type: none"> • MCU defective

544	A	Fusing Temperature: Error 2 (Hardware Detection)
		The fusing thermistor that monitors the temperature of the hot roller detected a fusing temperature of 235°C (455°F), due to a Triac short which interfered with fusing temperature control.

		<ul style="list-style-type: none"> • MCU defective • PSU defective • Fusing unit defective
545	A	Fusing Lamp Overheated: Error 2
		After the hot roller reached the ready temperature, the fusing lamp stayed on at full power for 50 sec. while the hot roller was not rotating.
		<ul style="list-style-type: none"> • Hot roller thermistor not positioned correctly • Fusing lamp harness loose, disconnected, defective • MCU defective
546	A	Fusing Temperature Errors
		The machine detected that the fusing temperature was fluctuating out of range for more than 60 sec. (7 readings detected temperature fluctuating more than $\pm 20^{\circ}\text{C}$)
		<ul style="list-style-type: none"> • Thermistor connection loose, disconnected, defective • Hot roller thermistor not positioned correctly • Fusing lamp connections loose, disconnected, defective • MCU defective
547	D	Zero-Cross Signal Errors
		This error occurs if the machine fails to detect 50/60 Hz on the power supply line. Note: The zero-cross signal from the ac power supply generates a trigger pulse to control the power supply of power. (It automatically detects 50/60 Hz.)
		<ul style="list-style-type: none"> • Check that the frequency of the power supply to the machine is correct • PSU defective • MCU defective
551	A	Pressure roller center thermistor error 1
		During the hot roller temperature control sequence, or while the hot roller and pressure roller were rotating, the pressure roller center thermistor measured a value higher than 3.3V 10 consecutive times at 600 ms intervals.

		<ul style="list-style-type: none"> • Pressure roller center thermistor not positioned properly • Pressure roller center thermistor connector loose, broken, defective • Pressure roller center thermistor defective • MCU defective
--	--	---

553	A	Pressure roller center thermistor error 2
		During the hot roller temperature control sequence, the pressure roller center thermistor measures a value lower than 0.2V.
		<ul style="list-style-type: none"> • Pressure roller center thermistor not positioned properly • Pressure roller center thermistor connector loose, broken, defective • Pressure roller center thermistor defective • MCU defective

557	C	Applied zero-cross waveform error
		The applied power ac frequency was detected less than 66 Hz more than 10 times.
		<ul style="list-style-type: none"> • Noise on the ac power supply line

559	A	Fusing paper jam errors
		Three consecutive paper jam errors occurred in the fusing unit. Note: This SC code is not issued unless SP1159 is switched on.
		<ul style="list-style-type: none"> • Paper jam in fusing unit • Pick-off pawl defective • Paper scraps in fusing unit • Exit sensor defective

561	A	Pressure roller end thermistor error 1
		During the hot roller temperature control sequence, or while the hot roller and pressure roller were rotating, the center thermistor on the pressure roller returned a digital reading of more than 3.3V.

		<ul style="list-style-type: none"> • Pressure roller center thermistor not positioned properly • Pressure roller center thermistor connector loose, broken, defective • Pressure roller end thermistor defective • MCU defective
--	--	--

563	A	Pressure roller end thermistor error 2
		During the hot roller temperature control sequence, the end thermistor on the pressure roller returned a digital reading of less than 0.2V.
		<ul style="list-style-type: none"> • Pressure roller end thermistor connector loose • Pressure roller end thermistor short circuit, defective • MCU defective

SC600

6

632	B	Key/card counter device error 1	CTL
		After 1 data frame is sent to the device, an ACK signal is not received within 100 ms, and is not received after 3 retries.	
		<ul style="list-style-type: none"> • Serial line from the device to the main machine is unstable, disconnected, or defective 	

633	B	Key/card counter device error 2	CTL
		During communication with the device, the MCU received a break (Low) signal.	
		<ul style="list-style-type: none"> • Serial line from the device to the main machine is unstable, disconnected, or defective 	

634	B	Key/card counter device error 3	CTL
		The backup battery of the counter device RAM is low.	
		<ul style="list-style-type: none"> • RAM backup battery exhausted • Counter device defective 	

635	B	Key/card counter device error 4	CTL
-----	---	---------------------------------	-----

		After installation of the device a message alerts user to a battery voltage abnormal error.
		<ul style="list-style-type: none"> • Device control board defective • Device control board backup battery defective

636-1	D	SD Card Error	CTL
		Expanded authentication module error	
		<ul style="list-style-type: none"> • No expanded authentication module in the machine. (Install expanded authentication module.) • Expanded authentication module file is corrupted. • Expanded authentication module SD card is damaged. • No DESS module in the machine. (Install DESS module.) 	
636-2	D	Version Error	CTL
		The version of the expanded authentication module is not correct.	
		<ul style="list-style-type: none"> • Install the correct file of the expanded authentication module. 	

SC641	D	Engine-Controller Communication Error: No Response	CTL
		There was no response to a frame sent from the controller board to the engine.	
		<ul style="list-style-type: none"> • Cycle the machine off/on. 	

650	B	@Remote communication errors 1	CTL
-----	---	--------------------------------	-----

650-1		Authentication error
		Authentication for Cumin-M failed at a dial up connection.
		<ul style="list-style-type: none"> • Incorrect SP settings • Disconnected telephone line • Disconnected modem board • Check and set the correct user name (SP5816-156) and password (SP5816-157).
650-4		Incorrect modem setting
		<ul style="list-style-type: none"> • Dial-up failed due to incorrect modem setting. (Possible causes same as 650-1 above.)
		<ul style="list-style-type: none"> • Check, correct modem settings (SP5819-160)
650-5		Communication line error
		The supplied voltage is not sufficient due to a defective communication line or defective connection.
		<ul style="list-style-type: none"> • Possible cause same as 650-1 above • Consult with the user's local telephone company.

651	C	@Remote communication error 2	CTL
		<p>An unexpected error occurred when the modem (Cumin-M) tried to call the center with a dial up connection due to:</p> <ul style="list-style-type: none"> • Program parameter error (001) • Program execution error (002). 	
		<ul style="list-style-type: none"> • Software bug • No action required because this SC does not interfere with operation of the machine. 	

652	D	@Remote Service ID2 Mismatch Error 1	CTL
		ID2 for the device did not match the ID2 stored in NVRAM. This error can occur if the controller has been replaced with the Cumin ID2 set for another machine, or if the NVRAM has been replaced with the NVRAM from another machine.	

		<ul style="list-style-type: none"> • If this error occurs when Cumin is set up, check the Cumin documentation and make sure that the NVRAM is compatible, set the common authentication, then try again.. • If this error occurs after Cumin has been set, clear the Cumin setting, check the Cumin documentation and make sure that the NVRAM is compatible, set the common authentication, then try again.
--	--	--

653	D	@Remote Service ID2 Mismatch Error 2	CTL
		<p>One of the following problems exist with the ID2 stored in NVRAM:</p> <ul style="list-style-type: none"> • ID2 has less than 17 digits • A non-printable character exists in ID2 • ID2 is all spaces • ID2 is NULL 	
		<ul style="list-style-type: none"> • Replace NVRAM. • Clear the Cumin setting, set the common authentication, then try again. 	

6

670	D	Engine startup error	CTL
		The MCU failed to respond within the prescribed time when the machine was turned on.	
		<ul style="list-style-type: none"> • Connections between MCU and controller board are loose, disconnected, or damaged • MCU defective • Controller board defective 	

671	D	Engine board mismatch error	CTL
		Engine board and controller mismatch detected.	
		<ul style="list-style-type: none"> • Wrong engine board installed. • Wrong controller board installed. • Check the type of engine board and controller board. • Replace BICU • Replace controller board 	

672	D	Controller startup error	CTL
-----	---	--------------------------	-----

		After power on, the line between the controller and the operation panel did not open for normal operation. -or- After normal startup, communication with the controller stopped.
		<ul style="list-style-type: none"> • Controller installed incorrectly • Controller board defective • Operation panel harness disconnected or defective

687	D	PER command error
		The main machine received no PER-command module from the GW controller.
		<ul style="list-style-type: none"> • Poor communication, cycle the machine power off/on

690	D	VDB communication error
		There was no serial communication with the VDB within 1 sec. after power on.
		<ul style="list-style-type: none"> • VDB-to-MCU harness or connectors broken, loose, defective • VDB defective • MCU defective

SC700

There are no SC700 level SC codes for this machine.

SC800

816	D	Energy save I/O subsystem error	CTL
-----	---	---------------------------------	-----

		<p>An error was detected in the signal from the ASIC (controller board) which controls the STR (Suspend to RAM) function.</p> <p>Note: STR is a feature of this machine that minimizes energy consumption while the machine is in the energy saver mode.</p>	
		<ul style="list-style-type: none"> • Reboot the machine. • Replace the controller board. 	
SC816-5	SCS		
	Machine attempted to enter STR mode before engine was OFF.		
SC816-39	Sub System		
	Error occurred during system start up.		
SC816-50	Hardware		
	Printer version only. Not used for this machine.		
SC816-67	NCS (Network Control Service)		
	<p>An error occurred in the access control port list:</p> <ul style="list-style-type: none"> • Number of registrations exceeded 125 • Data notifications exceeded 12 • Data extension incorrect 		
SC816-79	Sub System		
	Message mismatch.		
SC816-90	Hardware/System		
	A forced system reset (WDOG) occurred.		

819	D	Fatal kernel error	CTL
-----	---	--------------------	-----

		Due to a control error, a RAM overflow occurred during system processing. One of the following messages was displayed on the operation panel.	
		<ul style="list-style-type: none"> • System program defective • Controller board defective • Optional board defective • Replace controller firmware 	
		0x0000	
		0x5032	HAIC-P2 decompression error
			Error occurred in the compression/decompression module of ASIC Veena in HAIC-P2. If EFI (Fiery Controller) is connected, refer to the EFI manual. If EFI is not connected.
			<ul style="list-style-type: none"> • HDD defective • System memory defective
		0x6261	HDD Defective
			There was no response from HDD. The power supply to the HDD may have been interrupted suddenly.
			<ul style="list-style-type: none"> • Re-format HDD. • Replace HDD
		554C	USB loader defect
			USB loader was detected as defective.
		Note: For more details about these SC code errors, execute SP5990 to print an SMC report so you can read the error code list. The error code is not displayed on the operation panel.	

820	D	0008	Self-diagnostic Error: CPU: System Call Exception	CTL
		0612	Self-diagnostic Error: CPU: ASIC Interrupt Error	CTL

		<ul style="list-style-type: none"> • System program defective • Controller board defective • Optional board defective • Replace controller firmware <p>Note: For more details about these SC code errors, execute SP5990 to print an SMC report so you can read the error code. The error code is not displayed on the operation panel.</p>
--	--	--

821	D	Self-diagnostic error: ASIC	CTL
		The ASIC provides the central point for the control of bus arbitration for CPU access, for option bus and SDRAM access, for SDRAM refresh, and for management of the internal bus gate.	
		<ul style="list-style-type: none"> • Controller board defective 	

6

Note: For more details about this SC code error, execute **SP5990** to print an SMC report so that you can read the error code. The error code is not displayed on the operation panel.

833	D	Self-diagnostic error: Engine I/F ASIC	CTL
0F30		Device ID for ASIC could not be detected. Register error for ASIC.	
0F31		ASIC register error.	
0F41		The read/write check done for resident RAM on the mother board could not be done correctly.	
50B1		Could not initialize or read the bus connection.	
50B2		Value of the SSCG register is incorrect.	
		<ul style="list-style-type: none"> • One or more MB (Motherboard) connections loose, damaged, defective • MB defective 	

842	C	Verify error at NAND-Flash update	CTL
		A verify error occurred while writing to NAND-Flash when the ROM was being updated locally or remotely.	
		<ul style="list-style-type: none"> • Do the procedure again. • If not successful after two attempts, the machine will issue SC819 	

851	B	IEEE1394 I/F error	CTL
		There is an incorrect setting in the driver that prevented correct operation of the interface.	
		<ul style="list-style-type: none"> • Check and correct the driver settings • Network (PHY) LINK module defective • PCI interface defective • IEEE1394 I/F board defective • Controller board defective 	
853	B	Wireless LAN Error 1	CTL
		During machine start-up, the machine can access the board that holds the wireless LAN, but not to the wireless LAN card.	
		<ul style="list-style-type: none"> • Wireless LAN card missing (was removed) • Wireless LAN connection loose. 	
854	B	Wireless LAN Error 2	CTL
		During machine operation, the machine can get access to the board that holds the wireless LAN, but not to the wireless LAN card (802.11b or Bluetooth).	
		<ul style="list-style-type: none"> • Wireless LAN card missing (was removed) • Wireless LAN connection loose. 	
855	B	Wireless LAN error 3	CTL
		An error was detected on the wireless LAN card.	
		<ul style="list-style-type: none"> • Wireless LAN card defective • Wireless LAN card connection incorrect 	
856	B	Wireless LAN error 4	CTL
		An error was detected on the wireless LAN board.	
		<ul style="list-style-type: none"> • Wireless LAN board defective • PCI connector to MB loose 	

857	B	USB I/F Error	CTL
		The USB driver is not stable and caused an error.	
		<ul style="list-style-type: none"> • Poor USB card connection • Replace the controller board 	

858	A	Data Encryption Error 1	CTL
		These are errors of the HDD Data Encryption Option.	
	0	Key Acquisition	
		Key could be acquired.	
		<ul style="list-style-type: none"> • Replace the controller board 	
	1	HDD Key Setting Error	
		The key was acquired but the HDD could not be set.	
		<ul style="list-style-type: none"> • Turn the machine power off/on several times. • Replace the controller board. 	
	2	NVRAM Read Error	
		NVRAM data conversion failed (mismatch with nvram.conf).	
		<ul style="list-style-type: none"> • Replace the NVRAM 	
	30	NVRAM Before Replace Error	
		DFU. May occur during development.	
		<ul style="list-style-type: none"> • Turn the machine power off/on several times. • Replace the controller board. 	
	31	Other Error	
		An unexpected error occurred while data was being converted. This error is the same as SC991. See SC991 below.	

859	B	Data Encryption Error 2	CTL
-----	---	-------------------------	-----

		These are errors of the HDD Data Encryption Option D377.
8	HDD Check Error	
		Data conversion was attempted with no HDD unit present.
		<ul style="list-style-type: none"> • Confirm that HDD unit installed correctly • Initialize HDD with SP5832-1 Note: After installation, a new HDD should be formatted with SP5832-1
9	Power Loss During Data Conversion	
		Data conversion stopped before NVRAM/HDD data was converted.
		<ul style="list-style-type: none"> • Format HDD with SP5832-1
10	Data Read Command Error	
		More than two illegal DMAC communications were returned.
		<ul style="list-style-type: none"> • HDD defective • Format HDD with SP5832-1 • Replace HDD

860	B	HDD startup error at power on	CTL
		HDD is connected but a driver error is detected. -or- The driver does not respond with the status of the HDD within 30 s.	
		<ul style="list-style-type: none"> • HDD is not initialized • Level data corrupted • HDD is defective 	

861	D	HDD re-try failure	CTL
		At power on the HDD was detected. Power supply to the HDD was interrupted after the system entered the energy save mode, but after the HDD was awakened from the energy save mode it did not return to the ready status within 30 sec.	

		<ul style="list-style-type: none"> • Harness between HDD and controller board disconnected, defective • HDD power connector disconnected • HDD defective • Controller board defective
--	--	---

863	D	HDD data read failure	CTL
		The data written to the HDD cannot be read normally, due to bad sectors generated during operation.	
		<ul style="list-style-type: none"> • HDD defective 	

Note:

- If the bad sectors are generated at the image partition, the bad sector information is written to NVRAM.
- The next time the HDD is accessed, these bad sectors will not be accessed for read/write operation. The HDD will probably require replacement soon.

6

864	D	HDD data CRC error	CTL
		During HDD operation, the HDD cannot respond to a CRC error query. Data transfer did not execute normally while data was being written to the HDD.	
		<ul style="list-style-type: none"> • HDD defective 	

865	D	HDD access error	CTL
		HDD responded to an error during operation for a condition other than those for SC863, 864.	
		<ul style="list-style-type: none"> • HDD defective 	

866	B	SD card error 1: Confirmation error	CTL
		The machine detected an electronic license error in the application on the SD card in the controller slot immediately after the machine was turned on.	
		<ul style="list-style-type: none"> • Program missing from the SD card 	

867	D	SD card error 2: SD card removed	CTL
-----	---	----------------------------------	-----

		The SD card in the boot slot when the machine was turned on was removed while the machine was on.
		<ul style="list-style-type: none"> • Insert the SD card • Turn the machine's power off/on

868	D	SD card error 3: SD card access	CTL
		An error occurred while an SD card was used.	
		<ul style="list-style-type: none"> • SD card not inserted correctly • SD card defective • Controller board defective • To reformat the SC card, use SD Formatter Ver 1.1. 	

870	B	Address book data error	CTL
		Address book data on the hard disk was detected as abnormal when it was accessed from either the operation panel or the network. The address book data cannot be read from the HDD or SD card where it is stored, or the data read from the media is defective.	
		<ul style="list-style-type: none"> • Turn the machine power off/on. If this does not solve the problem, do the Procedure below. • HDD defective 	
		<p>Procedure</p> <ol style="list-style-type: none"> 1. Do SP5846-50 (UCS Settings – Initialize all Directory Info.) to reset all address book data. 2. After 3 sec. reset the user information with SP5832-6 (HDD Formatting– User Information). 3. Turn the main power switch off/on. 	

872	B	HDD mail receive data error	CTL
		An HDD error was detected immediately after power on, or the machine detected that the HDD was not operating correctly (data read or write) while receiving mail. The HDD may be defective or the machine was accidentally powered off while the HDD was being accessed.	
		<ul style="list-style-type: none"> • Reformat the mail RX data on the HDD with SP5832-7 • Replace the HDD 	

873	B	HDD mail send data error	CTL
		An error was detected on the HDD immediately after the machine was turned on, or power was turned of while the machine was using the HDD.	
		<ul style="list-style-type: none"> • Do SP5832-007 (Format HDD – Mail TX Data) to initialize the HDD. • Replace the HDD. 	

874	D	Delete All error 1: HDD	CTL
		A data error was detected for the HDD/NVRAM after the Delete All option was used. Note: The source of this error is the Data Overwrite Security Unit B735 running from the DOS SD card.	
		<ul style="list-style-type: none"> • Turn the main switch off/on, do the operation again. • Install the Data Overwrite Security Unit again. • HDD defective 	

875	D	Delete All error 2: Data area	CTL
		An error occurred when the machine deleted data from the HDD. Note: The source of this error is the Data Overwrite Security Unit B735 running from the DOS SD card.	
		<ul style="list-style-type: none"> • Turn the main switch off/on and try the operation again. 	

876	D	Log data errors	CTL
-----	---	-----------------	-----

		876-1	Log data error 1 An error was detected in the handling of the log data at power on or during machine operation. This can be caused by switching the machine off while it is operating. <ul style="list-style-type: none">Initialize the HDD with SP5832-4
		876-2	Log data error 2 HDD encryption unit not installed. <ul style="list-style-type: none">Install the HDD encryption unit.
		876-3	Log data error 3 Invalid log encryption key due to defective NVRAM data. <ul style="list-style-type: none">Initialize the HDD with SP5832-4Request customer's system administrator to disable HDD encryption with the User Tool.
		876-4	Log data error 4 Erratic HDD encryption due to defective NVRAM data. <ul style="list-style-type: none">Initialize HDD with SP5832-4
		876-5	Log data error 5 <ul style="list-style-type: none">Re-install the previous NVRAM or HDD.Initialize the HDD with SP5832-4.
		876-99	Log data error 6 An error other than Log Data Errors 1 to 5 occurred. <ul style="list-style-type: none">Request assistance from your supervisor.

877	B	Data Overwrite Security SD card error	CTL
		An error occurred, preventing successful execution of the Data Overwrite Security function, even though it has been set up and enabled.	

		<ul style="list-style-type: none"> • DOS card is not inserted completely into the SD card slot • DOS card has been removed from the SD card slot. • DOS card is damaged. <p>Note:</p> <ul style="list-style-type: none"> • If the SD card has been removed (or was not installed correctly), switch the machine off, insert the SD card, then switch on the machine again. • If the SD card has been damaged, procure a new SD card, replace the NVRAM, then do the DOS option installation.
--	--	--

878	D	TPM authentication error	CTL
		The system firmware could not be authenticated by the TMP security chip.	
		<ul style="list-style-type: none"> • System firmware updated incorrectly. • Flash ROM on controller board defective. • Replace controller board. 	

6

880	B	File Format Converter (MLB) error	CTL
		A request to access the MLB was not answered within the specified time (60 sec.).	
		<ul style="list-style-type: none"> • File format converter board defective 	

SC900

900	D	Electrical total counter error	CTL
		The total counter contains something that is not a number.	
		<ul style="list-style-type: none"> • NVRAM incorrect type • NVRAM defective • NVRAM data scrambled • Unexpected error from external source 	

901	D	Mechanical Total Counter	
		The mechanical counter is not connected.	

		<ul style="list-style-type: none"> • Mechanical counter connection loose, broken, defective • Mechanical counter defective
--	--	--

920	B	Printer error 1	CTL
		An internal application error was detected and operation cannot continue.	
		<ul style="list-style-type: none"> • Software defective • Turn the machine power off/on, or change the controller firmware • Insufficient memory 	

921	B	Printer Error 2	CTL
		When the printer application started, the font designated for use could not be found on the SD card.	
		<ul style="list-style-type: none"> • The font is not on the SD card 	

925	B	Net File function error	CTL
		The NetFile file management on the HDD cannot be used, or a NetFile management file is corrupted and operation cannot continue. The HDDs are defective and they cannot be debugged or partitioned, so the Scan Router functions (delivery of received faxes, document capture, etc.), Web services, and other network functions cannot be used. HDD status codes are displayed below the SC code:	
		<ul style="list-style-type: none"> • Refer to the four procedures below (Recovery from SC 925). 	

Here is a list of HDD status codes:

Display	Meaning
(-1)	HDD not connected
(-2)	HDD not ready
(-3)	No label
(-4)	Partition type incorrect
(-5)	Error returned during label read or check
(-6)	Error returned during label read or check

(-7)	"filesystem" repair failed
(-8)	"filesystem" mount failed
(-9)	Drive does not answer command
(-10)	Internal kernel error
(-11)	Size of drive is too small
(-12)	Specified partition does not exist
(-13)	Device file does not exist

Recovery from SC 925

Procedure 1

If the machine shows SC codes for HDD errors (SC860 to SC865) with SC 925, do the recovery procedures for SC860 to SC865.

Procedure 2

1. If the machine does not show one of the five HDD errors (SC860 to SC865), turn the machine power off and on.
2. If this is not the solution for the problem, then initialize the NetFile partition on the HDD with SP5832-1 1 (HDD Formatting – Ridoc I/F).

NetFiles: These are jobs printed from the document server using a PC and DeskTopBinder. Before you initialize the NetFile partition on the HDD, tell the customer:

- Received faxes on the delivery server will be erased
- All captured documents will be erased
- DeskTopBinder/Print Job Manager/Desk Top Editor job history will be erased
- Documents on the document server, and scanned documents, will not be erased.
- The first time that the network gets access to the machine, the management information must be configured again (this will use a lot of time).

3. Before you initialize the Netfile partition with SP5832-1 1, do these steps:
4. Go into the User Tools mode and do "Delivery Settings" to print all received fax documents that are scheduled for delivery. Then erase them.
5. In the User Tools mode, do Document Management> Batch Delete Transfer Documents.
6. Do SP5832-1 1, then turn the machine power off and on.

Procedure 3

1. If "Procedure 2" is not the solution for the problem, do SP5832-1 (HDD Formatting – All)
2. Cycle the machine off/on.

★ Important

- SP5832-001 erases all document and address book data on the hard disks. Consult with the customer before you do this SP code.

Procedure 4

If "Procedure 3" does not solve the problem, replace the HDD.

SC954	D	Printer Image Setting Error
		The IPU did not issue the signal required to start image processing for the printing mode within 60 s after the paper stops for registration.
		<ul style="list-style-type: none"> • Software defective • Replace the software (all firmware modules). • SIPU defective
965	D	Print Start Error
		During print processing, another command to start printing was received.
		<ul style="list-style-type: none"> • Printer firmware defective • Update printer firmware
967	D	Image write start error
		The paper stopped at the registration sensor and roller for buckle adjustment but the signal to start image writing was not received within 60 sec.
		<ul style="list-style-type: none"> • Printer firmware defective • Update printer firmware • Check the connections between the LPH sections (x3) and the VDB • LPH defective • VDB defective • MCU defective
984	D	Print image data send error
		No data was sent within 1 sec. after the print image data stream started.
		<ul style="list-style-type: none"> • Harness from IPU to controller board loose, broken, defective • SIPU defective

990	D	Software error 1	CTL
		The software performs an unexpected function and the program cannot continue.	
		<ul style="list-style-type: none"> • Firmware defective: re-boot • Update firmware*¹ 	
991	C	Software error 2	CTL
		The software performs an unexpected function. However, unlike SC990, recovery processing allows the program to continue.	
		<ul style="list-style-type: none"> • Software defective, re-boot*¹ 	

*¹: For more information about SC990 and SC991:

1. Execute SP7403 or print an SMC Report (SP5990) to read the history of the 10 most recent logged errors.
2. If you press [0] on the operation panel with the SP selection menu displayed, you will see detailed information about the recently logged SC990 or SC991 errors, including the software file name, line number, and so on. (1) above is the recommended method, because another SC could write over the information for the previous SC.

992	D	Erratic SC error	CTL
		There was an unusual operation by the software because of:	
		<ul style="list-style-type: none"> • An incorrect argument in the program. • An incorrect internal parameter. • Work memory not sufficient. • An error occurred that could not be detected by other SC codes. 	
		<ul style="list-style-type: none"> • Turn the main power switch off/on. • Go into the SP mode. Do SP7901 to display details about SC992 (software file name, line number, and variable), and inform your supervisor of the results. 	

994	C	Operation Panel Management Records Exceeded	CTL
		An error occurred because the number of records exceeded the limit for images managed in the service layer of the firmware. This can occur if there are too many application screens open on the operation panel.	
		<ul style="list-style-type: none"> • No action required because this SC does not interfere with operation of the machine. 	

997	B	Cannot select application function	CTL
		An application did not start after the user pushed the correct key on the operation panel.	
		<ul style="list-style-type: none"> • Software bug • A RAM or DIMM option required for the application is not installed or not installed correctly. 	

998	D	Application cannot start	CTL
		Register processing does not operate for an application within 60 s after the machine power is turned on. No applications start correctly, and all end abnormally.	
		<ul style="list-style-type: none"> • Software bug • A RAM or DIMM option needed for the application not installed, or not installed correctly • Controller board defective 	

Jam Code Tables, Cover Open

Overview

When a jam occurs:

- The jam indicator lights (🔴).
- A diagram on the LCD shows the location of the jam with instructions about how to correct the problem.
- The “Code” numbers in the table are also shown. Use SP7507 (Plotter Jam History) and SP7508 (Original Jam History) to see the most recent codes.

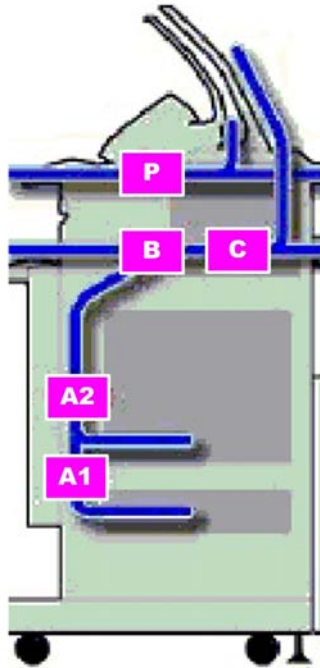

d093t560

Code	Location
A1	Paper Cassette Feed
A2	Roll Paper Feed
B	Bypass Paper Feed, Paper Registration
C	Fusing Unit (Exit)
P	Original feed

- The operator must open and close the upper unit to release a jam in the fusing unit.
- If the operator opens and closes the paper exit cover during copying, this is not recorded in the jam record.
- An original or paper feed jam that occurs just after the main power switch or operation switch comes on is not recorded in the jam record.

Scanner Jams

In the tables below "late" and "lag" have the following meanings:

- **Late.** Paper (or original) fails to arrive at the sensor location at the prescribed time.
- **Lag.** Paper (or original) fails to leave the sensor location at the prescribed time.
- **LE.** Leading edge of original or paper.
- **TE.** Trailing edge of original or paper.

Scanner Standby Jams

Code	Location	Display	Comment
001	Initial jam: Original Set Sensor	P	Sensor ON
	Initial jam: Original Registration Sensor	P	Sensor ON
	Initial jam: Original Width Sensor (A0)	P	Sensor ON
	Initial jam: Original Width Sensor (A1)	P	Sensor ON
	Initial jam: Original Width Sensor (A2)	P	Sensor ON
	Initial jam: Original Width Sensor (A3)	P	Sensor ON
	Initial jam: Original Width Sensor (A4)	P	Sensor ON
	Initial jam: Original Width Sensor (B1)	P	Sensor ON
	Initial jam: Original Width Sensor (B2)	P	Sensor ON
	Initial jam: Original Width Sensor (B3)	P	Sensor ON
	Initial jam: Original Width Sensor (B4)	P	Sensor ON
	Initial jam: Original Width Sensor (914)	P	Sensor ON
Initial jam: Original Exit Sensor	P	Sensor ON	

Code	Location	Display	Comment
008	Next Original Time Limit		P
	Next original was set on the original feed table too early. Original set sensor detected the trailing edge of the first original. The paper set sensor detected the leading edge of the next original (before the IPU received the scan end signal).		
006	Original Stop		P
	[Scanner Stop] button was pushed to remove the original.		

Scanner Late Jams

Code	Location	Display	Comment
002	Registration Jam	P	Registration sensor not ON
003	Registration Jam	P	Registration sensor OFF
007	Exit Jam	P	Fusing exit sensor not ON

Scanner Lag Jams

Code	Location	Display	Comment
004	Registration Jam (Sensor not OFF)	P	
005	Registration Jam	P	

Plotter (Printer) Jams

Plotter Standby Jams

Code	Location	Display	Comment
001	Initial Jam: Registration Sensor	B	
	Initial Jam: Paper Set Sensor	B	
	Initial Jam: Fusing Exit Sensor	C	

Plotter Late Jams

Code	Location	Display	Comment
003	Roll 1 Non-Feed Jam	A2	
004	Roll 2 Non-Feed Jam	A2	
005	Paper cassette Non-Feed Jam	A1	
008	Roll Feeder Exit Jam	A1	RF exit sensor not ON
013	Registration Jam	B	Registration sensor not ON
016	Fusing Exit Jam	C	Fusing exit sensor not ON.
034	Bypass Non-Feed	B	Paper set not ON.

Plotter Lag Jams

Code	Location	Display	Comment
053	Roll 1 Feed Lag	A2	Roll paper failed to feed
054	Roll 2 Feed Lag	A2	Roll paper failed to feed
055	Paper Cassette Lag	A1	Cut sheets failed to feed
058	Roll Feeder Exit Jam	A2	RF exit sensor failed to go OFF
063	Registration Jam	B	Paper registration sensor failed to go OFF.
066	Fusing Exit Jam	C	Fusing exit sensor failed to go OFF.
084	Bypass Jam	B	Paper set sensor failed to go OFF.

Cover Open

Location	Shuts Off Lines	Display
Drawer Connector	Roll feed motor, cutter motor, roll feed clutches (24 V dc line)	Cover Open
Exit Cover Sensor	Cooling fan, paper junction gate solenoid, quenching lamp, pick-off pawl solenoid, fusing motor, T&S power pack (24 V dc line), fusing lamp (power relay/ac line)	
Exit Cover Switch		
Exit Unit Switch		
Scanner Switch	Scanner motor (24 dc line)	
Toner Hopper Cover Switch	Toner supply clutch, paper registration clutch, drum motor, main motor, CGB power pack (24 V dc line)	
Upper Unit Sensor	Toner supply clutch, paper registration clutch, drum motor, main motor, CGB power pack, cooling fan, paper junction gate solenoid, quenching lamp, pick-off pawl solenoid, fusing motor, T&S power pack (24 V dc line), fusing lamp (power relay/ac line)	
Upper Unit Switch		

Electrical Component Diagrams

Main Unit 1

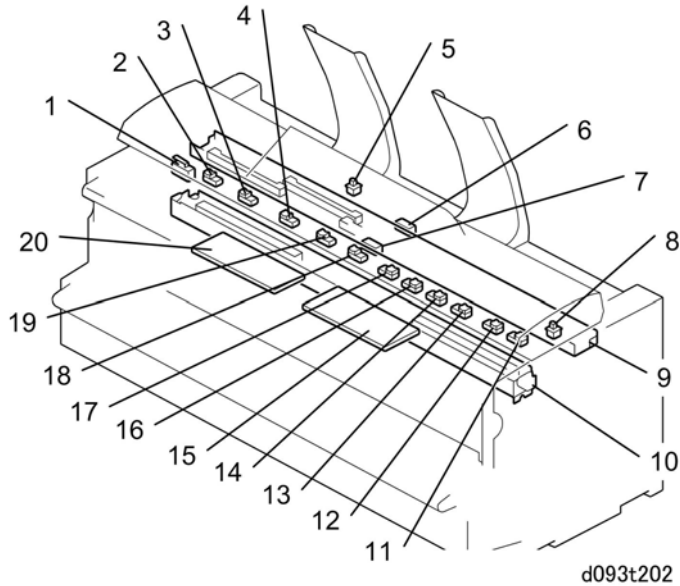

6

No.	Name	Function
1	Scanner Switch	This interlock switch stops power to the original feed unit when the original feed unit cover is lifted.
2	Original Width Sensor (B1/24")	Detects B1/24"-width paper.
3	Original Width Sensor (B2/18")	Detects B2/18"-width paper.
4	Original Width Sensor (B3/12")	Detects B3/12"-width paper.
5	Paper Exit Selection Switch	The upper output stacker depresses this switch and closes. This sets normal operation. The operator can select "Upper" or "Lower" on the operation panel. When the upper output stacker is removed, this opens the switch and sets the machine for paper exit to the lower path only. ("Upper" cannot be selected on the operation panel.)
6	Original Exit Sensor	Detects the leading edge and trailing edge of the original when it feeds out of the scanner.

No.	Name	Function
7	Original Registration Sensor	(1) Detects the leading edge of the original and stops the original feed roller. The user can then manually make the original straight. (2) Detects the trailing edge of the original, or detects a jam if it does not detect the trailing edge.
8	Scanner Stop Switch	The user pushes this switch on the right side of original feed unit to stop original feed if there is a problem during scanning.
9	CIS 1 - 5	Contact Image Sensors. Transfer the image signals from the CIS LEDs to the SIF.
10	LPH1 - 3	LED Print Heads. Each section writes a part of the image on the PCB drum. The VDB controls the LPH units.
11	Original Width Sensor (914mm/36")	Detects 914mm/36"-width paper.
12	Original Width Sensor (A1/34")	Detects A1/34"-width paper.
13	Original Width Sensor (30")	Detects 30"-width paper. (-17 version only)
14	Original Width Sensor (A1/22")	Detects A2/22"-width paper.
15	SIF (Scanner Interface)	Interfaces between the SIPU and CIS.
16	Original Width Sensor (A2/17")	Detects A2/22"-width paper.
17	Original Width Sensor (A3/11")	Detects A3/11"-width paper.
18	Original Set Sensor (A4/8.5" SEF)	Detects the leading edge of the original. This starts the scanner motor. This sensor also detects A4 or 8.5" width paper.
19	Original Width Sensor (B4/9")	Detects B4 or 9" width paper.
20	VDB (Video Drive Board)	This controls the image signals that are sent to the LPH (LED Print Head).

Main Unit 2

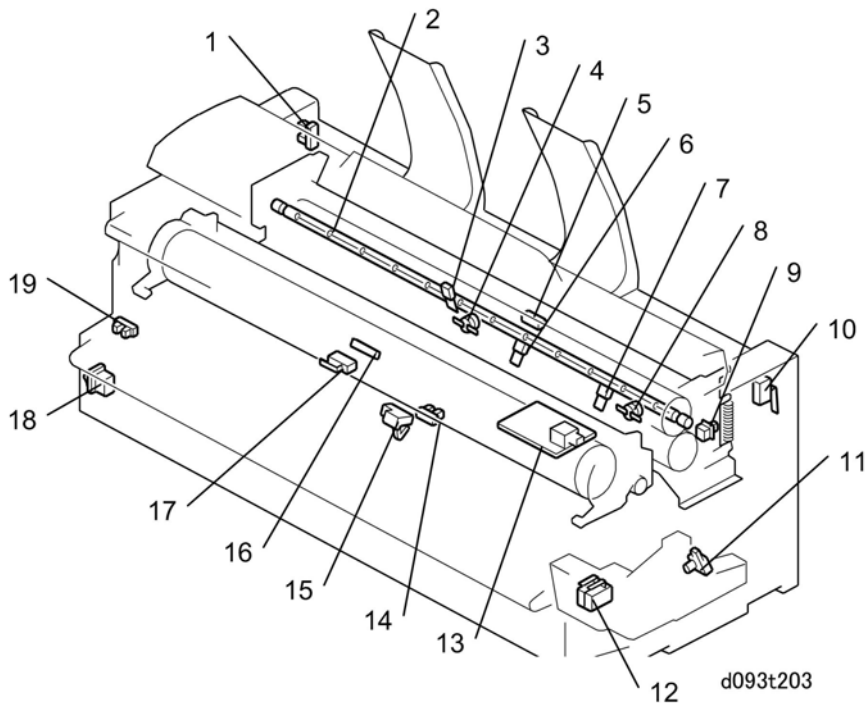

6

No.	Name	Function
1	Exit Cover Sensor	This detects if the exit cover on the rear of the machine is open or closed.
2	Fusing Lamp	One fusing lamp (1 100 W) in the hot roller.
3	Hot Roller Thermistor	The CPU uses this thermistor to monitor the temperature of the hot roller.
4	Thermostat 1 (199°C)	199°C. This safety device prevents overheating if the temperature control circuit fails.
5	Fusing Exit Sensor	Detects the leading edge and trailing edge of the paper as it leaves the fusing unit.
6	Pressure Roller Thermistor 2 (Center)	The CPU uses this thermistor to monitor the temperature of the pressure roller at the center.
7	Pressure Roller Thermistor 1 (End)	The CPU uses this thermistor to monitor the temperature of the pressure roller at the end.

No.	Name	Function
8	Thermostat 2 (200°C)	This safety device prevents overheating if the temperature control circuit fails.
9	Exit Unit Switch	Detects whether the fusing unit cover is open or closed. SC559 is issued after 3 consecutive jams occur in the fusing unit.* ¹
10	Exit Cover Switch	This detects if the exit cover on the rear of the machine is closed.
11	Toner Overflow Sensor	Detects toner overflow in the used toner collection bottle.
12	Upper Unit Switch 1	This detects if the upper unit is open on the left side.
13	CGB Power Pack	High voltage power supply for the charge corona wire (C), development bias (B), and charge corona grid (G).
14	Paper Registration Sensor	This detects paper at the registration rollers.
15	Paper Set Sensor	This detects when a cut sheet is placed on the manual feed table (by-pass).
16	ID Sensor	The machine uses this sensor to control toner supply, toner near-end, and toner end. There is no toner density sensor in this machine.
17	Toner Hopper Cover Switch	This detects if the toner supply cover is open or closed.
18	Main Power Switch	This switches the machine on and off.
19	Upper Unit Sensor	Detects when the upper unit is open.

Note*¹

- SC559 is not issued unless SP1159 is switched on (Default: "0" off).
- The fusing unit cover must always be opened and closed after this SC occurs to restore the machine to full operation.
- This ensures that the operator has opened and closed the cover to check for paper and/or paper scraps around the hot roller. Loose paper around the hot roller is a fire hazard.

Main Boards and Switches

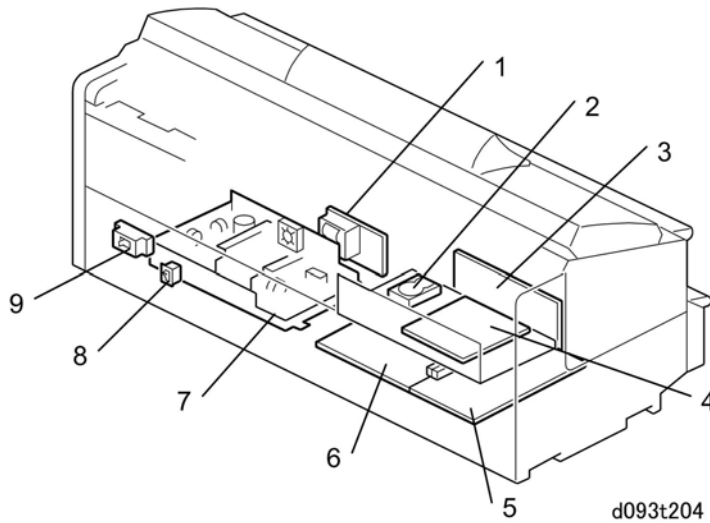

No.	Name	Function
1	T&S Power Pack	High voltage power supply for the transfer corona wire (T) and the separation corona wire (S) in the T&S (Transfer and Separation) unit.
2	HDD	Hard Disk Drive. One unit: 160 GB
3	Mother Board	Interfaces with the controller, SIPU, and optional devices such as interface board for the printer controller.
4	Controller Board	Controls the memory and all peripheral devices. The GW architecture allows the board to control all applications (copying, printing, and scanning).
5	SIPU	Scanner Image Processing Unit . This processes image data from the CIS (Contact Image Sensor), and sends it to the VDB (Video Drive Board) and LPH (LED Print Heads). The SIPU also controls the HDD unit and the PC interfaces.
6	MCU	Main Control Unit. This is the machine's main board. It contains the SCU (Scanner Control Unit) and ECU (Engine Control Unit). These units control all parts of the machine, and this includes the print engine, scanner, and image processing.
7	PSU	Power Supply Unit. This supplies dc power for the machine, heaters, and dehumidifiers in the roll feeder.

No.	Name	Function
8	Anti-condensation Heater Switch	Switches the anti-condensation heaters on/off in the main machine. There are two 13W heaters, one located at either end of the OPC drum. These heaters operate only when the main switch is switched off.
9	Circuit Breaker	Monitors the main power supply and cuts the main power if it detects an overload.

Roll Feeder

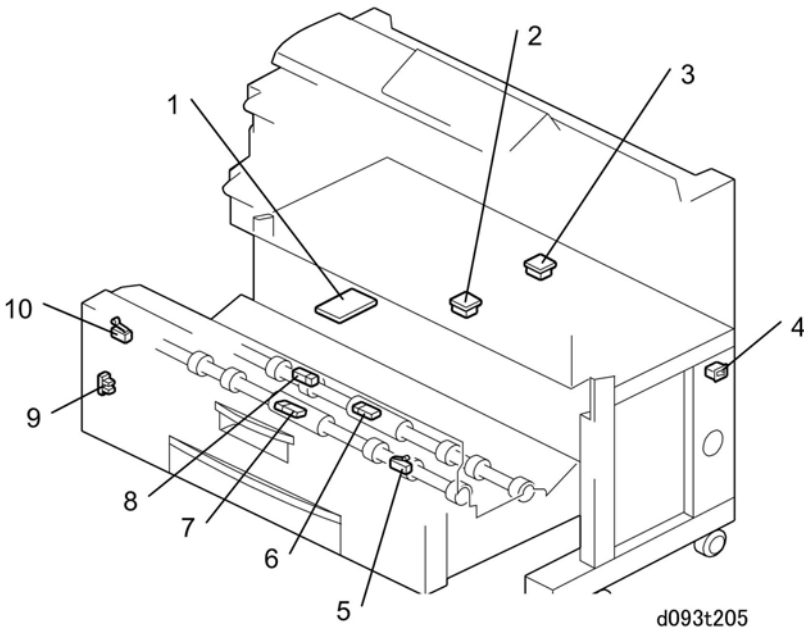

No.	Name	Function
1	RFDB	Roll Feed Drive Board. This is attached to the optional roll feeder. It controls the components of the roll feeder (motor, clutches, sensors, and switches).
2	Roll End Sensor 1	This reflective photosensor above Roll 1 detects the core of the roll (which is black), after there is no more paper on Roll 1.
3	Roll End Sensor 2	This reflective photosensor above Roll 2 detects the core of the roll (which is black), after there is no more paper on Roll 2.

No.	Name	Function
4	Dehumidifier Switch	Switches the dehumidifiers (x4) in the roll feeder on/off.
5	Right Cutter HP Switch	This detects if the cutter in the roller feeder is at the home position at the right side. In this condition, the paper holder of the cutter is locked open (the paper feed path is open).
6	Roll End Sensor 4	Detects the trailing edge of the roll after there is no more paper on Roll 2. This sensor is included because if the color of the roll core is not black, Roll End Sensor 2 cannot always detect roll end.
7	Roll End Sensor 3	Detects the trailing edge of the roll after there is no more paper on Roll 1. This sensor is included because if the color of the roll core is not black, Roll End Sensor 1 cannot always detect roll end.
8	RF Exit Sensor	(1) Detects the leading edge of the paper from the rolls. (2) Detects the trailing edge of cut sheets from the paper cassette and trailing edges of sheets cut from the paper rolls for paper feed timing and jam detection. (3) If this sensor does not detect a leading edge after feeding from Roll 1 or Roll 2, it also signals paper end for the roll.
9	RF Set Sensor	This detects if the spring-loaded lock lever of the roll feeder drawer is locked.
10	Left Cutter HP Switch	This detects if the cutter in the roller feeder is at the home position at the left side. In this condition, the paper holder of the cutter is locked open (the paper feed path is open).

Paper Cassette

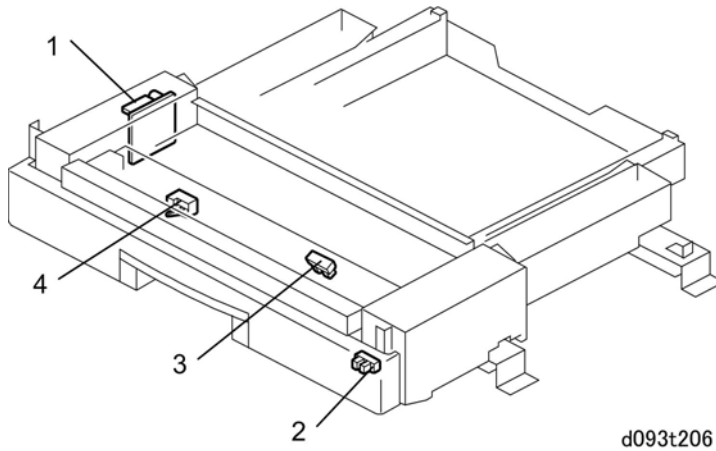

d093t206

6

No.	Name	Function
1	SFDB	Sheet Feed Drive Board. This is attached to the optional paper cassette. It controls the components of the paper cassette (motor, clutches, sensors, and switches).
2	Cassette Set Sensor	This detects when the cassette is set and locked in its place.
3	Cassette End Sensor	This sensor is above the paper cassette. It detects paper end after the last sheet feeds.
4	Relay Sensor	This sensor is near the grip rollers. It detects the leading edge of every cut sheet, switches off the cassette paper feed clutch, and switches on the grip rollers.

Fuses

The fuses differ slightly with geographic location.

PSU

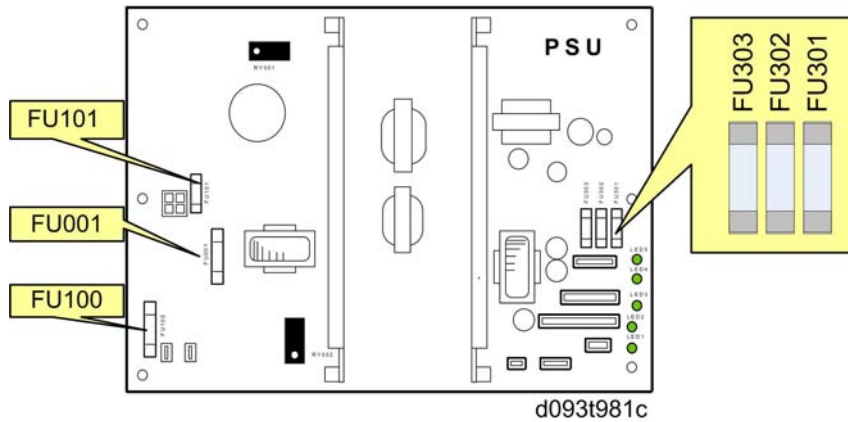

6

-17 Version (120V)

Name	Output Connector	Capacity	Voltage	Load Type
FU101	CN100-2	T10AH/250V	AC	DC Power
FU001	CN101-1	15A/250V	AC	Fusing lamps
FU100	-	15A/250V	AC	Input protection
FU303	CN126-3 CN402-1	T6.3AL/250V	24V	MCU, SIF
FU302	CN126-2	T6.3AL/250V	24V	MCU (via interlock)
FU301	CN126-1	T6.3AL/250V	24V	MCU (via interlock)

-21, -27 Versions (220-240V)

Name	Output Connector	Capacity	Voltage	Load Type
FU001	CN101-1	T6.3AH/250V	AC	Fusing lamps
FU100	-	8A/250V	AC	Input protection
FU303	CN126-3 CN402-1	T6.3AL/250V	24V	MCU, SIF
FU302	CN126-2	T6.3AL/250V	24V	MCU (via interlock)
FU301	CN126-1	T6.3AL/250V	24V	MCU (via interlock)

Board LEDS, DIP Switches

This section describes the functions of the LEDs on the most important PCBs.

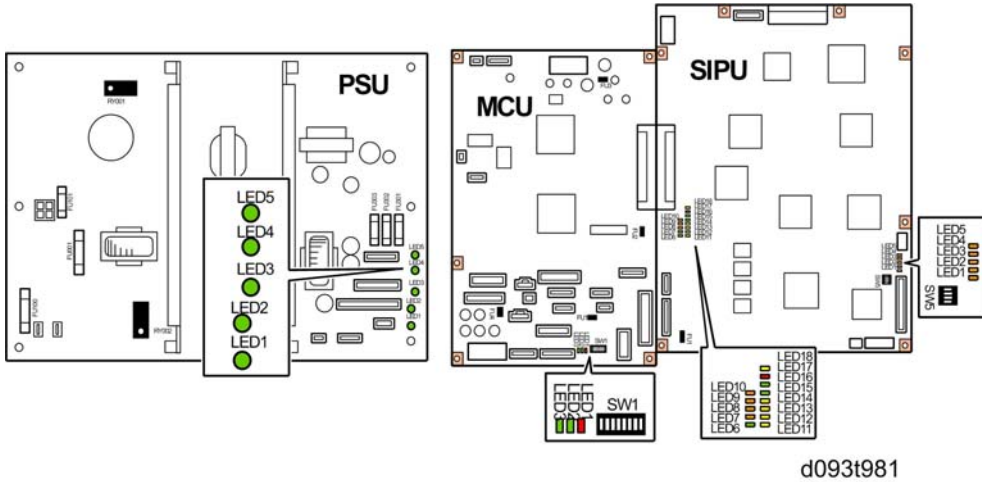

PSU

The PSU supplies dc current to electrical components and also controls the flow of ac current to the fusing lamp, dehumidifiers (x4), and anti-condensation heaters (x2).

The following LEDs indicate the status of elements operation on the PSU.<0}

LED	Color	LED Definition	LED State
LED 1	GREEN	+5VE	Output: ON No output: OFF
LED 2	GREEN	+5V	Output: ON No output: OFF
LED 3	GREEN	+12V	Output: ON No output: OFF
LED 4	GREEN	-12V	Output: ON No output: OFF
LED 5	GREEN	+24V	Output: ON No output, fuse blown: OFF

MCU

The MCU (Main Control Unit) performs system control, base engine control, scanner control, and also controls the SIPU. The MCU also controls:

- I/O for the base engine (high voltage power supply, motors, sensors, solenoids, clutches, fusing temperature, customer support systems, etc.)
- Scanning signals (sensors, motors)
- Power supply
- Scanner motor output

The following LEDs indicate the status of elements operation on the MCU.<0}

LED	Color	LED Definition	Downloading		Normal Operation
			Executing	Finished	
LED 1	Red	eSOC status	ON	OFF	OFF
LED 2	GREEN	eSOC status	OFF	FLASH	FLASH
LED 3	GREEN	Trio2 Status	OFF	ON	ON

6

DIP_SW 1

SW No.	DIP SW Definition	Factory Setting	Comments		
1	Destination Setting 1	OFF	Area	SW1	SW2
2	Destination Setting 2	OFF	-17	ON	OFF
			-27	OFF	ON
			-21	ON	ON
3	Jam Detect OFF	OFF	No jam detection at ON		
4	SC Detection OFF	OFF	No SC detection at ON		
5	Not Used	OFF	-		
6	Not Used	OFF	-		
7	Not Used	OFF	-		
8	Not Used	OFF	-		

SIPU

The SIPU (Image Processing Unit) processes the image data. After the scan data from the CIS has been processed, the data is sent via the VDB to the LPH for image writing.

The following LEDs indicate the status of elements operation on the SIPU<0}

LED	Color	LED Definition	LED State
LED 1	ORANGE	CIS Processing IC (IC10) Status Display	Normal: Flashing (Duty = 50%) Abnormal: OFF
LED 2	ORANGE	CIS Processing IC (IC10) Status Display	Normal: OFF Abnormal: ON
LED 3	ORANGE	CIS Processing IC(IC10) Status Display	Normal: ON Abnormal: OFF
LED 4	ORANGE	CIS Processing IC (IC10) Status Display	Normal: ON Abnormal: OFF
LED 5	ORANGE	CIS Processing IC (IC8) Status Display	Normal: OFF Abnormal: ON
LED 6	GREEN	Image Processing IC (IC23) Status Display	Standby: FLASH Operation: ON
LED 7	ORANGE	Image Processing IC (IC19) Status Display	Standby: FLASH Operation: ON
LED 8	ORANGE	Image Processing IC (IC18) Status Display	Standby: FLASH Operation: ON
LED 9	ORANGE	Image Processing IC (IC20) Status Display	Standby: FLASH Operation: ON
LED 10	ORANGE	Image Processing IC (IC30) Status Display	Standby: FLASH Operation: ON
LED 11	YELLOW	Image Processing IC (IC37) Status Display	Normal: ON DDR Lead Line Abnormal: OFF

LED	Color	LED Definition	LED State
LED 12	YELLOW	Image Processing IC (IC37) Status Display	No JPEG Line Over Interrupt: ON JPEG Line Over Interrupt: OFF (No abnormality if OFF.)
LED 13	YELLOW	Image Processing IC (IC37) Status Display	Normal: ON Memory Line Over Abnormal: OFF
LED14	YELLOW	Image Processing IC (IC37) Status Display	Standby: OFF Reading Original: ON (At power on, download end: ON)
LED15	GREEN	Power Display: 3.3V	Normal: ON Abnormal: OFF
LED16	GREEN	Power Display: 3.3V	Normal: ON Abnormal: OFF
LED17	RED	Power Display: 5VE	Normal: ON Abnormal: OFF
LED18	YELLOW	Power Display: 3.3VEP	Normal: ON Abnormal: OFF

DIP_SW5

SW No.	DIP SW Definition	Factory Setting	Comments
1	CIS Switching	ON	Never change these settings.
2	Not Used	OFF	
3	Not Used	OFF	
4	For debugging	OFF	

VDB, SIF

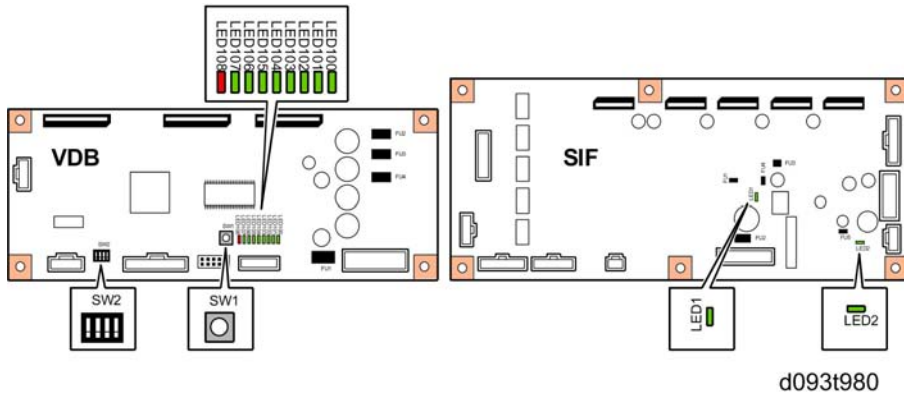

VDB

The VDB (Video Drive Board) controls the LPH (LED Print Head). The VDB receives the image processed data from the SIFPU and sends it to the LPH.

The following LEDs indicate the status of elements operation on the VDB<0}

LED	Color	LED Definition	LED State
LED100	GREEN	FPGA operation	Normal: FLASH
LED101	GREEN	PCLK Input Check	Input from SIFPU: FLASH. Else: OFF
LED102	GREEN	Internal GATE signal check	Signal assert: FLASH Else: OFF
LED103	GREEN	LSYNC signal check	Input from SIFPU: FLASH. Else: OFF
LED104	GREEN	FPGA Net Ver.	Distinguishing No. Bit 3: 1: ON 0: OFF
LED105	GREEN	FPGA Net Ver.	Distinguishing No. Bit 2: 1: ON 0: OFF
LED106	GREEN	FPGA Net Ver.	Distinguishing No. Bit 1: 1: ON 0: OFF

LED	Color	LED Definition	LED State
LED107	GREEN	FPGA Net Ver.	Distinguishing No. Bit 0: 1: ON: 0: OFF
LED108	RED	+3.3 V	On: ON

DIP_SW2

SW No.	DIP SW Definition	Factory Setting	Comments
SW2 (4-bit)	For debugging	OFF	Do Not Use

DIP_SW1

SW No.	Push-switch Definition	Factory Setting	Comments
SW1	VDB reset	-	Push to reset VDB (FPGA).

SIF

The SIF (Scanner Interface) controls and processes the analog-to-digital (AD) conversion of the image scanned with the CIS.

The following LEDs indicate the status of elements operation on the SIF<0}

LED	Color	LED Definition	LED State
LED 1	GREEN	Power supply monitoring	+5V input: ON (else OFF)
LED 2	GREEN	Power supply monitoring	+5V input: ON (else OFF)

GW Controller Board

The controller board interfaces with the SIPU and accesses all the expansion applications provided on boards and SD cards installed in the slots of the controller board.

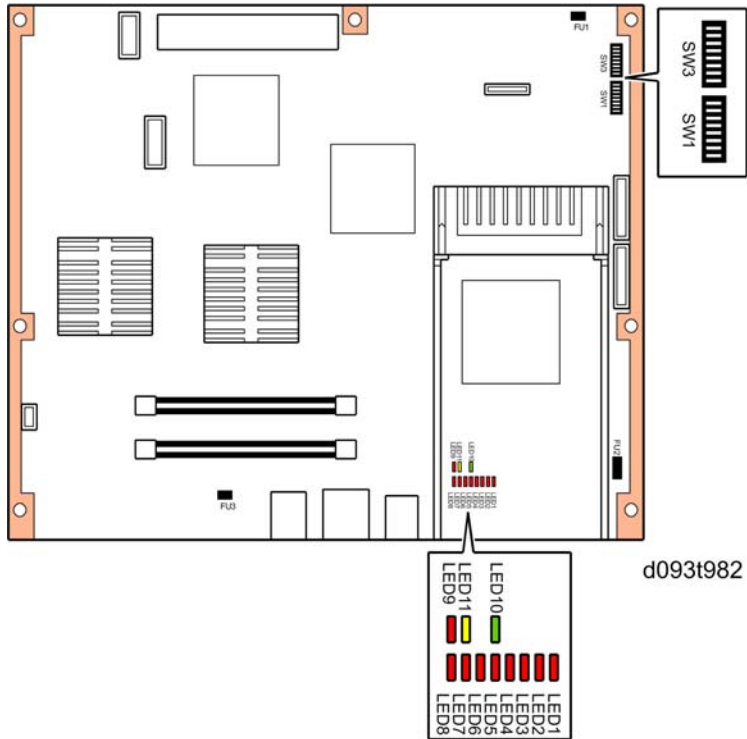

LEDs

The following LEDs indicate the status of elements operation on the controller board.<0}

LED	Color	LED Definition	LED State
LED 1	RED	BIOS Post Code	Normal: ON Installing: ON Installation END: ON
LED 2	RED	BIOS Post Code	Normal: ON Installing: ON Installation END: ON
LED 3	RED	BIOS Post Code	Normal: ON Installing: ON Installation END: ON

LED	Color	LED Definition	LED State
LED 4	RED	BIOS Post Code	Normal: ON Installing: ON or FLASH Installation END: ON
LED 5	RED	BIOS Post Code	Normal: ON Installing: OFF Installation END: ON
LED 6	RED	BIOS Post Code	Normal: ON Installing: OFF Installation END: ON
LED 7	RED	BIOS Post Code	Normal: OFF Installing: OFF Installation END: ON
LED 8	RED	BIOS Post Code	Normal: FLASH Installing: FLASH Install END: FLASH
LED 9	RED	BIOS/OS Distinction	Normal: FLASH Installing: FLASH Install END: FLASH
LED 10	GREEN	Power On	Normal: ON Installing: ON Installation END: ON
LED 11	YELLOW	Flash LED	Normal: FLASH Installing: FLASH Install END: FLASH

DIP Switches

DIP_SW1

SW No.	Application	Factory Setting	Comments
1	Selects boot device	OFF	Selects system software boot device.
2	Selects boot device	OFF	No.1 OFF, No.2 OFF, No.3 OFF: USB Boot No.1 ON, No.2 OFF, No.3 OFF: SD Card Boot
3	Selects boot device	OFF	
4	Selects "Quick Boot"	OFF	OFF: Quick Boot ON: Normal Boot
5	Selects Boot Prompt	OFF	OFF: Disable ON: Enable
6	-	OFF	Do Not Use
7	-	OFF	
8	-	OFF	

DIP_SW 3

SW No.	Application	Factory Setting	Comments
1	-	OFF	Do Not Use
2	-	OFF	Do Not Use
3	Initializes CMOS RAM in ICH6-M	OFF	OFF: Normal ON: Clear
4	-	OFF	Do Not Use
5	Selects boot device 2	ON:	Selects sub system boot device
6	Selects boot device 2	ON:	Flash ROM Boot No.5: ON No.6: ON SD Card Boot No.5: OFF No.6: OFF:

SW No.	Application	Factory Setting	Comments
7	Selects HDD common power supply.	OFF	OFF: VE System Power (Power always on, regardless of energy save status.) ON: VEP System Power (Power source goes off according to energy save mode (STR). However, ASIC: Whistle controls HDD common power source, regardless of this setting.)
8	-	OFF	Do Not Use

7. Energy Saving

Energy Save

Energy Saver Modes

Customers should use energy saver modes properly, to save energy and protect the environment.

Power Consump.

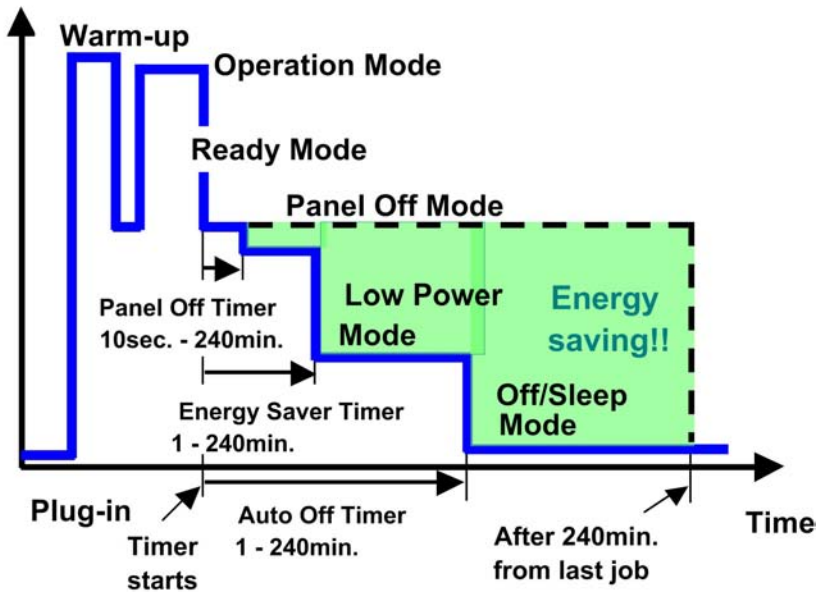

The area shaded grey in this diagram represents the amount of energy that is saved when the timers are at the default settings. If the timers are changed, then the energy saved will be different. For example, if the timers are all set to 240 min., the grey area will disappear, and no energy is saved before 240 min. expires.

Timer Settings

The user can set these timers with User Tools (System settings > Timer setting)

- Panel off timer (10 sec – 240 min): Panel Off Mode. Default setting: 60 sec.
- Energy saver timer (1 – 240 min): Low Power Mode. Default setting: 7 minute
- Auto off timer (1 – 240 min): Off/Sleep Mode. Default settings: 14 min.

Normally, Panel Off timer < Energy Saver timer < Auto Off timer. But, for example, if Auto Off timer < or = Panel Off timer and Energy Saver timer, the machine goes immediately to Off mode when the Auto Off timer expires. It skips the Panel Off and Energy Saver modes.

Example

- Panel off: 1 min.
- Low power: 15 min.
- Auto Off: 1 min.
- The machine goes to Off mode after 1 minute. Panel Off and Low Power modes are not used.

Return to Stand-by Mode

Low Power Mode

Recovery time: 78 sec.

Off/Sleep Mode

Recovery time: 120 sec.

Recommendation

7

We recommend that the default settings should be kept.

- If the customer requests that these settings should be changed, please explain that their energy costs could increase, and that they should consider the effects on the environment of extra energy use.
- If it is necessary to change the settings, please try to make sure that the Auto Off timer is not too long. Try with a shorter setting first, such as 30 min., then go to a longer one (such as 60 min.) if the customer is not satisfied.
- If the timers are all set to the maximum value, the machine will not begin saving energy until 240 minutes has expired after the last job. This means that after the customer has finished using the machine for the day, energy will be consumed that could otherwise be saved.
- If you change the settings, the energy consumed can be measured using SP8941, as explained below.

Energy Save Effectiveness

SP 8941 (Machine Status) keeps a record of the amount of time that the machine spends in each mode.

- 8941-001: Operating mode
- 8941-002: Standby mode
- 8941-003: Panel off mode
- 8941-004: Low power mode
- 8941-005: Off/sleep mode

With this data, and the power consumption values from the specifications, we can estimate the amount of energy that is used by the machine.

This should only be used as a reference value, because the power consumption specifications are measured in a controlled environment with a constant power supply.

To get an exact measurement at the customers site, a watt meter must be used to measure the actual energy consumed.

To use SP8941 to calculate the energy consumed:

- At the start of the measurement period, read the values of SP8941 001 to 005.
- At the end of the measurement period, read the values of SP8941 001 to 005 again.
- Find the amount of time spent in each mode (subtract the earlier measurement from the later measurement).
- Multiply this by the power consumption spec for each mode.
- Convert the result to kWh (kilowatt hours)

Here is an example calculation.

Machine Data	Power Consumption (W): Data: a	SP8941: Machine Status	Start Time: (min.) Data: b	End Time: (min.) Data: c	Time Differences (Data: b - Data: c) (min.) Data: d	Power Consumption (Data: a × Data: d) (W/min.) Data: e
① Operating mode	1081.8	001: Operating Time	21089.0	21386.0	297.0	321294.6
② Ready mode (stand by)	214.0	002: Standby Time	306163.0	308046.0	1883.0	402962.0
③ Energy mode (Panel off)	214.0	003: Energy Save Time	71386.0	75111.0	3725.0	797150.0
④ Low power mode	153.0	004: Low power Time	154084.0	156340.0	2256.0	345168.0
⑤ Off/Sleep mode	7.0	005: Off mode Time	508776.0	520377.0	11601.0	81207.0
Total Time of Data: d (min.)					19762.0	
Total Time of Data: d/60min. (Hour)					329.37	
Total Power Consumption of Data: e (W/min.)						1947781.60
Total Power Consumption of Data: e /60min./1000W (kWh)						32.46

d093r921

7

Paper Save

Effectiveness of Combine Function

The combine function reduces the amount of paper used. This means that less energy overall is used for paper production, which improves the environment.

To check the paper consumption, look at the total counter. The total counter counts all pages printed.

Recommendation

Please explain the above features to the customers, so that they can reduce their paper usage.

Model D093/D094

- Total counter: SP 8581-001
- Single-sided with combine mode: SP 8421-004

The following table shows paper savings and how the counters increase for some simple examples of Combine jobs.

2 in 1 mode (Combine)

Originals	Sheets	Paper Saved	Total counter: SP8581
1	1	0	1
2	1	1	1
3	2	1	2
4	2	2	2
5	3	2	3
10	5	5	5
20	5	10	10

Model N-C3
Machine Code: D093/D094

Appendices

30 November, 2010

TABLE OF CONTENTS

1. Appendix: Specifications

Specifications.....	3
Main Machine (D093/D094).....	3
Options.....	7

2. Appendix: SP Mode Tables

Service Program Mode.....	9
SP1-xxx Feed.....	10
Paper Thickness Default Selection.....	23
SP2-xxx Drum.....	44
SP3-xxx Process Control.....	66
SP4-xxx Scanner.....	68
SP5-xxx Mode.....	101
SP6-xxx Peripherals.....	172
SP7-xxx Data Log.....	173
SP8-xxx Data Log 2.....	182
Printer, Scanner SP Tables.....	215
Printer Service Mode.....	215
Scanner Service Mode.....	218

3. Appendix: UP Mode

User Tools.....	221
User Tool Map.....	221
INDEX	229



1. Appendix: Specifications

Specifications

Main Machine (D093/D094)

Configuration:	Desktop	
Copy Process:	Dry electrostatic transfer system	
Scanner	CIS (Contact Image Sensor), Monochrome/Color	
Scanning Speed	Monochrome	80 mm/sec.
	Color	26.7 mm/sec.
Image Transfer	Image Write	LED array
	Charger	Scorotron Method
Printing	Method	Digital dry electrostatic transfer
	Speed	80 mm/sec.
	Languages	RPCS, PostScript 3, GL/2&TIFF
Originals:	Sheet	
Original Image Size (W x L)	Maximum: 914.4 x 15,000 mm (36" x 590")	
	Minimum: 210 x 210 mm (8.5" x 8.5")	
	<ul style="list-style-type: none"> • Maximum length copying (15 m) is limited to wide paper. • Copies at maximum length must be done one at a time (multiple copies are not allowed). 	
Max Original Width:	960 mm (37.7")	
Original Weight	18 to 135 g/m ²	
	35 um to 1.0 mm	
	Note: Less than 70 μm must be used with carrier sheet.	

<p>Copy Paper Size (W x L):</p>	<p>Maximum: Manual feed: 914 x 2,000 mm (36" x 78") Roll Feed: 914 x 15,000 mm (36" x 590") Paper Cassette: 297 x 420mm (12" x 18")</p> <p>Minimum: Manual Feed: 210 x 257 mm (8½" x 10") Roll Feed: 210 x 280 mm (8½" x 11") Paper Cassette: 210 x 297 mm (8½" x 11")</p>	
<p>Margins (Copies)</p>	<p>Top</p>	<p>5 mm</p>
	<p>Bottom</p>	<p>8 mm</p>
	<p>Left, Right</p>	<p>2±2 mm (less than 5 mm each side)</p>
<p>Copy Paper Weight</p>	<p>52.3 - 110 g/m² (13.9 - 29.3 lb) 68 - 148 μm (Plain paper, Translucent) 3 - 4 mils (Film)</p>	
<p>Copying Speed (cpm: copies/minute):</p>	<p>D093: 2 cpm (A0/E SEF), 4 cpm (A1/D LEF) D094: 3 cpm (A0/E SEF), 6 cpm (A1/D LEF)</p>	
<p>Photoconductor:</p>	<p>OPC (Organic photoconductor drum)</p>	
<p>Reduction/Enlargement:</p>	<p>Inch Version, Engineering: Reduction: 25.0, 32.4, 50.0, 64.7% Enlargement: 129.4, 200.0, 258.8, 400.0%</p> <p>Inch Version, Architecture: Reduction: 25.0, 33.3, 50.0, 66.7% Enlargement: 133.3, 200.0, 266.7, 400.0%</p> <p>Metric Version Reduction: 25.0, 35.4, 50.0, 70.7% Enlargement: 141.4, 200.0, 282.8, 400.0%</p>	
<p>Zoom:</p>	<p>25 to 400% (0.1%/step) 200.1 to 400% (0.1%/step)</p>	
<p>Resolution:</p>	<p>Scanning/Printing: 600 dpi</p>	

Gradation:	Scanning: 256 levels Printing: 2 levels	
Display Languages (18)	English, German, French, Italian, Spanish, Dutch, Swedish, Norwegian, Danish, Czechoslovakian, Hungarian, Finish, Portuguese, Polish, Russian, Catalan, Turkish, Chinese (Simplified) Notes: <ul style="list-style-type: none"> • Only English, Spanish available in NA. • Only English, Chinese (Simplified) available in China. 	
Warm-up Time:	Less than 2 minutes Room temperature 23°C, Plain Paper mode AC 120V (-17 Model) AC 220-240V (-21, -27 Model)	
First Copy Time:	1st Roll Feed: 18 sec. (A1/LEF/D LEF) Cassette: 19 sec. (A3 LEF/B LEF) Manual Feed: 31 sec. (A1/LEF/D LEF)	
Copy Number Input:	1 to 99 (standard sizes only)	
Copy Paper Capacity:	Bypass Feed: 1 sheet Roll Feed: <ul style="list-style-type: none"> • Max. Diameter: 175 mm (6.9") • Max. Length: 150 m (16.4 yd) • Roll Core Diameter: 76.4 ±0.25 mm (about 3") Paper Cassette: 250 sheets	
Output Tray Capacity:	Upper Output Stocker Plain paper: 50 sheets (maximum A1/D LEF) Translucent: 10 sheets (maximum A1/D LEF) Roll Feeder or Table Plain paper: 40 sheets (A1/D or A0/E) Translucent: 1 sheet	
Original Stacker	1 original	
Memory Capacity:	DDR-DIMM	1GB + 1GB (Scanner Option)

	HDD (x1)	160 GB	
Toner Replenishment:	Cartridge exchange (800 g/cartridge)		
Toner Yield:	2,200 copies (A1 LEF, 6% full black, 1 to 99 copying, Text mode)		
Power Source:	-17 Ver.	AC 120V, 60 Hz, 15 A or more	
	-21, -27 Ver.	AC 220-240V, 50/60Hz, 10A or more	
Power Consumption*1	Mode	-17 (120V) kw	-27 (220-240V) kw
	Warm-up	1.31	1.39
	Ready*2	0.312	0.305
	Copying	1.37	1.46
	Maximum	1.44	1.50
	Low power*2	0.137	0.132
	Off*2	0.0075	0.0094

*1 Full System: Main Machine with Roll Feeder (2 rolls) and Paper Cassette.

*2 These are the values measured with the anti-condensation heater and tray heaters off.

Noise Emission:	The measurements were made in accordance with ISO 7779 at the operator position		
	Operation Mode	D093	D094
	Ready	41.4	41.4
	Copying	66.3	66.8
	Copying (from memory)	66.3	66.8
Max. Power Consumption:	North America: Less than 1.44 kW Europe/Asia: Less than 1.5 kW		
Dimensions (w x d x h):	1080 x 637 x 580 mm (43" x 25" x 23")		
Weight:	Less than 107 kg (235.9 lb)		

Optional Equipment:	1.	Roll Feeder Type 3601A/B (D504/D504)
	2.	Paper Cassette Type 240 (B853)
	3.	Table Type 240 (B854)
	4.	Rear Stacker (D312)
	5.	Original Hanger (D311)
	6.	USB2.0/SD Card Slot Type E (D534)
	7.	Roll Holder (B394)
	8.	Printer Option Type W3601 (D506)
	9.	Scanner Option Type W3601 (D507)
	10.	IEEE802.11a/g Interface Unit Type J (D377-01), Type K (D377-19)
	11.	Gigabit Ethernet Board Type B (D377-21)
	12.	File Format Converter Type F (D533)

Options

Roll Feeder (D503-21, -27/D504-17, -21, -27)

Copy Paper Size: (W x L)	Maximum: 914.4 x 15,000 mm (36" x 590") Minimum: 210 x 280 mm (8.5" x 11")
Copy Paper Weight	52.3 to 104.7g/m ² (13.9 - 27 lb.)
Copy Paper Capacity:	Max. Diameter: 175 mm (6.9") Max. Length: 150 m (137.6") Roll Core Diameter: 76.4 ±0.25 mm (about 3")
Power Source:	From main frame
Dimensions (w x d x h)	1080 x 720 x 700 mm (43" x 28" x 27")
Weight:	D503: 70 kg (154 lb.) D504: 72 kg (158.4 lb)

Paper Cassette B853

Type	Universal Cassette (installed in Roll Feeder B641/B642)
Paper Separation	Friction Pad
Paper Capacity:	250 sheets (A4) (up to 12"x18")
Copy Paper Size	A3 SEF, A4 SEF, B4 SEF LT SEF, LG SEF, DLT SEF, 8.5 x 13 SEF, 12 x 18 SEF
Copy Paper Weight	64 to 105 g/m ² (17 to 28 lb) plain paper
Power Source	From Roll Feeder
Weight	6 kg (13.2 lb)

2. Appendix: SP Mode Tables

Service Program Mode

Notation	What it means
[range/default step]	Example: [-9 to +9/+3.0/0.1 mm step]. Setting can be adjusted in the range ± 9 , value reset to +3.0 after and NVRAM reset, and the value can be changed in 0.1 mm steps with each key push.
DFU	“Design or Factory Use”. Do not change this value. The factory default setting provides optimum performance.
CTL	Means "controller". This is used to denote SP codes that are related to the GW controller.
Not Used	These SP's appear in the SP mode menus but these codes are not used because: <ul style="list-style-type: none">• Currently the feature is not available for the main machine, or its use has been discontinued.• The SP is intended for use with a peripheral that is currently under development but not available at this time. Note: Executing these SP's has no effect on operation of the main machine or any peripheral device.
Japan Only	This feature or item is for Japan only. Do not change this value.

★ Important

- Always cycle the machine off/on after changing an SP setting.

SP1-xxx Feed

1001	Leading Edge Registration	
1	1st Roll	Adjusts the leading edge registration for printing. To move the image down the page, increase the value. [-10.0 to +10.0/ 0 /0.1 mm step]
2	2nd Roll	
3	Cassette	
5	By-pass Feed	

1002	Side-to-Side Registration	
1	1st Roll	Adjusts the side-to-side registration for printing. [-10.0 to +10.0/ 0 /0.1 mm step] <ul style="list-style-type: none"> To move the start position to the right, increase the value (+). To move the start position to the left, decrease the value (-). Note: If you use paper 914 mm wide, adjust within the range of ± 2 mm. If you set the adjustment outside this range, part of the image will be cut off.
2	2nd Roll	
3	Cassette	
5	By-pass Feed	

1003	Registration Buckle Adjustment – Cassette Feed	
	<p>This SP eliminates the amount of buckle at the registration roller.</p> <ul style="list-style-type: none"> When paper is fed from the paper cassette, before the registration rollers start to rotate the leading edge of the paper stops and hits the nip of the registration rollers and stops. The registration rollers remain idle long enough to stop the paper from skewing in the paper path. This SP adjusts the amount of time that the registration rollers remain idle to reduce paper buckle. Raise this setting to lengthen the amount of time that the paper pauses at the nip of the registration rollers if you notice a large amount of skew in printouts. <p>[-20 to +20 / 5 / 1]</p>	

1105	Fusing Temperature Adjustment	
	Be sure to switch the main power switch off and on after adjustment.	
1	Copy Ready Temperature	

	<p>Sets the copy ready fusing temperature. The setting is the difference from the target fusing temperature that is set with SP1931.</p> <p>[0 to +50/10/1°C]</p> <p>Copying can start at this temperature before the hot roller reaches its target temperature (SP1931).</p>
3	Low Power Mode
	<p>Sets the copy ready temperature for low power mode.</p> <p>[80 to 150/90/1°C step]</p>
5	Fusing Temperature Calibration DFU
	<p>Calibrates the scale for the fusing temperature settings.</p> <p>[-10 to +10/0/1°C step]</p>
6	Pressure Temperature Calibration: Center DFU
	<p>Calibrates the scale for the pressure temperature control at the center of the pressure roller.</p> <p>[-10 to +10/0/1°C step]</p>
7	Pressure Temperature Calibration: Edge DFU
	<p>Calibrates the scale for the pressure temperature control at the end of the pressure roller.</p> <p>[-10 to +10/0/1°C step]</p>

1106	Fusing Temperature Display
	This SP displays the hot roller and pressure roller temperatures.
1	Hot Roller Temperature
2	Pressure Roller Temperature: Center
3	Pressure Roller Temperature: Edge

1159	Fusing Jam SC Setting
------	-----------------------

	<p>The setting of this SP determines whether the machine issues SC559 after three successive jams occur in the fusing unit.</p> <p>[0-1/0/1]</p> <p>0: Disabled. SC559 not issued after 3 successive jams in the fusing unit.</p> <p>1: Enabled. SC559 issued after 3 successive jams in the fusing unit. The operator cannot restore operation of the machine by cycling the machine off/on. SC559 is a Class "A" SC error. The service technician must restore operation of the machine.</p>
--	--

1801	<p>Motor Speed Adjustment DFU</p> <p>These SP's adjust the speeds of the feed motor (paper cassette), main motor, and fusing motor. The motor speeds can be adjusted to correct images that appear scratchy or of uneven density. This can occur when:</p> <ul style="list-style-type: none"> • Copying originals with large quantities of black. • Copying originals with a large quantity of black near the trailing edge. • Printing multiple copies of positive/negative (reverse) images.
1	<p>Feed Motor: 1st Roll DFU</p> <p>[-30 to +30/0/1]</p> <p>For every change of "1", speed is adjusted approximately 0.06%.</p>
2	<p>Feed Motor: 2nd Roll DFU</p> <p>[-30 to +30/0/1]</p> <p>For every change of "1", speed is adjusted approximately 0.06%.</p>
5	<p>Feed Motor : Cut Paper Tray DFU</p> <p>[-30 to +30/0/1]</p> <p>For every change of "1", speed is adjusted approximately 0.094%.</p>
6	<p>Main Motor DFU</p> <p>[-80 to +80/0/1]</p> <p>For every change of "1", speed is adjusted approximately 0.04%.</p>
7	<p>Fusing Motor DFU</p> <p>[-100 to +100/7/1]</p> <p>For every change of "1", speed is adjusted approximately 0.054%.</p>

1910	Motor Speed Adjustment
	This SP adjusts the speed of the roll feed motor for feeding plain roll paper, translucent roll paper, and film roll paper.
1	Feed Motor: Roll: Plain Paper [-100 to 100 / -10 / 1]
2	Feed Motor: Roll: Translucent Paper [-100 to 100 / 0 / 1]
3	Feed Motor: Roll: Film [-100 to 100 / -10 / 1]
1911	By-pass Feed Start Timing
	Adjusts the time that the operator has to adjust the paper skew manually when feeding paper manually from the bypass tray.. [1.0 to 8.0/2.0/0.1 sec.]
1912	Registration (Main Motor) Motor Speed-up
	This SP can increase the speed of the main motor just before the trailing edge of the paper leaves the nip of the registration rollers. <ul style="list-style-type: none"> • Normally, the speed of the fusing roller is slightly faster than the speed of the registration roller in order to pull the paper taut and stabilize paper feed. • However, this small difference in speed between the rollers can cause jitter when the trailing edge of the paper leaves the nip of the registration rollers. • In order to prevent this jitter, just before the paper leaves the registration roller the speed of the registration roller can be increased slightly to match the speed of the fusing roller. [0 to 125 / 0 / 1]
1915	Motor Speed Adjustment
	The fusing roller rotates slightly faster than the registration roller in order to keep the paper taut in the paper path. In some cases, this can cause "jitter" when the trailing edge is released by the registration roller. To correct this problem, this SP can be set to reduce the speed of the fusing roller just before the trailing edge of the paper is released by the registration roller in order to reduce the effect of the trailing edge snapping away from the registration roller. [-5 to 0 / 0 / 0.02 %]
1916	Fusing Motor Speed Adj.

	<p>SP1916 10 to 013 adjust the basic fusing motor speed and correct the speed for different widths of paper to prevent skew in the paper feed path.</p> <p>Note:The actual adjustment that the machine applies is the sum of the width adjustment (1916 010 to 013) and the paper type adjustment (1916 021 to 045).</p>	
10	Width:611mm more	[-100 to +100/0/1]
11	Width:461-610mm	[-100 to +100/5/1]
12	Width:298-460mm	[-100 to +100/9/1]
13	Width:297mm less	[-100 to +100/18/1]
	<p>Note: "Mode 1 to 5" below refer to the paper thickness set with [User Tools]> "System Settings"> "Tray Paper Settings"> "Paper Thickness: Paper Tray" or "Paper Thickness: Bypass Tray".</p>	
21	Plain:Mode1	[-100 to +100/0/1]
22	Plain:Mode2	
23	Plain:Mode3	
24	Plain:Mode4	
25	Plain:Mode5	[-100 to +100/25/1]
31	Trans.:Mode1	[-100 to +100/21/1]
32	Trans.:Mode2	
33	Trans.:Mode3	
34	Trans.:Mode4	
35	Trans.:Mode5	[-100 to +100/32/1]
41	Film:Mode1	[-100 to +100/23/1]
42	Film:Mode2	
43	Film:Mode3	
44	Film:Mode4	[-100 to +100/41/1]
45	Film:Mode5	[-100 to +100/18/1]

	<p>Note: These comments apply to 051 to 053 below.</p> <ul style="list-style-type: none"> • Changes to SP1916-51 to -53 affect the speed of the fusing motor. • For every change of "1", speed is adjusted $1/1848 = 0.054\%$. 	
51	Roll	[-100 to +100/0/1]
52	Bypass	[-100 to +100/0/1]
53	Cassette	[-100 to +100/0/1]

1918	Fusing/Main Mtr Speed Change	
	<p>These SP modes adjust the rate of the speed reduction between the main motor and the fusing motor.</p> <ul style="list-style-type: none"> • During normal operation, the line speed in the fusing unit is slightly faster than the line speed at registration. This keeps the paper slightly stretched to prevent wrinkling and skewing. • However, if the speed of the drum becomes slower as a result of a change in the amount of buckle at the registration roller, the tension on the paper will pull on the drum and rotate it faster than the rotation of the main motor. This can cause image distortion at the two LPH joints. • To prevent such distortion, use this SP to decrease the speed of the fusing motor. While this lowers the line speed slightly, it also keeps the correct amount of tension on the paper between the fusing unit and registration roller to prevent skewing and image distortion. <p>Important</p> <ul style="list-style-type: none"> • There are two adjustments for each feed source and paper width: (1) "Chg Timing" and (2) "%Chg". • Always do the "Chg Timing" adjustment before doing the "%Chg adjustment". • The "Chg Timing" adjustment sets the length of paper to feed before the speed reduction rate ("%Chg") takes effect. • The "%Chg" adjustment sets the rate of speed reduction between the main motor and fusing motor. 	
10	Roll/1st Chg Timing/Plain/Width > 611mm	[0 to 15000/170/1mm]
11	Roll/1st Chg Timing/Plain/Width 461-610mm	
12	Roll/1st Chg Timing/Plain/Width 298-460mm	
13	Roll/1st Chg Timing/Plain/Width < 297mm	

15	Roll/1st Chg %/Plain/Width > 611mm	[-9.99 to 9.99/-0.2/0.01%]
16	Roll/1st Chg %/Plain/Width 461-610mm	
17	Roll/1st Chg %/Plain/Width 298-460mm	[-9.99 to 9.99/-0.4/0.01%]
18	Roll/1st Chg %/Plain/Width < 297mm	[-9.99 to 9.99/-0.5/0.01%]
20	Roll/1st Chg Timing/Trans/Width > 611mm	[0 to 15000/170/1mm]
21	Roll/1st Chg Timing/Trans/Width 461-610mm	
22	Roll/1st Chg Timing/Trans/Width 298-460mm	
23	Roll/1st Chg Timing/Trans/Width < 297mm	
25	Roll/1st Chg %/Trans/Width > 611mm	[-9.99 to 9.99/-0.9/0.01%]
26	Roll/1st Chg %/Trans/Width 461-610mm	[-9.99 to 9.99/-1.1/0.01%]
27	Roll/1st Chg %/Trans/Width :298-460mm	
28	Roll/1st Chg %/Trans/Width < 297mm	[-9.99 to 9.99/-1.4/0.01%]
30	Roll/1st Chg Timing/Film/Width > 611mm	[0 to 15000/170/1mm]
31	Roll/1st Chg Timing/Film/Width 461-610mm	
32	Roll/1st Chg Timing/Film/Width 298-460mm	
33	Roll/1st Chg Timing/Film/Width < 297mm	
35	Roll/1st Chg %/Film/Width > 611mm	[-9.99 to 9.99/-1.2/0.01%]
36	Roll/1st Chg %/Film/Width 461-610mm	[-9.99 to 9.99/-1.3/0.01%]
37	Roll/1st Chg %/Film/Width 298-460mm	
38	Roll/1st Chg %/Film/Width < 297mm	[-9.99 to 9.99/-1.5/0.01%]
42	Cassette/1st Chg Timing/Width /298-460mm	[0 to 15000/170/1mm]
43	Cassette/1st Chg Timing/Width < 297mm	
47	Cassette/1st Chg %/Width 298-460mm	[-9.99 to 9.99/-1.0/0.01%]
48	Cassette/1st Chg %/Width < 297mm	[-9.99 to 9.99/-1.3/0.01%]

70	Bypass/1st Chg Timing/Plain/Width > 611mm	[0 to 15000/170/1mm]
71	Bypass/1st Chg Timing/Plain/Width 461-610mm	
72	Bypass/1st Chg Timing/ Plain/Width 298-460mm	
73	Bypass/1st Chg Timing/Plain/Width < 297mm	
75	Bypass/1st Chg %/ Plain/Width > 611mm	[-9.99 to 9.99/-0.5/0.01%]
76	Bypass/1st Chg %/ Plain/Width 461-610mm	
77	Bypass/1st Chg %/ Plain/Width 298-460mm	[-9.99 to 9.99/-1.0/0.01%]
78	Bypass/1st Chg %/ Plain/Width < 297mm	[-9.99 to 9.99/-1.3/0.01%]
80	Bypass/1st Chg Timing/Trans/Width > 611mm	[0 to 15000/170/1mm]
81	Bypass/1st Chg Timing/ Trans/Width 461-610mm	
82	Bypass/1st Chg Timing/Trans/Width 298-460mm	
83	Bypass/1st Chg %/ Trans/Width <297mm	
85	Bypass/1st Chg %/ Trans/Width >611mm	[-9.99 to 9.99/-0.5/0.01%]
86	Bypass/1st Chg %/ Trans/Width >611mm	
87	Bypass/1st Chg %/ Trans/Width 461-610mm	[-9.99 to 9.99/-1.0/0.01%]
88	Bypass/1st Chg Timing/Trans/Width 298-460mm	[-9.99 to 9.99/-1.3/0.01%]
90	Bypass/1st Chg Timing/Film/Width >611mm	[0 to 15000/170/1mm]
91	Bypass/1st Chg Timing/ Film/Width 461-610mm	
92	Bypass/1st Chg Timing/Film/Width 298-460mm	
93	Bypass/1st Chg %/ Film/Width <297mm	
95	Bypass/1st Chg %/ Film/Width <611mm	[-9.99 to 9.99/-0.5/0.01%]
96	Bypass/1st Chg %/ Film/Width 461-610mm	
97	Bypass/1st Chg %/ Film/Width 298-460mm	[-9.99 to 9.99/-1.0/0.01%]
98	Bypass/1st Chg %/Film/Width <297mm	[-9.99 to 9.99/-1.3/0.01%]

110	Roll/2nd Chg Timing/Plain/Width > 611mm	[0 to 15000/0/1mm]
111	Roll/2nd Chg Timing/Plain/Width 461-610mm	
112	Roll/2nd Chg Timing/Plain/Width 298-460mm	
113	Roll/2nd Chg Timing/Plain/Width < 297mm	
115	Roll/2nd Chg %/Plain/Width > 611mm	[-9.99 to 9.99/0/0.01%]
116	Roll/2nd Chg %/Plain/Width 461-610mm	
117	Roll/2nd Chg %/Plain/Width 298-460mm	
118	Roll/2nd Chg %/Plain/Width < 297mm	
120	Roll/2nd Chg Timing/Trans/Width > 611mm	[0 to 15000/0/1mm]
121	Roll/2nd Chg Timing/Trans/Width 461-610mm	
122	Roll/2nd Chg Timing/Trans/Width 298-460mm	
123	Roll/2nd Chg Timing/Trans/Width < 297mm	
125	Roll/2nd Chg %/Trans/Width > 611mm	[-9.99 to 9.99/0/0.01%]
126	Roll/2nd Chg %/Trans/Width 461-610mm	
127	Roll/2nd Chg %/Trans/Width 298-460mm	
128	Roll/2nd Chg %/Trans/Width < 297mm	
130	Roll/2nd Chg Timing/Film/Width > 611mm	[0 to 15000/0/1mm]
131	Roll/2nd Chg Timing/Film/Width 461-610mm	
132	Roll/2nd Chg Timing/Film/Width 298-460mm	
133	Roll/2nd Chg Timing/Film/Width < 297mm	
135	Roll/2nd Chg %/Film/Width > 611mm	[-9.99 to 9.99/0/0.01%]
136	Roll/2nd Chg %/Film/Width 461-610mm	
137	Roll/2nd Chg %/Film/Width 298-460mm	
138	Roll/2nd Chg %/Film/Width < 297mm	
142	Cassette/2nd Chg Timing/Width /298-460mm	[0 to 15000/0/1mm]
143	Cassette/2nd Chg Timing/Width < 297mm	

147	Cassette/2nd Chg %/Width 298-460mm	[-9.99 to 9.99/0/0.01%]
148	Cassette/2nd Chg %/Width < 297mm	
170	Bypass/2nd Chg Timing/Plain/Width > 611mm	[0 to 15000/0/1mm]
171	Bypass/2nd Chg Timing/ Plain/Width 461-610mm	
172	Bypass/2nd Chg Timing/ Plain/Width 298-460mm	
173	Bypass/2nd Chg Timing/ Plain/Width < 297mm	
175	Bypass/2nd Chg %/ Plain/Width > 611mm	[-9.99 to 9.99/0/0.01%]
176	Bypass/2nd Chg %/ Plain/Width 461-610mm	
177	Bypass/2nd Chg %/ Plain/Width 298-460mm	
178	Bypass/2nd Chg %/ Plain/Width < 297mm	
180	Bypass/2nd Chg Timing/Trans/Width > 611mm	[0 to 15000/0/1mm]
181	Bypass/2nd Chg Timing/ Trans/Width 461-610mm	
182	Bypass/2nd Chg Timing/ Trans/Width 298-460mm	
183	Bypass/2nd Chg Timing/ Trans/Width < 297mm	
185	Bypass/2nd Chg %/ Trans/Width > 611mm	[-9.99 to 9.99/0/0.01%]
186	Bypass/2nd Chg %/ Trans/Width 461-610mm	
187	Bypass/2nd Chg %/ Trans/Width 298-460mm	
188	Bypass/2nd Chg %/ Trans/Width < 297mm	
190	Bypass/2nd Chg Timing/Film/Width > 611mm	[0 to 15000/0/1mm]
191	Bypass/2nd Chg Timing/ Film/Width 461-610mm	
192	Bypass/2nd Chg Timing/ Film/Width 298-460mm	
193	Bypass/2nd Chg Timing/ Film/Width < 297mm	

195	Bypass/2nd Chg %/ Film/Width > 611mm	[-9.99 to 9.99/0/0.01%]
196	Bypass/2nd Chg %/ Film/Width 461-610mm	
197	Bypass/2nd Chg %/ Film/Width 298-460mm	
198	Bypass/2nd Chg %/ Film/Width < 297mm	
210	Roll/3rd Chg Timing/Plain/Width > 611mm	[0 to 15000/0/1mm]
211	Roll/3rd Chg Timing/Plain/Width 461-610mm	
212	Roll/3rd Chg Timing/Plain/Width 298-460mm	
213	Roll/3rd Chg Timing/Plain/Width < 297mm	
215	Roll/3rd Chg %/Plain/Width > 611mm	[-9.99 to 9.99/0/0.01%]
216	Roll/3rd Chg %/Plain/Width 461-610mm	
217	Roll/3rd Chg %/Plain/Width 298-460mm	
218	Roll/3rd Chg %/Plain/Width < 297mm	
220	Roll/3rd Chg Timing/Trans/Width > 611mm	[0 to 15000/0/1mm]
221	Roll/3rd Chg Timing/Trans/Width 461-610mm	
222	Roll/3rd Chg Timing/Trans/Width 298-460mm	
223	Roll/3rd Chg Timing/Trans/Width < 297mm	
225	Roll/3rd Chg %/Trans/Width > 611mm	[-9.99 to 9.99/0/0.01%]
226	Roll/3rd Chg %/Trans/Width 461-610mm	
227	Roll/3rd Chg %/Trans/Width :298-460mm	
228	Roll/3rd Chg %/Trans/Width < 297mm	
230	Roll/3rd Chg Timing/Film/Width > 611mm	[0 to 15000/0/1mm]
231	Roll/3rd Chg Timing/Film/Width 461-610mm	
232	Roll/3rd Chg Timing/Film/Width 298-460mm	
233	Roll/3rd Chg Timing/Film/Width < 297mm	

235	Roll/3rd Chg %/Film/Width > 611mm	[-9.99 to 9.99/0/0.01%]
236	Roll/3rd Chg %/Film/Width 461-610mm	
237	Roll/3rd Chg %/Film/Width 298-460mm	
238	Roll/3rd Chg %/Film/Width < 297mm	
250	1st Chg Speed Min Length	[0 to 300/0/1 mm]

2

1920	Cut Length Adjustment	
	These SP's adjust the cut length of the paper sizes below.	
22	1st Roll: 297mm: Plain Paper	[-10 to +10/0/0.1 mm]
23	1st Roll: 420mm: Plain Paper	
24	1st Roll: 594mm: Plain Paper	
25	1st Roll: 841mm: Plain Paper	[-20 to +20/0/0.1 mm]
26	1st Roll: 1189mm: Plain Paper	[-20.0 to +20.0/0/0.1 mm]
27	1st Roll: 2000mm: Plain Paper	[-30 to +30/0/1 mm]
28	1st Roll: 3600mm: Plain Paper	[-30 to +30/0/1 mm]
29	1st Roll: 6000mm: Plain Paper	
30	1st Roll: 15000mm: Plain Paper	[-100 to +100/0/1 mm]
42	1st Roll: 297mm: Translucent Paper	[-10.0 to +10.0/0/0.1 mm]
43	1st Roll: 420mm: Translucent Paper	
44	1st Roll: 594mm: Translucent Paper	
45	1st Roll: 841mm: Translucent Paper	[-20 to +20/0/0.1 mm]
46	1st Roll: 1189mm: Translucent Paper	
47	1st Roll: 2000mm: Translucent Paper	[-30 to +30/0/1 mm]
48	1st Roll: 3600mm: Translucent Paper	
49	1st Roll: 6000mm: Translucent Paper	

50	1st Roll: 15000mm: Translucent Paper	
62	1st Roll: 297mm: Film	[-100 to +100/0/ 1 mm]
63	1st Roll: 420mm: Film	
64	1st Roll: 594mm: Film	[-10 to +10/0/0.1 mm]
65	1st Roll: 841 mm: Film	[-20 to +20/0/0.1 mm]
66	1st Roll: 1189mm: Film	
67	1st Roll: 2000mm: Film	
68	1st Roll: 3600mm: Film	[-30 to +30/0.0/1 mm]
69	1st Roll: 6000mm: Film	
70	1st Roll: 15000mm: Film	[-100 to +100/0/ 1 mm]
82	2nd Roll: 297mm: Plain Paper	
83	2nd Roll: 420mm: Plain Paper	[-10 to +10/0/0.1 mm]
84	2nd Roll: 594mm: Plain Paper	
85	2nd Roll: 841 mm: Plain Paper	[-20 to +20/0/0.1 mm]
86	2nd Roll: 1189mm: Plain Paper	
87	2nd Roll: 2000mm: Plain Paper	
88	2nd Roll: 3600mm: Plain Paper	[-30 to +30/0/1 mm]
89	2nd Roll: 6000mm: Plain Paper	
90	2nd Roll: 15000mm: Plain Paper	[-100 to +100/0/ 1 mm]
102	2nd Roll: 297mm: Translucent Paper	
103	2nd Roll: 420mm: Translucent Paper	[-10 to +10/0/0.1 mm]
104	2nd Roll: 594mm: Translucent Paper	
105	2nd Roll: 841 mm: Translucent Paper	[-20 to +20/0/0.1 mm]
106	2nd Roll: 1189mm: Translucent Paper	

107	2nd Roll: 2000mm: Translucent Paper	[-30 to +30/0/1 mm]
108	2nd Roll: 3600mm: Translucent Paper	
109	2nd Roll: 6000mm: Translucent Paper	
110	2nd Roll: 15000mm: Translucent Paper	[-100 to +100/0/ 1 mm]
122	2nd Roll: 297mm: Film	[-10 to +10/0/0.1 mm]
123	2nd Roll: 420mm: Film	
124	2nd Roll: 594mm: Film	
125	2nd Roll: 841mm: Film	[-20 to +20/0/1 mm]
126	2nd Roll: 1189mm: Film	
127	2nd Roll: 2000mm: Film	[-30 to +30/0/1 mm]
128	2nd Roll: 3600mm: Film	
129	2nd Roll: 6000mm: Film	
130	2nd Roll: 15000mm: Film	[-100 to +100/0/ 1 mm]

1923	Paper Interval Adjustment
	<p>This SP slightly increases the gap between sheets in the paper path. When the machine shifts to the CPM down mode, the paper is fed by whichever interval between sheets is longer, the gap set with this SP or the gap determined by CPM down.</p> <p>[0 to 500/0/1 mm]</p> <p>Note:</p> <ul style="list-style-type: none"> • The "0" (default) setting does not mean that the gap is eliminated. • When set to "0" the standard gap between sheets is maintained (480 mm for the D093 and 168 mm for the D094.)

Paper Thickness Default Selection

★ Important

- Several SP codes in these tables reference the "Paper Thickness Default Selection". The paper thickness is selected on the operation panel before each copy job. The default settings can be selected with the User Tools.

	Sets the target fusing temperature of the hot roller. After you adjust these SP's, you must switch the main power switch off and on. Important: Modes "1" to "5" below refer to the paper type and thickness settings selected in User Tools (see "Paper Thickness Default Selection" in this section).	
1	Plain: Mode1	[120 to 220/195/5°C]
2	Plain: Mode2	
3	Plain: Mode3	
4	Plain: Mode4	[120 to 220/185/5°C]
5	Plain: Mode5	[120 to 220/175/5°C]
6	Trans.: Mode1	[120 to 220/205/5°C]
7	Trans.: Mode2	[120 to 220/195/5°C]
8	Trans.: Mode3	
9	Trans.: Mode4	[120 to 220/165/5°C]
10	Trans.: Mode5	[120 to 220/165/5°C]
11	Film: Mode1	[120 to 220/195/5°C]
12	Film: Mode2	[120 to 220/190/5°C]
13	Film: Mode3	[120 to 220/185/5°C]
14	Film: Mode4	
15	Film: Mode5	[120 to 220/175/5°C]
16	Plain: Low Temp Mode	[120 to 220/195/5°C]

1932	Target Temp: Press. Roller
	<p>Sets the target fusing temperature of the pressure roller for plain paper, translucent paper, and film. These temperatures are used for pressure roller feedback. Turn the machine power off/on after changing the settings.</p> <p>Important:</p> <ul style="list-style-type: none"> • Modes "1" to "5" below refer to the paper type and thickness settings selected in User Tools (see "Paper Thickness Default Selection" in this section). • After adjusting these SP's, you must turn the machine power off/on.

1	Plain: Mode1	[60 to 180 /100/5°C]
2	Plain: Mode2	[60 to 180 /85/5°C]
3	Plain: Mode3	[60 to 180 /60/5°C]
4	Plain: Mode4	
5	Plain: Mode5	
6	Trans.: Mode1	[60 to 180 /130/5°C]
7	Trans.: Mode2	[60 to 180 /100/5°C]
8	Trans.: Mode3	[60 to 180 /60/5°C]
9	Trans.: Mode4	
10	Trans.: Mode5	
11	Film: Mode1	
12	Film: Mode2	
13	Film: Mode3	
14	Film: Mode4	
15	Film: Mode5	
16	Plain: Low Temp Mode	[60 to 180 /120/5°C]

1934	Lower Limit Temp: Hot Roller	
	<p>This SP sets the minimum difference in temperature allowed between the actual temperature and the target temperature of the hot roller.</p> <p>Important: Modes "1" to "5" below refer to the paper and thickness settings selected in User Tools (see "Paper Thickness Default Selection" in this section).</p>	
1	Plain: Mode1	[0 to 50/20/5]
2	Plain: Mode2	[0 to 50/15/5]
3	Plain: Mode3	[0 to 50/25/5]

4	Plain: Mode4	[0 to 50/20/5]	
5	Plain: Mode5		
6	Trans.: Mode1		
7	Trans.: Mode2		
8	Trans.: Mode3		
9	Trans.: Mode4		
10	Trans.: Mode5		
11	Film: Mode1		
12	Film: Mode2		
13	Film: Mode3		
14	Film: Mode4		
15	Film: Mode5		
16	Plain: Low Temp Mode		[0 to 50/0/5]

1935	Upper Limit Temperature: Press Roller	
	<p>This SP changes the stepped adjustments of SP1932 (Target Temp: Pressure Roller) by using the sum of the settings of SP1932 (Target Temp: Pressure Roller) +SP1935 (Press FB Control Steps) as the steps.</p> <p>Example</p> <ul style="list-style-type: none"> • If the pressure roller temperature for SP1935-1 is 100°C, the target hot roller temperature is 195°C ("100" is SP1932, "195" is SP1931). • If the pressure roller temperature 120°C (= "100"+"20", this is SP1932+SP1935), the target hot roller temperature is 175°C (= "195"-20", this is SP1931 – SP1934) • If the setting is "0", the temperature settings of SP1931 do not change. 	
1	Plain: Mode1	[0 to 50/20/5]
2	Plain: Mode2	[0 to 50/25/5]
3	Plain: Mode3	[0 to 50/30/5]

4	Plain: Mode4	[0 to 50/20/5]	
5	Plain: Mode5		
6	Trans.: Mode1		
7	Trans.: Mode2		
8	Trans.: Mode3		
9	Trans.: Mode4		
10	Trans.: Mode5		
11	Film: Mode1		
12	Film: Mode2		
13	Film: Mode3		
14	Film: Mode4		
15	Film: Mode5		
16	Plain: Low temp. Mode		[0 to 50/0/5]

1936	Lower Limit Temp: Press Roller
	<p>This SP sets the minimum difference allowed between the actual temperature and the target temperature of the pressure roller.</p> <ul style="list-style-type: none"> • If the setting for the target temperature of the pressure roller is high (SP1932), the temperature of the pressure roller is lowered for continuous printing on plain paper. • At this time, if the temperature is below the temperature set for the pressure roller, paper feed will stop during a long job to perform inching to allow enough time for the pressure roller temperature to rise to the level of the prescribed setting, and then the job will continue. <p>Important: Modes "1" to "5" below refer to the paper and thickness settings selected in User Tools (see "Paper Thickness Default Selection" in this section).</p>

1	Plain: Mode1	[0 to 50/0/5°C]
2	Plain: Mode2	
3	Plain: Mode3	
4	Plain: Mode4	
5	Plain: Mode5	
6	Trans.: Mode1	[0 to 50/20/5°C]
7	Trans.: Mode2	[0 to 50/0/5°C]
8	Trans.: Mode3	
9	Trans.: Mode4	
10	Trans.: Mode5	
11	Film: Mode1	
12	Film: Mode2	
13	Film: Mode3	
14	Film: Mode4	
15	Film: Mode5	

1937	Low Temp Environ Detect Ctrl
	<p>These SP's are used to modify fusing temperature control sequence in a low temperature environment where room temperature is below the optimum room temperature of 20°C (68°F).</p> <p>Note</p> <ul style="list-style-type: none"> • At optimum room temperature, the machine should reach the target fusing temperature within 2 min. • If the hot roller does not reach the target fusing temperature within 4.5 minutes, the machine issues SC542 (Fusing Temperature Warmup Error).
2	Low Temp Time Setting

	<p>This SP sets the length of time within which the hot roller temperature should reach 140°C. If the hot roller does not reach 140°C within this time limit, copying cannot start until the hot roller reaches its target temperature.</p> <p>[0 to 120/85/1 sec.]</p>
3	<p>Pressure Inching Start: Temp</p>
	<p>If the inching target temperature (set with SP1948) is higher than 65°C, inching will start when the hot roller temperature reaches this target hot roller temperature. If the pressure roller temperature is less than 60°C, inching will start at the ready (reload) temperature.</p> <p>This SP sets the temperature at which inching starts in a low-temperature environment where fusing temperature control is handled with the settings of SP1937.</p> <p>[0 to 50/20/5]</p>
11	<p>Low Temp Mode Setting: Cold Start</p>
	<p>If the hot roller temperature is below the temperature set with this SP at the beginning of a cold start, the machine determines that it is in a low temperature environment</p> <p>[0 to 50/15/1]</p>
12	<p>Low Temp Mode Setting: Cold Start Hold Time</p>
	<p>This SP determines the length of time the machine remains in the low temperature cold start mode after the machine determines that that it has been cold started in a low temperature environment. After this time has elapsed, fusing temperature control will operate with the paper type and thickness settings (see "Paper Thickness Default Selection" in this section).</p> <p>[0 to 20 / 7 / 0.5 min.]</p>
13	<p>Low Temp Mode Paper Interval Ratio</p>
	<p>This SP sets the size of the gap between sheets of paper while the machine is in the low temperature environment cold start mode.</p> <p>[1 to 10 / 3 / 0.1 mm]</p>

1938	<p>Upper Limit Temperature Width Switch: Press</p>
	<p>This SP switches step control by width on and off. After this SP has been switched on, the step control by width can be set up with SP1939 002 to 004.</p> <p>Note:</p> <ul style="list-style-type: none"> • These settings can be done for each paper type and thickness mode. • Modes "1" to "5" below refer to the paper and thickness settings selected in User Tools (see "Paper Thickness Default Selection" in this section).

1	Plain: Mode1	[0 to 1/0/1] 0: Disabled 1: Enabled
2	Plain: Mode2	
3	Plain: Mode3	
4	Plain: Mode4	
5	Plain: Mode5	
6	Trans.: Mode1	
7	Trans.: Mode2	
8	Trans.: Mode3	
9	Trans.: Mode4	
10	Trans.: Mode5	
11	Film: Mode1	
12	Film: Mode2	
13	Film: Mode3	
14	Film: Mode4	
15	Film: Mode5	

1939	Upper Limit Temperature by Width: Press(ure) Roll(er)	
	Use these SP's to set up the step control used in the paper type and paper thickness selections done in the User Tools (see "Paper Thickness Default Selection" in this section). Note: First, use SP1938 to select the paper type and mode where the setting is to apply. Next, select the paper width here.	
1	> 611mm	[0 to 30 / 20 / 5]
2	461-610mm	[0 to 30 / 30 / 5]
3	298-460mm	
4	> 297mm	

1940	CPM Down Setting
------	------------------

	CPM down control attempts to achieve optimum fusing of toner to paper. To do this, it automatically adjusts the timing of paper feed, which increases the length of the interval between sheets. A longer interval between sheets creates a short delay, so that the temperature of the hot roller and pressure roller can rise.
1	Enable
	Switches CPM down off and on. [0 to 1/1/1] 0: Off 1: On
11	Temp Differential: Step 1
	The interval between sheets of paper in the paper path is determined by the temperature readings of the thermistors at the center and end of the pressure roller. This SP sets Step 1 of CPM down mode. If the amount of the difference between the actual temperature and target temperature falls in the range between this SP and SP1940 012, this is judged as Step 1. [0 to 150/50/5]
12	Temp Differential: Step 2
	This SP sets Step 2 of CPM down mode. If the amount of the difference between the actual temperature and target temperature falls in the range between this SP and SP1940 013, this is judged as Step 2. [0 to 150/75/5]
13	Temp Differential: Step 3 This SP sets Step 3 of CPM down mode. If the difference between actual and target temperature is larger than this SP setting, this is judged as Step 3. [0 to 150/100/5]
21	Paper Interval: Step 1

	<p>When the pressure roller center and end thermistor detect a temperature in the Step 1 range (SP1940 011), the setting of this SP is activated to set the length of the interval between sheets in the paper path.</p> <p>[1 to 10/1.4/0.1]</p> <p>The default setting (1.4) is the variable for Step 1 multiplied by the constant set for Step 1 of the machine:</p> <ul style="list-style-type: none"> • D093: 480 mm. The default interval is 672 mm (1.4 x 480 mm). • D094: 168 mm. The default interval is 235 mm (1.4 x 168 mm). <p>Setting a smaller or larger number decreases or increases the length of the interval with this simple calculation. This standard interval can be modified slightly with SP1923.</p>
22	Paper Interval Step 2
	<p>When the pressure roller center and end thermistor detect a temperature in the Step 2 range (SP1940 012), the setting of this SP is activated to set the length of the interval between sheets in the paper path.</p> <p>[1 to 10/2.1/0.1]</p> <p>The default setting (2.1) is the variable for Step 2 multiplied by the constant set for Step 2 of the machine:</p> <ul style="list-style-type: none"> • D093: 480 mm. The default interval is 1008 mm (2.1 x 480 mm). • D094: 168 mm. The default interval is 353 mm (2.1 x 168 mm). <p>Setting a smaller or larger number decreases or increases the length of the interval with this simple calculation. This standard interval can be modified slightly with SP1923.</p>
23	Paper Interval Step 3
	<p>When the pressure roller center and end thermistor detect a temperature in the Step 3 range (SP1940 013), the setting of this SP is activated to set the length of the interval between sheets in the paper path.</p> <p>[1.0 to 5.0/3.5/0.1]</p> <p>The default setting (3.5) is the variable for Step 3 multiplied by the constant set for Step 2 of the machine:</p> <ul style="list-style-type: none"> • D093: 480 mm. The default interval is 1680 mm (3.5 x 480 mm). • D094: 168 mm. The default interval is 588 mm (3.5 x 168 mm). <p>Setting a smaller or larger number decreases or increases the length of the interval with this simple calculation. This standard interval can be modified slightly with SP1923.</p>
51	Enable II

	<p>When the temperature of the hot roller drops during continuous printing, the machine enters the CPM down mode to increase the distance between sheets of paper going through the fusing unit. The slightly longer wait time between the trailing edge of the sheet going through the fusing unit and the leading edge of the next sheet, gives the hot roller more time to recover optimum temperature. This SP switches CPM Down Control II.</p> <p>[0 to 1 / 1 / 1]</p> <p>Note: The size of the interval between sheets in the paper path can be adjusted with SP1940-062.</p>
61	Paper Interval Step 2 II
	<p>When the temperature of the hot roller drops during continuous printing, the machine enters the CPM down mode to increase the distance between sheets of paper going through the fusing unit. This SP adjusts the size of the interval between sheets in the paper path after CPM Down Control II has been switched on with SP1940-51 (Enable 2).</p> <p>[1 to 10 / 2.9 / 0.1]</p> <p>Note: The size of the interval is adjusted for Step 3 II with SP1940-62.</p>
62	Paper Interval Step 3 II
	<p>When the temperature of the hot roller drops during continuous printing, the machine enters the CPM down mode to increase the distance between sheets of paper going through the fusing unit. This SP adjusts the size of the interval between sheets in the paper path after CPM Down Control II has been switched on with SP1940-51 (Enable 2).</p> <p>[1 to 10 / 8.5 / 0.1]</p> <p>Note: The size of the interval is adjusted with either SP1940-16, or SP1940-62.</p>
71	Enable III

	<p>[0 to 1 / 0 / 1]</p> <p>When this SP is set to "1":</p> <ul style="list-style-type: none"> • The thermistors at the center and end of the pressure roller measure the temperatures. • The temperature at the center of the pressure roller is subtracted from the temperature at the end of the pressure roller. • If the difference is greater than the setting of SP1940-081, the interval between sheets of translucent paper is calculated by multiplying the normal length of the paper and the setting for SP1940-091. <p>CPM down control compares the settings from among these three SP codes and selects the largest value for the paper interval:</p> <ul style="list-style-type: none"> • SP1940-001 I • SP1940-051 II • SP1940-071 III
81	Temp Differential: Step 1
	<p>[0 to 150 / 30 / 5]</p> <p>When SP1940-1 is set to "1":</p> <ul style="list-style-type: none"> • The thermistors at the center and end of the pressure roller measure the temperatures. • The temperature at the center of the pressure roller is subtracted from the temperature at the end of the pressure roller. • If the difference is greater than the setting of SP1940-081, the interval between sheets of translucent paper is calculated by multiplying the normal length of the paper and the setting for SP1940-091. <p>CPM down control compares the settings from among these three SP codes and selects the largest value for the paper interval:</p> <ul style="list-style-type: none"> • SP1940-001 I • SP1940-051 II • SP1940-071 III
91	Paper Interval Step 1

	<p>D093: [1 to 10 / 2.1 / 0.1] D094: [1 to 10 / 6.8 / 0.1]</p> <ul style="list-style-type: none"> • The thermistors at the center and end of the pressure roller measure the temperatures. • The temperature at the center of the pressure roller is subtracted from the temperature at the end of the pressure roller. • If the difference is greater than the setting of SP1940-081, the interval between sheets of translucent paper is calculated by multiplying the normal length of the paper and the setting for SP1940-091. <p>CPM down control compares the settings from among these three SP codes and selects the largest value for the paper interval:</p> <ul style="list-style-type: none"> • SP1940-001 I • SP1940-051 II • SP1940-071 III
--	---

1941	Press FB Ctrl Switch by Temp Diff
	<p>This SP sets the temperature differential that determines when the machine adjusts for pressure roller feedback control when the difference between the temperatures of the center and end of the pressure roller is greater than 20°C (Default: 20).</p> <p>[0 to 50/20/5]</p> <p>Example</p> <p>If this SP is set to "50": and there is a difference between the temperatures at the center and end of the pressure roller after more than 50 readings, then pressure roller feedback control shifts to the supplement mode.</p>

1942	Press FB Temp Hold Int: Normal
	<p>This SP sets the interval between temperature samplings for pressure roller feedback control.</p> <p>Note: Modes "1" to "5" below refer to the paper type and thickness settings selected in User Tools (see "Paper Thickness Default Selection" in this section).</p>
1	Plain: Mode1
2	Plain: Mode2
3	Plain: Mode3
4	Plain: Mode4
5	Plain: Mode5

[0 to 50/0/5°C]
 [0 to 50/5/5°C]
 [0 to 50/15/5°C]
 [0 to 50/0/5 °C]

1943	Press FB Temp High Temp: Special	
	This SP sets the high temperature used by pressure roller feedback temperature control for Custom paper. Note: Modes "1" to "5" below refer to the paper type and thickness settings selected in User Tools (see "Paper Thickness Default Selection" in this section).	
1	Plain: Mode1	[0 to 50/0/5°C]
2	Plain: Mode2	
3	Plain: Mode3	[0 to 50/20/5°C]
4	Plain: Mode4	
5	Plain: Mode5	[0 to 50/0/5 °C]

1944	Press FB Temp Low Temp: Special	
	This SP sets the low temperature used by pressure roller feedback temperature control for Custom paper. Note: Modes "1" to "5" below refer to the paper type and thickness settings selected in User Tools (see "Paper Thickness Default Selection" in this section).	
1	Plain: Mode1	[0 to 50/0/5°C]
2	Plain: Mode2	
3	Plain: Mode3	[0 to 50/10/5 °C]
4	Plain: Mode4	[0 to 50/5/5°C]
5	Plain: Mode5	[0 to 50/0/5°C]

1945	Length Level Setting	
	These SP's define the Length Levels for the following SP codes: <ul style="list-style-type: none"> • SP1946 Press FB Stop: Target Temp Diff. • SP1947 Press FB Stop: Time Period 	
1	Level 1	[1000 to 15000/1300/1 mm]
2	Level 2	[1000 to 15000/3700/1 mm]
3	Level 3	[1000 to 15000/6100/1 mm]

4	Level 4	[1000 to 15000/9100/1 mm]
5	Level 5	[1000 to 15000/12100/1 mm]

2

1946	Press FB Stop: Target Temp Diff	
	<p>This SP calculates the hot roller target temperature while pressure roller feedback control is stopped. This SP determines the target hot roller temperature while pressure roller feedback control is not operating. The temperature is determined based on the paper type and length of the paper (Length Level).</p> <p>Note: The Length Levels (1 to 5) are defined by SP1945.</p>	
1	Length Level 1: Normal	[0 to 30/15/1°C]
2	Length Level 2: Normal	[0 to 30/10/1°C]
3	Length Level 3: Normal	[0 to 30/7/1°C]
4	Length Level 4: Normal	[0 to 30/5/1°C]
5	Length Level 5: Normal	[0 to 30/3/1°C]
11	Length Level 1: Cold Start	[0 to 30/10/1°C]
12	Length Level 2: Cold Start	[0 to 30/5/1°C]
13	Length Level 3: Cold Start	[0 to 30/3/1°C]
14	Length Level 4: Cold Start	[0 to 30/0/1°C]
15	Length Level 5: Cold Start	
16	Length Level 0: Cold Start	

1947	Press FB Stop: Time Period	
	<p>This SP sets the length of time that pressure roller feedback is suspended for the paper lengths defined by SP1945.</p> <ul style="list-style-type: none"> • Pressure roller feedback control begins when the time set with this SP has elapsed after paper feed starts. • As more paper is fed for a multiple print job, the time setting for succeeding sheets is overwritten. • However, for succeeding sheets where the time prescribed for feedback suspension is "0", the "0" value is not overwritten, but feedback suspension control is maintained until countdown for the multiple copies is finished. 	

1	Length Level 1: Normal	[0 to 300/15/1 sec.]
2	Length Level 2: Normal	[0 to 300/30/1 sec.]
3	Length Level 3: Normal	[0 to 300/45/1 sec.]
4	Length Level 4: Normal	[0 to 300/60/1 sec.]
5	Length Level 5: Normal	[0 to 300/80/1 sec.]
11	Length Level 1: Cold Start	[0 to 300/20/1 sec.]
12	Length Level 2: Cold Start	[0 to 300/35/1 sec.]
13	Length Level 3: Cold Start	[0 to 300/50/1 sec.]
14	Length Level 4: Cold Start	[0 to 300/70/1 sec.]
15	Length Level 5: Cold Start	[0 to 300/100/1 sec.]
16	Length Level 0: Cold Start	<p>Normally, pressure roller feedback control does not operate when the paper length is not prescribed (length = 0). But if copying was started while feedback control was not operating, during a cold start for example, then feedback control operates using the setting of this SP code.</p> <p>[0 to 300/15/1 sec.]</p>
17	Length Level 0: False Start	<p>The target hot roller temperature for a flying start is determined by SP1931. This SP determines the time limit for the hot roller to reach that target hot roller temperature.</p> <p>[0 to 300/20/1 sec.]</p>
18	Standby After Cold Start	<p>This SP sets a time period that prohibits printing to begin even after the hot roller temperature reaches its target temperature after a cold start. If a job is started during this time period countdown, the countdown changes to the counts for -11 to -17 above.</p> <p>[0 to 300/60/1 sec.]</p>
1948	Press Roller Inching Target Temp	

	<p>This SP determines when inching starts.</p> <ul style="list-style-type: none"> Inching control is done when the pressure roller temperature is above this setting (65°C for example), but printing is prohibited until the pressure roller temperature reaches its target temperature. Inching (idle rotation of the rollers) starts after the temperature rises above the hot roller target temperature (SP1937 003). While the temperature is below 65°C copying (not printing) is possible before the temperature of the pressure roller reaches its target temperature and inching starts. 	
1	Plain: Mode1	[60 to 180/100/5°C]
2	Plain: Mode2	[60 to 180/65/5°C]
3	Plain: Mode3	[60 to 180/60/5°C]
4	Plain: Mode4	
5	Plain: Mode5	
6	Trans.: Mode1	[60 to 180/130/5°C]
7	Trans.: Mode2	[60 to 180/100/5°C]
8	Trans.: Mode3	[60 to 180/60/5°C]
9	Trans.: Mode4	
10	Trans.: Mode5	
11	Film: Mode1	
12	Film: Mode2	
13	Film: Mode3	
14	Film: Mode4	
15	Film: Mode5	
16	Plain Mode: Low Temp Cold Start	

	<p>When the machine determines that a cold start in a low-temperature environment has started, the machine uses this setting to start the machine and ignores the paper thickness mode settings.</p> <ul style="list-style-type: none"> • When the prescribed time has elapsed after a cold start, temperature control returns to the paper type and thickness settings. • However, this low temperature cold start does temperature control for plain paper only, not for either translucent paper or film. <p>[60 to 80/120/5°C]</p>
--	--

1949	Press FB Std Temp Coeff
	$\text{Press.Roller Ctr Temp.} + (\text{Press.Roller End Temp.} - \text{Press.Roller Ctr Temp.}) \times \text{SP1949-xxx} = \text{Press.Roller FB Temp.}$
	<p>The formula above uses the setting of this SP to determine the pressure roller feedback temperature. The result of this calculation is used to calculate the hot roller target temperature.</p> <p>Note:</p> <ul style="list-style-type: none"> • Settings can be selected below for the paper type, mode, and paper length. • Modes "1" to "5" below refer to the paper type and thickness settings selected in User Tools (see "Paper Thickness Default Selection" in this section).

11	Normal Mode1: > 611mm	[0 to 1/0/0.1]
12	Normal Mode1: 461-610mm	
13	Normal Mode1: 298-460	
14	Normal Mode1: < 297mm	
21	Normal Mode2: > 611mm	
22	Normal Mode2: 461-610mm	
23	Normal Mode2: 298-460	
24	Normal Mode2: < 297mm	
31	Normal Mode3: > 611mm	
32	Normal Mode3: 461-610mm	
33	Normal Mode3: 298-460	
34	Normal Mode3: < 297mm	
41	Normal Mode4: > 611mm	
42	Normal Mode4: 461-610mm	
43	Normal Mode4: 298-460	
44	Normal Mode4: < 297mm	

51	Normal Mode5: > 611mm	[0 to 1/0/0.1]
52	Normal Mode5: 461-610mm	
53	Normal Mode5: 298-460	
54	Normal Mode5: < 297mm	
61	Trans Mode: > 611mm	
62	Trans Mode: 461-610mm	
63	Trans Mode: 298-460	
64	Trans Mode: < 297mm	
111	Film Mode: > 611mm	
112	Film Mode: 461-610mm	
113	Film Mode: 298-460	
114	Film Mode: < 297mm	

1960	Forced Upper Paper Exit: A1/D
	<p>This SP sets the paper exit for printouts smaller than A1.</p> <ul style="list-style-type: none"> • If the paper exit is specified (set to "1") all printouts smaller than A1 are forced to exit at the top of the machine. • If the paper exit is not specified (set to "0"), the upper or rear exit can be selected on the machine control panel. <p>[0 to 1/0/1]</p> <p>0: OFF (Paper exit specified)</p> <p>1: ON (Paper exit not specified and can be selected on operation panel)</p>

1970	Fan Stop Time
	<p>This SP sets the stop timing for the controller box fan and cooling fan that cools the main PCBs.</p> <p>[0 to 30/1/1 min.]</p>

SP2-xxx Drum

2

2001	Charge Corona Adjustment
	This SP adjusts the charge corona outputs.
1	Total Corona Current
	Adjusts the charge corona output for total area. [650 to 1530/1220/1 V step]
2	Grid Voltage: Image Area
	Adjusts the charge grid output. [160 to 1080/800/1 uA step]
3	Grid Voltage: ID Sensor Pattern DFU
	Adjusts the charge grid output for the ID sensor pattern. [160 to 1080/600/1 V step]

2101	Print Erase Margin
	Adjusts the quantity of erase for copy mode (quantity of white space).
1	Leading Edge
2	Trailing Edge
3	Left edge
4	Right edge
	[0 to 10 / 2 / 0.1 mm step]
	[0 to 10/ 0.5 / 0.5 mm step]

2110	Test Mode dpi DFU
------	--------------------------

	<p>This SP adjusts the image resolution.</p> <ul style="list-style-type: none"> • This adjustment is required for Design checking and confirming FCI operation with the test patterns. • Once the machine leaves the SP mode, this SP automatically returns to its default settings. <p>[0 to 19/8/1]</p> <p>0: 400 x 400 dpi (reduction)</p> <p>4: 300 x 300 dpi (reduction)</p> <p>8: 600 x 600 dpi</p> <p>19: 200 x 200 dpi (reduction)</p>
--	--

2201	Development Bias Adjustment
	<p>This SP sets the development bias to adjust the amount of toner used in the image area.</p> <ul style="list-style-type: none"> • The amount charge applied by the CGB power pack for image transfer varies depending on whether CV is high or low. • Toner density is controlled to raise toner density in Low Duty mode when copy volume is high. • For this reason, SP2201-4 can be used to switch between High Duty Mode (> 400 m/day) and Low Duty Mode (< 400 m/day). • The default setting is Low Duty Mode.
1	Image Area
	<p>This SP sets the bias voltage applied to the image area in the development unit (adjusted at the factory).</p> <p>[100 to 1000 / 600 / 1 V step]</p>
2	ID Sensor Pattern: Low Duty Copy Jobs
	<p>This SP sets the development bias applied to create the ID sensor pattern when the Low Duty Mode is selected with SP2201-4 (factory adjusted).</p> <p>[100 to 1000 / 350 / 1 V step]</p>
3	ID Sensor Pattern: High Duty Copy Jobs
	<p>This SP sets the development bias applied to create the ID sensor pattern on the drum when the High Duty Mode is selected with SP2201-4 (factory adjusted).</p> <p>[100 to 1000 / 400 / 1 V step]</p>

4	Copy Jobs
	<p>This SP is used to switch between Low Duty Mode and High Duty Mode.</p> <p>Note: The Low Duty Mode is set as the default because wide format copiers are generally used for low volume copying and printing.</p> <p>[0 to 1/0/1]</p> <p>0: Low Duty Mode Copy Jobs (< 400 meters/day)</p> <p>1: High Duty Mode Copy Jobs (> 400 meters/day)</p>

2207	Forced Toner Supply
	<p>Push [Execute] to force toner supply. Make a copy and check the image density. This SP supplies more toner to make light copies darker. Each time this SP is done, toner is supplied one time.</p> <ul style="list-style-type: none"> • After [Execute] is pressed the main motor, charge unit, and other components turn on, then the machine supplies a prescribed amount of toner to the development unit. • If image density is light, use this SP to recover from a low toner supply problem. • After executing forced toner supply, the Vsp value displays in the range 0.1 to 0.4 V, and thereafter, the value is stabilized (near 0.4 V) for subsequent printouts.

2208	Toner Supply Setting
1	Gain
	<p>This SP setting determines the supply GAIN for toner supply based on the readings of the ID sensor (Vsp/Vsg). This value is the threshold setting used calculate toner supply with the toner supply coefficient set with SP2208-2.</p> <ul style="list-style-type: none"> • The Vsp/Vsg value is used to fetch the corresponding value from the GAIN lookup table. • Increasing the value of this setting raises GAIN for image density control. <p>[0 to 9/1/1]</p> <p>0: Lowest, 5: Medium, 9: Very High</p>
2	Supply Capacity

	<p>This SP sets the coefficient for toner supply control.</p> <ul style="list-style-type: none"> This coefficient is used in a calculation with GAIN value, and width of the paper to determine the amount of toner supply. Increasing the value of this setting raises the amount of toner applied to control image density. <p>[0 to 3.5 / 1.7 / /0.1 Steps]</p>
3	Toner Supply Mode
	<p>Sets the toner supply mode.</p> <ul style="list-style-type: none"> This SP sets the toner supply mode for toner supply control. This determines the supply GAIN based on the ID sensor reading of the ID sensor pattern. This determines the supply GAIN for the fixed toner supply mode for 3% coverage and 6% coverage. When fixed toner supply is selected, the image density is determined by the rate of coverage in the image passing through the machine. If the density of the image on the paper passing through is higher than the rate set for the fixed toner supply mode, the image will be lighter. <p>[0 to 2/ 0 / 1]</p> <p>0: Detect Mode (uses ID sensor)</p> <p>1: Fixed Mode (3%). Coverage fixed at 3% (medium)</p> <p>2: Fixed Mode (6%). Coverage fixed at 6% (darker)</p> <ul style="list-style-type: none"> If the ID sensor is damaged and cannot be replaced immediately, set either SP to "1". The operator can continue to use the machine until a new ID sensor becomes available. After the ID sensor has been replaced, reset the SP to 0.
5	Long Print: Drawing
	<p>The machine switches to the Long Print mode (fixed toner supply mode) for any original longer than 1189 mm (46.8 in.).</p> <ul style="list-style-type: none"> There are two Long Print modes (Long Print/Drawing and Long Print Graphic). If the operator is frequently running jobs that contain either a lot of lines or graphics then SP2208-7 (Long Print Mode Setting) should be set accordingly. The values set for this SP are reflected in the printed images after Long Print/Graphic has been selected. <p>[1 to 40 / 3 / 1%]</p>
6	Long Print: Graphic

	<p>The machine switches to the Long Print mode (fixed toner supply mode) for any original longer than 1189 mm (46.8 in.).</p> <ul style="list-style-type: none"> • There are two Long Print modes (Long Print/Drawing and Long Print Graphic). • If the operator is frequently running jobs that contain either a lot of lines or graphics then SP2208-7 (Long Print Mode Setting) should be set accordingly. • The values set for this SP are reflected in the printed images after Long Print/Graphic has been selected. <p>[1 to 40 / 6 / 1%]</p>
7	<p>Long Print: Mode Setting</p>
	<p>The machine switches to the Long Print mode (fixed toner supply mode) for any original longer than 1189 mm (46.8 in.).</p> <p>[0 to 1/0/1]</p> <p>0: Drawing</p> <p>1: Graphic</p> <ul style="list-style-type: none"> • This SP can be set for the graphic or line mode, depending on which type of job is most frequently required for printing. • For a Long Print mode job the setting of SP2208-5 is reflected when the operator selects graphic mode, and the setting of SP2208-6 is reflected when the operator selects line mode.
2301	<p>Transfer Current Adjustment</p>
	<p>Use these SP's to adjust the power output and power coefficient used to transfer the toner image from drum to paper. Four separate voltages are applied before the leading edge, at the leading edge of the paper, across the image area and at the trailing edge of the paper..</p> <p>Notes:</p> <ul style="list-style-type: none"> • The coefficient adjustment should be done before the power output. • The amount of voltage applied to each area can be set independently in each area for the type of paper in use.

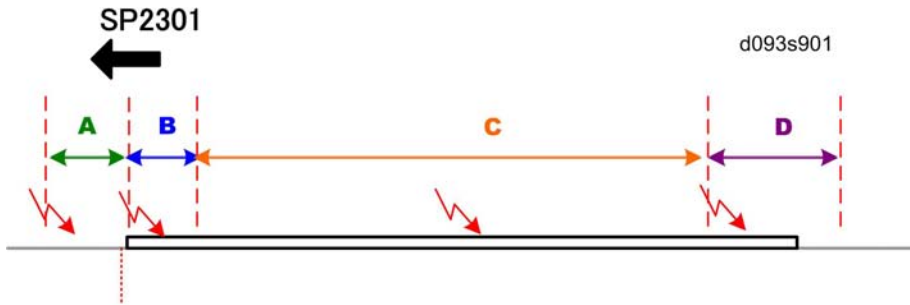

Transfer Current Adjustment Table

The four separate voltages for image transfer to paper are applied:

- A: Before paper leading edge
- B: Leading edge
- C: Image area
- D: Trailing edge

Default Voltages for Different Media

Paper	A		B		C		D	
	2301	uA	2301	uA	2301	uA	2301	uA
Plain: Roll	-001	60	-002	60	-003	60	-004	60
Translucent: Roll	-006	60	-007	60	-008	60	-009	60
Film: Roll	-011	80	-012	80	-013	80	-014	80
Plain: Cut Sheet	-021	60	-022	60	-023	60	-024	60
Translucent: Cut Sheet	-026	60	-027	60	-028	60	-029	60
Film: Cut Sheet	-031	80	-032	80	-033	80	-034	80

- The four voltages applied to the paper for image transfer can be adjusted at each area, depending on what type of paper is used.
- Note that the default voltages are slightly higher for Roll Film and Cut-Sheet Film.
- SP2301 sets the voltage levels. The timing for the application of the voltages is controlled by SP2925.

1	Roll Paper: Plain Paper: Before Leading Edge [0 to 230/60/1 uA]
---	--

2	Roll Paper: Plain Paper: Leading Edge [0 to 230/60/1 uA]
3	Roll Paper: Plain Paper: Image Area [0 to 230/60/1 uA]
4	Roll Paper: Plain Paper: Trailing Edge [0 to 230/60/1 uA]
5	Roll Paper: Plain Paper: Coefficient DFU
	Adjusts the transfer output coefficient for the image at the center, leading edge, and trailing edge on plain roll paper. [1 to 2 / 1/ 0.1]
6	Roll Paper: Translucent: Before Leading Edge [0 to 230/60/1 uA]
7	Roll Paper: Translucent: Leading Edge [0 to 230/60/1 uA]
8	Roll Paper: Translucent: Image Area [0 to 230/60/1 uA]
9	Roll Paper: Translucent Paper: Trailing Edge [0 to 230/60/1 uA]
10	Roll Paper: Translucent Paper: Coefficient DFU
	Adjusts the transfer output coefficient for the image at the center, leading edge, and trailing edge on translucent roll paper. [1 to 2 / 1/ 0.1]
11	Roll Paper: Film: Before Leading Edge [0 to 230/80/1 uA]
12	Roll Paper: Film: Leading Edge [0 to 230/80/1 uA]
13	Roll Paper: Film: Image Area [0 to 230/80/1 uA]

14	Roll Paper: Film: Trailing Edge [0 to 230/80/1 μ A]
15	Roll Paper: Film: Coefficient DFU
	Adjusts the transfer output coefficient for the image at the center, leading edge, and trailing edge on film roll paper. [1 to 2 / 1 / 0.1]
21	Cut Paper: Plain Paper: Before Leading Edge [0 to 230/60/1 μ A]
22	Cut Paper: Plain Paper: Leading Edge [0 to 230/60/1 μ A]
23	Cut Paper: Plain Paper: Image Area [0 to 230/60/1 μ A]
24	Cut Paper: Plain Paper: Trailing Edge [0 to 230/60/1 μ A]
25	Cut Paper: Plain Paper: Coefficient DFU
	Adjusts the transfer output coefficient for the image at the center, leading edge, and trailing edge on plain cut-sheet paper. [1 to 2 / 1 / 0.1]
26	Cut Paper: Translucent: Before Leading Edge [0 to 230/60/1 μ A]
27	Cut Paper: Translucent: Leading Edge [0 to 230/60/1 μ A]
28	Cut Paper: Translucent: Image Area [0 to 230/60/1 μ A]
29	Cut Paper: Translucent: Trailing Edge [0 to 230/60/1 μ A]

30	Cut Paper: Translucent: Coefficient DFU
	Adjusts the transfer output coefficient for the image at the center, leading edge, and trailing edge on translucent cut-sheet paper. [1 to 2 / 1 / 0.1]
31	Cut Paper: Film: Before Leading Edge [0 to 230/80/1 uA]
32	Cut Paper: Film: Leading Edge [0 to 230/80/1 uA]
33	Cut Paper: Film: Image Area [0 to 230/80/1 uA]
34	Cut Paper: Film: Trailing Edge [0 to 230/80/1 uA]
35	Cut Paper: Film: Coefficient DFU
	Adjusts the transfer output coefficient for the image at the center, leading edge, and trailing edge on film cut-sheet paper. [1 to 2 / 1 / 0.1]
2401	Separation Current Timing
	<p>This SP controls the timing of the application of the voltage that separates the paper from the drum after the toner image has been transferred from the drum to the paper.</p> <p>Notes:</p> <ul style="list-style-type: none"> • This adjustment can be done only for the standard feed sources (roll or cassette). The adjustment cannot be done for paper fed from the manual feed tray. • Independent adjustments for the type of paper (plain, translucent, film) cannot be done. • Both AC and DC voltages are applied. The applied AC voltage remains constant. Only the level of the applied DC voltage can be adjusted.

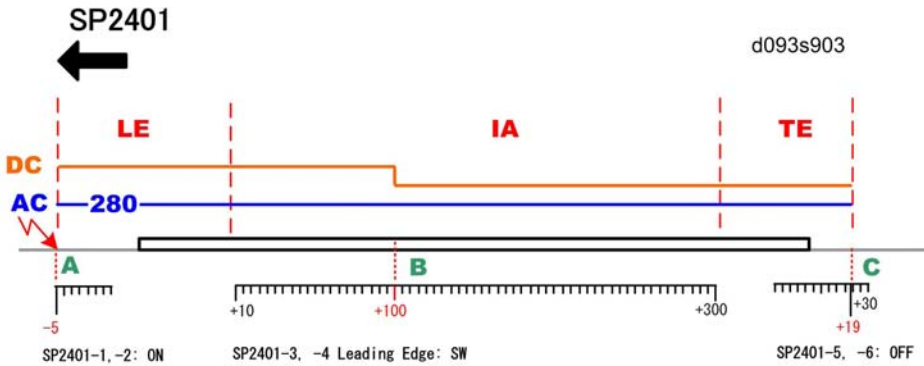

- Both AC/DC voltages switch on at [A].
- The level of the DC voltage switches to a lower level [B] and causes the total amount of applied voltage to drop.
- Both AC/DC voltages switch off at [C].
- The AC level remains constant. Only the DC level is switched to a lower voltage at [B].

Separation Current Timing Table

Paper		SP No.	Name	Comment
Roll Paper	A	2401-1	ON Timing: Roll Paper	AC/DC ON
	B	2401-3	Leading Edge: Roll Paper	DC Switching
	C	2401-5	OFF Timing: Roll Paper	AC/DC OFF
Cut Sheet Paper	A	2401-2	ON Timing: Cut Paper	AC/DC ON
	B	2401-4	Leading Edge Cut Paper	DC Switching
	C	2401-6	OFF Timing: Cut Paper	AC/DC OFF

1	ON Timing: Roll Paper [-5 to 30 / -5 / 1]
2	ON Timing: Cut Paper [-5 to 30 / -5 / 1]
3	Leading Edge: Roll Paper [10 to 300 / 100 / 1]
4	Leading Edge Cut Paper [10 to 300 / 100 / 1]

5	OFF Timing: Roll Paper [-30 to 30 / 19 / 1 mm]
6	OFF Timing: Cut Paper [-30 to 30 / 19 / 1 mm]

2402	Separation AC Current Adjustment	
	Adjusts the separation AC voltage for roll paper and cut sheets. Note: The AC charge applied to the paper remains constant. The AC voltage level cannot be switched during application of the transfer voltage. Only the DC current can be adjusted.	
1	Roll Paper	[18 to 466 / 280 / 1 uA step]
2	Cut Paper	

2403	Separation DC Current Adjustment	
	Adjusts the level of the separation DC current applied to separate the paper from the drum. The separation DC current can be set for plain paper, translucent paper, and film for the leading edge, trailing edge, and areas outside the image.	
1	Roll Paper: Plain Paper: Leading Edge	[0.0 to 66/25/0.1 uA]
2	Roll Paper: Plain Paper: Image Area	[0.0 to 66/15/0.1 uA]
3	Roll Paper: Translucent: Image Area	[0.0 to 66/25/0.1 uA]
4	Roll Paper: Translucent: Image Area	[0.0 to 66/15/0.1 uA]
5	Roll Paper: Film: Image Area	[0.0 to 66/25/0.1 uA]
6	Roll Paper: Film: Image Area	[0.0 to 66/15/0.1 uA]

11	Cut Paper: Plain Paper: Image Area
	[0.0 to 66/25/0.1 uA]
12	Cut Paper: Plain Paper: Image Area
	[0.0 to 66/15/0.1 uA]
13	Cut Paper: Translucent: Image Area
	[0.0 to 66/25/0.1 uA]
14	Cut Paper: Translucent: Image Area
	[0.0 to 66/15/0.1 uA]
15	Cut Paper: Film: Image Area
	[0.0 to 66/25/0.1 uA]
16	Cut Paper: Film: Image Area
	[0.0 to 66/15/0.1 uA]

2801	Developer Initial Setting
	<p>This SP supplies some toner to the development unit, mixes the developer and toner, and initializes the ID sensor. Execute this SP to mix the developer during machine installation or after the developer has been replaced. The machine requires two packs of developer. Two SP codes are provided for entering the lot numbers of both packages.</p> <p>Note:</p> <ul style="list-style-type: none"> • Always enter the lot numbers with SP2801-2 and -3 before doing SP2801-1. • Execution of this SP requires that 2 kg of developer be loaded in the development unit and that the toner cartridge be set. • If the lot numbers are not entered, then the developer cannot be initialized (complete failure with no operation). • The Lot Numbers are stored in NVRAM. • Even if the Lot Numbers are the same, the number must be entered twice, once for each packet. • Enter the Lot Numbers with the soft keyboard.
1	Initialize Developer
	Touch [EXECUTE] to mix developer and initialize the ID sensor

2	Lot Number 1
	This is the lot number of the 1st packet.
3	Lot Number 2
	This is the lot number of the 2nd packet.

2803	Corona Wire Cleaning
	Do this SP to clean the charge corona wire. This SP also moves the cleaning pad to the home position. The cleaning requires about 20 sec. to complete.

2804	Corona Wire Cleaning Interval
	<p>Sets the interval for charge corona wire cleaning.</p> <p>Note: The wire is cleaned only when the hot roller temperature is below 50 °C (122°F).</p> <p>[0 to 6/3/1 step]</p> <p>0: None (no cleaning)</p> <p>1: After the main switch is turned on.</p> <p>2: After 300 m of copies</p> <p>3: After 600 m of copies</p> <p>4: After 900 m of copies</p> <p>5: After 1200 m of copies</p> <p>6: After 1500 m of copies</p>

2902	Test Pattern										
	<p>Use these SP's to select and print test patterns. Select one of 25 available test patterns (1-25).</p> <p>[0 to 25/0/1]</p> <p>0: None (default)</p>										
	<table border="0"> <tr> <td>0: None</td> <td>13: 1-dot Vertical Line</td> </tr> <tr> <td>1: 1-dot Grid Pattern</td> <td>14: 2-dot Vertical Line</td> </tr> <tr> <td>2: 2-dot Grid Pattern</td> <td>15: 1-dot Horizontal Line</td> </tr> <tr> <td>3: 3-dot Grid Pattern</td> <td>16: 2-dot Horizontal Line</td> </tr> <tr> <td>4: 4-dot Grid Pattern</td> <td>17: Checkered Flag</td> </tr> </table>	0: None	13: 1-dot Vertical Line	1: 1-dot Grid Pattern	14: 2-dot Vertical Line	2: 2-dot Grid Pattern	15: 1-dot Horizontal Line	3: 3-dot Grid Pattern	16: 2-dot Horizontal Line	4: 4-dot Grid Pattern	17: Checkered Flag
0: None	13: 1-dot Vertical Line										
1: 1-dot Grid Pattern	14: 2-dot Vertical Line										
2: 2-dot Grid Pattern	15: 1-dot Horizontal Line										
3: 3-dot Grid Pattern	16: 2-dot Horizontal Line										
4: 4-dot Grid Pattern	17: Checkered Flag										

5: 5-dot Grid Pattern	18: 1-dot Alternating Dot Pattern
6: 6-dot Grid Pattern	19: 2-dot Alternating Dot Pattern
7: 1-dot Argyle Pattern	20: 4-dot Alternating Dot Pattern
8: 2-dot Argyle Pattern	21: Trimming Area
9: 3-dot Argyle Pattern	22: Full Dot Pattern
10: 4-dot Argyle Pattern	23: Vertical Black Band
11: 5-dot Argyle Pattern	24: Horizontal Black Band
12: 6-dot Argyle Pattern	25: Blank Image

2916	Fine Magnification
	<p>Adjusts the magnification for each paper type. These settings are enabled automatically for the paper type when the operator selects a magnification ratio for the copy job. These corrections are done during image processing after the original is scanned. Adjust the setting for a paper type if you consistently notice distortion in magnified images for a particular type.</p> <p>[-10 to +10/0/0.1%]</p> <p>Notes</p> <ul style="list-style-type: none"> SP2916-1, SP2916-2 should be adjusted at installation of the main machine. In "1. Installation" see SP Adjustments.
1	Plain Paper: Mode1-4: Main Scan
2	Plain Paper: Mode1-4: Sub Scan
3	Translucent: Mode1-4: Main Scan
4	Translucent: Mode1-4: Sub Scan
5	Film: Mode1-4: Main Scan
6	Film: Mode1-4: Sub Scan
7	Recycled Paper: Mode1-4: Main Scan
8	Recycled Paper: Mode1-4: Sub Scan
9	Plain Paper: Mode5: Main Scan
10	Plain Paper: Mode5: Sub Scan

11	Translucent: Mode5: Main Scan
12	Translucent: Mode5: Sub Scan
13	Film: Mode5: Main Scan
14	Film: Mode5: Sub Scan
15	Recycled Paper: Mode5: Main Scan
16	Recycled Paper: Mode5: Sub Scan

2923	Execute Cleaning Blade Replace Mode
	<p>Always do this SP after replacing the OPC or cleaning blade.</p> <p>This SP applies a small amount of toner to the drum and blade to reduce friction between the new drum and/or new blade. This prevents scratching the drum or bending the blade.</p>

2924	Developer Mixing
1	Warmup
	<p>Prevents the occurrence of dirty background on the first copy after the machine is switched on, or returns from the auto off mode or sleep mode.</p> <p>[0 to 3/1/1]</p> <p>0: Off</p> <p>1: On (50 sec.). Development motor rotates 50 sec. after the machine is switched on when fusing temperature is less than 50°C (122°F).</p> <p>2: On (30 sec.). Development motor rotates 30 sec. after the machine is switched on when fusing temperature is less than 50°C (122°F).</p> <p>3: Development motor rotates 50 sec., regardless of the current fusing temperature.</p>
2	Enable
	<p>If the upper unit remains open for a long time, external light can sometimes temporarily fatigue the drum and cause horizontal banding in prints. To solve this problem, set this SP to "1" so as soon as the upper unit is closed, the charge corona can apply a charge to the drum to correct the problem.</p> <p>[0 to 1/1/1]</p> <p>0: OFF</p> <p>1: ON</p>

2925	Transfer Current Timing DFU
	<p>These SP's adjust the transfer current timing.</p> <p>Notes:</p> <ul style="list-style-type: none"> • These adjustments can be done for each type of paper (plain, translucent, film) as well as for the feed source (roll or cassette). • There are four voltages applied. The level of each voltage is set with SP2301.

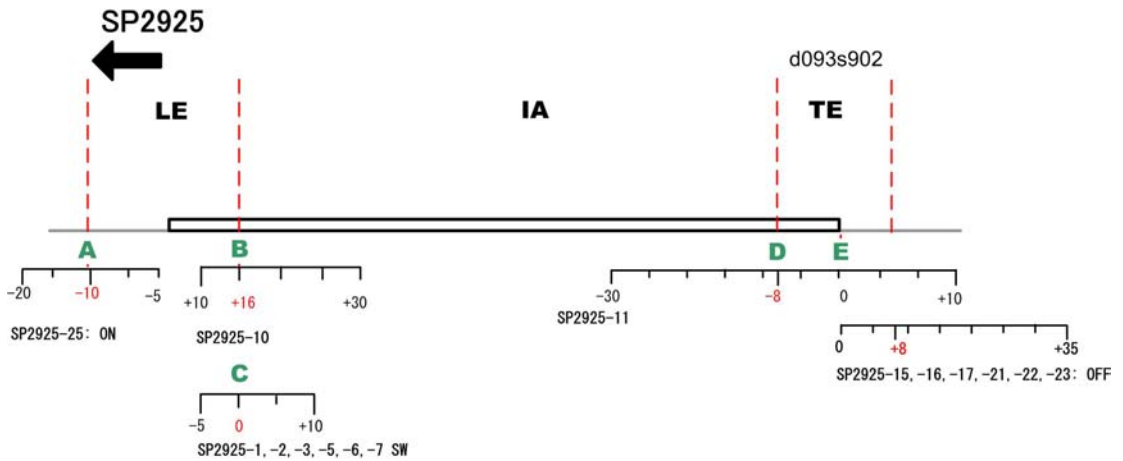

Transfer Current Timing Table

In the illustration above:

A	This is where voltage at the first level (SP2301-1) switches on before the leading edge (LE) of the paper.
B	This is where the voltage switches on the second voltage level (SP2301-2) at the leading edge of the paper.
C	This is where the voltage switches on the third voltage level (SP2301-3). This voltage is applied to the image area (IA) between the leading and trailing edges of the paper. Initially set at "0" this timing setting provides fine adjustments for the type of paper.
D	This is where the voltage switches on the fourth and last voltage level (SP2301-4) at the trailing edge (TE).
E	This is point where voltage is switched off.

SP2925

1	ON Timing: Roll Paper: Plain Paper [-5 to 10 / 0 / 1 mm]
2	ON Timing: Roll Paper: Translucent [-5 to 10 / 0 / 1 mm]
3	ON Timing: Roll Paper: Film [-5 to 10 / 0 / 1 mm]
5	ON Timing: Cut Paper: Plain Paper [-5 to 10 / 0 / 1 mm]
6	ON Timing: Cut Paper: Translucent [-5 to 10 / 0 / 1 mm]
7	ON Timing: Cut Paper: Film [-5 to 10 / 0 / 1 mm]
10	Leading Edge [10 to 30 / 16 / 1 mm]
11	Trailing Edge [-30 to 10 / -8 / 1 mm]
15	OFF Timing: Roll Paper: Plain Paper [0 to 35 / 8 / 1 mm]
16	OFF Timing: Roll Paper: Translucent [0 to 35 / 8 / 1 mm]
17	OFF Timing: Roll Paper: Film [0 to 35 / 8 / 1 mm]
21	OFF Timing: Cut Paper: Plain Paper [0 to 35 / 8 / 1 mm]
22	OFF Timing: Cut Paper: Translucent [0 to 35 / 8 / 1 mm]
23	OFF Timing: Cut Paper: Film [0 to 35 / 8 / 1 mm]

25	Transfer Current ON Timing [-5 to -20 / -10 / 1 mm]
----	--

2926	Used Toner Overflow Detect
	The used toner bottle motor operates a cam which vibrates against the side of the used toner bottle. This vibration settles and evens the level of the used toner inside the bottle.
1	Used Tnr M (Sensor Detection)
	Sets the length of time that the used toner bottle motor operates. The motor starts 10 sec. after the main power switch is switched on and if the fusing temperature is less than 50°C (122°F). [0 to 30/20/5] Note: Ten seconds after the machine is switched on if the machine detects that the toner collection bottle is full, the used toner bottle motor does not operate.
2	Used Tnr M (TE Recovery)
	Sets the length of time that the used toner bottle motor operates after TE (toner end). [0 to 80/30/5 sec.]
3	Used Toner Bottle Full Detect
	Sets the length of paper that can be printed from the time the toner bottle is detected near full until the used toner bottle is detected completely full. [1 to 50/30/1 m]

2927	Toner (Near) End Detection DFU
	These SP's set the levels for the toner near-end and toner end levels.
1	Near End Level
	Sets the level for toner near end detection. ($V_{sp}/V_{sg} = V_{end}$). [0.140 to 0.275/0.145/0.005 V]
2	Toner End Level
	Sets the V_{sp}/V_{sg} level for toner end detection. The ID sensor must detect this value three times in succession to detect toner end. The machine stops when toner end is detected. [0.150 to 300/0.165/0.005 V]

2928	Toner End Recovery
	<p>Recovery starts after the toner cartridge is replaced when a toner-end condition exists. [0.130 to 0.215/0.145/0.005 V]</p> <p>In the toner-end recovery process:</p> <ul style="list-style-type: none"> • The machine writes an ID sensor pattern on the surface of the drum. • The ID sensor reads the density of the ID sensor pattern and converts it to an electrical signal (Vsp). • The machine compares the Vsp value with Vsg, which is read from the bare sursection of the drum ($V_{sp}/V_{sg}=V_{ref}$) • If $V_{sp}/V_{sg} < V_{ref}$ (the value of this SP setting), recovery is completed and the machine goes back to normal operation.

2943	LED Duty Adjustment	
	<p>Adjusts the on timing (the “width” or “duty”) of the LEDs in the LPH units to change image exposure. Use this SP if it is necessary to make the output of one LPH block brighter or darker. Raising the setting creates darker pixels, lowering the setting creates lighter pixels.</p>	
1	LPH1	[1.0 to 20.0/12.0/0.1%]
2	LPH2	The optimum LPH settings are printed on the label that is attached to LPH replacement units. Always input these settings immediately after the LPH unit has been replaced.
3	LPH3	

2952	LPH Joint Adjustment
	<p>Adjust these settings only after you replace the LPH. For more, refer to “Replacement and Adjustment”.</p>
1	LPH1-2 Main Scan
	<p>Adjusts the LPH joint for main scan between LPH1 and LPH2. [0 to 999/500/1]</p>
2	LPH2-3 Main Scan
	<p>Adjusts the LPH joint for main scan between LPH2 and LPH3. [0 to 999/500/1]</p>
11	LPH1-2 Sub Scan

	Adjusts sub scanning at LPH 1-2 for paper more than 420 mm wide. [300 to 500/412/1]
12	LPH2-3 Sub Scan
	Adjusts sub scanning at LPH 2-3 for paper more than 420 mm wide. [2 to 100/16/1]
51	LPH1-2 Sub Scan: < 420mm
	Adjusts sub scanning at LPH 1-2 for paper less than 420 mm wide. This value is calculated automatically. [-50 to +50/0/1]
52	LPH2-3 Sub Scan: < 420mm
	Adjusts sub scanning at LPH 2-3 for paper less than 420 mm wide. This value is calculated automatically. [-50 to +50/0/1]

2953	LPH Joint Power Correction		
	Adjusts the four LEDs at each end of LPH 2. This fine adjustment is not usually necessary in the field. [-63 to +63 / 0 / 1]		
1	1-Dot: Left	11	1-Dot: Right
2	2-Dot: Left	12	2-Dot: Right
3	3-Dot: Left	13	3-Dot: Right
4	4-Dot: Left	14	4-Dot: Right

2954	Print Image Priority
------	----------------------

	<p>Sets level for line thickness processing for vertical lines wider than 2-dots. This SP is provided to adjust the settings if the desired image quality cannot be obtained with the default settings. However, with the content of some settings some scratchiness or other problems may occur in the images, so use this adjustment with caution.</p> <p>[0 to 3/1/1]</p> <p>0: Strongest processing (thinnest)</p> <p>1: Normal processing</p> <p>2: Weaker processing</p> <p>3: Weakest processing (thickest)</p>
--	--

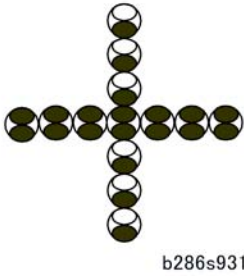

The illustration above shows how two elements comprise each dot. This example shows vertical and horizontal 1-dot lines.

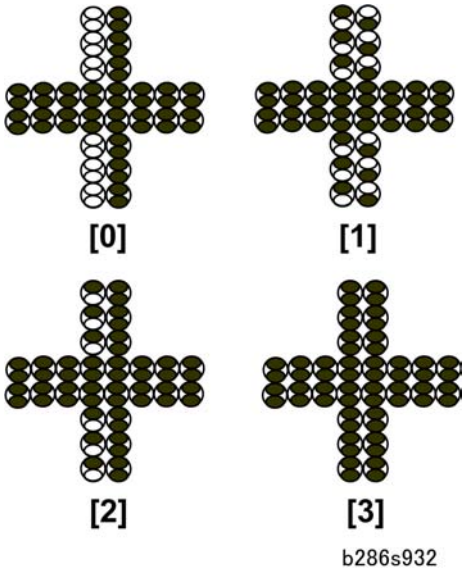

The diagram above illustrates the patterns for the settings SP2954-10 (0 to 3) on a 2-dot vertical line. The settings have no effect on the horizontal line.

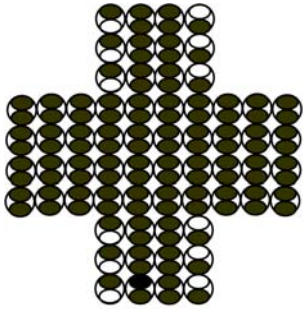

[1] b286s933

When line thickness more than 2 dots the value selected for SP2954-10 affects only the outer lines. The diagram above shows "1" selected for SP2954-10. The setting does not affect the horizontal line.

2959	Display VDB ID
	<p>This SP displays the 8-bit data that identifies the version of the FPGA flash program on the VDB (Video Drive Board). The VDB controls the signals sent to the LPH.</p> <p>Display: Hexadecimal</p>

SP3-xxx Process Control

2

3001	ID Sensor Initial Setting
	These SP's do the settings for the ID sensor LED.
1	PWM Setting: ID Sensor LED DFU
	Sets the level of the PWM (Pulse Width Modulation) of the ID sensor LED. [0 to 100/20/0.1%]
2	Initialize ID Sensor: Execute
	Automatically adjusts the ID sensor with a sensor reading of the bare drum. The initial setting is $4.0V \pm 0.2$. This SP requires about 4 sec. to execute. Always do this SP at installation, and after you replace these components: <ul style="list-style-type: none"> • OPC Drum • ID Sensor • NVRAM • MCU

3103	ID Sensor Output Display
	This SP displays the current readings of the bare drum surface (Vsg) and the ID sensor pattern (Vsp)
1	Vsg Bare drum reflection
2	Vsp ID sensor pattern reflection

3920	ID Sensor Pattern Interval
1	Job End
	This SP sets the distance between the readings of the previous and next ID sensor pattern. [20 to 1000 / 100 / 100 cm]
2	During Job ON/OFF

	<p>This setting is for ID sensor pattern reading during print jobs.</p> <p>[0 to 1 / 1 / 1]</p> <ul style="list-style-type: none">• If "0" (OFF) is selected the ID sensor pattern will not be read until the job ends (this means that the most recent V_{sp}/V_{sg} reading at the end of the previous job is used).• If "On" is selected the ID sensor will read the ID sensor patterns at the prescribed interval to stabilize toner supply control.
3	During Job
	<p>This SP sets the time interval between the readings of the previous and next ID sensor pattern during a job.</p> <p>[20 to 2000 / 100 / 10 cm]</p>

SP4-xxx Scanner

2

4008	Scanner Sub Scan Magnification
	Adjusts magnification in the sub scan direction by changing the speed of the main motor. [-0.9 to +0.9/0/0.1% step]

4010	Scanner Sub Scan Registration
1	Leading Edge
	This SP shifts the leading edge of the scanned image relative to the sub scan direction. [-10 to 10/0/ 0.1 mm step] <ul style="list-style-type: none"> • A higher setting "+" shifts the image down (opposite the sub scan direction). • A lower setting "-" shifts the image up (in the same direction as the sub scan direction).
2	Trailing Edge
	This SP shifts the trailing edge of the scanned image relative to the sub scan direction. [-10 to 10/0.0/0.1 mm step] <ul style="list-style-type: none"> • A higher setting "+" shifts the image down (opposite the sub scan direction). • A lower setting "-" shifts the image up (in the same direction as the sub scan direction).

4011	Scanner Main Scan Registration
	This SP shifts the scanned image relative to the main scan direction. [-4 to 4/0.0/0.1 mm] <ul style="list-style-type: none"> • A higher setting "+" shifts the image to the right (in the main scan direction). • A lower setting "-" shifts the image to the left (against the main scan direction).

4012	Scanner Erase Margin
	These SP's define borders around the image area output by the scanner. Each edge can be set independent of the others.
5	DF: LEdge
6	DF: TEdge
7	DF: Left
[0 to 9 / 1.5 /0.1 mm]	

8	DF: Right	[0 to 9 / 0.5 / 0.1 mm]
---	-----------	-------------------------

4013	Scanner Free Run	
	These SP's set up and start the scanner free run operation for testing.	
1	Start	
	This SP uses the most recent settings for the original length and interval between sheets to print virtual pages for a scanner free run. [ON] Start [OFF] Stop	
2	Page Interval Setting	
	Sets the interval between virtual prints for the scanner free run. [0 to 25 / 0.9 / 0.1 s]	
3	Original Length Setting	
	Sets the interval between multiple feeds for the DF free run. [0.2 to 15 / 0.6 / 0.1 m]	

4014	Scan HP Detection Disable DFU	
	Force executes color scanning, regardless of the scanner application. This SP is used during manufacturing processing. [0 to 1 / 0 / 1]	

4101	Scanner Main Scan Magnification	
	Adjusts the side-to-side scan magnification. [-0.9 to +0.9 / 0.0 / 0.1 %]	

4417	IPU Test Pattern	
	Enter the number for the desired test pattern, switch the display to the "Copy Window" then press the [Start] button. [0 to 28 / 0 / 1]	
	Scan Text Patterns	

	0	*0: Scanner Data
	1	1-dot Vertical Line: SCN
	2	2-dot Vertical Line: SCN
	3	1-dot Horizontal Line: SCN
	4	2-dot Horizontal Line: SCN
	5	1-dot Alternating Dot Pattern: SCN
	6	1-dot Grid Pattern: SCN
	7	Vertical Stripes: SCN
	8	Horizontal Grayscale: 16-Lvl:SCN
	9	Vertical Grayscale: 16-Lvl:SCN
	10	Density Patch: 16-Lvl: SCN
	11	Cross Pattern: SCN
	12	Argyle Pattern: SCN
	13	Density Patch: 256-Lvl: SCN
	14	Density Patch: 64-Lvl: SCN
	15	Trim Area: SCN
	16	Vert. Frequency Characteristics: SCN
	17	Horiz. Frequency Characteristics: SCN
	Print Text Patterns	
	18	1to4-dot Ind. Dot & Coverage: PRN
	19	Horizontal Grayscale: 16-Lvl: PRN
	20	Vertical Grayscale: 16-Lvl: PRN
	21	16-Lvl Grayscale: PRN
	22	Density Patch (256-Lvl): PRN
	23	Density Patch (64-Lvl): PRN
	24	Cross Pattern: PRN

25	Grid Pattern (96-dot Width)
26	Argyle Pattern
27	Horizontal Grayscale (8-Lvl) & Line
28	Grid Pattern (128-dot Width)

4550	Scanner: Text/Chart DFU
	These SP codes enhance the quality of originals scanned in the Text/Chart mode (selected on the operation panel).
5	MTF : 0(Off) 1-15 (Weak-Strong)
	Sets the MTF coefficient scanned in the Text/Chart mode. When the original image is converted to electrical signals, the contrast is reduced due to the influence that adjacent white and black pixels have on one another as a result of CIS properties. This may cause very narrow bands or spacing between black and white areas. Use the MTF adjust to correct this problem and emphasize image detail. [0 to 15 / 8 / 1] 0 (Weakest), 8 (Medium: Default), 15 (Strongest)
6	Smoothing: 0 (x1) 1-7 (Weak-Strong)
	Sets the level of smoothing for originals scanned in the Text/Chart mode. [0 to 7 / 0 / 1] 0 (Weakest), 4 (Medium: Default), 7 (Strongest)
7	Brightness:1-255
	Sets the overall brightness images scanned in the Text/Chart mode. [1 to 255 / 128 / 1] 1 (Weakest), 128 (Medium: Default), 255 (Strongest) Note: Raising the brightness level may increase moiré
8	Contrast:1-255
	Sets the overall contrast of images scanned in the text/chart mode. [1 to 255 / 128 / 1] 1 (Weakest), 128 (Medium: Default), 255 (Strongest) Note: Raising the contrast level may increase moiré

9	Ind. Dot Erase (x1) 1-7 (Weak-Strong)
	<p>Sets the level of independent dot erasure to improve the appearance in the backgrounds of images scanned in the Text/Chart mode.</p> <p>[0 to 7 / 0 / 1]</p> <p>0: Default (Off) 1 (Weakest) to 7 (Strongest)</p>
4551	Scanner: Text DFU
	These SP codes enhance the quality of originals scanned in the Text mode (selected on the operation panel).
5	MTF : 0(Off) 1-15 (Weak-Strong)
	<p>Sets the MTF coefficient scanned in the text mode. When the original image is converted to electrical signals, the contrast is reduced due to the influence that adjacent white and black pixels have on one another as a result of CIS properties. This may cause very narrow bands or spacing between black and white areas. Use the MTF adjust to correct this problem and emphasize image detail.</p> <p>[0 to 15 / 8 / 1]</p> <p>0 (Weakest), 8 (Medium: Default), 15 (Strongest)</p>
6	Smoothing: 0 (x1) 1-7 (Weak-Strong)
	<p>Sets the level of smoothing for originals scanned in the Text mode.</p> <p>[0 to 7 / 0 / 1]</p> <p>0 (Weakest), 4 (Medium: Default), 7 (Strongest)</p>
7	Brightness:1-255
	<p>Sets the overall brightness images scanned in the Text mode.</p> <p>[1 to 255 / 128 / 1]</p> <p>1 (Weakest), 128 (Medium: Default), 255 (Strongest)</p> <p>Note: Raising the brightness level may increase moiré</p>
8	Contrast:1-255
	<p>Sets the overall contrast of images scanned in the Text mode.</p> <p>[1 to 255 / 128 / 1]</p> <p>1 (Weakest), 128 (Medium: Default), 255 (Strongest)</p> <p>Note: Raising the contrast level may increase moiré</p>

9	Ind. Dot Erase (x1) 1-7 (Weak-Strong)
	<p>Sets the level of independent dot erasure to improve the appearance in the backgrounds of images scanned in the Text mode.</p> <p>[0 to 7 / 0 / 1]</p> <p>0: Default (Off) 1 (Weakest) to 7 (Strongest)</p>
4553	Scanner: Text/Photo DFU
	These SP codes enhance the quality of originals scanned in the Text/Photo mode (selected on the operation panel).
5	MTF : 0(Off) 1-15 (Weak-Strong)
	<p>Sets the MTF coefficient scanned in the Text/Photo mode. When the original image is converted to electrical signals, the contrast is reduced due to the influence that adjacent white and black pixels have on one another as a result of CIS properties. This may cause very narrow bands or spacing between black and white areas. Use the MTF adjust to correct this problem and emphasize image detail.</p> <p>[0 to 15 / 8 / 1]</p> <p>0 (Weakest), 8 (Medium: Default), 15 (Strongest)</p>
6	Smoothing: 0 (x1) 1-7 (Weak-Strong)
	<p>Sets the level of smoothing for originals scanned in the Text/Photo mode.</p> <p>[0 to 7 / 0 / 1]</p> <p>0 (Weakest), 4 (Medium: Default), 7 (Strongest)</p>
7	Brightness:1-255
	<p>Sets the overall brightness images scanned in the Text/Photo mode.</p> <p>[1 to 255 / 128 / 1]</p> <p>1 (Weakest), 128 (Medium: Default), 255 (Strongest)</p> <p>Note: Raising the brightness level may increase moiré</p>
8	Contrast:1-255
	<p>Sets the overall contrast of images scanned in the Text/Photo mode.</p> <p>[1 to 255 / 128 / 1]</p> <p>1 (Weakest), 128 (Medium: Default), 255 (Strongest)</p> <p>Note: Raising the contrast level may increase moiré</p>

9	Ind. Dot Erase (x1) 1-7 (Weak-Strong)
	<p>Sets the level of independent dot erasure to improve the appearance in the backgrounds of images scanned in the Text/Photo mode.</p> <p>[0 to 7 / 0 / 1]</p> <p>0: Default (Off) 1 (Weakest) to 7 (Strongest)</p>

4554	Scanner: Photo DFU
	These SP codes enhance the quality of originals scanned in the Photo mode (selected on the operation panel).
5	MTF : 0(Off) 1-15 (Weak-Strong)
	<p>Sets the MTF coefficient scanned in the Photo mode. When the original image is converted to electrical signals, the contrast is reduced due to the influence that adjacent white and black pixels have on one another as a result of CIS properties. This may cause very narrow bands or spacing between black and white areas. Use the MTF adjust to correct this problem and emphasize image detail.</p> <p>[0 to 15 / 8 / 1]</p> <p>0 (Weakest), 8 (Medium: Default), 15 (Strongest)</p>
6	Smoothing: 0 (x1) 1-7 (Weak-Strong)
	<p>Sets the level of smoothing for originals scanned in the Photo mode.</p> <p>[0 to 7 / 0 / 1]</p> <p>0 (Weakest), 4 (Medium: Default), 7 (Strongest)</p>
7	Brightness:1-255
	<p>Sets the overall brightness images scanned in the Photo mode.</p> <p>[1 to 255 / 128 / 1]</p> <p>1 (Weakest), 128 (Medium: Default), 255 (Strongest)</p> <p>Note: Raising the brightness level may increase moiré</p>
8	Contrast:1-255
	<p>Sets the overall contrast of images scanned in the Photo mode.</p> <p>[1 to 255 / 128 / 1]</p> <p>1 (Weakest), 128 (Medium: Default), 255 (Strongest)</p> <p>Note: Raising the contrast level may increase moiré</p>

9	Ind. Dot Erase (x1) 1-7 (Weak-Strong)
	<p>Sets the level of independent dot erasure to improve the appearance in the backgrounds of images scanned in the Photo mode.</p> <p>[0 to 7 / 0 / 1]</p> <p>0: Default (Off) 1 (Weakest) to 7 (Strongest)</p>
4555	Scanner: Drawing DFU
	These SP codes enhance the quality of originals scanned in the Line Drawing mode (selected on the operation panel).
5	MTF : 0(Off) 1-15 (Weak-Strong)
	<p>Sets the MTF coefficient scanned in the Drawing mode. When the original image is converted to electrical signals, the contrast is reduced due to the influence that adjacent white and black pixels have on one another as a result of CIS properties. This may cause very narrow bands or spacing between black and white areas. Use the MTF adjust to correct this problem and emphasize image detail.</p> <p>[0 to 15 / 8 / 1]</p> <p>0 (Weakest), 8 (Medium: Default), 15 (Strongest)</p>
6	Smoothing: 0 (x1) 1-7 (Weak-Strong)
	<p>Sets the level of smoothing for originals scanned in the Drawing mode.</p> <p>[0 to 7 / 0 / 1]</p> <p>0 (Weakest), 4 (Medium: Default), 7 (Strongest)</p>
7	Brightness:1-255
	<p>Sets the overall brightness images scanned in the Drawing mode.</p> <p>[1 to 255 / 128 / 1]</p> <p>1 (Weakest), 128 (Medium: Default), 255 (Strongest)</p> <p>Note: Raising the brightness level may increase moiré</p>
8	Contrast:1-255
	<p>Sets the overall contrast of images scanned in the Drawing mode.</p> <p>[1 to 255 / 128 / 1]</p> <p>1 (Weakest), 128 (Medium: Default), 255 (Strongest)</p> <p>Note: Raising the contrast level may increase moiré</p>

9	Ind. Dot Erase (x1) 1-7 (Weak-Strong)
	<p>Sets the level of independent dot erasure to improve the appearance in the backgrounds of images scanned in the Drawing mode.</p> <p>[0 to 7 / 0 / 1]</p> <p>0: Default (Off) 1 (Weakest) to 7 (Strongest)</p>

4565	Scanner: Grayscale DFU
	These SP codes enhance the quality of originals scanned in the Grayscale mode (selected on the operation panel).
5	MTF : 0(Off) 1-15 (Weak-Strong)
	<p>Sets the MTF coefficient scanned in the Grayscale mode. When the original image is converted to electrical signals, the contrast is reduced due to the influence that adjacent white and black pixels have on one another as a result of CIS properties. This may cause very narrow bands or spacing between black and white areas. Use the MTF adjust to correct this problem and emphasize image detail.</p> <p>[0 to 15 / 8 / 1]</p> <p>0 (Weakest), 8 (Medium: Default), 15 (Strongest)</p>
6	Smoothing: 0 (x1) 1-7 (Weak-Strong)
	<p>Sets the level of smoothing for originals scanned in the Grayscale mode.</p> <p>[0 to 7 / 0 / 1]</p> <p>0 (Weakest), 4 (Medium: Default), 7 (Strongest)</p>
7	Brightness:1-255
	<p>Sets the overall brightness images scanned in the Grayscale mode.</p> <p>[1 to 255 / 128 / 1]</p> <p>1 (Weakest), 128 (Medium: Default), 255 (Strongest)</p> <p>Note: Raising the brightness level may increase moiré</p>
8	Contrast:1-255
	<p>Sets the overall contrast of images scanned in the Grayscale mode.</p> <p>[1 to 255 / 128 / 1]</p> <p>1 (Weakest), 128 (Medium: Default), 255 (Strongest)</p> <p>Note: Raising the contrast level may increase moiré</p>

9	Ind. Dot Erase (x1) 1-7 (Weak-Strong)
	<p>Sets the level of independent dot erasure to improve the appearance in the backgrounds of images scanned in the Grayscale mode.</p> <p>[0 to 7 / 0 / 1]</p> <p>0: Default (Off) 1 (Weakest) to 7 (Strongest)</p>
4570	Scanner: Color Text/Photo DFU
	These SP codes enhance the quality of originals scanned in color in the Text/Chart mode (selected on the operation panel).
5	MTF : 0(Off) 1-15 (Weak-Strong)
	<p>Sets the MTF coefficient scanned in color in the Text/Photo mode. When the original image is converted to electrical signals, the contrast is reduced due to the influence that adjacent white and black pixels have on one another as a result of CIS properties. This may cause very narrow bands or spacing between black and white areas. Use the MTF adjust to correct this problem and emphasize image detail.</p> <p>[0 to 15 / 8 / 1]</p> <p>0 (Weakest), 8 (Medium: Default), 15 (Strongest)</p>
6	Smoothing: 0 (x1) 1-7 (Weak-Strong)
	<p>Sets the level of smoothing for originals scanned in color in the Text/Photo mode.</p> <p>[0 to 7 / 0 / 1]</p> <p>0 (Weakest), 4 (Medium: Default), 7 (Strongest)</p>
7	Brightness:1-255
	<p>Sets the overall brightness images scanned in color in the Text/Chart mode.</p> <p>[1 to 255 / 128 / 1]</p> <p>1 (Weakest), 128 (Medium: Default), 255 (Strongest)</p> <p>Note: Raising the brightness level may increase moiré</p>
8	Contrast:1-255
	<p>Sets the overall contrast of images scanned in color in the Text/Photo mode.</p> <p>[1 to 255 / 128 / 1]</p> <p>1 (Weakest), 128 (Medium: Default), 255 (Strongest)</p> <p>Note: Raising the contrast level may increase moiré</p>

9	Ind. Dot Erase (x1) 1-7 (Weak-Strong)
	Sets the level of independent dot erasure to improve the appearance in the backgrounds of images scanned in color in the Text/Photo mode. [0 to 7 / 0 / 1] 0: Default (Off) 1 (Weakest) to 7 (Strongest)

4571	Scanner: Color: Glossy Photo DFU
	These SP codes enhance the quality of originals scanned in color in the Glossy Photo mode (selected on the operation panel).
5	MTF : 0(Off) 1-15 (Weak-Strong)
	Sets the MTF coefficient scanned in color in the Glossy Photo mode. When the original image is converted to electrical signals, the contrast is reduced due to the influence that adjacent white and black pixels have on one another as a result of CIS properties. This may cause very narrow bands or spacing between black and white areas. Use the MTF adjust to correct this problem and emphasize image detail. [0 to 15 / 8 / 1] 0 (Weakest), 8 (Medium: Default), 15 (Strongest)
6	Smoothing: 0 (x1) 1-7 (Weak-Strong)
	Sets the level of smoothing for originals scanned in color in the Glossy Photo mode. [0 to 7 / 0 / 1] 0 (Weakest), 4 (Medium: Default), 7 (Strongest)
7	Brightness:1-255
	Sets the overall brightness images scanned in color in the Glossy Photo mode. [1 to 255 / 128 / 1] 1 (Weakest), 128 (Medium: Default), 255 (Strongest) Note: Raising the brightness level may increase moiré
8	Contrast:1-255
	Sets the overall contrast of images scanned in color in the Glossy Photo mode. [1 to 255 / 128 / 1] 1 (Weakest), 128 (Medium: Default), 255 (Strongest) Note: Raising the contrast level may increase moiré

9	Ind. Dot Erase (x1) 1-7 (Weak-Strong)
	<p>Sets the level of independent dot erasure to improve the appearance in the backgrounds of images scanned in color in the Glossy Photo mode.</p> <p>[0 to 7 / 0 / 1]</p> <p>0: Default (Off) 1 (Weakest) to 7 (Strongest)</p>

4603	AGC Correction DFU
------	---------------------------

4623	BkLvl Adj Value DFU
	<p>This SP displays the current black level offset DAC values of analog IC (LM98714) for CIS 1 to CIS 5. The settings stored in NVRAM can be changed, and the specified value is reflected in the black level offset DAC value of IC (LM98714) for CIS 1.</p> <p>Display format: hexadecimal</p> <p>[0 to 1023 / 520 / 1]</p>
1	BkLvl Adj Value CIS 1
2	BkLvl Adj Value CIS 2
3	BkLvl Adj Value CIS 3
4	BkLvl Adj Value CIS 4
5	BkLvl Adj Value CIS5

4654	BkLvl Adj Prev DFU
	<p>This SP displays the previous black level offset DAC values of analog IC (LM98714) for CIS 1 to CIS 5. The machine will use the adjusted value as the default setting when the machine is powered on.</p> <p>Display format: hexadecimal</p> <p>[0 to 1023 / 520 / 1]</p>
1	BkLvl Adj Prev CIS 1
2	BkLvl Adj Prev CIS 2
3	BkLvl Adj Prev CIS 3
4	BkLvl Adj Prev CIS 4

5	BkLvl Adj Prev CIS5
---	---------------------

4673	BkLvl Adj Value DFU
	This SP displays the black level offset DAC values of analog IC (LM98714) for CIS 1 to CIS 5 (factory setting). Display format: hexadecimal [0 to 1023 / 520 / 1]
1	BkLvl Adj Value CIS 1: Factory Setting
2	BkLvl Adj Value CIS 2: Factory Setting
3	BkLvl Adj Value CIS 3: Factory Setting
4	BkLvl Adj Value CIS 4: Factory Setting
5	BkLvl Adj Value CIS5: Factory Setting

4700	Display ID of FGPA
	This SP displays an 8-bit string that displays the ID of the FPGA (Volans) on the SIB.

4705	Gray Balance Adj DFU
	Adjusted before the machine leaves the factory.

4706	Gray Balance Adj DFU
1	Start
	Starts the grayscale balance adjustment after it was done at the factory.
4	Start
	Confirms the results of the grayscale balance adjustment after it was done at the factory.

4707	Gray Balance Target Value DFU
	These SP codes set the target grayscale values for three colors (RGB)
1	R [0 to 255 / 176 / 1]

2	G [0 to 255 / 174 / 1]
3	B [0 to 255 / 169 / 1]

4709	Gray Balance Adj Value: Present DFU
	<p>These SP codes store and display the RGB values set before and after shipping for each grayscale balance adjustment done for each of the five CIS elements.</p> <p>[-1024 to 1023 / 0 / 1]</p> <ul style="list-style-type: none"> • Display format: Hexadecimal • The values are stored after the machine is cycled off/on. • The settings are stored in the RI2005-SIB register
1	CIS 1: G Address: 0x64A0)
2	CIS 1: R Address: 0x64AA)
3	CIS 1: B Address: 0x64B6
4	CIS 2: G Address: 0x64A2
5	CIS 2: R Address: 0x64AC
6	CIS 2: B Address: 0x64B6
7	CIS 3: G Address: 0x64A4
8	CIS 3: R Address: 0x64AE
9	CIS 3: B Address: 0x64B8

10	CIS 4: G Address: 0x64A6
11	CIS 4: R Address: 0x64B0
12	CIS 4: B Address: 0x64BA
13	CIS 5: G Address: 0x64A8
14	CIS 5: R Address: 0x64B2
15	CIS 5: B Address: 0x64BC

4715	Gray Balance Adj; Factory DFU
	These SP codes display the RGB adjustments done by the manufacturer for each of the five CIS elements. Display: Hexadecimal [-1024 to 1023 / 0 / 1]
1	CIS 1: G
2	CIS 1: R
3	CIS 1: B
4	CIS 2: G
5	CIS 2: R
6	CIS 2: B
7	CIS 3: G
8	CIS 3: R
9	CIS 3: B
10	CIS 4: G

11	CIS 4: R
12	CIS 4: B
13	CIS 5: G
14	CIS 5: R
15	CIS 5: B

4718	Gray Balance Data: Present DFU
	Stores and displays the present (factory shipping) grayscale balance adjustment read for each CIS unit. [0 to 255 / 0 / 1]
1	CIS 1: G
2	CIS 1: R
3	CIS 1: B
4	CIS 2: G
5	CIS 2: R
6	CIS 2: B
7	CIS 3: G
8	CIS 3: R
9	CIS 3: B
10	CIS 4: G
11	CIS 4: R
12	CIS 4: B
13	CIS 5: G
14	CIS 5: R
15	CIS 5: B

4719	Gray Balance Data: Factory DFU
------	---------------------------------------

	<p>This SP stores and displays the B adjustment value for each grayscale balance adjustment done for each CIS unit by the manufacturer.</p> <p>[0 to 255 / 0 / 1]</p>
1	CIS 1: G
2	CIS 1: R
3	CIS 1: B
4	CIS 2: G
5	CIS 2: R
6	CIS 2: B
7	CIS 3: G
8	CIS 3: R
9	CIS 3: B
10	CIS 4: G
11	CIS 4: R
12	CIS 4: B
13	CIS 5: G
14	CIS 5: R
15	CIS 5: B

4724	<p>Black Level Data DFU</p>
	<p>Displays the minimum value for black level correction for each CIS unit after black level is adjusted after power on.</p> <p>[0 to 1023 / 0 / 1]</p>
1	CIS 1
2	CIS 2
3	CIS 3
4	CIS 4

5	CIS 5
---	-------

4732	CIS Gain Adjustment DFU
	<p>Displays the gain value of analog ASIC (LM98714) of each CIS unit after white level is adjusted when the machine is powered on.</p> <ul style="list-style-type: none"> • The peak value for standard white plate reading (the shading data peak value) is set to 880 ± 20 digits by white level adjustment. • The setting can be written with this SP and the set value is reflected in the analog ASIC (LM98174) of the CIS when an original is scanned. <p>[0 to 255 / 84 / 1]</p>
1	CIS 1
2	CIS 2
3	CIS 3
4	CIS 4
5	CIS 5

4733	LED Adjustment DFU
	<p>The following SP codes displays LAMPR OFF setting of each CIS element analog ASIC (LM98714) after RGB white level adjustment when the machine is powered on.</p> <ul style="list-style-type: none"> • The peak value for standard white plate reading (the shading data peak value) is set to 880 ± 20 digits by Red white level adjustment. • The setting can be written with this SP and the set value is reflected in the analog ASIC (LM98174) of the CIS when an original is scanned. <p>[23 to 523 / 304 / 1]</p>
1	CIS 1 R
2	CIS 2 R
3	CIS 3 R
4	CIS 4 R
5	CIS 5 R
6	CIS 1 G

7	CIS 2 G
8	CIS 3 G
9	CIS 4 G
10	CIS 5 G
11	CIS 1 B
12	CIS 2 B
13	CIS 3 B
14	CIS 4 B
15	CIS 5 B

4735	White Level Peak Data DFU
	Displays the shading peak data after to confirm the data of the last white level adjustment after white level has been adjusted for RGB for each of the five CIS units. [0 to 1023 / 0 / 1]
1	CIS 1 B
2	CIS 1 R
3	CIS 1 G
4	CIS 2 B
5	CIS 2 R
6	CIS 2 G
7	CIS 3 B
8	CIS 3 R
9	CIS 3 G
10	CIS 4 B
11	CIS 4 R
12	CIS 4 G
13	CIS 5 B

14	CIS 5 R
15	CIS 5 G

4744	Gray Balance Error Flag			
	This SP displays errors that occur during gray balance adjustment. [0 to 32768 / 0 / 1]			
		Error		Error
	1	GB_ERR_CIS1_G (LSB)	8	GB_ERR_CIS3_B
	2	GB_ERR_CIS1_R	9	GB_ERR_CIS4_G
	3	GB_ERR_CIS1_B	10	0 GB_ERR_CIS4_R
	4	GB_ERR_CIS2_G	11	GB_ERR_CIS4_B
	5	GB_ERR_CIS2_R	12	2 GB_ERR_CIS5_G
	6	GB_ERR_CIS2_B	13	3 GB_ERR_CIS5_R
	7	GB_ERR_CIS3_G	14	4 GB_ERR_CIS5_B (MSB

4745	CIS Adjustment Error Flag			
	White Level			
	1	White Level CIS 1		
	2	White Level CIS 2		
	3	White Level CIS 3		
	4	White Level CIS 4		
	5	White Level CIS 5		
	Displays AGC adjustment or error flags after white level adjustment of each of the five CIS units after the CIS unit self-adjusts when the machine is powered on. 0: Normal 1: Abnormal			
	Bit	(7) 0000 0000 (0)		
	7	0		

	6	0
	5	Green on-time control abnormal.
	4	0
	3	Red on-time control abnormal.
	2	0
	1	Blue on-time control abnormal
	0	0
	Black Level	
6	Black Level: CIS 1	
7	Black Level: CIS 2	
8	Black Level: CIS 3	
9	Black Level: CIS 4	
10	Black Level: CIS 5	
	<p>Displays AGC adjustment or error flags after black level adjustment of each of the five CIS units after the CIS unit self-adjusts when the machine is powered on.</p> <p>0: Normal 1: Abnormal</p>	
	Bit	(7) 0000 0000 (0)
	7	0
	6	0
	5	0
	4	0
	3	0
	2	0
	1	0
	0	Black level adjustment did not reach target values within 10 attempts.

4746	SIB Hard Error Flag	
	PLL lock of Volans DCM input on the SIF (abnormality) 0: Normal 1: Abnormal	
	Bit	(7) 0000 0000 (0)
	7	0
	6	0
	5	0
	4	DCM lock status display for CIS5
	3	DCM lock status display for CIS4
	2	DCM lock status display for CIS3
	1	DCM lock status display for CIS2
	0	DCM lock status display for CIS1

4750	CIS Output Mode Set	
	This SP sets the CIS output mode. [0 to 6 / 0 / 1] 0: Normal output 1: Black shading data output 2: White shading data output 3: Black raw data output 4: White raw data output 5: Raw data output 6: Test pattern output	

4751	Imaging Unit Test Pattern	
	This SP sets the mode for the CIS test pattern. [0 to 5 / 1 / 1]	
	0	Black coverage 0x000 fixed

1	Main Scan 1-Pitch Gradation (1 Step/1 Pixel 0x000 0x001 0x002, 0x3FE 0x3FF 0x000 0x001)
2	Main Scan 4-Pitch gradation (4-Step/1 pixel 0x000 > 0x004 0x008 0x3F8 0x3FC 0x000 0x001)
3	Main Scan 0, 1023 Alternate Pattern 1 (0x000 0x03FF 0x000 0x03FF)
4	Main Scan 0, 1023 Alternate Pattern 2 (0x000 0x03FF 0x000 0x03FF)
5	White Coverage 0x3FF Fixed

4762	CIS Gain Adjustment Normally DFU
	Displays the gain value of analog ASIC (LM98714) of each CIS unit after white level is adjusted when the machine is powered on. The peak value for standard white plate reading (the shading data peak value) is set to 880 +/-20 digits by white level adjustment.
1	CIS 1
2	CIS 2
3	CIS 3
4	CIS 4
5	CIS 5

4763	LED Adjustment Normally DFU
	Displays LAMPR OFF setting of the CIS1 analog ASIC (LM98714) after RGB white level adjustment when the machine is powered on. The peak value for standard white plate reading (the shading data peak value) is set to 880 +/-20 digits by Red white level adjustment. The adjusted value is used as the default setting for the white level adjustment done for Red when the machine is powered on. [23 to 523 / 304 / 1]
1	CIS 1 R
2	CIS 2 R
3	CIS 3 R
4	CIS 4 R
5	CIS 5 R

6	CIS 1 G
7	CIS 2 G
8	CIS 3 G
9	CIS 4 G
10	CIS 5 G
11	CIS 1 B
12	CIS 2 B
13	CIS 3 B
14	CIS 4 B
15	CIS 5 B

4781	Gain Adjustment at Factory DFU
1	CIS 1
2	CIS 2
3	CIS 3
4	CIS 4
5	CIS 5
	LED Adjustment at Factory
6	CIS 1 R
7	CIS 2 R
8	CIS 3 R
9	CIS 4 R
10	CIS 5 G
11	CIS 1 G
12	CIS 2 G
13	CIS 3 G

14	CIS 4 G
15	CIS 5 G
16	CIS 1 B
17	CIS 2 B
18	CIS 3 B
19	CIS 4 B
20	CIS 5 B

4820	Lamp Detection	
	Displays lamp error flags for the five CIS components. 0: Normal 1: Abnormal	
	Bit	(7) 0000 0000 (0)
	0	CIS 1 lamp
	1	CIS 2 lamp
	2	CIS 3 lamp
	3	CIS 4 lamp
	4	CIS 5 lamp

4901	Scan Correction DFU	
1	Shading Correction: AREF Setting	
	Displays the AREF value used to supplement shading processing. [-512 to 511 / 0 / 1]	
2	Shading Correction: Target Level Setting	
	This SP sets the correction coefficient used to achieve the optimum adjustment for shading correction in scanned images. [0 to 1023 / 800 / 1]	
3	AREF Correction Value	

	<p>This SP displays and sets the AEF value used to obtain the optimum results for shading correction in scanned images.</p> <p>[-63 to 63 / 25 / 1]</p>
4	<p>Low Limit</p>
	<p>Provides the boundary values to the digital A/E processing address for the scanned image data.</p> <p>[0 to 255 / 82 / 1]</p>
5	<p>Start Point</p>
	<p>Defines the start position for digital A/E processing of the scanned image data.</p> <p>[0 to 25.5 / 3 / 0.1 mm]</p>
6	<p>Left Start Point</p>
	<p>This SP sets the start position for digital AE processing P-Wind for scanned image data in the main scan direction (from the center of the original as a reference point), starting at the left side of the original.</p> <p>[0 to 512/60/0.1 mm]</p>
7	<p>Right Start Point</p>
	<p>This SP sets the start position for digital AE processing P-Wind for scanned image data in the main scan direction (from the center of the original as a reference point), stopping at the right side of the original.</p> <p>[0 to 512/60/0.1 mm]</p>
8	<p>Shading Correction Target Level Setting</p>
	<p>Sets the target level for shading correction.</p> <p>[0 to 1023 / 360 / 1]</p>
4903	<p>Image Quality Adjustment</p>
	<p>Use this if density is not equal in shaded areas of the copy. The change from high to low density areas in shaded areas must be smooth. Do these SP adjustments if you see "false outlines" in shaded areas of the copy.</p> <ul style="list-style-type: none"> • To increase the effect, use a higher setting. • To decrease the effect, use a lower setting. • The higher settings can make text look better, but can also decrease the quality of the image.

1	<p>Independent Dot Erase: Text</p> <p>Sets the independent dot erase mode for scanning Text Mode.</p> <p>[0 to 7 / 4 / 1]</p> <p>0 (Weakest), 4 (Medium: Default), 7 (Strongest)</p>
2	<p>Independent Dot Erase : Generation</p> <p>Sets the independent dot erase mode for scanning Generation Mode.</p> <p>[0 to 7 / 4 / 1]</p> <p>0 (Weakest), 4 (Medium: Default), 7 (Strongest)</p>
3	<p>Independent Dot Erase : Drawing</p> <p>Sets the independent dot erase mode for scanning independent dot erase in Line Drawing Mode.</p> <p>[0 to 7 / 0 / 1]</p> <p>0 (Weakest), 4 (Medium: Default), 7 (Strongest)</p>
11	<p>Line Width Corr : Text: Mode Select</p> <p>Sets the strength of line correction effect for Text Mode.</p> <p>[0 to 8 / 3 / 1]</p> <p>0 (Weakest)</p> <p>3: Default</p> <p>4 (Medium)</p> <p>8 (Strongest)</p>
12	<p>Line Width Corr : Text: Main Scan</p> <p>Sets the strength of line correction in the main scan direction for Text Mode</p> <p>[0 to 2 / 1 / 1]</p> <p>0: No line width correction</p> <p>1: Line width and shaded area correction</p> <p>2: Line width correction only</p>
13	<p>Line Width Corr : Text: Sub Scan</p> <p>Sets the strength of line correction effect for Text Mode in the sub scan direction.</p> <p>0 to 1 / 1 / 1]</p> <p>0: No line width correction</p> <p>1: Line width correction</p>

14	<p>Line Width Corr : Generation: Mode Select</p> <p>Sets the strength of line correction effect for Generation Mode</p> <p>[0 to 8 / 3 / 1]</p> <p>0 (Weakest)</p> <p>3: Default</p> <p>4 (Medium)</p> <p>8 (Strongest)</p>
15	<p>Line Width Corr : Generation: Main Scan</p> <p>Sets the strength of line correction in the main scan direction for Generation Mode.</p> <p>[0 to 2 / 1 / 1]</p> <p>0:No line width correction</p> <p>1:Line width and shaded area correction</p> <p>2: Line width correction</p>
16	<p>Line Width Corr : Generation: Sub Scan</p> <p>Sets the strength of line correction effect for Generation Mode.</p> <p>[0 to 1 / 1 / 1]</p> <p>0: No line width correction</p> <p>1: Line width correction</p>
17	<p>Line Width Corr : Drawing: Mode Select</p> <p>Sets the strength of line correction effect for Drawing Mode.</p> <p>[0 to 8 / 3 / 1]</p> <p>0 (Weakest)</p> <p>3: Default</p> <p>4 (Medium)</p> <p>8 (Strongest)</p>
18	<p>Line Width Corr : Drawing: Main Scan</p> <p>Sets the strength of line correction in the main scan direction for Drawing Mode.</p> <p>[0 to 2 / 1 / 1]</p> <p>0: No line width correction</p> <p>1:Line width and shaded area correction</p> <p>2: Line width correction</p>

19	<p>Line Width Corr : Drawing: Sub Scan</p> <p>Sets the strength of line correction effect for Drawing Mode in the sub scan direction.</p> <p>[0 to 1 / 1 / 1]</p> <p>0: No line width correction</p> <p>1: Line width correction</p>
----	--

4904	<p>Image Process Setting DFU</p> <p>These SP's set up image processing for each mode.</p> <ul style="list-style-type: none"> • The smoothing level filters remove false outlines. • Line width correction corrects thin vertical lines.
1	<p>Smoothing Filter Level: Text</p> <p>Sets the outline erase function for copy Text Mode.</p> <p>[0 to 3 / 1 / 1]</p> <p>0 (Weakest), 3 (Strongest)</p>
2	<p>Smoothing Filter Level: Photo</p> <p>Sets the outline erase function for copy Photo Mode..</p> <p>[1 to 3/2/1]</p> <p>0 (Weakest), 3 (Strongest)</p>
3	<p>Smoothing Filter Level: Text/Photo</p> <p>Sets the outline erase function for copy Text/Photo Mode.</p> <p>[1 to 3/1/1]</p> <p>0 (Weakest), 3 (Strongest)</p>
4	<p>Smoothing Filter Level: Generation</p> <p>Sets the outline erase function for copy Generation Mode.</p> <p>[1 to 3/1/1]</p> <p>0 (Weakest), 3 (Strongest)</p>
5	<p>Smoothing Filter Level: Drawing</p> <p>Sets the outline erase function for copy Drawing Mode.</p> <p>[1 to 3/1/1]</p> <p>0 (Weakest), 3 (Strongest)</p>

6	Smoothing Filter Level: Patched Original
	Sets the outline erase function for Patched Original Mode. [1 to 3/1/1] 0 (Weakest), 3 (Strongest)
7	Smoothing Filter Level: Blue Line
	Sets the outline erase function for copy Blue Line Mode. [1 to 3/1/1] 0 (Weakest), 3 (Strongest)

4905	Gray Scale Processing
	Selects the type of dithering done in Photo mode. [0 to 255/0/1] 0: 2-value dithering 8x8 1: 2-value dithering 16x16 2: 2-value dithering 16x16

4918	Manual Gamma DFU
	Adjusts the offset data of printer gamma for yellow in Photo mode.

4961	Original Adjustment
1	Synchro-cut Adjustment 210mm
	Adjusts the synchro-cut position. [-9.9 to +9.9/0.0/0.1 mm] Use the 210-mm position in the sample to check the difference. This setting is used to calculate the motor clock count for adjusting the difference.
2	Synchro-cut Adjustment 1000mm
	Adjusts the synchro-cut position. [-9.9 to +9.9/0.0/0.1 mm step] Use the 1000-mm position in the sample to check the difference. This setting is used to calculate the motor clock count for adjusting the difference.

3	Original Length Display
	Displays the original length.
4965	Scan Speed Switch Correction
	<p>The original feed roller tries to adjust for slippage of the feed rollers to allow the machine measure the length of the original accurately. The diameter of the feed roller (32 ± 0.05) differs slightly from the diameter of the exit roller (32 ± 0.05). The slightly higher speed of the exit roller could cause the original to feed faster than usual, and cause distortion of the image at the joints of the CIS. Use this SP to lower the speed of the original to correct this problem if image distortion at the CIS joints occurs.</p> <p>When to Use This SP</p> <ul style="list-style-type: none"> • Adjust this SP if you see image distortion after replacing the original feed roller or exit roller. • You may also need to adjust this SP if you see image distortion after CIS adjustments with SP4972. <p>For more about how to use SP4965, please refer to "Replacements and Adjustments" > "Scanner", "Original Feed Unit Rollers".</p> <p>[-1.0 to 0.0 / -0.2 / 0.1]</p>
1	Leading Edge
	<p>The original feed roller tries to adjust for slippage of the feed rollers to allow the machine measure the length of the original accurately. The diameter of the feed roller (32 ± 0.05) differs slightly from the diameter of the exit roller (32 ± 0.05). The slightly higher speed of the exit roller could cause the original to feed faster than usual, and cause distortion of the image at the joints of the CIS. Use this SP to lower the speed of the original to correct this problem if image distortion at the CIS joints occurs.</p> <p>When to Use This SP</p> <ul style="list-style-type: none"> • Adjust this SP if you see image distortion after replacing the original feed roller or exit roller. • You may also need to adjust this SP if you see image distortion after CIS adjustments with SP4972. <p>[-1 to 0 / -0.2 / 0.1%]</p>
2	Position to Switch
	<p>Sets the original position where the motor speed adjustment for SP4965-1 starts.</p> <p>[0 to 200 / 112 / 1 mm]</p>

3	Trailing Edge
	Specifies the point 14.5 mm past the original set sensor where the speed of the original exit motor should be adjusted. [-1 to 1 / 0 / 0.1%]

4966	Output Scanner Motor Speed
	This SP sets the speed of the motor when it is tested with SP5804-201 [8 to 320 / 80 / 0.1 mm/sec.]

4972	Scan Correction	
	These SP's correct the alignment the image scanned by the CIS. For more, see SP Adjustments.	
1	CIS1-2 Main Scan	[0 to 656 / 358 / 0]
2	CIS2 Main Scan	DFU
3	CIS2-3 Main Scan	[0 to 656 / 424 / 0]
4	CIS3-4 Main Scan	[0 to 656 / 425 / 0]
5	CIS4-5 Main Scan	[0 to 656 / 426 / 0]
6	CIS1-2 Sub Scan	[0 to 2815 / 620 / 1]
7	CIS2 Sub Scan	DFU
8	CIS2-3 Sub Scan	[0 to 2815 / 645 / 1]
9	CIS3-4 Sub Scan	[0 to 255 / 26 / 1]
10	CIS4-5 Sub Scan	[0 to 2815 / 643 / 1]

4973	Scan Correction
	This SP turns on image adjustment feature that corrects slight misalignment of the image at the joints of the CIS elements. [0 to 2 / 2 / 1] 0: No adjustment 1: Simple adjustment at joints 2: Gradation adjustment at joint

4975	Prevent Original Falling
	<p>This SP determines whether the machine stops and holds the edge of the original after the original is fed so that it does not fall.</p> <p>[0 to 1/0/1]</p> <p>0: Disable, 1: Enable</p>
4979	Scan Correction DFU
4991	IPU Image Data Path DFU
1	<p>RGB Frame Memory (Change 1)</p> <p>[0 to 255/0/1]</p> <p>0: Dot correction module</p> <p>1: Gray create module</p> <p>2: Scanner gamma module</p> <p>3: Registration adjustment & mirroring module</p> <p>4: Main scan magnification & left shift/right shift module</p> <p>5: Multi-rate_filter module</p> <p>6: Multi-rate_line correction module</p> <p>7: Multi-rate_independent dot erase module</p>
2	<p>RGB Frame Memory (Change 2)</p> <p>0: Multi-rate gamma conversion module</p> <p>1: Main scan fine adjust/simple magnification module</p> <p>2: Density gamma module</p> <p>3: Gradation processing (M-to-P) module</p> <p>4: Reserved</p> <p>5: Reserved</p> <p>6: Reserved</p> <p>7: Reserved</p>

SP5-xxx Mode

5024	mm/inch Display Selection	CTL
	0: Europe/Asia (mm), 1: North America (inch)	

5045	Accounting Counter	CTL	
	These SP codes setting the method and units for counting.		
1	Counter Method		
	Selects the counting method [0 to 1/0/1] 0: Development counter (black prints) 1: Paper counter. Shows the total page counts		
2	Counter Unit		
	[0 to 8/ 0 / 1] 0: Models -21/-27, 2: Model -17		
	0	Meters	
	1	Yards	
	2	Feet	
	3	Meters ²	
	4	Yards ²	
	5	Feet ²	
	6	A3=1	Surface area count
	7	0.1 meters	Only for counting devices by user.
	8	01. yards	

5055	Display IP Address	CTL
	<p>Switches the banner display of the IP address off and on. (Default: * Off)</p> <p>[OFF] ON</p> <p>For example, if this SP is switched on, the IP address will be displayed below "Ready" while the printer is in standby mode:</p> <p>Ready</p> <p>169.254.187.055</p>	
5056	Coverage Counter Display	CTL
	<p>This SP switches the counter list for the system administrator on/off.</p> <p>[0 to 1/0/1]</p> <p>0: On</p> <p>1: Off</p>	
5071	Set Bypass Paper Size Display	CTL
	<p>This SP determines whether long paper can be fed from the bypass tray.</p> <p>Note: Even if "1" is selected only paper up to 432 mm can be used.</p> <p>[0 to 1 / 0 / 1]</p> <p>0: Disable</p> <p>1: Enable</p>	
5101	Panel Off Level	
	<p>This SP sets the level of the low power mode, where the operation panel will switch off after the machine enters low power mode.</p> <p>[0 to 3/3/1]</p> <p>0: 195 degrees</p> <p>1: 180 degrees</p> <p>2: 170 degrees</p> <p>3: 155 degrees</p>	
5113	Optional Counter Type	CTL

1	Default Optional Counter Type
	<p>[0 to 12/0/1]</p> <p>Selects the type of counter:</p> <p>0: None</p> <p>1: Key Card (RK3, 4) Japan Only</p> <p>2: Key Card Down</p> <p>3: Pre-paid Card</p> <p>4: Coin Rack</p> <p>5: MF Key Card</p> <p>11: Exp Key Card (Add)</p> <p>12: Exp Key Card (Deduct)</p>
2	External Optional Counter Type
	<p>Enables the SDK application. This lets you select a number for the external device for user access control.</p> <p>Note: "SDK" refers to software on an SD card.</p> <p>[0 to 3/0/1]</p> <p>0: None</p> <p>1: Expansion Device 1</p> <p>2: Expansion Device 2</p> <p>3: Expansion Device 3</p>

5114	Optional Counter I/F	CTL
	<p>This SP code enables the interface for an optional counting device.</p> <p>[0 to 8/0/1]</p> <p>Important Note: Only settings that can be enabled for machines outside Japan are listed here.</p> <p>0: Disabled</p> <p>1: Key Cards (RK2, 3, 4)</p> <p>2: Decrementing keycard</p> <p>11: Incrementing key cards for use outside Japan</p> <p>12: Decrementing key cards for use outside Japan</p>	

5118	Disable Copying	CTL
<p>Temporarily denies access to the machine.</p> <p>[0 to 1/0/1]</p> <p>0: Release for normal operation</p> <p>1: Prohibit access to machine</p>		
5120	Mode Clear Count Removal	CTL
<p>For a machine that has a counting device, this SP sets the next action when a copy job stops because the card is removed, the card is expired, or if the paper supply runs out. Japan Only</p> <p>[0 to 2/0/1 step]</p> <p>0: Yes</p> <p>1: Stand-by</p> <p>2: No</p>		
5121	Counter Up Timing	CTL
<p>Determines whether the optional key counter counts up at paper feed-in or at paper exit.</p> <p>[0 to 1/1/1]</p> <p>0: Feed count</p> <p>1: No feed count</p>		
5127	APS Off Mode	CTL
<p>This SP can be used to switch APS (Auto Paper Select) off while a coin lock or pre-paid key card device is connected to the machine.</p> <p>[0 to 1/0/1]</p> <p>0: On</p> <p>1: Off</p>		
5162	App. Switch Method	CTL
<p>Determines if the application screen changes with a hardware switch or a software switch.</p> <p>[0 to 1/0/1]</p> <p>0: Soft Key Set</p> <p>1: Hard Key Set</p>		

5169	CE Login	CTL
	<p>This SP enables and disables the CE log in mode. With this SP enabled, the machine is in the CE (Customer Engineer/Service Technician) login mode.</p> <p>In the CE login mode:</p> <ul style="list-style-type: none"> The machine power can be turned off and on in the SP mode, and it will remain in the SP mode after power is restored. This SP is automatically reset to "0" (disabled) after the service technician closes the SP mode with the [Exit] soft button or after the log out timer expires. <p>Note: The Auto Logout Timer is in the "System Settings" of User Tools.</p> <p>[0 to 1/0/1]</p> <p>0: Disable, 1: Enable</p> <p>0: CE login mode disabled.</p> <p>1: CE login mode enabled.</p>	
5180	Charge Counter Method Japan Only	CTL
	<p>This SP codes sets the charge counter method.</p> <p>[0 to 1/0/1]</p> <p>0: Count number of sheets by paper size</p> <p>1: Count frequency by paper size</p>	
5188	Copy NV Version DFU	CTL
	<p>This SP displays the NVRAM version to determine whether the NVRAM has been initialized. Used during debugging.</p>	
5191	Mode Set DFU	CTL
	<p>This SP switches the STR mode off and on. The STR (Suspend to RAM) feature suspends the CPU controller, peripheral chips, PCI bus, etc. in the energy save mode (only the IC operates in energy save mode). This lowers the amount of power consumed in the energy save mode and enhances energy saving, compared to the Engine OFF mode (AOF mode) of the previous machine.</p> <p>[0 to 1 / 1 / 1] 1: ON, 0: OFF</p>	
5195	Limitless Switch	CTL

	<p>This SP selects the paper feed mode by switching between "productivity priority" (0) and "tray priority" (1). This SP operates only if the operator has selected "Auto Paper Select".</p> <p>[0 to 1 / 0 / 1]</p> <p>0: Productivity priority. Switches from the current feed tray to the priority tray as soon as the machine detects the priority tray, even if paper still remains in the current feed tray.</p> <p>1: Tray priority. Switches the feed tray only after the paper in the tray current tray runs out of paper.</p>
--	---

5199	Paper Exit After Staple End	CTL
	<p>This SP determines whether a machine that normally cannot continue to output paper if staple supply runs can continue to operate.</p> <p>[0 to 1 / 0 / 1]</p> <p>0: OFF. Paper cannot exit if no staples are available.</p> <p>1: ON. Paper can exit with no staples.</p>	

	Set Time	CTL
5302	<p>Sets the time clock for the local time. This setting is done at the factory before delivery. The setting is GMT expressed in minutes.</p> <p>[-1440 to 1440/1 min.]</p> <p>AS: +480 (Hong Kong)</p> <p>CH: +480 (Peking)</p> <p>EU: +60 (Paris)</p> <p>JA: +540 (Tokyo)</p> <p>KO: +540 (Korea)</p> <p>NA: -300 (NY)</p> <p>TW: +480 (Taipei)</p>	

	Auto Off Setting	CTL
5305	<p>This SP prevents the user from easily disabling the auto off timer. This is done to conform with international Energy Star standards that specifically state that the user shall not be able to easily switch off the auto off feature.</p> <p>[0 to 1 / 0 / 1]</p> <p>0: On (Auto Off cannot be released)</p> <p>1: Off (Auto Off can be released)</p>	

5307	Summer Time		CTL
	<p>Lets you set the machine to adjust its date and time automatically with the change to Daylight Savings time in the spring, and back to normal time in the fall. This SP lets you set these items:</p> <ul style="list-style-type: none"> • Day and time to go forward automatically in April • Day and time to go back automatically in October • Set the length of time to go forward and back automatically • The settings for 2 and 3 are done with 8-digit numbers 		
	Digits	Meaning	
	1st, 2nd	Month. 4: April, 10: October (for months 1 to 9, the first digit of 0 cannot be input, so the eight-digit setting for 2 or 3 becomes a seven-digit setting)	
	3rd	Day of the week. 0: Sunday, 1: Monday	
	4th	The number of the week for the day selected at the 3rd digit. If "0" is selected for "Sunday", for example, and the selected Sunday is the start of the 2nd week, then input a "2" for this digit.	
	5th, 6th	The time when the change occurs (24-hour as hex code). Example: 00:00 (Midnight) = 00, 01:00 (1 a.m.) = 01, and so on.	
	7th	The number of hours to change the time. 1 hour: 1	
	8th	If the time change is not a whole number (1.5 hours for example), digit 8 should be 3 (30 minutes).	
		Setting	
	1	Enables/disables the settings for 2 and 3. 0: Disable 1: Enable	
	3	Rule Set (Start)	
		The start of summer time.	
	4	Rule Set (End)	
		The end of summer time.	

5401	Access Control DFU	CTL
------	---------------------------	-----

	These SP's store settings that limit uses access to SDK (Software Development Kit) application data.	
103	Default Document ACL	
104	Authentication Time	
	This SP sets the length of time allowed for authentication. [1 to 255 / 0 / 1] (0 = 60 sec. standard)	
162	Extend Certification	
200	SDK1 Unique ID	"SDK" is the "Software Development Kit". This data can be converted from SAS (VAS) when installed or uninstalled. DFU
201	SDK1 Certification Method	
210	SDK2 Unique ID	
211	SDK2 Certification Method	
220	SDK3 Unique ID	
221	SDK3 Certification Method	
230	SDK Certification Device	
240	Detail Options	

5404	User Code Count Clear	CTL
	Clears the counts for the user codes assigned by the key operator to restrict the use of the machine. Press [Execute] to clear.	

5411	LDAP Certification	CTL
	This SP sets up LDAP certification.	
4	Easy Certification	
	When set to "1" does easy authentication according to the SP setting. [0 to 1 / 1 / 1]	
5	Password Null Permit	

	<p>This SP is referenced only when SP5411-4 is set to "1" (On).</p> <p>[0 to 1/1/1]</p> <p>0: Password NULL not permitted.</p> <p>1: Password NULL permitted</p>
6	Detail Options
	(7) 0000 0000 (0)

5413	Lockout Setting	CTL
1	<p>Lockout On/Off</p> <p>Switches on/off the lock on the local address book account.</p> <p>[0 to 1/0/1]</p> <p>0: Off</p> <p>1: On</p>	
2	<p>Lockout Threshold</p> <p>Sets a limit on the frequency of lockouts for account lockouts.</p> <p>[1 to 10/5/1]</p>	
3	<p>Cancellation On/Off</p> <p>Determines whether the system waits the prescribed time for input of a correct user ID and password after an account lockout has occurred.</p> <p>[0 to 1/0/1]</p> <p>0: Off (no wait time, lockout not cancelled)</p> <p>1: On (system waits, cancels lockout if correct user ID and password are entered.)</p>	
4	<p>Cancellation Time</p> <p>Determines the length of time that the system waits for correct input of the user ID and password after a lockout has occurred. This setting is used only if SP5413-3 is set to "1" (on).</p> <p>[1 to 999/60/1 min.]</p>	

5414	Access Mitigation
1	Mitigation On/Off

	Switches on/off masking of continuously used IDs and passwords that are identical. [0 to 1/0/1] 0: Off 1: On
2	Mitigation Time
	Sets the length of time for excluding continuous access for identical user IDs and passwords. [0 to 60/15/1 min.]

5415	Password Attack
1	Permissible Number
	Sets the number of attempts to attack the system with random passwords to gain illegal access to the system. [0 to 100/30/1 attempt]
2	Detect Time
	Sets the time limit to stop a password attack once such an attack has been detected. [1 to 10/5/1 sec.]

5416	Access Information
1	Access User Max Number
	Limits the number of users used by the access exclusion and password attack detection functions. [50 to 200/200/1 users]
2	Access Password Max Number
	Limits the number of passwords used by the access exclusion and password attack detection functions. [50 to 200/200/1 passwords]
3	Monitor Interval
	Sets the processing time interval for referencing user ID and password information. [1 to 10/3/1 sec.]

5417	Access Attack
1	Access Permissible Number
	Sets a limit on access attempts when an excessive number of attempts are detected for MFP features. [0 to 500/100/1]
2	Attack Detect Time
	Sets the length of time for monitoring the frequency of access to MFP features. [10 to 30/10/1 sec.]
3	Productivity Fall Wait
	Sets the wait time to slow down the speed of certification when an excessive number of access attempts have been detected. [0 to 9/3/1 sec.]
4	Attack Max Number
	Sets a limit on the number of requests received for certification in order to slow down the certification speed when an excessive number of access attempts have been detected. [50 to 200/200/1 attempt]

5420	User Authentication
	These settings should be done with the System Administrator. Note: These functions are enabled only after the user access feature has been enabled.
1	Copy
	Determines whether certification is required before a user can use the copy applications. [0 to 1/0/1] 0: On 1: Off 2: Color Security Setting

11	<p>Document Server</p> <p>Determines whether certification is required before a user can use the document server.</p> <p>[0 to 1/0/1]</p> <p>0: On</p> <p>1: Off</p>	
31	<p>Scanner</p> <p>Determines whether certification is required before a user can use the scan applications.</p> <p>[0 to 1/0/1]</p> <p>0: On</p> <p>1: Off</p>	
41	<p>Printer</p> <p>Determines whether certification is required before a user can use the printer applications.</p> <p>[0 to 1/0/1]</p> <p>0: On</p> <p>1: Off</p>	
51	SDK1	<p>[0 or 1 / 0 / 1] 0: ON. 1: OFF</p> <p>Determines whether certification is required before a user can use the SDK application.</p>
61	SDK2	
71	SDK3	

5430	Auth Dialog Message Change	CTL
1	Message Change On/Off	
	[0 to 1 / 0 / 1]	
2	Message Text Download	
	Touch [EXECUTE].	
3	Message Text ID	

5431	External Auth User Preset	CTL
10	Tag	
11	Entry	

12	Group
20	Mail
32	Folder
33	Protect Code
34	SMTP Auth
35	LDAP Auth
36	SMB FTP Folder Auth
37	Acnt Acl
38	Document Acl
40	Cert Crypt

5481	Authentication Error Code
	These SP codes determine how the authentication failures are displayed.
1	System Log Disp
	<p>Determines whether an error code appears in the system log after a user authentication failure occurs.</p> <p>[0 to 1/0/1]</p> <p>0: Off</p> <p>1: On</p>
2	Panel Disp
	<p>Determines whether an error code appears on the operation panel after a user authentication failure occurs.</p> <p>[0 to 1/1/1]</p> <p>1: On</p> <p>0: Off</p>

5490	MF Keycard Japan Only	CTL
	Sets up operation of the machine with a keycard. [0 to 1/0/1] 0: Disabled. Cancels operation if no code is input. 1: Enabled. Allows operation if another code is input and decrements the counter once for use of the entered code.	

5501	PM Alarm	CTL
1	PM Alarm Level	
	[0 to 9999 / 0 / 1 step] 0: Alarm off 1 to 9999: Alarm goes off when Value (1 to 9999) > PM counter	
2	Original Count Alarm	
	[0 to 1/0/1] 0: No alarm sounds 1: Alarm sounds after the number of originals passing through the ARDF > 10,000	

5504	Jam Alarm	CTL
	Sets the alarm to sound for the specified jam level (document misfeeds are not included). [0 to 3 / 3 / 1 step] 0: Zero (Off) 1: Low (2.5K jams) 2: Medium (3K jams) 3: High (6K jams)	

5505	Error Alarm	CTL
	Sets the error alarm level. [0 to 255 / 1 / 1 Step] Note: 1 Step is 100 m	

5507	Supply Alarm	CTL
------	--------------	-----

1	Paper Supply Alarm	
	<p>Switches the control call on/off for the paper supply.</p> <p>[0 to 1/0/1]</p> <p>0: Off, 1: On</p> <p>0: No alarm.</p> <p>1: Sets the alarm to sound for the specified number transfer sheets for each paper size (A3, A4, B4, B5, DLT, LG, LT, HLT)</p>	
3	Toner Supply Alarm	
	<p>Switches the control call on/off for the toner end.</p> <p>[0 to 1/0/1]</p> <p>0: Off, 1: On</p> <p>If you select "1" the alarm will sound when the main machine detects toner end.</p>	
80	Toner Call Timing	
	<p>This SP switches the toner supply call for @Remote.</p> <p>[0 to 1 / 0 / 1]</p> <p>0: Toner replacement. Triggers the alarm when toner should be replaced with new toner.</p> <p>1: Toner near-end. The alarm triggers at toner-end or toner near-end.</p>	
	Note: The "Interval nn" SP's below specify the paper control call interval for the referenced paper sizes.	
97	Interval: 841mm	[100 to 10000/300/1 Step]
98	Interval: 594mm	
99	Interval: 420mm	
100	Interval: 297mm	
101	Interval: 210mm	
106	Interval: 728mm	
107	Interval: 515mm	
108	Interval: 364mm	
109	Interval: 257mm	

128	Interval: Others	[250 to 10000/1000/1 Step]
132	Interval: A3	
133	Interval: A4	
141	Interval: B4	
160	Interval: DLT	
164	Interval: LG	
165	Interval: Foolschap	
166	Interval: LT	
175	Interval: 12x18	
225	Interval: 36inch	
226	Interval: 24inch	
227	Interval: 18inch	
228	Interval: 12inch	
229	Interval: 9inch	
234	Interval: 34inch	
235	Interval: 22inch	
236	Interval: 17inch	
237	Interval: 11inch	
238	Interval: 8.5inch	

5508	CC Call	CTL
1	Jam Remains	Enables/disables initiating a call. [0 to 1/1/1] [0 to 1/1] 0: Disable 1: Enable
2	Continuous Jams	
3	Continuous Door Open	
11	Jam Detection: Time Length	

	<p>Sets the length of time to determine the length of an unattended paper jam. [3 to 30/10/1] This setting is enabled only when SP5508-4 is enabled (set to 1).</p>
12	Jam Detection Continuous Count
	<p>Sets the number of continuous paper jams required to initiate a call. [2 to 10/5/1] This setting is enabled only when SP5508-4 is enabled (set to 1).</p>
13	Door Open: Time Length
	<p>Sets the length of time the remains opens to determine when to initiate a call. [3 to 30/10/1] This setting is enabled only when SP5508-4 is enabled (set to 1).</p>

	SC/Alarm Setting	CTL
5515	<p>Determines whether an SC call is issued when an SC error occurs while either CSS (Japan) or @Remote is enabled: [0 to 1/1/1] 1: An SC call is issued when an SC error occurs. 0: An SC call is not issued when an SC error occurs.</p>	
1	SC Call	
	<p>Determines whether an SC call is issued when an SC error occurs while either CSS or @Remote is enabled: [0 to 1/1/1] 1: An SC call is issued when an SC error occurs. 0: An SC call is not issued when an SC error occurs.</p>	
2	Service Parts Near End Call	
3	Service Parts End Call	
4	User Call	
6	Communication Test Call	
7	Machine Information Notice	
8	Alarm Notice	

10	Supply Automatic Ordering Call
11	Supply Management Report Call
12	Jam/Door Open Call

2

5801	Memory Clear
	Resets NVRAM data to the default settings. Before executing any of these SP's, print an SMC Report.
1	All Clear
	Initializes items 2 to 22 below.
2	Engine
	Initializes all registration settings for the engine and copy process settings.
3	SCS
	Initializes default system settings, SCS (System Control Service) settings, operation display coordinates, and ROM update information.
4	IMH Memory Clr
	Initializes the image file system. (IMH: Image Memory Handler)
5	MCS
	Initializes the automatic delete time setting for stored documents. (MCS: Memory Control Service)
6	Copier Application
	Initializes all main machine application settings.
8	Printer Application
	Initializes the printer defaults, programs registered, the printer SP bit switches, and the printer CSS counter.
9	Scanner Application
	Initializes the defaults for the scanner and all the scanner SP modes.
10	Web Service

	Deletes the Neffile (NFA) management files and thumbnails, and initializes the Job login ID. Neffiles: Jobs to be printed from the document server using a PC and the Desk Top Binder software
11	NCS
	Initializes the system defaults and intersection settings (IP addresses also), the Smart Net Monitor for Admin settings, Web Status Monitor settings, and the TELNET settings. (NCS: Network Control Service)
14	Clear DCS Setting
	Initializes the DCS (Delivery Control Service) settings.
15	Clear UCS Setting
	Initializes the UCS (User Information Control Service) settings.
16	MIRS Setting
	Initializes the MIRS (Machine Information Report Service) settings.
17	CCS
	Initializes the CCS (Certification and Charge-control Service) settings.
18	SRM Memory Clr
	Initializes information in non-volatile RAM.
19	LCS Memory Clr
	Initializes information in non-volatile RAM.
20	Web Uapli
	Initializes the web user application settings.
21	ECS
	Initializes the ECS settings.
22	Folder
	Initializes the folder settings.

5802	Printer Free Run
------	------------------

	Does a free run in the mode specified on the operation panel. Push On or Off to switch on or off.
--	--

2

5803	Input Check
	Displays the signals received from switches and sensors.
1	Roll Unit Open Sensor
2	Cutter Sensor
3	Roll Leading Edge Sensor
4	Roll Unit Sensor 1
5	Roll End Sensor 1
6	Roll End Sensor 1: White
7	Roll Unit: Sensor 2
8	Roll End Sensor 2
9	Roll End Sensor 2: White
10	Cassette Unit Sensor
11	Cassette Tray Set Sensor 1
12	Cassette 1 Feed Sensor
13	Paper End Sensor 1
14	Exit Fan Lock Sensor
15	Paper Set Sensor
16	Paper Registration Sensor
17	Paper Exit Sensor
18	Total Counter Set
19	Toner Overflow Sensor
20	Charge Corona Cleaner Motor Rotation Sensor
21	Clam Shell Open Sensor (Right) 24V

22	Clam Shell Open Sensor (Left) 5V
23	Exit Cover Open Sensor (Right) 24V
24	Exit Cover Open Sensor (Left) 5V
25	Fusing Unit Sensor
26	Toner Cover Open Sensor
27	Main Motor Lock Sensor
28	Drum Motor Lock Sensor
29	Fusing Motor Lock Sensor
30	Overheat Sensor
31	Zero Cross
32	DIP SW1
33	Key Card Set
34	Key Counter Set
35	Folder Connect Sensor
36	Model Detect
37	Copy Exit Switch
201	Original Width Sensor: A0
202	Original Width Sensor: A1
203	Original Width Sensor: A2
204	Original Width Sensor: A3
205	Original Width Sensor: B1
206	Original Width Sensor: B2
207	Original Width Sensor: B3
208	Original Width Sensor: B4
209	Original Width Sensor: 914 mm
210	Original Width Sensor: 30"

211	Original Set Sensor
212	Original Registration Sensor
213	Original Exit Sensor
214	Original Emergency Stop Sensor
215	Original Feed Unit Open Sensor

5804	Output Check
	Switches each electrical component to test its operation.
11	Roll Feed Motor: Forward
12	Roll Feed Motor: Reverse
15	1st Roll Feed Clutch
16	2nd Roll Feed Clutch
19	Cutter Motor
21	Cassette Feed Motor
25	Cassette Feed Clutch
32	Main Motor
33	Fusing Motor
34	Drum Motor
35	Registration Clutch
36	Paper Junction Gate Solenoid
37	Used Toner Motor
41	Charge Corona
42	Charge Grid: Image Area
43	Charge Grid: ID Sensor Pattern
44	Charge Corona/Grid: Image Area
45	Development Bias: Image Area

46	Development Bias: ID Sensor Pattern	
49	Separation Corona: Leading Edge	
50	Separation Corona	
52	Toner Supply Clutch	
53	Quenching Lamp	
54	Pick-off Pawl Solenoid	
55	ID Sensor LED	
66	Charge Corona Wire Cleaner Motor	
67	Recycle Counter	
68	Dehumidifier	
70	Transfer Corona: Leading Edge	
71	Transfer Corona: Pre-Leading Edge	
72	Transfer Corona	
73	Transfer Corona: Rear Edge	
74	Exit Fan	
201	Scanner Motor Off/On	
211	CIS LED R	
212	CIS LED G	
213	CIS LED B	

5810	SC Reset
	<p>Touch [EXECUTE] to release the machine for servicing.</p> <ul style="list-style-type: none"> • When the machine issues a "Level A" SC code, this indicates a serious problem in the fusing unit (SC542 to SC546, for example). • As soon as the Level A SC code is issued, the machine is disabled immediately. • The operator cannot reset the SC because the machine requires servicing immediately. • The machine cannot be used until the machine has been service.

2

5811	Machine No. Setting DFU	CTL
	This SP presents the screen used to enter the 1 1-digit number of the machine. The allowed entries are "A" to "Z" and "0" to "9". The setting is done at the factory, and should not be changed in the field.	

5812	Service Tel. No. Setting	CTL
	Use these SP modes to input service and support telephone numbers. Enter the number and press Press the [./*] key to input a pause. Press the "Clear modes" key to delete the telephone number.	
1	Service	Service representative telephone number.
2	Facsimile	Fax number of service representative
3	Supply	Supplier of consumables
4	Operation	Operation support

5816	Remote Service	CTL
1	I/F Setting	
	Turns the remote diagnostics off and on. [0 to 2/2/1] 0: Remote diagnostics off. 1: Serial (CSS or @Remote) remote diagnostics on. 2: Network remote diagnostics on for @Remote	
2	CE Call	
	Lets the operator engineer start or end of the remote machine check with CSS or @Remote; to do this, push the center report key	
3	Function Flag	
	Enables and disables remote diagnosis over the @Remote network. [0 to 1/0/1] 0: Disables remote diagnosis over the network. 1: Enables remote diagnosis over the network.	

7	SSL Disable
	<p>Controls if RCG (Remote Communication Gate) confirmation is done by SSL during an RCG send for the @Remote over a network intersection.</p> <p>[0 to 1/0/1]</p> <p>0: Yes. SSL not used. 1: No. SSL used.</p>
8	RCG Connect Timeout
	<p>Sets the length of time (seconds) for the time-out when the RCG (Remote Communication Gate) connects during a call via the @Remote network.</p> <p>[1 to 90/30/1 sec.]</p>
9	RCG Write to Timeout
	<p>Sets the length of time (seconds) for the time-out when sent data is written to the RCG during a call over the @Remote network.</p> <p>[0 to 100/60/1 sec.]</p>
10	RCG Read Timeout
	<p>Sets the length of time (seconds) for the timeout when sent data is written from the RCG during a call over the @Remote network.</p> <p>[0 to 100/60/1 sec.]</p>
11	Port 80 Enable
	<p>Controls if permission is given to get access to the SOAP method over Port 80 on the @Remote network.</p> <p>[0 to 1/0/1]</p> <p>0: No. Access denied 1: Yes. Access granted.</p>
13	RFU Timing
	<p>This SP determines how the machine receives forum (RFU: @Remote Forum Updates) updates.</p> <p>[0 to 1 / 1 / 1]</p> <p>0: All forum updates 1: Energy status update only</p>

21	RCG – C Registered
	This SP displays the Embedded RC Gate installation end flag. 1: Installation completed 2: Installation not completed
23	Connect Type (N/M)
	This SP displays and selects the Embedded RC Gate connection method. 0: Internet connection 1: Dial-up connection
61	Cert. Expire Timing DFU
	Proximity of the expiration of the certification.
62	Use Proxy
	This SP setting determines if the proxy server is used when the machine communicates with the service center.
63	Proxy Host
	This is the address of the HTTP proxy server used to effect communication between Embedded RC Gate-M and the Gateway. The length of the address is limited to 127 characters (characters beyond the 127th character are ignored).
64	Proxy Port Number
	This is the port number of the HTTP proxy used to effect communication between Embedded RC Gate-N and the Gateway. [0 to 0xffff/0/1]
65	Proxy User name
	This is the user name used for certification of the HTTP proxy. The length of the name is limited to 31 characters (characters beyond the 31st character are ignored).
66	Proxy Password
	This is the certification password of the HTTP proxy. The length of the password is limited to 31 characters (characters beyond the 31st character are ignored).

Note: The proxy number, user name, and password comprise proprietary operator information required by the service technician to do the necessary settings for Embedded RC Gate-N. To prevent unauthorized access this information, these SP settings do not appear in the SMC report.

	CERT: Up State
	Displays the state of the certification update used for Embedded RC Gate. If Embedded RC Gate has not been set up, These SP settings are done automatically as soon as Embedded RC Gate is set up.
	0 The certification used by Embedded RC Gate is set correctly.
	1 The certification request (SetAuthKey) for update has been received from the CTL URL and certification is presently being updated.
	2 The certification update is completed and the CTL URL is being notified of the successful update.
	3 The certification update failed, and the CTL URL is being notified of the failed update.
	4 The period of the certification has expired and new request for an update is being sent to the CTL URL.
67	11 A rescue update for certification has been issued and a rescue certification setting is in progress for the rescue CTL connection.
	12 The rescue certification setting is completed and the CTL URL is being notified of the certification update request.
	13 The notification of the request for certification update has completed successfully, and the system is waiting for the certification update request from the rescue CTL URL.
	14 The notification of the certification request has been received from the rescue CTL URL, and the certification is being stored.
	15 The certification has been stored, and the CTL URL is being notified of the successful completion of this event.
	16 The storing of the certification has failed, and the CTL URL is being notified of the failure of this event.
	17 The certification update request has been received from the CTL URL, the CTL URL was notified of the results of the update after it was completed, but a certification error has been received, and the rescue certification is being recorded.
	18 The rescue certification of No. 17 has been recorded, and the CTL URL is being notified of the failure of the certification update.

68	CERT: Error	
	Displays a number code that describes the reason for the notification requesting the certification update.	
	0	Normal. No request for certification update in progress.
	1	Certification update in progress due to expiration of certification.
	2	SSL error has been issued after the certification has expired.
	3	There has been a shift from a common to individual certification.
	4	There has been a common certification without ID2.
	5	No certification has been issued.
69	CERT: Up ID	
	The ID of the request for certification.	
83	Firm Up Status	
	Displays the status of the firmware update.	
85	Firm Up User Check	
	This SP setting determines if the operator can check the previous version of the firmware before the firmware update execution. If the option to check the previous version is selected, a notification is sent to the system manager and the firmware update is done with the firmware files from the URL.	
86	Firmware Size	
	Allows the service technician to check the size of the firmware data files during the firmware update execution.	
87	CERT: Macro Version	
	Displays the macro version of the @Remote certification	
88	CERT: PAC Version	
	Displays the PAC version of the @Remote certification.	

89	CERT: ID2 Code
	Displays ID2 for the @Remote certification. Spaces are displayed as underscores (_). Asterisks (****) indicate that no @Remote certification exists.
90	CERT: Subject
	Displays the common name of the @Remote certification subject. CN = the following 17 bytes. Spaces are displayed as underscores (_). Asterisks (****) indicate that no DESS exists.
91	CERT: Serial Number
	Displays serial number for the @Remote certification. Asterisks (****) indicate that no DESS exists.
92	CERT: Issuer
	Displays the common name of the issuer of the @Remote certification. CN = the following 30 bytes. Asterisks (****) indicate that no DESS exists.
93	CERT: Valid Start
	Displays the start time of the period for which the current @Remote certification is enabled.
94	CERT: Valid End
	Displays the end time of the period for which the current @Remote certification is enabled.
150	Selection Country DFU
	<p>Used only for Embedded RC Gate-M to select a country name. Once the number/country is selected, the following settings are checked:</p> <ul style="list-style-type: none"> • Access point telephone number • Dial-up user name • Modem parameters set for the country <p>[0 to 10/*/1] *: 0: Japan, 1: USA, 3: UK 0:Japan, 1:USA, 2:Canada, 3:UK, 4:Germany, 5:France, 6:Italy, 7:Netherlands, 8:Belgium, 9:Luxembourg, 10:Spain</p>

151	Line Type Automatic Judgement DFU	
	<p>Used only for Embedded RC Gate-M to determine whether the dial-up line is for manual rotary or push-button tone dialing.</p> <ul style="list-style-type: none"> • The status of the execution of this SP (dialing in progress, success, failure) is written to SP5816-152. • If the check succeeds, the number (dial or push number) written to SP5816-153 can be used • If the check succeeds, the number of the carrier line written to SP816-154 can be used. 	
152	Line Type Judgement Result DFU	
	<p>Used only for Embedded RC Gate-M to display the status of the execution of SP5816-151 identify the type of line.</p>	
	0	Success
	1	Currently dialing
	2	Line abnormal
	3	Could not confirm external line carrier with automatic detection.
	4	Line disconnected
	5	Power supply insufficient
	6	Line determination not supported
	7	Error due to fax transmission in progress.
	8	Other error
	9	Line type identification still in progress. Please wait.
153	Selection Dial/Push DFU	
	<p>Used only for Embedded RC Gate-M to set the telephone number of the dial-up access point of the line checked with SP5816-151. If a number is entered, use that number. If a number is not displayed, use the pre-set value for that country.</p>	
154	Outside Line Outgoing Number DFU	
	<p>Used only for Embedded RC Gate-M to set the number of the PSTN number to dial out where Embedded RC Gate-M is used with a PBX system. If a number is set here, the number will be replaced by the number returned by the successful execution of SP5816-151.</p>	

156	Dial Up User Name DFU
	This is the user name for dialing at the access point where Embedded RC Gate-M is used. Note: Numbers with spaces or # marks appear enclosed with quotation marks in the user name.
157	Dial Up Password DFU
	This is the password for dialing at the access point where Embedded RC Gate-M is used. Note: Numbers with spaces or # marks appear enclosed with quotation marks in the user name.
161	Local Phone Number DFU
	This is the number of the local line where Embedded RC Gate-M is connected. This is the line used to communicate with the Call Center.
162	Connection Timing Adjustment Incoming DFU
	When the Call Center calls out to the access point where Embedded RC Gate-M is used, the ID tone (*#1#) is sent repeatedly. This SP sets the amount of time to elapse for ID tone output. [0 to 24/1/1 pause count] 1 pause count = 2 sec.
163	Access Point DFU
	This is the dial-up telephone line number of the access point connected to Embedded RC Gate-M. If a number is entered here that number is used. If no number is entered here then the pre-set country setting is used.
164	Line Connecting DFU
	This SP code should be set for the customer using Embedded RC Gate-M, depending on the line usage (whether line is shared with a fax or not). [0 to 1/0/1] 0: Line shared with facsimile 1: Line not shared with facsimile
173	Modem Serial No. DFU
	This SP code displays the serial number of the Embedded RC Gate-M (modem).

174	Retransmission Limit DFU	
	Use this SP to manually send a registration update request to Embedded RC Gate-M.	
187	FAX TX Priority DFU	
	<p>This SP is used with SP5816-164 for users who are using a line shared with a facsimile unit.</p> <p>[0 to 1/0/1]</p> <p>0: Disabled. Embedded RC Gate-M continues to operate if a fax transmission starts on the same line.</p> <p>1: Enabled. Fax transmissions have priority. Embedded RC Gate-M will shut down when a fax transmission begins.</p>	
200	Manual Polling	
	Executes manual polling. Embedded RC Gate periodically polls the @Remote Gateway by HTTPS. This is called "center polling". Use this SP at any time to poll the @Remote supply center.	
201	Regist: Status	
	Displays a number that indicates the status of the @Remote service device.	
	0	Neither the @Remote device nor Embedded RC Gate device are set.
	1	The Embedded RC Gate device is being set. Only Box registration is completed. In this status the Basil unit cannot answer a polling request.
	2	The Embedded RC Gate device is set. In this status the Basil unit cannot answer a polling request.
	3	The @Remote device is being set. In this status the Embedded RC Gate device cannot be set.
202	Letter Number	
	Allows entry of the number of the request needed for the Embedded RC Gate device.	
203	Confirm Execute	
	Executes the inquiry request to the @Remote CTL URL.	

204	Confirm Result	
	Displays a number that indicates the result of the inquiry executed with SP5816203.	
	0	Succeeded
	1	Inquiry number error
	2	Registration in progress
	3	Proxy error (proxy enabled)
	4	Proxy error (proxy disabled)
	5	Proxy error (Illegal user name or password)
	6	Communication error
	7	Certification update error
	8	Other error
	9	Inquiry executing
205	Confirm Place	
	Displays the result of the notification sent to the device from the CTL URL in answer to the inquiry request. Displayed only when the result is registered at the CTL URL.	
206	Register Execute	
	Executes Embedded RC Gate Registration.	

207	Register Result	
	Displays a number that indicates the registration result.	
	0	Succeeded
	2	Registration in progress
	3	Proxy error (proxy enabled)
	4	Proxy error (proxy disabled)
	5	Proxy error (Illegal user name or password)
	6	Communication error
	7	Certification update error
	8	Other error
	9	Registration executing

	Error Code																																															
	Displays a number that describes the error code that was issued when either SP5816 204 or SP5816 207 was executed.																																															
	<table border="1"> <thead> <tr> <th>Cause</th> <th>Code</th> <th>Meaning</th> </tr> </thead> <tbody> <tr> <td rowspan="3">Illegal Modem Parameter</td> <td>-11001</td> <td>Chat parameter error</td> </tr> <tr> <td>-11002</td> <td>Chat execution error</td> </tr> <tr> <td>-11003</td> <td>Unexpected error</td> </tr> <tr> <td rowspan="3">Operation Error, Incorrect Setting</td> <td>-12002</td> <td>Inquiry, registration attempted without acquiring device status.</td> </tr> <tr> <td>-12003</td> <td>Attempted registration without execution of an inquiry and no previous registration.</td> </tr> <tr> <td>-12004</td> <td>Attempted setting with illegal entries for certification and ID2.</td> </tr> <tr> <td rowspan="11">208</td> <td rowspan="11">Error Caused by Response from CTL URL</td> <td>-2385</td> <td>Attempted dial up overseas without the correct international prefix for the telephone number.</td> </tr> <tr> <td>-2387</td> <td>Not supported at the Service Center</td> </tr> <tr> <td>-2389</td> <td>Database out of service</td> </tr> <tr> <td>-2390</td> <td>Program out of service</td> </tr> <tr> <td>-2391</td> <td>Two registrations for same device</td> </tr> <tr> <td>-2392</td> <td>Parameter error</td> </tr> <tr> <td>-2393</td> <td>Basil not managed</td> </tr> <tr> <td>-2394</td> <td>Device not managed</td> </tr> <tr> <td>-2395</td> <td>Box ID for Basil is illegal</td> </tr> <tr> <td>-2396</td> <td>Device ID for Basil is illegal</td> </tr> <tr> <td>-2397</td> <td>Incorrect ID2 format</td> </tr> <tr> <td>-2398</td> <td>Incorrect request number format</td> </tr> <tr> <td>209</td> <td>Instl Clear</td> </tr> <tr> <td></td> <td>Releases a machine from its embedded RCG setup.</td> </tr> </tbody></table>	Cause	Code	Meaning	Illegal Modem Parameter	-11001	Chat parameter error	-11002	Chat execution error	-11003	Unexpected error	Operation Error, Incorrect Setting	-12002	Inquiry, registration attempted without acquiring device status.	-12003	Attempted registration without execution of an inquiry and no previous registration.	-12004	Attempted setting with illegal entries for certification and ID2.	208	Error Caused by Response from CTL URL	-2385	Attempted dial up overseas without the correct international prefix for the telephone number.	-2387	Not supported at the Service Center	-2389	Database out of service	-2390	Program out of service	-2391	Two registrations for same device	-2392	Parameter error	-2393	Basil not managed	-2394	Device not managed	-2395	Box ID for Basil is illegal	-2396	Device ID for Basil is illegal	-2397	Incorrect ID2 format	-2398	Incorrect request number format	209	Instl Clear		Releases a machine from its embedded RCG setup.
Cause	Code	Meaning																																														
Illegal Modem Parameter	-11001	Chat parameter error																																														
	-11002	Chat execution error																																														
	-11003	Unexpected error																																														
Operation Error, Incorrect Setting	-12002	Inquiry, registration attempted without acquiring device status.																																														
	-12003	Attempted registration without execution of an inquiry and no previous registration.																																														
	-12004	Attempted setting with illegal entries for certification and ID2.																																														
208	Error Caused by Response from CTL URL	-2385	Attempted dial up overseas without the correct international prefix for the telephone number.																																													
		-2387	Not supported at the Service Center																																													
		-2389	Database out of service																																													
		-2390	Program out of service																																													
		-2391	Two registrations for same device																																													
		-2392	Parameter error																																													
		-2393	Basil not managed																																													
		-2394	Device not managed																																													
		-2395	Box ID for Basil is illegal																																													
		-2396	Device ID for Basil is illegal																																													
		-2397	Incorrect ID2 format																																													
-2398	Incorrect request number format																																															
209	Instl Clear																																															
	Releases a machine from its embedded RCG setup.																																															

250	CommLog Print	
	Prints the communication log.	
5821	Remote Service Address	CTL
	This SP sets the IP address for RCG (Remote Communication Gate) for processing calls to the @Remote service center.	
5824	NVRAM Data Upload	CTL
	<p>Uploads the UP and SP mode data (except for counters and the serial number) from NVRAM on the control board to an SD card inserted in Slot 2.</p> <ul style="list-style-type: none"> Remove the SD card slot cover on the back of the machine. Insert a blank SD card in Slot 2. Open this SP and touch [EXECUTE]. When you see "Completed", remove the SD card from Slot 2. 	
5825	NVRAM Data Download	CTL
	<p>Downloads the content of an SD card in Slot 2 to the NVRAM on the control board.</p> <ul style="list-style-type: none"> Remove the SD card slot cover on the back of the machine. Insert a blank SD card in Slot 2. Open this SP and touch [EXECUTE]. When you see "Completed", remove the SD card from Slot 2. 	
5828	Network Setting	CTL
50	1284 Compatibility (Centro)	
	<p>Enables and disables bi-directional communication on the parallel connection between the machine and a computer.</p> <p>[0 to 1 / 1 / 1]</p> <p>0:Off, 1: On</p>	
52	ECP (Centro)	

	Disables and enables the ECP feature (1284 Mode) for data transfer. [0 to 1 / 1 / 1] 0: Disabled, 1: Enabled			
65	Job Spool			
	Switches job spooling on and off. [0 to 1/0/1] 0: No spooling 1: Spooling enabled			
66	Job Spool Clear: Start Time			
	This SP determines whether the job interrupted at power off is resumed at the next power on. This SP operates only when SP5828065 is set to 1. [0 to 1/1/1] 1: Resumes printing spooled job. 0: Clears spooled job.			
69	Spooling (Protocol)			
	This SP determines whether job spooling is enabled or disabled for each proto to col. This is a 8-bit setting.			
	0	LPR	4	BMLinks (Japan Only)
	1	FTP (Not Used)	5	DIPRINT
	2	IPP	6	Reserved (Not Used)
	3	SMB	7	Reserved (Not Used)
90	TELNET (0:OFF 1:ON)			
	Disables or enables Telnet operation. If this SP is disabled, the Telnet port is closed. [0 to 1/1/1] 0: Disable 1: Enable			
91	Web (0:OFF 1:ON)			

	<p>Disables or enables the Web operation.</p> <p>[0 to 1/1/1]</p> <p>0: Disable</p> <p>1: Enable</p>
145	Active IPv6 Link Local Address
	<p>This is the IPv6 local address referenced on the Ethernet or wireless LAN (802.11b) in the format:</p> <p>"Link-Local address" + "Prefix Length"</p> <p>The IPv6 address consists of a total 128 bits configured in 8 blocks of 16 bits each. These notations can be abbreviated. See "Note: IPV6 Addresses " below this table.</p>
147	Active IPv6 Stateless Address 1
149	Active IPv6 Stateless Address 2
151	Active IPv6 Stateless Address 3
153	Active IPv6 Stateless Address 4
155	Active IPv6 Stateless Address 5
	<p>SP codes 147 to 155 are the IPv6 stateless addresses (1 to 5) referenced on the Ethernet or wireless LAN (802.11b) in the format:</p> <p>"Stateless Address" + "Prefix Length"</p> <p>The IPv6 address consists of a total 128 bits configured in 8 blocks of 16 bits each.</p>
156	IPv6 Manual Address
	<p>This SP is the IPv6 manually set address referenced on the Ethernet or wireless LAN (802.11b) in the format:</p> <p>"Manual Set Address" + "Prefix Length"</p> <p>The IPv6 address consists of a total 128 bits configured in 8 blocks of 16 bits each. These notations can be abbreviated. See "Note: IPV6 Addresses" below this table.</p>
158	IPv6 Gateway Address
	<p>This SP is the IPv6 gateway address referenced on the Ethernet or wireless LAN (802.11b). The IPv6 address consists of a total 128 bits configured in 8 blocks of 16 bits each. These notations can be abbreviated. See "Note: IPV6 Addresses " below this table.</p>
161	IPv6 Stateless Auto Setting

	<p>Sets the machine to reference the stateless auto setting for Ethernet and wireless LAN operation.</p> <p>[0 to 1 / 1 / 1]</p> <p>0: Disable</p> <p>1: Enable</p>
--	---

Ethernet and the Wireless LAN (802.11b) reference the IPV6 "Link-Local address + Prefix Length". The IPV6 address consists of 128 bits divided into 8 blocks of 16 bits:

aaa:bbb:ccc:ddd:eee:fff:ggg:hhh:

The prefix length is inserted at the 17th byte (Prefix Range: 0x0 to 0x80). The initial setting is 0x40(64).

For example, the data:

2001123456789012abcdef012345678940h

is expressed:

2001:1234:5678:9012:abcd:ef01:2345:6789: prefixlen 64

However, the actual IPV6 address display is abbreviated according to the following rules.

Rules for Abbreviating IPV6 Addresses

1. The IPV6 address is expressed in hexadecimal delimited by colons (:) with the following characters:
0123456789abcdefABCDEF
2. A colon is inserted as a delimiter every 4th hexadecimal character.
fe80:0000:0000:0000:0207:40ff:0000:340e
3. The notations can be abbreviated by eliminating zeros where the MSB and digits following the MSB are zero. The example in "2" above, then, becomes:
fe80:0:0:0207:40ff:0:340e
4. Sections where only zeros exist can be abbreviated with double colons (::). This abbreviation can be done also where succeeding sections contain only zeros (but this can be done only at one point in the address). The example in "2" and "3" above then becomes: fe80::207:40ff:0:340e (only the first null sets zero digits are abbreviated as "::")
-or-
fe80:0:0:0:207:40ff::340e (only the last null set before "340e" is abbreviated as "::")

236	Web Item visible	
	<p>Displays or does not display the Web system items. [0 x 0000 to 0 x ffff / 0 x ffff] 0: Not displayed, 1: Displayed bit0: Net RICOH bit1: Consumable Supplier bit2-15: Reserved (all)</p>	
237	Web shopping link visible	
	<p>Displays or does not display the link to Net RICOH on the top page and link page of the web system. [0 to 1 / 1 / 1] 0: Not display, 1:Display</p>	
238	Web supplies Link visible	
	<p>Displays or does not display the link to Consumable Supplier on the top page and link page of the web system. [0 to 1 / 1 / 1] 0: Not display, 1:Display</p>	
239	Web Link1 Name	
	<p>This SP confirms or changes the URL1 name on the link page of the web system. The maximum characters for the URL name are 31 characters.</p>	
240	Web Link1 URL	
	<p>This SP confirms or changes the link to URL1 on the link page of the web system. The maximum characters for the URL are 127 characters.</p>	
241	Web Link1 Visible	
	<p>Displays or does not display the link to URL1 on the top page of the web system. [0 to 1 / 1 / 1] 0: Not display, 1:Display</p>	
242	Web Link2 Name	Same as "-239"
243	Web Link2 URL	Same as "-240"
244	Web Link2 visible	Same as "-241"

5831	Initial Setting Clear
	This SP clears all the User Tools settings and restores them to their factory default settings.

5832	HDD	CTL
	Enter the SP number for the partition to initialize, then press #. When the execution ends, turn the machine power off and on.	
1	HDD Formatting (All)	
2	HDD Formatting (IMH)	
3	HDD Formatting (Thumbnail)	
4	HDD Formatting (Job Log)	
5	HDD Formatting (Printer Fonts)	
6	HDD Formatting (User Info)	
7	Mail RX Data	
8	Mail TX Data	
9	HDD Formatting (Data for Design)	
10	HDD Formatting (Log)	
11	HDD Formatting (Ridoc I/F) (for Ridoc DesktopBinder)	

5836	Capture Settings	CTL
1	Capture Function DFU	
	With this function disabled, the settings related to the capture feature cannot be initialized, displayed, or selected. [0 to 1/0/1] 0: Disable 1: Enable	
2	Panel Setting	

	<p>Determines whether each capture related setting can be selected or updated from the initial system screen.</p> <p>[0 to 1/0/1]</p> <p>0: Disable</p> <p>1: Enable</p> <p>The setting for SP5836-1 has priority.</p>
72	Reduction for Copy B&W Text
	<p>Determines the resolution conversion ratio when a Copy Text image document is sent to the Document Server via the MLB (Media Link Board).</p> <p>[0 to 6/0/1]</p> <p>0: 1,</p> <p>1: 1/2</p> <p>2: 1/3</p> <p>3: 1/4</p> <p>6: 2/3</p>
73	Reduction for Copy B&W Other
	<p>Determines the resolution conversion ratio when a Copy image document other than Text mode is sent to the Document Server via the MLB (Media Link Board).</p> <p>[0 to 6/0/1]</p> <p>0: 1</p> <p>1: 1/2</p> <p>2: 1/3</p> <p>3: 1/4</p> <p>6: 2/3</p>
75	Reduction for Printer B&W

	<p>Determines the resolution conversion ratio when a binary print image document is sent to the Document Server via the MLB (Media Link Board).</p> <p>[0 to 6/0/1]</p> <p>0: 1</p> <p>1: 1/2</p> <p>2: 1/3</p> <p>3: 1/4</p> <p>6: 2/3</p>
82	Format for Copy B&W Text
	<p>Determines the image format for Copy Text images sent to the Document Server via the MLB (Media Link Board).</p> <p>[0 to 3/1/1]</p> <p>0: JFIF/JPEG</p> <p>1: TIFF/MMR</p> <p>2: TIFF/MH</p> <p>3: TIFF/MR</p>
83	Format for Copy B&W Other
	<p>Determines the image format for Copy (other than text) images sent to the Document Server via the MLB (Media Link Board).</p> <p>[0 to 3/1/1]</p> <p>0: JFIF/JPEG</p> <p>1: TIFF/MMR</p> <p>2: TIFF/MH</p> <p>3: TIFF/MR</p>
85	Format for Printer B&W
	<p>Determines the image format for Binary Print images sent to the Document Server via the MLB (Media Link Board).</p> <p>[0 to 3/1/1]</p> <p>0: JFIF/JPEG</p> <p>1: TIFF/MMR</p> <p>2: TIFF/MH</p> <p>3: TIFF/MR</p>

91	Default for JPEG
	Determines the quality level of JPEG images sent to the Document Server via the MLB (Media Link Board). [5 to 95/50/1]
92	High Quality for JPEG
	Determines the quality level of JPEG images for high quality sent to the Document Server via the MLB (Media Link Board). [5 to 95/60/1]
93	Low Quality for JPEG
	Determines the quality level of JPEG images for low quality sent to the Document Server via the MLB (Media Link Board). [5 to 95/40/1]
98	Back Projection Removal
	Removes the ghost images transferred from the back sides of double-sided originals. [0 to 1/1/1] 1: Enable 0: Disable
101	Primary srv IP address
	This SP sets the IP address to be assigned to the computer that is operating as the Capture Server (CS). <ul style="list-style-type: none"> • Normally this address is specified remotely for IO registration of the Capture Server. • Only the IP address is enabled (referencing the name with DNS is not allowed). Default: 000.000.000.000 Allowed entry: 000.000.000.000 to 255.255.255.255
102	Primary srv scheme
	Normally this address is specified remotely for IO registration of the primary Capture Server. Default: None Character length: Up to 6 characters
103	Primary srv port number

	<p>Normally this address is specified remotely for IO registration of the port number of the primary Capture Server.</p> <p>[1 to 65 535 / 80 / 1]</p>
104	Primary srv URL path
	<p>Normally this address is specified remotely for IO registration of the URL path of the primary Capture Server.</p> <p>Default: None</p> <p>Allowed entry: 0 to 16 characters</p>
111	Secondary srv IP address
	<p>This SP sets the IP address to be assigned to the computer that is operating as the secondary Capture Server (CS).</p> <ul style="list-style-type: none"> • Normally this address is specified remotely for IO registration of the IP address of the secondary Capture Server. • Only the IP address is enabled (referencing the name with DNS is not allowed). <p>Default: 000.000.000.000</p> <p>000.000.000.000 to 255.255.255.255</p>
112	Secondary srv scheme
	<p>Normally this address is specified remotely for IO registration of the scheme of the secondary Capture Server.</p> <p>Default: None</p> <p>Character length: Up to 6 characters</p>
113	Secondary srv port number
	<p>Normally this address is specified remotely for IO registration of the port number of the secondary Capture Server.</p> <p>[1 to 65 535 / 80 / 1]</p>
114	Secondary srv URL path
	<p>Normally this address is specified remotely for IO registration of the URL path of the secondary Capture Server.</p> <p>Default: None</p> <p>0 to 16 characters</p>
120	Default Reso Rate Switch

	<p>Normally this address is specified remotely for IO registration of the resolution of documents on the Capture Server.</p> <p>[0 to 1 / 0 / 1]</p>
122	Reso: Copy(Mono)
	<p>Actually the specified resolution setting cannot be changed through hardware control, so in such a case an approximate resolution is used for the capture.</p> <p>[0 to 255 / 3 / 1]</p>
124	Reso: Print(Mono)
	<p>Normally this address is specified remotely for IO registration of the monochrome resolution for documents on the Capture Server. Actually the specified resolution setting cannot be changed through hardware control, so in such a case an approximate resolution is used for the capture.</p> <p>[0 to 255 / 3 / 1]</p>
127	Reso: Scan (Color)
	<p>This SP sets the image resolution for a captured image of a color original scanned with the scanner application.</p> <ul style="list-style-type: none"> • Normally this address is specified remotely for IO registration of the Capture Server, but it can be changed on the machine operation panel. • Actually the specified resolution setting cannot be changed through hardware control, so in such a case an approximate resolution is used for the capture. <p>[0 to 255 / 4 / 1]</p>
128	Reso: Scan (Mono)
	<p>This sets the image resolution for a captured image of a monochrome original scanned with the scanner application.</p> <ul style="list-style-type: none"> • Normally this address is specified remotely for IO registration of the Capture Server, but it can be changed on the machine operation panel. • Actually the specified resolution setting cannot be changed through hardware control, so in such a case an approximate resolution is used for the capture. <p>[0 to 255 / 3 / 1]</p>
141	All Addr Info Switch

	<p>Switch this SP off if the system is performing slowly due to a large number of resources in use. If this SP is switched off, only 2000 documents can be queued for sending to the Capture Server. (See SP5836-142 below.)</p> <p>[0 to 1 / 1 / 1]</p> <p>0: Off</p> <p>1: On</p>
142	Stand-by Doc Max Number
	<p>This SP sets the maximum number of documents to be held on stand-by before they are sent to the Capture Server. However, the maximum number (10,000) cannot be set unless SP5386-141 has been disabled (switched off).</p> <p>[10 to 10000 / 2000 / 1]</p>

5840	IEEE 802.11	CTL
6	Channel MAX	
	<p>Sets the maximum range of the bandwidth for the wireless LAN. This bandwidth setting varies for different countries.</p> <p>[1 to 14/14/1]</p>	
7	Channel MIN	
	<p>Sets the minimum range of the bandwidth for operation of the wireless LAN. This bandwidth setting varies for different countries.</p> <p>[1 to 14/1/1]</p>	
8	Transmission Speed	
	<p>0 x FF to Auto [Default]</p> <p>0 x 11 – 55M Fix</p> <p>0 x 10 – 48M Fix</p> <p>0 x 0F – 36M Fix</p> <p>0 x 0E – 18M Fix</p> <p>0 x 0D – 12M Fix</p> <p>0 x 0B – 9M Fix</p>	<p>0 x 0A – 6M Fix</p> <p>0 x 07 – 11M Fix</p> <p>0 x 05 – 5.5M Fix</p> <p>0 x 08 – 1M Fix</p> <p>0 x 13 – 0 x FE (reserved)</p> <p>0 x 12 – 72M (reserved)</p> <p>0 x 09 – 22M (reserved)</p>

11	WEP Key Select
	<p>Determines how the initiator (SBP-2) handles subsequent login requests. [00 to 11/00/1]</p> <p>Note: There are four settings (binary numbers): 00, 01, 10, 11. These settings are possible only after the wireless LAN card has been installed.</p> <p>00: 1st key. If the initiator receives another login request while logging in, the request is refused. 01, 10, 11: 2nd, 3rd, 4th keys are "Reserved".</p>
42	Fragment Thresh
	<p>Adjusts the fragment threshold for the IEEE802.11 card. [256 to 2346 / 2346 / 1]</p> <p>This SP is displayed only when the IEEE802.11 card is installed.</p>
43	11g CTS to Self
	<p>Determines whether the CTS self function is turned on or off. [0 to 1 / 1 / 1] 0: Off, 1: On</p> <p>This SP is displayed only when the IEEE802.11 card is installed.</p>
44	11g Slot Time
	<p>Selects the slot time for IEEE802.11. [0 to 1 / 0 / 1] 0: 20 μm, 1: 9 μm</p> <p>This SP is displayed only when the IEEE802.11 card is installed.</p>
45	WPA Debug Lvl
	<p>Selects the debug level for WPA authentication application. [1 to 3 / 3 / 1] 1: Info, 2: warning, 3: error</p> <p>This SP is displayed only when the IEEE802.11 card is installed.</p>

5841	Supply Name Setting	CTL
	Use the soft keyboard of this SP to enter the names and numbers of consumables. These are the names that appear on the display when [Inquiry] is pressed on the User Tools screen.	

5842	CTLWS Analysis DFU	CTL
------	---------------------------	-----

1	Setting 1	Bit	Groups
	This is a debugging tool. It sets the debugging output mode of each Net File process. Bit SW 0011 1111	0	System & other groups (LSB)
		1	Capture related
		2	Certification related
		3	Address book related
		4	Machine management related
		5	Output related (printing, delivery)
		6	Repository related
2	Setting 2	Bit	
	This SP codes sets the optional setting for message log time stamp. Bit 7 is the 5682 message log where the following are set:	0-6	Not Used
		7	Message log 1: mm:ss:ms 0: mm:ss (time)

5844	USB	CTL
1	Transfer Rate	
	Sets the speed for USB data transmission. [Full Speed], [Auto Change]	
2	Vendor ID DFU	
	Sets the vendor ID: Initial Setting: 0x05A Ricoh Company [0x0000 to 0xFFFF/1]	
3	Product ID DFU	
	Sets the product ID. [0x0000 to 0xFFFF/1]	
4	Device Release Number DFU	

	<p>Sets the device release number of the BCD (binary coded decimal) display. [0000 to 9999/100/1]</p> <p>Enter as a decimal number. NCS converts the number to hexadecimal number recognized as the BCD.</p>
5	Fixed USB Port
	<p>This SP standardizes for common use the model name and serial number for USB PnP (Plug & Play). It determines whether the driver requires re-installation. [0 to 2 / 0 / 4]</p> <p>0: Off 1: Level 1 2: Level 2</p>
6	PnP Model Name
	<p>This SP sets the model name to be used by the USB PnP when "Function Enable (Level 2) is set so the USB Serial No. can have a common name (SP5844-5). Default: Laser Printer (up to 20 characters allowed).</p>
7	PnP Serial Number
	<p>This SP sets the serial number to be used by the USB PnP when "Function Enable (Level 2) is set so the USB Serial No. can have a common name (SP5844-5). Default: None (up to 12 characters allowed for entry).</p> <ul style="list-style-type: none"> • Make sure that this entry is the same as the serial number in use. • At initialization the serial number generated from the model name is used, not the setting of this SP code. • At times other than initialization, the value set for this SP code is used.
100	Notify Unsupport

	<p>This SP determines whether an alert message appears on the control panel when a USB device (unsupported device) that cannot use an A-connector is connected.</p> <p>[0 to 1/1/1]</p> <p>0: Function enable</p> <p>1: Function disable</p> <ul style="list-style-type: none"> • An unsupported device is a device that cannot use the functions of the USB device. For example, a USB mouse cannot be used even if it connected. • If the PictBridge option is not mounted, even if a digital camera is connected it cannot be used because it is an unsupported device.
--	--

5845	Delivery Server Setting	CTL
	Provides items for delivery server settings.	
1	FTP Port No.	[0 to 65535 / 3670 / 1]
	Sets the FTP port number used when image files are sent to the Scan Router Server.	
2	IP Address (Primary)	Range: 000.000.000.000 to 255.255.255.255
	Use this SP to set the Scan Router Server address. The IP address under the transfer tab can be referenced by the initial system setting.	
6	Delivery Error Display Time	[0 to 999 / 300 / 1]
	Use this setting to determine the length of time the prompt message is displayed when a test error occurs during document transfer with the NetFile application and an external device.	
8	IP Address (Secondary)	Range: 000.000.000.000 to 255.255.255.255
	Specifies the IP address assigned to the computer designated to function as the secondary delivery server of Scan Router. This SP allows only the setting of the IP address without reference to the DNS setting.	
9	Delivery Server Model	[0 to 4/ 0 / 1]
	<p>Allows changing the model of the delivery server registered by the I/O device.</p> <p>0: Unknown</p> <p>1: SG1 Provided</p> <p>2: SG1 Package</p> <p>3: SG2 Provided</p> <p>4: SG2 Package</p>	

	Delivery Svr Capability	
	Changes the capability of the registered that the I/O device registered. [0 to 255 / 0 / 1] (7) [0000 0000] (1)	
10	Bit7 = 1 Comment information exists	
	Bit6 = 1 Direct specification of mail address possible	
	Bit5 = 1 Mail RX confirmation setting possible	
	Bit4 = 1 Address book automatic update function exists	
	Bit3 = 1 Fax RX delivery function exists	
	Bit2 = 1 Sender password function exists	
	Bit1 = 1 Function to link MK-1 user and Sender exists	
	Bit0 = 1 Sender specification required (if set to 1, Bit6 is set to "0")	
	11	Delivery Svr.Capability (Ext) These settings are for future use. They will let you increase the number of registered devices (in addition to those registered for SP5845-10). There are eight bits (Bit 0 to Bit 7). All are unused at this time.
	13	Server Scheme (Primary)
14	Server Port Number (Primary)	
15	Server URL Path (Primary)	
16	Server Scheme (Secondary)	
17	Server Port Number (Secondary)	
18	Server URL Path (Secondary)	
22	Rapid Sending Control	

	<p>Switches instant transmission off/on.</p> <p>[0 to 1/1/1]</p> <p>0: Off. Instant transmission not possible with network setting errors.</p> <p>1: On. Instant transmission possible with network setting errors.</p> <p>Note:</p> <ul style="list-style-type: none"> • The machine will continue to transmit over the network, even if the network settings are incorrect. (This causes multiple errors, of course.) • With this SP off, the machine will stop communicating with the network if the settings are wrong. This reduces the amount of spurious network traffic caused by errors due to incorrect settings.
--	--

5846	UCS Setting	CTL
	UCS (User Control Service) is the software that manages user codes and the address books for scan-to-email and scan-to-folder.	
	Machine ID (for Delivery Server)	
	Displays the unique device ID in use by the delivery server directory. The value is only displayed and cannot be changed.	
	This ID is created from the NIC MAC or IEEE 1394 EUI.	
1	The ID is displayed as either 6-byte or 8-byte binary.	
	6-byte	
	%02X.%02X.%02X.%02X.%02X.%02X	
	8-byte	
	%02X.%02X.%02X.%02X.%02X.%02X.%02X.%02X	
	Machine ID Clear (Delivery Server)	
2	Clears the unique ID of the device used as the name in the file transfer directory. Execute this SP if the connection of the device to the delivery server is unstable. After clearing the ID, the ID will be established again automatically by cycling the machine off and on.	
	Maximum Entries	
3	Changes the maximum number of entries that UCS can handle.	
	[2000 to 20000/2000/1]	
	If a value smaller than the present value is set, the UCS managed data is cleared, and the data (excluding user code information) is displayed.	

6	Delivery Server Retry Timer
	<p>Sets the interval for retry attempts when the delivery server fails to acquire the delivery server address book.</p> <p>[0 to 255/0/1 sec.]</p> <p>0: No retries</p>
7	Delivery Server Retry Times
	<p>Sets the number of retry attempts when the delivery server fails to acquire the delivery server address book.</p> <p>[0 to 255/0/1]</p>
8	Delivery Server Maximum Entries
	<p>Lets you set the maximum number of account entries and information about the users of the delivery server controlled by UCS.</p> <p>[2000 to 20000/2000/1]</p>
10	LDAP Search Timeout
	<p>Sets the length of the time-out for the search of the LDAP server.</p> <p>[1 to 255/60/1]</p>
20	WSD Maximum Entries
	<p>WSD (Web Services on Devices) is the Microsoft standard for connectivity to web-service enabled devices.</p> <p>[50 to 250/250/1]</p> <p>Default: 250</p>
21	Folder Auth Change
	<p>This SP determines whether the user login information (Login User name and Password) or address (destination setting in the address book for Scan-to-SMB) is used to permit folder access. The machine must be cycled off/on for this setting to take effect if it is changed.</p> <p>[0 to 1 / 0 / 1]</p> <p>0: Uses operator login information (initial value of main machine)</p> <p>1: Uses address authorization information</p>

40	<p>Addr Book Migration (SD -> HDD)</p> <p>This SP moves the address book data from an SD card to the HDD. You must turn the machine power off and on after executing this SP.</p> <ol style="list-style-type: none"> 1. Turn the machine off. 2. Install the HDD. 3. Insert the SD card with the address book data in SD card Slot C3. 4. Turn the machine on. 5. Do SP5846-40. 6. Turn the machine off. 7. Remove the SD card from SD card Slot C3. 8. Turn the machine on. <p>Notes:</p> <ul style="list-style-type: none"> • Executing this SP overwrites any address book data already on the HDD with the data from the SD card. • We recommend that you back up all directory information to an SD card with SP5846-51 before you execute this SP. • After the address book data is copied to HDD, all the address book data is deleted from the source SD card. If the operation fails, the data is not erased from the SD card.
41	<p>Fill Addr Acl Info.</p> <p>This SP must be executed immediately after installation of an HDD unit in a basic machine that previously had no HDD. The first time the machine is powered on with the new HDD installed, the system automatically takes the address book from the NVRAM and writes it to the new HDD. However, the new address book on the HDD can be accessed only by the system administrator at this stage. Executing this SP by the service technician immediately after power on grants full address book access to all users.</p> <p>Procedure</p> <ol style="list-style-type: none"> 1. Turn the machine off. 2. Install the new HDD. 3. Turn the machine on. 4. The address book and its initial data are created on the HDD automatically. However, at this point the address book can be accessed by only the system administrator or key operator. 5. Enter the SP mode and do SP5846-41. After this SP executes successfully, any user can access the address book.

43	Addr Book Media
	<p>This SP displays the media where the address book currently in use is stored.</p> <p>[0 to 30 / 0 / 1]</p> <p>0: Unconfirmed</p> <p>1: SD Slot 1</p> <p>2: SD Slot 2</p> <p>4: USB Flash ROM</p> <p>20: HDD</p> <p>30: Nothing</p>
47	Initialize Local Addr Book
	Clears all of the address information from the local address book of a machine managed with UCS.
48	Initialize Delivery Addr Book
	Push [Execute] to delete all items (this does not include user codes) in the delivery address book that is controlled by UCS.
49	Initialize LDAP Addr Book
	Push [Execute] to delete all items (this does not include user codes) in the LDAP address book that is controlled by UCS.
50	Initialize All Addr Book
	Clears everything (including user codes) in the directory information managed by UCS. However, the accounts and passwords of the system administrators are not deleted.
51	Backup All Addr Book
	Uploads all directory information to the SD card.
52	Restore All Addr Book
	Downloads all directory information from the SD card.
53	Clear Backup Info.
	<p>Deletes the address book uploaded from the SD card in the slot. Deletes only the files uploaded for that machine. This feature does not work if the card is write-protected.</p> <p>Note: After you do this SP, go out of the SP mode, turn the power off. Do not remove the SD card until the Power LED stops flashing.</p>

	Search Option																
	This SP uses bit switches to set up the fuzzy search options for the UCS local address book.																
	<table border="1"> <thead> <tr> <th>Bit</th> <th>Meaning</th> </tr> </thead> <tbody> <tr> <td>0</td> <td>Checks both upper/lower case characters</td> </tr> <tr> <td>1</td> <td rowspan="3">Japan Only</td> </tr> <tr> <td>2</td> </tr> <tr> <td>3</td> </tr> <tr> <td>4</td> <td>--- Not Used ---</td> </tr> <tr> <td>5</td> <td>--- Not Used ---</td> </tr> <tr> <td>6</td> <td>--- Not Used ---</td> </tr> <tr> <td>7</td> <td>--- Not Used ---</td> </tr> </tbody> </table>	Bit	Meaning	0	Checks both upper/lower case characters	1	Japan Only	2	3	4	--- Not Used ---	5	--- Not Used ---	6	--- Not Used ---	7	--- Not Used ---
Bit	Meaning																
0	Checks both upper/lower case characters																
1	Japan Only																
2																	
3																	
4	--- Not Used ---																
5	--- Not Used ---																
6	--- Not Used ---																
7	--- Not Used ---																
60																	
	Complexity Option 1																
	Use this SP to set the conditions for password entry to access the local address book. Specifically, this SP limits the password entry to upper case and sets the length of the password. [0 to 32/0/1]																
62	<p>Note:</p> <p>This SP does not normally require adjustment.</p> <p>This SP is enabled only after the system administrator has set up a group password policy to control access to the address book.</p>																
	Complexity Option 2																
	Use this SP to set the conditions for password entry to access the local address book. Specifically, this SP limits the password entry to lower case and defines the length of the password. [0 to 32/0/1]																
63	<p>Note:</p> <p>This SP does not normally require adjustment.</p> <p>This SP is enabled only after the system administrator has set up a group password policy to control access to the address book.</p>																

64	Complexity Option 3
	<p>Use this SP to set the conditions for password entry to access the local address book. Specifically, this SP limits the password entry to numbers and defines the length of the password. [0 to 32/0/1]</p> <p>Note: This SP does not normally require adjustment. This SP is enabled only after the system administrator has set up a group password policy to control access to the address book.</p>
65	Complexity Option 4
	<p>Use this SP to set the conditions for password entry to access the local address book. Specifically, this SP limits the password entry to symbols and defines the length of the password. [0 to 32/0/1]</p> <p>Note: This SP does not normally require adjustment. This SP is enabled only after the system administrator has set up a group password policy to control access to the address book.</p>
91	FTP Auth. Port Settings
	<p>Sets the FTP port to get the delivery server address book that is used in the individual authorization mode. [0 to 65535/3671/1]</p>
94	Encryption Stat
	Shows the status of the encryption function of the address book on the LDAP server.

5847	Rep. Resolution Reduction	CTL
	<p>These SP's change the default settings of image data sent externally by the Net File page reference function. [0 to 2/1]</p> <p>Note:</p> <ul style="list-style-type: none"> • "NetFile" refers to jobs to be printed from the document server with a PC and the DeskTopBinder software. • This SP is available only after the File Format Converter (B609) has been installed. 	

2	Rate for Copy B&W Text	[0 to 6/0/1]	0: 1x
3	Rate for Copy B&W Other		1: 1/2x
5	Rate for Printer B&W		2: 1/3x
7	Rate for Printer B&W 1200 dpi	[0 to 32/1/1]	3: 1/4x 4: 1/6x 5: 1/8x 6: 2/3x1
Note: "6:" above (2/3x) applies to 3, 5, 6 only.			
21	Network Quality Default for JPEG		
	Sets the default value for the quality of JPEG images sent as NetFile pages. This function is available only with the MLB (Media Link Board) option installed. [5 to 95/50/1]		

5848	Web Service	CTL
	5847 2 sets the 4-bit switch assignment for the access control setting. Setting of 5848 1 has no effect on access and delivery from Scan Router. 5847 100 sets the maximum size of images that can be downloaded. The default is equal to 1 gigabyte.	
2	Acc. Ctrl.: Repository (only Lower 4 Bits)	0000: No access control 0001: Denies access to DeskTop Binder.
3	Acc. Ctrl.: Doc. Svr. Print (Lower 4 Bits)	Switches access control on and off. 0000: OFF, 0001: ON
4	Acc. Ctrl.: User Directory (Lower 4 Bits)	
9	Acc. Ctrl.: Job Control (Lower 4 Bits)	
11	Acc. Ctrl: Device Management (Lower 4 Bits)	
21	Acc. Ctrl: Delivery (Lower 4 Bits)	
22	Acc. Ctrl: User Administration (Lower 4 Bits)	
99	Repository: Download Image Setting DFU	

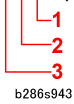
	<p>This is a bit-switch setting. Only the lower 4 bits are enabled/disabled.</p> <p>(7) 00000000 (0)</p>  <p>Set to "0" (disabled) or "1" (enabled) as needed for image download.</p> <p>(1) Mac OS (2) Windows OS (3) OS other than Mac or Windows</p> <p>Note: This SP is used primarily by designers.</p>	
100	Repository: Download Image Max. Size	[1 to 2048 /2048 /1 K]
210	Setting: Log Type: Job 1 DFU [0 to 0xFFFFFFFF/0/1]	<p>Note: These SP's are for display only; they cannot be changed.</p>
211	Setting: Log Type: Job 2 DFU [0 to 0xFFFFFFFF/0/1]	
212	Setting: Log Type: Access DFU [0 to 0xFFFFFFFF/0/1]	
213	Setting: Primary Srv DFU	
214	Setting: Secondary Srv DFU	
215	Setting: Start Time DFU [0 to 0xFFFFFFFF/0/1]	
216	Setting: Interval Time DFU [1 to 100/1/1]	
217	Setting: Timing DFU [0 to 2/0/1] 0: Transmission off 1: Transmission 1 by 1 2: Periodic transmission	

5849	Installation Date	CTL
	Displays or prints the installation date of the machine.	
1	Display	
	Displays the installation date. The installation date is set automatically after test copies are done at the installation site.	
2	Switch to Print	
	Determines whether the installation date or total count is printed on the total counter printout. [0 to 1/0/1] 0: Off. No Print 1: On. Print	
3	Total Counter	
	Displays the total count starting from the installation date (SP5849-1).	
5851	Bluetooth Not Used	
	Sets the operation mode for the Bluetooth Unit. Press either key. [0 to 1/0/1] [0:Public] [1: Private]	
5853	Stamp Data Download	CTL
	Push [Execute] to download the fixed stamp data from the machine ROM onto the hard disk so that these stamps can be used by the system. The customer will not be able to use these stamps ("Confidential", "Secret", etc.) until this SP has been executed. Note: <ul style="list-style-type: none"> • This SP must always be executed after the HDD has been reformatted or replaced. • Always switch the machine off and on after executing this SP. 	
5856	Remote ROM Update	CTL

	<p>When set to "1" allows reception of firmware data via the local port (IEEE 1284) during a remote ROM update. This setting is reset to zero after the machine is cycled off and on.</p> <p>[0 to 1 / 0 / 1]</p> <p>0: Not allowed</p> <p>1: Allowed</p>	
5857	Save Debug Log	CTL
	On/Off (1:ON 0:OFF)	
1	<p>Switches on the debug log feature. The debug log cannot be captured until this feature is switched on.</p> <p>[0 to 1/0/1]</p> <p>0: OFF</p> <p>1: ON</p>	
	Target (2: HDD 3: SD Card)	
2	<p>Selects the destination where the debugging information generated by the event selected by SP5858 will be s to red if an error is generated</p> <p>[2 to 3 /2/1]</p> <p>2: HDD</p> <p>3: SD Card</p>	
	Save to HDD	
5	Specifies the decimal key number of the log to be written to the hard disk.	
	Save to SD Card	
6	Specifies the decimal key number of the log to be written to the SD Card.	
	Copy HDD to SD Card (Latest 4 MB)	
9	<p>Takes the most recent 4 MB of the log written to the hard disk and copies them to the SD Card.</p> <p>A unique file name is generated to avoid overwriting existing file names on the SD Card. Up to 4MB can be copied to an SD Card. 4 MB segments can be copied one by one to each SD Card.</p>	

10	Copy HDD to SD Card Latest 4 MB Any Key)
	<p>Takes the log of the specified key from the log on the hard disk and copies it to the SD Card.</p> <p>A unique file name is generated to avoid overwriting existing file names on the SD Card. Up to 4 MB can be copied to an SD Card. 4 MB segments can be copied one by one to each SD Card. This SP does not execute if there is no log on the HDD with no key specified.</p>
11	Erase HDD Debug Data
	Erases all debug logs on the HDD
12	Erase SD Card Debug Data
	Erases all debug logs on the SD Card. If the card contains only debugging files generated by an event specified by SP5858, the files are erased when SP5857-10 or -11 is executed. to enable this SP, the machine must be cycled off and on.
13	Free Space on SD Card
	Displays the amount of space available on the SD card.
14	Copy SD to SD (Latest 4MB)
	Copies the last 4MB of the log (written directly to the card from shared memory) on to an SD card.
15	Copy SD to SD (Latest 4MB Any Key)
	This SP copies the log on an SD card (the file that contains the information written directly from shared memory) to a log specified by key number.
16	Make HDD Debug
	This SP creates a 32 MB file to store a log on the HDD.
17	Make SD Debug
	This SP creates a 4 MB file to store a log on an SD card.

5858	Debug Save When	CTL
	These SP's select the content of the debugging information to be saved to the destination selected by SP5857-2. SP58583 stores one SC error specified by number.	
1	Engine SC Error (0:OFF 1:ON) [0 to 1/0/1]	Stores SC codes generated by main machine engine errors.

2	Controller SC Error (0:OFF 1:ON [0 to 1/0/1])	Stores SC codes generated by CTL controller errors.
3	Any SC Error (0:OFF 1:ON [0 to 65535/0/1])	[0 to 65535 / 0 / 1]
4	Jam (0:OFF 1:ON [0 to 1/0/1])	Stores jam errors.

5859	Debug Save Key No.	CTL
	These SP's allow you to set up to 10 keys for log files for functions that use common memory on the controller board. [-9999999 to 9999999 / 0 / 1]	
1 to 10	Key 1 to Key 10	

5860	SMTP/POP3/IMAP4	CTL
20	Partial Mail Receive Timeout [1 to 168/72/1] Sets the amount of time to wait before saving a mail that breaks up during reception. The received mail is discarded if the remaining portion of the mail is not received during this prescribed time.	
	MDN Response RFC2298Compliance Determines whether RFC2298 compliance is switched on for MDN reply mail. [0 to 1/1/1] 0: No 1: Yes	
22	SMTP Auth. From Field Replacement Determines whether the FROM item of the mail header is switched to the validated account after the SMTP server is validated. [0 to 1/0/1] 0: No. "From" item not switched. 1: Yes. "From" item switched.	

25	SMTP Auth Direct Sending
	<p>Occasionally, all SMTP certifications may fail with SP5860-6 set to "2" to enable encryption during SMTP certification for the SMTP server. This can occur if the SMTP server does not meet RFC standards. In such cases you can use this SP to set the SMTP certification method directly. However, this SP can be used only after SP5860-3 has been set to "1" (On).</p> <p>Bit0: LOGIN Bit1: PLAIN Bit2: CRAM_MD5 Bit3: DIGEST_MD5 Bit4 to Bit 7: Not Used</p>
26	S/MIME:MIME Header Specification
	<p>This SP determines the standard type of header for e-mails sent with S/MIME.</p> <p>[0 to 1 / 0 / 1] 0: Microsoft Outlook Express 1: Internet Draft 2: RFC</p>

5866	Email Report	CTL
1	Report Validity	
	<p>Disables and re-enables the email notification feature.</p> <p>[0 to 1/0/1] 0: Enable 1: Disable</p>	
5	Add Date Field	
	<p>This SP adds the current date to the date field of an email alert that informs the operator that an error has occurred.</p> <p>[0 to 1/0/1] 0: Date not added 1: Date added</p>	

5870	Common Key Info Writing	CTL
	Writes to flash ROM the common proof for validating the device for @Remote specifications.	
1	Writing	Note: These SP's are for future use and currently are not used.
3	Initialize	

5873	SD Card Appli Move	CTL
	Moves an application from one SD card to another..	
1	Move Exec	Executes the move from one SD card to another.
2	Undo Exec	This is an undo function. It cancels the previous execution.

5875	SC Auto Reboot	CTL
1	Reboot Setting	
	<p>Determines whether the machine reboots automatically when an SC error occurs. [0 to 1/0/1]</p> <p>1: The machine does not reboot when an SC error occurs. However, the reboot does not occur for Type "A" SC codes.</p> <p>0: The machine reboots automatically when the machine issues an SC error and logs the SC error code. If the same SC occurs again, the machine does not reboot.</p>	
2	Reboot Type	
	<p>Selects the reboot method after an SC error occurs. [0 to 1/0/1]</p> <p>0: Manual reboot by operator or technician</p> <p>1: Automatic reboot</p>	

5878	Option Setup	CTL
	Press [Execute] to initialize the Data Overwrite Security and HDD Encryption option. Both options are available on SD cards.	
1	Data Overwrite Security	

	<p>This SP enables the Data Overwrite Security option.</p> <p>Note:</p> <ul style="list-style-type: none"> • Before execution the SD card must be in SD Card Slot 1 (option slot). • The SD card must reside in Slot 1 after execution.
2	HDD Encryption
	<p>This SP enables the HDD Encryption option.</p> <p>Note:</p> <ul style="list-style-type: none"> • Before execution the SD card must be in SD Card Slot 1 (option slot). • The SD card can be removed after execution.

5881	Fixed Phrase Block Erasing	CTL
	Press [EXECUTE] to erase fixed phrases supplied by SKB.	

5885	Set WIM Function	CTL	
	This SP determines how access to the Web Image Monitor document server is controlled. These are bit settings where "1" enables and "0" disables.		
20	DocSvr Acc Ctrl		
	Allows or disallows the functions of web image monitor. 0: OFF, 1: ON		
		(7) 0000 0000 (0)	
	LSB	0bit	Denies all access to document server
		1bit	Denies all access to User Tools
		2bit	Denies access to printing
		3bit	Denies access to fax
		4bit	Denies access to scan-to-email
		5bit	Denies access data downloading functions
		6bit	Denies access to data delete functions
	MSB	7bit	Forbid guest user

50	DocSvr Format	
	Selects the display type for the document box list. [0 to 2 / 0 / 1] 0: Thumbnail, 1: Icon, 2: Details	
51	DocSvr Trans	
	Sets the number of documents to be displayed in the document box list. [5 to 20 / 10 / 1]	
100	Set Signature	
	This SP determines whether a signature is attached to scanned documents queued for sending with Web Image Monitor. [0 to 2 / 0 / 1] 0: Set individually Operator selects signature on the send screen when documents are sent via email. Operator has the option of selecting or not selecting a signature. 1: Signature required. A signature must be selected for sending. 2: No signature. No signature required.	
101	Set Encryption	
	Determines whether the scanned documents with the WIM are encrypted when they are transmitted by an e-mail. [0 to 1 / 0 / 1] 0: Not encrypted, 1:Encryption	
200	Detect Mem Leak	
	This SP determines how Web Image Monitor memory leaks are handled. A "1" setting enables the function.	
		(7) 0000 0000 (0)
	Bit 0	Displays memory status at session timeouts.
	Bit 1	Displays memory status at the start/end of PF handler only.
	Bit2-7	Not used
201	DocSvr Timeout	

	This SP sets the length of time for session timeout. The default is 30 min. The time can be reduced to shorten the time between memory leak detections. [1 to 255 / 30 / 1 min.]	
5887	SD Get Counter	CTL
	<p>After you touch [EXECUTE] this SP sends a text file to an SD card inserted in SD card Slot 2. The file is stored in a folder created in the root directory of the SD card called SD_COUNTER. The file is saved as a text file (*.txt) prefixed with the number of the machine.</p> <ul style="list-style-type: none"> • Insert the SD card in SD card Slot 1 (lower slot). • Select SP5887 then touch [EXECUTE]. • Touch [EXECUTE] in the message when you are prompted. 	
5888	Personal Information Protect	CTL
	<p>Selects the protection level for logs. [0 to 1 / 0 / 1] 0: No authentication, No protection for logs 1: No authentication, Protected logs (only an administrator can see the logs)</p>	
	SDK Application Counter	CTL
5893	<p>The machine stores up to six registered names in the SDK application.</p> <ul style="list-style-type: none"> • This SP has been implemented for all machines using Engine O8S and later. • This SP is not needed if there are no SDK applications loaded. 	
1 to 6	SDK1 to SDK-6	
	Plug & Play Maker/Model Name	CTL
5907	<p>Selects the brand name and the production name for Windows Plug & Play. This information is stored in the NVRAM. If the NVRAM is defective, these names should be registered again. After selecting, press the "Original Type" key and "#" key at the same time. When the setting is completed, the beeper sounds five times.</p>	
5913	Switchover Permission Time	

	<p>Sets the length of time to elapse before allowing another application to take control of the display when the application currently controlling the display is not operating because a key has not been pressed.</p> <p>[3 to 30/3/1 s]</p>	
--	--	--

5967	Copy Server: Set Function	CTL
	<p>Disables and enables the document server. This is a security measure that prevents image data from being left in the temporary file sector of the HDD. After changing this setting, switch the main switch off and on to enable the new setting.</p> <p>[0 to 1/0/1]</p> <p>0: Enable 1: Disable</p>	

5974	Cherry Server	CTL
	<p>Selects which version of the Scan Router application program, "Light" or "Full (Professional)", is installed.</p> <p>[0 to 1 / 0 / 1 /step]</p> <p>0: Light version (supplied with this machine) 1: Full version (optional)</p>	

5985	Device Setting	CTL
	<p>The NIC and USB support features are built into the CTL controller. Use this SP to enable and disable these features. In order to use the NIC and USB functions built into the controller board, these SP's must be set to "1".</p> <p>[0 to 2/0/1]</p> <p>0: Disable 1: Enable 2: Enable for @Remote</p>	
1	On Board NIC	
2	On Board USB	

5990	SP Print Mode (SMC Printout)	CTL
------	------------------------------	-----

1	All (Data List)	<p>Prints all of the system parameter lists for the item selected.</p> <p>Input the number for the item that you want to print, and then press [1]: "Execute" on the touch panel.</p>
2	SP (Mode Data List)	
3	User Program	
4	Logging Data	
5	Diagnostic Report	
6	Non-Default	
7	NIB Summary	
8	Capture Log	
21	Copier User Program	
22	Scanner SP	
23	Scanner User Program	
24	SDK/J Summary	
25	SDK/J Application Info.	

SP6-xxx Peripherals

2

6969	Bypass Feed Setting DFU
	<p>This sets the how the bypass feed sensors read paper sizes.</p> <p>[0 to 1/0/1]</p> <p>0: DOM, EU (Japan, Europe)</p> <p>1: NA (North America)</p>

★ Important

- Other Group 6000 SP codes may be displayed but are not used with this machine. (These other SP codes are for peripheral units not support by this machine at the present time. July 2010)

SP7-xxx Data Log

2

7001	Operation Time	
1	Main Motor	
	Shows the total operation time of the main motor that drives the OPC drum.	
2	Scanner Motor	
	Shows the total operation time of the scanner motor that drives the scanner unit rollers that feed originals.	

7401	Total SC Counter	CTL
	Shows the total SC count as a 4-digit number.	

7403	SC History	CTL
1	Latest	Display the most recent service calls in their order of occurrence.
2	Latest 1	
3	Latest 2	
4	Latest 3	
5	Latest 4	
6	Latest 5	
7	Latest 6	
8	Latest 7	
9	Latest 8	
10	Latest 9	

7404	SC991 History	CTL
------	---------------	-----

	<p>This SP determines whether up to the last 10 occurrences of SC991 (Software Error 2) are recorded in the log information.</p> <ol style="list-style-type: none"> 1. Execute SP7403 or print an SMC Report (SP5990) to read the history of the 10 most recent logged errors. 2. If you press [0] on the operation panel with the SP selection menu displayed, you will see detailed information about the recently logged SC991 errors, including the software file name, line number, and so on. 	
1	Latest	<p>Display the occurrences of SC991 in order of occurrence.</p>
2	Latest 1	
3	Latest 2	
4	Latest 3	
5	Latest 4	
6	Latest 5	
7	Latest 6	
8	Latest 7	
9	Latest 8	
10	Latest 9	

7502	Total Paper Jam Counter	CTL
	<p>Displays the total number of copy jams. Display range: 0000 to 9999</p>	

7503	Total Original Jam Counter	CTL
	<p>Displays the total number of original jams. Display range: 0000 to 9999</p>	

7504	Paper Jam Loc(ation)	CTL
	<p>Displays the total number of copy jams by location.</p> <p>A "Paper Late" error occurs when the paper fails to activate the sensor at the precise time. A "Paper Lag" paper jam occurs when the paper remains at the sensor for longer than the prescribed time.</p> <p>Display range: 0000 to 9999</p>	
	Main Machine (D093/D094)	
	1: At Power On	
	3: Tray 1: No Feed	
	4: Tray 2: No Feed	
	5: Tray 3: No Feed	
	8: RF Exit Sn: Not On	
	13: Reg Sn: Not On	
	16: Exit Sn: Not On	
	34: Bypass: No Feed	
	53: Tray 1: Paper Lag	
	54: Tray 2: Paper Lag	
	55: Tray 3: Paper Lag	
	58: RF Exit Sn: Not Off	
	63: Reg Sn: Not Off	
	66: Exit Sn: Not Off	
	84: Bypass Sn: Not Off	
	Folder FD Unit (B889)	
	100 to 146	Not used for this machine

7505	Original Jam Det		CTL
	<p>Displays the total number of original jams by location. These jams occur when the original does not activate the sensors.</p> <p>Display range: 0000 to 9999</p> <p>Note:</p> <ul style="list-style-type: none"> • A "Check In" failure occurs when the paper fails to activate the sensor at the precise time. • A "Check Out" failure occurs when the paper remains at the sensor for longer than the prescribed time and causes a jam. • The 3rd column in the table below tells you the correct component name used in the service manual. 		
		Operation Panel Display	
	1	Org at Power On	
	2	Org Reg Sn: Not On	
	3	Org Reg Sn/Exit Sn: Both Off	
	4	Org Reg Sn: Not Off	
	5	Org Exit Sn: Not Off	
	6	Org Stop	
	7	Org Exit Sn: Not On	
8	Org Interval Error		

7506	Jam Count by Paper Size	CTL
	<p>This SP displays the counts for the number of jams by paper size.</p> <p>Note: In the paper size notations below, "T" means "SEF" (Short Edge Feed).</p>	
97	A0T/A1	
98	A1T/A2	
99	A2T/A3	
100	A3T/A4	
101	A4T	

106	B1T/B2
107	B2T/B3
108	B3T/B4
109	B4T
225	36x48T/24x36
226	24x36T/18x24
227	18x24T/12x18
228	12x18T/9x12
229	9x12T
234	34x44T/22x34
235	22x34T/17x22
236	17x22T/11x17
237	11x17T/8.5x11
238	8.5x11T
255	Others

7507	Plotter Jam History	CTL
	<p>Displays the copy jam history in groups of 10, starting with the most recent 10 jams. Display contents are as follows:</p> <p>CODE: SP7-504-*** number.</p> <p>SIZE: Paper size code in hex. (See the table below.)</p> <p>TOTAL :Total jam error count (SP7003)</p> <p>DATE: Previous jam occurred</p>	

1	Latest	Sample Display: CODE: 007 SIZE: 05h TOTAL: 0000334 DATE: Mon Mar 15 11:44:50 2000
2	Latest 1	
3	Latest 2	
4	Latest 3	
5	Latest 4	
6	Latest 5	
7	Latest 6	
8	Latest 7	
9	Latest 8	
10	Latest 9	

	Original Jam History	CTL
7508	Displays the original jam history in groups of 10, starting with the most recent 10 jams. Display contents are as follows: CODE: SP7505-*** number. SIZE: Paper size code in hex. (See table below.) TOTAL: Total jam error count (SP7003) DATE: Date the previous jam occurred	

1	Latest	Sample Display: CODE: 007 SIZE: 05h TOTAL: 0000334 DATE: Mon Mar 15 11:44:50 2000
2	Latest 1	
3	Latest 2	
4	Latest 3	
5	Latest 4	
6	Latest 5	
7	Latest 6	
8	Latest 7	
9	Latest 8	
10	Latest 9	

Paper Size Hex Codes

These codes are displayed by SP7507 and SP7508.

Paper Size	Code (hex)	Paper Size	Code (hex)
A4 LEF	05	B4 SEF	8D
A5 LEF	06	B5 SEF	8E
LT LEF	26	DLT SEF	A0
A3 SEF	84	LG SEF	A4
A4 SEF	85	LT SEF	A6
A5 SEF	86	Others	FF

7801	ROM No./Firmware Version	CTL
	Displays the ROM number, firmware version numbers, and other important information about the machine. Press ▲ or ▼ to see more information.	

7803	PM Counter Display	CTL
	Displays the PM counter since the last PM.	

7804	PM Counter Reset	CTL
	Resets the PM counter. To reset, press [Execute]	
7807	SC/Jam Counter Reset	CTL
	Resets the SC and jam counters. To reset, press [Execute]. This SP does not reset the jam history counters: SP7507, SP7508.	
7826	MF Error Counter Japan Only	CTL
	Displays the number of counts requested of the card/key counter.	
1	Error Total	
	A request for the count total failed at power on. This error will occur if the device is installed but disconnected.	
2	Error Staple	
	The request for a staple count failed at power on. This error will occur if the device is installed but disconnected.	
7827	MF Error Counter Clear	CTL
	Press [Execute] to reset the values of SP7826 to "0". Japan Only	
7832	Self-Diagnosis Result Display	CTL
	Opens the "Self-Diagnose Result Display" to view details about errors. Use the keys on in the display to scroll through all the information. If no errors have occurred, you will see "No Error".	
7836	Total Memory Size	CTL
	Displays the memory capacity of the controller system: "1024 MB".	
7901	Assert Info.	
	This SP displays the results of the last occurrence of SC990. SC990 is issued when unexpected branching and decision data is generated by the program, and the module name, line number, and values for the error are displayed for analysis. This data should be reported after SC990 occurs.	

1	File Name	Module name
2	Number of Lines	Lines where error occurred.
3	Location	Component affected by error

SP8-xxx Data Log 2

Here are some Group 8 SP's that when used in combination with others can provide useful information.

SP Numbers	What They Do
SP8211 to SP8216	The number of pages scanned to the document server.
SP8401 to SP8406	The number of pages printed from the document server
SP8691 to SP8696	The number of pages sent from the document server

Specifically, the following questions can be answered:

- How is the document server actually being used?
- What application is using the document server most frequently?
- What data in the document server is being reused?

The SP's in this group are prefixed with a letter that indicates the mode of operation (the mode of operation is referred to as an 'application'). Before reading the Group 8 Service Table, make sure that you understand what these prefixes mean.

Prefix	What It Means	
T:	Total: (Grand Total).	Grand total of the items counted for all applications (C, F, P, etc.)..
C:	Copy application.	Totals (pages, jobs, etc.) executed for each application when the job was not stored on the document server.
P:	Print application.	
S:	Scan application.	
L:	Local storage (document server)	Totals (jobs, pages, etc.) for the document server. The L: counters work differently case by case. Sometimes, they count jobs/pages stored on the document server; this can be in document server mode (from the document server window), or from another mode, such as from a printer driver or by pressing the Store File button in the Copy mode window. Sometimes, they include occasions when the user uses a file that is already on the document server. Each counter will be discussed case by case.

O:	Other applications (external network applications, for example)	Refers to network applications such as Web Image Monitor. Utilities developed with the SDK (Software Development Kit) will also be counted with this group in the future.
----	---	---

The Group 8 SP codes are limited to 17 characters, forced by the necessity of displaying them on the smaller LCD's of copiers, printers and faxes that also use these SP's. Read over the list of abbreviations below and refer to it again if you see the name of an SP that you do not understand.

2

Key for Abbreviations

Abbreviation	What It Means
/	"By", e.g. "T:Jobs/Apl" = Total Jobs "by" Application
>	More (2> "2 or more", 4> "4 or more")
AddBook	Address Book
Apl	Application
B/W	Black & White
Bk	Black
C	Cyan
ColCr	Color Create
ColMode	Color Mode
Comb	Combine
Comp	Compression
Deliv	Delivery
DesApl	Designated Application. The application (Copy, Fax, Scan, Print) used to store the job on the document server, for example.
Dev Counter	Development Count, no. of pages developed.
Dup, Duplex	Duplex, printing on both sides
Emul	Emulation
FC	Full Color
FIN	Post-print processing, i.e. finishing (punching, stapling, etc.)

Abbreviation	What It Means
Full Bleed	No Margins
GenCopy	Generation Copy Mode
GPC	Get Print Counter. For jobs 10 pages or less, this counter does not count up. For jobs larger than 10 pages, this counter counts up by the number that is in excess of 10 (e.g., for an 11-page job, the counter counts up $11 - 10 = 1$)
IFax	Internet Fax
ImgEdt	Image Edit performed on the original with the copier GUI, e.g. border removal, adding stamps, page numbers, etc.
K	Black (YMCK)
LS	Local Storage. Refers to the document server.
LSize	Large (paper) Size
Mag	Magnification
MC	One color (monochrome)
NRS	New Remote Service, which allows a service center to monitor machines remotely. "NRS" is used overseas, "CSS" is used in Japan.
Org	Original for scanning
OrgJam	Original Jam
Palm 2	Print Job Manager/Desk to p Edi to r: A pair of utilities that allows print jobs to be distributed evenly among the printers on the network, and allows files to be moved around, combined, and converted to different formats.
PC	Personal Computer
PGS	Pages. A page is the total scanned sursection of the original. Duplex pages count as two pages, and A3 simplex count as two pages if the A3/DLT counter SP is switched ON.
PJob	Print Jobs
Ppr	Paper
PrtJam	Printer (plotter) Jam
PrtPGS	Print Pages

Abbreviation	What It Means
R	Red (Toner Remaining). Applies to the wide format model A2 only. This machine is under development and currently not available.
Rez	Resolution
SC	Service Code (Error SC code displayed)
Scn	Scan
Sim, Simplex	Simplex, printing on 1 side.
S- to -Email	Scan- to -E-mail
SMC	SMC report printed with SP5990. All of the Group 8 counters are recorded in the SMC report.
Svr	Server
to nEnd	toner End
to nSave	toner Save
TXJob	Send, Transmission
YMC	Yellow, Magenta, Cyan
YMCK	Yellow, Magenta, Cyan, Black

All of the Group 8SP's are reset with SP5 801 1 Memory All Clear, or the Counter Reset SP7 808.

8001	T:Total Jobs	These SP's count the number of times each application is used to do a job. [0 to 9999999 / 0 / 1] Note: The L: counter is the total number of times the other applications are used to send a job to the document server, plus the number of times a file already on the document server is used.
8002	C:Total Jobs	
8004	P:Total Jobs	
8005	S:Total Jobs	
8006	L:Total Jobs	

- These SP's reveal the number of times an application is used, not the number of pages processed.
- When an application is opened for image input or output, this counts as one job.
- Interrupted jobs (paper jams, etc.) are counted, even though they do not finish.
- Only jobs executed by the operator are counted. Jobs executed by the operator engineer using the SP modes are not counted.

2

- When using secure printing (when a password is required to start the print job), the job is counted at the time when either “Delete Data” or “Specify Output” is specified.
- When a copy job on the document server is printed, SP8022 also increments, and when a print job stored on the document server is printed, SP8024 also increments.
- When an original is both copied and stored on the document server, the C: and L: counters both increment.
- When a print job is stored on the document server, only the L: counter increments.
- When the user presses the Document Server button to store the job on the document server, only the L: counter increments.
- When the user enters document server mode and prints data stored on the document server, only the L: counter increments.
- When an image received from Palm 2 is received and stored, the L: counter increments.
- When the operator prints a report (user code list, for example), the O: counter increments.

8011	T:Jobs/LS	<p>These SP's count the number of jobs stored to the document server by each application, to reveal how local storage is being used for input.</p> <p>[0 to 99999999 / 0 / 1]</p> <p>The L: counter counts the number of jobs stored from within the document server mode screen at the operation panel.</p>
8012	C:Jobs/LS	
8014	P:Jobs/LS	
8015	S:Jobs/LS	
8016	L:Jobs/LS	
8017	O:Jobs/LS	

- When a scan job is sent to the document server, the S: counter increments. When you enter document server mode and then scan an original, the L: counter increments.
- When a print job is sent to the document server, the P: counter increments.
- When a network application sends data to the document server, the O: counter increments.
- When an image from Palm 2 is stored on the document server, the O: counter increments.

8021	T:Pjob/LS	<p>These SP's reveal how files printed from the document server were stored on the document server originally.</p> <p>[0 to 99999999 / 0 / 1]</p> <p>The L: counter counts the number of jobs stored from within the document server mode screen at the operation panel.</p>
8022	C:Pjob/LS	
8024	P:Pjob/LS	
8025	S:Pjob/LS	
8026	L:Pjob/LS	
8027	O:Pjob/LS	

- When a copy job stored on the document server is printed with another application, the C: counter increments.
- When an application like DeskTopBinder merges a copy job that was stored on the document server with a print job that was stored on the document server, the C: and P: counters both increment.
- When a job already on the document server is printed with another application, the L: counter increments.
- When a scanner job stored on the document server is printed with another application, the S: counter increments. If the original was scanned from within document server mode, then the L: counter increments.
- When images stored on the document server by a network application (including Palm 2), are printed with another application, the O: counter increments.
- When a copy job stored on the document server is printed with a network application (Web Image Monitor, for example), the C: counter increments.

8031	T:Pjob/DesApl	<p>These SP's reveal what applications were used to output documents from the document server.</p> <p>[0 to 9999999 / 0 / 1]</p> <p>The L: counter counts the number of jobs printed from within the document server mode screen at the operation panel.</p>
8032	C:Pjob/DesApl	
8034	P:Pjob/DesApl	
8035	S:Pjob/DesApl	
8036	L:Pjob/DesApl	
8037	O:Pjob/DesApl	

- When documents already stored on the document server are printed, the count for the application that started the print job is incremented.
- When the print job is started from a network application (Desk to p Binder, Web Image Monitor, etc.) the L: counter increments.

8041	T:TX Jobs/LS	<p>These SP's count the applications that stored files on the document server that were later accessed for transmission over the telephone line or over a network (attached to an e-mail).</p> <p>[0 to 9999999 / 0 / 1]</p> <p>Note:</p> <ul style="list-style-type: none"> • Jobs merged for sending are counted separately. • The L: counter counts the number of jobs scanned from within the document server mode screen at the operation panel.
8042	C:TX Jobs/LS	
8044	P:TX Jobs/LS	
8045	S:TX Jobs/LS	
8046	L:TX Jobs/LS	
8047	O:TX Jobs/LS	

- When a stored copy job is sent from the document server, the C: counter increments.
- When images stored on the document server by a network application or Palm2 are sent as an e-mail, the O: counter increments.

8051	T:TX Jobs/DesApl	These SP's count the applications used to send files from the document server over the telephone line or over a network (attached to an e-mail. Jobs merged for sending are counted separately. [0 to 9999999 / 0 / 1] The L: counter counts the number of jobs sent from within the document server mode screen at the operation panel.
8052	C:TX Jobs/DesApl	
8054	P:TX Jobs/DesApl	
8055	S:TX Jobs/DesApl	
8056	L:TX Jobs/DesApl	
8057	O:TX Jobs/DesApl	

- If the send is started from Desk to p Binder or Web Image Monitor, for example, then the O: counter increments.

8061	T:FIN Jobs	[0 to 9999999 / 0 / 1]
	These SP's total the finishing methods. The finishing method is specified by the application.	
8062	C:FIN Jobs	[0 to 9999999 / 0 / 1]
	These SP's total finishing methods for copy jobs only. The finishing method is specified by the application.	
8064	P:FIN Jobs	[0 to 9999999 / 0 / 1]
	These SP's total finishing methods for print jobs only. The finishing method is specified by the application.	
8065	S:FIN Jobs	[0 to 9999999 / 0 / 1]
	These SP's total finishing methods for scan jobs only. The finishing method is specified by the application. Note: Finishing features for scan jobs are not available at this time.	
8066	L:FIN Jobs	[0 to 9999999 / 0 / 1]
	These SP's total finishing methods for jobs output from within the document server mode screen at the operation panel. The finishing method is specified from the print window within document server mode.	

8067	O:FIN Jobs Not Used		[0 to 9999999/ 0 / 1]
	These SP's total finishing methods for jobs executed by an external application, over the network. The finishing method is specified by the application.		
806x 1	Sort	Number of jobs started in Sort mode. When a stored copy job is set for Sort and then stored on the document server, the L: counter increments. (See SP8066 1)	
806x 2	Stack	Number of jobs started in Sort mode.	
806x 3	Staple	Number of jobs started in Staple mode.	
806x 4	Booklet	Number of jobs started in Booklet mode. If the machine is in staple mode, the Staple counter also increments.	
806x 5	Z-Fold	Number of jobs started in any mode other than the Booklet mode and set for folding (Z-fold).	
806x 6	Punch	Number of jobs started in Punch mode. When Punch is set for a print job, the P: counter increments. (See SP8064 6.)	
806x 7	Other	Reserved. Not used.	
		Important: Codes 8 to 14 are not used with this machine.	

8071	T:Jobs/PGS		[0 to 9999999/ 0 / 1]
	These SP's count the number of jobs broken down by the number of pages in the job, regardless of which application was used.		
8072	C:Jobs/PGS		[0 to 9999999/ 0 / 1]
	These SP's count and calculate the number of copy jobs by size based on the number of pages in the job.		
8074	P:Jobs/PGS		[0 to 9999999/ 0 / 1]
	These SP's count and calculate the number of print jobs by size based on the number of pages in the job.		
8075	S:Jobs/PGS		[0 to 9999999/ 0 / 1]
	These SP's count and calculate the number of scan jobs by size based on the number of pages in the job.		

8076	L:Jobs/PGS	[0 to 9999999/ 0 / 1]	
	These SP's count and calculate the number of jobs printed from within the document server mode window at the operation panel, by the number of pages in the job.		
8077	O:Jobs/PGS	[0 to 9999999/ 0 / 1]	
	These SP's count and calculate the number of "Other" application jobs (Web Image Monitor, Palm 2, etc.) by size based on the number of pages in the job.		
807x 1	1 Page	807x 8	21 to 50 Pages
807x 2	2 Pages	807x 9	51 to 100 Pages
807x 3	3 Pages	807x 10	101 to 300 Pages
807x 4	4 Pages	807x 11	301 to 500 Pages
807x 5	5 Pages	807x 12	501 to 700 Pages
807x 6	6 to ~ Pages	807x 13	701 to 1000 Pages
807x 7	11 ~ 20 Pages	807x 14	1001 to Pages

Example: When a copy job is printed on the document server in document server mode, the appropriate L: counter (SP8076 0xx) increments.

- Interrupted jobs (paper jam, etc.) are counted, even though they do not finish.
- If a job is paused and re-started, it counts as one job.
- If the finisher runs out of staples during a print and staple job, then the job is counted at the time the error occurs.
- For copy jobs (SP 8072) and scan jobs (SP 8075), the total is calculated by multiplying the number of sets of copies by the number of pages scanned. (One duplex page counts as 2.)
- The first test print and subsequent test prints to adjust settings are added to the number of pages of the copy job (SP 8072).
- When printing the first page of a job from within the document server screen, the page is counted.

8131	T:S-to-Email Jobs	[0 to 9999999/ 0 / 1]
	These SP's count the total number of jobs scanned and attached to an e-mail, regardless of whether the document server was used or not.	
8135	S:S-to-Email Jobs	
	These SP's count the number of jobs scanned and attached to an e-mail, without storing the original on the document server.	

- These counters count jobs, not pages.
- If the job is stored on the document server, after the job is stored it is determined to be color or black-and-white then counted.
- If the job is cancelled during scanning, or if the job is cancelled while the document is waiting to be sent, the job is not counted.
- If the job is cancelled during sending, it may or may not be counted, depending on what stage of the process had been reached when the job was cancelled.
- If several jobs are combined for sending to the Scan Router, Scan- to -Email, or Scan- to -PC, or if one job is sent to more than one destination. each send is counted separately. For example, if the same document is sent by Scan- to -Email as well as Scan- to -PC, then it is counted twice (once for Scan- to -Email and once for Scan- to -PC).

8141	T:Deliv Jobs/Svr	[0 to 99999999 / 0 / 1]
	These SP's count the total number of jobs scanned and sent to a Scan Router server.	
8145	S:Deliv Jobs/Svr	
	These SP's count the number of jobs scanned and sent to a Scan Router server.	

- These counters count jobs, not pages.
- The jobs are counted even though the arrival and reception of the jobs at the Scan Router server cannot be confirmed.
- If even one color image is mixed with black-and-white images, then the job is counted as a "Color" job.
- If the job is cancelled during scanning, or if the job is cancelled while the document is waiting to be delivered, the job is not counted.
- If the job is cancelled during sending, it may or may not be counted, depending on what stage of the process had been reached when the job was cancelled.
- Even if several files are combined for sending, the transmission counts as one job.

8151	T:Deliv Jobs/PC	[0 to 99999999 / 0 / 1]
	These SP's count the total number of jobs scanned and sent to a folder on a PC (Scan- to -PC). Note: At the present time, 8151 and 8155 perform identical counts.	
8155	S:Deliv Jobs/PC	
	These SP's count the total number of jobs scanned and sent with Scan- to -PC.	

- These counters count jobs, not pages.

2

- If the job is cancelled during scanning, it is not counted.
- If the job is cancelled while it is waiting to be sent, the job is not counted.
- If the job is cancelled during sending, it may or may not be counted, depending on what stage of the process had been reached when the job was cancelled.
- Even if several files are combined for sending, the transmission counts as one job.

8171	T: Deliv Jobs/WSD	
8175	S: Deliv Jobs/WSD	
	WSD (Web Services on Devices) is the Microsoft standard for connectivity to web-service enabled devices	
8181	T: Scan to Media Jobs	
8185	S: Scan to Media Jobs	
	Scan to media jobs refers to jobs sent to the USB2.0/SD Card Slot option installed on the main machine.	
1	B/W	
2	Color	
3	ACS	

8191	T:Total Scan PGS	These SP's count the pages scanned by each application that uses the scanner to scan images. [0 to 9999999 / 0 / 1]
8192	C:Total Scan PGS	
8195	S:Total Scan PGS	
8196	L:Total Scan PGS	

- SP 8191 to 8196 count the number of scanned sides of pages, not the number of physical pages.
- These counters do not count reading user stamp data, or reading color charts to adjust color.
- Previews done with a scanner driver are not counted.
- A count is done only after all images of a job have been scanned.
- Scans made in SP mode are not counted.

Examples

- If 3 B5 pages and 1 A3 page are scanned with the scanner application but not stored, the S: count is 4.

- If both sides of 3 A4 sheets are copied and stored to the document server using the Store File but to n in the Copy mode window, the C: count is 6 and the L: count is 6.
- If both sides of 3 A4 sheets are copied but not stored, the C: count is 6.
- If you enter document server mode then scan 6 pages, the L: count is 6.

8211	T:Scan PGS/LS	These SP's count the number of pages scanned in to the document server . [0 to 9999999/ 0 / 1] The L: counter counts the number of pages s to red from within the document server mode screen at the operation panel, and with the Store File but to n from within the Copy mode screen
8212	C:Scan PGS/LS	
8215	S:Scan PGS/LS	
8216	L:Scan PGS/LS	

- Reading user stamp data is not counted.
- If a job is cancelled, the pages output as far as the cancellation are counted.
- If the scanner application scans and stores 3 B5 sheets and 1 A4 sheet, the S: count is 4.
- If pages are copied but not stored on the document server, these counters do not change.
- If both sides of 3 A4 sheets are copied and stored to the document server, the C: count is 6 and the L: count is 6.
- If you enter document server mode then scan 6 pages, the L: count is 6.

8221	ADF Org Feeds		[0 to 9999999/ 0 / 1]
	These SP's count the number of pages fed through the ADF for front and back side scanning.		
1	Front	<p>Number of front sides fed for scanning:</p> <p>With an ADF that can scan both sides simultaneously, the Front side count is the same as the number of pages fed for either simplex or duplex scanning.</p> <p>With an ADF that cannot scan both sides simultaneously, the Front side count is the same as the number of pages fed for duplex front side scanning. (The front side is determined by which side the user loads section up.)</p>	
2	Back	<p>Number of rear sides fed for scanning:</p> <p>With an ADF that can scan both sides simultaneously, the Back count is the same as the number of pages fed for duplex scanning.</p> <p>With an ADF that cannot scan both sides simultaneously, the Back count is the same as the number of pages fed for duplex rear-side scanning.</p>	

- When 1 sheet is fed for duplex scanning the Front count is 1 and the Back count is 1.
- If a jam occurs during the job, recovery processing is not counted to avoid double counting. Also, the pages are not counted if the jam occurs before the first sheet is output.

8231	Scan PGS/Mode	[0 to 9999999/ 0 / 1]
	These SP's count the number of pages scanned by each ADF mode to determine the work load on the ADF.	
1	Large Volume	Selectable. Large copy jobs that cannot be loaded in the ADF a to ne time.
2	SADF	Selectable. Feeding pages one by one through the ADF.
3	Mixed Size	Selectable. Select "Mixed Sizes" on the operation panel.
4	Custom Size	Selectable. Originals of non-standard size.
5	Platen	Book mode. Raising the ADF and placing the original directly on the platen.
6	Mixed 1 side/2side	Job mixed with printing one/two sides.

- If the scan mode is changed during the job, for example, if the user switches from ADF to Platen mode, the count is done for the last selected mode.
- If the user selects "Mixed Sizes" for copying in the platen mode, the Mixed Size count is enabled.
- In the SADF mode if the user copies 1 page in platen mode and then copies 2 pages with SADF, the Platen count is 1 and the SADF count is 3.

8241	T:Scan PGS/Org	[0 to 9999999/ 0 / 1]		
	These SP's count the total number of scanned pages by original type for all jobs, regardless of which application was used.			
8242	C:Scan PGS/Org	[0 to 9999999/ 0 / 1]		
	These SP's count the number of pages scanned by original type for Copy jobs.			
8245	S:Scan PGS/Org	[0 to 9999999/ 0 / 1]		
	These SP's count the number of pages scanned by original type for Scan jobs.			
8246	L:Scan PGS/Org	[0 to 9999999/ 0 / 1]		
	These SP's count the number of pages scanned and stored from within the document server mode screen at the operation panel, and with the Store File but to n from within the Copy mode screen			
	8241	8242	8245	8246
824x 1: Text	Yes	Yes	Yes	Yes

824x 2: Text/Photo	Yes	Yes	Yes	Yes
824x 3: Photo	Yes	Yes	Yes	Yes
824x 4: GenCopy, Pale	Yes	No	Yes	Yes
824x 5: Map	Yes	Yes	No	Yes
824x 6: Normal/Detail	Yes	No	No	No
824x 7: Fine/Super Fine	Yes	No	No	No
824x 8: Binary	Yes	No	Yes	No
824x 9: Grayscale	Yes	No	No	No
824x 10: Color	Yes	No	No	No
824x 11: Other	Yes	Yes	Yes	Yes

- If the scan mode is changed during the job, for example, if the user switches from ADF to Platen mode, the count is done for the last selected mode.

8251	T:Scan PGS/ImgEdt	<p>These SP's show how many times Image Edit features have been selected at the operation panel for each application. Some examples of these editing features are:</p> <p>Erase> Border</p> <p>Erase> Center</p> <p>Image Repeat</p> <p>Centering</p> <p>Positive/Negative</p> <p>[0 to 9999999 / 0 / 1]</p> <p>Note: The count totals the number of times the edit features have been used. A detailed breakdown of exactly which features have been used is not given.</p>
8252	C:Scan PGS/ImgEdt	
8255	S:Scan PGS/ImgEdt	
8256	L:Scan PGS/ImgEdt	
8257	O:Scan PGS/ImgEdt	

- The L: counter counts the number of pages s to red from within the document server mode screen at the operation panel, and with the Store File but to n from within the Copy mode screen.

8281	T:Scan PGS/TWAIN	<p>These SP's count the number of pages scanned using a TWAIN driver. These counters reveal how the TWAIN driver is used for delivery functions.</p> <p>[0 to 9999999/ 0 / 1]</p> <p>Note: At the present time, these counters perform identical counts.</p>
8285	S:Scan PGS/TWAIN	

8291	T:Scan PGS/Stamp	<p>These SP's count the number of pages stamped with the stamp in the ADF unit.</p> <p>[0 to 9999999/ 0 / 1]</p>
8295	S:Scan PGS/Stamp	

8301	T:Scan PGS/Size	[0 to 9999999/ 0 / 1]	
	<p>These SP's count by size the total number of pages scanned by all applications. Use these totals to compare original page size (scanning) and output (printing) page size [SP 8-441].</p>		
8302	C:Scan PGS/Size	[0 to 9999999/ 0 / 1]	
	<p>These SP's count by size the total number of pages scanned by the Copy application. Use these totals to compare original page size (scanning) and output (printing) page size [SP 8-442].</p>		
8305	S:Scan PGS/Size	[0 to 9999999/ 0 / 1]	
	<p>These SP's count by size the total number of pages scanned by the Scan application. Use these totals to compare original page size (scanning) and output page size [SP 8-445].</p>		
8306	L:Scan PGS/Size	[0 to 9999999/ 0 / 1]	
	<p>These SP's count by size the total number of pages scanned and stored from within the document server mode screen at the operation panel, and with the Store File but to n from within the Copy mode screen. Use these totals to compare original page size (scanning) and output page size [SP 8-446].</p>		
830x 1	A3	830x 104	B1
830x 2	A4	830x 105	B2
830x 4	B4	830x 106	30x42
830x 6	DLT	830x 107	34x44
830x 8	LT	830x 108	22x34

830x 100	A2	830x 109	17x22
830x 101	B3	830x 254	Other (Standard)
830x 102	A0	830x 255	Other (Custom)
830x 103	A1		

2

8311	T:Scan PGS/Rez	[0 to 9999999 / 0 / 1]
	These SP's count by resolution setting the total number of pages scanned by applications that can specify resolution settings.	
8315	S:Scan PGS/Rez	[0 to 9999999 / 0 / 1]
	These SP's count by resolution setting the total number of pages scanned by applications that can specify resolution settings. Note: At the present time, 8311 and 8315 perform identical counts.	
831x 1	1200dpi ~	
831x 2	600dpi ~ 1199dpi	
831x 3	400dpi ~ 599dpi	
831x 4	200dpi ~ 399dpi	
831x 5	~ 199dpi	

- Copy resolution settings are fixed so they are not counted.
- The Fax application does not allow finely-adjusted resolution settings so no count is done for the Fax application.

8381	T:Total PrtPGS	These SP's count the number of pages printed by the operator. The counter for the application used for storing the pages increments. [0 to 99 999 999 / 0 / 1] The L: counter counts the number of pages stored from within the document server mode screen at the operation panel. Pages stored with the Store File but not from within the Copy mode screen go to the C: counter.
8382	C:Total PrtPGS	
8384	P:Total PrtPGS	
8385	S:Total PrtPGS	
8386	L:Total PrtPGS	
8387	O:Total PrtPGS	
838x 1	Field Number	Total number of copies (regardless of size)

838x 2	Length (High)	Total length
838x 3	Length (Low)	Total length
838x 4	Area (High)	Total area coverage
838x 5	Area (Low)	Total area coverage
	<p>Note:</p> <ul style="list-style-type: none"> • The values for "Length" are displayed in mm. If a "Length" reading is "42126" this is 42,126 mm (42.126 m). • The values for "Area" are displayed as mm². If an "Area" reading is "33213257" this is 33,213,257 mm² (33,213.257 m²). • The counts for the "Length" and "Area" start with "Low". Once the count exceeds the width of the field on the display the "Low" field will reset to "0" and the count overflows to the "High" SP codes. (This is necessary because the fields of the "Low" SP codes are limited to 8 digits and not wide enough to display the full reading for a reading larger than 8 digits.) • Always check the "Low" SP first. If the "Low" display is zero, check the "High" field. • When the length count reaches "99,999,999" in the "Low" field (8 digits), for example, after the next copy the count will show "1" in the "High" field and "00 000 000" in the "Low". Multiply the "1" in the "High" field by: 1) 10⁸ (100,000,000 mm), 2) 10⁵ (100,000 m) or 3) 10² (100 kilometers) to determine the accurate count. 	

- When several documents are merged for a print job, the number of pages s to red are counted for the application that stored them.
- These counters are used primarily to calculate charges on use of the machine, so the following pages are not counted as printed pages:
 - Blank pages in a duplex printing job.
 - Blank pages inserted as document covers, chapter title sheets, and slip sheets.
 - Reports printed to confirm counts.
 - All reports done in the service mode (service summaries, engine maintenance reports, etc.)
 - Test prints for machine image adjustment.
 - Error notification reports.
 - Partially printed pages as the result of a jam.

8401	T:PrtPGS/LS	<p>These SP's count the number of pages printed from the document server. The counter for the application used to print the pages is incremented.</p> <p>The L: counter counts the number of jobs stored from within the document server mode screen at the operation panel.</p> <p>[0 to 9999999 / 0 / 1]</p>
8402	C:PrtPGS/LS	
8404	P:PrtPGS/LS	
8405	S:PrtPGS/LS	
8406	L:PrtPGS/LS	

- Print jobs done with Web Image Monitor and Desk to p Binder are added to the L: count.
- Fax jobs done with Web Image Monitor and Desk to p Binder are added to the F: count.

8421	T:PrtPGS/Dup Comb	[0 to 9999999 / 0 / 1]
	These SP's count by binding and combine, and n-Up settings the number of pages processed for printing. This is the total for all applications.	
8422	C:PrtPGS/Dup Comb	[0 to 9999999 / 0 / 1]
	These SP's count by binding and combine, and n-Up settings the number of pages processed for printing by the application.	
8424	P:PrtPGS/Dup Comb	[0 to 9999999 / 0 / 1]
	These SP's count by binding and combine, and n-Up settings the number of pages processed for printing by the printer application.	
8425	S:PrtPGS/Dup Comb	[0 to 9999999 / 0 / 1]
	These SP's count by binding and combine, and n-Up settings the number of pages processed for printing by the scanner application.	
8426	L:PrtPGS/Dup Comb	[0 to 9999999 / 0 / 1]
	These SP's count by binding and combine, and n-Up settings the number of pages processed for printing from within the document server mode window at the operation panel.	
8427	O:PrtPGS/Dup Comb	[0 to 9999999 / 0 / 1]
	These SP's count by binding and combine, and n-Up settings the number of pages processed for printing by Other applications	
842x 1	Simplex> Duplex	
842x 2	Duplex> Duplex	

842x 3	Book> Duplex	
842x 4	Simplex Combine	
842x 5	Duplex Combine	
842x 6	2>	2 pages on 1 side (2-Up)
842x 7	4>	4 pages on 1 side (4-Up)
842x 8	6>	6 pages on 1 side (6-Up)
842x 9	8>	8pages on 1 side (8-Up)
842x 10	9>	9 pages on 1 side (9-Up)
842x 11	16>	16 pages on 1 side (16-Up)
842x 12	Booklet	
842x 13	Magazine	

- These counts (SP8421 to SP8427) are especially useful for operators who need to improve their compliance with ISO standards for the reduction of paper consumption.
- Pages that are only partially printed with the n-Up functions are counted as 1 page.
- Here is a summary of how the counters work for Booklet and Magazine modes:

Booklet		Magazine	
Original Pages	Count	Original Pages	Count
1	1	1	1
2	2	2	2
3	2	3	2
4	2	4	2
5	3	5	4
6	4	6	4
7	4	7	4
8	4	8	4

8431	T:PrtPGS/ImgEdt	[0 to 9999999/ 0 / 1]
	These SP's count the total number of pages output with the three features below, regardless of which application was used.	
8432	C:PrtPGS/ImgEdt	[0 to 9999999/ 0 / 1]
	These SP's count the total number of pages output with the three features below with the copy application.	
8434	P:PrtPGS/ImgEdt	[0 to 9999999/ 0 / 1]
	These SP's count the total number of pages output with the three features below with the print application.	
8436	L:PrtPGS/ImgEdt	[0 to 9999999/ 0 / 1]
	These SP's count the total number of pages output from within the document server mode window at the operation panel with the three features below.	
8437	O:PrtPGS/ImgEdt	[0 to 9999999/ 0 / 1]
	These SP's count the total number of pages output with the three features below with Other applications.	
843x 1	Cover/Slip Sheet	Total number of covers or slip sheets inserted. The count for a cover printed on both sides counts 2.
843x 2	Series/Book	The number of pages printed in series (one side) or printed as a book with booklet right/left pagination.
843x 3	User Stamp	The number of pages printed where stamps were applied, including page numbering and date stamping.

8441	T:PrtPGS/Ppr Size	[0 to 9999999/ 0 / 1]
	These SP's count by print paper size the number of pages printed by all applications.	
8442	C:PrtPGS/Ppr Size	[0 to 9999999/ 0 / 1]
	These SP's count by print paper size the number of pages printed by the copy application.	
8444	P:PrtPGS/Ppr Size	[0 to 9999999/ 0 / 1]
	These SP's count by print paper size the number of pages printed by the printer application.	

8445	S:PrtPGS/Ppr Size	[0 to 9999999/ 0 / 1]	
	These SP's count by print paper size the number of pages printed by the scanner application.		
8446	L:PrtPGS/Ppr Size	[0 to 9999999/ 0 / 1]	
	These SP's count by print paper size the number of pages printed from within the document server mode window at the operation panel.		
8447	O:PrtPGS/Ppr Size	[0 to 9999999/ 0 / 1]	
	These SP's count by print paper size the number of pages printed by Other applications.		
844x 1	A3	844x 240	841 mm Custom:-A0
844x 2	A4	844x 241	594 mm Custom
844x 4	B4	844x 242	420 mm Custom
844x 6	DLT	844x 243	297 mm Custom
844x 8	LT	844x 244	210 mm Custom
844x 100	A2	844x 245	728 mm Custom
844x 101	B3	844x 246	515 mm Custom
844x 102	A0	844x 247	364 mm Custom
844x 103	A1	844x 248	257 mm Custom
844x 104	B1	844x 249	30/34/36 inch Custom
844x 105	B2	844x 250	22 inch Custom
844x 106	30x42	844x 251	17 inch Custom
844x 107	34x44	844x 252	11 inch Custom
844x 108	22x34	844x 253	8.5 inch Custom
844x 109	17x22	844x 254	Other (Standard)
844x 239	841 mm Custom: A0-	844x 255	Other (Custom)

- These counters do not distinguish between LEF and SEF.

8451	PrtPGS/Ppr Tray	[0 to 9999999 / 0 / 1]
	These SP's count the number of sheets fed from each paper feed station.	
1	Bypass	Bypass Table
2	Tray 1	Copier
3	Tray 2	Copier
4	Tray 3	Paper Tray Unit (Option)
5	Tray 4	Paper Tray Unit (Option)
6	Tray 5	LCT (Option)
*	Tray 6 to 15	Not used.

8461	T:PrtPGS/Ppr Type	[0 to 9999999 / 0 / 1]
	<p>These SP's count by paper type the number pages printed by all applications.</p> <p>These counters are not the same as the PM counter. The PM counter is based on feed timing to accurately measure the service life of the feed rollers. However, these counts are based on output timing.</p> <p>Blank sheets (covers, chapter covers, slip sheets) are also counted.</p> <p>During duplex printing, pages printed on both sides count as 1, and a page printed on one side counts as 1.</p>	
8462	C:PrtPGS/Ppr Type	[0 to 9999999 / 0 / 1]
	These SP's count by paper type the number pages printed by the copy application.	
8464	P:PrtPGS/Ppr Type	[0 to 9999999 / 0 / 1]
	These SP's count by paper type the number pages printed by the printer application.	
8466	L:PrtPGS/Ppr Type	[0 to 9999999 / 0 / 1]
	These SP's count by paper type the number pages printed from within the document server mode window at the operation panel.	
846x 1	Normal	
846x 2	Recycled	
846x 3	Special	

846x 4	Thick
846x 5	Normal (Back)
846x 6	Thick (Back)
846x 7	OHP
846x 8	Other

8471	PrtPGS/Mag	[0 to 9999999 / 0 / 1]
	These SP's count by magnification rate the number of pages printed.	
1	~49%	
2	50%~99%	
3	100%	
4	101%~200%	
5	201%~	

- Counts are done for magnification adjusted for pages, not only on the operation panel but performed remotely with an external network application capable of performing magnification adjustment as well.
- Magnification adjustments done with printer drivers with PC applications such as Excel are also counted.
- Magnification adjustments done for adjustments after they have been stored on the document server are not counted.
- Magnification adjustments performed automatically during Au to Reduce/Enlarge copying are counted.
- The magnification rates of blank cover sheets, slip sheets, etc. are automatically assigned a rate of 100%.

8511	T:PrtPGS/Emul	[0 to 9999999 / 0 / 1]
	These SP's count by printer emulation mode the total number of pages printed.	
8514	P:PrtPGS/Emul	[0 to 9999999 / 0 / 1]
	These SP's count by printer emulation mode the total number of pages printed.	
851x 1	RPCS	

851x 2	RPDL	
851x 3	PS3	
851x 4	R98	
851x 5	R16	
851x 6	GL/GL2	
851x 7	R55	
851x 8	RTIFF	
851x 9	PDF	
851x 10	PCL5e/5c	
851x 11	PCL XL	
851x 12	IPDL-C	
851x 13	BM-Links	Japan Only
851x 14	Other	
851x 15	IPDS	

- SP8511 and SP8514 return the same results as they are both limited to the Print application.
- Print jobs output to the document server are not counted.

8521	T:PrtPGS/FIN	[0 to 9999999/ 0 / 1]
	These SP's count by finishing mode the total number of pages printed by all applications.	
8522	C:PrtPGS/FIN	[0 to 9999999/ 0 / 1]
	These SP's count by finishing mode the total number of pages printed by the Copy application.	
8524	P:PrtPGS/FIN	[0 to 9999999/ 0 / 1]
	These SP's count by finishing mode the total number of pages printed by the Print application.	
8525	S:PrtPGS/FIN	[0 to 9999999/ 0 / 1]
	These SP's count by finishing mode the total number of pages printed by the Scanner application.	

8526	L:PrtPGS/FIN	[0 to 9999999 / 0 / 1]
	These SP's count by finishing mode the total number of pages printed from within the document server mode window at the operation panel.	
852x 1	Sort	
852x 2	Stack	
852x 3	Staple	
852x 4	Booklet	
852x 5	Z-Fold	
852x 6	Punch	
852x 7	Other	
<p>Note:</p> <ul style="list-style-type: none"> • If stapling is selected for finishing and the stack is toolarge for stapling, the unstapled pages are still counted. • The counts for staple finishing are based on output to the staple tray, so jam recoveries are counted. 		

8531	Staples	Not Used
------	---------	----------

8551	T: PrtBooks/FIN	Not Used
8552	O: PrtBooks/FIN	
8554	P: PrtBooks/FIN	
8556	L: PrtBooks/FIN	
1	Perfect-Bind	
2	Ring-Bind	

	T:Counter	[0 to 99999999 / 0 / 1]
8581	<p>These SP's count the total output broken down by color output, regardless of the application used. In addition to being displayed in the SMC Report, these counters are also displayed in the User to ols display on the copy machine.</p> <p>Note: This SP is expanded for color MFP and color LP machines. For this machine, the count is done for black only.</p>	

8601	Coverage Counter	
1	B/W	
11	B/W Printing Pages	

8617	SDK Apli Counter	
1	SDK-1	
2	SDK-2	
3	SDK-3	
4	SDK-4	
5	SDK-5	
6	SDK-6	

8621	Func Use Counter DFU	
1 to 64	Function 001 to Function 064	

8651	T:S-to-Email PGS	[0 to 9999999 / 0 / 1]
	<p>These SP's count by color mode the total number of pages attached to an e-mail for both the Scan and document server applications.</p> <p>Note: This SP is expanded for color MFP and color LP machines. For this machine, the count is done for black only.</p>	
8655	S:S-to-Email PGS	[0 to 9999999 / 0 / 1]
	<p>These SP's count by color mode the total number of pages attached to an e-mail for the Scan application only.</p> <p>Note: This SP is expanded for color MFP and color LP machines. For this machine, the count is done for black only.</p>	

- The count for B/W pages is done after the document is stored on the HDD. If the job is cancelled before it is stored, the pages are not counted.
- If Scan- to -Email is used to send a 10-page document to 5 addresses, the count is 10 (the pages are sent to the same SMTP server to gether).
- If Scan- to -PC is used to send a 10-page document to 5 folders, the count is 50 (the document is sent to each destination of the SMB/FTP server).

- Due to restrictions on some devices, if Scan- to -Email is used to send a 10-page document to a large number of destinations, the count may be divided and counted separately. For example, if a 10-page document is sent to 200 addresses, the count is 10 for the first 100 destinations and the count is also 10 for the second 100 destinations, for a total of 20.

8671	T:Deliv PGS/PC	[0 to 99999999 / 0 / 1]
	<p>These SP's count by color mode the total number of pages sent to a folder on a PC (Scan- to -PC) with the Scan and LS applications.</p> <p>Note: This SP is expanded for color MFP and color LP machines. For this machine, the count is done for black only.</p>	
8675	S:Deliv PGS/PC	[0 to 99999999 / 0 / 1]
	<p>These SP's count by color mode the total number of pages sent with Scan- to -PC with the Scan application.</p> <p>Note: This SP is expanded for color MFP and color LP machines. For this machine, the count is done for black only.</p>	

8691	T:TX PGS/LS	<p>These SP's count the number of pages sent from the document server. The counter for the application that was used to store the pages is incremented.</p> <p>[0 to 99999999 / 0 / 1]</p> <p>The L: counter counts the number of pages stored from within the document server mode screen at the operation panel.</p>
8692	C:TX PGS/LS	
8694	P:TX PGS/LS	
8695	S:TX PGS/LS	
8696	L:TX PGS/LS	

- Print jobs done with Web Image Monitor and Desk to p Binder are added to the count.
- If several documents are merged for sending, the number of pages s to red are counted for the application that stored them.
- When several documents are sent by a Fax broadcast, the F: count is done for the number of pages sent to each destination.

8701	TX PGS/Port	[0 to 99999999 / 0 / 1]
	<p>These SP's count the number of pages sent by the physical port used to send them. For example, if a 3-page original is sent to 4 destinations via ISDN G4, the count for ISDN (G3, G4) is 12.</p>	
1	PSTN-1	
2	PSTN-2	

3	PSTN-3	
4	ISDN (G3,G4)	
5	Network	

8711	T:Scan PGS/Comp	[0 to 99999999/ 1]
	These SP's count the number of compressed pages scanned in to the document server, counted by the formats listed below.	
1	JPEG/JPEG2000	
2	TIFF (Multi/Single)	
3	PDF	
4	Other	
5	PDF Comp	

8715	S:Scan PGS/Comp	
	These SP's count the number of compressed pages scanned by the scan application, counted by the formats listed below.	
1	JPEG/JPEG2000	[0 to 99999999/ 1]
2	TIFF (Multi/Single)	
3	PDF	
4	Other	
5	PDF Comp	

8721	T: Deliv PGS/WSD	
	Total number of pages delivered to WSD (Web Service Device) by scanner/printer application. Note: WSD is the Microsoft standard for connectivity to web service enabled devices.	
8725	S: Deliv PGS/WSD	
	Total number of pages delivered to WSD by the scanner application.	

8731	T: Scan PGS/Media	
	Total number of pages scanned/printed for media.	
8735	S: Scan PGS/Media	
	Total number of pages scanned for media.	
1	B/W	
2	Color	

8741	RX PGS/Port	
	These SP's count the number of pages received by the physical port used to receive them. [0 to 9999999 / 0 / 1]	
1	PSTN-1	
2	PSTN-2	
3	PSTN-3	
4	ISDN (G3,G4)	
5	Network	

8771	Dev Counter	
	These SP's count the frequency of use (number of rotations of the development rollers) for black and other color toners. Note: For machines that do not support color, the Black toner count is the same as the total count. [0 to 9999999 / 0 / 1]	

8781	Toner Bottle Info	
	This SP displays the number of toner bottles used. The count is done based on the equivalent of 1,000 pages per bottle.	

8791	LS Memory Remain	
------	------------------	--

	This SP displays the percent of space available on the document server for storing documents. [0 to 100/ 0 / 1]	
8801	Toner Remain	
	This SP displays the percent of toner remaining for each color. This SP allows the user to check the toner supply at any time. Note: This method of measuring remaining toner supply (1% steps) is more precise better than other machines in the market that can only measure increments of 10 (10% steps). [0 to 100/ 0 / 1]	
8851	Cover Cnt: 0-10%	
	These SP's count the percentage of toner dot coverage. [0 to 9999999]	
11	0~2%: BK	
21	3~4%: BK	
31	5~7%: BK	
41	8~10%: BK	
8861	Cvr Cnt: 11-20%	
	This SP counts the number of copies in the toner dot coverage range 11-20% [0 to 9999999]	
8871	Cvr Cnt: 21-30%	
	This SP counts the number of copies in the toner dot coverage range 21-30% [0 to 9999999]	
8881	Cvr Cnt: 31%~	
	This SP counts the number of copies in the toner dot coverage range 31% and over. [0 to 9999999]	

8891	Page/Toner Bottle	Previous cartridge	These counts record the number of pages per toner cartridge.
8901	Page/Toner_Prev1	Previous but 1	
8911	Page/Toner_Prev2	Previous but 2	

2

8921	Cvr Cnt Total	
	These SP's display the percent and number of pages for black toner coverage.	
1	Coverage (%): BK	
11	Coverage (/P):BK	

8941	Machine Status	
	These SP's count the amount of time the machine spends in each operation mode. These SP's are useful for operators who need to investigate machine operation for improvement in their compliance with ISO Standards. [0 to 99999999 / 0 / 1]	
1	Operation Time	Engine operation time. Does not include time while controller is saving data to HDD (while engine is no to operating).
2	Standby Time	Engine no to operating. Includes time while controller saves data to HDD. Does not include time spent in Energy Save, Low Power, or Off modes.
3	Energy Save Time	Includes time while the machine is performing background printing.
4	Low Power Time	Includes time in Energy Save mode with Engine on. Includes time while machine is performing background printing.
5	Off Mode Time	Includes time while machine is performing background printing. Does not include time machine remains powered off with the power switches.
6	SC	Total down time due to SC errors.
7	PrtJam	Total down time due to paper jams during printing.
8	OrgJam	Total down time due to original jams during scanning.
9	Supply PM Unit End	Total down time due to toner end.

8951	AddBook Register		
	These SP's count the number of events when the machine manages data registration.		
1	User Code/User ID	User code registrations.	[0 to 9999999 / 0 / 1]
2	Mail Address	Mail address registrations.	
3	Fax Destination	Fax destination registrations.	
4	Group	Group destination registrations.	
5	Transfer Request	Fax relay destination registrations for relay TX.	
6	F-Code	F-Code box registrations.	
7	Copy Program	Copy application registrations with the Program (job settings) feature.	[0 to 255 / 0 / 255]
8	Fax Program	Fax application registrations with the Program (job settings) feature.	
9	Printer Program	Printer application registrations with the Program (job settings) feature.	
10	Scanner Program	Scanner application registrations with the Program (job settings) feature.	

8999	Admin. Counter List	
	This SP provides a central point for display of important information for the system administrator.	
1	Total	Print total (copies and prints)
3	Copy: BW	Copy totals (not print jobs)
7	Printer: BW	Print totals (not copy jobs)
15	Coverage: BW(%)	Total coverage (copies/prints)
17	Coverage: BW Print Page (%)	Total coverage (print jobs only)
101	Transmission Total: Color	

102	Transmission Total: BW	Jobs sent to document server, scan-to-email.
104	Scanner Transmission: Color	
105	Scanner Transmission: BW	Jobs scanned to document server, scan-to-email.

Printer, Scanner SP Tables

Printer Service Mode

2

1001	Bit Switch			
001	Bit Switch 1 Settings		0	1
	bit 0	DFU	-	-
	bit 1	DFU	-	-
	bit 2	DFU	-	-
	bit 3	No I/O Timeout	Disabled	Enabled
		Enables/disables MFP I/O timeouts. If enabled, the MFP I/O timeout setting will have no effect (I/O timeouts never occur.)		
	bit 4	SD Card Save Mode	Disabled	Enabled
		If enabled, print jobs will be output to the SD card slot (not to paper).		
	bit 5	DFU		
	bit 6	DFU		
bit 7	[RPCS,PCL]: Printable area frame border	Disabled	Enabled	
	If enabled, prints all RPCS and PCL jobs with a border around the printable area.			
002	Bit Switch 2 Settings DFU			
003	Bit Switch 3 Settings DFU			
004	Bit Switch 4 Settings DFU			
005	Bit Switch 5 Settings	0	1	

		Show "Collate Type", "Staple Type" and "Punch Type" buttons on the operation panel.	Disabled	Enabled
	bit 0	If enabled, users will be able to configure a Collate Type, Staple Type, and Punch Type from the operation panel. The available types will depend on the device and configured options. After enabling the function, the settings will appear under: "User Tools > Printer Features > System"		
	bit 1	DFU		
	bit 2	If enabled, SDK applications will not be able to alter print data. This is achieved by preventing SDK applications from accessing a module called the "GPS Filter". Note: The main purpose of this bit switch is for troubleshooting the effects of SDK applications on data.		
		[PS] PS Criteria	Pattern3	Pattern1
	bit 3	Changes the number of PS criterion used by the PS interpreter to determine whether a job is PS data or not. Pattern 3: Includes most PS commands. Pattern 1: A small number of PS tags and headers		
		Increase max number of the stored jobs to 1000 jobs.	Disable (100)	Enable (1000)
	bit 4	If enabled, changes the maximum number of jobs that can be stored on the HDD (via Job Type settings) to 1000. The default is 100.		
	bit 5	DFU		
	bit 6	If enabled, the image rotation will be performed according to specifications of older models (PCL: Pre-04A Models) for binding pages in mixed orientation jobs.		
	bit 7	DFU		
006	Bit Switch 6 Settings DFU			
007	Bit Switch 7 Settings DFU		-	-
008	Bit Switch 8 Settings DFU			
009	bit 0	PDL Auto Detection of Jobs Submitted via USB/IEEE1284		
		To be used if PDL auto detection fails. A failure of PDL auto detection does not necessarily mean that the job cannot be printed. This bit switch tells the device whether to execute a time out immediately (default) upon failure or to wait 10 sec.		

	bit 1	Forced Printing
		If enabled, the image will be printed regardless of whether the specified roller for the correct size paper or not. This is similar to "Form Feed" on a standard printer. Default: Enabled
	bit 2	Job Cancel
		If enabled, all jobs will be cancelled after a jam occurs. Note: If this bit switch is enabled, printing under the following conditions could cause problems: <ul style="list-style-type: none"> • Job submission via USB port or parallel port. • Spool printing: WIM> Configuration> Device Settings> System

1003	Clear Setting
1	Initialize Printer System
	Initializes settings in the "System" menu of the user mode.
3	Delete Program
	*This SP is for Japan model only.

1004	Print Summary
	Prints the service summary sheet (a summary of all the controller settings).

1005	Display Version
	Displays the version of the printer application.

1006	Sample/Locked Print
	Enables and disables the document server. When you select "0", the document server is enabled or disabled in accordance with Copy Service Mode SP5-967. When you select "1", the document server is enabled regardless of Copy Service Mode SP5-967. 0: Linked, 1: On

Scanner Service Mode

1001	Scan Nv Version
	Displays the scanner firmware version stored in NVRAM in a 9-digit format: Func. Name_Model Name_History No.
1004	Compression Type
	Selects the compression type for binary picture processing. [1-3/1/1] 1: MH, 2: MR, 3: MMR
1005	Erase Margin (Remote Scan)
	Creates an erase margin for all edges of the scanned image. If the machine has scanned the edge of the original, create a margin. [0 to 5/0/1 mm]
1009	Remote Scan Disable
	This SP switches the TWAIN scanner function on/off. This is one of the scanner application functions. [0 to 1 / 0 / 1] 0: ON (enabled- 1: OFF (disabled)
1011	Org Count Display
	This SP codes switches the original count display on/off. [0 to 1 / 0 / 1] 0: OFF (no display) 1: ON (count displays)

1012	User Info Release
	<p>This SP code sets the machine to release or not release the following items at job end]</p> <ul style="list-style-type: none"> • Destination (E-mail/Folder/CS) • Sender name • Mail Text • Subject line • File name <p>[0 to 1 / 1 / 1] 1: Release 0: Do not release</p>

1013	Multi Media Func
	<p>This SP code enables/disables the multi-media function option (USB 2.0/SD Slot) mounted on the left rear corner of the machine. Operators can scan documents to either an SD card or a USB memory device inserted into this unit. This SP must be enabled (set to "1") in order for the device to function.</p> <p>[0 to 1 / 0 / 1] 0: Disable 1: Enable</p>

2021	Summary Image Quality - Compression Level (Gray-scale)	
	Selects the compression ratio for grayscale processing mode (JPEG) for the three settings that can be selected at the operation panel.	
1	Comp1: 5-95	[5 to 95 / 40 / 1 /step]
2	Comp2: 5-95	[5 to 95 / 50 / 1 /step]
3	Comp3: 5-95	[5 to 95 / 30 / 1 /step]
4	Comp4: 5-95	[5 to 95 / 60 / 1 /step]
5	Comp5: 5-95	[5 to 95 / 20 / 1 /step]

3. Appendix: UP Mode

User Tools

User Tool Map

This is a list of the settings on the User Tools menus. For more details, refer to the operating instructions and other manuals.

Push [User Tools].

System Settings

General Features Tab

Program/Change/Delete User Text
Panel Key Sound
Warm Up Beeper
Copy Count Display
Function Priority
Print Priority
Function Reset Timer
Key Repeat
System Status/ Job List / Display Time
Interleave Print
Feed Start Method
Original Feed Delay 1
Original Feed Delay 2
[▼ Next]
Fine Ratio Adjustment: Copier
Adjust Scan Position

Preview Area Settings

Tray Paper Settings Tab

Paper Tray Priority: Copier

Tray Paper Size: Tray 1

Tray Paper Size: Tray 2

Tray Paper Size: Tray 3

[▼ Next]

Paper Type: Bypass

Paper Type: Tray 1

Paper Type: Tray 2

Paper Type: Tray 3

Paper Thickness: Paper Tray

Paper Thickness: Paper Bypass

Paper Thickness: Paper Tray		Cancel	OK		
Select level of thickness for each paper type.					
Paper Type	← Thicker		Thinner →		
▶ Plain Paper	1	2	3	4	5
▶ Recycled Paper	1	2	3	4	5
▶ Translucent Paper	1	2	3	4	5
▶ Film	1	2	3	4	5

b286s905

Paper Volume

Timer Settings Tab

Auto Off Timer

Energy Saver Timer

Panel Off Timer

System Auto Reset Timer
Copier/Document Server Auto Reset Timer
Set Date
Set Time
Auto Logout Timer

Interface Settings Tab

3

Machine IPv4 Address
IPv4 Gateway Address
Machine IPV6 Address
IPv6 Gateway Address
DNS Configuration
DDNS Configuration
IPsec
Domain Name
WINS Configuration
Effective Protocol
NCP Delivery Protocol
[▼ Next]
NW Frame Type
SMB Computer Name
SMB Work Group
Ethernet Speed
Ping Command
Permit SNMPv3 Communication
Permit SSL/TLS Communication

Host Name
Machine Name
IEEE 802.1X Authentication for Ethernet
Restore IEEE 802.1X Authentication to Defaults

File Transfer Tab

3

Delivery Option
SMTP Server
SMTP Authentication
POP before SMTP
Reception Protocol
POP3/IMAP4 Settings
Administrator's E-mail Address
E-mail Communication Port
E-mail Reception Interval
Max. Reception E-mail Size
E-mail Storage in Server
Default User Name/Password (Send)
Program/Change/Delete E-mail Message

Administrator Tools Tab

Address Book Management
Address Book: Program/Change/Delete Group
Address Book: Change Order
Address Book: Edit Title
Address Book: Switch Title
Back Up/Restore Address Book

Display/Print Counter
Display/Print Counter per User
[▼ Next]
User Authentication Management
Administrator Authentication Management
Program/Change Administrator
Key Counter Management
External Charge Unit Management
Enhanced External Charge Unit Management
Extended Security
Auto Delete File in Document Server
Delete All Files in Document Server
[▼ Next]
Program Change/Delete/LDAP Server
LDAP Search
Firmware Version
Network Security Level
Transfer Log Setting
Fixed USB Port
Program/Change/Delete Realm

Copier/Document Server Features

General Features Tab

Auto Image Density Priority

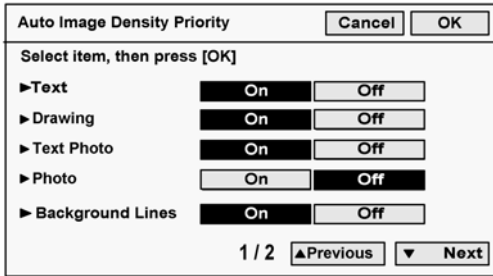

b286s906

3

Original Photo Type Priority

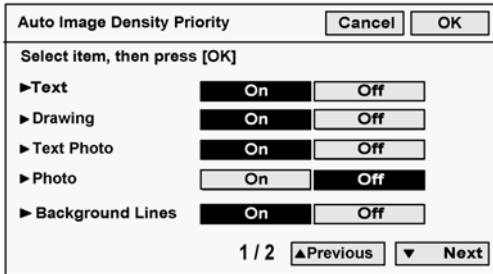

b286s906

Max Copy Quantity

Auto Tray Switches

Job End Call

Reproduction Ratio Tab

User Reduce/Enlarge Ratio

Reproduction Ratio

Reduce/Enlarge Ratio Priority

Reduce/Enlarge Priority

Select item then press [OK].

141.4% A4 → A3 A2 → A1	200.0% A4 → A2 A3 → A1	282.8% A4 → A1 A3 → A0	400.0% A4 → A0
25.0% A0 → A4	35.4% A1 → A4 A0 → A3	50.0% A2 → A4 A1 → A3	70.7% A3 → A4 A1 → A2

d093s909

User Auto Reduce / Enlarge: A0

User Auto Reduce / Enlarge: A1

User Auto Reduce / Enlarge: A2

User Auto Reduce / Enlarge: A3

User Auto Reduce / Enlarge: A4

User Auto Reduce / Enlarge: B1 JIS

User Auto Reduce / Enlarge: B2 JIS

User Auto Reduce / Enlarge: B3 JIS

User Auto Reduce / Enlarge: B4 JIS

Edit Tab

Adjust Position

Erase Border Width

Erase Original Shadow in Combine

Image Repeat Separation Line

Double Copies Separation Line

Separation Line in Combine

Copy Order in Combine

Program/Delete Format

Margin Adjustment Priority

Partial Copy Size

Stamp Tab

Background Numbering

Preset Stamp

User Stamp

Date Stamp

Page Numbering

Rotate Sort: Auto Paper Continue

Menu Protect

3

Espanol (or other language)

Switches the language selection

Enquiry



b286s910

Counter

Total Counter [1] Meters