



RICOH UNIVERSITY

Learning ♦ Knowledge ♦ Performance



D111/D142
SERVICE MANUAL

LANIER RICOH SAVIN

It is the reader's responsibility when discussing the information contained within this document to maintain a level of confidentiality that is in the best interest of Ricoh Americas Corporation and its member companies.

NO PART OF THIS DOCUMENT MAY BE REPRODUCED IN ANY FASHION AND DISTRIBUTED WITHOUT THE PRIOR PERMISSION OF RICOH AMERICAS CORPORATION.

All product names, domain names or product illustrations, including desktop images, used in this document are trademarks, registered trademarks or the property of their respective companies.

They are used throughout this book in an informational or editorial fashion only and for the benefit of such companies. No such use, or the use of any trade name, or web site is intended to convey endorsement or other affiliation with Ricoh products.

WARNING

The Service Manual contains information regarding service techniques, procedures, processes and spare parts of office equipment distributed by Ricoh Americas Corporation. Users of this manual should be either service trained or certified by successfully completing a Ricoh Technical Training Program.

Untrained and uncertified users utilizing information contained in this service manual to repair or modify Ricoh equipment risk personal injury, damage to property or loss of warranty protection.

Ricoh Americas Corporation

LEGEND

PRODUCT CODE	COMPANY		
	LANIER	RICOH	SAVIN
D111	MP C3002	Aficio MP C3002	MP C3002
D142	MP C3502	Aficio MP C3502	MP C3502

DOCUMENTATION HISTORY

REV. NO.	DATE	COMMENTS
*	02/2012	Original Printing

D111/D142

TABLE OF CONTENTS

1. PRODUCT INFORMATION	1-1
1.1 SPECIFICATIONS.....	1-1
1.2 PRODUCT OVERVIEW.....	1-2
1.2.1 COMPONENT LAYOUT.....	1-2
1.2.2 PAPER PATH.....	1-4
1.2.3 DRIVE LAYOUT.....	1-5
1.3 MACHINE CODES AND PERIPHERAL CONFIGURATION.....	1-7
1.4 GUIDANCE FOR THOSE WHO ARE FAMILIAR WITH PREDECESSOR PRODUCTS.....	1-12
2. INSTALLATION	2-1
2.1 INSTALLATION REQUIREMENTS.....	2-1
2.1.1 ENVIRONMENT.....	2-1
2.1.2 MACHINE LEVEL.....	2-2
2.1.3 MACHINE SPACE REQUIREMENTS.....	2-2
2.1.4 MACHINE DIMENSIONS.....	2-3
2.1.5 POWER REQUIREMENTS.....	2-3
2.2 COPIER INSTALLATION.....	2-4
2.2.1 POWER SOCKETS FOR PERIPHERALS.....	2-4
2.2.2 INSTALLATION FLOW CHART.....	2-5
2.2.3 INSTALLATION PROCEDURE.....	2-6
Tapes and Retainers.....	2-6
Developer and Toner Bottles.....	2-7
Paper Trays.....	2-8
Emblem and Decals.....	2-9
Initialize the Developer.....	2-9
Settings Relevant to the Service Contract.....	2-10
SP Operation Sound On/Off Setting.....	2-11
Settings for @Remote Service.....	2-12
VM Card Installation.....	2-16
Enabling App2Me.....	2-16
Security Function Installation.....	2-16

2.2.4	EXTERNAL USB KEYBOARD (EXTERNAL OPTION).....	2-25
2.2.5	MOVING THE MACHINE.....	2-26
2.2.6	TRANSPORTING THE MACHINE.....	2-26
2.3	PAPER FEED UNIT PB3120 (D579)	2-27
2.3.1	ACCESSORY CHECK.....	2-27
2.3.2	INSTALLATION PROCEDURE	2-27
2.4	CASTER TABLE TYPE D (D593)	2-31
2.4.1	COMPONENT CHECK.....	2-31
2.4.2	INSTALLATION PROCEDURE	2-31
2.5	PAPER FEED UNIT PB3130 (D580)	2-33
2.5.1	ACCESSORY CHECK.....	2-33
2.5.2	INSTALLATION PROCEDURE	2-33
2.6	ENVELOPE FEEDER EF3020 (D638).....	2-37
2.6.1	ACCESSORY CHECK.....	2-37
2.6.2	INSTALLATION PROCEDURE	2-38
2.7	LCIT RT3020 (D631)	2-39
2.7.1	COMPONENT CHECK.....	2-39
2.7.2	INSTALLATION PROCEDURE	2-40
2.7.3	SIDE FENCE POSITION CHANGE	2-42
2.8	LCIT PB3140 (D581)	2-43
2.8.1	ACCESSORY CHECK.....	2-43
2.8.2	INSTALLATION PROCEDURE	2-43
	SP Settings	2-46
2.9	ARDF DF3060 (D578)	2-47
2.9.1	COMPONENT CHECK.....	2-47
2.9.2	INSTALLATION PROCEDURE	2-48
2.10	ADF HANDLE TYPE B (D593).....	2-51
2.10.1	COMPONENT CHECK.....	2-51
2.10.2	INSTALLATION PROCEDURE	2-53
	Preparing before Installing the DF Handle	2-53
	Installing the DF Handle	2-54
2.11	1 BIN TRAY BN3100 (D632).....	2-58
2.11.1	COMPONENT CHECK.....	2-58
2.11.2	INSTALLATION PROCEDURE	2-59
2.12	INTERNAL SHIFT TRAY SH3060 (D633).....	2-61
2.12.1	COMPONENT CHECK.....	2-61
2.12.2	INSTALLATION PROCEDURE	2-61
2.13	SIDE TRAY TYPE C5502 (D635)	2-63

2.13.1	COMPONENT CHECK.....	2-63
2.13.2	INSTALLATION PROCEDURE	2-64
2.14	BRIDGE UNIT BU3060 (D634)	2-67
2.14.1	COMPONENT CHECK.....	2-67
2.14.2	INSTALLATION PROCEDURE	2-68
2.15	FINISHER SR3070 (D585).....	2-71
2.15.1	ACCESSORY CHECK.....	2-71
2.15.2	INSTALLATION PROCEDURE	2-72
2.16	FINISHER SR3090 (D588).....	2-75
2.16.1	ACCESSORY CHECK.....	2-75
2.16.2	INSTALLATION PROCEDURE	2-76
2.17	BOOKLET FINISHER SR3100 (D589).....	2-78
2.17.1	ACCESSORY CHECK.....	2-78
2.17.2	INSTALLATION PROCEDURE	2-79
2.18	PUNCH KIT PU3000 (B807)	2-83
2.18.1	COMPONENT CHECK.....	2-83
2.18.2	INSTALLATION	2-84
2.19	KEY COUNTER BRACKET TYPE H (A674).....	2-89
2.19.1	INSTALLATION PROCEDURE	2-89
2.20	COPY DATA SECURITY UNIT TYPE F (B829).....	2-91
2.20.1	COMPONENT CHECK.....	2-91
2.20.2	INSTALLATION	2-92
	User Tool Setting	2-93
2.21	OPTIONAL COUNTER INTERFACE UNIT TYPE A (B870)	2-94
2.21.1	COMPONENT CHECK.....	2-94
2.21.2	INSTALLATION PROCEDURE	2-94
2.22	CARD READER BRACKET TYPE 3352 (D593).....	2-96
2.22.1	COMPONENT CHECK.....	2-96
2.22.2	INSTALLATION PROCEDURE	2-97
2.23	ANTI-CONDENSATION HEATER (SCANNER).....	2-98
2.23.1	INSTALLATION PROCEDURE	2-98
2.24	ANTI-CONDENSATION HEATER TYPE A.....	2-100
2.24.1	COMPONENT CHECK.....	2-100
2.24.2	INSTALLATION PROCEDURE	2-100
	For installing the tray heater in the main machine.....	2-101
	For installing the tray heater in D537	2-101
	For Installing the Tray Heater in D538	2-103
	For Installing the Tray Heater in D387	2-106

2.25	CONTROLLER OPTIONS.....	2-109
2.25.1	OVERVIEW	2-109
	I/F Card Slots	2-109
	SD Card Slots	2-109
2.25.2	SD CARD APPLI MOVE.....	2-109
	Overview	2-109
	Move Exec	2-110
	Undo Exec.....	2-111
2.25.3	POSTSCRIPT3 UNIT TYPE C5502.....	2-112
2.25.4	IPDS UNIT TYPE C5502	2-113
2.25.5	FILE FORMAT CONVERTER TYPE E.....	2-114
2.25.6	IEEE 1284 INTERFACE BOARD TYPE A.....	2-115
	Installation Procedure.....	2-115
2.25.7	IEEE 802.11A/G G INTERFACE UNIT TYPE J/K.....	2-116
	Installation Procedure.....	2-116
	UP Mode Settings for Wireless LAN	2-117
	SP Mode and UP Mode Settings for IEEE 802.11 a/g g Wireless LAN	2-119
2.25.8	BLUETOOTH INTERFACE UNIT TYPE D	2-120
2.25.9	CAMERA DIRECT PRINT CARD TYPE J	2-121
2.25.10	SD CARD FOR NETWARE PRINTING TYPE H	2-122
2.25.11	BROWSER UNIT TYPE F	2-123
	Installation Procedure.....	2-123
	EXJS Firmware Update Procedure.....	2-124
2.25.12	GIGABIT ETHERNET TYPE B	2-132
2.25.13	CHECK ALL CONNECTIONS	2-133
3.	PREVENTIVE MAINTENANCE.....	3-1
3.1	MAINTENANCE TABLES	3-1
3.2	PM PARTS SETTINGS.....	3-2
3.2.1	BEFORE REMOVING THE OLD PM PARTS.....	3-2
3.2.2	AFTER INSTALLING THE NEW PM PARTS	3-3
3.2.3	PREPARATION BEFORE OPERATION CHECK.....	3-4
3.2.4	OPERATION CHECK	3-4
4.	REPLACEMENT AND ADJUSTMENT.....	4-1
4.1	BEFOREHAND.....	4-1
4.2	SPECIAL TOOLS.....	4-2
4.3	IMAGE ADJUSTMENT	4-3

4.3.1 SCANNING	4-3
Scanner sub-scan magnification	4-3
Scanner leading edge and side-to-side registration	4-3
4.3.2 ARDF	4-4
ARDF side-to-side, leading edge registration and trailing edge	4-4
ARDF sub-scan magnification	4-5
4.3.3 REGISTRATION	4-6
Image Area	4-6
Leading Edge	4-6
Side to Side	4-6
Adjustment Standard	4-6
Paper Registration Standard	4-6
Adjustment Procedure	4-7
4.3.4 ERASE MARGIN ADJUSTMENT	4-8
4.3.5 COLOR REGISTRATION	4-9
Line Position Adjustment	4-9
4.3.6 PRINTER GAMMA CORRECTION	4-9
Copy Mode	4-10
Printer Mode	4-15
4.4 EXTERIOR COVERS	4-16
4.4.1 FRONT DOOR	4-16
4.4.2 CONTROLLER COVER	4-17
4.4.3 LEFT COVER	4-17
4.4.4 REAR COVER	4-18
4.4.5 RIGHT REAR COVER	4-19
4.4.6 OPERATION PANEL	4-20
4.4.7 PAPER EXIT COVER	4-24
4.4.8 INNER TRAY	4-25
4.4.9 OZONE FILTER AND DUST FILTER	4-26
Ozone filters for the scanner unit	4-26
Ozone filter and dust filter for the AC controller	4-27
4.5 SCANNER UNIT	4-28
4.5.1 EXPOSURE GLASS	4-28
4.5.2 EXPOSURE LAMP	4-30
Reassembling	4-32
Chromaticity rank adjustment	4-33
4.5.3 SCANNER MOTOR	4-35
4.5.4 SENSOR BOARD UNIT (SBU)	4-35

When reassembling	4-36
4.5.5 ORIGINAL LENGTH SENSORS.....	4-37
4.5.6 LED RELAY BOARD	4-38
4.5.7 SIO (SCANNER IN/OUT) BOARD.....	4-39
4.5.8 SCANNER HP SENSOR	4-40
4.5.9 PLATEN COVER SENSOR.....	4-41
4.5.10 FRONT SCANNER WIRE.....	4-42
Reinstalling the Front Scanner Wire.....	4-43
4.5.11 REAR SCANNER WIRE.....	4-45
Reinstalling the Rear Scanner Wire	4-46
4.5.12 TOUCH PANEL POSITION ADJUSTMENT	4-47
4.6 LASER OPTICS.....	4-48
4.6.1 CAUTION DECAL LOCATION	4-48
4.6.2 LD SAFETY SWITCH	4-49
Error Messages.....	4-49
4.6.3 LASER OPTICS HOUSING UNIT.....	4-50
Preparing the new laser optics housing unit.....	4-50
Before removing the old laser optics housing unit.....	4-51
Recovery procedure for no replacement preparation of laser optics housing unit	4-51
Removing the old laser optics housing unit.....	4-52
Installing a new Laser Optics Housing Unit.....	4-53
After installing the new laser optics housing unit.....	4-53
4.6.4 POLYGON MIRROR MOTOR AND DRIVE BOARD	4-55
4.6.5 AIRFLOW FANS.....	4-56
4.6.6 LASER OPTICS REAR RIGHT THERMISTOR	4-57
4.7 IMAGE CREATION.....	4-59
4.7.1 PCDU.....	4-59
4.7.2 DRUM UNIT AND DEVELOPMENT UNIT.....	4-60
Developer.....	4-63
4.7.3 TONER COLLECTION BOTTLE	4-64
4.7.4 SECOND DUCT FAN	4-65
When reinstalling the second duct fan	4-66
4.7.5 THIRD DUCT FAN.....	4-66
When reinstalling the third duct fan	4-66
4.7.6 TONER PUMP UNIT.....	4-67
When you install the new toner pump unit.....	4-70
4.7.7 TONER END SENSOR.....	4-72

4.8	IMAGE TRANSFER	4-73
4.8.1	IMAGE TRANSFER BELT CLEANING UNIT	4-73
4.8.2	IMAGE TRANSFER BELT UNIT	4-74
4.8.3	IMAGE TRANSFER BELT	4-75
	When reinstalling the image transfer belt	4-78
4.9	PAPER TRANSFER	4-80
4.9.1	PAPER TRANSFER ROLLER UNIT	4-80
4.9.2	PAPER TRANSFER UNIT	4-81
4.9.3	ID SENSOR BOARD	4-83
	Cleaning for ID sensors	4-84
	After installing a new ID sensor unit/board	4-84
4.9.4	TEMPERATURE AND HUMIDITY SENSOR	4-85
4.10	DRIVE UNIT	4-86
4.10.1	GEAR UNIT	4-87
	When installing the drive unit	4-91
	Adjustment after replacing the gear unit	4-92
4.10.2	REGISTRATION MOTOR	4-93
4.10.3	PAPER FEED MOTOR	4-94
4.10.4	DRUM/DEVELOPMENT MOTORS FOR M, C, AND Y	4-95
4.10.5	DRUM/DEVELOPMENT MOTOR-K	4-96
4.10.6	ITB DRIVE MOTOR	4-96
4.10.7	FUSING/PAPER EXIT MOTOR	4-97
4.10.8	IMAGE TRANSFER BELT CONTACT MOTOR	4-97
4.10.9	DUPLEX INVERTER MOTOR	4-98
4.10.10	PRESSURE ROLLER CONTACT MOTOR	4-99
4.10.11	DUPLEX/BY-PASS MOTOR	4-100
4.10.12	PAPER TRANSFER CONTACT MOTOR	4-101
4.10.13	TONER TRANSPORT MOTOR	4-103
4.10.14	TONER COLLECTION UNIT	4-104
4.10.15	PAPER FEED CLUTCHES	4-105
4.10.16	DEVELOPMENT CLUTCH-Y	4-107
4.10.17	DEVELOPMENT CLUTCHES FOR M AND C	4-108
4.10.18	DEVELOPMENT CLUTCH-K	4-109
4.11	FUSING	4-110
4.11.1	FUSING UNIT PM PARTS	4-110
4.11.2	FUSING UNIT	4-110
4.11.3	FUSING EXIT SHUTTER PLATE	4-112
4.11.4	FUSING ENTRANCE GUIDE PLATE	4-112

Cleaning Requirement.....	4-113
4.11.5 FUSING EXIT GUIDE PLATE CLEANING PROCEDURE	4-114
4.11.6 FUSING UNIT UPPER COVER.....	4-115
4.11.7 FUSING UNIT LOWER COVER.....	4-117
4.11.8 HEATING SLEEVE BELT UNIT.....	4-119
4.11.9 PRESSURE ROLLER.....	4-122
4.11.10 STRIPPER PLATE	4-124
Cleaning Requirement.....	4-124
4.11.11 PRESSURE ROLLER THERMISTORS.....	4-125
4.11.12 PRESSURE ROLLER THERMOSTATS.....	4-126
4.11.13 NC SENSORS.....	4-127
4.11.14 FUSING FAN.....	4-128
When installing the fusing fan	4-128
4.11.15 PAPER EXIT FAN	4-129
When installing the paper exit fan	4-129
4.11.16 AC CONTROLLER BOARD FAN	4-130
When installing the AC controller board fan	4-130
4.11.17 FUSING ENTRANCE THERMOPILES.....	4-131
When cleaning the lens of the thermopile	4-132
4.11.18 PRESSURE ROLLER HP SENSOR.....	4-133
4.11.19 QSU FAN.....	4-134
4.11.20 FUSING UNIT SHUTTER PLATE DRIVE MOTOR	4-135
4.11.21 FUSING UNIT SHUTTER PLATE HOME POSITION SENSOR.....	4-136
4.11.22 FUSING UNIT SHUTTER PLATE DRIVE MECHANISM.....	4-137
4.12 PAPER FEED	4-139
4.12.1 PAPER FEED UNIT.....	4-139
4.12.2 PICK-UP, FEED AND SEPARATION ROLLERS	4-140
Tray 1 and Tray 2.....	4-140
4.12.3 TRAY LIFT MOTOR	4-140
4.12.4 VERTICAL TRANSPORT, PAPER OVERFLOW, PAPER END AND PAPER FEED SENSOR.....	4-141
4.12.5 REGISTRATION SENSOR.....	4-142
4.12.6 BY-PASS PAPER SIZE SENSOR AND BY-PASS PAPER LENGTH SENSOR.....	4-142
When reinstalling the by-pass paper size sensor	4-143
4.12.7 BY-PASS BOTTOM TRAY	4-144
4.12.8 BY-PASS PAPER END SENSOR	4-147

4.12.9	BY-PASS PICK-UP, FEED AND SEPARATION ROLLER, TORQUE LIMITER.....	4-147
4.12.10	BY-PASS FEED CLUTCH	4-149
4.12.11	PAPER EXIT UNIT	4-150
4.12.12	FUSING EXIT, PAPER OVERFLOW, JUNCTION PAPER JAM AND PAPER EXIT SENSOR.....	4-151
4.13	DUPLEX UNIT	4-153
4.13.1	DUPLEX UNIT	4-153
4.13.2	DUPLEX DOOR SENSOR.....	4-154
4.13.3	DUPLEX ENTRANCE SENSOR.....	4-155
4.13.4	DUPLEX EXIT SENSOR	4-156
4.14	ELECTRICAL COMPONENTS	4-157
4.14.1	BOARDS.....	4-157
4.14.2	CONTROLLER UNIT	4-159
4.14.3	CONTROLLER BOX RIGHT COVER.....	4-159
4.14.4	CONTROLLER BOX.....	4-160
	When opening the controller box.....	4-160
	When removing the controller box.....	4-161
4.14.5	IOB (IN/OUT BOARD)	4-164
4.14.6	IPU.....	4-165
4.14.7	BCU	4-166
	When installing the new BCU	4-166
4.14.8	PSU	4-167
	Shutdown Board.....	4-167
	PSU bracket.....	4-168
	PSU board.....	4-169
	PSU fans	4-170
4.14.9	ITB POWER SUPPLY BOARD.....	4-171
4.14.10	HIGH VOLTAGE SUPPLY BOARD.....	4-172
4.14.11	HIGH VOLTAGE SUPPLY BOARD BRACKET	4-172
4.14.12	AC CONTROLLER BOARD.....	4-173
4.14.13	AC CONTROLLER BOARD BRACKET	4-174
4.14.14	CONTROLLER BOARD	4-175
	When installing the new controller board.....	4-176
4.14.15	HDD FAN.....	4-176
4.14.16	HDD.....	4-177
	When installing a new HDD unit.....	4-177
	Disposal of HDD Units.....	4-177

Reinstallation.....	4-178
4.14.17 TONER BOTTLE DETECTION BOARD.....	4-179
4.14.18 NVRAM REPLACEMENT PROCEDURE.....	4-180
NVRAM on the BCU.....	4-180
NVRAM on the controller board	4-181
4.15 USING DIP SWITCHES.....	4-183
4.15.1 CONTROLLER BOARD	4-183
4.15.2 BCU BOARD	4-183

5. SYSTEM MAINTENANCE..... 5-1

5.1 SERVICE PROGRAM MODE.....	5-1
5.1.1 SP TABLES	5-1
5.1.2 ENABLING AND DISABLING SERVICE PROGRAM MODE	5-1
Entering SP Mode	5-1
Exiting SP Mode.....	5-1
5.1.3 TYPES OF SP MODES	5-2
SP Mode Button Summary.....	5-2
Switching Between SP Mode and Copy Mode for Test Printing.....	5-3
Selecting the Program Number	5-4
Exiting Service Mode.....	5-5
Service Mode Lock/Unlock.....	5-5
5.1.4 REMARKS	5-6
Display on the Control Panel Screen	5-6
Others	5-7
5.2 MAIN SP TABLES-1	5-8
5.2.1 SP1-XXX (FEED).....	5-8
5.3 MAIN SP TABLES-2	5-35
5.3.1 SP2-XXX (DRUM).....	5-35
5.4 MAIN SP TABLES-3	5-116
5.4.1 SP3-XXX (PROCESS).....	5-116
5.5 MAIN SP TABLES-4	5-150
5.5.1 SP4-XXX (SCANNER).....	5-150
5.6 MAIN SP TABLES-5	5-170
5.6.1 SP5-XXX (MODE).....	5-170
5.7 MAIN SP TABLES-6	5-240
5.7.1 SP6-XXX (PERIPHERALS)	5-240
5.8 MAIN SP TABLES-7	5-248
5.8.1 SP7-XXX (DATA LOG)	5-248
5.9 MAIN SP TABLES-8	5-286

5.9.1	SP8-XXX: DATA LOG2.....	5-286
5.10	MAIN SP TABLES-9.....	5-338
5.10.1	INPUT CHECK TABLE	5-338
	Copier.....	5-338
	Table 1: Paper Height Sensor	5-342
	Table 2: Paper Size Switch (Tray 2).....	5-343
	Table 3: Paper Size (By-pass Table)	5-344
	ARDF (D578)	5-345
	2000/3000-Sheet (Booklet) Finisher (B804, B805).....	5-347
	1000-Sheet Finisher (D588).....	5-350
	Bridge Unit (D634)/ Side Tray (D635)	5-351
	Internal Shift Tray (D633).....	5-351
	1 Bin Tray (D632).....	5-352
	Two-Tray PFU (D580)/ LCIT 2000 (D581)/ LCIT 1200 (D631).....	5-352
5.10.2	OUTPUT CHECK TABLE	5-353
	Copier.....	5-353
	ARDF (D578)	5-361
	1000-Sheet Finisher (D588).....	5-362
	2000/3000-Sheet (Booklet) Finisher (B804/B805).....	5-363
	Bridge Unit (D386)/ Side Tray (D634)	5-365
	Shift Tray (D633).....	5-365
	1 Bin Tray (D632).....	5-365
	Two-Tray PFU (D580)/ LCIT 2000 (D581)/ LCIT 1200 (D631).....	5-366
5.10.3	PRINTER SERVICE MODE.....	5-367
	SP1-XXX (Service Mode).....	5-367
5.10.4	SCANNER SP MODE.....	5-376
	SP1-xxx (System and Others).....	5-376
	SP2-XXX (Scanning-image quality)	5-377
5.11	FIRMWARE UPDATE	5-378
5.11.1	TYPE OF FIRMWARE	5-378
5.11.2	BEFORE YOU BEGIN	5-379
5.11.3	UPDATING FIRMWARE.....	5-380
	Preparation.....	5-380
	Updating Procedure	5-380
	Error Messages.....	5-382
	Firmware Update Error.....	5-382
	Recovery after Power Loss	5-382
5.11.4	UPDATING THE LCDC FOR THE OPERATION PANEL.....	5-383

5.11.5	UPDATE PROCEDURE FOR APP2ME PROVIDER.....	5-383
5.11.6	BROWSER UNIT UPDATE PROCEDURE.....	5-385
5.11.7	HANDLING FIRMWARE UPDATE ERRORS.....	5-386
	Error Message Table.....	5-386
5.12	INSTALLING ANOTHER LANGUAGE.....	5-388
5.13	REBOOT/SYSTEM SETTING RESET.....	5-391
	5.13.1 SOFTWARE RESET.....	5-391
	5.13.2 SYSTEM SETTINGS AND COPY SETTING RESET.....	5-391
	System Setting Reset.....	5-391
	Copier Setting Reset.....	5-392
5.14	DOWNLOADING STAMP DATA.....	5-393
5.15	NVRAM DATA UPLOAD/DOWNLOAD.....	5-394
	5.15.1 UPLOADED CONTENT OF NVRAM TO AN SD CARD.....	5-394
	5.15.2 DOWNLOADING AN SD CARD TO NVRAM.....	5-395
5.16	ADDRESS BOOK UPLOAD/DOWNLOAD.....	5-396
	5.16.1 INFORMATION LIST.....	5-396
	5.16.2 DOWNLOAD.....	5-396
	5.16.3 UPLOAD.....	5-397
5.17	USING THE DEBUG LOG.....	5-398
	5.17.1 OVERVIEW.....	5-398
	5.17.2 SWITCHING ON AND SETTING UP SAVE DEBUG LOG.....	5-398
	5.17.3 RETRIEVING THE DEBUG LOG FROM THE HDD.....	5-403
	5.17.4 RECORDING ERRORS MANUALLY.....	5-403
	5.17.5 DEBUG LOG CODES.....	5-403
	SP5857-015 Copy SD Card-to-SD Card: Any Desired Key.....	5-403
	SP5857-016 Create a File on HDD to Store a Log.....	5-404
	SP5857-017 Create a File on SD Card to Store a Log.....	5-404
5.18	CARD SAVE FUNCTION.....	5-405
	5.18.1 OVERVIEW.....	5-405
	Card Save:.....	5-405
	5.18.2 PROCEDURE.....	5-406
	5.18.3 ERROR MESSAGES.....	5-409
5.19	SMC LIST CARD SAVE FUNCTION.....	5-410
	5.19.1 OVERVIEW.....	5-410
	SMC List Card Save.....	5-410
	5.19.2 PROCEDURE.....	5-410
	5.19.3 FILE NAMES OF THE SAVED SMC LISTS.....	5-413
	5.19.4 ERROR MESSAGES.....	5-413

6. TROUBLESHOOTING	6-1
6.1 SERVICE CALL	6-1
6.1.1 SERVICE CALL CONDITIONS.....	6-1
SC Code Classification.....	6-2
6.1.2 SERVICE CALL TABLES - 1	6-4
SC1xx: Scanning.....	6-4
6.1.3 SERVICE CALL TABLES - 2	6-9
SC 2xx: Exposure	6-9
6.1.4 SERVICE CALL TABLES - 3	6-15
SC3xx: Image Processing – 1	6-15
SC3xx: Image Processing – 2.....	6-16
6.1.5 SERVICE CALL TABLES - 4	6-21
SC4xx: Image Processing - 3.....	6-21
6.1.6 SERVICE CALL TABLES - 5	6-26
SC5xx: Paper Feed and Fusing	6-26
6.1.7 SERVICE CALL TABLES - 6	6-46
SC6xx: Device Communication.....	6-46
6.1.8 SERVICE CALL TABLES - 7	6-57
SC7xx: Peripherals	6-57
6.1.9 SERVICE CALL TABLES - 8	6-73
SC8xx: Overall System	6-73
6.1.10 SERVICE CALL TABLES - 9	6-92
SC9xx: Miscellaneous.....	6-92
6.2 PROCESS CONTROL ERROR CONDITIONS.....	6-101
6.2.1 DEVELOPER INITIALIZATION RESULT.....	6-101
6.2.2 PROCESS CONTROL SELF-CHECK RESULT	6-102
Vsg Adjustment Result.....	6-104
6.2.3 LINE POSITION ADJUSTMENT RESULT.....	6-106
6.3 TROUBLESHOOTING GUIDE.....	6-107
6.3.1 IMAGE QUALITY.....	6-107
6.3.2 LINE POSITION ADJUSTMENT.....	6-109
Test.....	6-109
Countermeasure list for color registration errors	6-110
6.3.3 STAIN ON THE OUTPUTS.....	6-116
6.3.4 STACK PROBLEM IN THE 1-BIN TRAY.....	6-116
6.3.5 PROBLEM AT REGULAR INTERVALS.....	6-117
6.3.6 TONER END RECOVERY ERROR.....	6-117
Flow Chart for the Toner End Recovery Error	6-118

6.3.7	TONER BOTTLES DETECTION ERROR	6-119
6.3.8	SOLID IMAGE OR HALFTONE IMAGE ERROR.....	6-120
	Recovery Procedure	6-120
	Problem Prevention Procedure	6-121
6.3.9	FAULTY CLEANING.....	6-121
	Black or color lines (2-3mm).....	6-121
	Band Image Between 20mm and 30mm	6-121
6.3.10	DAMAGED LIFT SENSOR SWITCH OR MOTOR	6-122
	Cause.....	6-122
	Solution	6-122
6.3.11	ENCRYPTION KEY RESTORATION FOR NVRAM.....	6-125
	How to restore the old encryption key to the machine.....	6-125
	How to do a forced start up with no encryption key.....	6-126
6.3.12	FAX ICON IS NOT DISPLAYED.....	6-127
6.3.13	OTHER SYMPTOMS.....	6-128
	Flowchart for the error.....	6-128
	Countermeasure list for the error	6-129
6.4	JAM DETECTION	6-131
6.4.1	PAPER JAM DISPLAY	6-131
6.4.2	JAM CODES AND DISPLAY CODES.....	6-131
	Paper Size Code	6-140
	Sensor Locations	6-141
6.5	ELECTRICAL COMPONENT DEFECTS.....	6-142
6.5.1	SENSORS	6-142
6.5.2	BLOWN FUSE CONDITIONS.....	6-148
	Power Supply Unit.....	6-148
	AC Drive Board	6-149
6.6	SCANNER TEST MODE.....	6-150
6.6.1	SBU TEST MODE.....	6-150
7.	ENERGY SAVING.....	7-1
7.1	ENERGY SAVE	7-1
7.1.1	ENERGY SAVER MODES	7-1
	Timer Settings	7-1
	Return to Stand-by Mode	7-2
	Recommendation	7-2
7.1.2	ENERGY SAVE EFFECTIVENESS.....	7-3
7.2	PAPER SAVE	7-4
7.2.1	EFFECTIVENESS OF DUPLEX/COMBINE FUNCTION	7-4

1. Duplex:	7-4
2. Combine mode:	7-4
3. Duplex + Combine:	7-4
How to calculate the paper reduction ratio	7-5

READ THIS FIRST

Important Safety Notices

Prevention of Physical Injury

1. Before disassembling or assembling parts of the copier and peripherals, make sure that the copier power cord is unplugged.
2. The wall outlet should be near the copier and easily accessible.
3. If any adjustment or operation check has to be made with exterior covers off or open while the main switch is turned on, keep hands away from electrified or mechanically driven components.
4. The copier drives some of its components when it completes the warm-up period. Be careful to keep hands away from the mechanical and electrical components as the copier starts operation.
5. The inside and the metal parts of the fusing unit become extremely hot while the copier is operating. Be careful to avoid touching those components with your bare hands.

Health Safety Conditions

1. Toner and developer are non-toxic, but if you get either of them in your eyes by accident, it may cause temporary eye discomfort. Immediately wash eyes with plenty of water. If unsuccessful, get medical attention.
2. The copier, which use high voltage power source, can generate ozone gas. High ozone density is harmful to human health. Therefore, the machine must be installed in a well-ventilated room.

Observance of Electrical Safety Standards

The copier and its peripherals must be serviced by a customer service representative who has completed the training course on those models.

WARNING

- Ⓣ Keep the machine away from flammable liquids, gases, and aerosols. A fire or an explosion might occur.

CAUTION

- The Controller board on this machine contains a lithium battery. The danger of explosion exists if a battery of this type is incorrectly replaced. Replace only with the same or an equivalent type recommended by the manufacturer. Discard batteries in accordance with the manufacturer's instructions and local regulations.
- The optional fax and memory expansion units contain lithium batteries, which can explode if replaced incorrectly. Replace only with the same or an equivalent type recommended by the manufacturer. Do not recharge or burn the batteries. Used batteries must be handled in accordance with local regulations.

Safety and Ecological Notes for Disposal

1. Do not incinerate toner bottles or used toner. Toner dust may ignite suddenly when exposed to an open flame.
2. Dispose of used toner, the maintenance unit which includes developer or the organic photoconductor in accordance with local regulations. (These are non-toxic supplies.)
3. Dispose of replaced parts in accordance with local regulations.
4. When keeping used lithium batteries in order to dispose of them later, do not put more than 100 batteries per sealed box. Storing larger numbers or not sealing them apart may lead to chemical reactions and heat build-up.

Laser Safety

The Center for Devices and Radiological Health (CDRH) prohibits the repair of laser-based optical units in the field. The optical housing unit can only be repaired in a factory or at a location with the requisite equipment. The laser subsystem is replaceable in the field by a qualified Customer Engineer. The laser chassis is not repairable in the field. Customer engineers are therefore directed to return all chassis and laser subsystems to the factory or service depot when replacement of the optical subsystem is required.

WARNING

- **Use of controls, or adjustment, or performance of procedures other than those specified in this manual may result in hazardous radiation exposure.**

WARNING

- **WARNING:** Turn off the main switch before attempting any of the procedures in the Laser Optics Housing Unit section. Laser beams can seriously damage your eyes.
- **CAUTION MARKING:**



Warnings, Cautions, Notes

In this manual, the following important symbols and notations are used.

WARNING

- A Warning indicates a potentially hazardous situation. Failure to obey a Warning could result in death or serious injury.

CAUTION

- A Caution indicates a potentially hazardous situation. Failure to obey a Caution could result in minor or moderate injury or damage to the machine or other property.

Important







- **Obey these guidelines to avoid problems such as misfeeds, damage to originals, loss of valuable data and to prevent damage to the machine.**

Note

- This information provides tips and advice about how to best service the machine.

Symbols, Abbreviations and Trademarks

This manual uses several symbols and abbreviations. The meaning of those symbols and abbreviations are as follows:

	See or Refer to
	Clip ring
	Screw
	Connector
	Clamp
	E-ring
SEF	Short Edge Feed
LEF	Long Edge Feed

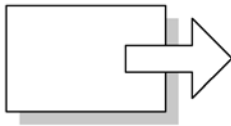

Short Edge Feed (SEF)

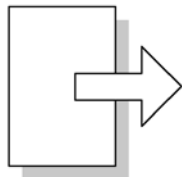

Long Edge Feed (LEF)

Trademarks

Microsoft[®], Windows[®], and MS-DOS[®] are registered trademarks of Microsoft Corporation in the United States and /or other countries.

PostScript[®] is a registered trademark of Adobe Systems, Incorporated.

PCL[®] is a registered trademark of Hewlett-Packard Company.

Ethernet[®] is a registered trademark of Xerox Corporation.

PowerPC[®] is a registered trademark of International Business Machines Corporation.

Other product names used herein are for identification purposes only and may be trademarks of their respective companies. We disclaim any and all rights involved with those marks.

PRODUCT INFORMATION

REVISION HISTORY		
Page	Date	Added/Updated/New
		None

1. PRODUCT INFORMATION

1.1 SPECIFICATIONS

See "Appendices" for the following information:

- General Specifications
- Supported Paper Sizes
- Software Accessories
- Optional Equipment

1.2 PRODUCT OVERVIEW

1.2.1 COMPONENT LAYOUT

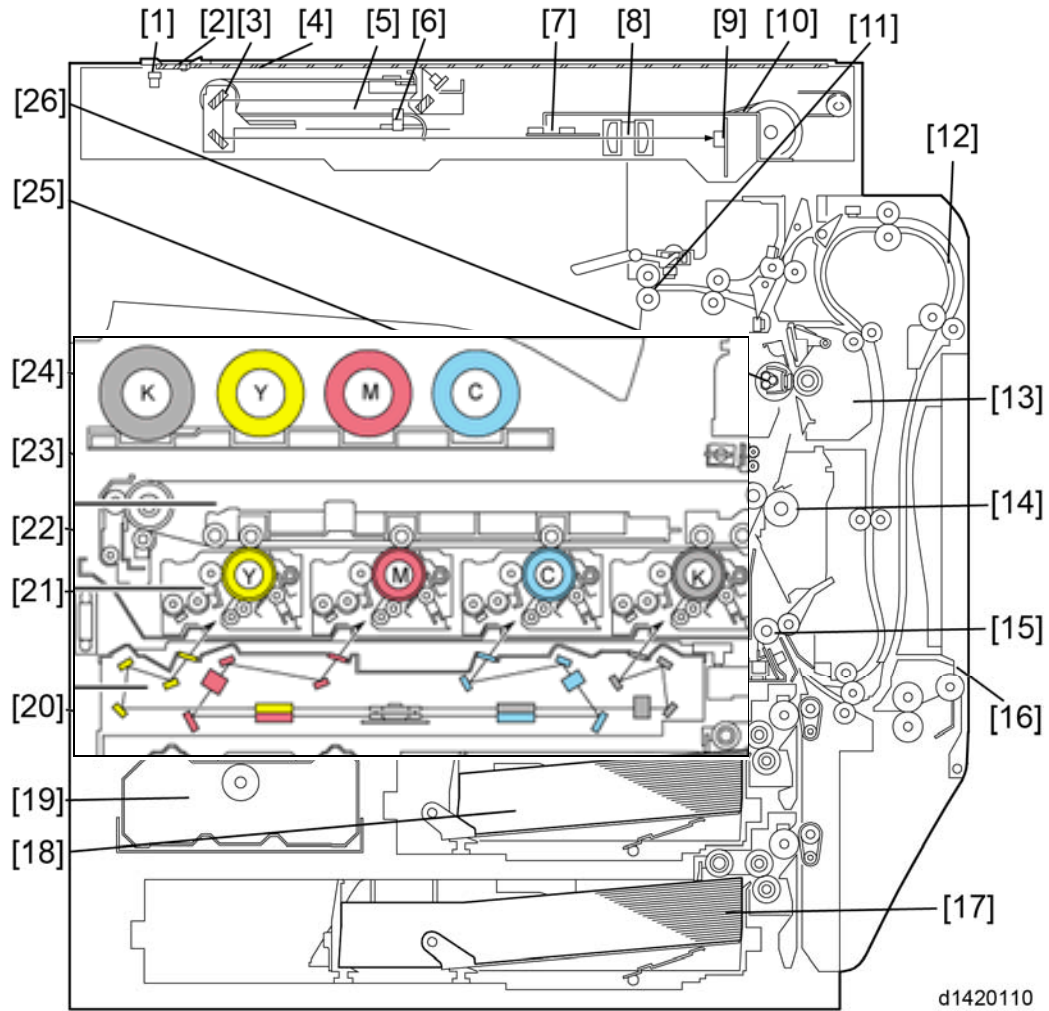

1. Scanner HP sensor	14. Paper transfer roller
2. ADF exposure glass	15. Registration roller
3. 2nd scanner (2nd carriage)	16. By-pass feed table
4. Exposure glass	17. Tray 2
5. 1st scanner (1st carriage)	18. Tray 1
6. Scanner lamp	19. Toner collection bottle
7. Original length sensor	20. Laser optics housing unit
8. Lens block	21. PCDU (4 colors)
9. Sensor board unit (SBU)	22. Image transfer belt cleaning unit
10. Scanner motor	23. Image transfer belt unit
11. Paper exit rollers	24. Toner bottle (4 colors)
12. Duplex unit	25. ID sensor
13. Fusing unit	26. Fusing sleeve belt unit

1.2.2 PAPER PATH

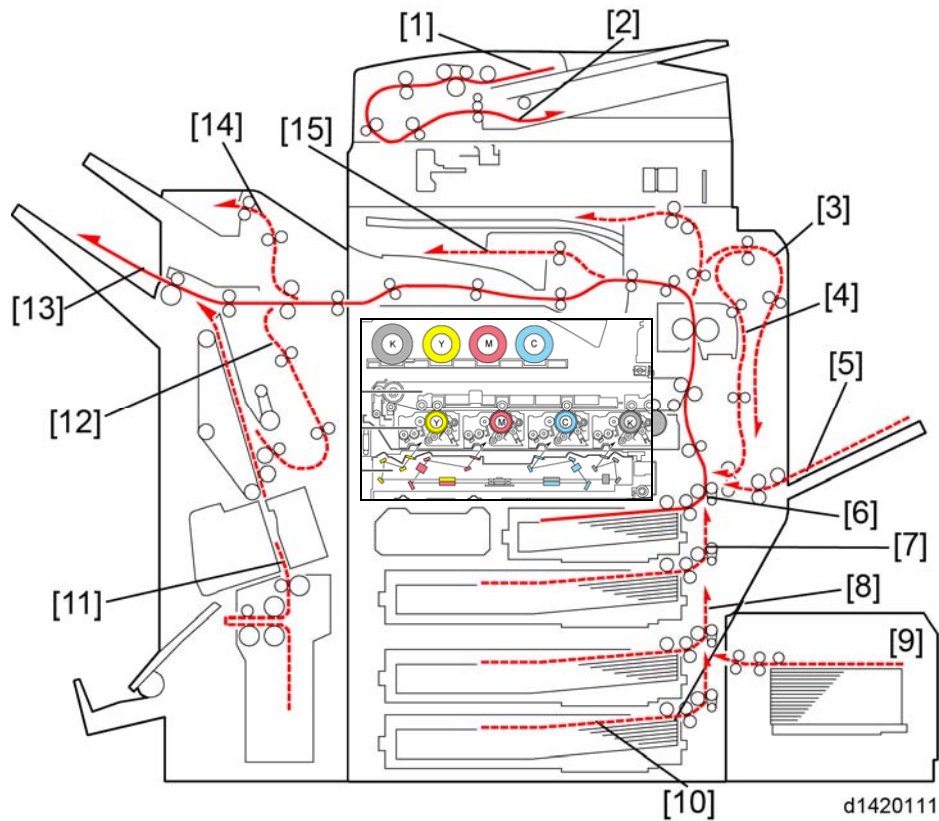

<p>1. Original tray</p> <p>2. Original exit tray</p> <p>3. Duplex inverter</p> <p>4. Duplex feed</p> <p>5. By-pass tray feed</p> <p>6. Tray 1 feed</p> <p>7. Tray 2 feed</p> <p>8. Tray 3: Optional paper feed unit/LCT</p>	<p>9. Tray 5: Optional LCT 1200</p> <p>10. Tray 4: Optional paper feed unit</p> <p>11. Finisher stapler (Optional)</p> <p>12. Finisher punch (Optional)</p> <p>13. Finisher lower tray (Optional)</p> <p>14. Finisher proof tray (Optional)</p> <p>15. Inner Tray</p>
---	---

The 1000-sheet finisher and 1000-sheet booklet finisher require the bridge unit and one from the two-tray paper feed unit or the LCT.

1.2.3 DRIVE LAYOUT

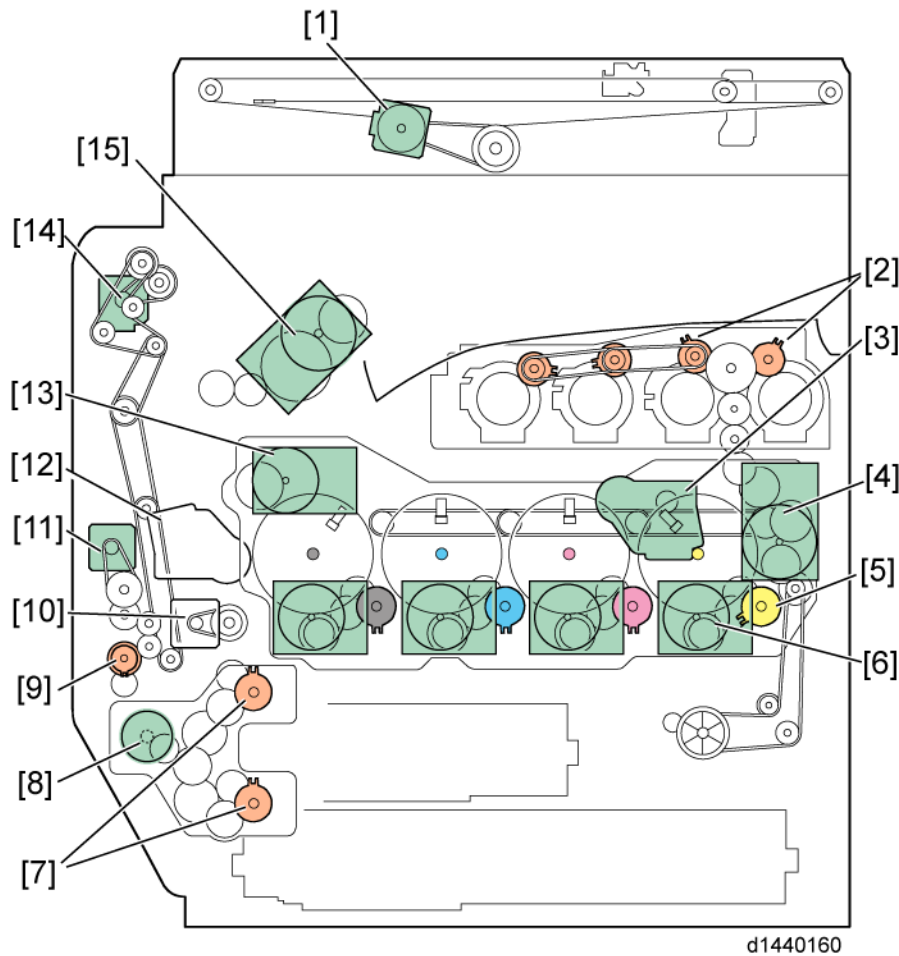

1. Scanner motor:	Drives the scanner unit.
2. Toner supply clutch-K and -CMY:	Turns on/off the drive power to the toner supply unit (K and -CMY).
3.ITB (Image Transfer Belt) contact motor:	Moves the ITB into contact and away from the color PCDUs.
4. Toner transport motor:	Drives the toner attraction pumps and the toner collection coils from the PCDUs, from the transfer belt unit, and inside the toner collection bottle. Also rotates the toner bottles.
5. Development clutch (K, Y, M, C):	Turns on/off the drive power to the development unit (K, Y, M, C).
6. Drum/Development drive motor (K, Y, M, C)	Drives the color drum unit and development unit (K, Y, M, C).

Product Overview

7. Paper feed clutch	Switches the drive power between tray 1 and tray 2.
8. Paper feed motor:	Drives the paper feed mechanisms (tray 1/tray 2).
9. By-pass feed clutch:	Turns on/off the drive power to the by-pass pick-up, feed and separation rollers.
10. Registration motor:	Drives the registration roller.
11. By-pass/duplex feed motor:	Drives the by-pass pick-up, feed and separation roller, and duplex transport rollers.
12. Paper transfer contact motor:	Moves the paper transfer roller in contact with the image transfer belt.
13. ITB drive motor:	Drives the image transfer belt unit.
14. Duplex inverter motor	Drives the duplex inverter rollers and duplex transport rollers.
15. Fusing/paper exit motor:	Drives the fusing unit and paper exit section.
16. Fusing unit shutter plate drive motor	Drives the fusing unit shutter plate.

1.3 MACHINE CODES AND PERIPHERAL CONFIGURATION

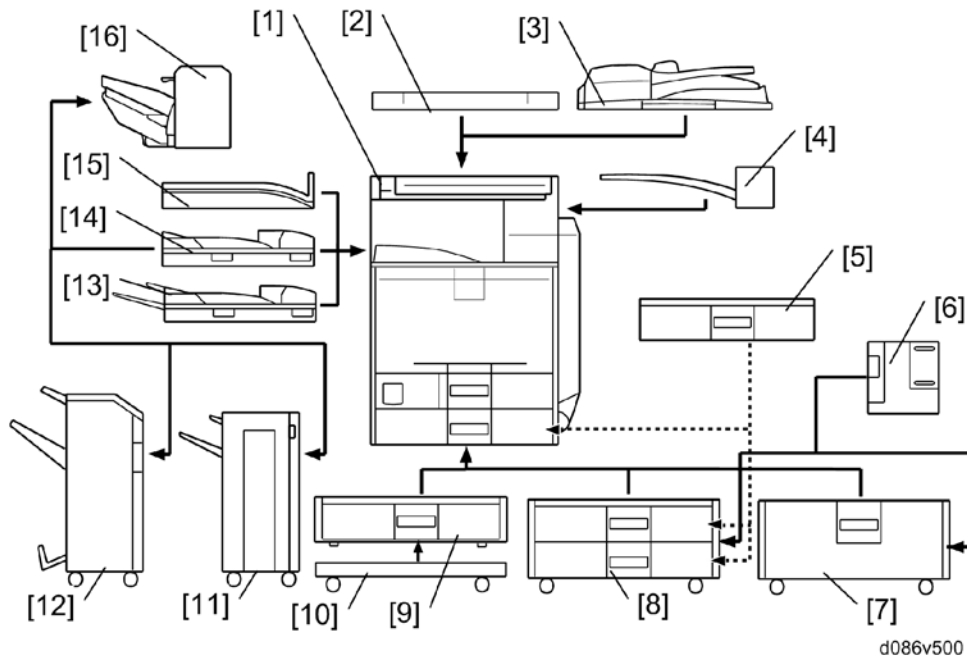

Item	Machine Code	Call out	Remarks
Mainframe	D111/D142	[1]	
Platen cover	D593	[2]	One from the two for all models.
ARDF	D578	[3]	
1-bin tray	D632	[4]	-
Envelope feeder ^{*1}	D638	[5]	Requires Tray 2 of the Mainframe or [8].
1200-sheet LCT	D631-17 (NA) D631-27 (EU/AA)	[6]	Requires [7] or [8].

*1: The Envelope Feeder EF3020 (D638) cannot be used in the one-tray paper feed unit (D579).

Machine Codes and Peripheral Configuration

Item	Machine Code	Call out	Remarks
2000-sheet LCT	D581-17 (NA) D581-27 (EU/AA)	[7]	One from [7], [8] and [9]; [9] requires [10].
Two-tray paper feed unit	D580-17	[8]	
One-tray paper feed unit	D579	[9]	
Caster table	D593	[10]	-
1000-sheet finisher	D588	[11]	One from [11], [12] and [16]; Requires [14] and one from [7] and [8].
1000-sheet booklet finisher	D589	[12]	
Side tray	D635	[13]	One from [13], [14] and [15].
Bridge unit	D634	[14]	
Shift tray	D633	[15]	
500-sheet finisher	D585	[16]	Requires [14].
Punch unit: 3/2 holes	B807-17	-	Requires [12].
Punch unit: 4/2 holes	B807-27	-	
Punch unit: 4 holes	B807-30	-	
Punch unit: 2 / 3 holes	D570-00 (NA)	-	
Punch unit: 2 / 4 holes	D570-01 (EU)	-	
Punch unit: 4 holes	D570-02 (Scandinavia)	-	
Card reader bracket	D593-61	-	One from the two.
Key counter bracket	A674	-	
Optional counter interface unit	B870	-	-

Item	Machine Code	Call out	Remarks
Scanner accessibility option	D423	- -	
ADF handle	D593-81	- -	
Handset (only for NA)	D645	-	The included bracket is not for these models.

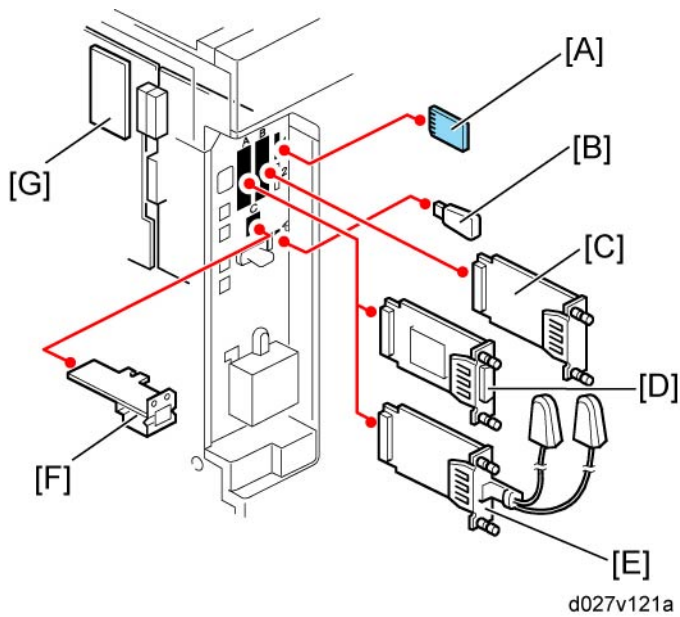

Item	Machine code	Call out	Remark
Gigabit Ethernet Type B	D377-21	[F]	-
IEEE 1284 Interface Board Type A	B679-17	[D]	You can only install one of these at a time.
Wireless LAN (IEEE 802.11a/g Interface Unit Type J)	D377-01 (NA) D377-02 (EU/AA)	[E]	

Machine Codes and Peripheral Configuration

Item	Machine code	Call out	Remark
Wireless LAN (IEEE 802.11g Interface Unit Type K)	D377-19 (EU)		
File Format Converter Type E	D377-04	[C]	
Bluetooth Interface Unit Type D (USB)	D566-01	[B]	-

Item	Machine code	Call out	Remark
PostScript 3 Unit Type C5502	D645-11 (NA) D645-12 (EU) D645-13 (AA)	[A]	Those cards should be installed from SD slot 2 (lower). If multiple applications are required, merge all applications in one SD card with SP mode. (p.2-109)
PictBridge Type J	- D645-15		
IPDS Unit Type C5502	D645-07 (NA) D645-08 (EU) D645-09 (AA)		
Browser Unit Type F	D645-17 (NA) D645-24 (EU) D645-25 (AA)		
SD Card for Netware Printing Type H	D645-23		
PDF Direct / VM / App2Me Card (Standard)	-	-	This card should already be in SD slot 1 (upper) when the machine leaves the factory.
Copy Data Security Unit Type G	D640-41	[G]	-

Item	Machine code	Call out	Remark
Fax Option Type C5502	D643-01 (NA) D643-02 (EU) D643-03 (AA)	- -	
G3 Interface Unit Type C5502	D643-11 (NA) D643-12 (EU/AA)	- -	
Memory Unit Type B	G578	- -	
Handset Type 3352 (only for NA)	D593-71	-	The included bracket is not for these models.

1.4 GUIDANCE FOR THOSE WHO ARE FAMILIAR WITH PREDECESSOR PRODUCTS

Machine D111/D142 is a successor model to Machine D086/D087. If you have experience with the predecessor products, the following information will be of help when you read this manual.

Different Points from Predecessor Products

	D111/D142	D086/D087
Controller Type	GW+ Controller	GW Controller
New Fusing Unit without the Decurler	Yes	No
Fusing Unit	New QSU-DH fusing system	IH roller fusing system
SMC data	SD card download or printing	Printing only
Operation Panel	Tiltable Operation Panel Includes USB/SD slot	Stationary Operation Panel
USB2.0/SD Slot	Standard	Optional
Scanner Lamp	LED	Xenon
Data Overwrite Security, HDD Encryption	Included in the controller ROM	SD card

INSTALLATION

REVISION HISTORY		
Page	Date	Added/Updated/New
26	6/27/2012	Transporting the machine
109	07/12/2012	Corrected Controller Options – <i>I/F Card Slots</i>

2. INSTALLATION

2.1 INSTALLATION REQUIREMENTS

2.1.1 ENVIRONMENT

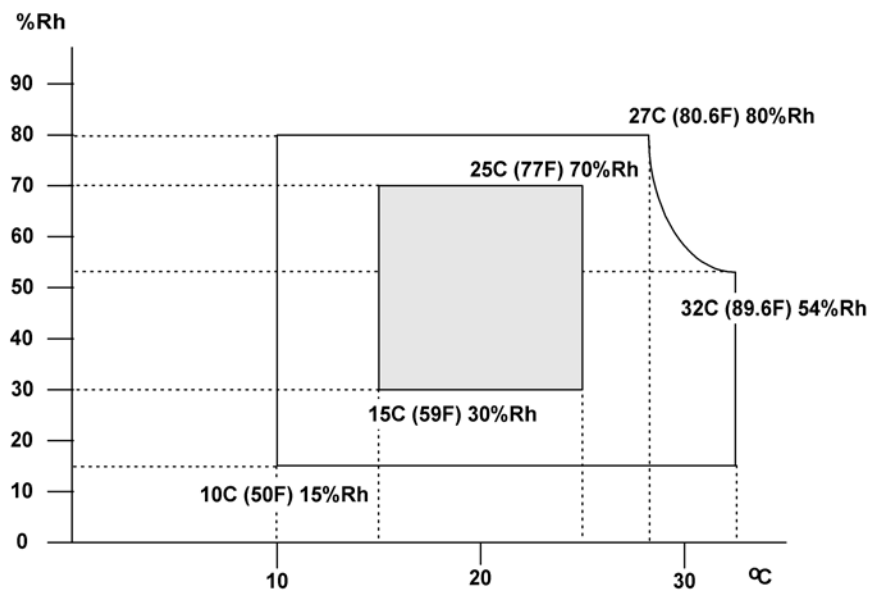

1. Temperature Range: 10°C to 32°C (50°F to 89.6°F)
2. Humidity Range: 15% to 80% RH
3. Ambient Illumination: Less than 1500 lux (do not expose to direct sunlight)
4. Ventilation: 3 times/hr/person or more
5. Do not let the machine get exposed to the following:
 - 1) Cool air from an air conditioner
 - 2) Heat from a heater
6. Do not install the machine in areas that are exposed to corrosive gas.
7. Install the machine at locations lower than 2,000 m (6,560 ft.) above sea level.
8. Install the machine on a strong, level base. (Inclination on any side must be no more than 5 mm.)
9. Do not install the machine in areas that get strong vibrations.

★ Important

- Do not leave the toner bottle in a place directly exposed to sunlight.
- The toner bottle must be kept at a temperature of 35°C (95°F) or less. Be careful not to leave the toner bottle in a hot place when transporting or storing it.

2.1.2 MACHINE LEVEL

Front to back: Within 5 mm (0.2")

Right to left: Within 5 mm (0.2")

2.1.3 MACHINE SPACE REQUIREMENTS

⚠ CAUTION

- This machine, which uses high voltage power sources, can generate ozone gas. High ozone density is harmful to human health. Therefore, the machine must be installed in a well-ventilated room.

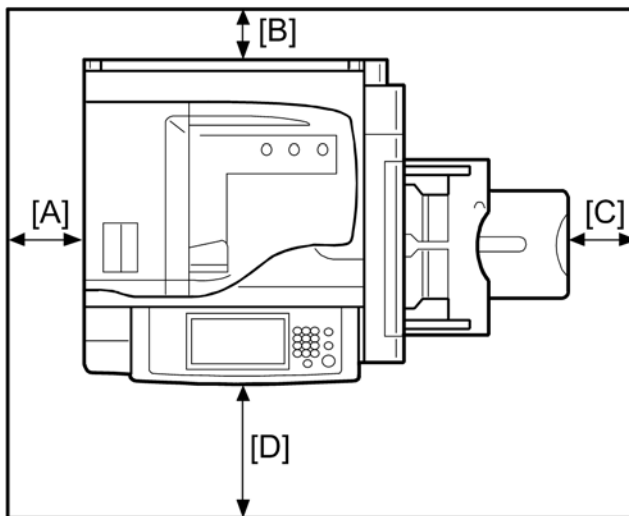

b222i109a

A: Over 100 mm (3.9")

B: Over 100 mm (3.9")

C: Over 100 mm (3.9")

D: Over 750 mm (29.5")

Put the machine near the power source with the clearance shown above.

2.1.4 MACHINE DIMENSIONS

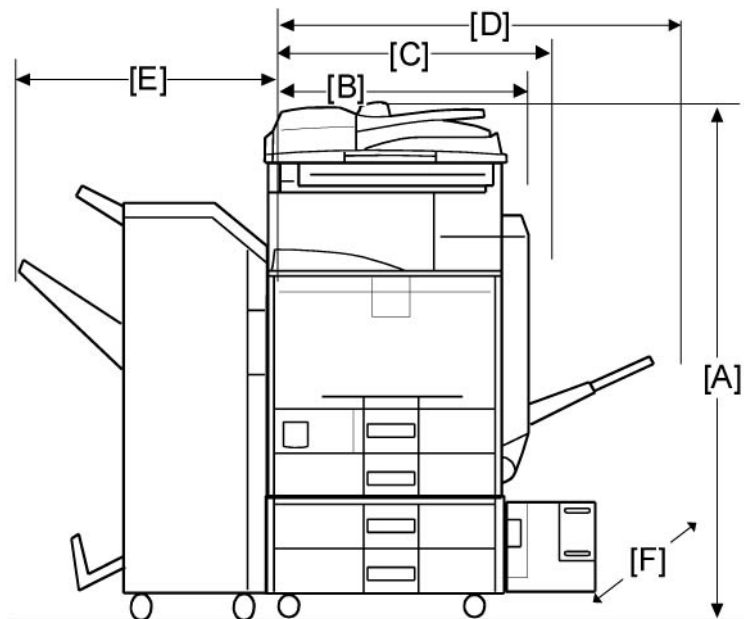

d1440118

[A]: 760 mm (mainframe) + 260 mm (PFU) + 120 mm (ARDF)

[B]: 580 mm

[C]: 670 mm

[D]: 1065 mm

[E]: 577 mm

[F]: 682 mm (Depth) (766 mm Max. with D580)

2.1.5 POWER REQUIREMENTS

⚠ CAUTION

- Insert the plug firmly in the outlet.
 - Do not use an outlet extension plug or cord.
 - Ground the machine.
1. Input voltage level:
 - 110 V, 60 Hz: 20 A (Taiwan)
 - 120 to 127 V, 60 Hz: More than 12 A (NA)
 - 220 V to 240 V, 50 Hz/60 Hz: 10 A (EU/AA/China/Korea)
 2. Permissible voltage fluctuation: +8.66 %/ -10 % (NA)
Permissible voltage fluctuation: ± 10 % (Others)
 3. Do not put things on the power cord.

2.2 COPIER INSTALLATION

⚠ CAUTION

- Make sure that the image transfer belt is in its correct position (away from the PCDUs) before you move the machine. Otherwise, the image transfer belt and the black PCDU can be damaged.

2.2.1 POWER SOCKETS FOR PERIPHERALS

⚠ CAUTION

- Rating voltage for peripherals.
- Make sure to plug the cables into the correct sockets.

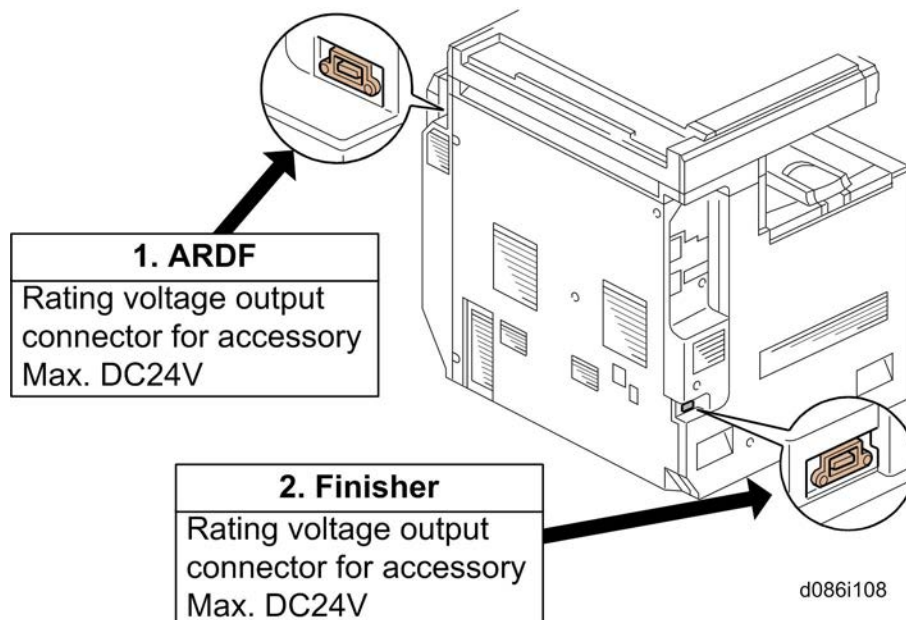

2.2.2 INSTALLATION FLOW CHART

This flow chart shows the best procedure for installation.

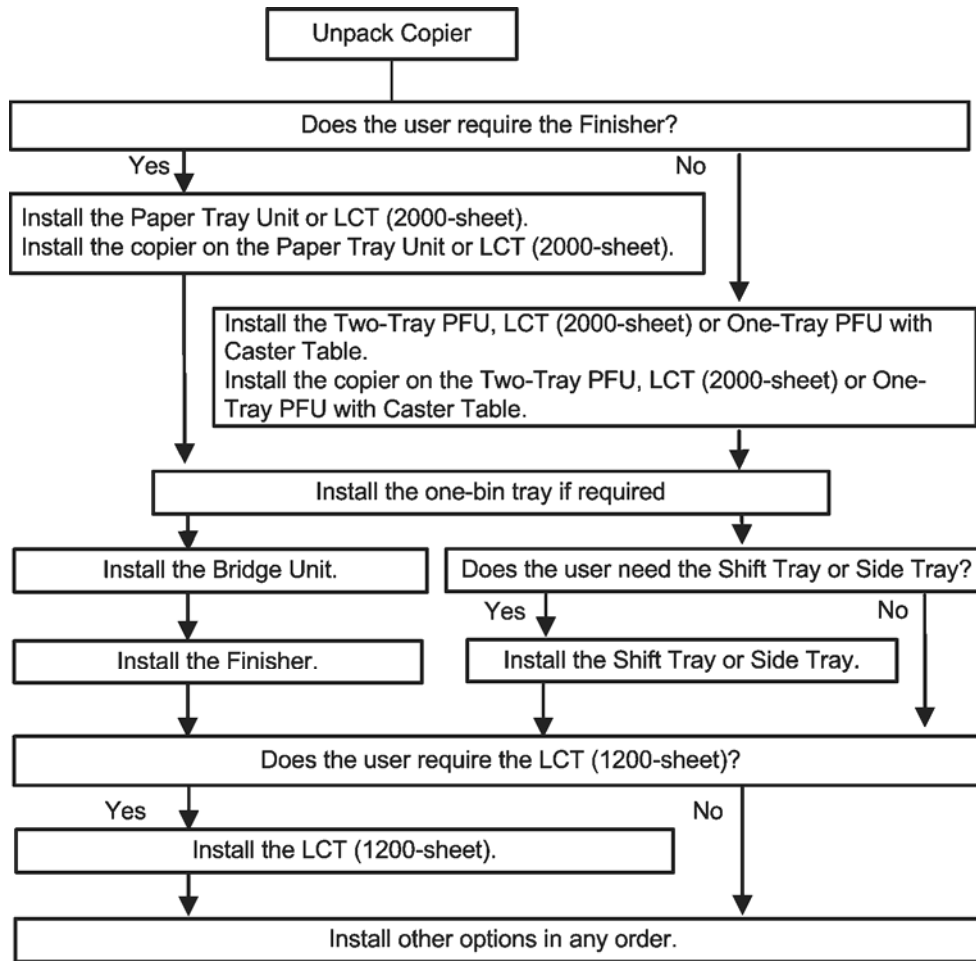

d086i510

You need the optional paper tray unit or the LCT if you want to install the finisher (D588 or D589) or 1200-sheet LCT (D631).

The punch unit is for the booklet finisher (D589).

2.2.3 INSTALLATION PROCEDURE

⚠ CAUTION

- Remove the tape from the development units before you turn the main switch on. The development units can be severely damaged if you do not remove the tape.

Put the machine on the paper tray unit or the LCT first if you install an optional paper tray unit or the optional LCT at the same time. Then install the machine and other options.

↓ Note

- Keep the shipping retainers after you install the machine. You may need them in the future if you transport the machine to another location.

Tapes and Retainers

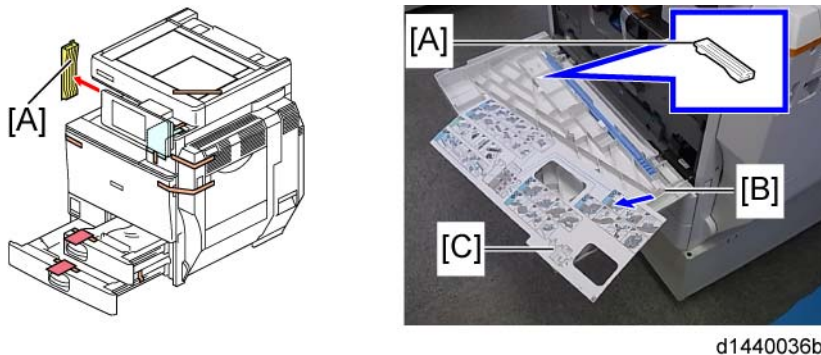

1. Remove all the tapes and retainers on the machine.
2. Remove all the tapes and retainers in trays 1 and 2, and then take out the power cord from tray 1 (if applicable).
3. Remove the scanner unit stay [A].
4. Open the front door [B], and then remove the jam location sheet [C].
5. Keep the scanner unit stay [A] inside the front door.
6. Reattach the jam location sheet.
7. Close the front door.

★ Important

- The scanner unit stay [A] should be reinstalled before the machine is transported.

Developer and Toner Bottles

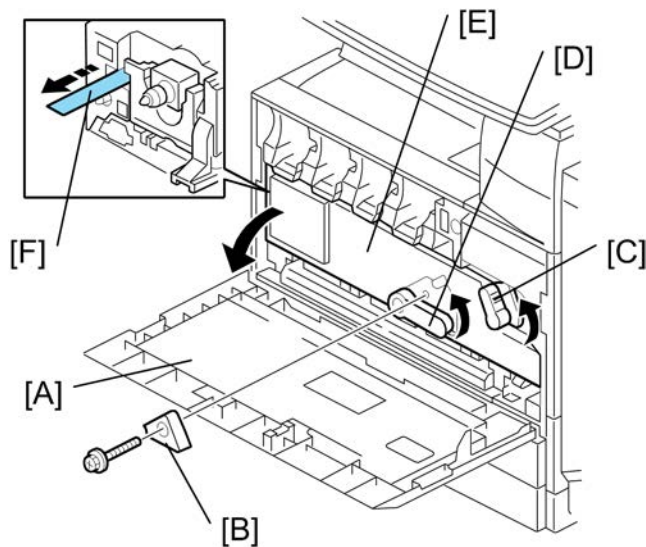

d027i106

1. Open the front door [A].
 - GSA model (-51) and EU models (-27) do not require steps from 2 to 7. Skip to step 8 if you install these models.
2. Remove the stopper [B] ( x 1).

Note

 - This stopper locks the drum positioning plate lever.
3. Release the image transfer unit lock lever [C], and turn the drum positioning plate lever [D] counterclockwise.
4. Open the drum positioning plate [E].
5. Remove the tape [F] from the Bk development unit.
6. Remove all tapes on the other development units (C, M, Y) in the same way as described in the previous step.

Note

 - When you remove the tape from the development unit, hold the development unit with your hand, and then pull the tape.
7. Close the drum positioning plate. Then lock the image transfer unit lock and turn the drum positioning plate lever clockwise.
8. Lock the drum positioning plate lever with the stopper [B] ( x 1).
9. Shake each toner bottle five or six times.

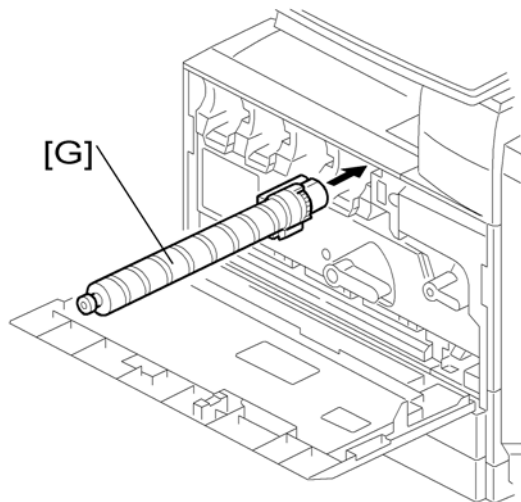

10. Install each toner bottle [G] in the machine.

Note

- The toner bottles are unique for the D111/D142 models. The toner bottles for the previous models (D086/D087) cannot be used in the D111/D142 models.

11. Close the front door.

Paper Trays

1. Pull each paper tray out. Then adjust the side guides and end guide to match the paper size.

Note

- To move the side guide, first pull out the tray fully. Then push down the green lock at the rear inside the tray.

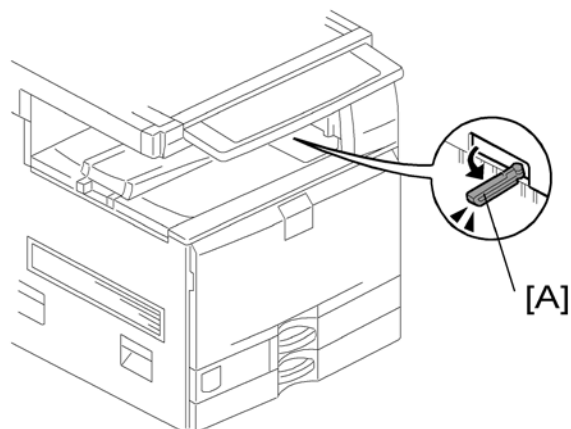

2. Pull out the feeler [A] for the output tray full detection mechanism.

Emblem and Decals

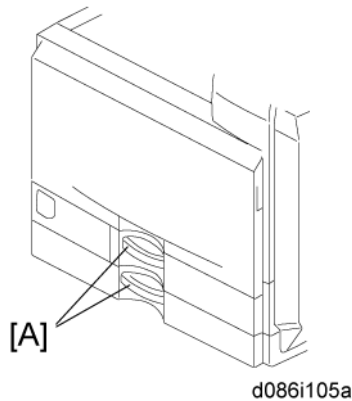

1. Attach the correct paper tray number and size decals to the paper trays [A].

Note

- Paper tray number and size decals are also used for the optional paper tray or the optional LCT. Keep these decals for use with these optional units.

Initialize the Developer

1. Plug in the machine.
2. Make sure that the platen or ARDF is closed and the main power is turned off.
3. Turn the main power switch on. The machine automatically starts the initialization procedure. The Start button LED (Ⓢ) turns green when this procedure has finished.
4. Make copies of image samples (text, photo, and text/photo modes).
5. Do the Automatic Color Calibration process (ACC) as follows:
 - 1). Print the ACC test pattern (User tools → Maintenance → ACC → Start).
 - 2). Put the printout on the exposure glass.
 - 3). Put 10 sheets of white paper on top of the test chart.
 - 4). Close the ARDF or the platen cover.
 - 5). Press "Start Scanning" on the LCD panel. The machine starts the ACC.
6. Check that the sample image has been copied normally.

Settings Relevant to the Service Contract

Change the necessary settings for the following SP modes if the customer has made a service contract.

Note

- You must select one of the counter methods (developments/prints) in accordance with the contract (See SP5-045-001).
- The SP operation sound can be turned on or off. For details, see “SP Operation Sound On/Off Setting” below.

Item	SP No.	Function	Default
Counting method	SP5-045-001	Specifies if the counting method used in meter charge mode is based on developments or prints.	“0”: Developments
A3/11" x 17" double counting	SP5-104-001	Specifies whether the counter is doubled for A3/11" x 17" paper. When you have to change this setting, contact your supervisor.	“No”: Single counting
Service Tel. No. Setting	SP5-812-001 through 004	5812-002 programs the service station fax number. The number is printed on the counter list when the meter charge mode is selected. This lets the user fax the counter data to the service station.	

SP Operation Sound On/Off Setting

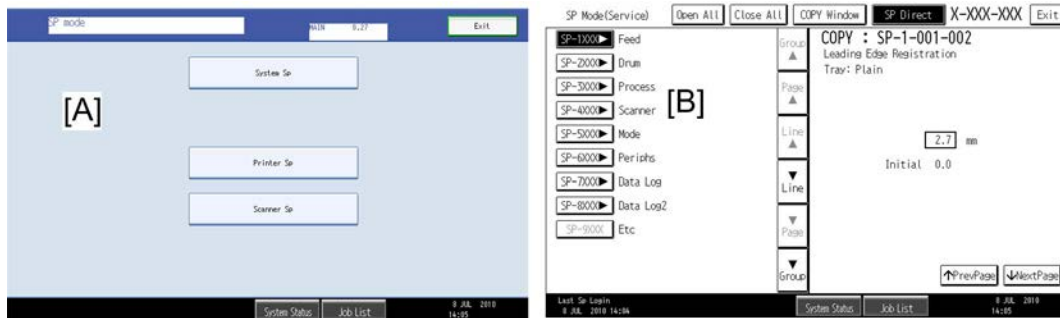

d086i120

To turn off the SP Operation Sound

1. Enter the SP mode.
2. On the top menu screen [A], hold down the "Clear" button until you hear a beep sound. This turns off the SP operation sound.
3. No SP operation sound can be heard in all levels [B] (SPx, SPx-xxx and SPx-xxx-xxx) of the SP mode.

To turn on the SP Operation Sound

1. Enter the SP mode.
2. On the top menu screen [A], hold down the "Clear" button again until you hear a beep sound. This turns on the SP operation sound.
3. SP operation sound can be heard in all levels [B] (SPx, SPx-xxx and SPx-xxx-xxx) of the SP mode.

Settings for @Remote Service

↓ Note

- Prepare and check the following check points before you visit the customer site. For details, ask the @Remote key person.

Check points before making @Remote settings

1. The setting of SP5816-201 in the mainframe must be "0".
2. Device ID2 (SP5811-003) must be correctly programmed.
 - 6 spaces must be put between the 3-digit prefix and the following 8-digit number (e.g. xxx____xxxxxxxx).
 - ID2 (SP5811-003) and the serial number (SP5811-001) must be the same (e.g. ID2: A01____23456789 = serial No. A0123456789)
3. The following settings must be correctly programmed.
 - Proxy server IP address (SP5816-063)
 - Proxy server Port number (SP5816-064)
 - Proxy User ID (SP5816-065)
 - Proxy Password (SP5816-066)

4. Get a Request Number

Execute the @Remote Settings

1. Enter the SP mode.
2. Input the Request number which you have obtained from @Remote Center GUI, and then enter [OK] with **SP5816-202**.
3. Confirm the Request number, and then click [EXECUTE] with **SP5816-203**.
4. Check the confirmation result with **SP5816-204**.

Value	Meaning	Solution/ Workaround
0	Succeeded	-
1	Request number error	Check the request number again.
3	Communication error (proxy enabled)	Check the network condition.
4	Communication error (proxy disabled)	Check the network condition.
5	Proxy error (Illegal user name or password)	Check Proxy user name and password.
6	Communication error	Check the network condition.

Value	Meaning	Solution/ Workaround
8	Other error	See "SP5816-208 Error Codes" below this.
9	Request number confirmation executing	Processing... Please wait.

5. Make sure that the screen displays the Location Information with **SP5816-205** only when it has been input at the Center GUI.
6. Click [EXECUTE] to execute the registration with **SP5816-206**.
7. Check the registration result with **SP5816-207**.

Value	Meaning	Solution/ Workaround
0	Succeeded	-
1	Request number error	Check the request number again.
2	Already registered	Check the registration status.
3	Communication error (proxy enabled)	Check the network condition.
4	Communication error (proxy disabled)	Check the network condition.
5	Proxy error (Illegal user name or password)	Check Proxy user name and password.
8	Other error	See "SP5816-208 Error Codes" below this.
9	Request number confirmation executing	Processing... Please wait.

8. Exit the SP mode.

SP5816-208 Error Codes

Cause	Code	Meaning	Solution/ Workaround
Operation Error, Incorrect Setting	-12002	Inquiry, registration attempted without acquiring Request No.	Obtain a Request Number before attempting the Inquiry or Registration.
	-12003	Attempted registration without execution of a confirmation and no previous registration.	Perform Confirmation before attempting the Registration.
	-12004	Attempted setting with illegal entries for certification and ID2.	Check ID2 of the mainframe.
	-12005	@Remote communication is prohibited. The device has an Embedded RC gate-related problem.	Make sure that "Remote Service" in User Tools is set to "Do not prohibit".
	-12006	A confirmation request was made after the confirmation had been already completed.	Execute registration.
Operation Error, Incorrect Setting	-12007	The request number used at registration was different from the one used at confirmation.	Check Request No.
	-12008	Update certification failed because mainframe was in use.	Check the mainframe condition. If the mainframe is in use, try again later.
	-12009	ID2 mismatch between an individual certification and NVRAM	Write a common certification, and then execute the confirmation request to the @Remote Center.

Cause	Code	Meaning	Solution/ Workaround
	-12010	Certification area is not initialized.	Write a common certification after initializing the certification area, and then execute the confirmation request to the @Remote Center.
Error Caused by Response from GW URL	-2385	Other error	
	-2387	Not supported at the Service Center	
	-2389	Database out of service	
	-2390	Program out of service	
	-2391	Two registrations for the same mainframe	Check the registration condition of the mainframe
	-2392	Parameter error	
	-2393	External RCG not managed	
	-2394	Mainframe not managed	
	-2395	Box ID for external RCG is illegal.	
	-2396	Mainframe ID for external RCG is illegal.	
	-2397	Incorrect ID2 format	Check the ID2 of the mainframe.
	-2398	Incorrect request number format	Check the Request No.

VM Card Installation

The following procedure basically should be done by a customer.

1. Press the [User Tools] key on the operation panel.
2. Touch the "Extended Feature Settings" button twice.
3. Touch the "Java TM Platform" line under the Startup Setting tab.
4. Touch the "Extended Feature Info" tab on the LCD.
5. Touch the " Java TM Platform " line.
6. Set "Auto Start" to "On".
7. Touch the "Exit" button.
8. Exit the "User Tools" settings.

Enabling App2Me

The following procedure basically should be done by a customer.

1. Press the [User Tools] key on the operation panel.
2. Touch the "Extended Feature Settings" button twice.
3. Touch the "App2Me" line under the Startup Setting tab.
4. Touch the "Extended Feature Info" tab on the LCD.
5. Touch the "App2Me" line.
6. Set "Auto Start" to "On".
7. Touch the "Exit" button.
8. Exit the "User Tools" settings.

Security Function Installation

The machine contains the Security function (Data Overwrite Security and HDD Encryption unit) built into the controller board.

If you are installing a new machine, it is recommended to activate the Data Overwrite Security and HDD Encryption unit by selecting "Format All Data" from "System Settings" on the operation panel.

Note

- This method is recommended because there is no user data on the hard drive yet (Address Book data, image data, etc.).

If the customer wishes to activate the Data Overwrite Security and HDD Encryption unit on a machine that is already running, it is recommended to activate the unit by selecting "All Data" from "System Settings" on the operation panel.

★ Important

- Selecting "All Data" will preserve the data that has already been saved to the hard drive. (If "Format All Data" is selected, all user data saved to the hard drive up to that point will be erased).

Immediately after encryption is enabled, the encryption setting process will take several minutes to complete before you can begin using the machine.

↓ Note

- If encryption is enabled after data has been stored on the disk, or of the encryption key is changed, this process can take up to three and a half hours or more.

The machine cannot be operated while data is being encrypted.

Once the encryption process begins, it cannot be stopped.

Make sure that the machine's main power is not turned off while the encryption process is in progress.

If the machine's main power is turned off while the encryption process is in progress, the hard disk will be damaged and all data on it will be unusable.

Print encryption key and keep the encryption key (which is printed as a paper sheet).

Keep the encryption key in a safe place. If the encryption key is lost and it need, the controller board, hard disk and NVRAM must all be replaced at the same time.

↓ Note

- "NVRAM" mentioned in here means the NVRAM on Controller Board.
- "NVRAM" or EEPROM on BCU has nothing to do with this.

Please use the following procedure when the Data Overwrite Security and HDD Encryption reinstalled.

Data Overwrite Security

- **Before You Begin the Procedure**

1. Make sure that the following settings (1) to (3) are not at their factory default values.

- Supervisor login password
- Administrator login name
- Administrator login password

If any of these settings is at a factory default value, tell the customer these settings must be changed before you do the installation procedure.

2. Make sure that "Admin. Authentication" is on.

[System Settings] → [Administrator Tools] → [Administrator Authentication Management] → [Admin. Authentication]

If this setting is off, tell the customer this setting must be on before you do the installation procedure.

Copier Installation

3. Make sure that “Administrator Tools” is enabled (selected).

[System Settings] → [Administrator Tools] → [Administrator Authentication Management] → [Available Settings]

If this setting is disabled (not selected), tell the customer this setting must be enabled (selected) before you do the installation procedure.

Installation Procedure

1. Connect the network cable if it needs to be connected.
2. Turn on the main power switch.
3. Go into the SP mode and push “EXECUTE” with SP5-878-001.
4. Exit the SP mode and turn off the operation switch. Then turn off the main power switch.
5. Turn on the machine power.
6. Do SP5-990-005 (SP print mode Diagnostic Report).
7. Go into the User Tools mode, and select [System Settings] → [Administrator Tools] → [Auto Erase Memory Setting] → [On].
8. Exit the User Tools mode.

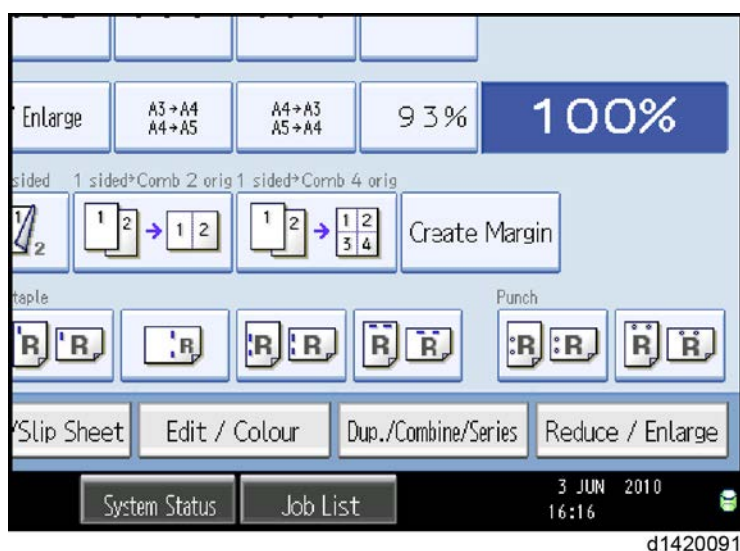

	Dirty	This icon is lit when there is temporary data to be overwritten, and blinks during overwriting.
	Clear	This icon is lit when there is no temporary data to be overwritten.

9. Check the display and make sure that the overwrite erase icon [1] shows.

10. Check the overwrite erase icon.

The icon [2] is lit when there is temporary data to be overwritten, and blinks during overwriting.

The icon [3] is lit when there is no temporary data to be overwritten.

HDD Encryption

▪ Before You Begin the Procedure

1. Make sure that the following settings (1) to (3) are not at the factory default settings.

- Supervisor login password
- Administrator login name
- Administrator login password

These settings must be set up by the customer before the HDD Encryption unit can be installed.

2. Confirm that "Admin. Authentication" is on.

[User tools/Counter] key → [System Settings] →

[Administrator Tools] → [Administrator Authentication Management] → [Admin. Authentication]
→

[On]

If this setting is off, tell the customer that this setting must be on before you can do the installation procedure.

3. Confirm that "Administrator Tools" is selected and enabled.

[User tools/Counter] key → [System Settings] → [Administrator Tools] →

[Administrator Authentication Management] → [Available Settings]

"Available Settings" is not displayed until step 2 is done.

If this setting is not selected, tell the customer that this setting must be selected before you can do the installation procedure.

▪ Installation Procedure

1. Turn on the main power switch, and then enter the SP mode.
2. Select SP5878-002, and then press "Execute" on the LCD.
3. Exit the SP mode after "Completed" is displayed on the LCD.

▪ Enable Encryption Setting

1. Press the [User tools/Counter] key.
2. Press [System Settings].
3. Press [Administrator Tools].
4. Press [Machine Data Encryption Settings]. If this item is not visible, press [Next] to display more settings.

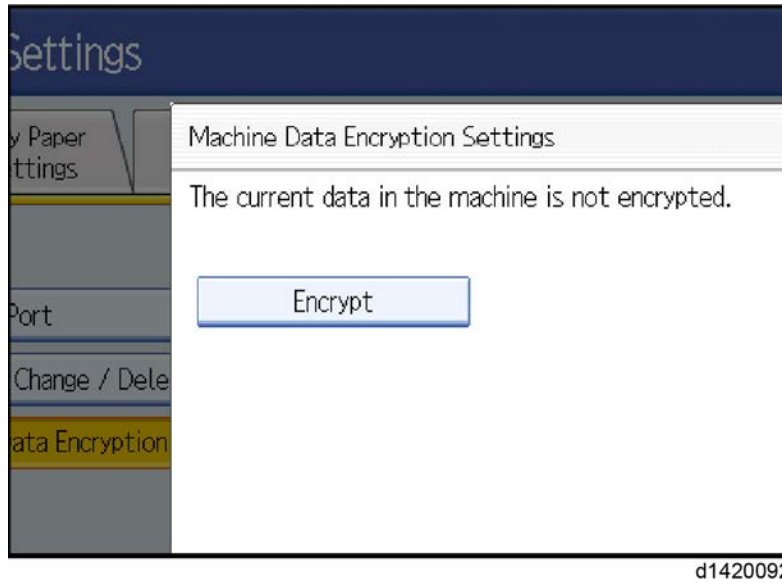

5. Press [Encrypt].

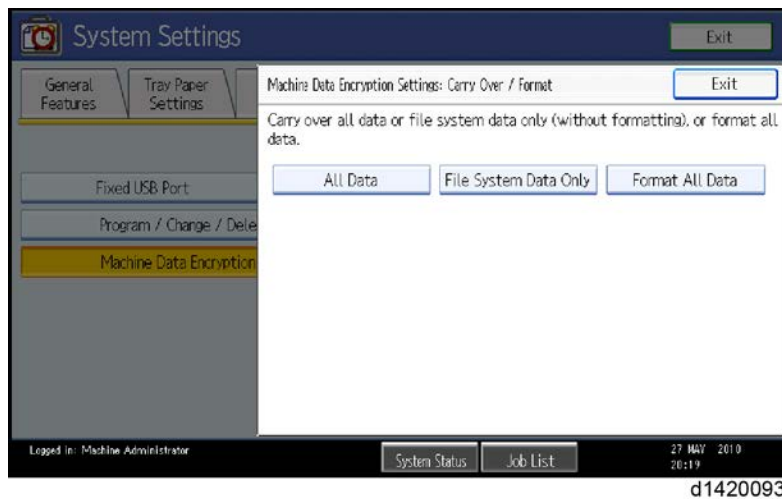

6. Select the data to be carried over to the hard disk and not be reset.

To carry all of the data over to the hard disk, select [All Data].

To carry over only the machine settings data, select [File System Data Only].

To reset all of the data, select [Format All Data].



d1420094

7. Press [Start] key.

The encryption key for backup data is printed.

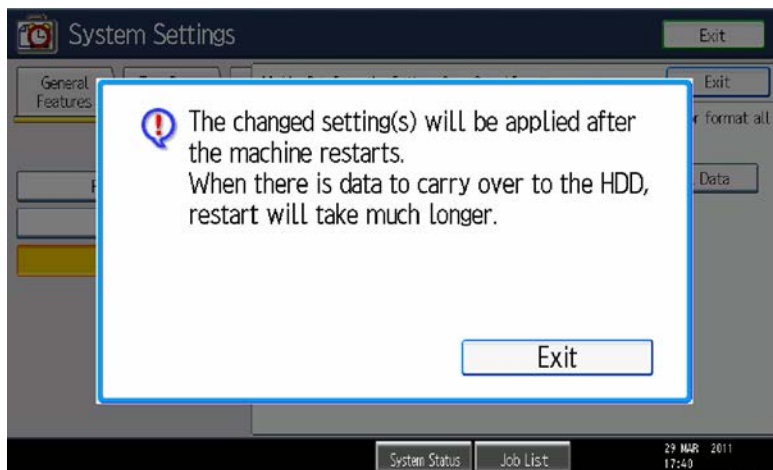

d1420095

8. Press [Exit].

9. Press [Exit].

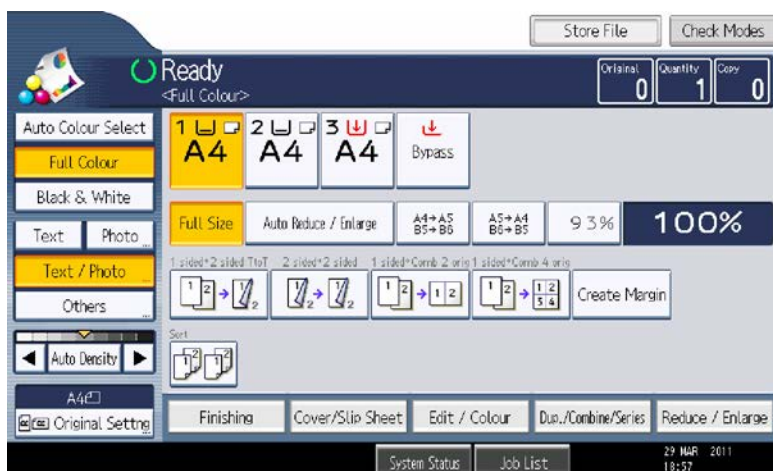

d1420096

10. Press the [User Tools/Counter] key.

Important

- After the step 11, turn to the below initial operation display. But, it is not be encrypted.

11. Turn off the power and the main power switch, and then turn the main power switch back.

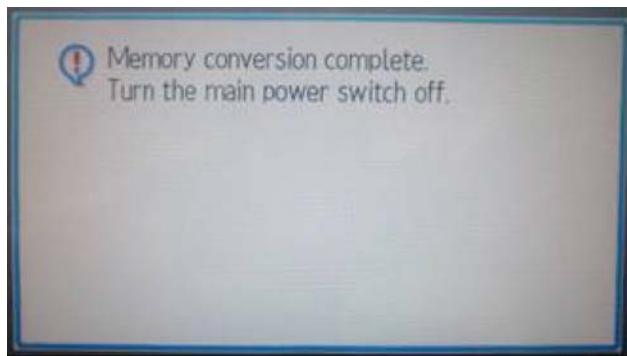

d1420097

12. Displayed "Memory Conversion complete. Turn the main power switch off" again, turn off the power and the main power switch, and then turn the main power switch back.

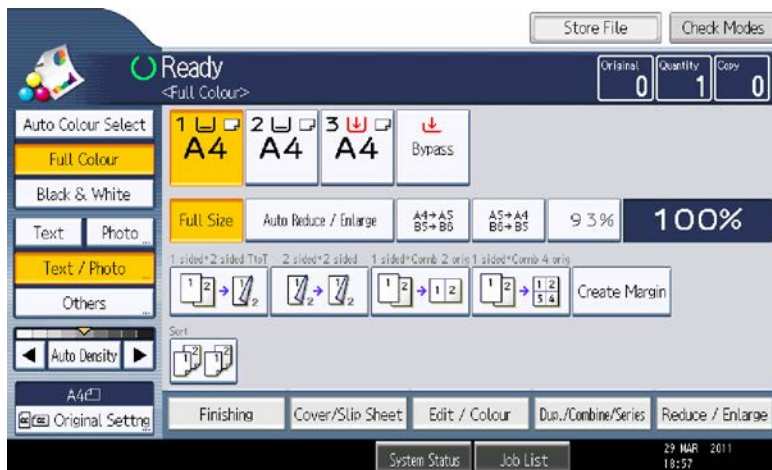

d1420096

13. Initial display.

- **Confirmation Encryption Setting**
 1. Press the [User tools/Counter] key.
 2. Press the [System Settings].
 3. Press the [Administer Tools].

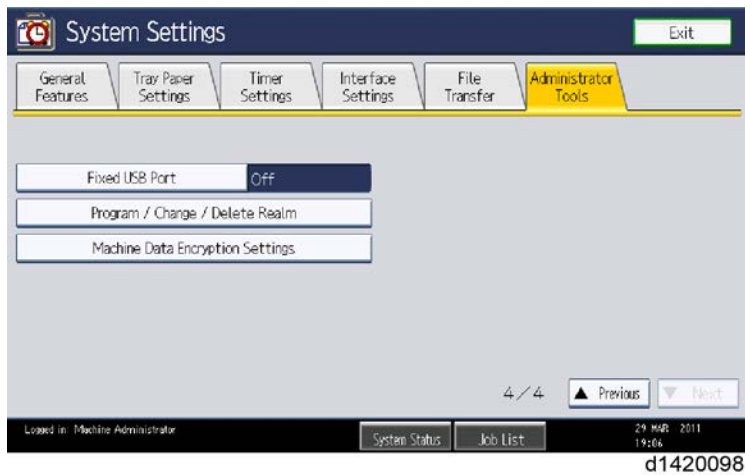

d1420098

4. Press the [Machine Data Encryption Settings].

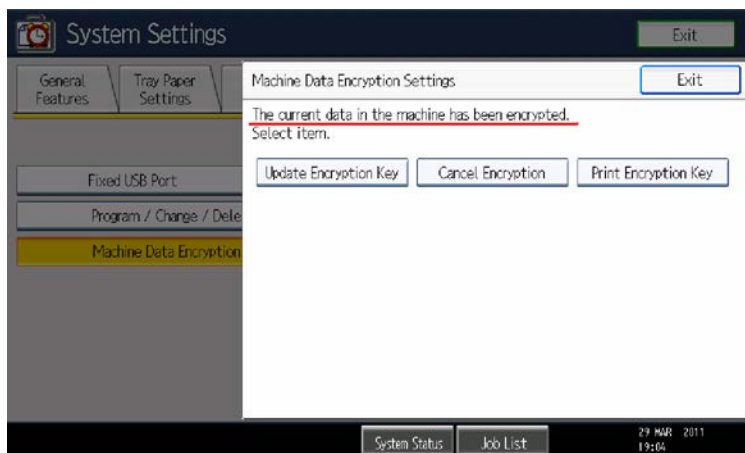

d1420099

5. Please confirm whether the encryption has been completed or not on this display.

- **Print to encryption key**

Use the following procedure to print the key again if it has been lost or misplaced.

1. Press the [User tools/Counter] key.
2. Press [System Settings].
3. Press [Administrator Tools].
4. Press [Machine Data Encryption Settings].
5. If this item is not visible, press [Next] to display more settings.
6. Press [Print Encryption Key].

Encryption key sample

Machine Data Encryption Key

This is an encryption key which allows you to protect confidential data stored in the machine.
It is essential that the safekeeping and destruction of this encryption key be under your direct responsibility.
Data saved and programmed on the machine (documents, image data, setting values, address book contents etc.) can be encrypted/decrypted with this encryption key.
If this machine breaks down, saved and programmed data in the machine can only be restored by entering this encryption key.
(Please note that it may not be possible to restore data in certain machine breakdown cases.)
This machine data encryption key will remain valid as long as the encryption is not cancelled or the encryption key is not changed.
After changing or cancelling the encryption key, please shred this document to destroy confidential data.

Output Date/Time:September 03,2010 08:55:25 AM
Machine Type:Afcio MP C400SR
Machine ID:S7500717004
Machine Data Encryption Key:
6pFIFFGH#EBiYkPafBjz6YE\$wYXk

d1420100

Encryption key is printed out as a sheet of paper like the sample shown above.
Please instruct the customer to keep it in a safe place.

2.2.4 EXTERNAL USB KEYBOARD (EXTERNAL OPTION)

Customers can use an external USB keyboard when the software keyboard is shown on the operation panel, if an external USB keyboard is connected to the USB port at the side of the operation panel or the controller box USB port.

If customers would like to use an external USB keyboard, execute the following steps to enable this feature.

1. Connect the external keyboard to the USB port at the right side of the operation panel or the controller box USB port.

Note

- The external keyboard that is available in this machine is principally for the Windows OS. However, no compatibility check is done, and there is no warranty.

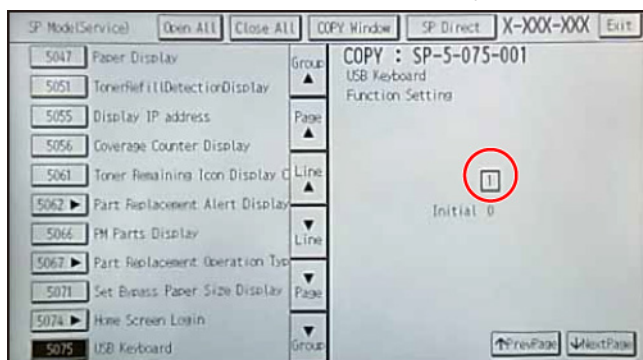

d1440139

2. Enter the SP mode and set SP5075-001 to ON (1) (USB keyboard).
3. Exit the SP mode and turn the main power off and on.

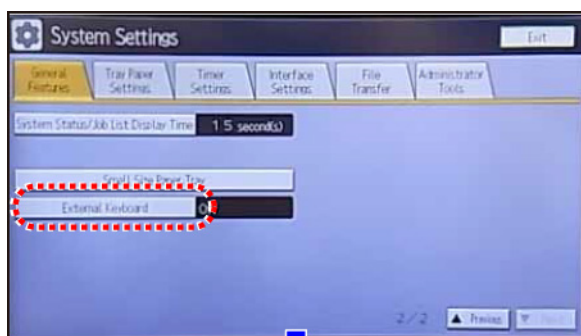

d1440140

4. Select a language type for the external USB keyboard with [User Tools] → [System Settings]

→ [General Features] → [External Keyboard].

5. Press [OK] to set it.
6. Turn the main power off and on.

2.2.5 MOVING THE MACHINE

This section shows you how to manually move the machine from one floor to another floor. See the section "Transporting the Machine" if you have to pack the machine and move it a longer distance.

1. Remove all trays from the optional paper feed unit or LCT.

2.2.6 TRANSPORTING THE MACHINE

Main Frame

- ⇒
1. Do SP 4806-001 to move the scanner carriage from the home position. This prevents dust from falling onto the scanner carriage during transportation.
 2. Remove the toner cartridges. This prevents toner flow into the toner supply tube, which is caused by vibration during transport. This can also cause the tube to be clogged with toner.
 3. Make sure there is no paper left in the paper trays. Then fix down the bottom plates with a sheet of paper and tape.
 4. Empty the toner collection bottle. Then attach securing tape to stop the toner bottle from coming out.
 5. Take out the scanner stay from inside the front door and install the scanner stay.
 6. Do one of the following:
 - Attach shipping tape to the covers and doors.
 - Shrink-wrap the machine tightly.
- ↓ **Note**
- After you move the machine, make sure you do the "Auto Color Registration" as follows. This optimizes color registration.
 1. Do the "Forced Line Position Adj. Mode c" (SP2-111-3).
 2. Then do the "Forced Line Position Adj. Mode a" (SP2-111-1).To check if SP 2-111-1 was successful, watch the screen during the process. A message is displayed at the end. Also, you can check the result with SP 2-194-10 to -12.
- ⇒
- Make sure that the side fences in the trays are correctly positioned to prevent side to side registration issues.

2.3 PAPER FEED UNIT PB3120 (D579)

2.3.1 ACCESSORY CHECK

Check the quantity and condition of the accessories against the following list.

No.	Description	Q'ty
1	Screw (M4x10)	2
2	Screw with Spring washer (M4x10)	2
3	Securing bracket	2

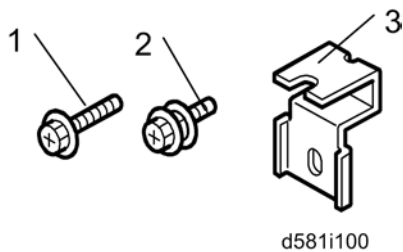

2.3.2 INSTALLATION PROCEDURE

⚠ CAUTION

- Turn off the main switch of the copier and unplug the power cord before you start the installation procedure.
- You need two or more persons to lift the copier. The copier is highly unstable when lifted by one person, and may cause human injury or property damage.
- Do not lift the copier with the paper feed unit installed. The handle and grips may be damaged.

↓ Note

- The one-tray paper feed unit must be installed on the caster table (D593). Prepare the caster table first before installing this unit.

Paper Feed Unit PB3120 (D579)

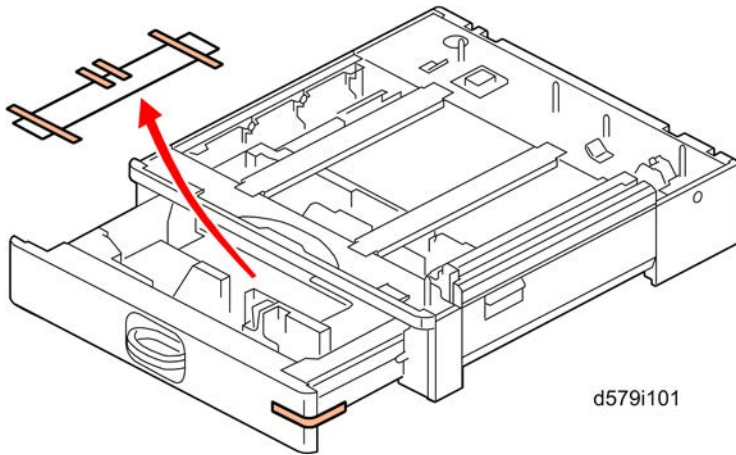

1. Remove all tape on the paper feed unit.
2. Remove the paper tray and remove all tapes and padding.
3. Put the paper tray unit on the caster table (D593).

Note

- For details about the installation of the caster table, see the “Caster Table (D593)” installation procedure.

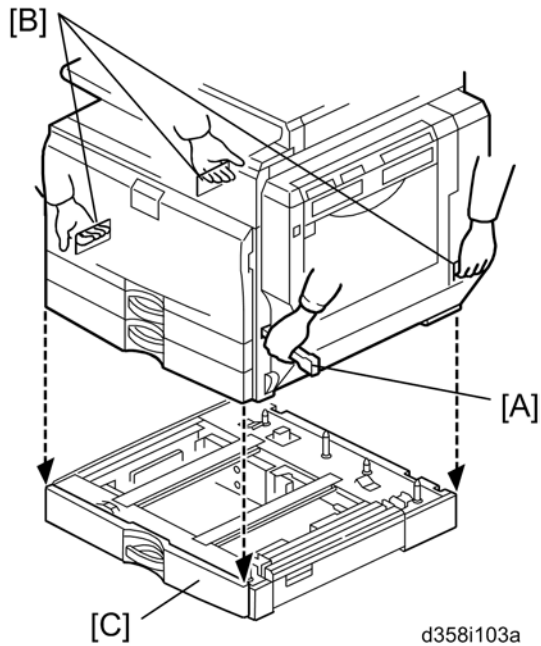

1. Pull out the handle [A], then hold the handle and grips [B], and then put the copier on the paper feed unit [C].

Important

- You need two or more persons to lift the copier.

Note

- Hold the handle and grips of the machine when you lift and move the machine.

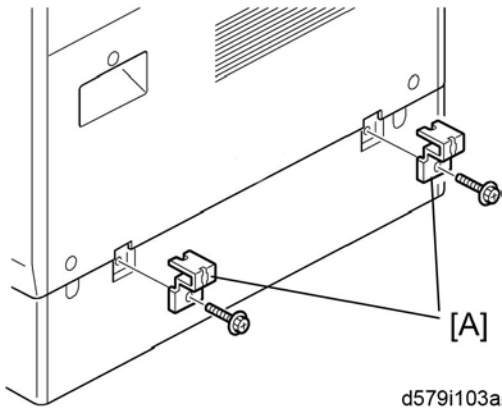

2. Attach the securing brackets [A] ( x 1; M4x10 each).

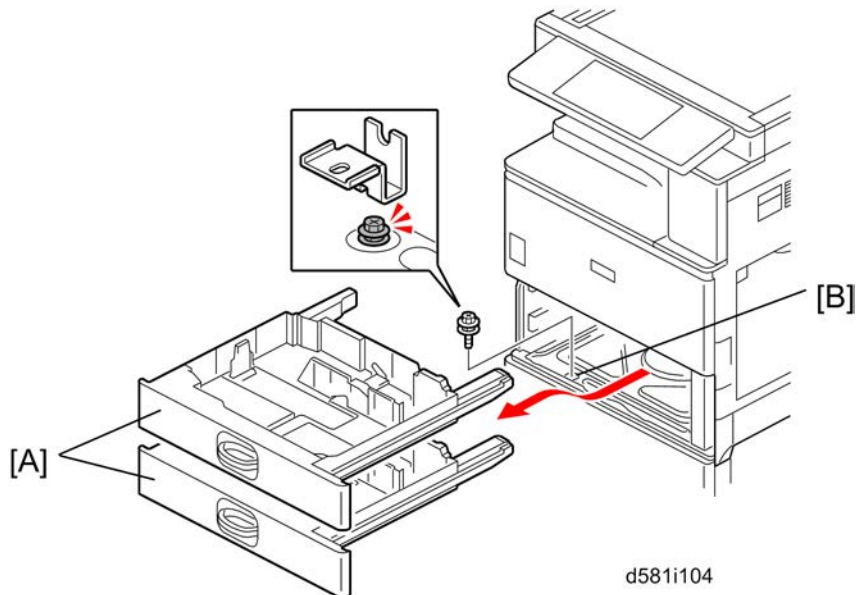

3. Remove the 1st and 2nd paper trays [A], and then secure the paper feed unit [B] ( spring washer x 1; M4x10).
4. Reinstall the 1st and 2nd paper trays.

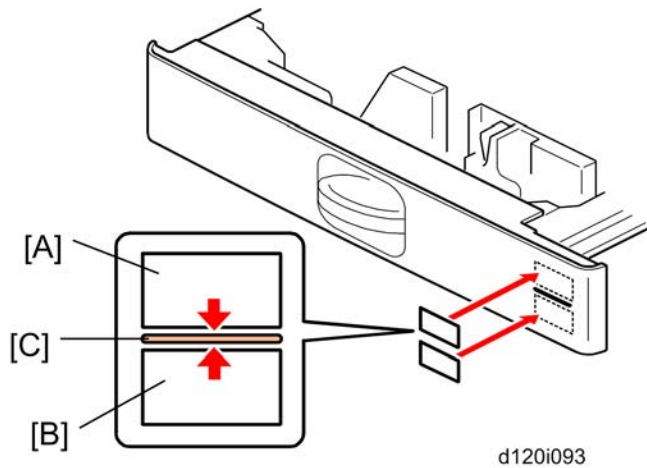

Paper Feed Unit PB3120 (D579)

5. Attach the appropriate paper tray number decal [A] and paper size decal [B] to the line [C] on the tray of the paper feed unit

Note

- The paper tray number and size sheet is in the accessory box of the main machine.
6. Lock the caster stoppers for the front two casters under the paper feed unit.
 7. Load paper into the paper tray and set the side fences and bottom fence.

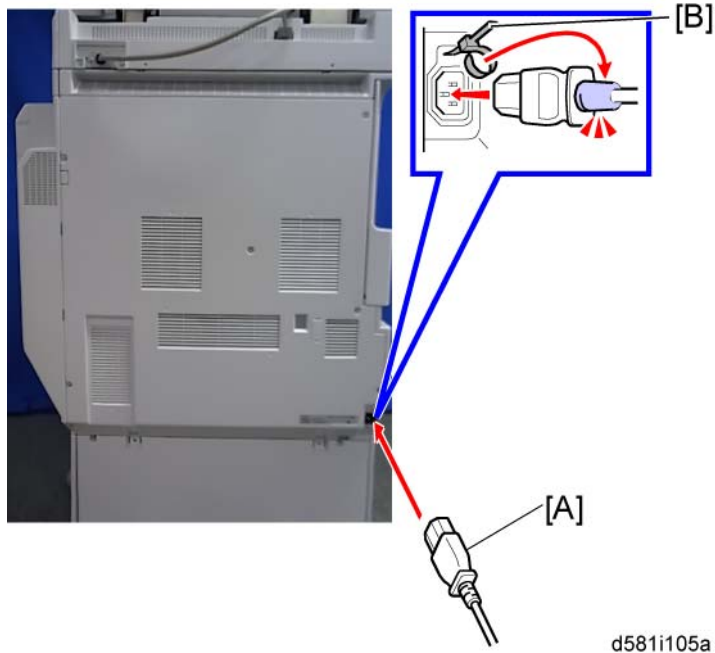

d581i105a

8. Connect the power cord [A] to the inlet of the main machine.
9. Secure the power cord with the clamp [B] on the main machine so that the power cord is never disconnected.

2.4 CASTER TABLE TYPE D (D593)

2.4.1 COMPONENT CHECK

No.	Description	Q'ty
1	Caster Table	1
2	Stud Screw	1

Installation

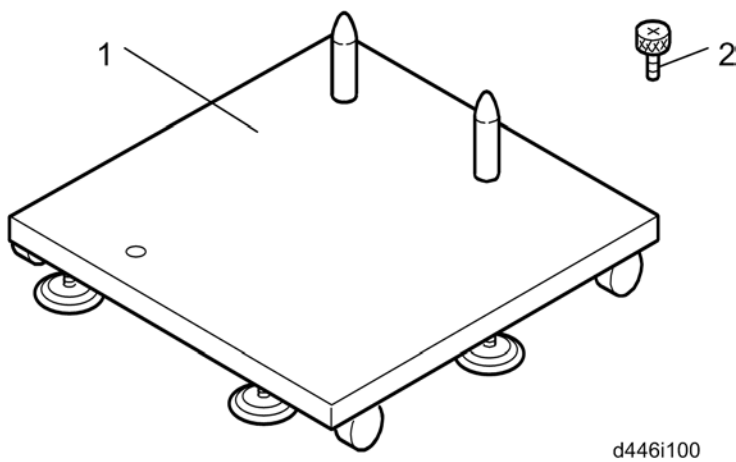

2.4.2 INSTALLATION PROCEDURE

1. Put the caster table on a flat place.

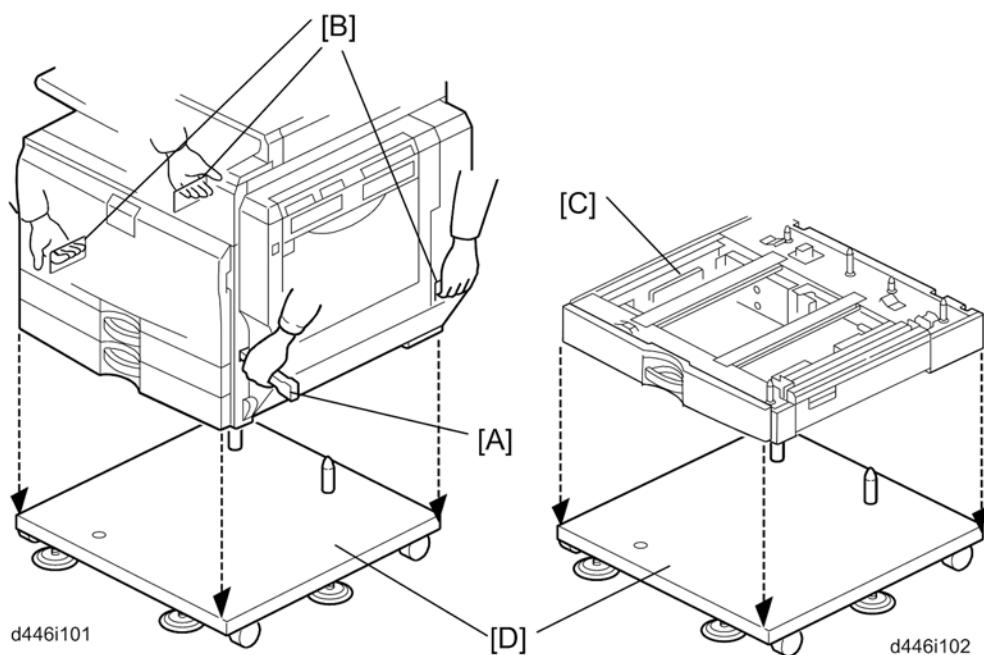

Caster Table Type D (D593)

2. Grasp the handle [A] and grips [B] of the machine, if the copier is to be installed on the caster table.
3. Lift the copier or one-tray paper feed unit [C], and then install it on the caster table [D].

Note

- Hold the handle and grips of the machine when you lift and move the machine.
4. Pull out tray 2 of the mainframe or the tray of the one-tray paper feed unit.

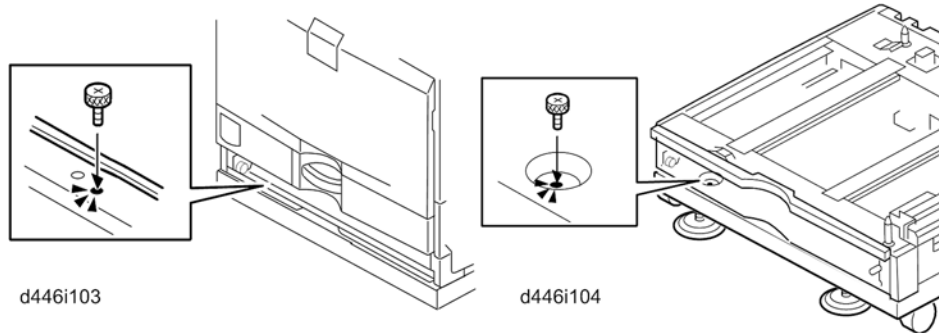

5. Secure the machine or one-tray paper feed unit to the caster table (stud screw x 1)
6. Reinstall the tray in the mainframe or one-tray paper feed unit.
7. Adjust the five leveling adjusters of the caster table.

2.5 PAPER FEED UNIT PB3130 (D580)

2.5.1 ACCESSORY CHECK

Check the quantity and condition of the accessories against the following list.

No.	Description	Q'ty
1	Screw (M4x10)	2
2	Screw with Spring Washer (M4 x 10)	1
3	Securing Bracket	2

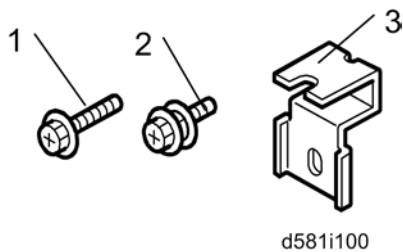

2.5.2 INSTALLATION PROCEDURE

⚠ CAUTION

- Unplug the machine power cord before starting the following procedure.
- The handles of the main machine for lifting must be inserted inside the machine and locked unless these handles are used for the installation or relocation of the main machine.
- You need two or more persons to lift the copier. The copier is highly unstable when lifted by one person, and may cause human injury or property damage.

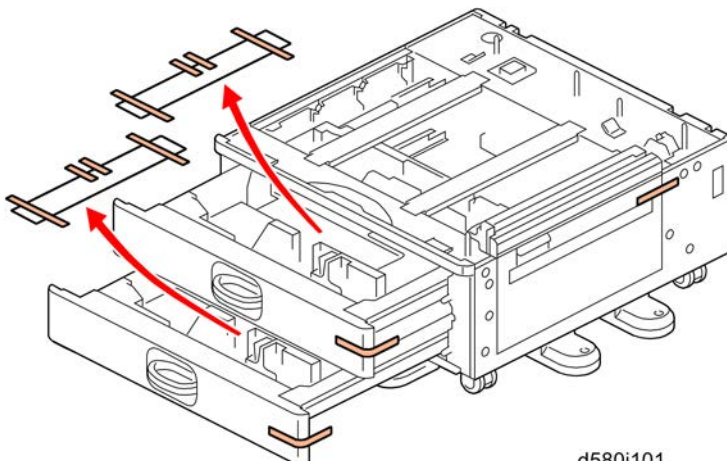

Paper Feed Unit PB3130 (D580)

1. Remove all tape on the paper feed unit.
2. Remove the paper trays and remove all tape and padding.

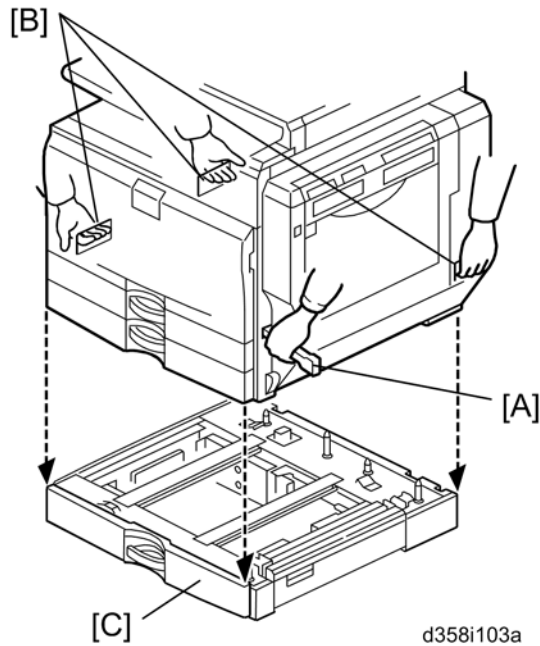

3. Pull out the handle [A], then hold the handle and grips [B].
4. Lift the copier and install it on the paper feed unit [C].

★ Important

- You need two or more persons to lift the copier.

↓ Note

- Hold the handle and grips of the machine when you lift and move the machine.

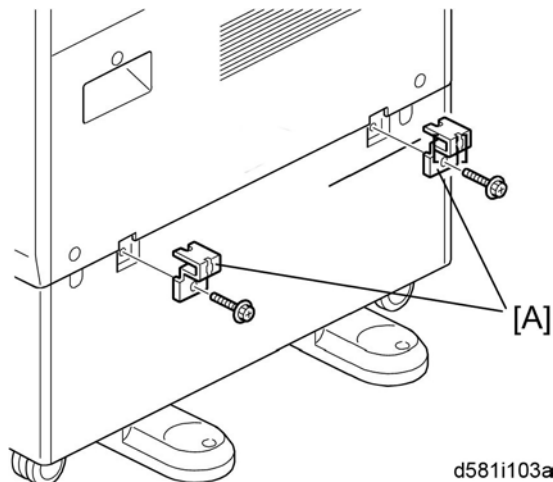

5. Attach a securing bracket [A] to each side of the paper tray unit, as shown (🔩 x 1; M4 x 10 each).

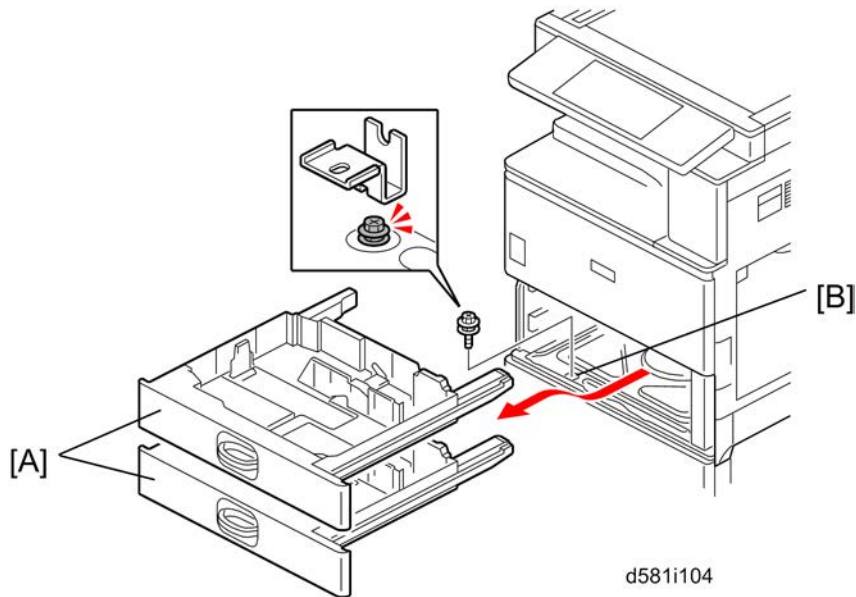

6. Remove trays 1 and 2 of the machine [A].
7. Fasten the paper tray unit at [B] ( spring washer x 1; M4 x 10).
8. Reinstall all the trays.

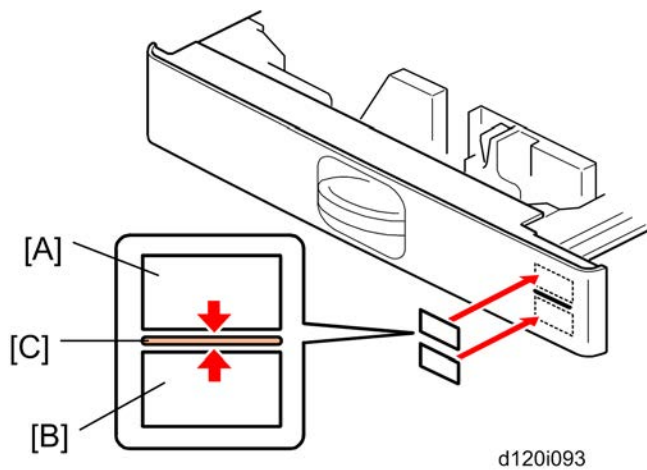

9. Attach the appropriate paper tray number decal [A] and paper size decal [B] to the line [C] on each tray of the paper feed unit.

 **Note**

- The paper tray number and size sheet is in the accessory box of the main machine.
10. Lock the caster stoppers for the front two casters under the paper feed unit.
 11. Load paper into the paper trays and set the side fences and bottom fence.

Paper Feed Unit PB3130 (D580)

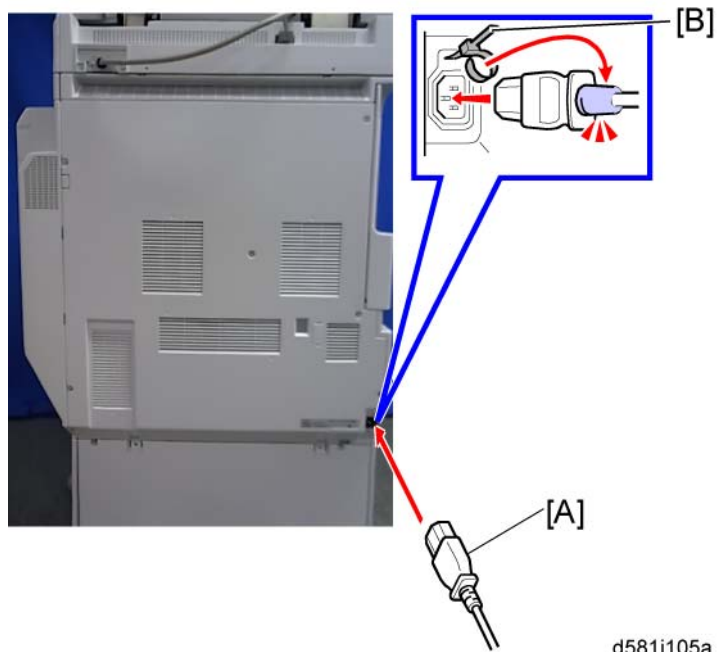

d581i105a

12. Connect the power cord [A] to the inlet of the main machine.
13. Secure the power cord with the clamp [B] on the main machine so that the power cord is never disconnected.

2.6 ENVELOPE FEEDER EF3020 (D638)

2.6.1 ACCESSORY CHECK

Check the quantity and condition of the accessories against the following list.

No.	Description	Q'ty
1	Envelope feeder	1
2	Paper size decal	1

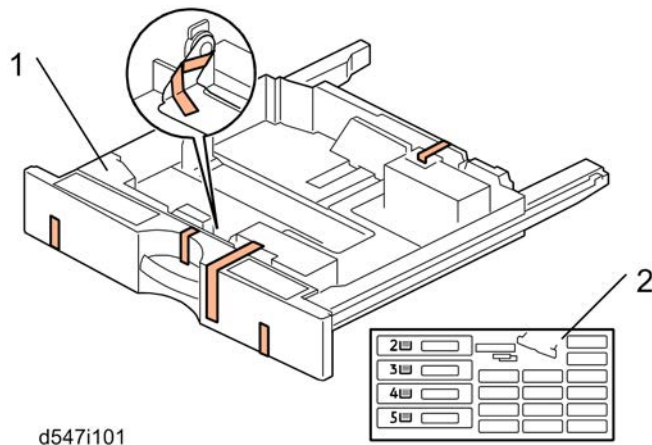

2.6.2 INSTALLATION PROCEDURE

Note

- This tray can be installed in tray 2 of the copier, or tray 3 or tray 4 of the paper feed unit (D580).
- There is no automatic paper size detection in the envelope feeder (D638). Adjust the paper size for the tray where the envelope feeder is to be installed with User Tools.

1. Remove all tape from the envelope feeder.

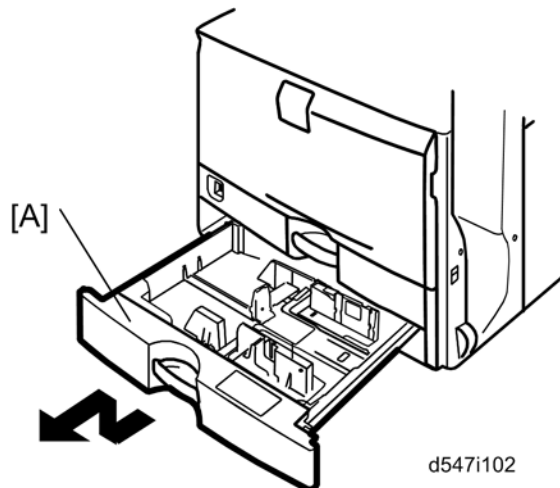

2. Pull out tray 2 [A] from the main machine.

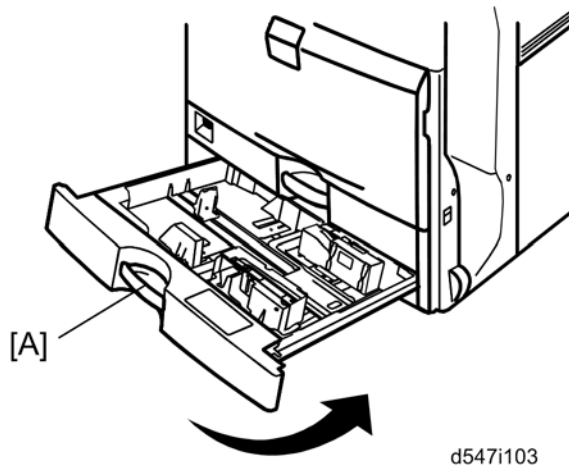

3. Install the envelope feeder [A] into tray 2 of the main machine.
4. Press the "User/Tools" key on the operation panel.
5. Enter "Small Paper Size Tray" under "General Features".
 - Initial Settings > General Features > Small Paper Size Tray
6. Select "On" for the tray where the envelope feeder is installed.
7. Turn the main machine off and on.

2.7 LCIT RT3020 (D631)

2.7.1 COMPONENT CHECK

Check the quantity and condition of the components against the following list.

No.	Description	Q'ty
1	Front Bracket	1
2	Rear Bracket	1
3	Stud Screw	4
4	Joint Pin	2
5	LCT	1

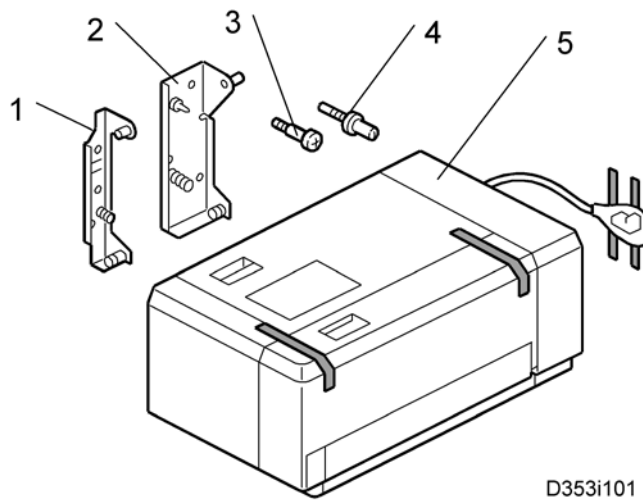

2.7.2 INSTALLATION PROCEDURE

⚠ CAUTION

- Unplug the main machine power cord before starting the following procedure.

↓ Note

- The Paper Feed Unit (D580) or LCT 2000-sheet (D581) must be installed before installing this 1200-sheet LCT.

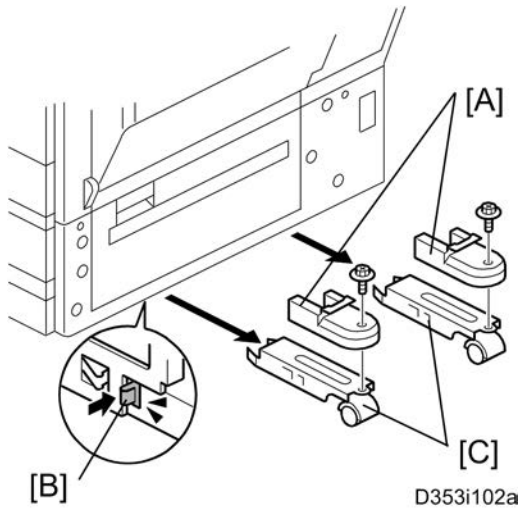

1. Unpack the LCT and remove the tapes.
2. Remove the stand covers [A].
3. Release the locks [B] of the front and rear caster stands.
4. Remove the caster stands [C].

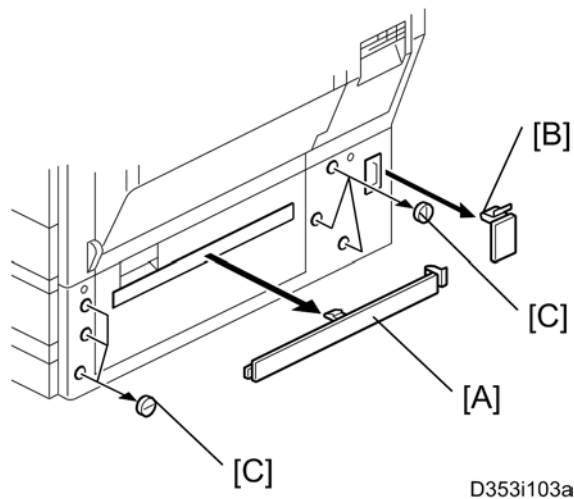

5. Remove the paper path cover [A], connector cover [B] and six hole covers [C].

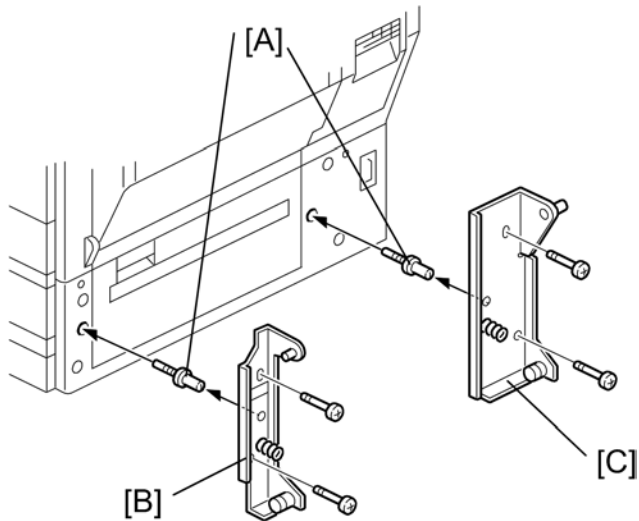

D353i104a

6. Insert the joint pins [A].
7. Attach the front [B] and rear brackets [C] ( x 2 each).

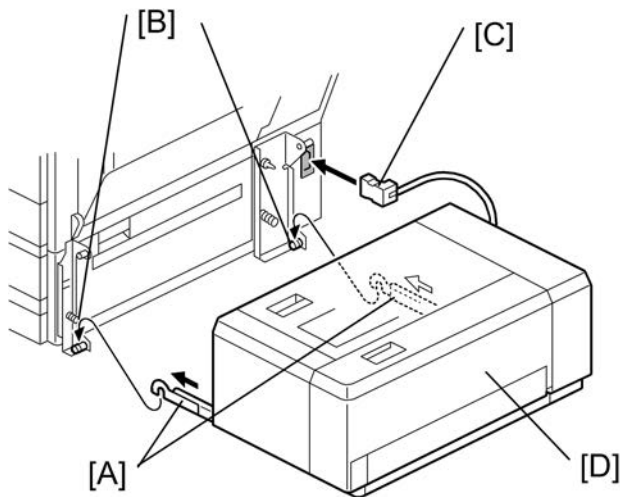



D353i105a

8. Pull out the front and rear rails [A], and then hang them on each bracket [B].
9. Connect the LCT cable [C] to the main machine.
10. Slide the LCT [D] into the main machine.
11. Make sure that the front and rear sides of the LCT are closely attached to the main machine.

2.7.3 SIDE FENCE POSITION CHANGE

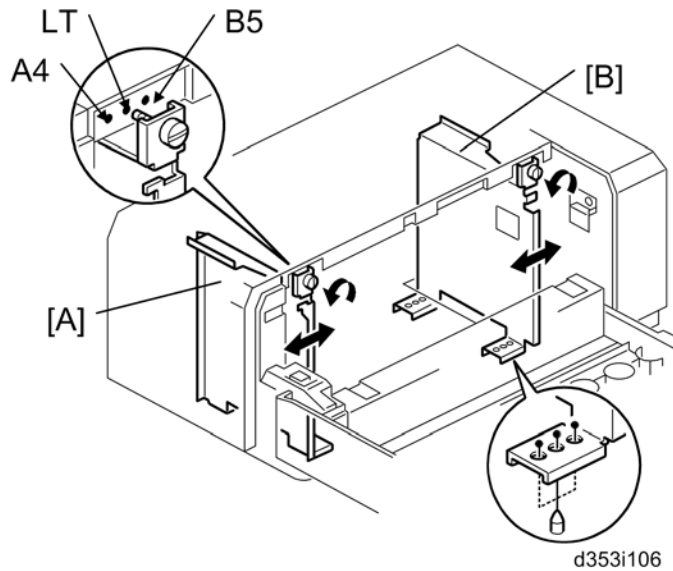
1. Open the right door of the LCT.
2. Push the down switch to lower the tray bottom plate until it reaches its lowest position.



3. Remove the front and rear side fences [A, B] ( x 1 each).
4. Install the side fences in the correct position (A4 LEF/ LT LEF/ B5 LEF).

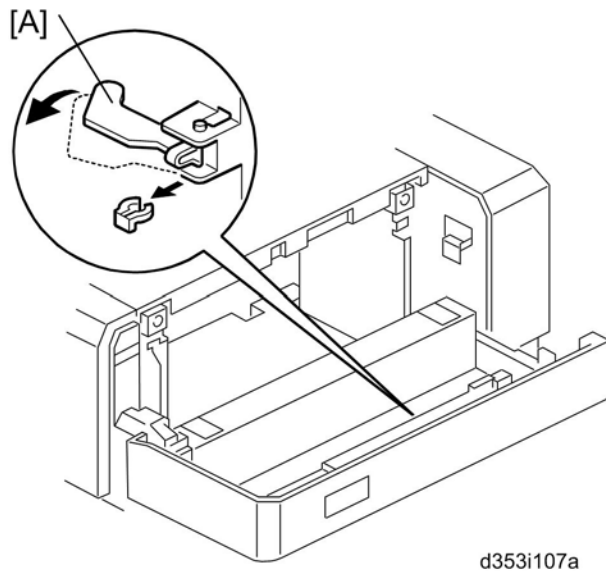

5. Pull the end fence [A] for B5 size paper as shown ( x 1) if the side fences are adjusted for B5 size paper.
6. Close the right door.
7. Turn on the main power switch, and then go into the SP mode.
8. Input the correct paper size for the 1200-sheet LCT with SP5181-018.

2.8 LCIT PB3140 (D581)

2.8.1 ACCESSORY CHECK

Check the quantity and condition of the accessories against the following list.

No.	Description	Q'ty
1	Screw (M4x10)	2
2	Screw with Spring Washer (M4x10)	1
3	Securing Bracket	2

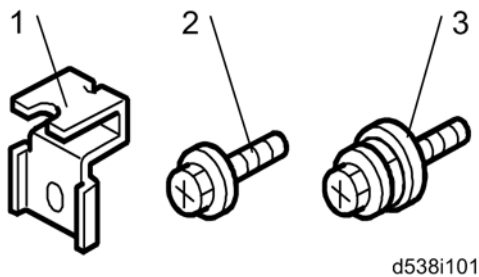

2.8.2 INSTALLATION PROCEDURE

⚠ CAUTION

- Unplug the machine power cord before starting the following procedure.
- The handles of the main machine for lifting must be inserted inside the machine and locked, unless these handles are used for the installation or relocation of the main machine.
- You need two or more persons to lift the copier. The copier is highly unstable when lifted by one person, and may cause human injury or property damage.

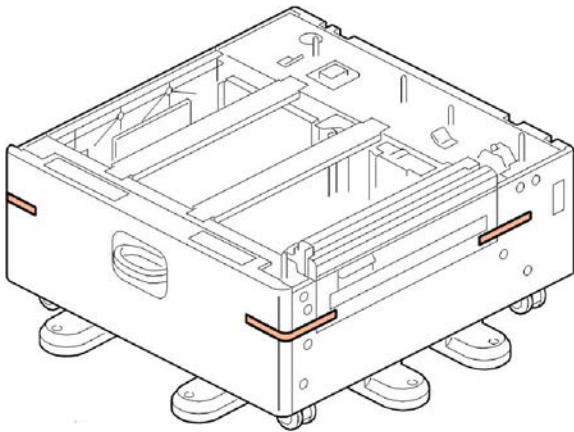

d581i101a

1. Remove the strips of tape.

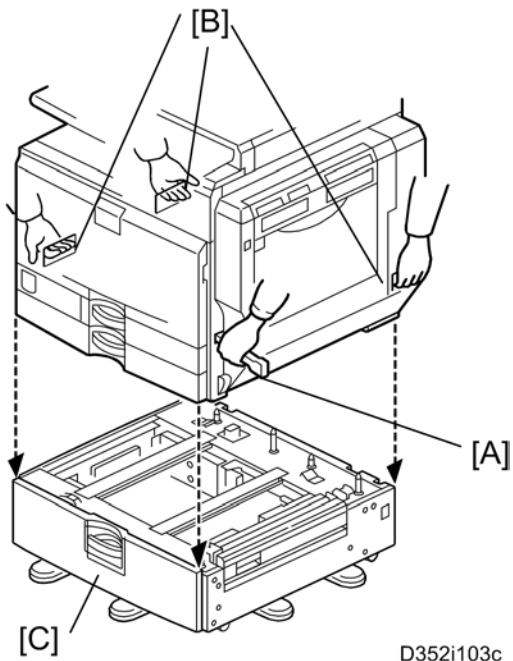

D352i103c

2. Grasp the handle [A] and grips [B] of the machine.
3. Lift the copier and install it on the LCT [C].

★ Important

- The copier should be lifted by two persons or more.

↓ Note

- Hold the handle [A] and grips [B] of the machine when you lift and move the machine.

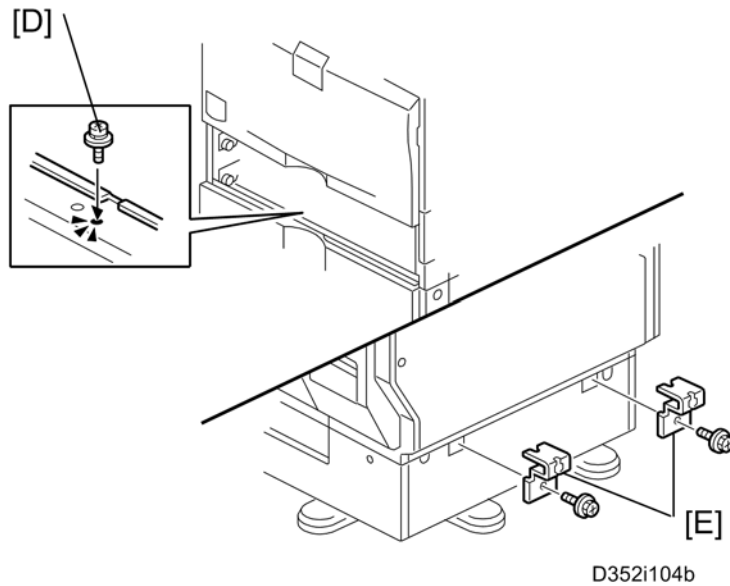

4. Remove trays 1 and 2 of the machine.
5. Fasten the spring washer screw [D].
6. Reinstall all trays.
7. Attach the securing brackets [E] ( x 1 each; M4x10).

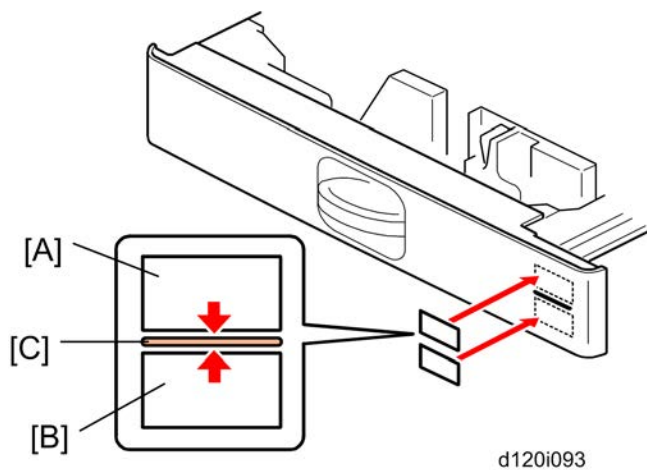

8. Attach the appropriate paper tray number decal [A] and paper size decal [B] to the line [C] on the tray of the LCT.

 **Note**

- The paper tray number and size sheet is in the accessory box of the main machine.

9. Lock the caster stoppers for the front two casters under the paper feed unit.
10. Load paper into the LCT.

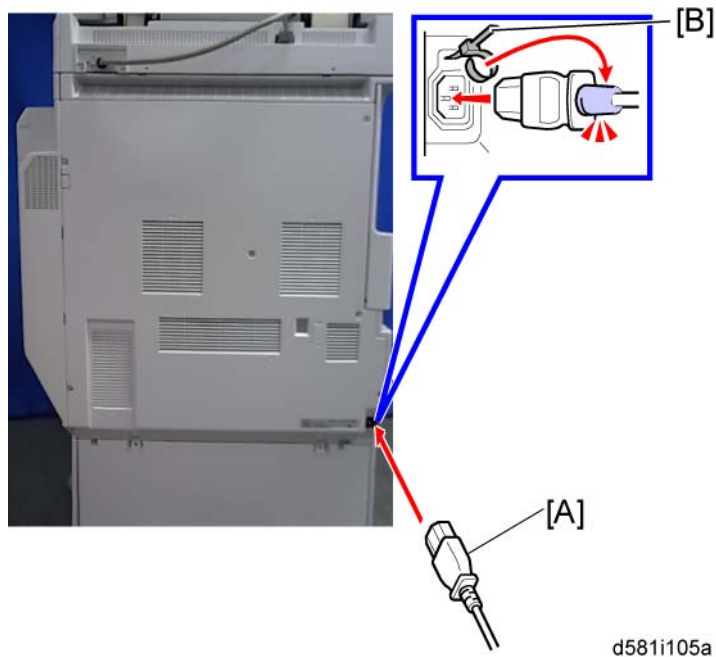

11. Connect the power cord [A] to the inlet of the main machine.
12. Secure the power cord with the clamp [B] on the main machine so that the power cord is never disconnected.

SP Settings

1. Connect the copier and turn the main machine on.
2. Do SP5-181-010 to set automatic paper size detection for the LCT paper tray.

LCT Paper Tray (Size Adjust Tray 3 / LCT

5-181-010	A4/LEF/LT/LEF	[0 to 1 / 0 / 1] 0: ISO (A3, A4, A5, etc.) 1: USA (DLT, LT, EXE, etc.)
-----------	---------------	--

3. Exit SP mode.
4. Do some test copies to make sure that the machine operates correctly.

2.9 ARDF DF3060 (D578)

2.9.1 COMPONENT CHECK

Check the quantity and condition of the components against the following list.

No.	Description	Q'ty
1	ARDF	1
2	Original Setting and ARDF Exposure Glass Cleaning Decal	1
3	Stamp Cartridge	1
4	Knob Screw	2
5	Stud Screw	2

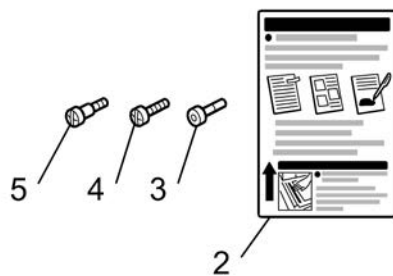
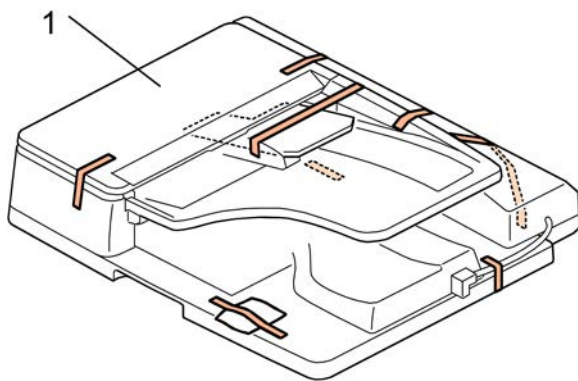

d578i101

2.9.2 INSTALLATION PROCEDURE

⚠ CAUTION

- Unplug the copier power cord before starting the following procedure.

1. Remove all tapes and shipping retainers.

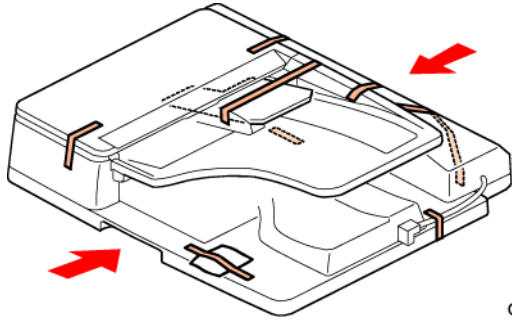

d120i208

↓ Note

- When unloading the ARDF from a pallet, hold the front and rear side of the ARDF.

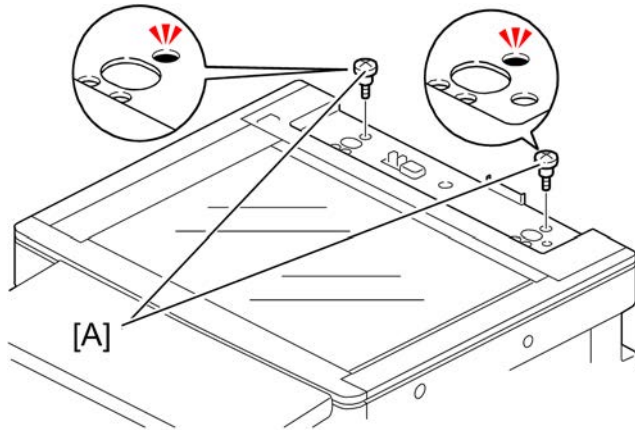

d578i102

2. Insert the two stud screws [A] on the top of the machine.

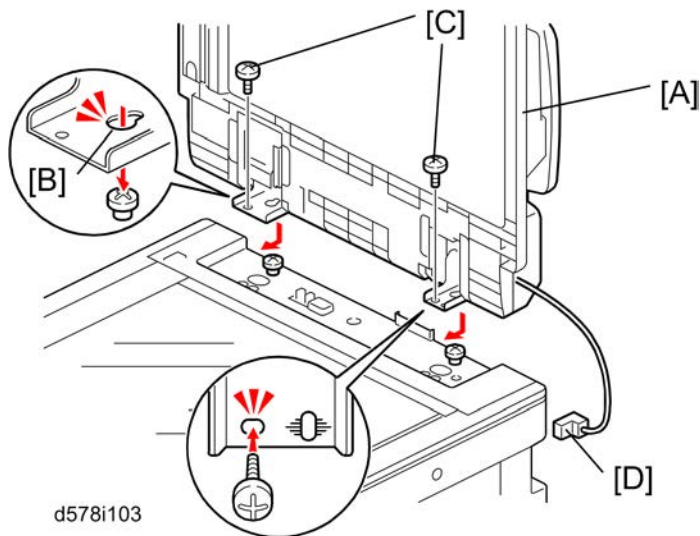

3. Mount the ARDF [A] by aligning the screw keyholes [B] of the ARDF support plate over the stud screws.
4. Slide the ARDF toward the front of the machine.
5. Secure the ARDF with the two knob screws [C].
6. Attach the interface cable [D] to the inlet of the machine.

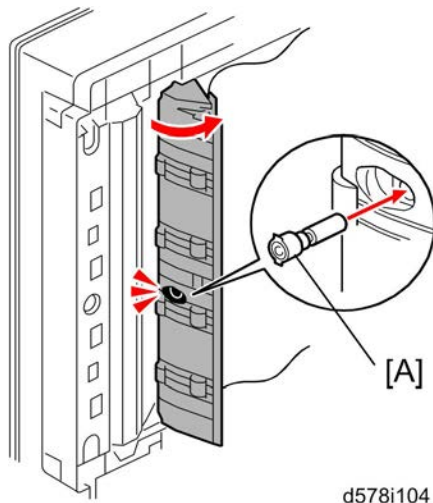

7. Install the stamp cartridge [A] in the ARDF.

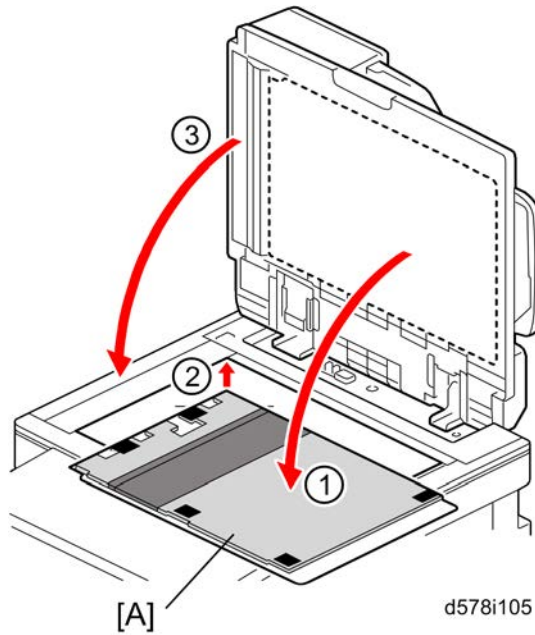

8. Peel off the platen sheet [A] and place it on the exposure glass.
9. Align the rear left corner (of the platen sheet) with the corner on the exposure glass.
10. Close the ARDF.
11. Open the ARDF and check that the platen sheet is correctly attached.

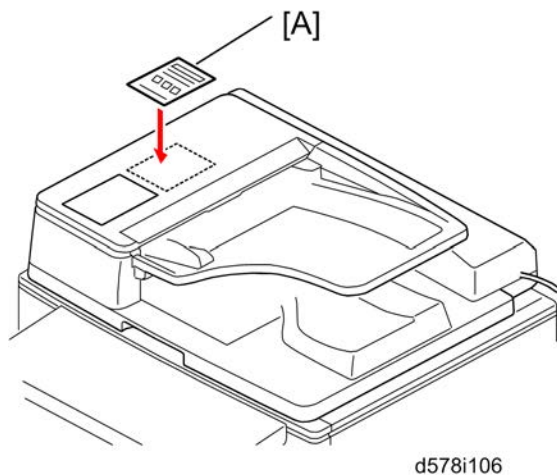

12. Attach the original setting and ARDF exposure glass cleaning decal [A] to the top cover as shown.
13. Plug in and turn on the main power switch of the machine, and then check the ARDF operation.
14. Make a full size copy. Check that the registrations (side-to-side and leading edge) and image skew are correct. If they are not, adjust the registrations and image skew, referring to the service manual ("Copy Adjustments" in the "Replacements and Adjustments").

2.10 ADF HANDLE TYPE B (D593)

2.10.1 COMPONENT CHECK

Check the quantity and condition of the accessories against the following list.

No.	Description	Q'ty
1	Handle Unit	1
2	Holder	1
3	Stud Bracket	1
4	Securing Bracket	1
5	Handle Bracket	1
6	Hinge Stopper - Right	1
7	Hinge Stopper - Left	1
8	Spacer	1
9	Bushing: M6	1
10	Bushing: 6MM	1
11	Tapping Screw: M3 x 12	2
12	Tapping Screw (Self Binding): M3 x 12	2
13	Screw: M3 x 8	3
14	Tapping Screw: M4 x 8	4
15	Operation Decal	1
16	Stud Decal	1

ADF Handle Type B (D593)

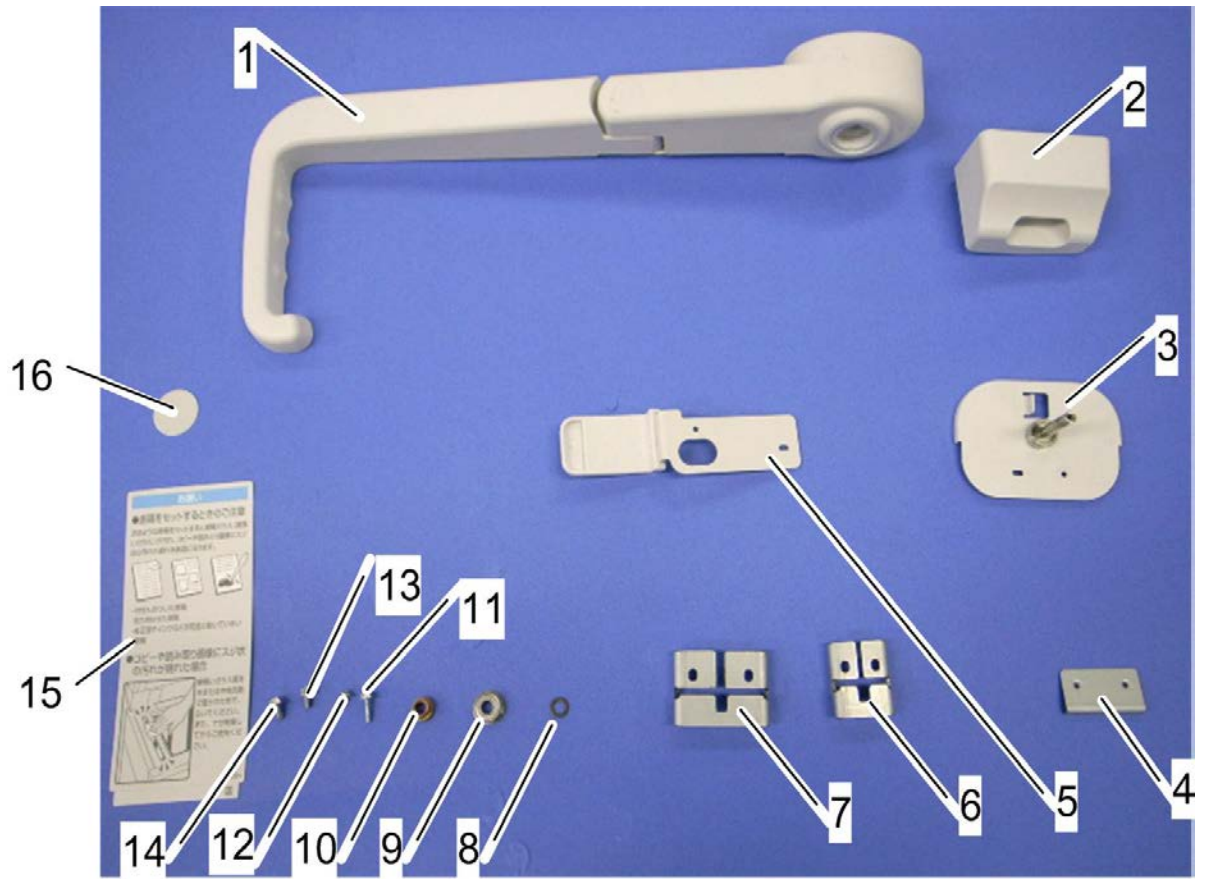

b862i516

2.10.2 INSTALLATION PROCEDURE

⚠ CAUTION

- Turn off the main switch of the copier and unplug the power cord before you start the installation procedure.

Preparing before Installing the DF Handle

- Open the ADF unit.

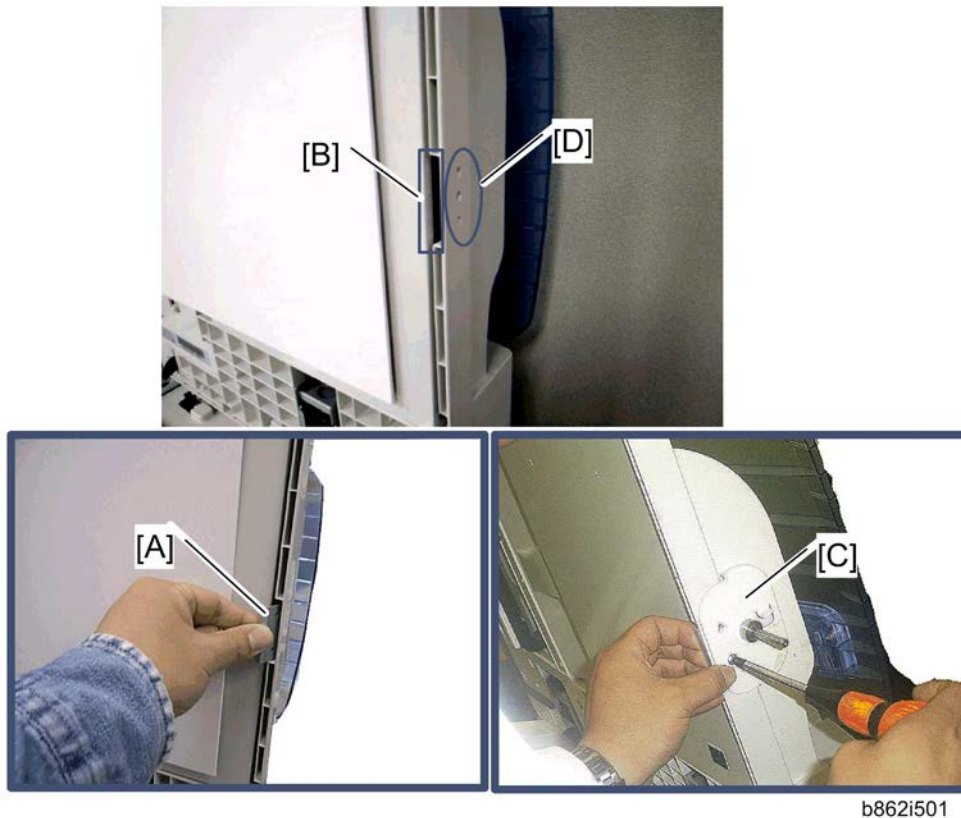

- Hold the securing bracket [A] at the location [B], inside the ADF cover.
- Secure the stud bracket [C] to the outside of the ADF cover at location [D] with two screws ( x 2: M3x8).

Note

- The two screws must go through the ADF cover and the securing bracket [A].

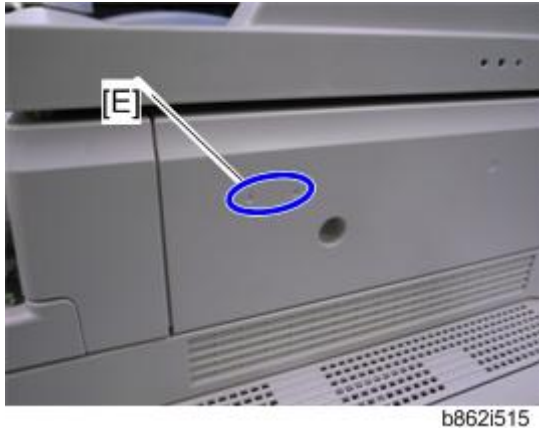

4. Make two screw holes [E] in the scanner right cover with an M3x12 tapping screw from the accessories.

Installing the DF Handle



1. Attach the holder [A] to the scanner right cover (Tapping Screw x 2: M3x12).
 - At first, secure the screw at the rear side (away from the operation panel) temporarily and then at the front side temporarily. After that, secure them fully.

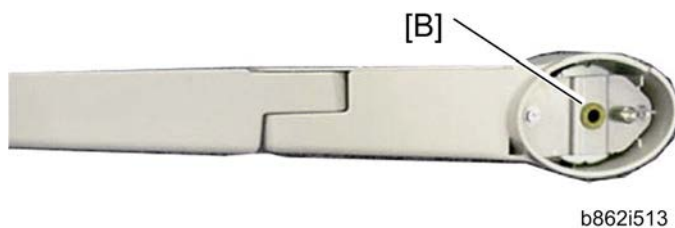

2. Install the bushing: 6MM [B] in the inside of the handle unit.
3. Attach the handle unit to the stud bracket on the left side of the ADF.

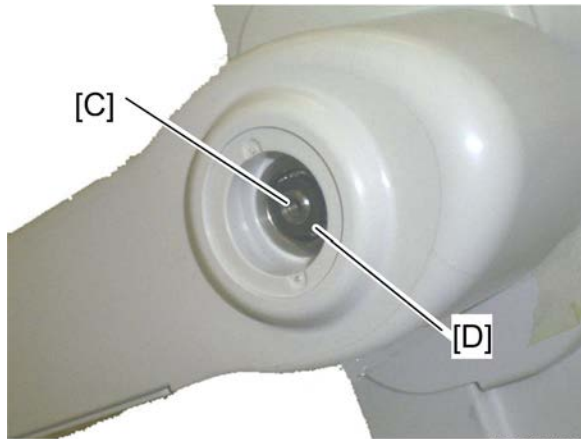

b862i510

4. In the outside of the handle unit, install the bushing - M6 [C] first, and then the spacer [D].



b862i514

5. Secure the handle unit with a screw ( x 1: M3x8).

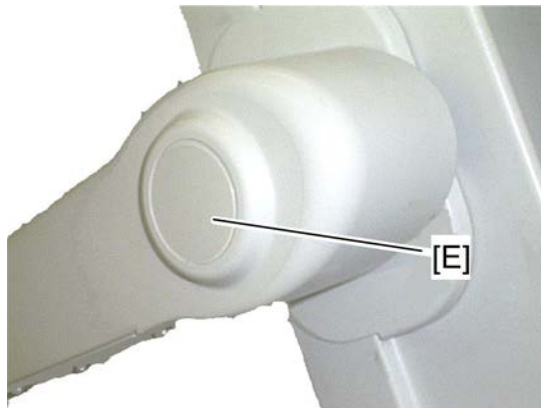

b862i511

6. Clean the handle unit with alcohol. Then attach the stud decal [E] at the location that was cleaned.

ADF Handle Type B (D593)

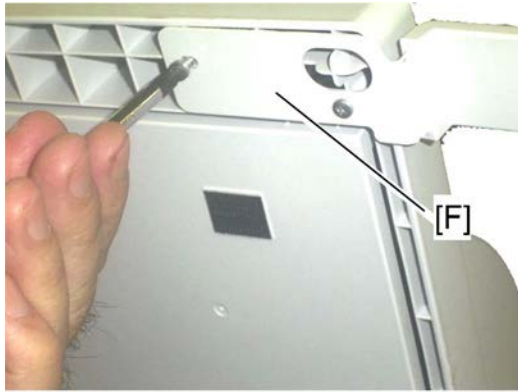

b862i503

7. Attach the handle bracket [F] at the front right side on the bottom of the ADF unit (Tapping Screw [Self Binding] x 2: M3x12).
8. Close the ADF unit.



b862i504

9. Attach the hinge stoppers (left [G] and right [H]) to the left and right hinges (Tapping screw x 2: M4x8 each).



b862i505

10. Clean the front side of the duplex unit with alcohol. Then attach the operation decal [I] at the location that was cleaned.



b862i506

11. Check the operation of the handle unit [J].

2.11 1 BIN TRAY BN3100 (D632)

2.11.1 COMPONENT CHECK

Check the quantity and condition of the components against the following list.

No.	Description	Q'ty
1	1 Bin Tray Unit	1
2	End-fence	1
3	Tray Support Bar	1
4	Screws (M3 x 16)	2
5	Screws (M3 x 8)	1
6	Harness Cover	1
7	Tray	1

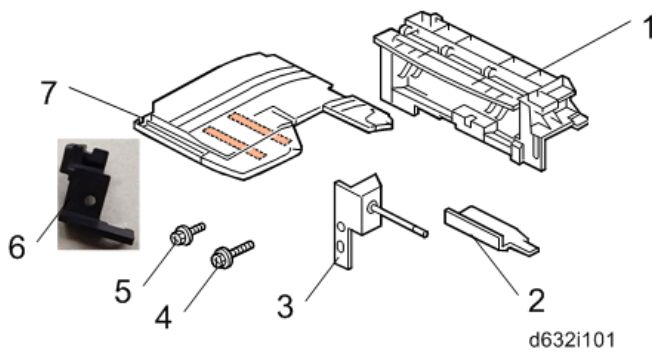

2.11.2 INSTALLATION PROCEDURE



⚠ CAUTION

- **Unplug the copier power cord before starting the following procedure.**

If the bridge unit (D634) or side tray (D635) has already been installed in the machine, remove it before installing the 1 bin tray unit (D632). This will make it easier for you to do the following procedure.

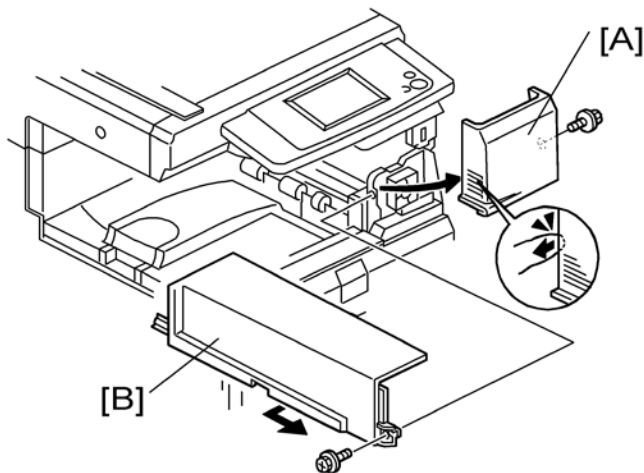
1. Remove all tapes.
2. Open the right door of the machine.



3. Remove the front right cover [A] ( x 1).
4. Remove the inner cover [B] ( x 1).

↓ Note

- Keep this screw for step 5.

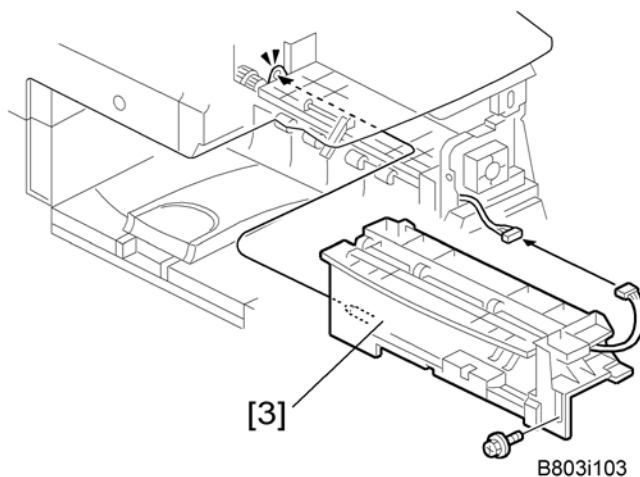



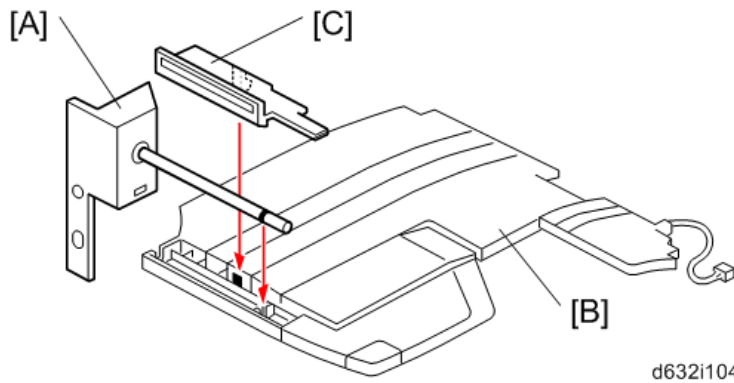

5. Install the 1 bin tray unit [3] ( x 1,  x 1 [This screw was removed in step 4]).

1 Bin Tray BN3100 (D632)

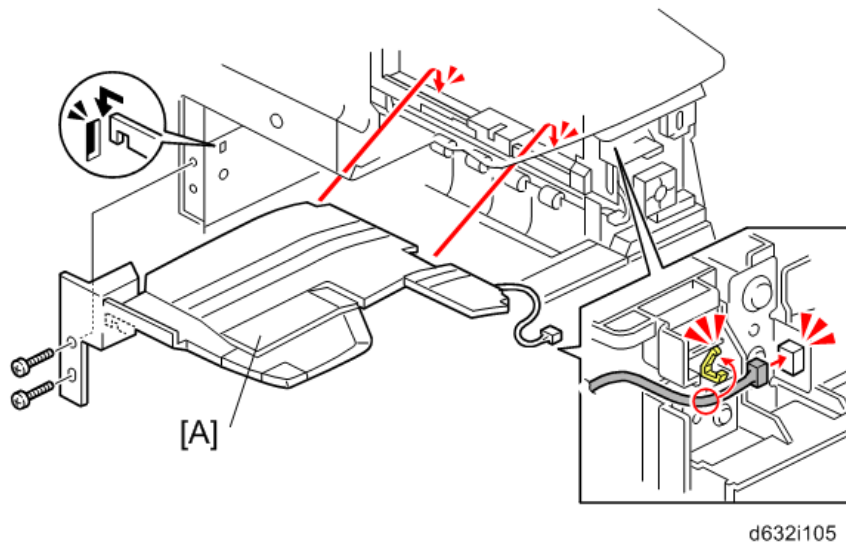

6. Attach the tray support bar [A] to the tray [B] as shown, and then attach the end-fence [C].



7. Install the tray [A] with the tray support bar in the machine ( x 2; M3 x 16).
8. Connect the harness to the connector of the 1-bin tray unit ( x 1,  x 1).

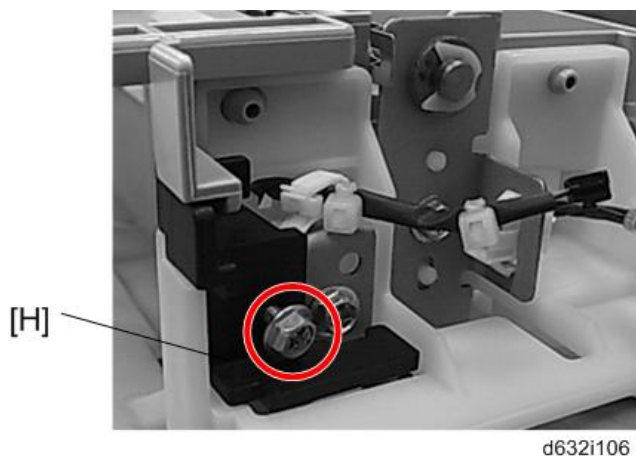

9. Attach the harness cover [H] ( x 1; M3 x 8).
10. Reinstall the front right cover on the machine, and then close the right door of the machine.
11. Turn on the main power switch of the machine.
12. Check the 1-bin tray unit operation.

2.12 INTERNAL SHIFT TRAY SH3060 (D633)

2.12.1 COMPONENT CHECK

Check the quantity and condition of the components against the following list.

No.	Description	Q'ty
1	Shift Tray Unit	1
2	Connector Cover	1
3	Paper Guide - Small	1

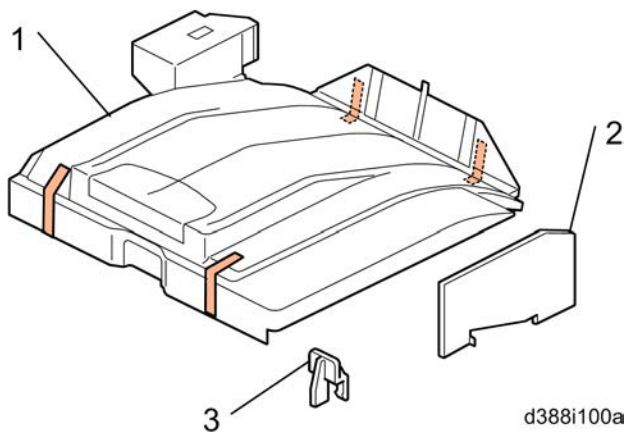

2.12.2 INSTALLATION PROCEDURE

⚠ CAUTION

- Unplug the copier power cord before starting the following procedure.

1. Remove all tapes.

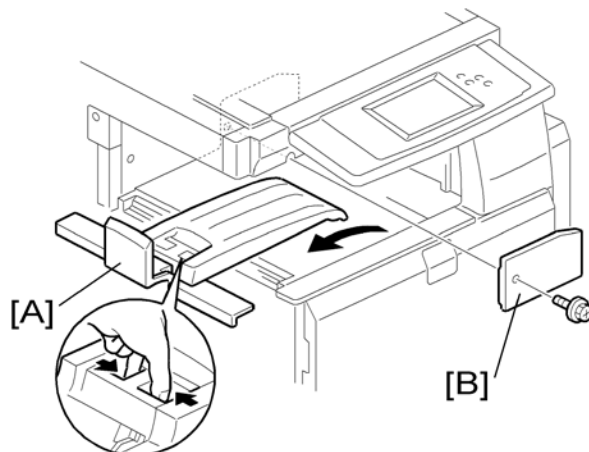

2. Remove the inner tray [A].

Internal Shift Tray SH3060 (D633)

3. Remove the connector cover [B] ( x 1).

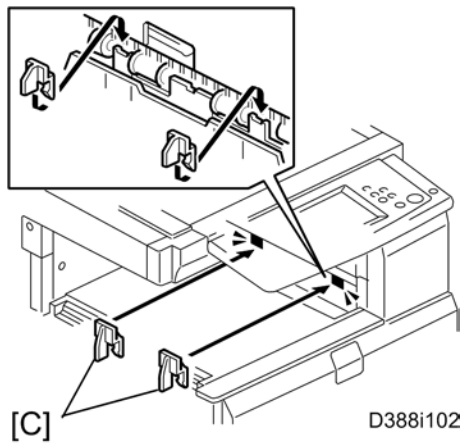

4. Install two small paper guides [C].

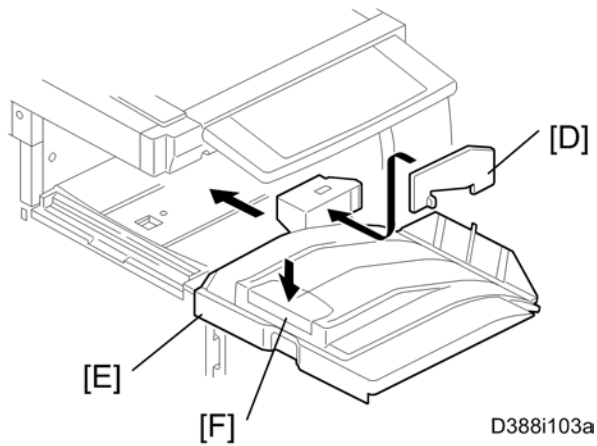

5. Attach the connector cover [D] to the shift tray unit [E].
6. Install the shift tray unit [E] on the machine.
7. Push down the left edge part [F] of the shift tray.
8. Turn on the main power switch of the machine.
9. Check the shift tray unit operation.

2.13 SIDE TRAY TYPE C5502 (D635)

2.13.1 COMPONENT CHECK

Check the quantity and condition of the accessories against the following list.

No.	Description	Q'ty
1	Side Tray Unit	1
2	Sub Output Tray	1
3	Main Output Tray	1
4	Screw	1
5	Knob screw	1
6	Frame Cover	1
7	Guide	2
8	Holder bracket	1

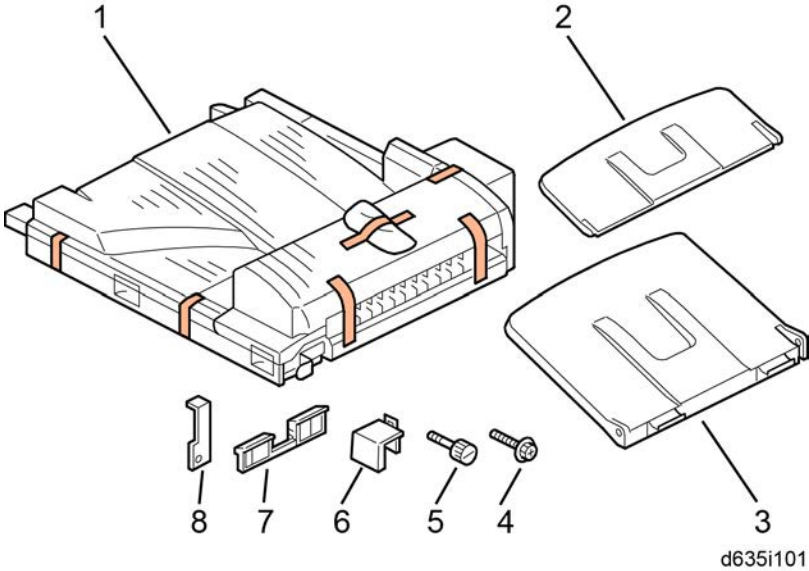

2.13.2 INSTALLATION PROCEDURE

⚠ CAUTION

- Turn off the main switch of the copier and unplug the power cord before you start the installation procedure.

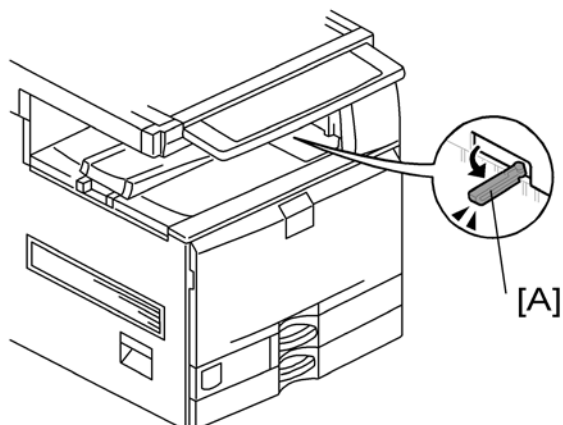

↓ Note

- If you will install the 1-bin tray (D632) on the machine, install the 1-bin tray first before installing the side tray (D635). This makes it easier to do the following procedure.

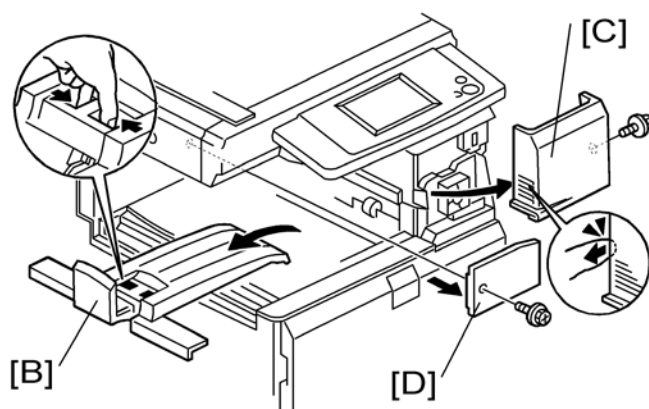

1. Remove all tapes.
2. If the sensor feeler [A] is out, fold it into the machine.
3. Open the right door of the machine.



4. Remove the upper inner tray [B].
5. Remove the front right cover [C] ( x 1).
6. Remove the connector cover [D] ( x 1).

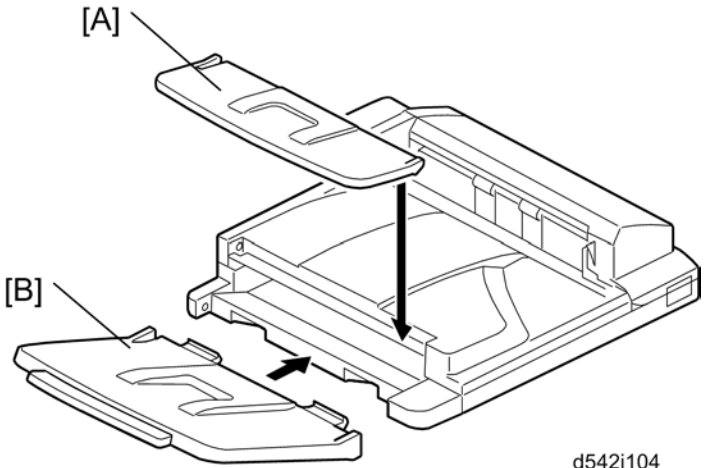

d542i104

7. Attach the main output tray [A] and sub output tray [B] to the side tray unit.

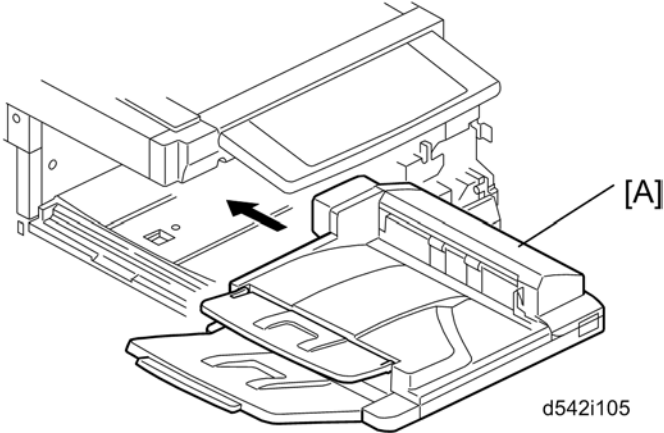

d542i105

8. Install the side tray unit [A] in the machine.

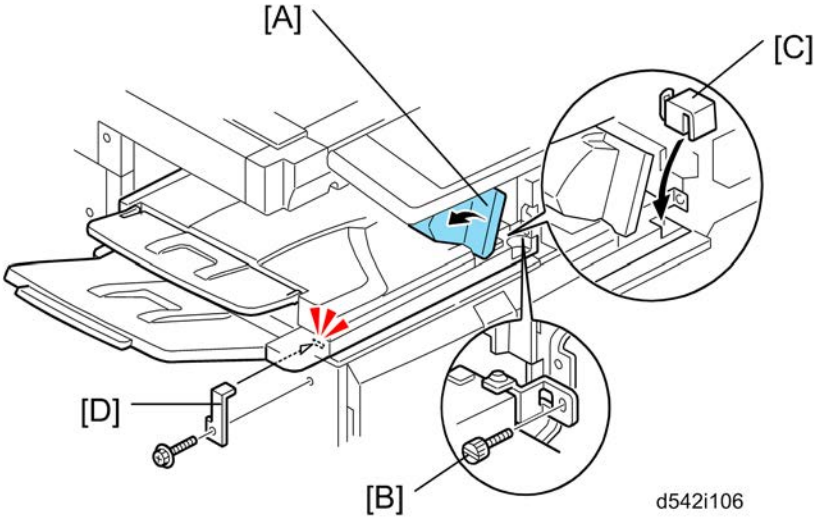

d542i106

- 9. Open the side tray cover [A].
- 10. Secure the side tray unit with the knob screw [B].
- 11. Attach the frame cover [C].
- 12. Reinstall the front right cover on the machine, and then close the right door of the machine.

Side Tray Type C5502 (D635)

Note

- Open the side tray cover [A] when installing the front right cover. Otherwise, it cannot be reinstalled.

13. Install the holder bracket [D] ( x 1)
14. Turn on the main power switch of the machine.
15. Check the side tray operation.

2.14 BRIDGE UNIT BU3060 (D634)

2.14.1 COMPONENT CHECK

Check the quantity and condition of the components against the following list.

No.	Description	Q'ty
1	Bridge Unit	1
2	Frame Cover	1
3	Knob screw	1
4	Long knob screw	1
5	Holder bracket	1
6	Guide	2

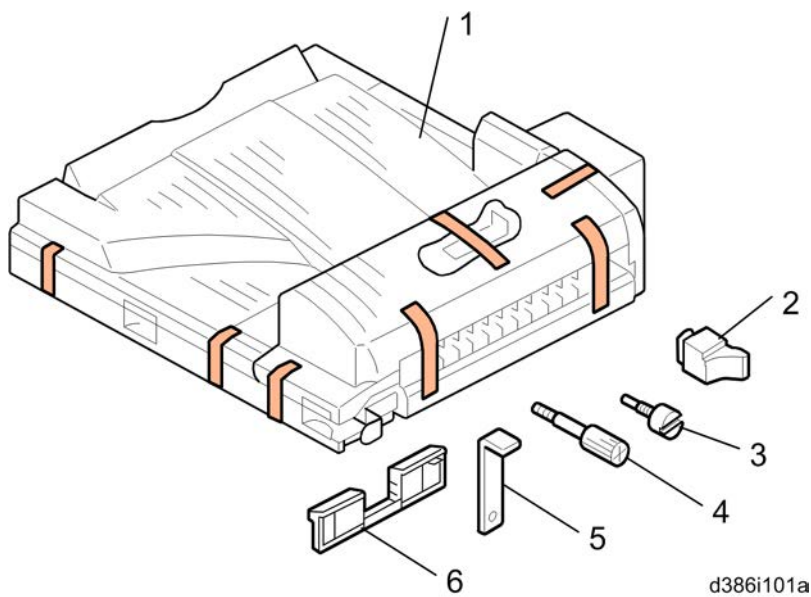

2.14.2 INSTALLATION PROCEDURE

⚠ CAUTION

- Unplug the copier power cord before starting the following procedure.

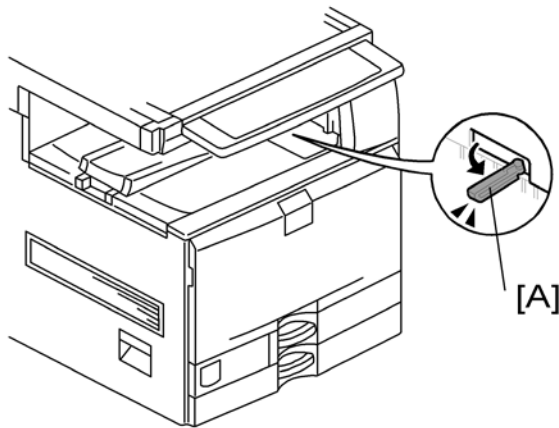

↓ Note

- If you will install the 1-bin tray (D632) on the machine, install the 1-bin tray first before installing the bridge unit (D634). This makes it easy to do the following procedure.
- If you will install a finisher unit (D585, D588, or D589) on the machine, install it after installing the bridge unit (D634).

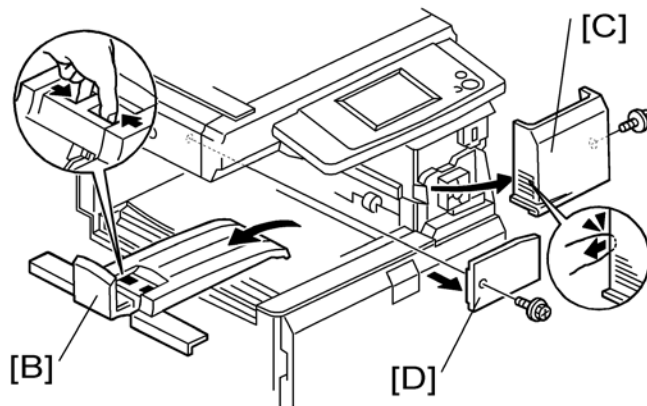

1. Remove all tapes.
2. If the sensor feeler [A] is out, fold it into the machine.
3. Open the right door of the machine.



4. Remove the upper inner tray [B].
5. Remove the front right cover [C] ( x 1).
6. Remove the connector cover [D] ( x 1).

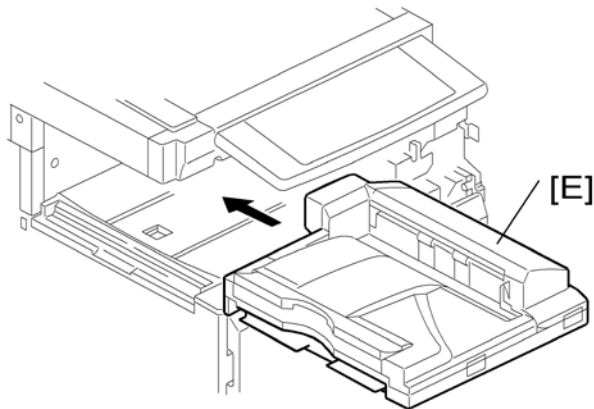

7. Install the bridge unit [E] in the machine.

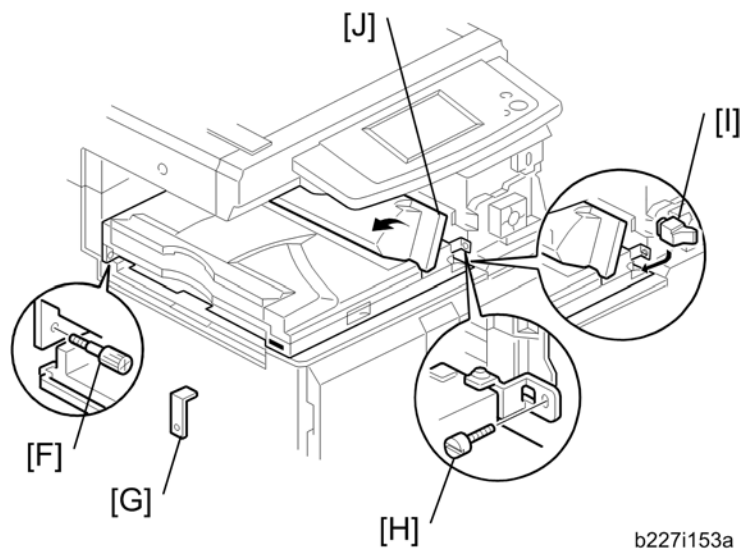

8. Secure the bridge unit with the long knob screw [F] and knob screw [H].
9. Attach the frame cover [I].
10. Reinstall the front right cover on the machine, and then close the right door of the machine.

Note

- Open the bridge unit cover [J] when installing the front right cover. Otherwise, it cannot be reinstalled.

11. Install the optional finisher (refer to the finisher installation procedure).

Note

- Holder bracket [G] is used in the installation procedure of the finisher (D585, D588 or D589). Do not install it at this time.

12. Turn on the main power switch of the machine.
13. Check the bridge unit operation.

Bridge Unit BU3060 (D634)

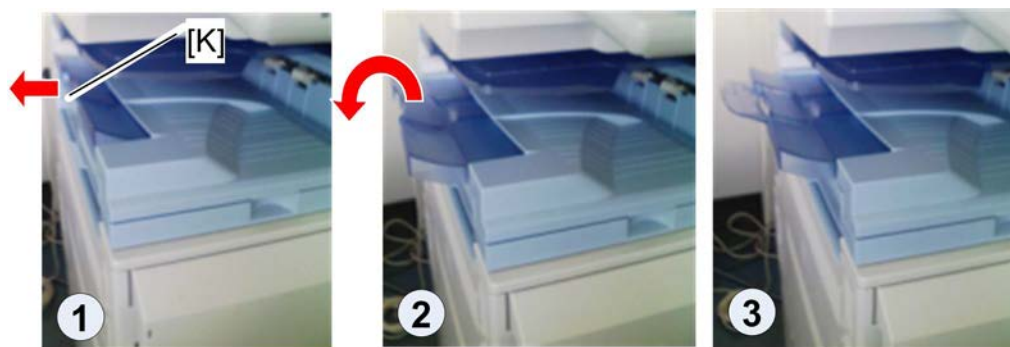

d386i509b

14. Pull the extension tray [K] only if the 1000-sheet finisher (D588) or the 500-sheet finisher (D585) is to be installed in the main machine.

2.15 FINISHER SR3070 (D585)

2.15.1 ACCESSORY CHECK

Check the quantity and condition of the accessories against the following list.

No	Description	Q'ty	For This Model
1	Unit Holder	1	Yes
2	Shift Tray	1	Yes
3	Holder Bracket	1	Yes
4	Screw: M3 x 8	4	Yes
5	Screw: M3 x 6	1	Yes
6	Screw: M4 x 14	4	Yes
7	Screw: M4 x 20	4	Yes
8	Screw: M4 x 25	3	Not used
9	Support Bracket	2	Yes
10	Support Bracket Cover	2	Yes

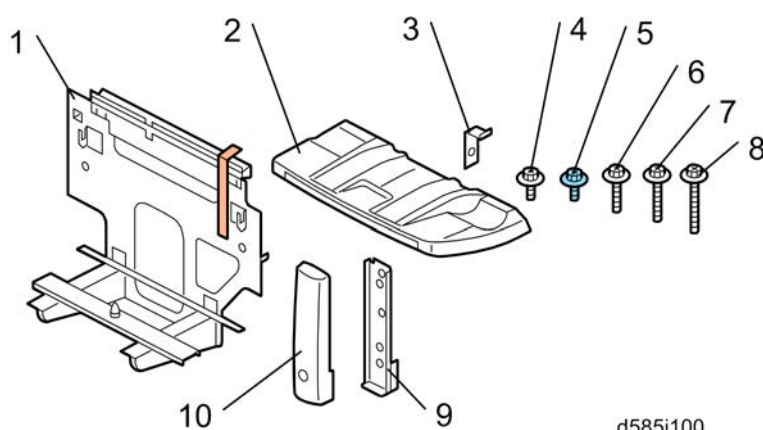

d585i100

2.15.2 INSTALLATION PROCEDURE

Important

- Whenever you lift or carry the SR3070, always **hold it by the bottom edges** of the front cover [C] and rear cover [A], as shown in the diagram below left. If you do not, SC798 will occur when you attach the finisher. **DO NOT** hold the finisher by the tray holder [B], as shown in the diagram below right.

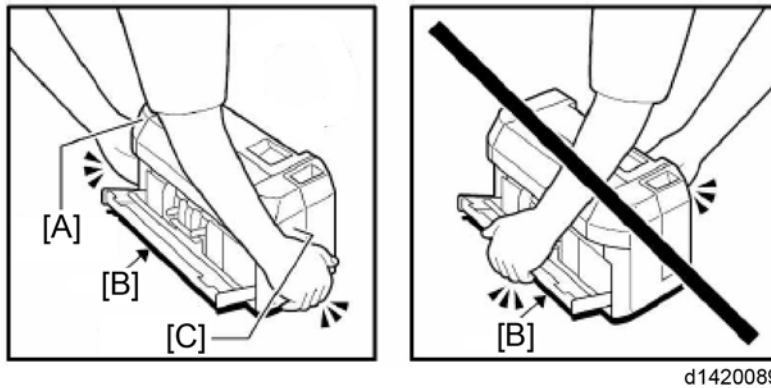

CAUTION

- Unplug the main machine power cord before starting the following procedure.

Note

- The optional bridge unit (D634) must be installed before installing this finisher (D585).

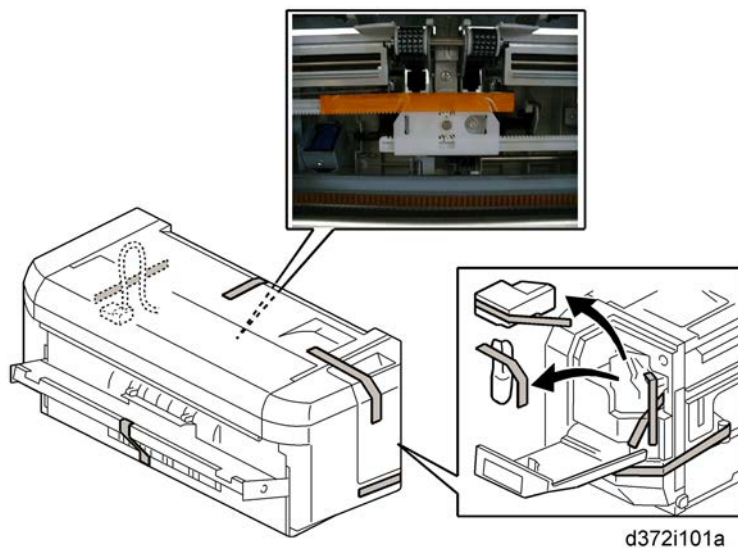

1. Unpack the finisher and remove the tapes.

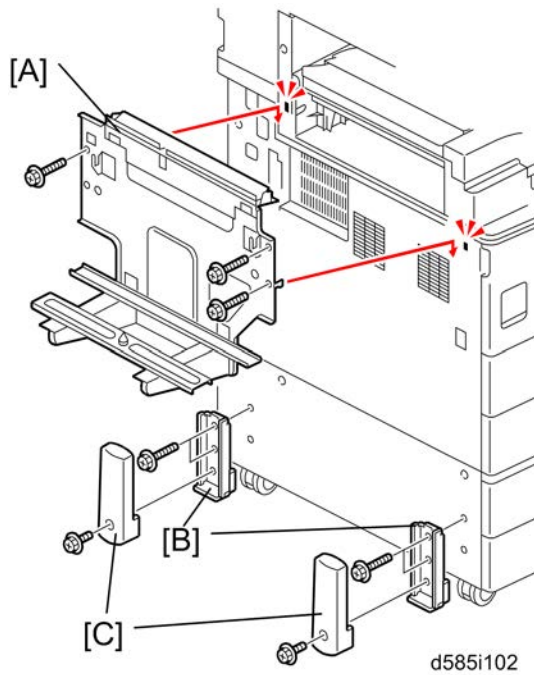

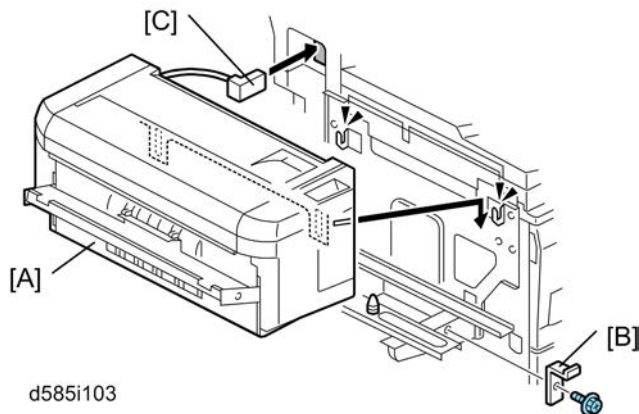

2. Install the unit holder [A] (4 x M4 x 14).
3. Install the support brackets [B] (2 each; M4 x 20).
4. Install the support bracket covers [C] (1 each; M3 x 8).

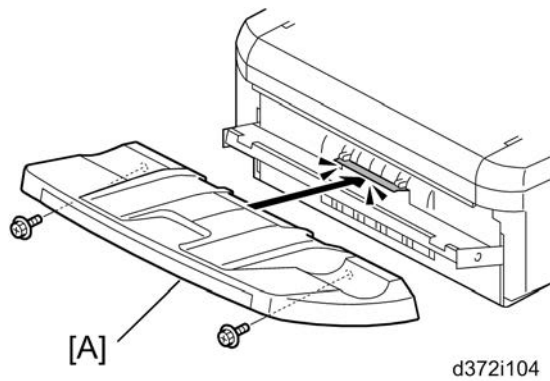

5. Install the 500-sheet finisher [A].
6. Install the holder bracket [B] (1; M3 x 6).
7. Connect the finisher cable [C].

Finisher SR3070 (D585)



8. Install the shift tray [A] ( x 2; M3 x 8).
9. Turn on the main power switch and check the finisher operation.

2.16 FINISHER SR3090 (D588)

2.16.1 ACCESSORY CHECK

Check the quantity and condition of the accessories against the following list.

No.	Description	Q'ty
1	Grounding Plate	1
2	Rear Joint Bracket (Not used)	1
3	Front Joint Bracket	1
4	Rear Joint Bracket	1
5	Copy Tray	1
6	Screw - M3 x 8	1
7	Screw - M4 x 13	4
8	Knob Screw - M3 x 8	1
9	Knob Screw - M4 x 10	1
10	Screw - M4 x 25 (Not used)	3
11	Staple Position Decal	1

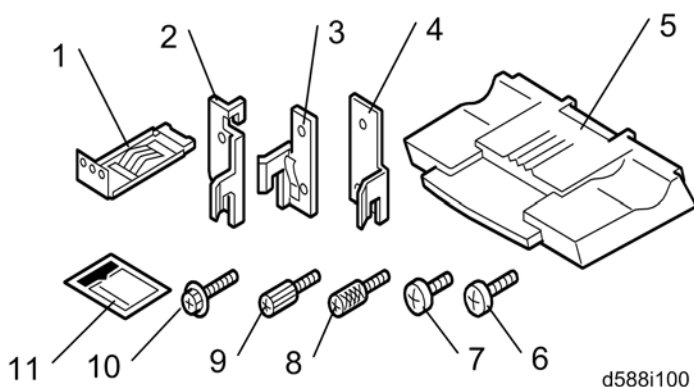

2.16.2 INSTALLATION PROCEDURE

⚠ CAUTION

- Unplug the main machine power cord before starting the following procedure.

The following options must be installed before installing this finisher:

- Bridge Unit (D634)
- Paper Feed Unit (D580) or LCT (D581)

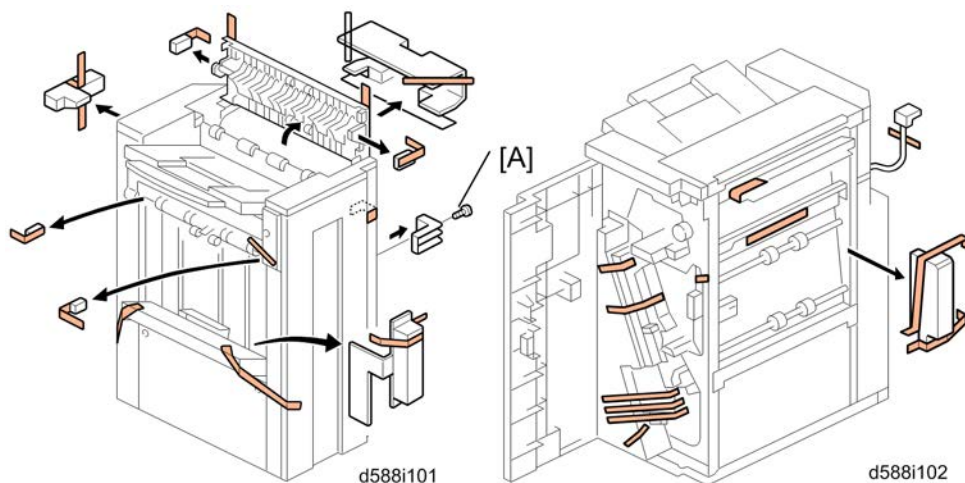

1. Unpack the finisher and remove the tapes.

ⓘ Note

- Be sure to keep screw [A]. It will be needed to secure the grounding plate in step 3.

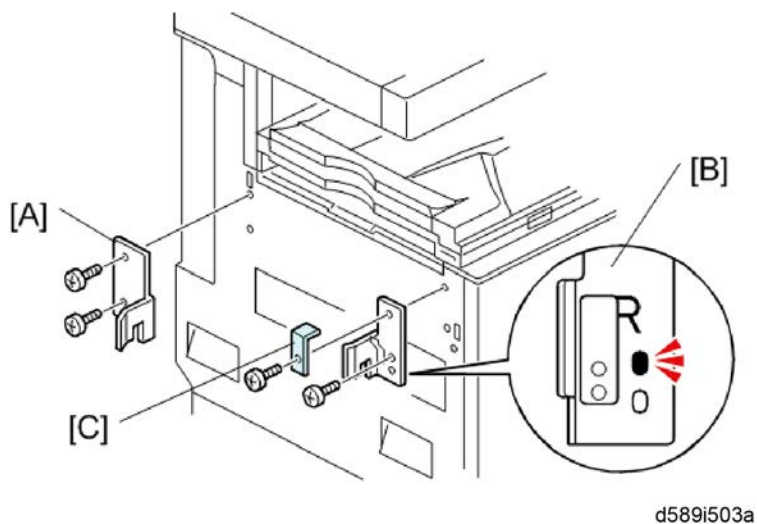

2. Install the rear joint bracket [A] (2; M4x13), and then attach the front joint bracket [B] and the holder bracket [C] (2; M4x13).

ⓘ Note

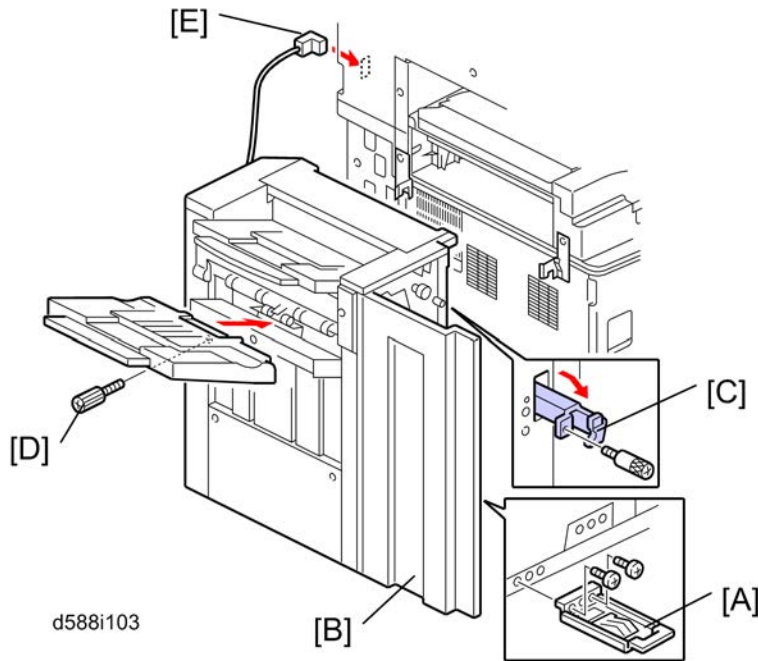

- Holder bracket [C] must be placed outside the front joint bracket [B]. This bracket is provided with the Bridge Unit (D634).



3. Install the grounding plate [A] on the finisher ( x 2; M3x8).

Note

- Use the screw removed in step 1 and the screw from the accessory box.

4. Open the front door [B]. Then pull the locking lever [C].
5. Align the finisher on the joint brackets, and lock it in place by pushing the locking lever.
6. Secure the locking lever ( x 1; knob M3x8) and close the front door.
7. Install the copy tray [D] ( x 1; knob M4x10).
8. Connect the finisher cable [E] to the main machine.

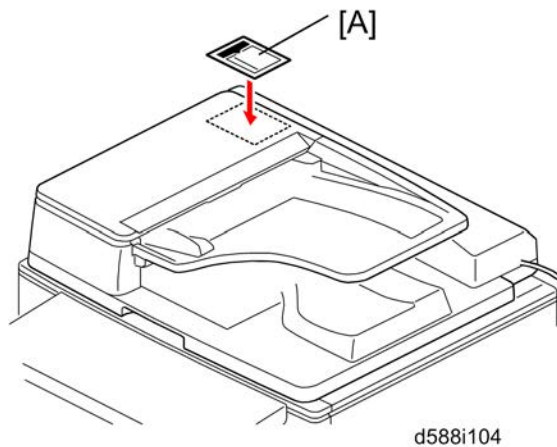

9. Attach the staple position decal [A] to the ARDF as shown.
10. Turn on the ac switch and check the finisher operation.

2.17 BOOKLET FINISHER SR3100 (D589)

2.17.1 ACCESSORY CHECK

Check the quantity and condition of the accessories against the following list.

No.	Description	Q'ty
1	Rear Joint Bracket (Not used)	1
2	Rear Joint Bracket	1
3	Front Joint Bracket	1
4	Grounding Plate	1
5	Upper Output Tray	1
6	Lower Output Tray	1
7	Short Knob Screw	1
8	Long Knob Screw	1
9	Screw (M4 x 13)	4
10	Screw (M3 x 8)	2
11	Screw (M4 x 25) (Not used)	3
12	Cushion	2

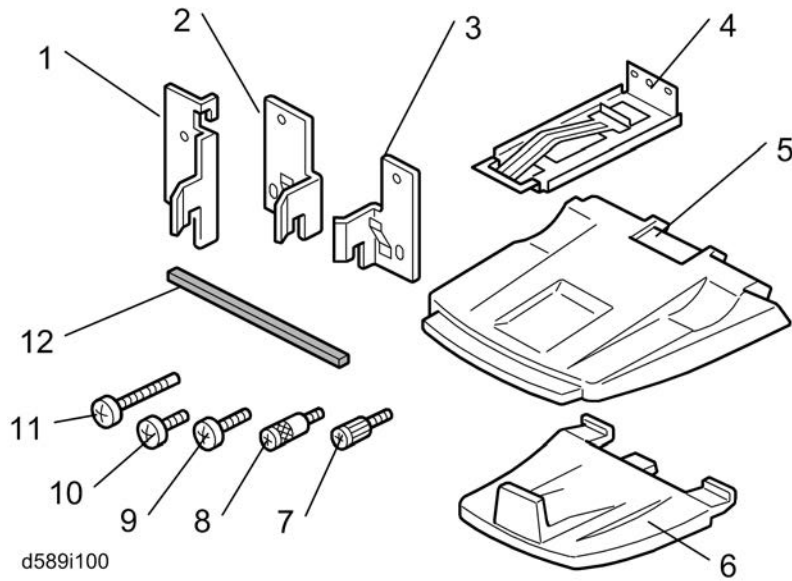

2.17.2 INSTALLATION PROCEDURE

⚠ CAUTION

- Unplug the main machine power cord before starting the following procedure.

The following optional units must be installed before installing this finisher (D589).

- Bridge Unit (D634)
- Paper Feed Unit (D580) or LCT (D581)

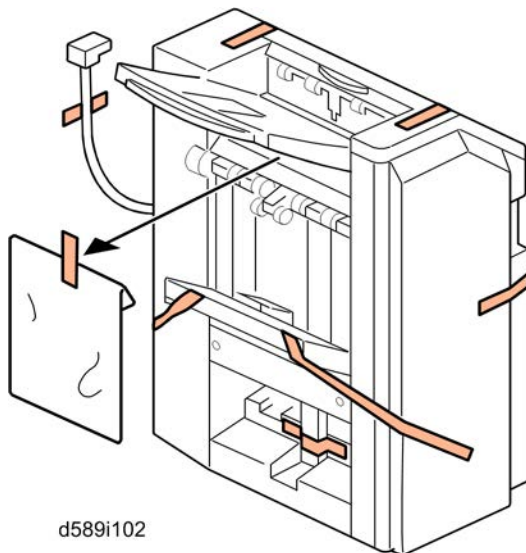

1. Unpack the finisher and remove all tapes and packing materials from the finisher.

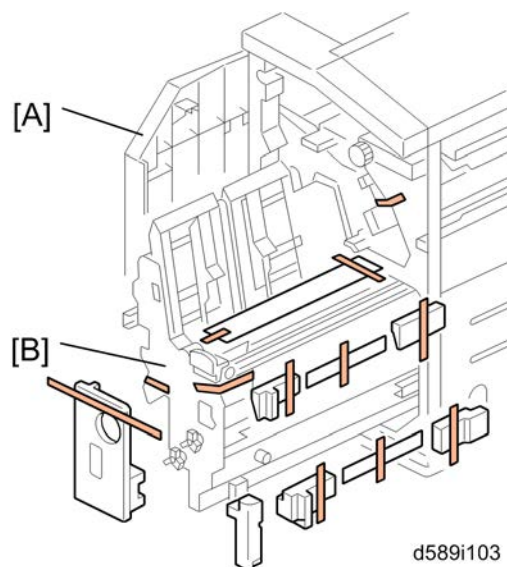

2. Open the front door [A] of the 1000-sheet booklet finisher, and then pull out the jogger unit [B].
3. Remove all tapes and packing materials from the inside of the finisher.

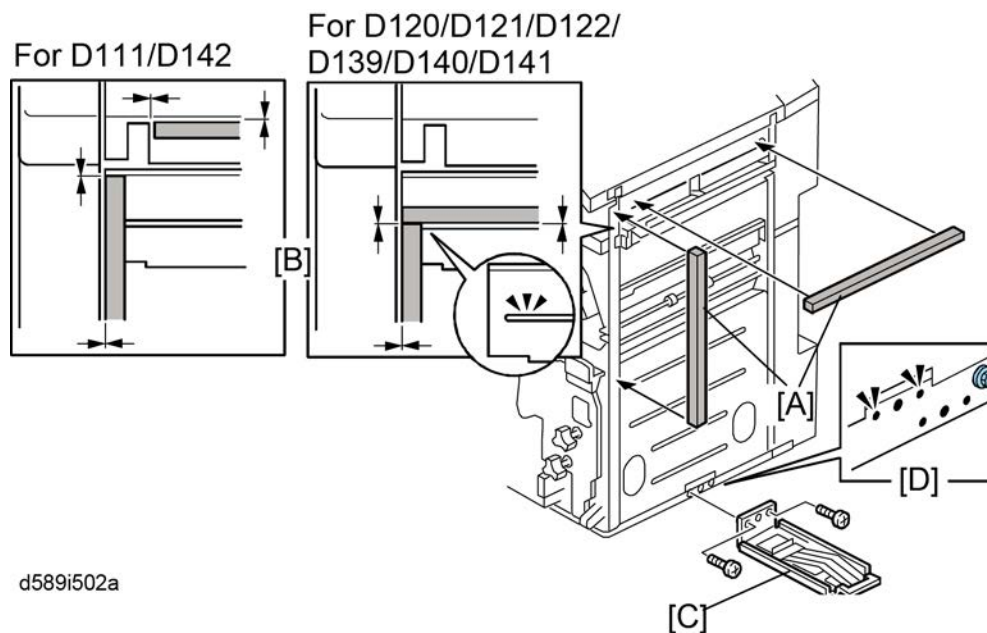

4. Attach the cushions [A] to the finisher.

Note

- Make sure that the cushions are placed within 0 to 1 mm [B] from the edge of the cover or frame.

5. Install the ground plate [C] on the finisher [D] (x 2; M3x8).

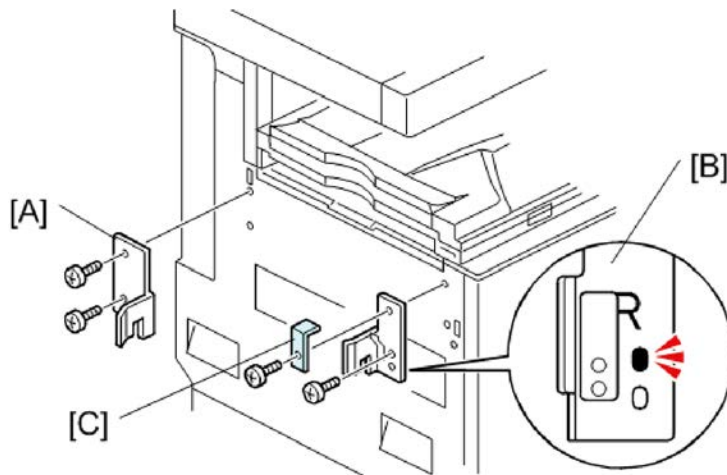

d589i503a

6. Install the rear joint bracket [A] (2; M4x13), and then attach the front joint bracket [B] and the holder bracket [C] (2; M4 x 13).

Note

- Holder bracket [C] must be placed outside the front joint bracket [B]. This bracket is provided with the Bridge Unit (D634).

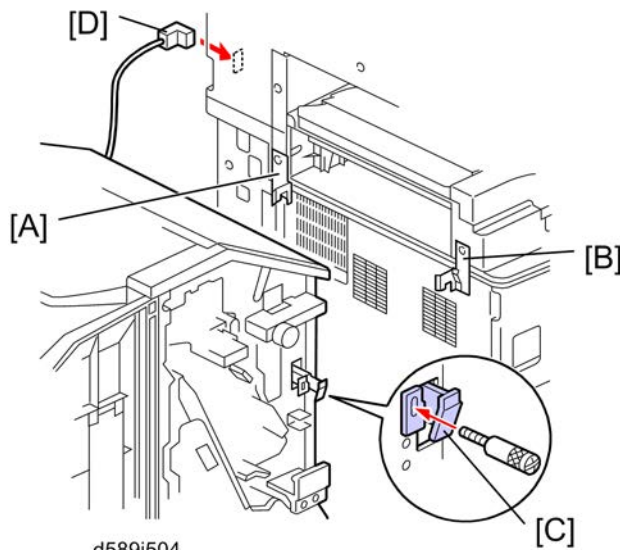

d589i504

7. Slowly push the finisher to the left side of the machine, keeping its front door open until the brackets [A] [B] go into their slots.
8. Push the lock lever [C], and then secure it (Long knob screw x 1).
9. Close the front door of the finisher.
10. Connect the finisher connector [D] to the machine.

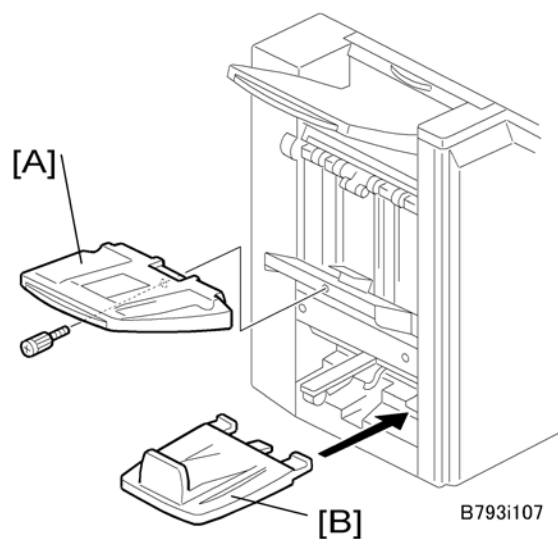

11. Install the upper output tray [A] (Short knob screw x 1).
12. Install the lower output tray [B].
13. Turn on the main power switch of the machine.
14. Check the 1000-sheet booklet finisher operation.

2.18 PUNCH KIT PU3000 (B807)

2.18.1 COMPONENT CHECK

Check the quantity and condition of the components against the following list.

No.	Description	Q'ty
1	Punch Unit	1
2	Punch Drive Motor	1
3	Hopper Full Sensor Arm	1
4	Sub-scan Registration Sensor Unit	1
5	Punch Unit Stay	1
6	Sub-scan Registration Sensor Guide	1
7	Hopper	1
8	Screw	8
9	Step Screw	1
10	Spring	1

Installation

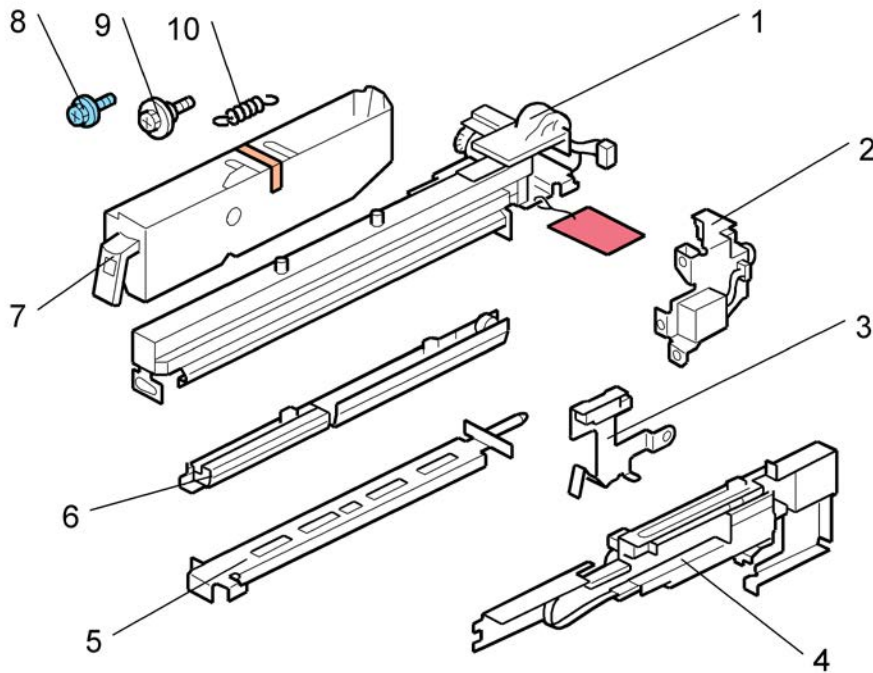

2.18.2 INSTALLATION

⚠ CAUTION

- Unplug the main machine power cord before starting the following procedure. If the 1000-sheet booklet finisher has been installed, disconnect it and pull it away from the machine.

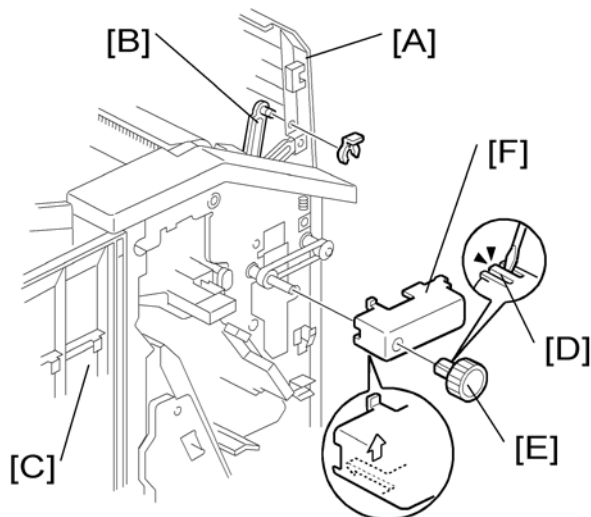

1. If the finisher is connected to the machine, disconnect it.
2. Open the top cover [A] and then release the guide arm [B] (⌘ x 1).
3. Open the front door [C].
4. Pull the hook [D] up then remove the knob [E].

5. Timing belt cover [F].

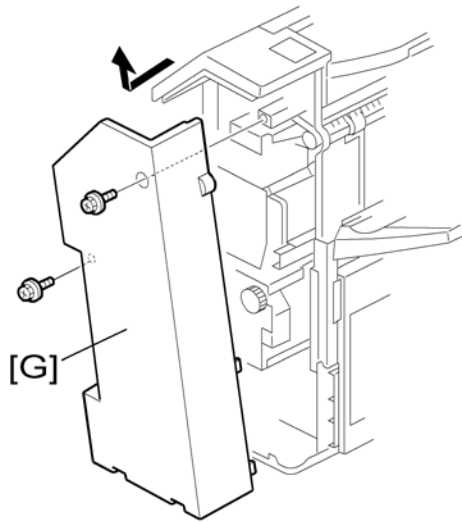

6. Rear cover of the 1000-sheet booklet finisher [G] (2 x).

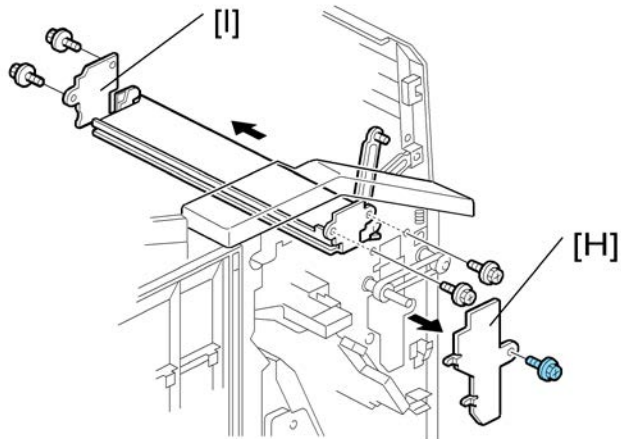

7. Cover bracket [H] (1 x)

8. Remove the paper guide plate [I] from the rear side (4 x).

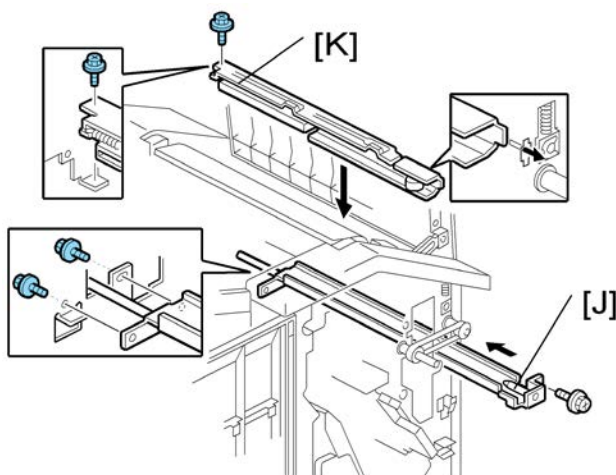

9. Install the punch unit stay [J] from the front side (3 x).

10. Install the sub-scan registration sensor guide [K] from the top ( x 1).

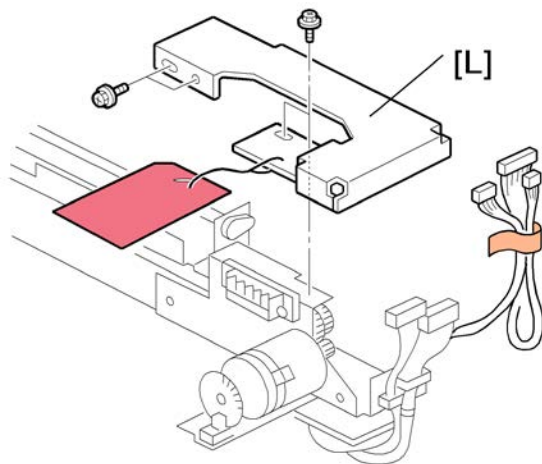

11. Remove the bracket [L] from the punch unit ( x 1).

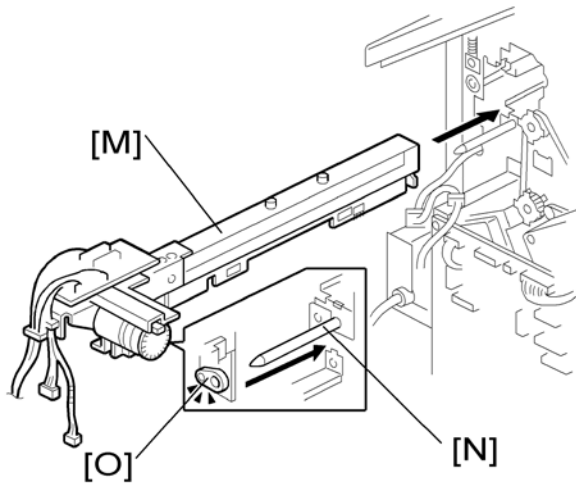

12. Install the punch unit [M] along the punch unit stay from the rear side.

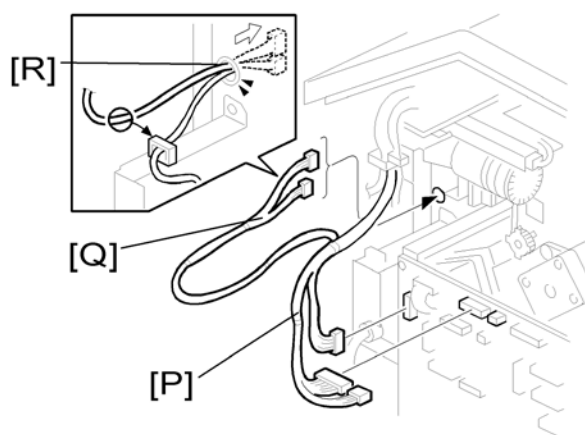

13. Make sure to put the punch unit stay pin [N] through the hole [O].



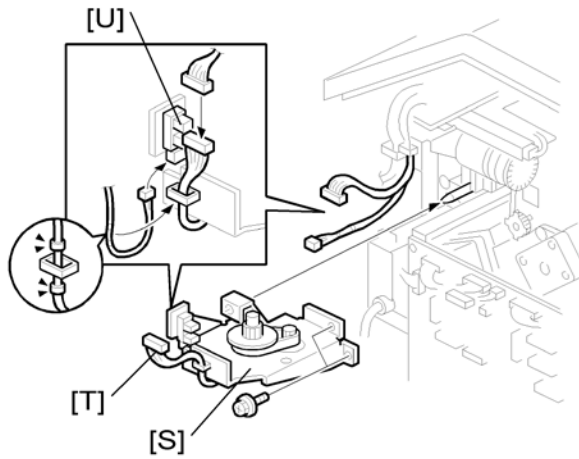

14. Connect the harnesses [P] to the main PCB.

15. Put the harnesses [Q] through the hole [R] in the rear frame ( x 1).

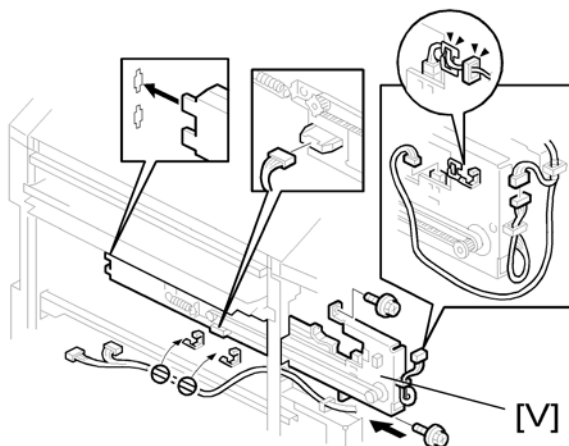

16. Install the punch drive motor [S] on the rear frame ( x 2).
17. Connect the drive motor harness [T] to the harness from the punch unit ( x 1).
18. Connect the home position sensor harness from the punch unit to the home position sensor [U].



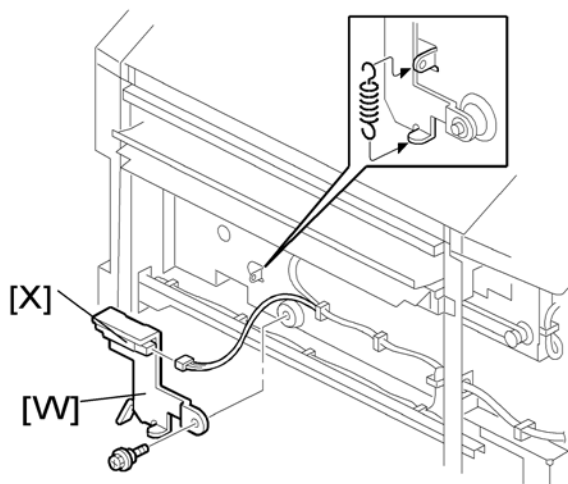

19. Install the sub-scan registration sensor unit [V] from the rear side ( x 2).
20. Route and connect the harnesses as shown ( x 2).

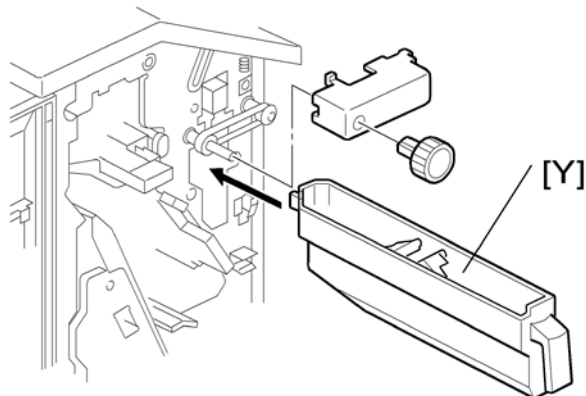

Punch Kit PU3000 (B807)

21. Install the hopper full sensor arm [W] ( x 1, spring x 1).
22. Connect the harness from the sub-scan registration sensor unit to the hopper full sensor [X].





23. Install the hopper [Y] from the front side.
24. Reinstall the timing belt cover and knob.
25. Reinstall the rear cover ( x 2).
26. Close the front door and top cover.
27. Install the 1000-sheet booklet finisher on the copier.
28. Plug in and turn on the main power switch.
29. Check the 1000-sheet booklet finisher operation.

2.19 KEY COUNTER BRACKET TYPE H (A674)

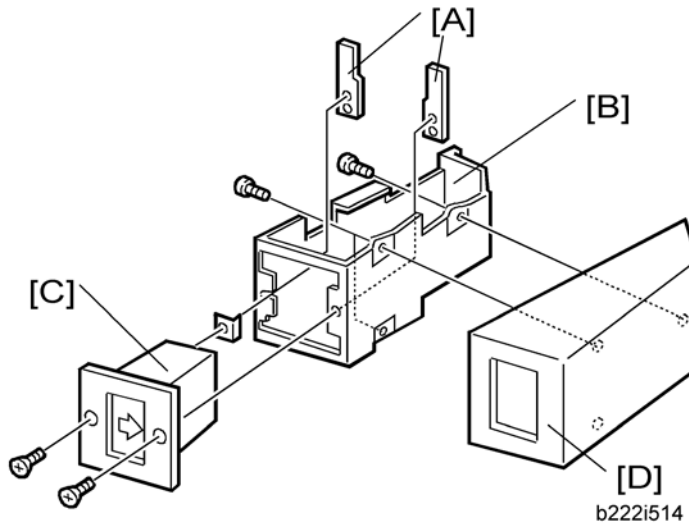
2.19.1 INSTALLATION PROCEDURE



1. Hold the key counter plate nuts [A] on the inside of the key counter bracket [B] and insert the key counter holder [C].
2. Secure the key counter holder to the bracket ( x 2).
3. Install the key counter cover [D] ( x 2).
4. Rear cover ( p.4-18)

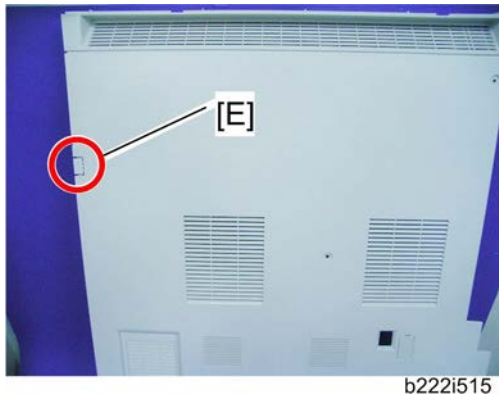

5. Cut off the part [E] of the rear cover.

Key Counter Bracket Type H (A674)



6. Connect the harness to the connector [F] inside the machine.

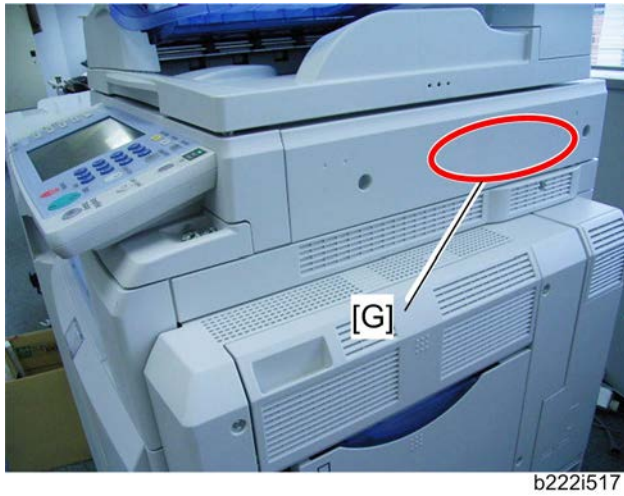

7. Peel off double sided tape on the key counter bracket and attach the key counter to the scanner right cover [G].
8. Reassemble the machine.

2.20 COPY DATA SECURITY UNIT TYPE F (B829)

2.20.1 COMPONENT CHECK

No.	Description	Q'ty	For this model
1	Bracket 1	1	Not used
2	ICIB-3	1	Yes
3	Flexible cable: Long	1	Not used
4	Flexible cable: Short	1	Not used
5	Harness with bands	1	Not used
6	Harness	1	Not used
7	Small Bracket	1	Not used
8	Saddle Clamp	1	Not used
9	Screws: M3x6	6	Not used
10	Screws: M3x4	2	Yes
11	Bracket 2	1	Not used

2.20.2 INSTALLATION

⚠ CAUTION

- Unplug the main machine power cord before you do the following procedure.

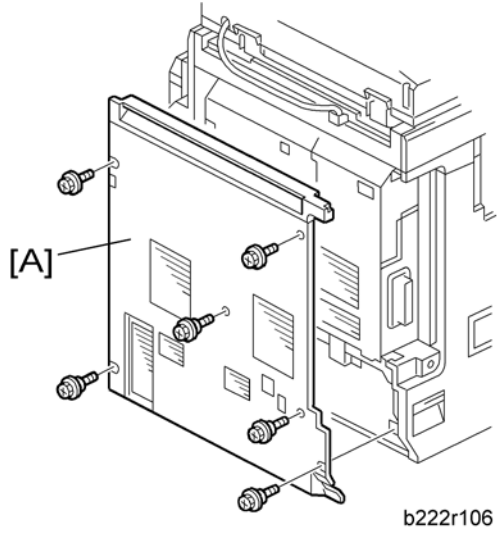

1. Remove the rear cover [A] of the machine ( x 5).

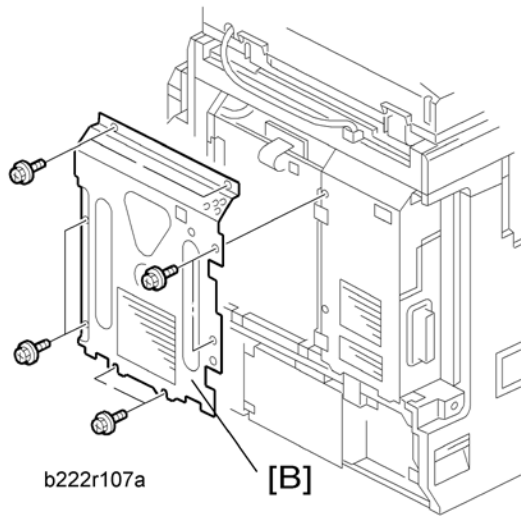

2. Remove the controller box right cover [B] ( x 8).

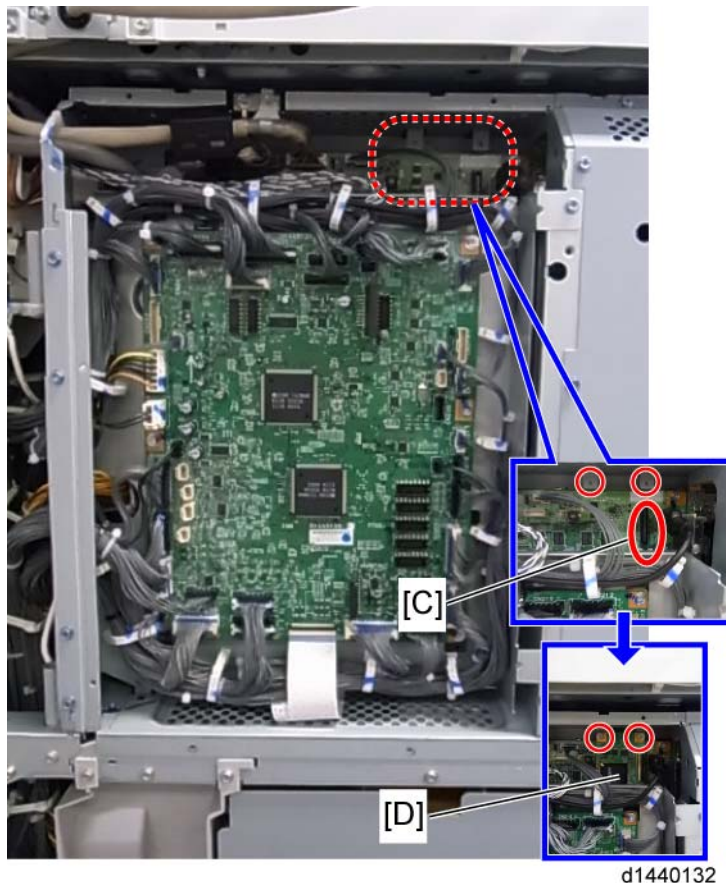

3. Attach the ICIB-3 [D] (copy data security board) to CN 187 [C] on the BCU (🔧 x 1, 🔧 x 2).
4. Reassemble the machine.

User Tool Setting

1. Plug in and turn on the main power switch.
2. Go into the User Tools mode, and select System Settings > Administrator Tools > Copy Data Security Option > “On”.
3. Exit User Tools.
4. Check the operation.

Note

- The machine will issue an SC165 error if the machine is powered on with the ICIB-3 removed and the “Data Security for Copying” feature set to “ON”.
- When you remove this option from the machine, first set the setting to “OFF” with the user tool before removing this board. If you forget to do this, “Data Security for Copying” feature cannot appear in the user tool setting. And then SC165 will appear every time the machine is switched on, and the machine cannot be used.

Make sure that the machine can recognize the option (see ‘Check All Connections’ at the end of this section).

2.21 OPTIONAL COUNTER INTERFACE UNIT TYPE A (B870)

2.21.1 COMPONENT CHECK

Check the quantity and condition of the accessories against the following list.

No.	Description	Q'ty
1	Key Counter Interface Board	1
2	Stud Stay	4
3	Wire Harness	1

2.21.2 INSTALLATION PROCEDURE

1. Rear cover (☞ p.4-18)
2. IOB bracket (☞ p.4-160)

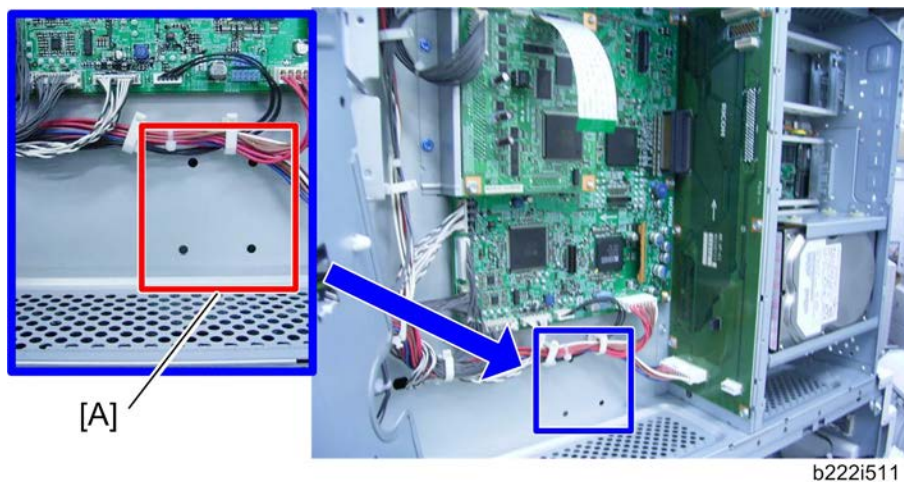

3. Install the four stud stays in the location [A] in the controller box.
4. Install the key counter interface board on the four stud stays in the controller box.
5. Connect the harness to CN3 on the key counter interface board.

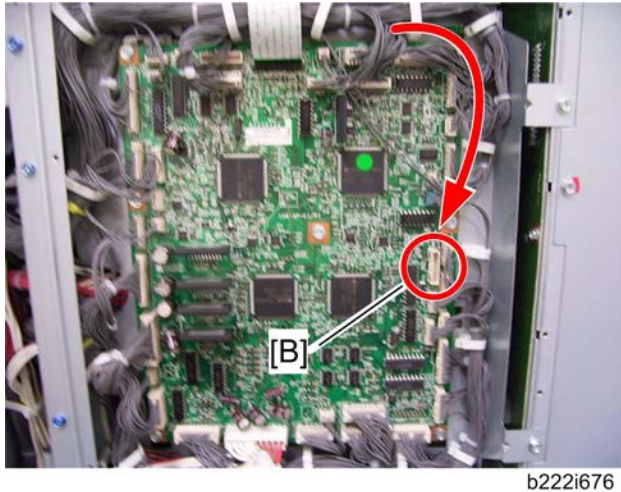

6. Close the IOB bracket and connect the other terminal to CN215 [B] on the IOB.

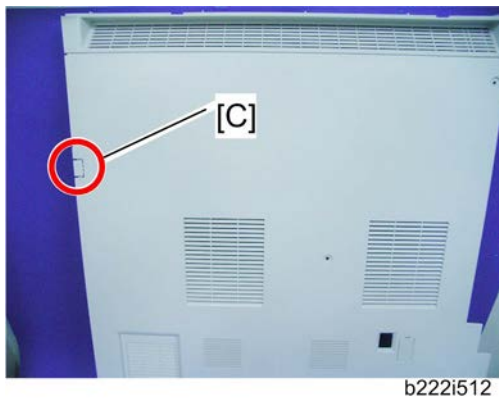

7. Cut off the part [C] of the rear cover.

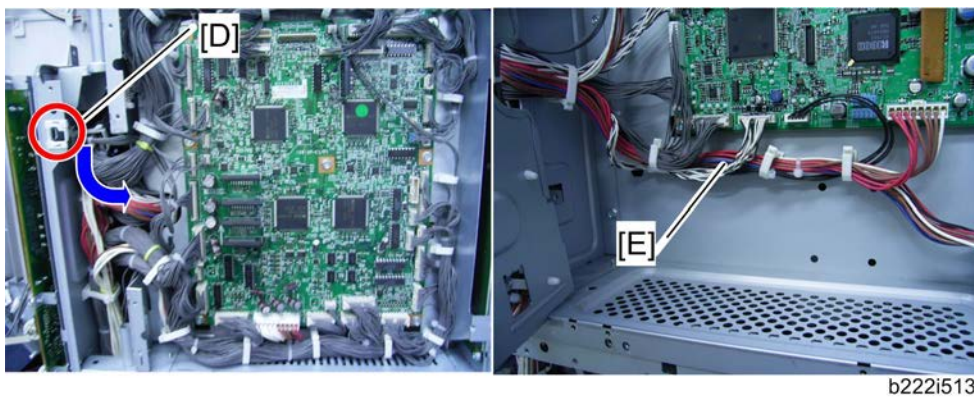

8. Clamp the harness from the counter device with the clamp [D] and put it as shown by the blue arrow (🔧 x 1).
9. Route the harness from the counter device in the same way as the other harnesses [E] (🔧 x 3).
10. Connect the harness from the counter device to CN4 on the key counter interface board.
11. Reattach the IOB bracket (🔧 p.4-160).
12. Reassemble the machine.

2.22 CARD READER BRACKET TYPE 3352 (D593)

2.22.1 COMPONENT CHECK

Check the quantity and condition of the accessories against the following list.

No.	Description	Q'ty
1	Screw: M3 x 8	2
2	Screw: M3 x 14	1
3	Screw: M3 x 25* ¹	1
4	Tapping Screw: M3 x 10	3
5	Upper Tray	1
6	Lower Tray	1
7	Tray Bracket	1
8	Clamp	5

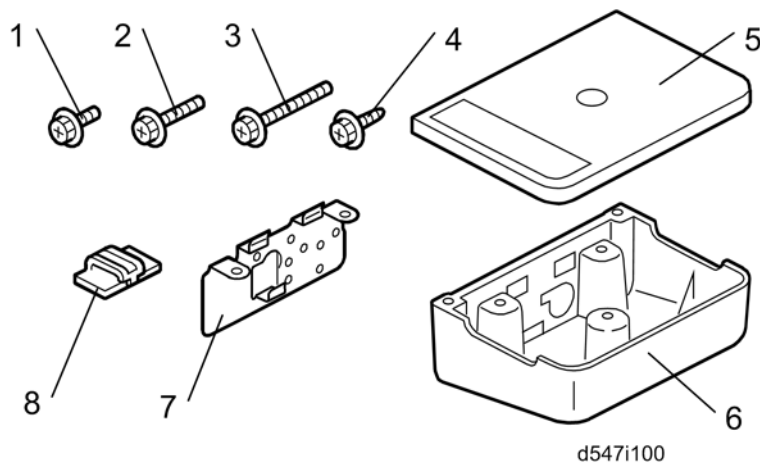

*1: Not used in this machine

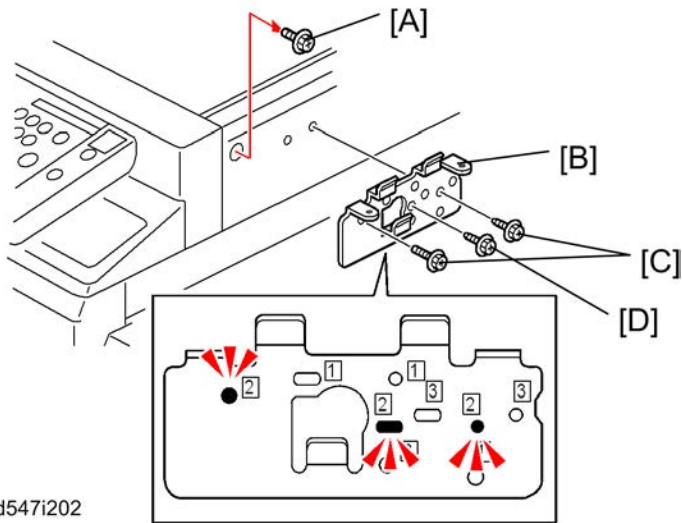

2.22.2 INSTALLATION PROCEDURE



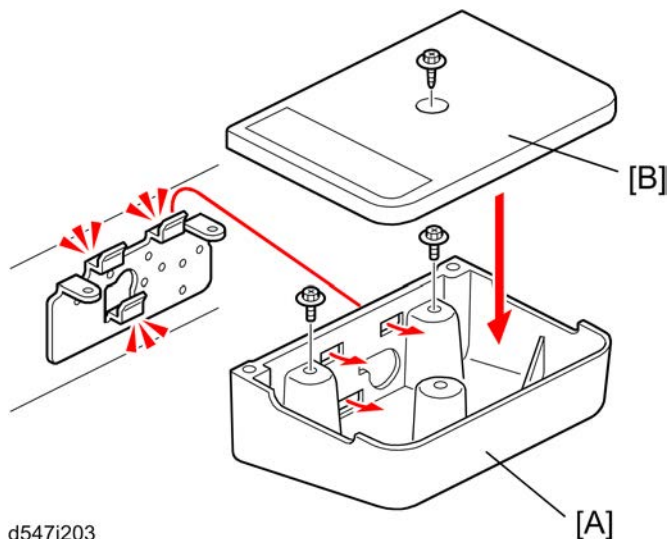

d547i202

1. Remove the screw [A] on the scanner right cover.
2. Attach the tray bracket [B] to the scanner right cover ( [C] x 2: M3x10,  [D] x 1: M3x14).
 - For this model, use the screw holes marked "2" on the table bracket.



d547i203

3. Attach the lower tray [A] to the tray bracket ( x 2: M3x8).
4. Attach the upper tray [B] to the tray bracket ( x 1: M3x8).
5. Use the clamps as necessary to clamp the cable of the card read/writer device.

★ Important

- The smart card reader must be placed on this card reader table. If not, some antenna or transmitter in the main machine may be interrupted.

2.23 ANTI-CONDENSATION HEATER (SCANNER)

Note

- This option is provided as a service part.

2.23.1 INSTALLATION PROCEDURE

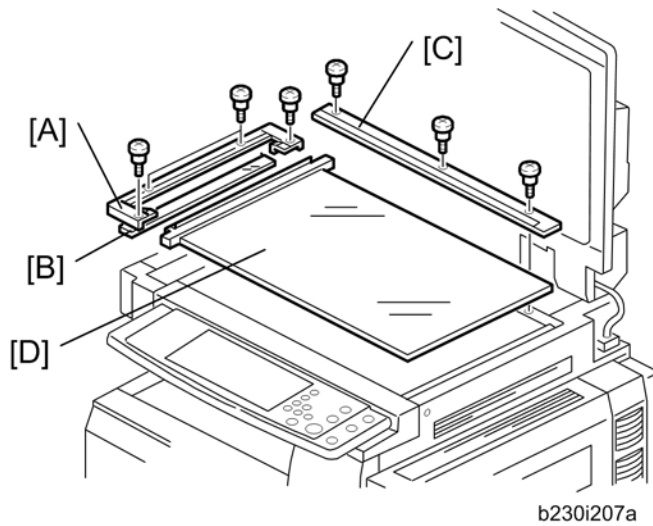

1. Rear cover (☞ p.4-18)
2. Open the ARDF or platen cover.
3. Glass cover [A] (☞ x 4)
4. ARDF exposure glass [B]
5. Rear scale [C] (☞ x 3)
6. Exposure glass with left scale [D]

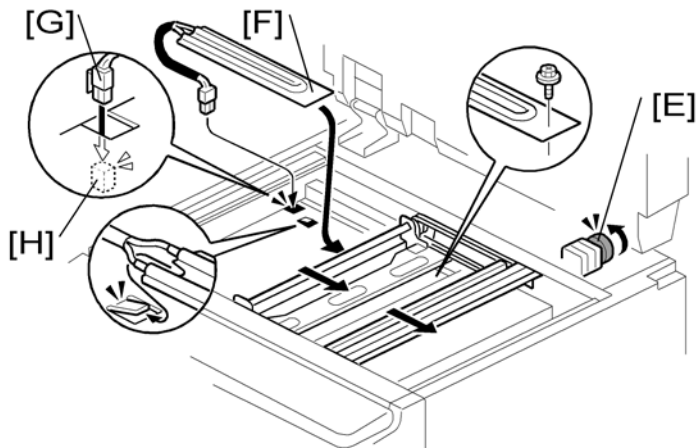

Installation

7. Move the scanner carriage to the right side by rotating the scanner motor [E].
8. Install the heater [F] in the scanner unit ( x 1, hook)
9. Put the connector [G] through the cutout.
10. Connect it to the connector [H] (blue and red cords) in the frame of the machine.
11. Reassemble the machine.

2.24 ANTI-CONDENSATION HEATER TYPE A

Note

- This option is provided as a service part.

2.24.1 COMPONENT CHECK

No.	Description	Q'ty
1	Tray heater	1
2	On-standby decal	1 (-90) or 2 (-91)
3	Harness 2 (For D387)	1
4	Harness 1 (For D537/D538)	1
5	Screw M4 x 10	2
-	Installation procedure	1

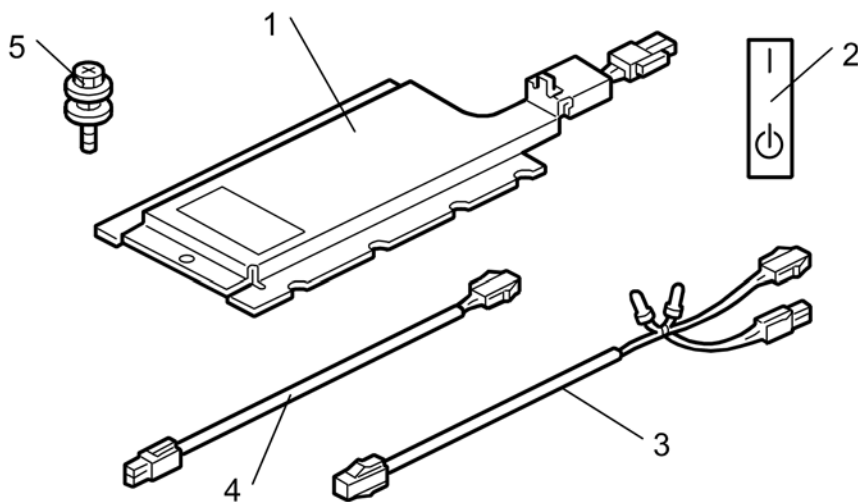



b800i191

2.24.2 INSTALLATION PROCEDURE

⚠ CAUTION

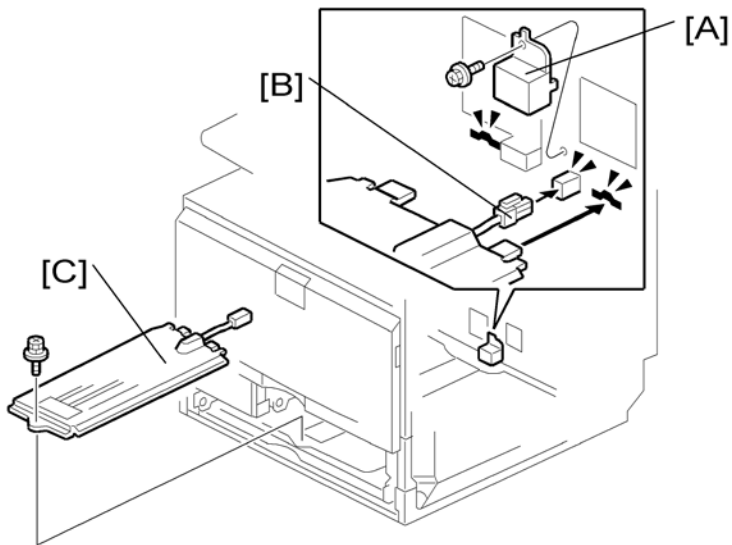
- Unplug the machine power cord before starting the following procedure.
- Do the following procedure not to damage any harnesses.
- Check that all harnesses are not damaged nor pinched after installation.

For installing the tray heater in the main machine

1. Remove trays 1 and 2 from the machine.
2. Remove the connector cover [A] ( x 1).
3. Connect the connector [B] of the heater to the connector of the main machine.
4. Install the heater [C] inside the machine ( x 1).
5. Reassemble the machine.

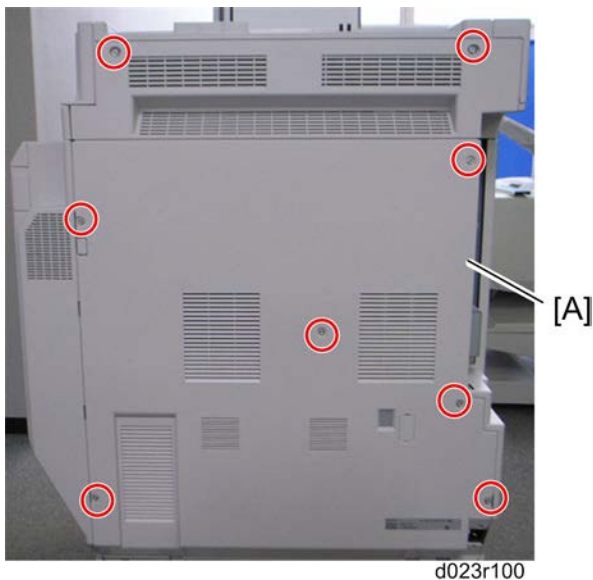
For installing the tray heater in D537

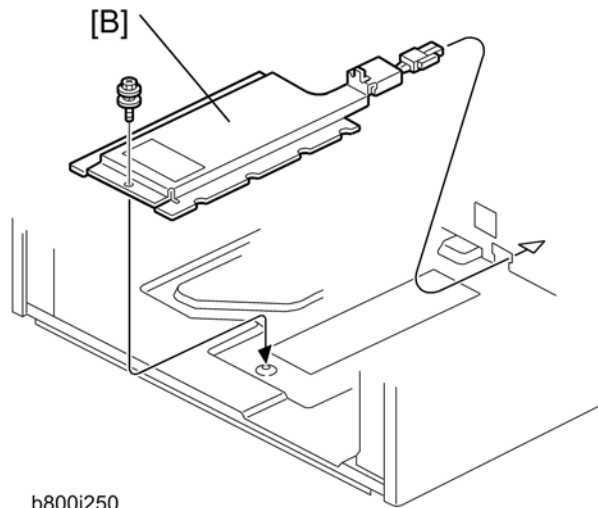

1. Rear cover [A] ( x 8)
2. Pull out the two trays in the optional paper feed unit.

Anti-Condensation Heater Type A

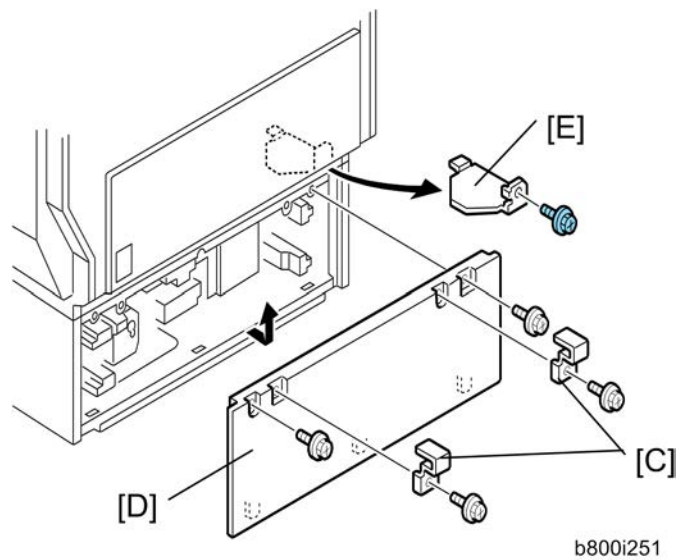

3. Install the tray heater [B] in the optional paper feed unit ( x 1).



4. Remove the two securing brackets [C] ( x 1 each), and then the rear cover [D] of the optional paper feed unit ( x 2).
5. Remove the harness cover bracket [E] ( x 1).

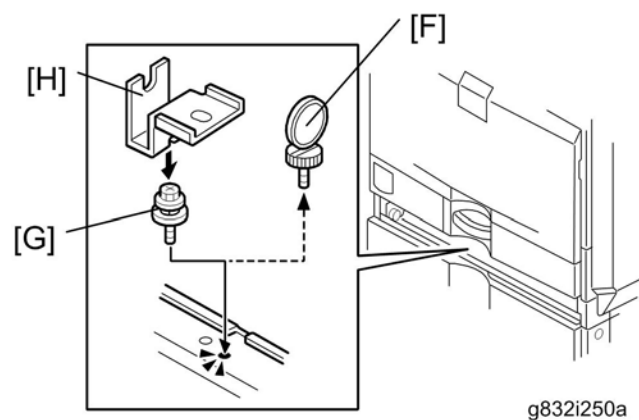

6. Pull out tray 2 from the mainframe.
7. Replace the shoulder screw [F] with the washer screw [G], using securing bracket [H] ( x

1).

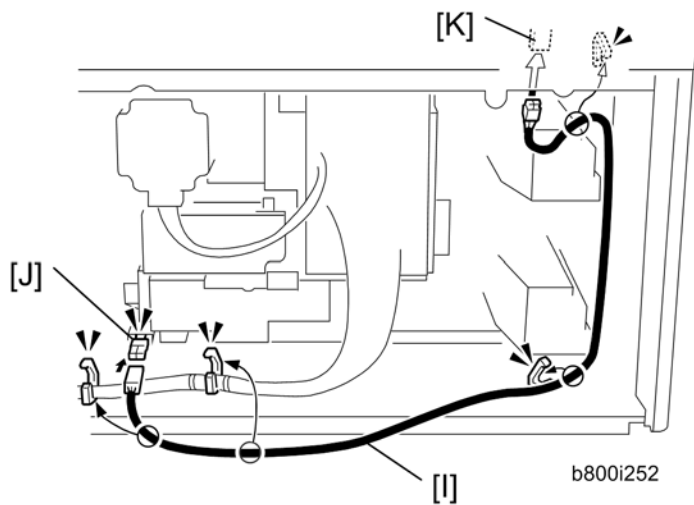

8. Connect the harness [I] to the connector [J] of the tray heater.
9. Route the harness [I] as shown and clamp it with four clamps (🔧 x 4).
10. Connect the harness [I] to the connector [K] of the mainframe.
11. Reassemble the mainframe and optional paper feed unit.

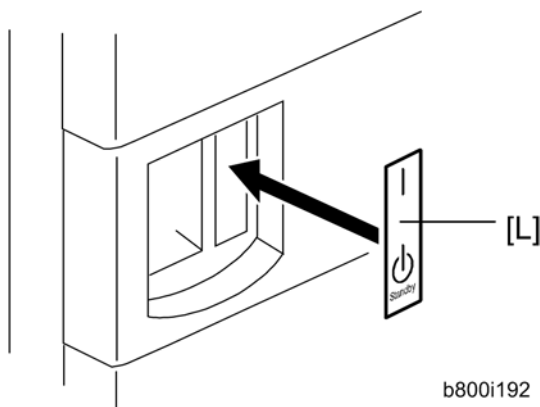

12. Attach the on/standby decal [L] to the right-hand side of the main power switch.

For Installing the Tray Heater in D538

1. Remove the rear cover of the mainframe. (See step 1 in “For Installing the Tray Heater in D537”.)
2. Pull out the LCT drawer.

Note

- If the right tray comes out with the left tray, push the right tray into the LCT.

Anti-Condensation Heater Type A

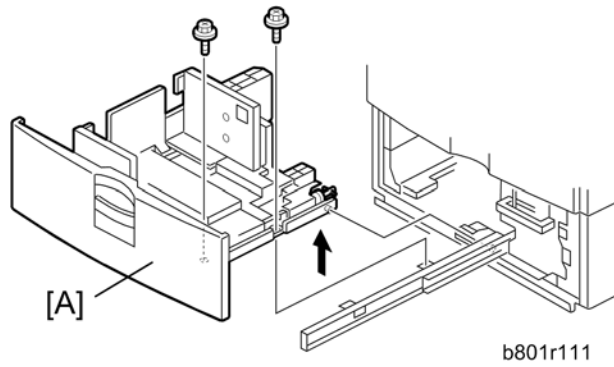

3. Left tray [A] ( x 2)

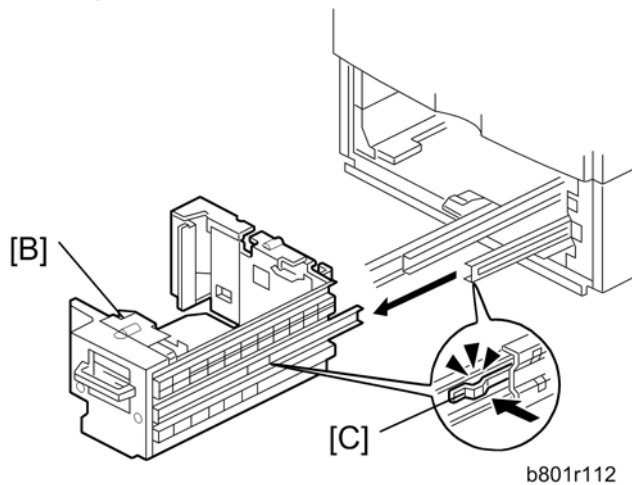

4. Remove the right tray [B] while pressing down the stopper [C].

 **Note**

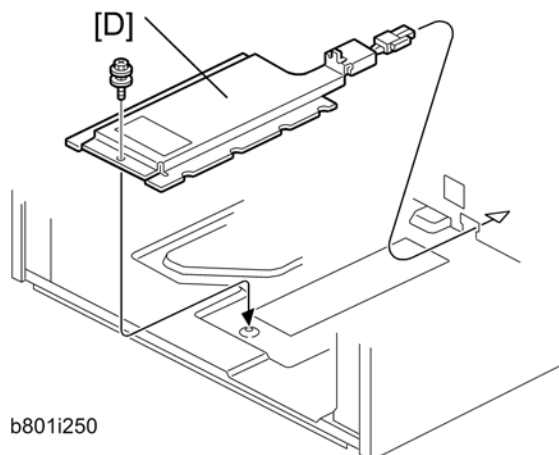

- When reinstalling the right tray, set the right tray on the guide rail and carefully push the tray in, making sure to keep the tray level.

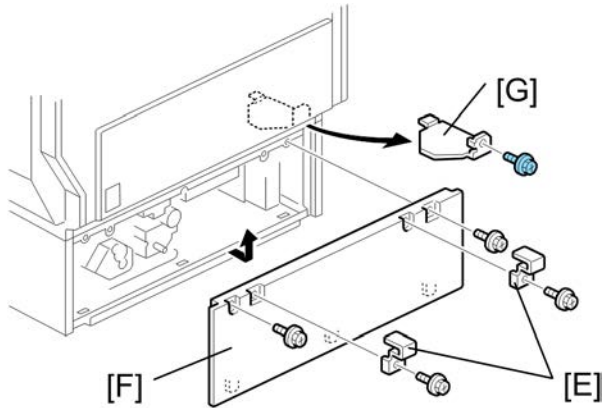

5. Install the tray heater [D] in the optional LCT ( x 1).



b801i251

6. Remove the two securing brackets [E] ( x 1 each), and then the rear cover [F] of the optional LCT ( x 2).
7. Remove the harness cover bracket [G] ( x 1).

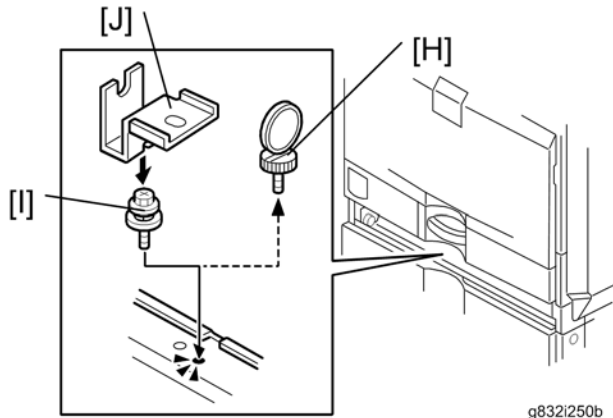

g832i250b

8. Pull out tray 2 from the mainframe.
9. Replace the shoulder screw [H] with the washer screw [I], using the securing bracket [J] ( x 1).

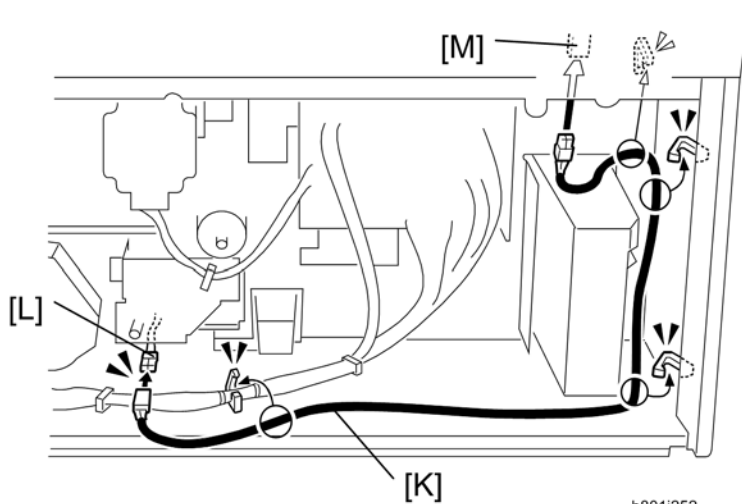

b801i252

10. Connect the harness [K] to the connector [L] of the tray heater.
11. Route the harness [K] as shown and clamp it with four clamps ( x 4).

Anti-Condensation Heater Type A

12. Connect the harness [K] to the connector [M] of the mainframe.
13. Reassemble the mainframe and optional LCT.

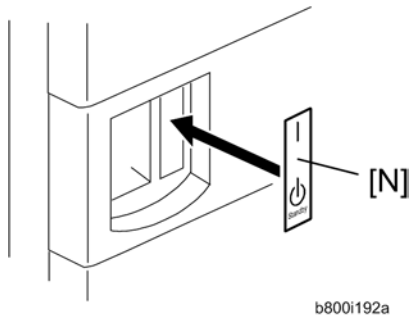

14. Reassemble the mainframe and optional paper feed unit.
15. Attach the on/standby decal [N] to the right-hand side of the main power switch.

For Installing the Tray Heater in D387

1. Remove the rear cover of the mainframe (step 1 in For Installing the Tray Heater in D537).
2. Pull out the tray in the optional paper tray.

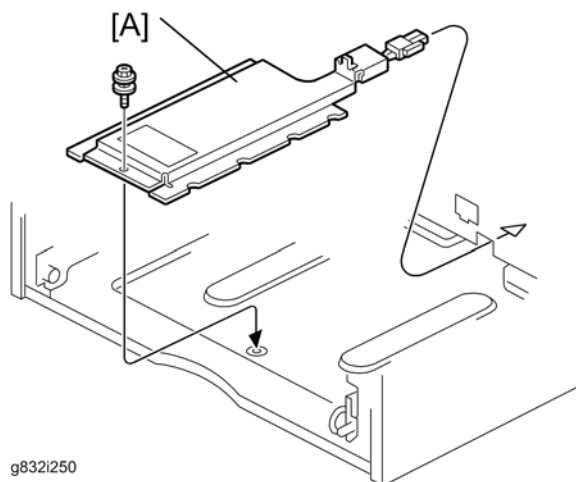

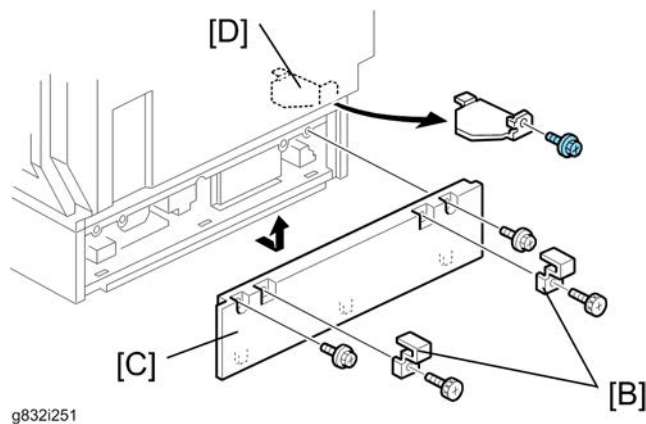

3. Install the tray heater [A] in the optional paper tray (1 x 1).



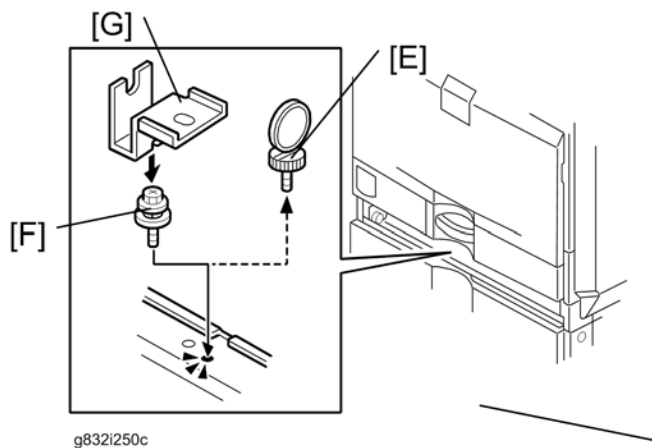

4. Remove the two securing brackets [B] (1 x 1 each), and then the rear cover [C] of the optional paper tray (1 x 2).

5. Remove the harness cover bracket [D] ( x 1).

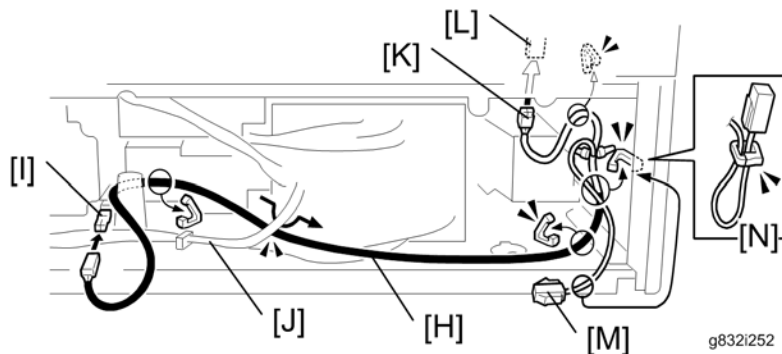

6. Pull out tray 2 from the mainframe.
 7. Replace the shoulder screw [E] with the washer screw [F], using securing bracket [G] ( x 1).



8. Connect the harness [H] to the connector [I] of the tray heater.
 9. Route the harness [H] as shown and clamp it with four clamps ( x 4).

Note

- Make sure that the harness [H] is placed below the harness [J].

10. Connect one harness [K] of the two-way harness to the connector [L] of the mainframe.

Note

- The harness [K] of the two-way harness, which has two binds, is for the connector of the mainframe. The harness [M], which has one bind, is for another optional paper feed unit.

11. Clamp the other harness [M] of the two-way harness as shown [N] if you do not install another optional paper feed unit.
 12. Reassemble the mainframe and optional paper tray.

Anti-Condensation Heater Type A

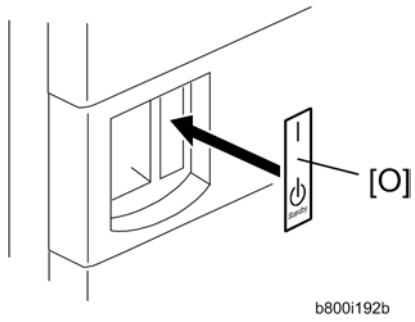

13. Attach the on/standby decal [O] to the right-hand side of the main power switch.

2.25 CONTROLLER OPTIONS

2.25.1 OVERVIEW

This machine has I/F card slots for optional I/F connections and SD card slots applications. After you install an option, check that the machine can recognize it, see "Check All Connections" at the end of this section (p.2-133).

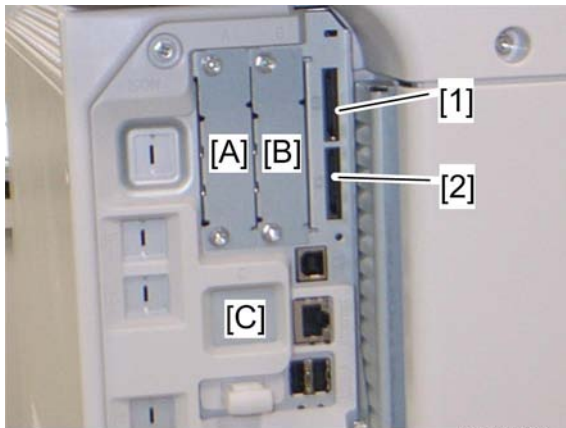

d088i400

⇒ I/F Card Slots

- Slot A is used for one of the optional I/F connections (only one can be installed): IEEE1284, IEEE802.11a/g (Wireless LAN).
- Slot B is used for the File Format Converter.
- Slot C is used for Gigabit Ethernet.

SD Card Slots

- Slot 1 (upper) is already occupied by the PDF direct print, VM and App2me SD Card by factory default, and is also used for optional applications (e.g.: Browser Unit, PostScript 3, PictBridge, IPDS unit, etc).
- Slot 2 (lower) is used for installing applications, or for service only (for example, updating the firmware).

2.25.2 SD CARD APPLI MOVE

Overview

The service program "SD Card Appli Move" (SP5-873) lets you move application programs from one SD card to another SD card.

If more than one application is required, the applications must be moved to one SD card with SP5873-1 (PostScript 3, Security Application, PictBridge, IPDS unit, PDF Direct, etc.).

Be very careful when you do the SD Card Appli Move procedure:

- The data necessary for authentication is transferred with the application program from an SD card to another SD card. Authentication fails if you try to use the SD card after you move the application program from one card to another card.
- Do not use the SD card if it has been used before for other purposes. Normal operation is not guaranteed when such an SD card is used.

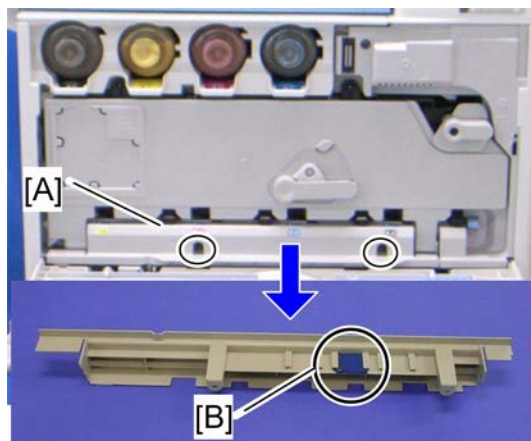

- Remove the cover [A] ( x 2), and then keep the SD card in the place [B] after you move the application program from one card to another card. This is done for the following reasons:
 - The SD card can be the only proof that the user is licensed to use the application program.
 - You may need to check the SD card and its data to solve a problem in the future.

Move Exec

The menu "Move Exec" (SP5-873-001) lets you move application programs from the original SD card to another SD card.

★ Important

- **Do not turn ON the write protect switch of the system SD card or application SD card on the machine. If the write protect switch is ON, a download error (e.g. Error Code 44) occurs during a firmware upgrade or application merge.**
1. Turn the main switch off.
 2. Make sure that a target SD card is in SD Card Slot 1 (upper). The application program is moved to this SD card.
 3. Insert the source SD card with the application program in SD Card Slot 2 (lower).The application program is copied from this source SD card.
 4. Turn the main switch on.
 5. Start the SP mode.
 6. Select SP5-873-001 "Move Exec".
 7. Follow the messages shown on the operation panel.

8. Turn the main switch off.
9. Remove the source SD card from SD Card Slot 2 (lower).
10. Turn the main switch on.
11. Check that the application programs run normally.

Undo Exec

"Undo Exec" (SP5-873-002) lets you move back application programs from an SD card in SD Card Slot 1 (upper) to the original SD card in SD Card Slot 2 (lower). You can use this program when, for example, you have mistakenly copied some programs by using Move Exec (SP5-873-001).

★ Important

- **Do not turn ON the write protect switch of the system SD card or application SD card on the machine. If the write protect switch is ON, a download error (e.g. Error Code 44) occurs during a firmware upgrade or application merge.**

1. Turn the main switch off.
2. Insert the original SD card in SD Card Slot 2 (lower). The application program is copied back into this card.
3. Insert the SD card with the application program in SD Card Slot 1 (upper). The application program is copied back from this SD card.
4. Turn the main switch on.
5. Start the SP mode.
6. Select SP5-873-002 "Undo Exec."
7. Follow the messages shown on the operation panel.
8. Turn the main switch off.
9. Remove the SD card from SD Card Slot 2 (lower).
10. Turn the main switch on.
11. Check that the application programs run normally.
12. Make sure that the machine can recognize the option, see "Check All Connections" at the end of this section (📖 p.2-126).

2.25.3 POSTSCRIPT3 UNIT TYPE C5502

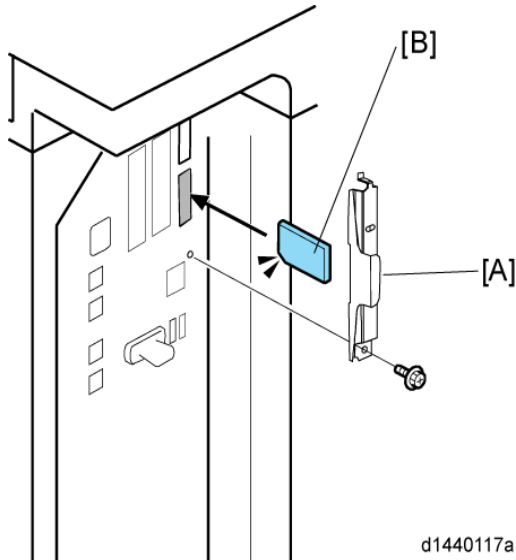

⚠ CAUTION

- Unplug the main machine power cord before you do the following procedure.

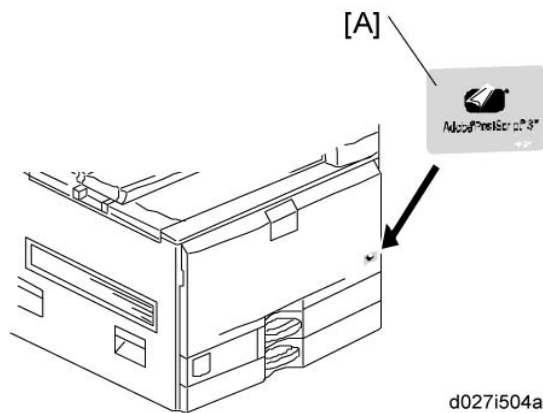

1. Remove the SD-card slot cover [A] from the SD card slots ( x 1).
2. Insert the SD card [C] (PostScript 3) in SD slot 2 (lower) with its label face [B] towards the front of the machine. Then push it slowly into SD slot 2 (lower) until you hear a click.







3. Attach the "Adobe PostScript 3" decal [A] to the front door.
4. Plug in, and then turn on the machine.
5. Move the PostScript3 application from the SD card in SD slot 2 (lower) to the SD card in SD slot 1 (upper) with SP5-873-001.
6. Turn off the machine.
7. Remove the SD card from SD slot 2 (lower), and then keep it in a safe place ( p.2-109).
8. Attach the SD-card slot cover, and then turn on the machine ( x 1).
9. Make sure that the machine can recognize the option, see "Check All Connections" at the end of this section ( p.2-126).

2.25.4 IPDS UNIT TYPE C5502

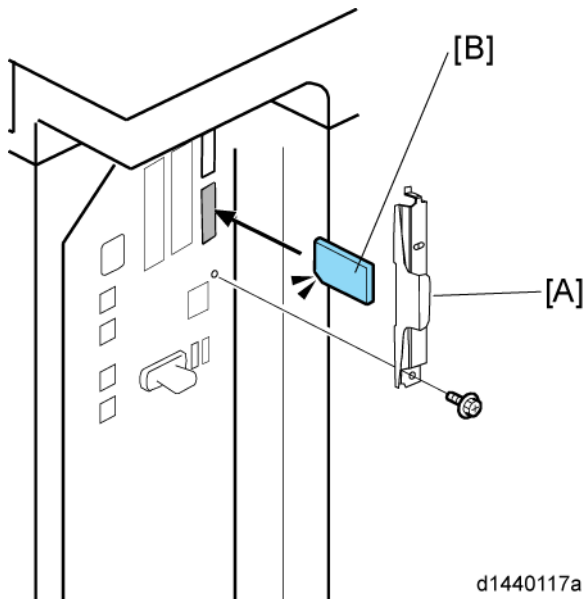
⚠ CAUTION

- Unplug the main machine power cord before you do the following procedure.



1. Remove the SD-card slot cover [A] from the SD card slots ( x 1).
2. Insert the SD card [C] (IPDS Unit) in SD slot 2 (lower) with its label face [B] towards the front of the machine.
3. Plug in, and then turn on the machine.
4. Move security applications from the SD card in SD slot 2 (lower) to the SD card in SD slot 1 (upper) with SP5-873-001.
5. Turn off the machine.
6. Remove the SD card from SD slot 2 (lower), and then keep it in a safe place ( p.2-109).
7. Attach the SD-card slot cover, and then turn on the machine ( x 1).

2.25.5 FILE FORMAT CONVERTER TYPE E

⚠ CAUTION

- Unplug the main machine power cord before you do the following procedure.



1. Remove the slot B cover [A] ( x 2).
2. Install the file format converter [B] into slot B and then fasten it with screws.
3. Plug in and turn on the main power switch.
4. Check or set the following SP codes with the values shown below.

SP No.	Title	Setting
SP5-836-001	Capture Function (0:Off 1:On)	"1"
SP5-836-002	Panel Setting	"0"

5. Check the operation.
6. Make sure that the machine can recognize the option, see "Check All Connections" at the end of this section ( p.2-126).

2.25.6 IEEE 1284 INTERFACE BOARD TYPE A

Installation Procedure

⚠ CAUTION

- Unplug the main machine power cord before you do the following procedure.

You can only install one of the following network interfaces at a time: (IEEE 802.11 a/g g (Wireless LAN), IEEE1284).



- Remove the slot A cover [A] (⚙ x 2).
- Install the interface board [B] (Knob-screw x 2) into the slot A.
- Make sure that the machine can recognize the option, see “Check All Connections” at the end of this section (🔧 p.2-126).

2.25.7 IEEE 802.11A/G G INTERFACE UNIT TYPE J/K

Installation Procedure

⚠ CAUTION

- Unplug the main machine power cord before you do the following procedure.

You can only install one of the following network interfaces at one time: (IEEE 802.11 a/g g (Wireless LAN), IEEE1284, Bluetooth).

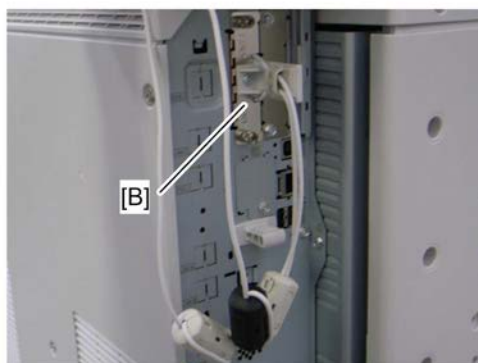
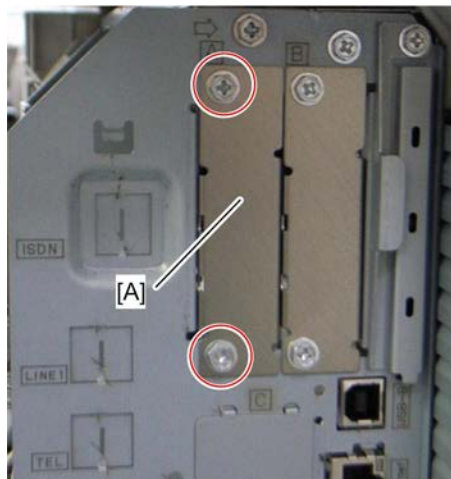

d027i403a

- Remove the slot cover [A] from the board slot (⚙ x 2).
- Install the wireless LAN board [B] (Knob-screw x 2) into the board slot.
- Make sure that the machine can recognize the option, see “Check All Connections” at the end of this section (🔧 p.2-126).

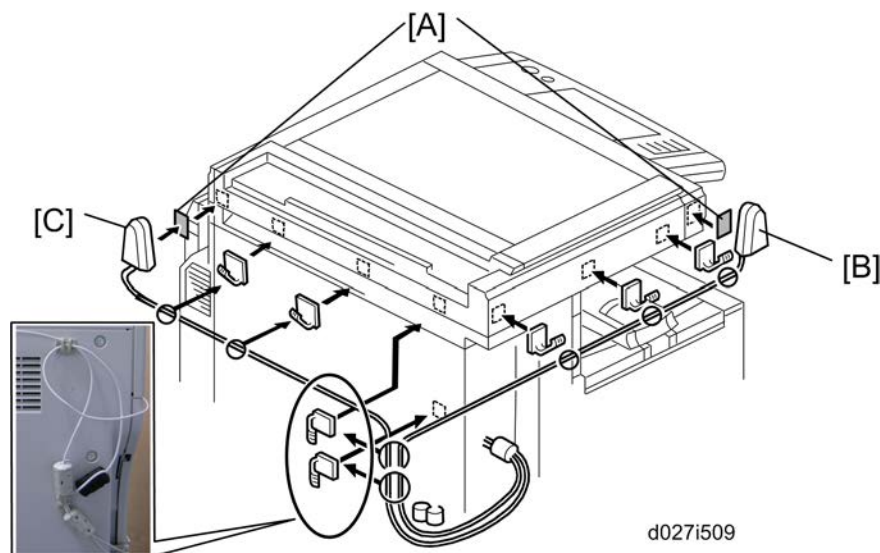

d027i509

- Peel off the double-sided tapes on the Velcro fasteners [A], and then attach them [A] at the front left and rear left of the machine.
- Attach "ANT1" (having a black ferrite core) [B] to the front left of the machine.
- Attach "ANT2" (having a white ferrite core) [C] to the rear right of the machine.

↓ **Note**

- "ANT1" is a transmission/reception antenna and "ANT2" is a reception antenna. Do not attach them at the wrong places.

7. Attach the clamps as shown above.
8. Wire the cables and clamp them (🔌 x 7).

↓ **Note**

▪ Make sure that the cables are not slack. Keep them wired tightly along the covers. You may have to move the machine if the reception is not clear.

- Make sure that the machine is not located near an appliance or any type of equipment that generates strong magnetic fields.
- Put the machine as close as possible to the access point.

Installing Various Hardware Combinations



d027i511a

- Refer to the above picture [A] when installing the handset.

UP Mode Settings for Wireless LAN

Enter the UP mode. Then do the procedure below to perform the initial interface settings for IEEE 802.11 a/g. These settings take effect every time the machine is powered on.

↓ **Note**

- You cannot use the wireless LAN if you use Ethernet.
 - The Bluetooth interface unit and the Wireless LAN interface unit can not be used simultaneously.
1. Press the "User Tools/Counter" key.
 2. On the touch panel, press "System Settings".

 **Note**

- The Network I/F (default: Ethernet) must be set for either Ethernet or wireless LAN.
3. Select "Interface Settings".
 4. Press "Wireless LAN". Only the wireless LAN options show.
 5. Communication Mode. Select either "802.11 Ad hoc" or "Infrastructure".
 6. SSID Setting. Enter the SSID setting. (The setting is case sensitive.)
 7. Channel. You need this setting when Ad Hoc Mode is selected.

Region A (mainly Europe and Asia)

Range: 1-13, 36, 40, 44 and 48 channels (default: 11)

In some countries, only the following channels are available:

Range: 1-11 channels (default: 11)

Region B (mainly North America)

Range: 1-11, 36, 40, 44 and 48 channels (default: 11)

 **Note**

- The allowed range for the channel settings may vary for different countries.
8. WEP (Encryption) Setting. The WEP (Wired Equivalent Privacy) setting is designed to protect wireless data transmission. The same WEP key is required on the receiving side in order to unlock encoded data. There are 64 bit and 128 bit WEP keys.

WEP:

Selects "Active" or "Inactive" ("Inactive" is default.).

Range of Allowed Settings:

64 bit: 10 characters

128 bit: 26 characters

9. Press "Return to Default" to initialize the wireless LAN settings.

Press "Yes" to initialize the following settings:

- Transmission mode
- Channel
- Transmission Speed
- WEP
- SSID
- WEP Key

SP Mode and UP Mode Settings for IEEE 802.11 a/g g Wireless LAN

The following SP commands and UP modes can be set for IEEE 802.11 a/g g.

SP No.	Name	Function
5840-008	transmission speed	Sets the transmission speed Auto, 54 Mbps, 48 Mbps, 36 Mbps, 24 Mbps, 18 Mbps, 12 Mbps, 9 Mbps, 6 Mbps, 11 Mbps, 5.5 Mbps, 2 Mbps, 1 Mbps (default: Auto)
5840-011	WEP Key Select	Used to select the WEP key (Default: 00).
UP mode	Name	Function
	SSID	Used to confirm the current SSID setting.
	WEP Key	Used to confirm the current WEP key setting.
	WEP Mode	Used to show the maximum length of the string that can be used for the WEP Key entry.

2.25.8 BLUETOOTH INTERFACE UNIT TYPE D

⚠ CAUTION

You can only install one of the following network interfaces at a time: (IEEE 802.11 a/g g (Wireless LAN), Bluetooth).

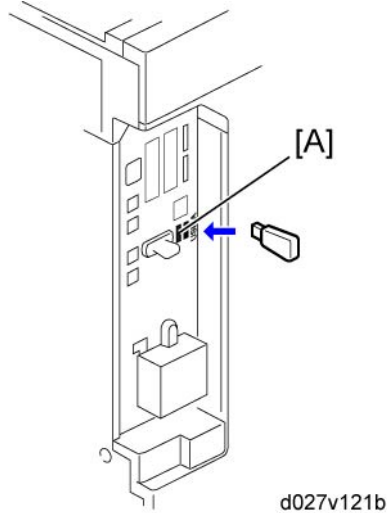

⚠ CAUTION



- Do not remove the Bluetooth unit while the power of the machine is on.
1. Turn off the power of the machine, and then unplug the power cable from the wall outlet.
 2. Insert the Bluetooth Interface adapter into the USB connector [A].
 3. Plug the power cable and turn on the power of the machine.
 4. Make sure that the machine can recognize the option see “Check All Connections” at the end of this section (👉 p.2-133).

↓ Note

- The Bluetooth interface unit and the Wireless LAN interface unit cannot be used simultaneously.

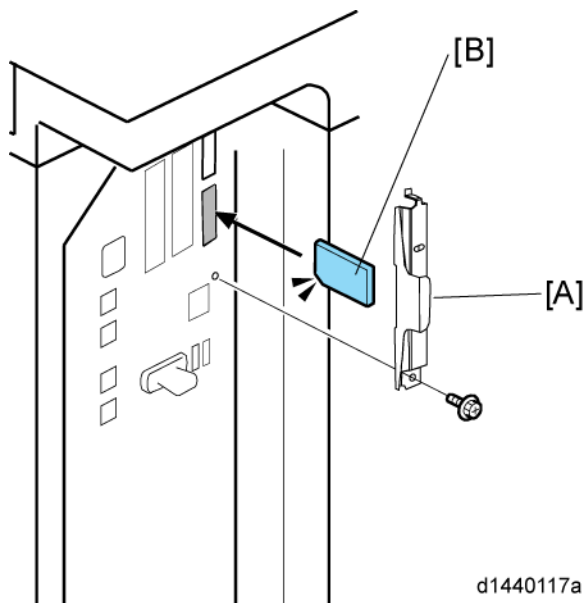

2.25.9 CAMERA DIRECT PRINT CARD TYPE J

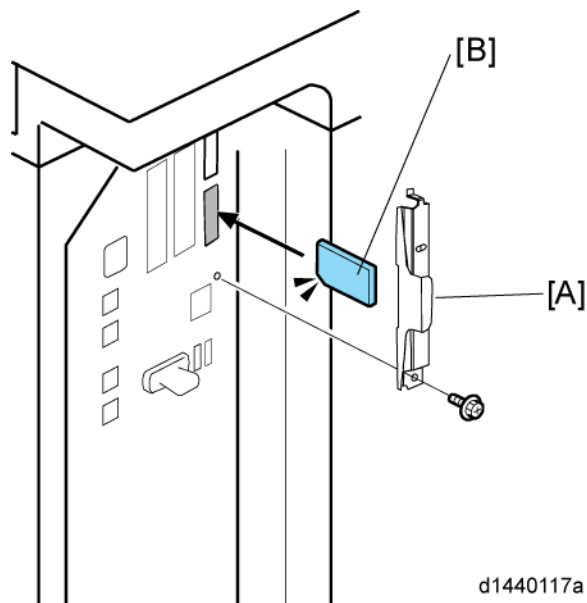

1. Remove the SD-card slot cover [A] from the SD card slots ( x 1).
2. Insert the SD card [C] (PictBridge) in SD slot 2 (lower) with its label face to the front of the machine.
3. Plug in, and then turn on the machine.
4. Move the PictBridge application from the SD card in SD slot 2 (lower) to the SD card in SD slot 1 (upper) with SP5-873-001.
5. Turn off the machine.
6. Remove the SD card from slot SD 2, and then keep it in a safe place.
7. Attach the SD-card slot cover, and then turn on the machine ( x 1).
8. Make sure that the machine can recognize the option, see “Check All Connections” at the end of this section ( p.2-133).

2.25.10 SD CARD FOR NETWARE PRINTING TYPE H



1. Remove the SD-card slot cover [A] from the SD card slots ( x 1).
2. Insert the SD card [C] (Netware Printing) in SD slot 2 (lower) with its label face [B] to the front of the machine.
3. Plug in, and then turn on the machine.
4. Move the Netware printing application from the SD card in SD slot 2 (lower) to the SD card in SD slot 1 (upper) with SP5-873-001.
5. Turn off the machine.
6. Remove the SD card from SD slot 2 (lower), and then keep it in a safe place.
7. Attach the SD-card slot cover, and then turn on the machine ( x 1).
8. Make sure that the machine can recognize the option see “Check All Connections” at the end of this section ( p.2-133).

2.25.11 BROWSER UNIT TYPE F

Use the following procedure to install the Browser Unit Type F.

Installation Procedure

1. Turn the Main Switch ON.
2. Press the “User Tools/Counter” key.
3. On the Touch Panel, press “System Settings”.
4. Make sure that the “Increase Scanner Memory by Disabling Browser” setting in the General Features tab is OFF.
5. Turn the Main Switch OFF.

Installation

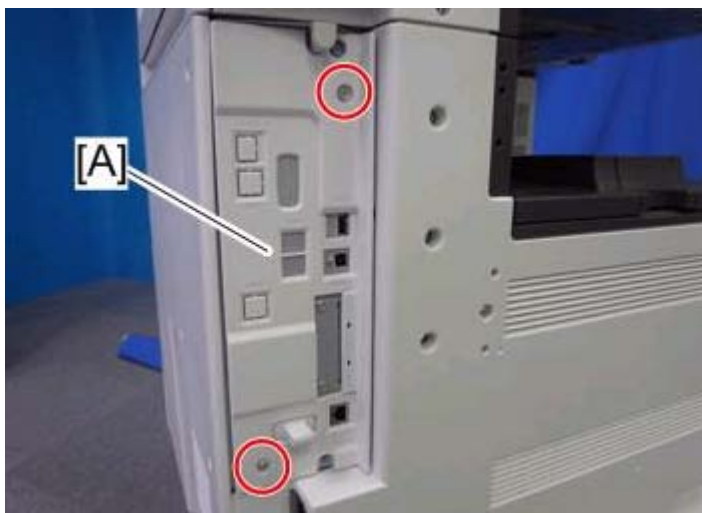

6. Remove the Control Cover [A] (⚙ x 2).



7. Insert the Browser Option SD card in the lower slot [A].
8. Turn the Main Switch ON.

Controller Options

9. Touch the “User Tools/Counter” key.

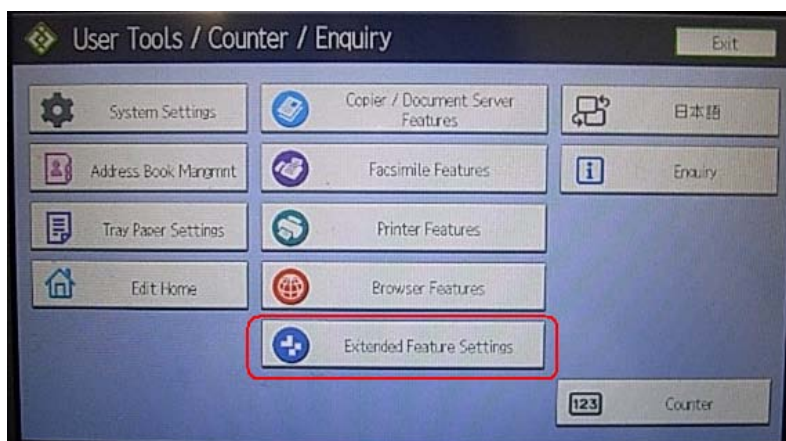

10. On the touch panel, touch “Extended Feature settings”.



11. Touch “Extended Feature settings” in the Extended Feature Settings Menu.

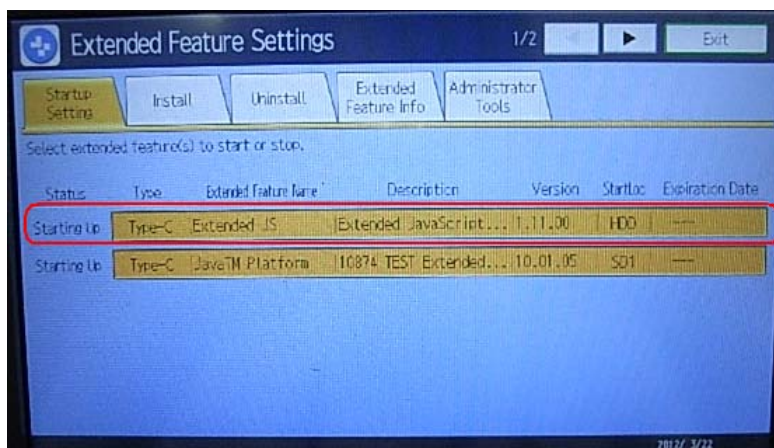

12. Make sure that “Extended JS” application was automatically installed in the Startup Settings tab.
13. Turn the Main Switch OFF/ON.
14. Move the application to the SD Card.

NOTE: See the Service Manual for details.

15. Press the “User Tools/Counter” key.

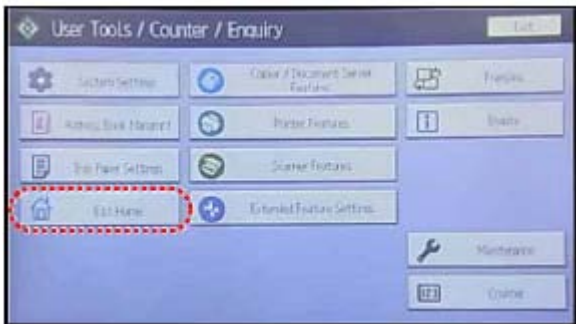

16. Touch “Edit home”.

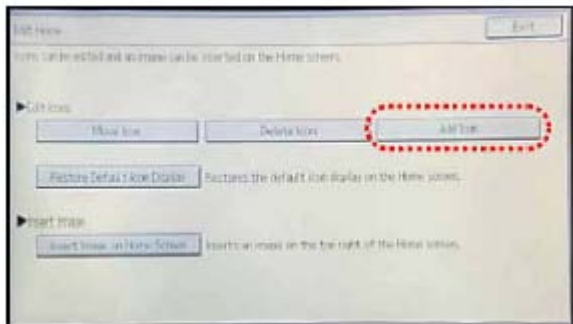

17. Touch “Add Icon”.

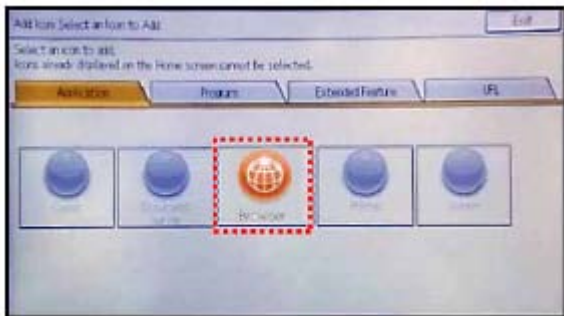

18. Touch “Browse”.

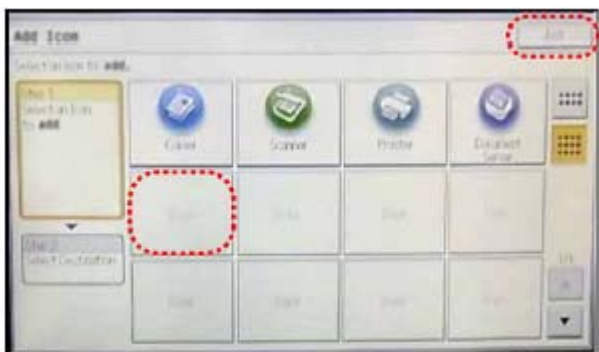

19. Touch a blank square to set the location for the browser icon.

20. Touch “Exit” to complete the addition of the FAX browser icon.

Controller Options

Do the following steps if the customer is using the Ricoh JavaScript connected to a Web application developed by Operius/RiDP.

1. Turn the Main Switch ON.
2. Press the “User Tools/Counter” key.



3. On the touch panel, touch “Browser Features”.

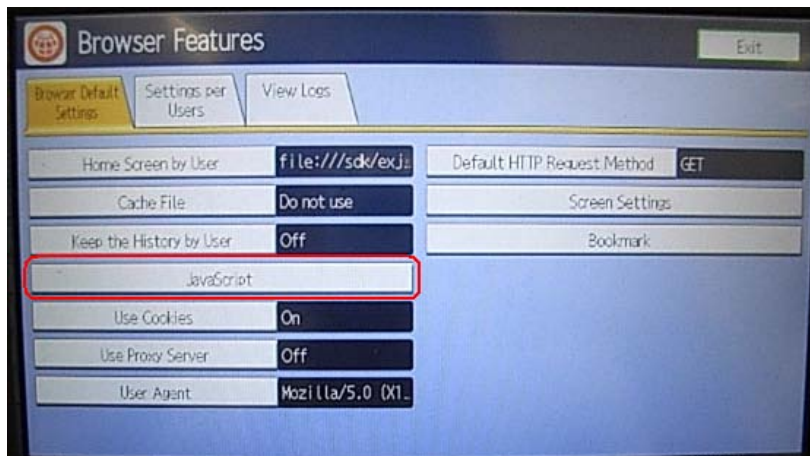

4. Touch “JavaScript”.

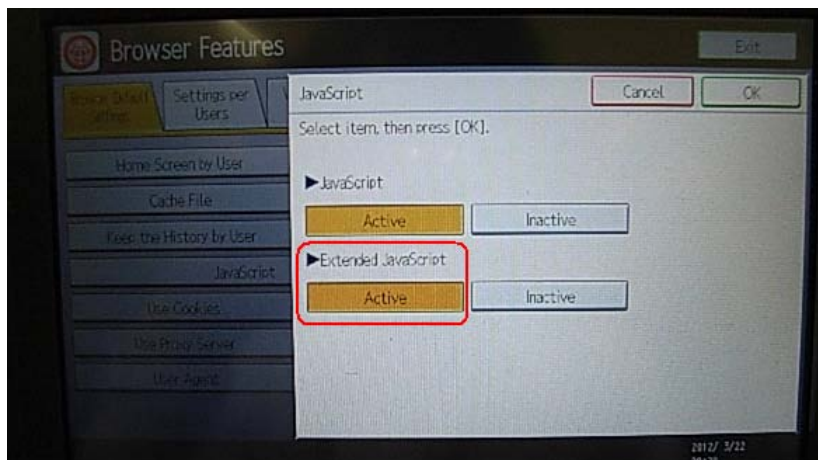

5. Change the Extended JavaScript setting to “Activate”.

EXJS Firmware Update Procedure

NOTE:

- The firmware configuration of the Browser Unit Type F has been changed to enhance browsing.
- The Browser Unit Type F consists of the Browser firmware and EXJS firmware. The EXJS firmware is equivalent to the existing browser firmware. Therefore, it is possible to update the EXJS firmware using the same procedure as that of SDK application firmware.
- Both the Browser firmware and EXJS firmware are automatically installed when the Browser SD card is inserted in the upper slot.

Preparation:

1. Download the latest EXJS firmware from the RISSN server.
2. Extract the exe file (XXXX. exe), after which the following two files are generated: XXXX_machine.exe/ XXXX_stock.exe.

NOTE: The file (XXXX_machine) is for updating the EXJS firmware in the field.

3. Extract the file (XXXX_machine), after which the “SDK” folder is created.
4. Copy the “SDK” folder to an SD card.

NOTE: XXXX = part number.

Main procedure:

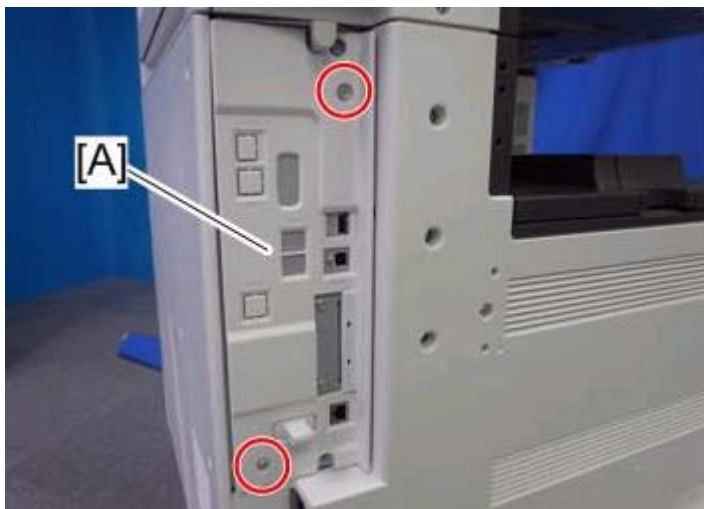

1. Remove the Control Cover [A] (⚙️ x 2).

Controller Options



2. Insert the SD Card included for firmware update into the lower slot [A].
3. Turn the Main Switch ON.
4. After the Update screen is displayed, select the "Browser".
5. Touch "Update (#)".
6. After the "Update Done" message appears on the screen, turn the main power switch OFF.
7. Remove the SD Card from the lower slot.

Do the following steps if you are updating the Extended JavaScript.

1. Turn the Main Switch ON.
2. Press the "User Tools/Counter" key.
3. On the Touch Panel, touch "Extended Feature settings".
4. Touch "Extended Feature settings" in the Extended Feature Settings Menu.

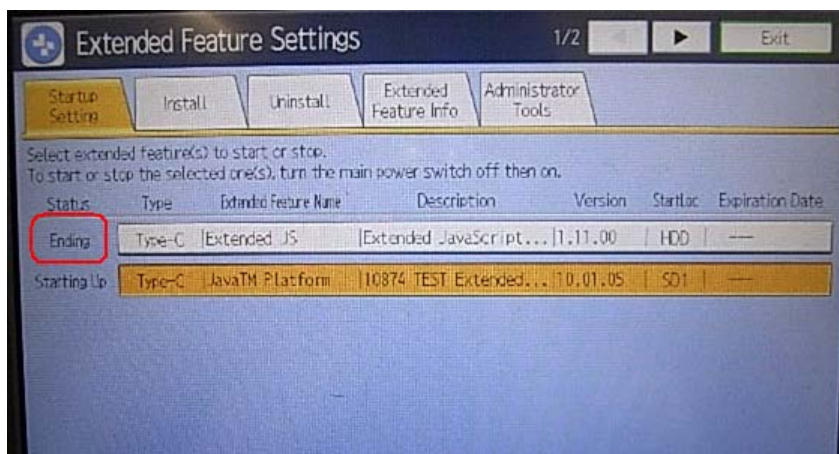

5. Change the status of "Extended JS" to "Ending" in the Startup Settings tab.
6. Turn the Main Switch OFF.

7. Insert the SD card containing the Extended JS firmware into the lower slot.
8. Turn the Main Switch ON.
9. Press the “User Tools/Counter” key.
10. On the touch panel, push “Extended Feature settings”.
11. Touch “Extended Feature settings” in the Extended Feature Settings Menu.

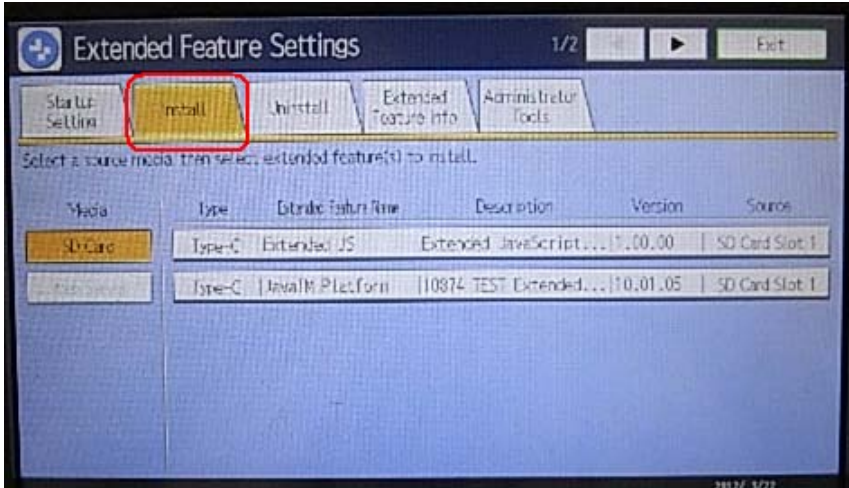

12. Touch the “Install” tab.

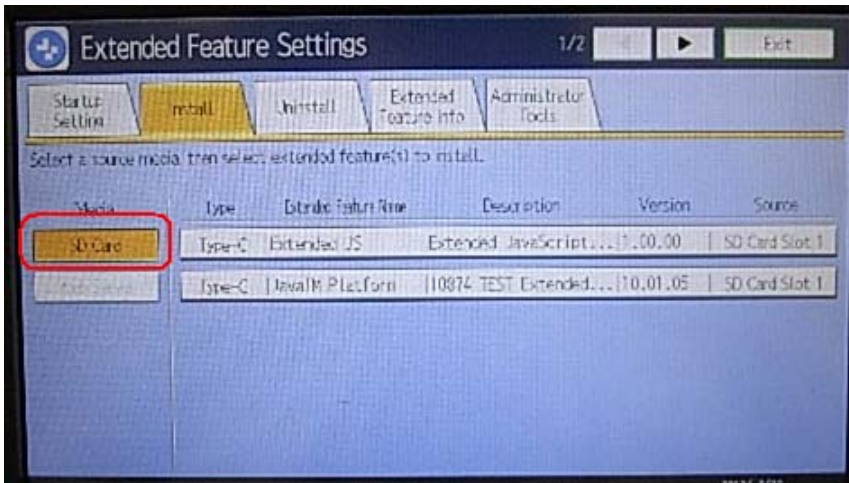

13. Touch “SD Card”, then select “Extended JS” from the list of Extended Features.

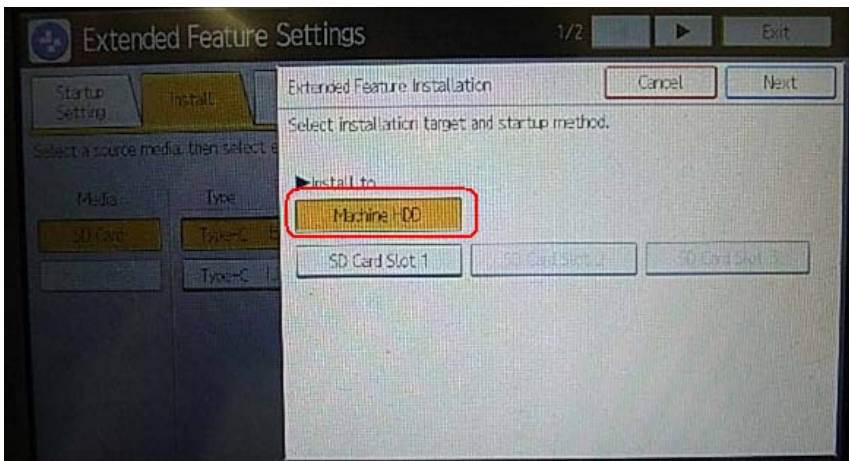

Controller Options

14. Select "Machine HDD" as the "Install to" destination, then touch "Next".
15. Check the Extended Features information on the "Ready to Install" screen, then press "OK".
16. After "The following extended feature has already been installed. Are you sure you want to overwrite it?" is displayed, press "Yes".
17. Change the status of Extended JS to "waiting" in the Startup Settings tab.
18. Turn the Main Switch OFF.
19. Remove the SD Card from slot 2 (lower slot).
20. Turn the Main Switch ON.
21. Press the "User Tools/Counter" key.
22. On the touch panel, touch "Extended Feature settings".
23. Touch "Extended Feature settings" in the Extended Feature settings Menu.
24. Make sure that the "Extended JS" has been updated to the latest version in the Startup Settings tab.

EXJS Firmware Un-install Procedure

1. Turn the Main Switch ON.
2. Press the "User Tools/Counter" key.
3. Login with an administrator user name and password.
4. On the touch panel, touch "Extended Feature settings".
5. Touch "Extended Feature settings" in the Extended Feature Settings Menu.

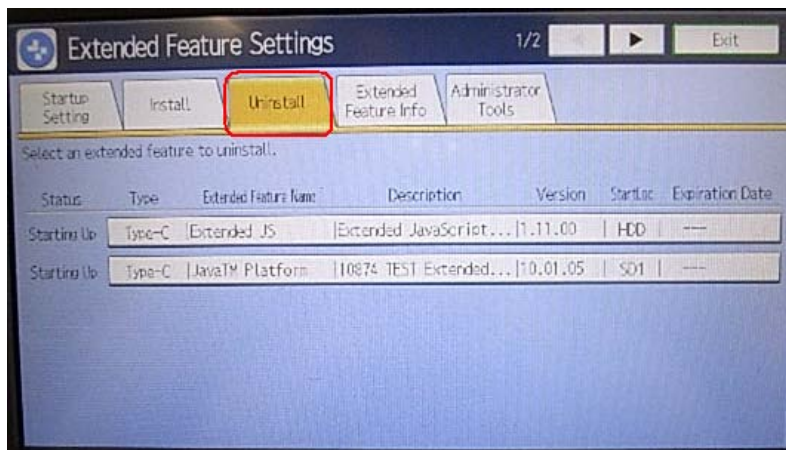

6. Touch "Uninstall".

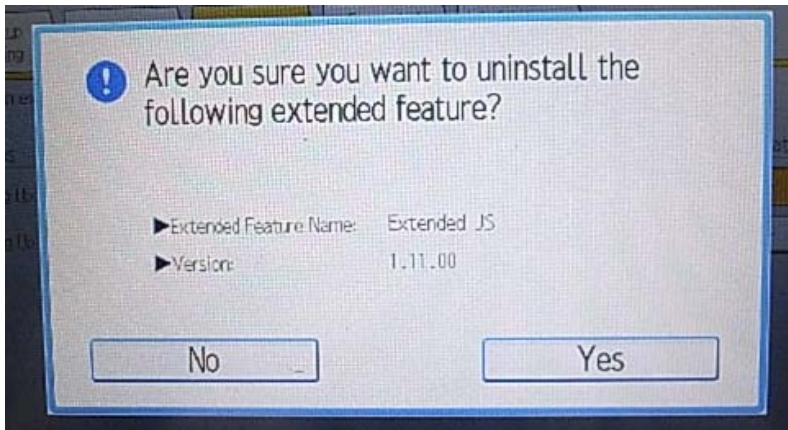

7. Touch "Browser", and then touch "Yes" after "Are you sure you want to uninstall the following extended feature?" is displayed.

NOTE: "Uninstalling the extended feature... Please wait" is then displayed on the touch screen.

8. After "Completed" is displayed, turn the Main Power Switch OFF

NOTE: The Browser firmware is un-installed from the machine when the Browser SD card is removed.

2.25.12 GIGABIT ETHERNET TYPE B

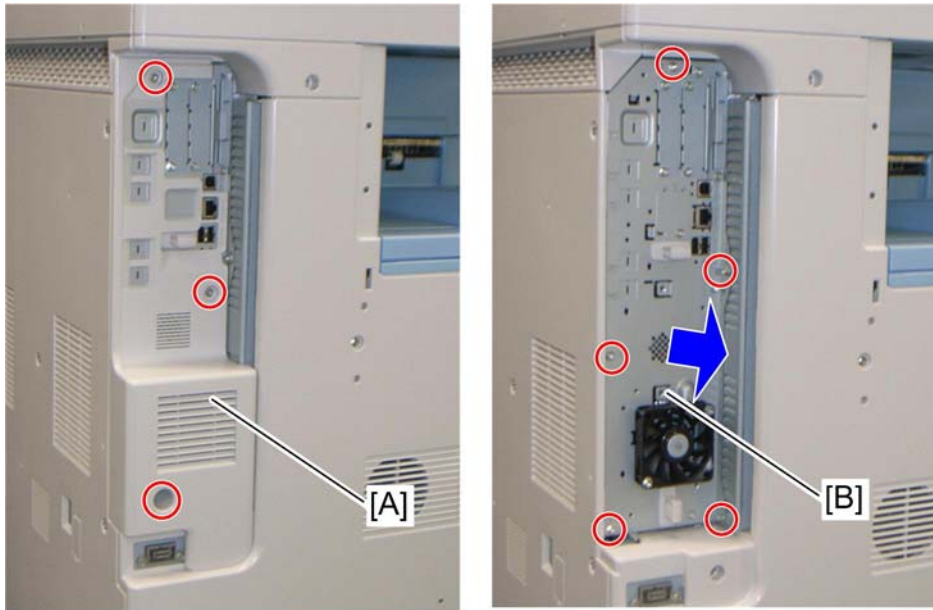

d393i101

1. Remove the controller cover [A] (⚙ x 3).
2. Pull out the controller board [B] (⚙ x 5).

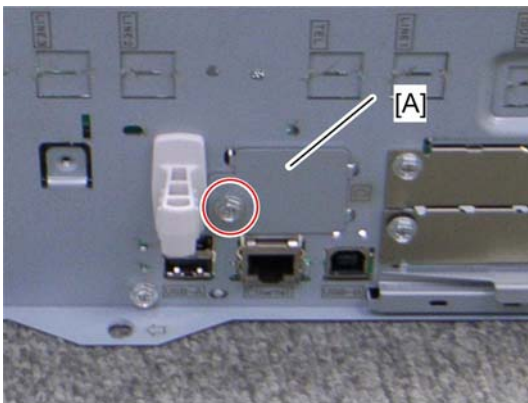

d027i409

3. Remove the slot cover [A] (⚙ x 1).

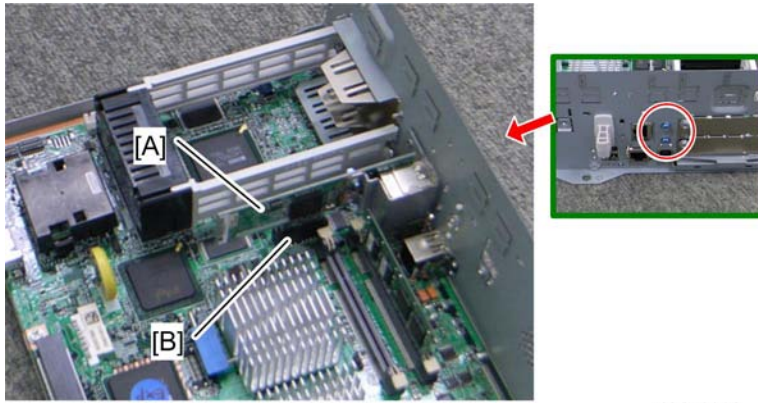

d027i410

4. Attach the Gigabit Ethernet controller [A] into the slot [B] (⚙ x 2).
5. Install the Ethernet connector cover included in the Gigabit Ethernet board kit on the 100M bit LAN connector.
6. Reassemble the machine.
7. Check the operation of the Gigabit Ethernet

2.25.13 CHECK ALL CONNECTIONS

1. Plug in the power cord. Then turn on the main switch.
2. Enter the printer user mode. Then print the configuration page.
User Tools → Printer Settings → List Test Print → Config. Page
All installed options are shown in the "System Reference" column.

PREVENTIVE MAINTENANCE

REVISION HISTORY		
Page	Date	Added/Updated/New
		None

3. PREVENTIVE MAINTENANCE

3.1 MAINTENANCE TABLES

See "Preventive Maintenance Tables" in "Appendices" for the following information:

- Preventive Maintenance Items
- Other Yield Parts

3.2 PM PARTS SETTINGS

3.2.1 BEFORE REMOVING THE OLD PM PARTS

1. Enter the SP mode.
2. Output the SMC logging data with SP5-990-004.
3. Set the following SPs to "1" before you turn the power off. Then, the machine will reset the PM counters automatically. In the case of developer, the developer initialization will also be done automatically.
4. Exit the SP mode.

Item	SP
Developer	Black: 3902-005 Yellow: 3902-006 Cyan: 3902-007 Magenta: 3902-008
Drum Unit	Black: 3902-009 Yellow: 3902-010 Cyan: 3902-011 Magenta: 3902-012
Heating sleeve belt unit and Pressure Roller (not necessary for complete fusing units; see below)	Heating belt: 3902-018 Pressure roller: 3902-019
Image Transfer Belt Cleaning Unit	3902-015
PTR Unit	3902-016
Toner Collection Bottle (if not full or near-full)	3902-017

★ Important

- After the PM counter for the heating sleeve belt unit reaches its PM life (300K pages), the machine stops the operation automatically. Replace the heating sleeve belt unit before the machine stops its operation (stop warning: 315K pages, stop: 330K pages).
- Change the setting of SP3-902-018 from "0" to "1" before replacing the heating sleeve belt unit. Otherwise, the machine will not recover.

For the following units, there is a new unit detection mechanism. It is not necessary to reset PM counters.

- PCDU
- Development unit
- Toner Collection Bottle (if full or near-full)
- Fusing unit

3.2.2 AFTER INSTALLING THE NEW PM PARTS

1. Turn on the main power switch.
2. Output the SMC logging data with SP5-990-004 and check the counter values.
3. Make sure that the PM counters for the replaced units are "0" with SP7-803. If the PM counter for a unit was not reset, then reset that counter with SP 7-804.
4. Make sure that the exchange counter counts up with SP7-853.
5. Make sure that the counters for the previous units (SP7-906) on the new SMC logging data list (from step 2 above) are equal to the counters (SP7-803) for these units on the previous SMC logging data list (the list that was output in the "Before removing the old parts" section).
6. Make sure that the unit replacement date is updated with SP7-950.

3.2.3 PREPARATION BEFORE OPERATION CHECK

1. Clean the exposure glasses (for DF and book scanning).
2. Enter the user tools mode.
3. Do the "Automatic Color Calibration(ACC)" for the copier mode & printer mode as follows:
 - Print the ACC test pattern (User Tools → Maintenance → ACC → Start).
 - Put the printout on the exposure glass.
 - Put 10 sheets of white paper on the test chart. This ensures the precise ACC adjustment.
 - Close the ARDF or the platen cover.
 - Press "Start Scanning" on the LCD. Then, the machine starts the ACC.
4. Exit the User Tools mode, and then enter the SP mode.
5. Do the "Forced line position adjustment" as follows.
 - First do SP2-111-3 (Mode c).
 - Then do SP2-111-1 (Mode a).
 - To check if SP 2-111-1 was successful, watch the screen during the process. A message is displayed at the end. Also, you can check the result with SP 2-194-10 to -12.
6. Exit the SP mode.

3.2.4 OPERATION CHECK

Check if the sample image has been copied normally.

REPLACEMENT AND ADJUSTMENT

REVISION HISTORY		
Page	Date	Added/Updated/New
84	6/27/2012	Clean the ID sensors with a blower brush
110	6/27/2012	Fusing unit

4. REPLACEMENT AND ADJUSTMENT

4.1 BEFOREHAND

CAUTION

- Before installing options, please do the following:
- If there is a fax unit in the machine, print out all messages stored in the memory, the lists of user-programmed items, and the system parameter list.
- If there are printer jobs in the machine, print out all jobs in the printer buffer.
- Turn off the main switch and disconnect the power cord, the telephone line, and the network cable.

Important

- Always touch a grounded surface to discharge static electricity from your hands before you handle SD cards, printed circuit boards, or memory boards.

4.2 SPECIAL TOOLS

Part Number	Description	Q'ty
B645 5010	SD Card	1
B645 6705	PCMCIA Card Adapter	1
B645 6820	USB Reader/Writer	1
VSSM9000	Digital Multimeter – FLUKE87	1
G021 9350	Loop-back Connector – Parallel ^{*NOTE}	1
C401 9503	20X Magnification Scope	1
A257 9300	Grease Barrierta – S552R	1
5203 9502	Silicone Grease G-501	1
A092 9503	C4 Color Test Chart (3 pcs/set)	1
A184 9501	Optics Adjustment Tool (2 pcs / set)	2
B679 5100	Plug - IEEE1284 Type A	1
B132 9700	Lubricant Powder	1

↓ Note

- The "Loop-back Connector–Parallel" requires the "Plug-IEEE1284 Type A", and the optional IEEE1284 interface option must also be installed.

4.3 IMAGE ADJUSTMENT

4.3.1 SCANNING

Check the printing registration/side-to-side adjustment and the blank margin adjustment before you do the following scanner adjustments.

Note

- Use S-2-1 test chart to do the following adjustments.

Scanner sub-scan magnification

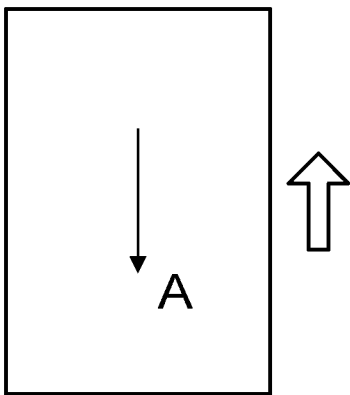

A: Sub-scan magnification

- Put the test chart on the exposure glass. Then make a copy from one of the feed stations.
- Check the magnification ratio. Adjust with SP4-008 if necessary.

Standard: $\pm 1.0\%$.

Scanner leading edge and side-to-side registration

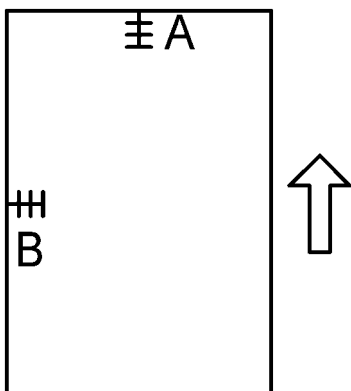

A: Leading Edge Registration

- Put the test chart on the exposure glass. Then make a copy from one of the feed stations.
- Check the leading edge and side-to-side registration. Adjust the following SP modes if

Image Adjustment

necessary.

Standard: $0 \pm 2\text{mm}$ for the leading edge registration, $0 \pm 2.5\text{mm}$ for the side-to-side registration.

	SP mode
Leading Edge Registration	SP4-010-001
Side-to-Side Registration	SP4-011-001

4.3.2 ARDF

ARDF side-to-side, leading edge registration and trailing edge

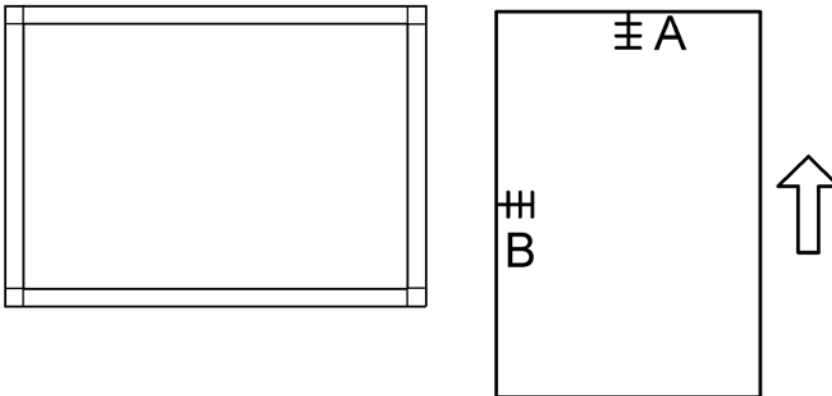

A: Leading edge registration

Use A3/DLT paper to make a temporary test chart as shown above.

1. Put the temporary test chart on the ARDF. Then make a copy from one of the feed stations.
2. Check the registration. Check the leading edge and side-to-side registration. Adjust the following SP modes if necessary.

Standard: $4.2 \pm 2\text{ mm}$ for the leading edge registration, $2 \pm 1\text{ mm}$ for the side-to-side registration. Use the following SP modes to adjust if necessary.

SP Code	What It Does	Adjustment Range
SP6-006-001	Side-to-Side Regist: Front	± 3.0 mm
SP6-006-003	Leading Edge Registration	± 5.0 mm
SP6-006-005	Buckle: Duplex Front	± 3.0 mm
SP6-006-006	Buckle: Duplex Rear	± 2.5 mm
SP6-006-007	Rear Edge Erase (Trailing Edge)	± 10.0 mm

ARDF sub-scan magnification

1. Put the temporary test chart on the ARDF. Then make a copy from one of the feed stations.
2. Check the magnification ratio. Adjust with SP6-017-001 if necessary.
 - Standard: ±5.0%
 - Reduction mode: ±1.0%
 - Enlargement mode: ±1.0%

4.3.3 REGISTRATION

Image Area

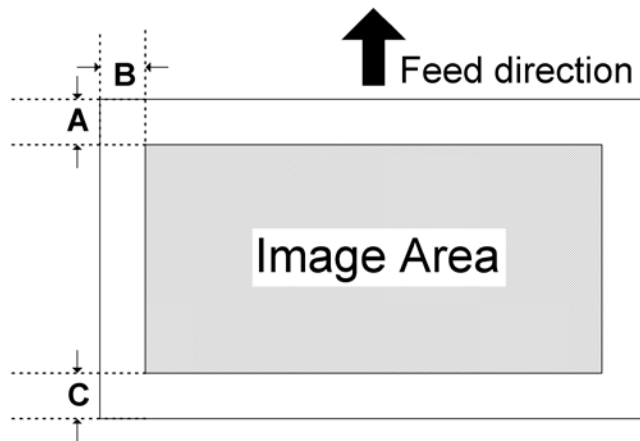

A = C = 5.2 mm (0.2"), B = 2.0 mm

Make sure that the registration is adjusted within the adjustment standard range as shown below.

Leading Edge

Adjusts the leading edge registration for each paper type and process line speed.

Side to Side

Adjusts the side-to-side registration for each paper feed station. Use SP mode (SP1-002) to adjust the side-to-side registration for the optional paper feed unit, LCT, and duplex unit.

Adjustment Standard

- Leading edge (sub-scan direction): 5.2 ± 2 mm
- Side to side (main-scan direction): 2 ± 1 mm

Paper Registration Standard

The registration in both main- and sub-scan directions can change within the following tolerance.

- Sub-scan direction: 0 ± 9 mm
- Main-scan direction: 0 ± 4 mm

Adjustment Procedure

1. Enter SP2-109-003.
2. Print out the test pattern (14: 1-dot trimming pattern) with SP2-109-003.

Note

- Registration can change slightly as shown on the previous page. Print some pages of the 1-dot trimming pattern for step 3 and 4. Then average the leading edge and side-to-side registration values, and adjust each SP mode.
3. Do the leading edge registration adjustment.
 - 1) Check the leading edge registration and adjust it with SP1-001.
 - 2) Select the adjustment conditions (paper type and process line speed).
 - 3) Input the value. Then press the **⊕** key.
 - 4) Generate a trim pattern to check the leading edge adjustment.
 4. Do the side-to-side registration adjustment.
 - 1) Check the side-to-side registration and adjust it with SP1-002.
 - 2) Select the adjustment conditions (paper feed station).
 - 3) Input the value. Then press the **⊕** key.
 - 4) Generate a trim pattern to check the leading edge adjustment.

4.3.4 ERASE MARGIN ADJUSTMENT

Note

- Adjust the erase margin C and D only if the registration (main scan and sub scan) cannot be adjusted within the standard values. Do the registration adjustment after adjusting the erase margin C and D, and then adjust the erase margin A and B.

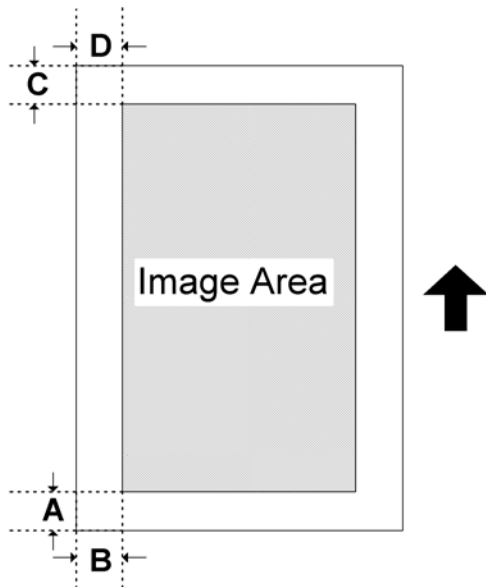

1. Enter SP2-109-003.
2. Print out the test pattern (14: 1-dot trimming pattern) with SP2-109-003.
3. Check the erase margin A and B. Adjust them with SP2-103-001 to -015 if necessary.
 - Leading edge: 0.0 to 9.0 mm (default: 4.2 mm)
 - Side-to-side: 0.0 to 9.0 mm (default: 2.0 mm)
 - Trailing edge: 0.0 to 9.0 mm (default: 4.2 mm)

4.3.5 COLOR REGISTRATION

Line Position Adjustment

The automatic line position adjustment usually is done for a specified condition to get the best color prints.

Do the following if color registration shifts:

- Do "Auto Color Registration" as follows to do the forced line position adjustment.
 1. First do SP2-111-3.
 2. Then do SP2-111-1.

To check if SP 2-111-1 was successful, watch the screen during the process. A message is displayed at the end. Also, you can check the result with SP 2-194-10 to -12.

- You should also do the line position adjustment at these times:
 - After you transport or move the machine (you should do the forced line position adjustment if you install the machine at the user location.) if the machine is pre-installed at the workshop and moved to the user location,
 - When you open the drum positioning plate
 - When you remove or replace the motors, clutches, and/or gears related to the drum/development/transfer sections
 - When you remove or replace the image transfer belt, image transfer belt unit or laser optical housing unit

4.3.6 PRINTER GAMMA CORRECTION

↓ Note

- The ACC is usually sufficient to adjust the color balance to get the best print output. You only need the printer gamma correction to fine-tune to meet user requirements.

Use SP modes if you want to modify the printer gamma curve created with ACC. You can adjust the gamma data for the following:

- Highlight
- Middle
- Shadow areas
- IDmax.

The adjustable range is from 0 to 30 (31 steps).

Copy Mode

- KCMY Color Balance Adjustment -

The adjustment uses only "Offset" values.

Note

- Never change "Option" values (default value is 0).

Highlight (Low ID)	Levels 2 through 5 in the C4 chart 10-level scale
Middle (Middle ID)	Levels 3 through 7 in the C4 chart 10-level scale
Shadow (High ID)	Levels 6 through 9 in the C4 chart 10-level scale
ID max	Level 10 in the C4 chart 10-level scale (affects the entire image density.)
Offset	The higher the number in the range associated with the low ID, middle ID, high ID, and ID max, the greater the density.

There are four adjustable modes (can be adjusted with SP4-918-009):

- Copy Photo mode
- Copy Letter mode
- Copy Letter (Single Color) mode
- Copy Photo (Single Color) mode

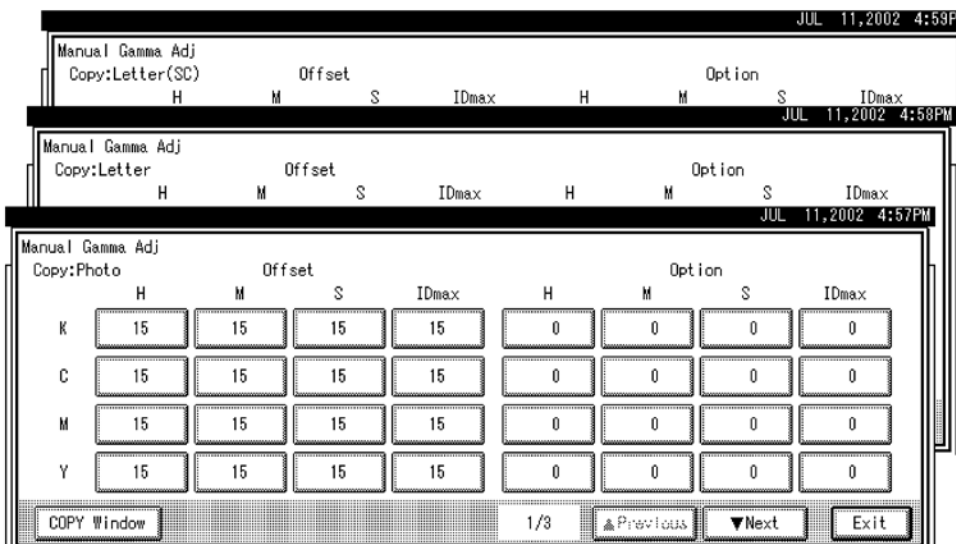

- Adjustment Procedure -

1. Copy the C-4 chart in the mode that you want to adjust.
2. Enter the SP mode.
3. Select "System SP."
4. Select SP4-918-009.
5. Adjust the offset values until the copy quality conforms to the standard (see the table below).

↓ Note

- 1. Never change "Option" value (default value is "0").
- 2. Adjust the density in this order: "ID Max", "Middle", "Shadow", "Highlight".

- Photo Mode, Full Color -

	Item to Adjust	Level on the C-4 chart	Adjustment Standard
1	ID max: (K, C, M, and Y)		Adjust the offset value so that the density of level 10 matches that of level 10 on the C-4 chart.
2	Middle (Middle ID) (K, C, M, and Y)		Adjust the offset value so that the density of level 6 matches that of level 6 on the C-4 chart.
3	Shadow (High ID) (K, C, M, and Y)		Adjust the offset value so that the density of level 8 matches that of level 8 on the C-4 chart.
4	Highlight (Low ID) (K, C, M, and Y)		Adjust the offset value so that dirty background does not show on the copy and the density of level 3 is slightly lighter than that of level 3 on the C-4 chart.

Image Adjustment

	Item to Adjust	Level on the C-4 chart	Adjustment Standard
5	K Highlight (Low ID) (C,M, and Y) <on the full color copy>		Adjust the offset value so that the color balance of black scale levels 3 through 5 in the copy is seen as gray (no C, M, or Y should be visible). If the black scale contains C, M, or Y, do steps 1 to 4 again.

- Photo Mode, Single Color -

	Item to Adjust	Level on the C-4 chart	Adjustment Standard
1	ID max: (K)		Adjust the offset value so that the density of level 10 matches that of level 10 on the C-4 chart.
2	Middle (Middle ID) (K)		Adjust the offset value so that the density of level 6 matches that of level 6 on the C-4 chart.
3	Shadow (High ID) (K)		Adjust the offset value so that the density of level 8 matches that of level 8 on the C-4 chart.
4	Highlight (Low ID) (K)		Adjust the offset value so that dirty background does not show on the copy and the density of level 3 is slightly lighter than that of level 3 on the C-4 chart.

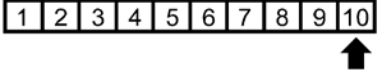
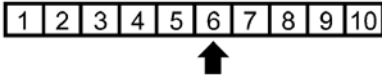
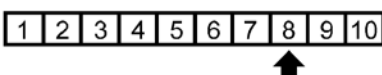
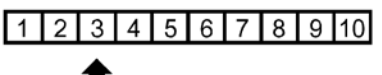
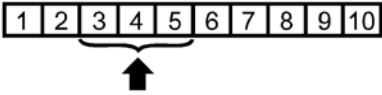
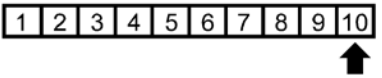
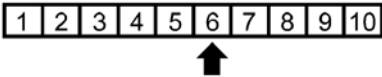
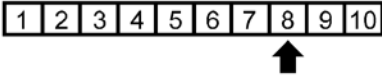
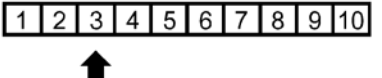
- Text (Letter) Mode, Full Color -

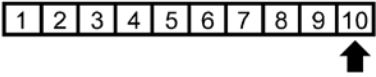
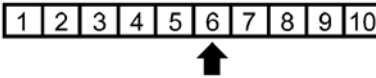
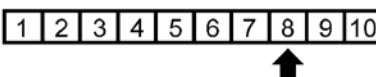
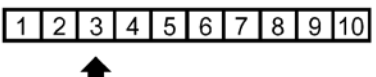
	Item to Adjust	Level on the C-4 chart (K)	Adjustment Standard
1	ID max: (K, C, M, and Y)		Adjust the offset value so that the density of level 10 matches that of level 10 on the C-4 chart.
2	Middle (Middle ID) (K, C, M, and Y)		Adjust the offset value so that the density of level 6 matches that of level 6 on the C-4 chart.
3	Shadow (High ID) (K, C, M, and Y)		Adjust the offset value so that the density of level 8 matches that of level 8 on the C-4 chart.
4	Highlight (Low ID) (K, C, M, and Y)		Adjust the offset value so that dirty background does not show on the copy and the density of level 3 is slightly lighter than that of level 3 on the C-4 chart.

Replacement and Adjustment

- Text (Letter) Mode, Single Color -

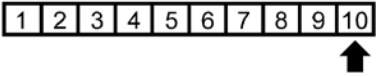
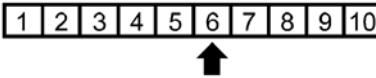
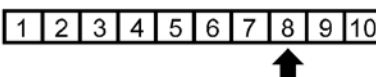
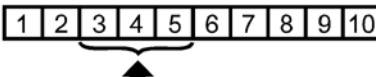
	Item to Adjust	Level on the C-4 chart (K)	Adjustment Standard
1	ID max: (K)		Adjust the offset value so that the density of level 10 matches that of level 10 on the C-4 chart.
2	Middle (Middle ID) (K)		Adjust the offset value so that the density of level 6 matches that of level 6 on the C-4 chart.
3	Shadow (High ID) (K)		Adjust the offset value so that the density of level 8 matches that of level 8 on the C-4 chart.
4	Highlight (Low ID) (K)		Adjust the offset value so that dirty background does not show on the copy and the density of level 3 is slightly lighter than that of level 3 on the C-4 chart.

Note

- Text parts of the test pattern cannot be printed clearly after you adjust "shadow" as shown above. At this time, check if the 5 line/mm pattern at each corner is printed clearly. If it is not, adjust the offset value of "shadow" again until it is.

Printer Mode

There are six adjustable modes (select these modes with printer SP1-102-001):

- 1200 x 1200 photo mode
- 1200 x 1200 text mode
- 2400 x 600 photo mode
- 2400 x 600 text mode
- 1800 x 600 photo mode
- 1800 x 600 text mode
- 600 x 600 photo mode
- 600 x 600 text mode

	K	C	M	Y
Highlight	SP1-104-1	SP1-104-21	SP1-104-41	SP1-104-61
Shadow	SP1-104-2	SP1-104-22	SP1-104-42	SP1-104-62
Middle	SP1-104-3	SP1-104-23	SP1-104-43	SP1-104-63
IDmax	SP1-104-4	SP1-104-24	SP1-104-44	SP1-104-64

- Adjustment Procedure -

1. Do ACC for the printer mode.
2. Turn the main power off and on.
3. Enter SP mode.
4. Select "Printer SP".
5. Select SP1-102-001. Then select the necessary print mode to adjust.
6. Choose SP1-103-1 to print out a tone control test sheet if you want to examine the image quality for these settings.
7. Adjust the color density with SP1-104. Compare the tone control test sheet with the C4 test chart.

↓ Note

- Adjust the density in this order: "ID Max", "Shadow", "Middle", "Highlight".
8. Use SP1-105-001 to keep the adjusted settings.

4.4 EXTERIOR COVERS

4.4.1 FRONT DOOR



d1420025

1. Open the front door [A].

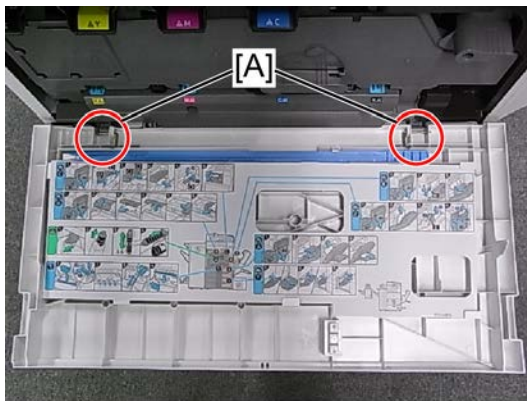

d1440042

2. Remove the two pins [A], and then remove the front cover.

4.4.2 CONTROLLER COVER

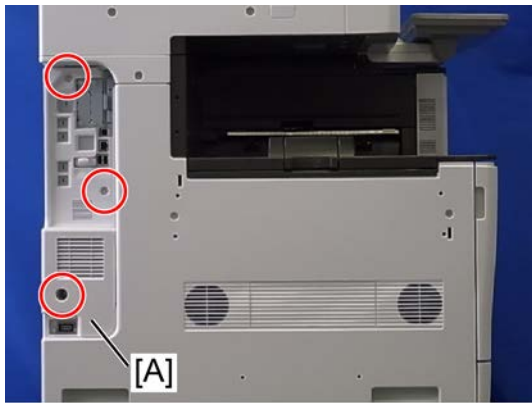

d1420015

1. Controller cover [A] ( x 3)

4.4.3 LEFT COVER

1. Controller cover ( p.4-17)

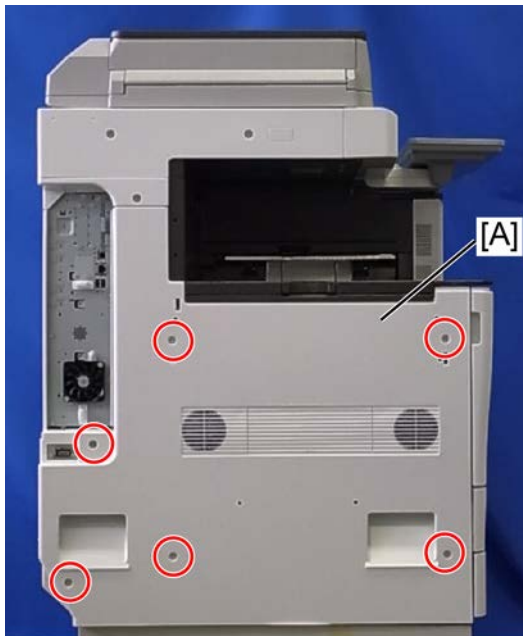



d1420016

2. Left cover [A] ( x 6)

Replacement
and
Adjustment

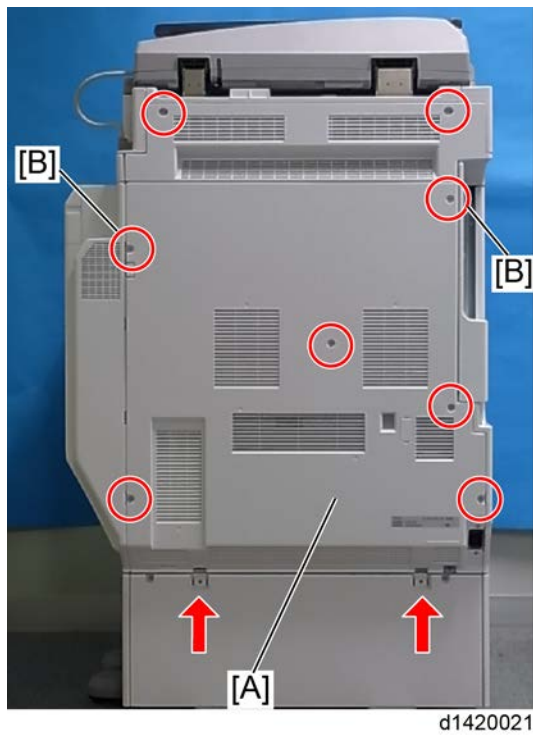
4.4.4 REAR COVER



1. Rear cover [A] ( x 2 [B], stepped screw x 6, hook x 2)

4.4.5 RIGHT REAR COVER

1. Rear cover (🔧 p.4-18)
2. Scanner right cover (🔧 p.4-26)
3. Right top cover (🔧 p.4-26)

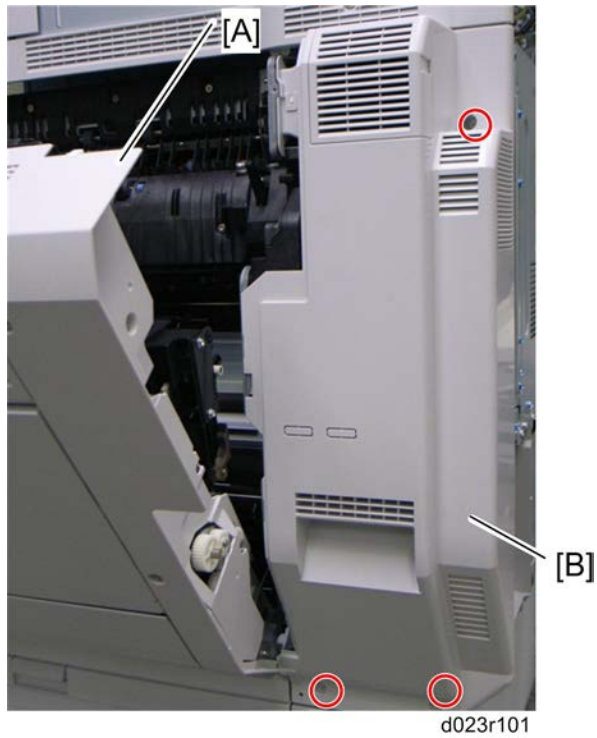

4. Open the right door [A].
5. Right rear cover [B] (🔧 x 3)

Replacement
and
Adjustment

4.4.6 OPERATION PANEL

1. Open the right door.



[A]

d1440046

2. Front right cover [A] ( x 1)



d1420014

3. Turn the operation panel upright.

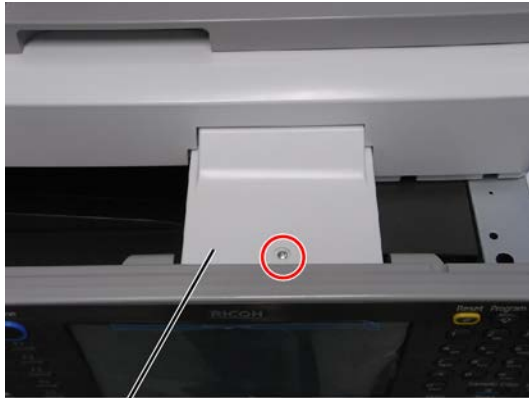



[A]

d1420017

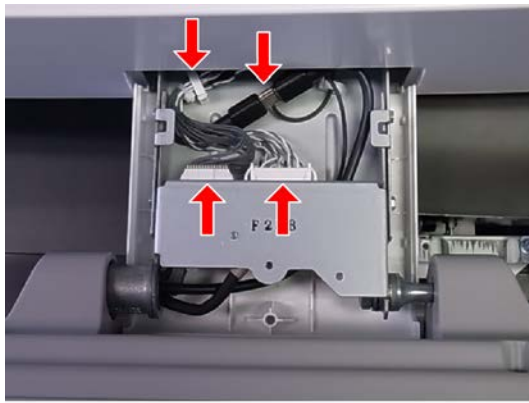
4. Upper cover [A] ( x 1)



d1420018

5. Disconnect the connectors. ( x 3,  x 1)
6. Return the operation panel to the flat position.

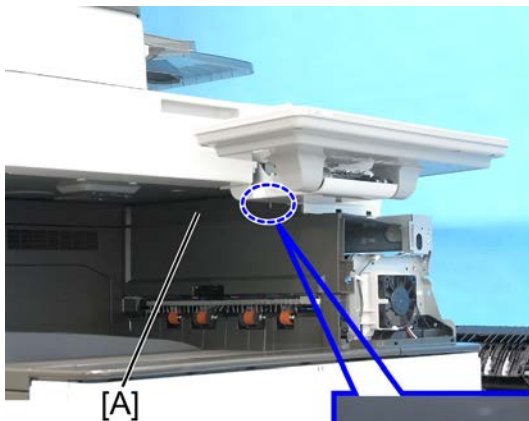

[A]



d1420019

7. Paper exit upper cover [A] (hook x 1)

Replacement and Adjustment

Exterior Covers



d1420002



d1420003

8. Take off the under cover [A] (hook x 1)
9. Turn the operation panel upright.
10. Scanner front cover (🔧 p.4-30)

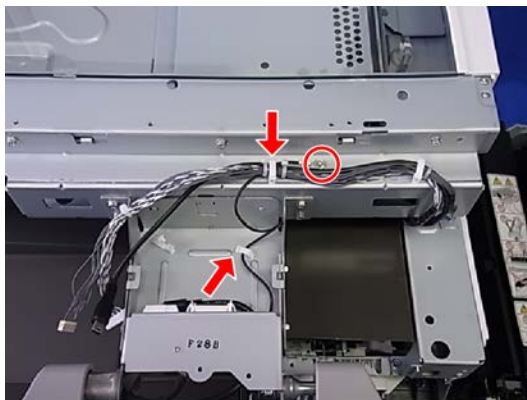

d1420026

11. Ground cable (🔧 x 1, 📡 x 2)

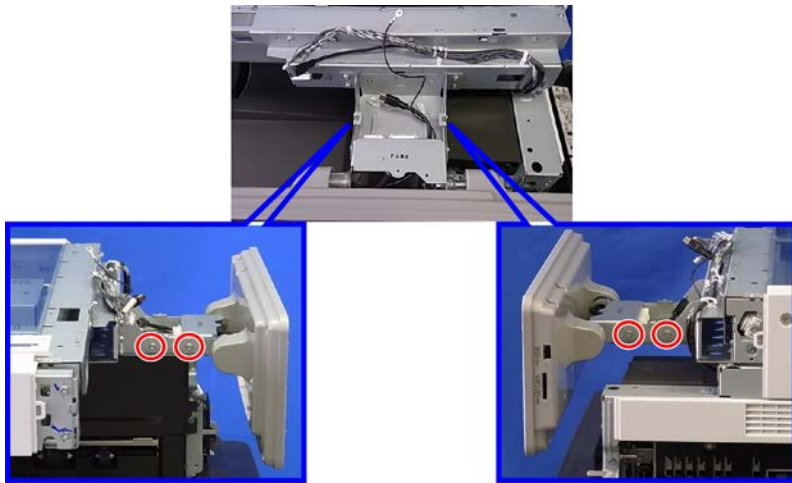

d1420027

12. Operation panel ( x 4)



d1420001

Replacement
and
Adjustment

4.4.7 PAPER EXIT COVER

1. Front right cover (🔧 p.4-20)

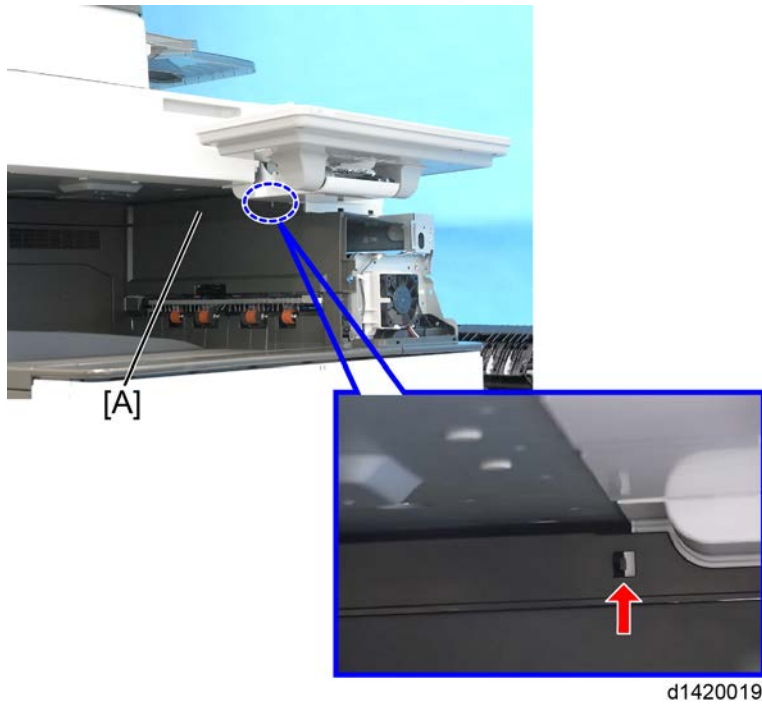

2. Paper exit upper cover [A] (hook x 1)

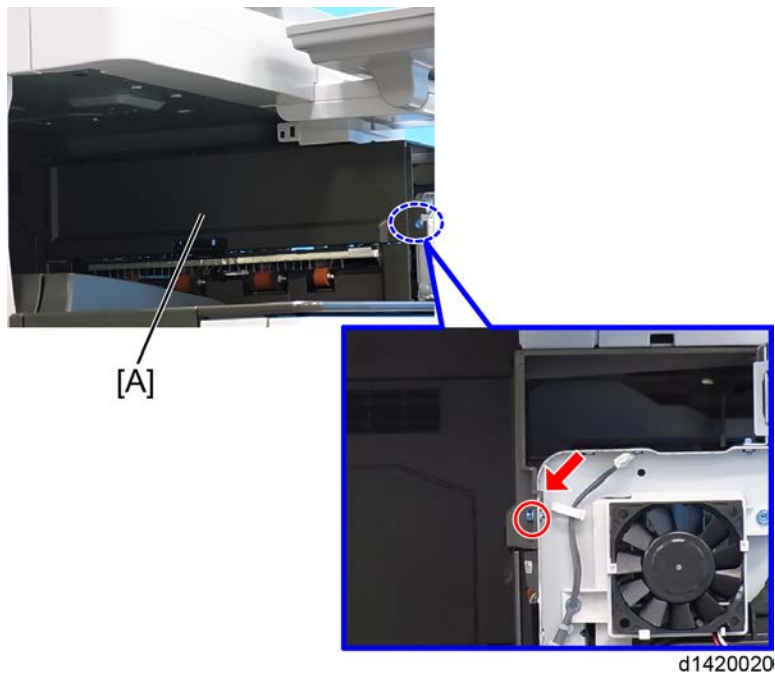

3. Paper exit cover [A] (🔧 x 1, hook x 1)

4.4.8 INNER TRAY

1. Image transfer belt unit (🔧 p.4-74)
2. Paper exit cover (🔧 p.4-24)
3. Left cover (🔧 p.4-17)

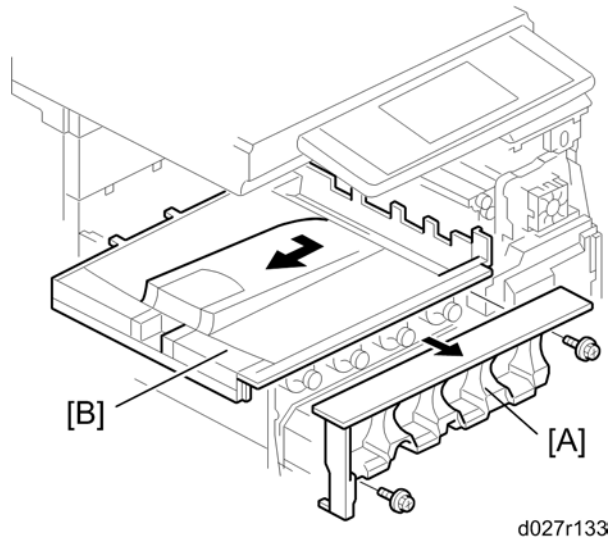



4. Toner cartridge cover [A] (🔧 x 2)
5. Inner tray [B]

4.4.9 OZONE FILTER AND DUST FILTER

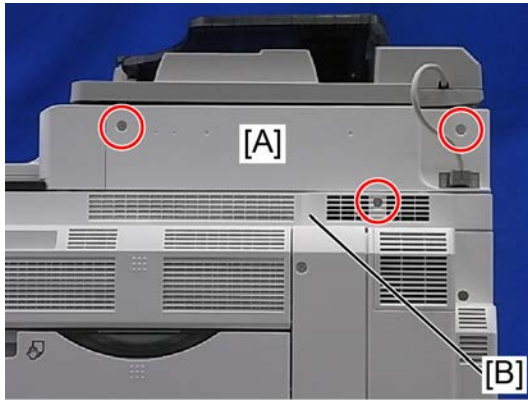
Ozone filters for the scanner unit



d1420037

1. Scanner right cover [A] ( x 2)
 - Loosen the top-right screw of the rear cover.
2. Right top cover [B] ( x 1)

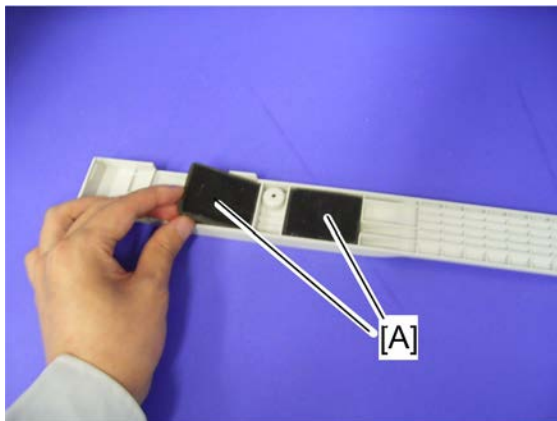

d027r671

3. Ozone filters [A] in the right top cover.

Ozone filter and dust filter for the AC controller

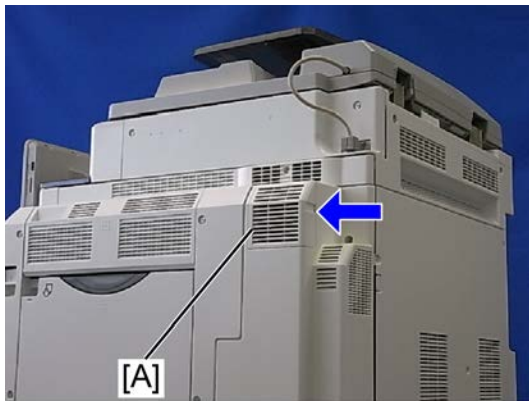

d1420038

1. AC controller board fan cover [A] (hook x 1)

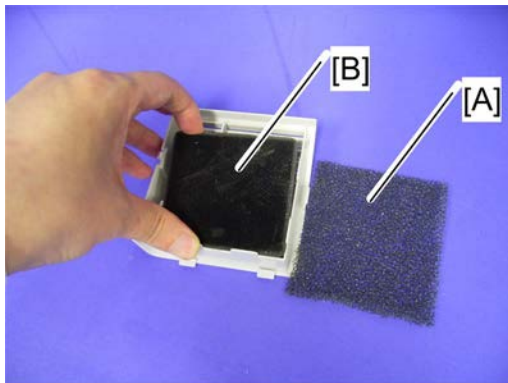

d027r673

2. Dust filter [A]
3. Ozone filter [B]

Replacement
and
Adjustment

4.5 SCANNER UNIT

4.5.1 EXPOSURE GLASS

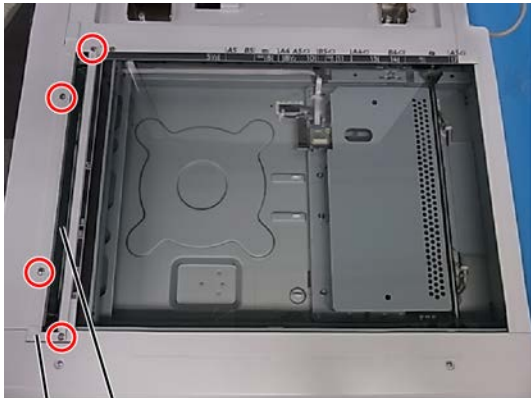

d1420004

1. Glass cover [A] ( x 4)
2. ARDF exposure glass [B]

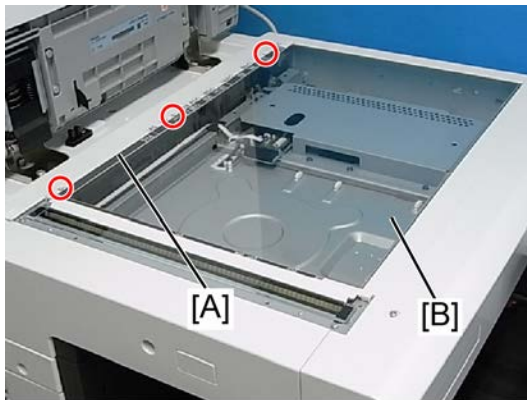

d1420005

3. Rear scale [A] ( x 3)
4. Exposure glass with left scale [B]

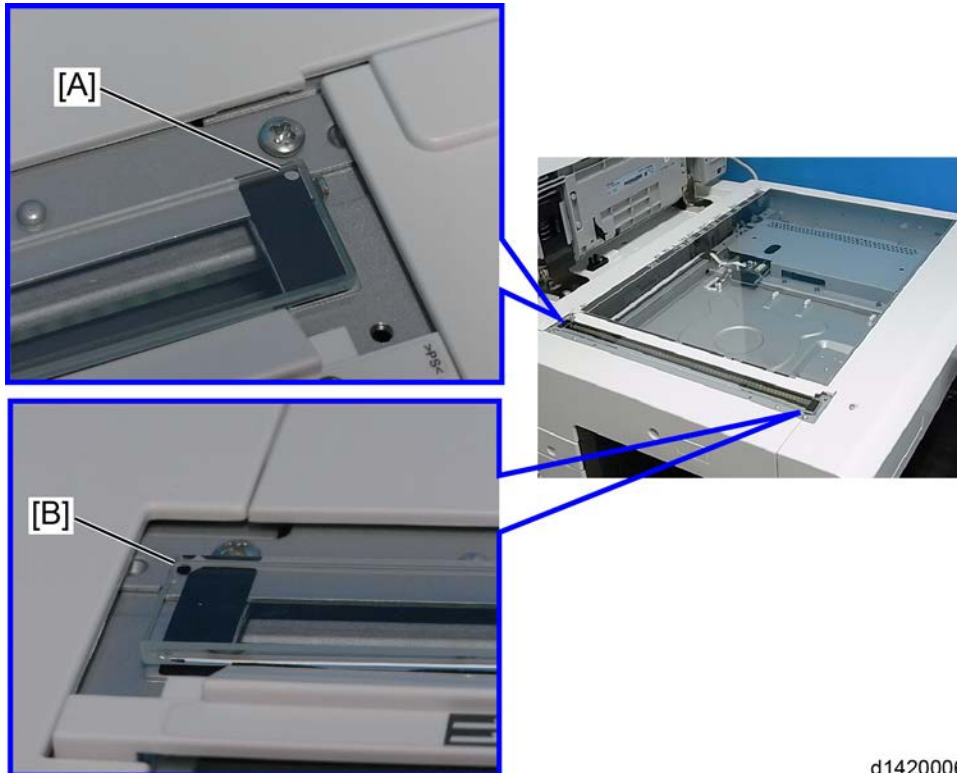

d1420006

Note

- Position the white marker [A] at the rear-left corner and the black or blue marker [B] at the front-left corner when you reattach the ARDF exposure glass.

**Replacement
and
Adjustment**

4.5.2 EXPOSURE LAMP

1. Exposure glass (🔧 p.4-28)
2. Upper cover (🔧 p.4-20)



3. Scanner front cover [A] (🔧 x 2, hook x 2)



4. ADF (🔧 x 2)



5. Scanner rear cover [A] (🔧 x 1)

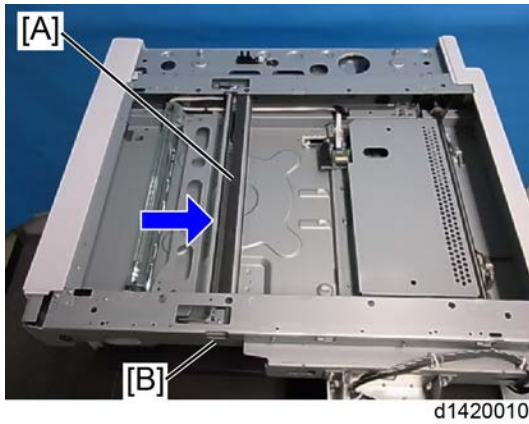

6. Move the 1st scanner carriage [A] to the cutout [B] in the front frame.

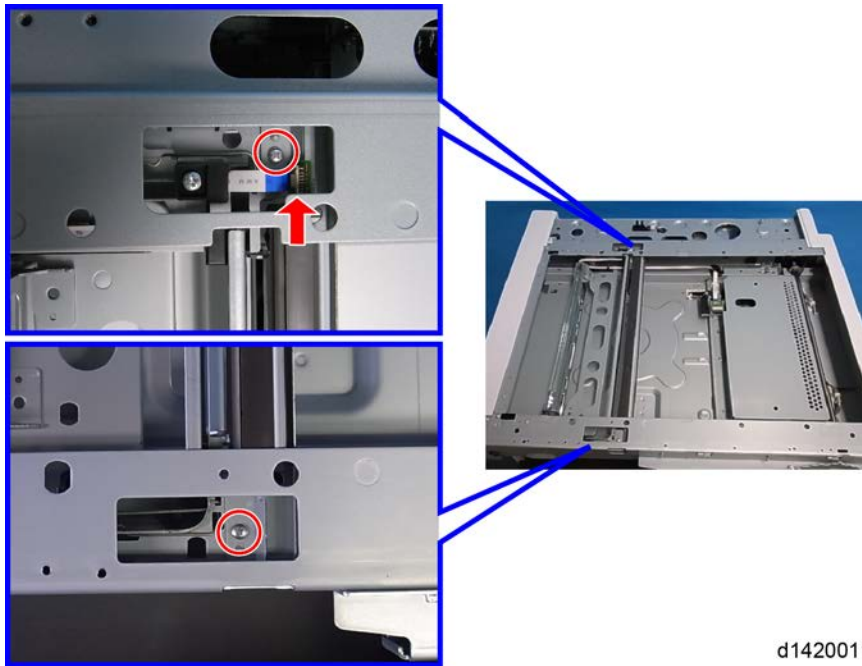

7. Disconnect the connector and remove the screw. (🔧 x 1, 🔩 x 2)



8. Pull out the exposure lamp from the cutout.

Replacement
and
Adjustment

Scanner Unit



d1420013

Reassembling

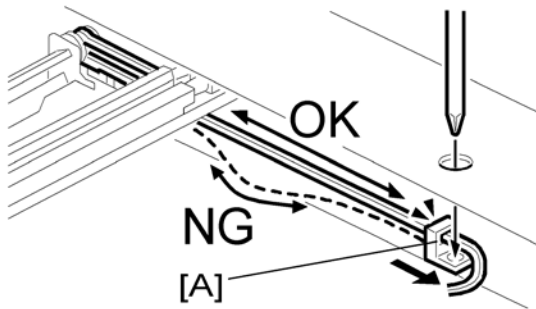

Run the cable so there is no slack. Slide the clamp [A] to adjust the cable slack.

Chromaticity rank adjustment

Each scanner lamp has a specific chromaticity rank. The chromaticity rank is indicated by the bar-code on the new scanner lamp. After replacing the lamp, adjust the chromaticity rank to correspond to the new scanner lamp.

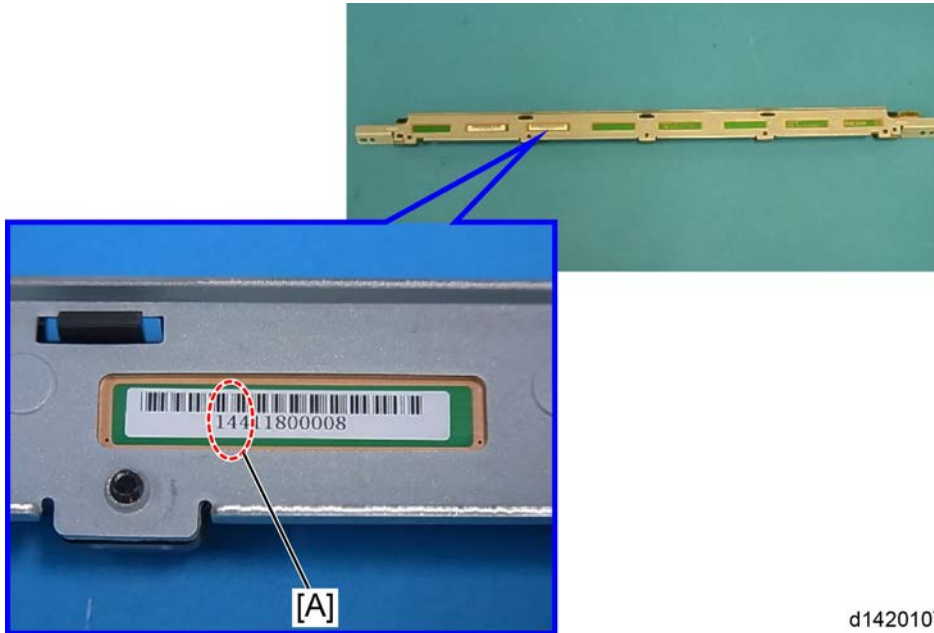

d1420107

Replacement
and
Adjustment

1. Check the first three digits [A] in the bar-code on the new scanner lamp before installing the new lamp.
2. After installing the new lamp, go to SP4-954-005 and enter the SP setting number referring to the table below.

1 st Three Digits	SP Setting (SP4-954-005)	1 st Three Digits	SP Setting (SP4-954-005)
139	3	166	12
140	2	167	11
141	1	168	10
142	6	169	15
143	5	170	14
144	4	171	13
145	9	172	18

Scanner Unit

1 st Three Digits	SP Setting (SP4-954-005)	1 st Three Digits	SP Setting (SP4-954-005)
146	8	173	17
147	7	174	16
148	12	204	3
149	11	205	2
150	10	206	1
151	15	207	6
152	14	208	5
153	13	209	4
154	18	210	9
155	17	211	8
156	16	212	7
157	3	213	12
158	2	214	11
159	1	215	10
160	6	216	15
161	5	217	14
162	4	218	13
163	9	219	18
164	8	220	17
165	7	221	16

4.5.3 SCANNER MOTOR

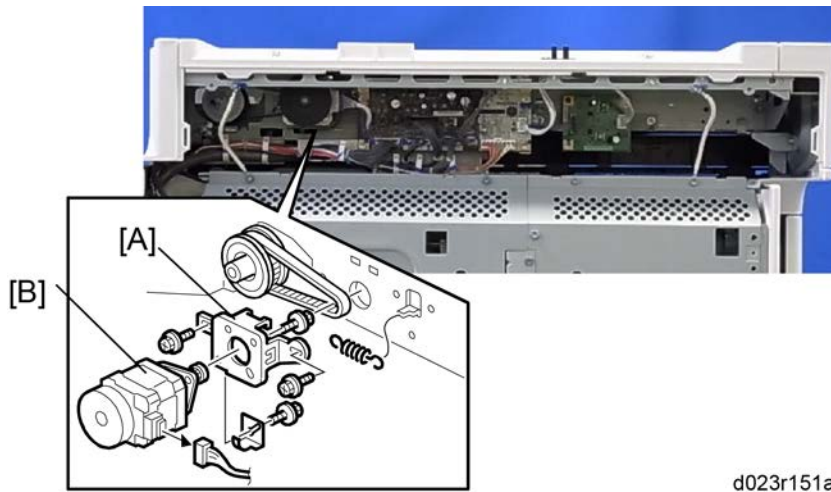

d023r151a

1. Rear cover (➡ p.4-18)
2. Scanner Rear cover (➡ p.4-30)
3. Scanner motor assembly [A] (⚙ x 2, 📦 x 1, spring x 1)
4. Scanner motor [B] (⚙ x 2)

4.5.4 SENSOR BOARD UNIT (SBU)

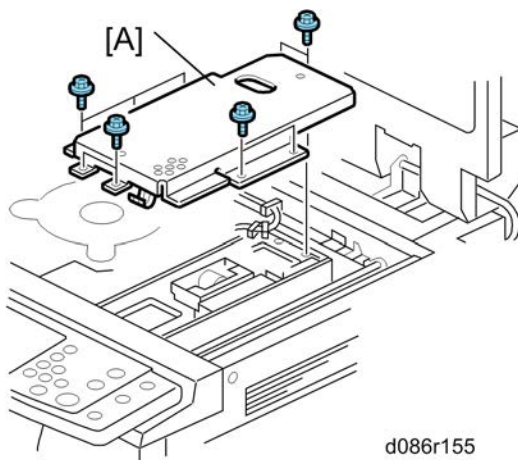



d086r155

1. Exposure glass (➡ p.4-28)
2. Original length sensor bracket (➡ p.4-37)
3. SBU cover bracket [A] (⚙ x 9)

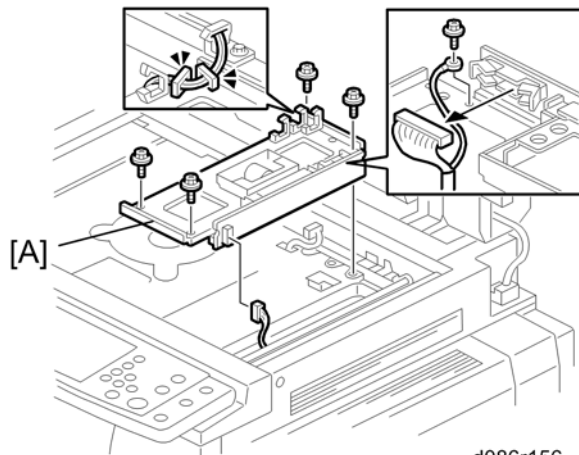
Scanner Unit



d086r156

4. Sensor board unit [A] ( x 4, Grand screw x 1,  x 2,  x 2)

When reassembling

Adjust the following SP modes after you replace the sensor board unit:

- SP4-008 (Sub Scan Mag): See "Image Adjustment: Scanning".
- SP4-010 (Sub Mag Reg.): See "Image Adjustment: Scanning".
- SP4-011 (Main Scan Reg): See "Image Adjustment: Scanning".
- SP4-688 (DF: Density Adjustment): Use this to adjust the density level if the ID of outputs made in the DF and Platen mode is different.

4.5.5 ORIGINAL LENGTH SENSORS

1. Exposure glass with left scale (🔧 p.4-28)



2. Original length sensor 1 [A] (hook x 2, 📎 x 1)

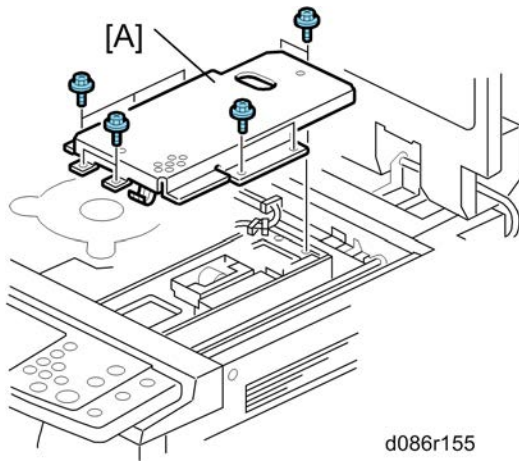

3. SBU cover bracket [A] (🔧 x 9)

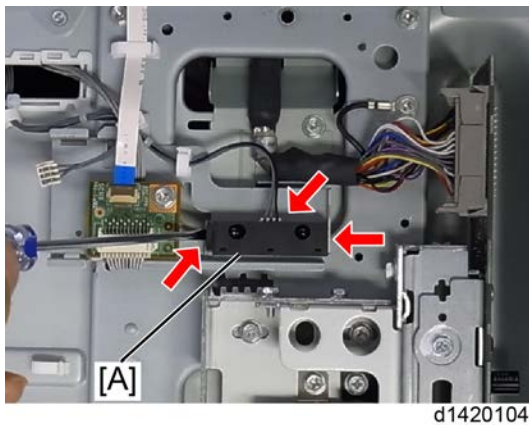

4. Original length sensor 2 [A] (hook x 2, 📎 x 1)

Replacement and Adjustment

4.5.6 LED RELAY BOARD

1. Rear cover (🔧 p.4-18)

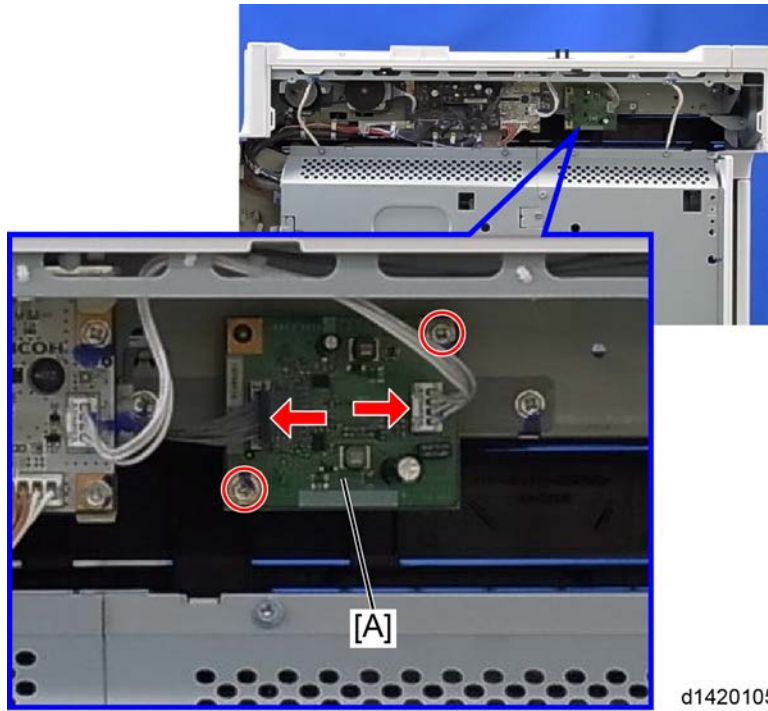

2. LED relay board (🔧 x 2, 📄 x 2)

4.5.7 SIO (SCANNER IN/OUT) BOARD

1. Rear cover (🔧 p.4-18)

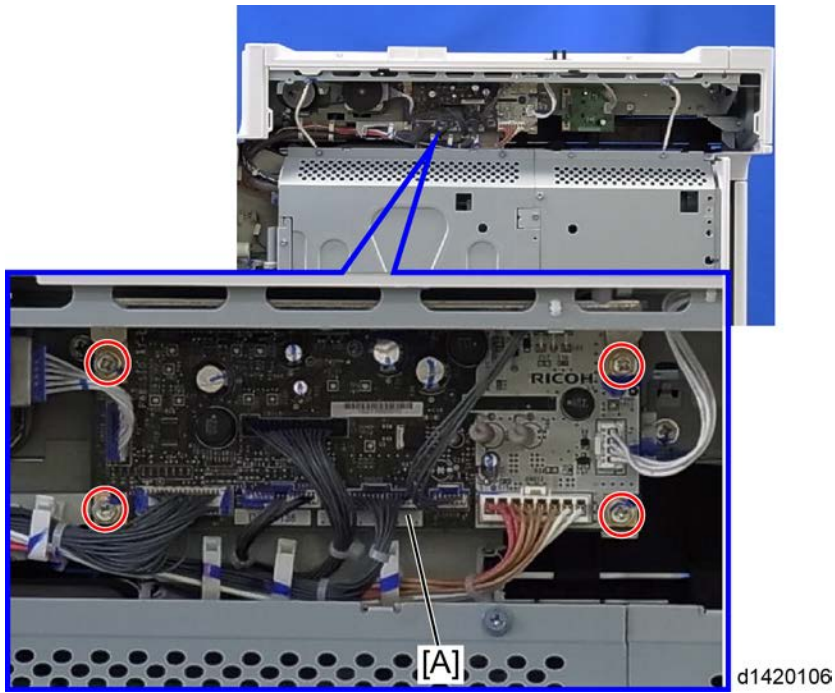

2. SIO [A] (🔧 x 4, 📄 x All)

4.5.8 SCANNER HP SENSOR

1. Scanner left cover and scanner rear cover (📄 p.4-30)
2. Exposure glass (📄 p.4-28)

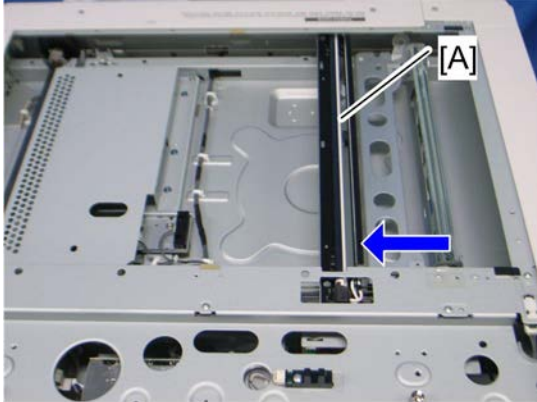

d086r111

3. Move the 1st scanner carriage [A] to the right side.

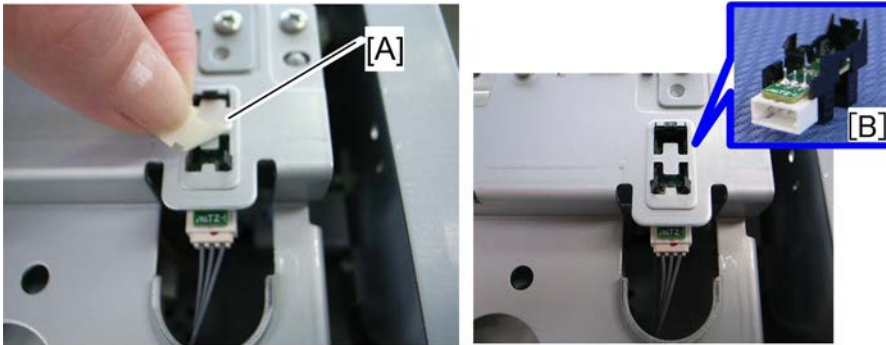

d023r112

4. Remove the mylar [A]
5. Remove the scanner HP sensor [B] (📄 x 1, three snaps)

4.5.9 PLATEN COVER SENSOR

1. Scanner left cover and scanner rear cover (🔧 p.4-30)

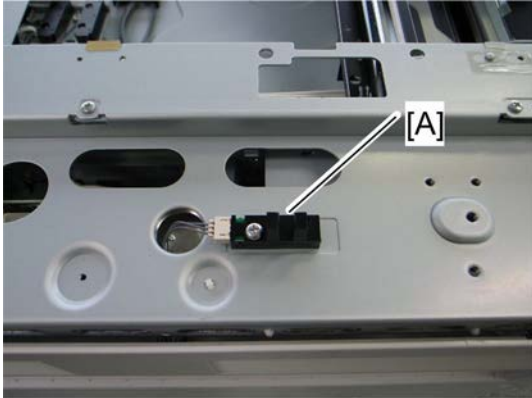

d023r113

2. Platen cover sensor [A] (🔧 x 1, 📦 x 1)

4.5.10 FRONT SCANNER WIRE

1. Exposure glass (☞ p.4-28)

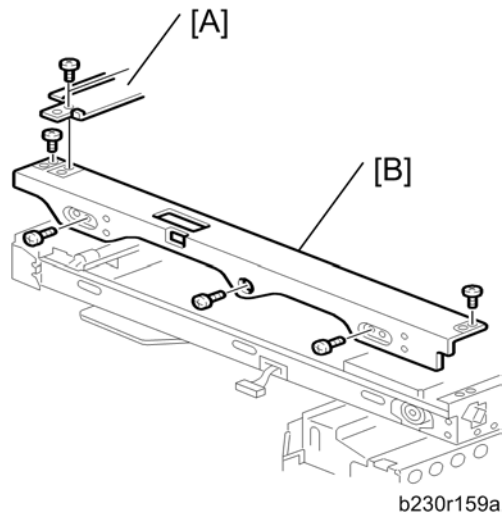

2. Scanner left stay [A] (☞ x 3)
3. Front frame [B] (☞ x 5)

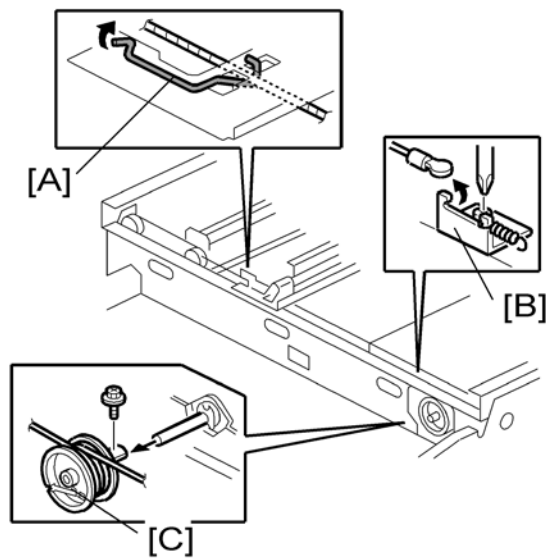

4. Front scanner wire clamp [A]
5. Front scanner wire bracket [B] (☞ x 1)
6. Front scanner wire and scanner drive pulley [C] (☞ x 1)

Reinstalling the Front Scanner Wire

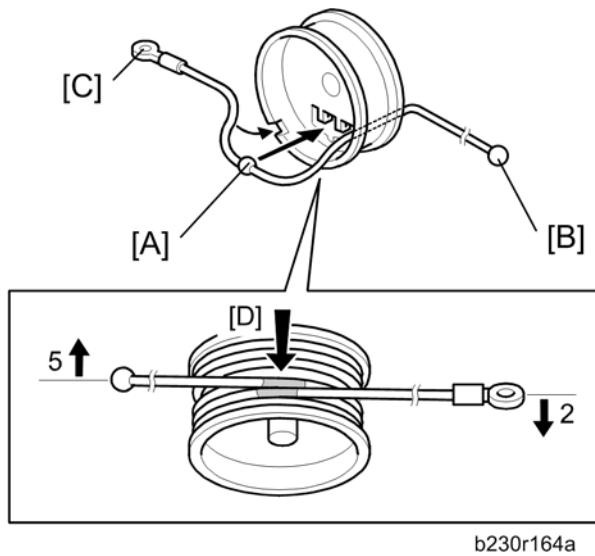

1. Position the center ball [A] in the middle of the forked holder.
2. Pass the right end (with the ball) [B] through the square hole. Pass the left end (with the ring) [C] through the notch.
3. Wind the right end counterclockwise (shown from the machine's front) five times. Wind the left end clockwise twice.

↓ Note

- The two red marks [D] come together when you have done this. Stick the wire to the pulley with tape. This lets you easily handle the assembly at the time of installation.

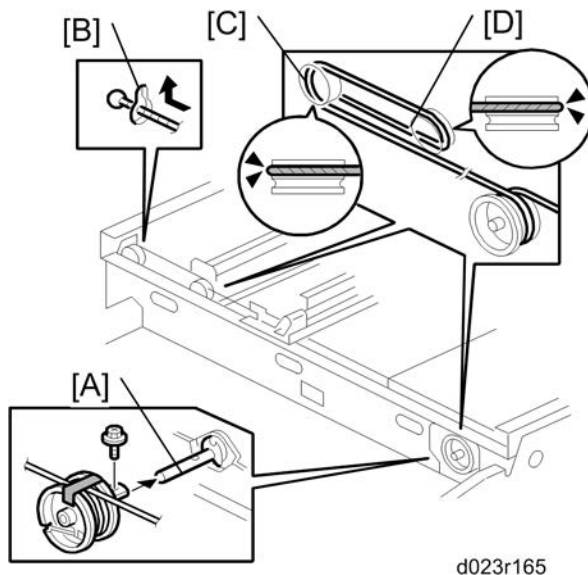

4. Install the drive pulley on the shaft [A].

↓ Note

- Do not attach the pulley to the shaft with the screw at this time.
5. Insert the left end into the slit [B]. The end should go via the rear track of the left pulley [C] and

the rear track of the movable pulley [D].

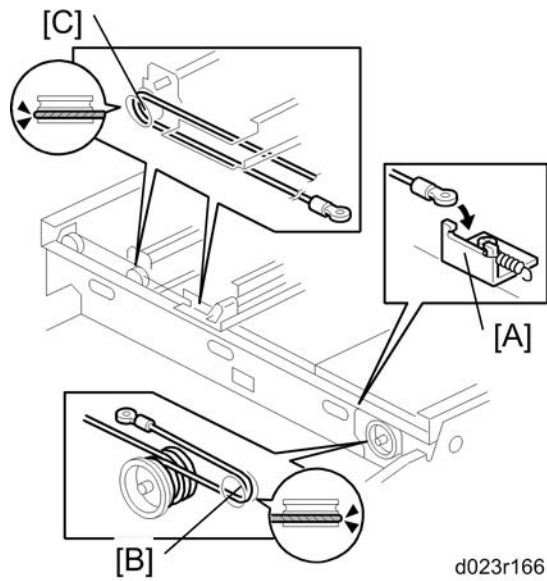

6. Hook the right end onto the front scanner wire bracket [A]. The end should go via the front track of the right pulley [B] and the front track of the movable pulley [C].

Note

- Do not attach the scanner wire bracket with the screw at this time.

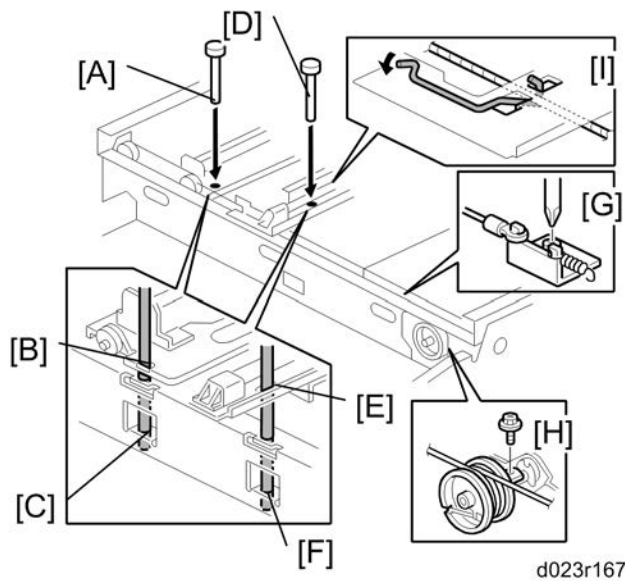

7. Remove the tape from the drive pulley.
8. Insert a scanner-positioning pin [A] through the 2nd carriage hole [B] and the left holes [C] in the front rail. Insert another scanner positioning pin [D] through the 1st carriage hole [E] and the right holes in the front rail [F].
9. Insert two more scanner positioning pins through the holes in the rear rail.
10. Screw the drive pulley to the shaft [G].
11. Screw the scanner wire bracket to the front rail [H].

12. Install the scanner wire clamp [I].
13. Pull out the positioning pins.

Note

- Make sure the 1st and 2nd carriages move smoothly after you remove the positioning pins. Do steps 8 through 13 again if they do not.

4.5.11 REAR SCANNER WIRE

1. Exposure glass (🔧 p.4-28)
2. Scanner left stay (🔧 p.4-42)

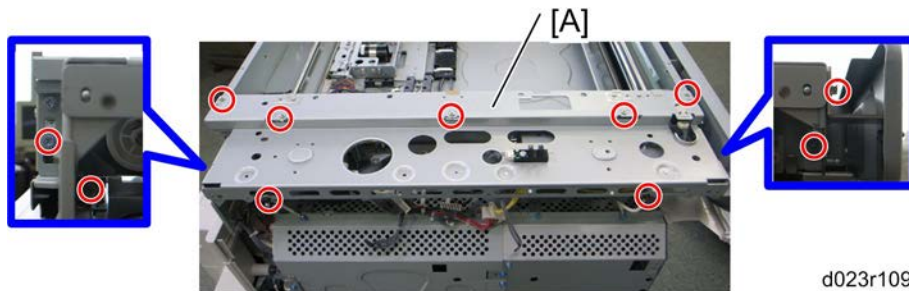

3. Scanner rear frame [A] (🔧 x 9, ground screw x 2, 📄 x All)
4. Follow the steps 3 through 5 in the “Reinstalling the Front Scanner Wire” Section. You can remove the rear scanner wire with the same manner for replacing the front scanner wire.

Reinstalling the Rear Scanner Wire

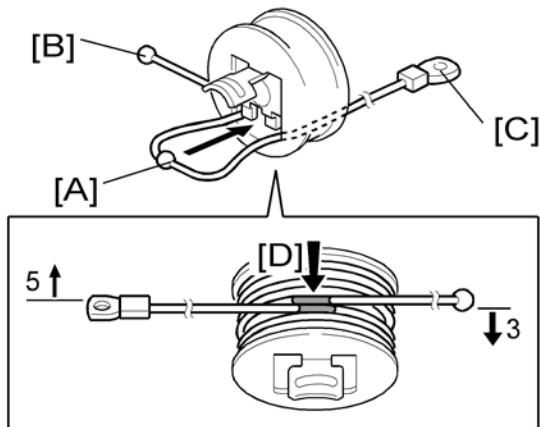

1. Position the center ball [A] in the middle of the forked holder.
2. Pass the left end (with the ball) [B] through the drive pulley notch. Pass the right end (with the ring) [C] through the drive pulley hole.
3. Wind the left end [B] clockwise (shown from the machine's front) five times. Wind the right end [C] counterclockwise three times.

Note

- The two red marks [D] come together when you do this. Attach the wire to the pulley with tape. This lets you easily handle the assembly at the time of installation.

4. Install the drive pulley on the shaft.

Note

- Do not attach the pulley on the shaft with the screw at this time.

5. Install the wire.

Note

- The winding of the wire on the three pulleys at the rear of the scanner should be the same as the winding on the three pulleys at the front. This must show as a mirror image.

Example: At the front of the machine, the side of the drive pulley with the three windings must face the front of the machine. At the rear of the machine, it must face the rear.



6. Do steps 7 through 13 again in the “Reinstalling the Front Scanner Wire” Section.

4.5.12 TOUCH PANEL POSITION ADJUSTMENT

Note

- It is necessary to calibrate touch panel at the following times:
- When you replace the operation panel.
- When you replace the controller board.
- When the touch panel detection function does not operate correctly.

Do not use items [2] to [9] on the Self-Diagnostic Menu. These items are for design use only.

1. Press , press "1", "9", "9", "3", then press  5 times to open the Self-Diagnostics menu.

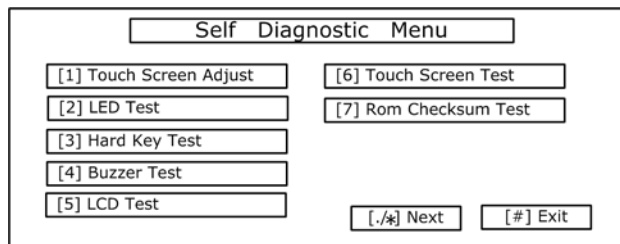

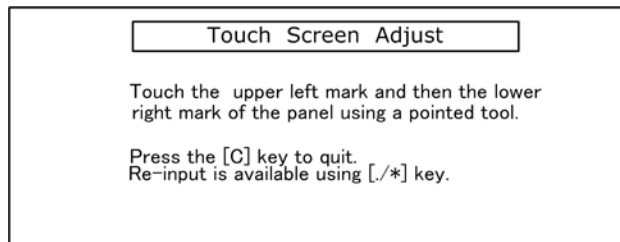

b178r548

2. On the touch screen press "Touch Screen Adjust" (or press "1").
3. Use a pointed (not sharp) tool to press the upper left mark "O" .



b178r549

4. Press the lower right mark when "O"  shows.
5. Press [#] OK on the screen (or press  when you are finished.
6. Touch [#] Exit on the screen to close the Self-Diagnostic menu. Save the calibration settings.

4.6 LASER OPTICS

⚠ WARNING

- Turn off the main switch and unplug the machine before beginning any of the procedures in this section. Laser beams can cause serious eye injury.

4.6.1 CAUTION DECAL LOCATION

Caution decals are placed as shown below.



⚠ WARNING

- Be sure to turn off the main switch and disconnect the power plug from the power outlet before beginning any disassembly or adjustment of the laser unit. This copier uses a class IIIb laser beam with a wavelength of 655 nm and an output of 7 mW. The laser can cause serious eye injury.

4.6.2 LD SAFETY SWITCH

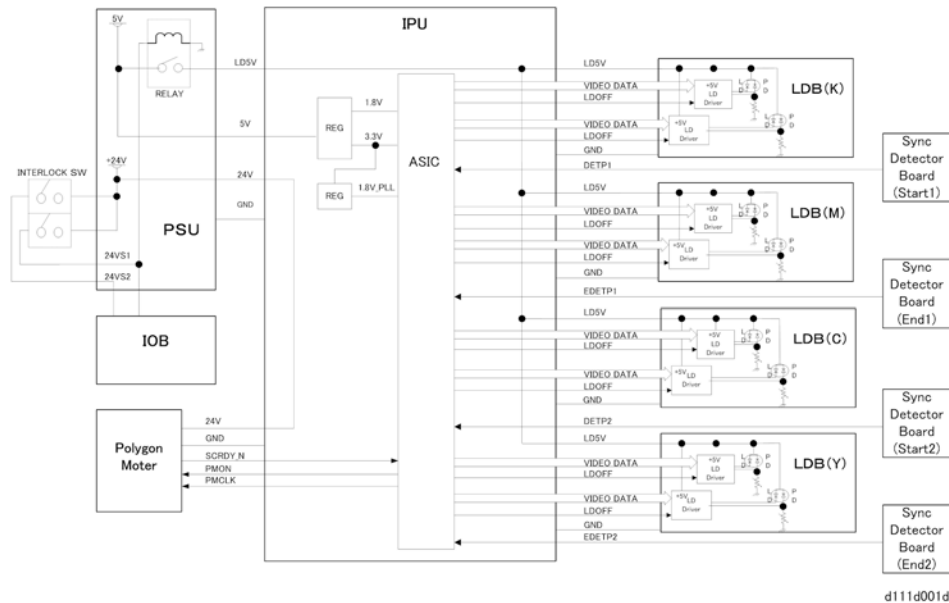

A relay on the PSU ensures technician and user safety. It also prevents the laser beam from turning on during servicing. This relay turns off when the front cover, upper left cover, or right door is opened. At this time it cuts the power (+5V) supplied to the LD board for each color through the IPU.

Two safety switches are turned on or off by the front door or right door, and this opens the relay.

- LD Driver: Precise Pulse Modulation ASIC on C-MOS technology
- LDB: LD Drive Board (included in the LD Unit)

Error Messages

Along with other switches, the LD safety switches help show error messages related to external covers. When one or more covers are open, the messages, "Cover is open." and "Close the indicated cover," show with a diagram. The diagram shows which cover is open.

4.6.3 LASER OPTICS HOUSING UNIT

⚠ CAUTION

- Before installing a new laser optics housing unit, remove the sponge padding and the tag from the new unit.

↓ Note

- A new laser optics housing unit has a bracket to protect the LD units. When you install the new unit, do not remove the bracket until near the end of the installation procedure (the correct time is stated in the manual).
- This bracket protects a capacitor on the unit. If the bracket is removed too early, you could break the capacitor on the corner of the main frame when you install the new unit.

Preparing the new laser optics housing unit

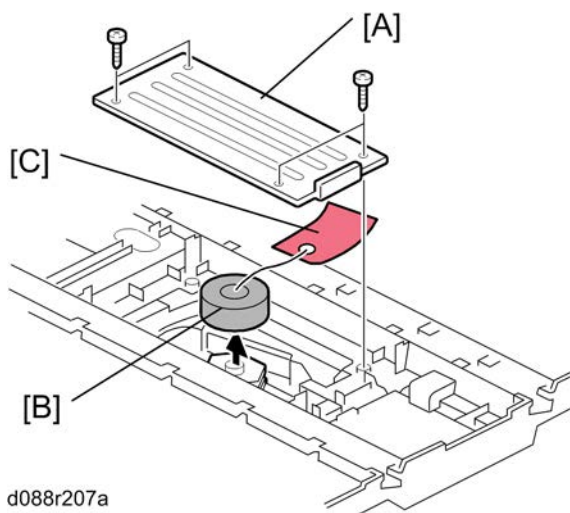

d088r207a

1. Polygon motor cover [A] of the laser optics housing unit ( x 4)
2. Sponge padding [B]
3. Tag [C]
4. Reinstall the polygon motor cover [A].

Before removing the old laser optics housing unit

Do the following settings before removing the laser optics housing unit. These are adjustments for skew adjustment motors in the laser optics housing unit.

1. Plug in and turn on the main power switch of the copier.
2. Enter the SP mode.
3. Execute SP2220-001 to clear the L2 lens positioning motor setting for Magenta.
4. Execute SP2220-002 to clear the L2 lens positioning motor setting for Cyan.
5. Execute SP2220-003 to clear the L2 lens positioning motor setting for Yellow.
6. Exit the SP mode.
7. Turn off the main power switch and disconnect the power cord of the copier.

Recovery procedure for no replacement preparation of laser optics housing unit

If you did not do the procedure in 'Before removing the old laser optics housing' before removing the old laser optics housing unit, you must do the following.



1. Turn off the main power switch and disconnect the power cord of the copier.
2. Remove the left cover and harness cover bracket (see the following "Removing the old laser optics housing unit")



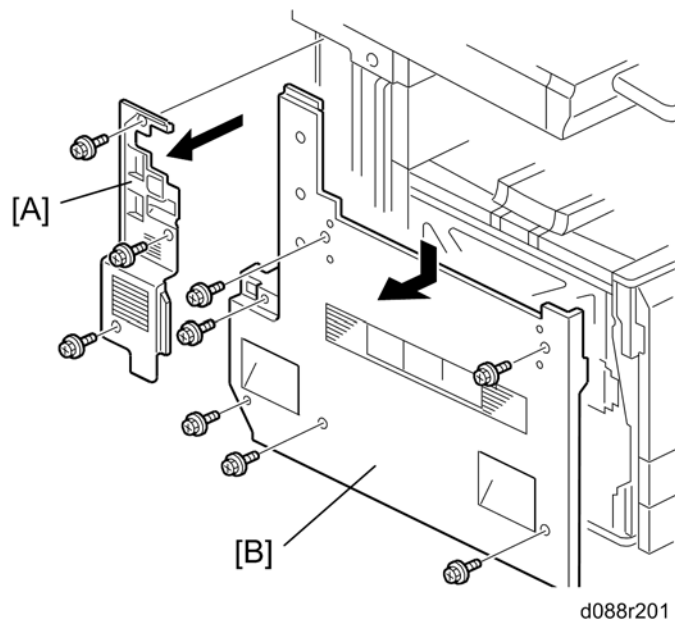

3. Disconnect the harness [A] of the skew correction motor.
4. Do steps 1 to 7 of "Before removing the old laser optics housing unit".
5. Connect the harness [A] and reinstall the harness bracket and left cover.
6. Plug in and turn on the main power switch.

Removing the old laser optics housing unit



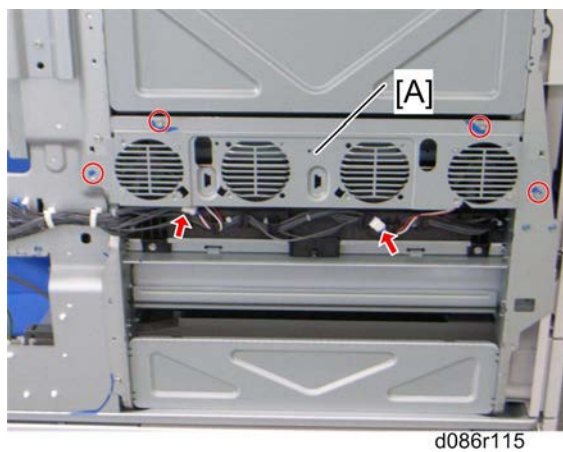

1. Controller cover [A] ( x 3)
2. Left cover [B] ( x 6)

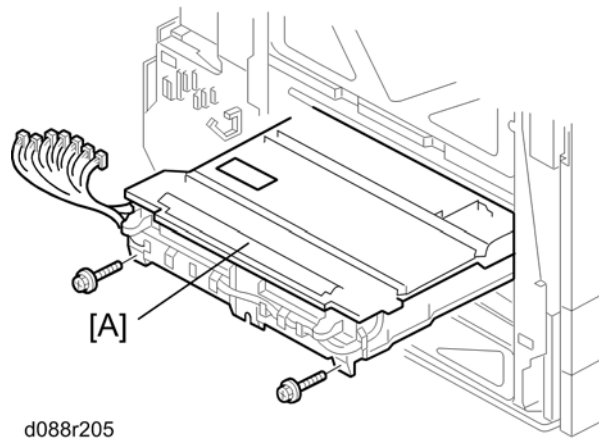

3. Left fan bracket [A] for the laser housing optics unit ( x 4,  x 2)



4. Remove the old laser optics housing unit [A] ( x 2, All 's,  x 3)

Installing a new Laser Optics Housing Unit

Note

- A new laser optics housing unit has a bracket to protect the LD units. When you install the new unit, do not remove the bracket until near the end of the installation procedure (the correct time is stated in the manual).
- This bracket protects a capacitor on the unit. If the bracket is removed too early, you could break the capacitor on the corner of the main frame when you install the new unit.

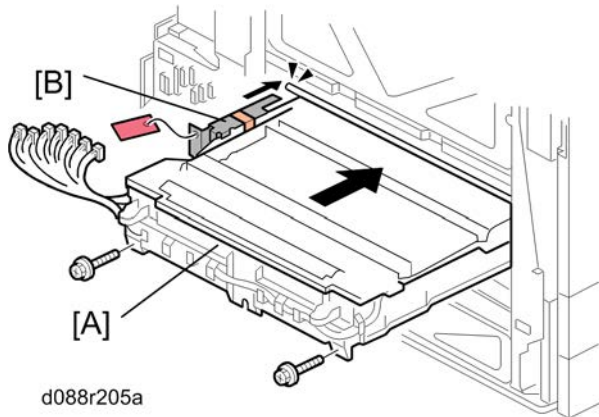

1. Push the new laser optics housing unit [A] slowly into the copier until the bracket [B] bumps against the frame of the copier.
2. Remove the bracket [B], and then push the new laser optics housing unit fully into the copier (x 2, All 's, x 3).
3. Reassemble the machine.

Replacement and Adjustment

After installing the new laser optics housing unit

Do the following adjustment after installing the new laser optics housing unit.

1. Plug in and turn on the main power switch.

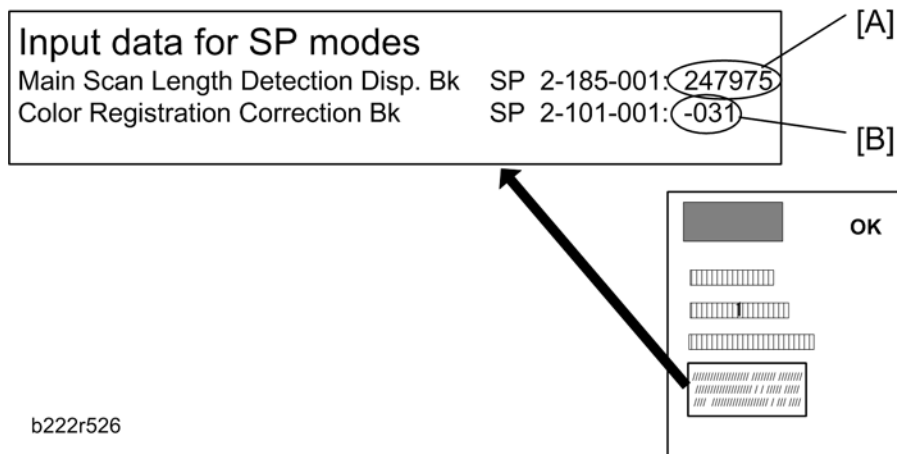

2. Adjust the main scan magnification only for black (Bk).
 - Input the standard value [A] provided with a new laser optics housing unit for the main scan magnification adjustment with SP2-185-001.

↓ **Note**

- The value [A] is different for each laser optics housing unit.
 - Print the test pattern (14: 1-dot trimming pattern in the SP2-109-003).
 - Check that the left and right trim margin is within 4 ± 1 mm. If not, change the standard value for the main scan magnification adjustment.
3. Adjust the main scan registration only for black (Bk).
- Input the registration value [B] provided with a new laser optics housing unit for the main scan registration adjustment with SP2101-001.

↓ **Note**

- The value [B] is different for each laser optics housing unit.
 - Print the test pattern (14: 1-dot trimming pattern in the SP2-109-003).
 - Check that the left trim margin is within 2 ± 1 mm. If not, change the registration value for the main scan registration adjustment.
4. Select "0" with SP2-109-003 after printing the "1-dot trimming pattern.
5. Do the line position adjustment.
- First do SP2-111-3.
 - Then do SP2-111-1.
- To check if SP 2-111-1 was successful, watch the screen during the process. A message is displayed at the end. Also, you can check the result with SP 2-194-10 to -12.
6. Exit the SP mode.

After you replace the housing unit, do the adjustments in the following section of the manual:
Image Adjustment – Registration.

4.6.4 POLYGON MIRROR MOTOR AND DRIVE BOARD

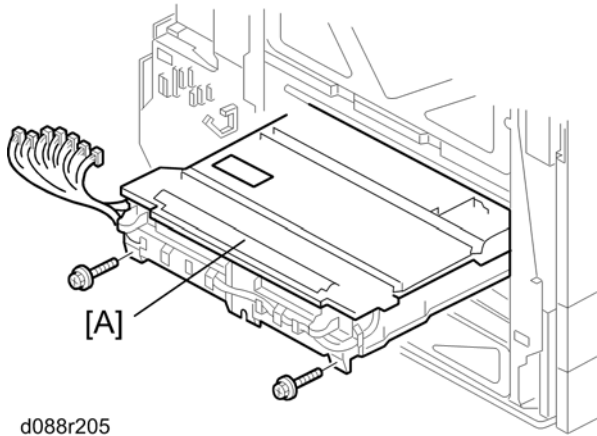



1. Laser optics housing unit [A] ( p.4-50)

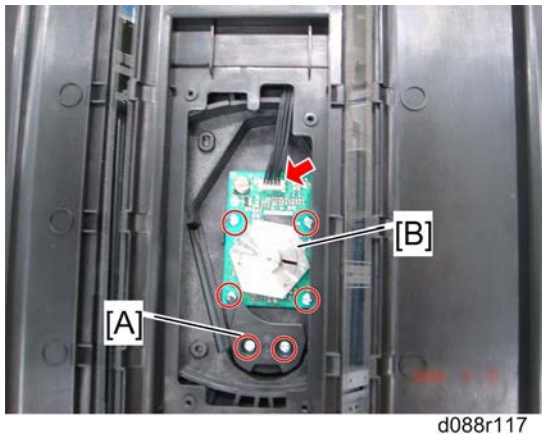

2. Polygon mirror motor cover [A] of the laser optics housing unit ( x 4)



3. Polygon mirror motor holder [A] ( x 2)
4. Polygon mirror motor [B] ( x 4,  x 1)

After installing the polygon mirror motor:

- 1) Do the "Forced Line Position Adj. Mode c" (SP2-111-3).
- 2) Then do the "Forced Line Position Adj. Mode a" (SP2-111-1).

Replacement
and
Adjustment

To check if SP2-111-1 was successful, watch the screen during the process. A message is displayed at the end. Also, you can check the result with SP2-194-10 to -12.

After you replace the motor, do the adjustments in the following section of the manual: Image Adjustment – Registration.

4.6.5 AIRFLOW FANS

1. Controller cover (🔧 p.4-17)
2. Left cover (🔧 p.4-17)

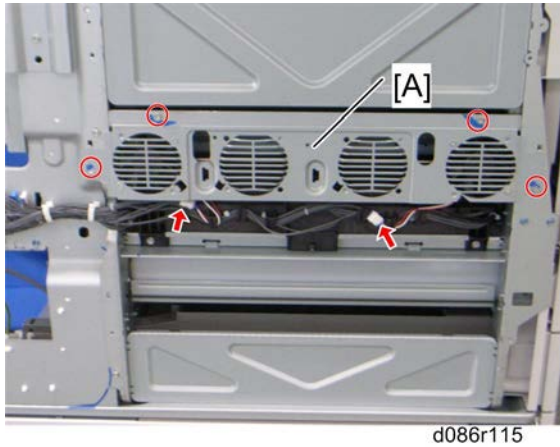

3. Airflow fan bracket [A] for the laser housing optics unit (🔧 x 4, 📦 x 2)

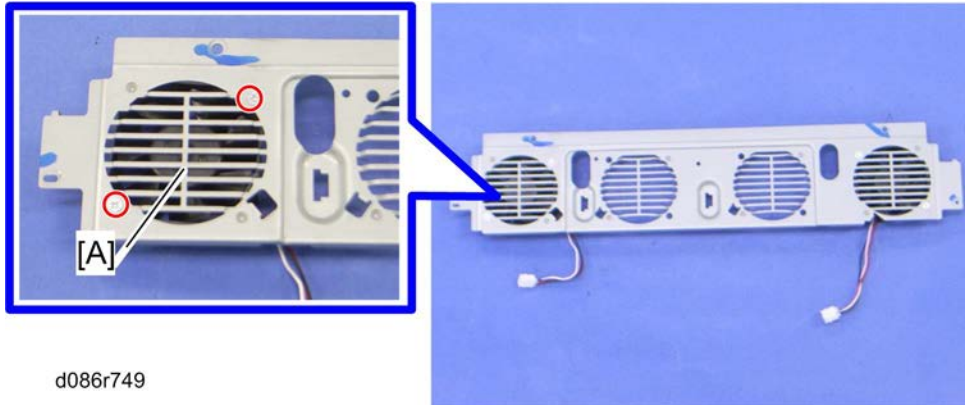

4. Airflow fans [A]
 - There are two airflow fans on the bracket.

4.6.6 LASER OPTICS REAR RIGHT THERMISTOR

1. Open the right door.
2. Fusing unit (☞ p.4-110)
3. Open the front door.
4. All PCDUs (☞ p.4-59)
5. Image transfer belt unit (☞ p.4-74)

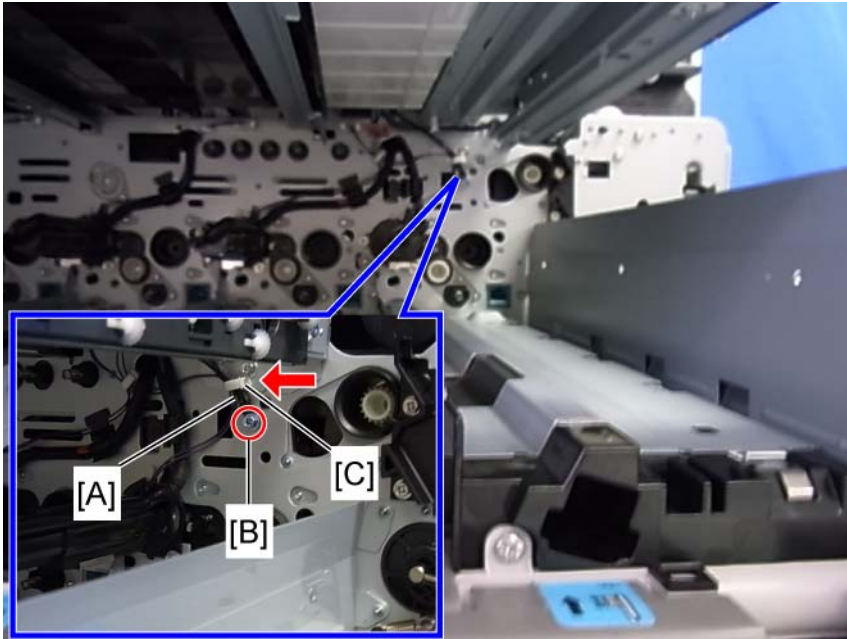

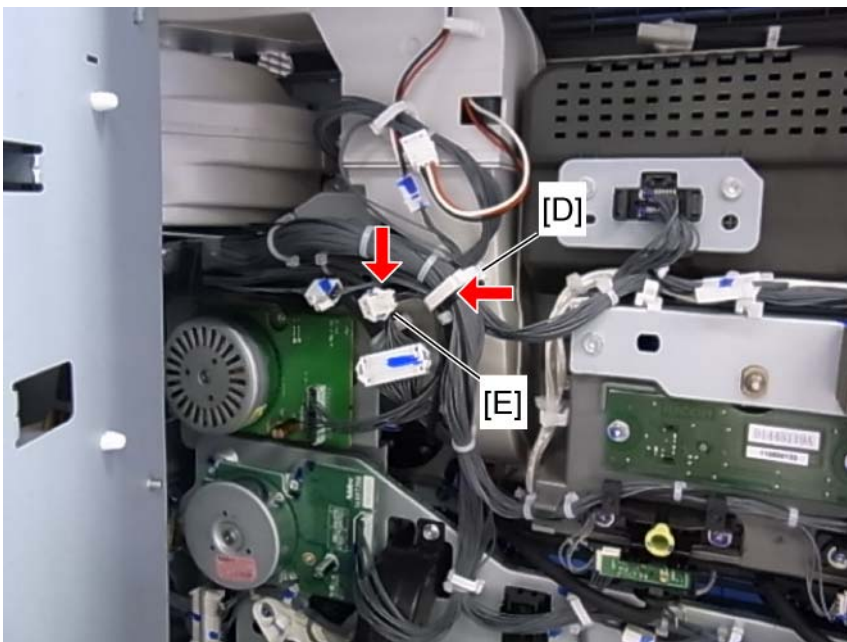

d1440141

6. Release the harness clamp [A] and remove the screw [B].
7. Open the controller box (☞ p.4-160).



d1440142

1. Release the harness clamp [D] and disconnect the thermistor connector [E].

2. Pull out the laser optics rear right thermistor [A] gently from behind by pinching its harness ( x 2,  x 1,  x 1).

Note

- **When reinstalling the laser optics rear right thermistor:**
- The thermistor harness is about 25 cm long. When routing the harness, use tweezers, and pay extra attention to avoid damaging the harness.

4.7 IMAGE CREATION

4.7.1 PCDU

Note

- Do not touch the OPC drum. Do not let metal objects touch the development sleeve.

- Open the front door.

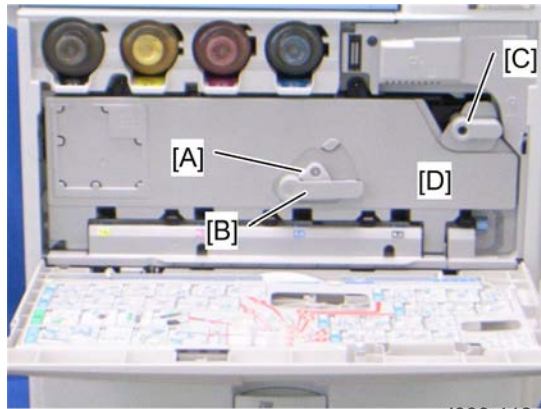

d088r118

- Lever lock [A] ( x 1)
- Turn the drum positioning plate lever [B] and the image transfer unit lock lever [C] counter-clockwise.
- Open the drum positioning plate [D].



d088r119

- Pull out the PCDU (hold the grip while you pull it out).

4.7.2 DRUM UNIT AND DEVELOPMENT UNIT

The new drum unit has a front cover and a front joint. When you attach the new drum unit to the development unit, remove a front cover and a front joint at first.

And use them for reassembling the new drum unit and development unit.

1. If you install a new drum unit, set SP 3902-xxx to "1".

- Black: 3902-009
- Yellow: 3902-010
- Cyan: 3902-011
- Magenta: 3902-012

Note

- If you do this, then the machine will reset the PM counter for the drum unit automatically, after you turn the power on again.

2. Turn the machine power off.

3. PCDU (🔧 p.4-59)

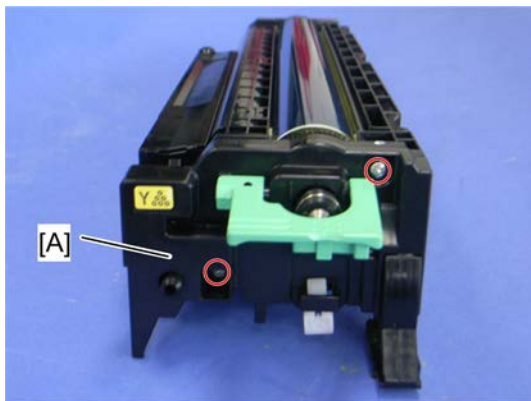

d027r120

4. Front cover [A] (🔧 x 2)

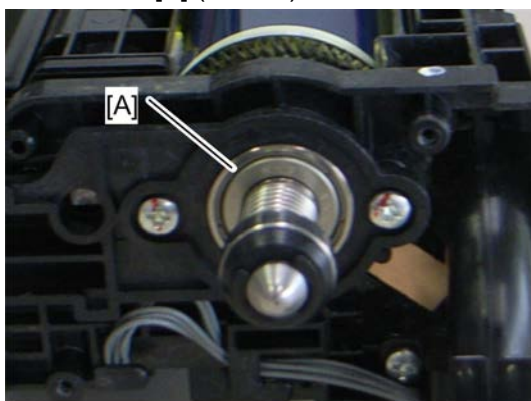

d027r121

Note

- Do not touch the bearing [A] after removing the front cover. The bearing is properly applied with lubricant.

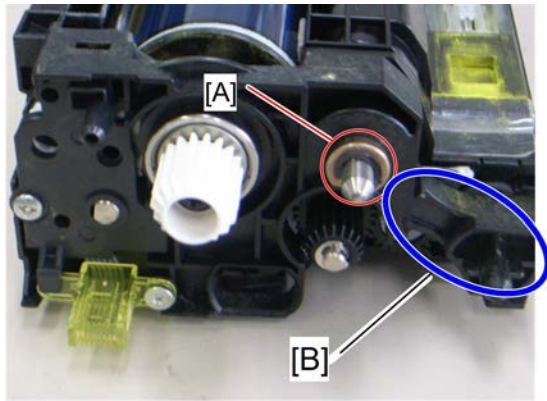

d027r122

5. Remove the bushing [A] of the development roller at the rear of the PCDU (Ⓢ x 1).

★ Important

- Do not put too much weight on the PCDU. Otherwise, the plastic frame [B] of the development unit may be damaged.

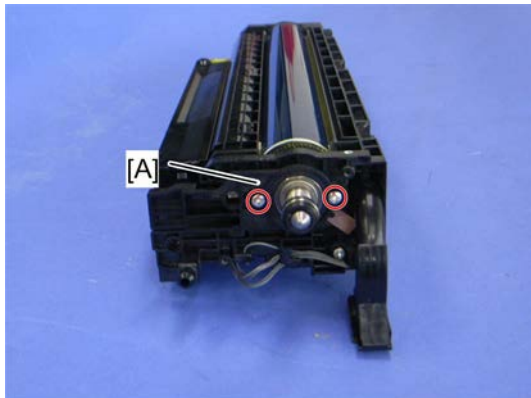

d027r123

6. Remove the front joint [A] (⚒ x 2, 📏 x 1).

↓ Note

- The front joint [A] is firmly set. Remove it with a flat screwdriver.

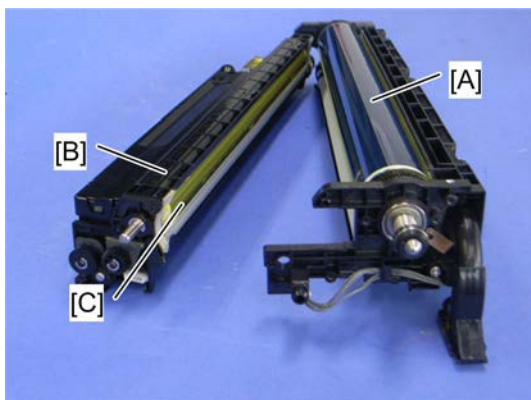

d027r124

7. Drum unit [A] and Development Unit [B]

↓ Note

- When the development unit is removed from the drum unit, clean the entrance mylar [C] with a vacuum.

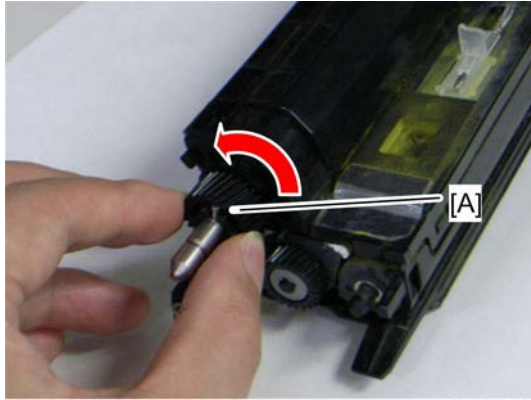

d027r412

8. Rotate the development roller [A] five or six times in the counterclockwise direction.

Note

- This step removes developer that has stuck to the development roller, which would cause color unevenness.

9. If you change the development unit, do the ACC procedure.
10. Execute the drum phase adjustment with SP1902-001 twice.

When reassembling the PCDU:

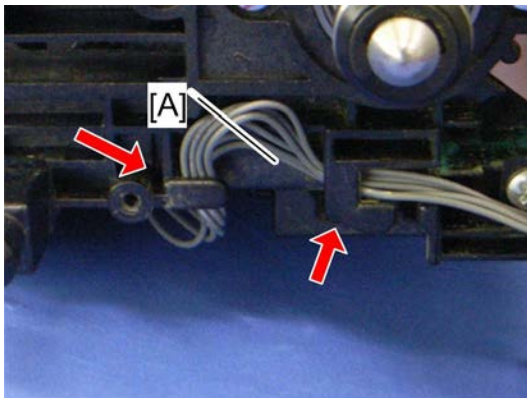

d027r681

- Make sure that the harness [A] is hooked as shown.

Developer

1. Set SP 3902-xxx to "1".
Black: 3902-005
Yellow: 3902-006
Cyan: 3902-007
Magenta: 3902-008
2. Turn the machine power off.
3. Development unit (📖 p.4-60)

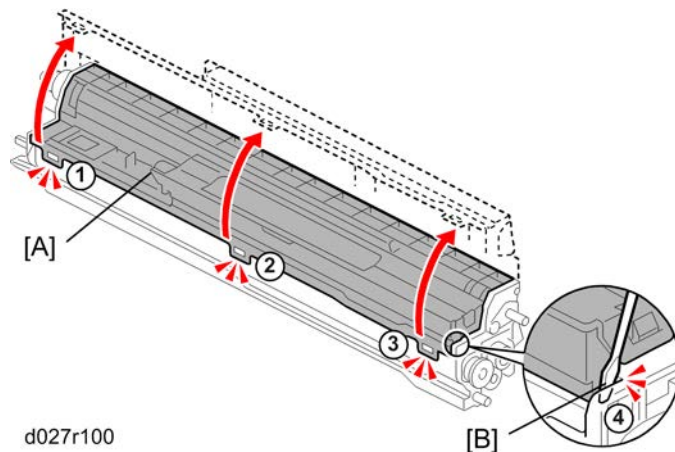

4. Hopper cover [A] (4 hooks)
 - Release the three hooks first in the correct order (from ① to ③).
 - Put the head of a screwdriver in the groove gap [B] as shown, and then release the hook ④.

⚠ CAUTION

- Follow the correct order ① to ④. Otherwise, the hopper cover may be damaged.
The hook ④ breaks easily.

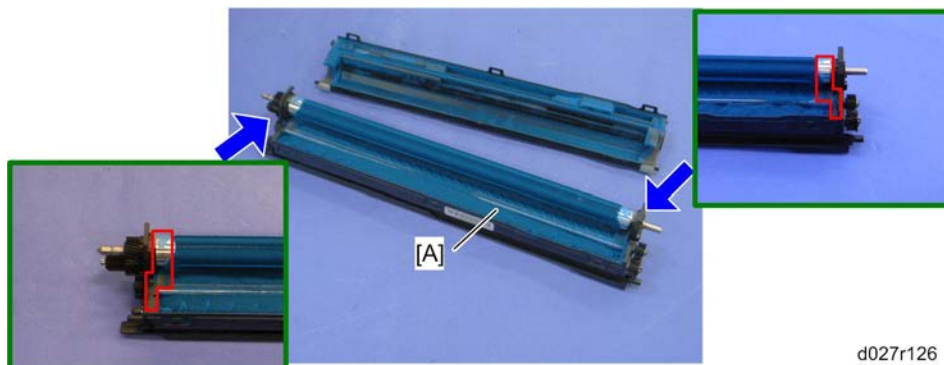

5. Shake a bag of developer and pour it into the development hopper [A].
6. Reattach the hopper cover (hook x 3).

⚠ CAUTION

- Keep the developer off at both ends of the development unit enclosed in red lines in the diagram.
7. Turn the machine power on. The machine initializes the developer and resets the PM counter for the developer. (For details of the developer initialization result, see "Developer Initialization Result" in the "Appendix: Process Control Error Conditions" chapter.
 8. Do the ACC procedure.

4.7.3 TONER COLLECTION BOTTLE

If you will install a new bottle, and the old bottle is not in a full or near-full condition, then set SP 3902-017 to 1.

Note

- If you do this, then the machine will reset the PM counter for the bottle automatically, after you turn the power on again.
 - If the bottle is in a full or near-full condition, it is not necessary to do this.
1. Turn off the main power switch.

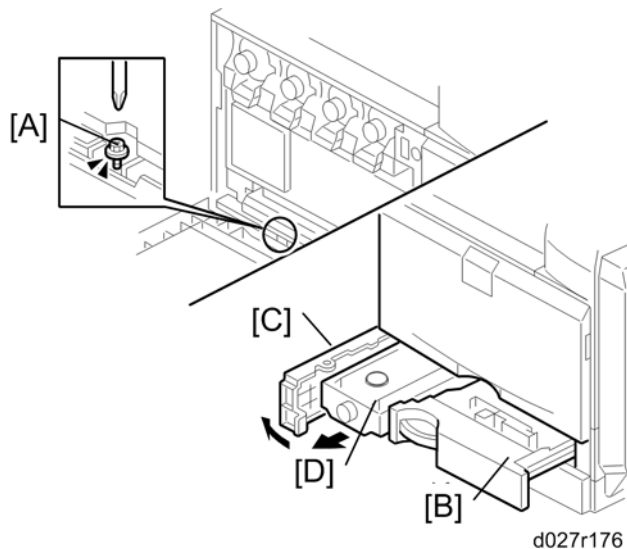

2. Open the front door and remove the screw [A].
3. Close the front door.
4. Pull out tray 1 [B].
5. Open the toner collection bottle door [C].
6. Pull out the toner collection bottle [D].

4.7.4 SECOND DUCT FAN

1. Rear cover (🔧 p.4-18)
2. Right rear cover (🔧 p.4-19)
3. Open the controller box (🔧 p.4-160)

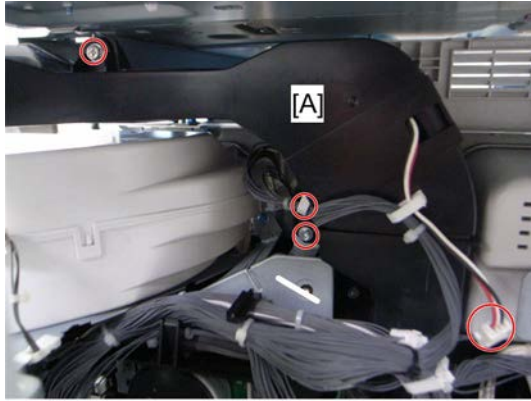

d027r127

4. Second duct [A] (🔧 x 2, 📏 x 1, 📏 x 2)

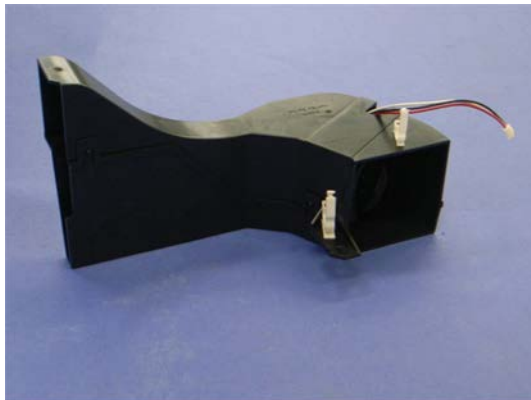

d027r128

5. Split the second duct (4 hooks).

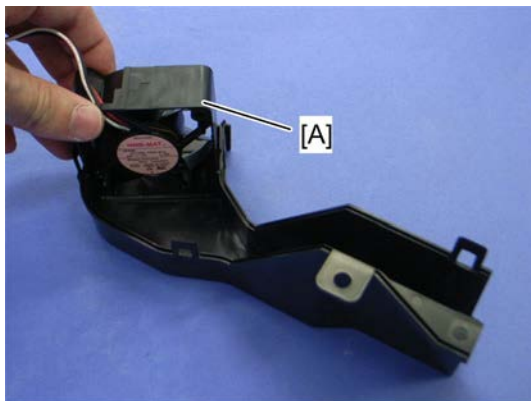

d027r129

6. Second duct fan [A]

When reinstalling the second duct fan

Make sure that the second duct fan is installed with its decal facing to the front of the machine.

4.7.5 THIRD DUCT FAN

1. Rear cover (🔧 p.4-18)
2. Right rear cover (🔧 p.4-19)
3. Open the controller box (🔧 p.4-160)

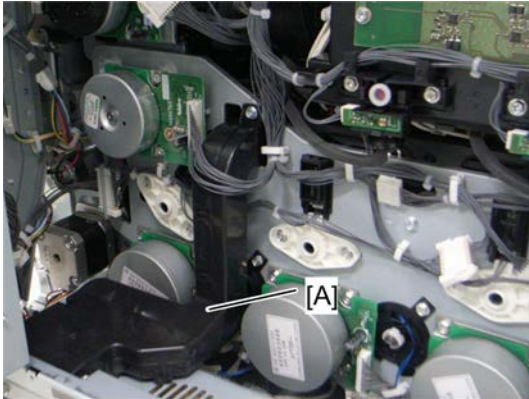

d027r130

4. Third duct [A] (🔧 x 2, 📏 x 1)



d027r131

5. Third duct fan [A] (3 hooks)

When reinstalling the third duct fan

Make sure that the third duct fan is installed with its decal facing to the upper side of the machine.

4.7.6 TONER PUMP UNIT

There are four pump units inside the machine. This procedure describes the replacement procedure only for one unit. If you need to replace another unit, do the same as this procedure.

Note

- Put some sheets of paper on the floor before doing this procedure. Toner may fall on the floor.

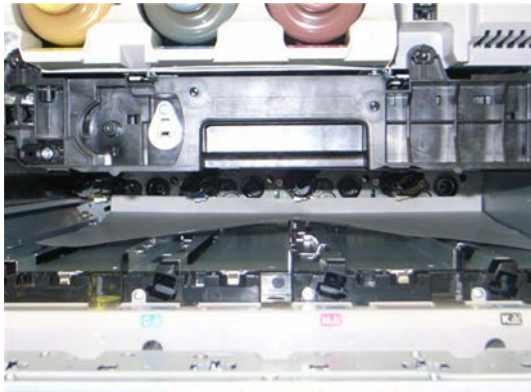

d027r132

- Rear cover (📖 p.4-18)
- Image transfer belt unit (📖 p.4-74)
- All PCUs (📖 p.4-59)
- Put a sheet of paper (A3/DLT) inside the machine as shown and on the floor.

Note

- The sheet of paper on the floor is used in a later step.

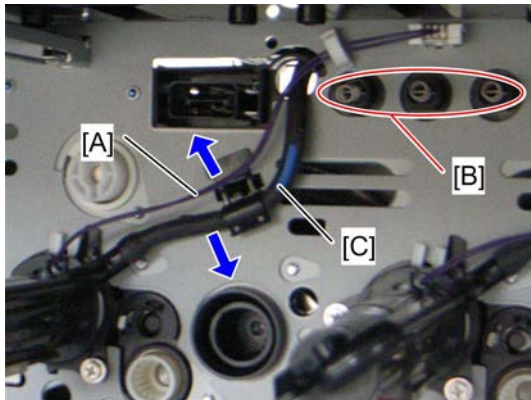

d027r134

- Release the harness [A] from the clamp (📖 x 1 for YCM, 📖 x 2 for K) and hook, and then disconnect the harness.

Image Creation

Note

- Avoid touching these spring terminals [B].

6. Release the toner supply tube [C].

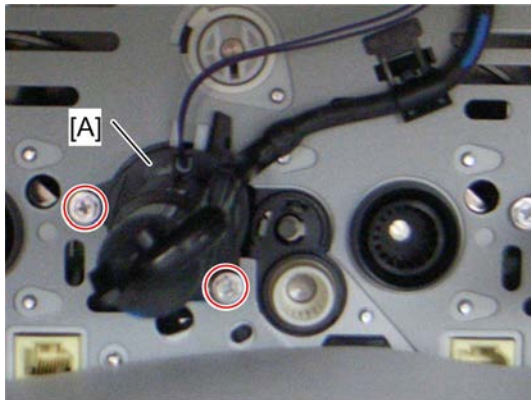

d027r135

7. Remove the toner pump unit [A] ( x 2)



d027r136

- Make sure that a sheet of paper is attached to the frame of the rear side. The picture on the left shows a sheet of paper that is correctly set, but the picture on the right shows a sheet of paper that is not correctly set. This sheet of paper prevents toner and screws from falling into the laser optics housing unit through cutouts.

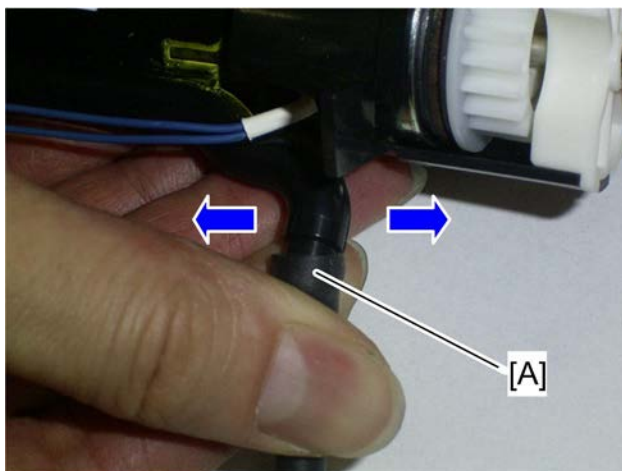

d027r705

8. Slowly remove the toner supply tube [A] from the toner pump unit by pulling the tube right and left.
9. Turn up the openings of the toner pump unit and toner supply tube just after removing the tube.

↓ **Note**

- If not, the toner may scatter away and fall down.

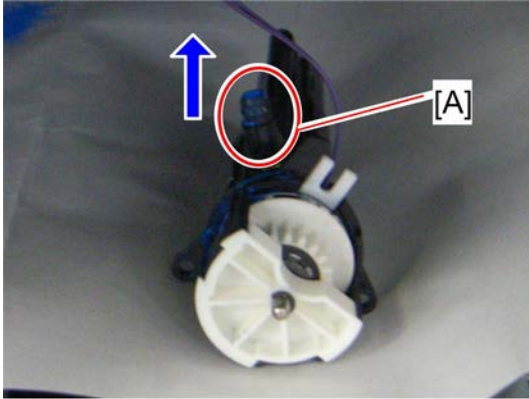

d027r137

10. Put the toner pump unit on the sheet of paper, which has been put in step 4, with its opening [A] up.

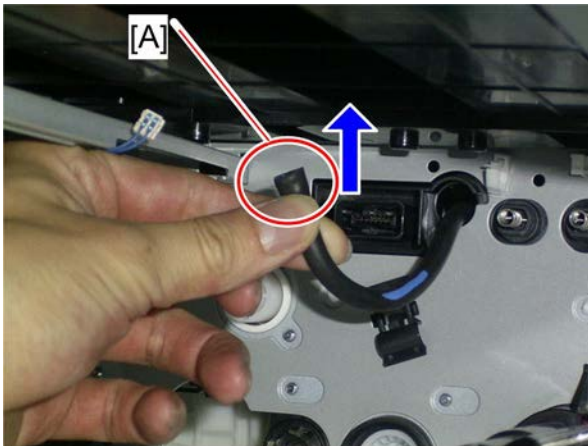

d027r707

11. Keep the opening [A] of the toner supply tube up, and then clip the opening of the toner supply.

When you install the new toner pump unit

Before installing the new toner pump unit, mask the opening of the old toner pump unit with tape. Dispose of it following local rules.

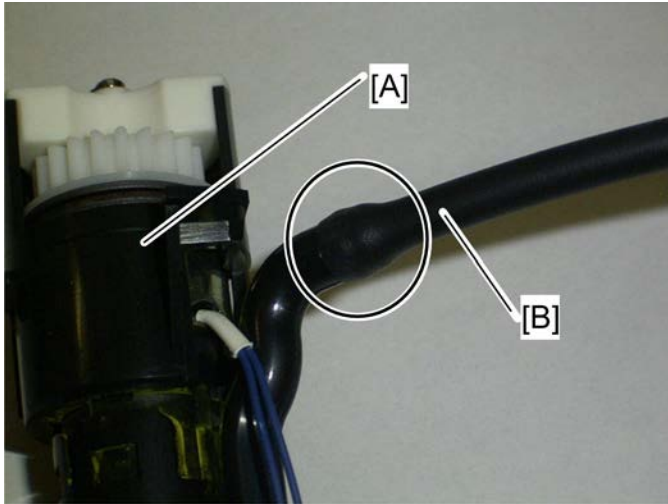

1. Put a sheet of paper (A3/DLT) inside the machine.
2. Turn up the opening of the toner supply tube, and then remove the object that was used to clip the opening of the toner supply tube.
3. Insert the opening of the toner pump unit [A] into the opening of the toner supply tube [B] as far as possible.

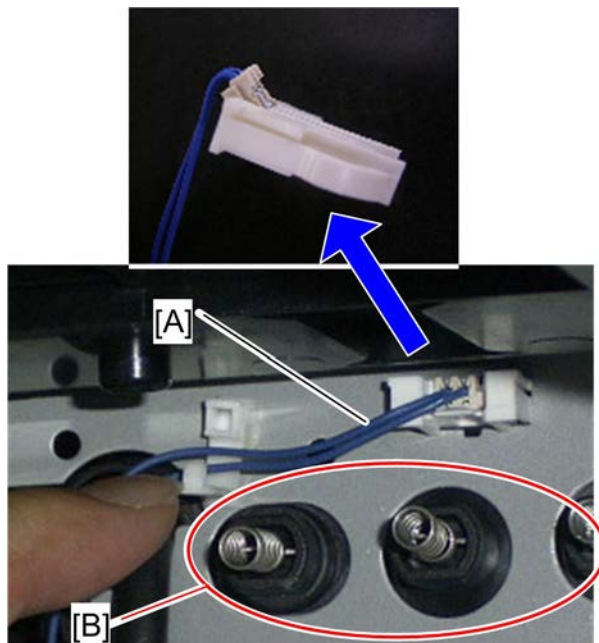

d027r709

4. Connect the harness [A] to the connector of the machine.

↓ **Note**

- On the above picture, the magnified picture of the connector shows the easiest way to connect it.

5. Clamp the harness [A] (🔧 x 1 for YCM, 🔧 x 2 for K).

↓ **Note**

- Avoid touching these spring terminals [B].

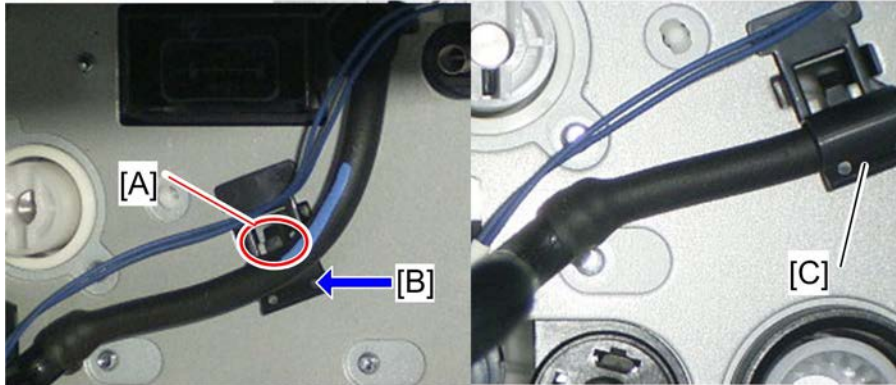

d027r710

6. Pass the harness of the toner pump unit behind the hook [A], while pressing at [B].
7. Secure the toner supply tube with the holder [C], lifting up the edge of the holder "very gently".

↓ **Note**

- Be careful when you lift the edge of the holder, because the holder is easily broken.

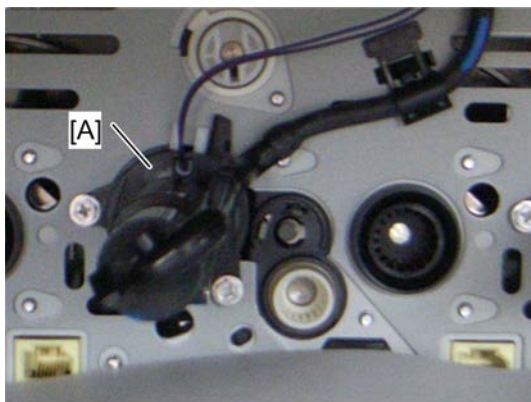

d027r135a

8. Insert the toner pump unit [A] into the rear frame of the machine (🔧 x 2).

4.7.7 TONER END SENSOR

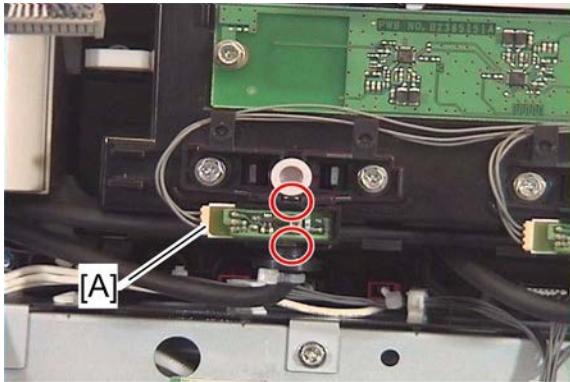

d027r042

1. Rear cover (🔧 p.4-18)
2. Open the controller box (🔧 p.4-160)
3. Toner end sensor [A] (🔧 x 1, 2 hooks each)

⚠ Note

- A toner end sensor is not installed in the entrance of the toner supply tube for black.

4.8 IMAGE TRANSFER

4.8.1 IMAGE TRANSFER BELT CLEANING UNIT

1. If you will install a new belt cleaning unit, then set SP 3902-015 to 1.

Note

- If you do this, then the machine will reset the PM counter for the belt cleaning unit automatically, after you turn the power on again.
- Do not use SP3902-015 or 013 if you replace the complete ITB unit.

2. Turn off the main power switch.
3. Open the right door.
4. Open the front door.
5. Open the drum positioning plate. (☞ p.4-59)

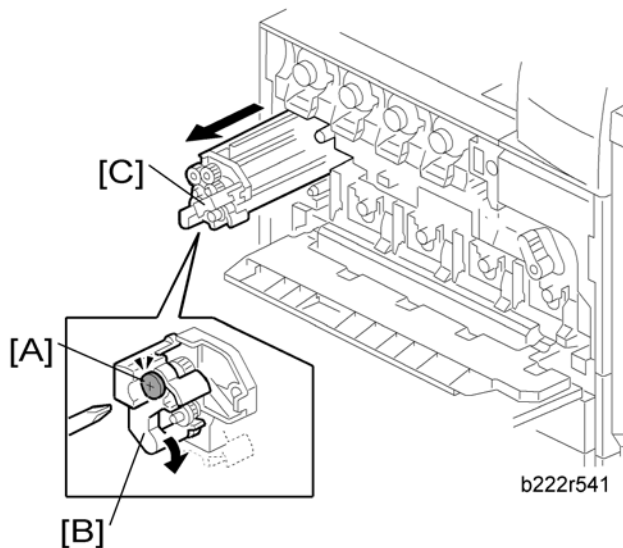

6. Loosen the screw [A].
7. Turn the lock lever [B] clockwise
8. Pull out the image transfer belt cleaning unit [C].

4.8.2 IMAGE TRANSFER BELT UNIT

1. Open the right door.
2. Open the front door.
3. Open the drum positioning plate. (▶ p.4-59)

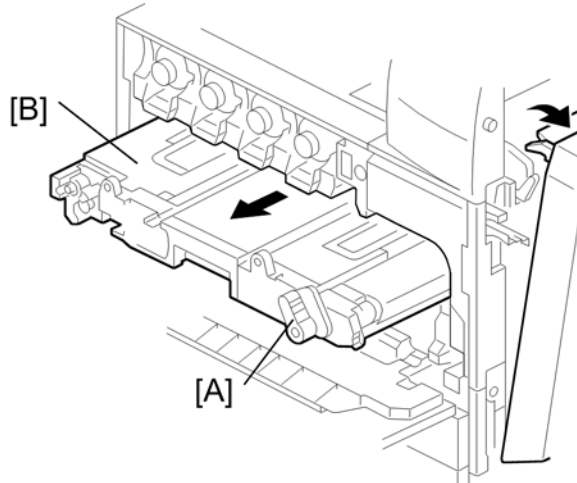

d027r171

4. Image transfer belt cleaning unit (▶ Image Transfer Belt Cleaning Unit)
5. Turn the image transfer belt unit lock lever [A] counterclockwise.
6. Pull out the image transfer belt unit [B] halfway.

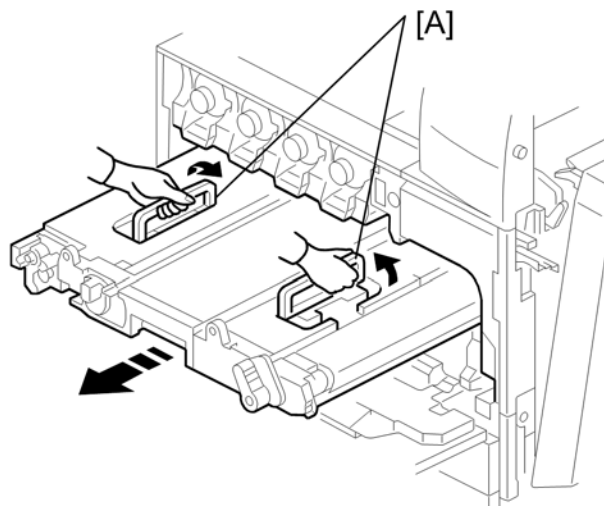

d027r172

7. Grasp the handles [A], and then pull out the image transfer belt unit fully.

4.8.3 IMAGE TRANSFER BELT

1. Image transfer belt cleaning unit (🔧 p.4-73)
2. Image transfer belt unit (🔧 p.4-74)

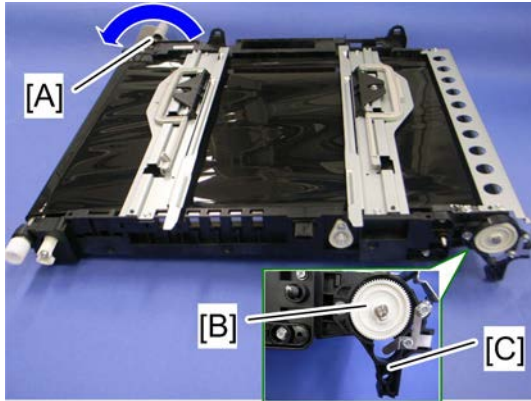

d027r138

3. Turn the image transfer unit contact lever [A] counterclockwise (as seen from the rear).
4. Gear [B] (hook x 1)
5. Turn the gear cover [C] clockwise (as seen from the rear) (🔧 x 1).

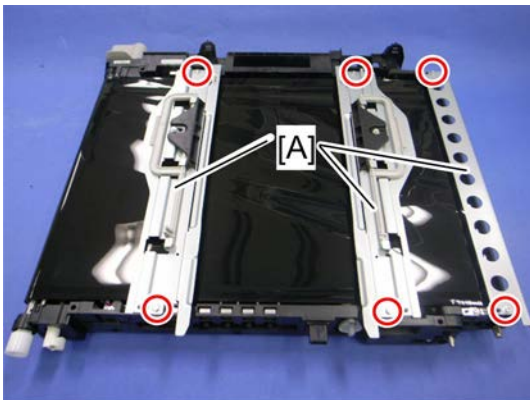

d027r139

6. Three stays [A] (🔧 x 6)

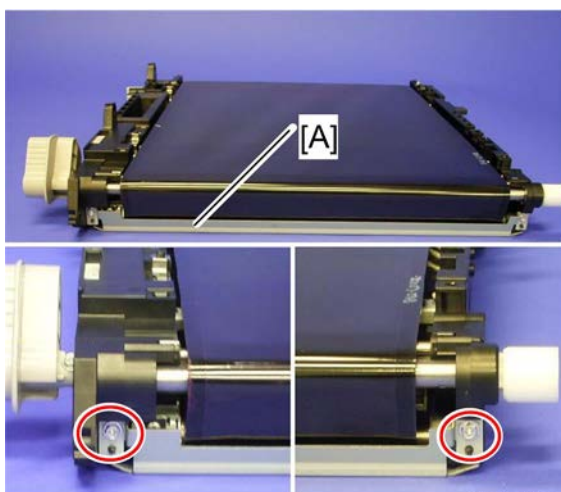

d027r545

7. Guide plate [A] (as seen from the right side of the machine) (🔧 x 2)

Image Transfer

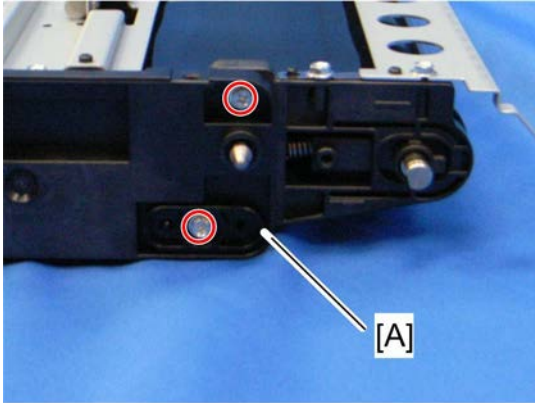

d027r545a

8. Remove the two screws and then the rear holder bracket [A] (as seen from the rear).

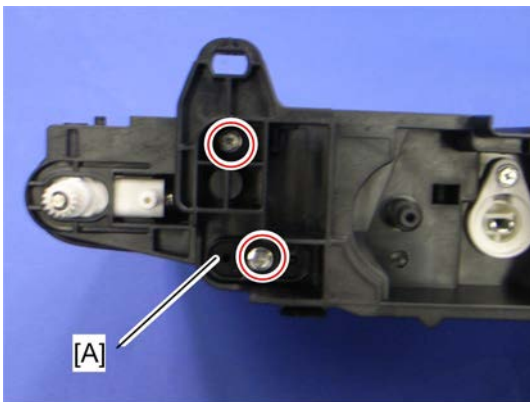

d027r140

9. Remove the two screws and then the front holder bracket [A] (as seen from the front).



b222r548

10. Put the front side of the image transfer belt unit on a corner of the table or a box as shown.

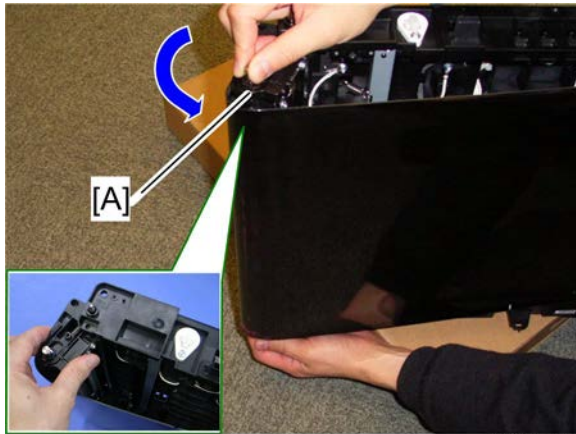

d027r549

11. Pull the tension roller [A] as shown.



d027r550

12. Image transfer belt [A]

Replacement
and
Adjustment

When reinstalling the image transfer belt

- Clean all rollers with dry cloth before installing the image transfer belt.

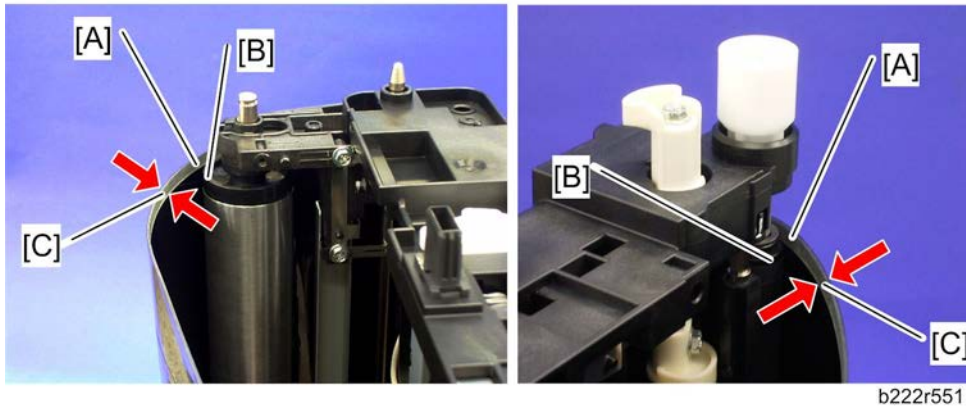

- There is a rim [A] at each edge of the transfer belt. The ends of all the rollers ([B] for example) in the transfer belt unit must be between the two rims.

Note

- There are two rims (width [C]: about 5 mm) on the underside of the front and rear edges of the image transfer belt.

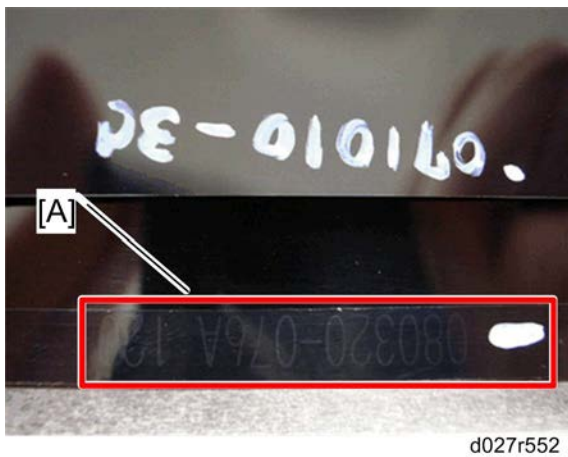

- This belt must be installed the correct way around. When you reinstall the image transfer belt unit, install it with the number [A] on the belt at the rear side of the unit.

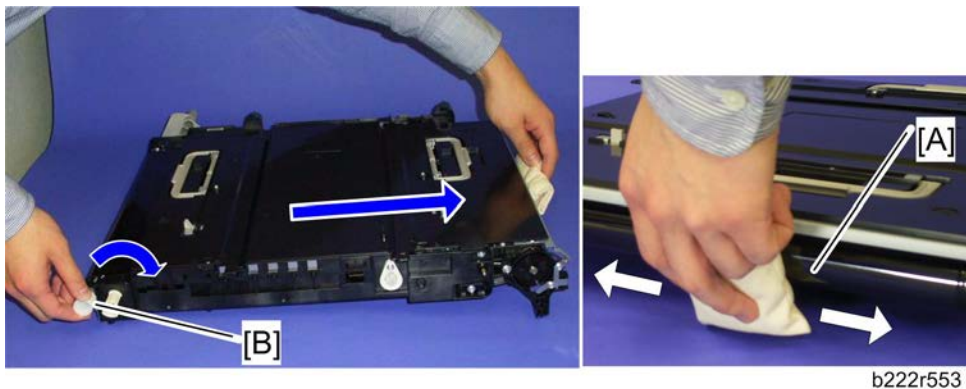

- Put "Lubricant Powder" (B132 9700) on the surface of the image transfer belt [A], while you turn the drive gear [B] at a constant speed, as shown. (The straight arrow in the picture shows belt movement direction.) Lubricant powder prevents the image transfer cleaning blade from turning up.

 **Note**

- Do not put the lubricant powder at the right side of the image transfer belt unit (the above picture is taken from the rear). Otherwise, lubricant powder may damage the encoder sensor.

4.9 PAPER TRANSFER

4.9.1 PAPER TRANSFER ROLLER UNIT

If you will install a new paper transfer unit, then set SP 3902-016 to 1.

Note

- If you do this, then the machine will reset the PM counter for the paper transfer unit automatically, after you turn the power on again.

1. Open the right door.

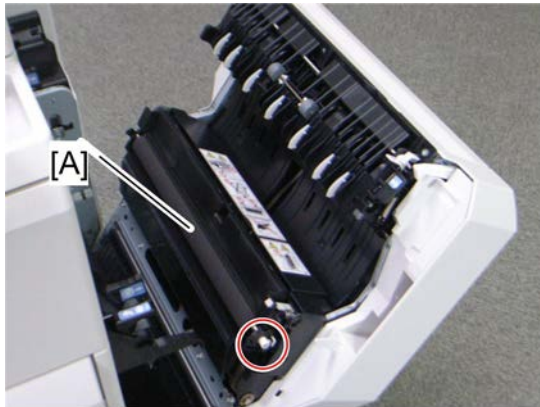

d088r141

2. Release the white hook.
3. Paper transfer roller unit [A]

4.9.2 PAPER TRANSFER UNIT

If you will install a new paper transfer unit, then set SP3-902-016 to 1.

Note

- If you do this, then the machine will reset the PM counter for the paper transfer unit automatically, after you turn the power on again.

1. Turn off the main power switch.

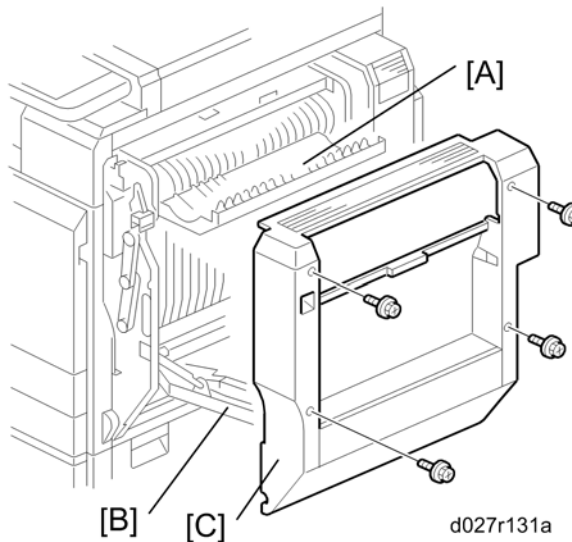

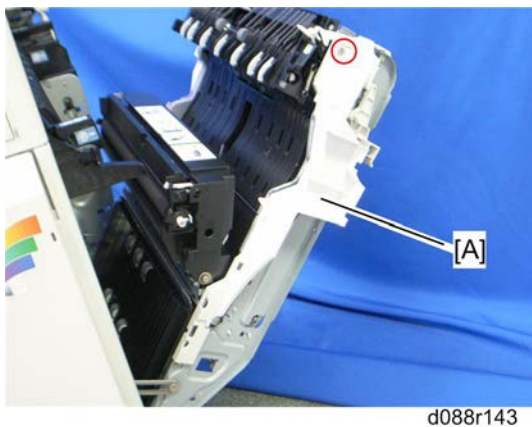

2. Open the duplex door [A].
3. Open the by-pass tray [B]
4. Right door cover [C] ( x 4)
5. Open the right door.

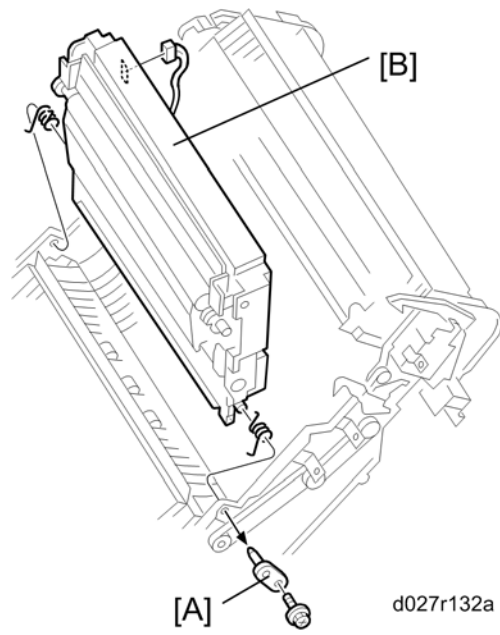

6. Right door inner cover [A] ( x 1)

Paper Transfer



7. Pivot bracket [A] ( x 1)
8. Paper transfer unit [B] ( x 1, 2 springs)

4.9.3 ID SENSOR BOARD

1. K PCDU (🔧 p.4-59)
2. Open the right door.
3. Fusing unit (🔧 p.4-110)
4. Image transfer belt unit (🔧 p.4-74)

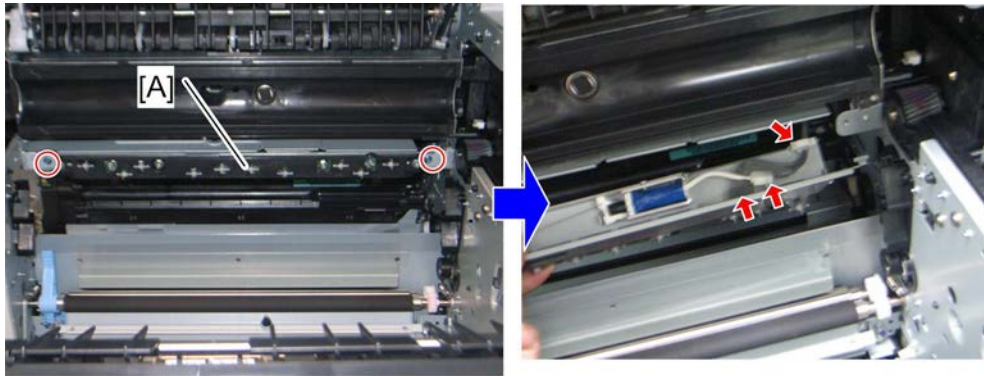

d088r145

5. ID sensor unit [A] (🔧 x 2, 📄 x 2, 📄 x 1)

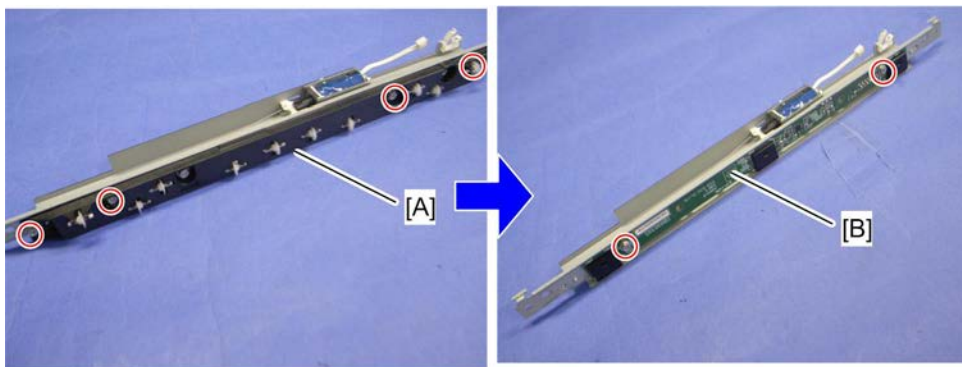

d088r146

6. ID sensor cover [A] (🔧 x 4)
7. ID sensor board [B] (🔧 x 2)

Replacement
and
Adjustment

Cleaning for ID sensors

ID sensors require a cleaning procedure every EM. Do the following steps for ID sensor cleaning.

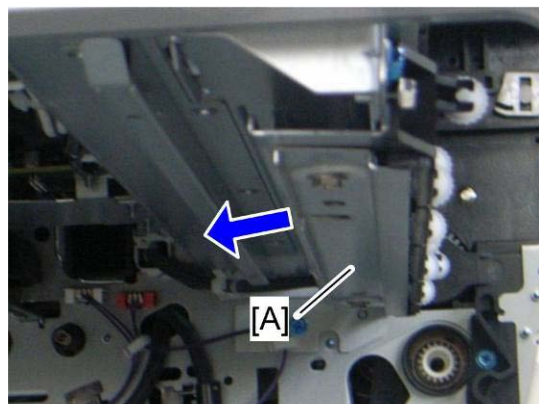

d027r147

1. K PCDU (☞ p.4-59)
 2. Fusing unit (☞ p.4-110)
 3. Image transfer belt unit (☞ p.4-74)
 4. Slide the ID sensor shutter [A] to the left side.
- ⇒ 5. Clean the ID sensors with a blower brush keeping the ID sensor shutter to the left.

After installing a new ID sensor unit/board

Do the following adjustment after installing a new ID sensor unit/board.

1. Plug in and turn on the main power switch of the copier.
2. Enter the SP mode.

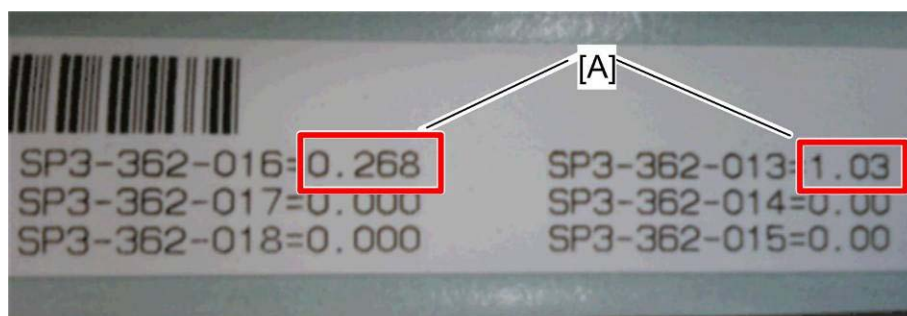

d088r502

3. Input two correction coefficients [A] for the ID sensor with SP3-362-013 and SP3-362-016 on the barcode sheet provided with the new ID sensor unit/board.

Note

- For example, input "1.03" with SP3-362-013.
 - SP numbers other than SP3-362-013 and -016 are not required for this procedure.
4. Exit the SP mode.

4.9.4 TEMPERATURE AND HUMIDITY SENSOR

1. Rear cover (🔧 p.4-18)
2. Right rear cover (🔧 p.4-19)

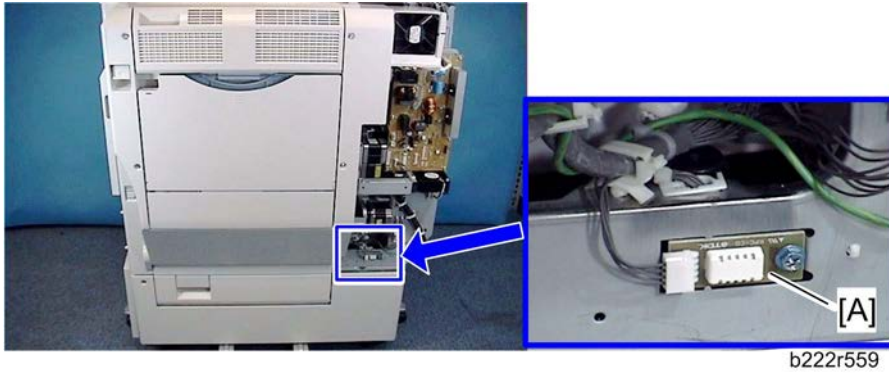

3. Temperature and humidity sensor [A] (🔧 x 1, 📦 x 1)

4.10 DRIVE UNIT

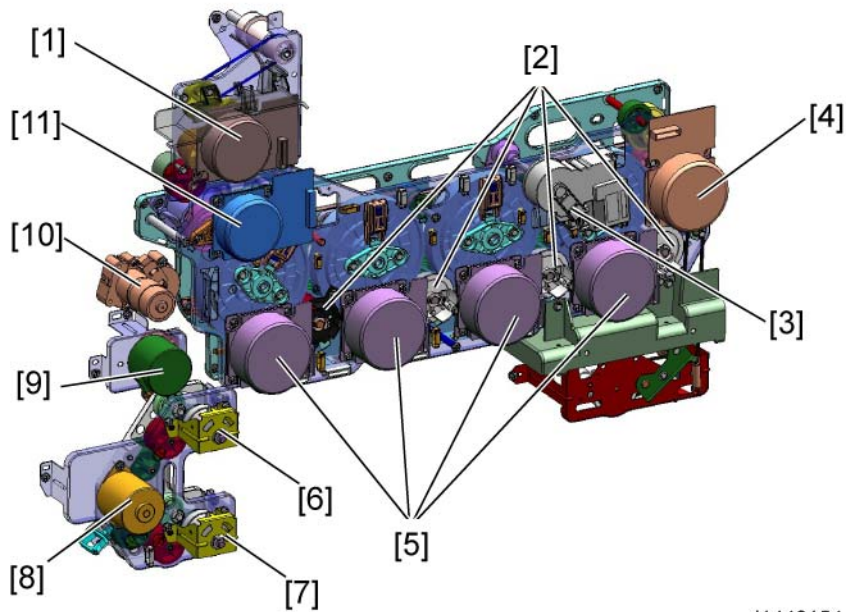

d1440154

The drawing above shows the drive unit layout.

<ol style="list-style-type: none"> 1. Fusing/paper exit motor 2. Development clutches 3. Image transfer belt contact motor 4. Toner transport motor 5. Drum/Development drive motors 6. Paper feed clutch – Tray 1 	<ol style="list-style-type: none"> 7. Paper feed clutch – Tray 2 8. Paper feed motor 9. Registration motor 10. Paper transfer contact motor 11. ITB drive motor
--	--

There are some motors and clutches that are not shown in the above drawing:

<ul style="list-style-type: none"> ▪ Tray lift motor 1 and 2 ▪ Duplex inverter motor ▪ Duplex/By-pass Motor 	<ul style="list-style-type: none"> ▪ Junction gate 1 motor ▪ Shutter motor ▪ By-pass clutch
--	--

4.10.1 GEAR UNIT

1. All PCDU's
2. Image transfer belt unit (🔧 p.4-74)
3. Rear cover (🔧 p.4-18)
4. Controller box (🔧 p.4-160)



d1440153

5. Toner sump cover [A] (🔧 x 2)
6. Third duct (🔧 p.4-66)
7. Left cover (🔧 p.4-17)
8. PSU bracket (🔧 p.4-168)

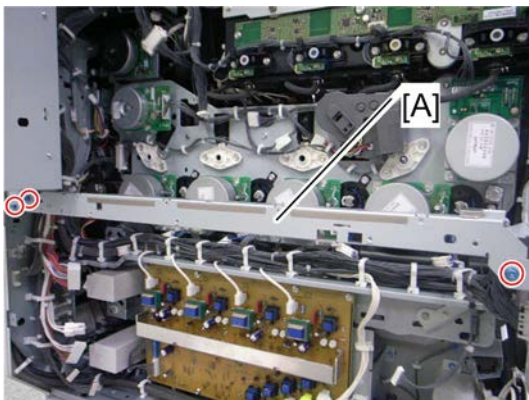

d027r148

9. Remove the rear stay [A] (🔧 x 3).

Replacement
and
Adjustment

Drive Unit



d027r149

10. Remove ten clamps (blue arrows).



d027r150

11. Release seven clamps and turn each harness aside.



d027r151

12. Disconnect four connectors (red arrows).

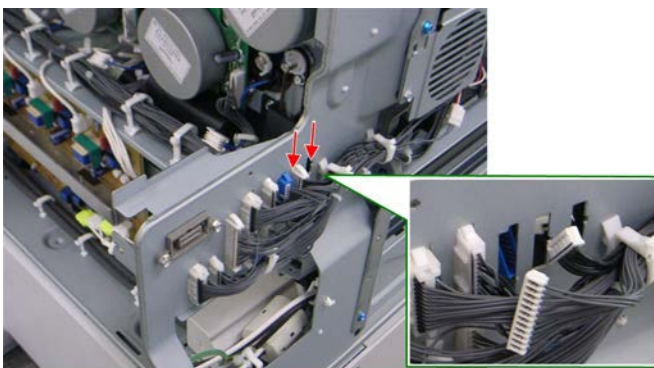

d027r152

13. Disconnect two connectors (red arrows) and put these harnesses inside the machine.

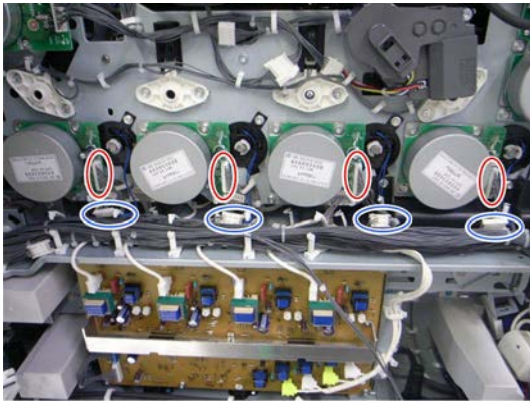

d027r153

14. Disconnect each connector (red circles) from the drum/development drive motors (🔌 x 1, 🗑️ x 1 each).
15. Disconnect each connector (blue circles) from the development clutches (🔌 x 1 each).

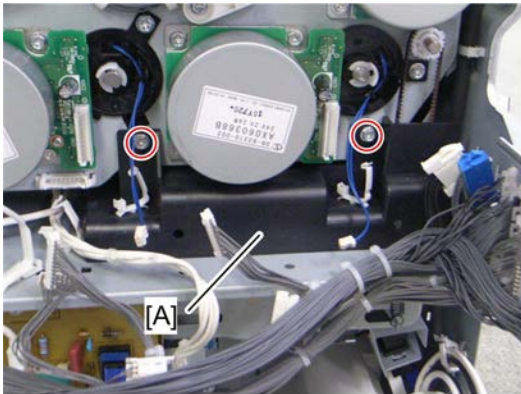

d027r155

16. Cover [A] (🔩 x 2)

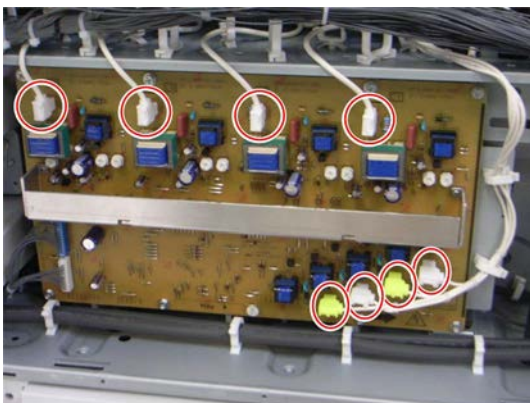

d027r156

17. Disconnect eight connectors from the high voltage supply board (🔌 x 8, 🗑️ x 2).

Replacement and Adjustment

Drive Unit

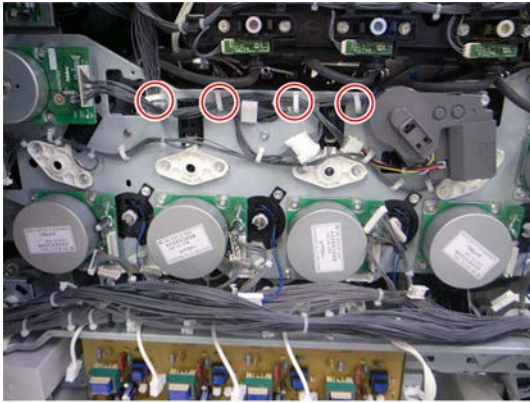

d027r157b

18. Release four clamps (red circles) and turn the harnesses aside.

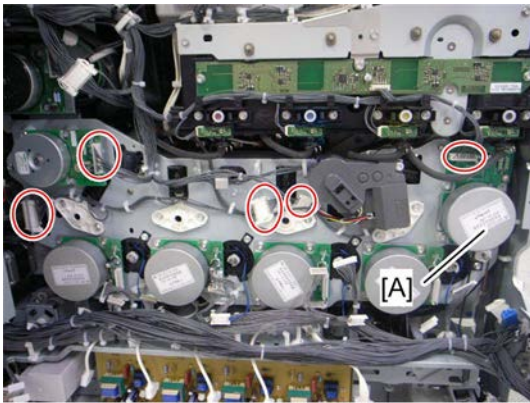

d027r158

19. Disconnect five connectors (red circles) (⚙️ x 5).
20. Toner transport motor [A] (⚙️ x 3)

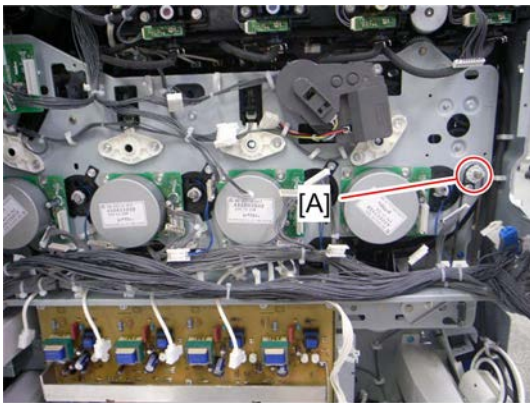

d027r159

21. Pulley [A] (timing belt)

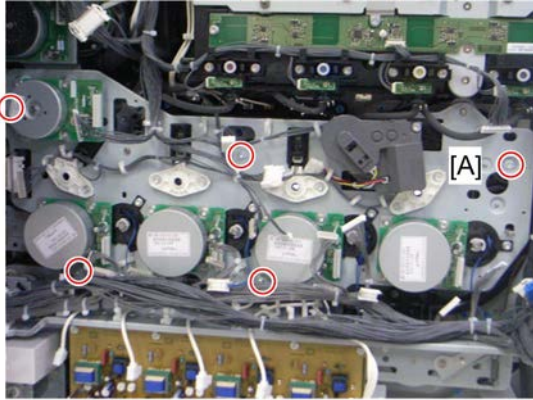

d027r160a

22. Gear unit [A] ( x 8)

When installing the drive unit

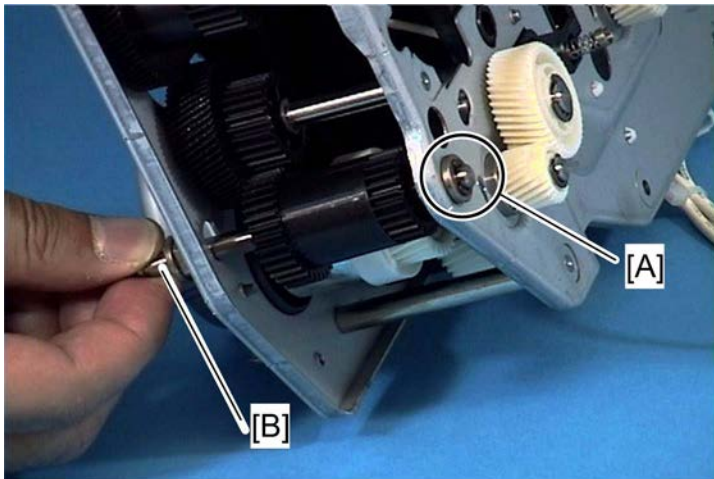

b222r573

Make sure that the bushing [A] is fully set in the frame of the gear unit before installing the timing belt and pulley to the shaft [B].

Replacement
and
Adjustment

Adjustment after replacing the gear unit

Do the following procedures after replacing the gear unit.

1. Turn on the main power switch.
2. Enter "System SP" in the SP mode.
3. Do "Amplitude Control" with SP1-902-001.
4. Check the result of the Amplitude Control with SP1-902-002.

0: Success, 2: Failure due to no sampling data,

3: Failure due to insufficient number of pattern detections

When the result of this adjustment is "2" or "3":

- Check that all the PCDUs are correctly set and that the image transfer belt unit is correctly set.
- Do "Amplitude Control" again after checking the PCDUs and image transfer belt unit.

When the result is still "2" or "3" after checking the PCDUs and image transfer belt unit:

- Check that the gear unit is installed correctly.

5. Exit the SP mode.

4.10.2 REGISTRATION MOTOR

1. Rear cover (🔧 p.4-18)
2. Right rear cover (🔧 p.4-19)
3. Ventilation duct (🔧 p.4-167)
4. PSU bracket (🔧 p.4-168)

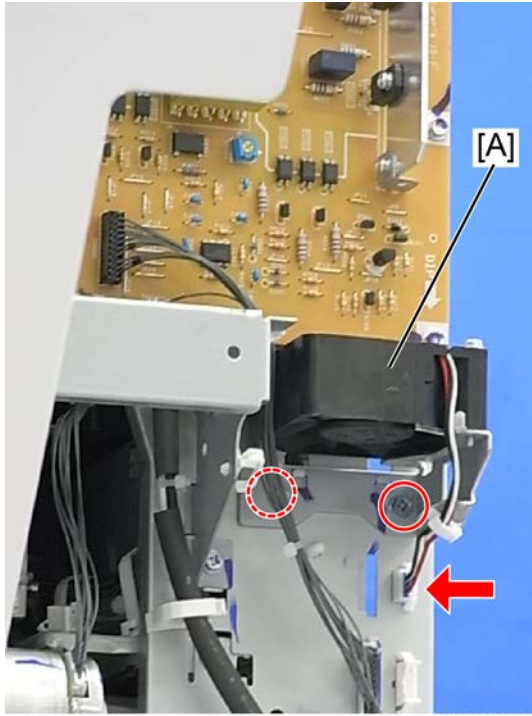

Replacement and Adjustment

5. Fusing power supply board fan bracket [A] (🔧 x 2, 📁 x 1)

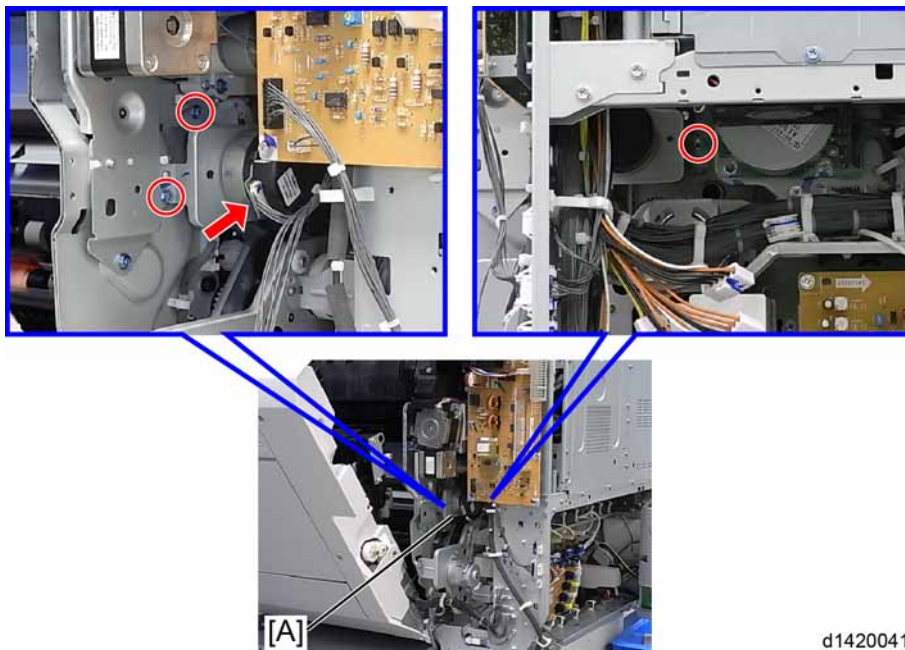

6. Registration motor assembly [A] (🔧 x 3, 📁 x 1)

Drive Unit

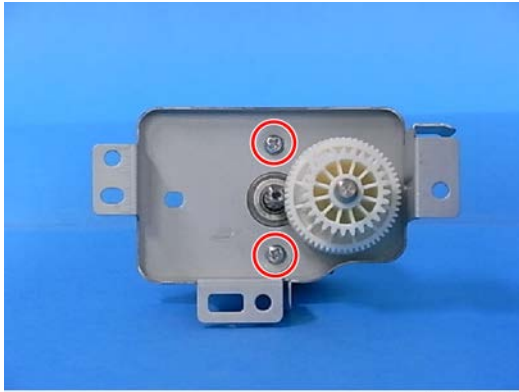

d1420042

1. Registration motor (🔧 x 2)

4.10.3 PAPER FEED MOTOR

1. Rear cover (🔧 p.4-18)
2. Right rear cover (🔧 p.4-19)

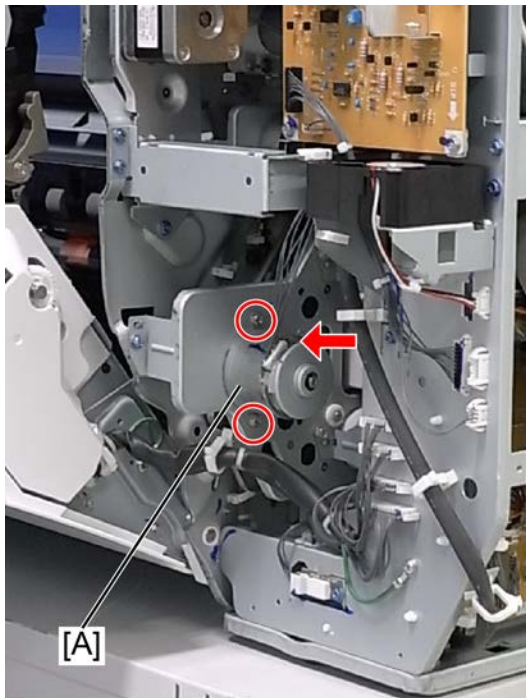

d1420040

3. Paper feed motor [A] (🔧 x 1, 🔧 x 2)

4.10.4 DRUM/DEVELOPMENT MOTORS FOR M, C, AND Y

1. Rear cover (🔧 p.4-18)
2. PSU bracket (🔧 p.4-168)
3. Open the controller box (🔧 p.4-160).

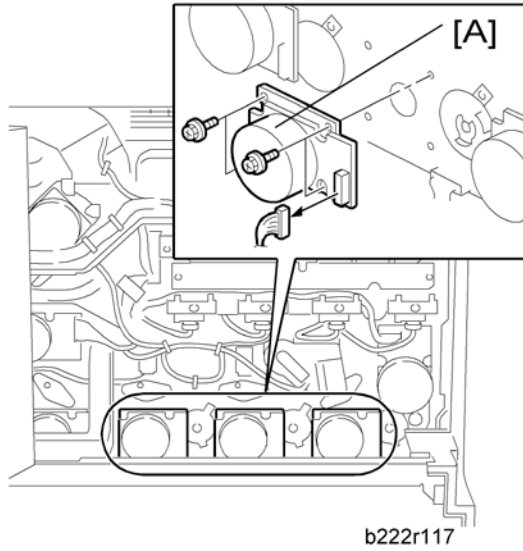

4. Drum/Development motors (three motors, one each for MCY) [A] (🔧 x 4, 📄 x 1 each)

4.10.5 DRUM/DEVELOPMENT MOTOR-K

1. Rear cover (🔧 p.4-18)
2. PSU bracket (🔧 p.4-168)
3. Controller box (🔧 p.4-160)

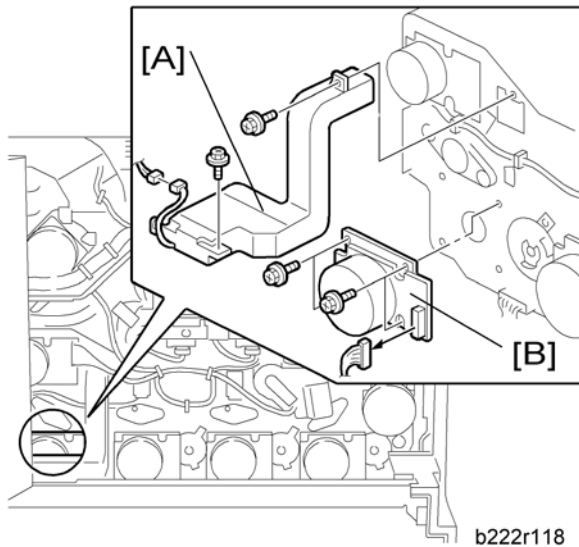

4. Third duct [A] (🔧 x 2, 📄 x 1)
5. Drum/Development motor-K [B] (🔧 x 4, 📄 x 1)

4.10.6 ITB DRIVE MOTOR

1. Rear cover (🔧 p.4-18)
2. Controller box (🔧 p.4-160)

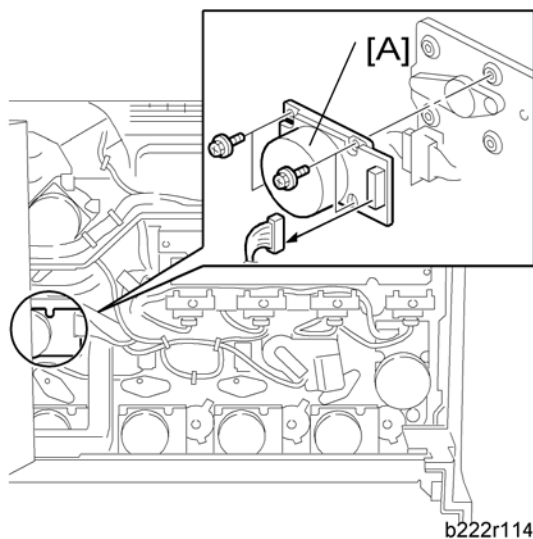

3. ITB drive motor [A] (🔧 x 4, 📄 x 1)

4.10.7 FUSING/PAPER EXIT MOTOR

1. Rear cover (🔧 p.4-18)
2. Open the controller box. (🔧 p.4-160)

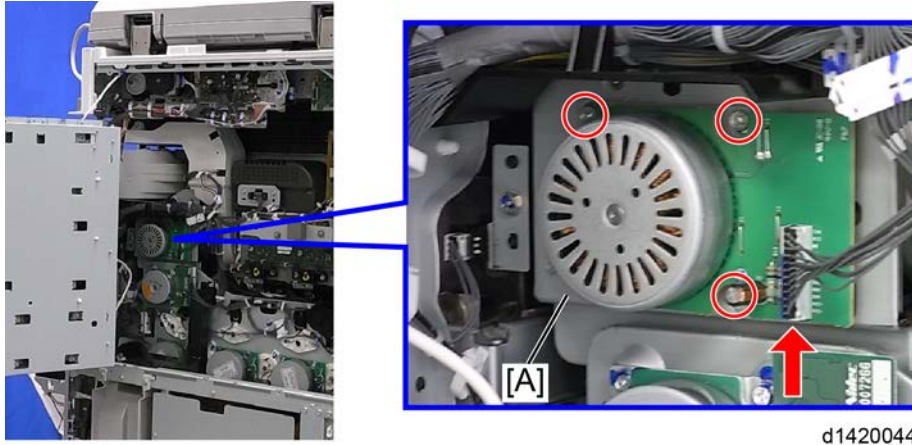

Note

- You will need a short screwdriver to attach the screw.

3. Fusing/paper exit motor [A] (🔧 x 3, 📦 x 1)

4.10.8 IMAGE TRANSFER BELT CONTACT MOTOR

1. Rear cover (🔧 p.4-18)
2. Controller box (🔧 p.4-160)

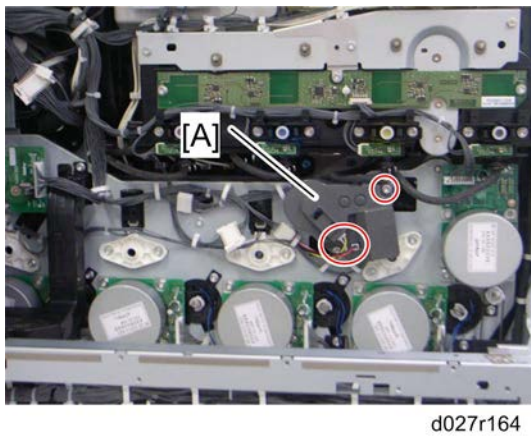

3. Transfer belt contact motor [A] (🔧 x 2, 📦 x 2)

Replacement and Adjustment

4.10.9 DUPLEX INVERTER MOTOR

1. Open the right door.
2. Right door cover ( p.4-144)

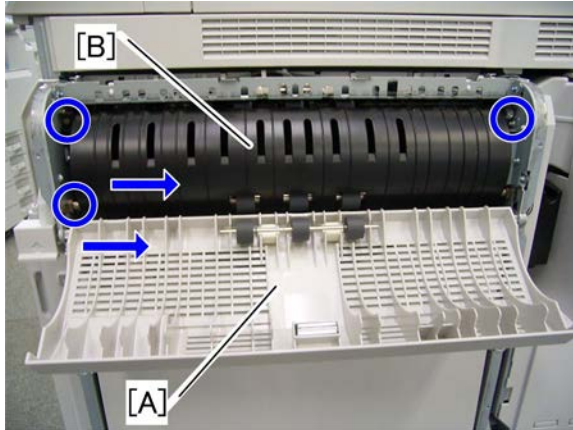

d027r659

3. Duplex door [A] (2 hooks)
4. Duplex guide plate [B] ( x 3, 2 hooks)

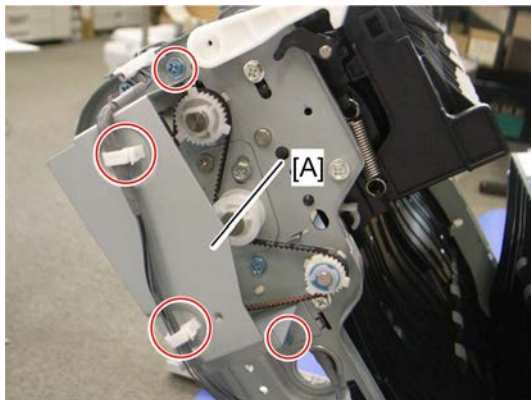

d027r166

5. Duplex inverter motor bracket cover [A] ( x 2,  x 2)

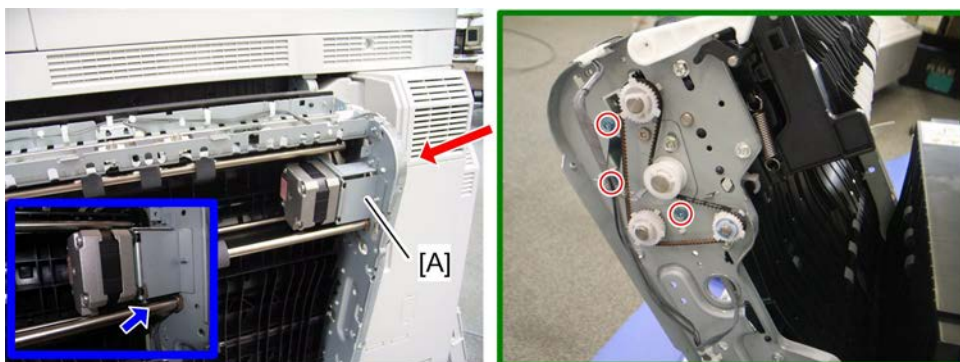

d027r660b

6. Duplex inverter motor bracket [A] ( x 3,  x 1,  x 1)

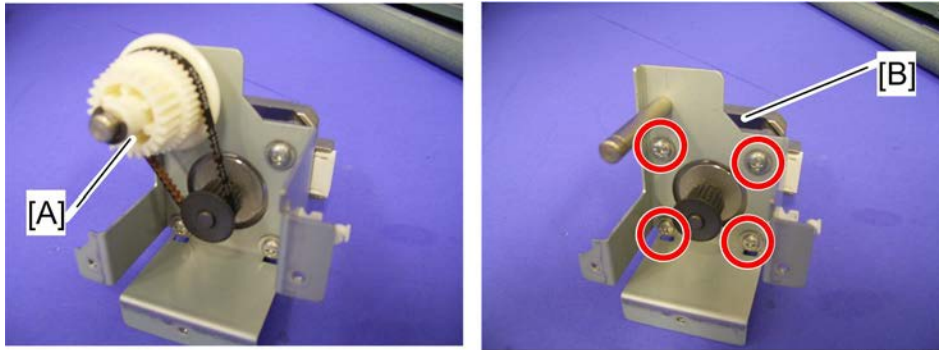

d027r661

7. Gear [A] (Ⓒ x 1, belt x 1)
8. Duplex inverter motor [B] (🔩 x 4)

4.10.10 PRESSURE ROLLER CONTACT MOTOR

1. Rear cover (🔧 p.4-18)
2. PSU bracket (🔧 p.4-168)
3. Open the controller box (🔧 p.4-160).

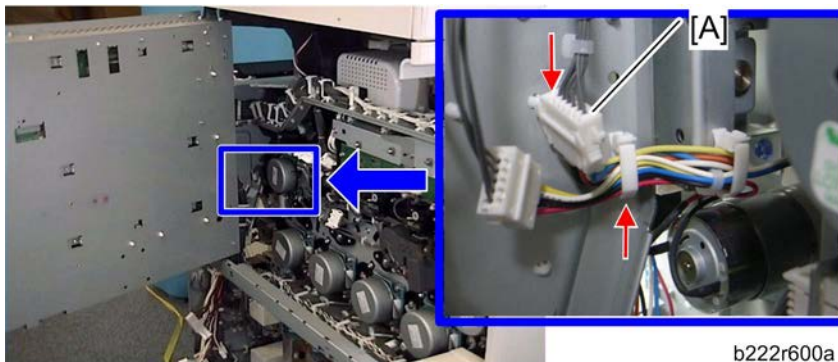

b222r600a

4. Disconnect the connector [A] (🔌 x 1).

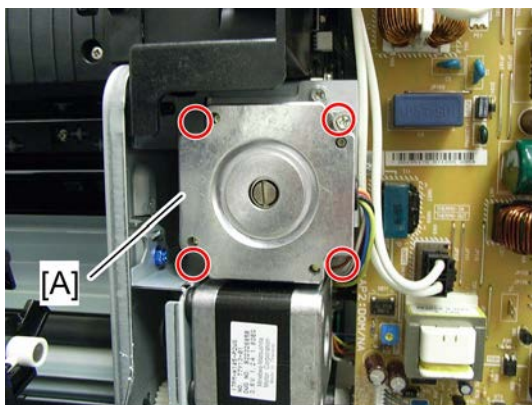

d027r724

5. Pressure roller contact motor [A] (🔩 x 4)

Replacement and Adjustment

4.10.11 DUPLEX/BY-PASS MOTOR

1. Rear cover (🔧 p.4-18)
2. PSU bracket (🔧 p.4-168)
3. Open the controller box (🔧 p.4-160).
4. Pressure roller contact motor (🔧 p.4-99)



5. Disconnect the connector [A] (🔧 x 1, 🛠️ x 1)

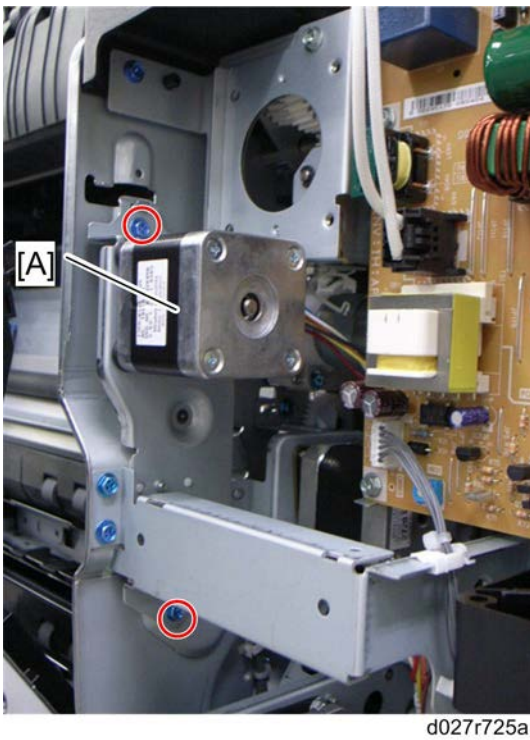

6. Duplex/by-pass motor bracket [A] (🔧 x 2)

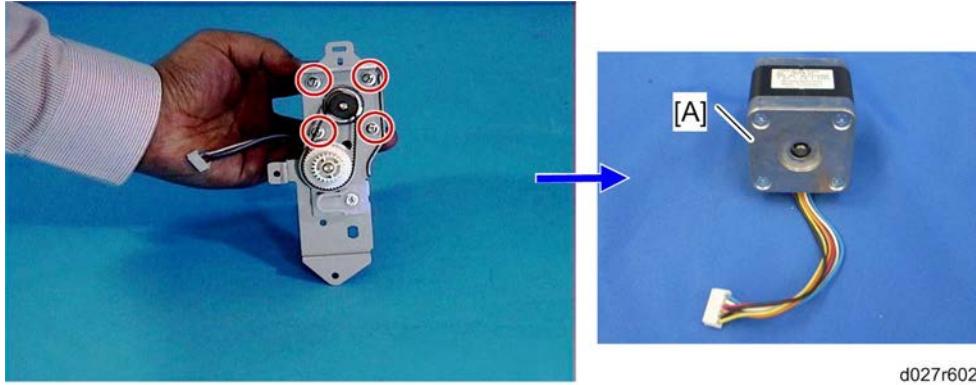

d027r602

7. Duplex/by-pass motor [A] (4 x 4, belt x 1)

4.10.12 PAPER TRANSFER CONTACT MOTOR

1. Rear cover (p.4-18)
2. PSU bracket (p.4-168)
3. Open the controller box (p.4-160).

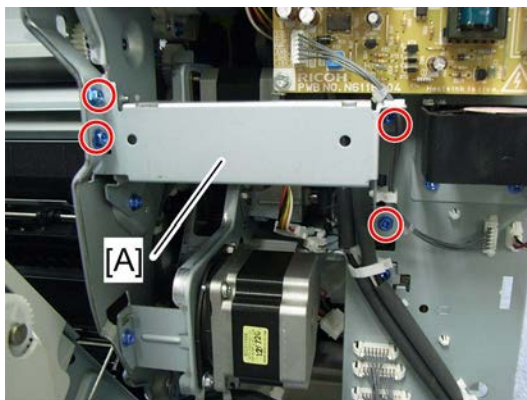

d027r723

4. Stay [A] (4 x 4)
5. Pressure roller contact motor (p.4-99)
6. Duplex/by-pass motor bracket (p.4-100)

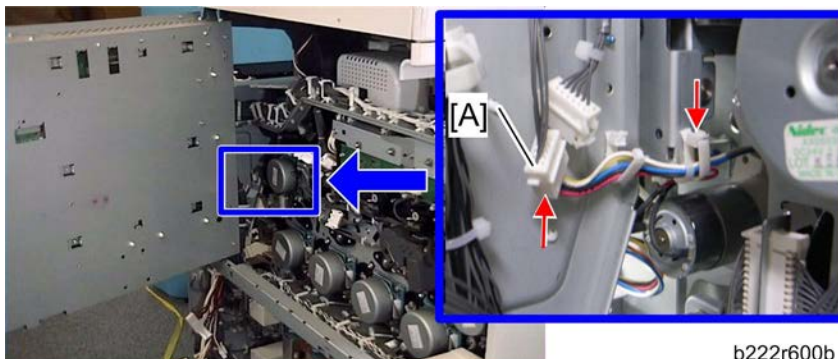

b222r600b

7. Disconnect the connector [A] (1 x 1)

Replacement and Adjustment

Drive Unit

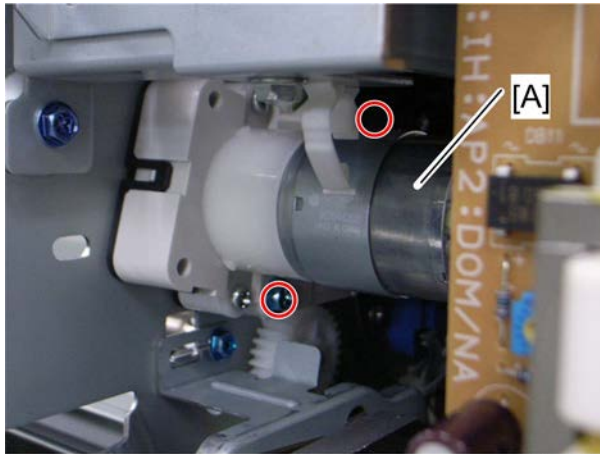

d027r726

8. Paper transfer contact motor [A] (x 2)

Note

- The picture below shows how to use the screwdriver to remove the screws of the paper transfer contact motor.

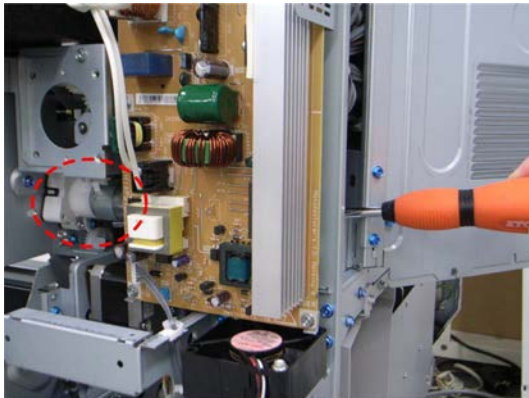

d027r727

4.10.13 TONER TRANSPORT MOTOR

1. Rear cover (🔧 p.4-18)
2. Open the controller box (🔧 p.4-160).

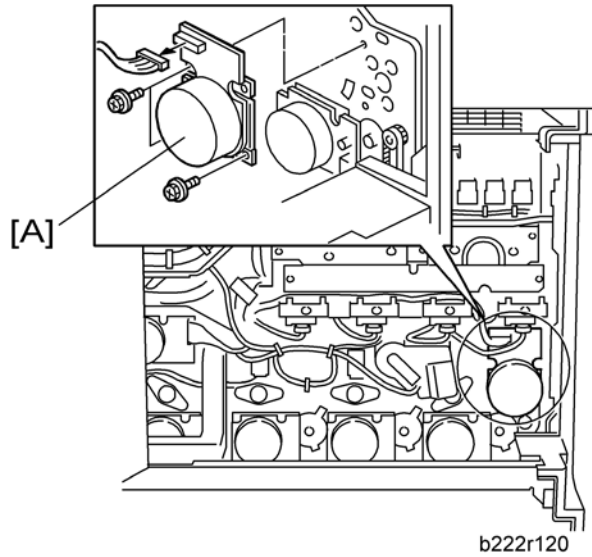

3. Toner transport motor [A] (🔧 x 3, 📄 x 1)

4.10.14 TONER COLLECTION UNIT

1. Gear Unit (🔧 p.4-87)

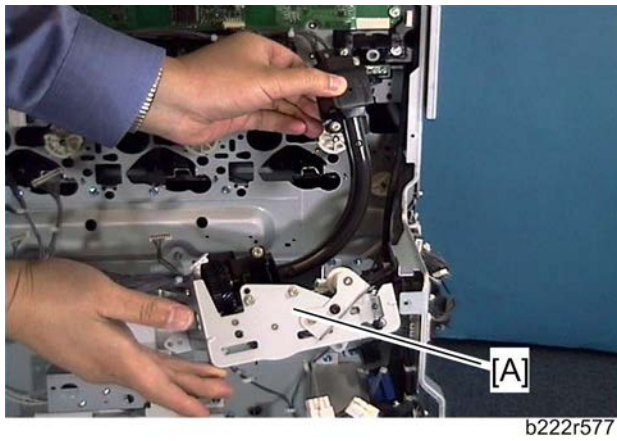
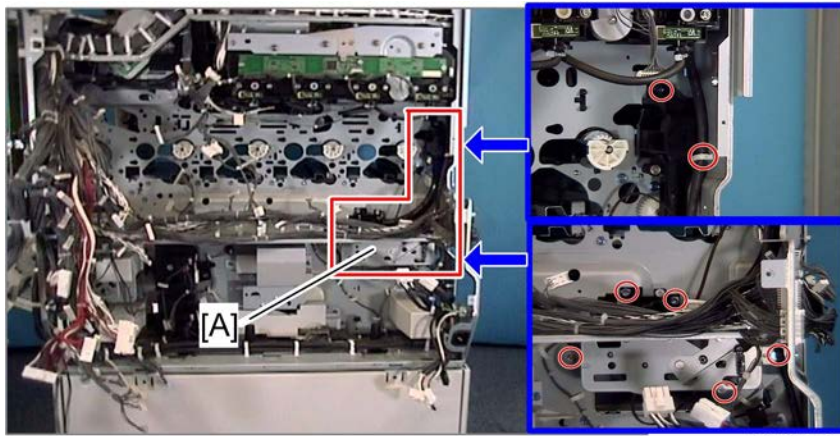

2. Toner collection unit [A] (🔧 x 6, 📦 x 1)

4.10.15 PAPER FEED CLUTCHES

1. Rear cover (🔧 p.4-18)
2. PSU bracket (🔧 p.4-168)

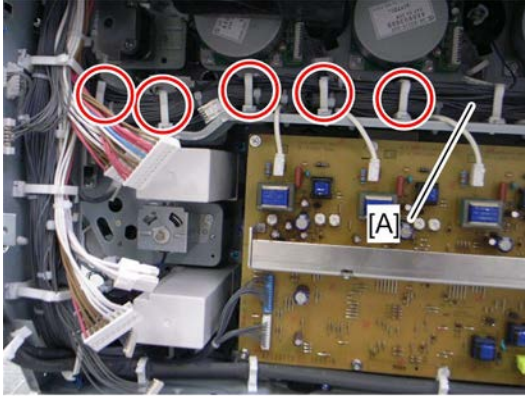

d027r578

3. Release five clamps, and then turn the harness [A] aside.

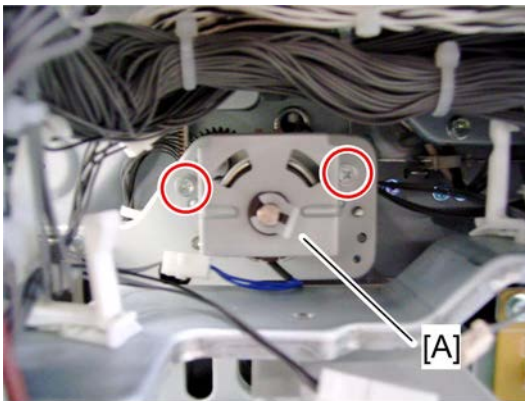

d027r580

4. Paper feed clutch 1 bracket [A] (🔧 x 2, ⚙️ x 1, 📏 x 1, 🛠️ x 1)

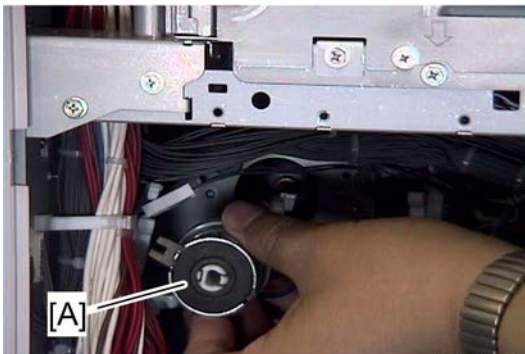

d027r581

5. Paper feed clutch 1 [A]

Replacement and Adjustment

Drive Unit

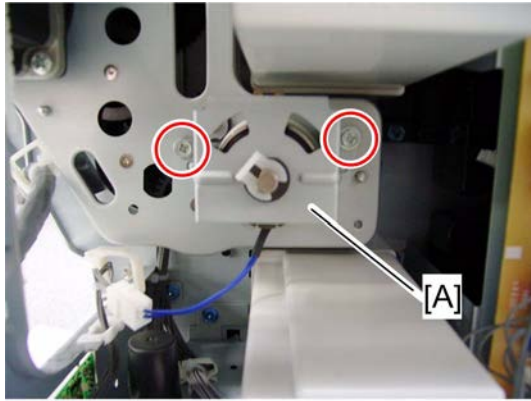

d027r582

6. Paper feed clutch 2 bracket [A] ( x 2,  x 1,  x 1)

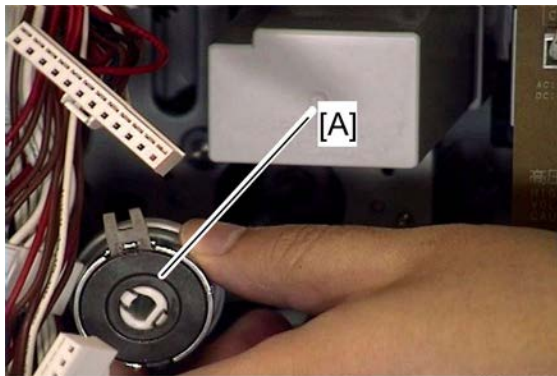

d027r583

7. Paper feed clutch 2 [A]

4.10.16 DEVELOPMENT CLUTCH-Y

1. Rear cover (☞ p.4-18)
2. PSU bracket (☞ p.4-168)
3. Open the controller box. (☞ p.4-160).
4. Toner sump cover (☞ p.4-87)
5. Drum/development motor-Y (☞ p.4-95)

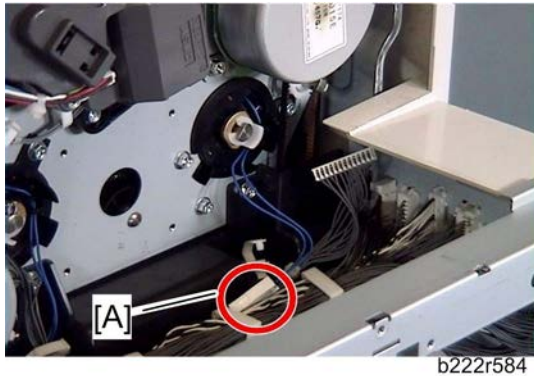

6. Disconnect the connector [A] (☞ x 1).

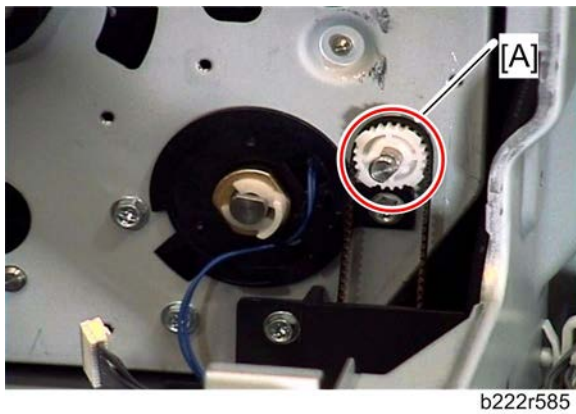

7. Remove the pulley and bushing [A].

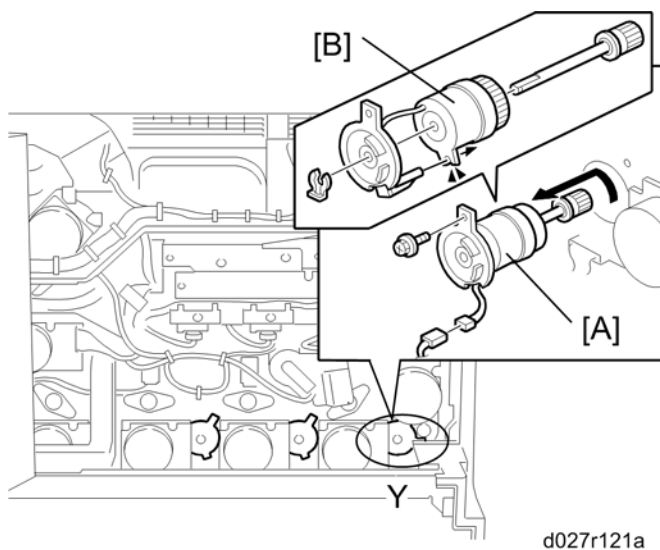

Replacement and Adjustment

8. Turn the development clutch unit [A] counter-clockwise and then pull it out (⚙️ x 1).
9. Development clutch-Y [B] (⚙️ x 1)

4.10.17 DEVELOPMENT CLUTCHES FOR M AND C

1. Rear cover (🔧 p.4-18)
2. PSU bracket (🔧 p.4-168)
3. Open the controller box. (🔧 p.4-160).
4. Toner sump cover (🔧 p.4-87)
5. Drum/development motors for M and C (🔧 p.4-95)
6. Disconnect the connector for each development clutch (🔌 x 1).

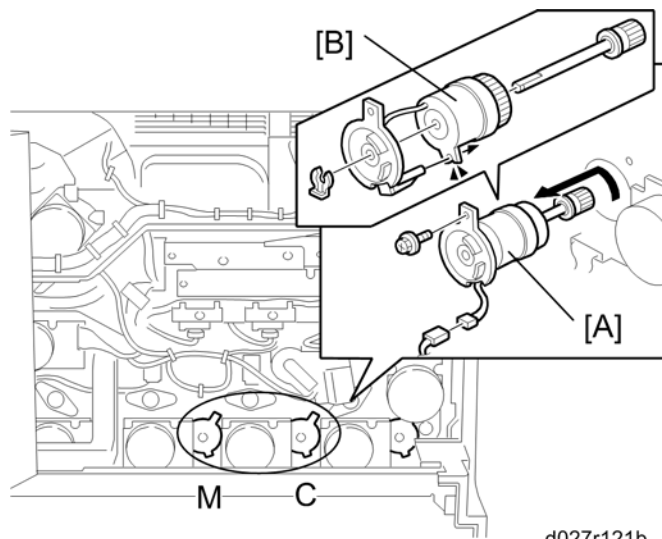

7. Turn the development clutch unit [A] counter-clockwise and then pull it out (⚙️ x 1).
8. Development clutches for M and C [B] (⚙️ x 1)

4.10.18 DEVELOPMENT CLUTCH-K

1. Rear cover (🔧 p.4-18)
2. PSU bracket (🔧 p.4-168)
3. Controller box (🔧 p.4-160)
4. Drum/development motor-K (🔧 p.4-96)

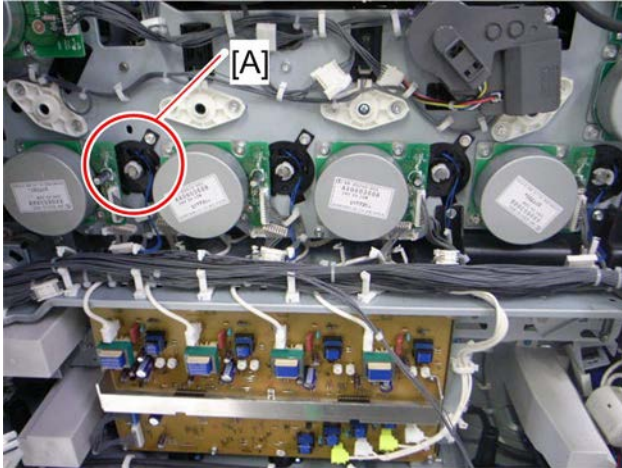

d027r586

5. Turn the development clutch unit [A] counter-clockwise and then pull it out (🔧 x 1).

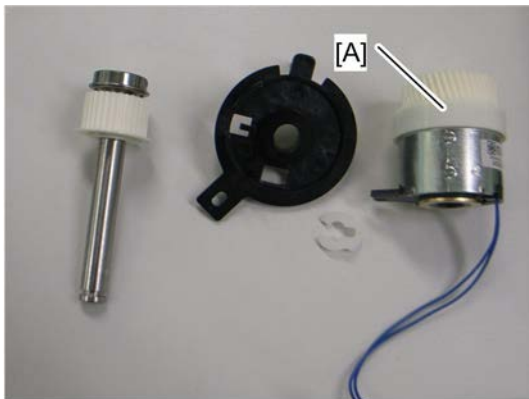

d027r167



6. Development clutch-K [A] (🔧 x 1)

Replacement and Adjustment

4.11 FUSING

4.11.1 FUSING UNIT PM PARTS

In the fusing unit, there are some PM parts. Refer to the following list to check the PM parts.

Maintenance Parts	Replacement Procedure
Heating sleeve belt unit	 p.4-119
Pressure Roller	 p.4-122

4.11.2 FUSING UNIT

CAUTION

- Turn off the main switch and wait until the fusing unit cools down before beginning any of the procedures in this section. The fusing unit can cause serious burns.

Important

- After the PM counter for the heating roller has reached its PM life (300K pages), the machine stops the operation automatically. Replace the heating roller before the machine stops its operation (stop warning: 315K pages, stop: 330K pages).
- Change the setting of SP3-902-018 from "0" to "1" before replacing the heating roller. Otherwise, the machine will not recover.

-  1. If you will replace the heating sleeve belt unit or pressure roller in the fusing unit (at PM for example), then reset each counter.
- Set SP 3902-018 to "1" for the heating sleeve belt unit replacement.
 - Set SP 3902-019 to "1" for the pressure roller replacement.

Note

- If you do this, then the machine will reset the PM counter for the heating roller or pressure roller automatically, after you turn the power on again.
 - It is not necessary to clear the PM counter for the fusing unit with SP mode when you replace the fusing unit. This is because the fusing unit has a new unit detection mechanism.
- Turn off the main power switch.
 - Open the right door.

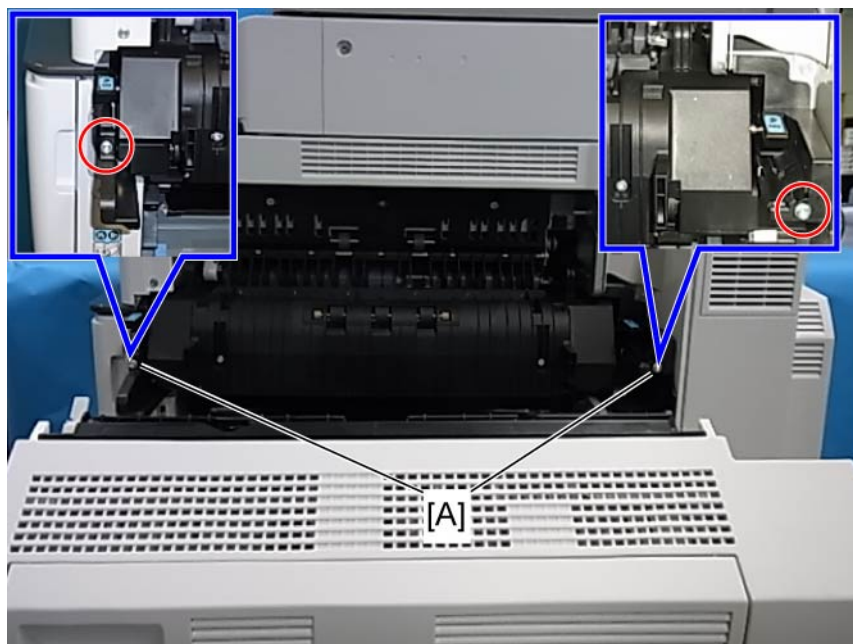

d1440035

4. Remove two transport brackets [A] if installed. ( x 1 each)

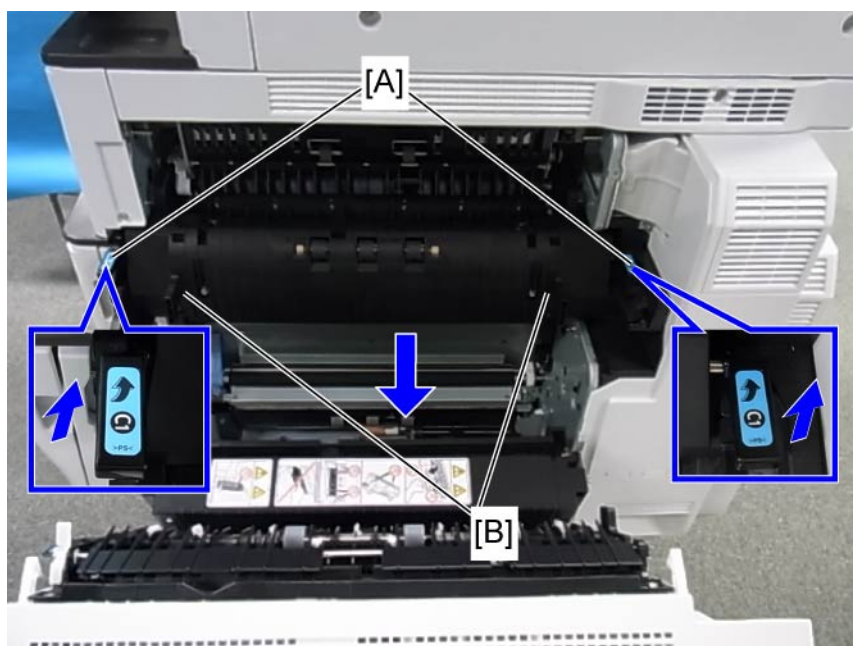

d1440003

5. Release the lock levers [A].
6. Hold the fusing unit handles [B], and then pull out the fusing unit.

4.11.3 FUSING EXIT SHUTTER PLATE

1. Fusing unit (☞ p.4-110)

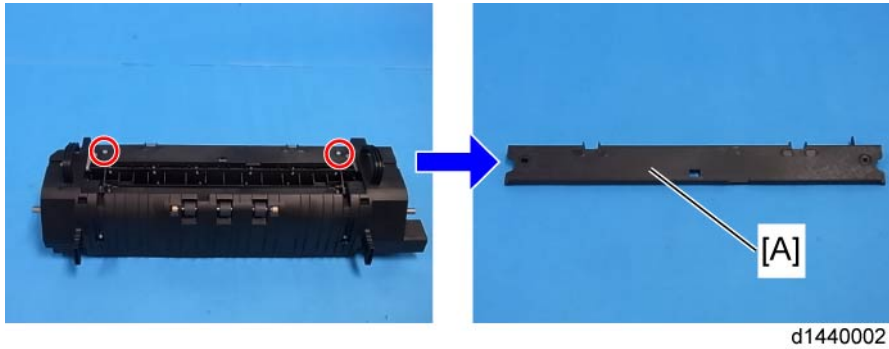

2. Fusing exit shutter plate [A] (☞ x 2)

4.11.4 FUSING ENTRANCE GUIDE PLATE

1. Fusing unit (☞ p.4-110)
2. Turn over the fusing unit.

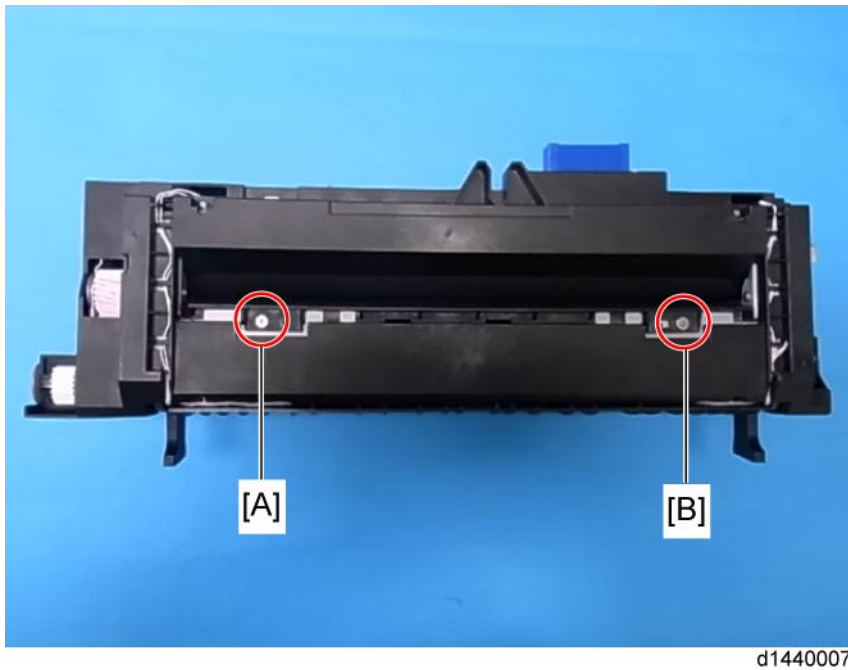



d1440008

3. Fusing entrance guide plate [C] ( x 2)

Note

- Screw [A] and screw [B] are different from each other.

Cleaning Requirement



d088r374

The fusing entrance guide plate requires cleaning maintenance every fusing unit maintenance interval. Clean the fusing entrance guide plate at the place shown above with a dry cloth, and then clean the fusing entrance guide plate again with a cloth moistened with alcohol.

4.11.5 FUSING EXIT GUIDE PLATE CLEANING PROCEDURE

The fusing exit guide plate requires cleaning maintenance every fusing unit maintenance interval.

1. Fusing unit (☞ p.4-110)

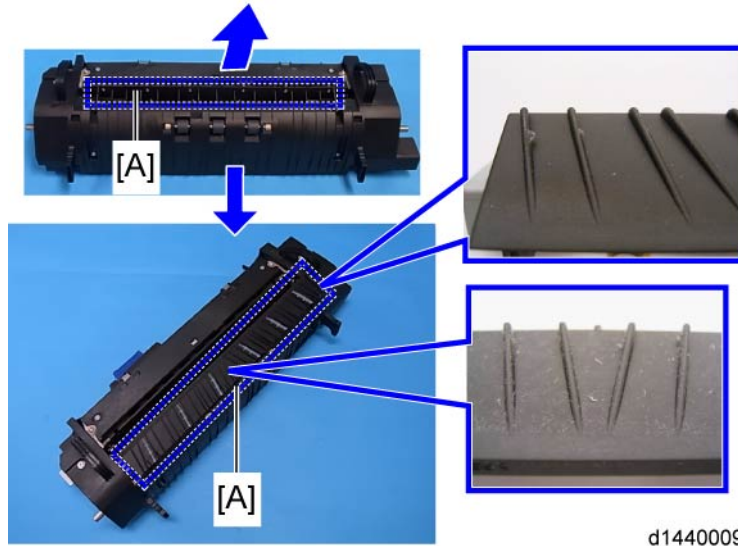

2. Open the exit guide plate [A].
3. Clean the exit guide plate with a dry cloth, and then clean the exit guide plate again with a cloth moistened with alcohol at the points shown above.

4.11.6 FUSING UNIT UPPER COVER

1. Fusing unit (☞ p.4-110)
2. Fusing exit shutter plate (☞ p.4-112)

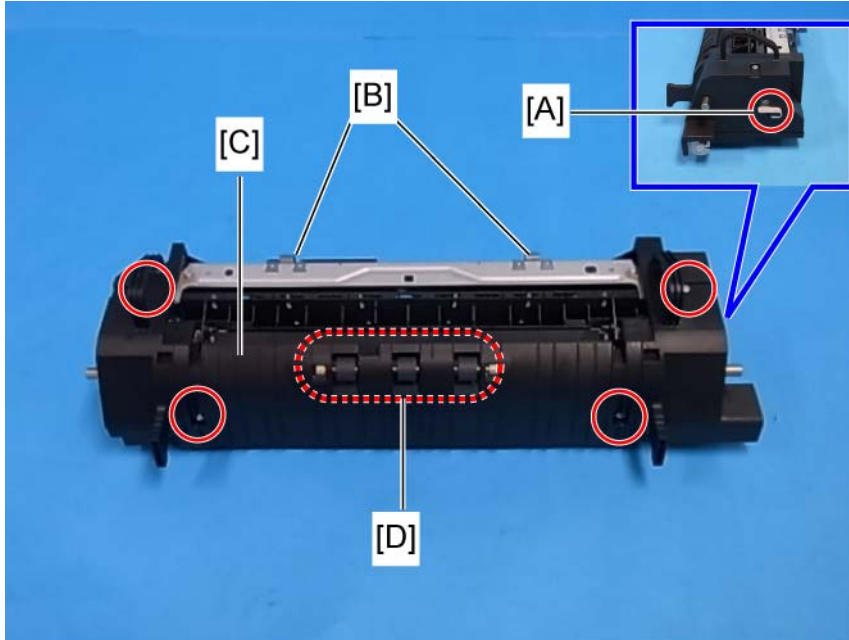

d1440004

3. Right guide bracket [A] (☞ x 1)
4. Springs [B]
5. Remove the fusing unit upper cover [C] while pressing down the rollers [D] (☞ x 4).

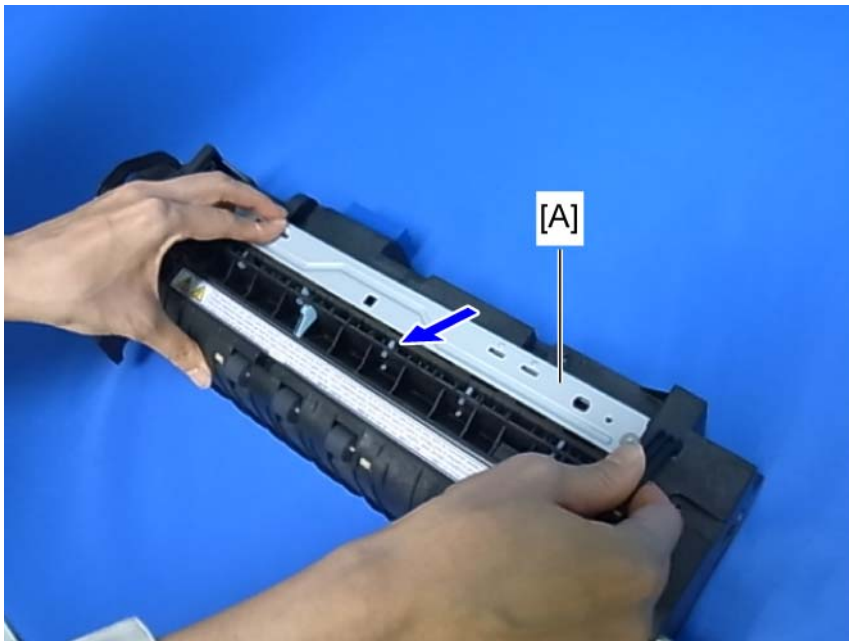

d1440121

Fusing

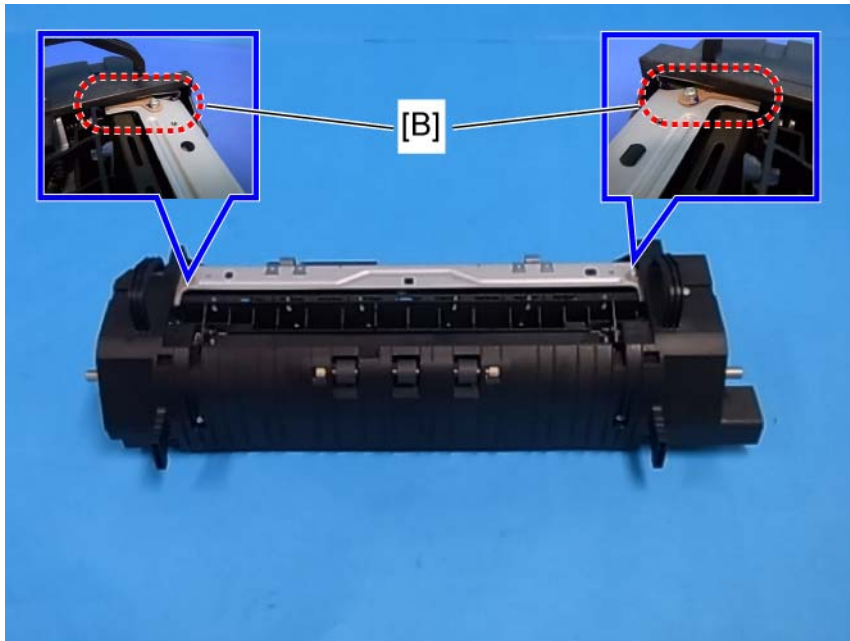

d1440122

★ Important

- The shutter plate [A] should be closed whenever the fusing unit upper cover is reinstalled. Otherwise, the ends of the shutter plate [B] may be damaged and this will result in a problem when opening and closing the shutter.

4.11.7 FUSING UNIT LOWER COVER

1. Fusing unit (🔧 p.4-110)
2. Fusing unit upper cover (🔧 p.4-115)

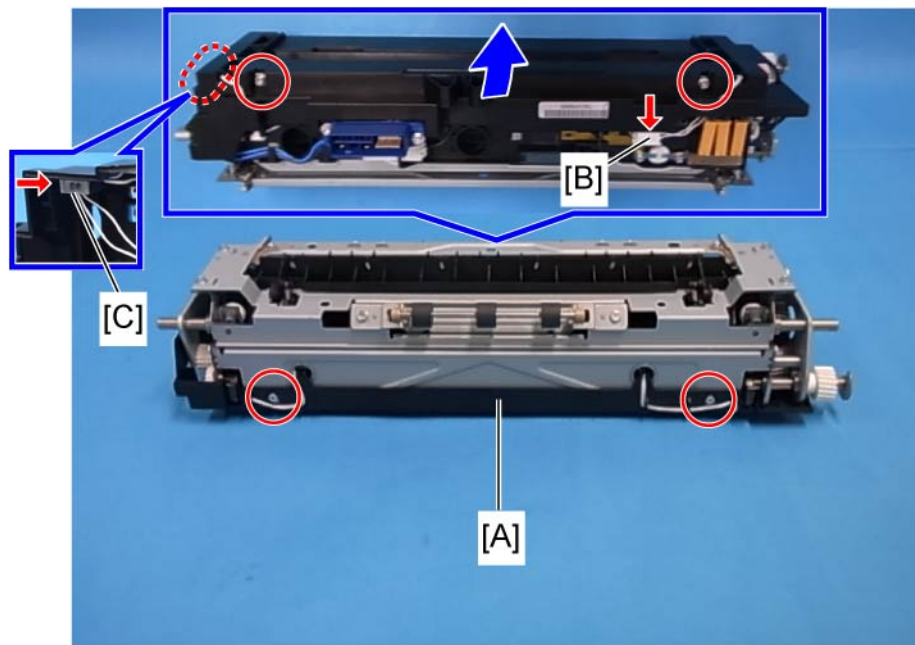

d1440005

3. Place the fusing unit upside down.
4. Lift up the fusing unit lower cover [A] half way (🔧 x 4).
5. Disconnect two connectors [B], [C] and remove the wire harnesses from their harness guides (🔧 x 2).

⬇️ **Note**

- The fusing lower cover cannot be removed from the fusing main body completely before removing the thermistors. Therefore, pay extra attention to handling the fusing lower cover when disassembling the fusing unit.

Fusing

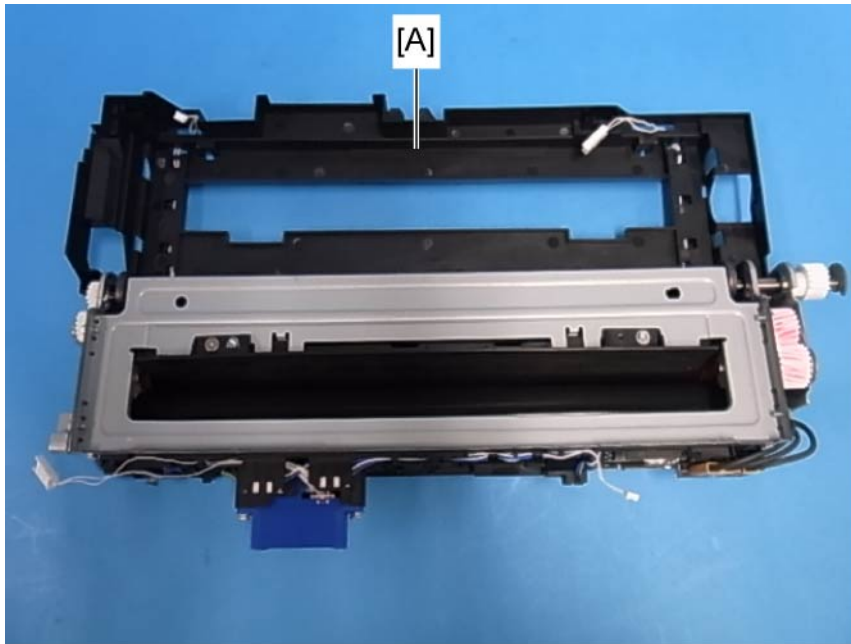

d1440006

6. Fusing unit lower cover [A]

4.11.8 HEATING SLEEVE BELT UNIT

★ Important

- After the PM counter for the heating roller has reached its PM life (300K pages), the machine stops automatically. Replace the heating roller before the machine stops (stop warning issued at 315K pages, stops at 330K pages).
- Change the setting of SP3-902-018 from "0" to "1" before replacing the heating roller. Otherwise, the machine will not recover.

1. Fusing unit (🔧 p.4-110)
2. Fusing unit upper cover (🔧 p.4-115)
3. Fusing unit lower cover (🔧 p.4-117)
4. Fusing entrance guide plate (🔧 p.4-112)

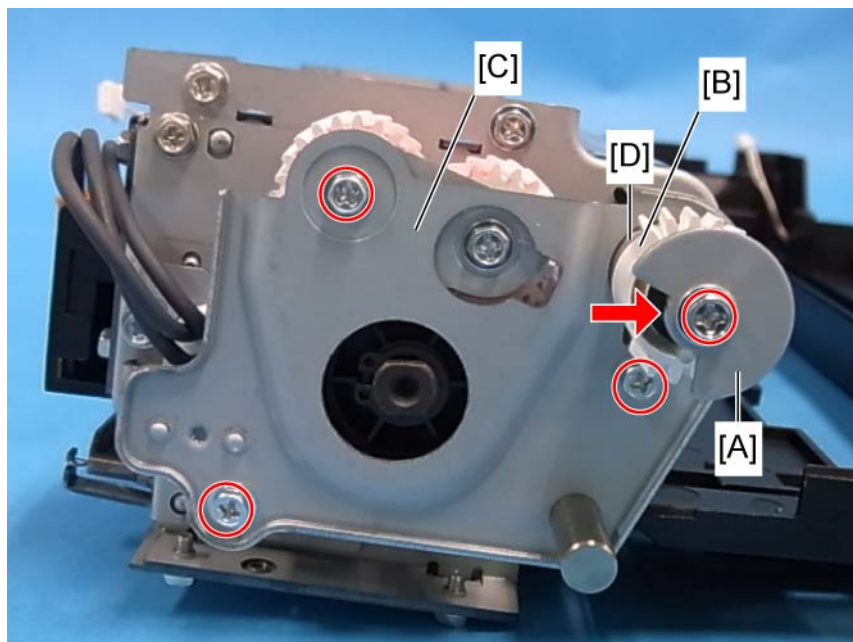

d1440010

5. Pressure roller contact shaft actuator [A] and pressure roller contact shaft gear [B] (🔧 x 1, Ⓒ x 1)
6. Bearing [D]
7. Right stay [C] (🔧 x 3)
8. Turn over the fusing unit gently to prevent damage to the harnesses.

Fusing

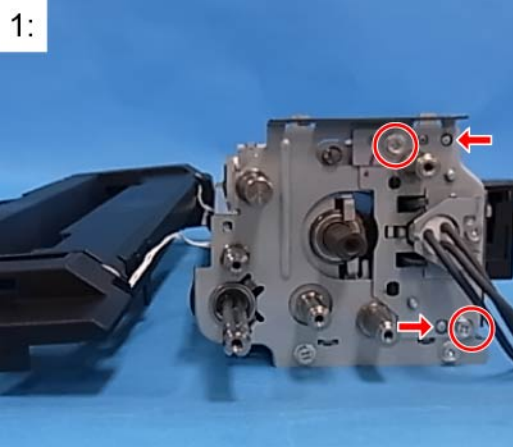

d1440011

1: Right side

9. Remove two screws at the right side ( x 2).

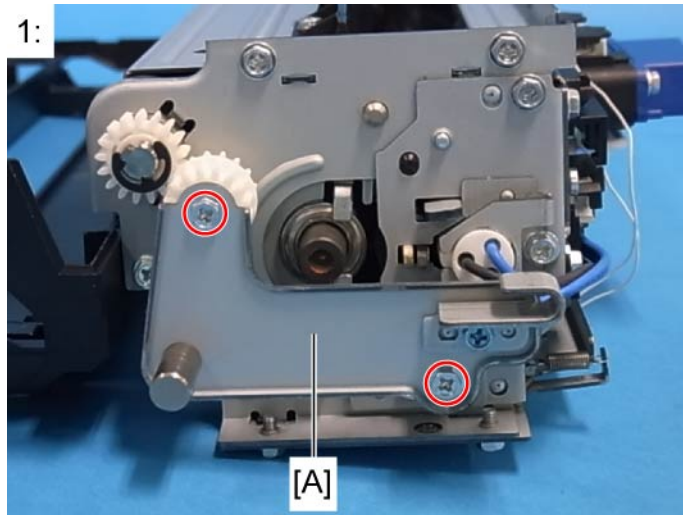

d1440012

1: Left side

10. Left bracket [A] ( x 2)

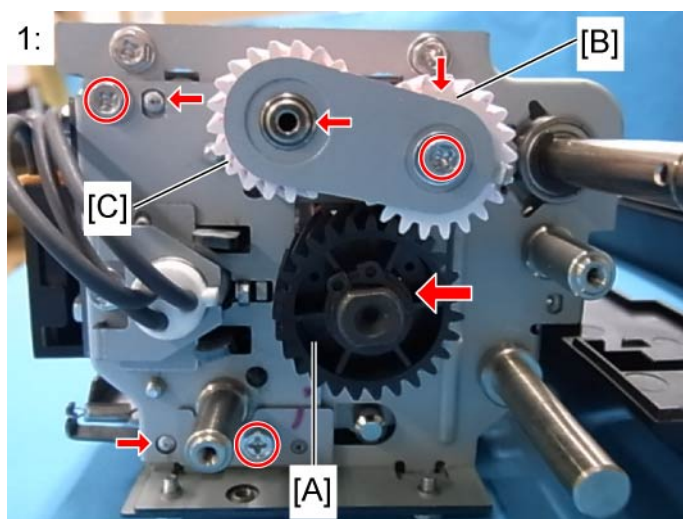

d1440013

1: Left side

11. Remove gears [A], [B], [C] (⚙️ x 1, ⚙️ x 1, bearings x 2).
12. Remove two screws on the left side (🔩 x 2).

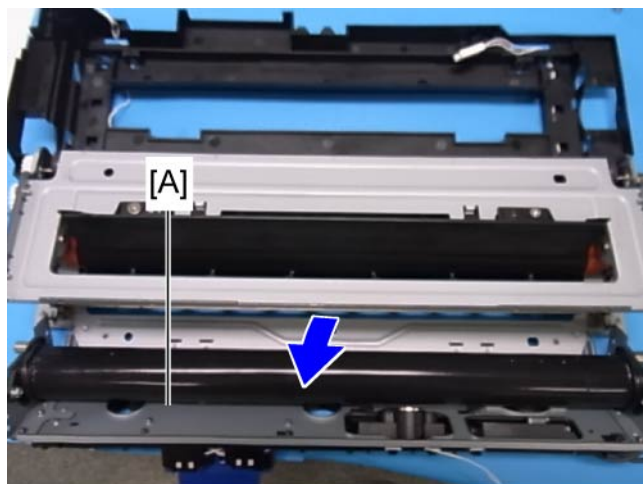

d1440014

13. Remove the heating sleeve belt unit while releasing 4 snapping points at the right and left side (See the photos of steps 9 and 11).

ⓘ Note

- The surface of the heating sleeve belt is delicate. Never touch the surface. Do not wipe the surface with anything. If the surface of the heating sleeve belt must be cleaned because of offset image for example, feed some sheets of white paper through the fusing unit instead.

4.11.9 PRESSURE ROLLER

1. Heating sleeve belt unit (☞ p.4-119)

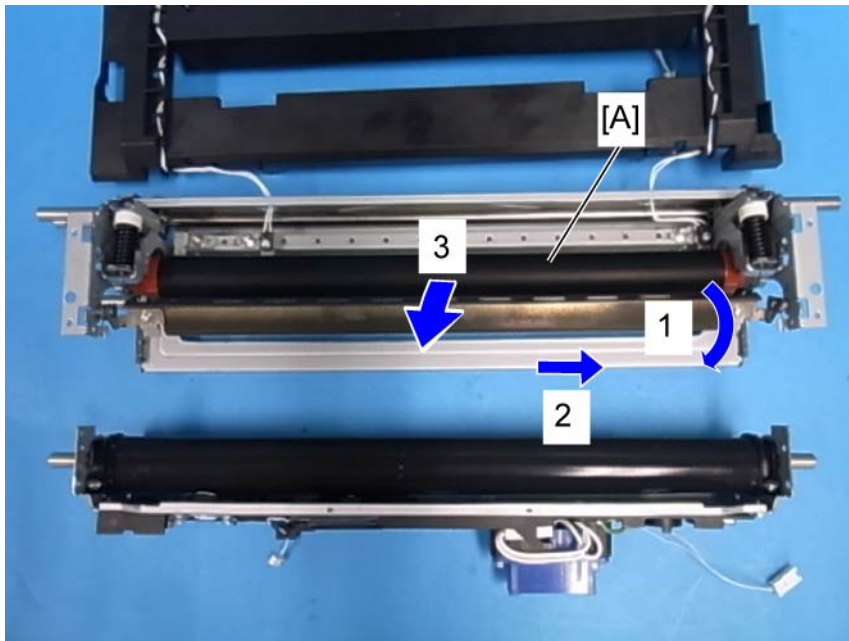

d1440015

2. Remove the pressure roller with bearings [A].

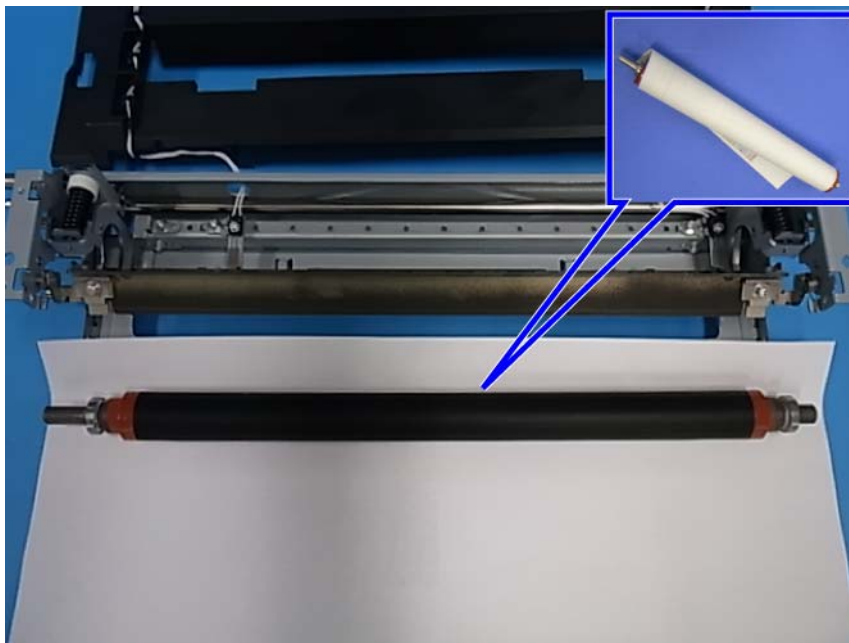

d1440016

↓ Note

- The surface of the pressure roller is fragile, so the pressure roller must be covered with a sheet of paper when it is placed on a table or floor.

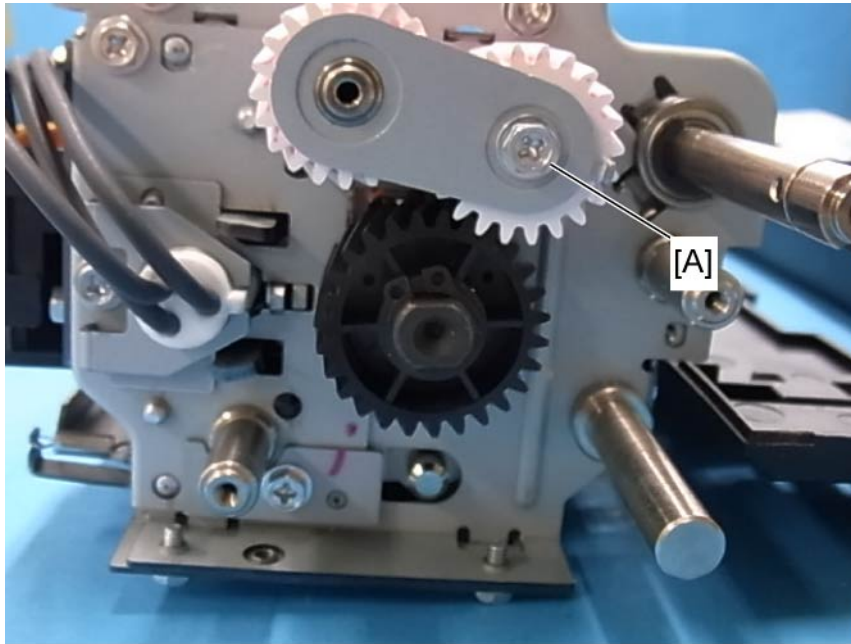

d1440017

↓ **Note**

- Do not wipe off the grease of the new fusing drive gear when replacing the fusing drive gear [A].

Replacement
and
Adjustment

4.11.10 STRIPPER PLATE

1. Fusing unit (☞ p.4-110)
2. Heating sleeve belt unit (☞ p.4-119)
3. Pressure roller (☞ p.4-122)

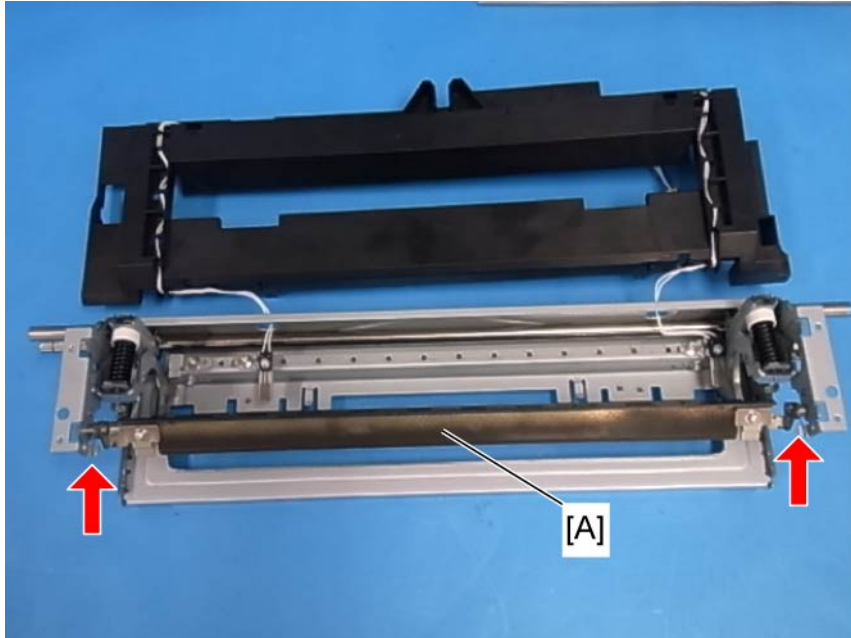

d1440018

4. Heating roller stripper plate [A] (spring x 2)

Cleaning Requirement

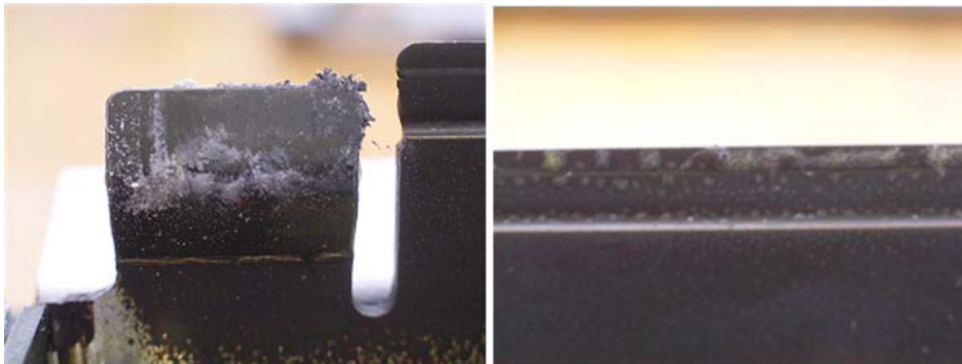

d037r377

The stripper plates require cleaning maintenance every fusing unit maintenance interval. Clean the stripper plates with a dry cloth, and then clean the stripper plates again with a cloth moistened with alcohol at the points shown above.

4.11.11 PRESSURE ROLLER THERMISTORS

1. Fusing unit (☞ p.4-110)
2. Heating sleeve belt unit (☞ p.4-119)
3. Pressure roller (☞ p.4-122)

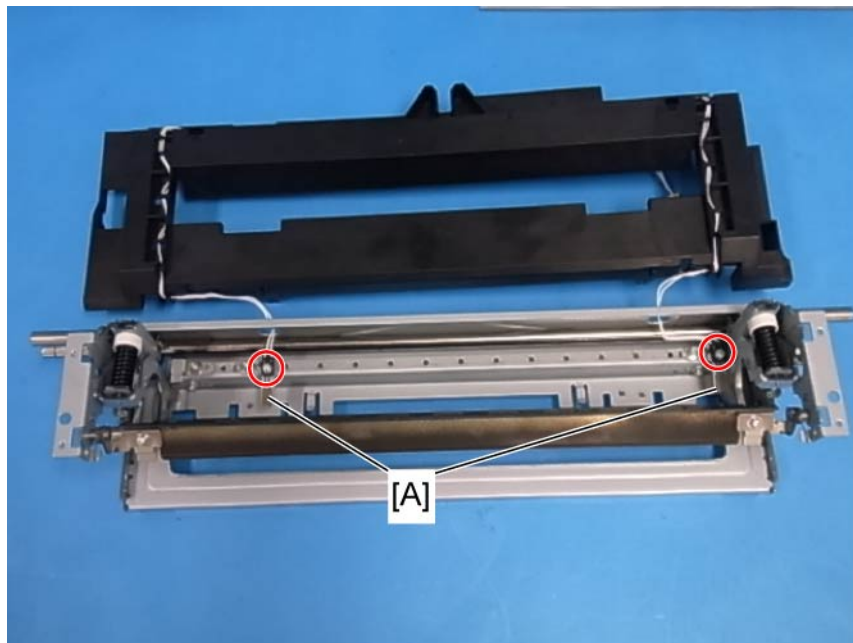

d1440019

4. Pressure roller thermistor [A] (☞ x 1 each)

4.11.12 PRESSURE ROLLER THERMOSTATS

1. Fusing unit (🔧 p.4-110)
2. Fusing unit upper cover (🔧 p.4-115)
3. Fusing unit lower cover (🔧 p.4-117)

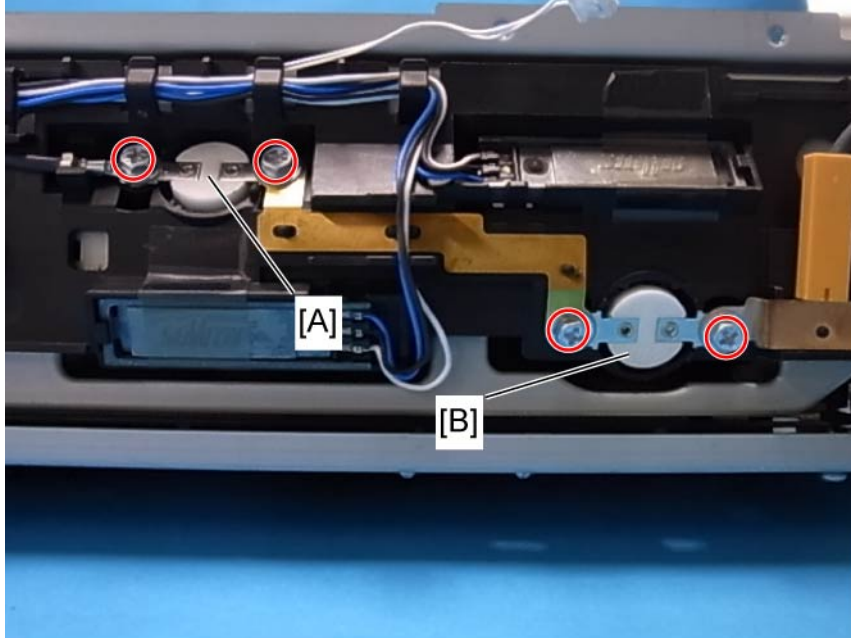

d1440020

4. Pressure roller thermostat (center) [A] and pressure roller thermostat (end) [B] (🔧 x 2 each)

4.11.13 NC SENSORS

1. Fusing unit (🔧 p.4-110)
2. Fusing unit upper cover (🔧 p.4-115)
3. Fusing unit lower cover (🔧 p.4-117)

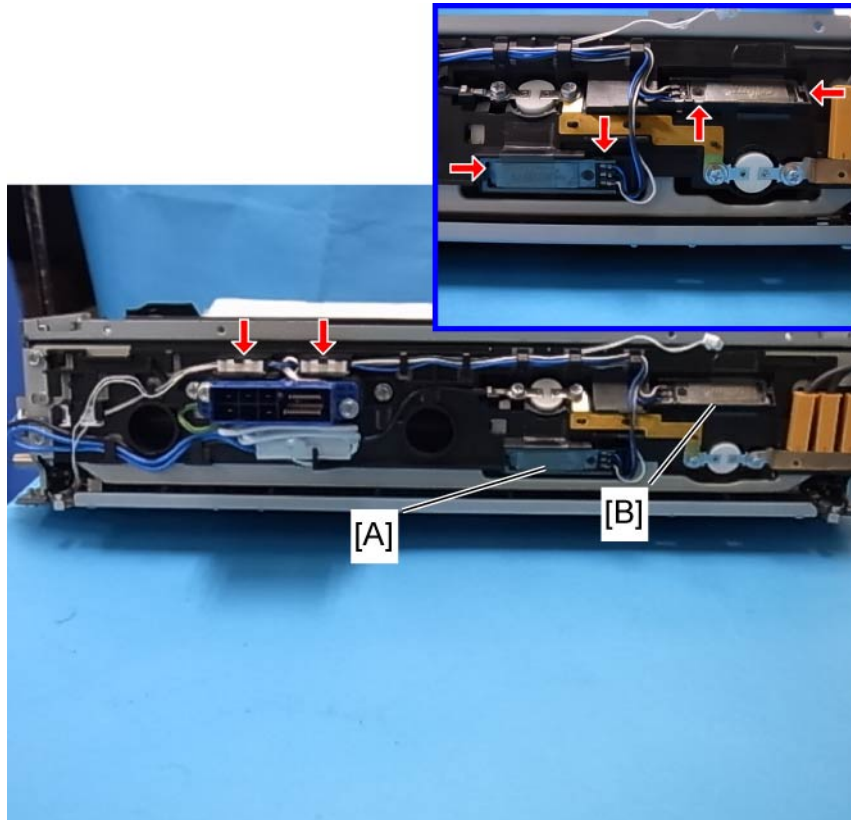

d1440021

4. NC sensor (center) [A] and NC sensor (end) [B] (hooks x 2 each, 🛠️ x 1 each)

4.11.14 FUSING FAN

1. Rear cover (🔧 p.4-18)
2. Right rear cover (🔧 p.4-19)

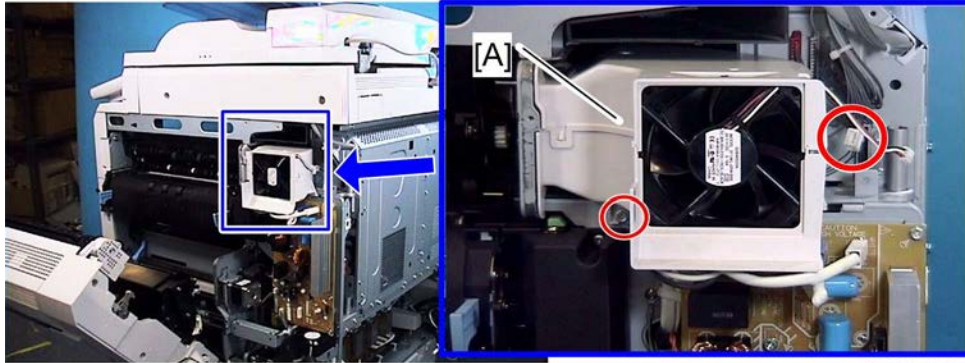

b222r588

3. Fusing duct [A] (🔧 x 1, 📄 x 1)

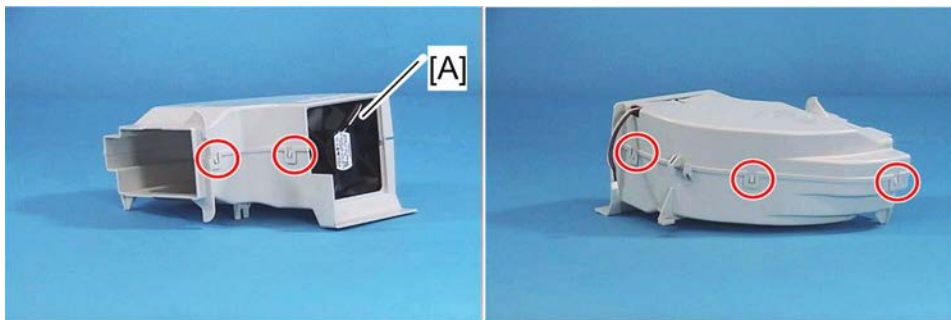

d027r589

4. Fusing fan [A] (hooks x 5)

When installing the fusing fan

Make sure that the fusing fan is installed with its decal facing the right side of the machine.

4.11.15 PAPER EXIT FAN

1. Open the right door.
2. Front right cover (☞ p.4-20)

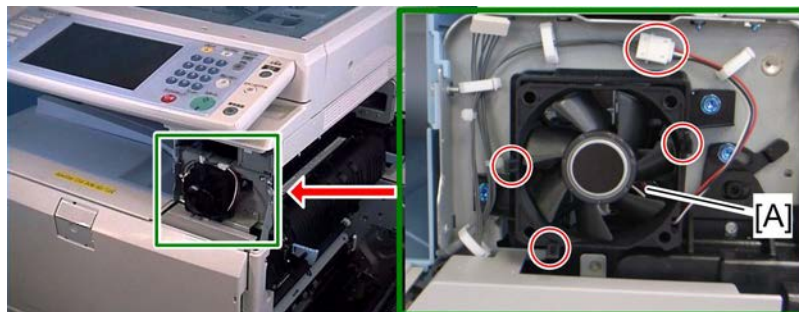

3. Paper exit fan [A] (☞ x 1, hook x 3)

When installing the paper exit fan

↓ Note

- Make sure that the paper exit fan is installed with its decal facing the rear of the machine.

4.11.16 AC CONTROLLER BOARD FAN

1. Rear cover (🔧 p.4-18)
2. Right rear cover (🔧 p.4-19)

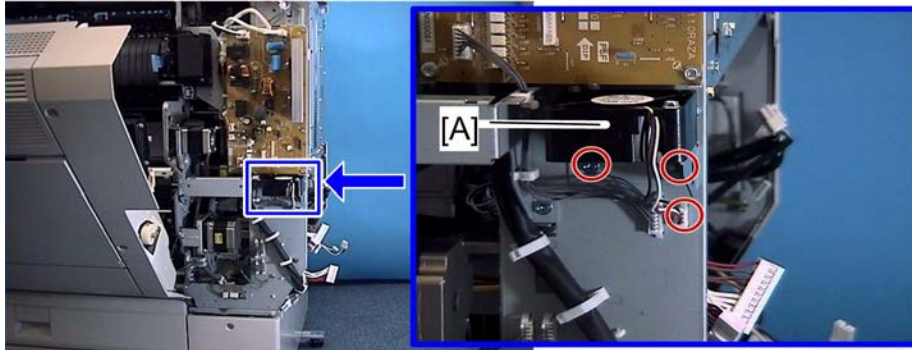

b222r591

3. AC controller board fan bracket [A] (🔧 x 2, 📄 x 1)

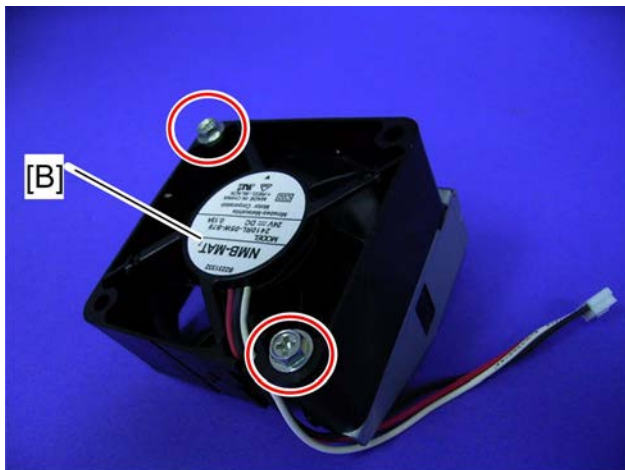

b222r592

4. AC controller board fan [B] (🔧 x 2)

When installing the AC controller board fan

Make sure that the AC controller board fan is installed with its decal facing the upper side of the machine.

4.11.17 FUSING ENTRANCE THERMOPILES

1. Open the right door.
2. Fusing unit (🔧 p.4-110)

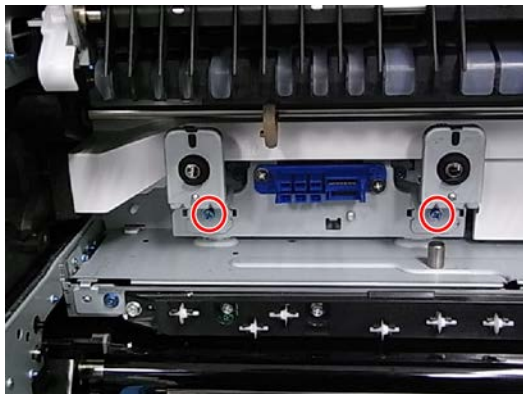

d1440055

3. Fusing entrance thermopile brackets (🔧 x 1 each)

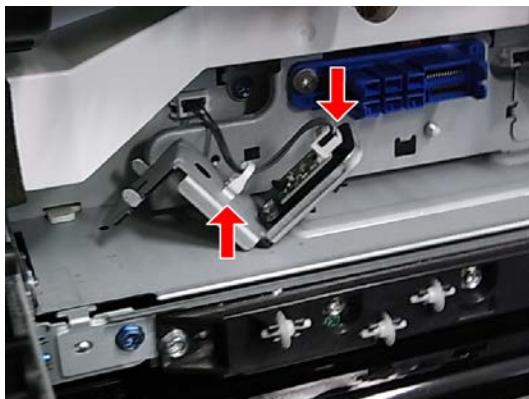

d1440056

4. Fusing entrance thermopiles (🔧 x 1 each, 🔧 x 1 each)

When cleaning the lens of the thermopile

⚠ CAUTION

- Do this cleaning procedure after the fusing unit has completely cooled down. Otherwise, you may get a serious burn.

1. Fusing unit (▶ p.4-110)

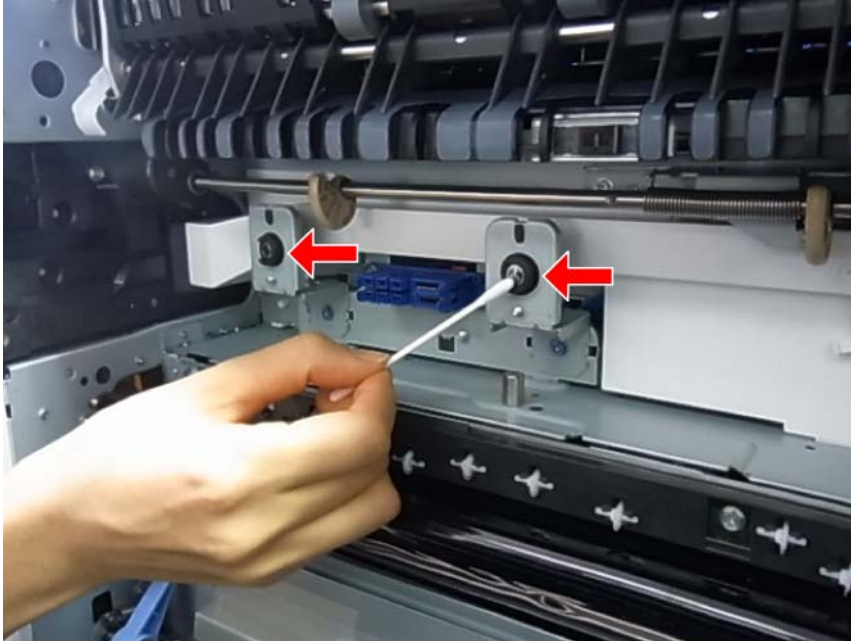

d1440123

2. Clean with a cotton-swab dipped in alcohol.

4.11.18 PRESSURE ROLLER HP SENSOR

1. Open the right door.
2. Fusing unit (☞ p.4-110)
3. AC controller board (☞ p.4-173)
4. AC controller board bracket (☞ p.4-174)

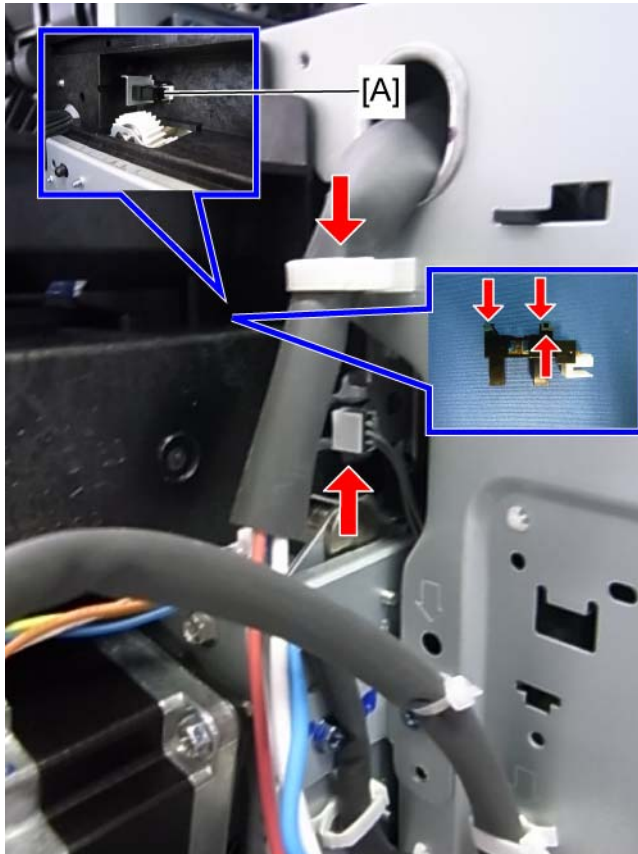

d1440125

5. Pressure roller HP sensor [A] (☞ x 1, ☞ x 1, hooks x 3)

4.11.19 QSU FAN

1. Open the right door.
2. Front right cover (🔧 p.4-20)
3. Pull out trays 1 and 2, and the image transfer belt unit.

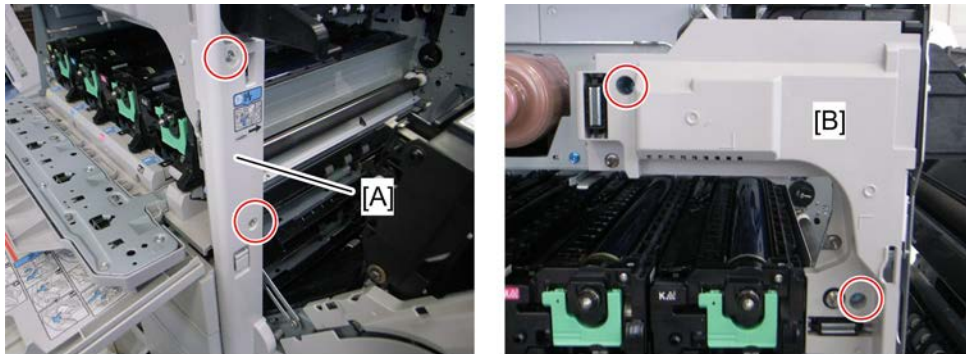

d027r219

4. Right front cover [A] and front inner cover [B].

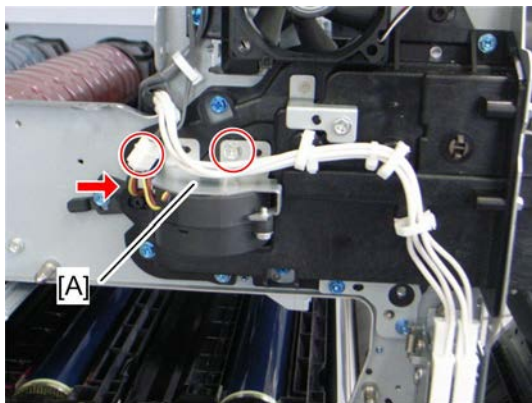

d027r220

5. QSU fan bracket [A] (🔧 x 1, 📄 x 1, 📄 x 1)
6. QSU fan (🔧 x 2)

4.11.20 FUSING UNIT SHUTTER PLATE DRIVE MOTOR

1. AC controller board (🔧 p.4-173)

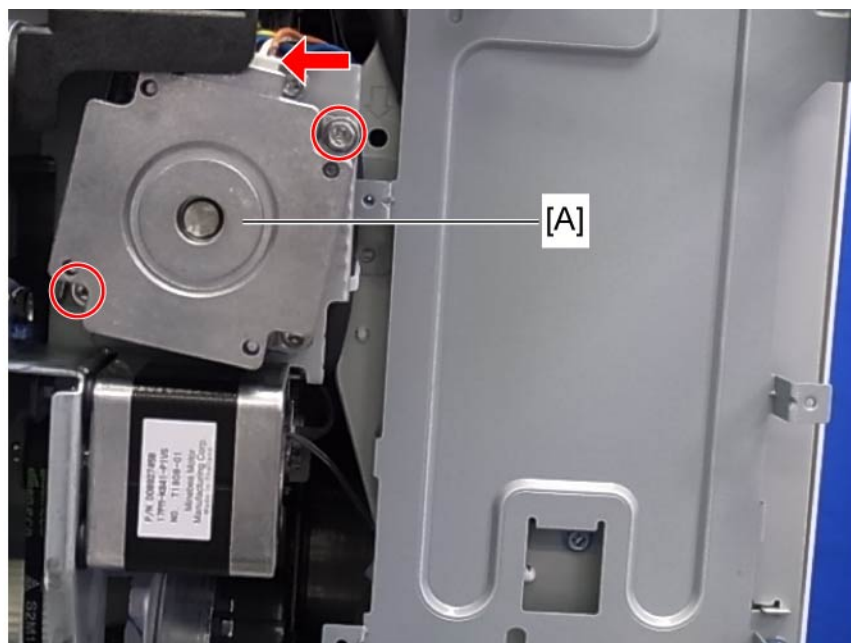

d1440104

2. Fusing unit shutter plate drive motor [A] (🔧 x 2, 📦 x 1)

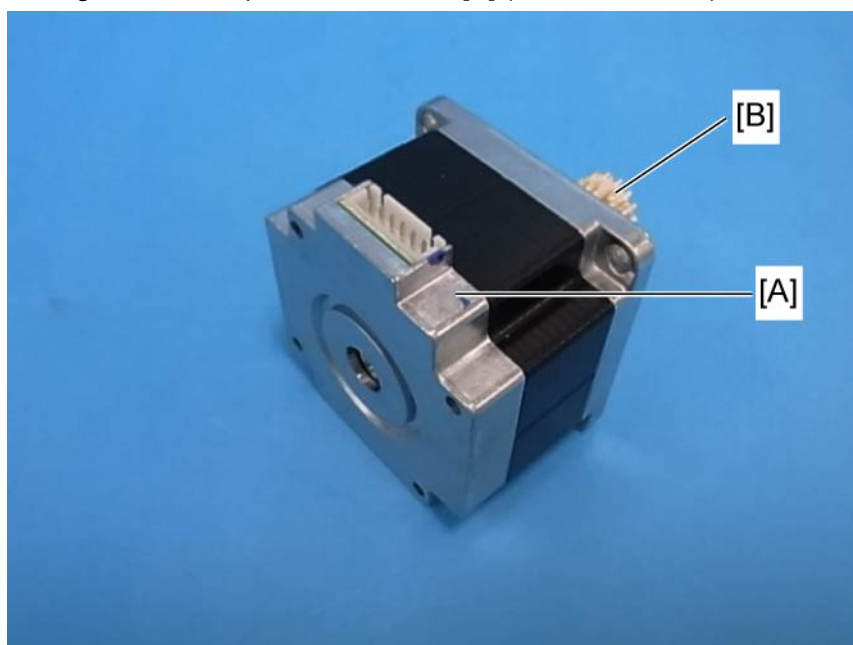

d1440105

⬇ Note

- Do not wipe off the grease of the gear [B] on the new motor [A] when replacing it.

4.11.21 FUSING UNIT SHUTTER PLATE HOME POSITION SENSOR

1. Open the right door.
2. Fusing unit (🔧 p.4-110)

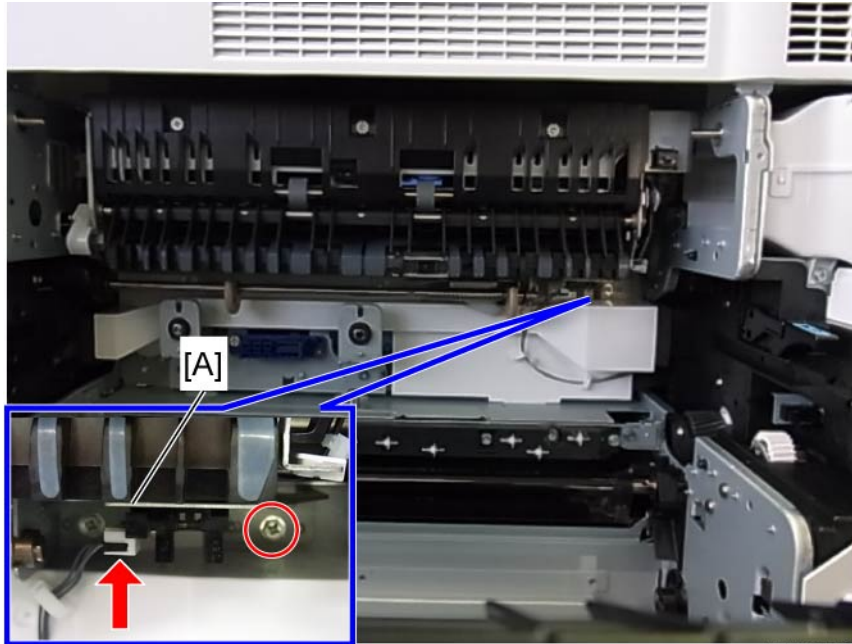

d1440106

3. Fusing unit shutter plate home position sensor bracket [A] (🔧 x 1, 📦 x 1)

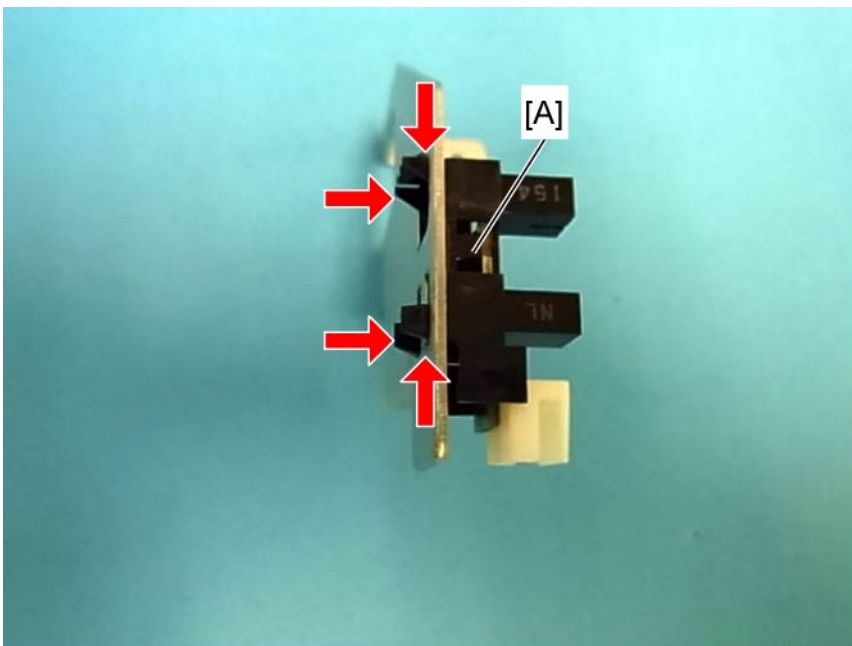

d1440107

4. Fusing unit shutter plate home position sensor [A] (Hooks x 4)

4.11.22 FUSING UNIT SHUTTER PLATE DRIVE MECHANISM

1. Open the right door.
2. Fusing unit (☞ p.4-110)
3. Fusing unit shutter plate home position sensor bracket (☞ p.4-136)

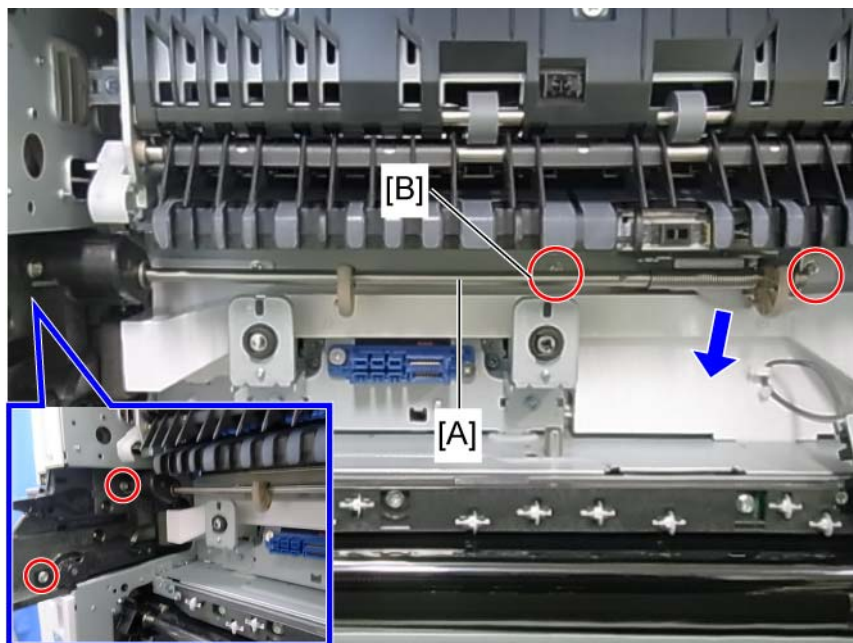

d1440149

1. Fusing unit shutter plate drive mechanism [A] (☞ x 4)

Note

- If the shaft interferes with the movement of the screwdriver, the screw [B] should be removed at the very last while pushing the shaft down slightly.

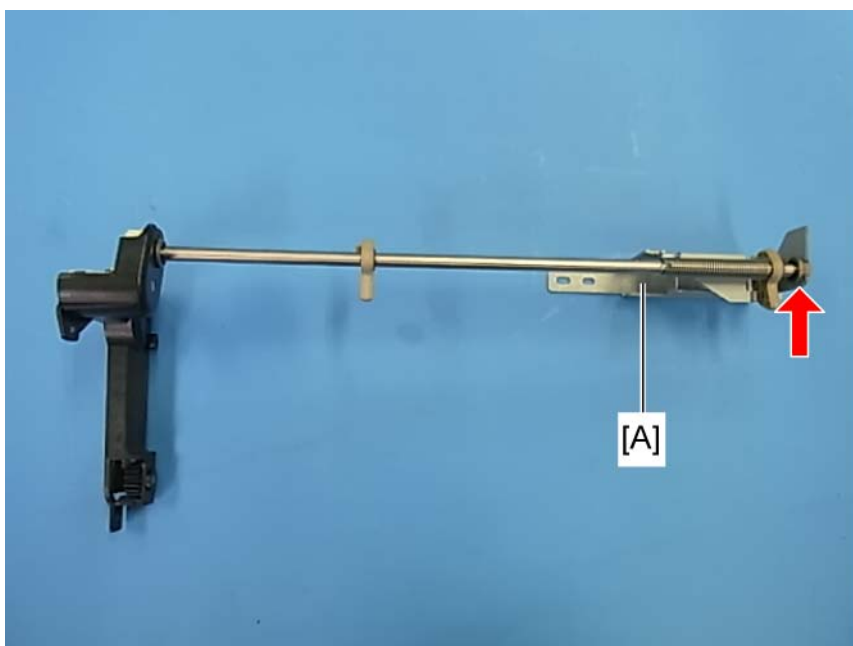

d1440150

2. Drive shaft stay [A] (Bearing x 1)

Fusing

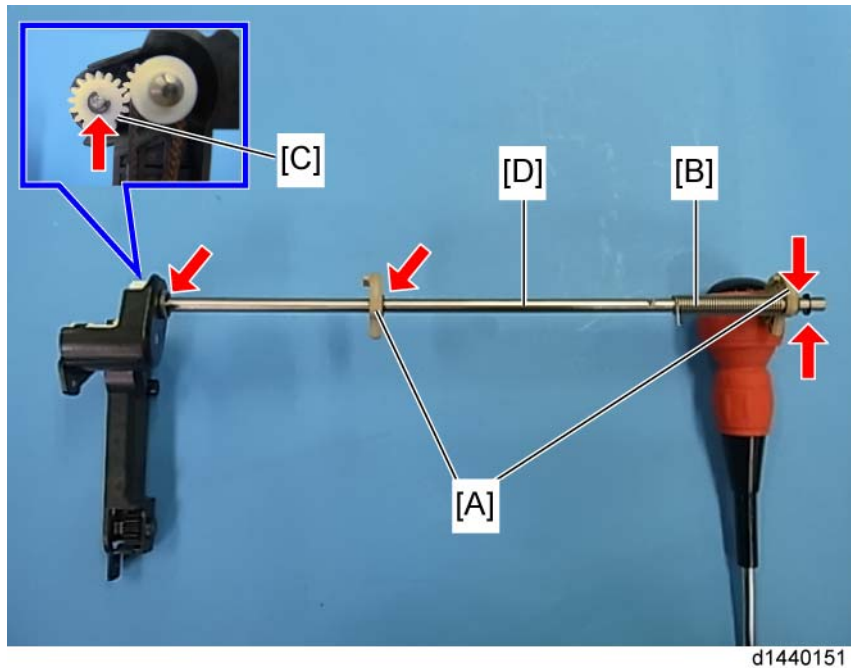

d1440151

3. Drive cams [A] (☉ x 3, ☉ [B] x 1)
4. Drive gear [C] and drive shaft [D] (Bearing x 1, ☉ x 1)

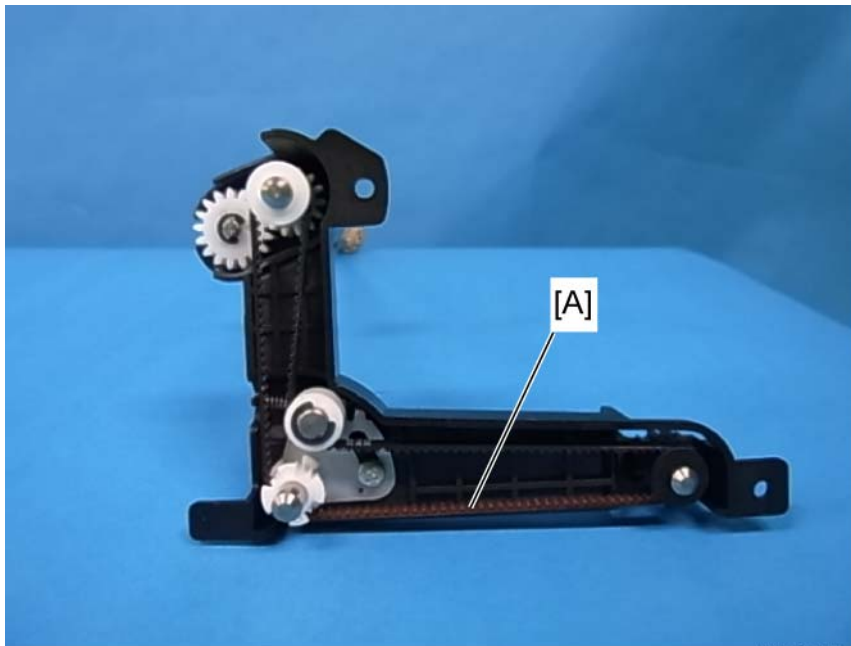

d1440152

5. Drive belt [A]

↓ Note

- **When reinstalling the fusing unit shutter plate drive mechanism:**
- Make sure that the tension of the coil spring on the drive shaft is correct before reinstallation. If the tension is weak, rotate the spring one revolution on the shaft and hook it.

4.12 PAPER FEED

4.12.1 PAPER FEED UNIT

1. Rear cover (🔧 p.4-18)
2. Right rear cover (🔧 p.4-19)
3. Duplex unit (🔧 p.4-153)
4. Pull out tray 1 and tray 2.

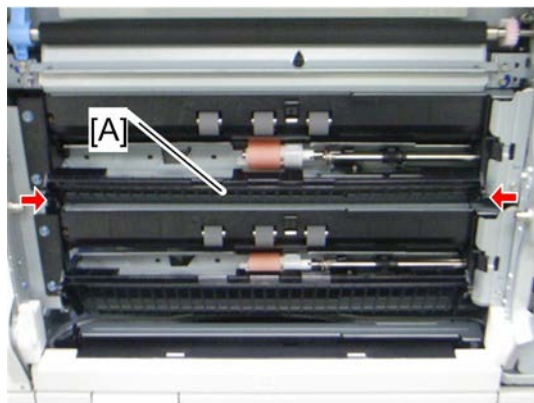

d088r168

5. Paper guide plate [A] (tab x 2)

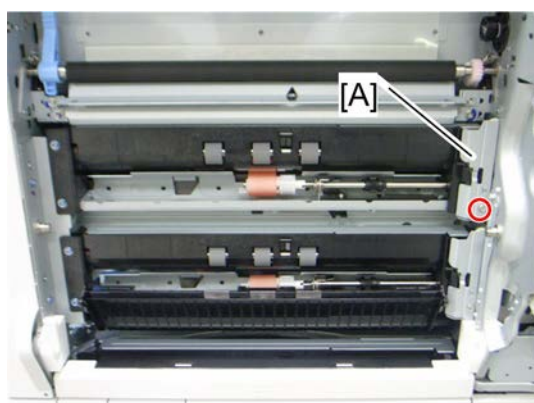

d088r169

6. Harness cover [A] (🔧 x 1)

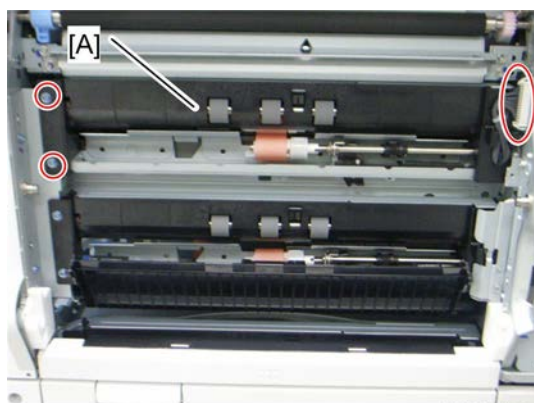

d088r170

7. Paper feed unit [A] (🔧 x 2, 📄 x 1)

4.12.2 PICK-UP, FEED AND SEPARATION ROLLERS

Tray 1 and Tray 2

1. Paper feed unit (🔧 p.4-139)

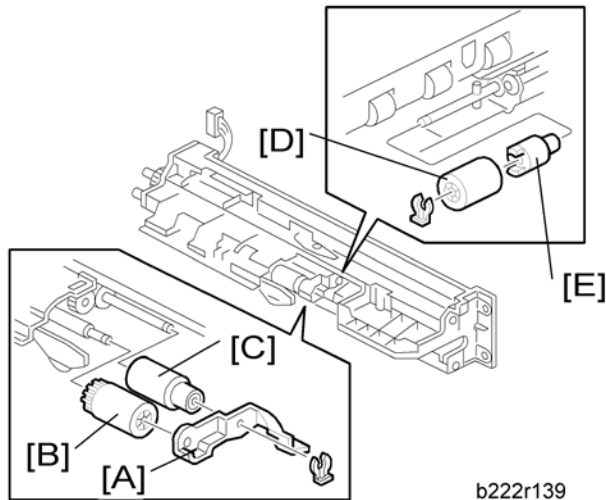

2. Roller holder [A] (🔧 x 1)
3. Pick-up roller [B]
4. Feed roller [C]
5. Separation roller [D] and torque limiter [E] (🔧 x 1)

4.12.3 TRAY LIFT MOTOR

1. Rear cover (🔧 p.4-18)
2. PSU bracket (🔧 p.4-168)
3. High voltage supply board bracket (🔧 p.4-172)

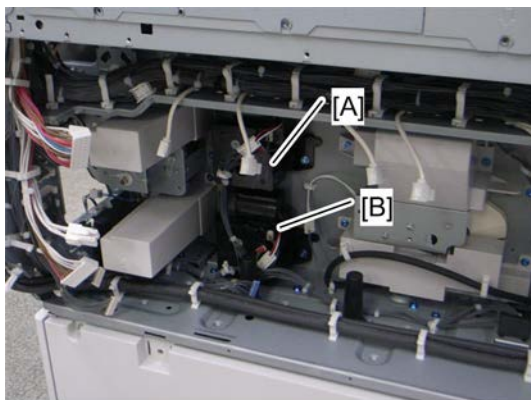

4. Tray lift motor 1 [A] or 2 [B] (🔧 x 2, 📎 x 3, 📎 x 1 each)

4.12.4 VERTICAL TRANSPORT, PAPER OVERFLOW, PAPER END AND PAPER FEED SENSOR

1. Rear cover (🔧 p.4-18)
2. Right rear cover (🔧 p.4-19)
3. Paper feed unit (🔧 p.4-139)

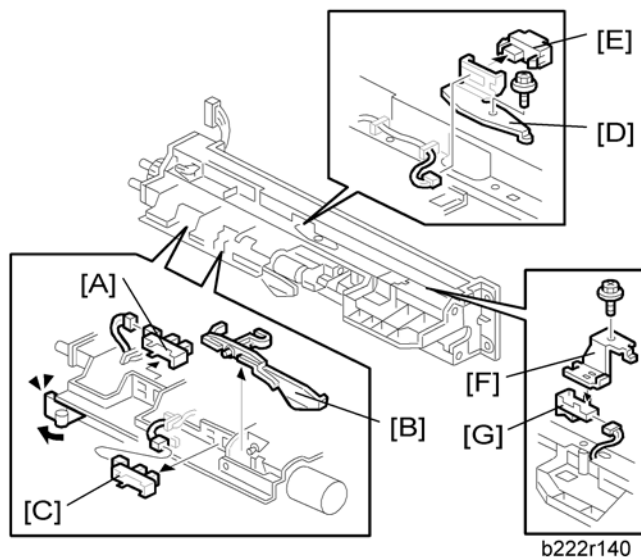

4. Paper overflow sensor [A]
5. Paper end feeler [B] and paper end sensor [C] (hook, 📄 x 1 each)
6. Vertical transport sensor bracket [D] (🔧 x 1, 📄 x 1)
7. Vertical transport sensor [E] (📄 x 1, hook)
8. Paper feed sensor bracket [F] (🔧 x 1)
9. Paper feed sensor [G] (📄 x 1, hook)

4.12.5 REGISTRATION SENSOR

1. Rear cover (🔧 p.4-18)
2. Right rear cover (🔧 p.4-19)

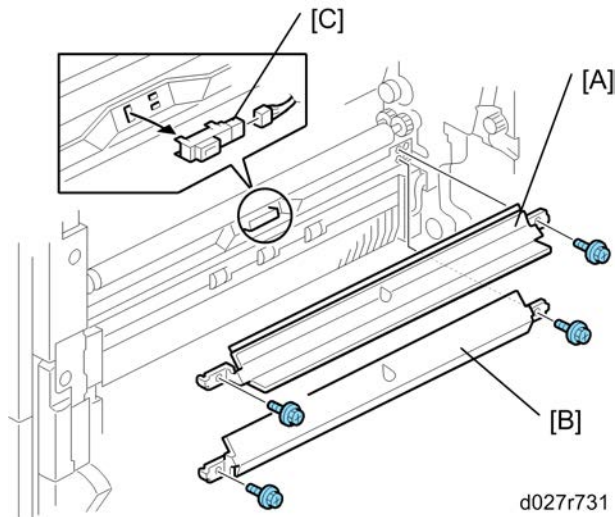

3. Paper guide plate 1 [A] and 2 [B] (🔧 x 2 each)
4. Registration sensor [C] (🔧 x 1, hook)

4.12.6 BY-PASS PAPER SIZE SENSOR AND BY-PASS PAPER LENGTH SENSOR

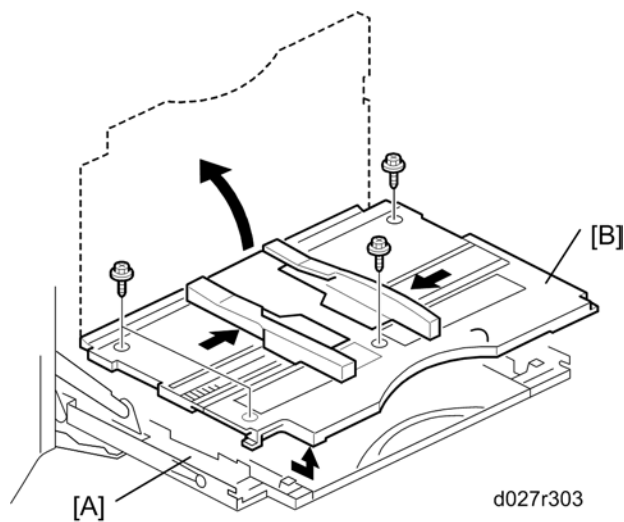

1. Open the by-pass tray [A].
2. Move the side fences to the center.
3. By-pass tray cover [B] (🔧 x 4)

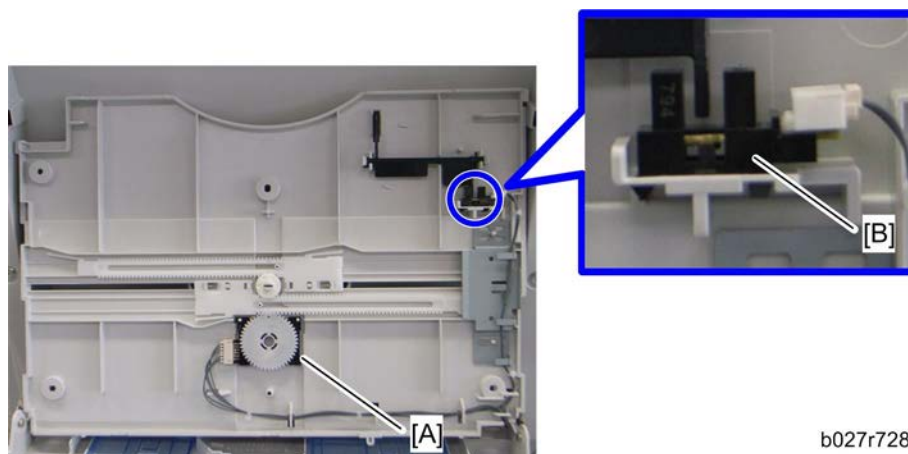

b027r728

4. By-pass paper size sensor [A] (☞ x 1)
5. By-pass paper length sensor [B] (☞ x 1)

When reinstalling the by-pass paper size sensor

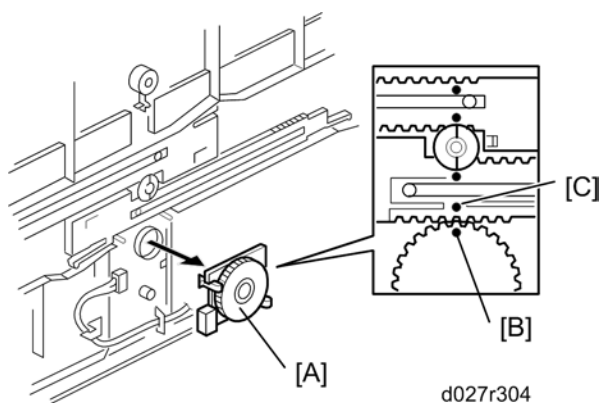

d027r304

1. Adjust the projection [A] of the left side fence bar (it must be centered).
2. Install the by-pass paper size detection switch so that the hole [B] in this switch faces the projection [C] of the left side fence bar.
3. Reassemble the copier.
4. Plug in and turn on the main power switch.
5. Check this switch operation with SP5803-011 (By-pass paper size < Input Check).

- Display on the LCD -

Paper Size	Display	Paper Size	Display
A3 SEF	00001110	A5 SEF	00001011
B4 SEF	00001100	B6 SEF	00000011
A4 SEF	00001101	A6 SEF	00000111
B5 SEF	00001001	Smaller A6 SEF	00001111

4.12.7 BY-PASS BOTTOM TRAY

1. Open the right door.
2. By-pass tray cover (🔧 p.4-142)

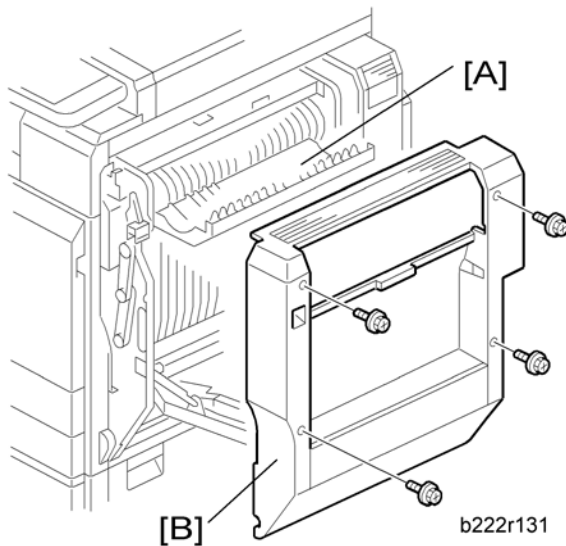

3. Open the duplex door [A].
4. Right door cover [B] (🔧 x 4)

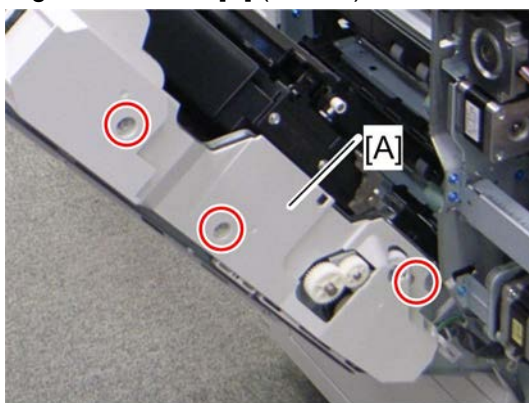

5. Right door rear cover [A] (🔧 x 3)

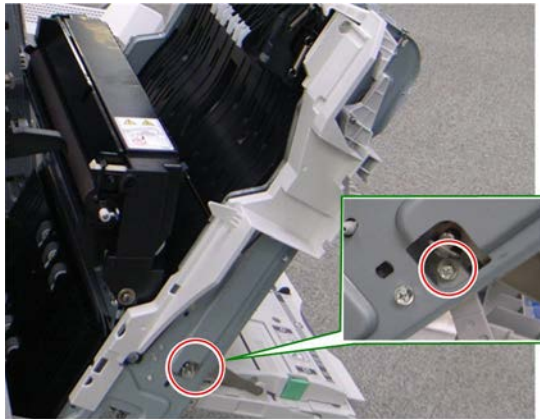

d027r175

6. Remove the screw at the front side ( x 1).

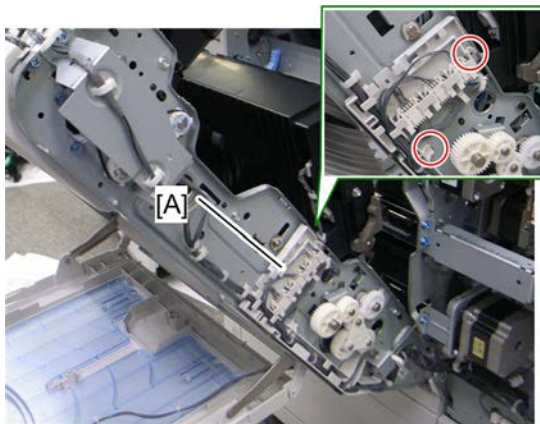

d027r177

7. Remove the cover [A] (2 hooks).



d027r178

8. Remove the screw at the rear side.

Paper Feed

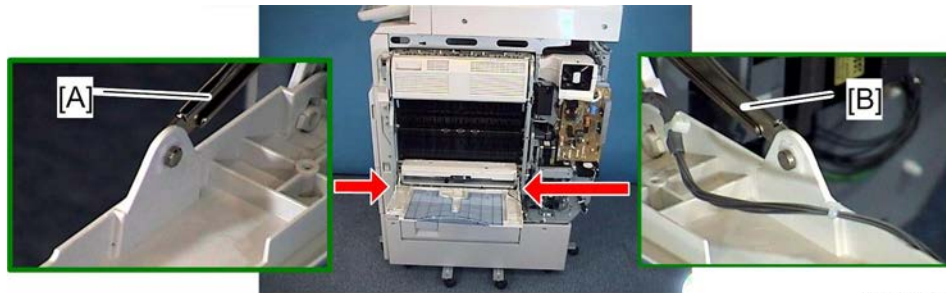

d027r597

9. Release the front [A] and rear [B] arms (🔧 x 1 each).

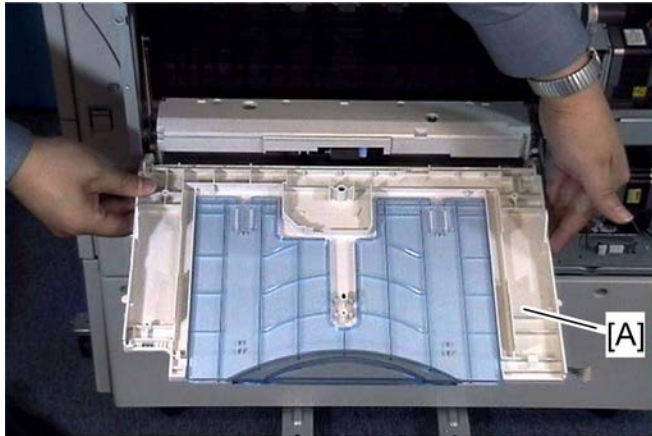

d027r598

10. By-pass bottom tray [A]

4.12.8 BY-PASS PAPER END SENSOR

1. Right door cover (☞ p.4-144)

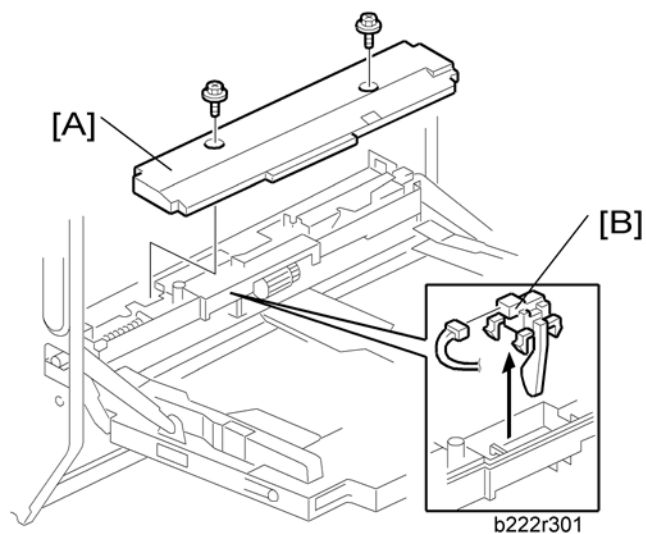

2. By-pass feed unit cover [A] (☞ x 2).
3. By-pass paper end sensor [B] (☞ x 1, hook)

4.12.9 BY-PASS PICK-UP, FEED AND SEPARATION ROLLER, TORQUE LIMITER

1. Right door cover (☞ p.4-144)

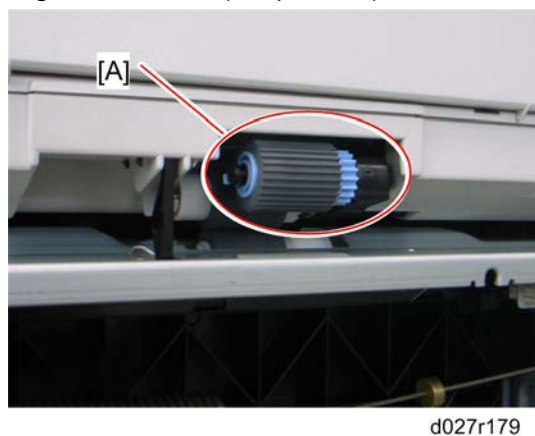

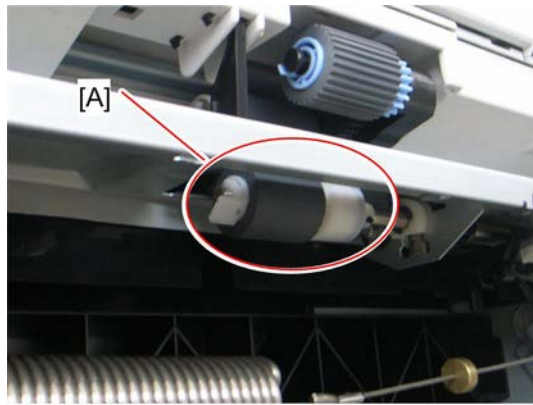

2. By-pass pick-up roller [A] (hook)

Paper Feed



d027r180

3. By-pass feed roller [A] ( x 1)
4. By-pass feed unit cover ( p.4-147)

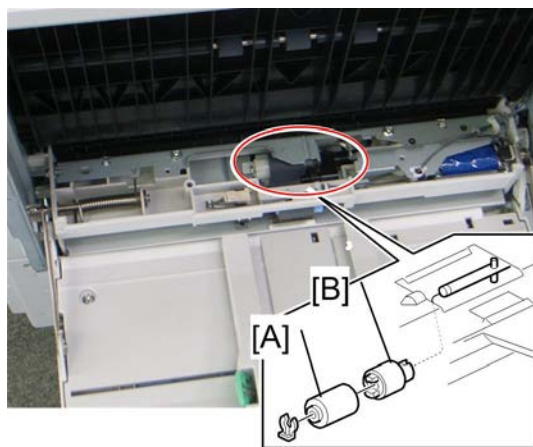

d027r302

5. By-pass separation roller [A] ( x 1)
6. Torque limiter [B]

4.12.10 BY-PASS FEED CLUTCH

1. Open the right door.
2. Right door rear cover (📄 p.4-144)

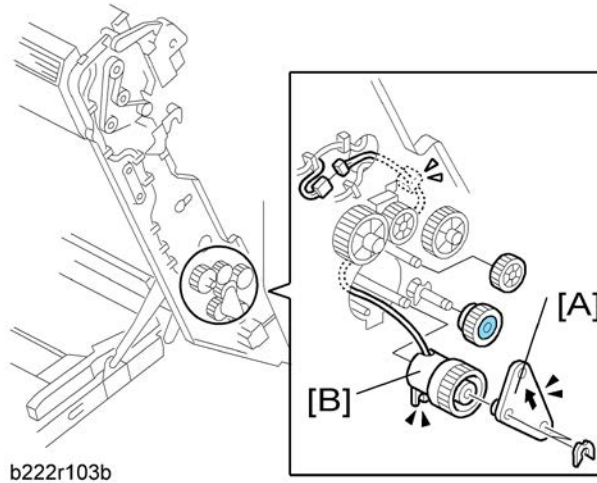

3. By-pass feed clutch holder [A] (📄 x 2)
4. By-pass feed clutch [B] (📄 x 1, 📄 x 1)

4.12.11 PAPER EXIT UNIT

1. Fusing Unit (🔧 p.4-110)
2. Front right cover (🔧 p.4-20)
3. Image transfer belt unit (🔧 p.4-74)
4. Inner Tray (🔧 p.4-25)
5. Rear cover (🔧 p.4-18)
6. Right rear cover (🔧 p.4-19)
7. Fusing entrance thermopiles (🔧 p.4-131)
8. Fusing duct (🔧 p.4-128)
9. Open the controller box (🔧 p.4-160).

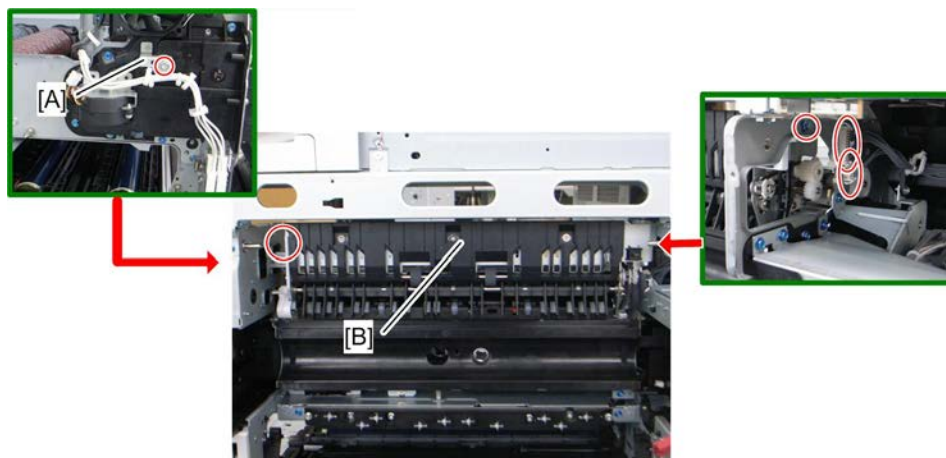

d027r181

10. Gear cover [A] (🔧 x 1)
11. Paper exit unit [B] (🔧 x 2, 📦 x 2)

4.12.12 FUSING EXIT, PAPER OVERFLOW, JUNCTION PAPER JAM AND PAPER EXIT SENSOR

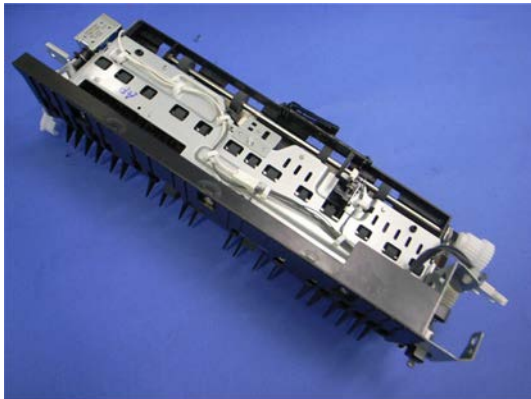

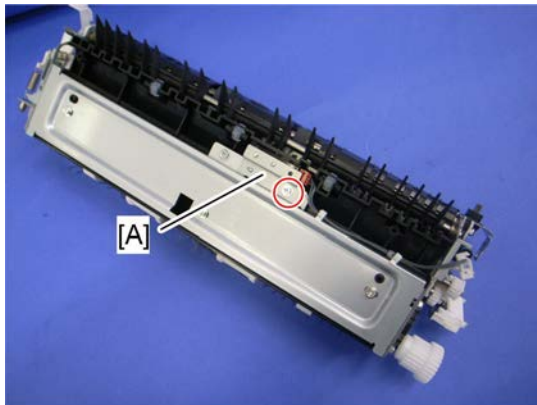

d027r182

1. Paper exit unit ( p.4-150)



d027r183

2. Fusing exit sensor bracket [A] ( x 1,  x 1)
3. Remove the fusing exit sensor from the fusing exit sensor bracket ( x 1)

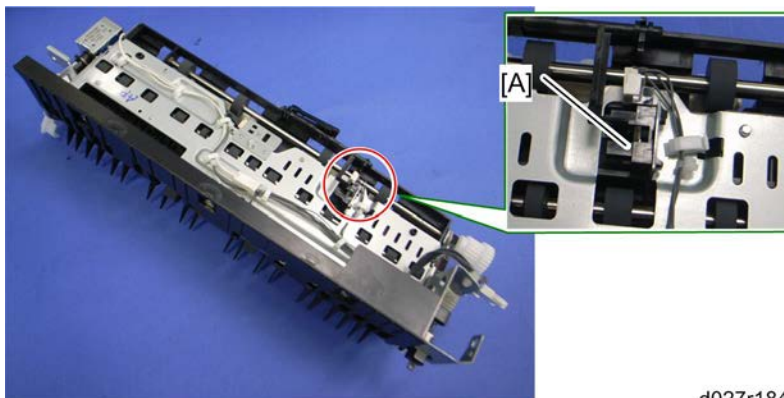



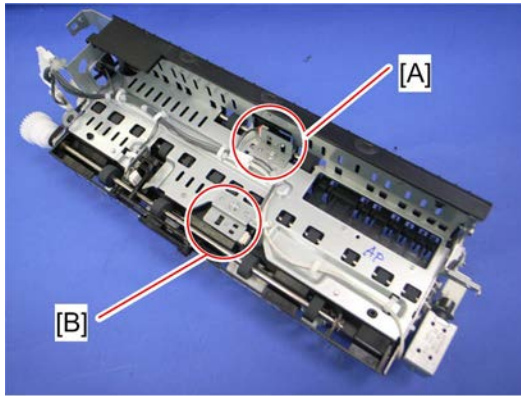

d027r184

4. Paper overflow sensor [A] ( x 1, hook)

Paper Feed



d027r185

5. Junction paper jam sensor bracket [A] ( x 1,  x 1)
6. Remove the junction paper jam sensor from the junction paper jam sensor bracket (hook)
7. Paper exit sensor bracket [B] ( x 1,  x 1)
8. Remove the paper exit sensor from the paper exit sensor bracket (hook)

4.13 DUPLEX UNIT

4.13.1 DUPLEX UNIT

1. Rear cover (☞ p.4-18)
2. Right rear cover (☞ p.4-19)
3. Right door cover (☞ p.4-81)

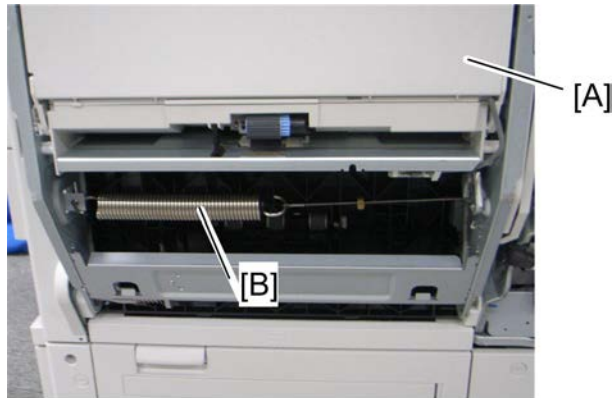

d088r554

4. Close the right door [A].
5. Remove the spring [B].
6. Open the right door [A].

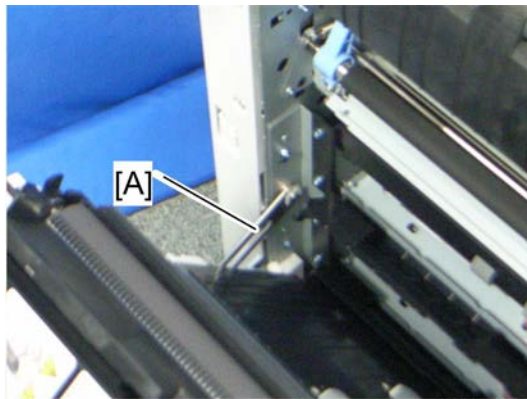

d088r555

7. Release the front link [A] (☞ x 1).
8. Keep the right door fully open.

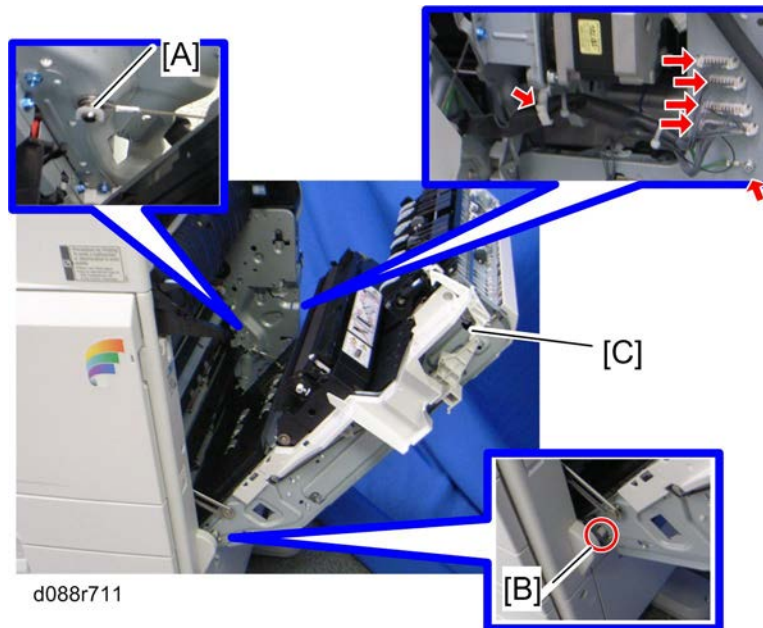

9. Hold the right door, and then release the wire [A] (🔗 x 1).

⚠ CAUTION

1. Keep holding the right door before removing the right door completely. Otherwise, the right door can fall down and injure you.

10. Press the projection [B] to pull the right door shaft into the unit, and then remove the duplex unit [C] (🔧 x 1, 🛠 x 1, 📄 x 4, ground cable x 1).

4.13.2 DUPLEX DOOR SENSOR

- Right door cover (📄 p.4-81)
- Open the right door.

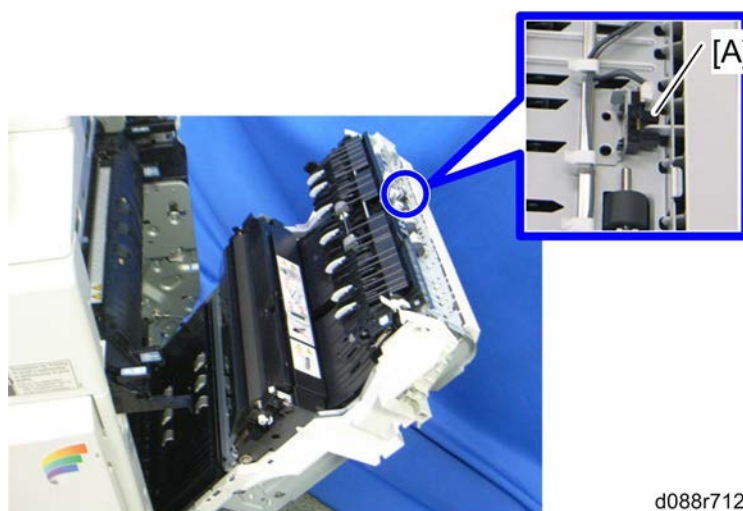

- Duplex door sensor [A] (📄 x 1, hook)

4.13.3 DUPLEX ENTRANCE SENSOR

- Right door cover (🔧 p.4-81)
- Open the right door.

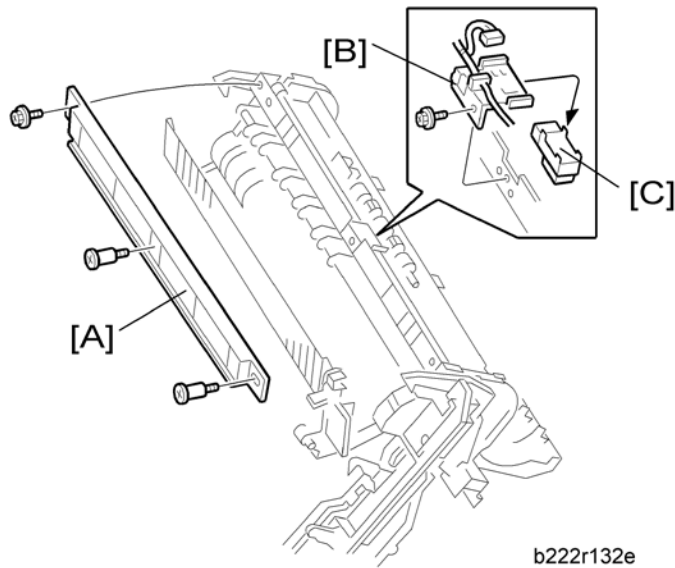

- Duplex entrance guide [A] (🔧 x1, stepped screw x 2)
- Duplex entrance sensor bracket [B] (🔧 x 1, 📄 x 1)
- Duplex entrance sensor [C] (hook)

4.13.4 DUPLEX EXIT SENSOR

- Paper transfer unit (📄 p.4-81)

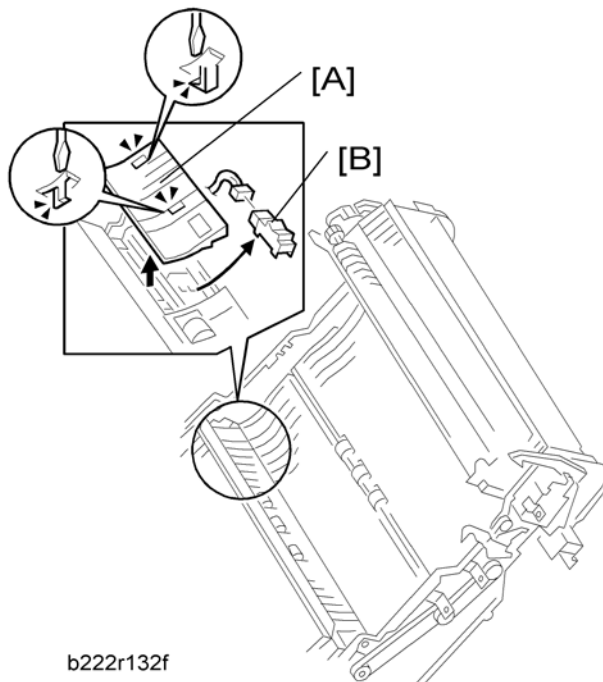

- Guide plate [A] (two hooks)
- Duplex exit sensor [B] (📄 x 1, hook)

4.14 ELECTRICAL COMPONENTS

4.14.1 BOARDS

Controller Box closed

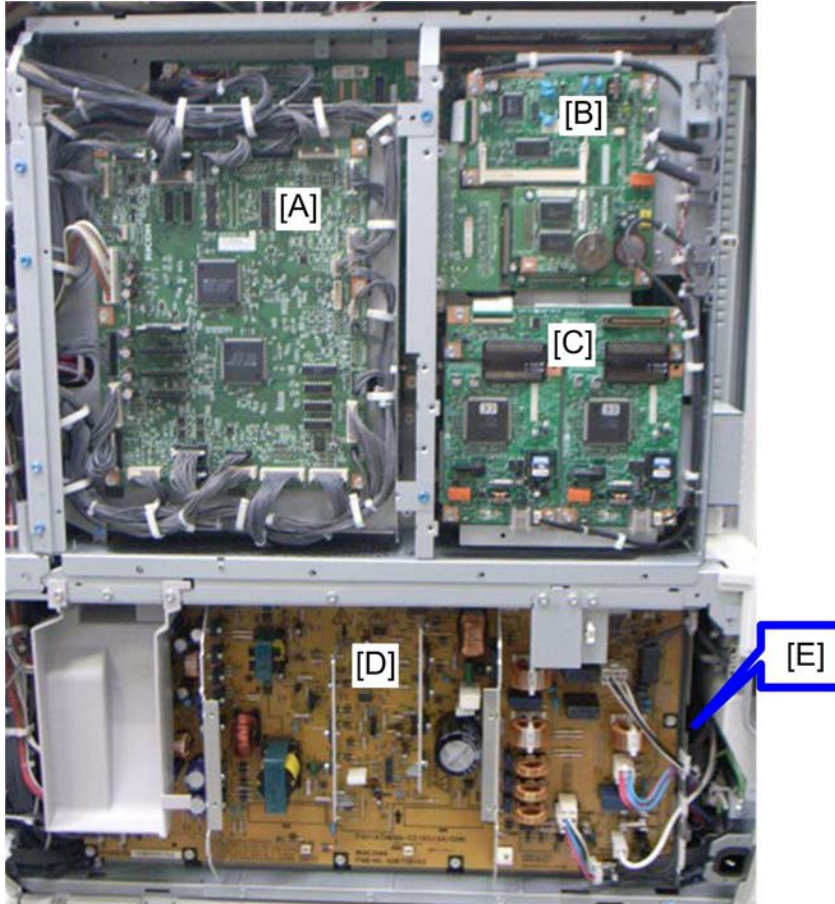

d027r729

Replacement
and
Adjustment

[A]	IOB
[B]	FCU (Option)
[C]	G3 Interface Unit (Option)
[D]	PSU
[E]	High Voltage Supply Board (Behind the PSU [D])

Behind the IOB, FCU and G3 Interface Unit

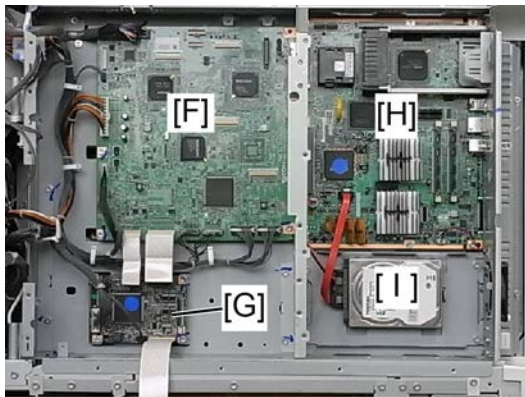

d1420030

[F]	IPU
[G]	BCU
[H]	Controller Board
[I]	HDD

Controller Box Open

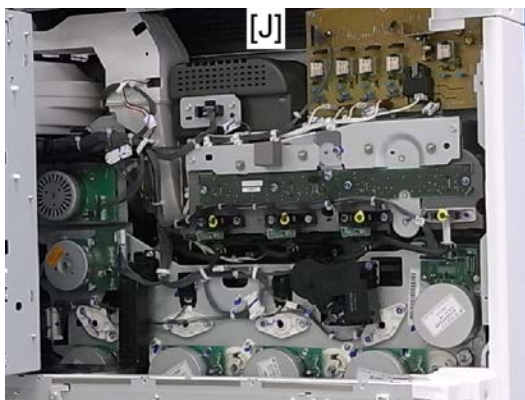

d1420039

[J]	ITB Power Supply Board
-----	------------------------

4.14.2 CONTROLLER UNIT

1. Controller cover (🔧 p.4-17)

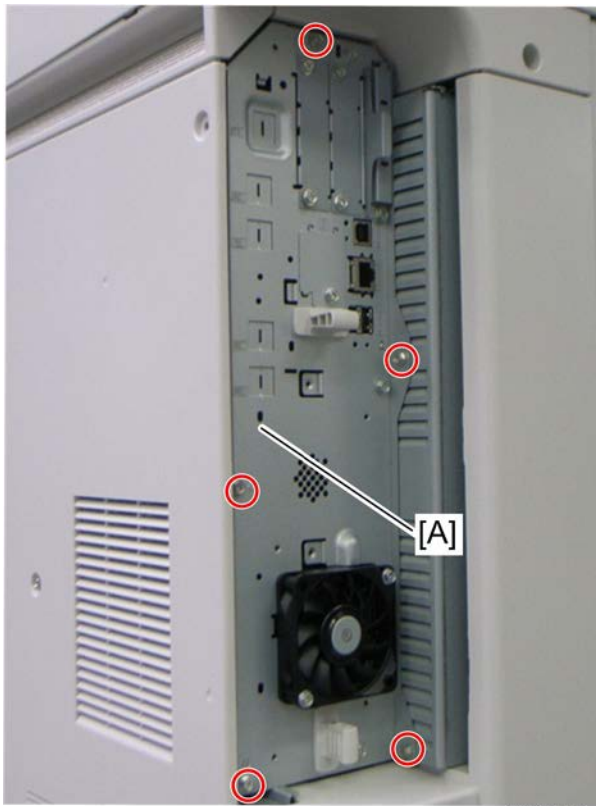

d088i075

2. Controller unit [A] (🔧 x 5)

4.14.3 CONTROLLER BOX RIGHT COVER

1. Rear cover (🔧 p.4-18)

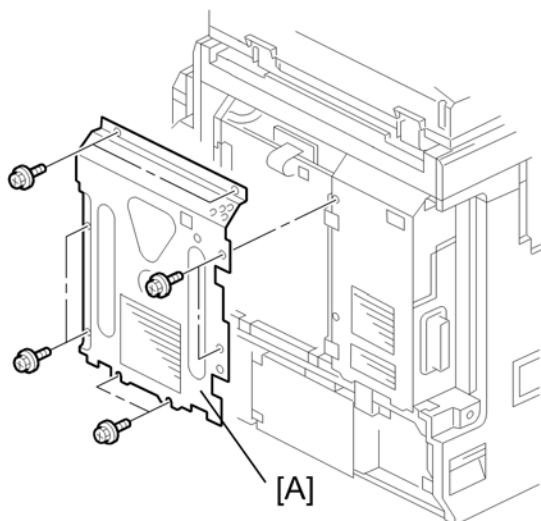

b222r107b

2. Controller box right cover [A] (🔧 x 8)

Replacement
and
Adjustment

4.14.4 CONTROLLER BOX

When opening the controller box

1. Rear cover (📄 p.4-18)

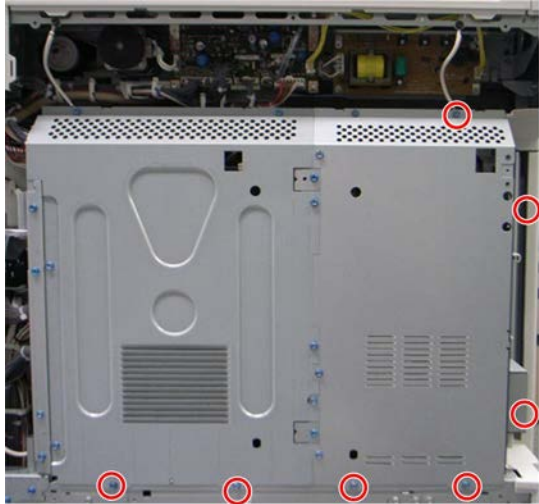

d023r603

2. Remove seven screws.



d023r110

3. Open the controller box [A].

When removing the controller box

1. Rear cover (🔧 p.4-18)
2. Controller cover (🔧 p.4-17)
3. Right rear cover (🔧 p.4-19)
4. Controller box right cover (🔧 p.4-159)

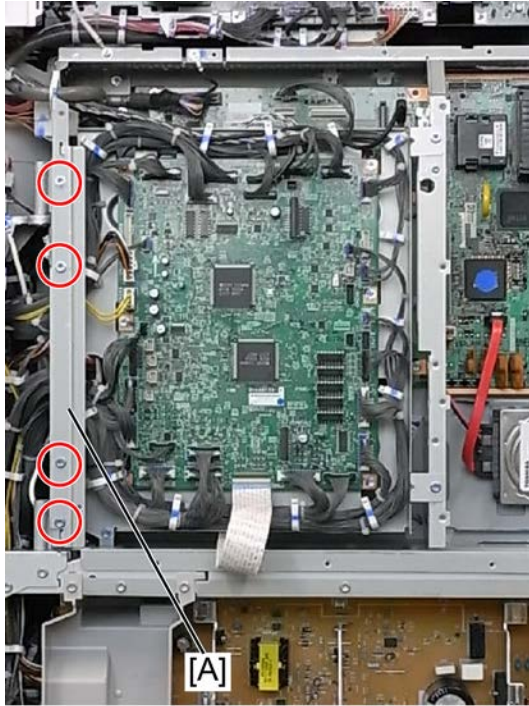

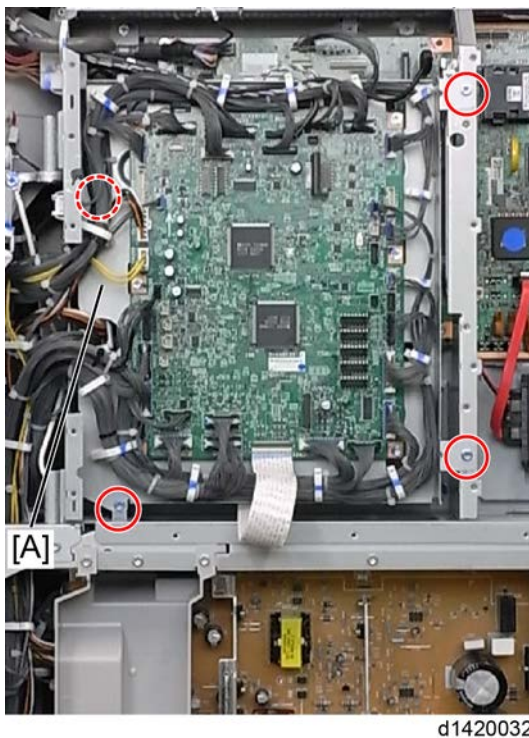

5. Controller box stay [A] (🔧 x 4)



Replacement
and
Adjustment

Electrical Components

6. IOB bracket [A] ( x 4,  x All)

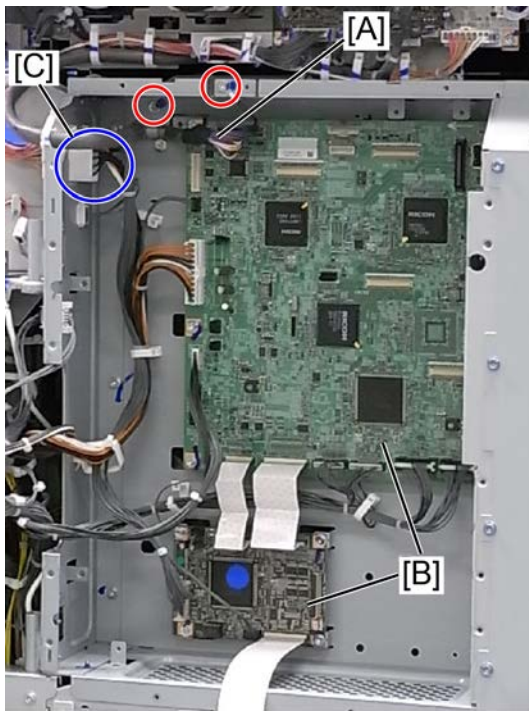

d1420033

7. Disconnect the scanner interface cable [A] (ground cable)
8. Release all clamps on the controller box frame.
9. Disconnect all connectors on the IPU board and the BCU board [B].
10. Disconnect the connector [C] at the outer controller box and at the inner controller box.



d1420034

11. Disconnect two ground cables. ( x 1, each)

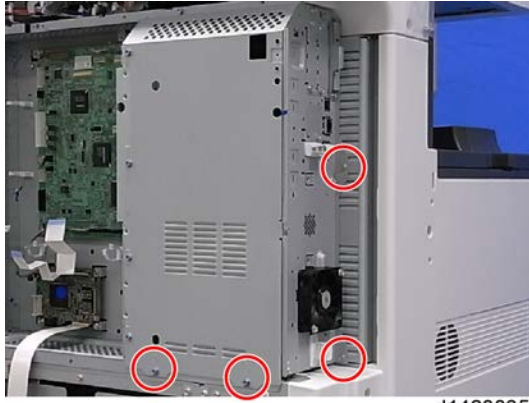

d1420035

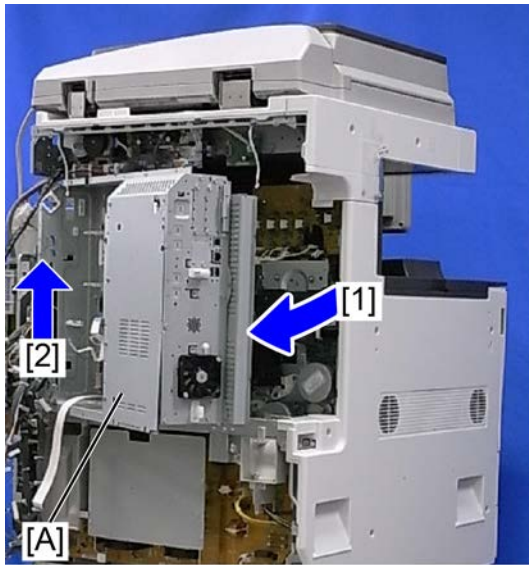

d1420036

Replacement
and
Adjustment

12. Open [1] and lift up [2] the controller box [A], and then remove it. ( x 4)

4.14.5 IOB (IN/OUT BOARD)

1. Rear cover (🔧 p.4-18)
2. Controller box right cover (🔧 p.4-159)

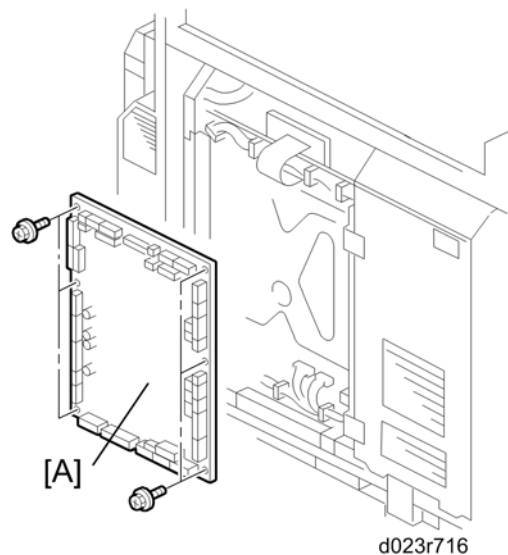

3. IOB [A] (🔧 x 6, All 📄s)

4.14.6 IPU

1. Rear cover (🔧 p.4-18)
2. Controller box right cover (🔧 p.4-159)
3. IOB bracket (🔧 p.4-160)

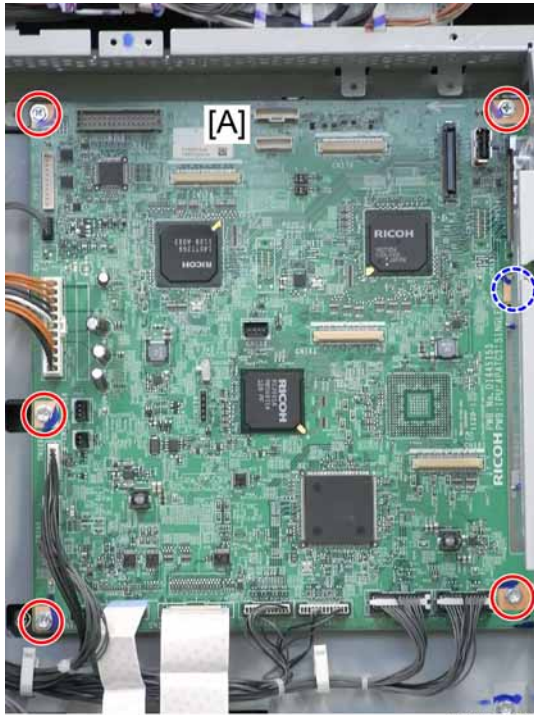

4. IPU [A] (🔧 x 6, 📄 x all)

Replacement
and
Adjustment

4.14.7 BCU

1. Rear cover (🔧 p.4-18)
2. Controller box right cover (🔧 p.4-159)
3. IOB bracket (🔧 p.4-160)

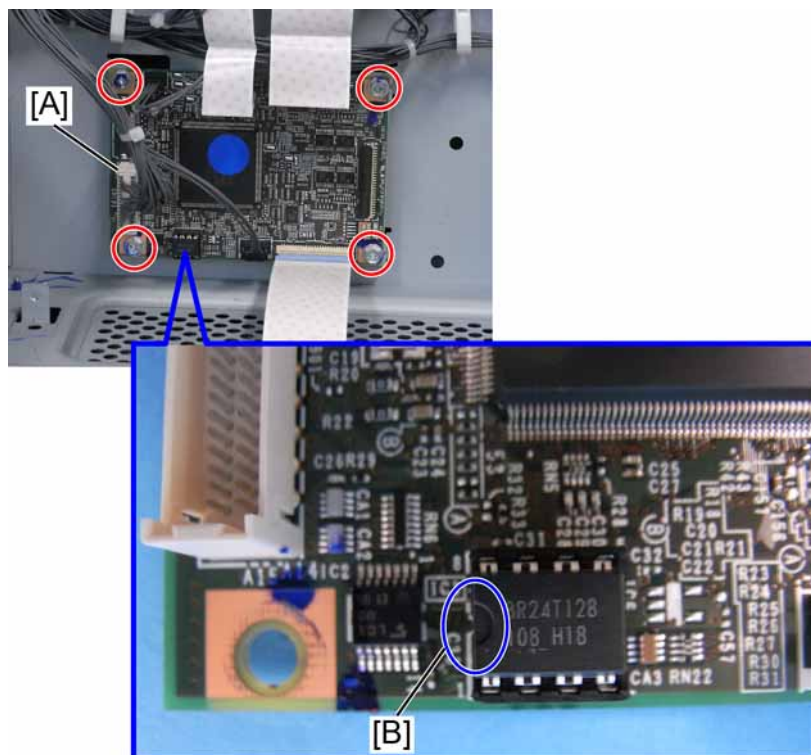

d1420029

4. BCU [A] (🔧 x 4, 📄 x All)

⬇ **Note**

1. Make sure the NVRAM is correctly installed on the BCU. Insert the NVRAM in the NVRAM slot with the "half-moon" pointing [B] to the left side.

When installing the new BCU

Remove the NVRAM from the old BCU. Then install it on the new BCU after you replace the BCU. Replace the NVRAM (🔧 p.4-180) if the NVRAM on the old BCU is defective.

⬇ **Note**

1. Make sure you print out the SMC reports ("SP Mode Data" and "Logging Data") before you replace the NVRAM.

⚠ CAUTION

1. Keep NVRAMs away from any objects that can cause static electricity. Static electricity can damage NVRAM data.
2. Make sure that the DIP-switch settings on the old BCU are the same for the new BCU when. Do not change the DIP switches on the BCU in the field.
3. Make sure the serial number is input in the machine for the NVRAM data; if not, SC 995-001 occurs.

4.14.8 PSU***Shutdown Board***

- Rear cover (🔧 p.4-18)

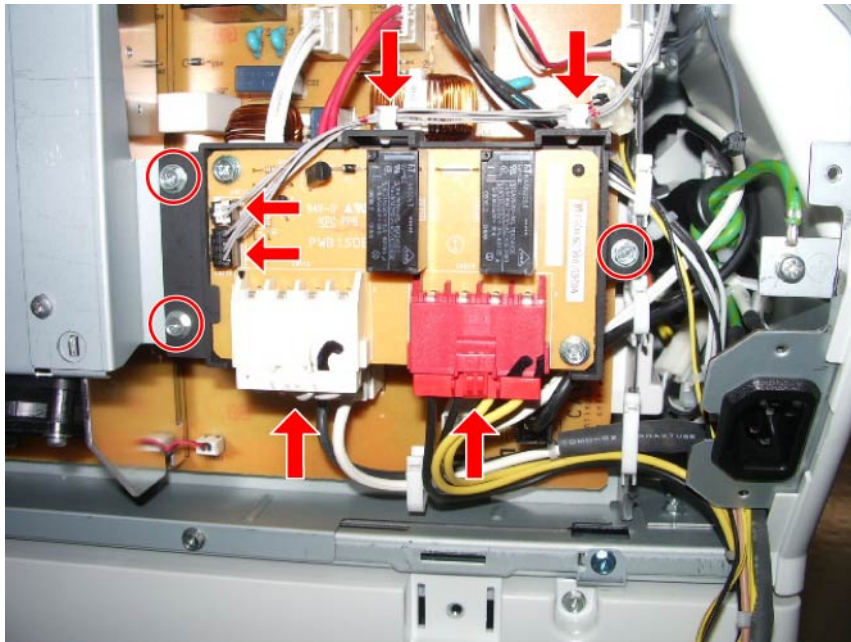

d1440119

- Shutdown board with bracket (🔧 x 4, 📦 x 2, 🔧 x 3)

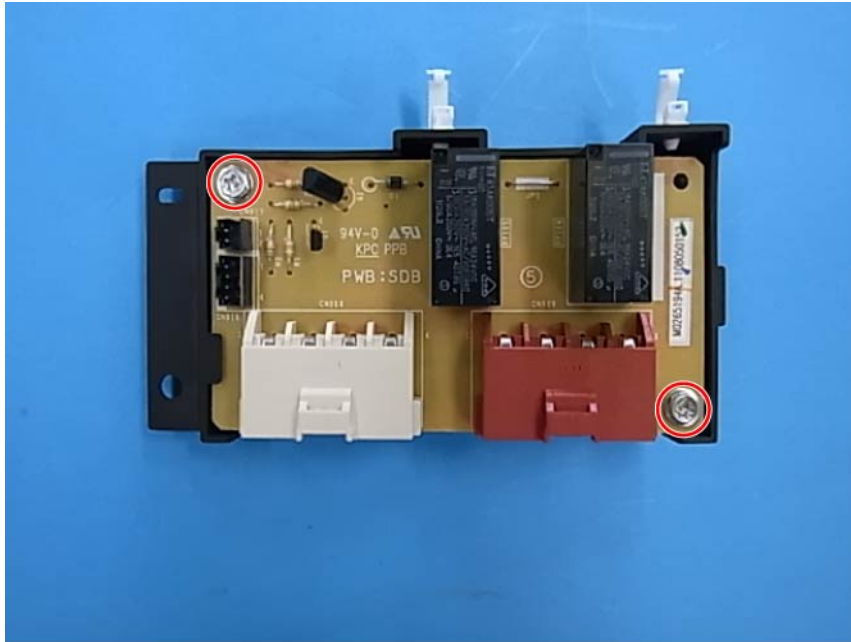

Electrical Components



d1440120

- Shutdown board ( x 2)

PSU bracket

- Rear cover ( p.4-18)
- Shutdown board with bracket ( Shutdown Board)

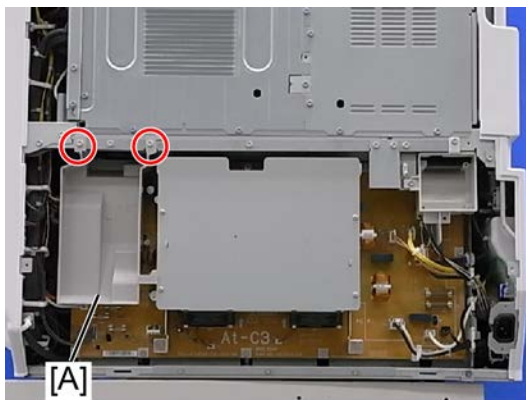

d1420045

- Ventilation duct [A] ( x 2)

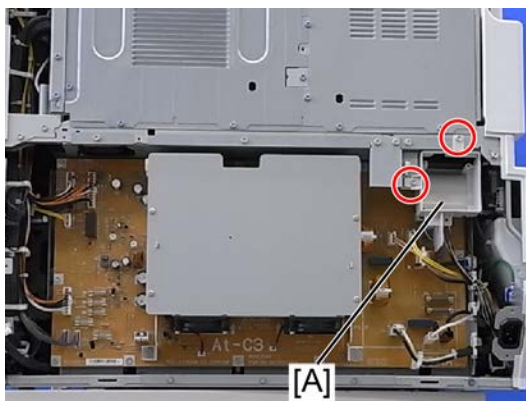

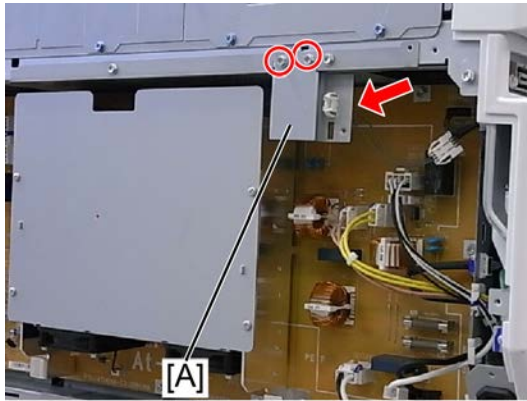

d1420046

- First duct fan bracket [A] ( x 2)



d1420047





- Remove [A] ( x 2,  x 1)



d1420048



- PSU bracket [A] ( x 6,  x All,  x All)

PSU board

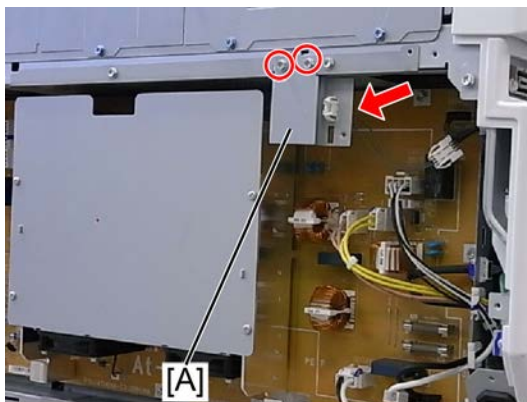
1. Rear cover ( p.4-18)
2. Shutdown board with bracket ( p.4-167)
3. Ventilation duct ( p.4-168)
4. First duct fan bracket ( p.4-168)



d1420047

5. Remove [A] ( x 2,  x 1)

Replacement and Adjustment

Electrical Components

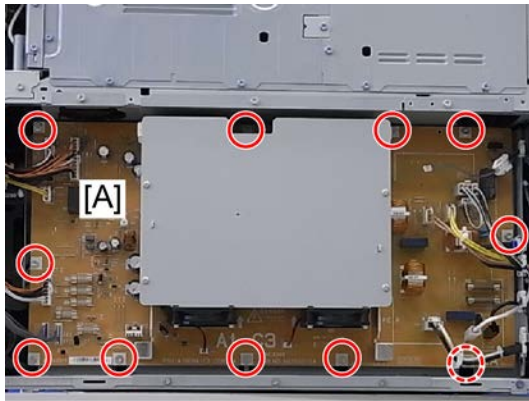

d1420052

6. PSU board [A] (🔩 x 11, all 📄s, all 📡s)

PSU fans

1. Rear cover (📄 p.4-18)
2. Shutdown board with bracket (📄 p.4-167)

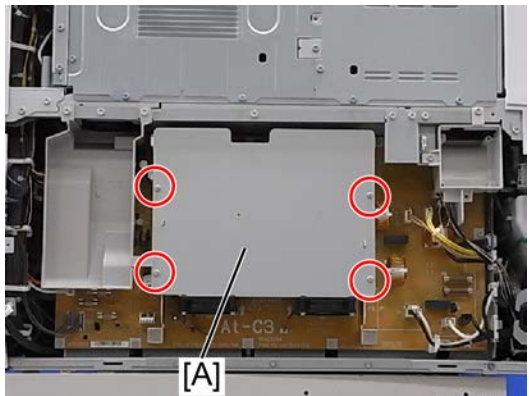

d1420049

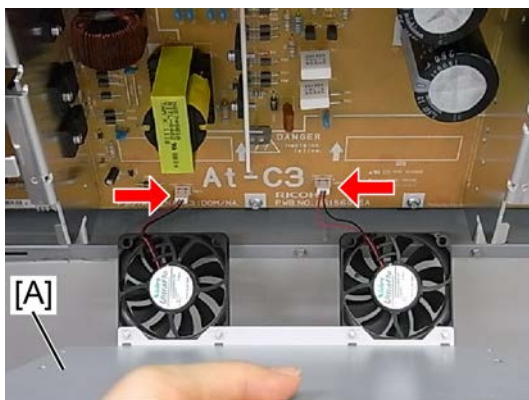

d1420050

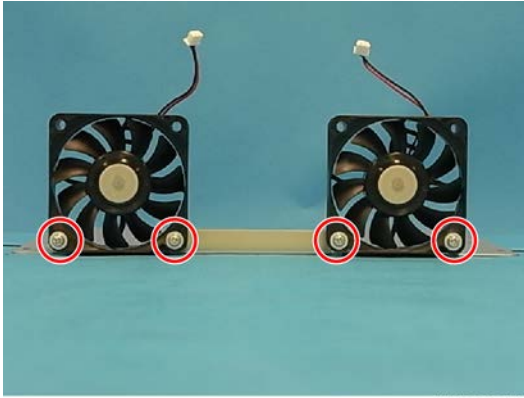

3. PSU fan bracket [A] (🔩 x 4, 📄 x 2)



d1420051



4. PSU fans ( x 2 each)

4.14.9 ITB POWER SUPPLY BOARD

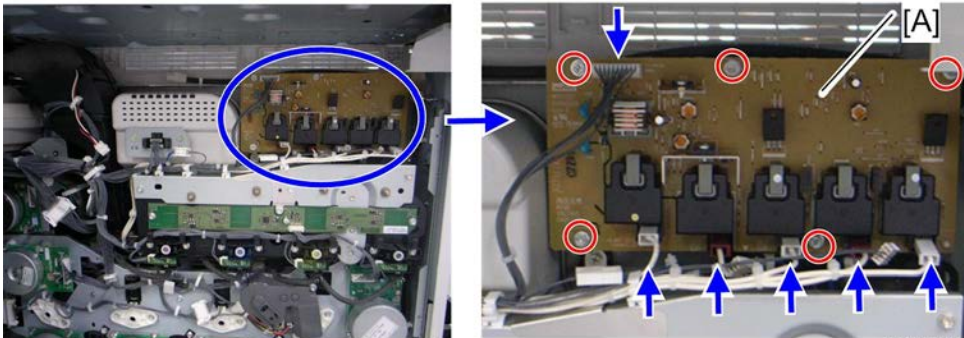
1. Rear cover ( p.4-18)
2. Scanner rear cover ( p.4-30)
3. Open the controller box ( p.4-160)



d027r717

4. ITB power supply board [A] ( x 5,  x 6)

Replacement and Adjustment

4.14.10 HIGH VOLTAGE SUPPLY BOARD

- Rear cover (🔧 p.4-18)
- PSU bracket (🔧 p.4-168)

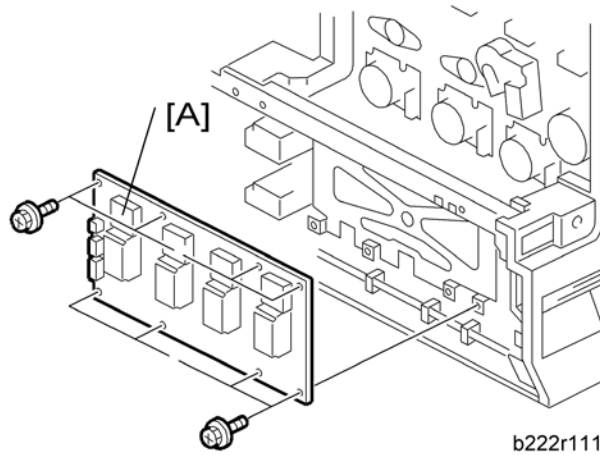

- High voltage supply board [A] (🔧 x 8, All 📄s, 📦 x 2)

4.14.11 HIGH VOLTAGE SUPPLY BOARD BRACKET

- Rear cover (🔧 p.4-18)
- PSU bracket (🔧 p.4-168)

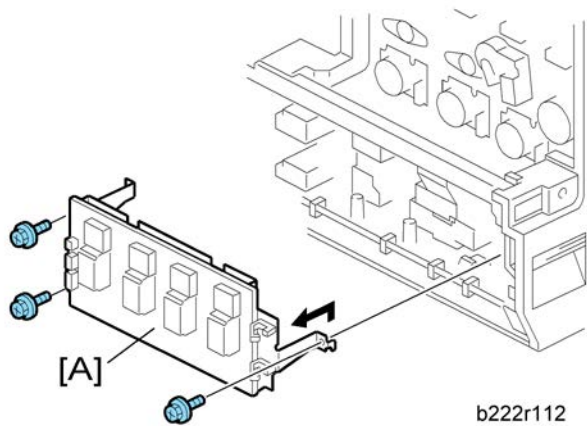

- High voltage supply board bracket [A] (🔧 x 3, 📄 x All, 📦 x 2)

4.14.12 AC CONTROLLER BOARD

1. Rear cover (🔧 p.4-18)
2. Right rear cover (🔧 p.4-19)
3. Fusing duct (🔧 p.4-128)

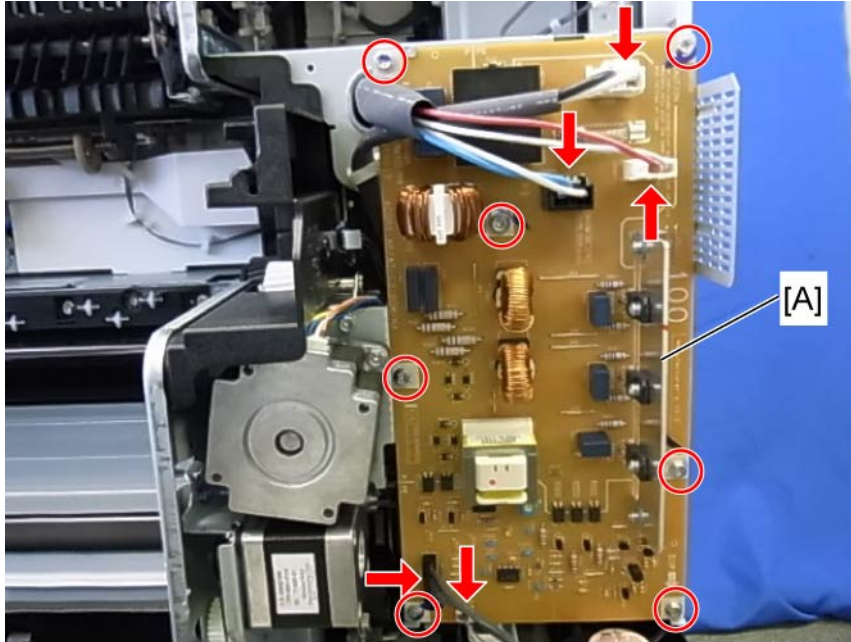

d1440108

4. AC Controller Board [A] (🔧 x 7, 📄 x 5)

Replacement
and
Adjustment

4.14.13 AC CONTROLLER BOARD BRACKET

- AC controller board (🔧 p.4-173)

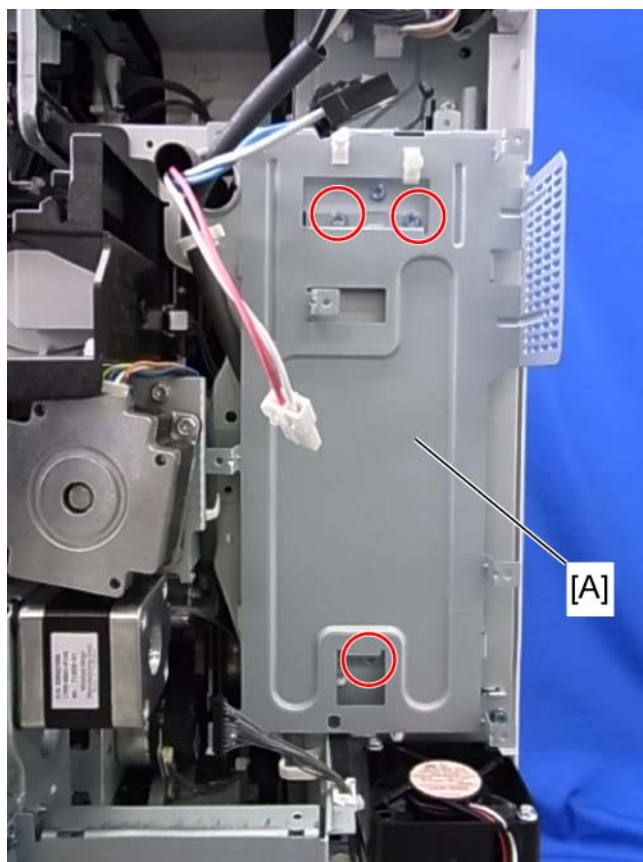

d1440124

- AC controller board bracket [A] (🔧 x 3)

4.14.14 CONTROLLER BOARD

1. Controller unit (🔧 p.4-159)

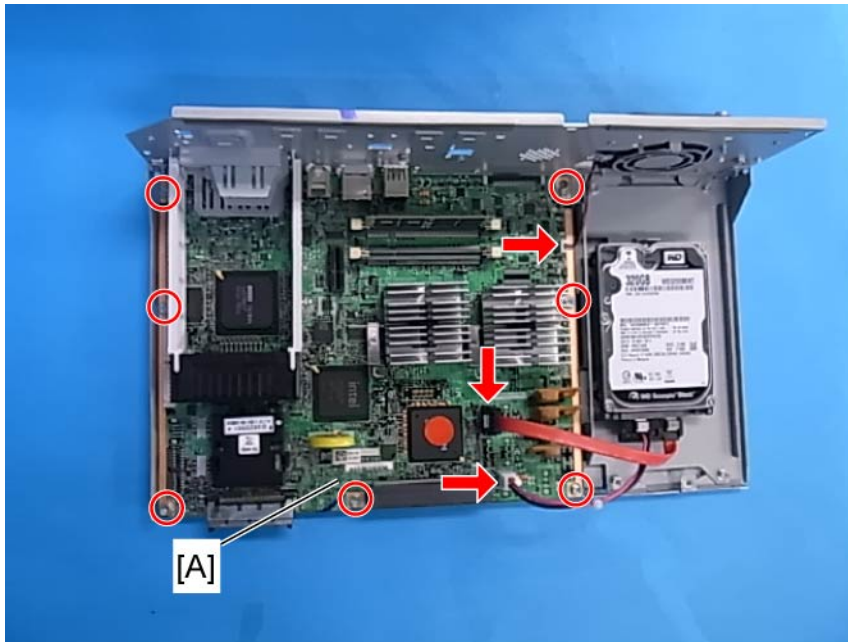

d1440112

2. Controller board [A] (🔧 x 7, 📁 x 3)

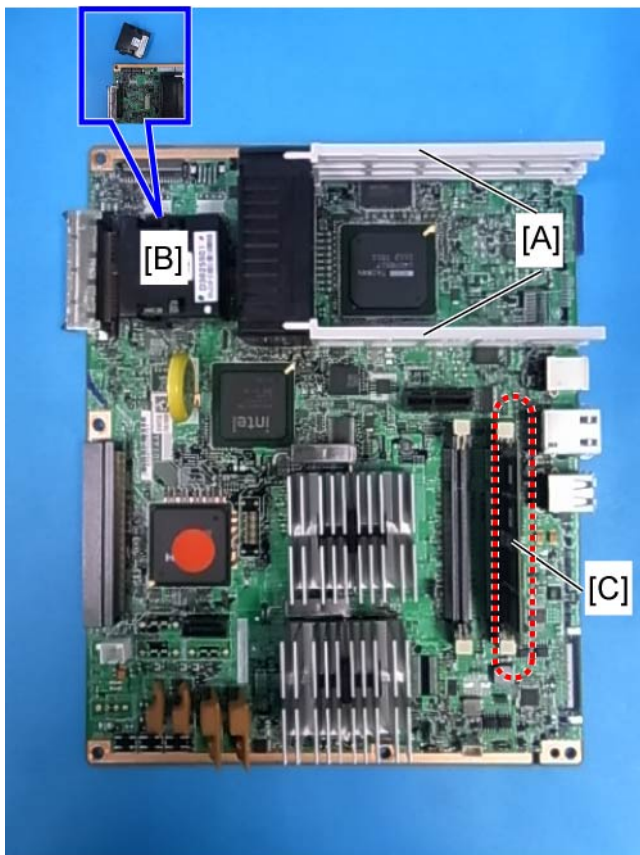

d1440113

3. Interface rails [A], NV-RAM [B], RAM-DIMM [C]

Replacement and Adjustment

When installing the new controller board

Remove the NVRAM from the old controller board. Then install it on the new controller board after you replace the controller board. Replace the NVRAM if the NVRAM on the old controller board is defective.

Note

- Make sure you print out the SMC reports ("SP Mode Data" and "Logging Data") before you replace the NVRAM.

CAUTION

- Keep NVRAMs away from any objects that can cause static electricity. Static electricity can damage NVRAM data.
- Make sure the NVRAM is correctly installed on the controller board.
- Make sure that the DIP-switch settings on the old controller board are the same for the new controller board. Do not change the DIP switches on the controller board in the field.

4.14.15 HDD FAN

1. Controller unit (📄 p.4-159)

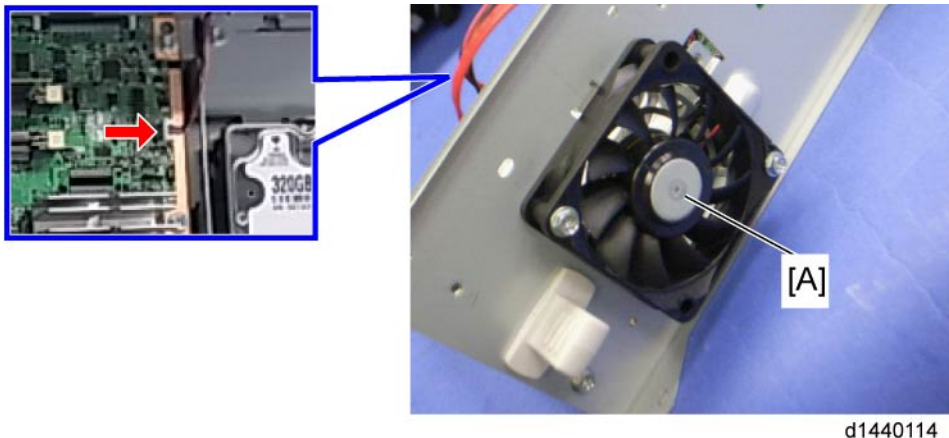



2. HDD fan [A] (🔧 x 2, 📄 x 1)

4.14.16 HDD

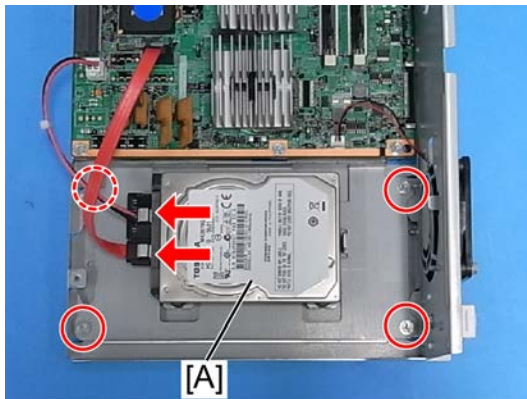
- Controller unit ( p.4-159)



d1420053

- Remove the HDD [A] with the bracket ( x 4,  x 2).

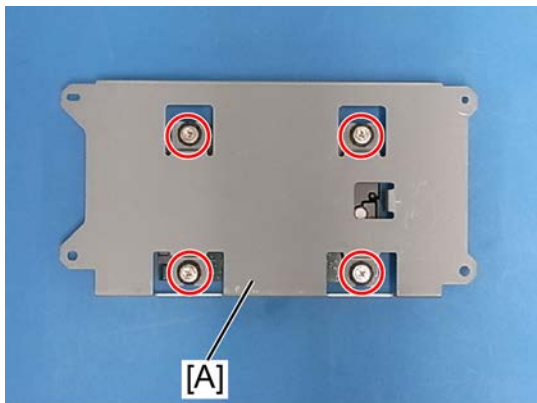

d1420054

- Remove the HDD from the bracket [A] ( x 4).

When installing a new HDD unit

- Turn the main power switch on. The disk is automatically formatted.
- Install the stamp data using "SP5853".
- Switch the machine off and on to enable the fixed stamps for use.

Disposal of HDD Units

- Never remove an HDD unit from the work site without the consent of the client.
- If the customer has any concerns about the security of any information on the HDD, the HDD must remain with the customer for disposal or safe keeping.
- The HDD may contain proprietary or classified (Confidential, Secret) information. Specifically, the HDD contains document server documents and data stored in temporary files created automatically during copy job sorting and jam recovery. Such data is stored on the HDD in a special format so it cannot normally be read but can be recovered with illegal methods.

Reinstallation

Explain to the customer that the following information stored on the HDD is lost when the HDD is replaced:

- Document server documents
- Custom-made stamps
- Document server address book

The address book and document server documents (if needed) must be input again.

If you previously backed up the address book to an SD card with SP5846 051, you can use SP 5846 052 to copy the data from the SD card to the hard disk.

If the customer is using the Data Overwrite Security feature, the DOS function must be set up again. For more, see Section 1 (Installation).

If the customer is using the optional Browser Unit, this unit must be installed again. For more, see Section 1 (Installation).

4.14.17 TONER BOTTLE DETECTION BOARD

1. Open the controller box (☞ p.4-160)

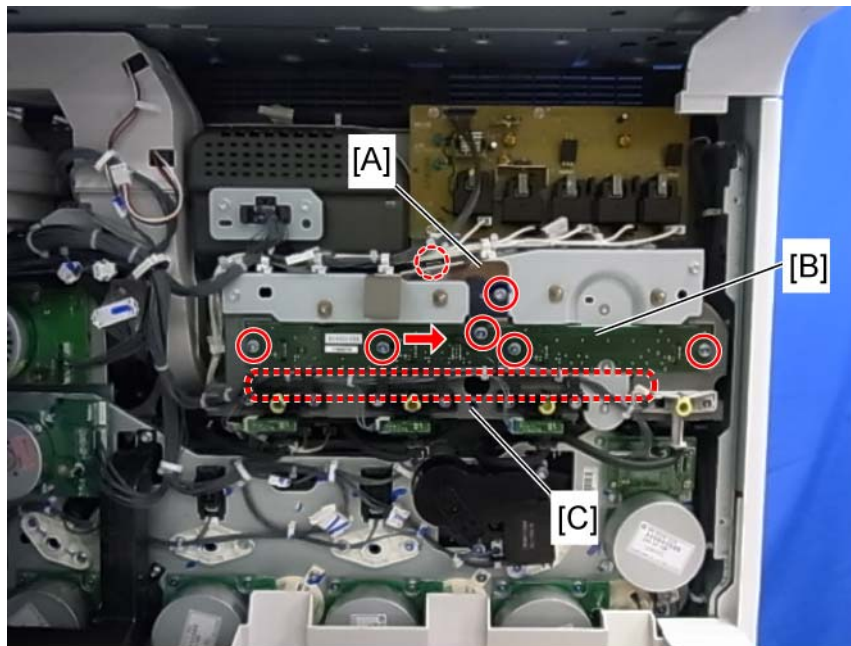

d1440167

2. Remove the grounding plate [A] completely (☞ x 3).
3. Move the harnesses [C] downward to prevent the board from catching on them.
4. Pull out the toner bottle detection board [B] gently and horizontally (☞ x 1, ☞ x 4)

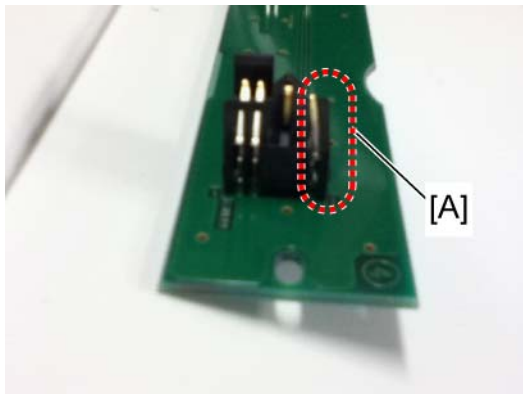

d1440168

★ Important

- The toner bottles detection board should be pulled out horizontally. If you ignore this, the toner bottle detection terminals [A] may be damaged.

4.14.18 NVRAM REPLACEMENT PROCEDURE

This machine has two types of NVRAM. One is on the BCU (📖 p.4-166); the other is on the controller board (📖 p.4-175).

NVRAM on the BCU

- Make sure that you have the SMC report (factory settings). This report comes with the machine.
- Output the SMC data (SP5-990-001) if possible.
- Turn the main switch off.
- Install an SD card into SD card slot 3. Then turn the main power on.
- Copy the NVRAM data to an SD card (SP5-824-001) if possible.
- Turn off the main switch. Then unplug the power cord.
- Replace the NVRAM on the BCU and reassemble the machine.
- Plug in the power cord. Then turn the main switch on.
- Select a paper-size type (SP5-131-001).
- Specify the serial number and destination code of the machine.

📌 Note

- Contact your supervisor for details on how to enter the serial number and destination code.
 - SC 999 or "Fusing Unit Setting Error" can be shown until the serial number and destination code are correctly programmed.
- Turn the main switch off and on.
 - Copy the data from the SD card to the NVRAM (SP5-825-001) if you have successfully copied them to the SD card.
 - Turn the main switch off. Then remove the SD card from SD card slot 2.
 - Turn the main switch on.
 - Specify the SP and UP mode settings.
 - Do the process control self-check.
 - Do ACC for the copier application program.
 - Do ACC for the printer application program.

📌 Note

- If the message "SD card for restoration is required." appears after the NVRAM replacement, the encryption key should be restored. See "Encryption Key Restoration for NVRAM" for the restoration procedure. (📖 p.6-125)

NVRAM on the controller board

- Make sure that you have the SMC report (factory settings). This report comes with the machine.
- Output the SMC data (“ALL”) using SP5-990-001. (SP5-990-001)
- Turn off the main switch.
- Insert a blank SD card into slot #2, and then turn on the main switch.
- Upload the NVRAM data to the blank SD card using SP5-824-001 (NVRAM Data Upload).
- Turn off the main power switch, and then unplug the AC power cord.
- Remove the SD card containing the NVRAM data from slot #2.
- Replace the NVRAM on the controller board with a new one.
- Plug in the AC power cord, and then turn on the main power switch.

★ Important

- **When you do this, SC995-02 (Defective NVRAM) will be displayed. However, DO NOT turn off the main power switch. Continue with this procedure.**
- Re-insert the SD card that you removed in step 7 back into slot #2.
- Download the old NVRAM data from the SD card onto the new NVRAM using SP5-825-001 (NVRAM Data Download).

↓ Note

1. This will take about 2 or 3 minutes.
- Turn off the main power switch, and then remove the SD card from slot #2.
 - Turn on the main power switch.
 - Output the SMC data (“ALL”) using SP5-990-001, and make sure that it matches the SMC data you printed out in step 2 above (except for the value of the total counter).

↓ Note

1. The value of the total counter is reset to “0” when the NVRAM is replaced.
- Do Process Control Self-check.
 - Do ACC for the Copier function.
 - Do ACC for the Printer function.

★ Important

- **Do all of the following if SP5-824-001 (NVRAM Data Upload) and SP5-825-001 (NVRAM Data Download) cannot be performed for some reason.**
 - **Manually enter all data on the SMC report (factory settings).**
 - **Install the Security function (Data Overwrite Security and HDD Encryption unit) again. For the procedure, see “Security function Installation” in “Installation Procedure” of “Copier Installation”. (📖 p.2-6)**

 **Note**

- If the message “SD card for restoration is required.” appears after the NVRAM replacement, the encryption key should be restored. See “Encryption Key Restoration for NVRAM” for the restoration procedure. (📖 p.6-125)

4.15 USING DIP SWITCHES

4.15.1 CONTROLLER BOARD

DIP SW No.	OFF	ON
1	Boot-up from Flash Memory	Boot-up from SD card
2 to 8	Factory Use Only: Do not change the switch settings.	

4.15.2 BCU BOARD

DIP SW No.	OFF	ON
1 and 2	Factory Use Only: Do not change the switch settings.	

SYSTEM MAINTENANCE

REVISION HISTORY		
Page	Date	Added/Updated/New
149	6/27/2012	SP3902

5. SYSTEM MAINTENANCE

5.1 SERVICE PROGRAM MODE

CAUTION

1. Make sure that the data-in LED (↻) is not on before you go into the SP mode. This LED indicates that some data is coming to the machine. When the LED is on, wait for the copier to process the data.

5.1.1 SP TABLES

See "[Appendices](#)" for the following information:

- System SP Tables
- Printer SP Tables
- Scanner SP Tables

5.1.2 ENABLING AND DISABLING SERVICE PROGRAM MODE

Note

- The Service Program Mode is for use by service representatives only. If this mode is used by anyone other than service representatives for any reason, data might be deleted or settings might be changed. In such case, product quality cannot be guaranteed any more.

Entering SP Mode

For details, ask your supervisor.

Exiting SP Mode

- Press "Exit" on the LCD twice to return to the copy window.

5.1.3 TYPES OF SP MODES

- System SP: SP modes related to the engine functions
- Printer SP: SP modes related to the controller functions
- Scanner SP: SP modes related to the scanner functions
- Fax SP: SP modes related to the fax functions



Select one of the Service Program modes (System, Printer, Scanner, or Fax) from the touch panel as shown in the diagram below after you access the SP mode. This section explains the functions of the System/Printer/Scanner SP modes. Refer to the Fax service manual for the Fax SP modes.

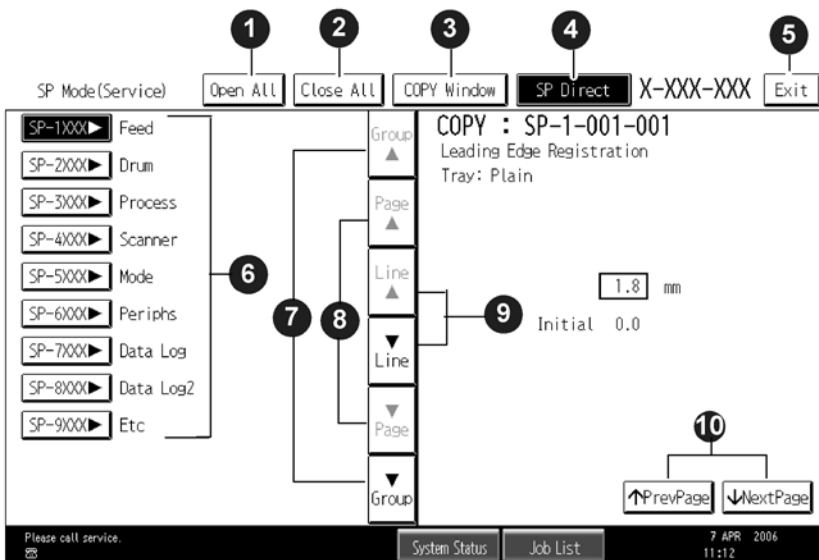

SP Mode Button Summary

Here is a short summary of the touch-panel buttons.



1	Opens all SP groups and sublevels.
2	Closes all open groups and sublevels and restores the initial SP mode display.
3	Opens the copy window (copy mode) so you can make test copies. Press SP Mode (highlighted) in the copy window to return to the SP mode screen,
4	Enter the SP code directly with the number keys if you know the SP number. Then press  . (The required SP Mode number will be highlighted when pressing  . If not, just press the required SP Mode number.)
5	Press two times to leave the SP mode and return to the copy window to resume normal operation.
6	Press any Class 1 number to open a list of Class 2 SP modes.
7	Press to scroll the show to the previous or next group.
8	Press to scroll to the previous or next display in segments the size of the screen display (page).
9	Press to scroll the show the previous or next line (line by line).
10	Press to move the highlight on the left to the previous or next selection in the list.

Switching Between SP Mode and Copy Mode for Test Printing

- In the SP mode, select the test print. Then press "Copy Window".
- Use the copy window (copier mode), to select the appropriate settings (paper size, etc.) for the test print.
- Press Start  to start the test print.
- Press SP Mode (highlighted) to return to the SP mode screen and repeat from step 1.

Selecting the Program Number

Program numbers have two or three levels.

- Refer to the Service Tables to find the SP that you want to adjust before you begin.
- Press the Group number on the left side SP Mode window that contains the SP that you want to adjust.
- Use the scrolling buttons in the center of the SP mode window to show the SP number that you want to open. Then press that number to expand the list.
- Use the center touch-panel buttons to scroll to the number and title of the item that you want to set and press it. The small entry box on the right activates and shows the below default or the current settings.

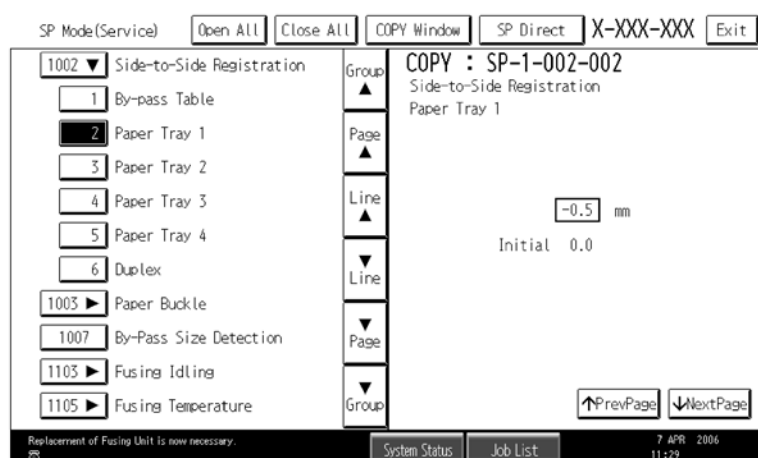

Note

- Refer to the Service Tables for the range of allowed settings.
- Do this procedure to enter a setting:
 - Press \ominus to toggle between plus and minus and use the keypad to enter the appropriate number. The number you enter writes over the previous setting.
 - Press \oplus to enter the setting. (The value is not registered if you enter a number that is out of range.)
 - Press "Yes" when you are prompted to complete the selection.
- If you need to perform a test print, press Copy Window to open the copy window and select the settings for the test print. Press Start \odot and then press SP Mode (highlighted) in the copy window to return to the SP mode display.
- Press Exit two times to return to the copy window when you are finished.

Exiting Service Mode

- Press the Exit key on the touch-panel.

Service Mode Lock/Unlock

At locations where the machine contains sensitive data, the customer engineer cannot operate the machine until the Administrator turns the service mode lock off. This function makes sure that work on the machine is always done with the permission of the Administrator.

- If you cannot go into the SP mode, ask the Administrator to log in with the User Tool and then set "Service Mode Lock" to OFF after he or she logs in:
User Tools > System Settings > Administrator Tools > Service Mode Lock > OFF
 - This unlocks the machine and lets you get access to all the SP codes.
 - The CE can service the machine and turn the machine off and on. It is not necessary to ask the Administrator to log in again each time the machine is turned on.
- Go into the SP mode and set SP5169 to "1" if you must use the printer bit switches.
- After machine servicing is completed:
 - Change SP5169 from "1" to "0".
 - Turn the machine off and on. Tell the administrator that you have completed servicing the machine.
 - The Administrator will then set the "Service Mode Lock" to ON.

5.1.4 REMARKS

Display on the Control Panel Screen

The maximum number of characters which can show on the control panel screen is limited to 30 characters. For this reason, some of the SP modes shown on the screen need to be abbreviated. The following are abbreviations used for the SP modes for which the full description is over 20 characters.

<p>Paper Weight Thin paper: 52-59 g/m² Plain Paper: 60-81 g/m², 16-21.6lb. Middle Thick: 82-105 g/m², 21.87-28lb. Thick Paper 1: 106-169 g/m², 28.5-44.9lb. Thick Paper 2: 170-220 g/m², 45-58lb. Thick Paper 3: 221-256 g/m², 59lb-68lb Thick 4: 257 g/m²-300 g/m², 68.4-79.8lb</p>	
<p>Paper Type N: Normal paper MTH: Middle thick paper TH: Thick paper</p>	<p>Paper Feed Station P: Paper tray B: By-pass table</p>
<p>Color Mode [Color] [K]: Black in B&W mode [Y], [M], or [C]: Yellow, Magenta, or Cyan in Full Color mode [YMC]: Only for Yellow, Magenta, and Cyan [FC]: Full Color mode [FC, K], [FC, Y], [FC, M], or [FC, C]: Black, Yellow, Magenta, or Cyan in full color mode</p>	
<p>Print Mode S: Simplex D: Duplex</p>	<p>Process Speed L: Low speed (77 mm/s) M: Middle speed (154 mm/s)</p>

Others

The following symbols are used in the SP mode tables.

FA: Factory setting

(Data may be adjusted from the default setting at the factory. Refer to the factory setting sheets enclosed. You can find it under the jammed paper removal decal.)

DFU: Design/Factory Use only

Do not touch these SP modes in the field.

A sharp (#) to the right hand side of the mode number column means that the main switch must be turned off and on to effect the setting change.

An asterisk (*) to the right hand side of the mode number column means that this mode is stored in the NVRAM. If you do a RAM clear, this SP mode will be reset to the default value. "ENG" and "CTL" show which NVRAM contains the data.

- ENG: NVRAM on the BCU board
- CTL: NVRAM on the controller board

The settings of each SP mode are explained in the right-hand column of the SP table in the following way.

[Adjustable range / **Default setting** / Step] Alphanumeric

Note

- If "Alphanumeric" is written to the right of the bracket as shown above, the setting of the SP mode shows on the screen using alphanumeric characters instead of only numbers. However, the settings in the bracket in the SP mode table are explained by using only the numbers.

SSP: This denotes a "Special Service Program" mode setting.

5.2 MAIN SP TABLES-1

5.2.1 SP1-XXX (FEED)

1001	[Leading Edge Registration] Leading Edge Registration Adjustment (Tray Location, Paper Type, Color Mode), Paper Type → Thin, Plain, Thick 1, Thick 2 or Thick 3		
	Adjusts the leading edge registration by changing the registration motor operation timing for each mode.		
002	Tray: Plain	*ENG	[-9 to 9 / 0.0 / 0.1 mm/step]
003	Tray: Middle Thick	*ENG	
004	Tray: Thick 1	*ENG	
005	Tray: Thick 2	*ENG	
007	By-pass: Plain	*ENG	
008	By-pass: Middle Thick	*ENG	
009	By-pass: Thick 1	*ENG	
010	By-pass: Thick 2	*ENG	
011	By-pass: Thick 3	*ENG	
013	Duplex: Plain	*ENG	
014	Duplex: Middle Thick	*ENG	
015	Duplex: Thick 1	*ENG	[-9 to 9 / 0.0 / 0.1 mm/step]
016	Tray: Thick 3	*ENG	
017	Tray: Plain:1200	*ENG	
018	Tray: Middle Thick:1200	*ENG	
019	Tray: Thick 1:1200	*ENG	
020	By-pass: Plain:1200	*ENG	

021	By-pass: Middle Thick:1200	*ENG	
022	By-pass: Thick 1:1200	*ENG	
023	Duplex: Plain:1200	*ENG	
024	Duplex: Middle Thick:1200	*ENG	
025	Duplex: Thick 1:1200	*ENG	
026	Tray: Thin	*ENG	
027	By-pass: Thin	*ENG	
028	Duplex: Thin	*ENG	
029	Tray: Thin: 1200	*ENG	
030	By-pass: Thin: 1200	*ENG	
031	Duplex: Thin: 1200	*ENG	

1002	[Side to Side Registration] Side-to-Side Registration Adjustment		
	Adjusts the side-to-side registration by changing the laser main scan start position for each mode.		
001	By-pass Table	*ENG	[-4 to 4 / 0.0 / 0.1 mm/step]
002	Paper Tray 1	*ENG	
003	Paper Tray 2	*ENG	
004	Paper Tray 3	*ENG	
005	Paper Tray 4	*ENG	
006	Duplex	*ENG	
007	Paper Tray 5	*ENG	
008	Large Capacity Tray	*ENG	

1003	[Paper Buckle] Paper Buckle Adjustment (Tray Location, Paper Type, Color mode), Paper Type → Plain, Thick, Thick1		
	Adjusts the amount of paper buckle at the registration roller by changing the paper feed timing.		
002	Paper Tray1: Plain	*ENG	[-9 to 5 / -2 / 1 mm/step]
003	Tray1: Middle Thick	*ENG	[-9 to 5 / -1 / 1 mm/step]
004	Paper Tray1: Thick1	*ENG	[-9 to 5 / -2 / 1 mm/step]
007	Paper Tray2/3/4/5/LCT: Plain	*ENG	
008	Tray 2/3/4/5/LCT: Middle Thick	*ENG	[-9 to 5 / -1 / 1 mm/step]
009	Paper Tray2/3/4/5/LCT: Thick 1	*ENG	[-9 to 5 / -2 / 1 mm/step]
012	By-pass: Plain	*ENG	[-9 to 5 / -1 / 1 mm/step]
013	By-pass: Middle Thick	*ENG	
014	By-pass: Thick 1	*ENG	[-9 to 5 / -2 / 1 mm/step]
018	Duplex: Plain	*ENG	[-9 to 5 / -1 / 1 mm/step]
019	Duplex: Middle Thick	*ENG	
020	Duplex: Thick 1	*ENG	[-9 to 5 / -2 / 1 mm/step]
021	Paper Tray1: Plain: 1200	*ENG	[-9 to 5 / 0 / 1 mm/step]
022	Tray1: Middle Thick: 1200	*ENG	
023	Tray 2/3/4/5LCT: Plain: 1200	*ENG	
024	Tray 2/3/4/5LCT: Mid: 1200	*ENG	
025	By-pass: Plain: 1200	*ENG	
026	By-pass: Middle Thick: 1200	*ENG	
027	Paper Tray1: Thick1: 1200	*ENG	[-9 to 5 / -2 / 1 mm/step]
028	Paper Tray2/3/4/5/LCT: Thick 1:1200	*ENG	

029	By-pass: Thick 1: 1200	*ENG	
030	Duplex: Plain: 1200	*ENG	[-9 to 5 / 0 / 1 mm/step]
031	Duplex: Middle Thick: 1200	*ENG	
032	Duplex: Thick 1: 1200	*ENG	[-9 to 5 / -2 / 1 mm/step]

1007	[By-Pass Size Detection] By-Pass Size Detection Display		
001	LG	*ENG	[0 or 1 / 0 / -] 0: OFF, 1: ON
	<p>Enables or disables the automatic paper size detection function of the by-pass tray.</p> <p>This SP determines what paper size the machine detects if the detected size is less than 8.5".</p> <p>0: OFF (Letter/SEF), 1: ON (Legal/SEF)</p>		

1101	[Reload Permit Setting]		
	Specifies the settings of the reload permit for cold temperature in color mode.		
001	Pre-rotation Start Temp.	*ENG	[-50 to 200 / -50 / 1 deg/step]
002	Reload Target Temp.:Center	*ENG	[0 to 180 / 145 / 1 deg/step]
003	Reload Target Temp.:Press	*ENG	[0 to 200 / 120 / 1 deg/step]
004	Temp.:Delta:Cold:Center	*ENG	[0 to 200 / 5 / 1 deg/step]
005	Temp.:Delta:Cold:End	*ENG	[40 to 200 / 5 / 1 deg/step]
006	Temp.:Delta:Cold:Press	*ENG	[0 to 200 / 80 / 1 deg/step]
	[Forced Ready Set]		
	Specifies the setting of the forced reload permit for cold temperature in color mode.		
007	Forced Reload Time :Cold	*ENG	[0 to 100 / 9 / 1 sec/step]
	[Reload Permit Setting]		
	Specifies the settings of the reload permit for warm temperature in color mode.		
008	Temp.:Delta:Warm:Center	*ENG	[0 to 200 / 5 / 1 deg/step]
009	Temp.:Delta:Warm:End	*ENG	[0 to 200 / 5 / 1 deg/step]

Main SP Tables-1

010	Temp.:Delta:Warm:Press	*ENG	[0 to 200 / 80 / 1 deg/step]
	[Reload Permit Setting] Specifies the setting of the forced reload permit for warm temperature in color mode.		
011	Forced Reload Time:Warm	*ENG	[0 to 100 / 9 / 1 sec/step]
	[Reload Permit Setting] Specifies the settings of the reload permit for hot temperature in color mode.		
012	Temp.:Delta:Hot:Center	*ENG	[0 to 200 / 5 / 1 deg/step]
013	Temp.:Delta:Hot:End	*ENG	[0 to 200 / 5 / 1 deg/step]
014	Temp.:Delta:Hot:Press	*ENG	[0 to 200 / 80 / 1 deg/step]
	[Reload Permit Setting] Specifies the setting of the forced reload permit for hot temperature in color mode.		
015	Forced Reload Time:Hot	*ENG	[0 to 100 / 9 / 1 sec/step]
	[Reload Permit Setting Temp.] Specifies the settings of the reload permit for cold temperature in BW mode.		
016	Temp.:Delta:Cold:BW:Center	*ENG	[0 to 200 / 5 / 1 deg/step]
017	Temp.:Delta:Cold:BW:End	*ENG	[0 to 200 / 5 / 1 deg/step]
018	Temp.Delta:Cold:BW:Press	*ENG	[0 to 200 / 80 / 1 deg/step]
	[Reload Permit Setting] Specifies the setting of the forced reload permit for cold temperature in BW mode.		
019	Forced Reload Time:Cold:BW	*ENG	[0 to 100 / 9 / 1 sec/step]
	[Reload Permit Setting] Specifies the settings of the reload permit for cold temperature in BW mode 2.		
020	Temp.:Delta:Cold:BW2:Center	*ENG	[0 to 200 / 15 / 1 deg/step]
021	Temp.:Delta:Cold:BW2:End	*ENG	[40 to 200 / 100 / 1 deg/step]

022	Temp.Delta:Cold:BW2:Press	*ENG	[0 to 200 / 100 / 1 deg/step]
	[Forced Ready Set] Specifies the setting of the forced reload permit for cold temperature in BW mode 2.		
023	Time:Cold:BW2	*ENG	[0 to 100 / 30 / 1 sec/step]

1102	[Feed Permit Setting]		
	Specified the settings of the paper feeding timing.		
001	Temp.:Lower Delta:Center	*ENG	[0 to 200 / 10 / 1 deg/step]
002	Temp.:Lower Delta:End	*ENG	[0 to 200 / 10 / 1 deg/step]
003	Temp.:Upper Delta:Center	*ENG	[0 to 200 / 30 / 1 deg/step]
004	Temp.:Upper Delta:End	*ENG	[0 to 200 / 30 / 1 deg/step]
005	Temp.:Lower Delta:Press	*ENG	[0 to 200 / 100 / 1 deg/step]
006	Rotation Time	*ENG	[0 to 100 / 0 / 1 sec/step]
007	Temp.:Lower Delta:Center:Sp.1	*ENG	[0 to 200 / 5 / 1 deg/step]
008	Temp.:Lower Delta:End:Sp.1	*ENG	[0 to 200 / 5 / 1 deg/step]
009	Temp.:Upper Delta:Center:Sp.1	*ENG	[0 to 200 / 30 / 1 deg/step]
010	Temp.:Upper Delta:End:Sp.1	*ENG	[0 to 200 / 30 / 1 deg/step]
011	Temp.:Lower Delta:Press:Sp.1	*ENG	[0 to 200 / 15 / 1 deg/step]
012	Rotation Time:Sp.1	*ENG	[0 to 100 / 0 / 1 sec/step]
013	Temp.:Lower Delta:Center:Sp.2	*ENG	[0 to 200 / 5 / 1 deg/step]

Main SP Tables-1

014	Temp.:Lower Delta:End:Sp.2	*ENG	[0 to 200 / 5 / 1 deg/step]
015	Temp.:Upper Delta:Center:Sp.2	*ENG	[0 to 200 / 15 / 1 deg/step]
016	Temp.:Upper Delta:End:Sp.2	*ENG	[0 to 200 / 15 / 1 deg/step]
017	Temp.:Lower Delta:Press:Sp.2	*ENG	[0 to 200 / 100 / 1 deg/step]
018	Rotation Time:Sp2	*ENG	[0 to 100 / 0 / 1 sec/step]
019	Feed Permit Time	*ENG	[0 to 200 / 60 / 1 sec/step]

1105	[Print Target Temp]		
	(Printing Mode, Roller Type, [Color], Simplex/Duplex) Roller Type → Center and Ends: Heating roller, Pressure → Pressure roller Paper Type → Plain, Thin, Thick, OHP, Middle Thick, Special		
001	Plain1:FC:Center	*ENG	[100 to 180 / 140 / 1 deg/step]
	Specifies the heating roller target temperature for the ready condition in full color printing.		
002	Plain1:FC:Press	*ENG	[0 to 200 / 120 / 1 deg/step]
	Specifies the pressure roller target temperature for the ready condition in full color printing.		
003	Plain1:BW:Center	*ENG	[180 to 100 / 140 / 1 deg/step]
	Specifies the heating roller target temperature for the ready condition in BW printing.		
004	Plain1:BW:Press	*ENG	[0 to 200 / 120 / 1 deg/step]
	Specifies the pressure roller target temperature for the ready condition in BW printing.		
005	Plain2:FC:Center	*ENG	[100 to 180 / 145 / 1 deg/step]

	Specifies the heating roller target temperature for the ready condition in full color printing.		
006	Plain2:FC:Press	*ENG	[0 to 200 / 120 / 1 deg/step]
	Specifies the pressure roller target temperature for the ready condition in full color printing.		
007	Plain2:BW:Center	*ENG	[100 to 180 / 140 / 1 deg/step]
	Specifies the heating roller target temperature for the ready condition in BW printing.		
008	Plain2:BW:Press	*ENG	[0 to 200 / 120 / 1 deg/step]
	Specifies the pressure roller target temperature for the ready condition in BW printing.		
009	Thin:FC:Center	*ENG	[100 to 180 / 135 / 1 deg/step]
010	Thin:FC:Press	*ENG	[0 to 200 / 120 / 1 deg/step]
011	Thin:BW:Center	*ENG	[100 to 180 / 135 / 1 deg/step]
012	Thin:BW:Press	*ENG	[0 to 200 / 120 / 1 deg/step]
013	M-thick:FC:Center	*ENG	[100 to 180 / 150 / 1 deg/step]
014	M-thick:FC:Press	*ENG	[0 to 200 / 120 / 1 deg/step]
015	M-thick:BW:Center	*ENG	[100 to 180 / 150 / 1 deg/step]
016	M-thick:BW:Press	*ENG	[0 to 200 / 120 / 1 deg/step]
017	Thick1:FC:Center	*ENG	[100 to 180 / 148 / 1 deg/step]
018	Thick1:FC:Press	*ENG	[0 to 200 / 120 / 1 deg/step]
019	Thick1:BW:Center	*ENG	[100 to 180 / 148 / 1 deg/step]
020	Thick1:BW:Press	*ENG	[0 to 200 / 120 / 1 deg/step]
021	Thick2:FC:Center	*ENG	[100 to 180 / 158 / 1 deg/step]
022	Thick2:FC:Press	*ENG	[0 to 200 / 120 / 1 deg/step]
023	Thick2:BW:Center	*ENG	[100 to 180 / 158 / 1 deg/step]

Main SP Tables-1

024	Thick2:BW:Press	*ENG	[0 to 200 / 120 / 1 deg/step]
025	Thick3:FC:Center	*ENG	[100 to 180 / 163 / 1 deg/step]
026	Thick3:FC:Press	*ENG	[0 to 200 / 120 / 1 deg/step]
027	Thick3:BW:Center	*ENG	[100 to 180 / 163 / 1 deg/step]
028	Thick3:BW:Press	*ENG	[0 to 200 / 120 / 1 deg/step]
029	Special1:FC:Center	*ENG	[100 to 180 / 145 / 1 deg/step]
030	Special1:FC:Press	*ENG	[0 to 200 / 120 / 1 deg/step]
031	Special1:BW:Center	*ENG	[100 to 180 / 145 / 1 deg/step]
032	Special1:BW:Press	*ENG	[0 to 200 / 120 / 1 deg/step]
033	Special2:FC:Center	*ENG	[100 to 180 / 168 / 1 deg/step]
034	Special2:FC:Press	*ENG	[0 to 200 / 120 / 1 deg/step]
035	Special2:BW:Center	*ENG	[100 to 180 / 168 / 1 deg/step]
036	Special2:BW:Press	*ENG	[0 to 200 / 120 / 1 deg/step]
037	Special3:FC:Center	*ENG	[100 to 180 / 158 / 1 deg/step]
038	Special3:FC:Press	*ENG	[0 to 200 / 120 / 1 deg/step]
039	Special3:BW:Center	*ENG	[100 to 180 / 158 / 1 deg/step]
040	Special3:BW:Press	*ENG	[0 to 200 / 120 / 1 deg/step]
041	Envelop:Center	*ENG	[100 to 180 / 168 / 1 deg/step]
042	Envelop:Press	*ENG	[0 to 200 / 120 / 1 deg/step]
101	Plain1:FC:Center:Low Speed	*ENG	[100 to 180 / 133 / 1 deg/step]
102	Plain1:FC:Press:Low Speed	*ENG	[0 to 200 / 120 / 1 deg/step]
103	Plain1:BW:Center:Low Speed	*ENG	[100 to 180 / 133 / 1 deg/step]

104	Plain1:BW:Press:Low Speed	*ENG	[0 to 200 / 120 / 1 deg/step]
105	Plain2:FC:Center:Low Speed	*ENG	[100 to 180 / 138 / 1 deg/step]
106	Plain2:FC:Press:Low Speed	*ENG	[0 to 200 / 120 / 1 deg/step]
107	Plain2:BW:Center:Low Speed	*ENG	[100 to 180 / 138 / 1 deg/step]
108	Plain2:BW:Press:Low Speed	*ENG	[0 to 200 / 120 / 1 deg/step]
109	M-thick:FC:Center:Low Speed	*ENG	[100 to 180 / 143 / 1 deg/step]
110	M-thick:FC:Press:Low Speed	*ENG	[0 to 200 / 120 / 1 deg/step]
111	M-thick:BW:Center:Low Speed	*ENG	[100 to 180 / 143 / 1 deg/step]
112	M-thick:BW:Press:Low Speed	*ENG	[0 to 200 / 120 / 1 deg/step]
113	Thick1:FC:Center:Low Speed	*ENG	[100 to 180 / 148 / 1 deg/step]
114	Thick1:FC:Press:Low Speed	*ENG	[0 to 200 / 120 / 1 deg/step]
115	Thick1:BW:Center:Low Speed	*ENG	[100 to 180 / 148 / 1 deg/step]
116	Thick1:BW:Press:Low Speed	*ENG	[0 to 200 / 120 / 1 deg/step]
117	Special1:FC:Center:Low Speed	*ENG	[100 to 180 / 138 / 1 deg/step]
118	Special1:FC:Press:Low Speed	*ENG	[0 to 200 / 120 / 1 deg/step]

Main SP Tables-1

119	Special1:BW:Center:Low Speed	*ENG	[100 to 180 / 138 / 1 deg/step]
120	Special1:BW:Press:Low Speed	*ENG	[0 to 200 / 120 / 1 deg/step]
121	Special2:FC:Center:Low Speed	*ENG	[100 to 180 / 148 / 1 deg/step]
122	Special2:FC:Press:Low Speed	*ENG	[0 to 200 / 120 / 1 deg/step]
123	Special2:BW:Center:Low Speed	*ENG	[100 to 180 / 148 / 1 deg/step]
124	Special2:BW:Press:Low Speed	*ENG	[0 to 200 / 120 / 1 deg/step]
125	Plain1:Glossy:Center	*ENG	[100 to 180 / 138 / 1 deg/step]
126	Plain1:Glossy:Press	*ENG	[0 to 200 / 120 / 1 deg/step]
127	Plain2:Glossy:Center	*ENG	[100 to 180 / 143 / 1 deg/step]
128	Plain2:Glossy:Press	*ENG	[0 to 200 / 120 / 1 deg/step]
129	M-thick:Glossy:Center	*ENG	[100 to 180 / 148 / 1 deg/step]
130	M-thick:Glossy:Press	*ENG	[0 to 200 / 120 / 1 deg/step]
131	OHP:Center	*ENG	[100 to 180 / 158 / 1 deg/step]
132	OHP:Press	*ENG	[0 to 200 / 120 / 1 deg/step]
133	Envelop:Center:Low Speed	*ENG	[100 to 180 / 163 / 1 deg/step]
134	Envelop:Press:Low Speed	*ENG	[0 to 200 / 120 / 1 deg/step]
135	Thin:FC:Center:Low Speed	*ENG	[100 to 180 / 128 / 1 deg/step]
136	Thin:FC:Press:Low Speed	*ENG	[0 to 200 / 120 / 1 deg/step]

137	Thin:BW:Center:Low Speed	*ENG	[100 to 180 / 128 / 1 deg/step]
138	Thin:BW:Press:Low Speed	*ENG	[0 to 200 / 120 / 1 deg/step]
139	Thick4:FC:Center	*ENG	[100 to 180 / 168 / 1 deg/step]
140	Thick4:FC:Press	*ENG	[0 to 200 / 120 / 1 deg/step]
141	Thick4:BW:Center	*ENG	[100 to 180 / 168 / 1 deg/step]
142	Thick4:BW:Press	*ENG	[0 to 200 / 120 / 1 deg/step]

1106	[Fusing Temp. Display]		
001	Heat Center	-	[-10 to 250 / - / 1 deg/step]
002	Heat End	-	Displays the temperature of the heating roller.
003	Press Center	-	[-10 to 250 / - / 1 deg/step]
004	Press End	-	Displays the temperature of the heating roller.

1107	[Standby Target Temp. Setting]		
001	Stanby/Preheat1:Center	*ENG	[0 to 125 / 90 / 1 sec/step]
	Specifies the time that the fusing heater turns off after the fusing unit temperature has reached its target temperature.		
002	Stanby/Preheat1: Press	*ENG	[0 to 125 / 90 / 1 deg/step]
	Specifies the temperature of the pressure roller for the ready or energy save 1 mode.		
003	Preheat2:Center	*ENG	[0 to 125 / 90 / 1 sec/step]
	Specifies the temperature of the heating roller for the ready or energy save 2 mode.		
004	Preheat2:Press	*ENG	[0 to 125 / 90 / 1 deg/step]
	Specifies the temperature of the pressure roller for the energy save 2 mode.		

Main SP Tables-1

005	Low Power:Center	*ENG	[0 to 125 / 90 / 1 sec/step]
	Specifies the temperature of the heating roller for the low power mode.		
006	Low Power:Press	*ENG	[0 to 125 / 60 / 1 deg/step]
	Specifies the temperature of the pressure roller for the low power mode.		
007	Print Ready:Center	*ENG	[0 to 180 / 145 / 1 deg/step]
	Specifies the temperature of the heating roller for the print ready condition.		
008	Print Ready:Press	*ENG	[0 to 200 / 120 / 1 deg/step]
	Specifies the temperature of the pressure roller for the print ready condition.		

1108	[After Reload/Job Target Temp.]		
001	Center	*ENG	[0 to 180 / 145 / 1 deg/step]
	Specifies the temperature of the heating roller after re-load or job.		
002	Press	*ENG	[0 to 200 / 120 / 1 deg/step]
	Specifies the temperature of the pressure roller after re-load or job.		

1111	[Environment Correction:Fusing]		
001	Temp.: Threshold: Low	*ENG	[0 to 100 / 17 / 1 deg/step]
	Specifies the threshold temperature for low temperature. If the fusing temperature is 17°C or less, the machine executes the fusing mode for low temperature.		
002	Temp.: Threshold: High	*ENG	[0 to 100 / 30 / 1 deg/step]
	Specifies the threshold temperature for high temperature. If the fusing temperature is 30°C or more, the machine executes the fusing mode for high temperature.		
003	Low Temp. Correction	*ENG	[0 to 15 / 5 / 1 deg/step]
	Specifies the additional temperature for the target temperature. If the fusing temperature is in low temperature condition, this temperature is added to the target temperature.		

004	High Temp. Correction	*ENG	[0 to 15 / 0 / 1 deg/step]
	Specifies the additional temperature for the target temperature. If the fusing temperature is in high temperature condition, this temperature is added to the target temperature.		
005	Job Low Temp. Correction	*ENG	[0 to 100 / 5 / 0.1 deg/step]
006	Job High Temp. Correction	*ENG	[0 to 100 / 0 / 0.1 deg/step]
007	Job Low Temp. Correction:Sp.	*ENG	[0 to 100 / 5 / 0.1 deg/step]
008	Job High Temp. Correction:Sp.	*ENG	[0 to 100 / 0 / 0.1 deg/step]

1113	[Curl Correction]		
001	Execute Pattern	*ENG	[0 to 2 / 0 / 1 /step] 0: Off, 1: On (No Decurl), 2: On
	Selects the curl correction type.		
002	Humidity:Threshold:M-humid	*ENG	[0 to 100 / 1 / 1 %/step]
	Specifies the threshold between low and middle humidity.		
003	Humidity:Threshold:H-humid	*ENG	[0 to 100 / 65 / 1 %/step]
	Specifies the threshold between middle and high humidity.		
004	Permit Temp.:Delta:Press:M-humid	*ENG	[0 to 200 / 60 / 1 deg/step]
	Specifies the threshold temperature for the curl control in middle humidity.		
005	Permit Temp.:Delta:Press:H-humid	*ENG	[0 to 200 / 50 / 1 deg/step]
	Specifies the threshold temperature for the curl control in high humidity.		

Main SP Tables-1

006	Permit Temp.:Delta:Press:M-humid:No Decurl	*ENG	[0 to 200 / 50 / 1 deg/step]
	Specifies the threshold temperature for the no curl control in middle humidity.		
007	Permit Temp.:Delta:Press:H-humid:No Decurl	*ENG	[0 to 200 / 40 / 1 deg/step]
	Specifies the threshold temperature for the no curl control in high humidity.		
008	CPM:M-humid	*ENG	[0 to 100 / 80 / 1 %/step]
	Specifies the CPM ratio of the decurl control against to the normal operation in middle humidity.		
009	CPM:H-humid	*ENG	[0 to 100 / 65 / 1 %/step]
	Specifies the CPM ratio of the decurl control against to the normal operation in high humidity.		
010	CPM:M-humid:No Decurl	*ENG	[0 to 100 / 80 / 1 %/step]
	Specifies the CPM ratio against of the no decurl control to the normal operation in middle humidity.		
011	CPM:H-humid:No Decurl	*ENG	[0 to 100 / 65 / 1 %/step]
	Specifies the CPM ratio against of the no decurl control to the normal operation in high humidity.		

1115	[Target Temp. Correction]		
001	Temp.:Delta:End	*ENG	[-100 to 100 / 0 / 1 deg/step]
	Specifies the different temperature between end and center of the heating roller.		

1141	[Fusing SC Issue Time Info]		
001	SC Number	*ENG	Displays the issued SC number.
101	Htg Roller:Ctr Det1	*ENG	[-50 to 300 / - / 1 deg/step] Displays the temperature at the center of the heating roller when an SC was issued.
102	Htg Rolloer:End Det1	*ENG	
103	Htg Roller:Ctr Det1	*ENG	
104	Htg Roller:End Det1	*ENG	
151	Htg Roller:Ctr Det2	*ENG	
152	Htg Rolloer:End Det2	*ENG	
153	Press Roller:Ctr Det2	*ENG	
154	Press Roller:End Det2	*ENG	
201	Htg Roller:Ctr Det3	*ENG	
202	Htg Rolloer:End Det3	*ENG	
203	Press Roller:Ctr Det3	*ENG	
204	Press Roller:End Det3	*ENG	

1142	[Fusing Jam Detection]		
001	SC Display	*ENG	[0 or 1 / 0 / -]
	Enables or disables the fusing consecutive jam (three times) SC detection. 0: No detection, 1: Detection		

Main SP Tables-1

1151	[Pressure Setting]		
001	Pressure Change ON/OFF	*ENG	[0 or 1 / 1 / -]
	Enables or disables the pressure switching control for the fusing unit. 0: OFF , 1: ON		
002	Pressure Position1	*ENG	[0 to 10,000 / 420 / 10 msec/step]
	Specifies the rotation time of the pressure roller contact motor for the pressure position 1.		
003	Pressure Position2	*ENG	[0 to 10,000 / 660 / 10 msec/step]
	Specifies the rotation time of the pressure roller contact motor for the pressure position 2.		
004	Pressure Position3	*ENG	[0 to 10,000 / 2130 / 10 msec/step]
	Specifies the rotation time of the pressure roller contact motor for the pressure position 3.		
005	Depressure Position	*ENG	[0 to 10,000 / 220 / 10 msec/step]
	Specifies the rotation time of the pressure roller contact motor for the depression position (no pressure).		
011	Shift Time	*ENG	[0 to 3600 / 60 / 1 sec/step]
	Specifies the timing for depressing the fusing unit. If the machine does not get any jobs for specified time by this SP after copying or printing, the machine depresses the fusing unit.		
101	Pressure:Plain1/2	*ENG	[0 to 3 / 3 / 1 /step]
Sets the default pressure position of the fusing unit for each paper type in normal speed. 0: Depression position (no pressure) 1: Position 1 (less pressure) 2: Position 2 3: Position 3 (strongest pressure)			

102	Pressure:Thin	*ENG	[0 to 3 / 3 / 1 /step]
103	Pressure:M-thick	*ENG	[0 to 3 / 3 / 1 /step]
104	Pressure:Thick1	*ENG	[0 to 3 / 3 / 1 /step]
105	Pressure:Thick2	*ENG	[0 to 3 / 3 / 1 /step]
106	Pressure:Thick3	*ENG	[0 to 3 / 3 / 1 /step]
107	Pressure:Special1	*ENG	[0 to 3 / 3 / 1 /step]
108	Pressure:Special2	*ENG	[0 to 3 / 3 / 1 /step]
109	Pressure:Special3	*ENG	[0 to 3 / 3 / 1 /step]
110	Pressure:Envelope	*ENG	[0 to 3 / 1 / 1 /step]
151	Pressure:Plain1/2:Low Speed	*ENG	[0 to 3 / 3 / 1 /step]
	<p>Sets the default pressure position of the fusing unit for each paper type in low speed.</p> <p>0: Depression position (no pressure)</p> <p>1: Position 1 (less pressure)</p> <p>2: Position 2</p> <p>3: Position 3 (strongest pressure)</p>		
152	Pressure:M-thick:Low Speed	*ENG	[0 to 3 / 3 / 1 /step]
153	Pressure:Thick1:Low Speed	*ENG	[0 to 3 / 3 / 1 /step]
154	Pressure:Special1:Low Speed	*ENG	[0 to 3 / 3 / 1 /step]
155	Pressure:Special2:Low Speed	*ENG	[0 to 3 / 3 / 1 /step]
156	Pressure:Plain1/2:Glossy	*ENG	[0 to 3 / 3 / 1 /step]
157	Pressure:M-thick:Glossy	*ENG	[0 to 3 / 3 / 1 /step]
158	Pressure:OHP	*ENG	[0 to 3 / 3 / 1 /step]
159	Pressure:Envelope:Low Speed	*ENG	[0 to 3 / 3 / 1 /step]

Main SP Tables-1

160	Pressure:Thin:Low Speed	*ENG	[0 to 3 / 3 / 1 /step]
161	Pressure:Thick4	*ENG	[0 to 3 / 3 / 1 /step]
	Sets the default pressure position of the fusing unit for thick 4 paper. 0: Depression position (no pressure) 1: Position 1 (less pressure) 2: Position 2 3: Position 3 (strongest pressure)		
162	Pressure:Postcard	*ENG	[0 to 3 / 3 / 1 /step]
	Sets the default pressure position of the fusing unit for postcard. 0: Depression position (no pressure) 1: Position 1 (less pressure) 2: Position 2 3: Position 3 (strongest pressure)		
201	Filler Edge Detection Counter	ENG	[0 to 9,000,000 / - / 1 /step]
	Displays the detection time for the edge of the pressure roller actuator.		

1152	[Fusing Nip Band Check]		
001	Execute	-	[0 or 1 / 0 / 1]
	Executes the nip band measurement between heating roller and pressure roller. If the nip band width is not 8 mm, and fusing is not good, replace the pressure roller or install a new fusing unit.		
002	Pre-idling Time	*ENG	[0 to 999 / 300 / 1 sec/step]
	Specifies the fusing rotation time before executing SP1109-001.		
003	Stop Time	* ENG	[0 to 100 / 20 / 1 sec/step]
	Specifies the time for measuring the nip.		
004	Pressure Position	* ENG	[1 to 3 / 3 / 1]
	Specifies the pressure position for measuring the nip.		

1153	[Fuser Cleaning]		
001	Compulsion execution	-	Execute the fusing cleaning mode.
002	Operation interval	*ENG	[1 to 300 / 0 / 1 K/step]
	Adjusts the execution interval for the fusing cleaning mode. 1K= 100 sheets		
003	Control Temp.	*ENG	[0 to 200 / 180 / 1°C/step]
	Specifies the heating roller temperature for the fusing cleaning mode.		
004	Page Count	*ENG	[1 to 300000 / - / 1 page/step]
	Displays the page counter for the fusing cleaning mode.		

1801	[Motor Speed Adj.]		
001	Registration:Plain:Low	*ENG	[-2 to 2 / -1.1 / 0.1 %/step]
002	Registration:Plain:High	*ENG	[-2 to 2 / -0.1 / 0.1 %/step]
003	Registration:Middle Thick:Low	*ENG	[-2 to 2 / -1.1 / 0.1 %/step]
004	Registration:Middle Thick:Mid	*ENG	[-2 to 2 / -0.1 / 0.1 %/step]
005	Registration:Middle Thick:High	*ENG	
006	Registration:Thick 1:Low	*ENG	[-2 to 2 / -1.1 / 0.1 %/step]
007	Registration:Thick1:Mid	*ENG	[-2 to 2 / -0.1 / 0.1 %/step]
008	Registration:Thick 2:Low	*ENG	[-2 to 2 / -1.1 / 0.1 %/step]
009	Registration:Thick 3:Low	*ENG	
010	Duplex CW:Plane:Low	*ENG	[-4 to 4 / 0.0 / 0.1 %/step]
011	Duplex CW:Normal:High	*ENG	
012	Duplex CW:Middle Thick:Low	*ENG	
013	Duplex CW:Middle Thick:Mid	*ENG	

Main SP Tables-1

014	Duplex CW:Middle Thick:High	*ENG	
015	Duplex CW:Thick1:Low	*ENG	
016	Duplex CW:Thick1:Mid	*ENG	
017	Duplex CW:Thick2:Low	*ENG	
018	Duplex CW:Thick3:Low	*ENG	
019	Duplex CCW:Normal:High	*ENG	[-4 to 4 / 0.0 / 0.1 %/step]
020	Duplex CCW:Middle Thick:Mid	*ENG	
021	Duplex CCW:Middle Thick:high	*ENG	
023	Duplex CCW:Thick1:Mid	*ENG	
024	Reverse CW:Normal:High	*ENG	[-4 to 4 / -0.5 / 0.1%/step]
025	Reverse CW:Middle Thick:Mid	*ENG	[-4 to 4 / 0 / 0.1 %/step]
026	Reverse CW:Middle Thick:High	*ENG	[-4 to 4 / -0.5 / 0.1%/step]
028	Reverse CW:Thick1:Mid	*ENG	[-4 to 4 / 0 / 0.1 %/step]
029	Reverse CCW:Normal:High	*ENG	
030	Reverse CCW:Middle Thick:Mid	*ENG	
031	Reverse CCW:Middle Thick:High	*ENG	
033	Reverse CCW:Thick1:Mid	*ENG	
034	Feed:Plain:Low	*ENG	[-2 to 2 / -1.1 / 0.1 %/step]
035	Feed:Plain:High	*ENG	[-2 to 2 / -0.1 / 0.1 %/step]
036	Feed:Middle thick:Low	*ENG	[-2 to 2 / -1.1 / 0.1 %/step]
037	Feed:Middle thick:Mid	*ENG	[-2 to 2 / -0.1 / 0.1 %/step]
038	Feed:Middle thick:High	*ENG	

039	Feed:Thick 1:Low	*ENG	[-2 to 2 / -1.1 / 0.1 %/step]
040	Feed:Thick 1:Mid	*ENG	[-2 to 2 / -0.1 / 0.1 %/step]
041	Feed:Thick 2:Low	*ENG	[-2 to 2 / -1.1 / 0.1 %/step]
042	Feed:Thick 3:Low	*ENG	
043	Bridge Motor:Low	*ENG	[-4 to 4 / 0 / 0.1 %/step]
044	Bridge Motor:Mid	*ENG	
045	Bridge Motor:High	*ENG	
060	KOpcDevMot:High	*ENG	[-4 to 4 / -0.3 / 0.01 %/step]
061	KOpcDevMot:Mid	*ENG	
062	KOpcDevMot:Low	*ENG	
063	MOpcDevMot:High	*ENG	[-10 to 10 / 0 / 1 step/step]
064	MOpcDevMot:Mid	*ENG	[-9 to 9 / 0 / 1 step/step]
065	MOpcDevMot:Low	*ENG	[-14 to 14 / 0 / 1 step/step]
066	COpcDevMot:High	*ENG	[-10 to 10 / 0 / 1 step/step]
067	COpcDevMot:Mid	*ENG	[-9 to 9 / 0 / 1 step/step]
068	COpcDevMot:Low	*ENG	[-14 to 14 / 0 / 1 step/step]
069	YOpcDevMot:High	*ENG	[-10 to 10 / 0 / 1 step/step]
070	YOpcDevMot:Mid	*ENG	[-9 to 9 / 0 / 1 step/step]
071	YOpcDevMot:Low	*ENG	[-14 to 14 / 0 / 1 step/step]
072	Fusing: High	*ENG	[-4 to 4 / -0.6 / 0.01 %/step]
073	Fusing: Mid	*ENG	[-4 to 4 / -0.8 / 0.01 %/step]
074	Fusing: Low	*ENG	[-4 to 4 / -0.3 / 0.01 %/step]

Main SP Tables-1

075	TransferMot:High	*ENG	
076	TransferMot:Mid	*ENG	[-4 to 4 / -0.1 / 0.01 %/step]
077	TransferMot:Low	*ENG	
078	TonerMot	*ENG	[-30 to 30 / 10 / 5 %/step]
079	Fusing: 1200	*ENG	[-4 to 4 / -0.6 / 0.01 %/step]
100	Drum Adjust	*ENG	[0 or 1 / 1 / 1] 0: Off, 1: On
	Enables or disables the drum amplitude adjustment.		
101	MOpcDevMot:High	*ENG	[-7 to 7 / 0 / 1 step/step]
102	COpcDevMot:High	*ENG	
103	YOpcDevMot:High	*ENG	
104	MOpcDevMot:Mid	*ENG	[-7 to 7 / 0 / 1 step/step]
105	COpcDevMot:Mid	*ENG	
106	YOpcDevMot:Mid	*ENG	
107	MOpcDevMot:Low	*ENG	[-14 to 14 / 0 / 1 step/step]
108	COpcDevMot:Low	*ENG	
109	YOpcDevMot:Low	*ENG	
110	MOpcDevMot:1200	*ENG	[- 7 to 7 / 0 / 1 step/step]
111	COpcDevMot:1200	*ENG	
112	YOpcDevMot:1200	*ENG	
120	Long:Registration:Plain:High	*ENG	[-2 to 2 / -0.1 / 0.1 %/step]
121	Long:Registration:Plain:Low	*ENG	[-2 to 2 / -1.1 / 0.1 %/step]

122	Long:Registration:Middle Thick:High	*ENG	[-2 to 2 / -0.1 / 0.1 %/step]
123	Long:Registration:Middle Thick:Middle	*ENG	
124	Long:Registration:Middle Thick:Low	*ENG	[-2 to 2 / -1.1 / 0.1 %/step]
125	Long:Registration:Thick 1:Middle	*ENG	[-2 to 2 / -1 / 0.1 %/step]
126	Long:Registration:Thick 1:Low	*ENG	[-2 to 2 / -1.1 / 0.1 %/step]
127	Long:Registration:Thick 2:Low	*ENG	[-2 to 2 / -1.1 / 0.1 %/step]
128	Long:Registration:Thick 3:Low	*ENG	[-2 to 2 / -1.1 / 0.1 %/step]
129	Long:Fusing:Plain:High	*ENG	[-4 to 4 / 1.9 / 0.01 %/step]
130	Long:Fusing:Plain:Low	*ENG	[-4 to 4 / 2.1 / 0.01 %/step]
131	Long:Fusing:Middle Thick:High	*ENG	[-4 to 4 / 1.9 / 0.01 %/step]
132	Long:Fusing:Middle Thick:Middle	*ENG	[-4 to 4 / 1.4 / 0.01 %/step]
133	Long:Fusing:Middle Thick:Low	*ENG	[-4 to 4 / 2.1 / 0.01 %/step]
134	Long:Fusing:Thick 1:Middle	*ENG	[-4 to 4 / 2.0 / 0.01 %/step]
135	Long:Fusing:Thick 1:Low	*ENG	[-4 to 4 / 1.7 / 0.01 %/step]
136	Long:Fusing:Thick 2:Low	*ENG	[-4 to 4 / 1.7 / 0.01 %/step]
137	Long:Fusing:Thick 3:Low	*ENG	[-4 to 4 / 1.7 / 0.01 %/step]

Main SP Tables-1

1902	[Amplitude Control]		
001	Execute	*ENG	Execute the drum phase adjustment.
002	Result	*ENG	[0 to 3 / 0 / 1] Displays the result of the drum phase adjustment. 0: Successfully done 2: Sampling failure 3: Insufficient detection number
003	Auto Execution	*ENG	[0 or 1 / 1 / -] Turns the automatic drum phase adjustment on or off. 0: Off, 1: On

1950	[Fan Cooling Time Set]		
	Adjust the rotation time for each fan motor after a job end.		
002	Fusing Exit Fan	*ENG	[0 to 120 / 0 / 0.1 min./step]
006	Main Suction Fan	*ENG	
007	Paper Exit Fan	*ENG	
008	PSU Fan	*ENG	
009	QSU Heater Cooling Fan	*ENG	
010	AC Control board Cooling Fan	*ENG	
011	Second Duct Fan	*ENG	
012	Toner Supply Cooling Fan	*ENG	

1951	[Fan Start Time Set]		
	Adjust the start time for each fan motor after a job end.		
002	Fusing Exit Fan	*ENG	[0 to 900 / 0 / 1 sec/step]
006	Main Suction Fan	*ENG	[0 to 900 / 120 / 1 sec/step]
007	Paper Exit Fan	*ENG	[0 to 900 / 0 / 1 sec/step]
008	PSU Fan	*ENG	[0 to 900 / 120 / 1 sec/step]
009	Fusing IH Coil Fan	*ENG	[0 to 900 / 0 / 1 sec/step]
010	IH Power Supply Fan	*ENG	
011	Second Duct Fan	*ENG	
012	Third Duct Fan	*ENG	

1952	[Fan Control Off Mode Time Set]		
	Specifies the time for fan control off mode.		
001	-	*ENG	[0 to 60 / 10 / 1 min./step]

1953	[Extra Fan Control]		
	Configures the settings of extra fan control.		
001	Extra Fan Cooling State	*ENG	[0 or 1 / 0 / 1 /step] 0: Off, 1: On
	Displays the extra fan cooling is On or Off.		
002	Extra Fan Cooling: Time: Threshold	*ENG	[0 to 180 / C2.5a: 110, C2.5b: 100 / 1 min./step]
003	Extra Fan Cooling: Rotat: Threshold	*ENG	[0 to 999999999 / 0 / 1 min./step]
004	Extra Fan Cooling: Start Date	*ENG	Displays the execution time and date of the extra fan cooling.

Main SP Tables-1

005	Extra Fan Cooling Time	*ENG	[0 to 120 / 30 / 0.1 min./step]
	Specifies the execution time for the extra fan cooling.		

1954	[Extra Fan Control]		
	Configures the settings of extra fan control.		
002	Fan Cooling Time:Fusing Exit Fan:Initial	*ENG	[0 to 120 / 0 / 0.1 min./step]
006	Fan Cooling Time:Main Suction Fan:Initial	*ENG	[0 to 120 / 0 / 0.1 min./step]
007	Fan Cooling Time:Paper Exit Fan:Initial	*ENG	[0 to 120 / 0 / 0.1 min./step]
008	Fan Cooling Time:PSU Fan:Initial	*ENG	[0 to 120 / 0 / 0.1 min./step]
009	Fan Cooling Time:Fusing IH Coil Fan:Initial	*ENG	[0 to 120 / 0 / 0.1 min./step]
010	Fan Cooling Time:IH Power Supply Fan:Initial	*ENG	[0 to 120 / 0 / 0.1 min./step]
011	Fan Cooling Time:Second Duct Fan:Initial	*ENG	[0 to 120 / 0 / 0.1 min./step]
012	Fan Cooling Time:Third Duct Fan:Initial	*ENG	[0 to 120 / 0 / 0.1 min./step]

5.3 MAIN SP TABLES-2

5.3.1 SP2-XXX (DRUM)

2005	[Charge DC Voltage] Charge Roller DC Voltage Adjustment (Paper Type, Process Speed, Color) Paper Type → Plain, Thick 1, Thick 2 Plain: High speed, Thick 1: Middle speed, Thick 2&FINE: Low speed		
	Adjusts the DC component of the charge roller bias in the various print modes. Charge bias (DC component) is automatically adjusted during process control; therefore, adjusting these settings does not effect while process control mode (SP3-041-1 Default: ON) is activated. When deactivating process control mode with SP3-041-1, the values in these SP modes are used for printing.		
001	Plain: Bk	*ENG	[0 to 1000 / 690 / 10 -V/step]
002	Plain: M	*ENG	
003	Plain: C	*ENG	
004	Plain: Y	*ENG	
005	Thick 1: Bk	*ENG	
006	Thick 1: M	*ENG	
007	Thick 1: C	*ENG	
008	Thick 1: Y	*ENG	
009	Thick 2&FINE: Bk	*ENG	
010	Thick 2&FINE: M	*ENG	
011	Thick 2&FINE: C	*ENG	
012	Thick 2&FINE: Y	*ENG	
	[Charge DC: Correction]		
013	PCU:Plain	*ENG	[-100 to 100 / C3c: -26, C3d: -28 / 1 -V/step]

Main SP Tables-2

014	PCU:Thick 1	*ENG	[-100 to 100 / -29 / 1 -V/step]
015	PCU:Thick 2&FINE	*ENG	[-100 to 100 / -28 / 1 -V/step]
016	HVP:Plain	*ENG	[-100 to 100 / 20 / 1 -V/step]
017	HVP:Thick 1	*ENG	[-100 to 100 / 20 / 1 -V/step]
018	HVP: Thick 2&FINE	*ENG	[-100 to 100 / 29 / 1 -V/step]

2006	<p>[Charge AC Voltage] Charge Roller AC Voltage Adjustment (Paper Type, Process Speed, Color) Paper Type → Plain, Thick 1, Thick 2 Plain: High speed, Thick 1: Middle speed, Thick 2&FINE: Low speed</p>		
	<p>Adjusts the AC component of the charge roller bias in the various print modes. Charge bias (AC component) is adjusted by environment correction (SP2-007-xxx to SP2-011-xxx). These SPs are activated only when SP2-012-1 is set to "1: manual control".</p>		
001	Plain: Bk	*ENG	[0 to 3 / 1.9 / 0.01 KV/step]
002	Plain: M	*ENG	[0 to 3 / 1.9 / 0.01 KV/step]
003	Plain: C	*ENG	[0 to 3 / 1.9 / 0.01 KV/step]
004	Plain: Y	*ENG	[0 to 3 / 1.9 / 0.01 KV/step]
005	Thick 1: Bk	*ENG	[0 to 3 / 1.9 / 0.01 KV/step]
006	Thick 1: M	*ENG	[0 to 3 / 1.9 / 0.01 KV/step]
007	Thick 1: C	*ENG	[0 to 3 / 1.9 / 0.01 KV/step]
008	Thick 1: Y	*ENG	[0 to 3 / 1.9 / 0.01 KV/step]
009	Thick 2&FINE: Bk	*ENG	[0 to 3 / 1.9 / 0.01 KV/step]
010	Thick 2&FINE: M	*ENG	[0 to 3 / 1.9 / 0.01 KV/step]
011	Thick 2&FINE: C	*ENG	[0 to 3 / 1.9 / 0.01 KV/step]
012	Thick 2&FINE: Y	*ENG	[0 to 3 / 1.9 / 0.01 KV/step]

2012	[Charge Output Control]		
001	AC Voltage	*ENG	<p>Selects the AC voltage control type.</p> <p>[0 or 1 / 0 / 1 /step]</p> <p>0: Process control</p> <p>1: Manual control (AC voltages are decided with SP2006.)</p>

2013	[Environmental Correction: PCU]		
001	Current Environmental FC: Display	*ENG	<p>Displays the environmental condition, which is measured in absolute humidity.</p> <p>[1 to 5 / - / 1 /step]</p> <p>1: LL (LL <= 4.3 g/m³)</p> <p>2: ML (4.3 < ML <= 11.3 g/m³)</p> <p>3: MM (11.3 < MM <= 18.0 g/m³)</p> <p>4: MH (18.0 < MH <= 24.0 g/m³)</p> <p>5: HH (24.0 g/m³ < HH)</p>
002	Forced Setting	*ENG	<p>Selects the environmental condition manually.</p> <p>[0 to 5 / 0 / 1 /step]</p> <p>0: The environmental condition is determined automatically.</p> <p>1: LL, 2: ML, 3: MM, 4: MH, 5: HH</p>
003	Absolute Humidity: Threshold 1	*ENG	<p>Changes the humidity threshold between LL and ML.</p> <p>[0 to 100 / 3.0 / 0.01 g/m³/step]</p>
004	Absolute Humidity: Threshold 2	*ENG	<p>Changes the humidity threshold between ML and MM.</p> <p>[0 to 100 / 8.0 / 0.01 g/m³/step]</p>

Main SP Tables-2

005	Absolute Humidity: Threshold 3	*ENG	Changes the humidity threshold between MM and MH. [0 to 100 / 15.0 / 0.01 g/m ³ /step]
006	Absolute Humidity: Threshold 4	*ENG	Changes the humidity threshold between MH and HH. [0 to 100 / 22.0 / 0.01 g/m ³ /step]
007	Current Temp. FC: Display	*ENG	Displays the current temperature. [0 to 100 / - / 1 deg/step]
008	Current Relative Humidity FC: Display	*ENG	Displays the current relative humidity. [0 to 100 / - / 1%RH/step]
009	Current Absolute Humidity FC: Display	*ENG	Displays the absolute humidity. [0 to 100 / - / 0.01 g/m ³ /step]
010	Previous Environmental Bk: Display	*ENG	Displays the previous environmental condition, which is measured in absolute humidity. [1 to 5 / - / 1 /step] 1: LL, 2: ML, 3: MM, 4: MH, 5: HH
011	Previous Temp. Bk: Display	*ENG	Displays the previous temperature. [0 to 100 / - / 1 deg/step]
012	Previous Relative Humidity Bk: Display	*ENG	Displays the previous relative humidity. [0 to 100 / - / 1%RH/step]
013	Previous Absolute Humidity Bk: Display	*ENG	Displays the previous absolute humidity. [0 to 100 / - / 0.01 g/m ³ /step]

2015	[Charge AC Adj: Result] Displays a result of the AC charge adjustment.		
001	Bk	*ENG	[0 to 9 / 0 / 1 /step]
002	M	*ENG	0: Success
003	C	*ENG	1: Out of tolerance range
004	Y	*ENG	2: Out of adjustable range
			3: Adjustment incompleted

2101	[Color Registration Correction] FA		
	These values are the parameters for the automatic line position adjustment and are adjusted at the factory. However, you must input a value for SP2101-001 after replacing the laser optics housing unit. For details, see "Laser Optics Housing Unit" in the "Replacement and Adjustment" section. The value should be provided with the new laser optics housing unit.		
001	Main Dot: Bk	*ENG	[-512 to 511 / 0 / 1 dot/step]
002	Main Dot: Ma	*ENG	
003	Main Dot: Cy	*ENG	
004	Main Dot: Ye	*ENG	
005	Sub Line: Bk	*ENG	[-16384 to 16383 / 0 / 1 line/step]
006	Sub Line: Ma	*ENG	
007	Sub Line: Cy	*ENG	
008	Sub Line: Ye	*ENG	

2103	[Erase Margin Adjustment] (Area, Paper Size)		
Adjusts the erase margin by deleting image data at the margins.			
001	Lead Edge Width	*ENG	[0 to 9.9 / 4.2 / 0.1 mm/step]
002	Trail. Edge Width	*ENG	
003	Left	*ENG	[0 to 9.9 / 2 / 0.1 mm/step]
004	Right	*ENG	
006	Duplex Trail. L Size	*ENG	[0 to 4 / 1 / 0.1 mm/step]
007	Duplex Trail. M Size	*ENG	[0 to 4 / 0.8 / 0.1 mm/step]
008	Duplex Trail. S Size	*ENG	[0 to 4 / 0.6 / 0.1 mm/step]
009	Duplex Left Edge	*ENG	[0 to 1.5 / 0.3 / 0.1 mm/step]

010	Duplex Right Edge	*ENG	
011	Duplex Trail. L Size:Thick	*ENG	[0 to 4 / 1 / 0.1 mm/step]
012	Duplex Trail. M Size:Thick	*ENG	[0 to 4 / 0.8 / 0.1 mm/step]
013	Duplex Trail. S Size:Thick	*ENG	[0 to 4 / 0.6 / 0.1 mm/step]
014	Duplex Left Edge:Thick	*ENG	[0 to 1.5 / 0.3 / 0.1 mm/step]
015	Duplex Right Edge:Thick	*ENG	
016	Lead Edge Width: Thin	*ENG	[0 to 9.9 / 4.2 / 0.1 mm/step]
017	Trail. Edge Width: Thin	*ENG	
018	Duplex Trail. L Size: Thin	*ENG	[0 to 4 / 1 / 0.1 mm/step]
019	Duplex Trail. M Size: Thin	*ENG	[0 to 4 / 0.8 / 0.1 mm/step]
020	Duplex Trail. S Size: Thin	*ENG	[0 to 4 / 0.6 / 0.1 mm/step]

2105	[LD Power Adj.] (Process Speed, Color)		
	Adjusts the LD power of each color for each process speed. Each LD power setting is decided by process control.		
001	High Speed: Bk	*ENG	[50 to 120 / 100 / 1%/step]
002	High Speed: Ma	*ENG	Decreasing a value makes lines thinner on the output. Increasing a value makes lines thicker on the output.
003	High Speed: Cy	*ENG	
004	High Speed: Ye	*ENG	
005	Middle Speed: Bk	*ENG	
006	Middle Speed: Ma	*ENG	Decreasing a value makes lines thinner on the output. Increasing a value makes lines thicker on the output.
007	Middle Speed: Cy	*ENG	
008	Middle Speed: Ye	*ENG	

009	Low Speed: Bk	*ENG	[50 to 120 / 100 / 1%/step]
010	Low Speed: Ma	*ENG	Decreasing a value makes lines thinner on the output. Increasing a value makes lines thicker on the output.
011	Low Speed: Cy	*ENG	
012	Low Speed: Ye	*ENG	

2109	[Test Pattern]		
	Generates the test pattern using "COPY Window" tab in the LCD.		
003	Pattern Selection	-	[0 to 23 / 0 / 1/step]
	0 None 1: Vertical Line (1dot) 2: Vertical Line (2dot) 3: Horizontal (1dot) 4: Horizontal (2dot) 5: Grid Vertical Line 6: Grid Horizontal Line 7: Grid pattern Small 8: Grid pattern Large 9: Argyle Pattern Small 10: Argyle Pattern Large		11. Independent Pattern (1dot) 12. Independent Pattern (2dot) 13. Independent Pattern (4dot) 14. Trimming Area 16: Hound's Tooth Check (Horizontal) 17: Band (Horizontal) 18: Band (Vertical) 19: Checker Flag Pattern 20: Grayscale Vertical Margin 21: Grayscale Horizontal Margin 23: Full Dot Pattern
005	Color Selection	-	Specifies the color for the test pattern. [1 to 4 / 1 / 1/step] 1: All colors, 2: Magenta, 3: Yellow, 4: Cyan
006	Density: Bk	-	Specifies the color density for the test pattern. [0 to 15 / 15 / 1 /step] 0: Lightest density 15: Darkest density
007	Density: Ma	-	
008	Density: Cy	-	
009	Density: Ye	-	

Main SP Tables-2

2111	[Forced Line Position Adj.]		
001	Mode a	-	Executes the fine line position adjustment twice. If this SP is not completed (NG is displayed), do SP2111-003 first and then try this SP again.
002	Mode b	-	Executes the fine line position adjustment once. If this SP is not completed, do SP2111-003 first and then try this SP again.
003	Mode c	-	Executes the rough line position adjustment once. After doing this SP, make sure to execute SP2111-001 or -002. Otherwise, the line position adjustment is not perfectly done.

2112	[TM/ID Sensor Check] ID Sensor Check FA		
001	Execute		[0 or 1 / 0 / 1 /step] This SP is used to check the ID sensors at the factory. The results of this SP are displayed in SP2140 to SP2145.

2117	[Skew Adjustment]		
	Specifies a skew adjustment value for the skew motor M, C or Y. These SPs must be used when a new laser optics housing unit is installed or when SC2.585 occurs. For details, see "Laser Optics Housing Unit" in the "Replacement and Adjustment" section.		
	001	Pulse: M	*ENG
	002	Pulse: C	*ENG
003	Pulse: Y	*ENG	[-50 to 50 / 0 / 1 pulse/step]

2118	[Skew Adjustment]		
001	Execute: M	*ENG	Changes the current skew adjustment values to the values specified with SP2117. These SPs must be used when a new laser optics housing unit is installed or when SC2.585 occurs. For details, see "Laser Optics Housing Unit" in the "Replacement and Adjustment" section.
002	Execute: C	*ENG	
003	Execute: Y	*ENG	

2119	[Skew Adjustment Display]		
	Displays the current skew adjustment value for each skew motor.		
001	M	*ENG	[-50 to 50 / - / 1 pulse/step]
002	C	*ENG	
003	Y	*ENG	

2150	[Area Mag. Correction] LD Pulse Area Correction (Color, Area) FA		
	Adjusts the magnification for each area. The main scan (297 mm) is divided into 8 areas. Area 1 is at the front side of the machine (left side of the image) and area 8 is at the rear side of the machine (right side of the image). Decreasing a value makes the image shift to the left side on the print. Increasing a value makes the image shift to the right side on the print. 1 pulse = 1/16 dot		
027	Area 0: Bk	*ENG	[-255 to 255 / 0 / 1 sub-dot/step]
028	Area 1: Bk	*ENG	Adjusts the area magnification for LD 0. [-255 to 255 / 0 / 1 sub-dot/step]
029	Area 2: Bk	*ENG	
030	Area 3: Bk	*ENG	
031	Area 4: Bk	*ENG	
032	Area 5: Bk	*ENG	
033	Area 6: Bk	*ENG	

Main SP Tables-2

034	Area 7: Bk	*ENG	
035	Area 8: Bk	*ENG	
036	Area 9: Bk	*ENG	Not used
037	Area 10: Bk	*ENG	
038	Area 11: Bk	*ENG	
039	Area 12: Bk	*ENG	
079	Area 0: Ma	*ENG	
080	Area 1: Ma	*ENG	Adjusts the area magnification for LD 0. [-255 to 255 / 0 / 1 sub-dot/step]
081	Area 2: Ma	*ENG	
082	Area 3: Ma	*ENG	
083	Area 4: Ma	*ENG	
084	Area 5: Ma	*ENG	
085	Area 6: Ma	*ENG	
086	Area 7: Ma	*ENG	
087	Area 8: Ma	*ENG	
088	Area 9: Ma	*ENG	Not used
089	Area 10: Ma	*ENG	
090	Area 11: Ma	*ENG	
091	Area 12: Ma	*ENG	
131	Area 0: Cy	*ENG	[-255 to 255 / 0 / 1 sub-dot/step]
132	Area 1: Cy	*ENG	Adjusts the area magnification for LD 0. [-255 to 255 / 0 / 1 sub-dot/step]
133	Area 2: Cy	*ENG	
134	Area 3: Cy	*ENG	

135	Area 4: Cy	*ENG	
136	Area 5: Cy	*ENG	
137	Area 6: Cy	*ENG	
138	Area 7: Cy	*ENG	
139	Area 8: Cy	*ENG	
140	Area 9: Cy	*ENG	Not used
141	Area 10: Cy	*ENG	
142	Area 11: Cy	*ENG	
143	Area 12: Cy	*ENG	
183	Area 0: Ye	*ENG	[-255 to 255 / 0 / 1 sub-dot/step]
184	Area 1: Ye	*ENG	Adjusts the area magnification for LD 0. [-255 to 255 / 0 / 1 sub-dot/step]
185	Area 2: Ye	*ENG	
186	Area 3: Ye	*ENG	
187	Area 4: Ye	*ENG	
188	Area 5: Ye	*ENG	
189	Area 6: Ye	*ENG	
190	Area 7: Ye	*ENG	
191	Area 8: Ye	*ENG	
192	Area 9: Ye	*ENG	Not used
193	Area 10: Ye	*ENG	
194	Area 11: Ye	*ENG	
195	Area 12: Ye	*ENG	

2152	[Area Shad. Correct. Setting] FA		
	<p>Adjusts the area correction value for each LD power.</p> <p>The main scan is divided into 16 areas. However, the image areas are limited from area 1 to area 14.</p> <p>For BK and Magenta, area 1 is at the rear side of the machine (left side of the image) and area 14 is at the front side of the machine (right side of the image).</p> <p>For Cyan and Yellow, area 1 is at the front side of the machine (right side of the image) and area 14 is at the rear side of the machine (left side of the image).</p>		
001	Area 0: Bk	*ENG	<p>This is for the synchronizing detection board.</p> <p>[50 to 150 / 100 / 1 %/step]</p>
002	Area 1: Bk	*ENG	
003	Area 2: Bk	*ENG	
004	Area 3: Bk	*ENG	
005	Area 4: Bk	*ENG	
006	Area 5: Bk	*ENG	
007	Area 6: Bk	*ENG	
008	Area 7: Bk	*ENG	
009	Area 8: Bk	*ENG	
010	Area 9: Bk	*ENG	
011	Area 10: Bk	*ENG	
012	Area 11: Bk	*ENG	
013	Area 12: Bk	*ENG	
014	Area 13: Bk	*ENG	
015	Area 14: Bk	*ENG	

016	Area 15: Bk	*ENG	This is out of the image area. [50 to 150 / 100 / 1 %/step]
033	Area 0: Ma	*ENG	This is for the synchronizing detection board. [50 to 150 / 100 / 1 %/step]
034	Area 1: Ma	*ENG	[50 to 150 / 100 / 1 %/step]
035	Area 2: Ma	*ENG	
036	Area 3: Ma	*ENG	
037	Area 4: Ma	*ENG	
038	Area 5: Ma	*ENG	
039	Area 6: Ma	*ENG	
040	Area 7: Ma	*ENG	
041	Area 8: Ma	*ENG	
042	Area 9: Ma	*ENG	
043	Area 10: Ma	*ENG	
044	Area 11: Ma	*ENG	
045	Area 12: Ma	*ENG	
046	Area 13: Ma	*ENG	
047	Area 14: Ma	*ENG	
048	Area 15: Ma	*ENG	This is out of the image area. [50 to 150 / 100 / 1 %/step]
065	Area 0: Cy	*ENG	This is for the synchronizing detection board. [50 to 150 / 100 / 1 %/step]
066	Area 1: Cy	*ENG	[50 to 150 / 100 / 1 %/step]

Main SP Tables-2

067	Area 2: Cy	*ENG	
068	Area 3: Cy	*ENG	
069	Area 4: Cy	*ENG	
070	Area 5: Cy	*ENG	
071	Area 6: Cy	*ENG	
072	Area 7: Cy	*ENG	
073	Area 8: Cy	*ENG	
074	Area 9: Cy	*ENG	
075	Area 10: Cy	*ENG	
076	Area 11: Cy	*ENG	
077	Area 12: Cy	*ENG	
078	Area 13: Cy	*ENG	
079	Area 14: Cy	*ENG	
080	Area 15: Cy	*ENG	
097	Area 0: Ye	*ENG	This is for the synchronizing detection board. [50 to 150 / 100 / 1 %/step]
098	Area 1: Ye	*ENG	[50 to 150 / 100 / 1 %/step]
099	Area 2: Ye	*ENG	
100	Area 3: Ye	*ENG	
101	Area 4: Ye	*ENG	
102	Area 5: Ye	*ENG	
103	Area 6: Ye	*ENG	

104	Area 7: Ye	*ENG		
105	Area 8: Ye	*ENG		
106	Area 9: Ye	*ENG		
107	Area 10: Ye	*ENG		
108	Area 11: Ye	*ENG		
109	Area 12: Ye	*ENG		
110	Area 13: Ye	*ENG		
111	Area 14: Ye	*ENG		
112	Area 15: Ye	*ENG		This is out of the image area. [50 to 150 / 100 / 1 %/step]

2181	[Line Position Adj. Result]		
	<p>Displays the values for each correction.</p> <ul style="list-style-type: none"> ▪ "Paper Int. Mag: Subdot" indicates the magnification correction value between two sheets of paper. ▪ "Mag.Cor. Subdot" indicates the magnification correction value. ▪ "M. Scan Erro." indicates the shift correction value in the main scan direction. ▪ "S. Scan Erro." Indicates the shift correction value in the sub scan direction. ▪ "M. Cor.: Dot" indicates the dot correction value in the main scan direction. ▪ "M. Cor.: Subdot" indicates the sub dot correction value in the main scan direction. ▪ Bk: Black, M: Magenta, C: Cyan, Y: Yellow 		
001	Paper Int. Mag: Subdot: Bk	*ENG	[-32768 to 32767 / - / 1 pulse/step]
002	Mag.Cor. Subdot: Bk	*ENG	[-32768 to 32767 / - / 1 pulse/step]
003	Skew: M	*ENG	[-5000 to 5000 / - / 0.001 um/step]

Main SP Tables-2

005	M. Scan Erro.: Left: M	*ENG	[-5000 to 5000 / - / 0.001 um/step]
006	M. Scan Erro.: Center: M	*ENG	
007	M. Scan Erro.: Right: M	*ENG	
008	S. Scan Erro.: Left: M	*ENG	
009	S. Scan Erro.: Center: M	*ENG	
010	S. Scan Erro.: Right: M	*ENG	
011	M. Cor.: Dot: M	*ENG	[-512 to 511 / - / 1 dot/step]
012	M. Cor.: Subdot: M	*ENG	[-15 to 15 / - / 1 pulse/step]
013	Paper Int. Mag: Subdot: M	*ENG	[-32768 to 32767 / - / 1 pulse/step]
014	Mag.Cor. Subdot: M	*ENG	
015	M. Left Mag.: Subdot: M	*ENG	
016	M. Right Mag.: Subdot: M	*ENG	
017	S. Cor.: 600 Line: M	*ENG	[-16384 to 16383 / - / 1 line/step]
018	S. Cor.: 600 Sub: M	*ENG	[-1 to 1 / - / 0.001 line/step]
019	S. Cor.: 1200 Line: M	*ENG	[-16384 to 16383 / - / 1 line/step]
020	S. Cor.: 1200 Sub: M	*ENG	[-1 to 1 / - / 0.001 line/step]
021	Skew: C	*ENG	[-5000 to 5000 / - / 0.001 um/step]
023	M. Scan Erro.: Left: C	*ENG	[-5000 to 5000 / - / 0.001 um/step]
024	M. Scan Erro.: Center: C	*ENG	
025	M. Scan Erro.: Right: C	*ENG	
026	S. Scan Erro.: Left: C	*ENG	
027	S. Scan Erro.: Center: C	*ENG	
028	S. Scan Erro.: Right: C	*ENG	

029	M. Cor.: Dot: C	*ENG	[−512 to 511 / - / 1 dot/step]
030	M. Cor.: Subdot: C	*ENG	[−15 to 15 / - / 1 pulse/step]
031	Paper Int. Mag: Subdot: C	*ENG	[−32768 to 32767 / - / 1 pulse/step]
032	Mag.Cor. Subdot: C	*ENG	
033	M. Left Mag.: Subdot: C	*ENG	
034	M. Right Mag.: Subdot: C	*ENG	
035	S. Cor.: 600 Line: C	*ENG	[−16384 to 16383 / - / 1 line/step]
036	S. Cor.: 600 Sub: C	*ENG	[−1 to 1 / - / 0.001 line/step]
037	S. Cor.: 1200 Line: C	*ENG	[−16384 to 16383 / - / 1 line/step]
038	S. Cor.: 1200 Sub: C	*ENG	[−1 to 1 / - / 0.001 line/step]
039	Skew: Y	*ENG	[−5000 to 5000 / - / 0.001 um/step]
041	M. Scan Erro.: Left: Y	*ENG	
042	M. Scan Erro.: Center: Y	*ENG	
043	M. Scan Erro.: Right: Y	*ENG	
044	S. Scan Erro.: Left: Y	*ENG	
045	S. Scan Erro.: Center: Y	*ENG	
046	S. Scan Erro.: Right: Y	*ENG	
047	M. Cor.: Dot: Y	*ENG	[−512 to 511 / - / 1 dot/step]
048	M. Cor.: Subdot: Y	*ENG	[−15 to 15 / - / 1 pulse/step]
049	Paper Int. Mag: Subdot: Y	*ENG	[−32768 to 32767 / - / 1 pulse/step]
050	Mag.Cor. Subdot: Y	*ENG	
051	M. Left Mag.: Subdot: Y	*ENG	
052	M. Right Mag.: Subdot: Y	*ENG	

Main SP Tables-2

053	S. Cor.: 600 Line: Y	*ENG	[-16384 to 16383 / - / 1 line/step]
054	S. Cor.: 600 Sub: Y	*ENG	[-1 to 1 / - / 0.001 line/step]
055	S. Cor.: 1200 Line: Y	*ENG	[-16384 to 16383 / - / 1 line/step]
056	S. Cor.: 1200 Sub: Y	*ENG	[-1 to 1 / - / 0.001 line/step]

2182	[Line Position Adj. Offset] (Color) M. Scan: Main scan, S. Scan: Sub-scan		
001	M Magnification	*ENG	Adjusts the line position manually. [-1 to 1 / 0 / 0.001%/step]
002	C Magnification	*ENG	
003	Y Magnification	*ENG	
	<p>When line shifts are not corrected by the automatic line position adjustment, do this SP.</p> <p>Increasing a value reduces the image in the main scan direction.</p> <p>Decreasing a value enlarges the image in the main scan direction.</p>		
004	M. Scan: High: Dot: M	*ENG	[-512 to 511 / 0 / 1 dot/step]
005	M. Scan: High: Subdot: M	*ENG	[-15 to 15 / 0 / 1 pulse/step]
006	M. Scan: Medium: Dot: M	*ENG	[-512 to 511 / 0 / 1 dot/step]
007	M. Scan: Medium: Subdot: M	*ENG	[-15 to 15 / 0 / 1 pulse/step]
008	M. Scan: Low: Dot: M	*ENG	[-512 to 511 / 0 / 1 dot/step]
009	M. Scan: Low: Subdot: M	*ENG	[-15 to 15 / 0 / 1 pulse/step]
010	M. Scan: High: Dot: C	*ENG	[-512 to 511 / 0 / 1 dot/step]
011	M. Scan: High: Subdot: C	*ENG	[-15 to 15 / 0 / 1 pulse/step]
012	M. Scan: Medium: Dot: C	*ENG	[-512 to 511 / 0 / 1 dot/step]
013	M. Scan: Medium: Subdot: C	*ENG	[-15 to 15 / 0 / 1 pulse/step]

014	M. Scan: Low: Dot: C	*ENG	[-512 to 511 / 0 / 1 dot/step]
015	M. Scan: Low: Subdot: C	*ENG	[-15 to 15 / 0 / 1 pulse/step]
016	M. Scan: High: Dot: Y	*ENG	[-512 to 511 / 0 / 1 dot/step]
017	M. Scan: High: Subdot: Y	*ENG	[-15 to 15 / 0 / 1 pulse/step]
018	M. Scan: Medium: Dot: Y	*ENG	[-512 to 511 / 0 / 1 dot/step]
019	M. Scan: Medium: Subdot: Y	*ENG	[-15 to 15 / 0 / 1 pulse/step]
020	M. Scan: Low: Dot: Y	*ENG	[-512 to 511 / 0 / 1 dot/step]
021	M. Scan: Low: Subdot: Y	*ENG	[-15 to 15 / 0 / 1 pulse/step]
022	S. Scan: High: Line: M	*ENG	[-16384 to 16383 / 0 / 1 line/step]
023	S. Scan: High: Subline: M	*ENG	[-1 to 1 / 0 / 0.001 /line]
024	S. Scan: Medium: Line: M	*ENG	[-16384 to 16383 / 0 / 1 line/step]
025	S. Scan: Medium: Subline: M	*ENG	[-1 to 1 / 0 / 0.001 /line]
026	S. Scan: Low: Line: M	*ENG	[-16384 to 16383 / 0 / 1 line/step]
027	S. Scan: Low: Subline: M	*ENG	Not used
028	S. Scan: High: Line: C	*ENG	[-16384 to 16383 / 0 / 1 line/step]
029	S. Scan: High: Subline: C	*ENG	[-1 to 1 / 0 / 0.001 /line]
030	S. Scan: Medium: Line: C	*ENG	[-16384 to 16383 / 0 / 1 line/step]
031	S. Scan: Medium: Subline: C	*ENG	[-1 to 1 / 0 / 0.001 /line]
032	S. Scan: Low: Line: C	*ENG	[-16384 to 16383 / 0 / 1 line/step]
033	S. Scan: Low: Subline: C	*ENG	Not used
034	S. Scan: High: Line: Y	*ENG	[-16384 to 16383 / 0 / 1 line/step]
035	S. Scan: High: Subline: Y	*ENG	[-1 to 1 / 0 / 0.001 /line]
036	S. Scan: Medium: Line: Y	*ENG	[-16384 to 16383 / 0 / 1 line/step]

Main SP Tables-2

037	S. Scan: Medium: Subline: Y	*ENG	[-1 to 1 / 0 / 0.001 /line]
038	S. Scan: Low: Line: Y	*ENG	[-16384 to 16383 / 0 / 1 line/step]
039	S. Scan: Low: Subline: Y	*ENG	Not used

2185	[Main Scan Length Target Display]		
	Displays/adjusts the target value for the main scan length correction of the line position adjustment.		
	After replacing the laser optics housing unit, input the standard value for Bk provided with the new unit. For details, see "Laser Optics Housing Unit" in the "Replacement Adjustment" section. It is not necessary to input the values for the other colors; these are automatically adjusted after doing the line position adjustment.		
	001	Bk	*ENG
	002	M	*ENG
003	C	*ENG	[0 to 266667 / 249449 / 1 sub-dot/step]
004	Y	*ENG	

2193	[MUSIC Condition Set] Line Position Adjustment: Condition Setting		
001	Auto Execution	*ENG	[0 or 1 / 1 / 1] 0: OFF, 1: ON
	Enables/disables the automatic line position adjustment		
002	Page: Job End: BW+FC	*ENG	[0 to 999 / 500 / 1 page/step]
	Adjusts the threshold of the line position adjustment for BW and color printing mode after job end.		
003	Page: Job End: FC	*ENG	[0 to 999 / 200 / 1 page/step]
	Adjusts the threshold of the line position adjustment for color printing mode after job end.		

004	Page: Interrupt: BW+FC	*ENG	[0 to 999 / 200 / 1 page/step]
	Adjusts the threshold of the line position adjustment for BW and color printing mode during job.		
005	Page: Interrupt: FC	*ENG	[0 to 999 / 200 / 1 page/step]
	Adjusts the threshold of the line position adjustment for color printing mode during jobs.		
006	Page: Stand-By: BW	*ENG	[0 to 999 / 100 / 1 page/step]
	Adjusts the threshold of the line position adjustment for BW printing mode in stand-by mode. The line position adjustment is done when the number of outputs in BW printing mode reaches the value specified with this SP and the condition of SP2-193-008 or SP2-193-009 is satisfied.		
007	Page: Stand-By: FC	*ENG	[0 to 999 / 100 / 1 page/step]
	Adjusts the threshold of the line position adjustment for FC printing mode in stand-by mode. The line position adjustment is done when the number of outputs in color printing mode reaches the value specified with this SP and the condition of SP2-193-008 or SP2-193-009 is satisfied.		
008	Temp.	*ENG	[0 to 100 / 5 / 1deg/step]
	Adjust the temperature change threshold for the line position adjustment (Mode b: adjustment once). The timing for line position adjustment depends on the combinations of several conditions.		
009	Time	*ENG	[1 to 1440 / 300 / 1 minute/step]
	Adjust the time threshold for the line position adjustment (Mode b: adjustment once). The timing for line position adjustment depends on the combinations of several conditions.		

010	Magnification	*ENG	[0 to 10 / 0.1 / 0.01%/step]
	Adjusts the magnification threshold for line position adjustment. If the length of the main scan is changed by this amount since the previous MUSIC, then MSUIC is done again.		
011	Temp. 2	*ENG	[0 to 100 / 10 / 1deg/step]
	Adjust the temperature change threshold for the line position adjustment (Mode a: adjustment twice). The timing for line position adjustment depends on the combinations of several conditions.		
012	Time 2	*ENG	[1 to 9999 / 600 / 1 minute/step]
	Adjust the time threshold for the line position adjustment (Mode a: adjustment twice). The timing for line position adjustment depends on the combinations of several conditions.		
013	Page: Power ON:BW+FC	*ENG	[0 to 999 / 200 / 1 page/step]
	Adjusts the threshold of the line position adjustment for BW and FC printing mode at power-on. The line position adjustment is done when the number of outputs in BW and color printing mode reaches the value specified with this SP and the condition of SP2-193-008 or SP2-193-009 is satisfied.		

2194	[MUSIC Execution Result] Line Position Adjustment: Execution Result		
001	Year	*ENG	[0 to 99 / - / 1 year/step]
	Displays the year of the last MUSIC execution.		
002	Month	*ENG	[1 to 12 / - / 1 month/step]
	Displays the month of the last MUSIC execution.		
003	Day	*ENG	[1 to 31 / - / 1 day/step]
	Displays the date of the last MUSIC execution.		
004	Hour	*ENG	[0 to 23 / - / 1 hour/step]
	Displays the time (hour) of the last MUSIC execution.		

005	Minute	*ENG	[0 to 59 / - / 1 minute/step]
	Displays the time (minute) of the last MUSIC execution.		
006	Temperature	*ENG	[0 to 100 / - / 1 deg/step]
	Displays the temperature of the last MUSIC execution.		
007	Execution Result	*ENG	[0 or 1 / - / 1 /step] 0: Completed successfully, 1: Failed
008	Number of Execution	*ENG	[0 to 999999 / - / 1 times/step]
009	Number of Failure	*ENG	[0 to 999999 / - / 1 times/step]
010	Error Result: M	*ENG	[0 to 9 / - / 1 /step] 0: Not done 1: Completed successfully 2: Cannot detect patterns 3: Fewer lines on the pattern than the target 4: Not used 5: Out of the adjustment range 6 to 9: Not used
011	Error Result: C	*ENG	
012	Error Result: Y	*ENG	

2198	[Music A/D Interval]		
	ADC Trigger Counter		
001	ADC Trigger Counter	*ENG	[7.5 to 20 / 10 / 0.1 μs/step]

2220	[Skew Origin Set]		
	Executes the skew motor initialization in the laser optics unit.		
001	M: Skew Motor	*ENG	-
002	C: Skew Motor	*ENG	-
003	Y: Skew Motor	*ENG	-

2221	[LD Power] LD Power Control		
	Adjusts the fixed LD power for each line speed and color. These SPs are activated only when SP3-041-002 is set to "0". Plain: High speed, Thick 1: Middle speed, Thick 2&Fine: Low speed		
001	Plain: Bk	*ENG	[0 to 200 / 100 / 1%/step] Increasing this value makes the image density darker.
002	Plain: M	*ENG	
003	Plain: C	*ENG	
004	Plain: Y	*ENG	
005	Thick 1: Bk	*ENG	
006	Thick 1: M	*ENG	
007	Thick 1: C	*ENG	
008	Thick 1: Y	*ENG	
009	Thick 2&FINE: Bk	*ENG	
010	Thick 2&FINE: M	*ENG	
011	Thick 2&FINE: C	*ENG	
012	Thick 2&FINE: Y	*ENG	

2229	[Development DC Vias] Development DC Bias Adjustment		
	<p>Adjusts the development bias.</p> <p>Development bias is automatically adjusted during process control; therefore, adjusting these settings has no effect while Process Control (SP3-041-001 Default: ON) is activated.</p> <p>After deactivating Process Control with SP3-041-001, the values in these SP modes are used for printing.</p> <p>Plain: High speed, Thick 1: Middle speed, Thick 2&Fine: Low speed</p>		
001	Plain: Bk	*ENG	[0 to 800 / 550 / 10 –V/step]
002	Plain: M	*ENG	
003	Plain: C	*ENG	
004	Plain: Y	*ENG	
005	Thick 1: Bk	*ENG	
006	Thick 1: M	*ENG	
007	Thick 1: C	*ENG	
008	Thick 1: Y	*ENG	
009	Thick 2&FINE:Bk	*ENG	
010	Thick 2&FINE:M	*ENG	
011	Thick 2&FINE:C	*ENG	
012	Thick 2&FINE:Y	*ENG	

Main SP Tables-2

2241	[Temperature/Humidity: Display]		
	Displays the environment temperature and humidity.		
001	Temperature	-	[-50 to 450 / - / 0.1deg/step]
002	Relative Humidity	-	[0 to 1000 / - / 0.1 %RH/step]
003	Absolute Humidity	-	[0 to 100 / - / 0.01 g/m ³ /step]
004	AIT Temperature	-	[0 to 70 / - / 0.1deg/step]
005	Correction Coefficient A	-	[0 to 70 / 1 / 0.1/step]
006	Correction Coefficient B	-	[-70 to 70 / 0 / 0.1/step]

2242	[TS Operation Env. Log]		
	Displays TS Operation Env. logs.		
001	TS <= 40	-	[0 to 99999999 / - / 1/mm]
002	40 < TS <= 45	-	[0 to 99999999 / - / 1/mm]
003	45 < TS	-	[0 to 99999999 / - / 1/mm]
004	Log Clear	-	[0 to 1 / 0 / 1/step] 1: Clear

2302	[Environmental Correction: Transfer] Environmental Correction: Image Transfer Belt Unit		
001	Current Environmental Display	-	Displays the current environment condition.
002	Forced Setting	*ENG	Sets the environment condition manually. [0 to 6 / 0 / 1 /step] 0: Automatic environment control 1: LL (Low temperature/ Low humidity) 2: ML (Middle temperature/ Low humidity) 3: MM (Middle temperature/ Middle humidity) 4: MH (Middle temperature/ High humidity) 5: HH (High temperature/ High humidity)
003	Absolute Humidity: Threshold 1	*ENG	Adjusts the threshold value between LL and ML. [0 to 100 / 4 / 0.01 g/m ³ /step]
004	Absolute Humidity: Threshold 2	*ENG	Adjusts the threshold value between ML and MM. [0 to 100 / 8 / 0.01 g/m ³ /step]
005	Absolute Humidity: Threshold 3	*ENG	Adjusts the threshold value between MM and MH. [0 to 100 / 16 / 0.01 g/m ³ /step]
006	Absolute Humidity: Threshold 4	*ENG	Adjusts the threshold value between MH and HH. [0 to 100 / 24 / 0.01 g/m ³ /step]
007	Temp Threshold	*ENG	[-5 to 30 / 5 / 1 deg/step]

2308	[Paper Size Correction]		
	Adjusts the threshold value for the paper size correction.		
001	Threshold 1	*ENG	[0 to 350 / 297 / 1 mm/step] Threshold 1 ≤ paper: Paper is detected as "S1" size.
002	Threshold 2	*ENG	[0 to 350 / 257 / 1 mm/step] Threshold 2 ≤ paper ≤ Threshold 1: Paper is detected as "S2" size.
003	Threshold 3	*ENG	[0 to 350 / 210 / 1 mm/step] Threshold 3 ≤ paper ≤ Threshold 2: Paper is detected as "S3" size.
004	Threshold 4	*ENG	[0 to 350 / 148 / 1 mm/step] Threshold 4 ≤ paper ≤ Threshold 3: Paper is detected as "S4" size. Paper ≤ Threshold 4: Paper is detected as "S5" size.

2311	[Non Image Area: Bias]		
001	Image Transfer	*ENG	Adjusts the bias of the image transfer belt between images. This value is added to the value of the image transfer belt bias. [10 to 250 / 100 / 5 %/step]
002	Paper Transfer	*ENG	Adjusts the bias of the paper transfer roller between images. [0 to 2100 / 500 / 100 V/step]

2326	[Transfer Roller CL: Bias] Transfer Roller Cleaning: Bias Adjustment		
001	Positive	*ENG	[0 to 2100 / 500 / 100 V /step]
	Adjusts the positive voltage of the paper transfer roller for cleaning the paper transfer roller.		
002	Negative	*ENG	[10 to 400 / 100 / 10 %/step]
	Adjusts the negative current of the paper transfer roller for cleaning the paper transfer roller.		
003	Positive	*ENG	[0 to 2100 / 2000 / 100 V/step]
	Adjusts the negative current limit of the paper transfer roller for cleaning the paper transfer roller.		
004	Negative	*ENG	[10 to 400 / 100 / 10 %/step]

2351	[Common: BW: Bias] Plain: High speed, Thick 1: Middle speed, Thick 2&Fine: Low speed		
001	ITB unit: Plain	*ENG	[0 to 80 / 25 / 1 μ A]
	Adjusts the current for the image transfer belt in B/W mode for plain paper.		
002	ITB unit: Thick 1	*ENG	[0 to 80 / 12 / 1 μ A]
	Adjusts the current for the image transfer belt in B/W mode for thick 1 paper.		
003	ITB unit: Thick 2 & FINE	*ENG	[0 to 80 / 12 / 1 μ A]
	Adjusts the current for the image transfer belt in B/W mode for thick 2 paper or FINE mode.		

2357	[Common: FC: Bias] Image Transfer Belt: Full Color: Bias Adjustment Plain: High speed, Thick 1: Middle speed, Thick 2&Fine: Low speed		
001	ITB unit: Plain: Bk	*ENG	[0 to 80 / 22 / 1 μ A]
	Adjusts the current for the image transfer belt for Black in full color mode for plain paper.		
002	ITB unit: Plain: M	*ENG	[0 to 80 / 25 / 1 μ A]
	Adjusts the current for the image transfer belt for Magenta in full color mode for plain paper.		
003	ITB unit: Plain: C	*ENG	[0 to 80 / 22 / 1 μ A]
	Adjusts the current for the image transfer belt for Cyan in full color mode for plain paper.		
004	ITB unit: Plain: Y	*ENG	[0 to 80 / 28 / 1 μ A]
	Adjusts the current for the image transfer belt for Yellow in full color mode for plain paper.		
005	ITB unit: Thick 1: Bk	*ENG	[0 to 80 / 11 / 1 μ A]
	Adjusts the current for the image transfer belt for Black in full color mode for thick 1 paper.		
006	ITB unit: Thick 1: M	*ENG	[0 to 80 / 12 / 1 μ A]
	Adjusts the current for the image transfer belt for Magenta in full color mode for thick 1 paper.		
007	ITB unit: Thick 1: C	*ENG	[0 to 80 / 11 / 1 μ A]
	Adjusts the current for the image transfer belt for Cyan in full color mode for thick 1 paper.		

008	ITB unit: Thick 1: Y	*ENG	[0 to 80 / 14 / 1 μ A]
	Adjusts the current for the image transfer belt for Yellow in full color mode for thick 1 paper.		
009	ITB unit: Thick 2 & FINE: Bk	*ENG	[0 to 80 / 11 / 1 μ A]
	Adjusts the current for the image transfer belt for Black in full color mode for Thick 2 and fine.		
010	ITB unit: Thick 2 & FINE: M	*ENG	[0 to 80 / 12 / 1 μ A]
	Adjusts the current for the image transfer belt for Magenta in full color mode for Thick 2 and fine.		
011	ITB unit: Thick 2 & FINE: C	*ENG	[0 to 80 / 11 / 1 μ A]
	Adjusts the current for the image transfer belt for Cyan in full color mode for Thick 2 and fine.		
012	ITB unit: Thick 2 & FINE: Y	*ENG	[0 to 80 / 14 / 1 μ A]
	Adjusts the current for the image transfer belt for Yellow in full color mode for Thick 2 and fine.		

2360	[Common: BW Env. Correction]		
001	ITB unit: Plain	*ENG	[1 to 60 / 1 / 1 /step]
002	ITB unit: Thick 1	*ENG	
003	ITB unit: Thick 2	*ENG	
004	ITB unit: Plain: Bk	*ENG	[1 to 60 / 13 / 1 /step]
005	ITB unit: Plain: M	*ENG	[1 to 60 / 2 / 1 /step]
006	ITB unit: Plain: C	*ENG	
007	ITB unit: Plain: Y	*ENG	
008	ITB unit: Thick 1: Bk	*ENG	[1 to 60 / 31 / 1 /step]
009	ITB unit: Thick 1: M	*ENG	[1 to 60 / 1 / 1 /step]

Main SP Tables-2

010	ITB unit: Thick 1: C	*ENG	[1 to 60 / 2 / 1 /step]
011	ITB unit: Thick 1: Y	*ENG	
012	ITB unit: Thick 2: Bk	*ENG	[1 to 60 / 31 / 1 /step]
013	ITB unit: Thick 2: M	*ENG	[1 to 60 / 1 / 1 /step]
014	ITB unit: Thick 2: C	*ENG	[1 to 60 / 2 / 1 /step]
015	ITB unit: Thick 2: Y	*ENG	[1 to 60 / 2 / 1 /step]

2401	[Plain: Bias]		
	Adjusts the DC voltage of the discharge plate for plain paper. Plain: High speed, Thick 1: Middle speed, Thick 2&Fine: Low speed		
001	Separation DC: Plain: 1st Side	*ENG	[0 to 4000 / 3500 / 10 -V/step]
002	Separation DC: Plain: 2nd Side	*ENG	[0 to 4000 / 3500 / 10 -V/step]
003	Separation DC: 1200: 1st Side	*ENG	[0 to 4000 / 3500 / 10 -V/step]
004	Separation DC: 1200: 2nd Side	*ENG	[0 to 4000 / 3500 / 10 -V/step]

2403	[Plain: Bias: BW]		
	Adjusts the current for the paper transfer roller for plain paper in black-and-white mode. Plain: High speed, Thick 1: Middle speed, Thick 2&Fine: Low speed		
001	Paper Transfer: Plain: 1st Side	*ENG	[0 to 250 / 22 / 1 -μA /step]
002	Paper Transfer: Plain: 2nd Side	*ENG	

003	Paper Transfer: 1200: 1st Side	*ENG	[0 to 250 / 7 / 1 - μ A /step]
004	Paper Transfer: 1200: 2nd Side	*ENG	[0 to 250 / 12 / 1 - μ A /step]



2407	[Plain: Bias: FC]		
	Adjusts the current for the paper transfer roller for plain paper in full color mode. Plain: High speed, Thick 1: Middle speed, Thick 2&Fine: Low speed		
001	Paper Transfer: Plain: 1st Side	*ENG	[0 to 250 / 27 / 1 - μ A /step]
002	Paper Transfer: Plain: 2nd Side	*ENG	[0 to 250 / 33 / 1 - μ A /step]
003	Paper Transfer: 1200: 1st Side	*ENG	[0 to 250 / 10 / 1 - μ A /step]
004	Paper Transfer: 1200: 2nd Side	*ENG	[0 to 250 / 12 / 1 - μ A /step]

2411	[Plain: Paper Size Correction]		
	Adjusts the size correction coefficient for the paper transfer roller current for each paper size. SP2403 and SP2407 are multiplied by these SP values. Plain: High speed, Thick 1: Middle speed, Thick 2&Fine: Low speed		
001	Paper Transfer: Plain : 1st Side: S1	*ENG	[100 to 600 / 100 / 5%/step]
002	Paper Transfer: Plain: 2nd Side: S1	*ENG	S1 size > 297 mm (Paper width)

Main SP Tables-2

003	Paper Transfer: 1200: 1st Side: S1	*ENG	
004	Paper Transfer: 1200: 2nd Side: S1	*ENG	
005	Paper Transfer: Plain: 1st Side: S2	*ENG	[100 to 600 / 105 / 5%/step] 297 mm > S2 size > 275 mm (Paper width)
006	Paper Transfer: Plain: 2nd Side: S2	*ENG	[100 to 600 / 120 / 5%/step] 297 mm > S2 size > 275 mm (Paper width)
007	Paper Transfer: 1200: 1st Side: S2	*ENG	[100 to 600 / 120 / 5%/step] 297 mm > S2 size > 275 mm (Paper width)
008	Paper Transfer: 1200: 2nd Side: S2	*ENG	[100 to 600 / 150 / 5%/step]
009	Paper Transfer: Plain: 1st Side: S3	*ENG	[100 to 600 / 110 / 5%/step] 275 mm > S3 size > 210 mm (Paper width)
010	Paper Transfer: Plain: 2nd Side: S3	*ENG	[100 to 600 / 140 / 5%/step] 275 mm > S3 size > 210 mm (Paper width)
011	Paper Transfer: 1200: 1st Side: S3	*ENG	
012	Paper Transfer: 1200: 2nd Side: S3	*ENG	[100 to 600 / 300 / 5%/step]
013	Paper Transfer: Plain: 1st Side: S4	*ENG	[100 to 600 / 115 / 5%/step] 210 mm > S4 size > 148 mm (Paper width)
014	Paper Transfer: Plain: 2nd Side: S4	*ENG	[100 to 600 / 160 / 5%/step] 210 mm > S4 size > 148 mm (Paper width)

015	Paper Transfer: 1200: 1st Side: S4	*ENG	[100 to 600 / 240 / 5%/step] 210 mm > S4 size > 148 mm (Paper width)
016	Paper Transfer: 1200: 2nd Side: S4	*ENG	[100 to 600 / 340 / 5%/step]
017	Paper Transfer: Plain: 1st Side: S5	*ENG	[100 to 600 / 120 / 5%/step] 148 mm > S5 size (Paper width)
018	Paper Transfer: Plain: 2nd Side: S5	*ENG	[100 to 600 / 180 / 5%/step] 148 mm > S5 size (Paper width)
019	Paper Transfer: 1200: 1st Side: S5	*ENG	[100 to 600 / 300 / 5%/step] 148 mm > S5 size (Paper width)
020	Paper Transfer: 1200: 2nd Side: S5	*ENG	[100 to 600 / 400 / 5%/step]

2421	[Plain: Leading Edge Correction] Plain Paper: Leading Edge Correction		
	Adjusts the correction to the paper transfer roller current at the paper leading edge in each mode. SP2403 and SP2407 are multiplied by these SP values. <div style="border: 1px solid black; border-radius: 10px; padding: 2px; display: inline-block;">  Note </div> <ul style="list-style-type: none"> ▪ The paper leading edge area can be adjusted with SP2422. 		
001	Paper Transfer: Plain: 1st Side	*ENG	[0 to 400 / 100 / 5%/step]
002	Paper Transfer: Plain: 2nd Side	*ENG	[0 to 400 / 100 / 5%/step]
003	Paper Transfer: 1200: 1st Side	*ENG	[0 to 400 / 100 / 5%/step]
004	Paper Transfer: 1200: 2nd side	*ENG	
2421	Adjusts the correction to the discharge plate current at the paper leading edge in each mode. SP2401 is multiplied by these SPs values. <div style="border: 1px solid black; border-radius: 10px; padding: 2px; display: inline-block;">  Note </div> <ul style="list-style-type: none"> ▪ The paper leading edge area can be adjusted with SP2422. 		

Main SP Tables-2

005	Separation DC: Plain: 1st Side	*ENG	[0 to 400 / 100 / 5%/step]
006	Separation DC: Plain: 2nd Side	*ENG	
007	Separation DC: 1200: 1st Side	*ENG	
008	Separation DC: 1200: 2nd Side	*ENG	

2422	[Plain: Switch Timing: Lead. Edge]		
	Adjusts the bias/ voltage switch timing of the paper transfer roller/ discharge plate at the paper leading edge between the erase margin area and the image area. Plain: High speed, Thick 1: Middle speed, Thick 2&Fine: Low speed		
001	Paper Transfer: Plain: 1st Side	*ENG	[0 to 50 / 0 / 2 mm/step]
002	Paper Transfer: Plain: 2nd Side	*ENG	
003	Paper Transfer: 1200: 1st Side	*ENG	
004	Paper Transfer: 1200: 2nd side	*ENG	
005	Separation DC: Plain: 1st Side	*ENG	
006	Separation DC: Plain: 2nd Side	*ENG	
007	Separation DC: 1200: 1st Side	*ENG	
008	Separation DC: 1200: 2nd Side	*ENG	

2423	[Plain: Trailing Edge Correction] Plain Paper: Trailing Edge Correction		
	Adjusts the correction coefficient to the paper transfer roller current for the paper trailing edge in each mode. SP2403 and SP2407 are multiplied by these SP values. <div style="border: 1px solid black; border-radius: 10px; padding: 2px; display: inline-block;">  Note </div> <ul style="list-style-type: none"> ▪ The paper trailing edge area can be adjusted with SP2424. 		
001	Paper Transfer: Plain: 1st Side	*ENG	[0 to 400 / 100 / 5%/step]
002	Paper Transfer: Plain: 2nd Side	*ENG	
003	Paper Transfer: 1200: 1st Side	*ENG	
004	Paper Transfer: 1200: 2nd side	*ENG	
005	Separation DC: Plain: 1st Side	*ENG	
006	Separation DC: Plain: 2nd Side	*ENG	
007	Separation DC: 1200: 1st Side	*ENG	
008	Separation DC: 1200: 2nd Side	*ENG	

2424	[Plain: Switch Timing: Trail. Edge]		
	Adjusts the bias/voltage switch timing of the paper transfer roller/discharge plate at the paper trailing edge between the erase margin area and the image area. Plain: High speed, Thick 1: Middle speed, Thick 2&Fine: Low speed		
001	Paper Transfer: Plain: 1st Side	*ENG	[0 to 50 / 0 / 2 mm/step]
002	Paper Transfer: Plain: 2nd Side	*ENG	

Main SP Tables-2

003	Paper Transfer: 1200: 1st Side	*ENG	
004	Paper Transfer: 1200: 2nd side	*ENG	
005	Separation DC: Plain: 1st Side	*ENG	
006	Separation DC: Plain: 2nd Side	*ENG	
007	Separation DC: 1200: 1st Side	*ENG	
008	Separation DC: 1200: 2nd Side	*ENG	

2451	[Thin: Bias]		
	Adjusts the DC voltage of the discharge plate for thin paper. Plain: High speed, Thick 1: Middle speed, Thick 2&Fine: Low speed		
001	Separation DC: Plain: 1st Side	*ENG	[0 to 4000 / 3500 / 10 -V/step]
002	Separation DC: Plain: 2nd Side		
003	Separation DC: 1200: 1st Side	*ENG	
004	Separation DC: 1200: 2nd Side		

2453	[Thin: Bias: BW]		
	Adjusts the current for the paper transfer roller for thin paper in black-and-white mode. Plain: High speed, Thick 1: Middle speed, Thick 2&Fine: Low speed		
001	Paper Transfer: Plain: 1st Side	*ENG	[0 to 250 / 22 / 1 - μ A/step]
002	Paper Transfer: Plain: 2nd Side		
003	Paper Transfer: 1200: 1st Side	*ENG	[0 to 250 / 11 / 1 - μ A/step]
004	Paper Transfer: 1200: 2nd Side		

2457	[Thin: Bias: FC]		
	Adjusts the current for the paper transfer roller for thin paper in full color mode. Plain: High speed, Thick 1: Middle speed, Thick 2&Fine: Low speed		
001	Paper Transfer: Plain: 1st Side	*ENG	[0 to 250 / 30 / 1 - μ A/step]
002	Paper Transfer: Plain: 2nd Side		
003	Paper Transfer: 1200: 1st Side	*ENG	[0 to 250 / 15 / 1 - μ A/step]
004	Paper Transfer: 1200: 2nd Side		

2461	[Thin: Paper Size Correction]		
	Adjusts the size correction coefficient for the paper transfer roller current for each paper size. SP2453 and SP2457 are multiplied by these SP values. Plain: High speed		
001	Paper Transfer: Plain: 1st Side: S1	*ENG	[100 to 600 / 100 / 5%/step] S1 size > 297 mm (Paper width)
002	Paper Transfer: Plain: 2nd Side: S1		
005	Paper Transfer: Plain: 1st Side: S2	*ENG	[100 to 600 / 120 / 5%/step] 297 mm > S2 size > 275 mm (Paper width)
006	Paper Transfer: Plain: 2nd Side: S2		
009	Paper Transfer: Plain: 1st Side: S3	*ENG	[100 to 600 / 140 / 5%/step] 297 mm > S2 size > 275 mm (Paper width)
010	Paper Transfer: Plain: 2nd Side: S3		
013	Paper Transfer: Plain: 1st Side: S4	*ENG	[100 to 600 / 160 / 5%/step] 297 mm > S2 size > 275 mm (Paper width)
014	Paper Transfer: Plain: 2nd Side: S4		

Main SP Tables-2

017	Paper Transfer: 1st Side: S5	*ENG	[100 to 600 / 180 / 5%/step]
018	Paper Transfer: 2nd Side: S5		

2471	[Thin: Leading Edge Correction] Thin Paper: Leading Edge Correction		
	<p>Adjusts the correction to the paper transfer roller current at the paper leading edge in each mode. SP2453 and SP2457 are multiplied by these SP values. Plain: High speed, 1200: Low speed</p> <p>Note</p> <ul style="list-style-type: none"> The paper leading edge area can be adjusted with SP2472. 		

001	Paper Transfer: Plain: 1st Side	*ENG	[0 to 400 / 100 / 5%/step]
002	Paper Transfer: Plain: 2nd Side		
003	Paper Transfer: 1200: 1st Side	*ENG	
004	Paper Transfer: 1200: 2nd Side		

2471	<p>Adjusts the correction to the discharge plate current at the paper leading edge in each mode. SP2451 is multiplied by these SP values.</p> <p>Note</p> <ul style="list-style-type: none"> The paper leading edge area can be adjusted with SP2472. 		
------	---	--	--

005	Separation DC: Plain: 1st Side	*ENG	[0 to 400 / 100 / 5%/step]
006	Separation DC: Plain: 2nd Side		
007	Separation DC: 1200: 1st Side	*ENG	
008	Separation DC: 1200: 2nd Side		

2472	[Thin: Switch Timing: Lead. Edge]		
	<p>Adjusts the bias/ voltage switch timing of the paper transfer roller/ discharge plate at the paper leading edge between the erase margin area and the image area. Plain: High speed, 1200: Low speed,</p>		
001	Paper Transfer: Plain: 1st Side	*ENG	[0 to 50 / 0 / 2 mm/step]
002	Paper Transfer: Plain: 2nd Side		

003	Paper Transfer: 1200: 1st Side	*ENG	
004	Paper Transfer: 1200: 2nd Side		
005	Separation DC: Plain: 1st Side	*ENG	
006	Separation DC: Plain: 2nd Side		
007	Separation DC: 1200: 1st Side	*ENG	
008	Separation DC: 1200: 2nd Side		

2473	[Thin: Trailing Edge Correction] Thin Paper: Trailing Edge Correction		
	<p>Adjusts the correction coefficient to the paper transfer roller current for the paper trailing edge in each mode. SP2453 and SP2457 are multiplied by these SP values.</p> <p>Plain: High speed, 1200: Low speed</p> <p> Note</p> <ul style="list-style-type: none"> The paper trailing edge area can be adjusted with SP2474. 		
001	Paper Transfer: Plain: 1st Side	*ENG	[0 to 400 / 100 / 5%/step]
002	Paper Transfer: Plain: 2nd Side		
003	Paper Transfer: 1200: 1st Side	*ENG	[0 to 400 / 100 / 5%/step]
004	Paper Transfer: 1200: 2nd Side		
005	Separation DC: Plain: 1st Side	*ENG	[0 to 400 / 100 / 5%/step]
006	Separation DC: Plain: 2nd Side		
007	Separation DC: 1200: 1st Side	*ENG	[0 to 400 / 100 / 5%/step]
008	Separation DC: 1200: 2nd Side		

2474	[Thin: Switch Timing: Trail. Edge]		
	Adjusts the bias/voltage switch timing of the paper transfer roller/discharge plate at the paper trailing edge between the erase margin area and the image area. Plain: High speed, 1200: Low speed		
001	Paper Transfer: Plain: 1st Side	*ENG	[0 to 50 / 0 / 2 mm/step]
002	Paper Transfer: Plain: 2nd Side		
003	Paper Transfer: 1200: 1st Side	*ENG	
004	Paper Transfer: 1200: 2nd Side		
005	Separation DC: Plain: 1st Side	*ENG	[0 to 50 / 0 / 1 mm/step]
006	Separation DC: Plain: 2nd Side		
007	Separation DC: 1200: 1st Side	*ENG	
008	Separation DC: 1200: 2nd Side		

2480	[Thin: Environment Correction]		
	Plain: High speed, 1200: Low speed		
001	Separation DC: Plain: 1st Side	*ENG	[1 to 60 / 26 / 1 /step]
002	Separation DC: Plain: 2nd Side		
003	Paper Transfer: Plain: BW: 1st Side	*ENG	[1 to 60 / 11 / 1 /step]
004	Paper Transfer: Plain: BW: 2nd Side		
005	Paper Transfer: Plain: FC: 1st Side	*ENG	[1 to 60 / 1 / 1 /step]

006	Paper Transfer: Plain: FC: 2nd Side		
007	Separation DC: 1200: 1st Side	*ENG	[1 to 60 / 26 / 1 /step]
008	Separation DC: 1200: 2nd Side		
009	Paper Transfer: 1200: BW: 1st Side	*ENG	[1 to 60 / 11 / 1 /step]
010	Paper Transfer: 1200: BW: 2nd Side		
011	Paper Transfer: 1200: FC: 1st Side	*ENG	[1 to 60 / 1 / 1 /step]
012	Paper Transfer: 1200: FC: 2nd Side		

2481	[Glossy: Bias]		
001	Separation DC: 1st Side	*ENG	[0 to 4000 / 3500 / 10 -V/step]
	Adjusts the DC voltage of the discharge plate for glossy paper.		

2482	[Glossy: Bias: BW]		
001	Paper Transfer: 1st Side	*ENG	[0 to 250 / 12 / 1 - μ A/step]
	Adjusts the current for the paper transfer roller for glossy paper in black-and-white mode.		

2483	[Glossy: Bias: FC]		
001	Paper Transfer: 1st Side	*ENG	[0 to 250 / 15 / 1 - μ A/step]
	Adjusts the current for the paper transfer roller for glossy paper in full color mode.		

Main SP Tables-2

2484	[Glossy: Paper Size Correction]		
001	Paper Transfer: 1st Side: S1	*ENG	[100 to 600 / 100 / 5%/step]
005	Paper Transfer: 1st Side: S2	*ENG	[100 to 600 / 120 / 5%/step]
009	Paper Transfer: 1st Side: S3	*ENG	[100 to 600 / 140 / 5%/step]
013	Paper Transfer: 1st Side: S4	*ENG	[100 to 600 / 160 / 5%/step]
017	Paper Transfer: 1st Side: S5	*ENG	[100 to 600 / 180 / 5%/step]

2485	[Plain: Leading Edge Correction]		
001	Paper Transfer: 1st Side	*ENG	[10 to 400 / 100 / 5%/step]
005	Separation DC: 1st Side	*ENG	[10 to 400 / 100 / 5%/step]]

2486	[Plain: Switch Timing: Lead. Edge]		
001	Paper Transfer: 1st Side	*ENG	[0 to 50 / 0 / 2 mm/step]
005	Separation DC: 1st Side	*ENG	

2487	[Plain: Trailing Edge Correction]		
001	Paper Transfer: 1st Side	*ENG	[0 to 400 / 100 / 5 %/step]
005	Separation DC: 1st Side	*ENG	

2488	[Plain:SwitchTiming:Trail. Edge]		
001	Paper Transfer: 1st Side	*ENG	[0 to 50 / 0 / 2 mm/step]
005	Separation DC: 1st Side	*ENG	

2489	[Glossy: Environment Correction]		
001	Separation DC: 1st Side	*ENG	[1 to 60 / 26 / 1 /step]
003	Paper Transfer: BW: 1st Side	*ENG	[1 to 60 / 11 / 1 /step]
005	Paper Transfer: FC: 1st Side	*ENG	[1 to 60 / 1 / 1 /step]

2501	[Thick 1: Bias]		
	Adjusts the DC voltage of the discharge plate for thick 1 paper. Plain: High speed, 1200: Low speed		
001	Separation DC: Plain: 1st Side	*ENG	[0 to 4000 / 3500 / 10 -V/step]
002	Separation DC: Plain: 2nd Side	*ENG	
003	Separation DC: 1200: 1st Side	*ENG	

2502	[Thick 1: Bias: BW]		
	Adjusts the current for the paper transfer roller for thick 1 paper in black-and-white mode. Plain: High speed, 1200: Low speed		
001	Paper Transfer: Plain: 1st Side	*ENG	[0 to 250 / 12 / 1 - μ A/step]
002	Paper Transfer: Plain: 2nd Side	*ENG	
003	Separation DC: 1200: 1st Side	*ENG	[0 to 250 / 12 / 1 - μ A/step]

2507	[Thick 1: Bias: FC]		
	Adjusts the current for the paper transfer roller for thick 1 paper in full color mode. Plain: High speed, 1200: Low speed		
001	Paper Transfer: Plain: 1st Side	*ENG	[0 to 250 / 15 / 1 - μ A /step]
002	Paper Transfer: Plain: 2nd Side	*ENG	
003	Separation DC: 1200: 1st Side	*ENG	[0 to 250 / 15 / 1 - μ A /step]

2511	[Thick 1: Paper Size Correction]		
	Adjusts the size correction coefficient for the paper transfer roller current for each paper size. SP2502 and SP2507 are multiplied by these SP values. Plain: High speed, 1200: Low speed		
001	Paper Transfer: Plain: 1st Side: S1	*ENG	[100 to 600 / 100 / 5%/step] S1 size > 297 mm (Paper width)
002	Paper Transfer: Plain: 2nd Side: S1	*ENG	
003	Paper Transfer: 1200: 1st Side: S1	*ENG	[100 to 600 / 100 / 5%/step] S1 size > 297 mm (Paper width)
005	Paper Transfer: Plain: 1st Side: S2	*ENG	[100 to 600 / 105 / 5%/step] 297 mm > S2 size > 275 mm (Paper width)
006	Paper Transfer: Plain: 2nd Side: S2	*ENG	[100 to 600 / 130 / 5%/step] 297 mm > S2 size > 275 mm (Paper width)
007	Paper Transfer: 1200: 1st Side: S2	*ENG	[100 to 600 / 120 / 5%/step] 297 mm > S2 size > 275 mm (Paper width)
009	Paper Transfer: Plain: 1st Side: S3	*ENG	[100 to 600 / 110 / 5%/step] 275 mm > S3 size > 210 mm (Paper width)

010	Paper Transfer: Plain: 2nd Side: S3	*ENG	[100 to 600 / 160 / 5%/step] 275 mm > S3 size > 210 mm (Paper width)
011	Paper Transfer: 1200: 1st Side: S3	*ENG	[100 to 600 / 140 / 5%/step] 275 mm > S3 size > 210 mm (Paper width)
013	Paper Transfer: Plain 1: 1st Side: S4	*ENG	[100 to 600 / 115 / 5%/step] 210 mm > S4 size > 148 mm (Paper width)
014	Paper Transfer: Plain: 2nd Side: S4	*ENG	[100 to 600 / 190 / 5%/step] 210 mm > S4 size > 148 mm (Paper width)
015	Paper Transfer: 1200: 1st Side: S4	*ENG	[100 to 600 / 160 / 5%/step] 210 mm > S4 size > 148 mm (Paper width)
017	Paper Transfer: Plain 1: 1st Side: S5	*ENG	[100 to 600 / 120 / 5%/step] 148 mm > S5 size (Paper width)
018	Paper Transfer: Plain: 2nd Side: S5	*ENG	[100 to 600 / 220 / 5%/step] 148 mm > S5 size (Paper width)
019	Paper Transfer: 1200: 1st Side: S5	*ENG	[100 to 600 / 180 / 5%/step] 148 mm > S5 size (Paper width)

2521	[Thick 1: Leading Edge Correction] Thick 1 Paper: Leading Edge Correction		
	Adjusts the correction to the paper transfer roller current at the paper leading edge in each mode. SP2502 and SP2507 are multiplied by these SP values. Plain: High speed, 1200: Low speed		
	<div style="border: 1px solid black; border-radius: 10px; padding: 2px; display: inline-block;">  Note </div> <ul style="list-style-type: none"> ▪ The paper leading edge area can be adjusted with SP2522. 		
	001	Paper Transfer: Plain: 1st Side	*ENG
002	Paper Transfer: Plain: 2nd Side	*ENG	[0 to 400 / 100 / 5%/step]
003	Paper Transfer: 1200: 1st Side	*ENG	[0 to 400 / 100 / 5%/step]

Main SP Tables-2

005	Separation DC: Plain: 1st Side	*ENG	[0 to 400 / 100 / 5%/step]
006	Separation DC: Plain: 2nd Side	*ENG	
007	Separation DC: 1200: 1st Side	*ENG	[0 to 400 / 100 / 5%/step]

2522	[Thick 1: Switch Timing: Lead. Edge]		
	Adjusts the bias/ voltage switch timing of the paper transfer roller/ discharge plate at the paper leading edge between the erase margin area and the image area. Plain: High speed, 1200: Low speed		
001	Paper Transfer: Plain 1: 1st Side	*ENG	[0 to 50 / 0 / 2 mm/step]
002	Paper Transfer: Plain: 2nd Side	*ENG	
003	Paper Transfer: 1200: 1st Side	*ENG	
005	Separation DC: Plain 1: 1st Side	*ENG	[0 to 50 / 0 / 2 mm/step]
006	Separation DC: Plain 1: 2nd Side	*ENG	
007	Separation DC: 1200: 1st Side	*ENG	

2523	[Thick 1: Trail. Edge Correction] Thick 1 Paper: Trailing Edge Correction		
	Adjusts the correction coefficient to the paper transfer roller current for the paper trailing edge in each mode. SP2502 and SP2507 are multiplied by these SP values. Plain: High speed, 1200: Low speed  Note <ul style="list-style-type: none"> ▪ The paper trailing edge area can be adjusted with SP2524. 		
001	Paper Transfer: Plain: 1st Side	*ENG	[0 to 400 / 100 / 5%/step]
002	Paper Transfer: Plain: 2nd Side	*ENG	
003	Paper Transfer: 1200: 1st Side	*ENG	

005	Separation DC: Plain: 1st Side	*ENG	
006	Separation DC: Plain: 2nd Side	*ENG	[0 to 400 / 100 / 5%/step]
007	Separation DC: 1200: 1st Side	*ENG	

2524	[Thick 1: Sw Timing: Trail. Edge]		
	Adjusts the bias/voltage switch timing of the paper transfer roller/discharge plate at the paper trailing edge between the erase margin area and the image area. Plain: High speed, 1200: Low speed		
001	Paper Transfer: Plain: 1st Side	*ENG	[0 to 50 / 0 / 1 mm/step]
002	Paper Transfer: Plain: 2nd Side	*ENG	
003	Paper Transfer: 1200: 1st Side	*ENG	
005	Separation DC: Plain: 1st Side	*ENG	
006	Separation DC: Plain: 2nd Side	*ENG	
007	Separation DC: 1200: 1st Side	*ENG	

2530	[Thick 1: Environment Correction]		
	Plain: High speed, 1200: Low speed		
001	Separation DC: Plain: 1st Side	*ENG	[1 to 60 / 22 / 1 /step]
002	Separation DC: Plain: 2nd Side	*ENG	
003	Paper Transfer: Plain: BW: 1st Side	*ENG	[1 to 60 / 11 / 1 /step]
004	Paper Transfer: Plain: BW:2nd Side	*ENG	
005	Paper Transfer: Plain: FC: 1st Side	*ENG	[1 to 60 / 1 / 1 /step]
006	Paper Transfer: Plain: FC:2nd Side	*ENG	[1 to 60 / 11 / 1 /step]
007	Separation DC: 1200: 1st Side	*ENG	[1 to 60 / 22 / 1 /step]
009	Paper Transfer: 1200: BW: 1st Side	*ENG	[1 to 60 / 11 / 1 /step]
011	Paper Transfer: 1200: FC: 1st Side	*ENG	[1 to 60 / 1 / 1 /step]

2551	[Thick 2: Bias]		
	Adjusts the DC voltage of the discharge plate for thick 2 paper.		
001	Separation DC: 1st Side	*ENG	[0 to 4000 / 3500 / 10 –V/step]
002	Separation DC: 2nd Side	*ENG	

2553	[Thick 2: Bias: BW]		
	Adjusts the current for the paper transfer roller for thick 2 paper in black-and-white mode.		
001	Paper Transfer: 1st Side	*ENG	[0 to 250 / 7 / 1 – μ A /step]
002	Paper Transfer: 2nd Side	*ENG	[0 to 250 / 12 / 1 – μ A /step]

2558	[Thick 2: Bias: FC]		
	Adjusts the current for the paper transfer roller for thick 2 paper in full color mode.		
001	Paper Transfer: 1st Side	*ENG	[0 to 250 / 16 / 1 – μ A /step]
002	Paper Transfer: 2nd Side	*ENG	[0 to 250 / 15 / 1 – μ A /step]

2561	[Thick 2: Paper Size Correction]		
	Adjusts the size correction coefficient for the paper transfer roller current for each paper size. SP2553 and SP2558 are multiplied by these SP values.		
001	Paper Transfer: 1st Side: S1	*ENG	[100 to 600 / 100 / 5%/step] S1 size > 297 mm (Paper width)
002	Paper Transfer: 2nd Side: S1	*ENG	
003	Paper Transfer: 1st Side: S2	*ENG	[100 to 600 / 105 / 5%/step] 297 mm > S2 size > 275 mm (Paper width)
004	Paper Transfer: 2nd Side: S2	*ENG	[100 to 600 / 160 / 5%/step] 297 mm > S2 size > 275 mm (Paper width)

005	Paper Transfer: 1st Side: S3	*ENG	[100 to 600 / 110 / 5%/step] 275 mm > S3 size > 210 mm (Paper width)
006	Paper Transfer: 2nd Side: S3	*ENG	[100 to 600 / 260 / 5%/step] 275 mm > S3 size > 210 mm (Paper width)
007	Paper Transfer: 1st Side: S4	*ENG	[100 to 600 / 120 / 5%/step] 210 mm > S4 size > 148 mm (Paper width)
008	Paper Transfer: 2nd Side: S4	*ENG	[100 to 600 / 430 / 5%/step] 210 mm > S4 size > 148 mm (Paper width)
009	Paper Transfer: 1st Side: S5	*ENG	[100 to 600 / 140 / 5%/step] 148 mm > S5 size (Paper width)
010	Paper Transfer: 2nd Side: S5	*ENG	[100 to 600 / 600 / 5%/step] 148 mm > S5 size (Paper width)

2571	[Thick 2: Leading Edge Correction] Thick 2 Paper: Leading Edge Correction		
	Adjusts the correction to the paper transfer roller current at the paper leading edge in each mode. SP2553 and SP2558 are multiplied by these SP values. <div style="border: 1px solid black; border-radius: 10px; padding: 2px; display: inline-block;"> ⬇ Note </div> <ul style="list-style-type: none"> ▪ The paper leading edge area can be adjusted with SP2572. 		
001	Paper Transfer: 1st Side	*ENG	[0 to 400 / 100 / 5%/step]
002	Paper Transfer: 2nd Side	*ENG	

2571	Adjusts the correction to the discharge plate current at the paper leading edge in each mode. SP2551 is multiplied by these SP values.  Note <ul style="list-style-type: none"> The paper leading edge area can be adjusted with SP2572. 		
003	Separation DC: 1st Side	*ENG	[0 to 400 / 100 / 5%/step]
004	Separation DC: 2nd Side	*ENG	

2572	[Thick 2: Sw Timing: Lead. Edge]		
	Adjusts the bias/ voltage switch timing of the paper transfer roller/ discharge plate at the paper leading edge between the erase margin area and the image area.		
001	Paper Transfer: 1st Side	*ENG	[0 to 50 / 0 / 2mm/step]
002	Paper Transfer: 2nd Side	*ENG	
003	Separation DC: 1st Side	*ENG	
004	Separation DC: 2nd Side	*ENG	

2573	[Thick 2: Trail. Edge Correction] Thick 2 Paper: Trailing Edge Correction		
	Adjusts the correction to the paper transfer roller current for the paper trailing edge in each mode. SP2553 and SP2558 are multiplied by these SP values.  Note <ul style="list-style-type: none"> The paper trailing edge area can be adjusted with SP2574. 		
001	Paper Transfer: 1st Side	*ENG	[0 to 400 / 100 / 5%/step]
002	Paper Transfer: 2nd Side	*ENG	
003	Separation DC: 1st Side	*ENG	[0 to 400 / 100 / 5%/step]
004	Separation DC: 2nd Side	*ENG	[0 to 400 / 100 / 5%/step]

2574	[Thick 2: Trail. Edge Correction]		
	Adjusts the bias/voltage switch timing of the paper transfer roller/discharge plate at the paper trailing edge between the erase margin area and the image area.		
001	Paper Transfer: 1st Side	*ENG	[0 to 50 / 0 / 2 mm/step]
002	Paper Transfer: 2nd Side	*ENG	
003	Separation DC: 1st Side	*ENG	
004	Separation DC: 2nd Side	*ENG	

2580	[Thick 2 Environment Correction]		
001	Separation DC: 1st Side	*ENG	[1 to 60 / 22 / 1 /step]
002	Separation DC: 2nd Side	*ENG	
003	Paper Transfer: BW: 1st Side	*ENG	[0 to 60 / 11 / 1 /step]
004	Paper Transfer: BW: 2nd Side	*ENG	
005	Paper Transfer: FC: 1st Side	*ENG	[1 to 60 / 53 / 1 /step]
006	Paper Transfer: FC: 2nd Side	*ENG	[1 to 60 / 11 / 1 /step]

2601	[OHP: Bias]		
	Adjusts the DC voltage of the discharge plate for OHP.		
001	Separation DC	*ENG	[0 to 4000 / 3500 / 10 -V/step]

2603	[OHP: Bias: BW]		
	Adjusts the current for the paper transfer roller for OHP in black-and-white mode.		
001	Paper Transfer	*ENG	[0 to 250 / 12 / 1 - μ A /step]

2608	[OHP: Bias: FC]		
	Adjusts the current for the paper transfer roller for OHP in full color mode.		
001	Paper Transfer	*ENG	[0 to 250 / 15 / 1 -µA /step]

2611	[OHP: Paper Size Correction]		
	Adjusts the size correction coefficient for the paper transfer roller current for each paper size. SP2603 and SP2608 are multiplied by these SP values.		
001	Paper Transfer: S1	*ENG	[100 to 600 / 100 / 5%/step] S1 size > 297 mm (Paper width)
002	Paper Transfer: S2	*ENG	[100 to 600 / 140 / 5%/step] 297 mm > S2 size > 275 mm (Paper width)
003	Paper Transfer: S3	*ENG	[100 to 600 / 200 / 5%/step] 275 mm > S3 size > 210 mm (Paper width)
004	Paper Transfer: S4	*ENG	[100 to 600 / 260 / 5%/step] 210 mm > S4 size > 148 mm (Paper width)
005	Paper Transfer: S5	*ENG	[100 to 600 / 330 / 5%/step] 148 mm > S5 size (Paper width)

2621	[OHP: Leading Edge Correction]		
	Adjusts the correction to the paper transfer roller current at the paper leading edge in each mode. SP2603 and SP2608 are multiplied by these SP values.		
<p> Note</p> <ul style="list-style-type: none"> ▪ The paper leading edge area can be adjusted with SP2622. 			
001	Paper Transfer	*ENG	[0 to 400 / 100 / 5%/step]

2621	Adjusts the correction to the discharge plate current at the paper leading edge in each mode. SP2601 is multiplied by these SP values. <div style="border: 1px solid black; border-radius: 10px; padding: 2px; display: inline-block;">  Note </div> <ul style="list-style-type: none"> ▪ The paper leading edge area can be adjusted with SP2622. 		
002	Separation DC	*ENG	[0 to 400 / 100 / 5%/step]

2622	[OHP: Switch Timing: Leading Edge]		
	Adjusts the bias/ voltage switch timing of the paper transfer roller/ discharge plate at the paper leading edge between the erase margin area and the image area.		
001	Paper Transfer	*ENG	[0 to 50 / 0 / 2 mm/step]
002	Separation DC	*ENG	

2623	[OHP: Trailing Edge Correction]		
	Adjusts the correction to the paper transfer roller current for the paper trailing edge in each mode. SP2603 and SP2608 are multiplied by these SP values. <div style="border: 1px solid black; border-radius: 10px; padding: 2px; display: inline-block;">  Note </div> <ul style="list-style-type: none"> ▪ The paper trailing edge area can be adjusted with SP2624. 		
001	Paper Transfer	*ENG	[0 to 400 / 100 / 5%/step]
002	Separation DC	*ENG	

2624	[OHP: Trailing Edge Correction]		
	Adjusts the bias/voltage switch timing of the paper transfer roller/discharge plate at the paper trailing edge between the erase margin area and the image area.		
001	Paper Transfer	*ENG	[0 to 50 / 0 / 1 mm/step]
002	Separation DC	*ENG	[0 to 50 / 0 / 2 mm/step]

Main SP Tables-2

2630	[OHP: Environment Correction]		
001	Separation DC	*ENG	[1 to 60 / 22 / 1 /step]
002	Paper Transfer: BW	*ENG	[1 to 60 / 11 / 1 /step]
003	Paper Transfer: FC	*ENG	[1 to 60 / 1 / 1 /step]



2650	[Thick3: Bias]		
	Adjusts the DC voltage of the discharge plate for thick paper 3.		
001	Separation DC: 1st Side	*ENG	[0 to 3500 / 0 / 10 -V/step]
002	Separation DC: 2nd Side	*ENG	

2651	[Thick3: Bias: BW]		
	Adjusts the current for the paper transfer roller for thick paper 3 in black-and-white mode.		
001	Paper Transfer: 1st Side	*ENG	[0 to 250 / 10 / 1 -μA /step]
002	Paper Transfer: 2nd Side	*ENG	[0 to 250 / 12 / 1 -μA /step]

2652	[Thick3: Bias: FC]		
	Adjusts the current for the paper transfer roller for thick paper 3 in full color mode.		
001	Paper Transfer: 1st Side	*ENG	[0 to 250 / 11 / 1 -μA /step]
002	Paper Transfer: 2nd Side	*ENG	[0 to 250 / 15 / 1 -μA /step]

2653	[Thick3: Paper Size Correction]		
	Adjusts the size correction coefficient for the paper transfer roller current for each paper size. SP2651 and SP2652 are multiplied by these SP values.		

001	Paper Transfer: 1st Side: S1	*ENG	[100 to 600 / 100 / 5%/step] S1 size > 297 mm (Paper width)
002	Paper Transfer: 1st Side: S2	*ENG	[100 to 600 / 100 / 5%/step] 297 mm > S2 size > 275 mm (Paper width)
003	Paper Transfer: 1st Side: S3	*ENG	[100 to 600 / 100 / 5%/step] 275 mm > S3 size > 210 mm (Paper width)
004	Paper Transfer: 1st Side: S4	*ENG	[100 to 600 / 160 / 5%/step] 210 mm > S4 size > 148 mm (Paper width)
005	Paper Transfer: 1st Side: S5	*ENG	[100 to 600 / 100 / 5%/step] 148 mm > S5 size (Paper width)
006	Paper Transfer: 2nd Side: S1	*ENG	[100 to 600 / 260 / 5%/step] S1 size > 297 mm (Paper width)
007	Paper Transfer: 2nd Side: S2	*ENG	[100 to 600 / 100 / 5%/step] 297 mm > S2 size > 275 mm (Paper width)
008	Paper Transfer: 2nd Side: S3	*ENG	[100 to 600 / 430 / 5%/step] 275 mm > S3 size > 210 mm (Paper width)
009	Paper Transfer: 2nd Side: S4	*ENG	[100 to 600 / 100 / 5%/step] 210 mm > S4 size > 148 mm (Paper width)
010	Paper Transfer: 2nd Side: S5	*ENG	[100 to 600 / 600 / 5%/step] 148 mm > S5 size (Paper width)

2654	[Thick 3: Leading Edge Correction] Thick 3 Paper: Leading Edge Correction		
	Adjusts the correction to the paper transfer roller current at the paper leading edge in each mode. SP2651 and SP2652 are multiplied by these SP values. <div style="border: 1px solid black; border-radius: 10px; padding: 2px; display: inline-block;">  Note </div> <ul style="list-style-type: none"> ▪ The paper leading edge area can be adjusted with SP2655. 		
001	Paper Transfer: 1st Side	*ENG	[0 to 400 / 100 / 5%/step]
002	Separation DC: 1st Side	*ENG	
2654	Adjusts the correction to the discharge plate current at the paper leading edge in each mode. SP2650 is multiplied by these SP values. <div style="border: 1px solid black; border-radius: 10px; padding: 2px; display: inline-block;">  Note </div> <ul style="list-style-type: none"> ▪ The paper leading edge area can be adjusted with SP2655. 		
	003	Paper Transfer: 2nd Side	*ENG
004	Separation DC: 2nd Side	*ENG	

2655	[Thick 3: Sw Timing: Lead. Edge]		
	Adjusts the bias/ voltage switch timing of the paper transfer roller/ discharge plate at the paper leading edge between the erase margin area and the image area.		
001	Paper Transfer: 1st Side	*ENG	[0 to 50 / 0 / 2 mm/step]
002	Separation DC: 1st Side	*ENG	
003	Paper Transfer: 2nd Side	*ENG	
004	Separation DC: 2nd Side	*ENG	

2656	[Thick 3: Trail. Edge Correction] Thick 3 Paper: Trailing Edge Correction		
	Adjusts the correction to the paper transfer roller current for the paper trailing edge in each mode. SP2651 and SP2652 are multiplied by these SP values. <div style="border: 1px solid black; border-radius: 10px; padding: 2px; display: inline-block;">  Note </div> <ul style="list-style-type: none"> ▪ The paper trailing edge area can be adjusted with SP2657. 		
001	Paper Transfer: 1st Side	*ENG	[0 to 400 / 100 / 5%/step]

002	Paper Transfer: 2nd Side	*ENG	
003	Separation DC: 1st Side	*ENG	
004	Separation DC: 2nd Side	*ENG	

2657	[Thick 3: Trail. Edge Correction]		
	Adjusts the bias/voltage switch timing of the paper transfer roller/discharge plate at the paper trailing edge between the erase margin area and the image area.		
001	Paper Transfer: 1st Side	*ENG	[0 to 50 / 0 / 2 mm/step]
002	Paper Transfer: 2nd Side	*ENG	
003	Separation DC: 1st Side	*ENG	
004	Separation DC: 2nd Side	*ENG	

2660	[Thick 3: Environment Correction] Thick 3 Paper: MM Environment Coefficient Adjustment		
	Adjusts the environment coefficient for each mode. When the environment is detected as MM, SP2651 and SP2652 are multiplied by these SP values.		
001	Separation DC: 1st Side	*ENG	[1 to 60 / 22 / 1 /step]
002	Separation DC: 2nd Side	*ENG	
	Adjusts the environment coefficient for each mode. When the environment is detected as MM, SP2650 is multiplied by these SP values.		
003	Paper Transfer: BW: 1st Side	*ENG	[1 to 60 / 11 / 1 /step]
004	Paper Transfer: BW: 2nd Side	*ENG	
005	Paper Transfer: FC: 1st Side	*ENG	[1 to 60 / 55 / 1 /step]
006	Paper Transfer: FC: 2nd Side	*ENG	[1 to 60 / 11 / 1 /step]

Main SP Tables-2

2670	[Thick4: Bias]		
	Adjusts the DC voltage of the discharge plate for thick paper 4.		
001	Separation DC: 1st Side	*ENG	[0 to 4000 / 3500 / 10 -V/step]
002	Separation DC: 2nd Side	*ENG	

2671	[Thick4: Bias: BW]		
	Adjusts the current for the paper transfer roller for thick paper 4 in black-and-white mode.		
001	Paper Transfer: 1st Side	*ENG	[0 to 250 / 10 / 1 - μ A /step]
002	Paper Transfer: 2nd Side	*ENG	[0 to 250 / 12 / 1 - μ A /step]

2672	[Thick4: Bias: FC]		
	Adjusts the current for the paper transfer roller for thick paper 4 in full color mode.		
001	Paper Transfer: 1st Side	*ENG	[0 to 250 / 11 / 1 - μ A /step]
002	Paper Transfer: 2nd Side	*ENG	[0 to 250 / 15 / 1 - μ A /step]

2673	[Thick4: Paper Size Correction]		
	Adjusts the size correction coefficient for the paper transfer roller current for each paper size. SP2671 and SP2672 are multiplied by these SP values.		
001	Paper Transfer: 1st Side: S1	*ENG	[100 to 600 / 100 / 5%/step] S1 size > 297 mm (Paper width)
002	Paper Transfer: 2nd Side: S1	*ENG	[100 to 600 / 100 / 5%/step] 297 mm > S2 size > 275 mm (Paper width)

003	Paper Transfer: 1st Side: S2	*ENG	[100 to 600 / 100 / 5%/step] 275 mm > S3 size > 210 mm (Paper width)
004	Paper Transfer: 2nd Side: S2	*ENG	[100 to 600 / 160 / 5%/step] 210 mm > S4 size > 148 mm (Paper width)
005	Paper Transfer: 1st Side: S3	*ENG	[100 to 600 / 100 / 5%/step] 148 mm > S5 size (Paper width)
006	Paper Transfer: 2nd Side: S3	*ENG	[100 to 600 / 260 / 5%/step] S1 size > 297 mm (Paper width)
007	Paper Transfer: 1st Side: S4	*ENG	[100 to 600 / 100 / 5%/step] 297 mm > S2 size > 275 mm (Paper width)
008	Paper Transfer: 2nd Side: S4	*ENG	[100 to 600 / 430 / 5%/step] 275 mm > S3 size > 210 mm (Paper width)
009	Paper Transfer: 1st Side: S5	*ENG	[100 to 600 / 100 / 5%/step] 210 mm > S4 size > 148 mm (Paper width)
010	Paper Transfer: 2nd Side: S5	*ENG	[100 to 600 / 600 / 5%/step] 148 mm > S5 size (Paper width)

2674	[Thick 4: Leading Edge Correction] Thick 4 Paper: Leading Edge Correction		
	Adjusts the correction to the paper transfer roller current at the paper leading edge in each mode. SP2671 and SP2672 are multiplied by these SP values.		
	<div style="border: 1px solid black; border-radius: 10px; padding: 2px; display: inline-block;">  Note </div> <ul style="list-style-type: none"> ▪ The paper leading edge area can be adjusted with SP2675. 		
001	Paper Transfer: 1st Side	*ENG	[0 to 400 / 100 / 5%/step]
002	Separation DC: 1st Side	*ENG	

Main SP Tables-2

2674	Adjusts the correction to the discharge plate current at the paper leading edge in each mode. SP2670 is multiplied by these SP values.  Note <ul style="list-style-type: none"> The paper leading edge area can be adjusted with SP2655. 		
003	Paper Transfer: 2nd Side	*ENG	[0 to 400 / 100 / 5%/step]
004	Separation DC: 2nd Side	*ENG	

2675	[Thick 4: Sw Timing: Lead. Edge]		
	Adjusts the bias/ voltage switch timing of the paper transfer roller/ discharge plate at the paper leading edge between the erase margin area and the image area.		
001	Paper Transfer: 1st Side	*ENG	[0 to 50 / 0 / 2 mm/step]
002	Separation DC: 1st Side	*ENG	
003	Paper Transfer: 2nd Side	*ENG	
004	Separation DC: 2nd Side	*ENG	

2676	[Thick 4: Trail. Edge Correction] Thick 4 Paper: Trailing Edge Correction		
	Adjusts the correction to the paper transfer roller current for the paper trailing edge in each mode. SP2671 and SP2672 are multiplied by these SP values.  Note <ul style="list-style-type: none"> The paper trailing edge area can be adjusted with SP2677. 		
001	Paper Transfer: 1st Side	*ENG	[0 to 400 / 100 / 5%/step]
002	Paper Transfer: 2nd Side	*ENG	
003	Separation DC: 1st Side	*ENG	
004	Separation DC: 2nd Side	*ENG	

2677	[Thick 4: Sw Timing: Trail. Edge]		
	Adjusts the bias/voltage switch timing of the paper transfer roller/discharge plate at the paper trailing edge between the erase margin area and the image area.		
001	Paper Transfer: 1st Side	*ENG	[0 to 50 / 0 / 2 mm/step]
002	Paper Transfer: 2nd Side	*ENG	
003	Separation DC: 1st Side	*ENG	
004	Separation DC: 2nd Side	*ENG	

2680	[Thick 4: Environment Correction] Thick 4 Paper: MM Environment Coefficient Adjustment		
	Adjusts the environment coefficient for each mode. When the environment is detected as MM, SP2671 and SP2672 are multiplied by these SP values.		
001	Separation DC: 1st Side	*ENG	[1 to 60 / 22 / 1 /step]
002	Separation DC: 2nd Side	*ENG	
2680	Adjusts the environment coefficient for each mode. When the environment is detected as MM, SP2670 is multiplied by these SP values.		
003	Paper Transfer: BW: 1st Side	*ENG	[1 to 60 / 11 / 1 /step]
004	Paper Transfer: BW: 2nd Side:	*ENG	
005	Paper Transfer: FC: 1st Side	*ENG	[1 to 60 / 55 / 1 /step]
006	Paper Transfer: FC: 2nd Side	*ENG	[1 to 60 / 11 / 1 /step]

2751	[Special1: Bias]		
	Adjusts the DC voltage of the discharge plate for special paper 1. Plain: High speed, Thick 1: Middle speed		
001	Separation DC: Plain: 1st Side	*ENG	[0 to 4000 / 3500 / 10 -V/step]
002	Separation DC: Plain: 2nd Side	*ENG	
003	Paper Transfer: Thick 1: 1st Side	*ENG	

2753	[Special1: Bias: BW]		
	Adjusts the current for the paper transfer roller for special paper 1 in black-and-white mode. Plain: High speed		
001	Paper Transfer: Plain: 1st Side	*ENG	[0 to 250 / 22 / 1 - μ A/step]
002	Paper Transfer: Plain: 2nd Side	*ENG	
003	Paper Transfer: Plain: 1st Side	*ENG	[0 to 250 / 11 / 1 - μ A/step]

2757	[Special1: Bias: FC]		
	Adjusts the current for the paper transfer roller for special paper 1 in full color mode. Plain: High speed, Fine: Low speed		
001	Paper Transfer: Plain: 1st Side	*ENG	[0 to 250 / 30 / 1 - μ A/step]
002	Paper Transfer: Plain: 2nd Side	*ENG	[0 to 250 / 33 / 1 - μ A/step]
003	Paper Transfer: Plain: 1st Side	*ENG	[0 to 250 / 15 / 1 - μ A/step]

2761	[Special1: Paper Size Correction]		
	Adjusts the size correction coefficient for the paper transfer roller current for each paper size. SP2753 and SP2757 are multiplied by these SP values.		
001	Paper Transfer: 1st Side: S1	*ENG	[100 to 600 / 100 / 5%/step]
002	Paper Transfer: 2nd Side: S1	*ENG	S1 size > 297 mm (Paper width)
005	Paper Transfer: 1st Side: S2	*ENG	[100 to 600 / 120 / 5%/step]
006	Paper Transfer: 2nd Side: S2	*ENG	297 mm > S2 size > 275 mm (Paper width)
009	Paper Transfer: 1st Side: S3	*ENG	[100 to 600 / 140 / 5%/step]
010	Paper Transfer: 2nd Side: S3	*ENG	275 mm > S3 size > 210 mm (Paper width)
013	Paper Transfer: 1st Side: S4	*ENG	[100 to 600 / 160 / 5%/step] 210 mm > S4 size > 148 mm (Paper width)
014	Paper Transfer: 2nd Side: S4	*ENG	[100 to 600 / 160 / 5%/step] 210 mm > S4 size > 148 mm (Paper width)
017	Paper Transfer: 1st Side: S5	*ENG	[100 to 600 / 180 / 5%/step] 148 mm > S5 size (Paper width)
018	Paper Transfer: 2nd Side: S5	*ENG	[100 to 600 / 180 / 5%/step] 148 mm > S5 size (Paper width)

	[Special 1: Leading Edge Correction] Special 1 Paper: Leading Edge Correction		
2771	Adjusts the correction to the paper transfer roller current at the paper leading edge in each mode. SP2753 and SP2757 are multiplied by these SP values. Plain: High speed, 1200: Low speed ↓ Note <ul style="list-style-type: none"> ▪ The paper leading edge area can be adjusted with SP2772. 		
001	Paper Transfer: Plain: 1st Side	*ENG	[0 to 400 / 100 / 5%/step]
002	Paper Transfer: Plain: 2nd Side	*ENG	[0 to 400 / 100 / 5%/step]
003	Paper Transfer: 1200: 1st Side	*ENG	[0 to 400 / 100 / 5%/step]
2771	Adjusts the correction to the discharge plate current at the paper leading edge in each mode. SP2751 is multiplied by these SP values. ↓ Note <ul style="list-style-type: none"> ▪ The paper leading edge area can be adjusted with SP2772. 		
005	Separation DC: Plain: 1st Side	*ENG	[0 to 400 / 100 / 5%/step]
006	Separation DC: Plain: 2nd Side	*ENG	
007	Separation DC: 1200: 1st Side	*ENG	[0 to 400 / 100 / 5%/step]

2772	[Special 1: Sw Timing: Lead. Edge]		
	Adjusts the bias/ voltage switch timing of the paper transfer roller/ discharge plate at the paper leading edge between the erase margin area and the image area. Plain: High speed, 1200: Low speed		
001	Paper Transfer: Plain: 1st Side	*ENG	[0 to 50 / 0 / 2 mm/step]
002	Paper Transfer: Plain: 2nd Side	*ENG	
003	Paper Transfer: 1200: 1st Side	*ENG	[0 to 50 / 0 / 1 mm/step]
005	Separation DC: Plain: 1st Side	*ENG	[0 to 50 / 0 / 2 mm/step]
006	Separation DC: Plain: 2nd Side	*ENG	
007	Separation DC: 1200: 1st Side	*ENG	

2773	[Special 1: Trail. Edge Correction] Special 1 Paper: Trailing Edge Correction		
	Adjusts the correction to the paper transfer roller current for the paper trailing edge in each mode. SP2753 and SP2757 are multiplied by these SP values. Plain: High speed, 1200: Low speed  Note <ul style="list-style-type: none"> ▪ The paper trailing edge area can be adjusted with SP2774. 		
001	Paper Transfer: Plain: 1st Side	*ENG	[0 to 400 / 100 / 5%/step]
002	Paper Transfer: Plain: 2nd Side	*ENG	
003	Paper Transfer: 1200: 1st Side	*ENG	
005	Separation DC: Plain: 1st Side	*ENG	
006	Separation DC: Plain: 2nd Side	*ENG	
007	Separation DC: 1200: 1st Side	*ENG	

2774	[Special 1: Sw Timing: Trail. Edge]		
	Adjusts the bias/voltage switch timing of the paper transfer roller/discharge plate at the paper trailing edge between the erase margin area and the image area. Plain: High speed, 1200: Low speed		
001	Paper Transfer: Plain: 1st Side	*ENG	[0 to 50 / 0 / 2 mm/step]
002	Paper Transfer: Plain: 2nd Side	*ENG	
003	Paper Transfer: 1200: 1st Side	*ENG	
005	Separation DC: Plain: 1st Side	*ENG	
006	Separation DC: Plain: 2nd Side	*ENG	
007	Separation DC: 1200: 1st Side	*ENG	

2780	[Special 1: Environment Correction]		
	Plain: High speed, 1200: Low speed		
001	Separation DC: Plain: 1st Side	*ENG	[1 to 60 / 26 / 1 /step]
002	Separation DC: Plain: 2nd Side	*ENG	[1 to 60 / 32 / 1 /step]
003	Paper Transfer: Plain: BW: 1st Side	*ENG	[1 to 60 / 11 / 1 /step]
004	Paper Transfer: Plain: BW:2nd Side	*ENG	
005	Paper Transfer: Plain: FC: 1st Side	*ENG	[1 to 60 / 1 / 1 /step]
006	Paper Transfer: Plain: FC:2nd Side	*ENG	[1 to 60 / 14 / 1 /step]
007	Separation DC: 1200: 1st Side	*ENG	[1 to 60 / 26 / 1 /step]
009	Paper Transfer: 1200: BW: 1st Side	*ENG	[1 to 60 / 11 / 1 /step]
011	Paper Transfer: 1200: FC: 1st Side	*ENG	[1 to 60 / 1 / 1 /step]

2801	[Special2: Bias]		
	Adjusts the DC voltage of the discharge plate for special paper 2. Plain: High speed, 1200: Low speed		
001	Separation DC: Plain: 1st Side	*ENG	[0 to 4000 / 3500 / 10 -V/step]
002	Separation DC: Plain: 2nd Side	*ENG	
003	Separation DC: 1200: 1st Side	*ENG	

2803	[Special2: Bias: BW]		
	Adjusts the current for the paper transfer roller for special paper 2 in black-and-white mode. Plain: High speed, 1200: Low speed		
001	Paper Transfer: Plain: 1st Side	*ENG	[0 to 250 / 22 / 1 - μ A/step]
002	Paper Transfer: Plain: 2nd Side	*ENG	
003	Paper Transfer: 1200: 1st Side	*ENG	[0 to 200 / 11 / 1 - μ A/step]

2807	[Special2: Bias: FC]		
	Adjusts the current for the paper transfer roller for special paper 2 in full color mode. Plain: High speed, Thick 2&Fine: Low speed		
001	Paper Transfer: Plain: 1st Side	*ENG	[0 to 250 / 30 / 1 - μ A/step]
002	Paper Transfer: Plain: 2nd Side	*ENG	[0 to 250 / 33 / 1 - μ A/step]
003	Paper Transfer: 1200: 1st Side	*ENG	[0 to 250 / 15 / 1 - μ A/step]

Main SP Tables-2

2811	[Special2: Paper Size Correction]		
	Adjusts the size correction coefficient for the paper transfer roller current for each paper size. SP2803 and SP2807 are multiplied by these SP values.		
001	Paper Transfer: 1st Side: S1	*ENG	[100 to 600 / 100 / 5%/step]
002	Paper Transfer: 2nd Side: S1	*ENG	S1 size > 297 mm (Paper width)
005	Paper Transfer: 1st Side: S2	*ENG	[100 to 600 / 120 / 5%/step] 297 mm > S2 size > 275 mm (Paper width)
006	Paper Transfer: 2nd Side: S2	*ENG	[100 to 600 / 120 / 5%/step] 297 mm > S2 size > 275 mm (Paper width)
009	Paper Transfer: 1st Side: S3	*ENG	[100 to 600 / 140 / 5%/step] 275 mm > S3 size > 210 mm (Paper width)
010	Paper Transfer: 2nd Side: S3	*ENG	[100 to 600 / 140 / 5%/step] 275 mm > S3 size > 210 mm (Paper width)
013	Paper Transfer: 1st Side: S4	*ENG	[100 to 600 / 160 / 5%/step] 210 mm > S4 size > 148 mm (Paper width)
014	Paper Transfer: 2nd Side: S4	*ENG	[100 to 600 / 160 / 5%/step] 210 mm > S4 size > 148 mm (Paper width)
017	Paper Transfer: 1st Side: S5	*ENG	[100 to 600 / 180 / 5%/step] 148 mm > S5 size (Paper width)
018	Paper Transfer: 2nd Side: S5	*ENG	[100 to 600 / 180 / 5%/step] 148 mm > S5 size (Paper width)

2821	[Special 2: Lead Edge Correction] Special 2 Paper: Leading Edge Correction		
	Adjusts the correction to the paper transfer roller current at the paper leading edge in each mode. SP2803 and SP2807 are multiplied by these SP values. Plain: High speed, 1200: Low speed Note <ul style="list-style-type: none"> The paper leading edge area can be adjusted with SP2822. 		
001	Paper Transfer: Plain: 1st Side	*ENG	[0 to 400 / 100 / 5%/step]
002	Paper Transfer: Plain: 2nd Side	*ENG	[0 to 400 / 100 / 5%/step]
003	Paper Transfer: 1200: 1st Side	*ENG	[0 to 400 / 100 / 5%/step]
2821	Adjusts the correction to the discharge plate current at the paper leading edge in each mode. SP2801 is multiplied by these SP values. Note <ul style="list-style-type: none"> The paper leading edge area can be adjusted with SP2822. 		
	005	Separation DC: Plain: 1st Side	*ENG
006	Separation DC: Plain: 2nd Side	*ENG	[0 to 400 / 100 / 5%/step]
007	Separation DC: 1200: 1st Side	*ENG	

2822	[Special 2: Sw Timing: Lead. Edge]		
	Adjusts the bias/ voltage switch timing of the paper transfer roller/ discharge plate at the paper leading edge between the erase margin area and the image area. Plain: High speed, 1200: Low speed		
001	Paper Transfer: Plain: 1st Side	*ENG	[0 to 50 / 0 / 2 mm/step]
002	Paper Transfer: Plain: 2nd Side	*ENG	
003	Paper Transfer: 1200: 1st Side	*ENG	
005	Separation DC: Plain: 1st Side	*ENG	
006	Separation DC: Plain: 2nd Side	*ENG	
007	Separation DC: 1200: 1st Side	*ENG	

2823	[Special 2: Trail. Edge Correction] Special 2 Paper: Trailing Edge Correction		
	Adjusts the correction to the paper transfer roller current for the paper trailing edge in each mode. SP2803 and SP2807 are multiplied by these SP values. Plain: High speed, 1200: Low speed <div style="border: 1px solid black; border-radius: 10px; padding: 2px; display: inline-block;">  Note </div> <ul style="list-style-type: none"> ▪ The paper trailing edge area can be adjusted with SP2824. 		
001	Paper Transfer: Plain: 1st Side	*ENG	[0 to 400 / 100 / 5%/step]
002	Paper Transfer: Plain: 2nd Side	*ENG	
003	Paper Transfer: 1200: 1st Side	*ENG	
005	Separation DC: Plain: 1st Side	*ENG	
006	Separation DC: Plain: 2nd Side	*ENG	
007	Separation DC: 1200: 1st Side	*ENG	

2824	[Special 2: Sw Timing: Trail. Edge]		
	Adjusts the bias/voltage switch timing of the paper transfer roller/discharge plate at the paper trailing edge between the erase margin area and the image area. Plain: High speed, 1200: Low speed		
001	Paper Transfer: Plain: 1st Side	*ENG	[0 to 50 / 0 / 2 mm/step]
002	Paper Transfer: Plain: 2nd Side	*ENG	
003	Paper Transfer: 1200: 1st Side	*ENG	
005	Separation DC: Plain: 1st Side	*ENG	
006	Separation DC: Plain: 2nd Side	*ENG	
007	Separation DC: 1200: 1st Side	*ENG	

2830	[Special 2: Environment Correction] Plain: High speed, 1200: Low speed		
001	Separation DC: Plain: 1st Side	*ENG	[1 to 60 / 26 / 1 /step]
002	Separation DC: Plain: 2nd Side	*ENG	[1 to 60 / 32 / 1 /step]
003	Paper Transfer: Plain: BW: 1st Side	*ENG	[1 to 60 / 11 / 1 /step]
004	Paper Transfer: Plain: BW:2nd Side	*ENG	[1 to 60 / 11 / 1 /step]
005	Paper Transfer: Plain: FC: 1st Side	*ENG	[1 to 60 / 1 / 1 /step]
006	Paper Transfer: Plain: FC:2nd Side	*ENG	[1 to 60 / 14 / 1 /step]
007	Separation DC: 1200: 1st Side	*ENG	[1 to 60 / 26 / 1 /step]
009	Paper Transfer: 1200: BW: 1st Side	*ENG	[1 to 60 / 11 / 1 /step]
011	Paper Transfer: 1200: FC: 1st Side	*ENG	[1 to 60 / 1 / 1 /step]

2851	[Special 3: Bias]		
	Adjusts the DC voltage of the discharge plate for special paper 3. Plain: High speed, 1200: Low speed		
	001	Separation DC: Plain: 1st Side	*ENG
	002	Separation DC: Plain: 2nd Side	*ENG
003	Separation DC: 1200: 1st Side	*ENG	[0 to 4000 / 3500 / 10 -V/step]



2852	[Special 3: Bias: BW]		
	Adjusts the current for the paper transfer roller for special paper 3 in black-and-white mode. Plain: High speed, 1200: Low speed		
	001	Paper Transfer: Plain: 1st Side	*ENG
	002	Paper Transfer: Plain: 2nd Side	*ENG
003	Paper Transfer: 1200: 1st Side	*ENG	[0 to 250 / 11 / 1 - μ A /step]

Main SP Tables-2

2857	[Special 3: Bias: FC]		
	Adjusts the current for the paper transfer roller for special paper 3 in full color mode. Plain: High speed, 1200: Low speed		
001	Paper Transfer: Plain: 1st Side	*ENG	[0 to 250 / 30 / 1 - μ A /step]
002	Paper Transfer: Plain: 2nd Side	*ENG	[0 to 250 / 33 / 1 - μ A /step]
003	Paper Transfer: 1200: 1st Side	*ENG	[0 to 250 / 15 / 1 - μ A /step]

2861	[Special 3: Paper Size Correction]		
	Adjusts the size correction coefficient for the paper transfer roller current for each paper size. SP2852 and SP2857 are multiplied by these SP values.		
001	Paper Transfer: 1st Side: S1	*ENG	[100 to 600 / 100 / 5%/step]
002	Paper Transfer: 2nd Side: S1	*ENG	S1 size > 297 mm (Paper width)
005	Paper Transfer: 1st Side: S2	*ENG	[100 to 600 / 120 / 5%/step] 297 mm > S2 size > 275 mm (Paper width)
006	Paper Transfer: 2nd Side: S2	*ENG	[100 to 600 / 120 / 5%/step] 297 mm > S2 size > 275 mm (Paper width)
009	Paper Transfer: 1st Side: S3	*ENG	[100 to 600 / 140 / 5%/step] 275 mm > S3 size > 210 mm (Paper width)
010	Paper Transfer: 2nd Side: S3	*ENG	[100 to 600 / 140 / 5%/step] 275 mm > S3 size > 210 mm (Paper width)
013	Paper Transfer: 1st Side: S4	*ENG	[100 to 600 / 160 / 5%/step] 210 mm > S4 size > 148 mm (Paper width)

014	Paper Transfer:: 2nd Side: S4	*ENG	[100 to 600 / 160 / 5%/step] 210 mm > S4 size > 148 mm (Paper width)
017	Paper Transfer:: 1st Side: S5	*ENG	[100 to 600 / 180 / 5%/step] 148 mm > S5 size (Paper width)
018	Paper Transfer:: 2nd Side: S5	*ENG	[100 to 600 / 180 / 5%/step] 148 mm > S5 size (Paper width)

2871	[Special 3: Lead. Edge Correction] Special 3 Paper: Leading Edge Correction		
	Adjusts the correction to the paper transfer roller current at the paper leading edge in each mode. SP2852 and SP2857 are multiplied by these SP values. Plain: High speed, 1200: Low speed		
	<p> Note</p> <ul style="list-style-type: none"> The paper leading edge area can be adjusted with SP2872. 		
	001	Paper Transfer: Plain: 1st Side	*ENG
002	Paper Transfer: Plain: 2nd Side	*ENG	[0 to 400 / 100 / 5%/step]
003	Paper Transfer: 1200: 1st Side	*ENG	
2871	Adjusts the correction to the discharge plate current at the paper leading edge in each mode. SP2851 is multiplied by these SP values.		
	<p> Note</p> <ul style="list-style-type: none"> The paper leading edge area can be adjusted with SP2872. 		
005	Separation DC: Plain: 1st Side	*ENG	[0 to 400 / 100 / 5%/step]
006	Separation DC: Plain: 2nd Side	*ENG	
007	Separation DC: 1200: 1st Side	*ENG	

2872	[Special 3: Sw Timing: Lead. Edge]		
	Adjusts the bias/ voltage switch timing of the paper transfer roller/ discharge plate at the paper leading edge between the erase margin area and the image area. Plain: High speed, 1200: Low speed		
001	Paper Transfer: Plain: 1st Side	*ENG	[0 to 50 / 0 / 2 mm/step]
002	Paper Transfer: Plain: 2nd Side	*ENG	
003	Paper Transfer: 1200: 1st Side	*ENG	
005	Separation DC: Plain: 1st Side	*ENG	
006	Separation DC: Plain: 2nd Side	*ENG	
007	Separation DC: 1200: 1st Page	*ENG	

2873	[Special 3: Trail. Edge Correction] Special 3 Paper: Trailing Edge Correction		
	Adjusts the correction to the paper transfer roller current for the paper trailing edge in each mode. SP2852 and SP2857 are multiplied by these SP values. Plain: High speed, 1200: Low speed Note <ul style="list-style-type: none"> ▪ The paper trailing edge area can be adjusted with SP2874. 		
001	Paper Transfer: Plain: 1st Side	*ENG	[0 to 400 / 100 / 5%/step]
002	Paper Transfer: Plain: 2nd Side	*ENG	
003	Paper Transfer: 1200: 1st Side	*ENG	
005	Separation DC: Plain: 1st Side	*ENG	
006	Separation DC: Plain: 2nd Side	*ENG	
007	Separation DC: 1200: 1st Page	*ENG	

2874	[Special 3: Sw Timing: Trail. Edge]		
	Adjusts the bias/voltage switch timing of the paper transfer roller/discharge plate at the paper trailing edge between the erase margin area and the image area. Plain: High speed, 1200: Low speed		
001	Paper Transfer: Plain: 1st Side	*ENG	[0 to 50 / 0 / 2 mm/step]
002	Paper Transfer: Plain: 2nd Side	*ENG	
003	Paper Transfer: 1200: 1st Side	*ENG	
005	Separation DC: Plain: 1st Side	*ENG	
006	Separation DC: Plain: 2nd Side	*ENG	
007	Separation DC: 1200: 1st Page	*ENG	

2880	[Special 3: Environment Correction]		
	Plain: High speed, 1200: Low speed		
001	Separation DC: Plain: 1st Side	*ENG	[1 to 60 / 26 / 1 /step]
002	Separation DC: Plain: 2nd Side	*ENG	[1 to 60 / 32 / 1 /step]
003	Paper Transfer: Plain: BW: 1st Side	*ENG	[1 to 60 / 11 / 1 /step]
004	Paper Transfer: Plain: BW:2nd Side	*ENG	
005	Paper Transfer: Plain: FC: 1st Side	*ENG	[1 to 60 / 1 / 1 /step]
006	Paper Transfer: Plain: FC:2nd Side	*ENG	[1 to 60 / 11 / 1 /step]
007	Separation DC: 1200: 1st Side	*ENG	[1 to 60 / 26 / 1 /step]
009	Paper Transfer: 1200: BW: 1st Side	*ENG	[1 to 60 / 11 / 1 /step]
011	Paper Transfer: 1200: FC: 1st Side	*ENG	[1 to 60 / 1 / 1 /step]

2905	[Dev Rvs Time] Development Roller Reverse Time		
	Specified the time of the development roller reverse rotation after the development unit has stopped. The reverse rotation of the development roller is used for removing dust from the development roller.		
001	K	*ENG	[0 to 200 / 80 / 10 msec/step]
002	M	*ENG	
003	C	*ENG	
004	Y	*ENG	
005	[Dev Rvs Threshold Counter]		
	Specified the threshold distance for the development roller reverse mode. This SP refers to the counters for SP2905-006 to -009.		
	All	*ENG	[0 to 400000 / 4000 / 10 mm/step]
	[Dev Rvs Counter]		
006	K	*ENG	[0 to 999999999 / - / 1 mm/step]
007	M	*ENG	
008	C	*ENG	
009	Y	*ENG	

2907	[Acs Setting (FC to Bk)]		
	Adjusts the threshold for moving away the image transfer belt from the color PCDUs. This SP moves the image transfer belt away from the color PCDUs when the number of B/W image printouts reaches the number of sheets specified with this SP after consecutive full color image printouts in the full color mode. If this SP is set to "0", the image transfer belt does not move away.		
001	Continuous Bk Pages	*ENG	[0 to 10 / 0 / 1 sheet/step]

2920	[Trans Mot Control]		
001	0: Encoder 1 :FG	*ENG	[0 or 1 / 0 / 1 /step]
	Selects the speed control mode for the ITB. If SC443 occurs and machine does not recover, change this setting to "1".		
002	SC443-00 Count	*ENG	[0 to 3 / 0 / 1 /step]
	Displays the number of the ITB encode error. SC443 is displayed if this counter counts to "3".		

2930	[SecondaryFB: Threshold] Paper Transfer Roller Feed-back: Threshold Adjustment		
	Adjusts the threshold between high resistance (division 1) and low resistance (division 2) at the paper transfer roller. This SP affects SP2931 to SP2939.		
001	Voltage	*ENG	[0 to 7000 / 6000 / 10 -V/step]

2960	[Process Interval]		
001	Additional Time	*ENG	[0 to 10 / 0 / 1 sec/step]
	Adjusts the additional time for ending the machine's process.		

2970	[Cleaning After JOB]		
001	No Refresh	*ENG	[0 to 100 / 33 / 1 /step] 0: No cleaning
	Specifies the threshold sheets for the cleaning of the paper transfer roller without the refresh mode.		
002	Refresh	*ENG	[0 or 1 / 1 / 1 /step] 0: No cleaning, 1: Cleaning

Main SP Tables-2

2971	T1 Non Image Area ON Timing		
001	Standard Speed	*ENG	[-400 to 290 / 0 / 10 msec/step]
	Adjusts the timing for the non-image area bias of the image transfer roller.		
002	Medium Speed	*ENG	[-400 to 290 / 0 / 10 msec/step]
003	Low Speed	*ENG	[-790 to 410 / 0 / 10 msec/step]

2972	B/W Image Request Timing		
001	Standard Speed	*ENG	[0 to 4000 / 0 / 10 msec/step]
002	Medium Speed	*ENG	[0 to 4000 / 0 / 10 msec/step]
003	Low Speed	*ENG	[0 to 4000 / 0 / 10 msec/step]

2973	Forced Process Down Threshold		
001	-	*ENG	[0 to 5000 / 0 / 10 page/step]

2974	OPC PreCharge Time Control		
001	Standard Speed	*ENG	[0 to 1500 / 136 / 1 msec/step]
002	Medium Speed	*ENG	[0 to 1500 / 146 / 1 msec/step]
003	Low Speed	*ENG	[0 to 2600 / 0 / 1 msec/step]

2980	Continuous Job Page		
001	-	*ENG	[0 to 300 / 100 / 10 page/step]
002	-	*ENG	[0 to 600 / 30 / 10 sec/step]
003	-	*ENG	[0 to 600 / 30 / 10 sec/step]

2990	Print Duty Control		
001	Duty Control State	*ENG	[0 or 1 / - / 1 /step] 0: No limit, 1: Limit
002	Exec Interval: Duty Control	*ENG	[60 to 3600 / 300 / 10 min./step]
003	Duty Control Thresh	*ENG	[0 to 999999999 / 0 / 1 mm/step]
004	Forced CPM Down Thresh: No Duty Control	*ENG	[0 to 5000 / 0 / 1 page/step]
005	Drum Stop Time: No Duty Control	*ENG	[300 to 1500 / 500 / 10 msec/step]
006	ITB Stop Time: No Duty Control	*ENG	[300 to 1500 / 500 / 10 msec/step]
007	Forced CPM Down Thresh: Duty Control	*ENG	[0 to 5000 / 1 / 1 page/step]
008	Drum Stop Time: Duty Control	*ENG	[300 to 20000 / 7500 / 10 msec/step]
009	ITB Stop Time: Duty Control	*ENG	[300 to 20000 / 7500 / 10 msec/step]
010	Duty Control: Start Time	*ENG	Displays the time of the duty control execution.
011	Execution Temp. Threshold	*ENG	Sets the threshold of the duty control execution temperature. [20 to 70 / 39.8 / 0.1/step]
012	Cancellation Temp. Threshold	*ENG	Sets the threshold of the duty control cancellation temperature. [0.1 to 20 / 1 / 0.1/step]
013	ON/OFF Setting	*ENG	Turns duty control off or on. 0: OFF 1: ON

5.4 MAIN SP TABLES-3

5.4.1 SP3-XXX (PROCESS)

3011	[Process Cont. Manual Execution]		
001	Normal	-	Executes the normal process control manually (potential control). Check the result with SP3-325-001 and 3-012-001 after executing this SP.
002	Density Adjustment	-	Executes the toner density adjustment manually.
003	Pre-ACC	-	Executes the process control that is normally done before ACC. The type of process control is selected with SP3-041-004.
004	Full MUSIC	-	Executes the process control that is normally done at the same time as MUSIC. This SP does the MUSIC (line position adjustment) twice.
005	Normal MUSIC	-	Executes the process control that is normally done at the same time as MUSIC. This SP does the MUSIC (line position adjustment) once.

3012	[Process Cont. Check Result] Process Control Self-check Result		
	<p>Displays the result of the latest process control self-check. All colors are displayed. The results are displayed in the order "Y C M K" e.g., 11 (Y) 99 (C) 11 (M) 11 (K): The self-check for Cyan failed but the others were successful. See the "Error Condition Tables" in the "Appendix: Process Control Error Conditions" section for details.</p>		
001	History: Latest	*ENG	[1111 to 99999999 / - / 1/step]

002	Result: Latest 1	*ENG	
003	Result: Latest 2	*ENG	
004	Result: Latest 3	*ENG	
005	Result: Latest 4	*ENG	
006	Result: Latest 5	*ENG	
007	Result: Latest 6	*ENG	
008	Result: Latest 7	*ENG	
009	Result: Latest 8	*ENG	
010	Result: Latest 9	*ENG	

3013	[T Sensor Initial Set: Exe] Developer Initialization Setting		
001	Execution: ALL	-	Executes the developer initialization for each color.
002	Execution: COL	-	
003	Execution: Bk	-	
004	Execution: M	-	
005	Execution: C	-	
006	Execution: Y	-	

3014	[T Sensor Initial Set:Exe] Developer Initialization Result: Display		
001	Display: YCMK	*ENG	[0 to 9999 / - / 1 /step] 1: Success, 2 to 9: Failure
	Displays the developer initialization result. See section "Developer Initialization Result" in the "Appendix: Process Control Error Conditions" section for details on the meaning of each code. All colors are displayed. Values are displayed in the order Y C M Bk. e.g., 1 (Y) 2 (C) 1 (M) 1 (Bk): Initialization of Cyan failed but the others succeeded.		

3015	[Forced Toner Supply: Execute] Forced Toner Supply ([Color])		
001	Execution: ALL	-	Executes the manual toner supply to the development unit.
002	Execution: COL	-	
003	Execution: Bk	-	
004	Execution: M	-	
005	Execution: C	-	
006	Execution: Y	-	

3016	[Forced Toner Supply: Setting]		
	Specifies the manual toner supply time for each color.		
001	Supply Time: Bk	*ENG	[0 to 30 / 4 / 1 sec/step]
002	Supply Time: M	*ENG	
003	Supply Time: C	*ENG	
004	Supply Time: Y	*ENG	

3041	[Process Control Type]		
001	Voltage Control	*ENG	[0 or 1 / 1 / 1/step] Alphanumeric 0: FIXED (Use the fixed values for the charge DC bias and development DC bias set with SP2-005 and SP2-229.) 1: CONTROL
	Enables or disables potential control.		
002	LD Power Control	*ENG	[0 or 1 / 1 / 1/step] Alphanumeric 0: FIXED (at the value in SP2221-xxx) 1: CONTROL (adjusted by process control)
	Selects the LD power control mode.		

003	AutoControl Prohibition Set	*ENG	[0 or 1 / 0 / -] 0: Permit, 1: Forbid
	Enables or disables the automatic process control prohibition.		
004	Pre-ACC Process Control	*ENG	[0 to 2 / 2 / 1/step] 0: Not Executed 1: Process Control 2: TC Control (TD Adjustment) 3: Not used
	Selects the process control mode that is done before ACC.		
005	Pattern Calculation Method	*ENG	[0 to 2 / 2 / 1/step] 0: FIXED 1: INITIALIZED 2: CALCULATED
	Selects the process control method.		

3043	[TD Adjustment Mode]		
001	Repeat Number: Power ON	*ENG	[0 to 9 / 4 / 1 time/step]
	Specifies the maximum number of repeats of the toner density adjustment at power on. 0: Disabled, 1 to 3: Repeat number, 4: Repeat three times (No consumption mode) 5: Repeat three times (Toner is supplied only when the toner density is too low, and toner is consumed only when the toner density is too dark.) 6 to 9: Disabled		
002	Repeat Number: Initialization	*ENG	[0 to 9 / 3 / 1 time/step]
	Specifies the maximum number of repeats of the toner density adjustment at the developer initialization. 0: Disabled, 1 to 3: Repeat number, 4: Repeat three times (No consumption mode) 5: Repeat three times (Toner is supplied only when the toner density is too low, and toner is consumed only when the toner density is too dark.) 6 to 9: Disabled		

003	Repeat Number: Non-use	*ENG	[0 to 9 / 0 / 1 time/step]
	<p>Specifies the maximum number of repeats of the toner density adjustment in stand by mode.</p> <p>0: Disabled, 1 to 3: Repeat number, 4: Repeat three times (No consumption mode) 5: Repeat three times (Toner is supplied only when the toner density is too low, and toner is consumed only when the toner density is too dark.) 6 to 9: Disabled</p>		
004	Repeat Number: ACC	*ENG	[0 to 9 / 3 / 1 time/step]
	<p>Specifies the maximum number of repeats of the toner density adjustment at ACC.</p> <p>0: Disabled, 1 to 3: Repeat number, 4: Repeat three times (No consumption mode) 5: Repeat three times (Toner is supplied only when the toner density is too low, and toner is consumed only when the toner density is too dark.) 6 to 9: Disabled</p>		
005	Repeat Number: Recovery	*ENG	[0 to 9 / 0 / 1 time/step]
	Not used		
006	Repeat Number: Job End	*ENG	[0 to 9 / 4 / 1 time/step]
	<p>Specifies the maximum number of repeats of the toner density adjustment at job end.</p> <p>0: Disabled, 1 to 3: Repeat number, 4: Repeat three times (No consumption mode) 5: Repeat three times (Toner is supplied only when the toner density is too low, and toner is consumed only when the toner density is too dark.) 6 to 9: Disabled</p>		
007	Repeat: Interrupt	*ENG	[0 to 9 / 0 / 1 time/step]
	Specifies the maximum number of repeats of the toner density adjustment during printing. DFU		
008	Toner Supply Coefficient	*ENG	[0 to 25.5 / 10 / 0.1 sec/step]
	Adjusts the time for the toner supply mode when a toner density is detected to be low.		

009	Consumption pattern: Bk	*ENG	[0 to 255 / 5 / 1 time/step]
	Specifies the belt mark generating time for checking the black toner density when toner density is detected to be low at the toner density adjustment.		
010	Consumption pattern: M	*ENG	[0 to 255 / 5 / 1 time/step]
	Specifies the belt mark generating time for checking the magenta toner density when toner density is detected to be low at the toner density adjustment.		
011	Consumption pattern: C	*ENG	[0 to 255 / 5 / 1 time/step]
	Specifies the belt mark generating time for checking the cyan toner density when toner density is detected to be low at the toner density adjustment.		
012	Consumption pattern: Y	*ENG	[0 to 255 / 5 / 1 time/step]
	Specifies the belt mark generating time for checking the yellow toner density when toner density is detected to be low at the toner density adjustment.		
013	T1 Bias: Bk	*ENG	[0 to 80 / 22 / 1 μ A/step]
	Adjusts the image transfer belt bias for Black.		
014	T2 Bias: M	*ENG	[0 to 80 / 25 / 1 μ A/step]
	Adjusts the image transfer belt bias for Magenta.		
015	T3 Bias: C	*ENG	[0 to 80 / 22 / 1 μ A/step]
	Adjusts the image transfer belt bias for Cyan.		
016	T4 Bias: Y	*ENG	[0 to 80 / 28 / 1 μ A/step]
	Adjusts the image transfer belt bias for Yellow.		
017	Developer Mixing Time	*ENG	[0 to 250 / 10 / 1 sec/step]
	Specifies the developer mixing time at the toner density adjustment.		
018	Consumption Pat: LD: DUTY: Bk	*ENG	[0 to 15 / 15 / 1 /step]
	Adjusts the LD duty for the toner consumption mode at the toner density adjustment. In toner consumption mode, toner is discharged when the detected development gamma values (SP3611-001) exceed the target values (SP3611-005) by more than the specified thresholds (SP3239-009).		

Main SP Tables-3

019	Consumption Pat: LD: DUTY: M	*ENG	[0 to 15 / 15 / 1 /step]
	Adjusts the LD duty for the toner consumption mode at the toner density adjustment. In toner consumption mode, toner is discharged when the detected development gamma values (SP3611-002) exceed the target values (SP3611-006) by more than the specified thresholds (SP3239-009).		
020	Consumption Pat: LD: DUTY: C	*ENG	[0 to 15 / 15 / 1 /step]
	Adjusts the LD duty for the toner consumption mode at the toner density adjustment. In toner consumption mode, toner is discharged when the detected development gamma values (SP3611-003) exceed the target values (SP3611-007) by more than the specified thresholds (SP3239-009).		
021	Consumption Pat: LD: DUTY: Y	*ENG	[0 to 15 / 15 / 1 /step]
	Adjusts the LD duty for the toner consumption mode at the toner density adjustment. In toner consumption mode, toner is discharged when the detected development gamma values (SP3611-004) exceed the target values (SP3611-008) by more than the specified thresholds (SP3239-009).		

3044	[Toner Supply Type]		
	Selects the toner supply method type.		
001	Bk	*ENG	[0 to 4 / 4 / 1/step] Alphanumeric 0: FIXED (with the supply rates stored with SP 3401) 1: PID (Vtref_Fixed) 2: PID (Vtref_Control) 3: Not used 4:MBD (Vtref_Control)
002	M	*ENG	
003	C	*ENG	
004	Y	*ENG	

3045	[Toner End Detection: Set]		
	Enables/disables the toner alert display on the LCD.		
001	ON/OFF	*ENG	[0 or 1 / 0 / 1/step] 0: Detect, 1: Not Detect

3102	[Toner End Recovery]		
	Adjusts the number of times toner supply is attempted for each color when the TD sensor continues to detect toner end during toner recovery.		
001	Repeat: Bk	*ENG	[1 to 20 / 5 / 1 time/step]
002	Repeat: M	*ENG	
003	Repeat: C	*ENG	
004	Repeat: Y	*ENG	

3131	[TE Count m: Display]		
	Display the number of toner end detections for each color.		
001	Bk	*ENG	[0 to 99 / - / 1 time/step]
002	M	*ENG	
003	C	*ENG	
004	Y	*ENG	

3201	[TD Sensor: Vt Display]		
	Display the current voltage of the TD sensor for each color.		
001	Current: Bk	*ENG	[0 to 5.5 / - / 0.01 V/step]
002	Current: M	*ENG	
003	Current: C	*ENG	
004	Current: Y	*ENG	

3211	[Vt Shift: Display/Set]		
	Adjusts the Vt correction value for each line speed. Thick 1: 154 mm/sec, Thick 2&Fine: 77 mm/sec		
001	Thick 1 Shift: Bk	*ENG	[0 to 5 / 0.26 / 0.01 V/step]

Main SP Tables-3

002	Thick 1 Shift: M	*ENG	[0 to 5 / 0.26 / 0.01 V/step]
003	Thick 1 Shift: C	*ENG	[0 to 5 / 0.26 / 0.01 V/step]
004	Thick 1 Shift: Y	*ENG	[0 to 5 / 0.31 / 0.01 V/step]
005	Thick 2 & FINE Shift: Bk	*ENG	[0 to 5 / 0.26 / 0.01 V/step]
006	Thick 2 & FINE Shift: M	*ENG	[0 to 5 / 0.26 / 0.01 V/step]
007	Thick 2 & FINE Shift: C	*ENG	[0 to 5 / 0.26 / 0.01 V/step]
008	Thick 2 & FINE Shift: Y	*ENG	[0 to 5 / 0.31 / 0.01 V/step]
009	Mid TCShift: Bk	*ENG	[-0.5 to 0.5 / 0 / 0.01 V/step]
010	Mid TCShift: M	*ENG	
011	Mid TCShift: C	*ENG	
012	Mid TCShift: Y	*ENG	
013	Low TCShift: Bk	*ENG	[-0.5 to 0.5 / 0 / 0.01 V/step]
014	Low TCShift: M	*ENG	
015	Low TCShift: C	*ENG	
016	Low TCShift: Y	*ENG	

3221	[Vtcnt: Display/Set]		
	Displays or adjusts the current Vtcnt value for each color.		
001	Current: Bk	*ENG	[0 to 5 / 3.86 / 0.01 V/step]
002	Current: M	*ENG	
003	Current: C	*ENG	
004	Current: Y	*ENG	
005-008	Displays or adjusts the Vtcnt value for each color at developer initialization. DFU		
005	Initial: Bk	*ENG	[0 to 5 / 3.86 / 0.01 V/step]
006	Initial: M	*ENG	

007	Initial: C	*ENG	
008	Initial: Y	*ENG	

3222	[Vtref: Display/Set]		
	Displays or adjusts the current Vtref value for each color.		
001	Current: Bk	*ENG	[0 to 5.5 / 3 / 0.01 V/step]
002	Current: M	*ENG	
003	Current: C	*ENG	
004	Current: Y	*ENG	
005-008	Displays or adjusts the Vtref value for each color at developer initialization. DFU		
005	Initial: Bk	*ENG	[0 to 5.5 / - / 0.01 V/step]
006	Initial: M	*ENG	
007	Initial: C	*ENG	
008	Initial: Y	*ENG	
009-012	Displays and adjusts Vtref correction by pixel coverage for each color. DFU		
009	Pixel Correction: Bk	*ENG	[-5 to 5.5 / - / 0.01 V/step]
010	Pixel Correction: M	*ENG	
011	Pixel Correction: C	*ENG	
012	Pixel Correction: Y	*ENG	

3239	[Vtref Correction: Setting]		
	Adjusts the parameter for Vtref correction at the process control.		
001	(+)Consumption: Bk	*ENG	[0 to 1 / 0.04 / 0.01 V/step]
002	(+)Consumption: M	*ENG	
003	(+)Consumption: C	*ENG	
004	(+)Consumption: Y	*ENG	
005	(-)Consumption: Bk	*ENG	
006	(-)Consumption: M	*ENG	
007	(-)Consumption: C	*ENG	
008	(-)Consumption: Y	*ENG	
009-012	Threshold for development gamma rank.		
009	P Rank 1 Threshold	*ENG	[0 to 2 / 0.2 / 0.1 /step]
010	P Rank 2 Threshold	*ENG	[0 to 2 / 0.05 / 0.1 /step]
011	P Rank 3 Threshold	*ENG	[-2 to 0 / -0.05 / 0.1 /step]
012	P Rank 4 Threshold	*ENG	[-2 to 0 / -0.2 / 0.1 /step]
013-014	Threshold for image density rank on the image transfer belt.		
013	T Rank 1 Threshold	*ENG	[-1 to 0 / -0.2 / 0.01 V/step]
014	T Rank 2 Threshold	*ENG	[0 to 1 / 0.2 / 0.01 V/step]
021-028	Sets the correction coefficient of the Vtref correction.		
021	Correction Coefficient 1: Bk	*ENG	[0 to 1 / 0.5 / 0.1/step]
022	Correction Coefficient 1: M	*ENG	[0 to 1 / 0.5 / 0.1/step]
023	Correction Coefficient 1: C	*ENG	[0 to 1 / 0.5 / 0.1/step]

024	Correction Coefficient 1: Y	*ENG	[0 to 1 / 0.5 / 0.1/step]
025	Correction Coefficient 2: Bk	*ENG	[0 to 1 / 0.5 / 0.1/step]
026	Correction Coefficient 2: M	*ENG	[0 to 1 / 0.5 / 0.1/step]
027	Correction Coefficient 2: C	*ENG	[0 to 1 / 0.5 / 0.1/step]
028	Correction Coefficient 2: Y	*ENG	[0 to 1 / 0.5 / 0.1/step]

3241	[Background Potential Setting]		
001	Coefficient: Bk	*ENG	These are parameters for calculating the charge bias referring to the development bias at process control. [-1000 to 1000 / 0 / 1 /step]
002	Coefficient: M	*ENG	
003	Coefficient: C	*ENG	
004	Coefficient: Y	*ENG	DC charge bias = Development bias x (1 + 0.001 x these vales) + SP3-241-005 to -008
005	Offset: Bk	*ENG	These are additional values for calculating the charge bias referring to the development bias at process control. [0 to 255 / 140 / 1 V/step]
006	Offset: M	*ENG	
007	Offset: C	*ENG	
008	Offset: Y	*ENG	DC charge bias = Development bias x (1 + 0.001 x SP3-241-001 to -004) + these values

3242	[LD Power Setting]		
	Adjusts the coefficient for LD power control value at the process control.		
001	StdSpd:Coefficient: Bk	*ENG	[-1000 to 1000 / 118 / 1 /step]
002	StdSpd:Coefficient: M	*ENG	[-1000 to 1000 / 117 / 1 /step]
003	StdSpd:Coefficient: C	*ENG	[-1000 to 1000 / 79 / 1 /step]
004	StdSpd:Coefficient: Y	*ENG	[-1000 to 1000 / 92 / 1 /step]
005	StdSpd:Offset: Bk	*ENG	[-1000 to 1000 / 47 / 1 /step]
006	StdSpd:Offset: M	*ENG	[-1000 to 1000 / 41 / 1 /step]
007	StdSpd:Offset: C	*ENG	[-1000 to 1000 / 72 / 1 /step]
008	StdSpd:Offset: Y	*ENG	[-1000 to 1000 / 59 / 1 /step]
009	MidSpd:coef:Bk	*ENG	[-1000 to 1000 / 118 / 1 /step]
010	MidSpd:Coef:M	*ENG	[-1000 to 1000 / 117 / 1 /step]
011	MidSpd:Coef:C	*ENG	[-1000 to 1000 / 79 / 1 /step]
012	MidSpd:Coef:Y	*ENG	[-1000 to 1000 / 92 / 1 /step]
013	MidSpd:offset:Bk	*ENG	[-1000 to 1000 / 47 / 1 /step]
014	MidSpd:offset:M	*ENG	[-1000 to 1000 / 41 / 1 /step]
015	MidSpd:offset:C	*ENG	[-1000 to 1000 / 72 / 1 /step]
016	MidSpd:offset:Y	*ENG	[-1000 to 1000 / 59 / 1 /step]
017	LowSpd:Coef:Bk	*ENG	[-1000 to 1000 / 98 / 1 /step]
018	LowSpd:Coef:M	*ENG	[-1000 to 1000 / 104 / 1 /step]
019	LowSpd:Coef:C	*ENG	[-1000 to 1000 / 78 / 1 /step]
020	LowSpd:Coef:Y	*ENG	[-1000 to 1000 / 84 / 1 /step]
021	LowSpd:offset:Bk	*ENG	[-1000 to 1000 / 59 / 1 /step]
022	LowSpd:offset:M	*ENG	[-1000 to 1000 / 45 / 1 /step]

023	LowSpd:offset:C	*ENG	[-1000 to 1000 / 69 / 1 /step]
024	LowSpd:offset:Y	*ENG	[-1000 to 1000 / 65 / 1 /step]

3251	[Coverage]		
	These (-001 to -016) are coefficients for SP3-222-009 to -012.		
001	Latest Pixel: Bk	*ENG	Displays the latest coverage for each color. [0 to 9999 / - / 1 cm ² /step]
002	Latest Pixel: M	*ENG	
003	Latest Pixel: C	*ENG	
004	Latest Pixel: Y	*ENG	
005-008	Displays the average coverage of each color for the Vtref correction. "Average S" is defined when the number of developed pages does not reach the number specified with SP3251-017.		
005	Average S: Bk	*ENG	[0 to 100 / - / 0.01 %/step]
006	Average S: M	*ENG	
007	Average S: C	*ENG	
008	Average S: Y	*ENG	
009-012	Displays the average coverage of each color for the Vtref correction. "Average M" is defined when the number of developed pages does not reach the number specified with SP3251-018.		
009	Average M: Bk	*ENG	[0 to 100 / - / 0.01 %/step]
010	Average M: M	*ENG	
011	Average M: C	*ENG	
012	Average M: Y	*ENG	
013-016	Displays the average coverage of each color for the Vtref correction. "Average L" is defined when the number of developed pages does not reach the number specified with SP3-251-019.		
013	Average L: Bk	*ENG	[0 to 100 / - / 0.01 %/step]

Main SP Tables-3

014	Average L: M	*ENG	
015	Average L: C	*ENG	
016	Average L: Y	*ENG	
017-019	Adjusts the threshold for SP3-251-005 to -016.		
017	Total Page Setting: S	*ENG	[1 to 100 / 10 / 1 sheet/step]
018	Total Page Setting: M	*ENG	[1 to 500 / 10 / 1 sheet/step]
019	Total Page Setting: L	*ENG	[1 to 999 / 50 / 1 sheet/step]
020-023	Adjusts the threshold for SP3-251-024 to -027.		
020	Total Page Setting: S2	*ENG	[1 to 100 / 40 / 1 sheet/step]
021	Total Page Setting: M2	*ENG	[1 to 500 / 10 / 1 sheet/step]
022	Total Page Setting: L2	*ENG	[1 to 999 / 50 / 1 sheet/step]
024-027	Displays the latest coverage ratio for each color.		
024	Latest Coverage: Bk	*ENG	[0 to 100 / - / 0.01 %/step]
025	Latest Coverage: M	*ENG	
026	Latest Coverage: C	*ENG	
027	Latest Coverage: Y	*ENG	
028	Displays the threshold of whether to perform developer churning or not.		
	DevMix Threshold	*ENG	[0 to 100 / 20 / 1 %/step]

3311	[ID Sensor DetectValue: Voffset]		
	Displays the ID sensor (regular) offset voltage for Vsg adjustments.		
001	Voffset reg: Bk	*ENG	[0 to 5 / - / 0.01 V/step]
002	Voffset reg: M	*ENG	[0 to 5.5 / - / 0.01 V/step]
003	Voffset reg: C	*ENG	
004	Voffset reg: Y	*ENG	
005-007	Displays the ID sensor (diffusion) offset voltage for Vsg adjustments.		
005	Voffset dif: M	*ENG	[0 to 5.5 / - / 0.01 V/step]
006	Voffset dif: C	*ENG	
007	Voffset dif: Y	*ENG	
008-010	Displays the ID sensor offset voltage for Vsg adjustments.		
008	Voffset TM (Front)	*ENG	[0 to 5.5 / - / 0.01 V/step]
009	Voffset TM (Center)	*ENG	
010	Voffset TM (Rear)	*ENG	

3321	[Vsg Adjustment: Execution]		
010	P/TM Sensor All	-	Execute the ID sensor initialization setting for all sensors

3322	[Vsg Adjustment Result: Vsg]		
	Displays the result value of the Vsg adjustment for each sensor.		
001	Vsg reg: Bk	*ENG	[0 to 5.5 / - / 0.01 V/step]
002	Vsg reg: M	*ENG	
003	Vsg reg: C	*ENG	
004	Vsg reg: Y	*ENG	

Main SP Tables-3

005	Vsg dif: M	*ENG	
006	Vsg dif: C	*ENG	
007	Vsg dif: Y	*ENG	
008	Vsg TM (Front)	*ENG	
009	Vsg TM (Center)	*ENG	
010	Vsg TM (Rear)	*ENG	

3325	[Vsg Adjustment Result]		
	<p>Displays the result of the Vsg adjustment.</p> <p>The displayed numbers mean the result of each sensor (sensor for Front, sensor for Bk, sensor for Cyan, sensor for Center, sensor for Magenta, sensor for Yellow and sensor for Rear).</p>		
001	Latest	*ENG	<p>[111 to 999 / - / 1 /step]</p> <p>9: Unexpected error</p> <p>3: Offset voltage error</p> <p>2: Vsg adjustment value error</p> <p>1: O.K</p>
002	Result: Latest 1	*ENG	
003	Result: Latest 2	*ENG	
004	Result: Latest 3	*ENG	
005	Result: Latest 4	*ENG	
006	Result: Latest 5	*ENG	
007	Result: Latest 6	*ENG	
008	Result: Latest 7	*ENG	
009	Result: Latest 8	*ENG	
010	Result: Latest 9	*ENG	

3401	[Fixed Supply Mode]		
	Adjusts the toner supply rate in the fixed toner supply mode.		
001	Fixed Rate: Bk	*ENG	[0 to 100 / 5 / 1 %/step] These SPs are used only when SP3-044 is set to "1".
002	Fixed Rate: M	*ENG	
003	Fixed Rate: C	*ENG	
004	Fixed Rate: Y	*ENG	

3411	[Toner Supply Rate: Display]		
	Displays the current toner supply rate.		
001	Latest: Bk	*ENG	[0 to 100 / - / 1 %/step]
002	Latest: M	*ENG	
003	Latest: C	*ENG	
004	Latest: Y	*ENG	

3421	[Toner Supply Range]		
001	Upper Limit: Bk	*ENG	Adjusts the toner supply rate during printing. [0 to 100 / 100 / 1%/step]
002	Upper Limit: M	*ENG	
003	Upper Limit: C	*ENG	
004	Upper Limit: Y	*ENG	
005	Minimum Supply Time: Bk	*ENG	Adjusts the minimum toner supply time. [0 to 1000 / 0 / 1 msec/step]
006	Minimum Supply Time: M	*ENG	
007	Minimum Supply Time: C	*ENG	
008	Minimum Supply Time: Y	*ENG	

3501	[Process Control Target M/A]		
	Adjusts the target M/A.		
001	Maximum M/A: Bk	*ENG	[0 to 1 / 0.4 / 0.001 mg/cm ² /step]
002	Maximum M/A: M	*ENG	
003	Maximum M/A: C	*ENG	
004	Maximum M/A: Y	*ENG	

3510	[ImageQuality Adj. Counter:Disp]		
	Displays the total page counter for each adjustment mode.		
001	Potential Control: BW	*ENG	[0 to 2000 / - / 1 page/step]
002	Potential Control: FC	*ENG	
003	Power ON: BW	*ENG	
004	Power ON: FC	*ENG	
005	MUSIC: BW	*ENG	
006	MUSIC: FC	*ENG	
007	Vsg Adj.	*ENG	
008	Charge AC Control	*ENG	
009	MUSIC: Power ON: BW	*ENG	
010	MUSIC: Power ON: FC	*ENG	

3511	[Execution Interval: Setting]		
	Adjusts the threshold for each adjustment mode.		
001	Job End: Potential Control: BW	*ENG	[0 to 2000 / 250 / 1 page/step]
002	Job End: Potential Control: FC	*ENG	[0 to 2000 / 100 / 1 page/step]
003	Interrupt: Potential Control: BW	*ENG	[0 to 2000 / 500 / 1 page/step]

004	Interrupt: Potential Control: FC	*ENG	[0 to 2000 / 200 / 1 page/step]
005	Initial: Potential Control: BW	*ENG	[0 to 2000 / 250 / 1 page/step]
006	Initial: Potential Control: FC	*ENG	[0 to 2000 / 100 / 1 page/step]
007	Vsg Adj. Counter	*ENG	[0 to 2000 / 0 / 1 page/step]
008	Charge AC Control Counter	*ENG	
019	Environmental Correction	*ENG	[0 or 1 / 1 / 1 /step] 0: Not Correct (OFF) 1: Correct (ON)
020	Gamma Correction	*ENG	[0 or 1 / 1 / 1 /step] 0: Not Correct (OFF) 1: Correct (ON)
021	Non-use Time Correction	*ENG	[0 or 1 / 1 / 1 /step] 0: Not Correct (OFF) 1: Correct (ON)
022	Correction Coef 1: JE: BW	*ENG	[0 to 1 / 0.2 / 0.01 page/step]
023	Correction Coef 2: JE: BW	*ENG	[0 to 1 / 1 / 0.01/step]
024	Correction Coef 1: JE: FC	*ENG	[0 to 1 / 0.5 / 0.01/step]
025	Correction Coef 2: JE: FC	*ENG	[0 to 1 / 1 / 0.01/step]
026	Cor Coef 1: Interrupt: BW	*ENG	[0 to 1 / 0.1 / 0.01/step]
027	Cor Coef 2: Interrupt: BW	*ENG	[0 to 1 / 1 / 0.01/step]
028	Cor Coef 1: Interrupt: FC	*ENG	[0 to 1 / 0.25 / 0.01/step]
029	Cor Coef 2: Interrupt: FC	*ENG	[0 to 1 / 1 / 0.01/step]
030	Max. Number Cor Threshold	*ENG	[0 to 99 / 5 / 1/step]
031	Max. Number Correction Counter	*ENG	[0 to 255 / - / 1/step]

3512	[Image Quality Adj.: Interval]		
	Adjusts the timing for execution of process control and line position adjustment.		
001	During Job	*ENG	[0 to 100 / 30 / 1 page/step]
002	During Stand-by	*ENG	[0 to 100 / 10 / 1 minute/step]

3513	[PCU Motor Stop Time: Bk]		
	Displays the last time that the PCDU motors stopped. These are used for process control execution timing.		
001	Year	*ENG	[0 to 99 / - / 1/step]
002	Month	*ENG	[1 to 12 / - / 1/step]
003	Date	*ENG	[1 to 31 / - / 1/step]
004	Hour	*ENG	[0 to 23 / - / 1/step]
005	Minute	*ENG	[0 to 59 / - / 1/step]

3514	[Environmental Display: Job End]		
	Displays the environmental conditions for the last job. These are used for process control execution timing.		
001	Temperature	*ENG	[-1280 to 1270 / - / 0.1°C/step]
002	Relative Humidity	*ENG	[0 to 1000 / - / 0.1%RH/step]
003	Absolute Humidity	*ENG	[0 to 1000 / - / 0.1 g/m ³ /step]
004	AIT Temperature	*ENG	[-1280 to 1270 / - / 0.1 deg/step]

3515	[Execution Interval: Display]		
	Displays the current interval for process control execution. When the machine calculates the timing for process control, it uses a number of conditions. These are the results after considering all the conditions.		
001	Job End: Pot Control: BW	*ENG	[0 to 2000 / - / 1 page/step]
002	Job End: Pot Control: FC	*ENG	[0 to 2000 / - / 1 page/step]
003	Interrupt: Pot Control: BW	*ENG	[0 to 2000 / - / 1 page/step]
004	Interrupt: Pot Control: FC	*ENG	[0 to 2000 / - / 1 page/step]

3517	[Blade damage prevention mode]		
	Adjusts the threshold temperature for preventing the cleaning blade in the transfer belt cleaning unit from being damaged. If the temperature is above this value, toner is applied to the transfer belt at set intervals during the job to prevent the blade from flipping over.		
001	Execution Temp. Threshold	*ENG	[0 to 50 / 40 / 1°C/step]

3519	[Toner End Prohibition Setting]		
	Enables or disables each adjustment at toner near end.		
001	Process Control	*ENG	[0 or 1 / 1 / 1/step]
002	MUSIC	*ENG	0: Permit (adjustment is done even toner near end condition) 1: Forbid (adjustment is not done at toner near end condition)
003	TC Adj.	*ENG	

3520	[ITB Idling Number]		
	Specifies the number of the ITB idling rotation for each condition.		
001	Temperature: H	*ENG	[0 or 3 / 0 / 1 revolution/step]
002	Temperature: M	*ENG	
003	Temperature: L	*ENG	
004	Temperature: L: Power ON	*ENG	

3521	[Temperature Threshold]		
	Specifies the threshold temperature for each condition. These settings affect the conditions of SP3-520. t1: Threshold between L (low temp.) and M (medium temp.) t2: Threshold between M (medium temp.) and H (high temps)		
001	Threshold: t2	*ENG	[20 or 30 / 25 / 1 deg/step]
002	Threshold: t1	*ENG	[0 or 15 / 15 / 1 deg/step]

3522	[Initial Process Control Set]		
	Adjusts the threshold for the process control at power on. When the current condition has changed by more than the values of these SPs when compared with the conditions at the previous operation, the process control at power on is executed.		
002	Non-use Time Setting	*ENG	[0 to 1440 / 360 / 1 minute/step]
003	Temperature Range	*ENG	[0 to 99 / 10 / 1°C/step]
004	Relative Humidity Range	*ENG	[0 to 99 / 50 / 1 %RH/step]
005	Absolute Humidity Range	*ENG	[0 to 99 / 6 / 1 g/m ³ /step]
006	AIT Temperature Range	*ENG	[0 to 99 / 25 / 1°C/step]
007	Vtref Temperature Range	*ENG	[0 to 99 / 20 / 1°C/step]

100	[Rapi_timer]		
	Time Setting	*ENG	[0 to 255 / 30 / 1 sec/step]
	Adjusts the time-out time for the Rapi timer.		

3531	[Non-use Time Process Control Set]		
	Adjusts the threshold for the process control at stand-by. When the current condition has changed by more than the values of these SPs when compared with the conditions at the previous operation, the process control at stand-by is executed.		
001	Non-use Time Setting	*ENG	[0 to 1440 / 360 / 1 minute/step]
002	Temperature Range	*ENG	[0 to 99 / 10 / 1°C/step]
003	Relative Humidity Range	*ENG	[0 to 99 / 50 / 1 %RH/step]
004	Absolute Humidity Range	*ENG	[0 to 99 / 6 / 1 g/m ³ /step]
005	Maximum Execution Number	*ENG	Adjusts the maximum execution time for the process control at stand-by. [0 to 99 / 10 / 1 time/step]

3611	[Development Gamma: Display/Set]		
001	Bk (Current)	*ENG	Displays the current development gamma for each color. [0 to 5 / - / 0.01 mg/cm ² /kV /step]
002	M (Current)	*ENG	
003	C (Current)	*ENG	
004	Y (Current)	*ENG	
005	Bk (Target Display)	*ENG	Displays the target development gamma for each color. [0 to 5 / - / 0.01 mg/cm ² /kV /step]
006	M (Target Display)	*ENG	
007	C (Target Display)	*ENG	
008	Y (Target Display)	*ENG	
009	Bk (Standard Target Set)	*ENG	Displays the standard target

Main SP Tables-3

010	M (Standard Target Set)	*ENG	development gamma for each color. [0 to 5 / 0.8 / 0.01 mg/cm ² /kv /step]
011	C (Standard Target Set)	*ENG	
012	Y (Standard Target Set)	*ENG	
013	Environmental Correction	*ENG	Turns on or off the environmental correction for target development gamma. [0 or 1 / 1 / -] 0: Not Correct, 1: Correct
014	K (Max Correction)	*ENG	Adjusts the maximum correction value for each color. These SPs are effective only when the setting of SP3-611-013 is set to "1". [0 to 5 / 0.15 / 0.01 mg/cm ² /kv/ step]
015	M (Max Correction)	*ENG	
016	C (Max Correction)	*ENG	
017	Y (Max Correction)	*ENG	
018	K (Max Abs Hum)	*ENG	Adjusts the maximum humidity correction value for each color. These SPs are effective only when the setting of SP3-611-013 is set to "1". [1 to 99 / 20 / 1 g/m ³ /step]
019	M (Max Abs Hum)	*ENG	
020	C (Max Abs Hum)	*ENG	
021	Y (Max Abs Hum)	*ENG	
022	K (Min Correction)	*ENG	[0 to 0.1 / 0 / 0.01 mg/cm ² /kv/ step]

3612	[Vk Display]		
	Displays Vk for each color.		
001	Bk	*ENG	[-300 to 300 / - / 1 V/step]
002	M	*ENG	
003	C	*ENG	
004	Y	*ENG	

3621	[Development DC Control: Disp] Plain: High speed, Thick 1: Middle speed, Thick 2 & FINE: Low speed		
	Displays the development DC bias adjusted with the process control for each line speed and color.		
001	Plain: Bk	*ENG	[0 to 800 / - / 1 -V/step]
002	Plain: M	*ENG	
003	Plain: C	*ENG	
004	Plain: Y	*ENG	
005	Thick 1: Bk	*ENG	[0 to 800 / - / 1 -V/step]
006	Thick 1: M	*ENG	
007	Thick 1: C	*ENG	
008	Thick 1: Y	*ENG	
009	Thick 2 & FINE: Bk	*ENG	[0 to 800 / - / 1 -V/step]
010	Thick 2 & FINE: M	*ENG	
011	Thick 2 & FINE: C	*ENG	
012	Thick 2 & FINE: Y	*ENG	

System
Maintenance

3631	[Charge DC Control: Display] Plain: High speed, Thick 1: Middle speed, Thick 2 & FINE: Low speed		
	Displays the charge DC voltage adjusted with the process control for each line speed and color.		
001	Plain: Bk	*ENG	[0 to 2000 / - / 1 -V/step]
002	Plain: M	*ENG	
003	Plain: C	*ENG	
004	Plain: Y	*ENG	
005	Thick 1 & FINE: Bk	*ENG	[0 to 2000 / - / 1 -V/step]

Main SP Tables-3

006	Thick 1 & FINE: M	*ENG	[0 to 2000 / - / 1 -V/step]
007	Thick 1 & FINE: C	*ENG	
008	Thick 1& FINE: Y	*ENG	
009	Thick 2 & FINE: Bk	*ENG	
010	Thick 2 & FINE: M	*ENG	
011	Thick 2 & FINE: C	*ENG	
012	Thick 2 & FINE: Y	*ENG	

3641	[Charge AC Control: Display] Plain: High speed		
	Displays the charge AC voltage adjusted with the process control for each color.		
001	Plain: Bk	*ENG	[0 to 3 / - / 0.01 kV/step]
002	Plain: M	*ENG	
003	Plain: C	*ENG	
004	Plain: Y	*ENG	

3651	[LD Power Control: Display] Plain: High speed, Thick 1: Middle speed, Thick 2 & FINE: Low speed		
	Displays the LD power adjusted for each environment.		
001	Plain: Bk	*ENG	[0 to 200 / - / 1 %/step]
002	Plain: M	*ENG	
003	Plain: C	*ENG	
004	Plain: Y	*ENG	
005	Thick 1: Bk	*ENG	[0 to 200 / - / 1 %/step]
006	Thick 1: M	*ENG	
007	Thick 1: C	*ENG	

008	Thick 1: Y	*ENG	
009	Thick 2 & FINE: Bk	*ENG	[0 to 200 / - / 1 %/step]
010	Thick 2 & FINE: M	*ENG	
011	Thick 2 & FINE: C	*ENG	
012	Thick 2 & FINE: Y	*ENG	

3710	[HST Concentration Control: Set] TD Sensor: Toner Concentration Control Setting		
	Selects the toner concentration control method by HST memory, which is in the TD sensor.		
001	Control Method: Selection	*ENG	[0 or 1 / 1 / -] 0: Not Use, 1: Use

3711	[HST Concentration Control: Bk]		
	Displays the factory settings of the black PCDU.		
001	Vcnt	*ENG	[0 to 5 / - / 0.1 V/step]
002	Vt	*ENG	[0 to 5 / - / 0.1 V/step]
003	Sensitivity: HL	*ENG	[1.22 to 3.77 / - / 0.01 V/step]
004	Sensitivity: HM	*ENG	[0 to 2.55 / - / 0.01 V/step]
005	Sensitivity: ML	*ENG	
006	Set Detection	*ENG	[0 to 5 / - / 0.1 V/step]
007	Without Developer	*ENG	[0 to 5 / - / 0.1 V/step]
008	With Developer	*ENG	[0 to 5 / - / 0.1 V/step]
009	Serial Number 1	*ENG	[0 to 255 / - / 1 V/step]
010	Serial Number 2	*ENG	
011	Adjustment: Vt	*ENG	[0 to 5 / - / 0.1 V/step]
012	Adjustment: Vtref	*ENG	[0 to 5 / - / 0.1 V/step]

Main SP Tables-3

013	Adjustment: Vtcnt	*ENG	[0 to 5 / - / 0.01 V/step]
014	Adjustment: Gamma	*ENG	[0 to 2.55 / - / 0.01 mg/cm ² /kV /step]
015	Adjustment: Vcnt Result	*ENG	[0 to 9 / - / 1 /step]

3712	[HST Concentration Control: M]		
	Displays the factory settings of the magenta PCDU.		
001	Vcnt	*ENG	[0 to 5 / - / 0.1 V/step]
002	Vt	*ENG	[0 to 5 / - / 0.1 V/step]
003	Sensitivity: HL	*ENG	[1.22 to 3.77 / - / 0.01 V/step]
004	Sensitivity: HM	*ENG	[0 to 2.55 / - / 0.01 V/step]
005	Sensitivity: ML	*ENG	
006	Set Detection	*ENG	[0 to 5 / - / 0.1 V/step]
007	Without Developer	*ENG	[0 to 5 / - / 0.1 V/step]
008	With Developer	*ENG	[0 to 5 / - / 0.1 V/step]
009	Serial Number 1	*ENG	[0 to 255 / - / 1 V/step]
010	Serial Number 2	*ENG	
011	Adjustment: Vt	*ENG	[0 to 5 / - / 0.1 V/step]
012	Adjustment: Vtref	*ENG	[0 to 5 / - / 0.1 V/step]
013	Adjustment: Vtcnt	*ENG	[0 to 5 / - / 0.01 V/step]
014	Adjustment: Gamma	*ENG	[0 to 2.55 / - / 0.01 mg/cm ² /kV /step]
015	Adjustment: Vcnt Result	*ENG	[0 to 9 / - / 1 /step]

3713	[HST Concentration Control: C]		
	Displays the factory settings of the cyan PCDU.		
001	Vcnt	*ENG	[0 to 5 / - / 0.1 V/step]
002	Vt	*ENG	[0 to 5 / - / 0.1 V/step]
003	Sensitivity: HL	*ENG	[1.22 to 3.77 / - / 0.01 V/step]
004	Sensitivity: HM	*ENG	[0 to 2.55 / - / 0.01 V/step]
005	Sensitivity: ML	*ENG	
006	Set Detection	*ENG	[0 to 5 / - / 0.1 V/step]
007	Without Developer	*ENG	[0 to 5 / - / 0.1 V/step]
008	With Developer	*ENG	[0 to 5 / - / 0.1 V/step]
009	Serial Number 1	*ENG	[0 to 255 / - / 1 V/step]
010	Serial Number 2	*ENG	
011	Adjustment: Vt	*ENG	[0 to 5 / - / 0.1 V/step]
012	Adjustment: Vtref	*ENG	[0 to 5 / - / 0.1 V/step]
013	Adjustment: Vtcnt	*ENG	[0 to 5 / - / 0.01 V/step]
014	Adjustment: Gamma	*ENG	[0 to 2.55 / - / 0.01 mg/cm ² /kV /step]
015	Adjustment: Vcnt Result	*ENG	[0 to 9 / - / 1 /step]

Main SP Tables-3

3714	[HST Concentration Control: Y]		
	Displays the factory settings of the yellow PCDU.		
001	Vcnt	*ENG	[0 to 5 / - / 0.1 V/step]
002	Vt	*ENG	[0 to 5 / - / 0.1 V/step]
003	Sensitivity: HL	*ENG	[1.22 to 3.77 / - / 0.01 V/step]
004	Sensitivity: HM	*ENG	[0 to 2.55 / - / 0.01 V/step]
005	Sensitivity: ML	*ENG	
006	Set Detection	*ENG	[0 to 5 / - / 0.1 V/step]
007	Without Developer	*ENG	[0 to 5 / - / 0.1 V/step]
008	With Developer	*ENG	[0 to 5 / - / 0.1 V/step]
009	Serial Number 1	*ENG	[0 to 255 / - / 1 V/step]
010	Serial Number 2	*ENG	
011	Adjustment: Vt	*ENG	[0 to 5 / - / 0.1 V/step]
012	Adjustment: Vtref	*ENG	[0 to 5 / - / 0.1 V/step]
013	Adjustment: Vcnt	*ENG	[0 to 5 / - / 0.01 V/step]
014	Adjustment: Gamma	*ENG	[0 to 2.55 / - / 0.01 mg/cm ² /kV /step]
015	Adjustment: Vcnt Result	*ENG	[0 to 9 / - / 1 /step]

3800	[Waste Toner Full Detection]		
	Displays/ adjusts the toner collection bottle detection settings. These SPs are used for NRS.		
001	Condition	*CTL	[0 to 4 / 0 / 1 /step]
002	Detection Times	*CTL	[0 to 50 / 0 / 1 /step]
003	Print Page After Near Full	*CTL	[0 to 1000 / 0 / 1 sheet/step]

004	Pixel Count After Near Full	*CTL	[0 to 200000 / 0 / 1 cm ² /step]
005	Pixel Count After Replacement	*CTL	Displays the pixel counter after replacement of toner collection bottle. [0 to 200000 / 0 / 1 cm ² /step]
008	Coefficient	*ENG	[0.1 to 1.5 / 1 / 0.1 /step]
011	Notice Setting	*ENG	Enables or disables the calling for @Remote. [0 or 1 / 1 / -] 0: Enable @Remote calling 1: Disable @Remote calling
	<p>NOTE: If the toner collection bottle has been replaced before the machine detects used toner near full when this setting is set to "0", the machine cannot detect toner collection bottle near full. In that case, set SP3-902-017 to "1".</p>		
012	Day Threshold: Toner Collection bottle:NF	*ENG	[1 to 30 / 5 / 1 day/step]
	Sets the threshold days for the near-full display. The near-full of the toner collection bottle is displayed after the toner collection full sensor has detected the actuator in the toner collection bottle.		
013	Total:Toner Collection Bottle	*ENG	Displays the total amount of the used toner. [0 to 999999999 / 0 / 1]
014	Mechanism Full Detection Date	*ENG	Displays the date of the full detection for he toner collection bottle.

Main SP Tables-3

3900	[Waste Toner New Detection]		
	Turns toner collection bottle full detection on or off.		
001	ON/OFF Setting	*ENG	[0 or 1 / 1 / -] 0: OFF, 1: ON

3901	[New PCU Detection]		
	Turns new PCDU detection on or off.		
001	ON/OFF Setting	*ENG	[0 or 1 / 1 / -] 0: OFF, 1: ON

3902	[Manual New Unit Set]		
	Turns the new unit detection flag for each PM unit on or off. The use of these counters is explained in the PM section and in the relevant parts of section 3 (Replacement and Adjustment).		
001	Development Unit: Bk	*ENG	[0 or 1 / 0 / -] 0: OFF, 1: ON
002	Development Unit: Y	*ENG	
003	Development Unit: C	*ENG	
004	Development Unit: M	*ENG	
005	Developer: Bk	*ENG	[0 or 1 / 0 / -] 0: OFF, 1: ON
006	Developer: Y	*ENG	
007	Developer: C	*ENG	
008	Developer: M	*ENG	
009	PCU: Bk	*ENG	[0 or 1 / 0 / -] 0: OFF, 1: ON
010	PCU: Y	*ENG	
011	PCU: C	*ENG	



012	PCU: M	*ENG	
013	Image Transfer Unit	*ENG	[0 or 1 / 0 / -] 0: OFF, 1: ON Do not use 3902-013 if you only change the cleaning unit. 3902-015: This is for the image transfer belt cleaning unit.
014	Fusing Unit	*ENG	
015	Cleaning Unit	*ENG	
016	Paper Transfer Unit	*ENG	
017	Toner Collection Bottle	*ENG	
018	Heating Sleeve Belt Unit	*ENG	
019	Pressure Roller	*ENG	[0 or 1 / 0 / -] 0: OFF, 1: ON "Fusing Roller" is designated as "Heating Roller" in this manual.
020	Pump Unit: Bk	*ENG	[0 or 1 / 0 / -] 0: OFF, 1: ON
021	Pump Unit: M	*ENG	
022	Pump Unit: C	*ENG	
023	Pump Unit: Y	*ENG	

5.5 MAIN SP TABLES-4

5.5.1 SP4-XXX (SCANNER)

4008	[Sub Scan Mag.Adjustment]		
	Adjusts the sub-scan magnification by changing the scanner motor speed.		
001	-	*ENG	[-1.0 to 1.0 / 0 / 0.1%/step] FA

4010	[L-Edge Regist Adjustment]		
	Adjusts the leading edge registration by changing the scanning start timing in the sub-scan direction.		
001	-	*ENG	[-2.0 to 2.0 / 0 / 0.1 mm/step] FA

4011	[S-to-S Regist Adjustment]		
	Adjusts the side-to-side registration by changing the scanning start timing in the main scan direction.		
001	-	*ENG	[-2.5 to 2.5 / 0 / 0.1 mm/step] FA

4012	[Scanner Erase Margin: Scale]		
	Sets the blank margin at each side for erasing the original shadow caused by the gap between the original and the scale.		
001	Book: Leading Edge	*ENG	[0 to 3.0 / 0 / 0.1 mm/step] FA
002	Book: Trailing Edge		
003	Book: Left		
004	Book: Right		
005	ADF: Leading Edge	*ENG	[0 to 3.0 / 0 / 0.1 mm/step] FA
007	ADF: Right		

008	ADF: Left		
-----	-----------	--	--

4013	[Scanner Free Run]		
	Performs the scanner free run with the exposure lamp on or off in the following mode. Full color mode / Full Size / A3 or DLT		
001	Lamp: OFF	*ENG	[0 or 1 / 0 / -] 0: OFF, 1: ON
002	Lamp: ON		

4014	[Scan]		
	Execute the scanner free fun with each mode.		
001	HP Detection Enable	-	Scanner free run with HP sensor check.
002	HP Detection Disable	-	Scanner free run without HP sensor check.

4020	[Dust Check]		
001	Dust Detect:On/Off	*ENG	Turns the ADF scan glass dust check on/off. [0 or 1 / 0 / 1 /step] 0: OFF, 1: ON
002	Dust Detect:Lvl	*ENG	Selects the detect level. [0 to 8 / 4 / 1 /step] 0: lowest detection level 8: highest detection level
003	Dust Reject:Lvl	*ENG	Selects the level of the sub scan line correction when using the ARDF. [0 to 4 / 0 / 1 /step] 0: Off 1: Weakest 2: Weak 3: Strong 4: Strongest

Main SP Tables-4

011	Dust Detect:On/Off:Rear	*ENG	Not used
012	Dust Detect:Lvl:Rear	*ENG	Not used

4301	[APS Operation Check]		
	Displays a code that represents the original size detected by the original sensors. (See "Input Check Table" in this section.)		
001	APS Operation Check	-	-

4303	[APS Min. Size]		
	Specifies the result of the detection when the outputs from the original sensors are all OFF.		
001	-	*ENG	[0 to 2 / 0 / 1 /step] 0: No Original 1: A5-Lengthwise (16K SEF if 4305 is set to 3)

4305	[8K/16K Detection]		
	This program enables the machine to automatically recognize the 8K/16K size.		
001	-	*ENG	[0 to 3 / 0 / 1 /step] 0: Normal Detection (the machine detects A4/LT size as A4 or LT, depending on the paper size setting) 1: A4-Sideways LT-Lengthwise 2: LT-Sideways A4-Lengthwise 3: 8K 16K

4308	[Scan Size Detection]		
001	Detection ON/OFF	*ENG	[0 or 1 / 1 / -] 0: OFF 1: ON
	Turns on or off the CCD original size detection. This detection is used only when an original is scanned in book scanning mode.		

4309	[Scan Size Detect:Setting]		
001	Original Density Thresh	*ENG	[0 to 255 / 32 / 1 digit/step]
	Specifies the threshold between an original area and non-original area for the scan original size detection in book scanning mode.		
002	Detection Time	*ENG	[20 to 100 / 60 / 20 msec/step]
	Specifies the detection time for the scan original size detection in book scanning mode.		
003	Lamp ON:Delay Time	*ENG	[0 to 200 / 40 / 20 msec/step]
	Specifies the lamp on timing for the scan original size detection in book scanning mode.		
004	LED PWM Duty	*ENG	[0 to 100 / 60 / 1/step]
	Sets the LED lamp intensity.		

4310	[Scan Size Detect Value]		
	Displays the detected value by CCD. Each detection point for paper size and color is displayed on the LCD.		
001	S1:R	*ENG	[0 to 255 / - / 1 digit/step]
002	S1:G	*ENG	
003	S1:B	*ENG	
004	S2:R	*ENG	

Main SP Tables-4

005	S2:G	*ENG	
006	S2:B	*ENG	
007	S3:R	*ENG	
008	S3:G	*ENG	
009	S3:B	*ENG	

4400	[Scanner Erase Margin]	*ENG	
	Set the Mask for Original. These SPs set the area to be masked during platen (book) mode scanning.		
001	Book: Leading Edge	[0 to 3.0 / 0 / 0.1 mm/step]	
002	Book: Trailing Edge		
003	Book: Left		
004	Book: Right		
005	ADF: Leading Edge		
007	ADF: Right		
008	ADF: Left		

4417	[IPU Test Pattern]	
	Selects the IPU test pattern.	
001	Test Pattern Selection	[0 to 24 / 0 / 1/step]
	0: Scanned image 1: Gradation main scan A 2: Gradation main scan B 3: Gradation main scan C 4: Gradation main scan D 5: Gradation sub scan (1) 6: Grid pattern 7: Slant grid pattern 8: Gradation RGBCMYK 9: UCR pattern 10: Color patch 16 (1) 11: Color patch 16 (2) 12: Color patch 64	13: Grid pattern CMYK 14: Color patch CMYK 15: Gray pattern (1) 16: Gray pattern (2) 17: Gray Pattern (3) 18: Shading pattern 19: Thin line pattern 20: Scanned + Grid pattern 21: Scanned + Gray scale 22: Scanned + Color patch 23: Scanned + Slant Grid C 24: Scanned + Slant Grid D

4429	[Illegal Copy Output]		
001	Copy	*ENG	[0 to 3 / 3 / 1 /step]
002	Scanner		
003	Fax		

4450	[Scan Image Path Selection]	
001	Black Subtraction ON/OFF	[0 or 1 / 1 / -] 0: OFF, 1: ON
	Uses or does not use the black reduction image path.	
002	SH ON/OFF	[0 or 1 / 0 / 1 /step] 0: ON, 1: OFF
	Uses or does not use the shading image path.	

Main SP Tables-4

4501	[ACC Target Den]		
	Selects the ACC result.		
001	Copy: K: Text	*ENG	[0 to 10 / 5 / 1 /step] 10: Darkest density
002	Copy: C: Text	*ENG	
003	Copy: M: Text	*ENG	
004	Copy: Y: Text	*ENG	
005	Copy: K: Photo	*ENG	
006	Copy: C: Photo	*ENG	
007	Copy: M: Photo	*ENG	
008	Copy: Y: Photo	*ENG	

4505	[ACC Cor:Bright]		
	Adjusts the offset correction for light areas of the ACC pattern.		
001	Text:K	*ENG	[-128 to 127 / 0 / 1 /step]
002	Text:C	*ENG	
003	Text:M	*ENG	
004	Text:Y	*ENG	
005	Photo:K	*ENG	[-128 to 127 / 0 / 1 /step]
006	Photo:C	*ENG	
007	Photo:M	*ENG	
008	Photo:Y	*ENG	

4506	[ACC Cor:Dark]		
	Adjusts the offset correction for dark areas of the ACC pattern.		
001	Text:K	*ENG	[-128 to 127 / 0 / 1 /step]
002	Text:C	*ENG	
003	Text:M	*ENG	
004	Text:Y	*ENG	
005	Photo:K	*ENG	[-128 to 127 / 0 / 1 /step]
006	Photo:C	*ENG	
007	Photo:M	*ENG	
008	Photo:Y	*ENG	

4540	[Print Coverage]		
	This SP corrects the printer coverage of 12 hues (RY, YR, YG, etc. x 4 Colors [R, G, B, Option]) for a total of 48 parameters.		
001-004	RY Phase: Option/R/G/B	*ENG	Specifies the printer vector correction value. [0 to 255 / 0 / 1 /step]
005-008	YR Phase: Option/R/G/B		
009-012	YG Phase: Option/R/G/B		
013-016	GY Phase: Option/R/G/B		
017-020	GC Phase: Option/R/G/B		
021-024	CG Phase: Option/R/G/B		
025-028	CB Phase: Option/R/G/B		
029-032	BC Phase: Option/R/G/B		
033-036	BM Phase: Option/R/G/B		
037-040	MB Phase: Option/R/G/B		
041-044	MR Phase: Option/R/G/B		

Main SP Tables-4

045-048	RM Phase: Option/R/G/B		
---------	------------------------	--	--

4600	[SBU Version Display]		
001	SBU ID	*ENG	Displays the ID of the SBU.
002	GASBU-N ID	*ENG	Displays the ID of the GASBU.
003	VSP5100 ID	*ENG	Displays the ID of the VSP5100.

4602	[Scanner Memory Access]		
001	Scanner Memory Access	-	Enables the read and write check for the SBU registers.

4603	[AGC Execution]		
001	HP Detection Enable	-	Executes the AGC.
002	HP Detection Disable	-	DFU

4609	[Gray Balance Set: R]		
001	Book Scan	*ENG	[-512 to 511 / -46 / 1 digit/step]
002	DF Scan	*ENG	[-512 to 511 / -46 / 1 digit/step]

4610	[Gray Balance Set: G]		
001	Book Scan	*ENG	[-384 to 255 / -20 / 1 digit/step]
002	DF Scan		

4611	[Gray Balance Set: B]		
001	Book Scan	*ENG	[-384 to 255 / -28 / 1 digit/step]
002	DF Scan		

4623	[Black Level Adj. Display] RE: Red Even signal, RO: Red Odd signal		
001	Latest: RE Color	*ENG	Displays the black offset value for the even red signal in the CCD circuit board. [0 to 16383 / 0 / 1 digit/step]
002	Latest: RO Color	*ENG	Displays the black offset value for the odd red signal in the CCD circuit board. [0 to 16383 / 0 / 1 digit/step]

4624	[Black Level Adj. Display] GE: Green Even signal, GO: Green Odd signal		
001	Latest: GE Color	*ENG	Displays the black offset value for the even green signal in the CCD circuit board. [0 to 16383 / 0 / 1 digit/step]
002	Latest: GO Color	*ENG	Displays the black offset value for the odd green signal in the CCD circuit board. [0 to 16383 / 0 / 1 digit/step]

4625	[Black Level Adj. Display] BE: Blue Even signal, BO: Blue Odd signal		
001	Latest: BE Color	*ENG	Displays the black offset value for the even blue signal in the CCD circuit board. [0 to 16383 / 0 / 1 digit/step]
002	Latest: BO Color	*ENG	Displays the black offset value for the odd blue signal in the CCD circuit board. [0 to 16383 / 0 / 1 digit/step]

4628	[Analog Gain Adjust]		
	Displays the gain value of the amplifiers on the controller for Red.		
001	Latest: R Color	*ENG	[0 to 7 / 0 / 1 digit/step]

Main SP Tables-4

4629	[Analog Gain Adjust]		
	Displays the gain value of the amplifiers on the controller for Green.		
001	Latest: G Color	*ENG	[0 to 7 / 0 / 1 digit/step]

4630	[Analog Gain Adjust]		
	Displays the gain value of the amplifiers on the controller for Blue.		
001	Latest: B Color	*ENG	[0 to 7 / 0 / 1 digit/step]

4631	[Digital Gain Adjust]		
	Displays the gain value of the amplifiers on the controller for Red.		
001	Latest: RE Color	*ENG	[0 to 1023 / 0 / 1 digit/step]
002	Latest: RO Color	*ENG	

4632	[Digital Gain Adjust]		
	Displays the gain value of the amplifiers on the controller for Green.		
001	Latest: GE Color	*ENG	[0 to 1023 / 0 / 1 digit/step]
002	Latest: GO Color	*ENG	

4633	[Digital Gain Adjust]		
	Displays the gain value of the amplifiers on the controller for Blue.		
001	Latest: BE Color	*ENG	[0 to 1023 / 0 / 1 digit/step]
002	Latest: BO Color	*ENG	

4645	[Scan Adjust Error]		
001	White level	*ENG	[0 to 65535 / - / 1 digit/step]
002	Black level	*ENG	

4647	[Scanner Hard Error]		
	Displays the result of the SBU connection check.		
001	Power-ON	*ENG	[0 to 35535 / - / 1digit /step] 0: OK, Other: SBU connection check failure If the SBU connection check fails, SC144 occurs.

4654	[Black Level Adj. Display]		
	RE: Red Even signal, RO: Red Odd signal		
001	Last Correct Value: RE Color	*ENG	Displays the black offset value for the even red signal in the CCD circuit board. [0 to 16383 / 0 / 1 digit/step]
002	Last Correct Value: RO Color	*ENG	Displays the black offset value for the odd red signal in the CCD circuit board. [0 to 16383 / 0 / 1 digit/step]

4655	[Black Level Adj. Display]		
	GE: Green Even signal, GO: Green Odd signal		
001	Last Correct Value: GE Color	*ENG	Displays the black offset value for the even green signal in the CCD circuit board. [0 to 16383 / 0 / 1 digit/step]
002	Last Correct Value: GO Color	*ENG	Displays the black offset value for the odd green signal in the CCD circuit board. [0 to 16383 / 0 / 1 digit/step]

4656	[Black Level Adj. Display]		
	BE: Blue Even signal, BO: Blue Odd signal		
001	Last Correct Value: BE Color	*ENG	Displays the black offset value for the even blue signal in the CCD circuit board. [0 to 16383 / 0 / 1 digit/step]

Main SP Tables-4

002	Last Correct Value: BO Color	*ENG	Displays the black offset value for the odd blue signal in the CCD circuit board. [0 to 16383 / 0 / 1 digit/step]
-----	------------------------------	------	--

4658	[Analog Gain Adjust]		
	Displays the previous gain value of the amplifiers on the controller for Red.		
001	Last Correct Value: R Color	*ENG	[0 to 7 / 0 / 1 digit/step]

4659	[Analog Gain Adjust]		
	Displays the previous gain value of the amplifiers on the controller for Green.		
001	Last Correct Value: G Color	*ENG	[0 to 7 / 0 / 1 digit/step]

4660	[Analog Gain Adjust]		
	Displays the previous gain value of the amplifiers on the controller for Blue.		
001	Last Correct Value: B Color	*ENG	[0 to 7 / 0 / 1 digit/step]

4661	[Digital Gain Adjust] RE: Red Even signal, RO: Red Odd signal		
001	Last Correct Value: RE Color	*ENG	[0 to 1023 / 0 / 1 digit/step]
002	Last Correct Value: RO Color	*ENG	

4662	[Digital Gain Adjust] GE: Green Even signal, GO: Green Odd signal		
001	Last Correct Value: GE Color	*ENG	[0 to 1023 / 0 / 1 digit/step]
002	Last Correct Value: GO Color	*ENG	

4663	[Digital Gain Adjust] BE: Blue Even signal, BO: Blue Odd signal		
001	Last Correct Value: BE Color	*ENG	[0 to 1023 / 0 / 1 digit/step]
002	Last Correct Value: BO Color	*ENG	

4673	[Black Level Adj. Display] RE: Red Even signal, RO: Red Odd signal		
001	Factory Setting: RE Color	*ENG	Displays the factory setting values of the black level adjustment for the even red signal in the CCD circuit board. [0 to 16383 / - / 1 digit/step]
002	Factory Setting: RO Color	*ENG	Displays the factory setting values of the black level adjustment for the odd red signal in the CCD circuit board. [0 to 16383 / - / 1 digit/step]

4674	[Black Level Adj. Display] GE: Green Even signal, GO: Green Odd signal		
001	Factory Setting: GE Color	*ENG	Displays the factory setting values of the black level adjustment for the even green signal in the CCD circuit board. [0 to 16383 / - / 1 digit/step]
002	Factory Setting: GO Color	*ENG	Displays the factory setting values of the black level adjustment for the odd green signal in the CCD circuit board. [0 to 16383 / - / 1 digit/step]

4675	[Black Level Adj. Display] BE: Blue Even signal, BO: Blue Odd signal		
001	Factory Setting: BE Color	*ENG	Displays the factory setting values of the black level adjustment for the even blue signal in the CCD circuit board. [0 to 16383 / - / 1 digit/step]
002	Factory Setting: BO Color	*ENG	Displays the factory setting values of the black level adjustment for the odd blue signal in the CCD circuit board. [0 to 16383 / - / 1 digit/step]

Main SP Tables-4

4677	[Analog Gain Adjust]		
	Displays the factory setting values of the gain adjustment for Red.		
001	Factory Setting: R Color	*ENG	[0 to 7 / - / 1 digit/step]

4678	[Analog Gain Adjust]		
	Displays the factory setting values of the gain adjustment for Green.		
001	Factory Setting: G Color	*ENG	[0 to 7 / - / 1 digit/step]

4679	[Analog Gain Adjust]		
	Displays the factory setting values of the gain adjustment for Blue.		
001	Factory Setting: B Color	*ENG	[0 to 7 / - / 1 digit/step]

4680	[Digital Gain Adjust]		
	Displays the gain value of the amplifiers on the controller for Red.		
001	Factory Setting: RE Color	*ENG	[0 to 1023 / - / 1 digit/step]
002	Factory Setting: RO Color	*ENG	

4681	[Digital Gain Adjust]		
	Displays the gain value of the amplifiers on the controller for Green.		
001	Factory Setting: GE Color	*ENG	[0 to 1023 / - / 1 digit/step]
002	Factory Setting: GO Color	*ENG	

4682	[Digital Gain Adjust]		
	Displays the gain value of the amplifiers on the controller for Blue.		
001	Factory Setting: BE Color	*ENG	[0 to 1023 / - / 1 digit/step]
002	Factory Setting: BO Color	*ENG	

4688	[Scan Image Density Adjustment]		
	Adjusts the white shading parameter when scanning an image with the ARDF or 1-pass DF. Adjusts the density level if the ID of outputs made in the DF and Platen mode is different.		
001	ARDF	*ENG	[80 to 120 / 98 / 1%/ step]
002	1-pass DF	*ENG	[80 to 120 / 98 / 1%/ step]

4690	[White Level Peak Read]		
	Displays the peak level of the white level scanning. If these scanned white levels are out of the correct range, SC142 may be issued.		
001	RE	*ENG	[0 to 1023 / - / 1 digit/step]
002	RO	*ENG	

4691	[White Level Peak Read]		
	Displays the peak level of the white level scanning. If these scanned white levels are out of the correct range, SC142 may be issued.		
001	GE	*ENG	[0 to 1023 / - / 1 digit/step]
002	GO	*ENG	

4692	[White Level Peak Read]		
	Displays the peak level of the white level scanning. If these scanned white levels are out of the correct range, SC142 may be issued.		
001	BE	*ENG	[0 to 1023 / - / 1 digit/step]
002	BO	*ENG	

Main SP Tables-4

4693	[Black Level Peak Read]		
	Displays the level of the black level scanning. If these scanned black levels are out of the correct range, SC141 may be issued.		
001	RE	*ENG	[0 to 1023 / - / 1 digit/step]
002	RO	*ENG	

4694	[Black Level Peak Read]		
	Displays the level of the black level scanning. If these scanned black levels are out of the correct range, SC141 may be issued.		
001	GE	*ENG	[0 to 1023 / - / 1 digit/step]
002	GO	*ENG	

4695	[Black Level Peak Read]		
	Displays the level of the black level scanning. If these scanned black levels are out of the correct range, SC141 may be issued.		
001	BE	*ENG	[0 to 1023 / - / 1 digit/step]
002	BO	*ENG	

4796	[Low Density Color Correction]		
001	Front Side	*ENG	[0 or 1 / 0 / -] 0: Off, 1: On
	Turns on or off the low color density correction for the front side of originals.		
002	Rear Side	*ENG	[0 or 1 / 0 / -] 0: Off, 1: On
	Turns on or off the low color density correction for the back side of originals.		

4802	[DF Shading FreeRun]		
001	Lamp OFF	*ENG	Executes the scanner free run of shading movement with exposure lamp on or off. Press "OFF" to stop this free run. Otherwise, the free run lasts.
002	Lamp ON		

4804	[Home Position]		
001	-	*ENG	Executes the scanner HP detection.

4806	[Carriage Save]		
001	-	*ENG	Moves the carriage from the scanner home position. Dust may fall through the DF exposure glass. Therefore, do this SP when you transport the machine a long distance.

4807	[SBU Test Pattern Change]		
001	-	*ENG	[0 to 255 / 0 / 1 /step] 0: Scanning image 1: Fixed pattern 2: Main scanning gradation 3: Sub scanning gradation 4: Grid pattern (5 to 255 : Scanning images)

4808	[Factory Setting Input]		
002	Execution Flag	*ENG	[0 or 1 / 0 / 1 /step]

4902	[Disp ACC Data]		
	This SP outputs the final data read at the end of ACC execution. A zero is returned if there was an error reading the data. [0 to 255 / - / 1 /step]		

Main SP Tables-4

001	R DATA1	*ENG	Photo C Patch Level 1 (8-bit)
002	G DATA1	*ENG	Photo M Patch Level 1 (8-bit)
003	B DATA1	*ENG	Photo Y Patch Level 1 (8-bit)
004	R DATA2	*ENG	Photo C Patch Level 17 (8-bit)
005	G DATA2	*ENG	Photo M Patch Level 17(8-bit)
006	B DATA2	*ENG	Photo Y Patch Level 17 (8-bit)

4918	[Man Gamma:Pht:Y]		
	Adjusts the offset data of the printer gamma for yellow in Photo mode. See "Printer Gamma Correction" in the Replacement and Adjustment for how to use.		
009	-	*ENG	Enter the manual gamma adjustment screen (-001 to 008). For details, see the "Printer Gamma Correction" in the section "Replace and Adjustment".

4954	[Read/Restore Std]		
001	Read New Chart	*ENG	Execute the scanning of the A4 chart.
002	Recall Prev Chart	*ENG	Clear the data of the scanned A4 chart.
003	Read Std Chart	*ENG	Execute the scanning of the A4 standard chart.
004	Set Std Chart	*ENG	Overwrite the standard data.
005	Chromaticity Rank	*ENG	Restores the standard chromaticity rank.

4991	[IPU Image Pass Selection]		
	Selects the image path. Enter the number to be selected using the 10-key pad.		
001	RGB Frame Memory	*ENG	[0 to 11 / 2 / 1 /step]

	0: Scanner input RGB images 1: Scanner I/F RGB images 2: RGB images done by Shading correction (Shading ON, Black offset ON) 3: Shading data 4 to 11: Not used
--	--

4993	[High Light Correction]		
001	Sensitivity Selection	*ENG	Selects the Highlight correction level. [0 to 9 / 4 / 1 /step] 0: weakest sensitivity 9: strongest sensitivity
002	Range Selection	*ENG	Selects the range level of Highlight correction. [0 to 9 / 4 / 1 /step] 0: weakest skew correction, 9: strongest skew correction

4994	[Text/Photo Detection Level Adj.]		
	Selects the definition level between Text and Photo for high compression PDF.		
001	High Compression PDF	*ENG	[0 to 2 / 1 / 1 /step] 0: Text priority 1: Normal 2: Photo priority

5.6 MAIN SP TABLES-5

5.6.1 SP5-XXX (MODE)

5024	[mm/inch Display Selection]		
	Display units (mm or inch) for custom paper sizes.		
001	0:mm 1:inch	*CTL	0: mm (Europe/Asia) 1: inch (USA)

5045	[Accounting counter]		
	Selects the counting method.  Note <ul style="list-style-type: none"> The counting method can be changed only once, regardless of whether the counter value is negative or positive. 		
001	Counter Method	*CTL	[0 or 1 / 1 / -] 0: Developments 1: Prints

5047	[Paper Display]		
	Turns on or off the printed paper display on the LCD.		
001	Backing Paper	*CTL	[0 or 1 / 0 / -] 0: OFF, 1: ON

5051	[TonerRefillDetectionDisplay]		
	Enables or disables the toner refill detection display.		
5051 1	-	*CTL	[0 or 1 / 0 / -] Alphanumeric 0: ON 1: OFF

5055	[Display IP Address]		
	Display or does not display the IP address on the LCD.		
001	-	*CTL	[0 or 1 / 0 / -] 0: OFF 1: ON

5056	[Coverage Counter Display]		
	Display or does not display the coverage counter on the LCD.		
001	-	*CTL	[0 or 1 / 0 / -] 0: Not display, 1: Display

5061	[Toner Remaining Icon Display Change]		
	Display or does not display the remaining toner display icon on the LCD.		
001	-	*CTL	[0 or 1 / 0 / -] 0: Not display, 1: Display

5062	[Parts Replacement Alert Display]		
	Display or does not display the PM part yield on the LCD.		
001	Drum Unit: Bk	*CTL	[0 or 1 / 0 / -] 0: Not display, 1: Display
002	Drum Unit: M	*CTL	
003	Drum Unit: C	*CTL	
004	Drum Unit: Y	*CTL	
005	Development Unit: Bk	*CTL	[0 or 1 / 0 / -] 0: Not display, 1: Display
006	Development Unit: M	*CTL	
007	Development Unit: C	*CTL	
008	Development Unit: Y	*CTL	
009	Developer: Bk	*CTL	

Main SP Tables-5

010	Developer: M	*CTL	0: Not display, 1: Display
011	Developer: C	*CTL	
012	Developer: Y	*CTL	
013	Image Transfer Belt	*CTL	[0 or 1 / 0 / -] 0: Not display, 1: Display
014	Image Transfer Cleaning Unit	*CTL	
015	Fusing Unit	*CTL	
016	Paper Transfer Roller Unit	*CTL	
017	Waster Toner bottle	*CTL	
018	Fusing Roller	*CTL	
019	Pressure Roller	*CTL	

5066	[PM Parts Display] Display or does not display the “PM parts” button on the LCD.		
001	-	*CTL	[0 or 1 / 0 / -] 0: Not display, 1: Display

5067	[Part Replacement Operation Type]		
	Selects the service maintenance or user maintenance for each PM parts. If the user service is selected, PM alert is displayed on the LCD.		
001	Drum Unit: Bk	*CTL	[0: Service] or [1: User]
002	Drum Unit: M	*CTL	
003	Drum Unit: C	*CTL	
004	Drum Unit: Y	*CTL	
005	Development unit: Bk	*CTL	[0: Service] or [1: User]
006	Development unit: M	*CTL	

007	Development unit: C	*CTL	
008	Development unit: Y	*CTL	
009	Developer: Bk	*CTL	
010	Developer: M	*CTL	
011	Developer: C	*CTL	
012	Developer: Y	*CTL	
013	Image Transfer Belt	*CTL	[0: Service] or [1: User]
014	Image Transfer Cleaning Unit	*CTL	[0: Service] or [1: User]
015	Fusing Unit	*CTL	[0: Service] or [1: User]
016	Paper Transfer Roller Unit	*CTL	[0: Service] or [1: User]
017	Waste Toner bottle	*CTL	[0: Service] or [1: User]
018	Fusing Roller	*CTL	[0: Service] or [1: User]
019	Pressure Roller	*CTL	[0: Service] or [1: User]

5071	[Set Bypass Paper Size Display]		
001	-	*CTL	[0 or 1 / 0 / -] 0: Off, 1: On
	Turn on or off the paper size confirmation pop-up on the LED. This pop-up prevents mismatching between a paper size selected by the operation panel and an actual paper size on the by-pass tray.		

5074	[Home Screen Login] Sets the application that appears when the home key is pressed.		
091	(0:OFF 1:SDK 2:Reserve)	*CTL	0: Function disable 1: SDK application 2: Legacy application (reserved)
092	Product ID	*CTL	Sets the Application product ID. [0x00 to 0xffff / - / 1/step]
093	Application ID	*CTL	Sets the display category of the application that is specified in the SP5075-001,002 [0 to 255 / 0 / 1/step]

5075	[USB Keyboard] Sets the function of the external keyboard.		
001	Function Setting	*CTL	0: Disable 1: Enable
002	Keyboard Type Setting	*CTL	Sets the external keyboard type. 0: None 1: English (NA) 2: Turkish 3: Korean 4: Chinese (Simplified) 5: Chinese (Traditional) 6: English (UK) 7: French (France) 8: French (Belgium) 9: French (Canada) 10: German 11: Italian 12: Spanish 13: Spanish (Latin America) 14: Dutch 15: Norwegian 16: Danish 17: Swedish 18: Portuguese 19: Portuguese (Brazil) 20: Finnish 21: Catalan 22: Portuguese 23: Hungarian 24: Czech 25: Russian 26: Japanese 27: Greek

Main SP Tables-5

5104*	[Counter: Size Setting] A3/DLT Double Count (SSP)
	<p>Specifies whether the counter is doubled for A3/DLT. "Yes" counts except from the bypass tray. When "Yes" is selected, A3 and DLT paper are counted twice, that is A4 x2 and LT x2 respectively.</p> <p>Default setting: Yes</p>

5113	[Optional Counter Type]		
001	Default Optional Counter Type	*CTL	<p>This program specifies the counter type.</p> <p>0: None, 1: Key card (RK 3, 4) 2: Key card (down), 3: Prepaid card 4: Coin rack, 5: MF key card 8: Key counter + Vendor 9: Bar-code Printer</p>
002	External Optional Counter Type	*CTL	<p>This program specifies the external counter type.</p> <p>0: None 1: Expansion Device 1 2: Expansion Device 2 3: Expansion Device 3</p>

5114	[Optional Counter I/F]		
001	MF Key Card Extension	*CTL	[0: Not installed/ 1: Installed (scanning accounting)]

5118	[Disable Copying]		
	This program disables copying.		
001	-	*CTL	[0: Not disabled/ 1: Disabled]

5120	[Mode Clear Opt. Counter Removal]		
	This program updates the information on the optional counter. When you install or remove an optional counter, check the settings.		
001	-	*CTL	[0: Yes (removed) / 1: Standby (installed but not used)/ 2: No (not removed)]

5121	[Counter Up Timing]		
	This program specifies when the counter goes up. The settings refer to “paper feed” and “paper exit” respectively.		
001	0:Feed 1:Exit	*CTL	[0: Feed / 1: Exit]

5126	[F Size Original Setting]		
	Selects F size original setting.		
001	-	*ENG	[0 to 2 / 0 / 1 /step] 0: 8 1/2" x 13" (Foolscap) 1: 8 1/4" x 13" (Folio) 2: 8" x 13" (F)

5127	[APS Mode]		
	This program disables the APS.		
001	-	*CTL	[0: Not disabled/ 1: Disabled]

5131	[Paper Size Type Selection]		
	The program selects a paper size system from the following alternatives: the AB system (0), the LT system (1), and the AF system (2).		
001	-	*ENG	[0: JP (Japan)/ 1: NA / 2: EU]

Main SP Tables-5

5148	Size Detection Off	*CTL	[0: OFF/ 1: ON]
	0: Detect 1: Not Detect		

5150	[Bypass Length Setting]		
	Determines whether the transfer sheet from the by-pass tray is used or not. Normally the paper length for sub scanning paper from the by-pass tray is limited to 600 mm, but this can be extended with this SP to 1260 mm.		
001	0: OFF 1: ON	*CTL	[0: OFF/ 1: ON]

5162	[App. Switch Method]	*CTL	[0: Soft Key Set/ 1: Hard Key Set]
001	This program specifies the switch that selects an application program.		

5167	[Fax Printing Mode at Optional Counter Off]		
	Enables or disables the automatic print out without an accounting device. This SP is used when the receiving fax is accounted by an external accounting device.		
001	-	*CTL	[0 or 1 / 0 / -] 0: Automatic printing 1: No automatic printing

5169	[CE Login]		
	If you will change the printer bit switches, you must 'log in' to service mode with this SP before you go into the printer SP mode.		
001	CE Login	*CTL	[0 or 1 / 0 / -] 0: Disabled 1: Enabled

5181	[Size Adjust]		
	Adjusts the paper size for each tray.		
001	TRAY 1	*ENG	[0 to 3 / 0 (EU/ASIA), 1 (NA) / 1 /step] 0: A4 LEF, 1: LT LEF, 2: B5 LEF, 3: A5 LEF
002	TRAY 2: 1	*ENG	[0 or 1 / 0 (EU/ASIA), 1 (NA) / -] 0: A4 LEF, 1: LT LEF
003	TRAY 2: 2	*ENG	[0 or 1 / 0 (EU/ASIA), 1 (NA) / -] 0: A3, 1: DLT
004	TRAY 2: 3	*ENG	[0 or 1 / 0 (EU/ASIA), 1 (NA) / -] 0: B4, 1: LG
005	TRAY 2: 4	*ENG	[0 or 1 / 0 (EU/ASIA), 1 (NA) / -] 0: B5 LEF, 1: Exe LEF
006	TRAY 3/T-LCT: 1	*ENG	[0 or 1 / 0 (EU/ASIA), 1 (NA) / -] 0: A4 LEF, 1: LT LEF
007	TRAY 3: 2	*ENG	[0 or 1 / 0 (EU/ASIA), 1 (NA) / -] 0: A3, 1: DLT
008	TRAY 3: 3	*ENG	[0 or 1 / 0 (EU/ASIA), 1 (NA) / -] 0: B4, 1: LG
009	TRAY 3: 4	*ENG	[0 or 1 / 0 (EU/ASIA), 1 (NA) / -] 0: B5 LEF, 1: Exe LEF
010	TRAY 4: 1	*ENG	[0 or 1 / 0 (EU/ASIA), 1 (NA) / -] 0: A4 LEF, 1: LT LEF
011	TRAY 4: 2	*ENG	[0 or 1 / 0 (EU/ASIA), 1 (NA) / -] 0: A3, 1: DLT
012	TRAY 4: 3	*ENG	[0 or 1 / 0 (EU/ASIA), 1 (NA) / -] 0: B4, 1: LG
013	TRAY 4: 4	*ENG	[0 or 1 / 0 (EU/ASIA), 1 (NA) / -] 0: B5 LEF, 1: Exe LEF

Main SP Tables-5

018	LCT	*ENG	[0 to 2 / 0 (EU/ASIA), 1 (NA) / -] 0: A4LEF, 1: LTLEF, 2: B5LEF
-----	-----	------	--

5186	[RK4]		
	Enables or disables the prevention for RK4 (accounting device) disconnection. If the RK4 is disconnected for 10 seconds when this SP is set to "1 (Enable)", the machine automatically jams a sheet of paper and stops.		

001	-	*ENG	[0 or 1 / 0 / 1/step] 0: Disable 1: Enable
-----	---	------	---

5188	[Copy Nv Version]		
	Displays the version number of the NVRAM on the controller board.		
001	-	-	-

5193	[External Controller Info. Settings]		
001	-	-	Sets the external controller type. This setting is appropriately adjusted if an external controller is installed in the machine. [0 to 10 / 0 / 1/step] 0: No external controller installed 1: EFI controller 2: Ratio controller 3: Egret controller 4 to 10: Reserved

5199	[Paper Exit After Staple End.]		
001	-	*CTL	[0 or 1 / 0 / -] 0: OFF, 1: ON
<p>Enables or disables the paper feeding out from the finisher without stapling.</p> <ul style="list-style-type: none"> ▪ If this setting is "1: ON", paper is fed out without stapling at the maximum number of the finisher stapling when the machine gets a multiple printing job (over maximum number). ▪ If this setting is "0: OFF", paper is fed out with stapling at the maximum number of the finisher stapling when the machine gets a multiple printing job (over maximum number). 			

5212	[Page Numbering]	*CTL	
<p>This program adjusts the position of the second side page numbers. A "- value" moves the page number positions to the left edge. A "+ value" moves the page number positions to the right edge.</p>			
003	Duplex Printout Right/Left Position		[-10 to 10 / 0 / 1 mm/step]
004	Duplex Printout High/Low Position		[-10 to 10 / 0 / 1 mm/step]

5302	[Set Time]		
	<p>Adjusts the RTC (real time clock) time setting for the local time zone. Examples: For Japan (+9 GMT), enter 540 (9 hours x 60 min.) DOM: +540 (Tokyo) NA: -300 (New York) EU: + 60 (Paris) CH: +480 (Peking) TW: +480 (Taipei) AS: +480 (Hong Kong)</p>		
002	Time Difference	*CTL #	[-1440 to 1440 / -300 / 1 min./step]

5307	[Summer Time]		
001	Setting		[0 to 1 / NA, EU, ASIA / 1 /step] 0: Disabled 1: Enabled NA and EUR: 1, ASIA: 0
	<p>Enables or disables the summer time mode.</p> <p> Note</p> <ul style="list-style-type: none"> Make sure that both SP5-307-3 and -4 are correctly set. Otherwise, this SP is not activated even if this SP is set to "1". 		
003	Rule Set (Start)		
	<p>Specifies the start setting for the summer time mode.</p> <p>There are 8 digits in this SP. For months 1 to 9, the "0" cannot be input in the first digit, so the eight-digit setting for -2 or -3 becomes a seven-digit setting.</p> <p>1st and 2nd digits: The month. [1 to 12] 3rd digit: The week of the month. [1 to 5] 4th digit: The day of the week. [0 to 6 = Sunday to Saturday] 5th and 6th digits: The hour. [00 to 23] 7th digit: The length of the advanced time. [0 to 9 / 1 hour /step] 8th digit: The length of the advanced time. [0 to 5 / 10 minutes /step]</p> <ul style="list-style-type: none"> The digits are counted from the left. Make sure that SP5-307-1 is set to "1". 		
<p>For example: 3500010 (EU default) The timer is advanced by 1 hour at am 0:00 on the 5th Sunday in March</p>			
004	Rule Set (End)	-	-
	<p>Specifies the end setting for the summer time mode.</p> <p>There are 8 digits in this SP.</p> <p>1st and 2nd digits: The month. [1 to 12] 3rd digit: The week of the month. [0 to 5] 4th digit: The day of the week. [0 to 7 = Sunday to Saturday] 5th and 6th digits: The hour. [00 to 23] The 7th and 8 digits must be set to "00".</p> <ul style="list-style-type: none"> The digits are counted from the left. Make sure that SP5-307-1 is set to "1". 		

5404	[User Code Count Clear]		
001	UCodeCtrClr		Clears all counters for users.

5411	[LDAP Certification]		
004	Easy Certification	*CTL	Determines whether easy LDAP certification is done. [0 or 1 / 1 / -] 1: On, 0: Off
005	Password Null Not Permit	*CTL	This SP is referenced only when SP5411-4 is set to "1" (On). [0 or 1 / 0 / -] 0: Password NULL not permitted. 1: Password NULL permitted.
006	Detail Option	*CTL	Determines whether LDAP option (anonymous certification) is turned on or off. Bit0 0: OFF, 1: ON

5413	[Lockout Setting]		
001	Lockout On/Off	*CTL	Switches on/off the lock on the local address book account. [0 or 1 / 0 / -] 0: Off, 1: On
002	Lockout Threshold	*CTL	Sets a limit on the frequency of lockouts for account lockouts. [1 to 10 / 5 / 1/step]

Main SP Tables-5

003	Cancellation On/Off	*CTL	Determines whether the system waits the prescribed time for input of a correct user ID and password after an account lockout has occurred. [0 or 1 / 0 / -] 0: Off (no wait time, lockout not cancelled) 1: On (system waits, cancels lockout if correct user ID and password are entered).
004	Cancellation Time	*CTL	Determines the length of time that the system waits for correct input of the user ID and password after a lockout has occurred. This setting is used only if SP5413-3 is set to "1" (on). [1 to 999 / 60 / 1 min./step]

5414	[Access Mitigation]		
001	Mitigation On/Off	*CTL	Switches on/off masking of continuously used IDs and passwords that are identical. [0 or 1 / 0 / -] 0: Off, 1: On
002	Mitigation Time	*CTL	Sets the length of time for excluding continuous access for identical user IDs and passwords. [0 to 60 / 15 / 1 min./step]

5415	[Password Attack]		
001	Permissible Number	*CTL	Sets the number of attempts to attack the system with random passwords to gain illegal access to the system. [0 to 100 / 30 / 1 attempt/step]
002	Detect Time	*CTL	Sets the time limit to stop a password attack once such an attack has been detected. [1 to 10 / 5 / 1 sec./step]

5416	[Access Information]		
001	Access User Max Num	*CTL	Limits the number of users used by the access exclusion and password attack detection functions. [50 to 200 / 200 / 1 users/step]
002	Access Password Max Num	*CTL	Limits the number of passwords used by the access exclusion and password attack detection functions. [50 to 200 / 200 / 1 password/step]
003	Monitor Interval	*CTL	Sets the processing time interval for referencing user ID and password information. [1 to 10 / 3 / 1 sec./step]

5417	[Access Attack]		
001	Access Permissible Number	*CTL	Sets a limit on access attempts when an excessive number of attempts are detected for MFP features. [0 to 500 / 100 / 1/step]
002	Attack Detect Time	*CTL	Sets the length of time for monitoring the frequency of access to MFP features. [10 to 30 / 10 / 1 sec./step]
003	Productivity Fall Wait	*CTL	Sets the wait time to slow down the speed of certification when an excessive number of access attempts have been detected. [0 to 9 / 3 / 1 sec./step]
004	Attack Max Num	*CTL	Sets a limit on the number of requests received for certification in order to slow down the certification speed when an excessive number of access attempts have been detected. [50 to 200 / 200 / 1 attempt/step]

5420	[User Authentication]		
	<p>These settings should be done with the System Administrator.</p> <p>Note</p> <ul style="list-style-type: none"> These functions are enabled only after the user access feature has been enabled. 		
001	Copy	*CTL	<p>Determines whether certification is required before a user can use the copy applications.</p> <p>[0 to 1 / 0 /1]</p> <p>0: On, 1: Off</p>
002	Color Security Setting	*CTL	-
	<p>Enables or disables the color copy limitation for each copy mode when the user authentication is "ON".</p> <p>0: Enable (default), 1: Disable</p> <p>Bit0: B/W mode Bit1: Mono color mode Bit2: Two colors mode Bit3: Full color mode Bit4: Automatic color mode Bit5 to 7: Reserved</p>		
011	DocumentServer	*CTL	<p>Determines whether certification is required before a user can use the document server.</p> <p>[0 or 1/ 0 /1]</p> <p>0: On, 1: Off</p>
021	Fax	*CTL	<p>Determines whether certification is required before a user can use the fax application.</p> <p>[0 or 1/ 0 /1]</p> <p>0: On, 1: Off</p>
031	Scanner	*CTL	<p>Determines whether certification is required before a user can use the scan applications.</p> <p>[0 or 1/ 0 /1]</p> <p>0: On, 1: Off</p>

041	Printer	*CTL	Determines whether certification is required before a user can use the printer applications. [0 or 1 / 0 / 1] 0: On, 1: Off
051	SDK1	*CTL	Determines whether certification is required before a user can use the SDK application. [0 or 1 / 0 / 1] 0: ON. 1: OFF
061	SDK2		
071	SDK3		

5481	[Authentication Error Code]		
	These SP codes determine how the authentication failures are displayed.		
001	System Log Disp	*CTL	Determines whether an error code appears in the system log after a user authentication failure occurs. [0 or 1 / 0 / 1] 0: Off, 1: On
002	Panel Disp	*CTL	Determines whether an error code appears on the operation panel after a user authentication failure occurs. [0 or 1 / 1 / 1] 1: On, 0: Off

5490	[MF KeyCard (Japan only)]		
001	Job Permit Setting	*CTL	Sets up operation of the machine with a keycard. [0 to 1 / 0 / 1] 0: Disabled. Cancels operation without a user code. 1: Enabled. Allows operation without a user code.
002	Count Mode Setting	*CTL	-

Main SP Tables-5

5501	[PM Alarm]	*CTL	-
001	PM Alarm Level	<p>[0 to 9999 / 0 / 1 /step]</p> <p>0: Alarm off</p> <p>1 to 9999: Alarm goes off when Value (1 to 9999) x 1000 > PM counter</p>	
002	Original Count Alarm	<p>[0 or 1 / 0 / -]</p> <p>0: No alarm sounds</p> <p>1: Alarm sounds after the number of originals passing through the ARDF > 10,000</p>	

5504	[Jam Alarm]	*CTL	-
001	<p>Sets the alarm to sound for the specified jam level (document misfeeds are not included).</p> <p>[0 to 3 / 3 / 1 /step]</p> <p>0: Zero (Off)</p> <p>1: Low (2.5K jams)</p> <p>2: Medium (3K jams)</p> <p>3: High (6K jams)</p>		

5505	[Error Alarm]		
	<p>Sets the error alarm level.</p> <p>The error alarm counter counts "1" when any SC is detected. However, the error alarm counter decreases by "1" when an SC is not detected during a set number of copied sheets (for example, default 1500 sheets).</p> <p>The error alarm occurs when the SC error alarm counter reaches "5".</p>		
001	-	*CTL	[0 to 255 / C3a: 25, C3b: 35 / 100 copies /step]

5508*	[CC Call]	*CTL	-
001*	Jam Remains	0: Disable, 1: Enable	
	Enables/disables initiating a call for an unattended paper jam.		
002*	Continuous Jams	0: Disable, 1: Enable	
	Enables/disables initiating a call for consecutive paper jams.		
003*	Continuous Door Open	0: Disable, 1: Enable	
	Enables/disables initiating a call when the front door remains open.		
011*	Jam Detection: Time Length	[3 to 30 / 10 / 1 minute /step]	
	Sets the time a jam must remain before it becomes an "unattended paper jam". This setting is enabled only when SP5508-004 is set to "1".		
012*	Jam Detection: Continuous Count	[2 to 10 / 5 / 1 /step]	
	Sets the number of consecutive paper jams required to initiate a call. This setting is enabled only when SP5508-004 is set to "1".		
013*	Door Open: Time Length	[3 to 30 / 10 / 1 /step]	
	Sets the length of time the door remains open before the machine initiates a call. This setting is enabled only when SP5-508-004 is set to "1".		

5515	[SC/Alarm Setting]	*CTL	-
	With NRS (New Remote Service) in use, these SP codes can be set to issue an SC call when an SC error occurs. If this SP is switched off, the SC call is not issued when an SC error occurs.		
001	SC Call	[0 or 1 / 1 / -] 0: Off 1: On	
002	Service Parts Near End Call		
003	Service Parts End Call		

Main SP Tables-5

004	User Call	
006	Communication Test Call	[0 or 1 / 1 / -] 0: Off 1: On
007	Machine Information Notice	
008	Alarm Notice	
009	Non Genuine Tonner Alarm	
010	Supply Automatic Ordering Call	
011	Supply Management Report Call	
012	Jam/Door Open Call	

5516	[Individual PM Part Alarm Call]	*CTL	-
	With @Remote in use, these SP codes can be set to issue an PM alarm call when one of SP parts reaches its yield.		
001	Disable/Enable Setting (0: Not send, 1: Send)		[0 or 1 / 1 / -] 0: Not send, 1: Send
004	Percent yield for triggering PM alert		[1 to 255 / 75 / 1 %/step]

5610	[Base Gamma Control Point: Command]		
004	Factory Setting	*ENG	-
	Recalls the factory settings.		
005	Restore	*ENG	-
	Overwrites the current values onto the factory settings.		
006	Restore	*ENG	-
	Recalls the previous settings.		

5611	[Toner Color in 2C]		
001	B-C	*ENG	[0 to 128 / 100 / 1 /step] 128: Darkest density
	Adjusts the Cyan correction value of the blue signal in two-color mode.		
002	B-M	*ENG	[0 to 128 / 100 / 1 /step] 128: Darkest density
	Adjusts the Magenta correction value of the blue signal in two-color mode.		
003	G-C	*ENG	[0 to 128 / 100 / 1 /step] 128: Darkest density
	Adjusts the Cyan correction value of the blue signal in two-color mode.		
004	G-Y	*ENG	[0 to 128 / 100 / 1 /step] 128: Darkest density
	Adjusts the Yellow correction value of the blue signal in two-color mode.		
005	R-M	*ENG	[0 to 128 / 100 / 1 /step] 128: Darkest density
	Adjusts the Magenta correction value of the blue signal in two-color mode.		
006	R-Y	*ENG	[0 to 128 / 100 / 1 /step] 128: Darkest density
	Adjusts the Yellow correction value of the blue signal in two-color mode.		

5618	[Color Mode Display Selection]		
001	-	*CTL	[0 or 1 / 1 / -] 0: ACS, Colour, Black & White, Two Colour, Single colour 1: ACD, Full Colour, Black & White
	Selects the color selection display on the LCD.		

 **Note**

- Memory Clear (SP5-801)
- The following tables list the items that are cleared. The serial number information, meter charge setting and meter charge counters (SP8-581, 582, 583, 584, and 586) are not cleared.

5801	[Memory Clear]	
001	All Clear	Resets all correction data for process control and all software counters, and returns all modes and adjustments to their default values.
002	Engine	Clears the engine settings.
003	SCS	Initializes default system settings, SCS (System Control Service) settings, operation display coordinates, and ROM update information.
004	IMH Memory Clr	Initializes the IMH settings.
005	Mcs	Initializes the Mcs settings.
006	Copier Application	Initializes all copier application settings.
007	Fax Application	Initializes the fax reset time, job login ID, all TX/RX settings, local storage file numbers, and off-hook timer.
008	Printer Application	<p>The following service settings:</p> <ul style="list-style-type: none"> ▪ Bit switches ▪ Gamma settings (User & Service) ▪ Toner Limit <p>The following user settings:</p> <ul style="list-style-type: none"> ▪ Tray Priority ▪ Menu Protect ▪ System Setting except for setting of Energy Saver ▪ I/F Setup (I/O Buffer and I/O Timeout) ▪ PCL Menu
009	Scanner Application	Initializes the scanner defaults for the scanner and all the scanner SP modes.

010	Web Service	Deletes the network file application management files and thumbnails, and initializes the job login ID.
011	NCS	All setting of Network Setup (User Menu) (NCS: Network Control Service)
012	R-Fax	Initializes the job login ID, SmartDeviceMonitor for Admin, job history, and local storage file numbers.
014	Clear DCS Setting	Initializes the DCS (Delivery Control Service) settings.
015	Clear UCS Setting	Initializes the UCS (User Information Control Service) settings.
016	MIRS Setting	Initializes the MIRS (Machine Information Report Service) settings.
017	CCS	Initializes the CCS (Certification and Charge-control Service) settings.
018	SRM Memory Clr	Initializes the SRM (System Resource Manager) settings.
019	LCS	Initializes the LCS settings.
020	Web Uapli	Initializes the web user application settings.
021	ECS	Initializes the ECS settings.

5802	[FreeRun]		
	<p>Performs a free run on the copier engine.</p> <p>Note</p> <ul style="list-style-type: none"> ▪ The machine starts free run in the same condition as the sequence of A4/LT, A3 or A4 SEF printing from the 1st or 2nd tray. Therefore, the correct paper should be loaded in the 1st tray or 2nd tray, but paper is not fed. ▪ The main switch has to be turned off and on after using the free run mode for a test. 		
001	B/W A4 LEF	-	-

Main SP Tables-5

002	FC A4 LEF	-	
003	FC A3 LEF	*ENG	

5803	[Input Check]	-	See "Input Check Table" in "Main SP Tables-9". (p.5-338)
044	Cooling Fan: Lock	*ENG	0: Unlock 1: Lock
045	2nd Duct Fan2: Lock	*ENG	0: Unlock 1: Lock

5804	[Output Check]	*ENG	See "Output Check Table" in "Main SP Tables-9". (p.5-353)
------	----------------	------	---

5805	[Anti-Condensation Heater]		
002	0:OFF / 1:ON	*ENG	-

5810	[SC Reset]		
	Resets a type A service call condition. <div style="border: 1px solid black; border-radius: 10px; padding: 2px; display: inline-block;"> Note </div> <ul style="list-style-type: none"> ▪ Turn the main switch off and on after resetting the SC code. 		
001	Fusing SC Reset	-	
002	Hard High Temp. Detection	-	-

5811	[MachineSerial] Machine Serial Number Display		
002	Display	*ENG	Displays the machine serial number.
004	BCU		Inputs

5812	[Service Tel. No. Setting]		
------	----------------------------	--	--

001	Service	*CTL	-
	<p>Sets the telephone number for a service representative. This number is printed on the Counter List, which can be printed with the user's "Counter" menu.</p> <p>This can be up to 20 characters (both numbers and alphabetic characters can be input).</p>		
002	Facsimile	*CTL	-
	<p>Sets the fax or telephone number for a service representative. This number is printed on the Counter List.</p> <p>This can be up to 20 characters (both numbers and alphabetic characters can be input).</p>		
003	Supply	*CTL	-
	<p>Use this to input the telephone number of your supplier for consumables. Enter the number and press #.</p>		
004	Operation	*CTL	-
	<p>Use this to input the telephone number of your sales agency. Enter the number and press #.</p>		

5816	[Remote Service]	*CTL	-
001	I/F Setting		
	Selects the remote service setting. [0 to 2 / 2 / 1 /step] 0: Remote service off 1: CSS remote service on 2: NRS remote service on		
002	CE Call		
	Performs the CE Call at the start or end of the service. [0 or 1 / 0 / 1 /step] 0: Start of the service 1: End of the service <div style="border: 1px solid black; border-radius: 10px; padding: 2px; display: inline-block;"> ⬇ Note </div> <ul style="list-style-type: none"> ▪ This SP is activated only when SP 5816-001 is set to “2”. 		
003	Function Flag		
	Enables or disables the remote service function. [0 to 1 / 0 / 1 /step] 0: Disabled 1: Enabled		
007	SSL Disable		
	Controls if RCG (Remote Communication Gate) confirmation is done by SSL during an RCG send for the @Remote over a network interface. [0 or 1 / 0 / 1 /step] 0: Yes. SSL not used. 1: No. SSL used.		

008	RCG Connect Timeout	
	Sets the length of time (seconds) for the time-out when the RCG (Remote Communication Gate) connects during a call via the @Remote network. [1 to 90 / 30 / 1 second /step]	
009	RCG Write Timeout	
	Sets the length of time (seconds) for the time-out when sent data is written to the RCG during a call over the @Remote network. [1 to 100 / 60 / 1 second /step]	
010	RCG Read Timeout	
	Sets the length of time (seconds) for the timeout when sent data is written from the RCG during a call over the @Remote network. [1 to 100 / 60 / 1 second /step]	
011	Port 80 Enable	-
	Controls if permission is given to get access to the SOAP method over Port 80 on the @Remote network. [0 or 1 / 0 / -] 0: No. Access denied 1: Yes. Access granted.	
013	RFU Timing	
	Selects the timing for the remote firmware updating. [0 or 1 / 1 / -] 0: Any status of a target machine 1: Sleep or panel off mode only	
021	RCG – C Registered	
	This SP displays the RCG-N installation end flag. 0: Installation not completed 1: Installation completed	

	Connect Type (N/M)	
023	<p>This SP displays and selects the RCG-N connection method.</p> <p>[0 or 1 / 0 / 1 /step]</p> <p>0: Internet connection</p> <p>1: Dial-up connection</p>	
061	<p>Cert Expire Timing</p> <p>DFU</p>	<p>Proximity of the expiration of the certification.</p> <p>[0 to 0xffffffff / 0 / 1 /step]</p>
062	<p>Use Proxy</p>	<p>This SP setting determines if the proxy server is used when the machine communicates with the service center.</p> <p>[0 or 1 / 0 / 1 /step]</p> <p>0: Not use</p> <p>1: Use</p>
	Proxy Host	
063	<p>This SP sets the address of the proxy server used for communication between the RCG device and the gateway. Use this SP to set up or display the customer proxy server address.</p> <p>The address is necessary to set up the embedded RCG-N.</p> <p>Note</p> <ul style="list-style-type: none"> ▪ The address display is limited to 128 characters. Characters beyond the 128 character are ignored. ▪ This address is customer information and is not printed in the SMC report. 	
	Proxy PortNumber	
064	<p>This SP sets the port number of the proxy server used for communication between the embedded RCG-N and the gateway. This setting is necessary to set up the embedded RC Gate-N.</p> <p>Note</p> <ul style="list-style-type: none"> ▪ This port number is customer information and is not printed in the SMC report. 	

065	Proxy User Name	
	<p>This SP sets the HTTP proxy certification user name.</p> <p>Note</p> <ul style="list-style-type: none"> ▪ The length of the name is limited to 31 characters. Any character beyond the 31st character is ignored. ▪ This name is customer information and is not printed in the SMC report. 	
066	Proxy Password	
	<p>This SP sets the HTTP proxy certification password.</p> <p>Note</p> <ul style="list-style-type: none"> ▪ The length of the password is limited to 31 characters. Any character beyond the 31st character is ignored. ▪ This name is customer information and is not printed in the SMC report. 	
067	CERT:Up State	
	Displays the status of the certification update.	
	0	The certification used by RCG-N is set correctly.
	1	The certification request (setAuthKey) for update has been received from the GW URL and certification is presently being updated.
	2	The certification update is completed and the GW URL is being notified of the successful update.
	3	The certification update failed, and the GW URL is being notified of the failed update.
	4	The period of the certification has expired and new request for an update is being sent to the GW URL.
	11	A rescue update for certification has been issued and a rescue certification setting is in progress for the rescue GW connection.
12	The rescue certification setting is completed and the GW URL is being notified of the certification update request.	

	13	The notification of the request for certification update has completed successfully, and the system is waiting for the certification update request from the rescue GW URL.
	14	The notification of the certification request has been received from the rescue GW controller, and the certification is being stored.
	15	The certification has been stored, and the GW URL is being notified of the successful completion of this event.
	16	The storing of the certification has failed, and the GW URL is being notified of the failure of this event.
	17	The certification update request has been received from the GW URL, the GW URL was notified of the results of the update after it was completed, but an certification error has been received, and the rescue certification is being recorded.
	18	The rescue certification of No. 17 has been recorded, and the GW URL is being notified of the failure of the certification update.
068	CERT:Error	
	Displays a number code that describes the reason for the request for update of the certification.	
	0	Normal. There is no request for certification update in progress.
	1	Request for certification update in progress. The current certification has expired.
	2	An SSL error notification has been issued. Issued after the certification has expired.
	3	Notification of shift from a common authentication to an individual certification.
	4	Notification of a common certification without ID2.
	5	Notification that no certification was issued.
	6	Notification that GW URL does not exist.
069	CERT:Up ID	The ID of the request for certification.

083	Firm Up Status	Displays the status of the firmware update.
085	Firm Up User Check	This SP setting determines if the operator can confirm the previous version of the firmware before the firmware update execution. If the option to confirm the previous version is selected, a notification is sent to the system manager and the firmware update is done with the firmware files from the URL.
086	Firmware Size	Allows the service technician to confirm the size of the firmware data files during the firmware update execution.
087	CERT: Macro Ver.	Displays the macro version of the @Remote certification.
088	CERT: PAC Ver.	Displays the PAC version of the @Remote certification.
089	CERT: ID2 Code	Displays ID2 for the @Remote certification. Spaces are displayed as underscores (_). Asterisks (****) indicate that no @Remote certification exists.
090	CERT: Subject	Displays the common name of the @Remote certification subject. CN = the following 17 bytes. Spaces are displayed as underscores (_). Asterisks (****) indicate that no DESS exists.
091	CERT: Serial No	Displays serial number for the NRS certification. Asterisks (****) indicate that no DESS exists.
092	CERT: Issuer	Displays the common name of the issuer of the @Remote certification. CN = the following 30 bytes. Asterisks (****) indicate that no DESS exists.
093	CERT: Valid Start	Displays the start time of the period for which the current @Remote certification is enabled.
094	CERT: Valid End	Displays the end time of the period for which the current @Remote certification is enabled.

102	CERT: Strength	Displays cryptic strength of the NRS certification. 1: 512 bit 2: 2048 bit
150	<p>Selection Country</p> <p>Select the country where embedded RCG-M is installed in the machine. After selecting the country, you must also set the following SP codes for embedded RCG-M:</p> <ul style="list-style-type: none"> ▪ SP5816-153 ▪ SP5816-154 ▪ SP5816-161 <p>0: Japan, 1: USA, 2: Canada, 3: UK, 4: Germany, 5: France, 6: Italy, 7: Netherlands, 8: Belgium, 9: Luxembourg, 10: Spain</p>	
151	<p>Line Type Automatic Judgment</p> <p>Press [Execute].</p> <p>Setting this SP classifies the telephone line where embedded RCG-M is connected as either dial-up (pulse dial) or push (DTMF tone) type, so embedded RCG-M can automatically distinguish the number that connects to the outside line.</p> <ul style="list-style-type: none"> ▪ The current progress, success, or failure of this execution can be displayed with SP5816-152. ▪ If the execution succeeded, SP5816-153 will display the result for confirmation and SP5816-154 will display the telephone number for the connection to the outside line. 	

152	<p>Line Type Judgment Result</p> <p>Displays a number to show the result of the execution of SP5816 151. Here is a list of what the numbers mean.</p> <p>0: Success</p> <p>1: In progress (no result yet). Please wait.</p> <p>2: Line abnormal</p> <p>3: Cannot detect dial tone automatically</p> <p>4: Line is disconnected</p> <p>5: Insufficient electrical power supply</p> <p>6: Line classification not supported</p> <p>7: Error because fax transmission in progress – ioctl() occurred.</p> <p>8: Other error occurred</p> <p>9: Line classification still in progress. Please wait.</p>
153	<p>Selection Dial / Push</p> <p>This SP displays the classification (tone or pulse) of the telephone line to the access point for embedded RCG-M. The number displayed (0 or 1) is the result of the execution of SP5816-151. However, this setting can also be changed manually.</p> <p>[0 or 1 / 0 / 1 /step]</p> <p>0: Tone Dialing Phone</p> <p>1: Pulse Dialing Phone</p> <p>Inside Japan "2" may also be displayed:</p> <p>0: Tone Dialing Phone</p> <p>1: Pulse Dialing Phone 10PPS</p> <p>2: Pulse Dialing Phone 20PPS</p>

154	<p>Outside Line Outgoing Number</p> <p>The SP sets the number that switches to PSTN for the outside connection for embedded RCG-M in a system that employs a PBX (internal line).</p> <ul style="list-style-type: none"> ▪ If the execution of SP5816-151 has succeeded and embedded RCG-M has connected to the external line, this SP display is completely blank. ▪ If embedded RCG-M has connected to an internal line, then the number of the connection to the external line is displayed. ▪ If embedded RCG-M has connected to an external line, a comma is displayed with the number. The comma is inserted for a 2 sec. pause. ▪ The number setting for the external line can be entered manually (including commas).
156	<p>Dial Up User Name</p> <p>Use this SP to set a user name for access to remote dial up. Follow these rules when setting a user name:</p> <ul style="list-style-type: none"> ▪ Name length: Up to 32 characters ▪ Spaces and # allowed but the entire entry must be enclosed by double quotation marks (").
157	<p>Dial Up Password</p> <p>Use this SP to set a password for access to remote dial up. Follow these rules when setting a user name:</p> <ul style="list-style-type: none"> ▪ Name length: Up to 32 characters ▪ Spaces and # allowed but the entire entry must be enclosed by double quotation marks (").
161	<p>Local Phone Number</p> <p>Use this SP to set the telephone number of the line where embedded RCG-M is connected. This number is transmitted to and used by the Call Center to return calls.</p> <p>Limit: 24 numbers (numbers only)</p>

	Connection Timing Adjustment Incoming	
162	<p>When the Call Center calls out to an embedded RCG-M modem, it sends a repeating ID tone (*#1#). This SP sets the time the line remains open to send these ID tones after the number of the embedded RCG-M modem is dialed up and connected.</p> <p>[0 to 24 / 1 / 1 /step]</p> <p>The actual amount of time is this setting x 2 sec. For example, if you set "2" the line will remain open for 4 sec.</p>	
	Access Point	
163	<p>This is the number of the dial-up access point for RCG-M. If no setting is done for this SP code, then a preset value (determined by the country selected) is used.</p> <p>Default: 0</p> <p>Allowed: Up to 16 alphanumeric characters</p>	
	Line Connecting	
164	<p>This SP sets the connection conditions for the customer. This setting dedicates the line to RCG-M only, or sets the line for sharing between RCG-M and a fax unit.</p> <p>[0 to 1 / 0 / 1 /step]</p> <p>0: Sharing Fax</p> <p>1: No Sharing Fax</p> <p>Note</p> <ul style="list-style-type: none"> ▪ If this setting is changed, the copier must be cycled off and on. ▪ SP5816 187 determines whether the off-hook button can be used to interrupt a RCG-M transmission in progress to open the line for fax transaction. 	
173	Modem Serial No.	This SP displays the serial number registered for the RCG-M.

	Retransmission Limit		
174	<p>Normally, it is best to allow unlimited time for certification and ID2 update requests, and for the notification that the certification has been completed. However, RCG-M generates charges based on transmission time for the customer, so a limit is placed upon the time allowed for these transactions. If these transactions cannot be completed within the allowed time, do this SP to cancel the time restriction.</p>		
	FAX TX Priority	-	
187	<p>This SP determines whether pushing the off-hook button will interrupt a RCG-M transmission in progress to open the line for fax transaction. This SP can be used only if SP5816 164 is set to "0".</p> <p>[0 or 1/ 0 / -]</p> <p>0: Disable, 1: Enable</p>		
200	Manual Polling	-	Executes the manual polling.
	Regist Status		
201	<p>Displays a number that indicates the status of the @Remote service device.</p> <p>0: Neither the registered device by the external nor embedded RCG device is set.</p> <p>1: The embedded RCG device is being set. Only Box registration is completed. In this status, this unit cannot answer a polling request from the external RCG.</p> <p>2: The embedded RCG device is set. In this status, the external RCG unit cannot answer a polling request.</p> <p>3: The registered device by the external RCG is being set. In this status the embedded RCG device cannot be set.</p> <p>4 The registered module by the external RCG has not started.</p>		
202	Letter Number	Allows entry of the number of the request needed for the RCG-N device.	
203	Confirm Execute	Executes the inquiry request to the @Remote GW URL.	

	Confirm Result	
204	<p>Displays a number that indicates the result of the inquiry executed with SP5816 203.</p> <p>0: Succeeded</p> <p>1: Inquiry number error</p> <p>2: Registration in progress</p> <p>3: Proxy error (proxy enabled)</p> <p>4: Proxy error (proxy disabled)</p> <p>5: Proxy error (Illegal user name or password)</p> <p>6: Communication error</p> <p>7: Certification update error</p> <p>8: Other error</p> <p>9: Inquiry executing</p>	
	Confirm Place	
205	<p>Displays the result of the notification sent to the device from the GW URL in answer to the inquiry request. Displayed only when the result is registered at the GW URL.</p>	
206	Register Execute	Executes "Embedded RCG Registration".
	Register Result	
207	<p>Displays a number that indicates the registration result.</p> <p>0: Succeeded</p> <p>2: Registration in progress</p> <p>3: Proxy error (proxy enabled)</p> <p>4: Proxy error (proxy disabled)</p> <p>5: Proxy error (Illegal user name or password)</p> <p>6: Communication error</p> <p>7: Certification update error</p> <p>8: Other error</p> <p>9: Registration executing</p>	

208	Error Code		
	Displays a number that describes the error code that was issued when either SP5816-204 or SP5816-207 was executed. [-2147483647 to 2147483647 / 0 / -]		
	Cause	Code	Meaning
	Illegal Modem Parameter	-11001	Chat parameter error
		-11002	Chat execution error
		-11003	Unexpected error
	Operation Error, Incorrect Setting	-12002	Inquiry, registration attempted without acquiring device status.
		-12003	Attempted registration without execution of an inquiry and no previous registration.
		-12004	Attempted setting with illegal entries for certification and ID2.
		-12005	@Remote communication is prohibited. The device has an Embedded RC gate-related problem.
	Operation Error, Incorrect Setting	-12006	A confirmation request was made after the confirmation had been already completed.
		-12007	The request number used at registration was different from the one used at confirmation.
		-12008	Update certification failed because mainframe was in use.
		-12009	ID2 mismatch between an individual certification and NVRAM
		-12010	Certification area is not initialized.

208	Error Caused by Response from GW URL	-2385	Attempted dial up overseas without the correct international prefix for the telephone number.
		-2387	Not supported at the Service Center
		-2389	Database out of service
		-2390	Program out of service
		-2391	Two registrations for same device
		-2392	Parameter error
		-2393	Basil not managed
		-2394	Device not managed
		-2395	Box ID for Basil is illegal
		-2396	Device ID for Basil is illegal
		-2397	Incorrect ID2 format
		-2398	Incorrect request number format
209	Instal Clear	Releases the machine from its embedded RCG setup.	
250	CommLog Print	Prints the communication log.	

5821	[Remote Service Address]		
002	RCG IP Address	*CTL	Sets the IP address of the RCG (Remote Communication Gate) destination for call processing at the remote service center.

5824	[NV-RAM Data Upload]		
	Uploads the UP and SP mode data (except for counters and the serial number) from the NVRAM to an SD card. For details, see the "NVRAM Data Upload/Download" in this section.		
001	NV-RAM Data Upload	#	-

5825	[NV-RAM Data Download]		
	Downloads the UP and SP mode data from an SD card to the NVRAM. For details, see the "NVRAM Data Upload/Download" in this section.		
001	NV-RAM Download	#	-

5828	[Network Setting]	*CTL	-
050	1284 Compatibility (Centro)	Enables or disables 1284 Compatibility. [0 or 1 / 1 / 1 / step] 0: Disabled, 1: Enabled	
052	ECP (Centro)	Enables or disables ECP Compatibility. [0 or 1 / 1 / 1 / step] 0: Disabled, 1: Enabled Note 1. This SP is activated only when SP5-828-50 is set to "1".	
065	Job Spooling	Enables/disables Job Spooling. [0 or 1 / 0 / 1 / step] 0: Disabled, 1: Enabled	
066	Job Spooling Clear: Start Time	Treatment of the job when a spooled job exists at power on. 0: ON (Data is cleared) 1: OFF (Automatically printed)	

069	Job Spooling (Protocol)	Validates or invalidates the job spooling function for each protocol. 0 : Validates 1: Invalidates bit0: LPR bit1: FTP bit2: IPP bit3: SMB bit4: BMLinkS bit5: DIPRINT bit6: sftp bit7: (Reserved)
090	TELNET (0: OFF 1: ON)	Enables or disables the Telnet protocol. [0 or 1 / 1 / –] 0: Disable, 1: Enable
091	Web (0: OFF 1: ON)	Enables or disables the Web operation. [0 or 1 / 1 / –] 0: Disable, 1: Enable
145	Active IPv6 Link Local Address	This is the IPv6 local address link referenced on the Ethernet or wireless LAN (802.11b) in the format: "Link Local Address" + "Prefix Length" The IPv6 address consists of a total 128 bits configured in 8 blocks of 16 bits each.
147	Active IPv6 Stateless Address 1	These SPs are the IPv6 status addresses (1 to 5) referenced on the Ethernet or wireless LAN (802.11b) in the format: "Status Address" + "Prefix Length" The IPv6 address consists of a total 128 bits configured in 8 blocks of 16 bits each.
149	Active IPv6 Stateless Address 2	
151	Active IPv6 Stateless Address 3	
153	Active IPv6 Stateless Address 4	
155	Active IPv6 Stateless Address 5	

156	IPv6 Manual Address	<p>This SP is the IPv6 manually set address referenced on the Ethernet or wireless LAN (802.11b) in the format: "Manual Set Address" + "Prefix Length" The IPv6 address consists of a total 128 bits configured in 8 blocks of 16 bits each.</p>
158	IPv6 Gateway Address	<p>This SP is the IPv6 gateway address referenced on the Ethernet or wireless LAN (802.11b). The IPv6 address consists of a total 128 bits configured in 8 blocks of 16 bits each.</p>
161	IPv6 Stateless Auto Setting	<p>Enables or disables the automatic setting for IPv6 stateless. [0 or 1 / 1 / 1 /step] 0: Disable, 1: Enable</p>
236	Web Item visible	<p>Displays or does not display the Web system items. [0 x 0000 to 0 x ffff / 0 x ffff] 0: Not displayed, 1: Displayed bit0: Net RICOH bit1: Consumable Supplier bit2-15: Reserved (all)</p>
237	Web shopping link visible	<p>Displays or does not display the link to Net RICOH on the top page and link page of the web system. [0 to 1 / 1 / 1] 0: Not display, 1:Display</p>
238	Web supplies Link visible	<p>Displays or does not display the link to Consumable Supplier on the top page and link page of the web system. [0 to 1 / 1 / 1] 0: Not display, 1:Display</p>
239	Web Link1 Name	<p>This SP confirms or changes the URL1 name on the link page of the web system. The maximum characters for the URL name are 31 characters.</p>

240	Web Link1 URL	This SP confirms or changes the link to URL1 on the link page of the web system. The maximum characters for the URL are 127 characters.
241	Web Link1 visible	Displays or does not display the link to URL1 on the top page of the web system. [0 to 1 / 1 / 1] 0: Not display, 1:Display
242	Web Link2 Name	Same as "-239"
243	Web Link2 URL	Same as "-240"
244	Web Link2 visible	Same as "-241"

5832	[HDD] HDD Initialization	*CTL	-
001	HDD Formatting (ALL)	Initializes the hard disk. Use this SP mode only if there is a hard disk error.	
002	HDD Formatting (IMH)		
003	HDD Formatting (Thumbnail)		
004	HDD Formatting (Job Log)		
005	HDD Formatting (Printer Fonts)		
006	HDD Formatting (User Info)		
007	Mail RX Data		
008	Mail TX Data		
009	HDD Formatting (Data for a Design)		
010	HDD Formatting (Log)		
011	HDD Formatting (Ridoc I/F)		

5836	[Capture Setting]	*CTL	-
001	Capture Function (0:Off 1:On)	0: Disable, 1: Enable	
	With this function disabled, the settings related to the capture feature cannot be initialized, displayed, or selected.		
002	Panel Setting	0: Displayed, 1: Not displayed	
	Displays or does not display the capture function buttons.		
<p>5836-71 to 5836-78, Copier and Printer Document Reduction</p> <p>The following 6 SP modes set the default reduction for stored documents sent to the document management server via the MLB.</p> <p>Enabled only when optional MLB (Media Link Board) is installed.</p>			
071	Reduction for Copy Color	0: 1to-1, 1: 1/2, 2: 1/3 , 3: 1/4	
072	Reduction for Copy B&W Text	0: 01 , 1: 1/2, 2: 1/3, 3: 1/4, 6: 2/3	
073	Reduction for Copy B&W Other	0: 01 , 1: 1/2, 2: 1/3, 3: 1/4, 6: 2/3	
074	Reduction for Printer Color	0: 1to-1, 1: 1/2, 2: 1/3 , 3: 1/4	
075	Reduction for Printer B&W	0: 01 , 1: 1/2, 2: 1/3, 3: 1/4, 6: 2/3	
076	Reduction for Printer B&W HQ	0: 1to-1 , 1: 1/2, 2: 1/3, 3: 1/4	
077	Reduction for Printer Color 1200dpi	1: 1/2, 3: 1/4, 4: 1/6 , 5: 1/8 (2: skipped) , 6: 2/3	
078	Reduction for Printer B&W 1200dpi	1: 1/2 , 3: 1/4, 4: 1/6, 5: 1/8 (2: skipped) , 6: 2/3	
<p>5836-81 to 5836-86, Stored document format</p> <p>The following 6 SP modes set Sets the default format for stored documents sent to the document management server via the MLB.</p> <p>Enabled only when optional MLB (Media Link Board) is installed.</p>			
081	Format for Copy Color	0: JFIF/JPEG , 1: TIFF/MMR, 2: TIFF/MH, 3: TIFF/MR  Note <ul style="list-style-type: none"> ▪ This SP is not used in this model. 	

082	Format for Copy B&W Text	0: JFIF/JPEG, 1: TIFF/MMR , 2: TIFF/MH, 3: TIFF/MR
083	Format Copy B&W Other	0: JFIF/JPEG, 1: TIFF/MMR , 2: TIFF/MH, 3: TIFF/MR
084	Format for Printer Color	0: JFIF/JPEG , 1: TIFF/MMR, 2: TIFF/MH, 3: TIFF/MR Note <ul style="list-style-type: none"> This SP is not used in this model.
085	Format for Printer B&W	0: JFIF/JPEG, 1: TIFF/MMR , 2: TIFF/MH, 3: TIFF/MR
086	Format for Printer B&W HQ	0: JFIF/JPEG, 1: TIFF/MMR, 2: TIFF/MH , 3: TIFF/MR
091	Default for JPEG	[5 to 95 / 50 / 1 /step]
	Sets the JPEG format default for documents sent to the document management server via the MLB with JPEG selected as the format. Enabled only when optional MLB (Media Link Board) is installed.	
101	Primary srv IP address	Sets the IP address for the primary capture server. This is basically adjusted by the remote system.
102	Primary srv scheme	This is basically adjusted by the remote system.
103	Primary srv port number	This is basically adjusted by the remote system.
104	Primary srv URL path	This is basically adjusted by the remote system.
111	Secondary srv IP address	Sets the IP address for the secondary capture server. This is basically adjusted by the remote system.
112	Secondary srv scheme	This is basically adjusted by the remote system.
113	Secondary srv port number	This is basically adjusted by the remote system.

114	Secondary srv URL path	This is basically adjusted by the remote system.
120	Default Reso Rate Switch	This is basically adjusted by the remote system.
121	Reso: Copy (Color)	[0 to 3 / 2 / 1/step]
	Selects the resolution for color copy mode. This is basically adjusted by the remote system. 0: 600dpi/ 1: 300dpi/ 2: 150dpi/ 3: 75dpi	
122	Reso: Copy (Mono)	[0 to 5 / 3 / 1/step]
	Selects the resolution for BW copy mode. This is basically adjusted by the remote system. 0: 600dpi/ 1: 400dpi/ 2: 300dpi/ 3: 200dpi/ 4: 150dpi/ 5: 100dpi	
123	Reso: Print (Color)	This is basically adjusted by the remote system. [0 to 3 / 2 / 1/step]
	Selects the resolution for color print mode. This is basically adjusted by the remote system. 0: 600dpi/ 1: 300dpi/ 2: 150dpi/ 3: 75dpi	
124	Reso: Print (Mono)	This is basically adjusted by the remote system. [0 to 5 / 3 / 1/step]
	Selects the resolution for BW print mode. This is basically adjusted by the remote system. 0: 600dpi/ 1: 400dpi/ 2: 300dpi/ 3: 200dpi/ 4: 150dpi/ 5: 100dpi	
125	Reso: Fax (Color)	This is basically adjusted by the remote system. [0 to 6 / 4 / 1/step]
	Selects the resolution for color fax mode. This is basically adjusted by the remote system. 0: 600dpi/ 1: 400dpi/ 2: 300dpi/ 3: 200dpi/ 4: 150dpi/ 5: 100dpi/ 6: 75dpi	

126	Reso: Fax (Mono)	This is basically adjusted by the remote system. [0 to 6 / 3 / 1/step]	
	Selects the resolution for BW fax mode. This is basically adjusted by the remote system. 0: 600dpi/ 1: 400dpi/ 2: 300dpi/ 3: 200dpi/ 4: 150dpi/ 5: 100dpi/ 6: 75dpi		
127	Reso: Scan (Color)	This is basically adjusted by the remote system. [0 to 6 / 4 / 1/step]	
	Selects the resolution for color scanning mode. This is basically adjusted by the remote system. 0: 600dpi/ 1: 400dpi/ 2: 300dpi/ 3: 200dpi/ 4: 150dpi/ 5: 100dpi/ 6: 75dpi		
128	Reso: Scan (Mono)	This is basically adjusted by the remote system. [0 to 6 / 3 / 1/step]	
	Selects the resolution for BW scanning mode. This is basically adjusted by the remote system. 0: 600dpi/ 1: 400dpi/ 2: 300dpi/ 3: 200dpi/ 4: 150dpi/ 5: 100dpi/ 6: 75dpi		

5840	[IEEE 802.11]		
006	Channel Max	*CTL	[1 to 11 or 13 / 11 or 13 / 1 /step] Europe/Asia: 1 to 13 NA/ Asia: 1 to 11
	Sets the maximum number of channels available for data transmission via the wireless LAN. The number of channels available varies according to location. The default settings are set for the maximum end of the range for each area. Adjust the upper 4 bits to set the maximum number of channels. DFU		
<p> Note</p> <ul style="list-style-type: none"> Do not change the setting. 			

	Channel Min	*CTL	[1 to 11 or 13 / 1 / 1 /step] Europe: 1 to 13 NA/ Asia: 1 to 11
007	<p>Sets the minimum number of channels available for data transmission via the wireless LAN. The number of channels available varies according to location. The default settings are set for the minimum end of the range for each area. Adjust the lower 4 bits to set the minimum number of channels. DFU</p> <p>Note</p> <ul style="list-style-type: none"> Do not change the setting. 		
008	Transmission Speed	*CTL	0 x 00 to 0 x FF / 0 x FF to Auto / -] 0 x FF to Auto [Default] 0 x 11 - 55M Fix 0 x 10 - 48M Fix 0 x 0F - 36M Fix 0 x 0E - 18M Fix 0 x 0D - 12M Fix 0 x 0B - 9M Fix 0 x 0A - 6M Fix 0 x 07 - 11M Fix 0 x 05 - 5.5M Fix 0 x 08 - 1M Fix 0 x 13 - 0 x FE (reserved) 0 x 12 - 72M (reserved) 0 x 09 - 22M (reserved)
011	WEP key Select	*CTL	Selects the WEP key. [00 to 11 / 00 / 1 binary] 00: Key #1 01: Key #2 (Reserved) 10: Key #3 (Reserved) 11: Key #4 (Reserved)
042	Fragment Thresh	*CTL	Adjusts the fragment threshold for the IEEE802.11 card. [256 to 2346 / 2346 / 1] This SP is displayed only when the IEEE802.11 card is installed.

043	11g CTS to Self	*CTL	Determines whether the CTS self function is turned on or off. [0 to 1 / 1 / 1] 0: Off, 1: On This SP is displayed only when the IEEE802.11 card is installed.
044	11g Slot Time	*CTL	Selects the slot time for IEEE802.11. [0 to 1 / 0 / 1] 0: 20 μ m, 1: 9 μ m
045	WPA Debug Lvl	*CTL	Selects the debug level for WPA authentication application. [1 to 3 / 3 / 1] 1: Info, 2: warning, 3: error This SP is displayed only when the IEEE802.11 card is installed.

5841	[Supply Name Setting]		
001	Toner Name Setting: Black	*CTL	Specifies supply names. These appear on the screen when the user presses the Inquiry button in the user tools screen.
002	Toner Name Setting: Cyan		
003	Toner Name Setting: Yellow		
004	Toner Name Setting: Magenta		
007	OrgStamp		
011	Staple Std1		
012	Staple Std2		
013	Staple Std3		
014	Staple Std4		
021	Staple Bind 1		
022	Staple Blind2		
023	Staple Blind 3		

5844	[USB]		
001	Transfer Rate	*CTL	0x01: Full speed 0x04: Auto Change
	Adjusts the USB transfer rate.		
002	Vendor ID	*CTL	Displays the vendor ID. DFU
003	Product ID	*CTL	Displays the product ID. DFU
004	Device Release Number	*CTL	Displays the development release version number. DFU

5845	[Delivery Server Setting]	*CTL	-
	Provides items for delivery server settings.		
001	FTP Port No.		[0 to 65535 / 3670 / 1 /step]
	Sets the FTP port number used when image files to the Scan Router Server.		
002	IP Address (Primary)		Range: 000.000.000.000 to 255.255.255.255
	Use this SP to set the Scan Router Server address. The IP address under the transfer tab can be referenced by the initial system setting.		
006	Delivery Error Display Time		[0 to 999 / 300 / 1 second /step]
	Use this setting to determine the length of time the prompt message is displayed when a test error occurs during document transfer with the NetFile application and an external device.		
008	IP Address (Secondary)		Range: 000.000.000.000 to 255.255.255.255
	Specifies the IP address assigned to the computer designated to function as the secondary delivery server of Scan Router. This SP allows only the setting of the IP address without reference to the DNS setting.		



009	Delivery Server Model	[0 to 4/ 0 / 1 /step]
	Allows changing the model of the delivery server registered by the I/O device. 0: Unknown 1: SG1 Provided 2: SG1 Package 3: SG2 Provided 4: SG2 Package	
010	Delivery Svr. Capability	[0 to 255 / - / 1 /step]
	Bit7 = 1 Comment information exists	Changes the capability of the registered that the I/O device registered.
	Bit6 = 1 Direct specification of mail address possible	
	Bit5 = 1 Mail RX confirmation setting possible	
	Bit4 = 1 Address book automatic update function exists	
	Bit3 = 1 Fax RX delivery function exists	
	Bit2 = 1 Sender password function exists	
	Bit1 = 1 Function to link MK-1 user and Sender exists	
	Bit0 = 1 Sender specification required (if set to 1, Bit6 is set to "0")	
011	Delivery Svr Capability (Ext)	[0 to 255 / - / 1 /step]
	Changes the capability of the registered that the I/O device registered. Bit7 = 1 Address book usage limitation (Limitation for each authorized user) Bit6 = 1 RDH authorization link Bit5 to 0: Not used	
013	Server Scheme (Primary) DFU	
	This is used for the scan router program.	
014	Server Port Number (Primary) DFU	
	This is used for the scan router program.	

015	Server URL Path (Primary) DFU
	This is used for the scan router program.
016	Server Scheme (Secondary) DFU
	This is used for the scan router program.
017	Server Port Number (Secondary) DFU
	This is used for the scan router program.
018	Server URL Path (Secondary) DFU
	This is used for the scan router program.
022	Rapid Sending Control
	Enables or disables the prevention function for the continuous data sending error. [0 to 1 / 1 / -] 0: Disable, 1: Enable

5846	[UCS Setting]	*CTL	-
001	Machine ID (For Delivery Server)	Displays ID	
	Displays the unique device ID in use by the delivery server directory. The value is only displayed and cannot be changed. This ID is created from the NIC MAC or IEEE 1394 EUI. The ID is displayed as either 6-byte or 8-byte binary.		
002	Machine ID Clear (For Delivery Server)	Clears ID	
	Clears the unique ID of the device used as the name in the file transfer directory. Execute this SP if the connection of the device to the delivery server is unstable. After clearing the ID, the ID will be established again automatically by cycling the machine off and on.		
003	Maximum Entries	[2000 to 20000/ 2000 /1 /step]	
	Changes the maximum number of entries that UCS can handle. If a value smaller than the present value is set, the UCS managed data is cleared, and the data (excluding user code information) is displayed.		

006	Delivery Server Retry Timer	[0 to 255 / 0 / 1 /step]
	Sets the interval for retry attempts when the delivery server fails to acquire the delivery server address book.	
007	Delivery Server Retry Times	[0 to 255 / 0 / 1 /step]
	Sets the number of retry attempts when the delivery server fails to acquire the delivery server address book.	
008	Delivery Server Maximum Entries	[2000 to 50000 / 2000 / 1/step]
	Sets the maximum number account entries of the delivery server user information managed by UCS.	
010	LDAP Search Timeout	[1 to 255 / 60 / 1 /step]
	Sets the length of the timeout for the search of the LDAP server.	
020	WSD Maximum Entries	[5 to 250 / 250 / 1 /step]
	Sets the maximum entries for the address book of the WSD (WS-scanner).	
040	Addr Book Migration (USB → HDD)	
	Not used in this machine.	

	Fill Addr Acl Info.	
041	<p>This SP must be executed immediately after installation of an HDD unit in a basic machine that previously had no HDD. The first time the machine is powered on with the new HDD installed, the system automatically takes the address book from the NVRAM and writes it onto the new HDD. However, the new address book on the HDD can be accessed only by the system administrator at this stage. Executing this SP by the service technician immediately after power on grants full address book access to all users.</p> <p>Procedure</p> <ol style="list-style-type: none"> 1. Turn the machine off. 2. Install the new HDD. 3. Turn the machine on. 4. The address book and its initial data are created on the HDD automatically. 5. However, at this point the address book can be accessed by only the system administrator or key operator. 6. Enter the SP mode and do SP5846-041. After this SP executes successfully, any user can access the address book. 	
043	Addr Book Media	<p>Displays the slot number where an address book data is in.</p> <p>[0 to 30 / - /1]</p> <p>0: Unconfirmed</p> <p>1: SD Slot 1</p> <p>2: SD Slot 2</p> <p>4: USB Flash ROM</p> <p>20: HDD</p> <p>30: Nothing</p>
047	Initialize Local Addr Book	Clears the local address book information, including the user code.
048	Initialize Delivery Addr Book	Clears the distribution address book information, except the user code.
049	Initialize LDAP Addr Book	Clears the LDAP address book information, except the user code.
050	Initialize All Addr Book	Clears all directory information managed by UCS, including all user codes.

051	Backup All Addr Book	Uploads all directory information to the SD card.
052	Restore All Addr Book	Downloads all directory information from the SD card.
053	Clear Backup Info	<p>Deletes the address book data from the SD card in the service slot.</p> <p>Deletes only the files that were uploaded from this machine.</p> <p>This feature does not work if the card is write-protected.</p> <p> Note</p> <ul style="list-style-type: none"> ▪ After you do this SP, go out of the SP mode, and then turn the power off. ▪ Do not remove the SD card until the Power LED stops flashing.
060	Search option	
	<p>This SP uses bit switches to set up the fuzzy search options for the UCS local address book.</p> <p>Bit: Meaning</p> <p>0: Checks both upper/lower case characters</p> <p>1: Japan Only</p> <p>2: Japan Only</p> <p>3: Japan Only</p> <p>4 to 7: Not Used</p>	
062	Complexity option 1	
	<p>Use this SP to set the conditions for password entry to access the local address book. Specifically, this SP limits the password entry to upper case and sets the length of the password.</p> <p>[0 to 32 / 0 / 1 /step]</p> <p> Note</p> <ul style="list-style-type: none"> ▪ This SP does not normally require adjustment. ▪ This SP is enabled only after the system administrator has set up a group password policy to control access to the address book. 	
063	Complexity Option 2 DFU	

Main SP Tables-5

064	Complexity Option 3 DFU	
065	Complexity Option 4 DFU	
091	FTP Auth Port Setting	Specifies the FTP port for getting a distribution server address book that is used in the identification mode. [0 to 65535 / 3671 / 1 /step]
094	Encryption Stat	Shows the status of the encryption function for the address book data.

5847	[Rep Resolution Reduction]	*CTL	-
	<p>SP5847-1 through SP5847-8 changes the default settings of image data transferred externally by the Net File page reference function. [0 to 5 / 2 / 1 /step]</p> <p>SP5847-21 sets the default for JPEG image quality of image files handled by NetFile.</p> <p>“Net files” are jobs to be printed from the document server using a PC and the DeskTopBinder software.</p>		
001	Rate for Copy Color	0: 1x 1: 1/2x 2: 1/3x 3: 1/4x 4: 1/6x 5: 1/8x	
002	Rate for Copy B&W Text		
003	Rate for Copy B&W Other		
004	Rate for Printer Color		
005	Rate for Printer B&W		
006	Rate for Printer Color 1200dpi	0: 1x 1: 1/2x 2: 1/3x 3: 1/4x 4: 1/6x 5: 1/8x	

007	Rate for Printer B&W 1200dpi	0: 1x 1: 1/2x 2: 1/3x 3: 1/4x 4: 1/6x 5: 1/8x
021	Network Quality Default for JPEG	
	Sets the default value for the quality of JPEG images sent as NetFile pages. This function is available only with the MLB (Media Link Board) option installed. [5 to 95 / 50 / 1 /step]	

5848	[Web Service]	*CTL	-
	5848 2 sets the 4-bit switch assignment for the access control setting. Setting of 0001 has no effect on access and delivery from Scan Router. 5848 100 sets the maximum size allowed for downloaded images. The default is equal to 1 gigabyte.		
002	Access Ctrl: Repository (only Lower 4 bits)	0000: No access control 0001: Denies access to DeskTop Binder. 0010: No writing control	
003	Access Control: Doc. Svr. Print (Lower 4 bits)	Switches access control on and off. 0000: No access control 0001: Denies access to DeskTop Binder.	
004	Access Control: uirectory (Lower 4 bits)		
007	Access Ctrl: Comm. Log Fax (Lower 4 bits)		
009	Access Ctrl: Job Ctrl (Lower 4 bits)		
011	Access Ctrl: Devicemanagement (Lower 4bits)		

Main SP Tables-5

021	Access Ctrl: Delivery (Lower 4 bits)	
022	Access Ctrl: uadministration (Lower 4bits)	
99	Repository: Download Image Setting	DFU
100	Repository: Download Image Max. Size	Specifies the max size of the image data that the machine can download. [1 to 2048 / 2048 / 1 MB /step]
210	Setting: LogType: Job1	NIA
211	Setting: LogType: Job2	
212	Setting: LogType: Access	
213	Setting: PrimarySrv	
214	Setting: SecondarySrv	
215	Setting: StartTime	
216	Setting: IntervalTime	
217	Setting: Timing	

5849	[Installation Date]	*CTL	-
5849 1	Display	The "Counter Clear Day" has been changed to "Installation Date" or "Inst. Date".	
5849 2	Switch to Print	Determines whether the installation date is printed on the printout for the total counter. [0 or 1 / 1 / -] 0: OFF (No Print) 1: ON (Print)	
003	Total Counter	-	

5850	[Address Book Function]	*CTL	-
003	Replacement of Circuit Classification Japan Only		
	The machine is sold ready to use with a G3 line. This SP allows you to switch all at once to convert to G4 after you add a G4 line. Conversely, if for some reason the G4 line becomes unusable, you can easily switch back to G3.		

5851	[Bluetooth]	*CTL	-
001	mode		
	Sets the operation mode for the Bluetooth Unit. Press either key. [0:Public] [1: Private]		

5853	[Stamp Data Download]		
	<p>Use this SP to download the fixed stamp data stored in the firmware of the ROM and copy it to the HDD. This SP can be executed as many times as required. This SP must be executed after replacing or formatting the hard disks.</p> <p> Note</p> <ul style="list-style-type: none"> This SP can be executed only with the hard disks installed. 		

5856	[Remote ROM Update]		
	Allows the technician to upgrade the firmware using a local port (IEEE1284) when updating the remote ROM.		
002	Local Port	*CTL	[0 to 1 / 0 / 1/step] 0: Disable 1: Enable

Main SP Tables-5

5857	[Save Debug Log]	*CTL	-
001	On/Off (1:ON 0:OFF)	0: OFF, 1: ON	
	Switches the debug log feature on and off. The debug log cannot be captured until this feature is switched on.		
002	Target (2: HDD 3: SD)	2: HDD, 3: SD Card	
	Selects the storage device to save debug logs information when the conditions set with SP5-858 are satisfied. [2 to 3 / 2 / 1 /step]		
005	Save to HDD		
	Saves the debug log of the input SC number in memory to the HDD. A unique file name is generated to avoid overwriting existing file names on the SD Card. Up to 4MB can be copied to an SD Card. 4 MB segments can be copied one by one to each SD Card.		
006	Save to SD Card		
	Saves the debug log of the input SC number in memory to the SD card.		
009	Copy HDD to SD Card (Latest 4 MB)		
010	Copy HDD to SD Card (Latest 4 MB Any Key)		
011	Erase HDD Debug Data		
012	Erase SD Card Debug Data		
013	Free Space on SD Card		
014	Copy SD to SD (Latest 4 MB)		
015	Copy SD to SD (Latest 4 MB Any Key)		
016	Make HDD Debug		
017	Make SD Debug		

	[Debug Save When]	*CTL	-
5858	<p>These SPs select the content of the debugging information to be saved to the destination selected by SP5857-002.</p> <p>SP5858-3 stores one SC specified by number. Refer to Section 4 for a list of SC error codes.</p>		
001	Engine SC Error (0: OFF, 1: ON)	<p>Turns on/off the debug save for SC codes generated by copier engine errors.</p> <p>[0 or 1 / 0 / 1/ step]</p>	
002	Controller SC Error (0: OFF, 1: ON)	<p>Turns on/off the debug save for SC codes generated by GW controller errors.</p> <p>[0 or 1 / 0 / 1/ step]</p>	
003	Any SC Error	<p>[0 to 65535 / 0 / 1 /step]</p>	
004	Jam (0: OFF, 1: ON)	<p>Turns on/off the debug save for jam errors.</p> <p>[0 or 1 / 0 / 1/ step]</p>	

5859	[Debug Save Key No.]	*CTL	-
001	Key 1	<p>These SPs allow you to set up to 10 keys for log files for functions that use common memory on the controller board.</p> <p>[–9999999 to 9999999 / 0 / –]</p>	
002	Key 2		
003	Key 3		
004	Key 4		
005	Key 5		
006	Key 6		
007	Key 7		
008	Key 8		
009	Key 9		
010	Key 10		

5860	[SMTP/POP3/IMAP4]	*CTL	-
020	Partial Mail Receive Timeout		[1 to 168 / 72 / 1 hour/step]
	Sets the amount of time to wait before saving a mail that breaks up during reception. The received mail is discarded if the remaining portion of the mail is not received during this prescribed time.		
021	MDN Response RFC2298 Compliance		[0 to 1 / 1 / -]
	Determines whether RFC2.5298 compliance is switched on for MDN reply mail. 0: No 1: Yes		
022	SMTP Auth. From Field Replacement		[0 to 1 / 0 / -]
	Determines whether the FROM item of the mail header is switched to the validated account after the SMTP server is validated. 0 : No. "From" item not switched. 1 : Yes. "From item switched.		
025	SMTP Auth. Direct Setting		[0 or 1 / - / -]
	Selects the authentication method for SMPT. Bit switch: <ul style="list-style-type: none"> ▪ Bit 0: LOGIN ▪ Bit 1: PLAIN ▪ Bit 2: CRAM MD5 ▪ Bit 3: DIGEST MD5 ▪ Bit 4 to 7: Not used <div style="border: 1px solid black; border-radius: 10px; padding: 2px; display: inline-block; margin-bottom: 5px;"> ⬇ Note </div> <ul style="list-style-type: none"> ▪ This SP is activated only when SMTP authorization is enabled by UP mode. 		
026	S/MIME: MIME Header Setting	-	Selects the MIME header type of an E-mail sent by S/MIME. [0 to 2 / 0 / 1] 0: Microsoft Outlook Express standard 1: Internet Draft standard 2: RFC standard

5870	[Common Key Info Writing]		
001	Writing	*CTL	Writes to flash ROM the common proof for validating the device for @Remote specifications.
003	Initialize	*CTL	Initializes the data area of the common proof for validating.

5873	[SD Card Appli Move]		
001	Move Exec	This SP copies the application programs from the original SD card in SD card slot 2 to an SD card in SD card slot 1.	
002	Undo Exec	This SP copies back the application programs from an SD card in SD Card Slot 2 to the original SD card in SD card slot 1. Use this menu when you have mistakenly copied some programs by using "Move Exec" (SP5873-1).	

5875	[SC Auto Reboot]		
001	Reboot Setting	*CTL	<p>Enables or disables the automatic reboot function when an SC error occurs.</p> <p>[0 or 1 / 0 / -]</p> <p>0: The machine reboots automatically when the machine issues an SC error and logs the SC error code. If the same SC occurs again, the machine does not reboot.</p> <p>1: The machine does not reboot when an SC error occurs.</p> <p>The reboot is not executed for Type A or C SC codes.</p>
002	Reboot Type	*CTL	<p>Selects the reboot method for SC.</p> <p>[0 or 1 / 0 / -]</p> <p>0: Manual reboot, 1: Automatic reboot</p>

Main SP Tables-5

5878	[Option Setup]		
001	Data Overwrite Security	-	Enables the Data Overwrite Security unit. Press "EXECUTE" on the operation panel. Then turn the machine off and on.
002	HDD Encryption	-	Installs the HDD Encryption unit.

5881	[Fixed Phrase Block Erasing]		
001	-	-	Deletes the fixed phrase.

5883	[Line Speed Selection]		
	Selects the line speed for middle thick paper.		
001	Middle Thick	*ENG	[0 or 1 / 0 / 1 /step] 0: MID CARD: Half Speed (115 mm/sec) 1: MID CARD: Normal Speed

5885	[Set WIM Function] Web Image Monitor Settings		
	Close or disclose the functions of web image monitor.		
020	DocSvr Acc Ctrl	*CTL	0: OFF, 1: ON Bit Meaning 0: Forbid all document server access (1) 1: Forbid user mode access (1) 2: Forbid print function (1) 3: Forbid fax TX (1) 4: Forbid scan sending (1) 5: Forbid downloading (1) 6: Forbid delete (1) 7: Reserved
050	DocSvr Format	*CTL	Selects the display type for the document box list. [0 to 2 / 0 / 1] 0: Thumbnail, 1: Icon, 2: Details

051	DocSvr Trans	*CTL	Sets the number of documents to be displayed in the document box list. [5 to 20 / 10 / 1]
100	Set Signature	*CTL	Selects whether the signature is added to the scanned documents with the WIM when they are transmitted by an e-mail. [0 to 2 / 0 / 1/step] 0: Setting for each e-mail 1: Signature for all 2: No signature
101	Set Encrypsion	*CTL	Determines whether the scanned documents with the WIM are encrypted when they are transmitted by an e-mail. [0 to 1 / 0 / 1] 0: Not encrypted, 1:Encryption
200	Detect Mem Leak	*CTL	Not Used
201	DocSvr Timeout	*CTL	Not Used

5887	[SD Get Counter]		
	This SP determines whether the ROM can be updated.		
001	-	*CTL	<p>This SP sends a text file to an SD card inserted in SD card Slot 2 (lower slot). The operation stores. The file is stored in a folder created in the root directory of the SD card called SD_COUNTER. The file is saved as a text file (*.txt) prefixed with the number of the machine.</p> <ul style="list-style-type: none"> ▪ Insert the SD card in SD card Slot 2 (lower slot). ▪ Select SP5887 then touch [EXECUTE]. <p>Touch [Execute] in the message when you are prompted.</p>

Main SP Tables-5

5888	[Personal Information Protect]		
001	-	*CTL	<p>Selects the protection level for logs. [0 to 1 / 0 / 1}</p> <p>0: No authentication, No protection for logs 1: No authentication, Protected logs (only an administrator can see the logs)</p>

5893	[SDK Application Counter]	*CTL	-
	Displays the counter name of each SDK application.		
001	SDK-1		
002	SDK-2		
003	SDK-3		
004	SDK-4		
005	SDK-5		
006	SDK-6		

5894	[External Counter Setting]		
	Test Name1_1		
001	Switch Charge Mode	*ENG	[0 to 2 / 0 / 1/step]

5895	[Application Invalidation]		
	<p>Enables or disables the printer or scanner application. These SPs are used only when an external controller is installed in the machine.</p>		
	001	Printer	*CTL
002	Scanner	*CTL	0: Enable 1: Disable

5907	[Plug & Play Maker/Model Name]		
001	<p>Selects the brand name and the production name for Windows Plug & Play. This information is stored in the NVRAM. If the NVRAM is defective, these names should be registered again.</p> <p>After selecting, press the "Original Type" key and "#" key at the same time. When the setting is completed, the beeper sounds five times.</p>		

5913	[Switchover Permission Time]		
002	Print Application Timer	*CTL	[3 to 30 / 3 / 1 second /step]
	Sets the amount of time to elapse while the machine is in standby mode (and the operation panel keys have not been used) before another application can gain control of the display.		

5967	[Copy Server : Set Function]	*CTL	0: ON, 1: OFF
001	Enables and disables the document server. This is a security measure that prevents image data from being left in the temporary area of the HDD. After changing this setting, you must switch the main switch off and on to enable the new setting.		

5974	[Cherry Server]		
	Specifies which version of ScanRouter, "Lite" or "Full", is installed.		
001	(0:Light 1:Full)	*CTL	[0 or 1 / 0 / -]

5985	[Device Setting]		
	The NIC and USB support features are built into the GW controller. Use this SP to enable and disable these features. In order to use the NIC and USB functions built into the controller board, these SP codes must be set to "1".		

Main SP Tables-5

001	On Board NIC	<p>[0 to 2 / 0 / 1 /step]</p> <p>0: Disable, 1: Enable, 2: Function limitation</p> <p>When the "Function limitation" is set, "On board NIC" is limited only for the NRS or LDAP/NT authentication.</p> <p>Note</p> <ul style="list-style-type: none"> Other network applications than NRS or LDAP/NT authentication are not available when this SP is set to "2". Even though you can change the initial settings of those network applications, the settings do not work.
002	On Board USB	<p>[0 or 1 / 0 / 1/step]</p> <p>0: Disable, 1: Enable</p>

5987	[Mech. Counter]		
001	0: OFF / 1: ON	*ENG	This SP detects that a mechanical counter device is removed. If it is detected, SC610 occurs.

5990	[SP print mode]		
	Prints out the SMC sheets.		
001	All (Data List)	-	
002	SP (Mode Data List)	-	
003	User Program	-	
004	Logging Data	-	
005	Diagnostic Report	-	
006	Non-Default	-	
007	NIB Summary	-	
008	Capture Log	-	
021	Copier User Program	-	
022	Scanner SP	-	

023	Scanner User Program	-	
024	SDK/J Summary	-	
025	SDK/J Application Info	-	

5992	[SP Text mode]		
	Exports the SMC sheet data to the SD Card.		
001	All (Data List)	-	Press "Execute" key to start exporting the SMC data in the SP mode display.
002	SP (Mode Data List)	-	
003	User Program	-	
004	Logging Data	-	
005	Diagnostic Report	-	
006	Non-Default	-	
007	NIB Summary	-	
008	Capture Log	-	
021	Copier User Program	-	
022	Scanner SP	-	
023	Scanner User Program	-	
024	SDK/J Summary	-	
025	SDK/J Application Info	-	
026	Printer SP mode	-	

5998	[Fusing Cont mode] Fusing Control Mode		
	Turns the silent fusing warm-up mode on or off.		
001	fast/silent	*ENG	[0 or 1 / 1 / -] 0: Silent (less noise) 1: Fast (less time)

5.7 MAIN SP TABLES-6

5.7.1 SP6-XXX (PERIPHERALS)

6006	[ADF Adjustment]		
	Adjusts the side-to-side and leading registration of originals with the ARDF.		
001	Side-to-Side Regist: Front	*ENG	[-3.0 to 3.0 / 0 / 0.1 mm/step]
002	Side-to-Side Regist: Rear		
003	Leading Edge Registration	*ENG	[-5.0 to 5.0 / 0 / 0.1 mm/step]
	Adjusts the amount of paper buckle to correct original skew for the front and rear sides.		
005	Buckle: Duplex Front	*ENG	[-3.0 to 3.0 / 0 / 0.1 mm/step]
006	Buckle: Duplex Rear		[-2.5 to 2.5 / 0 / 0.1 mm/step]
	Adjusts the erase margin at the original trailing edge.		
007	Rear Edge Erase	*ENG	[-10 to 10 / 0 / 0.1 mm/step]

6007	[ADF INPUT Check]		
	Displays the signals received from the sensors and switches of the ARDF. Only Bit 0 is used for ADF input check (👉 p.5-338).		

6008	[ADF OUTPUT Check]		
	Activates the electrical components for functional check. It is not possible to activate more than one component at the same time (👉 p.5-353).		

6009	[ADF Free Run]		
	Performs a DF free run in simplex, duplex mode or stamp mode.		
001	Free Run Simplex Motion	*ENG	-

002	Free Run Duplex Motion	*ENG	
003	Free Run Stamp Motion	*ENG	

6010	[Stamp Position Adj.] Fax Stamp Position Adjustment		
	Adjusts the horizontal position of the stamp on the scanned originals.		
001	-	*ENG	[-5.0 to 5.0 / 0 / 1 mm/step]

6016	[Original Size Detect Setting]			
	Specifies the original size for a size detected by the original sensor, since original sensors cannot recognize all sizes.			
001	-	*ENG	[0 or 1 / - / -] 0: Setting 1, 1: Setting 2	
		NA	Setting 1	Setting 2
			DLT SEF	Folio SEF 11" x 15"
			LG SEF	Foolscap SEF
			LT SEF	US EXE 8" x 10"
			LT LEF	US EXE LEF
		EU/ ASIA	DLT SEF	8K 267 x 390 mm
			LT SEF	16K 195 x 267 mm
			LT LEF	16K 267 x 195 mm

6017	[DF Magnification Adj.] DF Magnification Adjustment		
	Adjusts the magnification in the sub-scan direction for the ARDF.		
001	-	*CTL	[-5.0 to 5.0 / 0 / 0.1 %/step]

6020	[Skew Correction Moving Setting]		
	Turns the original skew correction in the ARDF for all original sizes on or off.		

Main SP Tables-6

001	-	*ENG	[0 or 1 / 0 / -] 0: Off (only for small original sizes) 1: On (for all original sizes)
-----	---	------	---

6128	[Punch Position: Sub Scan]		
	Adjusts the punching position in the sub scan direction.		
001	Domestic 2Hole (Europe 2Hole)	*ENG	[-7.5 to 7.5 / 0 / 0.5 mm/step]
002	North America 3Hole	*ENG	
003	Europe 4Hole	*ENG	
004	North Europe 4Hole	*ENG	
005	North America 2Hole	*ENG	

6129	[Punch Position: Main Scan]		
	Adjusts the punching position in the main scan direction.		
001	Domestic 2Hole (Europe 2Hole)	*ENG	[-2.0 to 2.0 / 0 / 0.4 mm/step]
002	North America 3Hole	*ENG	
003	Europe 4Hole	*ENG	
004	North Europe 4Hole	*ENG	
005	North America 2Hole	*ENG	

6130	[Skew Correction: Buckle Adj.]		
	Adjusts the paper buckle for each paper size.		
001	A3T	*ENG	[-5.0 to 5.0 / 0 / 0.25 mm/step]
002	B4T	*ENG	
003	A4T	*ENG	

004	A4Y	*ENG	
005	B5T	*ENG	
006	B5Y	*ENG	
007	DLT-T	*ENG	
008	LG-T	*ENG	
009	LT-T	*ENG	
010	LT-Y	*ENG	
011	12*18	*ENG	
012	Other	*ENG	

6131	[Skew Correction Control]		
	Selects the skew correction control for each paper size. These are only activated for B804/B805.		
001	A3T	*ENG	[0 or 1 / 0 / 1/step] 0: No (No skew correction) 1: Roller Stop Skew Correction
002	B4T	*ENG	
003	A4T	*ENG	
004	A4Y	*ENG	
005	B5T	*ENG	
006	B5Y	*ENG	
007	DLT-T	*ENG	
008	LG-T	*ENG	
009	LT-T	*ENG	
010	LT-Y	*ENG	
011	12*18	*ENG	
012	Other	*ENG	

Main SP Tables-6

6132	[Jogger Fence Fine Adj]		
	This SP adjusts the distance between the jogger fences and the sides of the stack on the finisher stapling tray in the (Booklet) Finisher B804/B805. The adjustment is done perpendicular to the direction of paper feed.		
001	A3T	*ENG	[-1.5 to 1.5 / 0 / 0.5 mm/step] + Value: Increases distance between jogger fences and the sides of the stack. - Value: Decreases the distance between the jogger fences and the sides of the stack.
002	B4T	*ENG	
003	A4T	*ENG	
004	A4Y	*ENG	
005	B5T	*ENG	
006	B5Y	*ENG	
007	DLT-T	*ENG	
008	LG-T	*ENG	
009	LT-T	*ENG	
010	LT-Y	*ENG	
011	12*18	*ENG	
012	Other	*ENG	

6133	[Staple Position Adjustment]		
	Adjusts the staple position for each finisher (B408/B804/B805). + Value: Moves the staple position to the rear side. - Value: Moves the staple position to the front side.		
001	Finisher1	*ENG	[-3.5 to 3.5 / 0 / 1/step]

6134	[Saddle Stitch Position Adjust]		
	Use this SP to adjust the stapling position of the booklet stapler when paper is stapled and folded in the Booklet Finisher B804.		
001	A3T	[-3.0 to 3.0 / 0 / 0.2 mm/step]	

002	B4T	<p>+ Value: Shifts staple position toward the crease. - Value: Shifts staple position away from the crease.</p>
003	A4T	
004	B5T	
005	DLT-T	
006	LG-T	
007	LT-T	
008	12*18	
009	Other	

6135	[Folder Position Adj.]	
	This SP corrects the folding position when paper is stapled and folded in the Booklet Finisher B804.	
001	A3T	<p>[-3.0 to 3.0 / 0 / 0.2 mm/step]</p> <p>+ Value: Shifts staple position toward the crease. - Value: Shifts staple position away from the crease.</p>
002	B4T	
003	A4T	
004	B5T	
005	DLT-T	
006	LG-T	
007	LT-T	
008	12*18	
009	Other	

System Maintenance

6136	[Folding Number]	
	Sets the number of times that folding is done in the Booklet Finisher B804.	
001	-	[2 to 30 / 2 / 1 time/step]

Main SP Tables-6

6139	[FIN (KIN) INPUT Check] Finisher (B408) Input Check
	Displays the signals received from sensors and switches of the booklet finisher. (🖨️ p.5-338)

6140	[FIN (EUP) INPUT Check] Finisher (B804/B805) Input Check
	Displays the signals received from sensors and switches of the (booklet) finisher. (🖨️ p.5-338)

6144	[FIN (KIN) OUPUT Check] Finisher (B408) Output Check
	Displays the signals received from sensors and switches of the booklet finisher. (🖨️ p.5-353)

6145	[FIN (EUP) OUPUT Check] Finisher (B804/B805) Output Check
	Displays the signals received from sensors and switches of the (booklet) finisher. (🖨️ p.5-353)

6149	[Max. Pre-Stack Sheet]	*ENG	Number of Pre-Stack Sheets
	This SP sets the number of sheets sent to the pre-stack tray. 📌 Note <ul style="list-style-type: none"> You may need to adjust this setting or switch it off when feeding thick or slick paper. 		
001	-	[0 to 3 / 3 / 1 sheet/step]	

6150	[INPUT Check]
	Displays the signals received from sensors and switches of the bridge unit (D386) / side tray (D542) (🖨️ p.5-338).

6151	[OUTPUT Check]
	Displays the signals received from sensors and switches of the bridge unit (D386)/ side tray (D542) (🖨️ p.5-353).

6152	[INPUT Check]
	Displays the signals received from sensors and switches of the shift tray (D388) (👉 p.5-338).
6153	[OUTPUT Check]
	Displays the signals received from sensors and switches of the shift tray (D388) (👉 p.5-353).
6154	[INPUT Check]
	Displays the signals received from sensors and switches of the 1 bin tray (D536) (👉 p.5-338).
6155	[OUTPUT Check]
	Displays the signals received from sensors and switches of the 1 bin tray (D536) (👉 p.5-353)
001	1 bin: Junction Solenoid
6160	[INPUT Check]
	Displays the signals received from sensors and switches of the two-tray paper feed unit (D537), LCT 2000 (D538) and LCT 1200 (D539) (👉 p.5-338)
6161	[OUTPUT Check]
	Displays the signals received from sensors and switches of the two-tray paper feed unit (D537), LCT 2000 (D538) and LCT 1200 (D539) (👉 p.5-353)

5.8 MAIN SP TABLES-7

5.8.1 SP7-XXX (DATA LOG)



7401	[Total SC]		
	Displays the number of SC codes detected.		
001	SC Counter	*CTL	[0 to 65535 / - / 1/step]
002	Total SC Counter	*CTL	[0 to 65535 / - / 1/step]

7403	[SC History]		
	Logs the SC codes detected. The 10 most recently detected SC Codes are not displayed on the screen, but can be seen on the SMC (logging) outputs.		
001	-	*CTL	-
002	-		
003	-		
004	-		
005	-		
006	-		
007	-		
008	-		
009	-		
010	-		



7502	[Total Paper Jam]		
	Displays the total number of jams detected.		
001	Jam Counter	* CTL	[0 to 65535 / - / 1/step]

002	Total Jam Counter	* CTL	[0 to 65535 / - / 1/step]
-----	-------------------	-------	----------------------------

7503	[Total Original Jam]		
	Displays the total number of original jams.		
001	Original Jam counter	*CTL	[0 to 9999 / - / 1 original/step]
002	Total Original Counter	*CTL	-

7504	[Paper Jam Loc] ON: On check, OFF: Off Check		
	Displays the number of jams according to the location where jams were detected. NOTE: The LCT is counted as the 3rd feed station.		
001	At Power On	*CTL	For details, see "Jam Detection". ( p.6-131)
003	Tray 1: On	*CTL	
004	Tray 2: On	*CTL	
005	Tray 3: On	*CTL	
006	Tray 4: On	*CTL	
007	LCT : On	*CTL	
008	Registration Sn: On (Bypass)	*CTL	
009	Registration Sn: On (Duplex)	*CTL	
011	Vertical Trans. 1: On	*CTL	
012	Vertical Trans. 2: On	*CTL	
013	Vertical Trans. 3: On	*CTL	For details, see "Jam Detection". ( p.6-131)
014	Vertical Trans. 4: On	*CTL	
017	Registration: On	*CTL	
018	Fusing Entrance: On	*CTL	
019	Fusing Exit: On	*CTL	

Main SP Tables-7

020	Paper Exit: On	*CTL		
021	Bridge Tray Exit: On	*CTL		
022	Bridge Relay: On	*CTL		
024	Junction Gate Sensor : On	*CTL		
025	Duplex Exit: On	*CTL	For details, see "Jam Detection". ( p.6-131)	
026	Duplex Entrance: On (In)	*CTL		
027	Duplex Entrance: On (Out)	*CTL		
051	Vertical Trans. 1: Off	*CTL		
052	Vertical Trans. 2: Off	*CTL		
053	Vertical Trans. 3: Off	*CTL		
054	Vertical Trans. 4: Off	*CTL		
057	Registration Sensor: Off	*CTL		
058	LCT Feed Sensor : Off			
060	Paper Exit Off	*CTL		
061	Bridge Tray Exit: Off	*CTL		
062	Bridge Relay: Off	*CTL		
064	Junction Gate Sensor : Off	*CTL		For details, see "Jam Detection". ( p.6-131)
065	Duplex Exit: Off	*CTL		
066	Duplex Entrance: Off (In)	*CTL		
067	Duplex entrance : Off (Out)	*CTL		
100	Finisher Entrance: KIN	*CTL		
101	Finisher Shift Tray Exit: KIN	*CTL		
102	Finisher Staple: KIN	*CTL		
103	Finisher Exit: KIN	*CTL		
105	Finisher Tray Lift Motor: KIN	*CTL		

106	Finisher Jogger Motor: KIN	*CTL	For details, see "Jam Detection". (p.6-131)
107	Finisher Shift Motor: KIN	*CTL	
108	Finisher Staple Motor: KIN	*CTL	
109	Finisher Exit Motor: KIN	*CTL	
191	Finisher Entrance: EUP	*CTL	
192	Finisher Proof Exit: EUP	*CTL	
193	Finisher Shift Tray Exit: EUP	*CTL	
194	Finisher Stapler Exit: EUP	*CTL	
195	Finisher Exit: EUP	*CTL	
198	Finisher Folder: EUP	*CTL	
199	Finisher Tray Motor: EUP	*CTL	
200	Finisher Jogger Motor: EUP	*CTL	
201	Finisher Shift Motor: EUP	*CTL	
202	Finisher Staple Moving Motor: EUP	*CTL	
203	Finisher Staple Motor: EUP	*CTL	
204	Finisher Folder Motor: EUP	*CTL	
206	Finisher Punch Motor: EUP	*CTL	

7505	[Original Jam Det]		
	Displays the total number of original jams by location.		
001	At Power On	*CTL	-
003	Skew Correction Sensor: On	*CTL	-
004	Registration Sensor: On	*CTL	
005	Original Exit Sensor: On	*CTL	
006	Registration Sensor: On	*CTL	

Main SP Tables-7

007	Original Exit Sensor: On	*CTL	
008	Reverse Sensor: On	*CTL	
053	Skew Correction Sensor: Off	*CTL	
054	Registration Sensor: Off	*CTL	
055	Original Exit Sensor: Off	*CTL	
056	Registration Sensor: Off	*CTL	
057	Original Exit Sensor: Off	*CTL	
058	Reverse Sensor: Off	*CTL	

7506	[Jam Count by Paper Size]		
	Displays the number of jams according to the paper size.		
005	A4 LEF	*CTL	[0 to 9999 / - / 1 sheet/step]
006	A5 LEF	*CTL	
014	B5 LEF	*CTL	
038	LT LEF	*CTL	
044	HLT LEF	*CTL	
132	A3 SEF	*CTL	
133	A4 SEF	*CTL	
134	A5 SEF	*CTL	
141	B4 SEF	*CTL	
142	B5 SEF	*CTL	
160	DLT SEF	*CTL	
164	LG SEF	*CTL	
166	LT SEF	*CTL	
172	HLT SEF	*CTL	

255	Others	*CTL	[0 to 9999 / - / 1 sheet/step]
-----	--------	------	---------------------------------

7507	[Plotter Jam History]		
	Displays the 10 most recently detected paper jams.		
001	-	*CTL	-
002	-		
003	-		
004	-		
005	-		
006	-		
007	-		
008	-		
009	-		
010	-		

7508	[Original Jam History]		
	Displays the 10 most recently detected original jams.		
001	-	*CTL	-
002	-		
003	-		
004	-		
005	-		
006	-		
007	-		
008	-		

Main SP Tables-7

009	-		
010	-		

7624	Part Replacement Operation ON/OFF		
	Selects the PM maintenance for each part.		
001	Drum unit: Bk	[0 or 1 / 1 -] 0: Not PM maintenance 1: PM maintenance	
002	Drum unit: M		
003	Drum unit: C		
004	Drum unit: Y		
005	Development unit: Bk		
006	Development unit: M		
007	Development unit: C		
008	Development unit: Y		
009	Developer: Bk		
010	Developer:M		
011	Developer:C		
012	Developer:Y		
013	Image Transfer Belt	[0 or 1 / 1 -] 0: Not PM maintenance 1: PM maintenance	
014	Image Transfer Cleaning Unit		
015	Fusing Unit		
016	Paper Transfer Roller Unit		
017	Waste Toner bottle		
018	Fusing Roller		
019	Pressure Roller		

7801	[ROM No/ Firmware Version]		
002	Engine	*CTL	Displays all versions and ROM numbers in the machine.

7803	[PM Counter Display] (Page, Unit, [Color])		
	<p>Displays the number of sheets printed for each current maintenance unit. PM counters click up based on the number of A4 (LT) LEF size sheets printed. Therefore, the A3 (DLT) Double Count is activated. The Double Count cannot be deactivated.</p> <p>When a unit is replaced, the machine automatically detects that the new unit is installed. Then, the current PM counter value is automatically moved to the PM Counter - Previous (SP7-906-1 to 10) and is reset to "0".</p> <p>The total number of sheets printed with the last unit replaced can be checked with SP7-906-1 to 10.</p> <p>NOTE: The LCT is counted as the 3rd feed station.</p>		
001	Paper	*CTL	-
002	Page: PCU: Bk	*ENG	-
003	Page: PCU: M		
004	Page: PCU: C		
005	Page: PCU: Y		
006	Page: Development Unit: Bk		
007	Page: Development Unit: M		
008	Page: Development Unit: C		
009	Page: Development Unit: Y		
010	Page: Developer: Bk		
011	Page: Developer: M		
012	Page: Developer: C		
013	Page: Developer: Y		
014	Page: Image Transfer		

Main SP Tables-7

015	Page: Cleaning Unit		
016	Page: Fusing Unit		
017	Page: Paper Transfer Unit		
018	Page: Toner Collection Bottle		
019	Page: Fusing Roller		
020	Page: Pressure Roller		
		<p>Displays the number of revolutions of motors or clutches for each current maintenance unit.</p> <p>[0 to 9999999 / 0 / 1 revolution/step]</p> <p>When a unit is replaced, and SP7804-xxx is executed, the current PM counter value is moved to the PM Counter - Previous (SP7-906-11 to 20) and is reset to "0". The total number of revolutions made with the last unit replaced can be checked with SP7-906-11 to 20.</p>	
021	-	*ENG	
		<p>Displays the number of pages of the pump unit for each current maintenance unit.</p> <p>[0 to 9999999 / - / 1 page/step]</p> <p>When a unit is replaced, and SP7804-xxx is executed, the current PM counter value is moved to the PM Counter - Previous (SP7-906-020 to 112) and is reset to "0". The total number of revolutions made with the last unit replaced can be checked with SP7-906-020 to 112.</p>	
021	Page: Pump Unit: Bk		
022	Page: Pump Unit: M	*ENG	[0 to 9999999 / - / 1 page/step]
023	Page: Pump Unit: C		
024	Page: Pump Unit: Y		
031	Rotation: PCU: Bk		
032	Rotation: PCU: M	*ENG	[0 to 999999999 / - / 1 mm/step]
033	Rotation: PCU: C		
034	Rotation: PCU: Y		

035	Rotation: Development Unit: Bk		
036	Rotation: Development Unit: M		
037	Rotation: Development Unit: C		
038	Rotation: Development Unit: Y		
039	Rotation: Developer: Bk		
040	Rotation: Developer: M		
041	Rotation: Developer: C		
042	Rotation: Developer: Y		
043	Rotation: Image Transfer	*ENG	
044	Rotation: Cleaning Unit	*ENG	
045	Rotation: Fusing Unit	*ENG	
046	Rotation: Paper Transfer Unit	*ENG	[0 to 999999999 / - / 1 mm/step]
047	Measurement: Toner Collection bottle	*ENG	
048	Rotation: Fusing Roller	*ENG	
049	Rotation: Pressure Roller	*ENG	
	<p>Displays the value given by the following formula: $(\text{Current revolution} / \text{Target revolution}) \times 100$. This shows how much of the unit's expected lifetime has been used up.</p> <p>The Rotation% counter is based on rotations, not prints. If the number of rotations reaches the limit, the machine enters the end condition for that unit. If the print count lifetime is reached first, the machine also enters the end condition, even though the R% counter is still less than 100%.</p>		

Main SP Tables-7

050	-	*ENG	
	<p>Displays the running time of the pump unit for each current maintenance unit. [0 to 999999999 / 0 / 1 msec/step]</p> <p>When a unit is replaced, and SP7804-xxx is executed, the current PM counter value is moved to the PM Counter - Previous (SP7-906-020 to 112) and is reset to "0". The total number of revolutions made with the last unit replaced can be checked with SP7-906-020 to 112.</p>		
050	Run Time: Pump Unit : Bk	*ENG	[0 to 999999999 / - / 1 msec/step]
051	Run Time: Pump Unit : M		
052	Run Time: Pump Unit : C		
053	Run Time: Pump Unit : Y		
061	Rotation (%): PCU: Bk	*ENG	[0 to 255 / - / 1 %/step] (See SP7-803-079 below.)
062	Rotation (%): PCU: M		
063	Rotation (%): PCU:C		
064	Rotation (%): PCU:Y		
065	Rotation (%): Development Unit: Bk		
066	Rotation (%): Development Unit: M		
067	Rotation (%): Development Unit: C		
068	Rotation (%): Development Unit: Y		
069	Rotation (%): Developer: Bk		
070	Rotation (%): Developer: M		
071	Rotation (%): Developer: C		
072	Rotation (%): Developer: Y		
073	Rotation (%): Image Transfer Belt	*ENG	[0 to 255 / - / 1 %/step]
074	Rotation (%): Cleaning Unit		
075	Rotation (%): Fusing Unit		

076	Rotation (%): Paper Transfer Unit		
077	Measurement (%): Toner Collection bottle		
078	Rotation (%): Fusing Roller		
079	Rotation (%): Pressure Roller		
	<p>Displays the value given by the following formula: $(\text{Current revolution} / \text{Target revolution}) \times 100$. This shows how much of the unit's expected lifetime has been used up.</p> <p>The Rotation (%) counter is based on rotations, not prints. If the number of rotations reaches the limit, the machine enters the end condition for that unit. If the print count lifetime is reached first, the machine also enters the end condition, even though the R (%) counter is still less than 100%.</p> <p>[0 to 255 / - / 1 %/step]</p>		
	-	*ENG	
080	<p>Displays the value given by the following formula: $(\text{Current running time} / \text{Target running time}) \times 100$. This shows how much of the unit's expected lifetime has been used up.</p> <p>The Run Time (%) counter is based on the running time, not printouts nor revolutions. If the number of printouts reaches the limit, the machine enters the end condition for that unit. If the revolution count lifetime is reached first, the machine also enters the end condition, even though the Run Time (%) counter is still less than 100%.</p> <p>[0 to 255 / - / 1 %/step]</p>		
080	Run Time(%): Pump Unit: Bk		
081	Run Time(%): Pump Unit: M	*ENG	[0 to 255 / - / 1 %/step]
082	Run Time(%): Pump Unit: C		
083	Run Time(%): Pump Unit: Y		

091	-		
	<p>Displays the value given by the following formula: $(\text{Current printouts} / \text{Target printouts}) \times 100$. This shows how much of the unit's expected lifetime has been used up.</p> <p>The Page (%) counter is based on printouts, not revolutions. If the number of printouts reaches the limit, the machine enters the end condition for that unit. If the revolution count lifetime is reached first, the machine also enters the end condition, even though the Page (%) counter is still less than 100%.</p> <p>[0 to 255 / - / 1 %/step]</p>		
091	Page (%): PCU: Bk	*ENG	[0 to 255 / - / 1 %/step]
092	Page (%): PCU: M		
093	Page (%): PCU: C		
094	Page (%): PCU: Y		
095	Page (%): Development Unit: Bk		
096	Page (%): Development Unit: M		
097	Page (%): Development Unit: C		
098	Page (%): Development Unit: Y		
099	Page (%): Developer: Bk	*ENG	[0 to 255 / - / 1 %/step] (See SP7-803-091 below.)
100	Page (%): Developer: M		
101	Page (%): Developer: C		
102	Page (%): Developer: Y		
103	Page (%): Image Transfer		
104	Page (%): Cleaning Unit		
105	Page (%): Fusing Unit		
106	Page (%): Paper Transfer Unit		
107	Page (%): Fusing Roller		
108	Page (%): Pressure Roller		

109	-	*ENG	
	<p>Displays the value given by the following formula: $(\text{Current printouts} / \text{Target printouts}) \times 100$. This shows how much of the unit's expected lifetime has been used up.</p> <p>The Page (%) counter is based on printouts, not revolutions. If the number of printouts reaches the limit, the machine enters the end condition for that unit. If the revolution count lifetime is reached first, the machine also enters the end condition, even though the Page (%) counter is still less than 100%.</p> <p>[0 to 255 / - / 1 %/step]</p>		
109	Page (%): Pump Unit: Bk	*ENG	[0 to 255 / - / 1 %/step]
110	Page (%): Pump Unit: M		
111	Page (%): Pump Unit: C		
112	Page (%): Pump Unit: Y		

7804	[PM Counter Reset] PM Counter Clear (Unit, [Color])		
	<p>Clears the PM counter.</p> <p>Press the Enter key after the machine asks "Execute?", which will store the PM counter value in SP7-906 (PM Counter - Previous) and reset the value of the current PM counter (SP7-803) to "0".</p>		
002	PCU (Drum Unit): Bk	-	-
003	PCU (Drum Unit): M	-	-
004	PCU (Drum Unit): C	-	-
005	PCU (Drum Unit): Y	-	-
006	PCU (Drum Unit): All	-	-
007	Development Unit: Bk	-	-
008	Development Unit: M	-	-
009	Development Unit: C	-	-
010	Development Unit: Y	-	-
011	Development Unit: All	-	-

Main SP Tables-7

012	Developer: Bk	-	-
013	Developer: M	-	-
014	Developer: C	-	-
015	Developer: Y	-	-
016	Developer: All	-	-
017	ITB Unit	-	-
018	Cleaning Unit	-	-
019	Fusing Unit	-	-
020	PTR Unit	-	-
021	Toner Collection Bottle	-	-
022	Fusing Roller (Heating Roller)	-	-
023	Pressure Roller	-	-
024	Pump Unit: Bk	-	-
025	Pump Unit: M	-	-
026	Pump Unit: C	-	-
027	Pump Unit: Y	-	-
028	Pump Unit: All	-	-
100	All	-	-

7807	[SC/Jam Counter Reset]		
	Clears the counters related to SC codes and paper jams.		
001	SC/Jam Clear	-	-

7832	[Self-Diagnose Result Display]		
	Displays the result of the diagnostics.		

001	Diag. Result	*CTL	-
-----	--------------	------	---

7835	[ACC Counter]		
001	Copy ACC	*CTL	Displays the ACC execution times for each mode.
002	Printer ACC	*CTL	

7836	Total Memory Size		
	Displays the memory capacity of the controller system.		

7852	[DF Glass Dust Check]		
	Counts the number of occurrences (0 to 65,535) when dust was detected on the scanning glass of the ADF or resets the dust detection counter. Counting is done only if SP4-020-1 (ADF Scan Glass Dust Check) is switched on.		
001	Dust Detection Counter	*ENG	[0 to 9999 / - / 1 /step]
002	Dust Detection Clear Counter	*ENG	[0 to 9999 / - / 1 /step]
003	Dust Detection Counter: Back	*ENG	[0 to 9999 / - / 1 /step]

7853	[Replacement Counter]		
	Displays the PM parts replacement number.		
001	PCU: Bk	*ENG	[0 to 255 / - / 1 /step]
002	PCU: M	*ENG	
003	PCU: C	*ENG	
004	PCU: Y	*ENG	
005	Development Unit: Bk	*ENG	
006	Development Unit: M	*ENG	
007	Development Unit: C	*ENG	
008	Development Unit: Y	*ENG	

Main SP Tables-7

009	Developer: Bk	*ENG	
010	Developer: M	*ENG	
011	Developer: C	*ENG	
012	Developer: Y	*ENG	
013	Image Transfer	*ENG	[0 to 255 / - / 1 /step]
014	Cleaning Unit	*ENG	
015	Fusing Unit	*ENG	
016	Paper Transfer Unit	*ENG	
017	Tonner Collection Bottle	*ENG	
018	Fusing Roller	*ENG	
019	Pressure Roller	*ENG	
020	Pump Unit: Bk	*ENG	[0 to 255 / - / 1 /step]
021	Pump Unit: M		
022	Pump Unit: C		
023	Pump Unit: Y		

7855	[Coverage Range]		
	<p>Sets the color coverage threshold.</p> <p>Coverage rate = Coverage per page / A4 full coverage (dots) x 100</p> <p>There are three coverage counters: Color 1, Color 2, and Color 3</p> <ul style="list-style-type: none"> ▪ [A] 5% (default) is adjustable with SP7855-001. ▪ [B] 20% (default) is adjustable with SP7855-002. <div style="text-align: center;"> <p>Color coverage 0% 200%</p> </div> <p>Note</p> <ul style="list-style-type: none"> ▪ The setting value [B] must be set larger than [A]. <p>The total numbers of printouts (BW printing plus color printing) for each coverage range are displayed with the following SPs.</p> <ul style="list-style-type: none"> ▪ Color1 counter: SP8601-021 ▪ Color2 counter: SP8601-022 ▪ Color3 counter: SP8601-023 		
	001	Coverage Range 1	*CTL
002	Coverage Range 2	*CTL	[1 to 200 / 20 /1]

7906	[Prev. Unit PM Counter]		
	(Page or Rotations, Unit, [Color]), Dev.: Development Unit		
	Displays the number of sheets printed with the previous maintenance units.		
001	Page: PCU: Bk	*ENG	[0 to 9999999 / 0 / 1 page/step]
002	Page: PCU: M		
003	Page: PCU: C		
004	Page: PCU: Y		
005	Page: Development Unit: Bk		
006	Page: Development Unit: M		
007	Page: Development Unit: C		

Main SP Tables-7

008	Page: Development Unit: Y		
009	Page: Developer: Bk		
010	Page: Developer: M		
011	Page: Developer: C		
012	Page: Developer: Y		
013	Page: Image Transfer	*ENG	[0 to 9999999 / 0 / 1 page/step]
014	Page: Cleaning Unit		
015	Page: Fusing Unit		
016	Page: Paper Transfer Unit		
017	Page: Toner Collection Bottle		
018	Page: Fusing Roller		
019	Page: Pressure Roller		
	Displays the number of revolutions for motors or clutches in the previous maintenance units. (See SP7-906-031 to 046 below.)		
020	Page: Pump Unit	*ENG	
	Displays the number of sheets printed with the previous maintenance units. [0 to 9999999 / 0 / 1 page/step]		
020	Page: Pump Unit: Bk	*ENG	[0 to 9999999 / 0 / 1 page/step]
021	Page: Pump Unit: M		
022	Page: Pump Unit: C		
023	Page: Pump Unit: Y		
031	Rotation: PCU: Bk	*ENG	[0 to 9999999 / 0 / 1 mm/step] (See SP7-906-019 above.)
032	Rotation: PCU: M		
033	Rotation: PCU: C		
034	Rotation: PCU: Y		
035	Rotation: Development Unit: Bk		

036	Rotation: Development Unit: M		
037	Rotation: Development Unit: C		
038	Rotation: Development Unit: Y		
039	Rotation: Developer: Bk		
040	Rotation: Developer: M		
041	Rotation: Developer: C		
042	Rotation: Developer: Y		
043	Rotation: Image Transfer	*ENG	[0 to 9999999 / 0 / 1 mm/step] (See SP7-906-019 above.)
044	Rotation: Cleaning Unit		
045	Rotation: Fusing Unit		
046	Rotation: Paper Transfer Unit		
047	Measurement: Toner Collection bottle		
048	Rotation: Fusing Roller		
049	Rotation: Pressure Roller		
	Displays the number of sheets printed with the previous maintenance unit or toner cartridge.		
050	Run Time: Pump Unit	*ENG	
	Displays the running time of the previous pump unit [0 to 999999999 / 0 / 1 msec/step]		
050	Run Time: Pump Unit: Bk	*ENG	[0 to 999999999 / 0 / 1 msec/step]
051	Run Time: Pump Unit: M		
052	Run Time: Pump Unit: C		
053	Run Time: Pump Unit: Y		
061	Rotation %: PCU:	*ENG	

Main SP Tables-7

	<p>Displays the value given by the following formula: $(\text{Current revolution} / \text{Target revolution}) \times 100$. This shows how much of the unit's expected lifetime has been used up. The Rotation % counter is based on rotations, not prints. If the number of rotations reaches the limit, the machine enters the end condition for that unit. If the print count lifetime is reached first, the machine also enters the end condition, even though the Rotation % counter is still less than 100%. [0 to 255 / 0 / 1 %/step]</p>		
061	Rotation %: PCU: BK	*ENG	[0 to 255 / 0 / 1 %/step]
062	Rotation %: PCU:M		
063	Rotation %: PCU:C		
064	Rotation %: PCU:Y		
065	Rotation %: Development Unit: Bk		
066	Rotation %: Development Unit: M		
067	Rotation %: Development Unit: C		
068	Rotation %: Development Unit: Y		
069	Rotation %: Developer: Bk	*ENG	[0 to 255 / 0 / 1 %/step]
070	Rotation %: Developer: M		
071	Rotation %: Developer: C		
072	Rotation %: Developer: Y		
073	Rotation %: Image Transfer Belt		
074	Rotation %: Cleaning Unit		
075	Rotation %: Fusing Unit		
076	Rotation %: Paper Transfer Unit		

077	Measurement %: Toner Collection bottle		
078	Rotation (%): Fusing Roller		
079	Rotation (%): Pressure Roller		
	Displays the value given by the following formula: (Current count / Yield count) x 100, where "Current count" is the current values in the counter for the part, and "Yield count" is the recommended yield.		
	Run Time (%): Pump Unit	*ENG	
080	<p>Displays the value given by the following formula: (Current running time / Target running time) × 100. This shows how much of the unit's expected lifetime has been used up.</p> <p>The Run Time (%) counter is based on the total running time, not printouts nor revolutions. If the number of printouts reaches the limit, the machine enters the end condition for that unit. If the revolution count lifetime is reached first, the machine also enters the end condition, even though the Run Time (%) counter is still less than 100%.</p> <p>[0 to 255 / 0 / 1 %/step]</p>		
080	Run Time (%): Pump Unit: Bk		
081	Run Time (%): Pump Unit: M	*ENG	[0 to 255 / 0 / 1 %/step]
082	Run Time (%): Pump Unit: C		
083	Run Time (%): Pump Unit: Y		
	Page %: PCU	*ENG	
091	<p>Displays the value given by the following formula: (Current printouts / Target printouts) × 100. This shows how much of the unit's expected lifetime has been used up.</p> <p>The Page% counter is based on printouts, not revolutions. If the number of printouts reaches the limit, the machine enters the end condition for that unit. If the revolution count lifetime is reached first, the machine also enters the end condition, even though the Page% counter is still less than 100%.</p> <p>[0 to 255 / 0 / 1 %/step]</p>		
091	Page %: PCU: Bk	*ENG	[0 to 255 / 0 / 1 %/step]

Main SP Tables-7

092	Page %: PCU: M		
093	Page %: PCU: C		
094	Page %: PCU: Y		
095	Page %: Development Unit: Bk		
096	Page %: Development Unit: M		
097	Page %: Development Unit: C		
098	Page %: Development Unit: Y		
099	Page %: Developer: Bk		
100	Page %: Developer: M		
101	Page %: Developer: C		
102	Page %: Developer: Y		
103	Page %: Image Transfer		
104	Page %: Cleaning Unit		
105	Page %: Fusing Unit		
106	Page %: Paper Transfer Unit		
107	Page (%): Fusing Roller		
108	Page (%): Pressure Roller		
109	Page (%): Pump Unit: Bk		
110	Page (%): Pump Unit: M		
111	Page (%): Pump Unit: C		
112	Page (%): Pump Unit: Y		

7931	[Toner Bottle Bk]		
	Displays the toner bottle information for Bk.		
001	Machine Serial ID	*ENG	

002	Cartridge Ver		
003	Brand ID		
004	Area ID		
005	Product ID		
006	Color ID		
007	Maintenance ID		
008	New Product Information		
009	Recycle Counter		
010	Date		
011	Serial No.		
012	Toner Remaining		
013	EDP Code		
014	End History		
015	Refill Information		
016	Attachment: Total Counter		
017	Attachment: Color Counter		
018	End: Total Counter		
019	End: Color Counter		
020	Attachment Date		
021	End Date		

7932	[Toner Bottle M]		
	Displays the toner bottle information for M.		
001	Machine Serial ID	*ENG	-
002	Cartridge Ver		

Main SP Tables-7

003	Brand ID				
004	Area ID				
005	Product ID				
006	Color ID				
007	Maintenance ID				
008	New Product Information				
009	Recycle Counter				
010	Date				
011	Serial No.				
012	Toner Remaining			*ENG	-
013	EDP Code				
014	End History				
015	Refill Information				
016	Attachment: Total Counter				
017	Attachment: Color Counter				
018	End: Total Counter				
019	End: Color Counter				
020	Attachment Date				
021	End Date				

7933	[Toner Bottle C]		
	Displays the toner bottle information for C.		
001	Machine Serial ID	*ENG	-
002	Cartridge Ver		
003	Brand ID		

004	Area ID				
005	Product ID				
006	Color ID				
007	Maintenance ID				
008	New Product Information				
009	Recycle Counter				
010	Date				
011	Serial No.				
012	Toner Remaining			*ENG	-
013	EDP Code				
014	End History				
015	Refill Information				
016	Attachment: Total Counter				
017	Attachment: Color Counter				
018	End: Total Counter				
019	End: Color Counter				
020	Attachment Date				
021	End Date				

7934	[Toner Bottle Y]		
	Displays the toner bottle information for Y.		
001	Machine Serial ID	*ENG	-
002	Cartridge Ver		
003	Brand ID		
004	Area ID		

Main SP Tables-7

005	Product ID		
006	Color ID		
007	Maintenance ID		
008	New Product Information		
009	Recycle Counter		
010	Date		
011	Serial No.		
012	Toner Remaining	*ENG	-
013	EDP Code		
014	End History		
015	Refill Information		
016	Attachment: Total Counter		
017	Attachment: Color Counter		
018	End: Total Counter		
019	End: Color Counter		
020	Attachment Date		
021	End Date		

7935	[Toner Bottle Log 1: Bk]		
001	Serial No.	*ENG	Displays the toner bottle information log 1 for Bk.
002	Attachment Date		
003	Attachment: Total Counter		
004	Refill Information		
011	Serial No.	*ENG	Displays the toner bottle information log 2 for Bk.
012	Attachment Date		

013	Attachment: Total Counter		
014	Refill Information		
021	Serial No.	*ENG	Displays the toner bottle information log 3 for Bk.
022	Attachment Date		
023	Attachment: Total Counter		
024	Refill Information		
031	Serial No.		
032	Attachment Date	*ENG	Displays the toner bottle information log 4 for Bk.
033	Attachment: Total Counter		
034	Refill Information		
041	Serial No.		
042	Attachment Date	*ENG	Displays the toner bottle information log 5 for Bk.
043	Attachment: Total Counter		
044	Refill Information		

7936	[Toner Bottle Log 1: M]		
001	Serial No.	*ENG	Displays the toner bottle information log 1 for M.
002	Attachment Date		
003	Attachment: Total Counter		
004	Refill Information		
011	Serial No.	*ENG	Displays the toner bottle information log 2 for M.
012	Attachment Date		
013	Attachment: Total Counter		
014	Refill Information		
021	Serial No.	*ENG	Displays the toner bottle

Main SP Tables-7

022	Attachment Date		information log 3 for M.
023	Attachment: Total Counter		
024	Refill Information		
031	Serial No.	*ENG	Displays the toner bottle information log 4 for M.
032	Attachment Date		
033	Attachment: Total Counter		
034	Refill Information		
041	Serial No.	*ENG	Displays the toner bottle information log 5 for M.
042	Attachment Date		
043	Attachment: Total Counter		
044	Refill Information		

7937	[Toner Bottle Log 1: C]		
001	Serial No.	*ENG	Displays the toner bottle information log 1 for C.
002	Attachment Date		
003	Attachment: Total Counter		
004	Refill Information		
011	Serial No.	*ENG	Displays the toner bottle information log 2 for C.
012	Attachment Date		
013	Attachment: Total Counter		
014	Refill Information		
021	Serial No.	*ENG	Displays the toner bottle information log 3 for C.
022	Attachment Date		
023	Attachment: Total Counter		
024	Refill Information		

031	Serial No.	*ENG	Displays the toner bottle information log 4 for C.
032	Attachment Date		
033	Attachment: Total Counter		
034	Refill Information		
041	Serial No.	*ENG	Displays the toner bottle information log 5 for C.
042	Attachment Date		
043	Attachment: Total Counter		
044	Refill Information		

7938	[Toner Bottle Log 1: Y]		
001	Serial No.	*ENG	Displays the toner bottle information log 1 for Y.
002	Attachment Date		
003	Attachment: Total Counter		
004	Refill Information		
011	Serial No.	*ENG	Displays the toner bottle information log 2 for Y.
012	Attachment Date		
013	Attachment: Total Counter		
014	Refill Information		
021	Serial No.	*ENG	Displays the toner bottle information log 3 for Y.
022	Attachment Date		
023	Attachment: Total Counter		
024	Refill Information		
031	Serial No.	*ENG	Displays the toner bottle information log 4 for Y.
032	Attachment Date		
033	Attachment: Total Counter		

Main SP Tables-7

034	Refill Information		
041	Serial No.	*ENG	Displays the toner bottle information log 5 for Y.
042	Attachment Date		
043	Attachment: Total Counter		
044	Refill Information		

7950	[Unit Replacement Date]		
	Displays the replacement date of each PM unit.		
001	Image Transfer Belt	*ENG	-
002	Cleaning Unit		
003	Paper Transfer Unit		
004	Fusing Unit		
005	Toner Collection Bottle		
006	AIT:Bk		
007	AIT:M		
008	AIT:C		
009	AIT:Y		
010	Fusing Roller		
011	Pressure Roller		
012	Pump Unit: Bk		
013	Pump Unit: M		
014	Pump Unit: C		
015	Pump Unit: Y		

7951	[Remaining Day Counter]
------	-------------------------

	Displays the remaining unit life of each PM unit.		
001	Page: PCU: Bk	*ENG	[0 to 255 / 255 / 1 day/step]
002	Page: PCU: M		
003	Page: PCU: C		
004	Page: PCU: Y		
005	Page: Development Unit: Bk		
006	Page: Development Unit: M		
007	Page: Development Unit: C		
008	Page: Development Unit: Y		
009	Page: Developer: Bk		
010	Page: Developer: M		
011	Page: Developer: C		
012	Page: Developer: Y		
013	Page: Image Transfer	*ENG	[0 to 255 / 255 / 1 day/step]
014	Page: Cleaning Unit		
015	Page: Fusing Unit		
016	Page: Paper Transfer Unit		
017	Page: Fusing Roller		
018	Page: Pressure Roller		
031	Rotation: PCU: Bk	*ENG	[0 to 255 / 255 / 1 day/step]
032	Rotation: PCU: M		
033	Rotation: PCU: C		
034	Rotation: PCU: Y		
035	Rotation: Development Unit: Bk		
036	Rotation: Development Unit: M		

Main SP Tables-7

037	Rotation: Development Unit: C		
038	Rotation: Development Unit: Y		
039	Rotation: Developer: Bk		
040	Rotation: Developer: M		
041	Rotation: Developer: C		
042	Rotation: Developer: Y		
043	Rotation: Image Transfer	*ENG	[0 to 255 / 255 / 1 day/step]
044	Rotation: Cleaning Unit		
045	Rotation: Fusing Unit		
046	Rotation: Paper Transfer Unit		
047	Measurement: Toner Collection bottle		
048	Rotation: Fusing Roller		
049	Rotation: Pressure Roller		
101	Minimum: PCU: Bk		
102	Minimum: PCU: M		
103	Minimum: PCU: C		
104	Minimum: PCU: Y		
105	Minimum: Development Unit: Bk		
106	Minimum: Development Unit: M	*ENG	Displays one of the three, Remaining Day Counter: Rotation or Runtime, or Remaining Day Counter: Page, which is the minimum value. [0 to 255 / 255 / 1 day/step] For toner collection bottle, this SP is not displayed because its Remaining Day Counters is calculated with its weights only.
107	Minimum: Development Unit: C		
108	Minimum: Development Unit: Y		
109	Minimum: Developer: Bk		
110	Minimum: Developer: M		
111	Minimum: Developer: C		

112	Minimum: Developer: Y		
113	Minimum: Image Transfer		
114	Minimum: Cleaning Unit		
115	Minimum: Fusing Unit		
116	Minimum: Paper Transfer Unit		
117	Minimum: Fusing Roller		
118	Minimum: Pressure Roller		
119	Minimum: Pump Unit: Bk	*ENG	Displays either Remaining Day Counter: time or Page, which is less value. [0 to 255 / 255 / 1 day/step]
120	Minimum: Pump Unit: M		
121	Minimum: Pump Unit: C		
122	Minimum: Pump Unit: Y		

7952	[PM Yield Setting]		
	Adjusts the unit yield of each PM unit.		
001	Rotation: Image Transfer Belt	*CTL	[0 to 999999999 / 256597000 / 1 mm/step]
002	Rotation: Cleaning Unit	*CTL	[0 to 999999999 / 128299000 / 1 mm/step]
003	Rotation: Fusing Unit	*CTL	[0 to 999999999 / 155595000 / 1 mm/step]
004	Rotation: Paper Transfer Unit	*CTL	[0 to 999999999 / 192448000 / 1 mm/step]
011	Page: Image Transfer Belt	*CTL	[0 to 999999 / 320000 / 1 sheet/step]
012	Page: Cleaning Unit	*CTL	[0 to 999999 / 160000 / 1 sheet/step]
013	Page: Fusing Unit	*CTL	[0 to 999999 / 160000 / 1 sheet/step]
014	Page: Paper Transfer Unit	*CTL	[0 to 999999 / 240000 / 1 sheet/step]
021	Day Threshold: PCU: Bk	*CTL	Adjusts the threshold day for the near end fro each PM unit.
022	Day Threshold: PCU: M		

Main SP Tables-7

023	Day Threshold: PCU: C		<p>[1 to 30 / 15 / 1 day/step]</p> <p>These threshold days are used for @Remote alarms.</p>
024	Day Threshold: PCU: Y		
025	Day Threshold: Development Unit: Bk		
026	Day Threshold: Development Unit: M		
027	Day Threshold: Development Unit: C		
028	Day Threshold: Development Unit: Y		
029	Day Threshold: Developer: Bk		
030	Day Threshold: Developer: M		
031	Day Threshold: Developer: C		
032	Day Threshold: Developer: Y		
033	Day Threshold: Image Transfer Belt	*CTL	<p>Adjusts the threshold day for the near end fro each PM unit.</p> <p>[1 to 30 / 15 / 1 day/step]</p> <p>These threshold days are used for @Remote alarms.</p>
034	Day Threshold: Cleaning Unit		
035	Day Threshold: Fusing Unit		
036	Day Threshold: Paper Transfer Unit		
037	Day Threshold: Toner Collection Bottle		
038	Rotation: PCU Bk	*CTL	[0 to 999999999 / 0 / 1 mm/step]

039	Rotation: PCU M		
040	Rotation: PCU C		
041	Rotation: PCU Y		
042	Rotation: Development Unit: Bk	*CTL	[0 to 999999999 / 0 / 1 mm/step]
043	Rotation: Development Unit: M		
044	Rotation: Development Unit: C		
045	Rotation: Development Unit: Y		
046	Rotation: Developer: Bk	*CTL	[0 to 999999999 / 0 / 1 mm/step]
047	Rotation: Developer: M		
048	Rotation: Developer: C		
049	Rotation: Developer: Y		
050	Page: PCU: Bk	*CTL	[0 to 999999 / 0 / 1 sheet/step]
051	Page: PCU: M		
052	Page: PCU: C		
053	Page: PCU: Y		
054	Page: Development Unit: Bk	*CTL	[0 to 999999 / 0 / 1 sheet/step]
055	Page: Development Unit: M		
056	Page: Development Unit: C		
057	Page: Development Unit: Y		

Main SP Tables-7

058	Page: Developer: Bk	*CTL	[0 to 999999 / 0 / 1 sheet/step]
059	Page: Developer: M		
060	Page: Developer: C		
061	Page: Developer: Y		

7953	[Operation Env. Log: PCU: Bk]		
	Displays the PCDU rotation distance in each specified operation environment. T: Temperature (°C), H: Relative Humidity (%)		
001	T<=0	*CTL	[0 to 99999999 / - / 1 mm/step]
002	0<T<=5:0<=H<30		
003	0<T<=5:30<=H<70		
004	0<T<=5:70<=H<=100		
005	5<T<15:0<=H<30		
006	5<T<15:30<=H<55		
007	5<T<15:55<=H<80		
008	5<T<15:80<=H<=100		
009	15<=T<25:0<=H<30		
010	15<=T<25:30<=H<55		
011	15<=T<25:55<=H<80	*CTL	[0 to 99999999 / - / 1 mm/step]
012	15<=T<25:80<=H<=100		
013	25<=T<30:0<=H<30		
014	25<=T<30:30<=H<55		
015	25<=T<30:55<=H<80		
016	25<=T<30:80<=H<=100		

017	30<=T<35:0<=H<30		
018	30<=T<35:30<=H<55		
019	30<=T<35:55<=H<80		
020	30<=T<35:80<=H<=100		
021	35 <= T		

7954	[Operation Env. Log Clear]		
	Clears the operation environment log.		
001		-	

7955	Fusing Stop		
001	Near End: Page	-	[1 to 999999 / 318000 / 1 sheet/step]
	Displays the threshold sheet for the heating roller near end.		
002	End: Page	-	[1 to 999999 / 330000 / 1 sheet/step]
	Displays the threshold sheet for the heating roller end.		
003	Near End: Rotation	-	[0 to 999999999 / C3a: 173327000, C3b: 162570000 / 1 mm/step]
	Displays the threshold distance for the heating roller near end.		
004	End: Rotation	-	[0 to 999999999 / C3a: 179868000, C3b: 168705000 / 1 mm/step]
	Displays the threshold distance for the heating roller end.		

5.9 MAIN SP TABLES-8

5.9.1 SP8-XXX: DATA LOG2

Many of these counters are provided for features that are currently not available, such as sending color faxes, and so on. However, here are some Group 8 codes that when used in combination with others, can provide useful information.

SP Numbers	What They Do
SP8211 to SP8216	The number of pages scanned to the document server.
SP8401 to SP8406	The number of pages printed from the document server
SP8691 to SP8696	The number of pages sent from the document server

Specifically, the following questions can be answered:

- How is the document server actually being used?
- What application is using the document server most frequently?
- What data in the document server is being reused?

Most of the SPs in this group are prefixed with a letter that indicates the mode of operation (the mode of operation is referred to as an "application"). Before reading the Group 8 Service Table, make sure that you understand what these prefixes mean.

Prefixes	What it means	
T:	Total: (Grand Total).	Grand total of the items counted for all applications (C, F, P, etc.).
C:	Copy application.	Totals (pages, jobs, etc.) executed for each application when the job was not stored on the document server.
F:	Fax application.	
P:	Print application.	
S:	Scan application.	

L:	Local storage (document server)	Totals (jobs, pages, etc.) for the document server. The L: counters work differently case by case. Sometimes, they count jobs/pages stored on the document server; this can be in document server mode (from the document server window), or from another mode, such as from a printer driver or by pressing the Store File button in the Copy mode window. Sometimes, they include occasions when the user uses a file that is already on the document server. Each counter will be discussed case by case.
O:	Other applications (external network applications, for example)	Refers to network applications such as Web Image Monitor. Utilities developed with the SDK (Software Development Kit) will also be counted with this group in the future.

The Group 8 SP codes are limited to 17 characters, forced by the necessity of displaying them on the small LCDs of printers and faxes that also use these SPs. Read over the list of abbreviations below and refer to it again if you see the name of an SP that you do not understand.

Key for Abbreviations

Abbreviation	What it means
/	"By", e.g. "T:Jobs/Apl" = Total Jobs "by" Application
>	More (2> "2 or more", 4> "4 or more")
AddBook	Address Book
Apl	Application
B/W	Black & White
Bk	Black
C	Cyan
ColCr	Color Create
ColMode	Color Mode

Abbreviation	What it means
Comb	Combine
Comp	Compression
Deliv	Delivery
DesApl	Designated Application. The application (Copy, Fax, Scan, Print) used to store the job on the document server, for example.
Dev Counter	Development Count, no. of pages developed.
Dup, Duplex	Duplex, printing on both sides
Emul	Emulation
FC	Full Color
FIN	Post-print processing, i.e. finishing (punching, stapling, etc.)
Full Bleed	No Margins
GenCopy	Generation Copy Mode
GPC	Get Print Counter. For jobs 10 pages or less, this counter does not count up. For jobs larger than 10 pages, this counter counts up by the number that is in excess of 10 (e.g., for an 11-page job, the counter counts up 11-10 =1)
IFax	Internet Fax
ImgEdt	Image Edit performed on the original with the copier GUI, e.g. border removal, adding stamps, page numbers, etc.
K	Black (YMCK)
LS	Local Storage. Refers to the document server.
LSize	Large (paper) Size
Mag	Magnification
MC	One color (monochrome)

Abbreviation	What it means
NRS	New Remote Service, which allows a service center to monitor machines remotely. "NRS" is used overseas, "CSS" is used in Japan.
Org	Original for scanning
OrgJam	Original Jam
Palm 2	Print Job Manager/Desk Top Editor: A pair of utilities that allows print jobs to be distributed evenly among the printers on the network, and allows files to moved around, combined, and converted to different formats.
PC	Personal Computer
PGS	Pages. A page is the total scanned surface of the original. Duplex pages count as two pages, and A3 simplex count as two pages if the A3/DLT counter SP is switched ON.
PJob	Print Jobs
Ppr	Paper
PrtJam	Printer (plotter) Jam
PrtPGS	Print Pages
R	Red (Toner Remaining). Applies to the wide format model A2 only. This machine is under development and currently not available.
Rez	Resolution
SC	Service Code (Error SC code displayed)
Scn	Scan
Sim, Simplex	Simplex, printing on 1 side.
S-to-Email	Scan-to-E-mail
SMC	SMC report printed with SP5990. All of the Group 8 counters are recorded in the SMC report.

Abbreviation	What it means
Svr	Server
TonEnd	Toner End
TonSave	Toner Save
TXJob	Send, Transmission
YMC	Yellow, Magenta, Cyan
YMCK	Yellow, Magenta, Cyan, Black

Note

- All of the Group 8 SPs are reset with SP5 801 1 Memory All Clear.

8 001	T:Total Jobs	*CTL	These SPs count the number of times each application is used to do a job. [0 to 9999999/ 0 / 1] Note: The L: counter is the total number of times the other applications are used to send a job to the document server, plus the number of times a file already on the document server is used.
8 002	C:Total Jobs	*CTL	
8 003	F:Total Jobs	*CTL	
8 004	P:Total Jobs	*CTL	
8 005	S:Total Jobs	*CTL	
8 006	L:Total Jobs	*CTL	

- These SPs reveal the number of times an application is used, not the number of pages processed.
- When an application is opened for image input or output, this counts as one job.
- Interrupted jobs (paper jams, etc.) are counted, even though they do not finish.
- Only jobs executed by the customer are counted. Jobs executed by the customer engineer using the SP modes are not counted.
- When using secure printing (when a password is required to start the print job), the job is counted at the time when either "Delete Data" or "Specify Output" is specified.
- A job is counted as a fax job when the job is stored for sending.
- When a fax is received to fax memory, the F: counter increments but the L: counter does not (the document server is not used).
- A fax broadcast counts as one job for the F: counter (the fax destinations in the broadcast are

not counted separately).

- A fax broadcast is counted only after all the faxes have been sent to their destinations. If one transmission generates an error, then the broadcast will not be counted until the transmission has been completed.
- A printed fax report counts as one job for the F: counter.
- The F: counter does not distinguish between fax sending or receiving.
- When a copy job on the document server is printed, SP8022 also increments, and when a print job stored on the document server is printed, SP8024 also increments.
- When an original is both copied and stored on the document server, the C: and L: counters both increment.
- When a print job is stored on the document server, only the L: counter increments.
- When the user presses the Document Server button to store the job on the document server, only the L: counter increments.
- When the user enters document server mode and prints data stored on the document server, only the L: counter increments.
- When an image received from Palm 2 is received and stored, the L: counter increments.
- When the customer prints a report (user code list, for example), the O: counter increments. However, for fax reports and reports executed from the fax application, the F: counter increments.

8 011	T:Jobs/LS	*CTL	<p>These SPs count the number of jobs stored to the document server by each application, to reveal how local storage is being used for input.</p> <p>[0 to 9999999/ 0 / 1]</p> <p>The L: counter counts the number of jobs stored from within the document server mode screen at the operation panel.</p>
8 012	C:Jobs/LS	*CTL	
8 013	F:Jobs/LS	*CTL	
8 014	P:Jobs/LS	*CTL	
8 015	S:Jobs/LS	*CTL	
8 016	L:Jobs/LS	*CTL	
8 017	O:Jobs/LS	*CTL	

- When a scan job is sent to the document server, the S: counter increments. When you enter document server mode and then scan an original, the L: counter increments.
- When a print job is sent to the document server, the P: counter increments.
- When a network application sends data to the document server, the O: counter increments.
- When an image from Palm 2 is stored on the document server, the O: counter increments.
- When a fax is sent to the document server, the F: counter increments.

Main SP Tables-8

8 021	T:Pjob/LS	*CTL	<p>These SPs reveal how files printed from the document server were stored on the document server originally.</p> <p>[0 to 9999999/ 0 / 1]</p> <p>The L: counter counts the number of jobs stored from within the document server mode screen at the operation panel.</p>
8 022	C:Pjob/LS	*CTL	
8 023	F:Pjob/LS	*CTL	
8 024	P:Pjob/LS	*CTL	
8 025	S:Pjob/LS	*CTL	
8 026	L:Pjob/LS	*CTL	
8 027	O:Pjob/LS	*CTL	

- When a copy job stored on the document server is printed with another application, the C: counter increments.
- When an application like DeskTopBinder merges a copy job that was stored on the document server with a print job that was stored on the document server, the C: and P: counters both increment.
- When a job already on the document server is printed with another application, the L: counter increments.
- When a scanner job stored on the document server is printed with another application, the S: counter increments. If the original was scanned from within document server mode, then the L: counter increments.
- When images stored on the document server by a network application (including Palm 2), are printed with another application, the O: counter increments.
- When a copy job stored on the document server is printed with a network application (Web Image Monitor, for example), the C: counter increments.
- When a fax on the document server is printed, the F: counter increments.

8 031	T:Pjob/DesApl	*CTL	<p>These SPs reveal what applications were used to output documents from the document server.</p> <p>[0 to 9999999/ 0 / 1]</p> <p>The L: counter counts the number of jobs printed from within the document server mode screen at the operation panel.</p>
8 032	C:Pjob/DesApl	*CTL	
8 033	F:Pjob/DesApl	*CTL	
8 034	P:Pjob/DesApl	*CTL	
8 035	S:Pjob/DesApl	*CTL	
8 036	L:Pjob/DesApl	*CTL	
8 037	O:Pjob/DesApl	*CTL	

- When documents already stored on the document server are printed, the count for the application that started the print job is incremented.
- When the print job is started from a network application (Desk Top Binder, Web Image Monitor, etc.) the L: counter increments.

8 041	T:TX Jobs/LS	*CTL	<p>These SPs count the applications that stored files on the document server that were later accessed for transmission over the telephone line or over a network (attached to an e-mail, or as a fax image by I-Fax).</p> <p>[0 to 9999999/ 0 / 1]</p> <p>Note: Jobs merged for sending are counted separately.</p> <p>The L: counter counts the number of jobs scanned from within the document server mode screen at the operation panel.</p>
8 042	C:TX Jobs/LS	*CTL	
8 043	F:TX Jobs/LS	*CTL	
8 044	P:TX Jobs/LS	*CTL	
8 045	S:TX Jobs/LS	*CTL	
8 046	L:TX Jobs/LS	*CTL	
8 047	O:TX Jobs/LS	*CTL	

- When a stored copy job is sent from the document server, the C: counter increments.
- When images stored on the document server by a network application or Palm2 are sent as an e-mail, the O: counter increments.

8 051	T:TX Jobs/DesApl	*CTL	These SPs count the applications used to send files from the document server over the telephone line or over a network (attached to an e-mail, or as a fax image by I-Fax). Jobs merged for sending are counted separately. [0 to 9999999/ 0 / 1] The L: counter counts the number of jobs sent from within the document server mode screen at the operation panel.
8 052	C:TX Jobs/DesApl	*CTL	
8 053	F:TX Jobs/DesApl	*CTL	
8 054	P:TX Jobs/DesApl	*CTL	
8 055	S:TX Jobs/DesApl	*CTL	
8 056	L:TX Jobs/DesApl	*CTL	
8 057	O:TX Jobs/DesApl	*CTL	

- If the send is started from Desk Top Binder or Web Image Monitor, for example, then the O: counter increments.

8 061	T:FIN Jobs	*CTL	[0 to 9999999/ 0 / 1]
	These SPs total the finishing methods. The finishing method is specified by the application.		
8 062	C:FIN Jobs	*CTL	[0 to 9999999/ 0 / 1]
	These SPs total finishing methods for copy jobs only. The finishing method is specified by the application.		
8 063	F:FIN Jobs	*CTL	[0 to 9999999/ 0 / 1]
	These SPs total finishing methods for fax jobs only. The finishing method is specified by the application. Note: Finishing features for fax jobs are not available at this time.		
8 064	P:FIN Jobs	*CTL	[0 to 9999999/ 0 / 1]
	These SPs total finishing methods for print jobs only. The finishing method is specified by the application.		
8 065	S:FIN Jobs	*CTL	[0 to 9999999/ 0 / 1]
	These SPs total finishing methods for scan jobs only. The finishing method is specified by the application. Note: Finishing features for scan jobs are not available at this time.		

8 066	L:FIN Jobs	*CTL	[0 to 9999999/ 0 / 1]
	These SPs total finishing methods for jobs output from within the document server mode screen at the operation panel. The finishing method is specified from the print window within document server mode.		
8 067	O:FIN Jobs	*CTL	[0 to 9999999/ 0 / 1]
	These SPs total finishing methods for jobs executed by an external application, over the network. The finishing method is specified by the application.		
8 06x 1	Sort	Number of jobs started in Sort mode. When a stored copy job is set for Sort and then stored on the document server, the L: counter increments. (See SP8 066 1)	
8 06x 2	Stack	Number of jobs started out of Sort mode.	
8 06x 3	Staple	Number of jobs started in Staple mode.	
8 06x 4	Booklet	Number of jobs started in Booklet mode. If the machine is in staple mode, the Staple counter also increments.	
8 06x 5	Z-Fold	Number of jobs started In any mode other than the Booklet mode and set for folding (Z-fold).	
8 06x 6	Punch	Number of jobs started in Punch mode. When Punch is set for a print job, the P: counter increments. (See SP8 064 6.)	
8 06x 7	Other	Reserved. Not used.	

8 071	T:Jobs/PGS	*CTL	[0 to 9999999/ 0 / 1]
	These SPs count the number of jobs broken down by the number of pages in the job, regardless of which application was used.		
8 072	C:Jobs/PGS	*CTL	[0 to 9999999/ 0 / 1]
	These SPs count and calculate the number of copy jobs by size based on the number of pages in the job.		

Main SP Tables-8

8 073	F:Jobs/PGS	*CTL	[0 to 9999999/ 0 / 1]
	These SPs count and calculate the number of fax jobs by size based on the number of pages in the job.		
8 074	P:Jobs/PGS	*CTL	[0 to 9999999/ 0 / 1]
	These SPs count and calculate the number of print jobs by size based on the number of pages in the job.		
8 075	S:Jobs/PGS		[0 to 9999999/ 0 / 1]
	These SPs count and calculate the number of scan jobs by size based on the number of pages in the job.		
8 076	L:Jobs/PGS	*CTL	[0 to 9999999/ 0 / 1]
	These SPs count and calculate the number of jobs printed from within the document server mode window at the operation panel, by the number of pages in the job.		
8 077	O:Jobs/PGS	*CTL	[0 to 9999999/ 0 / 1]
	These SPs count and calculate the number of "Other" application jobs (Web Image Monitor, Palm 2, etc.) by size based on the number of pages in the job.		
8 07x 1	1 Page	8 07x 8	21 to 50 Pages
8 07x 2	2 Pages	8 07x 9	51 to 100 Pages
8 07x 3	3 Pages	8 07x 10	101 to 300 Pages
8 07x 4	4 Pages	8 07x 11	301 to 500 Pages
8 07x 5	5 Pages	8 07x 12	501 to 700 Pages
8 07x 6	6 to 10 Pages	8 07x 13	701 to 1000 Pages
8 07x 7	11 to 20 Pages	8 07x 14	1001 to Pages

- For example: When a copy job stored on the document server is printed in document server mode, the appropriate L: counter (SP8076 0xx) increments.
- Printing a fax report counts as a job and increments the F: counter (SP 8073).
- Interrupted jobs (paper jam, etc.) are counted, even though they do not finish.
- If a job is paused and re-started, it counts as one job.
- If the finisher runs out of staples during a print and staple job, then the job is counted at the time the error occurs.
- For copy jobs (SP 8072) and scan jobs (SP 8075), the total is calculated by multiplying the number of sets of copies by the number of pages scanned. (One duplex page counts as 2.)
- The first test print and subsequent test prints to adjust settings are added to the number of pages of the copy job (SP 8072).
- When printing the first page of a job from within the document server screen, the page is counted.

8 111	T:FAX TX Jobs	*CTL	[0 to 9999999/ 0 / 1]
	<p>These SPs count the total number of jobs (color or black-and-white) sent by fax, either directly or using a file stored on the document server, on a telephone line.</p> <p>Note: Color fax sending is not available at this time.</p>		
8 113	F: FAX TX Jobs	*CTL	[0 to 9999999/ 0 / 1]
	<p>These SPs count the total number of jobs (color or black-and-white) sent by fax directly on a telephone line.</p> <p>Note: Color fax sending is not available at this time.</p>		
8 11x 1	B/W		
8 11x 2	Color		

- These counters count jobs, not pages.
- This SP counts fax jobs sent over a telephone line with a fax application, including documents stored on the document server.
- If the mode is changed during the job, the job will count with the mode set when the job started.
- If the same document is faxed to both a public fax line and an I-Fax at a destination where both are available, then this counter increments, and the I-Fax counter (8 12x) also increments.

Main SP Tables-8

- The fax job is counted when the job is scanned for sending, not when the job is sent.

8 121	T:IFAX TX Jobs	*CTL	[0 to 9999999/ 0 / 1]
	These SPs count the total number of jobs (color or black-and-white) sent, either directly or using a file stored on the document server, as fax images using I-Fax. Note: Color fax sending is not available at this time.		
8 123	F: IFAX TX Jobs	*CTL	[0 to 9999999/ 0 / 1]
	These SPs count the number of jobs (color or black-and-white) sent (not stored on the document server), as fax images using I-Fax. Note: Color fax sending is not available at this time.		
8 12x 1	B/W		
8 12x 2	Color		

- These counters count jobs, not pages.
- The counters for color are provided for future use; the color fax feature is not available at this time.
- The fax job is counted when the job is scanned for sending, not when the job is sent.

8 131	T:S-to-Email Jobs	*CTL	[0 to 9999999/ 0 / 1]
	These SPs count the total number of jobs (color or black-and-white) scanned and attached to an e-mail, regardless of whether the document server was used or not.		
8 135	S: S-to-Email Jobs	*CTL	[0 to 9999999/ 0 / 1]
	These SPs count the number of jobs (color or black-and-white) scanned and attached to e-mail, without storing the original on the document server.		
8 13x 1	B/W		
8 13x 2	Color		
8 13x 3	ACS		

- These counters count jobs, not pages.
- If the job is stored on the document server, after the job is stored it is determined to be color or black-and-white then counted.
- If the job is cancelled during scanning, or if the job is cancelled while the document is waiting to be sent, the job is not counted.
- If the job is cancelled during sending, it may or may not be counted, depending on what stage of the process had been reached when the job was cancelled.
- If several jobs are combined for sending to the Scan Router, Scan-to-Email, or Scan-to-PC, or if one job is sent to more than one destination. each send is counted separately. For example, if the same document is sent by Scan-to-Email as well as Scan-to-PC, then it is counted twice (once for Scan-to-Email and once for Scan-to-PC).

8 141	T:Deliv Jobs/Svr	*CTL	[0 to 9999999/ 0 / 1]
	These SPs count the total number of jobs (color or black-and-white) scanned and sent to a Scan Router server.		
8 145	S: Deliv Jobs/Svr	*CTL	[0 to 9999999/ 0 / 1]
	These SPs count the number of jobs (color or black-and-white) scanned in scanner mode and sent to a Scan Router server.		
8 14x 1	B/W		
8 14x 2	Color		
8 14x 3	ACS		

- These counters count jobs, not pages.
- The jobs are counted even though the arrival and reception of the jobs at the Scan Router server cannot be confirmed.
- If even one color image is mixed with black-and-white images, then the job is counted as a "Color" job.
- If the job is cancelled during scanning, or if the job is cancelled while the document is waiting to be delivered, the job is not counted.
- If the job is cancelled during sending, it may or may not be counted, depending on what stage of the process had been reached when the job was cancelled.
- Even if several files are combined for sending, the transmission counts as one job.

Main SP Tables-8

8 151	T:Deliv Jobs/PC	*CTL	[0 to 9999999/ 0 / 1]
	These SPs count the total number of jobs (color or black-and-white) scanned and sent to a folder on a PC (Scan-to-PC). Note: At the present time, 8 151 and 8 155 perform identical counts.		
8 155	S:Deliv Jobs/PC	*CTL	[0 to 9999999/ 0 / 1]
	These SPs count the total number of jobs (color or black-and-white) scanned and sent with Scan-to-PC.		
8 15x 1	B/W		
8 15x 2	Color		
8 15x 3	ACS		

- These counters count jobs, not pages.
- If the job is cancelled during scanning, it is not counted.
- If the job is cancelled while it is waiting to be sent, the job is not counted.
- If the job is cancelled during sending, it may or may not be counted, depending on what stage of the process had been reached when the job was cancelled.
- Even if several files are combined for sending, the transmission counts as one job.

8 161	T:PCFAX TX Jobs	*CTL	These SPs count the number of PC Fax transmission jobs. A job is counted from when it is registered for sending, not when it is sent. [0 to 9999999/ 0 / 1] Note: At the present time, these counters perform identical counts.
8 163	F:PCFAX TX Jobs	*CTL	

- This counts fax jobs started from a PC using a PC fax application, and sending the data out to the destination from the PC through the copier.

8 171	T:Deliv Jobs/WSD	*CTL	These SPs count the pages scanned by WS. [0 to 9999999/ 0 / 1]
8 175	S:Deliv Jobs/WSD	*CTL	
-001	B/W		
-002	Color		
-003	ACS		

8 181	T:Scan to Media Jobs	*CTL	These SPs count the scanned pages in a media by the scanner application. [0 to 9999999/ 0 / 1]
8 185	S:Scan to Media Jobs	*CTL	
-001	B/W		
-002	Color		
-003	ACS		

8 191	T:Total Scan PGS	*CTL	These SPs count the pages scanned by each application that uses the scanner to scan images. [0 to 9999999/ 0 / 1]
8 192	C:Total Scan PGS	*CTL	
8 193	F:Total Scan PGS	*CTL	
8 195	S:Total Scan PGS	*CTL	
8 196	L:Total Scan PGS	*CTL	

- SP 8 191 to 8 196 count the number of scanned sides of pages, not the number of physical pages.
- These counters do not count reading user stamp data, or reading color charts to adjust color.
- Previews done with a scanner driver are not counted.
- A count is done only after all images of a job have been scanned.
- Scans made in SP mode are not counted.

Examples

- If 3 B5 pages and 1 A3 page are scanned with the scanner application but not stored, the S: count is 4.
- If both sides of 3 A4 sheets are copied and stored to the document server using the Store File button in the Copy mode window, the C: count is 6 and the L: count is 6.
- If both sides of 3 A4 sheets are copied but not stored, the C: count is 6.
- If you enter document server mode then scan 6 pages, the L: count is 6.

8 201	T:LSize Scan PGS	*CTL	[0 to 9999999/ 0 / 1]
	These SPs count the total number of large pages input with the scanner for scan and copy jobs. Large size paper (A3/DLT) scanned for fax transmission are not counted. Note: These counters are displayed in the SMC Report, and in the User Tools display.		
8 203	F: LSize Scan PGS	*CTL	[0 to 9999999/ 0 / 1]
	These SPs count the total number of large pages input with the scanner for fax transmission. Note: These counters are displayed in the SMC Report, and in the User Tools display.		
8 205	S:LSize Scan PGS	*CTL	[0 to 9999999/ 0 / 1]
	These SPs count the total number of large pages input with the scanner for scan jobs only. Large size paper (A3/DLT) scanned for fax transmission are not counted. Note: These counters are displayed in the SMC Report, and in the User Tools display.		

8 211	T:Scan PGS/LS	*CTL	These SPs count the number of pages scanned into the document server . [0 to 9999999/ 0 / 1] The L: counter counts the number of pages stored from within the document server mode screen at the operation panel, and with the Store File button from within the Copy mode screen
8 212	C:Scan PGS/LS	*CTL	
8 213	F:Scan PGS/LS	*CTL	
8 215	S:Scan PGS/LS	*CTL	
8 216	L:Scan PGS/LS	*CTL	

- Reading user stamp data is not counted.
- If a job is cancelled, the pages output as far as the cancellation are counted.
- If the scanner application scans and stores 3 B5 sheets and 1 A4 sheet, the S: count is 4.
- If pages are copied but not stored on the document server, these counters do not change.
- If both sides of 3 A4 sheets are copied and stored to the document server, the C: count is 6 and the L: count is 6.
- If you enter document server mode then scan 6 pages, the L: count is 6.

8 221	ADF Org Feeds	*CTL	[0 to 9999999/ 0 / 1]
	These SPs count the number of pages fed through the ADF for front and back side scanning.		
8 221 1	Front	<p>Number of front sides fed for scanning:</p> <p>With an ADF that can scan both sides simultaneously, the Front side count is the same as the number of pages fed for either simplex or duplex scanning.</p> <p>With an ADF that cannot scan both sides simultaneously, the Front side count is the same as the number of pages fed for duplex front side scanning. (The front side is determined by which side the user loads face up.)</p>	
8 221 2	Back	<p>Number of rear sides fed for scanning:</p> <p>With an ADF that can scan both sides simultaneously, the Back count is the same as the number of pages fed for duplex scanning.</p> <p>With an ADF that cannot scan both sides simultaneously, the Back count is the same as the number of pages fed for duplex rear-side scanning.</p>	

- When 1 sheet is fed for duplex scanning the Front count is 1 and the Back count is 1.
- If a jam occurs during the job, recovery processing is not counted to avoid double counting. Also, the pages are not counted if the jam occurs before the first sheet is output.

8 231	Scan PGS/Mode	*CTL [0 to 9999999/ 0 / 1]
	These SPs count the number of pages scanned by each ADF mode to determine the work load on the ADF.	
8 231 1	Large Volume	Selectable. Large copy jobs that cannot be loaded in the ADF at one time.
8 231 2	SADF	Selectable. Feeding pages one by one through the ADF.
8 231 3	Mixed Size	Selectable. Select "Mixed Sizes" on the operation panel.
8 231 4	Custom Size	Selectable. Originals of non-standard size.
8 231 5	Platen	Book mode. Raising the ADF and placing the original directly on the platen.
8 231 6	Mixed 1side/ 2side	Simplex and Duplex mode.

- If the scan mode is changed during the job, for example, if the user switches from ADF to Platen mode, the count is done for the last selected mode.
- The user cannot select mixed sizes or non-standard sizes with the fax application so if the original's page sizes are mixed or non-standard, these are not counted.
- If the user selects "Mixed Sizes" for copying in the platen mode, the Mixed Size count is enabled.
- In the SADF mode if the user copies 1 page in platen mode and then copies 2 pages with SADF, the Platen count is 1 and the SADF count is 3.

8 241	T:Scan PGS/Org	*CTL	[0 to 9999999/ 0 / 1]			
	These SPs count the total number of scanned pages by original type for all jobs, regardless of which application was used.					
8 242	C:Scan PGS/Org	*CTL	[0 to 9999999/ 0 / 1]			
	These SPs count the number of pages scanned by original type for Copy jobs.					
8 243	F:Scan PGS/Org	*CTL	[0 to 9999999/ 0 / 1]			
	These SPs count the number of pages scanned by original type for Fax jobs.					
8 245	S:Scan PGS/Org	*CTL	[0 to 9999999/ 0 / 1]			
	These SPs count the number of pages scanned by original type for Scan jobs.					
8 246	L:Scan PGS/Org	*CTL	[0 to 9999999/ 0 / 1]			
	These SPs count the number of pages scanned and stored from within the document server mode screen at the operation panel, and with the Store File button from within the Copy mode screen					
		8 241	8 242	8 243	8 245	8 246
8 24x 1: Text		Yes	Yes	Yes	Yes	Yes
8 24x 2: Text/Photo		Yes	Yes	Yes	Yes	Yes
8 24x 3: Photo		Yes	Yes	Yes	Yes	Yes
8 24x 4: GenCopy, Pale		Yes	Yes	No	Yes	Yes
8 24x 5: Map		Yes	Yes	No	Yes	Yes
8 24x 6: Normal/Detail		Yes	No	Yes	No	No
8 24x 7: Fine/Super Fine		Yes	No	Yes	No	No
8 24x 8: Binary		Yes	No	No	Yes	No
8 24x 9: Grayscale		Yes	No	No	Yes	No

Main SP Tables-8

8 24x 10: Color	Yes	No	No	Yes	No
8 24x 11: Other	Yes	Yes	Yes	Yes	Yes

- If the scan mode is changed during the job, for example, if the user switches from ADF to Platen mode, the count is done for the last selected mode.

8 251	T:Scan PGS/ImgEdt	*CTL	<p>These SPs show how many times Image Edit features have been selected at the operation panel for each application. Some examples of these editing features are:</p> <ul style="list-style-type: none"> ▪ Erase> Border ▪ Erase> Center ▪ Image Repeat ▪ Centering ▪ Positive/Negative <p>[0 to 9999999/ 0 / 1]</p> <p>Note: The count totals the number of times the edit features have been used. A detailed breakdown of exactly which features have been used is not given.</p>
8 252	C:Scan PGS/ImgEdt	*CTL	
8 254	P:Scan PGS/ImgEdt	*CTL	
8 255	S : Scan PGS/ImgEdr	*CTL	
8 256	L:Scan PGS/ImgEdt	*CTL	
8 257	O:Scan PGS/ImgEdt	*CTL	

The L: counter counts the number of pages stored from within the document server mode screen at the operation panel, and with the Store File button from within the Copy mode screen.

8 261	T:Scan PGS/ColCr	*CTL	-
8 262	C:Scan PGS/ ColCr	*CTL	-
8 265	S:Scn PGS/Color	*CTL	-
8 266	L:Scn PGS/ColCr	*CTL	-
8 26x 1	Color Conversion	<p>These SPs show how many times color creation features have been selected at the operation panel.</p>	
8 26x 2	Color Erase		
8 26x 3	Background		
8 26x 4	Other		

8 281	T:Scan PGS/TWAIN	*CTL	These SPs count the number of pages scanned using a TWAIN driver. These counters reveal how the TWAIN driver is used for delivery functions. [0 to 9999999/ 0 / 1] Note: At the present time, these counters perform identical counts.
8 285	S:Scan PGS/TWAIN	*CTL	

8 291	T:Scan PGS/Stamp	*CTL	These SPs count the number of pages stamped with the stamp in the ADF unit. [0 to 9999999/ 0 / 1]
8 293	F:Scan PGS/Stamp	*CTL	
8 295	S:Scan PGS/Stamp	*CTL	The L: counter counts the number of pages stored from within the document server mode screen at the operation panel, and with the Store File button from within the Copy mode screen

8 301	T:Scan PGS/Size	*CTL	[0 to 9999999/ 0 / 1]
	These SPs count by size the total number of pages scanned by all applications. Use these totals to compare original page size (scanning) and output (printing) page size [SP 8-441].		
8 302	C:Scan PGS/Size	*CTL	[0 to 9999999/ 0 / 1]
	These SPs count by size the total number of pages scanned by the Copy application. Use these totals to compare original page size (scanning) and output (printing) page size [SP 8-442].		
8 303	F:Scan PGS/Size	*CTL	[0 to 9999999/ 0 / 1]
	These SPs count by size the total number of pages scanned by the Fax application. Use these totals to compare original page size (scanning) and output page size [SP 8-443].		

Main SP Tables-8

8 305	S:Scan PGS/Size	*CTL	[0 to 9999999/ 0 / 1]
	These SPs count by size the total number of pages scanned by the Scan application. Use these totals to compare original page size (scanning) and output page size [SP 8-445].		
8 306	L:Scan PGS/Size	*CTL	[0 to 9999999/ 0 / 1]
	These SPs count by size the total number of pages scanned and stored from within the document server mode screen at the operation panel, and with the Store File button from within the Copy mode screen. Use these totals to compare original page size (scanning) and output page size [SP 8-446].		
8 30x 1	A3		
8 30x 2	A4		
8 30x 3	A5		
8 30x 4	B4		
8 30x 5	B5		
8 30x 6	DLT		
8 30x 7	LG		
8 30x 8	LT		
8 30x 9	HLT		
8 30x 10	Full Bleed		
8 30x 254	Other (Standard)		
8 30x 255	Other (Custom)		

8 311	T:Scan PGS/Rez	*CTL	[0 to 9999999/ 0 / 1]
	These SPs count by resolution setting the total number of pages scanned by applications that can specify resolution settings.		
8 315	S: Scan PGS/Rez	*CTL	[0 to 9999999/ 0 / 1]
	These SPs count by resolution setting the total number of pages scanned by applications that can specify resolution settings. Note: At the present time, SP8-311 and SP8-315 perform identical counts.		
8 31x 1	1200dpi <		
8 31x 2	600dpi to 1199dpi		
8 31x 3	400dpi to 599dpi		
8 31x 4	200dpi to 399dpi		
8 31x 5	< 199dpi		

- Copy resolution settings are fixed so they are not counted.
- The Fax application does not allow finely-adjusted resolution settings so no count is done for the Fax application.

8 381	T:Total PrtPGS	*CTL	These SPs count the number of pages printed by the customer. The counter for the application used for storing the pages increments. [0 to 9999999/ 0 / 1] The L: counter counts the number of pages stored from within the document server mode screen at the operation panel. Pages stored with the Store File button from within the Copy mode screen go to the C: counter.
8 382	C:Total PrtPGS	*CTL	
8 383	F:Total PrtPGS	*CTL	
8 384	P:Total PrtPGS	*CTL	
8 385	S:Total PrtPGS	*CTL	
8 386	L:Total PrtPGS	*CTL	
8 387	O:Total PrtPGS	*CTL	

Main SP Tables-8

- When the A3/DLT double count function is switched on with SP5104, 1 A3/DLT page is counted as 2.
- When several documents are merged for a print job, the number of pages stored are counted for the application that stored them.
- These counters are used primarily to calculate charges on use of the machine, so the following pages are not counted as printed pages:
 - Blank pages in a duplex printing job.
 - Blank pages inserted as document covers, chapter title sheets, and slip sheets.
 - Reports printed to confirm counts.
 - All reports done in the service mode (service summaries, engine maintenance reports, etc.)
 - Test prints for machine image adjustment.
 - Error notification reports.
 - Partially printed pages as the result of a copier jam.

8 391	LSize PrtPGS	*CTL	[0 to 9999999/ 0 / 1]
	These SPs count pages printed on paper sizes A3/DLT and larger. Note: In addition to being displayed in the SMC Report, these counters are also displayed in the User Tools display on the copy machine.		

8 401	T:PrtPGS/LS	*CTL	These SPs count the number of pages printed from the document server. The counter for the application used to print the pages is incremented. The L: counter counts the number of jobs stored from within the document server mode screen at the operation panel. [0 to 9999999/ 0 / 1]
8 402	C:PrtPGS/LS	*CTL	
8 403	F:PrtPGS/LS	*CTL	
8 404	P:PrtPGS/LS	*CTL	
8 405	S:PrtPGS/LS	*CTL	
8 406	L:PrtPGS/LS	*CTL	

- Print jobs done with Web Image Monitor and Desk Top Binder are added to the L: count.
- Fax jobs done with Web Image Monitor and Desk Top Binder are added to the F: count.

8 411	Prints/Duplex	*CTL	This SP counts the amount of paper (front/back counted as 1 page) used for duplex printing. Last pages printed only on one side are not counted. [0 to 9999999/ 0 / 1]
-------	---------------	------	---

8 421	T:PrtPGS/Dup Comb	*CTL	[0 to 9999999/ 0 / 1]
	These SPs count by binding and combine, and n-Up settings the number of pages processed for printing. This is the total for all applications.		
8 422	C:PrtPGS/Dup Comb	*CTL	[0 to 9999999/ 0 / 1]
	These SPs count by binding and combine, and n-Up settings the number of pages processed for printing by the copier application.		
8 423	F:PrtPGS/Dup Comb	*CTL	[0 to 9999999/ 0 / 1]
	These SPs count by binding and combine, and n-Up settings the number of pages processed for printing by the fax application.		
8 424	P:PrtPGS/Dup Comb	*CTL	[0 to 9999999/ 0 / 1]
	These SPs count by binding and combine, and n-Up settings the number of pages processed for printing by the printer application.		
8 425	S:PrtPGS/Dup Comb	*CTL	[0 to 9999999/ 0 / 1]
	These SPs count by binding and combine, and n-Up settings the number of pages processed for printing by the scanner application.		
8 426	L:PrtPGS/Dup Comb	*CTL	[0 to 9999999/ 0 / 1]
	These SPs count by binding and combine, and n-Up settings the number of pages processed for printing from within the document server mode window at the operation panel.		
8 427	O:PrtPGS/Dup Comb	*CTL	[0 to 9999999/ 0 / 1]
	These SPs count by binding and combine, and n-Up settings the number of pages processed for printing by Other applications		
8 42x 1	Simplex> Duplex		

Main SP Tables-8

8 42x 2	Duplex> Duplex	
8 42x 3	Book> Duplex	
8 42x 4	Simplex Combine	
8 42x 5	Duplex Combine	
8 42x 6	2in1	2 pages on 1 side (2-Up)
8 42x 7	4 in1	4 pages on 1 side (4-Up)
8 42x 8	6 in1	6 pages on 1 side (6-Up)
8 42x 9	8 in1	8 pages on 1 side (8-Up)
8 42x 10	9 in1	9 pages on 1 side (9-Up)
8 42x 11	16 in1	16 pages on 1 side (16-Up)
8 42x 12	Booklet	
8 42x 13	Magazine	

- These counts (SP8 421 to SP8 427) are especially useful for customers who need to improve their compliance with ISO standards for the reduction of paper consumption.
- Pages that are only partially printed with the n-Up functions are counted as 1 page.
- Here is a summary of how the counters work for Booklet and Magazine modes:

Booklet			Magazine	
Original Pages	Count		Original Pages	Count
1	1		1	1
2	2		2	2
3	2		3	2
4	2		4	2
5	3		5	4
6	4		6	4
7	4		7	4

8	4		8	4
---	---	--	---	---

8 431	T:PrtPGS/ImgEdt	*CTL	[0 to 9999999/ 0 / 1]
	These SPs count the total number of pages output with the three features below, regardless of which application was used.		
8 432	C:PrtPGS/ImgEdt	*CTL	[0 to 9999999/ 0 / 1]
	These SPs count the total number of pages output with the three features below with the copy application.		
8 434	P:PrtPGS/ImgEdt	*CTL	[0 to 9999999/ 0 / 1]
	These SPs count the total number of pages output with the three features below with the print application.		
8 436	L:PrtPGS/ImgEdt	*CTL	[0 to 9999999/ 0 / 1]
	These SPs count the total number of pages output from within the document server mode window at the operation panel with the three features below.		
8 437	O:PrtPGS/ImgEdt	*CTL	[0 to 9999999/ 0 / 1]
	These SPs count the total number of pages output with the three features below with Other applications.		
8 43x 1	Cover/Slip Sheet	Total number of covers or slip sheets inserted. The count for a cover printed on both sides counts 2.	
8 43x 2	Series/Book	The number of pages printed in series (one side) or printed as a book with booklet right/left pagination.	
8 43x 3	User Stamp	The number of pages printed where stamps were applied, including page numbering and date stamping.	

Main SP Tables-8

8 441	T:PrtPGS/Ppr Size	*CTL	[0 to 9999999/ 0 / 1]
	These SPs count by print paper size the number of pages printed by all applications.		
8 442	C:PrtPGS/Ppr Size	*CTL	[0 to 9999999/ 0 / 1]
	These SPs count by print paper size the number of pages printed by the copy application.		
8 443	F:PrtPGS/Ppr Size	*CTL	[0 to 9999999/ 0 / 1]
	These SPs count by print paper size the number of pages printed by the fax application.		
8 444	P:PrtPGS/Ppr Size	*CTL	[0 to 9999999/ 0 / 1]
	These SPs count by print paper size the number of pages printed by the printer application.		
8 445	S:PrtPGS/Ppr Size	*CTL	[0 to 9999999/ 0 / 1]
	These SPs count by print paper size the number of pages printed by the scanner application.		
8 446	L:PrtPGS/Ppr Size	*CTL	[0 to 9999999/ 0 / 1]
	These SPs count by print paper size the number of pages printed from within the document server mode window at the operation panel.		
8 447	O:PrtPGS/Ppr Size	*CTL	[0 to 9999999/ 0 / 1]
	These SPs count by print paper size the number of pages printed by Other applications.		
8 44x 1	A3		
8 44x 2	A4		
8 44x 3	A5		
8 44x 4	B4		
8 44x 5	B5		
8 44x 6	DLT		

8 44x 7	LG	
8 44x 8	LT	
8 44x 9	HLT	
8 44x 10	Full Bleed	
8 44x 254	Other (Standard)	
8 44x 255	Other (Custom)	

- These counters do not distinguish between LEF and SEF.

8 451	PrtPGS/Ppr Tray	*CTL	[0 to 9999999/ 0 / 1]
	These SPs count the number of sheets fed from each paper feed station.		
8 451 1	Bypass Tray	Bypass Tray	
8 451 2	Tray 1	Copier	
8 451 3	Tray 2	Copier	
8 451 4	Tray 3	Paper Tray Unit (Option)	
8 451 5	Tray 4	Paper Tray Unit (Option)	
8 451 6	Tray 5	LCT (Option)	
8 451 7	Tray 6	Currently not used.	
8 451 8	Tray 7	Currently not used.	
8 451 9	Tray 8	Currently not used.	
8 451 10	Tray 9	Currently not used.	

Main SP Tables-8

8 461	T:PrtPGS/Ppr Type	*CTL	[0 to 9999999/ 0 / 1]
	<p>These SPs count by paper type the number pages printed by all applications.</p> <ul style="list-style-type: none"> ▪ These counters are not the same as the PM counter. The PM counter is based on feed timing to accurately measure the service life of the feed rollers. However, these counts are based on output timing. ▪ Blank sheets (covers, chapter covers, slip sheets) are also counted. ▪ During duplex printing, pages printed on both sides count as 1, and a page printed on one side counts as 1. 		
8 462	C:PrtPGS/Ppr Type	*CTL	[0 to 9999999/ 0 / 1]
	<p>These SPs count by paper type the number pages printed by the copy application.</p>		
8 463	F:PrtPGS/Ppr Type	*CTL	[0 to 9999999/ 0 / 1]
	<p>These SPs count by paper type the number pages printed by the fax application.</p>		
8 464	P:PrtPGS/Ppr Type	*CTL	[0 to 9999999/ 0 / 1]
	<p>These SPs count by paper type the number pages printed by the printer application.</p>		
8 466	L:PrtPGS/Ppr Type	*CTL	[0 to 9999999/ 0 / 1]
	<p>These SPs count by paper type the number pages printed from within the document server mode window at the operation panel.</p>		
8 46x 1	Normal		
8 46x 2	Recycled		
8 46x 3	Special		
8 46x 4	Thick		
8 46x 5	Normal (Back)		
8 46x 6	Thick (Back)		
8 46x 7	OHP		

8 46x 8	Other
---------	-------

8 471	PrtPGS/Mag	*CTL	[0 to 9999999/ 0 / 1]
	These SPs count by magnification rate the number of pages printed.		
8 471 1	< 49%		
8 471 2	50% to 99%		
8 471 3	100%		
8 471 4	101% to 200%		
8 471 5	201% <		

- Counts are done for magnification adjusted for pages, not only on the operation panel but performed remotely with an external network application capable of performing magnification adjustment as well.
- Magnification adjustments done with printer drivers with PC applications such as Excel are also counted.
- Magnification adjustments done for adjustments after they have been stored on the document server are not counted.
- Magnification adjustments performed automatically during Auto Reduce/Enlarge copying are counted.
- The magnification rates of blank cover sheets, slip sheets, etc. are automatically assigned a rate of 100%.

8 481	T:PrtPGS/TonSave	*CTL	
8 484	P:PrtPGS/TonSave	*CTL	
	<p>These SPs count the number of pages printed with the Toner Save feature switched on.</p> <p>Note: These SPs return the same results as this SP is limited to the Print application.</p> <p>[0 to 99999999/ 0 / 1]</p>		

8 491	T:PrtPGS/Col Mode	*CTL	These SPs count the number of pages printed in the Color Mode by each application.
-------	-------------------	------	--

Main SP Tables-8

8 492	C:PrtPGS/Col Mode	*CTL	
8 493	F:PrtPGS/Col Mode	*CTL	
8 496	L:PrtPGS/Col Mode	*CTL	
8 497	O:PrtPGS/Col Mode	*CTL	
8 49x 1	B/W		
8 49x 2	Single Color		
8 49x 3	Two Color		
8 49x 4	Full Color		

8 501	T:PrtPGS/Col Mode	*CTL	These SPs count the number of pages printed in the Color Mode by the print application.
8 504	P:PrtPGS/Col Mode	*CTL	
8 507	O:PrtPGS/Col Mode	*CTL	
8 50x 1	B/W		
8 50x 2	Mono Color		
8 50x 3	Full Color		
8 50x 4	Single Color		
8 50x 5	Two Color		

8 511	T:PrtPGS/Emul	*CTL	[0 to 9999999/ 0 / 1]
	These SPs count by printer emulation mode the total number of pages printed.		

8 514	P:PrtPGS/Emul	*CTL	[0 to 99999999/ 0 / 1]
	These SPs count by printer emulation mode the total number of pages printed.		
8 514 1	RPCS		
8 514 2	RPDL		
8 514 3	PS3		
8 514 4	R98		
8 514 5	R16		
8 514 6	GL/GL2		
8 514 7	R55		
8 514 8	RTIFF		
8 514 9	PDF		
8 514 10	PCL5e/5c		
8 514 11	PCL XL		
8 514 12	IPDL-C		
8 514 13	BM-Links		
8 514 14	Other		

- SP8 511 and SP8 514 return the same results as they are both limited to the Print application.
- Print jobs output to the document server are not counted.

Main SP Tables-8

8 521	T:PrtPGS/FIN	*CTL	[0 to 9999999 / 0 / 1]
	These SPs count by finishing mode the total number of pages printed by all applications.		
8 522	C:PrtPGS/FIN	*CTL	[0 to 9999999 / 0 / 1]
	These SPs count by finishing mode the total number of pages printed by the Copy application.		
8 523	F:PrtPGS/FIN	*CTL	[0 to 9999999 / 0 / 1]
	These SPs count by finishing mode the total number of pages printed by the Fax application. NOTE: Print finishing options for received faxes are currently not available.		
8 524	P:PrtPGS/FIN	*CTL	[0 to 9999999 / 0 / 1]
	These SPs count by finishing mode the total number of pages printed by the Print application.		
8 525	S:PrtPGS/FIN	*CTL	[0 to 9999999 / 0 / 1]
	These SPs count by finishing mode the total number of pages printed by the Scanner application.		
8 526	L:PrtPGS/FIN	*CTL	[0 to 9999999 / 0 / 1]
	These SPs count by finishing mode the total number of pages printed from within the document server mode window at the operation panel.		
8 52x 1	Sort		
8 52x 2	Stack		
8 52x 3	Staple		
8 52x 4	Booklet		
8 52x 5	Z-Fold		
8 52x 6	Punch		
8 52x 7	Other		

Note

- If stapling is selected for finishing and the stack is too large for stapling, the unstapled pages are still counted.
- The counts for staple finishing are based on output to the staple tray, so jam recoveries are counted.

8 531	Staples	*CTL	This SP counts the amount of staples used by the machine. [0 to 9999999 / 0 / 1]
-------	---------	------	---

	T:Counter	*CTL	[0 to 9999999 / 0 / 1]
8 581	These SPs count the total output broken down by color output, regardless of the application used. In addition to being displayed in the SMC Report, these counters are also displayed in the User Tools display on the copy machine.		
8 581 1	Total		
8 581 2	Total: Full Color		
8 581 3	B&W/Single Color		
8 581 4	Development: CMY		
8 581 5	Development: K		
8 581 6	Copy: Color		
8 581 7	Copy: B/W		
8 581 8	Print: Color		
8 581 9	Print: B/W		
8 581 10	Total: Color		
8 581 11	Total: B/W		
8 581 12	Full Color: A3		
8 581 13	Full Color: B4 JIS or Smaller		

Main SP Tables-8

8 581 14	Full Color Print
8 581 15	Mono Color Print
8 581 16	Full Color GPC
8 581 17	Twin Color Mode Print
8 581 18	Full Color Print (Twin)
8 581 19	Mono Color Print (Twin)
8 581 20	Full Color Total (CV)
8 581 21	Mono Color Total (CV)
8 581 22	Full Color Print (CV)

8 582	C:Counter	*CTL	[0 to 9999999/ 0 / 1]
	These SPs count the total output of the copy application broken down by color output.		
8 582 1	B/W		
8 582 2	Single Color		
8 582 3	Two Color		
8 582 4	Full Color		

8 583	F:Counter	*CTL	[0 to 9999999/ 0 / 1]
	These SPs count the total output of the fax application broken down by color output.		
8 583 1	B/W		
8 583 2	Single Color		

8 584	P:Counter	*CTL	[0 to 9999999/ 0 / 1]
	These SPs count the total output of the print application broken down by color output.		
8 584 1	B/W		
8 584 2	Mono Color		
8 584 3	Full Color		
8 584 4	Single Color		
8 584 5	Two Color		

8 586	L:Counter	*CTL	[0 to 9999999/ 0 / 1]
	These SPs count the total output of the local storage broken down by color output.		
8 582 1	B/W		
8 582 2	Single Color		
8 582 3	Two Color		
8 582 4	Full Color		

8 591	O:Counter	*CTL	[0 to 9999999/ 0 / 1]
	These SPs count the totals for A3/DLT paper use, number of duplex pages printed, and the number of staples used. These totals are for Other (O:) applications only.		
	8 591 1	A3/DLT	-
8 591 2	Duplex		

Main SP Tables-8

8 601	T: Coverage Counter	*CTL	[0 to 9999999/ 0 / 1]
	These SPs count the total coverage for each color and the total printout pages for each printing mode.		
8 601 1	B/W	-	
8 601 2	Color		
8 601 11	B/W Printing Pages		
8 601 12	Color Printing Pages		
8 601 21	Coverage Counter 1		
8 601 22	Coverage Counter 2		
8 601 23	Coverage Counter 3		

8 617	SDK Apli Counter	*CTL	[0 to 9999999/ 0 / 1]
	These SPs count the total printout pages for each SDK applicaion.		
8 617 1	SDK-1	-	
8 617 2	SDK-2		
8 617 3	SDK-3		
8 617 4	SDK-4		
8 617 5	SDK-5		
8 617 6	SDK-6		

8 631	T:FAX TX PGS	*CTL	[0 to 9999999/ 0 / 1]
	These SPs count by color mode the number of pages sent by fax to a telephone number.		
8 633	F:FAX TX PGS	*CTL	[0 to 9999999/ 0 / 1]
	These SPs count by color mode the number of pages sent by fax to a telephone number.		
8 63x 1	B/W		
8 63x 2	Color		

- If a document has color and black-and-white pages mixed, the pages are counted separately as B/W or Color.
- At the present time, this feature is provided for the Fax application only so SP8631 and SP8633 are the same.
- The counts include error pages.
- If a document is sent to more than one destination with a Group transmission, the count is done for each destination.
- Polling transmissions are counted but polling RX are not.
- Relay, memory, and confidential mailbox transmissions and are counted for each destination.

8 641	T:IFAX TX PGS	*CTL	[0 to 9999999/ 0 / 1]
	These SPs count by color mode the number of pages sent by fax to as fax images using I-Fax.		
8 643	F:IFAX TX PGS	*CTL	[0 to 9999999/ 0 / 1]
	These SPs count by color mode the number of pages sent by Fax as fax images using I-Fax.		
8 64x 1	B/W		
8 64x 2	Color		

Main SP Tables-8

- If a document has color and black-and-white pages mixed, the pages are counted separately as B/W or Color.
- At the present time, this feature is provided for the Fax application only so SP8641 and SP8643 are the same.
- The counts include error pages.
- If a document is sent to more than one destination with a Group transmission, the count is done for each destination.
- Polling transmissions are counted but polling RX are not.
- Relay, memory, and confidential mailbox transmissions and are counted for each destination.

8 651	T:S-to-Email PGS	*CTL	[0 to 99999999/ 0 / 1]
	These SPs count by color mode the total number of pages attached to an e-mail for both the Scan and document server applications.		
8 655	S:S-to-Email PGS	*CTL	[0 to 99999999/ 0 / 1]
	These SPs count by color mode the total number of pages attached to an e-mail for the Scan application only.		
8 65x 1	B/W		
8 65x 2	Color		

Note

- The count for B/W and Color pages is done after the document is stored on the HDD. If the job is cancelled before it is stored, the pages are not counted.
- If Scan-to-Email is used to send a 10-page document to 5 addresses, the count is 10 (the pages are sent to the same SMTP server together).
- If Scan-to-PC is used to send a 10-page document to 5 folders, the count is 50 (the document is sent to each destination of the SMB/FTP server).
- Due to restrictions on some devices, if Scan-to-Email is used to send a 10-page document to a large number of destinations, the count may be divided and counted separately. For example, if a 10-page document is sent to 200 addresses, the count is 10 for the first 100 destinations and the count is also 10 for the second 100 destinations, for a total of 20.).

8 661	T:Deliv PGS/Svr	*CTL	[0 to 9999999/ 0 / 1]
	These SPs count by color mode the total number of pages sent to a Scan Router server by both Scan and LS applications.		
8 665	S:Deliv PGS/Svr	*CTL	[0 to 9999999/ 0 / 1]
	These SPs count by color mode the total number of pages sent to a Scan Router server by the Scan application.		
8 66x 1	B/W		
8 66x 2	Color		

Note

- The B/W and Color counts are done after the document is stored on the HDD of the Scan Router server.
- If the job is canceled before storage on the Scan Router server finishes, the counts are not done.
- The count is executed even if regardless of confirmation of the arrival at the Scan Router server.

8 671	T:Deliv PGS/PC	*CTL	[0 to 9999999/ 0 / 1]
	These SPs count by color mode the total number of pages sent to a folder on a PC (Scan-to-PC) with the Scan and LS applications.		
8 675	S: Deliv PGS/PC	*CTL	[0 to 9999999/ 0 / 1]
	These SPs count by color mode the total number of pages sent with Scan-to-PC with the Scan application.		
8 67x 1	B/W		
8 67x 2	Color		

8 681	T:PCFAX TXPGS	*CTL	These SPs count the number of pages sent by PC Fax. These SPs are provided for the Fax application only, so the counts for SP8 681 and SP8 683 are the same. [0 to 9999999/ 0 / 1]
8 683	F:PCFAX TXPGS	*CTL	

1. This counts pages sent from a PC using a PC fax application, from the PC through the copier to the destination.
2. When sending the same message to more than one place using broadcasting, the pages are only counted once. (For example, a 10-page fax is sent to location A and location B. The counter goes up by 10, not 20.)

8 691	T:TX PGS/LS	*CTL	These SPs count the number of pages sent from the document server. The counter for the application that was used to store the pages is incremented. [0 to 9999999/ 0 / 1] The L: counter counts the number of pages stored from within the document server mode screen at the operation panel. Pages stored with the Store File button from within the Copy mode screen go to the C: counter.
8 692	C:TX PGS/LS	*CTL	
8 693	F:TX PGS/LS	*CTL	
8 694	P:TX PGS/LS	*CTL	
8 695	S:TX PGS/LS	*CTL	
8 696	L:TX PGS/LS	*CTL	

Note

- Print jobs done with Web Image Monitor and Desk Top Binder are added to the count.
- If several documents are merged for sending, the number of pages stored are counted for the application that stored them.
- When several documents are sent by a Fax broadcast, the F: count is done for the number of pages sent to each destination.

8 701	TX PGS/Port	*CTL	[0 to 9999999/ 0 / 1]
	These SPs count the number of pages sent by the physical port used to send them. For example, if a 3-page original is sent to 4 destinations via ISDN G4, the count for ISDN (G3, G4) is 12.		
8 701 1	PSTN-1		
8 701 2	PSTN-2		
8 701 3	PSTN-3		
8 701 4	ISDN (G3,G4)		
8 701 5	Network		

8 711	T:Scan PGS/Comp	*CTL	[0 to 9999999/ 0 / 1]
8 715	S:Scan PGS/Comp	*CTL	[0 to 9999999/ 0 / 1]
	These SPs count the number of pages sent by each compression mode.		
8 715 1	JPEG/JPEG2000		
8 715 2	TIFF(Multi/Single)		
8 715 3	PDF		
8 715 4	Other		
8 715 5	PDF/Comp		

8 721	T:Deliv PGS/WSD	*CTL	[0 to 9999999/ 0 / 1]
8 725	S: Dvliv PGS/WSD	*CTL	
	These SPs count the number of pages scanned by each scanner mode.		
x 1	B/W	-	
x 2	Color	-	

Main SP Tables-8

8 731	T:Scan PGS/Media	*CTL	[0 to 9999999/ 0 / 1]
8 735	S:Scan PGS/Media	*CTL	
	These SPs count the number of pages scanned and saved in a media by each scanner mode.		
	x 1	B/W	-
x 2	Color	-	

8 741	RX PGS/Port	*CTL	[0 to 9999999/ 0 / 1]
	These SPs count the number of pages received by the physical port used to receive them.		
8 741 1	PSTN-1	-	
8 741 2	PSTN-2	-	
8 741 3	PSTN-3	-	
8 741 4	ISDN (G3,G4)	-	
8 741 5	Network	-	

8 771	Dev Counter	*CTL	[0 to 9999999/ 0 / 1]
	These SPs count the frequency of use (number of rotations of the development rollers) for black and other color toners.		
8 771 1	Total		
8 771 2	K		
8 771 3	Y		
8 771 4	M		
8 771 5	C		

8 781	Toner_Bottle_Info.	*ENG	[0 to 9999999/ 0 / 1]
	<p>These SPs display the number of already replaced toner bottles.</p> <p>NOTE: Currently, the data in SP7-833-011 through 014 and the data in SP8-781-001 through 004 are the same.</p>		
8 781 1	Toner: BK	The number of black-toner bottles	
8 781 2	Toner: Y	The number of yellow-toner bottles	
8 781 3	Toner: M	The number of magenta-toner bottles	
8 781 4	Toner: C	The number of cyan-toner bottles	

8 791	LS Memory Remain	*CTL	<p>This SP displays the percent of space available on the document server for storing documents.</p> <p>[0 to 100 / 0 / 1]</p>
-------	------------------	------	--

8 801	Toner Remain	*CTL	[0 to 100/ 0 / 1]
	<p>These SPs display the percent of toner remaining for each color. This SP allows the user to check the toner supply at any time.</p> <p>Note: This precise method of measuring remaining toner supply (1% steps) is better than other machines in the market that can only measure in increments of 10 (10% steps).</p>		
8 801 1	K		
8 801 2	Y		
8 801 3	M		
8 801 4	C		

Main SP Tables-8

8 851	CVr Cnt: 0-10%	*ENG	[0 to 9999999/ 0 / 1]
	These SPs display the number of scanned sheets on which the coverage of each color is from 0% to 10%.		
8 851 11	0 to 2%: BK	8 851 31	5 to 7%: BK
8 851 12	0 to 2%: Y	8 851 32	5 to 7%: Y
8 851 13	0 to 2%: M	8 851 33	5 to 7%: M
8 851 14	0 to 2%: C	8 851 34	5 to 7%: C
8 851 21	3 to 4%: BK	8 851 41	8 to 10%: BK
8 851 22	3 to 4%: Y	8 851 42	8 to 10%: Y
8 851 23	3 to 4%: M	8 851 43	8 to 10%: M
8 851 24	3 to 4%: C	8 851 44	8 to 10%: C

8 861	CVr Cnt: 11-20%	*ENG	[0 to 9999999/ 0 / 1]
	These SPs display the number of scanned sheets on which the coverage of each color is from 11% to 20%.		
8 861 1	BK		
8 861 2	Y		
8 861 3	M		
8 861 4	C		

8 871	CVr Cnt: 21-30%	*ENG	[0 to 9999999/ 0 / 1]
	These SPs display the number of scanned sheets on which the coverage of each color is from 21% to 30%.		
8 871 1	BK		
8 871 2	Y		
8 871 3	M		
8 871 4	C		

8 881	CVr Cnt: 31%-	*ENG	[0 to 9999999/ 0 / 1]
	These SPs display the number of scanned sheets on which the coverage of each color is 31% or higher.		
8 881 1	BK		
8 881 2	Y		
8 881 3	M		
8 881 4	C		

8 891	Page/Toner Bottle	*ENG	[0 to 9999999/ 0 / 1]
	These SPs display the amount of the remaining current toner for each color.		
8 891 1	BK		
8 891 2	Y		
8 891 3	M		
8 891 4	C		

Main SP Tables-8

8 901	Page/Toner_prev1	*ENG	[0 to 9999999/ 0 / 1]
	These SPs display the amount of the remaining previous toner for each color.		
8 901 1	BK		
8 901 2	Y		
8 901 3	M		
8 901 4	C		

8 911	Page/Toner_prev2	*ENG	[0 to 9999999/ 0 / 1]
	These SPs display the amount of the remaining 2nd previous toner for each color.		
8 911 1	BK		
8 911 2	Y		
8 911 3	M		
8 911 4	C		

8 921	Cvr Cnt/Total	*CTL	[0 to 9999999/ 0 / 1]
	Displays the total coverage and total printout number for each color.		
8 921 1	Coverage (%) Bk		
8 921 2	Coverage (%) Y		
8 921 3	Coverage (%) M		
8 921 4	Coverage (%) C		
8 921 11	Coverage /P: Bk		
8 921 12	Coverage /P: Y		
8 921 13	Coverage /P: M		
8 921 14	Coverage /P: C		

	Machine Status	*CTL	[0 to 99999999/ 0 / 1]
8 941	These SPs count the amount of time the machine spends in each operation mode. These SPs are useful for customers who need to investigate machine operation for improvement in their compliance with ISO Standards.		
8 941 1	Operation Time	Engine operation time. Does not include time while controller is saving data to HDD (while engine is not operating).	
8 941 2	Standby Time	Engine not operating. Includes time while controller saves data to HDD. Does not include time spent in Energy Save, Low Power, or Off modes.	
8 941 3	Energy Save Time	Includes time while the machine is performing background printing.	
8 941 4	Low Power Time	Includes time in Energy Save mode with Engine on. Includes time while machine is performing background printing.	
8 941 5	Off Mode Time	Includes time while machine is performing background printing. Does not include time machine remains powered off with the power switches.	
8 941 6	SC	Total time when SC errors have been staying.	
8 941 7	PrtJam	Total time when paper jams have been staying during printing.	
8 941 8	OrgJam	Total time when original jams have been staying during scanning.	
8 941 9	Supply PM Unit End	Total time when toner end has been staying	

Main SP Tables-8

8 951	AddBook Register	*CTL	
	These SPs count the number of events when the machine manages data registration.		
8 951 1	User Code/User ID	User code registrations.	[0 to 9999999/ 0 / 1]
8 951 2	Mail Address	Mail address registrations.	
8 951 3	Fax Destination	Fax destination registrations.	
8 951 4	Group	Group destination registrations.	
8 951 5	Transfer Request	Fax relay destination registrations for relay TX.	
8 951 6	F-Code	F-Code box registrations.	
8 951 7	Copy Program	Copy application registrations with the Program (job settings) feature.	
8 951 8	Fax Program	Fax application registrations with the Program (job settings) feature.	
8 951 9	Printer Program	Printer application registrations with the Program (job settings) feature.	
8 951 10	Scanner Program	Scanner application registrations with the Program (job settings) feature.	

8 999	Admin. Counter List	*CTL	[0 to 9999999/ 0 / 1]
	Displays the total coverage and total printout number for each color.		
8 999 1	Total		
8 999 2	Copy: Full Color		
8 999 3	Copy: BW		
8 999 4	Copy: Single Color		
8 999 5	Copy: Two Color		
8 999 6	Printer Full Color		
8 999 7	Printer BW		
8 999 8	Printer Single Color		
8 999 9	Printer Two Color		
8 999 10	Fax Print: BW		
8 999 12	A3/DLT		
8 999 13	Duplex		
8 999 14	Coverage: Color (%)		
8 999 15	Coverage: BW (%)		
8 999 16	Coverage: Color Print Page (%)		
8 999 17	Coverage: BW Print Page (%)		
8 999 101	Transmission Total: Color		
8 999 102	Transmission Total: BW		
8 999 103	FAX Transmission		
8 999 104	Scanner Transmission: Color		
8 999 105	Scanner Transmission: BW		

5.10 MAIN SP TABLES-9

5.10.1 INPUT CHECK TABLE

When entering the Input Check mode, 8 digits display the result for a section. Each digit corresponds to a different device as shown in the table.

Bit No.	7	6	5	4	3	2	1	0
Result	0 or 1	0 or 1	0 or 1	0 or 1	0 or 1	0 or 1	0 or 1	0 or 1

Copier

5803	Description	Reading	
		0	1
5803 1	2nd Tray Size Detection	See table 2 following this table.	
5803 2	1st Tray Set Detection	Set	Not set
5803 3	1st Tray Paper Height Sensor1	See table 1 following this table.	
5803 4	1st Tray Paper Height Sensor2	See table 1 following this table.	
5803 5	2nd Tray Paper Height Sensor1	See table 1 following this table.	
5803 6	2nd Tray Paper Height Sensor2	See table 1 following this table.	
5803 7	1st Tray Paper End Detection	No paper	Paper remaining
5803 8	2nd Tray Paper End Detection	No paper	Paper remaining
5803 9	1st Tray Upper Limit Sensor	Not upper limit	Upper limit
5803 10	2nd Tray Upper Limit Sensor	Not upper limit	Upper limit
5803 11	Bypass Paper Width Detection	See table 3 following this table.	
5803 12	Bypass Paper End Detection	No paper	Paper remaining
5803 13	Bypass Paper Length Detection	See table 3 following this table.	

5803 14	1st Paper Feed Sensor	Paper detected	Paper not detected
5803 15	2nd Paper Feed Sensor	Paper detected	Paper not detected
5803 16	Exit Sensor	Paper detected	Paper not detected
5803 17	Tray Full Exit Sensor	Paper not full	Paper full
5803 18	Fusing Exit Sensor	Paper not detected	Paper detected
5803 19	Fusing Entrance Sensor	Paper detected	Paper not detected
5803 20	1st Feed Sensor	Paper detected	Paper not detected
5803 21	2nd Feed Sensor	Paper detected	Paper not detected
5803 22	Duplex Exit Sensor	Paper detected	Paper not detected
5803 23	Registration Sensor	Paper detected	Paper not detected
5803 24	Duplex Entrance Sensor	Paper detected	Paper not detected
5803 25	Junction Sensor	Paper detected	Paper not detected
5803 26	2nd Tray Set Detection	Set	Not set
5803 30	Toner End Sensor: Bk	Toner end	Toner remaining
5803 31	Toner End Sensor: M	Toner end	Toner remaining
5803 32	Toner End Sensor: C	Toner end	Toner remaining
5803 33	Toner End Sensor: Y	Toner end	Toner remaining

Main SP Tables-9

5803 34	Drum Phase Sensor: Bk	Actuator not detected	Actuator detected
5803 35	Drum Phase Sensor: M	Actuator not detected	Actuator detected
5803 36	Drum Phase Sensor: C	Actuator not detected	Actuator detected
5803 37	Drum Phase Sensor: Y	Actuator not detected	Actuator detected
5803 38	Interlock Release Detection 1	Front door open	Front door closed
5803 39	Interlock Release Detection 2	Front door open	Front door closed
5803 40	Right Door	Closed	Open
5803 41	Duplex Cover	Closed	Open
5803 42	Toner Collection Bottle Set	Set	Not set
5803 43	Toner Collection Full Sensor	Not full	Full
5803 46	ITB New Unit Detection	Not new	New
5803 50	Airflow Fan: Front: Lock	Normal	Lock
5803 51	Airflow Fan: Rear: Lock	Normal	Lock
5803 52	Fusing Exit Fan: Lock	Normal	Lock
5803 53	2nd Duct Fan: Lock	Normal	Lock
5803 54	3rd Duct Fan: Lock	Normal	Lock
5803 55	Paper Exit Fan:Lock	Normal	Lock
5803 56	Fusing Coil Fan: Lock	Normal	Lock
5803 57	IH Power Supply Cooling Fan: Lock	Normal	Lock
5803 60	ITB Contact Motor Position	Not contact	Contact

5803 61	Paper Transfer Contact Motor Position	Not contact	Contact
5803 62	Toner Relay Motor: Lock	Normal	Lock
5803 63	ITB Drive Motor: Lock	Normal	Lock
5803 64	K Drum/Development Drive Motor: Lock	Normal	Lock
5803 65	M Drum/Development Drive Motor: Lock	Normal	Lock
5803 66	C Drum/Development Drive Motor: Lock	Normal	Lock
5803 67	Y Drum/Development Drive Motor: Lock	Normal	Lock
5803 68	Fusing Exit Motor:Lock	Normal	Lock
5803 80	HVPS:TTS:SC Detection	SC detected	No SC
5803 81	HVPS:CB:SC Detection	SC detected	No SC
5803 82	HVPS:D:SC Detection	SC detected	No SC
5803 83	Fusing Destination Detection: DOM (Dom)	Set	Not set
5803 84	Fusing Destination Detection: NA	Set	Not set
5803 87	Fusing New Unit Detection	New	Not new
5803 90	Zero-cross Signal	-	-
5803 91	Fusing Rotation Sensor	Actuator not detected	Actuator detected
5803 92	Fusing Pressue Release Sensor	Not contact	Contact
5803 94	GAVD Open/Close Detection	Closed (LD5V ON)	Open (LD5V OFF)
5803 100	Keycard: Set	Set	Not set
5803 101	Mechanical Counter Bk: Set	Set	Not set

5803 102	Mechanical Counter FC: Set	Set	Not set
5803 103	Key Counter: Set	Set	Not set
5803 110	IOB Version	-	-
5803 200	Scanner HP Sensor	Not HP	HP
5803 201	Platen Cover Sensor	Open	Closed

Table 1: Paper Height Sensor

0: Deactivated, 1: Activated (actuator inside sensor)

Remaining paper	Paper height sensor 1	Paper height sensor 2
Full	0	0
Nearly full	1	0
Near end	1	1
Almost empty	0	1

Table 2: Paper Size Switch (Tray 2)

Switch 1 is used for tray set detection.

0: Pushed, 1: Not pushed

Models		Switch Location		
North America	Europe/Asia	4 (bit0)	3 (bit1)	2 (bit2)
11" x 17" SEF ^{*1} (A3 SEF)	A3 SEF ^{*1} (11" x 17" SEF)	0	0	1
8.5" x 14" SEF ^{*2} (B4 SEF)	B4 SEF ^{*2} (8.5" x 14" SEF)	0	0	0
A4 SEF	A4 SEF	1	1	0
8.5" x 11" SEF	8.5" x 11" SEF	1	1	1
B5 SEF	B5 SEF	0	1	1
11" x 8 1/2" LEF ^{*3} (A4 LEF)	A4 LEF ^{*3} (11" x 8 1/2" LEF)	1	0	0
10.5" x 7.25" LEF ^{*4} (B5 LEF)	B5 LEF ^{*4} (10.5" x 7.25" LEF)	0	1	0
A5 LEF	A5 LEF	1	0	1
<p>*1: The machine detects either 11" x 17" SEF or A3 SEF, depending on the setting of SP 5-181-003.</p> <p>*2: The machine detects either 8.5" x 14" SEF or B4 SEF, depending on the setting of SP 5-181-004.</p> <p>*3: The machine detects either 11" x 8 1/2" LEF or A4 LEF, depending on the setting of SP 5-181-002.</p> <p>*4: The machine detects either B5 LEF or 10.5" x 7.25" LEF, depending on the setting of SP 5-181-005.</p>				

Table 3: Paper Size (By-pass Table)

0: ON, 1: OFF

By-pass Paper Size Sensor				Length Sensor	NA	EU/ASIA
bit3	Bit2	Bit1	Bit0			
1	1	1	1	1	HLT SEF	A6 SEF
0	1	1	1	1	HLT SEF	A6 SEF
0	0	1	1	1	HLT SEF	A5 SEF
1	0	1	1	1	HLT SEF	A5 SEF
1	0	0	1	0	LT/LG SEF* ¹	A4 SEF
1	0	0	1	1	LT/LG SEF* ¹	A5 LEF
1	1	0	1	0	LT/LG SEF* ¹	A4 SEF
1	1	0	1	1	LT/LG SEF* ¹	A5 LEF
1	1	0	0	0	DLT SEF	A3 SEF
1	1	0	0	1	LT LEF	A4 LEF
1	1	1	0	0	DLT SEF	A3 SEF
1	1	1	0	1	LT LEF	A4 LEF

*1: The paper size (LT or LG) can be selected with SP1-007-001.

ARDF (D578)

6007	Description	Reading	
		0	1
6007 1	Original Length 1 (B5 Detection Sensor)	Paper not detected	Paper detected
6007 2	Original Length 2 (A4 Detection Sensor)	Paper not detected	Paper detected
6007 3	Original Length 3 (LG Detection Sensor)	Paper not detected	Paper detected
6007 4	Original Width 1	Paper not detected	Paper detected
6007 5	Original Width 2	Paper not detected	Paper detected
6007 6	Original Width 3	Paper not detected	Paper detected
6007 7	Original Width 4	Paper not detected	Paper detected
6007 8	Original Width 5	Paper not detected	Paper detected
6007 9	Original Detection	Paper not detected	Paper detected
6007 10	Separation Sensor	Paper not detected	Paper detected
6007 11	Skew Correction	Paper not detected	Paper detected
6007 12	Scan Entrance Secsor	Paper not detected	Paper detected

Main SP Tables-9

6007 13	Registration Sensor	Paper not detected	Paper detected
6007 14	Exit Sensor	Paper not detected	Paper detected
6007 15	Feed Cover Sensor	ADF cover close	ADF cover open
6007 16	Lift Up Sensor	ADF cover close	ADF cover open
6007 17	Inverter Sensor	Paper not detected	Paper detected
6007 18	Pick-Up Roller HP Sensor	Not HP	HP
6007 19	Original Set HP Sensor	Original not detected	Original detected
6007 23	Rear Edge Detection (Not used)	-	-

2000/3000-Sheet (Booklet) Finisher (B804, B805)

6140	Bit	Description	Reading	
			0	1
6140 1		Entrance Sensor	Paper not detected	Paper detected
6140 2		Proof Exit Sensor	Paper not detected	Paper detected
6140 3		Proof Full Detection Sensor	Not Full	Full
6140 4		Trailing Edge Detection: Shift	Paper not detected*1	Paper detected*1
6140 5		Staple Exit Sensor	Paper not detected	Paper detected
6140 6		Shift HP Sensor	Not HP	HP
6140 7		Shift Exit Sensor	Paper not detected	Paper detected
6140 8		Exit Guide Plate HP Sensor	Not HP	HP
6140 9		Paper Detection Sensor: Staple	Paper not detected	Paper detected
6140 10		Paper Detection Sensor: Shift	Paper not detected	Paper detected
6140 11		Paper Full Sensor: 2000-Sheet	Not Full	Full
6140 12		Oscillating Back Roller HP Sensor	Not HP	HP
6140 13		Jogger HP Sensor	Not HP	HP
6140 14		Exit Junction Gate HP Sensor	HP	Not HP
6140 15		Staple Tray Paper Sensor	Paper not detected	Paper detected
6140 16		Staple Moving HP Sensor	Not HP	HP

Main SP Tables-9

6140 17	Skew HP Sensor	Not HP	HP
6140 18	Limit SW	Not Limit	Limit
6140 19	DOOR SW	Closed	Open
6140 20	Stapler 1 Rotation	Not HP	HP
6140 21	Staple Detection	Staple not detected	Staple detected
6140 22	Staple Leading Edge Detection	Staple not detected	Staple detected
6140 23	Punch Moving HP Sensor	Not HP	HP
6140 24	Punch Registration HP Sensor	Not HP	HP
6140 25	Punch Registratioin Detection Sensor	Paper not detected	Paper detected
6140 26	Punch Chad Full Sensor	Not Full	Full
6140 27	Punch HP	Not HP	HP
6140 28	Punch Selection DIPSW 1	See *1	
6140 29	Punch Selection DIPSW 2	See *1	
6140 30	Stack Junction Gate Open/Closed HP Sensor	Not HP	HP
6140 31	Leading Edge Detection Sensor	Paper not detected	Paper detected
6140 32	Drive Roller HP Sensor	Not HP	HP
6140 33	Arrival Sensor	Paper not detected	Paper detected
6140 34	Rear Edge Fence HP Sensor	Not HP	HP
6140 35	Folder Cam HP Sensor	Not HP	HP
6140 36	Folder Plate HP Sensor	Not HP	HP

6140 37	Folder Pass Sensor	Paper not detected	Paper detected
6140 38	Saddle Full Sensor: Front	Paper not detected* ²	Paper detected* ²
6140 39	Saddle Full Sensor: Rear	Paper not detected* ²	Paper detected* ²
6140 40	Saddle Stitch Stapler 1 Rotation: Front	Not HP	HP
6140 41	Saddle Stitch Detection: Front	Staple not detected	Staple detected
6140 42	Saddle Stitch Leading Edge Detection: Front	Staple not detected	Staple detected
6140 43	Saddle Stitch Stapler 1 Rotation: Rear	Not HP	HP
6140 44	Saddle Stitch Detection: Rear	Staple not detected	Staple detected
6140 45	Saddle Stitch Leading Edge Detection: Rear	Staple not detected	Staple detected
6140 46	Full Sensor: 3000-Sheet	Not Full	Full

*1: Combination of DIP SW 1 and SW 2

DIP SW 1	DIP SW 2	Punch Type
0	0	Japan
1	0	Europe
0	1	North America
1	1	North Europe

*2: Please refer to "Lower Tray (B804 Only)" in the Service Manual for the "2000/3000 (Booklet) Finisher".

1000-Sheet Finisher (D588)

6139	Description	Reading	
		0	1
6139 1	Entrance Sensor	Paper detected	Paper not detected
6139 2	Shift Exit Sensor (Lower Tray Exit Sensor)	Paper not detected	Paper detected
6139 3	Staple Entrance Sensor (Stapler Tray Entrance Sensor)	Paper detected	Paper not detected
6139 4	Staple Moving HP Sensor (Stapler HP Sensor)	Not home position	Home position
6139 5	Jogger HP Sensor (Jogger Fence HP Sensor)	Not home position	Home position
6139 6	Stack Feed-out Belt HP Sensor	Home position	Not home position
6139 7	Staple Tray Paper Sensor	Paper not detected	Paper detected
6139 8	Staple Rotation Sensor (Staple Rotation HP Sensor)	Not home position	Home position
6139 9	Staple Sensor	Staple detected	Staple not detected
6139 10	Staple READY Detection	Staple detected	Staple not detected
6139 11	Exit Guide Plate HP (Exit Guide Plate HP Sensor)	Not home position	Home position
6139 12	Shift HP Sensor	Not home position	Home position
6139 13	Paper Sensor (Stack Height Sensor)	Output tray not detected	Output tray detected

6139 14	Tray Lower Sensor (Lower Tray Lower Limit Sensor)	Lower limit	Not lower limit
6139 15	Proof Full Sensor (Paper Limit Sensor)	Not full	Full

Bridge Unit (D634)/ Side Tray (D635)

6150	Description	Reading	
		0	1
6150 1	Bridge/Left: Exit Sensor	Paper detected	Paper not detected
6150 2	Bridge/Left: Feed Sensor	Paper detected	Paper not detected
6150 3	Bridge/Left: Set Detection	Set	Not set
6150 4	Bridge/Left: Exit Cover Detection	Closed	Open
6150 5	Bridge/Left: Feed Cover Detection	Closed	Open

Internal Shift Tray (D633)

6152	Description	Reading	
		0	1
6152 2	Shift: Position Sensor	Tray position: Front	Tray position: Rear

1 Bin Tray (D632)

6154	Description	Reading	
		0	1
6154 1	1 bin: Set Detection	Set	Not set
6154 2	1 bin: Paper Sensor	Paper detected	Paper not detected

Two-Tray PFU (D580)/ LCIT 2000 (D581)/ LCIT 1200 (D631)

6160	Description	Reading	
		0	1
6160 1	Bank: Tray3: Feed Sensor	Paper not detected	Paper detected
6160 2	Bank: Tray4: Feed Sensor	Paper not detected	Paper detected
6160 3	Bank: Tray5: Feed Sensor	Paper not detected	Paper detected
6160 4	Bank: Tray3: Relay Sensor	Paper not detected	Paper detected
6160 5	Bank: Tray4: Relay Sensor	Paper not detected	Paper detected
6160 6	Bank: Tray5: Relay Sensor	Paper not detected	Paper detected
6160 7	Bank: Feed Cover Detection	Closed	Open
6160 11	Bank: Palau: Paper Supply Switch	Closed	Open
6160 12	Bank: Palau: Slide Switch	Closed	Open

5.10.2 OUTPUT CHECK TABLE

Copier

5804	Display	Description
5804 3	Drum/Dev Motor: K: HighSpeed	Drum/Development Drive Motor-K: High Speed
5804 4	Drum/Dev Motor: K: MiddleSpeed	Drum/Development Drive Motor-K: Middle Speed
5804 5	Drum/Dev Motor: K: LowSpeed	Drum/Development Drive Motor-M: Low Speed
5804 10	Drum/Dev Motor: M: HighSpeed	Drum/Development Drive Motor- C: High Speed
5804 11	Drum/Dev Motor: M: MiddleSpeed	Drum/Development Drive Motor-Y: Middle Speed
5804 12	Drum/Dev Motor: M: LowSpeed	Drum/Development Drive Motor-Y: Low Speed
5804 17	Drum/Dev Motor: C: HighSpeed	Drum/Development Drive Motor- C: High Speed
5804 18	Drum/Dev Motor: C: MiddleSpeed	Drum/Development Drive Motor-Y: Middle Speed
5804 19	Drum/Dev Motor: C: LowSpeed	Drum/Development Drive Motor-Y: Low Speed
5804 24	Drum/Dev Motor: Y: HighSpeed	Drum/Development Drive Motor- C: High Speed
5804 25	Drum/Dev Motor: Y: MiddleSpeed	Drum/Development Drive Motor-Y: Middle Speed
5804 26	Drum/Dev Motor: Y: LowSpeed	Drum/Development Drive Motor-Y: Low Speed
5804 31	-	See the last of this table.

Main SP Tables-9

5804 32	-	See the last of this table.
5804 33	-	See the last of this table.
5804 35	-	See the last of this table.
5804 37	Toner Relay Motor	Toner Transport Motor
5804 40	Image Transfer Motor: HighSpeed	ITB Drive Motor: High Speed
5804 41	Image Transfer Motor: MiddleSpeed	ITB Drive Motor: Middle Speed
5804 42	Image Transfer Motor: LowSpeed	ITB Drive Motor: Low Speed
5804 50	Feed Motor: HighSpeed	Paper Feed Motor: High Speed
5804 51	Feed Motor: IncreaseSpeed	Paper Feed Motor: Increase Speed
5804 52	Feed Motor: MiddleSpeed	Paper Feed Motor: Middle Speed
5804 53	Feed Motor: MiddleIncreaseSpeed	Paper Feed Motor: Middle Increase Speed
5804 54	Feed Motor: LowSpeed	Paper Feed Motor: Low Speed
5804 55	Feed Motor: LowInceraseSpeed	Paper Feed Motor: Low Incerase Speed
5804 60	Regist Motor: HighSpeed	Registration Motor: High Speed
5804 61	Regist Motor: MiddleSpeed	Registration Motor: Middle Speed
5804 62	Regist Motor: LowSpeed	Registration Motor: Low Speed
5804 67	Duplex Feed M: CW: HighSpeed	Duplex/By-pass Motor: CW: High Speed
5804 68	Duplex Feed M: CW: MiddleSpeed	Duplex/By-pass Motor: CW: Middle Speed
5804 69	Duplex Feed Motor: CW: LowSpeed	Duplex/By-pass Motor: CW: Low Speed
5804 74	Duplex Feed M: CCW: HighSpeed	Duplex/By-pass Motor: CCW: High Speed

5804 75	Duplex Feed M:CCW:MiddleSpeed	Duplex/By-pass Motor: CCW: Middle Speed
5804 76	Duplex Feed Motor: CCW: LowSpeed	Duplex/By-pass Motor: CCW: Low Speed
5804 81	Duplex Reverse M:CW:HighSpeed	Duplex Inverter Motor: CW: High Speed
5804 82	Duplex Reverse M:CW:MiddleSpeed	Duplex Inverter Motor: CW: Middle Speed
5804 83	Duplex Reverse Motor: CW: LowSpeed	Duplex Inverter Motor: CW: Low Speed
5804 88	Duplex Reverse M:CCW:HighSpeed	Duplex Inverter Motor: CCW: High Speed
5804 89	Duplex Reverse M:CCW:MiddleSpeed	Duplex Inverter Motor: CCW: Middle Speed
5804 90	Duplex Reverse Motor: CCW: LowSpeed	Duplex Inverter Motor: CCW: Low Speed
5804 95	ITB Contact Motor	Image Transfer Belt Contact Motor
5804 96	Paper Transfer Contact Motor	Paper Transfer Contact Motor
5804 97	1st Tray Lift Motor: Up	Tray Lift Motor 1: Lift Up
5804 98	1st Tray Lift Motor: Down	Tray Lift Motor 1: Lift Down
5804 99	2nd Tray Lift Motor: Up	Tray Lift Motor 2: Lift Up
5804 100	2nd Tray Lift Motor: Down	Tray Lift Motor 2: Lift Down
5804 102	Fusing Pressue Release Motor	Pressure Roller Contact Motor
5804 104	Polygon Moter: LL	Polygon Motor: LL
5804 105	Polygon Moter: L	Polygon Motor: L
5804 107	Polygon Moter: HH	Polygon Motor: HH
5804 110	Air Flow Fan: Front	Ventilation Fan - Front
5804 111	Air Flow Fan:Rear	Ventilation Fan - Rear

Main SP Tables-9

5804 112	Fusing Fan:H	Fusing Fan: High Speed
5804 113	Fusing Fan:L	Fusing Fan: Low Speed
5804 114	PSU Cooling Fan	PSU Fan 1: High Speed
5804 115	2nd Duct Fan: H	Duct Fan 2: High Speed
5804 117	3rd Duct Fan: H	Duct Fan 3: High Speed
5804 119	Paper Exit Fan:H	Paper Exit Fan: High Speed
5804 121	Fusing Coil Fan	QSU Fan
5804 122	IH Power Supply Cooling Fan	AC controller board Fan
5804 126	Development Clutch: Bk	Development Clutch-K
5804 127	Development Clutch: M	Development Clutch-M
5804 128	Development Clutch: C	Development Clutch-C
5804 129	Development Clutch: Y	Development Clutch-Y
5804 130	Toner Bottle Clutch: Bk	Toner Bottle Clutch-K
5804 131	Toner Bottle Clutch: M	Toner Bottle Clutch-M
5804 132	Toner Bottle Clutch: C	Toner Bottle Clutch-C
5804 133	Toner Bottle Clutch:Y	Toner Bottle Clutch-Y
5804 134	Toner Supply Pump: Bk	Toner Supply Clutch: Bk
5804 135	Toner Supply Pump: M	Toner Supply Clutch: M
5804 136	Toner Supply Pump: C	Toner Supply Clutch: C
5804 137	Toner Supply Pump: Y	Toner Supply Clutch: Y
5804 138	1st Paper Feed Clutch	Paper Feed Clutch 1
5804 139	2nd Paper Feed Clutch	Paper Feed Clutch 2
5804 140	Bypass Feed Clutch	By-pass Feed Clutch
5804 141	Bypass Pickup Solenoid	Bypass Pickup Solenoid
5804 143	TD Sensor Shutter Solenoid	ID Sensor Shutter Solenoid

5804 144	Exit Junction Solenoid	Junction Gate 1 Solenoid
5804 145	1st Feed Pickup Solenoid	1st Pickup Solenoid
5804 146	2st Feed Pickup Solenoid	2nd Pickup Solenoid
5804 161	PCL: Bk	
5804 162	PCL: M	
5804 163	PCL: C	
5804 164	PCL: Y	
5804 166	HST Sensor:Bk	TD Sensor:Bk
5804 167	HST Sensor: M	TD Sensor: M
5804 168	HST Sensor: C	TD Sensor: C
5804 169	HST Sensor: Y	TD Sensor: Y
5804 170	Toner End Sensor: Bk	Toner End Sensor: Bk
5804 171	Toner End Sensor: M	Toner End Sensor: M
5804 172	Toner End Sensor: C	Toner End Sensor: C
5804 173	Toner End Sensor: Y	Toner End Sensor: Y
5804 174	TM Sensor: Front	ID Sensor: Front
5804 175	TM Sensor: Center	ID Sensor: Center
5804 176	TM Sensor: Rear	ID Sensor: Rear
5804 177	TM Sensor: M	ID Sensor: M
5804 178	TM Sensor: C	ID Sensor: C
5804 179	TM Sensor: Y	ID Sensor: Y
5804 181	PP:Charge AC:Y:HighSpeed	-
5804 182	PP:Charge AC:Y:MiddleSpeed	-
5804 183	PP:Charge AC:Y:LowSpeed	-
5804 186	PP:Development:K	-

Main SP Tables-9

5804 187	PP:Development:M	-
5804 188	PP:Development:C	-
5804 189	PP:Development:Y	-
5804 190	PP:Separation	-
5804 192	RFID ON/OFF: K	-
5804 193	RFID ON/OFF: Y	-
5804 194	RFID ON/OFF: C	-
5804 195	RFID ON/OFF: M	-
5804 196	RFID COM ON:K	-
5804 197	RFID COM ON: Y	-
5804 198	RFID COM ON: C	-
5804 199	RFID COM ON: M	-
5804 202	Scanner Lamp	-
5804 216	LD1: K	-
5804 217	LD2: K	-
5804 218	LD1: M	-
5804 219	LD2: M	-
5804 220	LD1: C	-
5804 221	LD2: C	-
5804 222	LD1: Y	-
5804 223	LD2: Y	-
5804 224	PP:ITB:K	PP: Image Transfer Roller: K
5804 225	PP:ITB:M	PP: Image Transfer Roller: M
5804 226	PP:ITB:C	PP: Image Transfer Roller: C
5804 227	PP:ITB:Y	PP: Image Transfer Roller: Y

5804 228	PP:PTR:+	PP: Paper Transfer Roller:+
5804 229	PP:PTR:-	PP: Paper Transfer Roller:-
5804 231	HVPS: ChargeDC: K	-
5804 232	HVPS: ChargeDC: M	-
5804 233	HVPS: ChargeDC: C	-
5804 234	HVPS: ChargeDC: Y	-
5804 237	PP:Charge AC:K:HighSpeed	-
5804 238	PP:Charge AC:K:MiddleSpeed	-
5804 239	HVPS: ChargeAC: K: LowSpeed	-
5804 244	PP:Charge AC:M:HighSpeed	-
5804 245	PP:Charge AC:M:MiddleSpeed	-
5804 246	HVPS: ChargeAC: M: LowSpeed	-
5804 251	PP:Charge AC:C:HighSpeed	-
5804 252	PP:Charge AC:C:MiddleSpeed	-
5804 253	HVPS: ChargeAC: C: LowSpeed	-

5804	Fusing Exit Motor Note: These SP modes will be moved to Super SP mode in the near future.
-------------	---

	<p>Important: Use the procedure below to do the output checks for the fusing exit motor. If you do not follow this procedure, a kink will form in the fusing belt sleeve, and the fusing sleeve belt unit will need to be replaced.</p> <ol style="list-style-type: none"> 1. Do one of the following: <ul style="list-style-type: none"> ▪ Open the right cover of the paper bank ▪ Remove one of the toner bottles ▪ Pull out the waste toner bottle half-way ▪ Remove the fusing unit 2. Enter SP mode. 3. Do the following out output checks: <ul style="list-style-type: none"> ▪ SP5-804-031 (Fusing exit motor: High speed) ▪ SP5-804-032 (Fusing exit motor: Middle speed) ▪ SP5-804-033 (Fusing exit motor: Low speed) ▪ SP5-804-035 (Fusing exit motor: Very low speed) 4. Without exiting SP mode, turn the main power switch off and then on again. <p>Important: If you exit SP mode before you turn the main power switch off, the fusing exit motor will stay off when the machine warms up. Heat will be concentrated in one area of the fusing belt sleeve and cause a kink to form. If this happens, you will need to replace the fusing sleeve belt unit.</p> <ol style="list-style-type: none"> 5. Do the reverse of what you did in step 1 (for example, reattach the fusing unit). 	
5804 31	Fusing Exit Motor: HighSpeed	Fusing/Paper Exit Motor: High Speed
5804 32	Fusing Exit Motor: MiddleSpeed	Fusing/Paper Exit Motor: Middle Speed
5804 33	Fusing Exit Motor: LowSpeed	Fusing/Paper Exit Motor: Low Speed
5804 35	Fusing Exit Motor: LLowSpeed	Fusing/Paper Exit Motor: LLow Speed

ARDF (D578)

6008	Display	Description
6008 1	Pick-Up Motor Forward	
6008 2	Pick-Up Motor Reverse	
6008 3	Feed Motor Forward	Feed Motor-Forward rotation
6008 4	Feed Motor Reverse	Feed Motor-Reverse rotation
6008 5	Relay Motor Forward	Transport Motor- Forward rotation
6008 7	Inverter Motor Reverse	Transport Motor- Forward rotation
6008 8	Inverter Motor Reverse	-
6008 11	Inverter Solenoid	-
6008 12	Stamp	Stamp Solenoid
6008 13	Fan Motor	-
6008 14	Feed Clutch	-
6008 15	Feed Solenoid	-

1000-Sheet Finisher (D588)

6144	Display	Description
6144 1	Relay Up Motor	Upper Transport Motor
6144 2	Relay Down Motor	Lower Transport Motor
6144 3	Exit Motor	-
6144 4	Proof Junction Gate SOL	Tray Junction Gate Solenoid
6144 5	Tray Up Motor	Lower Tray Lift Motor
6144 6	Jogger Motor	Jogger Fence Motor
6144 7	Staple Moving Motor	Stapler Motor
6144 8	Staple Motor	Stapler Hammer
6144 9	Staple Junction Gate SOL	Stapler Junction Gate Solenoid
6144 10	Positioning Roller Solenoid	Positioning Roller Solenoid
6144 11	Stack Feed-out Motor	-
6144 12	Shift Motor	-
6144 13	Exit Guide Plate Motor	-

2000/3000-Sheet (Booklet) Finisher (B804/B805)

6145	Display	Description
6145 1	Entrance Motor	Finisher Entrance Motor
6145 2	Upper Feed Motor	Upper Transport Motor
6145 3	Lower Feed Motor	Lower Transport Motor
6145 4	Exit Motor	Upper/Proof Tray Exit Motor
6145 5	Knock Roller Motor	Clamp Roller Retraction Motor
6145 6	Shift Motor	Shift Roller Motor
6145 7	Exit Guide Plate Open/Close Motor	Exit Guide Plate Motor
6145 8	Tray Lift Motor	Upper Tray Lift Motor
6145 9	Oscillating Back Roller Motor	Stacking Sponge Roller Motor
6145 10	Jogger Motor	Jogger Fence Motor
6145 11	Stack Feed-out Motor	Feed Out Belt Motor
6145 12	Staple Moving Motor	Corner Stapler Movement Motor
6145 13	Staple Skew Motor	Corner Stapler Rotation Motor
6145 14	Staple Motor	Corner Stapler EH530
6145 15	Upper Junction Gate Solenoid	Proof Junction Gate Solenoid
6145 16	Lower Junction Gate Solenoid	Stapling Tray Junction Gate Solenoid
6145 17	Knock Solenoid	Stapling Edge Pressure Plate Solenoid
6145 18	Trailing Edge Hold Solenoid	Positioning Roller Solenoid
6145 19	Saddle Stitch Hold Solonoid	Booklet Pressure Roller Solenoid
6145 20	Stack Junction Gate Open/Close Motor	Stack Junction Gate Motor

Main SP Tables-9

6145 21	Trailing Edge Fence Moving Motor	Fold Unit Bottom Fence Lift Motor
6145 22	Saddle Stitch Staple Motor: Front	Booklet Stapler EH185R: Front
6145 23	Saddle Stitch Staple Motor: Rear	Booklet Stapler EH185R: Rear
6145 24	Folder Plate Motor	Fold Plate Motor
6145 25	Folder Roller Motor	Fold Roller Motor
6145 26	Drive Roller Oscillating Motor	Positioning Roller Motor
6145 27	Punch Motor	Punch Drive Motor
6145 28	Punch Moving Motor	Punch Movement Motor
6145 29	Punch Registration Detection Motor	Paper Position Sensor Slide Motor

Bridge Unit (D386)/ Side Tray (D634)

6151	Display	Description
6151 1	Bridge/Left: Feed Motor: Current Selection	Bridge: Feed Motor: Current switching signal
6151 2	Bridge/Left: Feed Motor:Reset	Bridge: Feed Motor:Reset
6151 3	Bridge/Left: Feed Motor:Enable	Bridge: Feed Motor:Enable
6151 6	Bridge/Left: Feed Motor: High Speed	Bridge: Feed Motor: High Speed
6151 7	Bridge/Left: Feed Motor: Middle Speed	Bridge: Feed Motor: Middle Speed
6151 8	Bridge/Left: Feed Motor: Low Speed	Bridge: Feed Motor: Low Speed
6151 11	Bridge/Left: Junction Solenoid	Bridge: Junction Solenoid

Shift Tray (D633)

6153	Display	Description
6153 1	Shift Tray: Motor	-

1 Bin Tray (D632)

6155	Display	Description
6155 1	1 bin: Junction Solenoid	-

Two-Tray PFU (D580)/ LCIT 2000 (D581)/ LCIT 1200 (D631)

6161	Display	Description
6161 5	Bank1: Feed Motor: HighSpeed	Feed Motor:High Speed (D537/D538)
6161 6	Bank1: Feed Motor: IncreaseSpeed	Feed Motor: Increase Speed (D537/D538)
6161 8	Bank1: Feed Motor: MiddleSpeed	Feed Motor: Middle Speed (D537/D538)
6161 9	Bank1: Feed Motor: LowSpeed	Feed Motor: Low Speed (D537/D538)
6161 10	Bank1: Feed Motor: LowIncreaseSpeed	Feed Motor:Low Increase Speed (D537/D538)
6161 15	Bank2: Feed Motor:HighSpeed	Feed Motor:High Speed (D537)
6161 16	Bank2: Feed Motor: IncreaseSpeed	Feed Motor: Increase Speed (D537)
6161 18	Bank2: Feed Motor: MiddleSpeed	Feed Motor: Middle Speed (D537)
6161 19	Bank2: Feed Motor: LowSpeed	Feed Motor: Low Speed (D537)
6161 20	Bank2: Feed Motor: LowIncreaseSpeed	Feed Motor: Low Increase Speed (D537)
6161 30	Bank:Tray3: PU Solenoid	Pick-up Solenoid (D537/ D538)
6161 31	Bank:Tray4: PU Solenoid	Pick-up Solenoid (D537/ D539)
6161 32	Bank:Tray5: PU Solenoid	Pick-up Solenoid (D539)
6161 35	Bank:Tray3: Feed Clutch	Pick-up Solenoid (D537/ D538)
6161 36	Bank:Tray4: Feed Clutch	Pick-up Solenoid (D537/ D539)
6161 37	Bank:Tray5: Feed Clutch	Pick-up Solenoid (D539)

5.10.3 PRINTER SERVICE MODE

SP1-XXX (Service Mode)

1001	Bit Switch			
001	Bit Switch 1		0	1
	bit 0	DFU	-	-
	bit 1	DFU	-	-
	bit 2	DFU	-	-
	bit 3	No I/O Timeout	0: Disable	1: Enable
		Enable: The MFP I/O Timeout setting will have no effect. I/O Timeouts will never occur.		
	bit 4	SD Card Save Mode	0: Disable	1: Enable
		Enable: Print jobs will be saved to an SD Card in the GW SD slot. For details, see "Card Save Function" (p.5-405).		
	bit 5	DFU	-	-
bit 6	DFU	-	-	
bit 7	[RPCS,PCL]: Printable area frame border	0: Disable	1: Enable	
	Enable: The machine prints all RPCS and PCL jobs with a border on the edges of the printable area.			

1001	Bit Switch			
002	Bit Switch 2		0	1
	bit 0	DFU	-	-
	bit 1	DFU	-	-
	bit 2	Applying a collation Type	Shift Collate	Normal Collate

	<p>A collation type (shift or normal) will be applied to all jobs that do not already have a 'Collate Type' configured.</p> <p>Note</p> <p>1. If #5-0 is enabled, this Bit Switch has no effect.</p>		
bit 3	[PCL5e/c,PS]: PDL Auto Switching	0: Enable	1: Disable
	<p>Disable: The MFPs ability to change the PDL processor mid-job. Some host systems submit jobs that contain both PS and PCL5e/c. If Auto PDL switching is disabled, these jobs will not be printed properly.</p>		
bit 4	DFU	-	-
bit 5	DFU	-	-
bit 6	DFU	-	-
bit 7	DFU	-	-

1001	Bit Switch		
003	Bit Switch 3	0	1
bit 0	DFU	-	-
bit 1	DFU	-	-
bit 2	[PCL5e/c]: Legacy HP compatibility	0: Disable	1: Enable
	<p>Enable: Uses the same left margin as older HP models such as HP4000/HP8000. In other words, the left margin defined in the job (usually "<ESC>*r0A") will be changed to "<ESC>*r1A"</p>		
bit 3	DFU	-	-
bit 4	DFU	-	-
bit 5	DFU	-	-
bit 6	DFU	-	-
bit 7	DFU	-	-

1001	Bit Switch		
004	Bit Switch 4 DFU		
		0	1
	bit 0	DFU	-
	bit 1	DFU	-
	bit 2	DFU	-
	bit 3	IPDS print-side reversal	0: Disable 1: Enable
	If enabled, the simplex pages of IPDS jobs will be printed on the front side because of printing on the back side of the page. This might reduce printing speed.		
	bit 4	DFU	-
	bit 5	DFU	-
	bit 6	DFU	-
	bit 7	DFU	-

1001	Bit Switch		
005	Bit Switch 5		
		0	1
		Disable	Enable
	bit 0	Show "Collate Type", "Staple Type" and "Punch Type" buttons on the operation panel.	
	If enabled, users will be able to configure a Collate Type, Staple Type, and Punch Type from the operation panel. The available types will depend on the device and configured options. After enabling the function, the settings will appear under: "User Tools → Printer Features → System"		
	bit 1	Multiple copies if a paper size or type mismatch occurs	0: Disable (Single copy) 1: Enable (Multiple copy)

		If a paper size or type mismatch occurs during the printing of multiple copies, only a single copy is output by default. Using this BitSw, the device can be configured to print all copies even if a paper mismatch occurs.		
	bit 2	DFU	-	-
	bit 3	[PS] PS Criteria	Pattern3	Pattern1
		Change the number of PS criterion used by the PS interpreter to determine whether a job is PS data or not. Pattern3: includes most PS commands. Pattern1: A small number of PS tags and headers		
	bit 4	Increase max number of the stored jobs to 1000 jobs.	Disable (100)	Enable (1000)
		Enable: Changes the maximum number of jobs that can be stored on the HDD via Job Type settings to 1000. The default is 100.		
	bit 5	Face-up output	Disable	Enable
		Enable: All print jobs will be output face-up in the destination tray.		
	bit 6	Method for determining the image rotation for the edge to bind on.	0: Disable	1: Enable
		If enabled, the image rotation will be performed as they were in the specifications of older models for the binding of pages of mixed orientation jobs. The old models are below: - PCL: Pre-04A models - PS/PDF/RPCS:Pre-05S models		
	bit 7	Letterhead mode printing	0: Disable	1: Enable (Duplex)

1001	Bit Switch			
006	Bit Switch 6 DFU	-	-	

1001	Bit Switch		
007	Bit Switch 7	0	1
		Print path	0: Disable 1: Enable
	bit 0	If enabled, simplex pages (in mixed simplex/duplex PS/PCL5 jobs only) and the last page of an odd paged duplex job (PS, PCL5, PCL6), are always routed through the duplex unit. Not having to switch paper paths increases the print speed slightly.	
	bit 1 to 7	DFU	- -

1001	Bit Switch		
008	Bit Switch 8	0	1
	bit 0	DFU	- -
	bit 1	DFU	- -
	bit 2	DFU	- -
	bit 3	[PCL,PS]: Allow BW jobs to print without requiring User Code	Disable Enable
		Enable: BW jobs submitted without a user code will be printed even if usercode authentication is enabled.	
		<div style="border: 1px solid black; border-radius: 10px; padding: 2px; display: inline-block;"> ⬇ Note </div> <ol style="list-style-type: none"> 1. Color jobs will not be printed without a valid user code. 	
	bit 4	DFU	- -
	bit 5	DFU	- -
	bit 6	DFU	- -
	bit 7	DFU	- -

1001	Bit Switch			
005	Bit Switch 9	0	1	
	bit 0	PDL Auto Detection timeout of jobs submitted via USB or Parallel Port (IEEE 1284).	"Disabled (Immediately)"	"Enabled (10 seconds)"
		To be used if PDL auto-detection fails. A failure of PDL autodetection doesn't necessarily mean that the job can't be printed. This bit switch tells the device whether to time-out immediately (default) upon failure or to wait 10 seconds.		
	bit 1	DFU	-	-
	bit 2	Job Cancel	Disabled (Not cancelled)	Enabled (Cancelled)
		If this bit switch, all jobs will be cancelled after a jam occurs. Note: If this bitsw is enabled, printing under the following conditions might result in problems: - Job submission via USB or Parallel Port - Spool printing (WIM >Configuration > Device Settings > System)		
	bit 3	PCL/PS bypass tray paper rotation (SEF/LEF)	0: Disable	1: Enable
		This bitsw causes the device to revert to the behavior of previous generations. It only takes effect if "Bypass Tray Setting Priority" = "Driver/Command". Previous spec (bitsw=1): If a standard sized paper mismatch occurred in the bypass tray, the MFP always prompted for SEF paper. If this bitsw=0 (default) then in the event of a standard sized paper mismatch, the MFP will always prompt for paper of the rotation (SEF/LEF) determined by the MFP bypass tray paper setting or by the bypass tray sensor.		
	Bit 4 to 7	DFU	-	-

1003	[Clear Setting]
1003 1	Initialize Printer System
	Initializes settings in the "System" menu of the user mode.
1003 3	Delete Program

1004	[Print Summary]
1004 1	Print Summary
	Prints the service summary sheet (a summary of all the controller settings).

1005	[Display Version]
1005 1	Disp. Version
	Displays the version of the controller firmware.

1006	[Sample/Locked Print]	*CTL	0: Linked, 1: On
1006 1	Enables and disables the document server. When you select "0," the document server is enabled or disabled in accordance with Copy Service Mode SP5-967. When you select "1," the document server is enabled regardless of Copy Service Mode SP5-967.		

1101	[Data Recall]		
	Recalls a set of gamma settings. This can be either a) the factory setting, b) the previous setting, or c) the current setting.		
1101 1	Factory	*CTL	
1101 2	Previous		
1101 3	Current		
1101 4	ACC		

Main SP Tables-9

1102	[Resolution Setting]
	Selects the printing mode (resolution) for the printer gamma adjustment.
1102 1	2400x600 Photo , 1800x600 Photo, 600 x 600 Photo, 2400x600 Text, 1800x600, Text, 600x600 Text

1103	[Test Page]
	Prints the test page to check the color balance before and after the gamma adjustment.
1103 1	Color Gray Scale
1103 2	Color Pattern

1104	[Gamma Adjustment]		
	Adjusts the printer gamma for the mode selected in the "Mode Selection" menu.		
1104 1	Black: Highlight	*CTL	[0 to 30 / 15 / 1/step]
1104 2	Black: Shadow		
1104 3	Black: Middle		
1104 4	Black: IDmax		
1104 21	Cyan: Highlight	*CTL	[0 to 30 / 15 / 1/step]
1104 22	Cyan: Shadow		
1104 23	Cyan: Middle		
1104 24	Cyan: IDmax		
1104 41	Magenta: Highlight	*CTL	[0 to 30 / 15 / 1/step]
1104 42	Magenta: Shadow		
1104 43	Magenta: Middle		
1104 44	Magenta: IDmax		

1104 61	Yellow: Highlight	*CTL	[0 to 30 / 15 / 1/step]
1104 62	Yellow: Shadow		
1104 63	Yellow: Middle		
1104 64	Yellow: IDmax		

1105	[Save Tone Control Value]		
	Stores the print gamma adjusted with the "Gamma Adj." menu item as the current setting. Before the machine stores the new "current setting", it moves the data currently stored as the "current setting" to the "previous setting" memory storage location.		
1105 1	Save Tone Control Value		

1106	[Toner Limit]		
	Adjusts the maximum toner amount for image development.		
1106 1	Toner Limit Value	*CTL	[100 to 400 / 260 / 1 %/step]

5.10.4 SCANNER SP MODE

SP1-xxx (System and Others)

1004	[Compression Type]		
	Selects the compression type for binary picture processing.		
1004 1	Compression Type	*CTL	[1 to 3 / 1 / 1/step] 1: MH, 2: MR, 3: MMR

1005	[Erase Margin(Remote scan)]		
	Creates an erase margin for all edges of the scanned image. If the machine has scanned the edge of the original, create a margin. This SP is activated only when the machine uses TWAIN scanning.		
1005 1	Range from 0 to 5 mm	*CTL	[0 to 5 / 0 / 1 mm/step]

1009	[Remote scan disable]		
	Enable or disable remote scan.		
1009 1	0:enable 1:desable	*CTL	[0 or 1 / 0 / -] 0: enable, 1: disable

1010	[Non Display Clear Light PDF]		
	Enable or disable remote scan.		
1010 1	Non Display ClearLight PDF	*CTL	[0 or 1 / 0 / -] 0: Display, 1: No display

SP2-XXX (Scanning-image quality)

2021	[Compression Level(Grayscale)]		
	Selects the compression ratio for grayscale processing mode (JPEG) for the three settings that can be selected at the operation panel.		
2021 1	Comp1:5-95	*CTL	[5 to 95 / 20 / 1 /step]
2021 2	Comp2:5-95		[5 to 95 / 40 / 1 /step]
2021 3	Comp3:5-95		[5 to 95 / 65 / 1 /step]
2021 4	Comp4:5-95		[5 to 95 / 80 / 1 /step]
2021 5	Comp5:5-95		[5 to 95 / 95 / 1 /step]

2024	[Compression ratio of ClearLightPDF]		
	Selects the compression ratio for clearlight PDF for the two settings that can be selected at the operation panel.		
2024 1	Compression Ratio (Normal)	*CTL	[5 to 95 / 25 / 1 /step]
2024 2	Compression Ratio (High)		[5 to 95 / 20 / 1 /step]

5.11 FIRMWARE UPDATE

To update the firmware for this machine, you must have the new version of the firmware downloaded onto an SD (Secure Digital) Card. The SD Card is inserted into SD Card Slot 2 (lower) on the left rear side of the controller box.

5.11.1 TYPE OF FIRMWARE

There are several types of firmware as shown below.

Type of firmware	Function	Location of firmware	Message shown
Engine	Printer engine control	BCU Flash ROM	Engine
System/Copy Application	Operating system	Flash ROM on the controller board	System/Copy
Lcdc	Panel control	LCDC	Lcdc
ADF	ADF control	ADF Main Control Board	ADF
NetworkSupport		Controller Board	NetworkSupport
Language 1		LCDC	Language1
Language 2		LCDC	Language2
RPCS		Controller Board	RPCS
MediaPrint:JPEG/TIFF		Controller Board	MediaPrint:JPEG/TIFF
FONT		Controller Board	FONT
FONT1		Controller Board	FONT1
NetworkDocBox		Controller Board	NetworkDocBox
Printer		Controller Board	Printer
Scanner		Controller Board	Scanner
Websupport		Controller Board	Websupport
WebUapl		Controller Board	WebUapl

5.11.2 BEFORE YOU BEGIN

An SD card is a precision device. Always observe the following precautions when you handle SD cards:

- Always switch the machine off before you insert an SD card. Never insert the SD card into the slot with the power on.
- Do not remove the SD card from the service slot after the power has been switched on.
- Never switch the machine off while the firmware is downloading from the SD card.
- Keep SD cards in a safe location where they are not exposed to high temperature, high humidity, or exposure to direct sunlight.
- Always handle SD cards with care. Do not bend or scratch them. Do not let the SD card get exposed to shock or vibration.
- Make sure that the write protection of an SD card is unlocked when you download an application to it. If not, downloading fails and a download error (e.g. Error Code 44) occurs during a firmware upgrade.

Keep the following points in mind when you use the firmware update software:

1. "Upload" means to send data from the machine to the SD card. "Download" means to send data from the SD card to the machine.
2. To select an item on the LCD, touch the appropriate button on the soft touch-screen of the LCD, or, press the appropriate number key on the 10-key pad of the operation panel. For example, when "Exit (0)" shows on the screen you can touch the Exit button on the screen, or, press the "0" button on the operation panel of the copier.
3. Make sure that the machine is disconnected from the network to prevent a print job for arriving while the firmware update is in progress before you start the firmware update procedure.

5.11.3 UPDATING FIRMWARE

Preparation

1. If the SD card is blank, copy the entire "romdata" folder onto the SD card.
 2. If the card already contains the "romdata" folder, copy the "D142" folder onto the card.
- If the card already contains folders up to "D142", copy the necessary firmware files (e.g. D142xxxx.fwu) into this folder.

Note

- Do not put multiple machine firmware programs on the same SD card. Copy the only model firmware you want.

Updating Procedure

1. Turn the main power switch off.

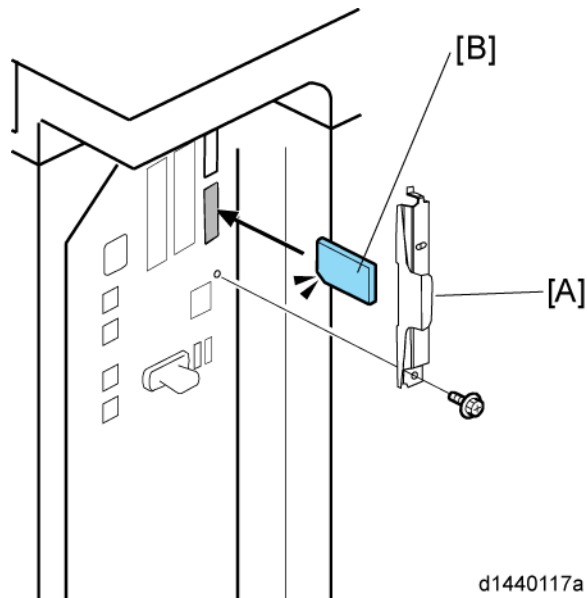

2. Remove the slot cover [A] ( x 1).
3. Insert the SD card into SD Card Slot 2 (lower). Make sure the label on the SD card faces [B] the front side of the machine.
4. Slowly push the SD card into the slot so it locks in place. You will hear it click. Make sure the SD card locks in place.

Note

- To remove the SD, push it in to unlock the spring lock. Then release it so it pops out of the slot.
5. Disconnect the network cable from the copier if the machine is connected to a network.
 6. Switch the main power switch on. After about 45 seconds, the initial version update screen appears on the LCD in English.
 7. On the screen, touch the button or press the corresponding number key on the operation panel to select the item in the menu that you want to update.

ROM/NEW	What it means
ROM:	Tells you the number of the module and name of the version currently installed. The first line is the module number, the second line the version name.
NEW:	Tells you the number of the module and name version on the SD card. The first line is the module number, the second line the version name.

Note

- Controller, engine and operation panel firmware cannot be updated at the same time. It is recommended to update firmware modules one by one.
8. Touch "UpDate (#)" (or ) to start the update.

Note

- The progress bar does not show for the operation panel firmware after you touch "OpPanel". The power on key flashes on and off at 0.5 s intervals when the LCDC firmware is updating. The power key flashes on and off at 3 s intervals when the update is finished.
9. The "Update is Done" message appears on the operation panel after completing the updating. The message differs depending on the firmware that has been updated.
 10. Switch the copier main power switch off when you see the "Update is Done" message or follow the procedure that is displayed on the operation panel.
 11. Press in the SD card to release it. Then remove it from the slot.
 12. Switch the copier on for normal operation.

Error Messages

An error message shows in the first line if an error occurs during the download.

The error code consists of the letter "E" and a number. The example above shows error "E24" displayed. For details, refer to the Error Message Table. (☞ p.5-386)

When SC818 is displayed while a firmware update is in progress, turn the main power off/on and make sure that the firmware update is done.

Firmware Update Error

If a firmware update error occurs, this means the update was cancelled during the update because the module selected for update was not on the SD card.

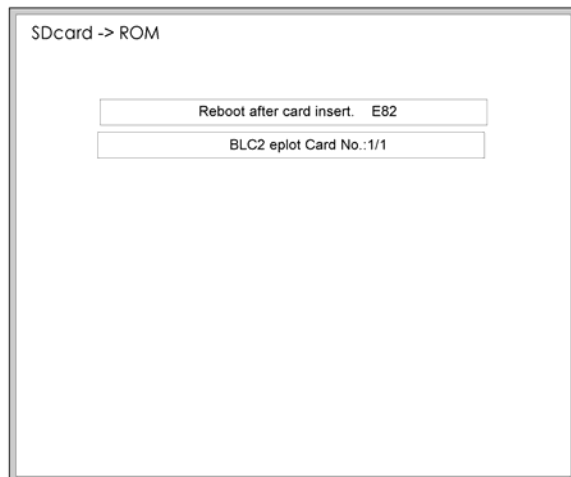

Recovery after Power Loss

If the ROM update is interrupted as a result of accidental loss of power while the firmware is updating, then the correct operation of the machine cannot be guaranteed after the machine is switched on again. If the ROM update does not complete successfully for any reason, then in order to ensure the correct operation of the machine, the ROM update error will continue to show until the ROM is updated successfully.



In this case, insert the card again and switch on the machine to continue the firmware download automatically from the card without the menu display.

5.11.4 UPDATING THE LCDC FOR THE OPERATION PANEL

Do the following procedure to update the LCDC (LCD Control Board).

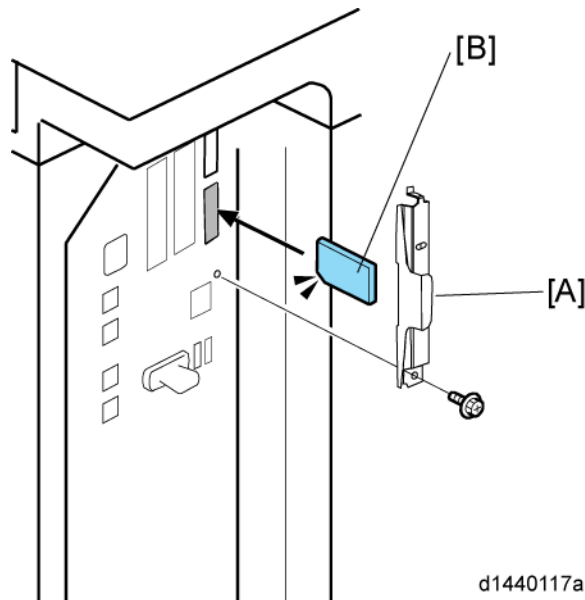
1. Turn the copier main switch off.



2. Remove the SD slot cover [A] ( x 1).
3. Insert the SD card into SD Card Slot 2 (lower).
4. Switch the copier main switch on.
5. The initial screen opens in English after about 45 seconds.
6. Touch "Ope Panel.xx".
7. "xx" differs depending on the destination.
8. Touch "UpDate(#)" or () to start the update.
9. Downloading starts after about 9 seconds.
10. The operation panel goes off and the main power on key flashes in red at 0.5 s intervals when the data is downloading. The same key starts flashing in green at 1 s intervals when the update is finished.
11. Switch the copier main power switch off and remove the SD card. Then switch the copier on.

5.11.5 UPDATE PROCEDURE FOR APP2ME PROVIDER

Follow this procedure to update App 2 Me if a new version is available.

1. Push the [User/Tools] key on the operation panel.
2. If an administrator setting is registered for the machine, Step 3 and Step 4 are required. Otherwise, skip to step 5.
3. Push [Login/Logout] on the operation panel.
4. Login with the administrator user name and password.
5. Touch "Extended Feature Settings" twice on the LCD.

Firmware Update

6. Touch each of the applications until the status changes to "Stop".
7. Turn the machine off, and then remove the VM Card.

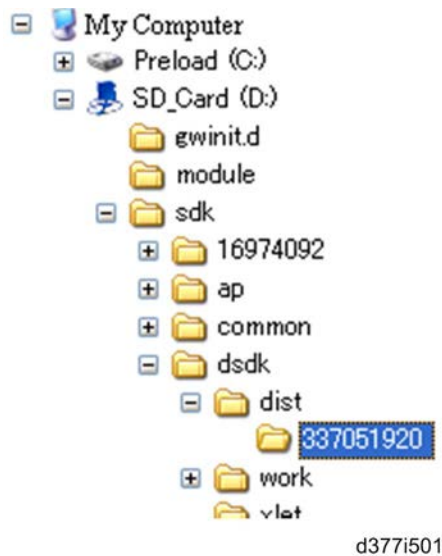



8. Prepare the newer App2Me Provider zip file from the Firmware Download Center, and then unzip the zip file. (The folder name is "337051920".)
9. Copy the App2Me Provider folder into the specified path for the VM card. The path is: "SD_Card Drive¥ sdk¥dsdk¥dist¥337051920"
10. Turn the SD card label face to the front of the machine, and then push it slowly into Slot 2 (lower) until you hear a click.
11. Turn the main power switch on.
12. Press [User Tools] on the operation panel.
13. Touch the "Extended Feature Settings" button twice.
14. Touch the "Extended Feature Info" tab on the LCD.
15. Touch the "App2Me" line.
16. Set the setting of the "Auto Start" to "On".
17. Touch the "Exit" button.
18. Exit the [User Tools/Counter] settings.

★ Important

- App2Me and all other running applications on the VM card must be shut down before removing the VM card in order to update the firmware, back up NVRAM, install the browser unit, or execute application move or undo with SP5873.
- After the VM card is re-inserted, App2Me (and any other VM card applications used by the customer) must be switched on after the machine is switched on.

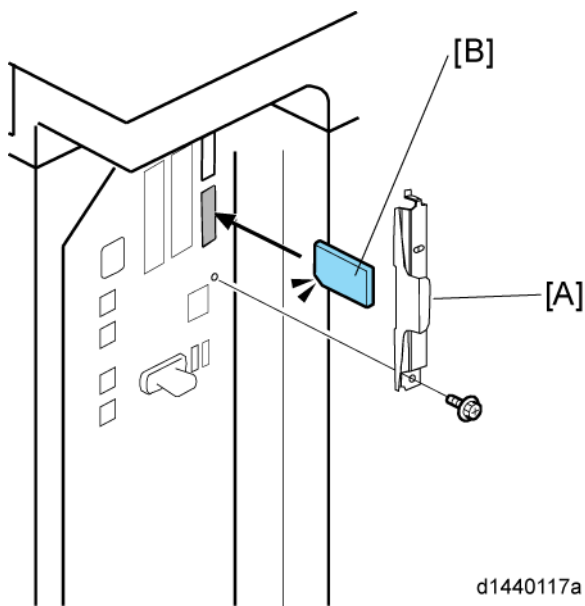
5.11.6 BROWSER UNIT UPDATE PROCEDURE



1. Remove the slot cover [A] for SD cards ( x 1).
 - Turn the SD-card label face of the browser unit to the front of the machine. Then push it slowly into slot 2 (lower) until you hear a click.
 - Plug in and turn on the main power switch.
 - Push the "User Tools" key.
 - If an administrator setting is registered for the machine, step 5 and 6 are required. Otherwise, skip to the step 7
 - Push the "Login/ Logout" key.
 - Login with the administrator user name and password.
 - Touch "Extended Feature Settings" twice on the LCD.
 - Touch "Uninstall" on the LCD.
 - Touch the "Browser" line
 - Confirmation message appears on the LCD.
 - Touch "Yes" to proceed.
 - Reconfirmation message appears on the LCD.
 - Touch "Yes" to uninstall the browser unit.
 - You will see "Uninstalling the extended feature... Please wait.", and then "Completed".
 - Touch "Exit" to go back to the setting screen.
 - Exit "User/Tools" setting, and then turn off the main power switch.
 - Remove the SD card of the browser unit from SD card slot 2 (lower).
 - Overwrite the updated program in the "sdk" folder of the browser unit application with PC.
 - Do the "Installation Procedure" to install the browser unit.

5.11.7 HANDLING FIRMWARE UPDATE ERRORS

An error message shows in the first line if an error occurs during a download. The error code consists of the letter "E" and a number ("E20", for example).

Error Message Table

Code	Meaning	Solution
20	Cannot map logical address	Make sure the SD card is inserted correctly.
21	Cannot access memory	HDD connection incorrect or replace hard disks.
22	Cannot decompress compressed data	Incorrect ROM data on the SD card, or data is corrupted.
23	Error occurred when ROM update program started	Controller program abnormal. If the second attempt fails, replace controller board.
24	SD card access error	Make sure SD card inserted correctly, or use another SD card.
30	No HDD available for stamp data download	HDD connection incorrect or replace hard disks.
31	Data incorrect for continuous download	Insert the SD card with the remaining data required for the download, the re-start the procedure.
32	Data incorrect after download interrupted	Execute the recovery procedure for the intended module download, then repeat the installation procedure.
33	Incorrect SD card version	Incorrect ROM data on the SD card, or data is corrupted.
34	Module mismatch - Correct module is not on the SD card)	SD update data is incorrect. Acquire the correct data (Japan, Overseas, OEM, etc.) then install again.
35	Module mismatch – Module on SD card is not for this machine	SD update data is incorrect. The data on the SD card is for another machine. Acquire correct update data then install again.

Code	Meaning	Solution
36	Cannot write module – Cause other than E34, E35	SD update data is incorrect. The data on the SD card is for another machine. Acquire correct update data then install again.
40	Engine module download failed	Replace the update data for the module on the SD card and try again, or replace the BCU board.
42	Operation panel module download failed	Replace the update data for the module on the SD card and try again, or replace the LCDC.
43	Stamp data module download failed	Replace the update data for the module on the SD card and try again, or replace the hard disks.
44	Controller module download failed	Replace the update data for the module on the SD card and tray again, or replace controller board.
50	Electronic confirmation check failed	SD update data is incorrect. The data on the SD card is for another machine. Acquire correct update data then install again.

5.12 INSTALLING ANOTHER LANGUAGE

Many languages are available. But you can only switch between two languages at a time. Do the following procedure to select the two languages you want. You can select both of the languages you want from the user interface on the operation panel.

1. Switch the copier main power switch off.
2. Remove the SD slot cover ( x 1).
3. Insert the SD card with the language data into SD Card Slot 2.
4. Switch the copier main power switch on. The initial screen opens after about 45 seconds.
5. Touch "Language Data (2)" on the screen (or press the "2" key).

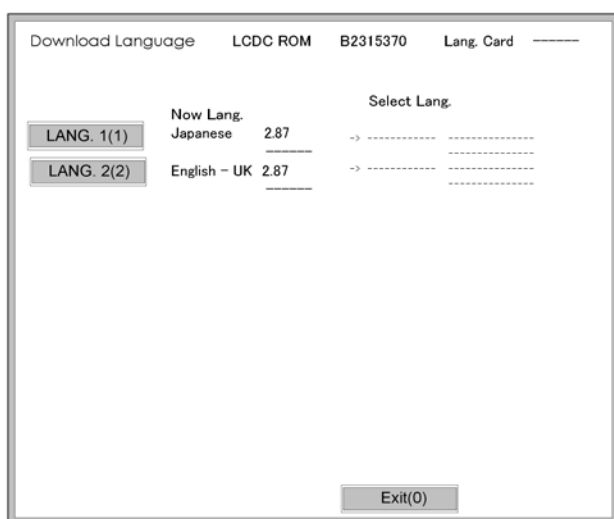

6. Touch "LANG. 1(1)" or "LANG. 2(2)"

Key	What it does
LANG. 1(1)	Touch this button on the screen (or press the "1" key on the 10-key pad) to open the next screen so you can select the 1st language.
LANG. 1(2)	Touch this button on the screen (or press the "2" key on the 10-key pad) to open the next screen so you can select the 2nd language.
Exit (0)	Touch this key on the screen (or press the "0" key on the 10-key pad) to quit the update procedure and return to normal screen.

7. Touch "LANG 1(1)" to select the 1st Language. Touch "LANG (2)" to select the 2nd Language.

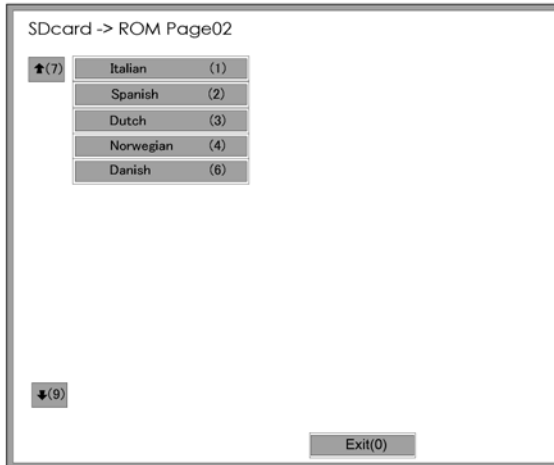

8. Touch the appropriate button on the screen (or press the number on the 10-keypad) to select a language as the 1st (or 2nd) language.
 - If a language is already selected, it will show in reverse.
 - Touching "Exit (0)" returns you to the previous screen.
9. If you do not see the language that you want to select, touch "↑ (7)" or "↓ (9)" on the screen (or press the "7" or "9" key) to show more choices.

The Download Screen opens after you select a language.

The 1st or 2nd language selected for updating shows.

The following show to right of the selection:

1. 1. The first column shows the language currently selected.
2. 2. The 2nd column shows the language selected to replace that language.

The example below shows that the download will replace "Japanese" with "Italian" as the 1st language.

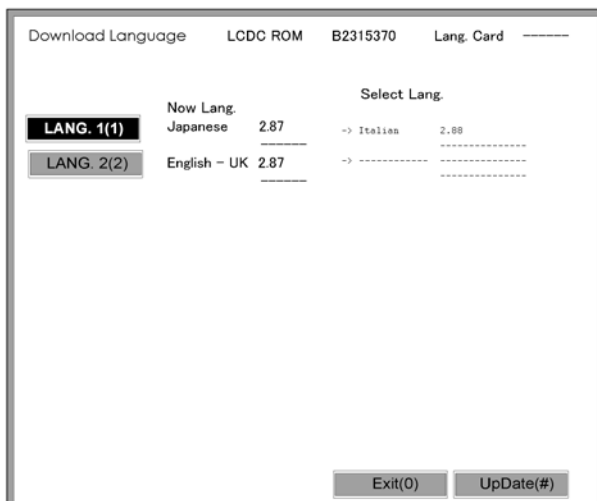

10. Touch "Update(#)" on the screen (or press ) to start the download.

Another screen with a progress bar does not show when the language is downloading.

The following occur at the time the language is downloading:

 - The operation panel switches off.



Installing Another Language

- The LED on the power on key flashes rapidly.
11. After the message of installation completed has shown on the LCD, switch the copier main power switch off. Then remove the SD card from the slot.
 12. Switch the copier main power switch on to resume normal operation.

5.13 REBOOT/SYSTEM SETTING RESET

5.13.1 SOFTWARE RESET



You can reboot the software with one of the following two procedures:

- Turn the main power switch off and on.
- Press and hold down  and  together for over 10 seconds. When the machine beeps once, release both buttons. After “Now loading. Please wait” shows for a few seconds, the copy window will open. The machine is ready for normal operation.

5.13.2 SYSTEM SETTINGS AND COPY SETTING RESET

System Setting Reset

The system settings in the UP mode can be reset to their defaults. Use the following procedure.

1. Press User Tools/Counter .
2. Hold down  and then press System Settings.

Note

- You must press  first.

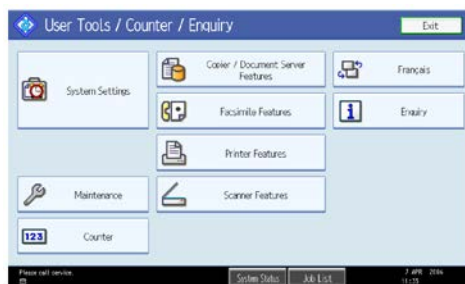

3. Press yes when the message prompts you to confirm that you want to reset the system settings.
4. Press exit when the message tells you that the settings have been reset.

Copier Setting Reset

Use the following procedure to reset the copy settings in the UP mode to their defaults.

- Press User Tools/Counter .
- Hold down  and then press Copier/Document Server Settings.

 **Note**

- You must press  first.

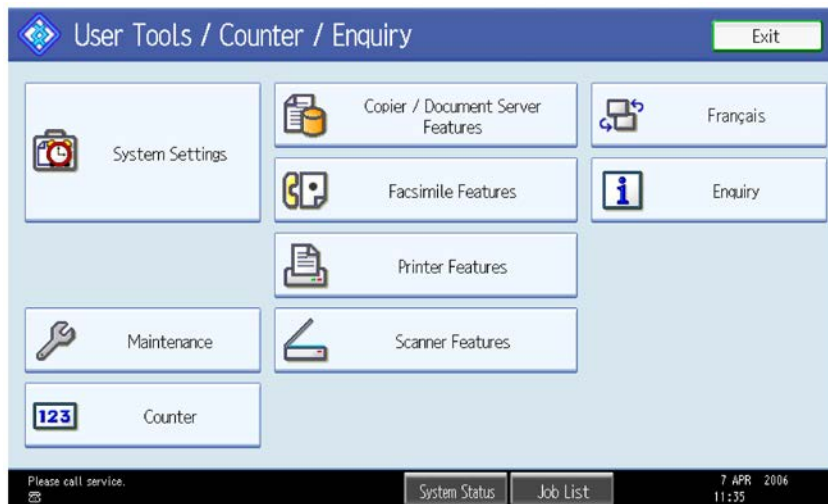

- Press “Yes” when the message prompts you to confirm that you want to reset the Copier Document Server settings.
- Press exit when the message tells you that the settings have been reset.

5.14 DOWNLOADING STAMP DATA

The stamp data should be downloaded from the controller firmware to the hard disks at the following times:

- After the hard disks have been replaced.

The print data contains the controller software. Execute SP 5853 to download the fixed stamp data required by the hard disks.

1. Enter the SP mode.
2. Select SP5853 and then press "EXECUTE". The following screen opens while the stamp data is downloading.

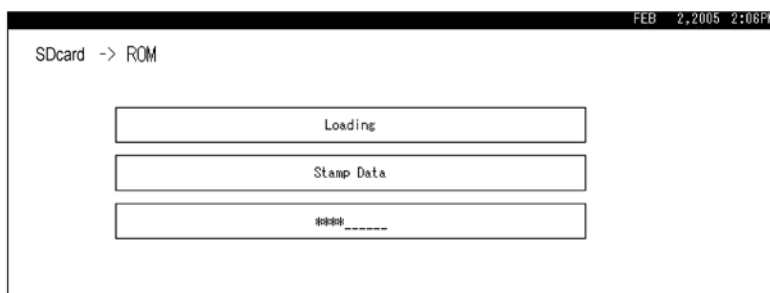

The download is finished when the message prompts you to close.

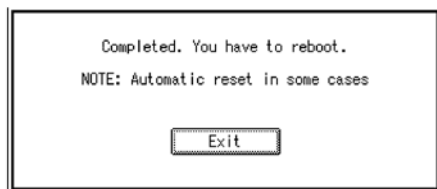

3. Press the "Exit" button. Then turn the copier off and on again.

5.15 NVRAM DATA UPLOAD/DOWNLOAD

5.15.1 UPLOADING CONTENT OF NVRAM TO AN SD CARD

Do the following procedure to upload SP code settings from NVRAM to an SD card.

Note

- This data should always be uploaded to an SD card before the NVRAM is replaced.
 - Make sure that the write protection of an SD card is unlocked
1. Do SP5990-001 (SMC Print) before you switch the machine off. You will need a record of the NVRAM settings if the upload fails.
 2. Switch the copier main power switch off.

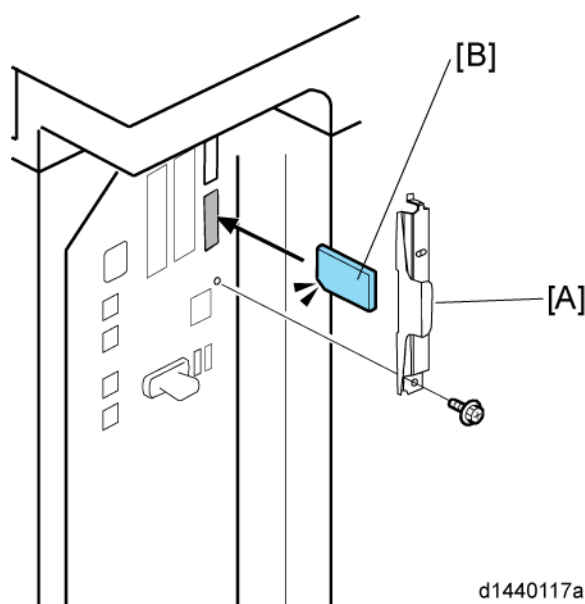

3. Remove the SD slot cover [A] ( x 1).
4. Insert the SD card [B] into SD card slot 2 (lower). Then switch the copier on.
5. Execute SP5824-001 (NVRAM Data Upload) and then press the “Execute” key.
6. The following files are copied to an NVRAM folder on the SD card when the upload procedure is finished. The file is saved to the path and the following filename:
NVRAM¥<serial number>.NV
 Here is an example with Serial Number “K5000017114”:
NVRAM¥K5000017114.NV
7. In order to prevent an error during the download, be sure to mark the SD card that holds the uploaded data with the number of the machine from which the data was uploaded.

Note

- You can upload NVRAM data from more than one machine to the same SD card.

5.15.2 DOWNLOADING AN SD CARD TO NVRAM

Do the following procedure to download SP data from an SD card to the NVRAM in the machine.

- The NVRAM data download may fail if the SD card with the NVRAM data is damaged, or if the connection between the controller and BCU is defective.
- Do the download procedure again if the download fails.
- Do the following procedure if the second attempt fails:
Enter the NVRAM data manually using the SMC print you created before uploading the NVRAM data.

1. Switch the copier main power switch off.

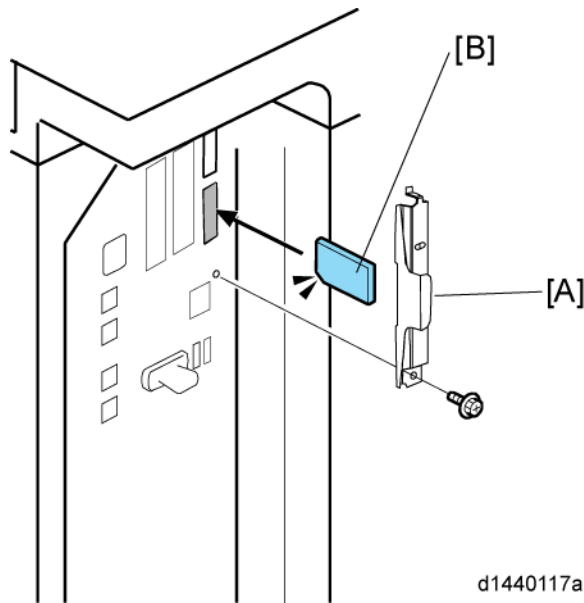

2. Remove the SD slot cover [A] ( x 1).
3. Insert the SD card [B] with the NVRAM data into SD Card Slot 2 (lower).
4. Switch the copier main power switch on.
5. Do SP5825-001 (NVRAM Data Download) and press the “Execute” key.

Note

- The serial number of the file on the SD card must match the serial number of the machine for the NVRAM data to download successfully. The download fails if the serial numbers do not match.

This procedure does not download the following data to the NVRAM:

- Total Count
- C/O, P/O Count

5.16 ADDRESS BOOK UPLOAD/DOWNLOAD

5.16.1 INFORMATION LIST

The following information is possible to be uploaded and downloaded.

Information	
<ul style="list-style-type: none"> ▪ Registration No. ▪ User Code ▪ E-mail ▪ Protection Code ▪ Fax Destination ▪ Fax Option ▪ Group Name ▪ Key Display 	<ul style="list-style-type: none"> ▪ Select Title ▪ Folder ▪ Local Authentication ▪ Folder Authentication ▪ Account ACL ▪ New Document Initial ACL ▪ LDAP Authentication

5.16.2 DOWNLOAD

- Prepare a formatted SD card.
- Make sure that the write-protection on the SD card is off.
- Turn off the main power switch of the main machine.
- Remove the SD slot cover at the left rear side of the machine ( x 1).
- Install the SD card into the SD card slot 2 (for service use).
- Turn on the main power switch.
- Enter the SP mode.
- Do SP5-846-051 (Backup All Addr Book).
- Exit the SP mode, and then turn off the main power switch.
- Remove the SD card from the SD card slot 2.
- Install the SD slot cover.

 **Note**

- If the capacity of SD card is not enough to store the local user information, an error message is displayed.
- Carefully handle the SD card, which contains user information. Do not take it back to your location.

5.16.3 UPLOAD

- Turn off the main power switch of the main machine.
- Remove the SD slot cover at the left rear side of the machine ( x 1).
- Install the SD card, which has already been uploaded, into the SD card slot 2.
- Turn on the main power switch.
- Enter the SP mode.
- Do SP5-846-052 (Restore All Addr Book).
- Exit the SP mode, and then turn off the main power switch.
- Remove the SD card from the SD card slot 2.
- Install the SD slot cover.

 **Note**

- The counter in the user code information is initialized after uploading.
- The information of an administrator and supervisor cannot be downloaded nor uploaded.
- If there is no data of address book information in the SD card, an error message is displayed.

5.17 USING THE DEBUG LOG

5.17.1 OVERVIEW

This machine provides a Save Debug Log feature that allows the Customer Engineer to save and retrieve error information for analysis.

Every time an error occurs, debug information is recorded in volatile memory. But this information is lost when the machine is switched off and on.

To capture this debug information, the Save Debug Log feature provides two main features:

1. Switching on the debug feature so error information is saved directly to the HDD for later retrieval.
2. Copying the error information from the HDD to an SD card.

Do the following procedure below to set up the machine so the error information is saved automatically to the HDD when a user has problems with the machine. Then ask the user to reproduce the problem.

5.17.2 SWITCHING ON AND SETTING UP SAVE DEBUG LOG

The debug information cannot be saved until the “Save Debug Log” function has been switched on and a target has been selected.

- Enter the SP mode and switch the Save Debug Log feature on.
 1. Enter the SP mode.
 2. Touch “System SP”.
 3. On the LCD panel, open SP5857.
- Under “5857 Save Debug Log”, touch “1 On/Off”.

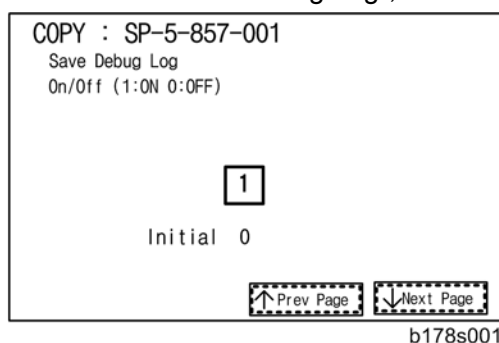

- On the control panel keypad, press “1”. Then press . This switches the Save Debug Log feature on.

Note

- The default setting is “0” (OFF). This feature must be switched on in order for the debug information to be saved.

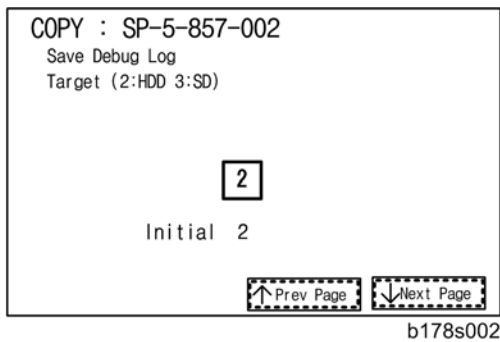

- Select the target destination where the debug information will be saved. Under “5857 Save Debug Log”, touch “2 Target”, enter “2” with the operation panel key to select the hard disk as the target destination. Then press \oplus .

Note

- Select “3 SD Card” to save the debug information directly to the SD card if it is inserted in the service slot.
- Now touch “5858” and specify the events that you want to record in the debug log. SP5858 (Debug Save When) provides the following items for selection.

1	Engine SC Error	Saves data when an engine-related SC code is generated.
2	Controller SC Error	Saves debug data when a controller-related SC Code is generated.
3	Any SC Error	Saves data only for the SC code that you specify by entering code number.
4	Jam	Saves data for jams.

Note

- More than one event can be selected.

Example 1: To Select Items 1, 2, 4

Touch the appropriate items(s). Press “ON” for each selection. This example shows “Engine SC Error” selected.

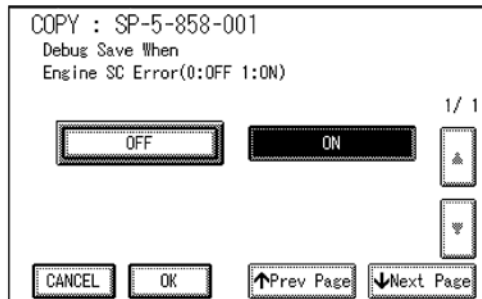

Example 2: To Specify an SC Code

Touch “3 Any SC Error”, enter the 3-digit SC code number with the control panel number keys. Then press \oplus . This example shows an entry for SC670.

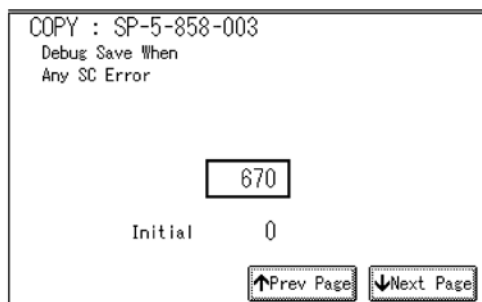

Note

- For details about SC code numbers, please refer to the SC tables in Section 4. “Troubleshooting”.
- Select one or more memory modules for reading and recording debug information. Touch “5859”.
Under “5859” press the necessary key item for the module that you want to record.
Enter the appropriate 4-digit number. Then press \oplus .

Note

- Refer to the two tables below for the 4-digit numbers to enter for each key.

The example below shows “Key 1” with “2222” entered.

COPY : SP-5-859-001
 Debug: Save Key No.
 Key 1

2222

Initial 0

Prev Page Next Page

The following keys can be set with the corresponding numbers. (The initials in parentheses indicate the names of the modules.)

4-Digit Entries for Keys 1 to 10

Key No.	Copy	Printer	Scanner	Web
1	2222 (SCS)			
2	14000 (SRM)			
3	256 (IMH)			
4	1000 (ECS)			
5	1025 (MCS)			
6	4848 (COPY)	4400 (GPS)	5375 (Scan)	5682 (NFA)
7	2224 (IPU)	4500 (PDL)	5682 (NFA)	6600 (WebDB)
8		4600 (GPS-PM)	3000 (UCS)	3300 (PTS)
9		2000 (NCS)	2000 (NCS)	6666 (WebSys)
10		2224 (IPU)	4126 (DCS)	2000 (NCS)

Note

- The default settings for Keys 1 to 10 are all zero (“0”).

Key to Acronyms

Using the Debug Log

Acronym	Meaning	Acronym	Meaning
ECS	Engine Control Service	NFA	Net File Application
GPS	GW Print Service	PDL	Printer Design Language
GSP-PM	GW Print Service – Print Module	PTS	Print Server
IMH	Image Memory Handler	SCS	System Control Service
MCS	Memory Control Service	SRM	System Resource Management
NCS	Network Control Service	WebDB	Web Document Box (Document Server)

- The machine is now set to record the debugging information automatically on the HDD (the target selected with SP5857-002) for the events that you selected with SP5858 and the memory modules selected with SP5859.

Please keep the following important points in mind when you do this setting:

1. Note that the number entries for Keys 1 to 5 are the same for the Copy, Printer, Scanner, and Web memory modules.
2. The initial settings are all zero.
3. These settings remain in effect until you change them. Be sure to check all the settings, especially the settings for Keys 6 to 10. To switch off a key setting, enter a zero for that key.
4. You can select any number of keys from 1 to 10 (or all) by entering the corresponding 4-digit numbers from the table.
5. You cannot mix settings for the groups (COPY, PRINTER, etc.) for 006 to 010. For example, if you want to create a PRINTER debug log you must select the settings from the 9 available selections for the “PRINTER” column only.
6. One area of the disk is reserved to store the debug log. The size of this area is limited to 4 MB.

5.17.3 RETRIEVING THE DEBUG LOG FROM THE HDD



Retrieve the debug log by copying it from the hard disk to an SD card.

- Insert the SD card into slot 2 (service slot) of the copier.
- Enter the SP mode and execute SP5857-009 (Copy HDD to SD Card (Latest 4 MB)) to write the debugging data to the SD card.
- Use a card reader to copy the file and send it for analysis to your local Ricoh representative by email. You can also send the SD card by regular mail if you want.

5.17.4 RECORDING ERRORS MANUALLY

SC errors and jams only are recorded to the debug log automatically. Please instruct the user to do the following immediately after occurrence to save the debug data for any other errors that occur while the customer engineer is not on site. Such problems also include a controller or panel freeze.

↓ Note

- You must previously switch on the Save Debug Feature (SP5857-001) and select the hard disk as the save destination (SP5857-002) if you want to use this feature.
- Press  (Clear Modes) on the operation panel when the error occurs.
- On the control panel, enter "01". Then hold down  for at least 3 seconds until the machine beeps and then release it. This saves the debug log to the hard disk for later retrieval with an SD card by the service representatives.
- Switch the machine off and on to resume operation.

The debug information for the error is saved on the hard disk. This lets the service representative retrieve it on their next visit by copying it from the HDD to an SD card.

5.17.5 DEBUG LOG CODES

SP5857-015 Copy SD Card-to-SD Card: Any Desired Key

This SP copies the log on an SD card (the file that contains the information written directly from shared memory) to a log specified by key number. The copy operation is executed in the log directory of the SD card inserted in the same slot. (This function does not copy from one slot to another.) Each SD card can hold up to 4 MB of file data. Unique file names are created for the data during the copy operation to prevent overwriting files of the same name. This means that log data from more than one machine can be copied onto the same SD card. This command does not execute if there is no log on the HDD for the name of the specified key.

SP5857-016 Create a File on HDD to Store a Log

This SP creates a 32 MB file to store a log on the HDD. However, this is not a completely empty file. The created file will hold the number “2225” as the SCS key number and other non-volatile information. Even if this SP is not executed, a file is created on the HDD when the first log is stored on the HDD (it takes some time to complete this operation). This creates the possibility that the machine may be switched off and on before the log can be created completely. If you execute this SP to create the log file beforehand, this will greatly reduce the amount of time required to acquire the log information and save onto the HDD. With the file already created on the HDD for the log file, the data only needs to be recorded. A new log file does not need to be created. To create a new log file, do SP5857-011 to delete the debug log data from the HDD. Then do SP5857-016.

SP5857-017 Create a File on SD Card to Store a Log

This SP creates a 4 MB file to store a log on an SD card. However, this is not a completely empty file. The created file will hold the number “2225” as the SCS key number and other non-volatile information. Even if this SP is not executed, a file is created on the SD card when the first log is stored on the SD card (it takes some time to complete this operation). This creates the possibility that the machine may be switched off and on before the log can be created completely. If you execute this SP to create the log file beforehand, this will greatly reduce the amount of time required to acquire the log information and save onto the SD card. With the file already created on the SD card for the log file, the data only needs to be recorded; a new log file does not require creation. To create a new log file, do SP5857-012 to delete the debug log data from the SD card. Then do SP5857-017.

5.18 CARD SAVE FUNCTION

5.18.1 OVERVIEW

Card Save:

- The Card Save function is used to save print jobs received by the printer on an SD card with no print output. Card Save mode is toggled using printer Bit Switch #1 bit number 4. Card Save will remain enabled until the SD card becomes full, or until all file names have been used.
- Captures are stored on the SD card in the folder /prt/cardsave. File names are assigned sequentially from PRT00000.prn to PRT99999.prn. An additional file PRT.CTL will be created. This file contains a list of all files created on the card by the card save function.
- Previously stored files on the SD card can be overwritten or left intact. Card Save SD has “Add” and “New” menu items.
 - **Card Save (Add):** Appends files to the SD Card. Does not overwrite existing files. If the card becomes full or if all file names are used, an error will be displayed on the operation panel. Subsequent jobs will not be stored.
 - **Card Save (New):** Overwrites files in the card's /prt/cardsave directory.

Limitation:

1. Card Save cannot be used with PjL Status Readback commands. PjL Status Readbacks will not work. In addition they will cause the Card Save to fail.

5.18.2 PROCEDURE

- Turn the main power switch OFF.
- Insert the SD card into slot 2. Then turn the power ON.
- Enter SP mode.
- Select the “Printer Sp”.
- Select SP-1001 “Bit Switch”.

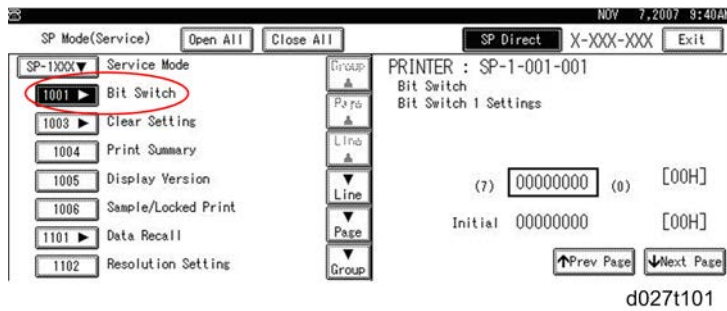

- Select “Bit Switch 1 Settings” and use the numeric keypad to turn bit 4 ON and then press the “#” button to register the change. The result should look like: **00010000**. By doing this, Card Save option will appear in the “List/Test Print” menu.

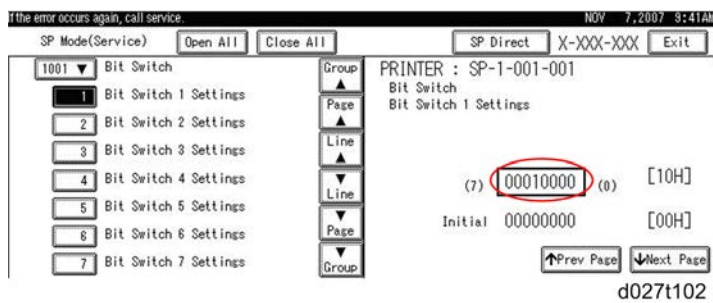

- Press “Exit” to exit SP Mode.
- Press the “User Tools/Counter” button.

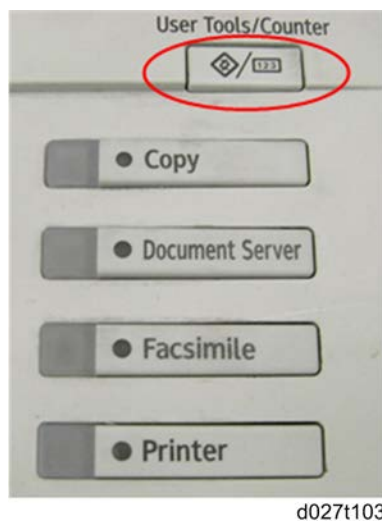

- Select “Printer Features”.

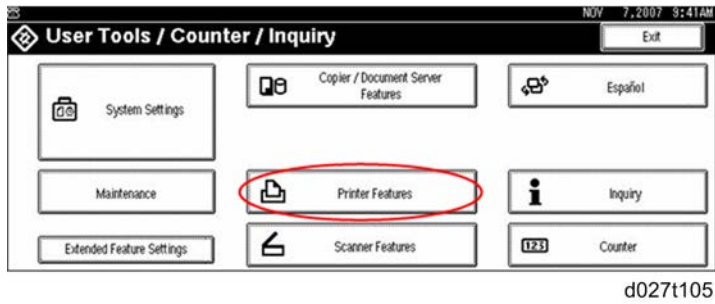

- Card Save (Add) and Card Save (New) should be displayed on the screen. Select Card Save (Add) or Card Save (New).

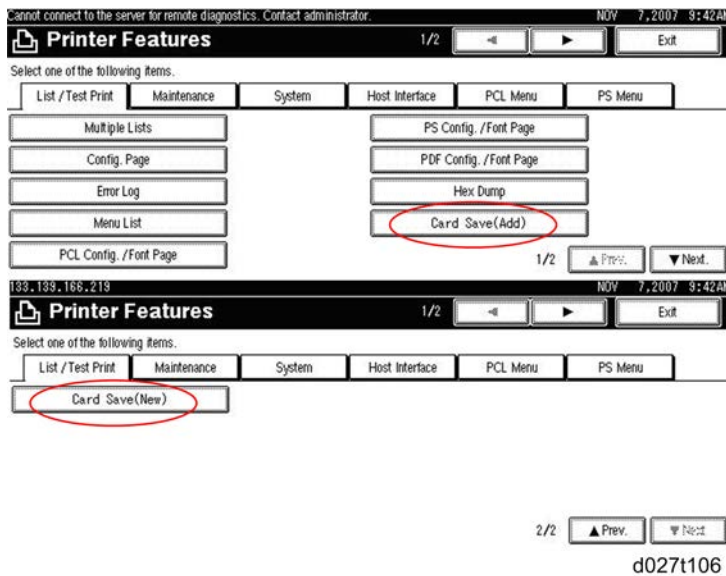

- Press "OK" and then exit the "User Tools/Counter" menu.

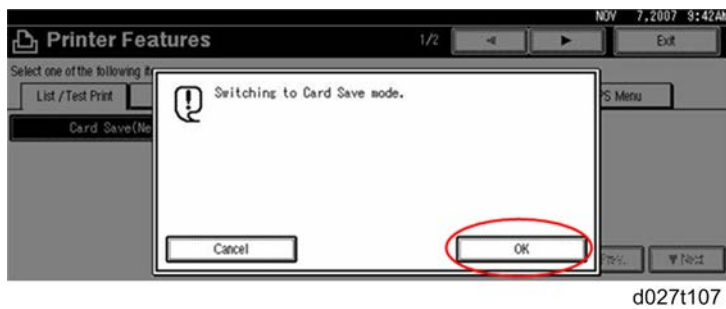

- Press the "Printer" button.

Card Save Function

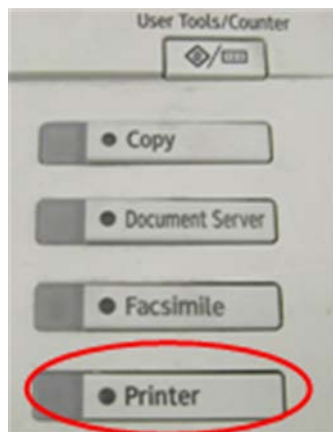

d027t108

- Card Save should be displayed in the top left of the display panel.

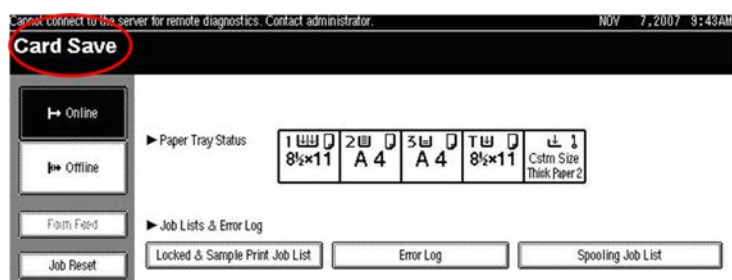

d027t109

- Send a job to the printer. The Communicating light should start blinking as shown below.

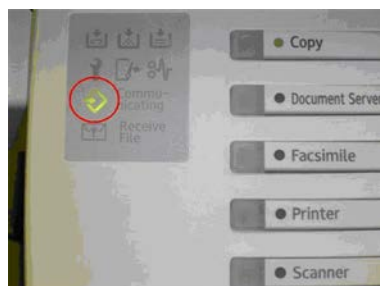

d027t110

- As soon as the printer receives the data, it will be stored on the SD card automatically with no print output. Nothing is displayed on the screen, indicating that a Card Save operation was successful.
- Press "Offline" and then the "Clear" button to exit Card Save mode.

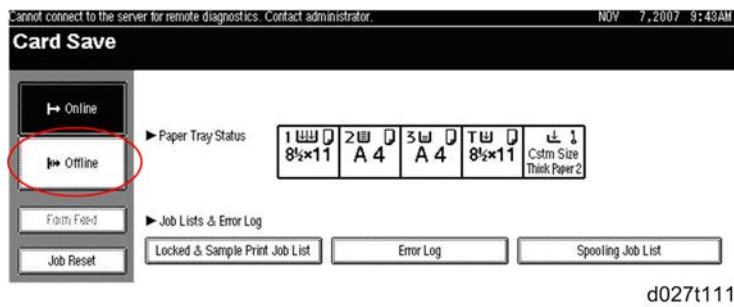

- Change the Bit Switch Settings back to the default **00000000**. Press the “#” button in the numeric keypad to register the changes.
- Remove the SD card after the main power switch is turned off.

5.18.3 ERROR MESSAGES

Card Save error messages:

1. **Init error:** A card save process (e.g. card detection, change to kernel mode) failed to initialize.
2. **Card not found:** Card cannot be detected in the slot.
3. **No memory:** Insufficient working memory to process the job.
4. **Write error:** Failed to write to the card.
5. **Other error:** An unknown error occurred.

If an error occurs, pressing “OK” will cause the device to discard the job and return to the ready state.

5.19 SMC LIST CARD SAVE FUNCTION

5.19.1 OVERVIEW

SMC List Card Save

- The SMC List Card Save (SP Text Mode) function is used to save the SMC list as CSV files to the SD-card inserted into service slot 2 or the operation panel card slot.

5.19.2 PROCEDURE

1. Turn the main power switch OFF.
2. Insert the SD card into slot 2 or the operation panel SD-card slot. Then turn the power ON.
3. Enter SP mode.
4. Select "Copy SP".

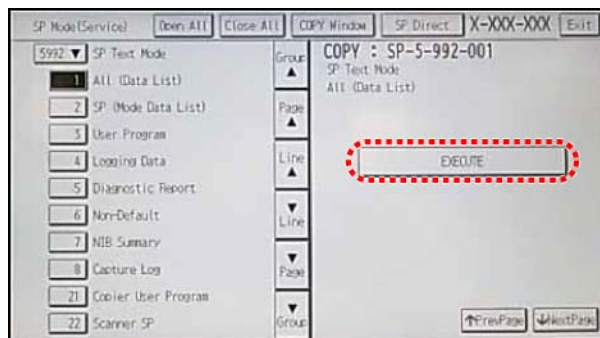

d1440127

5. Select SP-5992 "SP Text Mode".
6. Select a detail SP number shown below to save data on the SD card.
SP-5992-xxx (SP Text Mode)

Detail No.	SMC Categories to Save
001	All (Data List)
002	SP (Mode Data List)
003	User Program
004	Logging Data
005	Diagnostic Report
006	Non-Default
007	NIB Summary

Detail No.	SMC Categories to Save
008	Capture Log
021	Copier User Program
022	Scanner SP
023	Scanner User Program
024	SDK/J Summary
025	SDK/J Application Info
026	Printer SP

- Press [EXECUTE].

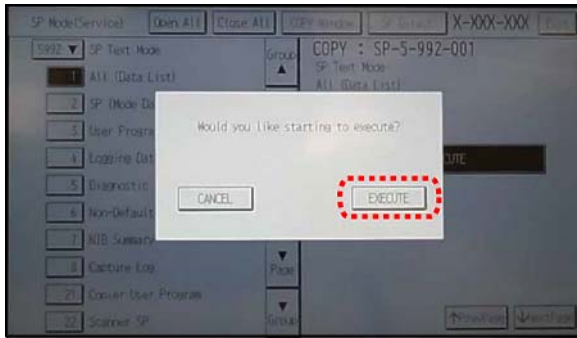

d1440128

- Press [EXECUTE] again to start. Press [CANCEL] to cancel the saving.



d1440130

- "It is executing it" is shown on the screen while executing.

SMC List Card Save Function

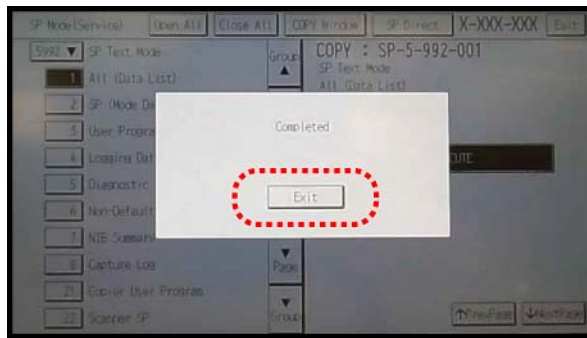

d1440129

10. Wait for 2 to 3 minutes until “Completed” is shown.

↓ Note

- The SMC list saving may take from 2 to 3 minutes to complete.
- Press [CANCEL] to abort executing.

11. Press [Exit] to exit from SP mode.

5.19.3 FILE NAMES OF THE SAVED SMC LISTS

The SMC list data saved on the SD-card will be named automatically. The file naming rules are as follows.

Example:

W490M000006_59921_20111011_53954.csv



d1440131

A:

Machine serial number (fixed for each machine)

B:

SP number saved in this file.

First four digits (5992) in this part are fixed. The other one or two digits are the detail SP number. In this case, it is one digit. Therefore, this file is of SP5-992-001 (All data list). See the upper SP table for the correspondence between SP detail numbers and the contents.

C:

File creation date

Year/Month/Day ("Zero" will be omitted if each is one digit.)

D:

File creation time

Hour/Minute/Second ("Zero" will be omitted if each is one digit.)

E:

File Extension CSV (Comma Separated Value)

This part is fixed.

↓ Note

1. A folder named by the machine serial number will be created on the SD card when this function is executed.

5.19.4 ERROR MESSAGES

SMC List Card Save error message:

- **Failed:**

FACTOR: Read-only file system, No space left on device.

If an error occurs, pressing "Exit" will cause the device to discard the job and return to the ready state.

TROUBLESHOOTING

REVISION HISTORY		
Page	Date	Added/Updated/New
57 ~ 61	07/12/2012	Altered SC720 to include SC722 -24, 30, 41, 42, 70 and 71.
64	07/12/2012	Altered SC720 to include SC722 -24, 30, 41, 42, 70 and 71.
66	07/12/2012	Altered SC720 to include SC722 -24, 30, 41, 42, 70 and 71.
146	06/27/2012	Sensor numbers

6. TROUBLESHOOTING

6.1 SERVICE CALL

6.1.1 SERVICE CALL CONDITIONS

The "SC Table" section shows the SC codes for controller errors and other errors. The latter (not controller errors) are put into four types. The type is determined by their reset procedures. The table shows the classification of the SC codes.

	Key	Definition	Reset Procedure
Controller errors	CTL	The error has occurred in the controller.	See "Troubleshooting Procedure" in the table.
Other errors	A	The error involves the fusing unit. The machine operation is disabled. The user cannot reset the error.	Turn the main switch off and on. Reset the SC (set SP5-810-1). Turn the main switch off and on.
	B	The error involves one or some specific units. The machine operates as usual, excluding the related units.	Turn the operation switch off and on.
	C	The error is logged. The SC-code history is updated. The machine operates as usual.	The SC will not show. Only the SC history is updated.
	D	The machine operation is disabled. You can reset the machine by turning the operation switch or main switch off and on. If the error occurs again, the same SC code is displayed.	Turn the operation switch or main power switch off and on.

Service Call

After you turn the main power switch off, wait for one second or more before you turn the main power switch on (SC 672). All SCs are logged. The print log data (SP5-990-004) in SP mode can check the latest 10 SC codes detected and total counters when the SC code is detected.

↓ Note

1. If the problem concerns electrical circuit boards, first disconnect then reconnect the connectors before you replace the PCBs.
2. If the problem concerns a motor lock, first check the mechanical load before you replace motors or sensors.

SC Code Classification

The table shows the classification of the SC codes:

Class 1	Section	SC Code	Detailed section
1XX	Scanning	100 -	Scanner
		190 -	Unique for a specific model
2XX	Laser exposure	200 -	Polygon motor
		220 -	Synchronization control
		230 -	FGATE signal related
		240 -	LD control
		280 -	Unique for a specific model
		290 -	Shutter
3XX	Image development 1	300 -	Charge
		330 -	Drum potential
		350 -	Development
		380 -	Unique for a specific model

Class 1	Section	SC Code	Detailed section
4XX	Image development 2	400 -	Image transfer
		420 -	Paper separation
		430 -	Cleaning
		440 -	Around drum
		460 -	Unit
		480 -	Others
5XX	Paper feed / Fusing	500 -	Paper feed
		515 -	Duplex
		520 -	Paper transport
5XX	Paper feed / Fusing	530 -	Fan motor
		540 -	Fusing
		560 -	Others
		570 -	Unique for a specific model
6XX	Communication	600 -	Electrical counters
		620 -	Mechanical counters
		630 -	Account control
		640 -	CSS
		650 -	Network
		670 -	Internal data processing
		680 -	Unique for a specific model
7XX	Peripherals	700 -	Original handling
		720 -	Two-tray finisher
		740 -	Booklet finisher

Class 1	Section	SC Code	Detailed section
8XX	Controller	800 -	Error after ready condition
		820 -	Diagnostics error
		860 -	Hard disk
		880 -	Unique for a specific model
9XX	Others	900 -	Counter
		920 -	Memory
		990 -	Others

6.1.2 SERVICE CALL TABLES - 1

SC1xx: Scanning

No.	Type	Details (Symptom, Possible Cause, Troubleshooting Procedures)
101	D	Exposure lamp error
		The peak white level is less than 64/255 digits (8 bits) when scanning the shading plate.
		<ul style="list-style-type: none"> ▪ Exposure lamp defective ▪ LED relay board defective ▪ Exposure lamp connector defective ▪ Standard white plate dirty ▪ Scanner mirror or scanner lens out of position or dirty
		<ol style="list-style-type: none"> 1. Check and clean the scanner mirror(s) and scanner lens. 2. Check and clean the shading plate. 3. Replace the exposure lamp. 4. Replace the LED relay board. 5. Replace the scanner mirror(s) or scanner lens.

No.	Type	Details (Symptom, Possible Cause, Troubleshooting Procedures)
120	D	Scanner home position error 1
		The scanner home position sensor does not detect the "OFF" condition during operation.
		<ul style="list-style-type: none"> ▪ Scanner motor driver defective ▪ Scanner motor defective ▪ Harness between SIO board and scanner motor disconnected ▪ Scanner HP sensor defective ▪ Harness between SIO and HP sensor disconnected
		<ol style="list-style-type: none"> 1. Check the cable connection between the SIO board and scanner motor. 2. Check the cable connection between the SIO and HP sensor. 3. Replace the scanner motor. 4. Replace the HP sensor.

No.	Type	Details (Symptom, Possible Cause, Troubleshooting Procedures)
121	D	Scanner home position error 2
		The scanner home position sensor does not detect the "ON" condition during operation.
		<ul style="list-style-type: none"> ▪ Scanner motor driver defective ▪ Scanner motor defective ▪ Harness between SIO board and scanner motor disconnected ▪ Scanner HP sensor defective ▪ Harness between SIO and HP sensor disconnected
		<ul style="list-style-type: none"> ▪ Check the cable connection between the SIO board and scanner motor. ▪ Check the cable connection between the SIO and HP sensor. ▪ Replace the scanner motor. ▪ Replace the HP sensor.

Service Call

No.	Type	Details (Symptom, Possible Cause, Troubleshooting Procedures)
141	D	Black level detection error
		The black level cannot be adjusted within the target value during the zero clamp.
		<ul style="list-style-type: none"> ▪ Harness disconnected ▪ Defective SBU
		<ol style="list-style-type: none"> 1. Check the cable connection 2. Replace the SBU.

No.	Type	Details (Symptom, Possible Cause, Troubleshooting Procedures)
142	D	White level detection error
		The white level cannot be adjusted within the target during auto gain control.
		<ul style="list-style-type: none"> ▪ Dirty exposure glass or optics section ▪ SBU board defective ▪ Exposure lamp defective ▪ LED relay board defective ▪ Scanner motor defective
		<ul style="list-style-type: none"> ▪ Clean the exposure glass, white plate, mirrors, and lens. ▪ Check if the exposure lamp is lit during initialization. ▪ Check the harness connection between SBU and IPU. ▪ Replace the exposure lamp. ▪ Replace the scanner motor. ▪ Replace the SBU board.

No.	Type	Details (Symptom, Possible Cause, Troubleshooting Procedures)
144	D	SBU communication error
		The SBU connection cannot be detected at power on or recovery from the energy save mode.
		<ol style="list-style-type: none"> 1. Defective SBU 2. Defective harness 3. Defective detection port on the BCU
		<ul style="list-style-type: none"> ▪ Replace the harness. ▪ Replace the SBU. ▪ Replace the BCU.

No.	Type	Details (Symptom, Possible Cause, Troubleshooting Procedures)
161		IPU error
-01	D	The error result of self-diagnostic by the ASIC on the IPU is detected.
		<ol style="list-style-type: none"> 1. Defective IPU 2. Defective connection between IPU and SBU
		<ul style="list-style-type: none"> ▪ Check the connection between IPU and SBU. ▪ Replace the IPU.
-02	D	The machine detects an error during an access to the Ri.
		<ol style="list-style-type: none"> 1. Defective IPU board
		Replace the IPU board.

No.	Type	Details (Symptom, Possible Cause, Troubleshooting Procedures)
165	D	Copy Data Security Unit error
		<ul style="list-style-type: none"> ▪ The copy data security board is not detected when the copy data security function is set "ON" with the initial setting. ▪ A device check error occurs when the copy data security function is set "ON" with the initial setting.
		<ol style="list-style-type: none"> 1. Incorrect installation of the copy data security board 2. Defective copy data security board
		<ul style="list-style-type: none"> ▪ Reinstall the copy data security board. ▪ Replace the copy data security board.

No.	Type	Details (Symptom, Possible Cause, Troubleshooting Procedures)
195	D	Serial Number Mismatch
		<ol style="list-style-type: none"> 1. Serial number stored in the memory does not have the correct code.
		<ul style="list-style-type: none"> ▪ NVRAM defective ▪ BCU replaced without original NVRAM
		<ol style="list-style-type: none"> 1. Check the serial number with SP5-811-002. 2. If the stored serial number is incorrect, contact your supervisor.

6.1.3 SERVICE CALL TABLES - 2

SC 2xx: Exposure

No.	Type	Details (Symptom, Possible Cause, Troubleshooting Procedures)
202	D	Polygon motor error 1: ON timeout
		The polygon mirror motor does not reach the targeted operating speed within the specified time after turning on or changing speed
		<ul style="list-style-type: none"> ▪ Defective or disconnected harness to polygon motor driver board ▪ Defective polygon motor driver board ▪ Defective polygon motor.
		<ol style="list-style-type: none"> 1. Replace the polygon motor. 2. Replace the laser optics housing unit. 3. Replace the harness. 4. Replace the IPU.

No.	Type	Details (Symptom, Possible Cause, Troubleshooting Procedures)
203	D	Polygon motor error 2: OFF timeout
		The polygon mirror motor does leave the READY status within 3 seconds after the polygon motor switches off.
		<ul style="list-style-type: none"> ▪ Disconnected or defective harness to polygon motor driver board ▪ Defective polygon motor driver board ▪ Defective polygon motor
		<ul style="list-style-type: none"> ▪ Check or replace the harness. ▪ Replace the polygon motor. ▪ Replace the IPU.

No.	Type	Details (Symptom, Possible Cause, Troubleshooting Procedures)
204	D	Polygon motor error 3: XSCRDY signal error
		The SCRDY_N signal goes HIGH (inactive) while the laser diode is firing.
		<ol style="list-style-type: none"> 1. Disconnected or defective harness to polygon motor driver board 2. Defective polygon motor 3. Defective polygon motor driver board
		<ul style="list-style-type: none"> ▪ Check or replace the harness. ▪ Replace the polygon motor. ▪ Replace the IPU.

No.	Type	Details (Symptom, Possible Cause, Troubleshooting Procedures)
210 -01	C	Laser synchronizing detection error: end position [K]
-02	C	Laser synchronizing detection error: end position [C]
-03	C	Laser synchronizing detection error: end position [M]
-04	C	Laser synchronizing detection error: end position [Y]
		<p>The laser synchronizing detection signal for the end position of LDB [K], [C], [M], [Y] is not detected for one second after the LDB unit turned on when detecting the main scan magnification.</p> <ol style="list-style-type: none"> 1. Disconnected or defective harness to synchronizing detector for end position 2. Defective synchronizing detector board 3. Defective LD board or driver 4. Defective IPU <ul style="list-style-type: none"> ▪ Check the connectors. ▪ Replace the harness of the LD board. ▪ Replace the laser optics housing unit. ▪ Replace the IPU.

No.	Type	Details (Symptom, Possible Cause, Troubleshooting Procedures)
220 -01	D	Laser synchronizing detection error: start position [K]: LD1
-02	D	Laser synchronizing detection error: start position [C]: LD1
-03	D	Laser synchronizing detection error: start position [M]: LD1
-04	D	Laser synchronizing detection error: start position [Y]: LD1
		<p>The laser synchronizing detection signal for the start position of the LDB [K], [C], [M], [Y] is not output for two seconds after LDB unit turns on while the polygon motor is rotating normally.</p> <ol style="list-style-type: none"> 1. Disconnected cable from the laser synchronizing detection unit or defective connection 2. Defective laser synchronizing detector 3. Defective LDB 4. Defective IPU <ul style="list-style-type: none"> ▪ Check the connectors. ▪ Replace the laser-synchronizing detector. ▪ Replace the LDB. ▪ Replace the IPU.

No.	Type	Details (Symptom, Possible Cause, Troubleshooting Procedures)
230 -01	D	FGATE ON error: K
-02	D	FGATE ON error: C
-03	D	FGATE ON error: M
-04	D	FGATE ON error: Y
		<p>The PFGATE ON signal does not assert within 5 seconds after processing the image in normal job or MUSIC for start position [K], [C], [M], [Y].</p>

Service Call

No.	Type	Details (Symptom, Possible Cause, Troubleshooting Procedures)
		<ol style="list-style-type: none"> 1. Defective ASIC (Lupus) 2. Poor connection between controller and IPU 3. Defective IPU
		<ul style="list-style-type: none"> ▪ Check the connection between the controller board and the IPU. ▪ Replace the IPU. ▪ Replace the controller board.

No.	Type	Details (Symptom, Possible Cause, Troubleshooting Procedures)
231 -01	D	FGATE OFF error: K
-02	D	FGATE OFF error: C
-03	D	FGATE OFF error: M
-04	D	FGATE OFF error: Y
		<ol style="list-style-type: none"> 1. The PFGATE ON signal still asserts within 5 seconds after processing the image in normal job or MUSIC for end position [K], [C], [M], [Y]. 2. The PFGATE ON signal still asserts when the next job starts.
		See SC 230 for troubleshooting details.

No.	Type	Details (Symptom, Possible Cause, Troubleshooting Procedures)
240 -01	C	LD error: K
-02	C	LD error: C
-03	C	LD error: M
-04	C	LD error: Y
		<p>The IPU detects LDB error a few times consecutively when LDB unit turns on after LDB initialization.</p> <ul style="list-style-type: none"> ▪ Worn-out LD ▪ Disconnected or broken harness of the LD <ul style="list-style-type: none"> ▪ Replace the harness of the LD. ▪ Replace the laser optics housing unit. ▪ Replace the IPU.

No.	Type	Details (Symptom, Possible Cause, Troubleshooting Procedures)
		GAVD communication error
		<p>The 12C bus device ID is not identified during initialization. A device-status error occurs during 12C bus communication. The 12C bus communication is not established due to an error other than a buffer shortage.</p>
270	D	<ol style="list-style-type: none"> 1. Loose connection 2. Defective GAVD 3. Defective BCU 4. Defective controller board <ul style="list-style-type: none"> ▪ Turn the power switch off and on. ▪ Check the cable connection. ▪ Replace the laser optics-housing unit. ▪ Replace the BCU.

Service Call

No.	Type	Details (Symptom, Possible Cause, Troubleshooting Procedures)
285	D	Line position adjustment (MUSIC) error
		Line position adjustment fails four consecutive times.
		<ol style="list-style-type: none"> 1. Pattern sampling error (insufficient image density) 2. Defective ID sensors for the line position adjustment 3. Defective image transfer belt unit 4. Defective PCDU(s) 5. Defective laser optics housing unit
		<ul style="list-style-type: none"> ▪ Check and reinstall the image transfer belt unit and PCDUs. ▪ Check if each toner bottle has enough toner. ▪ Replace the ID sensor. ▪ Replace the image transfer belt unit. ▪ Replace the PCDU(s). ▪ Replace the laser optics housing unit.

6.1.4 SERVICE CALL TABLES - 3

SC3xx: Image Processing – 1

No.	Type	Details (Symptom, Possible Cause, Troubleshooting Procedures)
312 -01	D	Charge P.P. output error: K
-02	D	Charge P.P. output error: C
-03	D	Charge P.P. output error: M
-04	D	Charge P.P. output error: Y
		The feedback voltage of the charge AC for each color is 0.3 V or less for 0.2 seconds after the charge AC has been turned on.
		<ol style="list-style-type: none"> 1. Disconnected or broken harnesses of the HVPS 2. Defective PCDU 3. Defective HVPS
		<ul style="list-style-type: none"> ▪ Check or replace the harnesses of the HVPS. ▪ Reinstall or replace the PCDU. ▪ Replace the HVPS.

SC3xx: Image Processing – 2

No.	Type	Details (Symptom, Possible Cause, Troubleshooting Procedures)
360 -01	D	TD sensor adjustment error: K
-02	D	TD sensor adjustment error: C
-03	D	TD sensor adjustment error: M
-04	D	TD sensor adjustment error: Y
		<p>During TD sensor initialization, the output value of the black, cyan, magenta, or yellow TD sensor is not within the range of the specified value with SP3-238-001 to -004 (default: 2.5V) \pm 0.2V</p> <ul style="list-style-type: none"> ▪ Heat seal not removed from a new developer pack ▪ TD harness sensor disconnected, loose or defective ▪ TD sensor defective ▪ Harness between TD sensor and drawer disconnected, defective <ol style="list-style-type: none"> 1. Remove the heat seal from each PCDU. 2. Replace the defective PCDU.

No.	Type	Details (Symptom, Possible Cause, Troubleshooting Procedures)
361 -01	D	TD sensor (Vt high) error 1: K
-02	D	TD sensor (Vt high) error 1: C
-03	D	TD sensor (Vt high) error 1: M
-04	D	TD sensor (Vt high) error 1: Y
-	-	<ul style="list-style-type: none"> ▪ The Vt value of the black, magenta, cyan, or yellow TD sensor exceeds the specified value (default: 4.7V) with SP3-020-002 for twenty counts. ▪ The [Vt - Vtref] value of the black, magenta, cyan, or yellow TD sensor exceeds the specified value (default: 5.0V) with SP3-020-001.
		<ol style="list-style-type: none"> 1. Black, magenta, cyan, or yellow TD sensor disconnected 2. Harness between TD sensor and PCDU defective 3. Defective TD sensor.
		<ul style="list-style-type: none"> ▪ Check the black, magenta, cyan, or yellow TD sensor connector and harness between the TD sensor and PCDU for damage. ▪ Check the drawer connector. ▪ Replace the defective PCDU.

No.	Type	Details (Symptom, Possible Cause, Troubleshooting Procedures)
362 -01	D	TD sensor (Vt low) error 2: K
-02	D	TD sensor (Vt low) error 2: C
-03	D	TD sensor (Vt low) error 2: M
-04	D	TD sensor (Vt low) error 2: Y
		The Vt value of the black, magenta, cyan, or yellow TD sensor is below the specified value with SP3-020-004 (default: 0.5V) for 10 counts.

Service Call

No.	Type	Details (Symptom, Possible Cause, Troubleshooting Procedures)
		<ol style="list-style-type: none"> 1. TD sensor harness disconnected, loose, defective 2. A drawer connector disconnected, loose, defective 3. TD sensor defective
		<ul style="list-style-type: none"> ▪ Check the black, magenta, cyan, or yellow TD sensor connector and harness between the TD sensor and PCDU for damage. ▪ Check the drawer connector. ▪ Replace the defective PCDU.

No.	Type	Details (Symptom, Possible Cause, Troubleshooting Procedures)
		ID sensor adjustment error
		When the Vsg error counter reaches "3", the machine detects "SC370". The Vsg error counter counts "1" when the Vsg detected by ID sensor is more than the value (default: 4.5V) specified with SP3-324-005 or less than the value (default: 3.5V) specified with SP3-324-006.
		<ol style="list-style-type: none"> 1. Dirty or defective ID sensor 2. ID sensor detection surface dirty
370	D	<ul style="list-style-type: none"> ▪ Check the harness of the ID sensor. ▪ Clean or replace the ID sensor. <p>Note</p> <ol style="list-style-type: none"> 1. After replacing the ID sensor, input the ID sensor correction coefficient with SP3362-013 to -018. For details, refer to "ID sensor board" in the Replacement and Adjustment section. <ul style="list-style-type: none"> ▪ Replace the BCU. ▪ Replace the ITB unit.

No.	Type	Details (Symptom, Possible Cause, Troubleshooting Procedures)
390 -01	C	Drum gear position sensor error: K
-02	C	Drum gear position sensor error: C
-03	C	Drum gear position sensor error: M
-04	C	Drum gear position sensor error: Y
		<p>The machine does not detect the drum position signal for 3 seconds at the drum phase adjustment.</p> <ul style="list-style-type: none"> ▪ Dirty or defective drum gear position sensor <ol style="list-style-type: none"> 1. Clean the drum gear position sensor. 2. Check the harness connection. 3. Replace the drum gear position sensor. 4. Replace the PCDU.

Service Call

No.	Type	Details (Symptom, Possible Cause, Troubleshooting Procedures)
396 -01	D	Drum/Development motor error: K
-02	D	Drum/Development motor error: C
-03	D	Drum/Development motor error: M
-04	D	Drum/Development motor error: Y
		<p data-bbox="418 674 1294 757">The machine detects a High signal from the drum/development motor for 2 seconds after the drum/development motor turned on.</p> <ul style="list-style-type: none"> <li data-bbox="418 797 999 831">▪ Overload on the drum/development motor <li data-bbox="418 844 916 878">▪ Defective drum/development motor <li data-bbox="418 891 703 925">▪ Defective harness <li data-bbox="418 938 852 972">▪ Shorted 24 V fuse on the PSU <li data-bbox="418 985 804 1019">▪ Defective interlock system <ol style="list-style-type: none"> <li data-bbox="418 1059 852 1093">1. Check or replace the harness. <li data-bbox="418 1106 954 1140">2. Replace the drum/development motor. <li data-bbox="418 1153 906 1187">3. Replace the 24V fuse on the PSU.

6.1.5 SERVICE CALL TABLES - 4

SC4xx: Image Processing - 3

No.	Type	Details (Symptom, Possible Cause, Troubleshooting Procedures)
441	D	Image transfer unit motor error
		The motor LOCK signal is not detected for more than two seconds while the motor START signal is on.
		<ul style="list-style-type: none"> ▪ Motor overload ▪ Defective image transfer unit motor
		<ol style="list-style-type: none"> 1. Replace the image transfer belt unit. 2. Replace the IOB.

No.	Type	Details (Symptom, Possible Cause, Troubleshooting Procedures)
442	D	Image transfer belt contact motor error
		The image transfer belt contact sensor does not detect the movement of actuator at the sensor while the polygon motor rotates.
		<ul style="list-style-type: none"> ▪ Dirty image transfer belt contact sensor ▪ Defective image transfer belt contact motor ▪ Disconnected connector of image transfer belt contact sensor or motor ▪ Disconnected cable
		<ol style="list-style-type: none"> 1. Replace the image transfer belt contact sensor. 2. Replace the image transfer belt contact motor.

No.	Type	Details (Symptom, Possible Cause, Troubleshooting Procedures)
443	C	Image transfer unit error
		The machine detects the encoder sensor error.
		<ul style="list-style-type: none"> ▪ Defective encoder sensor ▪ Image transfer unit installation error ▪ Defective image transfer unit motor
		<ol style="list-style-type: none"> 1. Check if the image transfer unit is correctly set. 2. Replace the image transfer unit motor. 3. Replace the image transfer unit.

No.	Type	Details (Symptom, Possible Cause, Troubleshooting Procedures)
452	D	Paper transfer unit contact error
		The paper transfer unit contact sensor does not detect the movement of actuator at the sensor while the polygon motor rotates.
		<ul style="list-style-type: none"> ▪ Defective paper transfer unit contact sensor ▪ Defective paper transfer unit contact motor ▪ Broken +24V fuse on PSU ▪ Defective IOB
		<ul style="list-style-type: none"> ▪ Check the connection between the paper transfer unit and PSU. ▪ Replace the paper transfer unit contact sensor. ▪ Replace the paper transfer unit contact motor. ▪ Replace the +24V fuse on the PSU. ▪ Replace the IOB.

No.	Type	Details (Symptom, Possible Cause, Troubleshooting Procedures)
460	D	Separation power pack output error
		An interrupt checks the status of the power pack every 20 ms. This SC is issued if the BCU detects a short in the power pack 10 times at D(ac).
		<ol style="list-style-type: none"> 1. Damaged insulation on the high-voltage supply cable 2. Damaged insulation around the high-voltage power supply.
		<ul style="list-style-type: none"> ▪ Replace the high-voltage supply cable. ▪ Replace the high-voltage power supply unit. ▪ Replace the IOB.

No.	Type	Details (Symptom, Possible Cause, Troubleshooting Procedures)
490	D	Toner transport motor error
		The LOCK signal is not detected for 2 seconds when the transport motor turns on.
		<ul style="list-style-type: none"> ▪ Toner transport motor overload ▪ Disconnected or broken harness ▪ Defective toner transport motor ▪ Opened +24V fuse on the PSU ▪ Defective interlock switch
		<ol style="list-style-type: none"> 1. Check or replace the harness. 2. Replace the toner transport motor. 3. Replace the +24V fuse on the PSU. 4. Replace the interlock switch.

No.	Type	Details (Symptom, Possible Cause, Troubleshooting Procedures)
491	D	High voltage power: Drum/ development bias output error
		An error signal is detected for 0.2 seconds when charging the drum or development.
		<ul style="list-style-type: none"> ▪ High voltage leak ▪ Broken harness ▪ Defective drum unit or development unit ▪ Defective high voltage supply unit
		<ul style="list-style-type: none"> ▪ Check or replace the harness. ▪ Replace the drum unit or paper transfer unit. ▪ Replace the high voltage supply unit.

No.	Type	Details (Symptom, Possible Cause, Troubleshooting Procedures)
492	C	High voltage power: Image transfer/ paper transfer bias output error
		An error signal is detected for 0.2 seconds when charging the separation, image transfer bet or paper transfer roller.
		<ol style="list-style-type: none"> 1. High voltage leak 2. Broken harness 3. Defective image transfer belt unit or paper transfer unit 4. Defective high voltage supply unit
		<ul style="list-style-type: none"> ▪ Check or replace the harness. ▪ Replace the image transfer belt unit or paper transfer unit. ▪ Replace the high voltage supply unit.

No.	Type	Details (Symptom, Possible Cause, Troubleshooting Procedures)
498	C	Temperature and humidity sensor error 2
		<ul style="list-style-type: none"> ▪ The thermistor output of the temperature sensor was not within the prescribed range (more than 0.5 V to less than 3.0 V). ▪ The thermistor output of the humidity sensor was not within the prescribed range (less than 2.4V).
		<ol style="list-style-type: none"> 1. Temperature and humidity sensor harness disconnected, loose, defective 2. Temperature and humidity sensor defective
		<ul style="list-style-type: none"> ▪ Check the connector and harness. ▪ Replace the temperature/humidity sensor.

6.1.6 SERVICE CALL TABLES - 5

SC5xx: Paper Feed and Fusing

No.	Type	Details (Symptom, Possible Cause, Troubleshooting Procedures)
501	B	Paper Tray 1 error
502	B	Paper Tray 2 error
		<ol style="list-style-type: none"> 1. When the tray lift motor rotates counterclockwise, (if the upper limit is not detected within 10 seconds), the machine asks the user to reset the tray. 2. When the tray lift motor rotates clockwise, (if the upper limit is not detected within 1.5 seconds), the machine asks the user to reset the tray. <p>If one of these conditions occurs three consecutive times, the SC is generated.</p>
		<ul style="list-style-type: none"> ▪ Disconnected or defective paper lift sensor ▪ Disconnected or defective tray lift motor ▪ Defective bottom plate lift mechanism ▪ Too much paper in the tray ▪ Defective IOB
		<ol style="list-style-type: none"> 1. Check if the paper is not loaded too much. 2. Check if the bottom plate smoothly moves up and down manually. 3. Check and / or replace the tray lift motor / paper lift sensor. 4. Replace the IOB.

No.	Type	Details (Symptom, Possible Cause, Troubleshooting Procedures)
503	B	Tray 3 error (Paper Feed Unit or LCT)
		<p>This SC is generated if the following condition occurs.</p> <p>For the paper feed unit: When the tray lift motor is turned on, the upper limit is not detected within 15 seconds</p> <p>For the LCT: The upper or lower limit is not detected within 8 seconds when the tray lift motor is turned on to lift or lower the tray.</p> <p>This SC is generated too if the following condition occurs 3 consecutive times.</p> <p>For the paper feed unit: When the tray lowers, the tray lift sensor does not go off within 1.5 sec.</p> <p>For the LCT: When the main switch is turned on or when the LCT is set, if the end fence is not in the home position (home position sensor ON), the tray lift motor stops.</p> <p>If the upper limit does not go off for 1.5 seconds even the tray lift motor turns on to lower the tray after the upper limit has been detected at power on.</p>
		<p>For the paper feed unit:</p> <ul style="list-style-type: none"> ▪ Defective tray lift motor or connector disconnection ▪ Defective lift sensor or connector disconnection <p>For the LCT:</p> <ol style="list-style-type: none"> 1. Defective stack transport clutch or connector disconnection 2. Defective tray motor or connector disconnection 3. Defective end fence home position sensor or connector disconnection 4. Defective upper limit sensor or connector disconnection 5. Defective tray lift motor or connector disconnection
		<ul style="list-style-type: none"> ▪ Check the cable connections. ▪ Check and/or replace the defective component.

No.	Type	Details (Symptom, Possible Cause, Troubleshooting Procedures)
504	B	Tray 4 error (Paper Feed Unit or LCT)
		<p>This SC is generated if the following condition occurs.</p> <p>For the two-tray paper feed unit When the tray lift motor is turned on, the upper limit is not detected within 15 seconds.</p> <p>For the LCT If the upper or lower limit is not detected within 8 seconds when the tray lift motor is turned on to lift up or lower the tray.</p> <p>This SC is generated too if the following condition occurs 3 consecutive times.</p> <p>For the two-tray paper feed unit When the tray lowers, the tray lift sensor does not go off within 1.5 sec.</p> <p>For the LCT If the upper limit does not go off for 1.5 seconds even the tray lift motor turns on to lower the tray after the upper limit has been detected at power on.</p>
		<p>For the two-tray paper feed unit:</p> <ol style="list-style-type: none"> 1. Defective tray lift motor or connector disconnection 2. Defective lift sensor or connector disconnection <p>For the LCT:</p> <ul style="list-style-type: none"> ▪ Defective stack transport clutch or connector disconnection ▪ Defective tray motor or connector disconnection ▪ Defective end fence home position sensor or connector disconnection ▪ Defective upper limit sensor or connector disconnection ▪ Defective tray lift motor or connector disconnection
		<ol style="list-style-type: none"> 1. Check the cable connections. 2. Check and/or replace the defective component.

No.	Type	Details (Symptom, Possible Cause, Troubleshooting Procedures)
505	B	Tray 5 error (Optional Paper Feed Unit or LCT)
		<p>This SC is generated if the following condition occurs.</p> <p>For the two-tray paper feed unit When the tray lift motor is turned on, the upper limit is not detected within 15 seconds.</p> <p>For the LCT 1200-sheet If the upper or lower limit is not detected within 8 seconds when the tray lift motor is turned on to lift up or lower the tray.</p> <p>This SC is generated too if the following condition occurs 3 consecutive times.</p> <p>For the two-tray paper feed unit When the tray lowers, the tray lift sensor does not go off within 1.5 sec.</p> <p>For the LCT 1200-sheet If the upper limit does not go off for 1.5 seconds even the tray lift motor turns on to lower the tray after the upper limit has been detected at power on.</p>
		<ul style="list-style-type: none"> ▪ Defective tray lift motor or connector disconnection ▪ Defective lift sensor or connector disconnection
		<ol style="list-style-type: none"> 1. Turn the power switch off and on.

Service Call

No.	Type	Details (Symptom, Possible Cause, Troubleshooting Procedures)
520 -01	C	Registration motor error
-02		Paper feed motor error
		The IOB does not receive the lock signal.
		<ul style="list-style-type: none"> ▪ Motor overload ▪ Defective registration motor ▪ Disconnected or broken harness ▪ Defective IOB
		<ol style="list-style-type: none"> 1. Check the cable connection. 2. Replace the harness. 3. Replace the registration motor. 4. Replace the IOB.

No.	Type	Details (Symptom, Possible Cause, Troubleshooting Procedures)
530	D	Fusing fan error
		The IOB does not receive the lock signal 100 ms after turning on the fusing fan.
		<ul style="list-style-type: none"> ▪ Defective fusing fan motor or connector disconnection ▪ Defective IOB
		<ol style="list-style-type: none"> 1. Check the connector and/or replace the fusing fan motor.

No.	Type	Details (Symptom, Possible Cause, Troubleshooting Procedures)
531	D	QSU fan error
		The machine does not detect the fan motor lock signal for 100 ms while the QSU fan turns on.
		<ul style="list-style-type: none"> ▪ Disconnected harness ▪ Overload on the QSU fan motor ▪ Defective QSU fan motor ▪ Defective IOB
		<ol style="list-style-type: none"> 1. Check or replace the harness. 2. Replace the QSU fan. 3. Replace the IOB.

No.	Type	Details (Symptom, Possible Cause, Troubleshooting Procedures)
532 -01	D	Ventilation fan (at the left side of the machine) motor error: front end
-02	D	Ventilation fan (at the left side of the machine) motor error: rear end
		The IOB does not receive the lock signal for 100 ms after turning on the ventilation fan motor in the front end or rear end.
		<ul style="list-style-type: none"> ▪ Defective ventilation fan motor in the front end or rear end ▪ Defective IOB
		<ol style="list-style-type: none"> 1. Replace the ventilation fan (at the left side of the machine) motor in the front end or rear end. 2. Replace the IOB.

No.	Type	Details (Symptom, Possible Cause, Troubleshooting Procedures)
533 -01	D	Second duct fan error 1
		The machine does not detect the fan motor lock signal for 100 ms while the second duct fan turns on.
		<ul style="list-style-type: none"> ▪ Disconnected harness ▪ Overload on the second duct fan motor ▪ Defective second duct motor ▪ Defective IOB
		<ol style="list-style-type: none"> 1. Check or replace the harness. 2. Replace the second duct fan. 3. Replace the IOB.

No.	Type	Details (Symptom, Possible Cause, Troubleshooting Procedures)
534 -01	D	Third duct fan error
		The machine does not detect the fan motor lock signal for 100 ms while the third duct fan turns on.
		<ul style="list-style-type: none"> ▪ Disconnected harness ▪ Overload on the third duct fan motor ▪ Defective third duct motor ▪ Defective IOB
		<ul style="list-style-type: none"> ▪ Check or replace the harness. ▪ Replace the third duct fan. ▪ Replace the IOB.

No.	Type	Details (Symptom, Possible Cause, Troubleshooting Procedures)
535	D	Paper exit fan error
		The machine does not detect the fan motor lock signal for 100 ms while the paper exit fan turns on.

No.	Type	Details (Symptom, Possible Cause, Troubleshooting Procedures)
		<ol style="list-style-type: none"> 1. Disconnected harness 2. Overload on the paper exit fan motor 3. Defective paper exit motor 4. Defective IOB
		<ul style="list-style-type: none"> ▪ Check or replace the harness. ▪ Replace the paper exit fan. ▪ Replace the IOB.

No.	Type	Details (Symptom, Possible Cause, Troubleshooting Procedures)
		AC controller board fan error
		The machine does not detect the fan motor lock signal for 100 ms while the AC controller board fan turns on.
538	D	<ol style="list-style-type: none"> 1. Disconnected harness 2. Overload on the AC controller board fan motor 3. Defective AC controller board fan motor 4. Defective IOB
		<ul style="list-style-type: none"> ▪ Check or replace the harness. ▪ Replace the AC controller board fan. ▪ Replace the IOB.

Trouble-Shooting

No.	Type	Details (Symptom, Possible Cause, Troubleshooting Procedures)
		Fusing/Paper exit motor error
		The IOB does not receive the lock signal 100 ms after turning on the fusing/paper exit motor.
540	D	<ol style="list-style-type: none"> 1. Motor overload 2. Defective fusing/paper exit motor 3. Shorted +24V fuse on the PSU
		<ul style="list-style-type: none"> ▪ Check or replace the harness. ▪ Replace the fusing/paper exit motor. ▪ Replace the +24V fuse on the PSU.

No.	Type	Details (Symptom, Possible Cause, Troubleshooting Procedures)
541	A	Heating roller thermopile error
		The temperature detected by the heating roller thermopile does not reach 0°C for 6 seconds.
		<ul style="list-style-type: none"> ▪ Loose connection of the heating roller thermopile ▪ Defective heating roller thermopile ▪ Defective thermopile
		<ol style="list-style-type: none"> 1. Check if the heating roller thermopile is firmly connected. 2. Replace the heating roller thermopile.

No.	Type	Details (Symptom, Possible Cause, Troubleshooting Procedures)
542	A	Heating roller warm-up error 1
		<ul style="list-style-type: none"> ▪ The heating roller temperature does not reach 80°C for 20 seconds after the inverter turned on. ▪ The center temperature of the heating roller does not reach the ready temperature for 90 seconds after the fusing lamp turned on.
		<ul style="list-style-type: none"> ▪ Dirty or defective thermopile
		<ol style="list-style-type: none"> 1. Check if the heating roller thermopile is firmly connected. 2. Replace the thermopile.

No.	Type	Details (Symptom, Possible Cause, Troubleshooting Procedures)
543	A	Heating roller overheat: Center (software error)
		The detected fusing temperature stays at 215°C for 1 second for 10 consecutive times.
		<ul style="list-style-type: none"> ▪ Defective AC controller board ▪ Defective IOB ▪ Defective IPU
		<ol style="list-style-type: none"> 1. Replace the AC controller board. 2. Replace the IOB. 3. Replace the IPU.

No.	Type	Details (Symptom, Possible Cause, Troubleshooting Procedures)
544	A	Heating roller overheat: Center (hardware error)
		During stand-by mode or a print job, the detected heating roller temperature reaches 220°C.
		<ul style="list-style-type: none"> ▪ Defective AC controller board ▪ Defective IOB ▪ Defective IPU ▪ Defective fusing control system
		Related SC code: SC 543
		<ol style="list-style-type: none"> 1. Replace the AC controller board. 2. Replace the IOB. 3. Replace the IPU. 4. Replace the fusing unit and reset the counter of the fusing unit using SP3-902-014.
		<p>★ Important</p> <ul style="list-style-type: none"> ▪ The fusing unit cannot be used because an abnormal high temperature was detected. ▪ After this SC occurs, the counter reset of the fusing unit should be done manually using SP3-902-014 because the counter reset is not done automatically.

Service Call

No.	Type	Details (Symptom, Possible Cause, Troubleshooting Procedures)
545	A	Fusing Heater error: Center
		The fusing heater keeps full power for 23 seconds or more.
		<ul style="list-style-type: none"> ▪ Defective thermistors ▪ Disconnected cables
		<ol style="list-style-type: none"> 1. Replace the thermistors. 2. Check and replace the cables.

No.	Type	Details (Symptom, Possible Cause, Troubleshooting Procedures)
547	D	Zero cross error
		<ul style="list-style-type: none"> ▪ The zero cross signal is detected three times even though the heater relay is off when turning on the main power. ▪ The zero cross signal is not detected for 3 seconds even though the heater relay is on after turning on the main power or closing the front door. ▪ The detection error occurs twice or more in the 11 zero cross signal detections. This error is defined when the detected zero cross signal is 39 or less.
		<ol style="list-style-type: none"> 1. Defective fusing relay 2. Defective fusing relay circuit 3. Shorted +24V fuse on the PSU 4. Unstable power supply
		<ul style="list-style-type: none"> ▪ Check the power supply source. ▪ Replace the +24V fuse on the PSU. ▪ Replace the AC controller board.

No.	Type	Details (Symptom, Possible Cause, Troubleshooting Procedures)
549	A	Fusing heater connection error
		The heating roller rotation sensor detects the target temperature as 50°C for 5 seconds or more after the fusing/paper exit motor has turned on.
		<ol style="list-style-type: none"> 1. Broken heater cables 2. Defective connectors
		<ul style="list-style-type: none"> ▪ Check the cable connection. ▪ Replace the heater cables.

No.	Type	Details (Symptom, Possible Cause, Troubleshooting Procedures)
551	A	Heating roller thermistor error
		The temperature at the end of the heating roller measured by the heating roller thermistor does not reach 0°C for 7 seconds.
		<ol style="list-style-type: none"> 1. Loose connection of pressure roller thermistor 2. Defective heating roller thermistor
		Related SC code: SC 541
		<ul style="list-style-type: none"> ▪ Check that the heating roller thermistor is firmly connected. ▪ Replace the heating roller thermistor.

No.	Type	Details (Symptom, Possible Cause, Troubleshooting Procedures)
552	A	Heating roller warm-up error 2
		<ol style="list-style-type: none"> 1. The heating roller temperature does not reach 80°C for 20 seconds after the inverter turned on. 2. The temperature at the end of the heating roller does not reach the ready temperature for 89 seconds after the fusing lamp turned on.
		<ul style="list-style-type: none"> ▪ Defective heating roller thermistor ▪ Defective inverter
		Related SC code: SC 542
		<ul style="list-style-type: none"> ▪ Check if the heating roller thermistor is firmly connected. ▪ Replace the inverter.

No.	Type	Details (Symptom, Possible Cause, Troubleshooting Procedures)
553	A	Heating roller overheat: End (software error)
		The detected heating roller temperature stays at 215°C or more for 1 second for 10 consecutive times.
		<ol style="list-style-type: none"> 1. Defective AC controller board 2. Defective IOB 3. Defective IPU
		Related SC code: SC 543
		<ul style="list-style-type: none"> ▪ Replace the AC controller board. ▪ Replace the IOB. ▪ Replace the IPU.

No.	Type	Details (Symptom, Possible Cause, Troubleshooting Procedures)
554	A	Heating roller overheat : End (hardware error)
		The heating roller thermistor detects 220°C or more.
		<ol style="list-style-type: none"> 1. Defective AC controller board 2. Defective IOB 3. Defective IPU 4. Defective fusing control system
		<ul style="list-style-type: none"> ▪ Replace the AC controller board. ▪ Replace the IOB. ▪ Replace the IPU.

No.	Type	Details (Symptom, Possible Cause, Troubleshooting Procedures)
555	A	Fusing Heater error: End
		The fusing heater keeps full power for 19 seconds or more.
		<ol style="list-style-type: none"> 1. Defective thermistors 2. Disconnected cables
		<ul style="list-style-type: none"> ▪ Replace the thermistors. ▪ Check and replace the cables.

No.	Type	Details (Symptom, Possible Cause, Troubleshooting Procedures)
557	C	Zero cross frequency error
		When the zero cross signal is 66 or more and it is detected 10 times or more in 11 detections, the machine determines that input 60 Hz and SC557 occurs.
		<ol style="list-style-type: none"> 1. Noise (High frequency) 2. Defective AC control board
		<ul style="list-style-type: none"> ▪ Check the power supply source. ▪ Replace the AC control board.

Service Call

No.	Type	Details (Symptom, Possible Cause, Troubleshooting Procedures)
559	A	Consecutive fusing jam
		The paper jam counter for the fusing unit reaches 3 times. The paper jam counter is cleared if the paper is fed correctly.
		This SC is activated only when SP1-159-001 is set to "1" (default "0").
		<ul style="list-style-type: none"> ▪ Paper jam in the fusing unit.
		Remove the paper that is jammed in the fusing unit. Then make sure that the fusing unit is clean and has no obstacles in the paper feed path.

No.	Type	Details (Symptom, Possible Cause, Troubleshooting Procedures)
561	A	Pressure roller thermistor error: End
		The temperature at the end of the pressure roller measured by the thermistor does not reach 0°C for 37 seconds.
		<ol style="list-style-type: none"> 1. Loose connection of the thermistor 2. Defective thermistor
		<ul style="list-style-type: none"> ▪ Check if the thermistor is firmly connected. ▪ Replace the thermistor at the end of the pressure roller.

No.	Type	Details (Symptom, Possible Cause, Troubleshooting Procedures)
562	A	Pressure roller thermistor warm-up error: End
		The heating roller rotation sensor does not reach 20°C for 100 seconds after the fusing/paper exit motor has turned on with sheets of 257 mm or more in width.
		<ol style="list-style-type: none"> 1. Dirty thermopile lenses 2. Defective thermistor
		<ul style="list-style-type: none"> ▪ Clean the thermopile lenses. ▪ Replace the thermistor at the end of the pressure roller.

No.	Type	Details (Symptom, Possible Cause, Troubleshooting Procedures)
563	A	Pressure roller overheat: End (software error)
		The detected pressure roller temperature stays at 215°C or more for 1 second for 10 consecutive times.
		<ol style="list-style-type: none"> 1. Defective AC controller board 2. Defective IOB 3. Defective IPU
		<ul style="list-style-type: none"> ▪ Replace the AC controller board. ▪ Replace the IOB. ▪ Replace the IPU.

No.	Type	Details (Symptom, Possible Cause, Troubleshooting Procedures)
564	A	Pressure roller overheat: End (hardware error)
		The thermistor detects 220°C or more.
		<ol style="list-style-type: none"> 1. Defective AC controller board 2. Defective IOB 3. Defective IPU 4. Defective fusing control system
		<ul style="list-style-type: none"> ▪ Replace the AC controller board. ▪ Replace the IOB. ▪ Replace the IPU. ▪ Replace the fusing unit and reset the counter of the fusing unit using SP3-902-014.
		<p>★ Important</p> <ol style="list-style-type: none"> 1. The fusing unit cannot be used because an abnormal high temperature was detected. 2. After this SC occurs, the counter reset of the fusing unit should be done manually using SP3-902-014 because the counter reset is not done automatically.

Service Call

No.	Type	Details (Symptom, Possible Cause, Troubleshooting Procedures)
569 -00	D	Pressure roller contact sensor error
		Pressure roller contact sensor does not detect the pressure roller position three times.
		<ul style="list-style-type: none"> ▪ Broken or defective pressure roller contact sensor ▪ Deformed or broken pressure roller contact sensor feeler ▪ Defective pressure roller contact motor ▪ Defective fusing unit
		<ol style="list-style-type: none"> 1. Check or replace the harness of the pressure roller contact sensor. 2. Replace the pressure roller contact sensor. 3. Replace the pressure roller contact motor.

No.	Type	Details (Symptom, Possible Cause, Troubleshooting Procedures)
569 -01	D	Fusing shutter sensor error
		Fusing shutter plate home position sensor error is detected three consecutive times.
		<ul style="list-style-type: none"> ▪ Defective fusing shutter plate home position sensor ▪ Defective connectors
		<ol style="list-style-type: none"> 1. Check or replace the harness of the fusing shutter plate home position sensor. 2. Replace the fusing shutter plate home position sensor.

No.	Type	Details (Symptom, Possible Cause, Troubleshooting Procedures)
571 -00	A	Pressure roller thermistor error: Center
		The center temperature of the pressure roller measured by the thermistor does not reach 0°C for 37 seconds.
		<ul style="list-style-type: none"> ▪ Loose connection of the thermistor ▪ Defective thermistor
		<ol style="list-style-type: none"> 1. Check if the thermistor is firmly connected. 2. Replace the center thermistor.

No.	Type	Details (Symptom, Possible Cause, Troubleshooting Procedures)
572 -02	A	Pressure roller thermistor warm-up error: Center
		The center temperature of the pressure roller measured by the thermistor does not reach 20°C within 100 seconds after the heater turns on.
		<ul style="list-style-type: none"> ▪ Dirty thermopile lenses ▪ Defective thermistor
		<ol style="list-style-type: none"> 1. Clean the thermopile lenses. 2. Replace the thermistor at the end of the pressure roller.

No.	Type	Details (Symptom, Possible Cause, Troubleshooting Procedures)
573	A	Pressure roller overheat : Center (software error)
		The detected pressure roller temperature stays at 215°C or more for 1 second for 10 consecutive times.
		<ul style="list-style-type: none"> ▪ Defective IOB ▪ Defective IPU
		<ol style="list-style-type: none"> 1. Replace the IOB. 2. Replace the IPU.

No.	Type	Details (Symptom, Possible Cause, Troubleshooting Procedures)
574	A	Pressure roller overheat : Center (hardware error)
		The thermistor detects 220°C or more.
		<ul style="list-style-type: none"> ▪ Defective IOB ▪ Defective IPU ▪ Defective fusing control system
		<ul style="list-style-type: none"> ▪ Replace the IOB. ▪ Replace the IPU.

No.	Type	Details (Symptom, Possible Cause, Troubleshooting Procedures)
581	A	NC sensor broken: Center
		The sensor detects -17°C or less for 100 seconds.
		<ol style="list-style-type: none"> 1. Broken cables of thermopile or thermistor 2. Defective connection of connectors
		<ul style="list-style-type: none"> ▪ Check and replace the connection of the cables and connectors.

No.	Type	Details (Symptom, Possible Cause, Troubleshooting Procedures)
591	A	NC sensor broken: End
		The sensor detects -17°C or less for 100 seconds.
		<ul style="list-style-type: none">▪ Broken cables of thermopile or thermistor▪ Defective connection of connectors
		<ol style="list-style-type: none">1. Check and replace the connection of the cables and connectors.

6.1.7 SERVICE CALL TABLES - 6

SC6xx: Device Communication

No.	Type	Details (Symptom, Possible Cause, Troubleshooting Procedures)
610	D	Mechanical counter error: K
		This SC is only for NA models. The machine detects the mechanical counter error when SP5-987-001 is set to "1 (ON)".
		<ul style="list-style-type: none"> ▪ Disconnected mechanical counter ▪ Defective mechanical counter
		1. Check or replace the mechanical counter.

No.	Type	Details (Symptom, Possible Cause, Troubleshooting Procedures)
620	D	ARDF communication error
		After the ARDF is detected, the break signal occurs or communication timeout occurs.
		<ul style="list-style-type: none"> ▪ Incorrect installation of ARDF ▪ ARDF defective ▪ IPU board defective ▪ External noise
		<ul style="list-style-type: none"> ▪ Check the cable connection of the ARDF. ▪ Shut out the external noise. ▪ Replace the ARDF. ▪ Replace the IPU board.

No.	Type	Details (Symptom, Possible Cause, Troubleshooting Procedures)
621	D	Finisher communication error
622	D	Paper tray unit communication error
		<p>While the IOB communicates with an optional unit, an SC code is displayed if one of following conditions occurs.</p> <ul style="list-style-type: none"> ▪ The IOB receives the break signal which is generated by the peripherals only just after the main switch is turned on. ▪ When the IOB does not receive an OK signal from a peripheral 100ms after sending a command to it. The IOB resends the command. The IOB does not receive an OK signal after sending the command 3 times.
		<ol style="list-style-type: none"> 1. Cable problems 2. IOB problems 3. BCU problems 4. PSU problems in the machine 5. Main board problems in the peripherals
		<ul style="list-style-type: none"> ▪ Check if the cables of peripherals are correctly connected. ▪ Replace the IOB or main board of peripherals. ▪ Replace the BCU if no power is supplied to peripherals.

No.	Type	Details (Symptom, Possible Cause, Troubleshooting Procedures)
623	D	2nd Paper Bank communication error
		<p>This SC is not issued for this machine.</p> <p>When a communication error signal between the 1st paper bank and 2nd paper bank is received.</p>
		<ul style="list-style-type: none"> ▪ Loose or disconnected connector
		Check the connection between the main machine and paper feed unit.

No.	Type	Details (Symptom, Possible Cause, Troubleshooting Procedures)
632	B	Counter device error 1
		After 3 attempts to send a data frame to the optional counter device via the serial communication line, no ACK signal was received within 100 ms.
		<ul style="list-style-type: none"> ▪ Serial line between the optional counter device, the relay board and copier control board is disconnected or damaged. ▪ Make sure that SP5113 is set to enable the optional counter device.
		<ol style="list-style-type: none"> 1. Check if the setting of the SP5113 is correctly set. 2. Check the connection between the main machine and optional counter device.

No.	Type	Details (Symptom, Possible Cause, Troubleshooting Procedures)
633	B	Counter device error 2
		After communication is established, the controller receives the brake signal from the accounting device.
		<ol style="list-style-type: none"> 1. Serial line between the optional counter device, the relay board and copier control board is disconnected or damaged. 2. Make sure that SP5113 is set to enable the optional counter device.
		<ol style="list-style-type: none"> 1. Check if the setting of the SP5113 is correctly set. 2. Check the connection between the main machine and optional counter device.

No.	Type	Details (Symptom, Possible Cause, Troubleshooting Procedures)
634	B	Counter device error 3
		A backup RAM error was returned by the counter device.
		<ol style="list-style-type: none"> 1. Counter device control board defective 2. Backup battery of counter device defective
		Replace the counter device.

No.	Type	Details (Symptom, Possible Cause, Troubleshooting Procedures)
635	B	Counter device error 4
		A backup battery error was returned by the counter device.
		<ul style="list-style-type: none"> ▪ Counter device control board defective ▪ Backup battery of counter device defective
		Replace the counter device.

No.	Type	Details (Symptom, Possible Cause, Troubleshooting Procedures)
636	D	SD Card Error
01	-	Expanded authentication module error
		There is no expanded authentication module in the machine. The SD card or the file of the expanded authentication module is broken.
		There is no DESS module in the machine.
		<ul style="list-style-type: none"> ▪ No expanded authentication module ▪ Defective SD card ▪ Defective file of the expanded authentication module ▪ No DESS module

No.	Type	Details (Symptom, Possible Cause, Troubleshooting Procedures)
		<ol style="list-style-type: none"> 1. Install the expanded authentication module. 2. Install the SD card. 3. Install the DESS module. 4. Set the super service SP as follows and turn the main switch off and on. <ol style="list-style-type: none"> 1. User limitation: Set SP5-401-160 (expanded authentication management setting) to 0. 2. User limitation: Set SP5-401-161 (expanded authentication management detailed setting) to 0. 5. Execute SP5-876-1 (security all clear). If this is a mass-produced machine, replace the NV.
02	-	<p>Version error</p> <p>The version of the expanded authentication module is not correct.</p> <ol style="list-style-type: none"> 1. Incorrect module version <p>Install the correct file of the expanded authentication module.</p>
11	-	<p>OSM user code file error</p> <p>The correct "usercode" file could not be found in the root folder of the SD card because the file is not present, or the existing file is corrupted or the wrong type file.</p> <p>Create the usercode files with the User Setting Tool "IDissuer.exe" and store the files in the root folder of the SD card.</p> <p> Note</p> <ol style="list-style-type: none"> 1. Make sure the eccm.mod file is in the root folder of the SD card.

No.	Type	Details (Symptom, Possible Cause, Troubleshooting Procedures)
637	D	Tracking information notice error
-001		Ttracking application error
		Tracking information is lost.
		The machine failed to give notice of the tracking information to the tracking SDK application. Tracking information is lost, and the machine cannot count correctly.
		1. Turn the main switch off and on.
-002		Management server error
		Tracking information is lost.
		The machine failed to give notice of the tracking information to the management server. Tracking information is lost, and the machine cannot count correctly.
		<ul style="list-style-type: none"> ▪ Turn the main switch off and on.

No.	Type	Details (Symptom, Possible Cause, Troubleshooting Procedures)
640	-	Communication error: Engine → Controller (Check sum error)
		Sum value is added each command frame. Sum check means: STX xx xx xx xx sum ETX → The least significant 7 bits of xx + xx + xx+ xx is compared with the sum Example: STX 80h 81h 82h 83h 06h ETX → 80h + 81h + 82h + 83h = 206h If sum value is 06h, data is correct. This SC is not displayed when it occurs; count is executed only by logging.
		Hard error with PCI
		<ul style="list-style-type: none"> ▪ Turn the main switch off and on.

Trouble-Shooting

Service Call

No.	Type	Details (Symptom, Possible Cause, Troubleshooting Procedures)
641	D	Communication error: Engine → Controller (No response)
		No response from engine to frame after frame sending from controller with RAPI protocol. (No response after 3 attempts of sending every 100 ms)
		Asserts the error detected by the serial driver from PSC module to SRM with RAPI command.
		1. Turn the main switch off and on.

No.	Type	Details (Symptom, Possible Cause, Troubleshooting Procedures)
641	D	Engine serial communication error
		An error occurs in serial communication with engine.
		<ul style="list-style-type: none"> ▪ SC641-001: Timeout error ▪ SC641-002: Retry over ▪ SC641-003: Download error ▪ SC641-004: UART error
		Turn the main switch off and on.

No.	Type	Details (Symptom, Possible Cause, Troubleshooting Procedures)
650	B	Communication error of the remote service modem (Cumin-M)
-01		Authentication error
		The authentication for the Cumin-M fails at a dial up connection.
		<ol style="list-style-type: none"> 1. Incorrect SP settings 2. Disconnected telephone line 3. Disconnected modem board 4. Disconnected wireless LAN card
		<ol style="list-style-type: none"> 1. Check and set the correct user name (SP5-816-156) and password (SP5-816-157).

No.	Type	Details (Symptom, Possible Cause, Troubleshooting Procedures)
-04		Incorrect modem setting
		Dial up fails due to the incorrect modem setting.
		Same as -01
		<ul style="list-style-type: none"> ▪ Check and set the correct AT command (SP5-816-160).
-05		Communication line error
		The supplied voltage is not sufficient due to the defective communication line or defective connection.
		Same as -01
		<ul style="list-style-type: none"> ▪ Consult with the user's local telephone company.
-13		No modem board
		Modem board is not installed even though the setting at Cumin-M (During the operation)
		Same as -01
		<ol style="list-style-type: none"> 1. Install the modem board if it is not installed. 2. Check correct setting value for modem driver (SP5-816-160, SP5-816-165 to 171, SP5-816-188 and 189). 3. Replace the modem board.
-14		The modem board is installed
		The modem board is installed even though the setting at Cumin-N. Or wired/wireless LAN is not working normally.
		Same as -01
		<ul style="list-style-type: none"> ▪ Uninstall the modem board if it is installed. ▪ Check that the wired/wireless LAN is working properly.

Service Call

No.	Type	Details (Symptom, Possible Cause, Troubleshooting Procedures)
651	C	Incorrect dial up connection
-01		Chat program parameter error
-02		Chat program execution error
		An unexpected error occurs when the modem (Cumin-M) tries to call the center with a dial up connection.
		<ul style="list-style-type: none"> ▪ Caused by a software bug
		No action required because this SC does not interfere with operation of the machine.

No.	Type	Details (Symptom, Possible Cause, Troubleshooting Procedures)
652	D	Remote service ID2 mismatching
		ID2 for @Remote certification is mismatching between the controller board and NVRAM.
		<ol style="list-style-type: none"> 1. Used controller board installed 2. Used NVRAM installed An unexpected error occurs when the modem (Embedded RCG-M) tries to call the center with a dial up connection.
		<ul style="list-style-type: none"> ▪ Install the correct controller board or anew controller board. ▪ Install the correct NVRAM or new NVRAM.

No.	Type	Details (Symptom, Possible Cause, Troubleshooting Procedures)
653	D	Incorrect remote service ID2
		ID2 stored in the NVRAM is incorrect.
		<ol style="list-style-type: none"> 1. Used NVRAM installed An unexpected error occurs when the modem (Embedded RCG-M) tries to call the center with a dial up connection
		<ul style="list-style-type: none"> ▪ Clear the ID2 in the NVRAM, and then input a correct ID2.

No.	Type	Details (Symptom, Possible Cause, Troubleshooting Procedures)
670	D	Engine start up error
		The BCU fails to respond within the prescribed time when the machine is turned on.
		Connections between BCU and controller board are loose, disconnected, or damaged.
		<ol style="list-style-type: none"> 1. Replace the BCU 2. Replace the controller board

No.	Type	Details (Symptom, Possible Cause, Troubleshooting Procedures)
672	D	Controller start up error
		<ul style="list-style-type: none"> ▪ After the machine is powered on, the communication between the controller and the operation panel is not established, or communication with controller is interrupted after a normal startup. ▪ After startup reset of the operation panel, the attention code (FDH) or the attention acknowledge code (FEH) is not sent from the controller within 30 seconds. ▪ After the controller issues a command to check the communication line with the controller at 30-second intervals, the controller fails to respond twice.
		<ol style="list-style-type: none"> 1. Controller stalled 2. Controller board installed incorrectly 3. Controller board defective 4. Operation panel connector loose or defective 5. The controller is not completely shut down when the main switch is turned off.
		<ul style="list-style-type: none"> ▪ Check the setting of SP5-875-001. If the setting is set to "1 (OFF)", change it to "0 (ON)"

No.	Type	Details (Symptom, Possible Cause, Troubleshooting Procedures)
681	D	Toner bottle ID: Communication error
		<ol style="list-style-type: none"> 1. Communication error occurs when the toner bottle ID starts to communicate with the toner bottle ID receptor. 2. Retry of toner bottle ID communication fails three times after the machine has detected the toner bottle ID communication error.
		<ul style="list-style-type: none"> ▪ Defective toner bottle ID reader and writer ▪ Disconnected ASAP I/F ▪ No memory chip on the toner cartridge ▪ Noise
		<ol style="list-style-type: none"> 1. Replace the toner bottle detection board. 2. Replace the toner cartridge.

No.	Type	Details (Symptom, Possible Cause, Troubleshooting Procedures)
682	D	Memory chip at TD sensor: Communication error
		<p>Retry of memory chip communication fails three times after the machine has detected the memory chip communication error.</p>
		<ul style="list-style-type: none"> ▪ Damaged memory chip data ▪ Disconnected inter face ▪ No memory chip on the development unit ▪ Noise
		<ul style="list-style-type: none"> ▪ Replace the PCDU. ▪ Replace the BCU.

No.	Type	Details (Symptom, Possible Cause, Troubleshooting Procedures)
687	D	Memory address command error
		The BCU does not receive a memory address command from the controller 120 seconds after paper is in the position for registration.
		<ol style="list-style-type: none"> 1. Loose connection 2. Defective controller 3. Defective BCU
		<ul style="list-style-type: none"> ▪ Check if the controller is firmly connected to the BCU. ▪ Replace the controller. ▪ Replace the BCU.

6.1.8 SERVICE CALL TABLES - 7

SC7xx: Peripherals

⇒ **NOTE:** SC720 and SC722-24, 30, 41, 42, 44, 70 and 71 share the same description, except SC720 is for 1000-Sheet Booklet Finisher and SC722 is for 1000-Sheet Finisher.

No.	Type	Details (Symptom, Possible Cause, Troubleshooting Procedures)
720 or 722 -24	B	Finisher exit guide plate motor error
		After moving away from the guide plate position sensor, the exit guide is not detected at the home position within the prescribed time. The 1st detection failure issues a jam error, and the 2nd failure issues this SC code.
		<ul style="list-style-type: none"> ▪ Guide plate motor disconnected, defective ▪ Guide plate motor overloaded due to obstruction ▪ Guide plate position sensor disconnected, defective
		<ul style="list-style-type: none"> ▪ Check the connections and cables for the components mentioned above. ▪ Check for blockages in the guide plate motor mechanism. ▪ Replace the guide plate position sensor and/or guide plate motor ▪ Replace the finisher main board.

Trouble-Shooting

No.	Type	Details (Symptom, Possible Cause, Troubleshooting Procedures)
720 -25	B	Finisher punch motor error
		The punch HP sensor is not activated within the specified time after the punch motor turned on. The 1st detection failure issues a jam error, and the 2nd failure issues this SC code.
		<ol style="list-style-type: none"> 1. Punch HP sensor disconnected, defective 2. Punch motor disconnected or defective 3. Punch motor overload due to obstruction
		<ul style="list-style-type: none"> ▪ Check the connections and cables for the punch motor and HP sensor. ▪ Check for blockages in the punch motor mechanism. ▪ Replace the punch HP sensor and/or punch motor ▪ Replace the finisher main board.

No.	Type	Details (Symptom, Possible Cause, Troubleshooting Procedures)
⇒ 720 or 722 -30	B	Finisher (D589 or D588) jogger motor error
		The jogger fences move out of the home position but the HP sensor output does not change within the specified number of pulses. The 1st failure issues an original jam message, and the 2nd failure issues this SC code.
		<ul style="list-style-type: none"> ▪ Jogger HP sensor disconnected, defective ▪ Jogger motor disconnected, defective ▪ Jogger motor overloaded due to obstruction ▪ Finisher main board and jogger motor
		<ul style="list-style-type: none"> ▪ Check the connections and cables for the components mentioned above. ▪ Check for blockages in the jogger motor mechanism. ▪ Replace the jogger HP sensor and/or jogger motor. ▪ Replace the finisher main board.

No.	Type	Details (Symptom, Possible Cause, Troubleshooting Procedures)
⇒ 720 or 722 -41	B	Stack feed-out motor error
		1. The stack feed-out HP sensor does not detect the home position of the stack feed-out belt 3000ms after the stack feed-out belt has moved to its home position. 2. The stack feed-out HP sensor does not turn off 200 ms after the stack feed-out belt has moved from its home position. 3. The 1st detection failure causes a jam error, and the 2nd failure causes this SC code.
		<ul style="list-style-type: none"> ▪ Defective stack feed-out HP sensor ▪ Overload on the stack feed-out motor ▪ Defective stack feed-out motor ▪ Defective main board ▪ Disconnected or defective harness
		1. Check the connections and cables for the components mentioned above. 2. Check for blockages in the stack feed-out motor mechanism. 3. Replace the stack feed-out HP sensor and/or stack feed-out motor. 4. Replace the finisher main board.

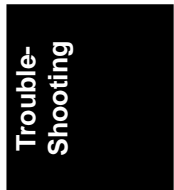



No.	Type	Details (Symptom, Possible Cause, Troubleshooting Procedures)
720 or 722 -44	B	Finisher corner stapler motor error
		<p>The 1st detection failure issues a jam error, and the 2nd failure issues this SC code.</p> <p>For the 2000/3000-sheet (booklet) finisher</p> <ul style="list-style-type: none"> ▪ Staple movement is not finished after a certain time. <p>For the 1000-sheet finisher</p> <ol style="list-style-type: none"> 1. The stapler motor does not switch off within the prescribed time after operating. 2. The HP sensor of the staple unit does not detect the home position after the staple unit moves to its home position. 3. The HP sensor of the staple unit detects the home position after the staple unit moves from its home position.
		<ul style="list-style-type: none"> ▪ Staple jam ▪ Motor overload ▪ Defective stapler motor
		<ol style="list-style-type: none"> 1. Check the connections and cables for the components mentioned above. 2. Replace the HP sensor and/or stapler motor 3. Replace the finisher main board.



No.	Type	Details (Symptom, Possible Cause, Troubleshooting Procedures)
720 -44	B	Finisher corner stapler motor error
		<p>The 1st detection failure issues a jam error, and the 2nd failure issues this SC code.</p> <p>For the 2000/3000-sheet (booklet) finisher</p> <ul style="list-style-type: none"> ▪ Staple movement is not finished after a certain time. <p>For the 1000-sheet finisher</p> <ol style="list-style-type: none"> 1. The stapler motor does not switch off within the prescribed time after operating. 2. The HP sensor of the staple unit does not detect the home position after the staple unit moves to its home position. 3. The HP sensor of the staple unit detects the home position after the staple unit moves from its home position.
		<ul style="list-style-type: none"> ▪ Staple jam ▪ Motor overload ▪ Defective stapler motor
		<ol style="list-style-type: none"> 1. Check the connections and cables for the components mentioned above. 2. Replace the HP sensor and/or stapler motor 3. Replace the finisher main board.

No.	Type	Details (Symptom, Possible Cause, Troubleshooting Procedures)
720 -52	B	Finisher folder plate motor error
		The folder plate moves but is not detected at the home position within the specified time. The 1st detection failure issues a jam error, and the 2nd failure issues this SC code.
		<ul style="list-style-type: none"> ▪ Folder plate HP sensor disconnected, defective ▪ Folder plate motor disconnected, defective ▪ Folder plate motor overloaded due to obstruction.
		<ol style="list-style-type: none"> 1. Check the connections and cables for the folder plate motor and HP sensor. 2. Check for blockages in the folder plate motor mechanism. 3. Replace the folder plate HP sensor and/or folder plate motor 4. Replace the finisher main board.

No.	Type	Details (Symptom, Possible Cause, Troubleshooting Procedures)
720 -53	B	Fold unit bottom fence motor error
		The bottom fence of the fold unit moves but is not detected at the home position within the specified time. The 1st detection failure issues a jam error, and the 2nd failure issues this SC code.
		<ul style="list-style-type: none"> ▪ Motor harness disconnected, loose, defective ▪ Defective motor
		<ol style="list-style-type: none"> 1. Check the connections to the fold unit bottom fence motor. 2. Replace the fold unit bottom fence motor.

No.	Type	Details (Symptom, Possible Cause, Troubleshooting Procedures)
720 -58	B	Clamp roller retraction motor error 1
		The clamp roller retraction motor moves but is not detected at the home position within the specified time. The 1st detection failure issues a jam error, and the 2nd failure issues this SC code.
		<ul style="list-style-type: none"> ▪ Motor harness disconnected, loose, defective ▪ Defective motor
		<ol style="list-style-type: none"> 1. Check the connections to the clamp roller retraction motor. 2. Replace the clamp roller retraction motor.

No.	Type	Details (Symptom, Possible Cause, Troubleshooting Procedures)
720 -59	B	Clamp roller retraction motor error 2
		The drive roller swing motor moves but is not detected at the home position within the specified time. The 1st detection failure issues a jam error, and the 2nd failure issues this SC code.
		<ul style="list-style-type: none"> ▪ Motor harness disconnected, loose, defective ▪ Defective motor
		<ol style="list-style-type: none"> 1. Check the connections to the drive roller swing motor. 2. Replace the drive roller swing motor.

No.	Type	Details (Symptom, Possible Cause, Troubleshooting Procedures)
⇒ 720 or 722 -70	B	1000/2000/3000-sheet (booklet) finisher: Tray lift motor error
		The 1st detection failure issues a jam error, and the 2nd failure issues this SC code. The upper tray paper height sensor does not change its status with the specified time after the tray raises or lowers.
		<ul style="list-style-type: none"> ▪ Motor overload ▪ Loose connection of the shift tray motor ▪ Defective shift tray motor
		<ol style="list-style-type: none"> 1. Check the connections to the shift tray motor. 2. Replace the shift tray motor.

No.	Type	Details (Symptom, Possible Cause, Troubleshooting Procedures)
⇒ 720 or 722 -71	B	Finisher Tray 1 shift motor error
		The shift roller HP sensor of the upper tray does not activate within the prescribed time after the shift tray starts to move toward or away from the home position. The 1st detection failure issues a jam error, and the 2nd failure issues this SC code.
		<ul style="list-style-type: none"> ▪ Shift tray HP sensor of the upper tray disconnected, defective ▪ Shift tray motor of the upper tray is disconnected, defective ▪ Shift tray motor of the upper tray overloaded due to obstruction
		<ol style="list-style-type: none"> 1. Check the connections and cables for the components mentioned above. 2. Check for blockages in shift motor mechanism. 3. Replace the shift tray HP sensor and/or shift motor 4. Replace the finisher main board.

No.	Type	Details (Symptom, Possible Cause, Troubleshooting Procedures)
720 -80	B	Punch movement motor error
		The punch unit moves but is not detected at the home position within the specified time. The 1st detection failure issues a jam error, and the 2 nd failure issues this SC code.
		<ul style="list-style-type: none"> ▪ Motor harness disconnected, loose, defective ▪ Defective motor
		<ol style="list-style-type: none"> 1. Check the connections to the punch movement motor. 2. Replace the punch movement motor

No.	Type	Details (Symptom, Possible Cause, Troubleshooting Procedures)
720 -81	B	Paper position sensor slide motor error
		The paper position sensor moves but is not detected at the home position within the specified time. The 1st detection failure issues a jam error, and the 2nd failure issues this SC code.
		<ul style="list-style-type: none"> ▪ Motor harness disconnected, loose, defective ▪ Defective motor
		<ol style="list-style-type: none"> 1. Check the connections to the paper position sensor slide motor. 2. Replace the paper position sensor slide motor.

⇒ **NOTE:** SC720 and SC722-24, 30, 41, 42, 44, 70 and 71 share the same description, except SC720 is for 1000-Sheet Booklet Finisher and SC722 is for 1000-Sheet Finisher.

No.	Type	Details (Symptom, Possible Cause, Troubleshooting Procedures)
722 -10	B	Paper feed motor error: proof tray
-14		Paper feed motor error: lower tray
-17		Paper feed motor error: inner tray
		Motor driver error signal is output.
		<ul style="list-style-type: none"> ▪ Motor harness disconnected, loose, defective ▪ Defective motor ▪ Overload on the motor
		<ol style="list-style-type: none"> 1. Check the connections to the paper feed motor. 2. Replace the paper feed motor.

No.	Type	Details (Symptom, Possible Cause, Troubleshooting Procedures)
722 -30	B	Finisher (D588) jogger motor error
		The jogger fences move out of the home position but the HP sensor output does not change within the specified number of pulses. The 1st failure issues an original jam message, and the 2nd failure issues this SC code.
		<ul style="list-style-type: none"> ▪ Jogger HP sensor disconnected, defective ▪ Jogger motor disconnected, defective ▪ Jogger motor overloaded due to obstruction ▪ Finisher main board and jogger motor
		<ul style="list-style-type: none"> ▪ Check the connections and cables for the components mentioned above. ▪ Check for blockages in the jogger motor mechanism. ▪ Replace the jogger HP sensor and/or jogger motor. ▪ Replace the finisher main board.

No.	Type	Details (Symptom, Possible Cause, Troubleshooting Procedures)
724 -31	B	Finisher front jogger motor error (D585)
		The jogger fences of the 500-sheet finisher (D585) move out of the home position but the HP sensor output does not change within the specified number of pulses. The 1st failure issues an original jam message, and the 2nd failure issues this SC code.
		<ul style="list-style-type: none"> ▪ Jogger HP sensor disconnected, defective ▪ Front jogger motor disconnected, defective ▪ Front jogger motor overloaded due to obstruction ▪ Finisher main board and front jogger motor defective
		<ul style="list-style-type: none"> ▪ Check or replace the harness. ▪ Check for blockages in the front jogger motor mechanism. ▪ Replace the jogger HP sensor. ▪ Replace the front jogger motor. ▪ Replace the finisher main board.

No.	Type	Details (Symptom, Possible Cause, Troubleshooting Procedures)
724 -32	B	Finisher rear jogger motor error (D585)
		The jogger fences of the 500-sheet finisher (D585) move out of the home position but the HP sensor output does not change within the specified number of pulses. The 1st failure issues an original jam message, and the 2nd failure issues this SC code.
		<ol style="list-style-type: none"> 1. Jogger HP sensor disconnected, defective 2. Rear Jogger motor disconnected, defective 3. Rear Jogger motor overloaded due to obstruction 4. Finisher main board and rear jogger motor defective
		<ul style="list-style-type: none"> ▪ Check or replace the harness. ▪ Check for blockages in the rear jogger motor mechanism. ▪ Replace the jogger HP sensor. ▪ Replace the rear jogger motor. ▪ Replace the finisher main board.

No.	Type	Details (Symptom, Possible Cause, Troubleshooting Procedures)
724 -33	B	Positioning roller arm motor error
		The positioning roller HP sensor does not turn on or off for a certain time at power-on. The positioning roller HP sensor does not turn on or off for a certain time when the positioning roller returns to its home position from the lower position. The 1st detection failure causes a jam error, and the 2nd failure causes this SC code.
		<ul style="list-style-type: none"> ▪ Disconnected or defective harness ▪ Overload on the positioning roller arm motor ▪ Defective positioning roller arm motor ▪ Defective positioning roller HP sensor
		<ol style="list-style-type: none"> 1. Check or replace the harness. 2. Check for blockages in the positioning roller arm mechanism. 3. Replace the positioning roller arm motor. 4. Replace the positioning roller HP sensor.

No.	Type	Details (Symptom, Possible Cause, Troubleshooting Procedures)
724 -38	B	Stack pressure solenoid error
		The stack pressure solenoid in the finisher is not operating.
		<ul style="list-style-type: none"> ▪ Solenoid harness loose, broken ▪ Solenoid obstructed ▪ Stack height sensor dirty, harness loose, broke ▪ Solenoid defective ▪ Stack height sensor defective
		<ol style="list-style-type: none"> 1. Check or replace the solenoid harness. 2. Check for blockages in the stack pressure mechanism. 3. Replace the stack height sensor.

No.	Type	Details (Symptom, Possible Cause, Troubleshooting Procedures)
724 -41	B	Stack feed-out motor error
		<p>The stack feed-out HP sensor does not detect the home position of the stack feed-out belt for a certain time after the stack feed-out belt has moved to its home position.</p> <p>The stack feed-out HP sensor does not turn off for a certain time after the stack feed-out belt has moved from its home position.</p> <p>The 1st detection failure causes a jam error, and the 2nd failure causes this SC code.</p>
		<ul style="list-style-type: none"> ▪ Defective stack feed-out HP sensor ▪ Overload on the stack feed-out motor ▪ Defective stack feed-out motor ▪ Defective main board ▪ Disconnected or defective harness
		<ol style="list-style-type: none"> 1. Check or replace the harness. 2. Check for blockages in the stack feed-out mechanism. 3. Replace the stack feed-out HP sensor. 4. Replace the stack feed-out motor. 5. Replace the main board.

No.	Type	Details (Symptom, Possible Cause, Troubleshooting Procedures)
724 -44	B	Finisher corner stapler motor error
		The 1st detection failure issues a jam error, and the 2nd failure issues this SC code. <ul style="list-style-type: none"> ▪ The stapler HP sensor does not detect "ON"/"OFF" signal even the stapler moves from the "OFF"/"ON" position for 0.6 seconds. ▪ The stapler HP sensor does not detect "ON" when a stapling job is commanded or the stapler moves.
		<ol style="list-style-type: none"> 1. Staple jam 2. Motor overload 3. Defective stapler motor
		<ul style="list-style-type: none"> ▪ Check the connections and cables for the components mentioned above. ▪ Replace the HP sensor and/or stapler motor ▪ Replace the finisher main board.

No.	Type	Details (Symptom, Possible Cause, Troubleshooting Procedures)
724 -42	B	Finisher stapler movement motor error
		<ol style="list-style-type: none"> 1. The stapler HP sensor does not detect "OFF" signal even the stapler moves from the "ON" position for 0.35 seconds. 2. The stapler HP sensor does not detect "ON" signal even the stapler moves from the "OFF" position for 5.5 seconds.
		<ul style="list-style-type: none"> ▪ Motor overload ▪ Loose connection of the stapler home position sensor ▪ Loose connection of the stapler movement motor ▪ Defective stapler home position sensor ▪ Defective stapler movement motor
		<ol style="list-style-type: none"> 1. Check the connection of the stapler movement motor. 2. Check the connection of the stapler home position sensor. 3. Replace the stapler home position sensor. 4. Replace the stapler movement motor.

No.	Type	Details (Symptom, Possible Cause, Troubleshooting Procedures)
724 -70	B	500-sheet finisher: Tray lift motor error
		<ul style="list-style-type: none"> ▪ Motor overload ▪ Loose connection of the shift tray motor ▪ Defective shift tray motor
		<ul style="list-style-type: none"> ▪ Check the connections to the tray lift motor. ▪ Replace the tray lift motor.

No.	Type	Details (Symptom, Possible Cause, Troubleshooting Procedures)
724 -85	B	Upper limit switch error (D585)
		The upper limit switch of the 500-sheet finisher (D585) is pushed due to tray lift error or some problems.
		<ol style="list-style-type: none"> 1. Upper limit switch pulled up 2. Defective upper limit switch
		<ul style="list-style-type: none"> ▪ Check the harness. ▪ Check for blockage around the upper limit switch. ▪ Replace the upper limit switch.

No.	Type	Details (Symptom, Possible Cause, Troubleshooting Procedures)
770	B	Shift motor error
		The shift motor HP sensor does not detect any change for 1.86 seconds after the shift motor has turned on at power on or during its operation.
		<ol style="list-style-type: none"> 1. Defective shift motor 2. Defective shift motor HP sensor
		<ol style="list-style-type: none"> 1. Check the connections to the shift motor and the shift motor HP sensor. 2. Replace the shift motor or the shift motor HP sensor.

Service Call

No.	Type	Details (Symptom, Possible Cause, Troubleshooting Procedures)
791	D	Bridge unit error
		The machine recognizes the finisher, but does not recognize the bridge unit.
		<ul style="list-style-type: none"> ▪ Defective connector ▪ Broken harness
		<ol style="list-style-type: none"> 1. Check the connections between the bridge unit and the machine. 2. Install a new bridge unit.

No.	Type	Details (Symptom, Possible Cause, Troubleshooting Procedures)
792	B	Finisher error
		The machine does not recognize the finisher, but recognizes the bridge unit.
		<ul style="list-style-type: none"> ▪ Defective connector ▪ Defective harness ▪ Incorrect installation
		<ul style="list-style-type: none"> ▪ Check the connections between the finisher and the machine. ▪ Install a new finisher.

6.1.9 SERVICE CALL TABLES - 8

SC8xx: Overall System

No.	Type	Details (Symptom, Possible Cause, Troubleshooting Procedures)
816	D	Energy saving I/O sub-system error
		The energy saving I/O sub-system detects an error.
		1. Controller board defective
		Replace the controller board.

No.	Type	Details (Symptom, Possible Cause, Troubleshooting Procedures)
817	D	Monitor error
		This is a file detection and electronic file signature check error when the boot loader attempts to read the self-diagnostic module, system kernel, or root system files from the OS Flash ROM, or the items on the SD card in the controller slot are false or corrupted.
		<ul style="list-style-type: none"> ▪ OS Flash ROM data defective ▪ SD card data defective
		<ol style="list-style-type: none"> 1. Change the controller firmware. 2. Use another SD card.

Service Call

No.	Type	Details (Symptom, Possible Cause, Troubleshooting Procedures)
819	D	Fatal kernel error
		Due to a control error, a RAM overflow occurred during system processing. One of the following messages was displayed on the operation panel.
[0x5032]		"0x455252nn" → HAIC-P2 error
[0x5245]		"0x53554D45" → Link up error
[0x5355]		"0x5350454E44" → L2 status time out
[0x696e]		"0x69742064" → gwinit process ending
[0x766d]		"0x5f706167" → VM is full
----		Other error cord → Error in the OS
		<ul style="list-style-type: none"> ▪ System program defective ▪ Controller board defective ▪ Optional board defective
		1. Replace the controller firmware.

No.	Type	Details (Symptom, Possible Cause, Troubleshooting Procedures)
821	D	Self-diagnostics error: ASIC
	[0B00]	ASIC register check error
		The write-&-verify check has occurred in the ASIC.
		Defective ASIC device
		<ul style="list-style-type: none"> ▪ Replace the controller board.
	[0B06]	ASIC detection error
		The I/O ASIC for system control is not detected.
		<ol style="list-style-type: none"> 1. Defective ASIC 2. Defective North Bridge and PCII/F
		<ul style="list-style-type: none"> ▪ Replace the controller board.

No.	Type	Details (Symptom, Possible Cause, Troubleshooting Procedures)
822	B	Self-diagnostics error: HDD
	[3003]	HDD timeout
		Check performed only when HDD is installed:
		<ol style="list-style-type: none"> 1. HDD device busy for over 31 seconds. 2. After a diagnostic command is set for the HDD, but the device remains busy for over 6 seconds.
		<ul style="list-style-type: none"> ▪ Defective HDD device ▪ Defective HDD connector ▪ Defective ASIC device
		<ol style="list-style-type: none"> 1. Replace or uninstall the HDD device. 2. Replace the HDD connector. 3. Replace the controller board.

No.	Type	Details (Symptom, Possible Cause, Troubleshooting Procedures)
[3004]		Diagnostics command error
		Result of the issuance of diagnostic command is error.
		<ul style="list-style-type: none"> ▪ Defective HDD device
		<ol style="list-style-type: none"> 1. Replace or remove the HDD device.
[3013]		HDD timeout (First machine)
		<p>HDD device busy for over 31 seconds. Mandolin is not detected. After a diagnostic command is set for the HDD, but the device remains busy for over 6 seconds.</p>
		<ul style="list-style-type: none"> ▪ Defective HDD device ▪ Defective HDD connector ▪ Defective ASIC device
		<ol style="list-style-type: none"> 1. Replace or remove the HDD device. 2. Replace the HDD connector 3. Replace the controller board
[3014]		Diagnostics command error (First machine)
		<p>Result of the issuance of diagnostic command is error. Mandolin is not detected. A w/r/c error of the HDD register</p>
		<ul style="list-style-type: none"> ▪ Defective HDD device
		<ol style="list-style-type: none"> 1. Replace the HDD device.

No.	Type	Details (Symptom, Possible Cause, Troubleshooting Procedures)
823	B	Self-diagnostics error: NIC
	[6101]	MAC address check sum error
		The result of the MAC address check sum does not match the check sum stored in ROM.
		<ul style="list-style-type: none"> ▪ Defective SEEP ROM ▪ Defective I2C bus (connection)
		1. Replace the controller board.
	[6104]	PHY IC error
		The PHY IC on the controller cannot be correctly recognized.
		<ul style="list-style-type: none"> ▪ Defective PHY chip ▪ Defective ASIC MII I/F
		1. Replace the controller board.
	[6105]	PHY IC loop-back error
		An error occurred during the loop-back test for the PHY IC on the controller.
		<ul style="list-style-type: none"> ▪ Defective PHY chip ▪ Defective MAC of ASIC (SIMAC/COMIC/CELLO) ▪ Defective I/F with the PHY board ▪ Defective solder on the PHY board
		1. Replace the controller board.

Service Call

No.	Type	Details (Symptom, Possible Cause, Troubleshooting Procedures)
824	D	Self-diagnostics error: NVRAM (resident)
	[1401]	NVRAM verify error
		NVRAM device does not exist or NVRAM device is damaged.
		<ul style="list-style-type: none"> ▪ No NVRAM device ▪ Destructive NVRAM device ▪ NVRAM backup battery exhausted ▪ NVRAM socket damaged
		1. Replace the NVRAM device.

No.	Type	Details (Symptom, Possible Cause, Troubleshooting Procedures)
833	D	Self-diagnostic error: Engine I/F ASIC
	[0F30]	ASIC (Mandolin) for engine control could not be detected. After the PCI configuration, the device ID for the ASIC could not be checked.
		<ul style="list-style-type: none"> ▪ Defective ASIC (Mandolin) for system control ▪ Defective North Bridge and AGPI/F
		1. Replace the Engine I/F board (mother board).
	[50B1]	Could not initialize or read the bus connection.
		<ul style="list-style-type: none"> ▪ Defective connection bus ▪ Defective SSCG
		1. Replace the Engine I/F board (mother board).
	[50B2]	Value of the SSCG register is incorrect.
		<ul style="list-style-type: none"> ▪ Defective connection bus ▪ Defective SSCG
		1. Replace the Engine I/F board (mother board).

No.	Type	Details (Symptom, Possible Cause, Troubleshooting Procedures)
834	D	Self-diagnostic error: Optional memory
	[5101]	An error occurs after write/verify check for optional RAM on the engine I/F board (mother board).
		<ul style="list-style-type: none"> ▪ Defective memory device
		1. Replace the Engine I/F board (mother board).

No.	Type	Details (Symptom, Possible Cause, Troubleshooting Procedures)
838	D	Self-diagnostic error: Clock generator
	[2701]	A verify error occurred when setting data was read from the clock generator via the I2C bus
		<ul style="list-style-type: none"> ▪ Defective clock generator ▪ Defective I2C bus ▪ Defective I2C port on the CPU
		1. Replace the controller board.

No.	Type	Details (Symptom, Possible Cause, Troubleshooting Procedures)
		EEPROM access error
840	D	During the I/O processing, reading error is occurred. The 3rd reading failure issues this SC code.
		During the I/O processing, writing error is occurred.
		<ul style="list-style-type: none"> ▪ Defective EEPROM
		1. Replace the EEPROM.

No.	Type	Details (Symptom, Possible Cause, Troubleshooting Procedures)
841	D	EEPROM read error
		Mirrored data of the EEPROM is different from the original data in EEPROM.
		<ul style="list-style-type: none"> ▪ Data in the EEPROM is overwritten for some reason.
		1. Turn the main switch off and on.

No.	Type	Details (Symptom, Possible Cause, Troubleshooting Procedures)
842	C	Nand-Flash updating verification error
		A writing error for the module written in Nand-Flash occurs when the remote ROM and ROM are updating.
		<ul style="list-style-type: none"> ▪ Damaged Nand-Flash
		1. Turn the main switch off and on.

No.	Type	Details (Symptom, Possible Cause, Troubleshooting Procedures)
850	B	Network I/F error
		<ul style="list-style-type: none"> ▪ Inoperative
		1. Turn the main switch off and on.

No.	Type	Details (Symptom, Possible Cause, Troubleshooting Procedures)
853	B	Bluetooth device connection error (The Bluetooth interface unit was installed while the machine was turned on.)
		The Bluetooth interface unit was installed while the machine was turned on.
		Turn off the main power switch, and then confirm that the Bluetooth interface unit was installed correctly. And then, turn on the main power switch again.

No.	Type	Details (Symptom, Possible Cause, Troubleshooting Procedures)
854	B	Bluetooth device removed (The Bluetooth interface unit was removed while the machine was turned on.)
		The Bluetooth interface unit was removed while the machine was turned on.
		Turn off the main power switch, and then confirm that the Bluetooth interface unit was installed correctly. And then, turn on the main power switch again.

No.	Type	Details (Symptom, Possible Cause, Troubleshooting Procedures)
855	B	Hardware Problem:wireless LAN board
		The wireless LAN board can be accessed, but an error was detected.
		<ul style="list-style-type: none"> ▪ Loose connection ▪ Defective wireless LAN card
		<ol style="list-style-type: none"> 1. Make sure that the Wireless LAN connection is good 2. Replace the wireless LAN card.

No.	Type	Details (Symptom, Possible Cause, Troubleshooting Procedures)
858	A	Data encryption conversion error
		A serious error occurs when data is encrypted to update an encryption key.
-00		Encryption key acquisition error: The controller fails to get a new encryption key.
		<ul style="list-style-type: none"> ▪ Defective controller board <ol style="list-style-type: none"> 1. Replace the controller board.
-01		Encryption key setting for HDD error: The controller fails to copy a new encryption key to the HDD.

No.	Type	Details (Symptom, Possible Cause, Troubleshooting Procedures)
		<ul style="list-style-type: none"> ▪ Defective SATA chip on the controller board <ol style="list-style-type: none"> 1. Turn the machine power off and on. 2. If the error reoccurs, replace the controller board.
-02		NVRAM data encryption error 1: An error occurs while the NVRAM data is encrypted.
		<ul style="list-style-type: none"> ▪ Defective SATA chip on the controller board <ol style="list-style-type: none"> 1. Replace the NVRAM.
-30		NVRAM data encryption error 2: An error occurs before the NVRAM data is encrypted.
		<ul style="list-style-type: none"> ▪ Defective controller board <ol style="list-style-type: none"> 1. Turn the machine power off and on. 2. If the error reoccurs, replace the controller board.
-31		Other error: A serious error occurs while the data is encrypted.
		Same as SC991

No.	Type	Details (Symptom, Possible Cause, Troubleshooting Procedures)
859	B	HDD data encryption error
		Encryption of data on the hard disk failed.
-08		HDD check error: The HDD is not correctly installed.
		<ul style="list-style-type: none"> ▪ No HDD installed ▪ Unformatted HDD ▪ The encryption key on the controller is different from the one on the HDD <ol style="list-style-type: none"> 1. Install the HDD correctly. 2. Initialize the HDD.
-09		Power failure during the data encryption: The data encryption (NVRAM and HDD) has not been completed.

No.	Type	Details (Symptom, Possible Cause, Troubleshooting Procedures)
		<ul style="list-style-type: none"> ▪ Power failure during the data encryption <ol style="list-style-type: none"> 1. Initialize the HDD.
-10		Data read/write error: The DMAC error is detected twice or more.
		Same as SC863.

No.	Type	Details (Symptom, Possible Cause, Troubleshooting Procedures)
860	D	HDD startup error at main power on
		HDD is connected but a driver error is detected. The driver does not respond with the HDD within 30 seconds.
		<ul style="list-style-type: none"> ▪ HDD not initialized ▪ Label data is corrupted ▪ Defective HDD
		<ol style="list-style-type: none"> 1. Initialize the HDD with SP5-832-001.

No.	Type	Details (Symptom, Possible Cause, Troubleshooting Procedures)
861	D	HDD: Reboot error
		The HDD does not become ready within 30 seconds after the power is supplied to the HDD.
		<ul style="list-style-type: none"> ▪ Disconnection of the cables between HDD and HDC ▪ Disconnection of the power supply connector ▪ Defective HDD ▪ Defective HDC
		<ol style="list-style-type: none"> 1. Turn the main power switch on. 2. Replace the HDD or the controller board.

No.	Type	Details (Symptom, Possible Cause, Troubleshooting Procedures)
862	D	Bad sector number error
		The number of bad sectors in the HDD (image data area) goes over 101.
		1. Defective HDD
		<ul style="list-style-type: none"> ▪ Format the HDD with SP4-911-002 and replace with the alternate sector. ▪ Replace the HDD.

No.	Type	Details (Symptom, Possible Cause, Troubleshooting Procedures)
863	D	HDD: Read error
		The data stored in the HDD cannot be read correctly.
		<ul style="list-style-type: none"> ▪ Defective HDD ▪ Defective controller
		<ol style="list-style-type: none"> 1. Replace the HDD. 2. Replace the controller.

No.	Type	Details (Symptom, Possible Cause, Troubleshooting Procedures)
864	D	HDD: CRC error
		While reading data from the HDD or storing data in the HDD, data transmission fails.
		<ul style="list-style-type: none"> ▪ Defective HDD
		<ol style="list-style-type: none"> 1. Format the HDD. 2. Replace the HDD.

No.	Type	Details (Symptom, Possible Cause, Troubleshooting Procedures)
865	D	HDD: Access error
		An error is detected while operating the HDD.
		<ul style="list-style-type: none"> ▪ Defective HDD
		<ol style="list-style-type: none"> 1. Replace the HDD.

No.	Type	Details (Symptom, Possible Cause, Troubleshooting Procedures)
866	B	SD card authentication error
		A correct license is not found in the SD card.
		<ul style="list-style-type: none"> ▪ SD-card data is corrupted.
		<ol style="list-style-type: none"> 1. Store correct data in the SD card.

No.	Type	Details (Symptom, Possible Cause, Troubleshooting Procedures)
867	D	SD card error
		The SD card is ejected from the slot.
		<ul style="list-style-type: none"> ▪ Install the SD card. ▪ Turn the main switch off and on.

No.	Type	Details (Symptom, Possible Cause, Troubleshooting Procedures)
868	D	SD card access error
		An error occurs while an SD card is used.
		<ul style="list-style-type: none"> ▪ SD card not inserted correctly ▪ SD card defective ▪ Controller board defective <p> Note</p> <ol style="list-style-type: none"> 1. If you want to try to reformat the SC card, use SD Formatter Ver 1.1.
		<ul style="list-style-type: none"> ▪ Check the SD card is inserted correctly. ▪ Replace the SD card. ▪ Replace the controller board.

No.	Type	Details (Symptom, Possible Cause, Troubleshooting Procedures)
870	B	Address book error
		Address book data stored on the hard disk was detected as abnormal when it was accessed from either the operation panel or the network.
		<ul style="list-style-type: none"> ▪ Defective software program ▪ Defective HDD ▪ Incorrect path to the server ▪ Incorrect encryption setting or encryption key ▪ Damaged address book data
		<ol style="list-style-type: none"> 1. Mount correctly the media that stores the address book data and turn the main power switch off and on. 2. Initialize the address book data (SP5-846-050). 3. Initialize the partition for the HDD address book (Turn the main power switch off and on) (SP5-832-006). 4. Replace the HDD.

No.	Type	Details (Symptom, Possible Cause, Troubleshooting Procedures)
872	B	HDD mail data error
		An error is detected in the HDD at power on.
		<ul style="list-style-type: none"> ▪ Defective HDD ▪ Power failure during an access to the HDD
		<ol style="list-style-type: none"> 1. Turn the main power switch off and on. 2. Initialize the HDD partition (SP5-832-007). 3. Replace the HDD.

No.	Type	Details (Symptom, Possible Cause, Troubleshooting Procedures)
873	B	HDD mail transfer error
		An error is detected in the HDD at machine initialization.
		<ul style="list-style-type: none"> ▪ Defective HDD ▪ Power failure during an access to the HDD
		<ol style="list-style-type: none"> 1. Initialize the HDD partition (SP5-832-008). 2. Replace the HDD.

No.	Type	Details (Symptom, Possible Cause, Troubleshooting Procedures)
874	D	Delete All error: Data area
		A data error is detected for the HDD/NVRAM after the Delete All option has been used.
		<p> Note</p> <ul style="list-style-type: none"> ▪ The source of this error is the Data Overwrite Security Unit running from an SD card.
		<ol style="list-style-type: none"> 1. Data Overwrite Security Unit (SD card) not installed 2. Defective HDD
		<ul style="list-style-type: none"> ▪ Turn the main switch off/on and try the operation again. ▪ Install the Data Overwrite Security Unit (D377) again. ▪ Replace the HDD.

No.	Type	Details (Symptom, Possible Cause, Troubleshooting Procedures)
875	D	Delete All error: HDD
		An error occurs while the machine deletes data from the HDD.
		<p> Note</p> <ol style="list-style-type: none"> The source of this error is the Data Overwrite Security Unit (D377) running from an SD card.
		<ul style="list-style-type: none"> The logical format for the HDD fails.
		<ol style="list-style-type: none"> Turn the main switch off/on and try the operation again

No.	Type	Details (Symptom, Possible Cause, Troubleshooting Procedures)
876	D	Log Data Error
		An error was detected in the handling of the log data at power on or during machine operation. This can be caused by switching the machine off while it is operating.
-01		Log Data Error 1
		<ul style="list-style-type: none"> Damaged log data file in the HDD
		<ol style="list-style-type: none"> Initialize the HDD with SP5-832-004.
-02		Log Data Error 2
		<ul style="list-style-type: none"> An encryption module not installed
		<ol style="list-style-type: none"> Replace or set again the encryption module. Disable the log encryption setting with SP9-730-004 ("0" is off.).
-03		Log Data Error 3
		<ul style="list-style-type: none"> Invalid log encryption key due to defective NVRAM data
		<ol style="list-style-type: none"> Initialize the HDD with SP5-832-004. Disable the log encryption setting with SP9-730-004 ("0" is off.).

No.	Type	Details (Symptom, Possible Cause, Troubleshooting Procedures)
-04		Log Data Error 4
		<ul style="list-style-type: none"> ▪ Unusual log encryption function due to defective NVRAM data
		<ol style="list-style-type: none"> 1. Initialize the HDD with SP5-832-004.
-05		Log Data Error 5
		<ol style="list-style-type: none"> 1. Installed NVRAM or HDD which is used in another machine.
		<ul style="list-style-type: none"> ▪ Reinstall the previous NVRAM or HDD. ▪ Initialize the HDD with SP5-832-004.
-99		Log Data Error 99
		<ol style="list-style-type: none"> 1. Other than the above causes
		<ul style="list-style-type: none"> ▪ Ask your supervisor.

No.	Type	Details (Symptom, Possible Cause, Troubleshooting Procedures)
877	B	HDD Data Overwrite Security SD card error
		The 'all delete' function cannot be executed but the Data Overwrite Security Unit (D377) is installed and activated.
		<ol style="list-style-type: none"> 1. Defective SD card 2. SD card not installed
		<ol style="list-style-type: none"> 1. Replace the NVRAM and then install the new SD card. 2. Check and reinstall the SD card.

No.	Type	Details (Symptom, Possible Cause, Troubleshooting Procedures)
878	D	TPM electronic recognition error
		The system firmware is not authenticated by TPM (security chip).
		<ol style="list-style-type: none"> 1. Incorrect updating for the system firmware 2. Incorrect operating of the USB flash 3. Defective flash ROM on the controller board
		<ul style="list-style-type: none"> ▪ Replace the controller board.

No.	Type	Details (Symptom, Possible Cause, Troubleshooting Procedures)
880	D	File format converter error
		A request to get access to the file format converter is not answered within the specified time.
		<ol style="list-style-type: none"> 1. Defective file format converter
		<ul style="list-style-type: none"> ▪ Replace the file format converter.

No.	Type	Details (Symptom, Possible Cause, Troubleshooting Procedures)
881	D	Authentication area error
		Authentication application error is detected.
		Error data in an authentication application reaches the management limit.
		<ol style="list-style-type: none"> 1. Turn the main power switch off and on.

No.	Type	Details (Symptom, Possible Cause, Troubleshooting Procedures)
899	D	Software performance error
		If the processing program shows abnormal performance and the program is abnormally ended, this SC is issued.
		<ul style="list-style-type: none">▪ Controller board defective▪ Software defective
		<ol style="list-style-type: none">1. Replace the controller board.2. Turn the main switch off and on.3. Update the firmware on the controller.

6.1.10 SERVICE CALL TABLES - 9**SC9xx: Miscellaneous**

No.	Type	Details (Symptom, Possible Cause, Troubleshooting Procedures)
900	D	Electric counter error
		The total count contains something that is not a number.
		<ol style="list-style-type: none"> 1. NVRAM incorrect type 2. Defective NVRAM 3. NVRAM data scrambled 4. Unexpected error from external source
		<ul style="list-style-type: none"> ▪ Check the connection between the NVRAM and controller. ▪ Replace the NVRAM. ▪ Replace the controller board.

No.	Type	Details (Symptom, Possible Cause, Troubleshooting Procedures)
910	B	External Controller Error 1
911		External Controller Error 2
912		External Controller Error 3
913		External Controller Error 4
914		External Controller Error 5
		The external controller alerted the machine about an error.
		<ol style="list-style-type: none"> 1. Please refer to the instructions for the external controller (application).

No.	Type	Details (Symptom, Possible Cause, Troubleshooting Procedures)
915	A	External Controller Error 6
		Egrt board error
		The external controller alerted the machine about an error.
		<ul style="list-style-type: none"> ▪ Replace the Egret controller board.

No.	Type	Details (Symptom, Possible Cause, Troubleshooting Procedures)
919	D	External Controller down
		While EAC (External Application Converter), the conversion module, was operating normally, the receipt of a power line interrupt signal from the FLUTE serial driver was detected, or BREAK signal from the other station was detected.
		<ol style="list-style-type: none"> 1. Power outage at the EFI controller 2. EFI controller was rebooted 3. Connection to EFI controller loose
		<ul style="list-style-type: none"> ▪ Turn the main power switch off and on.

Service Call

No.	Type	Details (Symptom, Possible Cause, Troubleshooting Procedures)
920	B	Printer application error
-00		No response when starting up the PM
-01		Timeout error during the PM operation
-02		Working memory error
-03		Cannot start-up the filtering process
-04		Abnormal exit from the filtering process
		An error is detected in the printer application program and operation cannot continue.
		<ul style="list-style-type: none"> ▪ Defective software ▪ Unexpected hardware resource (e.g., memory shortage)
		<ol style="list-style-type: none"> 1. Software defective; turning on and off the main power switch 2. Insufficient memory; additional memory

No.	Type	Details (Symptom, Possible Cause, Troubleshooting Procedures)
921	B	Printer font error
		A necessary font is not found when starting up the printer application.
		<ul style="list-style-type: none"> ▪ A necessary font is not found in the SD card.
		<ol style="list-style-type: none"> 1. Turn the main power switch off and on.

No.	Type	Details (Symptom, Possible Cause, Troubleshooting Procedures)
925	B	NetFile function error
-00		HDD is defective
-01		NetFile management file is broken
		<p>The NetFile file management on the HDD cannot be used, or a NetFile management file is corrupted and operation cannot continue.</p> <p>The HDDs are defective and they cannot be debugged or partitioned, so the Scan Router functions (delivery of received faxes, document capture, etc.), Web services, and other network functions cannot be used.</p> <p>HDD status codes are displayed below the SC code.</p>
		<ul style="list-style-type: none"> Refer to the four procedures below (Recovery from SC 925).

Here is a list of HDD status codes:

Display	Meaning
(-1)	HDD not connected
(-2)	HDD not ready
(-3)	No label
(-4)	Partition type incorrect
(-5)	Error returned during label read or check
(-6)	Error returned during label read or check
(-7)	"filesystem" repair failed
(-8)	"filesystem" mount failed
(-9)	Drive does not answer command
(-10)	Internal kernel error
(-11)	Size of drive is too small

Display	Meaning
(-12)	Specified partition does not exist
(-13)	Device file does not exist

Recovery from SC 925

Procedure 1

If the machine shows SC codes for HDD errors (SC860 to SC865) with SC 925, do the recovery procedures for SC860 to SC865.

Procedure 2

If the machine does not show one of the five HDD errors (SC860 to SC865), turn the machine power off and on. If this is not the solution for the problem, then initialize the NetFile partition on the HDD with SP5832-011 (HDD Formatting – Ridoc I/F).

NetFiles: Jobs printed from the document server using a PC and DeskTopBinder

- Before you initialize the NetFile partition on the HDD, tell the customer that:
- Received faxes on the delivery server will be erased
- All captured documents will be erased
- DeskTopBinder/Print Job Manager/Desk Top Editor job history will be erased
- Documents on the document server, and scanned documents, will not be erased.
- The first time that the network gets access to the machine, the management information must be configured again (this will use a lot of time).

Before you initialize the Netfile partition with SP5832-011, do these steps:

1. Go into the User Tools mode and do "Delivery Settings" to print all received fax documents that are scheduled for delivery. Then erase them.
2. In the User Tools mode, do Document Management> Batch Delete Transfer Documents.
3. Do SP5832-011, then turn the machine power off and on.

Procedure 3

If "Procedure 2" is not the solution for the problem, do SP5832-001 (HDD Formatting – All), then turn the machine power off and on.

SP5832-001 erases all document and address book data on the hard disks. Ask the customer before you do this SP code.

Procedure 4

If "Procedure 3" is not the solution for the problem, replace the HDD.

No.	Type	Details (Symptom, Possible Cause, Troubleshooting Procedures)
990	D	Software performance error
		The software makes an unexpected operation.
		<ul style="list-style-type: none"> ▪ Defective software ▪ Defective controller ▪ Software error
		<ol style="list-style-type: none"> 1. Turn the main switch off and on. 2. Reinstall the controller and/or engine main firmware.
		<p> Note</p> <ul style="list-style-type: none"> ▪ See Note 1 at the end of the SC table.

No.	Type	Details (Symptom, Possible Cause, Troubleshooting Procedures)
991	C	Software continuity error
		The software has attempted to perform an unexpected operation. However, unlike SC 990, the object of the error is continuity of the software.
		<ol style="list-style-type: none"> 1. Software program error 2. Internal parameter incorrect 3. Insufficient working memory
		<ul style="list-style-type: none"> ▪ This SC is not displayed on the LCD (logging only).

No.	Type	Details (Symptom, Possible Cause, Troubleshooting Procedures)
992	D	Undefined error
		Defective software program
		<ol style="list-style-type: none"> 1. An error undetectable by any other SC code occurred
		<ul style="list-style-type: none"> ▪ Turn the main power switch off and on.

No.	Type	Details (Symptom, Possible Cause, Troubleshooting Procedures)
994	C	Operation panel management records exceeded
		An error occurred because the number of records exceeded the limit for images managed in the service layer of the firmware. This can occur if too many application screens open on the operation panel.
		1. No action required because this SC does not interfere with operation of the machine.

No.	Type	Details (Symptom, Possible Cause, Troubleshooting Procedures)
995	D	CPM setting error
-01		<ul style="list-style-type: none"> ▪ Defective BCU ▪ NVRAM Replacement error
		<ol style="list-style-type: none"> 1. Install the previous NVRAM 2. Input the serial number with SP5-811-004, and turn the main power switch off and on.
-02		<ul style="list-style-type: none"> ▪ Defective NVRAM ▪ Defective controller
		<ul style="list-style-type: none"> ▪ Update the controller firmware. ▪ Install a new NVRAM, and turn off and on the main power switch after SC995-002 has occurred.
-03		<ol style="list-style-type: none"> 1. Incorrect type controller installed 2. Defective controller
		<ol style="list-style-type: none"> 1. Replace the controller with the correct type.
-04		<ol style="list-style-type: none"> 1. Incorrect model controller installed.
		<ol style="list-style-type: none"> 1. Replace the controller with the correct model.

No.	Type	Details (Symptom, Possible Cause, Troubleshooting Procedures)
997	B	Application function selection error
		The application selected by the operation panel key works abnormally (No response, abnormal ending).
		<ol style="list-style-type: none"> 1. Software (including the software configuration) defective 2. An option required by the application (RAM, DIMM, board) is not installed. 3. Nesting of the fax group addresses is too complicated.
		<ul style="list-style-type: none"> ▪ Check the devices necessary for the application program. If necessary devices have not been installed, install them. ▪ Check that application programs are correctly configured. ▪ For a fax operation problem, simplify the nesting of the fax group addresses. ▪ Take necessary countermeasures specific to the application program. If the logs can be displayed on the operation panel, see the logs.

No.	Type	Details (Symptom, Possible Cause, Troubleshooting Procedures)
998	D	Application start error
		No applications start within a specified time after the power is turned on.
		<ul style="list-style-type: none"> ▪ Loose connection of RAM-DIMM, ROM-DIMM ▪ Defective controller ▪ Software problem
		<ol style="list-style-type: none"> 1. Check the setting of SP5-875-001. If the setting is set to "1 (OFF)", change it to "0 (ON)". 2. Check if the RAM-DIMM and ROM-DIMM are correctly connected. 3. Reinstall the controller system firmware. 4. Replace the controller board.

Note 1

If a problem always occurs in a specific condition (for example. printer driver setting, image file), the problem may be caused by a software error. In this case, the following data and information needs to be sent back to your product specialist. Please understand that it may take some time to get a reply on how to solve the problem, because in some cases the design staff in Japan must analyze the data.

1. Symptom / Possible Causes / Action taken
2. Summary sheet (SP mode "Printer SP", SP1-004 [Print Summary])
3. SMC - All (SP5-990-001)
4. SMC - Logging (SP5-990-004)
5. Printer driver settings used when the problem occurs
6. All data displayed on the screen (SC code, error code, and program address where the problem is logged.)
7. Image file which causes the problem, if possible

6.2 PROCESS CONTROL ERROR CONDITIONS

6.2.1 DEVELOPER INITIALIZATION RESULT

SP-3-014-001 (Developer Initialization Result)

No.	Result	Description	Possible Causes/Action
1	Successfully completed	Developer initialization is successfully completed.	-
2	Forced termination	Developer initialization was forcibly terminated.	<ol style="list-style-type: none"> 1. A cover was opened or the main switch was turned off during the initialization. <ul style="list-style-type: none"> ▪ Do the developer initialization again when done in SP mode. Reinstall the engine main firmware if the result is the same. ▪ Turn the main switch off and on when done at unit replacement.
6	Vt error	Vt is more than 0.7V when Vcnt is 4.3V.	<ol style="list-style-type: none"> 1. Make sure that the heat seal on the development unit is not removed. 2. Defective TD sensor
7	Vcnt error 1	Vcnt is less than 4.7V when Vcnt is Vt target $\pm 0.2V$.	<ul style="list-style-type: none"> ▪ Defective TD sensor ▪ Vt target settings are not correct. ▪ Toner density error
8	Vcnt error 2	Vt is more than 0.7V when Vcnt is 4.3V and Vcnt is less than 4.7V when Vcnt is Vt target $\pm 0.2V$.	<ol style="list-style-type: none"> 1. Make sure that the heat seal on the development unit is not removed. 2. Defective TD sensor

No.	Result	Description	Possible Causes/Action
9	Vcnt error 3	Vcnt is less than 4.7V.	<ul style="list-style-type: none"> ▪ Make sure that the heat seal on the development unit is not removed ▪ Defective TD sensor ▪ Vt target settings are not correct. ▪ Toner density error

Note

1. The machine starts developer initialization after you set "Enable" in SP3-902-005, 006, 007, or 008. Developer initialization automatically resumes when you open and close the front door or turn the main switch off and on if an error other than Error 8 occurs.

6.2.2 PROCESS CONTROL SELF-CHECK RESULT

Displayed number shows results of each color sensor check.

00000000 = YYCCMMKK

SP3-012-001 to -010 (Process Control Self-check Result)

No.	Result	Description	Possible Causes/Action
11	Successfully completed	Process control self-check successfully completed.	Check the Vsg adjustment. See the "Vsg Adjustment Result" following this table.
41	Vt error	Vt maximum or minimum error is detected.	<ul style="list-style-type: none"> ▪ Defective development unit <p>Vt maximum error and an image is faint:</p> <ul style="list-style-type: none"> ▪ Replace the toner supply pump unit. <p>Vt maximum error and an image is O.K:</p> <ul style="list-style-type: none"> ▪ Replace the development unit. ▪ Replace the IOB board. <p>Vt minimum error:</p> <ol style="list-style-type: none"> 1. Replace the development unit. 2. Replace the IOB board.

No.	Result	Description	Possible Causes/Action
53	ID sensor coefficient (K5) detection error	Not enough data can be sampled.	<ul style="list-style-type: none"> ▪ Solid image is not sufficient density: ▪ Retry the process control. ▪ Replace the ID sensors. ▪ Replace the IOB board. ▪ Solid image is O.K. ▪ Replace the ID sensors. ▪ Replace the IOB board. ▪ ID sensor is dirty: 1. Clean the ID sensors. 2. Retry the process control.
54	ID sensor coefficient (K5) maximum/minimum error	When the K5 is more than the value of SP3-362-003 or less than the value of SP3-362-004, the error 54 is displayed.	<ul style="list-style-type: none"> ▪ ID sensor pattern density is too high or low. ▪ ID sensor or shutter is defective. Same as 53
55	Gamma error: Maximum	Gamma is out of range. $5.0 < \text{Gamma}$	1. ID sensor pattern density is too high. 2. Hardware defective. Same as 53
56	Gamma error: Minimum	Gamma is out of range. $\text{Gamma} < 0.15$	<ul style="list-style-type: none"> ▪ ID sensor pattern density is too low. ▪ Hardware defective. ▪ Same as 53 ▪ Replace the toner supply pump unit.
57	Vk error: Maximum	Vk is out of range. $150 < \text{Vk}$	<ul style="list-style-type: none"> ▪ ID sensor pattern density is too low. ▪ Hardware defective. Same as 53
58	Vk error: Minimum	Vk is out of range. $\text{Vk} < -150$	1. ID sensor pattern density is too high. 2. Background dirty 3. Hardware defective Same as 53

Trouble-Shooting

Process Control Error Conditions

No.	Result	Description	Possible Causes/Action
59	Sampling data error during gamma correction	Not enough data can be sampled during the gamma correction.	<ul style="list-style-type: none"> ▪ ID sensor pattern density is too high or low. ▪ Hardware defective Same as 53
99	Unexpected error	Process control fails.	<ul style="list-style-type: none"> ▪ Power Failure Check the power source.

Vsg Adjustment Result

SP3-325-001 to -010 (Vsg Adjustment Result)

No.	Result	Description	Possible Causes/Action
1	O.K	Vsg adjustment is correctly done.	-
2	ID sensor adjustment error	Vsg cannot be adjusted within $4.0 \pm 0.5V$.	<ul style="list-style-type: none"> ▪ Dirty ID sensor (toner, dust, or foreign material) ▪ Dirty transfer belt ▪ Scratched image transfer belt ▪ Defective ID sensor ▪ Poor connection ▪ Defective IOB <ol style="list-style-type: none"> 1. Clean the ID sensor. 2. Check the belt cleaning. Clean or replace the transfer belt. 3. Replace the image transfer belt. 4. Replace the ID sensor. 5. Check the connection. 6. Replace the IOB board.

No.	Result	Description	Possible Causes/Action
3	ID sensor output error	ID sensor output is more than "Voffset Threshold" (SP3-324-004)	<ul style="list-style-type: none"> ▪ Defective ID sensor ▪ Poor connection ▪ Defective IOB <ol style="list-style-type: none"> 1. Replace the ID sensor. 2. Check the connection. 3. Replace the IOB board.
9	Vsg Adjustment error	Vsg adjustment has not been completed.	<ul style="list-style-type: none"> ▪ Other cases Retry SP3-321-010.

6.2.3 LINE POSITION ADJUSTMENT RESULT

SP2-194-010 to -012 (Line Position Adjustment Result: M, C, Y)

This SP shows the number as a line position adjustment result on the LCD. It shows which color has an error (M, Y or C).

No.	Result	Description	Note
0	Not done	Line position adjustment has not been done.	-
1	Completed successfully	Line position adjustment has correctly been done,	-
2	Cannot detect patterns	ID sensors have not detected the patterns for line position adjustment.	See Note
3	Fewer lines on the pattern than the target	The patterns, which ID sensors have detected, are not enough for line position adjustment.	See Note
4	More lines on the pattern than the target	Not used in this machine.	-
5	Out of the adjustment range	ID sensors have correctly detected the patterns for line position adjustment, but a shift of patterns is out of adjustable range.	See Note
6-9	Not used	-	-

Note

- For details, see "Troubleshooting Guide - Line Position Adjustment" section. (p.6-109)

6.3 TROUBLESHOOTING GUIDE

6.3.1 IMAGE QUALITY

The following work-flow shows the basic troubleshooting steps for the image quality problems on this product.

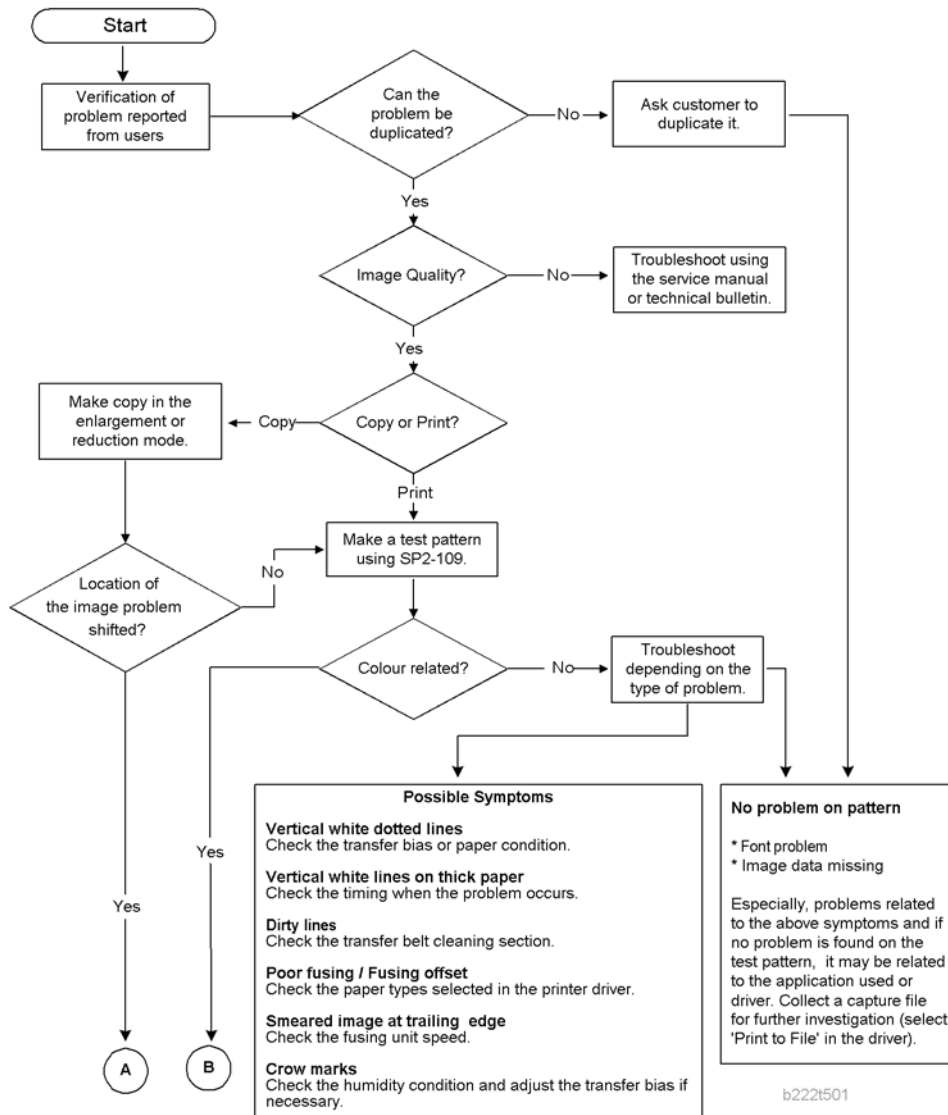

Trouble-Shooting

Troubleshooting Guide

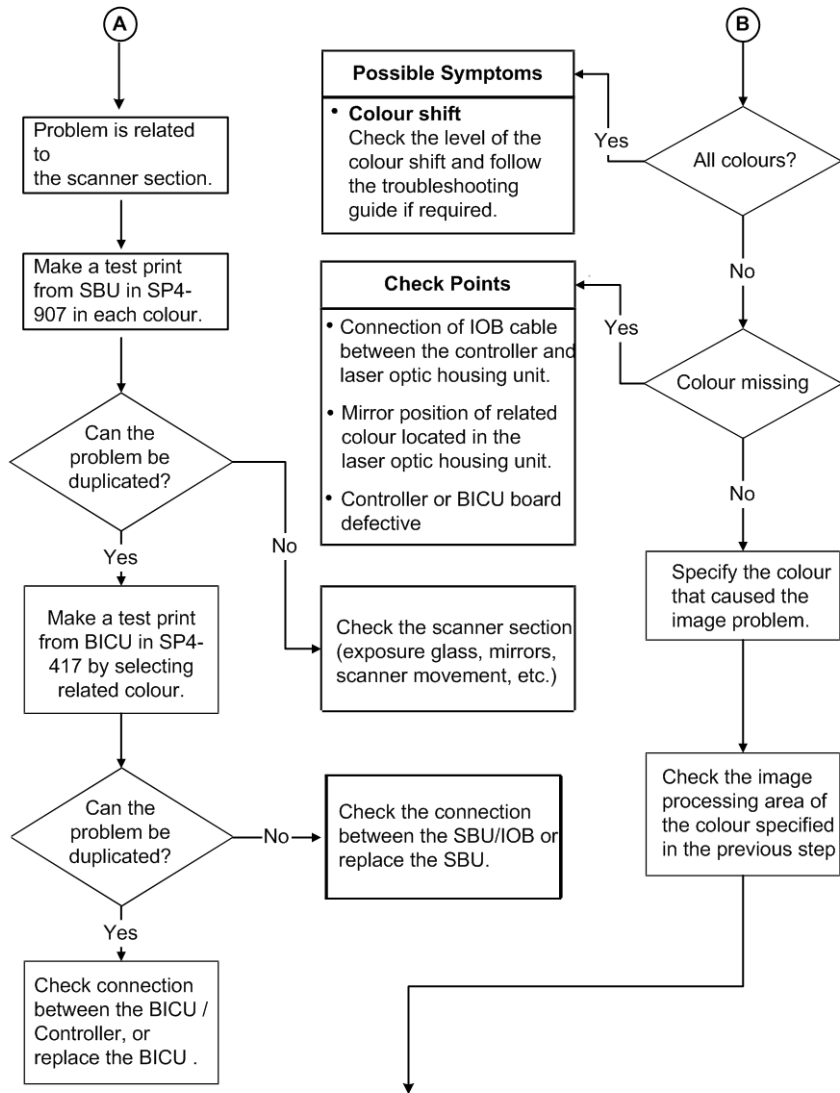

Considerable Symptoms
<ul style="list-style-type: none"> • Toner blasting Check which colour is blasting and adjust the toner limit or transfer bias. • Image density change Check when the problem is reported and follow the necessary steps. • Dirty Background Check in which condition the problem is reported, and follow the required procedure. • Colour vertical bands/lines/dirty background Check the OPC drum and/or development unit. • Colour shift Check the level of the colour shift and follow the troubleshooting guide if required. • Colour lines/bands/dirty background When the PCU/development unit is close to its life end, the developer or the cleaning blade of the PCU wears out, causing vertical colour lines, bands, or dirty background. Check the related colour unit and replace it if necessary.

d027t504

6.3.2 LINE POSITION ADJUSTMENT

When there are color registration errors on the output, do the line position adjustment as follows.

Note

1. Use A3/DLT size paper for this adjustment.

Test

- Do SP2-111-003 (Mode c: rough adjustment).
- Use SP2-194-007 to check if the result of the line position adjustment is correct (0: Completed successfully, 1: Not completed). If the result is "1", refer to 'Countermeasure list for color registration errors'.
- Do SP2-111-001 (Mode a: fine adjustment twice).
- Use SP2-194-007 to check if the result of the line position adjustment is correct (0: Completed successfully, 1: Not completed). If the result is "1", refer to 'Countermeasure list for color registration errors'.
- Put some A3/DLT paper on the by-pass tray.

Note

1. When you print a test pattern, use the by-pass tray to feed the paper.
- Print out test pattern "7" with SP2-109-003.
 - Check the printed output with a loupe.
 - If there are no color registration errors on the output, the line position adjustment is correctly done. If not, refer to the countermeasure list for color registration errors.

Countermeasure list for color registration errors

After Executing SP2-111-003

- Result: "1" in SP2-194-007
- Result: "2" or "3" (Line pattern detection failure) in SP2-194-010, -011, -012

Test pattern check	Possible cause/Countermeasure
White image, Abnormal image, Low density	<ol style="list-style-type: none"> 1. Defective laser optics housing unit shutter 2. Defective image processing unit 3. Low density of test pattern 4. Defective IPU <ul style="list-style-type: none"> ▪ Replace the shutter motor. ▪ Replace the high voltage power supply unit. ▪ Do the forced process control (SP3-011-001) or supply some toner (SP3-015-xxx). ▪ Replace the IPU.
Normal image, but with color registration errors	<ol style="list-style-type: none"> 1. Defective ID sensor shutter 2. Defective ID sensor 3. Defective IPU <ul style="list-style-type: none"> ▪ Replace the ID sensor shutter solenoid. ▪ Replace the ID sensor. ▪ Replace the IPU.

After Executing SP2-111-003

1. Result: "1" in SP2-194-007
2. One of results: "5" (Out of adjustable range) in SP2-194-010, -011, -012.

Test pattern check	Possible cause/Countermeasure
The main scan registrations of Y, M, C are shifted by more than ± 15 mm from the main scan registration of K.	<ul style="list-style-type: none"> ▪ Defective laser optics housing unit ▪ Defective IPU ▪ Replace the laser optics housing unit. ▪ Replace the IPU.
The sub scan registrations of Y, M, C are shifted by more than ± 20 mm from the sub scan registration of K.	<ul style="list-style-type: none"> ▪ Defective image transfer belt ▪ Defective drive units ▪ Defective IPU <ol style="list-style-type: none"> 1. Replace the image transfer belt. 2. Replace the drum motor. 3. Replace the IPU.
The main scan registration is shifted by more than ± 0.66 mm, but only at the central area of the image on the output.	<ul style="list-style-type: none"> ▪ Defective ID sensor at center ▪ Deformed center area on the image transfer belt ▪ Defective IPU <ol style="list-style-type: none"> 1. Replace the ID sensor. 2. Replace the image transfer belt. 3. Replace the IPU.
The skew for Y, M, C is more than ± 0.75 mm from the main scan registration of K	<ul style="list-style-type: none"> ▪ Defective PCDU ▪ Defective laser optics housing unit ▪ Defective IPU ▪ Reinstall or replace the PCDU. ▪ Replace the laser optics housing unit. ▪ Replace the IPU.
Others	<ul style="list-style-type: none"> ▪ Skew correction upper limit error ▪ Defective IPU ▪ Defective laser optics housing unit <ol style="list-style-type: none"> 1. Replace the IPU. 2. Replace the laser optics housing unit.



After Executing SP2-111-003

- Result: "1" in SP2-194-007
- Result: "0" in SP2-194-010, -011, -012.

Test pattern check	Possible cause/Countermeasure
	Do SP2-111-001 or -002.

After Executing SP2-111-001

1. Result: "1" in SP2-194-007
2. Result: "2" or "3" (Line pattern detection failure) in SP2-194-010, -011, -012

Test pattern check	Possible cause/Countermeasure
White image, Abnormal image, Low density	<ul style="list-style-type: none"> ▪ Defective laser optics housing unit shutter ▪ Defective image processing unit ▪ Low density of test pattern ▪ Defective IPU <ol style="list-style-type: none"> 1. Replace the shutter motor. 2. Replace the high voltage power supply unit. 3. Do the forced process control (SP3-011-001) or supply some toner (SP3-015-xxx). 4. Replace the IPU.
Normal image, but with color registration errors	<ul style="list-style-type: none"> ▪ Defective ID sensor shutter ▪ Defective ID sensor ▪ Defective IPU <ol style="list-style-type: none"> 1. Replace the ID sensor shutter solenoid. 2. Replace the ID sensor. 3. Replace the IPU.

After Executing SP2-111-001

- Result: "1" in SP2-194-007
- Result: "5" (Out of adjustable range) in SP2-194-010, -011, -012

Test pattern check	Possible cause/Countermeasure
Low image density on the output	1. Low pattern density Do the forced process control (SP3-011-001) or supply some toner (SP3-015-xxx).
The main scan registrations of Y, M, C are shifted by more than ± 1.4 mm from the main scan registration of K.	<ul style="list-style-type: none"> ▪ No defective component ▪ Defective laser optics housing unit ▪ Defective IPU ▪ Do SP2-111-003 again. ▪ Replace the laser optics housing unit. ▪ Replace the IPU.
The sub scan registrations of Y, M, C are shifted by more than ± 1.4 mm from the sub scan registration of K.	<ul style="list-style-type: none"> ▪ No defective component ▪ Defective image transfer belt ▪ Defective drive units ▪ Defective IPU ▪ Do SP2-111-003 again. ▪ Replace the image transfer belt. ▪ Replace the drum motor. ▪ Replace the IPU.
The main scan registration is shifted by more than ± 0.66 mm, but only at the central area of the image on the output.	<ul style="list-style-type: none"> ▪ Defective ID sensor at center ▪ Deformed center area on the image transfer belt ▪ Defective IPU ▪ Replace the ID sensor. ▪ Replace the image transfer belt. ▪ Replace the IPU.
The skew for Y, M, C is more than ± 0.75 mm from the main scan registration of K. – at the end of the scan line?	1. Defective PCDU 2. Defective laser optics housing unit 3. Defective IPU <ul style="list-style-type: none"> ▪ Reinstall or replace the PCDU. ▪ Replace the laser optics housing unit. ▪ Replace the IPU.



Test pattern check	Possible cause/Countermeasure
Others	<ol style="list-style-type: none"> 1. Skew correction upper limit error 2. Defective IPU 3. Defective laser optics housing unit <ul style="list-style-type: none"> ▪ Replace the IPU. ▪ Replace the laser optics housing unit.

After Executing SP2-111-001

1. Result: "0" in SP2-194-007
2. Result: No color registration errors in SP2-194-010, -011, -012

Test pattern check	Possible cause/Countermeasure
The main scan registration of K is shifted.	<ul style="list-style-type: none"> ▪ Abnormal SP setting value of main scan: K Adjust the value with SP2-101-001.
The main scan length of K is shifted.	<ol style="list-style-type: none"> 1. Abnormal SP setting value of main scan length detection: K Adjust the value with SP2-185-001.

After Executing SP2-111-001

- Result: "0" in SP2-194-007
- Result: Color registration errors in SP2-194-010, -011, -012

Test pattern check	Possible cause/Countermeasure
Low image density on the output	<ol style="list-style-type: none"> 1. Low pattern density Do the forced process control (SP3-011-001) or supply some toner (SP3-015-xxx).
The main scan registration is shifted, but only at the central area of the image on the output.	<ol style="list-style-type: none"> 1. Defective ID sensor at center 2. Deformed center area on the image transfer belt 3. Defective IPU <ul style="list-style-type: none"> ▪ Replace the ID sensor. ▪ Replace the image transfer belt. ▪ Replace the IPU.

Test pattern check	Possible cause/Countermeasure
The main scan registrations of Y, M, C are shifted.	<ul style="list-style-type: none"> ▪ Defective laser optics housing unit ▪ Defective ID sensor ▪ Defective IPU ▪ Incorrect SP value ▪ Replace the laser optics housing unit. ▪ Replace the ID sensor. ▪ Replace the IPU. ▪ Adjust the value with SP2-182-004 to -021.
The sub scan registrations of Y, M, C are shifted.	<ul style="list-style-type: none"> ▪ Defective image transfer belt ▪ Defective drive units ▪ Defective ID sensor ▪ Defective IPU ▪ Incorrect SP value ▪ Replace the image transfer belt. ▪ Replace the ID sensor. ▪ Replace the drum motor. ▪ Replace the IPU. ▪ Adjust the value with SP2-182-022 to -039.
The skew of Y, M, C is different.	<ol style="list-style-type: none"> 1. Defective PCDU 2. Defective laser optics housing unit 3. Defective IOB 1. Reinstall or replace the PCDU. 2. Replace the laser optics housing unit. 3. Replace the IOB.
The sub scan lines are shifted. Shifted lines appear cyclically.	<ol style="list-style-type: none"> 1. Defective PCDU 2. Defective drive unit 3. Drum phase adjustment error 1. Do SP1-902-001 (Drum phase adjustment); see Replacement and Adjustment – Drive Unit – Gear Unit for details. 2. Reinstall or replace the PCDU. 3. Check or replace the drive unit.



6.3.3 STAIN ON THE OUTPUTS

If a stain appears at the edge of the output, do the following procedure.

- Execute the fusing cleaning mode with SP1123-002.

Note

- It takes 160 seconds to complete the fusing cleaning mode.
- Make a sample copy, and then check if a stain appears on the output.

6.3.4 STACK PROBLEM IN THE 1-BIN TRAY

If a stack problem occurs on the 1-bin tray, raise the guide on the 1-bin tray.

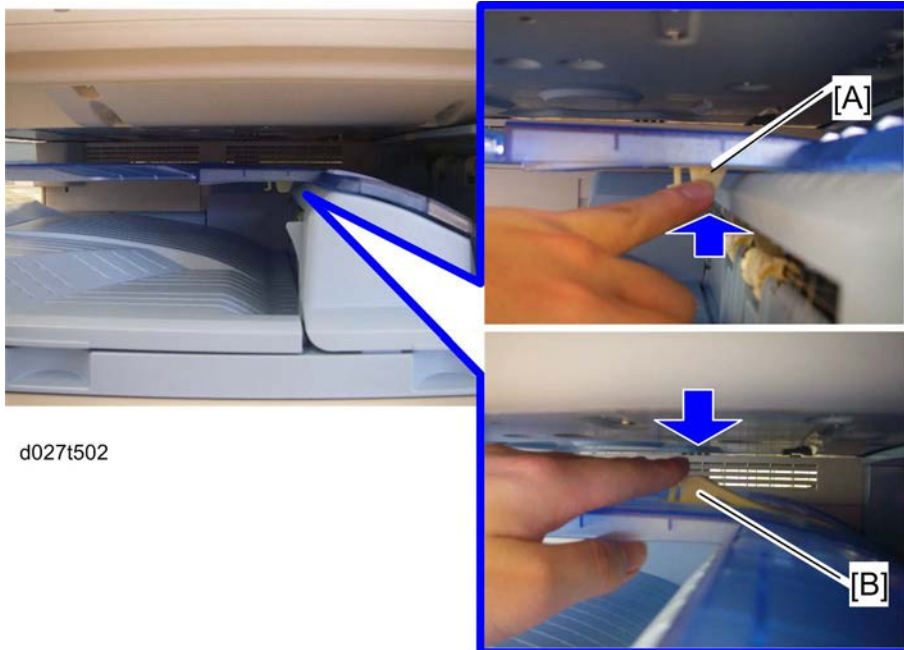

If a stack problem occurs;

- Push the guide to lift the guide [A].

If another type or size of paper is used;

- Press down the guide [B].

6.3.5 PROBLEM AT REGULAR INTERVALS

Image problems may appear at regular intervals that depend on the circumference of certain components.

The following diagram shows the possible symptoms (black or white dots at regular intervals).

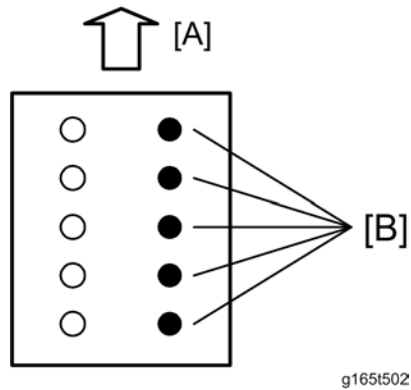

[A]: Paper feed direction

[B]: Problems at regular intervals

- Colored spots at 47-mm intervals: Development roller
- Abnormal image at 51-mm intervals: ITB drive or bias roller
- Abnormal image at 85-mm intervals: Paper transfer roller
- Colored spots at 119-mm intervals: Drum
- Abnormal image at 101-mm intervals: Fusing unit (Pressure roller)
- Abnormal image at 107-mm intervals: Fusing unit (Heating roller)

6.3.6 TONER END RECOVERY ERROR

If the toner end message on the LCD is displayed in the following conditions, there are some possible causes. Check the machine referring to the flow chart for the toner end recovery error.

1. After a new toner bottle has been installed in the machine
2. When a displayed color toner bottle still has toner inside



Flow Chart for the Toner End Recovery Error

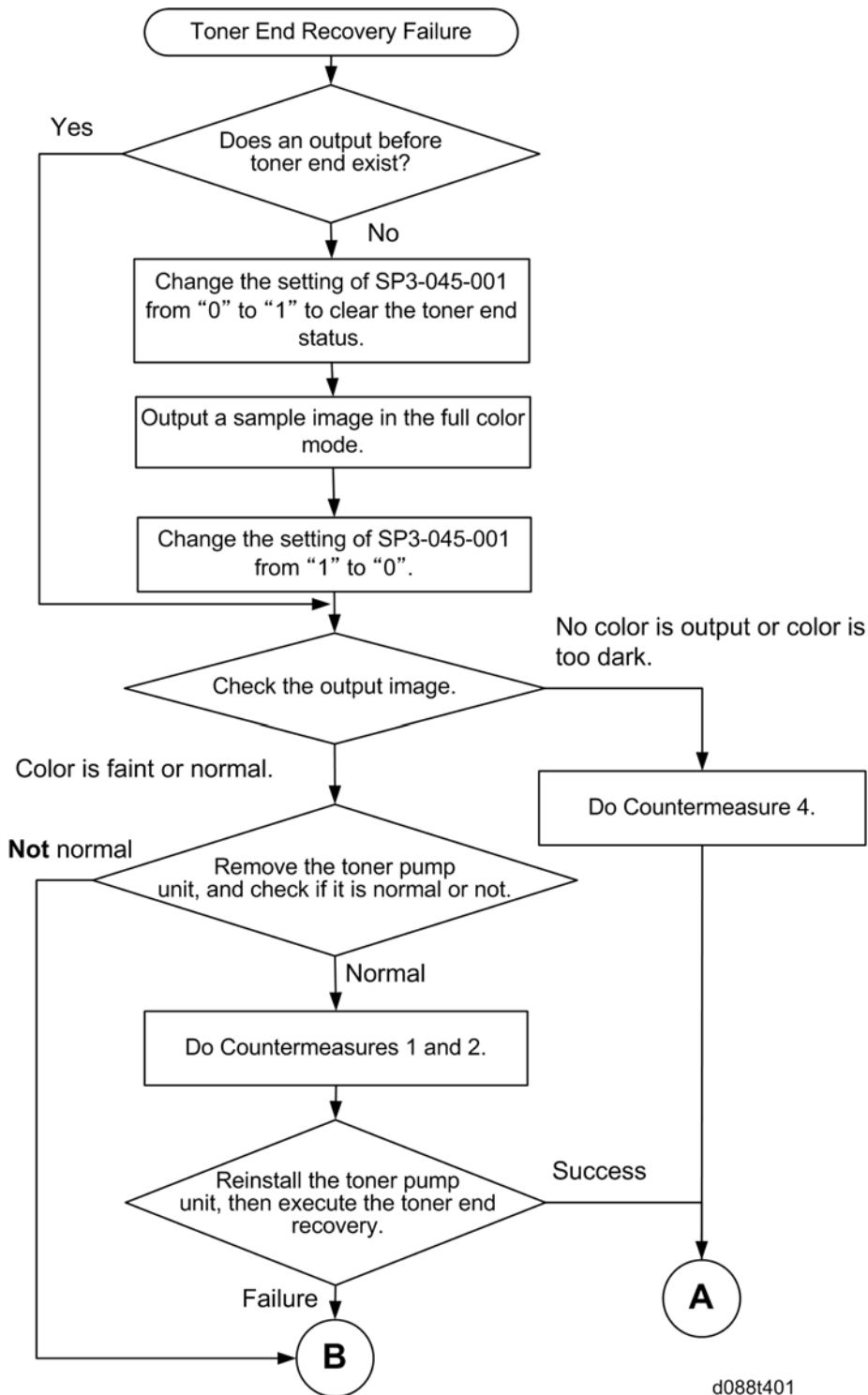

d088t401

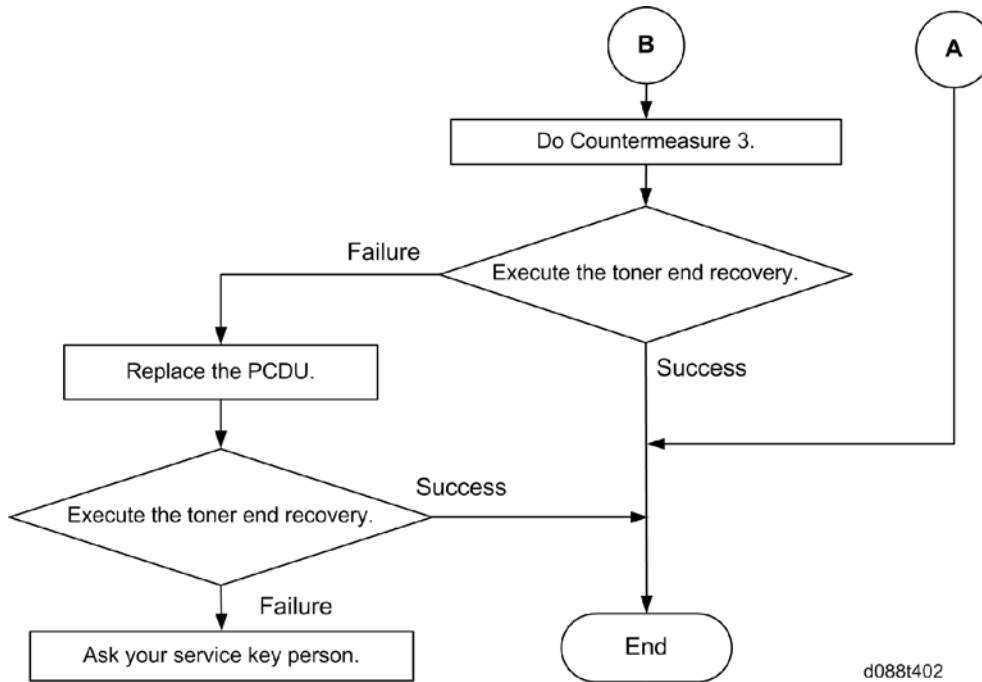

d088t402

Countermeasure 1

1. Check if the toner supply tube is bent or disconnected.
 - Straighten the toner supply tube or connect it correctly.

Countermeasure 2

- Remove the target color toner bottle.
- Disconnect the toner supply tube from the toner pump unit.
- Remove the blocked toner in the toner supply tube with a vacuum cleaner.

Countermeasure 3

- Replace the toner pump unit (🔧 p.4-67).

Countermeasure 4

- Replace the PCDU (🔧 p.4-59).

6.3.7 TONER BOTTLES DETECTION ERROR

If the no toner bottles message is displayed on the LCD when turning on the main power switch, or SC 681-11 to 14 occurs during operation, deformed detection terminals of toner bottles may cause a toner bottle ID communication error. If this occurs, follow the countermeasure below.

Countermeasure 1

- Replace the toner bottles.

Countermeasure 2

- Replace the toner bottle detection board (🔧 p.4-179).

Note

- When replacing the toner bottle detection board, make sure not to deform the toner bottle detection terminals. This error does not occur if toner bottles are replaced correctly.



6.3.8 SOLID IMAGE OR HALFTONE IMAGE ERROR

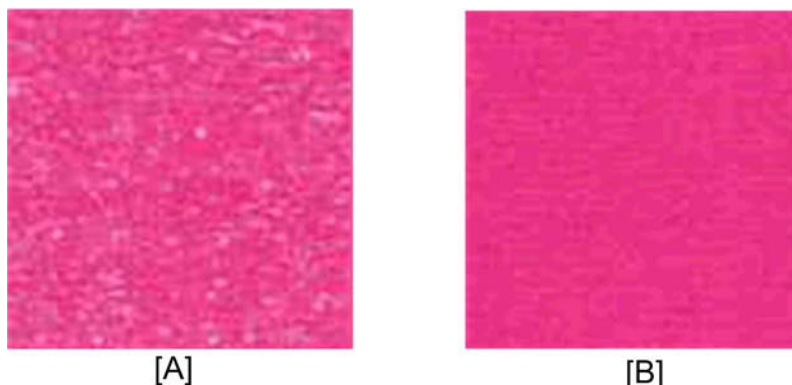

d088t403

The toner density of a solid image or halftone image may not be uniform ([A]: problem output, [B]: normal output) if a large amount of sheets is printed at low coverage. If this occurs, follow the countermeasure below.

Recovery Procedure

1. Enter the SP mode.
1. Set SP3-044-xxx (Toner Supply Type) to "1: PID (Vref Fixed)".
 - Chose a target color SP number from -001 (Bk), -002 (Magenta), -003 (Cyan), and -004 (Yellow).
2. Set SP3-222-xxx (Vtref: Display/Set) to "4V".
 1. Chose a target color SP number from -001 (Bk), -002 (Magenta), -003 (Cyan), and -004 (Yellow).
3. Set SP2-109-003 (Test Pattern; Pattern Selection) to "23: Full Dot Pattern".
4. Set SP2-109-005 (Test Pattern; Color Selection) to "1: All Color (black)", "2: Magenta", "3: Cyan", or "4: Yellow".
 - Chose a target color selection number.
5. Press "Copy Window" on the LCD.
6. Copy 20 sheets for A4 size or 30 sheets for A3 size, and then check the setting of SP3-222-xxx (Vtref: Display/Set).
 - If the setting of this SP is more than 4V, go to next step. If not, copy again until the setting of this SP is more than 4V.
7. Return the setting of SP3-044-xxx (Toner Supply Type) to "4: MBD (Vref_Control)".
 - Return the setting of the SP which you have changed in step 2 before.
8. Execute SP3-015-xxx (Forced Toner Supply: Execute) twice.
 1. Chose a target color SP number from -003 (Bk), -004 (Magenta), -005 (Cyan) and -006 (Yellow).
9. Execute the SP3-011-002 (Process Cont. Manual Execution; Density Adjustment).

Problem Prevention Procedure

- Set the setting of SP3-516-025 (Refresh Mode; Job End Area Coefficient) to "0.5".

6.3.9 FAULTY CLEANING

Black or color lines (2-3mm)

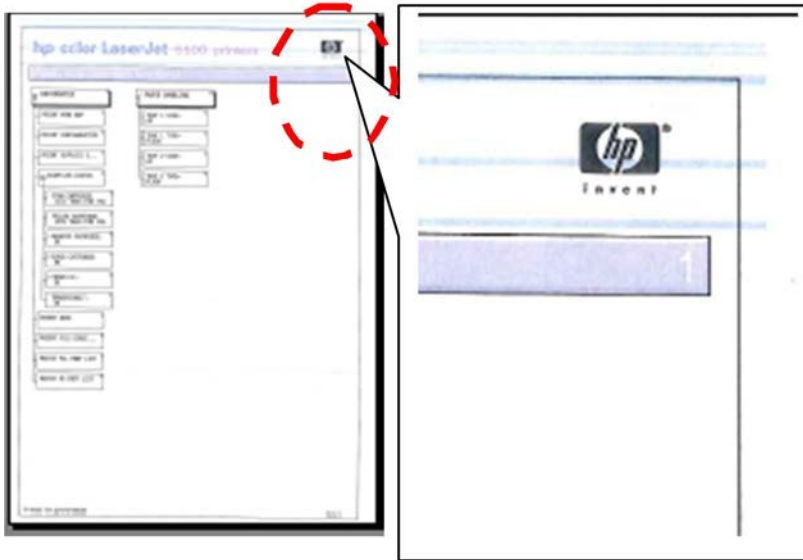

d088t404

Possible Cause:

Wear of the cleaning blade at a specific point by image creation in the same place many times.

Solution:

Replace the drum unit.

Band Image Between 20mm and 30mm

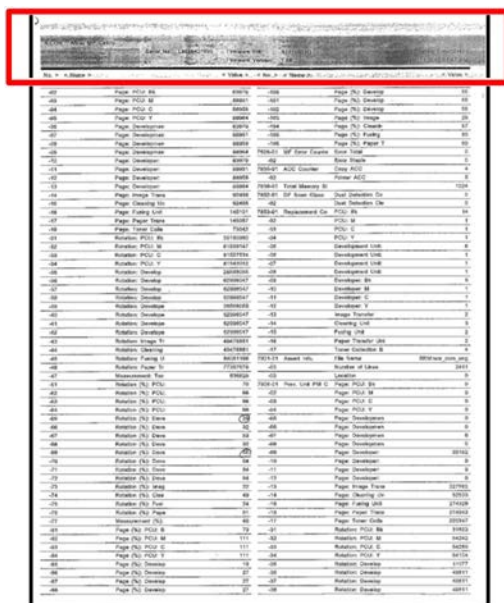

d088t405

Trouble-Shooting

Possible Cause:

Developer wear with time

Solution:

Replace the developer or the development unit.

6.3.10 DAMAGED LIFT SENSOR SWITCH OR MOTOR

SC798 is displayed when the SR3070 (D585) is unpacked or installed, or later during machine operation if the lift sensor switch or motor was damaged during machine installation.

Cause

- The section of the exit tray circled in the photo below is contacted (hit) during the shipping process.
- The customer lifts the tray all the way up.



d1420081

Solution

If the symptom occurs at machine installation, do Procedure 1 below.

If the symptom occurs during machine operation after installation, do Procedure 2 below.

Procedure 1

Do this procedure if the symptom occurs at machine installation.

- Turn off the main power switch.



d1420082

- Shift tray ( x 2)



d1420083



d1420084

- Shift tray bracket ( x 2)

Screws:



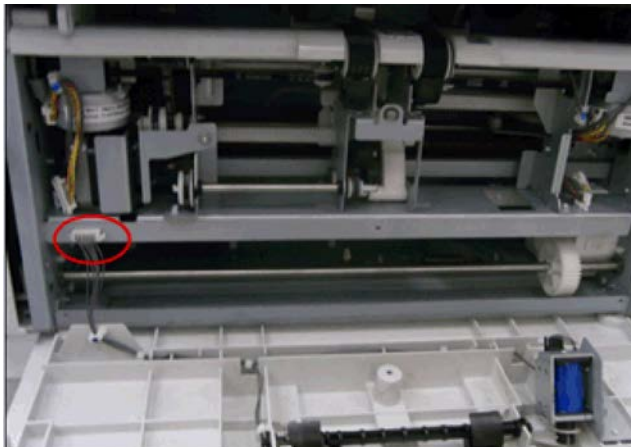

d1420085

Connector:



d1420086

Trouble-Shooting

- End fence ( x 3,  x 1)

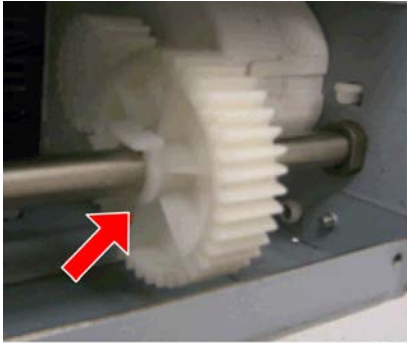

d1420087

- Snap attached beside the gear (snap x 1)



d1420088

- Push down the two tray support plates (left and right sides) all the way.
- Attach the above gear and snap (snap x 1).
- Attach all parts and connectors that you removed in steps 1 - 4.
- Turn on the main power switch and make sure that SC798 does not occur.

Procedure 2

Do this procedure if the symptom occurs after installation, during regular operation.

- Check the tray position.
- Check the position and ON-OFF response of the tray lift sensor switch.
- Check the tray lift motor and tray lift sensor harness.
- Remove and reattach the tray lift motor.
- Replace the tray lift motor or tray lift sensor.

★ Important

- Whenever you lift or carry the SR3070, always **hold it by the bottom edges** of the front cover [C] and rear cover [A], as the figure left below. If you do not, SC798 will occur when you attach the finisher. **DO NOT** hold the finisher by the tray holder [B], as the figure right below.

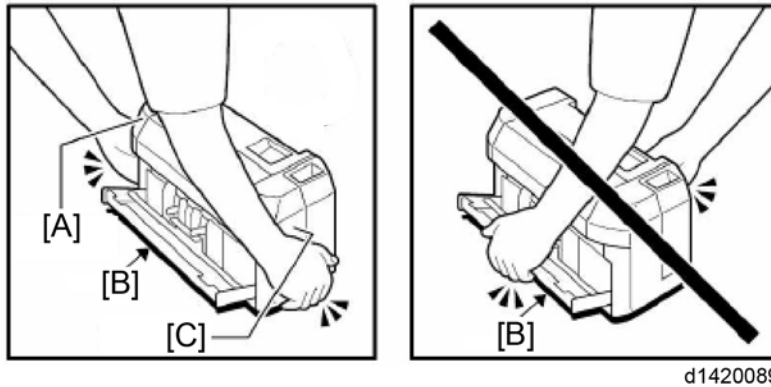

d1420089

6.3.11 ENCRYPTION KEY RESTORATION FOR NVRAM

How to restore the old encryption key to the machine

The following message appears after the controller board is replaced, or after the hard disk and controller board are replaced. In such cases, it is necessary to restore the encryption key to the new controller board.

SD card for restoration is required.
Turn the main power switch off and set the SD card, then turn the main power switch on.

d1420101

To do this, follow the procedure below.

- Prepare an SD card that has been initialized in FAT16 format.
- Using a PC, create a folder in the SD card and name it "restore_key".
- Create a folder in the "restore_key" folder and name it the same as machine's serial number, "xxxxxxxxxxx" (11 digits).
- Create a text file called "key_xxxxxxxxxx.txt" and save it in the "xxxxxxxxxxx" folder. Write the encryption key in the text file.

/restore_key/xxxxxxxxxxx/key_xxxxxxxxxx.txt

Note

- Ask an Administrator to enter the encryption key. The key has already been printed out by the user and may have been saved in the "key_xxxxxxxxxx.txt" file. (The function of back-up the encryption key to the SD card directly is provided 11A products or later.)
- Turn on the machine's main power switch.
- Confirm that a message is displayed on the LCD telling to insert the SD card that contains the encryption key.
- Turn off the main power switch.
- Insert the SD card that contains the encryption key into Slot 2 (the lower slot).

Trouble-Shooting

- Turn on the main power switch.

Note

- The machine will automatically restore the encryption key to the flash memory on the controller board.
- Turn off the main power switch when the machine has returned to normal status.
- Remove the SD card from Slot 2.

How to do a forced start up with no encryption key

If the encryption key back-up has been lost, follow the procedure below to do a forced start-up.

Important

- **The HDD will be formatted after the forced start-up.**
- **Encrypted data will be deleted.**
- **User settings will be cleared.**
- Prepare an SD card.
- Create a directory named “restore_key” inside the root directory of the SD card. Then, save the “nvram_key.txt” file using the following name:
/restore_key/nvram_key.txt
- Create a text file and write "nvclear".

Important

- **Write this string at the head of the file.**
- **Use all lower-case letters.**
- **Do not use quotation marks or blank spaces.**
- **It is judged that a forced start has been selected when the content of "nvclear" is executed and the machine shifts to the alternate system (forced start).**
- Confirm that a message is displayed on the LCD telling to insert the SD card that contains the encryption key.
- Turn off the main power switch.
- Insert the SD card that contains the encryption key into Slot 2 (the lower slot).
- Turn on the main power switch.
- Turn on the main power switch, the machine automatically clear the HDD encryption.
- Turn off the main power switch when the machine has returned to normal status.
- Remove the SD card from Slot 2.
- Turn on the main power switch.
- Memory clear SP5-801-xx (Exclude SP-5-801-001: All Clear and SP-5-801-002: Engine), and clear SP5-846-046: address book.
- Set necessary user settings in User Tools key.

6.3.12 FAX ICON IS NOT DISPLAYED

When the fax unit is installed on the machine, the fax icon [A] is displayed on the home screen of the operation panel, as shown below. (The figure shown below is an example of the home screen. The location of each icon depends on the settings.)



d1420109

If the fax icon is not displayed (as shown below), the FCU should be replaced. Refer to the Fax service manual for the FCU replacement procedure.

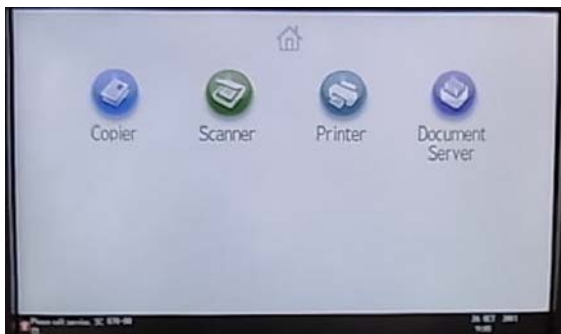

d1420108

6.3.13 OTHER SYMPTOMS

The following pages explain troubleshooting for the following symptoms:

- SC 861(HDD reboot error) to 865 (HDD access error)
- Any SC that indicates a defective controller board
- “Please wait” remains on display

Flowchart for the error

Test the machine using the flow chart below, to determine which parts are causing the problem.

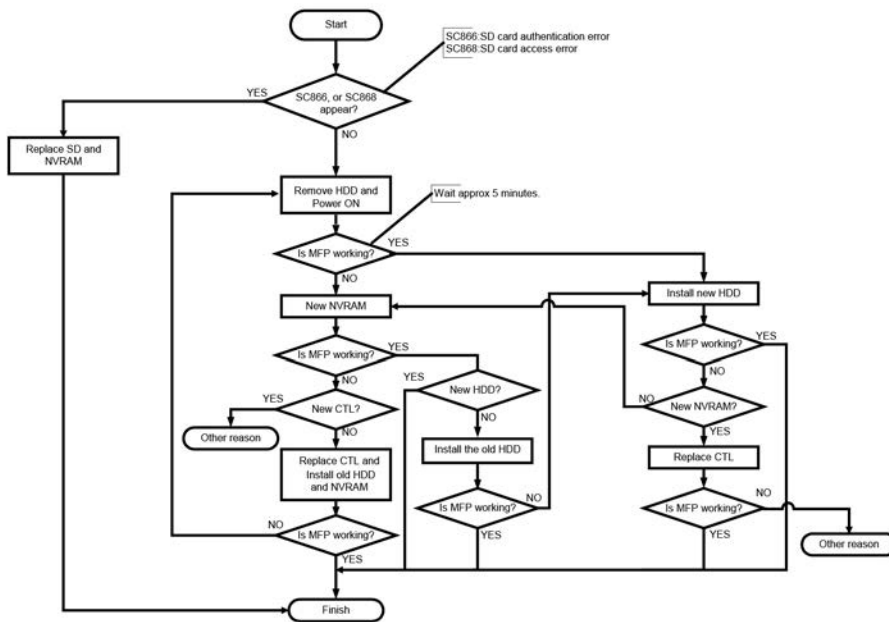

d1420102

Countermeasure list for the error

The following table shows what to do in each case: For example, if only the controller and HDD were found to be defective, then it is No 4 in the table below.

HDD Encryption OFF ^{*1}

CTL	HDD	NVRAM	SD Card	Action	No
R	R	R	R	Replace CTL / HDD / SD card / NVRAM	1
R	R	R	(R)	Replace CTL / HDD / SD card / NVRAM	2
R	R	-	R	Replace CTL / HDD / SD card	3
R	R	-	-	Replace CTL / HDD	4
R	-	R	R	Replace CTL / SD card / NVRAM	5
R	-	R	(R)	Replace CTL / SD card / NVRAM	6
R	-	-	R	Replace CTL / SD card	7
R	-	-	-	Replace CTL	8
-	R	R	R	Replace HDD / SD card / NVRAM	9
-	R	R	(R)	Replace HDD / SD card / NVRAM	10
-	R	-	R	Replace HDD / SD card	11
-	R	-	-	Replace HDD	12
-	-	R	R	Replace SD card / NVRAM	13
-	-	R	(R)	Replace SD card / NVRAM	14
-	-	-	R	Replace SD card	15



HDD Encryption ON *1

CTL	HDD	NVRAM	SD Card	Action	No
R	R	R	R	Replace CTL / HDD/SD card / NVRAM.	1
R	R	R	(R)	Replace CTL / HDD/SD card / NVRAM.	2
R	R	-	R	Replace CTL / HDD/SD card.	3
R	R	-	-	Replace CTL / HDD.	4
R	-	R	R	Replace CTL / SD Card/NVRAM, then the HDD is automatically formatted.	5
R	-	R	(R)	Replace CTL / SD Card/NVRAM, then the HDD is automatically formatted.	6
R	-	-	R	Replace CTL, then restore the old encryption key, then replace SD card.	7
R	-	-	-	Replace CTL, then restore the old encryption key.	8
-	R	R	R	Replace HDD / SD card / NVRAM.	9
-	R	R	(R)	Replace HDD / SD card / NVRAM.	10
-	R	-	R	Replace HDD / SD card.	11
-	R	-	-	Replace HDD.	12
-	-	R	R	Replace SD card / NVRAM.	13
-	-	R	(R)	Replace SD card / NVRAM.	14
-	-	-	R	Replace SD card.	15

(legends)

- : Not defective parts

R: Defective parts, must replace

(R): Not defective parts but must be replaced

*1: Data Overwrite Security (ON/OFF) does not affect the combination table.

6.4 JAM DETECTION

6.4.1 PAPER JAM DISPLAY

SP7-507 shows the paper jam history.

```

CODE :011
SIZE  :05h
TOTAL:000034
DATE  :Fri Feb 15 11:44:50 2006

```

- **CODE:** Indicates the jam code.
- **SIZE:** Indicates the paper Size Code.
- **TOTAL:** Indicates the total counter (SP7-502-001).
- **DATE:** indicates the date when the jam occurred.

6.4.2 JAM CODES AND DISPLAY CODES

SP7-504 shows how many jams occurred at each location.

Jam Code SP	Display	Description	LCD Display
7504 3	Tray 1: ON	Paper is not fed from tray 1.	A
7504 4	Tray 2: ON	Paper is not fed from tray 2.	A
7504 5	Tray 3: ON	Paper is not fed from tray 3 (LCT).	Y
7504 6	Tray 4: ON	Paper is not fed from tray 4.	Y
7504 7	LCT: ON	Paper is not fed from LCT.	U
7504 8	Bypass: ON	Paper is not fed from the by-pass tray.	A
7504 9	Duplex: ON	Paper is jammed at the duplex unit.	Z
7504 10	-	-	-
7504 11	Vertical Transport 1: ON	Vertical transport sensor 1 does not detect paper from tray 1.	A
7504 12	Vertical Transport 2: ON	Vertical transport sensor 2 does not detect paper from tray 2.	A

Jam Detection

Jam Code SP	Display	Description	LCD Display
7504 13	Bank Transport 1	Vertical transport sensor 3 does not detect paper from tray 3 (LCT).	Y
7504 14	-	Vertical transport sensor 4 does not detect paper from tray 4.	Y
7504 15	-	-	-
7504 16	-	-	-
7504 17	Registration: ON	Registration sensor does not detect paper.	A
7504 18	Fusing Entrance: ON	Fusing entrance sensor does not detect paper.	B
7504 19	Fusing Exit: ON	Fusing exit sensor does not detect paper.	B
7504 20	Paper Exit: ON	Paper exit sensor does not detect paper.	C
7504 21	Relay Exit: ON	Tray exit sensor (bridge unit) does not detect paper.	D
7504 22	Relay Transport: ON	Relay sensor (bridge unit) does not detect paper.	D
7504 23	-	-	-
7504 24	Junction Gate Feed: ON	Junction gate jam sensor does not detect paper.	C
7504 25	Duplex Exit: ON	Duplex exit sensor does not detect paper.	Z
7504 26	Duplex Entrance: ON (In)	Duplex entrance sensor does not detect paper.	Z
7504 27	Duplex Entrance: ON (Out)	Duplex entrance sensor does not detect paper again after paper has passed this sensor.	Z

Jam Code SP	Display	Description	LCD Display
7504 28	-	-	-
7504 51	SEF Sensor 1	Vertical transport sensor 1 does not turn off.	A
7504 52	SEF Sensor 2	Vertical transport sensor 2 does not turn off.	A
7504 53	Bank SEF Sensor 1	Vertical transport sensor 3 does not turn off.	Y
7504 54	Bank SEF Sensor 2	Vertical transport sensor 4 does not turn off.	Y
7504 55	-	-	-
7504 56	-	-	-
7504 57	Regist Sensor	Registration sensor does not turn off.	B
7504 58	LCT Sensor	LCT sensor does not turn off.	U
7504 59		-	-
7504 60	Exit Sensor	Paper exit sensor does not turn off.	C
7504 61	Relay Exit Sensor	Tray exit sensor (bridge unit) does not turn off.	D
7504 62	Relay Sensor	Relay sensor (bridge unit) does not turn off.	D
7504 63	-	-	-
7504 64	Junction Gate Feed: OFF	Junction gate jam sensor does not turn off.	C
7504 65	Duplex Exit Sensor	Duplex exit sensor does not turn off.	Z
7504 66	Duplex Entrance: OFF (In)	Duplex entrance sensor does not turn off.	Z

Jam Detection

Jam Code SP	Display	Description	LCD Display
7504 67	Duplex Entrance: OFF (Out)	Duplex entrance sensor does not turn off after paper has passed this sensor.	Z
7504 68	-	-	-
7504 100	Finisher Entrance (D588)	Paper does not reach to the entrance sensor or stay at the entrance sensor.	R1-R2
7504 101	Finisher Shift Tray Exit (D588)	Paper does not reach to the lower tray exit sensor or stay at the lower tray exit sensor.	R1-R2
7504 102	Finisher Staple (D588)	Paper does not reach to the staple tray entrance sensor or stay at the staple tray entrance sensor.	R3-R5
7504 103	Finisher Exit (D588)	Lower tray exit sensor does not detect paper after the stack feed-out belt has fed paper. Lower tray exit sensor still detects paper after the stack feed-out belt has returned to the home position.	R3-R5
7504 104	-	-	-
7504 105	Finisher Tray Lift Motor (D588)	Stack height sensor does not detect paper after the lower tray has lifted up. Stack height sensor still detects paper after the lower tray has lifted down.	R1-R2
7504 106	Finisher Jogger Motor (D588)	Jogger fence HP sensor does not turn off after the jogger fence has moved from its home position. Jogger fence HP sensor does not turn on after the jogger fence has returned to its home position.	R3-R5

Jam Code SP	Display	Description	LCD Display
7504 107	Finisher Shift Motor (D588)	Shift roller HP sensor does not turn off after the shift roller has moved from its home position. Shift roller HP sensor does not turn on after the shift roller has returned to its home position.	R1-R2
7504 108	Finisher Staple Motor (D588)	Stapler HP sensor does not turn off after the stapler has moved from its home position. Stapler HP sensor does not turn on after the stapler has returned to its home position.	R3-R5
7504 109	Finisher Exit Motor (D588)	Stack feed-out belt HP sensor does not turn off after the stack feed-out belt has moved from its home position. Stack feed-out belt HP sensor does not turn on after the stack feed-out belt has returned to its home position.	R3-R5
7504 130	-	-	R1-R3
7504 131	-	-	R1-R3
7504 132	-	-	R1-R3
7504 133	-	-	R4-R6
7504 134	-	-	R4-R6
7504 135	-	-	R7-R11
7504 136	-	-	R7-R11
7504 137	-	-	R1-R3
7504 138	-	-	R7-R11
7504 139	-	-	R1-R3

Jam Detection

Jam Code SP	Display	Description	LCD Display
7504 140	-	-	R1-R3
7504 141	-	-	R7-R11
7504 142	-	-	R1-R3
7504 143	-	-	R7-R11
7504 144	-	-	R7-R11
7504 145	-	-	R7-R11
7504 146	-	-	R7-R11
7504 147	-	-	R7-R11
7504 148	-	-	R7-R11
7504 160	-	Paper does not reach the entrance sensor.	R1
7504 161	-	Paper stays at the entrance sensor.	R1
7504 162	-	Exit problem at the exit tray	R2
7504 163	-	Exit home position sensor does not change after the positioning roller has driven.	R1
7504 164	-	Jogger home position sensor does not change after the jogger motor (front) has driven.	R1
7504 165	-	Jogger home position sensor does not change after the jogger motor (rear) has driven.	R1
7504 166	-	Exit home position sensor does not change after the exit motor has driven.	R1
7504 167	-	Stapler movement home position sensor does not change after the stapler movement motor has driven.	R1

Jam Code SP	Display	Description	LCD Display
7504 168	-	Stapler home position sensor does not change after the stapler motor has driven.	R1
7504 169	-	Paper height sensor does not change after the tray lift motor has driven.	R1
7504 170	-	Paper height sensor does not turn off after the solenoid has turned on.	R1
7504 191	Finisher Entrance: EUP (B804/B805)	Paper does not reach the finisher entrance sensor or stays at the finisher entrance sensor.	R1-R4
7504 192	Finisher Proof Exit: EUP (B804/B805)	Paper does not reach the proof tray exit sensor or stays at the proof tray exit sensor.	R1-R4
7504 193	Finisher Shift Tray Exit: EUP (B804/B805)	Paper does not reach the upper tray exit sensor or stays at the upper tray exit sensor.	R1-R4
7504 194	Finisher Stapler Exit: EUP (B804/B805)	Stapling tray paper sensor does not turn on after the finisher entrance sensor has turned on. Stapling tray paper sensor does not turn off after it has turned on.	R5-R7
7504 195	Finisher Exit: EUP (B804/B805)	Upper tray exit sensor does not turn on while the stack feed-out belt is turned on. Upper tray exit sensor does not turn off after the stack feed-out belt has returned to its home position.	R8-R12
7504 196	-	-	-
7504 197	-	-	-

Jam Detection

Jam Code SP	Display	Description	LCD Display
7504 198	Finisher Folder: EUP (B804 only)	<p>Fold bottom fence HP sensor does not turn on after the fold roller motor has stopped.</p> <p>Fold unit exit sensor does not turn on after the fold rollers have stopped.</p> <p>Fold unit exit sensor does not turn off after the fold rollers have stopped.</p>	R8-R12
7504 199	Finisher Tray Motor: EUP (B804/B805)	<p>Upper tray limit sensor does not turn on after the upper tray has lifted up.</p> <p>Upper tray limit sensor does not turn off after the upper tray has moved down.</p>	R1-R4
7504 200	Finisher Jogger Motor: EUP (B804/B805)	<p>Jogger fence HP sensor does not turn on/off after the jogger motor has turned on.</p> <p>Stack feed out belt HP sensor does not turn on/off after the feed out belt motor has turned on.</p>	R8-R12
7504 201	Finisher Shift Motor: EUP (B804/B805)	<p>Shift roller HP sensor does not turn on/off after the shift roller motor has turned on.</p> <p>Exit guide plate HP sensor does not turn on/off after the exit guide plate motor has turned on.</p> <p>Stacking roller HP sensor does not turn on/off after the stacking sponge roller motor has turned on.</p>	R1-R4
7504 202	Finisher Staple Moving Motor: EUP (B804/B805)	<p>Corner stapler HP sensor does not turn on/off after the corner stapler movement motor has turned on.</p> <p>Stapler rotation HP sensor does not turn on/off after the corner stapler rotation motor has turned on.</p>	R8-R12

Jam Code SP	Display	Description	LCD Display
7504 203	Finisher Staple Motor: EUP (B804/B805)	Corner stapler does not finish stapling after a specified time. Booklet stapler does not finish stapling after a specified time.	R8-R12
7504 204	Finisher Folder Motor: EUP (B804 only)	Fold plate HP sensor does not turn on/off after the fold plate motor has turned on. Clamp roller HP sensor does not turn on/off after the clamp roller retraction motor has turned on. Fold bottom fence HP sensor does not turn on/off after the fold unit bottom fence lift motor has turned on. Stack junction gate HP sensor does not turn on/off after the stack junction gate motor has turned on.	R8-R12
7504 205	-	-	-
7504 206	Finisher Punch Motor: EUP (B804/B805)	Punch encoder sensor does not turn on/off after the punch drive motor has turned on. Punch movement HP sensor does not turn on/off after the punch movement motor has turned on. Paper position slide HP sensor does not turn on/off after the paper position sensor slide motor has turned on.	R1-R4
7504 230	-	Finisher does not send the paper exit finish bin number.	R1-R3
7504 231	-	Finisher does not keep on accepting paper because of insufficient data or command from the main frame.	R1

Paper Size Code

Size Code	Paper Size	Size Code	Paper Size
05	A4 LEF	141	B4 SEF
06	A5 LEF	142	B5 SEF
14	B5 LEF	160	DLT SEF
38	LT LEF	164	LG SEF
44	HLT LEF	166	LT SEF
132	A3 SEF	172	HLT SEF
133	A4 SEF	255	Others
134	A5 SEF	-	-

Sensor Locations

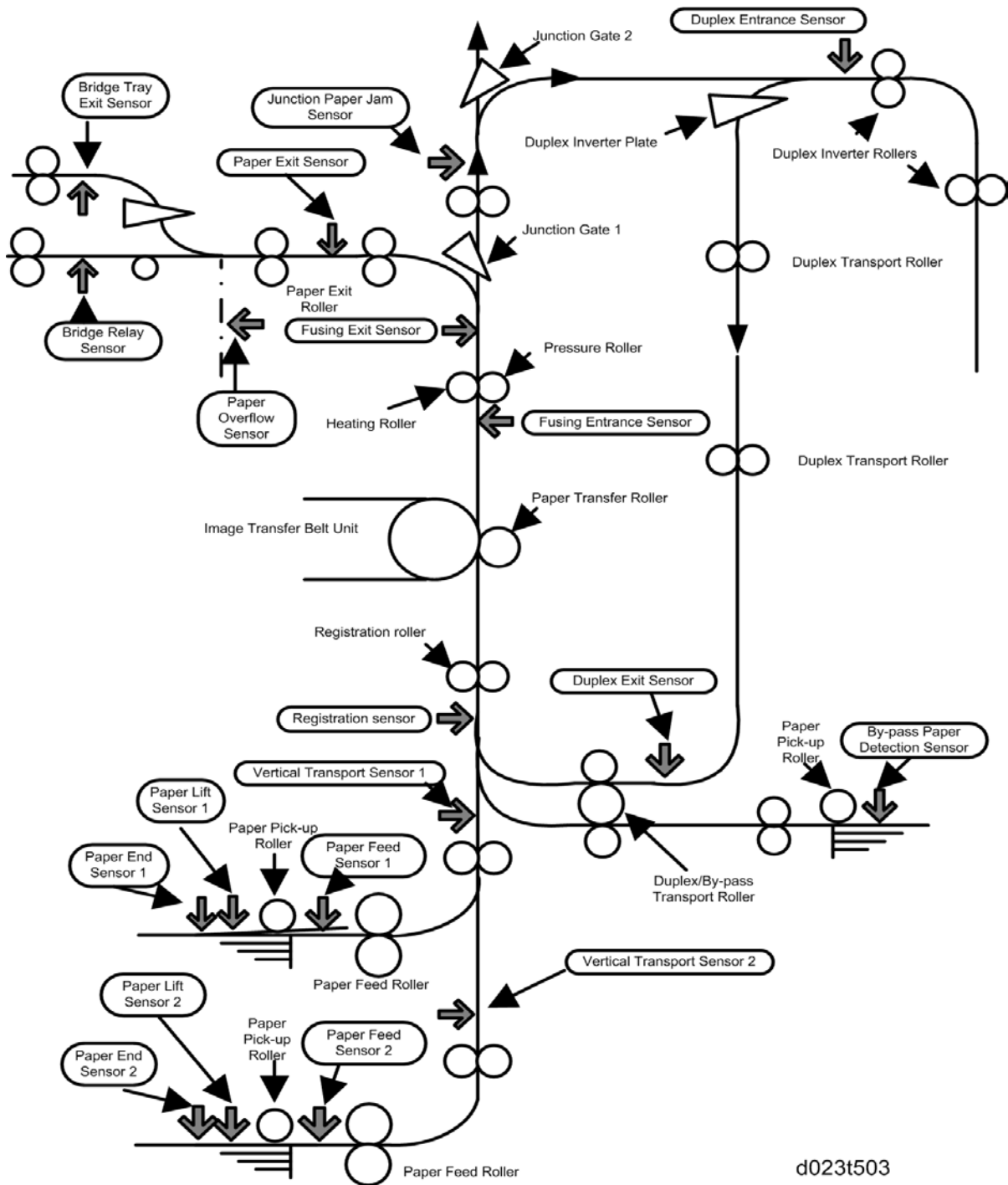

Trouble-Shooting

d023t503

6.5 ELECTRICAL COMPONENT DEFECTS

6.5.1 SENSORS

Note

- The CN numbers in the following table are the connector numbers on the IOB.

No.	Sensor Name/ Sensor Board Name	Active	CN	Condition	Symptom
SW1	Right Door Open Switch	L	CN204/1	Open	"Open Cover" is displayed.
				Shorted	"Open cover" cannot be detected.
S9	Duplex Door	L	CN232/B11	Open	"Open Cover" is displayed.
				Shorted	"Open cover" cannot be detected.
S1	ID Sensor: Front	A	CN219/1	Open/ Shorted	SC370
	ID Sensor: Center and K	A	CN219/2	Open/ Shorted	SC370
	ID Sensor: Rear	A	CN219/3	Open/ Shorted	SC370
S12	Registration Sensor	L	CN224/A2	Open	Jam A (Jam8, 17)
				Shorted	Jam A, B (Jam1)
S30	Drum Gear Position Sensor-K	H	CN222/A2	Open/ Shorted	SC390-01/SC396-01
S31	Drum Gear Position Sensor-C	H	CN222/A5	Open/ Shorted	SC390-02/SC396-02
S32	Drum Gear Position Sensor-M	H	CN222/A8	Open/ Shorted	SC390-03/SC396-03

No.	Sensor Name/ Sensor Board Name	Active	CN	Condition	Symptom
S33	Drum Gear Position Sensor-Y	H	CN222/A11	Open/ Shorted	SC390-04/SC396-04
S26	Toner End Sensor - K	L	CN207/ B14 CN207/B3 CN207/B9 CN207/B6	Open	Toner end cannot be detected.
S27	Toner End Sensor - Y			Shorted	Toner end is detected when there is enough toner.
S28	Toner End Sensor - C				
S29	Toner End Sensor - M				
S34	Image Transfer Belt Rotation Sensor	H/L	CN206/3	Open/ Shorted	SC443
S19	Vertical Transport Sensor 1	L	CN230/A7	Open	Jam A (Jam3, 11)
				Shorted	Jam A, B (Jam1)
S20 S24	Paper End Sensor 1, 2	L	CN230/ A10, B10	Open	Paper end is not detected when there is no paper in the paper tray.
				Shorted	Paper end is detected when there is paper in the paper tray.
S21 S25	Paper Lift Sensor 1, 2	H	CN230/ A13, B13	Open/ Shorted	SC501, SC502
S23	Vertical Transport Sensor 2	L	CN230/B7	Open	Jam A (Jam4, 12)
				Shorted	Jam A, B (Jam1)
S14 S15	Tray 1 Paper Height Sensor 1, 2	L	CN224/ B2, B5	Open/ Shorted	Remaining paper volume on the LCD is wrong.
S16 S17	Tray 2 Paper Height Sensor 1, 2	L	CN224/ B10, B13	Open/ Shorted	Remaining paper volume on the LCD is wrong.

Electrical Component Defects

No.	Sensor Name/ Sensor Board Name	Active	CN	Condition	Symptom
S18	Tray 1 Paper Feed Sensor	L	CN230/A4	Open/ Shorted	Jam A, B
S22	Tray 2 Paper Feed Sensor	L	CN230/B4	Open/ Shorted	Jam A, B
SW4	Tray 1 Set Switch	L	CN224/A9	Open	Tray 1 is not detected when tray 1 is set.
				Shorted	Tray 1 is detected when tray 1 is not set.
S11	By-pass Paper Size Sensor	L	CN232/ B16, B17, B19, B20	Open/ Shorted	Paper size error
SW2	By-pass Paper Detection Sensor	L	CN232/ A10	Open	Paper on the by-pass tray is not detected when paper is set.
				Shorted	Paper on the by-pass tray is detected when paper is not set.
S10	By-pass Paper Length Sensor	L	CN232/ B14	Open	Paper size error
				Shorted	
S8	Fusing Entrance Sensor	L	CN232/B2	Open	Jam C (Jam 18)
				Shorted	Jam C (Jam 1)
S6	Duplex Entrance Sensor	L	CN232/A2	Open	Jam Z (Jam 26/27)
				Shorted	Jam Z (Jam 1)
S7	Duplex Exit Sensor	L	CN232/B8	Open	Jam Z (Jam 25)
				Shorted	Jam Z (Jam 1)
S39	TD Sensor - K	A	CN227/A7	Open/ Shorted	SC360-01

No.	Sensor Name/ Sensor Board Name	Active	CN	Condition	Symptom
S40	TD Sensor - C	A	CN227/ A15	Open/ Shorted	SC360-02
S41	TD Sensor - M	A	CN227/B7	Open/ Shorted	SC360-03
S42	TD Sensor - Y	A	CN227/ B15	Open/ Shorted	SC360-04
S4	Fusing Exit Sensor	L	CN204/12	Open	Jam C (Jam 19)
				Shorted	Jam C (Jam 1)
S13	Waste Toner Sensor	H	CN224/A5	Open	Waste toner near full indicated when it is not near full.
				Shorted	Waste toner near full cannot be detected when the waste toner bottle is nearly full.
SW3	Waste Toner Bottle Set Switch	L	CN224/A7	Open	Waste toner bottle is not detected when the waste toner bottle is set.
				Shorted	Waste toner bottle is detected when the waste toner bottle is not set.
SW5	Tray 2 Paper Size Switch	L	CN224/ A11, A12, A13, A15	Open/ Shorted	Paper size error

No.	Sensor Name/ Sensor Board Name	Active	CN	Condition	Symptom
⇒ S8	Temperature/ Humidity Sensor	A	CN234/6, 8	Open/ Shorted	SC498 Printed image has some problems such as rough image, dirty background, weak image or poor fusing.
S36	Thermopile Center, Edge	A	CN212/3, 6	Open/ Shorted	SC541, SC551
TH1	Thermistor - Pressure Roller Center, Edge	A	CN212/21, 19	Open/ Shorted	SC561, SC571
S3	Paper Exit Sensor	L	CN204/9	Open	Jam C (Jam 20)
				Shorted	Jam C (Jam 1)
⇒ S25	Paper Overflow Sensor	L	CN204/15	Open	Paper overflow message is not displayed when the paper overflow condition still remains.
				Shorted	Paper overflow message is displayed when the paper overflow condition does not remain.

No.	Sensor Name/ Sensor Board Name	Active	CN	Condition	Symptom
	Original Length Sensor 2	A	CN313/5 SIO	Open/ Shorted	Original paper size cannot be detected.
S43	Original Length Sensor 3	A	CN313/2 SIO	Open/ Shorted	Original paper size cannot be detected.
S39	Scanner HP Sensor	H	CN318/2 SIO	Open	SC120
				Shorted	SC121
S40	Platen Cover Sensor	L	CN318/5 SIO	Open/ Shorted	Platen cover open cannot be detected.
S2	Junction Paper Jam Sensor	L	CN204/6	Open/ Shorted	Jam C (Jam 24/64)
-	NC Sensor Center, Edge	A	CN212/14,9	Open/ Shorted	SC581, SC591

6.5.2 BLOWN FUSE CONDITIONS

Power Supply Unit

Fuse	Rating		Symptom when turning on the main switch
	115V	220V - 240V	
FU1	15A/250V	8A/250V	No response. (5V power to the PSU is not supplied.)
FU2	15A/250V	6.3A/250V	No response. (5V power to the IPU and controller is not supplied.)
FU3*1	2A/250V	1A/250V	5V power to the scanner heater and tray heater is not supplied.
FU4*1	5A/250V	5A/250V	5VE power to the SIO and IOB is not supplied.
FU5*1	5A/250V	5A/250V	5V power to the IOB not supplied.
FU6*1	5A/250V	5A/250V	5V power to the IPU not supplied.
FU7	8A/250V	8A/250V	24VS power to the IOB not supplied.
FU8	8A/250V	8A/250V	24VS power to the IOB not supplied.
FU9	8A/250V	8A/250V	24V power to the IOB and IPU not supplied.
FU10	8A/250V	8A/250V	24V power to the SIO not supplied.
FU11	8A/250V	8A/250V	24V power to the PFU or LCT and finisher not supplied.

*1 Replace the whole board or unit if this fuse blows, because it is soldered.

AC Drive Board

Fuse	Rating		Symptom when turning on the main switch
	115V	220V - 240V	
FU1	15A/250V	8A/250V	SC574-02 occurs.
FU2	1A/250V	1A/250V	No voltage detection

⚠ CAUTION

- For continued protection against risk of fire, replace only with same type and rating of fuse.

6.6 SCANNER TEST MODE

6.6.1 SBU TEST MODE

Output the SBU test pattern with SP4-807-001 to make sure the scanner SBU operates correctly. The SBU test pattern prints out after you have set the SP mode settings and pressed the start key.

- The CCD on the SBU board may be defective if the copy is abnormal but the SBU test pattern is normal.
- The following can be the cause if the copy is abnormal and the SBU test pattern is also abnormal:
 - The harness may not be correctly connected between the SBU and the IPU.
 - The IPU or SBU board may be defective.

ENERGY SAVING

REVISION HISTORY		
Page	Date	Added/Updated/New
		None

7. ENERGY SAVING

7.1 ENERGY SAVE

7.1.1 ENERGY SAVER MODES

Customers should use energy saver modes properly, to save energy and protect the environment.

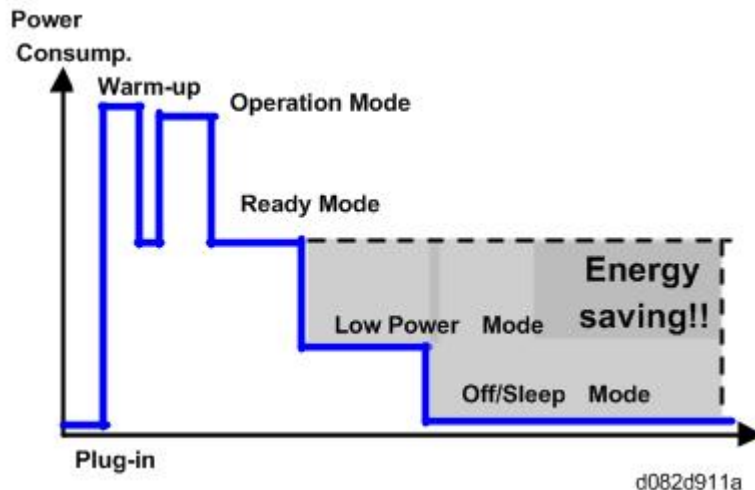

The area shaded grey in this diagram represents the amount of energy that is saved when the timers are at the default settings. If the timers are changed, then the energy saved will be different. For example, if the timers are all set to 240 min., the grey area will disappear, and no energy is saved before 240 min. expires.

Timer Settings

The user can set these timers with User Tools (System settings > Timer setting)

1. Energy saver timer (1 – 240 min): Low Power Mode. Default setting: 1 min (for NA and EU)/10 min (others).
2. Auto off timer (1 – 240 min): Off/Sleep Mode. Default setting: 1 min (for NA and EU)/16 min (others).

Normally, Energy Saver timer < Auto Off timer. But, for example, if Auto Off timer < or = Energy Saver timer, the machine goes immediately to Off mode when the Auto Off timer expires. It skips the Energy Saver mode.

Example

1. Low power: 15 min.
2. Auto Off: 1 min.
3. The machine goes to Off mode after 1 minute. Low Power mode is not used.



Return to Stand-by Mode

Low Power Mode

The recovery time depends on the model and the region.

1. C3a, b: 10 sec. or less.

Off/Sleep Mode

Recovery time.

1. C3a, b: 10 sec. or less.

Recommendation

We recommend that the default settings should be kept.

1. If the customer requests that these settings should be changed, please explain that their energy costs could increase, and that they should consider the effects on the environment of extra energy use.
2. If it is necessary to change the settings, please try to make sure that the Auto Off timer is not too long. Try with a shorter setting first, such as 30 min., then go to a longer one (such as 60 min.) if the customer is not satisfied.
3. If the timers are all set to the maximum value, the machine will not begin saving energy until 240 minutes has expired after the last job. This means that after the customer has finished using the machine for the day, energy will be consumed that could otherwise be saved.
4. If you change the settings, the energy consumed can be measured using SP8941, as explained below.

7.1.2 ENERGY SAVE EFFECTIVENESS

SP 8941 (Machine Status) keeps a record of the amount of time that the machine spends in each mode.

1. 8941-001: Operating mode
2. 8941-002: Standby mode
3. 8941-004: Low power mode
4. 8941-005: Off/sleep mode

With this data, and the power consumption values from the specifications, we can estimate the amount of energy that is used by the machine.

This should only be used as a reference value, because the power consumption specifications are measured in a controlled environment with a constant power supply.

To get an exact measurement at the customers site, a watt meter must be used to measure the actual energy consumed.

To use SP8941 to calculate the energy consumed:

1. At the start of the measurement period, read the values of SP8941 001 to 005.
2. At the end of the measurement period, read the values of SP8941 001 to 005 again.
3. Find the amount of time spent in each mode (subtract the earlier measurement from the later measurement).
4. Multiply this by the power consumption spec for each mode.
5. Convert the result to kWh (kilowatt hours)

7.2 PAPER SAVE

7.2.1 EFFECTIVENESS OF DUPLEX/COMBINE FUNCTION

Duplexing and the combine functions reduce the amount of paper used. This means that less energy overall is used for paper production, which improves the environment.

1. Duplex:

Reduce paper volume in half!

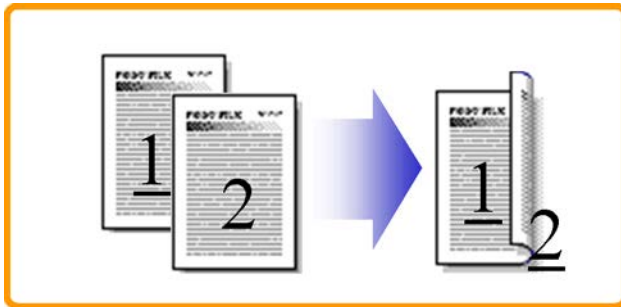

d062d102

2. Combine mode:

Reduce paper volume in half!

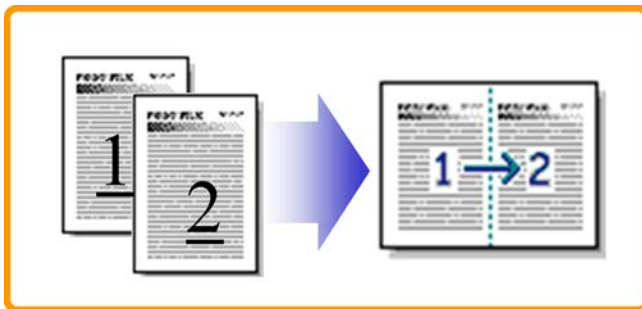

d062d100

3. Duplex + Combine:

Using both features together can further reduce paper volume by 3/4!

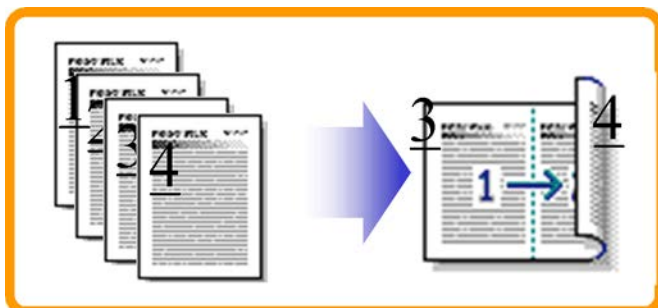

d062d101

To check the paper consumption, look at the total counter and the duplex counter.

The total counter counts all pages printed.

1. For one duplex page, the total counter goes up by 2.
2. For a duplex job of a three-page original, the total counter goes up by 3.

The duplex counter counts pages that have images on both sides.

1. For one duplex page, the duplex counter goes up by 1.
2. For a duplex job of a three-page original, the duplex counter will only increase by 1, even though two sheets are used.

How to calculate the paper reduction ratio

How to calculate the paper reduction ratio, when compared with Single-sided copying, with no 2-in-1 combine mode

Paper reduction ratio (%) = Number of sheets reduced: A / Number of printed original images: B x 100

1. Number of sheets reduced: A
 = Output pages in duplex mode/2 + Number of pages in Single-sided with combine mode +
 Number of pages in Duplex with combine mode x 3/2
 $A = ((2) + (3) + (4))/2 + (5) + (6) \times 3/2$
2. Number of printed original images: B
 = Total counter6 + Number of pages in Single-sided with combine mode + Number of pages in
 Duplex with combine mode
 $B = (1) + (5) + (6)$
3. (1) Total counter: SP 8581 001 (pages)
4. (2) Single-sided with duplex mode: SP 8421 001 (pages)
5. (3) Double-sided with duplex mode: SP 8421 002 (pages)
6. (4) Book with duplex mode: SP 8421 003 (pages)
7. (5) Single-sided with combine mode: SP 8421 004 (pages)
8. (6) Duplex with combine mode: SP 8421 005 (pages)

D111/D142
SERVICE MANUAL APPENDICES

D111/D142 APPENDIX

TABLE OF CONTENTS

1. SPECIFICATIONS.....	1-1
1.1 GENERAL SPECIFICATIONS	1-1
1.1.1 MAIN FRAME	1-1
1.1.2 PRINTER.....	1-6
1.1.3 SCANNER	1-7
1.2 SUPPORTED PAPER SIZES	1-8
1.2.1 PAPER FEED	1-8
North America	1-8
Europe/ Asia.....	1-10
1.2.2 PAPER EXIT.....	1-12
1000-Sheet Booklet Finisher	1-12
1000-Sheet Finisher and 500-Sheet Finisher.....	1-14
1.2.3 PLATEN/ARDF ORIGINAL SIZE DETECTION	1-17
1.3 SOFTWARE ACCESSORIES.....	1-19
1.3.1 PRINTER DRIVERS	1-19
1.3.2 SCANNER AND LAN FAX DRIVERS.....	1-20
1.3.3 UTILITY SOFTWARE	1-21
1.4 OPTIONAL EQUIPMENT.....	1-22
1.4.1 ARDF (D578).....	1-22
1.4.2 PAPER FEED UNIT (D580).....	1-23
1.4.3 LCT 2000-SHEET (D581).....	1-23
1.4.4 LCT 1200-SHEET (D631).....	1-24
1.4.5 1000-SHEET BOOKLET FINISHER & PUNCH UNIT (D589).....	1-24
1.4.6 1000-SHEET FINISHER (D588).....	1-26
Upper Tray	1-26
Lower Tray	1-26
1.4.7 500-SHEET FINISHER (D585).....	1-27
500-Sheet Finisher.....	1-28
1.4.8 BRIDGE UNIT (D634).....	1-29
1.4.9 SHIFT TRAY (D633).....	1-30
1.4.10 1-BIN TRAY UNIT (D632).....	1-30
2. PREVENTIVE MAINTENANCE TABLES.....	2-1

2.1 MAINTENANCE TABLES	2-1
2.1.1 PREVENTIVE MAINTENANCE ITEMS	2-1
Mainframe	2-1
ARDF (D578)	2-4
Two-tray Paper Feed Unit (D580)	2-5
1200-sheet LCT (D631).....	2-5
2000-sheet LCT (D581).....	2-6
1000-Sheet Booklet Finisher (D589).....	2-6
1000-Sheet Booklet Finisher Punch Kit (B807).....	2-6
1000-Sheet Finisher (D588).....	2-7
1 Bin Tray (D632).....	2-7
Bridge Unit (D634)	2-7
Shift Tray (D633).....	2-7
One-tray Paper Feed Unit (D579)	2-8
Side Tray (D635).....	2-8
Toner Scatterproof Filter Removal Procedure.....	2-8
2.1.2 OTHER YIELD PARTS	2-9
Mainframe	2-9
ARDF	2-9
3. SP MODE TABLES.....	3-1
3.1 MAIN SP TABLES-1	3-1
3.1.1 SP1-XXX (FEED).....	3-1
3.2 MAIN SP TABLES-2	3-52
3.2.1 SP2-XXX (DRUM).....	3-52
3.3 MAIN SP TABLES-3	3-134
3.3.1 SP3-XXX (PROCESS).....	3-134
3.4 MAIN SP TABLES-4	3-167
3.4.1 SP4-XXX (SCANNER).....	3-167
3.5 MAIN SP TABLES-5	3-187
3.5.1 SP5-XXX (MODE).....	3-187
3.6 MAIN SP TABLES-6	3-257
3.6.1 SP6-XXX (PERIPHERALS)	3-257
3.7 MAIN SP TABLES-7	3-266
3.7.1 SP7-XXX (DATA LOG)	3-266
3.8 MAIN SP TABLES-8	3-305
3.8.1 SP8-XXX: DATA LOG2.....	3-305
3.9 INPUT AND OUTPUT CHECK	3-357
3.9.1 INPUT CHECK TABLE	3-357

Copier.....	3-357
Table 1: Paper Height Sensor.....	3-362
Table 2: Paper Size Switch (Tray 2).....	3-363
Table 3: Paper Size (By-pass Table).....	3-364
ARDF (D578).....	3-365
2000/3000-Sheet (Booklet) Finisher (B804, B805).....	3-367
1000-Sheet Booklet Finisher (D589).....	3-370
1000-Sheet Finisher (D588).....	3-373
500-Sheet Finisher (D585).....	3-375
Bridge Unit (D634) / Side Tray (D635).....	3-376
Internal Shift Tray (D633).....	3-376
1 Bin Tray (D632).....	3-377
Two-Tray PFU (D580)/ LCIT 2000 (D581)/ LCIT 1200 (D631).....	3-377
3.9.2 OUTPUT CHECK TABLE.....	3-378
Copier.....	3-378
ARDF (D578).....	3-386
1000-Sheet Booklet Finisher (D589).....	3-386
1000-Sheet Finisher (D588).....	3-388
2000/3000-Sheet (Booklet) Finisher (B804/B805).....	3-389
500-Sheet Finisher (D585).....	3-390
Bridge Unit (D634) / Side Tray (D635).....	3-391
Shift Tray (D633).....	3-391
1 Bin Tray (D632).....	3-392
Two-Tray PFU (D580) / LCIT 2000 (D581) / LCIT 1200 (D631).....	3-392
3.10 PRINTER SERVICE MODE.....	3-394
3.10.1 SP1-XXX (SERVICE MODE).....	3-394
3.11 SCANNER SP MODE.....	3-403
3.11.1 SP1-XXX (SYSTEM AND OTHERS).....	3-403
3.11.2 SP2-XXX (SCANNING-IMAGE QUALITY).....	3-404
3.12 TEST PATTERN PRINTING.....	3-405

APPENDIX: SPECIFICATIONS

REVISION HISTORY		
Page	Date	Added/Updated/New
		None

1. SPECIFICATIONS

1.1 GENERAL SPECIFICATIONS

1.1.1 MAIN FRAME

Configuration:	Desktop
Print Process:	Laser beam scanning & Dry electrostatic transfer system 4 drums tandem method
Number of scans:	1
Resolution:	Scan: 600 dpi Print: 1,200 dpi
Gradation:	Scan: 600dpi / 10bits/pixel Print: 600dpi / 4 bits/pixel
Original type:	Sheets, book, objects
Maximum original size:	A3/11" x 17"
Original reference position:	Left rear corner, ad hoc lists

General Specifications

<p>Copy speed:</p>	<p>Plain (ADF 1 to 1, LT/ A4 LEF) C3a: 30 cpm (color/black & white) C3b: 35 cpm (color/black & white) Thick 1 (169 g/m² or less) C3a: 17.5 cpm (color/black & white) C3b 17.5 cpm (color/black & white) Thick 2 (220 g/m² or less) C3a: 17.5 cpm (color/black & white) C3b 17.5 cpm (color/black & white) Thick 3 (256 g/m² or less) C3a: 17.5 cpm (color/black & white) C3b 17.5 cpm (color/black & white) Thick 4 (300 g/m² or less) C3a: 15 cpm (color/black & white) from By-pass C3b: 15 cpm (color/black & white) from By-pass OHP, Glossy (1200 dpi) C3a: 17.5 cpm (color/black & white) C3b 17.5 cpm (color/black & white)</p>
<p>First copy (normal mode):</p>	<p>Color C3a: 7.3 seconds or less (A4/LT LEF) C3b: 7.2 seconds or less (A4/LT LEF) Black & white C3a: 4.7 seconds or less (A4/LT LEF) C3b: 4.8 seconds or less (A4/LT LEF)</p>
<p>Warm-up time:</p>	<p>22.1 seconds or less (23°C)</p>
<p>Print Paper Capacity: (80 g/m², 20 lb)</p>	<p>Standard tray: 550 sheets x 2 + 100 By-pass tray: 100 sheets (Normal), 40 sheets (Thick 1: 106 - 169g/m²), 20 sheets (Thick 2/3: 170 - 256 g/m²), 16 sheets (Thick 4: 257 - 300 g/m²), 35 sheets (Postcard) Optional paper feed tray: 550 sheets x 2 2000-sheet LCT: 2000 sheets 1200-sheet LCT: 1200 sheets</p>

Print Paper Size:	(Refer to "Supported Paper Sizes".)		
	-	Minimum	Maximum
	Tray 1	A4/8.5" x 11" (LEF)	
	Tray 2	A5 (LEF)/ 8.5" x 11"	A3/11" x 17"
	By-pass	90 x 148 mm	305 x 600 mm
	Optional Tray	A5 (LEF)/ 8.5" x 11"	A3/11" x 17"
	2000-sheet LCT	A4/8.5" x 11" (LEF)	
	1200-sheet LCT	B5 (LEF)/ 257 x 182mm	A4 (LEF)/ 297 x 210mm
	Envelope feeder	A6 (SEF)/ Postcard	A4/LT (SEF)
Printing Paper Weight:	Standard tray: 60 to 256 g/m ² (16 to 68 lb) Optional paper tray: 60 to 256 g/m ² (16 to 68 lb) By-pass tray: 60 to 300 g/m ² (16 to 79.8 lb) Duplex unit: 60 to 169 g/m ² (16 to 45 lb) LCT 1200: 60 to 216 g/m ² (10 to 571lb)		
Output Paper Capacity:	Standard exit tray: 500 sheets or more (face down)* ¹ Shift Tray: 250 sheets (80 g/m ²) 1-bin Tray: 125 (80 g/m ²) 500-sheet finisher 500 (80 g/m ²) 1000-sheet finisher: 250 + 1000 sheets (80 g/m ²) 1000-sheet booklet finisher: 100 + 1000 sheets (80 g/m ²) *1: T6200, A4 LEF		
Continuous copy:	Up to 999 sheets		

General Specifications

Zoom:	Arbitrary: From 25 to 400% (1% step)	
	Fixed:	
	North America	Europe
	25%	25%
	50%	50%
	65%	61%
	73%	71%
	78%	82%
	85%	87%
	93%	93%
	100%	100%
	121%	115%
	129%	122%
	155%	141%
	200%	200%
	400%	400%
Memory:	Standard: 1.5 GB	
Power Source:	120 V – 127 V, 60 Hz: More than 12A (for North America) 220 V – 240 V, 50/60 Hz: More than 10A (for Europe/Asia)	

Power Consumption:	-	120V	220 - 240V	
	Maximum	1584 W or less	1700 W or less	
	Energy Saver (Sleep Mode)	1.2 W or less	1.6 W or less	
Noise Emission: (Sound Power Level)	Model	State	Mainframe	Complete system (*1)
	C3a	Standby	40 dB(A) or Less	44 dB(A) or Less
			B/W: 66.5 dB(A) or Less	-
		Operating	Color: 67.0 dB(A) or Less	Color: 70.4 dB(A) or Less
	C3b		Standby	40 dB(A) or Less
		B/W: 68.3 dB(A) or Less		-
Operating		Color: 68.5 dB(A) or Less	Color: 71.9 dB(A) or Less	
	(*1) The complete system consists of mainframe, ARDF, finisher, and LCT. The above measurements were made in accordance with Ricoh standard methodology.			
Dimensions (W x D x H): Copier: 670 x 682 x 760 mm (26.4" x 26.9" x 29.9") Copier + PFU or LCT: 670 x 671 x 1020 mm (26.4" x 26.4" x 40.2")				
Weight:	Less than 120 kg (265 lb.) [with ARDF excluding toner]			

1.1.2 PRINTER

<p>Printer Languages:</p>	<p>PCL 6/5c RPCS (Refined Printing Command Stream) Adobe PostScript 3 (optional) PDF Direct IPDS (optional) PictBridge (optional) MediaPrint: JPEG/TIFF (optional)</p>
<p>Resolution and Gradation:</p>	<p>PCL 5c: 300 x 300 dpi : Available only in B/W mode 600 x 600 dpi : Fast (1 bit), Standard (2 bits), Fine (4 bits) PCL 6: 600 x 600 dpi : Fast (1 bit), Standard (2 bits), Fine (4 bits) / 1200 x 1200 dpi RPCS: 600 x 600 dpi, 1,800 x 600 dpi*, 9600 dpi x 600 dpi* *1,800 x 600 dpi = 600 x 600 dpi (2 bits) *9600 dpi x 600 dpi* = 600 x 600 dpi (4 bits) PS3: 600 x 600 dpi : Fast (1 bit), Standard (2 bits), Fine (4 bits)</p>
<p>Printing speed:</p>	<p>C3a: 30 ppm in Plain/Middle Thick mode 17.5 ppm in Thick/OHP mode (depending on paper type) C3b: 35 ppm in Plain/Middle Thick mode 17.5 ppm in Thick/OHP mode (depending on paper type)</p>
<p>Resident Fonts:</p>	<p>PCL 6/5c (Standard): 45 Compatible fonts 13 International fonts 1 Bitmap font Adobe PostScript 3 (Optional)/PDF (Standard): 136 fonts (24 Type 2 fonts, 112 Type 14 fonts) IPDS (Optional): 108 fonts</p>

Host Interfaces:	USB2.0 Type A and Type B: Standard USB Host (PictBridge): Optional Ethernet (100 Base-TX/10 Base-T): Standard Gigabit Ethernet (1000 Base-T): Optional IEEE1284 parallel x 1: Optional IEEE802.11a/b/g (Wireless LAN): Optional Bluetooth (Wireless): Optional
Network Protocols:	TCP/IP (IPv6), IPX/SPX

1.1.3 SCANNER

Standard Scanner Resolution:	Main scan/Sub scan 600 dpi
Available scanning Resolution Range:	Twain Mode: 100 to 1200 dpi Delivery Mode: 100/200/300/400/600 dpi
Grayscales:	1 bit or 8 bits/pixel each for RGB
Scanning Throughput (ARDF mode):	Scan to E-mail / Folder: BW: 51 ipm (A4LEF / BW Text (Print) / 200dpi / Compression: On (MH)) FC: 51 ipm (A4LEF / FC Text / Photo / 200dpi / Compression: Standard)
Interface:	Ethernet (100 Base-TX/10 Base-T/1000 Base-T for TCP/IP), Wireless LAN, GigaEthernet
Compression Method:	B&W: TIFF (MH, MR, MMR) Gray Scale, Full Color: JPEG

1.2 SUPPORTED PAPER SIZES

1.2.1 PAPER FEED

North America

BT: By-pass Tray, T1: Tray 1, T2/3/4: Tray 2/3/4, LCT 2000: Large Capacity Tray: 2000-sheet, LCT 1200: Large Capacity Tray: 1200-sheet, DU: Duplex Unit

Paper	Size (W x L)	BT	T1	T2/3/4	LCT 2000	LCT 1200	DU
A3 W	12" x 18"	M	-	-	-	-	-
A3 SEF	297 x 420mm	M	-	M	-	-	M
A4 SEF	210 x 297mm	M	-	A	-	-	M
A4 LEF	297 x 210mm	M	S	M	S	S	M
A5 SEF	148 x 210mm	M	-	-	-	-	-
A5 LEF	210 x 148mm	M	S	A	-	-	M
A6 SEF	105 x 148mm	M	-	-	-	-	-
B4 SEF	257 x 364mm	M	-	M	-	-	M
B5 SEF	182 x 257mm	M	-	A	-	-	M
B5 LEF	257 x 182mm	M	S	M	-	S	M
B6 SEF	128 x 182mm	M	-	-	-	-	-
Ledger	11" x 17"	A	-	A	-	-	M
Letter SEF	8.5" x 11"	A	-	A	-	-	M
Letter LEF	11" x 8.5"	A	M	A	M	M	M
Legal SEF	8.5" x 14"	M	-	A	-	-	M
Government Legal SEF	8.25" x 14"	M	-	M	-	-	M

Paper	Size (W x L)	BT	T1	T2/3/4	LCT 2000	LCT 1200	DU
Half Letter SEF	5.5" x 8.5"	A	-	-	-	-	-
Executive SEF	7.25" x 10.5"	M	-	M	-	-	M
Executive LEF	10.5" x 7.25"	M	-	A	-	-	M
F SEF	8" x 13"	M	-	M	-	-	M
Foolscap SEF	8.5" x 13"	M	-	M	-	-	M
Folio SEF	8.25" x 13"	M	-	M	-	-	M
	11" x 15"	M	-	M	-	-	M
	10" x 14"	M	-	M	-	-	M
	8" x 10"	M	-	M	-	-	M
8K	267 x 390mm	M	-	M	-	-	M
16K SEF	195 x 267mm	M	-	M	-	-	M
16K LEF	267 x 195mm	M	-	M	-	-	M
Custom		M	-	M	-	-	-
Com10 Env.	4.125" x 9.5"	M	-	-	-	-	-
Monarch Env.	3.875" x 7.5"	M	-	-	-	-	-
C6 Env.	114 x 162mm	M	-	-	-	-	-
C5 Env.	162 x 229mm	M	-	-	-	-	-
DL Env.	110 x 220mm	M	-	-	-	-	-

Supported Paper Sizes

Remarks:

A	Supported: the sensor detects the paper size.
M	Supported: the user specifies the paper size.
S	Supported: depends on a technician adjustment
-	Not supported

Europe/ Asia

BT: By-pass Tray, T1: Tray 1, T2/3/4: Tray 2/3/4, LCT 2000: Large Capacity Tray: 2000-sheet, LCT 1200: Large Capacity Tray: 1200-sheet, DU: Duplex Unit

Paper	Size (W x L)	BT	T1	T2/3/4	LCT 2000	LCT 1200	DU
A3 W	12" x 18"	M	-	-	-	-	-
A3 SEF	297 x 420mm	A	-	A	-	-	M
A4 SEF	210 x 297mm	A	-	A	-	-	M
A4 LEF	297 x 210mm	A	M	A	M	S	M
A5 SEF	148 x 210mm	A	-	-	-	-	-
A5 LEF	210 x 148mm	A	S	A	-	-	M
A6 SEF	105 x 148mm	A	-	-	-	-	-
B4 SEF	257 x 364mm	M	-	A	-	-	M
B5 SEF	182 x 257mm	M	-	A	-	-	M
B5 LEF	257 x 182mm	M	S	A	-	S	M
B6 SEF	128 x 182mm	M	-	-	-	-	-
Ledger	11" x 17"	M	-	M	-	-	M
Letter SEF	8.5" x 11"	M	-	A	-	-	M
Letter LEF	11" x 8.5"	M	S	M	S	S	M

Paper	Size (W x L)	BT	T1	T2/3/4	LCT 2000	LCT 1200	DU
Legal SEF	8.5" x 14"	M	-	M	-	-	M
Government Legal SEF	8.25" x 14"	M	-	M	-	-	M
Half Letter SEF	5.5" x 8.5"	M	-	-	-	-	-
Executive SEF	7.25" x 10.5"	M	-	M	-	-	M
Executive LEF	10.5" x 7.25"	M	-	M	-	-	M
F SEF	8" x 13"	M	-	M	-	-	M
Foolscap SEF	8.5" x 13"	M	-	M	-	-	M
Folio SEF	8.25" x 13"	M	-	M	-	-	M
	11" x 15"	M	-	M	-	-	M
	10" x 14"	M	-	M	-	-	M
	8" x 10"	M	-	M	-	-	M
8K	267 x 390mm	M	-	M	-	-	M
16K SEF	195 x 267mm	M	-	M	-	-	M
16K LEF	267 x 195mm	M	-	M	-	-	M
Custom		M	-	M	-	-	-
Com10 Env.	4.125" x 9.5"	M	-	-	-	-	-
Monarch Env.	3.875" x 7.5"	M	-	-	-	-	-
C6 Env.	114 x 162mm	M	-	-	-	-	-
C5 Env.	162 x 229mm	M	-	-	-	-	-
DL Env.	110 x 220mm	M	-	-	-	-	-

Remarks:

A	Supported: the sensor detects the paper size.
M	Supported: the user specifies the paper size.
S	Supported: depends on a technician adjustment
-	Not supported

1.2.2 PAPER EXIT***1000-Sheet Booklet Finisher***

MF: Main Frame, Prf: Proof, Clr: Clear, Shf: Shift, Stp: Staple, SS: Saddle Stitch,
2/3 P: 2/3 Holes Punch, 4 P: 4 Holes Punch, N4P: North Europe 4 Holes Punch

Paper	Size (W x L)	MF	1000-sheet booklet finisher							
			Prf	Clr	Shf	Stp	SS	2/3 P	4 P	N4P
A3 W	12" x 18"	Y	Y	Y	-	-	-	Y	Y	Y
A3 SEF	297 x 420 mm	Y	Y	Y	Y	30	30	Y	Y	Y
A4 SEF	210 x 297 mm	Y	Y	Y	Y	50	50	-	-	Y
A4 LEF	297 x 210 mm	Y	Y	Y	Y	50	50	Y	Y	Y
A5 SEF	148 x 210 mm	Y	Y	Y	Y	-	-	-	-	Y
A5 LEF	210 x 148 mm	Y	Y	Y	Y	-	-	-	-	Y
A6 SEF	105 x 148 mm	Y	Y	Y	-	-	-	-	-	-
B4 SEF	257 x 364 mm	Y	Y	Y	Y	30	30	Y	Y	Y
B5 SEF	182 x 257 mm	Y	Y	Y	Y	50	50	-	-	Y
B5 LEF	257 x 182 mm	Y	Y	Y	Y	50	50	Y	Y	Y
B6 SEF	128 x 182 mm	Y	Y	Y	-	-	-	-	-	Y
Ledger	11" x 17"	Y	Y	Y	Y	30	30	Y	Y	Y

Paper	Size (W x L)	MF	1000-sheet booklet finisher							
			Prf	Clr	Shf	Stp	SS	2/3 P	4 P	N4P
Letter SEF	8.5" x 11"	Y	Y	Y	Y	50	50	-	-	Y
Letter LEF	11" x 8.5"	Y	Y	Y	Y	50	-	Y	Y	Y
Legal SEF	8.5" x 14"	Y	Y	Y	Y	30	30	-	-	Y
Government Legal SEF	8.25" x 14"	Y	Y	Y	Y	30	30	Y	Y	Y
Half Letter SEF	5.5" x 8.5"	Y	Y	Y	Y	-	-	-	-	Y
Executive SEF	7.25" x 10.5"	Y	Y	Y	Y	50	-	-	-	Y
Executive LEF	10.5" x 7.25"	Y	Y	Y	Y	50	-	Y	Y	Y
F SEF	8" x 13"	Y	Y	Y	Y	30	-	-	-	Y
Foolscap SEF	8.5" x 13"	Y	Y	Y	Y	30	-	-	-	Y
Folio SEF	8.25" x 13"	Y	Y	Y	Y	30	-	-	-	Y
	11" x 15"	Y	Y	Y	Y	30	-	Y	Y	Y
	10" x 14"	Y	Y	Y	Y	30	-	Y	-	Y
	8" x 10"	Y	Y	Y	Y	30	-	-	-	Y
8K	267 x 390 mm	Y	Y	Y	Y	30	-	Y	Y	Y
16K SEF	195 x 267 mm	Y	Y	Y	Y	50	-	-	-	Y
16K LEF	267 x 195 mm	Y	Y	Y	Y	50	-	Y	Y	Y
Custom		Y	Y	Y	-	-	-	-	-	-
Com10 Env.	4.125" x 9.5"	Y	Y	-	-	-	-	-	-	-
Monarch Env.	3.875" x 7.5"	Y	Y	-	-	-	-	-	-	-
C6 Env.	114 x 162 mm	Y	Y	Y	-	-	-	-	-	-
C5 Env.	162 x 229 mm	Y	Y	Y	-	-	-	-	-	-
DL Env.	110 x 220 mm	Y	Y	Y	-	-	-	-	-	-

Supported Paper Sizes

Remarks:

Y	Supported
30	Output up to 30 sheets
50	Output up to 50 sheets
-	Not supported

1000-Sheet Finisher and 500-Sheet Finisher

MF: Main Frame, Prf: Proof, Clr: Clear, Shf: Shift, Stp: Staple

Paper	Size (W x L)	MF	1000-sheet finisher				500-sheet finisher			1-Bin	Shift
			Prf	Clr	Shf	Stp	Clr	Shf	Stp		
A3 W	12" x 18"	Y	Y	Y	-	-	-	-	-	-	Y
A3 SEF	297 x 420 mm	Y	Y	Y	Y	30	Y	Y	30	Y	Y
A4 SEF	210 x 297 mm	Y	Y	Y	Y	50	Y	Y	50	Y	Y
A4 LEF	297 x 210 mm	Y	Y	Y	Y	50	Y	Y	50	Y	Y
A5 SEF	148 x 210 mm	Y	Y	Y	Y	-	Y	Y	-	Y	Y
A5 LEF	210 x 148 mm	Y	Y	Y	Y	-	Y	Y	-	Y	Y
A6 SEF	105 x 148 mm	Y	-	-	-	-	Y	-	-	-	Y
B4 SEF	257 x 364 mm	Y	Y	Y	Y	30	Y	Y	30	Y	Y

Paper	Size (W x L)	MF	1000-sheet finisher				500-sheet finisher			1-Bin	Shift
			Prf	Clr	Shf	Stp	Clr	Shf	Stp		
B5 SEF	182 x 257 mm	Y	Y	Y	Y	50	Y	Y	50	Y	Y
B5 LEF	257 x 182 mm	Y	Y	Y	Y	50	Y	Y	50	Y	Y
B6 SEF	128 x 182 mm	Y	Y	-	-	-	Y	-	-	Y	Y
Ledger	11" x 17"	Y	Y	Y	Y	30	Y	Y	30	Y	Y
Letter SEF	8.5" x 11"	Y	Y	Y	Y	50	Y	Y	50	Y	Y
Letter LEF	11" x 8.5"	Y	Y	Y	Y	50	Y	Y	50	Y	Y
Legal SEF	8.5" x 14"	Y	Y	Y	Y	30	Y	Y	30	Y	Y
Government Legal SEF	8.25" x 14"	Y	Y	Y	Y	-	Y	Y	30	Y	Y
Half Letter SEF	5.5" x 8.5"	Y	Y	Y	Y	-	Y	Y	-	Y	Y
Executive SEF	7.25" x 10.5"	Y	Y	Y	Y	50	Y	Y	50	Y	Y
Executive LEF	10.5" x 7.25"	Y	Y	Y	Y	50	Y	Y	50	Y	Y
F SEF	8" x 13"	Y	Y	Y	Y	30	Y	Y	30	Y	Y
Foolscap SEF	8.5" x 13"	Y	Y	Y	Y	30	Y	Y	30	Y	Y
Folio SEF	8.25" x 13"	Y	Y	Y	Y	30	Y	Y	30	Y	Y
	11" x 15"	Y	Y	Y	Y	30	Y	Y	30	Y	Y
	10" x 14"	Y	Y	Y	Y	30	Y	Y	30	Y	Y

Appendix:
Specifications

Supported Paper Sizes

Paper	Size (W x L)	MF	1000-sheet finisher				500-sheet finisher			1-Bin	Shift
			Prf	Clr	Shf	Stp	Clr	Shf	Stp		
	8" x 10"	Y	Y	Y	Y	30	Y	Y	30	Y	Y
8K	267 x 390 mm	Y	Y	Y	Y	30	Y	Y	30	Y	Y
16K SEF	195 x 267 mm	Y	Y	Y	Y	50	Y	Y	50	Y	Y
16K LEF	267 x 195 mm	Y	Y	Y	Y	50	Y	Y	50	Y	Y
Custom		Y	Y	-	-	-	-	-	-	-	Y
Com10 Env.	4.125" x 9.5"	Y	-	-	-	-	Y	Y	-	Y	Y
Monarch Env.	3.875" x 7.5"	Y	-	-	-	-	-	-	-	Y	Y
C6 Env.	114 x 162 mm	Y	Y	-	-	-	-	-	-	Y	Y
C5 Env.	162 x 229 mm	Y	Y	-	-	-	-	-	-	Y	Y
DL Env.	110 x 220 mm	Y	Y	-	-	-	-	-	-	Y	Y

Remarks:

Y	Supported
30	Output up to 30 sheets
50	Output up to 50 sheets
-	Not supported

1.2.3 PLATEN/ARDF ORIGINAL SIZE DETECTION

Size (width x length) [mm]	Platen	ARDF	Platen	ARDF
	Inches	Inches	Metric	Metric
A3 (297 x 420) L	-	Y	Y*3	Y
B4 (257 x 364) L	-	-	Y*3	Y
A4 (210 x 297) L	Y*1	Y	Y*3	Y
A4 (297 x 210) S	Y*3	Y	Y*3	Y
B5 (182 x 257) L	-	-	Y*3	Y
B5 (257 x 182) S	-	-	Y*3	Y
A5 (148 x 210) L	-	-	_*1	Y
A5 (210 x 148) S	-	-	_*1	Y
B6 (128 x 182) L	-	-	-	-
B6 (182 x 128) S	-	-	-	-
11" x 17" (DLT)	Y	Y*2	-	Y*2
11" x 15"	-	Y*2	-	-
10" x 14"	-	Y	-	-
8.5" x 14" (LG)	Y	Y*2	-	-
8.5" x 13" (F4)	-	Y*2	Y*4	Y*4
8.25" x 13"	-	-	Y*4	Y*4
8" x 13"(F)	-	-	Y*4	Y*4
8.5" x 11" (LT)	Y*3	Y*2	Y*3	Y*2
11" x 8.5" (LT)	Y*3	Y*2	Y*3	Y*2
8" x 10"	-	Y*2	-	-
5.5" x 8.5" (HLT)	_*1	Y	-	-

Supported Paper Sizes

8.5" x 5.5" (HLT)	-* ¹	Y	-	-
8K (267 x 390)	-	-	Y* ³	Y* ²
16K L (195 x 267)	-	-	Y* ³	Y* ²
16K S (267 x 195)	-	-	Y* ³	Y* ²
7.25" x 10.5" (Executive)	-	Y	-	-
10.5" x 7.25" (Executive)	-	Y* ²	-	-

*1: Use SP4-303 to detect original sizes as A5 lengthwise/HLT when the message "Can't detect original size" shows.

*2: The machine can detect the paper size depending on the setting of SP6-016-1.

*3: The machine can detect the paper size depending on the setting of SP4-305-1.

*4: The machine can detect the paper size depending on the setting of SP5-126-1.

1.3 SOFTWARE ACCESSORIES

The printer drivers and utility software are provided as following two CD-ROMs;

- 1: Printer Drivers and Utilities CD-ROM
- 2: Scanner/PostScript® Drivers and Utilities CD-ROM.

An auto-run installer lets you to select the components you want to install.

1.3.1 PRINTER DRIVERS

Printer Language	Windows 2000, XP, Server 2003, Vista, Server 2008, 7	MacOS8.6 to 9.x, MacOSX10.1 or later
PCL5c / PCL6	Yes	No
PS3	Yes	Yes
RPCS	No	No

↓ Note

- The PCL5c/6 and PS3 drivers are provided on the printer drivers CD-ROM.
- The PS3 drivers are all genuine Adobe PS drivers, except for Windows 2000/XP/2003/Vista/7. Windows 2000 uses Microsoft PS. A PPD file for each operating system is provided with the driver.
- The PPD installer for Macintosh supports Mac OS X 10.1 or later versions.
- The LAN Fax driver lets you fax documents directly from your PC. Address Book Editor and Cover Sheet Editor are to be installed as well. (These require the optional fax unit.)

1.3.2 SCANNER AND LAN FAX DRIVERS

Printer Language	Windows 2000, XP, Server 2003, Vista, 7	MacOS8.6 to 9.x, MacOSX10.1 or later
Network TWAIN	Yes	No
LAN-FAX	Yes	No

Note

- The Network TWAIN and LAN Fax drivers are provided on the scanner drivers CD-ROM.
- This software lets you fax documents directly from your PC. Address Book Editor and Cover Sheet Editor are to be installed as well. (These require the optional fax unit.)

1.3.3 UTILITY SOFTWARE

Software	Description
Font Manager (2000/XP/Server 2003/7)	A font management utility with screen fonts for the printer This is provided on the printer drivers CD-ROM.
Smart Device Monitor for Admin (2000/XP/Server 2003/Vista/7)	A printer management utility for network administrators. NIB setup utilities are also available. This is provided on the printer drivers CD-ROM.
DeskTopBinder – SmartDeviceMonitor for Client (2000/XP/Server 2003/Vista/7)	A printer management utility for client users. A utility for peer-to-peer printing over a NetBEUI or TCP/IP network. A peer-to-peer print utility over a TCP/IP network. This provides the parallel printing and recovery printing features. This is provided on the printer drivers CD-ROM.
Printer Utility for Mac (Mac)	A utility for peer-to-peer printing over a NetBEUI or TCP This software provides several convenient functions for printing from Macintosh clients. This is provided on the scanner drivers CD-ROM.
DeskTopBinder Lite (2000/XP/Server 2003/7)	DeskTopBinder Lite itself can be used as personal document management software and can manage both image data converted from paper documents and application files saved in each client's PC. This is provided on the scanner drivers CD-ROM.

1.4 OPTIONAL EQUIPMENT

1.4.1 ARDF (D578)

Paper Size/Weight:	Simplex	Size	A3 to A5, DLT to HLT
		Weight	40 to 128 g/m ² (10 to 34 lb.)
	Duplex	Size	A3 to A5, DLT to HLT
		Weight	52 to 105 g/m ² (14 to 28 lb.)
Table Capacity:	50 sheets (80 g/m ² , 20 lb)		
Original Standard Position:	Rear left corner		
Separation:	Feed belt and separation roller		
Original Transport:	Roller transport		
Original Feed Order:	From the top original		
Supported Magnification Ratios:	Copy	-	32 to 200 %
	Fax	Color	32.6 to 200 %
		Black & white	48.9 to 200 %
Power Source:	DC 24V, 5V from the scanner unit		
Power Consumption:	50 W or less		
Dimensions (W × D × H):	550 mm x 491 mm x 120 mm (21.7" x 19.3" x 4.7")		
Weight:	10 kg (22 lb.)		

1.4.2 PAPER FEED UNIT (D580)

Paper Feed System:	FRR
Paper Height Detection:	5 steps (100%, 70%, 30%, 10% (Near end), and Empty)
Capacity:	500 sheets x 2 trays
Paper Weight:	60 to 256 g/m ² (16 to 68 lb.)
Paper Size:	A3 SEF to A5, DLT SEF to HLT
Power Source:	DC 24V, 5V (from the main frame)
Power Consumption:	Less than 60 W (Max.)/ Less than 35 W (Ave,)
Dimensions (W x D x H):	580 mm x 620 mm x 260 mm (22.8" x 24.4" x 10.2")
Weight:	26 kg (57.3 lb.)

1.4.3 LCT 2000-SHEET (D581)

Paper Size:	A4 LEF/LT LEF
Paper Weight:	60 g/m ² to 256 g/m ² (16 lb. to 68 lb.)
Tray Capacity:	2,000 sheets (80 g/m ² , 20lb.)
Remaining Paper Detection:	5 steps (100%, 70%, 30%, 10%, Empty): Right Tray 4 steps (100%, 70%, 30%, Empty): Left Tray
Power Source:	DC 24 V, 5 V (from copier/printer)
Power Consumption:	55 W (Max.)/30 W (Ave.)
Weight:	26 kg (57.3 lb.)
Size (W x D x H):	580 mm x 620 mm x 260 mm (22.8" x 24.4" x 10.2")

1.4.4 LCT 1200-SHEET (D631)

Paper Size:	A4 LEF/ LT LEF/ B5 LEF
Paper Weight:	60 g/m ² to 216 g/m ² (16 lb to 57 lb.)
Tray Capacity:	1,200 sheets (80 g/m ² , 20lb)
Remaining Paper Detection:	5 steps (100%, 75%, 30%, 10%, End)
Power Source:	24 Vdc, 5 Vdc (from copier/printer)
Power Consumption:	55 W (Max)/ 25 W (Ave.)
Weight:	14 kg (30.8 lb.)
Size (W x D x H):	348 mm x 540 mm x 290 mm (13.7" x 21.3" x 11.4")

1.4.5 1000-SHEET BOOKLET FINISHER & PUNCH UNIT (D589)

Print Paper Size:	<p>No punch mode: A3/11" x 17" to A5/8.5" x 5.5" (LEF)</p> <p>Punch mode:</p> <p>2 holes: A3/11" x 17" to B6/5.5" x 8.5" (SEF) or A4/8.5" x 11" to A5/8.5" x 5.5" (LEF)</p> <p>3 holes: A3, B4, 11" x 17" (SEF) or A4, B5, 8.5" x 11" (LEF)</p> <p>4 holes (Europe): A3, B4, 11" x 17" (SEF) or A4, B5, 8.5" x 11" (LEF)</p> <p>4 holes (North Europe): A3/11" x 17" to B6/5.5" x 8.5" (SEF)</p> <p>Staple mode: A3/11" x 17" to B5/8.5" x 11"</p>
-------------------	---

Paper Weight:	<p>No punch mode: 52 to 256 g/m² (14 to 68 lb.) (Shift tray) 52 to 105 g/m² (14 to 28 lb.) (Proof tray)</p> <p>Punch mode: 52 to 163 g/m² (14 to 43 lb.)</p> <p>Staple mode: 64 to 90 g/m² (17 to 24 lb.) Label/Thick paper/OHP cannot be stapled</p>	
Tray Capacity:	<p>[Proof tray] 100 sheets: A4, 8.5" x 11" or less 50 sheets: B4, 8.5" x 14" or more</p> <p>[Shift tray] 1000 sheets: A4, 8.5" x 11" (LEF) or smaller 500 sheets: B4, 8.5" x 14" or larger</p>	
Staple capacity:	<p>Single size: 50 sheets: A4, 8.5" x 11" or smaller 30 sheets: B4, 8.5" x 14" or larger</p>	
Staple position:	<p>3 positions 1-staple: 2 positions (Top Left, Top Right) 2-staples: 1 positions</p>	
Staple replenishment:	Cartridge (5000 staples)	
Power consumption:	60 W	
Dimensions (W x D x H):	535 mm x 600 mm x 930 mm (21.1" x 23.6" x 36.6")	
Weight	Without punch unit:	48 kg (105.8 lb.)
	With punch unit:	50 Kg (110.3 lb.)

1.4.6 1000-SHEET FINISHER (D588)

Upper Tray

Paper Size:	A3 to A6 11" x 17" to 5.5" x 8.5"
Paper Weight:	60 to 157 g/m ² (16 to 42 lb.)
Paper Capacity:	250 sheets (A4 LEF/8.5" x 11" SEF or smaller) 50 sheets (A4, 8.5" x 11" or smaller) 30 sheets (B4, 8.5" x 14" or larger)

Lower Tray

Paper Size:	No staple mode: A3 to B5, DLT to HLT Staple mode: A3, B4, A4, B5, DLT to LT			
Paper Weight:	No staple mode: 60 to 157 g/m ² (16 to 42 lb) Staple mode: 64 to 90 g/m ² (17 to 24 lb)			
Stapler Capacity:	30 sheets (A3, B4, DLT, LG) 50 sheets (A4, B5 LEF, LT)			
Paper Capacity:	No staple mode: 1,000 sheets (A4/LT or smaller: 80 g/m ² , 20 lb.) 500 sheets (A3, B4, DLT, LG: 80 g/m ² , 20 lb.) Staple mode: (80 g/m ² , 20 lb., number of sets)			
	Set Size	2 to 9	10 to 50	-
	Size		10 to 30	31 to 50
	A4/LT LEF B5 LEF	100	100 to 20	100 to 20
	A4/LT SEF	100	50 to 10	50 to 10

	A3, B4, DLT, LG	50	50 to 10	-
Staple positions:	1 Staple: 2 positions (Front, Rear) 2 Staples: 2 positions (Upper, Left)			
Staple Replenishment:	Cartridge (5,000 staples/cartridge)			
Power Source:	DC 24 V, 5 V (from the copier/printer)			
Power Consumption:	50 W			
Weight:	25 kg (55.2 lbs)			
Dimensions (W x D x H):	527 x 520 x 790 mm (20.8" x 20.5" x 31.1")			

1.4.7 500-SHEET FINISHER (D585)

Paper Size:	A3 to B6 (SEF)
Paper Weight:	52 to 128 g/m ² (14 to 34 lb.)
Tray Capacity:	500 sheets: A4, LT or smaller 250 sheets: B4, LG or larger
Staple capacity:	30 sheets (A3, B4, DLT, LG) 50 sheets (A4, LT or smaller)
Staple position:	3 positions 1-staple: 2 positions (Top right-oblique, Top left-oblique) 2-staples: 1 positions (Left)
Staple replenishment:	Cartridge (5000 staples)

500-Sheet Finisher

Target Line Speed	77 mm/sec. to 205 mm/sec		
Target CPM	35 cpm		
Face-down Output Size	12"x18", A3 SEF to A6 SEF, DLT to HLT SEF Shift sizes: A3 SEF to B5 SEF A5, B6, A6 SEF labels possible		
Paper Thickness	52 g/m ² (45 K) to 157 g/m ² (135 K) Up to 253 g/m ² (220K) without shift		
Stapling			
Stack Height for Stapling	50 sheets: A4, LT and smaller 30 sheets: B4, LG and larger		
Size	A3 SEF to B5 SEF (can be mixed if same width)		
Stack Thickness	64g/m ² (45 K) to 157 g/m (135 K)		
Stapling Positions	Front/Oblique: 1, Front/Parallel: 1 Rear/Oblique: 1, Rear/Parallel: 1, 2 locations		
Output Tray Capacity			
Non-staple Mode	500 sheets: A4, LT and smaller		
Staple Mode	250 sheets: B4, LG and larger Stack Size (Stapling)	Stacks	Size
	2 to 9 Sheets	55 to 46	A4, B5, LT LEF
	10 to 50 Sheets	45 to 10	
	2 to 9 Sheets	55 to 27	A4, B5, LT SEF
	10 to 50 Sheets	25 to 8	
	2 to 9 Sheets	55 to 27	A3, B4, DLT, LG
	10 to 30 Sheets	25 to 8	

Stacking	Non-Stapling Mode	Vertical: 15 mm or less
		Horizontal: 15 mm or less
Jogging Precision		
2 to 30 Sheets	2 mm	
31 to 50 Sheets	3 mm	
Dimensions (W x D x H)	396 x 551 x 276 mm (15.6 x 21.7 x 10.9 in.)	
Weight	12 kg (26.4 lb)	

1.4.8 BRIDGE UNIT (D634)

Paper Size:	Standard sizes A6 SEF to A3, HLT to DLT Non-standard sizes Width: 90 to 305 mm Length: 148 to 600 mm
Paper Weight:	52 g/m ² to 256 g/m ² , 16 lb. to 68 lb.
Paper Capacity:	125 sheets (80 g/m ² , 20 lb.): B4 or larger 250 sheets (80 g/m ² , 20 lb.): A4 or smaller
Power Source:	DC 24 V, 5 V (form the copier/printer)
Dimensions (W x D x H):	415 mm x 412 mm x 111 mm (16.3" x 16.2" x 4.4")
Weight	5 kg (11 lb.)

1.4.9 SHIFT TRAY (D633)

Paper Capacity:	250 sheet (A4/ 8 _{1/2} " x 11 _{1/2} " or smaller: 80g/m ² / 20 lbs) 125 sheet (B4 8 _{1/2} " x 11 _{1/2} " or larger: 80g/m ² / 20 lbs)
Paper Size:	Standard sizes A6 SEF to A3, HLT to DLT Non-standard sizes Width: 90 to 305 mm Length: 148 to 600 mm
Paper Weight:	52-256 g/m ² / 14 - 68 lbs
Power Consumption:	Max 10W (Power is supplied from the mainframe.)
Dimension (W x D x H):	423 mm x 468 mm x 114 mm (16.7" x 18.4" x 4.5")
Weight:	Approx. 2kg (4.4lbs)

1.4.10 1-BIN TRAY UNIT (D632)

Paper Size:	Standard Size: A3 /DLT to A5/ HLT SEF
Paper Weight:	60 to 169 g/m ² , 16 to 45 lb.
Tray Capacity:	125 sheets (80 g/m ² , 20 lb., A4)
Power Source:	DC 24 V, 5 V (from the copier)
Power Consumption:	Less than 1 W
Weight:	1.7 kg
Size (W x D x H):	565 mm x 410 mm x 115 mm (22.2" x 16.1" x 4.5")

APPENDIX:
PREVENTIVE MAINTENANCE TABLES

REVISION HISTORY		
Page	Date	Added/Updated/New
4	6/27/2012	ID sensor

2. PREVENTIVE MAINTENANCE TABLES

2.1 MAINTENANCE TABLES

2.1.1 PREVENTIVE MAINTENANCE ITEMS

Chart: A4 (LT)/5%

Mode: 3 copies / original (prints/job)

Ratio 30%

Environment: Normal temperature and humidity

Yield may change depending on circumstances and print conditions.

Symbol keys: C: Clean, R: Replace, L: Lubricant, I: Inspect

Mainframe

Item	150K	200K	300K	600K	EM	Remarks
Scanner						
Reflector			C			Optics cloth
1st/2nd/3rd mirrors			C			Optics cloth
Exposure Glass			C		C	Ricoh exposure glass cleaner
ADF Exposure Glass			C		C	Ricoh exposure glass cleaner
PCDU						
PCDU - K			R			
PCDU - Y, M, C	R					
Toner collection bottle	R					Replace when the waste toner bottle full message appears.
Dev. Unit - K				R		

Maintenance Tables

Item	150K	200K	300K	600K	EM	Remarks
Dev. Unit - Y, M, C					R: 480K	
Developer - K			R			
Developer - Y, M, C					R: 240	
Transfer						
Image Transfer Belt-cleaning Unit			R			
Image Transfer Belt				R		
Paper Transfer Roller Unit			R			
Fusing						
Heating Sleeve Belt Unit			R			
Pressure Roller			R			
Pressure Roller Bearing			R, C			S552R
Entrance Guide Plate			C		C	
Exit Guide Plate			C		C	
Exit Separation Plate			C		C	
Thermopile			C		C	Cotton swab with alcohol
Fusing Drive Gear					C	Replace if worn.
Pressure Roller Gear					C	Replace if worn.
Idler Gear					C	Replace if worn.
Paper Path						
Registration Roller					C	Damp cloth
Registration Sensor					C	Dry cloth

Item	150K	200K	300K	600K	EM	Remarks
Paper Dust Container					C	
Vertical Transport Roller					C	Damp cloth
Vertical Transport Sensor					C	Dry cloth
Paper Feed Sensor					C	Dry cloth
Feed Roller					C	Dry cloth
Separation Roller					C	Dry cloth
Pick-up Belt					C	Damp cloth
Inverter Roller					C	Damp cloth
Fusing Exit Sensor					C	Dry cloth
Junction Paper Jam Roller					C	Dry cloth
Junction Paper Jam Sensor					C	Dry cloth
Duplex Unit						
Duplex Transport Roller					C	Damp cloth
Duplex Entrance Sensor					C	Dry cloth
Duplex Exit Sensor					C	Dry cloth
Duplex Exit Roller					C	Damp cloth
Miscellaneous						
Ozone Filter			R			
Exhaust Filter			R			

Item	150K	200K	300K	600K	EM	Remarks
Toner Scatterproof Filter			R			See the last of this section for the toner scatterproof filter removal procedure.
Dust Glass					C	
⇒ ID Sensor					C	Blower brush

ARDF (D578)

Item	EM	Remarks
Sensors	C	Blower brush
Platen Sheet Cover	C	Damp cloth; alcohol (Replace if required.)
White Plate	C	Dry or damp cloth
Drive Gear	L	Grease G501
Transport Roller	C	Damp cloth; alcohol
Exit Roller	C	Damp cloth; alcohol
Inverter Roller	C	Damp cloth; alcohol
Idle Rollers	C	Damp cloth; alcohol

Two-tray Paper Feed Unit (D580)

Item	EM	Remarks
Feed Roller	C	Dry cloth
Separation Roller	C	Dry cloth
Pick-up Belt	C	Damp cloth
Paper Feed Sensor	C	Dry cloth
Relay Sensor	C	Dry cloth
Relay Roller	C	Damp cloth
Bottom Plate Pad	C	Damp cloth

1200-sheet LCT (D631)

Item	EM	Remarks
Feed Roller	C	Dry cloth
Separation Roller	C	Dry cloth
Pick-up Roller	C	Dry cloth
Paper Feed Sensor	C	Dry cloth
Relay Sensor	C	Dry cloth
Relay Roller	C	Damp cloth
Bottom Plate Pad	C	Damp cloth

2000-sheet LCT (D581)

Item	EM	Remarks
Feed Roller	C	Dry cloth
Separation Roller	C	Dry cloth
Pick-up Belt	C	Damp cloth
Paper Feed Sensor	C	Dry cloth
Relay Sensor	C	Dry cloth
Relay Roller	C	Damp cloth
Bottom Plate Pad	C	Damp cloth

1000-Sheet Booklet Finisher (D589)

Items	EM	Remarks
Rollers	C	Damp cloth
Discharge Brush	C	Dry cloth
Sensors	C	Blower brush

1000-Sheet Booklet Finisher Punch Kit (B807)

Items	EM	Remarks
Punch Chads	C	Discard chads.

1000-Sheet Finisher (D588)

Items	EM	Remarks
Rollers	C	Damp cloth
Discharge Brush	C	Dry cloth
Sensors	C	Blower brush

Appendix:
Preventive
Maintenance
Tables

1 Bin Tray (D632)

Items	EM	Remarks
Rollers	C	Damp cloth
Tray	C	Damp cloth
Sensor	C	Blower brush
Bearing	C	S552R

Bridge Unit (D634)

Items	EM	Remarks
Rollers	C	Damp cloth

Shift Tray (D633)

Items	EM	Remarks
Tray	C	Damp cloth

One-tray Paper Feed Unit (D579)

Item	EM	Remarks
Feed Roller	C	Dry cloth
Separation Roller	C	Dry cloth
Pick-up Roller	C	Dry cloth
Paper Feed Sensor	C	Dry cloth
Relay Sensor	C	Dry cloth
Relay Roller	C	Damp cloth
Bottom Plate Pad	C	Damp cloth

Side Tray (D635)

Items	EM	Remarks
Rollers	C	Damp cloth
Sensors	C	Blower brush

Toner Scatterproof Filter Removal Procedure

1. QSU fan (See "QSU Fan" in the "Main Chapters: 4. Replacement and Adjustment: Fusing".)

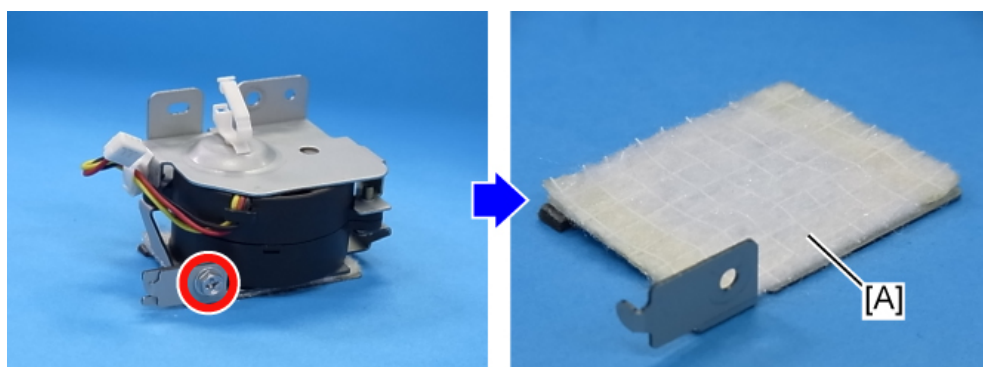

d1440273

2. Toner scatterproof filter [A] ( x 1)

2.1.2 OTHER YIELD PARTS

The parts mentioned in these tables have a target yield. However, the total copy/print volume made by the machine will not reach the target yield within the machine's targeted lifetime if the machine is used under the target usage conditions (ACV, color ratio, P/J, and C/O). So, these parts are categorized not as PM parts but as yield parts (EM parts).

Mainframe

Item	240K	480K	600K	1500K	2000K	Remarks
Dev. Unit - K			R			
Dev. Unit - Y, M, C		R				
Developer - Y, M, C	R					
ITB Unit			R			
Toner Supply Unit - K					R	
Toner Supply Unit - Y, M, C				R		

ARDF

Item	80K	120K	240K	Remarks
Pick-up Roller		R		Number of originals
Feed Belt		R		Number of originals
Separation Roller		R		Number of originals

APPENDIX:

SP MODE TABLES

REVISION HISTORY		
Page	Date	Added/Updated/New
192	8/2/2012	SP5083 LED Light Switch Setting - Toner Near End

3. SP MODE TABLES

3.1 MAIN SP TABLES-1

3.1.1 SP1-XXX (FEED)

1001	[Leading Edge Registration] Leading Edge Registration Adjustment (Tray Location, Paper Type, Color Mode), Paper Type → Thin, Plain, Thick 1, Thick 2 or Thick 3			
	Adjusts the leading edge registration by changing the registration motor operation timing for each mode.			
002	Tray: Plain	*ENG	[-9 to 9 / 0.0 / 0.1 mm/step]	
003	Tray: Middle Thick	*ENG		
004	Tray: Thick 1	*ENG		
005	Tray: Thick 2	*ENG		
007	By-pass: Plain	*ENG		
008	By-pass: Middle Thick	*ENG		
009	By-pass: Thick 1	*ENG		
010	By-pass: Thick 2	*ENG		
011	By-pass: Thick 3	*ENG		
013	Duplex: Plain	*ENG		
014	Duplex: Middle Thick	*ENG		
015	Duplex: Thick 1	*ENG		
016	Tray: Thick 3	*ENG		[-9 to 9 / 0.0 / 0.1 mm/step]
017	Tray: Plain:1200	*ENG		
018	Tray: Middle Thick:1200	*ENG		
019	Tray: Thick 1:1200	*ENG		

Main SP Tables-1

020	By-pass: Plain:1200	*ENG	
021	By-pass: Middle Thick:1200	*ENG	
022	By-pass: Thick 1:1200	*ENG	
023	Duplex: Plain:1200	*ENG	
024	Duplex: Middle Thick:1200	*ENG	
025	Duplex: Thick 1:1200	*ENG	
026	Tray: Thin	*ENG	
027	By-pass: Thin	*ENG	
028	Duplex: Thin	*ENG	
029	Tray: Thin: 1200	*ENG	
030	By-pass: Thin: 1200	*ENG	
031	Duplex: Thin: 1200	*ENG	

1002	[Side to Side Registration] Side-to-Side Registration Adjustment		
	Adjusts the side-to-side registration by changing the laser main scan start position for each mode.		
001	By-pass Table	*ENG	[-4 to 4 / 0.0 / 0.1 mm/step]
002	Paper Tray 1	*ENG	
003	Paper Tray 2	*ENG	
004	Paper Tray 3	*ENG	
005	Paper Tray 4	*ENG	
006	Duplex	*ENG	
007	Paper Tray 5	*ENG	
008	Large Capacity Tray	*ENG	

1003	[Paper Buckle] Paper Buckle Adjustment (Tray Location, Paper Type, Color mode), Paper Type → Plain, Thick, Thick1		
	Adjusts the amount of paper buckle at the registration roller by changing the paper feed timing.		
002	Paper Tray1: Plain	*ENG	[-9 to 5 / -2 / 1 mm/step]
003	Tray1: Middle Thick	*ENG	[-9 to 5 / -1 / 1 mm/step]
004	Paper Tray1: Thick1	*ENG	[-9 to 5 / -2 / 1 mm/step]
007	Paper Tray2/3/4/5/LCT: Plain	*ENG	
008	Tray 2/3/4/5/LCT: Middle Thick	*ENG	[-9 to 5 / -1 / 1 mm/step]
009	Paper Tray2/3/4/5/LCT: Thick 1	*ENG	[-9 to 5 / -2 / 1 mm/step]
012	By-pass: Plain	*ENG	[-9 to 5 / -1 / 1 mm/step]
013	By-pass: Middle Thick	*ENG	
014	By-pass: Thick 1	*ENG	[-9 to 5 / -2 / 1 mm/step]
018	Duplex: Plain	*ENG	[-9 to 5 / -1 / 1 mm/step]
019	Duplex: Middle Thick	*ENG	
020	Duplex: Thick 1	*ENG	[-9 to 5 / -2 / 1 mm/step]
021	Paper Tray1: Plain: 1200	*ENG	[-9 to 5 / 0 / 1 mm/step]
022	Tray1: Middle Thick: 1200	*ENG	
023	Tray 2/3/4/5LCT: Plain: 1200	*ENG	
024	Tray 2/3/4/5LCT: Mid: 1200	*ENG	
025	By-pass: Plain: 1200	*ENG	
026	By-pass: Middle Thick: 1200	*ENG	
027	Paper Tray1: Thick1: 1200	*ENG	[-9 to 5 / -2 / 1 mm/step]
028	Paper Tray2/3/4/5/LCT: Thick 1:1200	*ENG	
029	By-pass: Thick 1: 1200	*ENG	

Main SP Tables-1

030	Duplex: Plain: 1200	*ENG	[-9 to 5 / 0 / 1 mm/step]
031	Duplex: Middle Thick: 1200	*ENG	
032	Duplex: Thick 1: 1200	*ENG	[-9 to 5 / -2 / 1 mm/step]

1007	[By-Pass Size Detection] By-Pass Size Detection Display		
001	LG	*ENG	[0 or 1 / 0 / -] 0: OFF, 1: ON
	<p>Enables or disables the automatic paper size detection function of the by-pass tray.</p> <p>This SP determines what paper size the machine detects if the detected size is less than 8.5".</p> <p>0: OFF (Letter/SEF), 1: ON (Legal/SEF)</p>		

1101	[Reload Permit Setting]		
	Specifies the settings of the reload permit for cold temperature in color mode.		
001	Pre-rotation Start Temp.	*ENG	[-50 to 200 / -50 / 1 deg/step]
002	Reload Target Temp.:Center	*ENG	[0 to 180 / 145 / 1 deg/step]
003	Reload Target Temp.:Press	*ENG	[0 to 200 / 120 / 1 deg/step]
004	Temp.:Delta:Cold:Center	*ENG	[0 to 200 / 5 / 1 deg/step]
005	Temp.:Delta:Cold:End	*ENG	[40 to 200 / 5 / 1 deg/step]
006	Temp.:Delta:Cold:Press	*ENG	[0 to 200 / 80 / 1 deg/step]
	[Forced Ready Set]		
	Specifies the setting of the forced reload permit for cold temperature in color mode.		
007	Forced Reload Time :Cold	*ENG	[0 to 100 / 9 / 1 sec/step]
	[Reload Permit Setting]		
	Specifies the settings of the reload permit for warm temperature in color mode.		
008	Temp.:Delta:Warm:Center	*ENG	[0 to 200 / 5 / 1 deg/step]
009	Temp.:Delta:Warm:End	*ENG	[0 to 200 / 5 / 1 deg/step]

010	Temp.:Delta:Warm:Press	*ENG	[0 to 200 / 80 / 1 deg/step]
	[Reload Permit Setting] Specifies the setting of the forced reload permit for warm temperature in color mode.		
011	Forced Reload Time:Warm	*ENG	[0 to 100 / 9 / 1 sec/step]
	[Reload Permit Setting] Specifies the settings of the reload permit for hot temperature in color mode.		
012	Temp.:Delta:Hot:Center	*ENG	[0 to 200 / 5 / 1 deg/step]
013	Temp.:Delta:Hot:End	*ENG	[0 to 200 / 5 / 1 deg/step]
014	Temp.:Delta:Hot:Press	*ENG	[0 to 200 / 80 / 1 deg/step]
	[Reload Permit Setting] Specifies the setting of the forced reload permit for hot temperature in color mode.		
015	Forced Reload Time:Hot	*ENG	[0 to 100 / 9 / 1 sec/step]
	[Reload Permit Setting Temp.] Specifies the settings of the reload permit for cold temperature in BW mode.		
016	Temp.:Delta:Cold:BW:Center	*ENG	[0 to 200 / 5 / 1 deg/step]
017	Temp.:Delta:Cold:BW:End	*ENG	[0 to 200 / 5 / 1 deg/step]
018	Temp.:Delta:Cold:BW:Press	*ENG	[0 to 200 / 80 / 1 deg/step]
	[Reload Permit Setting] Specifies the setting of the forced reload permit for cold temperature in BW mode.		
019	Forced Reload Time:Cold:BW	*ENG	[0 to 100 / 9 / 1 sec/step]
	[Reload Permit Setting] Specifies the settings of the reload permit for cold temperature in BW mode 2.		
020	Temp.:Delta:Cold:BW2:Center	*ENG	[0 to 200 / 15 / 1 deg/step]
021	Temp.:Delta:Cold:BW2:End	*ENG	[40 to 200 / 100 / 1 deg/step]

Main SP Tables-1

022	Temp.Delta:Cold:BW2:Press	*ENG	[0 to 200 / 100 / 1 deg/step]
	[Forced Ready Set] Specifies the setting of the forced reload permit for cold temperature in BW mode 2.		
023	Time:Cold:BW2	*ENG	[0 to 100 / 30 / 1 sec/step]

1102	[Feed Permit Setting]		
	Specified the settings of the paper feeding timing.		
001	Temp.:Lower Delta:Center	*ENG	[0 to 200 / 10 / 1 deg/step]
002	Temp.:Lower Delta:End	*ENG	[0 to 200 / 10 / 1 deg/step]
003	Temp.:Upper Delta:Center	*ENG	[0 to 200 / 30 / 1 deg/step]
004	Temp.:Upper Delta:End	*ENG	[0 to 200 / 30 / 1 deg/step]
005	Temp.:Lower Delta:Press	*ENG	[0 to 200 / 100 / 1 deg/step]
006	Rotation Time	*ENG	[0 to 100 / 0 / 1 sec/step]
007	Temp.:Lower Delta:Center:Sp.1	*ENG	[0 to 200 / 5 / 1 deg/step]
008	Temp.:Lower Delta:End:Sp.1	*ENG	[0 to 200 / 5 / 1 deg/step]
009	Temp.:Upper Delta:Center:Sp.1	*ENG	[0 to 200 / 30 / 1 deg/step]
010	Temp.:Upper Delta:End:Sp.1	*ENG	[0 to 200 / 30 / 1 deg/step]
011	Temp.:Lower Delta:Press:Sp.1	*ENG	[0 to 200 / 15 / 1 deg/step]
012	Rotation Time:Sp.1	*ENG	[0 to 100 / 0 / 1 sec/step]

013	Temp.:Lower Delta:Center:Sp.2	*ENG	[0 to 200 / 5 / 1 deg/step]
014	Temp.:Lower Delta:End:Sp.2	*ENG	[0 to 200 / 5 / 1 deg/step]
015	Temp.:Upper Delta:Center:Sp.2	*ENG	[0 to 200 / 15 / 1 deg/step]
016	Temp.:Upper Delta:End:Sp.2	*ENG	[0 to 200 / 15 / 1 deg/step]
017	Temp.:Lower Delta:Press:Sp.2	*ENG	[0 to 200 / 100 / 1 deg/step]
018	Rotation Time:Sp2	*ENG	[0 to 100 / 0 / 1 sec/step]
019	Feed Permit Time	*ENG	[0 to 200 / 60 / 1 sec/step]

1105	[Print Target Temp]		
	(Printing Mode, Roller Type, [Color], Simplex/Duplex) Roller Type → Center and Ends: Heating roller, Pressure → Pressure roller Paper Type → Plain, Thin, Thick, OHP, Middle Thick, Special		
001	Plain1:FC:Center	*ENG	[100 to 180 / 140 / 1 deg/step]
	Specifies the heating roller target temperature for the ready condition in full color printing.		
002	Plain1:FC:Press	*ENG	[0 to 200 / 120 / 1 deg/step]
	Specifies the pressure roller target temperature for the ready condition in full color printing.		
003	Plain1:BW:Center	*ENG	[180 to 100 / 140 / 1 deg/step]
	Specifies the heating roller target temperature for the ready condition in BW printing.		

Main SP Tables-1

004	Plain1:BW:Press	*ENG	[0 to 200 / 120 / 1 deg/step]
	Specifies the pressure roller target temperature for the ready condition in BW printing.		
005	Plain2:FC:Center	*ENG	[100 to 180 / 145 / 1 deg/step]
	Specifies the heating roller target temperature for the ready condition in full color printing.		
006	Plain2:FC:Press	*ENG	[0 to 200 / 120 / 1 deg/step]
	Specifies the pressure roller target temperature for the ready condition in full color printing.		
007	Plain2:BW:Center	*ENG	[100 to 180 / 140 / 1 deg/step]
	Specifies the heating roller target temperature for the ready condition in BW printing.		
008	Plain2:BW:Press	*ENG	[0 to 200 / 120 / 1 deg/step]
	Specifies the pressure roller target temperature for the ready condition in BW printing.		
009	Thin:FC:Center	*ENG	[100 to 180 / 135 / 1 deg/step]
010	Thin:FC:Press	*ENG	[0 to 200 / 120 / 1 deg/step]
011	Thin:BW:Center	*ENG	[100 to 180 / 135 / 1 deg/step]
012	Thin:BW:Press	*ENG	[0 to 200 / 120 / 1 deg/step]
013	M-thick:FC:Center	*ENG	[100 to 180 / 150 / 1 deg/step]
014	M-thick:FC:Press	*ENG	[0 to 200 / 120 / 1 deg/step]
015	M-thick:BW:Center	*ENG	[100 to 180 / 150 / 1 deg/step]
016	M-thick:BW:Press	*ENG	[0 to 200 / 120 / 1 deg/step]
017	Thick1:FC:Center	*ENG	[100 to 180 / 148 / 1 deg/step]
018	Thick1:FC:Press	*ENG	[0 to 200 / 120 / 1 deg/step]
019	Thick1:BW:Center	*ENG	[100 to 180 / 148 / 1 deg/step]

020	Thick1:BW:Press	*ENG	[0 to 200 / 120 / 1 deg/step]
021	Thick2:FC:Center	*ENG	[100 to 180 / 158 / 1 deg/step]
022	Thick2:FC:Press	*ENG	[0 to 200 / 120 / 1 deg/step]
023	Thick2:BW:Center	*ENG	[100 to 180 / 158 / 1 deg/step]
024	Thick2:BW:Press	*ENG	[0 to 200 / 120 / 1 deg/step]
025	Thick3:FC:Center	*ENG	[100 to 180 / 163 / 1 deg/step]
026	Thick3:FC:Press	*ENG	[0 to 200 / 120 / 1 deg/step]
027	Thick3:BW:Center	*ENG	[100 to 180 / 163 / 1 deg/step]
028	Thick3:BW:Press	*ENG	[0 to 200 / 120 / 1 deg/step]
029	Special1:FC:Center	*ENG	[100 to 180 / 145 / 1 deg/step]
030	Special1:FC:Press	*ENG	[0 to 200 / 120 / 1 deg/step]
031	Special1:BW:Center	*ENG	[100 to 180 / 145 / 1 deg/step]
032	Special1:BW:Press	*ENG	[0 to 200 / 120 / 1 deg/step]
033	Special2:FC:Center	*ENG	[100 to 180 / 168 / 1 deg/step]
034	Special2:FC:Press	*ENG	[0 to 200 / 120 / 1 deg/step]
035	Special2:BW:Center	*ENG	[100 to 180 / 168 / 1 deg/step]
036	Special2:BW:Press	*ENG	[0 to 200 / 120 / 1 deg/step]
037	Special3:FC:Center	*ENG	[100 to 180 / 158 / 1 deg/step]
038	Special3:FC:Press	*ENG	[0 to 200 / 120 / 1 deg/step]
039	Special3:BW:Center	*ENG	[100 to 180 / 158 / 1 deg/step]
040	Special3:BW:Press	*ENG	[0 to 200 / 120 / 1 deg/step]
041	Envelop:Center	*ENG	[100 to 180 / 168 / 1 deg/step]
042	Envelop:Press	*ENG	[0 to 200 / 120 / 1 deg/step]
101	Plain1:FC:Center:Low Speed	*ENG	[100 to 180 / 133 / 1 deg/step]

Main SP Tables-1

102	Plain1:FC:Press:Low Speed	*ENG	[0 to 200 / 120 / 1 deg/step]
103	Plain1:BW:Center:Low Speed	*ENG	[100 to 180 / 133 / 1 deg/step]
104	Plain1:BW:Press:Low Speed	*ENG	[0 to 200 / 120 / 1 deg/step]
105	Plain2:FC:Center:Low Speed	*ENG	[100 to 180 / 138 / 1 deg/step]
106	Plain2:FC:Press:Low Speed	*ENG	[0 to 200 / 120 / 1 deg/step]
107	Plain2:BW:Center:Low Speed	*ENG	[100 to 180 / 138 / 1 deg/step]
108	Plain2:BW:Press:Low Speed	*ENG	[0 to 200 / 120 / 1 deg/step]
109	M-thick:FC:Center:Low Speed	*ENG	[100 to 180 / 143 / 1 deg/step]
110	M-thick:FC:Press:Low Speed	*ENG	[0 to 200 / 120 / 1 deg/step]
111	M-thick:BW:Center:Low Speed	*ENG	[100 to 180 / 143 / 1 deg/step]
112	M-thick:BW:Press:Low Speed	*ENG	[0 to 200 / 120 / 1 deg/step]
113	Thick1:FC:Center:Low Speed	*ENG	[100 to 180 / 148 / 1 deg/step]
114	Thick1:FC:Press:Low Speed	*ENG	[0 to 200 / 120 / 1 deg/step]
115	Thick1:BW:Center:Low Speed	*ENG	[100 to 180 / 148 / 1 deg/step]
116	Thick1:BW:Press:Low Speed	*ENG	[0 to 200 / 120 / 1 deg/step]

117	Special1:FC:Center:Low Speed	*ENG	[100 to 180 / 138 / 1 deg/step]
118	Special1:FC:Press:Low Speed	*ENG	[0 to 200 / 120 / 1 deg/step]
119	Special1:BW:Center:Low Speed	*ENG	[100 to 180 / 138 / 1 deg/step]
120	Special1:BW:Press:Low Speed	*ENG	[0 to 200 / 120 / 1 deg/step]
121	Special2:FC:Center:Low Speed	*ENG	[100 to 180 / 148 / 1 deg/step]
122	Special2:FC:Press:Low Speed	*ENG	[0 to 200 / 120 / 1 deg/step]
123	Special2:BW:Center:Low Speed	*ENG	[100 to 180 / 148 / 1 deg/step]
124	Special2:BW:Press:Low Speed	*ENG	[0 to 200 / 120 / 1 deg/step]
125	Plain1:Glossy:Center	*ENG	[100 to 180 / 138 / 1 deg/step]
126	Plain1:Glossy:Press	*ENG	[0 to 200 / 120 / 1 deg/step]
127	Plain2:Glossy:Center	*ENG	[100 to 180 / 143 / 1 deg/step]
128	Plain2:Glossy:Press	*ENG	[0 to 200 / 120 / 1 deg/step]
129	M-thick:Glossy:Center	*ENG	[100 to 180 / 148 / 1 deg/step]
130	M-thick:Glossy:Press	*ENG	[0 to 200 / 120 / 1 deg/step]
131	OHP:Center	*ENG	[100 to 180 / 158 / 1 deg/step]
132	OHP:Press	*ENG	[0 to 200 / 120 / 1 deg/step]
133	Envelop:Center:Low Speed	*ENG	[100 to 180 / 163 / 1 deg/step]
134	Envelop:Press:Low Speed	*ENG	[0 to 200 / 120 / 1 deg/step]

Main SP Tables-1

135	Thin:FC:Center:Low Speed	*ENG	[100 to 180 / 128 / 1 deg/step]
136	Thin:FC:Press:Low Speed	*ENG	[0 to 200 / 120 / 1 deg/step]
137	Thin:BW:Center:Low Speed	*ENG	[100 to 180 / 128 / 1 deg/step]
138	Thin:BW:Press:Low Speed	*ENG	[0 to 200 / 120 / 1 deg/step]
139	Thick4:FC:Center	*ENG	[100 to 180 / 168 / 1 deg/step]
140	Thick4:FC:Press	*ENG	[0 to 200 / 120 / 1 deg/step]
141	Thick4:BW:Center	*ENG	[100 to 180 / 168 / 1 deg/step]
142	Thick4:BW:Press	*ENG	[0 to 200 / 120 / 1 deg/step]

1106	[Fusing Temp. Display]		
001	Heat Center	-	[-10 to 250 / - / 1 deg/step]
002	Heat End	-	Displays the temperature of the heating roller.
003	Press Center	-	[-10 to 250 / - / 1 deg/step]
004	Press End	-	Displays the temperature of the heating roller.

1107	[Standby Target Temp. Setting]		
001	Stanby/Preheat1:Center	*ENG	[0 to 125 / 90 / 1 sec/step]
	Specifies the time that the fusing heater turns off after the fusing unit temperature has reached its target temperature.		
002	Stanby/Preheat1: Press	*ENG	[0 to 125 / 90 / 1 deg/step]
	Specifies the temperature of the pressure roller for the ready or energy save 1 mode.		

003	Preheat2:Center	*ENG	[0 to 125 / 90 / 1 sec/step]
	Specifies the temperature of the heating roller for the ready or energy save 2 mode.		
004	Preheat2:Press	*ENG	[0 to 125 / 90 / 1 deg/step]
	Specifies the temperature of the pressure roller for the energy save 2 mode.		
005	Low Power:Center	*ENG	[0 to 125 / 90 / 1 sec/step]
	Specifies the temperature of the heating roller for the low power mode.		
006	Low Power:Press	*ENG	[0 to 125 / 60 / 1 deg/step]
	Specifies the temperature of the pressure roller for the low power mode.		
007	Print Ready:Center	*ENG	[0 to 180 / 145 / 1 deg/step]
	Specifies the temperature of the heating roller for the print ready condition.		
008	Print Ready:Press	*ENG	[0 to 200 / 120 / 1 deg/step]
	Specifies the temperature of the pressure roller for the print ready condition.		

1108	[After Reload/Job Target Temp.]		
001	Center	*ENG	[0 to 180 / 145 / 1 deg/step]
	Specifies the temperature of the heating roller after re-load or job.		
002	Press	*ENG	[0 to 200 / 120 / 1 deg/step]
	Specifies the temperature of the pressure roller after re-load or job.		

1111	[Environment Correction:Fusing]		
001	Temp.: Threshold: Low	*ENG	[0 to 100 / 17 / 1 deg/step]
	Specifies the threshold temperature for low temperature. If the fusing temperature is 17°C or less, the machine executes the fusing mode for low temperature.		
002	Temp.: Threshold: High	*ENG	[0 to 100 / 30 / 1 deg/step]
	Specifies the threshold temperature for high temperature. If the fusing temperature is 30°C or more, the machine executes the fusing mode for high temperature.		
003	Low Temp. Correction	*ENG	[0 to 15 / 5 / 1 deg/step]
	Specifies the additional temperature for the target temperature. If the fusing temperature is in low temperature condition, this temperature is added to the target temperature.		
004	High Temp. Correction	*ENG	[0 to 15 / 0 / 1 deg/step]
	Specifies the additional temperature for the target temperature. If the fusing temperature is in high temperature condition, this temperature is added to the target temperature.		
005	Job Low Temp. Correction	*ENG	[0 to 100 / 5 / 0.1 deg/step]
006	Job High Temp. Correction	*ENG	[0 to 100 / 0 / 0.1 deg/step]
007	Job Low Temp. Correction:Sp.	*ENG	[0 to 100 / 5 / 0.1 deg/step]
008	Job High Temp. Correction:Sp.	*ENG	[0 to 100 / 0 / 0.1 deg/step]

1113	[Curl Correction]		
001	Execute Pattern	*ENG	[0 to 2 / 0 / 1 /step] 0: Off, 1: On (No Decurl), 2: On
	Selects the curl correction type.		
002	Humidity:Threshold:M-humid	*ENG	[0 to 100 / 1 / 1 %/step]
	Specifies the threshold between low and middle humidity.		
003	Humidity:Threshold:H-humid	*ENG	[0 to 100 / 65 / 1 %/step]
	Specifies the threshold between middle and high humidity.		
004	Permit Temp.:Delta:Press:M-humid	*ENG	[0 to 200 / 60 / 1 deg/step]
	Specifies the threshold temperature for the curl control in middle humidity.		
005	Permit Temp.:Delta:Press:H-humid	*ENG	[0 to 200 / 50 / 1 deg/step]
	Specifies the threshold temperature for the curl control in high humidity.		
006	Permit Temp.:Delta:Press:M-humid: Decurl	*ENG	[0 to 200 / 50 / 1 deg/step]
	Specifies the threshold temperature for the no curl control in middle humidity.		
007	Permit Temp.:Delta:Press:H-humid: Decurl	*ENG	[0 to 200 / 40 / 1 deg/step]
	Specifies the threshold temperature for the no curl control in high humidity.		
008	CPM:M-humid	*ENG	[0 to 100 / 80 / 1 %/step]
	Specifies the CPM ratio of the decurl control against to the normal operation in middle humidity.		

Main SP Tables-1

009	CPM:H-humid	*ENG	[0 to 100 / 65 / 1 %/step]
	Specifies the CPM ratio of the decurl control against to the normal operation in high humidity.		
010	CPM:M-humid:No Decurl	*ENG	[0 to 100 / 80 / 1 %/step]
	Specifies the CPM ratio against of the no decurl control to the normal operation in middle humidity.		
011	CPM:H-humid:No Decurl	*ENG	[0 to 100 / 65 / 1 %/step]
	Specifies the CPM ratio against of the no decurl control to the normal operation in high humidity.		

1115	[Target Temp. Correction]		
001	Temp.:Delta:End	*ENG	[-100 to 100 / 0 / 1 deg/step]
	Specifies the different temperature between end and center of the heating roller.		

1124	[CPM Down Setting]		
	Specifies the settings for the CPM down mode.		
001	Low:Down Temp.	*ENG	[-50 to 0 / -20 / 1 deg/step]
	Specifies the CPM down threshold temperature for the low temperature condition. If the fusing temperature decreases -20°C (adjustable) below the target temperature, the machine enters the CPM down mode.		
002	Low:Up Temp.	*ENG	[-50 to 0 / -15 / 1 deg/step]
	Specifies the CPM up threshold temperature for the low temperature condition. If the fusing temperature increases -15°C (adjustable) below the target temperature, the machine enters the CPM up mode.		

003	Low :1st CPM	*ENG	[10 to 100 / 80 / 1 %/step]
	Specifies the 1st CPM down ration against the normal CPM in the low temperature condition.		
004	Low :2nd CPM	*ENG	[10 to 100 / 65 / 1 %/step]
	Specifies the 2nd CPM down ration against the normal CPM in the low temperature condition.		
005	Low :3rd CPM	*ENG	[10 to 100 / 50 / 1 %/step]
	Specifies the 3rd CPM down ration against the normal CPM in the low temperature condition.		
006	High :1st CPM	*ENG	[10 to 100 / 80 / 1 %/step]
	Specifies the 1st CPM down ration against the normal CPM in the high temperature condition.		
007	High:2nd CPM	*ENG	[10 to 100 / 50 / 1 %/step]
	Specifies the 3rd CPM down ration against the normal CPM in the high temperature condition.		
008	High:3rd CPM	*ENG	[10 to 100 / 30 / 1 %/step]
	Specifies the 1st CPM down ration against the normal CPM in the high temperature condition.		
009	High:1st CPM Down Temp.:A3:Press End	*ENG	[100 to 250 / 180 / 1 deg/step]
	Specifies the heating roller temperature for 1st CPM down of A3 paper size.		
010	High:2nd CPM Down Temp.:A3:Press End	*ENG	[100 to 250 / 185 / 1 deg/step]
	Specifies the heating roller temperature for 2nd CPM down of A3 paper size.		
011	High:3rd CPM Down Temp.:A3:Press End	*ENG	[100 to 250 / 190 / 1 deg/step]
	Specifies the heating roller temperature for 3rd CPM down of A3 paper size.		

Main SP Tables-1

012	High:1st CPM Down Temp.:DLT:Press End	*ENG	[100 to 250 / 180 / 1 deg/step]
	Specifies the heating roller temperature for 1st CPM down of DLT paper size.		
013	High:2nd CPM Down Temp.:DLT:Press End	*ENG	[100 to 250 / 185 / 1 deg/step]
	Specifies the heating roller temperature for 2nd CPM down of DLT paper size.		
014	High:3rd CPM Down Temp.:DLT:Press End	*ENG	[100 to 250 / 190 / 1 deg/step]
	Specifies the heating roller temperature for 3rd CPM down of DLT paper size.		
015	High:1st CPM Down Temp.:B4:Press End	*ENG	[100 to 250 / 145 / 1 deg/step]
	Specifies the pressure roller temperature for 1st CPM down of B4 paper size.		
016	High:2nd CPM Down Temp.:B4:Press End	*ENG	[100 to 250 / 155 / 1 deg/step]
	Specifies the pressure roller temperature for 2nd CPM down of B4 paper size.		
017	High:3rd CPM Down Temp.:B4:Press End	*ENG	[100 to 250 / 160 / 1 deg/step]
	Specifies the pressure roller temperature for 3rd CPM down of B4 paper size.		
018	High:1st CPM Down Temp.:LT:Fuser End	*ENG	[100 to 250 / 190 / 1 deg/step]
	Specifies the pressure roller temperature for 1st CPM down of LT paper size.		
019	High:2nd CPM Down Temp.:LT:Fuser End	*ENG	[100 to 250 / 195 / 1 deg/step]
	Specifies the pressure roller temperature for 2nd CPM down of LT paper size.		

020	High:3rd CPM Down Temp.:LT:Fuser End	*ENG	[100 to 250 / 200 / 1 deg/step]
	Specifies the pressure roller temperature for 3rd CPM down of LT paper size.		
021	High:1st CPM Down Temp.:A4:Fuser End	*ENG	[100 to 250 / 190 / 1 deg/step]
	Specifies the pressure roller temperature for 1st CPM down of A4 paper size.		
022	High:2nd CPM Down Temp.:A4:Fuser End	*ENG	[100 to 250 / 195 / 1 deg/step]
	Specifies the pressure roller temperature for 2nd CPM down of A4 paper size.		
023	High:3rd CPM Down Temp.:A4:Fuser End	*ENG	[100 to 250 / 200 / 1 deg/step]
	Specifies the pressure roller temperature for 3rd CPM down of A4 paper size.		
024	High:1st CPM Down Temp.:B5:Press End	*ENG	[100 to 250 / 200 / 1 deg/step]
	Specifies the pressure roller temperature for 1st CPM down of B5 paper size.		
025	High:2nd CPM Down Temp.:B5:Press End	*ENG	[100 to 250 / 205 / 1 deg/step]
	Specifies the pressure roller temperature for 2nd CPM down of B5 paper size.		
026	High:3rd CPM Down Temp.:B5:Press End	*ENG	[100 to 250 / 210 / 1 deg/step]
	Specifies the pressure roller temperature for 3rd CPM down of B5 paper size.		
027	High:1st CPM Down Temp.:A5:Press End	*ENG	[100 to 250 / 200 / 1 deg/step]
	Specifies the pressure roller temperature for 1st CPM down of A5 paper size.		

Main SP Tables-1

028	High:2nd CPM Down Temp.:A5:Press End	*ENG	[100 to 250 / 205 / 1 deg/step]
	Specifies the pressure roller temperature for 2nd CPM down of A5 paper size.		
029	High:3rd CPM Down Temp.:A5:Press End	*ENG	[100 to 250 / 210 / 1 deg/step]
	Specifies the pressure roller temperature for 3rd CPM down of A5 paper size.		
030	High:1st CPM Down Temp.:B6:Press End	*ENG	[100 to 250 / 200 / 1 deg/step]
	Specifies the pressure roller temperature for 1st CPM down of B6 paper size.		
031	High:2nd CPM Down Temp.:B6:Press End	*ENG	[100 to 250 / 205 / 1 deg/step]
	Specifies the pressure roller temperature for 2nd CPM down of B6 paper size.		
032	High:3rd CPM Down Temp.:B6:Press End	*ENG	[100 to 250 / 210 / 1 deg/step]
	Specifies the pressure roller temperature for 3rd CPM down of B6 paper size.		
033	High:1st CPM:Down Temp.:A6:Press Center	*ENG	[100 to 250 / 200 / 1 deg/step]
	Specifies the pressure roller temperature for 1st CPM down of A6 paper size.		
034	High:2nd CPM:Down Temp.:A6:Press Center	*ENG	[100 to 250 / 205 / 1 deg/step]
	Specifies the pressure roller temperature for 2nd CPM down of A6 paper size.		
035	High:3rd CPM:Down Temp.:A6:Press Center	*ENG	[100 to 250 / 210 / 1 deg/step]
	Specifies the pressure roller temperature for 3rd CPM down of A6 paper size.		
051	Judging Interval	*ENG	[0 to 250 / 5 / 1 sec/step]
	Specifies the interval for CPM down judgment.		

101	High:1st CPM Down Time:A3	*ENG	[0 to 10,000 / 10,000 / 1 sec/step]
	Specifies the pressure roller temperature for 1st CPM down of A3 paper size.		
102	High:2nd CPM Down Time:A3	*ENG	[0 to 10,000 / 10,000 / 1 sec/step]
	Specifies the pressure roller temperature for 2nd CPM down of A3 paper size.		
103	High:3rd CPM Down Time:A3	*ENG	[0 to 10,000 / 10,000 / 1 sec/step]
	Specifies the pressure roller temperature for 3rd CPM down of A3 paper size.		
104	High :1st CPM:Down Time:DLT	*ENG	[0 to 10,000 / 10,000 / 1 sec/step]
	Specifies the pressure roller temperature for 1st CPM down of DLT.		
105	High :2nd CPM:Down Time:DLT	*ENG	[0 to 10,000 / 10,000 / 1 sec/step]
	Specifies the pressure roller temperature for 2nd CPM down of DLT.		
106	High :3rd CPM:Down Time:DLT	*ENG	[0 to 10,000 / 10,000 / 1 sec/step]
	Specifies the pressure roller temperature for 3rd CPM down of DLT.		
107	High :1st CPM:Down Time:B4	*ENG	[0 to 10,000 / C3c: 30, C3d: 20 / 1 sec/step]
	Specifies the pressure roller temperature for 1st CPM down of B4 paper size.		
108	High :2nd CPM:Down Time:B4	*ENG	[0 to 10,000 / 10,000 / 1 sec/step]
	Specifies the pressure roller temperature for 2nd CPM down of B4 paper size.		
109	High :3rd CPM:Down Time:B4	*ENG	[0 to 10,000 / 10,000 / 1 sec/step]
	Specifies the pressure roller temperature for 3rd CPM down of B4 paper size.		

Main SP Tables-1

110	High :1st CPM:Down Time:LT	*ENG	[0 to 10,000 / 10,000 / 1 sec/step]
	Specifies the pressure roller temperature for 1st CPM down of LT.		
111	High :2nd CPM:Down Time:LT	*ENG	[0 to 10,000 / 10,000 / 1 sec/step]
	Specifies the pressure roller temperature for 2nd CPM down of LT.		
112	High :3rd CPM:Down Time:LT	*ENG	[0 to 10,000 / 10,000 / 1 sec/step]
	Specifies the pressure roller temperature for 3rd CPM down of LT.		
113	High :1st CPM:Down Time:A4	*ENG	[0 to 10,000 / 10,000 / 1 sec/step]
	Specifies the pressure roller temperature for 1st CPM down of A4 paper size.		
114	High :2nd CPM:Down Time:A4	*ENG	[0 to 10,000 / 10,000 / 1 sec/step]
	Specifies the pressure roller temperature for 2nd CPM down of A4 paper size.		
115	High :3rd CPM:Down Time:A4	*ENG	[0 to 10,000 / 10,000 / 1 sec/step]
	Specifies the pressure roller temperature for 3rd CPM down of A4 paper size.		
116	High :1st CPM:Down Time:B5	*ENG	[0 to 10,000 / C3c: 30, C3d: 20 / 1 sec/step]
	Specifies the pressure roller temperature for 1st CPM down of B5 paper size.		
117	High :2nd CPM:Down Time:B5	*ENG	[0 to 10,000 / 10,000 / 1 sec/step]
	Specifies the pressure roller temperature for 2nd CPM down of B5 paper size.		

118	High :3rd CPM:Down Time:B5	*ENG	[0 to 10,000 / 10,000 / 1 sec/step]
	Specifies the pressure roller temperature for 3rd CPM down of B5 paper size.		
119	High :1st CPM:Down Time:A5	*ENG	[0 to 10,000 / C3c: 40, C3d: 20 / 1 sec/step]
	Specifies the pressure roller temperature for 1st CPM down of A5 paper size.		
120	High :2nd CPM:Down Time:A5	*ENG	[0 to 10,000 / 10,000 / 1 sec/step]
	Specifies the pressure roller temperature for 2nd CPM down of A5 paper size.		
121	High :3rd CPM:Down Time:A5	*ENG	[0 to 10,000 / 10,000 / 1 sec/step]
	Specifies the pressure roller temperature for 3rd CPM down of A5 paper size.		
122	High :1st CPM:Down Time:B6	*ENG	[0 to 10,000 / C3c: 40, C3d: 20 / 1 sec/step]
	Specifies the pressure roller temperature for 1st CPM down of B6 paper size.		
123	High :2nd CPM:Down Time:B6	*ENG	[0 to 10,000 / 10,000 / 1 sec/step]
	Specifies the pressure roller temperature for 2nd CPM down of B6 paper size.		
124	High :3rd CPM:Down Time:B6	*ENG	[0 to 10,000 / 10,000 / 1 sec/step]
	Specifies the pressure roller temperature for 3rd CPM down of B6 paper size.		
125	High :1st CPM:Down Time:A6	*ENG	[0 to 10,000 / C3c: 40, C3d: 20 / 1 sec/step]
	Specifies the pressure roller temperature for 1st CPM down of A6 paper size.		
126	High :2nd CPM:Down Time:A6	*ENG	[0 to 10,000 / 10,000 / 1 sec/step]
	Specifies the pressure roller temperature for 2nd CPM down of A6 paper size.		

Main SP Tables-1

127	High :3rd CPM:Down Time:A6	*ENG	[0 to 10,000 / 10,000 / 1 sec/step]
	Specifies the pressure roller temperature for 3rd CPM down of A6 paper size.		
151	High :1st CPM:Down Time:A3:Low Speed	*ENG	[0 to 10,000 / 10,000 / 1 sec/step]
	Specifies the pressure roller temperature for 1st CPM down of A3 paper size.		
152	High :2nd CPM:Down Time:A3:Low Speed	*ENG	[0 to 10,000 / 10,000 / 1 sec/step]
	Specifies the pressure roller temperature for 2nd CPM down of A3 paper size.		
153	High :3rd CPM:Down Time:A3:Low Speed	*ENG	[0 to 10,000 / 10,000 / 1 sec/step]
	Specifies the pressure roller temperature for 3rd CPM down of A3 paper size.		
154	High :1st CPM:Down Time:DLT:Low Speed	*ENG	[0 to 10,000 / 10,000 / 1 sec/step]
	Specifies the pressure roller temperature for 1st CPM down of DLT.		
155	High :2nd CPM:Down Time:DLT:Low Speed	*ENG	[0 to 10,000 / 10,000 / 1 sec/step]
	Specifies the pressure roller temperature for 2nd CPM down of DLT.		
156	High :3rd CPM:Down Time:DLT:Low Speed	*ENG	[0 to 10,000 / 10,000 / 1 sec/step]
	Specifies the pressure roller temperature for 3rd CPM down of DLT.		
157	High :1st CPM:Down Time:B4:Low Speed	*ENG	[0 to 10,000 / 10,000 / 1 sec/step]
	Specifies the pressure roller temperature for 1st CPM down of B4 paper size.		
158	High :2nd CPM:Down Time:B4:Low Speed	*ENG	[0 to 10,000 / 10,000 / 1 sec/step]
	Specifies the pressure roller temperature for 2nd CPM down of B4 paper size.		

159	High :3rd CPM:Down Time:B4:Low Speed	*ENG	[0 to 10,000 / 10,000 / 1 sec/step]
	Specifies the pressure roller temperature for 3rd CPM down of B4 paper size.		
160	High :1st CPM:Down Time:LT:Low Speed	*ENG	[0 to 10,000 / 10,000 / 1 sec/step]
	Specifies the pressure roller temperature for 1st CPM down of LT.		
161	High :2nd CPM:Down Time:LT:Low Speed	*ENG	[0 to 10,000 / 10,000 / 1 sec/step]
	Specifies the pressure roller temperature for 2nd CPM down of LT.		
162	High :3rd CPM:Down Time:LT:Low Speed	*ENG	[0 to 10,000 / 10,000 / 1 sec/step]
	Specifies the pressure roller temperature for 3rd CPM down of LT.		
163	High :1st CPM:Down Time:A4:Low Speed	*ENG	[0 to 10,000 / 10,000 / 1 sec/step]
	Specifies the pressure roller temperature for 1st CPM down of A4 paper size.		
164	High :2nd CPM:Down Time:A4:Low Speed	*ENG	[0 to 10,000 / 10,000 / 1 sec/step]
	Specifies the pressure roller temperature for 2nd CPM down of A4 paper size.		
165	High :3rd CPM:Down Time:A4:Low Speed	*ENG	[0 to 10,000 / 10,000 / 1 sec/step]
	Specifies the pressure roller temperature for 3rd CPM down of A4 paper size.		
166	High :1st CPM:Down Time:B5:Low Speed	*ENG	[0 to 10,000 / 10,000 / 1 sec/step]
	Specifies the pressure roller temperature for 1st CPM down of B5 paper size.		
167	High :2nd CPM:Down Time:B5:Low Speed	*ENG	[0 to 10,000 / 10,000 / 1 sec/step]
	Specifies the pressure roller temperature for 2nd CPM down of B5 paper size.		

Main SP Tables-1

168	High :3rd CPM:Down Time:B5:Low Speed	*ENG	[0 to 10,000 / 10,000 / 1 sec/step]
	Specifies the pressure roller temperature for 3rd CPM down of B5 paper size.		
169	High :1st CPM:Down Time:A5:Low Speed	*ENG	[0 to 10,000 / 10,000 / 1 sec/step]
	Specifies the pressure roller temperature for 1st CPM down of A5 paper size.		
170	High :2nd CPM:Down Time:A5:Low Speed	*ENG	[0 to 10,000 / 10,000 / 1 sec/step]
	Specifies the pressure roller temperature for 2nd CPM down of A5 paper size.		
171	High :3rd CPM:Down Time:A5:Low Speed	*ENG	[0 to 10,000 / 10,000 / 1 sec/step]
	Specifies the pressure roller temperature for 3rd CPM down of A5 paper size.		
172	High :1st CPM:Down Time:B6:Low Speed	*ENG	[0 to 10,000 / 10,000 / 1 sec/step]
	Specifies the pressure roller temperature for 1st CPM down of B6 paper size.		
173	High :2nd CPM:Down Time:B6:Low Speed	*ENG	[0 to 10,000 / 10,000 / 1 sec/step]
	Specifies the pressure roller temperature for 2nd CPM down of B6 paper size.		
174	High :3rd CPM:Down Time:B6:Low Speed	*ENG	[0 to 10,000 / 10,000 / 1 sec/step]
	Specifies the pressure roller temperature for 3rd CPM down of B6 paper size.		
175	High :1st CPM:Down Time:A6:Low Speed	*ENG	[0 to 10,000 / 10,000 / 1 sec/step]
	Specifies the pressure roller temperature for 1st CPM down of A6 paper size.		
176	High :2nd CPM:Down Time:A6:Low Speed	*ENG	[0 to 10,000 / 10,000 / 1 sec/step]
	Specifies the pressure roller temperature for 2nd CPM down of A6 paper size.		

177	High :3rd CPM:Down Time:A6:Low Speed	*ENG	[0 to 10,000 / 10,000 / 1 sec/step]
	Specifies the pressure roller temperature for 3rd CPM down of A6 paper size.		
1125	[CPM Down Setting]		
	Specifies the settings for the CPM down mode.		
001	High :1st CPM:A3:Large Size:Normal Speed	*ENG	[0 to 100 / 80 / 1 %/step]
	Specifies the pressure roller temperature for 1st CPM down of A3 Large paper size.		
002	High :2nd CPM:A3:Large Size:Normal Speed	*ENG	[0 to 100 / 50 / 1 %/step]
	Specifies the pressure roller temperature for 2nd CPM down of A3 Large paper size.		
003	High :3rd CPM:A3:Large Size:Normal Speed	*ENG	[0 to 100 / 30 / 1 %/step]
	Specifies the pressure roller temperature for 3rd CPM down of A3 Large paper size.		
004	High :1st CPM:A3:Small Size:Normal Speed	*ENG	[0 to 100 / 80 / 1 %/step]
	Specifies the pressure roller temperature for 1st CPM down of A3 Small paper size.		
005	High :2nd CPM:A3:Small Size:Normal Speed	*ENG	[0 to 100 / 50 / 1 %/step]
	Specifies the pressure roller temperature for 2nd CPM down of A3 Small paper size.		

Main SP Tables-1

006	High :3rd CPM:A3:Small Size:Normal Speed	*ENG	[0 to 100 / 30 / 1 %/step]
	Specifies the pressure roller temperature for 3rd CPM down of A3 Small paper size.		
007	High :1st CPM:DLT:Large Size:Normal Speed	*ENG	[0 to 100 / 80 / 1 %/step]
	Specifies the pressure roller temperature for 1st CPM down of DLT Large paper size.		
008	High :2nd CPM:DLT:Large Size:Normal Speed	*ENG	[0 to 100 / 50 / 1 %/step]
	Specifies the pressure roller temperature for 2nd CPM down of DLT Large paper size.		
009	High :3rd CPM:DLT:Large Size:Normal Speed	*ENG	[0 to 100 / 30 / 1 %/step]
	Specifies the pressure roller temperature for 3rd CPM down of DLT Large paper size.		
010	High :1st CPM:DLT:Small Size:Normal Speed	*ENG	[0 to 100 / 80 / 1 %/step]
	Specifies the pressure roller temperature for 1st CPM down of DLT Small paper size.		

011	High :2nd CPM:DLT:Small Size:Normal Speed	*ENG	[0 to 100 / 50 / 1 %/step]
	Specifies the pressure roller temperature for 2nd CPM down of DLT Small paper size.		
012	High :3rd CPM:DLT:Small Size:Normal Speed	*ENG	[0 to 100 / 30 / 1 %/step]
	Specifies the pressure roller temperature for 3rd CPM down of DLT Small paper size.		
013	High :1st CPM:B4:Large Size:Normal Speed	*ENG	[0 to 100 / C3c: 90, C3d: 75 / 1 %/step]
	Specifies the pressure roller temperature for 1st CPM down of B4 Large paper size.		
014	High :2nd CPM:B4:Large Size:Normal Speed	*ENG	[0 to 100 / 50 / 1 %/step]
	Specifies the pressure roller temperature for 2nd CPM down of B4 Large paper size.		
015	High :3rd CPM:B4:Large Size:Normal Speed	*ENG	[0 to 100 / 30 / 1 %/step]
	Specifies the pressure roller temperature for 3rd CPM down of B4 Large paper size.		
016	High :1st CPM:B4:Small Size:Normal Speed	*ENG	[0 to 100 / C3c: 90, C3d: 75 / 1 %/step]
	Specifies the pressure roller temperature for 1st CPM down of B4 Small paper size.		

017	High :2nd CPM:B4:Small Size:Normal Speed	*ENG	[0 to 100 / 50 / 1 %/step]
	Specifies the pressure roller temperature for 2nd CPM down of B4 Small paper size.		
018	High :3rd CPM:B4:Small Size:Normal Speed	*ENG	[0 to 100 / 30 / 1 %/step]
	Specifies the pressure roller temperature for 3rd CPM down of B4 Small paper size.		
019	High :1st CPM:LT:Large Size:Normal Speed	*ENG	[0 to 100 / 80 / 1 %/step]
	Specifies the pressure roller temperature for 1st CPM down of LT Large paper size.		
020	High :2nd CPM:LT:Large Size:Normal Speed	*ENG	[0 to 100 / 50 / 1 %/step]
	Specifies the pressure roller temperature for 2nd CPM down of LT Large paper size.		
021	High :3rd CPM:LT:Large Size:Normal Speed	*ENG	[0 to 100 / 30 / 1 %/step]
	Specifies the pressure roller temperature for 3rd CPM down of LT Large paper size.		
022	High :1st CPM:LT:Small Size:Normal Speed	*ENG	[0 to 100 / 80 / 1 %/step]
	Specifies the pressure roller temperature for 1st CPM down of LT Small paper size.		
023	High :2nd CPM:LT:Small Size:Normal Speed	*ENG	[0 to 100 / 50 / 1 %/step]
	Specifies the pressure roller temperature for 2nd CPM down of LT Small paper size.		

024	High :3rd CPM:LT:Small Size:Normal Speed	*ENG	[0 to 100 / 30 / 1 %/step]
	Specifies the pressure roller temperature for 3rd CPM down of LT Small paper size.		
025	High :1st CPM:A4:Large Size:Normal Speed	*ENG	[0 to 100 / 80 / 1 %/step]
	Specifies the pressure roller temperature for 1st CPM down of A4 Large paper size.		
026	High :2nd CPM:A4:Large Size:Normal Speed	*ENG	[0 to 100 / 50 / 1 %/step]
	Specifies the pressure roller temperature for 2nd CPM down of A4 Large paper size.		
027	High :3rd CPM:A4:Large Size:Normal Speed	*ENG	[0 to 100 / 30 / 1 %/step]
	Specifies the pressure roller temperature for 3rd CPM down of A4 Large paper size.		
028	High :1st CPM:A4:Small Size:Normal Speed	*ENG	[0 to 100 / 80 / 1 %/step]
	Specifies the pressure roller temperature for 1st CPM down of A4 Small paper size.		
029	High :2nd CPM:A4:Small Size:Normal Speed	*ENG	[0 to 100 / 50 / 1 %/step]
	Specifies the pressure roller temperature for 2nd CPM down of A4 Small paper size.		
030	High :3rd CPM:A4:Small Size:Normal Speed	*ENG	[0 to 100 / 30 / 1 %/step]
	Specifies the pressure roller temperature for 3rd CPM down of A4 Small paper size.		

Main SP Tables-1

031	High :1st CPM:B5:Large Size:Normal Speed	*ENG	[0 to 100 / C3c:80, C3d: 70 / 1 %/step]
	Specifies the pressure roller temperature for 1st CPM down of B5 Large paper size.		
032	High :2nd CPM:B5:Large Size:Normal Speed	*ENG	[0 to 100 / 50 / 1 %/step]
	Specifies the pressure roller temperature for 2nd CPM down of B5 Large paper size.		
033	High :3rd CPM:B5:Large Size:Normal Speed	*ENG	[0 to 100 / 30 / 1 %/step]
	Specifies the pressure roller temperature for 3rd CPM down of B5 Large paper size.		
034	High :1st CPM:B5:Small Size:Normal Speed	*ENG	[0 to 100 / C3c:80, C3d: 70 / 1 %/step]
	Specifies the pressure roller temperature for 1st CPM down of B5 Small paper size.		
035	High :2nd CPM:B5:Small Size:Normal Speed	*ENG	[0 to 100 / 50 / 1 %/step]
	Specifies the pressure roller temperature for 2nd CPM down of B5 Small paper size.		
036	High :3rd CPM:B5:Small Size:Normal Speed	*ENG	[0 to 100 / 30 / 1 %/step]
	Specifies the pressure roller temperature for 3rd CPM down of B5 Small paper size.		
037	High :1st CPM:A5:Normal Speed	*ENG	[0 to 100 / C3c: 85, C3d: 65 / 1 %/step]
	Specifies the pressure roller temperature for 1st CPM down of A5 paper size.		

038	High :2nd CPM:A5:Normal Speed	*ENG	[0 to 100 / 50 / 1 %/step]
	Specifies the pressure roller temperature for 2nd CPM down of A5 paper size.		
039	High :3rd CPM:A5:Normal Speed	*ENG	[0 to 100 / 30 / 1 %/step]
	Specifies the pressure roller temperature for 3rd CPM down of A5 paper size.		
040	High :1st CPM:B6:Normal Speed	*ENG	[0 to 100 / C3c: 85, C3d: 65 / 1 %/step]
	Specifies the pressure roller temperature for 1st CPM down of B6 paper size.		
041	High :2nd CPM:B6:Normal Speed	*ENG	[0 to 100 / 50 / 1 %/step]
	Specifies the pressure roller temperature for 2nd CPM down of B6 paper size.		
042	High :3rd CPM:B6:Normal Speed	*ENG	[0 to 100 / 30 / 1 %/step]
	Specifies the pressure roller temperature for 3rd CPM down of B6 paper size.		
043	High :1st CPM:A6:Normal Speed	*ENG	[0 to 100 / C3c: 85, C3d: 65 / 1 %/step]
	Specifies the pressure roller temperature for 1st CPM down of A6 paper size.		
044	High :2nd CPM:A6:Normal Speed	*ENG	[0 to 100 / 50 / 1 %/step]
	Specifies the pressure roller temperature for 2nd CPM down of A6 paper size.		
045	High :3rd CPM:A6:Normal Speed	*ENG	[0 to 100 / 30 / 1 %/step]
	Specifies the pressure roller temperature for 3rd CPM down of A6 paper size.		

Main SP Tables-1

101	High :1st CPM:A3:Large Size:Middle Speed	*ENG	[0 to 100 / 80 / 1 %/step]
	Specifies the pressure roller temperature for 1st CPM down of A3 Large paper size.		
102	High :2nd CPM:A3:Large Size:Middle Speed	*ENG	[0 to 100 / 50 / 1 %/step]
	Specifies the pressure roller temperature for 2nd CPM down of A3 Large paper size.		
104	High:1st CPM:A3:Small Size:Middle Speed	*ENG	[0 to 100 / 80 / 1 %/step]
	Specifies the pressure roller temperature for 1st CPM down of A3 Small paper size.		
105	High:2nd CPM:A3:Small Size:Middle Speed	*ENG	[0 to 100 / 50 / 1 %/step]
	Specifies the pressure roller temperature for 2nd CPM down of A3 Small paper size.		
107	High:1st CPM:DLT:Large Size:Middle Speed	*ENG	[0 to 100 / 80 / 1 %/step]
	Specifies the pressure roller temperature for 1st CPM down of DLT Large paper size.		
108	High:2nd CPM:DLT:Large Size:Middle Speed	*ENG	[0 to 100 / 50 / 1 %/step]
	Specifies the pressure roller temperature for 2nd CPM down of DLT Large paper size.		

110	High:1st CPM:DLT:Small Size:Middle Speed	*ENG	[0 to 100 / 80 / 1 %/step]
	Specifies the pressure roller temperature for 1st CPM down of DLT Small paper size.		
111	High:2nd CPM:DLT:Small Size:Middle Speed	*ENG	[0 to 100 / 50 / 1 %/step]
	Specifies the pressure roller temperature for 2nd CPM down of DLT Small paper size.		
113	High:1st CPM:B4:Large Size:Middle Speed	*ENG	[0 to 100 / 80 / 1 %/step]
	Specifies the pressure roller temperature for 1st CPM down of B4 Large paper size.		
114	High:2nd CPM:B4:Large Size:Middle Speed	*ENG	[0 to 100 / 50 / 1 %/step]
	Specifies the pressure roller temperature for 2nd CPM down of B4 Large paper size.		
116	High:1st CPM:B4:Small Size:Middle Speed	*ENG	[0 to 100 / 80 / 1 %/step]
	Specifies the pressure roller temperature for 1st CPM down of B4 Small paper size.		
117	High:2nd CPM:B4:Small Size:Middle Speed	*ENG	[0 to 100 / 50 / 1 %/step]
	Specifies the pressure roller temperature for 2nd CPM down of B4 Small paper size.		
119	High:1st CPM:LT:Large Size:Middle Speed	*ENG	[0 to 100 / 80 / 1 %/step]
	Specifies the pressure roller temperature for 1st CPM down of LT Large paper size.		

Main SP Tables-1

120	High:2nd CPM:LT:Large Size:Middle Speed	*ENG	[0 to 100 / 50 / 1 %/step]
	Specifies the pressure roller temperature for 2nd CPM down of LT Large paper size.		
122	High:1st CPM:LT:Small Size:Middle Speed	*ENG	[0 to 100 / 80 / 1 %/step]
	Specifies the pressure roller temperature for 1st CPM down of LT Small paper size.		
123	High:2nd CPM:LT:Small Size:Middle Speed	*ENG	[0 to 100 / 50 / 1 %/step]
	Specifies the pressure roller temperature for 2nd CPM down of LT Small paper size.		
125	High:1st CPM:A4:Large Size:Middle Speed	*ENG	[0 to 100 / 80 / 1 %/step]
	Specifies the pressure roller temperature for 1st CPM down of A4 Large paper size.		
126	High:2nd CPM:A4:Large Size:Middle Speed	*ENG	[0 to 100 / 50 / 1 %/step]
	Specifies the pressure roller temperature for 2nd CPM down of A4 Large paper size.		
128	High:1st CPM:A4:Small Size:Middle Speed	*ENG	[0 to 100 / 80 / 1 %/step]
	Specifies the pressure roller temperature for 1st CPM down of A4 Small paper size.		
129	High:2nd CPM:A4:Small Size:Middle Speed	*ENG	[0 to 100 / 50 / 1 %/step]
	Specifies the pressure roller temperature for 2nd CPM down of A4 Small paper size.		

131	High:1st CPM:B5:Large Size:Middle Speed	*ENG	[0 to 100 / 80 / 1 %/step]
	Specifies the pressure roller temperature for 1st CPM down of B5 Large paper size.		
132	High:2nd CPM:B5:Large Size:Middle Speed	*ENG	[0 to 100 / 50 / 1 %/step]
	Specifies the pressure roller temperature for 2nd CPM down of B5 Large paper size.		
134	High:1st CPM:B5:Small Size:Middle Speed	*ENG	[0 to 100 / 80 / 1 %/step]
	Specifies the pressure roller temperature for 1st CPM down of B5 Small paper size.		
135	High:2nd CPM:B5:Small Size:Middle Speed	*ENG	[0 to 100 / 50 / 1 %/step]
	Specifies the pressure roller temperature for 2nd CPM down of B5 Small paper size.		
137	High:1st CPM:A5:Middle Speed	*ENG	[0 to 100 / 80 / 1 %/step]
	Specifies the pressure roller temperature for 1st CPM down of A5 paper size.		
138	High:2nd CPM:A5:Middle Speed	*ENG	[0 to 100 / 50 / 1 %/step]
	Specifies the pressure roller temperature for 2nd CPM down of A5 paper size.		
140	High:1st CPM:B6:Middle Speed	*ENG	[0 to 100 / 80 / 1 %/step]
	Specifies the pressure roller temperature for 1st CPM down of B6 paper size.		

141	High:2nd CPM:B6:Middle Speed	*ENG	[0 to 100 / 50 / 1 %/step]
	Specifies the pressure roller temperature for 2nd CPM down of B6 paper size.		
143	High:1st CPM:A6:Middle Speed	*ENG	[0 to 100 / 80 / 1 %/step]
	Specifies the pressure roller temperature for 1st CPM down of A6 paper size.		
144	High:2nd CPM:A6:Middle Speed	*ENG	[0 to 100 / 50 / 1 %/step]
	Specifies the pressure roller temperature for 2nd CPM down of A6 paper size.		
201	High:1st CPM:A3:Large Size:Low Speed	*ENG	[0 to 100 / 80 / 1 %/step]
	Specifies the pressure roller temperature for 1st CPM down of A3 Large paper size.		
204	High:1st CPM:A3:Small Size:Low Speed	*ENG	[0 to 100 / 80 / 1 %/step]
	Specifies the pressure roller temperature for 1st CPM down of A3 Small paper size.		
207	High:1st CPM:DLT:Large Size:Low Speed	*ENG	[0 to 100 / 80 / 1 %/step]
	Specifies the pressure roller temperature for 1st CPM down of DLT Large paper size.		
210	High:1st CPM:DLT:Small Size:Low Speed	*ENG	[0 to 100 / 80 / 1 %/step]
	Specifies the pressure roller temperature for 1st CPM down of DLT Small paper size.		
213	High:1st CPM:B4:Large Size:Low Speed	*ENG	[0 to 100 / 80 / 1 %/step]
	Specifies the pressure roller temperature for 1st CPM down of B4 Large paper size.		

216	High:1st CPM:B4:Small Size:Low Speed	*ENG	[0 to 100 / 80 / 1 %/step]
	Specifies the pressure roller temperature for 1st CPM down of B4 Small paper size.		
219	High:1st CPM:LT:Large Size:Low Speed	*ENG	[0 to 100 / 80 / 1 %/step]
	Specifies the pressure roller temperature for 1st CPM down of LT Large paper size.		
222	High :1st CPM:LT:Small Size:Low Speed	*ENG	[0 to 100 / 80 / 1 %/step]
	Specifies the pressure roller temperature for 1st CPM down of LT Small paper size.		
225	High :1st CPM:A4:Large Size:Low Speed	*ENG	[0 to 100 / 80 / 1 %/step]
	Specifies the pressure roller temperature for 1st CPM down of A4 Large paper size.		
228	High :1st CPM:A4:Small Size:Low Speed	*ENG	[0 to 100 / 80 / 1 %/step]
	Specifies the pressure roller temperature for 1st CPM down of A4 Small paper size.		
231	High :1st CPM:B5:Large Size:Low Speed	*ENG	[0 to 100 / 80 / 1 %/step]
	Specifies the pressure roller temperature for 1st CPM down of B5 Large paper size.		
234	High :1st CPM:B5:Small Size:Low Speed	*ENG	[0 to 100 / 80 / 1 %/step]
	Specifies the pressure roller temperature for 1st CPM down of B5 Small paper size.		

Main SP Tables-1

237	High :1st CPM:A5:Low Speed	*ENG	[0 to 100 / 80 / 1 %/step]
	Specifies the pressure roller temperature for 1st CPM down of A5 paper size.		
240	High :1st CPM:B6:Low Speed	*ENG	[0 to 100 / 80 / 1 %/step]
	Specifies the pressure roller temperature for 1st CPM down of B6 paper size.		
243	High :1st CPM:A6:Low Speed	*ENG	[0 to 100 / 80 / 1 %/step]
	Specifies the pressure roller temperature for 1st CPM down of A6 paper size.		

1141	[Fusing SC Issue Time Info]		
001	SC Number	*ENG	Displays the issued SC number.
101	Htg Roller:Ctr Det1	*ENG	[-50 to 300 / - / 1 deg/step] Displays the temperature at the center of the heating roller when an SC was issued.
102	Htg Rolloer:End Det1	*ENG	
103	Htg Roller:Ctr Det1	*ENG	
104	Htg Roller:End Det1	*ENG	
151	Htg Roller:Ctr Det2	*ENG	
152	Htg Rolloer:End Det2	*ENG	
153	Press Roller:Ctr Det2	*ENG	
154	Press Roller:End Det2	*ENG	
201	Htg Roller:Ctr Det3	*ENG	
202	Htg Rolloer:End Det3	*ENG	
203	Press Roller:Ctr Det3	*ENG	
204	Press Roller:End Det3	*ENG	

1142	[Fusing Jam Detection]		
001	SC Display	*ENG	[0 or 1 / 0 / -]
	Enables or disables the fusing consecutive jam (three times) SC detection. 0: No detection, 1: Detection		

1151	[Pressure Setting]		
001	Pressure Change ON/OFF	*ENG	[0 or 1 / 1 / -]
	Enables or disables the pressure switching control for the fusing unit. 0: OFF , 1: ON		
002	Pressure Position1	*ENG	[0 to 10,000 / 420 / 10 msec/step]
	Specifies the rotation time of the pressure roller contact motor for the pressure position 1.		
003	Pressure Position2	*ENG	[0 to 10,000 / 660 / 10 msec/step]
	Specifies the rotation time of the pressure roller contact motor for the pressure position 2.		
004	Pressure Position3	*ENG	[0 to 10,000 / 2130 / 10 msec/step]
	Specifies the rotation time of the pressure roller contact motor for the pressure position 3.		
005	Depressure Position	*ENG	[0 to 10,000 / 220 / 10 msec/step]
	Specifies the rotation time of the pressure roller contact motor for the depression position (no pressure).		
011	Shift Time	*ENG	[0 to 3600 / 60 / 1 sec/step]
	Specifies the timing for depressing the fusing unit. If the machine does not get any jobs for specified time by this SP after copying or printing, the machine depresses the fusing unit.		

101	Pressure:Plain1/2	*ENG	[0 to 3 / 3 / 1 /step]
	Sets the default pressure position of the fusing unit for each paper type in normal speed. 0: Depression position (no pressure) 1: Position 1 (less pressure) 2: Position 2 3: Position 3 (strongest pressure)		
102	Pressure:Thin	*ENG	[0 to 3 / 3 / 1 /step]
103	Pressure:M-thick	*ENG	[0 to 3 / 3 / 1 /step]
104	Pressure:Thick1	*ENG	[0 to 3 / 3 / 1 /step]
105	Pressure:Thick2	*ENG	[0 to 3 / 3 / 1 /step]
106	Pressure:Thick3	*ENG	[0 to 3 / 3 / 1 /step]
107	Pressure:Special1	*ENG	[0 to 3 / 3 / 1 /step]
108	Pressure:Special2	*ENG	[0 to 3 / 3 / 1 /step]
109	Pressure:Special3	*ENG	[0 to 3 / 3 / 1 /step]
110	Pressure:Envelope	*ENG	[0 to 3 / 1 / 1 /step]
151	Pressure:Plain1/2:Low Speed	*ENG	[0 to 3 / 3 / 1 /step]
	Sets the default pressure position of the fusing unit for each paper type in low speed. 0: Depression position (no pressure) 1: Position 1 (less pressure) 2: Position 2 3: Position 3 (strongest pressure)		
152	Pressure:M-thick:Low Speed	*ENG	[0 to 3 / 3 / 1 /step]
153	Pressure:Thick1:Low Speed	*ENG	[0 to 3 / 3 / 1 /step]
154	Pressure:Special1:Low Speed	*ENG	[0 to 3 / 3 / 1 /step]
155	Pressure:Special2:Low Speed	*ENG	[0 to 3 / 3 / 1 /step]

156	Pressure:Plain1/2:Glossy	*ENG	[0 to 3 / 3 / 1 /step]
157	Pressure:M-thick:Glossy	*ENG	[0 to 3 / 3 / 1 /step]
158	Pressure:OHP	*ENG	[0 to 3 / 3 / 1 /step]
159	Pressure:Envelope:Low Speed	*ENG	[0 to 3 / 3 / 1 /step]
160	Pressure:Thin:Low Speed	*ENG	[0 to 3 / 3 / 1 /step]
161	Pressure:Thick4	*ENG	[0 to 3 / 3 / 1 /step]
	Sets the default pressure position of the fusing unit for thick 4 paper. 0: Depression position (no pressure) 1: Position 1 (less pressure) 2: Position 2 3: Position 3 (strongest pressure)		
162	Pressure:Postcard	*ENG	[0 to 3 / 3 / 1 /step]
	Sets the default pressure position of the fusing unit for postcard. 0: Depression position (no pressure) 1: Position 1 (less pressure) 2: Position 2 3: Position 3 (strongest pressure)		
201	Filler Edge Detection Counter	ENG	[0 to 9,000,000 / - / 1 /step]
	Displays the detection time for the edge of the pressure roller actuator.		

Main SP Tables-1

1152	[Fusing Nip Band Check]		
001	Execute	-	[0 or 1 / 0 / 1]
	Executes the nip band measurement between heating roller and pressure roller. If the nip band width is not 8 mm, and fusing is not good, replace the pressure roller or install a new fusing unit.		
002	Pre-idling Time	*ENG	[0 to 999 / 300 / 1 sec/step]
	Specifies the fusing rotation time before executing SP1109-001.		
003	Stop Time	* ENG	[0 to 100 / 20 / 1 sec/step]
	Specifies the time for measuring the nip.		
004	Pressure Position	* ENG	[1 to 3 / 3 / 1]
	Specifies the pressure position for measuring the nip.		

1153	[Fuser Cleaning]		
001	Compulsion execution	-	Execute the fusing cleaning mode.
002	Operation interval	*ENG	[1 to 300 / 0 / 1 K/step]
	Adjusts the execution interval for the fusing cleaning mode. 1K= 100 sheets		
003	Control Temp.	*ENG	[0 to 200 / 180 / 1°C/step]
	Specifies the heating roller temperature for the fusing cleaning mode.		
004	Page Count	*ENG	[1 to 300000 / - / 1 page/step]
	Displays the page counter for the fusing cleaning mode.		

1801	[Motor Speed Adj.]		
001	Registration:Plain:Low	*ENG	[-2 to 2 / -1.1 / 0.1 %/step]
002	Registration:Plain:High	*ENG	[-2 to 2 / -0.1 / 0.1 %/step]
003	Registration:Middle Thick:Low	*ENG	[-2 to 2 / -1.1 / 0.1 %/step]

004	Registration:Middle Thick:Mid	*ENG	[-2 to 2 / -0.1 / 0.1 %/step]
005	Registration:Middle Thick:High	*ENG	
006	Registration:Thick 1:Low	*ENG	[-2 to 2 / -1.1 / 0.1 %/step]
007	Registration:Thick1:Mid	*ENG	[-2 to 2 / -0.1 / 0.1 %/step]
008	Registration:Thick 2:Low	*ENG	[-2 to 2 / -1.1 / 0.1 %/step]
009	Registration:Thick 3:Low	*ENG	
010	Duplex CW:Plane:Low	*ENG	[-4 to 4 / 0.0 / 0.1 %/step]
011	Duplex CW:Normal:High	*ENG	
012	Duplex CW:Middle Thick:Low	*ENG	
013	Duplex CW:Middle Thick:Mid	*ENG	
014	Duplex CW:Middle Thick:High	*ENG	
015	Duplex CW:Thick1:Low	*ENG	
016	Duplex CW:Thick1:Mid	*ENG	
017	Duplex CW:Thick2:Low	*ENG	
018	Duplex CW:Thick3:Low	*ENG	
019	Duplex CCW:Normal:High	*ENG	
020	Duplex CCW:Middle Thick:Mid	*ENG	
021	Duplex CCW:Middle Thick:high	*ENG	
023	Duplex CCW:Thick1:Mid	*ENG	
024	Reverse CW:Normal:High	*ENG	[-4 to 4 / -0.5 / 0.1%/step]
025	Reverse CW:Middle Thick:Mid	*ENG	[-4 to 4 / 0 / 0.1 %/step]
026	Reverse CW:Middle Thick:High	*ENG	[-4 to 4 / -0.5 / 0.1%/step]
028	Reverse CW:Thick1:Mid	*ENG	[-4 to 4 / 0 / 0.1 %/step]
029	Reverse CCW:Normal:High	*ENG	
030	Reverse CCW:Middle Thick:Mid	*ENG	

Main SP Tables-1

031	Reverse CCW:Middle Thick:High	*ENG	
033	Reverse CCW:Thick1:Mid	*ENG	
034	Feed:Plain:Low	*ENG	[-2 to 2 / -1.1 / 0.1 %/step]
035	Feed:Plain:High	*ENG	[-2 to 2 / -0.1 / 0.1 %/step]
036	Feed:Middle thick:Low	*ENG	[-2 to 2 / -1.1 / 0.1 %/step]
037	Feed:Middle thick:Mid	*ENG	[-2 to 2 / -0.1 / 0.1 %/step]
038	Feed:Middle thick:High	*ENG	
039	Feed:Thick 1:Low	*ENG	[-2 to 2 / -1.1 / 0.1 %/step]
040	Feed:Thick 1:Mid	*ENG	[-2 to 2 / -0.1 / 0.1 %/step]
041	Feed:Thick 2:Low	*ENG	[-2 to 2 / -1.1 / 0.1 %/step]
042	Feed:Thick 3:Low	*ENG	
043	Bridge Motor:Low	*ENG	[-4 to 4 / 0 / 0.1 %/step]
044	Bridge Motor:Mid	*ENG	
045	Bridge Motor:High	*ENG	
060	KOpcDevMot:High	*ENG	[-4 to 4 / -0.3 / 0.01 %/step]
061	KOpcDevMot:Mid	*ENG	
062	KOpcDevMot:Low	*ENG	
063	MOpcDevMot:High	*ENG	[-10 to 10 / 0 / 1 step/step]
064	MOpcDevMot:Mid	*ENG	[-9 to 9 / 0 / 1 step/step]
065	MOpcDevMot:Low	*ENG	[-14 to 14 / 0 / 1 step/step]
066	COpcDevMot:High	*ENG	[-10 to 10 / 0 / 1 step/step]
067	COpcDevMot:Mid	*ENG	[-9 to 9 / 0 / 1 step/step]

068	COpcDevMot:Low	*ENG	[-14 to 14 / 0 / 1 step/step]
069	YOpcDevMot:High	*ENG	[-10 to 10 / 0 / 1 step/step]
070	YOpcDevMot:Mid	*ENG	[-9 to 9 / 0 / 1 step/step]
071	YOpcDevMot:Low	*ENG	[-14 to 14 / 0 / 1 step/step]
072	Fusing: High	*ENG	[-4 to 4 / -0.6 / 0.01 %/step]
073	Fusing: Mid	*ENG	[-4 to 4 / -0.8 / 0.01 %/step]
074	Fusing: Low	*ENG	[-4 to 4 / -0.3 / 0.01 %/step]
075	TransferMot:High	*ENG	[-4 to 4 / -0.1 / 0.01 %/step]
076	TransferMot:Mid	*ENG	
077	TransferMot:Low	*ENG	
078	TonerMot	*ENG	[-30 to 30 / 10 / 5 %/step]
079	Fusing: 1200	*ENG	[-4 to 4 / -0.6 / 0.01 %/step]
100	Drum Adjust	*ENG	[0 or 1 / 1 / 1] 0: Off, 1: On
	Enables or disables the drum amplitude adjustment.		
101	MOpcDevMot:High	*ENG	[-7 to 7 / 0 / 1 step/step]
102	COpcDevMot:High	*ENG	
103	YOpcDevMot:High	*ENG	
104	MOpcDevMot:Mid	*ENG	[-7 to 7 / 0 / 1 step/step]
105	COpcDevMot:Mid	*ENG	
106	YOpcDevMot:Mid	*ENG	
107	MOpcDevMot:Low	*ENG	[-14 to 14 / 0 / 1 step/step]
108	COpcDevMot:Low	*ENG	
109	YOpcDevMot:Low	*ENG	

Main SP Tables-1

110	MOpcDevMot:1200	*ENG	
111	COpcDevMot:1200	*ENG	[- 7 to 7 / 0 / 1 step/step]
112	YOpcDevMot:1200	*ENG	
120	Long:Registration:Plain:High	*ENG	[-2 to 2 / -0.1 / 0.1 %/step]
121	Long:Registration:Plain:Low	*ENG	[-2 to 2 / -1.1 / 0.1 %/step]
122	Long:Registration:Middle Thick:High	*ENG	[-2 to 2 / -0.1 / 0.1 %/step]
123	Long:Registration:Middle Thick:Middle	*ENG	
124	Long:Registration:Middle Thick:Low	*ENG	[-2 to 2 / -1.1 / 0.1 %/step]
125	Long:Registration:Thick 1:Middle	*ENG	[-2 to 2 / -1 / 0.1 %/step]
126	Long:Registration:Thick 1:Low	*ENG	[-2 to 2 / -1.1 / 0.1 %/step]
127	Long:Registration:Thick 2:Low	*ENG	[-2 to 2 / -1.1 / 0.1 %/step]
128	Long:Registration:Thick 3:Low	*ENG	[-2 to 2 / -1.1 / 0.1 %/step]
129	Long:Fusing:Plain:High	*ENG	[-4 to 4 / 1.9 / 0.01 %/step]
130	Long:Fusing:Plain:Low	*ENG	[-4 to 4 / 2.1 / 0.01 %/step]
131	Long:Fusing:Middle Thick:High	*ENG	[-4 to 4 / 1.9 / 0.01 %/step]
132	Long:Fusing:Middle Thick:Middle	*ENG	[-4 to 4 / 1.4 / 0.01 %/step]
133	Long:Fusing:Middle Thick:Low	*ENG	[-4 to 4 / 2.1 / 0.01 %/step]
134	Long:Fusing:Thick 1:Middle	*ENG	[-4 to 4 / 2.0 / 0.01 %/step]
135	Long:Fusing:Thick 1:Low	*ENG	[-4 to 4 / 1.7 / 0.01 %/step]
136	Long:Fusing:Thick 2:Low	*ENG	[-4 to 4 / 1.7 / 0.01 %/step]
137	Long:Fusing:Thick 3:Low	*ENG	[-4 to 4 / 1.7 / 0.01 %/step]

1902	[Amplitude Control]		
001	Execute	*ENG	Execute the drum phase adjustment.
002	Result	*ENG	[0 to 3 / 0 / 1] Displays the result of the drum phase adjustment. 0: Successfully done 2: Sampling failure 3: Insufficient detection number
003	Auto Execution	*ENG	[0 or 1 / 1 / -] Turns the automatic drum phase adjustment on or off. 0: Off, 1: On

1950	[Fan Cooling Time Set]		
	Adjust the rotation time for each fan motor after a job end.		
002	Fusing Exit Fan	*ENG	[0 to 120 / 0 / 0.1 min./step]
006	Main Suction Fan	*ENG	
007	Paper Exit Fan	*ENG	
008	PSU Fan	*ENG	
009	QSU Heater Cooling Fan	*ENG	
010	AC Control board Cooling Fan	*ENG	
011	Second Duct Fan	*ENG	
012	Toner Supply Cooling Fan	*ENG	

Main SP Tables-1

1951	[Fan Start Time Set]		
	Adjust the start time for each fan motor after a job end.		
002	Fusing Exit Fan	*ENG	[0 to 900 / 0 / 1 sec/step]
006	Main Suction Fan	*ENG	[0 to 900 / 120 / 1 sec/step]
007	Paper Exit Fan	*ENG	[0 to 900 / 0 / 1 sec/step]
008	PSU Fan	*ENG	[0 to 900 / 120 / 1 sec/step]
009	Fusing IH Coil Fan	*ENG	[0 to 900 / 0 / 1 sec/step]
010	IH Power Supply Fan	*ENG	
011	Second Duct Fan	*ENG	
012	Third Duct Fan	*ENG	

1952	[Fan Control Off Mode Time Set]		
	Specifies the time for fan control off mode.		
001	-	*ENG	[0 to 60 / 10 / 1 min./step]

1953	[Extra Fan Control]		
	Configures the settings of extra fan control.		
001	Extra Fan Cooling State	*ENG	[0 or 1 / 0 / 1 /step] 0: Off, 1: On
	Displays the extra fan cooling is On or Off.		
002	Extra Fan Cooling: Time: Threshold	*ENG	[0 to 180 / C2.5a: 110, C2.5b: 100 / 1 min./step]
003	Extra Fan Cooling: Rotat: Threshold	*ENG	[0 to 999999999 / 0 / 1 min./step]
004	Extra Fan Cooling: Start Date	*ENG	Displays the execution time and date of the extra fan cooling.

005	Extra Fan Cooling Time	*ENG	[0 to 120 / 30 / 0.1 min./step]
	Specifies the execution time for the extra fan cooling.		

1954	[Extra Fan Control]		
	Configures the settings of extra fan control.		
002	Fan Cooling Time:Fusing Exit Fan:Initial	*ENG	[0 to 120 / 0 / 0.1 min./step]
006	Fan Cooling Time:Main Suction Fan:Initial	*ENG	[0 to 120 / 0 / 0.1 min./step]
007	Fan Cooling Time:Paper Exit Fan:Initial	*ENG	[0 to 120 / 0 / 0.1 min./step]
008	Fan Cooling Time:PSU Fan:Initial	*ENG	[0 to 120 / 0 / 0.1 min./step]
009	Fan Cooling Time:Fusing IH Coil Fan:Initial	*ENG	[0 to 120 / 0 / 0.1 min./step]
010	Fan Cooling Time:IH Power Supply Fan:Initial	*ENG	[0 to 120 / 0 / 0.1 min./step]
011	Fan Cooling Time:Second Duct Fan:Initial	*ENG	[0 to 120 / 0 / 0.1 min./step]
012	Fan Cooling Time:Third Duct Fan:Initial	*ENG	[0 to 120 / 0 / 0.1 min./step]

3.2 MAIN SP TABLES-2

3.2.1 SP2-XXX (DRUM)

2005	[Charge DC Voltage] Charge Roller DC Voltage Adjustment (Paper Type, Process Speed, Color) Paper Type → Plain, Thick 1, Thick 2 Plain: High speed, Thick 1: Middle speed, Thick 2&FINE: Low speed		
	Adjusts the DC component of the charge roller bias in the various print modes. Charge bias (DC component) is automatically adjusted during process control; therefore, adjusting these settings does not effect while process control mode (SP3-041-1 Default: ON) is activated. When deactivating process control mode with SP3-041-1, the values in these SP modes are used for printing.		
001	Plain: Bk	*ENG	[0 to 1000 / 690 / 10 -V/step]
002	Plain: M	*ENG	
003	Plain: C	*ENG	
004	Plain: Y	*ENG	
005	Thick 1: Bk	*ENG	
006	Thick 1: M	*ENG	
007	Thick 1: C	*ENG	
008	Thick 1: Y	*ENG	
009	Thick 2&FINE: Bk	*ENG	
010	Thick 2&FINE: M	*ENG	
011	Thick 2&FINE: C	*ENG	
012	Thick 2&FINE: Y	*ENG	
[Charge DC: Correction]			
013	PCU:Plain	*ENG	[-100 to 100 / C3c: -26, C3d: -28 / 1 -V/step]

014	PCU:Thick 1	*ENG	[-100 to 100 / -29 / 1 -V/step]
015	PCU:Thick 2&FINE	*ENG	[-100 to 100 / -28 / 1 -V/step]
016	HVP:Plain	*ENG	[-100 to 100 / 20 / 1 -V/step]
017	HVP:Thick 1	*ENG	[-100 to 100 / 20 / 1 -V/step]
018	HVP: Thick 2&FINE	*ENG	[-100 to 100 / 29 / 1 -V/step]

2006	[Charge AC Voltage] Charge Roller AC Voltage Adjustment (Paper Type, Process Speed, Color) Paper Type → Plain, Thick 1, Thick 2 Plain: High speed, Thick 1: Middle speed, Thick 2&FINE: Low speed		
	Adjusts the AC component of the charge roller bias in the various print modes. Charge bias (AC component) is adjusted by environment correction (SP2-007-xxx to SP2-011-xxx). These SPs are activated only when SP2-012-1 is set to "1: manual control".		
001	Plain: Bk	*ENG	[0 to 3 / 1.9 / 0.01 KV/step]
002	Plain: M	*ENG	[0 to 3 / 1.9 / 0.01 KV/step]
003	Plain: C	*ENG	[0 to 3 / 1.9 / 0.01 KV/step]
004	Plain: Y	*ENG	[0 to 3 / 1.9 / 0.01 KV/step]
005	Thick 1: Bk	*ENG	[0 to 3 / 1.9 / 0.01 KV/step]
006	Thick 1: M	*ENG	[0 to 3 / 1.9 / 0.01 KV/step]
007	Thick 1: C	*ENG	[0 to 3 / 1.9 / 0.01 KV/step]
008	Thick 1: Y	*ENG	[0 to 3 / 1.9 / 0.01 KV/step]
009	Thick 2&FINE: Bk	*ENG	[0 to 3 / 1.9 / 0.01 KV/step]
010	Thick 2&FINE: M	*ENG	[0 to 3 / 1.9 / 0.01 KV/step]
011	Thick 2&FINE: C	*ENG	[0 to 3 / 1.9 / 0.01 KV/step]
012	Thick 2&FINE: Y	*ENG	[0 to 3 / 1.9 / 0.01 KV/step]

2012	[Charge Output Control]		
001	AC Voltage	*ENG	<p>Selects the AC voltage control type.</p> <p>[0 or 1 / 0 / 1 /step]</p> <p>0: Process control</p> <p>1: Manual control (AC voltages are decided with SP2006.)</p>

2013	[Environmental Correction: PCU]		
001	Current Environmental FC: Display	*ENG	<p>Displays the environmental condition, which is measured in absolute humidity.</p> <p>[1 to 5 / - / 1 /step]</p> <p>1: LL (LL ≤ 4.3 g/m³)</p> <p>2: ML (4.3 < ML ≤ 11.3 g/m³)</p> <p>3: MM (11.3 < MM ≤ 18.0 g/m³)</p> <p>4: MH (18.0 < MH ≤ 24.0 g/m³)</p> <p>5: HH (24.0 g/m³ < HH)</p>
002	Forced Setting	*ENG	<p>Selects the environmental condition manually.</p> <p>[0 to 5 / 0 / 1 /step]</p> <p>0: The environmental condition is determined automatically.</p> <p>1: LL, 2: ML, 3: MM, 4: MH, 5: HH</p>
003	Absolute Humidity: Threshold 1	*ENG	<p>Changes the humidity threshold between LL and ML.</p> <p>[0 to 100 / 3.0 / 0.01 g/m³/step]</p>
004	Absolute Humidity: Threshold 2	*ENG	<p>Changes the humidity threshold between ML and MM.</p> <p>[0 to 100 / 8.0 / 0.01 g/m³/step]</p>
005	Absolute Humidity: Threshold 3	*ENG	<p>Changes the humidity threshold between MM and MH.</p> <p>[0 to 100 / 15.0 / 0.01 g/m³/step]</p>

006	Absolute Humidity: Threshold 4	*ENG	Changes the humidity threshold between MH and HH. [0 to 100 / 22.0 / 0.01 g/m ³ /step]
007	Current Temp. FC: Display	*ENG	Displays the current temperature. [0 to 100 / - / 1 deg/step]
008	Current Relative Humidity FC: Display	*ENG	Displays the current relative humidity. [0 to 100 / - / 1%RH/step]
009	Current Absolute Humidity FC: Display	*ENG	Displays the absolute humidity. [0 to 100 / - / 0.01 g/m ³ /step]
010	Previous Environmental Bk: Display	*ENG	Displays the previous environmental condition, which is measured in absolute humidity. [1 to 5 / - / 1 /step] 1: LL, 2: ML, 3: MM, 4: MH, 5: HH
011	Previous Temp. Bk: Display	*ENG	Displays the previous temperature. [0 to 100 / - / 1 deg/step]
012	Previous Relative Humidity Bk: Display	*ENG	Displays the previous relative humidity. [0 to 100 / - / 1%RH/step]
013	Previous Absolute Humidity Bk: Display	*ENG	Displays the previous absolute humidity. [0 to 100 / - / 0.01 g/m ³ /step]

2015	[Charge AC Adj: Result] Displays a result of the AC charge adjustment.		
001	Bk	*ENG	[0 to 9 / 0 / 1 /step]
002	M	*ENG	0: Success
003	C	*ENG	1: Out of tolerance range
004	Y	*ENG	2: Out of adjustable range 3: Adjustment incompleted

2101	[Color Registration Correction] FA		
	These values are the parameters for the automatic line position adjustment and are adjusted at the factory. However, you must input a value for SP2101-001 after replacing the laser optics housing unit. For details, see "Laser Optics Housing Unit" in the "Main chapters: 4. Replacement and Adjustment: Laser Optics". The value should be provided with the new laser optics housing unit.		
001	Main Dot: Bk	*ENG	[-512 to 511 / 0 / 1 dot/step]
002	Main Dot: Ma	*ENG	
003	Main Dot: Cy	*ENG	
004	Main Dot: Ye	*ENG	
005	Sub Line: Bk	*ENG	[-16384 to 16383 / 0 / 1 line/step]
006	Sub Line: Ma	*ENG	
007	Sub Line: Cy	*ENG	
008	Sub Line: Ye	*ENG	

2103	[Erase Margin Adjustment] (Area, Paper Size)		
	Adjusts the erase margin by deleting image data at the margins.		
001	Lead Edge Width	*ENG	[0 to 9.9 / 4.2 / 0.1 mm/step]
002	Trail. Edge Width	*ENG	
003	Left	*ENG	[0 to 9.9 / 2 / 0.1 mm/step]
004	Right	*ENG	
006	Duplex Trail. L Size	*ENG	[0 to 4 / 1 / 0.1 mm/step]
007	Duplex Trail. M Size	*ENG	[0 to 4 / 0.8 / 0.1 mm/step]
008	Duplex Trail. S Size	*ENG	[0 to 4 / 0.6 / 0.1 mm/step]
009	Duplex Left Edge	*ENG	[0 to 1.5 / 0.3 / 0.1 mm/step]
010	Duplex Right Edge	*ENG	

011	Duplex Trail. L Size:Thick	*ENG	[0 to 4 / 1 / 0.1 mm/step]
012	Duplex Trail. M Size:Thick	*ENG	[0 to 4 / 0.8 / 0.1 mm/step]
013	Duplex Trail. S Size:Thick	*ENG	[0 to 4 / 0.6 / 0.1 mm/step]
014	Duplex Left Edge:Thick	*ENG	[0 to 1.5 / 0.3 / 0.1 mm/step]
015	Duplex Right Edge:Thick	*ENG	
016	Lead Edge Width: Thin	*ENG	[0 to 9.9 / 4.2 / 0.1 mm/step]
017	Trail. Edge Width: Thin	*ENG	
018	Duplex Trail. L Size: Thin	*ENG	[0 to 4 / 1 / 0.1 mm/step]
019	Duplex Trail. M Size: Thin	*ENG	[0 to 4 / 0.8 / 0.1 mm/step]
020	Duplex Trail. S Size: Thin	*ENG	[0 to 4 / 0.6 / 0.1 mm/step]

2105	[LD Power Adj.] (Process Speed, Color)		
	Adjusts the LD power of each color for each process speed. Each LD power setting is decided by process control.		
001	High Speed: Bk	*ENG	[50 to 120 / 100 / 1%/step]
002	High Speed: Ma	*ENG	Decreasing a value makes lines thinner on the output. Increasing a value makes lines thicker on the output.
003	High Speed: Cy	*ENG	
004	High Speed: Ye	*ENG	
005	Middle Speed: Bk	*ENG	
006	Middle Speed: Ma	*ENG	Decreasing a value makes lines thinner on the output. Increasing a value makes lines thicker on the output.
007	Middle Speed: Cy	*ENG	
008	Middle Speed: Ye	*ENG	
009	Low Speed: Bk	*ENG	
010	Low Speed: Ma	*ENG	Decreasing a value makes lines thinner on the output. Increasing a value makes lines thicker on the output.
011	Low Speed: Cy	*ENG	
012	Low Speed: Ye	*ENG	

2109	[Test Pattern]		
	Generates the test pattern using "COPY Window" tab in the LCD.		
003	Pattern Selection	-	[0 to 23 / 0 / 1/step]
	0 None 1: Vertical Line (1dot) 2: Vertical Line (2dot) 3: Horizontal (1dot) 4: Horizontal (2dot) 5: Grid Vertical Line 6: Grid Horizontal Line 7: Grid pattern Small 8: Grid pattern Large 9: Argyle Pattern Small 10: Argyle Pattern Large		11. Independent Pattern (1dot) 12. Independent Pattern (2dot) 13. Independent Pattern (4dot) 14. Trimming Area 16: Hound's Tooth Check (Horizontal) 17: Band (Horizontal) 18: Band (Vertical) 19: Checker Flag Pattern 20: Grayscale Vertical Margin 21: Grayscale Horizontal Margin 23: Full Dot Pattern
005	Color Selection	-	Specifies the color for the test pattern. [1 to 4 / 1 / 1/step] 1: All colors, 2: Magenta, 3: Yellow, 4: Cyan
006	Density: Bk	-	Specifies the color density for the test pattern. [0 to 15 / 15 / 1 /step] 0: Lightest density 15: Darkest density
007	Density: Ma	-	
008	Density: Cy	-	
009	Density: Ye	-	

2111	[Forced Line Position Adj.]		
001	Mode a	-	Executes the fine line position adjustment twice. If this SP is not completed (NG is displayed), do SP2111-003 first and then try this SP again.
002	Mode b	-	Executes the fine line position adjustment once. If this SP is not completed, do SP2111-003 first and then try this SP again.
003	Mode c	-	Executes the rough line position adjustment once. After doing this SP, make sure to execute SP2111-001 or -002. Otherwise, the line position adjustment is not perfectly done.

2112	[TM/ID Sensor Check] ID Sensor Check FA		
001	Execute	-	[0 or 1 / 0 / 1 /step] This SP is used to check the ID sensors at the factory. The results of this SP are displayed in SP2140 to SP2145.

2117	[Skew Adjustment]		
	Specifies a skew adjustment value for the skew motor M, C or Y. These SPs must be used when a new laser optics housing unit is installed or when SC2.585 occurs. For details, see "Laser Optics Housing Unit" in the "Main chapters: 4. Replacement and Adjustment: Laser Optics".		
	001	Pulse: M	*ENG
	002	Pulse: C	*ENG
003	Pulse: Y	*ENG	[-50 to 50 / 0 / 1 pulse/step]

2118	[Skew Adjustment]		
001	Execute: M	*ENG	Changes the current skew adjustment values to the values specified with SP2117. These SPs must be used when a new laser optics housing unit is installed or when SC2.585 occurs. For details, see "Laser Optics Housing Unit" in the "Main chapters: 4. Replacement and Adjustment: Laser Optics".
002	Execute: C	*ENG	
003	Execute: Y	*ENG	

2119	[Skew Adjustment Display]		
	Displays the current skew adjustment value for each skew motor.		
001	M	*ENG	[-50 to 50 / - / 1 pulse/step]
002	C	*ENG	
003	Y	*ENG	

2150	[Area Mag. Correction] LD Pulse Area Correction (Color, Area) FA		
	Adjusts the magnification for each area. The main scan (297 mm) is divided into 8 areas. Area 1 is at the front side of the machine (left side of the image) and area 8 is at the rear side of the machine (right side of the image). Decreasing a value makes the image shift to the left side on the print. Increasing a value makes the image shift to the right side on the print. 1 pulse = 1/16 dot		
027	Area 0: Bk	*ENG	[-255 to 255 / 0 / 1 sub-dot/step]
028	Area 1: Bk	*ENG	Adjusts the area magnification for LD 0. [-255 to 255 / 0 / 1 sub-dot/step]
029	Area 2: Bk	*ENG	
030	Area 3: Bk	*ENG	
031	Area 4: Bk	*ENG	
032	Area 5: Bk	*ENG	
033	Area 6: Bk	*ENG	

034	Area 7: Bk	*ENG	
035	Area 8: Bk	*ENG	
036	Area 9: Bk	*ENG	Not used
037	Area 10: Bk	*ENG	
038	Area 11: Bk	*ENG	
039	Area 12: Bk	*ENG	
079	Area 0: Ma	*ENG	
080	Area 1: Ma	*ENG	Adjusts the area magnification for LD 0. [-255 to 255 / 0 / 1 sub-dot/step]
081	Area 2: Ma	*ENG	
082	Area 3: Ma	*ENG	
083	Area 4: Ma	*ENG	
084	Area 5: Ma	*ENG	
085	Area 6: Ma	*ENG	
086	Area 7: Ma	*ENG	
087	Area 8: Ma	*ENG	
088	Area 9: Ma	*ENG	Not used
089	Area 10: Ma	*ENG	
090	Area 11: Ma	*ENG	
091	Area 12: Ma	*ENG	
131	Area 0: Cy	*ENG	[-255 to 255 / 0 / 1 sub-dot/step]
132	Area 1: Cy	*ENG	Adjusts the area magnification for LD 0. [-255 to 255 / 0 / 1 sub-dot/step]
133	Area 2: Cy	*ENG	
134	Area 3: Cy	*ENG	
135	Area 4: Cy	*ENG	
136	Area 5: Cy	*ENG	

Main SP Tables-2

137	Area 6: Cy	*ENG	
138	Area 7: Cy	*ENG	
139	Area 8: Cy	*ENG	
140	Area 9: Cy	*ENG	Not used
141	Area 10: Cy	*ENG	
142	Area 11: Cy	*ENG	
143	Area 12: Cy	*ENG	
183	Area 0: Ye	*ENG	[-255 to 255 / 0 / 1 sub-dot/step]
184	Area 1: Ye	*ENG	Adjusts the area magnification for LD 0. [-255 to 255 / 0 / 1 sub-dot/step]
185	Area 2: Ye	*ENG	
186	Area 3: Ye	*ENG	
187	Area 4: Ye	*ENG	
188	Area 5: Ye	*ENG	
189	Area 6: Ye	*ENG	
190	Area 7: Ye	*ENG	
191	Area 8: Ye	*ENG	
192	Area 9: Ye	*ENG	Not used
193	Area 10: Ye	*ENG	
194	Area 11: Ye	*ENG	
195	Area 12: Ye	*ENG	

2152	[Area Shad. Correct. Setting] FA		
	<p>Adjusts the area correction value for each LD power.</p> <p>The main scan is divided into 16 areas. However, the image areas are limited from area 1 to area 14.</p> <p>For BK and Magenta, area 1 is at the rear side of the machine (left side of the image) and area 14 is at the front side of the machine (right side of the image). For Cyan and Yellow, area 1 is at the front side of the machine (right side of the image) and area 14 is at the rear side of the machine (left side of the image).</p>		
001	Area 0: Bk	*ENG	<p>This is for the synchronizing detection board.</p> <p>[50 to 150 / 100 / 1 %/step]</p>
002	Area 1: Bk	*ENG	
003	Area 2: Bk	*ENG	
004	Area 3: Bk	*ENG	
005	Area 4: Bk	*ENG	
006	Area 5: Bk	*ENG	
007	Area 6: Bk	*ENG	
008	Area 7: Bk	*ENG	
009	Area 8: Bk	*ENG	
010	Area 9: Bk	*ENG	
011	Area 10: Bk	*ENG	
012	Area 11: Bk	*ENG	
013	Area 12: Bk	*ENG	
014	Area 13: Bk	*ENG	
015	Area 14: Bk	*ENG	
016	Area 15: Bk	*ENG	<p>This is out of the image area.</p> <p>[50 to 150 / 100 / 1 %/step]</p>

Main SP Tables-2

033	Area 0: Ma	*ENG	This is for the synchronizing detection board. [50 to 150 / 100 / 1 %/step]
034	Area 1: Ma	*ENG	[50 to 150 / 100 / 1 %/step]
035	Area 2: Ma	*ENG	
036	Area 3: Ma	*ENG	
037	Area 4: Ma	*ENG	
038	Area 5: Ma	*ENG	
039	Area 6: Ma	*ENG	
040	Area 7: Ma	*ENG	
041	Area 8: Ma	*ENG	
042	Area 9: Ma	*ENG	
043	Area 10: Ma	*ENG	
044	Area 11: Ma	*ENG	
045	Area 12: Ma	*ENG	
046	Area 13: Ma	*ENG	
047	Area 14: Ma	*ENG	
048	Area 15: Ma	*ENG	This is out of the image area. [50 to 150 / 100 / 1 %/step]
065	Area 0: Cy	*ENG	This is for the synchronizing detection board. [50 to 150 / 100 / 1 %/step]
066	Area 1: Cy	*ENG	[50 to 150 / 100 / 1 %/step]
067	Area 2: Cy	*ENG	
068	Area 3: Cy	*ENG	
069	Area 4: Cy	*ENG	

070	Area 5: Cy	*ENG	
071	Area 6: Cy	*ENG	
072	Area 7: Cy	*ENG	
073	Area 8: Cy	*ENG	
074	Area 9: Cy	*ENG	
075	Area 10: Cy	*ENG	
076	Area 11: Cy	*ENG	
077	Area 12: Cy	*ENG	
078	Area 13: Cy	*ENG	
079	Area 14: Cy	*ENG	
080	Area 15: Cy	*ENG	This is out of the image area. [50 to 150 / 100 / 1 %/step]
097	Area 0: Ye	*ENG	This is for the synchronizing detection board. [50 to 150 / 100 / 1 %/step]
098	Area 1: Ye	*ENG	[50 to 150 / 100 / 1 %/step]
099	Area 2: Ye	*ENG	
100	Area 3: Ye	*ENG	
101	Area 4: Ye	*ENG	
102	Area 5: Ye	*ENG	
103	Area 6: Ye	*ENG	
104	Area 7: Ye	*ENG	
105	Area 8: Ye	*ENG	
106	Area 9: Ye	*ENG	
107	Area 10: Ye	*ENG	

Main SP Tables-2

108	Area 11: Ye	*ENG	
109	Area 12: Ye	*ENG	
110	Area 13: Ye	*ENG	
111	Area 14: Ye	*ENG	
112	Area 15: Ye	*ENG	This is out of the image area. [50 to 150 / 100 / 1 %/step]

2181	[Line Position Adj. Result]		
	<p>Displays the values for each correction.</p> <ul style="list-style-type: none"> ▪ "Paper Int. Mag: Subdot" indicates the magnification correction value between two sheets of paper. ▪ "Mag.Cor. Subdot" indicates the magnification correction value. ▪ "M. Scan Erro." indicates the shift correction value in the main scan direction. ▪ "S. Scan Erro." Indicates the shift correction value in the sub scan direction. ▪ "M. Cor.: Dot" indicates the dot correction value in the main scan direction. ▪ "M. Cor.: Subdot" indicates the sub dot correction value in the main scan direction. ▪ Bk: Black, M: Magenta, C: Cyan, Y: Yellow 		
001	Paper Int. Mag: Subdot: Bk	*ENG	[-32768 to 32767 / - / 1 pulse/step]
002	Mag.Cor. Subdot: Bk	*ENG	[-32768 to 32767 / - / 1 pulse/step]
003	Skew: M	*ENG	[-5000 to 5000 / - / 0.001 um/step]
005	M. Scan Erro.: Left: M	*ENG	[-5000 to 5000 / - / 0.001 um/step]
006	M. Scan Erro.: Center: M	*ENG	
007	M. Scan Erro.: Right: M	*ENG	
008	S. Scan Erro.: Left: M	*ENG	
009	S. Scan Erro.: Center: M	*ENG	
010	S. Scan Erro.: Right: M	*ENG	

011	M. Cor.: Dot: M	*ENG	[-512 to 511 / - / 1 dot/step]
012	M. Cor.: Subdot: M	*ENG	[-15 to 15 / - / 1 pulse/step]
013	Paper Int. Mag: Subdot: M	*ENG	[-32768 to 32767 / - / 1 pulse/step]
014	Mag.Cor. Subdot: M	*ENG	
015	M. Left Mag.: Subdot: M	*ENG	
016	M. Right Mag.: Subdot: M	*ENG	
017	S. Cor.: 600 Line: M	*ENG	[-16384 to 16383 / - / 1 line/step]
018	S. Cor.: 600 Sub: M	*ENG	[-1 to 1 / - / 0.001 line/step]
019	S. Cor.: 1200 Line: M	*ENG	[-16384 to 16383 / - / 1 line/step]
020	S. Cor.: 1200 Sub: M	*ENG	[-1 to 1 / - / 0.001 line/step]
021	Skew: C	*ENG	[-5000 to 5000 / - / 0.001 um/step]
023	M. Scan Erro.: Left: C	*ENG	[-5000 to 5000 / - / 0.001 um/step]
024	M. Scan Erro.: Center: C	*ENG	
025	M. Scan Erro.: Right: C	*ENG	
026	S. Scan Erro.: Left: C	*ENG	
027	S. Scan Erro.: Center: C	*ENG	
028	S. Scan Erro.: Right: C	*ENG	
029	M. Cor.: Dot: C	*ENG	[-512 to 511 / - / 1 dot/step]
030	M. Cor.: Subdot: C	*ENG	[-15 to 15 / - / 1 pulse/step]
031	Paper Int. Mag: Subdot: C	*ENG	[-32768 to 32767 / - / 1 pulse/step]
032	Mag.Cor. Subdot: C	*ENG	
033	M. Left Mag.: Subdot: C	*ENG	
034	M. Right Mag.: Subdot: C	*ENG	

Main SP Tables-2

035	S. Cor.: 600 Line: C	*ENG	[-16384 to 16383 / - / 1 line/step]
036	S. Cor.: 600 Sub: C	*ENG	[-1 to 1 / - / 0.001 line/step]
037	S. Cor.: 1200 Line: C	*ENG	[-16384 to 16383 / - / 1 line/step]
038	S. Cor.: 1200 Sub: C	*ENG	[-1 to 1 / - / 0.001 line/step]
039	Skew: Y	*ENG	[-5000 to 5000 / - / 0.001 um/step]
041	M. Scan Erro.: Left: Y	*ENG	
042	M. Scan Erro.: Center: Y	*ENG	
043	M. Scan Erro.: Right: Y	*ENG	
044	S. Scan Erro.: Left: Y	*ENG	
045	S. Scan Erro.: Center: Y	*ENG	
046	S. Scan Erro.: Right: Y	*ENG	
047	M. Cor.: Dot: Y	*ENG	
048	M. Cor.: Subdot: Y	*ENG	[-15 to 15 / - / 1 pulse/step]
049	Paper Int. Mag: Subdot: Y	*ENG	[-32768 to 32767 / - / 1 pulse/step]
050	Mag.Cor. Subdot: Y	*ENG	
051	M. Left Mag.: Subdot: Y	*ENG	
052	M. Right Mag.: Subdot: Y	*ENG	
053	S. Cor.: 600 Line: Y	*ENG	[-16384 to 16383 / - / 1 line/step]
054	S. Cor.: 600 Sub: Y	*ENG	[-1 to 1 / - / 0.001 line/step]
055	S. Cor.: 1200 Line: Y	*ENG	[-16384 to 16383 / - / 1 line/step]
056	S. Cor.: 1200 Sub: Y	*ENG	[-1 to 1 / - / 0.001 line/step]

2182	[Line Position Adj. Offset] (Color) M. Scan: Main scan, S. Scan: Sub-scan		
001	M Magnification	*ENG	Adjusts the line position manually. [-1 to 1 / 0 / 0.001%/step]
002	C Magnification	*ENG	
003	Y Magnification	*ENG	
	<p>When line shifts are not corrected by the automatic line position adjustment, do this SP.</p> <p>Increasing a value reduces the image in the main scan direction.</p> <p>Decreasing a value enlarges the image in the main scan direction.</p>		
004	M. Scan: High: Dot: M	*ENG	[-512 to 511 / 0 / 1 dot/step]
005	M. Scan: High: Subdot: M	*ENG	[-15 to 15 / 0 / 1 pulse/step]
006	M. Scan: Medium: Dot: M	*ENG	[-512 to 511 / 0 / 1 dot/step]
007	M. Scan: Medium: Subdot: M	*ENG	[-15 to 15 / 0 / 1 pulse/step]
008	M. Scan: Low: Dot: M	*ENG	[-512 to 511 / 0 / 1 dot/step]
009	M. Scan: Low: Subdot: M	*ENG	[-15 to 15 / 0 / 1 pulse/step]
010	M. Scan: High: Dot: C	*ENG	[-512 to 511 / 0 / 1 dot/step]
011	M. Scan: High: Subdot: C	*ENG	[-15 to 15 / 0 / 1 pulse/step]
012	M. Scan: Medium: Dot: C	*ENG	[-512 to 511 / 0 / 1 dot/step]
013	M. Scan: Medium: Subdot: C	*ENG	[-15 to 15 / 0 / 1 pulse/step]
014	M. Scan: Low: Dot: C	*ENG	[-512 to 511 / 0 / 1 dot/step]
015	M. Scan: Low: Subdot: C	*ENG	[-15 to 15 / 0 / 1 pulse/step]
016	M. Scan: High: Dot: Y	*ENG	[-512 to 511 / 0 / 1 dot/step]
017	M. Scan: High: Subdot: Y	*ENG	[-15 to 15 / 0 / 1 pulse/step]
018	M. Scan: Medium: Dot: Y	*ENG	[-512 to 511 / 0 / 1 dot/step]

Main SP Tables-2

019	M. Scan: Medium: Subdot: Y	*ENG	[-15 to 15 / 0 / 1 pulse/step]
020	M. Scan: Low: Dot: Y	*ENG	[-512 to 511 / 0 / 1 dot/step]
021	M. Scan: Low: Subdot: Y	*ENG	[-15 to 15 / 0 / 1 pulse/step]
022	S. Scan: High: Line: M	*ENG	[-16384 to 16383 / 0 / 1 line/step]
023	S. Scan: High: Subline: M	*ENG	[-1 to 1 / 0 / 0.001 /line]
024	S. Scan: Medium: Line: M	*ENG	[-16384 to 16383 / 0 / 1 line/step]
025	S. Scan: Medium: Subline: M	*ENG	[-1 to 1 / 0 / 0.001 /line]
026	S. Scan: Low: Line: M	*ENG	[-16384 to 16383 / 0 / 1 line/step]
027	S. Scan: Low: Subline: M	*ENG	Not used
028	S. Scan: High: Line: C	*ENG	[-16384 to 16383 / 0 / 1 line/step]
029	S. Scan: High: Subline: C	*ENG	[-1 to 1 / 0 / 0.001 /line]
030	S. Scan: Medium: Line: C	*ENG	[-16384 to 16383 / 0 / 1 line/step]
031	S. Scan: Medium: Subline: C	*ENG	[-1 to 1 / 0 / 0.001 /line]
032	S. Scan: Low: Line: C	*ENG	[-16384 to 16383 / 0 / 1 line/step]
033	S. Scan: Low: Subline: C	*ENG	Not used
034	S. Scan: High: Line: Y	*ENG	[-16384 to 16383 / 0 / 1 line/step]
035	S. Scan: High: Subline: Y	*ENG	[-1 to 1 / 0 / 0.001 /line]
036	S. Scan: Medium: Line: Y	*ENG	[-16384 to 16383 / 0 / 1 line/step]
037	S. Scan: Medium: Subline: Y	*ENG	[-1 to 1 / 0 / 0.001 /line]
038	S. Scan: Low: Line: Y	*ENG	[-16384 to 16383 / 0 / 1 line/step]
039	S. Scan: Low: Subline: Y	*ENG	Not used

2185	[Main Scan Length Target Display]		
	<p>Displays/adjusts the target value for the main scan length correction of the line position adjustment.</p> <p>After replacing the laser optics housing unit, input the standard value for Bk provided with the new unit. For details, see "Laser Optics Housing Unit" in the "Main chapters: 4. Replacement and Adjustment: Laser Optics". It is not necessary to input the values for the other colors; these are automatically adjusted after doing the line position adjustment.</p>		
001	Bk	*ENG	[0 to 266667 / 249449 / 1 sub-dot/step]
002	M	*ENG	
003	C	*ENG	
004	Y	*ENG	

2193	[MUSIC Condition Set] Line Position Adjustment: Condition Setting		
001	Auto Execution	*ENG	[0 or 1 / 1 / 1] 0: OFF, 1: ON
	Enables/disables the automatic line position adjustment		
002	Page: Job End: BW+FC	*ENG	[0 to 999 / 500 / 1 page/step]
	Adjusts the threshold of the line position adjustment for BW and color printing mode after job end.		
003	Page: Job End: FC	*ENG	[0 to 999 / 200 / 1 page/step]
	Adjusts the threshold of the line position adjustment for color printing mode after job end.		
004	Page: Interrupt: BW+FC	*ENG	[0 to 999 / 200 / 1 page/step]
	Adjusts the threshold of the line position adjustment for BW and color printing mode during job.		

005	Page: Interrupt: FC	*ENG	[0 to 999 / 200 / 1 page/step]
	Adjusts the threshold of the line position adjustment for color printing mode during jobs.		
006	Page: Stand-By: BW	*ENG	[0 to 999 / 100 / 1 page/step]
	Adjusts the threshold of the line position adjustment for BW printing mode in stand-by mode. The line position adjustment is done when the number of outputs in BW printing mode reaches the value specified with this SP and the condition of SP2-193-008 or SP2-193-009 is satisfied.		
007	Page: Stand-By: FC	*ENG	[0 to 999 / 100 / 1 page/step]
	Adjusts the threshold of the line position adjustment for FC printing mode in stand-by mode. The line position adjustment is done when the number of outputs in color printing mode reaches the value specified with this SP and the condition of SP2-193-008 or SP2-193-009 is satisfied.		
008	Temp.	*ENG	[0 to 100 / 5 / 1deg/step]
	Adjust the temperature change threshold for the line position adjustment (Mode b: adjustment once). The timing for line position adjustment depends on the combinations of several conditions.		
009	Time	*ENG	[1 to 1440 / 300 / 1 minute/step]
	Adjust the time threshold for the line position adjustment (Mode b: adjustment once). The timing for line position adjustment depends on the combinations of several conditions.		
010	Magnification	*ENG	[0 to 10 / 0.1 / 0.01%/step]
	Adjusts the magnification threshold for line position adjustment. If the length of the main scan is changed by this amount since the previous MUSIC, then MSUIC is done again.		
011	Temp. 2	*ENG	[0 to 100 / 10 / 1deg/step]
	Adjust the temperature change threshold for the line position adjustment (Mode a: adjustment twice). The timing for line position adjustment depends on the combinations of several conditions.		

012	Time 2	*ENG	[1 to 9999 / 600 / 1 minute/step]
	Adjust the time threshold for the line position adjustment (Mode a: adjustment twice). The timing for line position adjustment depends on the combinations of several conditions.		
013	Page: Power ON:BW+FC	*ENG	[0 to 999 / 200 / 1 page/step]
	Adjusts the threshold of the line position adjustment for BW and FC printing mode at power-on. The line position adjustment is done when the number of outputs in BW and color printing mode reaches the value specified with this SP and the condition of SP2-193-008 or SP2-193-009 is satisfied.		

2194	[MUSIC Execution Result] Line Position Adjustment: Execution Result		
001	Year	*ENG	[0 to 99 / - / 1 year/step]
	Displays the year of the last MUSIC execution.		
002	Month	*ENG	[1 to 12 / - / 1 month/step]
	Displays the month of the last MUSIC execution.		
003	Day	*ENG	[1 to 31 / - / 1 day/step]
	Displays the date of the last MUSIC execution.		
004	Hour	*ENG	[0 to 23 / - / 1 hour/step]
	Displays the time (hour) of the last MUSIC execution.		
005	Minute	*ENG	[0 to 59 / - / 1 minute/step]
	Displays the time (minute) of the last MUSIC execution.		
006	Temperature	*ENG	[0 to 100 / - / 1 deg/step]
	Displays the temperature of the last MUSIC execution.		
007	Execution Result	*ENG	[0 or 1 / - / 1 /step] 0: Completed successfully, 1: Failed
008	Number of Execution	*ENG	[0 to 999999 / - / 1 times/step]
009	Number of Failure	*ENG	[0 to 999999 / - / 1 times/step]

Main SP Tables-2

010	Error Result: M	*ENG	[0 to 9 / - / 1 /step]
011	Error Result: C	*ENG	0: Not done 1: Completed successfully
012	Error Result: Y	*ENG	2: Cannot detect patterns 3: Fewer lines on the pattern than the target 4: Not used 5: Out of the adjustment range 6 to 9: Not used

2198	[Music A/D Interval]		
	ADC Trigger Counter		
001	ADC Trigger Counter	*ENG	[7.5 to 20 / 10 / 0.1 μs/step]

2220	[Skew Origin Set]		
	Executes the skew motor initialization in the laser optics unit.		
001	M: Skew Motor	*ENG	-
002	C: Skew Motor	*ENG	-
003	Y: Skew Motor	*ENG	-

2221	[LD Power] LD Power Control		
	Adjusts the fixed LD power for each line speed and color. These SPs are activated only when SP3-041-002 is set to "0". Plain: High speed, Thick 1: Middle speed, Thick 2&Fine: Low speed		
001	Plain: Bk	*ENG	[0 to 200 / 100 / 1%/step] Increasing this value makes the image density darker.
002	Plain: M	*ENG	
003	Plain: C	*ENG	
004	Plain: Y	*ENG	
005	Thick 1: Bk	*ENG	
006	Thick 1: M	*ENG	

007	Thick 1: C	*ENG	
008	Thick 1: Y	*ENG	
009	Thick 2&FINE: Bk	*ENG	
010	Thick 2&FINE: M	*ENG	
011	Thick 2&FINE: C	*ENG	
012	Thick 2&FINE: Y	*ENG	

2229	[Development DC Vias] Development DC Bias Adjustment		[0 to 800 / 550 / 10 –V/step]	
	<p>Adjusts the development bias.</p> <p>Development bias is automatically adjusted during process control; therefore, adjusting these settings has no effect while Process Control (SP3-041-001 Default: ON) is activated.</p> <p>After deactivating Process Control with SP3-041-001, the values in these SP modes are used for printing.</p> <p>Plain: High speed, Thick 1: Middle speed, Thick 2&Fine: Low speed</p>			
	001	Plain: Bk		*ENG
	002	Plain: M		*ENG
	003	Plain: C		*ENG
	004	Plain: Y		*ENG
	005	Thick 1: Bk		*ENG
	006	Thick 1: M		*ENG
	007	Thick 1: C		*ENG
	008	Thick 1: Y		*ENG
	009	Thick 2&FINE:Bk		*ENG
	010	Thick 2&FINE:M		*ENG
	011	Thick 2&FINE:C		*ENG
012	Thick 2&FINE:Y	*ENG		

Main SP Tables-2

2241	[Temperature/Humidity: Display]		
	Displays the environment temperature and humidity.		
001	Temperature	-	[-50 to 450 / - / 0.1deg/step]
002	Relative Humidity	-	[0 to 1000 / - / 0.1 %RH/step]
003	Absolute Humidity	-	[0 to 100 / - / 0.01 g/m ³ /step]
004	AIT Temperature	-	[0 to 70 / - / 0.1deg/step]
005	Correction Coefficient A	-	[0 to 70 / 1 / 0.1/step]
006	Correction Coefficient B	-	[-70 to 70 / 0 / 0.1/step]

2242	[TS Operation Env. Log]		
	Displays TS Operation Env. logs.		
001	TS <= 40	-	[0 to 999999999 / - / 1/mm]
002	40 < TS <= 45	-	[0 to 999999999 / - / 1/mm]
003	45 < TS	-	[0 to 999999999 / - / 1/mm]
004	Log Clear	-	[0 to 1 / 0 / 1/step] 1: Clear

2302	[Environmental Correction: Transfer] Environmental Correction: Image Transfer Belt Unit		
001	Current Environmental Display	-	Displays the current environment condition.
002	Forced Setting	*ENG	Sets the environment condition manually. [0 to 6 / 0 / 1 /step] 0: Automatic environment control 1: LL (Low temperature/ Low humidity) 2: ML (Middle temperature/ Low humidity) 3: MM (Middle temperature/ Middle humidity) 4: MH (Middle temperature/ High humidity) 5: HH (High temperature/ High humidity)
003	Absolute Humidity: Threshold 1	*ENG	Adjusts the threshold value between LL and ML. [0 to 100 / 4 / 0.01 g/m ³ /step]
004	Absolute Humidity: Threshold 2	*ENG	Adjusts the threshold value between ML and MM. [0 to 100 / 8 / 0.01 g/m ³ /step]
005	Absolute Humidity: Threshold 3	*ENG	Adjusts the threshold value between MM and MH. [0 to 100 / 16 / 0.01 g/m ³ /step]
006	Absolute Humidity: Threshold 4	*ENG	Adjusts the threshold value between MH and HH. [0 to 100 / 24 / 0.01 g/m ³ /step]
007	Temp Threshold	*ENG	[-5 to 30 / 5 / 1 deg/step]

2308	[Paper Size Correction]		
	Adjusts the threshold value for the paper size correction.		
001	Threshold 1	*ENG	[0 to 350 / 297 / 1 mm/step] Threshold 1 ≤ paper: Paper is detected as "S1" size.
002	Threshold 2	*ENG	[0 to 350 / 257 / 1 mm/step] Threshold 2 ≤ paper ≤ Threshold 1: Paper is detected as "S2" size.
003	Threshold 3	*ENG	[0 to 350 / 210 / 1 mm/step] Threshold 3 ≤ paper ≤ Threshold 2: Paper is detected as "S3" size.
004	Threshold 4	*ENG	[0 to 350 / 148 / 1 mm/step] Threshold 4 ≤ paper ≤ Threshold 3: Paper is detected as "S4" size. Paper ≤ Threshold 4: Paper is detected as "S5" size.

2311	[Non Image Area: Bias]		
001	Image Transfer	*ENG	Adjusts the bias of the image transfer belt between images. This value is added to the value of the image transfer belt bias. [10 to 250 / 100 / 5 %/step]
002	Paper Transfer	*ENG	Adjusts the bias of the paper transfer roller between images. [0 to 2100 / 500 / 100 V/step]

2326	[Transfer Roller CL: Bias] Transfer Roller Cleaning: Bias Adjustment		
001	Positive	*ENG	[0 to 2100 / 500 / 100 V /step]
	Adjusts the positive voltage of the paper transfer roller for cleaning the paper transfer roller.		
002	Negative	*ENG	[10 to 400 / 100 / 10 %/step]
	Adjusts the negative current of the paper transfer roller for cleaning the paper transfer roller.		
003	Positive	*ENG	[0 to 2100 / 2000 / 100 V/step]
	Adjusts the negative current limit of the paper transfer roller for cleaning the paper transfer roller.		
004	Negative	*ENG	[10 to 400 / 100 / 10 %/step]

2351	[Common: BW: Bias] Plain: High speed, Thick 1: Middle speed, Thick 2&Fine: Low speed		
001	ITB unit: Plain	*ENG	[0 to 80 / 25 / 1 μ A]
	Adjusts the current for the image transfer belt in B/W mode for plain paper.		
002	ITB unit: Thick 1	*ENG	[0 to 80 / 12 / 1 μ A]
	Adjusts the current for the image transfer belt in B/W mode for thick 1 paper.		
003	ITB unit: Thick 2 & FINE	*ENG	[0 to 80 / 12 / 1 μ A]
	Adjusts the current for the image transfer belt in B/W mode for thick 2 paper or FINE mode.		

2357	[Common: FC: Bias] Image Transfer Belt: Full Color: Bias Adjustment Plain: High speed, Thick 1: Middle speed, Thick 2&Fine: Low speed		
001	ITB unit: Plain: Bk	*ENG	[0 to 80 / 22 / 1 μ A]
	Adjusts the current for the image transfer belt for Black in full color mode for plain paper.		
002	ITB unit: Plain: M	*ENG	[0 to 80 / 25 / 1 μ A]
	Adjusts the current for the image transfer belt for Magenta in full color mode for plain paper.		
003	ITB unit: Plain: C	*ENG	[0 to 80 / 22 / 1 μ A]
	Adjusts the current for the image transfer belt for Cyan in full color mode for plain paper.		
004	ITB unit: Plain: Y	*ENG	[0 to 80 / 28 / 1 μ A]
	Adjusts the current for the image transfer belt for Yellow in full color mode for plain paper.		
005	ITB unit: Thick 1: Bk	*ENG	[0 to 80 / 11 / 1 μ A]
	Adjusts the current for the image transfer belt for Black in full color mode for thick 1 paper.		
006	ITB unit: Thick 1: M	*ENG	[0 to 80 / 12 / 1 μ A]
	Adjusts the current for the image transfer belt for Magenta in full color mode for thick 1 paper.		
007	ITB unit: Thick 1: C	*ENG	[0 to 80 / 11 / 1 μ A]
	Adjusts the current for the image transfer belt for Cyan in full color mode for thick 1 paper.		
008	ITB unit: Thick 1: Y	*ENG	[0 to 80 / 14 / 1 μ A]
	Adjusts the current for the image transfer belt for Yellow in full color mode for thick 1 paper.		

009	ITB unit: Thick 2 & FINE: Bk	*ENG	[0 to 80 / 11 / 1 μ A]
	Adjusts the current for the image transfer belt for Black in full color mode for Thick 2 and fine.		
010	ITB unit: Thick 2 & FINE: M	*ENG	[0 to 80 / 12 / 1 μ A]
	Adjusts the current for the image transfer belt for Magenta in full color mode for Thick 2 and fine.		
011	ITB unit: Thick 2 & FINE: C	*ENG	[0 to 80 / 11 / 1 μ A]
	Adjusts the current for the image transfer belt for Cyan in full color mode for Thick 2 and fine.		
012	ITB unit: Thick 2 & FINE: Y	*ENG	[0 to 80 / 14 / 1 μ A]
	Adjusts the current for the image transfer belt for Yellow in full color mode for Thick 2 and fine.		

2360	[Common: BW Env. Correction]		
001	ITB unit: Plain	*ENG	[1 to 60 / 1 / 1 /step]
002	ITB unit: Thick 1	*ENG	
003	ITB unit: Thick 2	*ENG	
004	ITB unit: Plain: Bk	*ENG	[1 to 60 / 13 / 1 /step]
005	ITB unit: Plain: M	*ENG	[1 to 60 / 2 / 1 /step]
006	ITB unit: Plain: C	*ENG	
007	ITB unit: Plain: Y	*ENG	
008	ITB unit: Thick 1: Bk	*ENG	[1 to 60 / 31 / 1 /step]
009	ITB unit: Thick 1: M	*ENG	[1 to 60 / 1 / 1 /step]
010	ITB unit: Thick 1: C	*ENG	[1 to 60 / 2 / 1 /step]

Main SP Tables-2

011	ITB unit: Thick 1: Y	*ENG	
012	ITB unit: Thick 2: Bk	*ENG	[1 to 60 / 31 / 1 /step]
013	ITB unit: Thick 2: M	*ENG	[1 to 60 / 1 / 1 /step]
014	ITB unit: Thick 2: C	*ENG	[1 to 60 / 2 / 1 /step]
015	ITB unit: Thick 2: Y	*ENG	[1 to 60 / 2 / 1 /step]



2401	[Plain: Bias]		
	Adjusts the DC voltage of the discharge plate for plain paper. Plain: High speed, Thick 1: Middle speed, Thick 2&Fine: Low speed		
001	Separation DC: Plain: 1st Side	*ENG	[0 to 4000 / 3500 / 10 -V/step]
002	Separation DC: Plain: 2nd Side	*ENG	[0 to 4000 / 3500 / 10 -V/step]
003	Separation DC: 1200: 1st Side	*ENG	[0 to 4000 / 3500 / 10 -V/step]
004	Separation DC: 1200: 2nd Side	*ENG	[0 to 4000 / 3500 / 10 -V/step]

2403	[Plain: Bias: BW]		
	Adjusts the current for the paper transfer roller for plain paper in black-and-white mode. Plain: High speed, Thick 1: Middle speed, Thick 2&Fine: Low speed		
001	Paper Transfer: Plain: 1st Side	*ENG	[0 to 250 / 22 / 1 - μ A /step]
002	Paper Transfer: Plain: 2nd Side	*ENG	
003	Paper Transfer: 1200: 1st Side	*ENG	[0 to 250 / 7 / 1 - μ A /step]
004	Paper Transfer: 1200: 2nd Side	*ENG	[0 to 250 / 12 / 1 - μ A /step]

2407	[Plain: Bias: FC]		
	Adjusts the current for the paper transfer roller for plain paper in full color mode. Plain: High speed, Thick 1: Middle speed, Thick 2&Fine: Low speed		
001	Paper Transfer: Plain: 1st Side	*ENG	[0 to 250 / 27 / 1 - μ A /step]
002	Paper Transfer: Plain: 2nd Side	*ENG	[0 to 250 / 33 / 1 - μ A /step]
003	Paper Transfer: 1200: 1st Side	*ENG	[0 to 250 / 10 / 1 - μ A /step]
004	Paper Transfer: 1200: 2nd Side	*ENG	[0 to 250 / 12 / 1 - μ A /step]

2411	[Plain: Paper Size Correction]		
	Adjusts the size correction coefficient for the paper transfer roller current for each paper size. SP2403 and SP2407 are multiplied by these SP values. Plain: High speed, Thick 1: Middle speed, Thick 2&Fine: Low speed		
001	Paper Transfer: Plain : 1st Side: S1	*ENG	[100 to 600 / 100 / 5%/step] S1 size > 297 mm (Paper width)
002	Paper Transfer: Plain: 2nd Side: S1	*ENG	
003	Paper Transfer: 1200: 1st Side: S1	*ENG	
004	Paper Transfer: 1200: 2nd Side: S1	*ENG	
005	Paper Transfer: Plain: 1st Side: S2	*ENG	[100 to 600 / 105 / 5%/step] 297 mm > S2 size > 275 mm (Paper width)
006	Paper Transfer: Plain: 2nd Side: S2	*ENG	[100 to 600 / 120 / 5%/step] 297 mm > S2 size > 275 mm (Paper width)
007	Paper Transfer: 1200: 1st Side: S2	*ENG	[100 to 600 / 120 / 5%/step] 297 mm > S2 size > 275 mm (Paper width)
008	Paper Transfer: 1200: 2nd Side: S2	*ENG	[100 to 600 / 150 / 5%/step]
009	Paper Transfer: Plain: 1st Side: S3	*ENG	[100 to 600 / 110 / 5%/step] 275 mm > S3 size > 210 mm (Paper width)

010	Paper Transfer: Plain: 2nd Side: S3	*ENG	[100 to 600 / 140 / 5%/step] 275 mm > S3 size > 210 mm (Paper width)
011	Paper Transfer: 1200: 1st Side: S3	*ENG	
012	Paper Transfer: 1200: 2nd Side: S3	*ENG	[100 to 600 / 300 / 5%/step]
013	Paper Transfer: Plain: 1st Side: S4	*ENG	[100 to 600 / 115 / 5%/step] 210 mm > S4 size > 148 mm (Paper width)
014	Paper Transfer: Plain: 2nd Side: S4	*ENG	[100 to 600 / 160 / 5%/step] 210 mm > S4 size > 148 mm (Paper width)
015	Paper Transfer: 1200: 1st Side: S4	*ENG	[100 to 600 / 240 / 5%/step] 210 mm > S4 size > 148 mm (Paper width)
016	Paper Transfer: 1200: 2nd Side: S4	*ENG	[100 to 600 / 340 / 5%/step]
017	Paper Transfer: Plain: 1st Side: S5	*ENG	[100 to 600 / 120 / 5%/step] 148 mm > S5 size (Paper width)
018	Paper Transfer: Plain: 2nd Side: S5	*ENG	[100 to 600 / 180 / 5%/step] 148 mm > S5 size (Paper width)
019	Paper Transfer: 1200: 1st Side: S5	*ENG	[100 to 600 / 300 / 5%/step] 148 mm > S5 size (Paper width)
020	Paper Transfer: 1200: 2nd Side: S5	*ENG	[100 to 600 / 400 / 5%/step]

2421	[Plain: Leading Edge Correction] Plain Paper: Leading Edge Correction		
	Adjusts the correction to the paper transfer roller current at the paper leading edge in each mode. SP2403 and SP2407 are multiplied by these SP values.  Note <ul style="list-style-type: none"> ▪ The paper leading edge area can be adjusted with SP2422. 		
001	Paper Transfer: Plain: 1st Side	*ENG	[0 to 400 / 100 / 5%/step]
002	Paper Transfer: Plain: 2nd Side	*ENG	[0 to 400 / 100 / 5%/step]
003	Paper Transfer: 1200: 1st Side	*ENG	[0 to 400 / 100 / 5%/step]
004	Paper Transfer: 1200: 2nd side	*ENG	
2421	Adjusts the correction to the discharge plate current at the paper leading edge in each mode. SP2401 is multiplied by these SPs values.  Note <ul style="list-style-type: none"> ▪ The paper leading edge area can be adjusted with SP2422. 		
005	Separation DC: Plain: 1st Side	*ENG	[0 to 400 / 100 / 5%/step]
006	Separation DC: Plain: 2nd Side	*ENG	
007	Separation DC: 1200: 1st Side	*ENG	
008	Separation DC: 1200: 2nd Side	*ENG	

2422	[Plain: Switch Timing: Lead. Edge]		
	Adjusts the bias/ voltage switch timing of the paper transfer roller/ discharge plate at the paper leading edge between the erase margin area and the image area. Plain: High speed, Thick 1: Middle speed, Thick 2&Fine: Low speed		
001	Paper Transfer: Plain: 1st Side	*ENG	[0 to 50 / 0 / 2 mm/step]
002	Paper Transfer: Plain: 2nd Side	*ENG	
003	Paper Transfer: 1200: 1st Side	*ENG	
004	Paper Transfer: 1200: 2nd side	*ENG	
005	Separation DC: Plain: 1st Side	*ENG	
006	Separation DC: Plain: 2nd Side	*ENG	
007	Separation DC: 1200: 1st Side	*ENG	
008	Separation DC: 1200: 2nd Side	*ENG	

2423	[Plain: Trailing Edge Correction] Plain Paper: Trailing Edge Correction		
	Adjusts the correction coefficient to the paper transfer roller current for the paper trailing edge in each mode. SP2403 and SP2407 are multiplied by these SP values. Note <ul style="list-style-type: none"> The paper trailing edge area can be adjusted with SP2424. 		
001	Paper Transfer: Plain: 1st Side	*ENG	[0 to 400 / 100 / 5%/step]
002	Paper Transfer: Plain: 2nd Side	*ENG	
003	Paper Transfer: 1200: 1st Side	*ENG	
004	Paper Transfer: 1200: 2nd side	*ENG	
005	Separation DC: Plain: 1st Side	*ENG	
006	Separation DC: Plain: 2nd Side	*ENG	
007	Separation DC: 1200: 1st Side	*ENG	
008	Separation DC: 1200: 2nd Side	*ENG	

2424	[Plain: Switch Timing: Trail. Edge]		
	Adjusts the bias/voltage switch timing of the paper transfer roller/discharge plate at the paper trailing edge between the erase margin area and the image area. Plain: High speed, Thick 1: Middle speed, Thick 2&Fine: Low speed		
001	Paper Transfer: Plain: 1st Side	*ENG	[0 to 50 / 0 / 2 mm/step]
002	Paper Transfer: Plain: 2nd Side	*ENG	
003	Paper Transfer: 1200: 1st Side	*ENG	
004	Paper Transfer: 1200: 2nd side	*ENG	
005	Separation DC: Plain: 1st Side	*ENG	
006	Separation DC: Plain: 2nd Side	*ENG	
007	Separation DC: 1200: 1st Side	*ENG	
008	Separation DC: 1200: 2nd Side	*ENG	



2451	[Thin: Bias]		
	Adjusts the DC voltage of the discharge plate for thin paper. Plain: High speed, Thick 1: Middle speed, Thick 2&Fine: Low speed		
001	Separation DC: Plain: 1st Side	*ENG	[0 to 4000 / 3500 / 10 -V/step]
002	Separation DC: Plain: 2nd Side		
003	Separation DC: 1200: 1st Side	*ENG	
004	Separation DC: 1200: 2nd Side		

2453	[Thin: Bias: BW]		
	Adjusts the current for the paper transfer roller for thin paper in black-and-white mode. Plain: High speed, Thick 1: Middle speed, Thick 2&Fine: Low speed		
001	Paper Transfer: Plain: 1st Side	*ENG	[0 to 250 / 22 / 1 - μ A/step]
002	Paper Transfer: Plain: 2nd Side		
003	Paper Transfer: 1200: 1st Side	*ENG	[0 to 250 / 11 / 1 - μ A/step]
004	Paper Transfer: 1200: 2nd Side		

2457	[Thin: Bias: FC]		
	Adjusts the current for the paper transfer roller for thin paper in full color mode. Plain: High speed, Thick 1: Middle speed, Thick 2&Fine: Low speed		
001	Paper Transfer: Plain: 1st Side	*ENG	[0 to 250 / 30 / 1 - μ A/step]
002	Paper Transfer: Plain: 2nd Side		
003	Paper Transfer: 1200: 1st Side	*ENG	[0 to 250 / 15 / 1 - μ A/step]
004	Paper Transfer: 1200: 2nd Side		

2461	[Thin: Paper Size Correction]		
	Adjusts the size correction coefficient for the paper transfer roller current for each paper size. SP2453 and SP2457 are multiplied by these SP values. Plain: High speed		
001	Paper Transfer: Plain: 1st Side: S1	*ENG	[100 to 600 / 100 / 5%/step] S1 size > 297 mm (Paper width)
002	Paper Transfer: Plain: 2nd Side: S1		
005	Paper Transfer: Plain: 1st Side: S2	*ENG	[100 to 600 / 120 / 5%/step] 297 mm > S2 size > 275 mm

006	Paper Transfer: Plain: 2nd Side: S2		(Paper width)
009	Paper Transfer: Plain: 1st Side: S3	*ENG	[100 to 600 / 140 / 5%/step] 297 mm > S2 size > 275 mm (Paper width)
010	Paper Transfer: Plain: 2nd Side: S3		
013	Paper Transfer: Plain: 1st Side: S4	*ENG	[100 to 600 / 160 / 5%/step] 297 mm > S2 size > 275 mm (Paper width)
014	Paper Transfer: Plain: 2nd Side: S4		
017	Paper Transfer: 1st Side: S5	*ENG	[100 to 600 / 180 / 5%/step]
018	Paper Transfer: 2nd Side: S5		

2471	[Thin: Leading Edge Correction] Thin Paper: Leading Edge Correction		
	Adjusts the correction to the paper transfer roller current at the paper leading edge in each mode. SP2453 and SP2457 are multiplied by these SP values. Plain: High speed, 1200: Low speed  Note <ul style="list-style-type: none"> The paper leading edge area can be adjusted with SP2472. 		
001	Paper Transfer: Plain: 1st Side	*ENG	[0 to 400 / 100 / 5%/step]
002	Paper Transfer: Plain: 2nd Side		
003	Paper Transfer: 1200: 1st Side	*ENG	
004	Paper Transfer: 1200: 2nd Side		
2471	Adjusts the correction to the discharge plate current at the paper leading edge in each mode. SP2451 is multiplied by these SP values.  Note <ul style="list-style-type: none"> The paper leading edge area can be adjusted with SP2472. 		
	005	Separation DC: Plain: 1st Side	*ENG
006	Separation DC: Plain: 2nd Side		

007	Separation DC: 1200: 1st Side	*ENG	
008	Separation DC: 1200: 2nd Side		

2472	[Thin: Switch Timing: Lead. Edge]		
	Adjusts the bias/ voltage switch timing of the paper transfer roller/ discharge plate at the paper leading edge between the erase margin area and the image area. Plain: High speed, 1200: Low speed,		
001	Paper Transfer: Plain: 1st Side	*ENG	[0 to 50 / 0 / 2 mm/step]
002	Paper Transfer: Plain: 2nd Side		
003	Paper Transfer: 1200: 1st Side	*ENG	
004	Paper Transfer: 1200: 2nd Side		
005	Separation DC: Plain: 1st Side	*ENG	
006	Separation DC: Plain: 2nd Side		
007	Separation DC: 1200: 1st Side	*ENG	
008	Separation DC: 1200: 2nd Side		

2473	[Thin: Trailing Edge Correction] Thin Paper: Trailing Edge Correction		
	Adjusts the correction coefficient to the paper transfer roller current for the paper trailing edge in each mode. SP2453 and SP2457 are multiplied by these SP values. Plain: High speed, 1200: Low speed  Note <ul style="list-style-type: none"> ▪ The paper trailing edge area can be adjusted with SP2474. 		
001	Paper Transfer: Plain: 1st Side	*ENG	[0 to 400 / 100 / 5%/step]
002	Paper Transfer: Plain: 2nd Side		
003	Paper Transfer: 1200: 1st Side	*ENG	[0 to 400 / 100 / 5%/step]
004	Paper Transfer: 1200: 2nd Side		

005	Separation DC: Plain: 1st Side	*ENG	[0 to 400 / 100 / 5%/step]
006	Separation DC: Plain: 2nd Side		
007	Separation DC: 1200: 1st Side	*ENG	[0 to 400 / 100 / 5%/step]
008	Separation DC: 1200: 2nd Side		

2474	[Thin: Switch Timing: Trail. Edge]		
	Adjusts the bias/voltage switch timing of the paper transfer roller/discharge plate at the paper trailing edge between the erase margin area and the image area. Plain: High speed, 1200: Low speed		
001	Paper Transfer: Plain: 1st Side	*ENG	[0 to 50 / 0 / 2 mm/step]
002	Paper Transfer: Plain: 2nd Side		
003	Paper Transfer: 1200: 1st Side	*ENG	[0 to 50 / 0 / 1 mm/step]
004	Paper Transfer: 1200: 2nd Side		
005	Separation DC: Plain: 1st Side	*ENG	[0 to 50 / 0 / 1 mm/step]
006	Separation DC: Plain: 2nd Side		
007	Separation DC: 1200: 1st Side	*ENG	[0 to 50 / 0 / 1 mm/step]
008	Separation DC: 1200: 2nd Side		

2480	[Thin: Environment Correction]		
	Plain: High speed, 1200: Low speed		
001	Separation DC: Plain: 1st Side	*ENG	[1 to 60 / 26 / 1 /step]
002	Separation DC: Plain: 2nd Side		
003	Paper Transfer: Plain: BW: 1st Side	*ENG	[1 to 60 / 11 / 1 /step]
004	Paper Transfer: Plain: BW: 2nd Side		

Main SP Tables-2

005	Paper Transfer: Plain: FC: 1st Side	*ENG	[1 to 60 / 1 / 1 /step]
006	Paper Transfer: Plain: FC: 2nd Side		
007	Separation DC: 1200: 1st Side	*ENG	[1 to 60 / 26 / 1 /step]
008	Separation DC: 1200: 2nd Side		
009	Paper Transfer: 1200: BW: 1st Side	*ENG	[1 to 60 / 11 / 1 /step]
010	Paper Transfer: 1200: BW: 2nd Side		
011	Paper Transfer: 1200: FC: 1st Side	*ENG	[1 to 60 / 1 / 1 /step]
012	Paper Transfer: 1200: FC: 2nd Side		

2481	[Glossy: Bias]		
001	Separation DC: 1st Side	*ENG	[0 to 4000 / 3500 / 10 -V/step]
	Adjusts the DC voltage of the discharge plate for glossy paper.		

2482	[Glossy: Bias: BW]		
001	Paper Transfer: 1st Side	*ENG	[0 to 250 / 12 / 1 - μ A/step]
	Adjusts the current for the paper transfer roller for glossy paper in black-and-white mode.		

2483	[Glossy: Bias: FC]		
001	Paper Transfer: 1st Side	*ENG	[0 to 250 / 15 / 1 - μ A/step]
	Adjusts the current for the paper transfer roller for glossy paper in full color mode.		

2484	[Glossy: Paper Size Correction]		
001	Paper Transfer: 1st Side: S1	*ENG	[100 to 600 / 100 / 5%/step]
005	Paper Transfer: 1st Side: S2	*ENG	[100 to 600 / 120 / 5%/step]
009	Paper Transfer: 1st Side: S3	*ENG	[100 to 600 / 140 / 5%/step]
013	Paper Transfer: 1st Side: S4	*ENG	[100 to 600 / 160 / 5%/step]
017	Paper Transfer: 1st Side: S5	*ENG	[100 to 600 / 180 / 5%/step]

2485	[Plain: Leading Edge Correction]		
001	Paper Transfer: 1st Side	*ENG	[10 to 400 / 100 / 5%/step]
005	Separation DC: 1st Side	*ENG	[10 to 400 / 100 / 5%/step]]

2486	[Plain: Switch Timing: Lead. Edge]		
001	Paper Transfer: 1st Side	*ENG	[0 to 50 / 0 / 2 mm/step]
005	Separation DC: 1st Side	*ENG	

2487	[Plain: Trailing Edge Correction]		
001	Paper Transfer: 1st Side	*ENG	[0 to 400 / 100 / 5 %/step]
005	Separation DC: 1st Side	*ENG	

Main SP Tables-2

2488	[Plain:SwitchTiming:Trail. Edge]		
001	Paper Transfer: 1st Side	*ENG	[0 to 50 / 0 / 2 mm/step]
005	Separation DC: 1st Side	*ENG	

2489	[Glossy: Environment Correction]		
001	Separation DC: 1st Side	*ENG	[1 to 60 / 26 / 1 /step]
003	Paper Transfer: BW: 1st Side	*ENG	[1 to 60 / 11 / 1 /step]
005	Paper Transfer: FC: 1st Side	*ENG	[1 to 60 / 1 / 1 /step]

2501	[Thick 1: Bias]		
	Adjusts the DC voltage of the discharge plate for thick 1 paper. Plain: High speed, 1200: Low speed		
001	Separation DC: Plain: 1st Side	*ENG	[0 to 4000 / 3500 / 10 -V/step]
002	Separation DC: Plain: 2nd Side	*ENG	
003	Separation DC: 1200: 1st Side	*ENG	

2502	[Thick 1: Bias: BW]		
	Adjusts the current for the paper transfer roller for thick 1 paper in black-and-white mode. Plain: High speed, 1200: Low speed		
001	Paper Transfer: Plain: 1st Side	*ENG	[0 to 250 / 12 / 1 - μ A/step]
002	Paper Transfer: Plain: 2nd Side	*ENG	
003	Separation DC: 1200: 1st Side	*ENG	[0 to 250 / 12 / 1 - μ A/step]

2507	[Thick 1: Bias: FC]		
	Adjusts the current for the paper transfer roller for thick 1 paper in full color mode. Plain: High speed, 1200: Low speed		
001	Paper Transfer: Plain: 1st Side	*ENG	[0 to 250 / 15 / 1 - μ A /step]
002	Paper Transfer: Plain: 2nd Side	*ENG	
003	Separation DC: 1200: 1st Side	*ENG	[0 to 250 / 15 / 1 - μ A /step]

2511	[Thick 1: Paper Size Correction]		
	Adjusts the size correction coefficient for the paper transfer roller current for each paper size. SP2502 and SP2507 are multiplied by these SP values. Plain: High speed, 1200: Low speed		
001	Paper Transfer: Plain: 1st Side: S1	*ENG	[100 to 600 / 100 / 5%/step] S1 size > 297 mm (Paper width)
002	Paper Transfer: Plain: 2nd Side: S1	*ENG	
003	Paper Transfer: 1200: 1st Side: S1	*ENG	[100 to 600 / 100 / 5%/step] S1 size > 297 mm (Paper width)
005	Paper Transfer: Plain: 1st Side: S2	*ENG	[100 to 600 / 105 / 5%/step] 297 mm > S2 size > 275 mm (Paper width)
006	Paper Transfer: Plain: 2nd Side: S2	*ENG	[100 to 600 / 130 / 5%/step] 297 mm > S2 size > 275 mm (Paper width)

007	Paper Transfer: 1200: 1st Side: S2	*ENG	[100 to 600 / 120 / 5%/step] 297 mm > S2 size > 275 mm (Paper width)
009	Paper Transfer: Plain: 1st Side: S3	*ENG	[100 to 600 / 110 / 5%/step] 275 mm > S3 size > 210 mm (Paper width)
010	Paper Transfer: Plain: 2nd Side: S3	*ENG	[100 to 600 / 160 / 5%/step] 275 mm > S3 size > 210 mm (Paper width)
011	Paper Transfer: 1200: 1st Side: S3	*ENG	[100 to 600 / 140 / 5%/step] 275 mm > S3 size > 210 mm (Paper width)
013	Paper Transfer: Plain 1: 1st Side: S4	*ENG	[100 to 600 / 115 / 5%/step] 210 mm > S4 size > 148 mm (Paper width)
014	Paper Transfer: Plain: 2nd Side: S4	*ENG	[100 to 600 / 190 / 5%/step] 210 mm > S4 size > 148 mm (Paper width)
015	Paper Transfer: 1200: 1st Side: S4	*ENG	[100 to 600 / 160 / 5%/step] 210 mm > S4 size > 148 mm (Paper width)
017	Paper Transfer: Plain 1: 1st Side: S5	*ENG	[100 to 600 / 120 / 5%/step] 148 mm > S5 size (Paper width)
018	Paper Transfer: Plain: 2nd Side: S5	*ENG	[100 to 600 / 220 / 5%/step] 148 mm > S5 size (Paper width)
019	Paper Transfer: 1200: 1st Side: S5	*ENG	[100 to 600 / 180 / 5%/step] 148 mm > S5 size (Paper width)

2521	[Thick 1: Leading Edge Correction] Thick 1 Paper: Leading Edge Correction		
	Adjusts the correction to the paper transfer roller current at the paper leading edge in each mode. SP2502 and SP2507 are multiplied by these SP values. Plain: High speed, 1200: Low speed Note <ul style="list-style-type: none"> The paper leading edge area can be adjusted with SP2522. 		
001	Paper Transfer: Plain: 1st Side	*ENG	[0 to 400 / 100 / 5%/step]
002	Paper Transfer: Plain: 2nd Side	*ENG	
003	Paper Transfer: 1200: 1st Side	*ENG	[0 to 400 / 100 / 5%/step]
005	Separation DC: Plain: 1st Side	*ENG	[0 to 400 / 100 / 5%/step]
006	Separation DC: Plain: 2nd Side	*ENG	
007	Separation DC: 1200: 1st Side	*ENG	[0 to 400 / 100 / 5%/step]

2522	[Thick 1: Switch Timing: Lead. Edge]		
	Adjusts the bias/ voltage switch timing of the paper transfer roller/ discharge plate at the paper leading edge between the erase margin area and the image area. Plain: High speed, 1200: Low speed		
001	Paper Transfer: Plain 1: 1st Side	*ENG	[0 to 50 / 0 / 2 mm/step]
002	Paper Transfer: Plain: 2nd Side	*ENG	
003	Paper Transfer: 1200: 1st Side	*ENG	
005	Separation DC: Plain 1: 1st Side	*ENG	[0 to 50 / 0 / 2 mm/step]
006	Separation DC: Plain 1: 2nd Side	*ENG	
007	Separation DC: 1200: 1st Side	*ENG	

2523	[Thick 1: Trail. Edge Correction] Thick 1 Paper: Trailing Edge Correction		
	<p>Adjusts the correction coefficient to the paper transfer roller current for the paper trailing edge in each mode. SP2502 and SP2507 are multiplied by these SP values.</p> <p>Plain: High speed, 1200: Low speed</p> <p> Note</p> <ul style="list-style-type: none"> The paper trailing edge area can be adjusted with SP2524. 		
001	Paper Transfer: Plain: 1st Side	*ENG	[0 to 400 / 100 / 5%/step]
002	Paper Transfer: Plain: 2nd Side	*ENG	
003	Paper Transfer: 1200: 1st Side	*ENG	
005	Separation DC: Plain: 1st Side	*ENG	[0 to 400 / 100 / 5%/step]
006	Separation DC: Plain: 2nd Side	*ENG	
007	Separation DC: 1200: 1st Side	*ENG	

2524	[Thick 1: Sw Timing: Trail. Edge]		
	<p>Adjusts the bias/voltage switch timing of the paper transfer roller/discharge plate at the paper trailing edge between the erase margin area and the image area.</p> <p>Plain: High speed, 1200: Low speed</p>		
001	Paper Transfer: Plain: 1st Side	*ENG	[0 to 50 / 0 / 1 mm/step]
002	Paper Transfer: Plain: 2nd Side	*ENG	
003	Paper Transfer: 1200: 1st Side	*ENG	
005	Separation DC: Plain: 1st Side	*ENG	
006	Separation DC: Plain: 2nd Side	*ENG	
007	Separation DC: 1200: 1st Side	*ENG	

2530	[Thick 1: Environment Correction]		
	Plain: High speed, 1200: Low speed		
001	Separation DC: Plain: 1st Side	*ENG	[1 to 60 / 22 / 1 /step]
002	Separation DC: Plain: 2nd Side	*ENG	
003	Paper Transfer: Plain: BW: 1st Side	*ENG	[1 to 60 / 11 / 1 /step]
004	Paper Transfer: Plain: BW:2nd Side	*ENG	
005	Paper Transfer: Plain: FC: 1st Side	*ENG	[1 to 60 / 1 / 1 /step]
006	Paper Transfer: Plain: FC:2nd Side	*ENG	[1 to 60 / 11 / 1 /step]
007	Separation DC: 1200: 1st Side	*ENG	[1 to 60 / 22 / 1 /step]
009	Paper Transfer: 1200: BW: 1st Side	*ENG	[1 to 60 / 11 / 1 /step]
011	Paper Transfer: 1200: FC: 1st Side	*ENG	[1 to 60 / 1 / 1 /step]



2551	[Thick 2: Bias]		
	Adjusts the DC voltage of the discharge plate for thick 2 paper.		
001	Separation DC: 1st Side	*ENG	[0 to 4000 / 3500 / 10 –V/step]
002	Separation DC: 2nd Side	*ENG	

2553	[Thick 2: Bias: BW]		
	Adjusts the current for the paper transfer roller for thick 2 paper in black-and-white mode.		
001	Paper Transfer: 1st Side	*ENG	[0 to 250 / 7 / 1 – μ A/step]
002	Paper Transfer: 2nd Side	*ENG	[0 to 250 / 12 / 1 – μ A/step]

2558	[Thick 2: Bias: FC]		
	Adjusts the current for the paper transfer roller for thick 2 paper in full color mode.		
001	Paper Transfer: 1st Side	*ENG	[0 to 250 / 16 / 1 – μ A /step]
002	Paper Transfer: 2nd Side	*ENG	[0 to 250 / 15 / 1 – μ A /step]

2561	[Thick 2: Paper Size Correction]		
	Adjusts the size correction coefficient for the paper transfer roller current for each paper size. SP2553 and SP2558 are multiplied by these SP values.		
001	Paper Transfer: 1st Side: S1	*ENG	[100 to 600 / 100 / 5%/step]
002	Paper Transfer: 2nd Side: S1	*ENG	S1 size > 297 mm (Paper width)
003	Paper Transfer: 1st Side: S2	*ENG	[100 to 600 / 105 / 5%/step] 297 mm > S2 size > 275 mm (Paper width)
004	Paper Transfer: 2nd Side: S2	*ENG	[100 to 600 / 160 / 5%/step] 297 mm > S2 size > 275 mm (Paper width)
005	Paper Transfer: 1st Side: S3	*ENG	[100 to 600 / 110 / 5%/step] 275 mm > S3 size > 210 mm (Paper width)
006	Paper Transfer: 2nd Side: S3	*ENG	[100 to 600 / 260 / 5%/step] 275 mm > S3 size > 210 mm (Paper width)
007	Paper Transfer: 1st Side: S4	*ENG	[100 to 600 / 120 / 5%/step] 210 mm > S4 size > 148 mm (Paper width)

008	Paper Transfer: 2nd Side: S4	*ENG	[100 to 600 / 430 / 5%/step] 210 mm > S4 size > 148 mm (Paper width)
009	Paper Transfer: 1st Side: S5	*ENG	[100 to 600 / 140 / 5%/step] 148 mm > S5 size (Paper width)
010	Paper Transfer: 2nd Side: S5	*ENG	[100 to 600 / 600 / 5%/step] 148 mm > S5 size (Paper width)

2571	[Thick 2: Leading Edge Correction] Thick 2 Paper: Leading Edge Correction		
	Adjusts the correction to the paper transfer roller current at the paper leading edge in each mode. SP2553 and SP2558 are multiplied by these SP values. <div style="border: 1px solid black; border-radius: 10px; padding: 2px; display: inline-block;">  Note </div> <ul style="list-style-type: none"> ▪ The paper leading edge area can be adjusted with SP2572. 		
001	Paper Transfer: 1st Side	*ENG	[0 to 400 / 100 / 5%/step]
002	Paper Transfer: 2nd Side	*ENG	
2571	Adjusts the correction to the discharge plate current at the paper leading edge in each mode. SP2551 is multiplied by these SP values. <div style="border: 1px solid black; border-radius: 10px; padding: 2px; display: inline-block;">  Note </div> <ul style="list-style-type: none"> ▪ The paper leading edge area can be adjusted with SP2572. 		
003	Separation DC: 1st Side	*ENG	[0 to 400 / 100 / 5%/step]
004	Separation DC: 2nd Side	*ENG	

2572	[Thick 2: Sw Timing: Lead. Edge]		
	Adjusts the bias/ voltage switch timing of the paper transfer roller/ discharge plate at the paper leading edge between the erase margin area and the image area.		
001	Paper Transfer: 1st Side	*ENG	[0 to 50 / 0 / 2mm/step]
002	Paper Transfer: 2nd Side	*ENG	
003	Separation DC: 1st Side	*ENG	
004	Separation DC: 2nd Side	*ENG	

2573	[Thick 2: Trail. Edge Correction] Thick 2 Paper: Trailing Edge Correction		
	Adjusts the correction to the paper transfer roller current for the paper trailing edge in each mode. SP2553 and SP2558 are multiplied by these SP values.  Note <ul style="list-style-type: none"> ▪ The paper trailing edge area can be adjusted with SP2574. 		
001	Paper Transfer: 1st Side	*ENG	[0 to 400 / 100 / 5%/step]
002	Paper Transfer: 2nd Side	*ENG	
003	Separation DC: 1st Side	*ENG	[0 to 400 / 100 / 5%/step]
004	Separation DC: 2nd Side	*ENG	[0 to 400 / 100 / 5%/step]

2574	[Thick 2: Trail. Edge Correction]		
	Adjusts the bias/voltage switch timing of the paper transfer roller/discharge plate at the paper trailing edge between the erase margin area and the image area.		
001	Paper Transfer: 1st Side	*ENG	[0 to 50 / 0 / 2 mm/step]
002	Paper Transfer: 2nd Side	*ENG	
003	Separation DC: 1st Side	*ENG	
004	Separation DC: 2nd Side	*ENG	

2580	[Thick 2 Environment Correction]		
001	Separation DC: 1st Side	*ENG	[1 to 60 / 22 / 1 /step]
002	Separation DC: 2nd Side	*ENG	
003	Paper Transfer: BW: 1st Side	*ENG	[0 to 60 / 11 / 1 /step]
004	Paper Transfer: BW: 2nd Side	*ENG	
005	Paper Transfer: FC: 1st Side	*ENG	[1 to 60 / 53 / 1 /step]
006	Paper Transfer: FC: 2nd Side	*ENG	[1 to 60 / 11 / 1 /step]

2601	[OHP: Bias]		
	Adjusts the DC voltage of the discharge plate for OHP.		
001	Separation DC	*ENG	[0 to 4000 / 3500 / 10 -V/step]

2603	[OHP: Bias: BW]		
	Adjusts the current for the paper transfer roller for OHP in black-and-white mode.		
001	Paper Transfer	*ENG	[0 to 250 / 12 / 1 - μ A /step]

2608	[OHP: Bias: FC]		
	Adjusts the current for the paper transfer roller for OHP in full color mode.		
001	Paper Transfer	*ENG	[0 to 250 / 15 / 1 - μ A /step]

2611	[OHP: Paper Size Correction]		
	Adjusts the size correction coefficient for the paper transfer roller current for each paper size. SP2603 and SP2608 are multiplied by these SP values.		
001	Paper Transfer: S1	*ENG	[100 to 600 / 100 / 5%/step] S1 size > 297 mm (Paper width)

Main SP Tables-2

002	Paper Transfer: S2	*ENG	[100 to 600 / 140 / 5%/step] 297 mm > S2 size > 275 mm (Paper width)
003	Paper Transfer: S3	*ENG	[100 to 600 / 200 / 5%/step] 275 mm > S3 size > 210 mm (Paper width)
004	Paper Transfer: S4	*ENG	[100 to 600 / 260 / 5%/step] 210 mm > S4 size > 148 mm (Paper width)
005	Paper Transfer: S5	*ENG	[100 to 600 / 330 / 5%/step] 148 mm > S5 size (Paper width)

2621	[OHP: Leading Edge Correction]		
	Adjusts the correction to the paper transfer roller current at the paper leading edge in each mode. SP2603 and SP2608 are multiplied by these SP values. <div style="border: 1px solid black; border-radius: 10px; padding: 2px; display: inline-block;"> Note </div> <ul style="list-style-type: none"> ▪ The paper leading edge area can be adjusted with SP2622. 		
001	Paper Transfer	*ENG	[0 to 400 / 100 / 5%/step]
2621	Adjusts the correction to the discharge plate current at the paper leading edge in each mode. SP2601 is multiplied by these SP values. <div style="border: 1px solid black; border-radius: 10px; padding: 2px; display: inline-block;"> Note </div> <ul style="list-style-type: none"> ▪ The paper leading edge area can be adjusted with SP2622. 		
002	Separation DC	*ENG	[0 to 400 / 100 / 5%/step]

2622	[OHP: Switch Timing: Leading Edge]		
	Adjusts the bias/ voltage switch timing of the paper transfer roller/ discharge plate at the paper leading edge between the erase margin area and the image area.		
001	Paper Transfer	*ENG	[0 to 50 / 0 / 2 mm/step]
002	Separation DC	*ENG	

2623	[OHP: Trailing Edge Correction]		
	Adjusts the correction to the paper transfer roller current for the paper trailing edge in each mode. SP2603 and SP2608 are multiplied by these SP values.		
<div style="border: 1px solid black; border-radius: 10px; padding: 2px; display: inline-block;">  Note </div>			
<ul style="list-style-type: none"> ▪ The paper trailing edge area can be adjusted with SP2624. 			
001	Paper Transfer	*ENG	[0 to 400 / 100 / 5%/step]
002	Separation DC	*ENG	

2624	[OHP: Trailing Edge Correction]		
	Adjusts the bias/voltage switch timing of the paper transfer roller/discharge plate at the paper trailing edge between the erase margin area and the image area.		
001	Paper Transfer	*ENG	[0 to 50 / 0 / 1 mm/step]
002	Separation DC	*ENG	[0 to 50 / 0 / 2 mm/step]

2630	[OHP: Environment Correction]		
001	Separation DC	*ENG	[1 to 60 / 22 / 1 /step]
002	Paper Transfer: BW	*ENG	[1 to 60 / 11 / 1 /step]
003	Paper Transfer: FC	*ENG	[1 to 60 / 1 / 1 /step]

2650	[Thick3: Bias]		
	Adjusts the DC voltage of the discharge plate for thick paper 3.		
001	Separation DC: 1st Side	*ENG	[0 to 3500 / 0 / 10 –V/step]
002	Separation DC: 2nd Side	*ENG	



Main SP Tables-2

2651	[Thick3: Bias: BW]		
	Adjusts the current for the paper transfer roller for thick paper 3 in black-and-white mode.		
001	Paper Transfer: 1st Side	*ENG	[0 to 250 / 10 / 1 - μ A/step]
002	Paper Transfer: 2nd Side	*ENG	[0 to 250 / 12 / 1 - μ A/step]

2652	[Thick3: Bias: FC]		
	Adjusts the current for the paper transfer roller for thick paper 3 in full color mode.		
001	Paper Transfer: 1st Side	*ENG	[0 to 250 / 11 / 1 - μ A/step]
002	Paper Transfer: 2nd Side	*ENG	[0 to 250 / 15 / 1 - μ A/step]

2653	[Thick3: Paper Size Correction]		
	Adjusts the size correction coefficient for the paper transfer roller current for each paper size. SP2651 and SP2652 are multiplied by these SP values.		
001	Paper Transfer: 1st Side: S1	*ENG	[100 to 600 / 100 / 5%/step] S1 size > 297 mm (Paper width)
002	Paper Transfer: 1st Side: S2	*ENG	[100 to 600 / 100 / 5%/step] 297 mm > S2 size > 275 mm (Paper width)
003	Paper Transfer: 1st Side: S3	*ENG	[100 to 600 / 100 / 5%/step] 275 mm > S3 size > 210 mm (Paper width)

004	Paper Transfer: 1st Side: S4	*ENG	[100 to 600 / 160 / 5%/step] 210 mm > S4 size > 148 mm (Paper width)
005	Paper Transfer: 1st Side: S5	*ENG	[100 to 600 / 100 / 5%/step] 148 mm > S5 size (Paper width)
006	Paper Transfer: 2nd Side: S1	*ENG	[100 to 600 / 260 / 5%/step] S1 size > 297 mm (Paper width)
007	Paper Transfer: 2nd Side: S2	*ENG	[100 to 600 / 100 / 5%/step] 297 mm > S2 size > 275 mm (Paper width)
008	Paper Transfer: 2nd Side: S3	*ENG	[100 to 600 / 430 / 5%/step] 275 mm > S3 size > 210 mm (Paper width)
009	Paper Transfer: 2nd Side: S4	*ENG	[100 to 600 / 100 / 5%/step] 210 mm > S4 size > 148 mm (Paper width)
010	Paper Transfer: 2nd Side: S5	*ENG	[100 to 600 / 600 / 5%/step] 148 mm > S5 size (Paper width)

2654	[Thick 3: Leading Edge Correction] Thick 3 Paper: Leading Edge Correction		
	Adjusts the correction to the paper transfer roller current at the paper leading edge in each mode. SP2651 and SP2652 are multiplied by these SP values. <div style="border: 1px solid black; border-radius: 10px; padding: 2px; display: inline-block;">  Note </div> <ul style="list-style-type: none"> ▪ The paper leading edge area can be adjusted with SP2655. 		
001	Paper Transfer: 1st Side	*ENG	[0 to 400 / 100 / 5%/step]
002	Separation DC: 1st Side	*ENG	
2654	Adjusts the correction to the discharge plate current at the paper leading edge in each mode. SP2650 is multiplied by these SP values. <div style="border: 1px solid black; border-radius: 10px; padding: 2px; display: inline-block;">  Note </div> <ul style="list-style-type: none"> ▪ The paper leading edge area can be adjusted with SP2655. 		
	003	Paper Transfer: 2nd Side	*ENG
004	Separation DC: 2nd Side	*ENG	

2655	[Thick 3: Sw Timing: Lead. Edge]		
	Adjusts the bias/ voltage switch timing of the paper transfer roller/ discharge plate at the paper leading edge between the erase margin area and the image area.		
001	Paper Transfer: 1st Side	*ENG	[0 to 50 / 0 / 2 mm/step]
002	Separation DC: 1st Side	*ENG	
003	Paper Transfer: 2nd Side	*ENG	
004	Separation DC: 2nd Side	*ENG	

2656	[Thick 3: Trail. Edge Correction] Thick 3 Paper: Trailing Edge Correction		
	Adjusts the correction to the paper transfer roller current for the paper trailing edge in each mode. SP2651 and SP2652 are multiplied by these SP values.		
<div style="border: 1px solid black; border-radius: 10px; padding: 2px; display: inline-block;">  Note </div> <ul style="list-style-type: none"> ▪ The paper trailing edge area can be adjusted with SP2657. 			
001	Paper Transfer: 1st Side	*ENG	[0 to 400 / 100 / 5%/step]
002	Paper Transfer: 2nd Side	*ENG	
003	Separation DC: 1st Side	*ENG	
004	Separation DC: 2nd Side	*ENG	

2657	[Thick 3: Trail. Edge Correction]		
	Adjusts the bias/voltage switch timing of the paper transfer roller/discharge plate at the paper trailing edge between the erase margin area and the image area.		
001	Paper Transfer: 1st Side	*ENG	[0 to 50 / 0 / 2 mm/step]
002	Paper Transfer: 2nd Side	*ENG	
003	Separation DC: 1st Side	*ENG	
004	Separation DC: 2nd Side	*ENG	

2660	[Thick 3: Environment Correction] Thick 3 Paper: MM Environment Coefficient Adjustment		
	Adjusts the environment coefficient for each mode. When the environment is detected as MM, SP2651 and SP2652 are multiplied by these SP values.		
001	Separation DC: 1st Side	*ENG	[1 to 60 / 22 / 1 /step]
002	Separation DC: 2nd Side	*ENG	
2660	Adjusts the environment coefficient for each mode. When the environment is detected as MM, SP2650 is multiplied by these SP values.		
003	Paper Transfer: BW: 1st Side	*ENG	[1 to 60 / 11 / 1 /step]

Main SP Tables-2

004	Paper Transfer: BW: 2nd Side	*ENG	
005	Paper Transfer: FC: 1st Side	*ENG	[1 to 60 / 55 / 1 /step]
006	Paper Transfer: FC: 2nd Side	*ENG	[1 to 60 / 11 / 1 /step]



2670	[Thick4: Bias]		
	Adjusts the DC voltage of the discharge plate for thick paper 4.		
001	Separation DC: 1st Side	*ENG	[0 to 4000 / 3500 / 10 -V/step]
002	Separation DC: 2nd Side	*ENG	

2671	[Thick4: Bias: BW]		
	Adjusts the current for the paper transfer roller for thick paper 4 in black-and-white mode.		
001	Paper Transfer: 1st Side	*ENG	[0 to 250 / 10 / 1 - μ A /step]
002	Paper Transfer: 2nd Side	*ENG	[0 to 250 / 12 / 1 - μ A /step]

2672	[Thick4: Bias: FC]		
	Adjusts the current for the paper transfer roller for thick paper 4 in full color mode.		
001	Paper Transfer: 1st Side	*ENG	[0 to 250 / 11 / 1 - μ A /step]
002	Paper Transfer: 2nd Side	*ENG	[0 to 250 / 15 / 1 - μ A /step]

2673	[Thick4: Paper Size Correction]		
	Adjusts the size correction coefficient for the paper transfer roller current for each paper size. SP2671 and SP2672 are multiplied by these SP values.		
001	Paper Transfer: 1st Side: S1	*ENG	[100 to 600 / 100 / 5%/step] S1 size > 297 mm (Paper width)

002	Paper Transfer: 2nd Side: S1	*ENG	[100 to 600 / 100 / 5%/step] 297 mm > S2 size > 275 mm (Paper width)
003	Paper Transfer: 1st Side: S2	*ENG	[100 to 600 / 100 / 5%/step] 275 mm > S3 size > 210 mm (Paper width)
004	Paper Transfer: 2nd Side: S2	*ENG	[100 to 600 / 160 / 5%/step] 210 mm > S4 size > 148 mm (Paper width)
005	Paper Transfer: 1st Side: S3	*ENG	[100 to 600 / 100 / 5%/step] 148 mm > S5 size (Paper width)
006	Paper Transfer: 2nd Side: S3	*ENG	[100 to 600 / 260 / 5%/step] S1 size > 297 mm (Paper width)
007	Paper Transfer: 1st Side: S4	*ENG	[100 to 600 / 100 / 5%/step] 297 mm > S2 size > 275 mm (Paper width)
008	Paper Transfer: 2nd Side: S4	*ENG	[100 to 600 / 430 / 5%/step] 275 mm > S3 size > 210 mm (Paper width)
009	Paper Transfer: 1st Side: S5	*ENG	[100 to 600 / 100 / 5%/step] 210 mm > S4 size > 148 mm (Paper width)
010	Paper Transfer: 2nd Side: S5	*ENG	[100 to 600 / 600 / 5%/step] 148 mm > S5 size (Paper width)

2674	[Thick 4: Leading Edge Correction] Thick 4 Paper: Leading Edge Correction		
	Adjusts the correction to the paper transfer roller current at the paper leading edge in each mode. SP2671 and SP2672 are multiplied by these SP values. <div style="border: 1px solid black; border-radius: 10px; padding: 2px; display: inline-block;">  Note </div> <ul style="list-style-type: none"> ▪ The paper leading edge area can be adjusted with SP2675. 		
001	Paper Transfer: 1st Side	*ENG	[0 to 400 / 100 / 5%/step]
002	Separation DC: 1st Side	*ENG	
2674	Adjusts the correction to the discharge plate current at the paper leading edge in each mode. SP2670 is multiplied by these SP values. <div style="border: 1px solid black; border-radius: 10px; padding: 2px; display: inline-block;">  Note </div> <ul style="list-style-type: none"> ▪ The paper leading edge area can be adjusted with SP2655. 		
	003	Paper Transfer: 2nd Side	*ENG
004	Separation DC: 2nd Side	*ENG	

2675	[Thick 4: Sw Timing: Lead. Edge]		
	Adjusts the bias/ voltage switch timing of the paper transfer roller/ discharge plate at the paper leading edge between the erase margin area and the image area.		
001	Paper Transfer: 1st Side	*ENG	[0 to 50 / 0 / 2 mm/step]
002	Separation DC: 1st Side	*ENG	
003	Paper Transfer: 2nd Side	*ENG	
004	Separation DC: 2nd Side	*ENG	

2676	[Thick 4: Trail. Edge Correction] Thick 4 Paper: Trailing Edge Correction		
	Adjusts the correction to the paper transfer roller current for the paper trailing edge in each mode. SP2671 and SP2672 are multiplied by these SP values.		
	<div style="border: 1px solid black; border-radius: 10px; padding: 2px; display: inline-block;">  Note </div> <ul style="list-style-type: none"> ▪ The paper trailing edge area can be adjusted with SP2677. 		
001	Paper Transfer: 1st Side	*ENG	[0 to 400 / 100 / 5%/step]
002	Paper Transfer: 2nd Side	*ENG	
003	Separation DC: 1st Side	*ENG	
004	Separation DC: 2nd Side	*ENG	

2677	[Thick 4: Sw Timing: Trail. Edge]		
	Adjusts the bias/voltage switch timing of the paper transfer roller/discharge plate at the paper trailing edge between the erase margin area and the image area.		
001	Paper Transfer: 1st Side	*ENG	[0 to 50 / 0 / 2 mm/step]
002	Paper Transfer: 2nd Side	*ENG	
003	Separation DC: 1st Side	*ENG	
004	Separation DC: 2nd Side	*ENG	

2680	[Thick 4: Environment Correction] Thick 4 Paper: MM Environment Coefficient Adjustment		
	Adjusts the environment coefficient for each mode. When the environment is detected as MM, SP2671 and SP2672 are multiplied by these SP values.		
001	Separation DC: 1st Side	*ENG	[1 to 60 / 22 / 1 /step]
002	Separation DC: 2nd Side	*ENG	

2680	Adjusts the environment coefficient for each mode. When the environment is detected as MM, SP2670 is multiplied by these SP values.		
003	Paper Transfer: BW: 1st Side	*ENG	[1 to 60 / 11 / 1 /step]
004	Paper Transfer: BW: 2nd Side	*ENG	
005	Paper Transfer: FC: 1st Side	*ENG	[1 to 60 / 55 / 1 /step]
006	Paper Transfer: FC: 2nd Side	*ENG	[1 to 60 / 11 / 1 /step]

2751	[Special1: Bias]		
	Adjusts the DC voltage of the discharge plate for special paper 1. Plain: High speed, Thick 1: Middle speed		
001	Separation DC: Plain: 1st Side	*ENG	[0 to 4000 / 3500 / 10 -V/step]
002	Separation DC: Plain: 2nd Side	*ENG	
003	Paper Transfer: Thick 1: 1st Side	*ENG	

2753	[Special1: Bias: BW]		
	Adjusts the current for the paper transfer roller for special paper 1 in black-and-white mode. Plain: High speed		
001	Paper Transfer: Plain: 1st Side	*ENG	[0 to 250 / 22 / 1 - μ A /step]
002	Paper Transfer: Plain: 2nd Side	*ENG	
003	Paper Transfer: Plain: 1st Side	*ENG	[0 to 250 / 11 / 1 - μ A /step]

2757	[Special1: Bias: FC]		
	Adjusts the current for the paper transfer roller for special paper 1 in full color mode. Plain: High speed, Fine: Low speed		
001	Paper Transfer: Plain: 1st Side	*ENG	[0 to 250 / 30 / 1 - μ A/step]
002	Paper Transfer: Plain: 2nd Side	*ENG	[0 to 250 / 33 / 1 - μ A/step]
003	Paper Transfer: Plain: 1st Side	*ENG	[0 to 250 / 15 / 1 - μ A/step]

2761	[Special1: Paper Size Correction]		
	Adjusts the size correction coefficient for the paper transfer roller current for each paper size. SP2753 and SP2757 are multiplied by these SP values.		
001	Paper Transfer: 1st Side: S1	*ENG	[100 to 600 / 100 / 5%/step]
002	Paper Transfer: 2nd Side: S1	*ENG	S1 size > 297 mm (Paper width)
005	Paper Transfer: 1st Side: S2	*ENG	[100 to 600 / 120 / 5%/step]
006	Paper Transfer: 2nd Side: S2	*ENG	297 mm > S2 size > 275 mm (Paper width)
009	Paper Transfer: 1st Side: S3	*ENG	[100 to 600 / 140 / 5%/step]
010	Paper Transfer: 2nd Side: S3	*ENG	275 mm > S3 size > 210 mm (Paper width)
013	Paper Transfer: 1st Side: S4	*ENG	[100 to 600 / 160 / 5%/step] 210 mm > S4 size > 148 mm (Paper width)
014	Paper Transfer: 2nd Side: S4	*ENG	[100 to 600 / 160 / 5%/step] 210 mm > S4 size > 148 mm (Paper width)
017	Paper Transfer: 1st Side: S5	*ENG	[100 to 600 / 180 / 5%/step] 148 mm > S5 size (Paper width)

Main SP Tables-2

018	Paper Transfer: 2nd Side: S5	*ENG	[100 to 600 / 180 / 5%/step] 148 mm > S5 size (Paper width)
-----	------------------------------	------	---

2771	[Special 1: Leading Edge Correction] Special 1 Paper: Leading Edge Correction		
	Adjusts the correction to the paper transfer roller current at the paper leading edge in each mode. SP2753 and SP2757 are multiplied by these SP values. Plain: High speed, 1200: Low speed ↓ Note <ul style="list-style-type: none"> ▪ The paper leading edge area can be adjusted with SP2772. 		
001	Paper Transfer: Plain: 1st Side	*ENG	[0 to 400 / 100 / 5%/step]
002	Paper Transfer: Plain: 2nd Side	*ENG	[0 to 400 / 100 / 5%/step]
003	Paper Transfer: 1200: 1st Side	*ENG	[0 to 400 / 100 / 5%/step]
2771	Adjusts the correction to the discharge plate current at the paper leading edge in each mode. SP2751 is multiplied by these SP values. ↓ Note <ul style="list-style-type: none"> ▪ The paper leading edge area can be adjusted with SP2772. 		
005	Separation DC: Plain: 1st Side	*ENG	[0 to 400 / 100 / 5%/step]
006	Separation DC: Plain: 2nd Side	*ENG	
007	Separation DC: 1200: 1st Side	*ENG	[0 to 400 / 100 / 5%/step]

2772	[Special 1: Sw Timing: Lead. Edge]		
	Adjusts the bias/ voltage switch timing of the paper transfer roller/ discharge plate at the paper leading edge between the erase margin area and the image area. Plain: High speed, 1200: Low speed		
001	Paper Transfer: Plain: 1st Side	*ENG	[0 to 50 / 0 / 2 mm/step]
002	Paper Transfer: Plain: 2nd Side	*ENG	
003	Paper Transfer: 1200: 1st Side	*ENG	[0 to 50 / 0 / 1 mm/step]
005	Separation DC: Plain: 1st Side	*ENG	[0 to 50 / 0 / 2 mm/step]
006	Separation DC: Plain: 2nd Side	*ENG	
007	Separation DC: 1200: 1st Side	*ENG	

2773	[Special 1: Trail. Edge Correction] Special 1 Paper: Trailing Edge Correction		
	Adjusts the correction to the paper transfer roller current for the paper trailing edge in each mode. SP2753 and SP2757 are multiplied by these SP values. Plain: High speed, 1200: Low speed  Note <ul style="list-style-type: none"> ▪ The paper trailing edge area can be adjusted with SP2774. 		
001	Paper Transfer: Plain: 1st Side	*ENG	[0 to 400 / 100 / 5%/step]
002	Paper Transfer: Plain: 2nd Side	*ENG	
003	Paper Transfer: 1200: 1st Side	*ENG	
005	Separation DC: Plain: 1st Side	*ENG	
006	Separation DC: Plain: 2nd Side	*ENG	
007	Separation DC: 1200: 1st Side	*ENG	

2774	[Special 1: Sw Timing: Trail. Edge]		
	Adjusts the bias/voltage switch timing of the paper transfer roller/discharge plate at the paper trailing edge between the erase margin area and the image area. Plain: High speed, 1200: Low speed		
001	Paper Transfer: Plain: 1st Side	*ENG	[0 to 50 / 0 / 2 mm/step]
002	Paper Transfer: Plain: 2nd Side	*ENG	
003	Paper Transfer: 1200: 1st Side	*ENG	
005	Separation DC: Plain: 1st Side	*ENG	
006	Separation DC: Plain: 2nd Side	*ENG	
007	Separation DC: 1200: 1st Side	*ENG	



2780	[Special 1: Environment Correction]		
	Plain: High speed, 1200: Low speed		
001	Separation DC: Plain: 1st Side	*ENG	[1 to 60 / 26 / 1 /step]
002	Separation DC: Plain: 2nd Side	*ENG	[1 to 60 / 32 / 1 /step]
003	Paper Transfer: Plain: BW: 1st Side	*ENG	[1 to 60 / 11 / 1 /step]
004	Paper Transfer: Plain: BW:2nd Side	*ENG	
005	Paper Transfer: Plain: FC: 1st Side	*ENG	[1 to 60 / 1 / 1 /step]
006	Paper Transfer: Plain: FC:2nd Side	*ENG	[1 to 60 / 14 / 1 /step]
007	Separation DC: 1200: 1st Side	*ENG	[1 to 60 / 26 / 1 /step]
009	Paper Transfer: 1200: BW: 1st Side	*ENG	[1 to 60 / 11 / 1 /step]
011	Paper Transfer: 1200: FC: 1st Side	*ENG	[1 to 60 / 1 / 1 /step]

2801	[Special2: Bias]		
	Adjusts the DC voltage of the discharge plate for special paper 2. Plain: High speed, 1200: Low speed		
001	Separation DC: Plain: 1st Side	*ENG	[0 to 4000 / 3500 / 10 -V/step]
002	Separation DC: Plain: 2nd Side	*ENG	
003	Separation DC: 1200: 1st Side	*ENG	

2803	[Special2: Bias: BW]		
	Adjusts the current for the paper transfer roller for special paper 2 in black-and-white mode. Plain: High speed, 1200: Low speed		
001	Paper Transfer: Plain: 1st Side	*ENG	[0 to 250 / 22 / 1 - μ A/step]
002	Paper Transfer: Plain: 2nd Side	*ENG	
003	Paper Transfer: 1200: 1st Side	*ENG	[0 to 200 / 11 / 1 - μ A/step]

2807	[Special2: Bias: FC]		
	Adjusts the current for the paper transfer roller for special paper 2 in full color mode. Plain: High speed, Thick 2&Fine: Low speed		
001	Paper Transfer: Plain: 1st Side	*ENG	[0 to 250 / 30 / 1 - μ A/step]
002	Paper Transfer: Plain: 2nd Side	*ENG	[0 to 250 / 33 / 1 - μ A/step]
003	Paper Transfer: 1200: 1st Side	*ENG	[0 to 250 / 15 / 1 - μ A/step]

2811	[Special2: Paper Size Correction]		
	Adjusts the size correction coefficient for the paper transfer roller current for each paper size. SP2803 and SP2807 are multiplied by these SP values.		
001	Paper Transfer: 1st Side: S1	*ENG	[100 to 600 / 100 / 5%/step]
002	Paper Transfer: 2nd Side: S1	*ENG	S1 size > 297 mm (Paper width)
005	Paper Transfer: 1st Side: S2	*ENG	[100 to 600 / 120 / 5%/step] 297 mm > S2 size > 275 mm (Paper width)
006	Paper Transfer: 2nd Side: S2	*ENG	[100 to 600 / 120 / 5%/step] 297 mm > S2 size > 275 mm (Paper width)
009	Paper Transfer: 1st Side: S3	*ENG	[100 to 600 / 140 / 5%/step] 275 mm > S3 size > 210 mm (Paper width)
010	Paper Transfer: 2nd Side: S3	*ENG	[100 to 600 / 140 / 5%/step] 275 mm > S3 size > 210 mm (Paper width)
013	Paper Transfer: 1st Side: S4	*ENG	[100 to 600 / 160 / 5%/step] 210 mm > S4 size > 148 mm (Paper width)
014	Paper Transfer: 2nd Side: S4	*ENG	[100 to 600 / 160 / 5%/step] 210 mm > S4 size > 148 mm (Paper width)
017	Paper Transfer: 1st Side: S5	*ENG	[100 to 600 / 180 / 5%/step] 148 mm > S5 size (Paper width)
018	Paper Transfer: 2nd Side: S5	*ENG	[100 to 600 / 180 / 5%/step] 148 mm > S5 size (Paper width)

2821	[Special 2: Lead Edge Correction] Special 2 Paper: Leading Edge Correction		
	Adjusts the correction to the paper transfer roller current at the paper leading edge in each mode. SP2803 and SP2807 are multiplied by these SP values. Plain: High speed, 1200: Low speed  Note <ul style="list-style-type: none"> The paper leading edge area can be adjusted with SP2822. 		
001	Paper Transfer: Plain: 1st Side	*ENG	[0 to 400 / 100 / 5%/step]
002	Paper Transfer: Plain: 2nd Side	*ENG	[0 to 400 / 100 / 5%/step]
003	Paper Transfer: 1200: 1st Side	*ENG	[0 to 400 / 100 / 5%/step]
2821	Adjusts the correction to the discharge plate current at the paper leading edge in each mode. SP2801 is multiplied by these SP values.  Note <ul style="list-style-type: none"> The paper leading edge area can be adjusted with SP2822. 		
	005	Separation DC: Plain: 1st Side	*ENG
006	Separation DC: Plain: 2nd Side	*ENG	[0 to 400 / 100 / 5%/step]
007	Separation DC: 1200: 1st Side	*ENG	

2822	[Special 2: Sw Timing: Lead. Edge]		
	Adjusts the bias/ voltage switch timing of the paper transfer roller/ discharge plate at the paper leading edge between the erase margin area and the image area. Plain: High speed, 1200: Low speed		
001	Paper Transfer: Plain: 1st Side	*ENG	[0 to 50 / 0 / 2 mm/step]
002	Paper Transfer: Plain: 2nd Side	*ENG	
003	Paper Transfer: 1200: 1st Side	*ENG	
005	Separation DC: Plain: 1st Side	*ENG	
006	Separation DC: Plain: 2nd Side	*ENG	
007	Separation DC: 1200: 1st Side	*ENG	

2823	[Special 2: Trail. Edge Correction] Special 2 Paper: Trailing Edge Correction		
	Adjusts the correction to the paper transfer roller current for the paper trailing edge in each mode. SP2803 and SP2807 are multiplied by these SP values. Plain: High speed, 1200: Low speed <div style="border: 1px solid black; border-radius: 10px; padding: 2px; display: inline-block;">  Note </div> <ul style="list-style-type: none"> ▪ The paper trailing edge area can be adjusted with SP2824. 		
001	Paper Transfer: Plain: 1st Side	*ENG	[0 to 400 / 100 / 5%/step]
002	Paper Transfer: Plain: 2nd Side	*ENG	
003	Paper Transfer: 1200: 1st Side	*ENG	
005	Separation DC: Plain: 1st Side	*ENG	
006	Separation DC: Plain: 2nd Side	*ENG	
007	Separation DC: 1200: 1st Side	*ENG	

2824	[Special 2: Sw Timing: Trail. Edge]		
	Adjusts the bias/voltage switch timing of the paper transfer roller/discharge plate at the paper trailing edge between the erase margin area and the image area. Plain: High speed, 1200: Low speed		
001	Paper Transfer: Plain: 1st Side	*ENG	[0 to 50 / 0 / 2 mm/step]
002	Paper Transfer: Plain: 2nd Side	*ENG	
003	Paper Transfer: 1200: 1st Side	*ENG	
005	Separation DC: Plain: 1st Side	*ENG	
006	Separation DC: Plain: 2nd Side	*ENG	
007	Separation DC: 1200: 1st Side	*ENG	

2830	[Special 2: Environment Correction] Plain: High speed, 1200: Low speed		
001	Separation DC: Plain: 1st Side	*ENG	[1 to 60 / 26 / 1 /step]
002	Separation DC: Plain: 2nd Side	*ENG	[1 to 60 / 32 / 1 /step]
003	Paper Transfer: Plain: BW: 1st Side	*ENG	[1 to 60 / 11 / 1 /step]
004	Paper Transfer: Plain: BW:2nd Side	*ENG	[1 to 60 / 11 / 1 /step]
005	Paper Transfer: Plain: FC: 1st Side	*ENG	[1 to 60 / 1 / 1 /step]
006	Paper Transfer: Plain: FC:2nd Side	*ENG	[1 to 60 / 14 / 1 /step]
007	Separation DC: 1200: 1st Side	*ENG	[1 to 60 / 26 / 1 /step]
009	Paper Transfer: 1200: BW: 1st Side	*ENG	[1 to 60 / 11 / 1 /step]
011	Paper Transfer: 1200: FC: 1st Side	*ENG	[1 to 60 / 1 / 1 /step]

2851	[Special 3: Bias]		
	Adjusts the DC voltage of the discharge plate for special paper 3. Plain: High speed, 1200: Low speed		
	001	Separation DC: Plain: 1st Side	*ENG
	002	Separation DC: Plain: 2nd Side	*ENG
003	Separation DC: 1200: 1st Side	*ENG	[0 to 4000 / 3500 / 10 -V/step]



2852	[Special 3: Bias: BW]		
	Adjusts the current for the paper transfer roller for special paper 3 in black-and-white mode. Plain: High speed, 1200: Low speed		
	001	Paper Transfer: Plain: 1st Side	*ENG
	002	Paper Transfer: Plain: 2nd Side	*ENG
003	Paper Transfer: 1200: 1st Side	*ENG	[0 to 250 / 11 / 1 - μ A /step]

Main SP Tables-2

2857	[Special 3: Bias: FC]		
	Adjusts the current for the paper transfer roller for special paper 3 in full color mode. Plain: High speed, 1200: Low speed		
001	Paper Transfer: Plain: 1st Side	*ENG	[0 to 250 / 30 / 1 - μ A /step]
002	Paper Transfer: Plain: 2nd Side	*ENG	[0 to 250 / 33 / 1 - μ A /step]
003	Paper Transfer: 1200: 1st Side	*ENG	[0 to 250 / 15 / 1 - μ A /step]

2861	[Special 3: Paper Size Correction]		
	Adjusts the size correction coefficient for the paper transfer roller current for each paper size. SP2852 and SP2857 are multiplied by these SP values.		
001	Paper Transfer: 1st Side: S1	*ENG	[100 to 600 / 100 / 5%/step]
002	Paper Transfer: 2nd Side: S1	*ENG	S1 size > 297 mm (Paper width)
005	Paper Transfer: 1st Side: S2	*ENG	[100 to 600 / 120 / 5%/step] 297 mm > S2 size > 275 mm (Paper width)
006	Paper Transfer: 2nd Side: S2	*ENG	[100 to 600 / 120 / 5%/step] 297 mm > S2 size > 275 mm (Paper width)
009	Paper Transfer: 1st Side: S3	*ENG	[100 to 600 / 140 / 5%/step] 275 mm > S3 size > 210 mm (Paper width)
010	Paper Transfer: 2nd Side: S3	*ENG	[100 to 600 / 140 / 5%/step] 275 mm > S3 size > 210 mm (Paper width)
013	Paper Transfer: 1st Side: S4	*ENG	[100 to 600 / 160 / 5%/step] 210 mm > S4 size > 148 mm (Paper width)

014	Paper Transfer:: 2nd Side: S4	*ENG	[100 to 600 / 160 / 5%/step] 210 mm > S4 size > 148 mm (Paper width)
017	Paper Transfer:: 1st Side: S5	*ENG	[100 to 600 / 180 / 5%/step] 148 mm > S5 size (Paper width)
018	Paper Transfer:: 2nd Side: S5	*ENG	[100 to 600 / 180 / 5%/step] 148 mm > S5 size (Paper width)

2871	[Special 3: Lead. Edge Correction] Special 3 Paper: Leading Edge Correction		
	Adjusts the correction to the paper transfer roller current at the paper leading edge in each mode. SP2852 and SP2857 are multiplied by these SP values. Plain: High speed, 1200: Low speed		
	<p> Note</p> <ul style="list-style-type: none"> The paper leading edge area can be adjusted with SP2872. 		
	001	Paper Transfer: Plain: 1st Side	*ENG
002	Paper Transfer: Plain: 2nd Side	*ENG	[0 to 400 / 100 / 5%/step]
003	Paper Transfer: 1200: 1st Side	*ENG	
2871	Adjusts the correction to the discharge plate current at the paper leading edge in each mode. SP2851 is multiplied by these SP values.		
	<p> Note</p> <ul style="list-style-type: none"> The paper leading edge area can be adjusted with SP2872. 		
005	Separation DC: Plain: 1st Side	*ENG	[0 to 400 / 100 / 5%/step]
006	Separation DC: Plain: 2nd Side	*ENG	
007	Separation DC: 1200: 1st Side	*ENG	

2872	[Special 3: Sw Timing: Lead. Edge]		
	Adjusts the bias/ voltage switch timing of the paper transfer roller/ discharge plate at the paper leading edge between the erase margin area and the image area. Plain: High speed, 1200: Low speed		
001	Paper Transfer: Plain: 1st Side	*ENG	[0 to 50 / 0 / 2 mm/step]
002	Paper Transfer: Plain: 2nd Side	*ENG	
003	Paper Transfer: 1200: 1st Side	*ENG	
005	Separation DC: Plain: 1st Side	*ENG	
006	Separation DC: Plain: 2nd Side	*ENG	
007	Separation DC: 1200: 1st Page	*ENG	

2873	[Special 3: Trail. Edge Correction] Special 3 Paper: Trailing Edge Correction		
	Adjusts the correction to the paper transfer roller current for the paper trailing edge in each mode. SP2852 and SP2857 are multiplied by these SP values. Plain: High speed, 1200: Low speed Note <ul style="list-style-type: none"> ▪ The paper trailing edge area can be adjusted with SP2874. 		
001	Paper Transfer: Plain: 1st Side	*ENG	[0 to 400 / 100 / 5%/step]
002	Paper Transfer: Plain: 2nd Side	*ENG	
003	Paper Transfer: 1200: 1st Side	*ENG	
005	Separation DC: Plain: 1st Side	*ENG	
006	Separation DC: Plain: 2nd Side	*ENG	
007	Separation DC: 1200: 1st Page	*ENG	

2874	[Special 3: Sw Timing: Trail. Edge]		
	Adjusts the bias/voltage switch timing of the paper transfer roller/discharge plate at the paper trailing edge between the erase margin area and the image area. Plain: High speed, 1200: Low speed		
001	Paper Transfer: Plain: 1st Side	*ENG	[0 to 50 / 0 / 2 mm/step]
002	Paper Transfer: Plain: 2nd Side	*ENG	
003	Paper Transfer: 1200: 1st Side	*ENG	
005	Separation DC: Plain: 1st Side	*ENG	
006	Separation DC: Plain: 2nd Side	*ENG	
007	Separation DC: 1200: 1st Page	*ENG	

2880	[Special 3: Environment Correction]		
	Plain: High speed, 1200: Low speed		
001	Separation DC: Plain: 1st Side	*ENG	[1 to 60 / 26 / 1 /step]
002	Separation DC: Plain: 2nd Side	*ENG	[1 to 60 / 32 / 1 /step]
003	Paper Transfer: Plain: BW: 1st Side	*ENG	[1 to 60 / 11 / 1 /step]
004	Paper Transfer: Plain: BW:2nd Side	*ENG	
005	Paper Transfer: Plain: FC: 1st Side	*ENG	[1 to 60 / 1 / 1 /step]
006	Paper Transfer: Plain: FC:2nd Side	*ENG	[1 to 60 / 11 / 1 /step]
007	Separation DC: 1200: 1st Side	*ENG	[1 to 60 / 26 / 1 /step]
009	Paper Transfer: 1200: BW: 1st Side	*ENG	[1 to 60 / 11 / 1 /step]
011	Paper Transfer: 1200: FC: 1st Side	*ENG	[1 to 60 / 1 / 1 /step]

2905	[Dev Rvs Time] Development Roller Reverse Time		
	Specified the time of the development roller reverse rotation after the development unit has stopped. The reverse rotation of the development roller is used for removing dust from the development roller.		
001	K	*ENG	[0 to 200 / 80 / 10 msec/step]
002	M	*ENG	
003	C	*ENG	
004	Y	*ENG	
005	[Dev Rvs Threshold Counter]		
	Specified the threshold distance for the development roller reverse mode. This SP refers to the counters for SP2905-006 to -009.		
	All	*ENG	[0 to 400000 / 4000 / 10 mm/step]
2905	[Dev Rvs Counter]		
006	K	*ENG	[0 to 999999999 / - / 1 mm/step]
007	M	*ENG	
008	C	*ENG	
009	Y	*ENG	

2907	[Acs Setting (FC to Bk)]		
	Adjusts the threshold for moving away the image transfer belt from the color PCDUs. This SP moves the image transfer belt away from the color PCDUs when the number of B/W image printouts reaches the number of sheets specified with this SP after consecutive full color image printouts in the full color mode. If this SP is set to "0", the image transfer belt does not move away.		
001	Continuous Bk Pages	*ENG	[0 to 10 / 0 / 1 sheet/step]

2920	[Trans Mot Control]		
001	0: Encoder 1 :FG	*ENG	[0 or 1 / 0 / 1 /step]
	Selects the speed control mode for the ITB. If SC443 occurs and machine does not recover, change this setting to "1".		
002	SC443-00 Count	*ENG	[0 to 3 / 0 / 1 /step]
	Displays the number of the ITB encode error. SC443 is displayed if this counter counts to "3".		

2930	[SecondaryFB: Threshold] Paper Transfer Roller Feed-back: Threshold Adjustment		
	Adjusts the threshold between high resistance (division 1) and low resistance (division 2) at the paper transfer roller. This SP affects SP2931 to SP2939.		
001	Voltage	*ENG	[0 to 7000 / 6000 / 10 -V/step]

2960	[Process Interval]		
001	Additional Time	*ENG	[0 to 10 / 0 / 1 sec/step]
	Adjusts the additional time for ending the machine's process.		

2970	[Cleaning After JOB]		
001	No Refresh	*ENG	[0 to 100 / 33 / 1 /step] 0: No cleaning
	Specifies the threshold sheets for the cleaning of the paper transfer roller without the refresh mode.		
002	Refresh	*ENG	[0 or 1 / 1 / 1 /step] 0: No cleaning, 1: Cleaning

Main SP Tables-2

2971	T1 Non Image Area ON Timing		
001	Standard Speed	*ENG	[-400 to 290 / 0 / 10 msec/step]
	Adjusts the timing for the non-image area bias of the image transfer roller.		
002	Medium Speed	*ENG	[-400 to 290 / 0 / 10 msec/step]
003	Low Speed	*ENG	[-790 to 410 / 0 / 10 msec/step]

2972	B/W Image Request Timing		
001	Standard Speed	*ENG	[0 to 4000 / 0 / 10 msec/step]
002	Medium Speed	*ENG	[0 to 4000 / 0 / 10 msec/step]
003	Low Speed	*ENG	[0 to 4000 / 0 / 10 msec/step]

2973	Forced Process Down Threshold		
001	-	*ENG	[0 to 5000 / 0 / 10 page/step]

2974	OPC PreCharge Time Control		
001	Standard Speed	*ENG	[0 to 1500 / 136 / 1 msec/step]
002	Medium Speed	*ENG	[0 to 1500 / 146 / 1 msec/step]
003	Low Speed	*ENG	[0 to 2600 / 0 / 1 msec/step]

2980	Continuous Job Page		
001	-	*ENG	[0 to 300 / 100 / 10 page/step]
002	-	*ENG	[0 to 600 / 30 / 10 sec/step]
003	-	*ENG	[0 to 600 / 30 / 10 sec/step]

2990	Print Duty Control		
001	Duty Control State	*ENG	[0 or 1 / - / 1 /step] 0: No limit, 1: Limit
002	Exec Interval: Duty Control	*ENG	[60 to 3600 / 300 / 10 min./step]
003	Duty Control Thresh	*ENG	[0 to 999999999 / 0 / 1 mm/step]
004	Forced CPM Down Thresh: No Duty Control	*ENG	[0 to 5000 / 0 / 1 page/step]
005	Drum Stop Time: No Duty Control	*ENG	[300 to 1500 / 500 / 10 msec/step]
006	ITB Stop Time: No Duty Control	*ENG	[300 to 1500 / 500 / 10 msec/step]
007	Forced CPM Down Thresh: Duty Control	*ENG	[0 to 5000 / 1 / 1 page/step]
008	Drum Stop Time: Duty Control	*ENG	[300 to 20000 / 7500 / 10 msec/step]
009	ITB Stop Time: Duty Control	*ENG	[300 to 20000 / 7500 / 10 msec/step]
010	Duty Control: Start Time	*ENG	Displays the time of the duty control execution.
011	Execution Temp. Threshold	*ENG	Sets the threshold of the duty control execution temperature. [20 to 70 / 39.8 / 0.1/step]
012	Cancellation Temp. Threshold	*ENG	Sets the threshold of the duty control cancellation temperature. [0.1 to 20 / 1 / 0.1/step]
013	ON/OFF Setting	*ENG	Turns duty control off or on. 0: OFF 1: ON

3.3 MAIN SP TABLES-3

3.3.1 SP3-XXX (PROCESS)

3011	[Process Cont. Manual Execution]		
001	Normal	-	Executes the normal process control manually (potential control). Check the result with SP3-325-001 and 3-012-001 after executing this SP.
002	Density Adjustment	-	Executes the toner density adjustment manually.
003	Pre-ACC	-	Executes the process control that is normally done before ACC. The type of process control is selected with SP3-041-004.
004	Full MUSIC	-	Executes the process control that is normally done at the same time as MUSIC. This SP does the MUSIC (line position adjustment) twice.
005	Normal MUSIC	-	Executes the process control that is normally done at the same time as MUSIC. This SP does the MUSIC (line position adjustment) once.

3012	[Process Cont. Check Result] Process Control Self-check Result		
	<p>Displays the result of the latest process control self-check. All colors are displayed. The results are displayed in the order "Y C M K" e.g., 11 (Y) 99 (C) 11 (M) 11 (K): The self-check for Cyan failed but the others were successful. See "Process Control Self-Check Result" in the "Main chapters: 6. Troubleshooting: Process Control Error Conditions" for details.</p>		
001	History: Latest	*ENG	[1111 to 99999999 / - / 1/step]

002	Result: Latest 1	*ENG	
003	Result: Latest 2	*ENG	
004	Result: Latest 3	*ENG	
005	Result: Latest 4	*ENG	
006	Result: Latest 5	*ENG	
007	Result: Latest 6	*ENG	
008	Result: Latest 7	*ENG	
009	Result: Latest 8	*ENG	
010	Result: Latest 9	*ENG	

3013	[T Sensor Initial Set: Exe] Developer Initialization Setting		
001	Execution: ALL	-	Executes the developer initialization for each color.
002	Execution: COL	-	
003	Execution: Bk	-	
004	Execution: M	-	
005	Execution: C	-	
006	Execution: Y	-	

3014	[T Sensor Initial Set:Exe] Developer Initialization Result: Display		
001	Display: YCMK	*ENG	[0 to 9999 / - / 1 /step] 1: Success, 2 to 9: Failure
	Displays the developer initialization result. See "Developer Initialization Result" in the "Main chapters: 6. Troubleshooting: Process Control Error Conditions" for details on the meaning of each code. All colors are displayed. Values are displayed in the order Y C M Bk. e.g., 1 (Y) 2 (C) 1 (M) 1 (Bk): Initialization of Cyan failed but the others succeeded.		

Main SP Tables-3

3015	[Forced Toner Supply: Execute] Forced Toner Supply ([Color])		
001	Execution: ALL	-	Executes the manual toner supply to the development unit.
002	Execution: COL	-	
003	Execution: Bk	-	
004	Execution: M	-	
005	Execution: C	-	
006	Execution: Y	-	

3016	[Forced Toner Supply: Setting]		
	Specifies the manual toner supply time for each color.		
001	Supply Time: Bk	*ENG	[0 to 30 / 4 / 1 sec/step]
002	Supply Time: M	*ENG	
003	Supply Time: C	*ENG	
004	Supply Time: Y	*ENG	

3041	[Process Control Type]		
001	Voltage Control	*ENG	[0 or 1 / 1 / 1/step] Alphanumeric 0: FIXED (Use the fixed values for the charge DC bias and development DC bias set with SP2-005 and SP2-229.) 1: CONTROL
	Enables or disables potential control.		
002	LD Power Control	*ENG	[0 or 1 / 1 / 1/step] Alphanumeric 0: FIXED (at the value in SP2221-xxx) 1: CONTROL (adjusted by process control)
	Selects the LD power control mode.		

003	AutoControl Prohibition Set	*ENG	[0 or 1 / 0 / -] 0: Permit, 1: Forbid
	Enables or disables the automatic process control prohibition.		
004	Pre-ACC Process Control	*ENG	[0 to 2 / 2 / 1/step] 0: Not Executed 1: Process Control 2: TC Control (TD Adjustment) 3: Not used
	Selects the process control mode that is done before ACC.		
005	Pattern Calculation Method	*ENG	[0 to 2 / 2 / 1/step] 0: FIXED 1: INITIALIZED 2: CALCULATED
	Selects the process control method.		

3043	[TD Adjustment Mode]		
001	Repeat Number: Power ON	*ENG	[0 to 9 / 4 / 1 time/step]
	Specifies the maximum number of repeats of the toner density adjustment at power on. 0: Disabled, 1 to 3: Repeat number, 4: Repeat three times (No consumption mode) 5: Repeat three times (Toner is supplied only when the toner density is too low, and toner is consumed only when the toner density is too dark.) 6 to 9: Disabled		
002	Repeat Number: Initialization	*ENG	[0 to 9 / 3 / 1 time/step]
	Specifies the maximum number of repeats of the toner density adjustment at the developer initialization. 0: Disabled, 1 to 3: Repeat number, 4: Repeat three times (No consumption mode) 5: Repeat three times (Toner is supplied only when the toner density is too low, and toner is consumed only when the toner density is too dark.) 6 to 9: Disabled		

003	Repeat Number: Non-use	*ENG	[0 to 9 / 0 / 1 time/step]
	<p>Specifies the maximum number of repeats of the toner density adjustment in stand by mode.</p> <p>0: Disabled, 1 to 3: Repeat number, 4: Repeat three times (No consumption mode) 5: Repeat three times (Toner is supplied only when the toner density is too low, and toner is consumed only when the toner density is too dark.) 6 to 9: Disabled</p>		
004	Repeat Number: ACC	*ENG	[0 to 9 / 3 / 1 time/step]
	<p>Specifies the maximum number of repeats of the toner density adjustment at ACC.</p> <p>0: Disabled, 1 to 3: Repeat number, 4: Repeat three times (No consumption mode) 5: Repeat three times (Toner is supplied only when the toner density is too low, and toner is consumed only when the toner density is too dark.) 6 to 9: Disabled</p>		
005	Repeat Number: Recovery	*ENG	[0 to 9 / 0 / 1 time/step]
	Not used		
006	Repeat Number: Job End	*ENG	[0 to 9 / 4 / 1 time/step]
	<p>Specifies the maximum number of repeats of the toner density adjustment at job end.</p> <p>0: Disabled, 1 to 3: Repeat number, 4: Repeat three times (No consumption mode) 5: Repeat three times (Toner is supplied only when the toner density is too low, and toner is consumed only when the toner density is too dark.) 6 to 9: Disabled</p>		
007	Repeat: Interrupt	*ENG	[0 to 9 / 0 / 1 time/step]
	Specifies the maximum number of repeats of the toner density adjustment during printing. DFU		
008	Toner Supply Coefficient	*ENG	[0 to 25.5 / 10 / 0.1 sec/step]
	Adjusts the time for the toner supply mode when a toner density is detected to be low.		

009	Consumption pattern: Bk	*ENG	[0 to 255 / 5 / 1 time/step]
	Specifies the belt mark generating time for checking the black toner density when toner density is detected to be low at the toner density adjustment.		
010	Consumption pattern: M	*ENG	[0 to 255 / 5 / 1 time/step]
	Specifies the belt mark generating time for checking the magenta toner density when toner density is detected to be low at the toner density adjustment.		
011	Consumption pattern: C	*ENG	[0 to 255 / 5 / 1 time/step]
	Specifies the belt mark generating time for checking the cyan toner density when toner density is detected to be low at the toner density adjustment.		
012	Consumption pattern: Y	*ENG	[0 to 255 / 5 / 1 time/step]
	Specifies the belt mark generating time for checking the yellow toner density when toner density is detected to be low at the toner density adjustment.		
013	T1 Bias: Bk	*ENG	[0 to 80 / 22 / 1 μ A/step]
	Adjusts the image transfer belt bias for Black.		
014	T2 Bias: M	*ENG	[0 to 80 / 25 / 1 μ A/step]
	Adjusts the image transfer belt bias for Magenta.		
015	T3 Bias: C	*ENG	[0 to 80 / 22 / 1 μ A/step]
	Adjusts the image transfer belt bias for Cyan.		
016	T4 Bias: Y	*ENG	[0 to 80 / 28 / 1 μ A/step]
	Adjusts the image transfer belt bias for Yellow.		
017	Developer Mixing Time	*ENG	[0 to 250 / 10 / 1 sec/step]
	Specifies the developer mixing time at the toner density adjustment.		
018	Consumption Pat: LD: DUTY: Bk	*ENG	[0 to 15 / 15 / 1 /step]
	Adjusts the LD duty for the toner consumption mode at the toner density adjustment. In toner consumption mode, toner is discharged when the detected development gamma values (SP3611-001) exceed the target values (SP3611-005) by more than the specified thresholds (SP3239-009).		

Main SP Tables-3

019	Consumption Pat: LD: DUTY: M	*ENG	[0 to 15 / 15 / 1 /step]
	Adjusts the LD duty for the toner consumption mode at the toner density adjustment. In toner consumption mode, toner is discharged when the detected development gamma values (SP3611-002) exceed the target values (SP3611-006) by more than the specified thresholds (SP3239-009).		
020	Consumption Pat: LD: DUTY: C	*ENG	[0 to 15 / 15 / 1 /step]
	Adjusts the LD duty for the toner consumption mode at the toner density adjustment. In toner consumption mode, toner is discharged when the detected development gamma values (SP3611-003) exceed the target values (SP3611-007) by more than the specified thresholds (SP3239-009).		
021	Consumption Pat: LD: DUTY: Y	*ENG	[0 to 15 / 15 / 1 /step]
	Adjusts the LD duty for the toner consumption mode at the toner density adjustment. In toner consumption mode, toner is discharged when the detected development gamma values (SP3611-004) exceed the target values (SP3611-008) by more than the specified thresholds (SP3239-009).		

3044	[Toner Supply Type]		
	Selects the toner supply method type.		
001	Bk	*ENG	[0 to 4 / 4 / 1/step] Alphanumeric
002	M	*ENG	0: FIXED (with the supply rates stored with SP 3401)
003	C	*ENG	1: PID (Vtref_Fixed)
004	Y	*ENG	2: PID (Vtref_Control)
			3: Not used
			4: MBD (Vtref_Control)

3045	[Toner End Detection: Set]		
	Enables/disables the toner alert display on the LCD.		
001	ON/OFF	*ENG	[0 or 1 / 0 / 1/step] 0: Detect, 1: Not Detect

3102	[Toner End Recovery]		
	Adjusts the number of times toner supply is attempted for each color when the TD sensor continues to detect toner end during toner recovery.		
001	Repeat: Bk	*ENG	[1 to 20 / 5 / 1 time/step]
002	Repeat: M	*ENG	
003	Repeat: C	*ENG	
004	Repeat: Y	*ENG	

3131	[TE Count m: Display]		
	Display the number of toner end detections for each color.		
001	Bk	*ENG	[0 to 99 / - / 1 time/step]
002	M	*ENG	
003	C	*ENG	
004	Y	*ENG	

3201	[TD Sensor: Vt Display]		
	Display the current voltage of the TD sensor for each color.		
001	Current: Bk	*ENG	[0 to 5.5 / - / 0.01 V/step]
002	Current: M	*ENG	
003	Current: C	*ENG	
004	Current: Y	*ENG	

3211	[Vt Shift: Display/Set]		
	Adjusts the Vt correction value for each line speed. Thick 1: 154 mm/sec, Thick 2&Fine: 77 mm/sec		
001	Thick 1 Shift: Bk	*ENG	[0 to 5 / 0.26 / 0.01 V/step]

Main SP Tables-3

002	Thick 1 Shift: M	*ENG	[0 to 5 / 0.26 / 0.01 V/step]
003	Thick 1 Shift: C	*ENG	[0 to 5 / 0.26 / 0.01 V/step]
004	Thick 1 Shift: Y	*ENG	[0 to 5 / 0.31 / 0.01 V/step]
005	Thick 2 & FINE Shift: Bk	*ENG	[0 to 5 / 0.26 / 0.01 V/step]
006	Thick 2 & FINE Shift: M	*ENG	[0 to 5 / 0.26 / 0.01 V/step]
007	Thick 2 & FINE Shift: C	*ENG	[0 to 5 / 0.26 / 0.01 V/step]
008	Thick 2 & FINE Shift: Y	*ENG	[0 to 5 / 0.31 / 0.01 V/step]
009	Mid TCShift: Bk	*ENG	[-0.5 to 0.5 / 0 / 0.01 V/step]
010	Mid TCShift: M	*ENG	
011	Mid TCShift: C	*ENG	
012	Mid TCShift: Y	*ENG	
013	Low TCShift: Bk	*ENG	[-0.5 to 0.5 / 0 / 0.01 V/step]
014	Low TCShift: M	*ENG	
015	Low TCShift: C	*ENG	
016	Low TCShift: Y	*ENG	

3221	[Vtcnt: Display/Set]		
	Displays or adjusts the current Vtcnt value for each color.		
001	Current: Bk	*ENG	[0 to 5 / 3.86 / 0.01 V/step]
002	Current: M	*ENG	
003	Current: C	*ENG	
004	Current: Y	*ENG	
005-008	Displays or adjusts the Vtcnt value for each color at developer initialization. DFU		
005	Initial: Bk	*ENG	[0 to 5 / 3.86 / 0.01 V/step]
006	Initial: M	*ENG	

007	Initial: C	*ENG	
008	Initial: Y	*ENG	

3222	[Vtref: Display/Set]		
	Displays or adjusts the current Vtref value for each color.		
001	Current: Bk	*ENG	[0 to 5.5 / 3 / 0.01 V/step]
002	Current: M	*ENG	
003	Current: C	*ENG	
004	Current: Y	*ENG	
005-008	Displays or adjusts the Vtref value for each color at developer initialization. DFU		
005	Initial: Bk	*ENG	[0 to 5.5 / - / 0.01 V/step]
006	Initial: M	*ENG	
007	Initial: C	*ENG	
008	Initial: Y	*ENG	
009-012	Displays and adjusts Vtref correction by pixel coverage for each color. DFU		
009	Pixel Correction: Bk	*ENG	[-5 to 5.5 / - / 0.01 V/step]
010	Pixel Correction: M	*ENG	
011	Pixel Correction: C	*ENG	
012	Pixel Correction: Y	*ENG	

3239	[Vtref Correction: Setting]		
	Adjusts the parameter for Vtref correction at the process control.		
001	(+)Consumption: Bk	*ENG	[0 to 1 / 0.04 / 0.01 V/step]
002	(+)Consumption: M	*ENG	
003	(+)Consumption: C	*ENG	

Main SP Tables-3

004	(+)Consumption: Y	*ENG	
005	(-)Consumption: Bk	*ENG	
006	(-)Consumption: M	*ENG	
007	(-)Consumption: C	*ENG	
008	(-)Consumption: Y	*ENG	
009-012	Threshold for development gamma rank.		
009	P Rank 1 Threshold	*ENG	[0 to 2 / 0.2 / 0.1 /step]
010	P Rank 2 Threshold	*ENG	[0 to 2 / 0.05 / 0.1 /step]
011	P Rank 3 Threshold	*ENG	[-2 to 0 / -0.05 / 0.1 /step]
012	P Rank 4 Threshold	*ENG	[-2 to 0 / -0.2 / 0.1 /step]
013-014	Threshold for image density rank on the image transfer belt.		
013	T Rank 1 Threshold	*ENG	[-1 to 0 / -0.2 / 0.01 V/step]
014	T Rank 2 Threshold	*ENG	[0 to 1 / 0.2 / 0.01 V/step]
021-028	Sets the correction coefficient of the Vtref correction.		
021	Correction Coefficient 1: Bk	*ENG	[0 to 1 / 0.5 / 0.1/step]
022	Correction Coefficient 1: M	*ENG	[0 to 1 / 0.5 / 0.1/step]
023	Correction Coefficient 1: C	*ENG	[0 to 1 / 0.5 / 0.1/step]
024	Correction Coefficient 1: Y	*ENG	[0 to 1 / 0.5 / 0.1/step]
025	Correction Coefficient 2: Bk	*ENG	[0 to 1 / 0.5 / 0.1/step]
026	Correction Coefficient 2: M	*ENG	[0 to 1 / 0.5 / 0.1/step]

027	Correction Coefficient 2: C	*ENG	[0 to 1 / 0.5 / 0.1/step]
028	Correction Coefficient 2: Y	*ENG	[0 to 1 / 0.5 / 0.1/step]

3241	[Background Potential Setting]		
001	Coefficient: Bk	*ENG	These are parameters for calculating the charge bias referring to the development bias at process control. [-1000 to 1000 / 0 / 1 /step]
002	Coefficient: M	*ENG	
003	Coefficient: C	*ENG	
004	Coefficient: Y	*ENG	DC charge bias = Development bias x (1 + 0.001 x these vales) + SP3-241-005 to -008
005	Offset: Bk	*ENG	These are additional values for calculating the charge bias referring to the development bias at process control. [0 to 255 / 140 / 1 V/step]
006	Offset: M	*ENG	
007	Offset: C	*ENG	
008	Offset: Y	*ENG	

3242	[LD Power Setting]		
	Adjusts the coefficient for LD power control value at the process control.		
001	StdSpd:Coefficient: Bk	*ENG	[-1000 to 1000 / 118 / 1 /step]
002	StdSpd:Coefficient: M	*ENG	[-1000 to 1000 / 117 / 1 /step]
003	StdSpd:Coefficient: C	*ENG	[-1000 to 1000 / 79 / 1 /step]
004	StdSpd:Coefficient: Y	*ENG	[-1000 to 1000 / 92 / 1 /step]
005	StdSpd:Offset: Bk	*ENG	[-1000 to 1000 / 47 / 1 /step]
006	StdSpd:Offset: M	*ENG	[-1000 to 1000 / 41 / 1 /step]
007	StdSpd:Offset: C	*ENG	[-1000 to 1000 / 72 / 1 /step]

Main SP Tables-3

008	StdSpd:Offset: Y	*ENG	[-1000 to 1000 / 59 / 1 /step]
009	MidSpd:coef:Bk	*ENG	[-1000 to 1000 / 118 / 1 /step]
010	MidSpd:Coef:M	*ENG	[-1000 to 1000 / 117 / 1 /step]
011	MidSpd:Coef:C	*ENG	[-1000 to 1000 / 79 / 1 /step]
012	MidSpd:Coef:Y	*ENG	[-1000 to 1000 / 92 / 1 /step]
013	MidSpd:offset:Bk	*ENG	[-1000 to 1000 / 47 / 1 /step]
014	MidSpd:offset:M	*ENG	[-1000 to 1000 / 41 / 1 /step]
015	MidSpd:offset:C	*ENG	[-1000 to 1000 / 72 / 1 /step]
016	MidSpd:offset:Y	*ENG	[-1000 to 1000 / 59 / 1 /step]
017	LowSpd:Coef:Bk	*ENG	[-1000 to 1000 / 98 / 1 /step]
018	LowSpd:Coef:M	*ENG	[-1000 to 1000 / 104 / 1 /step]
019	LowSpd:Coef:C	*ENG	[-1000 to 1000 / 78 / 1 /step]
020	LowSpd:Coef:Y	*ENG	[-1000 to 1000 / 84 / 1 /step]
021	LowSpd:offset:Bk	*ENG	[-1000 to 1000 / 59 / 1 /step]
022	LowSpd:offset:M	*ENG	[-1000 to 1000 / 45 / 1 /step]
023	LowSpd:offset:C	*ENG	[-1000 to 1000 / 69 / 1 /step]
024	LowSpd:offset:Y	*ENG	[-1000 to 1000 / 65 / 1 /step]

3251	[Coverage]		
	These (-001 to -016) are coefficients for SP3-222-009 to -012.		
001	Latest Pixel: Bk	*ENG	Displays the latest coverage for each color. [0 to 9999 / - / 1 cm ² /step]
002	Latest Pixel: M	*ENG	
003	Latest Pixel: C	*ENG	
004	Latest Pixel: Y	*ENG	

005-008	Displays the average coverage of each color for the Vtref correction. "Average S" is defined when the number of developed pages does not reach the number specified with SP3251-017.		
005	Average S: Bk	*ENG	[0 to 100 / - / 0.01 %/step]
006	Average S: M	*ENG	
007	Average S: C	*ENG	
008	Average S: Y	*ENG	
009-012	Displays the average coverage of each color for the Vtref correction. "Average M" is defined when the number of developed pages does not reach the number specified with SP3251-018.		
009	Average M: Bk	*ENG	[0 to 100 / - / 0.01 %/step]
010	Average M: M	*ENG	
011	Average M: C	*ENG	
012	Average M: Y	*ENG	
013-016	Displays the average coverage of each color for the Vtref correction. "Average L" is defined when the number of developed pages does not reach the number specified with SP3-251-019.		
013	Average L: Bk	*ENG	[0 to 100 / - / 0.01 %/step]
014	Average L: M	*ENG	
015	Average L: C	*ENG	
016	Average L: Y	*ENG	
017-019	Adjusts the threshold for SP3-251-005 to -016.		
017	Total Page Setting: S	*ENG	[1 to 100 / 10 / 1 sheet/step]
018	Total Page Setting: M	*ENG	[1 to 500 / 10 / 1 sheet/step]
019	Total Page Setting: L	*ENG	[1 to 999 / 50 / 1 sheet/step]
020-023	Adjusts the threshold for SP3-251-024 to -027.		
020	Total Page Setting: S2	*ENG	[1 to 100 / 40 / 1 sheet/step]

Main SP Tables-3

021	Total Page Setting: M2	*ENG	[1 to 500 / 10 / 1 sheet/step]
022	Total Page Setting: L2	*ENG	[1 to 999 / 50 / 1 sheet/step]
024-027	Displays the latest coverage ratio for each color.		
024	Latest Coverage: Bk	*ENG	[0 to 100 / - / 0.01 %/step]
025	Latest Coverage: M	*ENG	
026	Latest Coverage: C	*ENG	
027	Latest Coverage: Y	*ENG	
028	Displays the threshold of whether to perform developer churning or not.		
	DevMix Threshold	*ENG	[0 to 100 / 20 / 1 %/step]

3311	[ID Sensor DetectValue: Vofset]		
	Displays the ID sensor (regular) offset voltage for Vsg adjustments.		
001	Voffset reg: Bk	*ENG	[0 to 5 / - / 0.01 V/step]
002	Voffset reg: M	*ENG	[0 to 5.5 / - / 0.01 V/step]
003	Voffset reg: C	*ENG	
004	Voffset reg: Y	*ENG	
005-007	Displays the ID sensor (diffusion) offset voltage for Vsg adjustments.		
005	Voffset dif: M	*ENG	[0 to 5.5 / - / 0.01 V/step]
006	Voffset dif: C	*ENG	
007	Voffset dif: Y	*ENG	
008-010	Displays the ID sensor offset voltage for Vsg adjustments.		
008	Voffset TM (Front)	*ENG	[0 to 5.5 / - / 0.01 V/step]
009	Voffset TM (Center)	*ENG	
010	Voffset TM (Rear)	*ENG	

3321	[Vsg Adjustment: Execution]		
010	P/TM Sensor All	-	Execute the ID sensor initialization setting for all sensors

3322	[Vsg Adjustment Result: Vsg]		
	Displays the result value of the Vsg adjustment for each sensor.		
001	Vsg reg: Bk	*ENG	[0 to 5.5 / - / 0.01 V/step]
002	Vsg reg: M	*ENG	
003	Vsg reg: C	*ENG	
004	Vsg reg: Y	*ENG	
005	Vsg dif: M	*ENG	
006	Vsg dif: C	*ENG	
007	Vsg dif: Y	*ENG	
008	Vsg TM (Front)	*ENG	
009	Vsg TM (Center)	*ENG	
010	Vsg TM (Rear)	*ENG	

3325	[Vsg Adjustment Result]		
	Displays the result of the Vsg adjustment. The displayed numbers mean the result of each sensor (sensor for Front, sensor for Bk, sensor for Cyan, sensor for Center, sensor for Magenta, sensor for Yellow and sensor for Rear).		
001	Latest	*ENG	[111 to 999 / - / 1 /step] 9: Unexpected error 3: Offset voltage error 2: Vsg adjustment value error 1: O.K
002	Result: Latest 1	*ENG	
003	Result: Latest 2	*ENG	
004	Result: Latest 3	*ENG	
005	Result: Latest 4	*ENG	

Main SP Tables-3

006	Result: Latest 5	*ENG	
007	Result: Latest 6	*ENG	
008	Result: Latest 7	*ENG	
009	Result: Latest 8	*ENG	
010	Result: Latest 9	*ENG	

3401	[Fixed Supply Mode]		
	Adjusts the toner supply rate in the fixed toner supply mode.		
001	Fixed Rate: Bk	*ENG	[0 to 100 / 5 / 1 %/step] These SPs are used only when SP3-044 is set to "1".
002	Fixed Rate: M	*ENG	
003	Fixed Rate: C	*ENG	
004	Fixed Rate: Y	*ENG	

3411	[Toner Supply Rate: Display]		
	Displays the current toner supply rate.		
001	Latest: Bk	*ENG	[0 to 100 / - / 1 %/step]
002	Latest: M	*ENG	
003	Latest: C	*ENG	
004	Latest: Y	*ENG	

3421	[Toner Supply Range]		
001	Upper Limit: Bk	*ENG	Adjusts the toner supply rate during printing. [0 to 100 / 100 / 1%/step]
002	Upper Limit: M	*ENG	
003	Upper Limit: C	*ENG	
004	Upper Limit: Y	*ENG	
005	Minimum Supply Time: Bk	*ENG	Adjusts the minimum toner supply

006	Minimum Supply Time: M	*ENG	time. [0 to 1000 / 0 / 1 msec/step]
007	Minimum Supply Time: C	*ENG	
008	Minimum Supply Time: Y	*ENG	

3501	[Process Control Target M/A]		
	Adjusts the target M/A.		
001	Maximum M/A: Bk	*ENG	[0 to 1 / 0.4 / 0.001 mg/cm ² /step]
002	Maximum M/A: M	*ENG	
003	Maximum M/A: C	*ENG	
004	Maximum M/A: Y	*ENG	

3510	[ImageQuality Adj. Counter:Disp]		
	Displays the total page counter for each adjustment mode.		
001	Potential Control: BW	*ENG	[0 to 2000 / - / 1 page/step]
002	Potential Control: FC	*ENG	
003	Power ON: BW	*ENG	
004	Power ON: FC	*ENG	
005	MUSIC: BW	*ENG	
006	MUSIC: FC	*ENG	
007	Vsg Adj.	*ENG	
008	Charge AC Control	*ENG	
009	MUSIC: Power ON: BW	*ENG	
010	MUSIC: Power ON: FC	*ENG	

3511	[Execution Interval: Setting]		
	Adjusts the threshold for each adjustment mode.		
001	Job End: Potential Control: BW	*ENG	[0 to 2000 / 250 / 1 page/step]
002	Job End: Potential Control: FC	*ENG	[0 to 2000 / 100 / 1 page/step]
003	Interrupt: Potential Control: BW	*ENG	[0 to 2000 / 500 / 1 page/step]
004	Interrupt: Potential Control: FC	*ENG	[0 to 2000 / 200 / 1 page/step]
005	Initial: Potential Control: BW	*ENG	[0 to 2000 / 250 / 1 page/step]
006	Initial: Potential Control: FC	*ENG	[0 to 2000 / 100 / 1 page/step]
007	Vsg Adj. Counter	*ENG	[0 to 2000 / 0 / 1 page/step]
008	Charge AC Control Counter	*ENG	
019	Environmental Correction	*ENG	[0 or 1 / 1 / 1 /step] 0: Not Correct (OFF) 1: Correct (ON)
020	Gamma Correction	*ENG	[0 or 1 / 1 / 1 /step] 0: Not Correct (OFF) 1: Correct (ON)
021	Non-use Time Correction	*ENG	[0 or 1 / 1 / 1 /step] 0: Not Correct (OFF) 1: Correct (ON)
022	Correction Coef 1: JE: BW	*ENG	[0 to 1 / 0.2 / 0.01 page/step]
023	Correction Coef 2: JE: BW	*ENG	[0 to 1 / 1 / 0.01/step]
024	Correction Coef 1: JE: FC	*ENG	[0 to 1 / 0.5 / 0.01/step]
025	Correction Coef 2: JE: FC	*ENG	[0 to 1 / 1 / 0.01/step]
026	Cor Coef 1: Interrupt: BW	*ENG	[0 to 1 / 0.1 / 0.01/step]
027	Cor Coef 2: Interrupt: BW	*ENG	[0 to 1 / 1 / 0.01/step]
028	Cor Coef 1: Interrupt: FC	*ENG	[0 to 1 / 0.25 / 0.01/step]

029	Cor Coef 2: Interrupt: FC	*ENG	[0 to 1 / 1 / 0.01/step]
030	Max. Number Cor Threshold	*ENG	[0 to 99 / 5 / 1/step]
031	Max. Number Correction Counter	*ENG	[0 to 255 / - / 1/step]

3512	[Image Quality Adj.: Interval]		
	Adjusts the timing for execution of process control and line position adjustment.		
001	During Job	*ENG	[0 to 100 / 30 / 1 page/step]
002	During Stand-by	*ENG	[0 to 100 / 10 / 1 minute/step]

3513	[PCU Motor Stop Time: Bk]		
	Displays the last time that the PCDU motors stopped. These are used for process control execution timing.		
001	Year	*ENG	[0 to 99 / - / 1/step]
002	Month	*ENG	[1 to 12 / - / 1/step]
003	Date	*ENG	[1 to 31 / - / 1/step]
004	Hour	*ENG	[0 to 23 / - / 1/step]
005	Minute	*ENG	[0 to 59 / - / 1/step]

3514	[Environmental Display: Job End]		
	Displays the environmental conditions for the last job. These are used for process control execution timing.		
001	Temperature	*ENG	[-1280 to 1270 / - / 0.1°C/step]
002	Relative Humidity	*ENG	[0 to 1000 / - / 0.1%RH/step]
003	Absolute Humidity	*ENG	[0 to 1000 / - / 0.1 g/m ³ /step]
004	AIT Temperature	*ENG	[-1280 to 1270 / - / 0.1 deg/step]

Main SP Tables-3

3515	[Execution Interval: Display]		
	Displays the current interval for process control execution. When the machine calculates the timing for process control, it uses a number of conditions. These are the results after considering all the conditions.		
001	Job End: Pot Control: BW	*ENG	[0 to 2000 / - / 1 page/step]
002	Job End: Pot Control: FC	*ENG	[0 to 2000 / - / 1 page/step]
003	Interrupt: Pot Control: BW	*ENG	[0 to 2000 / - / 1 page/step]
004	Interrupt: Pot Control: FC	*ENG	[0 to 2000 / - / 1 page/step]

3517	[Blade damage prevention mode]		
	Adjusts the threshold temperature for preventing the cleaning blade in the transfer belt cleaning unit from being damaged. If the temperature is above this value, toner is applied to the transfer belt at set intervals during the job to prevent the blade from flipping over.		
001	Execution Temp. Threshold	*ENG	[0 to 50 / 40 / 1°C/step]

3519	[Toner End Prohibition Setting]		
	Enables or disables each adjustment at toner near end.		
001	Process Control	*ENG	[0 or 1 / 1 / 1/step]
002	MUSIC	*ENG	0: Permit (adjustment is done even toner near end condition) 1: Forbid (adjustment is not done at toner near end condition)
003	TC Adj.	*ENG	

3520	[ITB Idling Number]		
	Specifies the number of the ITB idling rotation for each condition.		
001	Temperature: H	*ENG	[0 or 3 / 0 / 1 revolution/step]
002	Temperature: M	*ENG	
003	Temperature: L	*ENG	
004	Temperature: L: Power ON	*ENG	

3521	[Temperature Threshold]		
	Specifies the threshold temperature for each condition. These settings affect the conditions of SP3-520. t1: Threshold between L (low temp.) and M (medium temp.) t2: Threshold between M (medium temp.) and H (high temps)		
001	Threshold: t2	*ENG	[20 or 30 / 25 / 1 deg/step]
002	Threshold: t1	*ENG	[0 or 15 / 15 / 1 deg/step]

3522	[Initial Process Control Set]		
	Adjusts the threshold for the process control at power on. When the current condition has changed by more than the values of these SPs when compared with the conditions at the previous operation, the process control at power on is executed.		
002	Non-use Time Setting	*ENG	[0 to 1440 / 360 / 1 minute/step]
003	Temperature Range	*ENG	[0 to 99 / 10 / 1°C/step]
004	Relative Humidity Range	*ENG	[0 to 99 / 50 / 1 %RH/step]
005	Absolute Humidity Range	*ENG	[0 to 99 / 6 / 1 g/m ³ /step]
006	AIT Temperature Range	*ENG	[0 to 99 / 25 / 1°C/step]
007	Vtref Temperature Range	*ENG	[0 to 99 / 20 / 1°C/step]
100	[Rapi_timer]		

Main SP Tables-3

	Time Setting	*ENG	[0 to 255 / 30 / 1 sec/step]
Adjusts the time-out time for the Rapi timer.			

3531	[Non-use Time Process Control Set]		
	Adjusts the threshold for the process control at stand-by. When the current condition has changed by more than the values of these SPs when compared with the conditions at the previous operation, the process control at stand-by is executed.		
001	Non-use Time Setting	*ENG	[0 to 1440 / 360 / 1 minute/step]
002	Temperature Range	*ENG	[0 to 99 / 10 / 1°C/step]
003	Relative Humidity Range	*ENG	[0 to 99 / 50 / 1 %RH/step]
004	Absolute Humidity Range	*ENG	[0 to 99 / 6 / 1 g/m ³ /step]
005	Maximum Execution Number	*ENG	Adjusts the maximum execution time for the process control at stand-by. [0 to 99 / 10 / 1 time/step]

3611	[Development Gamma: Display/Set]		
001	Bk (Current)	*ENG	Displays the current development gamma for each color. [0 to 5 / - / 0.01 mg/cm ² /kV /step]
002	M (Current)	*ENG	
003	C (Current)	*ENG	
004	Y (Current)	*ENG	
005	Bk (Target Display)	*ENG	Displays the target development gamma for each color. [0 to 5 / - / 0.01 mg/cm ² /kV /step]
006	M (Target Display)	*ENG	
007	C (Target Display)	*ENG	
008	Y (Target Display)	*ENG	
009	Bk (Standard Target Set)	*ENG	Displays the standard target development gamma for each color.
010	M (Standard Target Set)	*ENG	

011	C (Standard Target Set)	*ENG	[0 to 5 / 0.8 / 0.01 mg/cm ² /kv /step]
012	Y (Standard Target Set)	*ENG	
013	Environmental Correction	*ENG	Turns on or off the environmental correction for target development gamma. [0 or 1 / 1 / -] 0: Not Correct, 1: Correct
014	K (Max Correction)	*ENG	Adjusts the maximum correction value for each color. These SPs are effective only when the setting of SP3-611-013 is set to "1". [0 to 5 / 0.15 / 0.01 mg/cm ² /kv/ step]
015	M (Max Correction)	*ENG	
016	C (Max Correction)	*ENG	
017	Y (Max Correction)	*ENG	
018	K (Max Abs Hum)	*ENG	Adjusts the maximum humidity correction value for each color. These SPs are effective only when the setting of SP3-611-013 is set to "1". [1 to 99 / 20 / 1 g/m ³ /step]
019	M (Max Abs Hum)	*ENG	
020	C (Max Abs Hum)	*ENG	
021	Y (Max Abs Hum)	*ENG	
022	K (Min Correction)	*ENG	[0 to 0.1 / 0 / 0.01 mg/cm ² /kv/ step]

3612	[Vk Display]		
	Displays Vk for each color.		
001	Bk	*ENG	[-300 to 300 / - / 1 V/step]
002	M	*ENG	
003	C	*ENG	
004	Y	*ENG	

3621	[Development DC Control: Disp] Plain: High speed, Thick 1: Middle speed, Thick 2 & FINE: Low speed		
	Displays the development DC bias adjusted with the process control for each line speed and color.		
001	Plain: Bk	*ENG	[0 to 800 / - / 1 -V/step]
002	Plain: M	*ENG	
003	Plain: C	*ENG	
004	Plain: Y	*ENG	
005	Thick 1: Bk	*ENG	[0 to 800 / - / 1 -V/step]
006	Thick 1: M	*ENG	
007	Thick 1: C	*ENG	
008	Thick 1: Y	*ENG	
009	Thick 2 & FINE: Bk	*ENG	[0 to 800 / - / 1 -V/step]
010	Thick 2 & FINE: M	*ENG	
011	Thick 2 & FINE: C	*ENG	
012	Thick 2 & FINE: Y	*ENG	

3631	[Charge DC Control: Display] Plain: High speed, Thick 1: Middle speed, Thick 2 & FINE: Low speed		
	Displays the charge DC voltage adjusted with the process control for each line speed and color.		
001	Plain: Bk	*ENG	[0 to 2000 / - / 1 -V/step]
002	Plain: M	*ENG	
003	Plain: C	*ENG	
004	Plain: Y	*ENG	
005	Thick 1 & FINE: Bk	*ENG	[0 to 2000 / - / 1 -V/step]

006	Thick 1 & FINE: M	*ENG	[0 to 2000 / - / 1 -V/step]
007	Thick 1 & FINE: C	*ENG	
008	Thick 1& FINE: Y	*ENG	
009	Thick 2 & FINE: Bk	*ENG	
010	Thick 2 & FINE: M	*ENG	
011	Thick 2 & FINE: C	*ENG	
012	Thick 2 & FINE: Y	*ENG	

3641	[Charge AC Control: Display] Plain: High speed		[0 to 3 / - / 0.01 kV/step]
	Displays the charge AC voltage adjusted with the process control for each color.		
001	Plain: Bk	*ENG	[0 to 3 / - / 0.01 kV/step]
002	Plain: M	*ENG	
003	Plain: C	*ENG	
004	Plain: Y	*ENG	

3651	[LD Power Control: Display] Plain: High speed, Thick 1: Middle speed, Thick 2 & FINE: Low speed		[0 to 200 / - / 1 %/step]
	Displays the LD power adjusted for each environment.		
001	Plain: Bk	*ENG	[0 to 200 / - / 1 %/step]
002	Plain: M	*ENG	
003	Plain: C	*ENG	
004	Plain: Y	*ENG	
005	Thick 1: Bk	*ENG	[0 to 200 / - / 1 %/step]
006	Thick 1: M	*ENG	
007	Thick 1: C	*ENG	

Main SP Tables-3

008	Thick 1: Y	*ENG	
009	Thick 2 & FINE: Bk	*ENG	[0 to 200 / - / 1 %/step]
010	Thick 2 & FINE: M	*ENG	
011	Thick 2 & FINE: C	*ENG	
012	Thick 2 & FINE: Y	*ENG	

3710	[HST Concentration Control: Set] TD Sensor: Toner Concentration Control Setting		
	Selects the toner concentration control method by HST memory, which is in the TD sensor.		
001	Control Method: Selection	*ENG	[0 or 1 / 1 / -] 0: Not Use, 1: Use

3711	[HST Concentration Control: Bk]		
	Displays the factory settings of the black PCDU.		
001	Vcnt	*ENG	[0 to 5 / - / 0.1 V/step]
002	Vt	*ENG	[0 to 5 / - / 0.1 V/step]
003	Sensitivity: HL	*ENG	[1.22 to 3.77 / - / 0.01 V/step]
004	Sensitivity: HM	*ENG	[0 to 2.55 / - / 0.01 V/step]
005	Sensitivity: ML	*ENG	
006	Set Detection	*ENG	[0 to 5 / - / 0.1 V/step]
007	Without Developer	*ENG	[0 to 5 / - / 0.1 V/step]
008	With Developer	*ENG	[0 to 5 / - / 0.1 V/step]
009	Serial Number 1	*ENG	[0 to 255 / - / 1 V/step]
010	Serial Number 2	*ENG	
011	Adjustment: Vt	*ENG	[0 to 5 / - / 0.1 V/step]
012	Adjustment: Vtref	*ENG	[0 to 5 / - / 0.1 V/step]

013	Adjustment: Vtcnt	*ENG	[0 to 5 / - / 0.01 V/step]
014	Adjustment: Gamma	*ENG	[0 to 2.55 / - / 0.01 mg/cm ² /kV /step]
015	Adjustment: Vcnt Result	*ENG	[0 to 9 / - / 1 /step]

3712	[HST Concentration Control: M]		
	Displays the factory settings of the magenta PCDU.		
001	Vcnt	*ENG	[0 to 5 / - / 0.1 V/step]
002	Vt	*ENG	[0 to 5 / - / 0.1 V/step]
003	Sensitivity: HL	*ENG	[1.22 to 3.77 / - / 0.01 V/step]
004	Sensitivity: HM	*ENG	[0 to 2.55 / - / 0.01 V/step]
005	Sensitivity: ML	*ENG	
006	Set Detection	*ENG	[0 to 5 / - / 0.1 V/step]
007	Without Developer	*ENG	[0 to 5 / - / 0.1 V/step]
008	With Developer	*ENG	[0 to 5 / - / 0.1 V/step]
009	Serial Number 1	*ENG	[0 to 255 / - / 1 V/step]
010	Serial Number 2	*ENG	
011	Adjustment: Vt	*ENG	[0 to 5 / - / 0.1 V/step]
012	Adjustment: Vtref	*ENG	[0 to 5 / - / 0.1 V/step]
013	Adjustment: Vtcnt	*ENG	[0 to 5 / - / 0.01 V/step]
014	Adjustment: Gamma	*ENG	[0 to 2.55 / - / 0.01 mg/cm ² /kV /step]
015	Adjustment: Vcnt Result	*ENG	[0 to 9 / - / 1 /step]

3713	[HST Concentration Control: C]		
	Displays the factory settings of the cyan PCDU.		
001	Vcnt	*ENG	[0 to 5 / - / 0.1 V/step]
002	Vt	*ENG	[0 to 5 / - / 0.1 V/step]
003	Sensitivity: HL	*ENG	[1.22 to 3.77 / - / 0.01 V/step]
004	Sensitivity: HM	*ENG	[0 to 2.55 / - / 0.01 V/step]
005	Sensitivity: ML	*ENG	
006	Set Detection	*ENG	[0 to 5 / - / 0.1 V/step]
007	Without Developer	*ENG	[0 to 5 / - / 0.1 V/step]
008	With Developer	*ENG	[0 to 5 / - / 0.1 V/step]
009	Serial Number 1	*ENG	[0 to 255 / - / 1 V/step]
010	Serial Number 2	*ENG	
011	Adjustment: Vt	*ENG	[0 to 5 / - / 0.1 V/step]
012	Adjustment: Vtref	*ENG	[0 to 5 / - / 0.1 V/step]
013	Adjustment: Vtcnt	*ENG	[0 to 5 / - / 0.01 V/step]
014	Adjustment: Gamma	*ENG	[0 to 2.55 / - / 0.01 mg/cm ² /kV /step]
015	Adjustment: Vcnt Result	*ENG	[0 to 9 / - / 1 /step]

3714	[HST Concentration Control: Y]		
	Displays the factory settings of the yellow PCDU.		
001	Vcnt	*ENG	[0 to 5 / - / 0.1 V/step]
002	Vt	*ENG	[0 to 5 / - / 0.1 V/step]
003	Sensitivity: HL	*ENG	[1.22 to 3.77 / - / 0.01 V/step]
004	Sensitivity: HM	*ENG	[0 to 2.55 / - / 0.01 V/step]
005	Sensitivity: ML	*ENG	
006	Set Detection	*ENG	[0 to 5 / - / 0.1 V/step]
007	Without Developer	*ENG	[0 to 5 / - / 0.1 V/step]
008	With Developer	*ENG	[0 to 5 / - / 0.1 V/step]
009	Serial Number 1	*ENG	[0 to 255 / - / 1 V/step]
010	Serial Number 2	*ENG	
011	Adjustment: Vt	*ENG	[0 to 5 / - / 0.1 V/step]
012	Adjustment: Vtref	*ENG	[0 to 5 / - / 0.1 V/step]
013	Adjustment: Vtcnt	*ENG	[0 to 5 / - / 0.01 V/step]
014	Adjustment: Gamma	*ENG	[0 to 2.55 / - / 0.01 mg/cm ² /kV /step]
015	Adjustment: Vcnt Result	*ENG	[0 to 9 / - / 1 /step]

3800	[Waste Toner Full Detection]		
	Displays/ adjusts the toner collection bottle detection settings. These SPs are used for NRS.		
001	Condition	*CTL	[0 to 4 / 0 / 1 /step]
002	Detection Times	*CTL	[0 to 50 / 0 / 1 /step]
003	Print Page After Near Full	*CTL	[0 to 1000 / 0 / 1 sheet/step]
004	Pixel Count After Near Full	*CTL	[0 to 200000 / 0 / 1 cm ² /step]
005	Pixel Count After Replacement	*CTL	Displays the pixel counter after replacement of toner collection bottle. [0 to 200000 / 0 / 1 cm ² /step]
008	Coefficient	*ENG	[0.1 to 1.5 / 1 / 0.1 /step]
011	Notice Setting	*ENG	Enables or disables the calling for @Remote. [0 or 1 / 1 / -] 0: Enable @Remote calling 1: Disable @Remote calling
	NOTE: If the toner collection bottle has been replaced before the machine detects used toner near full when this setting is set to "0", the machine cannot detect toner collection bottle near full. In that case, set SP3-902-017 to "1".		
012	Day Threshold: Toner Collection bottle:NF	*ENG	[1 to 30 / 5 / 1 day/step]
	Sets the threshold days for the near-full display. The near-full of the toner collection bottle is displayed after the toner collection full sensor has detected the actuator in the toner collection bottle.		
013	Total:Toner Collection Bottle	*ENG	Displays the total amount of the used toner. [0 to 999999999 / 0 / 1]

014	Mechanism Full Detection Date	*ENG	Displays the date of the full detection for the toner collection bottle.
-----	-------------------------------	------	--

3900	[Waste Toner New Detection]		
	Turns toner collection bottle full detection on or off.		
001	ON/OFF Setting	*ENG	[0 or 1 / 1 / -] 0: OFF, 1: ON

3901	[New PCU Detection]		
	Turns new PCDU detection on or off.		
001	ON/OFF Setting	*ENG	[0 or 1 / 1 / -] 0: OFF, 1: ON

3902	[Manual New Unit Set]		
	Turns the new unit detection flag for each PM unit on or off. The use of these counters is explained in the PM section and in the relevant parts of section 3 (Replacement and Adjustment).		
001	Development Unit: Bk	*ENG	[0 or 1 / 0 / -] 0: OFF, 1: ON
002	Development Unit: Y	*ENG	
003	Development Unit: C	*ENG	
004	Development Unit: M	*ENG	
005	Developer: Bk	*ENG	[0 or 1 / 0 / -] 0: OFF, 1: ON
006	Developer: Y	*ENG	
007	Developer: C	*ENG	
008	Developer: M	*ENG	
009	PCU: Bk	*ENG	[0 or 1 / 0 / -] 0: OFF, 1: ON
010	PCU: Y	*ENG	
011	PCU: C	*ENG	

Main SP Tables-3

012	PCU: M	*ENG	
013	Image Transfer Unit	*ENG	<p>[0 or 1 / 0 / -] 0: OFF, 1: ON Do not use 3902-013 if you only change the cleaning unit. 3902-015: This is for the image transfer belt cleaning unit.</p>
014	Fusing Unit	*ENG	
015	Cleaning Unit	*ENG	
016	Paper Transfer Unit	*ENG	
017	Toner Collection Bottle	*ENG	
018	Fusing Roller	*ENG	<p>[0 or 1 / 0 / -] 0: OFF, 1: ON "Fusing Roller" is designated as "Heating Roller" in this manual.</p>
019	Pressure Roller	*ENG	
020	Pump Unit: Bk	*ENG	<p>[0 or 1 / 0 / -] 0: OFF, 1: ON</p>
021	Pump Unit: M	*ENG	
022	Pump Unit: C	*ENG	
023	Pump Unit: Y	*ENG	

3.4 MAIN SP TABLES-4

3.4.1 SP4-XXX (SCANNER)

4008	[Sub Scan Mag.Adjustment]		
	Adjusts the sub-scan magnification by changing the scanner motor speed.		
001	-	*ENG	[-1.0 to 1.0 / 0 / 0.1%/step] FA

4010	[L-Edge Regist Adjustment]		
	Adjusts the leading edge registration by changing the scanning start timing in the sub-scan direction.		
001	-	*ENG	[-2.0 to 2.0 / 0 / 0.1 mm/step] FA

4011	[S-to-S Regist Adjustment]		
	Adjusts the side-to-side registration by changing the scanning start timing in the main scan direction.		
001	-	*ENG	[-2.5 to 2.5 / 0 / 0.1 mm/step] FA

4012	[Scanner Erase Margin: Scale]		
	Sets the blank margin at each side for erasing the original shadow caused by the gap between the original and the scale.		
001	Book: Leading Edge	*ENG	[0 to 3.0 / 0 / 0.1 mm/step] FA
002	Book: Trailing Edge		
003	Book: Left		
004	Book: Right		
005	ADF: Leading Edge	*ENG	[0 to 3.0 / 0 / 0.1 mm/step] FA
007	ADF: Right		

Main SP Tables-4

008	ADF: Left		
-----	-----------	--	--

4013	[Scanner Free Run]		
	Performs the scanner free run with the exposure lamp on or off in the following mode. Full color mode / Full Size / A3 or DLT		
001	Lamp: OFF	*ENG	[0 or 1 / 0 / -] 0: OFF, 1: ON
002	Lamp: ON		

4014	[Scan]		
	Execute the scanner free fun with each mode.		
001	HP Detection Enable	-	Scanner free run with HP sensor check.
002	HP Detection Disable	-	Scanner free run without HP sensor check.

4020	[Dust Check]		
001	Dust Detect:On/Off	*ENG	Turns the ADF scan glass dust check on/off. [0 or 1 / 0 / 1 /step] 0: OFF, 1: ON
002	Dust Detect:Lvl	*ENG	Selects the detect level. [0 to 8 / 4 / 1 /step] 0: lowest detection level 8: highest detection level
003	Dust Reject:Lvl	*ENG	Selects the level of the sub scan line correction when using the ARDF. [0 to 4 / 0 / 1 /step] 0: Off 1: Weakest 2: Weak 3: Strong 4: Strongest

011	Dust Detect:On/Off:Rear	*ENG	Not used
012	Dust Detect:Lvl:Rear	*ENG	Not used

4301	[APS Operation Check]		
	Displays a code that represents the original size detected by the original sensors. See "Input Check Table" (p.3-357).		
001	APS Operation Check	-	-

4303	[APS Min. Size]		
	Specifies the result of the detection when the outputs from the original sensors are all OFF.		
001	-	*ENG	[0 to 2 / 0 / 1 /step] 0: No Original 1: A5-Lengthwise (16K SEF if 4305 is set to 3)

4305	[8K/16K Detection]		
	This program enables the machine to automatically recognize the 8K/16K size.		
001	-	*ENG	[0 to 3 / 0 / 1 /step] 0: Normal Detection (the machine detects A4/LT size as A4 or LT, depending on the paper size setting) 1: A4-Sideways LT-Lengthwise 2: LT-Sideways A4-Lengthwise 3: 8K 16K

4308	[Scan Size Detection]		
001	Detection ON/OFF	*ENG	[0 or 1 / 1 / -] 0: OFF 1: ON
	Turns on or off the CCD original size detection. This detection is used only when an original is scanned in book scanning mode.		

4309	[Scan Size Detect:Setting]		
001	Original Density Thresh	*ENG	[0 to 255 / 32 / 1 digit/step]
	Specifies the threshold between an original area and non-original area for the scan original size detection in book scanning mode.		
002	Detection Time	*ENG	[20 to 100 / 60 / 20 msec/step]
	Specifies the detection time for the scan original size detection in book scanning mode.		
003	Lamp ON:Delay Time	*ENG	[0 to 200 / 40 / 20 msec/step]
	Specifies the lamp on timing for the scan original size detection in book scanning mode.		
004	LED PWM Duty	*ENG	[0 to 100 / 60 / 1/step]
	Sets the LED lamp intensity.		

4310	[Scan Size Detect Value]		
	Displays the detected value by CCD. Each detection point for paper size and color is displayed on the LCD.		
001	S1:R	*ENG	[0 to 255 / - / 1 digit/step]
002	S1:G	*ENG	
003	S1:B	*ENG	
004	S2:R	*ENG	
005	S2:G	*ENG	
006	S2:B	*ENG	
007	S3:R	*ENG	
008	S3:G	*ENG	
009	S3:B	*ENG	

4400	[Scanner Erase Margin]	*ENG	
	Set the Mask for Original. These SPs set the area to be masked during platen (book) mode scanning.		
001	Book: Leading Edge	[0 to 3.0 / 0 / 0.1 mm/step]	
002	Book: Trailing Edge		
003	Book: Left		
004	Book: Right		
005	ADF: Leading Edge		
007	ADF: Right		
008	ADF: Left		

Main SP Tables-4

4417	[IPU Test Pattern]	
	Selects the IPU test pattern.	
001	Test Pattern Selection	[0 to 24 / 0 / 1/step]
	0: Scanned image 1: Gradation main scan A 2: Gradation main scan B 3: Gradation main scan C 4: Gradation main scan D 5: Gradation sub scan (1) 6: Grid pattern 7: Slant grid pattern 8: Gradation RGBCMYK 9: UCR pattern 10: Color patch 16 (1) 11: Color patch 16 (2) 12: Color patch 64	13: Grid pattern CMYK 14: Color patch CMYK 15: Gray pattern (1) 16: Gray pattern (2) 17: Gray Pattern (3) 18: Shading pattern 19: Thin line pattern 20: Scanned + Grid pattern 21: Scanned + Gray scale 22: Scanned + Color patch 23: Scanned + Slant Grid C 24: Scanned + Slant Grid D

4429	[Illegal Copy Output]		
001	Copy	*ENG	[0 to 3 / 3 / 1 /step]
002	Scanner		
003	Fax		

4450	[Scan Image Path Selection]	
001	Black Subtraction ON/OFF	[0 or 1 / 1 / -] 0: OFF, 1: ON
	Uses or does not use the black reduction image path.	
002	SH ON/OFF	[0 or 1 / 0 / 1 /step] 0: ON, 1: OFF
	Uses or does not use the shading image path.	

4501	[ACC Target Den]		
	Selects the ACC result.		
001	Copy: K: Text	*ENG	[0 to 10 / 5 / 1 /step] 10: Darkest density
002	Copy: C: Text	*ENG	
003	Copy: M: Text	*ENG	
004	Copy: Y: Text	*ENG	
005	Copy: K: Photo	*ENG	
006	Copy: C: Photo	*ENG	
007	Copy: M: Photo	*ENG	
008	Copy: Y: Photo	*ENG	

4505	[ACC Cor:Bright]		
	Adjusts the offset correction for light areas of the ACC pattern.		
001	Text:K	*ENG	[-128 to 127 / 0 / 1 /step]
002	Text:C	*ENG	
003	Text:M	*ENG	
004	Text:Y	*ENG	
005	Photo:K	*ENG	[-128 to 127 / 0 / 1 /step]
006	Photo:C	*ENG	
007	Photo:M	*ENG	
008	Photo:Y	*ENG	

Main SP Tables-4

4506	[ACC Cor:Dark]		
	Adjusts the offset correction for dark areas of the ACC pattern.		
001	Text:K	*ENG	[-128 to 127 / 0 / 1 /step]
002	Text:C	*ENG	
003	Text:M	*ENG	
004	Text:Y	*ENG	
005	Photo:K	*ENG	[-128 to 127 / 0 / 1 /step]
006	Photo:C	*ENG	
007	Photo:M	*ENG	
008	Photo:Y	*ENG	

4540	[Print Coverage]		
	This SP corrects the printer coverage of 12 hues (RY, YR, YG, etc. x 4 Colors [R, G, B, Option]) for a total of 48 parameters.		
001-004	RY Phase: Option/R/G/B	*ENG	Specifies the printer vector correction value. [0 to 255 / 0 / 1 /step]
005-008	YR Phase: Option/R/G/B		
009-012	YG Phase: Option/R/G/B		
013-016	GY Phase: Option/R/G/B		
017-020	GC Phase: Option/R/G/B		
021-024	CG Phase: Option/R/G/B		
025-028	CB Phase: Option/R/G/B		
029-032	BC Phase: Option/R/G/B		
033-036	BM Phase: Option/R/G/B		
037-040	MB Phase: Option/R/G/B		
041-044	MR Phase: Option/R/G/B		

045-048	RM Phase: Option/R/G/B		
---------	------------------------	--	--

4600	[SBU Version Display]		
001	SBU ID	*ENG	Displays the ID of the SBU.
002	GASBU-N ID	*ENG	Displays the ID of the GASBU.
003	VSP5100 ID	*ENG	Displays the ID of the VSP5100.

4602	[Scanner Memory Access]		
001	Scanner Memory Access	-	Enables the read and write check for the SBU registers.

4603	[AGC Execution]		
001	HP Detection Enable	-	Executes the AGC.
002	HP Detection Disable	-	DFU

4609	[Gray Balance Set: R]		
001	Book Scan	*ENG	[-512 to 511 / -46 / 1 digit/step]
002	DF Scan	*ENG	[-512 to 511 / -46 / 1 digit/step]

4610	[Gray Balance Set: G]		
001	Book Scan	*ENG	[-384 to 255 / -20 / 1 digit/step]
002	DF Scan		

4611	[Gray Balance Set: B]		
001	Book Scan	*ENG	[-384 to 255 / -28 / 1 digit/step]
002	DF Scan		

Main SP Tables-4

4623	[Black Level Adj. Display] RE: Red Even signal, RO: Red Odd signal		
001	Latest: RE Color	*ENG	Displays the black offset value for the even red signal in the CCD circuit board. [0 to 16383 / 0 / 1 digit/step]
002	Latest: RO Color	*ENG	Displays the black offset value for the odd red signal in the CCD circuit board. [0 to 16383 / 0 / 1 digit/step]

4624	[Black Level Adj. Display] GE: Green Even signal, GO: Green Odd signal		
001	Latest: GE Color	*ENG	Displays the black offset value for the even green signal in the CCD circuit board. [0 to 16383 / 0 / 1 digit/step]
002	Latest: GO Color	*ENG	Displays the black offset value for the odd green signal in the CCD circuit board. [0 to 16383 / 0 / 1 digit/step]

4625	[Black Level Adj. Display] BE: Blue Even signal, BO: Blue Odd signal		
001	Latest: BE Color	*ENG	Displays the black offset value for the even blue signal in the CCD circuit board. [0 to 16383 / 0 / 1 digit/step]
002	Latest: BO Color	*ENG	Displays the black offset value for the odd blue signal in the CCD circuit board. [0 to 16383 / 0 / 1 digit/step]

4628	[Analog Gain Adjust]		
	Displays the gain value of the amplifiers on the controller for Red.		
001	Latest: R Color	*ENG	[0 to 7 / 0 / 1 digit/step]

4629	[Analog Gain Adjust]		
	Displays the gain value of the amplifiers on the controller for Green.		
001	Latest: G Color	*ENG	[0 to 7 / 0 / 1 digit/step]

4630	[Analog Gain Adjust]		
	Displays the gain value of the amplifiers on the controller for Blue.		
001	Latest: B Color	*ENG	[0 to 7 / 0 / 1 digit/step]

4631	[Digital Gain Adjust]		
	Displays the gain value of the amplifiers on the controller for Red.		
001	Latest: RE Color	*ENG	[0 to 1023 / 0 / 1 digit/step]
002	Latest: RO Color	*ENG	

4632	[Digital Gain Adjust]		
	Displays the gain value of the amplifiers on the controller for Green.		
001	Latest: GE Color	*ENG	[0 to 1023 / 0 / 1 digit/step]
002	Latest: GO Color	*ENG	

4633	[Digital Gain Adjust]		
	Displays the gain value of the amplifiers on the controller for Blue.		
001	Latest: BE Color	*ENG	[0 to 1023 / 0 / 1 digit/step]
002	Latest: BO Color	*ENG	

4645	[Scan Adjust Error]		
001	White level	*ENG	[0 to 65535 / - / 1 digit/step]
002	Black level	*ENG	

Main SP Tables-4

4647	[Scanner Hard Error]		
	Displays the result of the SBU connection check.		
001	Power-ON	*ENG	[0 to 35535 / - / 1digit /step] 0: OK, Other: SBU connection check failure If the SBU connection check fails, SC144 occurs.

4654	[Black Level Adj. Display] RE: Red Even signal, RO: Red Odd signal		
	001	Last Correct Value: RE Color	*ENG
002	Last Correct Value: RO Color	*ENG	Displays the black offset value for the odd red signal in the CCD circuit board. [0 to 16383 / 0 / 1 digit/step]

4655	[Black Level Adj. Display] GE: Green Even signal, GO: Green Odd signal		
	001	Last Correct Value: GE Color	*ENG
002	Last Correct Value: GO Color	*ENG	Displays the black offset value for the odd green signal in the CCD circuit board. [0 to 16383 / 0 / 1 digit/step]

4656	[Black Level Adj. Display] BE: Blue Even signal, BO: Blue Odd signal		
	001	Last Correct Value: BE Color	*ENG

002	Last Correct Value: BO Color	*ENG	Displays the black offset value for the odd blue signal in the CCD circuit board. [0 to 16383 / 0 / 1 digit/step]
-----	------------------------------	------	--

4658	[Analog Gain Adjust]		
	Displays the previous gain value of the amplifiers on the controller for Red.		
001	Last Correct Value: R Color	*ENG	[0 to 7 / 0 / 1 digit/step]

4659	[Analog Gain Adjust]		
	Displays the previous gain value of the amplifiers on the controller for Green.		
001	Last Correct Value: G Color	*ENG	[0 to 7 / 0 / 1 digit/step]

4660	[Analog Gain Adjust]		
	Displays the previous gain value of the amplifiers on the controller for Blue.		
001	Last Correct Value: B Color	*ENG	[0 to 7 / 0 / 1 digit/step]

4661	[Digital Gain Adjust] RE: Red Even signal, RO: Red Odd signal		
001	Last Correct Value: RE Color	*ENG	[0 to 1023 / 0 / 1 digit/step]
002	Last Correct Value: RO Color	*ENG	

4662	[Digital Gain Adjust] GE: Green Even signal, GO: Green Odd signal		
001	Last Correct Value: GE Color	*ENG	[0 to 1023 / 0 / 1 digit/step]
002	Last Correct Value: GO Color	*ENG	

4663	[Digital Gain Adjust] BE: Blue Even signal, BO: Blue Odd signal		
001	Last Correct Value: BE Color	*ENG	[0 to 1023 / 0 / 1 digit/step]
002	Last Correct Value: BO Color	*ENG	

Main SP Tables-4

4673	[Black Level Adj. Display] RE: Red Even signal, RO: Red Odd signal		
001	Factory Setting: RE Color	*ENG	Displays the factory setting values of the black level adjustment for the even red signal in the CCD circuit board. [0 to 16383 / - / 1 digit/step]
002	Factory Setting: RO Color	*ENG	Displays the factory setting values of the black level adjustment for the odd red signal in the CCD circuit board. [0 to 16383 / - / 1 digit/step]

4674	[Black Level Adj. Display] GE: Green Even signal, GO: Green Odd signal		
001	Factory Setting: GE Color	*ENG	Displays the factory setting values of the black level adjustment for the even green signal in the CCD circuit board. [0 to 16383 / - / 1 digit/step]
002	Factory Setting: GO Color	*ENG	Displays the factory setting values of the black level adjustment for the odd green signal in the CCD circuit board. [0 to 16383 / - / 1 digit/step]

4675	[Black Level Adj. Display] BE: Blue Even signal, BO: Blue Odd signal		
001	Factory Setting: BE Color	*ENG	Displays the factory setting values of the black level adjustment for the even blue signal in the CCD circuit board. [0 to 16383 / - / 1 digit/step]
002	Factory Setting: BO Color	*ENG	Displays the factory setting values of the black level adjustment for the odd blue signal in the CCD circuit board. [0 to 16383 / - / 1 digit/step]

4677	[Analog Gain Adjust]		
	Displays the factory setting values of the gain adjustment for Red.		
001	Factory Setting: R Color	*ENG	[0 to 7 / - / 1 digit/step]

4678	[Analog Gain Adjust]		
	Displays the factory setting values of the gain adjustment for Green.		
001	Factory Setting: G Color	*ENG	[0 to 7 / - / 1 digit/step]

4679	[Analog Gain Adjust]		
	Displays the factory setting values of the gain adjustment for Blue.		
001	Factory Setting: B Color	*ENG	[0 to 7 / - / 1 digit/step]

4680	[Digital Gain Adjust]		
	Displays the gain value of the amplifiers on the controller for Red.		
001	Factory Setting: RE Color	*ENG	[0 to 1023 / - / 1 digit/step]
002	Factory Setting: RO Color	*ENG	

4681	[Digital Gain Adjust]		
	Displays the gain value of the amplifiers on the controller for Green.		
001	Factory Setting: GE Color	*ENG	[0 to 1023 / - / 1 digit/step]
002	Factory Setting: GO Color	*ENG	

4682	[Digital Gain Adjust]		
	Displays the gain value of the amplifiers on the controller for Blue.		
001	Factory Setting: BE Color	*ENG	[0 to 1023 / - / 1 digit/step]
002	Factory Setting: BO Color	*ENG	

4688	[Scan Image Density Adjustment]		
	Adjusts the white shading parameter when scanning an image with the ARDF or 1-pass DF. Adjusts the density level if the ID of outputs made in the DF and Platen mode is different.		
001	ARDF	*ENG	[80 to 120 / 98 / 1%/ step]
002	1-pass DF	*ENG	[80 to 120 / 98 / 1%/ step]

4690	[White Level Peak Read]		
	Displays the peak level of the white level scanning. If these scanned white levels are out of the correct range, SC142 may be issued.		
001	RE	*ENG	[0 to 1023 / - / 1 digit/step]
002	RO	*ENG	

4691	[White Level Peak Read]		
	Displays the peak level of the white level scanning. If these scanned white levels are out of the correct range, SC142 may be issued.		
001	GE	*ENG	[0 to 1023 / - / 1 digit/step]
002	GO	*ENG	

4692	[White Level Peak Read]		
	Displays the peak level of the white level scanning. If these scanned white levels are out of the correct range, SC142 may be issued.		
001	BE	*ENG	[0 to 1023 / - / 1 digit/step]
002	BO	*ENG	

4693	[Black Level Peak Read]		
	Displays the level of the black level scanning. If these scanned black levels are out of the correct range, SC141 may be issued.		
001	RE	*ENG	[0 to 1023 / - / 1 digit/step]
002	RO	*ENG	

4694	[Black Level Peak Read]		
	Displays the level of the black level scanning. If these scanned black levels are out of the correct range, SC141 may be issued.		
001	GE	*ENG	[0 to 1023 / - / 1 digit/step]
002	GO	*ENG	

4695	[Black Level Peak Read]		
	Displays the level of the black level scanning. If these scanned black levels are out of the correct range, SC141 may be issued.		
001	BE	*ENG	[0 to 1023 / - / 1 digit/step]
002	BO	*ENG	

4796	[Low Density Color Correction]		
001	Front Side	*ENG	[0 or 1 / 0 / -] 0: Off, 1: On
	Turns on or off the low color density correction for the front side of originals.		
002	Rear Side	*ENG	[0 or 1 / 0 / -] 0: Off, 1: On
	Turns on or off the low color density correction for the back side of originals.		

Main SP Tables-4

4802	[DF Shading FreeRun]		
001	Lamp OFF	*ENG	Executes the scanner free run of shading movement with exposure lamp on or off. Press "OFF" to stop this free run. Otherwise, the free run lasts.
002	Lamp ON		

4804	[Home Position]		
001	-	*ENG	Executes the scanner HP detection.

4806	[Carriage Save]		
001	-	*ENG	Moves the carriage from the scanner home position. Dust may fall through the DF exposure glass. Therefore, do this SP when you transport the machine a long distance.

4807	[SBU Test Pattern Change]		
001	-	*ENG	[0 to 255 / 0 / 1 /step] 0: Scanning image 1: Fixed pattern 2: Main scanning gradation 3: Sub scanning gradation 4: Grid pattern (5 to 255 : Scanning images)

4808	[Factory Setting Input]		
002	Execution Flag	*ENG	[0 or 1 / 0 / 1 /step]

4902	[Disp ACC Data]		
	This SP outputs the final data read at the end of ACC execution. A zero is returned if there was an error reading the data. [0 to 255 / - / 1 /step]		
001	R DATA1	*ENG	Photo C Patch Level 1 (8-bit)
002	G DATA1	*ENG	Photo M Patch Level 1 (8-bit)
003	B DATA1	*ENG	Photo Y Patch Level 1 (8-bit)
004	R DATA2	*ENG	Photo C Patch Level 17 (8-bit)
005	G DATA2	*ENG	Photo M Patch Level 17(8-bit)
006	B DATA2	*ENG	Photo Y Patch Level 17 (8-bit)

4918	[Man Gamma:Pht:Y]		
	Adjusts the offset data of the printer gamma for yellow in Photo mode. See "Printer Gamma Correction" in the "Main chapters: 4. Replacement and Adjustment: Image Adjustment" for how to use.		
009	-	*ENG	Enter the manual gamma adjustment screen (-001 to 008).

4954	[Read/Restore Std]		
001	Read New Chart	*ENG	Execute the scanning of the A4 chart.
002	Recall Prev Chart	*ENG	Clear the data of the scanned A4 chart.
003	Read Std Chart	*ENG	Execute the scanning of the A4 standard chart.
004	Set Std Chart	*ENG	Overwrite the standard data.
005	Chromaticity Rank	*ENG	Restores the standard chromaticity rank.

4991	[IPU Image Pass Selection]		
------	----------------------------	--	--

Main SP Tables-4

	Selects the image path. Enter the number to be selected using the 10-key pad.		
001	RGB Frame Memory	*ENG	[0 to 11 / 2 / 1 /step]
	0: Scanner input RGB images 1: Scanner I/F RGB images 2: RGB images done by Shading correction (Shading ON, Black offset ON) 3: Shading data 4 to 11: Not used		

4993	[High Light Correction]		
001	Sensitivity Selection	*ENG	Selects the Highlight correction level. [0 to 9 / 4 / 1 /step] 0: weakest sensitivity 9: strongest sensitivity
002	Range Selection	*ENG	Selects the range level of Highlight correction. [0 to 9 / 4 / 1 /step] 0: weakest skew correction, 9: strongest skew correction

4994	[Text/Photo Detection Level Adj.]		
	Selects the definition level between Text and Photo for high compression PDF.		
001	High Compression PDF	*ENG	[0 to 2 / 1 / 1 /step] 0: Text priority 1: Normal 2: Photo priority

3.5 MAIN SP TABLES-5

3.5.1 SP5-XXX (MODE)

5024	[mm/inch Display Selection]		
	Display units (mm or inch) for custom paper sizes.		
001	0:mm 1:inch	*CTL	0: mm (Europe/Asia) 1: inch (USA)

5045	[Accounting counter]		
	Selects the counting method.  Note <ul style="list-style-type: none"> The counting method can be changed only once, regardless of whether the counter value is negative or positive. 		
001	Counter Method	*CTL	[0 or 1 / 1 / -] 0: Developments 1: Prints

5047	[Paper Display]		
	Turns on or off the printed paper display on the LCD.		
001	Backing Paper	*CTL	[0 or 1 / 0 / -] 0: OFF, 1: ON

5051	[TonerRefillDetectionDisplay]		
	Enables or disables the toner refill detection display.		
5051 1	-	*CTL	[0 or 1 / 0 / -] Alphanumeric 0: ON 1: OFF

Main SP Tables-5

5055	[Display IP Address]		
	Display or does not display the IP address on the LCD.		
001	-	*CTL	[0 or 1 / 0 / -] 0: OFF 1: ON

5056	[Coverage Counter Display]		
	Display or does not display the coverage counter on the LCD.		
001	-	*CTL	[0 or 1 / 0 / -] 0: Not display, 1: Display

5061	[Toner Remaining Icon Display Change]		
	Display or does not display the remaining toner display icon on the LCD.		
001	-	*CTL	[0 or 1 / 0 / -] 0: Not display, 1: Display

5062	[Parts Replacement Alert Display]		
	Display or does not display the PM part yield on the LCD.		
001	Drum Unit: Bk	*CTL	[0 or 1 / 0 / -] 0: Not display, 1: Display
002	Drum Unit: M	*CTL	
003	Drum Unit: C	*CTL	
004	Drum Unit: Y	*CTL	
005	Development Unit: Bk	*CTL	[0 or 1 / 0 / -] 0: Not display, 1: Display
006	Development Unit: M	*CTL	
007	Development Unit: C	*CTL	
008	Development Unit: Y	*CTL	
009	Developer: Bk	*CTL	[0 or 1 / 0 / -]

010	Developer: M	*CTL	0: Not display, 1: Display
011	Developer: C	*CTL	
012	Developer: Y	*CTL	
013	Image Transfer Belt	*CTL	[0 or 1 / 0 / -] 0: Not display, 1: Display
014	Image Transfer Cleaning Unit	*CTL	
015	Fusing Unit	*CTL	
016	Paper Transfer Roller Unit	*CTL	
017	Waster Toner bottle	*CTL	
018	Fusing Roller	*CTL	
019	Pressure Roller	*CTL	

5066	[PM Parts Display] Display or does not display the "PM parts" button on the LCD.		
001	-	*CTL	[0 or 1 / 0 / -] 0: Not display, 1: Display

5067	[Part Replacement Operation Type]		
	Selects the service maintenance or user maintenance for each PM parts. If the user service is selected, PM alert is displayed on the LCD.		
001	Drum Unit: Bk	*CTL	[0: Service] or [1: User]
002	Drum Unit: M	*CTL	
003	Drum Unit: C	*CTL	
004	Drum Unit: Y	*CTL	
005	Development unit: Bk	*CTL	[0: Service] or [1: User]
006	Development unit: M	*CTL	

Main SP Tables-5

007	Development unit: C	*CTL	[0: Service] or [1: User]
008	Development unit: Y	*CTL	
009	Developer: Bk	*CTL	
010	Developer: M	*CTL	
011	Developer: C	*CTL	
012	Developer: Y	*CTL	
013	Image Transfer Belt	*CTL	[0: Service] or [1: User]
014	Image Transfer Cleaning Unit	*CTL	[0: Service] or [1: User]
015	Fusing Unit	*CTL	[0: Service] or [1: User]
016	Paper Transfer Roller Unit	*CTL	[0: Service] or [1: User]
017	Waste Toner bottle	*CTL	[0: Service] or [1: User]
018	Fusing Roller	*CTL	[0: Service] or [1: User]
019	Pressure Roller	*CTL	[0: Service] or [1: User]

5071	[Set Bypass Paper Size Display]		
001	-	*CTL	[0 or 1 / 0 / -] 0: Off, 1: On
	Turn on or off the paper size confirmation pop-up on the LED. This pop-up prevents mismatching between a paper size selected by the operation panel and an actual paper size on the by-pass tray.		

5074	[Home Screen Login] Sets the application that appears when the home key is pressed.		
091	(0:OFF 1:SDK 2:Reserve)	*CTL	0: Function disable 1: SDK application 2: Legacy application (reserved)
092	Product ID	*CTL	Sets the Application product ID. [0x00 to 0xffff / - / 1/step]
093	Application ID	*CTL	Sets the display category of the application that is specified in the SP5075-001,002 [0 to 255 / 0 / 1/step]

5075	[USB Keyboard] Sets the function of the external keyboard.		
001	Function Setting	*CTL	0: Disable 1: Enable

			Sets the external keyboard type. 0: None 1: English (NA) 2: Turkish 3: Korean 4: Chinese (Simplified) 5: Chinese (Traditional) 6: English (UK) 7: French (France) 8: French (Belgium) 9: French (Canada) 10: German 11: Italian 12: Spanish 13: Spanish (Latin America) 14: Dutch 15: Norwegian 16: Danish 17: Swedish 18: Portuguese 19: Portuguese (Brazil) 20: Finnish 21: Catalan 22: Portuguese 23: Hungarian 24: Czech 25: Russian 26: Japanese 27: Greek
002	Keyboard Type Setting	*CTL	



5083	[LED Light Switch Setting - Toner Near End]		
	Choose whether or not the [Check Status] key blinks when Toner Near End is reached.		
001	-	*CTL	[0: Does not blink/ 1: Blinks]

5104*	[Counter: Size Setting] A3/DLT Double Count (SSP)		
	Specifies whether the counter is doubled for A3/DLT. "Yes" counts except from the bypass tray. When "Yes" is selected, A3 and DLT paper are counted twice, that is A4 x2 and LT x2 respectively. Default setting: Yes		

5113	[Optional Counter Type]		
001	Default Optional Counter Type	*CTL	This program specifies the counter type. 0: None , 1: Key card (RK 3, 4) 2: Key card (down), 3: Prepaid card 4: Coin rack, 5: MF key card 8: Key counter + Vendor 9: Bar-code Printer
002	External Optional Counter Type	*CTL	This program specifies the external counter type. 0: None 1: Expansion Device 1 2: Expansion Device 2 3: Expansion Device 3

5114	[Optional Counter I/F]		
001	MF Key Card Extension	*CTL	[0: Not installed/ 1: Installed (scanning accounting)]

5118	[Disable Copying]		
	This program disables copying.		
001	-	*CTL	[0: Not disabled/ 1: Disabled]

Main SP Tables-5

5120	[Mode Clear Opt. Counter Removal]		
	This program updates the information on the optional counter. When you install or remove an optional counter, check the settings.		
001	-	*CTL	[0: Yes (removed) / 1: Standby (installed but not used)/ 2: No (not removed)]

5121	[Counter Up Timing]		
	This program specifies when the counter goes up. The settings refer to “paper feed” and “paper exit” respectively.		
001	0:Feed 1:Exit	*CTL	[0: Feed / 1: Exit]

5126	[F Size Original Setting]		
	Selects F size original setting.		
001	-	*ENG	[0 to 2 / 0 / 1 /step] 0: 8 1/2" x 13" (Foolscap) 1: 8 1/4" x 13" (Folio) 2: 8" x 13" (F)

5127	[APS Mode]		
	This program disables the APS.		
001	-	*CTL	[0: Not disabled/ 1: Disabled]

5131	[Paper Size Type Selection]		
	The program selects a paper size system from the following alternatives: the AB system (0), the LT system (1), and the AF system (2).		
001	-	*ENG	[0: JP (Japan)/ 1: NA / 2: EU]

5148	Size Detection Off	*CTL	[0: OFF/ 1: ON]
	0: Detect 1: Not Detect		

5150	[Bypass Length Setting]		
	Determines whether the transfer sheet from the by-pass tray is used or not. Normally the paper length for sub scanning paper from the by-pass tray is limited to 600 mm, but this can be extended with this SP to 1260 mm.		
001	0: OFF 1: ON	*CTL	[0: OFF/ 1: ON]

5162	[App. Switch Method]	*CTL	[0: Soft Key Set/ 1: Hard Key Set]
001	This program specifies the switch that selects an application program.		

5167	[Fax Printing Mode at Optional Counter Off]		
	Enables or disables the automatic print out without an accounting device. This SP is used when the receiving fax is accounted by an external accounting device.		
001	-	*CTL	[0 or 1 / 0 / -] 0: Automatic printing 1: No automatic printing

5169	[CE Login]		
	If you will change the printer bit switches, you must 'log in' to service mode with this SP before you go into the printer SP mode.		
001	CE Login	*CTL	[0 or 1 / 0 / -] 0: Disabled 1: Enabled

5181	[Size Adjust]		
	Adjusts the paper size for each tray.		
001	TRAY 1	*ENG	[0 to 3 / 0 (EU/ASIA), 1 (NA) / 1 /step] 0: A4 LEF, 1: LT LEF, 2: B5 LEF, 3: A5 LEF
002	TRAY 2: 1	*ENG	[0 or 1 / 0 (EU/ASIA), 1 (NA) / -] 0: A4 LEF, 1: LT LEF
003	TRAY 2: 2	*ENG	[0 or 1 / 0 (EU/ASIA), 1 (NA) / -] 0: A3, 1: DLT
004	TRAY 2: 3	*ENG	[0 or 1 / 0 (EU/ASIA), 1 (NA) / -] 0: B4, 1: LG
005	TRAY 2: 4	*ENG	[0 or 1 / 0 (EU/ASIA), 1 (NA) / -] 0: B5 LEF, 1: Exe LEF
006	TRAY 3/T-LCT: 1	*ENG	[0 or 1 / 0 (EU/ASIA), 1 (NA) / -] 0: A4 LEF, 1: LT LEF
007	TRAY 3: 2	*ENG	[0 or 1 / 0 (EU/ASIA), 1 (NA) / -] 0: A3, 1: DLT
008	TRAY 3: 3	*ENG	[0 or 1 / 0 (EU/ASIA), 1 (NA) / -] 0: B4, 1: LG
009	TRAY 3: 4	*ENG	[0 or 1 / 0 (EU/ASIA), 1 (NA) / -] 0: B5 LEF, 1: Exe LEF
010	TRAY 4: 1	*ENG	[0 or 1 / 0 (EU/ASIA), 1 (NA) / -] 0: A4 LEF, 1: LT LEF
011	TRAY 4: 2	*ENG	[0 or 1 / 0 (EU/ASIA), 1 (NA) / -] 0: A3, 1: DLT
012	TRAY 4: 3	*ENG	[0 or 1 / 0 (EU/ASIA), 1 (NA) / -] 0: B4, 1: LG
013	TRAY 4: 4	*ENG	[0 or 1 / 0 (EU/ASIA), 1 (NA) / -] 0: B5 LEF, 1: Exe LEF

018	LCT	*ENG	[0 to 2 / 0 (EU/ASIA), 1 (NA) / -] 0: A4LEF, 1: LTLEF, 2: B5LEF
-----	-----	------	--

5186	[RK4]		
	Enables or disables the prevention for RK4 (accounting device) disconnection. If the RK4 is disconnected for 10 seconds when this SP is set to "1 (Enable)", the machine automatically jams a sheet of paper and stops.		

001	-	*ENG	[0 or 1 / 0 / 1/step] 0: Disable 1: Enable
-----	---	------	---

5188	[Copy Nv Version]		
	Displays the version number of the NVRAM on the controller board.		
001	-	-	-

5193	[External Controller Info. Settings]		
001	-	-	Sets the external controller type. This setting is appropriately adjusted if an external controller is installed in the machine. [0 to 10 / 0 / 1/step] 0: No external controller installed 1: EFI controller 2: Ratio controller 3: Egret controller 4 to 10: Reserved

5199	[Paper Exit After Staple End.]		
001	-	*CTL	[0 or 1 / 0 / -] 0: OFF, 1: ON
	<p>Enables or disables the paper feeding out from the finisher without stapling.</p> <ul style="list-style-type: none"> ▪ If this setting is "1: ON", paper is fed out without stapling at the maximum number of the finisher stapling when the machine gets a multiple printing job (over maximum number). ▪ If this setting is "0: OFF", paper is fed out with stapling at the maximum number of the finisher stapling when the machine gets a multiple printing job (over maximum number). 		

5212	[Page Numbering]	*CTL	
	<p>This program adjusts the position of the second side page numbers. A "- value" moves the page number positions to the left edge. A "+ value" moves the page number positions to the right edge.</p>		
003	Duplex Printout Right/Left Position		[-10 to 10 / 0 / 1 mm/step]
004	Duplex Printout High/Low Position		[-10 to 10 / 0 / 1 mm/step]

	[Set Time]		
5302	<p>Adjusts the RTC (real time clock) time setting for the local time zone. Examples: For Japan (+9 GMT), enter 540 (9 hours x 60 min.) DOM: +540 (Tokyo) NA: -300 (New York) EU: + 60 (Paris) CH: +480 (Peking) TW: +480 (Taipei) AS: +480 (Hong Kong)</p>		
002	Time Difference	*CTL #	[-1440 to 1440 / -300 / 1 min./step]

5307	[Summer Time]		
001	Setting	-	[0 to 1 / NA, EU, ASIA / 1 /step] 0: Disabled 1: Enabled NA and EUR: 1, ASIA: 0
	<p>Enables or disables the summer time mode.</p> <p>Note</p> <ul style="list-style-type: none"> Make sure that both SP5-307-3 and -4 are correctly set. Otherwise, this SP is not activated even if this SP is set to "1". 		
003	Rule Set (Start)	-	-
	<p>Specifies the start setting for the summer time mode.</p> <p>There are 8 digits in this SP. For months 1 to 9, the "0" cannot be input in the first digit, so the eight-digit setting for -2 or -3 becomes a seven-digit setting.</p> <p>1st and 2nd digits: The month. [1 to 12] 3rd digit: The week of the month. [1 to 5] 4th digit: The day of the week. [0 to 6 = Sunday to Saturday] 5th and 6th digits: The hour. [00 to 23] 7th digit: The length of the advanced time. [0 to 9 / 1 hour /step] 8th digit: The length of the advanced time. [0 to 5 / 10 minutes /step]</p> <ul style="list-style-type: none"> The digits are counted from the left. Make sure that SP5-307-1 is set to "1". 		
<p>For example: 3500010 (EU default) The timer is advanced by 1 hour at am 0:00 on the 5th Sunday in March</p>			
004	Rule Set (End)	-	-
	<p>Specifies the end setting for the summer time mode.</p> <p>There are 8 digits in this SP.</p> <p>1st and 2nd digits: The month. [1 to 12] 3rd digit: The week of the month. [0 to 5] 4th digit: The day of the week. [0 to 7 = Sunday to Saturday] 5th and 6th digits: The hour. [00 to 23] The 7th and 8 digits must be set to "00".</p> <ul style="list-style-type: none"> The digits are counted from the left. Make sure that SP5-307-1 is set to "1". 		

Main SP Tables-5

5404	[User Code Count Clear]		
001	UCodeCtrClr	-	Clears all counters for users.

5411	[LDAP Certification]		
004	Easy Certification	*CTL	Determines whether easy LDAP certification is done. [0 or 1 / 1 / -] 1: On, 0: Off
005	Password Null Not Permit	*CTL	This SP is referenced only when SP5411-4 is set to "1" (On). [0 or 1 / 0 / -] 0: Password NULL not permitted. 1: Password NULL permitted.
006	Detail Option	*CTL	Determines whether LDAP option (anonymous certification) is turned on or off. Bit0 0: OFF, 1: ON

5413	[Lockout Setting]		
001	Lockout On/Off	*CTL	Switches on/off the lock on the local address book account. [0 or 1 / 0 / -] 0: Off, 1: On
002	Lockout Threshold	*CTL	Sets a limit on the frequency of lockouts for account lockouts. [1 to 10 / 5 / 1/step]

003	Cancellation On/Off	*CTL	Determines whether the system waits the prescribed time for input of a correct user ID and password after an account lockout has occurred. [0 or 1 / 0 / -] 0: Off (no wait time, lockout not cancelled) 1: On (system waits, cancels lockout if correct user ID and password are entered).
004	Cancellation Time	*CTL	Determines the length of time that the system waits for correct input of the user ID and password after a lockout has occurred. This setting is used only if SP5413-3 is set to "1" (on). [1 to 999 / 60 / 1 min./step]

5414	[Access Mitigation]		
001	Mitigation On/Off	*CTL	Switches on/off masking of continuously used IDs and passwords that are identical. [0 or 1 / 0 / -] 0: Off, 1: On
002	Mitigation Time	*CTL	Sets the length of time for excluding continuous access for identical user IDs and passwords. [0 to 60 / 15 / 1 min./step]

5415	[Password Attack]		
001	Permissible Number	*CTL	Sets the number of attempts to attack the system with random passwords to gain illegal access to the system. [0 to 100 / 30 / 1 attempt/step]
002	Detect Time	*CTL	Sets the time limit to stop a password attack once such an attack has been detected. [1 to 10 / 5 / 1 sec./step]

5416	[Access Information]		
001	Access User Max Num	*CTL	Limits the number of users used by the access exclusion and password attack detection functions. [50 to 200 / 200 / 1 users/step]
002	Access Password Max Num	*CTL	Limits the number of passwords used by the access exclusion and password attack detection functions. [50 to 200 / 200 / 1 password/step]
003	Monitor Interval	*CTL	Sets the processing time interval for referencing user ID and password information. [1 to 10 / 3 / 1 sec./step]

5417	[Access Attack]		
001	Access Permissible Number	*CTL	Sets a limit on access attempts when an excessive number of attempts are detected for MFP features. [0 to 500 / 100 / 1/step]
002	Attack Detect Time	*CTL	Sets the length of time for monitoring the frequency of access to MFP features. [10 to 30 / 10 / 1 sec./step]
003	Productivity Fall Wait	*CTL	Sets the wait time to slow down the speed of certification when an excessive number of access attempts have been detected. [0 to 9 / 3 / 1 sec./step]
004	Attack Max Num	*CTL	Sets a limit on the number of requests received for certification in order to slow down the certification speed when an excessive number of access attempts have been detected. [50 to 200 / 200 / 1 attempt/step]

5420	[User Authentication]		
	<p>These settings should be done with the System Administrator.</p> <p>Note</p> <ul style="list-style-type: none"> These functions are enabled only after the user access feature has been enabled. 		
001	Copy	*CTL	<p>Determines whether certification is required before a user can use the copy applications.</p> <p>[0 to 1 / 0 /1]</p> <p>0: On, 1: Off</p>
002	Color Security Setting	*CTL	-
	<p>Enables or disables the color copy limitation for each copy mode when the user authentication is "ON".</p> <p>0: Enable (default), 1: Disable</p> <p>Bit0: B/W mode Bit1: Mono color mode Bit2: Two colors mode Bit3: Full color mode Bit4: Automatic color mode Bit5 to 7: Reserved</p>		
011	DocumentServer	*CTL	<p>Determines whether certification is required before a user can use the document server.</p> <p>[0 or 1/ 0 /1]</p> <p>0: On, 1: Off</p>
021	Fax	*CTL	<p>Determines whether certification is required before a user can use the fax application.</p> <p>[0 or 1/ 0 /1]</p> <p>0: On, 1: Off</p>
031	Scanner	*CTL	<p>Determines whether certification is required before a user can use the scan applications.</p> <p>[0 or 1/ 0 /1]</p> <p>0: On, 1: Off</p>

Main SP Tables-5

041	Printer	*CTL	Determines whether certification is required before a user can use the printer applications. [0 or 1 / 0 / 1] 0: On, 1: Off
051	SDK1	*CTL	Determines whether certification is required before a user can use the SDK application. [0 or 1 / 0 / 1] 0: ON. 1: OFF
061	SDK2		
071	SDK3		

5481	[Authentication Error Code]		
	These SP codes determine how the authentication failures are displayed.		
001	System Log Disp	*CTL	Determines whether an error code appears in the system log after a user authentication failure occurs. [0 or 1 / 0 / 1] 0: Off, 1: On
002	Panel Disp	*CTL	Determines whether an error code appears on the operation panel after a user authentication failure occurs. [0 or 1 / 1 / 1] 1: On, 0: Off

5490	[MF KeyCard (Japan only)]		
001	Job Permit Setting	*CTL	Sets up operation of the machine with a keycard. [0 to 1 / 0 / 1] 0: Disabled. Cancels operation without a user code. 1: Enabled. Allows operation without a user code.
002	Count Mode Setting	*CTL	-

5501	[PM Alarm]	*CTL	-
001	PM Alarm Level	[0 to 9999 / 0 / 1 /step] 0: Alarm off 1 to 9999: Alarm goes off when Value (1 to 9999) x 1000 > PM counter	
002	Original Count Alarm	[0 or 1 / 0 / -] 0: No alarm sounds 1: Alarm sounds after the number of originals passing through the ARDF > 10,000	

5504	[Jam Alarm]	*CTL	-
001	Sets the alarm to sound for the specified jam level (document misfeeds are not included). [0 to 3 / 3 / 1 /step] 0: Zero (Off) 1: Low (2.5K jams) 2: Medium (3K jams) 3: High (6K jams)		

5505	[Error Alarm]		
	Sets the error alarm level. The error alarm counter counts "1" when any SC is detected. However, the error alarm counter decreases by "1" when an SC is not detected during a set number of copied sheets (for example, default 1500 sheets). The error alarm occurs when the SC error alarm counter reaches "5".		
001	-	*CTL	[0 to 255 / C3a: 25, C3b: 35 / 100 copies /step]

Main SP Tables-5

5508*	[CC Call]	*CTL	-
001*	Jam Remains	0: Disable, 1: Enable	
	Enables/disables initiating a call for an unattended paper jam.		
002*	Continuous Jams	0: Disable, 1: Enable	
	Enables/disables initiating a call for consecutive paper jams.		
003*	Continuous Door Open	0: Disable, 1: Enable	
	Enables/disables initiating a call when the front door remains open.		
011*	Jam Detection: Time Length	[3 to 30 / 10 / 1 minute /step]	
	Sets the time a jam must remain before it becomes an "unattended paper jam". This setting is enabled only when SP5508-004 is set to "1".		
012*	Jam Detection: Continuous Count	[2 to 10 / 5 / 1 /step]	
	Sets the number of consecutive paper jams required to initiate a call. This setting is enabled only when SP5508-004 is set to "1".		
013*	Door Open: Time Length	[3 to 30 / 10 / 1 /step]	
	Sets the length of time the door remains open before the machine initiates a call. This setting is enabled only when SP5-508-004 is set to "1".		

5515	[SC/Alarm Setting]	*CTL	-
	With NRS (New Remote Service) in use, these SP codes can be set to issue an SC call when an SC error occurs. If this SP is switched off, the SC call is not issued when an SC error occurs.		
001	SC Call	[0 or 1 / 1 / -] 0: Off 1: On	
002	Service Parts Near End Call		
003	Service Parts End Call		
004	User Call		

006	Communication Test Call	[0 or 1 / 1 / -] 0: Off 1: On
007	Machine Information Notice	
008	Alarm Notice	
009	Non Genuine Tonner Alarm	
010	Supply Automatic Ordering Call	
011	Supply Management Report Call	
012	Jam/Door Open Call	

5516	[Individual PM Part Alarm Call]	*CTL	-
	With @Remote in use, these SP codes can be set to issue an PM alarm call when one of SP parts reaches its yield.		
001	Disable/Enable Setting (0: Not send, 1: Send)		[0 or 1 / 1 / -] 0: Not send, 1: Send
004	Percent yield for triggering PM alert		[1 to 255 / 75 / 1 %/step]

5610	[Base Gamma Control Point: Command]		
004	Factory Setting	*ENG	-
	Recalls the factory settings.		
005	Restore	*ENG	-
	Overwrites the current values onto the factory settings.		
006	Restore	*ENG	-
	Recalls the previous settings.		

5611	[Toner Color in 2C]		
001	B-C	*ENG	[0 to 128 / 100 / 1 /step] 128: Darkest density

	Adjusts the Cyan correction value of the blue signal in two-color mode.		
002	B-M	*ENG	[0 to 128 / 100 / 1 /step] 128: Darkest density
	Adjusts the Magenta correction value of the blue signal in two-color mode.		
003	G-C	*ENG	[0 to 128 / 100 / 1 /step] 128: Darkest density
	Adjusts the Cyan correction value of the blue signal in two-color mode.		
004	G-Y	*ENG	[0 to 128 / 100 / 1 /step] 128: Darkest density
	Adjusts the Yellow correction value of the blue signal in two-color mode.		
005	R-M	*ENG	[0 to 128 / 100 / 1 /step] 128: Darkest density
	Adjusts the Magenta correction value of the blue signal in two-color mode.		
006	R-Y	*ENG	[0 to 128 / 100 / 1 /step] 128: Darkest density
	Adjusts the Yellow correction value of the blue signal in two-color mode.		

5618	[Color Mode Display Selection]		
001	-	*CTL	[0 or 1 / 1 / -] 0: ACS, Colour, Black & White, Two Colour, Single colour 1: ACD, Full Colour, Black & White
	Selects the color selection display on the LCD.		

Note

- Memory Clear (SP5-801)
- The following tables list the items that are cleared. The serial number information, meter charge setting and meter charge counters (SP8-581, 582, 583, 584, and 586) are not cleared.

5801	[Memory Clear]	
001	All Clear	Resets all correction data for process control and all software counters, and returns all modes and adjustments to their default values.
002	Engine	Clears the engine settings.
003	SCS	Initializes default system settings, SCS (System Control Service) settings, operation display coordinates, and ROM update information.
004	IMH Memory Clr	Initializes the IMH settings.
005	Mcs	Initializes the Mcs settings.
006	Copier Application	Initializes all copier application settings.
007	Fax Application	Initializes the fax reset time, job login ID, all TX/RX settings, local storage file numbers, and off-hook timer.
008	Printer Application	<p>The following service settings:</p> <ul style="list-style-type: none"> ▪ Bit switches ▪ Gamma settings (User & Service) ▪ Toner Limit <p>The following user settings:</p> <ul style="list-style-type: none"> ▪ Tray Priority ▪ Menu Protect ▪ System Setting except for setting of Energy Saver ▪ I/F Setup (I/O Buffer and I/O Timeout) ▪ PCL Menu
009	Scanner Application	Initializes the scanner defaults for the scanner and all the scanner SP modes.
010	Web Service	Deletes the network file application management files and thumbnails, and initializes the job login ID.
011	NCS	All setting of Network Setup (User Menu) (NCS: Network Control Service)

Main SP Tables-5

012	R-Fax	Initializes the job login ID, SmartDeviceMonitor for Admin, job history, and local storage file numbers.
014	Clear DCS Setting	Initializes the DCS (Delivery Control Service) settings.
015	Clear UCS Setting	Initializes the UCS (User Information Control Service) settings.
016	MIRS Setting	Initializes the MIRS (Machine Information Report Service) settings.
017	CCS	Initializes the CCS (Certification and Charge-control Service) settings.
018	SRM Memory Clr	Initializes the SRM (System Resource Manager) settings.
019	LCS	Initializes the LCS settings.
020	Web Uapli	Initializes the web user application settings.
021	ECS	Initializes the ECS settings.

5802	[FreeRun]		
	Performs a free run on the copier engine.		
	<p>Note</p> <ul style="list-style-type: none"> ▪ The machine starts free run in the same condition as the sequence of A4/LT, A3 or A4 SEF printing from the 1st or 2nd tray. Therefore, the correct paper should be loaded in the 1st tray or 2nd tray, but paper is not fed. ▪ The main switch has to be turned off and on after using the free run mode for a test. 		
	001	B/W A4 LEF	-
002	FC A4 LEF	-	-
003	FC A3 LEF	*ENG	

5803	[Input Check]	-	See "Input Check Table" (p.3-357).
044	Cooling Fan: Lock	*ENG	0: Unlock 1: Lock
045	2nd Duct Fan2: Lock	*ENG	0: Unlock 1: Lock

5804	[Output Check]	*ENG	See "Output Check Table" (p.3-378).
------	----------------	------	-------------------------------------

5805	[Anti-Condensation Heater]		
002	0:OFF / 1:ON	*ENG	-

5810	[SC Reset]		
	Resets a type A service call condition. <div style="border: 1px solid black; border-radius: 10px; padding: 2px; display: inline-block;"> Note </div> <ul style="list-style-type: none"> ▪ Turn the main switch off and on after resetting the SC code. 		
001	Fusing SC Reset	-	-
002	Hard High Temp. Detection	-	

5811	[MachineSerial] Machine Serial Number Display		
002	Display	*ENG	Displays the machine serial number.
004	BCU		Inputs

Main SP Tables-5

5812	[Service Tel. No. Setting]		
001	Service	*CTL	-
	<p>Sets the telephone number for a service representative. This number is printed on the Counter List, which can be printed with the user's "Counter" menu.</p> <p>This can be up to 20 characters (both numbers and alphabetic characters can be input).</p>		
002	Facsimile	*CTL	-
	<p>Sets the fax or telephone number for a service representative. This number is printed on the Counter List.</p> <p>This can be up to 20 characters (both numbers and alphabetic characters can be input).</p>		
003	Supply	*CTL	-
	<p>Use this to input the telephone number of your supplier for consumables. Enter the number and press #.</p>		
004	Operation	*CTL	-
	<p>Use this to input the telephone number of your sales agency. Enter the number and press #.</p>		

5816	[Remote Service]	*CTL	-
001	I/F Setting		
	<p>Selects the remote service setting.</p> <p>[0 to 2 / 2 / 1 /step]</p> <p>0: Remote service off</p> <p>1: CSS remote service on</p> <p>2: NRS remote service on</p>		

002	CE Call
	<p>Performs the CE Call at the start or end of the service.</p> <p>[0 or 1 / 0 / 1 /step]</p> <p>0: Start of the service</p> <p>1: End of the service</p> <p>Note</p> <ul style="list-style-type: none"> This SP is activated only when SP 5816-001 is set to “2”.
003	Function Flag
	<p>Enables or disables the remote service function.</p> <p>[0 to 1 / 0 / 1 /step]</p> <p>0: Disabled</p> <p>1: Enabled</p>
007	SSL Disable
	<p>Controls if RCG (Remote Communication Gate) confirmation is done by SSL during an RCG send for the @Remote over a network interface.</p> <p>[0 or 1 / 0 / 1 /step]</p> <p>0: Yes. SSL not used.</p> <p>1: No. SSL used.</p>
008	RCG Connect Timeout
	<p>Sets the length of time (seconds) for the time-out when the RCG (Remote Communication Gate) connects during a call via the @Remote network.</p> <p>[1 to 90 / 30 / 1 second /step]</p>
009	RCG Write Timeout
	<p>Sets the length of time (seconds) for the time-out when sent data is written to the RCG during a call over the @Remote network.</p> <p>[1 to 100 / 60 / 1 second /step]</p>
010	RCG Read Timeout
	<p>Sets the length of time (seconds) for the timeout when sent data is written from the RCG during a call over the @Remote network.</p> <p>[1 to 100 / 60 / 1 second /step]</p>

	Port 80 Enable	-
011	Controls if permission is given to get access to the SOAP method over Port 80 on the @Remote network. [0 or 1 / 0 / -] 0: No. Access denied 1: Yes. Access granted.	
	RFU Timing	
013	Selects the timing for the remote firmware updating. [0 or 1 / 1 / -] 0: Any status of a target machine 1: Sleep or panel off mode only	
	RCG – C Registered	
021	This SP displays the RCG-N installation end flag. 0: Installation not completed 1: Installation completed	
	Connect Type (N/M)	
023	This SP displays and selects the RCG-N connection method. [0 or 1 / 0 / 1 /step] 0: Internet connection 1: Dial-up connection	
061	Cert Expire Timing DFU	Proximity of the expiration of the certification. [0 to 0xffffffff / 0 / 1 /step]
062	Use Proxy	This SP setting determines if the proxy server is used when the machine communicates with the service center. [0 or 1 / 0 / 1 /step] 0: Not use 1: Use

063	<p>Proxy Host</p> <p>This SP sets the address of the proxy server used for communication between the RCG device and the gateway. Use this SP to set up or display the customer proxy server address.</p> <p>The address is necessary to set up the embedded RCG-N.</p> <p>Note</p> <ul style="list-style-type: none"> The address display is limited to 128 characters. Characters beyond the 128 character are ignored. This address is customer information and is not printed in the SMC report.
064	<p>Proxy PortNumber</p> <p>This SP sets the port number of the proxy server used for communication between the embedded RCG-N and the gateway. This setting is necessary to set up the embedded RC Gate-N.</p> <p>Note</p> <ul style="list-style-type: none"> This port number is customer information and is not printed in the SMC report.
065	<p>Proxy User Name</p> <p>This SP sets the HTTP proxy certification user name.</p> <p>Note</p> <ul style="list-style-type: none"> The length of the name is limited to 31 characters. Any character beyond the 31st character is ignored. This name is customer information and is not printed in the SMC report.
066	<p>Proxy Password</p> <p>This SP sets the HTTP proxy certification password.</p> <p>Note</p> <ul style="list-style-type: none"> The length of the password is limited to 31 characters. Any character beyond the 31st character is ignored. This name is customer information and is not printed in the SMC report.

	CERT:Up State
	Displays the status of the certification update.
	0 The certification used by RCG-N is set correctly.
	1 The certification request (setAuthKey) for update has been received from the GW URL and certification is presently being updated.
	2 The certification update is completed and the GW URL is being notified of the successful update.
	3 The certification update failed, and the GW URL is being notified of the failed update.
	4 The period of the certification has expired and new request for an update is being sent to the GW URL.
	11 A rescue update for certification has been issued and a rescue certification setting is in progress for the rescue GW connection.
067	12 The rescue certification setting is completed and the GW URL is being notified of the certification update request.
	13 The notification of the request for certification update has completed successfully, and the system is waiting for the certification update request from the rescue GW URL.
	14 The notification of the certification request has been received from the rescue GW controller, and the certification is being stored.
	15 The certification has been stored, and the GW URL is being notified of the successful completion of this event.
	16 The storing of the certification has failed, and the GW URL is being notified of the failure of this event.
	17 The certification update request has been received from the GW URL, the GW URL was notified of the results of the update after it was completed, but an certification error has been received, and the rescue certification is being recorded.

	18	The rescue certification of No. 17 has been recorded, and the GW URL is being notified of the failure of the certification update.
068	CERT:Error	
	Displays a number code that describes the reason for the request for update of the certification.	
	0	Normal. There is no request for certification update in progress.
	1	Request for certification update in progress. The current certification has expired.
	2	An SSL error notification has been issued. Issued after the certification has expired.
	3	Notification of shift from a common authentication to an individual certification.
	4	Notification of a common certification without ID2.
	5	Notification that no certification was issued.
	6	Notification that GW URL does not exist.
069	CERT:Up ID	The ID of the request for certification.
083	Firm Up Status	Displays the status of the firmware update.
085	Firm Up User Check	This SP setting determines if the operator can confirm the previous version of the firmware before the firmware update execution. If the option to confirm the previous version is selected, a notification is sent to the system manager and the firmware update is done with the firmware files from the URL.
086	Firmware Size	Allows the service technician to confirm the size of the firmware data files during the firmware update execution.
087	CERT: Macro Ver.	Displays the macro version of the @Remote certification.

088	CERT: PAC Ver.	Displays the PAC version of the @Remote certification.
089	CERT: ID2 Code	Displays ID2 for the @Remote certification. Spaces are displayed as underscores (_). Asterisks (****) indicate that no @Remote certification exists.
090	CERT: Subject	Displays the common name of the @Remote certification subject. CN = the following 17 bytes. Spaces are displayed as underscores (_). Asterisks (****) indicate that no DESS exists.
091	CERT: Serial No	Displays serial number for the NRS certification. Asterisks (****) indicate that no DESS exists.
092	CERT: Issuer	Displays the common name of the issuer of the @Remote certification. CN = the following 30 bytes. Asterisks (****) indicate that no DESS exists.
093	CERT: Valid Start	Displays the start time of the period for which the current @Remote certification is enabled.
094	CERT: Valid End	Displays the end time of the period for which the current @Remote certification is enabled.
102	CERT: Strength	Displays cryptic strength of the NRS certification. 1: 512 bit 2: 2048 bit
150	Selection Country	
	<p>Select the country where embedded RCG-M is installed in the machine. After selecting the country, you must also set the following SP codes for embedded RCG-M:</p> <ul style="list-style-type: none"> ▪ SP5816-153 ▪ SP5816-154 ▪ SP5816-161 <p>0: Japan, 1: USA, 2: Canada, 3: UK, 4: Germany, 5: France, 6: Italy, 7: Netherlands, 8: Belgium, 9: Luxembourg, 10: Spain</p>	

151	<p>Line Type AutomaticJudgment</p> <p>Press [Execute].</p> <p>Setting this SP classifies the telephone line where embedded RCG-M is connected as either dial-up (pulse dial) or push (DTMF tone) type, so embedded RCG-M can automatically distinguish the number that connects to the outside line.</p> <ul style="list-style-type: none"> ▪ The current progress, success, or failure of this execution can be displayed with SP5816-152. ▪ If the execution succeeded, SP5816-153 will display the result for confirmation and SP5816-154 will display the telephone number for the connection to the outside line.
152	<p>Line Type Judgment Result</p> <p>Displays a number to show the result of the execution of SP5816 151. Here is a list of what the numbers mean.</p> <p>0: Success</p> <p>1: In progress (no result yet). Please wait.</p> <p>2: Line abnormal</p> <p>3: Cannot detect dial tone automatically</p> <p>4: Line is disconnected</p> <p>5: Insufficient electrical power supply</p> <p>6: Line classification not supported</p> <p>7: Error because fax transmission in progress – ioctl() occurred.</p> <p>8: Other error occurred</p> <p>9: Line classification still in progress. Please wait.</p>

153	<p>Selection Dial / Push</p> <p>This SP displays the classification (tone or pulse) of the telephone line to the access point for embedded RCG-M. The number displayed (0 or 1) is the result of the execution of SP5816-151. However, this setting can also be changed manually.</p> <p>[0 or 1 / 0 / 1 /step]</p> <p>0: Tone Dialing Phone 1: Pulse Dialing Phone</p> <p>Inside Japan "2" may also be displayed:</p> <p>0: Tone Dialing Phone 1: Pulse Dialing Phone 10PPS 2: Pulse Dialing Phone 20PPS</p>
154	<p>Outside Line Outgoing Number</p> <p>The SP sets the number that switches to PSTN for the outside connection for embedded RCG-M in a system that employs a PBX (internal line).</p> <ul style="list-style-type: none"> ▪ If the execution of SP5816-151 has succeeded and embedded RCG-M has connected to the external line, this SP display is completely blank. ▪ If embedded RCG-M has connected to an internal line, then the number of the connection to the external line is displayed. ▪ If embedded RCG-M has connected to an external line, a comma is displayed with the number. The comma is inserted for a 2 sec. pause. ▪ The number setting for the external line can be entered manually (including commas).
156	<p>Dial Up User Name</p> <p>Use this SP to set a user name for access to remote dial up. Follow these rules when setting a user name:</p> <ul style="list-style-type: none"> ▪ Name length: Up to 32 characters ▪ Spaces and # allowed but the entire entry must be enclosed by double quotation marks (").

157	<p>Dial Up Password</p> <p>Use this SP to set a password for access to remote dial up. Follow these rules when setting a user name:</p> <ul style="list-style-type: none"> ▪ Name length: Up to 32 characters ▪ Spaces and # allowed but the entire entry must be enclosed by double quotation marks ("").
161	<p>Local Phone Number</p> <p>Use this SP to set the telephone number of the line where embedded RCG-M is connected. This number is transmitted to and used by the Call Center to return calls.</p> <p>Limit: 24 numbers (numbers only)</p>
162	<p>Connection Timing Adjustment Incoming</p> <p>When the Call Center calls out to an embedded RCG-M modem, it sends a repeating ID tone (*#1#). This SP sets the time the line remains open to send these ID tones after the number of the embedded RCG-M modem is dialed up and connected.</p> <p>[0 to 24 / 1 / 1 /step]</p> <p>The actual amount of time is this setting x 2 sec. For example, if you set "2" the line will remain open for 4 sec.</p>
163	<p>Access Point</p> <p>This is the number of the dial-up access point for RCG-M. If no setting is done for this SP code, then a preset value (determined by the country selected) is used.</p> <p>Default: 0</p> <p>Allowed: Up to 16 alphanumeric characters</p>

	Line Connecting		
164	<p>This SP sets the connection conditions for the customer. This setting dedicates the line to RCG-M only, or sets the line for sharing between RCG-M and a fax unit.</p> <p>[0 to 1 / 0 / 1 /step]</p> <p>0: Sharing Fax 1: No Sharing Fax</p> <p>Note</p> <ul style="list-style-type: none"> If this setting is changed, the copier must be cycled off and on. SP5816 187 determines whether the off-hook button can be used to interrupt a RCG-M transmission in progress to open the line for fax transaction. 		
173	Modem Serial No.	This SP displays the serial number registered for the RCG-M.	
174	Retransmission Limit		
	<p>Normally, it is best to allow unlimited time for certification and ID2 update requests, and for the notification that the certification has been completed. However, RCG-M generates charges based on transmission time for the customer, so a limit is placed upon the time allowed for these transactions. If these transactions cannot be completed within the allowed time, do this SP to cancel the time restriction.</p>		
	FAX TX Priority	-	
187	<p>This SP determines whether pushing the off-hook button will interrupt a RCG-M transmission in progress to open the line for fax transaction. This SP can be used only if SP5816 164 is set to "0".</p> <p>[0 or 1/ 0 / -]</p> <p>0: Disable, 1: Enable</p>		
200	Manual Polling	-	Executes the manual polling.

	<p>201</p> <p>Register Status</p> <p>Displays a number that indicates the status of the @Remote service device.</p> <p>0: Neither the registered device by the external nor embedded RCG device is set.</p> <p>1: The embedded RCG device is being set. Only Box registration is completed. In this status, this unit cannot answer a polling request from the external RCG.</p> <p>2: The embedded RCG device is set. In this status, the external RCG unit cannot answer a polling request.</p> <p>3: The registered device by the external RCG is being set. In this status the embedded RCG device cannot be set.</p> <p>4 The registered module by the external RCG has not started.</p>	
202	Letter Number	Allows entry of the number of the request needed for the RCG-N device.
203	Confirm Execute	Executes the inquiry request to the @Remote GW URL.
	<p>204</p> <p>Confirm Result</p> <p>Displays a number that indicates the result of the inquiry executed with SP5816 203.</p> <p>0: Succeeded</p> <p>1: Inquiry number error</p> <p>2: Registration in progress</p> <p>3: Proxy error (proxy enabled)</p> <p>4: Proxy error (proxy disabled)</p> <p>5: Proxy error (Illegal user name or password)</p> <p>6: Communication error</p> <p>7: Certification update error</p> <p>8: Other error</p> <p>9: Inquiry executing</p>	

205	Confirm Place		
	Displays the result of the notification sent to the device from the GW URL in answer to the inquiry request. Displayed only when the result is registered at the GW URL.		
206	Register Execute	Executes "Embedded RCG Registration".	
207	Register Result		
	<p>Displays a number that indicates the registration result.</p> <p>0: Succeeded</p> <p>2: Registration in progress</p> <p>3: Proxy error (proxy enabled)</p> <p>4: Proxy error (proxy disabled)</p> <p>5: Proxy error (Illegal user name or password)</p> <p>6: Communication error</p> <p>7: Certification update error</p> <p>8: Other error</p> <p>9: Registration executing</p>		
208	Error Code		
	<p>Displays a number that describes the error code that was issued when either SP5816-204 or SP5816-207 was executed.</p> <p>[-2147483647 to 2147483647 / 0 / -]</p>		
	Cause	Code	Meaning
	Illegal Modem Parameter	-11001	Chat parameter error
		-11002	Chat execution error
		-11003	Unexpected error
	Operation Error, Incorrect Setting	-12002	Inquiry, registration attempted without acquiring device status.
-12003		Attempted registration without execution of an inquiry and no previous registration.	

		-12004	Attempted setting with illegal entries for certification and ID2.
		-12005	@Remote communication is prohibited. The device has an Embedded RC gate-related problem.
	Operation Error, Incorrect Setting	-12006	A confirmation request was made after the confirmation had been already completed.
		-12007	The request number used at registration was different from the one used at confirmation.
		-12008	Update certification failed because mainframe was in use.
		-12009	ID2 mismatch between an individual certification and NVRAM
		-12010	Certification area is not initialized.
208	Error Caused by Response from GW URL	-2385	Attempted dial up overseas without the correct international prefix for the telephone number.
		-2387	Not supported at the Service Center
		-2389	Database out of service
		-2390	Program out of service
		-2391	Two registrations for same device
		-2392	Parameter error
		-2393	Basil not managed
		-2394	Device not managed
		-2395	Box ID for Basil is illegal
		-2396	Device ID for Basil is illegal
		-2397	Incorrect ID2 format

Main SP Tables-5

		-2398	Incorrect request number format
209	Instal Clear	Releases the machine from its embedded RCG setup.	
250	CommLog Print	Prints the communication log.	

5821	[Remote Service Address]		
002	RCG IP Address	*CTL	Sets the IP address of the RCG (Remote Communication Gate) destination for call processing at the remote service center.

5824	[NV-RAM Data Upload]		
	Uploads the UP and SP mode data (except for counters and the serial number) from the NVRAM to an SD card. For details, see "NVRAM Data Upload/Download" in the "Main chapters: 5. System Maintenance".		
001	NV-RAM Data Upload	#	-

5825	[NV-RAM Data Download]		
	Downloads the UP and SP mode data from an SD card to the NVRAM. For details, see "NVRAM Data Upload/Download" in the "Main chapters: 5. System Maintenance".		
001	NV-RAM Download	#	-

5828	[Network Setting]	*CTL	-
050	1284 Compatibility (Centro)	Enables or disables 1284 Compatibility. [0 or 1 / 1 / 1 / step] 0: Disabled, 1: Enabled	



052	ECP (Centro)	<p>Enables or disables ECP Compatibility. [0 or 1 / 1 / 1 / step] 0: Disabled, 1: Enabled</p> <p> Note</p> <ul style="list-style-type: none"> This SP is activated only when SP5-828-50 is set to "1".
065	Job Spooling	<p>Enables/disables Job Spooling. [0 or 1 / 0 / 1 / step] 0: Disabled, 1: Enabled</p>
066	Job Spooling Clear: Start Time	<p>Treatment of the job when a spooled job exists at power on. 0: ON (Data is cleared) 1: OFF (Automatically printed)</p>
069	Job Spooling (Protocol)	<p>Validates or invalidates the job spooling function for each protocol.</p> <p>0: Validates 1: Invalidates</p> <p>bit0: LPR bit1: FTP bit2: IPP bit3: SMB bit4: BMLinkS bit5: DIPRINT bit6: sftp bit7: (Reserved)</p>
090	TELNET (0: OFF 1: ON)	<p>Enables or disables the Telnet protocol. [0 or 1 / 1 / -] 0: Disable, 1: Enable</p>
091	Web (0: OFF 1: ON)	<p>Enables or disables the Web operation. [0 or 1 / 1 / -] 0: Disable, 1: Enable</p>

145	Active IPv6 Link Local Address	This is the IPv6 local address link referenced on the Ethernet or wireless LAN (802.11b) in the format: "Link Local Address" + "Prefix Length" The IPv6 address consists of a total 128 bits configured in 8 blocks of 16 bits each.
147	Active IPv6 Stateless Address 1	These SPs are the IPv6 status addresses (1 to 5) referenced on the Ethernet or wireless LAN (802.11b) in the format: "Status Address" + "Prefix Length" The IPv6 address consists of a total 128 bits configured in 8 blocks of 16 bits each.
149	Active IPv6 Stateless Address 2	
151	Active IPv6 Stateless Address 3	
153	Active IPv6 Stateless Address 4	
155	Active IPv6 Stateless Address 5	
156	IPv6 Manual Address	This SP is the IPv6 manually set address referenced on the Ethernet or wireless LAN (802.11b) in the format: "Manual Set Address" + "Prefix Length" The IPv6 address consists of a total 128 bits configured in 8 blocks of 16 bits each.
158	IPv6 Gateway Address	This SP is the IPv6 gateway address referenced on the Ethernet or wireless LAN (802.11b). The IPv6 address consists of a total 128 bits configured in 8 blocks of 16 bits each.
161	IPv6 Stateless Auto Setting	Enables or disables the automatic setting for IPv6 stateless. [0 or 1 / 1 / 1 /step] 0: Disable, 1: Enable

236	Web Item visible	Displays or does not display the Web system items. [0 x 0000 to 0 x ffff / 0 x ffff] 0: Not displayed, 1: Displayed bit0: Net RICOH bit1: Consumable Supplier bit2-15: Reserved (all)
237	Web shopping link visible	Displays or does not display the link to Net RICOH on the top page and link page of the web system. [0 to 1 / 1 / 1] 0: Not display, 1:Display
238	Web supplies Link visible	Displays or does not display the link to Consumable Supplier on the top page and link page of the web system. [0 to 1 / 1 / 1] 0: Not display, 1:Display
239	Web Link1 Name	This SP confirms or changes the URL1 name on the link page of the web system. The maximum characters for the URL name are 31 characters.
240	Web Link1 URL	This SP confirms or changes the link to URL1 on the link page of the web system. The maximum characters for the URL are 127 characters.
241	Web Link1 visible	Displays or does not display the link to URL1 on the top page of the web system. [0 to 1 / 1 / 1] 0: Not display, 1:Display
242	Web Link2 Name	Same as "-239"
243	Web Link2 URL	Same as "-240"
244	Web Link2 visible	Same as "-241"

5832	[HDD] HDD Initialization	*CTL	-
001	HDD Formatting (ALL)	Initializes the hard disk. Use this SP mode only if there is a hard disk error.	
002	HDD Formatting (IMH)		
003	HDD Formatting (Thumbnail)		
004	HDD Formatting (Job Log)		
005	HDD Formatting (Printer Fonts)		
006	HDD Formatting (User Info)		
007	Mail RX Data		
008	Mail TX Data		
009	HDD Formatting (Data for a Design)		
010	HDD Formatting (Log)		
011	HDD Formatting (Ridoc I/F)		

5836	[Capture Setting]	*CTL	-
001	Capture Function (0:Off 1:On)	0: Disable, 1: Enable	
	With this function disabled, the settings related to the capture feature cannot be initialized, displayed, or selected.		
002	Panel Setting	0: Displayed, 1: Not displayed	
	Displays or does not display the capture function buttons.		
<p>5836-71 to 5836-78, Copier and Printer Document Reduction</p> <p>The following 6 SP modes set the default reduction for stored documents sent to the document management server via the MLB.</p> <p>Enabled only when optional MLB (Media Link Board) is installed.</p>			
071	Reduction for Copy Color	0: 1to-1, 1: 1/2, 2: 1/3 , 3: 1/4	
072	Reduction for Copy B&W Text	0: 01 , 1: 1/2, 2: 1/3, 3: 1/4, 6: 2/3	

073	Reduction for Copy B&W Other	0: 01 , 1: 1/2, 2: 1/3, 3: 1/4, 6: 2/3
074	Reduction for Printer Color	0: 1to-1, 1: 1/2, 2: 1/3 , 3: 1/4
075	Reduction for Printer B&W	0: 01 , 1: 1/2, 2: 1/3, 3: 1/4, 6: 2/3
076	Reduction for Printer B&W HQ	0: 1to-1 , 1: 1/2, 2: 1/3, 3: 1/4
077	Reduction for Printer Color 1200dpi	1: 1/2, 3: 1/4, 4: 1/6 , 5: 1/8 (2: skipped) , 6: 2/3
078	Reduction for Printer B&W 1200dpi	1: 1/2 , 3: 1/4, 4: 1/6, 5: 1/8 (2: skipped) , 6: 2/3
<p>5836-81 to 5836-86, Stored document format</p> <p>The following 6 SP modes set Sets the default format for stored documents sent to the document management server via the MLB.</p> <p>Enabled only when optional MLB (Media Link Board) is installed.</p>		
081	Format for Copy Color	<p>0: JFIF/JPEG, 1: TIFF/MMR, 2: TIFF/MH, 3: TIFF/MR</p> <p> Note</p> <ul style="list-style-type: none"> This SP is not used in this model.
082	Format for Copy B&W Text	0: JFIF/JPEG, 1: TIFF/MMR , 2: TIFF/MH, 3: TIFF/MR
083	Format Copy B&W Other	0: JFIF/JPEG, 1: TIFF/MMR , 2: TIFF/MH, 3: TIFF/MR
084	Format for Printer Color	<p>0: JFIF/JPEG, 1: TIFF/MMR, 2: TIFF/MH, 3: TIFF/MR</p> <p> Note</p> <ul style="list-style-type: none"> This SP is not used in this model.
085	Format for Printer B&W	0: JFIF/JPEG, 1: TIFF/MMR , 2: TIFF/MH, 3: TIFF/MR
086	Format for Printer B&W HQ	0: JFIF/JPEG, 1: TIFF/MMR, 2: TIFF/MH , 3: TIFF/MR
091	Default for JPEG	[5 to 95 / 50 / 1 /step]

	Sets the JPEG format default for documents sent to the document management server via the MLB with JPEG selected as the format. Enabled only when optional MLB (Media Link Board) is installed.	
101	Primary srv IP address	Sets the IP address for the primary capture server. This is basically adjusted by the remote system.
102	Primary srv scheme	This is basically adjusted by the remote system.
103	Primary srv port number	This is basically adjusted by the remote system.
104	Primary srv URL path	This is basically adjusted by the remote system.
111	Secondary srv IP address	Sets the IP address for the secondary capture server. This is basically adjusted by the remote system.
112	Secondary srv scheme	This is basically adjusted by the remote system.
113	Secondary srv port number	This is basically adjusted by the remote system.
114	Secondary srv URL path	This is basically adjusted by the remote system.
120	Default Reso Rate Switch	This is basically adjusted by the remote system.
121	Reso: Copy (Color)	[0 to 3 / 2 / 1/step]
	Selects the resolution for color copy mode. This is basically adjusted by the remote system. 0: 600dpi/ 1: 300dpi/ 2: 150dpi/ 3: 75dpi	
122	Reso: Copy (Mono)	[0 to 5 / 3 / 1/step]
	Selects the resolution for BW copy mode. This is basically adjusted by the remote system. 0: 600dpi/ 1: 400dpi/ 2: 300dpi/ 3: 200dpi/ 4: 150dpi/ 5: 100dpi	

123	Reso: Print (Color)	This is basically adjusted by the remote system. [0 to 3 / 2 / 1/step]
	Selects the resolution for color print mode. This is basically adjusted by the remote system. 0: 600dpi/ 1: 300dpi/ 2: 150dpi/ 3: 75dpi	
124	Reso: Print (Mono)	This is basically adjusted by the remote system. [0 to 5 / 3 / 1/step]
	Selects the resolution for BW print mode. This is basically adjusted by the remote system. 0: 600dpi/ 1: 400dpi/ 2: 300dpi/ 3: 200dpi/ 4: 150dpi/ 5: 100dpi	
125	Reso: Fax (Color)	This is basically adjusted by the remote system. [0 to 6 / 4 / 1/step]
	Selects the resolution for color fax mode. This is basically adjusted by the remote system. 0: 600dpi/ 1: 400dpi/ 2: 300dpi/ 3: 200dpi/ 4: 150dpi/ 5: 100dpi/ 6: 75dpi	
126	Reso: Fax (Mono)	This is basically adjusted by the remote system. [0 to 6 / 3 / 1/step]
	Selects the resolution for BW fax mode. This is basically adjusted by the remote system. 0: 600dpi/ 1: 400dpi/ 2: 300dpi/ 3: 200dpi/ 4: 150dpi/ 5: 100dpi/ 6: 75dpi	
127	Reso: Scan (Color)	This is basically adjusted by the remote system. [0 to 6 / 4 / 1/step]
	Selects the resolution for color scanning mode. This is basically adjusted by the remote system. 0: 600dpi/ 1: 400dpi/ 2: 300dpi/ 3: 200dpi/ 4: 150dpi/ 5: 100dpi/ 6: 75dpi	
128	Reso: Scan (Mono)	This is basically adjusted by the remote system. [0 to 6 / 3 / 1/step]
	Selects the resolution for BW scanning mode. This is basically adjusted by the remote system. 0: 600dpi/ 1: 400dpi/ 2: 300dpi/ 3: 200dpi/ 4: 150dpi/ 5: 100dpi/ 6: 75dpi	

5840	[IEEE 802.11]		
006	Channel Max	*CTL	[1 to 11 or 13 / 11 or 13 / 1 /step] Europe/Asia: 1 to 13 NA/ Asia: 1 to 11
	<p>Sets the maximum number of channels available for data transmission via the wireless LAN. The number of channels available varies according to location. The default settings are set for the maximum end of the range for each area. Adjust the upper 4 bits to set the maximum number of channels. DFU</p> <p>Note</p> <ul style="list-style-type: none"> Do not change the setting. 		
007	Channel Min	*CTL	[1 to 11 or 13 / 1 / 1 /step] Europe: 1 to 13 NA/ Asia: 1 to 11
	<p>Sets the minimum number of channels available for data transmission via the wireless LAN. The number of channels available varies according to location. The default settings are set for the minimum end of the range for each area. Adjust the lower 4 bits to set the minimum number of channels. DFU</p> <p>Note</p> <ul style="list-style-type: none"> Do not change the setting. 		
008	Transmission Speed	*CTL	0 x 00 to 0 x FF / 0 x FF to Auto / -] 0 x FF to Auto [Default] 0 x 11 - 55M Fix 0 x 10 - 48M Fix 0 x 0F - 36M Fix 0 x 0E - 18M Fix 0 x 0D - 12M Fix 0 x 0B - 9M Fix 0 x 0A - 6M Fix 0 x 07 - 11M Fix 0 x 05 - 5.5M Fix 0 x 08 - 1M Fix 0 x 13 - 0 x FE (reserved) 0 x 12 - 72M (reserved) 0 x 09 - 22M (reserved)

011	WEP key Select	*CTL	Selects the WEP key. [00 to 11 / 00 / 1 binary] 00: Key #1 01: Key #2 (Reserved) 10: Key #3 (Reserved) 11: Key #4 (Reserved)
042	Fragment Thresh	*CTL	Adjusts the fragment threshold for the IEEE802.11 card. [256 to 2346 / 2346 / 1] This SP is displayed only when the IEEE802.11 card is installed.
043	11g CTS to Self	*CTL	Determines whether the CTS self function is turned on or off. [0 to 1 / 1 / 1] 0: Off, 1: On This SP is displayed only when the IEEE802.11 card is installed.
044	11g Slot Time	*CTL	Selects the slot time for IEEE802.11. [0 to 1 / 0 / 1] 0: 20 μ m, 1: 9 μ m
045	WPA Debug Lvl	*CTL	Selects the debug level for WPA authentication application. [1 to 3 / 3 / 1] 1: Info, 2: warning, 3: error This SP is displayed only when the IEEE802.11 card is installed.

5841	[Supply Name Setting]		
001	Toner Name Setting: Black	*CTL	Specifies supply names. These appear on the screen when the user presses the Inquiry button in the user tools screen.
002	Toner Name Setting: Cyan		
003	Toner Name Setting: Yellow		
004	Toner Name Setting: Magenta		
007	OrgStamp		
011	Staple Std1		

Main SP Tables-5

012	Staple Std2		
013	Staple Std3		
014	Staple Std4		
021	Staple Bind 1		
022	Staple Blind2		
023	Staple Blind 3		

5844	[USB]		
001	Transfer Rate	*CTL	0x01: Full speed 0x04: Auto Change
	Adjusts the USB transfer rate.		
002	Vendor ID	*CTL	Displays the vendor ID. DFU
003	Product ID	*CTL	Displays the product ID. DFU
004	Device Release Number	*CTL	Displays the development release version number. DFU

5845	[Delivery Server Setting]	*CTL	-
	Provides items for delivery server settings.		
001	FTP Port No.		[0 to 65535 / 3670 / 1 /step]
	Sets the FTP port number used when image files to the Scan Router Server.		
002	IP Address (Primary)		Range: 000.000.000.000 to 255.255.255.255
	Use this SP to set the Scan Router Server address. The IP address under the transfer tab can be referenced by the initial system setting.		
006	Delivery Error Display Time		[0 to 999 / 300 / 1 second /step]
	Use this setting to determine the length of time the prompt message is displayed when a test error occurs during document transfer with the NetFile application and an external device.		

008	IP Address (Secondary)	Range: 000.000.000.000 to 255.255.255.255	
	Specifies the IP address assigned to the computer designated to function as the secondary delivery server of Scan Router. This SP allows only the setting of the IP address without reference to the DNS setting.		
009	Delivery Server Model	[0 to 4/ 0 / 1 /step]	
	Allows changing the model of the delivery server registered by the I/O device. 0: Unknown 1: SG1 Provided 2: SG1 Package 3: SG2 Provided 4: SG2 Package		
010	Delivery Svr. Capability	[0 to 255 / - / 1 /step]	
	Bit7 = 1 Comment information exists		Changes the capability of the registered that the I/O device registered.
	Bit6 = 1 Direct specification of mail address possible		
	Bit5 = 1 Mail RX confirmation setting possible		
	Bit4 = 1 Address book automatic update function exists		
	Bit3 = 1 Fax RX delivery function exists		
	Bit2 = 1 Sender password function exists		
	Bit1 = 1 Function to link MK-1 user and Sender exists		
Bit0 = 1 Sender specification required (if set to 1, Bit6 is set to "0")			
011	Delivery Svr Capability (Ext)	[0 to 255 / - / 1 /step]	
	Changes the capability of the registered that the I/O device registered.		
	Bit7 = 1 Address book usage limitation (Limitation for each authorized user) Bit6 = 1 RDH authorization link Bit5 to 0: Not used		

Main SP Tables-5

013	Server Scheme (Primary) DFU
	This is used for the scan router program.
014	Server Port Number (Primary) DFU
	This is used for the scan router program.
015	Server URL Path (Primary) DFU
	This is used for the scan router program.
016	Server Scheme (Secondary) DFU
	This is used for the scan router program.
017	Server Port Number (Secondary) DFU
	This is used for the scan router program.
018	Server URL Path (Secondary) DFU
	This is used for the scan router program.
022	Rapid Sending Control
	Enables or disables the prevention function for the continuous data sending error. [0 to 1 / 1 / -] 0: Disable, 1: Enable

5846	[UCS Setting]	*CTL	-
001	Machine ID (For Delivery Server)	Displays ID	
	Displays the unique device ID in use by the delivery server directory. The value is only displayed and cannot be changed. This ID is created from the NIC MAC or IEEE 1394 EUI. The ID is displayed as either 6-byte or 8-byte binary.		
002	Machine ID Clear (For Delivery Server)	Clears ID	
	Clears the unique ID of the device used as the name in the file transfer directory. Execute this SP if the connection of the device to the delivery server is unstable. After clearing the ID, the ID will be established again automatically by cycling the machine off and on.		
003	Maximum Entries	[2000 to 20000/ 2000 /1 /step]	
	Changes the maximum number of entries that UCS can handle. If a value smaller than the present value is set, the UCS managed data is cleared, and the data (excluding user code information) is displayed.		
006	Delivery Server Retry Timer	[0 to 255 / 0 / 1 /step]	
	Sets the interval for retry attempts when the delivery server fails to acquire the delivery server address book.		
007	Delivery Server Retry Times	[0 to 255 / 0 / 1 /step]	
	Sets the number of retry attempts when the delivery server fails to acquire the delivery server address book.		
008	Delivery Server Maximum Entries	[2000 to 50000 / 2000 / 1/step]	
	Sets the maximum number account entries of the delivery server user information managed by UCS.		
010	LDAP Search Timeout	[1 to 255 / 60 / 1 /step]	
	Sets the length of the timeout for the search of the LDAP server.		
020	WSD Maximum Entries	[5 to 250 / 250 / 1 /step]	
	Sets the maximum entries for the address book of the WSD (WS-scanner).		

040	Addr Book Migration (USB → HDD)	
	Not used in this machine.	
041	Fill Addr Acl Info.	
	<p>This SP must be executed immediately after installation of an HDD unit in a basic machine that previously had no HDD. The first time the machine is powered on with the new HDD installed, the system automatically takes the address book from the NVRAM and writes it onto the new HDD. However, the new address book on the HDD can be accessed only by the system administrator at this stage. Executing this SP by the service technician immediately after power on grants full address book access to all users.</p> <p>Procedure</p> <ol style="list-style-type: none"> 1. Turn the machine off. 2. Install the new HDD. 3. Turn the machine on. 4. The address book and its initial data are created on the HDD automatically. 5. However, at this point the address book can be accessed by only the system administrator or key operator. 6. Enter the SP mode and do SP5846-041. After this SP executes successfully, any user can access the address book. 	
043	Addr Book Media	<p>Displays the slot number where an address book data is in.</p> <p>[0 to 30 / - /1]</p> <p>0: Unconfirmed</p> <p>1: SD Slot 1</p> <p>2: SD Slot 2</p> <p>4: USB Flash ROM</p> <p>20: HDD</p> <p>30: Nothing</p>
047	Initialize Local Addr Book	Clears the local address book information, including the user code.
048	Initialize Delivery Addr Book	Clears the distribution address book information, except the user code.
049	Initialize LDAP Addr Book	Clears the LDAP address book information, except the user code.

050	Initialize All Addr Book	Clears all directory information managed by UCS, including all user codes.
051	Backup All Addr Book	Uploads all directory information to the SD card.
052	Restore All Addr Book	Downloads all directory information from the SD card.
053	Clear Backup Info	<p>Deletes the address book data from the SD card in the service slot.</p> <p>Deletes only the files that were uploaded from this machine.</p> <p>This feature does not work if the card is write-protected.</p> <p>Note</p> <ul style="list-style-type: none"> ▪ After you do this SP, go out of the SP mode, and then turn the power off. ▪ Do not remove the SD card until the Power LED stops flashing.
060	Search option	
	<p>This SP uses bit switches to set up the fuzzy search options for the UCS local address book.</p> <p>Bit: Meaning</p> <p>0: Checks both upper/lower case characters</p> <p>1: Japan Only</p> <p>2: Japan Only</p> <p>3: Japan Only</p> <p>4 to 7: Not Used</p>	
062	Complexity option 1	
	<p>Use this SP to set the conditions for password entry to access the local address book. Specifically, this SP limits the password entry to upper case and sets the length of the password.</p> <p>[0 to 32 / 0 / 1 /step]</p> <p>Note</p> <ul style="list-style-type: none"> ▪ This SP does not normally require adjustment. ▪ This SP is enabled only after the system administrator has set up a group password policy to control access to the address book. 	

Main SP Tables-5

063	Complexity Option 2 DFU	
064	Complexity Option 3 DFU	
065	Complexity Option 4 DFU	
091	FTP Auth Port Setting	Specifies the FTP port for getting a distribution server address book that is used in the identification mode. [0 to 65535 / 3671 / 1 /step]
094	Encryption Stat	Shows the status of the encryption function for the address book data.

	[Rep Resolution Reduction]	*CTL	-
5847	<p>SP5847-1 through SP5847-8 changes the default settings of image data transferred externally by the Net File page reference function. [0 to 5 / 2 / 1 /step]</p> <p>SP5847-21 sets the default for JPEG image quality of image files handled by NetFile.</p> <p>“Net files” are jobs to be printed from the document server using a PC and the DeskTopBinder software.</p>		
001	Rate for Copy Color	0: 1x 1: 1/2x 2: 1/3x 3: 1/4x 4: 1/6x 5: 1/8x	
002	Rate for Copy B&W Text		
003	Rate for Copy B&W Other		
004	Rate for Printer Color		
005	Rate for Printer B&W		
006	Rate for Printer Color 1200dpi	0: 1x 1: 1/2x 2: 1/3x 3: 1/4x 4: 1/6x 5: 1/8x	

007	Rate for Printer B&W 1200dpi	0: 1x 1: 1/2x 2: 1/3x 3: 1/4x 4: 1/6x 5: 1/8x
021	Network Quality Default for JPEG	
	Sets the default value for the quality of JPEG images sent as NetFile pages. This function is available only with the MLB (Media Link Board) option installed. [5 to 95 / 50 / 1 /step]	

5848	[Web Service]	*CTL	-
	5848 2 sets the 4-bit switch assignment for the access control setting. Setting of 0001 has no effect on access and delivery from Scan Router. 5848 100 sets the maximum size allowed for downloaded images. The default is equal to 1 gigabyte.		
002	Access Ctrl: Repository (only Lower 4 bits)	0000: No access control 0001: Denies access to DeskTop Binder. 0010: No writing control	
003	Access Control: Doc. Svr. Print (Lower 4 bits)	Switches access control on and off. 0000: No access control 0001: Denies access to DeskTop Binder.	
004	Access Control: uirectory (Lower 4 bits)		
007	Access Ctrl: Comm. Log Fax (Lower 4 bits)		
009	Access Ctrl: Job Ctrl (Lower 4 bits)		
011	Access Ctrl: Devicemanagement (Lower 4bits)		

Main SP Tables-5

021	Access Ctrl: Delivery (Lower 4 bits)	
022	Access Ctrl: uadministration (Lower 4bits)	
099	Repository: Download Image Setting	DFU
100	Repository: Download Image Max. Size	Specifies the max size of the image data that the machine can download. [1 to 2048 / 2048 / 1 MB /step]
210	Setting: LogType: Job1	NIA
211	Setting: LogType: Job2	
212	Setting: LogType: Access	
213	Setting: PrimarySrv	
214	Setting: SecondarySrv	
215	Setting: StartTime	
216	Setting: IntervalTime	
217	Setting: Timing	

5849	[Installation Date]	*CTL	-
001	Display	The "Counter Clear Day" has been changed to "Installation Date" or "Inst. Date".	
002	Switch to Print	Determines whether the installation date is printed on the printout for the total counter. [0 or 1 / 1 / -] 0: OFF (No Print) 1: ON (Print)	
003	Total Counter	-	

5850	[Address Book Function]	*CTL	-
003	Replacement of Circuit Classification Japan Only		
	The machine is sold ready to use with a G3 line. This SP allows you to switch all at once to convert to G4 after you add a G4 line. Conversely, if for some reason the G4 line becomes unusable, you can easily switch back to G3.		

5851	[Bluetooth]	*CTL	-
001	mode		
	Sets the operation mode for the Bluetooth Unit. Press either key. [0:Public] [1: Private]		

5853	[Stamp Data Download]		
	Use this SP to download the fixed stamp data stored in the firmware of the ROM and copy it to the HDD. This SP can be executed as many times as required. This SP must be executed after replacing or formatting the hard disks.  Note ▪ This SP can be executed only with the hard disks installed.		

5856	[Remote ROM Update]		
	Allows the technician to upgrade the firmware using a local port (IEEE1284) when updating the remote ROM.		
002	Local Port	*CTL	[0 to 1 / 0 / 1/step] 0: Disable 1: Enable

5857	[Save Debug Log]	*CTL	-
001	On/Off (1:ON 0:OFF)	0 : OFF, 1: ON	
	Switches the debug log feature on and off. The debug log cannot be captured until this feature is switched on.		

	Target (2: HDD 3: SD)	2: HDD, 3: SD Card
002	Selects the storage device to save debug logs information when the conditions set with SP5-858 are satisfied. [2 to 3 / 2 / 1 /step]	
005	Save to HDD	
	Saves the debug log of the input SC number in memory to the HDD. A unique file name is generated to avoid overwriting existing file names on the SD Card. Up to 4MB can be copied to an SD Card. 4 MB segments can be copied one by one to each SD Card.	
006	Save to SD Card	
	Saves the debug log of the input SC number in memory to the SD card.	
009	Copy HDD to SD Card (Latest 4 MB)	
010	Copy HDD to SD Card (Latest 4 MB Any Key)	
011	Erase HDD Debug Data	
012	Erase SD Card Debug Data	
013	Free Space on SD Card	
014	Copy SD to SD (Latest 4 MB)	
015	Copy SD to SD (Latest 4 MB Any Key)	
016	Make HDD Debug	
017	Make SD Debug	

	[Debug Save When]	*CTL	-
5858	These SPs select the content of the debugging information to be saved to the destination selected by SP5857-002. SP5858-3 stores one SC specified by number. Refer to Section 4 for a list of SC error codes.		
001	Engine SC Error (0: OFF, 1: ON)	Turns on/off the debug save for SC codes generated by copier engine errors. [0 or 1 / 0 / 1/ step]	

002	Controller SC Error (0: OFF, 1: ON)	Turns on/off the debug save for SC codes generated by GW controller errors. [0 or 1 / 0 / 1/ step]
003	Any SC Error	[0 to 65535 / 0 / 1 /step]
004	Jam (0: OFF, 1: ON)	Turns on/off the debug save for jam errors. [0 or 1 / 0 / 1/ step]

5859	[Debug Save Key No.]	*CTL	-
001	Key 1	<p>These SPs allow you to set up to 10 keys for log files for functions that use common memory on the controller board.</p> <p>[–9999999 to 9999999 / 0 / –]</p>	
002	Key 2		
003	Key 3		
004	Key 4		
005	Key 5		
006	Key 6		
007	Key 7		
008	Key 8		
009	Key 9		
010	Key 10		

5860	[SMTP/POP3/IMAP4]	*CTL	-
020	Partial Mail Receive Timeout	[1 to 168 / 72 / 1 hour/step]	
	Sets the amount of time to wait before saving a mail that breaks up during reception. The received mail is discarded if the remaining portion of the mail is not received during this prescribed time.		

021	MDN Response RFC2298 Compliance		[0 to 1 / 1 / –]
	Determines whether RFC2.5298 compliance is switched on for MDN reply mail. 0: No 1: Yes		
022	SMTP Auth. From Field Replacement		[0 to 1 / 0 / –]
	Determines whether the FROM item of the mail header is switched to the validated account after the SMTP server is validated. 0: No. "From" item not switched. 1: Yes. "From item switched.		
025	SMTP Auth. Direct Setting		[0 or 1 / - / –]
	Selects the authentication method for SMPT. Bit switch: <ul style="list-style-type: none"> ▪ Bit 0: LOGIN ▪ Bit 1: PLAIN ▪ Bit 2: CRAM MD5 ▪ Bit 3: DIGEST MD5 ▪ Bit 4 to 7: Not used <div style="border: 1px solid black; border-radius: 10px; padding: 2px; display: inline-block;">  Note </div> <ul style="list-style-type: none"> ▪ This SP is activated only when SMTP authorization is enabled by UP mode. 		
026	S/MIME: MIME Header Setting	-	Selects the MIME header type of an E-mail sent by S/MIME. [0 to 2 / 0 / 1] 0: Microsoft Outlook Express standard 1: Internet Draft standard 2: RFC standard

5870	[Common Key Info Writing]		
001	Writing	*CTL	Writes to flash ROM the common proof for validating the device for @Remote specifications.
003	Initialize	*CTL	Initializes the data area of the common proof for validating.

5873	[SD Card Appli Move]		
001	Move Exec	This SP copies the application programs from the original SD card in SD card slot 2 to an SD card in SD card slot 1.	
002	Undo Exec	This SP copies back the application programs from an SD card in SD Card Slot 2 to the original SD card in SD card slot 1. Use this menu when you have mistakenly copied some programs by using "Move Exec" (SP5873-1).	

5875	[SC Auto Reboot]		
001	Reboot Setting	*CTL	<p>Enables or disables the automatic reboot function when an SC error occurs.</p> <p>[0 or 1 / 0 / -]</p> <p>0: The machine reboots automatically when the machine issues an SC error and logs the SC error code. If the same SC occurs again, the machine does not reboot.</p> <p>1: The machine does not reboot when an SC error occurs.</p> <p>The reboot is not executed for Type A or C SC codes.</p>
002	Reboot Type	*CTL	<p>Selects the reboot method for SC.</p> <p>[0 or 1 / 0 / -]</p> <p>0: Manual reboot, 1: Automatic reboot</p>

Main SP Tables-5

5878	[Option Setup]		
001	Data Overwrite Security	-	Enables the Data Overwrite Security unit. Press "EXECUTE" on the operation panel. Then turn the machine off and on.
002	HDD Encryption	-	Installs the HDD Encryption unit.

5881	[Fixed Phrase Block Erasing]		
001	-	-	Deletes the fixed phrase.

5883	[Line Speed Selection]		
	Selects the line speed for middle thick paper.		
001	Middle Thick	*ENG	[0 or 1 / 0 / 1 /step] 0: MID CARD: Half Speed (115 mm/sec) 1: MID CARD: Normal Speed (C2.5c: 154, C2.5d: 205 mm/sec)

5885	[Set WIM Function] Web Image Monitor Settings		
	Close or disclose the functions of web image monitor.		
020	DocSvr Acc Ctrl	*CTL	0: OFF, 1: ON Bit Meaning 0: Forbid all document server access (1) 1: Forbid user mode access (1) 2: Forbid print function (1) 3: Forbid fax TX (1) 4: Forbid scan sending (1) 5: Forbid downloading (1) 6: Forbid delete (1) 7: Reserved

050	DocSvr Format	*CTL	Selects the display type for the document box list. [0 to 2 / 0 / 1] 0: Thumbnail, 1: Icon, 2: Details
051	DocSvr Trans	*CTL	Sets the number of documents to be displayed in the document box list. [5 to 20 / 10 / 1]
100	Set Signature	*CTL	Selects whether the signature is added to the scanned documents with the WIM when they are transmitted by an e-mail. [0 to 2 / 0 / 1/step] 0: Setting for each e-mail 1: Signature for all 2: No signature
101	Set Encrypsion	*CTL	Determines whether the scanned documents with the WIM are encrypted when they are transmitted by an e-mail. [0 to 1 / 0 / 1] 0: Not encrypted, 1:Encryption
200	Detect Mem Leak	*CTL	Not Used
201	DocSvr Timeout	*CTL	Not Used

5887	[SD Get Counter]		
	This SP determines whether the ROM can be updated.		
001	-	*CTL	<p>This SP sends a text file to an SD card inserted in SD card Slot 2 (lower slot). The operation stores. The file is stored in a folder created in the root directory of the SD card called SD_COUNTER. The file is saved as a text file (*.txt) prefixed with the number of the machine.</p> <ol style="list-style-type: none"> 1. Insert the SD card in SD card Slot 2 (lower slot). 2. Select SP5887 then touch [EXECUTE]. <p>Touch [Execute] in the message when you are prompted.</p>

5888	[Personal Information Protect]		
001	-	*CTL	<p>Selects the protection level for logs. [0 to 1 / 0 / 1}</p> <p>0: No authentication, No protection for logs</p> <p>1: No authentication, Protected logs (only an administrator can see the logs)</p>

5893	[SDK Application Counter]	*CTL	-
	Displays the counter name of each SDK application.		
001	SDK-1		
002	SDK-2		
003	SDK-3		
004	SDK-4		
005	SDK-5		

006	SDK-6
-----	-------

5894	[External Counter Setting]		
	Test Name1_1		
001	Switch Charge Mode	*ENG	[0 to 2 / 0 / 1/step]

5895	[Application Invalidation]		
	Enables or disables the printer or scanner application. These SPs are used only when an external controller is installed in the machine.		
001	Printer	*CTL	[0 or 1 / 0 / -]
002	Scanner	*CTL	0: Enable 1: Disable

5907	[Plug & Play Maker/Model Name]		
001	Selects the brand name and the production name for Windows Plug & Play. This information is stored in the NVRAM. If the NVRAM is defective, these names should be registered again. After selecting, press the "Original Type" key and "#" key at the same time. When the setting is completed, the beeper sounds five times.		

5913	[Switchover Permission Time]		
002	Print Application Timer	*CTL	[3 to 30 / 3 / 1 second /step]
	Sets the amount of time to elapse while the machine is in standby mode (and the operation panel keys have not been used) before another application can gain control of the display.		

5967	[Copy Server : Set Function]	*CTL	0: ON, 1: OFF
001	Enables and disables the document server. This is a security measure that prevents image data from being left in the temporary area of the HDD. After changing this setting, you must switch the main switch off and on to enable the new setting.		

5974	[Cherry Server]		
	Specifies which version of ScanRouter, "Lite" or "Full", is installed.		
001	(0:Light 1:Full)	*CTL	[0 or 1 / 0 / -]

5985	[Device Setting]		
	The NIC and USB support features are built into the GW controller. Use this SP to enable and disable these features. In order to use the NIC and USB functions built into the controller board, these SP codes must be set to "1".		
001	On Board NIC	[0 to 2 / 0 / 1 /step] 0: Disable, 1: Enable, 2: Function limitation When the "Function limitation" is set, "On board NIC" is limited only for the NRS or LDAP/NT authentication.  Note <ul style="list-style-type: none"> Other network applications than NRS or LDAP/NT authentication are not available when this SP is set to "2". Even though you can change the initial settings of those network applications, the settings do not work. 	
002	On Board USB	[0 or 1 / 0 / 1/step] 0: Disable, 1: Enable	

5987	[Mech. Counter]		
001	0: OFF / 1: ON	*ENG	This SP detects that a mechanical counter device is removed. If it is detected, SC610 occurs.

5990	[SP print mode]		
	Prints out the SMC sheets.		
001	All (Data List)	-	
002	SP (Mode Data List)	-	
003	User Program	-	
004	Logging Data	-	
005	Diagnostic Report	-	
006	Non-Default	-	
007	NIB Summary	-	
008	Capture Log	-	
021	Copier User Program	-	
022	Scanner SP	-	
023	Scanner User Program	-	
024	SDK/J Summary	-	
025	SDK/J Application Info	-	

5992	[SP Text mode]		
	Exports the SMC sheet data to the SD Card.		
001	All (Data List)	-	Press "Execute" key to start exporting the SMC data in the SP mode display.
002	SP (Mode Data List)	-	
003	User Program	-	
004	Logging Data	-	
005	Diagnostic Report	-	
006	Non-Default	-	
007	NIB Summary	-	

Main SP Tables-5

008	Capture Log	-	
021	Copier User Program	-	
022	Scanner SP	-	
023	Scanner User Program	-	
024	SDK/J Summary	-	
025	SDK/J Application Info	-	
026	Printer SP mode	-	

5998	[Fusing Cont mode] Fusing Control Mode		
	Turns the silent fusing warm-up mode on or off.		
001	fast/silent	*ENG	[0 or 1 / 1 / -] 0: Silent (less noise) 1: Fast (less time)

3.6 MAIN SP TABLES-6

3.6.1 SP6-XXX (PERIPHERALS)

6006	[ADF Adjustment]		
	Adjusts the side-to-side and leading registration of originals with the ARDF.		
001	Side-to-Side Regist: Front	*ENG	[-3.0 to 3.0 / 0 / 0.1 mm/step]
002	Side-to-Side Regist: Rear		
003	Leading Edge Registration	*ENG	[-5.0 to 5.0 / 0 / 0.1 mm/step]
	Adjusts the amount of paper buckle to correct original skew for the front and rear sides.		
005	Buckle: Duplex Front	*ENG	[-3.0 to 3.0 / 0 / 0.1 mm/step]
006	Buckle: Duplex Rear		[-2.5 to 2.5 / 0 / 0.1 mm/step]
	Adjusts the erase margin at the original trailing edge.		
007	Rear Edge Erase	*ENG	[-10 to 10 / 0 / 0.1 mm/step]

6007	[ADF INPUT Check]		
	Displays the signals received from the sensors and switches of the ARDF. Only Bit 0 is used for ADF input check (🖱️ p.3-357).		

6008	[ADF OUTPUT Check]		
	Activates the electrical components for functional check. It is not possible to activate more than one component at the same time (🖱️ p.3-378).		

6009	[ADF Free Run]		
	Performs a DF free run in simplex, duplex mode or stamp mode.		
001	Free Run Simplex Motion	*ENG	-

Main SP Tables-6

002	Free Run Duplex Motion	*ENG	
003	Free Run Stamp Motion	*ENG	

6010	[Stamp Position Adj.] Fax Stamp Position Adjustment		
	Adjusts the horizontal position of the stamp on the scanned originals.		
001	-	*ENG	[-5.0 to 5.0 / 0 / 1 mm/step]

6016	[Original Size Detect Setting]			
	Specifies the original size for a size detected by the original sensor, since original sensors cannot recognize all sizes.			
001	-	*ENG	[0 or 1 / - / -] 0: Setting 1, 1: Setting 2	
		NA	Setting 1	Setting 2
			DLT SEF	Folio SEF 11" x 15"
			LG SEF	Foolscap SEF
			LT SEF	US EXE 8" x 10"
			LT LEF	US EXE LEF
		EU/ ASIA	DLT SEF	8K 267 x 390 mm
			LT SEF	16K 195 x 267 mm
			LT LEF	16K 267 x 195 mm

6017	[DF Magnification Adj.] DF Magnification Adjustment		
	Adjusts the magnification in the sub-scan direction for the ARDF.		
001	-	*CTL	[-5.0 to 5.0 / 0 / 0.1 %/step]

6020	[Skew Correction Moving Setting]		
	Turns the original skew correction in the ARDF for all original sizes on or off.		
001	-	*ENG	[0 or 1 / 0 / -] 0: Off (only for small original sizes) 1: On (for all original sizes)

6128	[Punch Position: Sub Scan]		
	Adjusts the punching position in the sub scan direction.		
001	Domestic 2Hole (Europe 2Hole)	*ENG	[-7.5 to 7.5 / 0 / 0.5 mm/step]
002	North America 3Hole	*ENG	
003	Europe 4Hole	*ENG	
004	North Europe 4Hole	*ENG	
005	North America 2Hole	*ENG	

6129	[Punch Position: Main Scan]		
	Adjusts the punching position in the main scan direction.		
001	Domestic 2Hole (Europe 2Hole)	*ENG	[-2.0 to 2.0 / 0 / 0.4 mm/step]
002	North America 3Hole	*ENG	
003	Europe 4Hole	*ENG	
004	North Europe 4Hole	*ENG	
005	North America 2Hole	*ENG	

6130	[Skew Correction: Buckle Adj.]		
	Adjusts the paper buckle for each paper size.		
001	A3T	*ENG	[-5.0 to 5.0 / 0 / 0.25 mm/step]
002	B4T	*ENG	
003	A4T	*ENG	
004	A4Y	*ENG	
005	B5T	*ENG	
006	B5Y	*ENG	
007	DLT-T	*ENG	
008	LG-T	*ENG	
009	LT-T	*ENG	
010	LT-Y	*ENG	
011	12*18	*ENG	
012	Other	*ENG	

6131	[Skew Correction Control]		
	Selects the skew correction control for each paper size. These are only activated for B804/B805.		
001	A3T	*ENG	[0 or 1 / 0 / 1/step] 0: No (No skew correction) 1: Roller Stop Skew Correction
002	B4T	*ENG	
003	A4T	*ENG	
004	A4Y	*ENG	
005	B5T	*ENG	
006	B5Y	*ENG	
007	DLT-T	*ENG	

008	LG-T	*ENG	
009	LT-T	*ENG	
010	LT-Y	*ENG	
011	12*18	*ENG	
012	Other	*ENG	

6132	[Jogger Fence Fine Adj]		
	This SP adjusts the distance between the jogger fences and the sides of the stack on the finisher stapling tray in the (Booklet) Finisher B804/B805. The adjustment is done perpendicular to the direction of paper feed.		
001	A3T	*ENG	[-1.5 to 1.5 / 0 / 0.5 mm/step] + Value: Increases distance between jogger fences and the sides of the stack. - Value: Decreases the distance between the jogger fences and the sides of the stack.
002	B4T	*ENG	
003	A4T	*ENG	
004	A4Y	*ENG	
005	B5T	*ENG	
006	B5Y	*ENG	
007	DLT-T	*ENG	
008	LG-T	*ENG	
009	LT-T	*ENG	
010	LT-Y	*ENG	
011	12*18	*ENG	
012	Other	*ENG	

Main SP Tables-6

6133	[Staple Position Adjustment]		
	Adjusts the staple position for each finisher (B408/B804/B805). + Value: Moves the staple position to the rear side. - Value: Moves the staple position to the front side.		
001	Finisher1	*ENG	[-3.5 to 3.5 / 0 / 1/step]

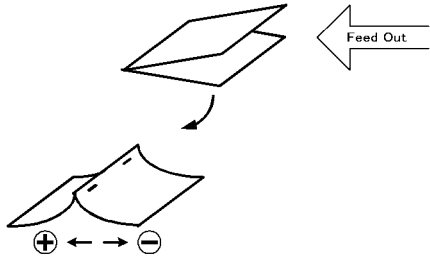
6134	[Saddle Stitch Position Adjust]	
	Use this SP to adjust the stapling position of the booklet stapler when paper is stapled and folded in the Booklet Finisher B804.	
001	A3T	<p>[-3.0 to 3.0 / 0 / 0.2 mm/step]</p> <p>+ Value: Shifts staple position toward the crease. - Value: Shifts staple position away from the crease.</p> 
002	B4T	
003	A4T	
004	B5T	
005	DLT-T	
006	LG-T	
007	LT-T	
008	12*18	
009	Other	

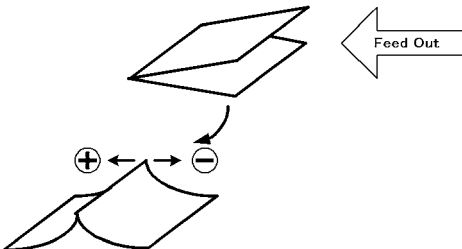
6135	[Folder Position Adj.]	
	This SP corrects the folding position when paper is stapled and folded in the Booklet Finisher B804.	
001	A3T	<p>[-3.0 to 3.0 / 0 / 0.2 mm/step]</p> <p>+ Value: Shifts staple position toward the crease.</p> <p>- Value: Shifts staple position away from the crease.</p> 
002	B4T	
003	A4T	
004	B5T	
005	DLT-T	
006	LG-T	
007	LT-T	
008	12*18	
009	Other	

6136	[Folding Number]	
	Sets the number of times that folding is done in the Booklet Finisher B804.	
001	-	[2 to 30 / 2 / 1 time/step]

6139	[FIN (KIN) INPUT Check] Finisher (B408) Input Check	
	Displays the signals received from sensors and switches of the booklet finisher. (p.3-357)	

6140	[FIN (EUP) INPUT Check] Finisher (B804/B805) Input Check	
	Displays the signals received from sensors and switches of the (booklet) finisher. (p.3-357)	

6144	[FIN (KIN) OUPUT Check] Finisher (B408) Output Check
	Displays the signals received from sensors and switches of the booklet finisher. (🖨️ p.3-378)

6145	[FIN (EUP) OUPUT Check] Finisher (B804/B805) Output Check
	Displays the signals received from sensors and switches of the (booklet) finisher. (🖨️ p.3-378)

6149	[Max. Pre-Stack Sheet]	*ENG	Number of Pre-Stack Sheets
	This SP sets the number of sheets sent to the pre-stack tray. 📌 Note <ul style="list-style-type: none"> You may need to adjust this setting or switch it off when feeding thick or slick paper. 		
001	-	[0 to 3 / 3 / 1 sheet/step]	

6150	[INPUT Check]
	Displays the signals received from sensors and switches of the bridge unit (D386) / side tray (D542) (🖨️ p.3-357).

6151	[OUTPUT Check]
	Displays the signals received from sensors and switches of the bridge unit (D386)/ side tray (D542) (🖨️ p.3-378).

6152	[INPUT Check]
	Displays the signals received from sensors and switches of the shift tray (D388) (🖨️ p.3-357).

6153	[OUTPUT Check]
	Displays the signals received from sensors and switches of the shift tray (D388) (☛ p.3-378).

6154	[INPUT Check]
	Displays the signals received from sensors and switches of the 1 bin tray (D536) (☛ p.3-357).

6155	[OUTPUT Check]
	Displays the signals received from sensors and switches of the 1 bin tray (D536) (☛ p.3-378).
001	1 bin: Junction Solenoid

6160	[INPUT Check]
	Displays the signals received from sensors and switches of the two-tray paper feed unit (D537), LCT 2000 (D538) and LCT 1200 (D539) (☛ p.3-357).

6161	[OUTPUT Check]
	Displays the signals received from sensors and switches of the two-tray paper feed unit (D537), LCT 2000 (D538) and LCT 1200 (D539) (☛ p.3-378).

3.7 MAIN SP TABLES-7

3.7.1 SP7-XXX (DATA LOG)

7401	[Total SC]		
	Displays the number of SC codes detected.		
001	SC Counter	*CTL	[0 to 65535 / - / 1/step]
002	Total SC Counter	*CTL	[0 to 65535 / - / 1/step]

7403	[SC History]		
	Logs the SC codes detected. The 10 most recently detected SC Codes are not displayed on the screen, but can be seen on the SMC (logging) outputs.		
001	-	*CTL	-
002	-		
003	-		
004	-		
005	-		
006	-		
007	-		
008	-		
009	-		
010	-		

7502	[Total Paper Jam]		
	Displays the total number of jams detected.		
001	Jam Counter	* CTL	[0 to 65535 / - / 1/step]
002	Total Jam Counter	* CTL	[0 to 65535 / - / 1/step]

7503	[Total Original Jam]		
	Displays the total number of original jams.		
001	Original Jam counter	*CTL	[0 to 9999 / - / 1 original/step]
002	Total Original Counter	*CTL	-

7504	[Paper Jam Loc] ON: On check, OFF: Off Check		
	Displays the number of jams according to the location where jams were detected. <div style="border: 1px solid black; border-radius: 10px; padding: 2px; display: inline-block;"> ↓ Note </div> <ul style="list-style-type: none"> ▪ The LCT is counted as the 3rd feed station. 		
001	At Power On	*CTL	For details, see "Jam Detection" in the "Main Chapters: 6. Troubleshooting".
003	Tray 1: On	*CTL	
004	Tray 2: On	*CTL	
005	Tray 3: On	*CTL	
006	Tray 4: On	*CTL	
007	LCT : On	*CTL	
008	Registration Sn: On (Bypass)	*CTL	
009	Registration Sn: On (Duplex)	*CTL	
011	Vertical Trans. 1: On	*CTL	
012	Vertical Trans. 2: On	*CTL	

Main SP Tables-7

013	Vertical Trans. 3: On	*CTL	For details, see "Jam Detection" in the "Main Chapters: 6. Troubleshooting".
014	Vertical Trans. 4: On	*CTL	
017	Registration: On	*CTL	
018	Fusing Entrance: On	*CTL	
019	Fusing Exit: On	*CTL	
020	Paper Exit: On	*CTL	
021	Bridge Tray Exit: On	*CTL	
022	Bridge Relay: On	*CTL	
024	Junction Gate Sensor : On	*CTL	
025	Duplex Exit: On	*CTL	
026	Duplex Entrance: On (In)	*CTL	
027	Duplex Entrance: On (Out)	*CTL	
051	Vertical Trans. 1: Off	*CTL	
052	Vertical Trans. 2: Off	*CTL	
053	Vertical Trans. 3: Off	*CTL	
054	Vertical Trans. 4: Off	*CTL	
057	Registration Sensor: Off	*CTL	
058	LCT Feed Sensor : Off		
060	Paper Exit Off	*CTL	
061	Bridge Tray Exit: Off	*CTL	For details, see "Jam Detection" in the "Main Chapters: 6. Troubleshooting".
062	Bridge Relay: Off	*CTL	
064	Junction Gate Sensor : Off	*CTL	
065	Duplex Exit: Off	*CTL	
066	Duplex Entrance: Off (In)	*CTL	
067	Duplex entrance : Off (Out)	*CTL	

100	Finisher Entrance: KIN	*CTL	
101	Finisher Shift Tray Exit: KIN	*CTL	
102	Finisher Staple: KIN	*CTL	
103	Finisher Exit: KIN	*CTL	
105	Finisher Tray Lift Motor: KIN	*CTL	
106	Finisher Jogger Motor: KIN	*CTL	
107	Finisher Shift Motor: KIN	*CTL	
108	Finisher Staple Motor: KIN	*CTL	
109	Finisher Exit Motor: KIN	*CTL	
191	Finisher Entrance: EUP	*CTL	
192	Finisher Proof Exit: EUP	*CTL	
193	Finisher Shift Tray Exit: EUP	*CTL	
194	Finisher Stapler Exit: EUP	*CTL	
195	Finisher Exit: EUP	*CTL	
198	Finisher Folder: EUP	*CTL	
199	Finisher Tray Motor: EUP	*CTL	
200	Finisher Jogger Motor: EUP	*CTL	
201	Finisher Shift Motor: EUP	*CTL	
202	Finisher Staple Moving Motor: EUP	*CTL	
203	Finisher Staple Motor: EUP	*CTL	
204	Finisher Folder Motor: EUP	*CTL	
206	Finisher Punch Motor: EUP	*CTL	

7505	[Original Jam Det]
	Displays the total number of original jams by location.

Main SP Tables-7

001	At Power On	*CTL	-
003	Skew Correction Sensor: On	*CTL	
004	Registration Sensor: On	*CTL	
005	Original Exit Sensor: On	*CTL	
006	Registration Sensor: On	*CTL	
007	Original Exit Sensor: On	*CTL	
008	Reverse Sensor: On	*CTL	
053	Skew Correction Sensor: Off	*CTL	
054	Registration Sensor: Off	*CTL	
055	Original Exit Sensor: Off	*CTL	
056	Registration Sensor: Off	*CTL	
057	Original Exit Sensor: Off	*CTL	
058	Reverse Sensor: Off	*CTL	

7506	[Jam Count by Paper Size]		
	Displays the number of jams according to the paper size.		
005	A4 LEF	*CTL	[0 to 9999 / - / 1 sheet/step]
006	A5 LEF	*CTL	
014	B5 LEF	*CTL	
038	LT LEF	*CTL	
044	HLT LEF	*CTL	
132	A3 SEF	*CTL	[0 to 9999 / - / 1 sheet/step]
133	A4 SEF	*CTL	
134	A5 SEF	*CTL	
141	B4 SEF	*CTL	

142	B5 SEF	*CTL	
160	DLT SEF	*CTL	
164	LG SEF	*CTL	
166	LT SEF	*CTL	
172	HLT SEF	*CTL	
255	Others	*CTL	[0 to 9999 / - / 1 sheet/step]

7507	[Plotter Jam History]		
	Displays the 10 most recently detected paper jams.		
001	-	*CTL	-
002	-		
003	-		
004	-		
005	-		
006	-		
007	-		
008	-		
009	-		
010	-		

7508	[Original Jam History]		
	Displays the 10 most recently detected original jams.		
001	-	*CTL	-
002	-		
003	-		
004	-		
005	-		
006	-		
007	-		
008	-		
009	-		
010	-		

7624	Part Replacement Operation ON/OFF	
	Selects the PM maintenance for each part.	
001	Drum unit: Bk	[0 or 1 / 1 / -] 0: Not PM maintenance 1: PM maintenance
002	Drum unit: M	
003	Drum unit: C	
004	Drum unit: Y	
005	Development unit: Bk	
006	Development unit: M	
007	Development unit: C	
008	Development unit: Y	
009	Developer: Bk	
010	Developer: M	

011	Developer:C	[0 or 1 / 1 / -] 0: Not PM maintenance 1: PM maintenance
012	Developer:Y	
013	Image Transfer Belt	
014	Image Transfer Cleaning Unit	
015	Fusing Unit	
016	Paper Transfer Roller Unit	
017	Waste Toner bottle	
018	Fusing Roller	
019	Pressure Roller	

7801	[ROM No/ Firmware Version]		
002	Engine	*CTL	Displays all versions and ROM numbers in the machine.

7803	[PM Counter Display] (Page, Unit, [Color])		
	<p>Displays the number of sheets printed for each current maintenance unit. PM counters click up based on the number of A4 (LT) LEF size sheets printed. Therefore, the A3 (DLT) Double Count is activated. The Double Count cannot be deactivated.</p> <p>When a unit is replaced, the machine automatically detects that the new unit is installed. Then, the current PM counter value is automatically moved to the PM Counter - Previous (SP7-906-1 to 10) and is reset to "0".</p> <p>The total number of sheets printed with the last unit replaced can be checked with SP7-906-1 to 10.</p> <p>NOTE: The LCT is counted as the 3rd feed station.</p>		
	001	Paper	*CTL -
	002	Page: PCU: Bk	*ENG -
003	Page: PCU: M		
004	Page: PCU: C		

Main SP Tables-7

005	Page: PCU: Y		
006	Page: Development Unit: Bk		
007	Page: Development Unit: M		
008	Page: Development Unit: C		
009	Page: Development Unit: Y		
010	Page: Developer: Bk	*ENG	-
011	Page: Developer: M		
012	Page: Developer: C		
013	Page: Developer: Y		
014	Page: Image Transfer		
015	Page: Cleaning Unit		
016	Page: Fusing Unit		
017	Page: Paper Transfer Unit		
018	Page: Toner Collection Bottle		
019	Page: Fusing Roller		
020	Page: Pressure Roller		
	<p>Displays the number of revolutions of motors or clutches for each current maintenance unit.</p> <p>[0 to 9999999 / 0 / 1 revolution/step]</p> <p>When a unit is replaced, and SP7804-xxx is executed, the current PM counter value is moved to the PM Counter - Previous (SP7-906-11 to 20) and is reset to "0". The total number of revolutions made with the last unit replaced can be checked with SP7-906-11 to 20.</p>		

021	-	*ENG	
	<p>Displays the number of pages of the pump unit for each current maintenance unit.</p> <p>[0 to 9999999 / - / 1 page/step]</p> <p>When a unit is replaced, and SP7804-xxx is executed, the current PM counter value is moved to the PM Counter - Previous (SP7-906-020 to 112) and is reset to "0". The total number of revolutions made with the last unit replaced can be checked with SP7-906-020 to 112.</p>		
021	Page: Pump Unit: Bk	*ENG	[0 to 9999999 / - / 1 page/step]
022	Page: Pump Unit: M		
023	Page: Pump Unit: C		
024	Page: Pump Unit: Y		
031	Rotation: PCU: Bk	*ENG	[0 to 999999999 / - / 1 mm/step]
032	Rotation: PCU: M		
033	Rotation: PCU: C		
034	Rotation: PCU: Y		
035	Rotation: Development Unit: Bk		
036	Rotation: Development Unit: M		
037	Rotation: Development Unit: C		
038	Rotation: Development Unit: Y		
039	Rotation: Developer: Bk		
040	Rotation: Developer: M		
041	Rotation: Developer: C		
042	Rotation: Developer: Y		
043	Rotation: Image Transfer	*ENG	[0 to 999999999 / - / 1
044	Rotation: Cleaning Unit	*ENG	mm/step]

Main SP Tables-7

045	Rotation: Fusing Unit	*ENG	
046	Rotation: Paper Transfer Unit	*ENG	
047	Measurement: Toner Collection bottle	*ENG	
048	Rotation: Fusing Roller	*ENG	
049	Rotation: Pressure Roller	*ENG	
	<p>Displays the value given by the following formula: $(\text{Current revolution} / \text{Target revolution}) \times 100$. This shows how much of the unit's expected lifetime has been used up.</p> <p>The Rotation% counter is based on rotations, not prints. If the number of rotations reaches the limit, the machine enters the end condition for that unit. If the print count lifetime is reached first, the machine also enters the end condition, even though the R% counter is still less than 100%.</p>		
050	-	*ENG	
	<p>Displays the running time of the pump unit for each current maintenance unit. [0 to 999999999 / 0 / 1 msec/step]</p> <p>When a unit is replaced, and SP7804-xxx is executed, the current PM counter value is moved to the PM Counter - Previous (SP7-906-020 to 112) and is reset to "0". The total number of revolutions made with the last unit replaced can be checked with SP7-906-020 to 112.</p>		
050	Run Time: Pump Unit : Bk	*ENG	[0 to 999999999 / - / 1 msec/step]
051	Run Time: Pump Unit : M		
052	Run Time: Pump Unit : C		
053	Run Time: Pump Unit : Y		
061	Rotation (%): PCU: Bk	*ENG	[0 to 255 / - / 1 %/step] (See SP7-803-079 below.)
062	Rotation (%): PCU: M		
063	Rotation (%): PCU:C		
064	Rotation (%): PCU:Y		
065	Rotation (%): Development Unit: Bk		

066	Rotation (%): Development Unit: M		
067	Rotation (%): Development Unit: C		
068	Rotation (%): Development Unit: Y		
069	Rotation (%): Developer: Bk		
070	Rotation (%): Developer: M		
071	Rotation (%): Developer: C		
072	Rotation (%): Developer: Y		
073	Rotation (%): Image Transfer Belt		
074	Rotation (%): Cleaning Unit		
075	Rotation (%): Fusing Unit		
076	Rotation (%): Paper Transfer Unit	*ENG	[0 to 255 / - / 1 %/step]
077	Measurement (%): Toner Collection bottle		
078	Rotation (%): Fusing Roller		
079	Rotation (%): Pressure Roller		
	<p>Displays the value given by the following formula: $(\text{Current revolution} / \text{Target revolution}) \times 100$. This shows how much of the unit's expected lifetime has been used up.</p> <p>The Rotation (%) counter is based on rotations, not prints. If the number of rotations reaches the limit, the machine enters the end condition for that unit. If the print count lifetime is reached first, the machine also enters the end condition, even though the R (%) counter is still less than 100%.</p> <p>[0 to 255 / - / 1 %/step]</p>		

	-	*ENG	
080	<p>Displays the value given by the following formula: $(\text{Current running time} / \text{Target running time}) \times 100$. This shows how much of the unit's expected lifetime has been used up.</p> <p>The Run Time (%) counter is based on the running time, not printouts nor revolutions. If the number of printouts reaches the limit, the machine enters the end condition for that unit. If the revolution count lifetime is reached first, the machine also enters the end condition, even though the Run Time (%) counter is still less than 100%.</p> <p>[0 to 255 / - / 1 %/step]</p>		
080	Run Time(%): Pump Unit: Bk	*ENG	[0 to 255 / - / 1 %/step]
081	Run Time(%): Pump Unit: M		
082	Run Time(%): Pump Unit: C		
083	Run Time(%): Pump Unit: Y		
091	-		
	<p>Displays the value given by the following formula: $(\text{Current printouts} / \text{Target printouts}) \times 100$. This shows how much of the unit's expected lifetime has been used up.</p> <p>The Page (%) counter is based on printouts, not revolutions. If the number of printouts reaches the limit, the machine enters the end condition for that unit. If the revolution count lifetime is reached first, the machine also enters the end condition, even though the Page (%) counter is still less than 100%.</p> <p>[0 to 255 / - / 1 %/step]</p>		
091	Page (%): PCU: Bk	*ENG	[0 to 255 / - / 1 %/step]
092	Page (%): PCU: M		
093	Page (%): PCU: C		
094	Page (%): PCU: Y		
095	Page (%): Development Unit: Bk		
096	Page (%): Development Unit:M		

097	Page (%): Development Unit:C		
098	Page (%): Development Unit:Y		
099	Page (%): Developer: Bk	*ENG	[0 to 255 / - / 1 %/step] (See SP7-803-091 below.)
100	Page (%): Developer: M		
101	Page (%): Developer: C		
102	Page (%): Developer: Y		
103	Page (%): Image Transfer		
104	Page (%): Cleaning Unit		
105	Page (%): Fusing Unit		
106	Page (%): Paper Transfer Unit		
107	Page (%): Fusing Roller		
108	Page (%): Pressure Roller		
109	-	*ENG	
<p>Displays the value given by the following formula: $(\text{Current printouts} / \text{Target printouts}) \times 100$. This shows how much of the unit's expected lifetime has been used up.</p> <p>The Page (%) counter is based on printouts, not revolutions. If the number of printouts reaches the limit, the machine enters the end condition for that unit. If the revolution count lifetime is reached first, the machine also enters the end condition, even though the Page (%) counter is still less than 100%.</p> <p>[0 to 255 / - / 1 %/step]</p>			
109	Page (%): Pump Unit: Bk	*ENG	[0 to 255 / - / 1 %/step]
110	Page (%): Pump Unit: M		
111	Page (%): Pump Unit: C		
112	Page (%): Pump Unit: Y		

7804	[PM Counter Reset] PM Counter Clear (Unit, [Color])		
	<p>Clears the PM counter.</p> <p>Press the Enter key after the machine asks "Execute?", which will store the PM counter value in SP7-906 (PM Counter - Previous) and reset the value of the current PM counter (SP7-803) to "0".</p>		
002	PCU (Drum Unit): Bk	-	-
003	PCU (Drum Unit): M	-	-
004	PCU (Drum Unit): C	-	-
005	PCU (Drum Unit): Y	-	-
006	PCU (Drum Unit): All	-	-
007	Development Unit: Bk	-	-
008	Development Unit: M	-	-
009	Development Unit: C	-	-
010	Development Unit: Y	-	-
011	Development Unit: All	-	-
012	Developer: Bk	-	-
013	Developer: M	-	-
014	Developer: C	-	-
015	Developer: Y	-	-
016	Developer: All	-	-
017	ITB Unit	-	-
018	Cleaning Unit	-	-
019	Fusing Unit	-	-
020	PTR Unit	-	-
021	Toner Collection Bottle	-	-

022	Fusing Roller (Heating Roller)	-	-
023	Pressure Roller	-	-
024	Pump Unit: Bk	-	-
025	Pump Unit: M	-	-
026	Pump Unit: C	-	-
027	Pump Unit: Y	-	-
028	Pump Unit: All	-	-
100	All	-	-

7807	[SC/Jam Counter Reset]		
	Clears the counters related to SC codes and paper jams.		
001	SC/Jam Clear	-	-

7832	[Self-Diagnose Result Display]		
	Displays the result of the diagnostics.		
001	Diag. Result	*CTL	-

7835	[ACC Counter]		
001	Copy ACC	*CTL	Displays the ACC execution times for each mode.
002	Printer ACC	*CTL	

7836	Total Memory Size		
	Displays the memory capacity of the controller system.		

7852	[DF Glass Dust Check]		
------	-----------------------	--	--

Main SP Tables-7

	Counts the number of occurrences (0 to 65,535) when dust was detected on the scanning glass of the ADF or resets the dust detection counter. Counting is done only if SP4-020-1 (ADF Scan Glass Dust Check) is switched on.		
001	Dust Detection Counter	*ENG	[0 to 9999 / - / 1 /step]
002	Dust Detection Clear Counter	*ENG	[0 to 9999 / - / 1 /step]
003	Dust Detection Counter: Back	*ENG	[0 to 9999 / - / 1 /step]

7853	[Replacement Counter]		
	Displays the PM parts replacement number.		
001	PCU: Bk	*ENG	[0 to 255 / - / 1 /step]
002	PCU: M	*ENG	
003	PCU: C	*ENG	
004	PCU: Y	*ENG	
005	Development Unit: Bk	*ENG	
006	Development Unit: M	*ENG	
007	Development Unit: C	*ENG	
008	Development Unit: Y	*ENG	
009	Developer: Bk	*ENG	
010	Developer: M	*ENG	
011	Developer: C	*ENG	
012	Developer: Y	*ENG	
013	Image Transfer	*ENG	[0 to 255 / - / 1 /step]
014	Cleaning Unit	*ENG	
015	Fusing Unit	*ENG	
016	Paper Transfer Unit	*ENG	
017	Tonner Collection Bottle	*ENG	

018	Fusing Roller	*ENG	
019	Pressure Roller	*ENG	
020	Pump Unit: Bk	*ENG	[0 to 255 / - / 1 /step]
021	Pump Unit: M		
022	Pump Unit: C		
023	Pump Unit: Y		

7855	[Coverage Range]		
	<p>Sets the color coverage threshold.</p> <p>Coverage rate = Coverage per page / A4 full coverage (dots) x 100</p> <p>There are three coverage counters: Color 1, Color 2, and Color 3</p> <ul style="list-style-type: none"> ▪ [A] 5% (default) is adjustable with SP7855-001. ▪ [B] 20% (default) is adjustable with SP7855-002.  <p style="font-size: small;">Color coverage 0% 200%</p>		
	<p>Note</p> <ul style="list-style-type: none"> ▪ The setting value [B] must be set larger than [A]. <p>The total numbers of printouts (BW printing plus color printing) for each coverage range are displayed with the following SPs.</p> <ul style="list-style-type: none"> ▪ Color1 counter: SP8601-021 ▪ Color2 counter: SP8601-022 ▪ Color3 counter: SP8601-023 		
001	Coverage Range 1	*CTL	[1 to 200 / 5 /1]
002	Coverage Range 2	*CTL	[1 to 200 / 20 /1]

7906	[Prev. Unit PM Counter]		
	(Page or Rotations, Unit, [Color]), Dev.: Development Unit		
	Displays the number of sheets printed with the previous maintenance units.		
001	Page: PCU: Bk	*ENG	[0 to 9999999 / 0 / 1 page/step]
002	Page: PCU: M		
003	Page: PCU: C		
004	Page: PCU: Y		
005	Page: Development Unit: Bk		
006	Page: Development Unit: M		
007	Page: Development Unit: C		
008	Page: Development Unit: Y		
009	Page: Developer: Bk		
010	Page: Developer: M		
011	Page: Developer: C		
012	Page: Developer: Y		
013	Page: Image Transfer	*ENG	[0 to 9999999 / 0 / 1 page/step]
014	Page: Cleaning Unit		
015	Page: Fusing Unit		
016	Page: Paper Transfer Unit		
017	Page: Toner Collection Bottle		
018	Page: Fusing Roller		
019	Page: Pressure Roller		
	Displays the number of revolutions for motors or clutches in the previous maintenance units. (See SP7-906-031 to 046 below.)		

020	Page: Pump Unit	*ENG	
	Displays the number of sheets printed with the previous maintenance units. [0 to 9999999 / 0 / 1 page/step]		
020	Page: Pump Unit: Bk	*ENG	[0 to 9999999 / 0 / 1 page/step]
021	Page: Pump Unit: M		
022	Page: Pump Unit: C		
023	Page: Pump Unit: Y		
031	Rotation: PCU: Bk	*ENG	[0 to 9999999 / 0 / 1 mm/step] (See SP7-906-019 above.)
032	Rotation: PCU: M		
033	Rotation: PCU: C		
034	Rotation: PCU: Y		
035	Rotation: Development Unit: Bk		
036	Rotation: Development Unit: M		
037	Rotation: Development Unit: C		
038	Rotation: Development Unit: Y		
039	Rotation: Developer: Bk		
040	Rotation: Developer: M		
041	Rotation: Developer: C		
042	Rotation: Developer: Y		
043	Rotation: Image Transfer	*ENG	[0 to 9999999 / 0 / 1 mm/step] (See SP7-906-019 above.)
044	Rotation: Cleaning Unit		
045	Rotation: Fusing Unit		
046	Rotation: Paper Transfer Unit		
047	Measurement: Toner Collection bottle		

Main SP Tables-7

048	Rotation: Fusing Roller		
049	Rotation: Pressure Roller		
	Displays the number of sheets printed with the previous maintenance unit or toner cartridge.		
050	Run Time: Pump Unit	*ENG	
	Displays the running time of the previous pump unit [0 to 999999999 / 0 / 1 msec/step]		
050	Run Time: Pump Unit: Bk	*ENG	[0 to 999999999 / 0 / 1 msec/step]
051	Run Time: Pump Unit: M		
052	Run Time: Pump Unit: C		
053	Run Time: Pump Unit: Y		
061	Rotation %: PCU:	*ENG	
	<p>Displays the value given by the following formula: $(\text{Current revolution} / \text{Target revolution}) \times 100$. This shows how much of the unit's expected lifetime has been used up.</p> <p>The Rotation % counter is based on rotations, not prints. If the number of rotations reaches the limit, the machine enters the end condition for that unit. If the print count lifetime is reached first, the machine also enters the end condition, even though the Rotation % counter is still less than 100%.</p> <p>[0 to 255 / 0 / 1 %/step]</p>		
061	Rotation %: PCU: BK	*ENG	[0 to 255 / 0 / 1 %/step]
062	Rotation %: PCU:M		
063	Rotation %: PCU:C		
064	Rotation %: PCU:Y		
065	Rotation %: Development Unit: Bk		
066	Rotation %: Development Unit: M		

067	Rotation %: Development Unit: C		
068	Rotation %: Development Unit: Y		
069	Rotation %: Developer: Bk	*ENG	[0 to 255 / 0 / 1 %/step]
070	Rotation %: Developer: M		
071	Rotation %: Developer: C		
072	Rotation %: Developer: Y		
073	Rotation %: Image Transfer Belt		
074	Rotation %: Cleaning Unit		
075	Rotation %: Fusing Unit		
076	Rotation %: Paper Transfer Unit		
077	Measurement %: Toner Collection bottle		
078	Rotation (%): Fusing Roller		
079	Rotation (%): Pressure Roller		
	Displays the value given by the following formula: (Current count / Yield count) x 100, where "Current count" is the current values in the counter for the part, and "Yield count" is the recommended yield.		
	Run Time (%): Pump Unit	*ENG	
080	<p>Displays the value given by the following formula: (Current running time / Target running time) × 100. This shows how much of the unit's expected lifetime has been used up.</p> <p>The Run Time (%) counter is based on the total running time, not printouts nor revolutions. If the number of printouts reaches the limit, the machine enters the end condition for that unit. If the revolution count lifetime is reached first, the machine also enters the end condition, even though the Run Time (%) counter is still less than 100%.</p> <p>[0 to 255 / 0 / 1 %/step]</p>		

Main SP Tables-7

080	Run Time (%): Pump Unit: Bk	*ENG	[0 to 255 / 0 / 1 %/step]
081	Run Time (%): Pump Unit: M		
082	Run Time (%): Pump Unit: C		
083	Run Time (%): Pump Unit: Y		
091	Page %: PCU	*ENG	
	<p>Displays the value given by the following formula: (Current printouts / Target printouts) × 100. This shows how much of the unit's expected lifetime has been used up.</p> <p>The Page% counter is based on printouts, not revolutions. If the number of printouts reaches the limit, the machine enters the end condition for that unit. If the revolution count lifetime is reached first, the machine also enters the end condition, even though the Page% counter is still less than 100%.</p> <p>[0 to 255 / 0 / 1 %/step]</p>		
091	Page %: PCU: Bk	*ENG	[0 to 255 / 0 / 1 %/step]
092	Page %: PCU: M		
093	Page %: PCU: C		
094	Page %: PCU: Y		
095	Page %: Development Unit: Bk		
096	Page %: Development Unit: M		
097	Page %: Development Unit: C		
098	Page %: Development Unit: Y		
099	Page %: Developer: Bk		
100	Page %: Developer: M		
101	Page %: Developer: C		
102	Page %: Developer: Y		
103	Page %: Image Transfer	*ENG	[0 to 255 / 0 / 1 %/step]
104	Page %: Cleaning Unit		

105	Page %: Fusing Unit		
106	Page %: Paper Transfer Unit		
107	Page (%): Fusing Roller		
108	Page (%): Pressure Roller		
109	Page (%): Pump Unit: Bk		
110	Page (%): Pump Unit: M		
111	Page (%): Pump Unit: C		
112	Page (%): Pump Unit: Y		

7931	[Toner Bottle Bk]		
	Displays the toner bottle information for Bk.		
001	Machine Serial ID	*ENG	-
002	Cartridge Ver		
003	Brand ID		
004	Area ID		
005	Product ID		
006	Color ID		
007	Maintenance ID		
008	New Product Information		
009	Recycle Counter		
010	Date		
011	Serial No.		
012	Toner Remaining	*ENG	-
013	EDP Code		
014	End History		

Main SP Tables-7

015	Refill Information		
016	Attachment: Total Counter		
017	Attachment: Color Counter		
018	End: Total Counter		
019	End: Color Counter		
020	Attachment Date		
021	End Date		

7932	[Toner Bottle M]		
	Displays the toner bottle information for M.		
001	Machine Serial ID	*ENG	-
002	Cartridge Ver		
003	Brand ID		
004	Area ID		
005	Product ID		
006	Color ID		
007	Maintenance ID		
008	New Product Information		
009	Recycle Counter		
010	Date		
011	Serial No.		
012	Toner Remaining	*ENG	-
013	EDP Code		
014	End History		
015	Refill Information		

016	Attachment: Total Counter		
017	Attachment: Color Counter		
018	End: Total Counter		
019	End: Color Counter		
020	Attachment Date		
021	End Date		

7933	[Toner Bottle C]		
	Displays the toner bottle information for C.		
001	Machine Serial ID	*ENG	-
002	Cartridge Ver		
003	Brand ID		
004	Area ID		
005	Product ID		
006	Color ID		
007	Maintenance ID		
008	New Product Information		
009	Recycle Counter		
010	Date		
011	Serial No.		
012	Toner Remaining	*ENG	-
013	EDP Code		
014	End History		
015	Refill Information		
016	Attachment: Total Counter		

Main SP Tables-7

017	Attachment: Color Counter		
018	End: Total Counter		
019	End: Color Counter		
020	Attachment Date		
021	End Date		

7934	[Toner Bottle Y]		
	Displays the toner bottle information for Y.		
001	Machine Serial ID	*ENG	-
002	Cartridge Ver		
003	Brand ID		
004	Area ID		
005	Product ID		
006	Color ID		
007	Maintenance ID		
008	New Product Information		
009	Recycle Counter		
010	Date		
011	Serial No.		
012	Toner Remaining	*ENG	-
013	EDP Code		
014	End History		
015	Refill Information		
016	Attachment: Total Counter		
017	Attachment: Color Counter		

018	End: Total Counter		
019	End: Color Counter		
020	Attachment Date		
021	End Date		

7935	[Toner Bottle Log 1: Bk]		
001	Serial No.	*ENG	Displays the toner bottle information log 1 for Bk.
002	Attachment Date		
003	Attachment: Total Counter		
004	Refill Information		
011	Serial No.	*ENG	Displays the toner bottle information log 2 for Bk.
012	Attachment Date		
013	Attachment: Total Counter		
014	Refill Information		
021	Serial No.	*ENG	Displays the toner bottle information log 3 for Bk.
022	Attachment Date		
023	Attachment: Total Counter		
024	Refill Information		
031	Serial No.	*ENG	Displays the toner bottle information log 4 for Bk.
032	Attachment Date		
033	Attachment: Total Counter		
034	Refill Information		
041	Serial No.	*ENG	Displays the toner bottle information log 5 for Bk.
042	Attachment Date		
043	Attachment: Total Counter		

Main SP Tables-7

044	Refill Information		
-----	--------------------	--	--

7936	[Toner Bottle Log 1: M]		
001	Serial No.	*ENG	Displays the toner bottle information log 1 for M.
002	Attachment Date		
003	Attachment: Total Counter		
004	Refill Information		
011	Serial No.	*ENG	Displays the toner bottle information log 2 for M.
012	Attachment Date		
013	Attachment: Total Counter		
014	Refill Information		
021	Serial No.	*ENG	Displays the toner bottle information log 3 for M.
022	Attachment Date		
023	Attachment: Total Counter		
024	Refill Information		
031	Serial No.	*ENG	Displays the toner bottle information log 4 for M.
032	Attachment Date		
033	Attachment: Total Counter		
034	Refill Information		
041	Serial No.	*ENG	Displays the toner bottle information log 5 for M.
042	Attachment Date		
043	Attachment: Total Counter		
044	Refill Information		

7937	[Toner Bottle Log 1: C]		
------	-------------------------	--	--

001	Serial No.	*ENG	Displays the toner bottle information log 1 for C.
002	Attachment Date		
003	Attachment: Total Counter		
004	Refill Information		
011	Serial No.	*ENG	Displays the toner bottle information log 2 for C.
012	Attachment Date		
013	Attachment: Total Counter		
014	Refill Information		
021	Serial No.	*ENG	Displays the toner bottle information log 3 for C.
022	Attachment Date		
023	Attachment: Total Counter		
024	Refill Information		
031	Serial No.	*ENG	Displays the toner bottle information log 4 for C.
032	Attachment Date		
033	Attachment: Total Counter		
034	Refill Information		
041	Serial No.	*ENG	Displays the toner bottle information log 5 for C.
042	Attachment Date		
043	Attachment: Total Counter		
044	Refill Information		

7938	[Toner Bottle Log 1: Y]		
001	Serial No.	*ENG	Displays the toner bottle information log 1 for Y.
002	Attachment Date		
003	Attachment: Total Counter		

Main SP Tables-7

004	Refill Information		
011	Serial No.	*ENG	Displays the toner bottle information log 2 for Y.
012	Attachment Date		
013	Attachment: Total Counter		
014	Refill Information		
021	Serial No.	*ENG	Displays the toner bottle information log 3 for Y.
022	Attachment Date		
023	Attachment: Total Counter		
024	Refill Information		
031	Serial No.	*ENG	Displays the toner bottle information log 4 for Y.
032	Attachment Date		
033	Attachment: Total Counter		
034	Refill Information		
041	Serial No.	*ENG	Displays the toner bottle information log 5 for Y.
042	Attachment Date		
043	Attachment: Total Counter		
044	Refill Information		

7950	[Unit Replacement Date]		
	Displays the replacement date of each PM unit.		
001	Image Transfer Belt	*ENG	-
002	Cleaning Unit		
003	Paper Transfer Unit		
004	Fusing Unit		
005	Toner Collection Bottle		

006	AIT:Bk		
007	AIT:M		
008	AIT:C		
009	AIT:Y		
010	Fusing Roller		
011	Pressure Roller		
012	Pump Unit: Bk		
013	Pump Unit: M		
014	Pump Unit: C		
015	Pump Unit: Y		

7951	[Remaining Day Counter]		
	Displays the remaining unit life of each PM unit.		
001	Page: PCU: Bk		
002	Page: PCU: M		
003	Page: PCU: C		
004	Page: PCU: Y		
005	Page: Development Unit: Bk		
006	Page: Development Unit: M	*ENG	[0 to 255 / 255 / 1 day/step]
007	Page: Development Unit: C		
008	Page: Development Unit: Y		
009	Page: Developer: Bk		
010	Page: Developer: M		
011	Page: Developer: C		
012	Page: Developer: Y		

Main SP Tables-7

013	Page: Image Transfer	*ENG	[0 to 255 / 255 / 1 day/step]
014	Page: Cleaning Unit		
015	Page: Fusing Unit		
016	Page: Paper Transfer Unit		
017	Page: Fusing Roller		
018	Page: Pressure Roller		
031	Rotation: PCU: Bk	*ENG	[0 to 255 / 255 / 1 day/step]
032	Rotation: PCU: M		
033	Rotation: PCU: C		
034	Rotation: PCU: Y		
035	Rotation: Development Unit: Bk		
036	Rotation: Development Unit: M		
037	Rotation: Development Unit: C		
038	Rotation: Development Unit: Y		
039	Rotation: Developer: Bk		
040	Rotation: Developer: M		
041	Rotation: Developer: C		
042	Rotation: Developer: Y		
043	Rotation: Image Transfer	*ENG	[0 to 255 / 255 / 1 day/step]
044	Rotation: Cleaning Unit		
045	Rotation: Fusing Unit		
046	Rotation: Paper Transfer Unit		
047	Measurement: Toner Collection bottle		
048	Rotation: Fusing Roller		

049	Rotation: Pressure Roller		
101	Minimum: PCU: Bk	*ENG	Displays one of the three, Remaining Day Counter: Rotation or Runtime, or Remaining Day Counter: Page, which is the minimum value. [0 to 255 / 255 / 1 day/step] For toner collection bottle, this SP is not displayed because its Remaining Day Counters is calculated with its weights only.
102	Minimum: PCU: M		
103	Minimum: PCU: C		
104	Minimum: PCU: Y		
105	Minimum: Development Unit: Bk		
106	Minimum: Development Unit: M		
107	Minimum: Development Unit: C		
108	Minimum: Development Unit: Y		
109	Minimum: Developer: Bk		
110	Minimum: Developer: M		
111	Minimum: Developer: C		
112	Minimum: Developer: Y		
113	Minimum: Image Transfer		
114	Minimum: Cleaning Unit		
115	Minimum: Fusing Unit		
116	Minimum: Paper Transfer Unit		
117	Minimum: Fusing Roller		
118	Minimum: Pressure Roller		
119	Minimum: Pump Unit: Bk	*ENG	Displays either Remaining Day Counter: time or Page, which is less value. [0 to 255 / 255 / 1 day/step]
120	Minimum: Pump Unit: M		
121	Minimum: Pump Unit: C		
122	Minimum: Pump Unit: Y		

7952	[PM Yield Setting]
------	--------------------

Main SP Tables-7

	Adjusts the unit yield of each PM unit.		
001	Rotation: Image Transfer Belt	*CTL	[0 to 999999999 / 256597000 / 1 mm/step]
002	Rotation: Cleaning Unit	*CTL	[0 to 999999999 / 128299000 / 1 mm/step]
003	Rotation: Fusing Unit	*CTL	[0 to 999999999 / 155595000 / 1 mm/step]
004	Rotation: Paper Transfer Unit	*CTL	[0 to 999999999 / 192448000 / 1 mm/step]
011	Page: Image Transfer Belt	*CTL	[0 to 999999 / 320000 / 1 sheet/step]
012	Page: Cleaning Unit	*CTL	[0 to 999999 / 160000 / 1 sheet/step]
013	Page: Fusing Unit	*CTL	[0 to 999999 / 160000 / 1 sheet/step]
014	Page: Paper Transfer Unit	*CTL	[0 to 999999 / 240000 / 1 sheet/step]
021	Day Threshold: PCU: Bk	*CTL	Adjusts the threshold day for the near end fro each PM unit. [1 to 30 / 15 / 1 day/step] These threshold days are used for @Remote alarms.
022	Day Threshold: PCU: M		
023	Day Threshold: PCU: C		
024	Day Threshold: PCU: Y		
025	Day Threshold: Development Unit: Bk		
026	Day Threshold: Development Unit: M		
027	Day Threshold: Development Unit: C		
028	Day Threshold: Development Unit: Y		
029	Day Threshold: Developer: Bk		
030	Day Threshold: Developer: M		

031	Day Threshold: Developer: C		
032	Day Threshold: Developer: Y		
033	Day Threshold: Image Transfer Belt	*CTL	Adjusts the threshold day for the near end fro each PM unit. [1 to 30 / 15 / 1 day/step] These threshold days are used for @Remote alarms.
034	Day Threshold: Cleaning Unit		
035	Day Threshold: Fusing Unit		
036	Day Threshold: Paper Transfer Unit		
037	Day Threshold: Toner Collection Bottle		
038	Rotation: PCU Bk	*CTL	[0 to 999999999 / 0 / 1 mm/step]
039	Rotation: PCU M		
040	Rotation: PCU C		
041	Rotation: PCU Y		
042	Rotation: Development Unit: Bk	*CTL	[0 to 999999999 / 0 / 1 mm/step]
043	Rotation: Development Unit: M		
044	Rotation: Development Unit: C		
045	Rotation: Development Unit: Y		
046	Rotation: Developer: Bk	*CTL	[0 to 999999999 / 0 / 1 mm/step]
047	Rotation: Developer: M		
048	Rotation: Developer: C		

Main SP Tables-7

049	Rotation: Developer: Y		
050	Page: PCU: Bk	*CTL	[0 to 999999 / 0 / 1 sheet/step]
051	Page: PCU: M		
052	Page: PCU: C		
053	Page: PCU: Y		
054	Page: Development Unit: Bk		
055	Page: Development Unit: M	*CTL	[0 to 999999 / 0 / 1 sheet/step]
056	Page: Development Unit: C		
057	Page: Development Unit: Y		
058	Page: Developer: Bk		
059	Page: Developer: M	*CTL	[0 to 999999 / 0 / 1 sheet/step]
060	Page: Developer: C		
061	Page: Developer: Y		

7953	[Operation Env. Log: PCU: Bk]		
	Displays the PCDU rotation distance in each specified operation environment. T: Temperature (°C), H: Relative Humidity (%)		
001	T<=0	*CTL	[0 to 99999999 / - / 1 mm/step]
002	0<T<=5:0<=H<30		
003	0<T<=5:30<=H<70		
004	0<T<=5:70<=H<=100		
005	5<T<15:0<=H<30		

006	5<T<15:30<=H<55		
007	5<T<15:55<=H<80		
008	5<T<15:80<=H<=100		
009	15<=T<25:0<=H<30		
010	15<=T<25:30<=H<55		
011	15<=T<25:55<=H<80		
012	15<=T<25:80<=H<=100		
013	25<=T<30:0<=H<30		
014	25<=T<30:30<=H<55		
015	25<=T<30:55<=H<80		
016	25<=T<30:80<=H<=100	*CTL	[0 to 99999999 / - / 1 mm/step]
017	30<=T<35:0<=H<30		
018	30<=T<35:30<=H<55		
019	30<=T<35:55<=H<80		
020	30<=T<35:80<=H<=100		
021	35 <= T		

7954	[Operation Env. Log Clear]		
	Clears the operation environment log.		
001	-	-	-

Main SP Tables-7

7955	Fusing Stop		
001	Near End: Page	-	[1 to 999999 / 318000 / 1 sheet/step]
	Displays the threshold sheet for the heating roller near end.		
002	End: Page	-	[1 to 999999 / 330000 / 1 sheet/step]
	Displays the threshold sheet for the heating roller end.		
003	Near End: Rotation	-	[0 to 999999999 / C3a: 173327000, C3b: 162570000 / 1 mm/step]
	Displays the threshold distance for the heating roller near end.		
004	End: Rotation	-	[0 to 999999999 / C3a: 179868000, C3b: 168705000 / 1 mm/step]
	Displays the threshold distance for the heating roller end.		

3.8 MAIN SP TABLES-8

3.8.1 SP8-XXX: DATA LOG2

Many of these counters are provided for features that are currently not available, such as sending color faxes, and so on. However, here are some Group 8 codes that when used in combination with others, can provide useful information.

SP Numbers	What They Do
SP8211 to SP8216	The number of pages scanned to the document server.
SP8401 to SP8406	The number of pages printed from the document server
SP8691 to SP8696	The number of pages sent from the document server

Specifically, the following questions can be answered:

- How is the document server actually being used?
- What application is using the document server most frequently?
- What data in the document server is being reused?

Most of the SPs in this group are prefixed with a letter that indicates the mode of operation (the mode of operation is referred to as an "application"). Before reading the Group 8 Service Table, make sure that you understand what these prefixes mean.

Prefixes	What it means	
T:	Total: (Grand Total).	Grand total of the items counted for all applications (C, F, P, etc.).
C:	Copy application.	Totals (pages, jobs, etc.) executed for each application when the job was not stored on the document server.
F:	Fax application.	
P:	Print application.	
S:	Scan application.	

Main SP Tables-8

L:	Local storage (document server)	Totals (jobs, pages, etc.) for the document server. The L: counters work differently case by case. Sometimes, they count jobs/pages stored on the document server; this can be in document server mode (from the document server window), or from another mode, such as from a printer driver or by pressing the Store File button in the Copy mode window. Sometimes, they include occasions when the user uses a file that is already on the document server. Each counter will be discussed case by case.
O:	Other applications (external network applications, for example)	Refers to network applications such as Web Image Monitor. Utilities developed with the SDK (Software Development Kit) will also be counted with this group in the future.

The Group 8 SP codes are limited to 17 characters, forced by the necessity of displaying them on the small LCDs of printers and faxes that also use these SPs. Read over the list of abbreviations below and refer to it again if you see the name of an SP that you do not understand.

Key for Abbreviations

Abbreviation	What it means
/	"By", e.g. "T:Jobs/Apl" = Total Jobs "by" Application
>	More (2> "2 or more", 4> "4 or more")
AddBook	Address Book
Apl	Application
B/W	Black & White
Bk	Black
C	Cyan
ColCr	Color Create
ColMode	Color Mode

Abbreviation	What it means
Comb	Combine
Comp	Compression
Deliv	Delivery
DesApl	Designated Application. The application (Copy, Fax, Scan, Print) used to store the job on the document server, for example.
Dev Counter	Development Count, no. of pages developed.
Dup, Duplex	Duplex, printing on both sides
Emul	Emulation
FC	Full Color
FIN	Post-print processing, i.e. finishing (punching, stapling, etc.)
Full Bleed	No Margins
GenCopy	Generation Copy Mode
GPC	Get Print Counter. For jobs 10 pages or less, this counter does not count up. For jobs larger than 10 pages, this counter counts up by the number that is in excess of 10 (e.g., for an 11-page job, the counter counts up 11-10 =1)
IFax	Internet Fax
ImgEdt	Image Edit performed on the original with the copier GUI, e.g. border removal, adding stamps, page numbers, etc.
K	Black (YMCK)
LS	Local Storage. Refers to the document server.
LSize	Large (paper) Size
Mag	Magnification
MC	One color (monochrome)

Main SP Tables-8

Abbreviation	What it means
NRS	New Remote Service, which allows a service center to monitor machines remotely. "NRS" is used overseas, "CSS" is used in Japan.
Org	Original for scanning
OrgJam	Original Jam
Palm 2	Print Job Manager/Desk Top Editor: A pair of utilities that allows print jobs to be distributed evenly among the printers on the network, and allows files to moved around, combined, and converted to different formats.
PC	Personal Computer
PGS	Pages. A page is the total scanned surface of the original. Duplex pages count as two pages, and A3 simplex count as two pages if the A3/DLT counter SP is switched ON.
PJob	Print Jobs
Ppr	Paper
PrtJam	Printer (plotter) Jam
PrtPGS	Print Pages
R	Red (Toner Remaining). Applies to the wide format model A2 only. This machine is under development and currently not available.
Rez	Resolution
SC	Service Code (Error SC code displayed)
Scn	Scan
Sim, Simplex	Simplex, printing on 1 side.
S-to-Email	Scan-to-E-mail
SMC	SMC report printed with SP5990. All of the Group 8 counters are recorded in the SMC report.

Abbreviation	What it means
Svr	Server
TonEnd	Toner End
TonSave	Toner Save
TXJob	Send, Transmission
YMC	Yellow, Magenta, Cyan
YMCK	Yellow, Magenta, Cyan, Black

Note

- All of the Group 8 SPs are reset with SP5 801 1 Memory All Clear.

8 001	T:Total Jobs	*CTL	<p>These SPs count the number of times each application is used to do a job.</p> <p>[0 to 9999999/ 0 / 1]</p> <p>Note</p> <ul style="list-style-type: none"> The L: counter is the total number of times the other applications are used to send a job to the document server, plus the number of times a file already on the document server is used.
8 002	C:Total Jobs	*CTL	
8 003	F:Total Jobs	*CTL	
8 004	P:Total Jobs	*CTL	
8 005	S:Total Jobs	*CTL	
8 006	L:Total Jobs	*CTL	

- These SPs reveal the number of times an application is used, not the number of pages processed.
- When an application is opened for image input or output, this counts as one job.
- Interrupted jobs (paper jams, etc.) are counted, even though they do not finish.
- Only jobs executed by the customer are counted. Jobs executed by the customer engineer using the SP modes are not counted.
- When using secure printing (when a password is required to start the print job), the job is counted at the time when either "Delete Data" or "Specify Output" is specified.
- A job is counted as a fax job when the job is stored for sending.
- When a fax is received to fax memory, the F: counter increments but the L: counter does not (the document server is not used).
- A fax broadcast counts as one job for the F: counter (the fax destinations in the broadcast are

Main SP Tables-8

not counted separately).

- A fax broadcast is counted only after all the faxes have been sent to their destinations. If one transmission generates an error, then the broadcast will not be counted until the transmission has been completed.
- A printed fax report counts as one job for the F: counter.
- The F: counter does not distinguish between fax sending or receiving.
- When a copy job on the document server is printed, SP8022 also increments, and when a print job stored on the document server is printed, SP8024 also increments.
- When an original is both copied and stored on the document server, the C: and L: counters both increment.
- When a print job is stored on the document server, only the L: counter increments.
- When the user presses the Document Server button to store the job on the document server, only the L: counter increments.
- When the user enters document server mode and prints data stored on the document server, only the L: counter increments.
- When an image received from Palm 2 is received and stored, the L: counter increments.
- When the customer prints a report (user code list, for example), the O: counter increments. However, for fax reports and reports executed from the fax application, the F: counter increments.

8 011	T:Jobs/LS	*CTL	<p>These SPs count the number of jobs stored to the document server by each application, to reveal how local storage is being used for input.</p> <p>[0 to 9999999/ 0 / 1]</p> <p>The L: counter counts the number of jobs stored from within the document server mode screen at the operation panel.</p>
8 012	C:Jobs/LS	*CTL	
8 013	F:Jobs/LS	*CTL	
8 014	P:Jobs/LS	*CTL	
8 015	S:Jobs/LS	*CTL	
8 016	L:Jobs/LS	*CTL	
8 017	O:Jobs/LS	*CTL	

- When a scan job is sent to the document server, the S: counter increments. When you enter document server mode and then scan an original, the L: counter increments.
- When a print job is sent to the document server, the P: counter increments.
- When a network application sends data to the document server, the O: counter increments.
- When an image from Palm 2 is stored on the document server, the O: counter increments.
- When a fax is sent to the document server, the F: counter increments.

8 021	T:Pjob/LS	*CTL	<p>These SPs reveal how files printed from the document server were stored on the document server originally.</p> <p>[0 to 9999999/ 0 / 1]</p> <p>The L: counter counts the number of jobs stored from within the document server mode screen at the operation panel.</p>
8 022	C:Pjob/LS	*CTL	
8 023	F:Pjob/LS	*CTL	
8 024	P:Pjob/LS	*CTL	
8 025	S:Pjob/LS	*CTL	
8 026	L:Pjob/LS	*CTL	
8 027	O:Pjob/LS	*CTL	

- When a copy job stored on the document server is printed with another application, the C: counter increments.
- When an application like DeskTopBinder merges a copy job that was stored on the document server with a print job that was stored on the document server, the C: and P: counters both increment.
- When a job already on the document server is printed with another application, the L: counter increments.
- When a scanner job stored on the document server is printed with another application, the S: counter increments. If the original was scanned from within document server mode, then the L: counter increments.
- When images stored on the document server by a network application (including Palm 2), are printed with another application, the O: counter increments.
- When a copy job stored on the document server is printed with a network application (Web Image Monitor, for example), the C: counter increments.
- When a fax on the document server is printed, the F: counter increments.

8 031	T:Pjob/DesApl	*CTL	<p>These SPs reveal what applications were used to output documents from the document server.</p> <p>[0 to 9999999/ 0 / 1]</p> <p>The L: counter counts the number of jobs printed from within the document server mode screen at the operation panel.</p>
8 032	C:Pjob/DesApl	*CTL	
8 033	F:Pjob/DesApl	*CTL	
8 034	P:Pjob/DesApl	*CTL	
8 035	S:Pjob/DesApl	*CTL	
8 036	L:Pjob/DesApl	*CTL	
8 037	O:Pjob/DesApl	*CTL	

Main SP Tables-8

- When documents already stored on the document server are printed, the count for the application that started the print job is incremented.
- When the print job is started from a network application (Desk Top Binder, Web Image Monitor, etc.) the L: counter increments.

8 041	T:TX Jobs/LS	*CTL	<p>These SPs count the applications that stored files on the document server that were later accessed for transmission over the telephone line or over a network (attached to an e-mail, or as a fax image by I-Fax). [0 to 9999999/ 0 / 1]</p> <p>Note</p> <ul style="list-style-type: none"> ▪ Jobs merged for sending are counted separately. ▪ The L: counter counts the number of jobs scanned from within the document server mode screen at the operation panel.
8 042	C:TX Jobs/LS	*CTL	
8 043	F:TX Jobs/LS	*CTL	
8 044	P:TX Jobs/LS	*CTL	
8 045	S:TX Jobs/LS	*CTL	
8 046	L:TX Jobs/LS	*CTL	
8 047	O:TX Jobs/LS	*CTL	

- When a stored copy job is sent from the document server, the C: counter increments.
- When images stored on the document server by a network application or Palm2 are sent as an e-mail, the O: counter increments.

8 051	T:TX Jobs/DesApl	*CTL	<p>These SPs count the applications used to send files from the document server over the telephone line or over a network (attached to an e-mail, or as a fax image by I-Fax). Jobs merged for sending are counted separately. [0 to 9999999/ 0 / 1]</p> <p>The L: counter counts the number of jobs sent from within the document server mode screen at the operation panel.</p>
8 052	C:TX Jobs/DesApl	*CTL	
8 053	F:TX Jobs/DesApl	*CTL	
8 054	P:TX Jobs/DesApl	*CTL	
8 055	S:TX Jobs/DesApl	*CTL	
8 056	L:TX Jobs/DesApl	*CTL	
8 057	O:TX Jobs/DesApl	*CTL	

- If the send is started from Desk Top Binder or Web Image Monitor, for example, then the O:

counter increments.

8 061	T:FIN Jobs	*CTL	[0 to 9999999/ 0 / 1]
	These SPs total the finishing methods. The finishing method is specified by the application.		
8 062	C:FIN Jobs	*CTL	[0 to 9999999/ 0 / 1]
	These SPs total finishing methods for copy jobs only. The finishing method is specified by the application.		
8 063	F:FIN Jobs	*CTL	[0 to 9999999/ 0 / 1]
	<p>These SPs total finishing methods for fax jobs only. The finishing method is specified by the application.</p> <p>Note</p> <ul style="list-style-type: none"> Finishing features for fax jobs are not available at this time. 		
8 064	P:FIN Jobs	*CTL	[0 to 9999999/ 0 / 1]
	These SPs total finishing methods for print jobs only. The finishing method is specified by the application.		
8 065	S:FIN Jobs	*CTL	[0 to 9999999/ 0 / 1]
	<p>These SPs total finishing methods for scan jobs only. The finishing method is specified by the application.</p> <p>Note</p> <ul style="list-style-type: none"> Finishing features for scan jobs are not available at this time. 		
8 066	L:FIN Jobs	*CTL	[0 to 9999999/ 0 / 1]
	These SPs total finishing methods for jobs output from within the document server mode screen at the operation panel. The finishing method is specified from the print window within document server mode.		
8 067	O:FIN Jobs	*CTL	[0 to 9999999/ 0 / 1]
	These SPs total finishing methods for jobs executed by an external application, over the network. The finishing method is specified by the application.		

Main SP Tables-8

8 06x 1	Sort	Number of jobs started in Sort mode. When a stored copy job is set for Sort and then stored on the document server, the L: counter increments. (See SP8-066-1)
8 06x 2	Stack	Number of jobs started out of Sort mode.
8 06x 3	Staple	Number of jobs started in Staple mode.
8 06x 4	Booklet	Number of jobs started in Booklet mode. If the machine is in staple mode, the Staple counter also increments.
8 06x 5	Z-Fold	Number of jobs started In any mode other than the Booklet mode and set for folding (Z-fold).
8 06x 6	Punch	Number of jobs started in Punch mode. When Punch is set for a print job, the P: counter increments. (See SP8-064-6.)
8 06x 7	Other	Reserved. Not used.

8 071	T:Jobs/PGS	*CTL	[0 to 9999999/ 0 / 1]
	These SPs count the number of jobs broken down by the number of pages in the job, regardless of which application was used.		
8 072	C:Jobs/PGS	*CTL	[0 to 9999999/ 0 / 1]
	These SPs count and calculate the number of copy jobs by size based on the number of pages in the job.		
8 073	F:Jobs/PGS	*CTL	[0 to 9999999/ 0 / 1]
	These SPs count and calculate the number of fax jobs by size based on the number of pages in the job.		
8 074	P:Jobs/PGS	*CTL	[0 to 9999999/ 0 / 1]
	These SPs count and calculate the number of print jobs by size based on the number of pages in the job.		
8 075	S:Jobs/PGS	*CTL	[0 to 9999999/ 0 / 1]
	These SPs count and calculate the number of scan jobs by size based on the number of pages in the job.		
8 076	L:Jobs/PGS	*CTL	[0 to 9999999/ 0 / 1]

	These SPs count and calculate the number of jobs printed from within the document server mode window at the operation panel, by the number of pages in the job.		
8 077	O:Jobs/PGS	*CTL	[0 to 9999999/ 0 / 1]
	These SPs count and calculate the number of "Other" application jobs (Web Image Monitor, Palm 2, etc.) by size based on the number of pages in the job.		
8 07x 1	1 Page	8 07x 8	21 to 50 Pages
8 07x 2	2 Pages	8 07x 9	51 to 100 Pages
8 07x 3	3 Pages	8 07x 10	101 to 300 Pages
8 07x 4	4 Pages	8 07x 11	301 to 500 Pages
8 07x 5	5 Pages	8 07x 12	501 to 700 Pages
8 07x 6	6 to 10 Pages	8 07x 13	701 to 1000 Pages
8 07x 7	11 to 20 Pages	8 07x 14	1001 to Pages

- For example: When a copy job stored on the document server is printed in document server mode, the appropriate L: counter (SP8076 0xx) increments.
- Printing a fax report counts as a job and increments the F: counter (SP 8073).
- Interrupted jobs (paper jam, etc.) are counted, even though they do not finish.
- If a job is paused and re-started, it counts as one job.
- If the finisher runs out of staples during a print and staple job, then the job is counted at the time the error occurs.
- For copy jobs (SP 8072) and scan jobs (SP 8075), the total is calculated by multiplying the number of sets of copies by the number of pages scanned. (One duplex page counts as 2.)
- The first test print and subsequent test prints to adjust settings are added to the number of pages of the copy job (SP 8072).
- When printing the first page of a job from within the document server screen, the page is counted.

8 111	T:FAX TX Jobs	*CTL	[0 to 9999999/ 0 / 1]
	<p>These SPs count the total number of jobs (color or black-and-white) sent by fax, either directly or using a file stored on the document server, on a telephone line.</p> <p>Note</p> <ul style="list-style-type: none"> Color fax sending is not available at this time. 		
8 113	F: FAX TX Jobs	*CTL	[0 to 9999999/ 0 / 1]
	<p>These SPs count the total number of jobs (color or black-and-white) sent by fax directly on a telephone line.</p> <p>Note</p> <ul style="list-style-type: none"> Color fax sending is not available at this time. 		
8 11x 1	B/W		
8 11x 2	Color		

- These counters count jobs, not pages.
- This SP counts fax jobs sent over a telephone line with a fax application, including documents stored on the document server.
- If the mode is changed during the job, the job will count with the mode set when the job started.
- If the same document is faxed to both a public fax line and an I-Fax at a destination where both are available, then this counter increments, and the I-Fax counter (8 12x) also increments.
- The fax job is counted when the job is scanned for sending, not when the job is sent.

8 121	T:IFAX TX Jobs	*CTL	[0 to 9999999/ 0 / 1]
	<p>These SPs count the total number of jobs (color or black-and-white) sent, either directly or using a file stored on the document server, as fax images using I-Fax.</p> <p>Note</p> <ul style="list-style-type: none"> Color fax sending is not available at this time. 		
8 123	F: IFAX TX Jobs	*CTL	[0 to 9999999/ 0 / 1]
	<p>These SPs count the number of jobs (color or black-and-white) sent (not stored on the document server), as fax images using I-Fax.</p> <p>Note</p> <ul style="list-style-type: none"> Color fax sending is not available at this time. 		
8 12x 1	B/W		
8 12x 2	Color		

- These counters count jobs, not pages.
- The counters for color are provided for future use; the color fax feature is not available at this time.
- The fax job is counted when the job is scanned for sending, not when the job is sent.

8 131	T:S-to-Email Jobs	*CTL	[0 to 9999999/ 0 / 1]
	<p>These SPs count the total number of jobs (color or black-and-white) scanned and attached to an e-mail, regardless of whether the document server was used or not.</p>		
8 135	S: S-to-Email Jobs	*CTL	[0 to 9999999/ 0 / 1]
	<p>These SPs count the number of jobs (color or black-and-white) scanned and attached to e-mail, without storing the original on the document server.</p>		
8 13x 1	B/W		
8 13x 2	Color		
8 13x 3	ACS		

Main SP Tables-8

- These counters count jobs, not pages.
- If the job is stored on the document server, after the job is stored it is determined to be color or black-and-white then counted.
- If the job is cancelled during scanning, or if the job is cancelled while the document is waiting to be sent, the job is not counted.
- If the job is cancelled during sending, it may or may not be counted, depending on what stage of the process had been reached when the job was cancelled.
- If several jobs are combined for sending to the Scan Router, Scan-to-Email, or Scan-to-PC, or if one job is sent to more than one destination. each send is counted separately. For example, if the same document is sent by Scan-to-Email as well as Scan-to-PC, then it is counted twice (once for Scan-to-Email and once for Scan-to-PC).

8 141	T:Deliv Jobs/Svr	*CTL	[0 to 9999999/ 0 / 1]
	These SPs count the total number of jobs (color or black-and-white) scanned and sent to a Scan Router server.		
8 145	S: Deliv Jobs/Svr	*CTL	[0 to 9999999/ 0 / 1]
	These SPs count the number of jobs (color or black-and-white) scanned in scanner mode and sent to a Scan Router server.		
8 14x 1	B/W		
8 14x 2	Color		
8 14x 3	ACS		

- These counters count jobs, not pages.
- The jobs are counted even though the arrival and reception of the jobs at the Scan Router server cannot be confirmed.
- If even one color image is mixed with black-and-white images, then the job is counted as a "Color" job.
- If the job is cancelled during scanning, or if the job is cancelled while the document is waiting to be delivered, the job is not counted.
- If the job is cancelled during sending, it may or may not be counted, depending on what stage of the process had been reached when the job was cancelled.
- Even if several files are combined for sending, the transmission counts as one job.

8 151	T:Deliv Jobs/PC	*CTL	[0 to 9999999/ 0 / 1]
	<p>These SPs count the total number of jobs (color or black-and-white) scanned and sent to a folder on a PC (Scan-to-PC).</p> <p> Note</p> <ul style="list-style-type: none"> At the present time, 8 151 and 8 155 perform identical counts. 		
8 155	S:Deliv Jobs/PC	*CTL	[0 to 9999999/ 0 / 1]
	<p>These SPs count the total number of jobs (color or black-and-white) scanned and sent with Scan-to-PC.</p>		
8 15x 1	B/W		
8 15x 2	Color		
8 15x 3	ACS		

- These counters count jobs, not pages.
- If the job is cancelled during scanning, it is not counted.
- If the job is cancelled while it is waiting to be sent, the job is not counted.
- If the job is cancelled during sending, it may or may not be counted, depending on what stage of the process had been reached when the job was cancelled.
- Even if several files are combined for sending, the transmission counts as one job.

8 161	T:PCFAX TX Jobs	*CTL	<p>These SPs count the number of PC Fax transmission jobs. A job is counted from when it is registered for sending, not when it is sent.</p> <p>[0 to 9999999/ 0 / 1]</p> <p> Note</p> <ul style="list-style-type: none"> At the present time, these counters perform identical counts.
8 163	F:PCFAX TX Jobs	*CTL	

- This counts fax jobs started from a PC using a PC fax application, and sending the data out to the destination from the PC through the copier.

Main SP Tables-8

8 171	T:Deliv Jobs/WSD	*CTL	These SPs count the pages scanned by WS. [0 to 9999999/ 0 / 1]
8 175	S:Deliv Jobs/WSD	*CTL	
-001	B/W		
-002	Color		
-003	ACS		

8 181	T:Scan to Media Jobs	*CTL	These SPs count the scanned pages in a media by the scanner application. [0 to 9999999/ 0 / 1]
8 185	S:Scan to Media Jobs	*CTL	
-001	B/W		
-002	Color		
-003	ACS		

8 191	T:Total Scan PGS	*CTL	These SPs count the pages scanned by each application that uses the scanner to scan images. [0 to 9999999/ 0 / 1]
8 192	C:Total Scan PGS	*CTL	
8 193	F:Total Scan PGS	*CTL	
8 195	S:Total Scan PGS	*CTL	
8 196	L:Total Scan PGS	*CTL	

- SP 8 191 to 8 196 count the number of scanned sides of pages, not the number of physical pages.
- These counters do not count reading user stamp data, or reading color charts to adjust color.
- Previews done with a scanner driver are not counted.
- A count is done only after all images of a job have been scanned.
- Scans made in SP mode are not counted.

Examples

- If 3 B5 pages and 1 A3 page are scanned with the scanner application but not stored, the S: count is 4.

- If both sides of 3 A4 sheets are copied and stored to the document server using the Store File button in the Copy mode window, the C: count is 6 and the L: count is 6.
- If both sides of 3 A4 sheets are copied but not stored, the C: count is 6.
- If you enter document server mode then scan 6 pages, the L: count is 6.

8 201	T:LSize Scan PGS	*CTL	[0 to 9999999/ 0 / 1]
	<p>These SPs count the total number of large pages input with the scanner for scan and copy jobs. Large size paper (A3/DLT) scanned for fax transmission are not counted.</p> <p>Note</p> <ul style="list-style-type: none"> ▪ These counters are displayed in the SMC Report, and in the User Tools display. 		
8 203	F: LSize Scan PGS	*CTL	[0 to 9999999/ 0 / 1]
	<p>These SPs count the total number of large pages input with the scanner for fax transmission.</p> <p>Note</p> <ul style="list-style-type: none"> ▪ These counters are displayed in the SMC Report, and in the User Tools display. 		
8 205	S:LSize Scan PGS	*CTL	[0 to 9999999/ 0 / 1]
	<p>These SPs count the total number of large pages input with the scanner for scan jobs only. Large size paper (A3/DLT) scanned for fax transmission are not counted.</p> <p>Note</p> <ul style="list-style-type: none"> ▪ These counters are displayed in the SMC Report, and in the User Tools display. 		

8 211	T:Scan PGS/LS	*CTL	These SPs count the number of pages scanned into the document server.
8 212	C:Scan PGS/LS	*CTL	
8 213	F:Scan PGS/LS	*CTL	The L: counter counts the number of pages stored from within the document server mode screen at the operation panel, and with the Store File button from within the Copy mode screen
8 215	S:Scan PGS/LS	*CTL	
8 216	L:Scan PGS/LS	*CTL	

Main SP Tables-8

- Reading user stamp data is not counted.
- If a job is cancelled, the pages output as far as the cancellation are counted.
- If the scanner application scans and stores 3 B5 sheets and 1 A4 sheet, the S: count is 4.
- If pages are copied but not stored on the document server, these counters do not change.
- If both sides of 3 A4 sheets are copied and stored to the document server, the C: count is 6 and the L: count is 6.
- If you enter document server mode then scan 6 pages, the L: count is 6.

8 221	ADF Org Feeds	*CTL	[0 to 9999999/ 0 / 1]
	These SPs count the number of pages fed through the ADF for front and back side scanning.		
8 221 1	Front	<p>Number of front sides fed for scanning:</p> <p>With an ADF that can scan both sides simultaneously, the Front side count is the same as the number of pages fed for either simplex or duplex scanning.</p> <p>With an ADF that cannot scan both sides simultaneously, the Front side count is the same as the number of pages fed for duplex front side scanning. (The front side is determined by which side the user loads face up.)</p>	
8 221 2	Back	<p>Number of rear sides fed for scanning:</p> <p>With an ADF that can scan both sides simultaneously, the Back count is the same as the number of pages fed for duplex scanning.</p> <p>With an ADF that cannot scan both sides simultaneously, the Back count is the same as the number of pages fed for duplex rear-side scanning.</p>	

- When 1 sheet is fed for duplex scanning the Front count is 1 and the Back count is 1.
- If a jam occurs during the job, recovery processing is not counted to avoid double counting. Also, the pages are not counted if the jam occurs before the first sheet is output.

8 231	Scan PGS/Mode	*CTL	[0 to 9999999/ 0 / 1]
	These SPs count the number of pages scanned by each ADF mode to determine the work load on the ADF.		
8 231 1	Large Volume	Selectable. Large copy jobs that cannot be loaded in the ADF at one time.	
8 231 2	SADF	Selectable. Feeding pages one by one through the ADF.	
8 231 3	Mixed Size	Selectable. Select "Mixed Sizes" on the operation panel.	
8 231 4	Custom Size	Selectable. Originals of non-standard size.	
8 231 5	Platen	Book mode. Raising the ADF and placing the original directly on the platen.	
8 231 6	Mixed 1side/ 2side	Simplex and Duplex mode.	

- If the scan mode is changed during the job, for example, if the user switches from ADF to Platen mode, the count is done for the last selected mode.
- The user cannot select mixed sizes or non-standard sizes with the fax application so if the original's page sizes are mixed or non-standard, these are not counted.
- If the user selects "Mixed Sizes" for copying in the platen mode, the Mixed Size count is enabled.
- In the SADF mode if the user copies 1 page in platen mode and then copies 2 pages with SADF, the Platen count is 1 and the SADF count is 3.

8 241	T:Scan PGS/Org	*CTL	[0 to 9999999/ 0 / 1]
	These SPs count the total number of scanned pages by original type for all jobs, regardless of which application was used.		
8 242	C:Scan PGS/Org	*CTL	[0 to 9999999/ 0 / 1]
	These SPs count the number of pages scanned by original type for Copy jobs.		
8 243	F:Scan PGS/Org	*CTL	[0 to 9999999/ 0 / 1]

Main SP Tables-8

	These SPs count the number of pages scanned by original type for Fax jobs.				
8 245	S:Scan PGS/Org	*CTL	[0 to 9999999/ 0 / 1]		
	These SPs count the number of pages scanned by original type for Scan jobs.				
8 246	L:Scan PGS/Org	*CTL	[0 to 9999999/ 0 / 1]		
	These SPs count the number of pages scanned and stored from within the document server mode screen at the operation panel, and with the Store File button from within the Copy mode screen				
	8 241	8 242	8 243	8 245	8 246
8 24x 1: Text	Yes	Yes	Yes	Yes	Yes
8 24x 2: Text/Photo	Yes	Yes	Yes	Yes	Yes
8 24x 3: Photo	Yes	Yes	Yes	Yes	Yes
8 24x 4: GenCopy, Pale	Yes	Yes	No	Yes	Yes
8 24x 5: Map	Yes	Yes	No	Yes	Yes
8 24x 6: Normal/Detail	Yes	No	Yes	No	No
8 24x 7: Fine/Super Fine	Yes	No	Yes	No	No
8 24x 8: Binary	Yes	No	No	Yes	No
8 24x 9: Grayscale	Yes	No	No	Yes	No
8 24x 10: Color	Yes	No	No	Yes	No
8 24x 11: Other	Yes	Yes	Yes	Yes	Yes

- If the scan mode is changed during the job, for example, if the user switches from ADF to Platen mode, the count is done for the last selected mode.

8 251	T:Scan PGS/ImgEdt	*CTL	<p>These SPs show how many times Image Edit features have been selected at the operation panel for each application. Some examples of these editing features are:</p> <ul style="list-style-type: none"> ▪ Erase> Border ▪ Erase> Center ▪ Image Repeat ▪ Centering ▪ Positive/Negative <p>[0 to 9999999/ 0 / 1]</p> <p> Note</p> <ul style="list-style-type: none"> ▪ The count totals the number of times the edit features have been used. A detailed breakdown of exactly which features have been used is not given.
8 252	C:Scan PGS/ImgEdt	*CTL	
8 254	P:Scan PGS/ImgEdt	*CTL	
8 255	S : Scan PGS/ImgEdr	*CTL	
8 256	L:Scan PGS/ImgEdt	*CTL	
8 257	O:Scan PGS/ImgEdt	*CTL	

The L: counter counts the number of pages stored from within the document server mode screen at the operation panel, and with the Store File button from within the Copy mode screen.

8 261	T:Scan PGS/ColCr	*CTL	-
8 262	C:Scan PGS/ ColCr	*CTL	-
8 265	S:Scn PGS/Color	*CTL	-
8 266	L:Scn PGS/ColCr	*CTL	-
8 26x 1	Color Conversion	<p>These SPs show how many times color creation features have been selected at the operation panel.</p>	
8 26x 2	Color Erase		
8 26x 3	Background		
8 26x 4	Other		

8 281	T:Scan PGS/TWAIN	*CTL	<p>These SPs count the number of pages scanned using a TWAIN driver. These counters reveal how the TWAIN driver is used for delivery functions.</p> <p>[0 to 9999999/ 0 / 1]</p> <p>Note</p> <ul style="list-style-type: none"> At the present time, these counters perform identical counts.
8 285	S:Scan PGS/TWAIN	*CTL	

8 291	T:Scan PGS/Stamp	*CTL	<p>These SPs count the number of pages stamped with the stamp in the ADF unit.</p> <p>[0 to 9999999/ 0 / 1]</p> <p>The L: counter counts the number of pages stored from within the document server mode screen at the operation panel, and with the Store File button from within the Copy mode screen</p>
8 293	F:Scan PGS/Stamp	*CTL	
8 295	S:Scan PGS/Stamp	*CTL	

8 301	T:Scan PGS/Size	*CTL	[0 to 9999999/ 0 / 1]
	<p>These SPs count by size the total number of pages scanned by all applications. Use these totals to compare original page size (scanning) and output (printing) page size [SP 8-441].</p>		
8 302	C:Scan PGS/Size	*CTL	[0 to 9999999/ 0 / 1]
	<p>These SPs count by size the total number of pages scanned by the Copy application. Use these totals to compare original page size (scanning) and output (printing) page size [SP 8-442].</p>		
8 303	F:Scan PGS/Size	*CTL	[0 to 9999999/ 0 / 1]
	<p>These SPs count by size the total number of pages scanned by the Fax application. Use these totals to compare original page size (scanning) and output page size [SP 8-443].</p>		
8 305	S:Scan PGS/Size	*CTL	[0 to 9999999/ 0 / 1]

	These SPs count by size the total number of pages scanned by the Scan application. Use these totals to compare original page size (scanning) and output page size [SP 8-445].	
8 306	L:Scan PGS/Size	*CTL [0 to 9999999/ 0 / 1]
	These SPs count by size the total number of pages scanned and stored from within the document server mode screen at the operation panel, and with the Store File button from within the Copy mode screen. Use these totals to compare original page size (scanning) and output page size [SP 8-446].	
8 30x 1	A3	
8 30x 2	A4	
8 30x 3	A5	
8 30x 4	B4	
8 30x 5	B5	
8 30x 6	DLT	
8 30x 7	LG	
8 30x 8	LT	
8 30x 9	HLT	
8 30x 10	Full Bleed	
8 30x 254	Other (Standard)	
8 30x 255	Other (Custom)	

8 311	T:Scan PGS/Rez	*CTL	[0 to 9999999/ 0 / 1]
	These SPs count by resolution setting the total number of pages scanned by applications that can specify resolution settings.		
8 315	S: Scan PGS/Rez	*CTL	[0 to 9999999/ 0 / 1]
	These SPs count by resolution setting the total number of pages scanned by applications that can specify resolution settings. Note <ul style="list-style-type: none"> At the present time, SP8-311 and SP8-315 perform identical counts. 		
8 31x 1	1200dpi <		
8 31x 2	600dpi to 1199dpi		
8 31x 3	400dpi to 599dpi		
8 31x 4	200dpi to 399dpi		
8 31x 5	< 199dpi		

- Copy resolution settings are fixed so they are not counted.
- The Fax application does not allow finely-adjusted resolution settings so no count is done for the Fax application.

8 381	T:Total PrtPGS	*CTL	These SPs count the number of pages printed by the customer. The counter for the application used for storing the pages increments. [0 to 9999999/ 0 / 1] The L: counter counts the number of pages stored from within the document server mode screen at the operation panel. Pages stored with the Store File button from within the Copy mode screen go to the C: counter.
8 382	C:Total PrtPGS	*CTL	
8 383	F:Total PrtPGS	*CTL	
8 384	P:Total PrtPGS	*CTL	
8 385	S:Total PrtPGS	*CTL	
8 386	L:Total PrtPGS	*CTL	
8 387	O:Total PrtPGS	*CTL	

- When the A3/DLT double count function is switched on with SP5104, 1 A3/DLT page is counted as 2.
- When several documents are merged for a print job, the number of pages stored are counted for the application that stored them.
- These counters are used primarily to calculate charges on use of the machine, so the following pages are not counted as printed pages:
 - Blank pages in a duplex printing job.
 - Blank pages inserted as document covers, chapter title sheets, and slip sheets.
 - Reports printed to confirm counts.
 - All reports done in the service mode (service summaries, engine maintenance reports, etc.)
 - Test prints for machine image adjustment.
 - Error notification reports.
 - Partially printed pages as the result of a copier jam.

8 391	LSize PrtPGS	*CTL	[0 to 9999999/ 0 / 1]
	<p>These SPs count pages printed on paper sizes A3/DLT and larger.</p> <p> Note</p> <ul style="list-style-type: none"> ▪ In addition to being displayed in the SMC Report, these counters are also displayed in the User Tools display on the copy machine. 		

8 401	T:PrtPGS/LS	*CTL	<p>These SPs count the number of pages printed from the document server. The counter for the application used to print the pages is incremented.</p> <p>The L: counter counts the number of jobs stored from within the document server mode screen at the operation panel.</p> <p>[0 to 9999999/ 0 / 1]</p>
8 402	C:PrtPGS/LS	*CTL	
8 403	F:PrtPGS/LS	*CTL	
8 404	P:PrtPGS/LS	*CTL	
8 405	S:PrtPGS/LS	*CTL	
8 406	L:PrtPGS/LS	*CTL	

- Print jobs done with Web Image Monitor and Desk Top Binder are added to the L: count.
- Fax jobs done with Web Image Monitor and Desk Top Binder are added to the F: count.

Main SP Tables-8

8 411	Prints/Duplex	*CTL	This SP counts the amount of paper (front/back counted as 1 page) used for duplex printing. Last pages printed only on one side are not counted. [0 to 9999999/ 0 / 1]
-------	---------------	------	---

8 421	T:PrtPGS/Dup Comb	*CTL	[0 to 9999999/ 0 / 1]
	These SPs count by binding and combine, and n-Up settings the number of pages processed for printing. This is the total for all applications.		
8 422	C:PrtPGS/Dup Comb	*CTL	[0 to 9999999/ 0 / 1]
	These SPs count by binding and combine, and n-Up settings the number of pages processed for printing by the copier application.		
8 423	F:PrtPGS/Dup Comb	*CTL	[0 to 9999999/ 0 / 1]
	These SPs count by binding and combine, and n-Up settings the number of pages processed for printing by the fax application.		
8 424	P:PrtPGS/Dup Comb	*CTL	[0 to 9999999/ 0 / 1]
	These SPs count by binding and combine, and n-Up settings the number of pages processed for printing by the printer application.		
8 425	S:PrtPGS/Dup Comb	*CTL	[0 to 9999999/ 0 / 1]
	These SPs count by binding and combine, and n-Up settings the number of pages processed for printing by the scanner application.		
8 426	L:PrtPGS/Dup Comb	*CTL	[0 to 9999999/ 0 / 1]
	These SPs count by binding and combine, and n-Up settings the number of pages processed for printing from within the document server mode window at the operation panel.		
8 427	O:PrtPGS/Dup Comb	*CTL	[0 to 9999999/ 0 / 1]
	These SPs count by binding and combine, and n-Up settings the number of pages processed for printing by Other applications		
8 42x 1	Simplex> Duplex		

8 42x 2	Duplex> Duplex	
8 42x 3	Book> Duplex	
8 42x 4	Simplex Combine	
8 42x 5	Duplex Combine	
8 42x 6	2in1	2 pages on 1 side (2-Up)
8 42x 7	4 in1	4 pages on 1 side (4-Up)
8 42x 8	6 in1	6 pages on 1 side (6-Up)
8 42x 9	8 in1	8 pages on 1 side (8-Up)
8 42x 10	9 in1	9 pages on 1 side (9-Up)
8 42x 11	16 in1	16 pages on 1 side (16-Up)
8 42x 12	Booklet	
8 42x 13	Magazine	

- These counts (SP8 421 to SP8 427) are especially useful for customers who need to improve their compliance with ISO standards for the reduction of paper consumption.
- Pages that are only partially printed with the n-Up functions are counted as 1 page.
- Here is a summary of how the counters work for Booklet and Magazine modes:

Booklet			Magazine	
Original Pages	Count		Original Pages	Count
1	1		1	1
2	2		2	2
3	2		3	2
4	2		4	2
5	3		5	4
6	4		6	4
7	4		7	4

Main SP Tables-8

8	4		8	4
---	---	--	---	---

8 431	T:PrtPGS/ImgEdt	*CTL	[0 to 9999999/ 0 / 1]
	These SPs count the total number of pages output with the three features below, regardless of which application was used.		
8 432	C:PrtPGS/ImgEdt	*CTL	[0 to 9999999/ 0 / 1]
	These SPs count the total number of pages output with the three features below with the copy application.		
8 434	P:PrtPGS/ImgEdt	*CTL	[0 to 9999999/ 0 / 1]
	These SPs count the total number of pages output with the three features below with the print application.		
8 436	L:PrtPGS/ImgEdt	*CTL	[0 to 9999999/ 0 / 1]
	These SPs count the total number of pages output from within the document server mode window at the operation panel with the three features below.		
8 437	O:PrtPGS/ImgEdt	*CTL	[0 to 9999999/ 0 / 1]
	These SPs count the total number of pages output with the three features below with Other applications.		
8 43x 1	Cover/Slip Sheet	Total number of covers or slip sheets inserted. The count for a cover printed on both sides counts 2.	
8 43x 2	Series/Book	The number of pages printed in series (one side) or printed as a book with booklet right/left pagination.	
8 43x 3	User Stamp	The number of pages printed where stamps were applied, including page numbering and date stamping.	

8 441	T:PrtPGS/Ppr Size	*CTL	[0 to 9999999/ 0 / 1]
	These SPs count by print paper size the number of pages printed by all applications.		
8 442	C:PrtPGS/Ppr Size	*CTL	[0 to 9999999/ 0 / 1]
	These SPs count by print paper size the number of pages printed by the copy application.		
8 443	F:PrtPGS/Ppr Size	*CTL	[0 to 9999999/ 0 / 1]
	These SPs count by print paper size the number of pages printed by the fax application.		
8 444	P:PrtPGS/Ppr Size	*CTL	[0 to 9999999/ 0 / 1]
	These SPs count by print paper size the number of pages printed by the printer application.		
8 445	S:PrtPGS/Ppr Size	*CTL	[0 to 9999999/ 0 / 1]
	These SPs count by print paper size the number of pages printed by the scanner application.		
8 446	L:PrtPGS/Ppr Size	*CTL	[0 to 9999999/ 0 / 1]
	These SPs count by print paper size the number of pages printed from within the document server mode window at the operation panel.		
8 447	O:PrtPGS/Ppr Size	*CTL	[0 to 9999999/ 0 / 1]
	These SPs count by print paper size the number of pages printed by Other applications.		
8 44x 1	A3		
8 44x 2	A4		
8 44x 3	A5		
8 44x 4	B4		
8 44x 5	B5		
8 44x 6	DLT		

Main SP Tables-8

8 44x 7	LG	
8 44x 8	LT	
8 44x 9	HLT	
8 44x 10	Full Bleed	
8 44x 254	Other (Standard)	
8 44x 255	Other (Custom)	

- These counters do not distinguish between LEF and SEF.

8 451	PrtPGS/Ppr Tray	*CTL	[0 to 9999999/ 0 / 1]
	These SPs count the number of sheets fed from each paper feed station.		
8 451 1	Bypass Tray	Bypass Tray	
8 451 2	Tray 1	Copier	
8 451 3	Tray 2	Copier	
8 451 4	Tray 3	Paper Tray Unit (Option)	
8 451 5	Tray 4	Paper Tray Unit (Option)	
8 451 6	Tray 5	LCT (Option)	
8 451 7	Tray 6	Currently not used.	
8 451 8	Tray 7	Currently not used.	
8 451 9	Tray 8	Currently not used.	
8 451 10	Tray 9	Currently not used.	

8 461	T:PrtPGS/Ppr Type	*CTL	[0 to 9999999/ 0 / 1]
	<p>These SPs count by paper type the number pages printed by all applications.</p> <ul style="list-style-type: none"> ▪ These counters are not the same as the PM counter. The PM counter is based on feed timing to accurately measure the service life of the feed rollers. However, these counts are based on output timing. ▪ Blank sheets (covers, chapter covers, slip sheets) are also counted. ▪ During duplex printing, pages printed on both sides count as 1, and a page printed on one side counts as 1. 		
8 462	C:PrtPGS/Ppr Type	*CTL	[0 to 9999999/ 0 / 1]
	These SPs count by paper type the number pages printed by the copy application.		
8 463	F:PrtPGS/Ppr Type	*CTL	[0 to 9999999/ 0 / 1]
	These SPs count by paper type the number pages printed by the fax application.		
8 464	P:PrtPGS/Ppr Type	*CTL	[0 to 9999999/ 0 / 1]
	These SPs count by paper type the number pages printed by the printer application.		
8 466	L:PrtPGS/Ppr Type	*CTL	[0 to 9999999/ 0 / 1]
	These SPs count by paper type the number pages printed from within the document server mode window at the operation panel.		
8 46x 1	Normal		
8 46x 2	Recycled		
8 46x 3	Special		
8 46x 4	Thick		
8 46x 5	Normal (Back)		
8 46x 6	Thick (Back)		
8 46x 7	OHP		

Main SP Tables-8

8 46x 8	Other
---------	-------

8 471	PrtPGS/Mag	*CTL	[0 to 9999999/ 0 / 1]
	These SPs count by magnification rate the number of pages printed.		
8 471 1	< 49%		
8 471 2	50% to 99%		
8 471 3	100%		
8 471 4	101% to 200%		
8 471 5	201% <		

- Counts are done for magnification adjusted for pages, not only on the operation panel but performed remotely with an external network application capable of performing magnification adjustment as well.
- Magnification adjustments done with printer drivers with PC applications such as Excel are also counted.
- Magnification adjustments done for adjustments after they have been stored on the document server are not counted.
- Magnification adjustments performed automatically during Auto Reduce/Enlarge copying are counted.
- The magnification rates of blank cover sheets, slip sheets, etc. are automatically assigned a rate of 100%.

8 481	T:PrtPGS/TonSave	*CTL	
8 484	P:PrtPGS/TonSave	*CTL	
	These SPs count the number of pages printed with the Toner Save feature switched on. Note: These SPs return the same results as this SP is limited to the Print application. [0 to 99999999/ 0 / 1]		

8 491	T:PrtPGS/Col Mode	*CTL	These SPs count the number of pages printed in the Color Mode by each application.
8 492	C:PrtPGS/Col Mode	*CTL	
8 493	F:PrtPGS/Col Mode	*CTL	
8 496	L:PrtPGS/Col Mode	*CTL	
8 497	O:PrtPGS/Col Mode	*CTL	
8 49x 1	B/W		
8 49x 2	Single Color		
8 49x 3	Two Color		
8 49x 4	Full Color		

8 501	T:PrtPGS/Col Mode	*CTL	These SPs count the number of pages printed in the Color Mode by the print application.
8 504	P:PrtPGS/Col Mode	*CTL	
8 507	O:PrtPGS/Col Mode	*CTL	
8 50x 1	B/W		
8 50x 2	Mono Color		
8 50x 3	Full Color		
8 50x 4	Single Color		
8 50x 5	Two Color		

Main SP Tables-8

8 511	T:PrtPGS/Emul	*CTL	[0 to 9999999/ 0 / 1]
	These SPs count by printer emulation mode the total number of pages printed.		
8 514	P:PrtPGS/Emul	*CTL	[0 to 9999999/ 0 / 1]
	These SPs count by printer emulation mode the total number of pages printed.		
8 514 1	RPCS		
8 514 2	RPDL		
8 514 3	PS3		
8 514 4	R98		
8 514 5	R16		
8 514 6	GL/GL2		
8 514 7	R55		
8 514 8	RTIFF		
8 514 9	PDF		
8 514 10	PCL5e/5c		
8 514 11	PCL XL		
8 514 12	IPDL-C		
8 514 13	BM-Links		
8 514 14	Other		

- SP8 511 and SP8 514 return the same results as they are both limited to the Print application.
- Print jobs output to the document server are not counted.

8 521	T:PrtPGS/FIN	*CTL	[0 to 9999999 / 0 / 1]
	These SPs count by finishing mode the total number of pages printed by all applications.		

8 522	C:PrtPGS/FIN	*CTL	[0 to 9999999 / 0 / 1]
	These SPs count by finishing mode the total number of pages printed by the Copy application.		
8 523	F:PrtPGS/FIN	*CTL	[0 to 9999999 / 0 / 1]
	These SPs count by finishing mode the total number of pages printed by the Fax application. NOTE: Print finishing options for received faxes are currently not available.		
8 524	P:PrtPGS/FIN	*CTL	[0 to 9999999 / 0 / 1]
	These SPs count by finishing mode the total number of pages printed by the Print application.		
8 525	S:PrtPGS/FIN	*CTL	[0 to 9999999 / 0 / 1]
	These SPs count by finishing mode the total number of pages printed by the Scanner application.		
8 526	L:PrtPGS/FIN	*CTL	[0 to 9999999 / 0 / 1]
	These SPs count by finishing mode the total number of pages printed from within the document server mode window at the operation panel.		
8 52x 1	Sort		
8 52x 2	Stack		
8 52x 3	Staple		
8 52x 4	Booklet		
8 52x 5	Z-Fold		
8 52x 6	Punch		
8 52x 7	Other		

Note

- If stapling is selected for finishing and the stack is too large for stapling, the unstapled pages are still counted.
- The counts for staple finishing are based on output to the staple tray, so jam recoveries are counted.

8 531	Staples	*CTL	This SP counts the amount of staples used by the machine. [0 to 9999999 / 0 / 1]
-------	---------	------	---

	T:Counter	*CTL	[0 to 9999999 / 0 / 1]
8 581	These SPs count the total output broken down by color output, regardless of the application used. In addition to being displayed in the SMC Report, these counters are also displayed in the User Tools display on the copy machine.		
8 581 1	Total		
8 581 2	Total: Full Color		
8 581 3	B&W/Single Color		
8 581 4	Development: CMY		
8 581 5	Development: K		
8 581 6	Copy: Color		
8 581 7	Copy: B/W		
8 581 8	Print: Color		
8 581 9	Print: B/W		
8 581 10	Total: Color		
8 581 11	Total: B/W		
8 581 12	Full Color: A3		
8 581 13	Full Color: B4 JIS or Smaller		

8 581 14	Full Color Print
8 581 15	Mono Color Print
8 581 16	Full Color GPC
8 581 17	Twin Color Mode Print
8 581 18	Full Color Print (Twin)
8 581 19	Mono Color Print (Twin)
8 581 20	Full Color Total (CV)
8 581 21	Mono Color Total (CV)
8 581 22	Full Color Print (CV)

8 582	C:Counter	*CTL	[0 to 9999999/ 0 / 1]
	These SPs count the total output of the copy application broken down by color output.		
8 582 1	B/W		
8 582 2	Single Color		
8 582 3	Two Color		
8 582 4	Full Color		

8 583	F:Counter	*CTL	[0 to 9999999/ 0 / 1]
	These SPs count the total output of the fax application broken down by color output.		
8 583 1	B/W		
8 583 2	Single Color		

Main SP Tables-8

8 584	P:Counter	*CTL	[0 to 9999999/ 0 / 1]
	These SPs count the total output of the print application broken down by color output.		
8 584 1	B/W		
8 584 2	Mono Color		
8 584 3	Full Color		
8 584 4	Single Color		
8 584 5	Two Color		

8 586	L:Counter	*CTL	[0 to 9999999/ 0 / 1]
	These SPs count the total output of the local storage broken down by color output.		
8 582 1	B/W		
8 582 2	Single Color		
8 582 3	Two Color		
8 582 4	Full Color		

8 591	O:Counter	*CTL	[0 to 9999999/ 0 / 1]
	These SPs count the totals for A3/DLT paper use, number of duplex pages printed, and the number of staples used. These totals are for Other (O:) applications only.		
	8 591 1	A3/DLT	-
8 591 2	Duplex		

8 601	T: Coverage Counter	*CTL	[0 to 9999999/ 0 / 1]
	These SPs count the total coverage for each color and the total printout pages for each printing mode.		
8 601 1	B/W	-	
8 601 2	Color		
8 601 11	B/W Printing Pages		
8 601 12	Color Printing Pages		
8 601 21	Coverage Counter 1		
8 601 22	Coverage Counter 2		
8 601 23	Coverage Counter 3		

8 617	SDK Apli Counter	*CTL	[0 to 9999999/ 0 / 1]
	These SPs count the total printout pages for each SDK applicaion.		
8 617 1	SDK-1	-	
8 617 2	SDK-2		
8 617 3	SDK-3		
8 617 4	SDK-4		
8 617 5	SDK-5		
8 617 6	SDK-6		

Main SP Tables-8

8 631	T:FAX TX PGS	*CTL	[0 to 9999999/ 0 / 1]
	These SPs count by color mode the number of pages sent by fax to a telephone number.		
8 633	F:FAX TX PGS	*CTL	[0 to 9999999/ 0 / 1]
	These SPs count by color mode the number of pages sent by fax to a telephone number.		
8 63x 1	B/W		
8 63x 2	Color		

- If a document has color and black-and-white pages mixed, the pages are counted separately as B/W or Color.
- At the present time, this feature is provided for the Fax application only so SP8631 and SP8633 are the same.
- The counts include error pages.
- If a document is sent to more than one destination with a Group transmission, the count is done for each destination.
- Polling transmissions are counted but polling RX are not.
- Relay, memory, and confidential mailbox transmissions and are counted for each destination.

8 641	T:IFAX TX PGS	*CTL	[0 to 9999999/ 0 / 1]
	These SPs count by color mode the number of pages sent by fax to as fax images using I-Fax.		
8 643	F:IFAX TX PGS	*CTL	[0 to 9999999/ 0 / 1]
	These SPs count by color mode the number of pages sent by Fax as fax images using I-Fax.		
8 64x 1	B/W		
8 64x 2	Color		

- If a document has color and black-and-white pages mixed, the pages are counted separately as B/W or Color.
- At the present time, this feature is provided for the Fax application only so SP8641 and

SP8643 are the same.

- The counts include error pages.
- If a document is sent to more than one destination with a Group transmission, the count is done for each destination.
- Polling transmissions are counted but polling RX are not.
- Relay, memory, and confidential mailbox transmissions and are counted for each destination.

8 651	T:S-to-Email PGS	*CTL	[0 to 99999999/ 0 / 1]
	These SPs count by color mode the total number of pages attached to an e-mail for both the Scan and document server applications.		
8 655	S:S-to-Email PGS	*CTL	[0 to 99999999/ 0 / 1]
	These SPs count by color mode the total number of pages attached to an e-mail for the Scan application only.		
8 65x 1	B/W		
8 65x 2	Color		

Note

- The count for B/W and Color pages is done after the document is stored on the HDD. If the job is cancelled before it is stored, the pages are not counted.
- If Scan-to-Email is used to send a 10-page document to 5 addresses, the count is 10 (the pages are sent to the same SMTP server together).
- If Scan-to-PC is used to send a 10-page document to 5 folders, the count is 50 (the document is sent to each destination of the SMB/FTP server).
- Due to restrictions on some devices, if Scan-to-Email is used to send a 10-page document to a large number of destinations, the count may be divided and counted separately. For example, if a 10-page document is sent to 200 addresses, the count is 10 for the first 100 destinations and the count is also 10 for the second 100 destinations, for a total of 20.).

Main SP Tables-8

8 661	T:Deliv PGS/Svr	*CTL	[0 to 9999999/ 0 / 1]
	These SPs count by color mode the total number of pages sent to a Scan Router server by both Scan and LS applications.		
8 665	S:Deliv PGS/Svr	*CTL	[0 to 9999999/ 0 / 1]
	These SPs count by color mode the total number of pages sent to a Scan Router server by the Scan application.		
8 66x 1	B/W		
8 66x 2	Color		

Note

- The B/W and Color counts are done after the document is stored on the HDD of the Scan Router server.
- If the job is canceled before storage on the Scan Router server finishes, the counts are not done.
- The count is executed even if regardless of confirmation of the arrival at the Scan Router server.

8 671	T:Deliv PGS/PC	*CTL	[0 to 9999999/ 0 / 1]
	These SPs count by color mode the total number of pages sent to a folder on a PC (Scan-to-PC) with the Scan and LS applications.		
8 675	S: Deliv PGS/PC	*CTL	[0 to 9999999/ 0 / 1]
	These SPs count by color mode the total number of pages sent with Scan-to-PC with the Scan application.		
8 67x 1	B/W		
8 67x 2	Color		

8 681	T:PCFAX TXPGS	*CTL	These SPs count the number of pages sent by PC Fax. These SPs are provided for the Fax application only, so the counts for SP8 681 and SP8 683 are the same. [0 to 9999999/ 0 / 1]
8 683	F:PCFAX TXPGS	*CTL	

- This counts pages sent from a PC using a PC fax application, from the PC through the copier to the destination.
- When sending the same message to more than one place using broadcasting, the pages are only counted once. (For example, a 10-page fax is sent to location A and location B. The counter goes up by 10, not 20.)

8 691	T:TX PGS/LS	*CTL	These SPs count the number of pages sent from the document server. The counter for the application that was used to store the pages is incremented. [0 to 9999999/ 0 / 1] The L: counter counts the number of pages stored from within the document server mode screen at the operation panel. Pages stored with the Store File button from within the Copy mode screen go to the C: counter.
8 692	C:TX PGS/LS	*CTL	
8 693	F:TX PGS/LS	*CTL	
8 694	P:TX PGS/LS	*CTL	
8 695	S:TX PGS/LS	*CTL	
8 696	L:TX PGS/LS	*CTL	

Note

- Print jobs done with Web Image Monitor and Desk Top Binder are added to the count.
- If several documents are merged for sending, the number of pages stored are counted for the application that stored them.
- When several documents are sent by a Fax broadcast, the F: count is done for the number of pages sent to each destination.

8 701	TX PGS/Port	*CTL	[0 to 9999999/ 0 / 1]
	These SPs count the number of pages sent by the physical port used to send them. For example, if a 3-page original is sent to 4 destinations via ISDN G4, the count for ISDN (G3, G4) is 12.		

Main SP Tables-8

8 701 1	PSTN-1	
8 701 2	PSTN-2	
8 701 3	PSTN-3	
8 701 4	ISDN (G3,G4)	
8 701 5	Network	

8 711	T:Scan PGS/Comp	*CTL	[0 to 9999999/ 0 / 1]
8 715	S:Scan PGS/Comp	*CTL	[0 to 9999999/ 0 / 1]
	These SPs count the number of pages sent by each compression mode.		
8 715 1	JPEG/JPEG2000		
8 715 2	TIFF(Multi/Single)		
8 715 3	PDF		
8 715 4	Other		
8 715 5	PDF/Comp		

8 721	T:Deliv PGS/WSD	*CTL	[0 to 9999999/ 0 / 1]
8 725	S: Dlviv PGS/WSD	*CTL	
	These SPs count the number of pages scanned by each scanner mode.		
x 1	B/W	-	
x 2	Color	-	

8 731	T:Scan PGS/Media	*CTL	[0 to 9999999/ 0 / 1]
8 735	S:Scan PGS/Media	*CTL	
	These SPs count the number of pages scanned and saved in a meia by each scanner mode.		
x 1	B/W	-	

x 2	Color	-
-----	-------	---

8 741	RX PGS/Port	*CTL	[0 to 9999999/ 0 / 1]
	These SPs count the number of pages received by the physical port used to receive them.		
8 741 1	PSTN-1	-	
8 741 2	PSTN-2	-	
8 741 3	PSTN-3	-	
8 741 4	ISDN (G3,G4)	-	
8 741 5	Network	-	

8 771	Dev Counter	*CTL	[0 to 9999999/ 0 / 1]
	These SPs count the frequency of use (number of rotations of the development rollers) for black and other color toners.		
8 771 1	Total		
8 771 2	K		
8 771 3	Y		
8 771 4	M		
8 771 5	C		

Main SP Tables-8

8 781	Toner_Bottle_Info.	*ENG	[0 to 9999999/ 0 / 1]
	<p>These SPs display the number of already replaced toner bottles. NOTE: Currently, the data in SP7-833-011 through 014 and the data in SP8-781-001 through 004 are the same.</p>		
8 781 1	Toner: BK	The number of black-toner bottles	
8 781 2	Toner: Y	The number of yellow-toner bottles	
8 781 3	Toner: M	The number of magenta-toner bottles	
8 781 4	Toner: C	The number of cyan-toner bottles	

8 791	LS Memory Remain	*CTL	<p>This SP displays the percent of space available on the document server for storing documents. [0 to 100 / 0 / 1]</p>
-------	------------------	------	--

8 801	Toner Remain	*CTL	[0 to 100/ 0 / 1]
	<p>These SPs display the percent of toner remaining for each color. This SP allows the user to check the toner supply at any time. Note: This precise method of measuring remaining toner supply (1% steps) is better than other machines in the market that can only measure in increments of 10 (10% steps).</p>		
8 801 1	K		
8 801 2	Y		
8 801 3	M		
8 801 4	C		

8 851	CVr Cnt: 0-10%	*ENG	[0 to 9999999/ 0 / 1]
	These SPs display the number of scanned sheets on which the coverage of each color is from 0% to 10%.		
8 851 11	0 to 2%: BK	8 851 31	5 to 7%: BK
8 851 12	0 to 2%: Y	8 851 32	5 to 7%: Y
8 851 13	0 to 2%: M	8 851 33	5 to 7%: M
8 851 14	0 to 2%: C	8 851 34	5 to 7%: C
8 851 21	3 to 4%: BK	8 851 41	8 to 10%: BK
8 851 22	3 to 4%: Y	8 851 42	8 to 10%: Y
8 851 23	3 to 4%: M	8 851 43	8 to 10%: M
8 851 24	3 to 4%: C	8 851 44	8 to 10%: C

8 861	CVr Cnt: 11-20%	*ENG	[0 to 9999999/ 0 / 1]
	These SPs display the number of scanned sheets on which the coverage of each color is from 11% to 20%.		
8 861 1	BK		
8 861 2	Y		
8 861 3	M		
8 861 4	C		

Main SP Tables-8

8 871	CVr Cnt: 21-30%	*ENG	[0 to 9999999/ 0 / 1]
	These SPs display the number of scanned sheets on which the coverage of each color is from 21% to 30%.		
8 871 1	BK		
8 871 2	Y		
8 871 3	M		
8 871 4	C		

8 881	CVr Cnt: 31%-	*ENG	[0 to 9999999/ 0 / 1]
	These SPs display the number of scanned sheets on which the coverage of each color is 31% or higher.		
8 881 1	BK		
8 881 2	Y		
8 881 3	M		
8 881 4	C		

8 891	Page/Toner Bottle	*ENG	[0 to 9999999/ 0 / 1]
	These SPs display the amount of the remaining current toner for each color.		
8 891 1	BK		
8 891 2	Y		
8 891 3	M		
8 891 4	C		

8 901	Page/Toner_prev1	*ENG	[0 to 9999999/ 0 / 1]
	These SPs display the amount of the remaining previous toner for each color.		
8 901 1	BK		
8 901 2	Y		
8 901 3	M		
8 901 4	C		

8 911	Page/Toner_prev2	*ENG	[0 to 9999999/ 0 / 1]
	These SPs display the amount of the remaining 2nd previous toner for each color.		
8 911 1	BK		
8 911 2	Y		
8 911 3	M		
8 911 4	C		

8 921	Cvr Cnt/Total	*CTL	[0 to 9999999/ 0 / 1]
	Displays the total coverage and total printout number for each color.		
8 921 1	Coverage (%) Bk		
8 921 2	Coverage (%) Y		
8 921 3	Coverage (%) M		
8 921 4	Coverage (%) C		
8 921 11	Coverage /P: Bk		
8 921 12	Coverage /P: Y		
8 921 13	Coverage /P: M		
8 921 14	Coverage /P: C		

	Machine Status	*CTL	[0 to 99999999/ 0 / 1]
8 941	These SPs count the amount of time the machine spends in each operation mode. These SPs are useful for customers who need to investigate machine operation for improvement in their compliance with ISO Standards.		
8 941 1	Operation Time	Engine operation time. Does not include time while controller is saving data to HDD (while engine is not operating).	
8 941 2	Standby Time	Engine not operating. Includes time while controller saves data to HDD. Does not include time spent in Energy Save, Low Power, or Off modes.	
8 941 3	Energy Save Time	Includes time while the machine is performing background printing.	
8 941 4	Low Power Time	Includes time in Energy Save mode with Engine on. Includes time while machine is performing background printing.	
8 941 5	Off Mode Time	Includes time while machine is performing background printing. Does not include time machine remains powered off with the power switches.	
8 941 6	SC	Total time when SC errors have been staying.	
8 941 7	PrtJam	Total time when paper jams have been staying during printing.	
8 941 8	OrgJam	Total time when original jams have been staying during scanning.	
8 941 9	Supply PM Unit End	Total time when toner end has been staying	

8 951	AddBook Register	*CTL	
	These SPs count the number of events when the machine manages data registration.		
8 951 1	User Code/User ID	User code registrations.	[0 to 9999999/ 0 / 1]
8 951 2	Mail Address	Mail address registrations.	
8 951 3	Fax Destination	Fax destination registrations.	
8 951 4	Group	Group destination registrations.	
8 951 5	Transfer Request	Fax relay destination registrations for relay TX.	
8 951 6	F-Code	F-Code box registrations.	
8 951 7	Copy Program	Copy application registrations with the Program (job settings) feature.	
8 951 8	Fax Program	Fax application registrations with the Program (job settings) feature.	
8 951 9	Printer Program	Printer application registrations with the Program (job settings) feature.	
8 951 10	Scanner Program	Scanner application registrations with the Program (job settings) feature.	

Main SP Tables-8

8 999	Admin. Counter List	*CTL	[0 to 9999999/ 0 / 1]
	Displays the total coverage and total printout number for each color.		
8 999 1	Total		
8 999 2	Copy: Full Color		
8 999 3	Copy: BW		
8 999 4	Copy: Single Color		
8 999 5	Copy: Two Color		
8 999 6	Printer Full Color		
8 999 7	Printer BW		
8 999 8	Printer Single Color		
8 999 9	Printer Two Color		
8 999 10	Fax Print: BW		
8 999 12	A3/DLT		
8 999 13	Duplex		
8 999 14	Coverage: Color (%)		
8 999 15	Coverage: BW (%)		
8 999 16	Coverage: Color Print Page (%)		
8 999 17	Coverage: BW Print Page (%)		
8 999 101	Transmission Total: Color		
8 999 102	Transmission Total: BW		
8 999 103	FAX Transmission		
8 999 104	Scanner Transmission: Color		
8 999 105	Scanner Transmission: BW		

3.9 INPUT AND OUTPUT CHECK

3.9.1 INPUT CHECK TABLE

When entering the Input Check mode, 8 digits display the result for a section. Each digit corresponds to a different device as shown in the table.

Bit No.	7	6	5	4	3	2	1	0
Result	0 or 1	0 or 1	0 or 1	0 or 1	0 or 1	0 or 1	0 or 1	0 or 1

Copier

5803	Description	Reading	
		0	1
5803 1	2nd Tray Size Detection	See table 2 following this table.	
5803 2	1st Tray Set Detection	Set	Not set
5803 3	1st Tray Paper Height Sensor1	See table 1 following this table.	
5803 4	1st Tray Paper Height Sensor2	See table 1 following this table.	
5803 5	2nd Tray Paper Height Sensor1	See table 1 following this table.	
5803 6	2nd Tray Paper Height Sensor2	See table 1 following this table.	
5803 7	1st Tray Paper End Detection	No paper	Paper remaining
5803 8	2nd Tray Paper End Detection	No paper	Paper remaining
5803 9	1st Tray Upper Limit Sensor	Not upper limit	Upper limit
5803 10	2nd Tray Upper Limit Sensor	Not upper limit	Upper limit
5803 11	Bypass Paper Width Detection	See table 3 following this table.	
5803 12	Bypass Paper End Detection	No paper	Paper remaining
5803 13	Bypass Paper Length Detection	See table 3 following this table.	

Input and Output Check

5803	Description	Reading	
		0	1
5803 14	1st Paper Feed Sensor	Paper detected	Paper not detected
5803 15	2 nd Paper Feed Sensor	Paper detected	Paper not detected
5803 16	Exit Sensor	Paper detected	Paper not detected
5803 17	Tray Full Exit Sensor	Paper not full	Paper full
5803 18	Fusing Exit Sensor	Paper not detected	Paper detected
5803 19	Fusing Entrance Sensor	Paper detected	Paper not detected
5803 20	1st Feed Sensor	Paper detected	Paper not detected
5803 21	2 nd Feed Sensor	Paper detected	Paper not detected
5803 22	Duplex Exit Sensor	Paper detected	Paper not detected
5803 23	Registration Sensor	Paper detected	Paper not detected
5803 24	Duplex Entrance Sensor	Paper detected	Paper not detected
5803 25	Junction Sensor	Paper detected	Paper not detected
5803 26	2nd Tray Set Detection	Set	Not set
5803 30	Toner End Sensor: Bk	Toner end	Toner remaining
5803 31	Toner End Sensor: M	Toner end	Toner remaining
5803 32	Toner End Sensor: C	Toner end	Toner remaining

5803	Description	Reading	
		0	1
5803 33	Toner End Sensor: Y	Toner end	Toner remaining
5803 34	Drum Phase Sensor: Bk	Actuator not detected	Actuator detected
5803 35	Drum Phase Sensor: M	Actuator not detected	Actuator detected
5803 36	Drum Phase Sensor: C	Actuator not detected	Actuator detected
5803 37	Drum Phase Sensor: Y	Actuator not detected	Actuator detected
5803 38	Interlock Release Detection 1	Front door open	Front door closed
5803 39	Interlock Release Detection 2	Front door open	Front door closed
5803 40	Right Door	Closed	Open
5803 41	Duplex Cover	Closed	Open
5803 42	Toner Collection Bottle Set	Set	Not set
5803 43	Toner Collection Full Sensor	Not full	Full
5803 46	ITB New Unit Detection	Not new	New
5803 49	Duplex Fan: Lock	Normal	Lock
5803 50	Airflow Fan: Front: Lock	Normal	Lock
5803 51	Airflow Fan: Rear: Lock	Normal	Lock
5803 52	Fusing Exit Fan: Lock	Normal	Lock
5803 53	2nd Duct Fan: Lock	Normal	Lock
5803 54	3rd Duct Fan: Lock	Normal	Lock
5803 55	Paper Exit Fan:Lock	Normal	Lock

Input and Output Check

5803	Description	Reading	
		0	1
5803 56	Fusing Coil Fan: Lock	Normal	Lock
5803 57	IH Power Supply Cooling Fan: Lock	Normal	Lock
5803 58	Airflow Fan: Middle 1: Lock	Not used	
5803 59	Airflow Fan: Middle 2: Lock	Not used	
5803 60	ITB Contact Motor Position	Not contact	Contact
5803 61	Paper Transfer Contact Motor Position	Not contact	Contact
5803 62	Toner Relay Motor: Lock	Normal	Lock
5803 63	ITB Drive Motor: Lock	Normal	Lock
5803 64	K Drum/Development Drive Motor: Lock	Normal	Lock
5803 65	M Drum/Development Drive Motor: Lock	Normal	Lock
5803 66	C Drum/Development Drive Motor: Lock	Normal	Lock
5803 67	Y Drum/Development Drive Motor: Lock	Normal	Lock
5803 68	Fusing Exit Motor:Lock	Normal	Lock
5803 80	HVPS:TTS:SC Detection	SC detected	No SC
5803 81	HVPS:CB:SC Detection	SC detected	No SC
5803 82	HVPS:D:SC Detection	SC detected	No SC
5803 83	Fusing Destination Detection: DOM (Dom)	Set	Not set
5803 84	Fusing Destination Detection: NA	Set	Not set
5803 87	Fusing New Unit Detection	New	Not new

5803	Description	Reading	
		0	1
5803 90	Zero-cross Signal	-	-
5803 91	Fusing Rotation Sensor	Actuator not detected	Actuator detected
5803 92	Fusing Pressure Release Sensor	Not contact	Contact
5803 94	GAVD Open/Close Detection	Closed (LD5V ON)	Open (LD5V OFF)
5803 100	Keycard: Set	Set	Not set
5803 101	Mechanical Counter: Set	Set	Not set
5803 102	Mechanical Counter FC: Set	Set	Not set
5803 103	Key Counter: Set	Set	Not set
5803 110	IOB Version	-	-
5803 200	Scanner HP Sensor	Not HP	HP
5803 201	Platen Cover Sensor	Open	Closed

Table 1: Paper Height Sensor

0: Deactivated, 1: Activated (actuator inside sensor)

Remaining paper	Paper height sensor 1	Paper height sensor 2
Full	0	0
Nearly full	1	0
Near end	1	1
Almost empty	0	1

Table 2: Paper Size Switch (Tray 2)

Switch 1 is used for tray set detection.

0: Pushed, 1: Not pushed

Models		Switch Location		
North America	Europe/Asia	4 (bit0)	3 (bit1)	2 (bit2)
11" x 17" SEF ^{*1} (A3 SEF)	A3 SEF ^{*1} (11" x 17" SEF)	0	0	1
8.5" x 14" SEF ^{*2} (B4 SEF)	B4 SEF ^{*2} (8.5" x 14" SEF)	0	0	0
A4 SEF	A4 SEF	1	1	0
8.5" x 11" SEF	8.5" x 11" SEF	1	1	1
B5 SEF	B5 SEF	0	1	1
11" x 8 1/2" LEF ^{*3} (A4 LEF)	A4 LEF ^{*3} (11" x 8 1/2" LEF)	1	0	0
10.5" x 7.25" LEF ^{*4} (B5 LEF)	B5 LEF ^{*4} (10.5" x 7.25" LEF)	0	1	0
A5 LEF	A5 LEF	1	0	1
<p>*1: The machine detects either 11" x 17" SEF or A3 SEF, depending on the setting of SP 5-181-003.</p> <p>*2: The machine detects either 8.5" x 14" SEF or B4 SEF, depending on the setting of SP 5-181-004.</p> <p>*3: The machine detects either 11" x 8 1/2" LEF or A4 LEF, depending on the setting of SP 5-181-002.</p> <p>*4: The machine detects either B5 LEF or 10.5" x 7.25" LEF, depending on the setting of SP 5-181-005.</p>				

Table 3: Paper Size (By-pass Table)

0: ON, 1: OFF

By-pass Paper Size Sensor				Length Sensor	NA	EU/ASIA
Bit3	Bit2	Bit1	Bit0			
1	1	1	1	1	HLT SEF	A6 SEF
0	1	1	1	1	HLT SEF	A6 SEF
0	0	1	1	1	HLT SEF	A5 SEF
1	0	1	1	1	HLT SEF	A5 SEF
1	0	0	1	0	LT/LG SEF* ¹	A4 SEF
1	0	0	1	1	LT/LG SEF* ¹	A5 LEF
1	1	0	1	0	LT/LG SEF* ¹	A4 SEF
1	1	0	1	1	LT/LG SEF* ¹	A5 LEF
1	1	0	0	0	DLT SEF	A3 SEF
1	1	0	0	1	LT LEF	A4 LEF
1	1	0	0	0	DLT SEF	A3 SEF
1	1	1	0	1	LT LEF	A4 LEF

*1: The paper size (LT or LG) can be selected with SP1-007-001.

ARDF (D578)

6007	Description	Reading	
		0	1
6007 1	Original Length 1 (B5 Detection Sensor)	Paper not detected	Paper detected
6007 2	Original Length 2 (A4 Detection Sensor)	Paper not detected	Paper detected
6007 3	Original Length 3 (LG Detection Sensor)	Paper not detected	Paper detected
6007 4	Original Width S	Paper not detected	Paper detected
6007 5	Original Width M	Paper not detected	Paper detected
6007 6	Original Width L	Paper not detected	Paper detected
6007 7	Original Width LL	Paper not detected	Paper detected
6007 8	Original Width 5	Paper not detected	Paper detected
6007 9	Original Detection	Paper not detected	Paper detected
6007 10	Rear Edge Detection	Paper not detected	Paper detected
6007 11	Skew Correction	Paper not detected	Paper detected
6007 12	Scan Entrance Secsor	Paper not detected	Paper detected

Input and Output Check

6007	Description	Reading	
		0	1
6007 13	Registration Sensor	Paper not detected	Paper detected
6007 14	Exit Sensor	Paper not detected	Paper detected
6007 15	Feed Cover	ADF cover close	ADF cover open
6007 16	Lift Up	ADF cover close	ADF cover open
6007 17	Inverter Sensor	Paper not detected	Paper detected
6007 18	Pick-Up Roller HP Sensor	Not HP	HP
6007 19	Original Set HP Sensor	Original not detected	Original detected
6007 23	Rear Edge Detection (Not used)	-	-

2000/3000-Sheet (Booklet) Finisher (B804, B805)

6140	Bit	Description	Reading	
			0	1
6140 1		Entrance Sensor	Paper not detected	Paper detected
6140 2		Proof Exit Sensor	Paper not detected	Paper detected
6140 3		Proof Full Detection Sensor	Not Full	Full
6140 4		Trailing Edge Detection: Shift	Paper not detected*1	Paper detected*1
6140 5		Staple Exit Sensor	Paper not detected	Paper detected
6140 6		Shift HP Sensor	Not HP	HP
6140 7		Shift Exit Sensor	Paper not detected	Paper detected
6140 8		Exit Guide Plate HP Sensor	Not HP	HP
6140 9		Paper Detection Sensor: Staple	Paper not detected	Paper detected
6140 10		Paper Detection Sensor: Shift	Paper not detected	Paper detected
6140 11		Paper Full Sensor: 2000-Sheet	Not Full	Full
6140 12		Oscillating Back Roller HP Sensor	Not HP	HP
6140 13		Jogger HP Sensor	Not HP	HP
6140 14		Exit Junction Gate HP Sensor	HP	Not HP
6140 15		Staple Tray Paper Sensor	Paper not detected	Paper detected
6140 16		Staple Moving HP Sensor	Not HP	HP

Input and Output Check

6140	Bit	Description	Reading	
			0	1
6140 17		Skew HP Sensor	Not HP	HP
6140 18		Limit SW	Not Limit	Limit
6140 19		DOOR SW	Closed	Open
6140 20		Stapler 1 Rotation	Not HP	HP
6140 21		Staple Detection	Staple not detected	Staple detected
6140 22		Staple Leading Edge Detection	Staple not detected	Staple detected
6140 23		Punch Moving HP Sensor	Not HP	HP
6140 24		Punch Registration HP Sensor	Not HP	HP
6140 25		Punch Registration Detection Sensor	Paper not detected	Paper detected
6140 26		Punch Chad Full Sensor	Not Full	Full
6140 27		Punch HP	Not HP	HP
6140 28		Punch Selection DIPSW 1	See *1	
6140 29		Punch Selection DIPSW 2	See *1	
6140 30		Stack Junction Gate Open/Closed HP Sensor	Not HP	HP
6140 31		Leading Edge Detection Sensor	Paper not detected	Paper detected
6140 32		Drive Roller HP Sensor	Not HP	HP
6140 33		Arrival Sensor	Paper not detected	Paper detected
6140 34		Rear Edge Fence HP Sensor	Not HP	HP
6140 35		Folder Cam HP Sensor	Not HP	HP

6140	Bit	Description	Reading	
			0	1
6140 36		Folder Plate HP Sensor	Not HP	HP
6140 37		Folder Pass Sensor	Paper not detected	Paper detected
6140 38		Saddle Full Sensor: Front	Paper not detected*2	Paper detected*2
6140 39		Saddle Full Sensor: Rear	Paper not detected*2	Paper detected*2
6140 40		Saddle Stitch Stapler 1 Rotation: Front	Not HP	HP
6140 41		Saddle Stitch Detection: Front	Staple not detected	Staple detected
6140 42		Saddle Stitch Leading Edge Detection: Front	Staple not detected	Staple detected
6140 43		Saddle Stitch Stapler 1 Rotation: Rear	Not HP	HP
6140 44		Saddle Stitch Detection: Rear	Staple not detected	Staple detected
6140 45		Saddle Stitch Leading Edge Detection: Rear	Staple not detected	Staple detected
6140 46		Full Sensor: 3000-Sheet	Not Full	Full

Input and Output Check

*1: Combination of DIP SW 1 and SW 2

DIP SW 1	DIP SW 2	Punch Type
0	0	Japan
1	0	Europe
0	1	North America
1	1	North Europe

*2: Please refer to "Lower Tray (B804 Only)" in the Service Manual for the "2000/3000 (Booklet) Finisher".

1000-Sheet Booklet Finisher (D589)

6138	Description	Reading	
		0	1
6138 1	Interference Escape Sensor (Stapler Safety Sensor)	Not interfered	Interfered
6138 2	Staple Moving HP Sensor (Staple Unit HP Sensor)	Not home position	Home position
6138 3	Stuck Relay1 Release HP Sensor (Stopper S HP Sensor)	Not home position	Home position
6138 4	Exit Junction Gate HP Sensor (Stack Feed Out HP Sensor)	Home position	Not home position
6138 5	Jogger HP Sensor (Jogger Fence HP Sensor)	Not home position	Home position
6138 6	Staple Tray Paper Sensor (Staple Tray Paper Sensor)	Paper not detected	Paper detected
6138 7	Rear Edge Fence HP Sensor (Paper Stack Stopper HP Sensor)	Not home position	Home position

6138	Description	Reading	
		0	1
6138 8	Saddle Stitch Exit Sensor	Paper detected	Paper not detected
6138 9	Stuck Relay2 Roller HP Sensor (Clamp Roller HP Sensor)	Home position	Not home position
6138 10	Folder Tray Full Sensor 1 (Bottom Tray HP 1 Sensor)	Full	Not full
6138 11	Folder Tray Full Sensor 2 (Bottom Tray HP 2 Sensor)	Not full	Full
6138 12	Folder Plate HP Sensor (Fold Plate HP Sensor)	Not home position	Home position
6138 13	Saddle Stitch Arrival Sensor (Fold Unit Entrance Sensor)	Paper not detected	Paper detected
6138 14	Folder Cam HP Sensor (Fold Plate Cam HP Sensor)	Not home position	Home position
6138 15	Staple Exit Sensor (Stapler Tray Exit Sensor)	Paper detected	Paper not detected
6138 16	Shift Tray Paper Sensor (Shift Tray Paper Position Sensor)	Shift tray not detected	Shift tray detected
6138 17	Shift Tray Full	Full	Nor full
6138 18	Shift Roller HP Sensor	Not home position	Home position
6138 20	Entrance Sensor (Finisher Entrance Sensor)	Paper detected	Paper not detected
6138 21	Shift Exit Sensor (Shift Tray Exit Sensor)	Paper not detected	Paper detected
6138 22	Proof Exit Sensor (Proof Tray Exit Sensor)	Paper detected	Paper not detected
6138 23	Exit Guide Plate HP Sensor	Not home position	Home position

Input and Output Check

6138	Description	Reading	
		0	1
6138 24	Proof Full Sensor (Proof Tray Full Sensor)	Not full	Full
6138 25	Upper Cover Sensor	Open	Close
6138 26	Door SW (Front Door Switch)	Close	Open
6138 27	Clincher Timing Sensor	Encoder	
6138 28	Clincher HP Sensor	Home position	Not home position
6138 29	Driver Timing Sensor	Encoder	
6138 30	Staple Near End	Staple remaining	Staple near end
6138 31	Self Priming	Staple detected	Staple not detected
6138 32	Driver HP Sensor	Home position	Not home position
6138 33	Punch Registration Detection HP Sensor	Not home position	Home position
6138 34	Punch Moving HP Sensor (Punch Movement HP Sensor)	Not home position	Home position
6138 35	Punch HP Sensor (Punch HP Sensor)	Home position	Not home position
6138 36	Punch Pulse Count Sensor (Punch Encoder Sensor)	Encoder	
6138 37	Punch Chad Full Sensor (Punch Hopper Full Sensor)	Not full	Full
6138 38	Punch Registration Detection Sensor (Paper Position Sensor)	Paper detected	Paper not detected

1000-Sheet Finisher (D588)

6139	Bit	Description	Reading	
			0	1
6139 1		Entrance Sensor	Paper detected	Paper not detected
6139 2		Shift Exit Sensor (Lower Tray Exit Sensor)	Paper not detected	Paper detected
6139 3		Staple Entrance Sensor (Stapler Tray Entrance Sensor)	Paper detected	Paper not detected
6139 4		Staple Moving HP Sensor (Stapler HP Sensor)	Not home position	Home position
6139 5		Jogger HP Sensor (Jogger Fence HP Sensor)	Not home position	Home position
6139 6		Stack Feed-out Belt HP Sensor	Home position	Not home position
6139 7		Staple Tray Paper Sensor	Paper not detected	Paper detected
6139 8		Staple Rotation Sensor (Staple Rotation HP Sensor)	Not home position	Home position
6139 9		Staple Sensor	Staple detected	Staple not detected
6139 10		Staple READY Detection	Staple detected	Staple not detected
6139 11		Exit Guide Plate HP (Exit Guide Plate HP Sensor)	Not home position	Home position
6139 12		Shift HP Sensor	Not home position	Home position

Input and Output Check

6139	Bit	Description	Reading	
			0	1
6139 13		Paper Sensor (Stack Height Sensor)	Output tray not detected	Output tray detected
6139 14		Tray Lower Sensor (Lower Tray Lower Limit Sensor)	Lower limit	Not lower limit
6139 15		Proof Full Sensor (Paper Limit Sensor)	Not full	Full

500-Sheet Finisher (D585)

6145	Description	Reading	
		0	1
6145 1	Entrance Sensor	Paper detected	Paper not detected
6145 2	Hitroll HP Sensor	Paper not detected	Paper detected
6145 3	Front Jogger HP Sensor (Front Jogger Fence HP Sensor)	Home position	Not home position
6145 4	Rear Jogger HP Sensor (Rear Jogger Fence HP Sensor)	Home position	Not home position
6145 5	Staple Tray Paper Sensor	Paper detected	Paper not detected
6145 6	Staple Moving HP Sensor	Not HP	HP
6145 7	Stack Feed-out Belt HP	Not HP	HP
6145 8	Shift Tray Paper Sensor	Paper detected	Paper not detected
6145 9	Upper Cover Sensor	HP	Not HP
6145 10	Staple Rotation Sensor	HP	Not HP
6145 11	Staple Near End	HP	Not HP
6145 12	Self Priming	HP	Not HP
6145 13	Shift Tray Limit Sensor	Not full	Full

Bridge Unit (D634) / Side Tray (D635)

6150	Description	Reading	
		0	1
6150 1	Bridge/Left: Exit Sensor	Paper detected	Paper not detected
6150 2	Bridge/Left: Feed Sensor	Paper detected	Paper not detected
6150 3	Bridge/Left: Shift Set Detection	Set	Not set
6150 4	Bridge/Left: Exit Cover Detection	Closed	Open
6150 5	Bridge/Left: Feed Cover Detection	Closed	Open
6150 6	Left/Left Exit Sensor	Paper detected	Paper not detected

Internal Shift Tray (D633)

6152	Description	Reading	
		0	1
6152 1	Shift:Set Sensor	Set	Not Set
6152 2	Shift: Position Sensor	Tray position: front	Tray position: rear

1 Bin Tray (D632)

6154	Description	Reading	
		0	1
6154 1	1 bin: Set Sensor	Set	Not Set
6154 2	1 bin: Paper Sensor	Paper detected	Paper not detected

Two-Tray PFU (D580)/ LCIT 2000 (D581)/ LCIT 1200 (D631)

6160	Description	Reading	
		0	1
6160 1	Bank: Tray3: Feed Sensor	Paper not detected	Paper detected
6160 2	Bank: Tray4: Feed Sensor	Paper not detected	Paper detected
6160 3	Bank: Tray5: Feed Sensor	Paper not detected	Paper detected
6160 4	Bank: Tray3: Relay Sensor	Paper not detected	Paper detected
6160 5	Bank: Tray4: Relay Sensor	Paper not detected	Paper detected
6160 6	Bank: Tray5: Relay Sensor	Paper not detected	Paper detected
6160 7	Bank: Feed Cover Detection	Closed	Open
6160 11	Bank: Palau: Paper Supply Switch	Closed	Open
6160 12	Bank: Palau: Slide Switch	Closed	Open

3.9.2 OUTPUT CHECK TABLE***Copier***

5804	Display	Description
5804 3	Drum/Dev Motor: K: HighSpeed	Drum/Development Drive Motor-K: HighSpeed
5804 4	Drum/Dev Motor: K: MiddleSpeed	Drum/Development Drive Motor-K: Middle Speed
5804 5	Drum/Dev Motor: K: LowSpeed	Drum/Development Drive Motor-M: Low Speed
5804 10	Drum/Dev Motor: M: HighSpeed	Drum/Development Drive Motor- C: HighSpeed
5804 11	Drum/Dev Motor: M: MiddleSpeed	Drum/Development Drive Motor-Y: Middle Speed
5804 12	Drum/Dev Motor: M: LowSpeed	Drum/Development Drive Motor-Y: Low Speed
5804 17	Drum/Dev Motor: C: HighSpeed	Drum/Development Drive Motor- C: HighSpeed
5804 18	Drum/Dev Motor: C: MiddleSpeed	Drum/Development Drive Motor-Y: Middle Speed
5804 19	Drum/Dev Motor: C: LowSpeed	Drum/Development Drive Motor-Y: Low Speed
5804 24	Drum/Dev Motor: Y: HighSpeed	Drum/Development Drive Motor- C: HighSpeed
5804 25	Drum/Dev Motor: Y: MiddleSpeed	Drum/Development Drive Motor-Y: Middle Speed
5804 26	Drum/Dev Motor: Y: LowSpeed	Drum/Development Drive Motor-Y: Low Speed
5804 31	-	See the last of this table.

5804	Display	Description
5804 32	-	See the last of this table.
5804 33	-	See the last of this table.
5804 35	-	See the last of this table.
5804 37	Toner Relay Motor	Toner Transport Motor
5804 40	Image Transfer Motor: HighSpeed	ITB Drive Motor: HighSpeed
5804 41	Image Transfer Motor: MiddleSpeed	ITB Drive Motor: Middle Speed
5804 42	Image Transfer Motor: LowSpeed	ITB Drive Motor: Low Speed
5804 50	Feed Motor: HighSpeed	Paper Feed Motor: High Speed
5804 51	Feed Motor: IncreaseSpeed	Paper Feed Motor: Increase Speed
5804 52	Feed Motor: MiddleSpeed	Paper Feed Motor: Middle Speed
5804 53	Feed Motor: MiddleIncreaseSpeed	Paper Feed Motor: Middle Increase Speed
5804 54	Feed Motor: LowSpeed	Paper Feed Motor: Low Speed
5804 55	Feed Motor: LowInceraseSpeed	Paper Feed Motor: Low Incerase Speed
5804 60	Regist Motor: HighSpeed	Registration Motor: High Speed
5804 61	Regist Motor: MiddleSpeed	Registration Motor: Middle Speed
5804 62	Regist Motor: LowSpeed	Registration Motor: Low Speed
5804 67	Duplex Feed M: CW: HighSpeed	Duplex/By-pass Motor: CW: High Speed
5804 68	Duplex Feed M: CW: MiddleSpeed	Duplex/By-pass Motor: CW: Middle Speed
5804 69	Duplex Feed Motor: CW: LowSpeed	Duplex/By-pass Motor: CW: Low Speed
5804 74	Duplex Feed M: CCW: HighSpeed	Duplex/By-pass Motor: CCW: High Speed

Input and Output Check

5804	Display	Description
5804 75	Duplex Feed M:CCW:MiddleSpeed	Duplex/By-pass Motor: CCW: Middle Speed
5804 76	Duplex Feed Motor: CCW: LowSpeed	Duplex/By-pass Motor: CCW: Low Speed
5804 81	Duplex Reverse M:CW:HighSpeed	Duplex Inverter Motor: CW: High Speed
5804 82	Duplex Reverse M:CW:MiddleSpeed	Duplex Inverter Motor: CW: Middle Speed
5804 83	Duplex Reverse Motor: CW: LowSpeed	Duplex Inverter Motor: CW: Low Speed
5804 88	Duplex Reverse M:CCW:HighSpeed	Duplex Inverter Motor: CCW: High Speed
5804 89	Duplex Reverse M:CCW:MiddleSpeed	Duplex Inverter Motor: CCW: Middle Speed
5804 90	Duplex Reverse Motor: CCW: LowSpeed	Duplex Inverter Motor: CCW: Low Speed
5804 95	ITB Contact Motor	Image Transfer Belt Contact Motor
5804 96	Paper Transfer Contact Motor	Paper Transfer Contact Motor
5804 97	1st Tray Lift Motor: Up	Tray Lift Motor 1: Lift Up
5804 98	1st Tray Lift Motor: Down	Tray Lift Motor 1: Lift Down
5804 99	2nd Tray Lift Motor: Up	Tray Lift Motor 2: Lift Up
5804 100	2nd Tray Lift Motor: Down	Tray Lift Motor 2: Lift Down
5804 102	Fusing Pressue Release Motor	Pressure Roller Contact Motor
5804 104	Polygon Moter: LL	Polygon Motor: LL
5804 105	Polygon Moter: L	Polygon Motor: L
5804 107	Polygon Moter: HH	Polygon Motor: HH
5804 110	Air Flow Fan: Front	Ventilation Fan – Front

5804	Display	Description
5804 111	Air Flow Fan:Rear	Ventilation Fan – Rear
5804 112	Fusing Fan:H	Fusing Fan: High Speed
5804 113	Fusing Fan:L	Fusing Fan: Low Speed
5804 114	PSU Cooling Fan	PSU Fan 1: High Speed
5804 115	2nd Duct Fan: H	Duct Fan 2: High Speed
5804 117	3rd Duct Fan: H	Duct Fan 3: High Speed
5804 119	Paper Exit Fan:H	Paper Exit Fan: High Speed
5804 121	Fusing Coil Fan	QSU Fan
5804 122	IH Power Supply Cooling Fan	AC controller board Fan
5804 126	Development Clutch: Bk	Development Clutch-K
5804 127	Development Clutch: M	Development Clutch-M
5804 128	Development Clutch: C	Development Clutch-C
5804 129	Development Clutch: Y	Development Clutch-Y
5804 130	Toner Bottle Clutch: Bk	Toner Bottle Clutch-K
5804 131	Toner Bottle Clutch: M	Toner Bottle Clutch-M
5804 132	Toner Bottle Clutch: C	Toner Bottle Clutch-C
5804 133	Toner Bottle Clutch:Y	Toner Bottle Clutch-Y
5804 134	Toner Supply Pump: Bk	Toner Supply Clutch: Bk
5804 135	Toner Supply Pump: M	Toner Supply Clutch: M
5804 136	Toner Supply Pump: C	Toner Supply Clutch: C
5804 137	Toner Supply Pump: Y	Toner Supply Clutch: Y
5804 138	1st Paper Feed Clutch	Paper Feed Clutch 1
5804 139	2nd Paper Feed Clutch	Paper Feed Clutch 2
5804 140	Bypass Feed Clutch	By-pass Feed Clutch

Input and Output Check

5804	Display	Description
5804 141	Bypass Pickup Solenoid	Bypass Pickup Solenoid
5804 143	TD Sensor Shutter Solenoid	ID Sensor Shutter Solenoid
5804 144	Exit Junction Solenoid	Junction Gate 1 Solenoid
5804 145	1st Feed Pickup Solenoid	1st Pickup Solenoid
5804 146	2nd Feed Pickup Solenoid	2nd Pickup Solenoid
5804 150	Duplex Fan: HighSpeed	-
5804 151	Duplex Fan: LowSpeed	-
5804 152	Air Flow Fan: Middle 1	-
5804 153	Reserve Fan1: LowSpeed	-
5804 154	Air Flow Fan: Middle 2	-
5804 155	Reserve Fan2: LowSpeed	-
5804 161	PCL: Bk	-
5804 162	PCL: M	-
5804 163	PCL: C	-
5804 164	PCL: Y	-
5804 166	HST Sensor:Bk	TD Sensor:Bk
5804 167	HST Sensor: M	TD Sensor: M
5804 168	HST Sensor: C	TD Sensor: C
5804 169	HST Sensor: Y	TD Sensor: Y
5804 170	Toner End Sensor: Bk	Toner End Sensor: Bk
5804 171	Toner End Sensor: M	Toner End Sensor: M
5804 172	Toner End Sensor: C	Toner End Sensor: C
5804 173	Toner End Sensor: Y	Toner End Sensor: Y
5804 174	TM Sensor: Front	ID Sensor: Front

5804	Display	Description
5804 175	TM Sensor: Center	ID Sensor: Center
5804 176	TM Sensor: Rear	ID Sensor: Rear
5804 177	TM Sensor: M	ID Sensor: M
5804 178	TM Sensor: C	ID Sensor: C
5804 179	TM Sensor: Y	ID Sensor: Y
5804 181	PP:Charge AC:Y:HighSpeed	-
5804 182	PP:Charge AC:Y:MiddleSpeed	-
5804 183	PP:Charge AC:Y:LowSpeed	-
5804 186	PP:Development:K	-
5804 187	PP:Development:M	-
5804 188	PP:Development:C	-
5804 189	PP:Development:Y	-
5804 190	PP:Separation	-
5804 192	RFID ON/OFF: K	-
5804 193	RFID ON/OFF: Y	-
5804 194	RFID ON/OFF: C	-
5804 195	RFID ON/OFF: M	-
5804 196	RFID COM ON:K	-
5804 197	RFID COM ON: Y	-
5804 198	RFID COM ON: C	-
5804 199	RFID COM ON: M	-
5804 202	Scanner Lamp	-
5804 216	LD1: K	-
5804 217	LD2: K	-

Input and Output Check

5804	Display	Description
5804 218	LD1: Ma	-
5804 219	LD2: Ma	-
5804 220	LD1: Cy	-
5804 221	LD2: Cy	-
5804 222	LD1: Ye	-
5804 223	LD2: Ye	-
5804 224	PP:ITB:K	PP: Image Transfer Roller: K
5804 225	PP:ITB:M	PP: Image Transfer Roller: M
5804 226	PP:ITB:C	PP: Image Transfer Roller: C
5804 227	PP:ITB:Y	PP: Image Transfer Roller: Y
5804 228	PP:PTR:+	PP: Paper Transfer Roller:+
5804 229	PP:PTR:-	PP: Paper Transfer Roller:-
5804 231	PP: ChargeDC: K	-
5804 232	PP: ChargeDC: M	-
5804 233	PP: ChargeDC: C	-
5804 234	PP: ChargeDC: Y	-
5804 237	PP:Charge AC:K:HighSpeed	-
5804 238	PP:Charge AC:K:MiddleSpeed	-
5804 239	HVPS: ChargeAC: K: LowSpeed	-
5804 244	PP:Charge AC:M:HighSpeed	-
5804 245	PP:Charge AC:M:MiddleSpeed	-
5804 246	HVPS: ChargeAC: M: LowSpeed	-
5804 251	PP:Charge AC:C:HighSpeed	-
5804 252	PP:Charge AC:C:MiddleSpeed	-

5804	Display	Description
5804 253	HVPS: ChargeAC: C: LowSpeed	-

5804			
-31 to -35	Fusing Exit Motor Note: These SP modes will be moved to Super SP mode in the near future.		
	<p>Important: Use the procedure below to do the output checks for the fusing exit motor. If you do not follow this procedure, a kink will form in the fusing belt sleeve, and the fusing sleeve belt unit will need to be replaced.</p> <p>1. Do one of the following:</p> <ul style="list-style-type: none"> ▪ Open the right cover of the paper bank ▪ Remove one of the toner bottles ▪ Pull out the waste toner bottle half-way ▪ Remove the fusing unit <p>2. Enter SP mode.</p> <p>3. Do the following out output checks:</p> <ul style="list-style-type: none"> ▪ SP5-804-031 (Fusing exit motor: High speed) ▪ SP5-804-032 (Fusing exit motor: Middle speed) ▪ SP5-804-033 (Fusing exit motor: Low speed) ▪ SP5-804-035 (Fusing exit motor: Very low speed) <p>4. Without exiting SP mode, turn the main power switch off and then on again.</p> <p>Important: If you exit SP mode before you turn the main power switch off, the fusing exit motor will stay off when the machine warms up. Heat will be concentrated in one area of the fusing belt sleeve and cause a kink to form. If this happens, you will need to replace the fusing sleeve belt unit.</p> <p>5. Do the reverse of what you did in step 1 (for example, reattach the fusing unit).</p>		
	5804 31	Fusing Exit Motor: HighSpeed	Fusing/Paper Exit Motor: HighSpeed
	5804 32	Fusing Exit Motor: MiddleSpeed	Fusing/Paper Exit Motor: Middle Speed
	5804 33	Fusing Exit Motor: LowSpeed	Fusing/Paper Exit Motor: Low Speed
5804 35	Fusing Exit Motor: LLowSpeed	Fusing/Paper Exit Motor: LLowSpeed	

Appendix:
SP Mode
Tables

ARDF (D578)

6008	Display	Description
6008 1	Pick-Up Motor Forward	-
6008 2	Pick-Up Motor Reverse	-
6008 3	Feed Motor Forward	Feed Motor-Forward rotation
6008 4	Feed Motor Reverse	Feed Motor-Reverse rotation
6008 5	Relay Motor Forward	Transport Motor- Forward rotation
6008 6	Relay Motor Reverse	Transport Motor- Forward rotation
6008 7	Inverter Motor Reverse	Transport Motor- Forward rotation
6008 8	Inverter Motor Reverse	-
6008 9	Feed Clutch	-
6008 10	Feed Solenoid	Pick-up Solenoid
6008 11	Inverter Solenoid	-
6008 12	Stamp	Stamp Solenoid
6008 13	Fan Motor	-
6008 14	Feed Clutch	-
6008 15	Feed Solenoid	-

1000-Sheet Booklet Finisher (D589)

6143	Display	Description
6143 1	Shift Motor	Shift Tray Motor
6143 2	Entrance Motor	-
6143 3	Staple Relay Motor	Stapler Unit Motor
6143 4	Knock Solenoid	-

6143	Display	Description
6143 5	Junction Gate SOL 1	Proof Tray Gate Solenoid
6143 6	Junction Gate SOL 2	Staple Tray Gate Solenoid
6143 7	Folder Roller Rotation Motor	Fold Roller Motor
6143 8	Staple Motor	Staple Fold Motor
6143 10	Exit Guide Plate Motor	-
6143 11	Shift Relay Motor	Upper Transport Motor
6143 12	Tray Motor	Shift Tray Motor
6143 13	Stack Feed-out Motor	Positioning Roller Solenoid
6143 14	Stuck Relay1 Motor	Upper Clamp Roller Motor
6143 15	Stuck Relay1 Release Motor	Upper Retraction Motor
6143 16	Rear Edge Fence Drive Motor	Bottom Fence Lift Motor
6143 17	Folder Plate Motor	-
6143 18	Drive Roller Oscillating Motor	Lower Retraction Motor
6143 19	Staple Moving Motor	Staple Unit Driver Motor
6143 20	Jogger Motor	Jogger Motor
6143 21	Punch Registration Moving Motor	Paper Position Sensor Slide Motor
6143 22	Punch Motor	-
6143 23	Punch Moving Motor	Punch Movement Motor

1000-Sheet Finisher (D588)

6144	Display	Description
6144 1	Relay Up Motor	Upper Transport Motor
6144 2	Relay Down Motor	Lower Transport Motor
6144 3	Exit Motor	-
6144 4	Proof Junction Gate SOL	Tray Junction Gate Solenoid
6144 5	Tray Up Motor	Lower Tray Lift Motor
6144 6	Jogger Motor	Jogger Fence Motor
6144 7	Staple Moving Motor	Stapler Motor
6144 8	Staple Motor	Stapler Hammer
6144 9	Staple Junction Gate SOL	Stapler Junction Gate Solenoid
6144 10	Positioning Roller Solenoid	Positioning Roller Solenoid
6144 11	Stack Feed-out Motor	-
6144 12	Shift Motor	-
6144 13	Exit Guide Plate Motor	-

2000/3000-Sheet (Booklet) Finisher (B804/B805)

6145	Display	Description
6145 1	Entrance Motor	Finisher Entrance Motor
6145 2	Upper Feed Motor	Upper Transport Motor
6145 3	Lower Feed Motor	Lower Transport Motor
6145 4	Exit Motor	Upper/Proof Tray Exit Motor
6145 5	Knock Roller Motor	Clamp Roller Retraction Motor
6145 6	Shift Motor	Shift Roller Motor
6145 7	Exit Guide Plate Open/Close Motor	Exit Guide Plate Motor
6145 8	Tray Lift Motor	Upper Tray Lift Motor
6145 9	Oscillating Back Roller Motor	Stacking Sponge Roller Motor
6145 10	Jogger Motor	Jogger Fence Motor
6145 11	Stack Feed-out Motor	Feed Out Belt Motor
6145 12	Staple Moving Motor	Corner Stapler Movement Motor
6145 13	Staple Skew Motor	Corner Stapler Rotation Motor
6145 14	Staple Motor	Corner Stapler EH530
6145 15	Upper Junction Gate Solenoid	Proof Junction Gate Solenoid
6145 16	Lower Junction Gate Solenoid	Stapling Tray Junction Gate Solenoid
6145 17	Knock Solenoid	Stapling Edge Pressure Plate Solenoid
6145 18	Trailing Edge Hold Solenoid	Positioning Roller Solenoid
6145 19	Saddle Stitch Hold Solonoid	Booklet Pressure Roller Solenoid
6145 20	Stack Junction Gate Open/Close Motor	Stack Junction Gate Motor

Input and Output Check

6145	Display	Description
6145 21	Trailing Edge Fence Moving Motor	Fold Unit Bottom Fence Lift Motor
6145 22	Saddle Stitch Staple Motor: Front	Booklet Stapler EH185R: Front
6145 23	Saddle Stitch Staple Motor: Rear	Booklet Stapler EH185R: Rear
6145 24	Folder Plate Motor	Fold Plate Motor
6145 25	Folder Roller Motor	Fold Roller Motor
6145 26	Drive Roller Oscillating Motor	Positioning Roller Motor
6145 27	Punch Motor	Punch Drive Motor
6145 28	Punch Moving Motor	Punch Movement Motor
6145 29	Punch Registration Detection Motor	Paper Position Sensor Slide Motor

500-Sheet Finisher (D585)

6146	Display	Description
6146 1	Carry Motor	Transport Motor
6146 2	Hitroll Motor	Positioning Roller Arm Motor
6146 3	Front Jogger Motor	Front Fence Motor
6146 4	Rear Jogger Motor	Rear Fence Motor
6146 5	Staple Moving Motor	Stapler Movement Motor
6146 6	Stack Feed-out Motor	Feed-Out Belt Motor
6146 7	Tray Motor	Tray Lift Motor
6146 8	Staple Motor	Stapler Motor
6146 9	Stopper Solenoid	Stack Depressor Solenoid

Bridge Unit (D634) / Side Tray (D635)

6151	Display	Description
6151 1	Bridge/Left: Feed Motor: Current Selection	Bridge: Feed Motor: Current switching signal
6151 2	Bridge/Left: Feed Motor:Reset	Bridge: Feed Motor:Reset
6151 3	Bridge/Left: Feed Motor:Enable	Bridge: Feed Motor:Enable
6151 6	Bridge/Left: Feed Motor: High Speed	Bridge: Feed Motor: High Speed
6151 7	Bridge/Left: Feed Motor: Middle Speed	Bridge: Feed Motor: Middle Speed
6151 8	Bridge/Left: Feed Motor: Low Speed	Bridge: Feed Motor: Low Speed
6151 11	Bridge/Left: Junction Solenoid	Bridge: Junction Solenoid

Appendix:
SP Mode
Tables**Shift Tray (D633)**

6153	Display	Description
6153 1	Shift: Lift-up Motor	-

1 Bin Tray (D632)

6155	Display	Description
6155 1	1 bin: Junction Solenoid	-

Two-Tray PFU (D580) / LCIT 2000 (D581) / LCIT 1200 (D631)

6161	Display	Description
6161 5	Bank1: Feed Motor: HighSpeed	Feed Motor:High Speed (D580/ D581)
6161 6	Bank1: Feed Motor: IncreaseSpeed	Feed Motor: Increase Speed (D580/ D581)
6161 7	Bank1: Feed Motor:242mm/s	Feed Motor:242 mm/s (D580/ D581)
6161 8	Bank1: Feed Motor: MiddleSpeed	Feed Motor: Middle Speed (D580/ D581)
6161 9	Bank1: Feed Motor: LowSpeed	Feed Motor: Low Speed (D580/ D581)
6161 10	Bank1: Feed Motor: LowIncreaseSpeed	Feed Motor:Low Increase Speed (D580/ D581)
6161 15	Bank2: Feed Motor:HighSpeed	Feed Motor:High Speed (D580)
6161 16	Bank2: Feed Motor: IncreaseSpeed	Feed Motor: Increase Speed (D580)
6161 17	Bank2: Feed Motor:242mm/s	Feed Motor:242 mm/s (D631)
6161 18	Bank2: Feed Motor: MiddleSpeed	Feed Motor: Middle Speed (D580)
6161 19	Bank2: Feed Motor: LowSpeed	Feed Motor: Low Speed (D580)
6161 20	Bank2: Feed Motor: LowIncreaseSpeed	Feed Motor: Low Increase Speed (D580)
6161 21	Bank2: Feed Motor:154mm/s	Feed Motor:154 mm/s (D631)

6161	Display	Description
6161 30	Bank:Tray3: PU Solenoid	Pick-up Solenoid (D580/D581 or D579)
6161 31	Bank:Tray4: PU Solenoid	Pick-up Solenoid (D580/D631)
6161 32	Bank:Tray5: PU Solenoid	Pick-up Solenoid (D631)
6161 35	Bank:Tray3: Feed Clutch	Pick-up Solenoid (D580/D581 or D579)
6161 36	Bank:Tray4: Feed Clutch	Pick-up Solenoid (D580/D631)
6161 37	Bank:Tray5: Feed Clutch	Pick-up Solenoid (D631)

3.10 PRINTER SERVICE MODE

3.10.1 SP1-XXX (SERVICE MODE)

1001	Bit Switch			
001	Bit Switch 1		0	1
	bit 0	DFU	-	-
	bit 1	DFU	-	-
	bit 2	DFU	-	-
	bit 3	No I/O Timeout	0: Disable	1: Enable
		Enable: The MFP I/O Timeout setting will have no effect. I/O Timeouts will never occur.		
	bit 4	SD Card Save Mode	0: Disable	1: Enable
		Enable: Print jobs will be saved to an SD Card in the GW SD slot. For details, see "Card Save Function" in the "Main chapters: 5. System Maintenance".		
	bit 5	DFU	-	-
	bit 6	DFU	-	-
bit 7	[RPCS,PCL]: Printable area frame border	0: Disable	1: Enable	
	Enable: The machine prints all RPCS and PCL jobs with a border on the edges of the printable area.			

1001	Bit Switch			
002	Bit Switch 2		0	1
	bit 0	DFU	-	-
	bit 1	DFU	-	-
	bit 2	Applying a collation Type	Shift Collate	Normal Collate
		<p>A collation type (shift or normal) will be applied to all jobs that do not already have a 'Collate Type' configured.</p> <p>Note</p> <ul style="list-style-type: none"> If #5-0 is enabled, this Bit Switch has no effect. 		
	bit 3	[PCL5e/c,PS]: PDL Auto Switching	0: Enable	1: Disable
		<p>Disable: The MFPs ability to change the PDL processor mid-job. Some host systems submit jobs that contain both PS and PCL5e/c. If Auto PDL switching is disabled, these jobs will not be printed properly.</p>		
	bit 4	DFU	-	-
	bit 5	DFU	-	-
	bit 6	DFU	-	-
bit 7	DFU	-	-	

1001		Bit Switch		
003	Bit Switch 3		0	1
	bit 0	DFU	-	-
	bit 1	DFU	-	-
	bit 2	[PCL5e/c]: Legacy HP compatibility	0: Disable	1: Enable
		Enable: Uses the same left margin as older HP models such as HP4000/HP8000. In other words, the left margin defined in the job (usually "<ESC>*r0A") will be changed to "<ESC>*r1A"		
	bit 3	DFU	-	-
	bit 4	DFU	-	-
	bit 5	DFU	-	-
	bit 6	DFU	-	-
bit 7	DFU	-	-	

1001		Bit Switch	
004	Bit Switch 4 DFU	-	-

1001	Bit Switch			
005	Bit Switch 5		0	1
	bit 0	Show "Collate Type", "Staple Type" and "Punch Type" buttons on the operation panel.	Disable	Enable
		If enabled, users will be able to configure a Collate Type, Staple Type, and Punch Type from the operation panel. The available types will depend on the device and configured options. After enabling the function, the settings will appear under: "User Tools → Printer Features → System"		
	bit 1	DFU	-	-
	bit 2	DFU	-	-
	bit 3	[PS] PS Criteria	Pattern3	Pattern1
		Change the number of PS criterion used by the PS interpreter to determine whether a job is PS data or not. Pattern3: includes most PS commands. Pattern1: A small number of PS tags and headers		
	bit 4	Increase max number of the stored jobs to 1000 jobs.	Disable (100)	Enable (1000)
		Enable: Changes the maximum number of jobs that can be stored on the HDD via Job Type settings to 1000. The default is 100.		
	bit 5	Face-up output	Disable	Enable
Enable: All print jobs will be output face-up in the destination tray.				
bit 6	DFU	-	-	
bit 7	DFU	-	-	

1001	Bit Switch		
006	Bit Switch 6 DFU	-	-

1001	Bit Switch		
007	Bit Switch 7 DFU	-	-

1001	Bit Switch			
008	Bit Switch 8		0	1
	bit 0	DFU	-	-
	bit 1	DFU	-	-
	bit 2	DFU	-	-
	bit 3	[PCL,PS]: Allow BW jobs to print without requiring User Code	Disable	Enable
		Enable: BW jobs submitted without a user code will be printed even if usercode authentication is enabled. Note ■ Color jobs will not be printed without a valid user code.		
	bit 4	DFU	-	-
	bit 5	DFU	-	-
	bit 6	[PS]: Orientation Auto Detect Function	Enable	Disable
		Disable: Automatically chooses page orientations of PostScript jobs (Landscape or Portrait) based on the content printed on the page.		
bit 7	[PDF]: Orientation Auto Detect Function	Enable	Disable	
	Automatically chooses page orientations of PDF jobs (Landscape or Portrait) based on the content printed on the page.			

1003	[Clear Setting]
1003 1	Initialize Printer System
	Initializes settings in the "System" menu of the user mode.
1003 3	Delete Program

1004	[Print Summary]
1004 1	Print Summary
	Prints the service summary sheet (a summary of all the controller settings).

1005	[Display Version]
1005 1	Disp. Version
	Displays the version of the controller firmware.

1006	[Sample/Locked Print]	*CTL	0: Linked, 1: On
1006 1	Enables and disables the document server. When you select "0," the document server is enabled or disabled in accordance with Copy Service Mode SP5-967. When you select "1," the document server is enabled regardless of Copy Service Mode SP5-967.		

Appendix:
SP Mode
Tables

1101	[Data Recall]		
	Recalls a set of gamma settings. This can be either a) the factory setting, b) the previous setting, or c) the current setting.		
1101 1	Factory	*CTL	
1101 2	Previous		
1101 3	Current		
1101 4	ACC		

1102	[Resolution Setting]		
	Selects the printing mode (resolution) for the printer gamma adjustment.		
1102 1	2400x600 Photo , 1800x600 Photo, 600 x 600 Photo, 2400x600 Text, 1800x600, Text, 600x600 Text		

1103	[Test Page]		
	Prints the test page to check the color balance before and after the gamma adjustment.		
1103 1	Color Gray Scale		
1103 2	Color Pattern		

1104	[Gamma Adjustment]		
	Adjusts the printer gamma for the mode selected in the "Mode Selection" menu.		
1104 1	Black: Highlight	*CTL	[0 to 30 / 15 / 1/step]
1104 2	Black: Shadow		
1104 3	Black: Middle		
1104 4	Black: IDmax		
1104 21	Cyan: Highlight		
1104 22	Cyan: Shadow		
1104 23	Cyan: Middle		
1104 24	Cyan: IDmax		
1104 41	Magenta: Highlight		
1104 42	Magenta: Shadow		
1104 43	Magenta: Middle		
1104 44	Magenta: IDmax		
1104 61	Yellow: Highlight		
1104 62	Yellow: Shadow		
1104 63	Yellow: Middle		
1104 64	Yellow: IDmax		

Appendix:
SP Mode
Tables

Printer Service Mode

1105	[Save Tone Control Value]		
	Stores the print gamma adjusted with the "Gamma Adj." menu item as the current setting. Before the machine stores the new "current setting", it moves the data currently stored as the "current setting" to the "previous setting" memory storage location.		
1105 1	Save Tone Control Value		

1106	[Toner Limit]		
	Adjusts the maximum toner amount for image development.		
1106 1	Toner Limit Value	*CTL	[100 to 400 / 260 / 1 %/step]

3.11 SCANNER SP MODE

3.11.1 SP1-XXX (SYSTEM AND OTHERS)

1004	[Compression Type]		
	Selects the compression type for binary picture processing.		
1004 1	Compression Type	*CTL	[1 to 3 / 1 / 1/step] 1: MH, 2: MR, 3: MMR

1005	[Erase margin(Remote scan)]		
	Creates an erase margin for all edges of the scanned image. If the machine has scanned the edge of the original, create a margin. This SP is activated only when the machine uses TWAIN scanning.		
1005 1	Range from 0 to 5 mm	*CTL	[0 to 5 / 0 / 1 mm/step]

1009	[Remote scan disable]	*CTL	[0 or 1 / 0 / -] 0: enable, 1: disable
1009 1	0:enable 1:desable		

1010	[Non Display Clear Light PDF]	*CTL	[0 or 1 / 0 / -] 0: Display, 1: No display
1010 1	Non Display ClearLight PDF		

1015	[Time Stamp to Name File]	*CTL	[0 or 1 / 1 / -] 0: OFF, 1: ON (Default)
1015 1	Enables Time Stamps on Scanner Filenames		

3.11.2 SP2-XXX (SCANNING-IMAGE QUALITY)

2021	[Compression Level (Gray-scale)]		
	Selects the compression ratio for grayscale processing mode (JPEG) for the three settings that can be selected at the operation panel.		
2021 1	Comp1:5-95	*CTL	[5 to 95 / 20 / 1 /step]
2021 2	Comp2:5-95		[5 to 95 / 40 / 1 /step]
2021 3	Comp3:5-95		[5 to 95 / 65 / 1 /step]
2021 4	Comp4:5-95		[5 to 95 / 80 / 1 /step]
2021 5	Comp5:5-95		[5 to 95 / 95 / 1 /step]

2024	[Compression ratio of ClearLight PDF]		
	Selects the compression ratio for clearlight PDF for the two settings that can be selected at the operation panel.		
2024 1	Compression Ratio (Normal image)	*CTL	[5 to 95 / 25 / 1 /step]
2024 2	Compression Ratio (High comp image)		[5 to 95 / 20 / 1 /step]

3.12 TEST PATTERN PRINTING

Printing Test pattern: SP2-109

Some of these test patterns are used for copy image adjustments but most are used primarily for design testing.

Note

- Do not operate the machine until the test pattern is printed out completely. Otherwise, an SC occurs.
1. Enter the SP mode and select **SP2-109-003**.
 2. Enter the number for the test pattern that you want to print and press [#].
 3. When you want to select the single color of Magenta, Yellow or Cyan for printing a test pattern, select the color with SP2-109-005 (2: Magenta, 3: Yellow, 4: Cyan).
 4. When you want to change the density of printing a test pattern, select the density with SP2-109-006 to -009 for each color.

Note

- If you select "0" with SP2-109-006 to -009, the color to be adjusted to "0" does not come up on a test pattern.
5. When you are prompted to confirm your selection, touch "Yes" to select the test pattern for printing.
 6. Touch "Copy Window" to open the copy window, then select the settings for the test print (paper size etc.).

Note

- If you want to use black and white printing, touch "Black & White" on the LCD. If you want to use color printing, touch "Full Colour" on the LCD.
7. Press the "Start" key to start the test print.
 8. After checking the test pattern, touch "SP Mode" on the LCD to return to the SP mode display.
 9. Reset all settings to the default values.
 10. Touch "Exit" twice to exit SP mode.

Test Pattern Printing

No.	Pattern	No.	Pattern
0	None	11	Independent Pattern (1-dot)
1	Vertical Line (1dot)	12	Independent Pattern (2-dot)
2	Vertical Line (2dot)	13	Independent Pattern (4-dot)
3	Horizontal Line (1dot)	14	Triming Area
4	Horizontal Line (2dot)	16	Tooth Check (Horizontal)
5	Grid Vertical Line	17	Band (Horizontal)
6	Grid Horizontal Line	18	Band (Vertical)
7	Grid Pattern Small	19	Checker Flag Pattern
8	Grid Pattern Large	20	Grayscale (Vertical Margin)
9	Argyle Pattern Small	21	Grayscale (Horizontal Margin)
10	Argyle Pattern Large	23	Full Dot Pattern

SR790(B408)/SR3090(D588)
1000-SHEET FINISHER

REVISION HISTORY		
Page	Date	Added/Updated/New
		None

1000-SHEET FINISHER B408/D588

TABLE OF CONTENTS





1. REPLACEMENT AND ADJUSTMENT	1
1.1 MAIN PCB	1
1.2 STAPLER UNIT	2
1.3 MOTORS.....	3
1.3.1 SHIFT MOTOR.....	3
1.3.2 STAPLER MOTOR.....	3
1.3.3 UPPER TRANSPORT MOTOR AND EXIT MOTOR	4
1.3.4 LOWER TRANSPORT MOTOR	4
1.4 MOTORS AND SENSORS.....	5
1.4.1 PREPARATION.....	5
1.4.2 STACK HEIGHT SENSOR	6
1.4.3 STAPLER TRAY PAPER SENSOR.....	6
1.4.4 LOWER TRAY LIFT MOTOR	7
1.4.5 STACK FEED-OUT MOTOR	7
2. TROUBLESHOOTING	8
2.1 JAM DETECTION.....	8
3. SERVICE TABLES	9
3.1 DIP SWITCH SETTINGS	9
4. DETAILED DESCRIPTIONS	10
4.1 GENERAL LAYOUT	10
4.2 ELECTRICAL COMPONENT LAYOUT.....	11
4.3 ELECTRICAL COMPONENT DESCRIPTION.....	13
4.4 DRIVE LAYOUT	15
4.5 JUNCTION GATES	16
Upper Tray Mode.....	16
Sort/Stack Mode	16
Staple Mode.....	16
4.6 UPPER TRAY.....	17
4.7 LOWER TRAY UP/DOWN MECHANISMS	18
4.8 PAPER SHIFT MECHANISM	19
4.9 JOGGER UNIT PAPER POSITIONING MECHANISM.....	20
4.10 EXIT GUIDE PLATE.....	21
4.11 STAPLER MECHANISM	22
4.12 STAPLER UNIT MOVEMENT MECHANISM	23
4.13 PAPER FEED-OUT MECHANISM	24

1. REPLACEMENT AND ADJUSTMENT

⚠ CAUTION



Turn off the main power switch and unplug the machine before beginning any of the procedures in this section.

NOTE: This manual uses the following symbols.

 : See or Refer to
  : Screws
  : Connector
  : Clip ring
 : E-ring

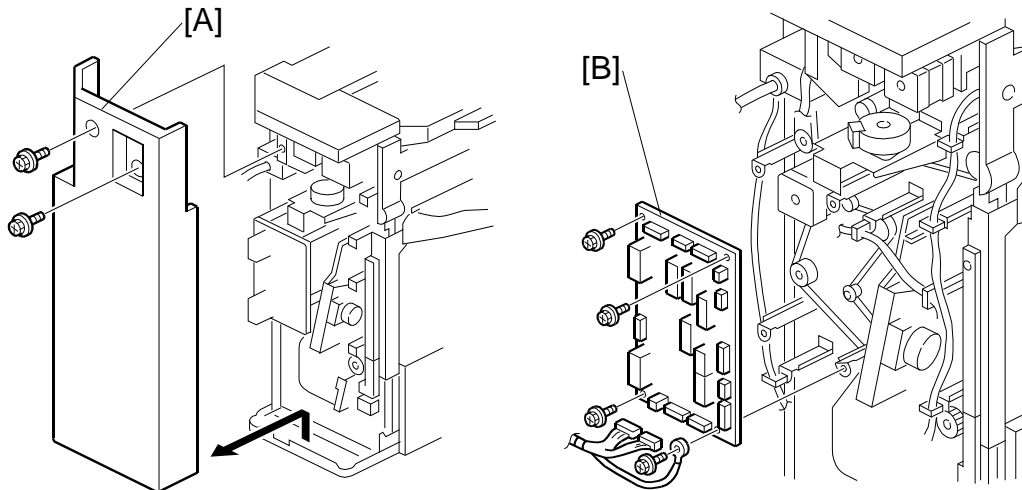
1.1 MAIN PCB



1. Rear cover [A] ( x 2)
2. Main PCB [B] ( x 4, All 

1000-Sheet
Finisher
SR790/SR3090
B408/D588

STAPLER UNIT

1.2 STAPLER UNIT

1. Side cover [A] (🔩 x 2)
2. Open exit guide plate [B]
3. Upper side cover [C] (🔩 x 2)

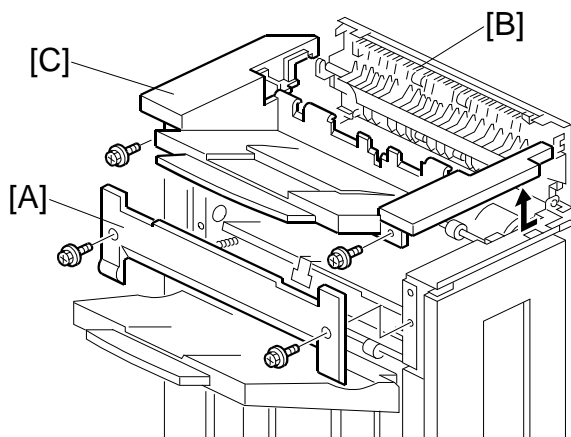

4. Front cover support plate [D] (🔩 x 1)
5. Front cover [E]
6. Front inner cover [F] (🔩 x 2)

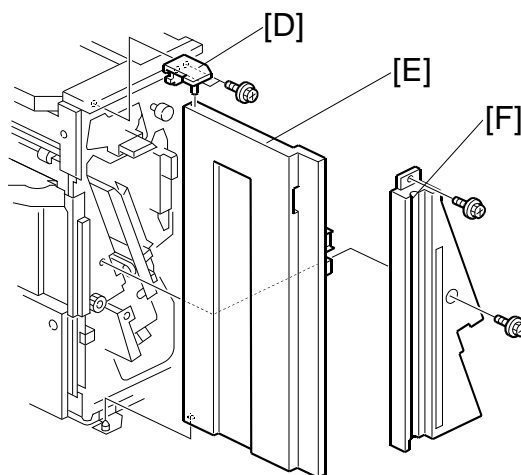

7. Harness [G]
8. Unhook the spring [H]
9. Turn the stapler unit [I] and take it out.
10. Bracket [J] (🔩 x 2)

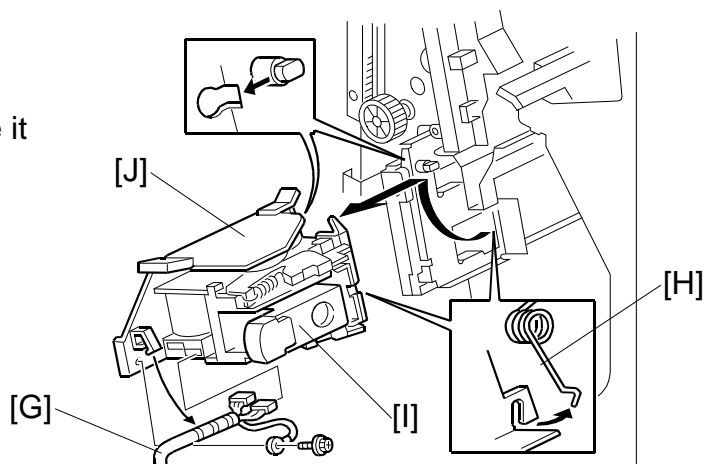

1.3 MOTORS

1.3.1 SHIFT MOTOR

1. Rear cover (☞1.1)
2. Shift motor [A] (🔩 x 2, 📡 x 1)

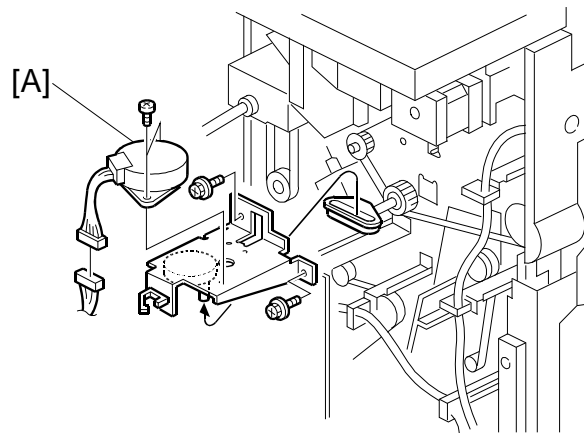

1.3.2 STAPLER MOTOR

1. Rear cover (☞1.1)
2. Stapler motor [A] (🔩 x 2, 📡 x 1)

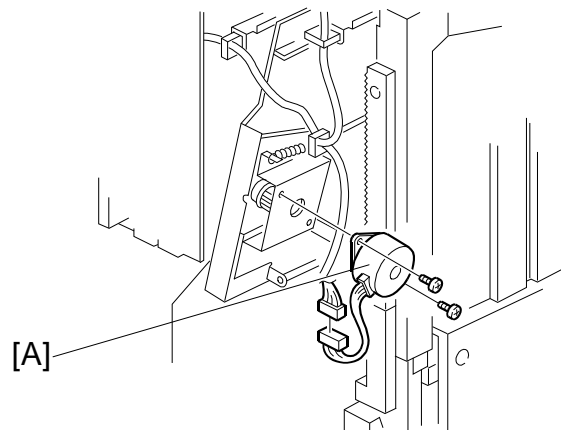

1000-Sheet
Finisher
SR790/SR3090
B408/D588

MOTORS

1.3.3 UPPER TRANSPORT MOTOR AND EXIT MOTOR

1. Rear cover (☛1.1)
2. Motor assembly [A] (🔩 x 4, 📏 x 2)
3. Upper transport motor [B] (🔩 x 4)
4. Exit motor [C] (🔩 x 4)

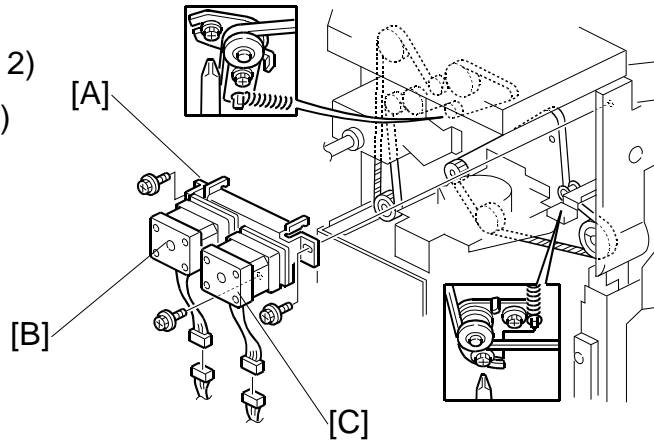

1.3.4 LOWER TRANSPORT MOTOR

1. Main PCB (☛1.1)
2. Lower transport motor [A] (🔩 x 2, 📏 x 1)

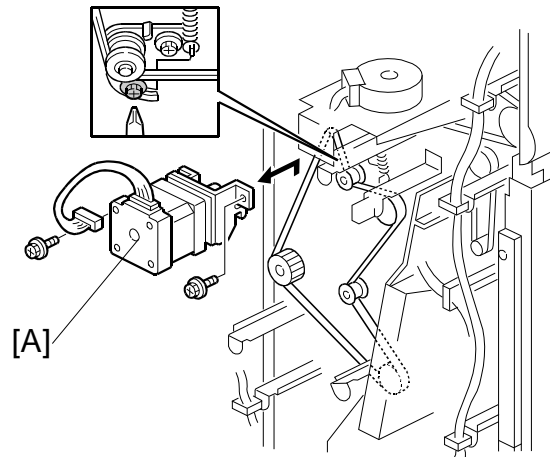

1.4 MOTORS AND SENSORS

1.4.1 PREPARATION

- 1. Front cover and inner cover (☛1.2)
- 2. Upper side cover [A] (🔩 x 2)
- 3. Upper tray [B] (🔩 x 1)

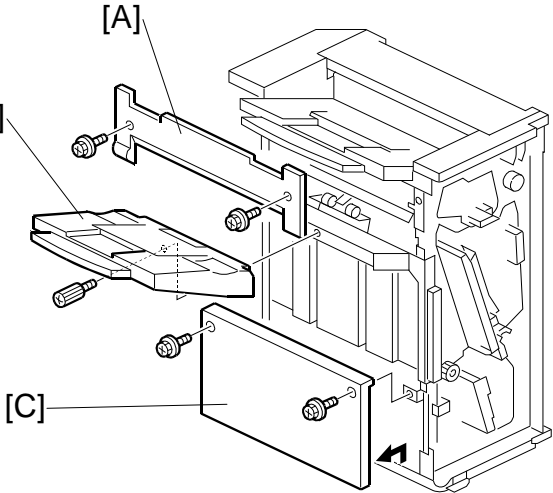

- 4. Lower side cover [C] (🔩 x 2)
- 5. Loosen the 2 screws [D].
- 6. Lower the lower tray guide plate [E].

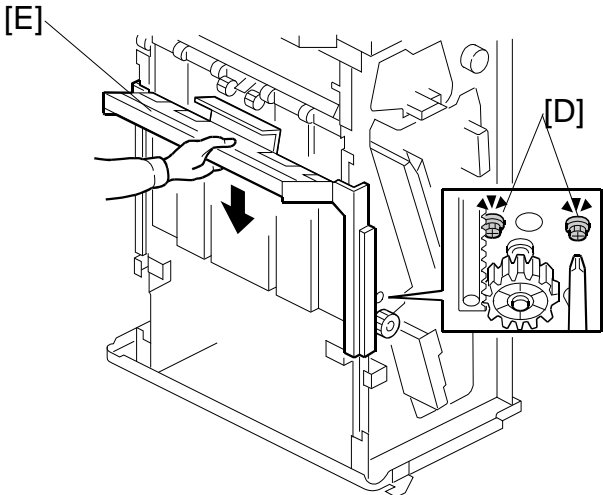

- 7. Guide plate [F] (🔩 x 4)

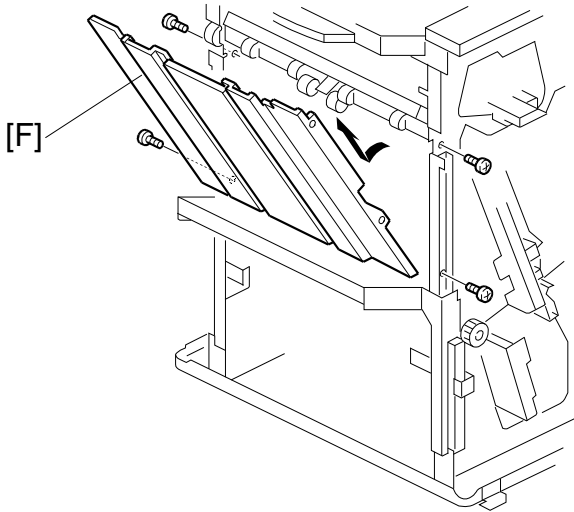

1000-Sheet
Finisher
SR790/SR3090
B408/D588

1.4.2 STACK HEIGHT SENSOR

1. Stack height sensor assembly [A] (🔩 x 1)
2. Stack height sensor [B] (🔌 x 1)

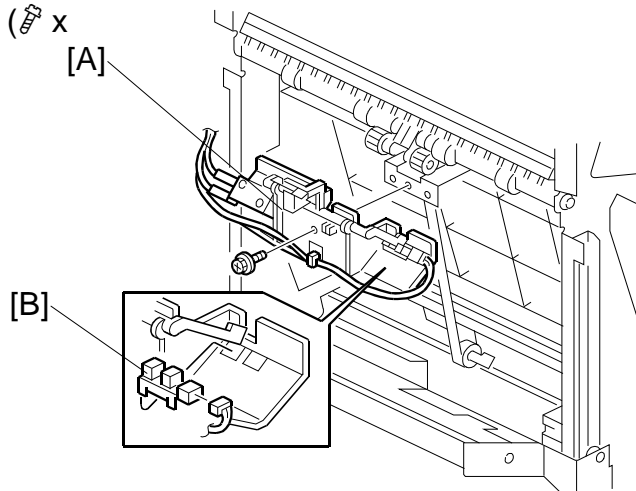

1.4.3 STAPLER TRAY PAPER SENSOR

1. Stapler tray paper sensor [A] (🔌 x 1)

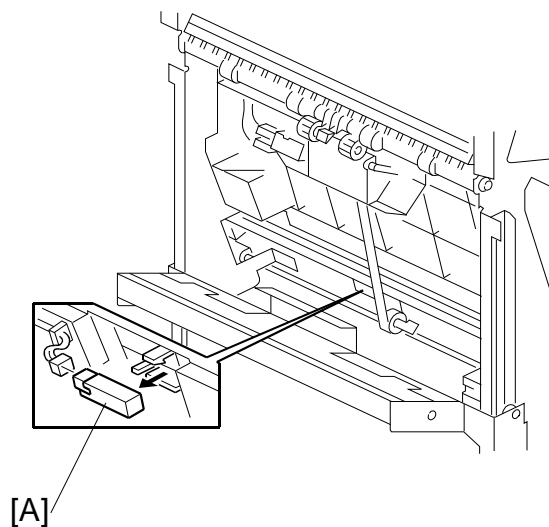

1.4.4 LOWER TRAY LIFT MOTOR

- 1. Lower tray lift motor [A] (⚙️ x 2, 📡 x 1)

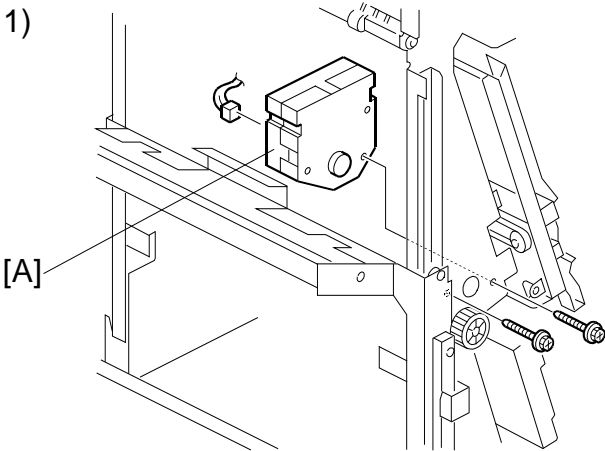

1.4.5 STACK FEED-OUT MOTOR

- 1. Stack feed-out motor [A] (⚙️ x 2, 📡 x 1)

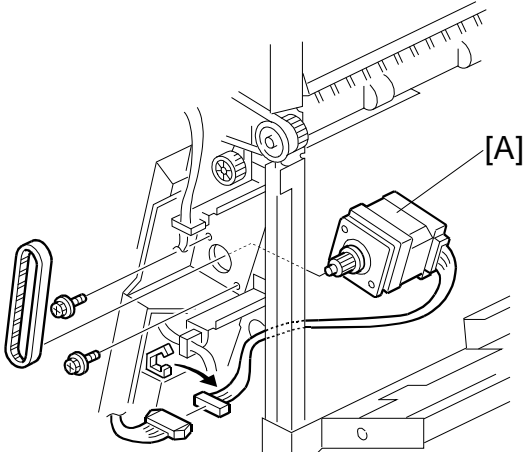

1000-Sheet
Finisher
SR790/SR3090
B408/D588

2. TROUBLESHOOTING

2.1 JAM DETECTION

Mode		Jam	Content
Shift	Staple		
✓	✓	Entrance sensor: On check	The entrance sensor does not turn on within the normal time after the main machine exit sensor turns on
✓	✓	Entrance sensor: Off check	The entrance sensor does not turn off within the normal time after it turns on.
✓		Lower tray exit sensor: On check	The lower tray exit sensor does not turn on within the normal time after the entrance sensor turns off.
✓		Tray exit sensor: Off check	The tray exit sensor does not turn off within the normal time after it turns on.
	✓	Stapler tray entrance sensor: On check	The stapler tray entrance sensor does not switch on within the normal time after the entrance sensor switched on.
	✓	Stapler tray entrance sensor: Off check	The staple tray entrance sensor does not turn off within the normal time after it turns on.
	✓	Lower tray exit sensor: On check	The lower exit sensor does not turn on after the feed-out pawl feeds out the outputs.
	✓	Lower tray exit sensor: Off check	The lower exit sensor turns on when the feed-out pawl returns to its home position after feeding out the outputs.

3. SERVICE TABLES

3.1 DIP SWITCH SETTINGS

The DIP switches should not be set to any combination other than those listed in the table below.

SW100		Description
1	2	
0	0	Normal operation mode (Default)
1	0	Packing mode.

- Before packing the machine, do the following: Set switch 1 to 1 then back to zero. The lower tray moves to the lowest position. Then turn off the main switch.
- After unpacking the machine, do the following: After turning the main switch back on, the lower tray returns to home position automatically.

1000-Sheet
Finisher
SR790/SR3090
B408/D588

4. DETAILED DESCRIPTIONS

4.1 GENERAL LAYOUT

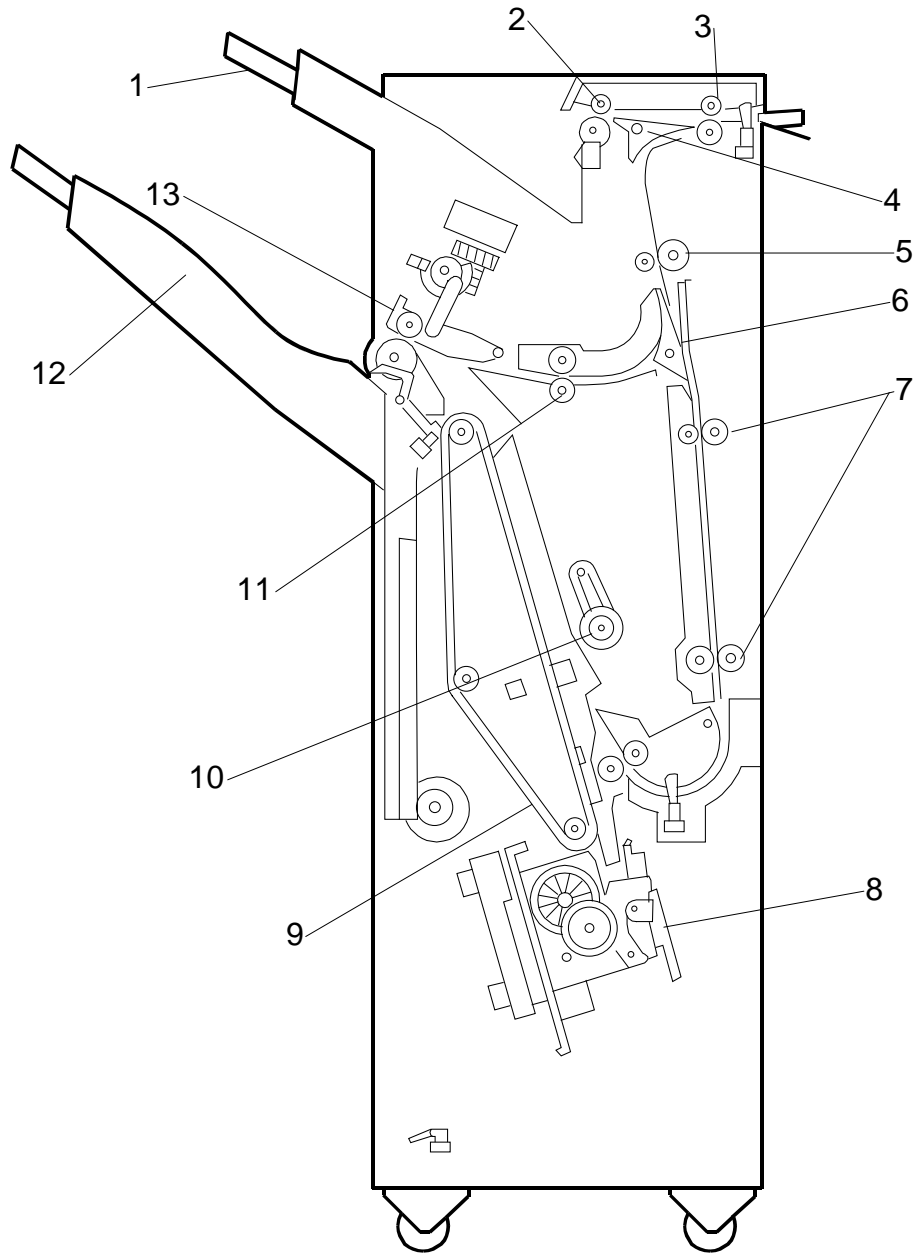

- | | |
|----------------------------|----------------------------|
| 1. Upper Tray | 8. Stapler |
| 2. Upper Tray Exit Roller | 9. Stack Feed-out Belt |
| 3. Entrance Roller | 10. Positioning Roller |
| 4. Tray Junction Gate | 11. Shift Roller |
| 5. Upper Transport Roller | 12. Lower Tray |
| 6. Stapler Junction Gate | 13. Lower Tray Exit Roller |
| 7. Lower Transport Rollers | |

4.2 ELECTRICAL COMPONENT LAYOUT

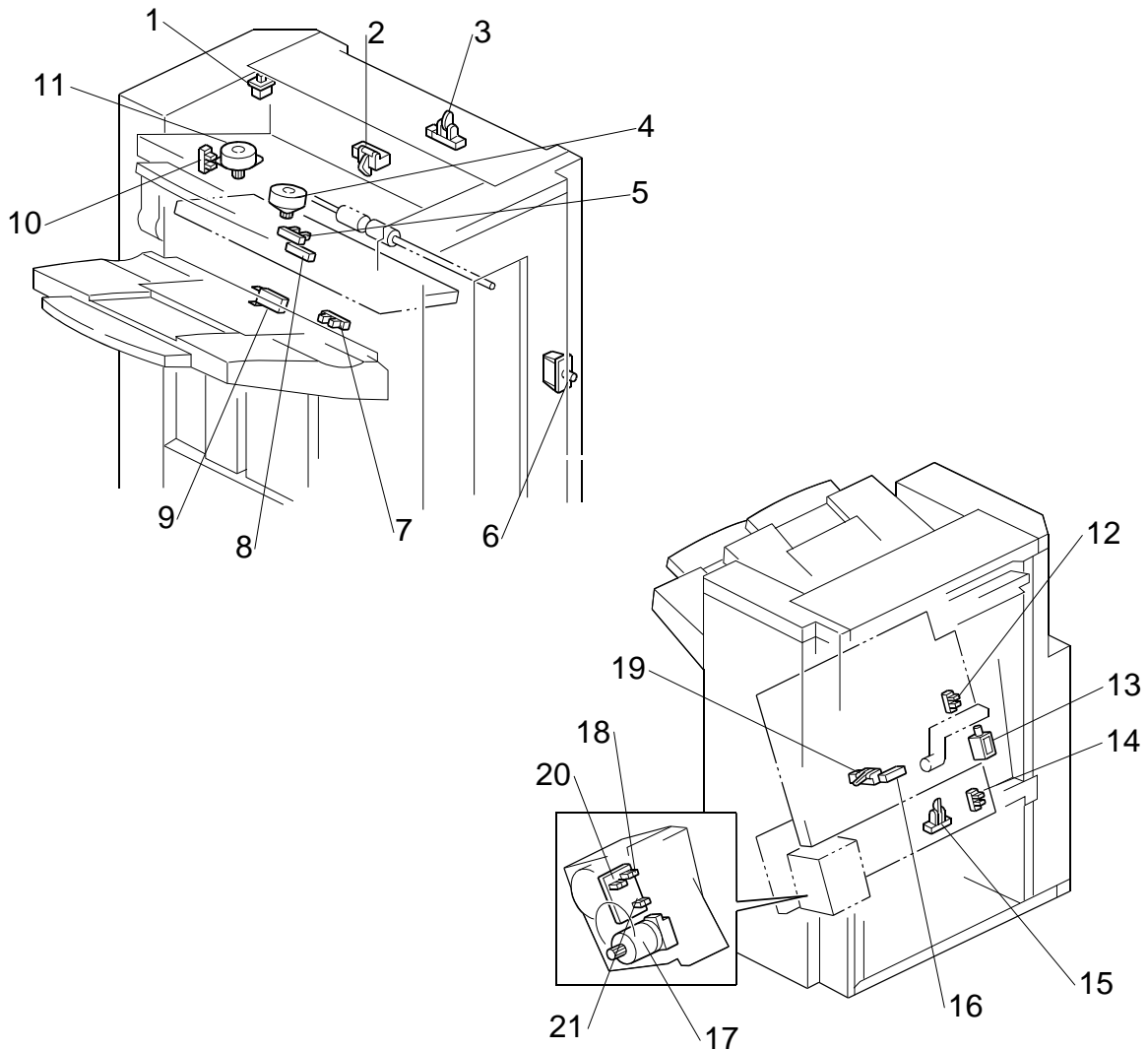

1000-Sheet
Finisher
SR790/SR3090
B408/D588

- | | |
|----------------------------------|-----------------------------------|
| 1. Upper Cover Switch | 12. Jogger Fence HP Sensor |
| 2. Paper Limit Sensor | 13. Positioning Roller Solenoid |
| 3. Entrance Sensor | 14. Stapler HP Sensor |
| 4. Exit Guide Plate Motor | 15. Stapler Tray Entrance Sensor |
| 5. Exit Guide Plate HP Sensor | 16. Stapler Tray Paper Sensor |
| 6. Front Door Safety Switch | 17. Stapler Hammer Motor |
| 7. Stack Height Sensor | 18. Staple Sheet Sensor |
| 8. Lower Tray Exit Sensor | 19. Stack Feed-out Belt HP Sensor |
| 9. Lower Tray Upper Limit Switch | 20. Stapler Rotation HP Sensor |
| 10. Shift HP Sensor | 21. Staple Sensor |
| 11. Shift Motor | |

ELECTRICAL COMPONENT LAYOUT

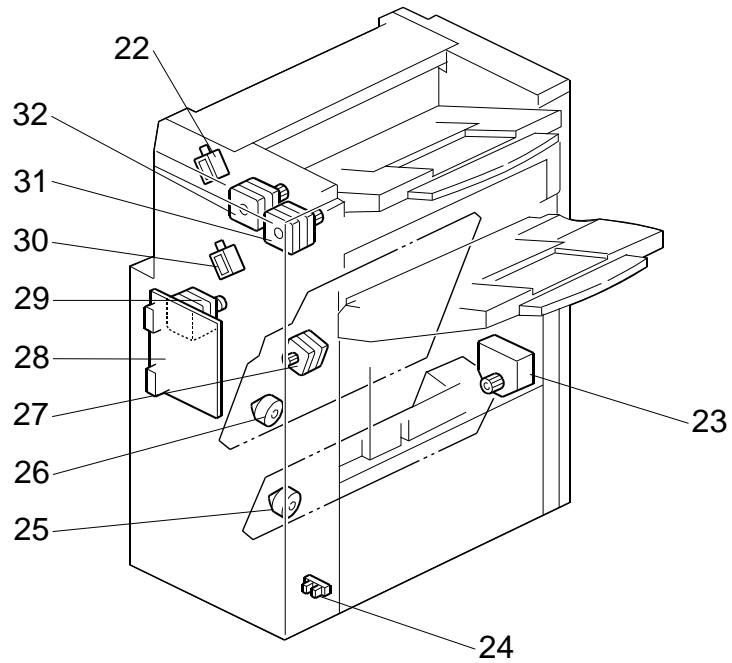

- 22. Tray Junction Gate Solenoid
- 23. Lower Tray Lift Motor
- 24. Lower Tray Lower Limit Sensor
- 25. Stapler Motor
- 26. Jogger Fence Motor
- 27. Stack Feed-out Motor
- 28. Main Board
- 29. Lower Transport Motor
- 30. Stapler Junction Gate Solenoid
- 31. Exit Motor
- 32. Upper Transport Motor

4.3 ELECTRICAL COMPONENT DESCRIPTION

Symbol	Name	Function	Index No.
Motors			
M1	Upper Transport	Drives the entrance roller and upper transport rollers.	32
M2	Lower Transport	Drives the lower transport rollers and the positioning roller.	29
M3	Jogger Fence	Drives the jogger fences.	26
M4	Staple Hammer	Drives the staple hammer.	17
M5	Stack Feed-out	Drives the stack feed-out belt.	27
M6	Exit Guide Plate	Opens and closes the exit guide plate.	4
M7	Exit	Drives the exit roller.	31
M8	Lower Tray Lift	Moves the lower tray up or down.	23
M9	Shift	Moves the shift roller from side to side.	11
M10	Stapler	Moves the stapler unit from side to side.	25
Sensors			
S1	Entrance	Detects copy paper entering the finisher and checks for misfeeds.	3
S2	Paper Limit	Detects when the paper stack height in the upper tray is at its limit.	2
S3	Jogger Fence HP	Detects when the jogger fence is at home position.	12
S4	Shift HP	Detects when the shift roller is at home position.	10
S5	Stack Feed-out Belt HP	Detects when the stack feed-out belt is at home position.	19
S6	Stapler HP	Detects when the stapler is at home position.	14
S7	Exit Guide Plate HP	Detects when the exit guide plate is at home position.	5
S8	Stapler Tray Entrance	Detects copy paper entering the stapler tray and checks for misfeeds.	15
S9	Lower Tray Exit	Checks for misfeeds.	8
S10	Stack Height	Detects the top of the copy paper stack.	7
S11	Lower Tray Lower Limit	Detects when the lower tray is at its lower limit position.	24
S12	Stapler Tray Paper	Detects when there is copy paper in the stapler tray.	16
S13	Staple Sheet	Detects the leading edge of the staple sheet.	18
S14	Stapler Rotation HP	Detects when the staple hammer is at home position.	20
S15	Staple	Detects whether there are staples in the staple cartridge.	21
Solenoids			
SOL1	Tray Junction Gate	Drives the tray junction gate.	22
SOL2	Stapler Junction Gate	Drives the stapler junction gate.	30

1000-Sheet
Finisher
SR790/SR3090
B408/D588

ELECTRICAL COMPONENT DESCRIPTION

Symbol	Name	Function	Index No.
SOL3	Positioning Roller	Moves the positioning roller.	13
Switches			
SW1	Lower Tray Upper Limit	Detects when the lower tray is at its upper limit position.	9
SW2	Front Door Safety	Cuts the dc power when the front door is opened.	6
SW3	Upper Cover	Cuts the dc power when the upper cover is opened.	1
PCBs			
PCB1	Main	Controls the finisher and communicates with the copier/printer.	28

4.4 DRIVE LAYOUT

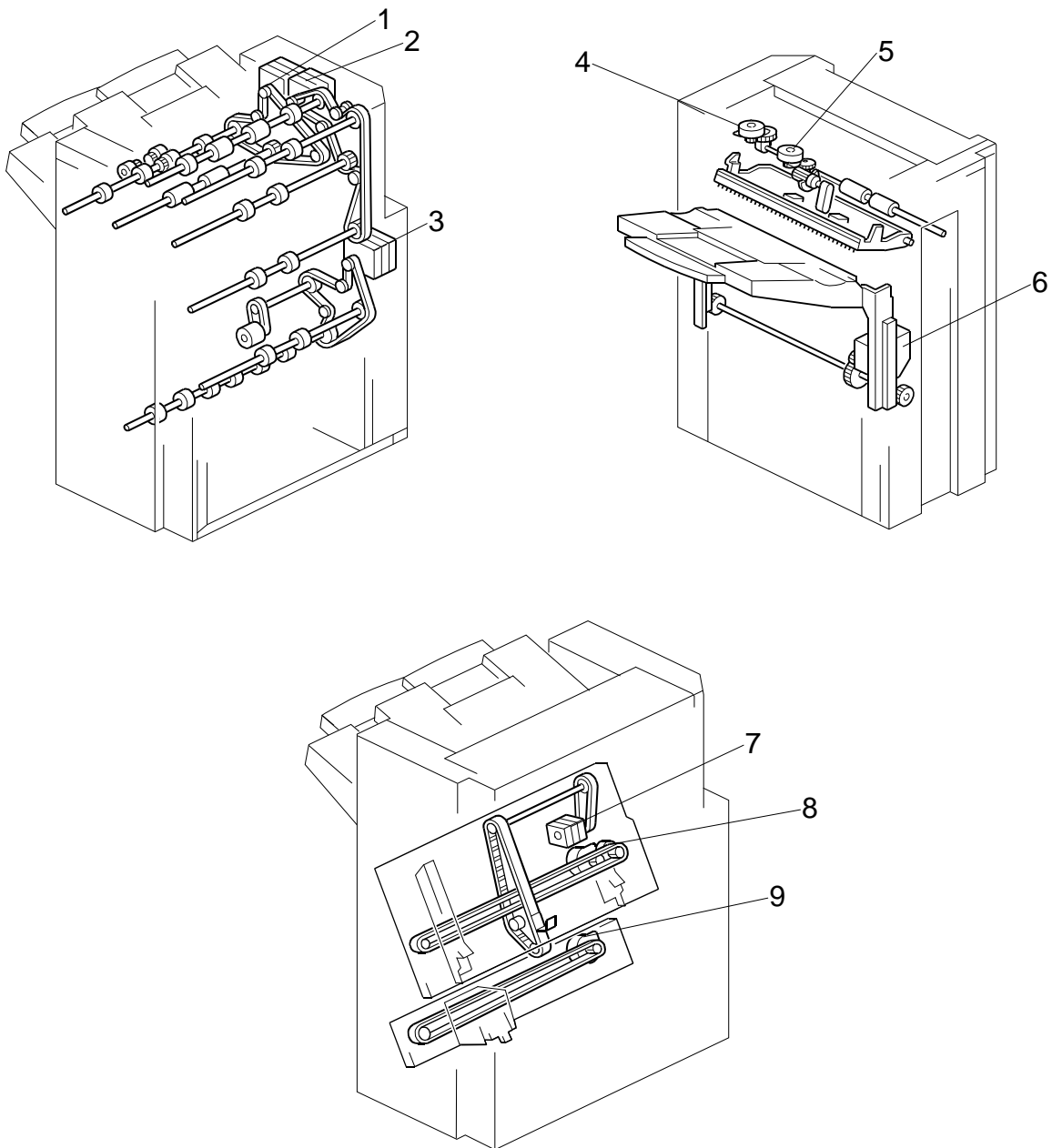

- | | |
|---------------------------|--------------------------|
| 1. Exit Motor | 6. Lower Tray Lift Motor |
| 2. Upper Transport Motor | 7. Stack Feed-out Motor |
| 3. Lower Transport Motor | 8. Jogger Motor |
| 4. Shift Motor | 9. Stapler Motor |
| 5. Exit Guide Plate Motor | |

1000-Sheet
Finisher
SR790/SR3090
B408/D588

4.5 JUNCTION GATES

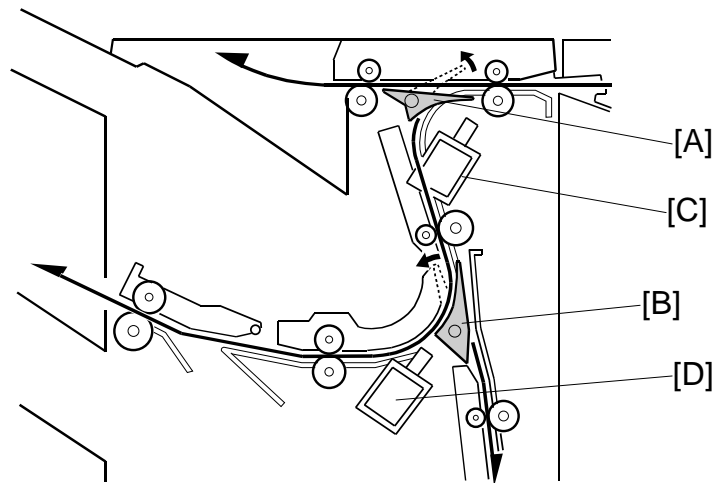

Depending on the finishing mode, the copies are directed up, straight through, or down by the combination of the tray junction gate [A] and stapler junction gate [B]. These gates are controlled by the tray junction gate solenoid [C] and stapler junction gate solenoid [D].

Upper Tray Mode

The tray junction gate solenoid remains off. The copies go up to the upper tray.

Sort/Stack Mode

The tray junction gate solenoid turns on and the stapler junction gate solenoid remains off. The copies are sent to the lower tray directly.

Staple Mode

The tray junction gate solenoid and the stapler junction gate solenoid both turn on. The copies go down to the jogger unit.

4.6 UPPER TRAY

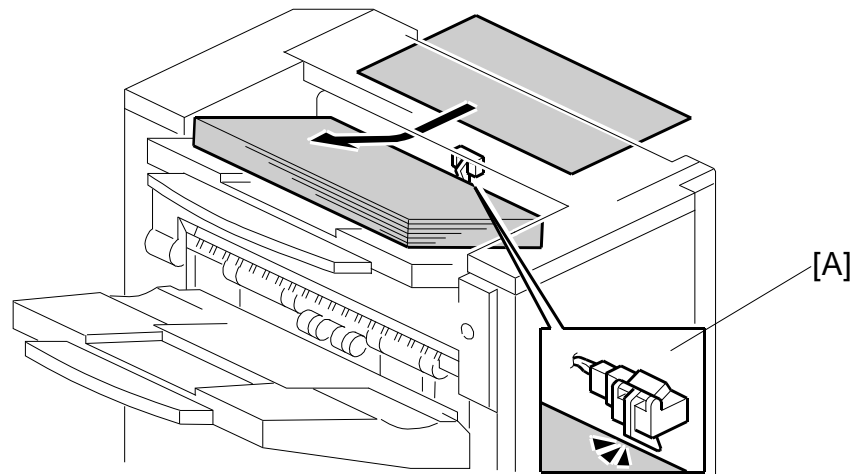

When the paper limit sensor [A] switches on during feed-out for each of three consecutive sheets of paper, paper overflow is detected.

1000-Sheet
Finisher
SR790/SR3090
B408/D588

4.7 LOWER TRAY UP/DOWN MECHANISMS

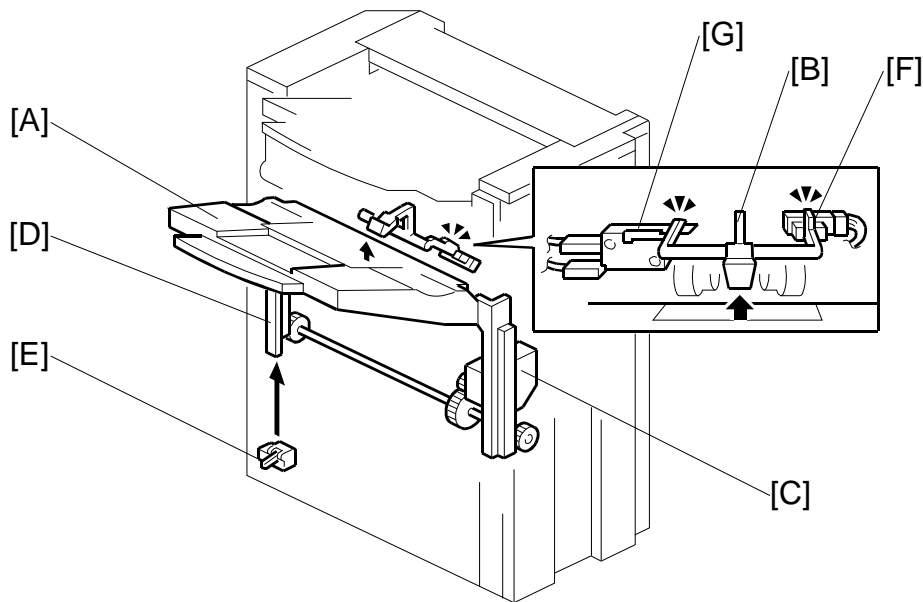

The vertical position of the lower tray [A] depends on the height of the copied paper stack on the lower tray. The stack height sensor feeler [B] contacts the top of the stack, and the lower tray lift motor [C] controls the tray height.

When the lower tray reaches its lowest possible position, the actuator [D] turns on the lower tray lower limit sensor [E], and copying stops.

Tray Up

When the copy paper on the tray is removed, the stack height sensor [F] turns off and the tray lifts up. Then, the tray stops when the sensor turns on again (the tray pushes up the feeler).

If the stack height sensor fails, the lower tray upper limit switch [G] detects the tray and stops the motor. This is a safety measure against stack height sensor failure.

Sort/Stack Mode (Tray Down)

Every five sheets of paper, the tray goes down until the sensor turns off again. Then, it goes up until the sensor is on again.

Staple Mode (Tray Down)

After a stapled copy is fed out, the tray goes up for 220 ms and stops for 300 ms. Then, it goes down for 1 second, waits for 500 ms, then goes up until the sensor turns on.

4.8 PAPER SHIFT MECHANISM

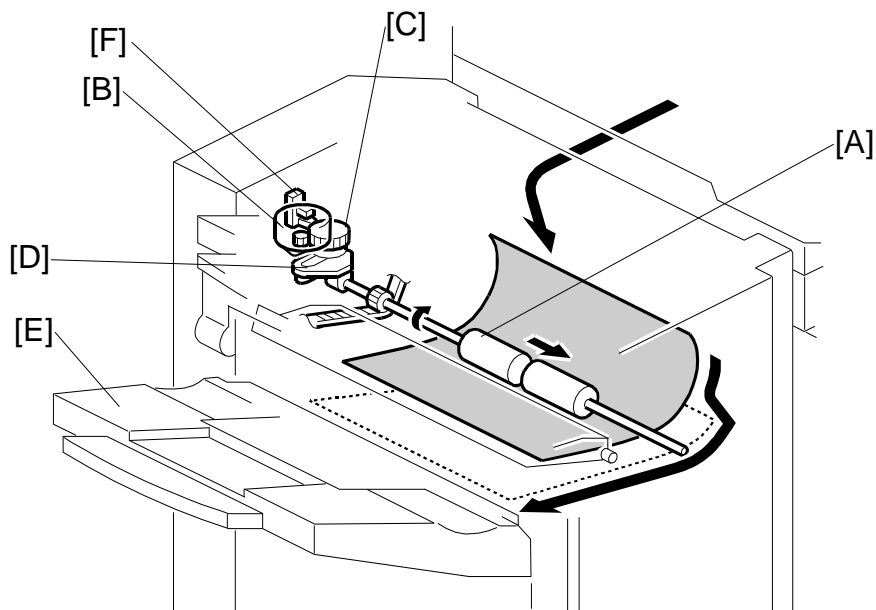

In the sort/stack mode, the shift roller [A] moves from side to side to separate the sets of copies.

The horizontal position of the shift roller is controlled by the shift motor [B] and the shift gear disk [C]. After the trailing edge of the copy passes the upper transport roller, the shift motor turns on, driving the shift gear disk and the link [D].

After the paper is delivered to the lower tray [E], the shift roller moves to its home position, which is detected by the shift HP sensor [F]. Then, when the trailing edge of the next copy passes the upper transport roller, the shift roller shifts again. This operation is done every sheet.

When the trailing edge of each page in the next set of copies passes the upper transport roller, the shift roller shifts in the opposite direction.

1000-Sheet
Finisher
SR790/SR3090
B408/D588

4.9 JOGGER UNIT PAPER POSITIONING MECHANISM

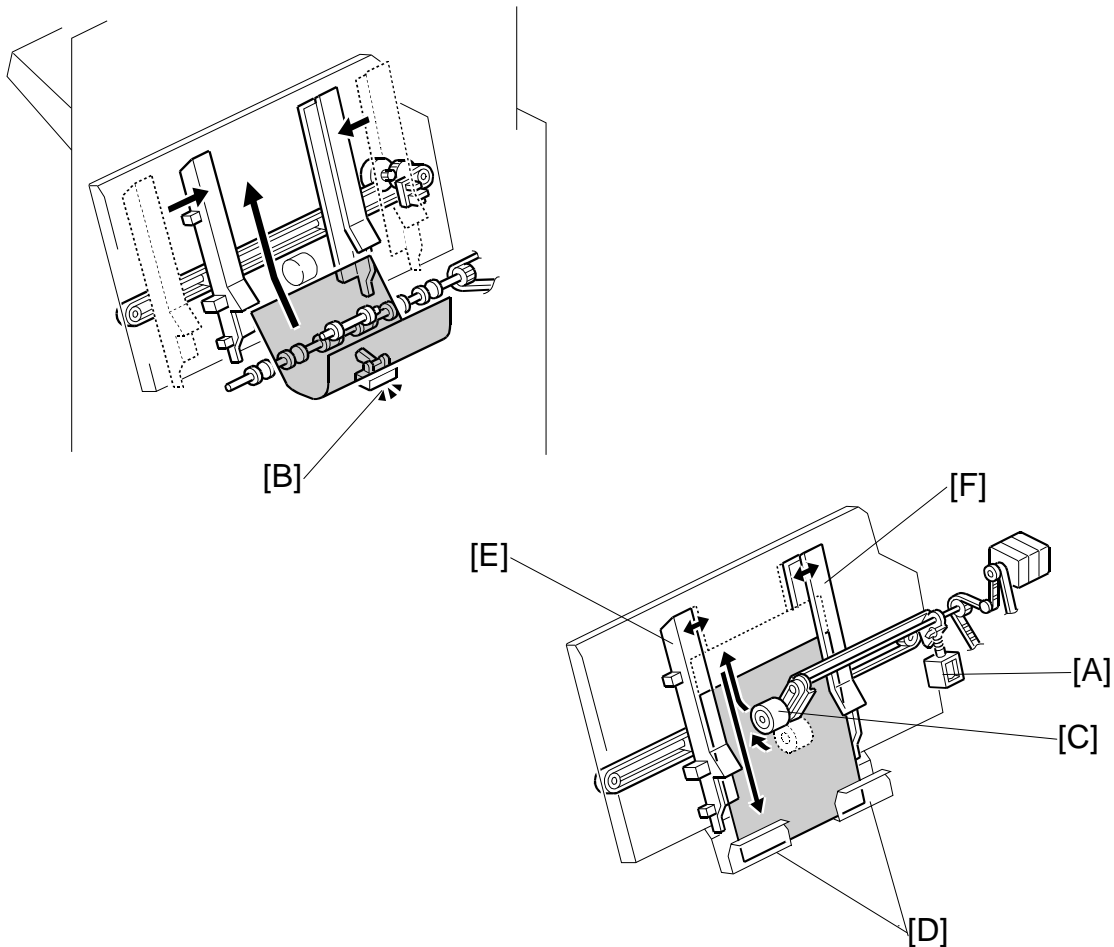

In staple mode, each sheet of copy paper is vertically and horizontally aligned when it arrives in the jogger unit.

For the vertical paper alignment, the positioning roller solenoid [A] turns on shortly after the stapler tray entrance sensor [B] turns off, and the positioning roller [C] pushes the copy against the bottom of the stack stopper [D].

For the horizontal paper alignment, the jogger front fence [E] and the rear fence [F] move to the waiting position, which is 18 mm away from the side of the paper. When aligning the paper vertically, the jogger fence moves in 14 mm from the waiting position. After the vertical position has been aligned, the jogger fence pushes the paper 4 mm against the rear fence to align the paper horizontally. Then the jogger fence moves back to the previous position.

4.10 EXIT GUIDE PLATE

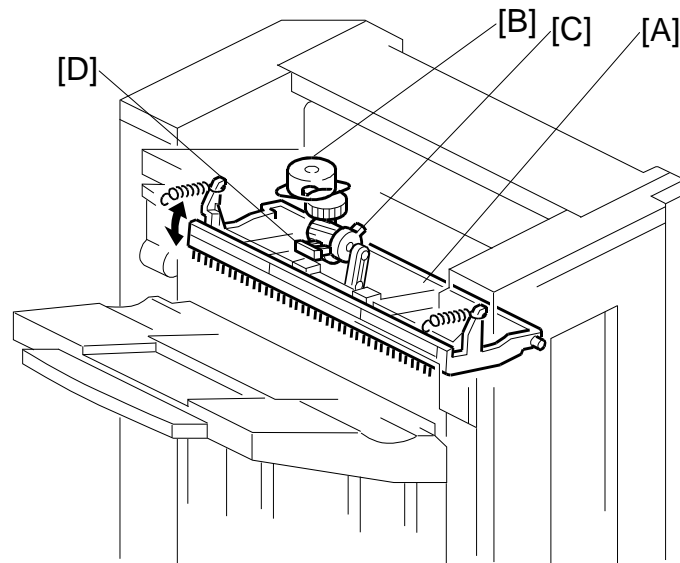

When stacking a large size of paper (such as A3, DLT) in the jogger unit, the leading edge of the paper reaches the exit rollers. To prevent the paper from running into the exit rollers and not being aligned correctly, the exit guide plate [A] is moved up to make a gap between the exit rollers. This operation is done for all paper sizes, but is only needed for the larger sizes.

The exit guide plate motor [B] and exit roller release cam [C] control the exit guide plate movement. When the exit guide plate motor starts, the cam turns and the exit guide plate moves up. When stapling is finished, the exit guide plate motor turns on again to close the exit guide plate. When the exit guide plate HP sensor [D] turns on, the motor stops.

1000-Sheet
Finisher
SR790/SR3090
B408/D588

4.11 STAPLER MECHANISM

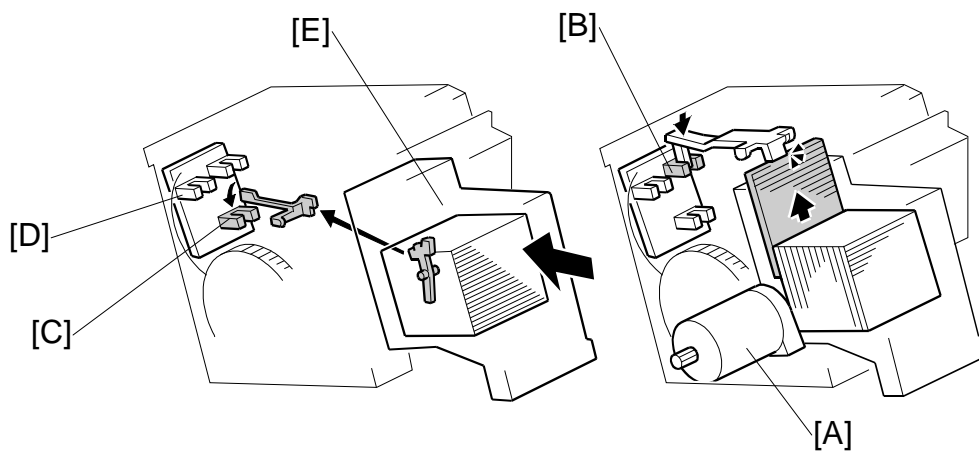

The staple hammer motor [A] drives the staple hammer.

The staple sheet sensor [B] detects the leading edge of the staple sheet at the stapling position to prevent the hammer from operating if there are no staples at the stapling position.

If there is no staple cartridge in the stapler unit or no staples in the staple cartridge, staple end is indicated on the operation panel. The stapler sensor [C] detects this.

The stapler rotation HP sensor [D] checks whether the staple hammer mechanism returns to home position after each stack has been stapled.

When excessive load is applied to the staple hammer motor, the copier detects a staple jam. When a staple jam has occurred, the jammed staple is inside the staple cartridge [E]. Therefore, the jammed staple can be removed easily after pulling out the staple cartridge.

4.12 STAPLER UNIT MOVEMENT MECHANISM

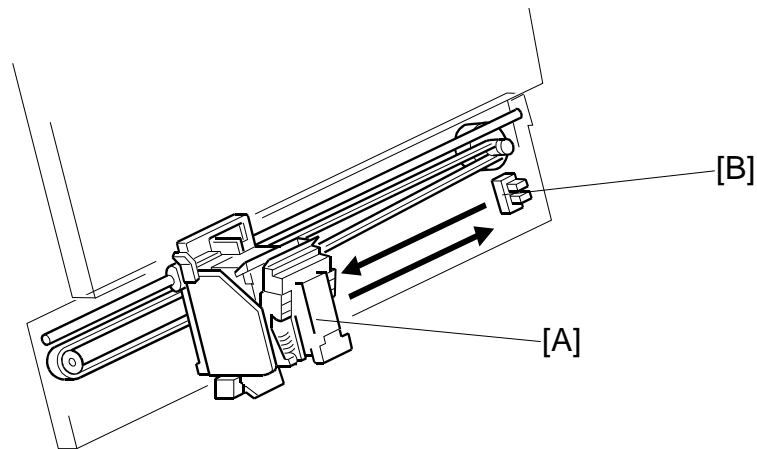

The stapler motor moves the stapler [A] from side to side. After the start key is pressed, the stapler moves from its home position to the stapling position.

If two-staple-position mode is selected, the stapler moves to the front stapling position first, then moves to the rear stapling position. However, for the next copy set, it staples in the reverse order (at the rear side first, then at the front side).

After the job is completed, the stapler moves back to its home position. The stapler HP sensor [B] detects this.

1000-Sheet
Finisher
SR790/SR3090
B408/D588

4.13 PAPER FEED-OUT MECHANISM

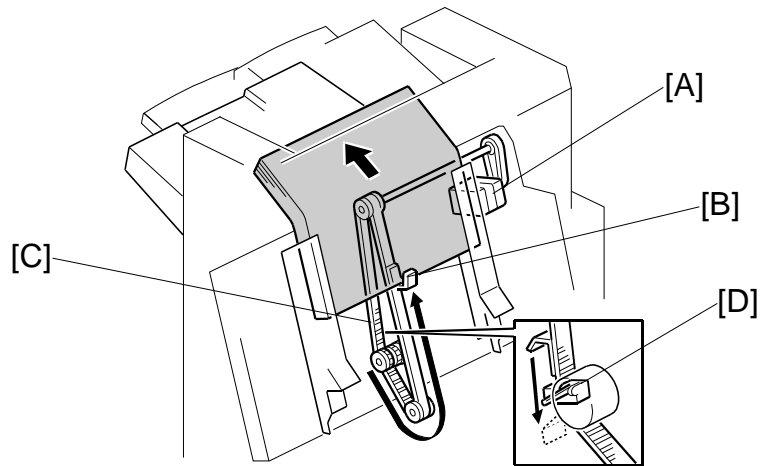

After the copies have been stapled, the stack feed-out motor [A] starts. The pawl [B] on the stack feed-out belt [C] transports the set of stapled copies up and feeds it to the shift roller. The shift roller takes over stack feed-out after the leading edge reaches this roller.

Just before the stapled stack passes through the lower tray exit sensor, the stack-feed-out motor turns off until the shift rollers have completely fed the stack out to the lower tray. Then, the stack-feed-out motor turns on again until the pawl [B] actuates the stack feed-out belt home position sensor [D].

SR3050(D584)/SR3070(D585)
500-SHEET FINISHER

REVISION HISTORY		
Page	Date	Added/Updated/New
		None

500-SHEET FINISHER D372/D585

TABLE OF CONTENTS

1. REPLACEMENT AND ADJUSTMENT	1
1.1 COMMON PROCEDURES	1
1.1.1 DISCONNECTING, REMOVING THE FINISHER.....	1
1.1.2 FRONT COVER.....	2
1.1.3 REAR COVER	2
1.1.4 TRANSPORT UNIT	3
1.2 SENSORS	6
1.2.1 ENTRANCE SENSOR	6
1.2.2 PAPER SENSOR.....	7
1.3 MOTORS	8
1.3.1 TRAY LIFT MOTOR.....	8
1.3.2 TRANSPORT MOTOR.....	9
1.3.3 POSITIONING ROLLER ARM MOTOR.....	10
1.3.4 STAPLER MOVEMENT MOTOR.....	11
1.3.5 FRONT FENCE MOTOR	12
1.3.6 FEED-OUT BELT MOTOR, REAR FENCE MOTOR	13
1.4 BOARDS	14
1.4.1 MAIN BOARD	14
1.5 OTHERS	15
1.5.1 STAPLER.....	15
1.5.2 POSITIONING ROLLER	16
2. DETAILED SECTION DESCRIPTIONS	17
2.1 OVERVIEW.....	17
2.1.1 IMPORTANT PARTS.....	17
2.1.2 EXTERNAL DIMENSIONS	18
2.1.3 GENERAL OPERATION.....	18
2.1.4 INITIALIZATION: WHAT HAPPENS AT POWER ON.....	20
2.2 PAPER TRANSPORT	22
2.2.1 OVERVIEW.....	22
2.2.2 TRANSPORT ROLLERS	23

2.2.3 POSITIONING ROLLER	24
2.2.4 POSITIONING ROLLER INITIALIZATION	27
2.3 JOGGING (PAPER ALIGNMENT)	28
2.3.1 OVERVIEW.....	28
2.3.2 SIDE FENCE OPERATION	30
2.3.3 SIDE FENCE INITIALIZATION	33
2.3.4 SIDE FENCE MOTOR ERRORS.....	33
2.3.5 SIDE FENCE OPERATION ADJUSTMENT	34
2.4 STAPLING	36
2.4.1 OVERVIEW.....	36
2.4.2 STAPLER MOVEMENT MOTOR INITIALIZATION	39
2.4.3 STAPLER ERRORS	40
2.5 PAPER OUTPUT	41
2.5.1 OVERVIEW.....	41
2.5.2 FEED-OUT.....	44
2.5.3 FEED-OUT BELT INITIALIZATION	45
2.5.4 FEED-OUT BELT ERRORS	45
2.5.5 FEED-OUT EXTENSION.....	46
2.6 TRAY OPERATION	48
2.6.1 OVERVIEW.....	48
2.6.2 TRAY LIFT CONTROL.....	49
2.6.3 TRAY INITIALIZATION	53
2.6.4 TRAY LIFT ERRORS.....	54
2.7 ELECTRICAL COMPONENTS	57
2.7.1 COMPONENT LAYOUT	57
2.7.2 SUMMARY OF ELECTRICAL COMPONENTS.....	58
2.7.3 TIMING CHARTS.....	61
2.7.4 ERROR LIST	63
3. SPECIFICATIONS	69
3.1 SPECIFICATIONS	69

Read This First

Safety, Conventions, Trademarks

SAFETY

PREVENTION OF PHYSICAL INJURY

1. Before disassembling or assembling parts of the printer and peripherals, make sure that the printer and peripheral power cords are unplugged.
2. The power source should be near the printer and easily accessible.
3. Note that some components of the printer and the paper tray unit are supplied with electrical voltage even if the main power switch is turned off.
4. If any adjustment or operation check has to be made with exterior covers off or open while the main switch is turned on, keep hands away from electrified or mechanically driven components.
5. If the Start key is pressed before the copier completes the warm-up period (the Start key starts blinking red and green alternatively), keep hands away from the mechanical and the electrical components as the copier starts making copies as soon as the warm-up period is completed.
6. The inside and the metal parts of the fusing unit become extremely hot while the printer is operating. Be careful to avoid touching those components with your bare hands.
7. To prevent a fire or explosion, keep the machine away from flammable liquids, gases, and aerosols.

HEALTH SAFETY CONDITIONS

1. Never operate the copier without the ozone filters installed.
2. Always replace the ozone filters with the specified ones at the specified intervals.
3. Toner and developer are non-toxic, but if you get either of them in your eyes by accident, it may cause temporary eye discomfort. Try to remove with eye drops or flush with water as first aid. If unsuccessful, get medical attention.

OBSERVANCE OF ELECTRICAL SAFETY STANDARDS

1. The copier and its peripherals must be installed and maintained by a customer service representative who has completed the training course on those models.

SAFETY AND ECOLOGICAL NOTES FOR DISPOSAL

1. Do not incinerate toner bottles or used toner. Toner dust may ignite suddenly when exposed to an open flame.
2. Dispose of used toner, developer, and organic photoconductors in accordance with

local regulations. (These are non-toxic supplies.)







3. Dispose of replaced parts in accordance with local regulations.
4. When keeping used lithium batteries in order to dispose of them later, do not put more than 100 batteries per sealed box. Storing larger numbers or not sealing them apart may lead to chemical reactions and heat build-up.

CAUTION

- The danger of explosion exists if a battery of this type is incorrectly replaced. Replace only with the same or an equivalent type recommended by the manufacturer. Discard used batteries in accordance with the manufacturer's instructions.

CONVENTIONS AND TRADEMARKS

CONVENTIONS

Symbol	What it means
	Core Tech Manual
	Screw
	Connector
	E-ring
	C-ring
	Clamp
FFC	Flexible Film Connector

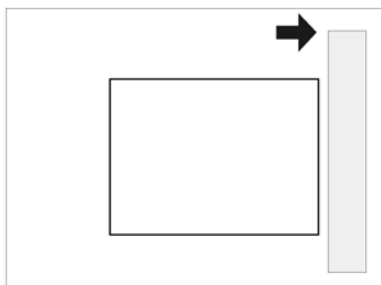

SEF (Short Edge Feed)

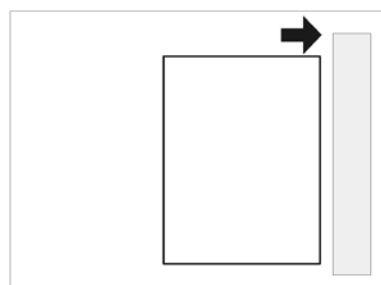

LEF (Long Edge Feed)

The notations "SEF" and "LEF" describe the direction of paper feed. The arrows indicate the direction of paper feed.

WARNINGS, CAUTIONS, NOTES

In this manual, the following important symbols and notations are used.

WARNING

- A Warning indicates a potentially hazardous situation. Failure to obey a Warning could result in death or serious injury.

CAUTION

- A Caution indicates a potentially hazardous situation. Failure to obey a Caution could result in minor or moderate injury or damage to the machine or other property

Important

- Obey these guidelines to avoid problems such as misfeeds, damage to originals, loss of valuable data and to prevent damage to the machine

Note

- This information provides tips and advice about how to best service the machine.

Trademarks

- Microsoft[®], Windows[®], and MS-DOS[®] are registered trademarks of Microsoft Corporation in the United States and /or other countries.
- PostScript[®] is a registered trademark of Adobe Systems, Incorporated.
- PCL[®] is a registered trademark of Hewlett-Packard Company.
- Ethernet[®] is a registered trademark of Xerox Corporation.
- PowerPC[®] is a registered trademark of International Business Machines Corporation.
- Other product names used herein are for identification purposes only and may be trademarks of their respective companies. We disclaim any and all rights involved with those marks.

1. REPLACEMENT AND ADJUSTMENT

1.1 COMMON PROCEDURES

1.1.1 DISCONNECTING, REMOVING THE FINISHER

★ Important

- The finisher must be removed from the machine for these procedures. The front and rear covers cannot be removed while the finisher is attached to the side of the machine.

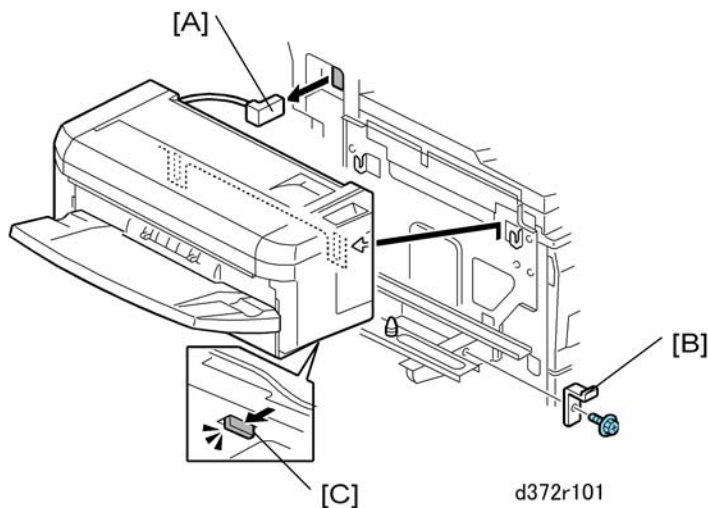

1. Disconnect the finisher I/F cable [A] on the left side of the machine.
2. Remove the lock plate [B] (⚙ x1).
3. Press the spring release [C] toward the rear of the finisher, then lift the finisher off its center post.

Common Procedures

1.1.2 FRONT COVER

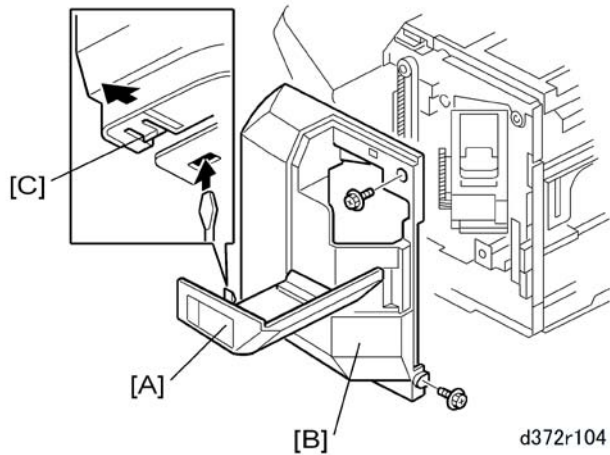

Preparation

- Disconnect the finisher.
- Remove the finisher from the side of the machine.

1. Open the stapler door [A].
2. Remove the front cover [B] (⚙ x2)

Release tab [C] after removing the screws, then raise the bottom of the front cover to remove it.

1.1.3 REAR COVER

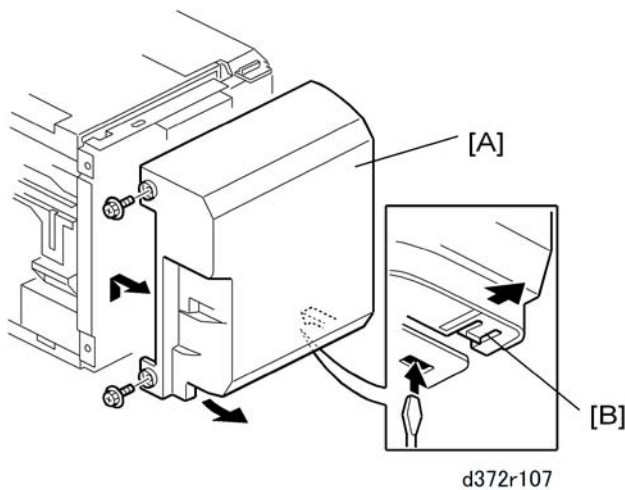

Preparation

- Disconnect the finisher.
- Remove the finisher from the side of the machine.

1. Remove the rear cover [A] (⚙ x2)

Release tab [B] after removing the screws, then raise the bottom of the rear cover to remove it.

1.1.4 TRANSPORT UNIT

Preparation

Remove:

- Front cover
- Rear cover

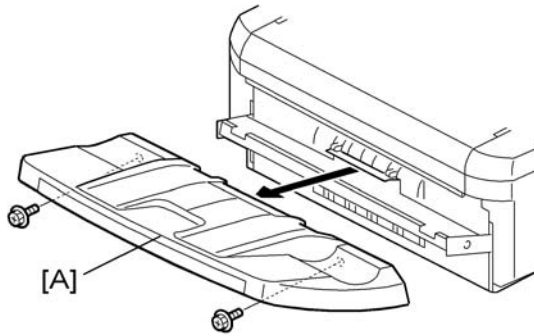

d372d102

1. Remove the paper output tray [A] (⚙️ x2).

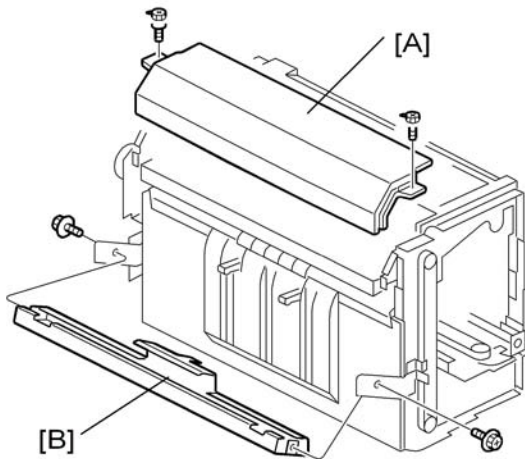

d372r114

2. Remove the left top cover [A] (⚙️ x2).
3. Remove the tray support [B] (⚙️ x2).

Common Procedures

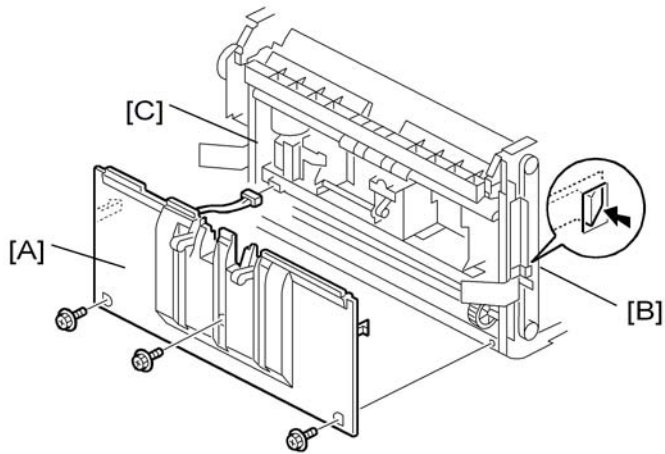

d372r115

4. Remove the screws of the end fence [A] (🔩 x3).
5. Release tabs [B] and [C].
6. Remove the end fence.

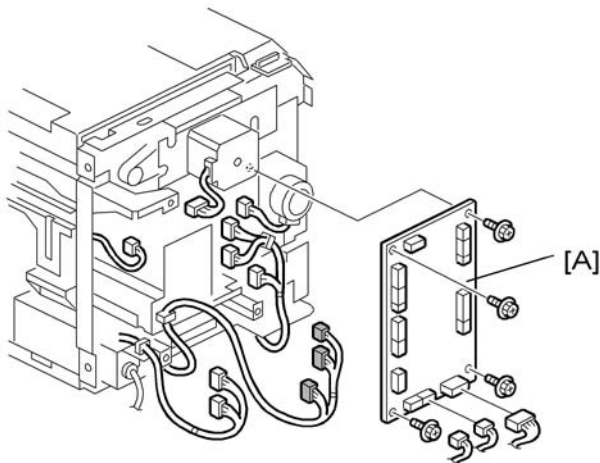

d372r108

7. Remove the main board [A] (🔩 x 14, 🛠️ x4)

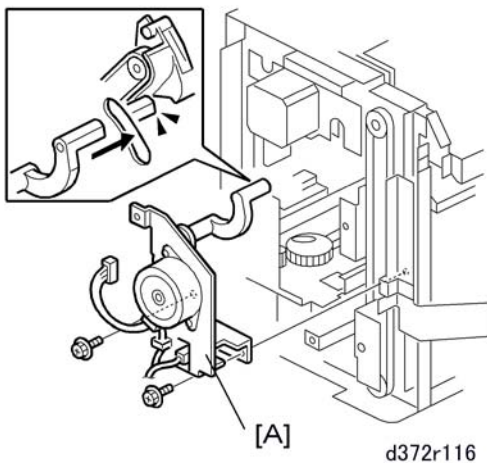

d372r116

Common Procedures

8. Remove the positioning roller arm motor bracket [A] (⚙️ x2).

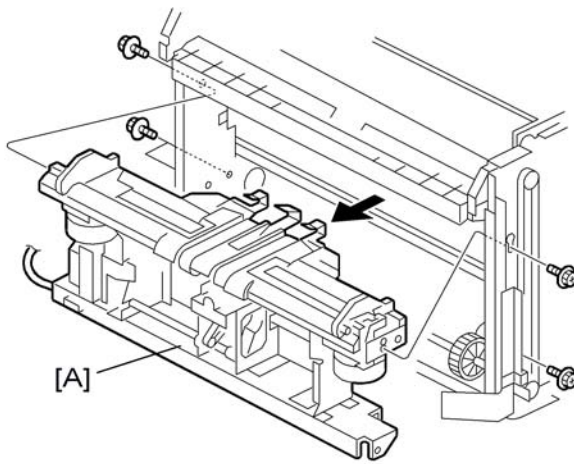

d372r117

9. Remove the transport unit [A] (⚙️ x3 Rear, ⚙️ x2 Front).

Sensors

1.2 SENSORS

1.2.1 ENTRANCE SENSOR

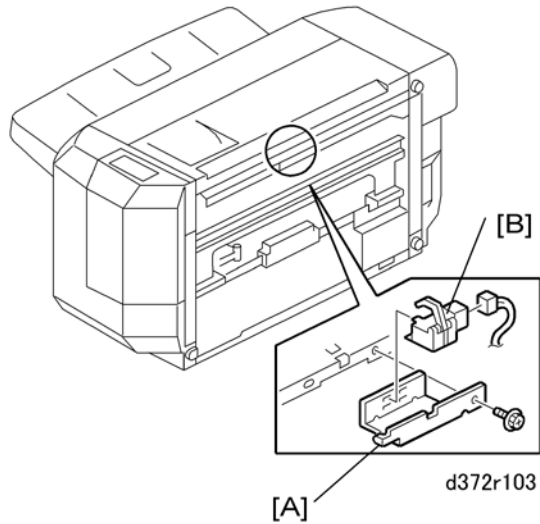

Preparation

- Disconnect the finisher.
 - Remove the finisher from the side of the machine.
1. Remove the sensor bracket [A] (⚙️ x1).
 2. Disconnect the entrance sensor [B] (Pawls x4, ⚙️ x1).

1.2.2 PAPER SENSOR

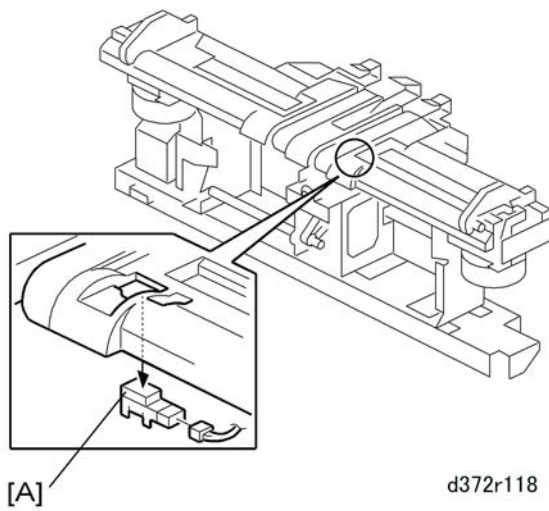

Preparation

- Disconnect the finisher.
 - Remove the finisher from the side of the machine.
 - Remove the transport unit
1. Disconnect the sensor [A] (🔌 x1, Pawls x3, 📏 x1)

Motors

1.3 MOTORS

1.3.1 TRAY LIFT MOTOR

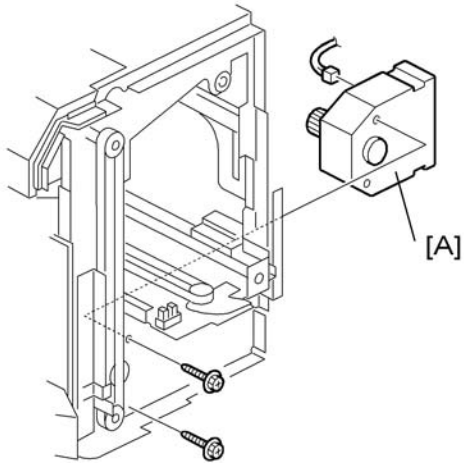

d372r106

Preparation

- Disconnect the finisher.
 - Remove the finisher from the side of the machine.
 - Remove the front cover
1. Remove the tray lift motor [A] (⚙️ x2, 🛠️ x1).

1.3.2 TRANSPORT MOTOR

Preparation

- Disconnect the finisher.
- Remove the finisher from the side of the machine.
- Remove the rear cover.

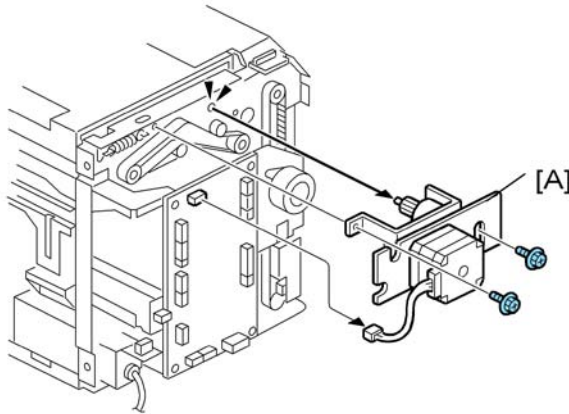

d372r110

1. Remove the motor bracket [A] (⚙️ x2, 🏷️ x1)

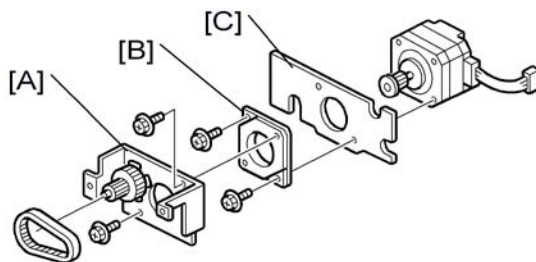

d372r111

2. Remove:
 - [A] 1st bracket (Timing belt x1, ⚙️ x2)
 - [B] 2nd bracket (⚙️ x2)
 - [C] 3rd bracket

Reinstallation

- After reattaching the motor, rotate its drive gear and confirm that the timing belt is set correctly.
- Rotate the motor drive gear by hand and confirm that these rollers are turning: 1) entrance roller, 2) positioning roller, and 3) return rollers. (The return rollers are the two small sponge rollers below the positioning roller.)

Motors

1.3.3 POSITIONING ROLLER ARM MOTOR

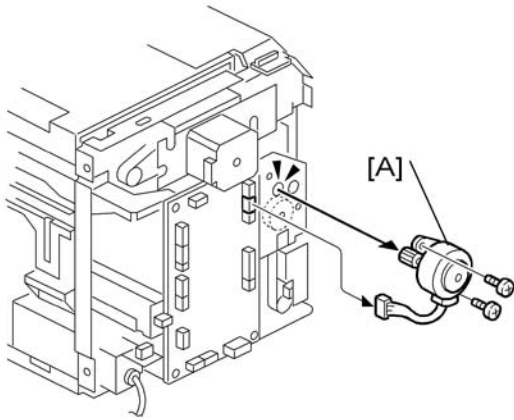

d372r109

Preparation

- Disconnect the finisher.
 - Remove the finisher from the side of the machine.
 - Remove the rear cover.
1. Remove the positioning roller arm motor [A] (🔧 x2, 🛠️ x1).

1.3.4 STAPLER MOVEMENT MOTOR

Preparation

- Disconnect the finisher.
- Remove the finisher from the side of the machine.
- Remove the rear cover.

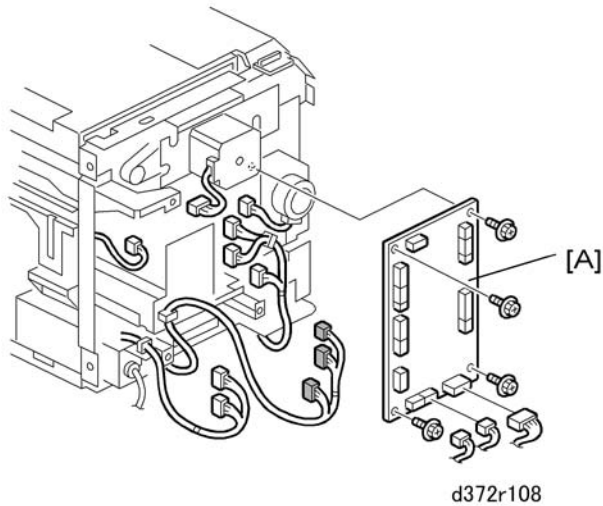

1. Remove the main board [A] (⌘ x 14, ⚙ x 4).

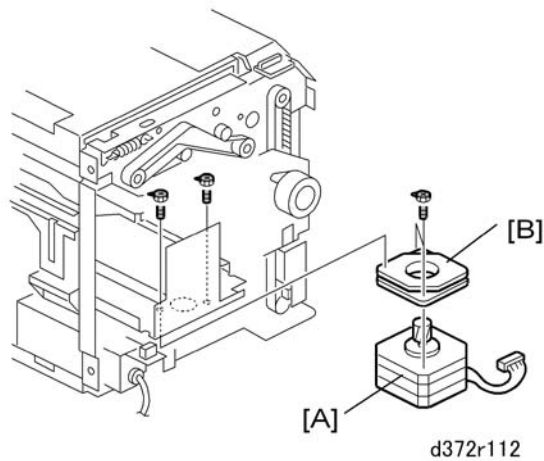

2. Remove the stapler movement motor [A] (⚙ x 2, ⌘ x 1).
3. Remove the bracket [B] (⚙ x 2).

Motors

1.3.5 FRONT FENCE MOTOR

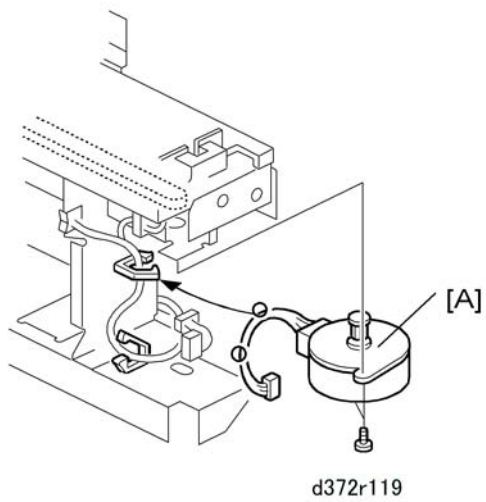

Preparation

- Disconnect the finisher.
 - Remove the finisher from the side of the machine.
 - Remove the transport unit
1. Remove the front fence motor [A] (⚙️ x1, 🔩 x2, 🛠️ x1).

1.3.6 FEED-OUT BELT MOTOR, REAR FENCE MOTOR

Preparation

- Disconnect the finisher.
- Remove the finisher from the side of the machine.
- Remove the transport unit

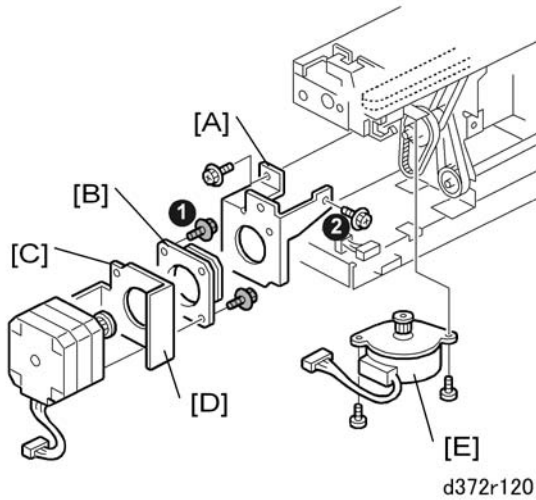

1. Remove the feed-out belt motor mount [A] ①, ② (⌘ x2).
2. Remove:
 - [B] 1st bracket (⌘ x2)
 - [C] 2nd bracket (⌘ x2)
 - [D] 3rd bracket
3. Remove the rear fence motor [E] (⌘ x2, ⌘ x1)

Boards

1.4 BOARDS

1.4.1 MAIN BOARD

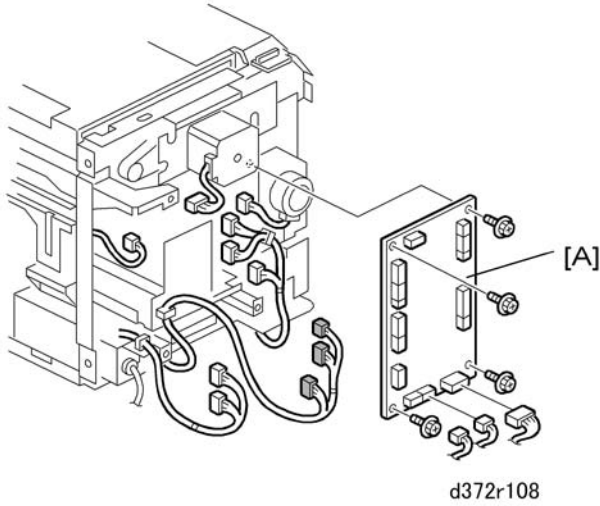

Preparation

- Disconnect the finisher.
 - Remove the finisher from the side of the machine.
 - Remove the rear cover.
1. Remove the main board [A] (🔩 x14, 🪪 x4)

1.5 OTHERS

1.5.1 STAPLER

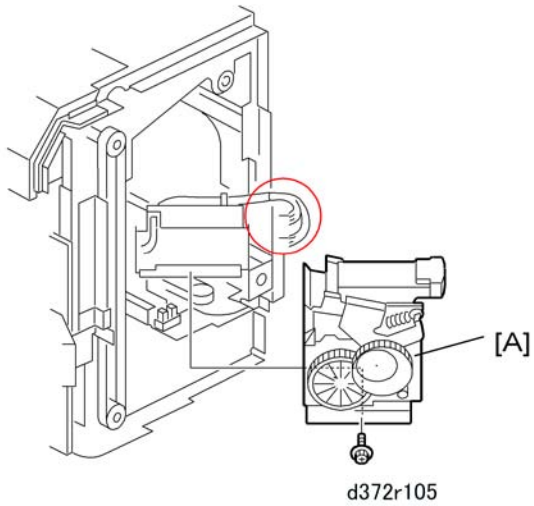

Preparation

- Remove the front cover.
1. Remove the stapler [A] (🔧 x1, 🛠️ x2)

Others

1.5.2 POSITIONING ROLLER

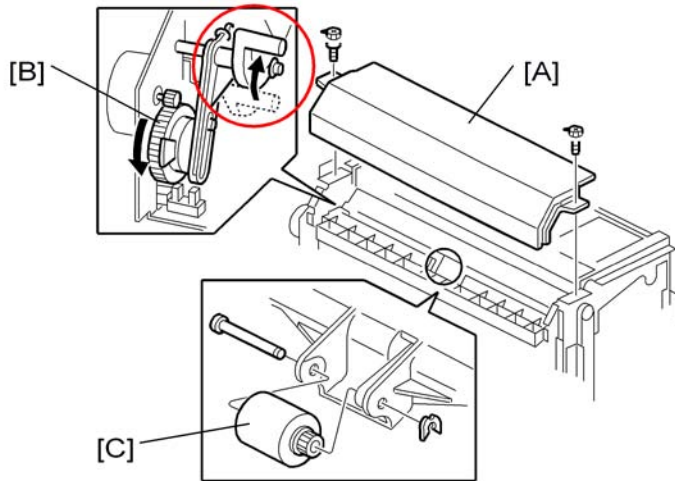

d372r113

Preparation

- Disconnect the finisher.
 - Remove the finisher from the side of the machine.
 - Remove the front cover.
 - Remove the rear cover.
1. Remove the left top cover [A] (⚙️ x2)
 2. Rotate drive gear [B] of the positioning roller arm motor to raise the positioning roller to its highest position.
 3. Remove the positioning roller [C] (🔧 x1)

2. DETAILED SECTION DESCRIPTIONS

2.1 OVERVIEW

2.1.1 IMPORTANT PARTS

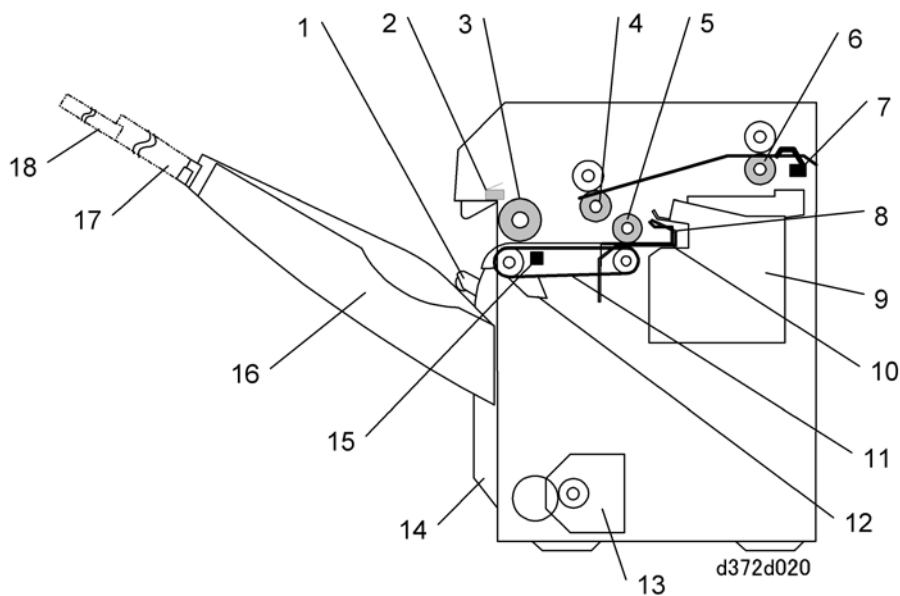

500-Sheet
Finisher
D372/D585

1.	Stack Edge Depressors (x2)	10.	Bottom Fences
2.	Tray Upper Limit Switch	11.	Feed-out Belt
3.	Positioning Roller	12.	Feed-out Belt Pawls (x2)
4.	Exit Roller	13.	Tray Lift Motor
5.	Return Roller	14.	End Fence
6.	Entrance Roller	15.	Paper Sensor
7.	Entrance Sensor	16.	Output Tray
8.	Mobile Fence (x1)	17.	Tray Extension (Middle)
9.	Stapler	18.	Tray Extension (End)

Overview

2.1.2 EXTERNAL DIMENSIONS

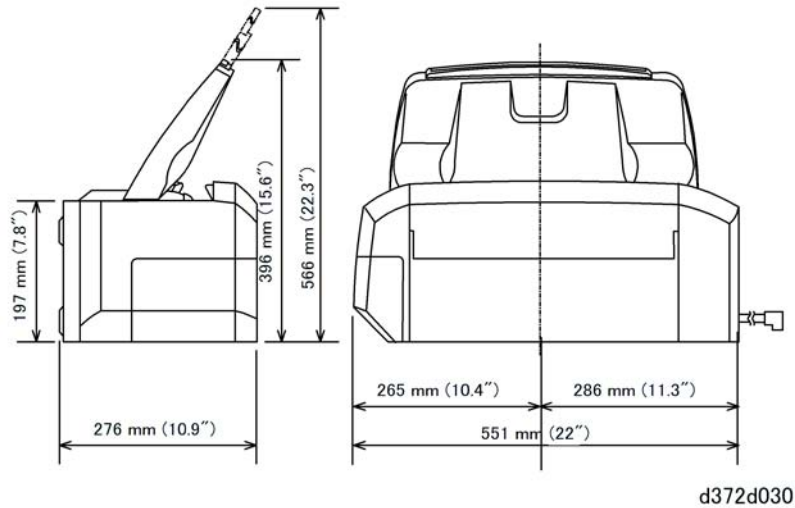

2.1.3 GENERAL OPERATION

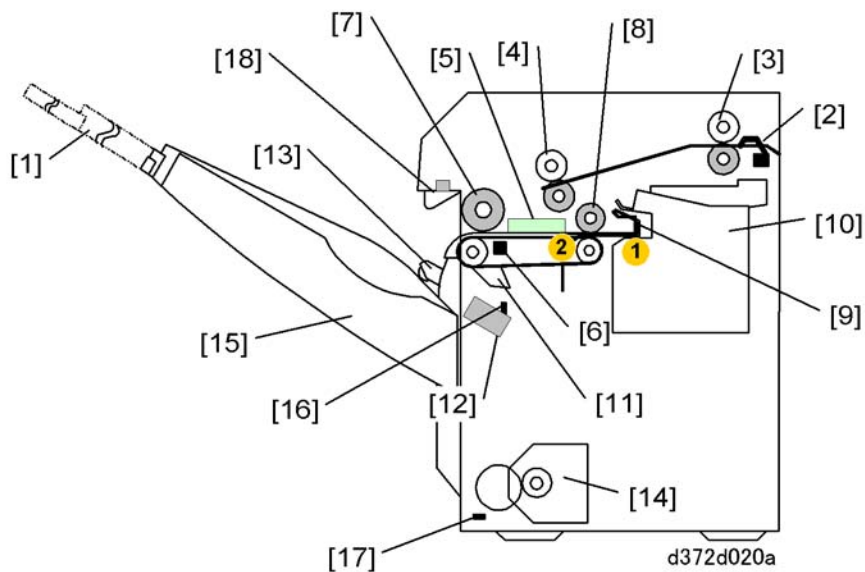

Here is a brief summary of what happens inside the finisher. For more details, see the other sections of this manual.

First, the operator pulls out the tray extension [1], and selects the paper size and operation mode for the job (Normal, Shift, or Stapling).

Paper Transport

The entrance sensor [2] detects the paper when it enters the finisher. The entrance rollers [3] feed the paper to the exit rollers [4]. The paper falls between the front and side fences [5].

Positioning

The paper sensor [6] detects the paper on the tray. The positioning roller [7] (mounted on a free-swinging arm) descends and touches the paper. The positioning roller (turning counterclockwise) and the return roller [8] push the trailing edge of the paper against the two bottom fences and the mobile fence at [9]. (The mobile fence is centered between the stationary bottom fences.)

Jogging

The front and side fences move in to align the sheets for stacking.

Stapling

The stapler [10] staples the stack with one or two staples.

Paper Output

The feed-out belt motor switches on, moves the mobile fence forward and rotates the feed-out belt with the feed-out belt pawls [11]. The mobile fence pushes the stack from ① to ②, then the pawls come around and push the stack out of the finisher. Before the next stack exits, the edge depressor solenoid [12] switches on and retracts the edge depressors just before the feed-out belt pawls push the stack out. The two stack edge depressors [13] lightly push down on the trailing edge of the stack to keep it down against the end fence. The edge depressors are attached to the paper height sensor, so this action checks if it is necessary to move the tray up or down.

Tray Operation

The tray lift motor [14] raises and lowers the output tray [15] to keep the tray at the correct height. The readings of the paper height sensor [16] are used to control the raising and lowering of the tray with the tray lift motor.

The tray-full sensor [17] located at the bottom of the tray rail at the back of the finisher switches on after the tray descends to its lowest point. This signals that the tray is full. A spring-loaded bar [18] and its push-switch also signal tray full if the top of the paper load in the tray pushes this bar up and trips the switch. (This is a backup device to signal tray full if the tray-full sensor fails.)

Overview

2.1.4 INITIALIZATION: WHAT HAPPENS AT POWER ON

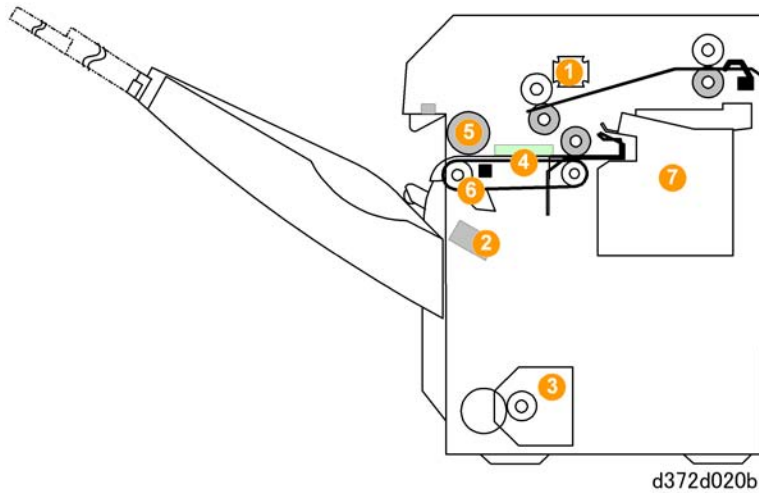

Here is a summary of what happens during the initialization of the finisher after the system power is turned on.

↓ Note

- The initialization halts if the entrance sensor or paper sensor on the stapling tray detects paper inside the finisher.

Overview

No.	What Happens
1	The transport motor roller switches on and off.
2	The edge depressor solenoid switches on, retracts the edge depressors, and then switches off to allow the depressors to lower.
3	The tray lift motor switches on, lowers the tray slightly, raises it to the start position and switches off.
4	The front and side fence motors switch on and off to position both side fences at their home positions (both retracted).
5	The positioning roller arm motor switches on and off to bring the positioning roller to its home position (up).
6	The feed-out belt motor switches on and moves the belt pawls to their home positions below the paper sensor on the stapling tray.
7	The stapler movement motor switches on, reverses, and then switches off to make sure that the stapler is at its home position.

500-Sheet
Finisher
D372/D585

2.2 PAPER TRANSPORT

2.2.1 OVERVIEW

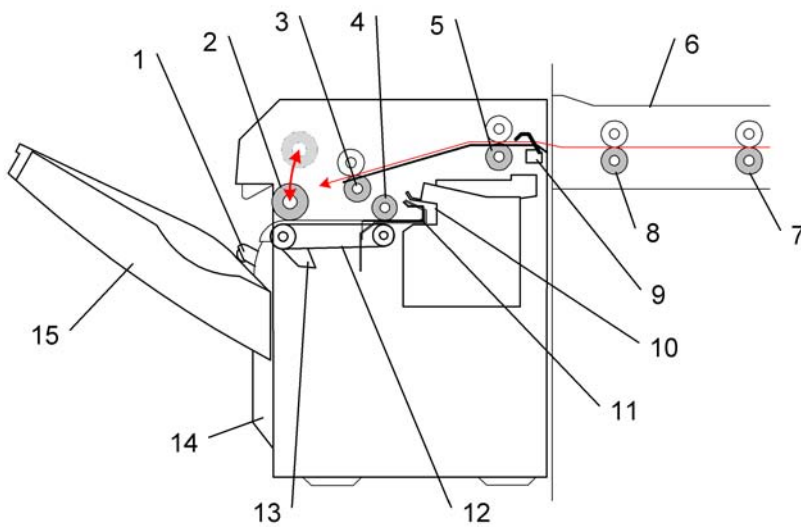

d372d040

1.	Stack Edge Depressors	9.	Entrance Sensor
2.	Positioning Roller	10.	Mobile Fence
3.	Exit Roller	11.	Bottom Fences (x2)
4.	Return Rollers	12.	Feed-Out Belts (x2)
5.	Entrance Roller	13.	Feed-Out Belt Pawls (x2)
6.	Bridge Unit (Copier)	14.	End Fence
7.	Transport Roller (Main Machine)	15.	Output Tray
8.	Exit Roller (Main Machine)		

2.2.2 TRANSPORT ROLLERS

Paper Feed Rollers

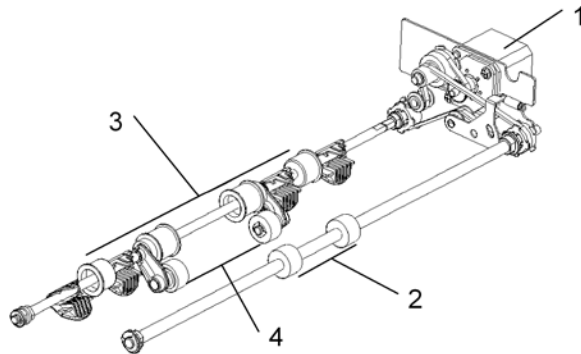

d372d050

1.	Transport Motor
2.	Entrance Rollers
3.	Exit Rollers (Teflon)
4.	Return Rollers (Sponge)

The transport motor [1] uses timing belts to drive all the rollers in the unit.

The entrance rollers [2] take the paper from the copier and feed it to the exit rollers [3], where the paper drops onto the jogging and stapling tray. The return rollers [4] rotate in the opposite direction and feed each sheet against the bottom fences inside the finisher. The positioning roller (described in the next section) assists the return rollers in feeding each sheet against the end fences.

500-Sheet
Finisher
D372/D585

2.2.3 POSITIONING ROLLER

Positioning Roller Mechanism

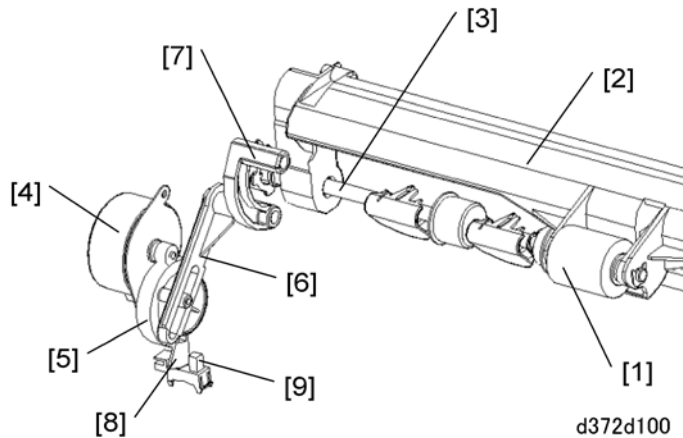

The positioning roller [1] (driven by the transport motor) is mounted on the positioning roller arm [2] that swings freely on the shaft [3].

The positioning roller arm motor [4] drives a cam [5]. The eccentric rotation of this cam raises and lowers the coupler [6] that pushes against the positioning roller arm [7]. This motion raises and lowers the rotating positioning roller as the cam turns through one full rotation.

An actuator [8] attached to the cam wheel deactivates the positioning roller HP sensor [9] and stops the motor. This stops the positioning roller arm and positioning roller at the highest point (home position).

When the positioning roller is lowered:

- The transport motor slows down to match the speed of the main machine's exit roller.
- At the same time, the positioning roller motor accelerates briefly, lowers the positioning roller arm and then stops.

When the positioning roller touches the paper:

- The positioning roller (driven by the transport roller) continues to rotate.
- The positioning roller (and the smaller two sponge rollers), rotating against the direction of paper feed, touch the paper and send it back against the bottom fences.
- The number of sheets that stack on the staple tray while the positioning roller motor is stopped is different for each job.
- To meet the requirement for the increasing number of sheets, the length of prescribed time that the positioning roller is in contact with each sheet of paper is very short, regardless of the size of the stack.
- The positioning roller arm motor remains off just long enough for the positioning roller to send the sheet against the bottom fences.

Paper Transport

When the positioning roller is raised:

- The motor switches on again, raises the positioning roller arm, slows down slightly, and then the arm stops at the home position.
- The motor slows down slightly before reaching the home position to reduce the impact and noise of the arm returning to the home position.

This cycle of lowering the positioning roller, touching the paper with the positioning roller and return rollers, and then lifting them again and stopping at the home position, is done for each sheet of paper.

Paper Transport

Transport Motor Control

The transport motor drives all the rollers inside the finisher and controls the line speed of the finisher.

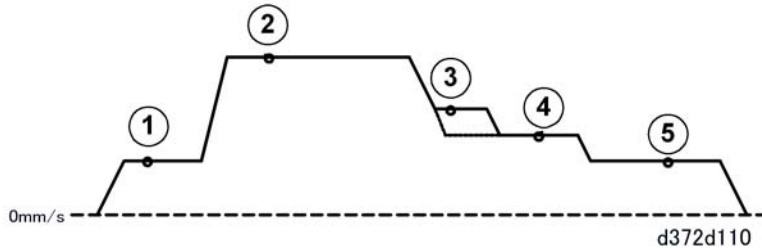

①	The transport motor accelerates to match the line speed of the main machine (150 mm/s).
②	The transport motor speed accelerates to 600 mm/s after the leading edge of the sheet passes the entrance sensor and feeds 21.5 mm.
③	After the trailing edge goes 96 mm past the entrance sensor, the transport motor slows the line speed to 200 mm/s for paper shorter than 300 mm, or to 300 mm/s for paper longer than 300 mm.
④	After the paper sensor detects that the trailing has fed 45 mm past the exit roller, the transport motor slows the line speed to 200 mm/s so that the sheet can be positioned for jogging. At this time, the positioning roller arm motor switches on and starts to lower the positioning roller arm and positioning roller.
⑤	The transport motor slows the line speed in the finisher to match the line speed of the paper path in the main machine. The positioning roller reaches the end of its downward stroke and remains in that position long enough to feed the sheet back against the bottom fences. The positioning roller arm motor reverses and raises the positioning roller arm to the end of its upward stroke and stops at the home position. While the sheet is being jogged between the front and rear side fences, the cycle repeats from ② when the next sheet feeds.

2.2.4 POSITIONING ROLLER INITIALIZATION

The following sequence occurs when the system is switched on:

Paper in Paper Path (Jam)

If paper is detected in the paper path between the copier exit roller and finisher entrance roller, the transport motor switches on then immediately switches off.

Normal Startup

The transport motor switches on and rotates the positioning roller to home position. The positioning roller arm motor switches on, lowers the positioning roller arm, raises the positioning roller to the up position and then stops when the actuator of the positioning roller HP sensor switches off the sensor.

- If the HP sensor does not go OFF within the prescribed time, this indicates an error.
- If the HP sensor does not go ON after the motor has switched on, this also indicates an error.

In either case, the positioning roller arm motor is switched off. The first occurrence causes a jam error. An SC code is issued if the error occurs again.

This initialization sequence is executed:

- When the copier is powered on
- When the stapler door is opened or closed
- When the top cover of the finisher is opened or closed to remove a jam

Jogging (Paper Alignment)

2.3 JOGGING (PAPER ALIGNMENT)

2.3.1 OVERVIEW

Two side fences, a rear fence and a front fence, move in and out to align the sides of the paper stack. Each fence is controlled by an independent timing belt and motor.

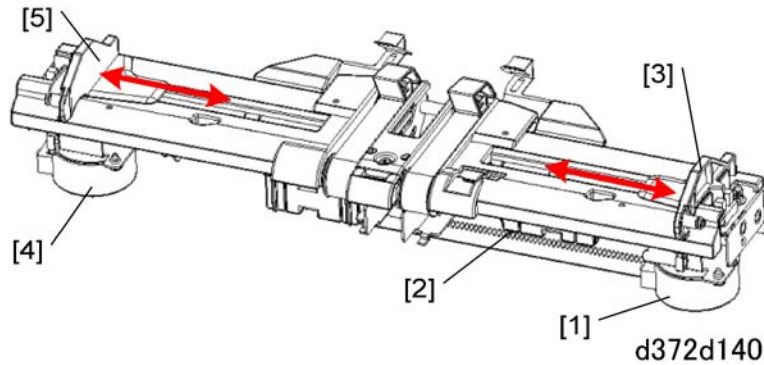

The front fence motor [1] and timing belt [2] move the front fence [3] backward and forward. The rear fence motor [4] and timing belt (not shown) move the rear fence [5] forward and backward.

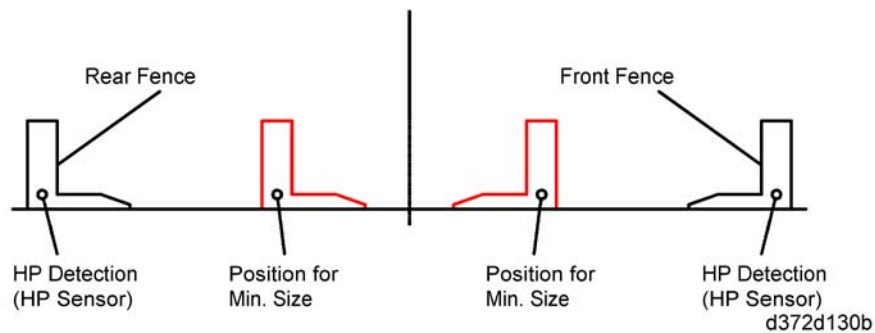

The diagram above shows the positions of the side fences.

1. When the copier exit sensor signals that a sheet of paper has been sent from the copier to the finisher, both fence motors switch on and move the side fences to the start position.

The start position for each fence is set wider than the paper size selected for the job:

- 15 mm wider than the paper for shift mode.
- 7 mm wider than the paper for staple mode
- 10 mm wider than 12-in. paper for oblique stapling
- 12 mm wider than 12-in. paper for straight stapling

2. The paper is fed onto the output tray. The transport motor slows down the rotation of

Jogging (Paper Alignment)

the positioning roller and return rollers. The positioning roller descends. The positioning roller and return rollers feed the trailing edge of the paper to the right against the bottom fences. The side fence motors switch on and jog the edges of the sheet so that the first sheet is properly aligned.

3. The side fences return to the start position after the next sheet has feed 50 mm past the entrance sensor.
4. Steps 2 and 3 are repeated for the next sheet.
5. In stapling mode: After the last page of the document has fed and been aligned on top of the stack by the rear and front fences, the side fences retract and advance two more times against the sides of the complete stack.
6. The stack is now ready to be output from the finisher. The side fences stop at the sides of the stack and wait for the stack to be output. After output, the side fence motors switch on and move the fences to the jog start position.
 - As soon as 10 sheets stack on the jogging tray in shift mode, the stack is output regardless of whether the document has finished printing or not.
 - In stapling mode, the side fence that jogs the side of the stack stops and waits for stapling to end. After stapling, the side fence motor switches on and retracts the side fence 0.5 mm. (If the stack is centered, both fences retract 0.25 mm).
 - After the stack is output by the feed-out belt, the side fence motors switch on and once again move the fences to the jog start position.
7. In the shift mode: The rear side fence does the jogging against the side of the stack, and the front fence does not move. For the next stack, the roles of the side fences are reversed: the front fence does the jogging and the rear fence does not move. The operation continues to alternate for the next stacks so that each stack is shifted to the front (or back) depending how it was jogged between the side fences. (Steps 2, 3, 6 repeat.)

In the staple mode, the steps are done in sequence (2), (3), (5), (6).
8. After the last stack of the job has been output, the main machine sends a STOP signal to end the job, and the front and rear side fence motors switch on and the side fences retract to their home positions.

Jogging (Paper Alignment)

2.3.2 SIDE FENCE OPERATION

Shift Mode

Side Fence Operation: Shift Mode

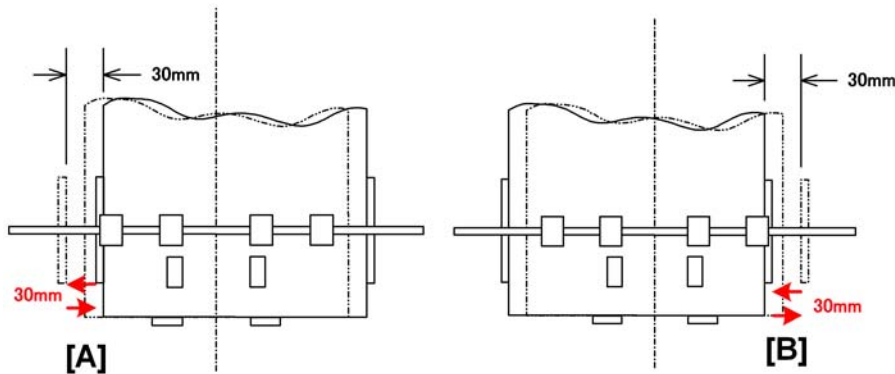

d372d170a

The diagram above illustrates the operation of the side fences in shift mode with no stapling.

- Every sheet of the first set is pushed by the front fence [A] against the rear fence, which does not move.
- Every sheet of the second set is pushed by the rear fence [B] against the front fence, which does not move.
- The sequence alternates for every set in the print job. At the end of the job, every set is stacked on the output tray neatly offset by 30 mm, making them easy to separate.

Normal (Non-Shift) Mode

The diagram above illustrates the operation of the side fences in normal (non-shift) mode.

The operation is slightly different, depending on the paper size. There are three cases:

- Standard paper sizes (other than "wide" or "small" paper)
- Wide paper sizes (133 to 147 mm)
- Small paper sizes (up to 133 mm)

Standard Paper Sizes

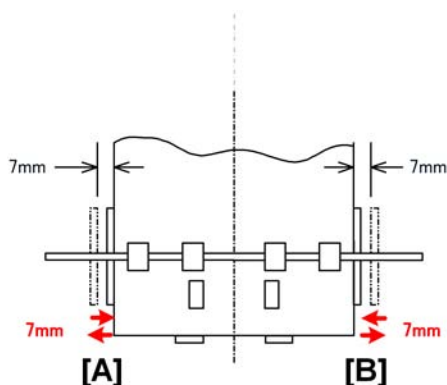

Every time a sheet is fed the front fence [A] and rear fence [B] both push against the sides of the stack within the space of 7 mm on each side.

Wide and Small Paper Sizes

Wide Paper

Paper Width: 133 mm to 147 mm

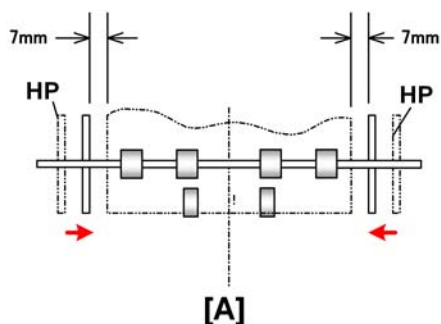

Smaller Paper

Paper Width: up to 133 mm

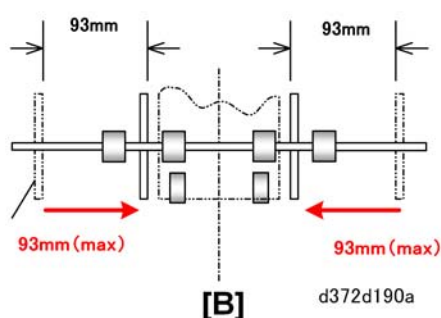

Every time a wide sheet [A] is fed, the front fence and rear fence both push against the sides of the stack within the space of 7 mm on each side.

Every time a smaller sheet [B] is fed, the front fence and rear fence both push against the sides of the fence with the space of 93 mm on each side.

Staple Mode

The operation of the side fences is slightly different, depending on the type of stapling selected for the job:

- One staple (front/oblique, front/straight, rear/oblique, rear straight)
- Two staples at two positions

500-Sheet Finisher D372/D585

Jogging (Paper Alignment)

Staple Mode: 1 Staple

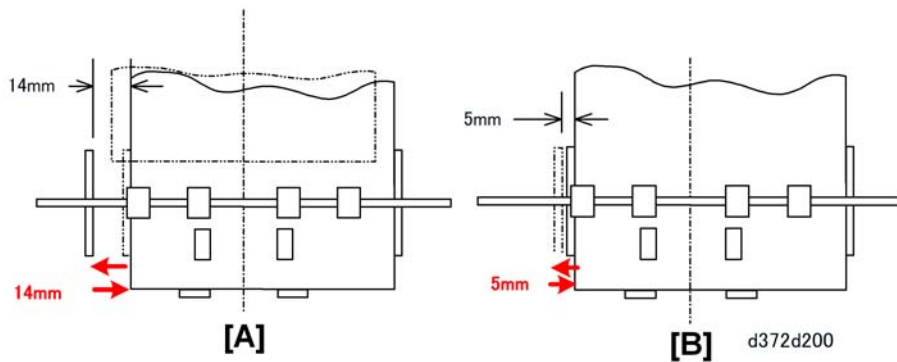

In the One-Staple Mode, one side fence jogs one side of the stack. The diagram above illustrates the operation of the side fences for stapling at one position (front/oblique, front/straight, rear/oblique, or rear/straight).

- Every time a sheet [A] is fed, the front fence pushes the sheet against the rear fence, which does not move.
- After the last sheet [B] is pushed against the rear fence, the front fence moves front to back twice (5 mm) to align the side of the stack for stapling.

Staple Mode: 2 Staples

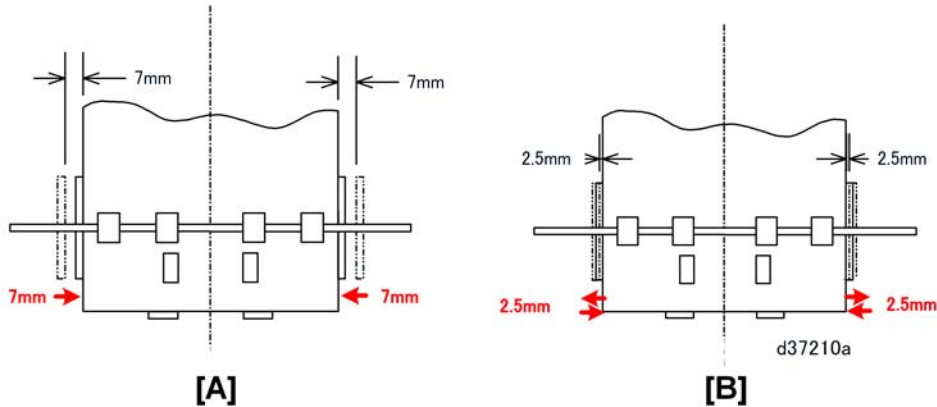

In the Two-Staple Mode, both side fences jog the sides of the stack. The diagram above illustrates the operation of the side fences for stapling at two positions.

- Every time a sheet [A] is fed, the front and rear side fences push the sheet to center it.
- After the last sheet [B] is centered, the front and side fences push and retract twice (5 mm) to align the sides of the stack centered for stapling.

2.3.3 SIDE FENCE INITIALIZATION

Initialization of the front and rear side fence positions at power on is determined by the states of the front fence HP sensor and rear fence HP sensor. The descriptions below apply to both HP sensors.

- Paper on Stapling Tray
Initialization is not executed if the paper sensor on the stapling tray detects paper present.
- Fence HP Sensor OFF
The fence motor switches on until the HP sensor goes ON, advances 0.25 mm, then switches OFF. This is the home position.
- Fence HP sensor ON
The fence motor drives the fence toward the center until the HP sensor goes OFF, advances 15 mm, then switches off. The motor switches ON again, advances the fence 0.25 mm, then switches off. (This is the home position.)

2.3.4 SIDE FENCE MOTOR ERRORS

A side fence motor error can occur in two cases:

- The HP sensor does not go OFF even after the side fence has run long enough to advance the fence 12.5 mm from the fence home position, far enough to deactivate the fence HP sensor.
- The HP sensor does not go ON even after the motor has run long enough for the side fence to retract 105.0 mm, far enough for the fence to reach the side fence HP sensor.

When an error occurs the finisher ceases to operate (all motors are switched off with the exception of the stapler movement motor).

Errors for the front fence and rear fence motors are counted separately.

- The first occurrence of an error issues a paper jam alert.
- The second occurrence of an error issues an SC code. SC721 is issued for the front fence motor and SC722 for the rear fence motor.

To recover from an error:

- At the first occurrence of the error after a paper jam error, opening and closing either the top cover or the stapler door triggers the initial check and restores normal operation if no problems are detected.
- At the second occurrence after an SC code is issued, cycling the main machine off/on may restore full operation if no problems are detected.

Jogging (Paper Alignment)

2.3.5 SIDE FENCE OPERATION ADJUSTMENT

The distance between the front and rear side fences can be adjusted with DIP SW100. The DIP SW adjustment is done in increments of 0.5 mm (Max. Range: ± 3.5 mm).

- The adjustment is halved for center jogging. If the adjustment is 0.5 mm, for example, this means the position adjustment 0.25 mm for each side fence.

The table below shows the adjustments done with DIP SW100 on the main board of the finisher.

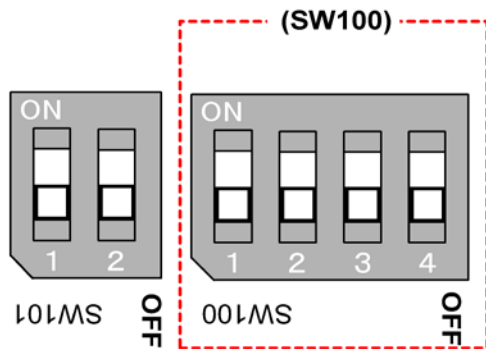

DIP SW

1	2	3	4	Adjustment (mm)
ON	ON	ON	ON	-3.5
ON	ON	ON	OFF	-3.0
ON	ON	OFF	ON	-2.5
ON	ON	OFF	OFF	-2.0
ON	OFF	ON	ON	-1.5
ON	OFF	ON	OFF	-1.0
ON	OFF	OFF	ON	-0.5
ON	OFF	OFF	OFF	0.0
OFF	ON	ON	ON	3.5
OFF	ON	ON	OFF	3.0
OFF	ON	OFF	ON	2.5

Jogging (Paper Alignment)

1	2	3	4	Adjustment (mm)
OFF	ON	OFF	OFF	2.0
OFF	OFF	ON	ON	1.5
OFF	OFF	ON	OFF	1.0
OFF	OFF	OFF	ON	0.5
OFF	OFF	OFF	OFF	0.0

500-Sheet
Finisher
D372/D585

Stapling

2.4 STAPLING

2.4.1 OVERVIEW

Stapler Movement

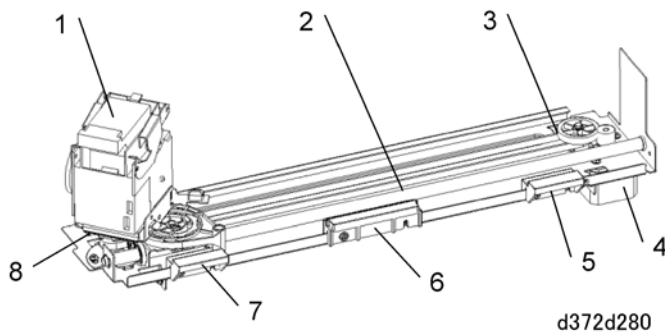

1.	Stapler Unit	5.	Trip Plate – Rear
2.	Guide Rail	6.	Trip Plate – Center
3.	Driver Gear, Timing Belt	7.	Trip Plate – Front
4.	Stapler Movement Motor	8.	Stapler HP Sensor

The illustration below shows how the stapler moves during each stapling mode.

[Note](#)

- When the plate on the bottom of the stapler unit strikes a trip plate, this swivels the stapler unit from straight to oblique or vice versa.

Staple Positions

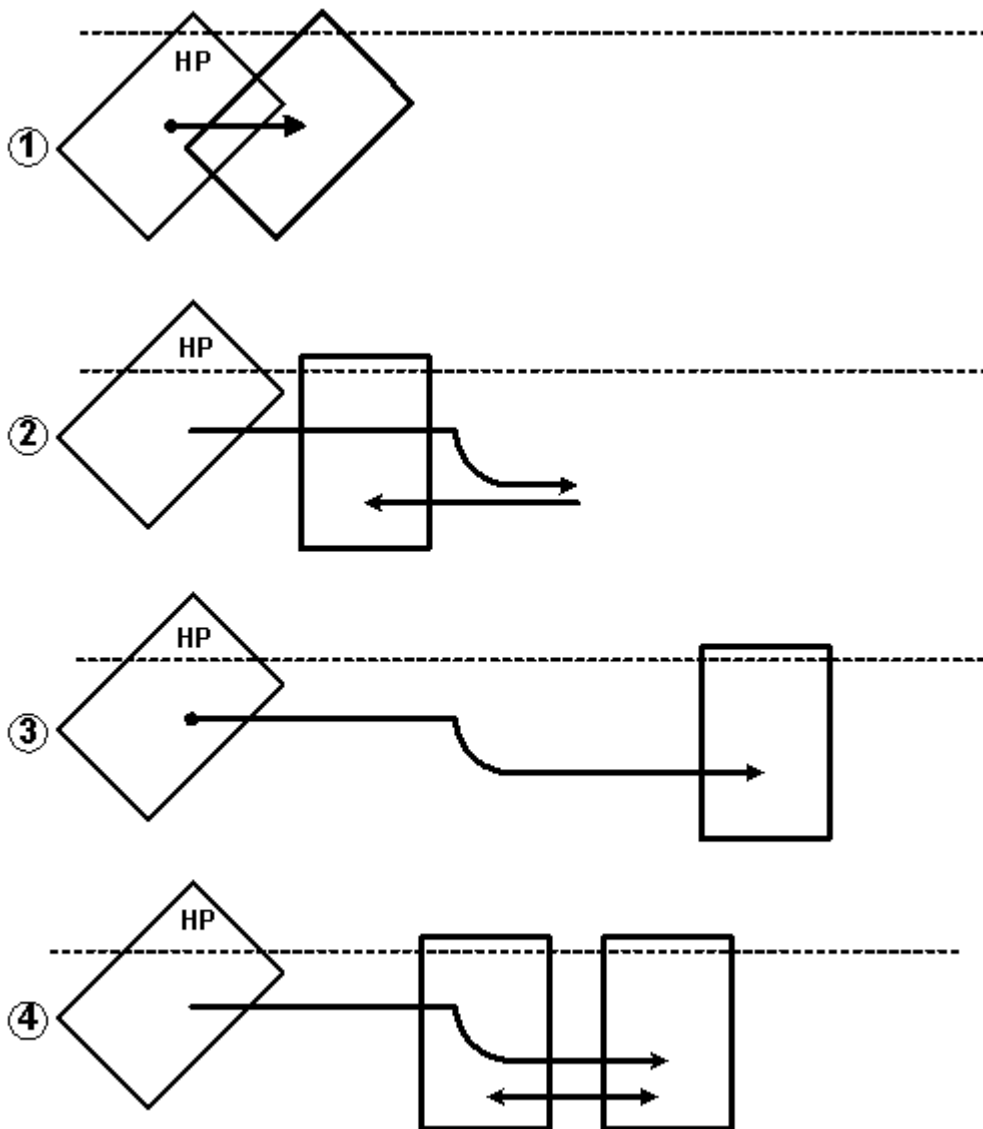

d372d300a

①	Front Oblique Stapling: 1 Staple
②	Front Straight Stapling: 1 Staple
③	Rear Straight Stapling: 1 Staple
④	2 Staples (Rear then Front)

500-Sheet
Finisher
D372/D585

Stapling

Stapler EH-530

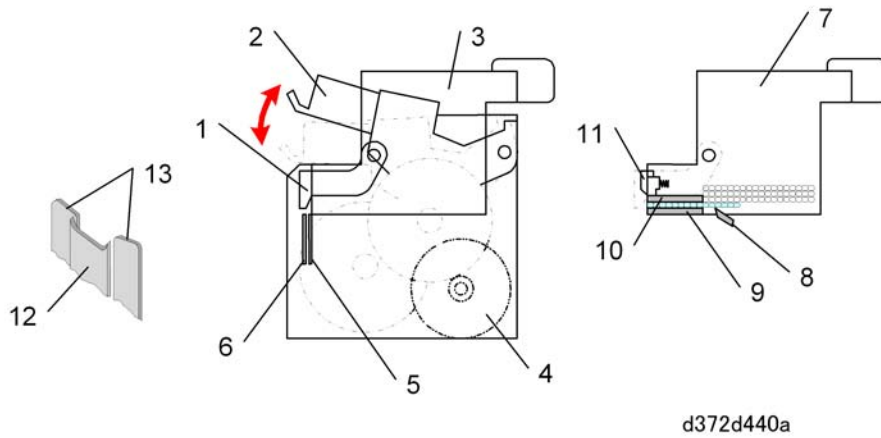

1.	Faceplate	8.	Staple Supply Pawl
2.	Clincher	9.	Staple Sheet
3.	Cartridge	10.	Base
4.	Stapler Motor	11.	Plunger
5.	Homing Plates	12.	Driver Plate
6.	Driver Plate	13.	Homing Plates
7.	Cartridge		

The stapler motor (4) drives both the driver plate (12) and homing plates (13) toward the clincher. The driver plate and homing plates separate and feed the staples to the clincher (2) that performs the stapling.

The pressure of the plunger (11) feeds the next staple for firing. A staple supply pawl below the staple sheet moves to the front and back to assist in staple supply. The plunger feeds only one staple at a time, but the staple supply pawl can feed up to 10 staples.

2.4.2 STAPLER MOVEMENT MOTOR INITIALIZATION

Initialization of the stapler unit position is determined by the state of the stapler HP sensor. One of the following sequences occurs at power on, depending on the state of the stapler HP sensor.

- Stapler HP sensor OFF
The motor turns on and brings the stapler forward until the stapler HP sensor goes ON. Then the motor remains on to move the stapler an additional 1.2 mm, then stops. This is the home position.
- Stapler HP sensor ON
The stapler movement motor turns on and moves the stapler to the rear until the stapler HP sensor goes OFF. The motor stays on to move the stapler 12 mm, then stops. Next, the motor turns on again and brings the stapler forward until the stapler HP sensor goes ON, the motor stays on to move the stapler 1.2 mm, then stops. This is the home position.

Stapling

2.4.3 STAPLER ERRORS

A stapler position error can occur in two cases:

- Stapler HP sensor does not go OFF.
The stapler HP sensor does not go OFF even after the stapler movement motor has been on long enough to move the stapler away from the home position.
- Stapler HP sensor does not go ON
While the stapler is out of the home position, the stapler HP sensor does not go ON even after the stapler movement motor has been on long enough to move the stapler into the home position.
- Stapler is out of staples.
At power on, if staples are not detected in the stapler, the staple detection sequence executes up to 10 times until "staples present" is detected. If staples cannot be detected after 10 attempts, then the staples out alert is issued.

When one of these errors occurs, the exciter current to the stapler motor is switched off. Both of the HP sensor errors described above are counted as the same error. In either case, the first occurrence of the error is considered a jam, and the second occurrence issues SC742 (Stapler Movement Motor Error).

To recover from an error:

- At the first occurrence of a stapler HP sensor error, removing the jam then opening and closing either the top cover or the stapler door triggers the initial check and restores normal operation if no problems are detected.
- At the second occurrence after SC742 is issued, cycling the main machine power off/on may restore full operation if no problems are detected.

2.5 PAPER OUTPUT

2.5.1 OVERVIEW

Feed-Out Mechanism

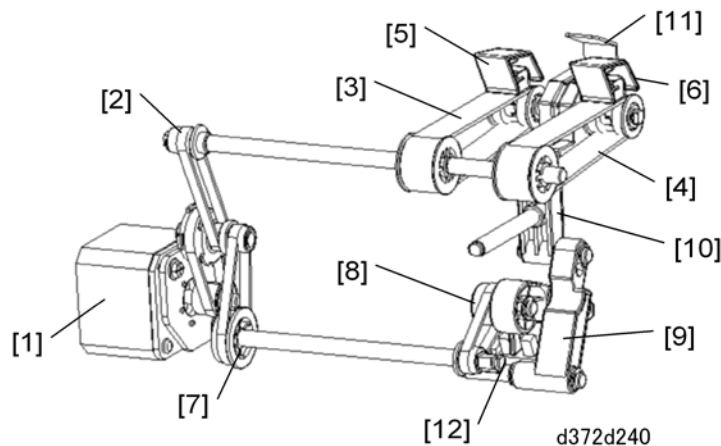

1.	Feed-Out Belt Motor	7.	Mobile Fence Drive Shaft
2.	Feed-Out Belt Drive Shaft	8.	Mobile Fence Cam
3.	Rear Feed-Out Belt	9.	Mobile Fence Follower
4.	Rear Feed-Out Belt Pawl	10.	Mobile Fence Link and Slider
5.	Front Feed-Out Belt	11.	Mobile Fence
6.	Front Feed-Out Belt Pawl	12.	Feed-Out Belt HP Sensor

The feed-out belt motor [1] drives the timing belt and shaft [2] that rotates the feed-out belts [3] and [4]. The rear pawl [5] and front pawl [6] attached to the rear and front belts push the stack out of the finisher after stapling.

The feed-out belt motor also drives the timing belt and shaft [7] that rotates the mobile fence cam [8]. The mobile fence follower [9] converts the rotary movement of the cam to rectilinear movement (left-to-right) and transmits this movement via the link/slider [10] to the mobile fence [11]. The mobile fence is moved forward to start pushing the stack out of the finisher. The pawls on the rapidly moving feed-out belt complete pushing the stack out of the finisher. After the cam releases the follower, a spring pulls the mobile fence back to its home position.

Paper Output

When the actuator attached to the mobile fence cam switches the feed-out belt HP sensor [12] ON, this stops the feed-out belt motor with the pawls at their home positions.

Bottom Fences

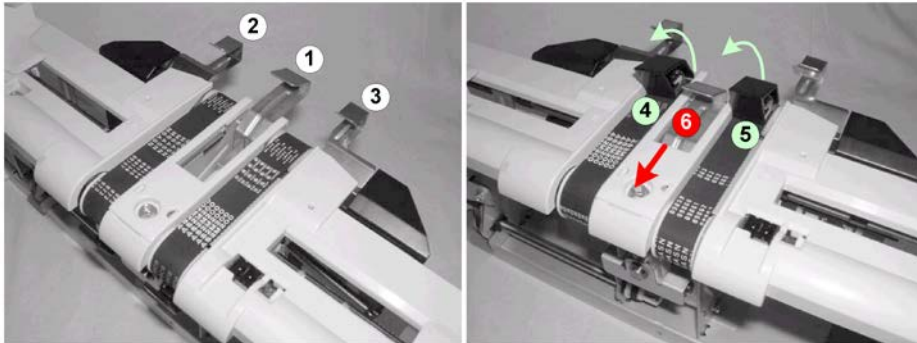

d372d901

There are three bottom fences. A mobile fence (1) resides between two stationary bottom fences (2) and (3). When the mobile fence (1) is at its home position, the positioning roller and return rollers feed the trailing edge of each sheet against these fences.

When the stack is ready to be moved to the output tray, the mobile fence (6) pushes the stack to the right. The rear pawl (4) and front pawl (5), mounted on the rear and front feed-out belts, swing up from below and push the stack onto the tray. The mobile fence (6) returns to its home position between the stationary bottom fences.

Feed-Out Mechanism: Right and Front View

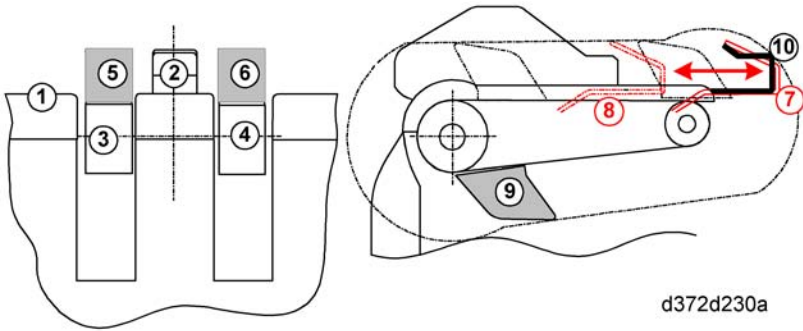

d372d230a

1.	Stapling Tray	6.	Rear Feed-Out Belt Pawl
2.	Mobile Fence	7.	Mobile Fence HP
3.	Front Feed-Out Belt	8.	Mobile Fence (Forward Position)
4.	Rear Feed-Out Belt	9.	Feed-Out Pawls (HP)
5.	Front Feed-Out Belt Pawl	10.	Bottom Fences x2

500-Sheet Finisher D372/D585

In the left illustration, just before that stack is output:

- The stack is on the stapling tray (1).
- The mobile fence (2) has pushed the stack forward to start moving it out of the finisher.
- The front and rear feed-out belts (3) and (4) have rotated the front and rear pawls (5) and (6) behind the stack so they can push the stack out of the finisher.

In the right illustration, after stack output:

- The mobile fence (driven by its cam, follower, and lever below) moved from its home position (7) to (8) to start pushing the stack out of the finisher.
- The feed-out belt pawls pushed the stack out of the finisher then stopped at their home positions (9).
- A long spring pulled the mobile fence back to its home position between the stationary bottom fences (10)

Paper Output

2.5.2 FEED-OUT

The diagram below shows how the feed-out belt and mobile fence work together to push the stack to the output tray.

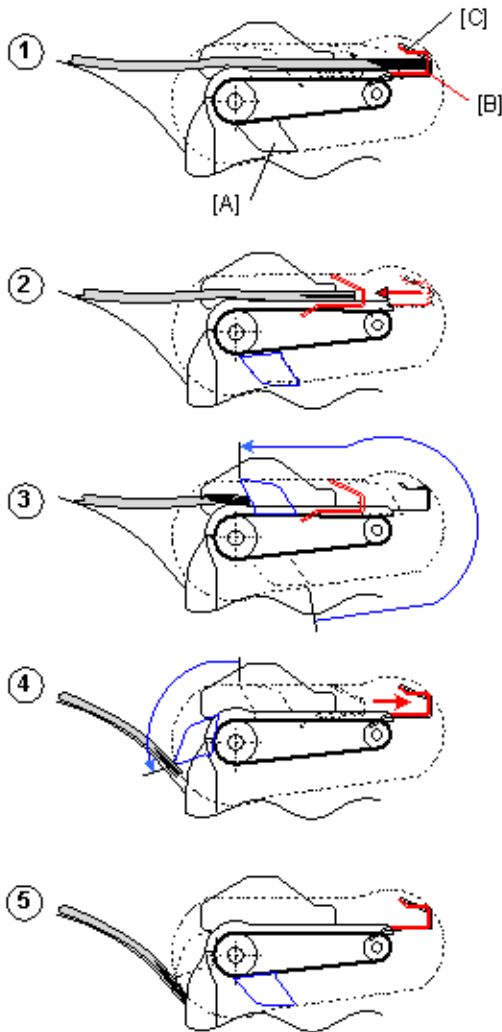

d372 d260

①	Document stacking has finished and the stack is ready to be output. The output belt pawls are at their home positions [A]. The mobile fence [B] is at its home position between the front and rear bottom fences [C].
②	The mobile fence pushes the stack to the right and stops.
③	The feed-out belt pawls rapidly swing up and push the stack toward the output tray.
④	The feed-out belt pawls push the stack onto the output tray. A spring (not shown) retracts the mobile fence.

⑤	<p>The actuator on the mobile fence cam activates the feed-out belt pawl HP sensor. This switches the motor off and the pawls stop at the home position.</p>
---	--

2.5.3 FEED-OUT BELT INITIALIZATION

Initialization of the positions of the feed-out belt pawls at power on is determined by the state of the feed-out belt HP sensor. This operation does not affect the mobile fence because it is held in its home position by a spring.

One of the following sequences occurs at power on, depending on the state of the feed-out belt HP sensor.

- Feed-out belt HP sensor ON
The feed-out belt motor switches on and rotates clockwise until the HP sensor goes OFF. The motor reverses for 50 ms until the HP sensor goes ON again and stops. This is the home position.
- Feed-out belt HP sensor OFF
The feed-out belt motor rotates counter-clockwise until the HP goes ON and then stops. This is the home position.

2.5.4 FEED-OUT BELT ERRORS

A feed-out belt error can occur in two cases:

- The feed-out belt HP sensor does not go OFF even after the motor has started.
- The feed-out belt does not go ON after the feed-out belt motor has started at power on and the finisher is ready to operate.
- Stapler out of staples

When an error occurs, the feed-out belt motor is switched off.

Either of the errors caused by the states of the feed-out belt HP sensor is counted as the same error.

- The first occurrence of an error issues a paper jam alert.
- The second occurrence of an error issues an SC723 (Feed-out Belt Motor Error).

To recover from an error:

- At the first occurrence of the error after a paper jam error, opening and closing either the top cover or the stapler door triggers the initial check and restores normal operation if no problems are detected.
- At the second occurrence after SC723 is issued, cycling the main machine power off/on may restore full operation if no problems are detected.

Paper Output

2.5.5 FEED-OUT EXTENSION

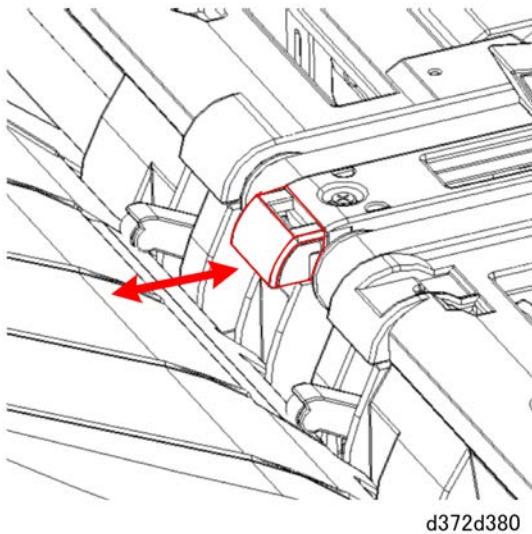

d372d380

A retractable extension is attached to the center of the stapling tray. The operator can pull it out manually if the trailing edges of the stacks are catching on the end fence and not falling straight down onto the tray.

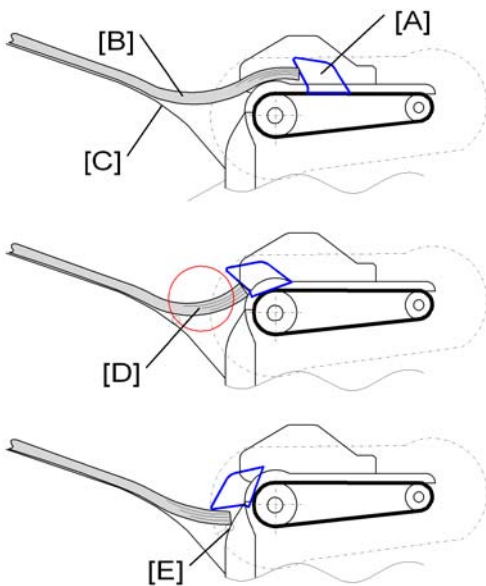

d372d391

When the feed-out belt pawls [A] push a stack of paper [B] onto the tray [C], a bend [D] forms at the trailing edge. With some types of paper (especially larger paper such as A3), this bend can cause the edge of the stack to catch on the end fence [E] when it falls into the tray.

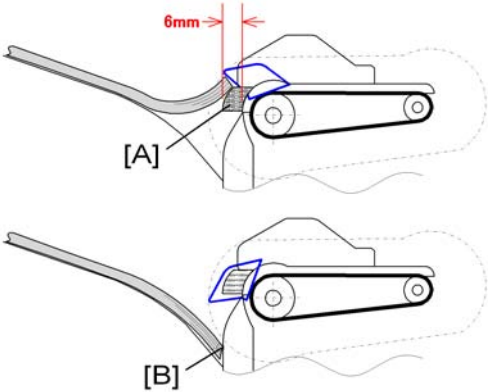

d372d392

Pulling the stapling tray extension [A] out by hand extends by 6 mm the distance that the pawls must push the trailing edge of the stack. The extra 6 mm forces the edge of the stack to bend more so it will snap down with more force and not catch on the end fence. This prevents the trailing edge of the stack [B] from catching on the end fence when it falls into the tray.

500-Sheet
Finisher
D372/D585

Tray Operation

2.6 TRAY OPERATION

2.6.1 OVERVIEW

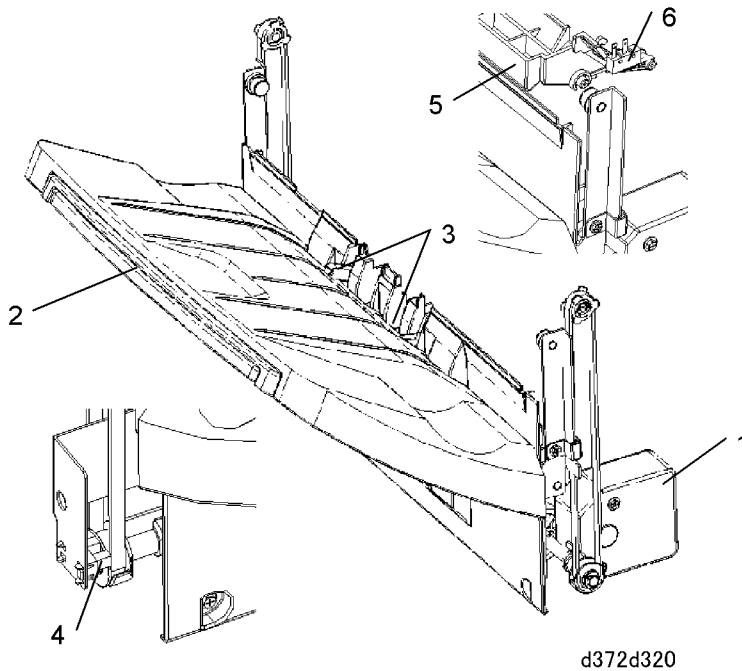

1.	Tray Lift Motor
2.	Output Tray
3.	Edge Depressors
4.	Tray Full Sensor
5.	Upper Limit Push-bar
6.	Tray Upper Limit Switch

The tray lift motor (1) raises and lowers the output tray (2).

The edge depressors (3) lightly press down on the trailing edges of stacks already on the tray to keep them down against the end fence.

When the actuator on the bottom of the rear rail switches the tray full sensor (4) ON, this means that the tray is at its lowest point and the tray is full.

If the tray becomes overloaded, the top of the stack pushes up the spring-loaded push-bar

(5). This will turn on the tray upper limit switch (6) and turn off the tray lift motor. This is a safety device to signal tray full in case the tray full sensor fails.

2.6.2 TRAY LIFT CONTROL

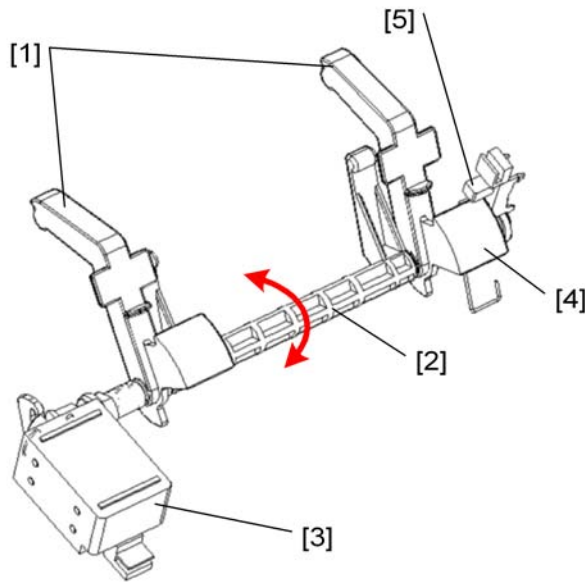

d372d340

1.	Edge Depressors
2.	Rotating Shaft
3.	Edge Depressor Solenoid
4.	Actuator
5.	Paper Height Sensor

While the feed-out belt motor is running, the tray lift motor switches on (300 ms for shift mode, 500 ms for stapling mode), lowers the output tray, stops, then waits to receive the stack.

Just before a stack falls onto the output tray, the edge depressor solenoid (3) switches ON and retracts the edge depressors (1) away from the top of the stack already on the tray so that the next stack can fall freely.

The feed-out belt motor stops immediately after the stack has fallen between the side fences. The edge depressor solenoid switches OFF, and the edge depressors fall onto the trailing edge of the stack against the end fence.

Tray Operation

The edge depressors touch the top of the stack, and they are connected to the paper height sensor [5], so this action checks if it is necessary to move the tray up or down.

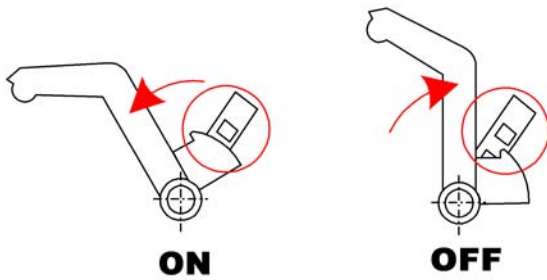

- After 200 ms if the paper height sensor is **ON**, the tray lift motor switches ON and raises the tray.
- If the paper height sensor is **OFF**, the tray lift motor lowers the tray until the paper height sensor switches ON, pauses for 100 ms, switches on again briefly to raise tray to the prescribed position to receive the next stack.

Tray Operation

The diagram below shows how the feed-out belt pawls, output tray, and edge depressors operate together.

Stack Output to Tray

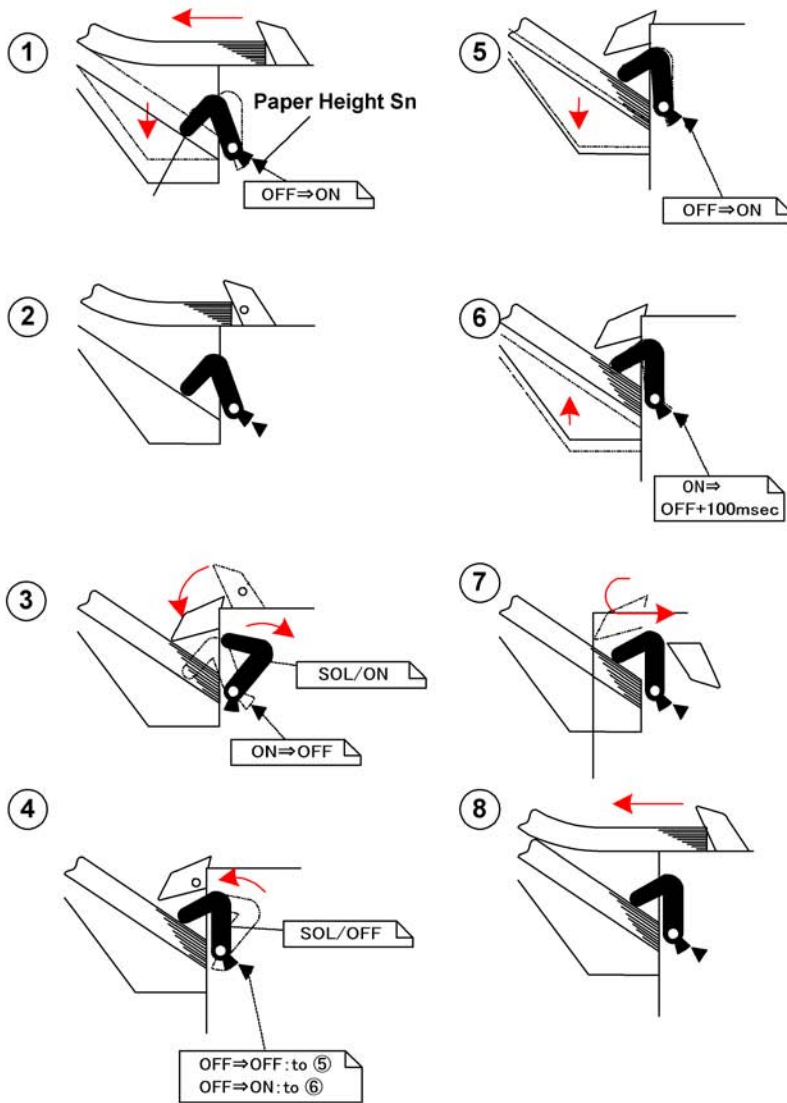

d372d360

500-Sheet
Finisher
D372/D585

Tray Operation

①	The feed-out motor switches on and starts to move the feed-out belts and pawls, pushing the stack toward the output tray. The tray motor switches on and lowers the tray until the paper height sensor switches on.
②	The motor stops briefly to stop the pawls.
③	The motor starts, and just as the pawls start to push the stack onto the tray the edge depressor solenoid switches on and retracts the edge depressors
④	The stack is on the tray. The solenoid switches off, and the depressors move forward and press down lightly on the trailing edge of the stack. <ul style="list-style-type: none">▪ If the paper height sensor is OFF, go to ⑤▪ If the paper height sensor is ON, go to ⑥
⑤	The tray lift motor switches on, lowers the tray, and then stops when the paper height sensor goes ON.
⑥	The tray lift motor reverses for 100 ms to raise the tray to the start position.
⑦	The pawls move to their home positions and stop.
⑧	The sequence starts again with the next finished stack,.

2.6.3 TRAY INITIALIZATION

The following sequence occurs at power on depending on the states of the paper height sensor and tray full sensor:

①	The edge depressor solenoid switches from ON to OFF.
②	<ul style="list-style-type: none"> ▪ If paper height sensor ON, then go to ③. ▪ Paper height sensor OFF. <p>If the tray full sensor is ON and the paper height sensor is OFF, this signals that the output tray is full. Removing the paper from the tray will switch the paper height sensor ON. The tray lift motor switches on, lowers the tray, reverses for briefly to raise the tray to the start position, then switches OFF.</p>
③	The tray lift motor continues to lift the tray until the paper height sensor goes OFF, continues to run 100 ms, and stops.

500-Sheet
Finisher
D372/D585

Tray Operation

2.6.4 TRAY LIFT ERRORS

Tray Lift Motor Error

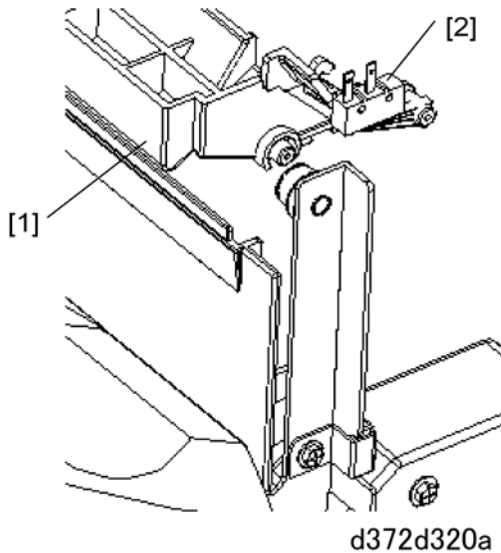

If the tray becomes overloaded and the paper pushes and raises the push-bar [1], this will switch ON the upper limit switch [2] (a push-switch). Activating this switch switches off the tray lift motor. This is a backup device that will switch off the tray lift motor if the tray full sensor or paper height sensors fail.

The table below shows how the state of the two sensors and one switch signal an error.

Tray Upper Limit SW	Tray Full Sn	Paper Hgt Sn	What Happens
ON	OFF	OFF	Tray Full. One or both sensors has failed.
OFF	ON	OFF	Tray Full
OFF	ON	ON	Lift motor starts to raise tray
OFF	OFF	OFF	Lift motor starts to lower tray
OFF	OFF	ON	Lift motor starts to raise tray.

Tray Operation

The machine issues a tray-full alert when the tray becomes full:

- Tray full sensor ON
The tray has reached its lowest position.
- Paper height sensor OFF (full upright)
The paper on the tray has pushed the edge depressors to the full upright position.

Normally, removing the paper from the tray restores normal operation. The actuator falls and the paper height sensor switches ON. This signals the lift motor to raise the tray to the start position.

An error will occur if an abnormal condition exists:

- After the paper height sensor switches ON and the tray lift motor raises the tray, if paper height sensor does not go OFF after 20 sec., this signals an error and the tray lift motor will switch OFF.
- With the paper height sensor OFF and the tray full sensor OFF, the tray lift motor lowers the tray. The tray lift motor will switch off if the paper height sensor does not go ON within 3 sec.

These two errors are counted as the same error. The first occurrence of the error is considered a jam, and at the second occurrence SC750 (Tray Lift Motor Error) is issued.

To recover from an error:

- At the first occurrence of the error after a paper jam error, opening and closing either the top cover or the stapler door triggers the initial check and restores normal operation if no problems are detected.
- At the second occurrence after SC750 is issued, cycling the main machine off/on may restore full operation if no problems are detected.

Tray Operation

Edge Depressor Solenoid Error

At power on, or while the stack starts being output to the tray (the solenoid starts to go OFF), if the paper height sensor remains OFF this indicates a solenoid error. When this error occurs:

- All motors switch off.
- The error is logged.

The first occurrence is considered a jam, and the second occurrence causes SC751 (Edge Depressor Solenoid).

To recover from an error:

- At the first occurrence of the error after a paper jam error, opening and closing either the top cover or the stapler door triggers the initial check and restores normal operation if no problems are detected.
- At the second occurrence after SC750 is issued, cycling the main machine off/on may restore full operation if no problems are detected.

2.7 ELECTRICAL COMPONENTS

2.7.1 COMPONENT LAYOUT

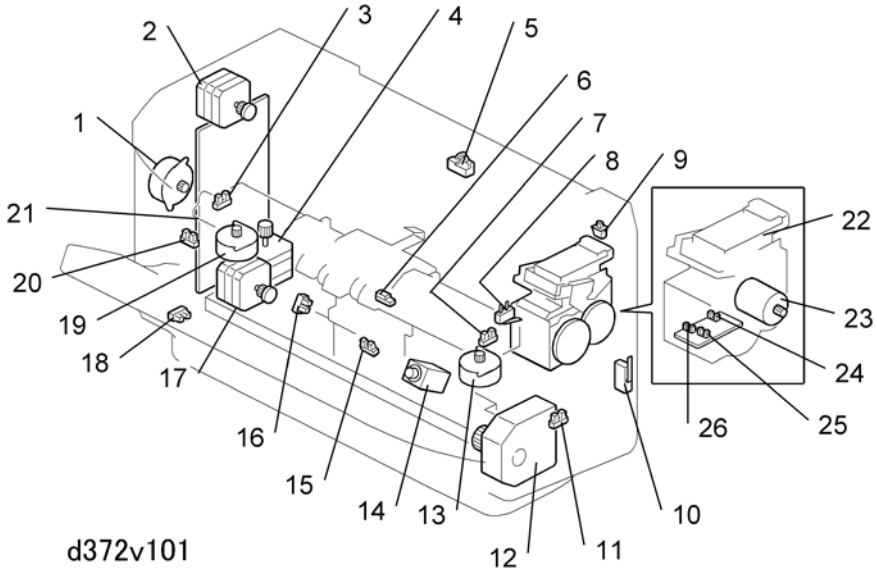

1.	Positioning Roller Motor	14.	Stack Depressor Solenoid
2.	Transport Motor	15.	Feed-Out Belt HP Sensor
3.	Rear Fence HP Sensor	16.	Paper Height Sensor
4.	Stapler Movement Motor	17.	Feed-Out Belt Motor
5.	Entrance Sensor	18.	Output Tray Full Sensor
6.	Stapling Tray Paper Sensor	19.	Rear Fence Motor
7.	Front Fence HP Sensor	20.	Positioning Roller HP Sensor
8.	Tray Upper Limit Switch	21.	Main Board
9.	Top Cover Switch	22.	Stapler
10.	Stapler Door Switch	23.	Stapler Motor
11.	Stapler HP Sensor	24.	Staple Cartridge Set Sensor
12.	Tray Lift Motor	25.	Stapler Hammer HP Sensor
13.	Front Fence Motor	26.	Staple End Sensor

500-Sheet
Finisher
D372/D585

Electrical Components

2.7.2 SUMMARY OF ELECTRICAL COMPONENTS

Motors		
M1	Feed-Out Belt Motor	Drives the two feed-out belts (1 pawl each). The pawls push the finished stack out of the finisher.
M2	Front Fence Motor	Moves the front fence to the back and front.
M3	Positioning Roller Arm Motor	Lowers and raises the positioning roller arm and positioning roller.
M4	Rear Fence Motor	Moves the rear fence to the front and back.
M5	Stapler Movement Motor	Moves the stapler to the front and back.
M6	Transport Motor	Drives all the rollers in the finisher: entrance roller, positioning roller, return rollers, exit roller
M7	Tray Lift Motor	Raises and lowers the output tray.
M8	Stapler Motor	The motor inside the stapler that drives staple supply and stapling.

Board		
PCB1	Main Board	Controls operation of the finisher. DIP switches can be changed to adjust the positions of the front and rear side fences.

Electrical Components

Sensors		
S1	Entrance Sensor	Detects the leading edge of the paper when it enters the finisher. Readings of this sensor are used for timing of finisher operation. Also detects jams.
S	Feed Out Belt HP Sensor	Detects the HP of the feed-out belt pawls on the two feed-out belts (one pawl on each belt).
S2	Front Fence HP Sensor	Detects the HP of the front fence at the front of the finisher.
S3	Output Tray Full Sensor	Located at the bottom left corner of the finisher. When the actuator on the tray rail switches this sensor ON, this signals tray full.
S4	Paper Height Sensor	Used to monitor the positions of the edge depressors that press down on the trailing edge of the stack at the end fence. When the top of the stack pushes the depressors up, this switches the sensor OFF and signals the tray lift motor to lower the tray.
S5	Positioning Roller HP Sensor	Detects the HP of the positioning roller when it is up.
S6	Rear Fence HP Sensor	Detects the HP of the rear fence at the back of the finisher.
S7	Stapler HP Sensor	Detects HP of the stapler at the front of the finisher.
S8	Stapling Tray Paper Sensor	Detects paper on the stapling tray,

500-Sheet
Finisher
D372/D585

Electrical Components

Solenoid		
SOL	Stack Depressor Solenoid	When a stack is output, the tray lift motor lowers the tray slightly. At this time, the stack depressor solenoid switches ON and retracts the edge depressors briefly so that the trailing edge of the stack can fall onto the tray. The solenoid then switches OFF and lowers the arms against the trailing edge of the stack to keep it down against the end fence.

Switches		
SW1	Stapler Door Switch	Detects when the stapler top cover is open or closed.
SW2	Top Cover Switch	Detects when the top cover is opened or closed.
SW3	Tray Upper Limit Switch	If the tray becomes full, the top of the stack will push up a plate that activates this switch and switches off the finisher. This is a backup feature that will shut down operation if the tray full sensor or paper height sensor fails with the output tray full.

Other		
Stapler	Stapler Unit	Staples sheets stacked on the stapling tray.

2.7.3 TIMING CHARTS

The first flowchart below is the operational timing chart for shift mode, the second chart is for stapling mode.

Shift Mode

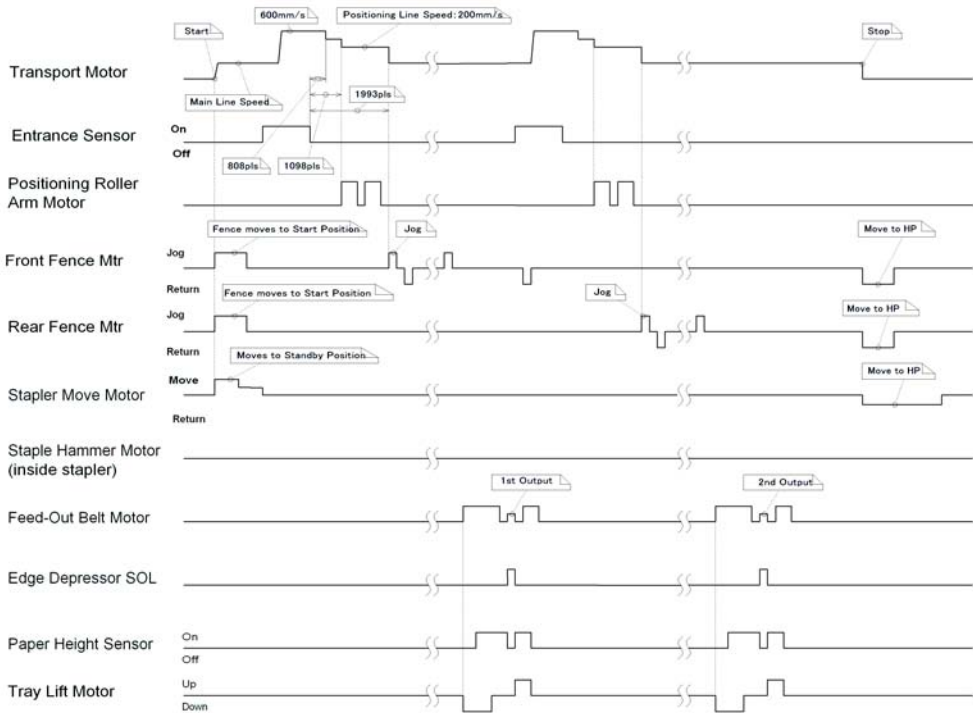

d372d420

500-Sheet
Finisher
D372/D585

Electrical Components

Staple Mode: Rear/Oblique

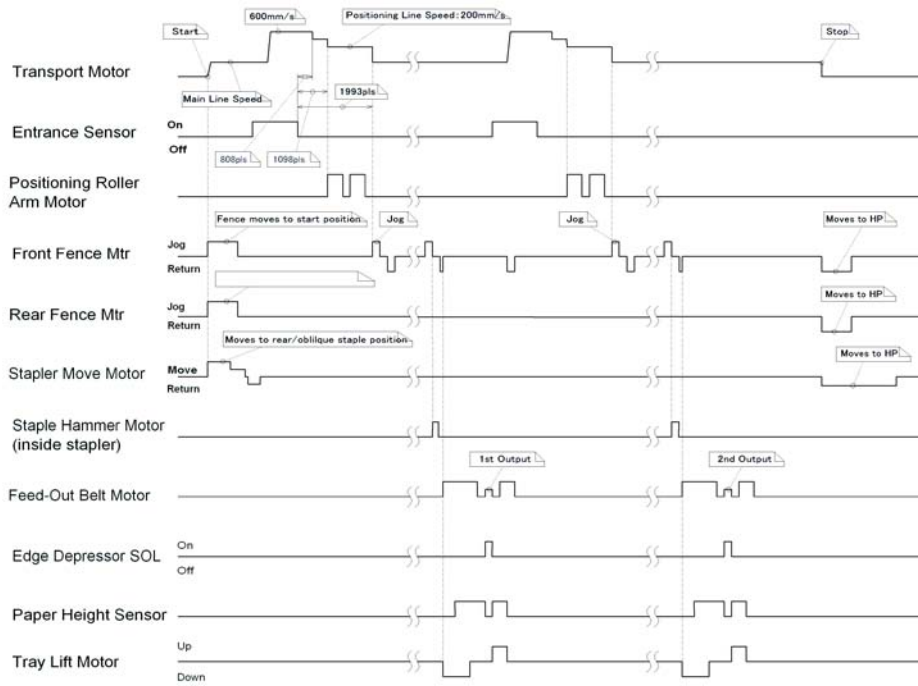

d372d430

2.7.4 ERROR LIST

Here is a comprehensive list of finisher errors.

Solution Key

Symbol	Solution
①	<ol style="list-style-type: none"> 1. Open top cover (or stapler door). 2. Remove jammed paper (or staple). 3. Close the top cover (or stapler door).
②	<p>1st Occurrence (Jam Error):</p> <ol style="list-style-type: none"> 1. Open top cover (or stapler door). 2. Remove jammed paper (or staple). 3. Close the top cover (or stapler door). <p>2nd Occurrence (SC Code):</p> <ol style="list-style-type: none"> 1. Cycle the machine power off/on 2. If this does not solve the problem, refer to Section "4. Troubleshooting". 3. Look up the SC code in table and do the service procedure.

500-Sheet
Finisher
D372/D585

No.	Error	Problem/Solution
1	Entrance sensor	<p>Problem: Lag errorOccurs during paper feed. A paper exit signal (ON) was received from the main machine, but the entrance sensor did not switch ON after the finisher transport motor ran long enough to feed paper 500 mm.</p> <p>Solution: ①</p>
2	Entrance sensor	<p>Problem: Late errorOccurs during paper feed. The entrance detected the paper, but the entrance sensor did not go OFF after the finisher transport motor ran long enough to feed 1.5 times the length of the paper size signaled by the main machine.</p>

Electrical Components

No.	Error	Problem/Solution
		Solution: ①
3	Paper in paper path	<p>Problem:</p> <p>Occurs at power on, or after the top cover or stapler door has been closed.</p> <p>After the top or stapler cover switch is closed, the stapler cover switch goes OFF but the entrance sensor remains ON for longer than 50 ms.</p> <p>Solution: ①</p>
4	No paper present	<p>Problem:</p> <p>Occurs during stapling, stapling mode WAIT.</p> <p>The paper sensor on the stapling tray remains OFF for more than 50 ms.</p> <p>Solution: No action required.</p>
5	Positioning roller motor error	<p>Problem:</p> <p>Occurs during initialization or during operation of the positioning roller motor.</p> <ul style="list-style-type: none"> ▪ During initialization or while the positioning roller arm was being lowered, the HP sensor remained ON did not go OFF within the prescribed time. ▪ During initialization, the positioning roller HP sensor remained OFF did not go ON within the prescribed time. ▪ When the positioning roller arm is raised from the down position, the HP sensor does not go ON even after the positioning roller motor remained on for 450 pulses. <p>Solution: ②</p>

No.	Error	Problem/Solution
6	Front side fence motor error	<p>Problem: Occurs at power on, when the paper moves to the start position in the finisher, or in standby mode.</p> <ul style="list-style-type: none"> ▪ The front side fence HP sensor did not switch from ON to OFF after the front side fence motor remained on for 50 pulses to move the fence toward the rear. ▪ The front side fence HP sensor did not switch from OFF to ON after the front side fence motor remained on for 420 pulses. <p>Solution: ②</p>
7	Rear side fence motor error	<p>Problem: Occurs at power on, when the paper moves to the start position in the finisher, or in standby mode.</p> <ul style="list-style-type: none"> ▪ The rear side fence HP sensor did not switch from ON to OFF after the rear side fence motor remained on for 50 pulses to move the fence forward. ▪ The front side fence HP sensor did not switch from OFF to ON after the front side fence motor remained on for 420 pulses to move the fence toward the rear. <p>Solution: ②</p>
8	Feed-out belt motor	<p>Problem: Occurs at initialization or during feed-out belt operation.</p> <ul style="list-style-type: none"> ▪ The feed-out belt HP sensor did not switch from ON to OFF after the feed-out belt motor ran for 100 pulses. ▪ The feed-out belt HP sensor did not switch from OFF to ON after the feed-out belt motor ran for 1000 pulses. <p>Solution: ②</p>

500-Sheet
Finisher
D372/D585

Electrical Components

No.	Error	Problem/Solution
9	Stapler movement motor error 1	<p>Problem: Occurs at initialization or while the paper is being fed to the start position in the finisher.</p> <ul style="list-style-type: none"> ▪ The stapler HP sensor did not switch from ON to OFF after the stapler movement motor ran for 200 pulses. ▪ The stapler HP sensor did not switch from OFF to ON after the stapler movement motor ran for 5600 pulses. <p>Solution: ②</p>
10	Stapler motor error	<p>Problem: Occurs during staple supply to the stapler. The stapler operation (stapling) did not end after 600 ms. A staple jam can also cause this error.</p>
11	Tray lift motor error	<p>Problem: Occurs at initialization, after return to standby, or during feed-out belt operation.</p> <ul style="list-style-type: none"> ▪ The paper height sensor did not go OFF after the tray lift motor ran for 3 sec. to lower the tray. ▪ The paper height sensor did not go OFF after the tray lift motor ran for 20 sec. to raise the tray. <p>Solution: ②</p>
12	Edge depressor solenoid	<p>Problem: Occurs at initialization or during feed-out belt operation.</p> <ul style="list-style-type: none"> ▪ The paper height sensor remained ON after the solenoid went OFF. <p>Solution: ②</p>
13	Tray full sensor	<p>Problem: The tray full sensor went ON with the edge depressor solenoid OFF and paper height sensor OFF.</p> <p>Solution: Tray full, remove paper.</p>

Electrical Components

No.	Error	Problem/Solution
14	Staple out	<p>Problem: Occurs during standby or during stapling.</p> <ul style="list-style-type: none"> ▪ The staple near-end sensor went ON, or during staple supply the self-priming sensor did not go ON, even after 10 attempts to supply more staples to the stapler. <p>Solution: Replace the empty staple cartridge.</p>
15	Top cover open	<p>Problem: The top cover remained open longer than 2 ms.</p> <p>Solution: Close the top cover.</p>
16	Stapler cover open	<p>Problem: The stapler cover remained open longer than 2 ms.</p> <p>Solution: Close the stapler cover.</p>
17	Tray upper limit switch is ON	<p>Problem: The tray upper limit switch remained on longer than 2 ms.</p> <p>Solution: Before determining that an error has occurred:</p> <ul style="list-style-type: none"> ▪ Lower the safety lever. ▪ Cycle the machine power off/on
18	System error	<p>Problem: An abnormal condition was detected and existed longer than 60 sec.</p> <p>Solution: DFU</p>

500-Sheet
Finisher
D372/D585

Electrical Components

No.	Error	Problem/Solution
19	Exceeded system limitation	Problem: Occurs when the number of command requests received has exceeded the limit. The entrance detected the paper, but the entrance sensor did not go OFF after the finisher transport motor ran long enough to feed 1.5 times the length of the paper size signaled by the main machine. Solution: DFU
20	Abnormal data transfer	Problem: A problem has been detected at ASAP during data transmission. Solution: ①

3. SPECIFICATIONS

3.1 SPECIFICATIONS

Target Line Speed	77 mm/sec. to 205 mm/sec		
Target CPM	35 cpm		
Face-down Output Size	12"x18", A3 SEF to A6 SEF, DLT to HLT SEF Shift sizes: A3 SEF to B5 SEF A5, B6, A6 SEF labels possible		
Paper Thickness	52 g/m ² (45 K) to 157 g/m ² (135 K) Up to 253 g/m ² (220K) without shift		
Stapling			
Stack Height for Stapling	50 sheets: A4, LT and smaller 30 sheets: B4, LG and larger		
Size	A3 SEF to B5 SEF (can be mixed if same width)		
Stack Thickness	64g/m ² (45 K) to 157 g/m (135 K)		
Stapling Positions	Front/Oblique: 1, Front/Parallel: 1 Rear/Oblique: 1, Rear/Parallel: 1, 2 locations		

Specifications

Output Tray Capacity				
Non-staple Mode		500 sheets: A4, LT and smaller		
Staple Mode		250 sheets: B4, LG and larger Stack Size (Stapling)	Stacks	Size
	2 to 9 Sheets		55 to 46	A4, B5, LT LEF
	10 to 50 Sheets		45 to 10	
	2 to 9 Sheets		55 to 27	A4, B5, LT SEF
	10 to 50 Sheets		25 to 8	
	2 to 9 Sheets		55 to 27	A3, B4, DLT, LG
	10 to 30 Sheets		25 to 8	

Specifications

Stacking		Non-Stapling Mode	Vertical: 15 mm or less	
			Horizontal: 15 mm or less	
Jogging Precision				
2 to 30 Sheets		2 mm		
31 to 50 Sheets		3 mm		
Dimensions (w x d x h)		396 x 551 x 276 mm (15.6 x 21.7 x 10.9 in.)		
Weight		12 kg (26.4 lb.)		

500-Sheet
Finisher
D372/D585

D386/D634

BRIDGE UNIT BU3030/BU3060

REVISION HISTORY		
Page	Date	Added/Updated/New
		None

BRIDGE UNIT BU3030/BU3060 (D386/D634)

TABLE OF CONTENTS

1. REPLACEMENT AND ADJUSTMENT.....	1
1.1 BRIDGE UNIT CONTROL BOARD.....	1
1.2 BRIDGE UNIT DRIVE MOTOR.....	2
1.3 TRAY EXIT SENSOR	3
1.4 RELAY SENSOR	4
2. DETAILS	5
2.1 MECHANICAL COMPONENT LAYOUT	5
2.2 DRIVE LAYOUT.....	6
2.3 ELECTRICAL COMPONENT LAYOUT	7
2.4 ELECTRICAL COMPONENT DESCRIPTION	8
2.5 JUNCTION GATE MECHANISM	9

READ THIS FIRST

Safety and Symbols

Replacement Procedure Safety

CAUTION

- Turn off the main power switch and unplug the machine before beginning any of the replacement procedures in this manual.

When taking apart the bridge unit, first take the unit out of the copier.

Symbols Used in this Manual

This manual uses the following symbols.

: See or Refer to

: Screws

: Connector

: Clip ring

: E-ring

1. REPLACEMENT AND ADJUSTMENT

1.1 BRIDGE UNIT CONTROL BOARD

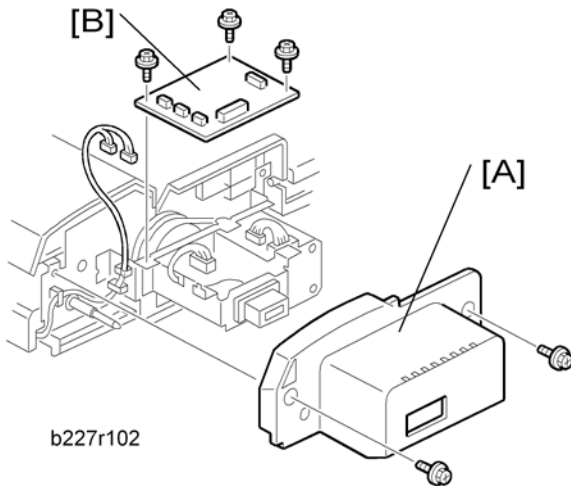

1. Bridge unit (➔ "Installation Procedure" in the base copier manual)
2. Rear cover [A] (🔩 x 2)
3. Bridge unit control board [B] (🔩 x 3, 🛠️ x 4)

1.2 BRIDGE UNIT DRIVE MOTOR

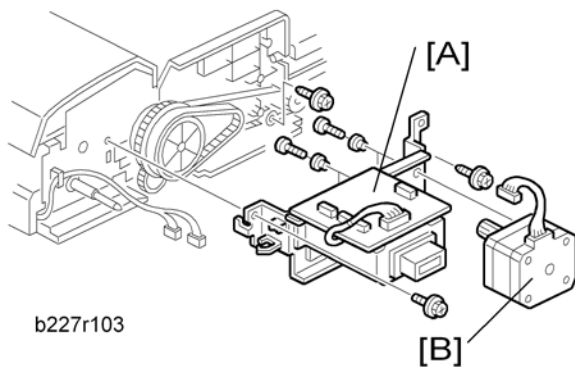

1. Bridge unit (➔ "Installation Procedure" in the base copier manual)
2. Rear cover (➔ "Bridge Unit Control Board")
3. Bracket [A] (⚙ x 3, ⚙ x 2)
4. Bridge unit drive motor [B] (⚙ x 4, ⚙ x 1)

1.3 TRAY EXIT SENSOR

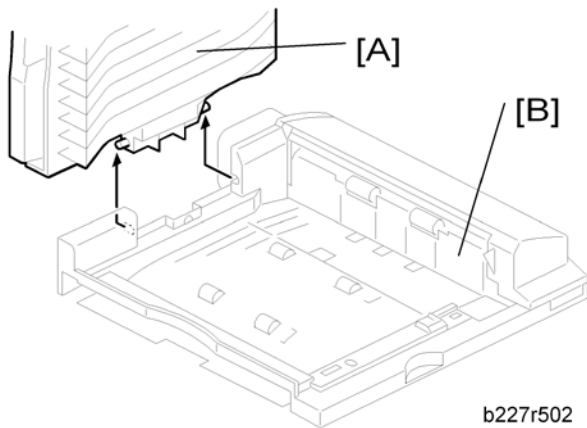

1. Bridge unit (➔ "Installation Procedure" in the base copier manual)
2. Rear cover (➔ "Bridge Unit Control Board")
3. Paper tray [A]
4. Exit guide [B] (🔩 x 1)

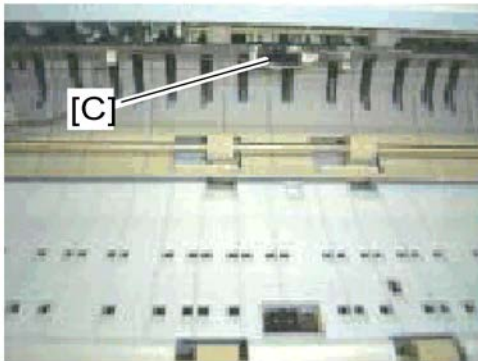

5. Tray exit sensor [C] (🔩 x 1)

1.4 RELAY SENSOR

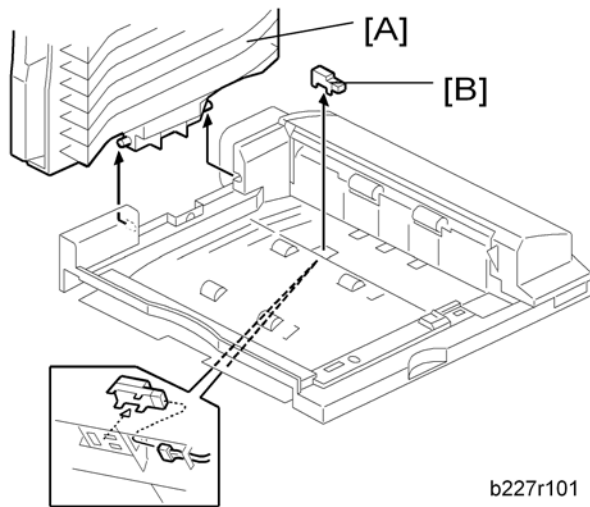

1. Bridge unit (➔ "Installation Procedure" in the base copier manual)
2. Paper tray [A]
3. Relay sensor [B] (☞ x 1)

2. DETAILS

2.1 MECHANICAL COMPONENT LAYOUT

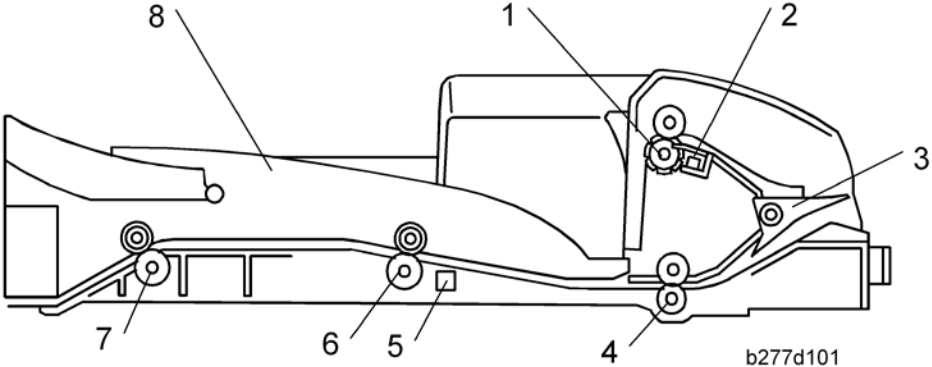

1. Upper Exit Roller	5. Relay Sensor
2. Tray Exit Sensor	6. 2nd Transport Roller
3. Junction Gate	7. Left Exit Roller
4. 1st Transport Roller	8. Paper Tray

Bridge Unit
BU3030/
BU3060
(D386/D634)

2.2 DRIVE LAYOUT

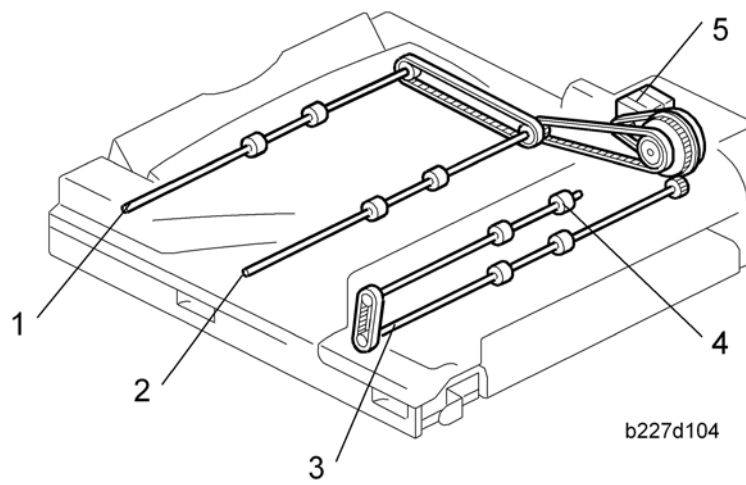

1. Left Exit Roller
2. 2nd Transport Roller
3. 1st Transport Roller
4. Upper Exit Roller
5. Bridge Unit Drive Motor

2.3 ELECTRICAL COMPONENT LAYOUT

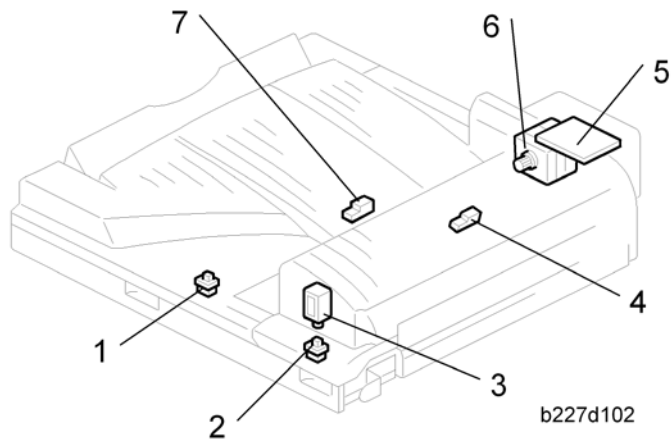

1. Left Guide Switch
2. Right Guide Switch
3. Junction Gate Solenoid
4. Tray Exit Sensor
5. Bridge Unit Control Board
6. Bridge Unit Drive Motor
7. Relay Sensor

2.4 ELECTRICAL COMPONENT DESCRIPTION

Symbol	Name	Function	Index No.
Motors			
M1	Drive Motor	Drives the bridge unit.	6
Sensors			
S1	Tray Exit	Checks for misfeeds.	4
S2	Relay	Checks for misfeeds.	7
Switches			
SW2	Right Guide	Detects when the right guide is opened.	2
SW3	Left Guide	Detects when the left guide is opened.	1
Solenoids			
SOL1	Junction Gate	Moves the junction gate to direct the paper to the upper tray (on top of the bridge unit) or to the finisher.	3
PCBs			
PCB1	Bridge Unit Control Board	Controls the bridge unit.	5

2.5 JUNCTION GATE MECHANISM

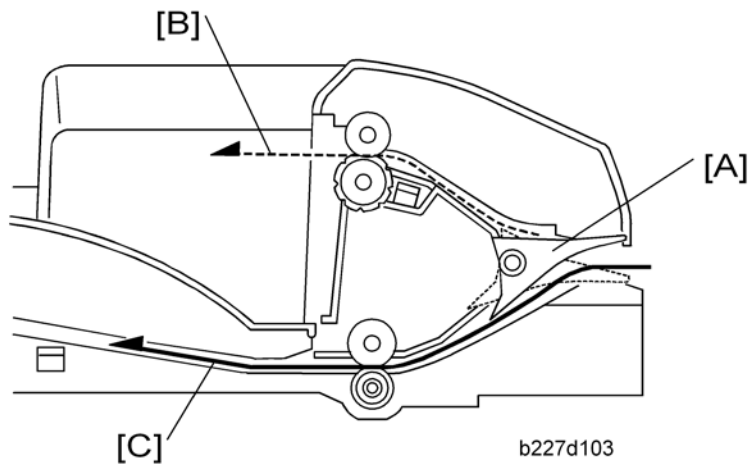

The junction gate [A] directs any paper reaching the bridge unit to either the upper tray (on top of the bridge unit) or to the finisher, depending on which has been selected.

If the junction gate solenoid has been activated, the junction gate [A] points downward and directs the paper to the upper tray [B] (dotted line path in illustration). When the solenoid is off, the junction gate points upward and the paper is fed out to the finisher [C] by the transport and left exit rollers (solid line).

PB3110(D537)/PB3130(D580)

PAPER FEED UNIT

REVISION HISTORY		
Page	Date	Added/Updated/New
		None

PAPER FEED UNIT (D537/D580)

TABLE OF CONTENTS



1. REPLACEMENT AND ADJUSTMENT.....	1
1.1 EXTERIOR COVER.....	1
1.1.1 REAR COVER.....	1
1.2 ELECTRICAL COMPONENTS.....	2
1.2.1 LIFT MOTORS.....	2
1.2.2 UPPER AND LOWER PAPER FEED CLUTCHES.....	3
1.2.3 PAPER FEED MOTOR.....	4
1.2.4 MAIN BOARD.....	4
1.3 FEED.....	5
1.3.1 PAPER FEED UNIT.....	5
1.3.2 PICK-UP, PAPER FEED AND SEPARATION ROLLERS.....	6
1.3.3 LIFT, PAPER END, AND RELAY SENSORS.....	7

1. REPLACEMENT AND ADJUSTMENT

1.1 EXTERIOR COVER

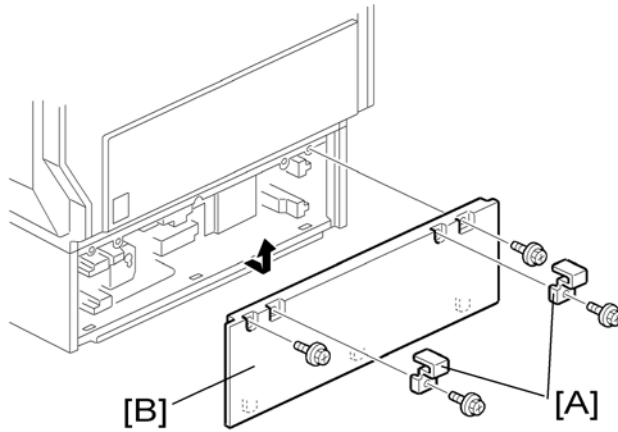
1.1.1 REAR COVER



1. Securing brackets [A] ( x 1 each)
2. Rear cover [B] ( x 2)

1.2 ELECTRICAL COMPONENTS

1.2.1 LIFT MOTORS

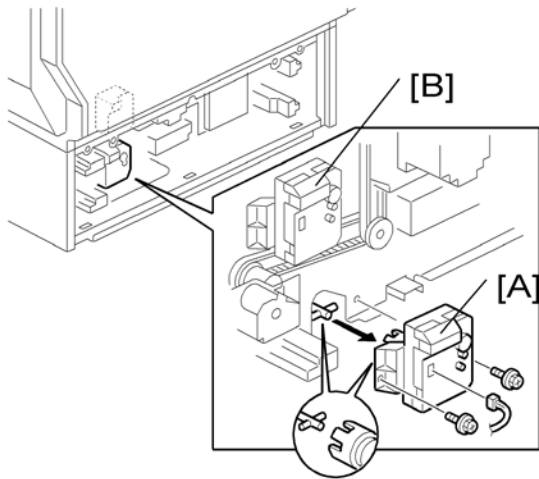

1. Rear cover (🔧 "Rear Cover")
2. Lift motors [A][B] (🔧 x 2, 📦 x 1 each)

1.2.2 UPPER AND LOWER PAPER FEED CLUTCHES

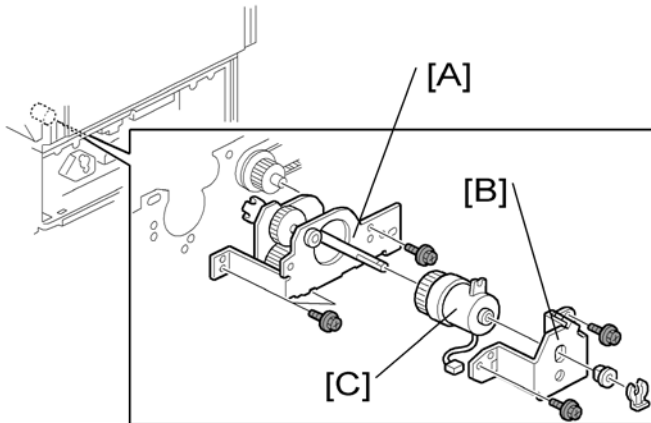

1. Rear cover (Rear Cover)
2. Upper paper feed gear unit [A] (x 3, x 1)
3. Upper paper feed clutch bracket [B] (x 1, x 2, bushing x 1)
4. Upper paper feed clutch [C]

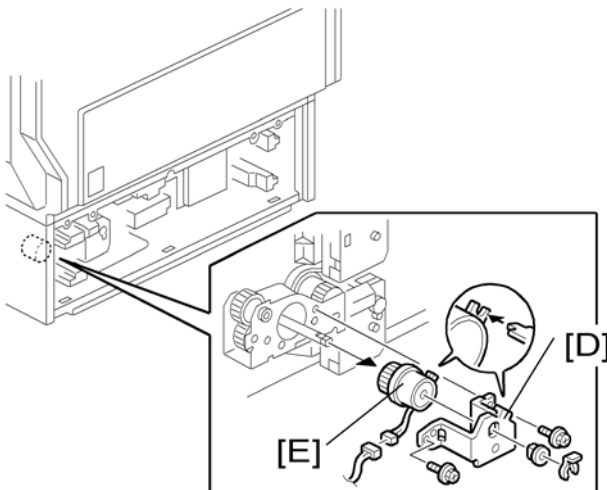

5. Lower paper feed clutch bracket [D] (x 1, bushing x 1, x 2)
6. Lower paper feed clutch [E] (x 1)

Paper Feed
Unit PB3110/
PB3130
D537/D580

1.2.3 PAPER FEED MOTOR

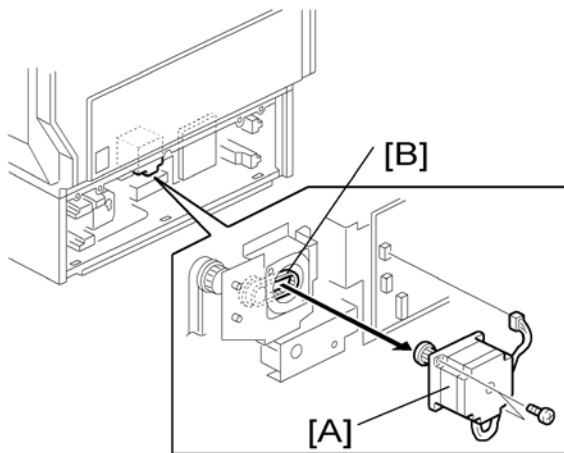

1. Rear cover (🔧 "Rear Cover")
2. Paper feed motor [A] (🔧 x 1, 🔩 x 2)

↓ Note

- When installing the paper feed motor, make sure that the gear of the paper feed motor holds the timing belt [B].

1.2.4 MAIN BOARD

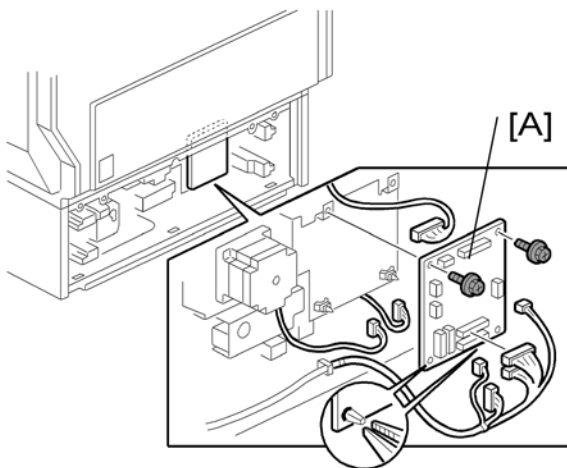

1. Rear cover (🔧 "Rear Cover")
2. Main board [A] (All 🔧s, 🔩 x 2, snap pin x 2)

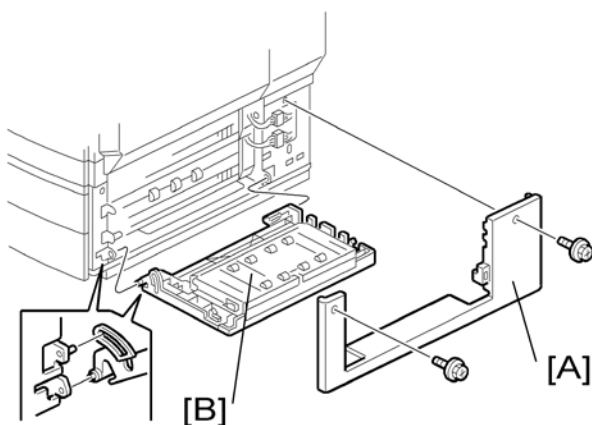

1.3 FEED

1.3.1 PAPER FEED UNIT

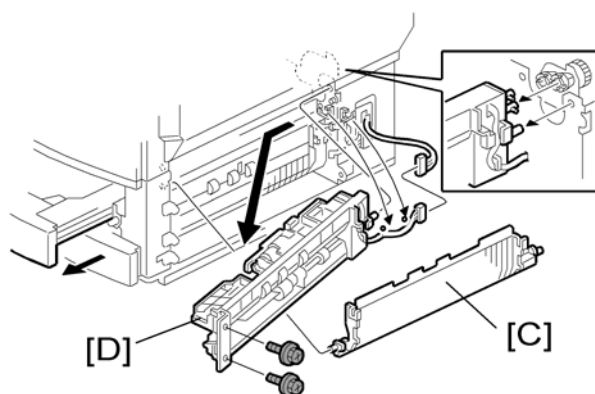

1. Right cover [A] ( x 2)
2. Vertical transport guide [B] of the paper feed unit



3. Pull the tray 3 (or 4).
4. Paper guide [C]
5. Paper feed unit [D] ( x 2,  x 1,  x 2)

When replacing the paper feed unit of tray 4, do the same.

1.3.2 PICK-UP, PAPER FEED AND SEPARATION ROLLERS

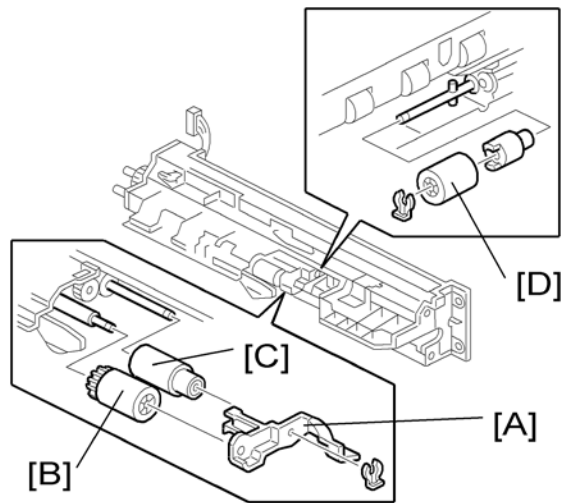

1. Paper feed unit (Paper Feed Unit)
2. Roller holder [A] (x 1)
3. Pick-up roller [B]
4. Paper feed roller [C]
5. Separation roller [D] (x 1)

1.3.3 LIFT, PAPER END, AND RELAY SENSORS

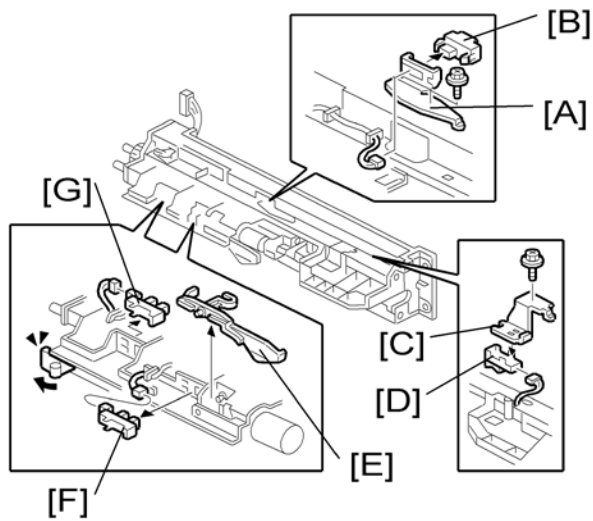

1. Paper feed unit (🔧 "Paper Feed Unit")
2. Vertical transport sensor bracket [A] (🔧 x 1)
3. Vertical transport sensor [B] (🔧 x 1)
4. Paper feed sensor bracket [C] (🔧 x 1)
5. Paper feed sensor [D] (🔧 x 1)
6. Paper end sensor filler [E]
7. Paper end sensor [F] (🔧 x 1)
8. Lift sensor [G] (🔧 x 1)

Paper Feed
Unit PB3110/
PB3130
D537/D580

PB3110(D538)/PB3140(D581)

LARGE CAPACITY TRAY

REVISION HISTORY		
Page	Date	Added/Updated/New
		None

LARGE CAPACITY TRAY (D538/D581)

TABLE OF CONTENTS

1. REPLACEMENT AND ADJUSTMENT	1
1.1 EXTERIOR COVER.....	1
1.1.1 LEFT AND RIGHT TRAY.....	1
1.1.2 CHANGING THE TRAY SIZE.....	2
1.2 ELECTRICAL COMPONENTS.....	3
1.2.1 PAPER HEIGHT SENSORS ON PAPER STORAGE SIDE.....	3
1.2.2 END FENCE HP SENSOR/PAPER END SENSOR 2.....	3
1.2.3 TRAY LIFT MOTOR.....	4
1.2.4 TRAY MOTOR.....	5
1.2.5 MAIN BOARD.....	5
1.2.6 STACK TRANSPORT CLUTCH.....	6
1.3 FEED.....	7
1.3.1 PAPER FEED UNIT.....	7
1.3.2 PICK-UP, FEED AND SEPARATION ROLLERS.....	8
1.3.3 PAPER FEED, PAPER END, LIFT AND RELAY SENSORS.....	9

1. REPLACEMENT AND ADJUSTMENT

1.1 EXTERIOR COVER

1.1.1 LEFT AND RIGHT TRAY

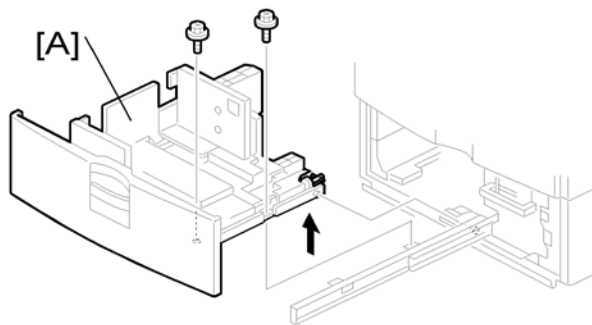

1. Pull the LCT drawer.

↓ Note

- If the right tray comes up with the left tray, push the right tray into the LCT.

2. Left tray [A] ( x 2)

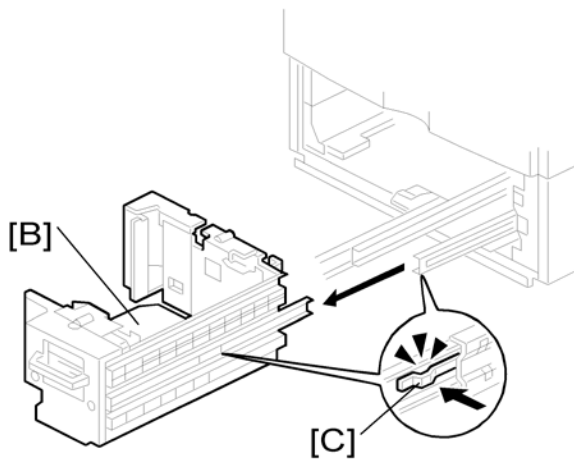

3. Remove the right tray [B] pressing down the stopper [C].

↓ Note

- When reinstalling the tray, set the tray on the guide rail and carefully push the tray in, making sure to keep the tray level.

Large
Capacity Tray
PB3110/
PB3140
D538/D581

1.1.2 CHANGING THE TRAY SIZE

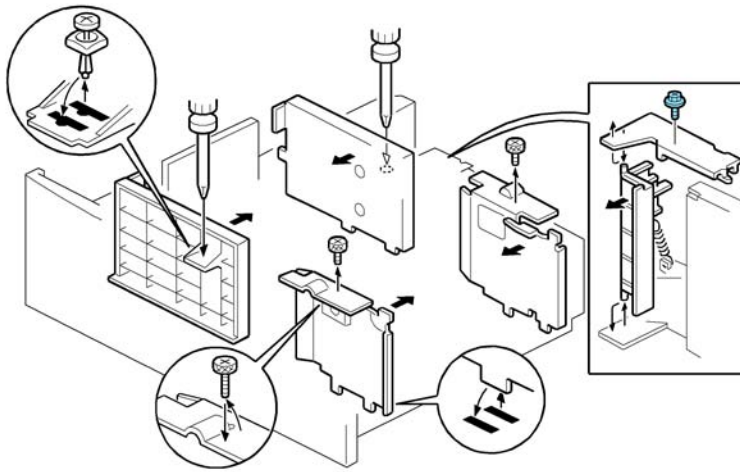

1. Remove the fence screws ( x 5).
2. Change the position of the fences.

 Note

- Before fastening the screws, set paper in the tray.

1.2 ELECTRICAL COMPONENTS

1.2.1 PAPER HEIGHT SENSORS ON PAPER STORAGE SIDE

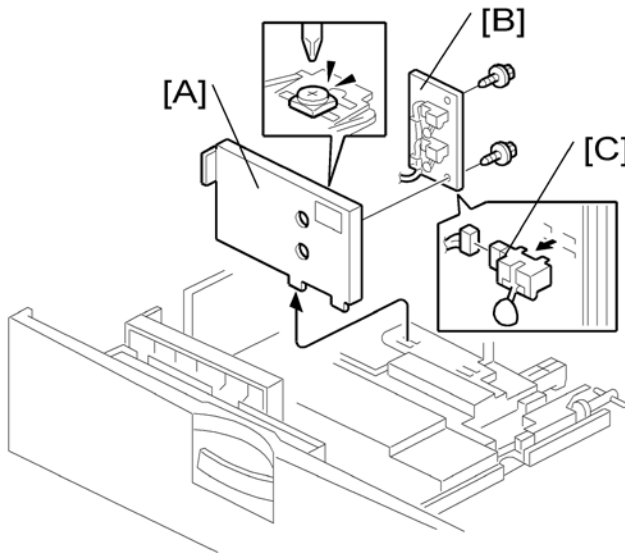

1. Tray (☞ "Left and Right Tray")
2. Rear fence [A] (🔩 x 1)
3. Rear fence bracket [B] (🔩 x 2)
4. Paper height sensors [C] (🔩 x 1 each)

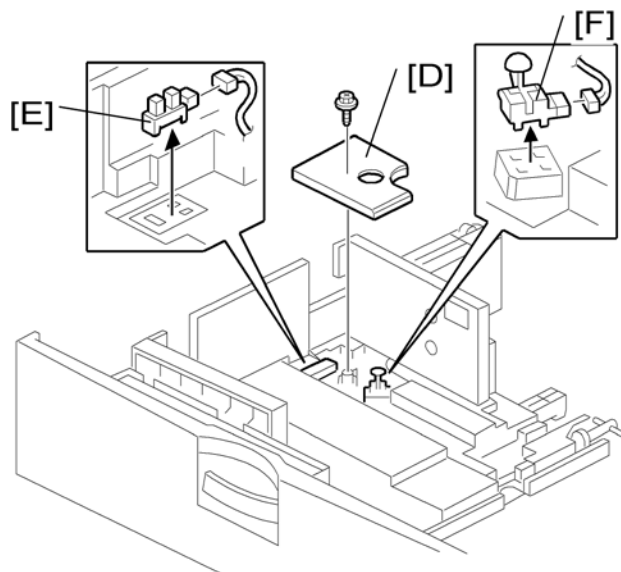

1.2.2 END FENCE HP SENSOR/PAPER END SENSOR 2



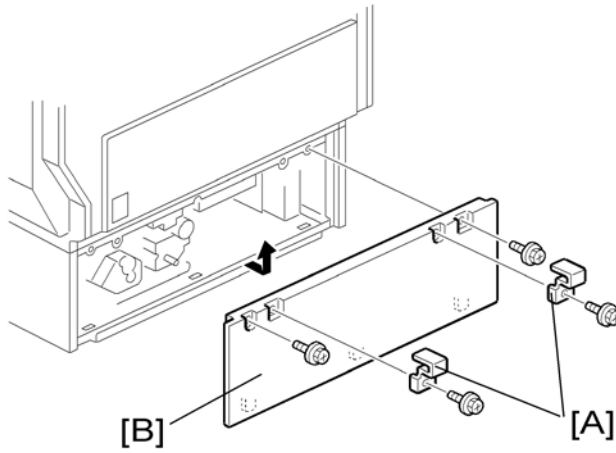

1. Bottom cover [D] (🔩 x 1)
2. End fence HP sensor [E] (🔩 x 1)
3. Paper end sensor 2 (paper storage side) [F] (🔩 x 1)

1.2.3 TRAY LIFT MOTOR

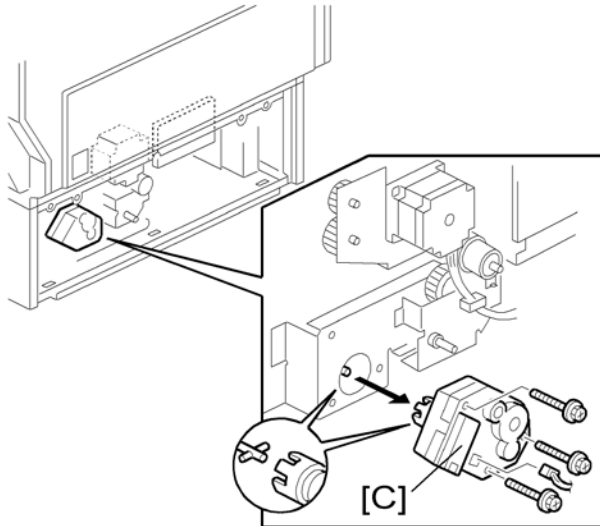

1. Securing brackets [A] ( x 1 each)
2. Rear cover [B] ( x 2)



3. Tray lift motor [C] ( x 1,  x 3)

1.2.4 TRAY MOTOR

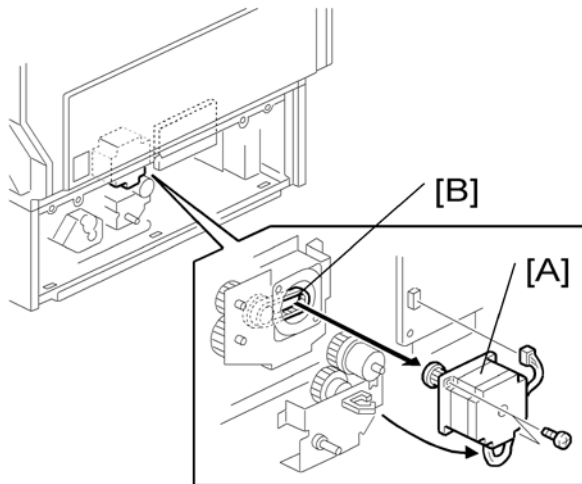

1. Rear cover (🔧 "Tray Lift Motor")
2. Tray motor [A] (🔧 x 1, 🔩 x 2)

↓ Note

- When installing the tray motor, make sure that the gear of the tray motor holds the timing belt [B].

1.2.5 MAIN BOARD

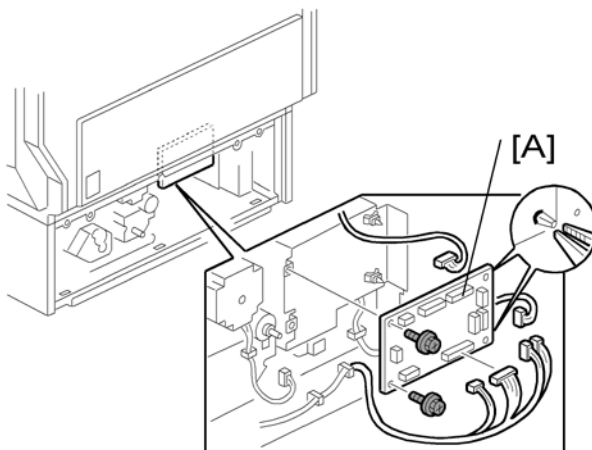

1. Rear cover (🔧 "Tray Lift Motor")
2. Main board [A] (All 🔧s, 🔩 x 2, snap x 2)

Large
Capacity Tray
PB3110/
PB3140
D538/D581

1.2.6 STACK TRANSPORT CLUTCH

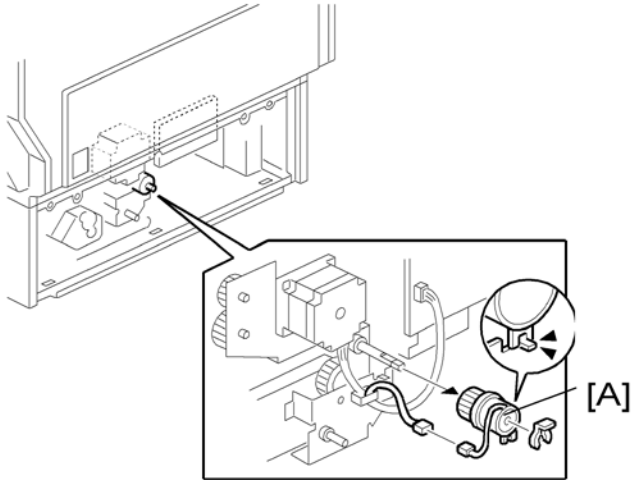

1. Rear cover (🔧 "Tray Lift Motor")
2. Stack transport clutch [A] (🔧 x 1, ⚙️ x 1)

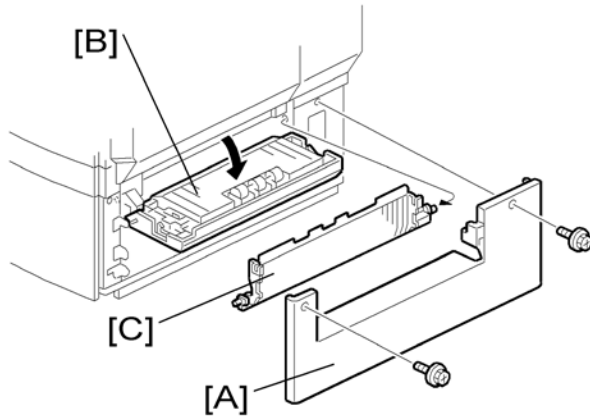

1.3 FEED

1.3.1 PAPER FEED UNIT

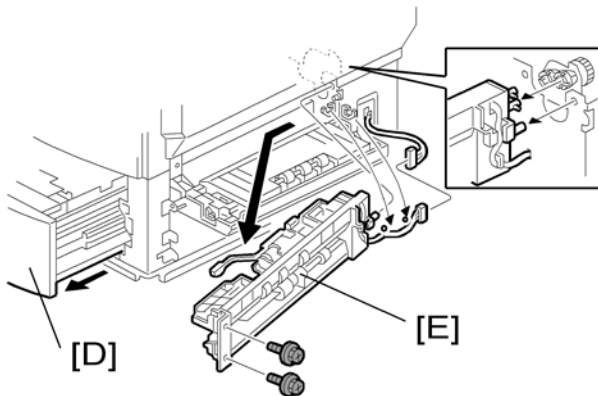

1. Right cover [A]
2. Open the vertical guide plate [B]
3. Guide plate [C]



4. Pull the LCT drawer [D].
5. Paper feed unit [E] ( x 2  x 1)

Large
Capacity Tray
PB3110/
PB3140
D538/D581

1.3.2 PICK-UP, FEED AND SEPARATION ROLLERS

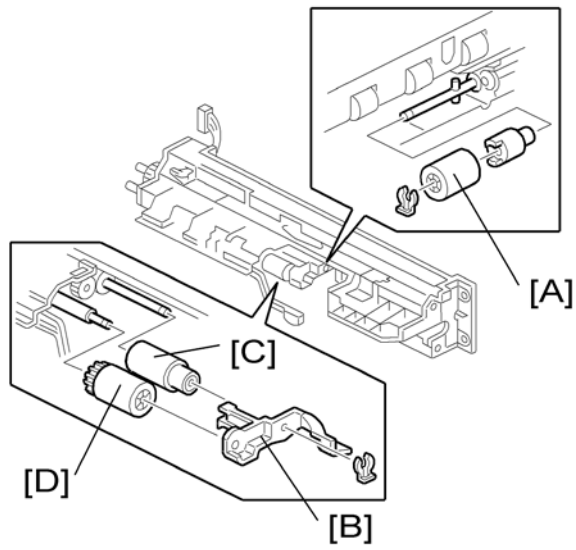

1. Paper feed unit (🔌 "Paper Feed Unit")
2. Separation roller [A] (🔧 x 1)
3. Roller holder [B] (🔧 x 1)
4. Feed roller [C] and pick-up roller [D]

1.3.3 PAPER FEED, PAPER END, LIFT AND RELAY SENSORS

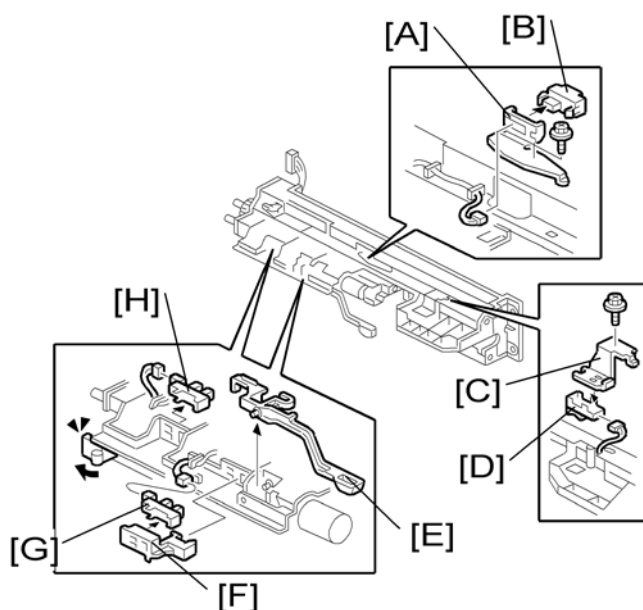

1. Paper feed unit (🔧 "Paper Feed Unit")
2. Vertical transport sensor bracket [A] (🔩 x 1, 🪝 x 1)
3. Relay sensor [B]
4. Paper feed sensor bracket [C]
5. Paper feed sensor [D]
6. Paper end feeler [E]
7. Paper end sensor holder [F] (hook x 3)
8. Paper end sensor [G] (🪝 x 1, hook x 3)
9. Lift sensor (🪝 x 1, hook x 3)

Large
Capacity Tray
PB3110/
PB3140
D538/D581

D542/D635
SIDE TRAY TYPE C5501/C5502

REVISION HISTORY		
Page	Date	Added/Updated/New
		None

SIDE TRAY TYPE C5501/C5502 (D542/D635)

TABLE OF CONTENTS

1. REPLACEMENT AND ADJUSTMENT.....	1
1.1 TRAYS AND COVERS	1
1.1.1 SUB AND MAIN OUTPUT TRAYS	1
1.1.2 TRAY LEFT FRONT AND REAR COVERS.....	2
1.2 ELECTRICAL COMPONENTS	3
1.2.1 SIDE TRAY CONTROL BOARD.....	3
1.2.2 SIDE TRAY DRIVE MOTOR.....	4
1.2.3 SIDE TRAY RELAY SENSOR	5
1.2.4 SIDE TRAY EXIT SENSOR.....	6

1. REPLACEMENT AND ADJUSTMENT

1.1 TRAYS AND COVERS

1.1.1 SUB AND MAIN OUTPUT TRAYS

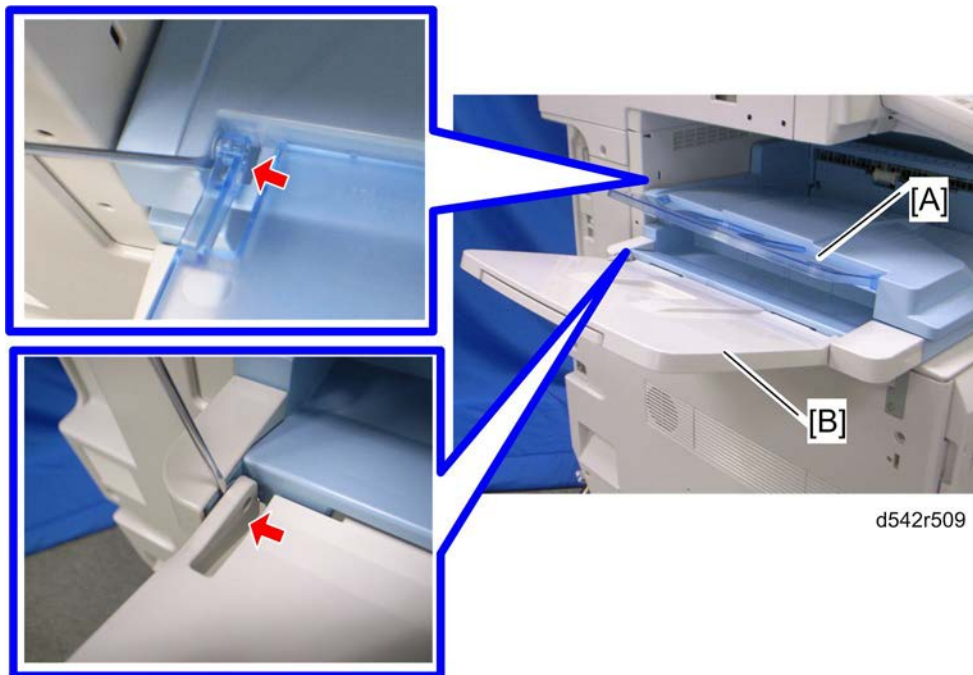

1. Sub output tray [A]
 - Release the rear tab of the sub output tray.
2. Main output tray [B]
 - Release the rear tab of the sub output tray.

1.1.2 TRAY LEFT FRONT AND REAR COVERS

1. Sub and main output trays (🖨️ Sub and Main Output Trays)

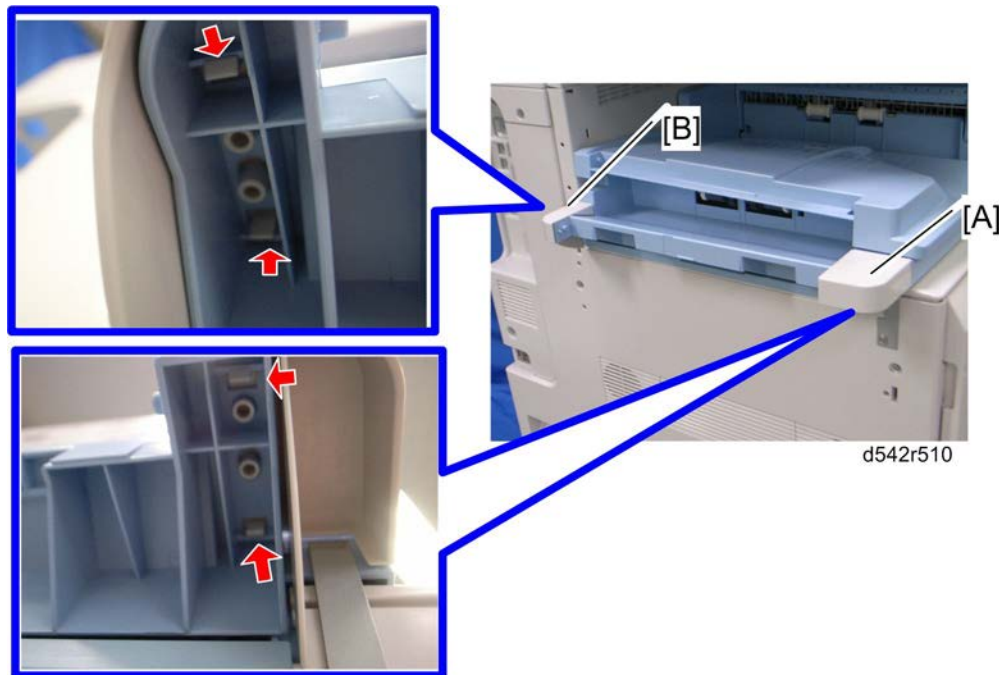

2. Tray left front cover [A]
 - Release the hooks of the tray left front cover.
3. Tray left rear cover [B]
 - Release the hooks of the tray left rear cover.

1.2 ELECTRICAL COMPONENTS

1.2.1 SIDE TRAY CONTROL BOARD

1. Sub and main output trays (🔧 Sub and Main Output Trays)
2. Tray left front and rear covers (🔧 Tray Left Front and Rear Covers)
3. Side tray (🔧 Installation Procedure in the base copier manual)

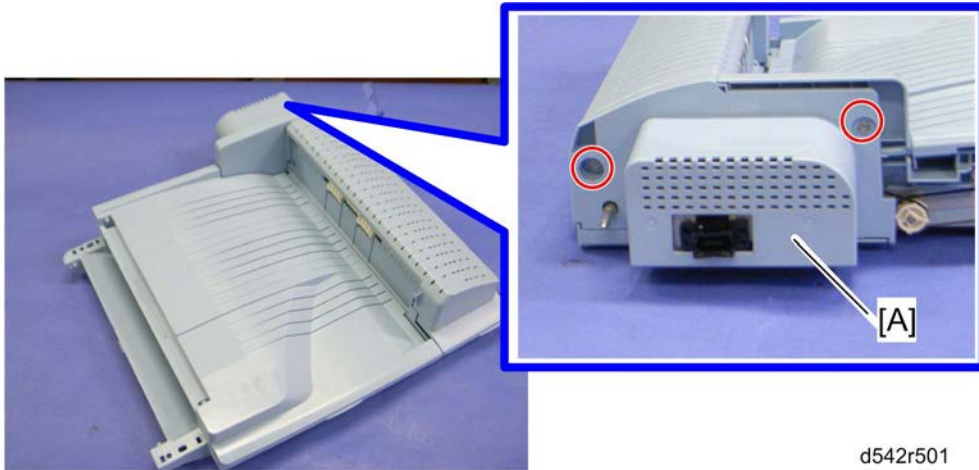

d542r501

4. Rear cover [A] (🔧 x 2)

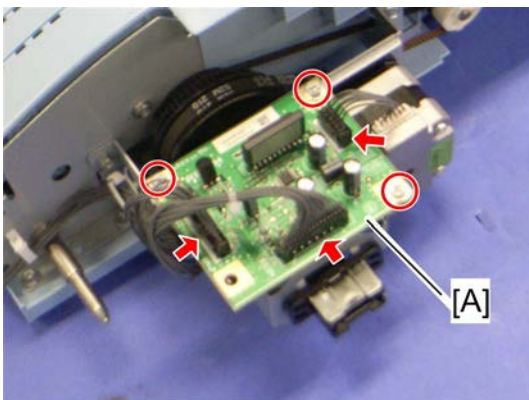

d542r502

5. Side tray control board [A] (🔧 x 3, 📄 x 3)

Side Tray
Type
C5501/C5502
(D542/D635)

1.2.2 SIDE TRAY DRIVE MOTOR

1. Sub and main output trays (🔧 Sub and Main Output Trays)
2. Tray left front and rear covers (🔧 Tray Left Front and Rear Covers)
3. Side tray (🔧 Installation Procedure in the base copier manual)
4. Rear cover (🔧 Side Tray Control Board)

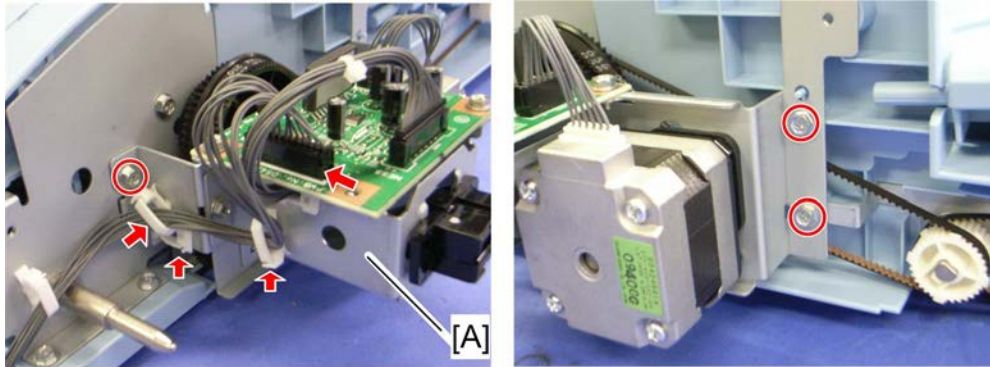

5. Bracket [A] (🔧 x 3, 📏 x 3, 📏 x 1, timing belt x 1)

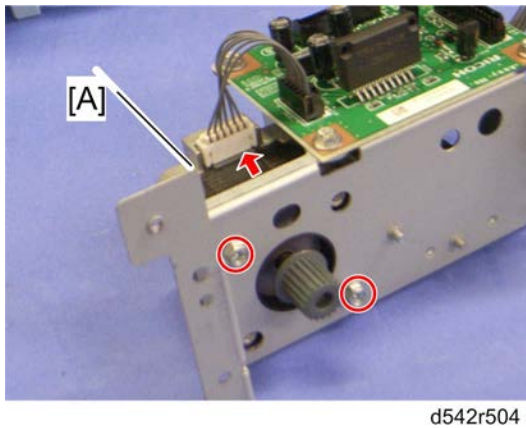

6. Side tray drive motor [A] (🔧 x 4, 📏 x 1)

1.2.3 SIDE TRAY RELAY SENSOR

1. Sub and main output trays (🔧 Sub and Main Output Trays)
2. Tray left front and rear covers (🔧 Tray Left Front and Rear Covers)
3. Side tray (🔧 Installation Procedure in the base copier manual)

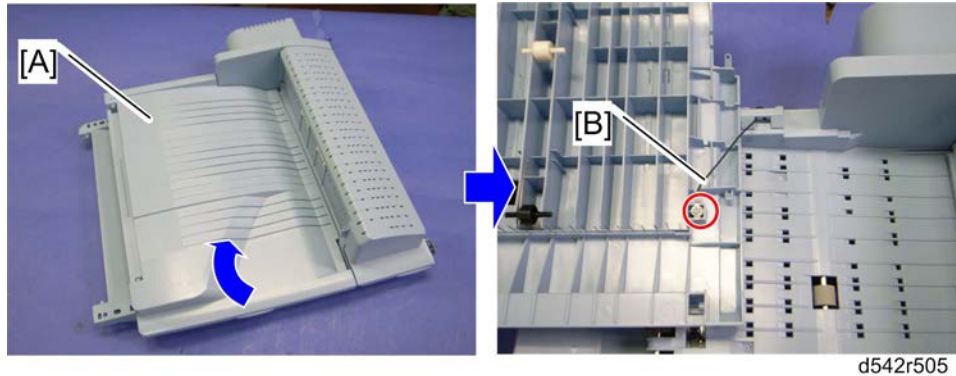

d542r505

4. Open the paper tray [A].
5. Remove the ground cable [B] (🔧 x 1).
6. Remove the paper tray [A].
7. Turn over the side tray.

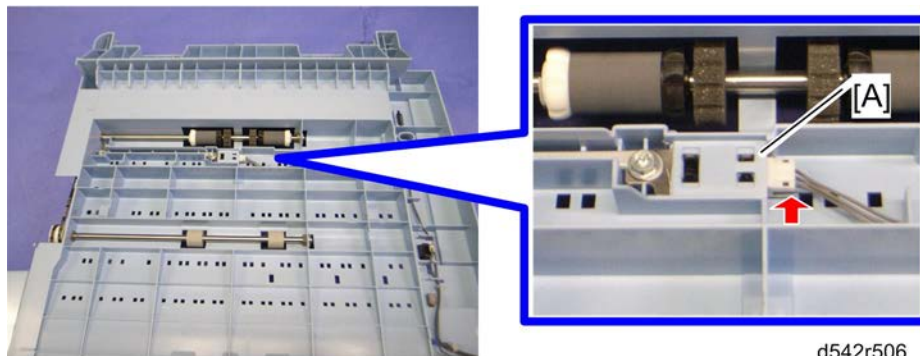

d542r506

8. Side tray relay sensor [A] (🔧 x 1, hooks)
9. Turn over the side tray, and then remove the side tray relay sensor.

Side Tray
Type
C5501/C5502
(D542/D635)

1.2.4 SIDE TRAY EXIT SENSOR

1. Sub and main output trays (📄 Sub and Main Output Trays)
2. Tray left front and rear covers (📄 Tray Left Front and Rear Covers)
3. Side tray (📄 Installation Procedure in the base copier manual)
4. Paper tray (📄 Side Tray Relay Sensor)

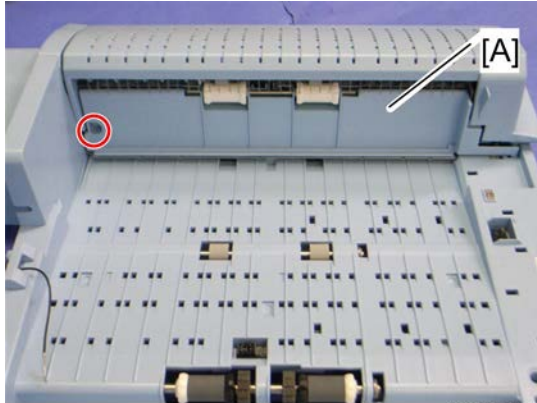

d542r507

5. Exit guide [A] (🔧 x 1)



d542r508

6. Side tray exit sensor [A] (📄 x 1, 📄 x 1, hooks)

D631

RT3020 - 1200-SHEET LCT

REVISION HISTORY		
Page	Date	Added/Updated/New
		None

RT3020 - 1200-SHEET LCT (D631)

TABLE OF CONTENTS

1. REPLACEMENT AND ADJUSTMENT.....	1
1.1 COVERS.....	1
1.1.1 REAR COVER.....	1
1.1.2 RIGHT DOOR.....	1
1.1.3 FRONT AND TOP COVERS.....	2
1.2 PAPER FEED.....	3
1.2.1 PICK-UP, PAPER FEED AND SEPARATION ROLLERS.....	3
1.3 DRIVE.....	4
1.3.1 PAPER FEED CLUTCH.....	4
1.3.2 PAPER FEED MOTOR.....	4
1.3.3 TRAY LIFT MOTOR.....	5
1.4 ELECTRICAL COMPONENTS.....	6
1.4.1 MAIN BOARD.....	6
1.4.2 LCT SET SWITCHES.....	6
Rear.....	6
Front.....	7
1.4.3 DOWN SWITCH.....	7
1.4.4 PAPER FEED, PAPER END, TRAY LIFT AND RELAY SENSORS.....	8
1.4.5 STACK SENSOR.....	9
1.5 SIDE FENCE POSITION CHANGE.....	10
2. DETAILS.....	11
2.1 COMPONENT LAYOUT.....	11
2.1.1 COMPONENT LAYOUT.....	11
2.1.2 ELECTRICAL COMPONENT LAYOUT.....	12
2.1.3 ELECTRICAL COMPONENT DESCRIPTIONS.....	13
2.1.4 DRIVE LAYOUT.....	15
2.2 PAPER FEED.....	16
2.2.1 PAPER FEED MECHANISM.....	16
2.2.2 TRAY LIFT MECHANISM.....	17
Tray lifting conditions.....	17
Tray lowering conditions (Paper supply position).....	17
Tray lowering conditions (Full-down position).....	17

2.2.3 PAPER HEIGHT AND END DETECTION	18
Paper Height	18
Paper End	18

Read This First

Safety and Symbols

Replacement Procedure Safety

CAUTION

- Turn off the main power switch and unplug the machine before beginning any of the replacement procedures in this manual.

Symbols Used in this Manual

This manual uses the following symbols.

: See or Refer to

: Screws

: Connector

: Clip ring

: E-ring

: Clamp

1. REPLACEMENT AND ADJUSTMENT

1.1 COVERS

1.1.1 REAR COVER

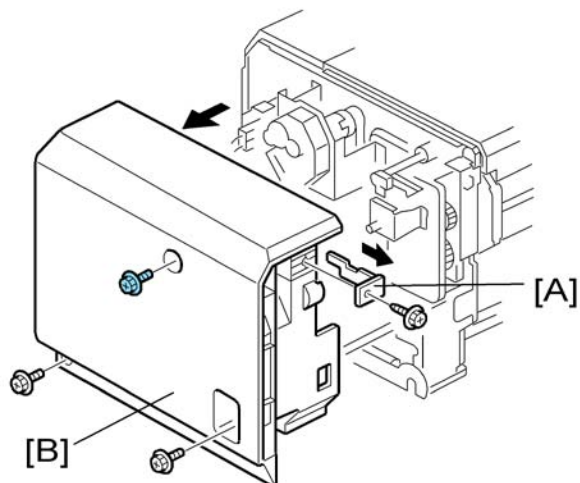

d353r102

1. Cover [A] (🔩 x 1)
2. Rear cover [B] (🔩 x 3)

1.1.2 RIGHT DOOR

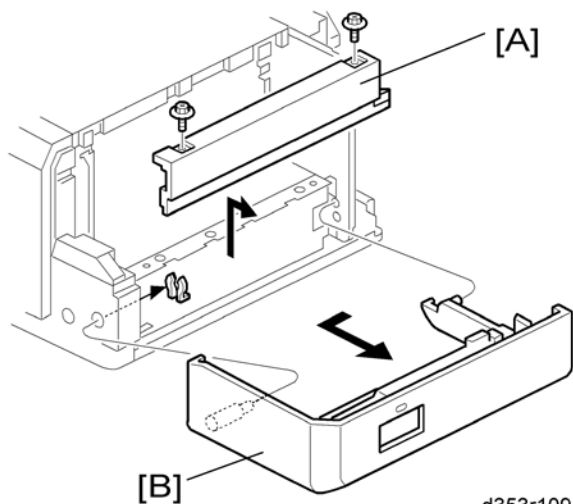

d353r109

1. Right lower cover [A] (🔩 x 2)
2. Right door [B] (🚪 x 1)

RT3020 -
1200-SHEET
LCT
(D631)

1.1.3 FRONT AND TOP COVERS

1. Right door (→ p.1 "Rear Cover")

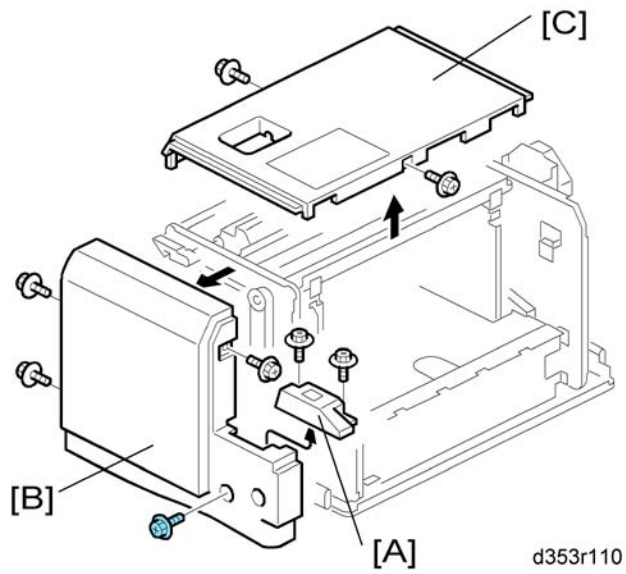

2. Switch cover [A] (🔩 x 2)
3. Front cover [B] (🔩 x 4)
4. Top cover [C] (🔩 x 2)

1.2 PAPER FEED

1.2.1 PICK-UP, PAPER FEED AND SEPARATION ROLLERS

1. Open the right door.

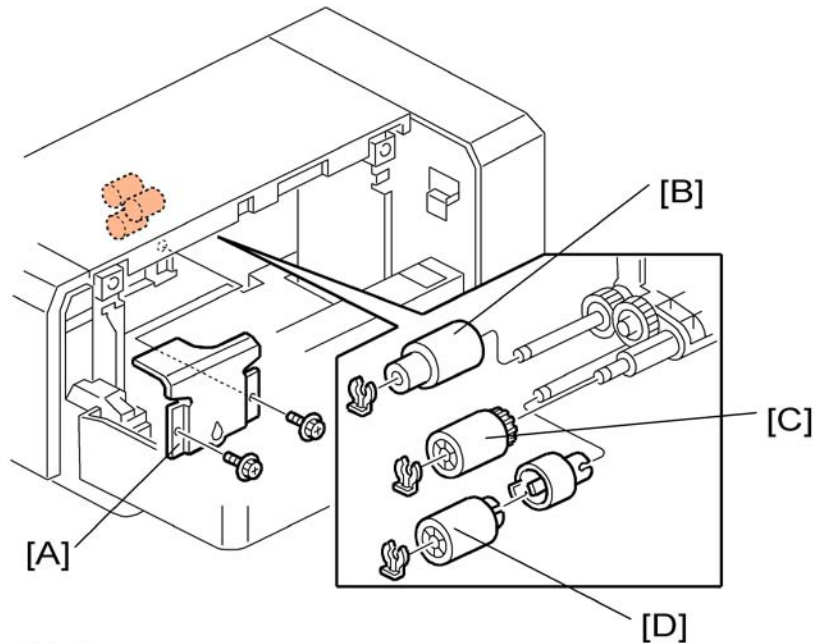

d353r101

2. Sensor bracket [A] (🔩 x 2)
3. Rollers [B], [C], [D] (🌀 x 1 each)
 - [B]: Paper feed roller
 - [C]: Pick-up roller
 - [D]: Separation roller

RT3020 -
1200-SHEET
LCT
(D631)

1.3 DRIVE

1.3.1 PAPER FEED CLUTCH

1. Rear cover (→ p.1 "Rear Cover")

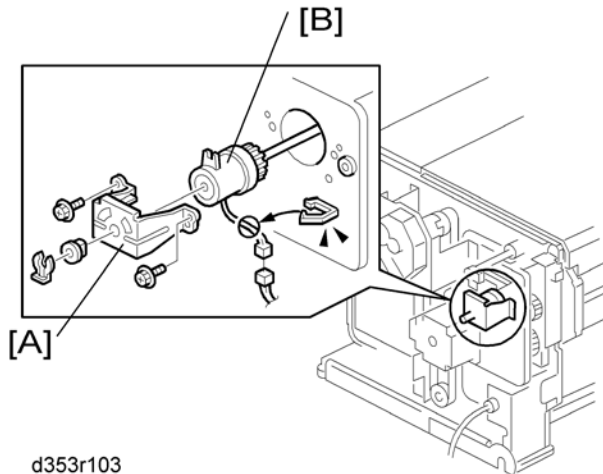

2. Bracket [A] (🔩 x 1, 🌀 x 2, bushing x 1)
3. Paper feed clutch [B] (🔩 x 1, 🌀 x 1)

1.3.2 PAPER FEED MOTOR

1. Rear cover (→ p.1 "Rear Cover")

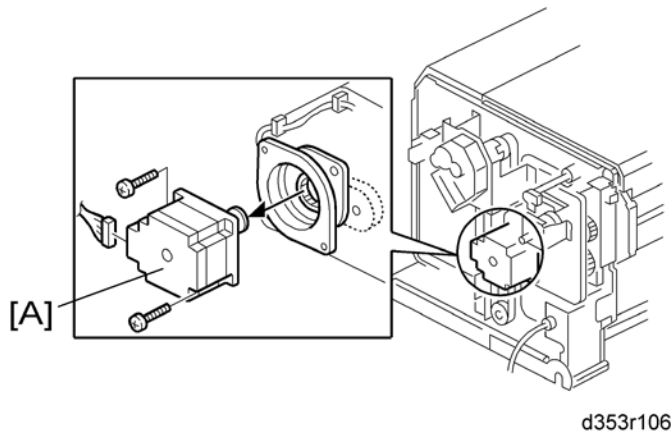

1. Paper feed motor [A] (🌀 x 2)

1.3.3 TRAY LIFT MOTOR

1. Rear cover (→ p.1 "Rear Cover")

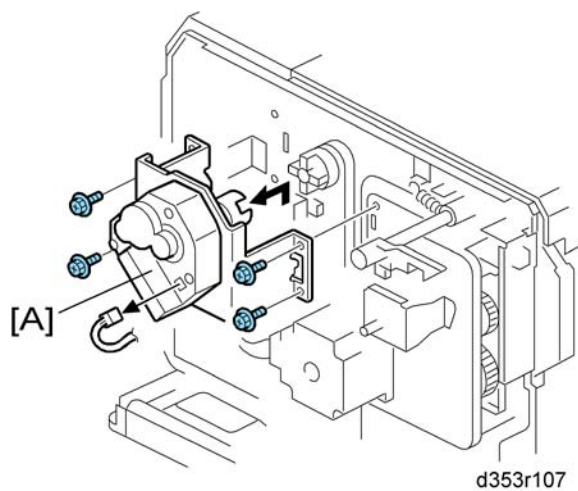

2. Tray lift motor unit [A] (⚙️ x 4, 📏 x 1)

RT3020 -
1200-SHEET
LCT
(D631)

1.4 ELECTRICAL COMPONENTS

1.4.1 MAIN BOARD

1. Rear cover (→ p.1 "Rear Cover")

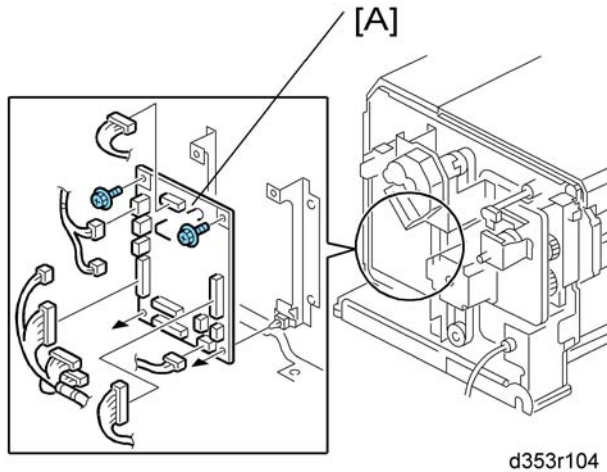

2. Main board (⌘ x 2, all ⌘'s)

1.4.2 LCT SET SWITCHES

Rear

1. Rear cover (→ p.1 "Rear Cover")

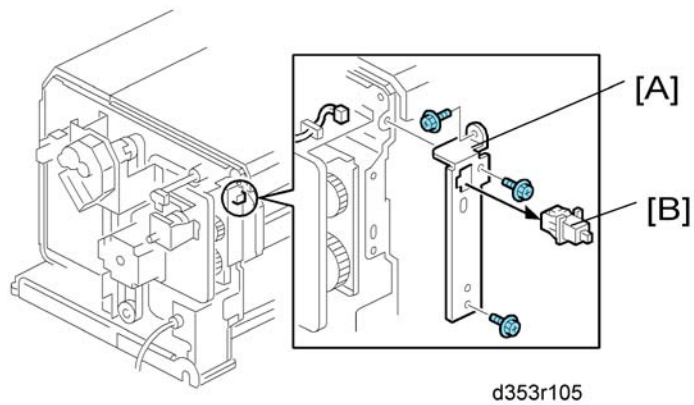

2. Switch bracket [A] (⌘ x 3)
3. Rear LCT set switch [B]

Front

1. Front cover (➔ p.2 "Front and Top Covers")

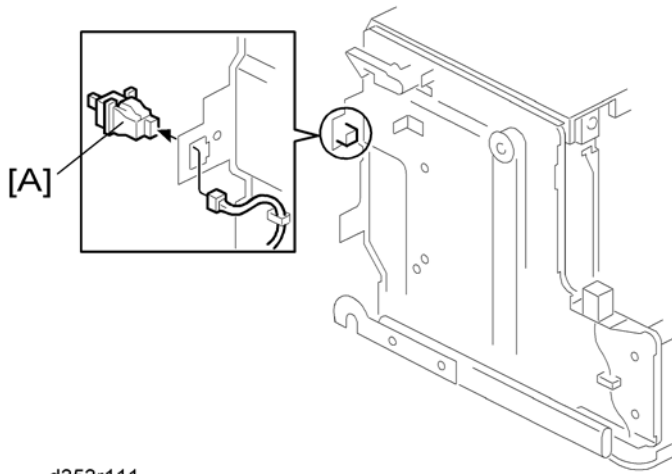

d353r111

2. Front LCT set switch [A] (🔌 x 1)

1.4.3 DOWN SWITCH

1. Front cover (➔ p.2 "Front and Top Covers")

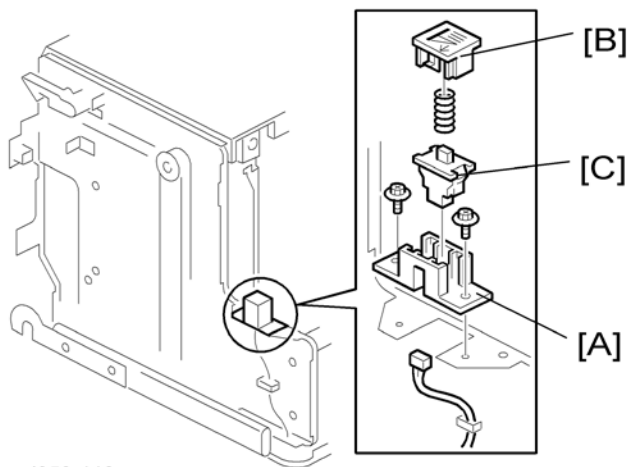

d353r112

2. Switch base [A] (🔌 x 2, 🔌 x 1)
3. Down button [B] (spring x 1)
4. Down switch [C] (hook)

RT3020 -
1200-SHEET
LCT
(D631)

1.4.4 PAPER FEED, PAPER END, TRAY LIFT AND RELAY SENSORS

1. Front cover (↔ p.2 "Front and Top Covers")
2. Top Cover (↔ Front and Top Covers)

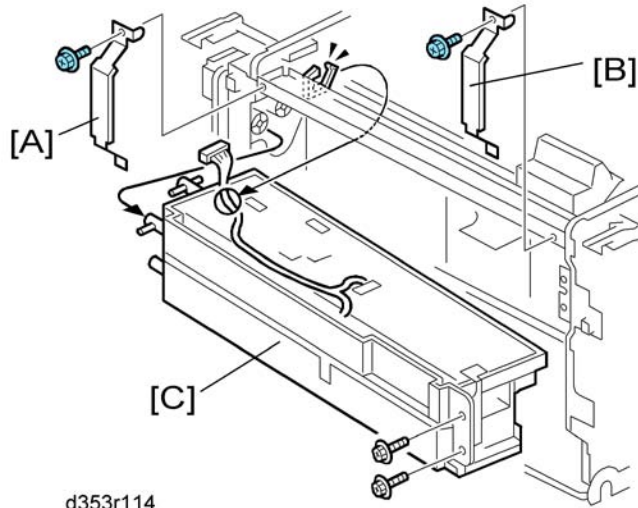

3. Rear ground plate [A] (⚙ x 1)
4. Front ground plate [B] (⚙ x 1)
5. Paper feed unit [C] (⚙ x 2, 📄 x 1, 📄 x 1)

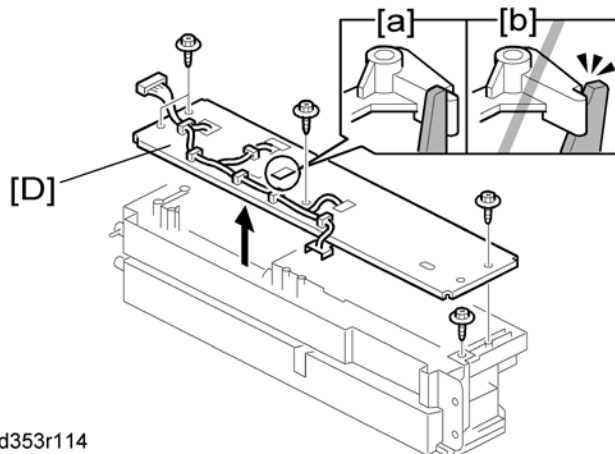

6. Paper feed unit cover [D] (⚙ x 5, 📄 x 1)

Note

- Before you re-install the paper feed unit cover, make sure that the pick-up solenoid holds the pick-up roller lever ([a]: correct, [b]: incorrect) and the pick-up roller works properly.

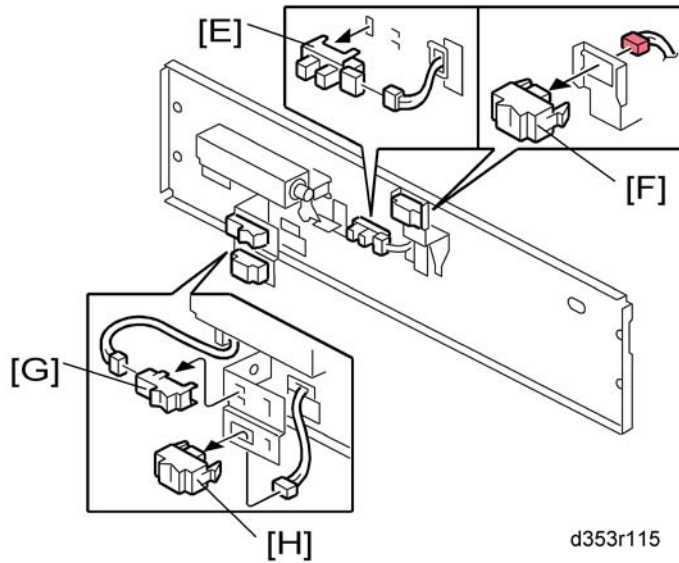

7. Sensors [E], [F], [G], [H] (☞ x 1, hooks each)
 - [E]: Tray lift sensor
 - [F]: Relay sensor
 - [G]: Paper feed sensor
 - [H]: Paper end sensor

1.4.5 STACK SENSOR

1. Open the right door
2. Paper feed unit (☞ p.8 "Paper Feed, Paper End, Tray Lift and Relay Sensors")

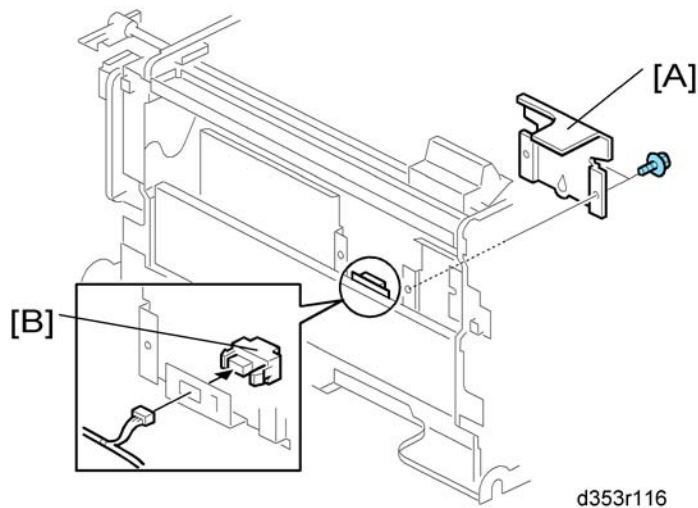

3. Sensor bracket [A] (☞ x 2)
4. Stack sensor [B] (☞ x 1)

1.5 SIDE FENCE POSITION CHANGE

1. Open the right door of the LCT.
2. Push the down switch to lower the tray bottom plate until it reaches its lowest position.

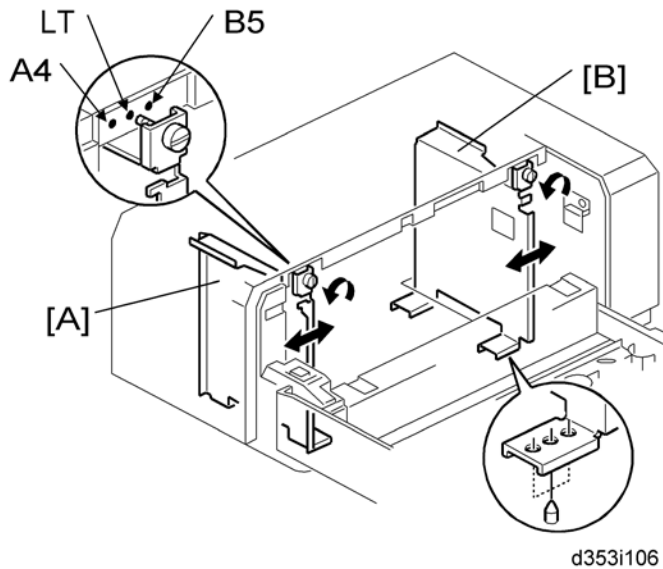

3. Remove the front and rear side fences [A, B] (1 x 1 each).
4. Install the side fences in the correct position (A4 LEF/ LT LEF/ B5 LEF).

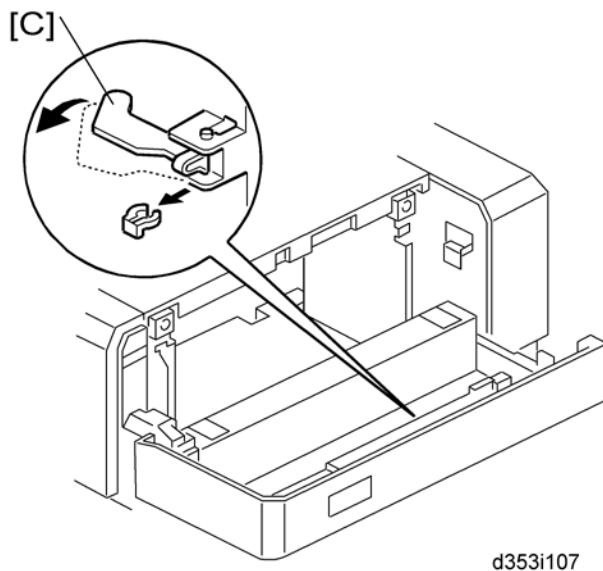

5. Pull the end fence [C] for B5 size paper as shown (1 x 1) if the the side fences are adjusted for B5 size paper.
6. Close the right door.
7. Turn on the main power switch, and then go into the SP mode.
8. Input the correct paper size for the 1200-sheet LCT with SP5181-017.

2. DETAILS

2.1 COMPONENT LAYOUT

2.1.1 COMPONENT LAYOUT

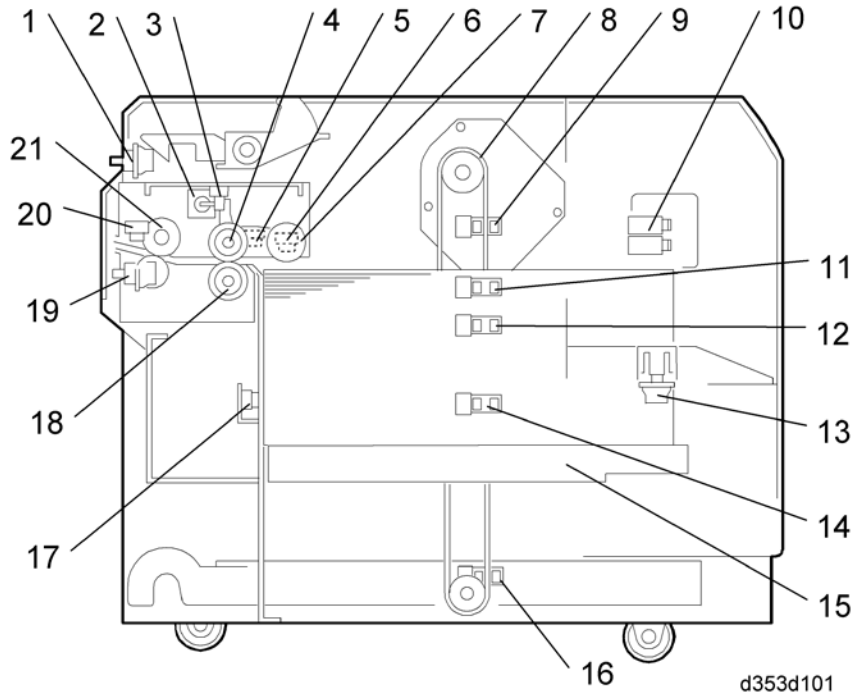

RT3020 -
1200-SHEET
LCT
(D631)

1. Rear LCT Set Switch
2. Pick-up Roller Solenoid
3. Tray Lift Sensor
4. Paper Feed Roller
5. Paper Feed Sensor
6. Paper End Sensor
7. Pick-up Roller
8. Tray Lift Motor
9. Paper Height Sensor 1
10. Interlock Switches
11. Paper Height Sensor 2

12. Sub Paper Height Sensor
13. Tray Down Switch
14. Paper Height Sensor 3
15. Paper Tray
16. Lower Limit Sensor
17. Stack Sensor
18. Separation Roller
19. Front LCT Set Switch
20. Relay Sensor 5
21. Relay Roller

2.1.2 ELECTRICAL COMPONENT LAYOUT

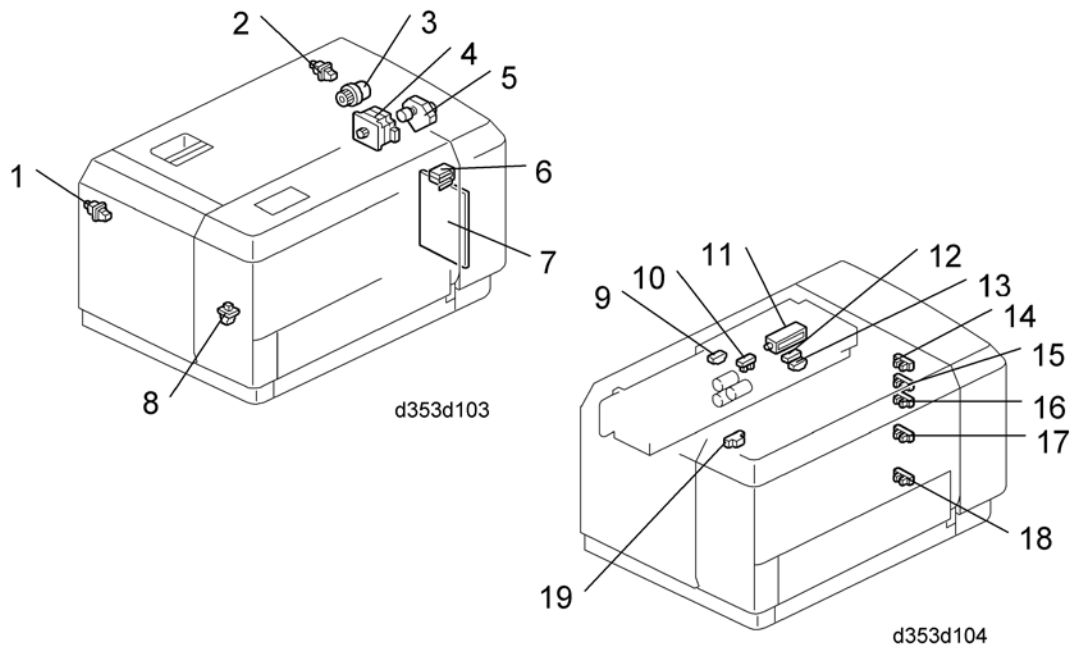

1. Front LCT Set Switch
2. Rear LCT Set Switch
3. Paper Feed Clutch
4. Paper Feed Motor
5. Tray Lift Motor
6. Interlock Switches
7. Main Board
8. Tray Down Switch
9. Relay Sensor
10. Tray Lift Sensor

11. Pick-up Roller Solenoid
12. Paper Feed Sensor
13. Paper End Sensor
14. Paper Height Sensor 1
15. Paper Height Sensor 2
16. Sub Paper Height Sensor
17. Paper Height Sensor 3
18. Lower Limit Sensor
19. Stack Sensor

2.1.3 ELECTRICAL COMPONENT DESCRIPTIONS

Symbol	Name	Function	Index No.
Motors			
M1	Paper Feed	Drives all rollers.	4
M2	Tray Lift	Drives the paper tray up or down.	5
Sensors			
S1	Paper Feed	Detects whether the paper is jammed at the LCT.	12
S2	Relay	Detects the copy paper coming to the relay roller and checks for misfeeds.	9
S3	Paper End	Informs the mainframe when the paper in the tray has been used up and indicates paper end.	13
S4	Tray Lift	Detects when the paper is at the correct paper feed height.	10
S5	Paper Height 1	Detects the amount of paper remaining in the tray.	14
S6	Paper Height 2		15
S7	Sub Paper Height		16
S8	Paper Height 3		17
S9	Lower Limit		Detects when the tray is completely lowered, to stop the tray lift motor.

RT3020 -
1200-SHEET
LCT
(D631)

Component Layout

Symbol	Name	Function	Index No.
S10	Stack	Detects a) when the tray has moved down to the paper supply position after paper end, to stop the tray lift motor or b) when the top of the paper stack has moved down to the paper supply position, to stop the tray lift motor after the down switch has been pressed.	19
Switches			
SW1	Right Door	Detects whether the right door is open and starts to drive the tray lift motor.	6
SW2	Front LCT Set	Detects whether the LCT is correctly set.	1
SW3	Rear LCT Set	Detects whether the LCT is correctly set.	2
SW4	Down	Lowers the tray to the paper supply position if pressed.	8
Magnetic Clutches			
MC1	Paper Feed	Drives the paper feed unit.	3
Solenoids			
SOL1	Pick-up	Pushes the pick-up roller up or down.	11
PCBs			
PCB1	Main	Controls the LCT and communicates with the copier/printer.	7

2.1.4 DRIVE LAYOUT

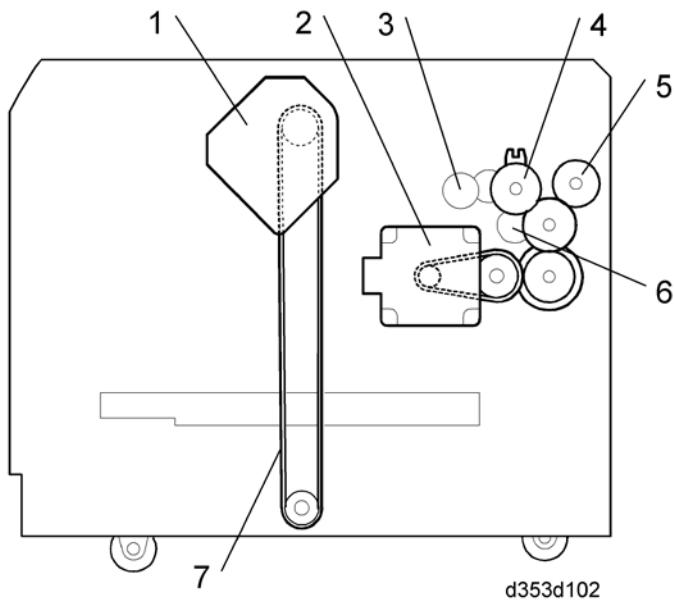

1. Tray Lift Motor

2. Paper Feed Motor

3. Pick-up Roller

4. Paper Feed Clutch

5. Relay Roller

6. Separation Roller

7. Tray Drive Belt

RT3020 -
1200-SHEET
LCT
(D631)

2.2 PAPER FEED

2.2.1 PAPER FEED MECHANISM

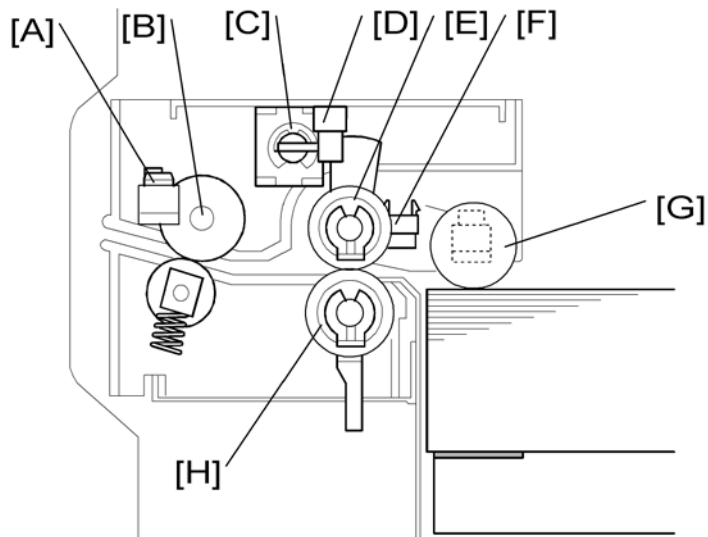

d353d105

This machine uses the FRR paper feed system (paper feed roller [E], separation roller [H], pick-up roller [G]).

When the right door is closed, the tray lift motor raises the tray to the position where the top of the paper stack in the tray interrupts the tray lift sensor [D]. The paper feed motor switches on, then the pick-up solenoid [C] switches off and the pick-up roller drops onto the top of the stack of paper. The paper feed clutch transfers drive to the paper feed roller [E], pick-up roller [G] and separation roller [H].

The rotating pick-up roller lowers and feeds the first sheet when it contacts the top of the stack.

The separation roller [H], in contact with the feed roller, only allows one sheet out of the tray.

As soon as the paper feed sensor [F] detects the leading edge of the paper, it switches off the pick-up solenoid which raises the pick-up roller. The feed roller feeds the sheet to the registration roller in the main machine through the relay roller [B].

This process is repeated for each sheet.

The paper feed sensor [F] detects "JAM7" and the relay sensor [A] detects "JAM58".

2.2.2 TRAY LIFT MECHANISM

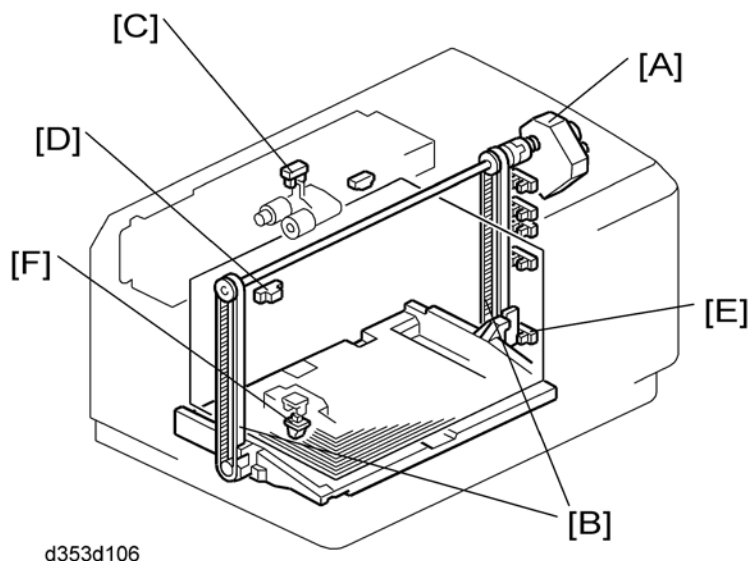

The lift motor [A] controls the vertical position of the tray through the timing belts [B].

Tray lifting conditions

When the tray lift sensor [C] turns off in the following conditions, the tray lift motor raises the tray bottom plate until the tray lift sensor [C] turns on again.

- Just after the main switch is turned on
- During copying
- Just after the tray cover is closed
- Just after leaving the energy saving mode

Tray lowering conditions (Paper supply position)

In the following conditions, the tray lift motor lowers the tray until the stack sensor [D] turns on (this is the correct tray position for supplying paper).

- Just after the paper end sensor turns on
- Just after the down switch is pressed by the user

Tray lowering conditions (Full-down position)

In the following condition, the tray lift motor lowers the tray until the lower limit sensor [E] turns on (this is the correct tray position for adding 500 sheets of paper after installing the first stack of paper in the LCT tray).

- Just after the down switch [F] is pressed for 3 seconds or more when the tray is at the paper supply position.

RT3020 -
1200-SHEET
LCT
(D631)

2.2.3 PAPER HEIGHT AND END DETECTION

Paper Height

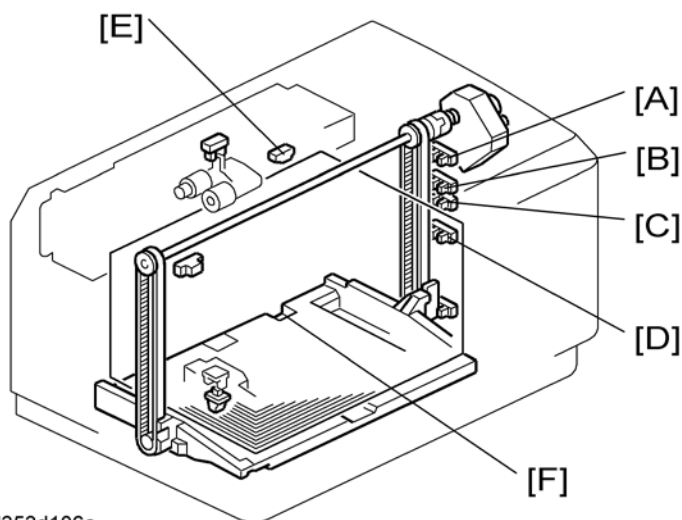

d353d106a

The amount of the paper in the tray is detected by combination of high (1)/low (0) outputs from three sensors (paper height sensor 1 [A], 2 [B], 3 [D] and sub paper height sensor [C]).

Amount of paper	PH S-1	PH S-2	PH S-3	Sub PH S	Indicator on the operation panel
100%	0	0	0	0	Four lines
70%	0	0	1	-	Three lines
	0	0	0	1	
30%	0	1	-	-	Two lines
10%	1	-	-	-	One line
End	-	-	-	-	No line

0: No interruption (low), 1: Interruption (high), -: No checking

PH S: Paper Height Sensor

Paper End

The paper end sensor [E] monitors the light reflected by each sheet on top of the stack.

When the last sheet feeds, the cutout [F] is exposed, and the paper end sensor receives no reflected light from below because there is no paper. As a result, this signals paper end.

RT3020 -
1200-SHEET
LCT
(D631)

D632

1 BIN TRAY BN3100

REVISION HISTORY		
Page	Date	Added/Updated/New
		None

1 BIN TRAY BN3100 (D632)

TABLE OF CONTENTS

1. REPLACEMENT AND ADJUSTMENT.....	1
1.1 ELECTRICAL COMPONENTS	1
1.1.1 PAPER SENSOR.....	1
1.1.2 1-BIN CONTROL BOARD	3

Read This First

Safety and Symbols

Replacement Procedure Safety

CAUTION

- Turn off the main power switch and unplug the machine before beginning any of the replacement procedures in this manual.

Symbols Used in this Manual

This manual uses the following symbols.

: See or Refer to

: Screws

: Connector

: Clip ring

: E-ring

1. REPLACEMENT AND ADJUSTMENT

1.1 ELECTRICAL COMPONENTS

1.1.1 PAPER SENSOR



d129r800

1. Open the right door of the machine [A].



d129r820

2. Remove the front right cover [A] ( x 1).

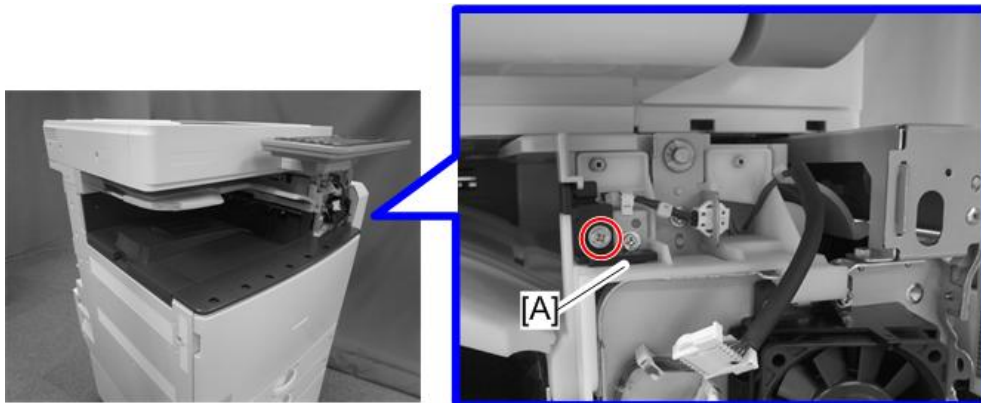

d632r106

3. Harness cover [A] ( x 1)

1 Bin Tray
BN3100
(D632)

Electrical Components

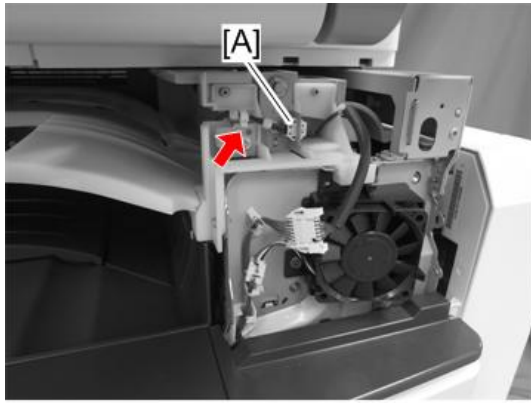

d632r101

4. Disconnect the connector of the 1-bin tray [A] (🔧 x 1).

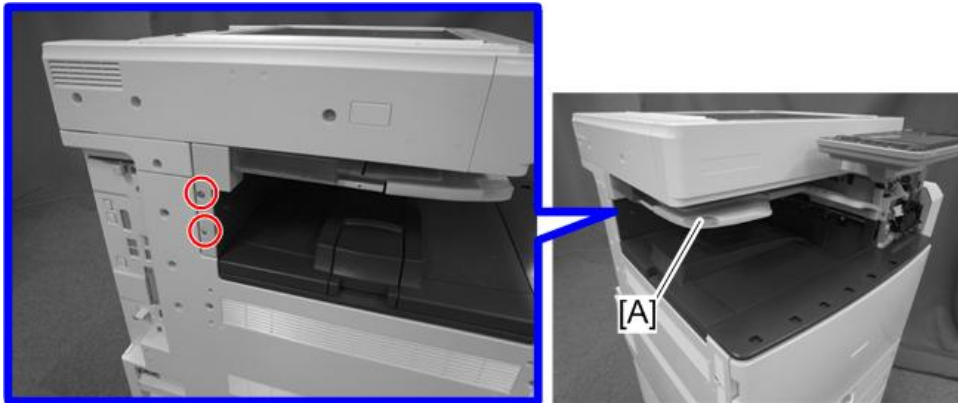

d632r100

5. 1-bin tray [A] (🔧 x 2)

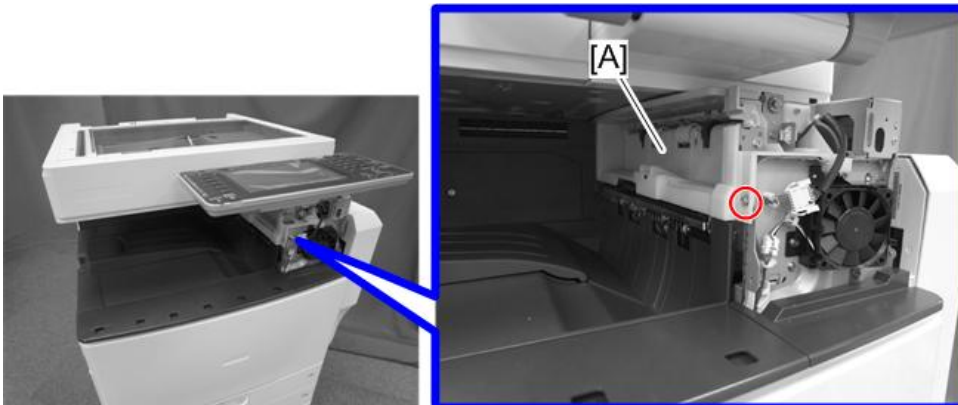

d632r102

6. 1-bin sorter unit [A] (🔧 x 1)

1 Bin Tray
BN3100
(D632)



- 7. Paper sensor cover [A] (🔧 x 2)

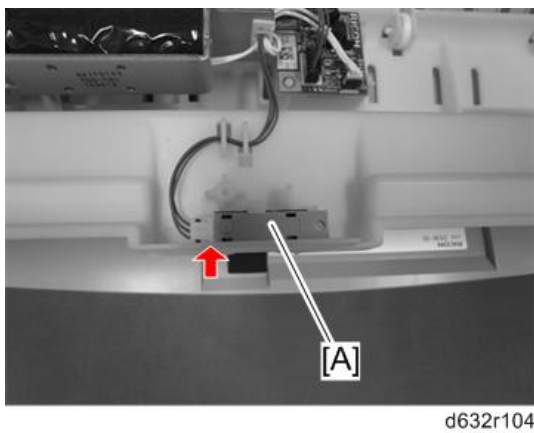

- 8. Paper sensor [A] (🔧 x 1, hook)

1.1.2 1-BIN CONTROL BOARD

- 1. 1-bin tray (🔧 p.1 "Paper Sensor")
- 2. 1-bin sorter unit (🔧 p.1 "Paper Sensor")

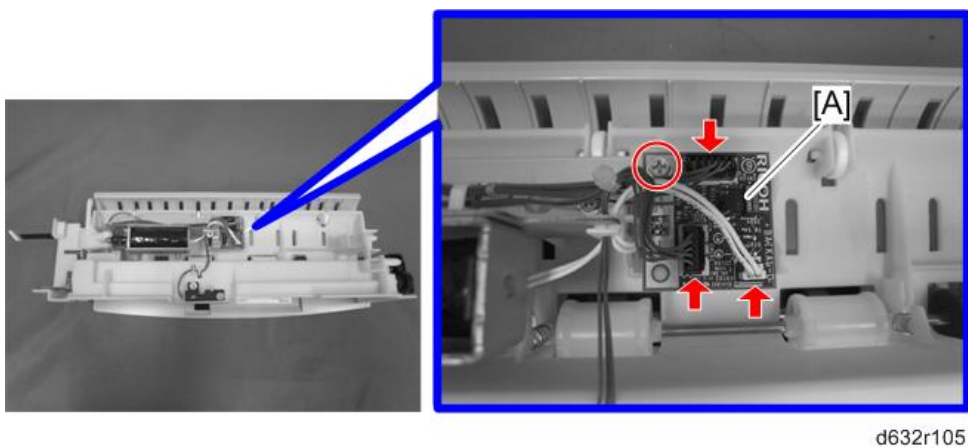

- 3. 1-bin control board [A] (🔧 x 1, 📄 x 3)

D388/D633
INTERNAL SHIFT TRAY
SH3040/SH3060

REVISION HISTORY		
Page	Date	Added/Updated/New
		None

INTERNAL SHIFT TRAY SH3040/SH3060 (D388/D633)

TABLE OF CONTENTS

1. REPLACEMENT AND ADJUSTMENT.....	1
1.1 TRAY COVER.....	1
1.2 TRAY MOTOR AND HALF TURN SENSOR BOARD.....	2

Read This First

Safety and Symbols

Replacement Procedure Safety

CAUTION

- Turn off the main power switch and unplug the machine before beginning any of the replacement procedures in this manual.

Symbols Used in this Manual

This manual uses the following symbols.

: See or Refer to

: Screws

: Connector

: Clip ring

: Clamp

: E-ring

1. REPLACEMENT AND ADJUSTMENT

1.1 TRAY COVER

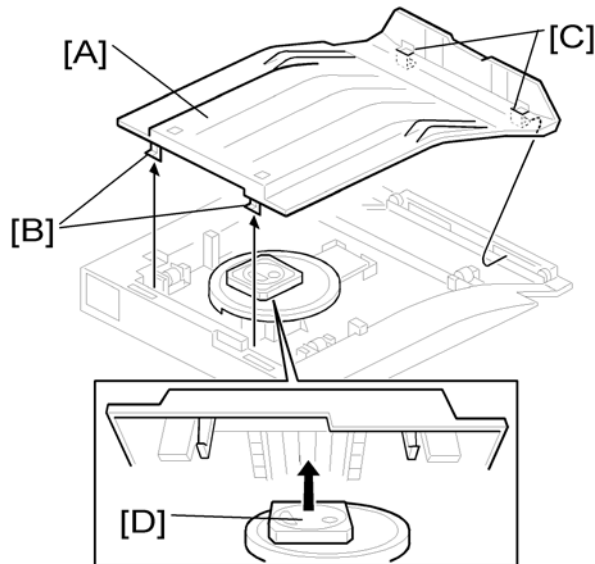

1. Remove the tray cover [A] by pressing on the two pawls [B] on the left side of the cover.

– When Attaching the Tray Cover –

↓ Note

- The right side of the tray cover should be attached first.
1. Fit the pawls [C] on the shift tray.
 2. Align the square [D] so that it fits into the groove in the underside of the tray cover and does not interfere with the attachment of the cover.
 3. Complete the attachment by inserting the left side pawls [B] into place.

1.2 TRAY MOTOR AND HALF TURN SENSOR BOARD

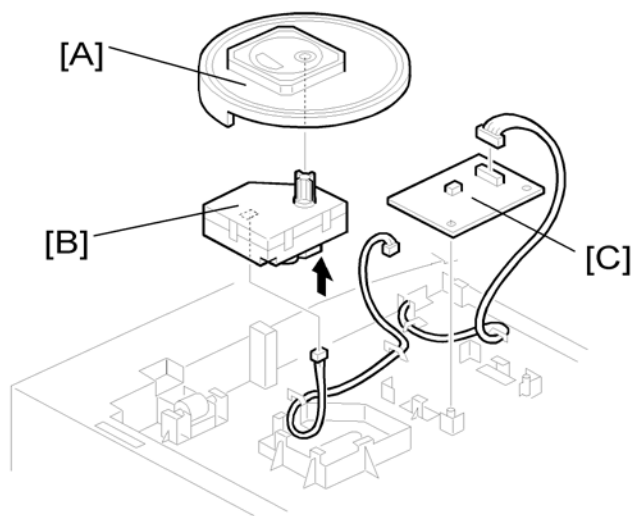

1. Top cover (➔ p.1 "Tray Cover")
2. Slip disc [A]
3. Tray motor [B] (🔌 x 1)
4. Half turn sensor board [C] (🔌 x 1).

D643-01

FAX OPTION TYPE C5502

REVISION HISTORY		
Page	Date	Added/Updated/New
23 ~ 31	07/13/2012	Updated <i>Fax Connection Unit Type B Installation</i> .

FAX OPTION TYPE C5502 (D643-01)

TABLE OF CONTENTS

1. INSTALLATION	1
1.1 FAX UNIT (D643-01)	1
1.1.1 COMPONENT CHECK.....	1
1.1.2 INSTALLATION PROCEDURE	2
1.1.3 FAX ICON ADDITION.....	9
1.2 G3 INTERFACE UNIT (D643-11)	11
1.2.1 COMPONENT CHECK.....	11
1.2.2 INSTALLATION PROCEDURE	12
1.3 FAX UNIT OPTIONS	18
1.3.1 MEMORY UNIT (G578)	18
1.3.2 HANDSET (D645-27).....	20
1.4 FAX CONNECTION UNIT TYPE B (REMOTE FAX) INSTALLATION.....	23
1.4.1 INSTALLATION PROCEDURE (D645-19)	23
2. REPLACEMENT AND ADJUSTMENT	32
2.1 FCU	32
2.1.1 SRAM DATA TRANSFER PROCEDURE.....	32
3. TROUBLESHOOTING	42
3.1 ERROR CODES	42
3.2 IFAX TROUBLESHOOTING	64
3.3 IP-FAX TROUBLESHOOTING	67
3.3.1 IP-FAX TRANSMISSION	67
3.3.2 IP-FAX RECEPTION	71
4. SERVICE TABLES	75
4.1 CAUTIONS	75
4.2 SERVICE PROGRAM TABLES.....	76
4.2.1 SP1-XXX (BIT SW).....	76
4.2.2 SP2-XXX (RAM)	78
4.2.3 SP3-XXX (MACHINE SET).....	79
4.2.4 SP4-XXX (ROM VERSIONS)	81
4.2.5 SP5-XXX (RAM CLEAR)	82

4.2.6 SP6-XXX (REPORTS)	83
4.2.7 SP7-XXX (TESTS).....	86
4.3 BIT SWITCHES - 1	88
4.3.1 SYSTEM SWITCHES	88
4.4 BIT SWITCHES - 2	104
4.4.1 I-FAX SWITCHES.....	104
4.4.2 PRINTER SWITCHES	112
4.5 BIT SWITCHES - 3	120
4.5.1 COMMUNICATION SWITCHES.....	120
4.6 BIT SWITCHES - 4	131
4.6.1 G3 SWITCHES	131
4.7 BIT SWITCHES - 5	142
4.7.1 G3-2 AND G3-3 SWITCHES	142
4.7.2 G4 INTERNAL SWITCHES	151
4.7.3 G4 PARAMETER SWITCHES.....	151
4.8 BIT SWITCHES - 6	152
4.8.1 IP FAX SWITCHES.....	152
4.9 NCU PARAMETERS	162
4.10 DEDICATED TRANSMISSION PARAMETERS.....	177
4.10.1 PROGRAMMING PROCEDURE	177
4.10.2 PARAMETERS	178
4.11 SERVICE RAM ADDRESSES	186
5. DETAILED SECTION DESCRIPTIONS	197
5.1 OVERVIEW.....	197
5.2 BOARDS.....	198
5.2.1 FCU	198
5.2.2 SG3 BOARD.....	199
5.3 VIDEO DATA PATH.....	201
5.3.1 TRANSMISSION	201
5.3.2 RECEPTION.....	203
5.4 FAX COMMUNICATION FEATURES.....	204
5.4.1 MULTI-PORT	204
5.4.2 DOCUMENT SERVER	205
5.4.3 INTERNET MAIL COMMUNICATION.....	206
5.5 IP-FAX	216
5.5.1 WHAT IS IP-FAX?	216
5.5.2 T.38 PACKET FORMAT	216
5.5.3 SETTINGS.....	216

6. SPECIFICATIONS	217
6.1 GENERAL SPECIFICATIONS	217
6.1.1 FCU	217
6.2 CAPABILITIES OF PROGRAMMABLE ITEMS	219
6.3 IFAX SPECIFICATIONS	221
6.4 IP-FAX SPECIFICATIONS.....	223
6.5 FAX UNIT CONFIGURATION.....	224

READ THIS FIRST

Important Safety Notices

WARNING

- Never install telephone wiring during a lightning storm.
- Never install telephone jacks in wet locations unless the jack is specifically designed for wet locations.
- Never touch uninsulated telephone wires or terminals unless the telephone line has been disconnected at the network interface.
- Use caution when installing or modifying telephone lines.
- Avoid using a telephone (other than a cordless type) during an electrical storm. There may be a remote risk of electric shock from lightning.
- Do not use a telephone or cellular phone to report a gas leak in the vicinity of the leak.

CAUTION

- Before installing the fax unit, switch off the main switch, and disconnect the power cord.
- The fax unit contains a lithium battery. The danger of explosion exists if a battery of this type is incorrectly replaced. Replace only with the same or an equivalent type recommended by the manufacturer. Discard batteries in accordance with the manufacturer's instructions and local regulations.







Note

- **Note for Australia:**
- Unit must be connected to Telecommunication Network through a line cord that meets the requirements of ACA Technical Standard TS008.

Symbols and Abbreviations

Conventions Used in this Manual

This manual uses several symbols.

Symbol	What it means
	Refer to section number
	Screw
	Connector
	E-ring
	Clip ring
	Clamp



Cautions, Notes, etc.

The following headings provide special information:

WARNING

- Failure to obey warning information could result in serious injury or death.

CAUTION

- Obey these guidelines to ensure safe operation and prevent minor injuries.

Important.

- Obey these guidelines to avoid problems such as misfeeds, damage to originals, loss of valuable data and to prevent damage to the machine.**
- Always obey these guidelines to avoid serious problems such as misfeeds, damage to originals, loss of valuable data and to prevent damage to the machine. bold is added for emphasis.**

Note

- This document provides tips and advice about how to best service the machine.

1. INSTALLATION

1.1 FAX UNIT (D643-01)

1.1.1 COMPONENT CHECK

Check the quantity and condition of the components against the following list.

No.	Description	Q'ty
1	FCU I/F Board	1
2	FCU	1
3	FCU I/F Board Bracket	1
4	Support Bracket	1
5	Speaker	1
6	Modular Bracket	1
7	Telephone Cable (NA only)	1
8	Harness: TEL and LINE	2
9	Serial Number Decal	1
10	FCC Decal (NA only)	1
11	Ferrite Core	1 (NA), 3 (EU), 2 (Others)
12	Screw: M3x6	13
13	Clamp	3
14	Fax Key top decal	2
15	EMC Address Decal	1 (EU Only)
16	Quick Reference Fax Guide	1 (Excluding EU)

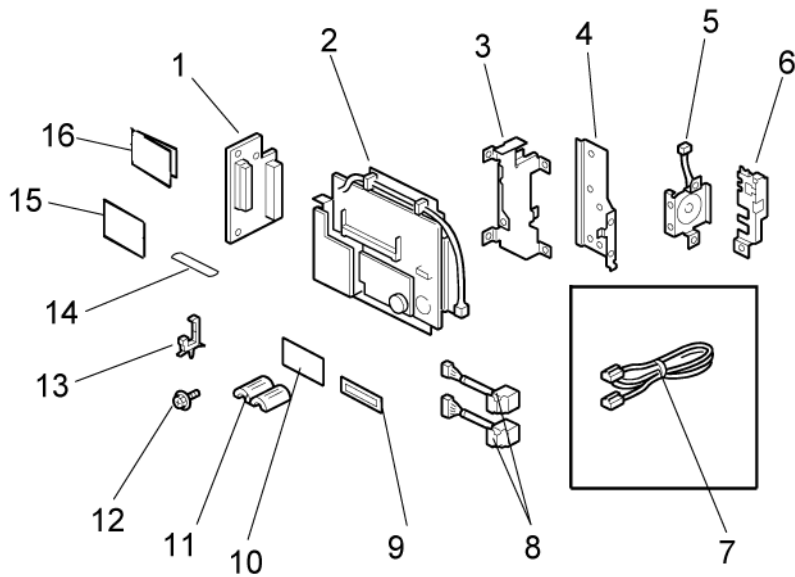

d545i100a

1.1.2 INSTALLATION PROCEDURE

CAUTION

- Before installing this fax unit:
- Print out all data in the printer buffer.
- Turn off the main power switch and disconnect the power cord and the network cable.



d1420055

1. Remove the controller box cover [A] (🔩 x 3).

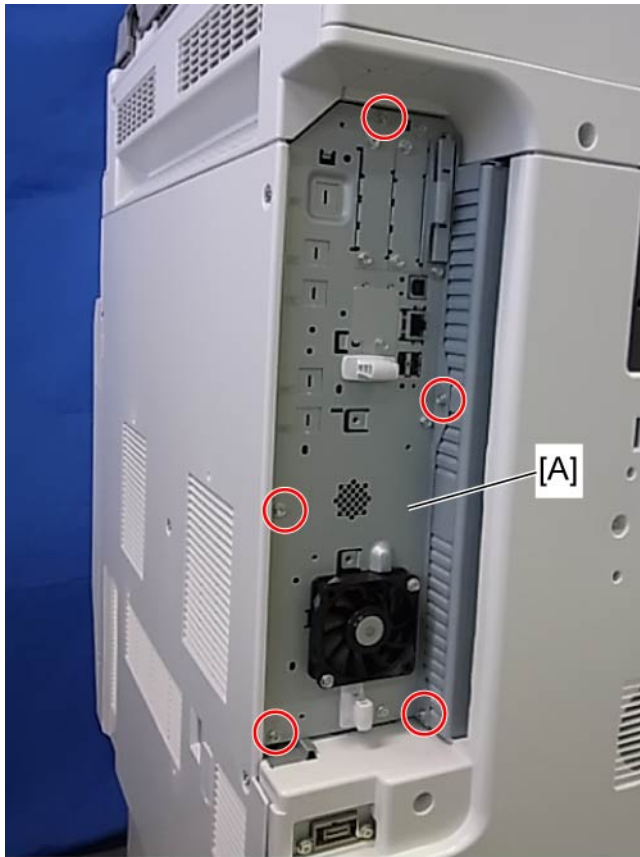

d1420056

2. Remove the controller box [A] (🔩 x 5).

Fax Unit (D643-01)

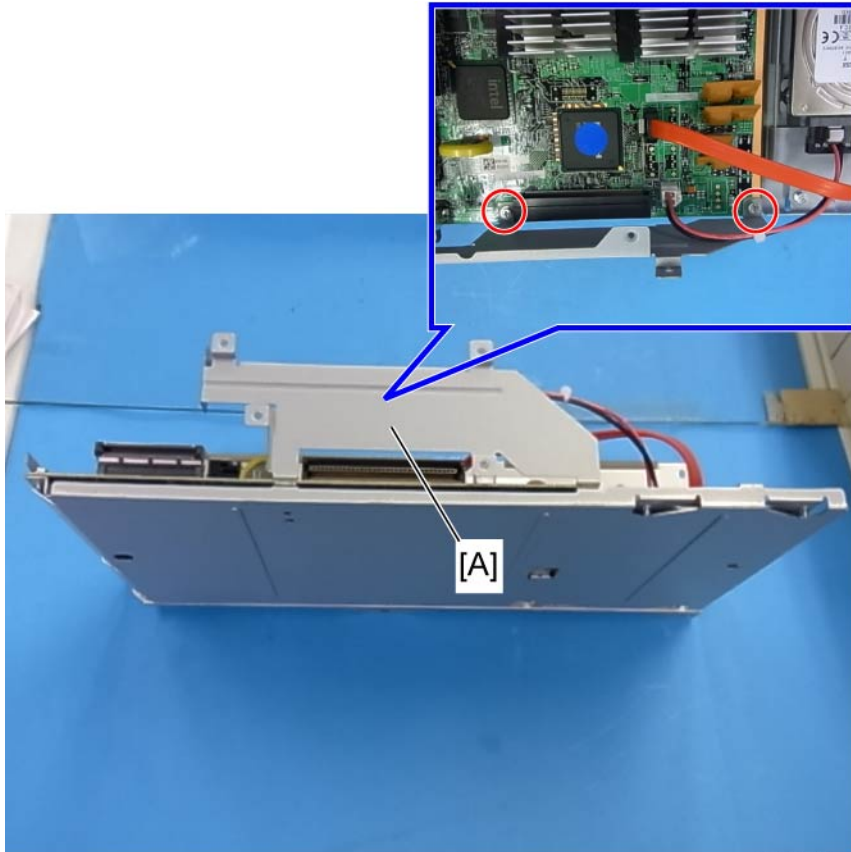

d1420057

3. Attach the FCU I/F board bracket [A] to the controller board (🔩 x 2).

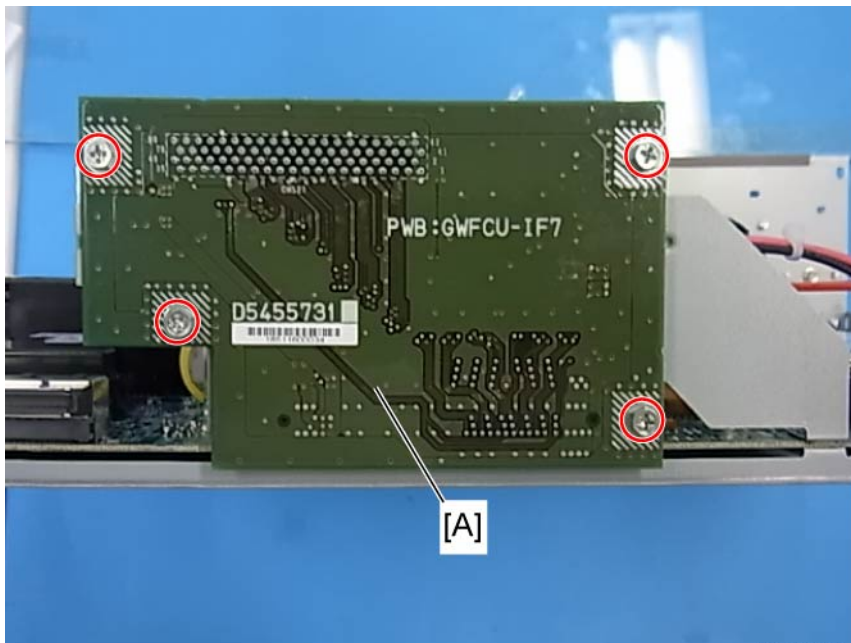

d1420058

4. Attach the FCU I/F board [A] to the FCU I/F board bracket (🔩 x 4).

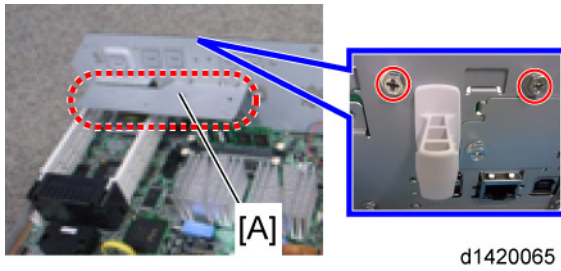

5. Attach the support bracket [A] to the controller box (🔩 x 2).

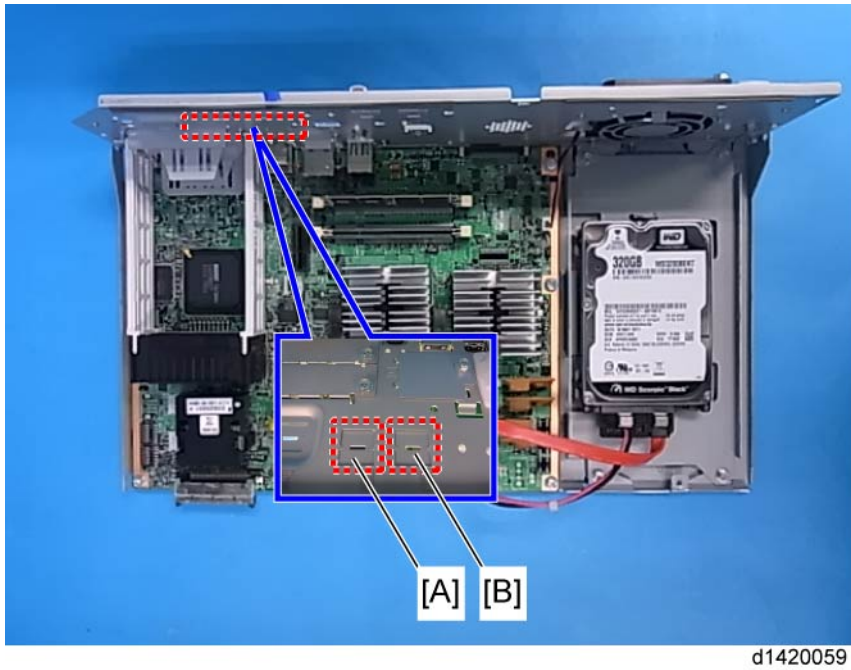

6. Remove the "TEL" [B] and "LINE1" [A] covers with a screw driver.

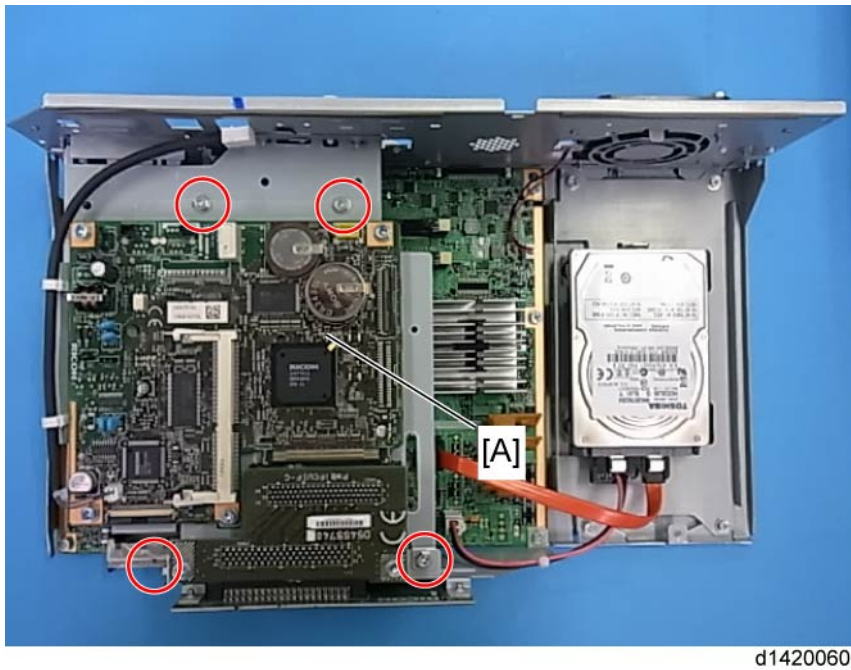

7. Install the FCU [A] to the controller board (🔩 x 4).

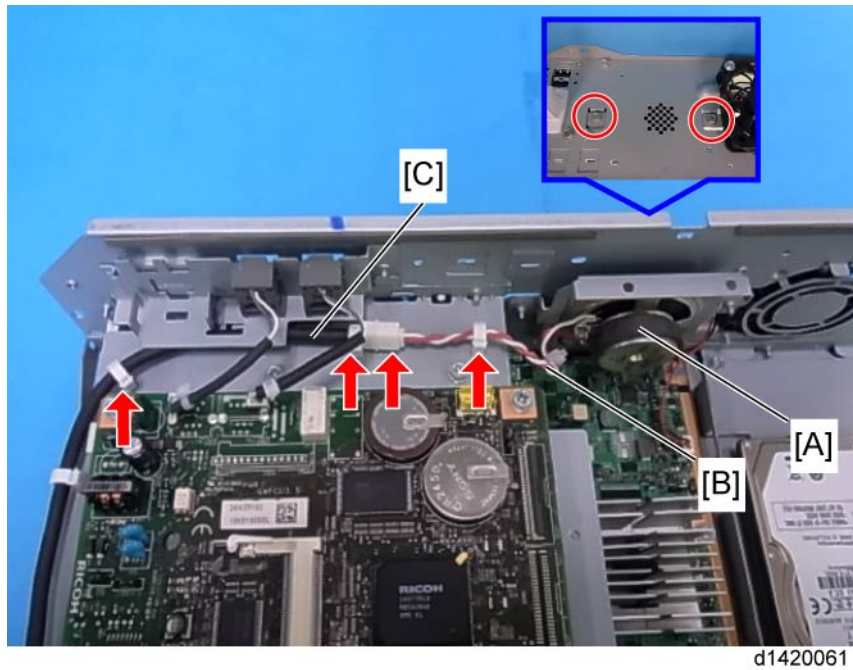

d1420061

8. Install the speaker [A] to the controller box (🔧 x 2) and connect the speaker cable [B] with the speaker relay cable [C] (🔧 x 1, 📧 x 3).

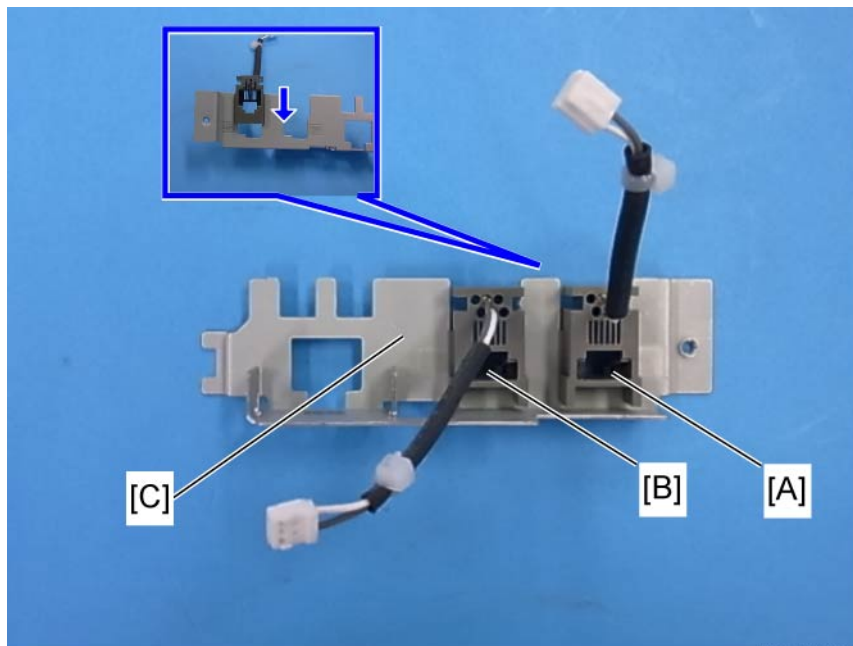

d1420062

9. Connect the two modular harnesses [A] (TEL), [B] (LINE1) to the modular bracket [C].

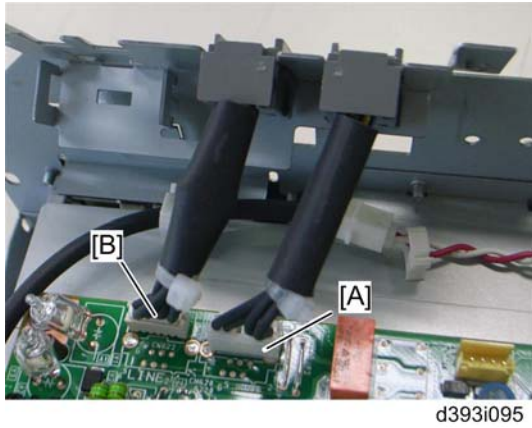

10. Connect the two modular harnesses [A] (TEL), [B] (LINE1) to the FCU.

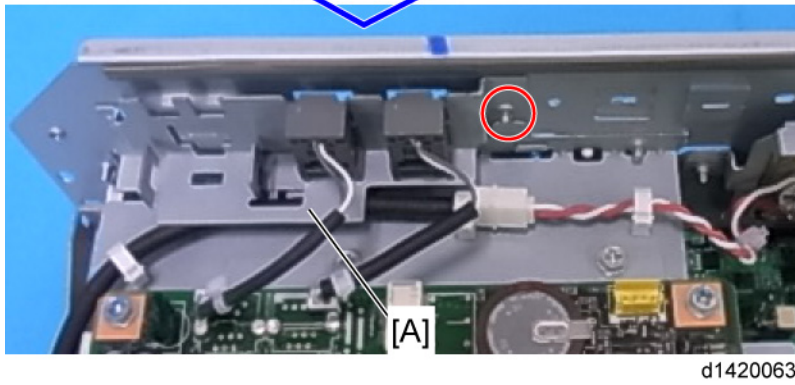

11. Attach the modular bracket [A] to the controller box (🔩 x 1).

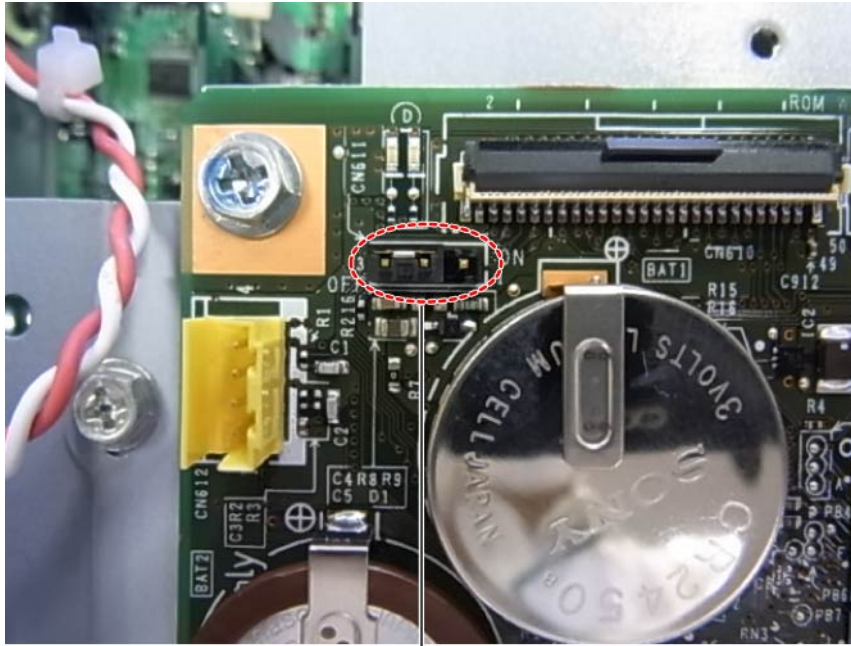

[A]

d1420064

12. Switch the battery jumper switch [A] to "ON" position.
13. Reinstall the controller box.
14. Attach the handset support bracket and handset bracket to the copier, and then connect the handset cord with the ferrite core to the "TEL" jack if you install the handset to the machine.

↓ Note

- For details, refer to the "Hand Set Installation" in the Service Manual for the Fax Unit (D643).

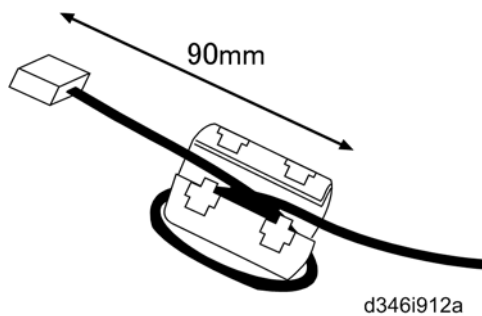

15. Attach the ferrite core to the telephone cord.
16. Connect the telephone cord to the "LINE 1" jack.

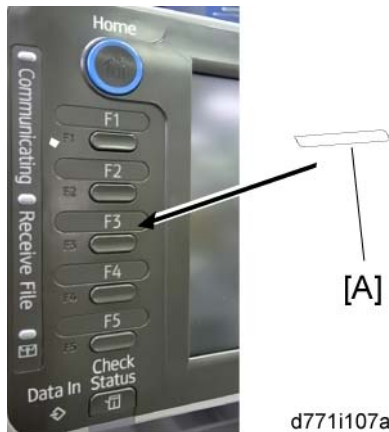

d771i107a

17. Attach the fax key decal [A] to the third key top from bottom.
18. Attach the serial number decal under the copier serial number decal on the rear cover of the machine.
19. Attach FCC decal on the rear cover of the machine (NA only).
20. Put the power plug into the outlet and turn on the main power of the machine.

↓ Note

- Make sure that the outlet is grounded.
 - "SRAM formatted" shows on the operation panel after you have turned the main switch on. Turn the main switch off and on again for normal use.
21. Make sure that the date and time are correctly set.

1.1.3 FAX ICON ADDITION

This procedure allows the fax icon to appear on the home screen of the operation panel.

1. Press [User Tools].

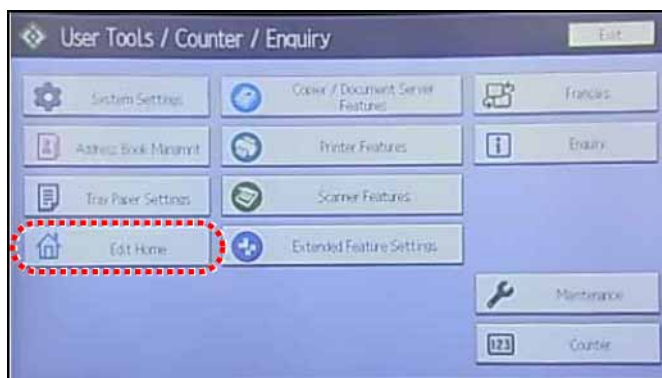

d1440144

2. Press [Edit Home].

Fax Unit (D643-01)

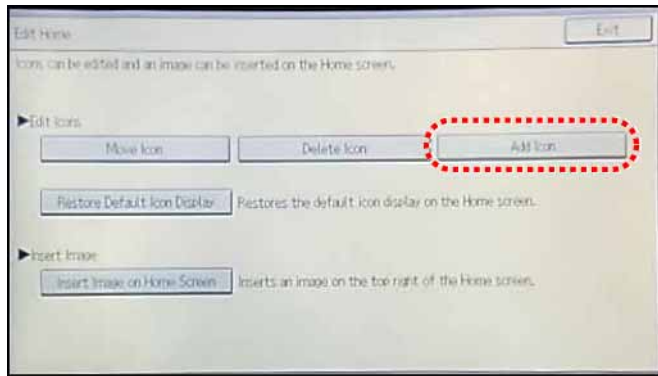

d1440145

3. Press [Add Icon].

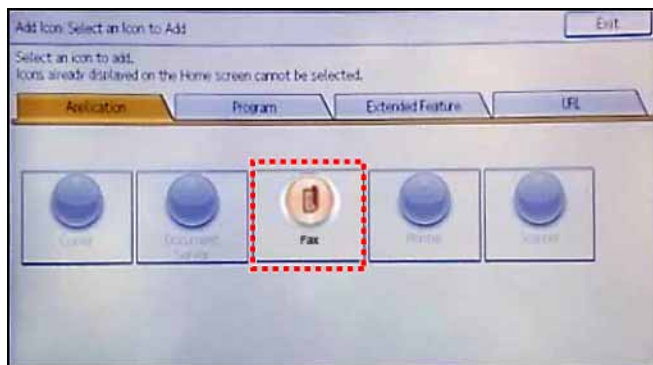

d1440146

4. Press [Fax].

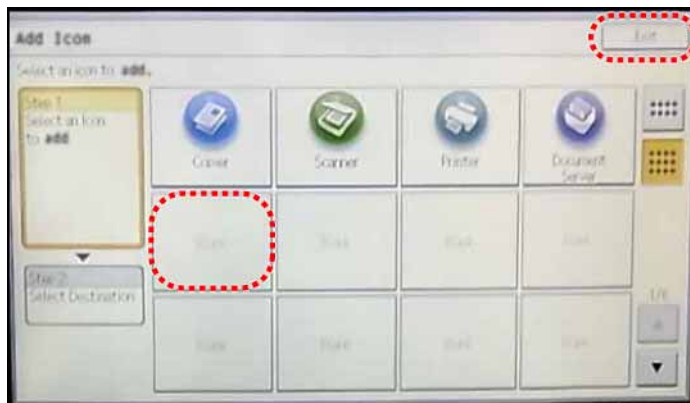

d1440147

5. Press a [Blank] to set a location for the fax icon.
6. Press [Exit] to end the fax icon addition.

1.2 G3 INTERFACE UNIT (D643-11)

1.2.1 COMPONENT CHECK

Check the quantity and condition of the components against the following list.

No.	Description	Q'ty
1	SG3 Interface Unit	1
2	Modular Bracket for SG3	1
3	Clamp	2
4	Clamp	4
5	Screw: M3x6	6
6	Ferrite Core	1
7	Telephone Cable (NA only)	1
8	Flat Cable	1
9	Harness	1
10	EMC Address Decal (EU only)	1
11	FCC Decal (NA only)	1

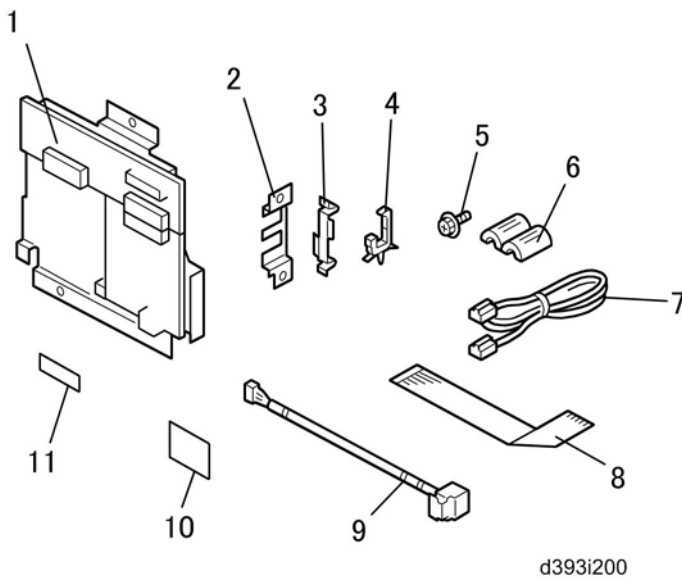

1.2.2 INSTALLATION PROCEDURE

⚠ CAUTION

- **Before installing this optional unit:**
- Print out all data in the printer buffer.
- Turn off the main switch and disconnect the power cord and the network cable.

You can add two more SG3 boards to this model. Follow the procedures for adding the single SG3 board installation or double SG3 boards installation as a customer needs.

For Installing the single G3 Board

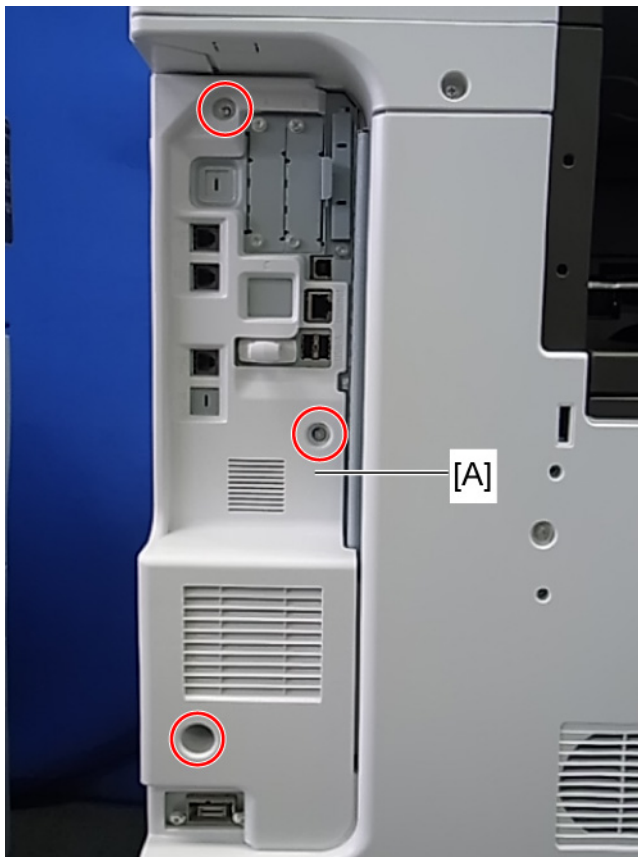

d1420076

1. Remove the controller box cover [A] (🔩 x 3).

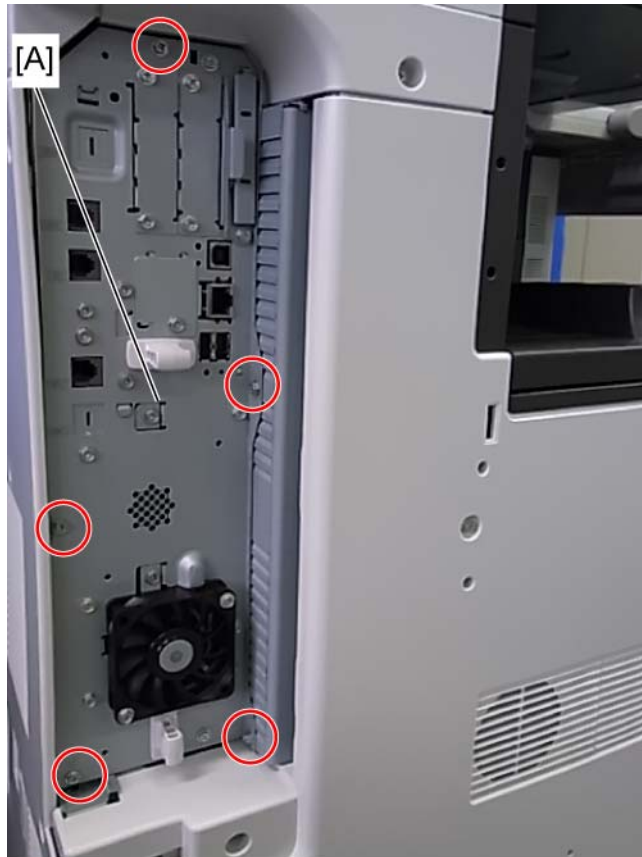

d1420077

2. Remove the controller box [A] (⚙️ x 5).

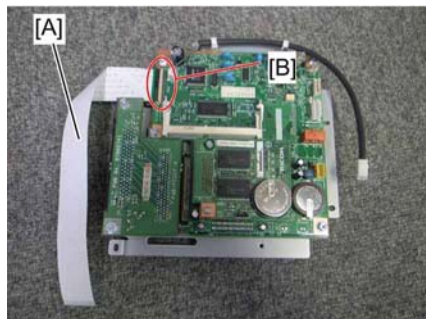

d393i011



d393i012

3. Attach one end (short length) of the flat cable [A] to the connector [B] of the FCU board.
4. Hold the flat cable with two clamps and pass the other end of the flat cable through the cutout as shown above.

G3 Interface Unit (D643-11)

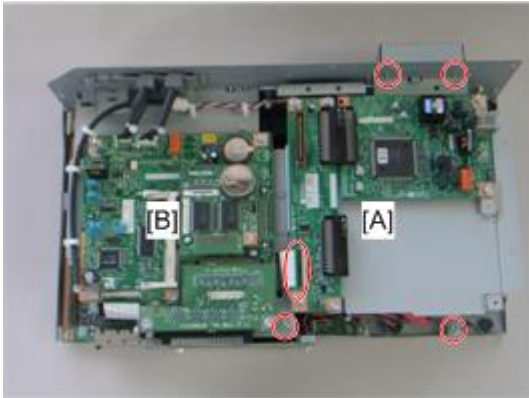

d393i081

5. Connect the SG3 interface unit [A] to the controller board [B] with the flat cable (🔧 x 4).

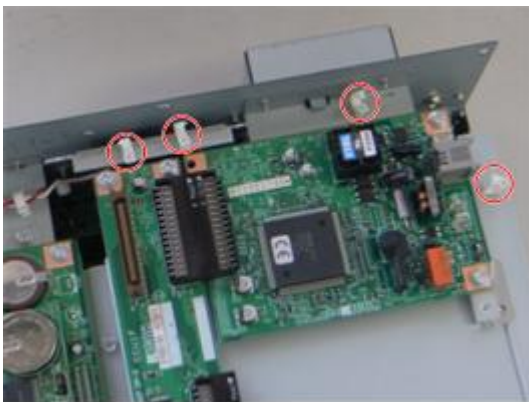

d393i048

6. Attach four clamps to the brackets.



d393i088C

7. Remove the "LINE2" cover with a screwdriver.

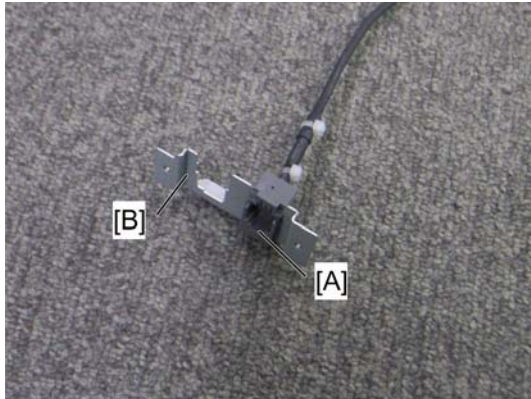

d393i047

8. Attach the socket of harness [A] (LINE2) to the modular bracket [B] for SG3.

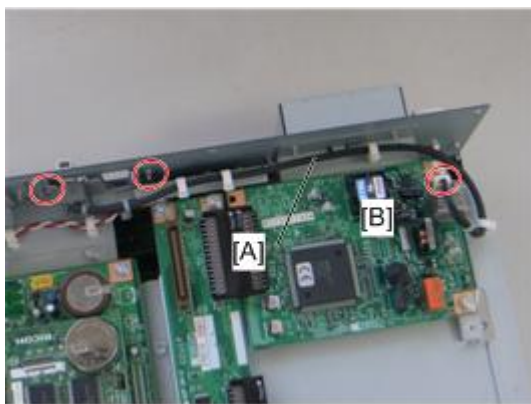

d393i091

9. Connect the harness [A] to the SG3 interface unit [B] (🔌 x 4).
10. Attach the modular bracket for SG3 to the controller box (🔌 x 2).
11. Reinstall the controller box.

For Installing the Double G3 Boards



d393i090

1. Remove one of SG3 boards from the SG3 interface units and then attach the SG3 board to the other SG3 interface unit (🔧 x 2).
2. Remove the controller box.

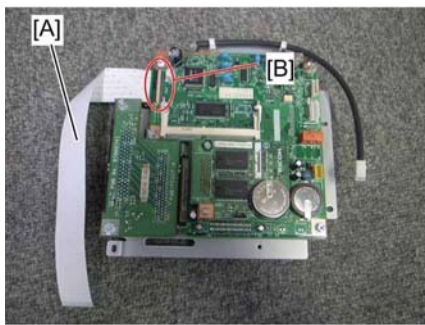

d393i011



d393i012

3. Attach one end (short length) of the flat cable [A] to the connector [B] of the FCU board.
4. Hold the flat cable with two clamps and pass the other end of the flat cable through the cutout as shown above.

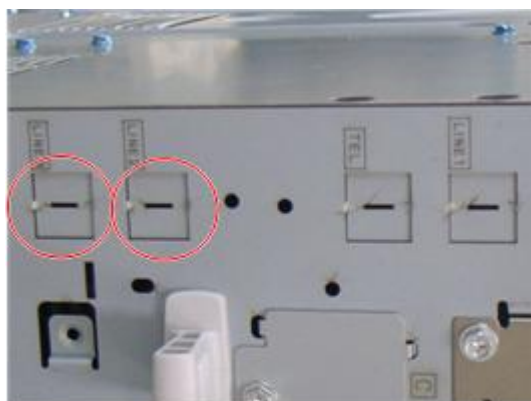

d393i088D

5. Remove the "LINE2" cover and "LINE3" cover with a screwdriver.

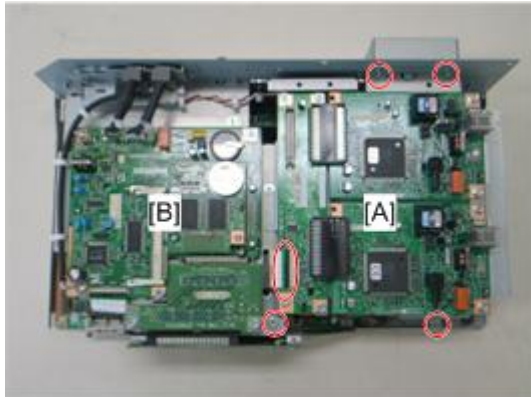

d393i081

6. Connect the SG3 interface unit [A] to the controller board [B] with the flat cable (🔌 x 4).

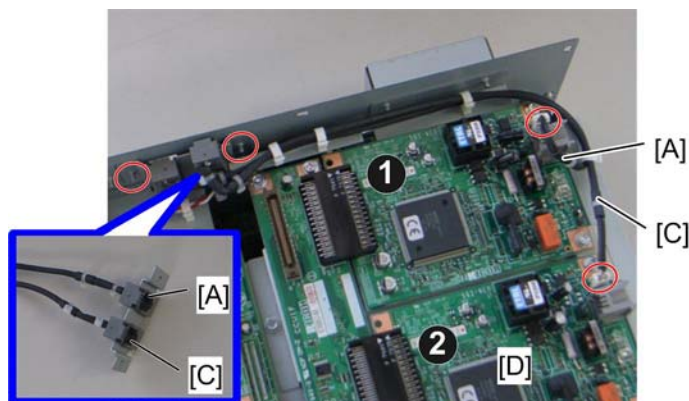

d393i092

7. Attach the socket of harness [A] (LINE2) and the socket of harness [C] (LINE3) to the modular bracket for SG3.
8. Connect the harness [A] (LINE2) to the first SG3 board ❶ and the harness [C] (LINE3) to the second SG3 board ❷ (🔌 x 4).
9. Attach the modular bracket for SG3 to the controller box (🔌 x 2).
10. Reinstall the controller box.
11. Attach the ferrite core to the telephone cord for single SG3 board installation, or the two ferrite cores to the telephone cords for double-SG3 board installation.
12. Connect the telephone cord to the "LINE 2" jack for single SG3 board installation, or connect the telephone cords to the "LINE2" and "LINE3" jacks for double-SG3 board installation.
13. Connect the power plug to a power outlet and turn on the main power switch.
14. Enter the service mode. Set bit 1 of communication switch 16 to "1" (SP1-104-023).
15. Set bit 3 of communication switch 16 to "1" (SP1-104-023) if you have installed two SG3 boards.
16. Exit the service mode.
17. Turn the main power switch off and on.
18. Print out the system parameter list. Then check that "G3" shows as an option.
19. Set up and program the items required for PSTN-2 communications.

1.3 FAX UNIT OPTIONS

1.3.1 MEMORY UNIT (G578)

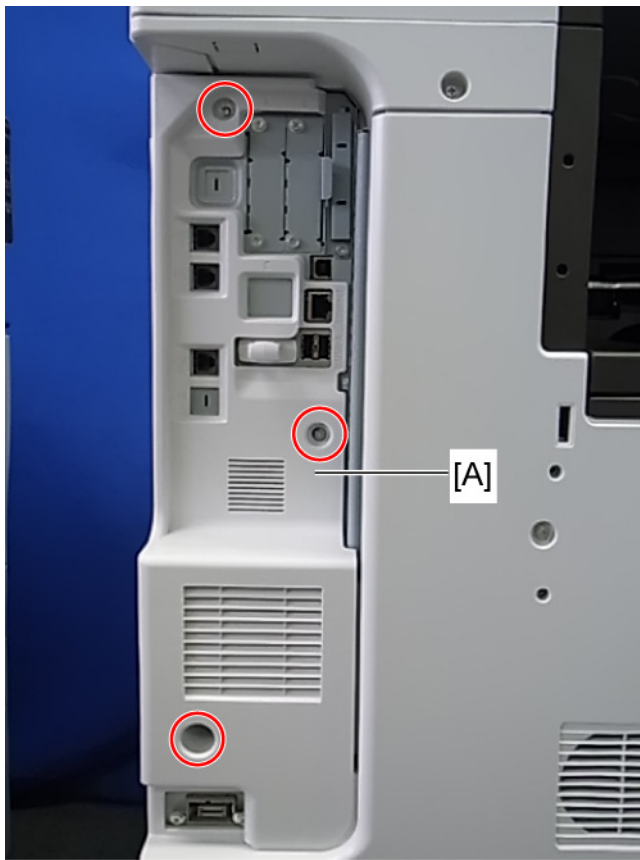

d1420076

1. Controller cover [A] (🔩 x 3)

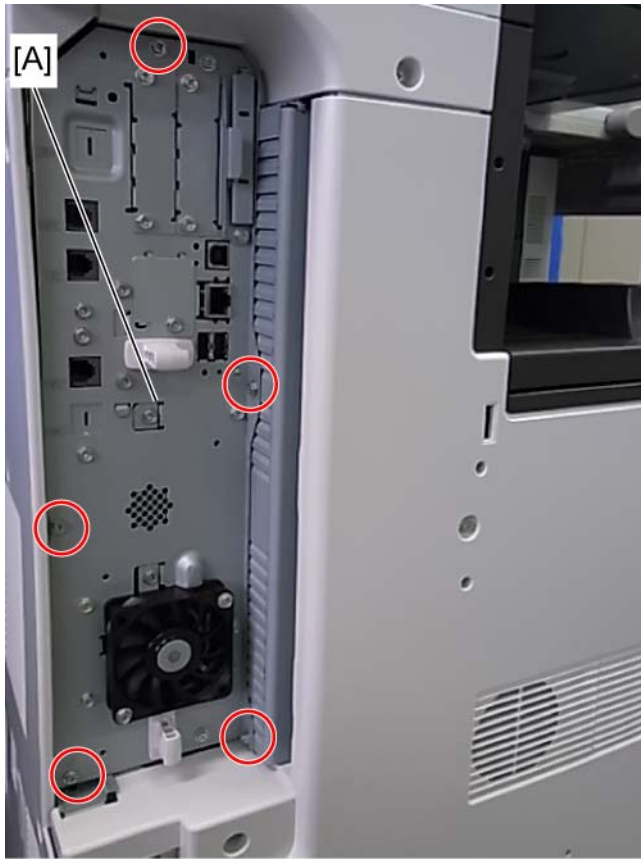

d1420077

2. Controller unit [A] (🔩 x 5)

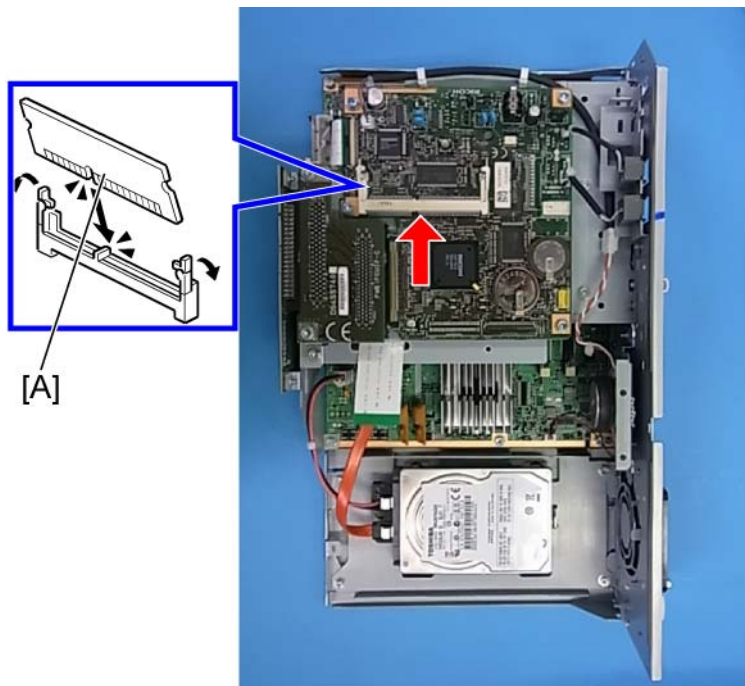

d1420074

3. Install the memory option [A] on the FCU.
4. Re-assemble the machine

1.3.2 HANDSET (D645-27)



For D111/D142

 Note

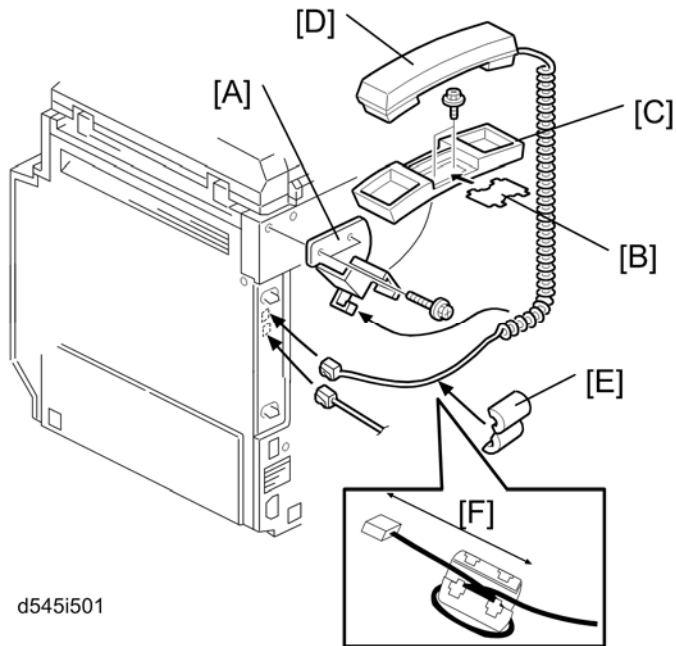
- The optional handset is available for the U.S. version only.



d545i501

1. Make two holes in the scanner left cover.
2. Attach the bracket [A] enclosed with the fax unit ( x 2: M3 x 12) as shown.
3. Remove the label [B] from the handset cradle [C]. Attach the cradle [C] to the bracket [A] ( x 2: M3 x 8), and then replace the label [B].
4. Install the handset [D] on the cradle [C].
5. Attach the ferrite core [E] to the cable. The length [F] must be 90 mm.
6. Attach the two clamps [G] as shown.
7. Line the cable [H] as shown ( x 2).
8. Connect the cable [H] to the "TEL" jack at the rear of the machine.

For D143/D144

↓ Note

- The optional handset is available for the U.S. version only.



b433i502

1. Remove the scanner left cover [A] (🔧 x 2).

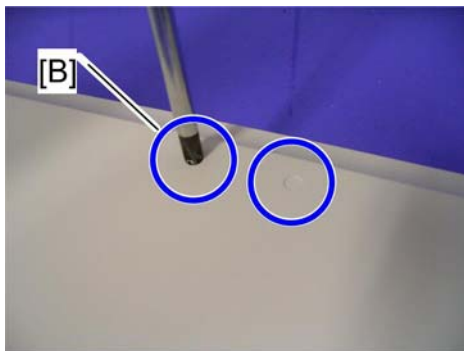

b433i503

2. Make two holes in the scanner left cover.

↓ Note

- Drill a hole from the outside of the cover with a screwdriver.

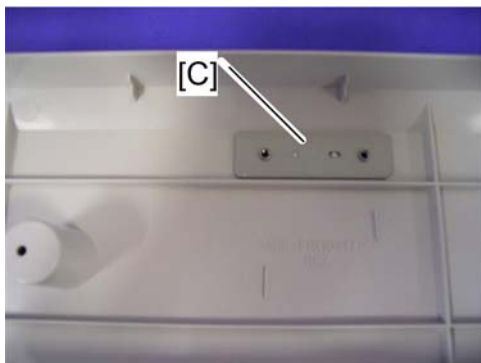

b433i504

3. Attach the hand set support bracket [C] inside the scanner left cover.

Fax Unit Options

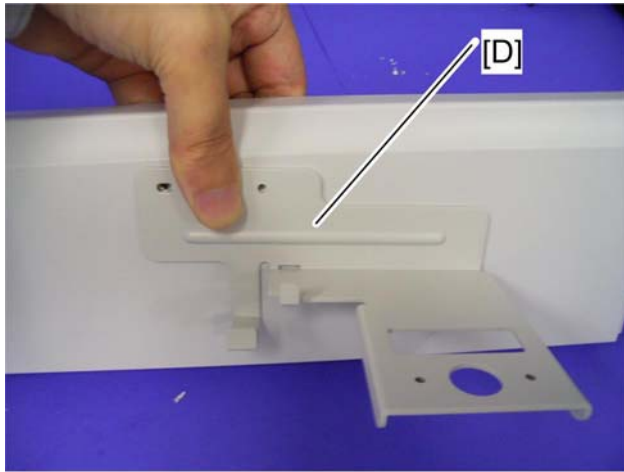

b433i505

4. Hold the handset bracket [D] and handset support bracket (set inside the scanner left cover).
5. Secure the handset bracket [D] (⚙ x 2).

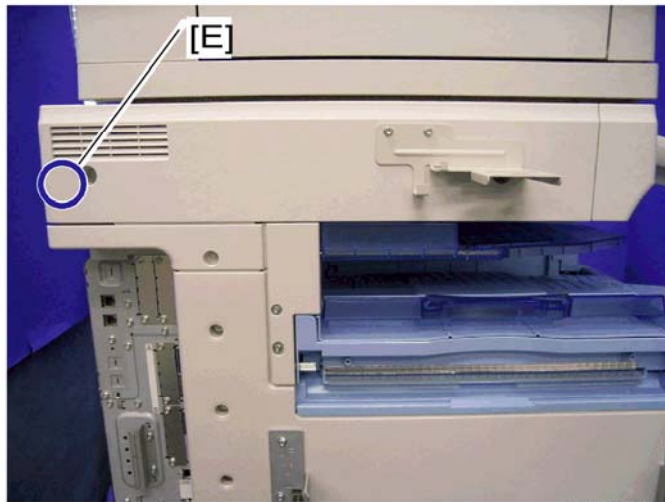

b433i506

6. Install the scanner left cover on the machine.
7. Attach the clamp to the location [E].
8. Set the handset on the handset bracket.

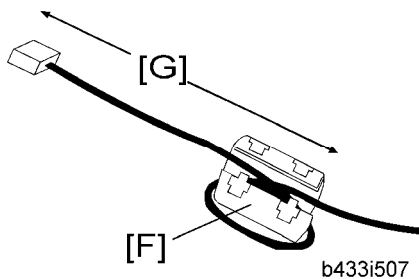

b433i507

9. Put the ferrite core [F] on the handset cord as shown. The length [G] must be 90 mm.
10. Clamp the hand set cord.
11. Connect the handset cable to the "TEL" jack at the rear of the machine.

1.4 FAX CONNECTION UNIT TYPE B (REMOTE FAX) INSTALLATION

1.4.1 INSTALLATION PROCEDURE (D645-19)

This unit allows a machine without the FAX unit installed (“Client-side Machine”) to send and receive faxes via a machine with the FAX unit installed (“Remote Machine”).

Requirements:

- Both the Client-side Machine and Remote Machine must have this unit, the Printer unit, and Scanner unit installed.
- Up to six machines can be registered as the Client-side Machines.
- Machines that have the FAX unit installed **cannot** be used as the Client-side Machine.
- Only machine can be registered as the Remote Machine.
- Firmware for this unit: “**aics**” (software number: **D1445546**)
- Remote Fax transmissions are possible on a G3 line.
- The remote fax function does not support User Code Authentication. Disable the User Code Authentication on the Remote machine.
- Use this function to check the contents of a file that is stored in memory and not yet sent. Also, use this function to cancel a transmission from the Client-side Machine.

CAUTION

Before installing this option:

- Upgrade the machine firmware to the following versions or newer.

FIRMWARE	D143/D144			D111/D142		
	P/N	SUFFIX	VER.	P/N	SUFFIX	VER.
System/Copy	D1445562	H	2.00.3	D1425562	H	2.00.3
Network Support	D1445563	E	11.77.2	D1425563	E	11.77.2
Fax	D1445569	E	03.02.00	D1425569	E	03.02.00
RemoteFax	D1445564	E	03.00.00	D1425564	E	03.00.00
Websupport	D1445565	E	1.11	D1425565	E	1.11
WebUapl	D1445566	E	1.04	D1425566	E	1.04
Network DocBox	D1445567	E	2.01	D1425567	E	2.01
Scanner	D1445570	E	01.11	D1425570	E	01.11
Printer	D1445572	E	1.06	D1425572	E	1.06
PCL	D1445580	D	1.08	D1445580	E	02.00.00
Powersaving Sys	D1445560	D	F.11	D1425560	E	1.08
FCU	D6435570	E	02.00.00	D6435570	D	F.11
Java VM	D1445594	G	10.03.01	D1445594	D	10.04.02

Installing the Application

On both the Remote Machine and the Client-side Machines:

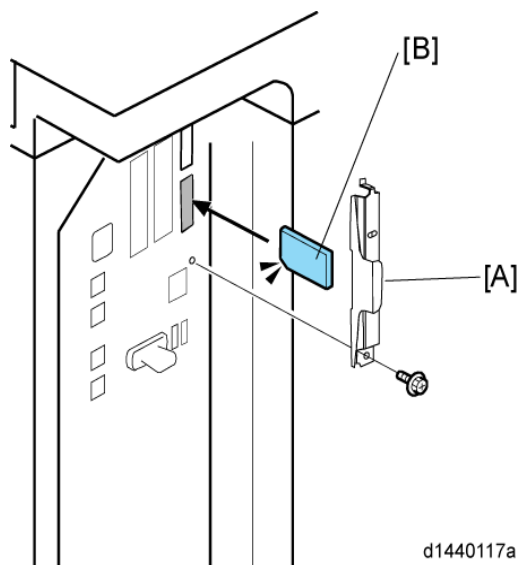

1. Remove the SD-Card Slot Cover [A] from the SD Card Slots (🔧 x 1)
2. Insert the SD card (Fax Connection Unit Type B) in SD slot 2 (lower) with its label face [B] towards the front of the machine. Then push it slowly into SD slot 2 (lower) until you hear a click.
3. Plug in, and then turn ON the machine.
4. Move the Fax Connection Unit Type B application from the SD card in SD slot 2 (lower) to the SD card in SD slot 1 (upper) with SP5-873-001.
5. Turn OFF the machine.
6. Remove the SD card from SD slot 2 (lower), and then keep it in a safe place (see “SD Card Appli Move” in the manual for the main frame).
7. Attach the SD-Card Slot Cover (🔧 x 1), and then turn ON the machine.
- ⇒ 8. Make sure that the machine can recognize the option. (☛ ‘Check All Connections’ in the controller option section of the manual for the main frame.)

Registering the Remote Machine (Machine With the hardware Fax Option)

Note

- Only 1 machine can be registered as the Remote Machine.

On the Client-side Machine(s): (Machine without the hardware Fax Option)

1. Press the [User Tools/Counter] key on the operation panel
- ⇒ 2. Press [Administrator Tools] to select.
3. Press [Program/Delete Remote Machine] to select.
4. Enter the IP address or host name of the Remote Machine and press [OK] to set.
5. Press [Exit] to exit from the set-up procedure.

Registering the Client-side Machine(s) (Machine(s) without the hardware Fax Option)

Note

- Up to six machines can be registered as the Client-side Machines.

On the Remote Machine: (Machine With the hardware Fax Option)

1. Press the [User Tools/Counter] key on the operation panel
- ⇒ 2. Press [Administrator Tools] to select.
3. Press [Program/Delete Remote Machine] to select.
4. Enter the IP address or host name of the Client-side Machines and press [Set] to set.

Configuring the Remote Reception Settings

Do the following procedure to enable the Client-side Machine(s) to receive faxes via the Remote Machine. You can forward or route received documents per line or special sender or box.

Note

- By performing procedures #1-3 above, the Client-side Machines can **send** faxes via the Remote Machine. The procedures shown below are necessary to enable the Client-side Machines to **receive** faxes.

On the Remote Machine:**1) If you use "Remote Reception Setting per Line"**

- ⇒ 1. Press [Facsimile Features] to select.
 2. Press [Remote Reception Setting per Line] in [Reception Settings] to select.
 3. Enter an IP address or a host name of the client-side machine to connect.
 4. Press [Set], and [Exit] to exit from the setting.

2) If you use "Remote Reception per Sender"

- ⇒ 1. Press [Facsimile Features] to select.
 2. Press [Program Special Sender] in [Reception Settings] to select.
 3. Select the Special Sender.

Program Special Sender Exit

Select destination to program or change.

Program / Change Delete Initial Set Up

001 Tokyo branch	Full Agree	002 Head office of Osaka	Full Agree
003 branch	Part. Agree	004 ✕Not Programmed	Full Agree
005 ✕Not Programmed	Full Agree	006 ✕Not Programmed	Part. Agree
007 ✕Not Programmed	Full Agree	008 ✕Not Programmed	Full Agree
009 ✕Not Programmed	Full Agree	010 ✕Not Programmed	Full Agree

1 / 2
 ▲ Previous
 ▼ Next

4. Press [Remote Reception Setting per Sender] to select.

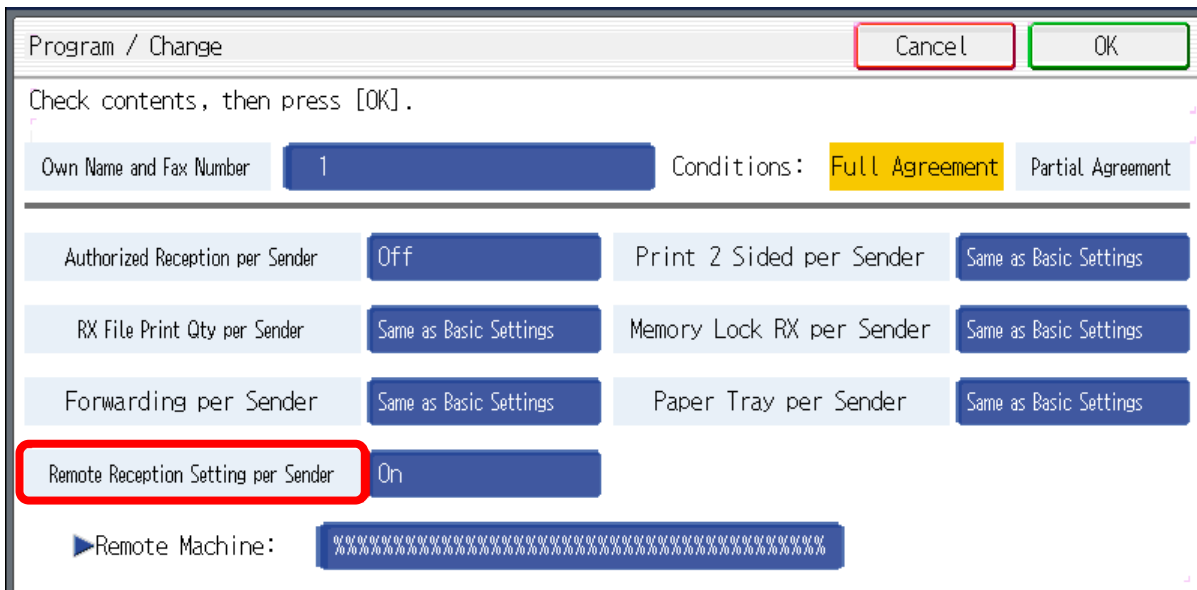

5. Press [On] and [Remote Machine] to select.

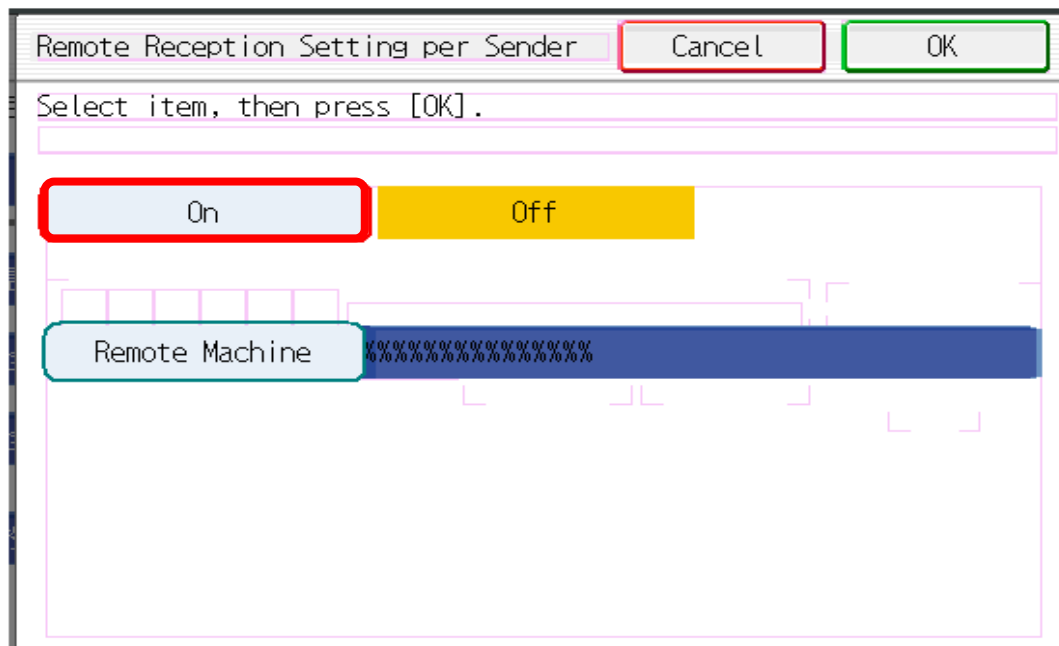

6. Enter an IP address or a host name of the client-side machine to connect.

7. Press [OK] to exit from the setting.

3) If you use "Remote Reception per Box"

- ⇒ 1. Press [Facsimile Features] to select.
2. Press [Box Setting] in [General Settings] to select.

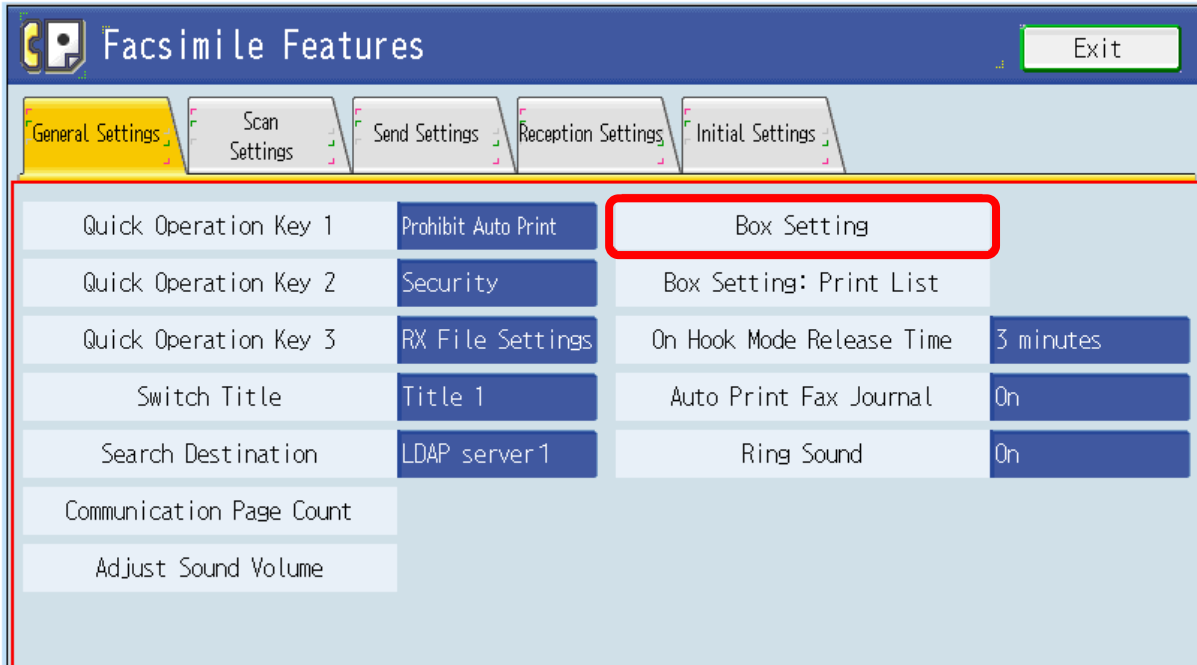

3. Select the box.

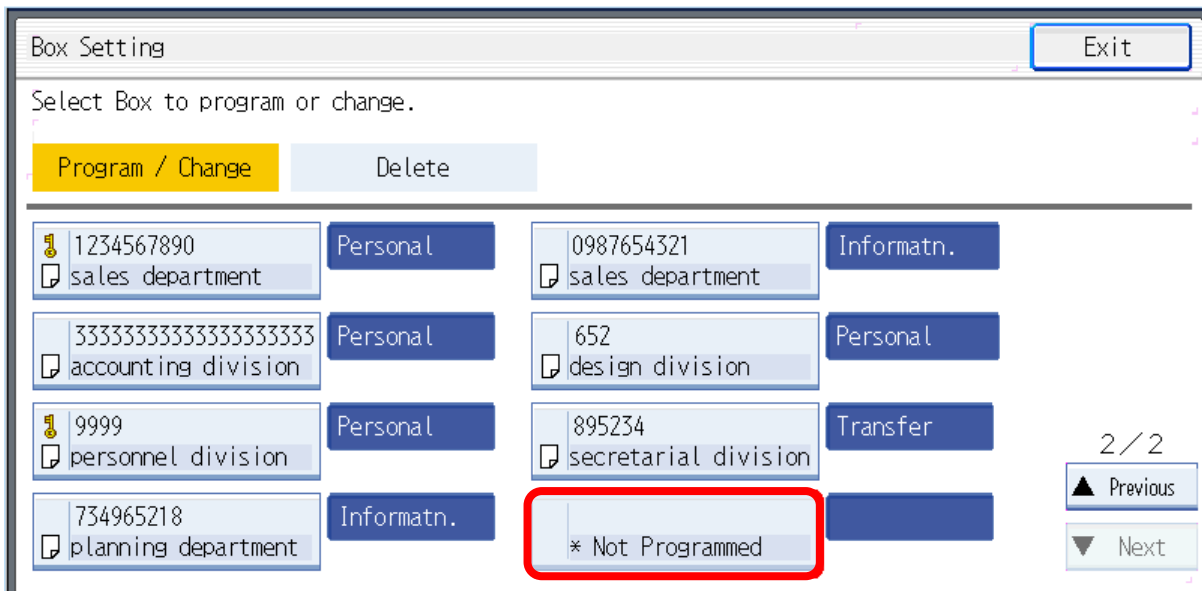

- 4. Press [Personal Box] to select.

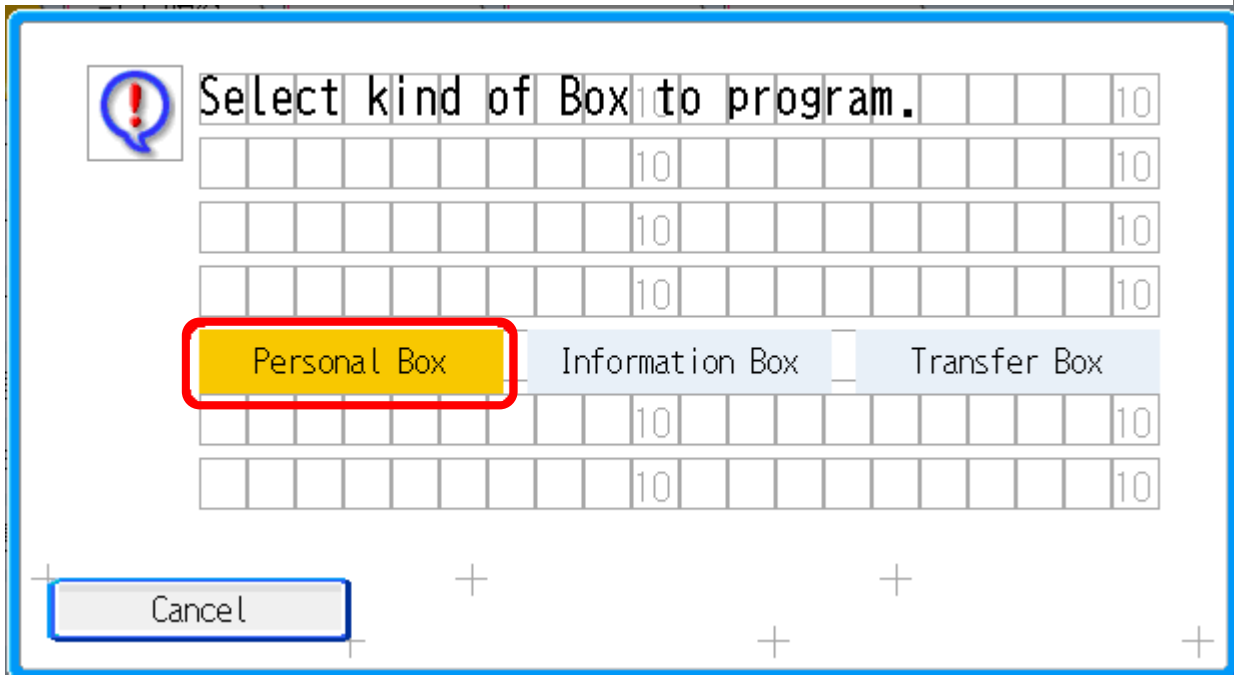

- 5. Enter a dial-in number.
- 6. Press [Remote Machine] to select.

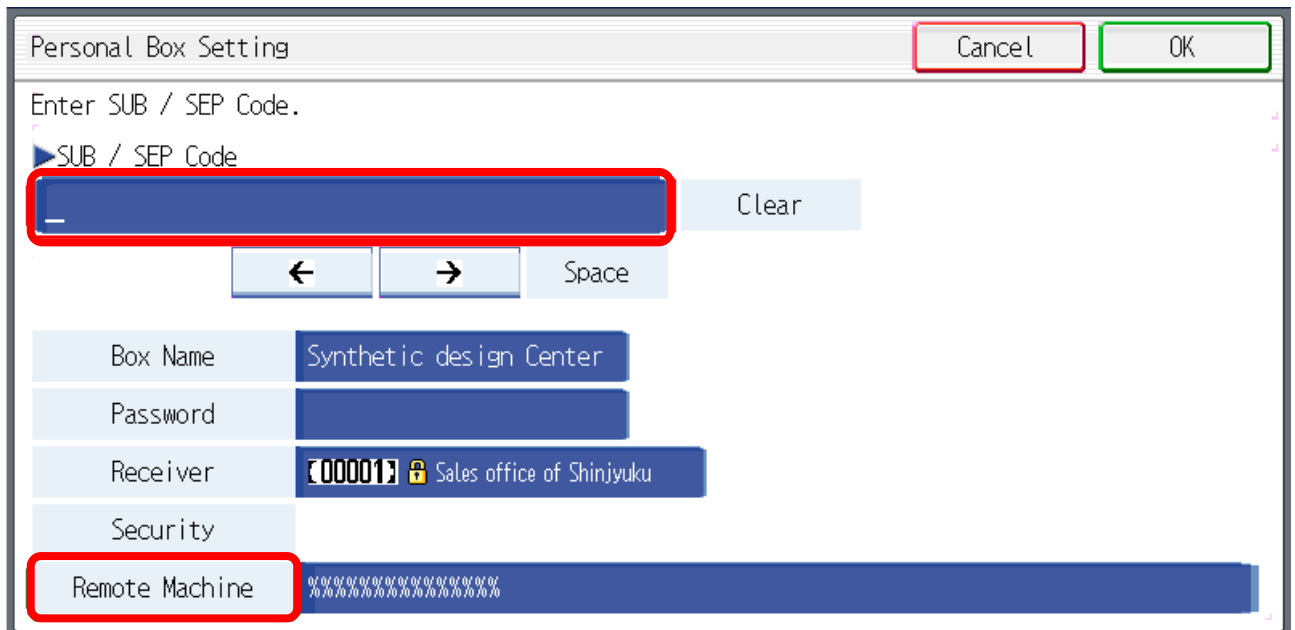

- 7. Enter an IP address or a host name of the client-side machine to connect.
- 8. Press [OK] to exit from the set-up procedure.

Remote Fax Icon Addition

This procedure allows the remote fax icon to appear on the home screen of the operation panel.

On both the Remote Machine and the Client-side Machines:

1. Press [User Tools].
2. Press [Edit Home].

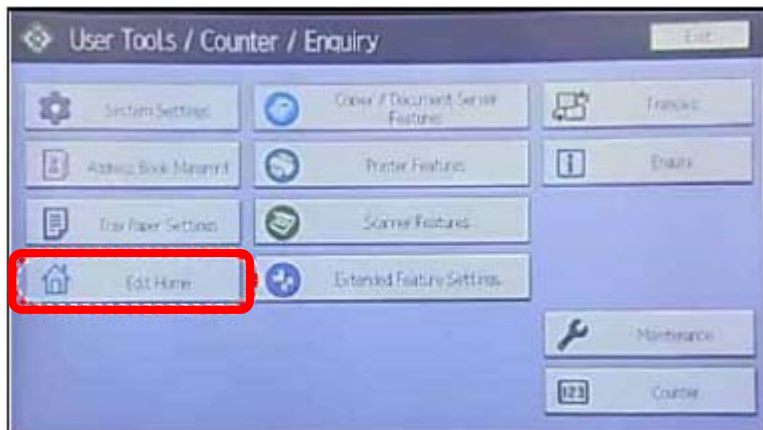

d1440144

3. Press [Add Icon].

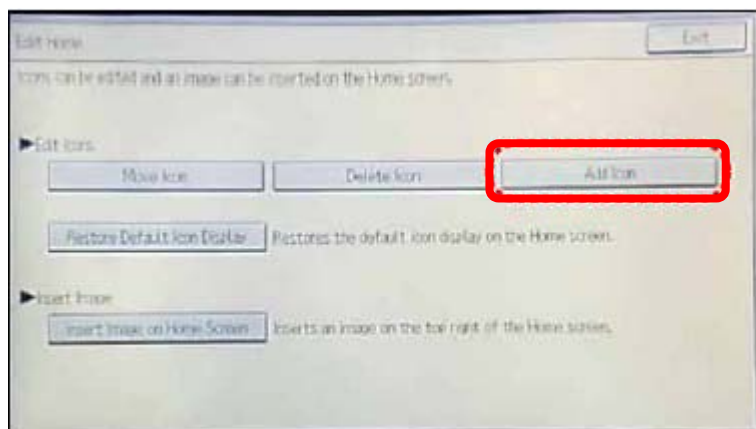

d1440145

4. Press [Remote Fax].

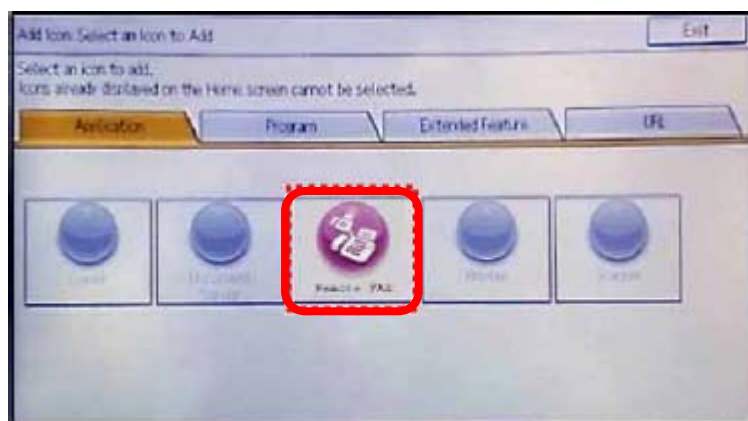

d1440146a

- 5. Press a [Blank] to set a location for the remote fax icon.

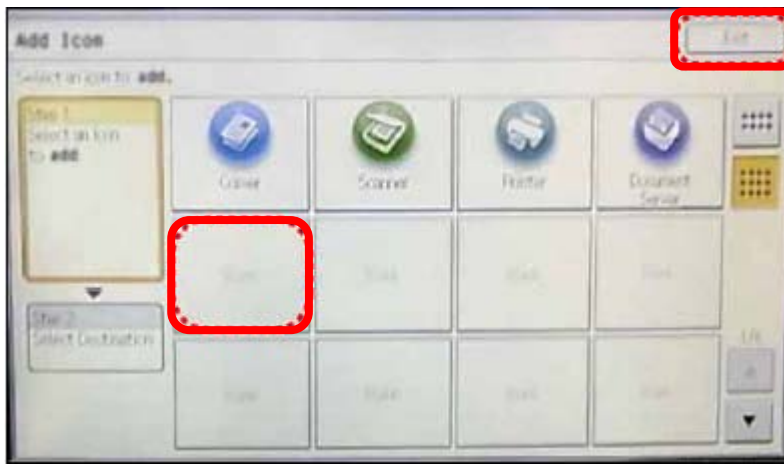

d1440147

- 6. Press [Exit] to exit from the set-up procedure.

Fax Option
Type C5502
(D643)

2. REPLACEMENT AND ADJUSTMENT

2.1 FCU

2.1.1 SRAM DATA TRANSFER PROCEDURE

When you replace the FCU board, transfer the SRAM data from the old FCU board to the new FCU board. Do the following procedure to back up the SRAM data.

Note

- The following data can be transferred: TTI, RTI, CSI, Fax bit switch settings, RAM address settings, NCU parameter settings

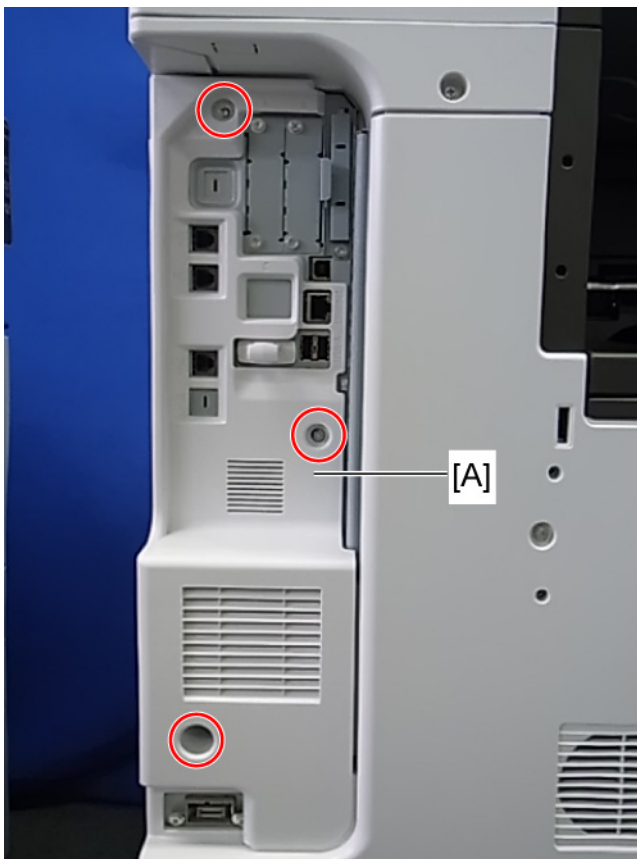

d1420076

1. Remove the controller cover [A] (🔩 x 3).



d1420077

2. Remove the fax unit [A] (⚙️ x 5).
3. Replace the FCU board.

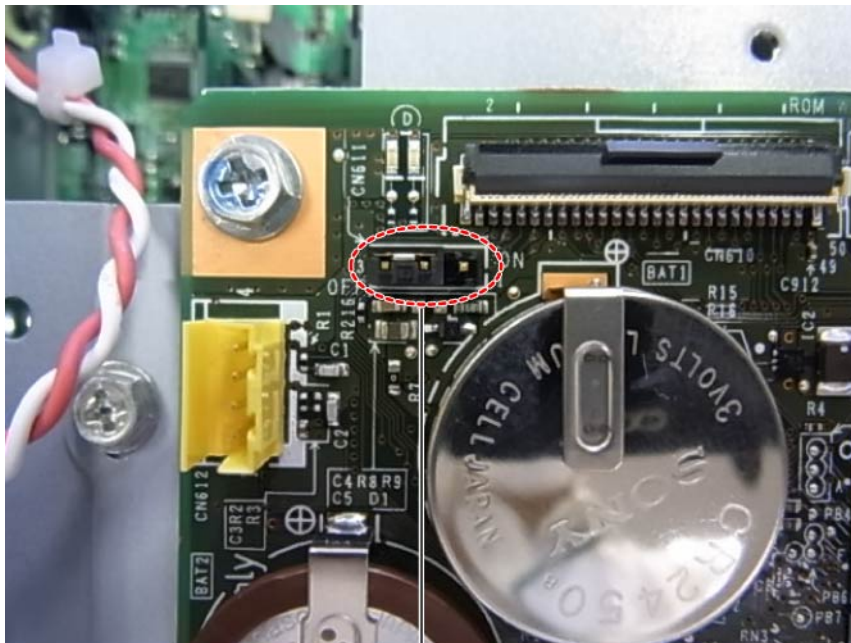

[A]

d1420064

4. Move the jumper switch [A] of the new FCU board from "OFF" to "ON".

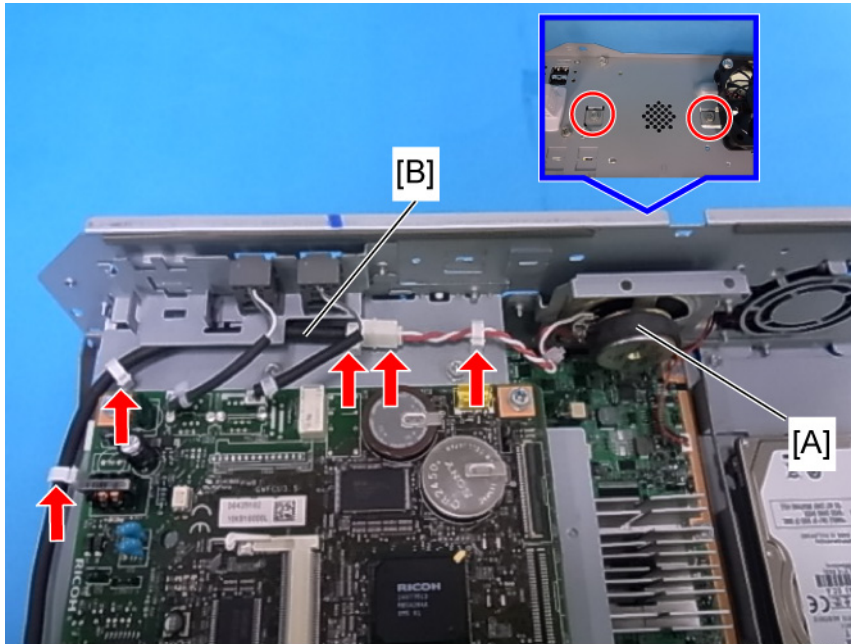

d1420061a

5. Remove the speaker [A] from the controller unit (⚙️ x 2, 🛠️ x 2, 🛠️ x 1).
6. Remove the speaker harness [B] from clamps (🛠️ x 2).

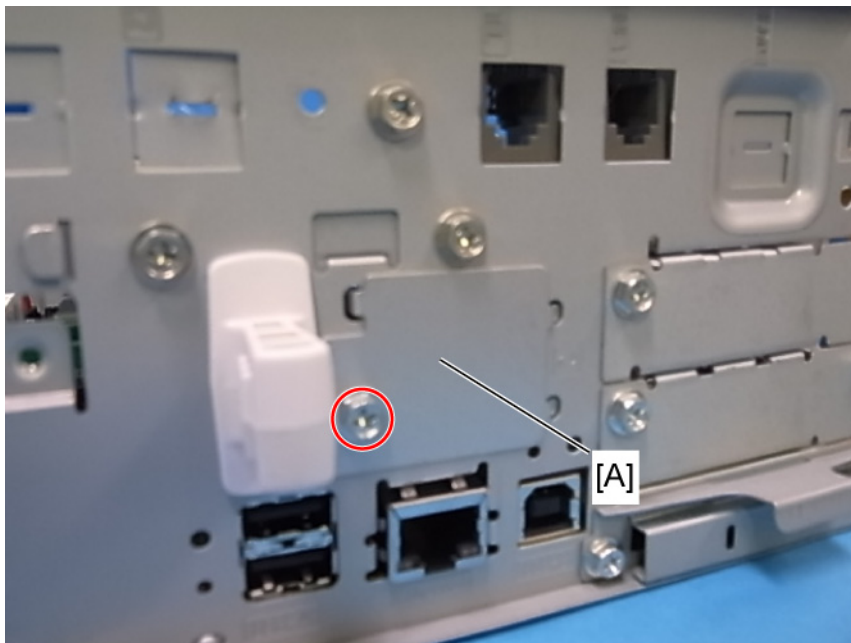

d1420066

7. Remove the hole cover [A] (⚙️ x 1).

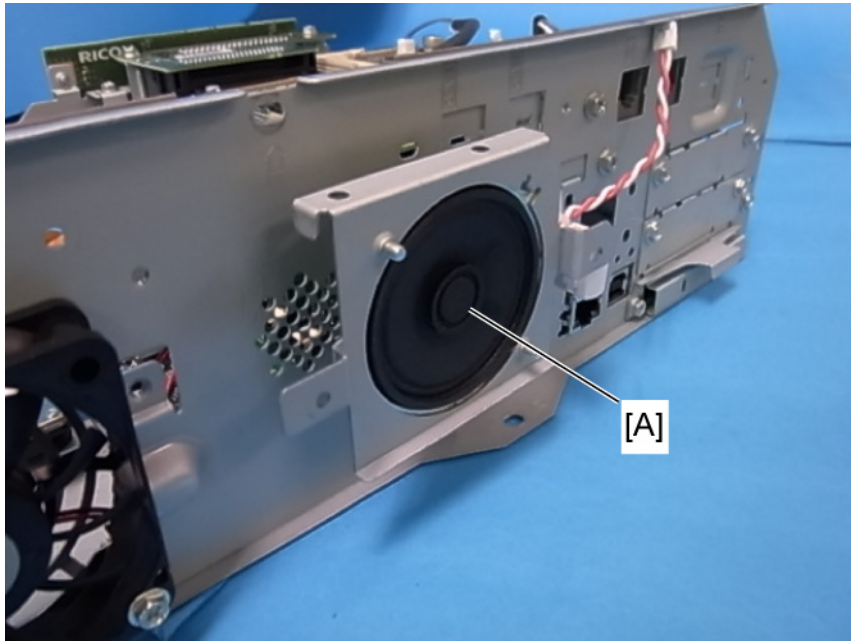

d1420067

8. Attach the speaker [A] to the fax unit as shown above.

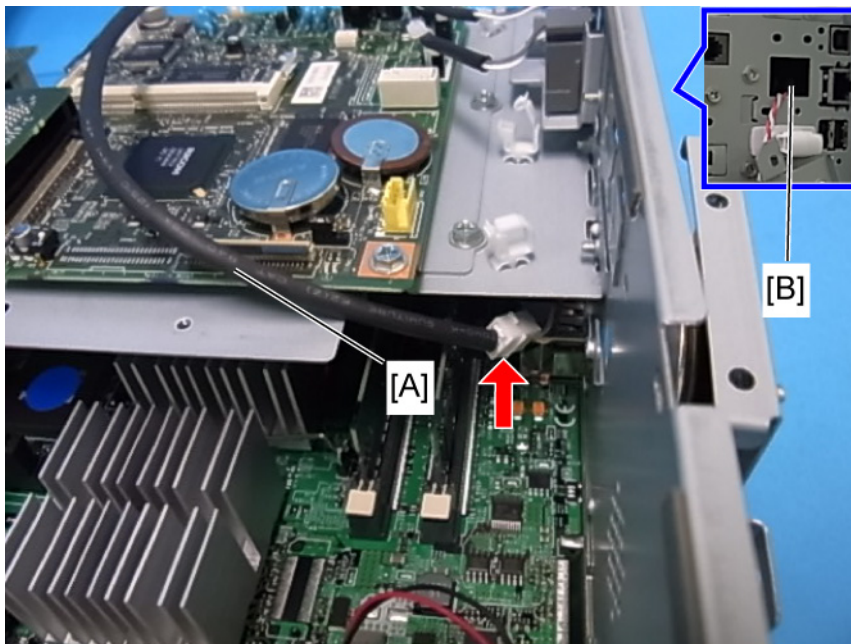

d1420068

9. Connect the speaker harness to the new FCU board [A] through the hole [B] (🔧 x 1).

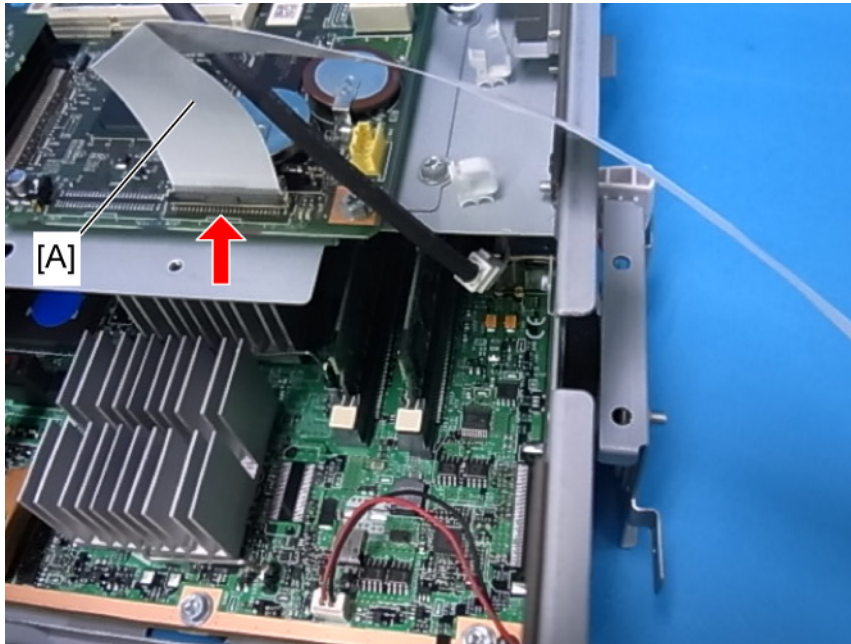

d1420069

10. Connect a flat flexible cable [A] to the new FCU board (FCU x 1). This flexible cable is shipped with the new FCU board.

★ Important

- The blue side [A] of the flat flexible cable must face outward as shown below.

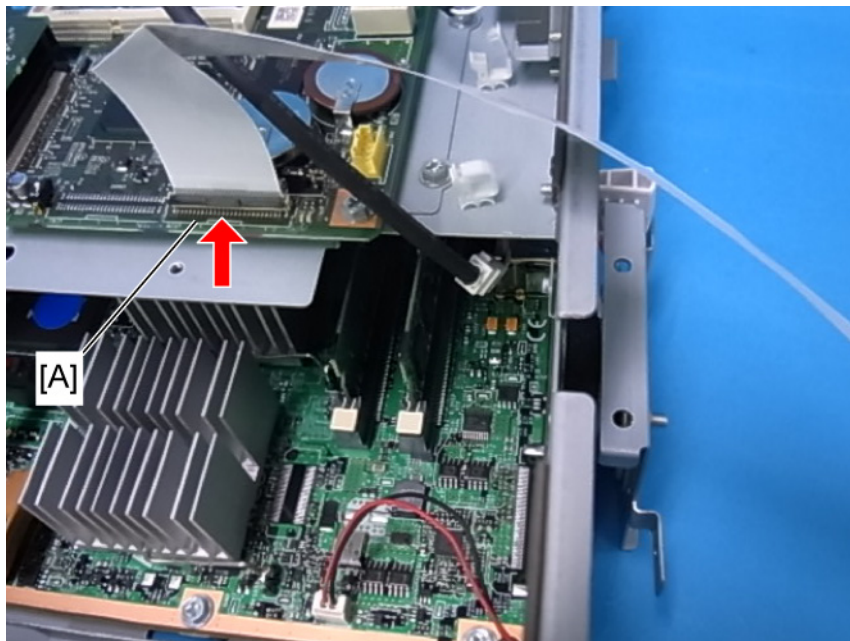

d1420069a

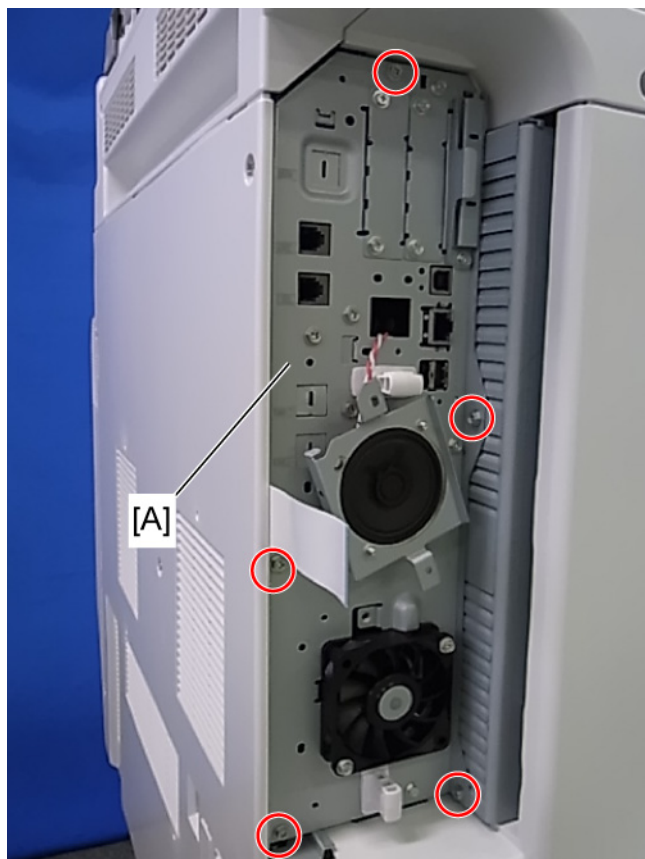

d1420070

11. Install the controller unit with the new FCU [A] in the main machine (🔩 x 5).

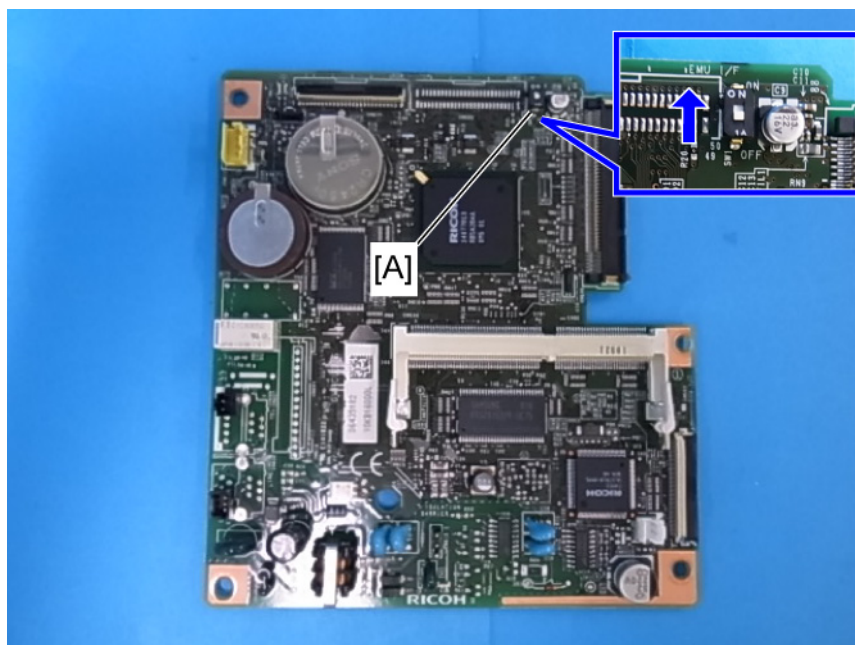

d1420071

12. Move the Dip Switch [A] of the old FCU board from “OFF” to “ON”.

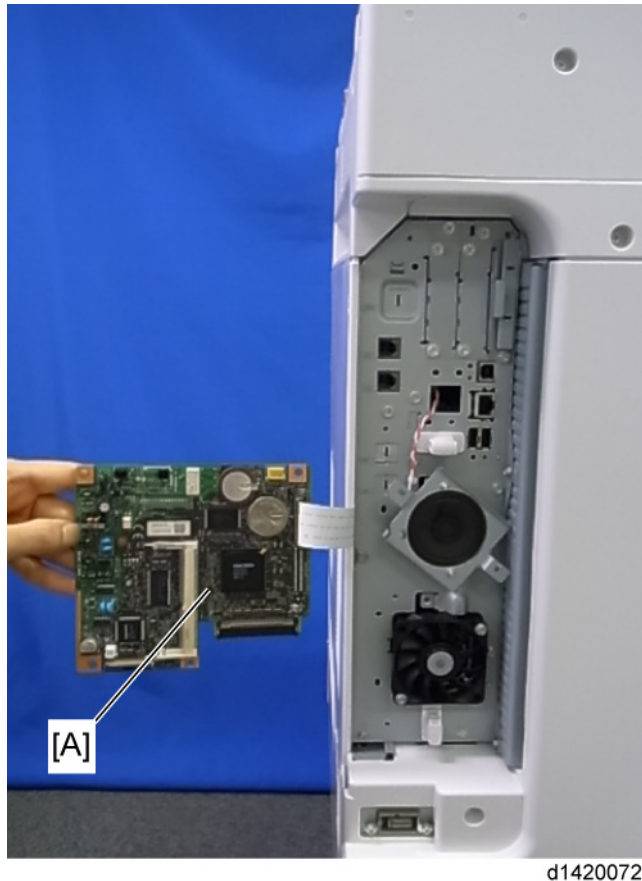

d1420072

13. Connect the flat flexible cable to the old FCU board [A].
14. Turn on the main power switch.
15. SRAM data transmission starts. When the transmission is completed, you will hear a beeper sound.

↓ Note

- The beeper sound is the same volume as the speaker sound.
 - The beeper sounds even if the speaker sound is turned off.
 - If the beeper does not sound, turn the main power switch on and off repeatedly and do the transmission procedure 2 or 3 times.
 - If the beeper does not sound after turning the main switch on and off 3 times, you need to input the settings stored in SRAM memory manually.
16. When “Ready” appears on the copy display, turn off the main power switch, and then disconnect the flat flexible cable from the old FCU board.
 17. Remove the controller unit with FCU from the main machine (🔧 x 5).
 18. Disconnect the flat flexible cable from the new FCU board.

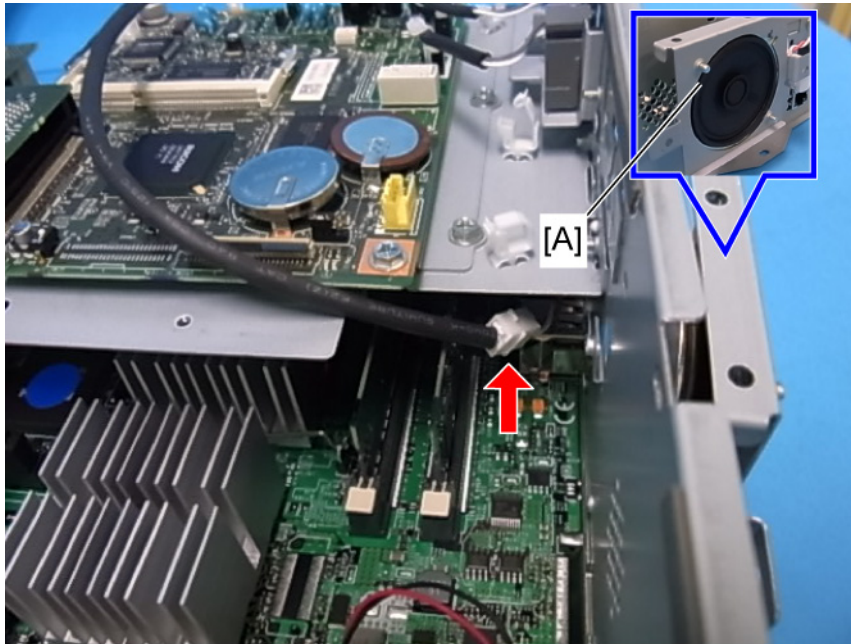

d1420073

19. Remove the speaker [A] from the controller unit (🔊 x 1).

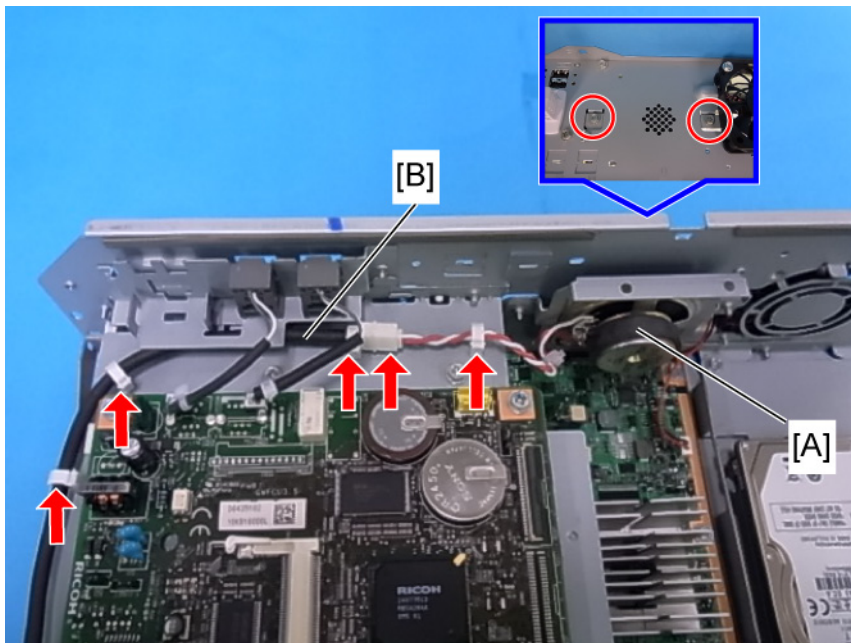

d1420061a

20. Install the speaker [A] in the controller unit as shown above (🔊 x 2, 🖨️ x 5, 📠 x 1).

FCU

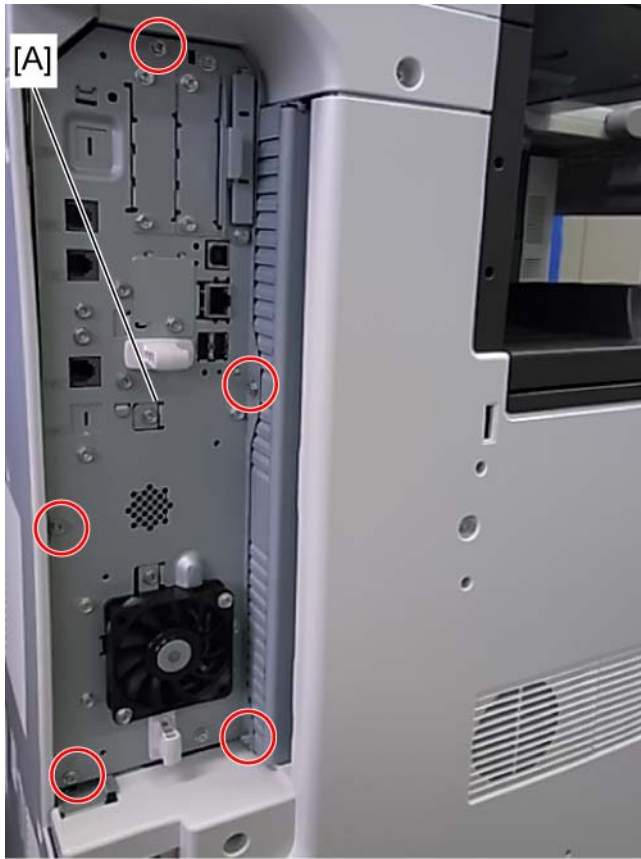

d1420077

21. Slide the controller unit [A] into the main machine and then secure it (🔩 x 5).

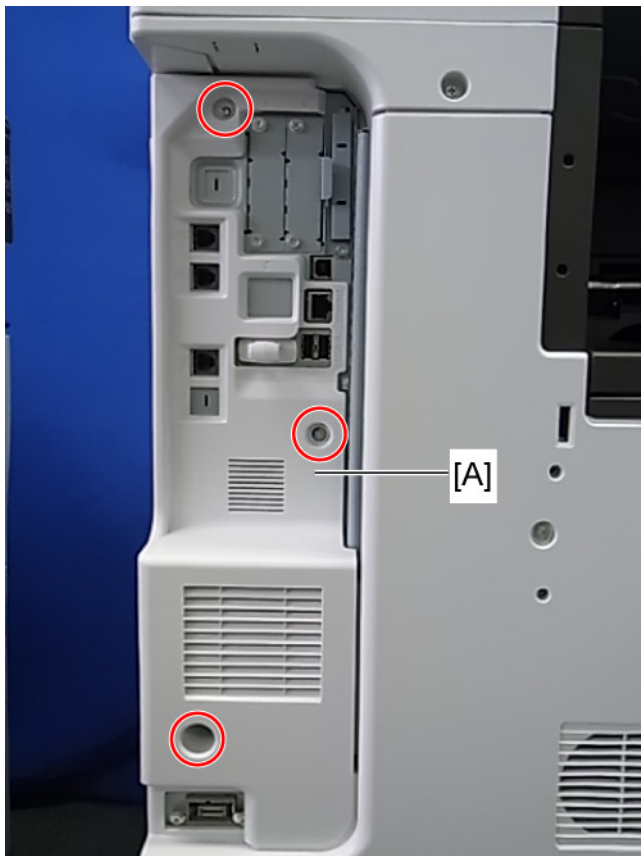

d1420076

22. Reattach the controller cover (🔑 x 3).
23. Turn on the main power switch, then do SP6-101 to print the system parameter list.
24. Check the system parameter list to make sure that the data was transferred correctly.
25. Set the correct date and time with the User Tools: User Tools > System Settings > Timer Setting > Set Date/Time.

↓ Note

- If any of the SRAM data was not transferred, input those settings manually.

3. TROUBLESHOOTING

3.1 ERROR CODES

If an error code occurs, retry the communication. If the same problem occurs, try to fix the problem as suggested below. Note that some error codes appear only in the error code display and on the service report.

Code	Meaning	Suggested Cause/Action
0-00	DIS/NSF not detected within 40 s of Start being pressed	<ul style="list-style-type: none"> ▪ Check the line connection. ▪ The machine at the other end may be incompatible. ▪ Replace the FCU. ▪ Check for DIS/NSF with an oscilloscope. ▪ If the rx signal is weak, there may be a bad line.
0-01	DCN received unexpectedly	<ul style="list-style-type: none"> ▪ The other party is out of paper or has a jammed printer. ▪ The other party pressed Stop during communication.
0-03	Incompatible modem at the other end	The other terminal is incompatible.
0-04	CFR or FTT not received after modem training	<ul style="list-style-type: none"> ▪ Check the line connection. ▪ Try changing the tx level and/or cable equalizer settings. ▪ Replace the FCU. ▪ The other terminal may be faulty; try sending to another machine. ▪ If the rx signal is weak or defective, there may be a bad line. <p>Cross reference</p> <p>Tx level - NCU Parameter 01 (PSTN) Cable equalizer - G3 Switch 07 (PSTN) Dedicated Tx parameters in Service Program Mode</p>

Code	Meaning	Suggested Cause/Action
0-05	Modem training fails even G3 shifts down to 2400 bps.	<ul style="list-style-type: none"> ▪ Check the line connection. ▪ Try adjusting the tx level and/or cable equalizer. ▪ Replace the FCU. ▪ Check for line problems. <p>Cross reference See error code 0-04.</p>
0-06	The other terminal did not reply to DCS	<ul style="list-style-type: none"> ▪ Check the line connection. ▪ Try adjusting the tx level and/or cable equalizer settings. ▪ Replace the FCU. ▪ The other end may be defective or incompatible; try sending to another machine. ▪ Check for line problems. <p>Cross reference See error code 0-04.</p>
0-07	No post-message response from the other end after a page was sent	<ul style="list-style-type: none"> ▪ Check the line connection. ▪ Replace the FCU. ▪ The other end may have jammed or run out of paper. ▪ The other end user may have disconnected the call. ▪ Check for a bad line. ▪ The other end may be defective; try sending to another machine.

Error Codes

Code	Meaning	Suggested Cause/Action
0-08	The other end sent RTN or PIN after receiving a page, because there were too many errors	<ul style="list-style-type: none"> ▪ Check the line connection. ▪ Replace the FCU. ▪ The other end may have jammed, or run out of paper or memory space. ▪ Try adjusting the tx level and/or cable equalizer settings. ▪ The other end may have a defective modem/FCU; try sending to another machine. ▪ Check for line problems and noise. <p>Cross reference</p> <ul style="list-style-type: none"> ▪ Tx level - NCU Parameter 01 (PSTN) ▪ Cable equalizer - G3 Switch 07 (PSTN) ▪ Dedicated Tx parameters in Service Program Mode
0-14	Non-standard post message response code received	<ul style="list-style-type: none"> ▪ Incompatible or defective remote terminal; try sending to another machine. ▪ Noisy line: resend. ▪ Try adjusting the tx level and/or cable equalizer settings. ▪ Replace the FCU. <p>Cross reference</p> <p>See error code 0-08.</p>
0-15	The other terminal is not capable of specific functions.	<p>The other terminal is not capable of accepting the following functions, or the other terminal's memory is full.</p> <ul style="list-style-type: none"> ▪ Confidential rx ▪ Transfer function ▪ SEP/SUB/PWD/SID

Code	Meaning	Suggested Cause/Action
0-16	CFR or FTT not detected after modem training in confidential or transfer mode	<ul style="list-style-type: none"> ▪ Check the line connection. ▪ Replace the FCU. ▪ Try adjusting the tx level and/or cable equalizer settings. ▪ The other end may have disconnected, or it may be defective; try calling another machine. ▪ If the rx signal level is too low, there may be a line problem. <p>Cross reference See error code 0-08.</p>
0-17	Communication was interrupted by pressing the Stop key	If the Stop key was not pressed and this error keeps occurring, replace the operation panel or the operation panel drive board.
0-20	Facsimile data not received within 6 s of retraining	<ul style="list-style-type: none"> ▪ Check the line connection. ▪ Replace the FCU. ▪ Check for line problems. ▪ Try calling another fax machine. ▪ Try adjusting the reconstruction time for the first line and/or rx cable equalizer setting. <p>Cross reference Reconstruction time - G3 Switch 0A, bit 6 Rx cable equalizer - G3 Switch 07 (PSTN)</p>
0-21	EOL signal (end-of-line) from the other end not received within 5 s of the previous EOL signal	<ul style="list-style-type: none"> ▪ Check the connections between the FCU and line. ▪ Check for line noise or other line problems. ▪ Replace the FCU. ▪ The remote machine may be defective or may have disconnected. <p>Cross reference Maximum interval between EOLs and between ECM frames - G3 Bit Switch 0A, bit 4</p>

Error Codes

Code	Meaning	Suggested Cause/Action
0-22	The signal from the other end was interrupted for more than the acceptable modem carrier drop time (default: 200 ms)	<ul style="list-style-type: none"> ▪ Check the line connection. ▪ Replace the FCU. ▪ Defective remote terminal. ▪ Check for line noise or other line problems. ▪ Try adjusting the acceptable modem carrier drop time. <p>Cross reference Acceptable modem carrier drop time - G3 Switch 0A, bits 0 and 1</p>
0-23	Too many errors during reception	<ul style="list-style-type: none"> ▪ Check the line connection. ▪ Replace the FCU. ▪ Defective remote terminal ▪ Check for line noise or other line problems. ▪ Try asking the other end to adjust their tx level. ▪ Try adjusting the rx cable equalizer setting and/or rx error criteria. <p>Cross reference Rx cable equalizer - G3 Switch 07 (PSTN) Rx error criteria - Communication Switch 02, bits 0 and 1</p>
0-29	Data block format failure in ECM reception	<ul style="list-style-type: none"> ▪ Check for line noise or other line problems. ▪ Check the FCU - NCU connectors. ▪ Replace the NCU or FCU.
0-30	The other terminal did not reply to NSS(A) in AI short protocol mode	<ul style="list-style-type: none"> ▪ Check the line connection. ▪ Try adjusting the tx level and/or cable equalizer settings. ▪ The other terminal may not be compatible. <p>Cross reference Dedicated tx parameters - Section 4</p>
0-32	The other terminal sent a DCS, which contained functions that the receiving machine cannot handle.	<ul style="list-style-type: none"> ▪ Check the protocol dump list. ▪ Ask the other party to contact the manufacturer.

Code	Meaning	Suggested Cause/Action
0-33	The data reception (not ECM) is not completed within 10 minutes.	<ul style="list-style-type: none"> ▪ Check the line connection. ▪ The other terminal may have a defective modem/FCU.
0-52	Polarity changed during communication	<ul style="list-style-type: none"> ▪ Check the line connection. ▪ Retry communication.
0-55	FCU does not detect the SG3.	<ul style="list-style-type: none"> ▪ FCU firmware or board defective. ▪ SG3 firmware or board defective.
0-56	The stored message data exceeds the capacity of the mailbox in the SG3.	SG3 firmware or board defective.
0-70	The communication mode specified in CM/JM was not available (V.8 calling and called terminal)	<ul style="list-style-type: none"> ▪ The other terminal did not have a compatible communication mode (e.g., the other terminal was a V.34 data modem and not a fax modem.) ▪ A polling tx file was not ready at the other terminal when polling rx was initiated from the calling terminal.
0-74	The calling terminal fell back to T.30 mode, because it could not detect ANSam after sending CI.	<ul style="list-style-type: none"> ▪ The calling terminal could not detect ANSam due to noise, etc. ▪ ANSam was too short to detect. ▪ Check the line connection and condition. ▪ Try making a call to another V.8/V.34 fax.
0-75	The called terminal fell back to T.30 mode, because it could not detect a CM in response to ANSam (ANSam timeout).	<ul style="list-style-type: none"> ▪ The terminal could not detect ANSam. ▪ Check the line connection and condition. ▪ Try receiving a call from another V.8/V.34 fax.
0-76	The calling terminal fell back to T.30 mode, because it could not detect a JM in response to CM (CM timeout).	<ul style="list-style-type: none"> ▪ The called terminal could not detect a CM due to noise, etc. ▪ Check the line connection and condition. ▪ Try making a call to another V.8/V.34 fax.

Error Codes

Code	Meaning	Suggested Cause/Action
0-77	The called terminal fell back to T.30 mode, because it could not detect a CJ in response to JM (JM timeout).	<ul style="list-style-type: none"> ▪ The calling terminal could not detect a JM due to noise, etc. ▪ A network that has narrow bandwidth cannot pass JM to the other end. ▪ Check the line connection and condition. ▪ Try receiving a call from another V.8/V.34 fax.
0-79	The called terminal detected CI while waiting for a V.21 signal.	<ul style="list-style-type: none"> ▪ Check for line noise or other line problems. ▪ If this error occurs, the called terminal falls back to T.30 mode.
0-80	The line was disconnected due to a timeout in V.34 phase 2 – line probing.	<ul style="list-style-type: none"> ▪ The guard timer expired while starting these phases. Serious noise, narrow bandwidth, or low signal level can cause these errors. <p>If these errors happen at the transmitting terminal:</p> <ul style="list-style-type: none"> ▪ Try making a call at a later time. ▪ Try using V.17 or a slower modem using dedicated tx parameters. ▪ Try increasing the tx level. ▪ Try adjusting the tx cable equalizer setting. <p>If these errors happen at the receiving terminal:</p> <ul style="list-style-type: none"> ▪ Try adjusting the rx cable equalizer setting. ▪ Try increasing the tx level. ▪ Try using V.17 or a slower modem if the same error is frequent when receiving from multiple senders.
0-81	The line was disconnected due to a timeout in V.34 phase 3 – equalizer training.	
0-82	The line was disconnected due to a timeout in the V.34 phase 4 – control channel start-up.	
0-83	The line was disconnected due to a timeout in the V.34 control channel restart sequence.	
0-84	The line was disconnected due to abnormal signaling in V.34 phase 4 – control channel start-up.	
		<ul style="list-style-type: none"> ▪ The signal did not stop within 10 s. ▪ Turn off the main power switch, then turn it back on. ▪ If the same error is frequent, replace the FCU.

Code	Meaning	Suggested Cause/Action
0-85	The line was disconnected due to abnormal signaling in V.34 control channel restart.	<ul style="list-style-type: none"> ▪ The signal did not stop within 10 s. ▪ Turn off the main power switch, then turn it back on. ▪ If the same error is frequent, replace the FCU.
0-86	The line was disconnected because the other terminal requested a data rate using MPh that was not available in the currently selected symbol rate.	<ul style="list-style-type: none"> ▪ The other terminal was incompatible. ▪ Ask the other party to contact the manufacturer.
0-87	The control channel started after an unsuccessful primary channel.	<ul style="list-style-type: none"> ▪ The receiving terminal restarted the control channel because data reception in the primary channel was not successful. ▪ This does not result in an error communication.
0-88	The line was disconnected because PPR was transmitted/received 9 (default) times within the same ECM frame.	<ul style="list-style-type: none"> ▪ Try using a lower data rate at the start. ▪ Try adjusting the cable equalizer setting.
2-11	Only one V.21 connection flag was received	<ul style="list-style-type: none"> ▪ Replace the FCU.
2-12	Modem clock irregularity	<ul style="list-style-type: none"> ▪ Replace the FCU.
2-13	Modem initialization error	<ul style="list-style-type: none"> ▪ Turn off the machine, then turn it back on. ▪ Update the modem ROM. ▪ Replace the FCU.
2-22	Counter overflow error of JBIG chip	If error occurs frequently, change the settings for resolution, paper size, compression type.
2-23	JBIG compression or reconstruction error	Turn off the machine, then turn it back on.

Error Codes

Code	Meaning	Suggested Cause/Action
2-24	JBIG ASIC error	<ul style="list-style-type: none"> Turn off the machine, then turn it back on.
2-25	JBIG data reconstruction error (BIH error)	<ul style="list-style-type: none"> JBIG data error Check the sender's JBIG function. Update the FCU ROM.
2-26	JBIG data reconstruction error (Float marker error)	
2-27	JBIG data reconstruction error (End marker error)	
2-28	JBIG data reconstruction error (Timeout)	
2-29	JBIG trailing edge maker error	<ul style="list-style-type: none"> FCU defective Check the destination device.
2-50	The machine resets itself for a fatal FCU system error	<ul style="list-style-type: none"> If this is frequent, update the ROM, or replace the FCU.
2-51	The machine resets itself because of a fatal communication error	<ul style="list-style-type: none"> If this is frequent, update the ROM, or replace the FCU.
2-53	Snd msg() in the manual task is an error because the mailbox for the operation task is full.	<ul style="list-style-type: none"> The user did the same operation many times, and this gave too much load to the machine.
4-01	Line current was cut	<ul style="list-style-type: none"> Check the line connector. Check for line problems. Replace the FCU.
4-10	Communication failed because of an ID Code mismatch (Closed Network) or Tel. No./CSI mismatch (Protection against Wrong Connections)	<ul style="list-style-type: none"> Get the ID Codes the same and/or the CSIs programmed correctly, then resend. The machine at the other end may be defective.

Code	Meaning	Suggested Cause/Action
5-00	Data reconstruction not possible	Replace the FCU.
5-10	DCR timer expired	<ul style="list-style-type: none"> ▪ Replace the FCU.
5-20	Storage impossible because of a lack of memory	<ul style="list-style-type: none"> ▪ Temporary memory shortage. ▪ Test the SAF memory.
5-21	Memory overflow	
5-23	Print data error when printing a substitute rx or confidential rx message	<ul style="list-style-type: none"> ▪ Test the SAF memory. ▪ Ask the other end to resend the message.
5-25	SAF file access error	<ul style="list-style-type: none"> ▪ Replace an SD card or HDD. ▪ Replace the FCU.
6-00	G3 ECM - T1 time out during reception of facsimile data	<ul style="list-style-type: none"> ▪ Try adjusting the rx cable equalizer. ▪ Replace the FCU.
6-01	G3 ECM - no V.21 signal was received	
6-02	G3 ECM - EOR was received	
6-04	G3 ECM - RTC not detected	<ul style="list-style-type: none"> ▪ Check the line connection. ▪ Check for a bad line or defective remote terminal. ▪ Replace the FCU.
6-05	G3 ECM - facsimile data frame not received within 18 s of CFR, but there was no line fail	<ul style="list-style-type: none"> ▪ Check the line connection. ▪ Check for a bad line or defective remote terminal. ▪ Replace the FCU. ▪ Try adjusting the rx cable equalizer <p>Cross reference</p> <ul style="list-style-type: none"> ▪ Rx cable equalizer - G3 Switch 07 (PSTN)
6-06	G3 ECM - coding/decoding error	<ul style="list-style-type: none"> ▪ Defective FCU. ▪ The other terminal may be defective.

Error Codes

Code	Meaning	Suggested Cause/Action
6-08	G3 ECM - PIP/PIN received in reply to PPS.NULL	<ul style="list-style-type: none"> ▪ The other end pressed Stop during communication. ▪ The other terminal may be defective.
6-09	G3 ECM - ERR received	<ul style="list-style-type: none"> ▪ Check for a noisy line. ▪ Adjust the tx levels of the communicating machines. ▪ See code 6-05.
6-10	G3 ECM - error frames still received at the other end after all communication attempts at 2400 bps	<ul style="list-style-type: none"> ▪ Check for line noise. ▪ Adjust the tx level (use NCU parameter 01 or the dedicated tx parameter for that address). ▪ Check the line connection. ▪ Defective remote terminal.
6-21	V.21 flag detected during high speed modem communication	<ul style="list-style-type: none"> ▪ The other terminal may be defective or incompatible.
6-22	The machine resets the sequence because of an abnormal handshake in the V.34 control channel	<ul style="list-style-type: none"> ▪ Check for line noise. ▪ If the same error occurs frequently, replace the FCU. ▪ Defective remote terminal.
6-99	V.21 signal not stopped within 6 s	Replace the FCU.
13-17	SIP user name registration error	<ul style="list-style-type: none"> ▪ Double registration of the SIP user name. ▪ Capacity for user-name registration in the SIP server is not sufficient.
13-18	SIP server access error	<ul style="list-style-type: none"> ▪ Incorrect initial setting for the SIP server. ▪ Defective SIP server.
13-24	SIP authentication error	<ul style="list-style-type: none"> ▪ Registered password in the device does not match the password in the SIP server.
13-25	Network I/F setting error	<ul style="list-style-type: none"> ▪ IPV4 is not active in the active protocol setting. ▪ IP address of the device is not registered.

Code	Meaning	Suggested Cause/Action
13-26	Network I/F setting error at power on	<ul style="list-style-type: none"> ▪ Active protocol setting does not match the I/F setting for SIP server. ▪ IP address of the device is not registered.
13-27	IP address setting error	<ul style="list-style-type: none"> ▪ IP address of the device is not registered.
14-00	SMTP Send Error	<ul style="list-style-type: none"> ▪ Error occurred during sending to the SMTP server. Occurs for any error other than 14-01 to 16. For example, the mail address of the system administrator is not registered.
14-01	SMTP Connection Failed	<ul style="list-style-type: none"> ▪ Failed to connect to the SMTP server (timeout) because the server could not be found. ▪ The PC is not ready to transfer files. ▪ SMTP server not functioning correctly. ▪ The DNS IP address is not registered. ▪ Network not operating correctly. ▪ Destination folder selection not correct.
14-02	No Service by SMTP Service (421)	<ul style="list-style-type: none"> ▪ SMTP server operating incorrectly, or the destination for direct SMTP sending is not correct. ▪ Contact the system administrator and check that the SMTP server has the correct settings and operates correctly. ▪ Contact the system administrator for direct SMTP sending and check the sending destination.

Error Codes

Code	Meaning	Suggested Cause/Action
14-03	Access to SMTP Server Denied (450)	<ul style="list-style-type: none"> ▪ Failed to access the SMTP server because the access is denied. ▪ SMTP server operating incorrectly. Contact the system administrator to determine if there is a problem with the SMTP server and to check that the SMTP server settings are correct. ▪ Folder send destination is incorrect. Contact the system administrator to determine that the SMTP server settings and path to the server are correct. ▪ Device settings incorrect. Confirm that the user name and password settings are correct. ▪ Direct SMTP destination incorrect. Contact the system administrator to determine if there is a problem at the destination at that the settings at the destination are correct.
14-04	Access to SMTP Server Denied (550)	<ul style="list-style-type: none"> ▪ SMTP server operating incorrectly ▪ Direct SMTP sending not operating correctly

Code	Meaning	Suggested Cause/Action
14-05	SMTP Server HDD Full (452)	<ul style="list-style-type: none"> ▪ Failed to access the SMTP server because the HDD on the server is full. ▪ Insufficient free space on the HDD of the SMTP server. Contact the system administrator and check the amount of space remaining on the SMTP server HDD. ▪ Insufficient free space on the HDD where the destination folder is located. Contact the system administrator and check the amount of space remaining on the HDD where the target folder is located. ▪ Insufficient free space on the HDD at the target destination for SMTP direct sending. Contact the system administrator and check the amount of space remaining on the target HDD.
14-06	User Not Found on SMTP Server (551)	<ul style="list-style-type: none"> ▪ The designated user does not exist. ▪ The designated user does not exist on the SMTP server. ▪ The designated address is not for use with direct SMTP sending.
14-07	Data Send to SMTP Server Failed (4XX)	<ul style="list-style-type: none"> ▪ Failed to access the SMTP server because the transmission failed. ▪ PC not operating correctly. ▪ SMTP server operating incorrectly ▪ Network not operating correctly. ▪ Destination folder setting incorrect. ▪ Direct SMTP sending not operating correctly.

Error Codes

Code	Meaning	Suggested Cause/Action
14-08	Data Send to SMTP Server Failed (5XX)	<ul style="list-style-type: none"> ▪ Failed to access the SMTP server because the transmission failed. ▪ SMTP server operating incorrectly ▪ Destination folder setting incorrect. ▪ Direct SMTP sending not operating correctly. ▪ Software application error.
14-09	Authorization Failed for Sending to SMTP Server	<ul style="list-style-type: none"> ▪ POP-Before-SMTP or SMTP authorization failed. ▪ Incorrect setting for file transfer
14-10	Addresses Exceeded	<ul style="list-style-type: none"> ▪ Number of broadcast addresses exceeded the limit for the SMTP server.
14-11	Buffer Full	<ul style="list-style-type: none"> ▪ The send buffer is full so the transmission could not be completed. Buffer is full due to using Scan-to-Email while the buffer is being used send mail at the same time.
14-12	Data Size Too Large	<ul style="list-style-type: none"> ▪ Transmission was cancelled because the detected size of the file was too large.
14-13	Send Cancelled	<ul style="list-style-type: none"> ▪ Processing is interrupted because the user pressed Stop.
14-14	Security Locked File Error	<ul style="list-style-type: none"> ▪ Update the software because of the defective software.
14-15	Mail Data Error	<ul style="list-style-type: none"> ▪ The transmitting a mail is interrupted via DCS due to the incorrect data. ▪ Update the software because of the defective software.
14-16	Maximum Division Number Error	<ul style="list-style-type: none"> ▪ When a mail is divided for the mail transmission and the division number of a mail are more than the specified number, the mail transmission is interrupted. ▪ Update the software because of the defective software.

Code	Meaning	Suggested Cause/Action
14-17	Incorrect Ticket	<ul style="list-style-type: none"> Update the software because of the defective software.
14-18	Access to MCS File Error	<ul style="list-style-type: none"> The access to MCS file is denied due to the no permission of access. Update the software because of the defective software.
14-20	SMTP Authentication error	Make sure the administrator's e-mail address is same as the SMTP authentication address or POP before SMTP address.
14-21	Transmission error of S/MIME	Register the correct user certificate and device certificate.
14-30	MCS File Creation Failed	Failed to create the MCS file because: <ul style="list-style-type: none"> The number of files created with other applications on the Document Server has exceeded the limit. HDD is full or not operating correctly. Software error.
14-31	UFS File Creation Failed	UFS file could not be created: <ul style="list-style-type: none"> Not enough space in UFS area to handle both Scan-to-Email and IFAX transmission. HDD full or not operating correctly. Software error.
14-32	Cancelled the Mail Due to Error Detected by NFAX	<ul style="list-style-type: none"> Error detected with NFAX and send was cancelled due to a software error.
14-33	No Mail Address For the Machine	<ul style="list-style-type: none"> Neither the mail address of the machine nor the mail address of the network administrator is registered.

Error Codes

Code	Meaning	Suggested Cause/Action
14-34	Address designated in the domain for SMTP sending does not exist	<ul style="list-style-type: none"> ▪ Operational error in normal mail sending or direct SMTP sending. ▪ Check the address selected in the address book for SMTP sending. ▪ Check the domain selection.
14-50	Mail Job Task Error	<p>Due to an FCU mail job task error, the send was cancelled:</p> <ul style="list-style-type: none"> ▪ Address book was being edited during creation of the notification mail. ▪ Software error.
14-51	UCS Destination Download Error	<p>Not even one return notification can be downloaded:</p> <ul style="list-style-type: none"> ▪ The address book was being edited. ▪ The number for the specified destination does not exist (it was deleted or edited after the job was created).
14-60	Send Cancel Failed	<ul style="list-style-type: none"> ▪ The cancel operation by the user failed to cancel the send operation.
14-61	Notification Mail Send Failed for All Destinations	<ul style="list-style-type: none"> ▪ All addresses for return notification mail failed.
14-62	Transmission Error due to the existence of zero line page	<ul style="list-style-type: none"> ▪ When the 0 line page exists in received pages with G3 communication, the transmission is interrupted.
15-01	POP3/IMAP4 Server Not Registered	<ul style="list-style-type: none"> ▪ At startup, the system detected that the IP address of the POP3/IMAP4 server has not been registered in the machine.
15-02	POP3/IMAP4 Mail Account Information Not Registered	<ul style="list-style-type: none"> ▪ The POP3/IMAP4 mail account has not been registered.
15-03	Mail Address Not Registered	<ul style="list-style-type: none"> ▪ The mail address has not been registered.
15-10	DCS Mail Receive Error	<ul style="list-style-type: none"> ▪ Error other than 15-11 to 15-18.

Code	Meaning	Suggested Cause/Action
15-11	Connection Error	The DNS or POP3/IMAP4 server could not be found: <ul style="list-style-type: none"> ▪ The IP address for DNS or POP3/IMAP4 server is not stored in the machine. ▪ The DNS IP address is not registered. ▪ Network not operating correctly.
15-12	Authorization Error	POP3/IMAP4 send authorization failed: <ul style="list-style-type: none"> ▪ Incorrect IFAX user name or password. ▪ Access was attempted by another device, such as the PC. ▪ POP3/IMAP4 settings incorrect.
15-13	Receive Buffer Full	<ul style="list-style-type: none"> ▪ Occurs only during manual reception. Transmission cannot be received due to insufficient buffer space. The buffer is being used for mail send or Scan-to-Email.
15-14	Mail Header Format Error	<ul style="list-style-type: none"> ▪ The mail header is not standard format. For example, the Date line description is incorrect.
15-15	Mail Divide Error	<ul style="list-style-type: none"> ▪ The e-mail is not in standard format. There is no boundary between parts of the e-mail, including the header.
15-16	Mail Size Receive Error	<ul style="list-style-type: none"> ▪ The mail cannot be received because it is too large.
15-17	Receive Timeout	<ul style="list-style-type: none"> ▪ May occur during manual receiving only because the network is not operating correctly.
15-18	Incomplete Mail Received	<ul style="list-style-type: none"> ▪ Only one portion of the mail was received.
15-31	Final Destination for Transfer Request Reception Format Error	<ul style="list-style-type: none"> ▪ The format of the final destination for the transfer request was incorrect.

Error Codes

Code	Meaning	Suggested Cause/Action
15-39	Send/Delivery Destination Error	<p>The transmission cannot be delivered to the final destination:</p> <ul style="list-style-type: none"> ▪ Destination file format is incorrect. ▪ Could not create the destination for the file transmission.
15-41	SMTP Receive Error	<ul style="list-style-type: none"> ▪ Reception rejected because the transaction exceeded the limit for the "Auth. E-mail RX" setting.
15-42	Off Ramp Gateway Error	<ul style="list-style-type: none"> ▪ The delivery destination address was specified with Off Ramp Gateway OFF.
15-43	Address Format Error	<ul style="list-style-type: none"> ▪ Format error in the address of the Off Ramp Gateway.
15-44	Addresses Over	<ul style="list-style-type: none"> ▪ The number of addresses for the Off Ramp Gateway exceeded the limit of 30.
15-61	Attachment File Format Error	<ul style="list-style-type: none"> ▪ The attached file is not TIFF format.
15-62	TIFF File Compatibility Error	<p>Could not receive transmission due to:</p> <ul style="list-style-type: none"> ▪ Resolution error ▪ Image of resolution greater than 200 dpi without extended memory. ▪ Resolution is not supported. ▪ Page size error ▪ The page size was larger than A3. ▪ Compression error ▪ File was compressed with other than MH, MR, or MMR.
15-63	TIFF Parameter Error	<p>The TIFF file sent as the attachment could not be received because the TIFF header is incorrect:</p> <ul style="list-style-type: none"> ▪ The TIFF file attachment is a type not supported. ▪ The TIFF file attachment is corrupted. ▪ Software error.

Code	Meaning	Suggested Cause/Action
15-64	TIFF Decompression Error	The file received as an attachment caused the TIFF decompression error: <ul style="list-style-type: none"> ▪ The TIFF format of the attachment is corrupted. ▪ Software error.
15-71	Not Binary Image Data	<ul style="list-style-type: none"> ▪ The file could not be received because the attachment was not binary image data.
15-73	MDN Status Error	<ul style="list-style-type: none"> ▪ Could not find the Disposition line in the header of the Return Receipt, or there is a problem with the firmware.
15-74	MDN Message ID Error	<ul style="list-style-type: none"> ▪ Could not find the Original Message ID line in the header of the Return Receipt, or there is a problem with the firmware.
15-80	Mail Job Task Read Error	<ul style="list-style-type: none"> ▪ Could not receive the transmission because the destination buffer is full and the destination could not be created (this error may occur when receiving a transfer request or a request for notification of reception).
15-81	Repeated Destination Registration Error	<ul style="list-style-type: none"> ▪ Could not repeat receive the transmission because the destination buffer is full and the destination could not be created (this error may occur when receiving a transfer request or a request for notification of reception).
15-91	Send Registration Error	Could not receive the file for transfer to the final destination: <ul style="list-style-type: none"> ▪ The format of the final destination or the transfer destination is incorrect. ▪ Destinations are full so the final and transfer destinations could not be created.

Error Codes

Code	Meaning	Suggested Cause/Action
15-92	Memory Overflow	<ul style="list-style-type: none"> Transmission could not be received because memory overflowed during the transaction.
15-93	Memory Access Error	<ul style="list-style-type: none"> Transaction could not complete due to a malfunction of SAF memory.
15-94	Incorrect ID Code	<ul style="list-style-type: none"> The machine rejected an incoming e-mail for transfer request, because the ID code in the incoming e-mail did not match the ID code registered in the machine.
15-95	Transfer Station Function	<ul style="list-style-type: none"> The machine rejected an incoming e-mail for transfer because the transfer function was unavailable.
22-00	Original length exceeded the maximum scan length	<ul style="list-style-type: none"> Divide the original into more than one page. Check the resolution used for scanning. Lower the scan resolution if possible. Add optional page memory.
22-01	Memory overflow while receiving	<ul style="list-style-type: none"> Wait for the files in the queue to be sent. Delete unnecessary files from memory. Transfer the substitute reception files to an another fax machine, if the machine's printer is busy or out of order. Add an optional SAF memory card or hard disk.
22-02	Tx or rx job stalled due to line disconnection at the other end	<ul style="list-style-type: none"> The job started normally but did not finish normally; data may or may not have been received fully. Restart the machine.
22-04	The machine cannot store received data in the SAF	<ul style="list-style-type: none"> Update the ROM Replace the FCU.
22-05	No G3 parameter confirmation answer	<ul style="list-style-type: none"> Defective FCU board or firmware.

Code	Meaning	Suggested Cause/Action
23-00	Data read timeout during construction	<ul style="list-style-type: none"> ▪ Restart the machine. ▪ Replace the FCU.
25-00	The machine software resets itself after a fatal transmission error occurred	<ul style="list-style-type: none"> ▪ Update the ROM ▪ Replace the FCU.
F0-xx	V.34 modem error	<ul style="list-style-type: none"> ▪ Replace the FCU.
F6-xx	SG3 modem error	<ul style="list-style-type: none"> ▪ Update the SG3 modem ROM. ▪ Replace the SG3 board. ▪ Check for line noise or other line problems. ▪ Try communicating another V.8/V.34 fax.

3.2 IFAX TROUBLESHOOTING

Use the following procedures to determine whether the machine or another part of the network is causing the problem.

Communication Route	Item	Action [Remarks]
General LAN	1. Connection with the LAN	<ul style="list-style-type: none"> ▪ Check that the LAN cable is connected to the machine. ▪ Check that the LEDs on the hub are lit.
	2. LAN activity	Check that other devices connected to the LAN can communicate through the LAN.
Between IFAX and PC	1. Network settings on the PC	<ul style="list-style-type: none"> ▪ Check the network settings on the PC. [Is the IP address registered in the TCP/IP properties in the network setup correct? Check the IP address with the administrator of the network.]
	2. Check that PC can connect with the machine	<ul style="list-style-type: none"> ▪ Use the “ping” command on the PC to contact the machine. [At the MS-DOS prompt, type ping then the IP address of the machine, then press Enter.]
	3. LAN settings in the machine	<ul style="list-style-type: none"> ▪ Check the LAN parameters ▪ Check if there is an IP address conflict with other PCs. [Use the “Network” function in the User Tools. If there is an IP address conflict, inform the administrator.]
Between machine and e-mail server	1. LAN settings in the machine	<ul style="list-style-type: none"> ▪ Check the LAN parameters ▪ Check if there is an IP address conflict with other PCs. [Use the “Network” function in the User Tools. If there is an IP address conflict, inform the administrator.]

Communication Route	Item	Action [Remarks]
	2. E-mail account on the server	<ul style="list-style-type: none"> ▪ Make sure that the machine can log into the e-mail server. ▪ Check that the account and password stored in the server are the same as in the machine. <p>[Ask the administrator to check.]</p>
	3. E-mail server	<ul style="list-style-type: none"> ▪ Make sure that the client devices which have an account in the server can send/receive e-mail. <p>[Ask the administrator to check.]</p> <p>Send a test e-mail with the machine's own number as the destination. The machine receives the returned e-mail if the communication is performed successfully.]</p>

Communication Route	Item	Action [Remarks]
Between e-mail server and internet	1. E-mail account on the Server	<ul style="list-style-type: none"> ▪ Make sure that the PC can log into the e-mail server. ▪ Check that the account and password stored in the server are the same as in the machine. <p>[Ask the administrator to check.]</p>
	2. E-mail server	<ul style="list-style-type: none"> ▪ Make sure that the client devices which have an account in the server can send/receive e-mail. <p>[Ask the administrator to check. Send a test e-mail with the machine's own number as the destination. The machine receives the returned e-mail if the communication is performed successfully.]</p>
	3. Destination e-mail address	<ul style="list-style-type: none"> ▪ Make sure that the e-mail address is actually used. ▪ Check that the e-mail address contains no incorrect characters such as spaces.
	4. Router settings	<ul style="list-style-type: none"> ▪ Use the "ping" command to contact the router. ▪ Check that other devices connected to the router can sent data over the router. <p>[Ask the administrator of the server to check.]</p>
	5. Error message by e-mail from the network of the destination.	<ul style="list-style-type: none"> ▪ Check whether e-mail can be sent to another address on the same network, using the application e-mail software. ▪ Check the error e-mail message. <p>[Inform the administrator of the LAN.]</p>

3.3 IP-FAX TROUBLESHOOTING

3.3.1 IP-FAX TRANSMISSION

Cannot send by IP Address/Host Name

Check Point		Action
1	LAN cable connected?	Check the LAN cable connection.
2	Specified IP address/host name correct?	Check the IP address/host name.
3	Firewall/NAT is installed?	Cannot breach the firewall. Send by using another method (Fax, Internet Fax)
4	Transmission sent manually?	Manual sending not supported.
5	IP address of local machine registered?	Register the IP address.
6	Remote terminal port number setting other than 1720 (when using H.323) or 5060 (when using SIP)?	Send by specifying the port number.
7	Specified port number correct?	Confirm the port number of the remote fax.
8	DNS server registered when host name specified?	Contact the network administrator.
9	Remote fax a T.38 terminal?	Check whether the remote fax is a T38 terminal.
10	Remote fax switched off or busy?	Check that the remote fax is switched on.

11	Network bandwidth too narrow?	Request the network administrator to increase the bandwidth.
		Raise the delay level. IPFAX SW 01 Bit 0 to 3
		IP-Fax bandwidth is the same as the DCS speed. Set IP-Fax SW00 Bit 6 to 1.
12	Remote fax cancelled transmission?	Check whether the remote fax cancelled the transmission.

Cannot send via VoIP Gateway

Check Point		Action
1	LAN cable connected?	Check the LAN cable connection.
2	VoIP Gateway T.38 standard?	Contact the network administrator.
3	VoIP Gateway installed correctly?	Contact the network administrator.
4	VoIP Gateway power switched on?	Contact the network administrator.
5	Is the IP address/host name of the specified Gateway correct?	Check the IP address/host name.
6	Number of the specified fax correct?	Check the remote fax number.
7	Firewall/NAT is installed?	Cannot breach the firewall. Send by using another method (Fax, Internet Fax)
8	Transmission sent manually?	Manual sending not supported.
9	IP address of local fax registered?	Register the IP address.
10	DNS registered when host name specified?	Contact the network administrator.
11	Remote fax a G3 fax?	Check that the remote fax is a G3 fax.

12	G3 fax is connected to VoIP gateway?	Check that G3 fax is connected.
13	Remote G3 fax turned on?	Check that G3 fax is switched on.
14	Network bandwidth too narrow?	Request the network administrator to increase the bandwidth.
		Raise the network delay level. IPFAX SW 01 Bit 0 to 3
		IP-Fax bandwidth is the same as the DCS speed. Set IP-Fax SW00 Bit 6 to 1.

Cannot send by Alias Fax number.

Check Point		Action
1	LAN cable connected?	Check the LAN cable connection.
2	Number of specified Alias fax correct?	Confirm the Alias of the remote fax. Error Code: 13-14
3	Firewall/NAT installed?	Cannot breach the firewall. Send by using another method (Fax, Internet Fax)
4	Transmission sent manually?	Manual sending not supported.
5	Gatekeeper/SIP server installed correctly?	Contact the network administrator.
6	Gatekeeper/SIP server power switched on?	Contact the network administrator.
7	IP address/host name of Gatekeeper/SIP server correct?	Check the IP address/host name.
8	DNS server registered when Gatekeeper/SIP server host name specified?	Contact the network administrator.

9	Enable H.323/Enable SIP SW is set to on?	Check the settings. See User Parameter SW 34 Bit 0/SW 34 Bit 1
10	IP address of local fax registered?	Register the IP address of the local fax.
11	Alias number of local fax registered?	Register the Alias number of the local fax.
12	Remote fax registered in Gatekeeper?	Contact the network administrator.
13	Remote fax a T.38 terminal?	Check whether the remote fax is a T38 terminal.
14	Remote fax switched off or busy?	Contact the network administrator.
15	Network bandwidth too narrow?	Request the system administrator to increase the bandwidth.
		Raise the delay level. IPFAX SW 01 Bit 0 to 3
		Lower the modem transmission baud rate. IPFAX SW 05
16	Remote fax cancelled transmission?	Check whether the remote fax cancelled the transmission.

3.3.2 IP-FAX RECEPTION





Cannot receive via IP Address/Host Name.

Check Point		Action
1	LAN cable connected?	Check the LAN cable connection.
2	Firewall/NAT is installed?	Cannot breach the firewall. Send by using another method (Fax, Internet Fax)
3	IP address of local fax registered?	Register the IP address.
4	Port number specified at remote sender fax (if required)?	Request the sender to specify the port number.
5	Specified port number correct (if required)?	Request the sender to check the port number.
6	DNS server registered when host name specified on sender side?	<p>Contact the network administrator.</p> <p> Note</p> <ul style="list-style-type: none"> The sender machine displays this error code if the sender fax is a Ricoh model.
7	Network bandwidth too narrow?	Request the system administrator to increase the bandwidth.
		Lower the start modem reception baud rate on the receiving side. IPFAX SW06
8	Remote fax cancelled transmission?	Check whether the remote fax cancelled the transmission.

Cannot receive by VoIP Gateway.

Check Point		Action
1	LAN cable connected?	Check the LAN cable connection.
2	Firewall/NAT is installed?	Cannot breach the firewall. Request the remote fax to send by using another method (Fax, Internet Fax)
3	VoIP Gateway installed correctly?	Contact the network administrator.
4	VoIP Gateway power switched on?	Contact the network administrator.
5	IP address/host name of specified VoIP Gateway correct on sender's side?	Request the remote fax to check the IP address/host name.
6	DNS server registered when host name specified on sender side?	Contact the network administrator.
7	Network bandwidth too narrow?	Request the network administrator to increase the bandwidth.
8	G3 fax connected?	Check that G3 fax is connected.
9	G3 fax power switched on?	Check that G3 fax is switched on.

Cannot receive by Alias Fax number.

Check Point		Action
1	LAN cable connected?	Check the LAN cable connection.
2	Firewall/NAT is installed?	Cannot the breach firewall. Request the remote fax to send by using another method (Fax, Internet Fax)
3	Gatekeeper/SIP server installed correctly?	Contact the network administrator.  Note <ul style="list-style-type: none"> The sender machine displays this error code when the sender fax is a Ricoh model.
4	Power to Gatekeeper/SIP server switched on?	Contact the network administrator.  Note <ul style="list-style-type: none"> The sender machine displays this error code when the sender fax is a Ricoh model.
5	IP address/host name of Gatekeeper/SIP server correct on the sender's side?	Request the sender to check the IP address/host name.  Note <ul style="list-style-type: none"> The sender machine displays this error code when the sender fax is a Ricoh model.
6	DNS server registered when Gatekeeper/SIP server host name specified on sender's side?	Contact the network administrator.  Note <ul style="list-style-type: none"> The sender machine displays this error code when the sender fax is a Ricoh model.
7	Enable H.323/Enable SIP SW is set to on?	Request the sender to check the settings. User Parameter SW 34 Bit 0/SW 34 Bit 1  Note <ul style="list-style-type: none"> Only if the remote sender fax is a Ricoh fax.

8	Local fax IP address registered?	Register the IP address.
9	Local fax Alias number registered?	Register the Alias number.
10	Network bandwidth too narrow?	Request the system administrator to increase the bandwidth.
		Lower the start modem reception baud rate on the receiving side. IPFAX SW06
11	Remote fax cancelled transmission?	Check whether the remote fax cancelled the transmission.
12	Local fax registered in Gatekeeper/SIP server?	<p>Contact the network administrator.</p> <p> Note</p> <ul style="list-style-type: none"> The sender machine displays this error code when the sender fax is a Ricoh model.

4. SERVICE TABLES

4.1 CAUTIONS

★ Important

- Never turn off the main power switch when the power LED is lit or flashing. To avoid damaging the hard disk or memory, press the operation power switch to switch the power off, wait for the power LED to go off, and then switch the main power switch off.

↓ Note

- The main power LED lights or flashes while the platen cover or ARDF is open, while the main machine is communicating with a facsimile or the network server, or while the machine is accessing the hard disk or memory for reading or writing data.

4.2 SERVICE PROGRAM TABLES

4.2.1 SP1-XXX (BIT SW)

☛ p.84

1	Mode No.	Function
101	System Switch	
	001 – 032	00 – 1F Change the bit switches for system settings for the fax option ☛ "Bit Switches - 1" : "p.84"
102	Ifax Switch	
	001 – 016	00 – 0F Change the bit switches for internet fax settings for the fax option ☛ "Bit Switches - 2" : "p.100"
103	Printer Switch	
	001 – 016	00 – 0F Change the bit switches for printer settings for the fax option ☛ "Bit Switches - 2" : "p.108"
104	Communication Switch	
	001 – 032	00 – 1F Change the bit switches for communication settings for the fax option ☛ "Bit Switches - 3" : "p.116"
105	G3-1 Switch	
	001 – 016	00 – 0F Change the bit switches for the protocol settings of the standard G3 board ☛ "Bit Switches - 4" : "p.127"
106	G3-2 Switch	
	001 – 016	00 – 0F Change the bit switches for the protocol settings of the optional G3 board ☛ "Bit Switches - 5" : "p.138"
107	G3-3 Switch	

	001 – 016	00 – 0F	Change the bit switches for the protocol settings of the optional G3 board ☛ " Bit Switches - 5" : "p.138"
108	G4 Internal Switch		
	001 – 032	00 – 1F	Not used (Do not change the bit switches)
109	G4 Parameter Switch		
	001 – 016	00 – 0F	Not used (Do not change the bit switches)
111	IP fax Switch		
	001 – 016	00 – 0F	Change the bit switches for optional IP fax parameters ☛ " Bit Switches - 6 : "p.148"

4.2.2 SP2-XXX (RAM)

2	Mode No.		Function
101	RAM Read/Write		
	001		Change RAM data for the fax board directly. ☛ p.182
102	Memory Dump		
	001	G3-1 Memory Dump	Print out RAM data for the fax board. ☛ p.182
	002	G3-2 Memory Dump	Print out RAM data for the optional SG3 board.
	003	G3-3 Memory Dump	Print out RAM data for the optional SG3 board.
	004	G4 Memory Dump	Not used
103	G3-1 NCU Parameters		
	001 – 023	CC, 01 – 22	NCU parameter settings for the standard G3 board. ☛ p.158
104	G3-2 NCU Parameters		
	001 – 023	CC, 01 – 22	NCU parameter settings for the optional G3 board. ☛ p.158
105	G3-3 NCU Parameters		
	001 – 023	CC, 01 – 22	NCU parameter settings for the optional G3 board. ☛ p.158

4.2.3 SP3-XXX (MACHINE SET)

3	Mode No.		Function
101	Service Station		
	001	Fax Number	Enter the fax number of the service station.
	002	Select Line	Select the line type.
102	Serial Number		
	000		Enter the fax unit's serial number.
103	PSTN-1 Port Settings		
	001	Select Line	Select the line type setting for the G3-1 line. If the machine is installed on a PABX line, select "PABX", "PABX(GND)" or "PABX(FLASH)".
	002	PSTN Access Number	Enter the PSTN access number for the G3-1 line.
	003	Memory Lock Disabled	Not used
104	PSTN-2 Port Settings		
	001	Select Line	Select the line setting for the G3-2 line. If the machine is installed on a PABX line, select "PABX", "PABX(GND)" or "PABX(FLASH)".
	002	PSTN Access Number	Enter the PSTN access number for the G3-2 line.
	003	Memory Lock Disabled	Not used
	004	Transmission Disabled	If you turn this SP on, the machine does not send any fax messages on the G3-2 line.

105	PSTN-3 Port Settings		
	001	Select Line	Select the line setting for the G3-3 line. If the machine is installed on a PABX line, select "PABX", "PABX(GND)" or "PABX(FLASH)".
	002	PSTN Access Number	Enter the PSTN access number for the G3-3 line.
	003	Memory Lock Disabled	Not used
	004	Transmission Disabled	If you turn this SP on, the machine does not send any fax messages on the G3-3 line.
106	ISDN Port Settings		
	001	Select Line	Not used (Do not change the settings.)
	002	PSTN Access Number	
	003	Memory Lock Disabled	
004	Transmission Disabled		
107	IPFAX Port Settings		
	001	H323 Port	Sets the H323 port number.
	002	SIP Port	Sets the SIP port number.
	003	RAS Port	Sets the RAS port number.
	004	Gatekeeper port	Sets the Gatekeeper port number.
	005	T.38 Port	Sets the T.38 port number.
	006	SIP Server Port	Sets the SIP port number.
007	IPFAX Protocol Priority	Select "H323" or "SIP".	

201	FAX SW		
	001 – 032	00 – 1F	

4.2.4 SP4-XXX (ROM VERSIONS)

4	Mode No.		Function
101	001	FCU ROM Version	Displays the FCU ROM version.
102	001	Error Codes	Displays the latest 64 fax error codes.
103	001	G3-1 ROM Version	Displays the G3-1 modem version.
104	001	G3-2 ROM Version	Displays the G3-2 modem version.
105	001	G3-3 ROM Version	Displays the G3-3 modem version.
106	001	G4 ROM Version	Not used (Do not change the settings.)

4.2.5 SP5-XXX (RAM CLEAR)

5	Mode No.	Function
101	Initialize SRAM (except Secure)	
	000	Initializes the bit switches and user parameters, user data in the SRAM, files in the SAF memory, and clock.
102	Erase All Files	
	000	Erases all files stored in the SAF memory.
103	Reset Bit Switches (except Secure)	
	000	Resets the bit switches and user parameters.
104	Factory Setting	
	000	Resets the bit switches and user parameters, user data in the SRAM and files in the SAF memory.
105	Reset All Bit Switches	
	000	Resets all the current bit switch settings.
106	Reset Security Bit Switches	
	000	Resets only the security bit switches. If you select automatic output/display for the user parameter switches, the security settings are initialized.

4.2.6 SP6-XXX (REPORTS)

6	Mode No.		Function
101	System Parameter List		
	000	-	Touch the "ON" button to print the system parameter list.
102	Service Monitor Report		
	000	-	Touch the "ON" button to print the service monitor report.
103	G3 Protocol Dump List		
	001	G3 All Communications	Prints the protocol dump list of all communications for all G3 lines.
	002	G3-1 (All Communications)	Prints the protocol dump list of all communications for the G3-1 line.
	003	G3-1 (1 Communication)	Prints the protocol dump list of the last communication for the G3-1 line.
	004	G3-2 (All Communications)	Prints the protocol dump list of all communications for the G3-2 line.
	005	G3-2 (1 Communication)	Prints the protocol dump list of the last communication for the G3-2 line.
	006	G3-3 (All Communications)	Prints the protocol dump list of all communications for the G3-3 line.
	007	G3-3 (1 Communication)	Prints the protocol dump list of the last communication for the G3-3 line.

104	G4 Protocol Dump List		
	001	Dch + Bch 1	Not used (Do not change the settings.)
	002	Dch	
	003	Bch 1 Link Layer	
	004	Dch Link Layer	
	005	Dch +Bch 2	
	006	Bch 2 Link Layer	
105	All Files print out		
	000	-	<p>Prints out all the user files in the SAF memory, including confidential messages.</p> <p> Note</p> <ul style="list-style-type: none"> Do not use this function, unless the customer is having trouble printing confidential messages or recovering files stored using the memory lock feature.
106	Journal Print out		
	001	All Journals	The machine prints all the communication records on the report.
	002	Specified Date	The machine prints all communication records after the specified date.

Fax Option
Type C5502
(D643)

107	Log List Print out		
	001	All log files	These log print out functions are for designer use only.
	002	Printer	
	003	SC/TRAP Stored	
	004	Decompression	
	005	Scanner	
	006	JOB/SAF	
	007	Reconstruction	
	008	JBIG	
	009	Fax Driver	
	010	G3CCU	
	011	Fax Job	
	012	CCU	
013	Scanner Condition		
108	IP Protocol Dump List		
	001	All Communications	Prints the protocol dump list of all communications for the IP fax line.
	002	1 Communication	Prints the protocol dump list of the last communication for the IP fax line.

4.2.7 SP7-XXX (TESTS)

These are the test modes for PTT approval.

7	Function
101	G3-1 Modem Tests
102	G3-1 DTMF Tests
103	Ringer Test
104	G3-1 V34 (S2400baud)
105	G3-1 V34 (S2800baud)
106	G3-1 V34 (S3000baud)
107	G3-1 V34 (S3200baud)
108	G3-1 V34 (S3429baud)
109	Recorded Message Test
110	G3-2 Modem Tests
111	G3-2 DTMF Tests
112	G3-2 V34 (S2400baud)
113	G3-2 V34 (S2800baud)
114	G3-2 V34 (S3000baud)
115	G3-2 V34 (S3200baud)
116	G3-2 V34 (S3429baud)
117	G3-3 Modem Tests
118	G3-3 DTMF Tests
119	G3-3 V34 (S2400baud)
120	G3-3 V34 (S2800baud)
121	G3-3 V34 (S3000baud)

122	G3-3 V34 (S3200baud)
123	G3-3 V34 (S3429baud)
124	IG3-1 Modem Tests - Not used
125	IG3-1 DTMF Tests - Not used
126	IG3-1 V34 (S2400baud) - Not used
127	IG3-1 V34 (S2800baud) - Not used
128	IG3-1 V34 (S3000baud) - Not used
129	IG3-1 V34 (S3200baud) - Not used
130	IG3-1 V34 (S3429baud) - Not used
131	IG3-2 Modem Tests - Not used
132	IG3-2 DTMF Tests - Not used
133	IG3-2 V34 (S2400baud) - Not used
134	IG3-2 V34 (S2800baud) - Not used
135	IG3-2 V34 (S3000baud) - Not used
136	IG3-2 V34 (S3200baud) - Not used
137	IG3-2 V34 (S3429baud) - Not used

4.3 BIT SWITCHES - 1

↓ Note

- Do not adjust a bit switch or use a setting that is described as "Not used", as this may cause the machine to malfunction or to operate in a manner that is not accepted by local regulations. Such bits are for use only in other areas, such as Japan.

Default settings for bit switches are not listed in this manual. Refer to the System Parameter List printed by the machine.

4.3.1 SYSTEM SWITCHES

System Switch 00 (SP No. 1-101-001)		
No	Function	Comments
0	Dedicated transmission parameter programming 0: Disabled 1: Enabled	Set this bit to 1 before changing any dedicated transmission parameters. This setting is automatically reset to "0" after turning off and on.
1	Not used	Do not change
2	Technical data printout on the Journal 0: Disabled 1: Enabled	1: Instead of the personal name, the following data are listed on the Journal for each G3 communication.

	<p>Example:</p> <p>0000 32V34 288/264 L0100 03 04 (1) (2)(3) (4) (5) (6) (7) (8)</p> <p>(1): EQM value (Line quality data). A larger number means more errors. (2): Symbol rate (V.34 only) (3): Final modem type used (4): Starting data rate (for example, 288 means 28.8 kbps) (5): Final data rate (6): Rx level (see below for how to read the rx level) (7): Total number of error lines that occurred during non-ECM reception. (8): Total number of burst error lines that occurred during non-ECM reception.</p> <p> Note</p> <ul style="list-style-type: none"> ▪ EQM and rx level are fixed at "FFFF" in tx mode. ▪ The seventh and eighth numbers are fixed at "00" for transmission records and ECM reception records. 	
	<p>Rx level calculation</p> <p>Example:</p> <p>0000 32V34 288/264 L0100 03 04 (1) (2)(3) (4) (5) (6) (7) (8)</p> <p>The four-digit hexadecimal value (N) after "L" indicates the rx level. The high byte is given first, followed by the low byte. Divide the decimal value of N by -16 to get the rx level. In the above example, the decimal value of N (= 0100 [H]) is 256. So, the actual rx level is 256/-16 = -16 dB</p>	
3	Not used	Do not change this setting.
4	Line error mark print 0: OFF, 1: ON (print)	When "1" is selected, a line error mark is printed on the printout if a line error occurs during reception. This shows error locations when ECM is turned off.
5	G3/G4 communication parameter display 0: Disabled 1: Enabled	This is a fault-finding aid. The LCD shows the key parameters (see "G3 Communication Parameters" below this table). This is normally disabled because it cancels the CSI display for the user. Be sure to reset this bit to "0" after testing.

6	<p>Protocol dump list output after each communication</p> <p>0: Off</p> <p>1: On</p>	<p>This is only used for communication troubleshooting. It shows the content of the transmitted facsimile protocol signals. Always reset this bit to 0 after finishing testing.</p> <p>If system switch 09 bit 6 is at "1", the list is only printed if there was an error during the communication.</p>
7	Not used	Do not change the setting.

G3 Communication Parameters

Modem rate	<p>336: 33600 bps 168: 16800 bps</p> <p>312: 31200 bps 144: 14400 bps</p> <p>288: 28800 bps 120: 12000 bps</p> <p>264: 26400 bps 96: 9600 bps</p> <p>240: 24000 bps 72: 7200 bps</p> <p>216: 21600 bps 48: 4800 bps</p> <p>192: 19200 bps 24: 2400 bps</p>
Resolution	<p>S: Standard (8 x 3.85 dots/mm)</p> <p>D: Detail (8 x 7.7 dots/mm)</p> <p>F: Fine (8 x 15.4 dots/mm)</p> <p>SF: Superfine (16 x 15.4 dots/mm)</p> <p>21: Standard (200 x 100 dpi)</p> <p>22: Detail (200 x 200 dpi)</p> <p>44: Superfine (400 x 400 dpi)</p>
Compression mode	<p>MMR: MMR compression</p> <p>MR: MR compression</p> <p>MH: MH compression</p> <p>JBO: JBIG compression (Optional mode)</p> <p>JBB: JBIG compression (Basic mode)</p>
Communication mode	<p>ECM: With ECM</p> <p>NML: With no ECM</p>

Width and reduction	A4: A4 (8.3"), no reduction B4: B4 (10.1"), no reduction A3: A3 (11.7"), no reduction
I/O rate	0: 0 ms/line 5: 5 ms/line 10: 10 ms/line 20: 20 ms/line 25: 2.5 ms/line 40: 40 ms/line <div style="border: 1px solid blue; padding: 2px; display: inline-block;"> Note </div> <ul style="list-style-type: none"> ▪ "40" is displayed while receiving a fax message using AI short protocol.

System Switch 01 - Not used (Do not change the factory settings.)

System Switch 02 (SP No. 1-101-003)				
No	Function		Comments	
0	Not used		Do not change these settings.	
2	Forced reset after transmission stalls 0: Off 1: On		With this setting on, the machine resets itself automatically if a transmission stalls and fails to complete the job.	
3	Not used		Do not change these settings.	
4	File retention time 0: Depends on User Parameter 24 [18(H)] 1: No limit		1: A file that had a communication error will not be erased unless the communication is successful.	
5	Not used		Do not change this setting.	
6-7	Memory read/write by RDS		(0,0): All RDS systems are always locked out. (0,1), (1,0): Normally, RDS systems are locked out, but the user can temporarily switch RDS on to allow RDS operations to take place. RDS	
	Bit 7	Bit 6		Setting
	0	0		Always disabled

	0	1	User selectable	will automatically be locked out again after a certain time, which is stored in System Switch 03. Note that if an RDS operation takes place, RDS will not switch off until this time limit has expired. (1,1): At any time, an RDS system can access the machine.
	1	0	User selectable	
	1	1	Always enabled	

System Switch 03 (SP No. 1-101-004)		
No	Function	Comments
0 to 7	Length of time that RDS is temporarily switched on when bits 6 and 7 of System Switch 02 are set to "User selectable"	00 - 99 hours (BCD). This setting is only valid if bits 6 and 7 of System Switch 02 are set to "User selectable". The default setting is 24 hours.

System Switch 04 (SP No. 1-101-005)		
No	Function	Comments
0-2	Not used	Do not change these settings.
3	Printing dedicated tx parameters on Quick/Speed Dial Lists 0: Disabled 1: Enabled	1: Each Quick/Speed dial number on the list is printed with the dedicated tx parameters (10 bytes each). The first 10 bytes of data are the programmed dedicated tx parameters; 34 bytes of data are printed (the other 24 bytes have no use for service technicians).
4-7	Not used	Do not change these settings.

System Switch 05 - Not used (Do not change the factory settings.)
System Switch 06 - Not used (Do not change the factory settings.)
System Switch 07 - Not used (Do not change the factory settings.)
System Switch 08 - Not used (Do not change the factory settings.)

System Switch 09 (SP No. 1-101-010)		
No	Function	Comments
0	Addition of image data from confidential transmissions on the transmission result report 0: Disabled 1: Enabled	If this feature is enabled, the top half of the first page of confidential messages will be printed on transmission result reports.
1	Print timing of communication reports on the Journal when no image data was exchanged. 0: After DCS/NSS communication (default), 1: After polling	0: The Journal is printed only when image data is sent. 1: The Journal is printed when any data is sent.
2	Automatic error report printout 0: Disabled 1: Enabled	0: Error reports will not be printed. 1: Error reports will be printed automatically after failed communications.
3	Printing of the error code on the error report 0: No 1: Yes	1: Error codes are printed on the error reports. This can be used for detecting an error which occurs rarely.
4	Not used	Do not change this setting.
5	Power failure report 0: Disabled 1: Enabled (default)	1: A power failure report will be automatically printed after the power is switched on if a fax message disappeared from the memory when the power was turned off last. NOTE: If "0" is selected, no reports are printed and no one may recognize that fax data is gone due to a power failure.

6	<p>Conditions for printing the protocol dump list</p> <p>0: Print for all communications</p> <p>1: Print only when there is a communication error</p>	<p>This switch becomes effective only when system switch 00 bit 6 is set to 1.</p> <p>1: Set this bit to 1 when you wish to print a protocol dump list only for communications with errors.</p> <p>NOTE: The memory size is limited. Use this bit switch only when some log reports are necessary.</p>
7	<p>Priority given to various types of remote terminal ID when printing reports</p> <p>0: RTI > CSI > Dial label > Tel. number</p> <p>1: Dial label > Tel. number > RTI > CSI</p>	<p>This bit determines which set of priorities the machine uses when listing remote terminal names on reports.</p> <p>Dial Label: The name stored, by the user, for the Quick/Speed Dial number.</p>

System Switch 0A (SP No. 1-101-011)		
No	Function	Comments
0	<p>Automatic port selection</p> <p>0: Disabled, 1: Enabled</p>	<p>When "1" is selected, a suitable port is automatically selected if the selected port is not used.</p> <p>NOTE: This bit is useful if all communication lines at a customer site are not the same quality</p>
1-3	Not used	Do not change these settings.
4	<p>Dialing on the ten-key pad when the external telephone is off-hook</p> <p>0: Disabled 1: Enabled</p>	<p>0: Prevents dialing from the ten-key pad while the external telephone is off-hook. Use this setting when the external telephone is not by the machine, or if a wireless telephone is connected as an external telephone.</p> <p>1: The user can dial on the machine's ten-key pad when the handset is off-hook.</p>
5	<p>On hook dial</p> <p>0: Disabled 1: Enabled</p>	0: On hook dial is disabled.

6-7	Not used	Do not change the factory settings
-----	----------	------------------------------------

System Switch 0B - Not used (Do not change the factory settings.)

System Switch 0C - Not used (Do not change the factory settings.)

System Switch 0D - Not used (Do not change the factory settings.)

System Switch 0E (SP No. 1-101-015)

No	Function	Comments
0-1	Not used	Do not change the settings.
2	Enable/disable for direct sending selection 0: Direct sending off 1: Direct sending on	Direct sending cannot operate when the capture function is on during sending. Setting this switch to "1" enables direct sending without capture. Setting this switch to "0" masks the direct sending function on the operation panel so direct sending with ScanRouter cannot be selected.
3	Action when the external handset goes off-hook 0: Manual tx and rx operation 1: Memory tx and rx operation (the display remains the same)	0: Manual tx is possible while the external handset is off-hook. However, manual tx during handset off-hook may not be sent to a correct direction. Manual tx is not possible. 1: The display stays in standby mode even when the external handset is used, so that other people can use the machine for memory tx operation. Note that manual tx and rx are not possible with this setting.
4-7	Not used	Do not change these settings.

System Switch 0F (SP No. 1-101-016)			
No	Function	Comments	
0 to 7	Country/area code for functional settings (Hex)	This country/area code determines the factory settings of bit switches and RAM addresses. However, it has no effect on the NCU parameter settings and communication parameter RAM addresses. Cross reference NCU country code: SP No. 2-103-001 for G3-1 SP No. 2-104-001 for G3-2 SP No. 2-105-001 for G3-3	
	00: France		12: Asia
	01: Germany		13: Japan
	02: UK		14: Hong Kong
	03: Italy		15: South Africa
	04: Austria		16: Australia
	05: Belgium		17: New Zealand
	06: Denmark		18: Singapore
	07: Finland		19: Malaysia
	08: Ireland		1A: China
	09: Norway		1B: Taiwan
	0A: Sweden		1C: Korea
	0B: Switz.		1D: Brazil
	0C: Portugal		20: Turkey
	0D: Holland		21: Greece
	0E: Spain		22: Hungary
	0F: Israel		23: Czech
10: ---	24: Poland		
11: USA			

System Switch 10 (SP No. 1-101-017)		
No	Function	Comments
0-7	Threshold memory level for parallel memory transmission	Threshold = N x 128 KB + 256 KB N can be between 00 - FF(H) Default setting: 02(H) = 512 KB

System Switch 11 (SP No. 1-101-018)		
No	Function	Comments
0	TTI printing position 0: Superimposed on the page data 1: Printed before the data leading edge	Change this bit to 1 if the TTI overprints information that the customer considers to be important (G3 transmissions). NOTE: If "1" is selected, it is possible that sent data is printed on two sheets of paper.
1-2	Not used	Do not change the factory settings.
3	TTI used for broadcasting 0: The TTIs selected for each Quick/Speed dial are used 1: The same TTI is used for all destinations	1: The TTI (TTI_1 or TTI_2) which is selected for all destinations during broadcasting.
4-7	Not used	Do not change the factory settings.

System Switch 12 (SP No. 1-101-019)		
No	Function	Comments
0-7	TTI printing position in the main scan direction	TTI: 08 to 92 (BCD) mm Input even numbers only. This setting determines the print start position for the TTI from the left edge of the paper. If the TTI is moved too far to the right, it may overwrite the file number which is on the top right of the page. On an A4 page, if the TTI is moved over by more than 50 mm, it may overwrite the page number.

System Switch 13 - Not used (do not change these settings)

System Switch 14 - Not used (do not change these settings)

System Switch 15 (SP No. 1-101-022)		
No	Function	Comments
0	Not used	Do not change the settings.
1	Going into the Energy Saver mode automatically 0: Enabled 1: Disabled	1: The machine will restart from the Energy Saver mode quickly, because the +5V power supply is active even in the Energy Saver mode. The LED of the operation switch is flashing instead of entering Energy Saver mode. Use this setting if an external telephone has to be used when the machine is in the Energy Saver mode.
2-3	Not used	Do not change these settings.

4-5	Interval for preventing the machine from entering Energy Saver mode if there is a pending transmission file.		<p>If there is a file waiting for transmission, the machine does not go to Energy Saver mode during the selected period.</p> <p>After transmitting the file, if there is no file waiting for transmission, the machine goes to the Energy Saver mode.</p>	
	Bit 5	Bit 4		Setting
	0	0		1 min
	0	1		30 min
	1	0		1 hour
1	1	24 hours		
6-7	Not used		Do not change	

System Switch 16 (SP No. 1-101-023)		
No	Function	Comments
0	Parallel Broadcasting 0: Disabled 1: Enabled	1: The machine sends messages simultaneously using all available ports during broadcasting. NOTE: If a customer wants to keep a line available for fax reception or other reasons, select "0" (Disable).
1	Priority setting for the G3 line. 0: PSTN-1 > PSTN-2 or 3 1: PSTN-2 or 3 > PSTN-1	This function allows the user to select the default G3 line type. The optional SG3 units are required to use the PSTN-2 or 3 setting.
2-7	Not used	Do not change these settings.

System Switch 17 - Not used (do not change these settings)

System Switch 18 - Not used (do not change these settings)

System Switch 19 (SP No. 1-101-026)		
No	Function	Comments
0-5	Not used	Do not change the settings.
6	Extended scanner page memory after memory option is installed 0: Disabled 1: Enabled	0: After installing the memory expansion option, the scanner page memory is extended to 4 MB from 2 MB. 1: If this bit is set to 1 after installing the memory expansion option, the scanner page memory is extended to 12 MB. But the SAF memory decreases to 18 MB.
7	Special Original mode 0: Disabled 1: Enabled	1: If the customer frequently wishes to transmit a form or letterhead which has a colored or printed background, change this bit to "1". "Original 1" and "Original 2" can be selected in addition to the "Text", "Text/Photo" and "Photo" modes.

System Switch 1A (SP No. 1-101-027)		
No	Function	Comments
0 to 7	LS RX memory capacity threshold setting 00-FF (0-1020 Kbyte: Hex)	Sets the value to x4KB. When the amount of available memory drops below this setting, RX documents are printed to conserve memory. Initial setting 0x80 (512 KB) NOTE: If a customer wants available memory size to be larger, decrease this threshold

System Switch 1B - Not used (do not change these settings)

System Switch 1C - Not used (do not change these settings)

System Switch 1D (SP No. 1-101-030)		
No	Function	Comments
0	RTI/CSI/CPS code display 0: Enable 1: Disable	0: RTI, CSI, CPS codes are displayed on the top line of the LCD panel during communication. 1: Codes are switched off (no display)
1-7	Not used	Do not change these settings.

System Switch 1E (SP No. 1-101-031)		
No	Function	Comments
0	Communication after the Journal data storage area has become full 0: Impossible 1: Possible	0: When this switch is on and the journal history becomes full, the next report prints. If the journal history is not deleted, the next transmission cannot be received. This prevents overwriting communication records before the machine can print them. 1: If the buffer memory of the communication records for the Journal is full, fax communications are still possible. But the machine will overwrite the oldest communication records. <div style="border: 1px solid blue; padding: 2px; display: inline-block;"> ↓ Note </div> <ul style="list-style-type: none"> ▪ This setting is effective only when Automatic Journal printout is enabled but the machine cannot print the report (e.g., no paper).

1	<p>Action when the SAF memory has become full during scanning</p> <p>0: The current page is erased. 1: The entire file is erased.</p>	<p>0: If the SAF memory becomes full during scanning for a memory transmission, the successfully scanned pages are transmitted.</p> <p>1: If the SAF memory becomes full during scanning for a memory transmission, the file is erased and no pages are transmitted.</p> <p> Note</p> <ul style="list-style-type: none"> This setting is effective only when Automatic Journal printout is enabled but the machine cannot print the report (e.g., no paper).
2	<p>RTI/CSI display priority</p> <p>0: RTI 1: CSI</p>	<p>This bit determines which identifier, RTI or CSI, is displayed on the LCD while the machine is communicating in G3 non-standard mode.</p>
3	<p>File No. printing</p> <p>0: Enabled 1: Disabled</p>	<p>1: File numbers are not printed on any reports.</p> <p>NOTE: The file numbers may not be printed in the sequential order. If a customer does not like this numbering, select "0".</p>
4	<p>Action when authorized reception is enabled but authorized RTIs/CSIs are not yet programmed</p> <p>0: Faxes can be received if the sender has an RTI or CSI 1: All fax reception is disabled</p>	<p>0: If the user has stored no acceptable sender RTIs or CSIs, the user can select "ON" in the authorized reception setting but the setting becomes invalid ("OFF"). The machine will not be able to receive any fax messages.</p> <p>If the customer wishes to receive messages from any sender that includes an RTI or CSI, and to block messages from senders that do not include an RTI or CSI, change this bit to "0", then enable Authorized Reception. Otherwise, keep this bit at "1 (default setting)".</p>
5-7	Not used	Do not change the settings

System Switch 1F (SP No. 1-101-032)		
No	Function	Comments
0	Not used	Do not change the settings.
1	Report printout after an original jam during SAF storage or if the SAF memory fills up 0: Enabled 1: Disabled	0: When an original jams, or the SAF memory overflows during scanning, a report will be printed. Change this bit to "1" if the customer does not want to have a report in these cases. Memory tx – Memory storage report Parallel memory tx – Transmission result report
2	Not used	Do not change the settings.
3	Received fax print start timing (G3 reception) 0: After receiving each page 1: After receiving all pages	0: The machine prints each page immediately after the machine receives it. 1: The machine prints the complete message after the machine receives all the pages in the memory.
4-6	Not used	Do not change the factory settings.
7	Action when a fax SC has occurred 0: Automatic reset 1: Fax unit stops	0: When the fax unit detects a fax SC code other than SC1201 and SC1207, the fax unit automatically resets itself. 1: When the fax unit detects any fax SC code, the fax unit stops. Cross Reference Fax SC codes - See "Troubleshooting"

4.4 BIT SWITCHES - 2

Note

- Do not adjust a bit switch or use a setting that is described as "Not used", as this may cause the machine to malfunction or to operate in a manner that is not accepted by local regulations. Such bits are for use only in other areas, such as Japan.

Default settings for bit switches are not listed in this manual. Refer to the System Parameter List printed by the machine.

4.4.1 I-FAX SWITCHES

I-fax Switch 00 (SP No. 1-102-001)		
No	Function	Comments
Original Width of TX Attachment File		This setting sets the maximum size of the original that the destination can receive. (Bits 3~7 are reserved for future use or not used.)
0	A4	-
1	B4	
2	A3	
3-6	Reserved	
7	Not used	

I-fax Switch 01 (SP No. 1-102-002)

No	Function	Comments
Original Line Resolution of TX Attachment File		These settings set the maximum resolution of the original that the destination can receive.
0	200x100 Standard	0: Not selected 1: Selected If more than one of these three bits is set to "1", the higher resolution has priority. For example, if both Bit 0 and Bit 2 are set to "1" Then The Resolution is set for "Bit 2 200 x 400.
1	200x200 Detail	
2	200x400 Fine	
3	300 x 300 Reserve	
4	400 x 400 Super Fine	
5	600 x 600 Reserve	
6	Reserve	
7	mm/inch	
<p>This setting selects mm/inch conversion for mail transmission. 0: Off (No conversion), 1: On (Conversion) When on (set to "1"), the machine converts millimeters to inches for sending mail. There is no switch for converting inches to millimeters. Unlike G3 fax transmissions which can negotiate between sender and receiver to determine the setting, mail cannot negotiate between terminals; the mm/inch selection is determined by the sender fax. When this switch is Off (0):</p> <ul style="list-style-type: none"> ▪ Images scanned in inches are sent in inches. ▪ Images scanned in mm are sent in mm. ▪ Images received in inches are transmitted in inches. ▪ Images received in mm are transmitted in mm. <p>When this switch is On (1):</p> <ul style="list-style-type: none"> ▪ Images scanned in inches are sent in inches. ▪ Images scanned in mm are converted to inches. ▪ Images received in inches are transmitted in inches. ▪ Images received in mm are converted to inches. 		

I-fax Switch 02 (SP No. 1-102-003)		
No	Function	Comments
0	RX Text Mail Header Processing	
		<p>This setting determines whether the header information is printed with text e-mails when they are received.</p> <p>0: Prints only text mail. 1: Prints mail header information attached to text mail.</p> <p>When a text mail is received with this switch On (1), the "From" address and "Subject" address are printed as header information.</p> <p>When a mail with only binary data is received (a TIFF-F file, for example), this setting is ignored and no header is printed.</p>
1	Output from Attached Document at E-mail TX Error	
		<p>This setting determines whether only the first page or all pages of an e-mail attachment are printed at the sending station when a transmission error occurs.</p> <p>This allows the customer to see which documents have not reached their intended destinations if sent to the wrong e-mail addresses, for example.</p> <p>0: Prints 1st page only. 1: Prints all pages.</p>
2-3	Text String for Return Receipt	
		<p>This setting determines the text string output for the Return Receipt that confirms the transmission was received normally at the destination.</p>

	<p>00: "Dispatched" Sends from PC mail a request for a Return Receipt. Receives the Return Receipt with "dispatched" in the 2nd part: Disposition: Automatic-action/MDN-send automatically; dispatched The "dispatched" string is included in the Subject string.</p> <p>01: "Displayed" Sends from PC mail a request for a Return Receipt. Receives the Return Receipt with "displayed" in the 2nd part: Disposition: Automatic-action/MDN-send automatically; displayed The "displayed" string is included in the Subject string.</p> <p>10: Reserved 11: Reserved</p> <p>A mail requesting a Return Receipt sent from an IFAX with this switch set to "00" (for "dispatched") received by Microsoft Outlook 2000 may cause an error. If any setting other than "displayed" (01) causes a problem, change the setting to "01" to enable normal sending of the Return Receipt.</p>
4	<p>Media accept feature</p> <p>This setting adds or does not add the media accept feature to the answer mail to confirm a reception.</p> <p>0: Does not add the media accept feature to the answer mail 1: Adds the media accept feature to the answer mail.</p> <p>Use this bit switch if a problem occurs when the machine receives an answer mail, which contains the media accept feature field.</p>
5-6	Not Used
7	<p>Image Resolution of RX Text Mail</p> <p>This setting determines the image resolution of the received mail.</p> <p>0: 200 x 200 1: 400 x 400</p> <p>The "1" setting requires installation of the Memory Unit in order to have enough SAF (Store and Forward) memory to receive images at 400 x 400 resolution.</p>

I-fax Switch 03 - Not used (do not change these settings)

I-fax Switch 04 (SP No. 1-102-005)		
No	Function	Comments
0	<p>Subject for Delivery TX/Memory Transfer</p> <p>This setting determines whether the RTI/CSI registered on this machine or the RTI/CSI of the originator is used in the subject lines of transferred documents.</p> <p>0: Puts the RTI/CSI of the originator in the Subject line. If this is used, either the RTI or CSI is used. Only one of these can be received for use in the subject line.</p> <p>1: Puts the RTI/CSI registered on this machine in the Subject line.</p> <p>When this switch is used to transfer and deliver mail to a PC, the information in the Subject line that indicates where the transmission originated can be used to determine automatically the destination folder for each e-mail.</p>	
1	<p>Subject corresponding to mail post database</p> <p>0: Standard subject</p> <p>1: Mail post database subject</p> <p>The standard subject is replaced by the mail post database subject in the following three cases:</p> <p>1) When the service technician sets the service (software) switch.</p> <p>2) When memory sending or delivery specified by F code is applied by the SMTP server</p> <p>3) With relay broadcasting (1st stage without the Schmidt 4 function).</p> <p> Note</p> <ul style="list-style-type: none"> ▪ This switch does not apply for condition 3) when the RX system is set up for memory sending, delivery by F-code, sending with SMTP RX and when operators are using FOL (to prevent problems when receiving transmissions). 	
2-7	Not Used	

I-fax Switch 05 (SP No. 1-102-006)		
No	Function	Comments
0	Mail Addresses of SMTP Broadcast Recipients	
	Determines whether the e-mail addresses of the destinations that receive transmissions broadcasted using SMTP protocol are recorded in the Journal. For example: "1st destination + Total number of destinations: 9" in the Journal indicates a broadcast to 9 destinations. 0: Not recorded 1: Recorded	
1-7	Not Used	

I-fax Switch 06 - Not used (do not change the settings)

I-fax Switch 07 - Not used (do not change the settings)

I-fax Switch 08 (SP No. 1-102-009)		
No	Function	Comments
0-7	Memory Threshold for POP Mail Reception	
	This setting determines the amount of SAF (Store and Forward) memory. (SAF stores fax messages to send later for transmission to more than one location, and also holds incoming messages if they cannot be printed.) When the amount of SAF memory available falls below this setting, mail can no longer be received; received mail is then stored on the mail server. 00-FF (0 to 1024 KB: HEX) The hexadecimal number you enter is multiplied by 4 KB to determine the amount of memory.	

I-fax Switch 09 (SP No. 1-102-010)		
No	Function	Comments
0-3	Not used	Do not change the settings
4-7	Restrict TX Retries	This setting determines the number of retries when connection and transmission fails due to errors. 01-F (1-15 Hex)

I-fax Switch 0A - Not used (do not change the settings)
I-fax Switch 0B - Not used (do not change the settings)
I-fax Switch 0C - Not used (do not change the settings)

I-fax Switch 0D (SP No. 1-102-014)				
No	Function			Comments
0-1	Not used			Do not change the settings
2-3	Set to select the signature when sending mail notification of the send results			In response to IEEE2600.1.
	Bit 2	Bit 3	Setting	
	0	0	No sign	
	0	1	No setting	
	1	0	Individual setting	
4-5	Set to select the signature when sending mail.			In response to IEEE2600.1.
	Bit 5	Bit 4	Setting	
	0	0	No sign	

	0	1	No setting	
	1	0	Individual setting	
	1	1	Always sign	
6-7	Not used		Do not change the settings.	

I-fax Switch 0E - Not used (do not change the settings)

I-fax Switch 0F (SP No. 1-102-016)		
No	Function	Comments
0	Delivery Method for SMTP RX Files	
	This setting determines whether files received with SMTP protocol are delivered or output immediately. 0: Off. Files received via SMTP are output immediately without delivery. 1: On. Files received via SMTP are delivered immediately to their destinations.	
1-7	Not used	

4.4.2 PRINTER SWITCHES

Printer Switch 00 (SP No. 1-103-001)		
No	Function	Comments
0	Select page separation marks 0: Off 1: On	<p>0: If a 2 page RX transmission is split, [*] is printed in the bottom right corner of the 1st page and only a [2] is printed in the upper right corner of the 2nd page.</p> <p>1: If a 2 page RX transmission is split into two pages, for example, [*] [2] is printed in the bottom right corner of the 1st page and only a [2] is printed in the upper right corner of the 2nd page.</p> <p> Note</p> <ul style="list-style-type: none"> This helps the user to identify pages that have been split because the size of the paper is smaller than the size of the document received. (When A5 is used to print an A4 size document, for example.)
1	Repetition of data when the received page is longer than the printer paper 0: Off 1: On	<p>1: Default. 10 mm of the trailing edge of the previous page are repeated at the top of the next page.</p> <p>0: The next page continues from where the previous page stopped without any repeated text.</p>
2	Prints the date and time on received fax messages 0: Disabled 1: Enabled	<p>This switch is only effective when user parameter 02 - bit 2 (printing the received date and time on received fax messages) is enabled.</p> <p>1: The machine prints the received and printed date and time at the bottom of each received page.</p>
3-7	Not used	Do not change the settings.

Printer Switch 01 (SP No. 1-103-002)				
No	Function		Comments	
0-2	Not used		Do not change the settings.	
3-4	Maximum print width used in the setup protocol		These bits are only effective when bit 7 of printer switch 01 is "1".	
	Bit 4	Bit 3		Setting
	0	0		Not used
	0	1		A3
	1	0		B4
	1	1	A4	
5-6	Not used		Do not change the settings.	
7	Received message width restriction in the protocol signal to the sender 0: Disabled 1: Enabled		0: The machine informs the transmitting machine of the print width depending on the paper size available from the paper feed stations. Refer to the table on the next page for how the machine chooses the paper width used in the setup protocol (NSF/DIS). 1: The machine informs the transmitting machine of the fixed paper width which is specified by bits 3 and 4 above.	

Relationship between available paper sizes and printer width used in the setup protocol

Available Paper Size	Printer width used in the Protocol (NSF/DIS)
A4 or 8.5" x 11"	297 mm width
B5	256 mm width
A5 or 8.5" x 5.5"	216 mm width
No paper available (Paper end)	216 mm width

Printer Switch 02 (SP No. 1-103-003)		
No	Function	Comments
0	1st paper feed station usage for fax printing 0: Enabled 1: Disabled	<p>0: The paper feed station can be used to print fax messages and reports. 1: The specified paper feed station will not be used for printing fax messages and reports.</p> <p>Note</p> <ul style="list-style-type: none"> Do not disable usage for a paper feed station which has been specified by User Parameter Switch 0F (15), or which is used for the Specified Cassette Selection feature.
1	2nd paper feed station usage for fax printing 0: Enabled 1: Disabled	
2	3rd paper feed station usage for fax printing 0: Enabled 1: Disabled	
3	4th paper feed station usage for fax printing 0: Enabled 1: Disabled	
4	LCT usage for fax printing 0: Enabled 1: Disabled	
5-7	Not used	

Printer Switch 03 (SP No. 1-103-004)		
No	Function	Comments
0	Length reduction of received data 0: Disabled 1: Enabled	0: Incoming pages are printed without length reduction. (Page separation threshold: Printer Switch 03, bits 4 to 7) 1: Incoming page length is reduced when printing. (Maximum reducible length: Printer Switches 04, bits 0 to 4)
1-3	Not used	Do not change the settings
4 to 7	Page separation setting when sub scan compression is forbidden 00-0F (0-15 mm: Hex) Default: 6 mm	Page separation threshold (with reduction disabled with switch 03-0 above). For example, if this setting is set to "10", and A4 is the selected paper size: If the received document is 10 mm or less longer than A4, then the 10 mm are cut and only 1 page prints. If the received document is 10 mm longer than A4, then the document is split into 2 pages.

Printer Switch 04 (SP No. 1-103-005)						
No	Function			Comments		
0 to 4	Maximum reducible length when length reduction is enabled with switch 03-0 above. [Maximum reducible length] = [Paper length] + (N x 5mm) "N" is the decimal value of the binary setting of bits 0 to 4.					
	Bit 4	Bit 3	Bit 2	Bit 1	Bit 0	Setting
	0	0	0	0	0	0 mm
	0	0	0	0	1	5 mm
	0	0	1	0	0	20 mm

Bit Switches - 2

	1	1	1	1	1	155 mm
	For A5 sideways and B5 sideways paper $[Maximum\ reducible\ length] = [Paper\ length] + 0.75 \times (N \times 5mm)$					
5 6	Length of the duplicated image on the next page, when page separation has taken place.					
	Bit 6		Bit 5		Setting	
	0		0		4 mm	
	0		1		10 mm	
	1		0		15 mm	
	1		1		Not used	
7	Not used.		Do not change the setting.			

Printer Switch 05 - Not used (do not change the settings)

Printer Switch 06 (SP No. 1-103-007)

No	Function	Comments
0	Printing while a paper cassette is pulled out, when the Just Size Printing feature is enabled. 0: Printing will not start 1: Printing will start if another cassette has a suitable size of paper, based on the paper size selection priority tables.	Cross reference Just size printing on/off – User switch 05, bit 5
1-7	Not used.	Do not change the settings.

Printer Switch 07 (SP No. 1-103-008)		
No	Function	Comments
0-3	Not used.	Do not change the settings.
4	List of destinations in the Communication Failure Report for broadcasting 0: All destinations 1: Only destinations where communication failure occurred	1: Only destinations where communication failure occurred are printed on the Communication Failure Report.
5-7	Not used.	Do not change the settings.

Printer Switch 08 - Not used (do not change the settings)

Printer Switch 09 - Not used (do not change the settings)

Printer Switch 0A - Not used (do not change the settings)

Printer Switch 0B - Not used (do not change the settings)

Printer Switch 0C - Not used (do not change the settings)

Printer Switch 0E (SP No. 1-103-015)				
No	Function		Comments	
0	Paper size selection priority 0: Width 1: Length		0: A paper size that has the same width as the received data is selected first. 1: A paper size which has enough length to print all the received lines without reduction is selected first.	
1	Paper size selected for printing A4 width fax data 0: 8.5" x 11" size 1: A4 size		This switch determines which paper size is selected for printing A4 width fax data, when the machine has both A4 and 8.5" x 11" size paper.	
2	Page separation 0: Enabled 1: Disabled		1: If all paper sizes in the machine require page separation to print a received fax message, the machine does not print the message (Substitute Reception is used). After a larger size of paper is set in a cassette, the machine automatically prints the fax message.	
3-4	Printing the sample image on reports		"Same size" means the sample image is printed at 100%, even if page separation occurs. User Parameter Switch 19 (13H) bit 4 must be set to "0" to enable this switch. Refer to Detailed Section Descriptions for more on this feature.	
	Bit 4	Bit 3		Setting
	0	0		The upper half only
	0	1		50% reduction (sub-scan only)
	1	0		Same size
1	1	Not used		

5-6	Not used	Do not change the settings.
7	<p>Equalizing the reduction ratio among separated pages (Page Separation)</p> <p>0: Enabled 1: Disabled</p>	<p>0: When page separation has taken place, all the pages are reduced with the same reduction ratio.</p> <p>1: Only the last page is reduced to fit the selected paper size when page separation has taken place. Other pages are printed without reduction.</p>

Printer Switch 0F (SP No. 1-103-016)				
No	Function			Comments
0-1	Smoothing feature			(0, 0) (0, 1): Disable smoothing if the machine receives halftone images from other manufacturers fax machines frequently.
	Bit 1	Bit 0	Setting	
	0	0	Disabled	
	0	1	Disabled	
	1	0	Enabled	
1	1	Not used		
2	<p>Duplex printing</p> <p>0: Disabled 1: Enabled</p>			1: The machine always prints received fax messages in duplex printing mode:
3	<p>Binding direction for Duplex printing</p> <p>0: Left binding 1: Top binding</p>			<p>0: Sets the binding for the left edge of the stack.</p> <p>1: Sets the binding for the top of the stack.</p>
4-7	Not used			Do not change the settings.

4.5 BIT SWITCHES - 3

↓ Note

- Do not adjust a bit switch or use a setting that is described as "Not used", as this may cause the machine to malfunction or to operate in a manner that is not accepted by local regulations. Such bits are for use only in other areas, such as Japan.

Default settings for bit switches are not listed in this manual. Refer to the System Parameter List printed by the machine.

4.5.1 COMMUNICATION SWITCHES

Communication Switch 00 (SP No. 1-104-001)				
No	Function			Comments
0-1	Compression modes available in receive mode			These bits determine the compression capabilities to be declared in phase B (handshaking) of the T.30 protocol.
	Bit 1	Bit 0	Modes	
	0	0	MH only	
	0	1	MH/MR	
	1	0	MH/MR/MMR	
	1	1	MH/MR/MMR/JBIG	
2-3	Compression modes available in transmit mode			These bits determine the compression capabilities to be used in the transmission and to be declared in phase B (handshaking) of the T.30 protocol.
	Bit 3	Bit 2	Modes	
	0	0	MH only	
	0	1	MH/MR	
	1	0	MH/MR/MMR	
	1	1	MH/MR/MMR/JBIG	
4	Not used			Do not change the settings.
5	JBIG compression method: Reception 0: Only basic supported 1: Basic and optional both supported			Change the setting when communication problems occur using JBIG compression.

6	JBIG compression method: Transmission 0: Basic mode priority 1: Optional mode priority	Change the setting when communication problems occur using JBIG compression.
7	Closed network (reception) 0: Disabled 1: Enabled	1: Reception will not go ahead if the polling ID code of the remote terminal does not match the polling ID code of the local terminal. This function is only available in NSF/NSS mode.

Fax Option
Type C5502
(D643)

Communication Switch 01 (SP No. 1-104-002)				
No	Function		Comments	
0	ECM 0: Off 1: On		If this bit is set to 0, ECM is switched off for all communications. In addition, V.8 protocol and JBIG compression are switched off automatically.	
1	Not used		Do not change the setting.	
2-3	Wrong connection prevention method		(0,1): The machine will disconnect the line without sending a fax message, if the last 8 digits of the received CSI do not match the last 8 digits of the dialed telephone number. This does not work when manually dialed. (1,0): The same as above, except that only the last 4 digits are compared. (1,1): The machine will disconnect the line without sending a fax message, if the other end does not identify itself with an RTI or CSI. (0,0): Nothing is checked; transmission will always go ahead. <div style="border: 1px solid blue; padding: 2px; display: inline-block;"> ↓ Note </div> <ul style="list-style-type: none"> ▪ This function does not work when dialing is done from the external telephone. 	
	Bit 3	Bit 2		Setting
	0	0		None
	0	1		8 digit CSI
	1	0		4 digit CSI
	1	1		CSI/RTI
4-5	Not used		Do not change the setting.	
6-7	Maximum printable page length available		The setting determined by these bits is informed to the transmitting terminal in the pre-message protocol exchange (in the DIS/NSF frames).	
	Bit 7	Bit 6		Setting
	0	0		No limit
	0	1		B4 (364 mm)
	1	0		A4 (297 mm)
1	1	Not used		

Communication Switch 02 (SP No. 1-104-003)		
No	Function	Comments
0	G3 Burst error threshold 0: Low 1: High	If there are more consecutive error lines in the received page than the threshold, the machine will send a negative response. The Low and High threshold values depend on the sub-scan resolution, and are as follows.
		100 dpi 6(L) →12(H)
		200 dpi 12(L) →24(H)
		300 dpi 18(L) →36(H)
		400 dpi 24(L) →48(H)
1	Acceptable total error line ratio 0: 5% 1: 10%	If the error line ratio for a page exceeds the acceptable ratio, RTN will be sent to the other end.
2	Treatment of pages received with errors during G3 reception 0: Deleted from memory without printing 1: Printed	0: Pages received with errors are not printed.
3	Hang-up decision when a negative code (RTN or PIN) is received during G3 immediate transmission 0: No hang-up, 1: Hang-up	0: The next page will be sent even if RTN or PIN is received. 1: The machine will send DCN and hang up if it receives RTN or PIN. This bit is ignored for memory transmissions or if ECM is being used.
4-7	Not used	Do not change the settings.

Communication Switch 03 (SP No. 1-104-004)		
No	Function	Comments
0-7	Maximum number of page retransmissions in a G3 memory transmission	00 - FF (Hex) times. This setting is not used if ECM is switched on. Default setting - 03(H)

Communication Switch 04 - Not used (do not change the settings)
Communication Switch 05 - Not used (do not change the settings)
Communication Switch 06 - Not used (do not change the settings)
Communication Switch 07 - Not used (do not change the settings)
Communication Switch 08 - Not used (do not change the settings)
Communication Switch 09 - Not used (do not change the settings)

Communication Switch 0A (SP No. 1-104-011)		
No	Function	Comments
0	Point of resumption of memory transmission upon redialing 0: From the error page 1: From page 1	0: The transmission begins from the page where transmission failed the previous time. 1: Transmission begins from the first page, using normal memory transmission.
1-7	Not used	Do not change the settings.

Communication Switch 0B (SP No. 1-104-012)		
No	Function	Comments
0-3	Not used	Do not change the settings.
4	Printout of the message when acting as a Transfer Station 0: Disabled, 1: Enabled	When the machine is acting as a Transfer Station, this bit determines whether the machine prints the fax message coming in from the Requesting Terminal.

5-7	Not used	Do not change the settings.
-----	----------	-----------------------------

Communication Switch 0C - Not used (do not change the settings)

Communication Switch 0D (SP No. 1-104-014)		
No	Function	Comments
0-7	The available memory threshold, below which ringing detection (and therefore reception into memory) is disabled	<p>00 to FF (Hex), unit = 4 kbytes (e.g., 06(H) = 24 kbytes) One page is about 24 kbytes.</p> <p>The machine refers to this setting before each fax reception. If the amount of remaining memory is below this threshold, the machine cannot receive any fax messages.</p> <p>If this setting is kept at 0, the machine will detect ringing signals and go into receive mode even if there is no memory available. This will result in communication failure.</p>

Communication Switch 0E (SP No. 1-104-015)		
No	Function	Comments
0-7	Minimum interval between automatic dialing attempts	<p>06 to FF (Hex), unit = 2 s (e.g., 06(H) = 12 s)</p> <p>This value is the minimum time that the machine waits before it dials the next destination.</p>

Communication Switch 0F – Not used (do not change the settings.)

Communication Switch 10 (SP No. 1-104-017)		
No	Function	Comments
0-7	Memory transmission: Maximum number of dialing attempts to the same destination	01 – FE (Hex) times

Communication Switch 11 – Not used (do not change the settings.)

Communication Switch 12 (SP No. 1-104-019)		
No	Function	Comments
0-7	Memory transmission: Interval between dialing attempts to the same destination	01 – FF (Hex) minutes

Communication Switch 13 – Not used (do not change the settings.)

Communication Switch 14 (SP No. 1-104-021)				
No	Function		Comments	
0	Inch-to-mm conversion during transmission 0: Disabled, 1: Enabled		0: In immediate transmission, data scanned in inch format are transmitted without conversion. In memory transmission, data stored in the SAF memory in mm format are transmitted without conversion. Note: When storing the scanned data into SAF memory, the fax unit always converts the data into mm format. 1: The machine converts the scanned data or stored data in the SAF memory to the format which was specified in the set-up protocol (DIS/NSF) before transmission.	
1-5	Not used		Do not change the factory settings.	
6-7	Available unit of resolution in which fax messages are received		For the best performance, do not change the factory settings. The setting determined by these bits is informed to the transmitting terminal in the pre-message protocol exchange (in the DIS/NSF frames).	
	Bit 7	Bit 6		Unit
	0	0		mm
	0	1		inch
	1	0		mm and inch
	1	1	Not used	

Communication Switch 15 – Not used (do not change the settings)

Communication Switch 16 (SP No. 1-104-023)		
No	Function	Comments
0	Not used	Do not change the settings.
1	Optional G3 unit (G3-2) 0: Not installed 1: Installed	Change this bit to 1 when installing the first optional G3 unit.
2	Not used	
3	Select PSTN connection 0: Off 1: On	This switch enables the G3-2. 0: Off, no connection 1: Recognizes and enables G3-2. This switch can be used only after G3-2 has been installed.
4-7	Not used	Do not change the settings.

Communication Switch 17 (SP No. 1-104-024)		
No	Function	Comments
0	SEP reception 0: Disabled 1: Enabled	0: Polling transmission to another maker's machine using the SEP (Selective Polling) signal is disabled.
1	SUB reception 0: Disabled 1: Enabled	0: Confidential reception to another maker's machine using the SUB (Sub-address) signal is disabled.
2	PWD reception 0: Disabled 1: Enabled	0: Disables features that require PWD (Password) signal reception.
3-4	Not used	Do not change the settings.

5	PSTN dial-in routing setting 0: OFF 1: ON	1: The machine sets multiple PSTN dial-in numbers in the PSTN dial-in line and transfers received data from each PSTN dial-in number to each address.
6	Not used	Do not change the settings.
7	Action when there is no box with an F-code that matches the received SUB code 0: Disconnect the line 1: Receive the message (using normal reception mode)	Change this setting when the customer requires.

Communication Switch 18 (SP No. 1-104-025)		
No	Function	Comments
0-4	Not used	Do not change the settings.
5	IP-Fax dial-in routing selection 0: Off 1: On	1: Transfers received data to each IP-Fax dial-in number. IP-Fax dial-in number is a 4-digit number.
6	PSTN 2 dial-in routing 0: Off 1: On	Enables or disables dial-in routing for the PSTN 2 connection.
7	PSTN 3 dial-in routing 0: Off 1: On	Enables or disables dial-in routing for the PSTN 3 connection.

Communication Switch 19 - Not used (do not change the settings)

Communication Switch 1A - Not used (do not change the settings)

Communication Switch 1B (SP No. 1-104-028)		
No	Function	Comments
0-7	Extension access code (0 to 7) to turn V.8 protocol On/Off 0: On 1: Off	If the PABX does not support V.8/V.34 protocol procedure, set this bit to "1" to disable V.8. Example: If "0" is the PSTN access code, set bit 0 to 1. When the machine detects "0" as the first dialed number, it automatically disables V.8 protocol. (Alternatively, if "3" is the PSTN access code, set bit 3 to 1.)

Communication Switch 1C (SP No. 1-104-029)		
No	Function	Comments
0-1	Extension access code (8 and 9) to turn V.8 protocol On/Off 0: On 1: Off	Refer to communication switch 1B. Example: If "8" is the PSTN access code, set bit 0 to 1. When the machine detects "8" as the first dialed number, it automatically disables V.8 protocol. (If "9" is the PSTN access code, use bit 1.)
2-7	Not used	Do not change the settings.

Communication Switch 1D - Not used (do not change the settings)
Communication Switch 1E - Not used (do not change the settings)
Communication Switch 1F - Not used (do not change the settings)

4.6 BIT SWITCHES - 4

↓ Note

- Do not adjust a bit switch or use a setting that is described as "Not used", as this may cause the machine to malfunction or to operate in a manner that is not accepted by local regulations. Such bits are for use only in other areas, such as Japan.

Default settings for bit switches are not listed in this manual. Refer to the System Parameter List printed by the machine.

4.6.1 G3 SWITCHES

G3 Switch 00 (SP No. 1-105-001)				
No	Function			Comments
0 1	Monitor speaker during communication (tx and rx)			(0, 0): The monitor speaker is disabled all through the communication. (0, 1): The monitor speaker is on up to phase B in the T.30 protocol. (1, 0): Used for testing. The monitor speaker is on all through the communication. Make sure that you reset these bits after testing.
	Bit 1	Bit 0	Setting	
	0	0	Disabled	
	0	1	Up to Phase B	
	1	0	All the time	
	1	1	Not used	
2	Monitor speaker during memory transmission 0: Disabled 1: Enabled			1: The monitor speaker is enabled during memory transmission.
3-7	Not used			Do not change the settings.

G3 Switch 01 (SP No. 1-105-002)		
No	Function	Comments
0-3	Not used	Do not change the settings.
4	DIS frame length 0: 10 bytes 1: 4 bytes	1: The bytes in the DIS frame after the 4th byte will not be transmitted (set to 1 if there are communication problems with PC-based faxes which cannot receive the extended DIS frames).
5	Not used	Do not change the setting.
6	Forbid CED/AMsam output 0: Off 1: On (Forbid output)	Do not change this setting (Default: 0: Off), unless communication problem is caused by a CED or ANSam transmission.
7	Not used	Do not change the setting.

G3 Switch 02 (SP No. 1-105-003)		
No	Function	Comments
0	G3 protocol mode used 0: Standard and non-standard 1: Standard only	Change this bit to 1 only when the other end can only communicate with machines that send T.30-standard frames only. 1: Disables NSF/NSS signals (these are used in non-standard mode communication)
1-6	Not used	Do not change the settings.
7	Short preamble 0: Disabled 1: Enabled	Refer to Appendix B in the Group 3 Facsimile Manual for details about Short Preamble.

G3 Switch 03 (SP No. 1-105-004)		
No	Function	Comments
0	DIS detection number (Echo countermeasure) 0: 1 1: 2	0: The machine will hang up if it receives the same DIS frame twice. 1: Before sending DCS, the machine will wait for the second DIS which is caused by echo on the line.
1	Not Used	Do not change the settings.
2	V.8 protocol 0: Disabled 1: Enabled	0: V.8/V.34 communications will not be possible. Note <ul style="list-style-type: none"> ▪ Do not set to 0 unless the line condition is always bad enough to slow down the data rate to 14.4 kbps or lower.
3	ECM frame size 0: 256 bytes 1: 64 bytes	Keep this bit at "0" in most cases.
4	CTC transmission conditions 0: After one PPR signal received 1: After four PPR signals received (ITU-T standard)	0: When using ECM in non-standard (NSF/NSS) mode, the machine sends a CTC to drop back the modem rate after receiving a PPR, if the following condition is met in communications at 14.4, 12.0, 9.6, and 7.2 kbps. $\sqrt{N_{\text{Transmit}}} \leq N_{\text{Resend}}$ N _{Transmit} - Number of transmitted frames N _{Resend} - Number of frames to be retransmitted 1: When using ECM, the machine sends a CTC to drop back the modem rate after receiving four PPRs. PPR, CTC: These are ECM protocol signals. This bit is not effective in V.34 communications.

5	Modem rate used for the next page after receiving a negative code (RTN or PIN) 0: No change 1: Fallback	1: The machine's tx modem rate will fall back before sending the next page if a negative code is received. This bit is ignored if ECM is being used.
6	Not used	Do not change the settings
7	Select detection of reverse polarity in ringing 0: Off 1: On	This switch is used to prevent reverse polarity in ringing on the phone line (applied to PSTN-G3 ringing). Do not change this setting 0: No detection 1: Detection (Japan and Korea only)

G3 Switch 04 (SP No. 1-105-005)		
No	Function	Comments
0-3	Training error detection threshold	0 - F (Hex); 0 - 15 bits If the number of error bits in the received TCF is below this threshold, the machine informs the sender that training has succeeded.
4-7	Not used	Do not change the settings.

G3 Switch 05 (SP No. 1-105-006)						
No	Function					Comments
0-3	Initial Tx modem rate (kbps)					These bits set the initial starting modem rate for transmission. Use the dedicated transmission parameters if you need to change this for specific receivers. If a modem rate 14.4 kbps or slower is selected, V.8 protocol should be disabled manually. Cross reference V.8 protocol on/off - G3 switch 03, bit 2
	Bit 3	Bit 2	Bit 1	Bit 0	kbps	
	0	0	0	1	2.4	
	0	0	1	0	4.8	
	0	0	1	1	7.2	
	0	1	0	0	9.6	
0	1	0	1	12.0		

	0	1	1	0	14.4	
	0	1	1	1	16.8	
	1	0	0	0	19.2	
	1	0	0	1	21.6	
	1	0	1	0	24.0	
	1	0	1	1	26.4	
	1	1	0	0	28.8	
	1	1	0	1	31.2	
	0	0	1	1	33.6	
	Other settings - Not used					
4-5	Initial modem type for 9.6 k or 7.2 kbps.					These bits set the initial modem type for 9.6 and 7.2 kbps, if the initial modem rate is set at these speeds.
	Bit 5	Bit 4	Setting			
	0	0	V.29			
	0	1	V.17			
	1	0	V.34			
1	1	Not used				
6-7	Not used				Do not change the settings.	

G3 Switch 06 (SP No. 1-105-007)						
No	Function					Comments
0-3	Initial Rx modem rate(kbps)					These bits set the initial starting modem rate for reception. Use a lower setting if high speeds pose problems during reception. If a modem rate 14.4 kbps or slower is selected, V.8 protocol should be disabled manually. Cross reference V.8 protocol on/off - G3 switch 03, bit2
	Bit 3	Bit 2	Bit 1	Bit 0	kbps	
	0	0	0	1	2.4	
	0	0	1	0	4.8	
	0	0	1	1	7.2	
	0	1	0	0	9.6	
	0	1	0	1	12.0	
	0	1	1	0	14.4	
	0	1	1	1	16.8	
	1	0	0	0	19.2	
	1	0	0	1	21.6	
	1	0	1	0	24.0	
	1	0	1	1	26.4	
	1	1	0	0	28.8	
	1	1	0	1	31.2	
Other settings - Not used						
4-7	Modem types available for reception The setting of these bits is used to inform the transmitting terminal of the available modem type for the machine in receive mode. If V.34 is not selected, V.8 protocol must be disabled manually. Cross reference V.8 protocol on/off - G3 switch 03, bit 2					
	Bit 7	Bit 6	Bit 5	Bit 4	Types	
	0	0	0	1	V.27ter	

	0	0	1	0	V.27ter, V.29
	0	0	1	1	V.27ter, V.29, V.33
	0	1	0	0	V.27ter, V.29, V.17/V.33
	0	1	0	1	V.27ter, V.29, V.17/V33, V.34
	Other settings - Not used				

G3 Switch 07 (SP No. 1-105-008)					
No	Function			Comments	
0-1	PSTN cable equalizer (tx mode: Internal)			Use a higher setting if there is signal loss at higher frequencies because of the length of wire between the modem and the telephone exchange. Use the dedicated transmission parameters for specific receivers. Also, try using the cable equalizer if one or more of the following symptoms occurs. Communication error Modem rate fallback occurs frequently. ↓ Note <ul style="list-style-type: none"> ▪ This setting is not effective in V.34 communications. 	
	Bit 1	Bit 0	Setting		
	0	0	None		
	0	1	Low		
	1	0	Medium		
	1	1	High		

2-3	PSTN cable equalizer (rx mode: Internal)			<p>Use a higher setting if there is signal loss at higher frequencies because of the length of wire between the modem and the telephone exchange.</p> <p>Also, try using the cable equalizer if one or more of the following symptoms occurs.</p> <p>Communication error with error codes such as 0-20, 0-23, etc.</p> <p>Modem rate fallback occurs frequently.</p> <p> Note</p> <ul style="list-style-type: none"> This setting is not effective in V.34 communications.
	Bit 3	Bit 2	Setting	
	0	0	None	
	0	1	Low	
	1	0	Medium	
	1	1	High	
4	PSTN cable equalizer (V.8/V.17 rx mode: External) 0: Disabled 1: Enabled			Keep this bit at "1".
5	Not used			Do not change the settings.
6	Parameter selection for dial tone detection 0: Normal parameter 1: Specific parameter			<p>0: This uses the fixed table in the ROM for dial tone detection.</p> <p>1: This uses the specific parameter adjusted with SRAM (69ECBEH - 69ECDEH). Select this if the dial tone cannot be detected when the "Normal parameter: 0" is selected.</p>
7	Not used			Do not change the settings.

G3 Switch 08 - Not used (do not change the settings)

G3 Switch 09 - Not used (do not change the settings)

G3 Switch 0A (SP No. 1-105-011)				
No	Function			Comments
0-1	Maximum allowable carrier drop during image data reception			These bits set the acceptable modem carrier drop time. Try a longer setting if error code 0-22 is frequent.
	Bit 1	Bit 0	Value (ms)	
	0	0	200	
	0	1	400	
	1	0	800	
	1	1	Not used	
2	Select cancellation of high-speed RX if carrier signal lost while receiving 0: Off 1: On			This switch setting determines if high-speed receiving ends if the carrier signal is lost when receiving during non-ECM mode
3	Not used			Do not change the settings
4	Maximum allowable frame interval during image data reception. 0: 5 s 1: 13 s			This bit set the maximum interval between EOL (end-of-line) signals and the maximum interval between ECM frames from the other end. Try using a longer setting if error code 0-21 is frequent.
5	Not used			Do not change the settings.

6	Reconstruction time for the first line in receive mode 0: 6 s 1: 12 s	When the sending terminal is controlled by a computer, there may be a delay in receiving page data after the local machine accepts set-up data and sends CFR. This is outside the T.30 recommendation. But, if this delay occurs, set this bit to 1 to give the sending machine more time to send data. Refer to error code 0-20. ITU-T T.30 recommendation: The first line should come within 5 s of CFR.
7	Not used	Do not change the settings.

G3 Switch 0B Not used (do not change the settings).

G3 Switch 0C Not used (do not change the settings).

G3 Switch 0D Not used (do not change the settings).

G3 Switch 0E (SP No. 1-105-015)		
No	Function	Comments
0-7	Set CNG send time interval Some machines on the receiving side may not be able to automatically switch the 3-second CNG interval.	
	High order bit	3000-2250ms: 3000-50xNms 3000 – 50 x Nms 0F (3000 ms) <= N <= FF (2250 ms)
	Low order bit	00-0E(3000-3700ms: 3000+50xNms 3000 – 50 x Nms 0F (3000 ms) <= N <= 0F (3700 ms)

G3 Switch 0F (SP No. 1-105-016)		
No	Function	Comments
0	Alarm when an error occurred in Phase C or later 0: Disabled 1: Enabled	If the customer wants to hear an alarm after each error communication, change this bit to "1".
1	Alarm when the handset is off-hook at the end of communication 0: Disabled 1: Enabled	If the customer wants to hear an alarm if the handset is off-hook at the end of fax communication, change this bit to "1".
2-3	Not used	Do not change the settings.
4	Sidaa manual calibration setting 0: Off 1: On	1: manually calibrates for communication with a line whose current change occurs such as an optical fiber line.
5-7	Not used	Do not change the settings.

4.7 BIT SWITCHES - 5



- Do not adjust a bit switch or use a setting that is described as "Not used", as this may cause the machine to malfunction or to operate in a manner that is not accepted by local regulations. Such bits are for use only in other areas, such as Japan.

Default settings for bit switches are not listed in this manual. Refer to the System Parameter List printed by the machine.

4.7.1 G3-2 AND G3-3 SWITCHES

These switches require an optional G3 interface unit.

G3-3 switches are the same as for G3-2 switches.

G3-2 Switch 00 (SP No. 1-106-001)				
No	Function			Comments
0	Monitor speaker during communication (tx and rx)			(0, 0): The monitor speaker is disabled all through the communication. (0, 1): The monitor speaker is on up to phase B in the T.30 protocol. (1, 0): Used for testing. The monitor speaker is on all through the communication. Make sure that you reset these bits after testing.
	Bit 1	Bit 0	Setting	
	0	0	Disable	
	0	1	Up to Phase B	
	1	0	All the time	
	1	1	Not used	
2	Monitor speaker during memory transmission 0: Disabled 1: Enabled			1: The monitor speaker is enabled during memory transmission.
3-7	Not used			Do not change the settings.

G3-2 Switch 01 (SP No. 1-106-002)		
No	Function	Comments
0-3	Not used	Do not change the settings.
4	DIS frame length 0: 10 bytes 1: 4 bytes	1: The bytes in the DIS frame after the 4th byte will not be transmitted (set to 1 if there are communication problems with PC-based faxes which cannot receive the extended DIS frames).
5	Not used	Do not change the setting.
6	Forbid CED/AMsam output 0: Off 1: On (Forbid output)	Do not change this setting (Default: 0: Off), unless communication problem is caused by a CED or ANSam transmission.
7	Not used	Do not change the setting.

G3-2 Switch 02 (SP No. 1-106-003)		
No	Function	Comments
0	G3 protocol mode used 0: Standard and non-standard 1: Standard only	Change this bit to 1 only when the other end can only communicate with machines that send T.30-standard frames only. 1: Disables NSF/NSS signals (these are used in non-standard mode communication)
1-6	Not used	Do not change the settings.
7	Short preamble 0: Disabled 1: Enabled	Refer to Appendix B in the Group 3 Facsimile Manual for details about Short Preamble.

G3-2 Switch 03 (SP No. 1-106-004)		
No	Function	Comments
0	DIS detection number (Echo countermeasure) 0: 1 1: 2	0: The machine will hang up if it receives the same DIS frame twice. 1: Before sending DCS, the machine will wait for the second DIS which is caused by echo on the line.
1	Not Used	Do not change the settings.
2	V.8 protocol 0: Disabled 1: Enabled	0: V.8/V.34 communications will not be possible.  Note <ul style="list-style-type: none"> ▪ Do not set to 0 unless the line condition is always bad enough to slow down the data rate to 14.4 kbps or lower.
3	ECM frame size 0: 256 bytes 1: 64 bytes	Keep this bit at "0" in most cases.
4	CTC transmission conditions 0: After one PPR signal received 1: After four PPR signals received (ITU-T standard)	0: When using ECM in non-standard (NSF/NSS) mode, the machine sends a CTC to drop back the modem rate after receiving a PPR, if the following condition is met in communications at 14.4, 12.0, 9.6, and 7.2 kbps. $\sqrt{N_{\text{Transmit}}} \leq N_{\text{Re send}}$ N _{transmit} = Number of transmitted frames N _{resend} = Number of frames to be retransmitted 1: When using ECM, the machine sends a CTC to drop back the modem rate after receiving four PPRs. PPR, CTC: These are ECM protocol signals. This bit is not effective in V.34 communications.

5	Modem rate used for the next page after receiving a negative code (RTN or PIN) 0: No change 1: Fallback	1: The machine's tx modem rate will fall back before sending the next page if a negative code is received. This bit is ignored if ECM is being used.
6	Not used	Do not change the settings
7	Select detection of reverse polarity in ringing 0: Off 1: On	This switch is used to prevent reverse polarity in ringing on the phone line (applied to PSTN-G3 ringing). Do not change this setting 0: No detection 1: Detection (Japan and Korea only)

G3-2 Switch 04 (SP No. 1-106-005)		
No	Function	Comments
0-3	Training error detection threshold	0 - F (Hex); 0 - 15 bits If the number of error bits in the received TCF is below this threshold, the machine informs the sender that training has succeeded.
4-7	Not used	Do not change the settings.

G3-2 Switch 05 (SP No. 1-106-006)						
No	Function					Comments
0-3	Initial Tx modem rate (kbps)					These bits set the initial starting modem rate for transmission. Use the dedicated transmission parameters if you need to change this for specific receivers. If a modem rate 14.4 kbps or slower is selected, V.8 protocol should be disabled manually. Cross reference V.8 protocol on/off - G3 switch 03, bit 2
	Bit 3	Bit 2	Bit 1	Bit 0	kbps	
	0	0	0	1	2.4	
	0	0	1	0	4.8	
	0	0	1	1	7.2	
	0	1	0	0	9.6	
0	1	0	1	12.0		

Bit Switches - 5

	0	1	1	0	14.4	
	0	1	1	1	16.8	
	1	0	0	0	19.2	
	1	0	0	1	21.6	
	1	0	1	0	24.0	
	1	0	1	1	26.4	
	1	1	0	0	28.8	
	1	1	0	1	31.2	
	Other settings - Not used					
4-5	Initial modem type for 9.6 k or 7.2 kbps.					These bits set the initial modem type for 9.6 and 7.2 kbps, if the initial modem rate is set at these speeds.
	Bit 5	Bit 4	Setting			
	0	0	V.29			
	0	1	V.17			
	1	0	V.34			
1	1	Not used				
6-7	Not used				Do not change the settings.	

G3-2 Switch 06 (SP No. 1-106-007)						
No	Function					Comments
0-3	Initial Rx modem rate(kbps)					These bits set the initial starting modem rate for reception. Use a lower setting if high speeds pose problems during reception. If a modem rate 14.4 kbps or slower is selected, V.8 protocol should be disabled manually. Cross reference V.8 protocol on/off - G3 switch 03, bit2
	Bit 3	Bit 2	Bit 1	Bit 0	kbps	
	0	0	0	1	2.4	
	0	0	1	0	4.8	
	0	0	1	1	7.2	
	0	1	0	0	9.6	
	0	1	0	1	12.0	
	0	1	1	0	14.4	
	0	1	1	1	16.8	
	1	0	0	0	19.2	
	1	0	0	1	21.6	
	1	0	1	0	24.0	
	1	0	1	1	26.4	
	1	1	0	0	28.8	
	1	1	0	1	31.2	
Other settings - Not used						

4-7	Modem types available for reception The setting of these bits is used to inform the transmitting terminal of the available modem type for the machine in receive mode. If V.34 is not selected, V.8 protocol must be disabled manually. Cross reference V.8 protocol on/off - G3 switch 03, bit 2				
	Bit 7	Bit 6	Bit 5	Bit 4	Types
	0	0	0	1	V.27ter
	0	0	1	0	V.27ter
	0	0	1	1	V.27ter
	0	1	0	0	V.27ter
	0	1	0	1	V.27ter
Other settings - Not used					

G3-2 Switch 07 (SP No. 1-106-008)				
No	Function			Comments
0-1	PSTN cable equalizer (tx mode: Internal)			Use a higher setting if there is signal loss at higher frequencies because of the length of wire between the modem and the telephone exchange. Use the dedicated transmission parameters for specific receivers. Also, try using the cable equalizer if one or more of the following symptoms occurs. Communication error Modem rate fallback occurs frequently.
	Bit 1	Bit 0	Setting	
	0	0	None	
	0	1	Low	
	1	0	Medium	
	1	1	High	
				Communication error Modem rate fallback occurs frequently. ↓ Note <ul style="list-style-type: none"> This setting is not effective in V.34 communications.

2-3	PSTN cable equalizer (rx mode: Internal)			<p>Use a higher setting if there is signal loss at higher frequencies because of the length of wire between the modem and the telephone exchange.</p> <p>Also, try using the cable equalizer if one or more of the following symptoms occurs.</p> <p>Communication error with error codes such as 0-20, 0-23, etc.</p> <p>Modem rate fallback occurs frequently.</p> <p> Note</p> <ul style="list-style-type: none"> This setting is not effective in V.34 communications.
	Bit 3	Bit 2	Setting	
	0	0	None	
	0	1	Low	
	1	0	Medium	
	1	1	High	
4	PSTN cable equalizer (V.8/V.17 rx mode: External) 0: Disabled 1: Enabled			Keep this bit at "1".
5-7	Not used			Do not change the settings.

G3-2 Switch 08 - Not used (do not change the settings)

G3-2 Switch 09 - Not used (do not change the settings)

G3-2 Switch 0A (SP No. 1-106-011)

No	Function			Comments
0-1	Maximum allowable carrier drop during image data reception			<p>These bits set the acceptable modem carrier drop time.</p> <p>Try a longer setting if error code 0-22 is frequent.</p>
	Bit 1	Bit 0	Value (ms)	
	0	0	200	
	0	1	400	
	1	0	800	
	1	1	Not used	

2	Select cancellation of high-speed RX if carrier signal lost while receiving 0: Off 1: On	This switch setting determines if high-speed receiving ends if the carrier signal is lost when receiving during non-ECM mode
3	Not used	Do not change the settings
4	Maximum allowable frame interval during image data reception. 0: 5 s 1: 13 s	This bit set the maximum interval between EOL (end-of-line) signals and the maximum interval between ECM frames from the other end. Try using a longer setting if error code 0-21 is frequent.
5	Not used	Do not change the settings.
6	Reconstruction time for the first line in receive mode 0: 6 s 1: 12 s	When the sending terminal is controlled by a computer, there may be a delay in receiving page data after the local machine accepts set-up data and sends CFR. This is outside the T.30 recommendation. But, if this delay occurs, set this bit to 1 to give the sending machine more time to send data. Refer to error code 0-20. ITU-T T.30 recommendation: The first line should come within 5 s of CFR.
7	Not used	Do not change the settings.

G3-2 Switch 0B- Not used (do not change the settings)

G3-2 Switch 0C- Not used (do not change the settings)

G3-2 Switch 0E- Not used (do not change the settings)

G3-2 Switch 0F- Not used (do not change the settings)

4.7.2 G4 INTERNAL SWITCHES

The G4 internal switches (SW00 to 1F) are displayed but do not change these settings.

4.7.3 G4 PARAMETER SWITCHES

The G4 parameter switches (SW00 to 0F) are displayed but do not change these settings.

4.8 BIT SWITCHES - 6

Note

- Do not adjust a bit switch or use a setting that is described as "Not used", as this may cause the machine to malfunction or to operate in a manner that is not accepted by local regulations. Such bits are for use only in other areas, such as Japan.

Default settings for bit switches are not listed in this manual. Refer to the System Parameter List printed by the machine.

4.8.1 IP FAX SWITCHES

IP Fax Switch 00 (SP No. 1-111-001)		
No.	Function	Comments
0	Not used	Do not change this setting.
1	IP Fax Transport 0: TCP, 1: UDP	Selects TCP or UDP protocol for IP-Fax
2	IP Fax single port selection 0: OFF, 1: ON (enable)	Selects single data port.
3	IP Fax double ports (single data port) selection 0: OFF, 1: ON (enable)	Selects whether IP-Fax uses a double port.
4	IP Fax Gatekeeper 0: OFF, 1: ON (enable)	Enables/disables the gatekeeper for IP-Fax.
5	IP Fax T30 bit signal reverse 0: LSB first, 1: MSB first	Reverses the T30 bit signal.
6	IP Fax max bit rate setting 0: Not affected, 1: Affected	When "0" is selected, the max bit rate does not affect the value of the DIS/DCS. When "1" is selected, the max bit rate affects the value of the DIS/DCS.

7	<p>IP Fax received telephone number confirmation 0: No confirmation, 1: Confirmation</p>	<p>When "0" is selected, fax data is received without checking the telephone number. When "1" is selected, fax data is received only when confirming that the telephone number from the sender matches the registered telephone number in this machine. If this confirmation fails, the line is disconnected.</p>
---	--	---

IP Fax Switch 01 (SP No. 1-111-002)					
No.	Function			Comments	
0-3	<p>IP Fax delay level setting Selects the acceptable delay level. Level 0 is the highest quality Default is "0000" (level 0).</p>				
	Bit 3	Bit 2	Bit 1	Bit 0	
	0	0	0	0	Level 0
	0	0	0	1	Level 1
	0	0	1	0	Level 2
0	0	1	1	Level 3	
4-7	<p>IP Fax preamble wait time setting</p>			<p>Selects the preamble wait time. [00 to 0f] There are 16 values in this 4-bit binary switch combination. Waiting time: set value level x 100 ms Max: 0f (1500 ms) Min: 00 (No wait time) The default is "0000" (00H).</p>	

IP Fax Switch 02 (SP No. 1-111-003)		
No.	Function	Comments
0	IP Fax bit signal reverse setting 0: Maker code setting 1: Internal bit switch setting	When "0" is selected, the bit signal reverse method is decided by the maker code. When "1" is selected, the bit signal reverse method is decided by the internal bit switch. (When communicating between IP Fax devices, LSB first is selected.)
1	IP Fax transmission speed setting 0: Modem speed 1: No limitation	Selects the transmit speed for IP Fax communication.
2	SIP transport setting 0: TCP 1: UDP	This bit switch sets the transport that has priority for receiving IP Fax data. This function is activated only when the sender has both TCP and UDP.
3	CCM connection 0: No CCM connection 1: CCM connection	When "1" is selected, only the connection call message with H.323 or no tunneled H.245 is transmitted via CCM.
4	Message reception selection from non-registered SIP server 0: Answer 1: Not answer	0: This answers the INVITE message from the SIP server not registered for the machine. 1: This does not receive the INVITE message from the SIP server not registered for the machine and send a refusal message.

5	ECM communication setting 0: No limit for image compression 1: Limit for image compression	0: This does not limit the type of the image compression with ECM communication. 1: When the other end machine is Cisco, this permits the image compression other than JBIG or MMR with ECM communication.
6-7	Not used	Do not change these settings.

IP Fax Switch 03 (SP No. 1-111-004)		
No.	Function	Comments
0	Effective field limitation for G3 standard function information 0: OFF, 1: 4byte (DIS)	Limits the effective field for standard G3 function information.
1	Switching between G3 standard and G3 non standard 0: Enable switching 1: G3 standard only	Enables/disables switching between G3 standard and G3 non-standard.
2	Not used	Do not change this setting.
3	ECM frame size selection at transmitting 0: 256byte, 1: 64byte	Selects the ECM frame size for sending.
4	DIS detection times for echo prevention 0: 1 time, 1: 2 times	Sets the number of times for DIS to detect echoes.
5	CTC transmission selection 0: PPRx1 1: PPRx4	When "0" is selected, the transmission condition is decided by error frame numbers. When "1" is selected, the transmission condition is based on the ITU-T method.

6	Shift down setting at receiving negative code 0: OFF, 1: ON	Selects whether to shift down when negative codes are received.
7	Not used	Do not change this setting.

IP Fax Switch 04 (SP No. 1-111-005)		
No.	Function	Comments
0-3	TCF error threshold	Sets the TCF error threshold level. [00 to 0f] The default is "1111" (0fH).
4-7	Not used	Do not change these settings.

IP Fax Switch 05 (SP No. 1-111-006)						
No.	Function					Comments
0-3	Modem bit rate setting for transmission (kbps)					Sets the modem bit rate for transmission. The default is "0110" (14.4K bps).
	Bit 3	Bit 2	Bit 1	Bit 0	kbps	
	0	0	0	1	2.4	
	0	0	1	1	4.8	
	0	0	1	1	7.2	
	0	1	0	0	9.6	
	0	1	0	1	12.0	
	0	1	1	0	14.4	

4-5	Modem setting for transmission			Sets the modem type for transmission. The default is "00" (V29).
	Bit 5	Bit 4	Types	
	0	0	V29	
	0	1	V17	
	1	0	Not used	
	1	1	Not used	
6-7	Not used			Do not change these settings.

IP Fax Switch 06 (SP No. 1-111-007)					
No.	Function			Comments	
0-3	Modem bit rate setting for reception Sets the modem bit rate for reception. The default is "0110" (14.4K bps).				
4-7	Modem setting for reception Sets the modem type for reception. The default is "0100" (V27ter, V29, V17).				
	Bit 7	Bit 6	Bit 5	Bit 4	Types
	0	0	0	1	V.27ter
	0	0	1	0	V.27ter, V.29
	0	0	1	1	V.27ter, V.29, V.33
	0	1	0	0	V.27ter, V.29, V.17/V.33
Other settings - Not used					

IP Fax Switch 07 (SP No. 1-111-008)		
No.	Function	Comments
0	TSI information 0: Not added, 1: Added	Adds or does not add TSI information to NSS(S).
1	DCN transmission setting at T1 timeout 0: Not transmitted 1: Transmitted	Transmits or does not transmit DCN at T1 timeout.
2	Not used	Do not change this setting.
3	Hang up setting at DIS reception disabled 0: No hang up 1: Hang up after transmitting DCN	Sets whether the machine disconnects after DIS reception.
4	Number of times for training 0: 1 time, 1: 2 times	Selects the number of times training is done at the same bit rate.
5	Space CSI transmission setting at no CSI registration 0: Not transmitted 1: Transmitted	When "0" is selected, frame data is enabled. When "1" is selected, the transmitted data is all spaces.
6-7	Not used	Do not change these settings.

IP Fax Switch 08 (SP No. 1-111-009)				
No.	Function			Comments
0-1	T1 timer adjustment			Adjusts the T1 timer. The default is "00" (35 seconds).
	Bit 1	Bit 0		
	0	0	35 s	
	0	1	40 s	
	1	0	50 s	
	1	1	60 s	
2-3	T4 timer adjustment			Adjust the T4 timer. The default is "00" (3 seconds).
	Bit 3	Bit 2		
	0	0	3 s	
	0	1	3.5 s	
	1	0	4 s	
	1	1	5 s	
4-5	T0 timer adjustment			Adjusts the fail safe timer. This timer sets the interval between "setup" data transmission and T.38 phase decision. If your destination return is late on the network or G3 fax return is late, adjust the longer interval timer. The default is "00" (75 seconds).
	Bit 5	Bit 4		
	0	0	75 s	
	0	1	120 s	
	1	0	180 s	
	1	1	240 s	
6-7	Not used			Do not change these settings.

IP Fax Switch 09 (SP No. 1-111-010)				
No.	Function		Comments	
0	Network I/F setting for SIP connection 0: IPv4 1: IPv6.		Selects the connection type (IPV4 or IPV6) to connect to the SIP server.	
1	Network I/F setting for Fax communication 0: Same setting as SIP server connection 1: Automatic setting		0: The I/F setting for fax communication follows the setting for SIP server connection. 1: The negotiation between the SIP server and the device decides whether IPv4 or IPv6 is used for the I/F setting for fax communication.	
2	Record-route setting 0: Disable 1: Enable		0: Disables the record-route function of the SIP server. 1: Enables the record-route function of the SIP server.	
3-4	re-INVITE transmission delay timer setting			This changes the interval for transmit re-INVITE after receiving the ACK message transmitted by T.38 device.
	Bit 4	Bit 3		
	0	0	No delay	
	0	1	1 sec	
	1	0	2 sec	
	1	1	3 sec	
5-7	Not used.		Do not change these settings.	

IP Fax Switch 0A - Not used (do not change the settings)
IP Fax Switch 0B - Not used (do not change the settings)
IP Fax Switch 0C - Not used (do not change the settings)
IP Fax Switch 0D - Not used (do not change the settings)
IP Fax Switch 0E - Not used (do not change the settings)

Fax Option
Type C5502
(D643)

4.9 NCU PARAMETERS

The following tables give the RAM addresses and the parameter calculation units that the machine uses for ringing signal detection and automatic dialing. The factory settings for each country are also given. Most of these must be changed by RAM read/write (SP2-102), but some can be changed using NCU Parameter programming (SP2-103, 104 and 105); if SP2-103, 104 and 105 can be used, this will be indicated in the Remarks column. The RAM is programmed in hex code unless (BCD) is included in the Unit column.

Note

- The following addresses describe settings for the standard NCU.
- Change the fourth digit from "5" to "6" (e.g. 680500 to 680600) for the settings for the first optional G3 interface unit and from "5" to "7" (e.g. 680700) for the settings for the second optional G3 interface unit.

Address	Function						
680500	Country/Area code for NCU parameters						
	Use the Hex value to program the country/area code directly into this address, or use the decimal value to program it using SP2-103-001						
		Country /Area	Decimal	Hex	Country /Area	Decimal	Hex
	France	00	00	Asia	18	12	
	Germany	01	01	Japan	19	13	
	UK	02	02	Hong Kong	20	14	
	Italy	03	03	South Africa	21	15	
	Austria	04	04	Australia	22	16	
	Belgium	05	05	New Zealand	26	17	
	Denmark	06	06	Singapore	24	18	
	Finland	07	07	Malaysia	25	19	
	Ireland	08	08	China	26	1A	
	Norway	09	09	Taiwan	27	1B	
	Sweden	10	0A	Korea	28	1C	

Fax Option
Type C5502
(D643)

Address	Function					
	Switzerland	11	0B	Brazil	29	1D
	Portugal	12	0C	Turkey	32	20
	Holland	13	0D	Greece	33	21
	Spain	14	0E	Hungary	34	22
	Israel	15	0F	Czech	35	23
	USA	17	11	Poland	36	24

Address	Function	Unit	Remarks
680501	Line current detection time	20 ms	Line current detection is disabled. Line current is not detected if 680501 contains FF.
680502	Line current wait time		
680503	Line current drop detect time		
680504	PSTN dial tone frequency upper limit (high byte)	Hz (BCD)	If both addresses contain FF(H), tone detection is disabled.
680505	PSTN dial tone frequency upper limit (low byte)		
680506	PSTN dial tone frequency lower limit (high byte)	Hz (BCD)	If both addresses contain FF(H), tone detection is disabled.
680507	PSTN dial tone frequency lower limit (low byte)		
680508	PSTN dial tone detection time	20 ms	If 680508 contains FF(H), the machine pauses for the pause time (address 68050D / 68050E). Italy: See Note 2.
680509	PSTN dial tone reset time (LOW)		
68050A	PSTN dial tone reset time (HIGH)		
68050B	PSTN dial tone continuous tone time		
68050C	PSTN dial tone permissible drop time		

NCU Parameters

Address	Function	Unit	Remarks
68050D	PSTN wait interval (LOW)		
68050E	PSTN wait interval (HIGH)		-
68050F	PSTN ring-back tone detection time	20 ms	Detection is disabled if this contains FF.
680510	PSTN ring-back tone off detection time	20 ms	-
680511	PSTN detection time for silent period after ring-back tone detected (LOW)	20 ms	-
680512	PSTN detection time for silent period after ring-back tone detected (HIGH)	20 ms	-
680513	PSTN busy tone frequency upper limit (high byte)	Hz (BCD)	If both addresses contain FF(H), tone detection is disabled.
680514	PSTN busy tone frequency upper limit (low byte)		
680515	PSTN busy tone frequency lower limit (high byte)	Hz (BCD)	If both addresses contain FF(H), tone detection is disabled.
680516	PSTN busy tone frequency lower limit (low byte)		
680517	PABX dial tone frequency upper limit (high byte)	Hz (BCD)	If both addresses contain FF(H), tone detection is disabled.
680518	PABX dial tone frequency upper limit (low byte)		
680519	PABX dial tone frequency lower limit (high byte)	Hz (BCD)	If both addresses contain FF(H), tone detection is disabled.
68051A	PABX dial tone frequency lower limit (low byte)		
68051B	PABX dial tone detection time	20 ms	If 68051B contains FF,

Address	Function	Unit	Remarks
68051C	PABX dial tone reset time (LOW)		the machine pauses for the pause time (680520 / 680521).
68051D	PABX dial tone reset time (HIGH)		
68051E	PABX dial tone continuous tone time		
68051F	PABX dial tone permissible drop time		
680520	PABX wait interval (LOW)		
680521	PABX wait interval (HIGH)	-	
680522	PABX ringback tone detection time	20 ms	If both addresses contain FF(H), tone detection is disabled.
680523	PABX ringback tone off detection time	20 ms	
680524	PABX detection time for silent period after ringback tone detected (LOW)	20 ms	If both addresses contain FF(H), tone detection is disabled.
680525	PABX detection time for silent period after ringback tone detected (HIGH)	20 ms	
680526	PABX busy tone frequency upper limit (high byte)	Hz (BCD)	If both addresses contain FF(H), tone detection is disabled.
680527	PABX busy tone frequency upper limit (low byte)		
680528	PABX busy tone frequency lower limit (high byte)	Hz (BCD)	If both addresses contain FF(H), tone detection is disabled.
680529	PABX busy tone frequency lower limit (low byte)		
68052A	Busy tone ON time: range 1	20 ms	-
68052B	Busy tone OFF time: range 1		
68052C	Busy tone ON time: range 2		

NCU Parameters

Address	Function	Unit	Remarks
68052D	Busy tone OFF time: range 2	20 ms	
68052E	Busy tone ON time: range 3		
68052F	Busy tone OFF time: range 3		
680530	Busy tone ON time: range 4		
680531	Busy tone OFF time: range 4		
680532	Busy tone continuous tone detection time		
680533	<p>Busy tone signal state time tolerance for all ranges, and number of cycles required for detection (a setting of 4 cycles means that ON-OFF-ON or OFF-ON-OFF must be detected twice).</p> <p>Tolerance (\pm)</p> <p>Bit 1: 0, Bit 0: 0 = 75% Bits 2 and 3 must always be kept at 0.</p> <p>Bit 1: 0, Bit 0: 0 = 50% Bits 2 and 3 must always be kept at 0.</p> <p>Bit 1: 0, Bit 0: 0 = 25%</p> <p>Bit 1: 0, Bit 0: 0 = 12.5%</p> <p>Bits 7, 6, 5, 4 - number of cycles required for cadence detection</p>		
680534	International dial tone frequency upper limit (high byte)	Hz (BCD)	If both addresses contain FF(H), tone detection is disabled.
680535	International dial tone frequency upper limit (low byte)		
680536	International dial tone frequency lower limit (high byte)	Hz (BCD)	If both addresses contain FF(H), tone detection is disabled.
680537	International dial tone frequency lower limit (low byte)		
680538	International dial tone detection time	20 ms	If 680538 contains FF, the machine pauses for the pause time (68053D / 68053E).
680539	International dial tone reset time (LOW)		

Address	Function	Unit	Remarks
68053A	International dial tone reset time (HIGH)		Belgium: See Note 2.
68053B	International dial tone continuous tone time		
68053C	International dial tone permissible drop time		
68053D	International dial wait interval (LOW)		
68053E	International dial wait interval (HIGH)		
68053F	Country dial tone upper frequency limit (HIGH)	Hz (BCD)	If both addresses contain FF(H), tone detection is disabled.
680540	Country dial tone upper frequency limit (LOW)		
680541	Country dial tone lower frequency limit (HIGH)		
680542	Country dial tone lower frequency limit (LOW)		
680543	Country dial tone detection time	20 ms	If 680543 contains FF, the machine pauses for the pause time (680548 / 680549).
680544	Country dial tone reset time (LOW)		
680545	Country dial tone reset time (HIGH)		
680546	Country dial tone continuous tone time	-	-
680547	Country dial tone permissible drop time	20 ms	-
680548	Country dial wait interval (LOW)		

Address	Function	Unit	Remarks
680549	Country dial wait interval (HIGH)		
68054A	Time between opening or closing the DO relay and opening the OHDI relay	1 ms	See Notes 3, 6 and 8. SP2-103-012 (parameter 11).
68054B	Break time for pulse dialing	1 ms	See Note 3. SP2-103-013 (parameter 12).
68054C	Make time for pulse dialing	1 ms	See Note 3. SP2-103-014 (parameter 13).
68054D	Time between final OHDI relay closure and DO relay opening or closing	1 ms	See Notes 3, 6 and 8. SP2-103-015 (parameter 14). This parameter is only valid in Europe.
68054E	Minimum pause between dialed digits (pulse dial mode)	20 ms	See Note 3 and 8. SP2-103-016 (parameter 15).
68054F	Time waited when a pause is entered at the operation panel		SP2-103-017 (parameter 16). See Note 3.
680550	DTMF tone on time	1 ms	SP2-103-018 (parameter 17).
680551	DTMF tone off time		SP2-103-019 (parameter 18).
680552	Tone attenuation level of DTMF signals while dialing	-N x 0.5 -3.5 dBm	SP2-103-020 (parameter 19). See Note 5.

Address	Function	Unit	Remarks
680553	Tone attenuation value difference between high frequency tone and low frequency tone in DTMF signals	-dBm x 0.5	SP2-103-021 (parameter 20). The setting must be less than -5dBm, and should not exceed the setting at 680552h above. See Note 5.
680554	PSTN: DTMF tone attenuation level after dialling	-N x 0.5 -3.5 dBm	SP2-103-022 (parameter 21). See Note 5.
680555	ISDN: DTMF tone attenuation level after dialling	-dBm x 0.5	See Note 5
680556	Not used	-	Do not change the settings.
680557	Time between 68054Dh (NCU parameter 14) and 68054Eh (NCU parameter 15)	1 ms	This parameter takes effect when the country code is set to France.
680558	Not used	-	Do not change the setting.
680559	Grounding time (ground start mode)	20 ms	The Gs relay is closed for this interval.
68055A	Break time (flash start mode)	1 ms	The OHDI relay is open for this interval.
68055B	International dial access code (High)	BCD	For a code of 100: 68055B - F1 68055C - 00
68055C	International dial access code (Low)		

Address	Function	Unit	Remarks
68055D	PSTN access pause time	20 ms	This time is waited for each pause input after the PSTN access code. If this address contains FF[H], the pause time stored in address 68054F is used. Do not set a number more than 7 in the UK.
68055E	Progress tone detection level, and cadence detection enable flags	Bit 7: 0, Bit 6: 0, Bit 5: 0 = -25.0 dBm Bit 7: 0, Bit 6: 0, Bit 5: 1 = -35.0 dBm Bit 7: 0, Bit 6: 1, Bit 5: 0 = -30.0 dBm Bit 7: 1, Bit 6: 0, Bit 5: 0 = -40.0 dBm Bit 7: 1, Bit 6: 1, Bit 5: 0 = -49.0 dBm Bits 2, 0 - See Note 2.	
68055F To 680564	Not used	-	Do not change the settings.
680565	Long distance call prefix (HIGH)	BCD	For a code of 0: 680565 – FF 680566 - FF
680566	Long distance call prefix (LOW)	BCD	
680567 to 680571	Not used	-	Do not change the settings.
680572	Acceptable ringing signal frequency: range 1, upper limit	1000/ N (Hz).	SP2-103-003 (parameter 02).
680573	Acceptable ringing signal frequency: range 1, lower limit		SP2-103-004 (parameter 03).
680574	Acceptable ringing signal frequency: range 2, upper limit		SP2-103-005 (parameter 04).
680575	Acceptable ringing signal frequency: range 2, lower limit		SP2-103-006 (parameter 05).

Fax Option
Type C5502
(D643)

Address	Function	Unit	Remarks
680576	Number of rings until a call is detected	1	SP2-103-007 (parameter 06). The setting must not be zero.
680577	Minimum required length of the first ring	20 ms	See Note 4. SP2-103-008 (parameter 07).
680578	Minimum required length of the second and subsequent rings	20 ms	SP2-103-009 (parameter 08).
680579	Ring signal detection reset time (LOW)	20 ms	SP2-103-010 (parameter 09).
68057A	Ring signal detection reset time (HIGH)		SP2-103-011 (parameter 10).
68057B to 680580	Not used	-	Do not change the settings.
680581	Interval between dialing the last digit and switching the Oh relay over to the external telephone when dialing from the operation panel in handset mode.	20 ms	Factory setting: 500 ms
680582	Bits 0 and 1 - Handset off-hook detection time Bit 1:0, Bit 0: 0 = 200 ms Bit 1:0, Bit 0: 1 = 800 ms Other Not used Bits 2 and 3 - Handset on-hook detection time Bit 3: 0, Bit 2: 0 = 200 ms Bit 3: 0, Bit 2: 1 = 800 ms Other Not used Bits 4 to 7 - Not used	-	

Address	Function	Unit	Remarks
680583 To 6805A0	Not used	-	Do not change the settings.
6805A1	Acceptable CED detection frequency upper limit (high byte)	BCD (Hz)	If both addresses contain FF(H), tone detection is disabled.
6805A2	Acceptable CED detection frequency upper limit (low byte)		
6805A3	Acceptable CED detection frequency lower limit (high byte)	BCD (Hz)	If both addresses contain FF(H), tone detection is disabled.
6805A4	Acceptable CED detection frequency lower limit (low byte)		
6805A5	CED detection time	20 ms ± 20 ms	Factory setting: 200 ms
6805A6	Acceptable CNG detection frequency upper limit (high byte)	BCD (Hz)	If both addresses contain FF(H), tone detection is disabled.
6805A7	Acceptable CNG detection frequency upper limit (low byte)		
6805A8	Acceptable CNG detection frequency lower limit (high byte)	BCD (Hz)	If both addresses contain FF(H), tone detection is disabled.
6805A9	Acceptable CNG detection frequency lower limit (low byte)		
6805AA	Not used	-	Do not change the setting.
6805AB	CNG on time	20 ms	Factory setting: 500 ms
6805AC	CNG off time	20 ms	Factory setting: 3000 ms
6805AD	Number of CNG cycles required for detection	-	The data is coded in the same way as address 680533.

Address	Function	Unit	Remarks
6805AE	Not used	-	Do not change the settings.
6805AF	Acceptable AI short protocol tone (800Hz) detection frequency upper limit (high byte)	Hz (BCD)	If both addresses contain FF(H), tone detection is disabled.
6805B0	Acceptable AI short protocol tone (800Hz) detection frequency upper limit (low byte)		
6805B1	Acceptable AI short protocol tone (800Hz) detection frequency lower limit (high byte)	Hz(BCD)	If both addresses contain FF(H), tone detection is disabled.
6805B2	Acceptable AI short protocol tone (800Hz) detection frequency lower limit (low byte)		
6805B3	Detection time for 800 Hz AI short protocol tone	20 ms	Factory setting: 360 ms
6805B4	PSTN: Tx level from the modem	-N – 3 dBm	SP2-103-002 (parameter 01).
6805B5	PSTN: 1100 Hz tone transmission level	- N 6805B4 - 0.5N 6805B5 –3.5 (dB) See Note 7.	
6805B6	PSTN: 2100 Hz tone transmission level	- N6805B4 - 0.5N 6805B6 –3 (dB) See Note 7.	
6805B7	PABX: Tx level from the modem	- dBm	
6805B8	PABX: 1100 Hz tone transmission level	- N 6805B7 - 0.5N 6805B8 (dB)	
6805B9	PABX: 2100 Hz tone transmission level	- N 6805B7 - 0.5N 6805B9 (dB)	
6805BD	Modem turn-on level (incoming signal detection level)	-37-0.5N (dBm)	

Address	Function	Unit	Remarks
6805BE to 6805C6	Not used	-	Do not change the settings.
6805C7	Bits 0 to 3 – Not used Bit 4 = V.34 protocol dump 0: Simple, 1: Detailed (default) Bits 5 to 7 – Not used.		
6805C8 to 6805D9	Not used	-	Do not change the settings.
6805DA	T.30 T1 timer	1 s	
6805E0 bit 3	Maximum wait time for post message	0: 12 s 1: 30 s	1: Maximum wait time for post message (EOP/EOM/MPS) can be changed to 30 s. Change this bit to “1” if communication errors occur frequently during V.17 reception.
6805E3	Bits 0 and 1 – DCV (TIP/RING) Voltage Bit 1:0, Bit 0: 0 = 3.1 V Bit 1:0, Bit 0: 1 = 3.2 V Bit 1:1, Bit 0: 0 = 3.35 V Bit 1:1, Bit 0: 1 = 3.5 V Bits 2 and 3 – MINI (minimum loop electric current) Bit 2:0, Bit 3: 0 = 10 mA Bit 2:0, Bit 2: 1 = 12 mA Bit 2:1, Bit 3: 0 = 14 mA Bit 2:1, Bit 3: 1 = 16 mA Bits 6 and 7 – ACIM (AC impedance) Bit 7:0, Bit 6: 0 Bit 5:0, Bit 4: 0= 600 Bit 7:0, Bit 6: 0 Bit 5:1, Bit 4: 0= TBR21		

Address	Function	Unit	Remarks
6805E4	Bit 0 – OHS (on hook speed) 0: OHS=0 1: OHS=1 Bit 1 – SQ (spark quench) 0: SQ=00 1: SQ=11 Bit 2 – RZ (call signal Impedance) 0: RZ=0 (high) 1: RZ=1 (low) Bit 3 – RT (call signal detection level) 0: RT=0 (low) 1: RT=1 (high) Bit 4 – ILIM (DC limitation) 0: ILIM=0 (CTR 21) 1: ILIM=1 (other than CTR 21) Bit 5 –FILTER 0: FILTER=0 (around 5Hz) 1: FILTER=1 (around 200Hz) Bits 6 to 7 – Calibration in off hook state Bit 6:0, Bit 7: 0 = off hook to ACAL:128 ms, off hook to MCAL: 1000 ms Bit 6:1, Bit 7: 0 = off hook to ACAL:128 ms, off hook to MCAL: 500 ms Bit 6:0, Bit 7: 1 = off hook to ACAL:128 ms (no MCAL) Bit 6:1, Bit 7: 1 = off hook to ACAL:8 ms (no MCAL)		
6805E5	Bits 0 to 6 – Not used Bits 7 – Energy saving for DSP, COMBLK, SiDAA 0: Does not save energy 1: Saves energy		

NOTES

1. If a setting is not required, store FF in the address.
2. Italy and Belgium only
 RAM address 68055E: the lower four bits have the following meaning.
 Bit 2 - 1: International dial tone cadence detection enabled (Belgium)
 Bit 1 - Not used
 Bit 0 - 1: PSTN dial tone cadence detection enabled (Italy)

If bit 0 or bit 2 is set to 1, the functions of the following RAM addresses are changed.

680508 (if bit 0 = 1) or 680538 (if bit 2 = 1): tolerance for on or off state

duration (%), and number of cycles required for detection, coded as in address 680533.

68050B (if bit 0 = 1) or 68053B (if bit 2 = 1): on time, hex code (unit = 20 ms)

68050C (if bit 0 = 1) or 68053C (if bit 2 = 1): off time, hex code (unit = 20 ms)

3. Pulse dial parameters (addresses 68054A to 68054F) are the values for 10 pps. If 20 pps is used, the machine automatically compensates.
4. The first ring may not be detected until 1 to 2.5 wavelengths after the time specified by this parameter.
5. The calculated level must be between 0 and 10.

The attenuation levels calculated from RAM data are:

High frequency tone:

- $-0.5 \times N_{680552/680554} - 3.5$ dBm
- $-0.5 \times N_{680555}$ dBm

Low frequency tone:

- $-0.5 \times (N_{680552/680554} + N_{680553}) - 3.5$ dBm
- $-0.5 \times (N_{680555} + N_{680553})$ dBm



- N_{680552} , for example, means the value stored in address 680552(H)

6. 68054A: Europe - Between Ds opening and Di opening, France - Between Ds closing and Di opening
68054D: Europe - Between Ds closing and Di closing, France - Between Ds opening and Di closing
7. Tone signals which frequency is lower than 1500Hz (e.g., 800Hz tone for AI short protocol) refer to the setting at 6805B5h. Tones which frequency is higher than 1500Hz refer to the setting at 6805B6h.
8. 68054A, 68054D, 68054E: The actual inter-digit pause (pulse dial mode) is the sum of the period specified by the RAM addresses 68054A, 68054D, and 68054E.

4.10 DEDICATED TRANSMISSION PARAMETERS

There are two sets of transmission parameters: Fax and E-mail

Each Quick Dial Key and Speed Dial Code has eight bytes of programmable parameters allocated to it. If transmissions to a particular machine often experience problems, store that terminal's fax number as a Quick Dial or Speed Dial, and adjust the parameters allocated to that number.

The programming procedure will be explained first. Then, the eight bytes will be described.

4.10.1 PROGRAMMING PROCEDURE

1. Set the bit 0 of System Bit Switch 00 to 1.
2. Enter Address Book Management mode ([User Tools]> System Settings> Key Operator> Address Book Management).
3. Select the address book that you want to program.
4. For the fax parameter, select "Fax Dest.", for the E-mail parameter, select "E-mail", then press "Start". Make sure that the LED of the Start button lights green.
5. The settings for the switch 00 are now displayed. Press the bit number that you wish to change.
6. To scroll through the parameter switches, either:
7. Select the next switch: press "Next" or Select the previous switch: "Prev." until the correct switch is displayed. Then go back to step 6.
8. After the setting is changed, press "OK".
9. After finishing, reset bit 0 of System Bit Switch 00 to 0.

4.10.2 PARAMETERS

Fax Parameters

The initial settings of the following fax parameters are all FF(H) - all the parameters are disabled.

Switch 00
FUNCTION AND COMMENTS
<p>ITU-T T1 time (for PSTN G3 mode)</p> <p>If the connection time to a particular terminal is longer than the NCU parameter setting, adjust this byte. The T1 time is the value stored in this byte (in hex code), multiplied by 1 second.</p> <p>Range: 0 to 120 s (00h to 78h)</p> <p>FFh - The local NCU parameter factory setting is used.</p> <p>Do not program a value between 79h and FEh.</p>

Switch 01							
No	FUNCTION					COMMENTS	
0-4	Tx level					<p>If communication with a particular remote terminal often contains errors, the signal level may be inappropriate. Adjust the Tx level for communications with that terminal until the results are better.</p> <p>If the setting is "Disabled", the NCU parameter 01 setting is used.</p> <p>↓ Note</p> <ul style="list-style-type: none"> Do not use settings other than listed on the left. 	
	Bit4	Bit3	Bit2	Bit1	Bit0		
	0	0	0	0	0		0
	0	0	0	0	1		-1
	0	0	0	1	0		-2
	0	0	0	1	1		-3
	0	0	1	0	0		-4
	↓	↓	↓	↓	↓		↓
	0	1	1	1	1		-15
	1	1	1	1	1		Disabled

5-7	<p>Cable equalizer</p> <p>Bit 7: 0, Bit 6: 0, Bit 5: 0 = None</p> <p>Bit 7: 0, Bit 6: 0, Bit 5: 1 = Low</p> <p>Bit 7: 0, Bit 6: 1, Bit 5: 0 = Medium</p> <p>Bit 7: 0, Bit 6: 1, Bit 5: 1 = High</p> <p>Bit 7: 1, Bit 6: 1, Bit 5: 1 = Disabled</p>	<p>Use a higher setting if there is signal loss at higher frequencies because of the length of wire between the modem and the telephone exchange when calling the number stored in this Quick/Speed Dial.</p> <p>Also, try using the cable equalizer if one or more of the following symptoms occurs.</p> <p>Communication error with error codes such as 0-20, 0-23, etc.</p> <p>Modem rate fallback occurs frequently.</p> <p> Note</p> <ul style="list-style-type: none"> ▪ Do not use settings other than listed on the left. <p>If the setting is "Disabled", the bit switch setting is used.</p>
-----	--	--

Switch 02						
No	FUNCTION					COMMENTS
0-3	Initial Tx modem rate					<p>If training with a particular remote terminal always takes too long, the initial modem rate may be too high. Reduce the initial Tx modem rate using these bits.</p> <p>For the settings 14.4 or kbps slower, Switch 04 bit 4 must be changed to 0.</p> <p> Note</p> <ul style="list-style-type: none"> ▪ Do not use settings other than listed on the left. If the setting is "Disabled", the bit switch setting is used.
	Bit3	Bit2	Bit1	Bit0	bps	
	0	0	0	0	Not used	
	0	0	0	1	2400	
	0	0	1	0	4800	
	0	0	1	1	7200	
	0	1	0	0	9600	
	0	1	0	1	12000	
	0	1	1	0	14400	
	0	1	1	1	16800	

Dedicated Transmission Parameters

	1	0	0	0	19200	
	1	0	0	1	21600	
	1	0	1	0	24000	
	1	0	1	1	26400	
	1	1	0	0	28800	
	1	1	0	1	31200	
	1	1	1	0	33600	
	1	1	1	1	Disabled	
	Other settings: Not used					
4-7	Not used				Do not change the settings.	

Switch 03		
No	FUNCTION	COMMENTS
0-1	Inch-mm conversion before tx Bit 1: 0, Bit 0: 0 = Inch-mm conversion available Bit 1: 0, Bit 0: 1 = Inch only Bit 1: 1, Bit 0: 0 = Not used Bit 1: 1, Bit 0: 1 = Disabled	If "inch only" is selected on the machine uses inch-based resolutions for scanning, the printed copy may be slightly distorted at the other end if that machine uses mm-based resolutions. If the setting is "Inch-mm conversion available ", Inch-mm conversion become effective to the special senders. If the setting is "Disabled", the bit switch setting is used.
2-3	DIS/NSF detection method Bit 3: 0, Bit 2: 0 = First DIS or NSF Bit 3: 0, Bit 2: 1 = Second DIS or NSF Bit 3: 1, Bit 2: 0 = Not used Bit 3: 1, Bit 2: 1 = Disabled	(0, 1): Use this setting if echoes on the line are interfering with the set-up protocol at the start of transmission. The machine will then wait for the second DIS or NSF before sending DCS or NSS. If the setting is "Disabled", the bit switch setting is used.

4	V.8 protocol 0: Off 1: Disabled	If transmissions to a specific destination always end at a lower modem rate (14,400 bps or lower), disable V.8 protocol so as not to use V.34 protocol. 0: V.34 communication will not be possible. If the setting is "Disabled", the bit switch setting is used.
5	Compression modes available in transmit mode 0: MH only 1: Disabled	This bit determines the capabilities that are informed to the other terminal during transmission. If the setting is "Disabled", the bit switch setting is used.
6-7	ECM during transmission Bit 7: 0, Bit 6: 0 = Off Bit 7: 0, Bit 6: 1 = On Bit 7: 1, Bit 6: 0 = Not used Bit 7: 1, Bit 6: 1 = Disabled	For example, if ECM is switched on but is not wanted when sending to a particular terminal, use the (0, 0) setting. <div style="border: 1px solid blue; padding: 2px; display: inline-block;">  Note </div> <ul style="list-style-type: none"> ▪ V.8/V.34 protocol and JBIG compression are automatically disabled if ECM is disabled. ▪ If the setting is "Disabled", the bit switch setting is used.

Switch 04 - Not used (do not change the settings)
Switch 05 - Not used (do not change the settings)
Switch 06 - Not used (do not change the settings)
Switch 07 - Not used (do not change the settings)
Switch 08 - Not used (do not change the settings)
Switch 09 - Not used (do not change the settings)

E-mail Parameters

The initial settings of the following e-mail parameters are all "0" (all parameters disabled).

Switch 00		
No	FUNCTION	COMMENTS
0	MH Compression mode for e-mail attachments 0: Off 1: On	Switches MH compression on and off for files attached to e-mails for sending.
1	MR Compression mode for e-mail attachments 0: Off 1: On	Switches MR compression on and off for files attached to e-mails for sending.
2	MMR Compression mode for e-mail attachments 0: Off 1: On	Switches MMR compression on and off for files attached to e-mails for sending.
3-6	Not used	Do not change these settings.
7	Designates the bits to reference for compression method of e-mail attachments 0: Registered (Bit 0 to 6) 1: No registration.	The "0" selection (default) references the settings for Bits 00, 01, 02 above. The "1" selection ignores the selections of Bits 00, 01, 02.

Switch 01		
No	FUNCTION	COMMENTS
0	Original width of e-mail attachment: A4 0: Off 1: On	Sets the original width of the e-mail attachment as A4.
1	Original width of e-mail attachment: B4 0: Off 1: On	Sets the original width of the e-mail attachment as B4.
2	Original width of e-mail attachment: A3 0: Off 1: On	Sets the original width of the e-mail attachment as A3.
3-6	Not used	Do not change these settings.
7	Designates the bits to reference for original size of e-mail attachments 0: Registered (Bit 0 to 6) 1: No registration.	The "0" selection (default) references the settings for Bits 00, 01, 02 above. The "1" selection ignores the selections of Bits 00, 01, 02.

Dedicated Transmission Parameters

Switch 02		
No	FUNCTION	COMMENTS
0	Line resolution of e-mail attachment: 200 x 100 0: Off 1: On	Sets the line resolution of the e-mail attachment as 200 x100.
1	Line resolution of e-mail attachment: 200 x 200 0: Off 1: On	Sets the line resolution of the e-mail attachment as 200 x 200.
2	Line resolution of e-mail attachment: 200 x 400 0: Off 1: On	Sets the line resolution of the e-mail attachment as 200 x 400.
3	Not used	Do not change these settings.
4	Line resolution of e-mail attachment: 400 x 400 0: Off 1: On	Sets the line resolution of the e-mail attachment as 400 x 400.
5-6	Not used	Do not change these settings.
7	Designates the bits to reference for original size of e-mail attachments 0: Registered (Bit 0 to 6) 1: No registration.	The "0" selection (default) references the settings for Bits 00, 01, 02, 04 above. The "1" selection ignores the selections of Bits 00, 01, 02, 04.

Switch 03 - Not used (do not change the settings)

Switch 04		
No	FUNCTION	COMMENTS
0	Full mode address selection 0: Full mode address 1: No full mode (simple mode)	If the other ends have the addresses, which have the full mode function flag ("0"), this machine determines them as full mode standard machines. <ul style="list-style-type: none"> ▪ This machine attaches the "demand of reception confirmation" to a message when transmitting. ▪ This machine updates the reception capability to the address book when receiving.
1-7	Not used	Do not change these settings.

Switch 05		
No	FUNCTION	COMMENTS
0	Direct transmission selection to SMTP server 0: ON 1: OFF	Allows or does not allow the direct transmission to SMTP server.
1-7	Not used	Do not change these settings.

Switch 06 - Not used (do not change the settings)

Switch 07 - Not used (do not change the settings)

Switch 08 - Not used (do not change the settings)

Switch 09 - Not used (do not change the settings)

4.11 SERVICE RAM ADDRESSES

CAUTION

- Do not change the settings which are marked as “Not used” or “Read only.”

680001 to 680004(H) - ROM version (Read only)

680001(H) - Revision number (BCD)

680002(H) - Year (BCD)

680003(H) - Month (BCD)

680004(H) - Day (BCD)

680006 to 680015(H) - Machine's serial number (16 digits - ASCII)

680018(H) - Total program checksum (low)

680019(H) - Total program checksum (high)

680020 to 68003F(H) - System bit switches

680050 to 68005F(H) - Printer bit switches

680060 to 68007F(H) - Communication bit switches

680080 to 68008F(H) - G3 bit switches

680090 to 68009F(H) - G3-2 bit switches: Not used

6800A0 to 6800AF(H) - G3-3 bit switches: Not used

6800D0(H) - User parameter switch 00 (SWUER_00) : Not used

6800D1(H) - User parameter switch 01 (SWUSR_01) : Not used

6800D2(H) - User parameter switch 02 (SWUSR_02)

Bit 0: Forwarding mark printing on forwarded messages 0: Disabled, 1: Enabled

Bit 1: Center mark printing on received copies

(This switch is not printed on the user parameter list.)

0: Disabled, 1: Enabled

Bit 2: Reception time printing

(This switch is not printed on the user parameter list.)

0: Disabled, 1: Enabled

Bit 3: TSI print on received messages 0: Disabled, 1: Enabled

Bit 4: Checkered mark printing

(This switch is not printed on the user parameter list.)

0: Disabled, 1: Enabled

Bit 5: Not used

Bit 6: Not used

Bit 7: Not used

6800D3(H) - User parameter switch 03 (SWUSR_03: Automatic report printout)

Bit 0: Transmission result report (memory transmissions) 0: Off, 1: On

Bit 1: Not used

Bit 2: Memory storage report 0: Off, 1: On

Bit 3: Polling reserve report (polling reception) 0: Off, 1: On

Bit 4: Polling result report (polling reception) 0: Off, 1: On

Bit 5: Transmission result report (immediate transmissions) 0: Off, 1: On

Bit 6: Not used

Bit 7: Journal 0: Off, 1: On

6800D4(H) - User parameter switch 04 (SWUSR_04: Automatic report printout)

Bit 0: Not used

Bit 1: Automatic communication failure report and transfer result report output 0: Off, 1: On

Bits 2 to 3: Not used

Bit 4: Indicates the parties 0: Not indicated, 1: Indicated

Bit 5: Include sender's name on reports 0: Off, 1: On

Bit 6: Not used

Bit 7: Inclusion of a sample image on reports 0: Off, 1: On

6800D5(H) - User parameter switch 05 (SWUSR_05)

Bit 0: Substitute reception when the base copier is in an SC condition

0: Enabled, 1: Disabled

Bits 1 and 2: Condition for substitute rx when the machine cannot print messages (Paper end, toner end, jam, and during night mode)

Bit 2: 0, Bit 1: 0 = The machine receives all the fax messages.

Bit 2: 0, Bit 1: 1 = The machine receives the fax messages with RTI or CSI.

Bit 2: 1, Bit 1: 0 = The machine receives the fax messages with the same ID code.

Bit 2: 1, Bit 1: 1 = The machine does not receive anything.

Bit 3: Not used

Bit 4: Not used

Bit 5: Just size printing 0: Off, 1: On

Bit 6: Not used

Bit 7: Add paper display when a cassette is empty 0: Off, 1: On

6800D6(H) - User parameter switch 06 (SWUSR_06): Not used

6800D7(H) - User parameter switch 07 (SWUSR_07)

Bit 0 Ringing 0: Off, 1: On

Bit 1: Automatic answering message 0: Off, 1: On

Bit 2: Parallel memory transmission 0: Off, 1: On

Bits 3 and 4: Not used

Bit 5: Remote control 0: Off, 1: On

Bits 6 and 7: Not used

6800D8(H) - User parameter switch 08 (SWUSR_08)

Bits 0 and 1: Not used.

Bit 2: Authorized reception

0: Only faxes from senders whose RTIs/CSIs are specified for this feature are accepted.

1: Only faxes from senders whose RTIs/CSIs are not specified for this feature are accepted.

Bits 3 to 7: Not used.

6800D9(H) - User parameter switch 09 (SWUSR_09): Not used

6800DA(H) - User parameter switch 10 (SWUSR_0A)

Bits 0 to 2: Not used

Bit 3: Page reduction 0: Off, 1: On

Bits 4 and 5: Not used

Bit 6: Use both e-mail notification and printed reports to confirm the transmission results 0: Off, 1: On

Bit 7: Not used

6800DB(H) - User parameter switch 11 (SWUSR_0B)

Bits 0 and 1: Not used

Bit 2: White original detection 0: Off, 1: On (alarm and alert message on the LCD)

Bit 3: Receive rejection for 1300 Hz transmission 0: Off (receive), 1: On (not receive)

Bit 5: Not used

Bit 6: Printout of messages received while acting as a forwarding station 0: Off, 1: On

Bit 7: Not used

6800DC(H) - User parameter switch 12 (SWUSR_0C): Not used

6800DD(H) - User parameter switch 13 (SWUSR_0D): Not used

6800DE(H) - User parameter switch 14 (SWUSR_0E)

Bit 0: Message printout while the machine is in Night Printing mode 0: On, 1: Off

Bit 1: Maximum document length detection 0: Double letter, 1: Longer than double-letter (well log) – up to 1,200 mm

Bit 2: Not used

Bit 3: Fax mode settings, such as resolution, before a mode key (Copy/Fax/Printer/Scanner) is pressed 0: Not cleared, 1: Cleared

Bits 4 to 6: Not used

Bit 7: Not used

6800DF(H) - User parameter switch 15 (SWUSR_0F)

(This switch is not printed on the user parameter list.)

Bits 0, 1 and 2: Cassette for fax printout

Bit 2: 0, Bit 1: 0, Bit 0: 1 = 1st paper feed station

Bit 2: 0, Bit 1: 1, Bit 0: 0 = 2nd paper feed station

Bit 2: 0, Bit 1: 1, Bit 0: 1 = 3rd paper feed station

Bit 2: 1, Bit 1: 0, Bit 0: 0 = 4th paper feed station

Bit 2: 1, Bit 1: 0, Bit 0: 1 = LCT

Other settings Not used

Bits 3 and 4: Not used

Bit 5: Using the cassette specified by bits 0, 1 and 2 above only 0: On, 1: Off

Bits 6 and 7: Not used

6800E0(H) – User parameter switch 16 (SWUSR_10)

(This switch is not printed on the user parameter list.)

Bits 0 and 1: Not used

Bit 2: Paper size selection priority for an A4 size fax message when A4/LT size paper is not available. 0: A3 has priority, 1: B4 has priority

Bits 3 to 7: Not used

6800E1(H) – User parameter switch 17 (SWUSR_11)

Bit 0: Not used

Bit 1: Not used

Bit 2: Inclusion of the “Add” button when a sequence of Quick/Speed dials is selected for broadcasting 0:Not needed, 1: Needed

Bits 3 to 6: Not used

Bit 7: Press “Start” key without an original when using the on hook dial or the external telephone, 0: displays “Cannot detect original size”. 1: Receives fax messages.

6800E2(H) - User parameter switch 18 (SWUSR_12)

Bit 0: TTI date 0: Off, 1: On

Bit 1: TTI sender 0: Off, 1: On

Bit 2: TTI file number 0: Off, 1: On

Bit 3: TTI page number 0: Off, 1: On

Bits 4 to 6: Not used

Bit 7: Japan only

6800E3(H) - User parameter switch 19 (SWUSR_13)

Bit 0: Not used

Bit 1: Journal format

0: The Journal is separated into transmissions and receptions

1: The Journal is separated into G3-1, G3-2, and G3-3 communications

Bit 2: Not used

Bit 3: 90° image rotation during B5 portrait Tx (This switch is not printed on the user parameter list.) 0: Off, 1: On

Bit 4: Reduction of sample images on reports to 50% in the main scan and sub-scan directions. (This switch is not printed on the user parameter list.) 0: Technician adjustment (printer switch 0E bits 3 and 4), 1: 50% reduction

Bit 5: Use of A5 size paper for reports (This switch is not printed on the user parameter list.) 0: Off, 1: On

Bits 6 and 7: Not used

6800E4(H) - User parameter switch 20 (SWUSR_14)

Bit 0: Automatic printing of the LAN fax result report 0: Off, 1: On

Bit 1: Not used.

Bits 2 to 5: Store documents in memory which could not be printed from PC fax (LAN fax) driver

Bit 5	Bit 4	Bit 3	Bit 2	Setting
0	0	0	0	0 min.
0	0	0	1	1 min.
↓	↓	↓	↓	↓
1	1	1	0	14 min.
1	1	1	1	15 min.

Bits 6 and 7: Not used.

6800E5(H) - User parameter switch 21 (SWUSR_15)

Bit 0: Print results of sending reception notice request message 0: Disabled (print only when error occurs), 1: Enabled

Bit 1: Respond to e-mail reception acknowledgment request 0: Disabled, 1: Enabled

Bit 2: Not used

Bit 3: File format for forwarded folders 0: TIFF, 1:PDF

Bit 4: Transmit Journal by E-mail 0: Disabled, 1: Enabled

Bit 5: Not used

Bit 6: Network error display 0: Displayed, 1: Not displayed

Bit 7: Transmit error mail notification 0: Enabled, 1: Disabled

6800E6(H) - User parameter switch 22 (SWUSR_16)

(This switch is not printed on the user parameter list.)

Bit 0: Dial tone detection (PSTN 1) 0: Disabled, 1: Enabled

Bits 1 to 7: Not used

6800E7(H) – User parameter switch 23 (SWUSR_17): Not used

6800E8(H) - User parameter switch 24 (SWUSR_18): Not used

6800E9(H) - User parameter switch 25 (SWUSR_19)

Bit 0: Not used

Bit 1: Reception mode switch timer 0: Off, 1: On (switching Fax or Fax/Tel)

Bit 2: Mode priority switch 0: Fax first, 1: Tel first

Bit 3: Dial in function (Japan Only)

Bit 4: RDS operation 0: Not acceptable, 1: Acceptable for the limit specified by system switch 03



- This bit is only effective when RDS operation can be selected by the user (see system switch 02).

Bits 5 to 7: Not used

6800EA(H) and 6800EB(H) - User parameter switches 26 and 27 (SWUSR_1A and 1B): Not used

6800EC(H) - User parameter switch 28(SWUSR_1C): Not used

6800ED(H) - User parameter switch 29(SWUSR_1D): Not used

6800EE(H) and 6800EF(H) - User parameter switches 30 and 31 (SWUSR_1E and 1F): Not used

6800F0(H) - User parameter switch 32 (SWUSR_20)

Bit 0: Quotation priority for a destination when there is no destination of the specified type

0: Paper output priority = Priority order: 1. IP-fax destination, 2. Fax Number, 3. E-mail address, 4. Folder

1: Electric putout order = Priority order: 1. E-mail address, 2. Folder, 3. IP-fax destination, 4. Fax number

Bits 1 to 7: Not used

6800F1(H) - User parameter switch 33 (SWUSR_21): Not used

6800F2(H) - User parameter switch 34 (SWUSR_22)

Bit 0: Gatekeeper server used with IP-Fax 0: Disabled, 1: Enabled

Bit 1: SIP server used with IP-Fax 0: Disabled, 1: Enabled

Bits 2 to 7: Not used

6800F3(H) - User parameter switch 35 (SWUSR_23)

Redial interval when sending a backup file

6800F4(H) - User parameter switch 36 (SWUSR_24)

Maximum number of redials when sending a backup file

6800F5-6800F8(H) - User parameter switch 37 (SWUSR_25)

Bit 0: Stop sending a backup file if the destination folder becomes full while the machine is sending or waiting to send a fax or the backup file 0: Disabled, 1: Enabled

Bit 1: Not used

Bit 2 and 3: Backup file is printed along with the TX communication failure report when a backup file transmission failure occurs. 00: Do not print, 01: Print first page only, 10: Print whole file

Bit 4: Display the sender's information in the file name of documents that are forwarded to folder destinations. 0: Disabled, 1: Enabled

Bit 5: Limit the file names of documents that are forwarded to folder destinations to plain characters only. 0: Disabled, 1: Enabled

Bit 6 to 7: Not used

6800F9(H) - User parameter switch 40 (SWUSR_28)

Bit 0: When memory space is insufficient, the machine prints and then deletes the oldest faxes, creating memory space for storage of new faxes. 0: Disabled, 1: Enabled

Bit 1 to 7: Not used

6800FF(H) - User parameter switch 45 (SWUSR_2D)

Bit 0 and 1: File format for files transmitted to e-mail addresses and folders registered as forwarding, destinations of backup file transmission, receivers for Personal Box, or end receivers for Transfer Box. 0: PDF 1: PDF/A

Bit 2 to 7: Not used

680100 to 68010F(H) - G4 Parameter Switches – Not used

680110 to 68012F(H) - G4 Internal Switches – Not used

680130 to 68016F(H) - Service Switches

680170 to 68017F(H) - IFAX Switches

680180 to 68018F(H) - IP-FAX Switches

680190 to 6801AF(H) - Service station's fax number (SP3-101)

6801B0 to 6801B9(H) - Own fax PABX extension number – Not used

6801BA to 6801C3(H) - Own fax number (PSTN) – Not used

6801C4 to 6801D7(H) - Own fax number (ISDN G4) – Not used

6801D8 to 6801E3(H) - The first subscriber number (ISDN G3) – Not used

6801E4 to 6801EF(H) - The second subscriber number (ISDN G3) – Not used

6801F0 to 6801FB(H) - The first subscriber number (ISDN G4) – Not used

6801FC to 680207(H) - The second subscriber number (ISDN G4) – Not used

680208 to 68021B(H) - PSTN-1 RTI (Max. 20 characters - ASCII) - See the following note.

68021C to 68022F(H) - PSTN-2 RTI (Max. 20 characters - ASCII) - Not used

680230 to 680246(H) - PSTN-3 RTI (Max. 20 characters - ASCII) - Not used

680247 to 680286(H) - TTI 1 (Max. 64 characters - ASCII) - See the following note.

680287 to 6802C6(H) - TTI 2 (Max. 64 characters - ASCII) - Not used

6802C7 to 680306(H) - TTI 3 (Max. 64 characters - ASCII) - Not used

680307 to 68031A(H) - PSTN-1 CSI (Max. 20 characters - ASCII)

68031B to 68032E(H) - PSTN-2 CSI (Max.20 characters - ASCII) - Not used

68032F to 680342(H) - PSTN-3 CSI (Max.20 characters - ASCII) - Not used

680343(H) - Number of PSTN-1 CSI characters (Hex)

680344(H) - Number of PSTN-2 CSI characters (Hex) - Not used

680345(H) Number of PSTN-3 CSI characters (Hex) - Not used



- If the number of characters is less than the maximum (20 for RTI, 32 for TTI), add a stop code (00[H]) after the last character.

680380 to 680387(H) - Last power off time (Read only)

680380(H) - 01(H) - 24-hour clock, 00(H) - 12-hour clock (AM), 02(H) - 12-hour clock (PM)

680381(H) - Year (BCD)

680382(H) - Month (BCD)

680383(H) - Day (BCD)

680384(H) – Hour

680385(H) – Minute

680386(H) – Second

680387(H) - 00: Monday, 01: Tuesday, 02: Wednesday, /// , 06: Sunday

680394(H) - Optional equipment (Read only – Do not change the settings)

Bit 0: Page Memory 0: Not installed, 1: Installed

Bit 1: SAF Memory 0: Not installed, 1: Installed

Bits 2 to 7; Not used

680395(H) - Optional equipment (Read only – Do not change the settings)

Bits 0 to 3: Not used

Bit 4: G3-2 0: Not installed, 1: Installed

Bit 5: G3-3 0: Not installed, 1: Installed

Bit 6 and 7: Not used

680406 to 68040A – Option G3 board (G3-2) ROM information (Read only)

680406(H) - Suffix (BCD)

680407(H) - Version (BCD)

680408(H) - Year (BCD)

680409(H) - Month (BCD)

68040A(H) - Day (BCD)

68040B to 68040F – Option G3 board (G3-3) ROM information (Read only)
68040B(H) - Suffix (BCD)
68040C(H) - Version (BCD)
68040D(H) - Year (BCD)
68040E(H) - Month (BCD)
68040F(H) - Day (BCD)
680410(H) - G3-1 Modem ROM version (Read only)
680412(H) - G3-2 Modem ROM version (Read only)
680414(H) - G3-3 Modem ROM version (Read only)
680420(H) - Number of multiple sets print (Read only)
680476(H) - Time for economy transmission (hour in 24h clock format - BCD)
680477(H) - Time for economy transmission (minute - BCD)
680492(H) - Transmission monitor volume 00 - 07(H)
680493(H) - Reception monitor volume 00 - 07(H)
680494(H) - On-hook monitor volume 00 - 07(H)
680495(H) - Dialing monitor volume 00 - 07(H)
680496(H) - Buzzer volume 00 - 07(H)
680497(H) - Beeper volume 00 - 07(H)
6804A8(H) - Machine code (Check ram 4)
68AFDA(H) - IP-Fax backup data 00 - 600 (H) - Not used
69A614(H) - Own e-mail address for internet fax (Max. 128 characters - ASCII)
69A794(H) - User code for fax e-mail account (Max. 192 characters - ASCII)
69A854(H) – Password for fax e-mail account (Max. 128 characters - ASCII)
69A914(H) - Transmission mail size restriction for internet fax (Max. 4 bit)
69A918(H) - E-mail address for SMTP reception (Max. 128 characters - ASCII)
69A998(H) – Destination number for reception report e-mail (Max. 4 byte)
69FB40(H) to 69FDC0(H) - SIP server address (Read only)
69FB40(H) - Proxy server - Main (Max. 128 characters - ASCII)
69FBC0(H) - Proxy server - Sub (Max. 128 characters - ASCII)
69FC40(H) - Redirect server - Main (Max. 128 characters - ASCII)
69FCC0(H) - Redirect server - Sub (Max. 128 characters - ASCII)
69FD40(H) - Registrar server - Main (Max. 128 characters - ASCII)
69FDC0(H) - Registrar server - Sub (Max. 128 characters - ASCII)
69FE40(H) - Gatekeeper server address - Main (Max. 128 characters - ASCII)
69FEC0(H) - Gatekeeper server address - Sub (Max. 128 characters - ASCII)
69FF40(H) - Arias Number (Max. 128 characters - ASCII)
69FFC0(H) - SIP user name (Max. 128 characters - ASCII)

6A0040H(H) - SIP digest authentication password (Max. 128 characters - ASCII)

6A00C0H(H) - Gateway address information (Max. 7100 characters - ASCII)

6A1C7C(H) - Stand-by port number for H.323 connection

6A1C7E(H) - Stand-by port number for SIP connection

6A1C80(H) - RAS port number

6A1C82(H) - Gatekeeper port number

6A1C84(H) - Port number of data waiting for T.38

6A1C86(H) - Port number of SIP server

6A1C88(H) - Priority for SIP and H.323 0: H.323, 1: SIP

6A1C89(H) - SIP function 0: Disabled, 1: Enabled

6A1C8A(H) - H.323 function 0: Disabled, 1: Enabled

6A1C8B(H) - SIP digest authentication function 0: Disabled, 1: Enabled

6B9000 to 6B91FF(H) - Error code (Max. 512 byte)

6B9200 to 6BD61F - Reception results (Max. 17440 byte)

6BD620 to 6BDFA7 - Transmission error (Max. 2440 byte)

6BEBFE(H) - 6BEC1E (H) - Dial tone detection parameter (Max. 11 x 3 lines)

This initializes following order. [0x04, 0x40, 0x03, 0x60, 0x64, 0xf4, 0x01, 0x64, 0x04, 0xc8, 0x00]

6BEBFE(H) – Dial tone detection frequency – Upper limit (High)

Defaults: NA: 06, EU: 06, ASIA: 06

6BEBFF(H) – Dial tone detection frequency – Upper Limit (Low)

Defaults: NA: 50, EU: 50, ASIA: 50

6BEC00(H) – Dial tone detection frequency – Lower Limit (High)

Defaults: NA: 03, EU: 02, ASIA: 02

6BEC01(H) – Dial tone detection frequency – Lower Limit (Low)

Defaults: NA: 60, EU: 90, ASIA: 90

6BEC02(H) –Dial tone detection waiting time (20 ms)

Defaults: NA: 64, EU 64, ASIA: 64

6BEC03 to 6BEC04 – Dial tone detection monitoring time (20 ms)

Defaults

Area	6BEC03	6BEC04
NA	F4	01
EU	F4	01
ASIA	F4	01

Service RAM Addresses

6BEC05(H) – Dial tone detect judge time (20 ms)

Defaults: NA: 64, EU: 1B, ASIA: 32

6BEC06(H) – Dial tone disconnect permission time (20 ms)

Defaults: NA: 11, EU: 0F, ASIA: 11

5. DETAILED SECTION DESCRIPTIONS

5.1 OVERVIEW

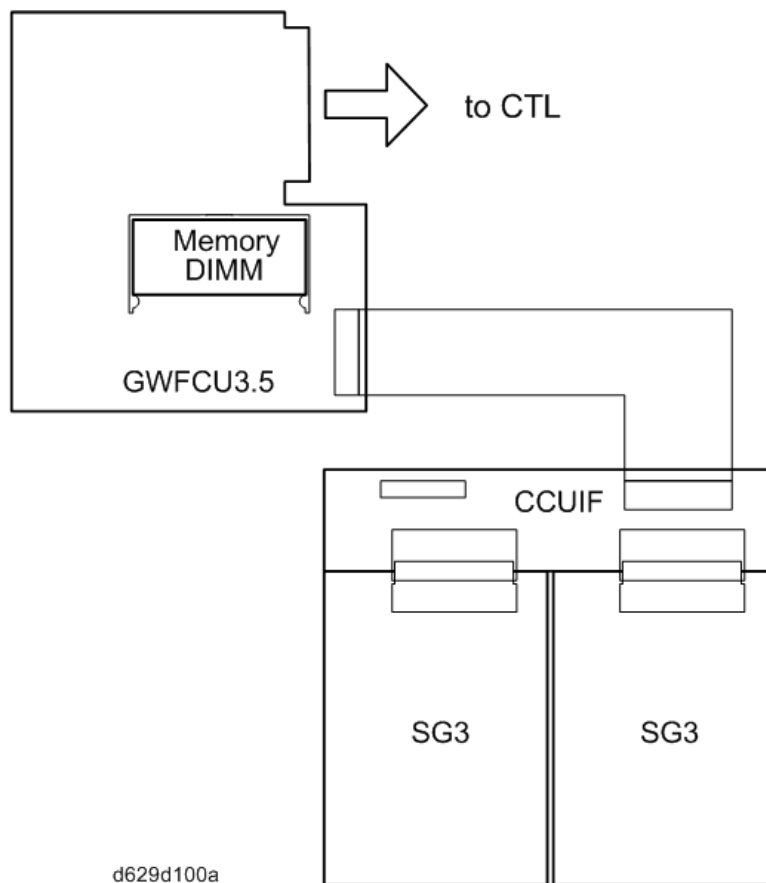

The FCU controls all the fax communications and fax features, in cooperation with the controller board. Also, the FCU contains the ROM, SRAM and NCU circuit.

Fax Options:

- Extra G3 Interface option: This provides one more analog line interface. This allows full dual access. Two extra G3 interface options can be installed.
- Memory Expansion: This expands the SAF memory and the page memory (used for image rotation); without this expansion, the page memory is not big enough for image rotation at 400 dpi, so transmission at 400 dpi is not possible.

5.2 BOARDS

5.2.1 FCU

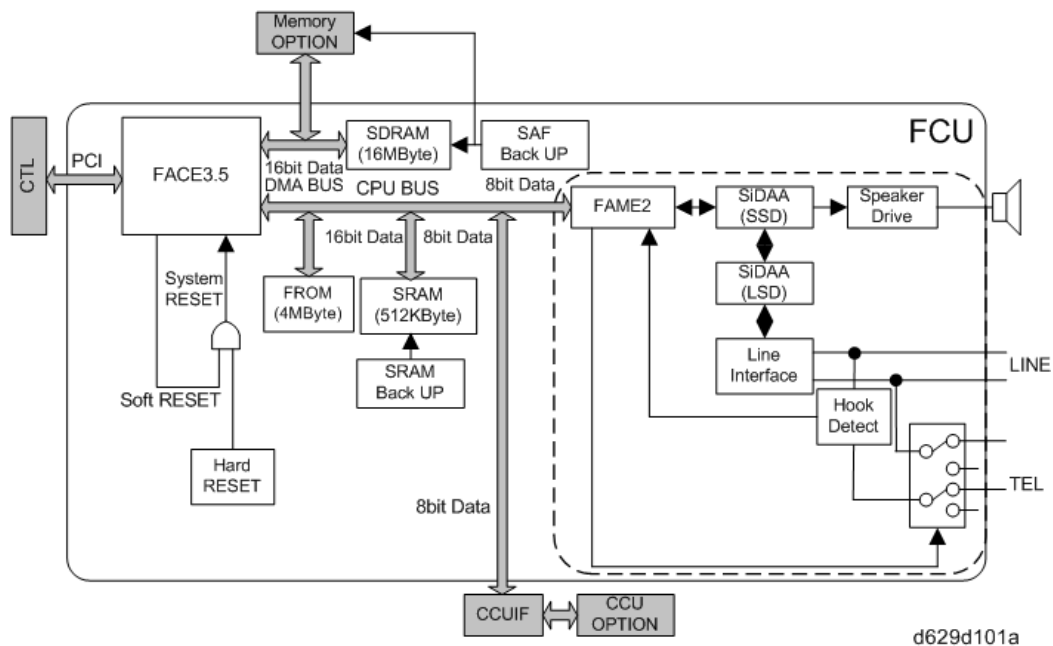

The FCU (Facsimile Control Unit) controls fax communications, the video interface to the base copier's engine, and all the fax options.

FACE3.5 (Fax Application Control Engine)

- CPU
- Data compression and reconstruction (DCR)
- DMA control
- Clock generation
- DRAM backup control

Modem (FAME2)

- V.34, V.33, V.17, V.29, V.27ter, V.21, and V.8

DRAM

- The 16 MB of DRAM is shared as follows.
 - SAF memory: 4MB
 - Working memory: 4MB
 - Page memory: 8MB
 - The SAF memory is backed up by a rechargeable battery.

ROM

- 4MB flash ROMs for system software storage

SRAM

- The 512 KB SRAM for system and user parameter storage is backed up by a lithium battery.

Memory Back-up

- A rechargeable battery backs up the SAF memory (DRAM) for 12 hours.
- A lithium battery backs up the system parameters and programmed items in the SRAM, in case the base copier's main switch is turned off.

Switches

Item	Description
SW1	Switches the SRAM backup battery on/off.

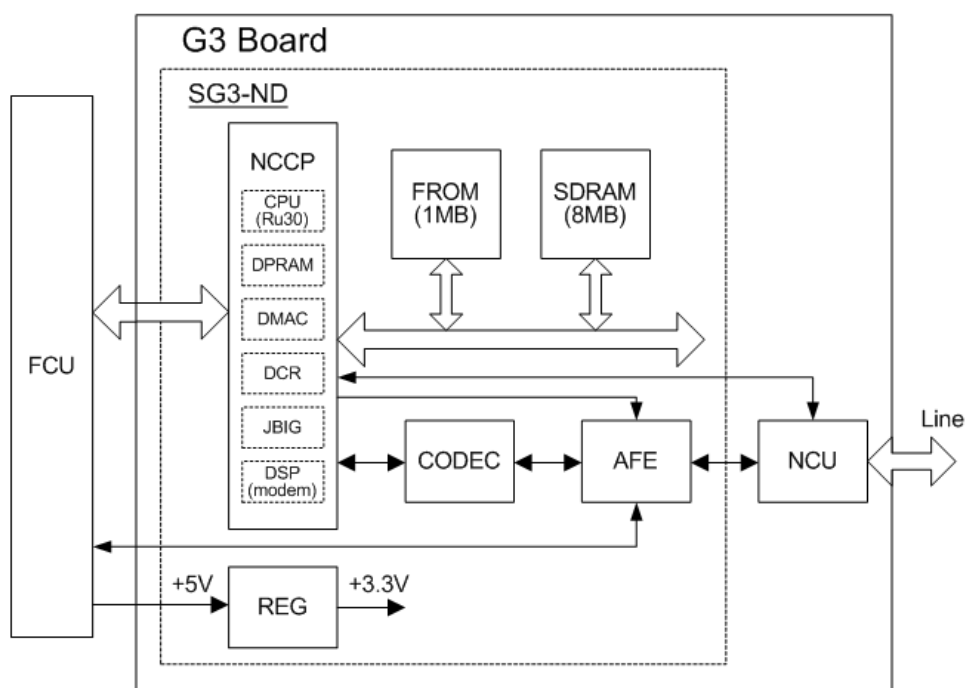
5.2.2 SG3 BOARD

b766d903a

The SG3 board allows up to three simultaneous communications when used in combination with the FCU and optional G3 boards. The NCU is on the same board as the common SG-3 board. This makes the total board structure smaller. But, the specifications of the SG3 board do not change.

NCCP (New Communication Control Processor)

- Controls the SG3 board.
- CPU (RU30)
- DPRAM (Dual Port RAM): Handshaking with the FCU is done through this block.
- DMA controller
- JBIG
- DSP V34 modem (RL5T892): Includes the DTMF Receiver function
- DCR for MH, MR, MMR, and JBIG compression and decompression

FROM

- 1Mbyte flash ROM for SG3 software storage and modem software storage

SDRAM

- 4Mbyte DRAM shared between ECM buffer, line buffer, and working memory

AFE (Analog Front End)

- Analog processing

CODEC (COder-DECoder)

- A/D & D/A conversions for modem

REG

- Generates +3.3 V from the +5V from the FCU

5.3 VIDEO DATA PATH

5.3.1 TRANSMISSION

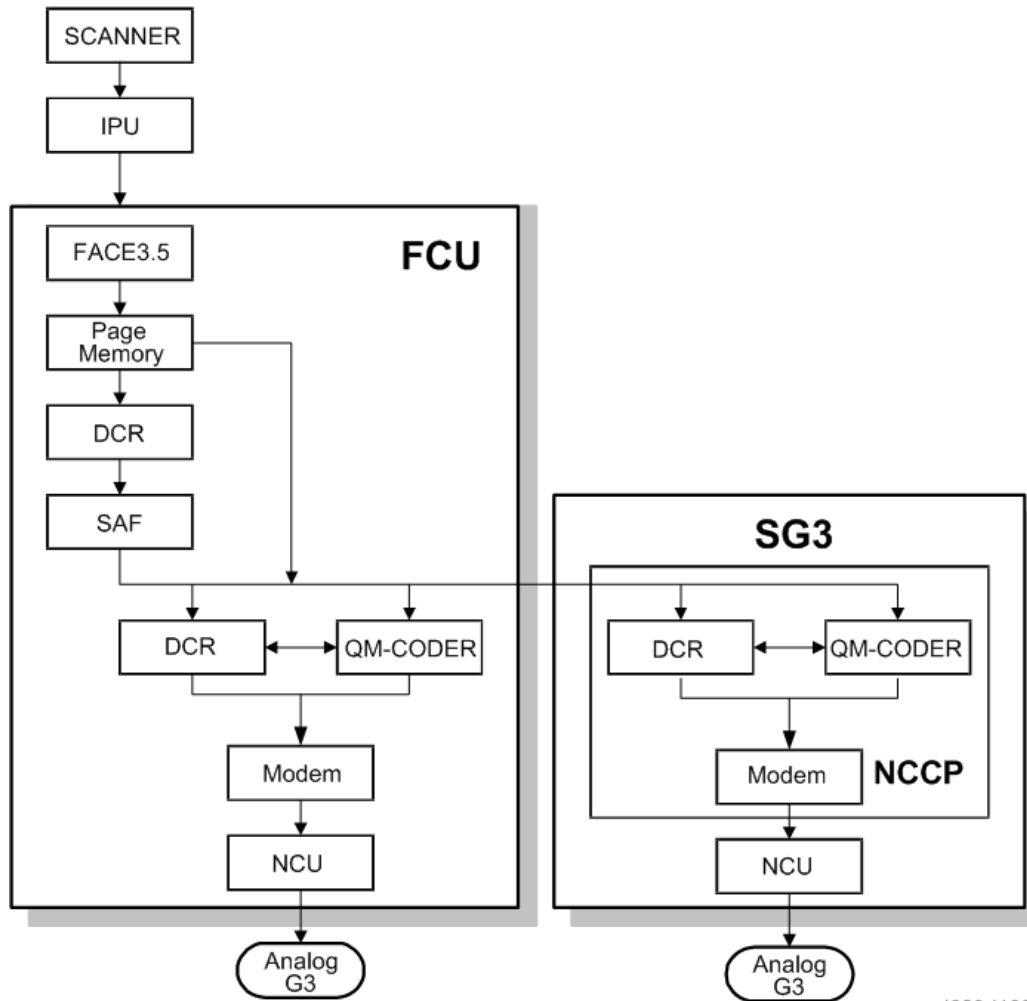

Memory Transmission and Parallel Memory Transmission

The base copier's scanner scans the original at the selected resolution in inch format. The IPU processes the data and transfers it to the FCU.

Note

- When scanning a fax original, the IPU uses the MTF, independent dot erase and thresholding parameter settings programmed in the fax unit's scanner bit switches, not the copier's SP modes.

Then, the FCU converts the data to mm format, and compresses the data in MMR or raw format to store it in the SAF memory. If image rotation will be done, the image is rotated in page memory before compression.

At the time of transmission, the FCU decompresses the stored data, then re-compresses and/or reduces the data if necessary for transmission. The NCU transmits the data to the line.

Immediate Transmission

The base copier's scanner scans the original at the resolution agreed with the receiving terminal. The IPU video processes the data and transfers it to the FCU.

Note

- When scanning a fax original, the IPU uses the MTF, independent dot erase and thresholding parameter settings programmed in the fax unit's scanner bit switches, not the copier's SP modes.

Then the FCU stores the data in page memory, and compresses the data for transmission. The NCU transmits the data to the line.

JBIG Transmission

Memory transmission: If the receiver has JBIG compression, the data goes from the DCR to the QM-Coder. Then the NCU transmits the data to the line. When an optional G3 unit (SG3) is installed and PSTN2 is selected as the line type, JBIG compression is available, but only for the PSTN-2 line.

Immediate transmission: If the receiver has JBIG compression, the data goes from the page memory to the QM-Coder. Then the NCU transmits the data to the line. When an optional G3 unit (SG3) is installed and PSTN2 is selected as the line type, JBIG compression is available, but only for the PSTN-2 line.

Adjustments

- Priority for the line used for G3 transmissions (PSTN 1/PSTN 2 or 3): System switch 16 bit 1

5.3.2 RECEPTION

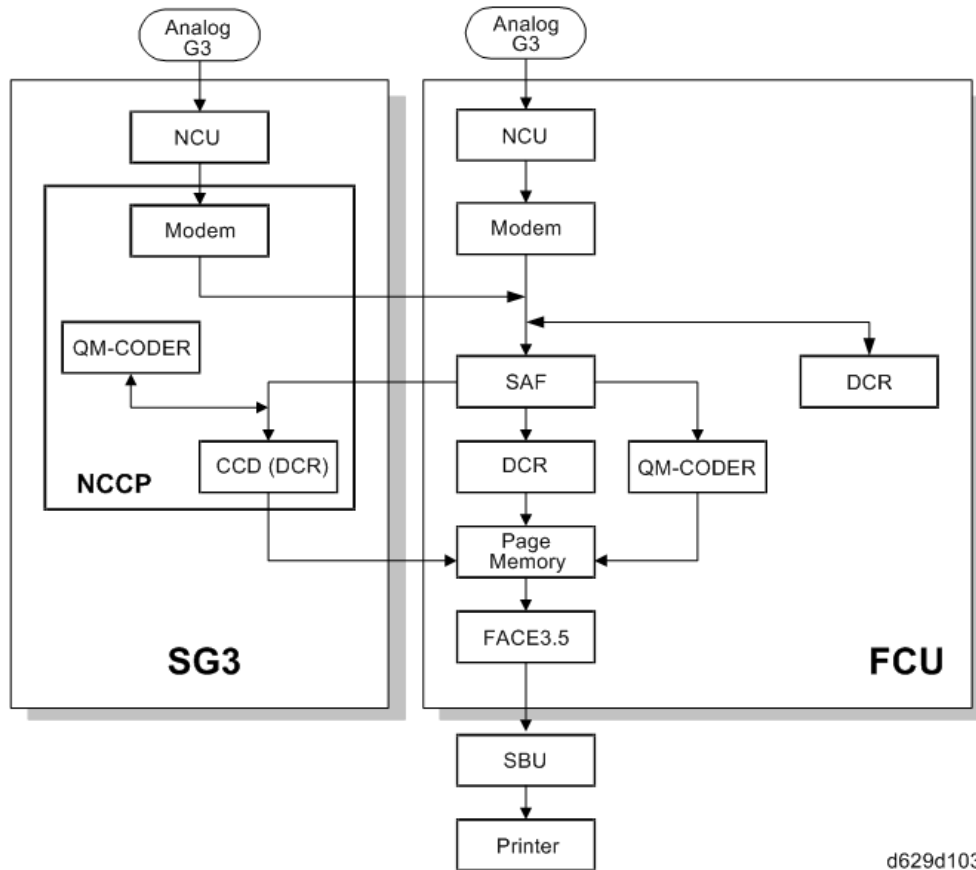

Fax Option
Type C5502
(D643)

First, the FCU stores the incoming data from either an analog line to the SAF memory. (The data goes to the FACE3 at the same time, and is checked for error lines/frames.)

The FCU then decompresses the data and transfers it to page memory. If image rotation will be done, the image is rotated in the page memory. The data is transferred to the IPU.

If the optional G3 unit is installed, the line that the message comes in on depends on the telephone number dialled by the other party (the optional G3 unit has a different telephone number from the main fax board).

JBIG Reception

When data compressed with JBIG comes in on PSTN-1 (the standard analog line), the data is sent to the QM-CODER for decompression. Then the data is stored in the page memory, and transferred to the IPU.

When data compressed with JBIG comes in on PSTN-2 (optional extra analog line), the data is sent to the QM-CODER on the SG3 board for decompression.

5.4 FAX COMMUNICATION FEATURES

5.4.1 MULTI-PORT

When the optional extra G3 Interface Unit is installed, communication can take place at the same time through the two or three lines at once.

Option	Available Line Type	Available protocol Combinations
Standard only	PSTN	G3
Extra G3 Interface Unit (single)	PSTN + PSTN	G3 + G3
Extra G3 Interface Unit (double)	PSTN + PSTN +PSTN	G3 + G3 +G3

5.4.2 DOCUMENT SERVER

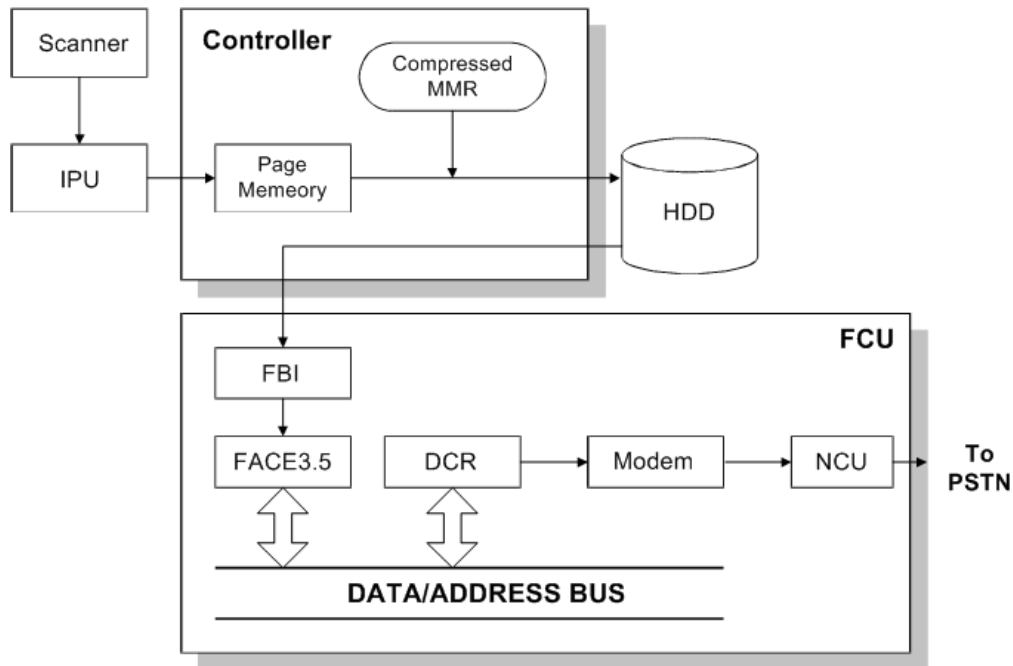

d629d104

The base copier's scanner scans the original at the selected resolution. The IPU video processes the data and transfers it to the controller board.

Then the controller stores the data in the page memory for the copier function, and compresses the data in MMR (by software) to store it in the HDD. If image rotation will be done, the image is rotated in the page memory before compression.

For transmission, the stored image data is transferred to the FCU. The FCU decompresses the image data, then recompresses and/or reduces the data if necessary for transmission. The NCU transmits the data to the line.

The documents can be stored in the HDD (Document Server) from the fax application. The stored documents in the document sever can be used for the fax transmission in many times. More than one document and the scanned document can be combined into one file and then the file can be transmitted.

- When using the document server, the SAF memory is not used.
- The document is compressed with MMR and stored.
- Up to 9,000 pages can be stored (1 file: Up to 1,000 pages) from the fax application.
- Only stored documents from the fax application can be transmitted.
- Scanned documents are given a name automatically, such as "FAX001". But it is possible to change the file name, user name and password.
- Up to 30 files can be selected at once.

Note

- The compression method of the fax application is different from the copy application. The storing time is longer than the copier storing.
- When selecting "Print 1st page", the stored document will be reduced to A4 size.

5.4.3 INTERNET MAIL COMMUNICATION

Mail Transmission

T.37 simple and full modes

This machine supports T.37 full mode. (ITU-T Recommendation, RFC2532). The difference between T.37 simple mode and full mode is as follows.

Function	T.37 Simple Mode	T.37 Full Mode
Resolution	200 x 100 200 x 200	200 x100 200 x 200 200 x 400 400 x 400 (if available)
RX Paper Width	A4	A4, B4, A3
RX Data Compression Method	MH	MH (default), MR, MMR,
Signals	Image data transmission only	Image data transmission, exchange of capability information between the two terminals, and acknowledgement of receipt of fax messages

Data Formats

The scanned data is converted into a TIFF-F formatted file.

The fields of the e-mail and their contents are as follows:

Field	Content
From	Mail address of the sender
Reply To	Destination requested for reply
To	Mail address of the destination
Bcc	Backup mail address
Subject	From CSI or RTI (Fax Message No. xxxx)
Content Type	Multipart/mixed Attached files: image/tiff
Content Transfer Encoding	Base 64, 7-bit, 8-bit, Quoted Printable
Message Body	MIME-converted TIFF-F (MIME standards specify how files are attached to e-mail messages)

Direct SMTP Transmission

Internet Fax documents can be sent directly to their destinations without going through the SMTP server. (Internet Faxes normally transmit via the SMTP server.)

For example:

e-mail address:	gts@ricoh.co.jp
SMTP server address:	gts.abcd.com

In this case, this feature destination e-mail address (gts@ricoh.co.jp) is read as the SMTP server address "gts.abcd.com", and the transmissions bypass the SMTP server.

Selectable Options

These options are available for selection:

- With the default settings, the scan resolution can be either standard or detail. Inch-mm conversion before TX depends on IFAX SW01 Bit 7. Detail resolution will be used if Super Fine resolution is selected, unless Fine resolution is enabled with IFAX SW01.
- The requirements for originals (document size, scan width, and memory capacity) are the same as for G3 fax memory TX.
- The default compression is TIFF-F format.
- IFAX SW00: Acceptable paper widths for sending
- IFAX SW09: Maximum number of attempts to the same destination

Secure Internet Transmission

SMTP Authentication:

- User Tools> System Settings> File Transfer> SMTP Authentication

POP Before SMTP:

- User Tools> System Settings> File Transfer> POP Before SMTP

Mail Reception

Three Types

This machine supports three types of e-mail reception:

- POP3 (Post Office Protocol Ver. 3.)
- IMAP4 (Internet Messaging Access Protocol)
- SMTP (Simple Mail Transfer Protocol)



- For details: Core Technology Manual – Facsimile Processes – Faxing from a PC – Internet/LAN Fax Boards – Mail Reception

POP3/IMAP4 Mail Reception Procedure

The machine automatically picks up e-mail from the server at an interval which is adjustable in the range 2 to 1440 min. in 1-minute steps:

- User Tools> System Settings> File Transfer> E-mail Reception Interval

SMTP Reception

1. The IFAX must be registered as an SMTP server in the MX record of the DNS server, and the address of the received mail must specify the IFAX.
2. To enable SMTP reception: User Tools> System Settings> File Transfer> Reception Protocol
 - Even if the MX record on the DNS server includes the IFAX, mail cannot be received with SMTP until SMTP reception is enabled:
 - However, if SMTP reception is selected and the machine is not registered in the MX record of the DNS server, then either IMAP4 or POP3 is used, depending on the setting: User Tools> System Settings> File Transfer> Reception Protocol

Mail Delivery Conditions: Transferring Mail Received With SMTP

1. The machine must be set up for SMTP mail delivery:
 - User Tools> Facsimile Features> Reception Settings> SMTP RX File Delivery Settings
2. If the user wishes to limit this feature so that the machine will only deliver mail from designated senders, the machine's "Auth. E-mail RX" feature must be set (User Tools> Facsimile Features> Reception Settings> SMTP RX File Delivery Settings).
3. If the "SMTP RX File Delivery Setting" is set to "Off" to prohibit SMTP receiving, and if there is mail designated for delivery, then the machine responds with an error. (User Tools> Facsimile Features> Reception Settings> SMTP RX File Delivery Settings)
4. If the quick dial, speed dial, or group dial entry is incorrect, the mail transmission is lost, and the IFAX issues an error to the SMTP server and outputs an error report.

Auth. E-mail RX

In order to limit access to mail delivery with IFAX, the addresses of senders must be limited using the Access Limit Entry. Only one entry can be registered.

1. Access Limit Entry

For example, to limit access to @IFAX.ricoh.co.jp:

gts@IFAX.ricoh.co.jp	Matches and is delivered.
gts@IFAX.abcde.co.jp	Does not match and is not delivered.
IFAX@ricoh.co.jp	Does not match and is not delivered.

1. Conditions
 - The length of the Access Limit Entry is limited to 127 characters.
 - If the Access Limit Entry address and the mail address of the incoming mail do not match, the incoming mail is discarded and not delivered, and the SMTP server responds with an error. However, in this case an error report is not output.
 - If the Access Limit Entry address is not registered, and if the incoming mail specifies a delivery destination, then the mail is delivered unconditionally.

Handling Mail Reception Errors

Abnormal files

When an error of this type occurs, the machine stops receiving and commands the server to erase the message. Then the machine prints an error report and sends information about the error by e-mail to the sender address (specified in the "From" or "Reply-to" field of the message). If there is an incomplete received message in the machine memory, it will be erased.

The machine prints an error message when it fails to send the receive error notification after a certain number of attempts.

The following types of files are judged to be abnormal if one or more of the following are detected:

1. Unsupported MIME headers.

Supported types of MIME header

Header	Supported Types
Content-Type	Multipart/mixed, text/plain, message/rfc822 Image/tiff
Charset	US-ASCII, ISO 8859 X. Other types cannot be handled, and some garbage may appear in the data.
Content-Transfer-Encoding	Base 64, 7-bit, 8-bit, Quoted Printable

2. MIME decoding errors
3. File format not recognized as TIFF-F format
4. Resolution, document size, or compression type cannot be accepted

Remaining SAF capacity error

The machine calls the server but does not receive e-mail if the remaining SAF capacity is less than a certain value (the value depends on IFAX Switch 08. The e-mail will be received when the SAF capacity increases (for example, after substitute reception files have been printed). The error handling method for this type of error is the same as for "Abnormal files".

If the capacity of the SAF memory drops to zero during reception, the machine operates in the same way as when receiving an abnormal file (refer to "Abnormal files" above).

Secure Internet Reception

To enable password encryption and higher level security: User Tools> System Settings> File Transfer> POP3/IMAP4 Settings> Encryption (set to "On")

Transfer Request: Request By Mail

For details: Core Technology Manual – Facsimile Processes – Faxing from a PC – Internet/LAN Fax Boards – Transfer Request

The fields of the e-mail and their contents are as follows:

Field	Content
From	E-mail address of the requesting terminal
To	Destination address (Transfer Station address)
Bcc	Backup mail address
Subject	From TSI (Fax Message No. xxxx)
Content-Type	Multipart/mixed Text/Plain (for a text part), image/tiff (for attached files)
Content-Transfer-Encoding	Base 64, 7-Bit, 8-bit, Quoted Printable
Mail body (text part)	RELAY-ID-: xxxx (xxxx: 4 digits for an ID code) RELAY: #01#*X#**01....
Message body	MIME-converted TIFF-F.

E-Mail Options (Sub TX Mode)

The following features are available as options for mail sending: entering a subject, designating the level of importance, confirming reception of the mail.

Subject and Level of Importance

You can enter a subject message with: TX Mode> Subject

The Subject entry for the mail being sent is limited to 128 characters. The subject can also be prefixed with an "Confidential", "Urgent", "Please phone" or "Copy to corres. Section" notation.

- How the Subject Differs According to Mail Type -

Fax Communication Features

Mail Type	Item 1	Item 2		Item 3
Subject Entry	---	Entry Condition		Fax Message No. + File No.
No Subject Entry		1. "CSI" ("RTI")		
		2. "RTI"	CSI not registered	
		3. "CSI"	RTI not registered	
		4. None	CSI, RTI not registered	
Confirmation of Reception	From	1. "CSI" ("RTI")		Normal: Return Receipt (dispatched). You can select "displayed" with IFAX SW02 Bits 2 and 3.
		2. "RTI"	CSI not registered	
		3. "CSI"	RTI not registered	Error: Return Receipt (processed/error)
		4. None	CSI, RTI not registered	
Mail delivery, memory transfer, SMTP receiving and delivery	From	RTI or CSI of the station designated for delivery	Mail delivery	Fax Message No. + File Number
		RTI or CSI of sender	Mail sending from G3 memory	
		Mail address of sender	Memory sending	
		Mail address of sender	SMTP receiving and delivery (Off Ramp Gateway)	
Mail error notification	---	Error Message No. xxxx From CSI (RTI)		

Items 1, 2, and 3 in the table above are in the Subject.

- Subjects Displayed on the PC -

Sender	Date	Size	Subject
Substation 2	04/25/2002	1,513	Parts List
Substation 2	04/26/2002	1,147	Specifications
Main Station	05/09/2002	33,551	[Urgent] Memo 2041
		21,624,288	

b766d907

E-mail Messages

After entering the subject, you can enter a message with: TX Mode> Text

An e-mail message (up to 5 lines) can be pre-registered with: User Tools> System Settings> File Transfer> Program/Change/Delete E-mail Message

- Limitations on Entries -

Item	Maximum
Number of Lines	5 lines
Line Length	80 characters
Name Length	20 characters

Message Disposition Notification (MDN)

For details: Core Technology Manual – Facsimile Processes – Faxing from a PC – Internet/LAN Fax Boards – E-mail Options

The network system administrator can confirm whether a sent mail has been received correctly or not. This confirmation is done in four steps.

1. Send request for confirmation of mail reception. To enable or disable this request (known as MDN): TX Mode> Reception Notice
2. Mail reception (receive confirmation request)
3. Send confirmation of mail reception
4. Receive confirmation of mail reception

The other party's machine will not respond to the request unless the two conditions below are met:

- The other party's machine must be set up to respond to the confirmation request.
- The other party's machine must support MDN (Message Disposition Notification).

- Setting up the Receiving Party -

The receiving party will respond to the confirmation request if:

1. The "Disposition Notification To" field is in the received mail header (automatically inserted in the 4th line in the upper table on the previous page, if MDN is enabled), and

2. Sending the disposition notification must be enabled (User Parameter Setting SW21 (15 [H]) Bit 1 for this model). The content of the response is as follows:

Normal reception:	"Return Receipt (dispatched)" in the Subject line
IFAX SW02 (Bit 2, 3)	"Return Receipt (displayed)" in the Subject line
Error:	"Return Receipt (processed/error)" in the Subject line

Handling Reports

- Sending a Request for a Return Receipt by Mail -

After the mail sender transmits a request for a return receipt, the mail sender's journal is annotated with two hyphens (--) in the Result column and a "Q" in the Mode column.

- Mail Receipt (Request for Receipt Confirmation) and Sending Mail Receipt Response -

After the mail receiver sends a response to the request for a return receipt, the mail receiver's journal is annotated with two hyphens (--) in the Result column and an "A" in the Mode column.

- Receiving the Return Receipt Mail -

- After the mail sender receives a return receipt, the information in the mail sender's journal about the receipt request is replaced, i.e. the journal is annotated with "OK" in the Result column.
- When the return receipt reports an error, the journal is annotated with an "E" in the Result column.
- The arrival of the return receipt is not recorded in the journal as a separate communication. Its arrival is only reported by the presence of "OK" or "E" in the Result column.
- If the mail address used by the sender specifies a mailing list (i.e., a Group destination; the machine sends the mail to more than one location. See "How to set up Mail Delivery"), the Result column of the Journal is updated every time a return receipt is received. For example, if the mailing list was to 5 destinations, the Result column indicates the result of the communication with the 5th destination only. The results of the communications to the first 4 destinations are not shown.

Exceptions:

If one of the communications had an error, the Result column will indicate E, even if subsequent communications were OK.

If two of the communications had an error, the Journal will indicate the destination for the first error only.

- Report Sample -

DATE	TIME	ADDRESS	MODE	TIME	PAGE	RESULT
MAY. 5	10:15	fuser_01@domlg. ricoh. co.	Mail SM	0'09"	2	--
	10:16	fuser_01@domlg. ricoh. co.	Mail SMQ	0'05"	1	--
	10:17	s_tadashi@domlg. ricoh. co.	Mail SMQ	0'09"	2	OK
	10:19	m_masataka@domlg. ricoh. co.	Mail SMA	0'05"	1	--

b771d506

Fax Option
Type C5502
(D643)

5.5 IP-FAX

5.5.1 WHAT IS IP-FAX?

For details: Core Technology Manual – Facsimile Processes – Faxing from a PC – Internet/LAN Fax Boards – IP-FAX

5.5.2 T.38 PACKET FORMAT

TCP is selected by default for this machine, but you can change this to UDP with IPFAX SW 00 Bit 1.

UDP Related Switches

IP-Fax Switch 01						
No.	Function					Comments
0-3	Select IP FAX Delay Level					Raise the level by selecting a higher setting if too many transmission errors are occurring on the network. If TCP/UDP is enabled on the network, raise this setting on the T.30 machine. Increasing the delay time allows the recovery of more lost packets. If only UDP is enabled, increase the number of redundant packets. Level 1~2: 3 Redundant packets Level 3: 4 Redundant packets
	Bit 3	Bit 2	Bit 1	Bit 0	Level	
	0	0	0	0	0	
	0	0	0	1	1	
	0	0	1	0	2	
	0	0	1	1	3	

5.5.3 SETTINGS

User parameter switch 34 (22[H]), bit 0

IP-Fax Gate Keeper usage, 0: No, 1: Yes

IP Fax Switches: Various IP-FAX settings (see the bit switch table)

6. SPECIFICATIONS

6.1 GENERAL SPECIFICATIONS

6.1.1 FCU

Type:	Desktop type transceiver
Circuit:	PSTN (max. 3ch.) PABX
Connection:	Direct couple
Original Size:	Book (Face down) Maximum Length: 432 mm [17 ins] Maximum Width: 297 mm [11.7 ins] ARDF (Face up) (Single-sided document) Length: 128 - 1200 mm [5.0 - 47.2 ins] Width: 105 - 297 mm [4.1 - 11.7 inch] (Double-sided document) Length: 128 - 432 mm [5.0 - 17 inch] Width: 105 - 297 mm [4.1 - 11.7 inch]
Scanning Method:	Flat bed, with CCD
Resolution:	G3 8 x 3.85 lines/mm (Standard) 8 x 7.7 lines/mm (Detail) 8 x 15.4 line/mm (Fine) See Note1 16 x15.4 line/mm (Super Fine) See Note 1 200 x 100 dpi (Standard) 200 x 200 dpi (Detail) 400 x 400 dpi (Super Fine) See Note 1 ↓ Note <ul style="list-style-type: none"> ▪ Optional Expansion Memory required
Transmission Time:	G3: 3 s at 28800 bps; Measured with G3 ECM using memory for an ITU-T #1 test document (Slerexe letter) at standard resolution

General Specifications

Data Compression:	MH, MR, MMR, JBIG
Protocol:	Group 3 with ECM
Modulation:	V.34, V.33, V.17 (TCM), V.29 (QAM), V.27ter (PHM), V.8, V.21 (FSK)
Data Rate:	G3: 33600/31200/28800/26400/24000/21600/ 19200/16800/14400/12000/9600/7200/4800/2400 bps Automatic fallback
I/O Rate:	With ECM: 0 ms/line Without ECM: 2.5, 5, 10, 20, or 40 ms/line
Memory Capacity:	SAF Standard: 4 MB With optional Expansion Memory: 28 MB (4 MB+ 24 MB) Page Memory Standard: 8 MB (Print: 4 MB + Scanner: 4 MB) With optional Expansion Memory: 16 MB (8 MB + 8 MB) (Print 8 MB + Scanner: 8 MB)

6.2 CAPABILITIES OF PROGRAMMABLE ITEMS

The following table shows the capabilities of each programmable items.

Item	Standard
Quick Dial	2000
Groups	100
Destination per Group	500
Destinations dialed from the ten-key pad overall	500
Programs	100
Auto Document	6
Communication records for Journal stored in the memory	200
Specific Senders	30

The following table shows how the capabilities of the document memory will change after the Expansion Memory are installed.

Capabilities of Programmable Items

	Without the Expansion Memory	With the Expansion Memory
Memory Transmission file	400	400
Maximum number of page for memory transmission	1000	1000
Memory capacity for memory transmission (Note1)	320	2240

↓ Note

- Measured using an ITU-T #1 test document (Slerexe letter) at the standard resolution, the auto image density mode and the Text mode.

6.3 IFAX SPECIFICATIONS

Connectivity:	Local area network Ethernet 100base-Tx/10base-T Gigabit Ethernet 1000 Base-T IEEE802.11a/g, g (wireless LAN),
Resolution:	200 × 100 dpi (Standard resolution), 200 × 200 dpi (Detail resolution), 200 × 400 dpi (Fine resolution)*1, 400 × 400 dpi (Super Fine resolution)*1 ↓ Note <ul style="list-style-type: none"> To use 200 × 400 dpi and 400 × 400 dpi, IFAX SW01 Bit 2 and/or Bit 4 must be set to “1”.
Transmission Time:	1 s (through a LAN to the server) Condition: ITU-T #1 test document (Selerexe Letter) MTF correction: OFF TTI: None Resolution: 200 x 100 dpi Communication speed: 10 Mbps Correspondent device: E-mail server Line conditions: No terminal access
Document Size:	Maximum Original Size: A3/DLT. ↓ Note <ul style="list-style-type: none"> To use B4 and A3 width, IFAX SW00 Bit 1 (B4) and/or Bit 2 (A3) must be set to “1”.
E-mail File Format:	Single/multi-part MIME conversion Image: TIFF-F (MH, MR, MMR)
Protocol:	Transmission: SMTP, TCP/IP Reception: POP3, SMTP, IMAP4, TCP/IP
Data Rate:	1000 Mbps (1000 Base-T) 100 Mbps (100base-Tx) 10 Mbps (10base-T)

IFAX Specifications

Authentication Method:	SMTP-AUTH POP before SMTP A-POP
Remark:	The machine must be set up as an e-mail client before installation. Any client PCs connected to the machine through a LAN must also be e-mail clients, or some features will not work (e.g. Autorouting).

6.4 IP-FAX SPECIFICATIONS

Network:	Local Area Network Ethernet/10base-T, 100base-TX Gigabit Ethernet/1000 Base-T IEEE802.11a/g, g (wireless LAN)
Scan line density:	8 x 3.85 lines/mm, 200x100dpi (standard character), 8 x 7.7lines/mm, 200x200dpi (detail character), 8 x 15.4lines/mm (fine character: optional expansion memory required), 16 x 15.4lines/mm, 400x400dpi (super fine character: optional expansion memory required)
Maximum Original size:	A3 or 11" x 17" (DLT) Custom: 297mm x 1200mm (11.7" x 47.3")
Maximum scanning size:	297mm x 1200mm (11.7" x 47.3")
Transmission protocol:	Recommended: T.38 Annex protocol, TCP, UDP/IP communication, SIP (RFC 3261 compliant), H.323 v2
Compatible machines:	IP-Fax compatible machines
IP-Fax transmission function:	Specify IP address and send faxes to an IP-Fax compatible fax through a network. Also capable of sending faxes from a G3 fax connected to a telephone line via a VoIP gateway.
IP-Fax reception function:	Receive faxes sent from an IP-Fax compatible fax through a network. Also capable of receiving faxes from a G3 fax connected to a telephone line via a VoIP gateway.

6.5 FAX UNIT CONFIGURATION

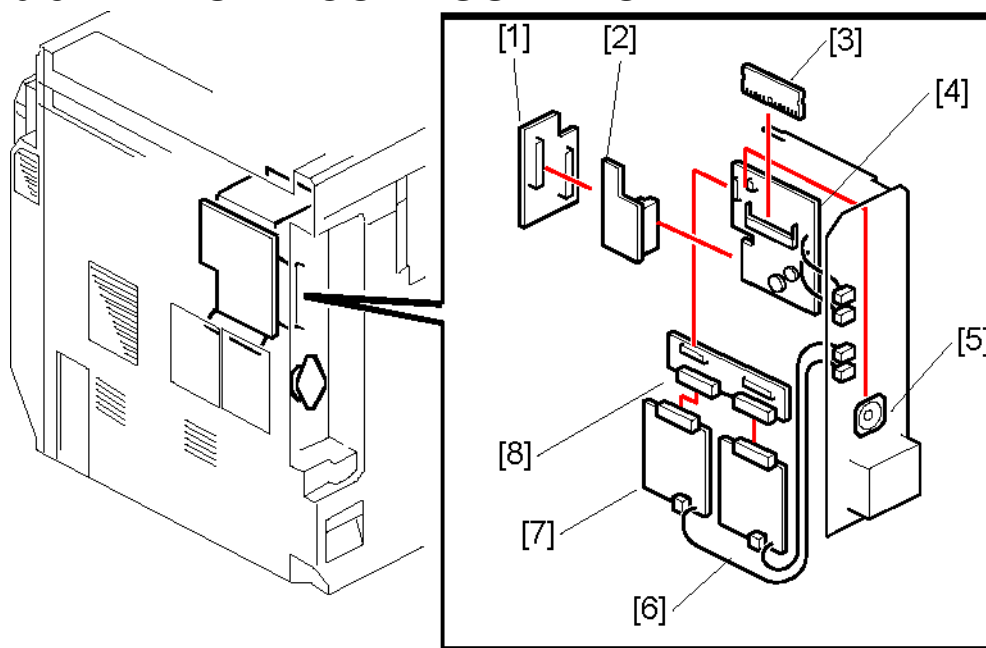

d393v101a

Component	Code	No.	Remarks
FCU	D643	4	Included with the fax unit
FCU I/F		2	
GWFCU I/F		1	
Speaker		5	
Expansion Memory	G578	3	Optional
CCU I/F Board	D643	8	Included with optional G3 unit
SG3 Board		6	Optional
SG3 Board (2nd)	D643	7	Optional
Handset Type C5502	D645	-	NA only.

D650/D651
COLOR CONTROLLER E-3300/5300

REVISION HISTORY		
Page	Date	Added/Updated/New
		None

Color Controller E-3300/5300 (D650/D651)

TABLE OF CONTENTS

1. INSTALLATION	1
1.1 INSTALLATION REQUIREMENTS.....	1
1.1.1 ENVIRONMENT	1
1.1.2 MACHINE LEVEL	1
1.1.3 MINIMUM SPACE REQUIREMENTS.....	2
1.1.4 POWER REQUIREMENTS	2
1.2 INSTALLATION FLOW CHART.....	3
1.3 MACHINE INSTALLATION.....	4
1.3.1 SETTING CUSTOMER EXPECTATIONS	4
1.3.2 UNPACKING THE E-3300/5300.....	5
1.3.3 FRONT AND BACK PANELS	6
1.3.4 CONNECTING E-3300/5300 TO THE COPIER	8
Preparation for Installing the Color Controller E-3300/5300.....	8
1.3.5 FIERY ICON ADDITION	11
Disabling the GW Scanner (Customization).....	13
1.3.6 STARTUP AND INITIAL SETUP	14
1.3.7 VERIFYING THE CONNECTION (LOCAL TEST PRINT)	16
1.3.8 VERIFYING CONNECTION TO THE NETWORK.....	17
1.4 INSTALLING OPTIONAL FEATURES.....	19
1.4.1 OVERVIEW	19
1.4.2 ACTIVATE / DEACTIVATE AN OPTIONAL FEATURE USING A DONGLE.....	20
2. GENERAL OPERATIONS FOR SERVICING.....	23
2.1 START-UP, SHUT-DOWN, AND REBOOT	23
2.1.1 STARTING THE COPIER AND THE E-3300/5300.....	23
2.1.2 SHUTTING DOWN THE COPIER AND THE E-3300/5300	23
2.1.3 SHUTTING DOWN THE E-3300/5300 ONLY.....	24
2.1.4 RESTARTING THE E-3300/5300	25
2.1.5 REBOOTING THE E-3300/5300.....	26
2.2 CANCELLING THE CURRENT PRINT JOB.....	27

2.3 PRINTING THE CONFIGURATION PAGE OR TEST SHEETS	28
2.4 RUNNING THE E-3300/5300 SETUP	29
2.4.1 TO ACCESS THE SETUP MENU.....	29
2.4.2 TO EXIT FROM THE SETUP MENU.....	30
2.5 BACKUP / RESTORE THE SYSTEM SETTINGS	31
2.5.1 TO ACCESS CONFIGURE WEBTOOLS USING A INTERNET WEB BROWSER	32
2.5.2 TO BACK UP E-3300/5300 SETTINGS.....	33
2.5.3 TO RESTORE THE E-3300/5300 SETTINGS	33
3. REPLACEMENT	34
3.1 GENERAL CAUTION.....	34
3.2 COVER REMOVAL.....	35
3.2.1 SIDE COVER FOR THE E-3300/5300.....	35
3.3 UNIT REMOVAL	36
3.3.1 VIDEO BOARD	36
3.3.2 DIAGNOSTIC LED BOARD.....	37
3.3.3 HARD DISK DRIVE (HDD)	37
3.3.4 POWER SUPPLY UNIT	38
3.3.5 FANS	39
3.3.6 MOTHERBOARD.....	40
3.3.7 MEMORY – 1GB DIMM	42
3.3.8 CPU AND COOLING ASSEMBLY	43
Overview	43
Cooling assembly removal procedure	43
CPU removal procedure.....	44
3.3.9 LITHIUM BATTERY	45
3.3.10 GIGABIT ETHERNET CONTROLLER.....	45
3.3.11 CABLES CONNECTED TO THE FRONT PANEL	46
3.3.12 SOFT POWER PUSH BUTTON	47
3.4 CLEARING PROCEDURE FOR CMOS	48
4. SOFTWARE MAINTENANCE	49
4.1 GENERAL NOTES AND CAUTIONS	49
4.2 CLEARING THE QUEUED PRINT JOBS IN THE E-3300/5300.....	51
4.3 RESTORING THE E-3300/5300 TO FACTORY DEFAULTS	53
4.4 SYSTEM SOFTWARE INSTALLATION PROCEDURE.....	55
4.4.1 OVERVIEW	55
4.4.2 INSTALLING SYSTEM SOFTWARE OVER THE NETWORK PORT.....	56

4.4.3	INSTALLING SYSTEM SOFTWARE USING A USB DRIVE	60
	Preparation.....	60
	Installation Procedure.....	60
4.5	PATCH INSTALLATION PROCEDURE	65
5.	TROUBLESHOOTING	66
5.1	OVERVIEW.....	66
5.2	LED DIAGNOSTIC CODES	67
5.2.1	OVERVIEW	67
1:	Rebooting the E-3300/5300	67
2:	Checking the components.....	67
3:	Turn on the E-3300/5300 Power	68
5.2.2	LED DIAGNOSTIC CODE TABLES.....	68
5.3	ERRORS AND SUGGESTED ACTIONS.....	73
5.3.1	START-UP PROBLEMS.....	73
5.3.2	SYSTEM PROBLEMS	77
5.3.3	SYSTEM SOFTWARE INSTALLATION	79
	Network Port Method.....	80
	USB Drive Method	81
5.3.4	NETWORK PROBLEMS.....	84
5.3.5	PRINTING PROBLEMS.....	86
5.4	TEST THE VOLTAGE SUPPLIES	92
6.	DETAILED SECTION DESCRIPTIONS	94
6.1	BLOCK DIAGRAM AND FUNCTIONS.....	94
6.2	PRINT DATA PROCESSING.....	96
6.2.1	FLOW CHART	96
7.	SPECIFICATIONS.....	97
7.1	GENERAL SPECIFICATIONS.....	97

No table of contents entries found.

READ THIS FIRST

Safety Information

When using this machine, the following safety precautions should always be followed.

Safety During Operation

In this manual, the following important symbols are used:

WARNING

Indicates a potentially hazardous situation which, if instructions are not followed, could result in death or serious injury.

CAUTION

Indicates a potentially hazardous situation which, if instructions are not followed, may result in minor or moderate injury or damage to property.

WARNING

- Connect the power cord directly into a wall outlet and never use an extension cord.
- Disconnect the power plug (by pulling the plug, not the cable) if the power cable or plug becomes frayed or otherwise damaged.
- To avoid hazardous electric shock, do not remove any covers or screws other than those specified in this manual.
- Turn off the power and disconnect the power plug (by pulling the plug, not the cable) if any of the following occurs:
 - 1) You spill something into the machine.
 - 2) You suspect that your machine needs service or repair.
 - 3) The external housing of your machine has been damaged.

CAUTION

- Protect the machine from dampness or wet weather, such as rain and snow.
- Unplug the power cord from the wall outlet before you move the machine. While moving the machine, you should take care that the power cord will not be damaged under the machine.
- When you disconnect the plug from the wall outlet, always pull the plug (not the cable).
- Risk of explosion if battery is replaced by an incorrect type.
- Dispose of used batteries according to the instructions.

ACHTUNG (Deutsch)

- Die batterie darf nur durch eine des gleichen Typs ersetzt werden, da anderenfalls Explosionsgefahr besteht.
- Sie die debrauchten Batterien entsprechend den gegebenen Anweisungen.

Power Cord Precautions

To reduce the risk of electric shock or damage to the equipment:

- User the appropriate power cord which was set up by your manufacturer's authorized service provider.
- Do not place objects on AC power cords or cables. Arrange them so that no one may accidentally step on or trip over them.
- Do not pull on a cord or cable. When unplugging from the electrical outlet, grasp the cord by the plug.
- Do not disable the power cord grounding plug. The grounding plug is an important safety feature.
- Plug the power cord into a grounded (earthed) electrical outlet that is easily accessible at all times.

Power Supply

The socket-outlet shall be installed near the product and shall be easily accessible.

Netzanschluss (Deutsch)

Die Wandsteckdose sollte in der Nähe Geräts installiert und leicht zugänglich sein.

WARNING

- Use of controls, adjustment or performance of procedures other than those specified in this manual may result in hazardous radiation exposure.

IMPORTANT SAFETY NOTICES

PREVENTION OF PHYSICAL INJURY

- 1). Before disassembling or assembling parts of the controller, make sure that the AC power cord is unplugged.
- 2). The wall outlet should be near the controller and easily accessible.
- 3). Note that some components of the controller are supplied with electrical voltage even if the main power switch is turned off.
- 4). If any operation check has to be made with exterior covers off while the main switch is turned on, keep hands away from electrified or mechanically driven components.





OBSERVANCE OF ELECTRICAL SAFETY STANDARDS

- 1). The controller must be installed and maintained by a customer service representative who has completed the training course on the controller.
- 2). The danger of explosion exists if the battery on the motherboard is incorrectly replaced. Replace the battery only with the equivalent type recommended by the manufacturer. Discard the used motherboard battery in accordance with the manufacturer's instructions and local regulations.

SAFETY AND ECOLOGICAL NOTES FOR DISPOSAL

- 1). Dispose of replaced parts in accordance with local regulations.
- 2). When keeping used lithium batteries in order to dispose of them later, do not put more than 100 batteries per sealed box. Storing larger numbers or not sealing them apart may lead to chemical reactions and heat build-up.

Symbols:

Symbol	What it means
	Refer to section number/document
	Screw
	Connector
	Clamp

Trademarks:

Windows ® is a registered trademark of Microsoft Corporation in the United States and /or other countries.

Fiery ® is a registered trademark of Electronics For Imaging, Incorporated.

PostScript ® is a registered trademark of Adobe Systems, Incorporated.

Ethernet ® is a registered trademark of Xerox Corporation.

Macintosh ® is a registered trademark of Apple Computer, Incorporated.

Pentium ® is a registered trademark of Intel Corporation.

Other product names used herein are for identification purposes only and may be trademarks of their respective companies. We disclaim any and all rights involved with those marks.

1. INSTALLATION

1.1 INSTALLATION REQUIREMENTS

1.1.1 ENVIRONMENT

1. Temperature Range:
5°C to 40°C (41°F to 104°F)
2. Humidity Range:
10% to 85% RH
3. Ambient Illumination:
Less than 1500 lux (do not expose to direct sunlight or strong light)
4. Ambient Dust:
Less than 0.10 mg/m³
5. If the place of installation is air-conditioned or heated, do not place the machine where it will be:
 - 1) Subjected to sudden temperature changes
 - 2) Directly exposed to cool air from an air-conditioner
 - 3) Directly exposed to heat from a heater
6. Do not place the machine where it will be exposed to corrosive gases.
7. Do not install the machine at any location over 3,048 m (10,000 feet) above sea level.
8. Place the controller on a strong and level base.
9. Do not place the machine where it may be subjected to strong vibrations.
10. Do not connect the machine to a power source shared with another electrical appliance.
11. The machine can generate an electromagnetic field, which could interfere with radio or television reception.

1.1.2 MACHINE LEVEL

1. Front to back: Within $\pm 5^\circ$ (0.2") away from level
2. Right to left: Within $\pm 5^\circ$ (0.2") away from level

1.1.3 MINIMUM SPACE REQUIREMENTS

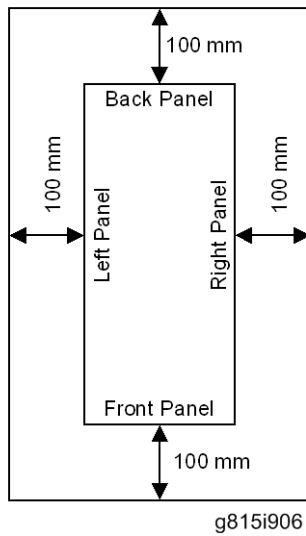

Place the machine near the power source, providing clearance as shown.

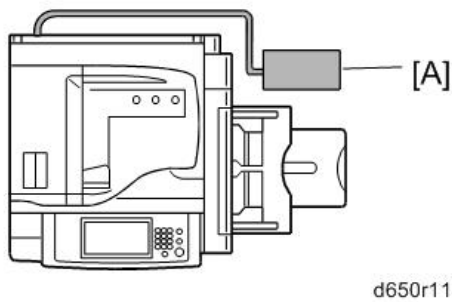

You may place the machine [A] on the right side of the large capacity tray or copier as shown (top view) in the illustration.

1.1.4 POWER REQUIREMENTS

⚠ CAUTION

- Insert firmly the plug in the outlet.
 - Avoid using an outlet extension plug or cord.
 - Ground the machine. Avoid using a 3-pronged adapter in a 2-hole ungrounded outlet.
 - Use the supplied AC power cord with this product.
1. Input voltage level: 100 - 240V, 50 - 60Hz; 3A
 2. Do not put anything on the AC power cord.

1.2 INSTALLATION FLOW CHART

Recommended installation steps are as follows:

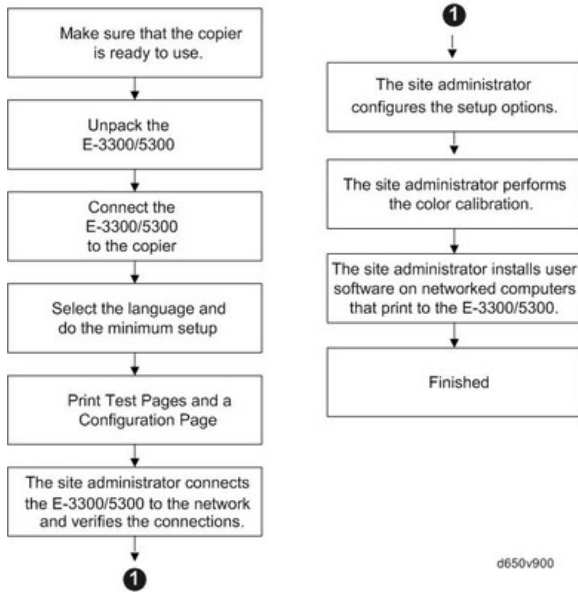

**Color
Controller
E-3300/E-5300
(D650/D651)**

1.3 MACHINE INSTALLATION

1.3.1 SETTING CUSTOMER EXPECTATIONS

Before installation, the customer should be informed of the following:

- Some nodes on the network may be unavailable for up to one hour.
- The copier may be unavailable for up to one hour
- The site administrator should be available during the installation for assistance with network connectivity issues.
- Equipment downtime and impact on the network can be minimized if the site administrator installs a network node for the E-3300/5300 and confirms network connection for the E-3300/5300 installation.
- The site administrator should have a networked computer available during the installation. The appropriate software should already be installed. Documentation for the networked computer and the network operating software should be available.
- The site administrator should install the user software shipped with the E-3300/5300 (user documentation is also included) onto the networked PCs and Mac OS computers that will print to the E-3300/5300.

 Note

- This guide covers hardware installation and service. It provides general information on connecting the E-3300/5300 to the customer's network. For network setup and configuration information, refer the site administrator to the "Configuration and Setup" manual.

1.3.2 UNPACKING THE E-3300/5300

1. Open the box and remove the packing material.
2. Remove the contents from the top container. Inspect the contents for visible damage. The top container should include the following items:

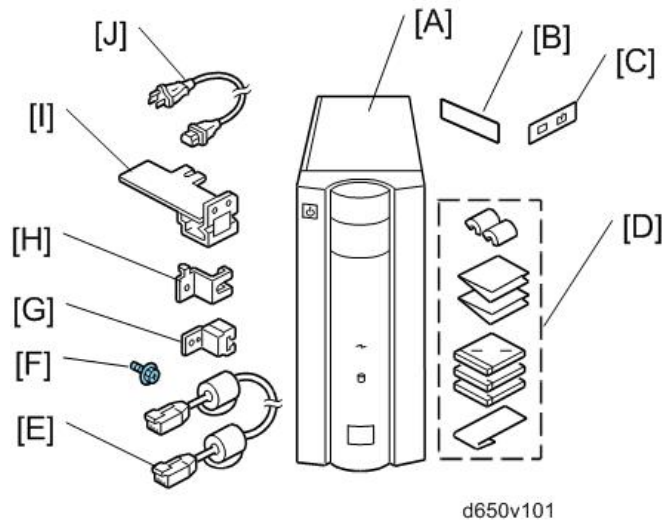

Color
Controller
E-3300/E-5300
(D650/D651)

[A]: E-3300/5300	[F]: Screw (M3 x 2)
[B]: Fiery Keytop Seal	[G]: Protection Plate (For E-3300/5300)
[C]: Fierydriven Logo	[H]: Protection Plate (For Copier)
[D]: Media Pack	[I]: Gigabit Ethernet PCB
[E]: Interface Cable	[J]: AC Power Cord

3. Give the Media Pack [D] to the site administrator.
4. Take the remaining components out of the top container.
5. Remove the top container and any packing materials.
6. Carefully lift the E-3300/5300 out of the box.

1.3.3 FRONT AND BACK PANELS

After unpacking the E-3300/5300, familiarize yourself with the front and back panels before you connect the E-3300/5300 to the Copier.

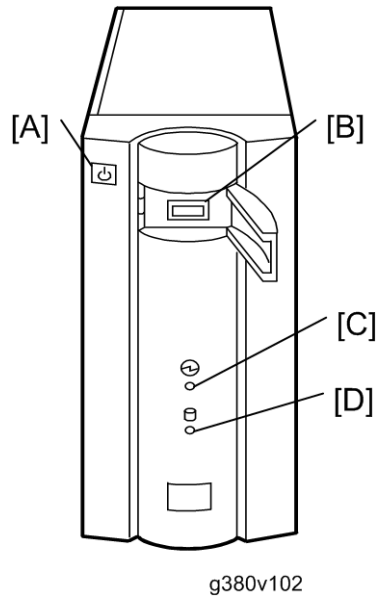

Front Panel

[A]: Soft Power Push Button
[B]: Front Panel USB Port
[C]: Power Indicator
[D]: HDD Access Indicator

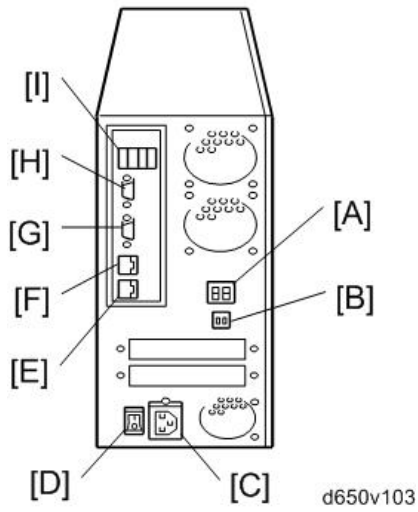

**Color
Controller
E-3300/E-5300
(D650/D651)**

Back Panel

[A]: Diagnostic LEDs (For service use only)
[B]: Service Switches (For service use only)
[C]: Power Connector
[D]: Main Power Switch
[E]: Gigabit Ethernet connector
[F]: LAN Connector (For customer use)
[G]: Not used (Monitor port)
[H]: Not used (Serial Port)
[I]: Back Panel USB Ports

1.3.4 CONNECTING E-3300/5300 TO THE COPIER

Preparation for Installing the Color Controller E-3300/5300

After you unpack the E-3300/5300, connect the E-3300/5300 to the copier before you connect it to the network. This is to confirm that there are no problems with the hardware and controller itself.

⚠ WARNING

- Turn the controller main power switch and copier main power switch to off and disconnect the power cords before you do these procedures.

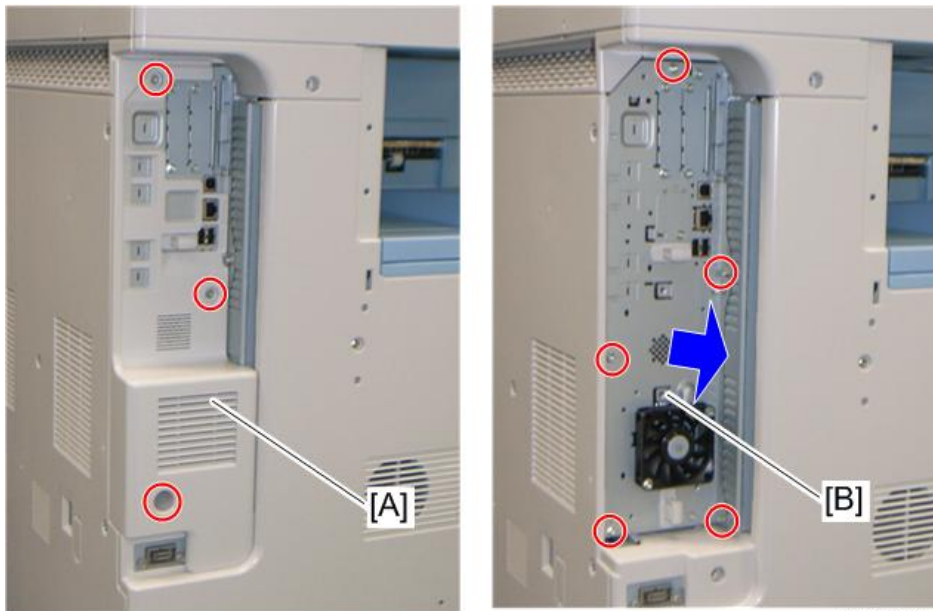

1. Remove the controller cover [A] (⚙ x 3).
2. Pull out the controller board [B] (⚙ x 5).

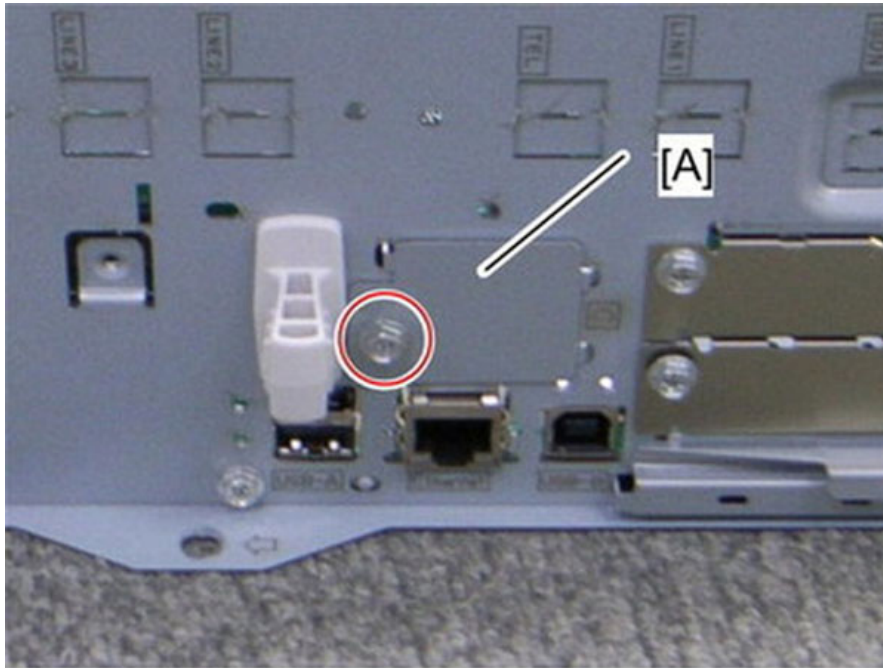

d027i409

3. Remove the slot cover [A] (🔩 x 1).

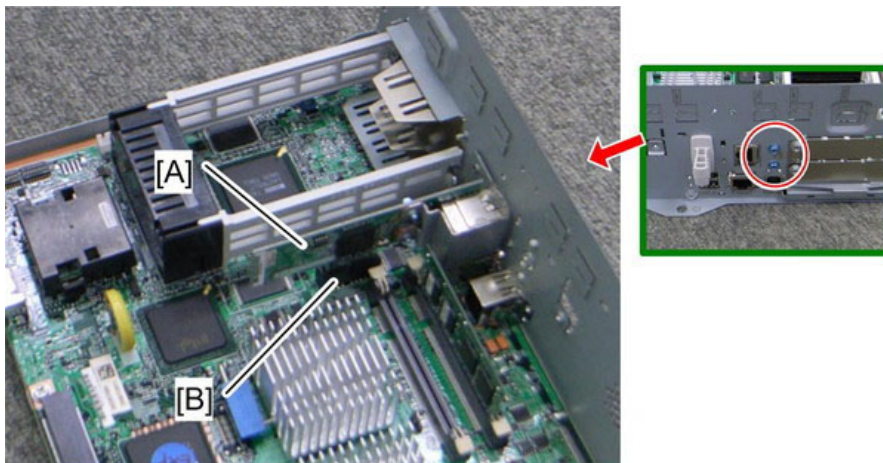

d027i410

4. Attach the Gigabit Ethernet controller [A] into the slot [B] (🔩 x 2).
5. Reassemble the controller board.
6. Reassemble the controller cover.

Color
Controller
E-3300/E-5300
(D650/D651)

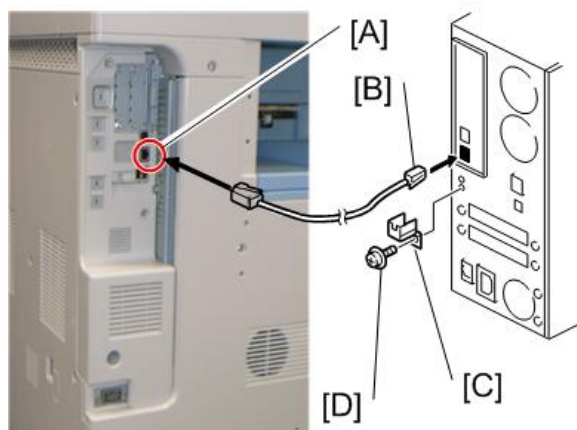

d650r116

7. Connect the power cord of the copier to a power outlet.
8. Turn the copier main power switch on, and enter SP mode.
9. Change the setting of SP5193-001 from "0" to "1".
10. Change the setting of SP5895-001 from "0" to "1".
11. Press the **On** switch (operation switch) on the copier operation panel and wait until the **On** indicator is off.
12. Connect the interface cable [B] to both of the Gigabit Ethernet connectors [A]. Attach this with the prong of the protector plates [C] and [D] (🔩 x 1 each).

↓ Note

- Make sure that the Gigabit Ethernet PCB is inserted straight and firmly.

13. Connect the appropriate AC power cord to the power connector at the back of the E-3300/5300.

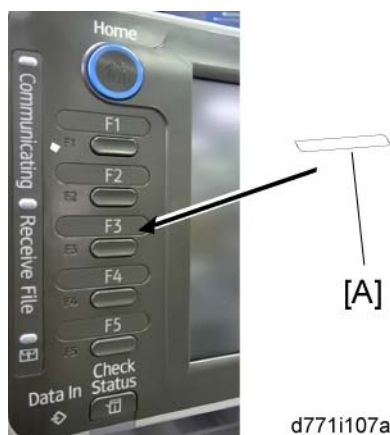

d771i107a

14. Attach the Fiery key top seal [A] to the operation panel.

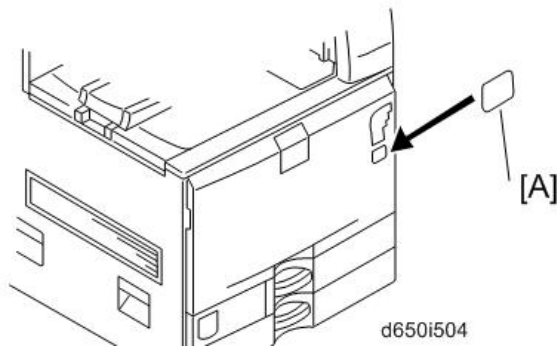

15. Attach the Fiery Decal [A] to the copier front cover.

1.3.5 FIERY ICON ADDITION

This procedure allows the Fiery icon to appear on the home screen of the operation panel.

1. Press [User Tools].

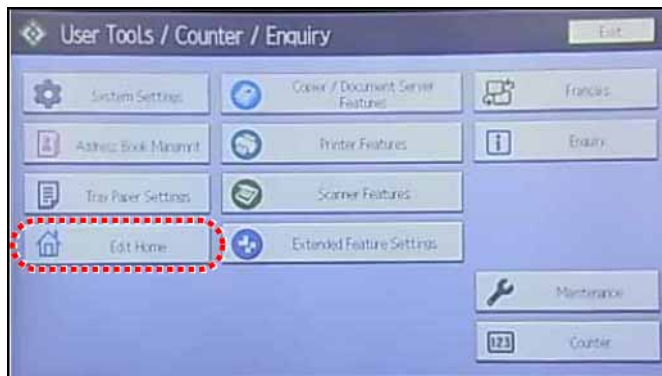

d1440144

2. Press [Edit Home].

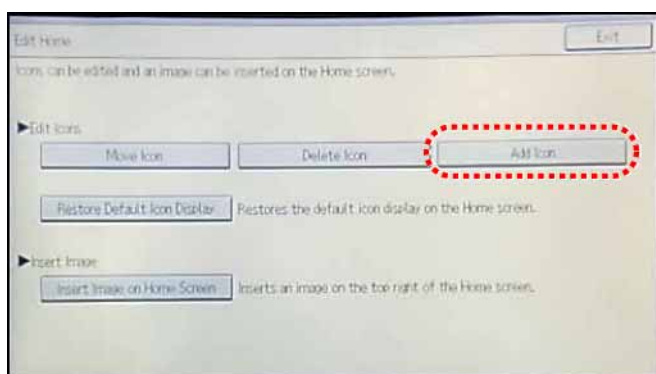

d1440145

3. Press [Add Icon].

Machine Installation

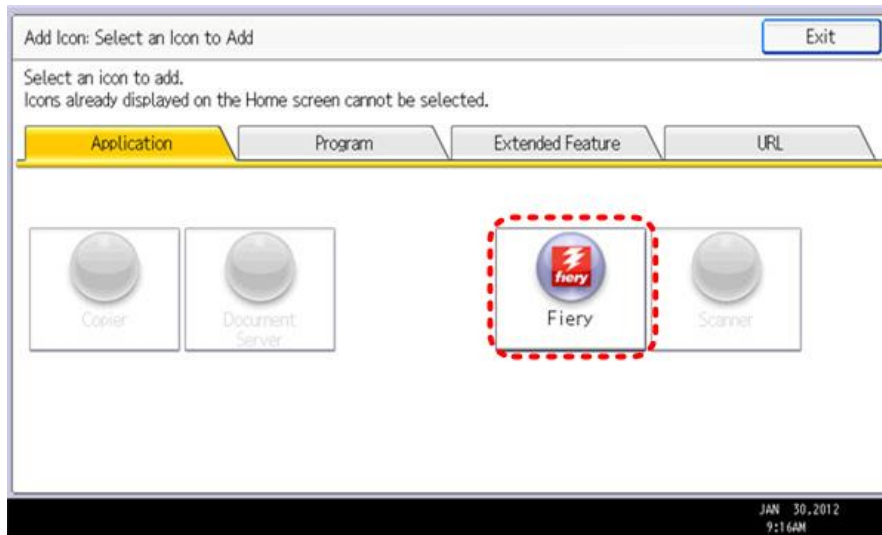

d6500146

4. Press [Fiery].

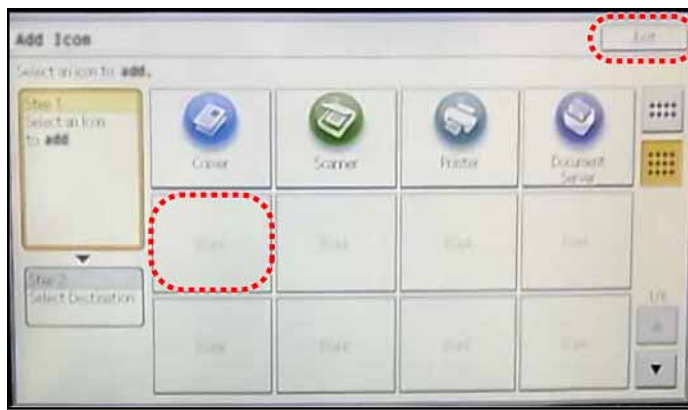

d1440147

5. Press a [Blank] to set a location for the Fiery icon.
6. Press [Exit] to end the Fiery icon addition.

Disabling the GW Scanner (Customization)

The GW Scanner feature can still be used when a Fiery controller is installed.

However, if the customer wants to disable the GW Scanner feature (customization request), it can be disabled by the following procedure.

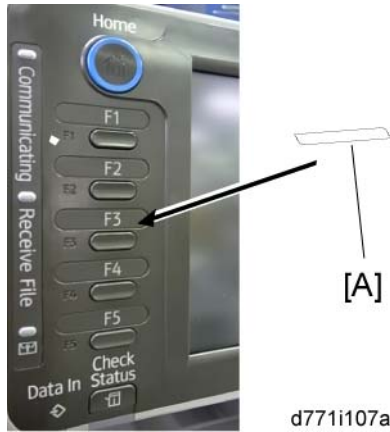

1. Change the setting of SP5895-002 from "0" to "1".
2. Remove the scanner key top seal [A] on the operation panel of the copier.
3. Press [User Tools].
4. Press [Edit Home].
5. Press [Delete icon].
6. Select the Scanner icon.
7. Press [OK].
8. Press the [User Tools/Counter] key.

Color
Controller
E-3300/E-5300
(D650/D651)

1.3.6 STARTUP AND INITIAL SETUP

1. Make sure that the power cord of the copier is connected to a power outlet and switch on the copier main power.

 Note

- The copier must be turned on before you turn the E-3300/5300 on.
 - Make sure that all firmware modules for the copier are updated to the newest versions. If they are not, update them before you turn on the E-3300/5300. (See Copier Service Manual)
2. Turn the main power switch on the E-3300/5300 back panel to ON.
 3. Press and release the soft power push button on the front panel of the E-3300/5300.
 4. Allow startup to proceed without interruption, while you watch the diagnostic LEDs on the back panel of the E-3300/5300.
 5. When the diagnostic LEDs remain at '00', go to the copier operation panel and press the **Fierydriven** key. 'Please wait' may be shown on the copier operation panel.
 6. Within about three minutes, the language selection screen is shown. (If this screen is not shown, then press the **Fierydriven** key again.)
 7. Select the desired language button, and touch "**Continue**".
 - English
 - Dutch
 - Spanish
 - Italian
 - German
 - French

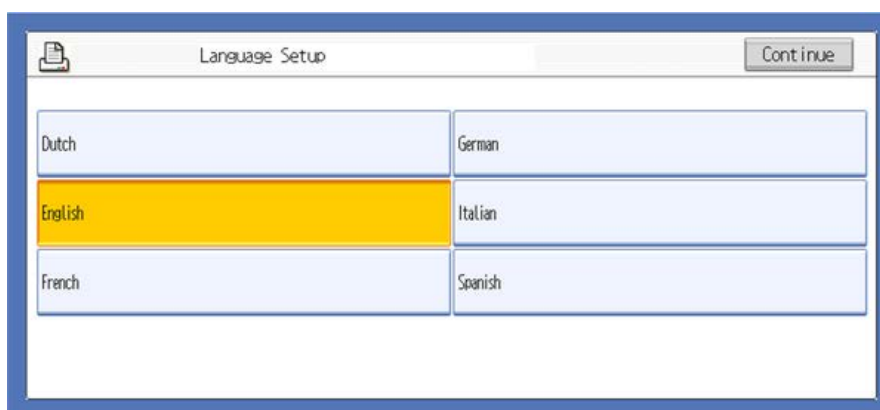

d502i500

↓ Note

- After you have selected a language, you cannot change the language unless you perform "**Factory Defaults**" (p.53 "Restoring the E-3300/5300 to Factory Defaults") or re-install the system software.
- The default settings for the E-3300/5300 depend on the language selection as follows:

		Selected Language & Measurement Unit	
		English - US	English - Metric / Dutch / Spanish / Italian / German/ French
PS Setting	Default Paper Sizes	US	Metric
PCL Setting	Paper Size	Letter	A4
	Paper Size System Pages	US	Metric

Color Controller E-3300/E-5300 (D650/D651)

If you selected "**English**" at the language selection screen, you are prompted to select the Measurement Units. Select either "**US**" or "**Metric**", and then touch "**Continue**".

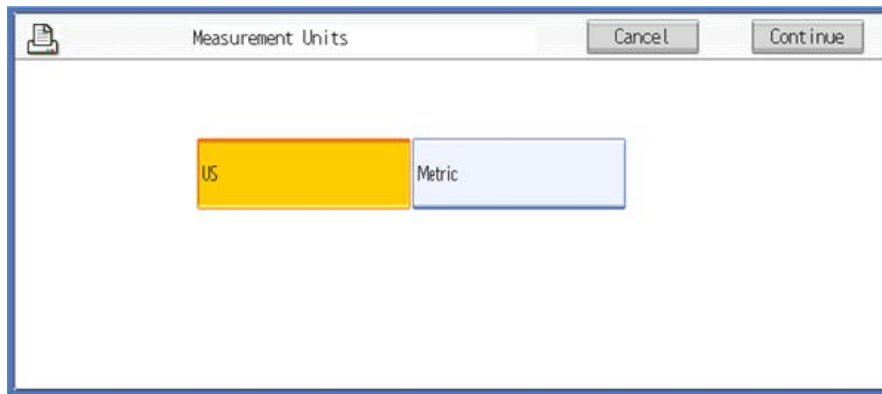

d502i501

8. The System will reboot. After a few minutes, to confirm that the reboot was successful, press the "**Fierydriven**" key.
9. Now the E-3300/5300 can be used with the default settings (minimum setup).

↓ Note

- The E-3300/5300 setup options should be configured later by the site administrator.

1.3.7 VERIFYING THE CONNECTION (LOCAL TEST PRINT)

After you connect the E-3300/5300 to the copier, print the Test Page and the Configuration Page to verify that the connection between the E-3300/5300 and the copier is good.

1. Make sure that the copier is not in use.
2. Check the settings in the following table, and make sure that Letter or A4 paper is loaded in at least one of the paper trays of the copier.

	PS Setting Default Paper Size		PCL Setting Paper Size for System Setting	
	"US"	"Metric"	"US"	"Metric"
Setup Option	"US"	"Metric"	"US"	"Metric"
Configuration Page requires...	Letter	A4	-	-
PS Test Page requires...	Letter	A4	-	-
PCL Test Page requires...	-	-	Letter	A4

3. On the operation panel of the copier, press the "**Fierydriven**" key to access the Fiery menu screen.
4. Move to the "**Fiery**" tab.



5. Touch "**Printable Info**".

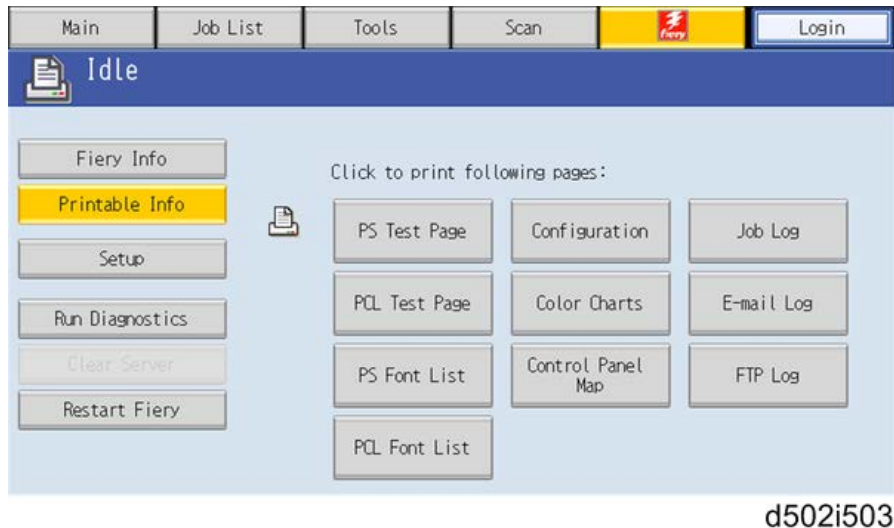

6. Print the following pages:
 - Configuration Page
 - PS Test Page
 - PCL Test Page
7. Examine the quality of the test pages.
 - All patches should be visible, but it is acceptable if they are very faint in the 5% and 2% ranges.
 - Each patch set should show uniform gradation from patch to patch as the shade lightens from 100% to 0%.
 - Poor image quality may indicate that the copier needs service. For more information, see the documentation provided with the copier.

1.3.8 VERIFYING CONNECTION TO THE NETWORK

The E-3300/5300 provides twisted pair connectivity to an Ethernet network.

Cable requirements:

- 10BaseT (Ethernet): Unshielded Twisted Pair (UTP), Category 3 or higher
- 100BaseTX (Fast Ethernet): UTP, Category 5 or higher (4-pair/8-wire, short length)
- 1000BaseT (Gigabit Ethernet): UTP, Category 5e or higher (4-pair/8-wire, short-length)

↓ Note

- If the print engine is 230V, use a shielded network cable.
1. Turn off the E-3300/5300 power before connecting the E-3300/5300 to any network device.
 2. Connect the network cable to the LAN connector on the E-3300/5300.
 3. Make sure that the copier power is switched on.
 4. Turn the power switch on the E-3300/5300 back panel to ON.
 5. Press and release the soft power push button on the front panel of the E-3300/5300.
 6. Allow startup to proceed without interruption, while you watch the diagnostic LED on the back

panel of the E-3300/5300. When the diagnostic LEDs show '00', go to the copier operation panel.

7. Press the **Fierydriven** key on the copier operation panel to access the fiery menu screen.
8. Move to the **Fiery** tab.
9. Touch "**Setup**".



10. You are asked to enter an administrator password. (The default is "**Fiery .1**")
11. Ask the site administrator to configure the Setup options.

Note

- It is the site administrator's responsibility to configure the correct setup options for the network and user environment. The default settings in the setup may be adequate, but they may not be optimal for the user's environment. Refer the site administrator to the "Configuration and Setup" manual for setup information.
- If more than one E-3300/5300 unit should be installed at the customer site with almost the same system settings, tell the site administrator that the "Backup and Restore" feature will be useful. (This feature is explained in the "Configuration and Setup" manual.)

12. After configuring the Setup options, verify the network connection.
13. Ask the site administrator to install the printer driver on a client PC, and to make a test print from that PC.

1.4 INSTALLING OPTIONAL FEATURES

1.4.1 OVERVIEW

The system software for the E-3300/5300 contains the following optional features:

- EFI Hot Folders
- EFI Auto Trap
- EFI Spot On
- Fiery Productivity Package
- Ricoh GA Basic Package

Initially, the above three optional functions cannot be used. When the customer purchases these options, a hardware USB dongle which includes a license for the optional feature will be provided. After the license for the feature is transferred to the E-3300/5300, the dongle will be locked to that particular E-3300/5300 (a unique value will be written to the dongle).

- To transfer the license from the dongle to the E-3300/5300, you turn off the E-3300/5300 power, connect the dongle, turn on the E-3300/5300 power, wait for the E-3300/5300 to get to the idle condition, then remove the dongle. The feature is now activated. There is a detailed procedure on the next page.

After this, the same dongle cannot be used on another E-3300/5300, unless the license is first removed from the original E-3300/5300 using that dongle. (You must use the same dongle.)

- To remove the license from the E-3300/5300, do exactly the same procedure that you use when you transfer the license from the dongle to the E-3300/5300. This deactivates the feature.

When the feature is removed from the original E-3300/5300, the unique value will be removed from the dongle. The dongle can now be used on another E-3300/5300.

If a dongle that has already a unique value (had its unit ID locked to an E-3300/5300) is inserted into another E-3300/5300 unit, the dongle will have no effect.

The number of times the license can be removed from the E-3300/5300 is limited as shown in the table below. (Activate 4 times and deactivate 3 times.) When this limit is reached, the dongle can no longer be used to remove the license, so the license will stay on the E-3300/5300. If a dongle is inserted to remove a feature but the limit has been reached, there will be no effect.

E-3300/5300 Power Turned On (or E-3300/5300 Rebooted) with Dongle Connected	Activates/Deactivates the feature on the E-3300/5300	License Transferred to
1st time	Activates	E-3300/5300
2nd time	Deactivates	Original Dongle
3rd time	Activates	E-3300/5300
4th time	Deactivates	Original Dongle
5th time	Activates	E-3300/5300
6th time and after	No effect	No effect

1.4.2 ACTIVATE / DEACTIVATE AN OPTIONAL FEATURE USING A DONGLE

The optional feature dongle can be used to either activate or deactivate a feature. The operation for both of these procedures is exactly the same, and the successful activation or deactivation can be confirmed by printing the configuration page.

The purpose of the ability to remove the license (deactivation) is to handle cases where the license was accidentally installed on the wrong E-3300/5300 unit.

Immediately after the E-3300/5300 main power is turned on or the E-3300/5300 is rebooted, the E-3300/5300 checks for the presence of the feature activation dongle.

1. Print the configuration page of the E-3300/5300. (☛ p.28 "Printing the Configuration Page or Test Sheets")
2. With the configuration sheet, check the condition of the optional feature that you will activate/deactivate. (If activated, the option name will appear on the configuration page.)
3. Shut down the E-3300/5300 and turn the power of the E-3300/5300 OFF. (☛ p.24 "Shutting Down the E-3300/5300 Only")
4. Insert the dongle in one of the USB ports.
5. Make sure that the copier main power is already ON.
6. Turn the power switch of the E-3300/5300 ON, then press and release the soft power push button on the front of the E-3300/5300.
7. Wait for the E-3300/5300 to come to the idle status. During this startup sequence, the optional feature will be activated/deactivated.

↓ Note

- If the E-3300/5300 already has a particular feature activated, and a new dongle for the same feature is inserted, the license will not be affected and the new dongle will remain active.
 - If the E-3300/5300 already has a particular feature activated and the matching dongle is inserted, the feature will be removed, and the dongle can then be re-used on another E-3300/5300 unit.
8. Remove the dongle from the USB port.

⚠ CAUTION

- Do not forget to remove the dongle at this time.
 - If you leave the dongle in the USB port and the E-3300/5300 main power is restarted or the E-3300/5300 is rebooted, then the condition of the optional feature will be reversed. (For example, if you wanted to activate the feature, it is now deactivated.) The only exception is that after you activate a feature for the 4th time, it cannot be deactivated.
9. Print a configuration page (☛ p.23 "Shutting Down the Copier and the E-3300/5300").
10. On the configuration page, check if the desired optional feature is activated/deactivated. (If activated, the option name will appear on the configuration page.)

If you have activated an optional feature, keep the configuration page. You may need it later for troubleshooting purposes, as shown in the following caution.

⚠ CAUTION

- After an optional feature has been activated, the optional feature license information is kept inside the U601 chip on the video board of the E-3300/5300.
- If the U601 chip becomes defective, the following are needed as evidence in order to get a new U601 chip and optional feature dongle:
 - The defective U601 chip
 - The configuration page that shows that the defective U601 chip had the optional feature license installed.
- Therefore, always print a configuration page and keep it when you activate a new optional feature on the E-3300/5300.

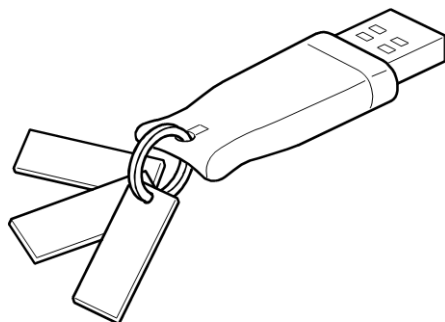

g815r023

Installing Optional Features

11. Three tags with six labels are attached to each optional feature dongle.

- a) Optional Feature Name: **Printed**
- b) Optional dongle serial number: **Printed**
- c) Installed Controller Model Name: **Blank**
- d) Installed Controller Serial Number: **Blank**
- e) 4 check boxes for Activation: **Not checked**
- f) 3 check boxes for Deactivation: **Not checked**

For the labels c) to f), you can fill in the related information or check the boxes, if you want to keep a record of the status of each dongle.

2. GENERAL OPERATIONS FOR SERVICING

2.1 START-UP, SHUT-DOWN, AND REBOOT

The copier and the E-3300/5300 have separate main power switches. During normal operation, you can leave the E-3300/5300 main power switch in the ON (I) position.

Color
Controller
E-3300/E-5300
(D650/D651)

2.1.1 STARTING THE COPIER AND THE E-3300/5300

1. Turn on the main power switch of the copier.
2. If the main power switch of the E-3300/5300 is OFF (O), turn on the main power switch of the E-3300/5300.
3. Press and release the soft power push button on the front of the E-3300/5300.
The controller enters into the boot-up sequence.
4. After the E-3300/5300 and the copier become idle, press the **Fierydriven** key. The Fiery menu screen will appear on the copier operation panel.

2.1.2 SHUTTING DOWN THE COPIER AND THE E-3300/5300

1. Press the **Fierydriven** key on the operation panel of the copier. The fiery menu screen appears.
2. Move to the **Fiery** tab.
3. Touch **Restart Fiery**.

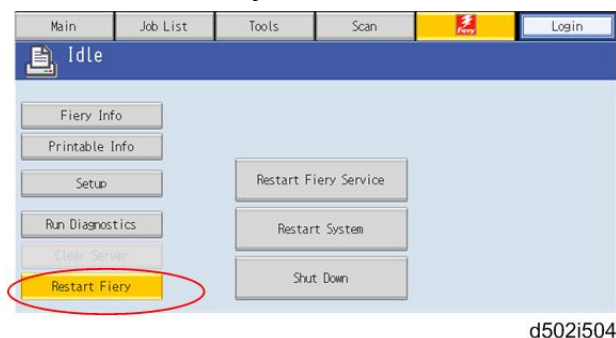

4. Touch **Shut Down**, then touch **OK**.
The E-3300/5300 enters into the shut down sequence.
The diagnostic LEDs on the back panel of the E-3300/5300 will turn off.

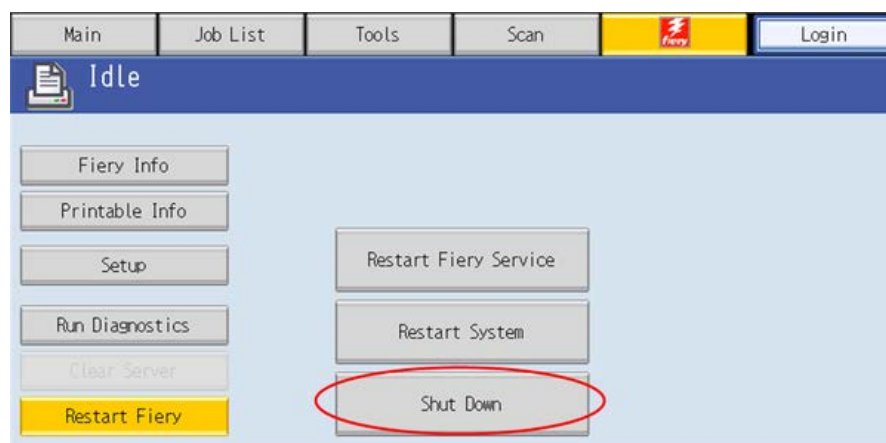

5. Press the **On** switch (operation switch) on the copier operation panel and wait until the **On** indicator is off.

Note

- Do not turn off the main power switch of the copier when the On indicator is on or blinking. Doing so could cause system problems such as hard disk drive or memory problems.
6. Turn the copier main power switch off.
 7. If the E-3300/5300 is being taken out of service, turn off the E-3300/5300 using its main power switch. (For example, if someone needs to move the E-3300/5300, disconnect cables, or open the chassis.)

2.1.3 SHUTTING DOWN THE E-3300/5300 ONLY

1. Press the **Fierydriven** key on the operation panel of the copier. The Fiery menu screen appears.
2. Move to the **Fiery** tab.
3. Touch "**Restart Fiery**".
4. Touch "**Shut Down**", then touch "**OK**".
The E-3300/5300 enters into the shut down sequence.
The diagnostic LEDs on the back panel of the E-3300/5300 will turn off.
5. If the E-3300/5300 is being taken out of service, turn off the E-3300/5300 using its main power switch. (For example, if someone needs to move the E-3300/5300, disconnect cables, or open the chassis.)

2.1.4 RESTARTING THE E-3300/5300

When restarting the E-3300/5300 to recover from a problem, try this procedure first. However, this procedure will only restart the E-3300/5300 application software that is now running on the system OS. To reboot the system OS (for example, after downloading a patch), see the next section “Rebooting the E-3300/5300 (p.26)”.

1. Make sure that the E-3300/5300 is not in use.
2. Press the **Fierydriven** key on the operation panel of the copier. The Fiery menu screen appears.
3. Move to the **Fiery** tab.
4. Touch “**Restart Fiery**”.

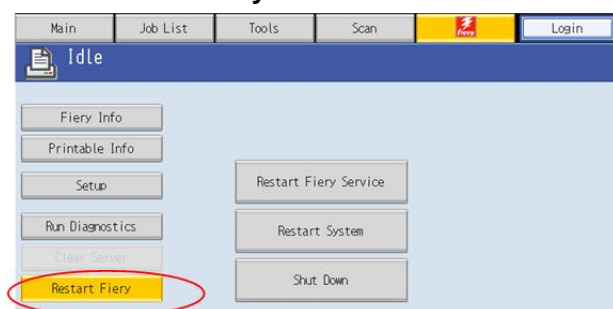

d502i504

5. Touch “**Restart Fiery Service**”

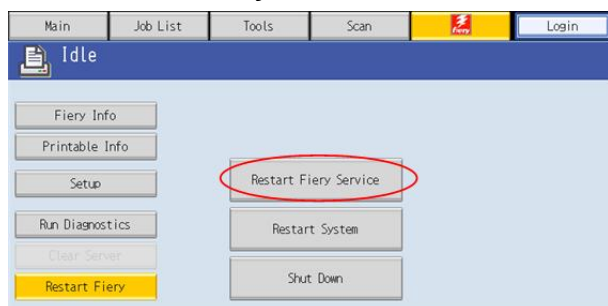

d502i504b

6. Wait until the E-3300/5300 becomes idle.

2.1.5 REBOOTING THE E-3300/5300

Use this procedure to reboot the system OS (for example, after downloading a patch).

1. Make sure that the E-3300/5300 is not in use.
2. Press the **Fierydriven** key on the operation panel of the copier. The Fiery menu screen appears.
3. Move to the **Fiery** tab.
4. Touch **“Restart Fiery”**.

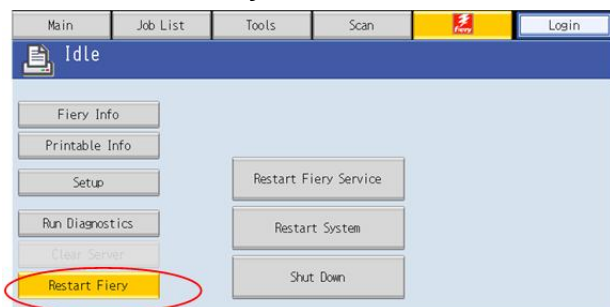

d502i504

5. Touch **“Restart System”**

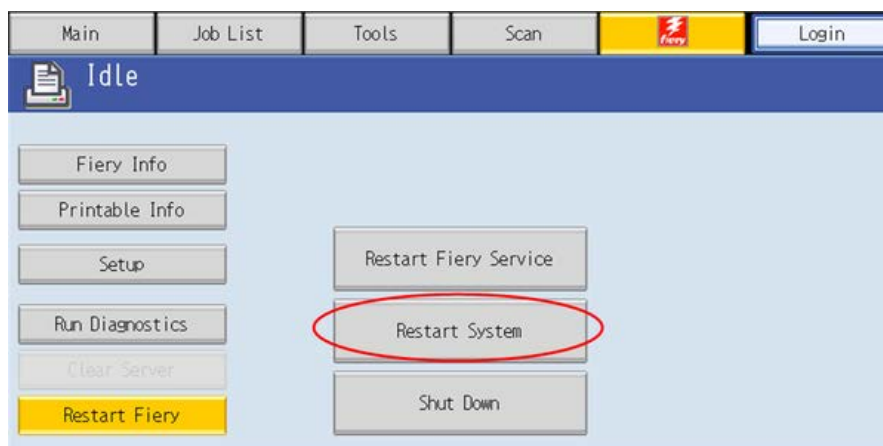

d502i504c

6. Wait until the E-3300/5300 becomes idle.

2.2 CANCELLING THE CURRENT PRINT JOB

When you want to cancel the current print job, do the following:

1. Press the **Fierydriven** key on the operation panel of the copier to access the Fiery menu screen.
2. Move to the **Job list** tab.

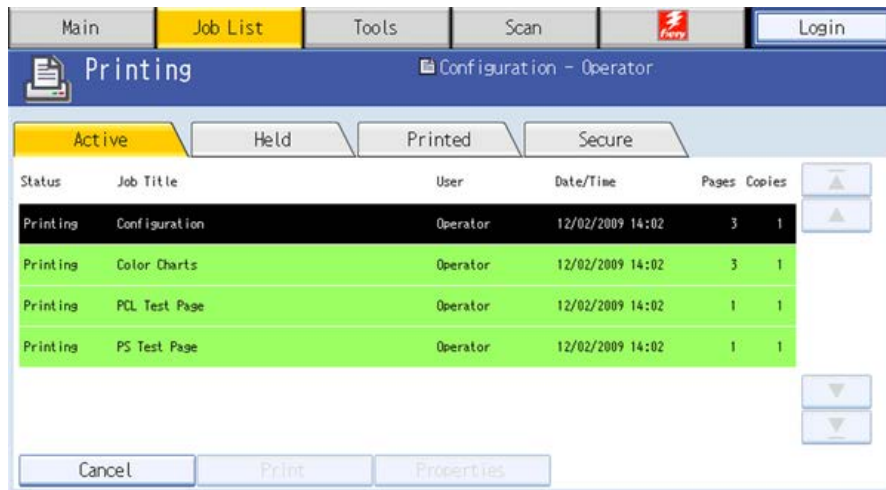

d502i505

3. From the Job List, touch the job that you want to cancel.
4. Touch **“Cancel”**.

2.3 PRINTING THE CONFIGURATION PAGE OR TEST SHEETS

1. Make sure that the E-3300/5300 is not in use.
2. Press the **Fierydriven** key on the operation panel of the copier to access the Fiery menu screen.
3. Move to the **Fiery** tab.
4. Touch "**Printable Info**", then touch the desired key.
 - Configuration Page
 - PS Test Page
 - PCL Test Page

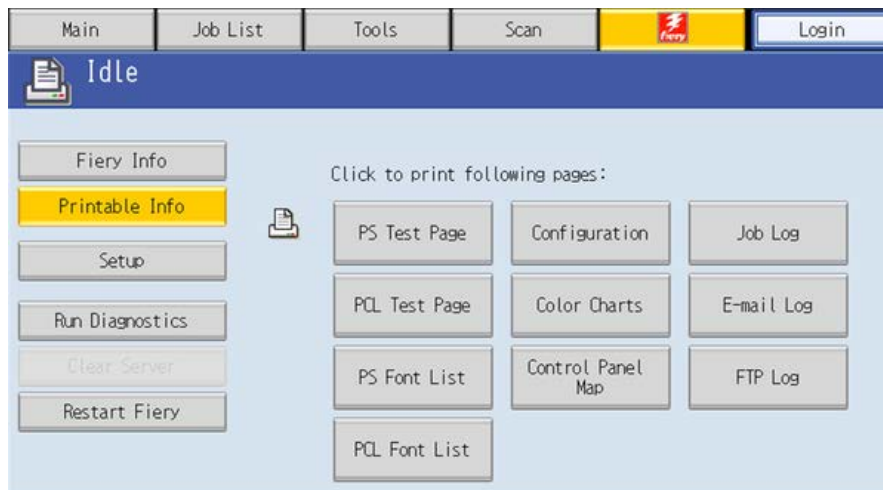

d502i503

2.4 RUNNING THE E-3300/5300 SETUP

The following procedures show how to access the Setup menu from the Fiery menu screen.

Note

- When the network settings (protocol, IP Address, etc.) are already configured and the “Enable Web Service” option is set to ON, you can also configure the E-3300/5300 setup from “Configure Webtools”. To do this, use a web browser on a personal computer which is connected to the network. For more detailed instructions, please refer to the “Configuration and Setup” manual.
- When you try to get access to the Setup menu, you are always asked to input an administrator password. (The default password is “**Fiery.1**”) Ask the site administrator to input the administrator password when you must get access to the Setup menu.

Color
Controller
E-3300/E-5300
(D650/D651)

2.4.1 TO ACCESS THE SETUP MENU

1. Make sure that the E-3300/5300 is not in use.
2. Press the **Fierydriven** key on the operation panel of the copier to access the Fiery menu screen.
3. Move to the **Fiery** tab.
4. Touch “**Setup**”.

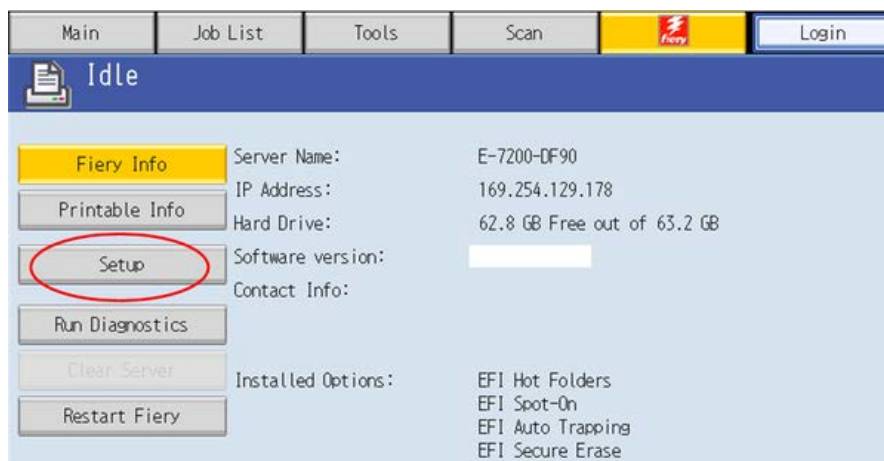

d502i502a

5. You may be asked to enter an administrator password. (Ask the site administrator to enter the password. The default password is “**Fiery.1**”)
6. The main setup screen appears.
For the details of each setup option value, refer to the “Configuration and Setup” manual.

2.4.2 TO EXIT FROM THE SETUP MENU

1. At the main setup screen, touch "**Exit Setup**".
The Fiery menu screen will disappear.
2. When you are prompted "System Requires to Reboot for Changes to Apply", touch "**Reboot now**".

2.5 BACKUP / RESTORE THE SYSTEM SETTINGS

The administrator at the customer site can back up the current E-3300/5300 configuration and restore it later.

This feature is also useful when...

1. The customer purchases more than one unit of E-3300/5300 and wants to configure all of them with almost the same system configuration.
2. The E-3300/5300 needs to be re-configured after system software installation.

The following items can be backed up to a configuration settings file:

- All system settings with the exclusion of Date / Time.
- Imposition templates saved in the default directory for these files on the E-3300/5300
- Address books
- Virtual Printer settings
- Users and Groups information (login names and passwords)
- Custom spot colors

 Note

- The configuration settings file is saved on the computer from which you access Configure Webtools. Make sure that you do not save the configuration settings file to the E-3300/5300 itself. Otherwise, when you reinstall system software, the configuration settings file residing on the E-3300/5300 is deleted.

2.5.1 TO ACCESS CONFIGURE WEBTOOLS USING A INTERNET WEB BROWSER

Note

- The network settings (protocol, IP Address, etc) should be already configured and the “Enable Web Service” option should be set to ON (default), in order to access the Configure Webtools.
1. Start your internet web browser and type the IP address of the E-3300/5300.
 2. Click the Configure tab on the E-3300/5300 home page.
 3. Click “**Launch Configure**”.
 4. Log on as an Administrator with the appropriate password.

(The default password is “**Fiery.1**”.)



Note

- The same menu can also be accessed from inside the Command WorkStation, Windows Edition (Server > SetUp > Server > Backup / Restore).

2.5.2 TO BACK UP E-3300/5300 SETTINGS

1. Choose Configure > Server > **Backup / Restore**.
2. Click **Backup Fiery Settings**.
3. In the dialog box that appears, accept the default file name or type a new name for the backup file.
4. Click **Save**.



- The saved configuration settings file can only be restored to the same model (E-3300/5300).

Color
Controller
E-3300/E-5300
(D650/D651)

2.5.3 TO RESTORE THE E-3300/5300 SETTINGS

1. Choose Configure > Server > **Backup / Restore**.
2. Click **Backup Fiery Settings**.
3. In the dialog box that appears, type the name of the configuration settings file or select it from the list.
4. Click **Open**.



- The server name and static IP address are restored therefore if the restore operation is used on more than one E-3300/5300 you must reconfigure them to be unique.

3. REPLACEMENT

3.1 GENERAL CAUTION

WARNING

- Turn off the power and unplug the E-3300/5300 before attempting any of the procedures in this section.

Before accessing internal components, position the E-3300/5300 so that it is resting on its right-hand side on a flat, anti-static surface.

3.2 COVER REMOVAL

3.2.1 SIDE COVER FOR THE E-3300/5300

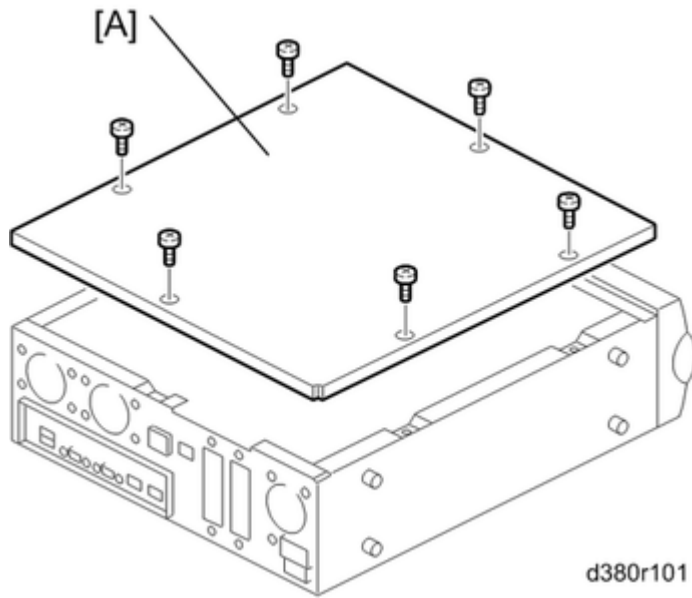

[A]: Side cover (🔩 x 6)

Color
Controller
E-3300/E-5300
(D650/D651)

3.3 UNIT REMOVAL

3.3.1 VIDEO BOARD

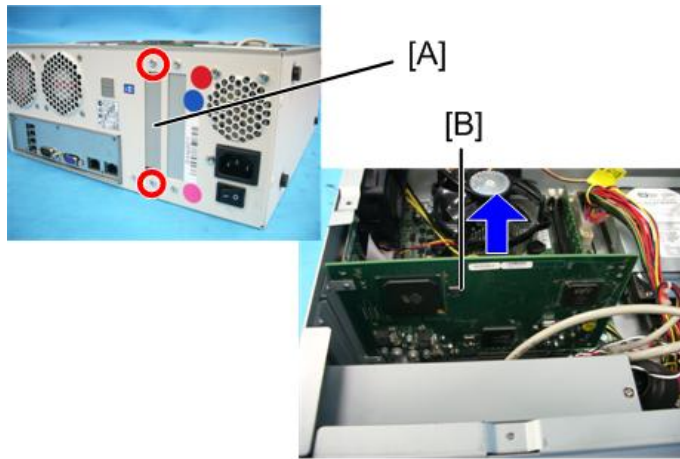

d650r102

1. Remove the Video board with bracket [A] (⚙️ x 2)
2. Pull the Video board [B].

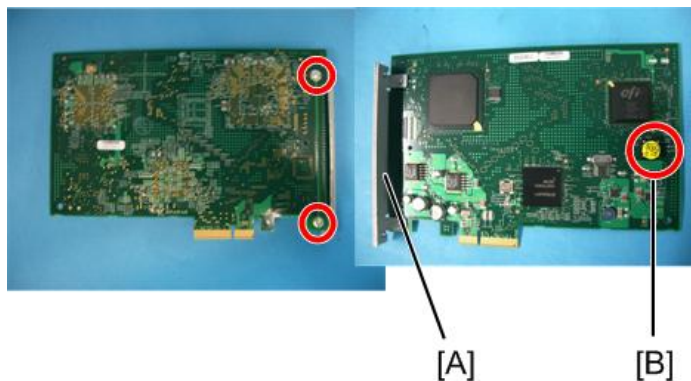

d650r103

3. Remove the Bracket [A] (⚙️ x 2)
4. Remove the Keychip [B] (U601)

↓ Note

- The video board that you use as a spare part does not include the Keychip (U601).
- When you replace the video board, do not forget to move the Keychip (U601) from the old board to the new board.

Keychip (U601): Contains option upgrade information and licensing information for the E-3300/5300.

3.3.2 DIAGNOSTIC LED BOARD

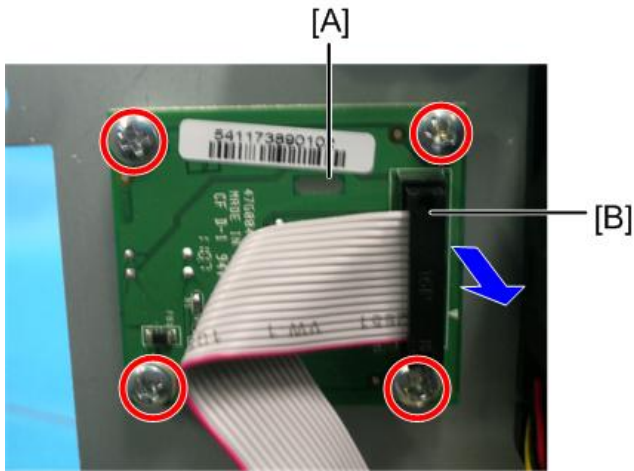

d650r104

1. Remove the 16-pin DIAG cable [B] (🔌 x 1)
2. Remove the DIAG board [A] (🔩 x 4)

Color Controller E-3300/E-5300 (D650/D651)

3.3.3 HARD DISK DRIVE (HDD)

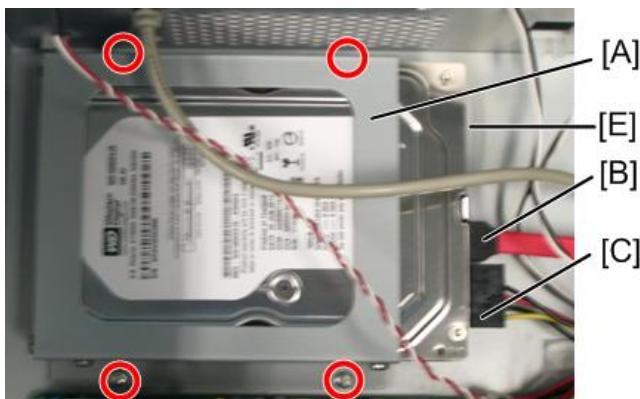

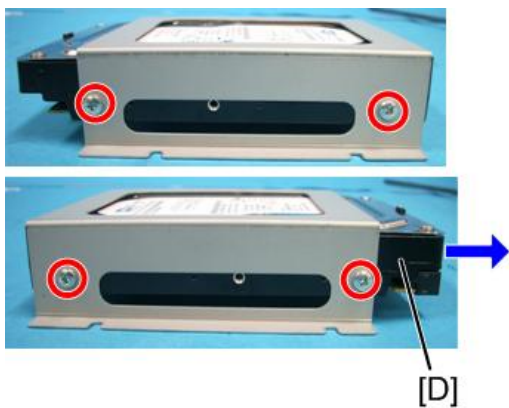

d650r105





d650r105a

1. Remove the HDD with bracket [A] (🔩 x 4)
2. Remove the SATA data cable [B] (🔌 x 1)

Unit Removal



3. Remove the SATA power cable [C] ( x 1)
4. Remove the HDD [D] ( x 4)
5. Legacy power connector [E] (**DO NOT USE**)

Note

- System software is not included on replacement HDDs. After installing a new HDD, be sure to install system software ( p.55 "System Software Installation Procedure").
- If you notice that the E-3300/5300 takes longer than usual to start up after installing a new HDD and system software, clear the CMOS. For details, see "Clearing Procedure for CMOS" shown below ( p.48 "Clearing Procedure for CMOS").

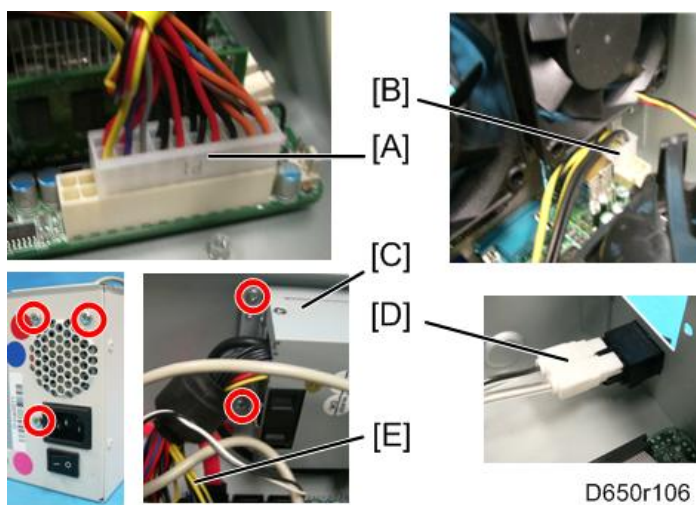
3.3.4 POWER SUPPLY UNIT



1. Remove the Power supply cable ( x 4).
 - HDD power connector [E].
 - 4-pin power connector [B] for the PW2 socket on the motherboard.
 - 20-pin power connector [A] for the PW1 socket on the motherboard.
 - Main power switch [D].
2. Remove the Power supply unit [C] ( x 5)

3.3.5 FANS

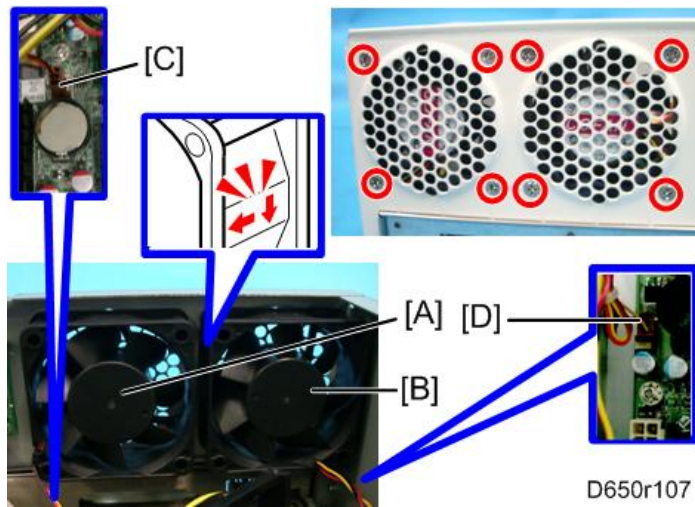

Video board (🖥️ p.36)

1. Remove the Cables (🔌 x 2):
 - [D] from FAN2
 - [C] from FAN3
2. Remove the Fan [A] (🔩 x 4)
3. Remove the Fan [B] (🔩 x 4)

⏴ Note

- Connect the [A-2] cable (Short) to FAN2 on the motherboard.
- Connect the [A-3] cable (Long) to FAN3 on the motherboard.

Color
Controller
E-3300/E-5300
(D650/D651)

3.3.6 MOTHERBOARD

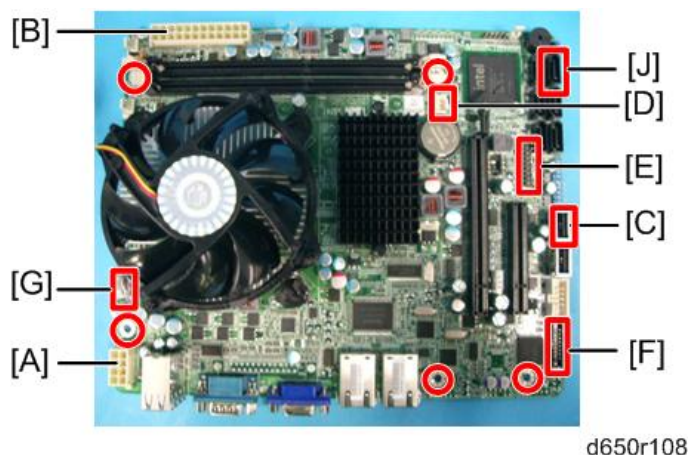

d650r108

1. Remove the Video board (🔧 p.36)
2. Remove the Fan case (🔧 p.39 "Fans")
3. Remove the Cables (🔌 x 8):
 - 4-pin power connector from PW2 [A].
 - 20-pin power connector from PW [B].1
 - USB cable from USB3 [C].
 - Fan cable from FAN3 [D].
 - Front panel cable from J25 [E].

PIN1 & 3	HDD LED
PIN2 & 4	Power LED
PIN6 & 8	Soft Switch

- DIAG cable from J26 [F].
 - Fan cable from FAN2 [G].
 - SATA data cable from SATA0 [J].
4. Remove the Screws (🔧 x 5)
 5. Remove the Memory (🔧 p.42 "Memory – 1GB DIMM")
 6. Remove the CPU Cooling Assembly (🔧 p.43 "CPU and Cooling Assembly")
 7. Remove the CPU (🔧 p.43 "CPU and Cooling Assembly")

Note

- When you replace the motherboard, remove the CPU and memory and attach them to the new motherboard (🔧 p.43 "CPU and Cooling Assembly").

For reassembling:

- Make sure of where to connect the connectors for each cable.
- Make sure that all connectors are inserted firmly in the sockets. Also, do not put the connectors in the sockets the wrong way around.

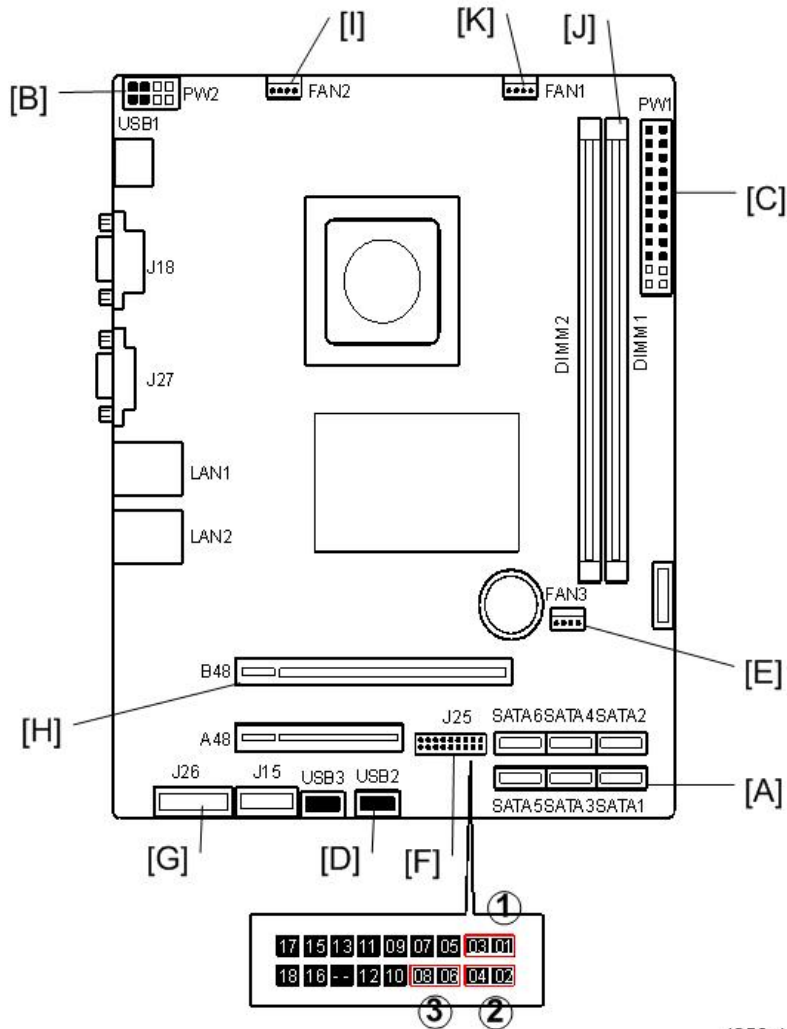

**Color
Controller
E-3300/E-5300
(D650/D651)**

d650r119

	Connector	Location
[A]	SATA data cable	SATA0
[B]	4-pin power	PW2
[C]	20-pin power	PW1
[D]	Front panel USB port	USB3
[E]	Bottom chassis fan	FAN3

[F]	Soft power button cable and activity LED cables	J25	①	For HDD LED
			②	For Power LED
			③	For Soft Switch
[G]	DIAG cable	J26		
[H]	Video interface board	PCIE2		
[I]	Top chassis fan	FAN2		
[J]	Memory	DIMM2		
[K]	CPU fan	FAN1		

3.3.7 MEMORY – 1GB DIMM

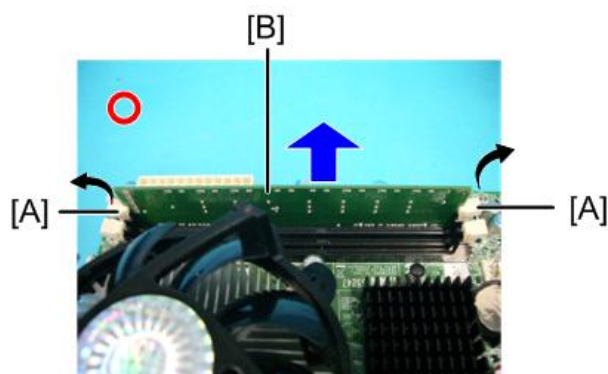

d650r110

1. Push outward on the levers [A] on each side of the DIMM.
2. Slide the DIMM [B] straight out of the socket.

Note

- Always attach the DIMM [B] to the DIMM2 socket.
- Gently slide the DIMM straight down into the socket and press so that the levers lock the DIMM into place. Make sure that the levers close securely around the ends of the DIMM.
- DIMMs fit in the socket only one way.
- If you installed a new or additional DIMM, clear the CMOS. Clear the CMOS after installing a new or additional DIMM to ensure compatibility between the new component and previous settings stored in the BIOS (p.48 "Clearing Procedure for CMOS").

3.3.8 CPU AND COOLING ASSEMBLY

Overview

You can replace the following parts.

- Cooling Assembly only
- CPU and Cooling Assembly (as a set). If you replace the CPU, you must replace the cooling assembly also, as a set.

The cooling assembly consists of a fan with heat sink and a clip assembly.

Note

- Be careful not to damage the motherboard, the CPU, or the CPU socket when you replace the cooling assembly. Remove the memory before you remove the cooling assembly.
- When you want to replace the CPU, replace the CPU and the cooling assembly as a set. This is very important, because the thermal pad that is attached to a new heat sink will make a good contact between the CPU and the heat sink when heated. If you attach a used cooling assembly to a new CPU by mistake, the heat sink will not contact the CPU properly, and this will cause the CPU to overheat.
- If you installed a new CPU, clear the CMOS. Clear the CMOS after installing a new CPU to ensure compatibility between the new component and previous settings stored in the BIOS (👉 p.48 "Clearing Procedure for CMOS").

Cooling assembly removal procedure

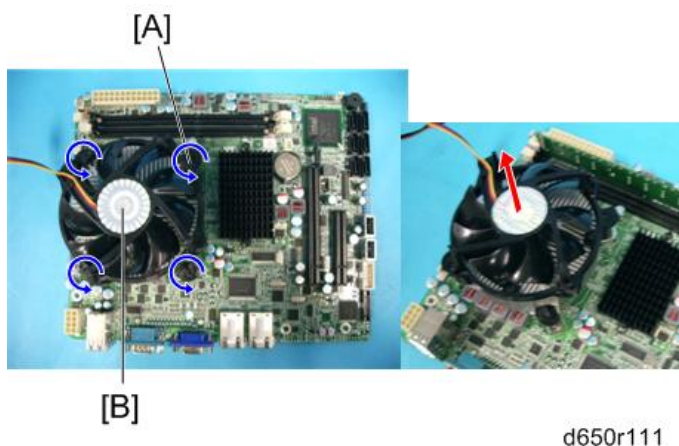

1. Remove the cooling assembly cable from the motherboard (🔌 x 1).
2. Turn counterclockwise to lock pin 4, to unlock [A].
3. Remove the cooling assembly [B] (🔧 x 4).

Reassembling the Cooling Assembly

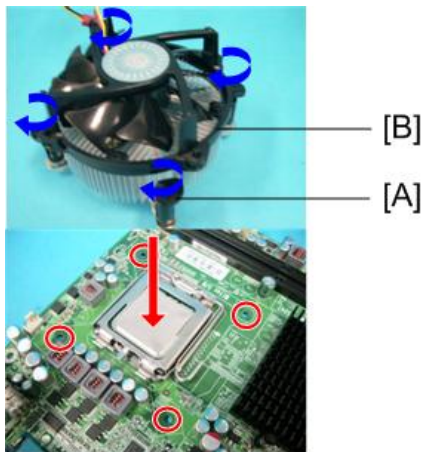

d650r111a

1. Plug the holes in the motherboard of the 4 locking pins [A].
2. Hold down and rotate clockwise, install a cooling assembly [B].

CPU removal procedure

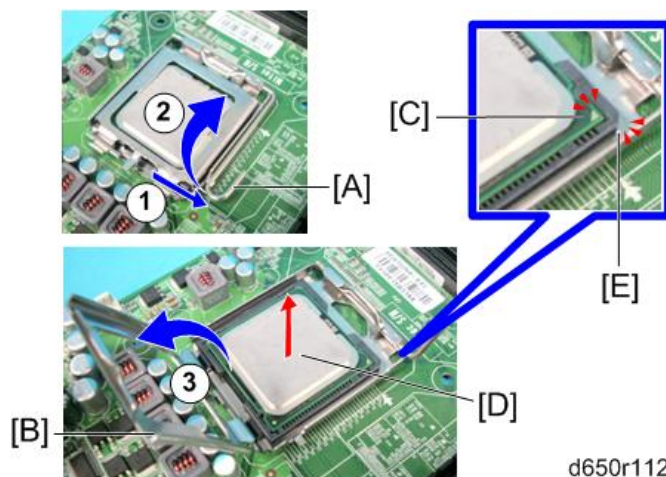

d650r112

1. Release the loadlever [A] .
2. Open loadplate [B].
3. Grasp the CPU by its edges and gently lift it from the socket.

For Re-attaching:

- Check the location of the arrow [C] on the CPU [D] when you insert the CPU into the socket [E]. (See the illustration above.)
- Be careful not to bend the pins when you insert the CPU into the socket.
- Set the CPU in the socket completely and without forcing it.

3.3.9 LITHIUM BATTERY

⚠ CAUTION

- There is danger of explosion if the battery is replaced with the incorrect type. Replace with only with the same lithium battery supplied as a spare part.
- Discard the used motherboard battery in accordance with the manufacturer's instructions and local regulations.

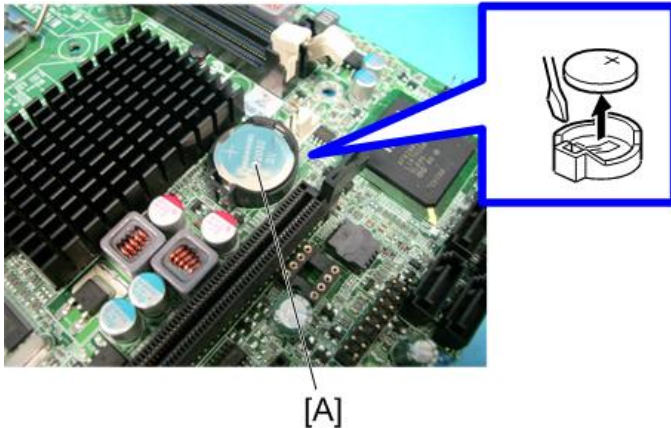

d650r113

For Re-assembling:

- You need to re-configure the system date and time.
- To configure the system date and time, enter the 'Server setup' menu from the Setup main menu. (☛ p.29 "To Access the Setup Menu")

3.3.10 GIGABIT ETHERNET CONTROLLER

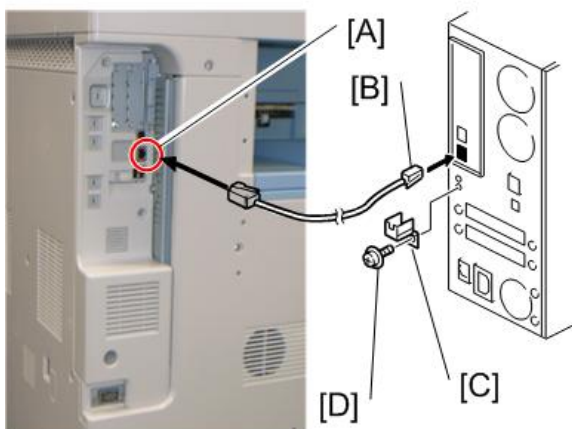

d650r116

1. Connect the interface cable [B] to both of the Gigabit Ethernet connectors [A]. Attach this with the prong of the protector plates [C] and [D] (☛ x 1)

For Re-assembling:

- Make sure that the Gigabit Ethernet controller is inserted straight.

3.3.11 CABLES CONNECTED TO THE FRONT PANEL

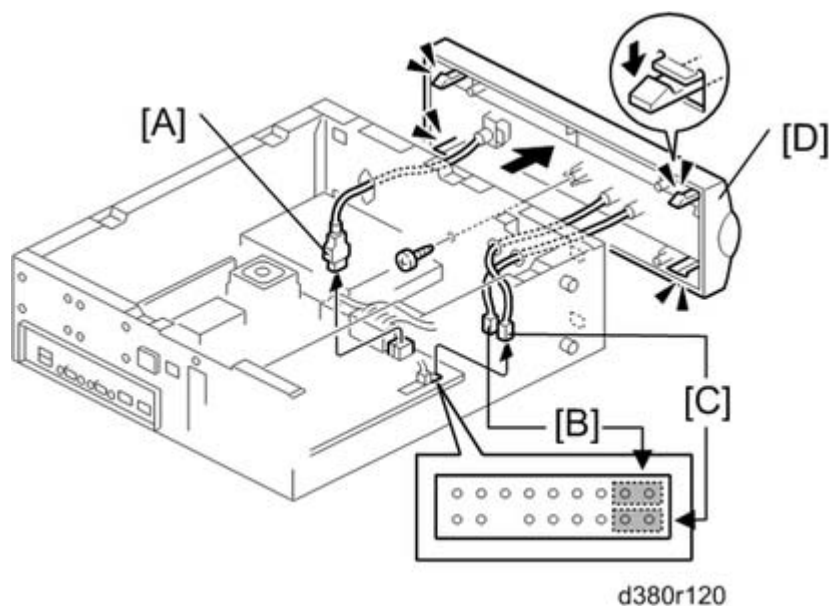

1. Side cover
2. Video board (☛ p.36)
3. Front panel USB port cable [A] from USB3
4. HDD LED cable [B] from J25
5. Power LED cable [C] from J25
6. Front panel [D] (🔩 x 1)

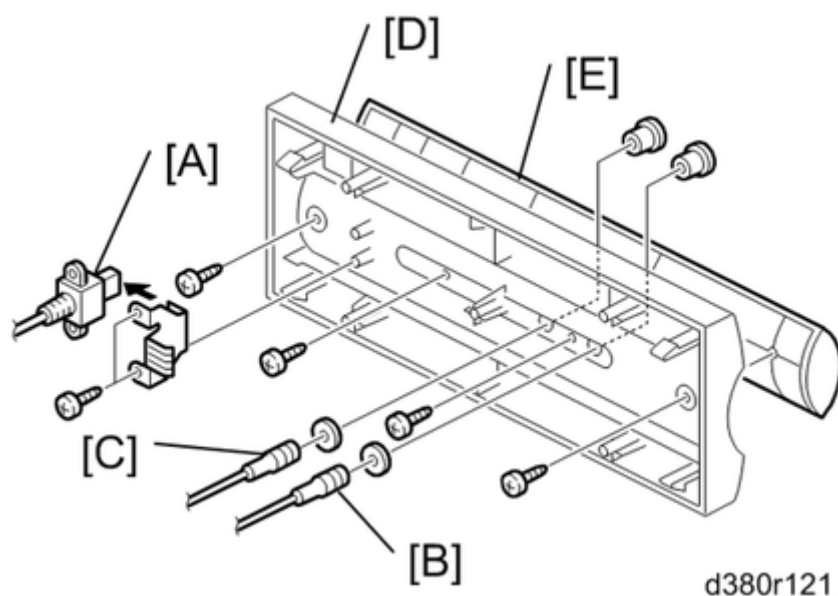

7. Front panel USB port cable [A] from front panel (🔩 x 2).
8. HDD LED cable [B] from front panel.
9. Power LED cable [C] from front panel.
10. Center panel [E] from the front panel [D] (🔩 x 4)

For Re-assembling:

- Make sure of where to connect the connectors for each cable.
- Make sure that all connectors are inserted firmly in the sockets. Also, do not put the connectors in the sockets the wrong way around.

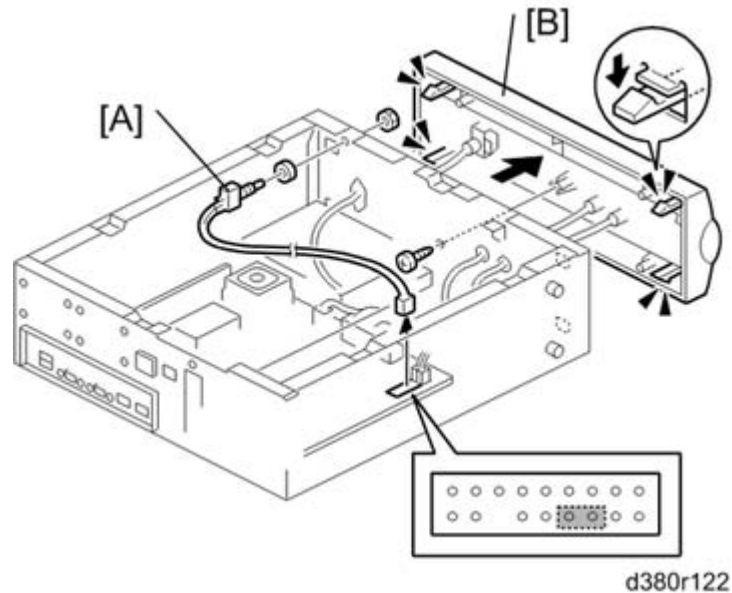
3.3.12 SOFT POWER PUSH BUTTON

1. Side cover
2. Video board (☛ p.36)
3. Soft Power Push Button cable from J25
4. Front panel [B] (☛ x 1)
5. Soft power button cable from the front panel.

For Re-assembling:

- Make sure of where to connect the connectors for each cable.

3.4 CLEARING PROCEDURE FOR CMOS

1. Make sure that the external power cable is removed from the back panel of the E-3300/5300.
2. Remove the battery (☛ p.45 "Lithium Battery").
3. Wait two minutes to allow the motherboard electrical components to fully discharge.
4. Reinstall the battery (☛ p.45 "Lithium Battery").
5. After reassembling the E-3300/5300, configure the time and date in Setup. For more information, see Configuration and Setup on the User Documentation CD.

4. SOFTWARE MAINTENANCE

4.1 GENERAL NOTES AND CAUTIONS

You may use one of the following when you have a problem with the system software or the HDD.

- Clear Server: Deletes all queued print jobs from the E-3300/5300
- Factory Defaults: Restores the E-3300/5300 to the factory defaults
- System Software Reinstallation

The following table shows whether the current data on the E-3300/5300 will remain or be deleted when each of these is used.

	"Clear Server"	"Factory Defaults"	System Software Reinstallation / Upgrade
Job Log	Not Deleted	Deleted	Deleted
Queued Jobs	Deleted	Deleted	Deleted
Scanned Jobs	Deleted	Deleted	Deleted
MailBox	Deleted	Deleted	Deleted
Archived Jobs	Deleted	Deleted	Deleted
FreeForm masters	Deleted	Deleted	Deleted
Resident Fonts	Not Deleted	Not Deleted	Deleted
Downloaded Fonts	Not Deleted	Deleted	Deleted
Language Selection	Not Deleted	Deleted	Deleted
Setup Options	Not Deleted	Deleted	Deleted
Patches	Not Deleted	Not Deleted	Deleted
Administrator Password	Not Deleted	Not Deleted	Deleted
Option Activation	Not Deleted	Not Deleted	Not Deleted



- In "System Software Reinstallation/Upgrade", "Upgrade" refers to replacing the software with a new version. It does not refer to the application of patches. When you apply a patch, data is not deleted.

Before you use any of the above features, make sure you inform the site administrator that the indicated data and settings will be deleted and should be re-installed after the feature has been used.

Job Log:

The list of jobs in the Job Log and all jobs in the queues are deleted. The site administrator can use E-3300/5300 Spooler to save a current list of jobs from the Job Log (the actual jobs are not saved, only a list of them).

Queued Jobs:

All queued print jobs (in the Print, Hold, and Printed queues) will be deleted.

Archived Jobs and Free Form masters:

Archived jobs on the E-3300/5300 HDD and FreeForm masters are deleted. The lists of archived jobs and FreeForm masters are deleted as well.

Fonts:

All fonts on the HDD are deleted when you reinstall the system software. Resident fonts are reinstalled when you reinstall the system software. Any customer-supplied fonts will need to be reinstalled by the site administrator using E-3300/5300 Downloader.

Administrator Password:

The administrator password will be deleted when system software is re-installed. (The administrator password will return to "Fiery.1" after the system software is re-installed.)

Configuration:

Make sure to print a configuration page before reinstalling the system software. The current Setup configuration will be lost when you reinstall the system software.

Compatibility:

When you upgrade the system software, make sure the latest user software is installed onto all computers that print to the E-3300/5300. Using incompatible versions of the system and user software can result in system problems.

4.2 CLEARING THE QUEUED PRINT JOBS IN THE E-3300/5300

The "**Clear Server**" command allows you to clear all queued print jobs from the E-3300/5300; which means jobs from the E-3300/5300 Print, Hold, and Printed queues. Clear Server also clears all jobs archived on the E-3300/5300 hard disk, the index of archived jobs, and finally, all E-3300/5300 FreeForm masters and the index of E-3300/5300 FreeForm masters.

Note

- Before using Clear Server, inform the site administrator that data on the E-3300/5300 hard disk will be deleted.
1. Make sure the E-3300/5300 is not in use.
 2. Press the Fierydriven key on the operation panel of the copier to access the Fiery menu screen. (p.29 "Running the E-3300/5300 Setup")
 3. Move to the **Login** tab.

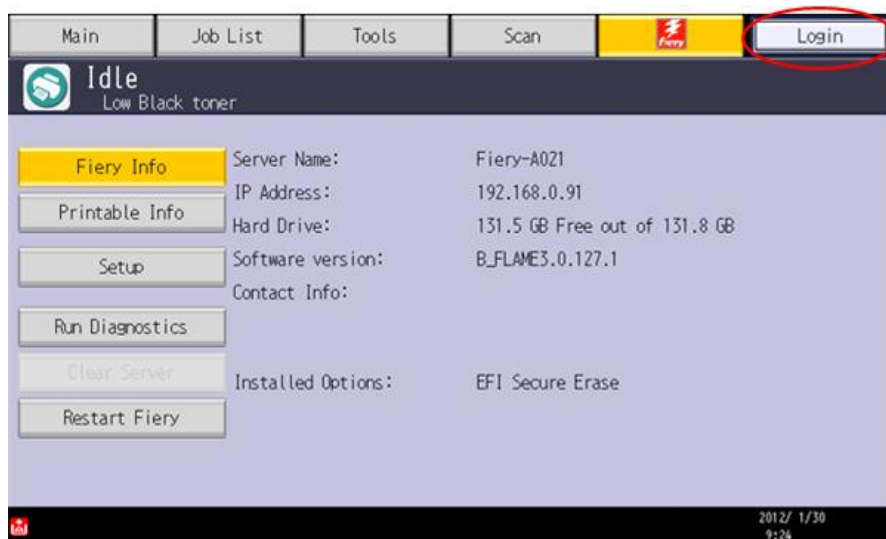

4. You are asked to enter an administrator password. (The default password is "**Fiery.1**").
5. The main setup screen appears.
6. Move to **Fiery** tab.
7. Touch "**Clear Server**".

Clearing the Queued Print Jobs in the E-3300/5300

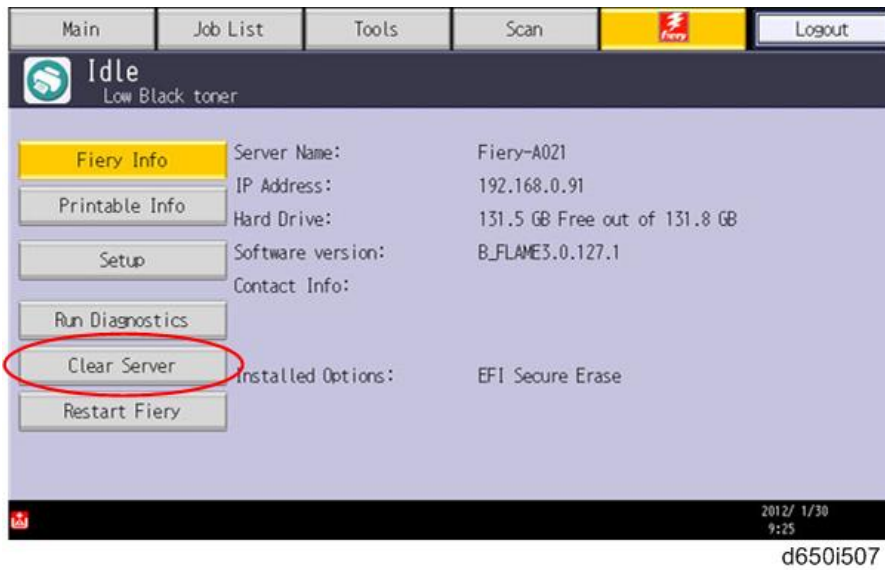

8. When you are prompted “Clear all jobs from all queues?”, touch “**OK**”
9. The Fiery menu screen will disappear and data will be cleared before the system restarts.
10. Press the **Fierydriven** key and check if the E-3300/5300 becomes idle.

4.3 RESTORING THE E-3300/5300 TO FACTORY DEFAULTS

To restore the default settings of E-3300/5300 and delete all the data stored on the HDD, use the “**Factory Defaults**” feature. Also use “**Factory Defaults**” when you want to change the language selection.

↓ Note

- Before using “**Factory Defaults**”, inform the site administrator that all data (including the downloaded fonts) stored on the HDD and setup options will be deleted.
- Performing “**Factory Defaults**” will not delete the current administrator password, which was set for the E-3300/5300 (the initial password is “**Fiery.1**”). Before performing “**Factory Defaults**”, check if the site administrator can input the current administrator password after the system software is restored.
- If a unique administrator password is already set for the E-3300/5300, but the site administrator does not remember the password, you must re-install the system software from the DVD (or from a prepared the USB drive).

↓ Note

- There is a similar feature called “Restore Fiery Default Settings” in the Webtools.
- This feature will return the settings to the defaults (factory settings) but will not clear the language selection or data in the HDD, and does not require the E-3300/5300 to reboot. For details, refer to the “Configuration and Setup” manual.

1. Make sure the E-3300/5300 is not in use.
2. Print a configuration page (you may refer to this configuration page when you re-enter the setup options). (🖨️ p.28 "Printing the Configuration Page or Test Sheets")
3. Access the setup menu. (🖨️ p.29 "Running the E-3300/5300 Setup")
4. Touch “**Factory Defaults**”.

Restoring the E-3300/5300 to Factory Defaults

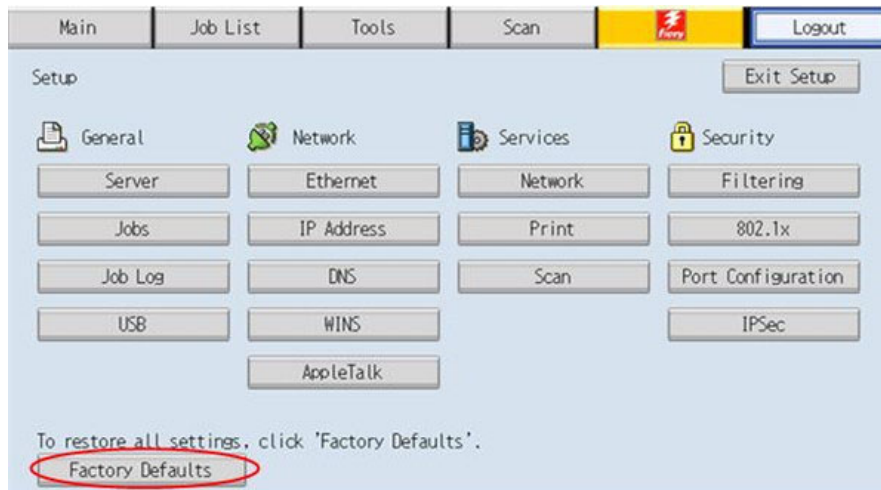

d380i506

5. When you are prompted "Change all settings (including network) back to Factory Defaults and Shutdown?", touch "**Continue**".
6. Wait for the diagnostic LEDs on the E-3300/5300 to turn off.
7. Press and release the soft power push button on the front panel of the E-3300/5300. The E-3300/5300 takes less than three minutes to reach the idle condition.
8. Go to the copier and press the **Fierydriven** key.
9. The language selection screen will appear. Start to configure the E-3300/5300.
(For details, go to step 25 of the system software installation procedure. 📄 p.55 "System Software Installation Procedure")

4.4 SYSTEM SOFTWARE INSTALLATION PROCEDURE

4.4.1 OVERVIEW

System software should be installed in the following cases:

- You replace the HDD with a new one (on which the System Software is not installed)
- You update to a more recent version of the system software (this is not necessary when you apply a patch; it is necessary when you install a major version change)
- You have trouble with the system software (e.g. software corruption) and the problem cannot be solved by performing "Factory Defaults".
- The site administrator forgets the administrator password for the E-3300/5300.

The system software is provided as follows:

- **System Software DVD:**
System software and an installation program for the network port method are included.
- **USB Prep Tool CD:**
Windows application program for copying the system software DVD to the USB drive, and at the same time making the USB drive bootable.

There are two ways to install/reinstall system software on the E-3300/5300:

- **Installing system software over the network port:**
Connect a PC to the E-3300/5300 directly, or through a hub using two network cables. Install the system software from the System Software DVD.
- **Installing system software by booting the E-3300/5300 from a USB drive:**
Use the USB Prep Tool CD to install the USB Prep Tool Windows application on a PC. Then use the system software DVD, a USB drive, and the USB Prep Tool Windows application on the PC to make a bootable USB drive that includes E-3300/5300 system software. At the customer site, connect the USB port and turn the power ON. System installation will be done automatically.

↓ Note

- Before you start system installation, give the site administrator the opportunity to print the Job Log and to save any custom simulations.
- Also, print the **Configuration Page** and **Font Lists**.
- Backup and Restore feature are sometimes useful in order to reduce the time to re-configure the E-3300/5300 system settings after the system installation (☛ p.31 "Backup / Restore the System Settings").

4.4.2 INSTALLING SYSTEM SOFTWARE OVER THE NETWORK PORT

The system software DVD contains the system software and E-3300/5300 System Software Installer. To install system software using the LAN port on the E-3300/5300, you need:

Either:

Two Ethernet cables and an isolated hub/switch

Cables must be 4-pair/8-wire, short-length Cat 5 (for 100BaseT) or Cat 5e (for 1000BaseT)

Or:

- For 100BaseTX: One Category 5 or higher Ethernet cross-over cable (4-pin/8-wire, short-length)
- For 1000BaseT: One Category 5e or higher Ethernet cross-over cable (4-pin/8-wire, short-length)

A Windows XP/2000/Vista computer ("PC") with:

- CD/DVD drive, built in or attached
- Support for 100BaseTX or 1000BaseT



- This procedure describes using one cross-over cable. Instead of using a cross-over cable, you may use two Ethernet cables and an isolated hub/switch. (Do not connect any other devices to the hub/switch. Do not put the hub/switch on the LAN. Do not use the hub's optical port or uplink switch.)
 - If the print engine is 230V, use shielded network cables.
1. Print the Configuration Page (☛ p.28 "Printing the Configuration Page or Test Sheets").
 2. If possible, back up the system settings to a configuration settings file with the Backup feature (☛ p.31 "Backup / Restore the System Settings").
 3. Perform the shut down procedure from the copier operation panel (☛ p.24 "Shutting Down the E-3300/5300 Only").
 4. When the E-3300/5300 power is down (that is when the diagnostic LEDs are off), turn the main power switch of the E-3300/5300 to OFF.
 5. Disconnect all cables from the E-3300/5300 connector panel.
 6. Connect the Ethernet cross-over cable to the LAN port and to the Windows XP/2000/Vista PC.
 7. Turn on the PC's power and do the following procedure:
 - Close all software applications.
 - Stop all File Transfer Protocol (FTP) and Trivial FileTransfer Protocol (TFTP) services.
 - Disable all anti-virus and anti-spyware programs.
 - Make sure that the PC is configured to obtain its IP address automatically (DHCP).
 - Remove any network cables between the PC and the customer network.

- Disable all wireless network connections.
 - Turn off the Windows Firewall.
 - Disable all power-save and hibernation settings.
8. Insert the system software DVD into the PC's CD/DVD drive.
 9. Navigate to the CD/DVD drive and click the icon for the Installer.exe file, if it does not start automatically.
 10. Click Next at the Welcome screen. Read the Software License Agreement and click the "I Agree" checkbox if you wish to continue the installation process, then click Next.
 11. At the Connection Type screen, make sure Ethernet is selected. Click Next to advance to the Confirmation screen.
 12. Set the E-3300/5300 service switches to the service mode position: ON.

↓ Note

- Ignore the steps shown on the PC screen because they may be confusing at this stage of the procedure. Please continue to follow the steps of this procedure.

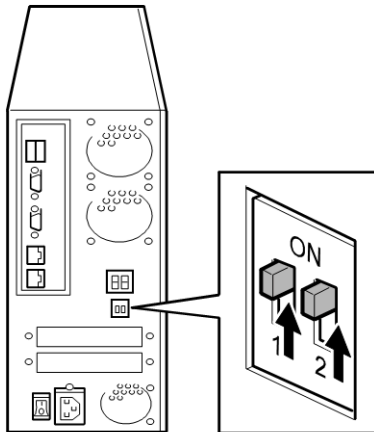

d380r114

13. Turn the main power switch of the E-3300/5300 to ON, then press and release the soft power push button on the front of the E-3300/5300.
14. Wait 10 seconds, then click Next on the PC screen.
15. At the Installation screen, click Next to start the installation. Wait while the files are copied and installed.
 - The progress is slow at first.
For most computers, you must wait approximately 30 min. Do not click Cancel.
 - **If you do click Cancel:** Click **Finish** then turn the main power switch of the E-3300/5300 to OFF. Wait 10 seconds, and then repeat this procedure from the beginning. If the installation terminates abnormally, you may need to reboot the PC also.

 Note

- If Windows detects more than one NIC card in the PC, Windows will prompt you to choose the NIC card that is connected to the E-3300/5300. The NIC card to choose may be a card that is associated with IP Address 0.0.0.0.
16. Click Exit when the screen shows that the installation is successful. Remove the System Software DVD from the PC.
 17. Turn the main power switch of the E-3300/5300 to OFF.
 18. Set the service switches in the normal position (not ON).

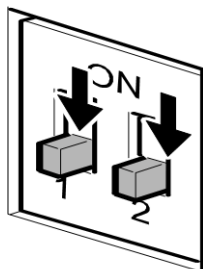

g815r021

19. Disconnect the cross-over cable from the LAN port and the Windows XP/2000/Vista PC.
20. Reconnect all cables that you removed earlier from the E-3300/5300 panel.
21. Turn on the main power switch of the copier.
22. Turn on the main power switch of the E-3300/5300.
23. Allow startup to proceed without interruption while you watch the diagnostic LEDs on the back panel of the E-3300/5300.
24. When the diagnostic LEDs show '00', go to the copier operation panel and press the **FierDriven** key. 'Please wait' may be shown on the copier operation panel.
25. The language selection screen is shown. (If this screen is not shown, then press the **FierDriven** key again.)

Select the desired language, and touch "**Continue**".

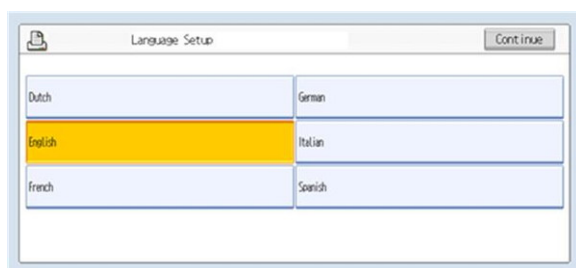

d380i500

- English
- Dutch
- Spanish
- Italian
- German
- French

↓ Note

- After you have selected a language, you cannot change the language unless you perform “Factory Defaults” (see p.53 "Restoring the E-3300/5300 to Factory Defaults") or re-install the system software.
- The default settings for the E-3300/5300 depend on the language selection as follows:

		Selected Language & Measurement Unit	
		English - US	English - Metric / Dutch / Spanish / Italian / German/ French
PS Setting	Default Paper Sizes	US	Metric
PCL Setting	Paper Size	Letter	A4
	Paper Size System Pages	US	Metric

If you selected “**English**” at the language selection screen, you are prompted to select the Measurement Unit. Select either “**US**” or “**Metric**”, and then touch “**Continue**”.

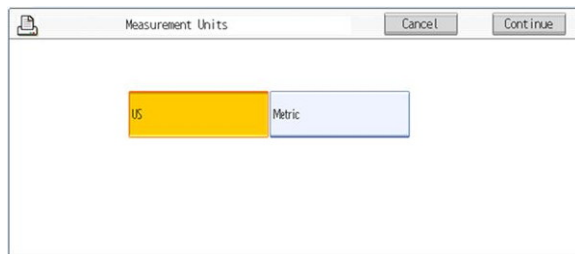

d380i501

26. Wait for a short time, then press the **Fierydriven** key on the operation panel. Repeat if necessary until “Please wait” no longer appears.
27. Press the Fiery tab to access Setup, and press Setup at the Fiery menu screen.
28. You are asked to enter the administrator password. (The default password is “**Fiery.1**”.)
29. Input the customer’s settings from the Configuration pages that you printed earlier. If a

backup exists of configuration settings file, restore it after the network configuration is completed. (☛ p.31 "Backup / Restore the System Settings")

↓ Note

- Ask the site administrator for the other settings that are not on the Configuration pages, You must reboot the E-3300/5300 to apply the settings. For more information, see the "Configuration and Setup" manual.

30. If you have been given any patches (system update files) for the version of system software you have just installed, install the patches now. See the instructions provided with each patch.

4.4.3 INSTALLING SYSTEM SOFTWARE USING A USB DRIVE

Preparation

To prepare a USB drive, which is bootable and includes system software, the following items should be prepared:

- E-3300/5300 System Software DVD
- USB Prep Tool CD
- USB drive, more than 5 GB capacity
Example: Seagate USB 2.0 Pocket Hard Drive, model number ST650211
- Windows XP SP2/Vista computer ("PC") with:
 - CD/DVD drive, built-in or attached
 - USB port (support for USB 2.0 or later is recommended)

↓ Note

- USB1.x can also be used, but it will take more time to copy the system software.

Installation Procedure

1. Install the USB Prep Tool application on the PC, if it is not already installed:
 1. Insert the USB Prep Tool CD in the PC's CD/DVD drive.
 2. Turn off the PC's power.
 3. Turn on the PC and wait while the PC boots to Windows.
 4. Navigate to the CD/DVD drive and click Setup.exe.
 5. Select Install and wait a few moments for the application to be installed on the PC.

↓ Note

- After the application is installed, it will automatically launch. If you are not ready to prepare the USB drive now, you can click Cancel and remove the USB Prep Tool CD.
- After the application is installed on the PC, the USB Prep Tool CD is no longer needed. When you wish to prepare a USB drive, go to the Windows Start Menu, navigate to All Programs > Electronics For Imaging > USB Prep Tool and follow the prompts.

2. Prepare the USB drive.

- 1) Remove the USB Prep Tool CD from the PC's CD/DVD drive (if it has not been removed already).
- 2) Insert the system software DVD in the PC's CD/DVD drive.
- 3) Attach the USB drive to the PC.

Note

- All data on the USB drive will be lost when the USB drive is reformatted during the next step of this procedure. You may wish at this time to make sure that no valuable data resides on the USB drive.

- 4) Follow the on-screen prompts to the USB drive:

- Start screen: Specify the drive to copy from (the drive letter of the CD/DVD drive). Specify the drive to copy to (the drive letter of the USB drive). Click Proceed when the Proceed button appears and is available.
- Prepare screen: The progress bar and time remaining show that the files are being copied. Copying the files usually takes 15-30 minutes, but may take considerably longer depending on your PC. Do not cancel. Click Proceed when the Proceed button appears and is available.
- Finish screen:

Confirm that the contents of the system software DVD were copied successfully to the USB drive. Click Finish to exit the application. The DVD will eject automatically. Remove the system software DVD.

3. Install system software on the E-3300/5300 using the prepared USB drive:
 - 1) Print the Configuration Page. Then perform the Shut Down procedure from the copier operation panel (see p.24 "Shutting Down the E-3300/5300 Only")
 4. When the E-3300/5300 power is down (that is when the diagnostic LEDs are off), turn the main power switch of the E-3300/5300 to OFF.
 5. Disconnect all cables from the E-3300/5300 connector panel.
 6. Set the E-3300/5300 service switches as shown below. ("1" ON, "2" OFF)

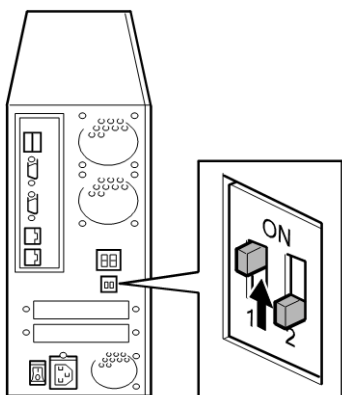

7. Attach the prepared USB drive to one of the USB ports on the E-3300/5300.

↓ Note

- If dust covers are attached to the USB Type A connectors, remove one dust cover using needle-nosed pliers.
8. Turn the main power switch of the E-3300/5300 to ON, then press and release the soft power push button on the front of the E-3300/5300 and wait until installation is complete. (The E-3300/5300 shuts down automatically after installation is complete.)
The diagnostic LEDs increment quickly to initialize, then the diagnostic LEDs display 00 and increment every 30 seconds while the files transfer.
Installation takes approximately 15-25 minutes. The LED on the USB drive should show that files are being transferred.
 9. Turn the main power switch of the E-3300/5300 to OFF and remove the USB drive from the E-3300/5300.
 10. Reconnect all cables that you removed earlier from the E-3300/5300 panel.
 11. Set the service switches in the normal position. (Not ON)

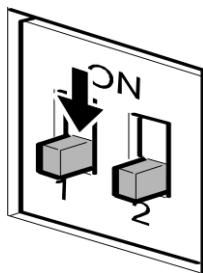

g815r021a

12. Turn on the main power switch of the copier.
13. Turn the main power switch of the E-3300/5300 ON, then press and release the soft power push button on the front of the E-3300/5300.
14. Allow startup to proceed without interruption while you watch the diagnostic LEDs on the back panel of the E-3300/5300

↓ Note

- Do not power off the E-3300/5300.
15. When the diagnostic LEDs remain at '00', go to the copier operation panel and press the **Fierydriven** key. 'Please wait' may be shown on the copier operation panel.
 16. The language selection screen is shown. (If this screen is not shown, then press the **Fierydriven** key again.)
Select the desired language, and touch "**Continue**".

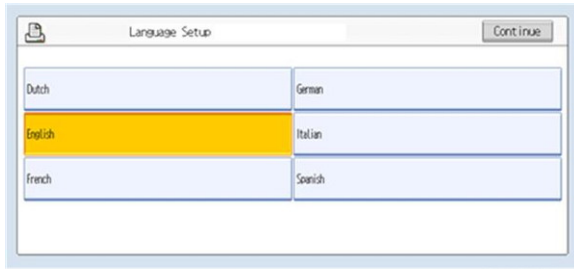

d380i500

Color
Controller
E-3300/E-5300
(D650/D651)

- English
- Dutch
- Spanish
- Italian
- German
- French

↓ Note

- 1) After you have selected a language, you cannot change the language unless you perform “**Factory Defaults**” (p.53 "Restoring the E-3300/5300 to Factory Defaults") or re-install the system software.
- 2) The default settings for the E-3300/5300 depends on the language selection as follows:

		Selected Language & Measurement Unit	
		English - US	English - Metric / Dutch / Spanish / Italian / German/ French
PS Setting	Default Paper Sizes	US	Metric
PCL Setting	Paper Size	Letter	A4
	Paper Size System Pages	US	Metric

If you selected “**English**” at the language selection screen, you are prompted to select the Measurement Unit. Select either “**US**” or “**Metric**”, and then touch “**Continue**”.

System Software Installation Procedure



17. Wait for a short time, then press the **Fierydriven** key on the operation panel. Repeat if necessary until “Please wait” no longer appears.
18. Press the Fiery tab to access Setup, and press Setup at the Fiery menu screen.
19. You are asked to enter the administrator password. (The default password is “**Fiery.1**”.)
20. Input the customer’s settings from the Configuration pages that you printed earlier. If there exists a backed up configuration settings file, restore it after the network configuration is completed. (☛ p.31 “Backup / Restore the System Settings”)

↓ Note

- Ask the site administrator for the other settings that are not on the Configuration pages. You must reboot the E-3300/5300 to apply the settings. For more information, see the “Configuration and Setup” manual.
21. If you have been any patches (system update files) for the version of system software you have just installed, installed the patches now. See the instructions provided with each patch.

4.5 PATCH INSTALLATION PROCEDURE

When a software bug is found and fixed, or a new feature is added, a patch file (ps file) may be additionally released.

The patch installation procedure may vary depending on the patch; the download destination queue or system rebooting procedure may be different. Some patches may require prerequisite patches.

Therefore, when you install a patch, make sure to carefully read the attached release note and follow the instructions.

5. TROUBLESHOOTING

5.1 OVERVIEW

When a problem occurs during normal operation, check in the following order.

1. Verify that the service switches are in normal operation mode, not in a service mode. (The switches should be in the lower position.)

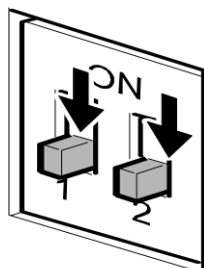

g815r021

2. Check that the Fiery menu appears on the copier's operation panel.
3. Verify that the network is functioning, no unauthorized software or hardware is installed on the E-3300/5300, and there are no problems with a particular print job or application. The site administrator can help you to verify these issues.
4. Verify that the E-3300/5300 and its connection with the copier has no problem by printing test pages. (☛ p.28 "Printing the Configuration Page or Test Sheets")
5. If the E-3300/5300 can boot, check if the diagnostic LEDs on the back panel of E-3300/5300 stop on a particular diagnostic code. (☛ p.67 "LED Diagnostic Codes")
6. Check that all cables, connectors, and replacements are present, appear undamaged and are correctly installed and connected. (☛ p.34 "Replacement")
7. Try to solve the problem by performing "Clear Server" or "Factory Defaults". Inform the site administrator that the data stored in the HDD will be deleted. (☛ p.51 "Clearing the Queued Print Jobs in the E-3300/5300" and p.53 "Restoring the E-3300/5300 to Factory Defaults")
8. Check if a newer version of system software, firmware, or patch for the E-3300/5300 and copier has been released. If so, install it. (☛ p.55 "System Software Installation Procedure")
9. If the problem will not disappear, reinstall the system software. (☛ p.55 "System Software Installation Procedure")
10. If the problem will still not disappear, you may need to replace parts of the hardware. (☛ p.73 "Errors and Suggested Actions")

5.2 LED DIAGNOSTIC CODES

During startup, the E-3300/5300 advances through a standard diagnostic sequence. Each diagnostic code flashes rapidly on the LED display during this sequence until the E-3300/5300 reaches the Idle condition. In the Idle condition, the LED display shows the 00 code. This shows that the E-3300/5300 is in normal operation mode. The E-3300/5300 may flicker or drift from 00 during normal operation, but it will always return to 00.

If the LED display stops on a diagnostic code before the E-3300/5300 completes the boot up process, one or more diagnostic tests may have failed. Look up the diagnostic code in the following table to determine the troubleshooting actions that you should take.

↓ Note

- A component may be faulty without an error code being displayed. Also, it is possible for an error code to indicate a defective component but that component may not be defective. Use the error codes only as a guide for what to investigate further.

5.2.1 OVERVIEW

Try the following procedures if the E-3300/5300 is hanging up on a diagnostic code.

1: Rebooting the E-3300/5300

When the E-3300/5300 is already ON and hanging up on a diagnostic code, reboot the E-3300/5300 properly to see if the problem persists. Results are unpredictable when the E-3300/5300 is rebooted incorrectly.

1. Press and hold the soft power button until the E-3300/5300 turns off.
2. Wait a full 30 seconds.
3. Press (but do not hold) the soft power button.
4. Wait to see if the E-3300/5300 reaches idle.

2: Checking the components

Always check the unit for visible problems.

1. Check the interior for foreign objects.
2. Check the cables to make sure they are intact, with no visible damage, and that each is the correct cable, and correctly installed.
3. Check all connectors for visible damage.
4. Check the replaceable parts for visible damage, and that each is the correct part and correctly installed.

3: Turn on the E-3300/5300 Power

After you reassemble the unit, turn on the E-3300/5300 power properly to see if the problem persists. Results are unpredictable when the E-3300/5300 power is turned on incorrectly.

1. Connect the AC power cord to the AC power outlet.
2. Toggle the AC power switch to the ON position.
3. Wait a full 30 seconds.
4. Press (but do not hold) the soft power button.

Wait to see if the E-3300/5300 reaches the idle status.

5.2.2 LED DIAGNOSTIC CODE TABLES

*1: Try in the listed order. If the problem persists, try the next one.

LED diagnostic Code	Details (Possible cause, Suggested action *1)
Any specific code not listed in this table that the machine hangs up on before the system reaches idle status.	<ul style="list-style-type: none"> ▪ BIOS settings on the motherboard are corrupted. ▪ Motherboard defective <ol style="list-style-type: none"> 1. Clear CMOS using the following procedure: <ol style="list-style-type: none"> 1. Turn off the controller and unplug the AC power cord. 2. Open the controller and remove the battery from the motherboard. 3. Wait a full 5 minutes. 4. Re-install the battery. 5. Reassemble the E-3300/5300 and turn the power on properly (👉 p.66). 2. If you have checked all cables, connections, and components (👉 p.66) 3. Replace the motherboard.

LED diagnostic Code	Details (Possible cause, Suggested action *1)
00	<p>When the E-3300/5300 is idle and in operational mode, the LED display shows 00. If the LED display shows 00 but the E-3300/5300 is not functioning properly, one or more components may be at fault depending on the problems you are experiencing with the E-3300/5300 (☛ p.73 "Errors and Suggested Actions")</p> <ul style="list-style-type: none"> ▪ Battery missing or defective ▪ Chassis fan missing or defective ▪ CPU and/or CPU cooling assembly defective ▪ HDD defective ▪ BIOS settings on the motherboard are corrupted. ▪ Motherboard defective <ol style="list-style-type: none"> 1. If date/time cannot be set or are slow, replace the battery. 2. If no air or fan noise is evident at the fan, replace the fan. 3. Replace the HDD 4. Clear the CMOS (☛ Any specific code not listed in this table that the machine hangs up on before the system reaches idle status) 5. Replace the motherboard.
40	<ul style="list-style-type: none"> ▪ Video board defective ▪ CPU defective ▪ BIOS settings on the motherboard are corrupted. ▪ Motherboard defective <ol style="list-style-type: none"> 1. Replace the video board 2. Replace the CPU 3. Clear the CMOS (☛ Any specific code not listed in this table that the machine hangs up on before the system reaches idle status) 4. Replace the motherboard

LED diagnostic Code	Details (Possible cause, Suggested action *1)
2A	<ul style="list-style-type: none"> ▪ DIMM defective ▪ Video board defective ▪ BIOS settings on the motherboard are corrupted. ▪ Motherboard defective <ol style="list-style-type: none"> 1. Check the DIMM(s) and reseal them to remove oxidation on the connectors. 2. Replace the video board. 3. Clear the CMOS (🔌 Any specific code not listed in this table that the machine hangs up on before the system reaches idle status) 4. Replace the motherboard.
D7, D8	<ul style="list-style-type: none"> ▪ DIMM defective ▪ BIOS settings on the motherboard are corrupted. ▪ Motherboard defective <ol style="list-style-type: none"> 1. Check the DIMM(s) and reseal them to remove oxidation on the connectors. 2. Clear the CMOS (🔌 Any specific code not listed in this table that the machine hangs up on before the system reaches idle status) 3. Replace the motherboard.
<p>One of the following: 31, 3B, 52, D3, D4, D5, D9, E1, E2, E3, E4, E5, E6, E7, E8, EC, ED, EE, EF</p>	<p>Possibly one of the following:</p> <ul style="list-style-type: none"> ▪ DIMM missing, defective, or in the wrong slot ▪ BIOS settings on the motherboard are corrupted. ▪ Motherboard defective ▪ Shut down the Copier and the E-3300/5300. Then power on the Copier and E-3300/5300 (🔌 p.66). <ol style="list-style-type: none"> 1. Check this DIMM is in the correct (outer) slot. 2. Reseat them to remove oxidation on the connectors. 3. Replace the DIMM. 4. Clear the CMOS (🔌 Any specific code not listed in this table that the machine hangs up on before the system reaches idle status) 5. Replace the motherboard.

LED diagnostic Code	Details (Possible cause, Suggested action *1)
One of the following: 07, 08, 20, 37, A7, B1, C0, C1, C2, C3, C4, C5, C6, C7, D0, D1, DA	Possibly one of the following: <ul style="list-style-type: none"> ▪ CPU defective ▪ BIOS settings on the motherboard are corrupted. ▪ Motherboard defective <ol style="list-style-type: none"> 1. Shut down the Copier and the E-3300/5300. Then power on the Copier and E-3300/5300 (🖱️ p.66). 2. Replace the CPU. 3. Clear the CMOS (🖱️ Any specific code not listed in this table that the machine hangs up on before the system reaches idle status) 4. Replace the motherboard.
04	Possibly one of the following: <ul style="list-style-type: none"> ▪ BIOS settings on the motherboard are corrupted. ▪ Motherboard battery is defective or dead. ▪ Motherboard defective <ol style="list-style-type: none"> 1. Clear the CMOS (🖱️ Any specific code not listed in this table that the machine hangs up on before the system reaches idle status) 2. Replace the battery. 3. Replace the motherboard.
05, 38, 90, 2E, 8C, 8E	Possibly one of the following: <ul style="list-style-type: none"> ▪ Video board is incorrectly installed in the PCI slot. ▪ Video board defective ▪ BIOS settings on the motherboard are corrupted. ▪ Motherboard defective <ol style="list-style-type: none"> 1. Shut down the Copier and the E-3300/5300. Then power on the Copier and E-3300/5300 (🖱️ p.66). 2. Reinstall the video board. 3. Replace the video board. 4. Clear the CMOS (🖱️ Any specific code not listed in this table that the machine hangs up on before the system reaches idle status) 5. Replace the motherboard.

LED diagnostic Code	Details (Possible cause, Suggested action *1)
EA, EB	<p>Possibly one of the following:</p> <ul style="list-style-type: none"> ▪ HDD is faulty. ▪ BIOS settings on the motherboard are corrupted. ▪ Motherboard defective <ol style="list-style-type: none"> 1. Shut down the Copier and the E-3300/5300. Then power on the Copier and E-3300/5300 (☛ p.66). 2. Reconnect the power and SATA data cables to the HDD. 3. Replace the SATA data cable. 4. Replace the HDD. 5. Clear the CMOS (☛ Any specific code not listed in this table that the machine hangs up on before the system reaches idle status) 6. Replace the motherboard.
FF	<p>Possibly one of the following:</p> <ul style="list-style-type: none"> ▪ Service switches are set to Service mode. ▪ DIMM missing or defective ▪ HDD defective ▪ CPU missing or defective ▪ BIOS settings on the motherboard are corrupted. ▪ Motherboard missing or defective <ol style="list-style-type: none"> 1. Make sure the E-3300/5300 service switches are set to Normal mode (away from “ON”). 2. Shut down the Copier and the E-3300/5300. Then power on the Copier and E-3300/5300 (☛ p.66). 3. Reconnect the power and SATA data cables to the HDD. 4. Replace the HDD. 5. Replace the CPU. 6. Check the DIMM. For details, see the Action for code C1 (above). 7. Clear the CMOS (☛ Any specific code not listed in this table that the machine hangs up on before the system reaches idle status) 8. Replace the motherboard.

5.3 ERRORS AND SUGGESTED ACTIONS

The most common causes of hardware problems are loose connections. Before you decide to replace any parts of E-3300/5300, make sure that the parts and connectors are correctly and firmly installed. (☛ p.34 "Replacement")

5.3.1 START-UP PROBLEMS

The following symptoms are described in the tables below:

1. When the main power switch is turned on, no power is supplied to the E-3300/5300.
2. The E-3300/5300 main power switch can be turned on, but the E-3300/5300 will not continue to boot-up.
3. The E-3300/5300 starts up and reaches 00 on the LED display. But after 5 minutes, the Fiery menu still does not appear on the copier operation panel when you press the **Fierydriven** key.
4. The CPU cooling fan is not working.
5. The CPU cooling fan is making noise.
6. If the Fiery menu screen does not appear on the copier operation panel when you press the **Fierydriven** key.

Color
Controller
E-3300/E-5300
(D650/D651)

Start-Up Problem-1
<p>Symptom: When the main power switch is turned on, no power is supplied to the E-3300/5300.</p>
<p>Possible cause:</p> <ul style="list-style-type: none"> ▪ The AC power cord of the E-3300/5300 is not connected. ▪ The soft power push button is not pressed. ▪ Defective power supply
<p>Suggested action:</p> <ol style="list-style-type: none"> 1. Connect the AC power cord. 2. Press and release the soft power push button. 3. Check if the connector of the power supply unit is correctly inserted into the motherboard PW1 socket. 4. If the connector is inserted correctly, replace the parts in the following order. <ol style="list-style-type: none"> 1) AC Power cord 2) Power supply unit 3) Motherboard

Start-Up Problem-2
<p>Symptom: The E-3300/5300 main power switch can be turned on, but the E-3300/5300 will not continue to boot-up.</p>
<p>Possible cause:</p> <ul style="list-style-type: none"> ▪ Motherboard, Memory or CPU is incorrectly installed. ▪ Motherboard defective ▪ Memory defective ▪ CPU defective ▪ Power supply unit defective
<p>Suggested action:</p> <ol style="list-style-type: none"> 1. Disconnect the AC power cord to the E-3300/5300. 2. Check if the memory installed in the DIMM2 socket, and is it installed firmly and correctly. 3. Check if CPU installed properly (no pins of the CPU bent or broken) 4. Check if cable of the CPU cooling assembly connected to the FAN1 socket. 5. Try to install the following parts correctly, and then try to replace the parts in the following order: <ul style="list-style-type: none"> ▪ Power supply unit ▪ CPU ▪ Memory ▪ Motherboard

Start-Up Problems-3
<p>Symptom: The E-3300/5300 starts up and reaches 00 on the LED display. But after 5 minutes, the Fiery menu still does not appear on the copier operation panel when you press the Fierydriven key.</p> <p>-or-</p> <p>The E-3300/5300 shuts down after reaching idle (00).</p>

Start-Up Problems-3
<p>Possible cause:</p> <ul style="list-style-type: none"> ▪ System software corruption. ▪ Defective video board. ▪ Missing or defective security chip
<p>Suggested action:</p> <ol style="list-style-type: none"> 1. Replace the interface cable. (☛ p.8 "Connecting E-3300/5300 to the Copier") 2. Reinstall the system software. (☛ p.55 "System Software Installation Procedure") 3. Make sure that the U601 chip is correctly installed on the video board. 4. Replace the video board. 5. Replace the U601 chip.

Start-Up Problems-4
<p>Symptom: The CPU cooling fan is not working.</p>
<p>Possible cause:</p> <ul style="list-style-type: none"> ▪ Incomplete cable connection. ▪ CPU cooling fan defective.
<p>Suggested action:</p> <ol style="list-style-type: none"> 1. Check if the cable of the CPU cooling assembly is connected firmly to FAN1. 2. Replace the CPU cooling assembly.

Start-Up Problems-5
<p>Symptom: The CPU cooling fan is making noise.</p>
<p>Possible cause:</p> <ul style="list-style-type: none"> ▪ Dirty cooling fan.
<p>Suggested action:</p> <ol style="list-style-type: none"> 1. Remove the cooling fan, clean it, and re-attach it.

Start-Up Problems-6
<p>Symptom: The Fiery menu screen does not appear on the copier operation panel when you press the Fierydriven key.</p>
<p>Possible cause:</p> <ul style="list-style-type: none">▪ Controller not ready▪ Loose connection of the Gigabit Ethernet PCB.▪ Gigabit Ethernet PCB defective▪ System software corruption▪ Copier SP is not properly set.
<p>Suggested action:</p> <ol style="list-style-type: none">1. Check if the Gigabit Ethernet PCB is inserted straight and connected firmly into the C slot on the copier. (☛ p.8 "Connecting E-3300/5300 to the Copier")2. If the above checks do not solve the problem, replace the interface cable or Gigabit Ethernet PCB3. Check if SP5-193-001 is set to "1".4. Check if SP5-895-001 is set to "1".

5.3.2 SYSTEM PROBLEMS

The following symptoms are described in the tables below:

1. The system date on the configuration page will always be returned to an old date (factory defaults date) after you turn on the E-3300/5300; or the time and date settings that appear on the configuration page are sometimes earlier or later than the actual time and date.
2. The system performs slowly or stops sometimes.

**Color
Controller
E-3300/E-5300
(D650/D651)**

System Problem-1
<p>Symptom: The system date on the configuration page will always be returned to an old date (factory defaults date) after you turn on the E-3300/5300; or the time and date settings that appear on the configuration page are sometimes earlier or later than the actual time and date.</p>
<ul style="list-style-type: none"> ▪ BIOS settings were lost due to a dead battery. ▪ Motherboard defective
<p>Suggested action:</p> <ol style="list-style-type: none"> 1. Replace the lithium battery on the motherboard, and re-configure the system time and date. 2. Replace the motherboard.

System Problem-2
<p>Symptom: The system performs slowly or stops sometimes.</p>
<p>Possible cause:</p> <ul style="list-style-type: none"> ▪ DIMM defective or faulty DIMM connection ▪ HDD defective ▪ CPU overheated and/or defective ▪ Motherboard defective

System Problem-2

Suggested action:

1. Reconnect the DIMM.
2. Replace the DIMM.
3. Check if the connectors of the power supply unit and HDD are firmly inserted in the sockets.
4. Replace the soft power push button cable or activity LED cables.
5. Replace the HDD.
6. Make sure that the CPU on the motherboard is connected correctly and that the fan cable is connected.
7. Replace the CPU.
8. Replace the motherboard

5.3.3 SYSTEM SOFTWARE INSTALLATION

The following symptoms are described in the tables below:

1. The E-3300/5300 start page fails to print from the copier after the installation is complete.
2. One of the following:
 - Installer screen hangs up at Waiting for E-3300/5300 to be ready, FTP/TFTP Setup, or Transferring boot file for longer than 15 minutes.
 - Installation fails repeatedly.
3. Installation stalls for 5 minutes (or longer) while downloading.
4. Cannot load the contents of the System Software onto the USB drive using the USB Prep Tool CD.
5. When installing the system software from the USB drive, the E-3300/5300 remains on for 30 minutes (or longer) after beginning the installation.
6. When installing the system software from the USB drive, the LED on the USB drive remains off or on (not blinking).

Color
Controller
E-3300/E-5300
(D650/D651)

System Software Installation-1
<p>Symptom: The E-3300/5300 start page fails to print from the copier after the installation is complete.</p>
<p>Possible cause:</p> <ul style="list-style-type: none"> ▪ The copier is not loaded with the required paper stock.
<p>Suggested action:</p> <ol style="list-style-type: none"> 1. Load the copier tray with the size of paper that is appropriate for the national language selected for the E-3300/5300 system.

Network Port Method

System Software Installation-2
<p>Symptom: One of the following:</p> <ul style="list-style-type: none">▪ Installer screen hangs up at Waiting for E-3300/5300 to be ready, FTP/TFTP Setup, or Transferring boot file for longer than 15 minutes.▪ Installation fails repeatedly.
<p>Possible cause:</p> <ul style="list-style-type: none">▪ There is a conflict between the installer or the security settings on the PC.▪ Incorrect or defective RJ-45 cable▪ The installer is not compatible with the PC.
<p>Suggested action:</p> <ol style="list-style-type: none">1. Check again that you have disabled all software programs and network and security settings on the PC. Then retry the installation. Before you retry the installation, turn off the E-3300/5300 power using its dedicated AC power switch and wait 10 seconds.2. Make sure you are using a cross-over RJ-45 cable. As an alternative, you can use two straight-through RJ-45 cables and a network hub. Connect only the PC and the E-3300/5300 to the hub. If the cable appears damaged, replace it.3. If the problem persists, retry the installation using a different PC.

System Software Installation-3
<p>Symptom: Installation stalls for 5 minutes (or longer) while downloading.</p>
<p>Possible cause:</p> <ul style="list-style-type: none">▪ The service switches are set to normal mode▪ Incorrect or defective RJ-45 cable▪ Motherboard defective

System Software Installation-3
<p>Suggested action:</p> <ol style="list-style-type: none"> 1. Make sure the E-3300/5300 service switches are set to service mode (toward "ON"). 2. Make sure you are using a cross-over RJ-45 cable. As an alternative, you can use two straight-through RJ-45 cables and a network hub. Connect only the PC and the E-3300/5300 to the hub. If the cable appears damaged, replace it. 3. Replace the motherboard.

USB Drive Method

System Software Installation-4
<p>Symptom: Cannot load the contents of the System Software onto the USB drive using the USB Prep Tool CD.</p>
<p>Possible cause:</p> <ul style="list-style-type: none"> ▪ The USB drive and/or PC do not meet the minimum system requirements. ▪ There is a conflict between the USB Prep Tool CD and the USB drive.
<p>Suggested action:</p> <ol style="list-style-type: none"> 1. Make sure that the USB drive and the PC meet the minimum system requirements described in this manual (p.60 "Installing System Software Using a USB Drive"). 2. If the problem persists, try using a different PC. If you have been using a laptop PC, try a desktop PC instead. 3. If the problem persists, try using a different USB drive.

System Software Installation-5
<p>Symptom: When installing the system software from the USB drive, the E-3300/5300 remains on for 30 minutes (or longer) after beginning the installation.</p>

System Software Installation-5
<p>Possible cause:</p> <ul style="list-style-type: none"> ▪ The position of the service switches are incorrect. ▪ HDD defective ▪ Motherboard defective ▪ USB drive defective.
<p>Suggested action:</p> <ol style="list-style-type: none"> 1. Make sure that the service switches are set to 1=ON 2=OFF during the USB drive system software installation. 2. Check the LED on the USB drive. If the LED is not blinking (remains off or on), the drive may be connected incorrectly. Turn off the E-3300/5300 main power switch, and reconnect the drive. Then turn the main power switch on, and press and release the soft power push button and allow the installation to resume. 3. Check the connection of the power and SATA data cables. 4. Replace the SATA data cable. 5. Replace the HDD. 6. Replace the motherboard. 7. Replace the CPU. 8. Retry the installation with a different USB drive.

System Software Installation-6
<p>Symptom:</p> <p>When installing the system software from the USB drive, the LED on the USB drive remains off or on (not blinking).</p>
<p>Possible cause:</p> <ul style="list-style-type: none"> ▪ USB drive defective or not correctly connected ▪ Motherboard defective ▪ HDD defective

System Software Installation-6**Suggested action:**

1. Turn off the E-3300/5300 main power switch and reconnect the USB drive. Then turn the power on, and press and release the soft power push button and allow the installation to resume.
2. Retry the installation with a different USB drive.
3. Replace the motherboard.
4. Check the connection of the power and SATA data cables.
5. Replace the SATA data cable.
6. Replace the HDD.

Color
Controller
E-3300/E-5300
(D650/D651)

5.3.4 NETWORK PROBLEMS

The following symptoms are described in the tables below:

1. E-3300/5300 does not communicate with the network.
2. Unable to connect to the network; or no LED on the 10/100/1000BaseT network connector is lit.
3. The system starts up slowly (seems to stop); and the Configuration Page shows an error on the "IP Address" line under "Network Setup".

Network Problem-1
<p>Symptom: The E-3300/5300 does not communicate with the network.</p>
<p>Possible cause:</p> <ul style="list-style-type: none"> ▪ Wrong cables because the cross-over cable and the straight through network cable look alike.
<p>Suggested action:</p> <ol style="list-style-type: none"> 1. Check the labeling on the cable connectors and /or the wire color sequence on the connectors to make sure you are using a network straight-through cable to the customer's LAN from the RJ-45 second from the bottom.

Network Problem-2
<p>Symptom: Unable to connect to the network; or no LED on the 10/100/1000BaseT network connector is lit.</p>
<p>Possible cause:</p> <ul style="list-style-type: none"> ▪ The cable is connected to a port that is not used. ▪ Defective network cable or connection ▪ Network problem ▪ Defective Ethernet interface on the motherboard

Network Problem-2
<p>Suggested action:</p> <ol style="list-style-type: none"> 1. Make sure the network cable is the correct type and connected to the correct network port on the E-3300/5300. 2. Check the cable connection to the network port. 3. Replace the cable with a new or tested cable. 4. Ask the network administrator to check other devices on the network. 5. If other devices are not functioning, it could be a problem with the network. 6. If the rest of the network operates correctly and the problem persists, replace the motherboard.

Network Problem-3
<p>Symptom:</p> <p>The system starts up slowly (seems to stop); and the Configuration Page shows an error on the "IP Address" line under "Network Setup".</p>
<p>Possible cause:</p> <p>Normal behavior. The system is searching for a nonexistent DHCP server. DHCP is enabled by default on the E-3300/5300, but the customer's network is not using DHCP. If the customer's network is using DHCP:</p> <ul style="list-style-type: none"> ▪ Defective network cable or connection. ▪ Network problem. ▪ Defective Ethernet interface on the motherboard.
<p>Suggested action:</p> <ol style="list-style-type: none"> 1. If the problem persists, ask the network administrator to change the default in the E-3300/5300 network setup. 2. If no LED is lit on the E-3300/5300's network port, check the cable connection to the E-3300/5300 and the network. Make sure the cable is the correct type. 3. Ask the network administrator to check other devices on the network. 4. If other devices are not functioning, it could be a problem with the network. 5. If the rest of the network operates correctly and the problem persists, replace the motherboard.

5.3.5 PRINTING PROBLEMS

The following symptoms are described in the tables below:

1. A test page or configuration page cannot be printed, or the images on the printed pages are abnormal.
2. The E-3300/5300 appears on the list of printers on the customer's workstation, but certain jobs do not print.
3. A print job stops after one or few pages.
4. Print Quality is poor.
5. Pages come out blank, or tinted with green or some other color.

Printing Problem-1
Symptom: A test page or configuration page cannot be printed, or the images on the printed pages are abnormal.
Possible cause: <ul style="list-style-type: none">▪ The copier is not ready to print.▪ Copier problem▪ Loose cable connection▪ Interface cable defective▪ Loose connection of the Gigabit Ethernet PCB▪ Gigabit Ethernet PCB defective▪ Video board defective▪ Corrupted system software.▪ HDD defective.

Printing Problem-1

Suggested action:

1. Make sure the copier main power switch is on and the copier is ready to print.
2. Check the copier operation panel for indications or messages about the copier status.
3. Check that the copier operates correctly. (Check if you can make hard copies without any problem)
4. Make sure the E-3300/5300 main power switch is in the "ON" position.
5. Shut down the Copier and the E-3300/5300. Then power on the Copier and the E-3300/5300.
6. Make sure the Fiery menu screen appears when you press the **Fierydriven** key.
7. Check if the Gigabit Ethernet PCB is inserted straight and connected firmly into the C slot on the copier. (☛ p.8 "Connecting E-3300/5300 to the Copier")
8. Check again that the video board is present and properly connected to the motherboard.
9. Replace the Gigabit Ethernet PCB.
10. Replace the video board.
11. If the problem persists, you may need to service the copier.
12. Try "Clear Server", "Factory Defaults", or re-install the system software. (☛ p.51 "Clearing the Queued Print Jobs in the E-3300/5300"/ p.53 "Restoring the E-3300/5300 to Factory Defaults")
13. Replace the HDD
14. If replacing the HDD does not correct the problem, make sure you install the old HDD back in the E-3300/5300.

Printing Problem-2
Symptom: The E-3300/5300 appears on the list of printers on the customer's workstation, but certain jobs do not print.
Possible cause: <ul style="list-style-type: none">▪ PostScript error▪ Application problem
Suggested action: <ol style="list-style-type: none">1. Make sure 'Print to PostScript Error' in Setup is set to Yes. Check for error messages on the E-3300/5300 output.2. Print a job from a different application to determine if the problem is associated with a particular application.3. Make sure the connection between the E-3300/5300 and the workstation is operating. To do this, download a test page from the workstation or print a simple test file.4. Resend the problem file.

Printing Problem-2
Symptom: The configuration page is completely or mostly blank.
Possible cause: <ul style="list-style-type: none">▪ Defective DIMM▪ Corrupted system software
Suggested action: <ol style="list-style-type: none">1. Check the DIMM and reconnect it, to remove oxidation on the connectors.2. Reinstall the system software. (☛ p.55 "System Software Installation Procedure")3. Replace the DIMM.

Printing Problem-3
<p>Symptom: A print job stops after one or few pages.</p>
<p>Possible cause:</p> <ul style="list-style-type: none"> ▪ Normal process, if this occurs when printing the first copy of a multi-copy print job. ▪ PostScript or application error ▪ Defective DIMM.
<p>Suggested action:</p> <ol style="list-style-type: none"> 1. The working area memory became full during ripping, and the printer switched to rip-only mode until all pages were ripped. 2. Cancel the E-3300/5300 print job. 3. If this fails to clear the problem, turn on and off the Copier and E-3300/5300. 4. If the problem persists, perform Clear Server. (☛ p.51 "Clearing the Queued Print Jobs in the E-3300/5300") 5. Check the DIMM and reconnect it, to remove oxidation on the connectors. 6. Reinstall the system software. (☛ p.55 "System Software Installation Procedure") 7. Replace the DIMM.

Printing Problem-4
<p>Symptom: Print Quality is poor.</p>
<p>Possible cause:</p> <ul style="list-style-type: none"> ▪ Missing or outdated printer description file. ▪ The application cannot find the necessary printer description file. ▪ Problem with the copier ▪ Out of calibration or calibration information/curves on the active partition are corrupted. ▪ Calibration information/curves on the active partition are corrupted.

Printing Problem-4

Suggested action:

1. Make sure the necessary printer description file is installed.

For information on printer files, see "Printing from Windows and Printing from Mac OS" on the user documentation CD.

1. Test the copier and service it if necessary (see the copier service manual).
2. Start ColorWise Pro Tools from a client computer and click the Calibrator icon. Then click Restore Device in the calibrator window. Restore Device restores the E-3300/5300 calibration information to the factory defaults. If restoring the default calibration does not solve the problem, you may need to service the copier.
3. If restoring the default calibration corrects the color quality, a custom calibration may have been the cause of the problem. Ask the site administrator to recalibrate the E-3300/5300.
4. If the problem persists after recalibration, the calibration information on the HDD may be corrupted. Reinstall the system software. (☛ p.55 "System Software Installation Procedure")
5. If the problem persists, the HDD may be corrupted. Verify that all HDD cabling is correct.
6. If HDD cabling is correct, you may need to replace the HDD.

Printing Problem-5

Symptom:

Pages come out blank, or tinted with green or some other color.

Possible cause:

- Bad connection between the E-3300/5300 and the Copier.
- Problem with the copier.

Suggested action:

1. Turn on and off the Copier and E-3300/5300.
2. Test the copier and service it if necessary (refer to the copier service manual).

If the customer can print the Configuration Page from the copier operation panel but cannot print a job from a computer on the network, ask the network administrator to do the following:

- Check all components of the network, including cables, connectors, network adapter boards, and network drivers.
- Activate the network and use it to communicate with other printers.
- Confirm that the applicable network setting in Setup (such as AppleTalk zone, IP address, Subnet mask, and Gateway address) match the settings used in the network.

 Note

- EPS file generation is not fully standardized among applications. Some users may encounter problems while printing certain EPS files.

5.4 TEST THE VOLTAGE SUPPLIES

To check if the power supply is working, use a multimeter at the following locations on the power supply unit.

Test the voltages on the ends of the connectors coming from the power supply unit. The following table lists the power connectors.

Connector No.	Connected To	Position	Output	Wire Color
20-pin connector	Motherboard (PW1)	1	+3.3V	Orange
		2	+3.3V	Orange
		3	Ground	Black
		4	+5V	Red
		5	Ground	Black
		6	+5V	Red
		7	Ground	Black
		8	PW-OK	Gray
		9	+5Vsb	Violet
		10	+12V	Yellow
		11	+3.3V and +3.3V Remote Sense	Orange and Brown
		12	-12V	Blue
		13	Ground	Black
		14	PS-ON	Green
		15	Ground	Black
		16	Ground	Black
		17	Ground	Black

Connector No.	Connected To	Position	Output	Wire Color
		18	(Not Connected)	-
		19	+5V	Red
		20	+5V	Red
4-pin connector	PW2	1	Ground	Black
		2	Ground	Black
		3	+12V	Yellow and Black
		4	+12V	Yellow and Black

Color Controller E-3300/E-5300 (D650/D651)

6. DETAILED SECTION DESCRIPTIONS

6.1 BLOCK DIAGRAM AND FUNCTIONS

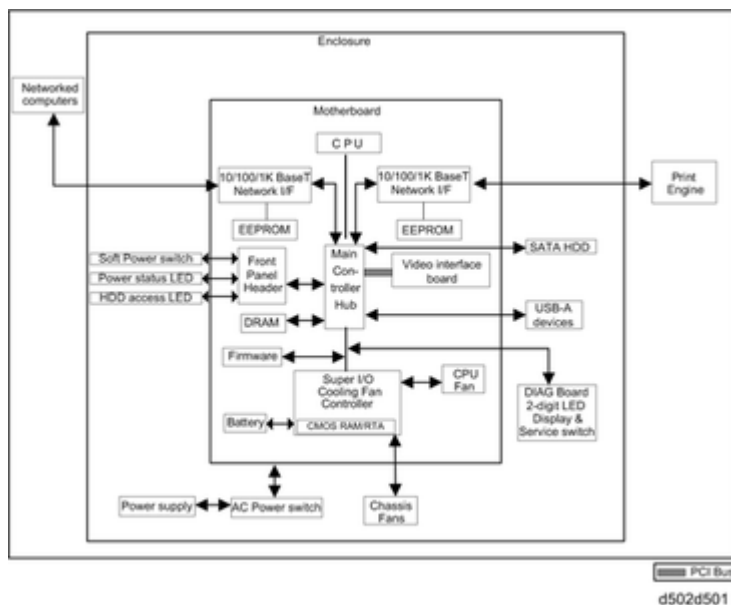

Components

Component	Type	Configuration
Processor	Intel Pentium Dual Core E5300	2.60GHz
Hard Drive	Serial ATA	160GB
SDRAM	PC3200 DDR2	1GB, 240 pin
BIOS ROM	Flash	8MB
EEPROM	EEPROM	1Kbit

Networking

Cable requirements:

- 10BaseT (Ethernet): Unshielded Twisted Pair (UTP), Category 3 or higher
- 100BaseTX (Fast Ethernet): UTP, Category 5 or higher (4-pair/8-wire, short length)
- 1000BaseT (Gigabit Ethernet): UTP, Category 5e or higher (4-pair/8-wire, short-length)

 Note

- If the print engine is 230V, use a shielded network cable.

Video Board

The Video Board functions include:

- High speed data transmission
- High speed data decompression
- Engine output at maximum rated output speed

The video interface controls such aspects of the print job as:

- Hardware decompression
- Print quality enhancement technologies

Hard Disk Drive

The hard disk drive is used to optimize many parts of the printing system as well as improving throughput and ease-of-use. The hard disk drive stores the following information:

- System software
- Non-volatile spooled print jobs
- Additional storage for compressed pages
- Non-volatile record of printed jobs (Job Log)
- Resource storage space for downloaded fonts

Non-Volatile Memory

- The 8MB Flash Memory contains the BIOS, etc.
- The 1Kbit EEPROM holds the MAC address data.

Volatle Memory

- SDRAM is one 1GB, PC3200, Double Data Rate 2 (DDR2), 240-pin.

Color
Controller
E-3300/E-5300
(D650/D651)

6.2 PRINT DATA PROCESSING

6.2.1 FLOW CHART

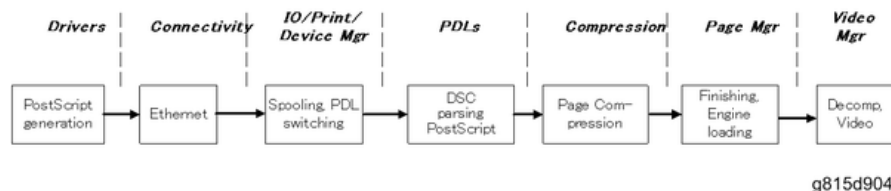

The key roles of each part of the print system are outlined below.

- The drivers are responsible for generating the page description on the host system and for transmitting data to the printer.
- The I/O manager mediates the connection with the network interface and establishes a device or print manager connection.
- The print manager is responsible for spooling the job (if appropriate) and for feeding jobs to the correct PDL interpreter.
- The PDL interpreters are responsible for turning page descriptions into rendered pages and for parsing job management comments.
- The compression subsystem manages compressed pages in memory.
- The page manager coordinates pages for sending to the engine for the most efficient printing, finishing, and accessory handling.
- The video subsystem is responsible for decompressing pages and feeding the engine with appropriate engine signals. The video subsystem also handles certain print quality processing functions.

7. SPECIFICATIONS

7.1 GENERAL SPECIFICATIONS

Configuration:	External Type Printer Controller Unit
Motherboard:	CPU: Intel Pentium Dual Core E5300 2.60GHz Network Interface: RJ-45 Network port (1000-Base/100-Base/10-BaseT)
Memory:	1GB (standard and max.) 240 pin SDRAM: PC3200 DDR2
HDD:	Internal HDD: 160GB
Operating System:	Linux
Network Protocols:	AppleTalk (Auto switching) TCP/IP (IPv4/IPv6) SMB
Printer Description Languages:	Adobe PostScript3 (Standard), PCL6/5c (Standard)
Supported Driver Language:	English, French, German, Italian, Spanish and Dutch
Print Resolution:	1200dpi (1bit), 600dpi (4-bit)
Gradation:	1 bit/pixel, 4 bits/pixel
Scan Resolution:	Max. 600 dpi
Scan Source:	ADF / Exposure Glass
Scan Sides:	Simplex / Duplex

Color
Controller
E-3300/E-5300
(D650/D651)

General Specifications

Scan Destination:	Hold Queue / MailBox / Email / FTP Server/ Internet Fax Client PC Disk (E-3300/5300 Remote Scan only)
Scan Format:	PDF/ TIFF/ JPEG
Printing Speed:	AT-C3a: 30 ppm in Plain/Middle Thick mode 17.5 ppm in Thick/OHP mode (depending on paper type) AT-C3b: 35 ppm in Plain/Middle Thick mode 17.5 ppm in Thick/OHP mode (depending on paper type) AP-C3c: 45 ppm in Plain/Middle Thick mode 17.5 ppm in Thick/OHP mode (depending on paper type) AP-C3d: 55 ppm in Plain mode 25 ppm in Middle Thick mode 17.5 ppm in Thick/OHP mode (depending on paper type)
Resident Fonts:	PostScript: 138 fonts PCL: 80 AGFA fonts
Power Consumption:	Rated: 80W
Noise Emission: (Sound Power Level)	Sound Power Level: Less than 51db(A) Sound Pressure Level: Less than 41db(A)
Dimensions (W x D x H):	124.3mm x 362.5mm x 294.6mm, 4.9" x 14.3" x 11.6"
Weight:	5.8 kg (12.5 lb)