

More Service Manuals at www.service-manual.net

D086/D087 POINT TO POINT DIAGRAM (1/2)

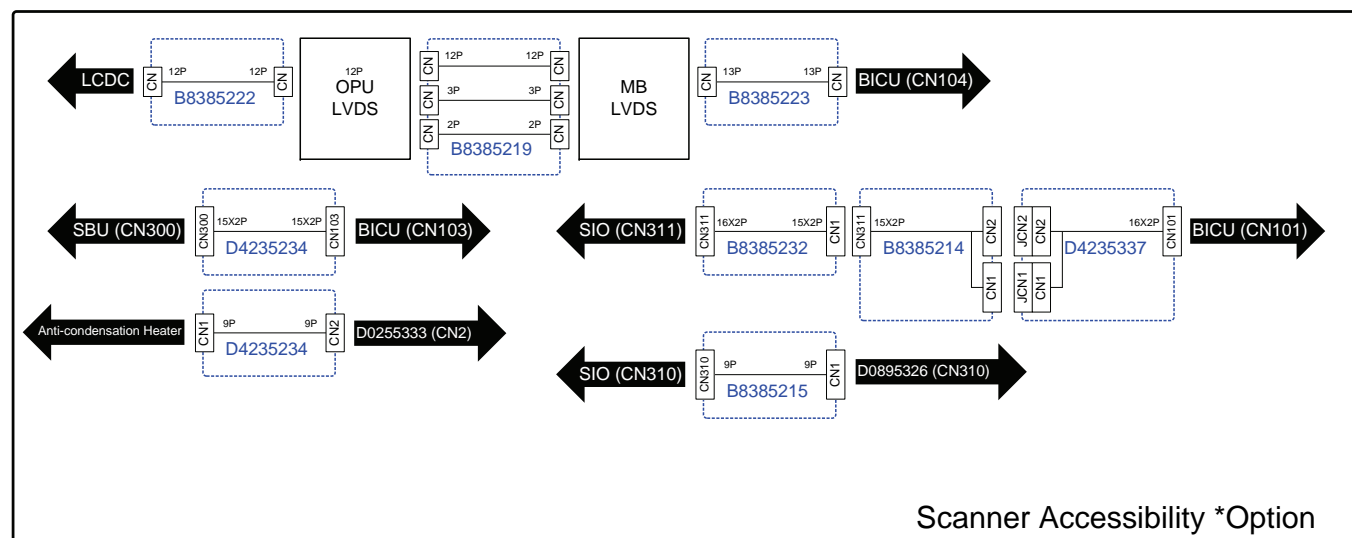
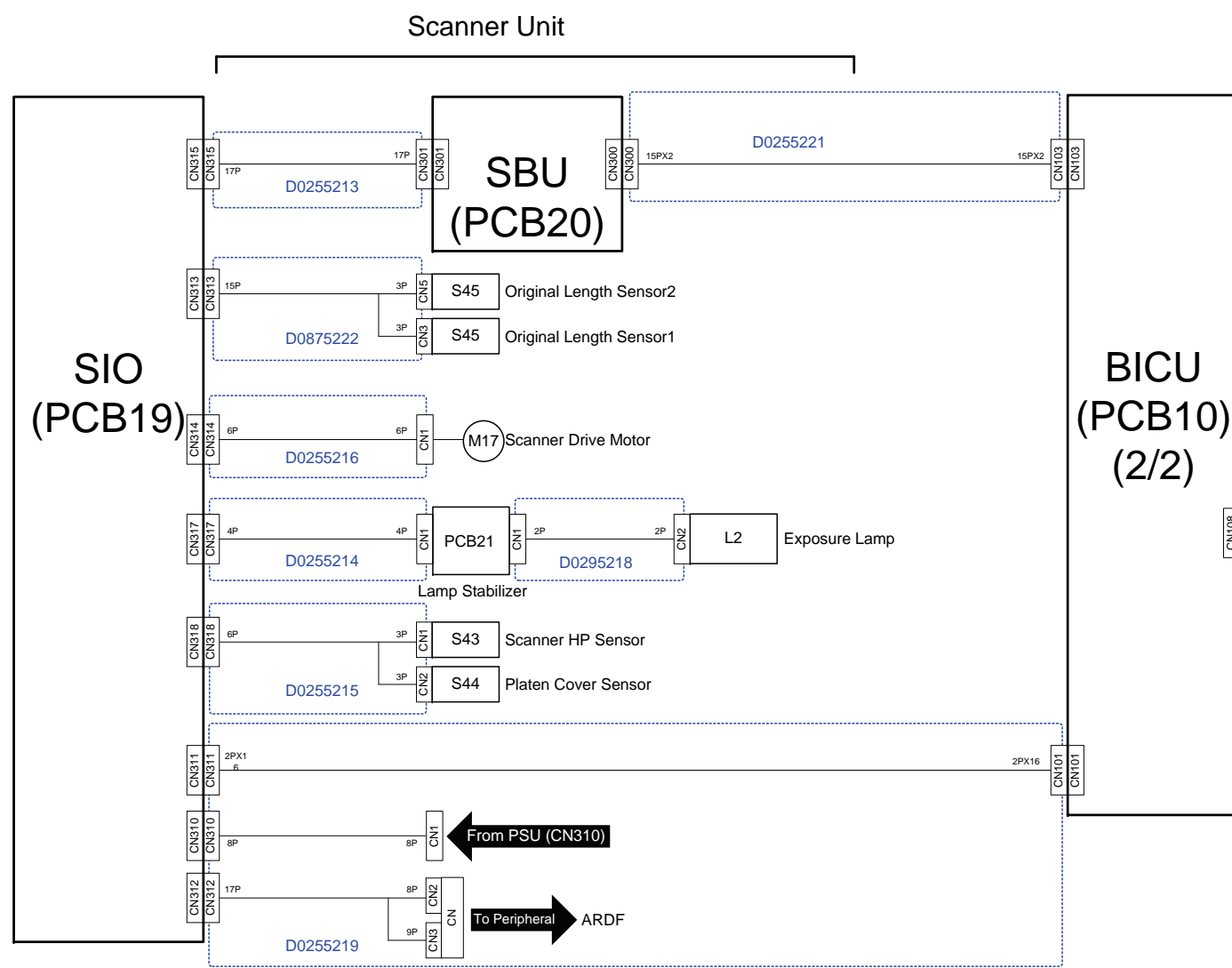

D086/D087 POINT TO POINT DIAGRAM (2/2)

D086/D087 ELECTRICAL COMPONENT LAYOUT (1/2)

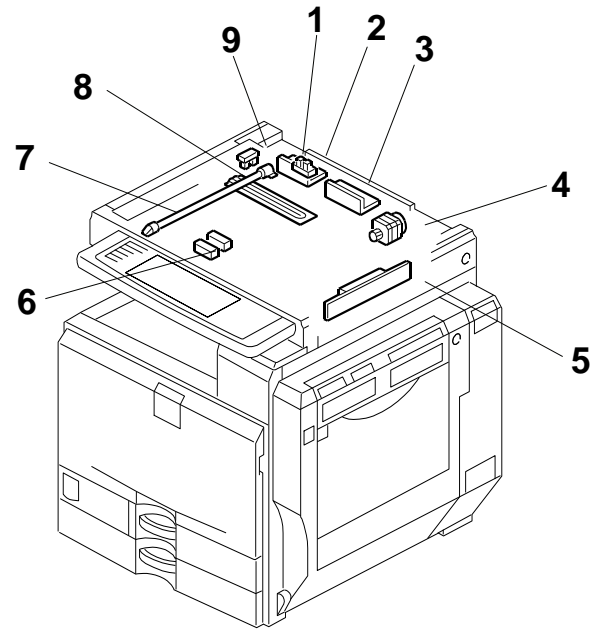
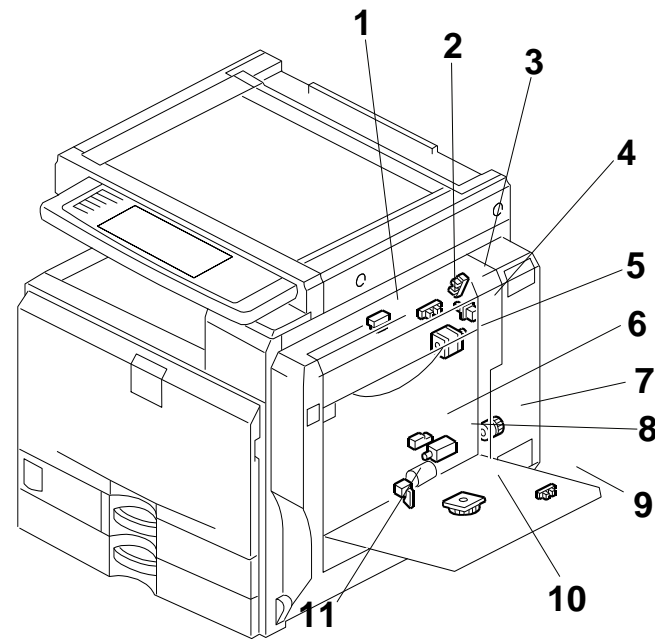

Fig-1 d027v101



d027v102 **Fig-2**

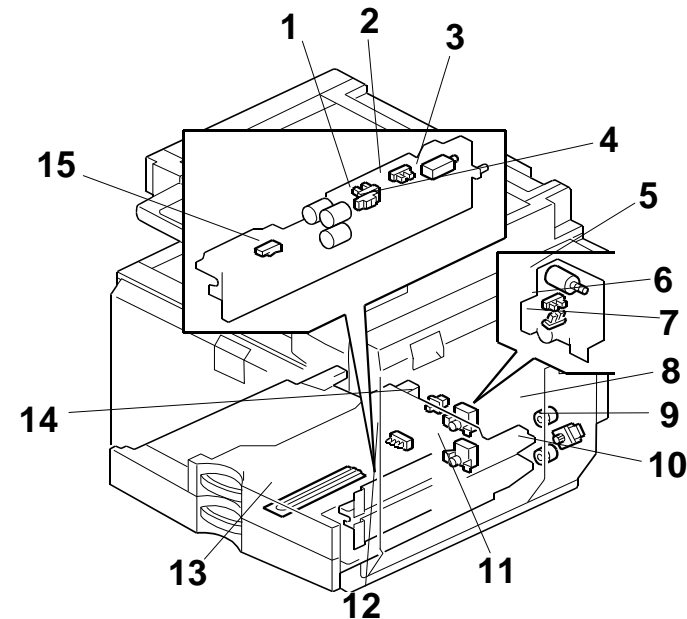
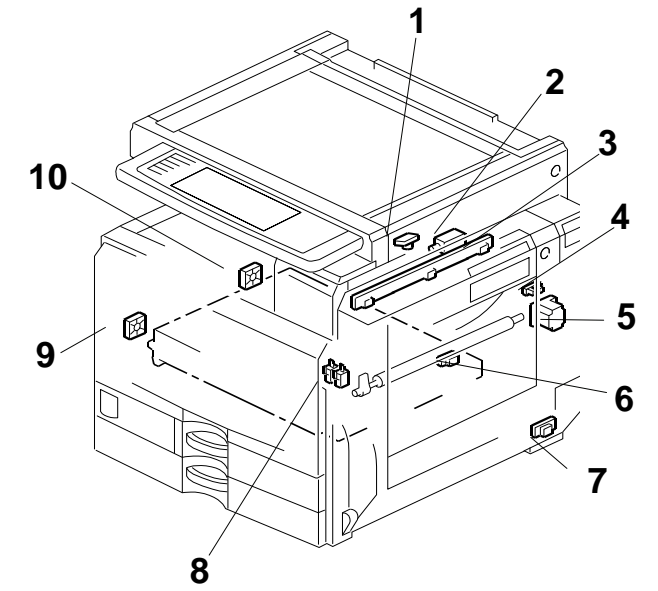
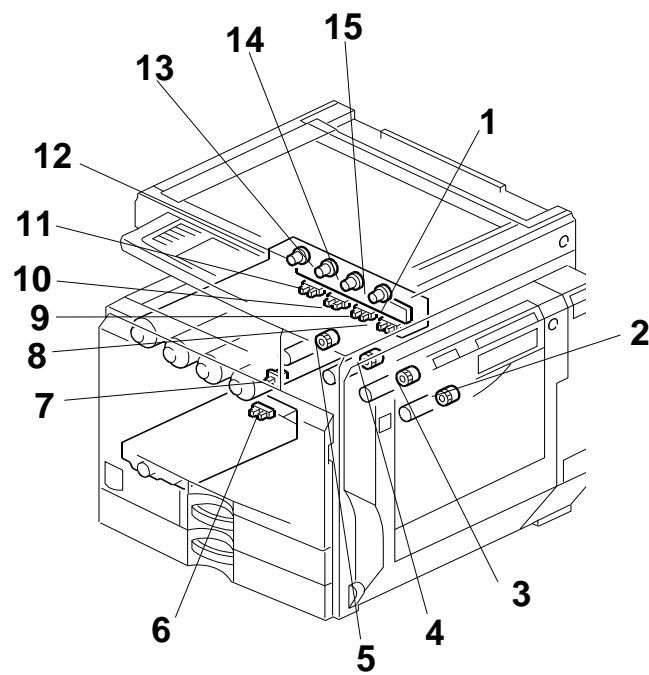

Fig-3 d088v103



d086V104

Fig-4



B222V105

Fig-5

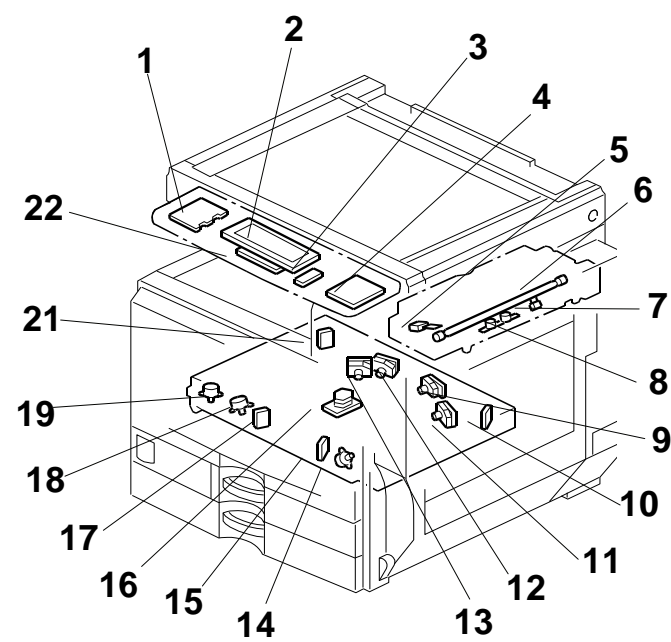

B222V106

Fig-6

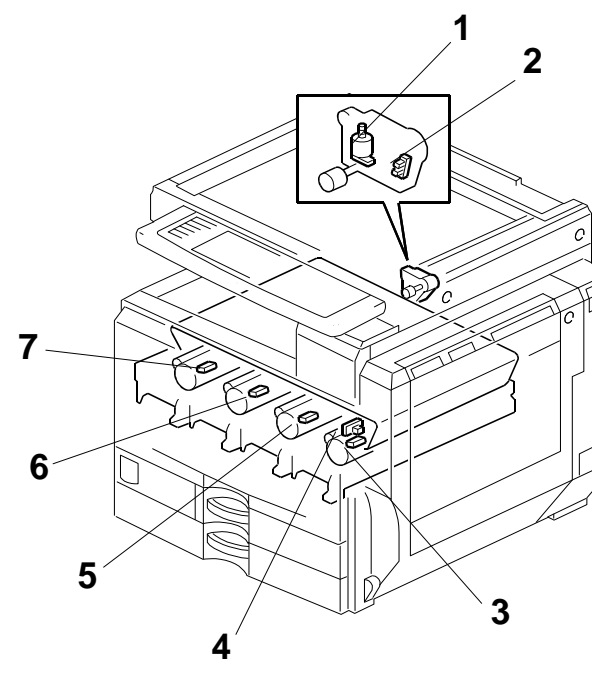

B222V107

Fig-7

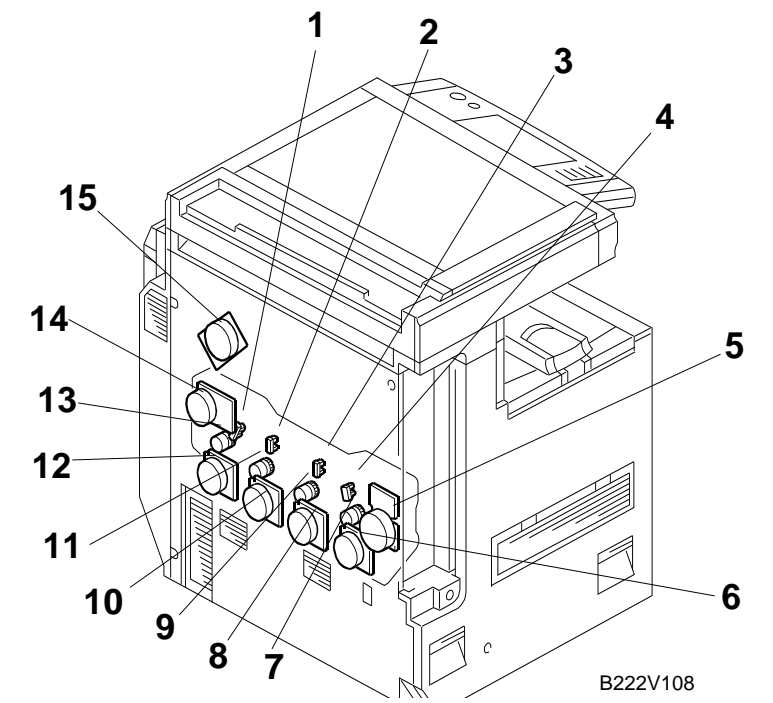

B222V108

Fig-8

D086/D087 ELECTRICAL COMPONENT LAYOUT (2/2)

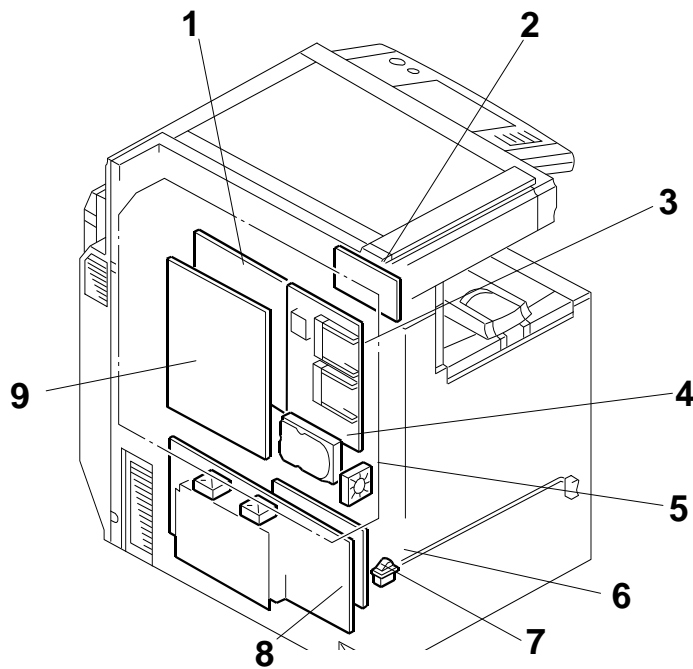

Fig-9

d027v109

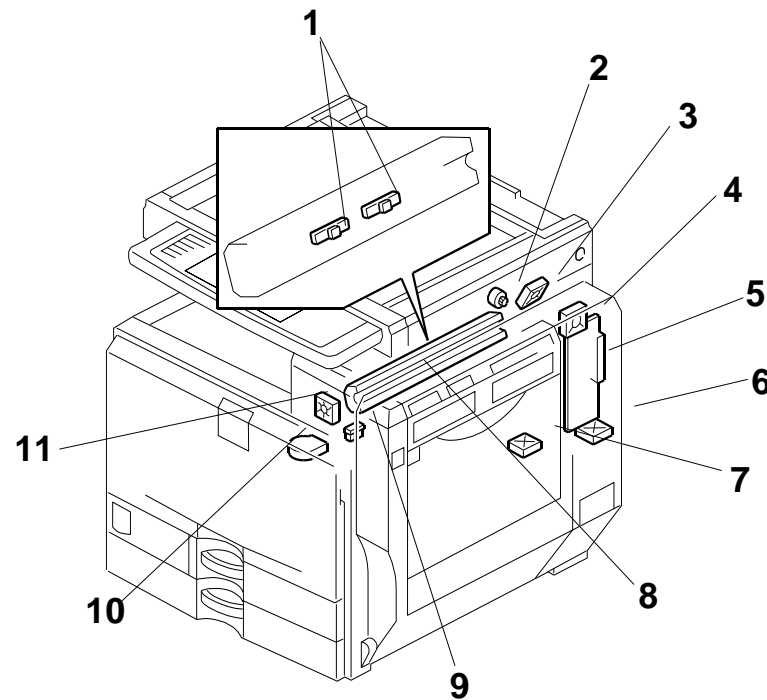

Fig-10

d027V110

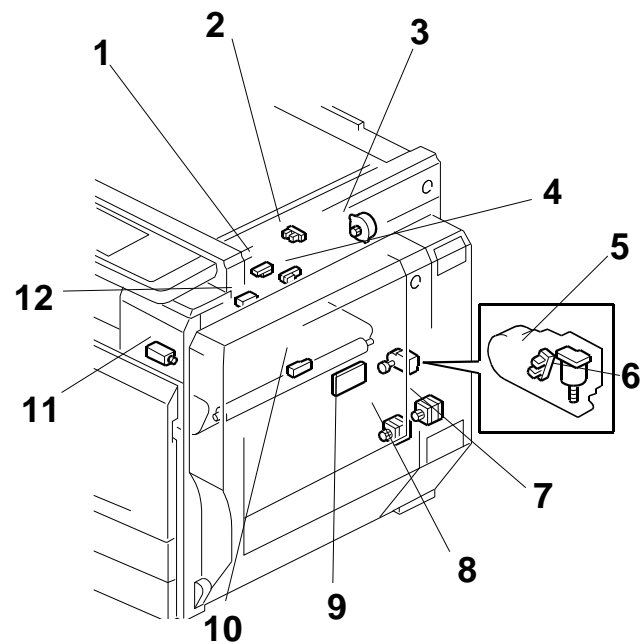

Fig-11

d027v111

Symbol	Index No.	Description	P to P	Page
PCBs				
PCB1	-	Counter Interface Board	-	-
PCB2	F9-2	HVPS: TTS	F13	1/2
PCB3	F9-7	HVPS: C/B	E10	1/2
PCB4	F9-9	I/OB	K8	1/2
PCB5	F5-1	RFID	D13	1/2
PCB6	F9-8	PSU	C4	1/2
PCB7	F10-5	IH Inverter Board	B5	1/2
PCB8	F11-9	HVPS - Discharge Plate	I9	1/2
PCB9	F9-3	Controller Board	D9	2/2
PCB10	F9-1	BICU	D6/D8	1/2
PCB11	F6-9	LDB: K	E8/F8	1/2
PCB12	F6-11	LDB: M	E8	1/2
PCB13	F6-12	LDB: C	E8	1/2
PCB14	F6-13	LDB: Y	E8/F8	1/2
PCB15	F6-21	Laser Synchronizing Detector Board-KC-TE	C8	1/2
PCB16	F6-17	Laser Synchronizing Detector Board-KC-LE	C8	1/2
PCB17	F6-15	Laser Synchronizing Detector Board-YM-TE	C8	1/2
PCB18	F6-10	Laser Synchronizing Detector Board-YM-LE	C8	1/2
PCB19	F1-3	SIO	E2	2/2
PCB20	F1-5	SBU	C5	2/2
PCB21	F1-1	Lamp Stabilizer	D5	2/2
PCB22	F6-22	LCDC	G6	1/2
PCB23	F6-2	Inverter TFT	H6	1/2
PCB24	F6-1	OPU-L	G5	1/2
PCB25	F6-4	OPU-R	G7	1/2
Heaters				
H1	F3-13	Tray Heater (Option)	A5	1/2
H2	F3-13	Tray Heater (Option for PTU)	A5	1/2
H3	F1-8	Anti-condensation Heater	B6	1/2

Symbol	Index No.	Description	P to P	Page
Sensors				
S1	F4-3	ID Sensors	G13	1/2
S2	F11-4	Junction Paper Jam	B13	1/2
S3	F11-1	Paper Exit	B13	1/2
S4	F11-12	Fusing Exit	B13	1/2
S5	F11-2	Paper Overflow	B13	1/2
S6	F2-1	Duplex Entrance	J9	1/2
S7	F2-6	Duplex Exit	I9	1/2
S8	F11-10	Fusing Entrance	H9	1/2
S9	F2-2	Duplex Door	H9	1/2
S10	F2-9	By-pass Paper Length Sensor	H9	1/2
S11	F2-10	By-pass Paper Size	H9	1/2
S12	F4-6	Registration	D9	1/2
S13	F5-6	Waste Toner	D9	1/2
S14	F3-6	Tray1 Paper Height Sensor1	C10	1/2
S15	F3-7	Tray1 Paper Height Sensor2	C10	1/2
S16	F3-6	Tray2 Paper Height Sensor1	C10	1/2
S17	F3-7	Tray2 Paper Height Sensor2	B10	1/2
S18	F3-15	Tray1 Paper Feed	G10	1/2
S19	F3-4	Tray1 Vertical Transport	G10	1/2
S20	F3-1	Tray1 Paper End	G10	1/2
S21	F3-2	Tray1 Paper Lift	G10	1/2
S22	F3-15	Tray2 Paper Feed	F10	1/2
S23	F3-4	Tray2 Vertical Transport	F10	1/2
S24	F3-1	Tray2 Paper End	E10	1/2
S25	F3-2	Tray2 Paper Lift	E10	1/2
S26	F5-11	Toner End Sensor:K	C13	1/2
S27	F5-10	Toner End Sensor:Y	D13	1/2
S28	F5-8	Toner End Sensor:C	D13	1/2
S29	F5-9	Toner End Sensor:M	D13	1/2
S30	F8-1	Drum Gear Position Sensor:K	H3	1/2
S31	F8-2	Drum Gear Position Sensor:M	I3	1/2
S32	F8-3	Drum Gear Position Sensor:C	H3	1/2
S33	F8-4	Drum Gear Position Sensor:Y	I3	1/2
S34	F7-4	ITB Rotation	E14	1/2
S35	F4-7	Temperature/Humidity	B10	1/2
S36	F4-1	Thermopile	J14	1/2
S37	F10-9	Heating Roller Rotation	H13	1/2
S38	F4-4	Pressure Roller Contact	H13	1/2
S39	F7-3	TD Sensor:K	G2	1/2
S40	F7-5	TD Sensor:M	G2	1/2
S41	F7-6	TD Sensor:C	G2	1/2
S42	F7-7	TD Sensor:Y	H2	1/2
S43	F1-9	Scanner H.P	E5	2/2
S44	F1-2	Platen Cover	E5	2/2
S45	F1-6	Original Width Sensor1,2	C5	2/2
FANs				
FAN1	F10-7	Third Duct	K3	1/2
FAN2	F4-9	Airflow Fan - Front	K2	1/2
FAN3	F4-12	Airflow Fan - Rear	K2	1/2
FAN4	F10-10	IH Coil	I13	1/2
FAN5	F10-4	Fusing	J13	1/2
FAN6	F10-3	Second Duct	J13	1/2
FAN7	F10-11	Paper Exit	J13	1/2
FAN8	F10-6	IH Inverter	J3	1/2
FAN9	F9-5	HDD	E11	2/2
Others				
TS1	F6-8	Thermostat - Pressure Roller	E1	1/2
TS2	F6-8	Thermostat - Pressure Roller	E1	1/2
TS3	F10-1	Thermostat - IH	B6	1/2
TH1	F6-7	Thermistor - Pressure Roller	D1	1/2
TH2	F6-5	Thermistor - Heating Roller	D1	1/2
HDD1	F9-4	HDD	C11	2/2
-	F10-8	IH Coil Unit		1/2

Symbol	Index No.	Description	P to P	Page
Motors				
M1	F2-5	Duplex Inverter	J9	1/2
M2	F11-7	Duplex/By-pass	I13	1/2
M3	F11-8	Registration	I13	1/2
M4	F3-9	Paper Feed	I13	1/2
M5	F3-5	Tray1 Lift	C10	1/2
M6	F3-11	Tray2 Lift	B10	1/2
M7	F8-14	ITB Unit Drive	B13	1/2
M8	F8-15	Fusing/Paper Exit	C13	1/2
M9	F8-8	Drum/Development Motor:C	F3	1/2
M10	F8-6	Drum/Development Motor:Y	F3	1/2
M11	F8-12	Drum/Development Motor:K	F3	1/2
M12	F8-10	Drum/Development Motor:M	F3	1/2
M13	F7-1	ITB Contact	F13	1/2
M14	F11-6	PTR Contact	G13	1/2
M15	F8-5	Toner Transport	F13	1/2
M16	F4-5	Pressure Roller Contact	H13	1/2
M17	F1-4	Scanner Drive	D5	2/2
M18	F6-14	L2 Lens Positioning Motor:M	D8	1/2
M19	F6-18	L2 Lens Positioning Motor:C	D8	1/2
M20	F6-19	L2 Lens Positioning Motor:Y	D8	1/2
M21	F6-16	Polygon Mirror	D8	1/2
Clutches				
MC1	F2-7	By-pass Feed	I9	1/2
MC2	F3-8	Tray1 Paper Feed	B10	1/2
MC3	F3-10	Tray2 Paper Feed	B10	1/2
MC4	F5-2	Toner Supply Clutch:K	E14	1/2
MC5	F5-3	Toner Supply Clutch:M	E14	1/2
MC6	F5-4	Toner Supply Clutch:C	E14	1/2
MC7	F5-5	Toner Supply Clutch:Y	E14	1/2
MC8	F5-12	Toner Bottle Clutch - K	D13	1/2
MC9	F5-15	Toner Bottle Clutch - M	C13	1/2
MC10	F5-14	Toner Bottle Clutch - C	C13	1/2
MC11	F5-13	Toner Bottle Clutch - Y	C13	1/2
MC12	F8-13	Development Clutch:K	I3	1/2
MC13	F8-11	Development Clutch:M	I3	1/2
MC14	F8-9	Development Clutch:C	I3	1/2
MC15	F8-7	Development Clutch:Y	I3	1/2
Solenoids				
SOL1	F11-11	Junction Gate 1 Solenoid	A14	1/2
SOL2	F2-8	By-pass Pick-up	I9	1/2
SOL3	F3-3	Tray1 Pick-up	G10	1/2
SOL4	F3-3	Tray2 Pick-up	F10	1/2
SOL5	F4-2	ID Sensor Shutter	G14	1/2
Switches				
SW1	F2-4	Right Door Open	B13	1/2
SW2	F2-10	By-pass Paper Detection	I9	1/2
SW3	F5-7	Waste Toner Bottle Set	D10	1/2
SW4	F3-14	Tray1 Set	D10	1/2
SW5	F3-12	Tray2 Paper Size	C10	1/2
SW6	F9-6	Main	A3	1/2
SW7	F4-8	Interlock	B3	1/2
Lamps				
L1	F6-6	Pressure Roller Fusing Lamp	E1	1/2
L2	F1-7	Exposure Lamp	D6	2/2

FINISHER (B408) Point to Point Diagram

Rev. 10/2003

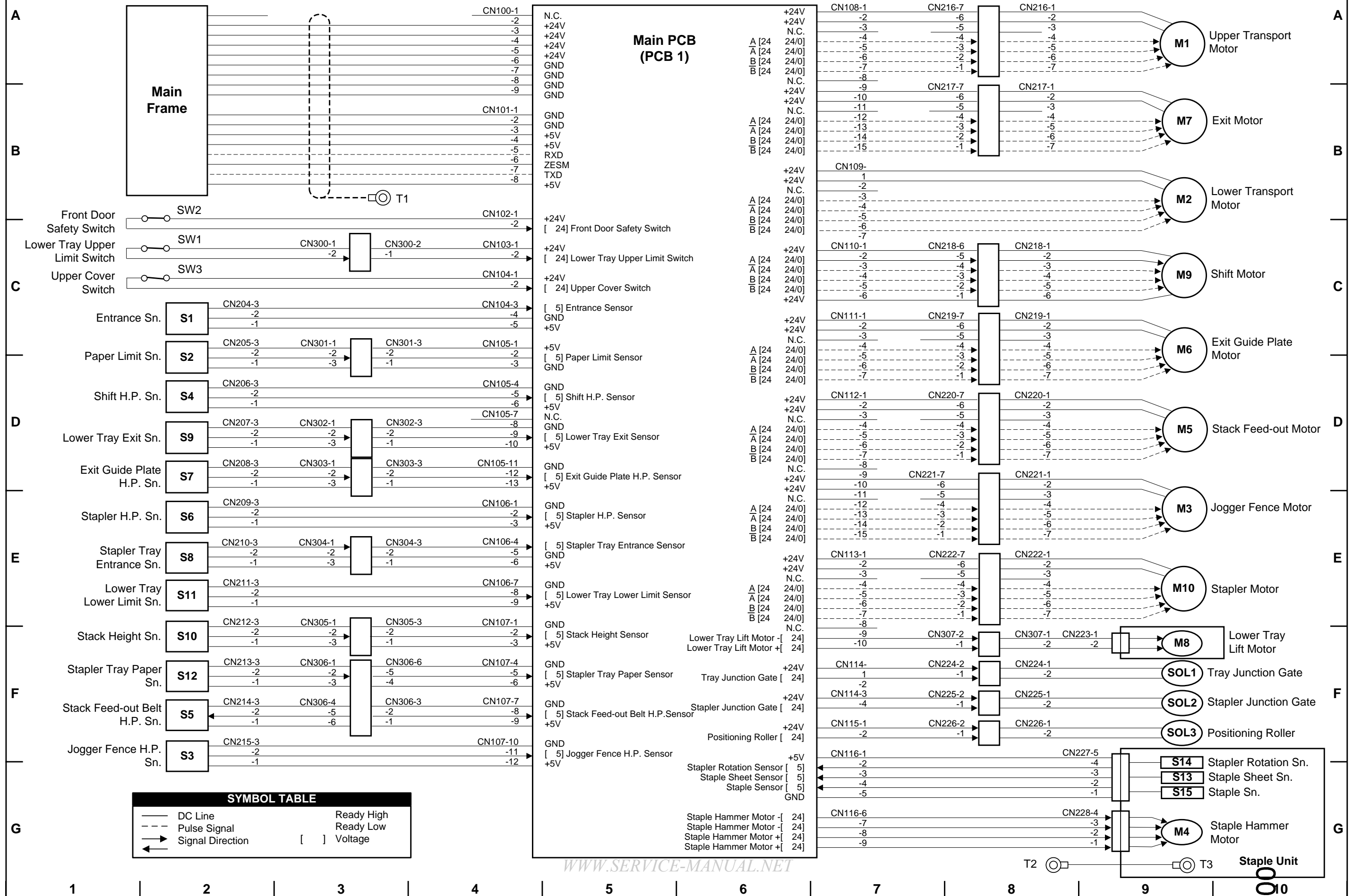

30030

1000-SHEET FINISHER (B408) ELECTRICAL COMPONENT LAYOUT

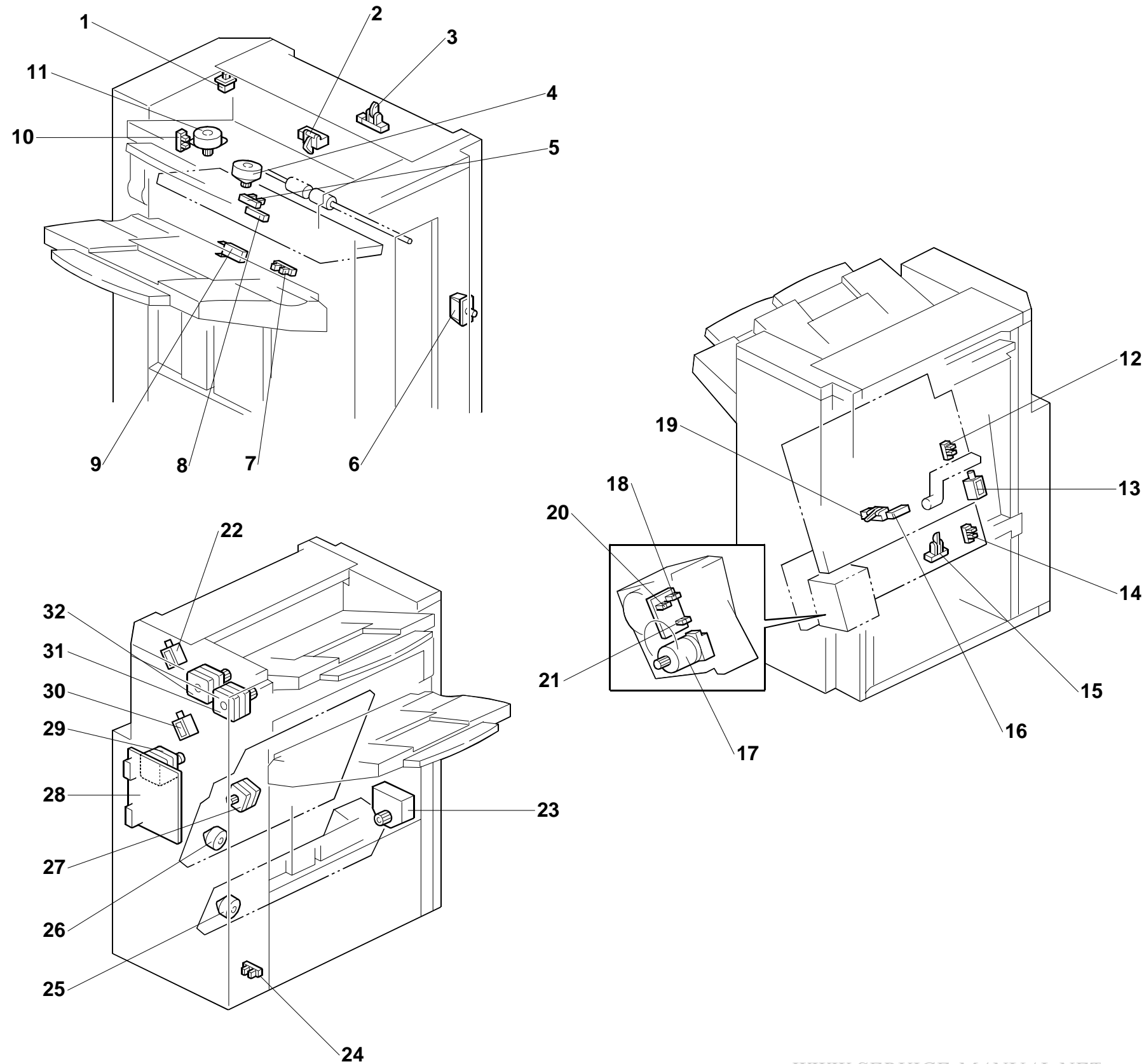

Symbol	Name	Index No.	P to P
Motors			
M1	Upper Transport	32	A9
M2	Lower Transport	29	B9
M3	Jogger Fence	26	E9
M4	Staple Hammer	17	G4
M5	Stack Feed-out	27	D9
M6	Exit Guide Plate	4	C9
M7	Exit	31	B9
M8	Lower Tray Lift	23	F9
M9	Shift	11	C9
M10	Stapler	25	E9
Sensors			
S1	Entrance	3	C2
S2	Paper Limit	2	D2
S3	Jogger Fence HP	12	F2
S4	Shift HP	10	D2
S5	Stack Feed-out Belt HP	19	F2
S6	Stapler HP	14	E2
S7	Exit Guide Plate HP	5	D2
S8	Stapler Tray Entrance	15	E2
S9	Lower Tray Exit	8	D2
S10	Stack Height	7	F2
S11	Lower Tray Lower Limit	24	E2
S12	Stapler Tray Paper	16	F2
S13	Staple Sheet	18	G9
S14	Stapler Rotation HP	20	G9
S15	Staple	21	G9
Solenoids			
SOL1	Tray Junction Gate	22	F9
SOL2	Stapler Junction Gate	30	F9
SOL3	Positioning Roller	13	F9
Switches			
SW1	Lower Tray Upper Limit	9	C2
SW2	Front Door Safety	6	C2
SW3	Upper Cover	1	C2
PCBs			
PCB1	Main	28	A5

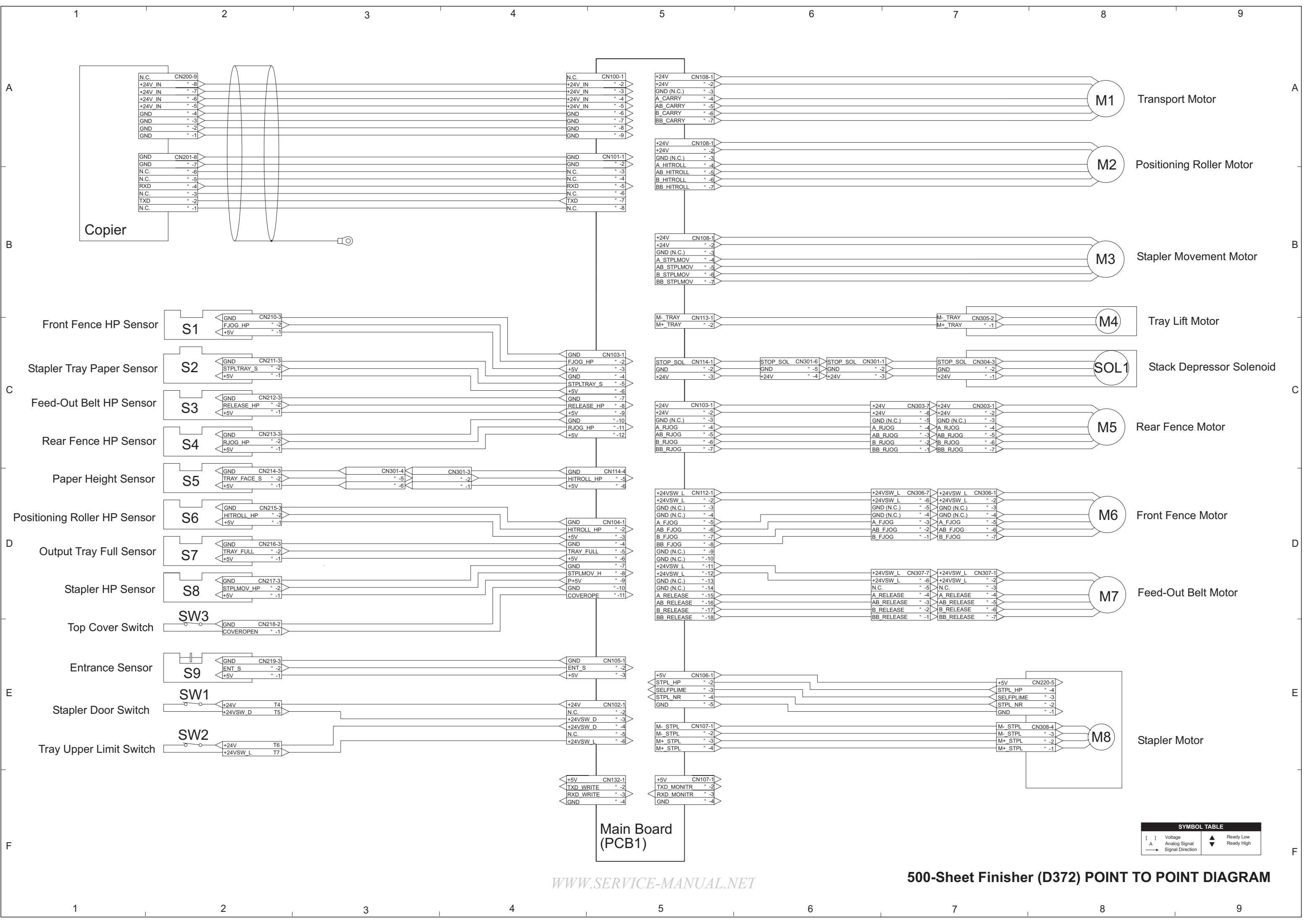

500-Sheet Finisher (D372) ELECTRICAL COMPONENT LAYOUT

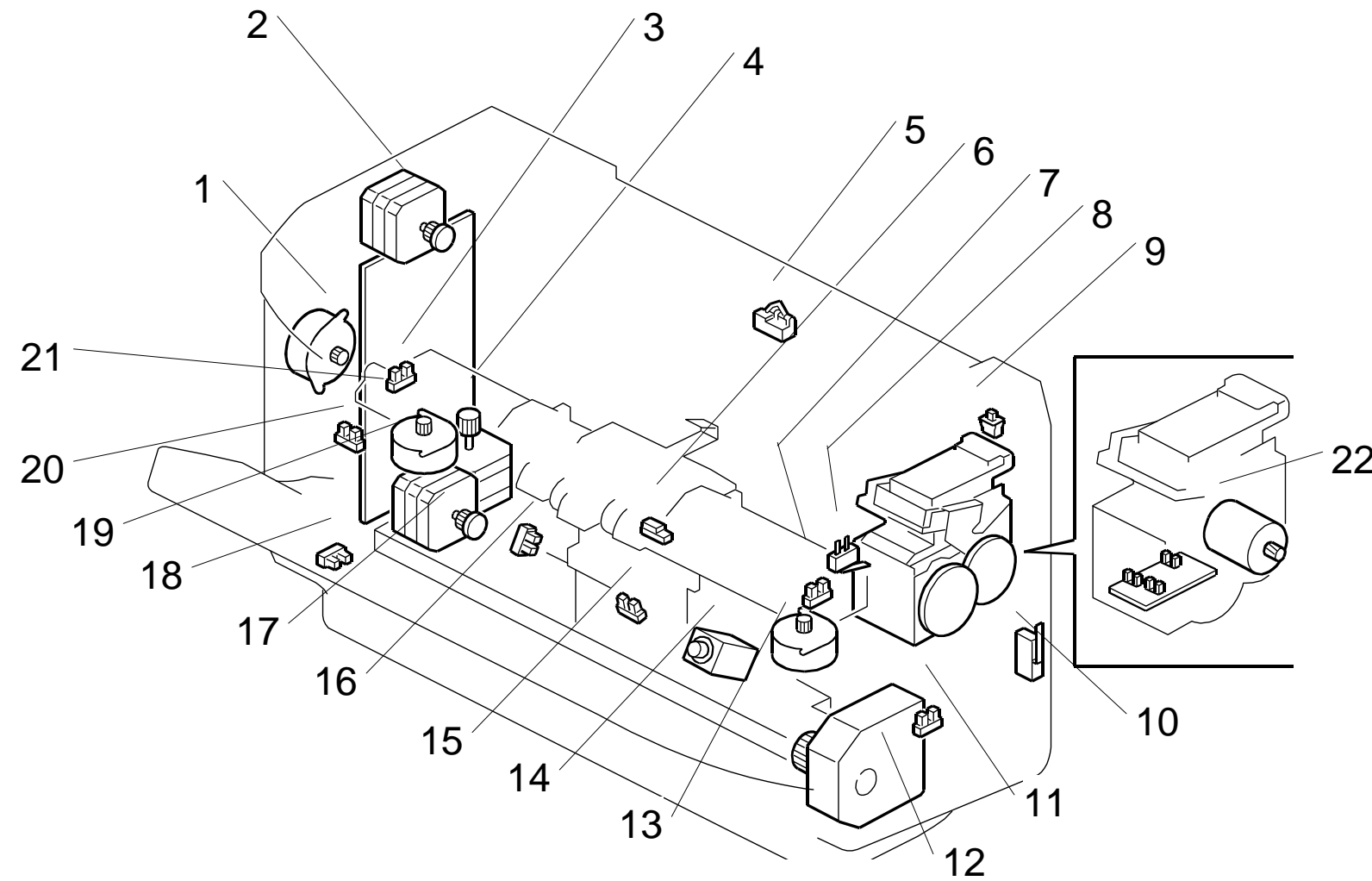

Symbol	Name	Index No.	P to P
Motors			
M1	Transport Motor	2	A8
M2	Positioning Roller Motor	1	A8
M3	Stapler Movement Motor	4	B8
M4	Tray Lift Motor	12	C8
M5	Rear Fence Motor	19	C8
M6	Front Fence Motor	13	D8
M7	Feed-Out Belt Motor	17	D8
M8	Stapler Motor	22	E8
Sensors			
S1	Front Fence HP Sensor	7	C2
S2	Stapler Tray Paper	6	C2
S3	Feed-Out Belt HP	15	C2
S4	Rear Fence HP Sensor	3	C2
S5	Paper Height Sensor	16	D2
S6	Positioning Roller HP Sensor	20	D2
S7	Output Tray Full Sensor	18	D2
S8	Stapler HP Sensor	11	D2
S9	Entrance Sensor	5	E2

Symbol	Name	Index No.	P to P
Switches			
SW1	Stapler Door Switch	10	E2
SW2	Tray Upper Limit Switch	8	E2
SW3	Top Cover Switch	9	E2
Solenoid			
SOL1	Stack Depressor	14	C8
PCB			
PCB1	Main Board	21	F5

Bridge Unit (D386) Point to Point Diagram

A

B

C

D

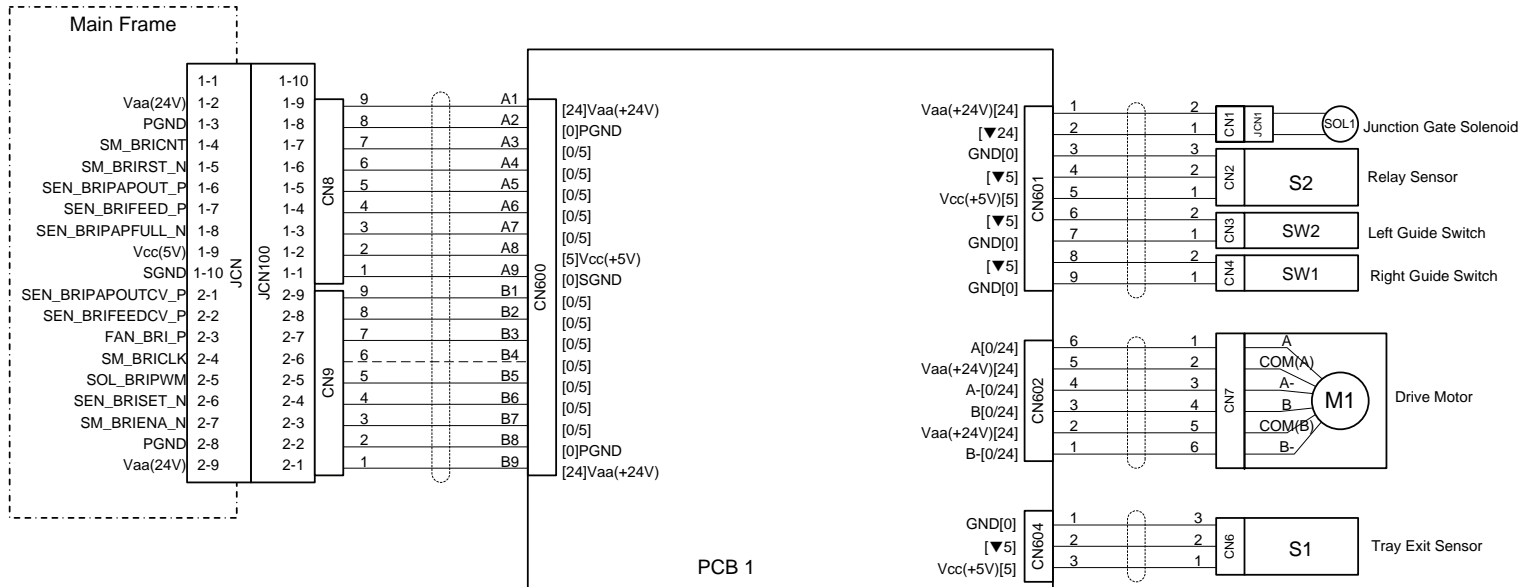

SYMBOL TABLE	
—————	DC Line
- - - - -	Pulse Signal
—————>	Signal Direction
▲	Ready Low
▼	Ready High
[]	Voltage

BRIDGE UNIT (D386) ELECTRICAL COMPONENT LAYOUT

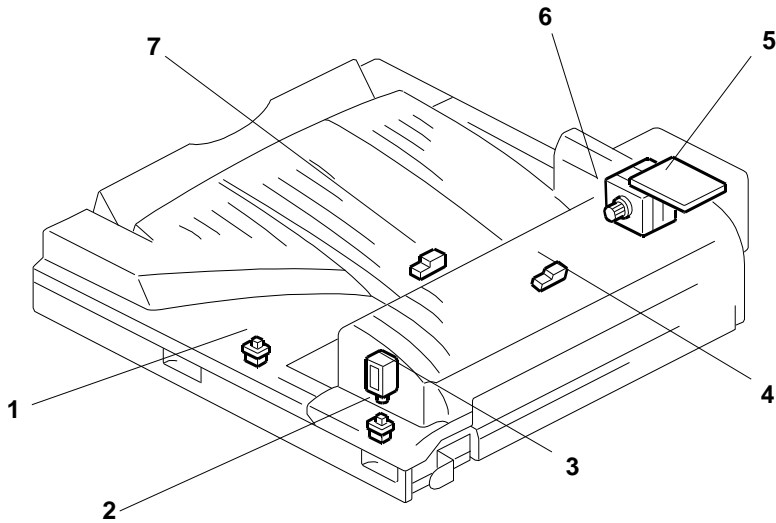

Symbol	Name	Index No.	P-to-P
Motors			
M1	Drive	6	B5
Sensors			
S1	Tray Exit	4	C5
S2	Relay	7	B5
Switches			
SW1	Right Guide	2	B5
SW2	Left Guide	1	B5
PCBs			
PCB1	Bridge Unit Control	5	B3-C4
Magnetic Clutches			
MC1	Junction Gate	3	B5

D387 POINT TO POINT DIAGRAM

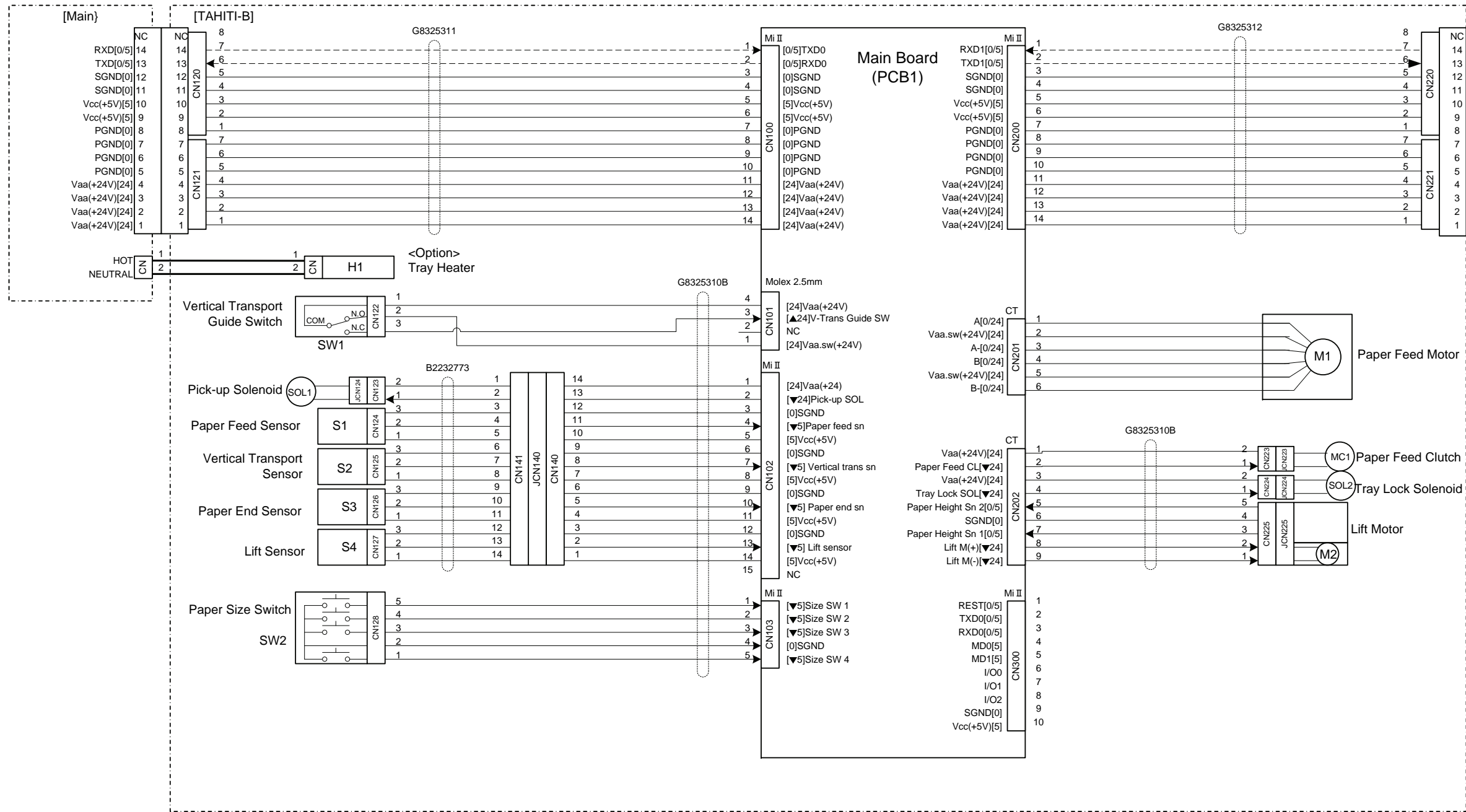

SYMBOL TABLE	
— AC LINE	▲ Ready Low
— DC LINE	▼ Ready High
..... Pulse	[] Voltage
→ Direction	

D387 ELECTRICAL COMPONENT LAYOUT

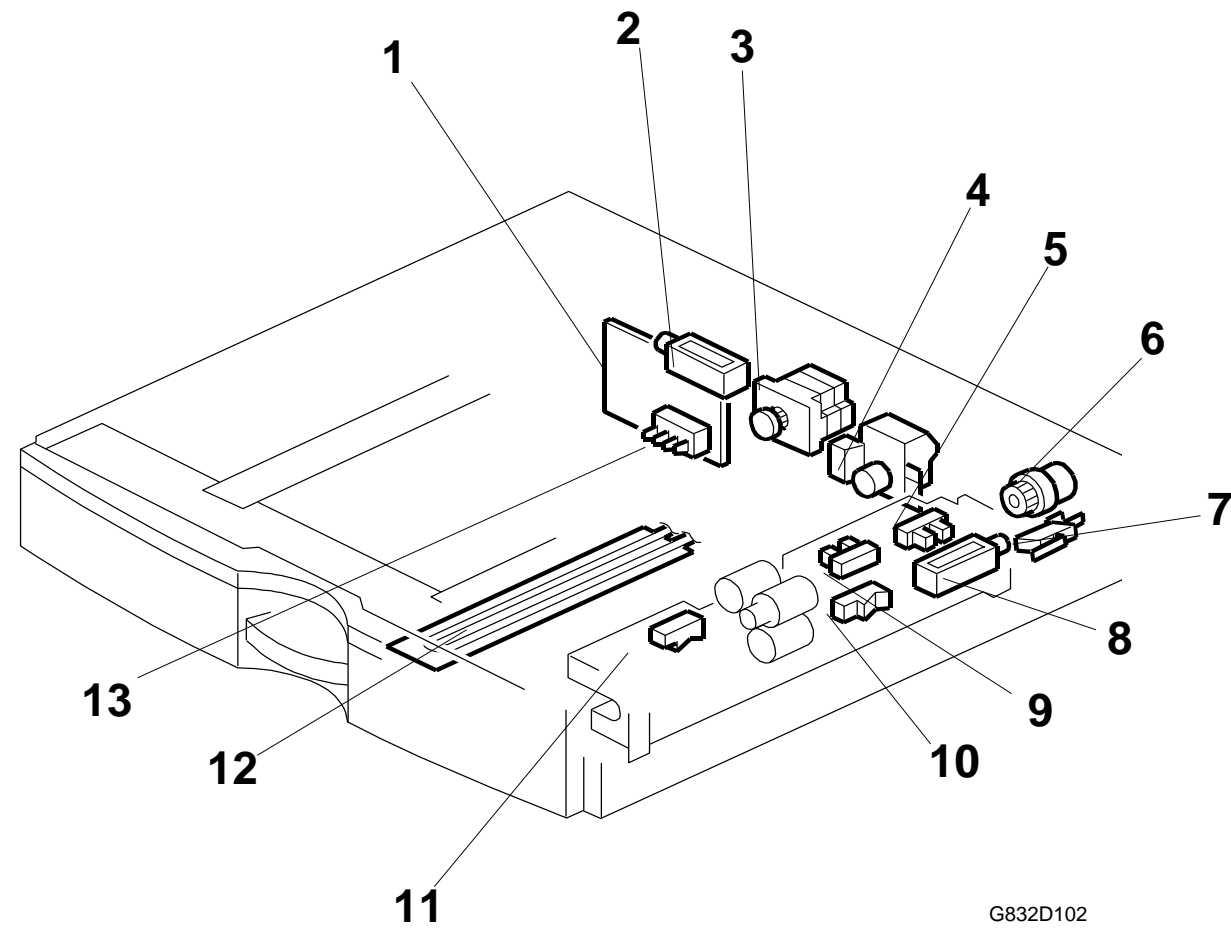

Symbol	Name	Index No.	P-to-P
Motors			
M1	Paper Feed	3	C8
M2	Tray Lift	4	D8
Sensors			
S1	Paper Feed	11	D3
S2	Vertical Transport	10	D3
S3	Paper End	9	D3
S4	Lift	5	D3
Solenoids			
SOL1	Pick-up	8	D2
SOL2	Tray Lock	2	D8
Switches			
SW1	Vertical Transport Guide	7	C3
SW2	Paper Size	13	E2
Magnetic Clutches			
MC1	Paper Feed	6	D8
PCBs			
PCB1	Main Board	1	B6
Others			
H1	Optional Tray Heater	12	C3

1 2 3 4 5 6 7

D388 POINT TO POINT DIAGRAM

A

A

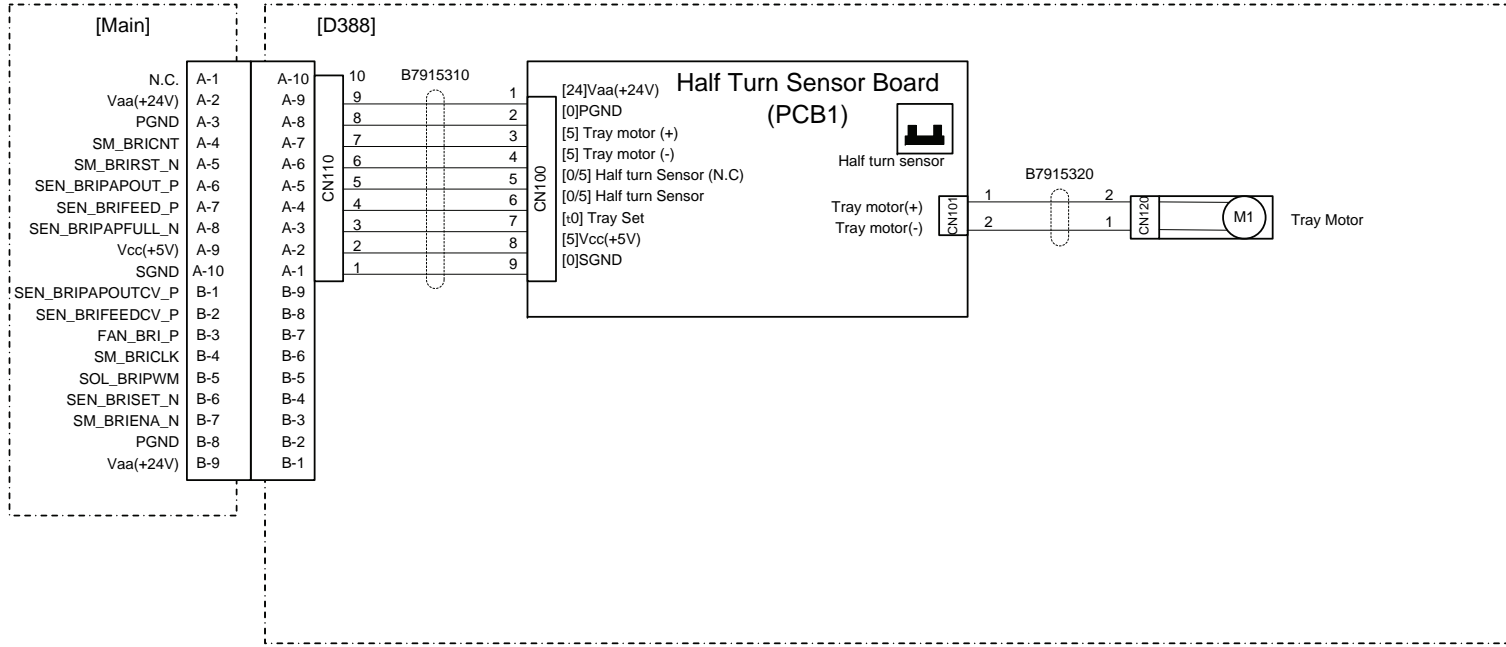

B

B

C

C

SYMBOL TABLE			
	AC LINE		Ready Low
	DC LINE		Ready High
	Pulse		Voltage
	Direction		

D

D

E

E

1 2 3 4 5 6 7

D388 ELECTRICAL COMPONENT LAYOUT

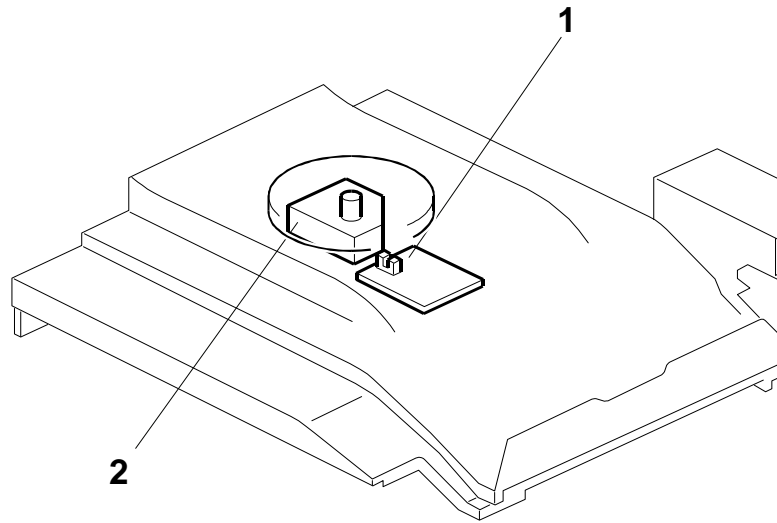

B791D102

Symbol	Name	Index No.	P-to-P
Motors			
M1	Tray	1	B5
PCBs			
PCB1	Half Turn Sensor	2	B3-B4

D536 POINT TO POINT DIAGRAM

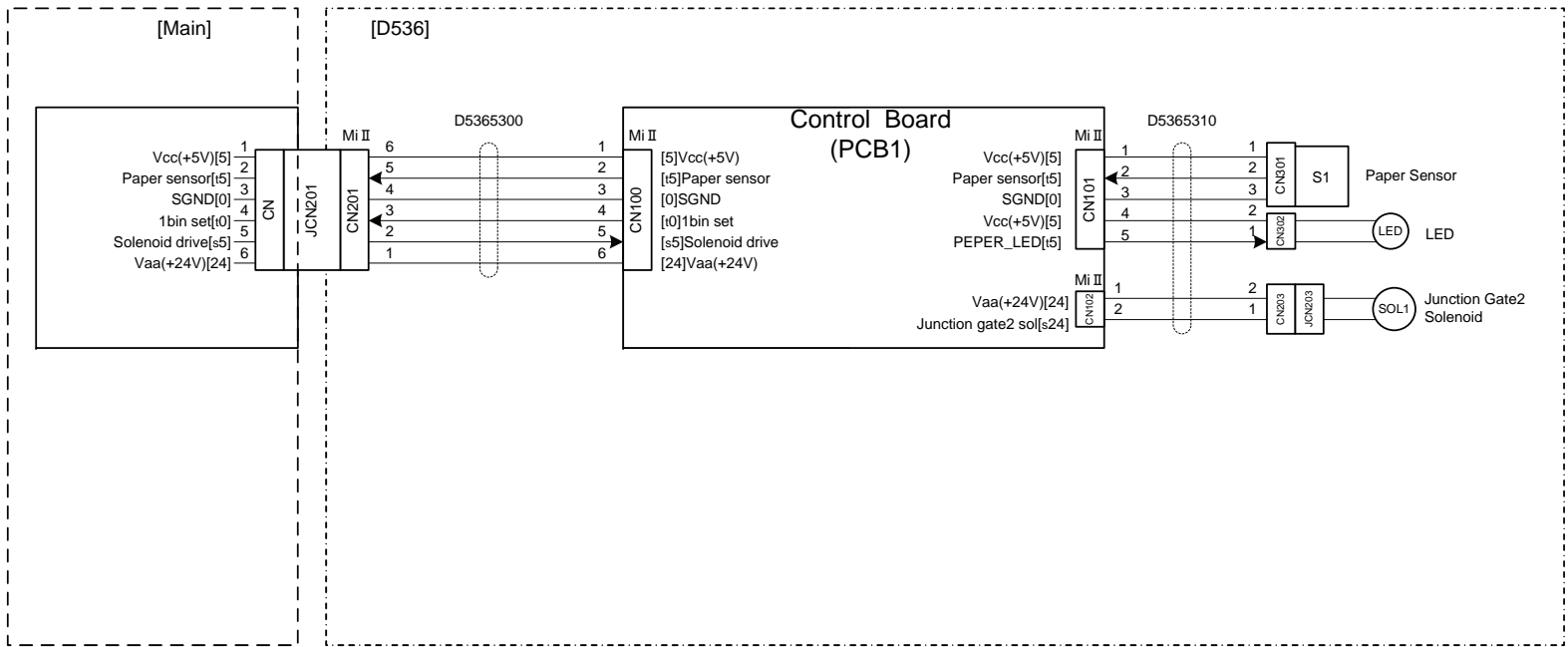

SYMBOL TABLE

—	DC Line
- - - -	Pulse Signal
—▶	Signal Direction
▲	Ready Low
▼	Ready High
[]	Voltage

D536 ELECTRICAL COMPONENT LAYOUT

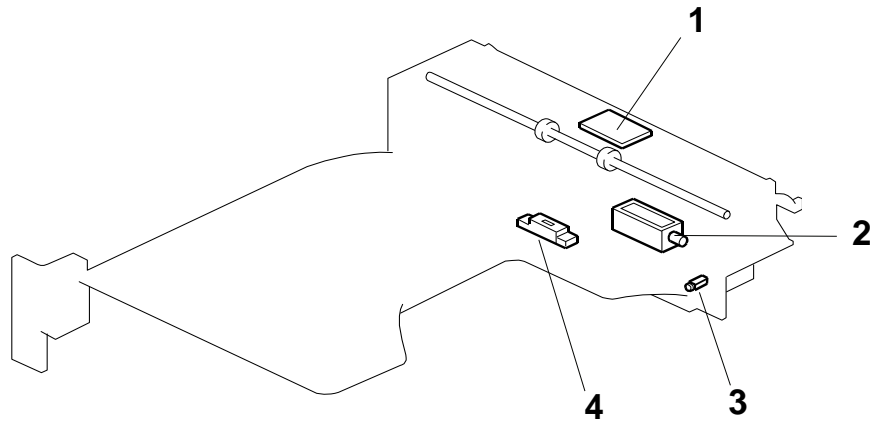

Symbol	Name	Index No.	P-to-P
Sensor			
S1	Paper	4	B5
Solenoid			
SOL1	Junction Gate 2 Solenoid	2	B6
PCB			
PCB1	Main Control Board	1	B4
LED			
LED	LED	3	B6

D537 POINT TO POINT DIAGRAM

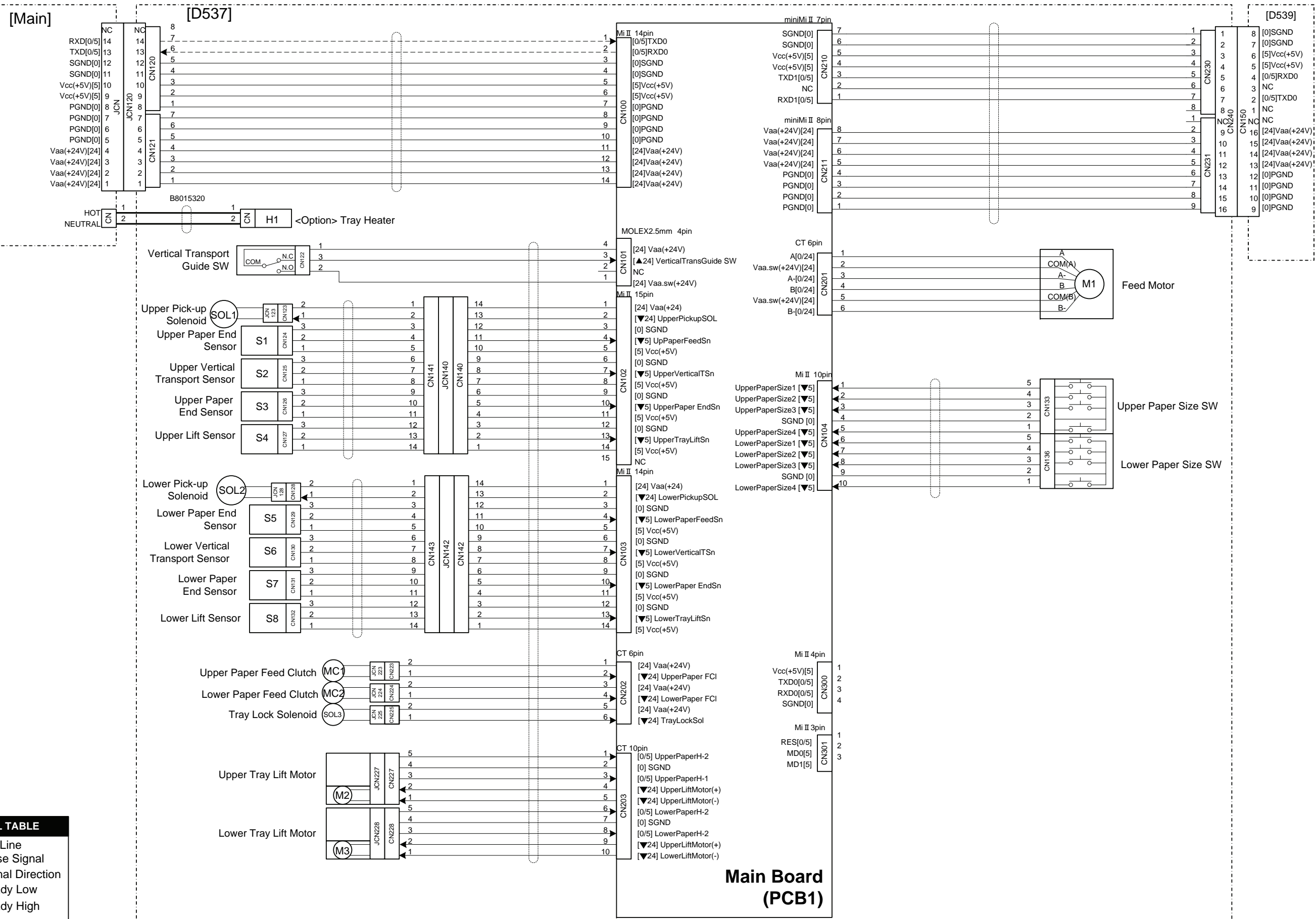

SYMBOL TABLE	
—	DC Line
---	Pulse Signal
→	Signal Direction
▲	Ready Low
▼	Ready High
[]	Voltage

D538 POINT TO POINT DIAGRAM

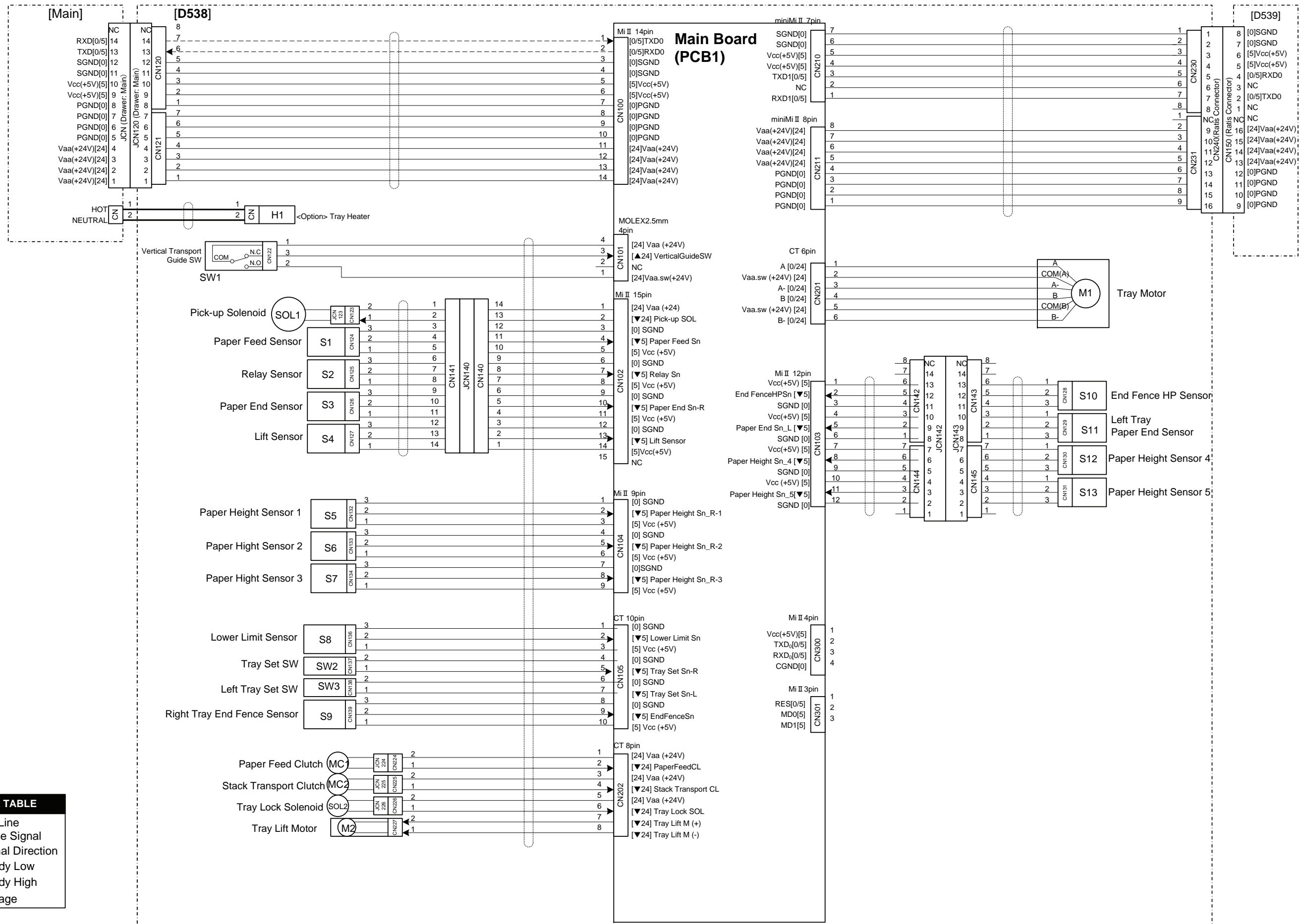

SYMBOL TABLE	
—	DC Line
- - - -	Pulse Signal
→	Signal Direction
▲	Ready Low
▼	Ready High
[]	Voltage

ELECTRICAL COMPONENT LAYOUT (D537)

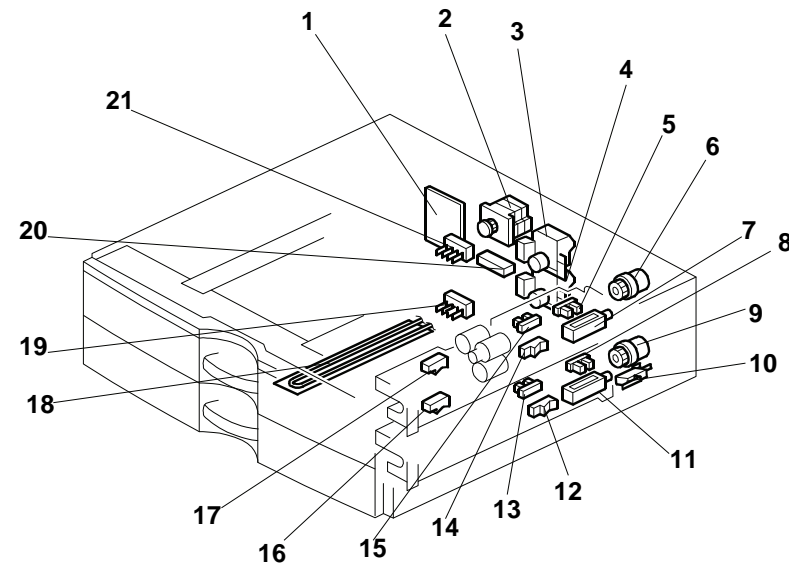

Symbol	Name	Index No.	P-to-P
Motors			
M1	Feed Motor	2	B7
M2	Upper Tray Lift Motor	3	E3
M3	Lower Tray Lift Motor	4	E3
Sensors			
S1	Upper Paper Feed	17	C2
S2	Upper Vertical Transport 1	14	C2
S3	Upper Paper End	15	C2
S4	Upper Lift	5	C2
S5	Lower Paper Feed	16	D2
S6	Lower Vertical Transport 2	12	D2
S7	Lower Paper End	13	D2
S8	Lower Lift	8	D2
Solenoids			
SOL1	Upper Pick-up	7	C2
SOL2	Lower Pick-up	11	D2
SOL3	Tray Lock	20	E3
Switches			
SW1	Upper Paper Size	21	C7
SW2	Lower Paper Size	19	C7
SW3	Vertical Transport Guide	10	B2
Magnetic Clutches			
MC1	Upper Paper Feed	6	E3
MC2	Lower Paper Feed	9	E3
PCBs			
PCB1	Main Board	1	A5-F5
Others			
H1	Optional Tray Heater	18	B2-3

ELECTRICAL COMPONENT LAYOUT (D538)

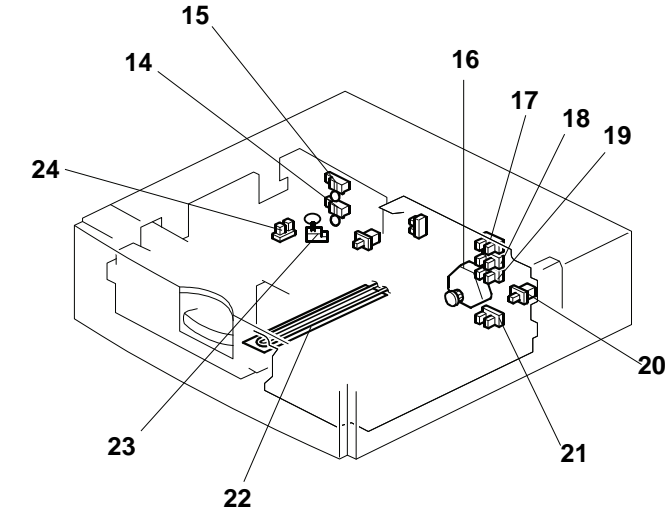
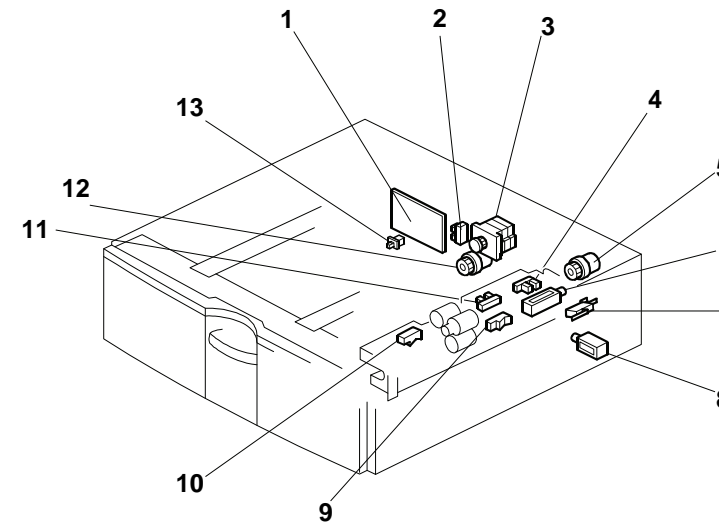

Symbol	Name	Index No.	P-to-P
Motors			
M1	Tray Motor	3	B7
M2	Tray Lift Motor	16	E3
Sensors			
S1	Paper Feed	10	C2
S2	Relay	9	C2
S3	Paper End	11	C2
S4	Lift	4	C2
S5	Paper Height 1	17	D2
S6	Paper Height 2	18	D2
S7	Paper Height 3	19	D2
S8	Lower Limit	21	D2
S9	Right Tray End Fence	2	E2
S10	End Fence HP	24	C7
S11	Left Tray Paper	23	C7
S12	Paper Height 4	15	C7
S13	Paper Height 5	14	D7
Solenoids			
SOL1	Pick-up	6	C2
SOL2	Tray Lock	8	E3
Switches			
SW1	Vertical Guide	7	B2
SW2	Right Tray Set	20	E2
SW3	Left Tray set	13	E2
Magnetic Clutches			
MC1	Paper Feed	5	E3
MC2	Stack Transport	12	E3
PCBs			
PCB1	Main Board	1	A5-F5
Others			
H1	Optional Tray Heater	22	B2-3

LCT 1200 Sheet (D539) POINT TO POINT DIAGRAM

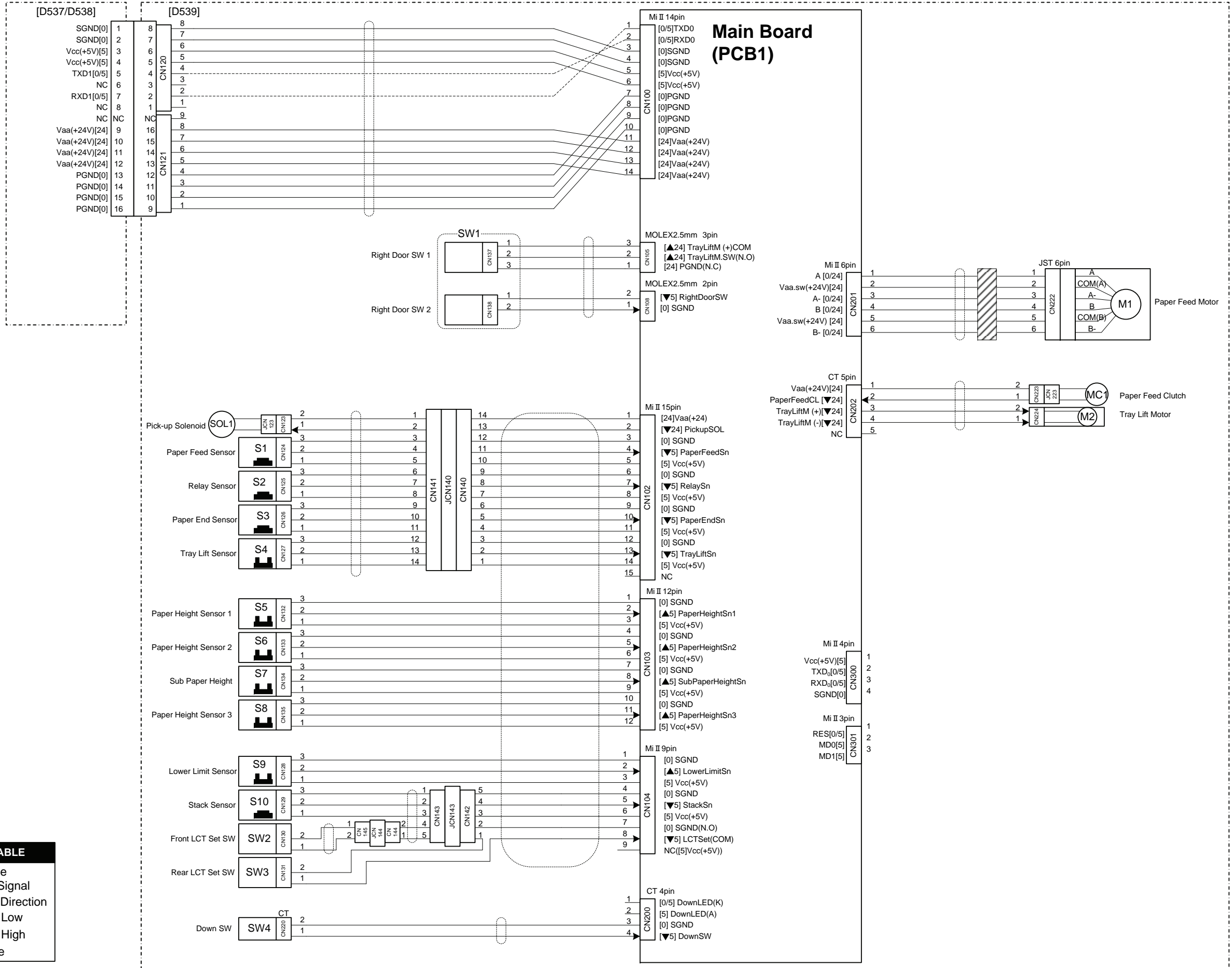

SYMBOL TABLE	
—	DC Line
- - -	Pulse Signal
→	Signal Direction
▲	Ready Low
▼	Ready High
[]	Voltage

LCT 1200-Sheet (D539) ELECTRICAL COMPONENT LAYOUT

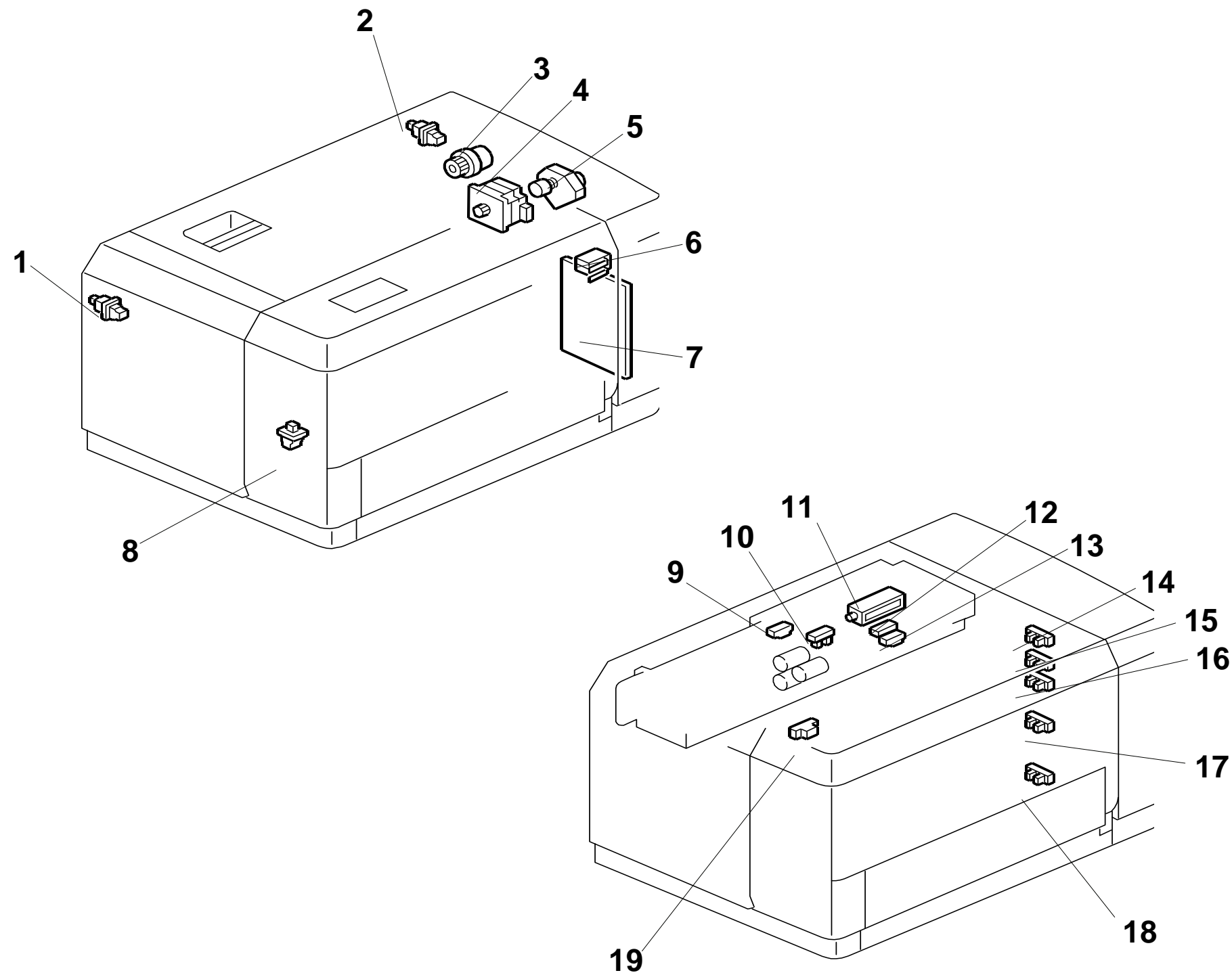

Symbol	Name	Index No.	P-to-P
Motors			
M1	Tray Motor	4	C9
M2	Tray Lift Motor	5	D9
Sensors			
S1	Paper Feed	12	D3
S2	Relay	9	D3
S3	Paper End	13	D3
S4	Tray Lift	10	E3
S5	Paper Height 1	14	E3
S6	Paper Height 2	15	E3
S7	Sub Paper Height	16	E3
S8	Paper Height 3	17	F3
S9	Lower Limit	18	F3
S10	Stack	19	F3
Solenoids			
SOL1	Pick-up	11	D3
Switches			
SW1	Right Door	L-6	C5
SW2	Front LCT Set	L-1	F3
SW3	Rear LCT Set	L-2	G3
SW4	Down	L-8	G3
Magnetic Clutches			
MC1	Paper Feed	11	D9
PCBs			
PCB1	Main	7	A6

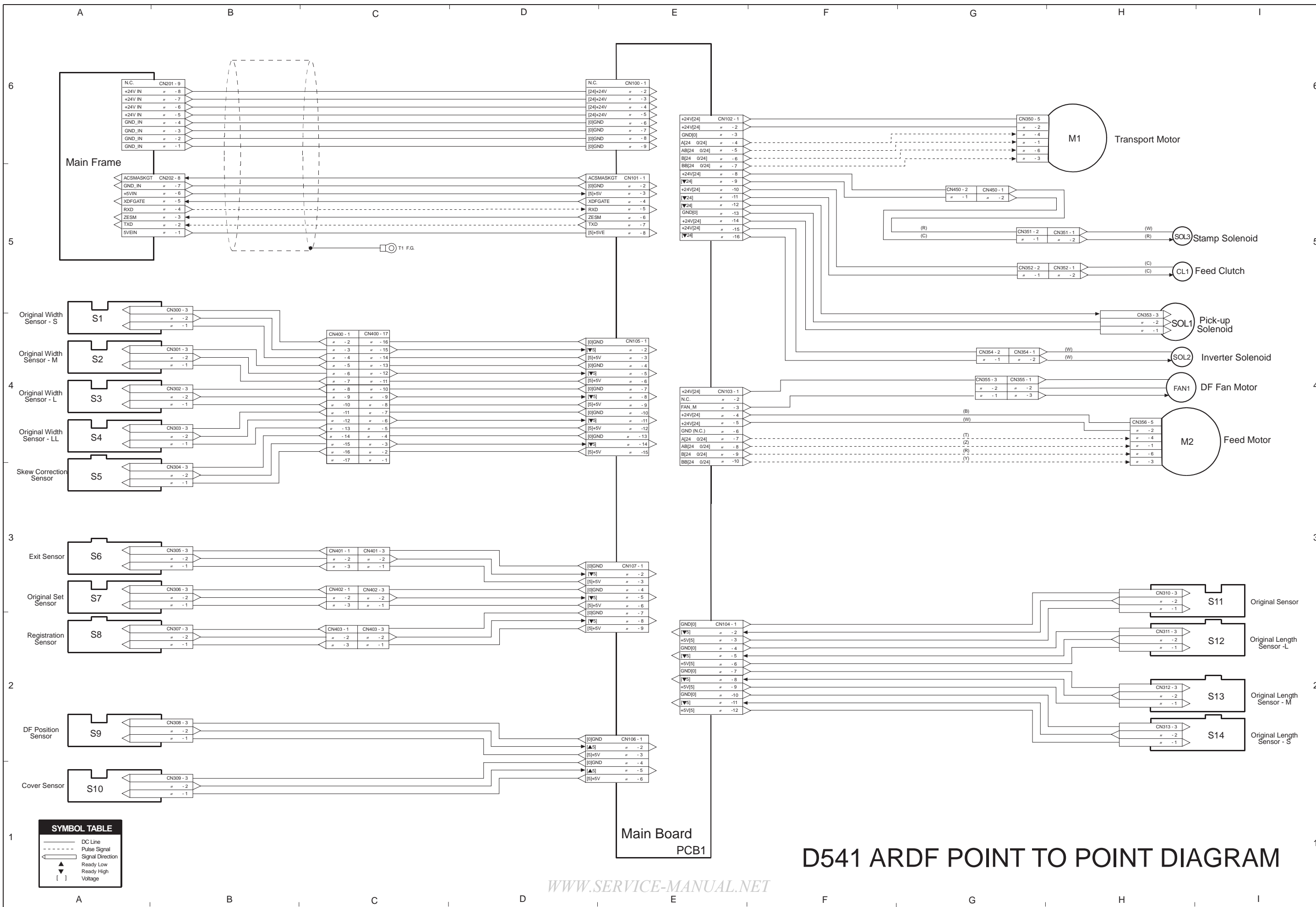

D541 ARDF POINT TO POINT DIAGRAM

ARDF (D541) ELECTRICAL COMPONENT LAYOUT

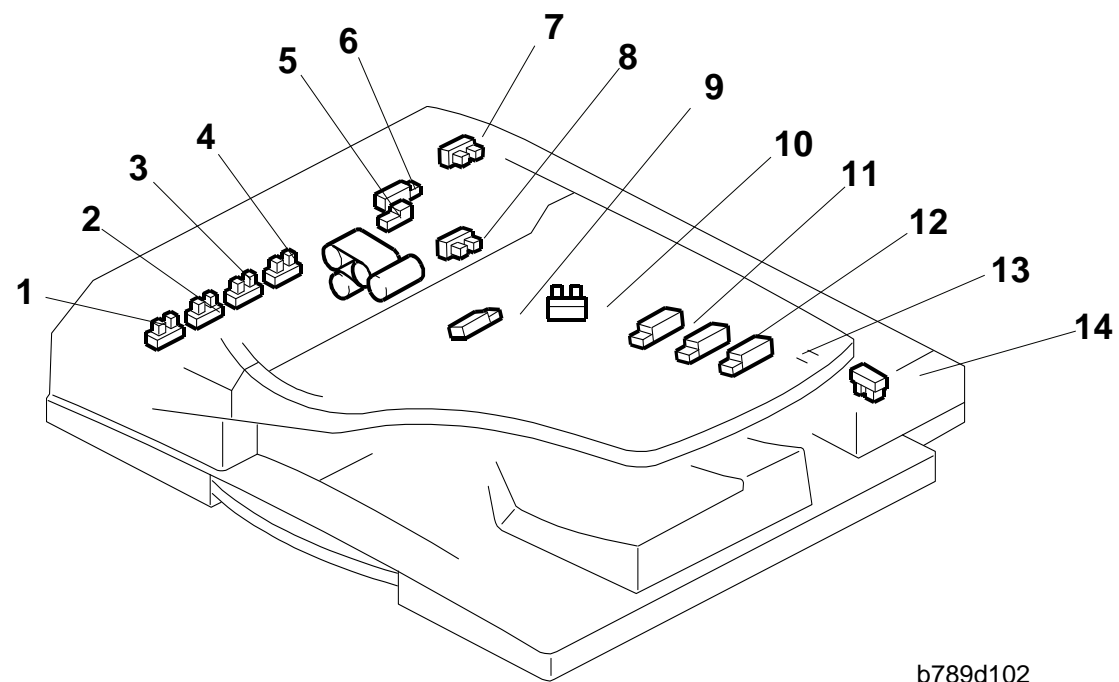

b789d102

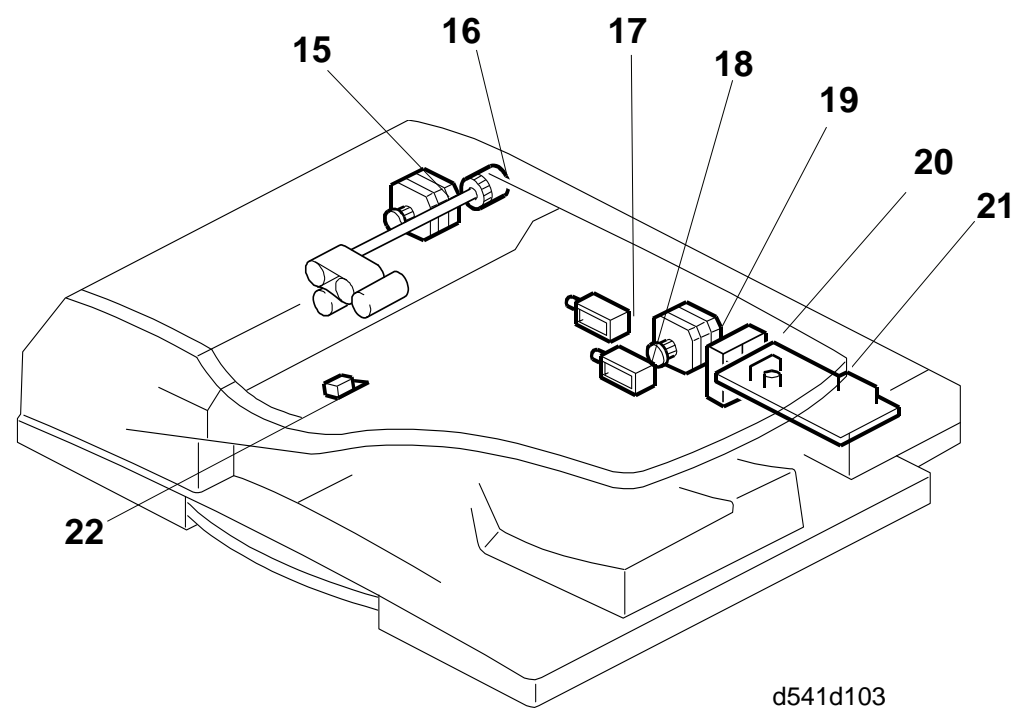

d541d103

Symbol	Name	Index No.	P-to-P
Motors			
M1	Transport	15	H6
M2	Feed	19	H4
Sensors			
S1	Original Width S	4	A4
S2	Original Width M	3	A4
S3	Original Width L	2	A4
S4	Original Width LL	1	A4
S5	Skew Correction	5	A3
S6	Exit	9	A3
S7	Original Set	8	A3
S8	Registration	6	A2
S9	DF Position	14	A2
S10	Cover	7	A1
S11	Original	10	I3
S12	Original Length L	13	I2
S13	Original Length M	12	I2
S14	Original Length S	11	I2
Solenoids			
SOL1	Pick-up	17	H4
SOL2	Inverter	18	H4
SOL3	Stamp	22	H5
Magnetic Clutch			
MC1	Feed	16	H5
PCB			
PCB1	Main Board	21	E1-6
Fan			
FAN1	DF Fan	20	H4

D542 POINT TO POINT DIAGRAM

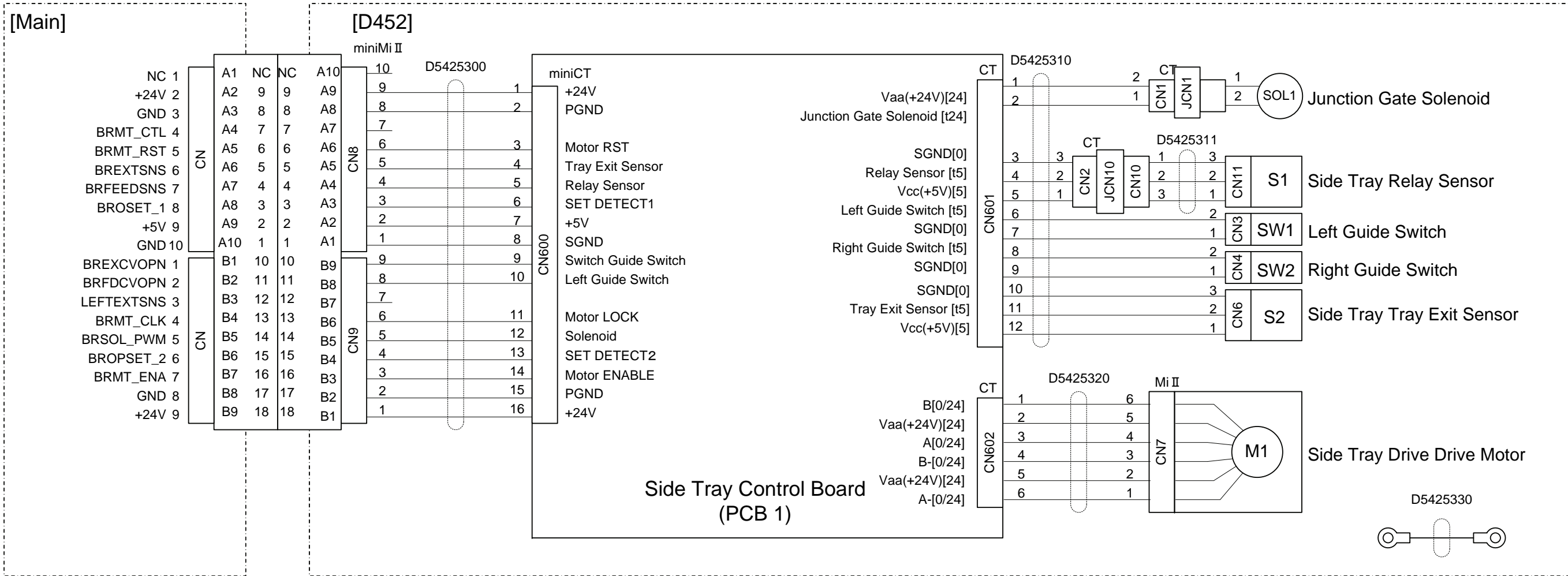

D542 ELECTRICAL COMPONENT LAYOUT

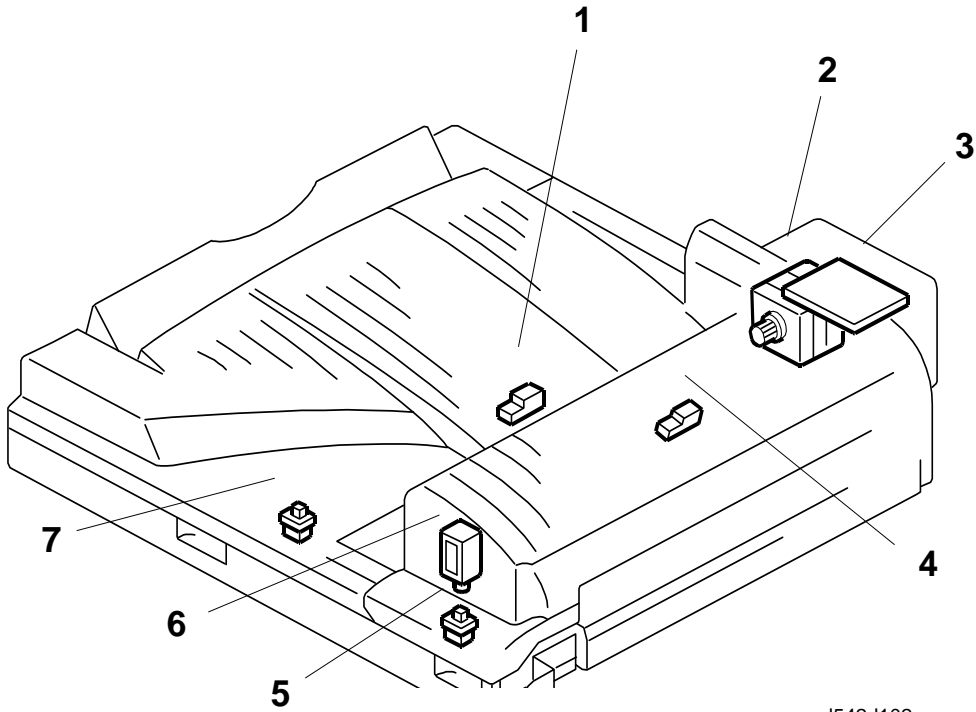

d542d102

Symbol	Name	Index No.	P-to-P
Motors			
M1	Side Tray Drive Drive	6	D8
Sensors			
S1	Side Tray Exit	4	D8
S2	Side Tray Relay	7	C8
Switches			
SW1	Right Guide	2	C8
SW2	Left Guide	1	C8
PCBs			
PCB1	Side Tray Control	5	E5
Solenoid			
SOL1	Junction Gate	3	B8