

D129/D130 POINT TO POINT DIAGRAM

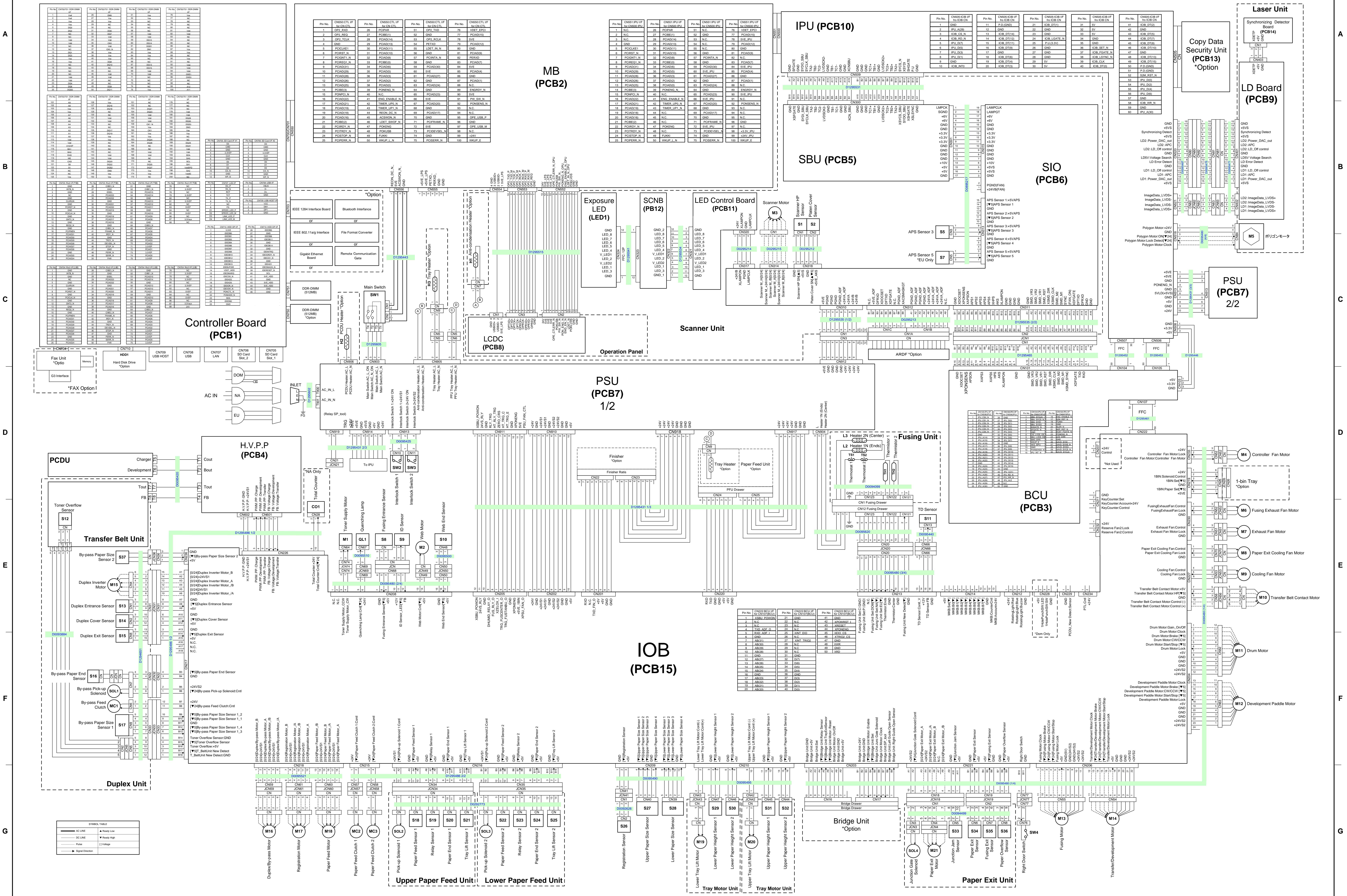

D129/D130 ELECTRICAL COMPONENT LAYOUT 1/2

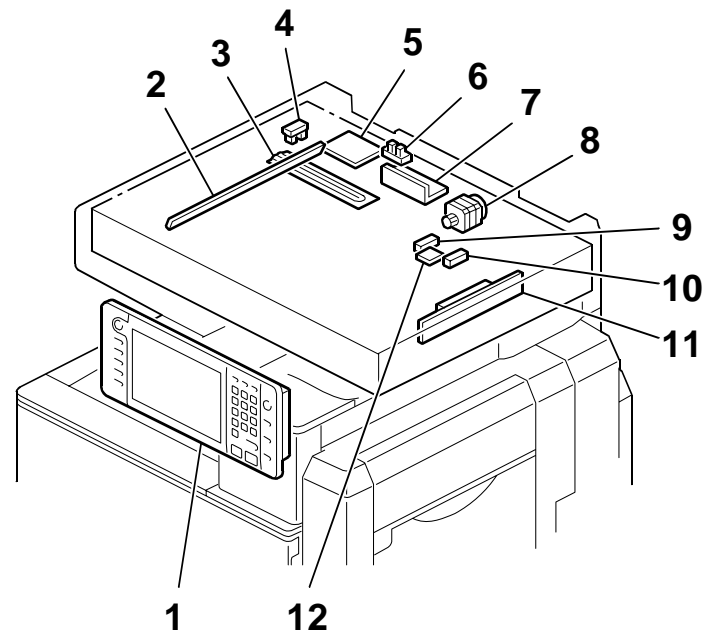

D129V101.Wmf

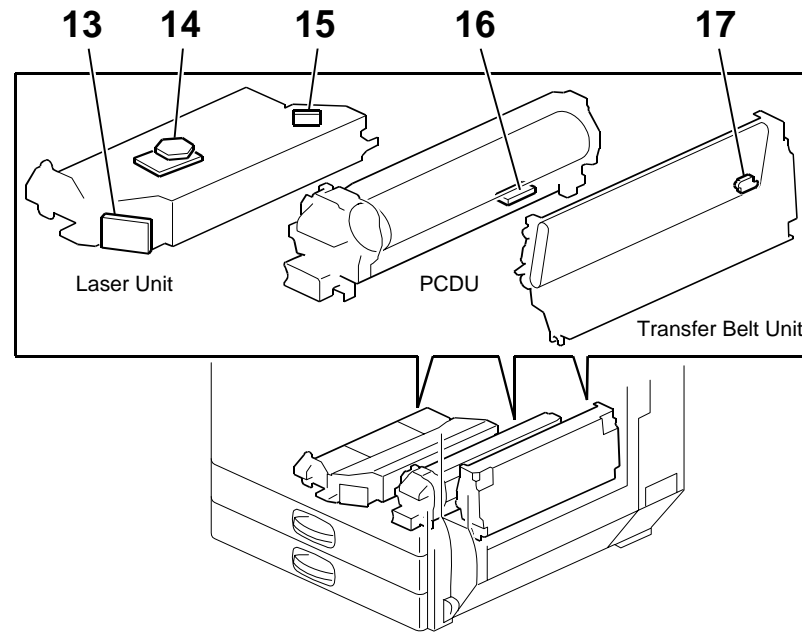

D129V102.Wmf

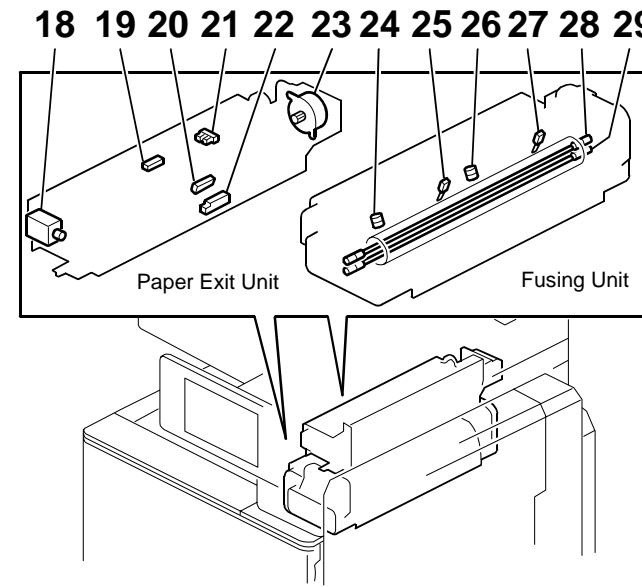

D129V103.Wmf

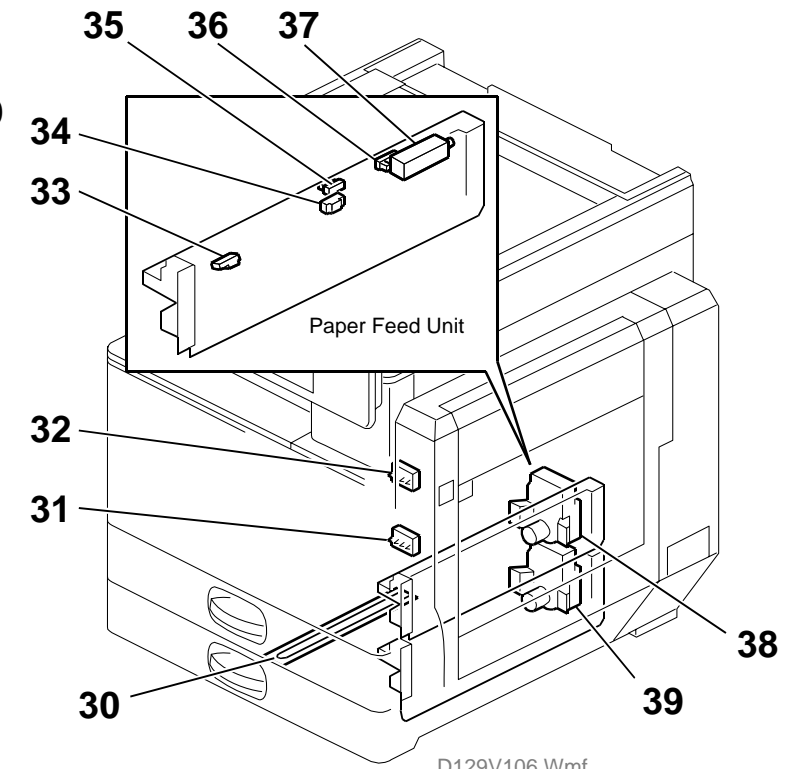

D129V106.Wmf

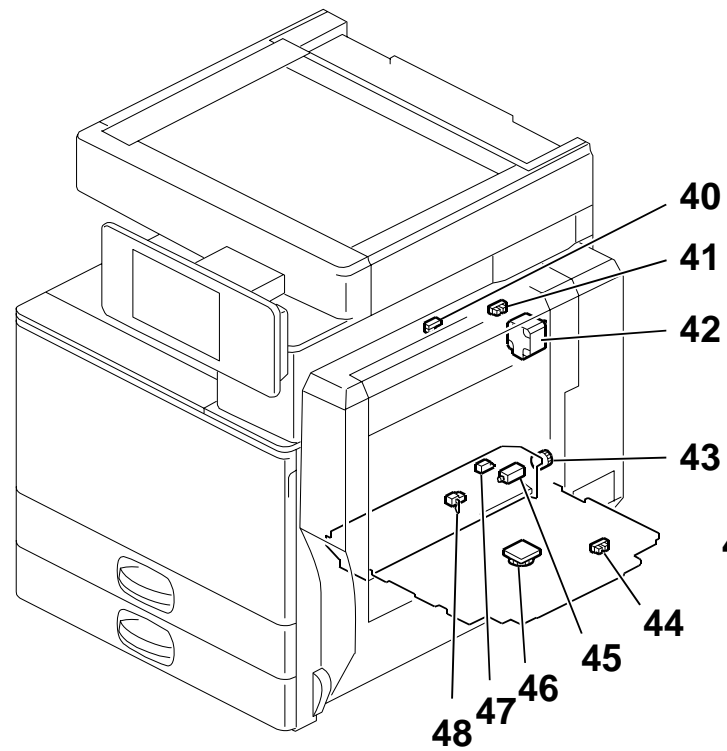

D129V105.Wmf

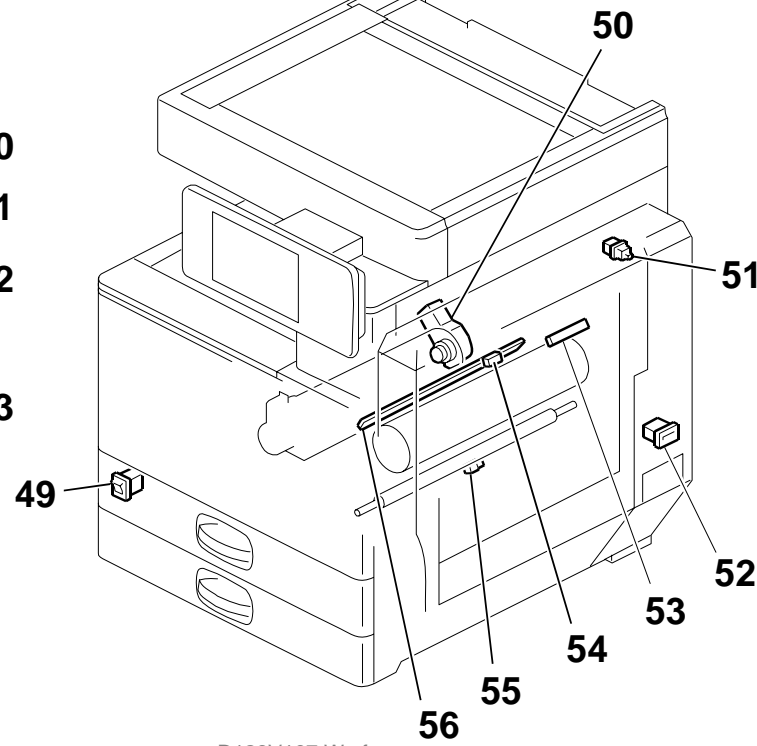

D129V107.Wmf

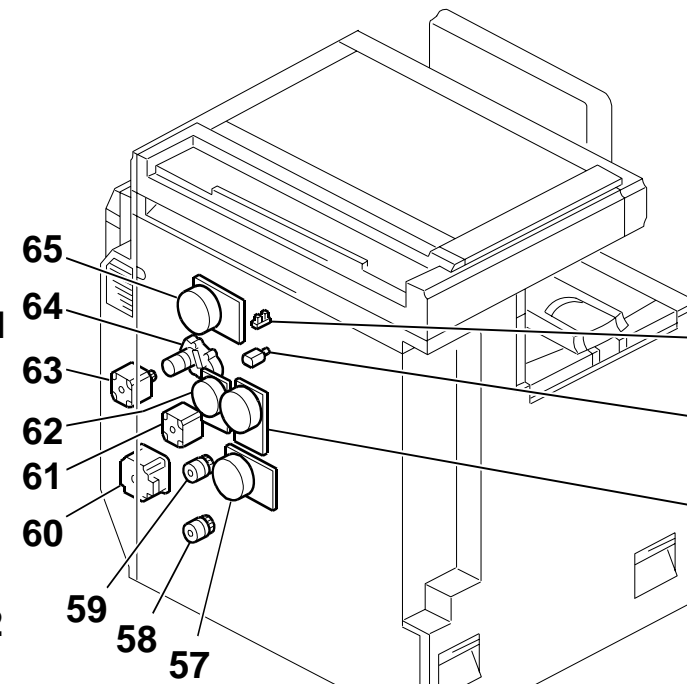

D129V104.Wmf

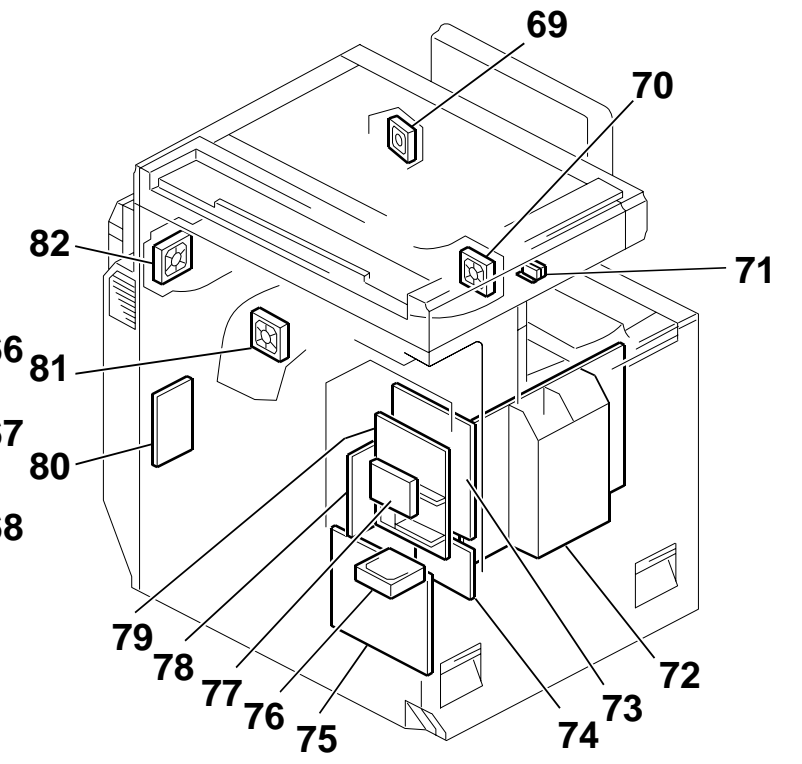

D129V108.Wmf

D129/D130 ELECTRICAL COMPONENT LAYOUT 2/2

Symbol	Index No.	Description	P to P
Motors			
M1	50	Toner Supply Motor	E3
M2	67	Web Motor	E4
M3	8	Scanner Motor	B6
M4	76	Controller Fan Motor	D10
M5	14	Polygon Motor	B10
M6	82	Fusing Exhaust Fan Motor	E10
M7	81	Exhaust Fan Motor	E10
M8	69	Paper Exit Cooling Fan Motor	E10
M9	70	Cooling Fan Motor	E10
M10	64	Transfer Belt Contact Motor	E10
M11	68	Drum Motor	F10
M12	62	Development Paddle Motor	F10
M13	65	Fusing Motor	G9
M14	57	Transfer/Development Motor	G8
M15	42	Duplex Inverter Motor	E10
M16	63	Duplex/By-pass Motor	G2
M17	61	Registration Motor	G3
M18	60	Paper Feed Motor	G3
M19	39	Lower Tray Lift Motor	G6
M20	38	Upper Tray Lift Motor	G6
M21	23	Paper Exit Motor	G7
Magnetic Clutches			
MC1	43	By-pass Feed Clutch	F10
MC2	59	Paper Feed Clutch 1	G3
MC3	58	Paper Feed Clutch 2	G3
PCBs			
PCB1	79	Controller Board	C2
PCB2	78	MB (Mother Board)	A5
PCB3	74	BCU	D8
PCB4	80	H.V.P.P	D2
PCB5	11	SBU	B7
PCB6	7	SIO	B8
PCB7	72	PSU	D5
PCB8	-	LCDC	C4
PCB9	13	LD Board	A10
PCB10	73	IPU	A7
PCB11	5	LED Control Board	B6
PCB12	12	SCNB	E5
PCB13	-	Copy Data Security Unit (Option)	A10
PCB14	15	Synchronizing Detector Board	A10
PCB15		IOB	F5

Symbol	Index No.	Description	P to P
Sensors			
S1	4	Scanner HP Sensor	B6
S2	6	Platen Cover Sensor	B7
S5	9	APS Sensor 3	B8
S7	10	APS Sensor 5 (EU Only)	C8
S8	54	Fusing Entrance Sensor	E3
S9	53	ID Sensor	E3
S10	66	Web End Sensor	E4
S11	16	TD Sensor	E7
S12	17	Toner Overflow Sensor	E1
S13	40	Duplex Entrance Sensor	E1
S14	41	Duplex Cover Sensor	E1
S15	47	Duplex Exit Sensor	F1
S16	48	By-pass Paper End Sensor	F1
S17	46	By-pass Paper Size Sensor 1	F1
S18,22	33	Paper Feed Sensor 1,2	G4
S19,23	34	Relay Sensor 1,2	G4
S20,24	35	Paper End Sensor 1,2	G4
S21,25	36	Tray Lift Sensor 1,2	G4,G5
S26	55	Registration Sensor	G5
S27	32	Upper Paper Size Sensor	G5
S28	31	Lower Paper Size Sensor	G6
S29	-	Lower Paper Height Sensor 1	G6
S30	-	Lower Paper Height Sensor 2	G6
S31	-	Upper Paper Height Sensor 1	G6
S32	-	Upper Paper Height Sensor 2	G6
S33	20	Junction Jam Sensor	G8
S34	19	Paper Exit Sensor	G8
S35	22	Fusing Exit Sensor	G8
S36	21	Paper Overflow Sensor	G8
S37	44	By-pass Paper Size Sensor 2	E1

Symbol	Index No.	Description	P to P
Solenoids			
SOL1	45	By-pass Pick-up Solenoid	F1
SOL2,3	37	Pick-up Solenoid 1,2	G3,G4
SOL4	18	Junction Gate Solenoid	G7
Switches			
SW1	49	Main Switch	C3
SW2,3	71	Interlock Switch 1,2	D3,D4
SW4	51	Right Door Switch	G8
Thermistors			
TH1	27	Thermistor 1	E7
TH2	25	Thermistor 2	E7
Thermostats			
TS1	24	Thermostat 1	E7
TS2	26	Thermostat 2	E7
Others			
OP1	1	Operation Panel	C5
QL1	56	Quenching Lamp	E3
CO1	52	Total Counter (NA Only Option)	E3
HDD1	77	Hard Disk Drive	C1
H1	3	Anti-condensation Heater (Option)	C4
H2	-	PCDU Heater (Option)	C3
H3	30	Tray Heater (Option)	C4
L2	28	Heater 1N (Ends)	E7
L3	29	Heater 2N (Center)	E7
LED1	2	Exposure LED	B5

ARDF (D630) ELECTRICAL COMPONENT LAYOUT

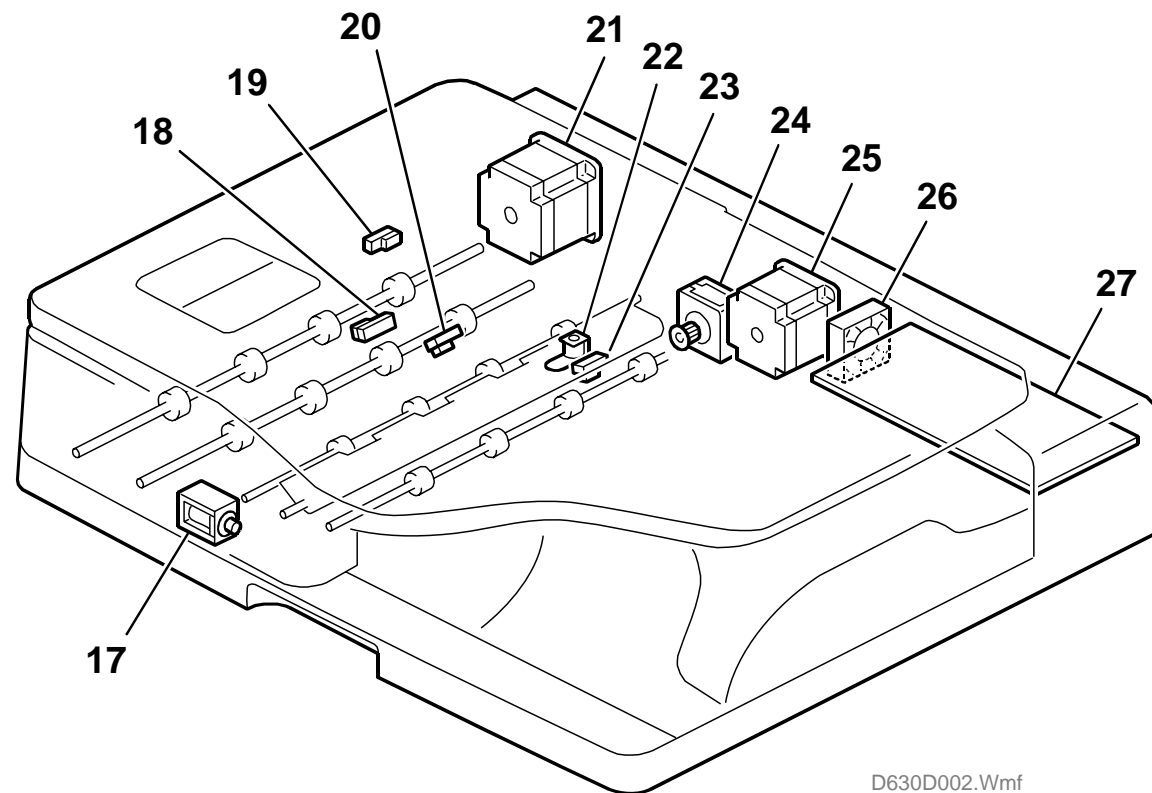
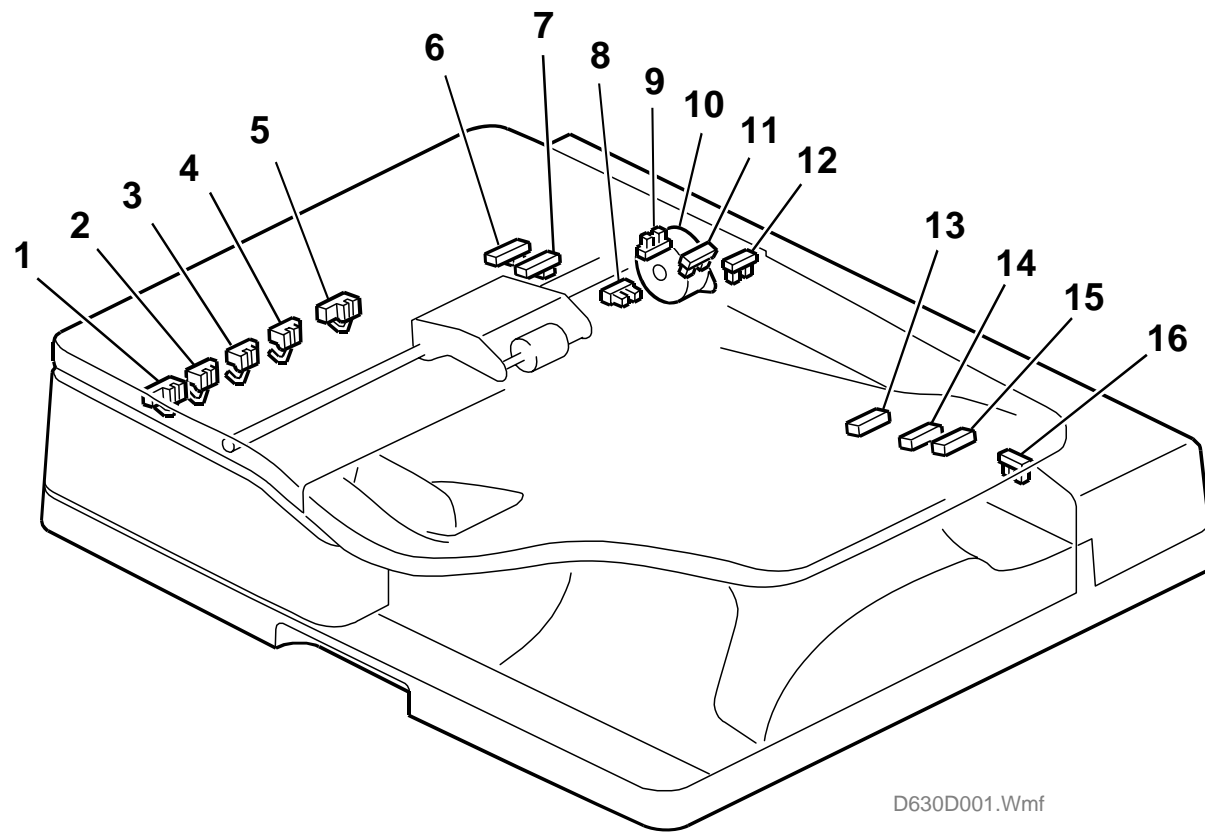

Symbol	Index No.	Description	P to P
Motors			
M1	10	Pick-up Motor	D1
M2	25	Feed Motor	A9
M3	21	Transport Motor	B9
M4	24	Inverter Motor	C9
M5	26	Cooling Fan Motor	G9
PCB			
PCB1	27	Main Board	A5
Sensors			
S1	19	Scanning Entrance Sensor	E2
S2	6	Skew Correction Sensor	E2
S3	9	Left Cover Sensor	F9
S4	1	Pick-up Roller HP Sensor	G9
S5	12	Original Stopper HP Sensor	F9
S6	13	Original Length 1 Sensor	E9
S7	14	Original Length 2 Sensor	E9
S8	15	Original Length 3 Sensor	E9
S9	23	Original Trailing Edge Sensor	F9
S10	8	Original Set Sensor	E2
S11	7	Separation Sensor	D2
S12	20	Original Exit Sensor	F2
S13	18	Registration Sensor	F2
S14	1	Original Width 5 Sensor	C2
S15	2	Original Width 4 Sensor	C2
S16	3	Original Width 3 Sensor	D2
S17	4	Original Width 2 Sensor	D2
S18	5	Original Width 1 Sensor	D2
S19	16	DF Position Sensor	F2
Solenoids			
SOL1	22	Stamp Solenoid	D9
SOL2	17	Junction Gate Solenoid	D9

ARDF (D630) POINT TO POINT DIAGRAM

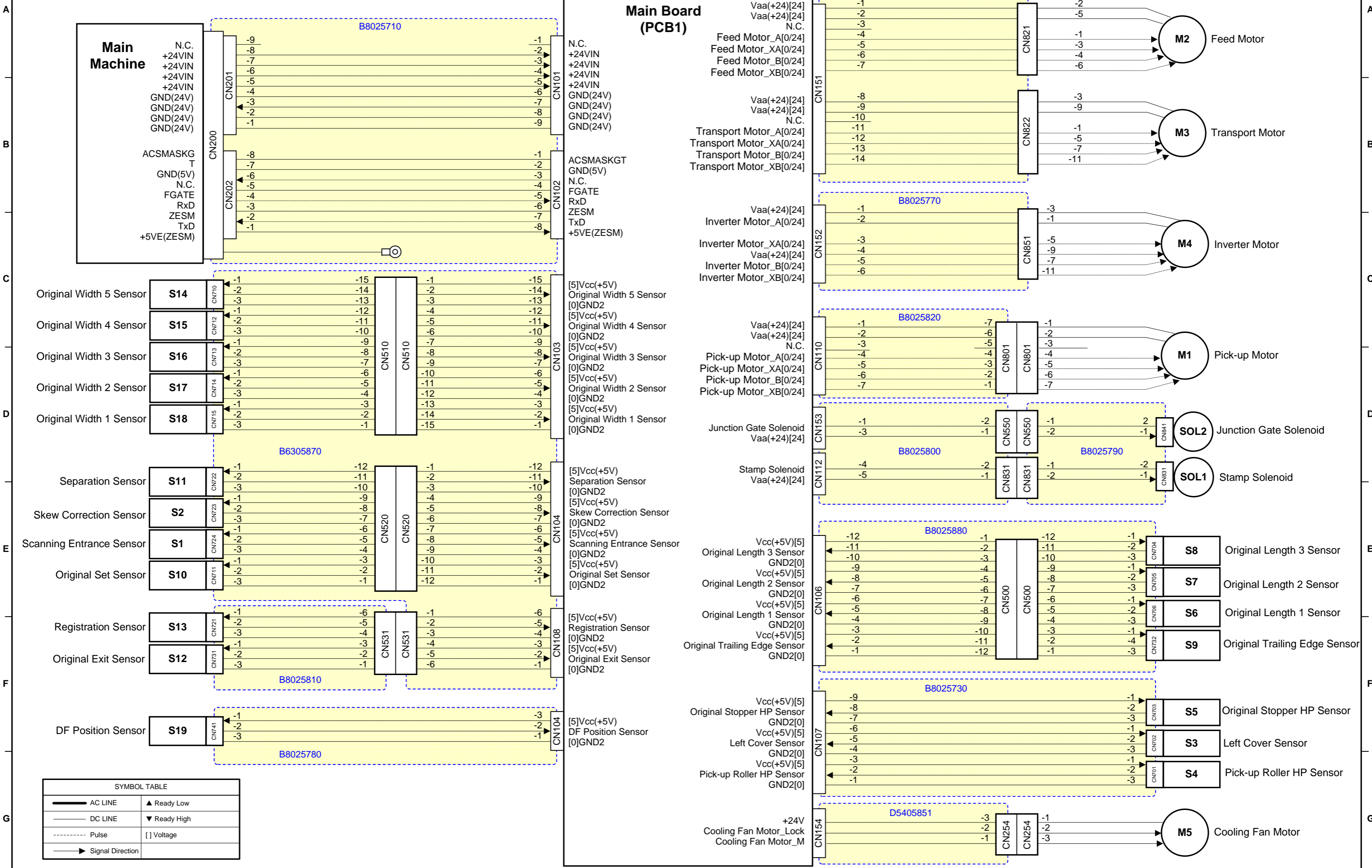

LCIT (D631) ELECTRICAL COMPONENT LAYOUT

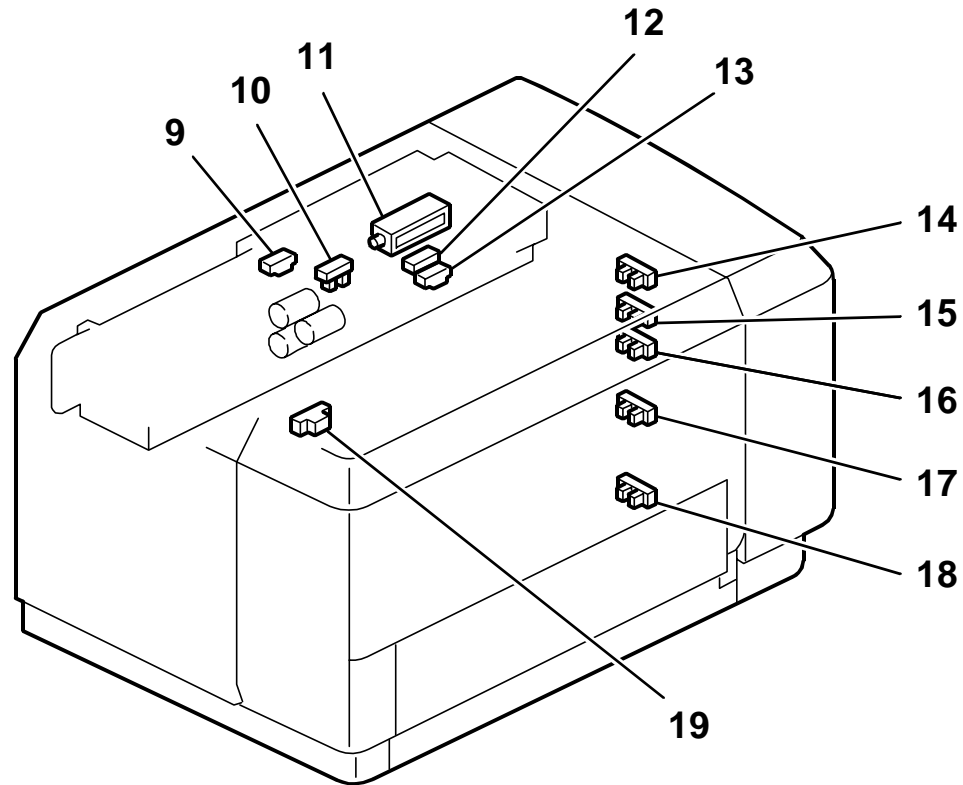
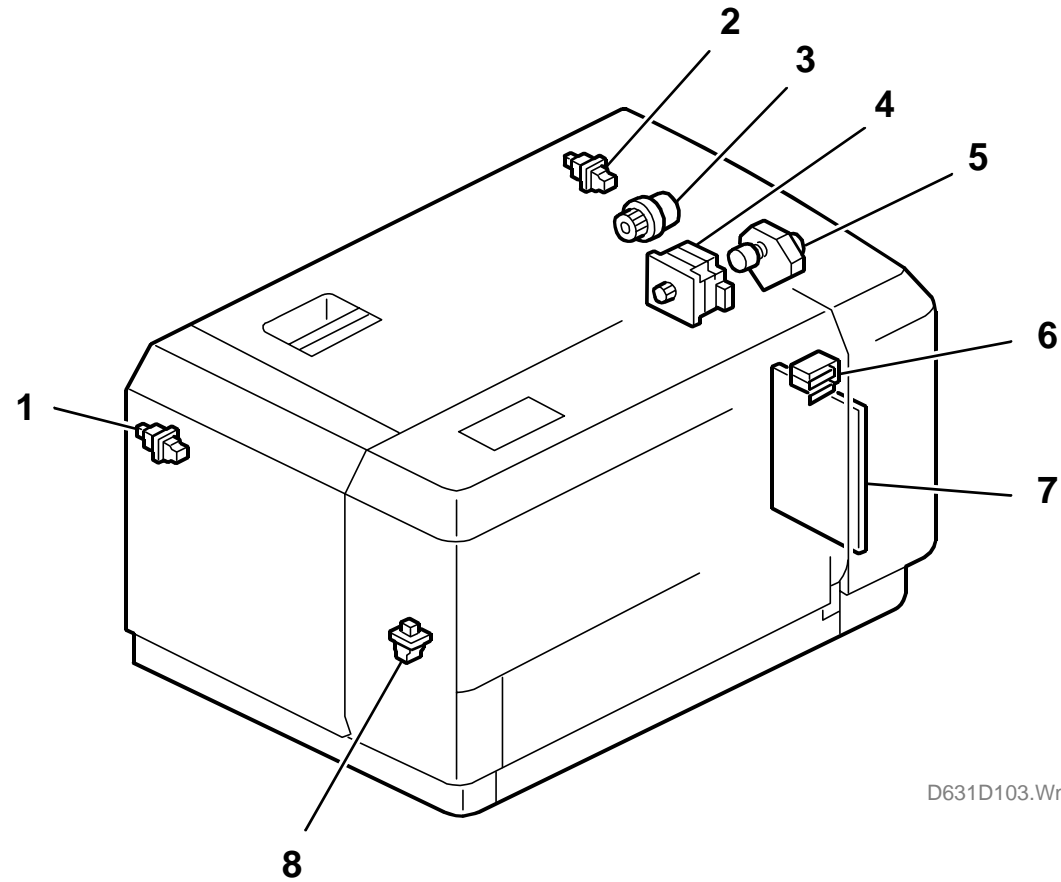

Symbol	Index No.	Description	P to P
Motors			
M1	4	Paper Feed Motor	C9
M2	5	Tray Lift Motor	C9
Magnetic Clutche			
MC1	3	Paper Feed Clutch	D9
PCB			
PCB1	7	Main Board	A6
Sensors			
S1	12	Paper Feed Sensor	D3
S2	9	Relay Sensor	D3
S3	13	Paper End Sensor	D3
S4	10	Tray Lift Sensor	D3
S5	14	Paper Height Sensor 1	E3
S6	15	Paper Height Sensor 2	E3
S7	16	Sub Paper Height	E3
S8	17	Paper Height Sensor 3	F3
S9	18	Lower Limit Sensor	F3
S10	19	Stack Sensor	F3
Solenoid			
SOL1	11	Pick-up Solenoid	C2
Switches			
SW1	6	Right Door SW 1,2	C4
SW2	1	Front LCT Set SW	F3
SW3	2	Rear LCT Set SW	E3
SW4	8	Tray Down SW	G3

LCIT (D631) POINT TO POINT DIAGRAM

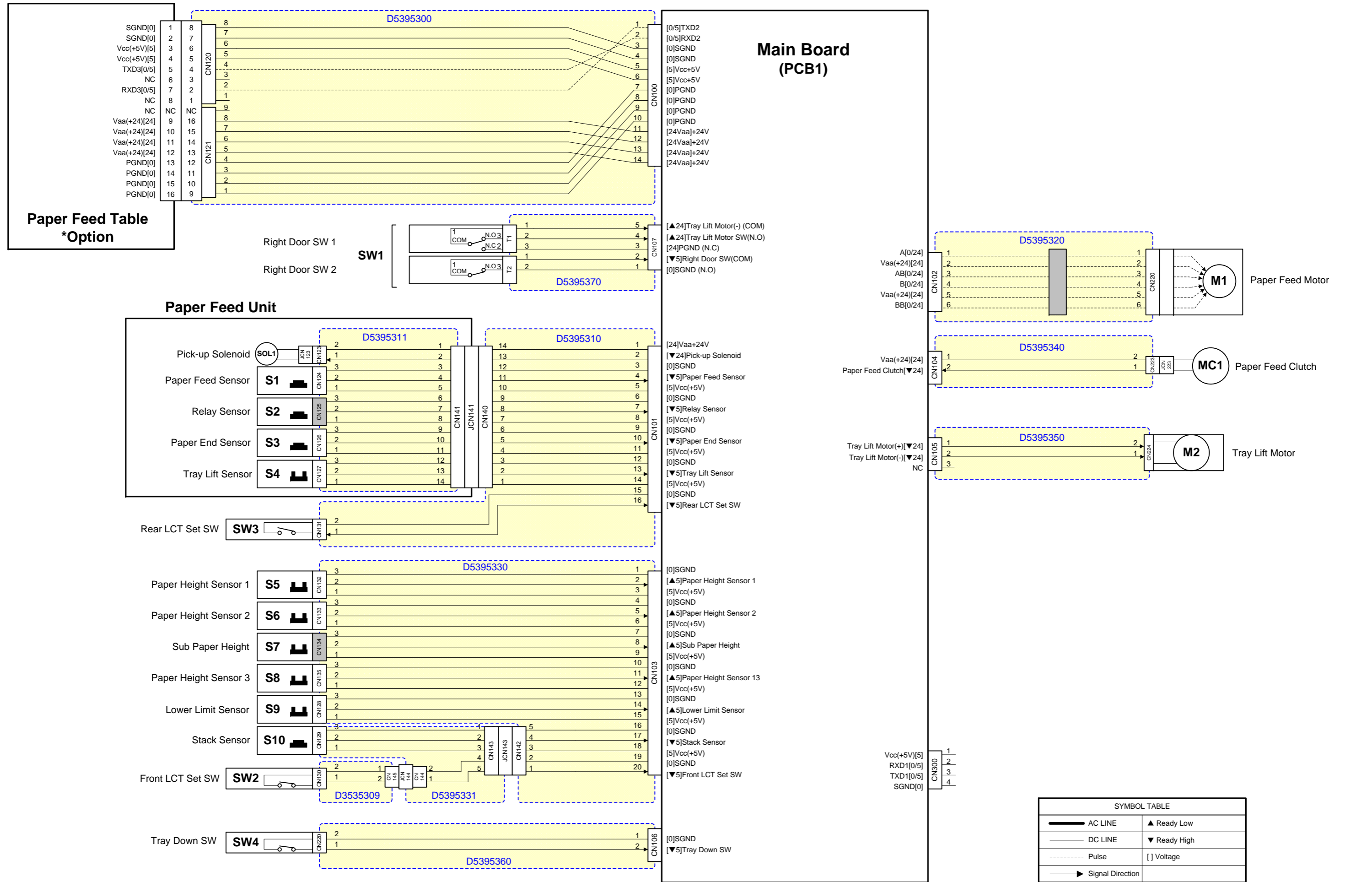

SYMBOL TABLE	
	AC LINE
	DC LINE
	Pulse
	Signal Direction
	Ready Low
	Ready High
[]	Voltage

1 Bin Tray (D632) ELECTRICAL COMPONENT LAYOUT

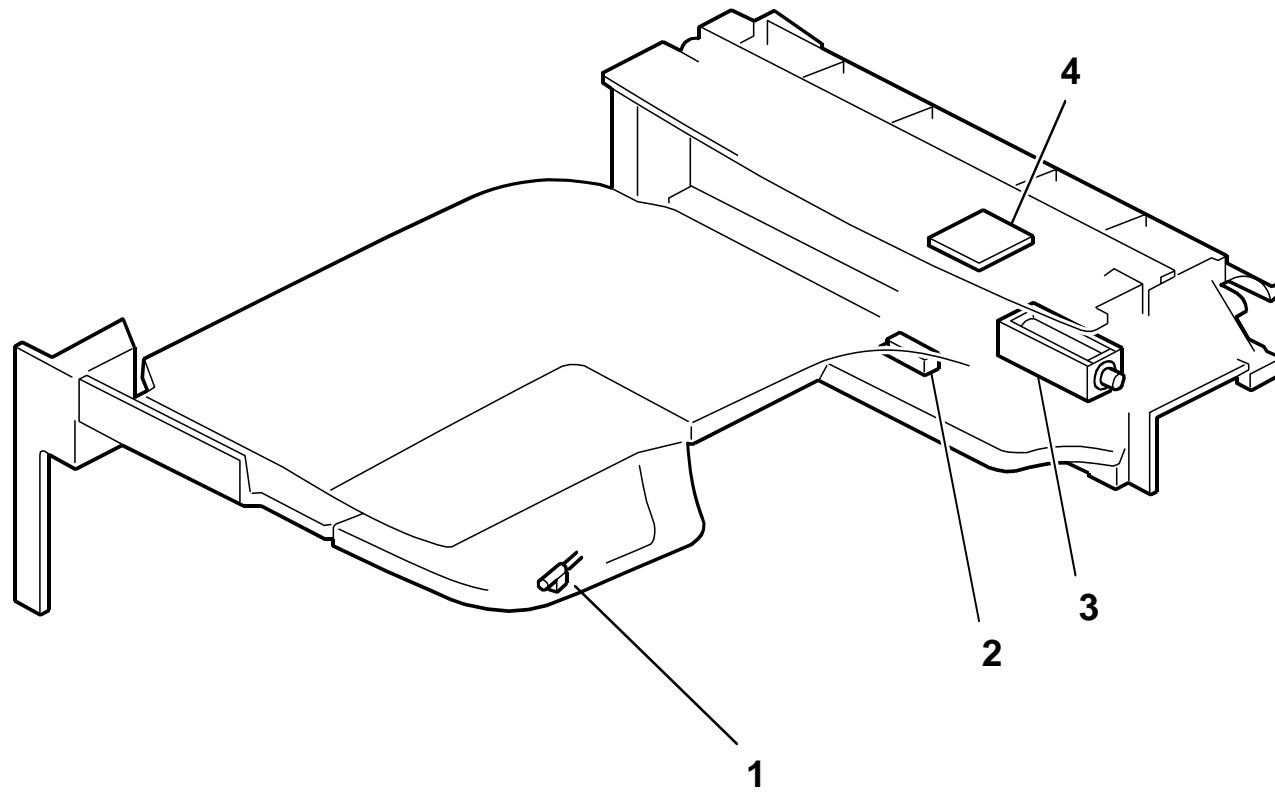

D632D102.Wmf

Symbol	Index No.	Description	P to P
PCB			
PCB1	4	Control Board	D5
Sensor			
S1	2	Paper sensor	C7
Solenoid			
SOL1	3	Junction Gate Solenoid	D7
Other			
LED1	1	Paper LED	D10

1 Bin Tray (D632) POINT TO POINT DIAGRAM

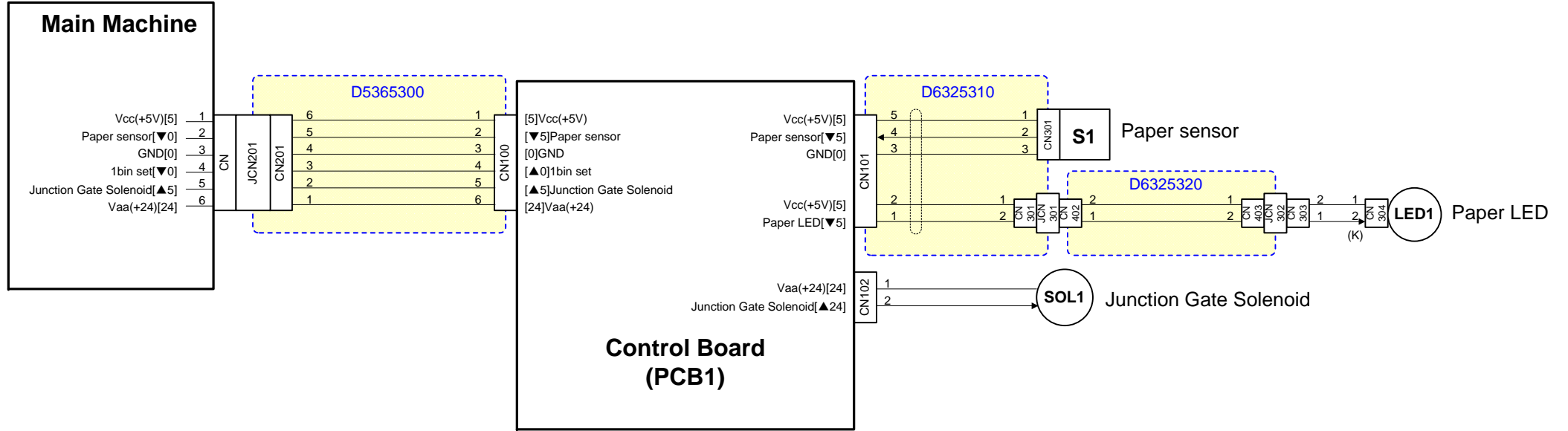

SYMBOL TABLE	
	AC LINE
	DC LINE
	Pulse
	Signal Direction
	Ready Low
	Ready High
	Voltage

Internal Shift Tray (D633) ELECTRICAL COMPONENT LAYOUT

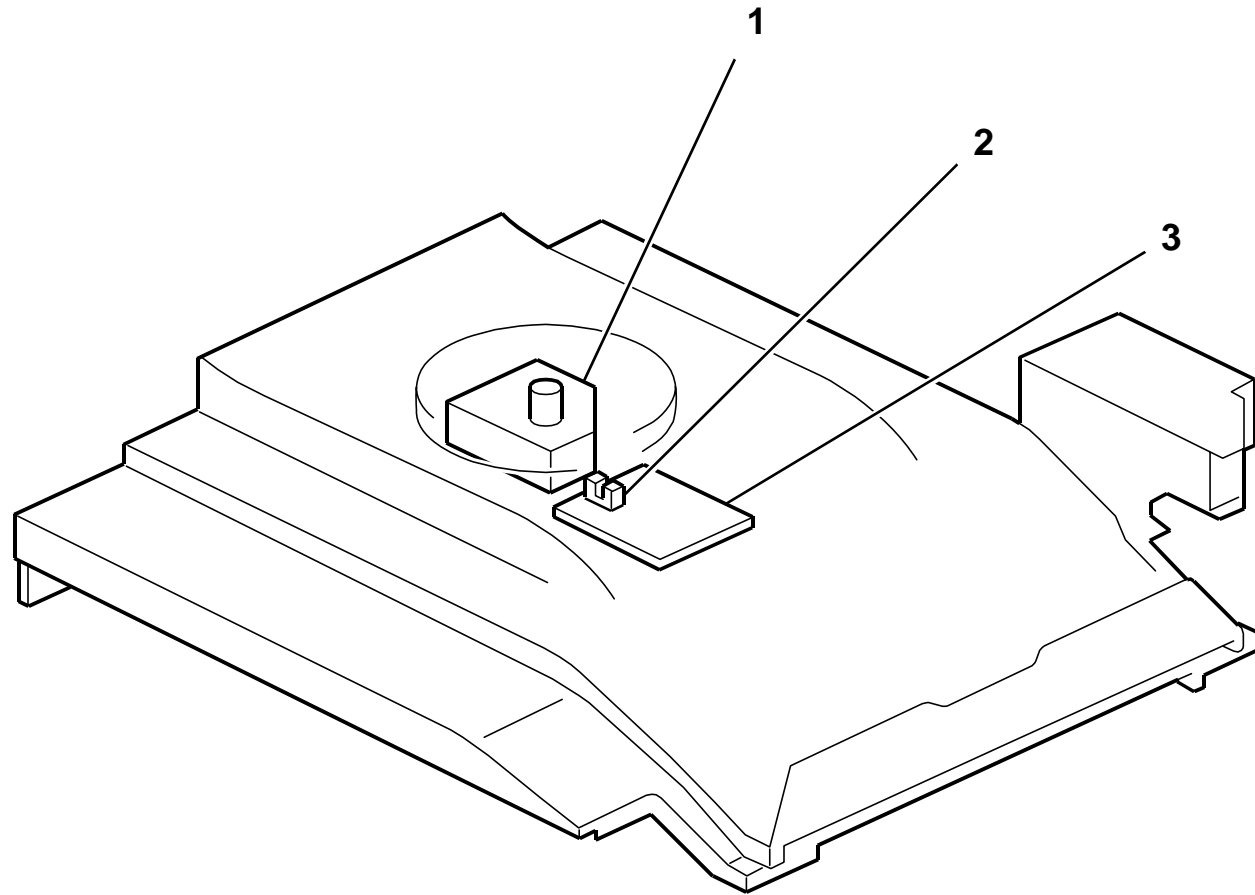

D633D102.Wmf

Symbol	Index No.	Description	P to P
Motor			
M1	1	Tray Motor	D9
PCB			
PCB1	3	Half Turn Sensor Board	D6
Sensor			
S1	2	Paper sensor	C7

Internal Shift Tray (D633) POINT TO POINT DIAGRAM

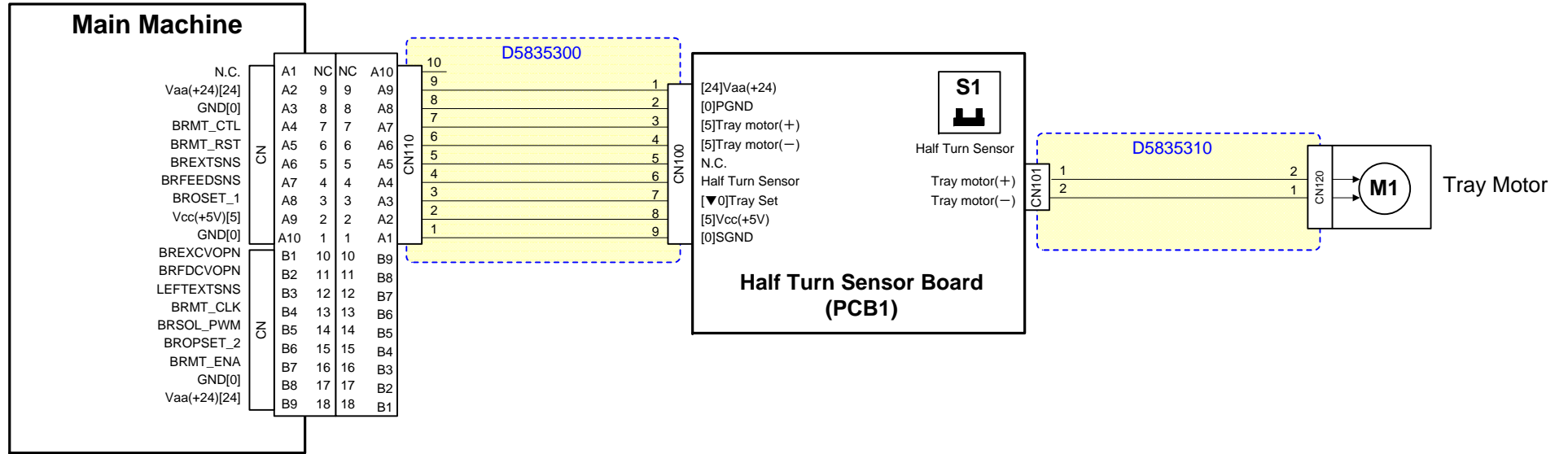

SYMBOL TABLE	
	AC LINE
	DC LINE
	Pulse
	Signal Direction
	Ready High
	Ready Low
	Voltage

Bridge Unit (D634) ELECTRICAL COMPONENT LAYOUT

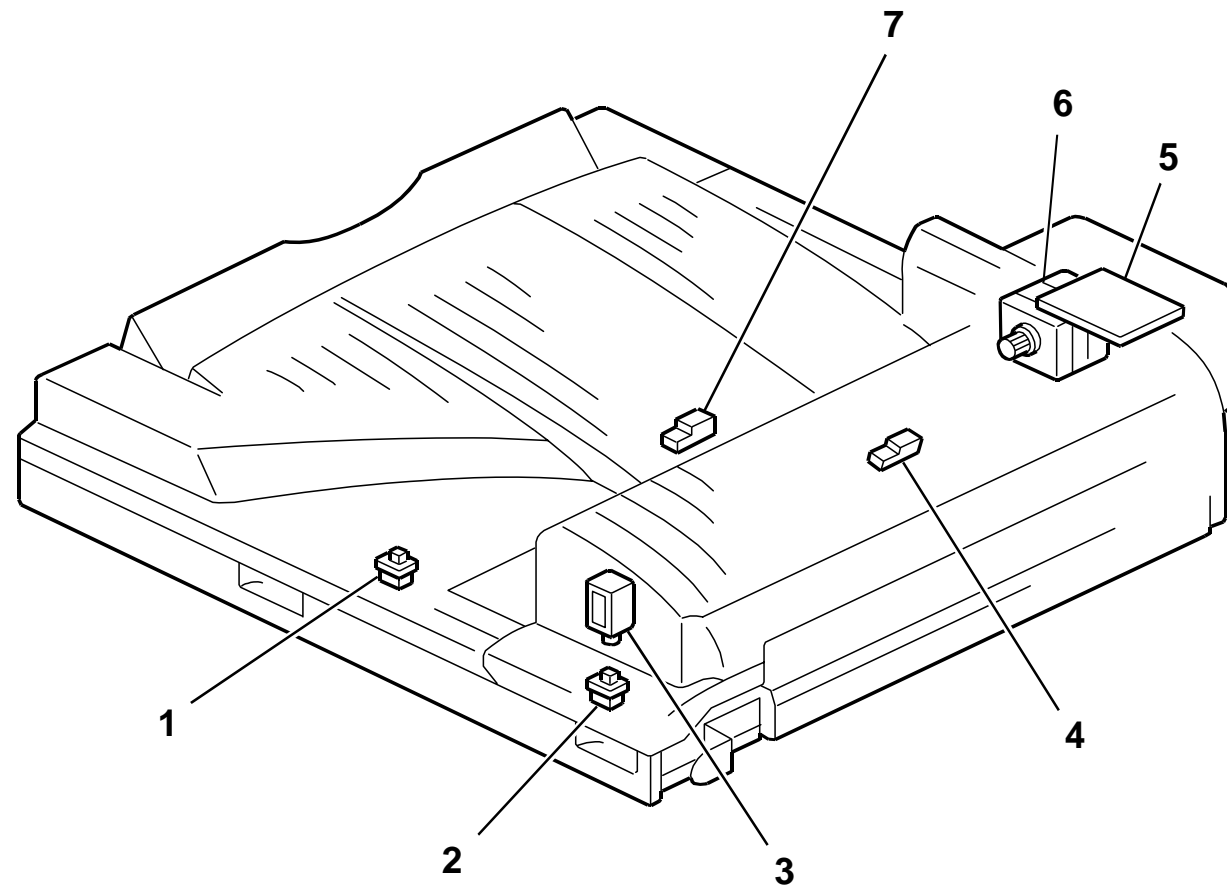

D634D102.Wmf

Symbol	Index No.	Description	P to P
Motor			
M1	6	Side Tray Drive Motor	E8
PCB			
PCB1	5	Main Board	C5
Sensors			
S1	7	Side Tray Relay Sensor	C8
S2	4	Side Tray Exit Sensor	D8
Solenoid			
SOL1	3	Junction Gate Solenoid	B8
Switches			
SW1	1	Left Guide Switch	C8
SW2	2	Right Guide Switch	D8

Bridge Unit (D634) POINT TO POINT DIAGRAM

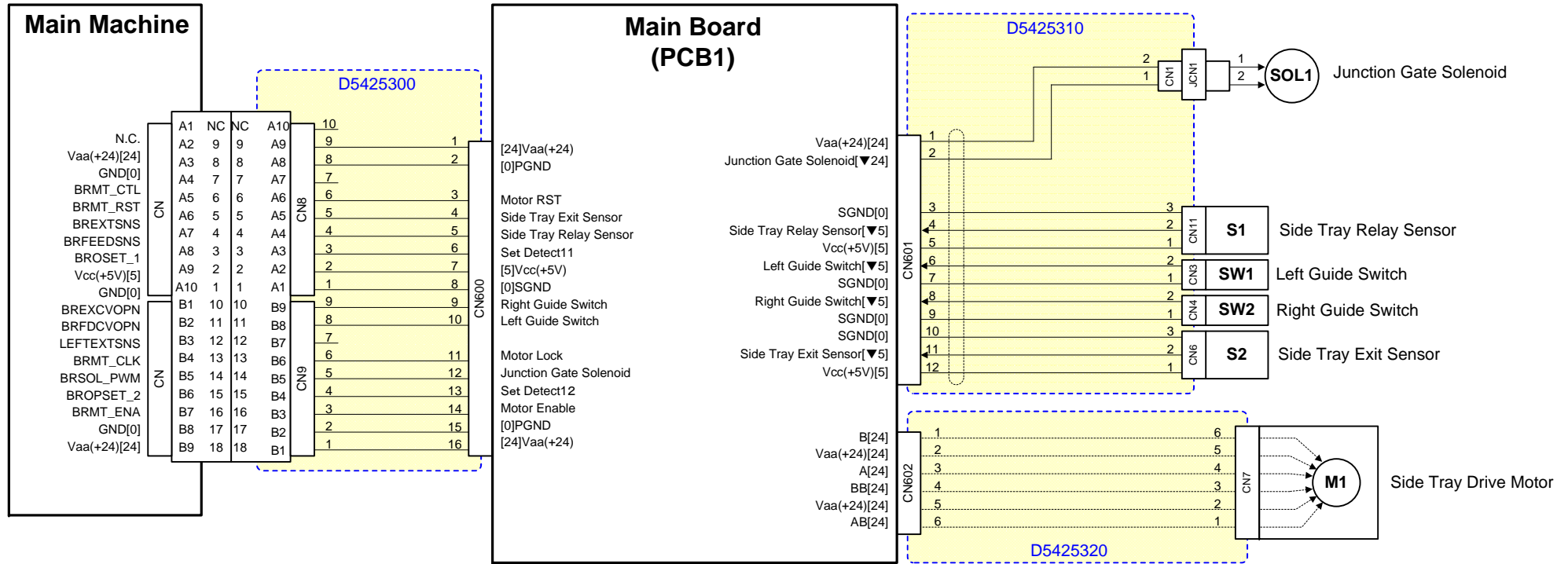

SYMBOL TABLE	
	AC LINE
	DC LINE
	Pulse
	Signal Direction
	Ready Low
	Ready High
	Voltage

Side Tray (D635) ELECTRICAL COMPONENT LAYOUT

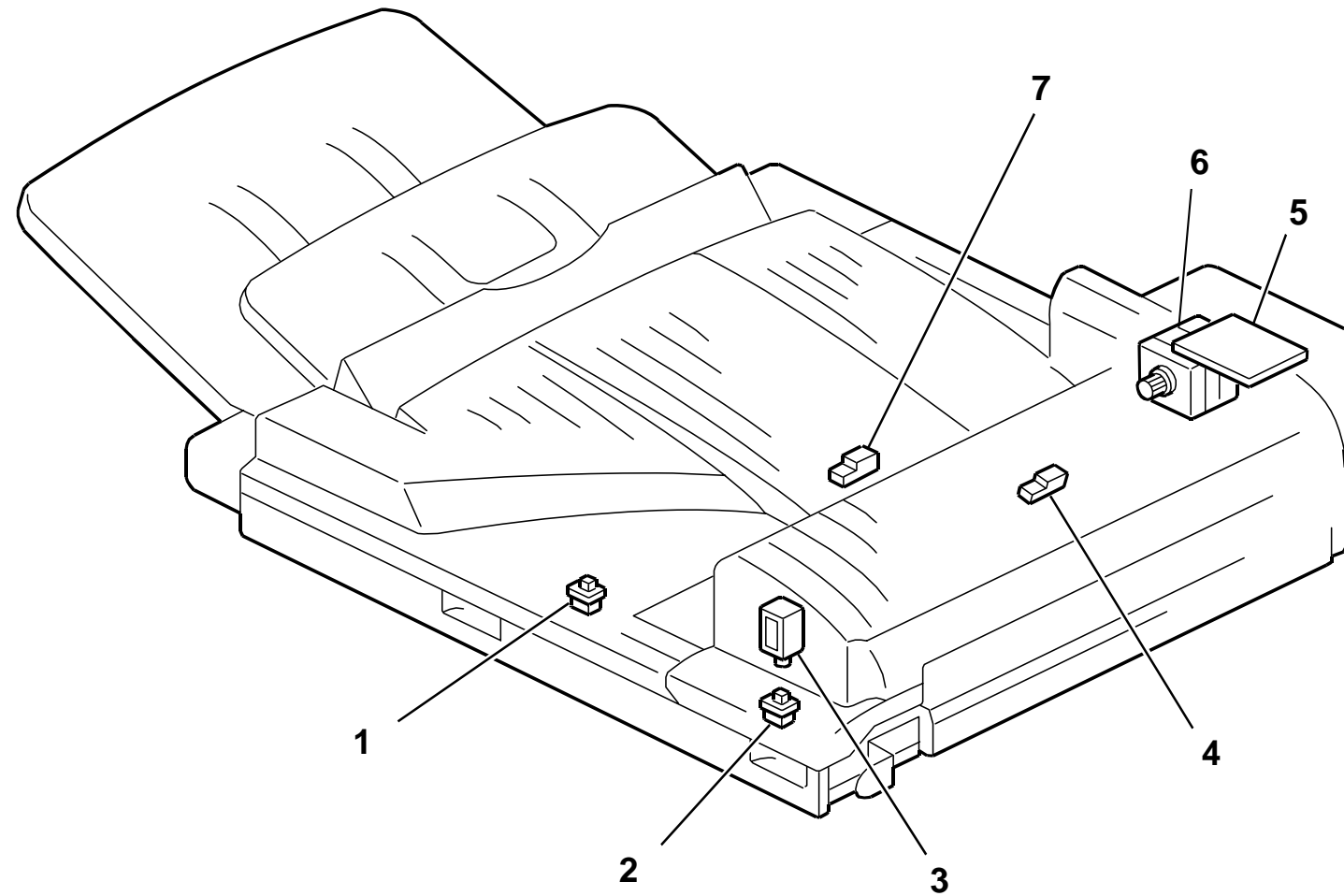

D635D102.Wmf

Symbol	Index No.	Description	P to P
Motor			
M1	6	Side Tray Drive Motor	E8
PCB			
PCB1	5	Main Board	C5
Sensors			
S1	7	Side Tray Relay Sensor	C8
S2	4	Side Tray Exit Sensor	D8
Solenoid			
SOL1	3	Junction Gate Solenoid	B8
Switches			
SW1	1	Left Guide Switch	C8
SW2	2	Right Guide Switch	D8

Side Tray (D635) POINT TO POINT DIAGRAM

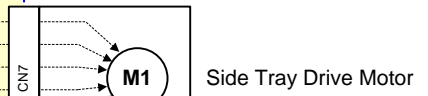
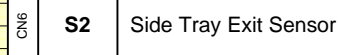
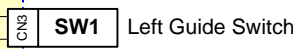
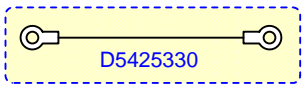
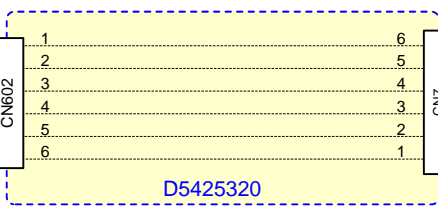
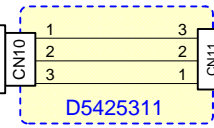
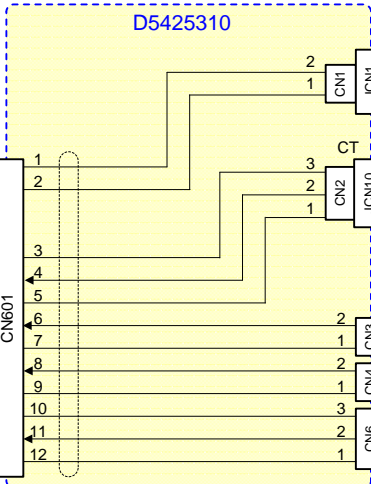
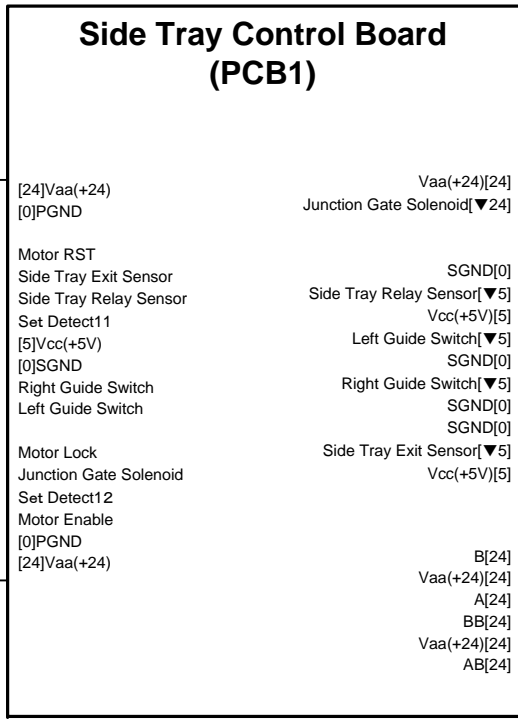
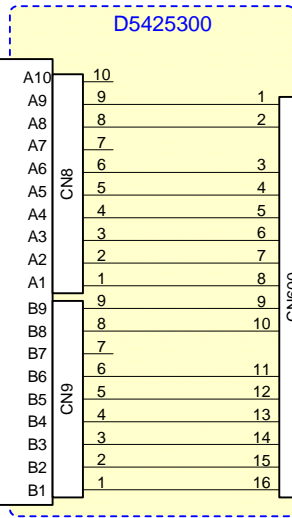
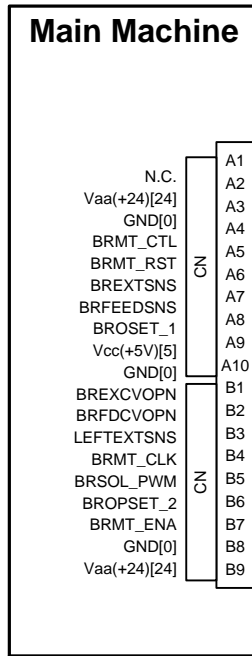

SYMBOL TABLE	
	AC LINE
	DC LINE
	Pulse
	Signal Direction
	Ready Low
	Ready High
	Voltage

Finisher/Booklet Finisher (D636/D637) ELECTRICAL COMPONENT LAYOUT 1/2

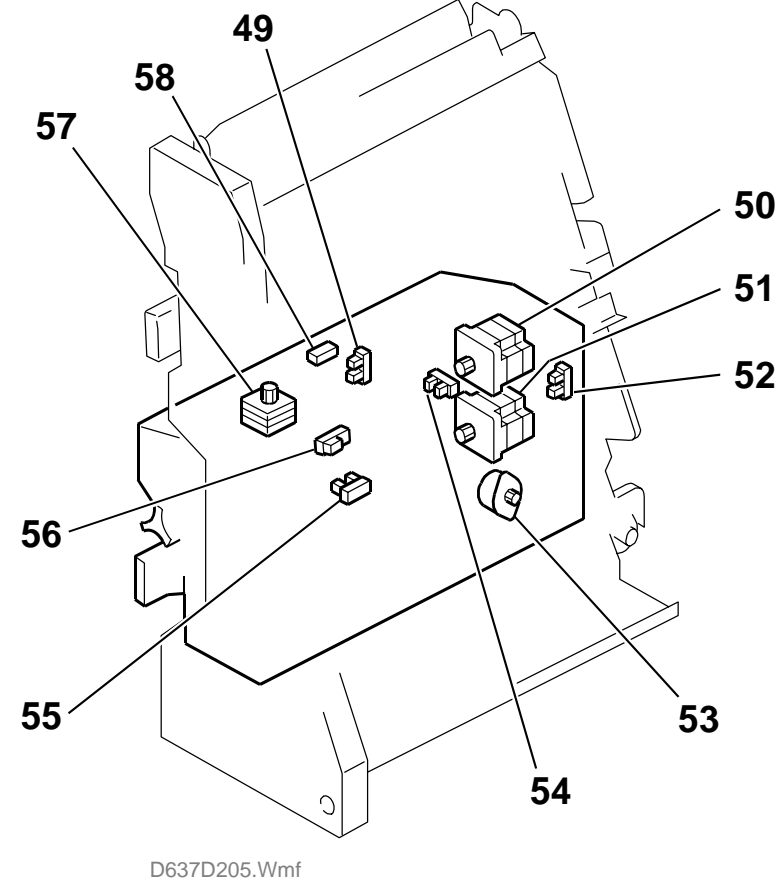
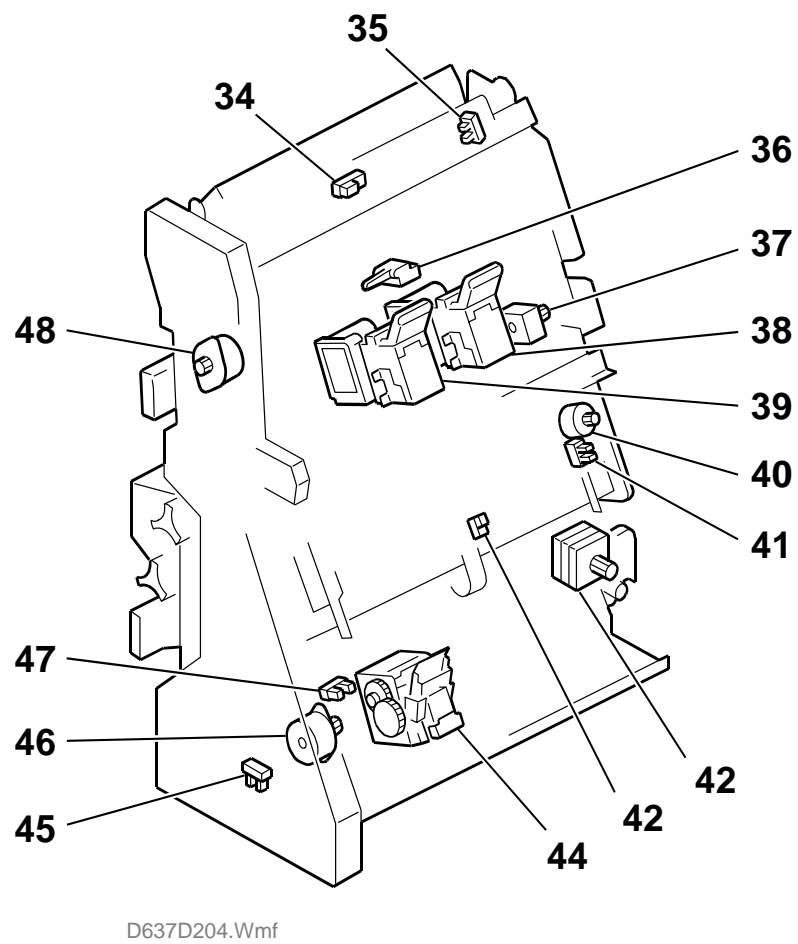
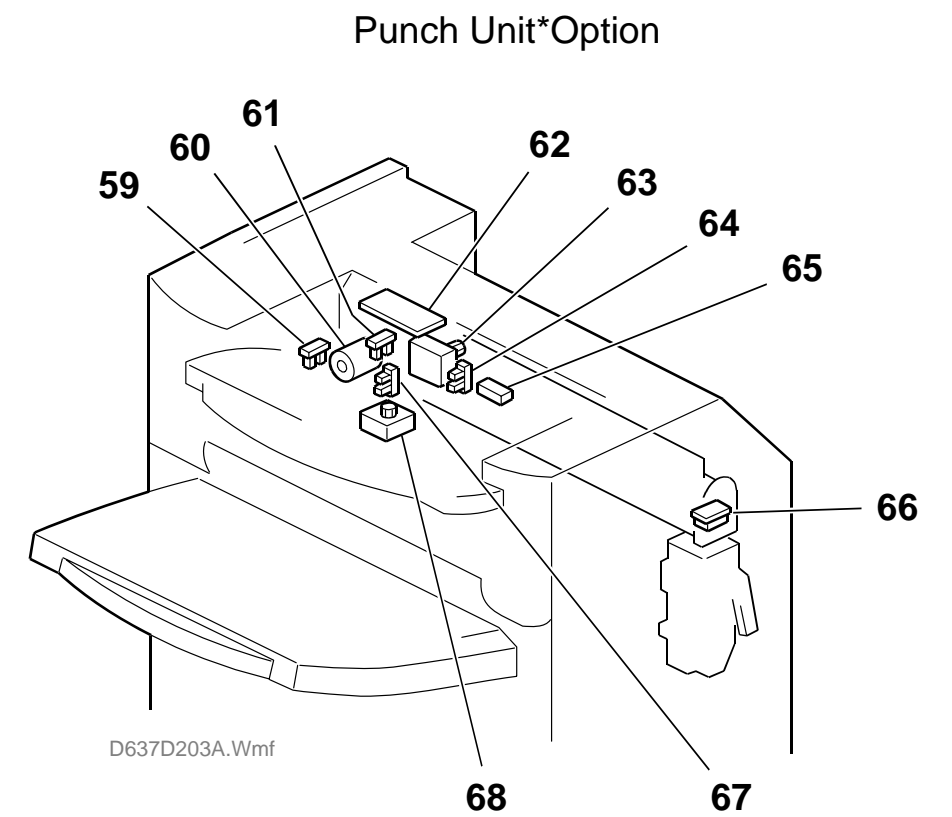
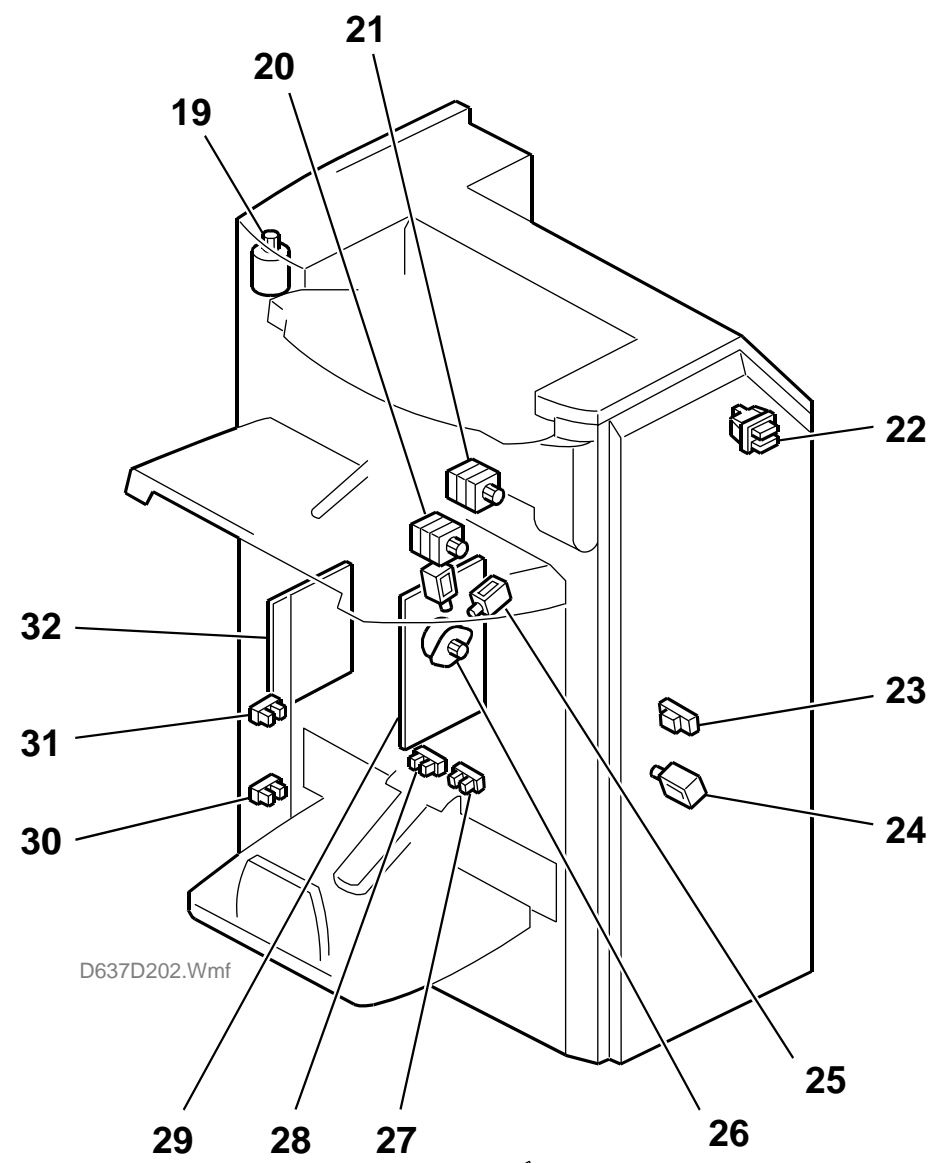
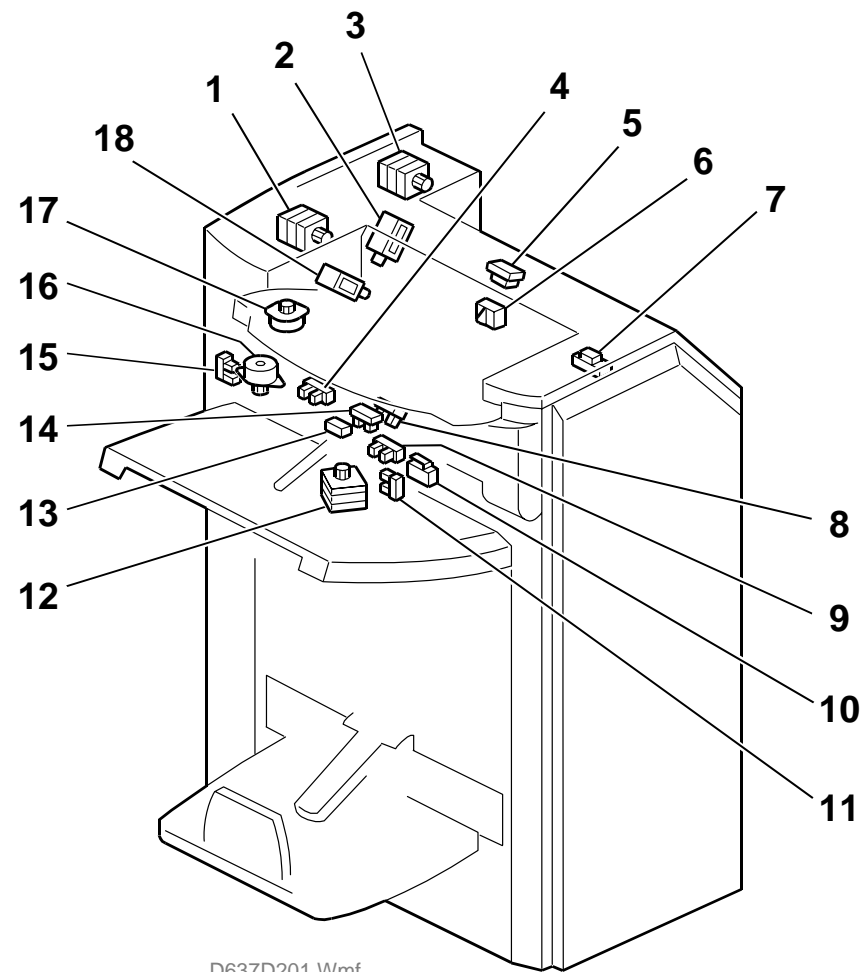

Finisher/Booklet Finisher (D636/D637) ELECTRICAL COMPONENT LAYOUT 2/2

Symbol	Index No.	Description	P to P	Page
PCBs				
PCB1	29	Main Board	G6	1/2
PCB2	32	Booklet Stapler Board	D6	2/2
PCB3	62	Punch Unit Board	G3	1/2
Motors				
M1	21	Entrance Motor	A10	1/2
M2	3	Upper Transport Motor	B10	1/2
M3	20	Lower Transport Motor	A10	1/2
M4	1	Upper/Proof Tray Exit Motor	B10	1/2
M5	37	Feed Out Belt Motor	E10	1/2
M6	42	Corner Stapler Movement Motor	E10	1/2
M7	63	Paper Position Sensor Slide Motor	F2	1/2
M8	57	Clamp Roller Retraction Motor	E9	2/2
M9	68	Punch Movement Motor	F2	1/2
M10	12	Stacking Sponge Roller Motor	G10	1/2
M11	51	Fold Plate Motor	F9	2/2
M12	50	Fold Roller Motor	G9	2/2
M13	45	Corner Stapler Rotation Motor	F10	1/2
M14	26	Positioning Roller Motor	B10	1/2
M15	40	Jogger Fence Motor	D10	1/2
M16	53	Fold Unit Bottom Fence Lift Motor	F9	2/2
M17	48	Stack Junction Gate Motor	E9	2/2
M18	16	Shift Roller Motor	B10	1/2
M19	17	Exit Guide Plate Motor	B10	1/2
M20	44	Corner Stapler	F10	1/2
M21	19	Upper Tray Lift Motor	F10	1/2
M22	39	Booklet Stapler - Front	D2	1/2
M23	38	Booklet Stapler - Rear	F2	1/2
M24	60	Punch Drive Motor	G2	1/2
M25	44	Stapler	D2	1/2

Symbol	Index No.	Description	P to P	Page
Sensors				
S1	7	Finisher Entrance Sensor	B6	1/2
S2	23	Pre-stack Tray Exit Sensor	C6	1/2
S3	65	Paper Position Sensor	C6	1/2
S4	66	Punch Hopper Full Sensor	C6	1/2
S5	15	Shift Roller HP Sensor	A2	1/2
S6	13	Upper Tray Exit Sensor	A2	1/2
S7	4	Exit Guide Plate HP Sensor	B2	1/2
S8	14	Upper Tray Paper Height Sensor (Staple Mode)	B2	1/2
S9	8	Upper Tray Paper Height Sensor (Non-Staple Mode)	B2	1/2
S10	5	Proof Tray Exit Sensor	B2	1/2
S11	6	Proof Tray Full Sensor	C2	1/2
S12	9	Upper Tray Limit Sensor	C2	1/2
S13	11	Stacking Roller HP Sensor	C2	1/2
S14	43	Stapling Tray Paper Sensor	C2	1/2
S15	41	Jogger Fence HP Sensor	C2	1/2
S16	36	Stack Feed-Out Belt HP Sensor	D2	1/2
S17	46	Corner Stapler HP Sensor	D2	1/2
S18	47	Stapler Rotation HP Sensor	D2	1/2
S19	31	Upper Tray Full Sensor	E2	1/2
S20	30	Upper Tray Full Sensor (D636)	E2	1/2
S21	67	Punch Movement HP Sensor	E2	1/2
S22	64	Paper Position Side HP Sensor	F2	1/2
S23	61	Punch HP Sensor	G2	1/2
S24	59	Punch Encoder Sensor	G2	1/2
S25	49	Clamp Roller HP Sensor	A2	2/2
S26	56	Fold Unit Entrance Sensor	B2	2/2
S27	35	Stack Junction Gate HP Sensor	B2	2/2
S28	55	Fold Bottom Fence HP Sensor	B2	2/2
S29	52	Fold Plate HP Sensor	C2	2/2
S30	54	Fold Cam HP Sensor	C2	2/2
S31	58	Fold Unit Exit Sensor	C2	2/2
S32	34	Stack Present Sensor	D2	2/2
S33	28	Lower Tray Full Sensor - Rear	G2	2/2
S34	27	Lower Tray Full Sensor - Front	G2	2/2
Solenoids				
SOL1	18	Proof Junction Gate Solenoid	D10	1/2
SOL2	2	Stapling Tray Junction Gate	D10	1/2
SOL3	25	Positioning Roller Solenoid	D10	1/2
SOL4	24	Stapling Edge Pressure Plate Solenoid	D10	1/2
SOL5	33	Booklet Pressure Roller	G9	2/2
Switches				
SW1	22	Front Door Safety Switch	B6	1/2
SW2	10	Upper Tray Limit SW	F10	1/2

Finisher/Booklet Finisher (D636/D637) POINT TO POINT DIAGRAM 1/2

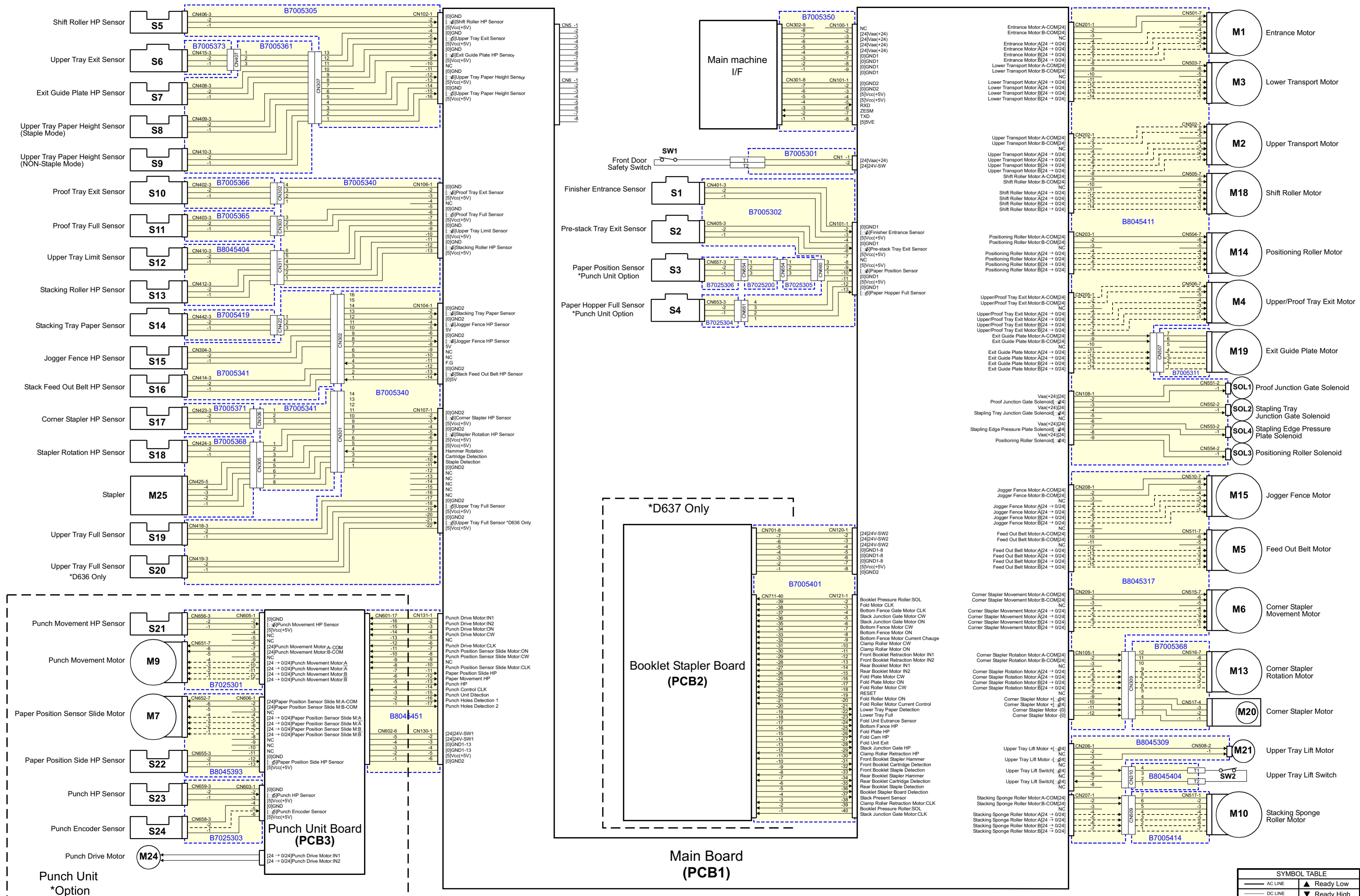

SYMBOL TABLE	
—	AC LINE
—▲	Ready Low
—▼	Ready High
---	Pulse
[]	Voltage
→	Signal Direction

Finisher/Booklet Finisher (D636/D637) POINT TO POINT DIAGRAM 2/2

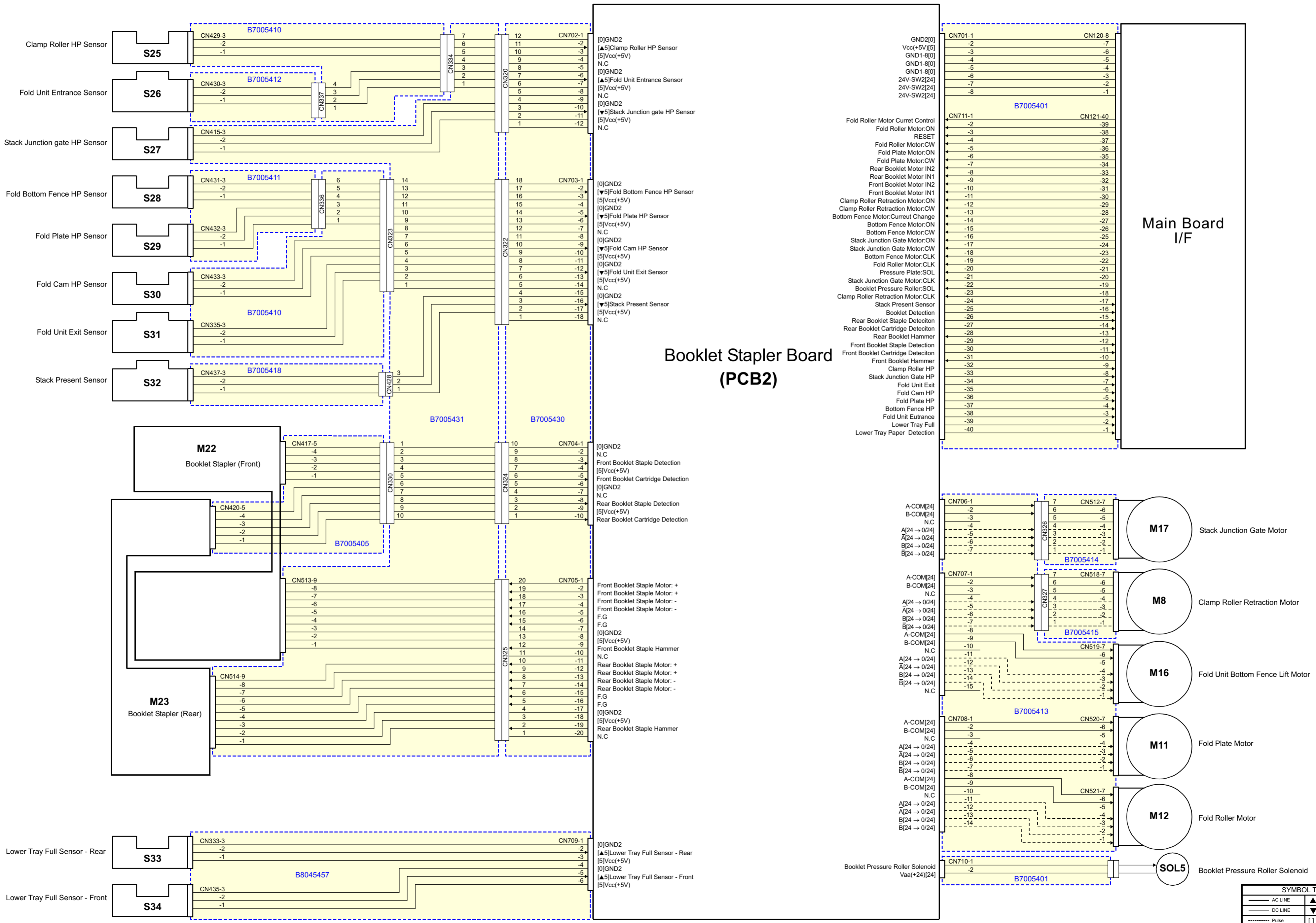

SYMBOL TABLE	
— AC LINE	▲ Ready Low
— DC LINE	▼ Ready High
----- Pulse	[] Voltage
→	Signal Direction

ELECTRICAL COMPONENT LAYOUT (D580)

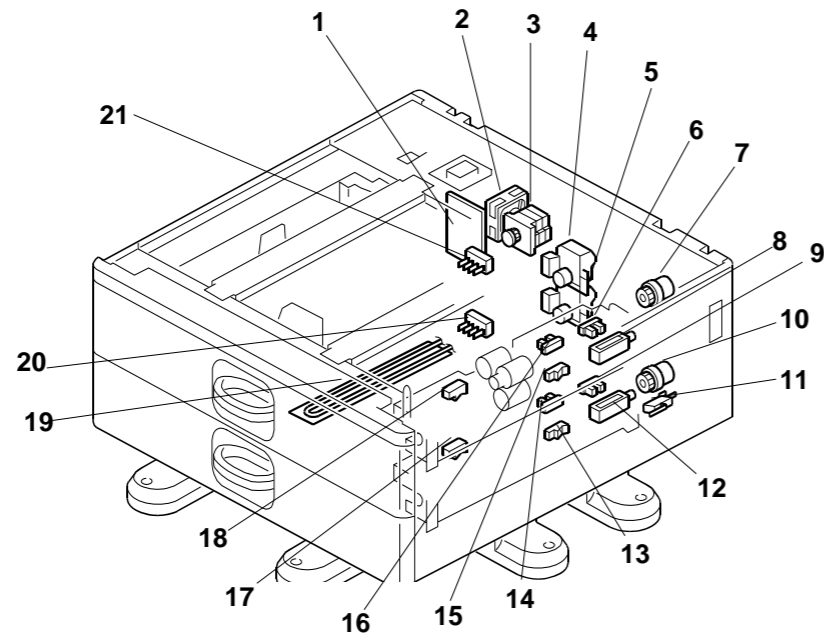

Symbol	Name	Index No.	P to P
Motors			
M1	Feed Motor	3	B9
M2	Upper Tray Lift Motor	4	E9
M3	Lower Tray Lift Motor	5	E9
Sensors			
S1	Upper Paper Feed	18	E3
S2	Upper Vertical Transport	15	E3
S3	Upper Paper End	16	F3
S4	Upper Lift	6	F3
S5	Lower Paper Feed	17	F3
S6	Lower Vertical Transport	13	F3
S7	Lower Paper End	14	G3
S8	Lower Lift	9	G3
Solenoids			
SOL1	Lower Pick-up	8	E3
SOL1	Upper Pick-up	12	F3
Switches			
SW1	Vertical Transport Guide	11	D3
SW2	Upper Paper Size	21	C9
SW3	Lower Paper Size	20	D9
Magnetic Clutches			
MC1	Upper Paper Feed	7	E9
MC2	Lower Paper Feed	10	E9
PCBs			
PCB1	Main Board	1	B6
Others			
H1	Optional Tray Heater	19	C3
Fan			
FAN1	Fan Motor	2	F9

D580 POINT TO POINT DIAGRAM

[Main Frame]

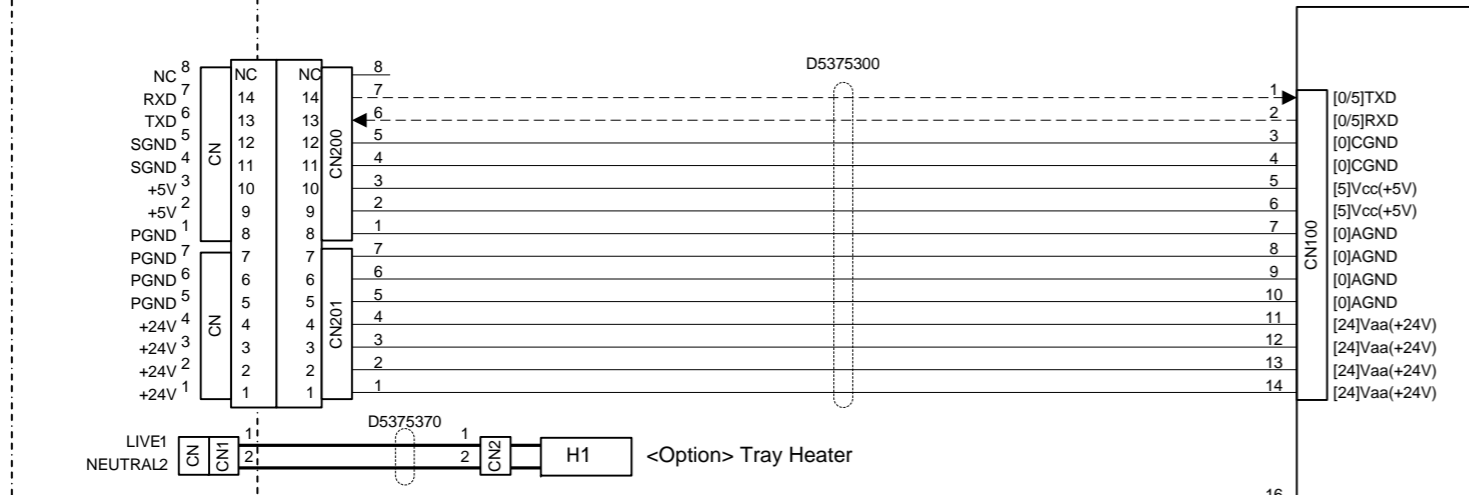

LCT[D539]

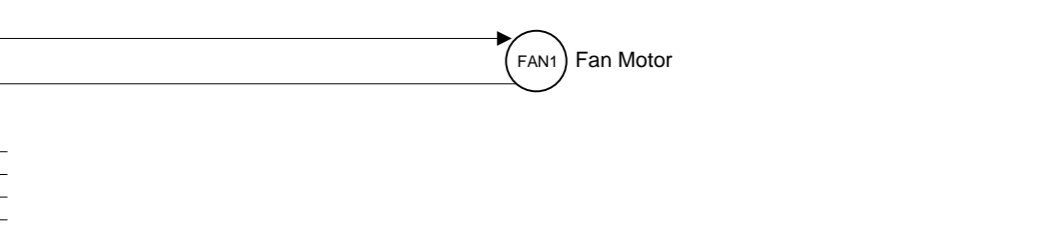
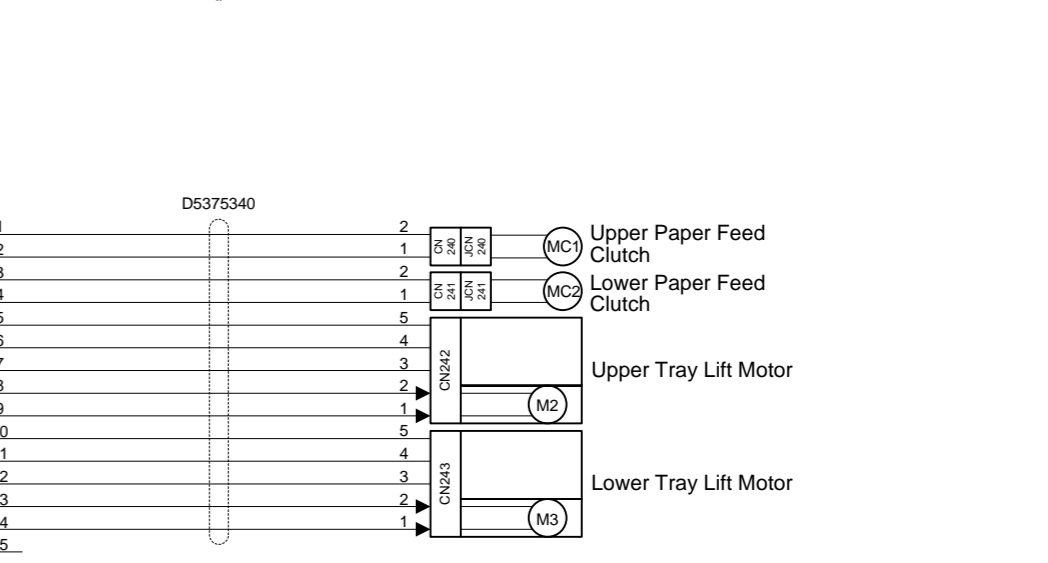
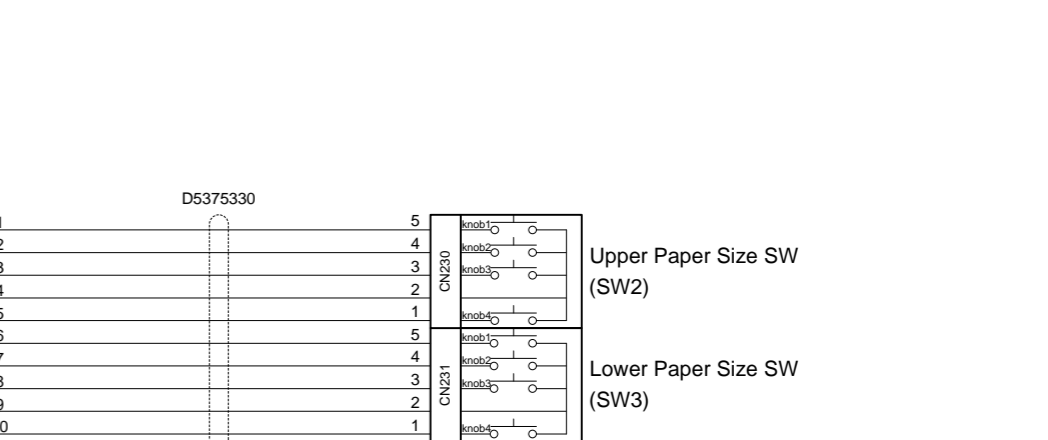
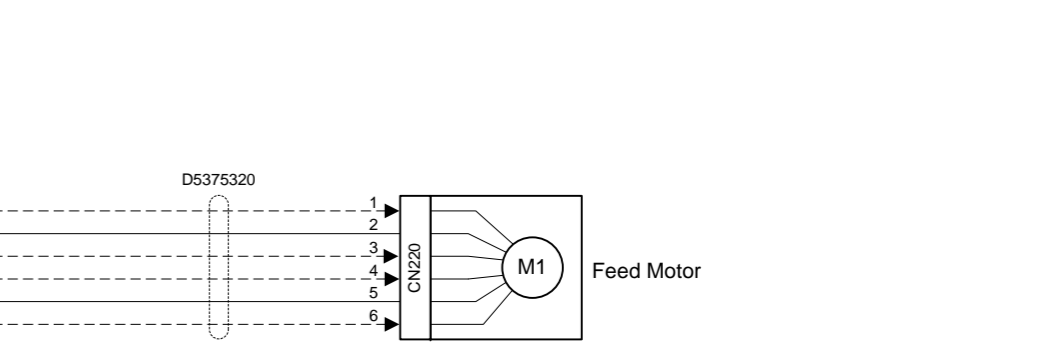
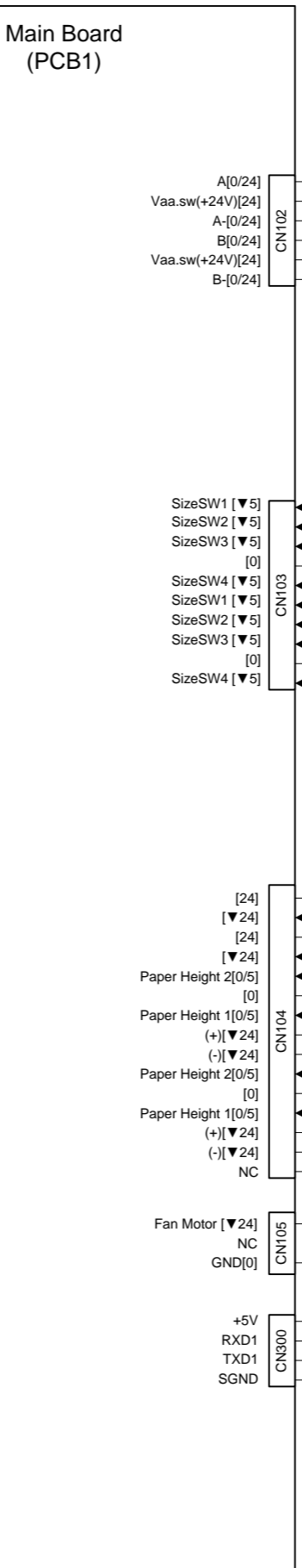
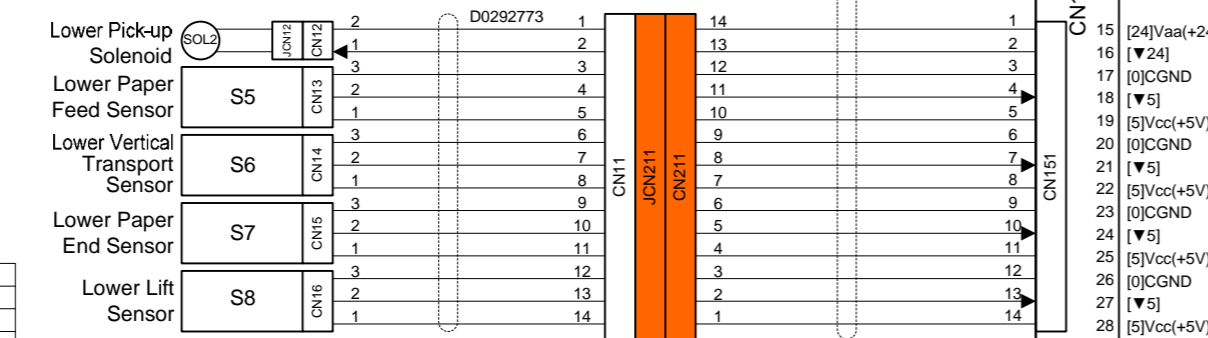
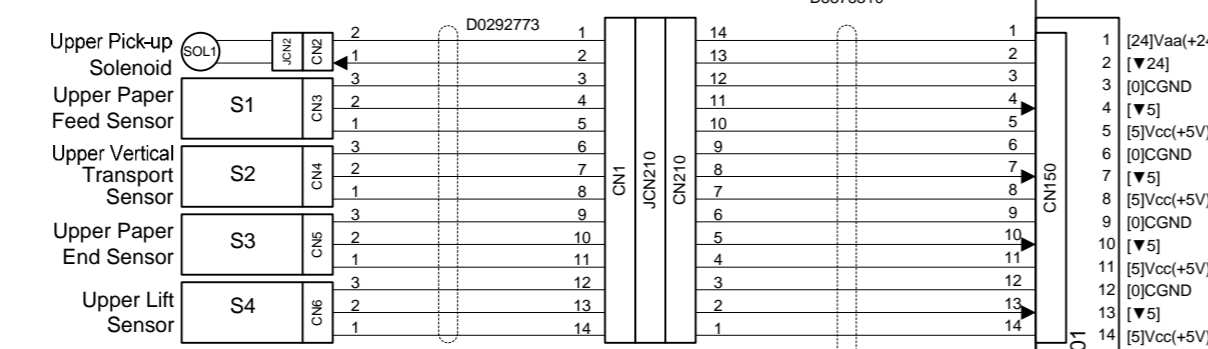
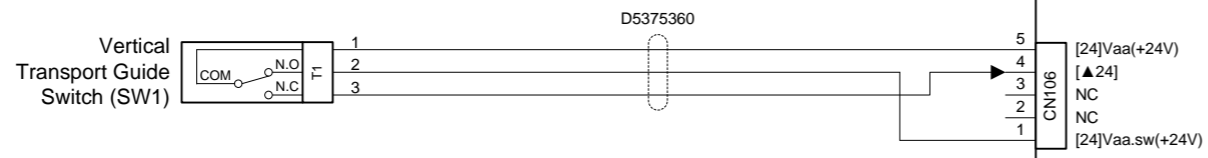
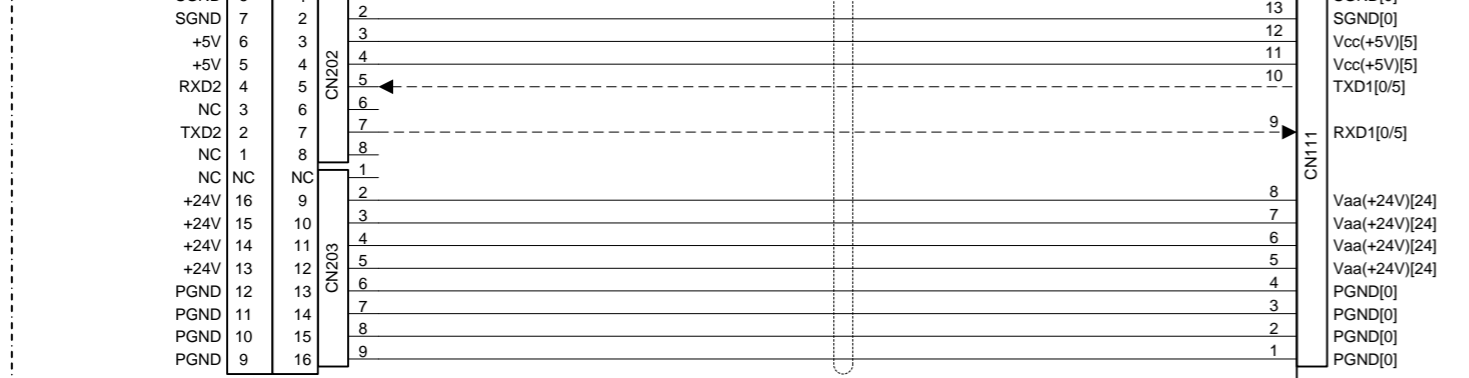

SYMBOL TABLE	
	AC LINE
	DC LINE
	Pulse Signal
	Signal Direction
	Ready Low
	Ready High
	Voltage

ELECTRICAL COMPONENT LAYOUT (D581)

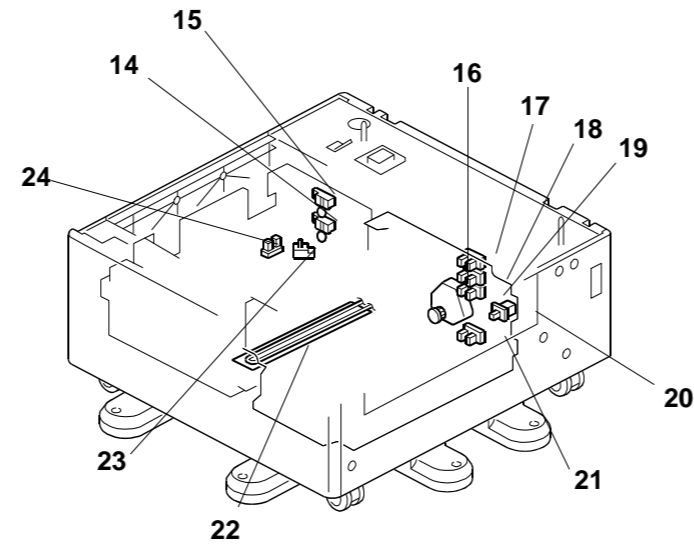
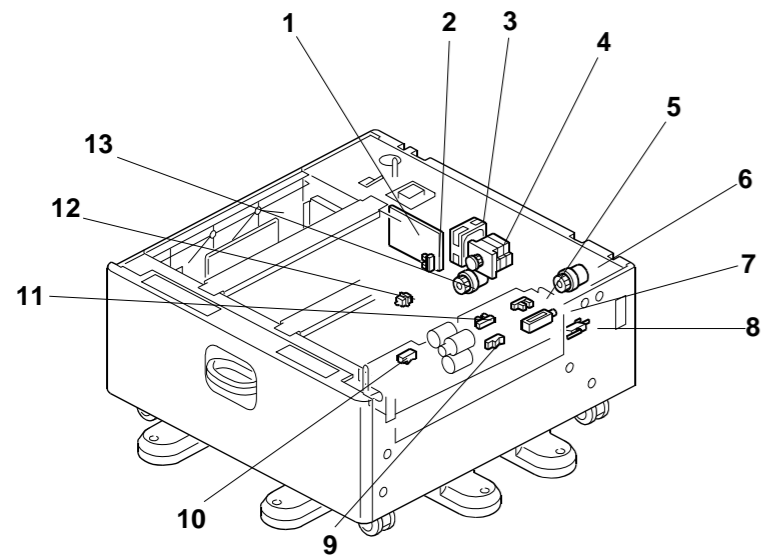

Symbol	Name	Index No.	P to P
Motors			
M1	Tray Motor	4	B9
M2	Tray Lift Motor	16	E9
Sensors			
S1	Paper Feed	10	E3
S2	Relay	9	E3
S3	Paper End	11	F3
S4	Lift	5	F3
S5	End Fence HP	24	C9
S6	Left Tray Paper End	23	C9
S7	Paper Height 4	15	C9
S8	Paper Height 5	14	C9
S9	Paper Height 1	17	D9
S10	Paper Height 2	18	D9
S11	Paper Height 3	19	D9
S12	Lower Limit	21	D9
S13	Right Tray End Fence	2	E9
Solenoids			
SOL1	Pick-up	7	E3
Switches			
SW1	Vertical Guide	8	D3
SW2	Right Tray Set	20	E9
SW3	Left Tray Set	12	E9
Magnetic Clutches			
MC1	Paper Feed	6	E9
MC2	Stack Transport	13	E9
PCBs			
PCB1	Main Board	1	B6
Others			
H1	Optional Tray Heater	22	C3
Fan			
FAN1	Fan Motor	3	F9

D581 POINT TO POINT DIAGRAM

[Main Frame]

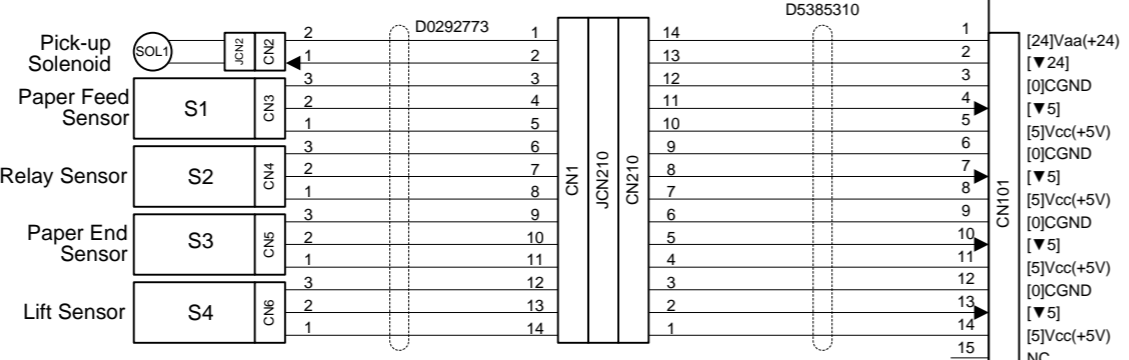
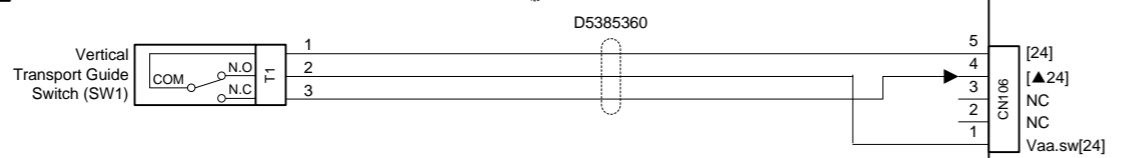
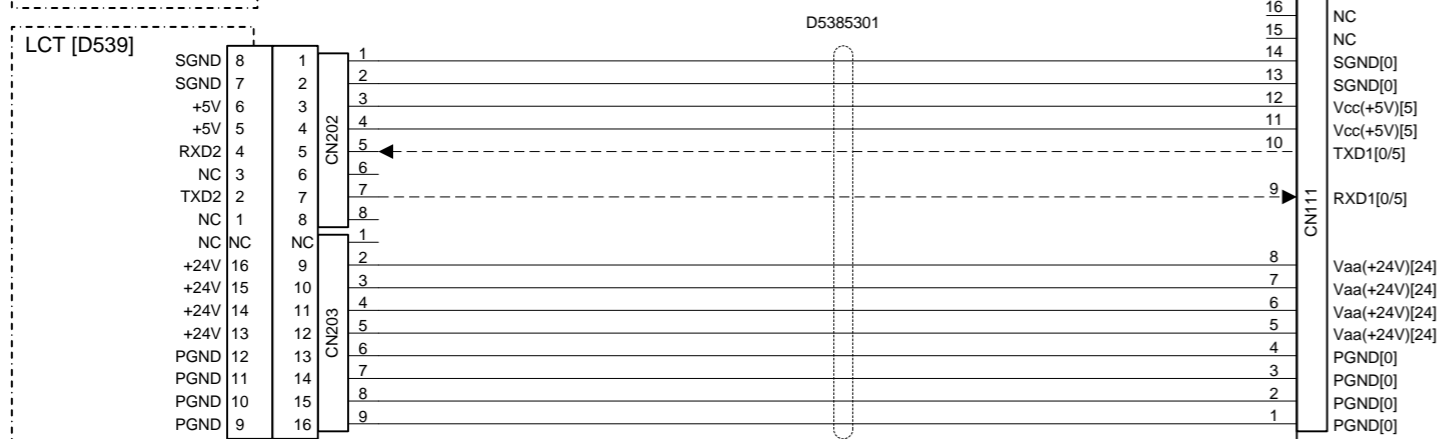
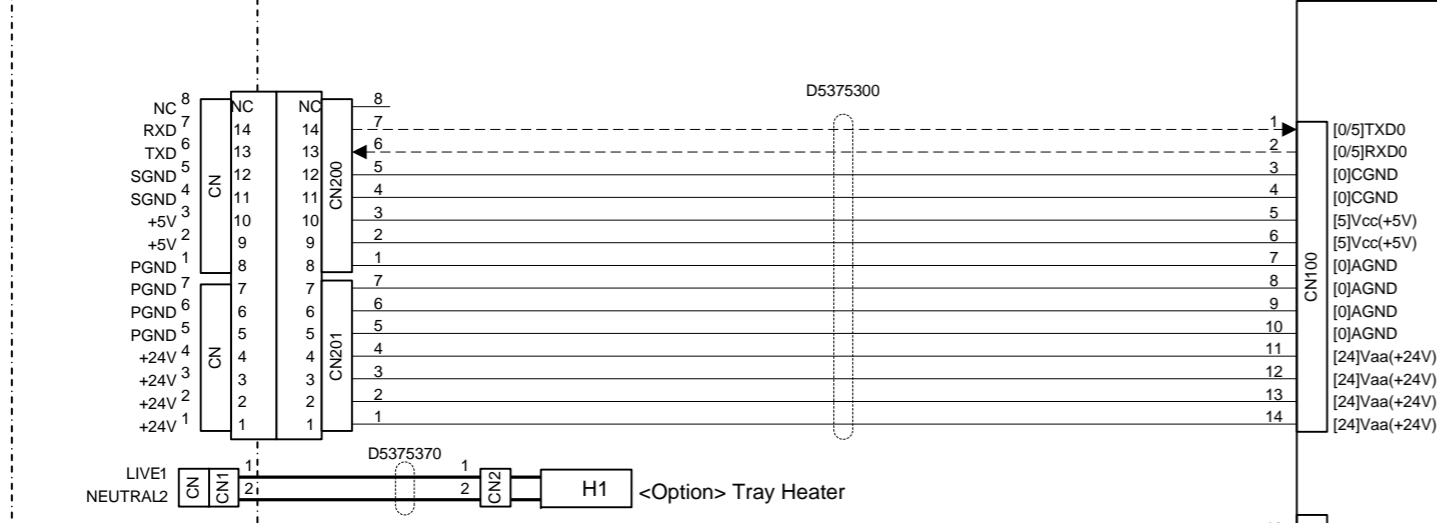

Main Board (PCB1)

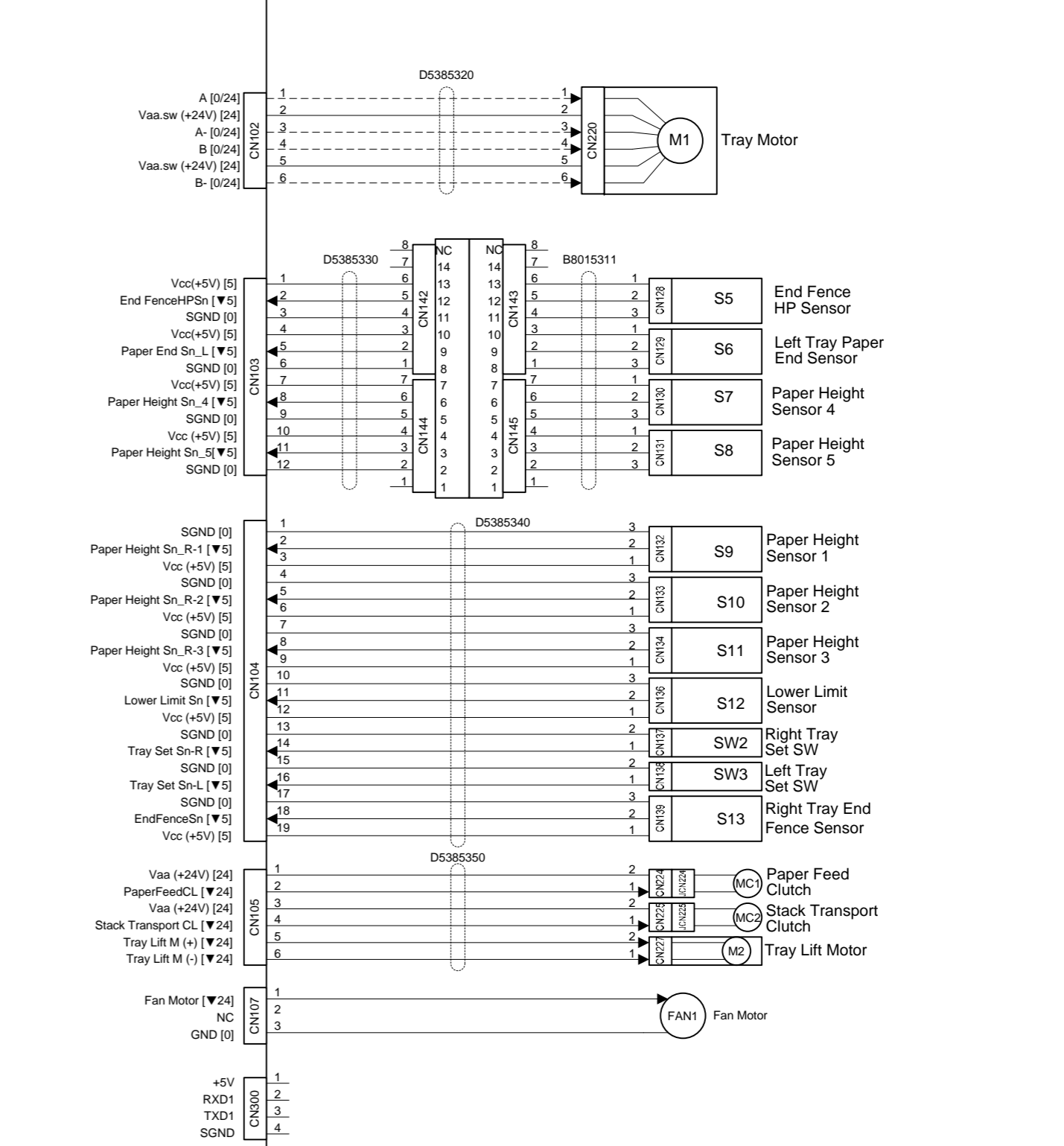

SYMBOL TABLE	
AC LINE	Ready Low
DC LINE	Ready High
Pulse	[] Voltage
Signal Direction	