



RICOH UNIVERSITY

Learning ♦ Knowledge ♦ Performance



**D009/D011/D012/
D013/D091/D092**
SERVICE MANUAL

003315MIU

LANIER RICOH SAVIN



**D009/D011/D012/
D013/D091/D092
SERVICE MANUAL**

**LANIER
RICOH
Savin**



RICOH UNIVERSITY

Learning ♦ Knowledge ♦ Performance

**D009/D011/D012/
D013/D091/D092
SERVICE MANUAL**

003315MIU

LANIER RICOH SAVIN

It is the reader's responsibility when discussing the information contained within this document to maintain a level of confidentiality that is in the best interest of Ricoh Americas Corporation and its member companies.

NO PART OF THIS DOCUMENT MAY BE REPRODUCED IN ANY FASHION AND DISTRIBUTED WITHOUT THE PRIOR PERMISSION OF RICOH AMERICAS CORPORATION.

All product names, domain names or product illustrations, including desktop images, used in this document are trademarks, registered trademarks or the property of their respective companies.

They are used throughout this book in an informational or editorial fashion only and for the benefit of such companies. No such use, or the use of any trade name, or web site is intended to convey endorsement or other affiliation with Ricoh products.

WARNING

The Service Manual contains information regarding service techniques, procedures, processes and spare parts of office equipment distributed by Ricoh Americas Corporation. Users of this manual should be either service trained or certified by successfully completing a Ricoh Technical Training Program.

Untrained and uncertified users utilizing information contained in this service manual to repair or modify Ricoh equipment risk personal injury, damage to property or loss of warranty protection.

Ricoh Americas Corporation

LEGEND

PRODUCT CODE	COMPANY			
	GESTETNER	LANIER	RICOH	SAVIN
D009	MP 4000B	LD040B	Aficio MP 4000B	9040b
D011	MP 4000	LD040	Aficio MP 4000	9040
D012	MP 5000B	LD050B	Aficio MP 5000B	9050b
D013	MP5000	LD050	Aficio MP 5000	9050
D091-17	MP 4001SP	LD140SP	Aficio MP 4001SP	9240SP
D092-17	MP 5001SP	LD150SP	Aficio MP 5001SP	9250SP
D091-57	MP 4001G	LD140G	Aficio MP 4001G	9240G
D092-57	MP 5001G	LD150G	Aficio MP 5001G	9250G

DOCUMENTATION HISTORY

REV. NO.	DATE	COMMENTS
*	01/2010	Original Printing

D009/D011/D012/D013/D091/D092

TABLE OF CONTENTS

PRODUCT INFORMATION

1. PRODUCT INFORMATION.....	1-1
1.1 SPECIFICATIONS	1-1
1.2 MACHINE CONFIGURATION	1-2
1.2.1 COPIER	1-2
1.3 GUIDANCE FOR THOSE WHO ARE FAMILIAR WITH PREDECESSOR PRODUCTS.....	1-5
1.4 OVERVIEW.....	1-6
1.4.1 COMPONENT LAYOUT	1-6
1.4.2 PAPER PATH	1-8
1.4.3 DRIVE LAYOUT.....	1-9

INSTALLATION

2. INSTALLATION	2-1
2.1 INSTALLATION REQUIREMENTS.....	2-1
2.1.1 ENVIRONMENT	2-2
2.1.2 MACHINE LEVEL	2-3
2.1.3 MINIMUM SPACE REQUIREMENTS.....	2-3
2.1.4 POWER REQUIREMENTS.....	2-4
2.2 INSTALLATION FLOW CHART	2-5
2.3 MAIN MACHINE INSTALLATION	2-6
2.3.1 ACCESSORY CHECK.....	2-6
2.3.2 INSTALLATION PROCEDURE.....	2-8
Preliminary Procedures	2-8
Fire Prevention Cover	2-10
PCDU (Photoconductor and Development Unit)	2-10
Toner Bottle.....	2-13
Paper Trays.....	2-14

Initialize TD Sensor and Developer	2-14
Set Paper Size for Paper Trays.....	2-15
Electrical Total Counter	2-15
Exposure Glass Cleaner	2-16
Operation Instructions Holder.....	2-16
Settings Relevant to the Service Contract.....	2-17
App 2 Me Setting (D091/D092 only).....	2-17
2.3.3 MOVING THE MACHINE.....	2-19
2.3.4 TRANSPORTING THE MACHINE.....	2-19
2.4 PAPER FEED UNIT INSTALLATION (D351).....	2-20
2.4.1 ACCESSORY CHECK.....	2-20
2.4.2 INSTALLATION PROCEDURE.....	2-20
2.5 LCT 2000-SHEET	2-24
2.5.1 ACCESSORY CHECK.....	2-24
2.5.2 INSTALLATION PROCEDURE.....	2-24
2.6 1200-SHEET LCT (D353)	2-27
2.6.1 COMPONENT CHECK.....	2-27
2.6.2 INSTALLATION PROCEDURE.....	2-28
2.7 AUTO REVERSE DOCUMENT FEEDER (B802)	2-30
2.7.1 COMPONENT CHECK.....	2-30
2.7.2 INSTALLATION PROCEDURE.....	2-31
2.8 PLATEN COVER INSTALLATION (G329).....	2-35
2.9 1-BIN TRAY UNIT (D389)	2-36
2.9.1 COMPONENT CHECK.....	2-36
2.9.2 INSTALLATION PROCEDURE.....	2-36
2.10 BRIDGE UNIT (D386)	2-39
2.10.1 COMPONENT CHECK.....	2-39
2.10.2 INSTALLATION PROCEDURE.....	2-39
2.11 2000/3000-SHEET FINISHERS (B804/B805)	2-43
2.11.1 ACCESSORY CHECK.....	2-43
2.11.2 INSTALLATION PROCEDURE.....	2-44
Support Tray Installation	2-48
2.12 PUNCH UNIT	2-49
2.12.1 COMPONENT CHECK.....	2-49
2.12.2 INSTALLATION PROCEDURE.....	2-50
2.13 1000-SHEET FINISHER (B408).....	2-54

2.13.1	ACCESSORY CHECK.....	2-54
2.13.2	INSTALLATION PROCEDURE.....	2-55
2.14	KEY COUNTER BRACKET.....	2-58
2.14.1	INSTALLATION PROCEDURE.....	2-58
2.15	KEY COUNTER INTERFACE UNIT.....	2-60
2.15.1	INSTALLATION PROCEDURE.....	2-60
2.16	ANTI-CONDENSATION HEATER (SCANNER).....	2-62
2.16.1	INSTALLATION PROCEDURE.....	2-62
2.17	TRAY HEATER	2-64
2.17.1	INSTALLATION PROCEDURE.....	2-64
2.18	TRAY HEATER (OPTIONAL PAPER FEED UNIT).....	2-66
2.18.1	COMPONENT CHECK	2-66
2.18.2	INSTALLATION PROCEDURE.....	2-67
	For installing the tray heater in the D351 (Two-tray paper feed unit)..	2-67
	For installing the tray heater in the D352 (LCT).....	2-70
2.19	HDD OPTION (D362, ONLY FOR D009/D012).....	2-74
2.19.1	COMPONENT CHECK	2-74
2.19.2	INSTALLATION PROCEDURE.....	2-75
	After Installing the HDD	2-76
2.20	COPY DATA SECURITY UNIT	2-77
2.20.1	INSTALLATION PROCEDURE.....	2-77
	User Tool Setting.....	2-78
2.21	CONTROLLER OPTIONS.....	2-80
2.21.1	CONTROLLER BOARD SLOTS.....	2-80
	SD Slot 1, Slot 2	2-80
	Board Slot.....	2-81
2.21.2	IEEE1284.....	2-82
	Installation Procedure.....	2-82
2.21.3	IEEE 802.11A/G, G (WIRELESS LAN).....	2-82
	Installation Procedure.....	2-82
	UP Mode Settings for Wireless LAN.....	2-84
	SP Mode Settings for IEEE 802.11a/g, g Wireless LAN.....	2-86
2.21.4	BLUETOOTH.....	2-87
2.21.5	GIGABIT ETHERNET	2-88
2.21.6	FILE FORMAT CONVERTER.....	2-89
2.21.7	POSTSCRIPT 3.....	2-90

2.21.8	IPDS UNIT	2-91
	Accessories	2-91
	Installation	2-91
2.21.9	HDD ENCRYPTION UNIT	2-93
	Before You Begin the Procedure	2-93
	Seal Check and Removal	2-94
	Installation Procedure	2-94
	Recovery from a Device Problem	2-96
2.21.10	DATAOVERWRITESECURITY UNIT TYPE I (D362)	2-98
	Before You Begin the Procedure	2-98
	Seal Check and Removal	2-99
	Installation Procedure	2-100
2.21.11	BROWSER UNIT TYPE D	2-102
	Installation Procedure	2-102
	Update Procedure	2-104
2.21.12	VM CARD TYPE F (D377)	2-105
	Accessories	2-105
	Installation	2-106
2.21.13	PRINTER AND P/S OPTIONS (ONLY FOR D009/D012)	2-106
	Overview	2-106
	Kit Contents	2-108
	Printer/Scanner Installation	2-110
	Printer Enhance, Scanner Enhance Options	2-112
2.21.14	CHECK ALL CONNECTIONS	2-117

PREVENTIVE MAINTENANCE

3.	PREVENTIVE MAINTENANCE	3-1
3.1	PM TABLES	3-1

REPLACEMENT AND ADJUSTMENT

4. REPLACEMENT AND ADJUSTMENT	4-1
4.1 GENERAL CAUTIONS	4-1
4.1.1 LASER UNIT	4-1
4.1.2 USED TONER	4-1
4.2 SPECIAL TOOLS AND LUBRICANTS.....	4-2
4.2.1 SPECIAL TOOLS.....	4-2
4.2.2 LUBRICANTS	4-2
4.3 EXTERIOR COVERS.....	4-3
4.3.1 FRONT DOOR, UPPER AND LOWER INNER COVER	4-3
Upper Inner Cover.....	4-3
Lower Inner Cover.....	4-3
4.3.2 LEFT COVER	4-4
4.3.3 REAR COVER	4-4
4.3.4 RIGHT REAR COVER	4-5
4.3.5 OPERATION PANEL	4-6
4.3.6 PAPER EXIT COVER	4-7
4.3.7 INNER TRAY	4-8
4.4 SCANNER -1	4-9
4.4.1 EXPOSURE GLASS	4-9
4.4.2 ORIGINAL LENGTH/WIDTH SENSORS	4-10
Monochrome Scanner Model (D009/D012)	4-10
Color Scanner Model (D011/D013/D091/D092)	4-11
4.4.3 EXPOSURE LAMP	4-11
Color Scanner Model (D011/D013/D091/D092)	4-11
Monochrome Scanner Model (D009/D012)	4-13
4.4.4 SCANNER MOTOR	4-13
4.4.5 SENSOR BOARD UNIT (SBU)	4-14
Monochrome Scanner Model (D009/D012)	4-14
Color Scanner Model (D011/D013/D091/D092)	4-15
When reassembling.....	4-15
4.4.6 LAMP STABILIZER.....	4-16
4.4.7 SIO (SCANNER IN/OUT) BOARD	4-16

4.4.8	SCANNER HP SENSOR	4-17
4.4.9	PLATEN COVER SENSOR	4-18
4.5	SCANNER-2	4-19
4.5.1	FRONT SCANNER WIRE	4-19
	Reassembling the Front Scanner Wire.....	4-19
4.5.2	REAR SCANNER WIRE	4-22
	Reassembling the Rear Scanner Wire	4-23
4.5.3	TOUCH PANEL POSITION ADJUSTMENT	4-24
4.6	LASER UNIT	4-26
4.6.1	CAUTION DECAL LOCATIONS	4-26
4.6.2	LASER UNIT	4-26
4.6.3	POLYGON MIRROR MOTOR	4-28
4.6.4	LASER SYNCHRONIZATION DETECTOR	4-28
4.6.5	LD UNIT	4-29
	Laser Beam Pitch Adjustment	4-29
4.7	PCDU	4-32
4.7.1	PCDU (PHOTOCONDUCTOR AND DEVELOPMENT UNIT).....	4-32
	Reinstallation.....	4-32
4.7.2	DRUM	4-33
	Re-installation.....	4-35
4.7.3	PICK-OFF PAWLS.....	4-36
	Pick-off Pawl Position Adjustment	4-36
4.7.4	CHARGE ROLLER AND CLEANING ROLLER	4-37
4.7.5	DRUM CLEANING BLADE 1	4-38
	Re-installation.....	4-38
4.7.6	ID SENSOR	4-39
4.8	DEVELOPMENT	4-40
4.8.1	DEVELOPMENT FILTER.....	4-40
4.8.2	DEVELOPMENT ROLLER.....	4-41
	Cleaning Procedure.....	4-41
4.8.3	DEVELOPER	4-43
4.8.4	TD SENSOR	4-45
4.9	TRANSFER.....	4-46
4.9.1	TRANSFER BELT UNIT	4-46
4.9.2	TRANSFER BELT	4-47
4.9.3	TONER OVERFLOW SENSOR.....	4-49

4.9.4	TRANSFER BELT CLEANING BLADE	4-49
4.10	PAPER FEED.....	4-50
4.10.1	PAPER FEED UNIT.....	4-50
Tray 1 and Tray 2	4-50	
4.10.2	PICK-UP, FEED AND SEPARATION ROLLERS.....	4-51
Tray 1 and Tray 2	4-51	
4.10.3	TRAY LIFT MOTOR.....	4-52
4.10.4	RELAY, TRAY LIFT, PAPER END AND PAPER FEED SENSORS	4-53
Tray 1 and Tray 2	4-53	
4.10.5	REGISTRATION SENSOR.....	4-54
Reinstall the registration sensor	4-55	
4.11	FUSING.....	4-56
4.11.1	FUSING UNIT	4-56
4.11.2	WEB ROLLER UNIT	4-57
4.11.3	BRAKE PAD	4-57
4.11.4	WEB HOLDER ROLLER AND WEB ROLLERS	4-58
Installing a new web holder roller	4-60	
Installing new web rollers	4-60	
4.11.5	PRESSURE ROLLER CLEANING ROLLER	4-61
4.11.6	THERMOSTAT	4-62
4.11.7	THERMISTOR	4-63
4.11.8	HOT ROLLER STRIPPERS.....	4-64
4.11.9	FUSING LAMPS	4-65
4.11.10	HOT ROLLER AND PRESSURE ROLLER	4-66
4.12	PAPER EXIT	4-67
4.12.1	PAPER EXIT UNIT	4-67
4.12.2	FUSING EXIT, PAPER OVERFLOW, AND PAPER EXIT SENSORS	4-67
Paper Exit Sensor	4-68	
Paper Overflow Sensor	4-68	
Fusing Exit Sensor	4-68	
4.12.3	JUNCTION JAM SENSOR	4-68
4.12.4	PAPER EXIT MOTOR	4-69
4.13	DUPLEX.....	4-70
4.13.1	DUPLEX UNIT	4-70

4.13.2	RIGHT DOOR COVER	4-72
4.13.3	DUPLEX DOOR SENSOR.....	4-72
4.13.4	DUPLEX ENTRANCE SENSOR.....	4-73
4.13.5	DUPLEX EXIT SENSOR	4-73
4.13.6	DUPLEX/BY-PASS MOTOR.....	4-75
4.13.7	DUPLEX INVERTER MOTOR	4-76
4.14	BY-PASS.....	4-78
4.14.1	BY-PASS PAPER SIZE SENSOR	4-78
	When reinstalling the by-pass paper size sensor	4-78
4.14.2	BY-PASS PAPER END SENSOR.....	4-79
4.14.3	BY-PASS PICK-UP, FEED AND SEPARATION ROLLER, TORQUE LIMITER.....	4-80
4.14.4	BY-PASS FEED CLUTCH	4-81
4.15	DRIVE AREA.....	4-82
4.15.1	PAPER FEED CLUTCH.....	4-82
	Tray 1 and Tray 2	4-82
4.15.2	DEVELOPMENT PADDLE MOTOR	4-83
4.15.3	TRANSFER/DEVELOPMENT MOTOR	4-83
4.15.4	DRUM MOTOR.....	4-84
4.15.5	FUSING MOTOR	4-84
4.15.6	WEB MOTOR	4-85
4.15.7	PAPER FEED MOTOR.....	4-85
4.15.8	TRANSFER BELT CONTACT MOTOR	4-86
4.15.9	REGISTRATION MOTOR.....	4-86
4.15.10	TONER SUPPLY MOTOR.....	4-87
4.16	ELECTRICAL COMPONENTS.....	4-88
4.16.1	CONTROLLER UNIT	4-88
4.16.2	HDD UNIT (STANDARD FOR D011/D013/D091/D092)	4-88
	Before replacing the HDD unit.....	4-88
	Replacement Procedure.....	4-89
	After installing the new HDD unit.....	4-89
4.16.3	CONTROLLER BOARD.....	4-90
	Before replacing the controller board in the model without HDD	4-90
	Replacement Procedure.....	4-90
	When installing the new controller board.....	4-91
	After installing the controller board	4-91

4.16.4	MOTHER BOARD.....	4-92
4.16.5	BICU	4-93
4.16.6	IOB.....	4-93
	When installing a new IOB	4-94
4.16.7	PSU	4-94
4.16.8	HIGH VOLTAGE POWER SUPPLY BOARD.....	4-95
4.16.9	FUSING EXHAUST FAN	4-95
	When installing the fusing exhaust fan	4-96
4.16.10	CONTROLLER FAN	4-96
	When installing the controller fan	4-96
4.17	COPY ADJUSTMENTS.....	4-97
4.17.1	OVERVIEW	4-97
4.17.2	PRINTING.....	4-97
	Registration - Leading Edge/Side-to-Side	4-97
	Blank Margin	4-99
	Main Scan Magnification	4-100
	Parallelogram Image Adjustment	4-100
4.17.3	SCANNING.....	4-101
	Registration: Platen Mode	4-102
	Magnification	4-102
4.17.4	ADF IMAGE ADJUSTMENT	4-103
	Registration	4-103
4.17.5	TOUCH SCREEN CALIBRATION	4-104

SERVICE TABLES

5.	SERVICE TABLES.....	5-1
5.1	SERVICE PROGRAM MODE	5-1
	5.1.1 SERVICE PROGRAM MODE OPERATION	5-1
	Service Mode Lock/Unlock	5-2
	5.1.2 SERVICE PROGRAM MODE TABLES	5-3
	Service Table Key	5-3
5.2	SERVICE PROGRAM MODE TABLES	5-4
	5.2.1 SP TABLES	5-4
5.3	USING SP MODES.....	5-5

5.3.1 TEST PATTERN PRINTING	5-5
5.3.2 SMC PRINT OUT LISTS: SP5-990.....	5-7
5.3.3 NIP BAND WIDTH ADJUSTMENT: SP1-109	5-8
5.3.4 MEMORY CLEAR: SP5-801	5-9
5.3.5 SOFTWARE RESET.....	5-11
5.3.6 SYSTEM SETTINGS AND COPY SETTING RESET	5-12
5.3.7 COPIER SETTING RESET	5-13
5.4 UPDATING THE FIRMWARE	5-14
5.4.1 BEFORE YOU BEGIN	5-14
5.4.2 UPDATING FIRMWARE	5-15
Preparation.....	5-15
Firmware Update Error.....	5-16
Recovery after Power Loss	5-17
5.4.3 HANDLING FIRMWARE UPDATE ERRORS	5-17
Error Message Table.....	5-17
5.5 NVRAM DATA UPLOAD/DOWNLOAD	5-19
5.5.1 UPLOADED NVRAM DATA (SP5-824)	5-19
5.5.2 DOWNLOADING NVRAM DATA (SP5-825).....	5-19
5.6 SD CARD APPLI MOVE	5-20
5.6.1 OVERVIEW.....	5-20
Use caution when you do the SD Card Appli Move procedure:.....	5-20
5.6.2 MOVE EXEC.....	5-21
5.6.3 UNDO EXEC.....	5-22
5.7 SELF-DIAGNOSTIC MODE	5-23
5.7.1 SELF-DIAGNOSTIC MODE AT POWER ON	5-23
5.7.2 SELF-DIAGNOSTIC TEST FLOW	5-24
5.7.3 DETAILED SELF-DIAGNOSTIC MODE	5-25
5.7.4 EXECUTING DETAILED SELF-DIAGNOSIS.....	5-25
5.8 USING THE DEBUG LOG	5-26
5.8.1 OVERVIEW.....	5-26
5.8.2 SWITCHING ON AND SETTING UP SAVE DEBUG LOG	5-26
4-Digit Entries for Keys 1 to 10.....	5-29
Key to Acronyms	5-30
Retrieving the Debug Log from the HDD	5-31
Recording Errors Manually	5-31
5.9 DIP SWITCHES	5-32

5.9.1 I/O BOARD: DIP SW101.....	5-32
---------------------------------	------

TROUBLESHOOTING

6. TROUBLESHOOTING	6-1
6.1 SERVICE CALL CONDITIONS.....	6-1
6.2 ELECTRICAL COMPONENT DEFECTS	6-2
6.2.1 SENSORS	6-2
6.2.2 SWITCHES.....	6-7
6.3 BLOWN FUSE CONDITIONS.....	6-8

ENERGY SAVING

7. ENERGY SAVING.....	7-1
7.1 ENERGY SAVE	7-1
7.1.1 ENERGY SAVER MODES.....	7-1
Timer Settings	7-1
Return to Stand-by Mode	7-2
Recommendation	7-2
7.1.2 ENERGY SAVE EFFECTIVENESS.....	7-3
7.2 PAPER SAVE	7-5
7.2.1 EFFECTIVENESS OF DUPLEX/COMBINE FUNCTION	7-5
1. Duplex:	7-5
2. Combine mode:.....	7-5
3. Duplex + Combine:.....	7-6

D009/D011/D012/D013/D091/D092

SERVICE MANUAL APPENDICES

SEE D009/D011/D012/D013/D091/D092 SERVICE MANUAL APPENDICES
SECTION FOR DETAILED TABLE OF CONTENTS

B408 1000-SHEET FINISHER SR790

SEE SECTION B408 FOR DETAILED TABLE OF CONTENTS

B802 AUTO REVERSE DOCUMENT FEEDER DF3010

SEE SECTION B802 FOR DETAILED TABLE OF CONTENTS

B804/B805 BOOKLET FINISHER SR3020/FINISHER SR3030

SEE SECTION B804/B805 FOR DETAILED TABLE OF CONTENTS

B838 SCANNER ACCESSIBILITY OPTION TYPE 4045

SEE SECTION B838 FOR DETAILED TABLE OF CONTENTS

D346 FAX OPTION TYPE 5000

SEE SECTION D346 FOR DETAILED TABLE OF CONTENTS

D351 PAPER FEED UNIT PB3040

SEE SECTION D351 FOR DETAILED TABLE OF CONTENTS

D352 LCT PB3050

SEE SECTION D352 FOR DETAILED TABLE OF CONTENTS

D353 1200-SHEET LCIT RT3000

SEE SECTION D353 FOR DETAILED TABLE OF CONTENTS

D381 PRINTER/SCANNER OPTION TYPE 5000

SEE SECTION D381 FOR DETAILED TABLE OF CONTENTS

D386 BRIDGE UNIT BU3030

SEE SECTION D386 FOR DETAILED TABLE OF CONTENTS

D389 1-BIN TRAY BN3040

SEE SECTION D389 FOR DETAILED TABLE OF CONTENTS

PRODUCT INFORMATION

APPENDIX: SPECIFICATIONS

B802 ARDF DF3010

D346 FAX OPTION TYPE 5000

TAB
POSITION 1

INSTALLATION

APPENDIX: PREVENTIVE MAINTENANCE

D351 PAPER FEED UNIT PB3040

TAB
POSITION 2

PREVENTIVE MAINTENANCE

APPENDIX: SERVICE CALL CONDITIONS

D352 LCIT PB3050

D353 1200-SHEET LCIT RT3000

TAB
POSITION 3

REPLACEMENT & ADJUSTMENT

APPENDIX: SERVICE PROGRAM MODE TABLES

B408 1000-SHEET FINISHER SR790

B804/B805 BOOKLET FINISHER SR3020/FINISHER SR3030

D381 PRINTER/SCANNER OPTION TYPE 5000

B838 SCANNER ACCESSIBILITY OPTION TYPE 4045

TAB
POSITION 4

SERVICE TABLES

APPENDIX: SERVICE PROGRAM MODE TABLES

TAB
POSITION 5

TROUBLESHOOTING

D389 1-BIN TRAY BN3040

TAB
POSITION 6

ENERGY SAVING

D386 BRIDGE UNIT BU3030

TAB
POSITION 7

Read This First

Safety Notices

Important Safety Notices

Prevention of Physical Injury

1. Before disassembling or assembling parts of the copier and peripherals, make sure that the copier power cord is unplugged.
2. The wall outlet should be near the copier and easily accessible.
3. Note that some components of the copier and the paper tray unit are supplied with electrical voltage even if the main power switch is turned off.
4. If any adjustment or operation check has to be made with exterior covers off or open while the main switch is turned on, keep hands away from electrified or mechanically driven components.
5. If the Start key is pressed before the copier completes the warm-up period (the Start key starts blinking red and green alternatively), keep hands away from the mechanical and the electrical components as the copier starts making copies as soon as the warm-up period is completed.
6. The inside and the metal parts of the fusing unit become extremely hot while the copier is operating. Be careful to avoid touching those components with your bare hands.

WARNING

- To prevent a fire or explosion, keep the machine away from flammable liquids, gases, and aerosols.

Health Safety Conditions

1. Toner and developer are non-toxic, but if you get either of them in your eyes by accident, it may cause temporary eye discomfort. Immediately wash eyes with plenty of water. If unsuccessful, get medical attention.
2. This machine, which uses a high voltage power source, can generate ozone gas. High ozone density is harmful to human health. Therefore, the machine must be installed in a well-ventilated room.

Observance of Electrical Safety Standards

1. This machine and its peripherals must be serviced by a customer service representative who has completed the training course on those models.
2. The NVRAM on the system control board has a lithium battery which can explode if replaced incorrectly. Replace the NVRAM only with an identical one. The manufacturer recommends replacing the entire NVRAM. Do not recharge or burn this battery. Used NVRAM must be handled in accordance with local regulations.

Handling Toner

- Work carefully when removing paper jams or replacing toner bottles or cartridges to avoid spilling toner on clothing or the hands.
- If toner is inhaled, immediately gargle with large amounts of cold water and move to a well ventilated location. If there are signs of irritation or other problems, seek medical attention.
- If toner gets on the skin, wash immediately with soap and cold running water.
- If toner gets into the eyes, flush the eyes with cold running water or eye wash. If there are signs of irritation or other problems, seek medical attention.
- If toner is swallowed, drink a large amount of cold water to dilute the ingested toner. If there are signs of any problem, seek medical attention.
- If toner spills on clothing, wash the affected area immediately with soap and cold water. Never use hot water! Hot water can cause toner to set and permanently stain fabric.
- Always store toner and developer supplies such as toner and developer packages, cartridges, and bottles (including used toner and empty bottles and cartridges) out of the reach of children.
- Always store fresh toner supplies or empty bottles or cartridges in a cool, dry location that is not exposed to direct sunlight.

Safety and Ecological Notes for Disposal

1. Do not incinerate toner bottles or used toner. Toner dust may ignite suddenly when exposed to an open flame.
2. Dispose of used toner, the maintenance unit which includes developer or the organic photoconductor in accordance with local regulations. (These are non-toxic supplies.)
3. Dispose of replaced parts in accordance with local regulations.
4. When keeping used lithium batteries in order to dispose of them later, do not put more than 100 batteries per sealed box. Storing larger numbers or not sealing them apart may lead to chemical reactions and heat build-up.

Laser Safety

The Center for Devices and Radiological Health (CDRH) prohibits the repair of laser-based optical units in the field. The optical housing unit can only be repaired in a factory or at a location with the requisite equipment. The laser subsystem is replaceable in the field by a qualified Customer Engineer. The laser chassis is not repairable in the field. Customer engineers are therefore directed to return all chassis and laser subsystems to the factory or service depot when replacement of the optical subsystem is required.

WARNING

- Use of controls, or adjustment, or performance of procedures other than those specified in this manual may result in hazardous radiation exposure.

WARNING

- Turn off the main switch before attempting any of the procedures in the Laser Optics Housing Unit section. Laser beams can seriously damage your eyes.

CAUTION MARKING:

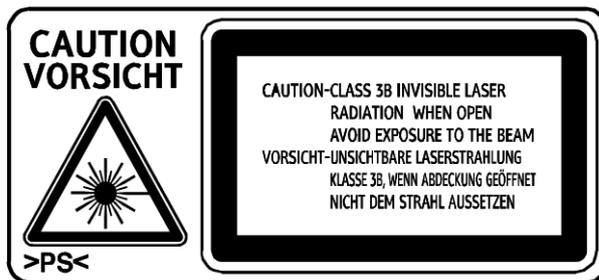

3d-laser_decal

Symbols and Abbreviations

Symbols and Abbreviations

This manual uses several symbols and abbreviations. The meaning of those symbols and abbreviations are as follows:

	See or Refer to
	Clip ring
	Screw
	Connector
	Clamp
	E-ring
SEF	Short Edge Feed
LEF	Long Edge Feed

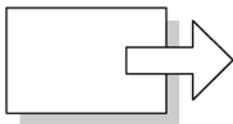

Short Edge Feed (SEF)

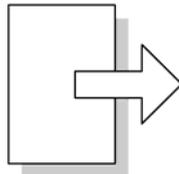

Long Edge Feed (LEF)

Cautions, Notes, etc.

The following headings provide special information:

WARNING

- FAILURE TO OBEY WARNING INFORMATION COULD RESULT IN SERIOUS INJURY OR DEATH.

CAUTION

- Obey these guidelines to ensure safe operation and prevent minor injuries.

Note

- This information provides tips and advice about how to best service the machine.

PRODUCT INFORMATION

REVISION HISTORY		
Page	Date	Added/Updated/New
		None

1. PRODUCT INFORMATION

1.1 SPECIFICATIONS

See "Appendices" for the following information:

- General Specifications
- Optional Equipment

1.2 MACHINE CONFIGURATION

1.2.1 COPIER

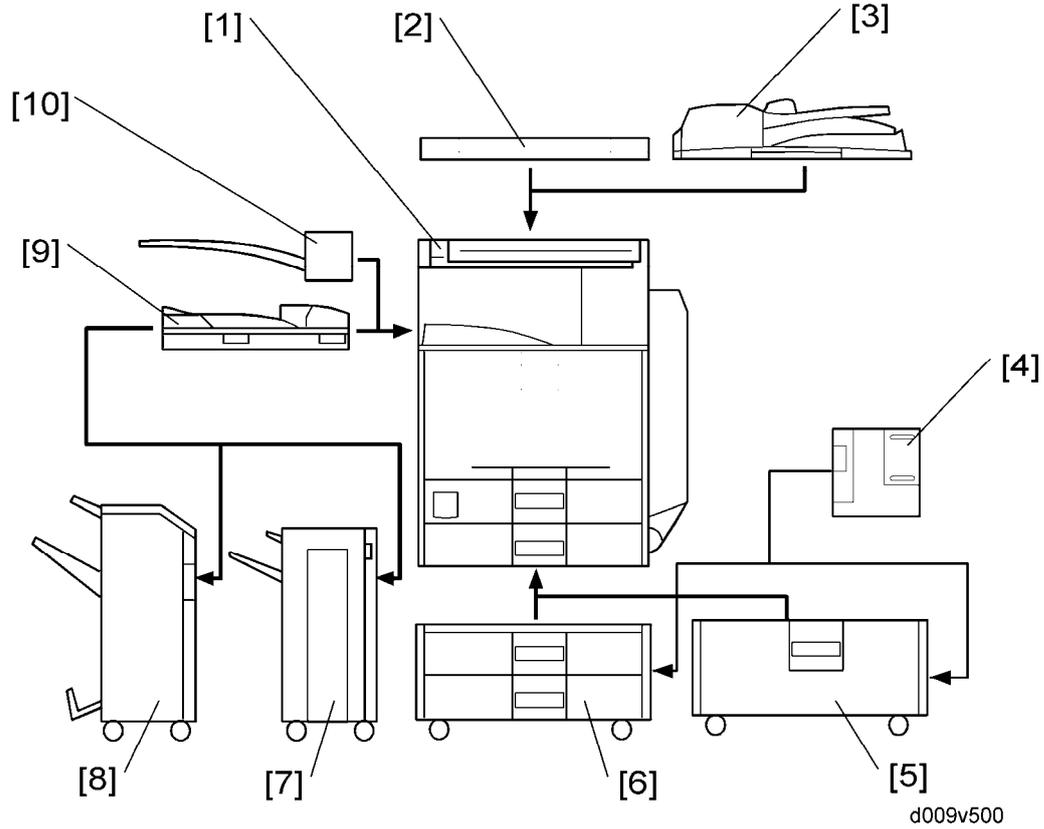

Key: Symbol: **U**: Unique option, **C**: Option also used with other products

	Item	Callout	Key	Machine Code
Copier	D009/D011 D012/D013 D091/D092	[1]	-	D009/D011 D012/D013 D091/D092
	ARDF (See Note 1)	[3]	C	B802
	Platen Cover (See Note 1)	[2]	C	G329
	Two-Tray Paper Feed Unit	[6]	C	D351
	2000-sheet LCT	[5]	C	D352

Machine Configuration

	Item	Callout	Key	Machine Code
	1200-sheet LCT	[4]	C	D353
	1-Bin Tray	[10]	U	D389
	Bridge Unit	[9]	U	D386
	1000-sheet Finisher (See Note 2.)	[7]	C	B408
	2000/3000-Sheet (Booklet) Finisher (See Note 2)	[8]	C	B804/B805
	-Punch Unit (See Note 3.)	-	C	B702-17 (2/3-hole) US
	-Punch Unit (See Note 3.)	-	C	B702-27 (2/4-hole) Metric
	-Punch Unit (See Note 3.)	-	C	B702-28 (4-hole) Scandinavia
	Key Counter Bracket	-	C	A674
	HDD (for D009/D012 only)	-	U	D362
	DataOverwriteSecurity	-	U	D362
	Copy Data Security Unit	-	C	B829
	HDD Encryption Unit	-	C	D377
	Scanner Accessibility Option	-	C	B838
Fax	Fax Option for D009/D011/D012/D013	-	U	D346
	G3 Interface Unit	-	U	D346
	SAF Memory	-	C	G578
	Handset (USA model only)	-	C	B433

Machine Configuration

Printer/ Scanner	Printer/Scanner Unit	-	U	D381
	Printer Unit	-	U	D381
	RPCS Printer Unit	-	U	D381
	Printer Upgrade Unit	-	U	D381
	Scanner Upgrade Unit	-	U	D381
	PostScript3 Unit	-	U	D381
	IPDS Unit	-	U	D381
	Gigabit Ethernet	-	C	G874
	IEEE 1284	-	C	B679
	IEEE 802.11a/g, g Wireless LAN	-	C	D377
	Bluetooth	-	C	B826
	Memory Unit 256 MB	-	U	D362
	File Format Converter	-	C	D377

NOTE:

1. The ARDF and platen cover cannot be installed together.
2. The finisher requires the bridge unit and two-tray paper feed unit or 2000-sheet LCT. The 1000-sheet finisher and 2000/3000-sheet (Booklet) finisher cannot be installed together.
3. The punch unit requires the 2000/3000-sheet (Booklet) finisher.

1.3 GUIDANCE FOR THOSE WHO ARE FAMILIAR WITH PREDECESSOR PRODUCTS

The D091/D092 series are successor models to the D009/D011/D012/D013 series. If you have experience with the predecessor products, the following information will be of help when you read this manual.

Different Points from Predecessor Products

	D091/D092	D009/D011/D012/D013
Scanner	Color only	Color and B/W
VM Card	Standard	Option

1.4 OVERVIEW

1.4.1 COMPONENT LAYOUT

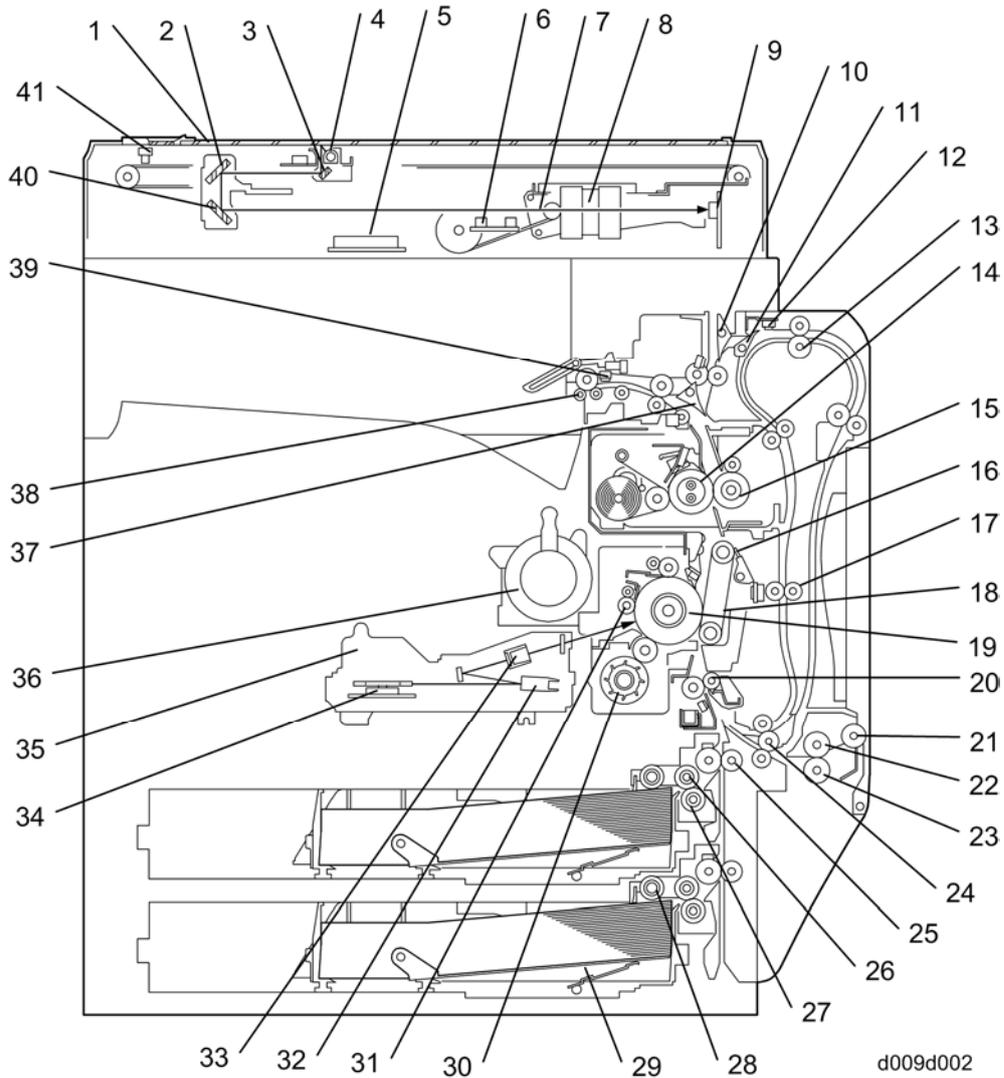

1	Exposure Glass	22	By-pass Feed Roller
2	2nd Mirror	23	By-pass Separation Roller
3	1st Mirror	24	Duplex/by-pass transport roller
4	Exposure Lamp	25	Upper Relay Roller

5	Original Width Sensors	26	Feed Roller
6	Original Length Sensors	27	Separation Roller
7	Scanner Motor	28	Pick-up Roller
8	Lens	29	Bottom Plate
9	SBU	30	Development Unit
10	Junction Gate 2	31	Charge Roller
11	Duplex Inverter Gate	32	F θ Mirror
12	Duplex Entrance Sensor	33	Barrel Toroidal Lens (BTL)
13	Duplex Inverter Roller	34	Polygonal Mirror Motor
14	Hot Roller	35	Laser Unit
15	Pressure Roller	36	Toner Bottle Holder
16	Transfer Belt Cleaning Blade	37	Junction Gate 1
17	Duplex Transport Roller	38	Exit Roller
18	Transfer Belt	39	Paper Exit Sensor
19	OPC Drum	40	3rd Mirror
20	Registration Roller	41	Scanner HP Sensor
21	By-pass Pick-up Roller		

Overview

1.4.2 PAPER PATH

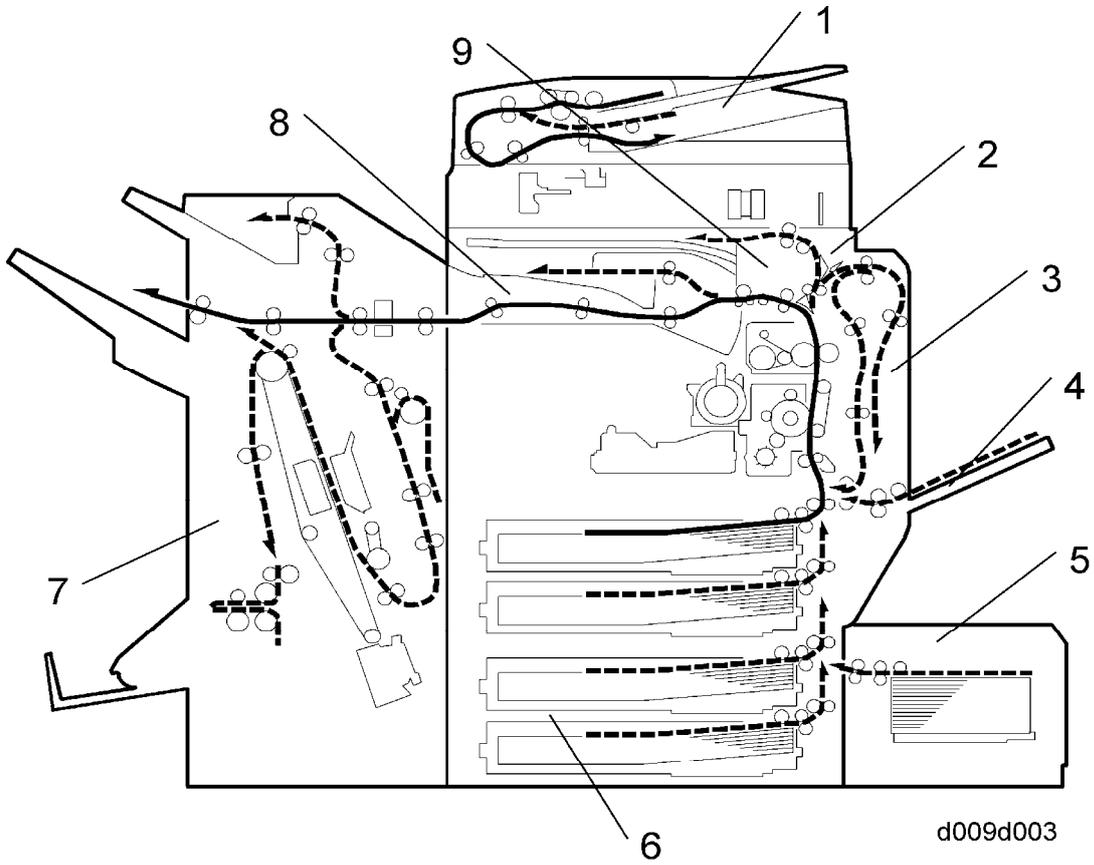

1	ARDF
2	Interchange Unit
3	Duplex Unit
4	By-pass Tray
5	Large Capacity Tray (LCT: 1200-sheet)
6	Paper Tray Unit
7	Two-Tray Finisher
8	Bridge Unit
9	1-Bin Tray

1.4.3 DRIVE LAYOUT

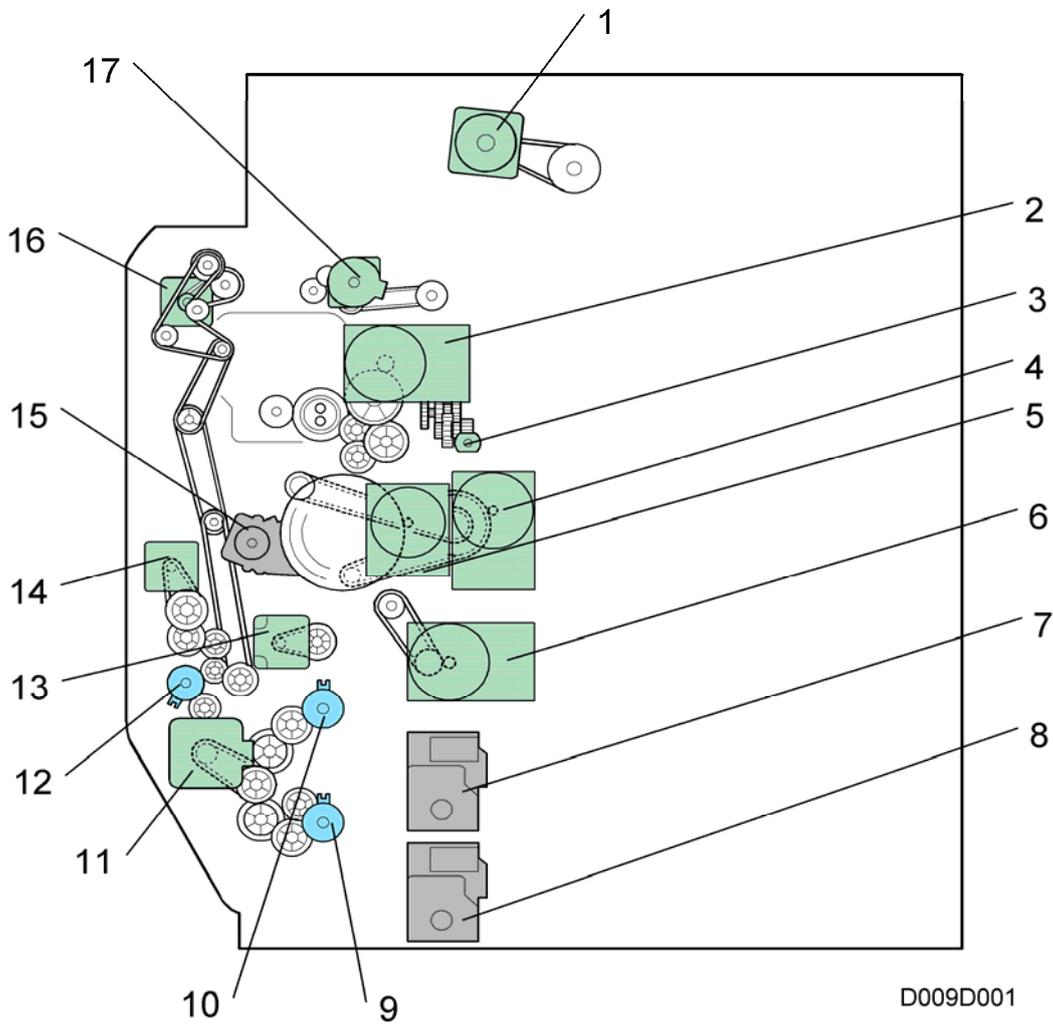

Overview

1	Scanner Motor	10	Paper Feed Clutch 1
2	Fusing Motor	11	Feed Motor
3	Web Motor	12	By-pass Paper Feed Clutch
4	Transfer/Development Motor	13	Registration Motor
5	Drum Motor	14	Duplex/By-pass Motor
6	Development Paddle Motor	15	Transfer Belt Contact Motor
7	Tray Lift Motor 1	16	Duplex Inverter Motor
8	Tray Lift Motor 2	17	Paper Exit Motor
9	Paper Feed Clutch 2		

INSTALLATION

REVISION HISTORY		
Page	Date	Added/Updated/New
		None

2. INSTALLATION

2.1 INSTALLATION REQUIREMENTS

CAUTION

- Never turn off the main power switch when the power LED is lit or flashing. To avoid damaging the hard disk or memory, press the operation power switch to switch the power off, wait for the power LED to go off, and then switch the main power switch off.

Important

- Install the machine in a safe place for keeping security.
- Make sure that the operation instructions are kept at a customer's hand.

Note

- The main power LED lights or flashes while the platen cover or ARDF is open, while the main machine is communicating with a facsimile or the network server, or while the machine is accessing the hard disk or memory for reading or writing data.

CAUTION

- Rating voltage for peripherals: Make sure to plug the cables into the correct sockets.

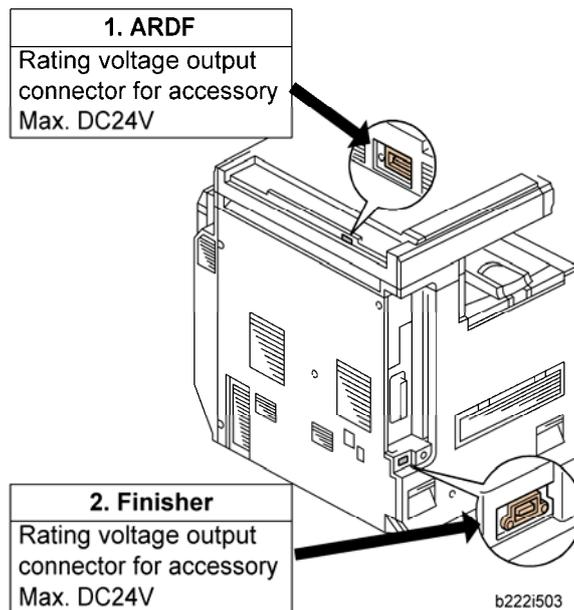

Installation Requirements

2.1.1 ENVIRONMENT

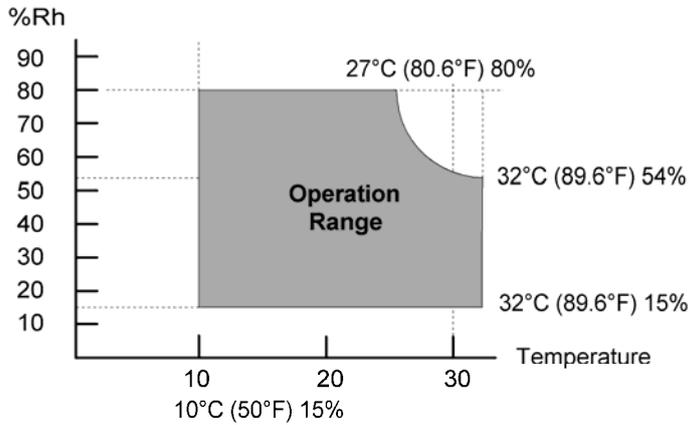

b291i900

Temperature Range:	10°C to 32°C (50°F to 90°F)
Humidity Range:	15% to 80% RH
Ambient Illumination:	Less than 1,500 lux (do not expose to direct sunlight.)
Ventilation:	Room air should turn at least 30 m ³ /hr/person
Ambient Dust:	Less than 0.10 mg/m ³ (2.7 x 10 ⁻⁶ oz/yd ³)
<ol style="list-style-type: none"> 1. Avoid areas exposed to sudden temperature changes: <ol style="list-style-type: none"> 1) Areas directly exposed to cool air from an air conditioner. 2) Areas directly exposed to heat from a heater. 2. Do not place the machine where it will be exposed to corrosive gases. 3. Do not install the machine at any location over 2,000 m (6,500 ft.) above sea level. 4. Place the main machine on a strong and level base. Inclination on any side should be no more than 5 mm (0.2"). 5. Do not place the machine where it may be subjected to strong vibrations. 	

2.1.2 MACHINE LEVEL

Front to back:	Within 5 mm (0.2") of level
Right to left:	Within 5 mm (0.2") of level

2.1.3 MINIMUM SPACE REQUIREMENTS

Place the main machine near the power source, providing clearance as shown:

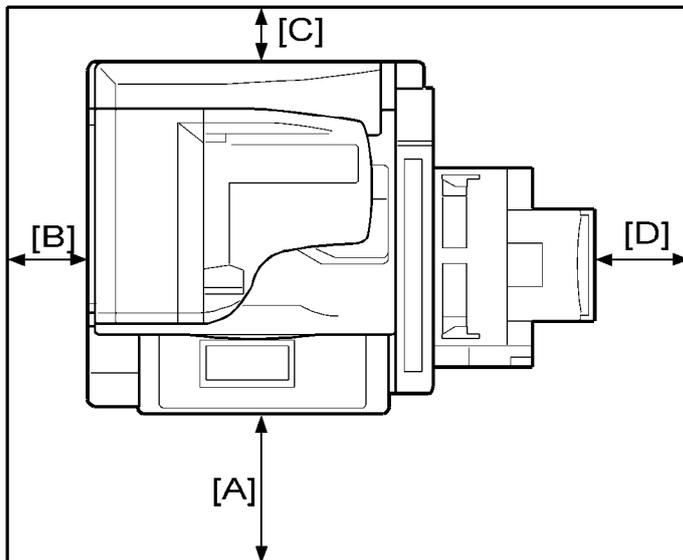

b230i109

A: Front: >75 cm (29.6")

B: Left: > 10 cm (4")

C: Rear: > 10 cm (4")

D: Right > 55 cm (21.7")

Note

- The 75 cm (29.6") recommended for the space at the front is for pulling out the paper tray only. If the operator stands at the front of the main machine, more space is required.

2.1.4 POWER REQUIREMENTS

CAUTION

- Make sure that the wall outlet is near the main machine and easily accessible.
Make sure the plug is firmly inserted in the outlet.
 - Avoid multi-wiring.
 - Be sure to ground the machine.
1. Input voltage level:
North America 120 V, 60 Hz: More than 12.5 A
Europe/Asia 220 V to 240V, 50 Hz/60 Hz: more than 6.8 A
 2. Permissible voltage fluctuation: 10% to 15%
 3. Never set anything on the power cord.

2.2 INSTALLATION FLOW CHART

The following flow chart shows how to install the optional units more efficiently.

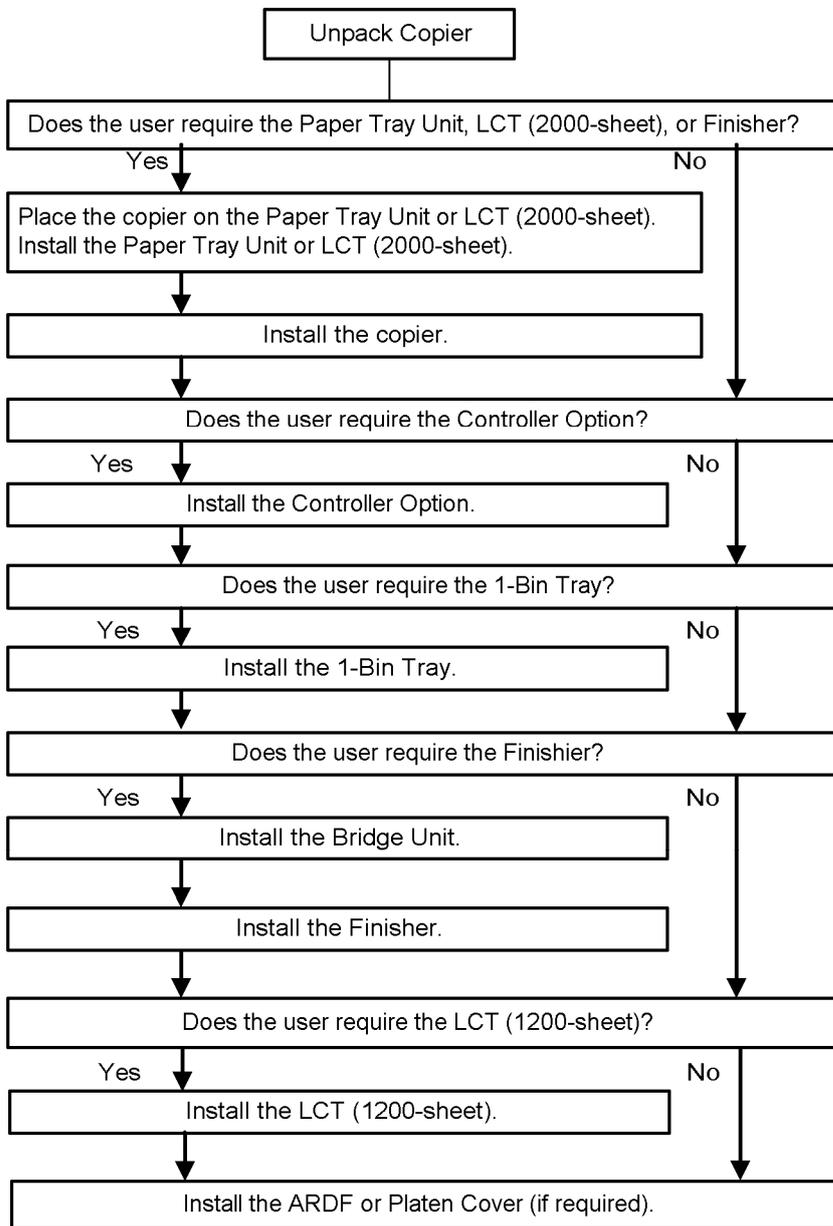

D009i510

Bridge Unit: Needed for the finishers.

Paper Tray Unit or LCT 2000-sheet: Needed for the LCT 1200-sheet and finishers.

2.3 MAIN MACHINE INSTALLATION

2.3.1 ACCESSORY CHECK

Check the quantity and condition of the accessories in the box against the following list:

	Description	D009/D011/ D012/D013	D091/D092
1	Operation Instruction (-17, -19, -21, -29)	1	-
2	Operation Instruction - Quick Reference (-17, -19, -21, -29)	1	-
3	Operation Instruction - Troubleshooting (-17, -19, -29)	1	1
4	Operation Instruction - About This Machine (-17, -19, -29)	1	1
5	Quick Reference Guide - Copy (-29)	-	1
6	Quick Reference Guide - Printer (-29)	-	1
7	Quick Reference Guide - Scanner (-29)	-	1
8	Quick Reference Guide - App 2 Me (-17, -19, -29)	-	1
9	CD-ROM - Instruction (-17, -29)	1	-
10	CD-ROM: Printer Instruction for D011/D013 only (-17, -27, -28, -29)	1	-
11	CD-ROM: Scanner Instruction for D011/D013 only (-17, -27, -28, -29)	1	-
12	CD-ROM: Printer/ Scanner (-27, -29)	-	1
13	CD-ROM: Operation Instruction - User (-17, -19, -29)	-	1

Main Machine Installation

	Description	D009/D011/ D012/D013	D091/D092
14	CD-ROM: Operation Instruction - Administrator (-17, -19, -29)	-	1
15	CD-ROM: Operation Instruction - App 2 Me (-17, -19, -29)	-	1
16	CD-ROM: SDK (-17, -19, -27, -29)	-	1
17	CD-ROM: P2600 (-17, -19, -27, -29)	-	1
18	CD-ROM: Driver (-19, only)	-	1
19	Model Name Decal (-17, -29)	1	1
20	Emblem Cover	1	1
21	Stamp (-17)	1	1
22	Cloth Holder	1	1
23	Exposure Glass Cleaning Cloth	1	1
24	Operating Instructions Holder	1	1
25	Ferrite Core	1	1
26	Rivet	1	1
27	Power Supply Cord	1	1
28	Decal - Paper Tray	1	1
29	Decal - Caution - Original (-17)	1	1
30	Sheet - EULA: 16 Languages	1	1

Main Machine Installation

	Description	D009/D011/ D012/D013	D091/D092
31	Sheet - Caution: 16 Languages	1	1
32	Sheet: NECR (-17)	1	1
33	Sheet - Warranty: Chinese (-21)	1	-
34	Sheet - Name - Tel (-21)	1	-

2.3.2 INSTALLATION PROCEDURE

Preliminary Procedures

Put the machine on the paper feed unit or the LCT first if you will install an optional paper feed unit or the optional LCT at the same time. Then install the machine and other options.

Note

- Keep the shipping retainers after you install the machine. You may need them in the future if you transport the machine to another location.

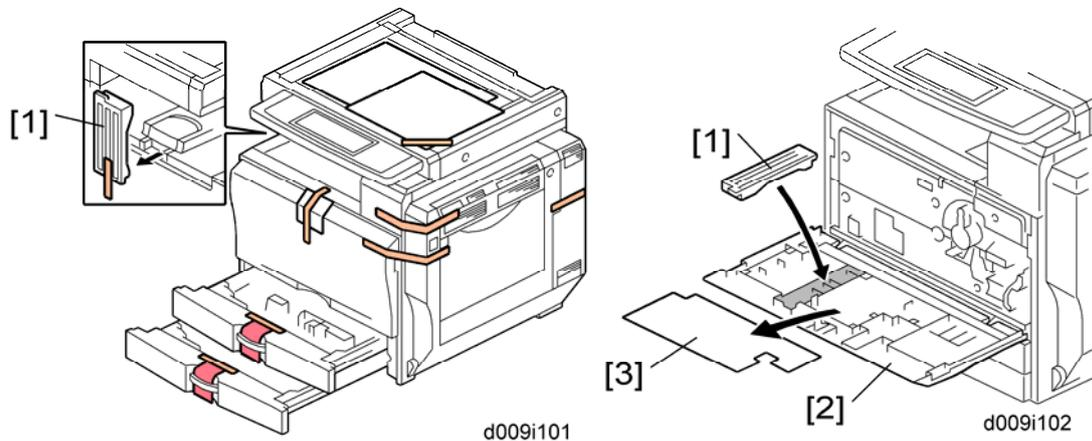

1. Remove all the tapes and retainers on the machine.
2. Remove all the tapes and retainers in trays 1 and 2, and then take out the power cord from tray 1 (if applicable).
3. Remove the scanner unit stay [1].
4. Open the front door [2], and then remove the jam location sheet [3].
5. Keep the scanner unit stay [1] inside the front door [2].
6. Reattach the jam location sheet.

7. Close the front door.

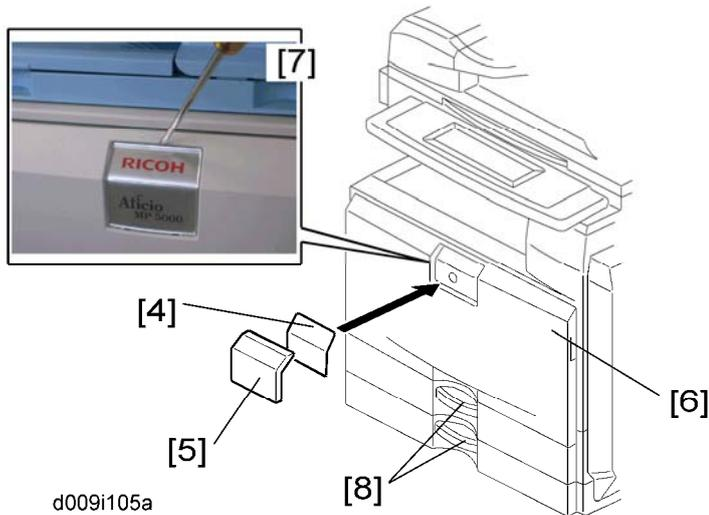

8. Attach the correct emblem [4] and the cover [5] to the front door [6] of the machine, if the emblem is not attached.

↓ Note

- If you want to change the emblem that has been already attached, remove the panel with a small screwdriver as shown [7], and then install the correct emblem.

9. Attach the correct paper tray number and size decals to the paper trays [8].

↓ Note

- Paper tray number and size decals are also used for the optional paper feed unit or LCT. Keep these decals for use with these optional units.

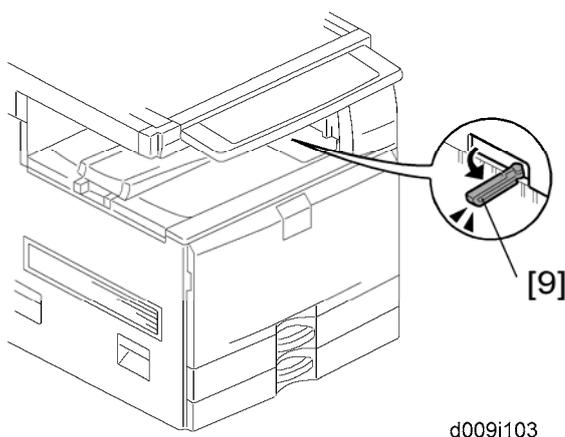

10. Pull out the feeler [9] for the output tray full detection mechanism.

Main Machine Installation

Fire Prevention Cover

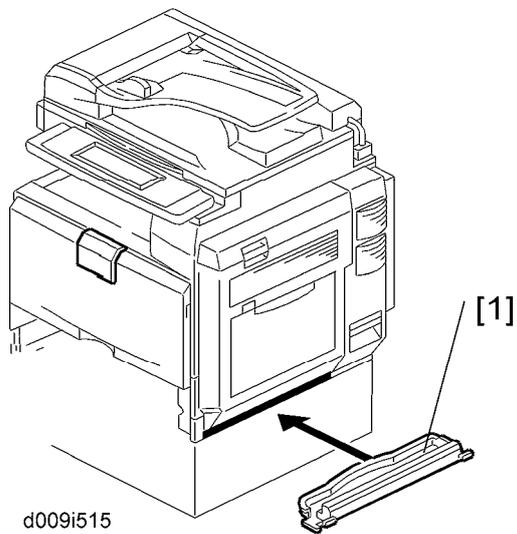

When the copier is installed on the floor without the optional paper tray unit or a table, the cover [1] must be attached to the copier.

- Install the cover [1] at the right side of the copier.

PCDU (Photoconductor and Development Unit)

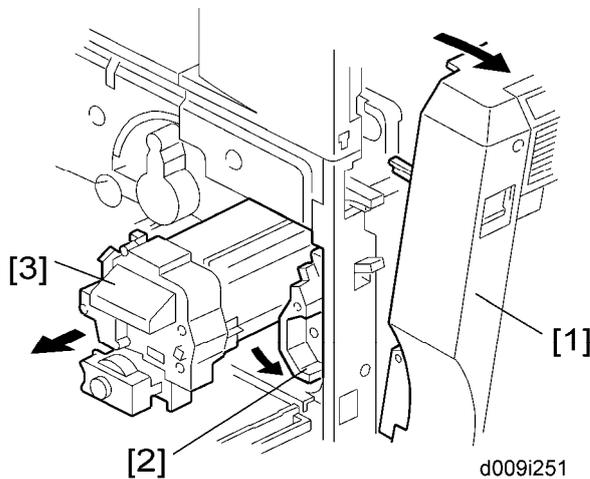

1. Open the front door.
2. Open the right door [1].
3. Release the lock lever [2].
4. Pull out the PCDU [3] and place it on a clean flat surface.

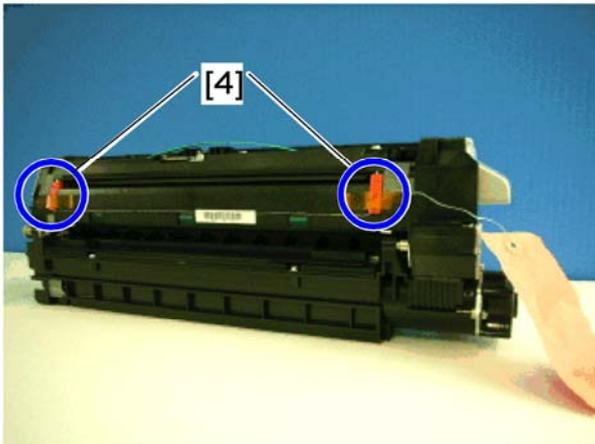

d009i108

5. Remove the two stoppers [4].
6. Spread a large piece of paper on a flat surface.

↓ Note

- Make sure the area is free of pins, paper clips, staples, etc. to avoid attraction to the magnetic development roller.

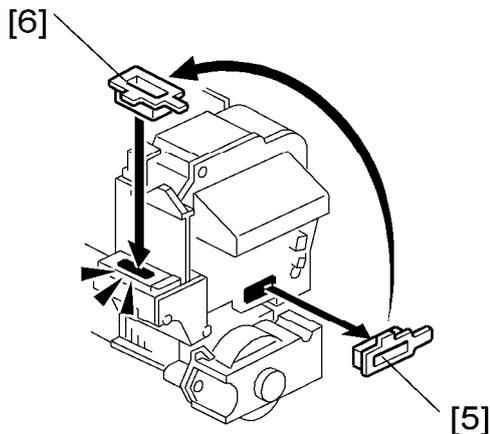

d009i252

7. Remove the opening cap [5], and then install it in the opening [6] of the PCDU.

Main Machine Installation

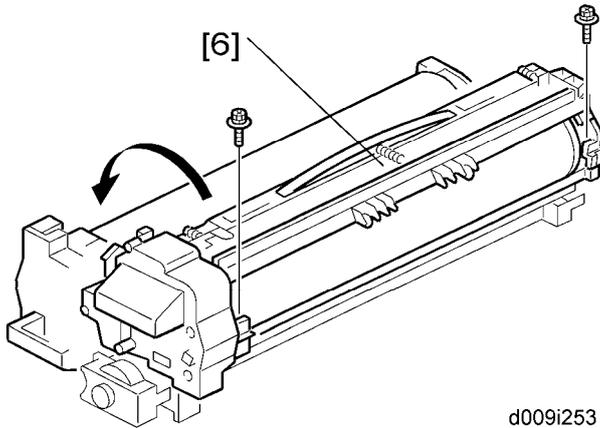

8. Open the PCU [6] (⚙️ x 2).

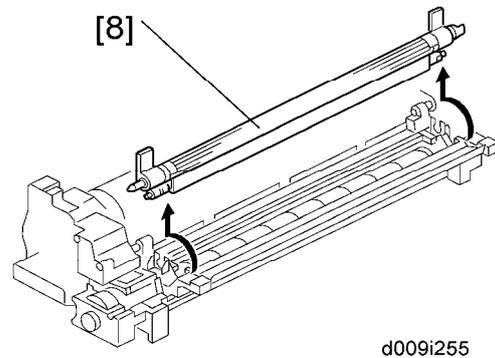
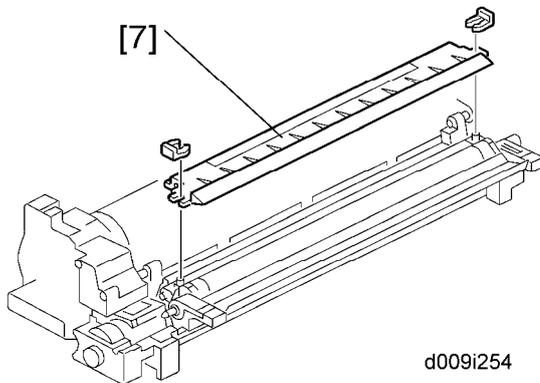

9. Remove the entrance seal plate [7] (🔧 x 2).
10. Remove the development roller unit [8], and set it on the paper.

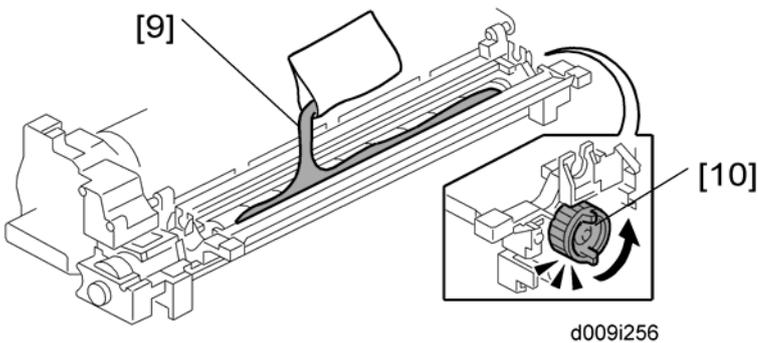

11. Pour the developer [9] into the development unit.

↓ Note

- The developer lot number is embossed on the end of the developer package. Do not discard the package until you have recorded the lot number. (📄 p.4-43 "Developer")

- 1) Pour approximately 1/3 of the developer evenly along the length of the development unit.
 - 2) Rotate the drive gear [10] to work the developer into the unit.
 - 3) Repeat until all the developer is in the development unit.
 - 4) Continue to turn the drive gear until the developer is even with the top of the unit.
12. Put the opening cap [4] back in its original place.
 13. Reassemble the PCDU.
 14. Re-install the PCDU.

Toner Bottle

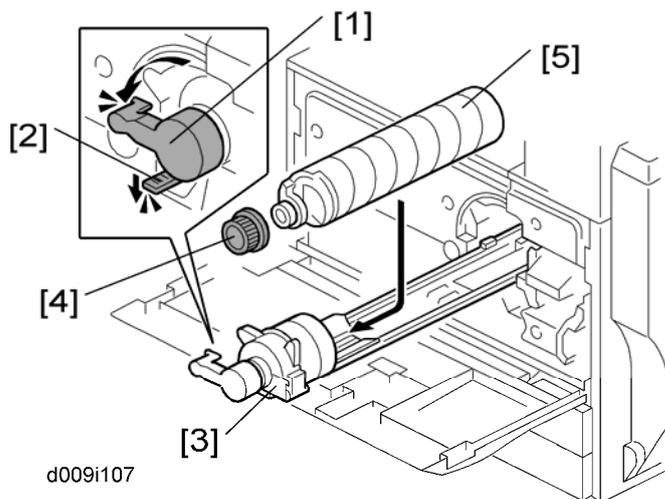

1. Open the front door.
2. Turn the toner bottle holder lever [1] counterclockwise, push down the lever [2], and then pull out the toner bottle holder [3].
3. Hold the toner bottle [5] horizontally, and shake it 5 or 6 times.
4. Unscrew the bottle cap [4] and set the bottle [5] in the holder.
5. Push the toner bottle holder into the main machine until it locks in place.
6. Turn the toner bottle holder lever [1] clockwise to lock it.
7. Close the front door.

Main Machine Installation

Paper Trays

1. Open the 1st paper tray, and then press down on the right side of the lock switch to unlock the side fences.
2. Press in on the sides of the fence release, and slide the side fences to the appropriate mark for the paper size.
3. Pinch the sides of the end fence and move it to the appropriate mark for the paper size, then load the paper.
4. Check the position of the stack.
 - Confirm that there is no gap between the stack and the side fences. If you see a gap, adjust the position of the side fences.
5. Press down the lock to lock the side fences.
6. Repeat this procedure to load paper in the 2nd paper tray.

Initialize TD Sensor and Developer

1. Connect the main machine to the power outlet, switch on the main machine, and wait for the fusing unit to warm up.
2. Enter Copy SP Mode.
3. Press SP Direct to highlight "SP Direct", enter 2801, and then press .
4. When the message prompts you to enter the lot number of the developer, enter the 7-digit lot number, press [Yes], and then press [Execute] on the touch-panel. This initializes the TD sensor.



- The lot number is printed on the end of the developer package. Recording the lot number could help troubleshoot problems later. If the lot number is unavailable, enter any seven-digit number.
5. Press SP Direct to highlight "SP Direct" and enter 2805, press , and then press "Execute" on the touch-panel. This initializes the developer.
 6. Press "Exit" twice to return to the copy window.

Set Paper Size for Paper Trays

1. Press User Tools/Counter .
2. On the touch panel, press "System Settings".
3. Press the "Paper Size Setting" tab.
4. Press the button for the tray to change.
5. Change the setting and press the [OK] button.
6. Repeat for each tray installed.
7. Press Exit twice to return to the main display
 - The 1st, 2nd, 3rd, and 4th paper trays are provided with the paper size switches. The detected paper size by the paper size switches has priority over the UP settings. However, if you change the "Auto Detect" with the UP setting, you can select the paper size.
8. Check the copy quality and machine operation.

Electrical Total Counter

The electrical total counter no longer requires initialization. The new incrementing counter is set to "0" at the factory.

Exposure Glass Cleaner

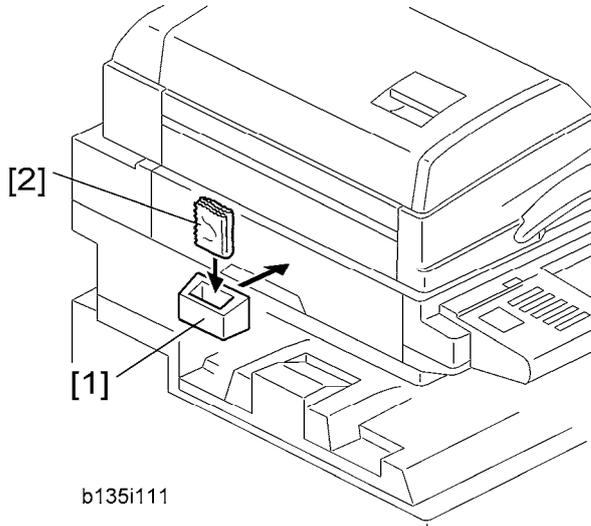

1. Attach the exposure glass cleaner holder [1] to the left side of the machine.
2. Place the exposure glass cleaner [2] inside the holder.

Note

- The exposure glass cleaner is used to clean the ARDF exposure glass, the glass strip to the left of the large exposure glass.

Operation Instructions Holder

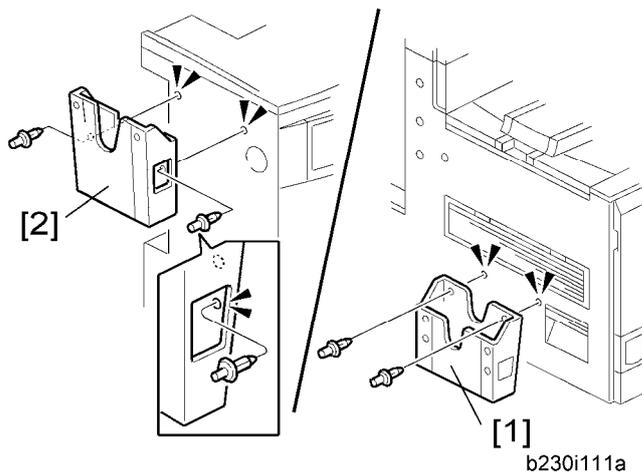

1. Attach the operation instructions holder [1] to the left side of the copier (snap rivet x 2).
2. If a finisher has been installed, attach the operation instructions holder [2] to the rear side of the finisher (snap rivet x 2).

Settings Relevant to the Service Contract

Change the necessary settings for the following SP modes if the customer has made a service contract.

Item	SP No.	Function	Default
A3/11" x 17" double counting	SP5-104-001 (SSP)	Specifies whether the counter is doubled for A3/11" x 17" paper. When you have to change this setting, contact your supervisor.	"No": Single counting
Service Tel. No. Setting	SP5-812-001 through 004	5812-002 programs the service station fax number. The number is printed on the counter list when the meter charge mode is selected. This lets the user fax the counter data to the service station.	

App 2 Me Setting (D091/D092 only)

D091/D092 models have VM Card including "App 2 Me" provider by default. Do the following procedure if a customer want to use the "App 2 Me".

1. Press "User Tools" key on the operation panel.
2. Touch the "Extended Feature Settings" button twice.
3. Touch the "App 2 Me" line in the Startup Setting tab.
4. Touch the "Extended Feature Info" tab on the LCD.
5. Touch the "App 2 Me" line.
6. Set the setting of "Auto Start" to "On".
7. Touch the "Exit" button.
8. Exit the "User Tools" settings.

Main Machine Installation

Update Procedure for App 2 Me Provider

1. Push the "User/Tools" key.
2. If an administrator setting is registered for the machine, step 2 and 3 are required. Otherwise, skip to step 4.
3. Push the "Login/Logout" key.
4. Login with the administrator user name and password.
5. Touch "Extended Feature Settings" twice on the LCD.
6. Touch the all applications. Then, the status will be changed to "Stop".
7. Turn off the machine. And then remove the VM Card.

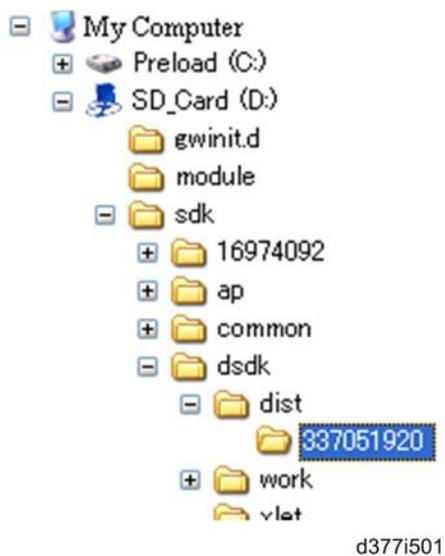

8. Prepare newer App 2 Me Provider zip file from Firmware Download Center. Unzip the zip file. (The folder name is "337051920".) And then copy the App 2 Me Provider folder in the specified path of VM card. The path is "SD_Card Drive¥ sdk¥dsdk¥dist¥337051920" as shown above.
9. Turn the SD card label face to the rear of the machine. Then push it slowly into slot 2 until you hear a click.
10. Turn on the main power switch.
11. Press the "User Tools" key on the operation panel.
12. Touch the "Extended Feature Settings" button twice.
13. Touch the "Extended Feature Info" tab on LCD.
14. Touch the "App2Me" line.
15. Set the setting of the "Auto Start" to "On".
16. Touch the "Exit" button.
17. Exit the "User Tools/Counter" settings.

2.3.3 MOVING THE MACHINE

This section shows you how to manually move the machine from one floor to another floor. See the section "Transporting the Machine" if you have to pack the machine and move it a longer distance.

1. Remove all trays from the optional paper feed unit or LCT.

2.3.4 TRANSPORTING THE MACHINE

1. Do SP 4806-001 to move the scanner carriage from the home position. This prevents dust from falling into the machine during transportation.
2. Make sure there is no paper left in the paper trays. Then fix down the bottom plates with a sheet of paper and tape.
3. Do one of the following:
 - Attach shipping tape to the covers and doors.
 - Shrink-wrap the machine tightly.

2.4 PAPER FEED UNIT INSTALLATION (D351)

2.4.1 ACCESSORY CHECK

Check the quantity and condition of the accessories against the following list.

No.	Description	Q'ty
1	Securing bracket	2
2	Screw (M4x10)	2
3	Spring Washer Screw	1
4	Knob screw	3

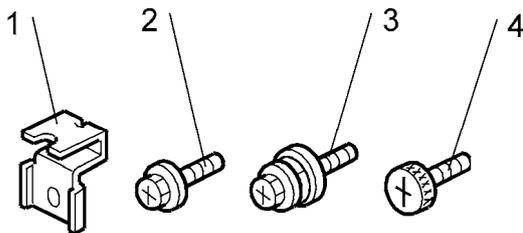

D351i101

2.4.2 INSTALLATION PROCEDURE

CAUTION

- Turn off the main switch of the copier and unplug the power cord before you start the installation procedure.
- You need two or more persons to lift the copier. The copier is highly unstable when lifted by one person, and may cause injury or property damage.
- Do not lift the copier with the paper feed unit installed. The handle and grips may be damaged.

Paper Feed Unit Installation (D351)

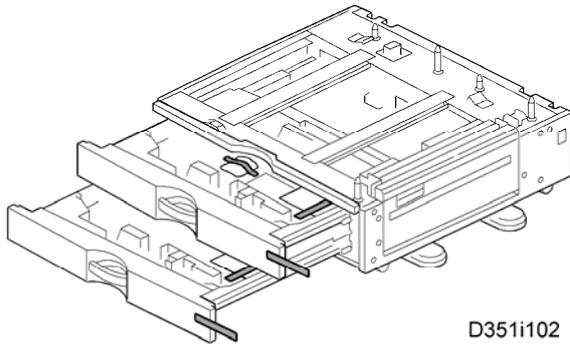

1. Remove all tape on the paper feed unit.
2. Remove the paper trays and remove all tape and padding.

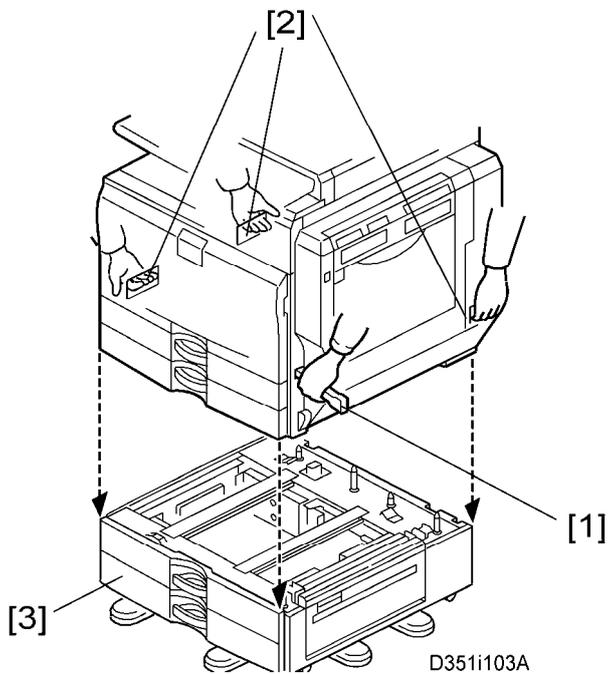

3. Grasp the handle [1] and grips [2] of the machine.
4. Lift the copier and install it on the paper feed unit [3].

↓ Note

- Hold the handle and grips of the machine when you lift and move the machine.

Paper Feed Unit Installation (D351)

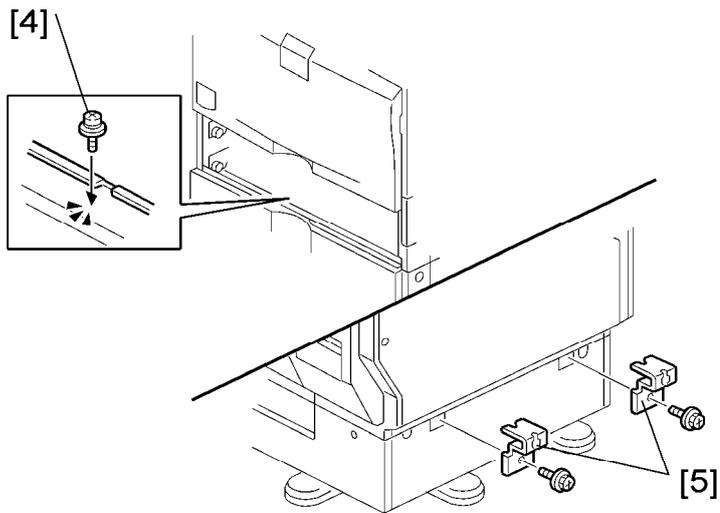

D351i104a

5. Remove the tray 1 and 2 of the machine.
6. Fasten the Spring Washer Screw [4].
7. Reinstall all trays.
8. Attach the securing brackets [5] (x 1 each; M4x10).

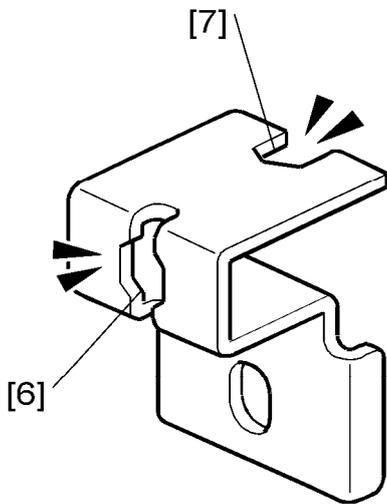

B800i101A

↓ Note

- One of the securing brackets is used as a securing tool (the cutout [6] is used in step 6). But the cutout [7] is for attaching the tray heater. Therefore, attach the securing brackets [5] after installing the tray heater if you install the tray heater.
9. Load paper into the paper feed unit.
 10. Turn on the main power switch of the machine.
 11. Check the paper feed unit operation and copy quality.

2.5 LCT 2000-SHEET

2.5.1 ACCESSORY CHECK

Check the quantity and condition of the accessories against the following list.

No.	Description	Q'ty
1	Securing bracket	2
2	Screw (M4x10)	2
3	Spring washer screw	1
4	Knob screw	3

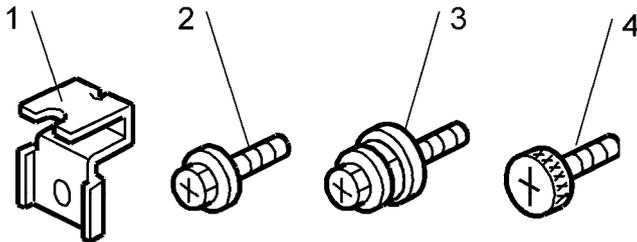

D352i101

2.5.2 INSTALLATION PROCEDURE

CAUTION

- Turn off the main switch of the copier and unplug the power cord before you start the installation procedure.
- You need two or more persons to lift the copier. The copier is highly unstable when lifted by one person, and may cause injury or property damage.
- Do not lift the copier with the paper feed unit installed. The handle and grips may be damaged.

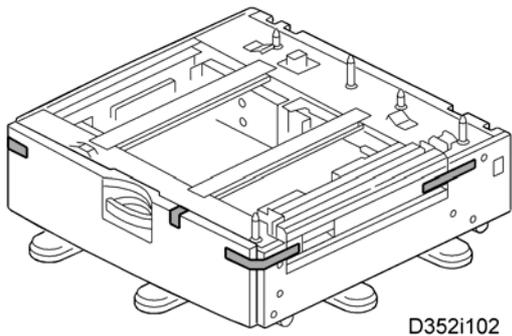

D352i102

1. Remove all tapes and retainers in the LCT.

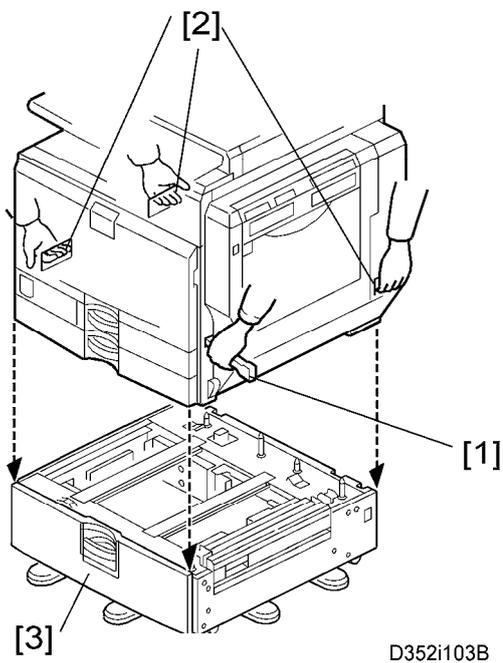

D352i103B

2. Grasp the handle [1] and grips [2] of the machine.
3. Lift the copier and install it on the LCT [3].

↓ Note

- Hold the handle [1] and grips [2] of the machine when you lift and move the machine.

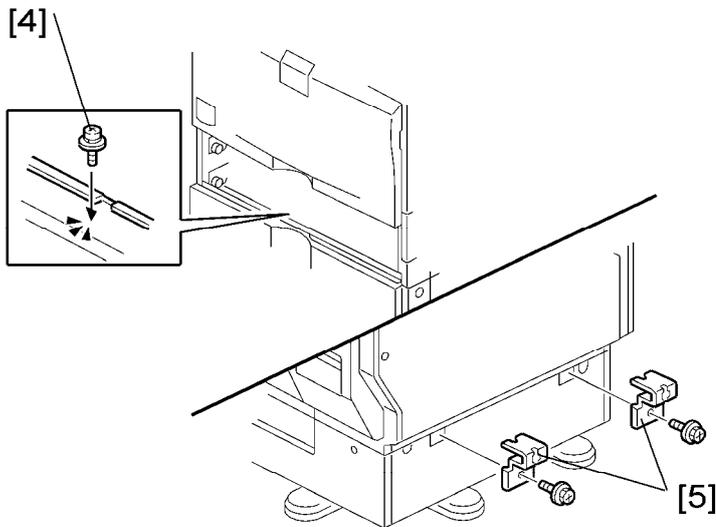

D352i104a

4. Remove the tray 1 and 2 of the machine.
5. Fasten the Spring Washer Screw [4].
6. Reinstall all trays.
7. Attach the securing brackets [5] (1 x 1 each; M4x10).

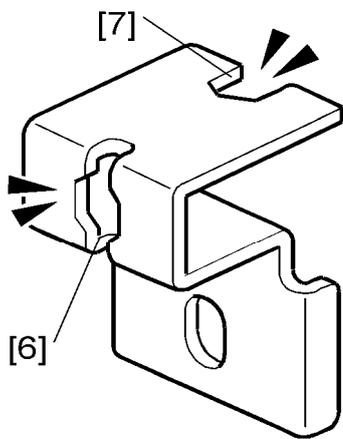

B801i101A

↓ Note

- One of the securing brackets is used as a securing tool (the cutout [6] is used in step 5). But the cutout [7] is for attaching the tray heater. Therefore, attach the securing brackets [2] after installing the tray heater if you install the tray heater.
8. Load paper into the LCT.
 9. Turn on the main power switch of the machine.
 10. Check the LCT operation and copy quality.

2.6 1200-SHEET LCT (D353)

2.6.1 COMPONENT CHECK

Check the quantity and condition of the components against the following list.

No.	Description	Q'ty
1	Front Bracket	1
2	Rear Bracket	1
3	Stud Screw	4
4	Joint Pin	2
5	LCT	1

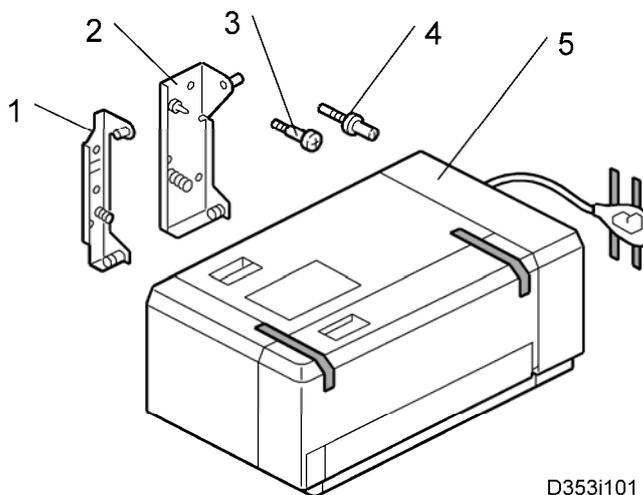

2.6.2 INSTALLATION PROCEDURE

CAUTION

- Unplug the main machine power cord before starting the following procedure.

Note

- The Paper Tray Unit (D351) or LCT 2000-sheet (D352) must be installed before installing this 1200-sheet LCT.

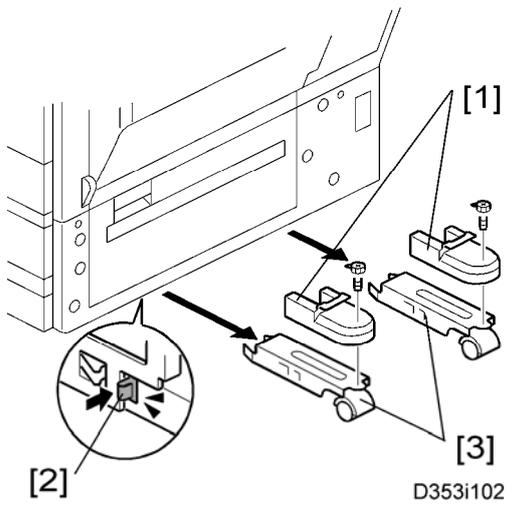

1. Unpack the LCT and remove the tapes.
2. Remove the stand covers [1].
3. Release the locks [2] of the front and rear caster stands.
4. Remove the caster stands [3].

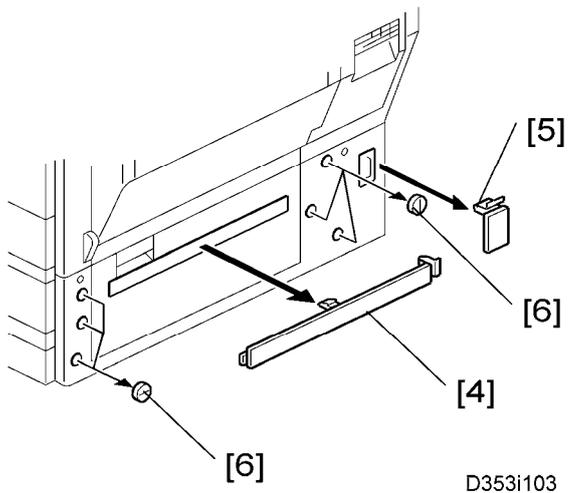

5. Remove the paper path cover [4], connector cover [5] and the six hole cover [6].

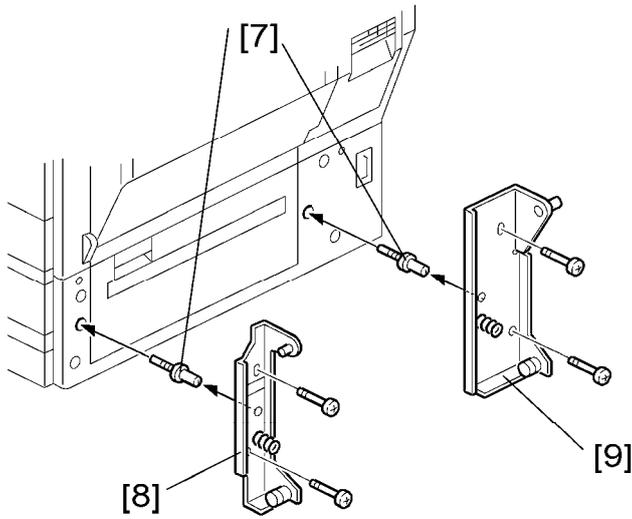

D353i104

6. Insert the joint pins [7].
7. Attach the front [8] and rear brackets [9].

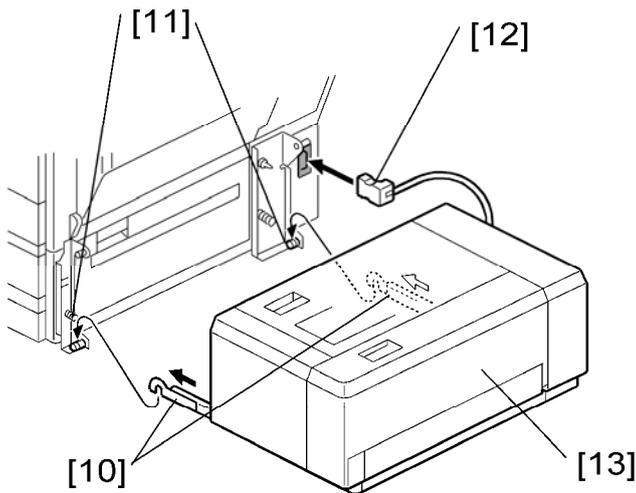

D353i105

8. Pull out the front and rear rails [10], and then hang them on each bracket [11].
9. Connect the LCT cable [12] to the main machine.
10. Slide the LCT [13] into the main machine.
11. Make sure that the front and rear sides of the LCT are closely attached to the main machine.

2.7 AUTO REVERSE DOCUMENT FEEDER (B802)

2.7.1 COMPONENT CHECK

Check the quantity and condition of the accessories against the following list.

No.	Description	Q'ty
1	ARDF	1
2	Attention Decal Sheet – Top Cover	1
3	Stamp	1
4	Knob Screw	2
5	Stud Screw	2
6	Platen Sheet	1

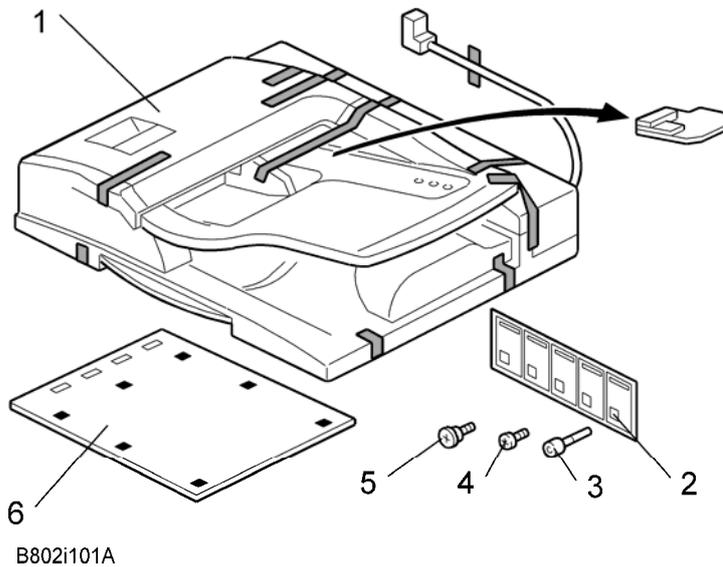

2.7.2 INSTALLATION PROCEDURE

CAUTION

- Unplug the copier power cord before starting the following procedure.

1. Remove the all tapes and shipping retainers.

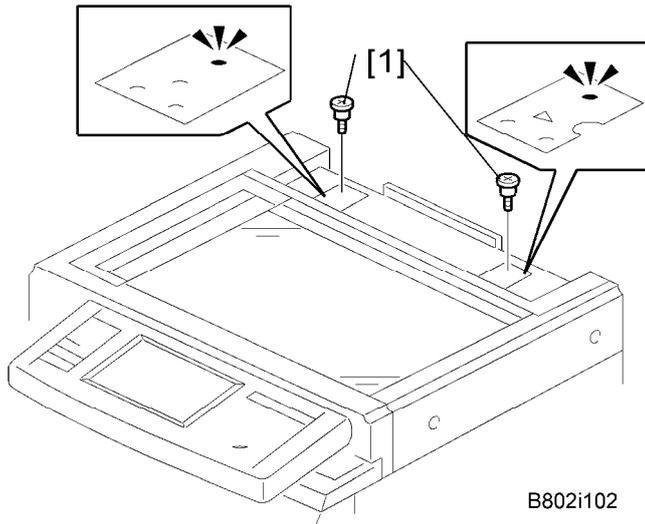

2. Insert the two stud screws [1] on the top of the machine.

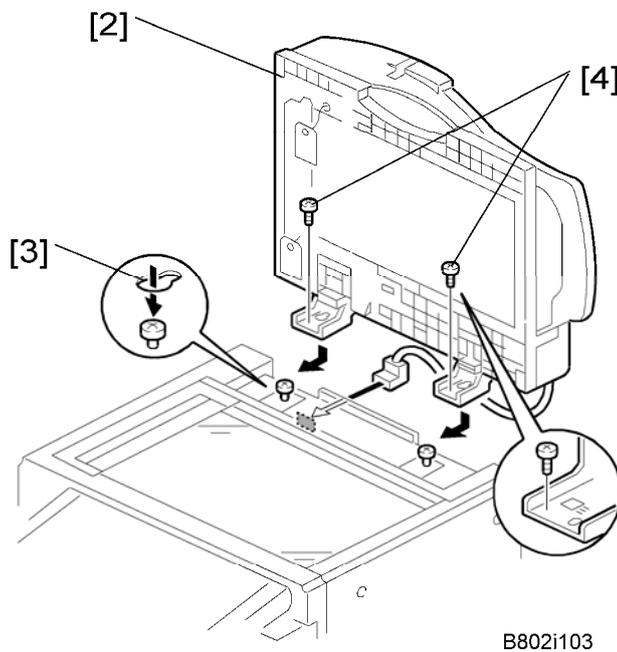

3. Mount the ARDF [2] by aligning the screw keyholes [3] of the ARDF support plate over the stud screws.

Auto Reverse Document Feeder (B802)

- Slide the ARDF toward the front of the machine.
- Secure the ARDF with the two knob screws [4].

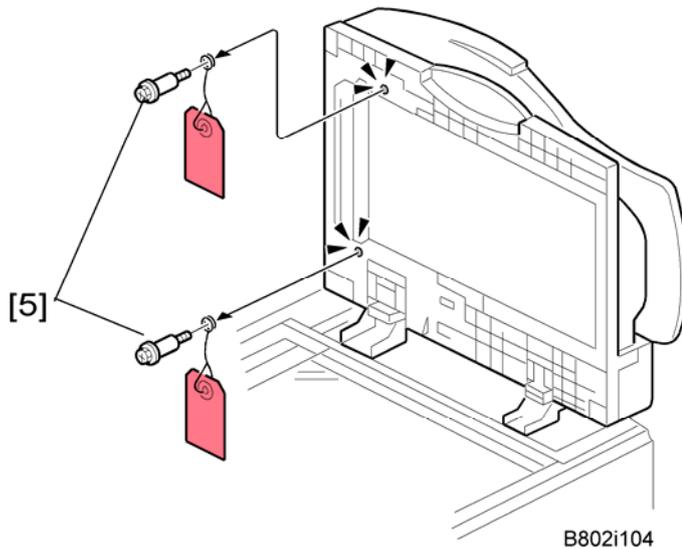

- Remove two screws [5] from the bottom of the ARDF.
- Remove all tapes on the ARDF.

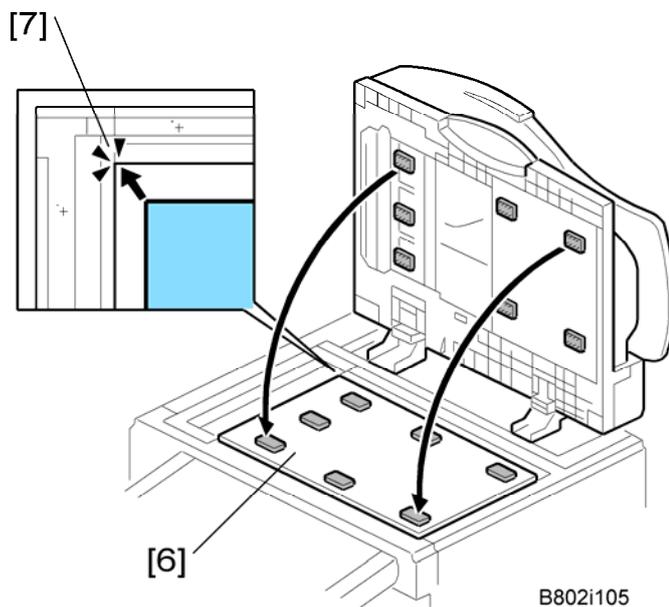

- Place the platen sheet [6] on the exposure glass.
- Align the rear left corner (of the platen sheet) with the corner [7] on the exposure glass.
- Close the ARDF.
- Open the ARDF and check that the platen sheet is correctly attached.

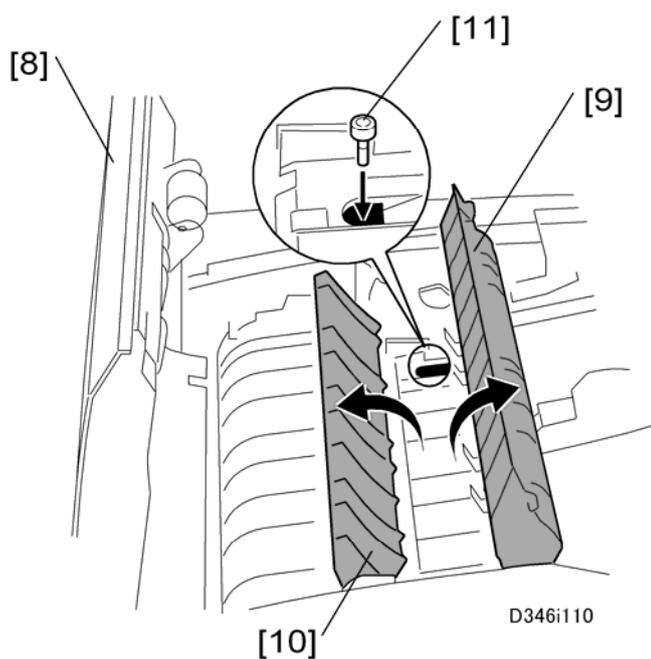

12. Open the ARDF cover [8].
13. Open the feed-in guide plate [9] and feed-out guide plate [10].
14. Install the stamp [11] into the ARDF.
15. Close two guide plates [10] [9].
16. Close the ARDF cover [8].

Auto Reverse Document Feeder (B802)

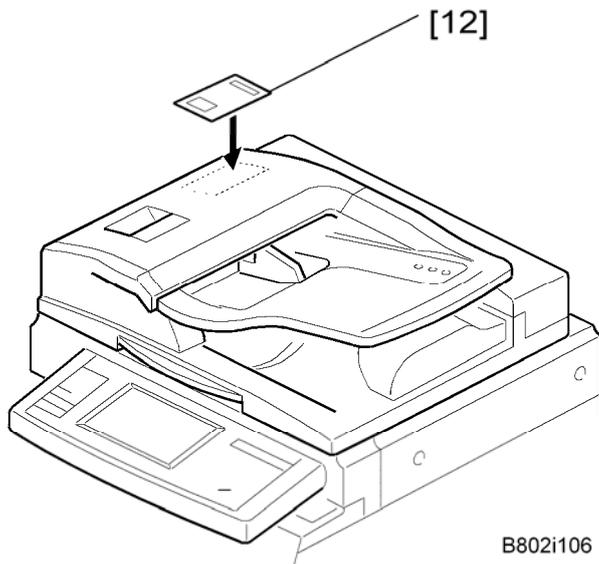

17. Attach the decal [12] to the top cover as shown. Choose the language you want.
18. Plug in and turn on the main power switch of the machine, and then check the ARDF operation.
19. Make a full size copy. Check that the registrations (side-to-side and leading edge) and image skew are correct. If they are not, adjust the registrations and image skew referring to the "Copy Adjustments" in the section of the "Replacements and Adjustments".

2.8 PLATEN COVER INSTALLATION (G329)

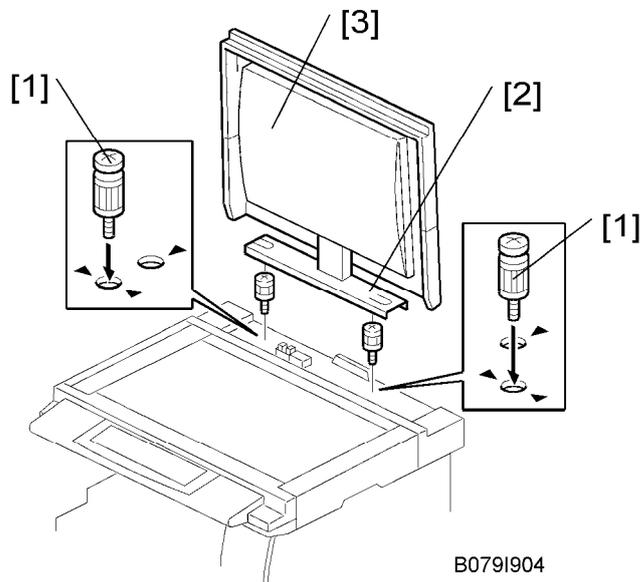

1. Install screws [1] (x 2) on the top cover as shown.
2. Position the platen cover bracket [2] on the heads of the stud screws, and slide the platen cover [3] to the left.

1-Bin Tray Unit (D389)

2.9 1-BIN TRAY UNIT (D389)

2.9.1 COMPONENT CHECK

Check the quantity and condition of the components against the following list.

No.	Description	Q'ty
1	1-Bin Tray Unit	1
2	End-fence	1
3	Tray Support Bar	1
4	Screws (M3 x 16)	3
5	Tray	1

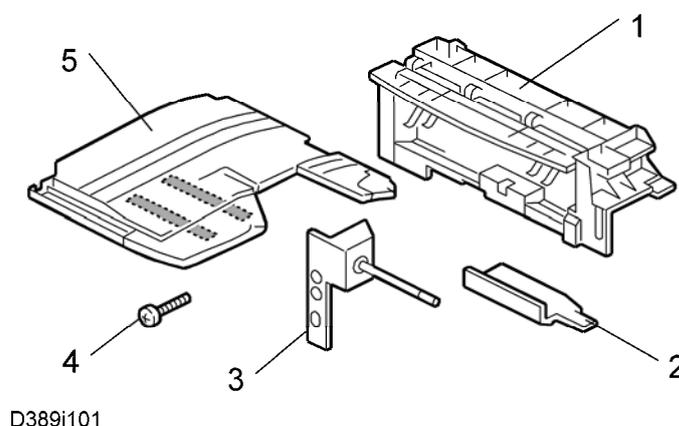

2.9.2 INSTALLATION PROCEDURE

CAUTION

- Unplug the copier power cord before starting the following procedure.

Note

- If the bridge unit (D386) has already been installed on the machine, remove it before installing 1-bin tray unit (D389). This makes it easy to do the following procedure.

1-Bin Tray Unit (D389)

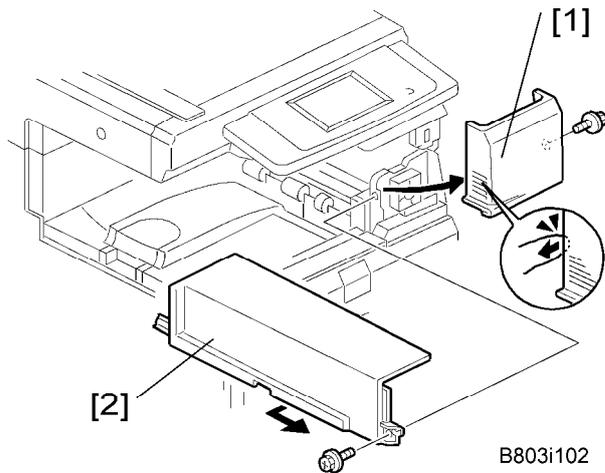

1. Remove all tapes.
2. Open the right door of the machine.
3. Remove the front right cover [1] (🔧 x 1).
4. Remove the paper exit cover [2] (🔧 x 1).

↓ Note

- Keep this screw for step 5.

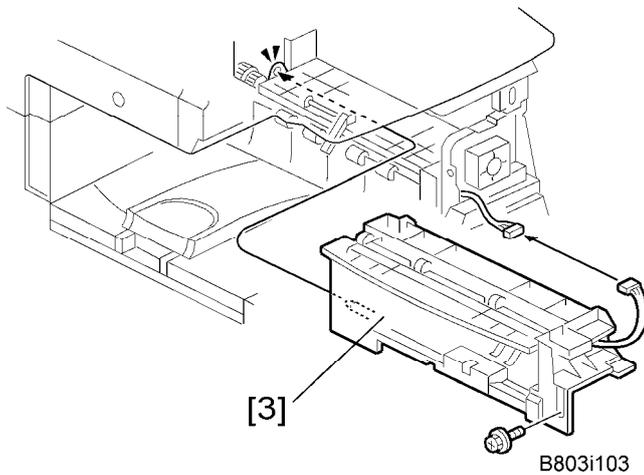

5. Install the 1-bin tray unit [3] (🔧 x 1, 🔩 x 1 [This screw was removed in step 4]).

1-Bin Tray Unit (D389)

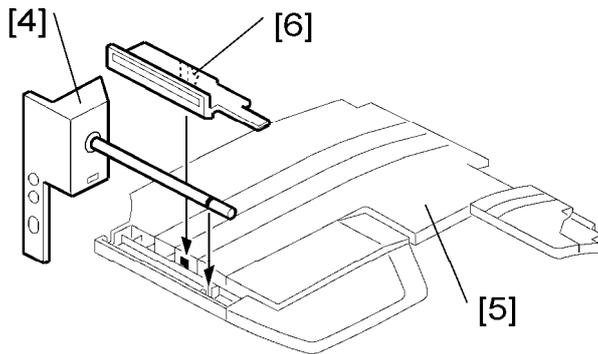

d389i104

6. Attach the tray support bar [4] to the tray [5] as shown, and then attach the end-fence [6].

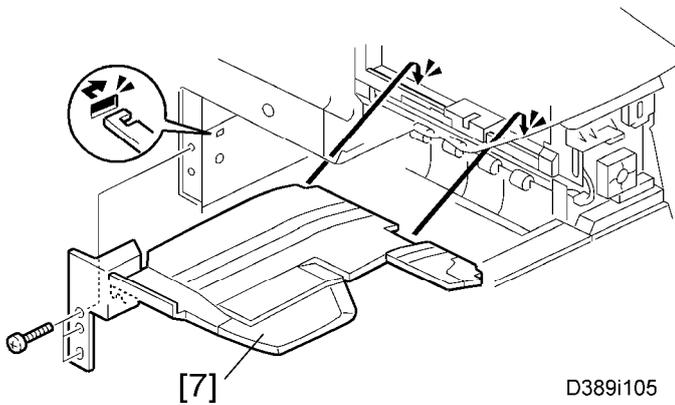

D389i105

7. Install the tray [7] with the tray support bar on the machine (⚙ x 3; M3 x 16).
8. Reinstall the front right cover on the machine, and then close the right door of the machine.
9. Turn on the main power switch of the machine.
10. Check the 1-bin tray unit operation.

2.10 BRIDGE UNIT (D386)

2.10.1 COMPONENT CHECK

Check the quantity and condition of the components against the following list.

No.	Description	Q'ty
1	Bridge Unit	1
2	Knob screw	1
3	Long Knob Screw	1
4	Holder bracket	1
5	Guide	2

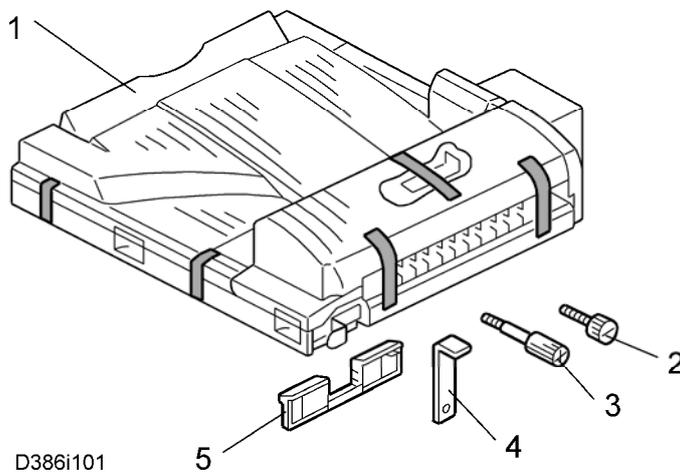

2.10.2 INSTALLATION PROCEDURE

⚠ CAUTION

- Unplug the copier power cord before starting the following procedure.

↓ Note

- If you will install the 1-bin tray (D389) on the machine, install the 1-bin tray first before installing the bridge unit (D386). This makes it easy to do the following procedure.

Bridge Unit (D386)

- If you will install the finisher unit (B408, B804 or B805) on the machine, install it after installing the bridge unit (D386).

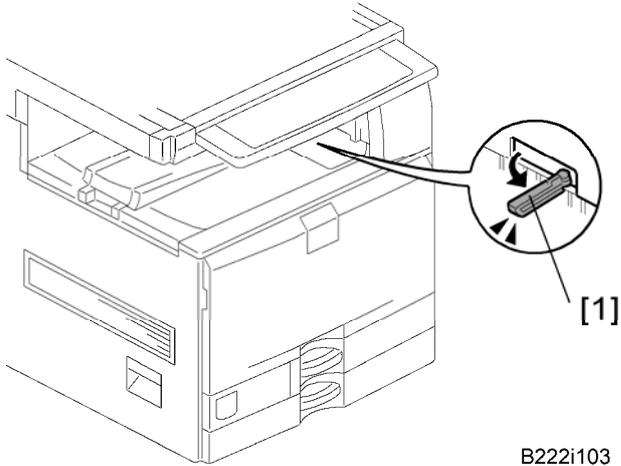

1. Remove all tapes.
2. If the sensor feeler [1] is out, fold it into the machine.
3. Open the right door of the machine.

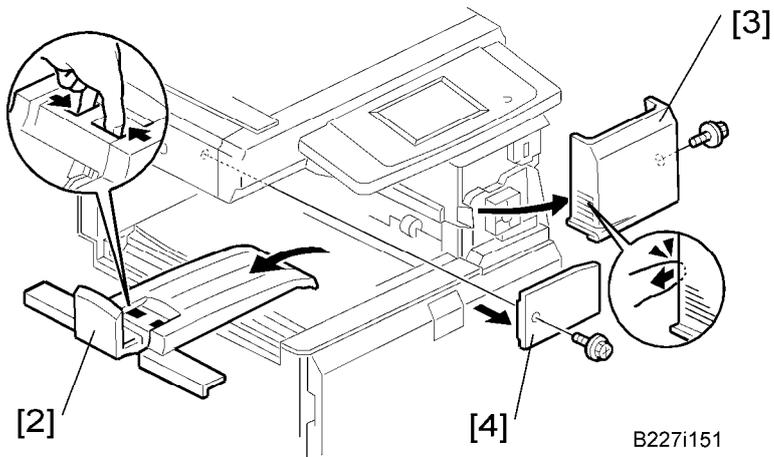

4. Remove the upper inner tray [2].
5. Remove the front right cover [3] (⚙ x 1).
6. Remove the connector cover [4] (⚙ x 1).

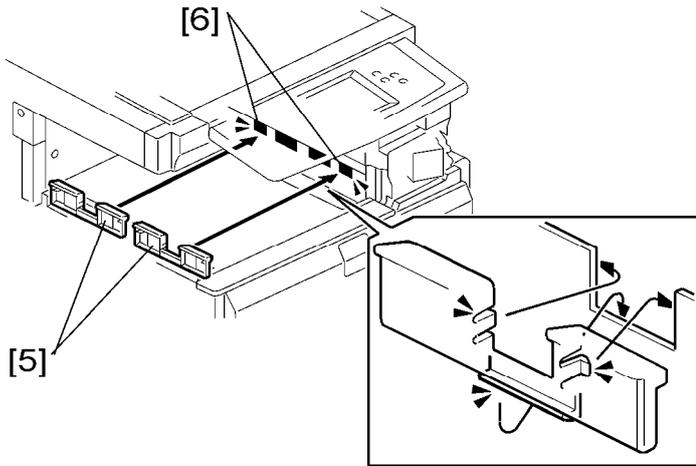

D386i102A

7. Attach the two guides [5] to the cutouts [6] in the inner tray.

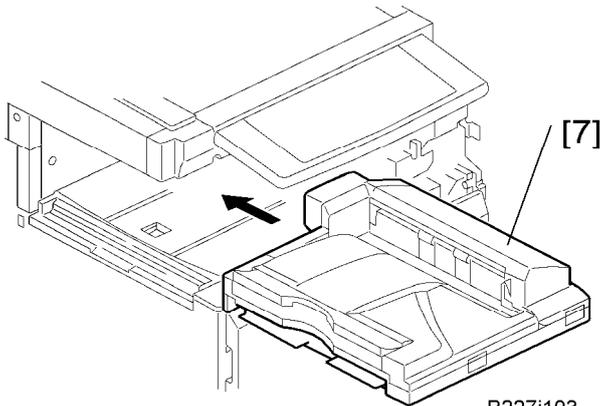

B227i103

8. Install the bridge unit [7] in the machine.

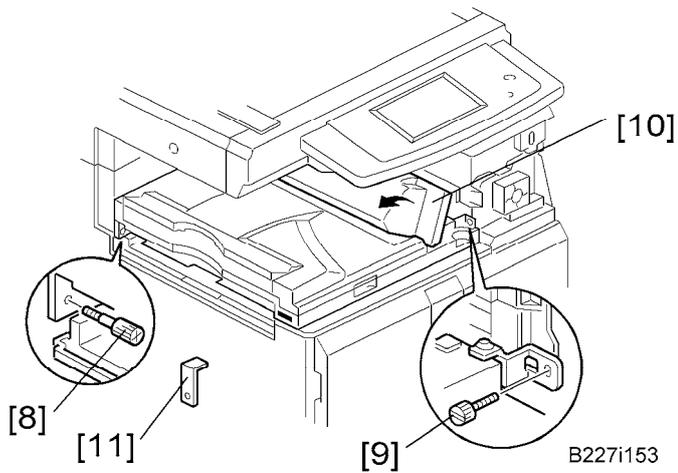

B227i153

9. Secure the bridge unit with the long knob screw [8] and knob screw [9].

Bridge Unit (D386)

10. Reinstall the front right cover on the machine, and then close the right door of the machine.

↓ Note

- Open the bridge unit cover [10] when installing the front right cover. Otherwise, you cannot reinstall it.

11. Install the optional finisher (refer to the finisher installation procedure).

↓ Note

- Holder bracket [11] is used in the installation procedure of the finisher (B408, B804 or B805). Do not install it at this time.

12. Turn on the main power switch of the machine.
13. Check the bridge unit operation.

2.11 2000/3000-SHEET FINISHERS (B804/B805)

2.11.1 ACCESSORY CHECK

Check the quantity and condition of the accessories against the following list.

No.	Description	Q'ty
1	Rear joint bracket	1
2	Front joint bracket	1
3	Ground (earth) plate	1
4	Tapping screws - M4 x14	4
5	Tapping screws - M3 x 8	1
6	Tapping screws - M3 x 6	2 (B804) or 6 (B805)* ¹
7	Upper output tray	1
8	Support Tray	1
9	Lower output tray (B804 only)	1
10	Cushion (with double-sided tape)	1
11	Small ground (earth) plate (B805 only)* ²	2

*¹: Four of these six screws are not used for this model.

*²: Item No.11 is not used for this model.

2000/3000-Sheet Finishers (B804/B805)

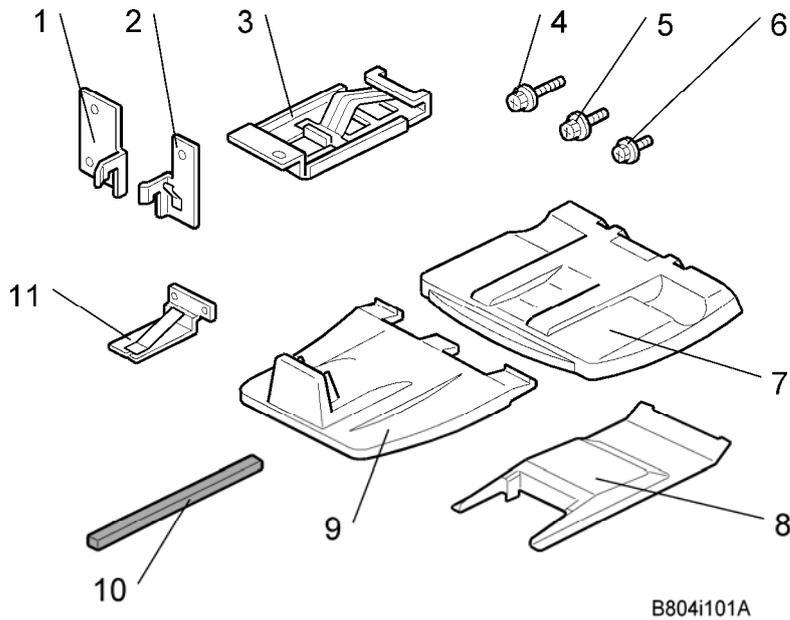

2.11.2 INSTALLATION PROCEDURE

CAUTION

- Unplug the main machine power cord before starting the following procedure.

If this finisher is installed on this machine, the following options must be installed before installing this finisher.

- Bridge Unit (D886)
- Paper Feed Unit (D351) or LCT (D352)

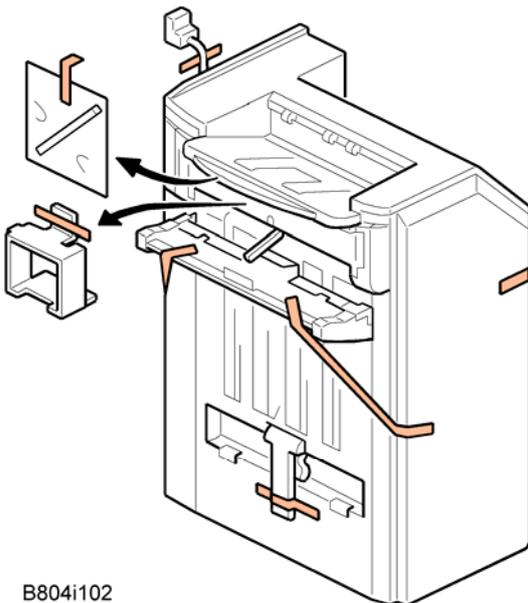

1. Unpack the finisher and remove all tapes and packing materials from the finisher.

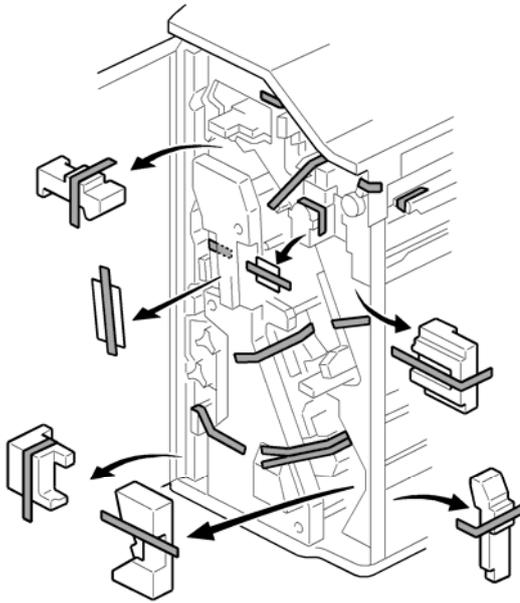

B804i103

2. Open the front door, and then remove all tapes and packing materials from the inside of the finisher.

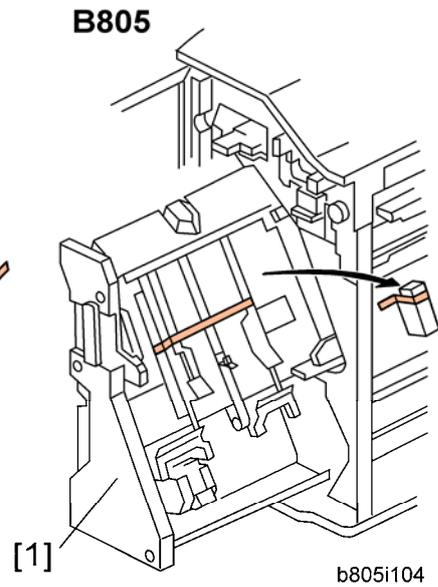
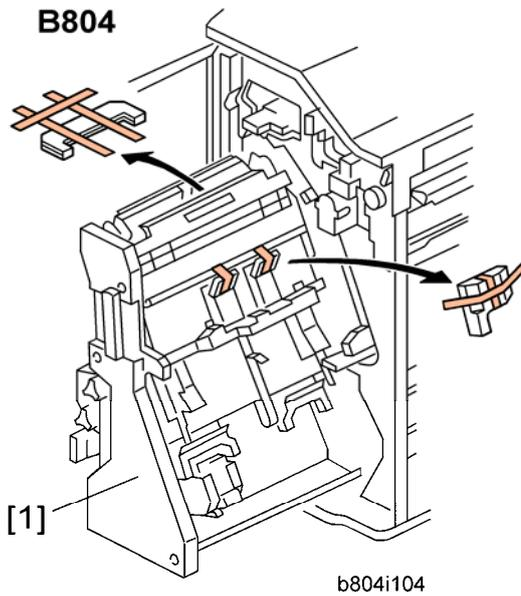

3. Pull out the jogger unit [1], and then remove all tapes and retainers.

2000/3000-Sheet Finishers (B804/B805)

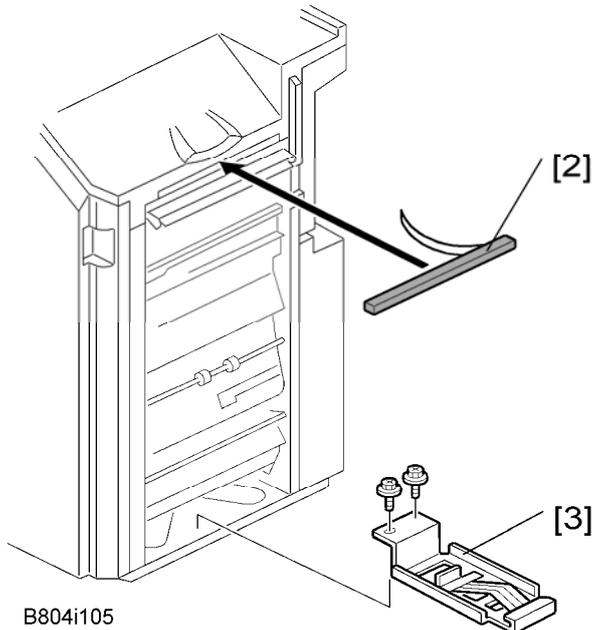

4. Attach the cushion [2] to the finisher.



- Make sure that the cushion is placed within 0 to 1 mm from the edge of the cover.

5. Install the ground plate [3] on the finisher (⚙ x 2; M3 x 6).

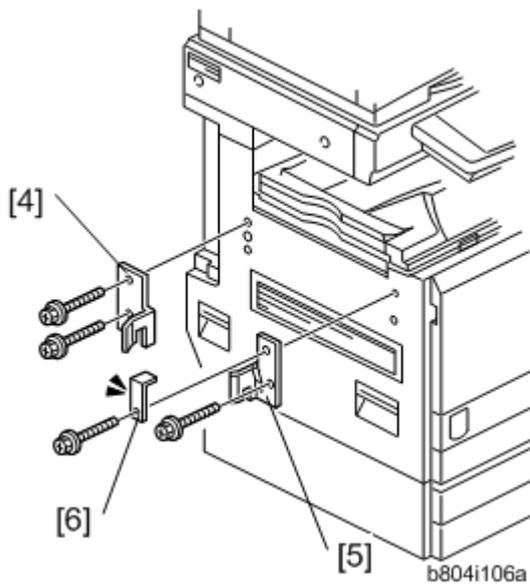

6. Attach the rear joint bracket [4] (⚙ x 2; M4 x 14).
7. Attach the front joint bracket [5] and the holder bracket [6] (⚙ x 2; M4 x 14).

↓ Note

- Holder bracket [6] must be placed outside the front joint bracket [5]. This bracket is provided with the Bridge Unit (D386).

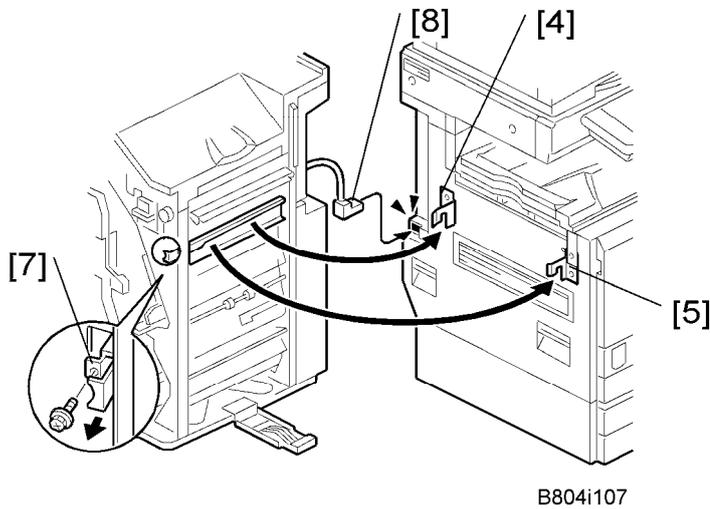

- Pull the lock lever [7] (🔑 x 1).
- Slowly push the finisher to the left side of the machine, keeping its front door open until the brackets [4] [5] go into their slots.
- Push the lock lever [7], and then secure it (🔑 x 1).
- Close the front door of the finisher.
- Connect the finisher connector [8] to the machine.

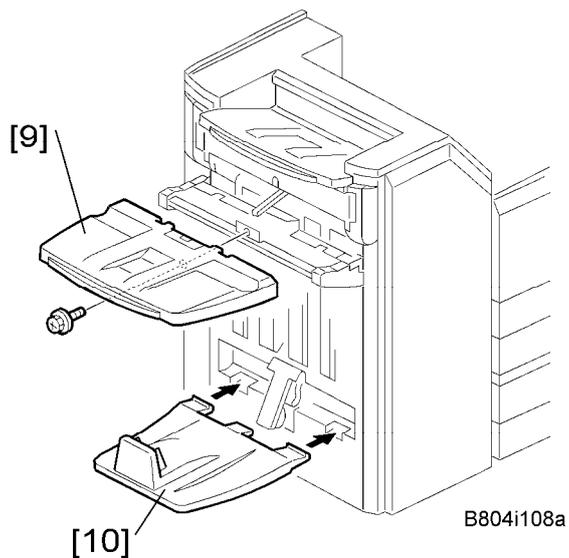

- Install the upper output tray [9] (🔑 x 1; M3 x 8).
- Only for B804, install the lower output tray [10].

2000/3000-Sheet Finishers (B804/B805)

15. Turn on the main power switch of the machine.

16. Check the finisher operation.

Support Tray Installation

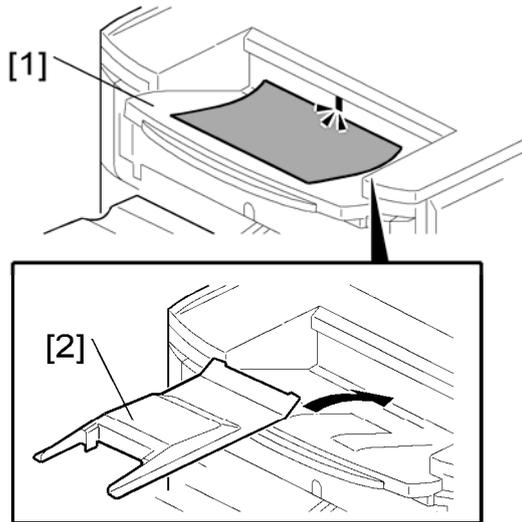

B804i901

If a stacking problem occurs several times on the upper output tray [1], put the support tray [2] on the tray as shown.

Note

- Keep this tray in the manual pocket if this tray does not need to be installed.

2.12 PUNCH UNIT

The Punch Unit B702 can be installed in the 2000/3000 Sheet (Booklet) Finisher B804/B805.

2.12.1 COMPONENT CHECK

Check the quantity and condition of the components against the following list.

No.	Description	Q'ty
1	Punch-out Waste Unit	1
2	Slide Drive Unit	1
3	Punch Waste Hopper	1
4	Screws (M3 x 6)	5
5	Side-to-Side Detection Unit	1
6	Punching Unit	1

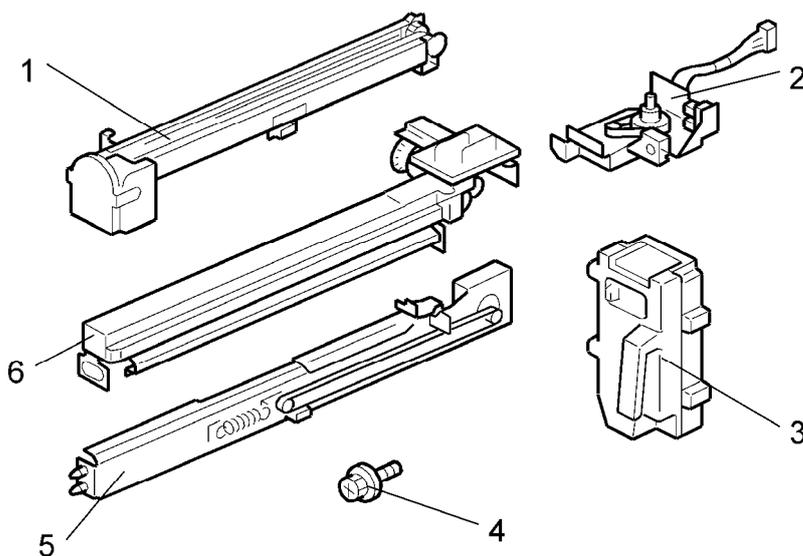

b702i101

2.12.2 INSTALLATION PROCEDURE

CAUTION

- Unplug the main machine power cord before starting the following procedure. If the 2000/3000-sheet booklet finisher has been installed, disconnect it and pull it away from the machine.

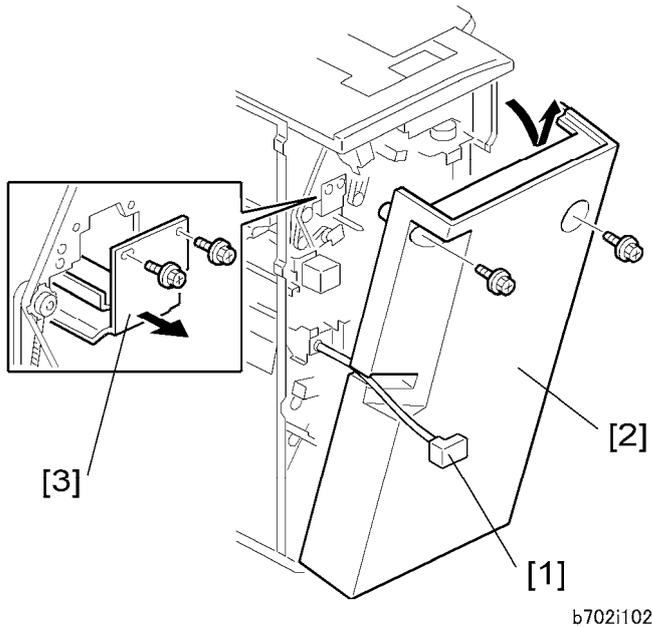

1. If the finisher is connected to the copier, disconnect the power connector [1] and move the finisher away from the copier.
2. Remove the rear cover [2] (⚙ x 2) and open the front door.

Note

- At the bottom of the rear cover, make sure to disconnect the tabs that attach the cover to the frame.
3. Remove the guide plate [3] (⚙ x 2).



4. Remove the bracket [4] from the punch unit (🔧 x 3).

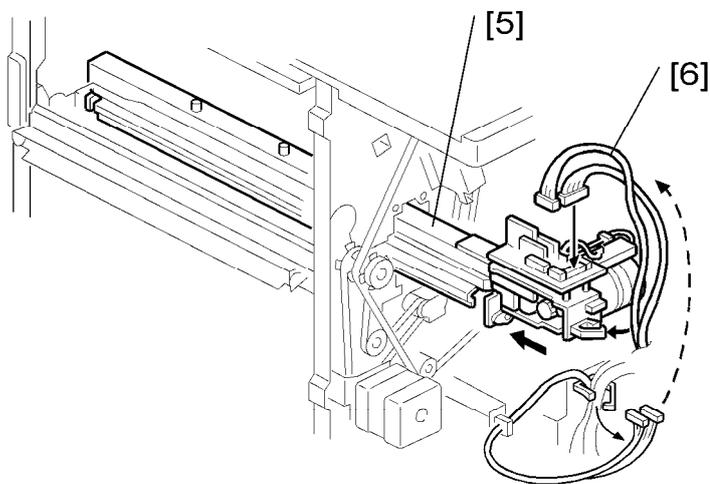

b702i103

5. Move the punch unit [5] along its rails into the finisher. Make sure that the pin engages correctly at the front and rear.
6. Connect the cables [6] of the finisher to the connectors (CN601 and CN602) on the punch unit board (🔧 x 2, 🖨️ x 1).
- The cables [6] are coiled and attached to the PCB.

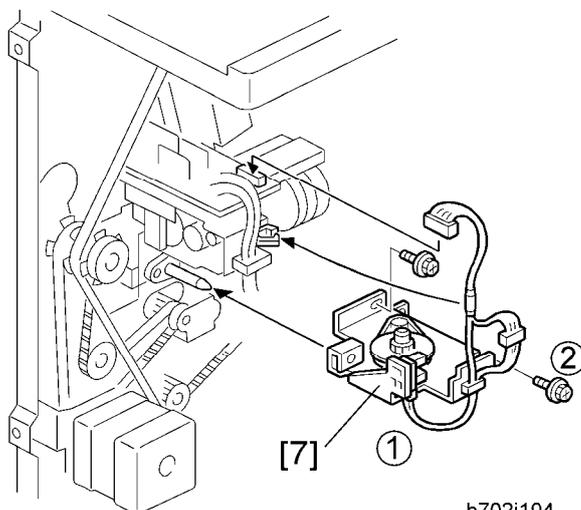

b702i104

7. Attach the slide drive unit [7] to the finisher and connect it to the punch unit (🔧 x 2, 🖨️ x 1). Push in the slide drive unit at ① when you attach the screw ②.
8. Make sure that the punch unit moves freely and is not blocked by the screws.

Punch Unit

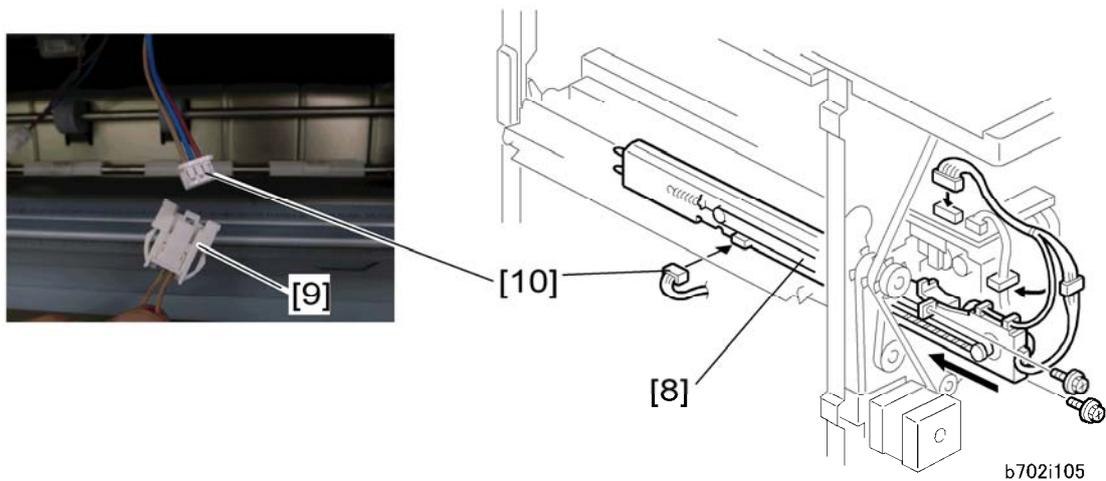

9. Put the side-to-side detection unit [8] in the machine. Make sure that the two pins are engaged correctly at the front.
10. Make sure that the side-to-side detection unit moves smoothly on its rails. If it does not, make sure that the rails are aligned with their grooves.
11. Attach the side-to-side detection unit and connect it at the rear (🔧 x 2, 🛠️ x 1, 📏 x 1).
12. Pull the short connector [9] out of the connector [10], then connect the cable [10] of the finisher (📏 x 1).

↓ Note

- This is the 3-pin connector.

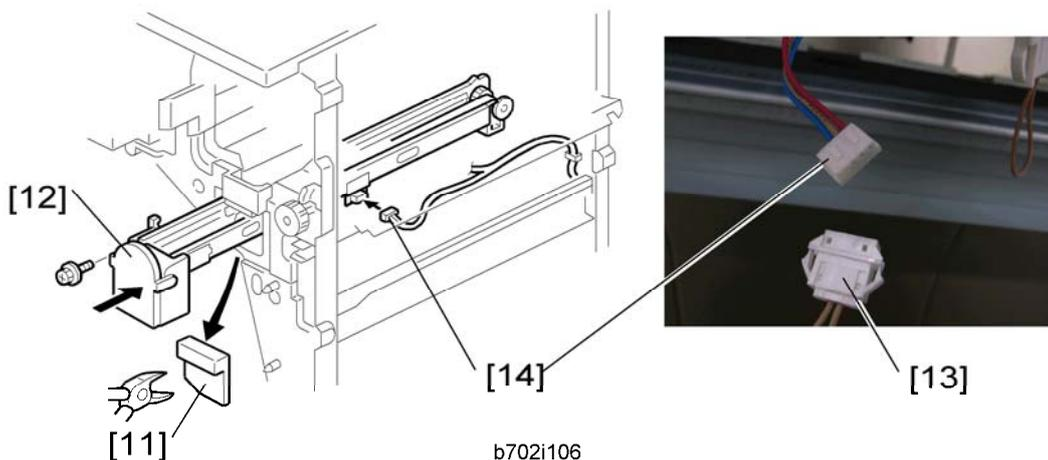

13. At the front, use a pair of wire cutters to remove the part [11] of the cover.
14. Install the punch-waste transport unit [12] in the finisher.
15. Make sure that the punch-waste transport unit moves smoothly on its rails. If it does not, make sure that the rails are aligned with the grooves.
16. Remove the short connector [13] from the connector [14].

Note

- This is the 4-pin connector.

17. Connect the cable [14] and attach the punch-waste transport unit ( x 1,  x 1,  x 1).

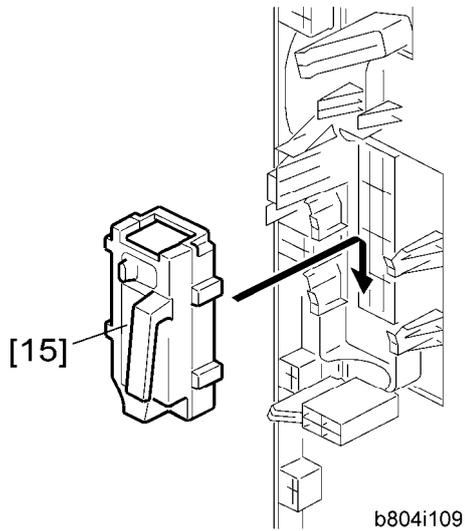

18. Set the hopper [15] in its holder.
19. Reassemble the finisher, and then install it on the main machine.
20. Connect the power cord to the outlet, and then turn the main power switch on.
21. Check the punch unit operation.

2.13 1000-SHEET FINISHER (B408)

2.13.1 ACCESSORY CHECK

Check the quantity and condition of the accessories against the following list.

No.	Description	Q'ty	For this model
1	Front Joint Bracket	1	✓
2	Screw - M4 x 14	4	✓ (Use 4)
3	Knob Screw - M4 x 10	1	✓
4	Copy Tray	1	✓
5	Knob Screw - M3 x 8	1	✓
6	Screw - M3 x 8	1	✓
7	Rear Joint Bracket	1	✓
8	Grounding Plate	1	✓
9	Staple Position Decal	1	✓
10	Rear Joint Bracket	1	---

✓ = Necessary, --- = Not necessary

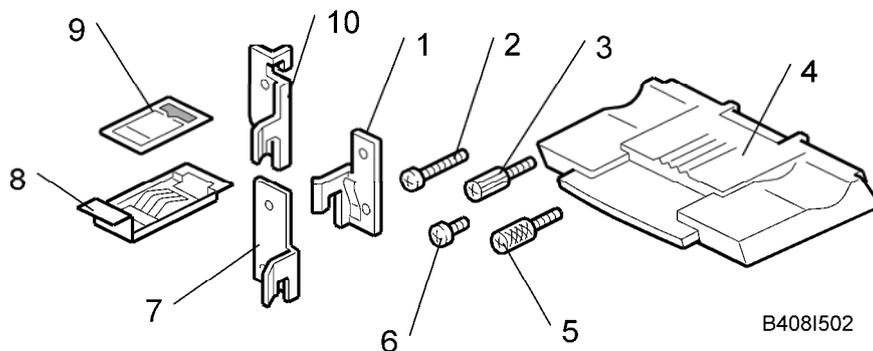

2.13.2 INSTALLATION PROCEDURE

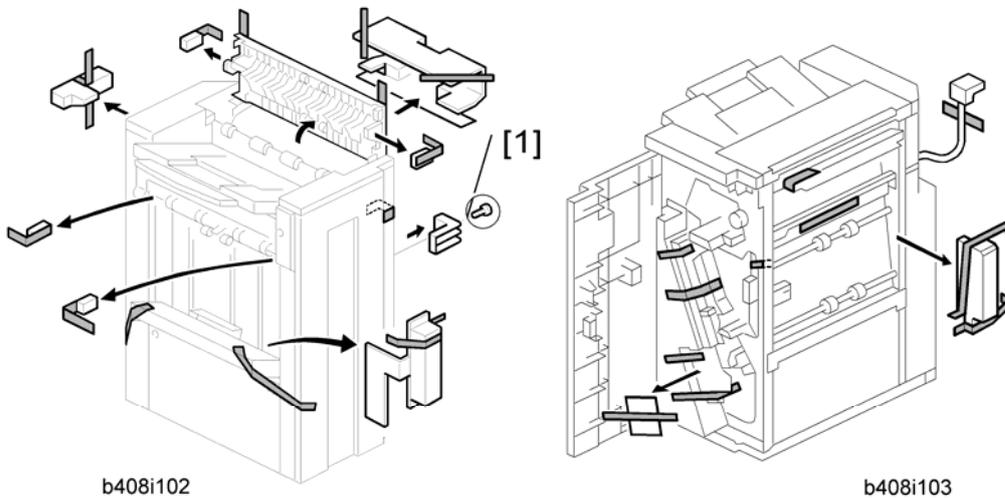

CAUTION

- Unplug the main machine power cord before starting the following procedure. If this finisher is installed, the Bridge Unit (D386) and Paper Feed Unit (D351) or LCT (D352) must be installed before installing this finisher.

- Unpack the finisher and remove the tapes.

Note

- Be sure to keep screw [1] shown at the top left drawing above. It will be needed to secure the grounding plate later in this procedure.

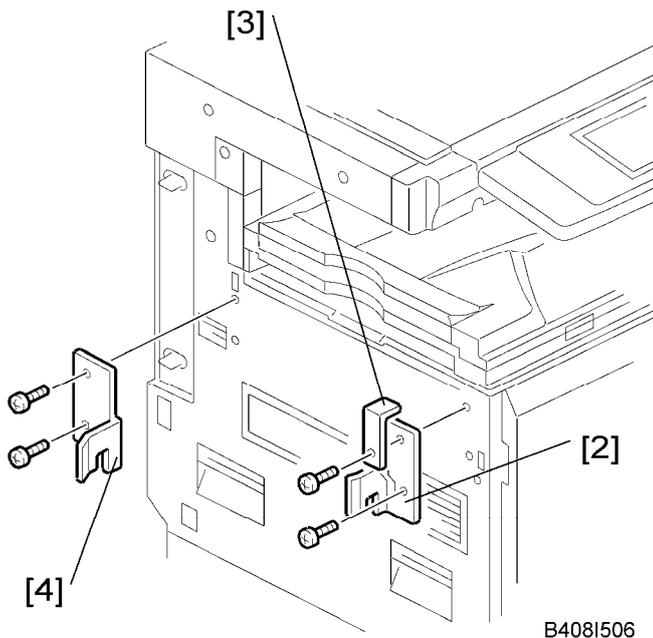

- Install the front joint bracket [2] / holder bracket [3] (x 2; M4 x 14) and rear joint bracket [4] (x 2; M4 x 14).

1000-Sheet Finisher (B408)

↓ Note

- The holder bracket [3] must be placed outside the front joint bracket [2]. The holder bracket [3] is provided with the Bridge Unit (D386).

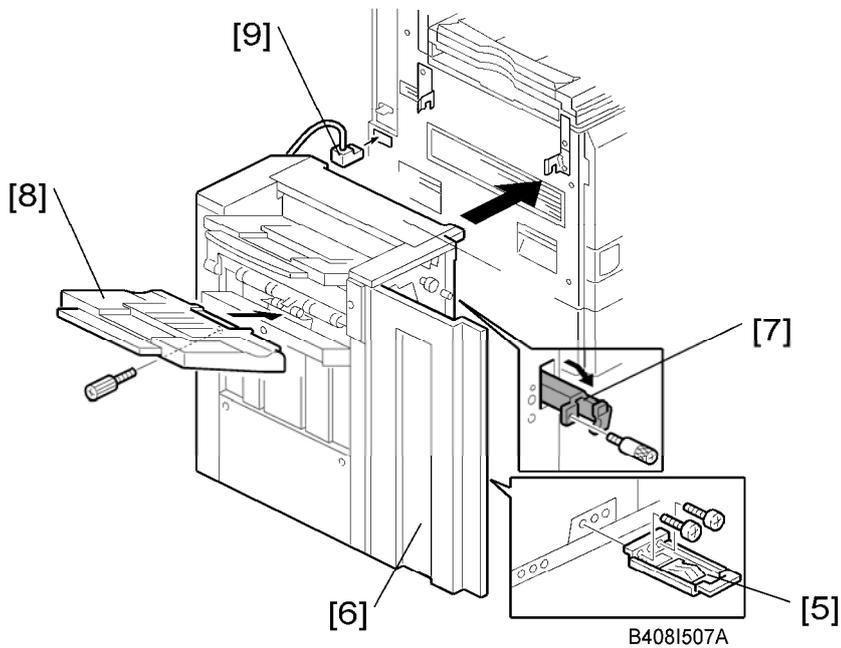

3. Install the grounding plate [5] on the finisher (1 x 2; M3 x 8)

↓ Note

- Use the screw removed in step 1 and the screw from the accessory box.
4. Open the front door [6] then pull the locking lever [7].
 5. Align the finisher on the joint brackets, and lock it in place by pushing the locking lever.
 6. Secure the locking lever (1 knob screw; M3 x 8).
 7. Close the front door.
 8. Install the copy tray [8] (1 knob screw; M4 x 10).
 9. Connect the finisher cable [9] to the main machine as shown above.

1000-Sheet Finisher (B408)

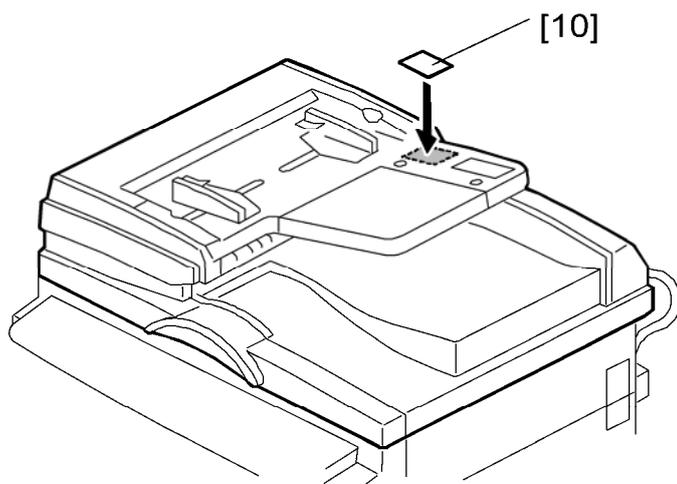

b408i501

10. Attach the staple position decal [10] to the ARDF as shown.
11. Turn on the main power switch and check the finisher operation.

2.14 KEY COUNTER BRACKET

2.14.1 INSTALLATION PROCEDURE

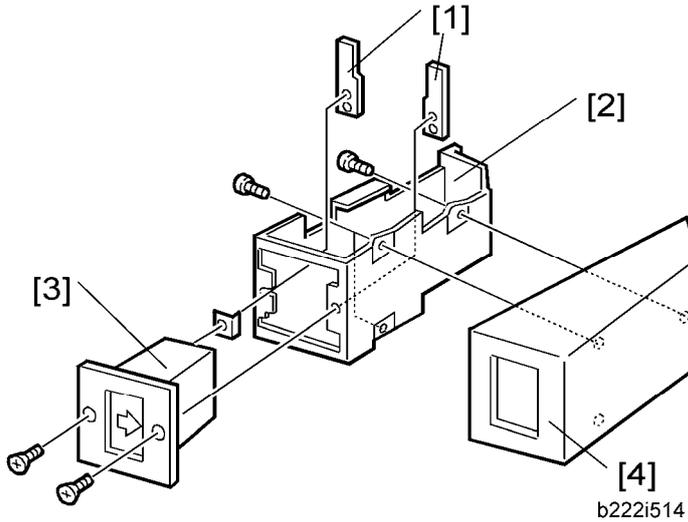

1. Hold the key counter plate nuts [1] on the inside of the key counter bracket [2] and insert the key counter holder [3].
2. Secure the key counter holder to the bracket (🔩 x 2).
3. Install the key counter cover [4] (🔩 x 2).

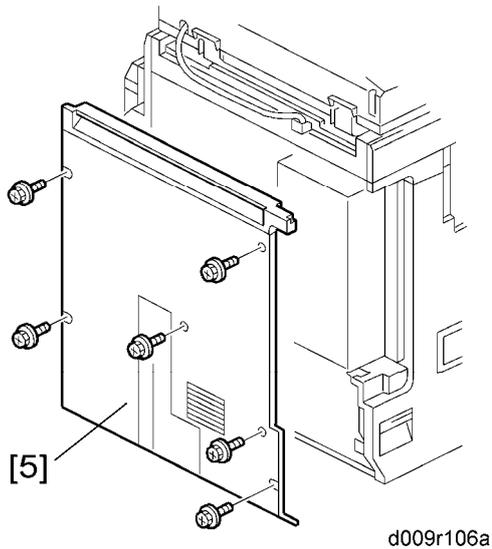

4. Rear cover [5] (🔩 x 5)

Key Counter Bracket

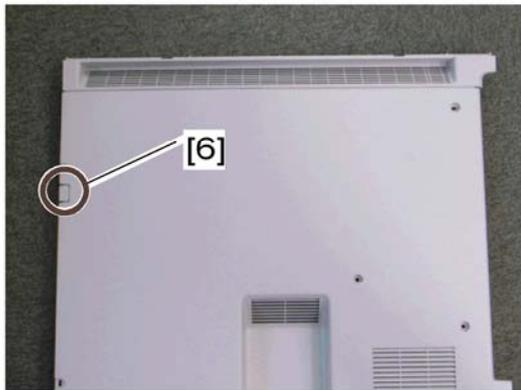

d009i514

5. Cut off the part [6] of the rear cover.

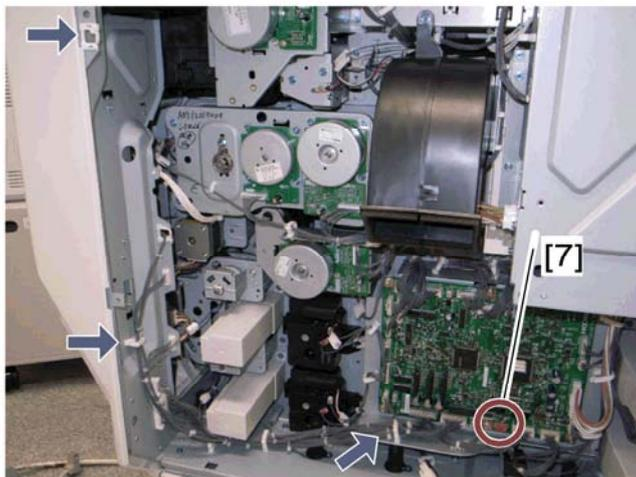

d009i516

6. Connect the harness to CN211 [7] on the IOB (🖨️ x 3).

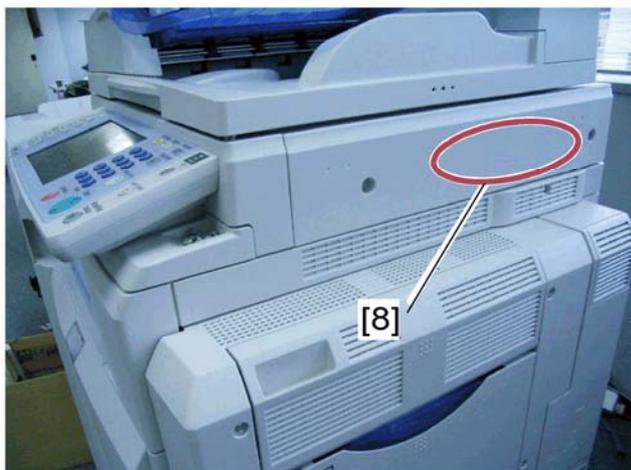

b222i517

7. Peel off the double-sided tape on the key counter bracket and attach the key counter to the scanner right cover [8].
8. Reassemble the machine.

2.15 KEY COUNTER INTERFACE UNIT

2.15.1 INSTALLATION PROCEDURE

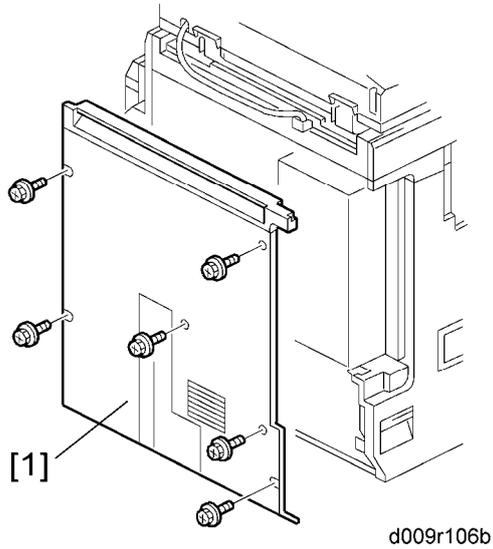

1. Rear cover [1] (🔩 x 3)

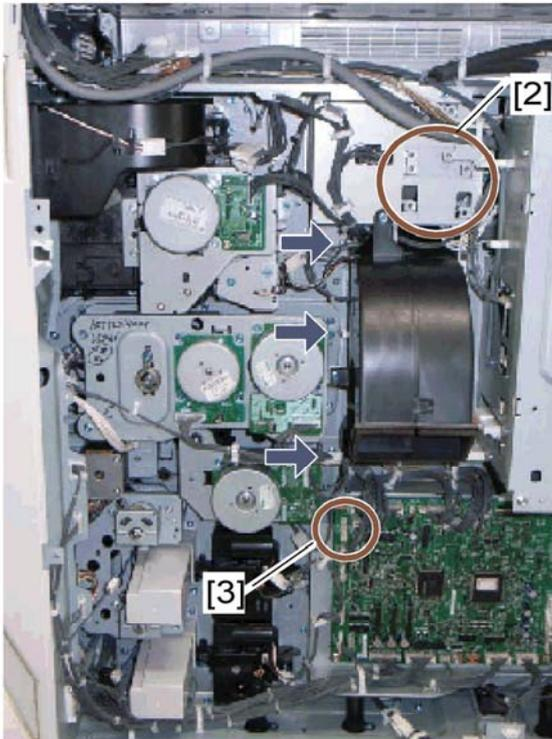

2. Install the key counter interface board in the location [2] (🔩 x 4).
3. Connect the harness to CN3 on the key counter interface board.

Key Counter Interface Unit

4. Connect the other terminal of the harness to CN214 [3] on the IOB (🔌 x 3).

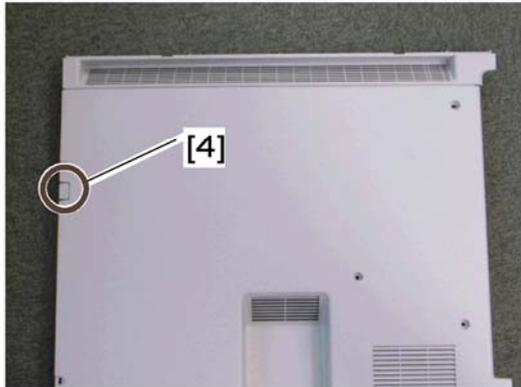

d009i514a

5. Cut off the part [4] of the rear cover.

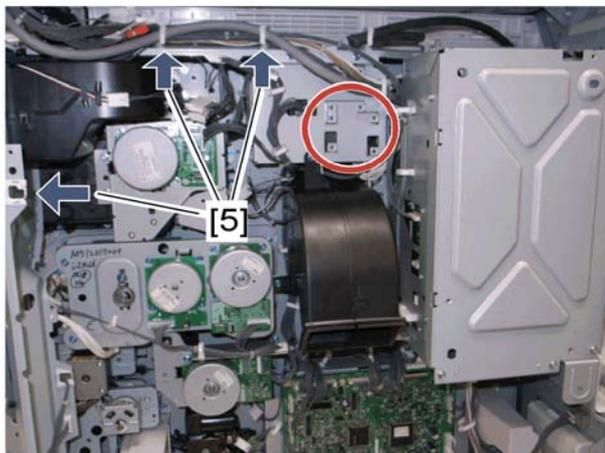

d009i516a

6. Connect the harness from the counter device to CN4 on the key counter interface board and clamp it with three clamps [5].
7. Reassemble the machine.

2.16 ANTI-CONDENSATION HEATER (SCANNER)

2.16.1 INSTALLATION PROCEDURE

1. Remove the ARDF or platen cover (see "ARDF" or "Platen Cover" in the "Installation" section.)
2. Rear cover (🔧 p.4-4)
3. ARDF exposure glass and exposure glass with left scale (🔧 p.4-9).
4. Scanner rear frame (🔧 p.4-13).

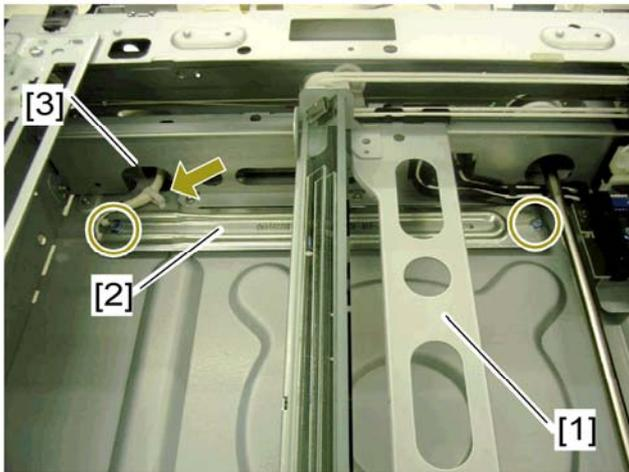

5. Move the scanner carriage [1] to the right side by rotating the scanner motor.
6. Install the heater [2] in the scanner unit (🔧 x 2, 📏 x 1)
7. Put the cable through the cutout [3].

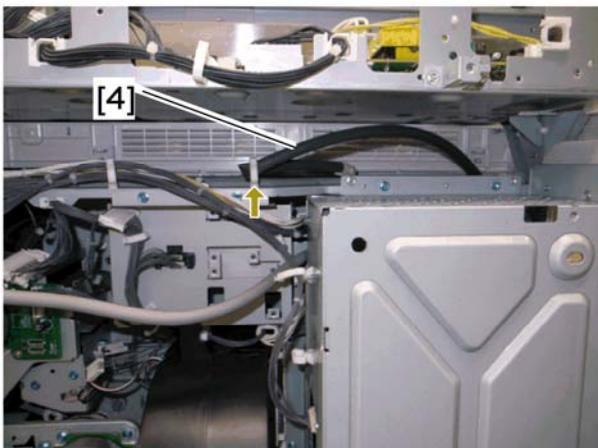

8. Release the heater relay cable [4] (🔧 x 1).

Anti-Condensation Heater (Scanner)

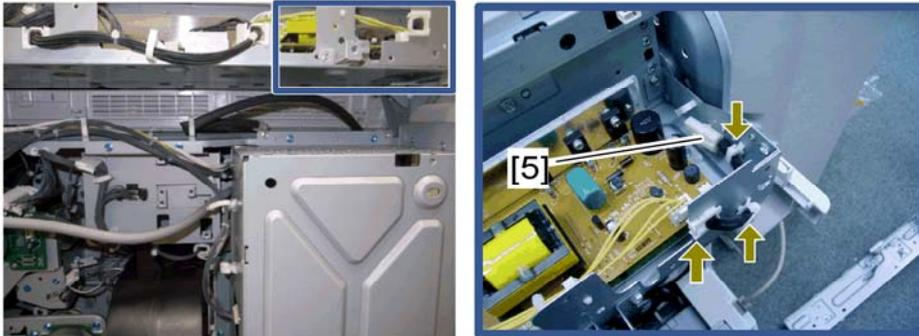

d009i520

9. Route the heater relay cable [5] as shown (🖨️ x 3).

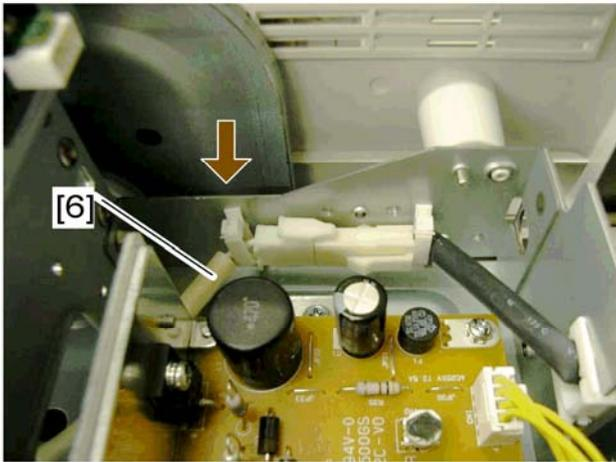

b222i521

10. Connect the heater cable [6] to the heater relay cable (🖨️ x 1).
11. Reassemble the machine.

2.17 TRAY HEATER

2.17.1 INSTALLATION PROCEDURE

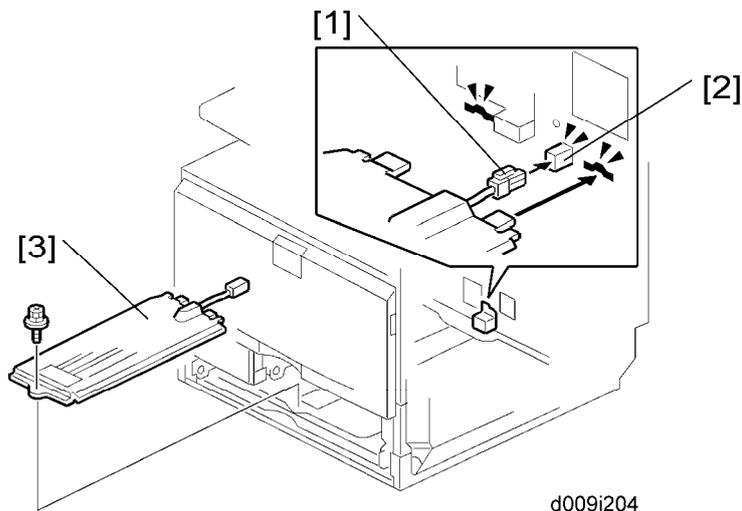

d009i204

1. Remove trays 1 and 2 from the machine.
2. Connect the connector [1] of the heater to the connector [2] of the main machine.
3. Install the heater [3] inside the machine (⚙️ x 1).

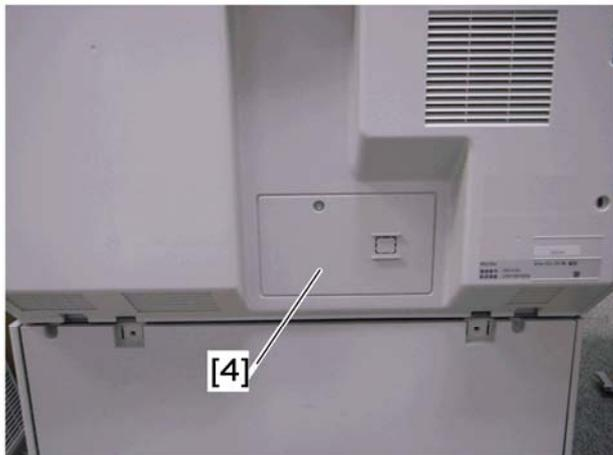

d009i205

4. Remove the connector cover [4] (⚙️ x 1).

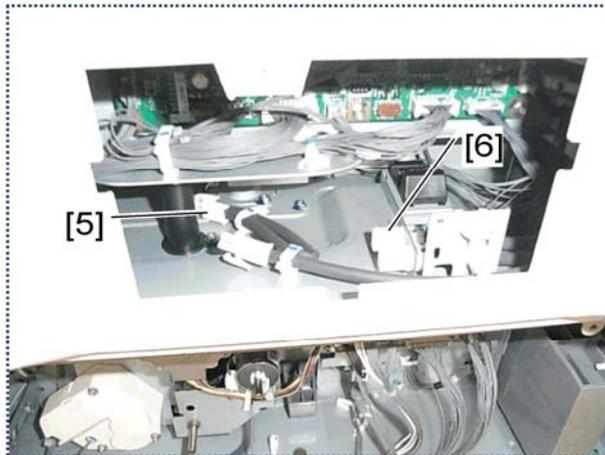

d009i206

5. Release the heater relay connector [5] (🔌 x 1).
6. Connect the heater relay connector to the connector [6] (front side) of the main frame (🔌 x 1).
7. Reassemble the machine.

2.18 TRAY HEATER (OPTIONAL PAPER FEED UNIT)

2.18.1 COMPONENT CHECK

No.	Description	Q'ty
1	Tray heater	1
2	On-standby decal	1 (-90) or 2 (-91)
3	Harness 2 (For G832)	1
4	Harness 1 (For B800/B801)	1
5	Screw M4 x 10	2
-	Installation procedure	1

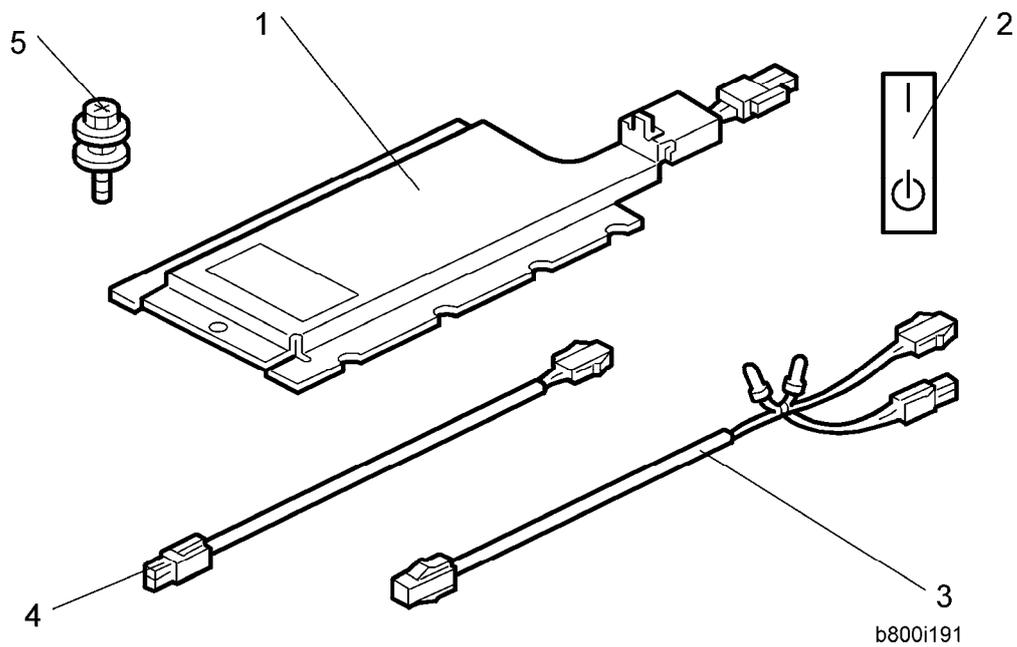

2.18.2 INSTALLATION PROCEDURE

CAUTION

- Unplug the machine power cord before starting the following procedure.

For installing the tray heater in the D351 (Two-tray paper feed unit)

1. Remove the rear cover of the mainframe (🔩 x 6).
2. Pull out the two trays from the optional paper feed unit.

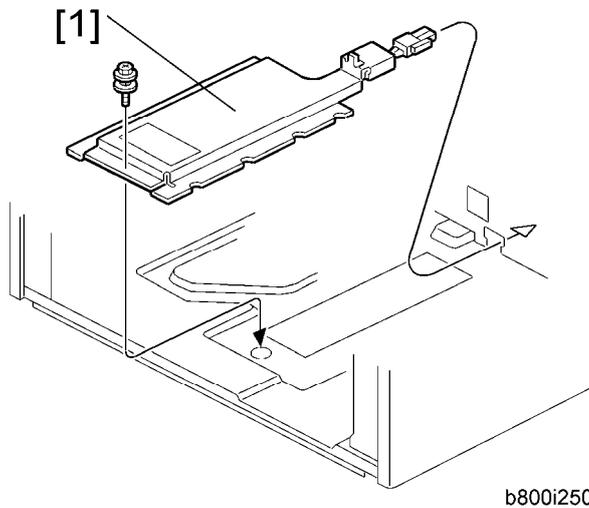

3. Install the tray heater [1] in the optional paper feed unit (🔩 x 1).

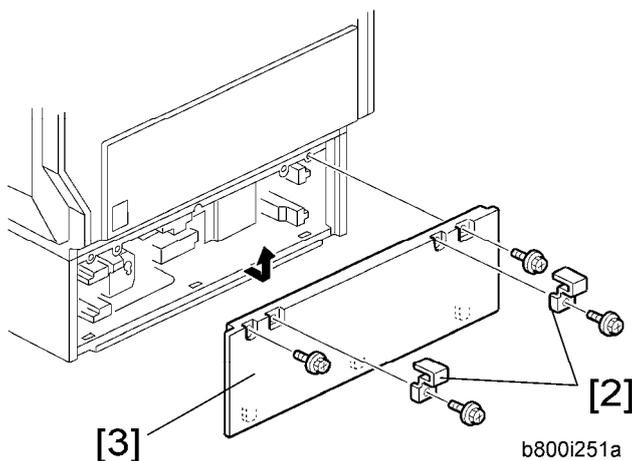

4. Remove the two securing brackets [2] (🔩 x 1 each), and then the rear cover [3] of the optional paper feed unit (🔩 x 2).

Tray Heater (Optional Paper Feed Unit)

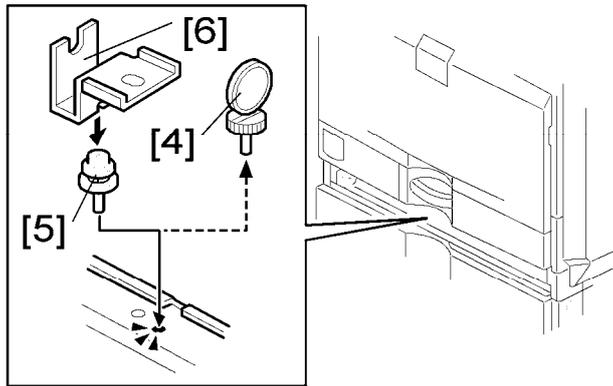

g832i250a

5. Pull out tray 2 from the mainframe.
6. Replace the shoulder screw [4] with the washer screw [5], using the securing bracket [6] (1 x 1).

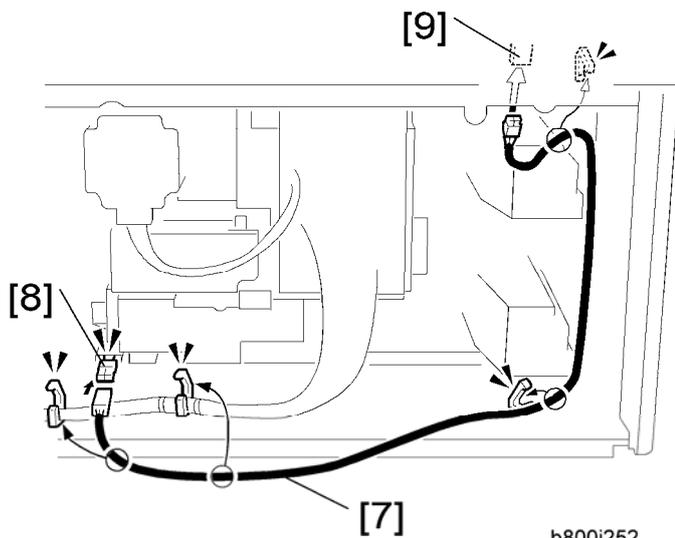

b800i252

7. Connect the harness [7] to the connector [8] of the tray heater.
8. Route the harness [7] as shown and clamp it with four clamps (4 x 4).
9. Connect the harness [7] to the connector [9] of the mainframe.

Tray Heater (Optional Paper Feed Unit)

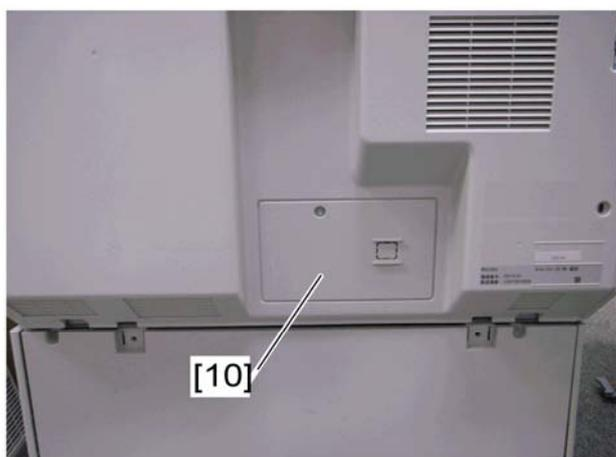

d009i205a

10. Remove the connector cover [10] (🔧 x 1).

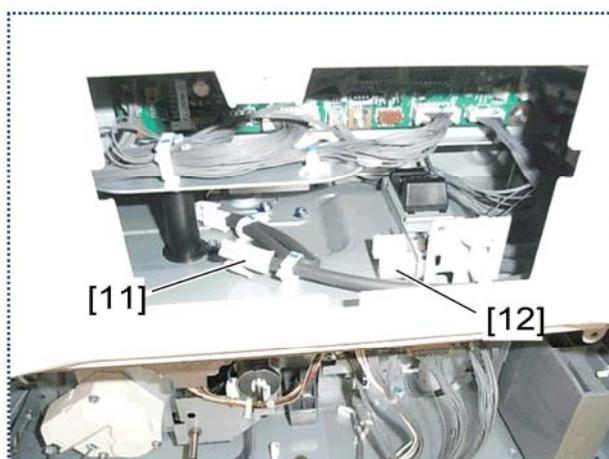

d009i206a

11. Release the optional heater relay connector [11] (🔧 x 1).
12. Connect the optional heater relay connector to the connector [12] (rear side) of the main frame (🔧 x 1).
13. Reassemble the mainframe and optional paper feed unit.

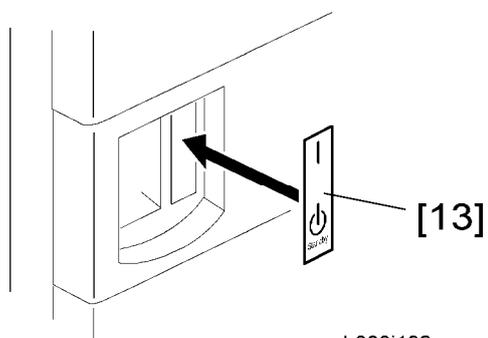

b800i192

14. Attach the on/standby decal [13] to the right-hand side of the main power switch.

Tray Heater (Optional Paper Feed Unit)

For installing the tray heater in the D352 (LCT)

1. Remove the rear cover of the mainframe (🔩 x 6).
2. Pull out the LCT drawer.

↓ Note

- If the right tray comes out with the left tray, push the right tray into the LCT.

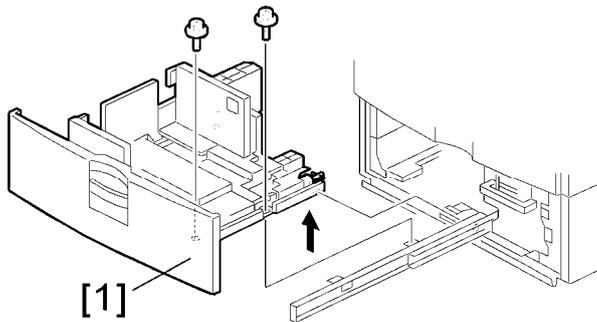

3. Left tray [A] (🔩 x 2)

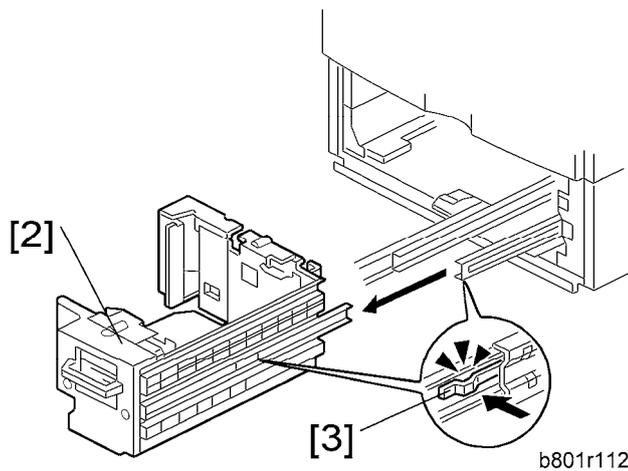

4. Remove the right tray [2] while pressing down the stopper [3].

↓ Note

- When reinstalling the right tray, set the right tray on the guide rail and carefully push the tray in, making sure to keep the tray level.

Tray Heater (Optional Paper Feed Unit)

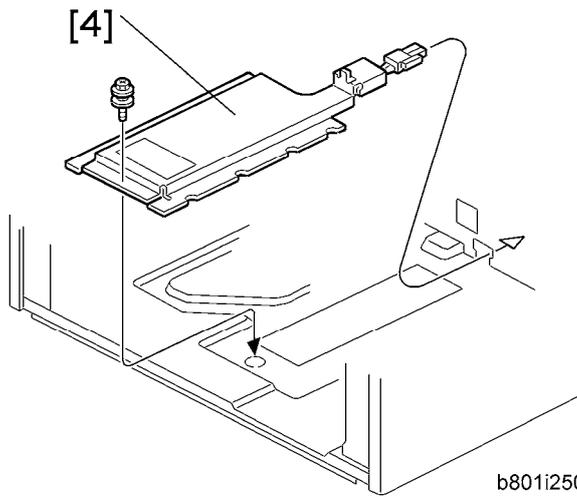

5. Install the tray heater [4] in the optional LCT (🔩 x 1).

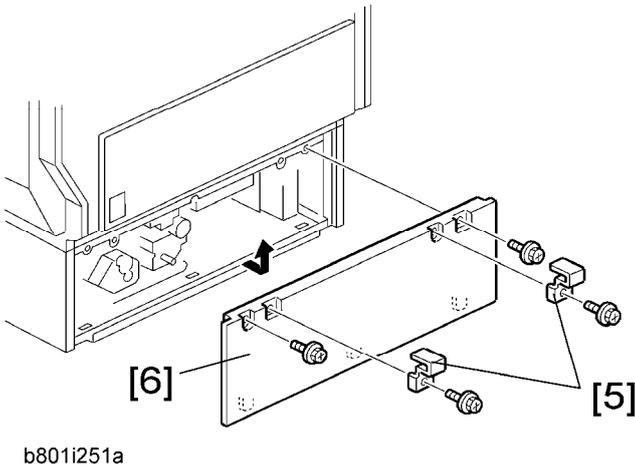

6. Remove the two securing brackets [5] (🔩 x 1 each), and then the rear cover [6] of the optional LCT (🔩 x 2).

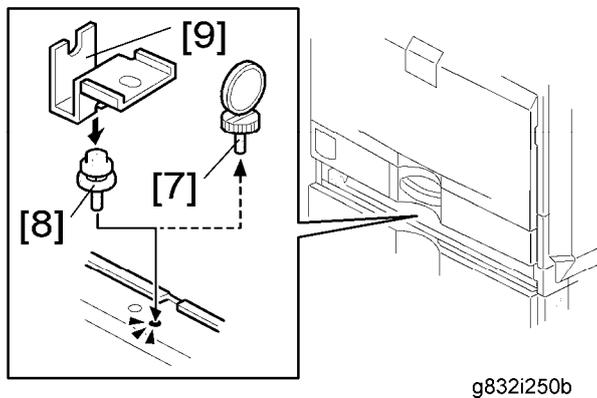

7. Pull out tray 2 from the mainframe.

Tray Heater (Optional Paper Feed Unit)

8. Replace the shoulder screw [7] with the washer screw [8], using the securing bracket [9] (🔩 x 1).

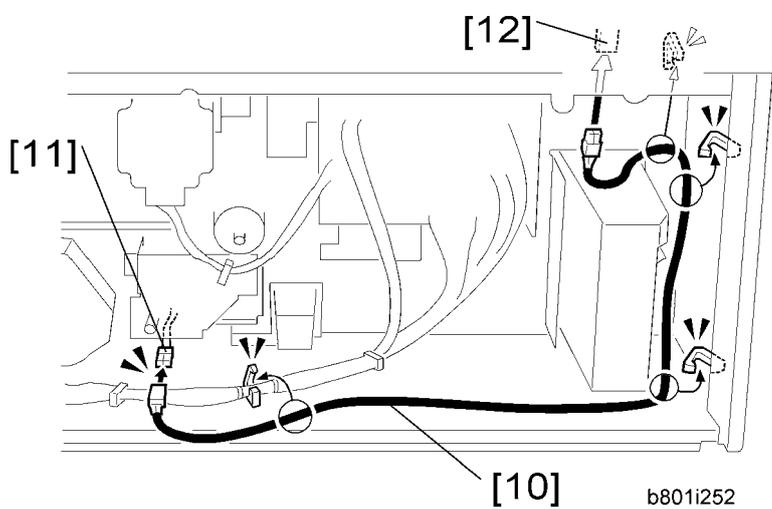

9. Connect the harness [10] to the connector [11] of the tray heater.
10. Route the harness [10] as shown and clamp it with four clamps (🔧 x 4).
11. Connect the harness [10] to the connector [12] of the mainframe.

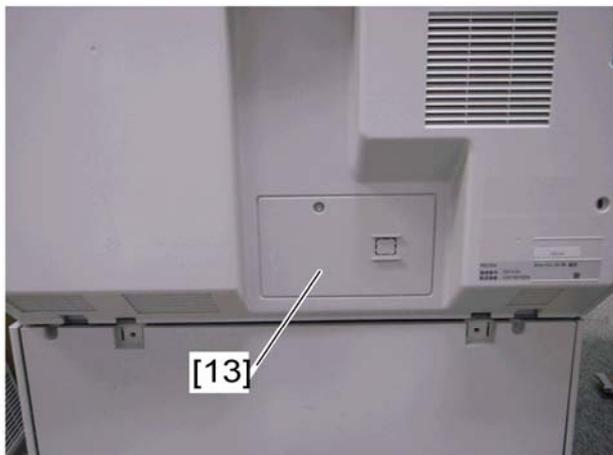

12. Remove the connector cover [13] (🔩 x 1).

Tray Heater (Optional Paper Feed Unit)

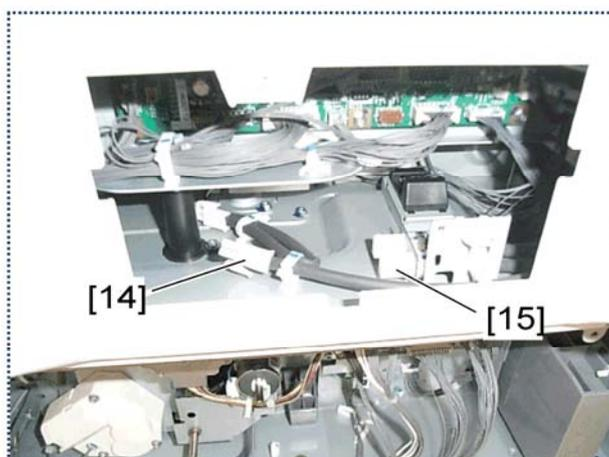

d009i206b

13. Release the optional heater relay connector [14] (🔧 x 1).
14. Connect the optional heater relay connector to the connector [15] (rear side) of the main frame (🔧 x 1).
15. Reassemble the mainframe and optional LCT.

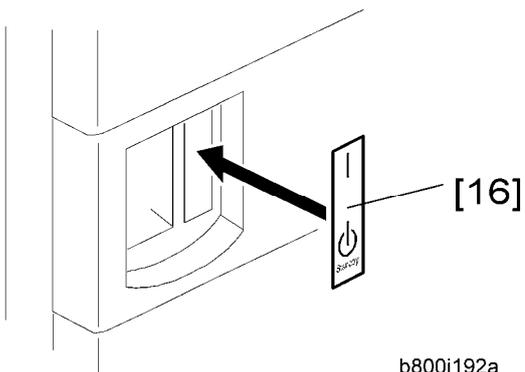

b800i192a

16. Attach the on/standby decal [16] to the right-hand side of the main power switch.

HDD Option (D362, only for D009/D012)

2.19 HDD OPTION (D362, ONLY FOR D009/D012)

2.19.1 COMPONENT CHECK

No.	Description	Q'ty	For D009/D012
1	HDD Unit	1	✓
2	Screw	3	✓
3	Keytop: Copy	2	✓
	Keytop: Document Server	2	✓
-	Knob Screw	3	---

✓ = Necessary, --- = Not necessary

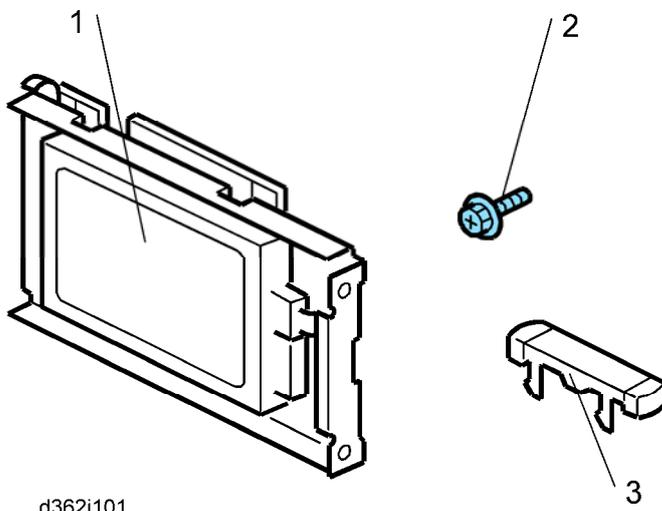

2.19.2 INSTALLATION PROCEDURE

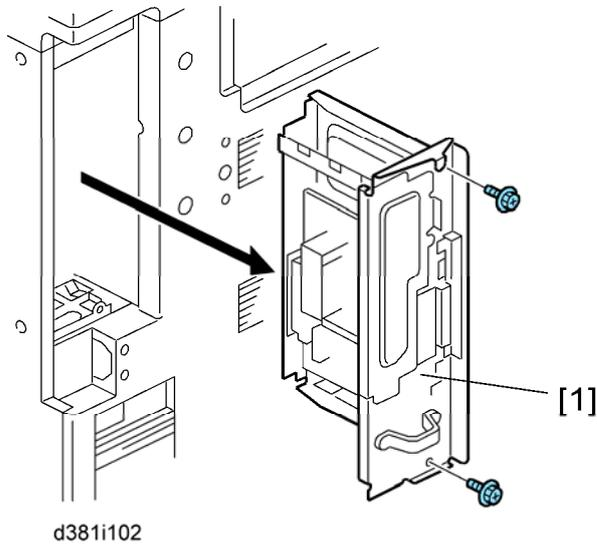

1. Remove the controller board [1] (⚙️ x 2).

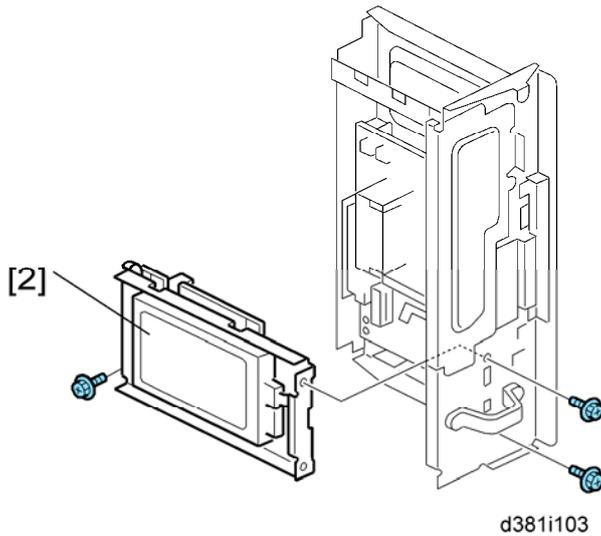

2. Install the HDD unit [2] in the controller board (⚙️ x 3).
3. Reinstall the controller board in the machine.
4. Remove the dummy keytops (top and second from the top).
5. Install the copy and document server keytops.

HDD Option (D362, only for D009/D012)

After Installing the HDD

1. Do **SP5832-001** to format the hard disk.
2. Do **SP5853-001** to copy the preset stamp data from the firmware to the hard disk.
3. Do **SP5846-040** to copy the address book to the hard disk from the controller board.
4. Do **SP5846-041** to let the user get access to the address book.
5. Turn the main power switch off/on.

2.20 COPY DATA SECURITY UNIT

2.20.1 INSTALLATION PROCEDURE

⚠ CAUTION

- Unplug the main machine power cord before you do the following procedure.

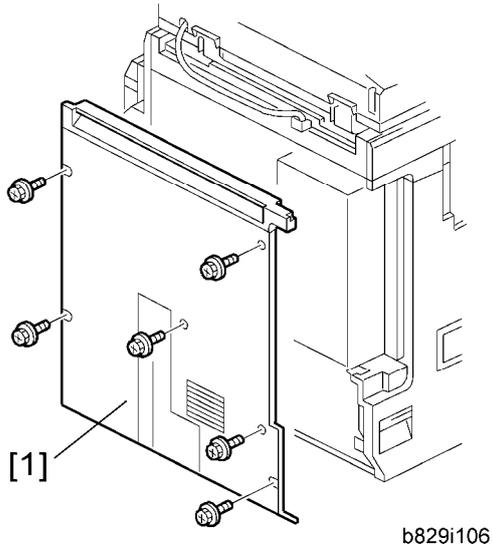

1. Rear cover [1] (⚙ x 6)

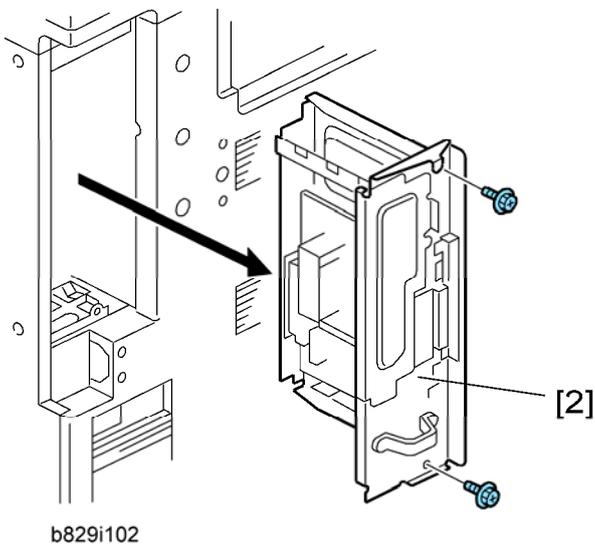

2. Controller unit [2] (⚙ x 2)

Copy Data Security Unit

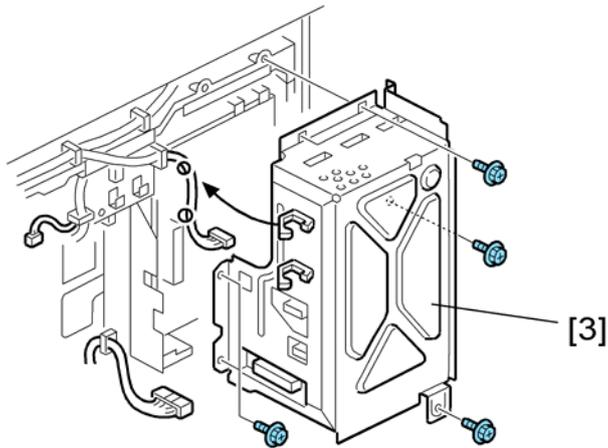

b829i004

3. Controller box [3] (🔩 x 6)

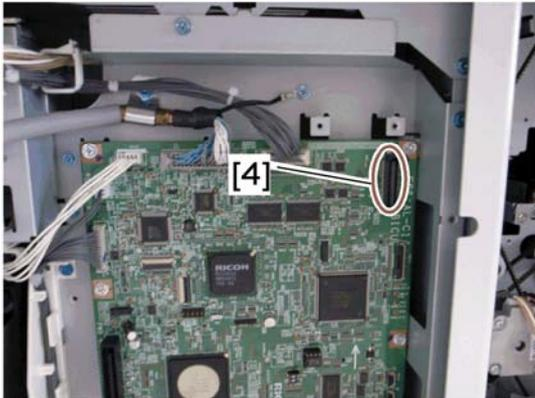

b829i501

4. Attach the ICIB-1 (copy data security board) to CN 111 [4] on the BICU (🔩 x 2).
5. Reassemble the machine.

User Tool Setting

1. Plug in and turn on the main power switch.
2. Go into the User Tools mode, and select System Settings > Administrator Tools > Data Security for Copying > "On".
3. Exit the User Tools.
4. Check the operation.

Note

- The machine will issue an SC165 error if the machine is powered on with the ICIB-1 removed and the "Data Security for Copying" feature is set to "ON".
 - When you remove this option from the machine, first set the setting to "OFF" with the user tool before removing this board. If you forget to do this, "Data Security for Copying" feature cannot appear in the user tool settings. And then SC165 will appear every time the machine is switched on, and the machine cannot be used.
5. Make sure that the machine can recognize the option (☑ Check All Connections at the end of this section).

2.21 CONTROLLER OPTIONS

2.21.1 CONTROLLER BOARD SLOTS

The machine controller box has one board slot and two SD card slots. Make sure that each board and SD card is put in the correct slot.

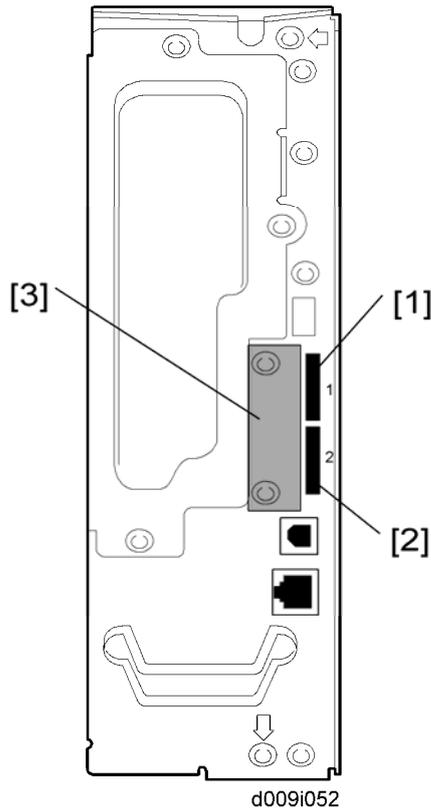

The names of the slots for the board and SD cards are embossed on the face of the controller plate.

SD Slot 1, Slot 2

Slot	SD Card
[1]	RPCS Printer Unit Printer Unit Printer/Scanner Unit Data Overwrite Security

Slot	SD Card
	PostScript3 IPDS Unit
[2]	<ul style="list-style-type: none"> ▪ Service slot for firmware version updates ▪ Installing the optional browser unit, VM card or HDD encryption unit ▪ Moving applications to an SD card in slot 1 ▪ Downloading/uploading NVRAM contents

Board Slot

Slot	Board
[3]	<ul style="list-style-type: none"> ▪ File Format Converter (MLB): D377 ▪ Bluetooth Interface Unit: B826 ▪ IEEE 802.11a/g, g: D377 ▪ IEEE 1284 Interface Board: B679 ▪ Gigabit Ethernet: G874

 Note

- Only one of these boards can be installed at one time.

2.21.2 IEEE1284

Installation Procedure

⚠ CAUTION

- Unplug the main machine power cord before you do the following procedure.

You can only install one of the following network interfaces at one time: (IEEE 802.11a/g, g (Wireless LAN), IEEE1284, Bluetooth).

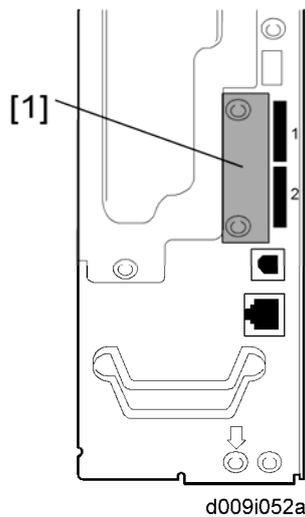

1. Remove the slot cover [1] from the board slot (⚙ x 2).
2. Install the interface board (Knob-screw x 2) into the board slot.
3. Make sure that the machine can recognize the option (see "Check All Connections" at the end of this section).

2.21.3 IEEE 802.11A/G, G (WIRELESS LAN)

Installation Procedure

⚠ CAUTION

- Unplug the main machine power cord before you do the following procedure.

You can only install one of the following network interfaces at one time: (IEEE 802.11a/g, g (Wireless LAN), IEEE1284, Bluetooth).

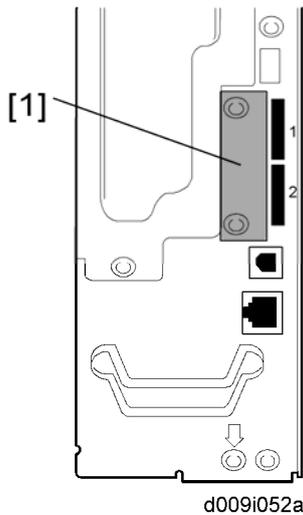

1. Remove the slot cover [1] from the board slot (🔩 x 2).
2. Install the wireless LAN board (Knob-screw x 2) into the board slot.
3. Make sure that the machine can recognize the option (see 'Check All Connections' at the end of this section).

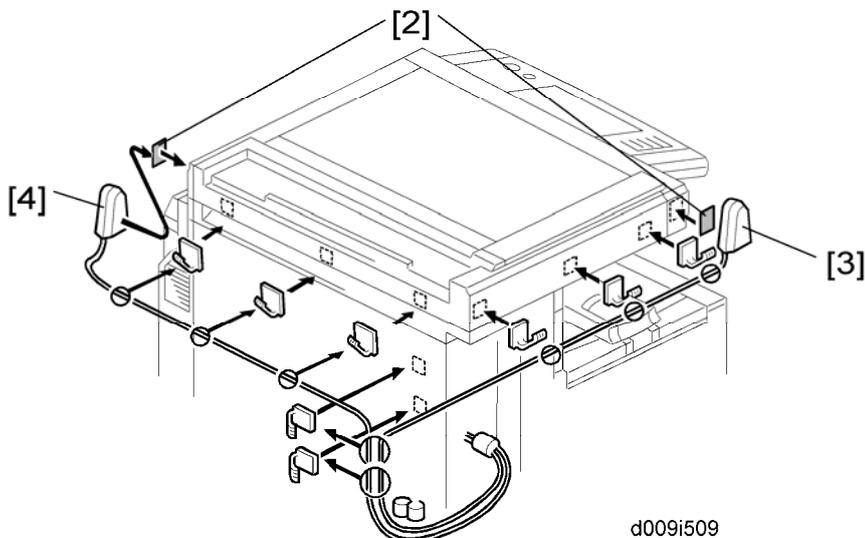

4. Peel off the double-sided tapes on the Velcro fasteners [2], and then attach them [2] at the front left and rear right of the machine.
5. Attach the "ANT1" (having a black ferrite core) to the front left of the machine.
6. Attach the "ANT2" (having a white ferrite core) to the rear right of the machine.

↓ Note

- "ANT1" is a transmission/reception antenna and "ANT2" is a reception antenna. Do not attach them at the wrong places.
7. Attach the clamps as shown above.
 8. Wire the cables and clamp them (🔧 x 8).

Controller Options



- Make sure that the cables are not slack. Keep them wired tightly along the covers.

You may have to move the machine if the reception is not clear.

- Make sure that the machine is not located near an appliance or any type of equipment that generates strong magnetic fields.
- Put the machine as close as possible to the access point.

UP Mode Settings for Wireless LAN

Enter the UP mode. Then do the procedure below to perform the initial interface settings for IEEE 802.11a/g, g. These settings take effect every time the machine is powered on.



- You cannot use the wireless LAN if you use Ethernet.
1. Press the "User Tools/Counter" key.
 2. On the touch panel, press "System Settings".



- The Network I/F (default: Ethernet) must be set for either Ethernet or wireless LAN.
3. Select "Interface Settings".
 4. Press "Wireless LAN". Only the wireless LAN options show.
 5. Communication Mode. Select either "802.11 Ad hoc", "Ad hoc" or "Infrastructure".
 6. SSID Setting. Enter the SSID setting. (The setting is case sensitive.)
 7. Channel. You need this setting when Ad Hoc Mode is selected.
Range: 1 to 14 (default: 11)



- The allowed range for the channel settings may vary for different countries.
8. WEP (Encryption) Setting. The WEP (Wired Equivalent Privacy) setting is designed to protect wireless data transmission. The same WEP key is required on the receiving side in order to unlock encoded data. There are 64 bit and 128 bit WEP keys.

WEP:

Selects "Active" or "Inactive". ("Inactive" is default.)

Range of Allowed Settings:

64 bit: 10 characters

128 bit: 26 characters

9. Transmission Speed. Press the Next button to show more settings. Then select the transmission speed for the mode: Auto, 11 Mbps, 5.5 Mbps, 2 Mbps, 1 Mbps (default:

Auto). This setting should match the distance between the closest machine or access point. This depends on which mode is selected.

↓ Note

- For the Ad Hoc Mode, this is the distance between the machine and the closest PC in the network. For the Infrastructure Mode, this is the distance between the machine and the closest access point.

11 Mbps: 140 m (153 yd.)

5.5 Mbps: 200 m (219 yd.)

2 Mbps: 270 m (295 yd.)

1 Mbps: 400 m (437 yd.)

10. Press "Return to Default" to initialize the wireless LAN settings.

Press "Yes" to initialize the following settings:

- Transmission mode
- Channel
- Transmission Speed
- WEP
- SSID
- WEP Key

Controller Options

SP Mode Settings for IEEE 802.11a/g, g Wireless LAN

The following SP commands and UP modes can be set for IEEE 802.11a/g, g.

SP No.	Name	Function
5840-006	Channel MAX	Sets the maximum range of the channel settings for the country.
5840-007	Channel MIN	Sets the minimum range of the channels settings allowed for your country.
5840-011	WEP Key Select	Used to select the WEP key (Default: 00).
UP mode	Name	Function
	SSID	Used to confirm the current SSID setting.
WEP Key	Used to confirm the current WEP key setting.	
WEP Mode	Used to show the maximum length of the string that can be used for the WEP Key entry.	

2.21.4 BLUETOOTH

CAUTION

- Unplug the main machine power cord before you do the following procedure.

You can only install one of the following network interfaces at one time: (IEEE 802.11 a/g, g (Wireless LAN), IEEE1284, IEEE1394, Bluetooth).

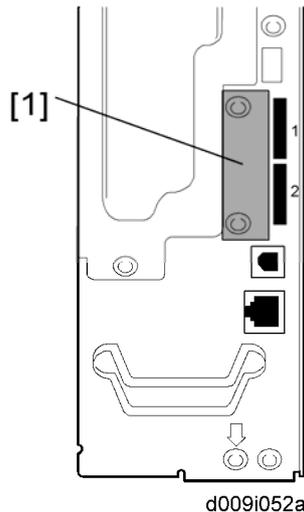

1. Remove the slot cover [1] from the board Slot (⚙️ x 2).
2. Install the Bluetooth board (Knob-screw x 2) into the board slot.
3. Insert the Bluetooth card into the Bluetooth card adaptor.
4. Attach the antenna cap to the Bluetooth card.
5. Install the Bluetooth card adaptor into the Bluetooth board.
6. Make sure that the machine can recognize the option (see "Check All Connections" at the end of this section).

2.21.5 GIGABIT ETHERNET

CAUTION

- Unplug the main machine power cord before you do the following procedure.

You can only install one of the following network interfaces at one time: (IEEE 802.11a/g, g (Wireless LAN), IEEE1284, IEEE1394, Bluetooth).

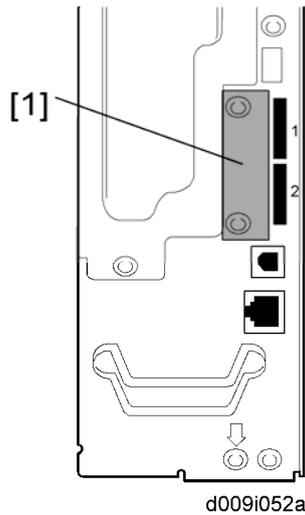

1. Remove the slot cover [1] from the board slot ( x 2).
2. Insert the Gigabit Ethernet Board into the I/F slot and fasten it with the screws.
3. Print a configuration page to confirm that the machine recognizes the installed board for USB2.0:

User Tools > Printer Features > List/Test Print > Configuration Page

2.21.6 FILE FORMAT CONVERTER

⚠ CAUTION

- Unplug the main machine power cord before you do the following procedure.

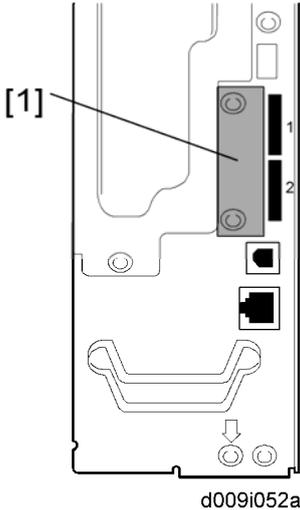

Installation

1. Remove the slot cover [1] from the board slot (⚙ x 2).
2. Install the file format converter into the board slot, and then fasten it with screws.
3. Plug in and turn on the main power switch.
4. Check or set the following SP codes with the values shown below.

SP No.	Title	Setting
SP5-836-001	Capture Function (0:Off 1:On)	"1"
SP5-836-002	Panel Setting	"0"

5. Check the operation.
6. Make sure that the machine can recognize the option (🔍 "Check All Connections" at the end of this section).

2.21.7 POSTSCRIPT 3

CAUTION

- Unplug the main machine power cord before you do the following procedure.

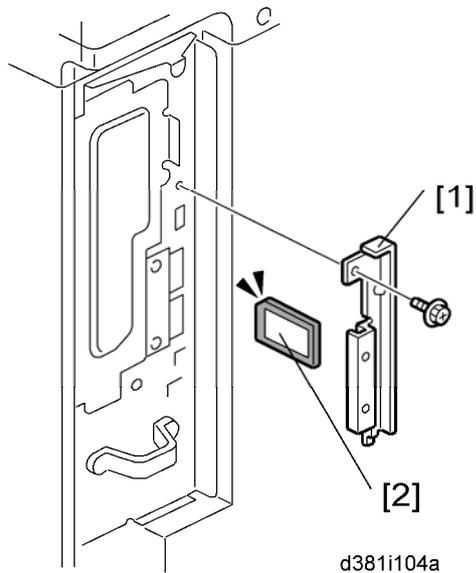

1. Remove the slot cover [1] (🔩 x 1).
2. Turn the SD-card label face [2] to the rear of the machine. Then push it slowly into slot 1 until you hear a click.
3. Attach the slot cover [1] (🔩 x 1).

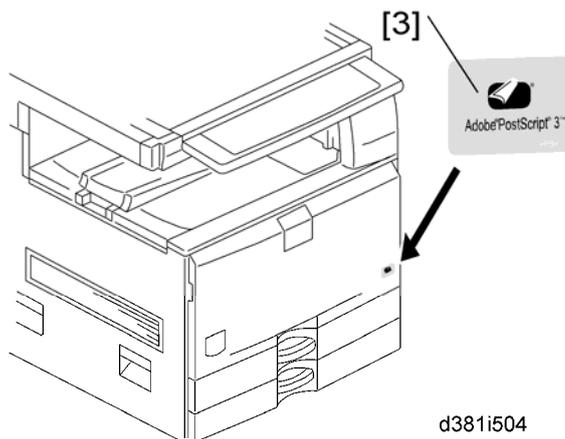

4. Attach the "Adobe PostScript 3" decal [3] to the front door.
5. Make sure that the machine can recognize the option (🔍 "Check All Connections" at the end of this section).

2.21.8 IPDS UNIT

Accessories

Check the accessories and their quantities against the table below.

No.	Description	Q'ty
1	IPDS Emulation SD Card	1
2	Decal	1

↓ Note

- Only one slot (C1) is available for SD cards that contain applications. If you want to use more than one application, merge all applications into one SD card (SP5873-001).

Installation

- Check the software version.
 - Make sure the following versions are installed:

Firmware Name	Version	Firmware Number
NCS	V7.12 or later	D0135754D
Websys	V1.09 or later	D0135755D
Printer	V1.05 or later	D0135758G
System/Copy (For D011/D013/D091/D092)	V1.08 or later	D0135751P
System/Copy (For D009/D012)	V1.08 or later	D0125751P
IPDS	V4.732 or later	D0125756A

- If necessary, update the firmware to the version(s) listed above.
- Turn off the main switch.

Controller Options

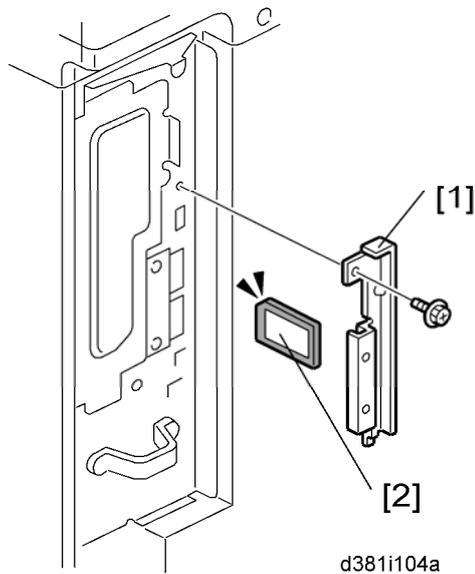

4. Remove the slot cover [1] (x 1).
5. Insert the IPDS SD Card [2] into slot 1.
 - If slot 1 is occupied, insert it in to slot 2, then merge this application into slot 1.

★ Important

- Pushing in the SD Card releases it for removal. Make sure the SD Card is inserted and locked in place. If it is partially out of the slot, push it in gently until it locks in place.
6. Reattach the slot cover and turn ON the main switch.
 7. Do one of the following ("A" or "B") to enable the IPDS function.

A. [Enable the IPDS function via telnet]

1. Connect the machine via telnet.
2. Execute the following commands:

```
msh> set ipds up
```

***If you want to stop the function.

```
msh> set ipds down
```

B. [Enable the IPDS option via WebImageMonitor]

1. Log in to WebImageMonitor.
2. Change the setting to enable IPDS.

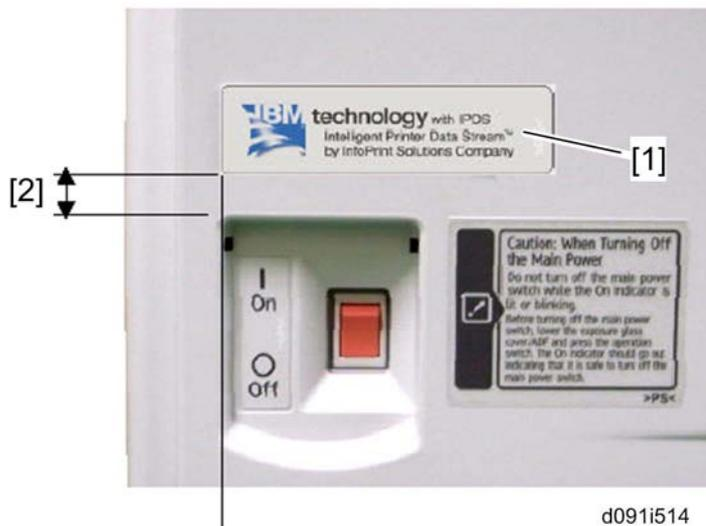

8. Attach the decal [1] as shown in the photo above.
 - Line up the left side of the decal with the left edge of the main power switch. ([2]: 10 mm or more)

2.21.9 HDD ENCRYPTION UNIT

Before You Begin the Procedure

1. Make sure that the following settings are not at the factory default settings:
 - Supervisor login password
 - Administrator login name
 - Administrator login password

★ Important

 - These settings must be set up by the customer before the HDD Encryption unit can be installed.
2. Confirm that "Admin. Authentication" is on:

[User Tools] > "System Settings"> "Administrator Tools"> "Administrator Authentication Management"> "Admin. Authentication"> "On"

If this setting is "Off", tell the customer that this setting must be "On" before you can do the installation procedure.
3. Confirm that "Administrator Tools" is selected and enabled:

[User Tools]> "System Settings"> "Administrator Tools"> "Administrator Authentication Management"> "Available Settings"

↓ Note

 - "Available Settings" is not displayed until Step 2 is done.

If this setting is not selected, tell the customer that this setting must be selected before you can do the installation procedure.

Controller Options

Seal Check and Removal

★ Important

- You must check the box seals to make sure that they were not removed after the items were sealed in the box at the factory before you do the installation.

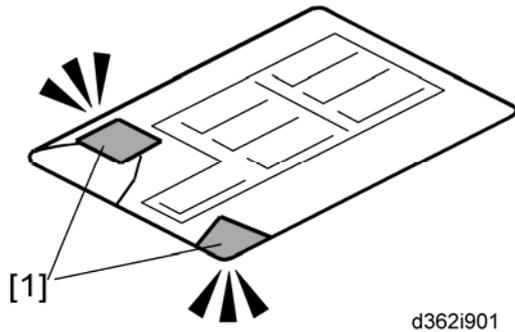

1. Check the box seals [1] on each corner of the box.
 - Make sure that a tape is attached to each corner.
2. Open the box.

Installation Procedure

1. For models which have the VM card, do the followings:
 - Press "User Tools" button to enter the User Tools mode.

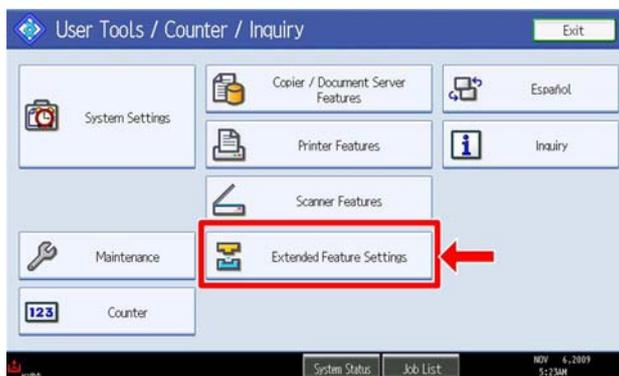

- Press "Extended Feature Settings" on the LCD.

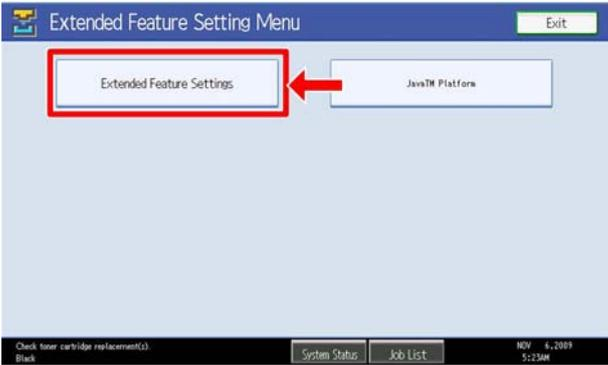

d377i503

- Press "Extended Feature Settings" on the LCD again.



d377i504

- Press "Startup Setting" tab.
- Stop all SDK applications with touching application lines.
- Exit the UP mode, and then turn off the machine.
- Remove the VM card from slot 2.

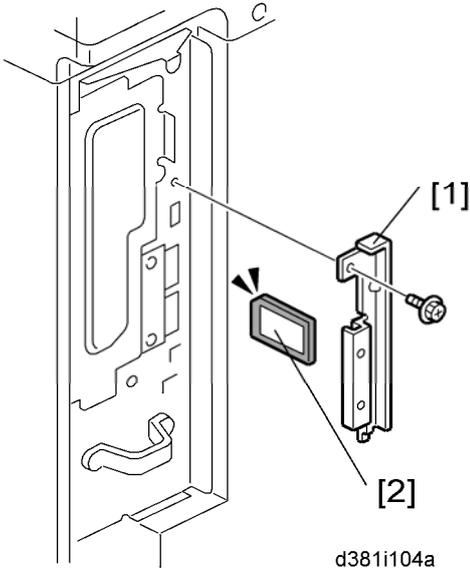

d381i104a

2. Remove the slot cover [1] (x 1).

Controller Options

- Turn the SD-card label [2] to face the rear of the machine. Then push it slowly into slot 2 until you hear a click.
- Turn on the main power switch, and then enter the SP mode.
- Select SP5878-002, and then press "Execute" on the LCD.
- Exit the SP mode after "Completed" is displayed on the LCD.
- Turn off the main power switch.
- Remove the SD card from slot 2.
- Attach the slot cover [1] (🔑 x 1).

Recovery from a Device Problem

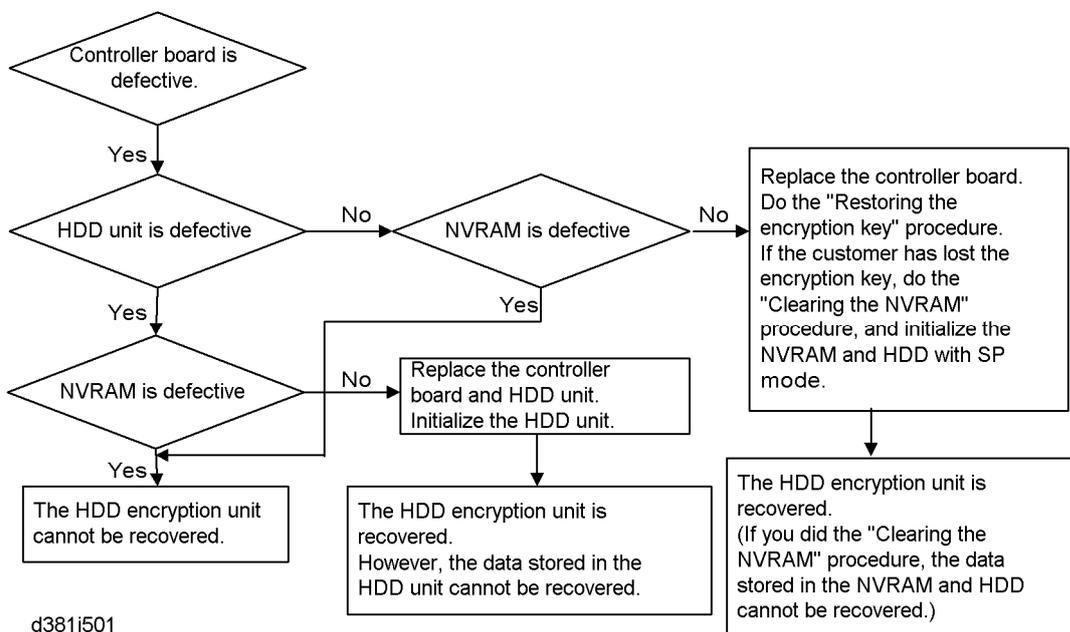

Restoring the encryption key

When replacing the controller board for a model in which the HDD encryption unit has been installed, updating the encryption key is required.

- Prepare an SD card which is initialized.
- Make the "restore_key" folder in the SD card.
- Make an "nvrn_key.txt" file in the "restore_key" folder in the SD card.
- Ask an administrator to input the encryption key (this has been printed out earlier by the user) into the "nvrn_key.txt" file.
- Remove only the HDD unit (🖱️ p.4-88).
- Turn on the main power switch.
- Confirm that the prompt on the LCD tells you to install the SD card (storing the encryption key) in the machine.

8. Turn off the main power switch.
9. Insert the SD card that contains the encryption key into slot 2.
10. Turn on the main power switch, and the machine automatically restores the encryption key in the flash memory on the controller board.
11. Turn off the main power switch after the machine has returned to normal status.
12. Remove the SD card from slot 2.
13. Reinstall the HDD unit.

Clearing the NVRAM

When replacing the controller board for a model in which the HDD encryption unit has been installed and a customer has lost the encryption key, clearing the NVRAM is required to recover the HDD encryption unit.

1. Prepare an SD card which is initialized.
2. Make the "restore_key" folder in the SD card.
3. Make an "nvram_key.txt" file in the "restore_key" folder in the SD card.
4. Input "nvclear" into the "nvram_key.txt" file.
5. Turn on the main power switch.
6. Confirm that the prompt on the LCD tells you to install the SD card (storing the encryption key) in the machine.
7. Turn off the main power switch.
8. Insert the SD card that contains "nvclear" into slot 2.
9. Turn on the main power switch, and the machine automatically restores the encryption key in the flash memory on the controller board.
10. Turn off the main power switch after the machine has returned to normal status.
11. Remove the SD card from slot 2.
12. Turn on the main power switch.
13. Initialize the NVRAM (SP5801-001) and HDD unit (SP5832-001) with SP mode.
14. The user must enable the HDD encryption unit with a user tool.

2.21.10 DATAOVERWRITESECURITY UNIT TYPE I (D362)

Before You Begin the Procedure

1. Confirm that the DataOverwriteSecurity unit SD card is the correct type for the machine. The correct type for this machine is "**Type I**".



- If you install any version other than "**Type I**", you will have to replace the NVRAM and do this installation procedure again.
2. Make sure that the following settings are not at their factory default values:
 - Supervisor login password
 - Administrator login name
 - Administrator login password

If any of these settings is at a factory default value, tell the customer these settings must be changed before you do the installation procedure.

3. Make sure that "Admin. Authentication" is ON.
[System Settings] – [Administrator Tools] – [Administrator Authentication Management]
- [Admin. Authentication]

If this setting is OFF, tell the customer this setting must be ON before you do the installation procedure.

4. Make sure that "Administrator Tools" is enabled (selected).
[System Settings] – [Administrator Tools] – [Administrator Authentication Management]
- [Available Settings]

If this setting is disabled (not selected), tell the customer this setting must be enabled (selected) before you do the installation procedure.

Seal Check and Removal

★ Important

- You must check the box seals to make sure that they were not removed after the items were sealed in the box at the factory before you do the installation.

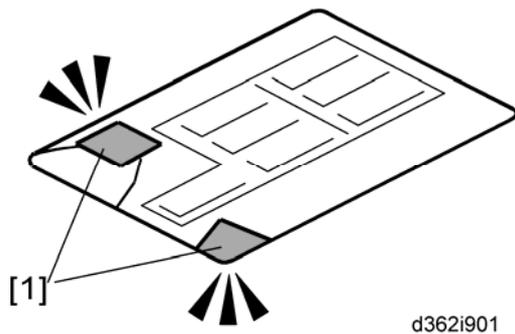

- Check the box seals [1] on each corner of the box.
 - Make sure that a tape is attached to each corner.
 - The surfaces of the tapes must be blank. If you see "VOID" on the tapes, do not install the components in the box.
- If the surfaces of the tapes do not show "VOID", remove them from the corners of the box.

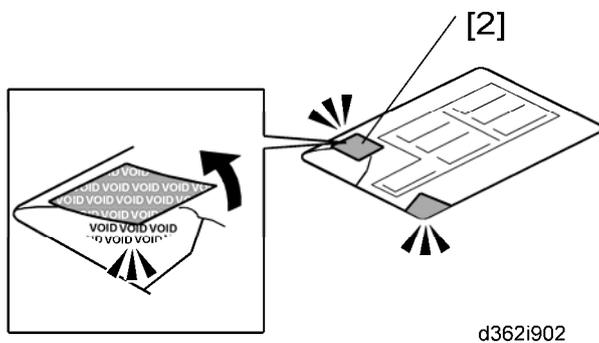

- You can see the "VOID" marks [2] when you remove each seal. In this condition, they cannot be attached to the box again.

Installation Procedure

CAUTION

- Unplug the main machine power cord before you do the following procedure.

Note

- You must install the DataOverwriteSecurity unit in SD Card slot 1. However, the Postscript option and others are also installed in SD Card slot 1. You must do the "SD Card Appli Move" procedure first if you want to install the DataOverwriteSecurity unit.

1. Turn off the main power switch if the machine is turned on.
2. Disconnect the network cable if it is connected.

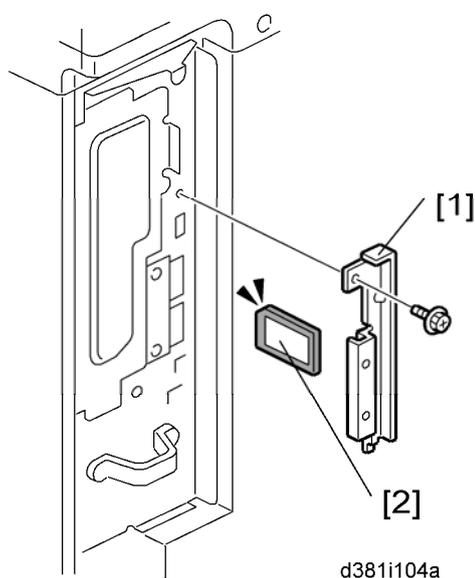

3. Remove the slot cover [1] for SD cards ( x 1).
4. Turn the SD-card label face [2] to the rear of the machine. Then push it slowly into slot 1 until you hear a click.
5. Connect the network cable if it needs to be connected.
6. Turn on the main power switch.
7. Go into the SP mode and push "EXECUTE" with SP5-878-001.
8. Exit the SP mode and turn off the operation switch. Then turn off the main power switch.
9. Turn on the machine power.
10. Do SP5990-005 (SP print mode Diagnostic Report).
11. Make sure the ROM number and firmware version in area [a] of the diagnostic report are the same as those in area [b].

- [a]: "ROM Number/Firmware Version" – "HDD Format Option"
- [b]: "Loading Program" – "GW2a_zoffy"

Diagnostic Report:	"ROM No. / Firmware Version" [a]	"Loading Program" [b]
DataOverwriteSecurity Unit	HDD Format Option: D3775912 / 1.00m	GW2a_zoffy: D3775912 / 1.00m

★ Important

- The ROM number and firmware version number change when the firmware is upgraded. However, the important thing is to make sure the numbers in [a] are the same as the numbers in [b].
- If the ROM numbers are not the same, or the version numbers are not the same, this means the unit was not installed correctly.

If this happens:

Make sure of the unit type (must be Type I).

If they do not match:

- 1) Replace the NV-RAM on the controller.
 - 2) Replace the "DataOverwriteSecurity Unit" (SD card) with the correct type
 - 3) Do the installation procedure in this procedure again, from Step 1.
12. Go into the User Tools mode, and select System Settings> Administrator Tools> Auto Erase Memory Setting> On.
13. Exit the User Tools mode.

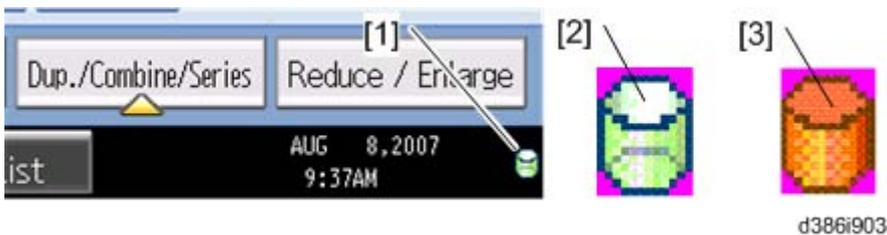

14. Check the display and make sure that the overwrite erase icon [1] shows.
15. Make a Sample Copy.
16. Check the overwrite erase icon.
 - The icon [2] changes to [3] when job data is stored in the HDD.
 - The icon goes back to its usual shape [2] after this function has completed a data overwriting in the HDD.

Controller Options

2.21.11 BROWSER UNIT TYPE D

Installation Procedure

This option requires a HDD unit.

CAUTION

- Unplug the main machine power cord before you do the following procedure.

SD card slot 2 is basically used only for service maintenance and VM card. Do not leave an SD card in slot 2 after installing an application.

1. For models which have the VM card, do the followings:

- Press "User Tools" button to enter the User Tools mode.

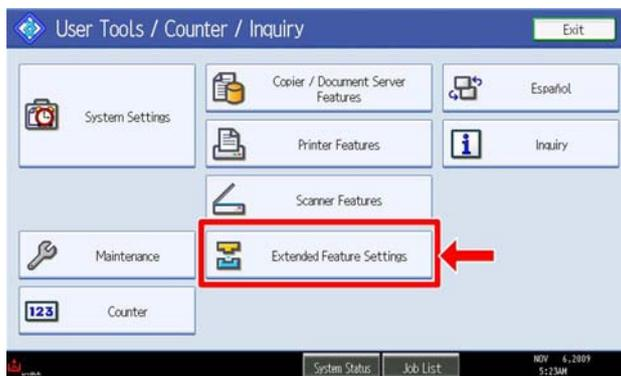

d377i502

- Press "Extended Feature Settings" on the LCD.

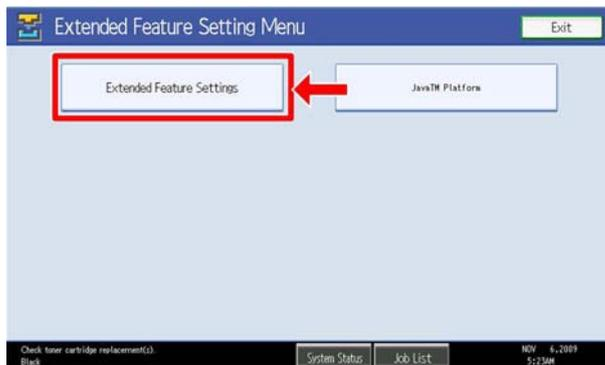

d377i503

- Press "Extended Feature Settings" on the LCD again.

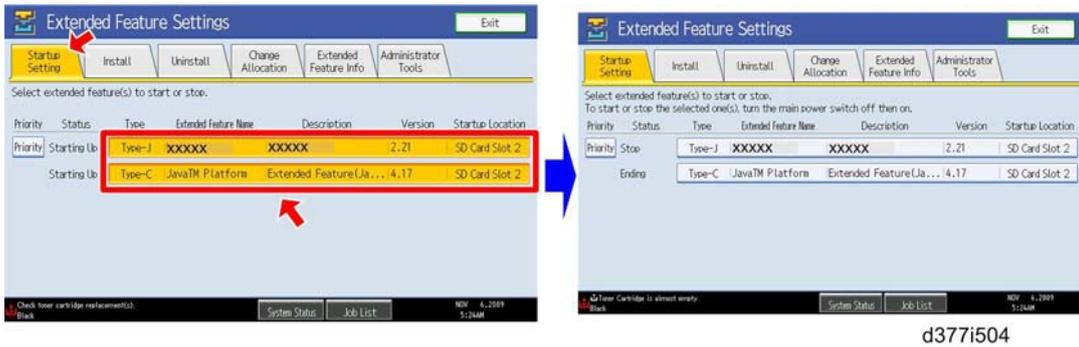

d377i504

- Press "Startup Setting" tab.
- Stop all SDK applications with touching application lines.
- Exit the UP mode, and then turn off the machine.
- Remove the VM card from slot 2.

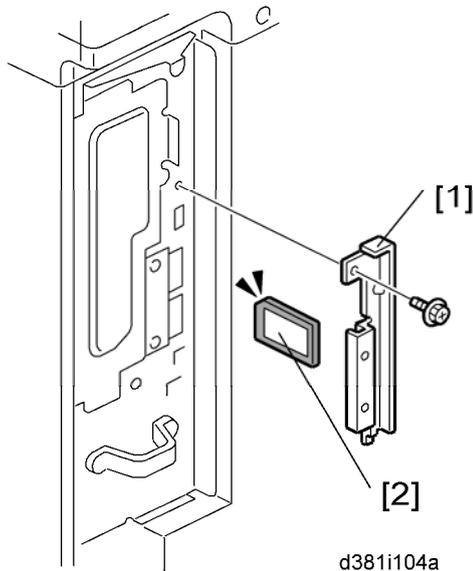

d381i104a

2. Remove the slot cover [1] for SD cards (🔑 x 1).
3. Turn the SD-card label face [2] to the rear of the machine. Then push it slowly into slot 2 until you hear a click.
4. Plug in and turn on the main power switch.
5. Push the "User Tools" key.
If an administrator setting is registered for the machine, steps 5 and 6 are required. Otherwise, skip to step 7.
6. Push the "Login/Logout" key.
7. Login with the administrator user name and password.
8. Touch "Extended Feature Settings" twice on the LCD.
9. Touch "Install" on the LCD.

Controller Options

10. Touch "SD Card".
11. Touch the "Browser" line.
12. Under "Install to", touch "Machine HDD" and touch "Next".
13. When you see "Ready to Install", check the information on the screen to confirm your previous selection.
14. Touch "OK". You will see "Installing the extended feature... Please wait.", and then "Completed".
15. Touch "Exit" to go back to the setting screen.
16. Touch "Change Allocation".
17. Touch the "Browser" line.
18. Press one of the hard keys, which you want to use for the Browser Unit. By default, this function is assigned to the "Other Functions" key (bottom key of the function keys).
19. Touch "OK".
20. Touch "Exit" twice to go back to the copy screen.
21. Turn off the main power switch.
22. Install the key for "Browser Unit" to the place where you want it.
23. Remove the SD card from slot 2.
24. Attach the slot cover [1] (🔑 x 1).
25. Tell a customer to keep the SD card in a safe place (👉 p.5-20) after you have installed the application program from the card to the HDD.
This is because:
 - The SD card is the only proof that the user is licensed to use the application program.
 - You may need to check the SD card and its data to solve a problem in the future.

Update Procedure

1. Remove the slot cover [1] for SD cards (🔑 x 1).
2. Turn the SD-card label face [2] to the rear of the machine. Then push it slowly into slot 2 until you hear a click.
3. Plug in and turn on the main power switch.
4. Push the "User Tools" key.
If an administrator setting is registered for the machine, step 5 and 6 are required.
Otherwise, skip to step 7.
5. Push the "Login/ Logout" key.
6. Login with the administrator user name and password.
7. Touch "Extended Feature Settings" twice on the LCD.

8. Touch "Uninstall" on the LCD.
9. Touch the "Browser" line
10. A confirmation message appears on the LCD.
11. Touch "Yes" to proceed.
12. A reconfirmation message appears on the LCD.
13. Touch "Yes" to uninstall the browser unit.
14. You will see "Uninstalling the extended feature... Please wait.", and then "Completed".
15. Touch "Exit" to go back to the setting screen.
16. Exit "User/Tools" setting, and then turn off the main power switch.
17. Remove the SD card from the SD card slot 2.
18. Overwrite the updated program in the "sdk" folder of the browser unit application with PC.
19. Do the "Installation Procedure" to install the browser unit.

2.21.12 VM CARD TYPE F (D377)

This option is only for D009/D011/D012/D013 models.

Accessories

Check the accessories and their quantities against the table below.

Description	Q'ty
1. VM SD Card	1
2. Decal	1

Installation

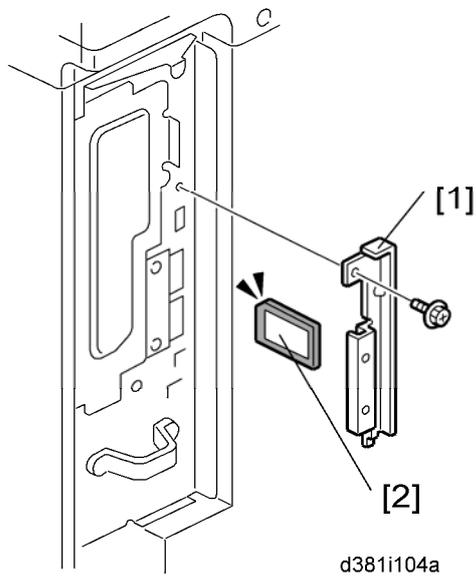

1. Switch the machine off.
2. Remove the SD card slot cover [1] (x1).
3. Insert the SD card [2] into slot 2 (lower).

★ Important

- This SD card must be inserted into slot 2, the lower slot.

2.21.13 PRINTER AND P/S OPTIONS (ONLY FOR D009/D012)

Overview

This section describes the installation of the following items:

- RPCS Printer Unit
- Printer Unit
- Printer/Scanner Unit
- 256 Memory. Optional memory is required for each unit.
- Printer Enhance Option
- Scanner Enhance Option

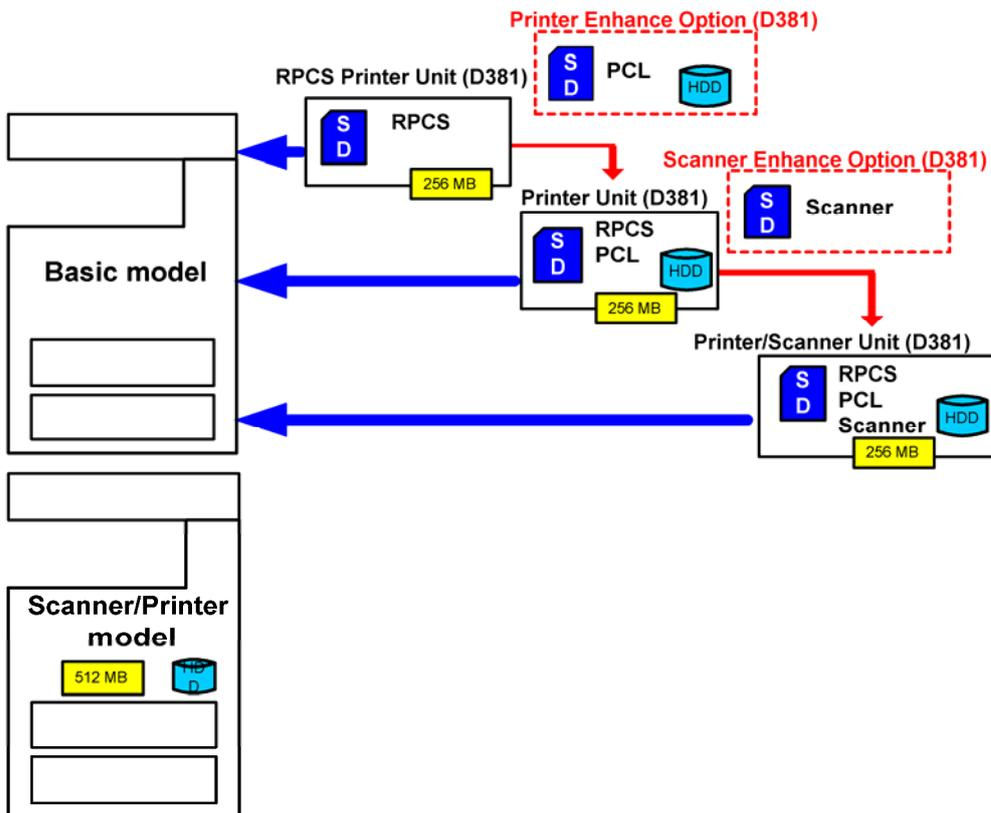

d381i501a

Three Main Units

- **RPCS Printer Unit Type 5000:**
For customers who require only basic copying and printing and the RPCS printer language. The 256 MB memory is required.
- **Printer Unit Type 5000:**
For customers who do not require the extended scanning features but need more printing capability (both RPCS and PCL printer languages are provided). The 256 MB memory is required.
- **Printer/Scanner Unit Type 5000:**
For customers who require the full range of DS features (advanced scanning and printing features such as "scan-to" solutions, virtual mailboxes, PCL, etc.). The 256 MB memory unit is required.

Separate Options

There are two separate options not provided with the kits: 256 MB memory and PS3.

- **256 MB memory:**
Not provided with any option. However, every unit (RPCS, Printer Unit, P/S unit) requires installation of the 256 MB memory.

Controller Options

- **PostScript 3 Unit:**

The PS3 option can be used with the RPCS Unit, the Printer Unit, or the Printer/Scanner Unit.

Enhance Options

There are two enhance options:

- **Printer Enhance Option Type 5000:**

Updates the RPCS unit by adding PCL.

- **Scanner Enhance Option Type 5000:**

Updates the RPCS unit or Printer Unit by adding the advanced scanning features.

Kit Contents

Check the accessories and their quantities against the list below and the illustration on the next page. This is a common list for all the kits.

Common Accessory Table

This common accessory table lists all the items of the following units and options for the D009/D012 Series machines:

- RPCS: RPCS Printer Unit
- PU: Printer Unit
- P/S: Printer/Scanner Unit
- PEO: Printer Enhance Unit
- SEO: Scanner Enhance Unit

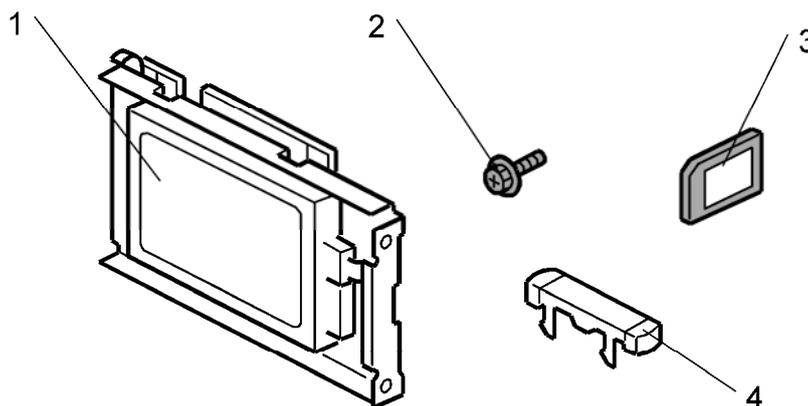

d381i101a

No.	Description	Q'ty	Kit Contents				
			RPCS	PU	P/S	PEO	SEO
	256 MB Memory* ¹	-	No	No	No	No	No
1	HDD Unit	1	No	Yes	Yes	Yes	No
2	Screw	3	No	Yes	Yes	Yes	No
3	SD Card	1	Yes	Yes	Yes	Yes	Yes
4	Keytop Set: NA* ²	1	Yes	Yes	Yes	Yes	Yes
	Keytop Set: EU* ²	1	Yes	Yes	Yes	Yes	Yes

*1: The 256 Memory is a separate option and it is not provided in the kits. However, one memory unit is required for the installation of every print unit.

*2: The number of keytops provided varies:

Kit	Keytops			
	Copy	Document Server	Printer	Scanner
RPCS Unit	1		1	
Printer Unit	1	1	1	
Printer/Scanner Unit	1	1	1	1
Printer Enhance Unit		1		
Scanner Enhance Unit				1

Printer/Scanner Installation

CAUTION

- Turn off the main power switch and disconnect the power supply cord.

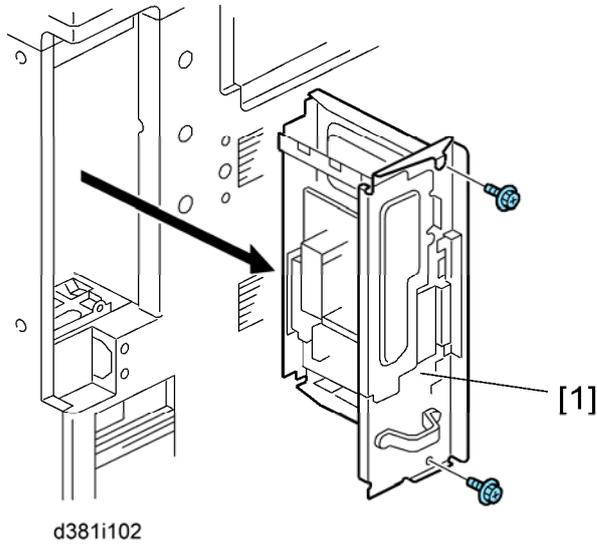

1. Remove the controller board [1] ( x 2).

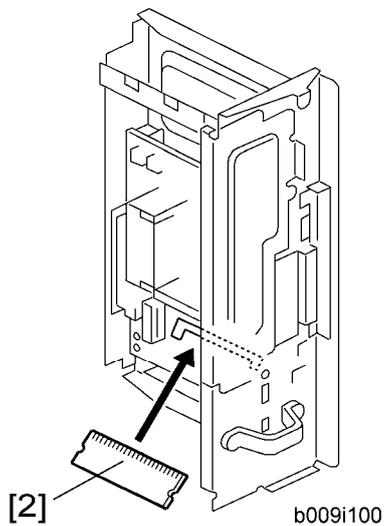

2. Install the 256 MB memory DIMM [2].
3. Install a hard disk (except RPCS Printer Kit). ( p.2-74)
4. Reinstall the controller board.

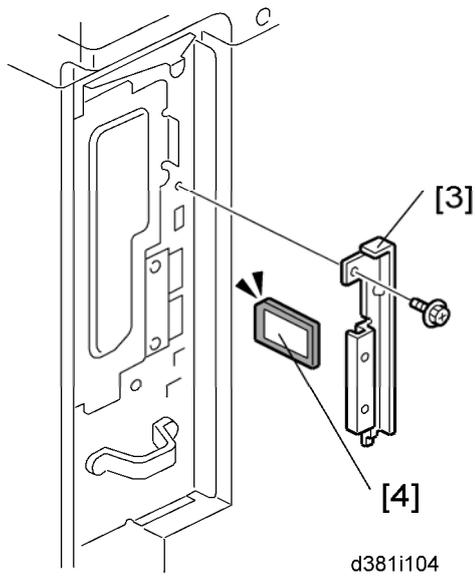

5. Remove the SD card slot cover [3] (x1).
6. Insert the Printer/Scanner SD card [4] in SD card slot 1.
7. Reattach the cover.
8. Connect the LAN cable to the "NIC" connection.
9. Connect the USB cable to the "USB" connection.

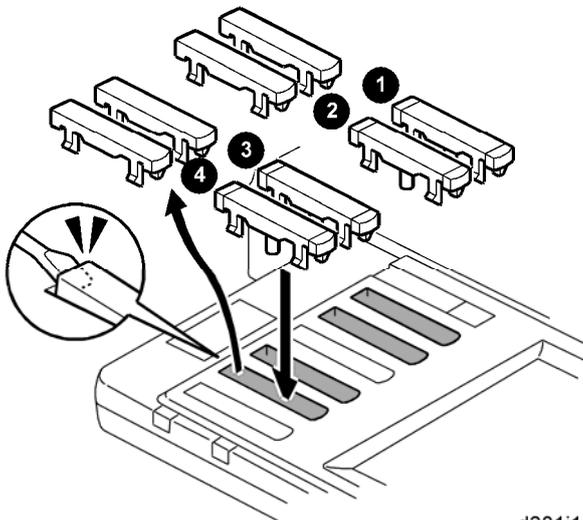

10. Remove the 1st, 2nd, 4th, and 5th blank key tops.

Controller Options



- The 3rd blank keytop from the top is reserved for the "Fax" keytop. Do not remove it at this time.

11. Replace the blank keytops:

- 1: Copy
- 2: Document Server
- 3: Printer
- 4: Scanner

12. Connect the machine's power cord and turn the main power switch on.

13. Enable the NIB and/or USB function.

- To enable the NIB function, enter the SP mode and set SP5985-001 (On Board NIC) to "1" (Enable).
- To enable the USB function, enter the SP mode and set SP5985-002 (On Board USB) to "1" (Enable).

Printer Enhance, Scanner Enhance Options

Accessory Check

Refer to the "Common Accessory Table" in this chapter.

Installation (Application Merge)

The installation of the printer enhance option and scanner enhance option are done with **SP5873-001 (Application Move)**.



- If you are going to update the RPCS unit with both the printer and scanner enhance options, the order of execution is not important.
1. For models which have the VM card, do the followings:
 - Press "User Tools" button to enter the User Tools mode.

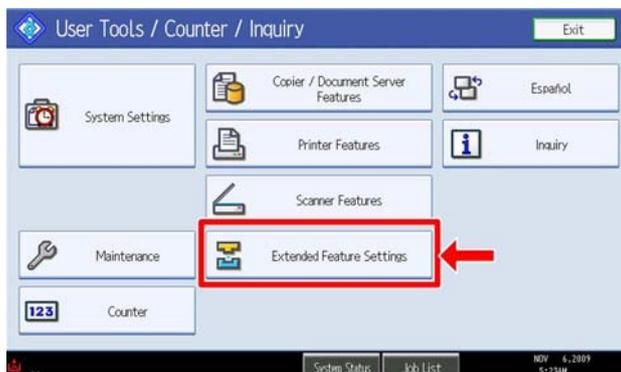

- Press "Extended Feature Settings" on the LCD.

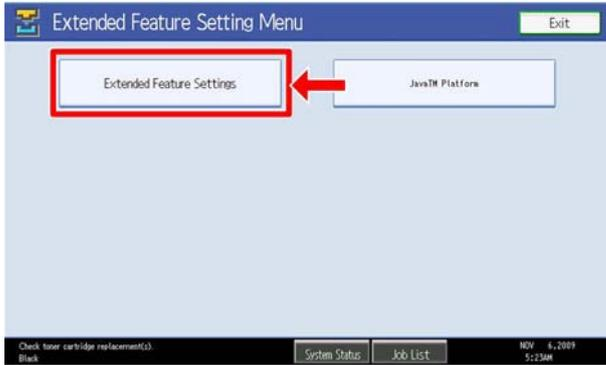

d377i503

- Press "Extended Feature Settings" on the LCD again.



d377i504

- Press "Startup Setting" tab.
 - Stop all SDK applications with touching application lines.
 - Exit the UP mode, and then turn off the machine.
2. Turn off the copier.
 3. Remove the cover (🔧 x1).
 4. Remove the VM card from SD card slot 2 if installed.
 5. Confirm that the RPCS Unit or Printer Unit SD card is in SD card Slot 1.
 6. Put the option SD Card (Printer Enhance Option or Scanner Enhance Option) in SD card slot 2.
 7. Open the front door.
 8. Turn the copier on.
 9. Go into the SP mode and select **SP5873-001**.
 10. Touch "Execute".
 11. Read the instructions on the display and touch "Execute" to start.
 12. When the display tells you copying is completed, touch "Exit", then turn the copier off.
 13. Remove the option SD card from slot 2.
 14. Turn the copier on.
 15. Go into the User Tools mode and confirm that update was successful.

Controller Options

16. User Tools> System Settings> Administrator Tools> Firmware Version> Next
17. Turn the copier off again, then reattach the cover.
18. Return the copied SD card to the customer for safekeeping, or tape it to the faceplate of the controller.

To undo an option update

1. For models which have the VM card, do the followings:
 - Press "User Tools" button to enter the User Tools mode.

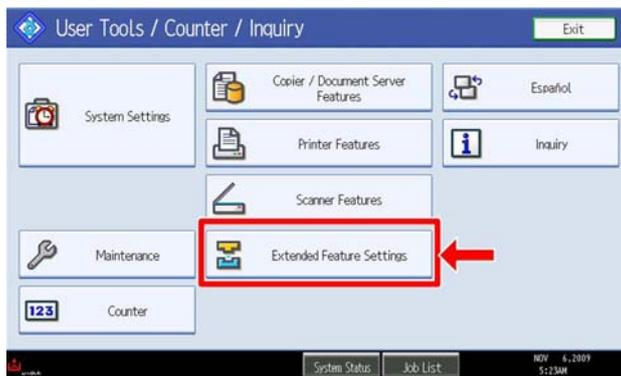

d377i502

- Press "Extended Feature Settings" on the LCD.

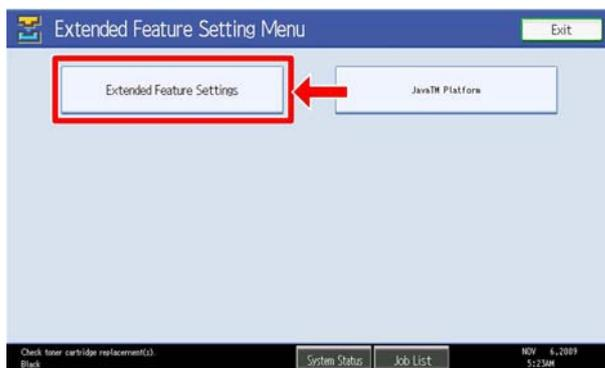

d377i503

- Press "Extended Feature Settings" on the LCD again.



d377i504

- Press "Startup Setting" tab.

- Stop all SDK applications with touching application lines.
 - Exit the UP mode, and then turn off the machine.
2. Turn the main switch off.
 3. Remove the cover (🔑 x1).
 4. Remove the VM card from SD card slot 2 if installed.
 5. Confirm that the RPCS Unit or Printer Unit SD card is in SD card Slot 1.
 6. Put the original option SD card (Printer Enhance Option or Scanner Enhance Option) in SD card slot 2.
 7. Turn the main switch on.
 8. Go into the SP mode and do **SP5873-002** (Undo Exec).
 9. Follow the messages on the operation panel to complete the procedure.
 10. Turn the main switch off.
 11. Remove the option SD card from Slot 2.
 12. Turn the main switch on.
 13. Go into the User Tools mode and confirm that undo was successful.
User Tools> System Settings> Administrator Tools> Firmware Version> Next
 14. Turn the copier off again, then reattach the cover.

Important Notes about SD Cards

Here are some basic rules about merging applications on SD cards.

- The data necessary for authentication is transferred with the application program to the target SD card.
- The SD card is the only evidence that the customer is licensed to use the application program. The service technician may occasionally need to check the SD card and its data to solve problems. SD cards must be stored in a safe location at the work site.
- Once the merge is completed, the SD card from which the application was copied cannot be used again, but the customer must keep the card to serve as proof of purchase.
- An SD card from which an application has been moved to another SD card can be restored to full operation with **SP5873-002** (Undo).
- Before storing the card from which an application has been copied, label it carefully so that you can identify it easily if you need to do the undo procedure later.

Application Merge

This machine has two SD card slots only. However, more than two optional applications are supplied for this machine. Always keep SD card slot 2 vacant for servicing (except VM Card Type F). Because of this, SD card merge is required if a customer wants to use many applications.

Controller Options

Consider the following limitations when you try to merge SD cards.

- PostScript3 cannot be moved to the other SD card.
- Due to limitations, the VM Card (D377) can be neither merged nor moved to another SD card. This card must be installed in Slot 2 (lower).
- The destination SD card should have the largest memory size of all the application SD cards. Refer to the following table for the memory size of each SD card.

SD Card Options	SD Card Size	Module Size
Printer/Scanner Unit Type 5000	32 MB	9.3 MB
RPCS Printer Unit Type 5000	32 MB	6.3 MB
Printer Unit Type 5000	32 MB	8.3 MB
Printer Enhance Option Type 5000	16 MB	4 MB
Scanner Enhance Option Type 5000	16 MB	3 MB
DataOverwriteSecurity Unit Type I	16 MB	4 MB
PostScript3 Unit Type 5000	64 MB	14.6 MB
IPDS Unit Type 5000	32 MB	13.5 MB

Case 1: PostScript3 is not installed

Merge all applications which the customer wants to use into one SD card (Destination Card).



- The destination card should have the largest memory size of all the application SD cards.
- The VM Card Type F cannot be merged, nor moved to another SD card. This card must be installed in slot 2.

Case 2: PostScript3 is installed

Merge all applications which the customer wants to use into the PostScript3 SD card.

2.21.14 CHECK ALL CONNECTIONS

Plug in the power cord. Then turn on the main switch.

Enter the printer user mode. Then print the configuration page.

User Tools > Printer Settings > List Test Print > Config. Page

All installed options are shown in the "System Reference" column.

PREVENTIVE MAINTENANCE

REVISION HISTORY		
Page	Date	Added/Updated/New
		None

3. PREVENTIVE MAINTENANCE

3.1 PM TABLES

See "Appendices" for the following information:

- PM Tables

REPLACEMENT AND ADJUSTMENT

REVISION HISTORY		
Page	Date	Added/Updated/New
		None

4. REPLACEMENT AND ADJUSTMENT

4.1 GENERAL CAUTIONS

CAUTION

- To avoid damage to the transfer belt, drum, or development unit when it is removed or re-installed, never turn off power switch while electrical components are active.

CAUTION

- Turn off the main power switch and unplug the machine before attempting any of the procedures in this section.

4.1.1 LASER UNIT

1. Do not loosen the screws that secure the LD drive board to the laser diode casing. Doing so would throw the LD unit out of adjustment.
2. Do not adjust the variable resistors on the LD unit, as they are adjusted in the factory.
3. The polygon mirror and F-theta lenses are very sensitive to dust. Do not open the optical housing unit.
4. Do not touch the glass surface of the polygon mirror motor unit with bare hands.
5. After replacing the LD unit, do the laser beam pitch adjustment.

4.1.2 USED TONER

Dispose of used toner in accordance with local regulations. Never throw toner into an open flame, for toner dust may ignite.

4.2 SPECIAL TOOLS AND LUBRICANTS

4.2.1 SPECIAL TOOLS

Part Number	Description	Q'ty
A0069104	Scanner Positioning Pin (4 pc./set)	1
A2929500	Test Chart – S5S (10 pc./set)	1
VSSM9000	Digital Multimeter – FLUKE 187	1
A2309003	Adjustment Cam – Laser Unit	1
A2309004	Positioning Pin – Laser Unit	1
B6455010	SD Card	1
B6456830	USB Read/Writer	1
G0219350	Loop Back Connector	1

4.2.2 LUBRICANTS

Part Number	Description	Q'ty
A2579300	Grease Barrierta S552R	1
52039502	Silicone Grease G-501	1

4.3 EXTERIOR COVERS

4.3.1 FRONT DOOR, UPPER AND LOWER INNER COVER

1. Left Cover (☛ p.4-4)

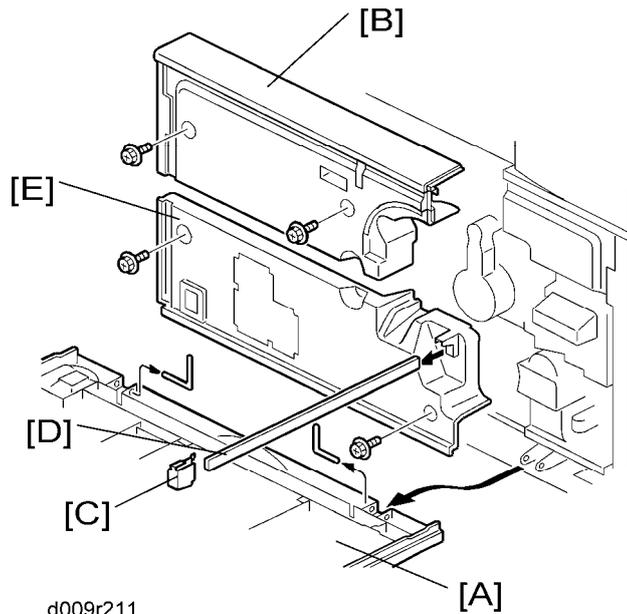

2. Open and remove the front door [A] (pin x 2).

Upper Inner Cover

1. Open the front door [A].
2. Upper inner cover [B] (☛ x 2)

Lower Inner Cover

1. Remove the front door [A] (pin x 2)
2. Shield glass cover [C]
3. Shield glass [D] (☛ x 2)
4. Lower inner cover [E]

Exterior Covers

4.3.2 LEFT COVER

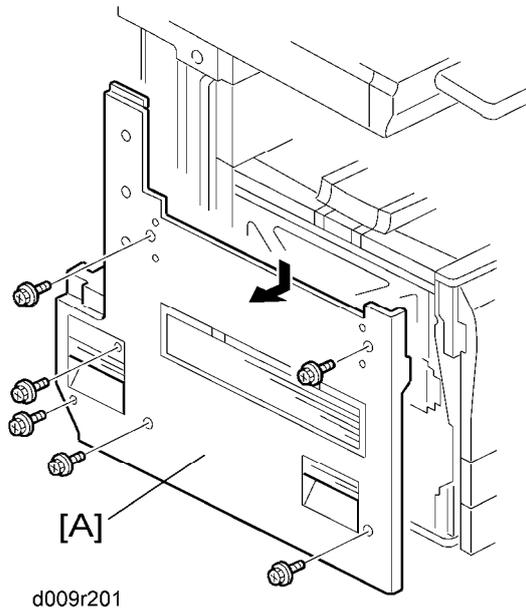

d009r201

1. Left cover [A] (🔩 x 6)

4.3.3 REAR COVER

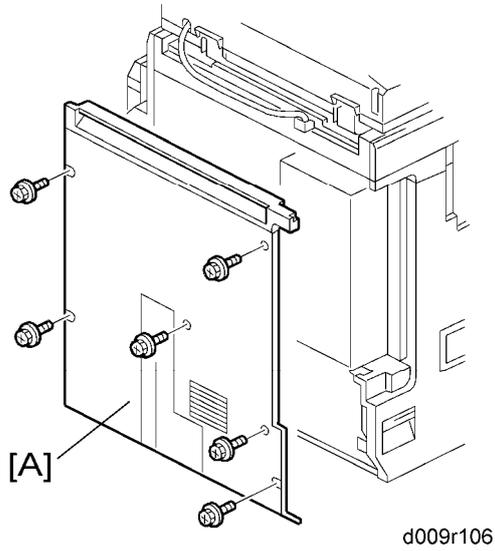

d009r106

1. Rear cover [A] (🔩 x 6)

4.3.4 RIGHT REAR COVER

1. Rear cover (☛ p.4-4)

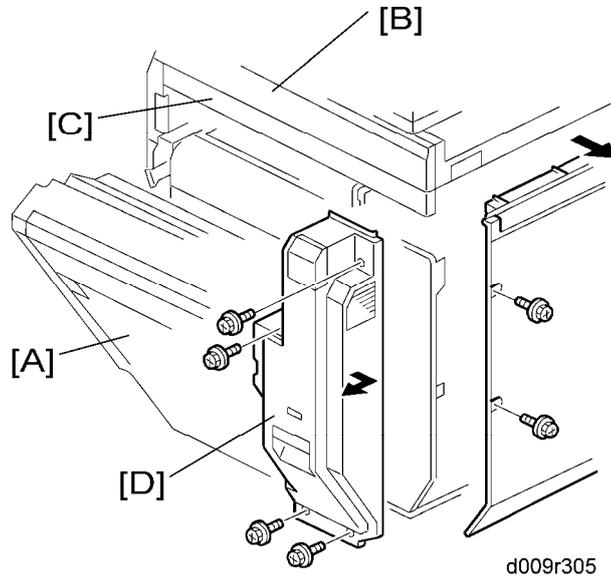

2. Open the right door [A].
3. Scanner right cover [B] (☛ x 2)
4. Right top cover [C] (☛ x 1)
5. Right rear cover [D] (☛ x 4)

4.3.5 OPERATION PANEL

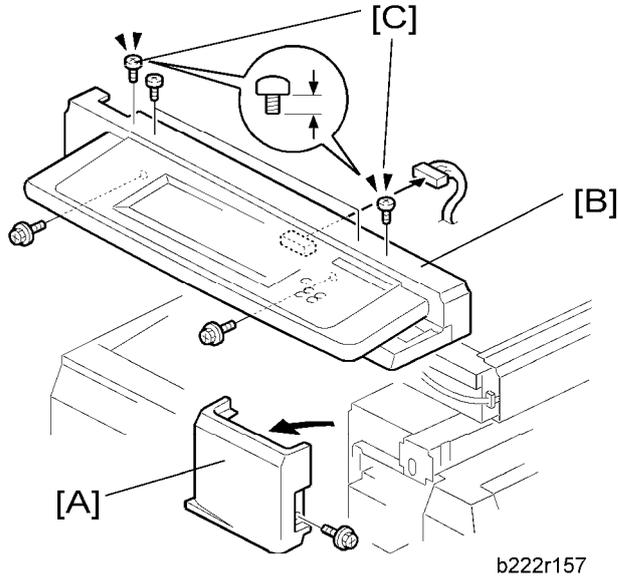

1. Open the right door.
2. Front right cover [A] (🔩 x 1)
3. Operation panel with the scanner front cover [B] (🔩 x 6, 📄 x 1, 🖨️ x 1)

⏴ Note

- The two screws [C] are shorter than the other screws installed in the inner two screw holes. Make sure that the two screws [C] are installed in the outer screw holes on the scanner front cover.



4. Scanner front cover [D] (🔩 x 2)

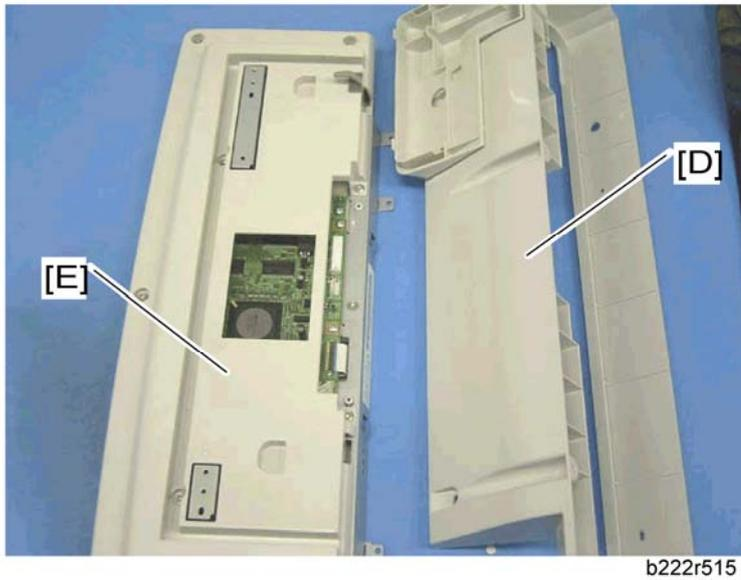

- 5. Operation panel [E]

4.3.6 PAPER EXIT COVER

- 1. Front right cover (🔧 p.4-6)

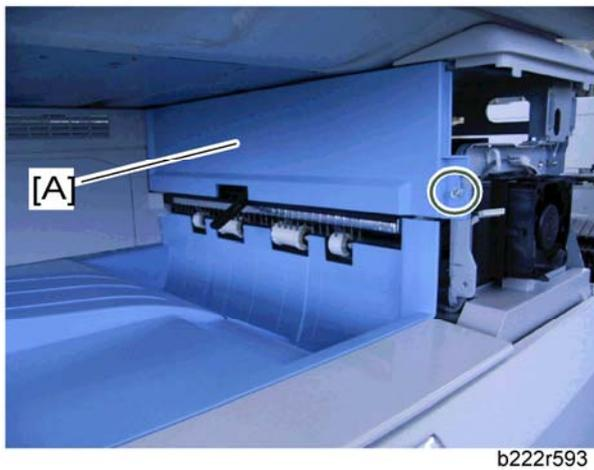

- 2. Paper exit cover [A] (🔧 x 1)

Replacement
&
Adjustment

Exterior Covers

4.3.7 INNER TRAY

1. Left cover (☛ p.4-4)
2. Upper inner cover (☛ p.4-3)
3. Paper exit cover (☛ p.4-7)

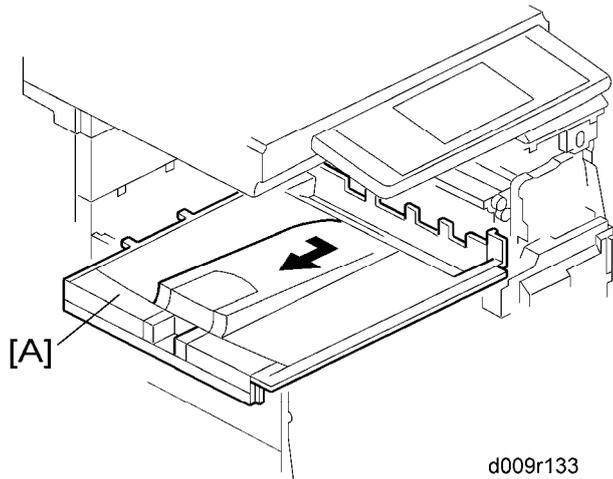

d009r133

4. Inner tray [A]

4.4 SCANNER -1

4.4.1 EXPOSURE GLASS

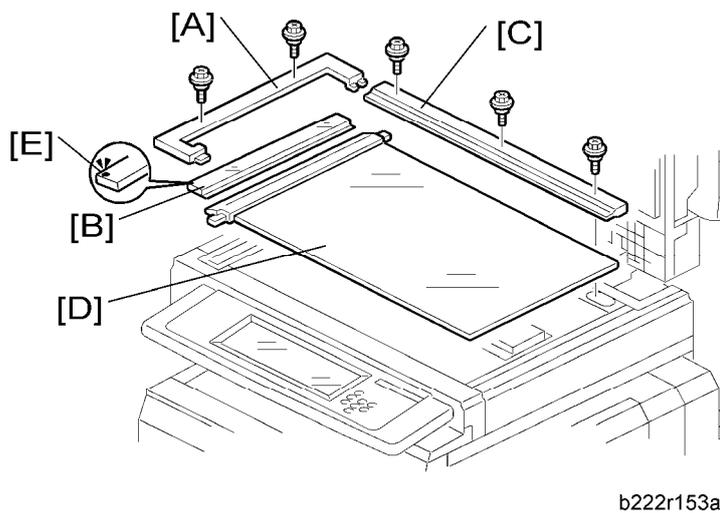

1. Glass cover [A] (🔩 x 2)
2. ARDF exposure glass [B]
3. Rear scale [C] (🔩 x 3)
4. Exposure glass with left scale [D]

↓ Note

- Position the black marker [E] at the front-left corner when you reattach the ARDF exposure glass.

4.4.2 ORIGINAL LENGTH/WIDTH SENSORS

Monochrome Scanner Model (D009/D012)

1. Exposure glass with left scale (☛ p.4-9)

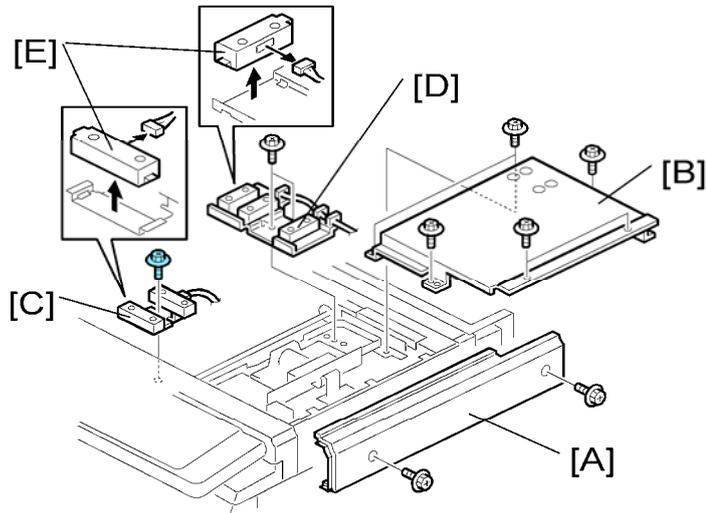

d009r040

2. Scanner right cover [A] (☛ x 2)
3. Lens cover [B] (☛ x 2)
4. Original width sensor bracket [C] (☛ x 1)
5. Original length sensor bracket [D] (☛ x 2)
6. Original width and length sensors [E] (☛ x 1 each)

Color Scanner Model (D011/D013/D091/D092)

1. Exposure glass with left scale (☛ p.4-9)
2. Ground plate (☛ p.4-14)

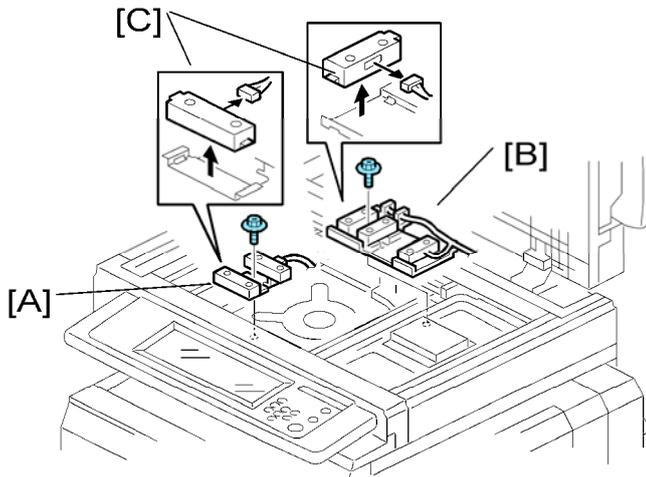

d009r154

3. Original width sensor bracket [A] (☛ x 1)
4. Original length sensor bracket [B] (☛ x 1, ☛ x 2)
5. Original width and length sensors [C] (☛ x 1 each)

4.4.3 EXPOSURE LAMP

Color Scanner Model (D011/D013/D091/D092)

1. Operation panel with scanner front cover (☛ p.4-6)
2. Exposure glass (☛ p.4-9)

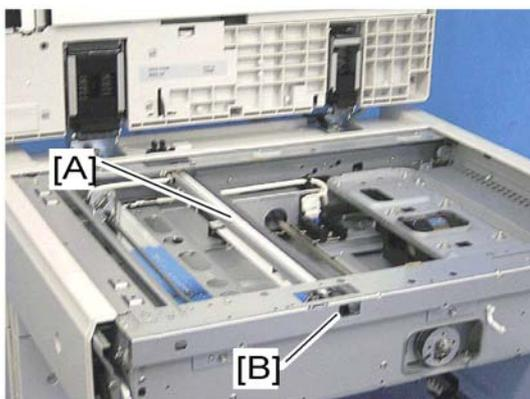

b222r518

3. Move the 1st scanner carriage [A] to the cutout [B] in the front frame.

Scanner -1

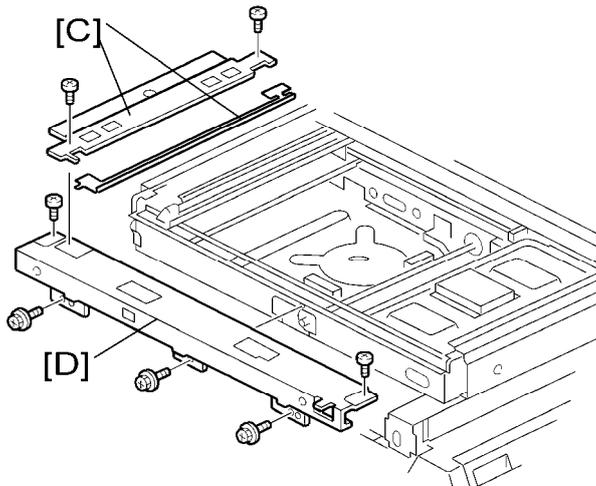

d009r157a

4. Scanner left stays [C] (🔩 x 2)
5. Scanner front frame [D] (🔩 x 5)

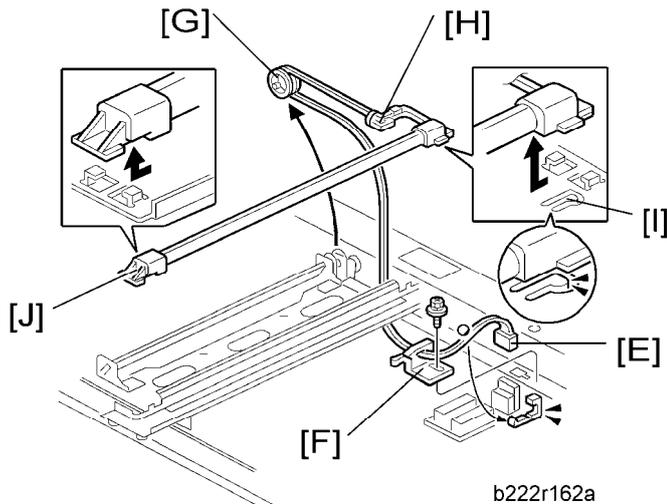

b222r162a

6. Disconnect the connector [E] (🔌 x 1).
7. Remove the clamp [F] (🔩 x 1)
8. Remove the pulley [G].
9. Release the cable clamp [H].
10. Hold down the snap [I], and then slide the exposure lamp [J] to the front side.
11. Exposure lamp [J]

Monochrome Scanner Model (D009/D012)

1. Operation panel with scanner front cover (☛ p.4-6)
2. Exposure glass (☛ p.4-9)
3. Rear cover (☛ p.4-4)
4. Scanner rear frame (☛ p.4-13)
5. Disconnect the exposure lamp cable from the lamp stabilizer (☛ x 1, ☛ x 2).
6. Do steps 7 to 11 in the "Color Scanner Model" described above.

4.4.4 SCANNER MOTOR

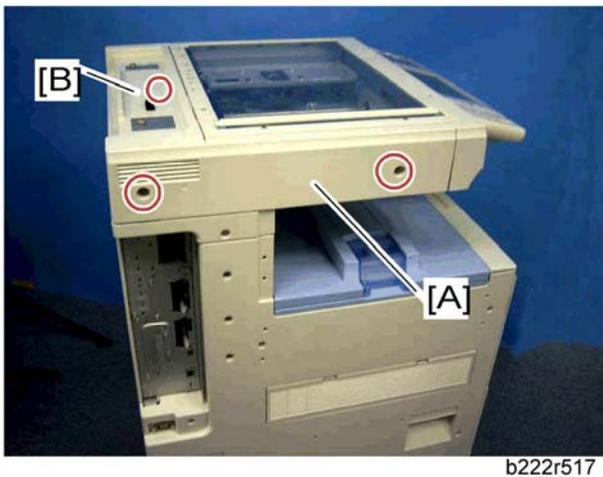

b222r517

1. Rear cover (☛ p.4-4)
2. Scanner left cover [A] (☛ x 2)
3. Scanner top rear cover [B] (☛ x 1)

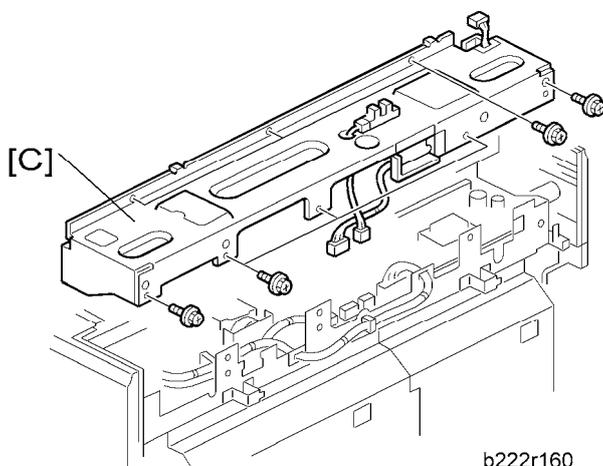

b222r160

4. Scanner rear frame [C] (☛ x 8, ☛ x 3, ☛ x 2)

Scanner -1

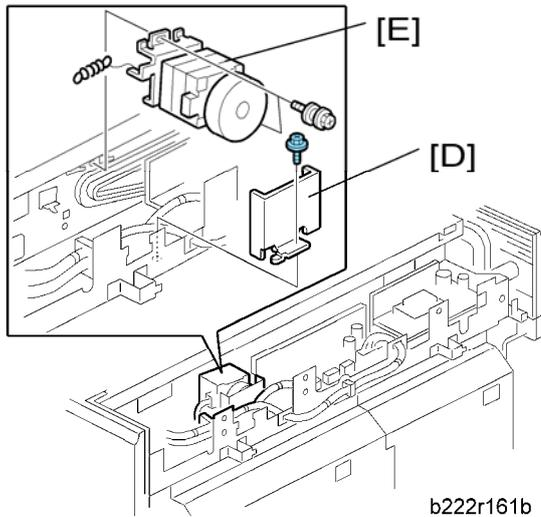

5. Scanner motor bracket [D] (🔩 x 1)
6. Scanner motor [E] (🔩 x 2, spring x 1)

⏴ Note

- After replacing the scanner motor, do the image adjustments in the following section of the manual (📖 p.4-101).

4.4.5 SENSOR BOARD UNIT (SBU)

Monochrome Scanner Model (D009/D012)

1. Exposure glass (📖 p.4-9)
2. Original length sensor bracket (📖 p.4-10)

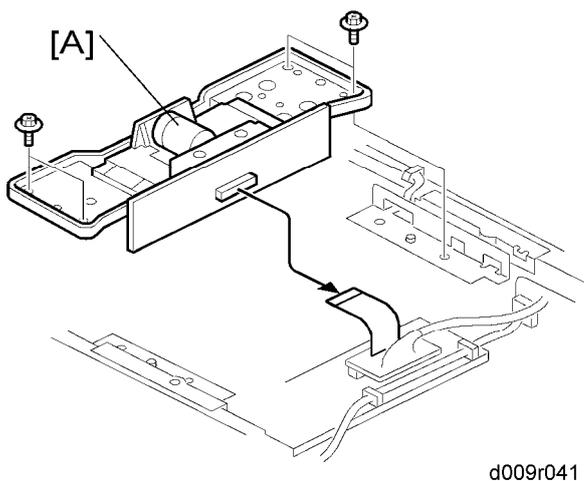

3. Sensor board unit [A] (🔩 x 4, flat cable x 1)

Color Scanner Model (D011/D013/D091/D092)

1. Exposure glass (☛ p.4-9)

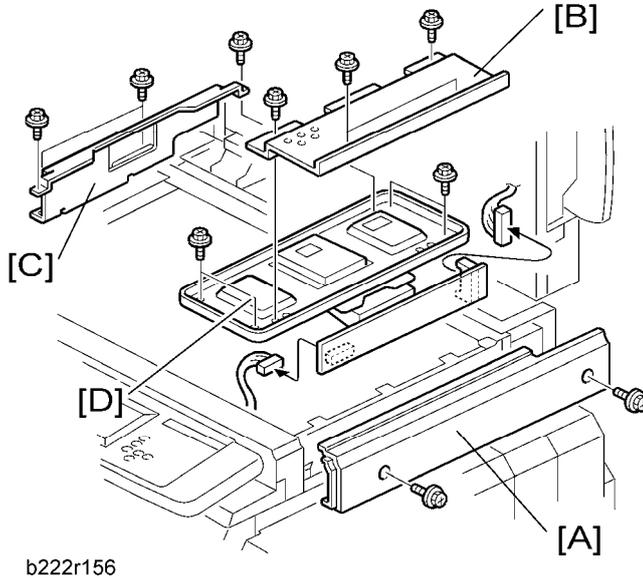

2. Scanner right cover [A] (☛ x 2)
3. SBU cover bracket [B] (☛ x 4)
4. Ground plate [C] (☛ x 4)
5. Sensor board unit [D] (☛ x 4, ☛ x 3, ☛ x 1)

When reassembling

Adjust the following SP modes after you replace the sensor board unit:

- SP4-008 (Sub Scan Mag): (☛ p.4-101)
- SP4-010 (Sub Mag Reg.): (☛ p.4-101)
- SP4-011 (Main Scan Reg.): (☛ p.4-101)
- SP4-688 (DF: Density Adjustment): Use this to adjust the density level if the ID of outputs made in the DF and Platen mode is different.

4.4.6 LAMP STABILIZER

1. Rear cover (🔩 p.4-4)
2. Scanner rear frame (🔩 p.4-13)

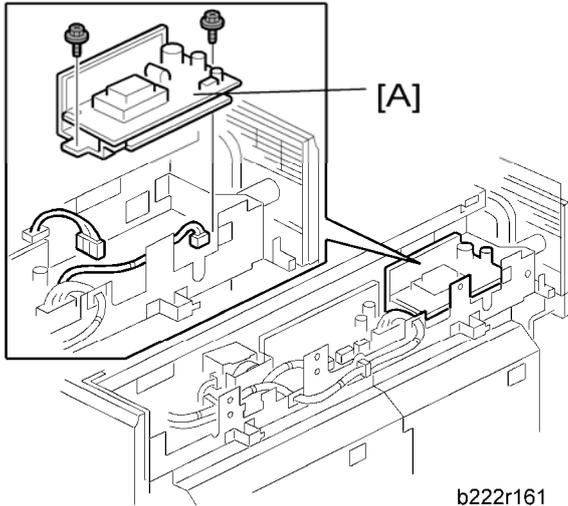

3. Lamp stabilizer unit [A] (🔩 x 2, 📏 x 2)
4. Lamp stabilizer (CS model: 📏 x 4, MS model: stud x 2)

4.4.7 SIO (SCANNER IN/OUT) BOARD

1. Rear cover (🔩 p.4-4)
2. Scanner rear frame (🔩 p.4-13)

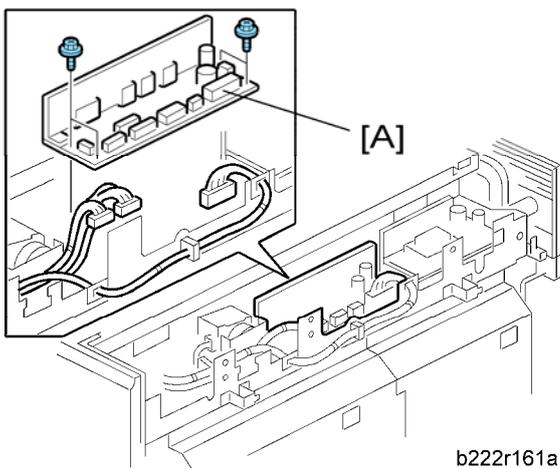

3. SIO board with bracket [A] (🔩 x 4, All 📏s)

4.4.8 SCANNER HP SENSOR

1. Rear cover (🔧 p.4-4)
2. Scanner left cover and Scanner top rear cover (🔧 p.4-13)
3. Exposure glass (🔧 p.4-9)

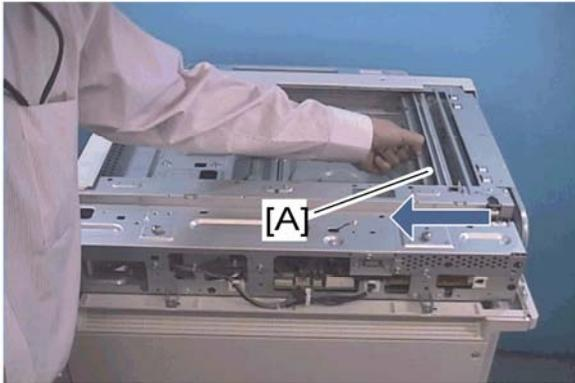

b222r523

4. Move the 1st scanner carriage [A] to the right side.

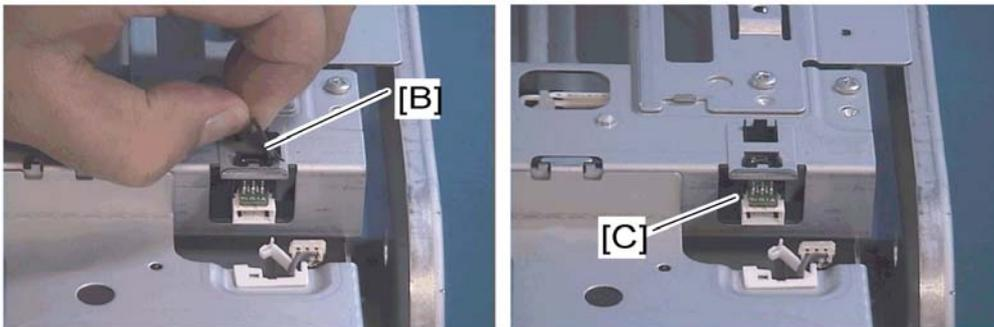

b222r524

5. Remove the mylar [B]
6. Remove the scanner HP sensor [C] (🔧 x 1, 📷 x 1, two snaps)

Scanner -1

4.4.9 PLATEN COVER SENSOR

1. Rear cover (🔧 p.4-4)
2. Scanner left cover and scanner top rear cover (🔧 p.4-13)

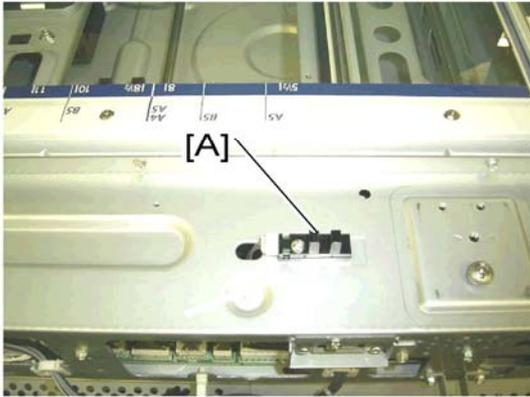

b222r525

3. Platen cover sensor [A] (🔧 x 1, 🖨️ x 1)

4.5 SCANNER-2

4.5.1 FRONT SCANNER WIRE

1. Operation panel with the scanner front cover (☛ p.4-6)
2. Front frame (☛ p.4-11)
3. Slide the first scanner to the right to make reassembly easy.

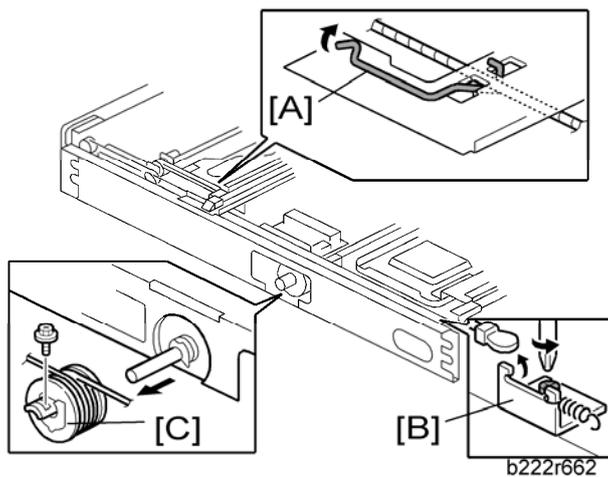

4. Front scanner wire clamp [A]
5. Front scanner wire bracket [B] (☛ x 1)
6. Front scanner wire and scanner drive pulley [C] (☛ x 1)

Reassembling the Front Scanner Wire

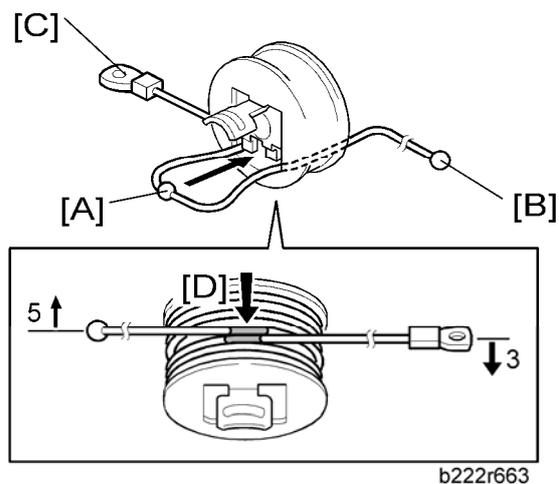

1. Position the center ball [A] in the middle of the forked holder.

Scanner-2

2. Pass the right end (with the ball) [B] through the square hole. Pass the left end (with the ring) [C] through the notch.
3. Wind the right end counterclockwise (shown from the machine's front) five times. Wind the left end clockwise twice.

↓ Note

- The two red marks [D] come together when you have done this. Stick the wire to the pulley with tape. This lets you easily handle the assembly at the time of installation.

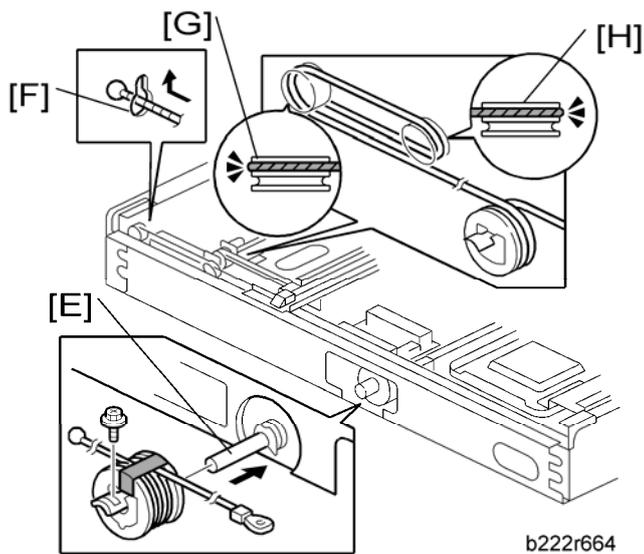

4. Install the drive pulley on the shaft [E].

↓ Note

- Do not attach the pulley to the shaft with the screw at this time.
5. Insert the left end into the slit [F]. The end should go via the rear track of the left pulley [G] and the rear track of the movable pulley [H].

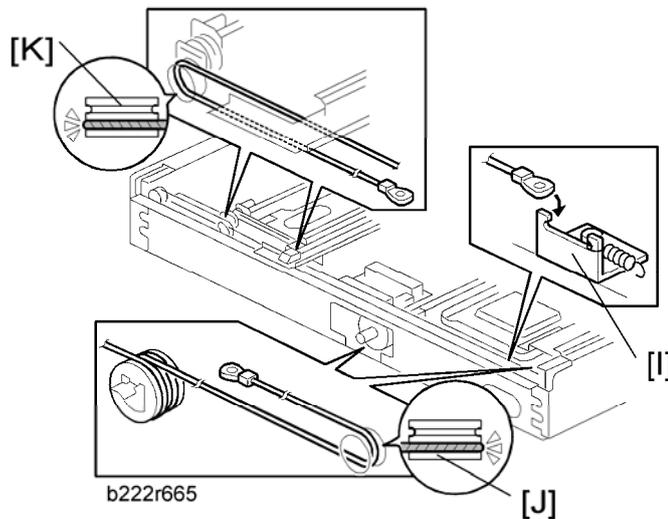

6. Hook the right end onto the front scanner wire bracket [I]. The end should go via the front track of the right pulley [J] and the front track of the movable pulley [K].

↓ Note

- Do not attach the scanner wire bracket with the screw at this time.

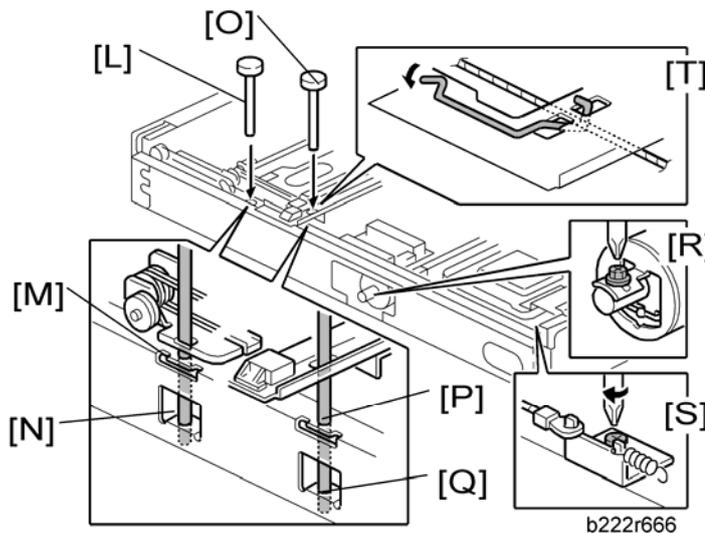

7. Remove the tape from the drive pulley.
8. Insert a scanner-positioning pin [L] through the 2nd carriage hole [M] and the left holes [N] in the front rail. Insert another scanner positioning pin [O] through the 1st carriage hole [P] and the right holes in the front rail [Q].
9. Insert two more scanner positioning pins through the holes in the rear rail.
10. Screw the drive pulley to the shaft [R].
11. Screw the scanner wire bracket to the front rail [S].
12. Install the scanner wire clamp [T].

Scanner-2

13. Pull out the positioning pins.

↓ Note

- Make sure the 1st and 2nd carriages move smoothly after you remove the positioning pins. Do steps 8 through 13 again if they do not.

↓ Note

- After replacing the scanner wire, do the image adjustments in the following section of the manual (☛ p.4-101).

4.5.2 REAR SCANNER WIRE

1. Exposure glass (☛ p.4-9)
2. Scanner rear frame (☛ p.4-13)
3. Scanner motor (☛ p.4-13)

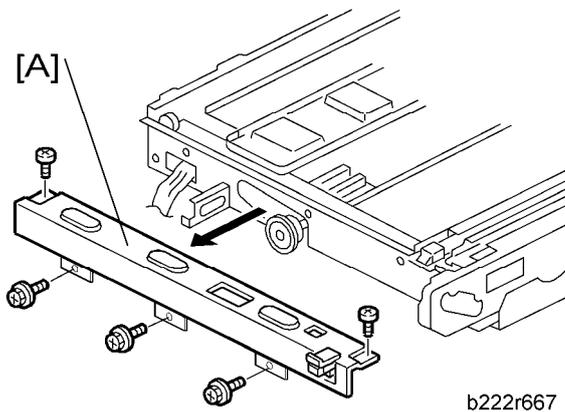

4. Rear rail frame [A] (☛ x 5)

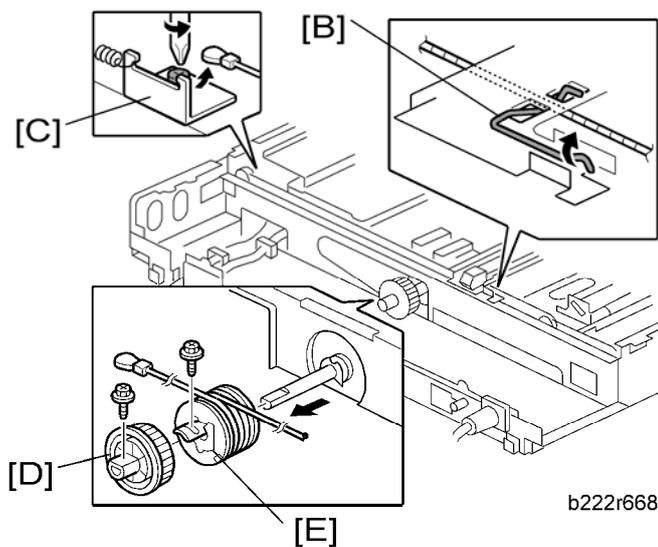

5. To make reassembly easy, slide the first scanner to the center.
6. Rear scanner wire clamp [B]
7. Rear scanner wire bracket [C] (🔩 x 1)
8. Scanner motor gear [D] (🔩 x 1)
9. Rear scanner wire and scanner drive pulley [E] (🔩 x 1)

Reassembling the Rear Scanner Wire

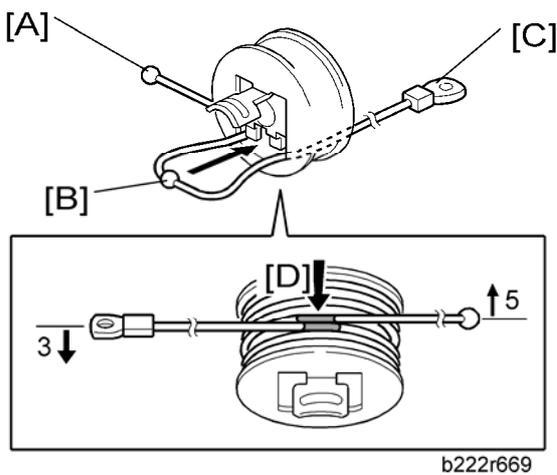

1. Position the center ball [B] in the middle of the forked holder.
2. Pass the end with the ball [A] through the right square hole from the front.
3. Position the center ball [B] in the middle of the notch, as shown by the arrow.
4. Pass the ball end [A] through the drive pulley notch.
5. Wind the end with the ring [C] clockwise (shown from the machine's front) three times; wind the ball end [A] clockwise (shown from the machine's front) five times.

↓ Note

- The two red marks [D] should meet when you have done this.

6. Stick the wire to the pulley with tape, so you can easily handle the pulley and wire during installation.
7. Install the drive pulley on the shaft.

↓ Note

- Do not screw the pulley onto the shaft yet.

8. Install the wire.

↓ Note

- The winding of the wire on the three pulleys at the rear of the scanner should be the same as the winding on the three pulleys at the front. This must show as a mirror image. Example: At the front of the machine, the side of the drive

Scanner-2

pulley with the three windings must face the front of the machine. At the rear of the machine, it must face the rear.

9. Perform steps 8 through 13 in "Reassembling the Front Scanner Wire".

↓ Note

- After replacing the scanner wire, do the image adjustments in the following section of the manual (☛ p.4-101).

4.5.3 TOUCH PANEL POSITION ADJUSTMENT

↓ Note

- It is necessary to calibrate touch panel at the following times:
- When you replace the operation panel.
- When you replace the controller board.
- When the touch panel detection function does not operate correctly

Do not use items [2] to [9] on the Self-Diagnostic Menu. These items are for design use only.

1. Press , press "1", "9", "9", "3", press  5 times to open the Self-Diagnostics menu.

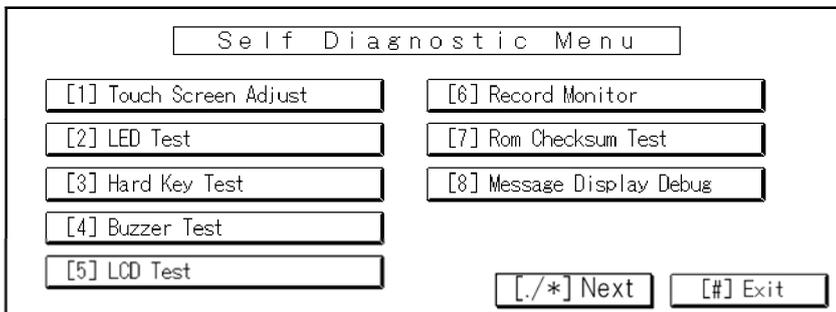

b195r834

2. On the touch screen press "Touch Screen Adjust" (or press "1").
3. Use a pointed (not sharp) tool to press the upper left mark .

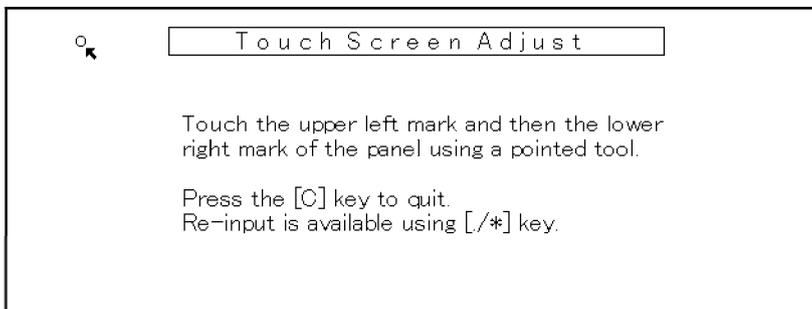

b195r9835

4. Press the lower right mark when "" shows.

5. Touch a few spots on the touch panel to make sure that the marker "+" shows exactly where the screen is touched.
6. Press Cancel. Then start from Step 2 again if the "+" mark does not show where the screen is touched.
7. Press [#] OK on the screen (or press ) when you are finished.
8. Touch [#] Exit on the screen to close the Self-Diagnostic menu. Save the calibration settings.

4.6 LASER UNIT

WARNING

- Turn off the main power switch and unplug the machine before attempting any of the procedures in this section. Laser beams can seriously damage your eyes.

4.6.1 CAUTION DECAL LOCATIONS

Two caution decals are located in the laser section as shown below. (See the next page for removal instructions.)

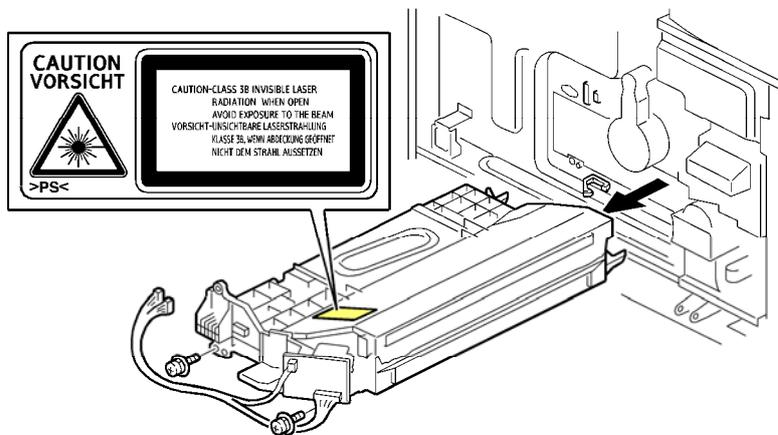

d009r500

4.6.2 LASER UNIT

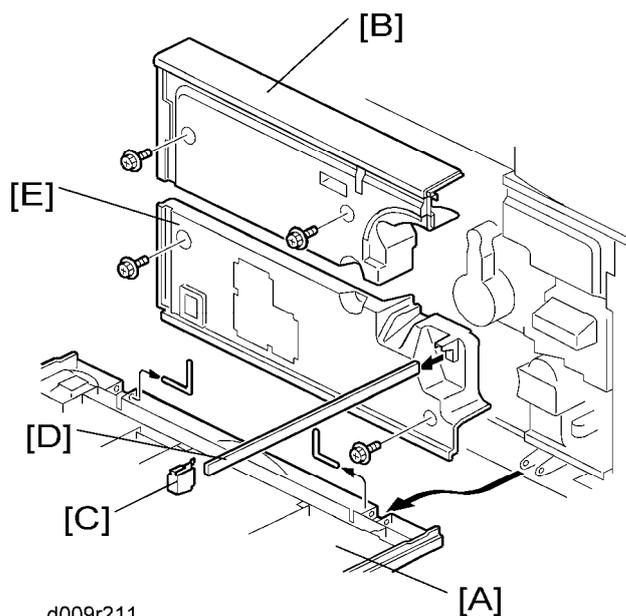

d009r211

1. Open the front door.
2. Front door [A] (pins x 2)
3. Upper inner cover [B] (🔩 x 2)
4. Glass cap [C]
5. Shield glass [D]
6. Lower inner cover [E] (🔩 x 2)

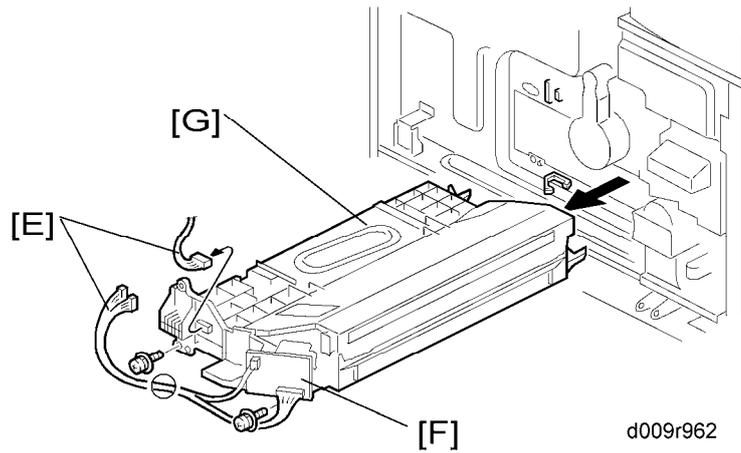

7. Laser unit connectors [E] (🔌 x 3, 📡 x 1)

★ Important

- Do not disconnect the harnesses on the LD board [F] unless the LD unit has to be replaced. This board is precisely adjusted in the factory.

8. Laser unit [G] (🔩 x 2)

★ Important

- When sliding out the laser unit, do not hold the LD board. Hold the laser unit.

Laser Unit

4.6.3 POLYGON MIRROR MOTOR

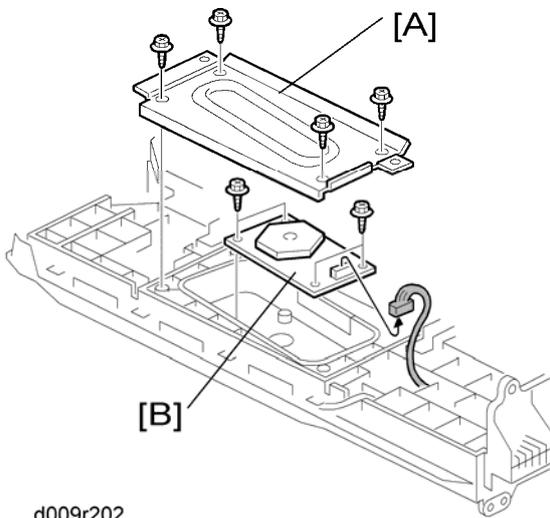

d009r202

1. Laser unit (🔧 p.4-26)
2. Laser unit cover [A] (🔧 x 4)
3. Polygon mirror motor [B] (🔧 x 4, 📏 x 1)
4. After replacing the polygon mirror motor, do the image adjustment (🔧 p.4-97).

4.6.4 LASER SYNCHRONIZATION DETECTOR

1. Laser unit (🔧 p.4-26)

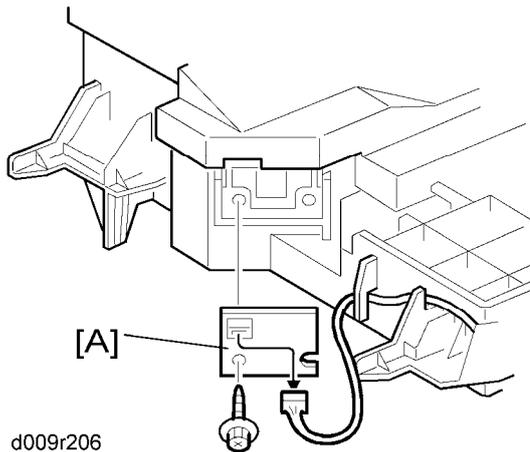

d009r206

2. Laser synchronization detector [A] (🔧 x1, 📏 x1)

4.6.5 LD UNIT

1. Laser unit (🔧 p.4-26)

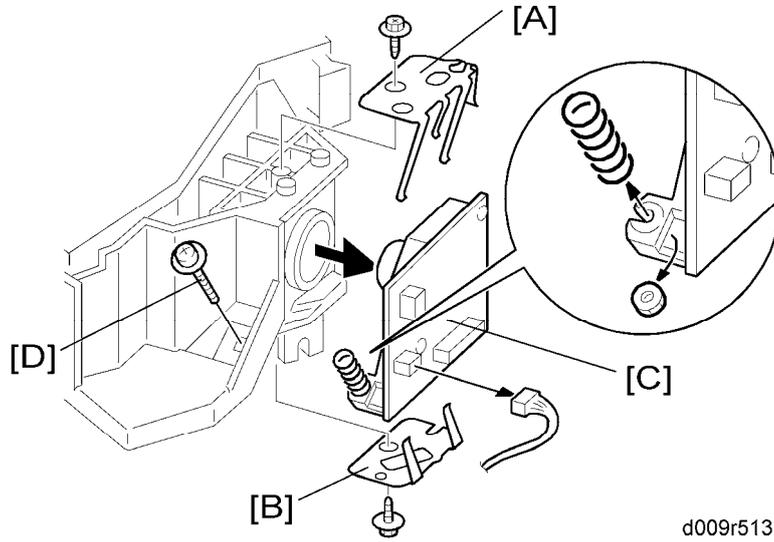

2. Upper spring plate [A] (🔧 x 1)
3. Lower spring plate [B] (🔧 x 1)
4. LD unit [C] (🔧 x 1, 📦 x1, spring x 1)

⬇ Note

- To avoid damaging the LD board, hold it securely when disconnecting the connectors. Hold the laser unit casing.
5. After replacing the LD board, do the "Laser Beam Pitch Adjustment" (described in the following section). Keep the lower inner cover removed before doing this adjustment because you need to adjust the adjustor screw [D] on the LD unit with a screwdriver.

Laser Beam Pitch Adjustment

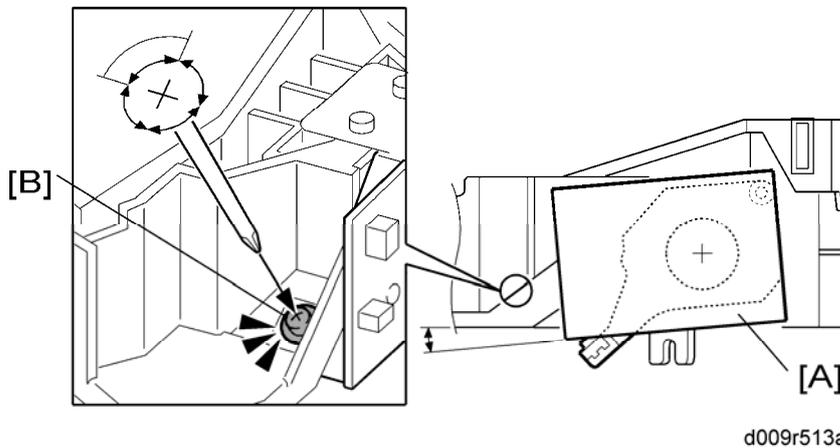

Laser Unit

1. Install a (new) LD unit [A] with the left side of the LD unit being lower than the right side. (This makes this adjustment easier.)
2. Print the test pattern "Hounds Tooth Check (2-Dot Horizontal)" (No. 16 in SP2109-001).
3. Check if the vertical stripes appear on the second pattern (counted from the leading edge) of the printout.
 - Correct: No vertical stripes appear (see the sample following this procedure.)
 - Wrong: Vertical stripes appear (see the sample following this procedure.)
4. Turn the adjustor screw [B] by 90 degrees clockwise (counterclockwise).
 - If the image of the printout is getting worse, try reverse rotation (clockwise ↔ counterclockwise)
5. Print the test pattern and check it out.
6. Try steps 2 to 4 again until you get an image with no vertical stripes.
7. Reassemble the machine after completing this adjustment.

↓ Note

- If the image of the printout is getting worse, try reverse rotation (clockwise ↔ counterclockwise)

Correct: No vertical stripes appear

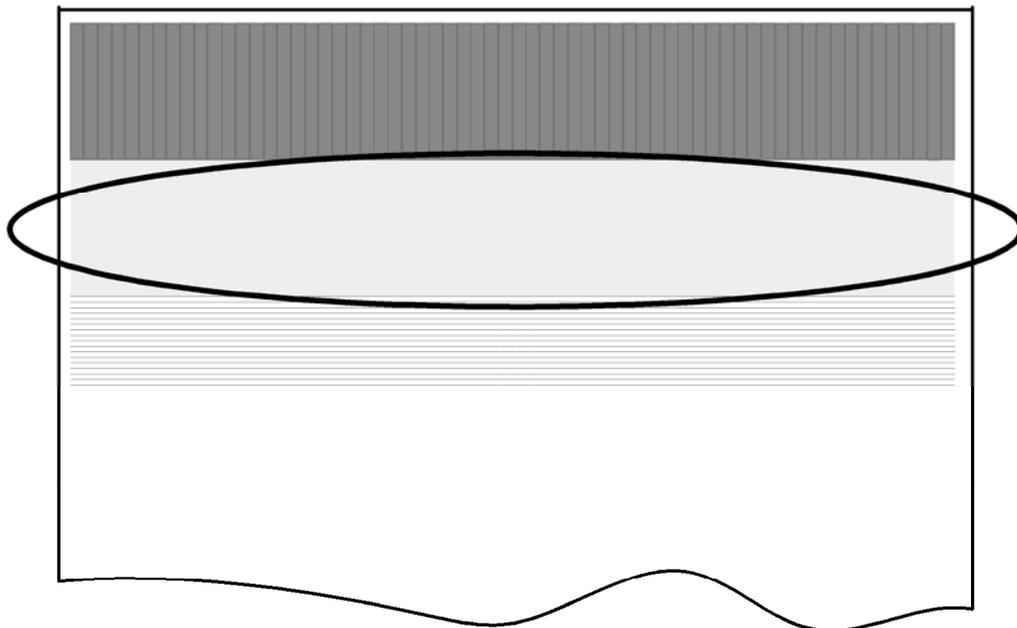

d009r552

Incorrect: Vertical stripes appear

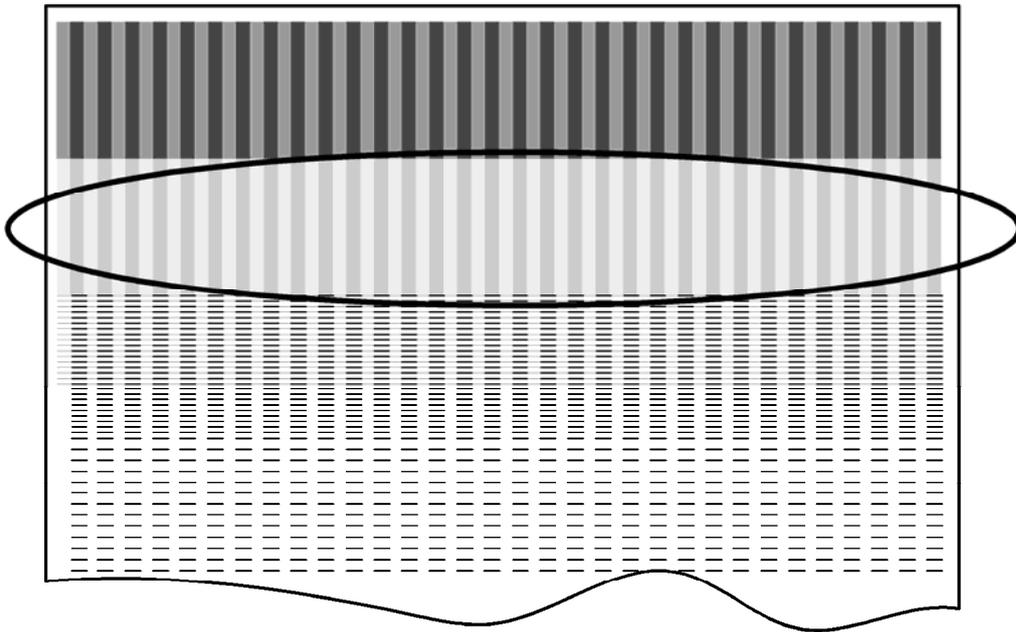

d009r553

4.7 PCDU

4.7.1 PCDU (PHOTOCONDUCTOR AND DEVELOPMENT UNIT)

1. Open the front door.

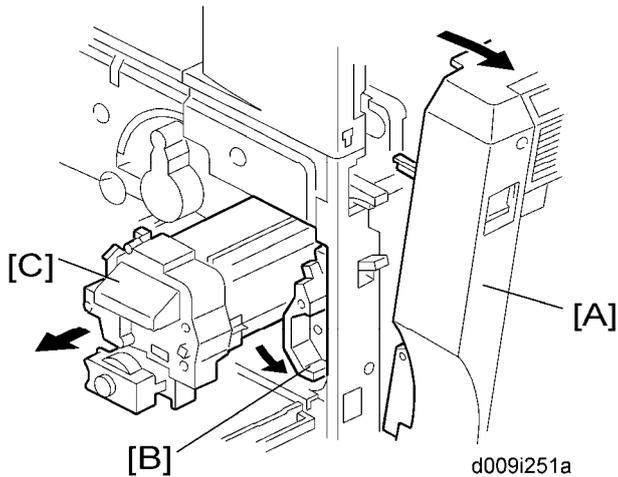

2. Open the right door [A].
3. Release the lock lever [B].
4. Pull out the PCDU [C] and place it on a clean flat surface.
5. Spread a large piece of paper on a flat surface.

Note

- Make sure the area is free of pins, paper clips, staples, etc. to avoid attraction to the magnetic development roller.

Reinstallation

Open the right cover before you install the PCDU in the machine.

4.7.2 DRUM

1. Remove the PCDU (☛ p.4-32)

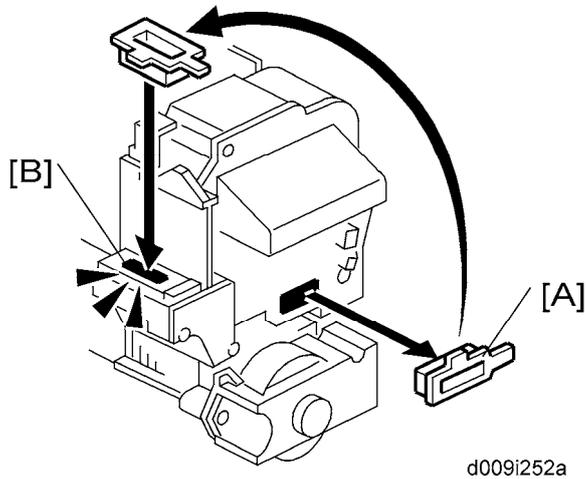

2. Toner cap [A]
3. Insert cap [A] into the opening of the PCDU [B].

Note

- Make sure that the cap is inserted completely into the opening.

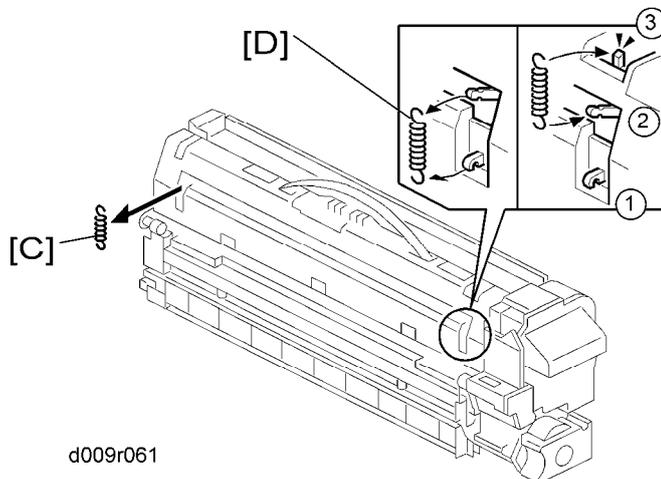

4. Remove the spring [C] on the rear side of the PCDU.
5. Remove the spring [D] on the front side of the PCDU and attach it to the hooks as shown.
 - To prevent breaking the weaker hook ①, use a pair of needle-nose pliers to disconnect the spring at ②, remove the spring, then re-attach to ② and ③.
 - When you move this spring, this retracts the movable drum cleaning blade so that it does not touch the surface of the drum when the drum is re-installed.

PCDU

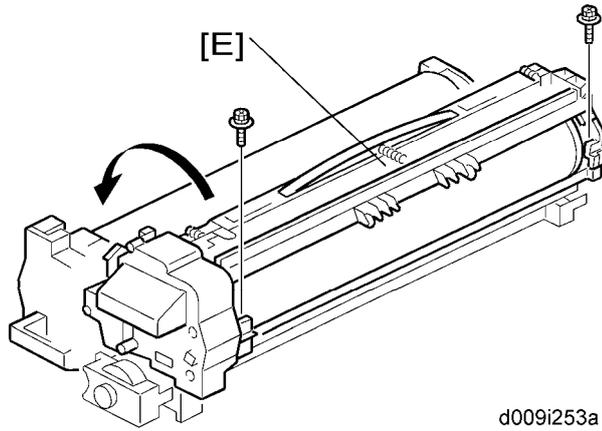

d009i253a

6. Open the PDCU [E] (⚙️ x 2).

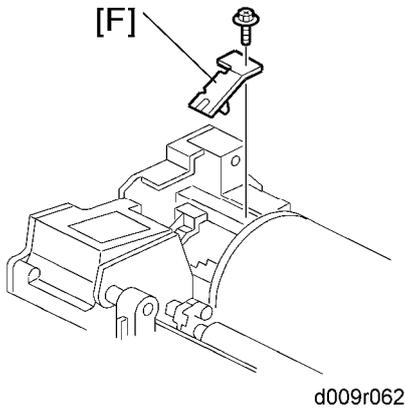

d009r062

7. Bracket [F] (⚙️ x 1)

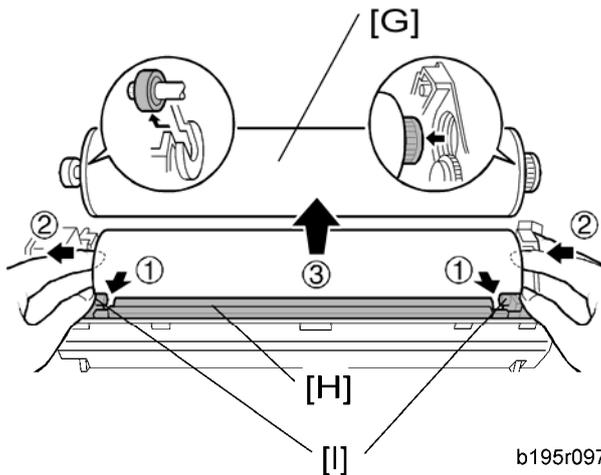

b195r097

8. Pull the drum [G] towards the front ② (the left side in the illustration) while releasing the charge roller [H] using the release levers ① [I], and then remove the drum ③.

⚠ CAUTION

- Never touch the drum surface with bare hands.

Re-installation

1. Replace the drum and close the PCDU (⚙ x 2).

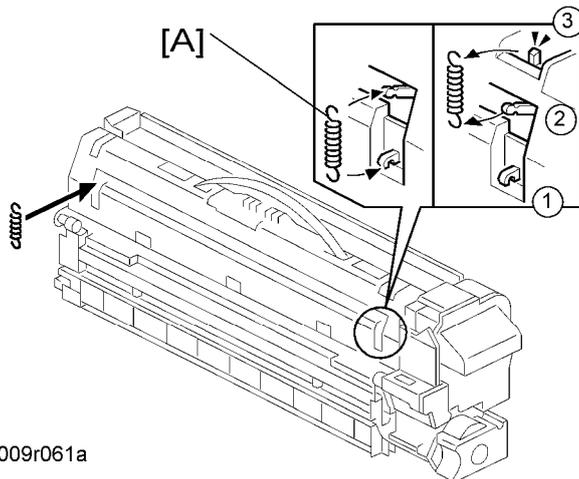

d009r061a

2. Put the opening cap [A in the previous procedure] back in its original place.
3. Detach the spring [A] from ②, ③ and re-attach it to ①, ②.

⚠ CAUTION

- You must re-attach the spring to ①, ② for the cleaning blade to operate correctly. If you fail to re-attach the spring to ① and ②, the movable cleaning blade will not contact the drum for cleaning, but the machine will operate without generating an error. However, copies will gradually become dirty due to toner collecting on the drum.
4. Re-attach the spring on the rear side of the PCDU.
 5. After replacing the drum, do these SPs:
 - SP 2001: Drum charge roller voltage – make sure that this is at the default setting
 - SP 3001-2: ID sensor initial setting
 - SP 2805: Process initial setting
 - SP 2810-1: Grayscale Setting

4.7.3 PICK-OFF PAWLS

1. Drum (☛ p.4-33)

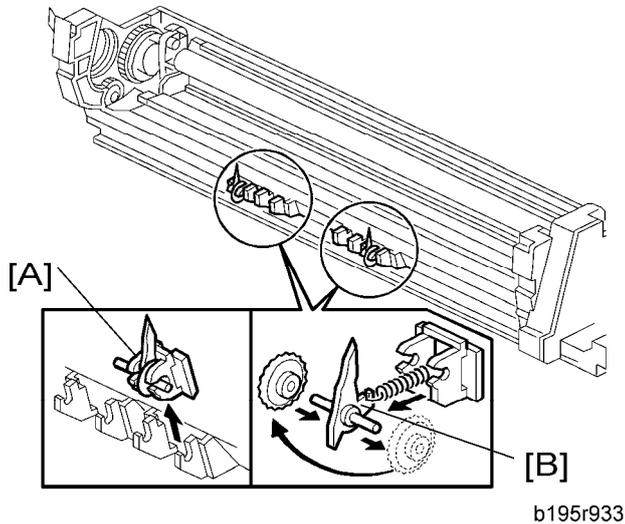

2. Pawl assembly [A]
3. Pick-off pawl [B] (spring x 1, spur x 1)

Pick-off Pawl Position Adjustment

If the pick-off pawl has marked the drum with a line, the pick-off pawl position can be adjusted using either method:

- Changing the spur position
- Changing the pick-off pawl assembly position

⚠ CAUTION

- After re-assembly, make sure that the front spring of the movable cleaning blade is re-attached to the ①, ② position. (☛ p.4-33)

4.7.4 CHARGE ROLLER AND CLEANING ROLLER

1. Drum (☛ p.4-33)

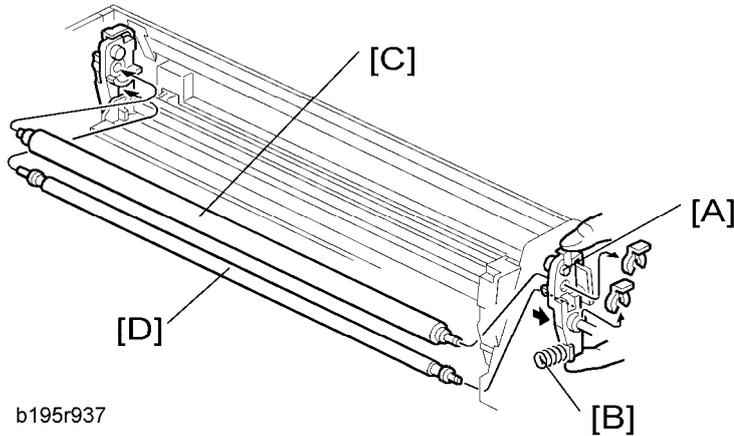

b195r937

2. Push the charge roller holder [A] toward the front of the drum unit (☛ x 2) and remove the spring [B].
3. Charge roller [C].

↓ Note

- Disengage the charge roller on the right side to remove it. Try to avoid touching the charge roller.

4. Cleaning roller [D]

↓ Note

- Disengage the cleaning roller on the left to remove it.

5. After replacing the charge roller and cleaning roller, check the value of SP2001-001. If it is not at the standard value (1500), set SP2001-001 to "1500".

↓ Note

- If this is not done, the carrier will be attracted to the drum because the charge roller voltage will be too high.

⚠ CAUTION

- After re-assembly, make sure that the front spring of the movable cleaning blade is re-attached to the ①, ② position. (☛ p.4-33)

4.7.5 DRUM CLEANING BLADE 1

1. Drum (☛ p.4-33)
2. Charge roller and cleaning roller (☛ p.4-37)

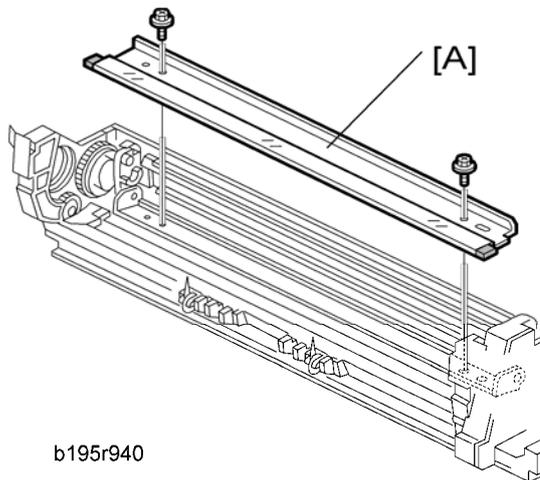

3. Remove drum cleaning blade 1 [A] (☛ x 2)

Re-installation

Put toner on the edge of cleaning blade 1 and the mylar at the back side of cleaning blade 1 before re-installing this blade.

⚠ CAUTION

- After re-assembly, make sure that the front spring of the movable cleaning blade is re-attached to the ①, ② position. (☛ p.4-33)

4.7.6 ID SENSOR

1. Left cover (☛ p.4-4)
2. Paper exit cover (☛ p.4-7)
3. Inner tray (☛ p.4-8)
4. Exhaust duct (☛ p.4-87)
5. PCDU (☛ p.4-32)
6. Fusing unit (☛ p.4-56)

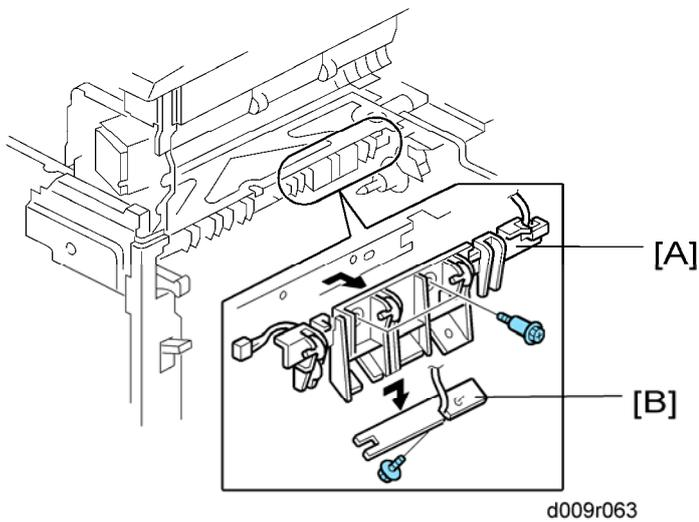

7. ID sensor bracket [A] (☛ x 2, ☛ x 1)
8. ID sensor [B] (☛ x 1)

Note

- Do SP3-001-002 to initialize the ID sensor after replacing.

4.8 DEVELOPMENT

4.8.1 DEVELOPMENT FILTER

1. PCDU (☛ p.4-32)
2. Open the PCDU. (☛ p.4-33)

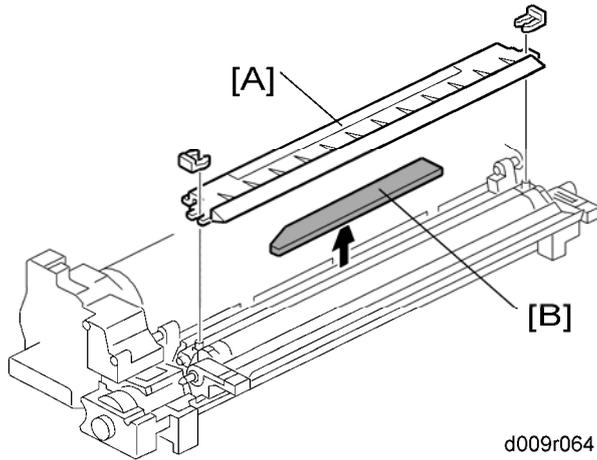

d009r064

3. Upper development cover [A] (☛ x2)
4. Development filter [B]

4.8.2 DEVELOPMENT ROLLER

1. PCDU (☛ p.4-32)
2. Open the PCDU. (☛ p.4-33)
3. Upper development cover (☛ p.4-40)

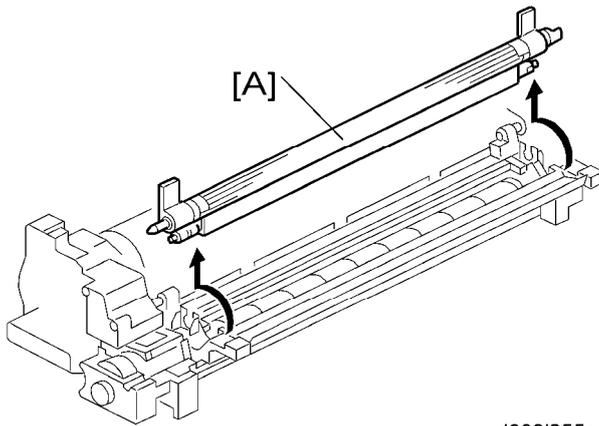

4. Development roller [A]



- Work carefully to avoid scratching or nicking the development roller.

Cleaning Procedure

1. PCDU (☛ p.4-32)

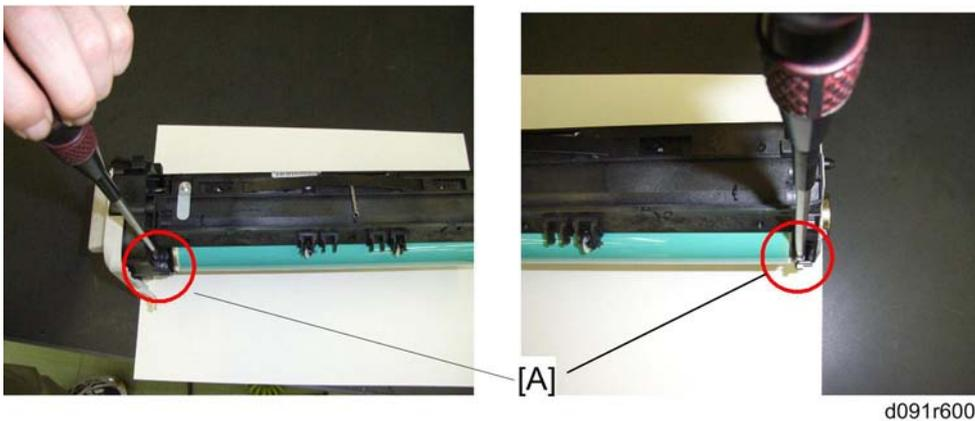

2. Remove the two screws [A] and open the PCDU as shown above.

Development

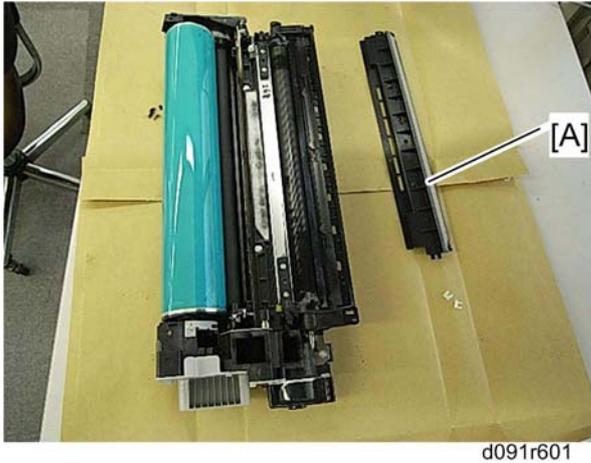

3. Remove the upper development cover [A] (☞ x 2).

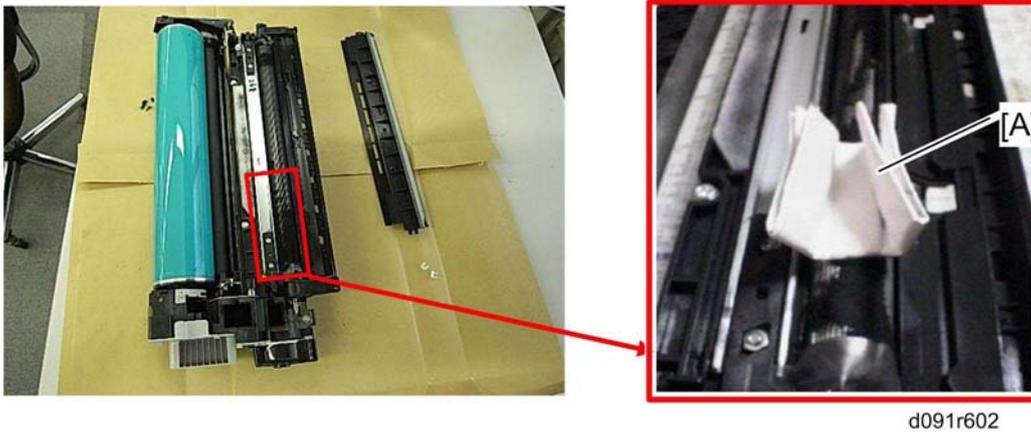

4. Fold up a sheet of copy paper [A] to fit the width of the uncovered area of the development roller, as shown below.
5. Slide the paper [A] along the length of the roller to clean the toner off the surface.

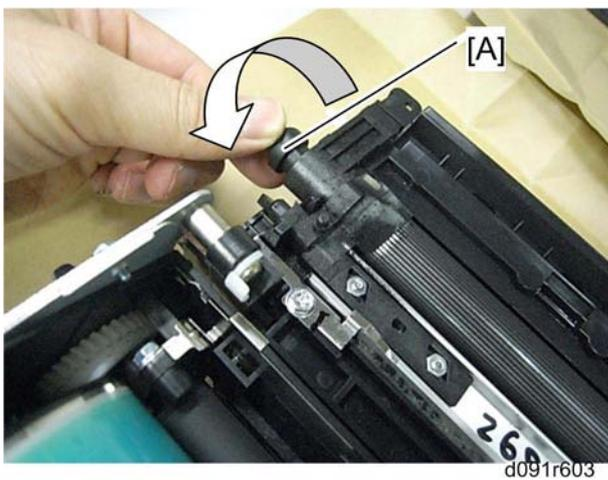

6. Rotate the development roller [A] in the direction of the arrow until the section you cleaned is no longer visible.

7. Repeat steps 5 and 6 until you have cleaned the entire surface of the roller.
8. Reassemble the PCDU and install the PCDU into the machine.

4.8.3 DEVELOPER

1. PCDU (☛ p.4-32)
2. Open the PCDU. (☛ p.4-33)
3. Development roller (☛ p.4-41)

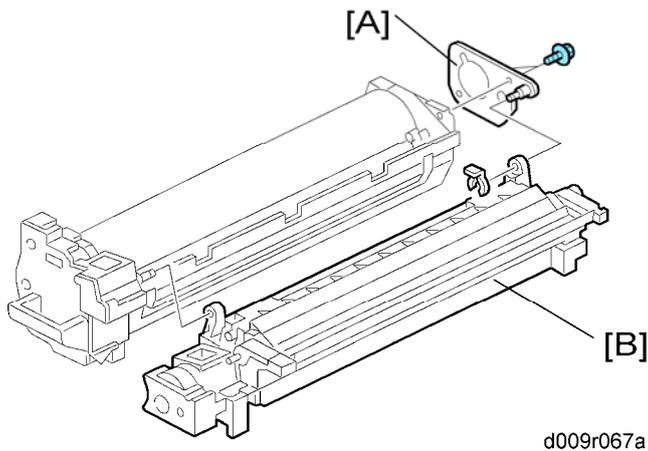

4. Joint bracket [A] (☛ x 2)
5. Development unit [B]

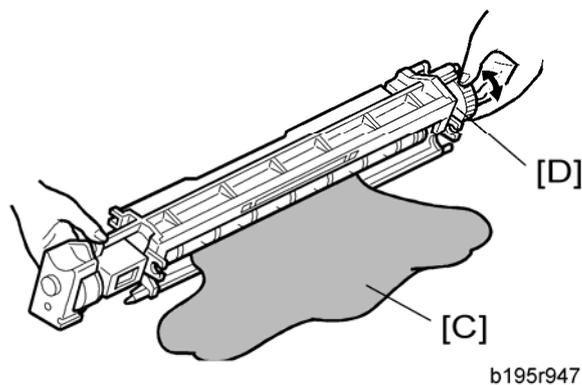

6. Tip out the old developer [C].
7. Turn drive gear [D] to ensure that no developer remains in the unit or on the developer roller.

↓ Note

- Dispose of the used developer in accordance with local regulations. Work carefully to avoid scratching or nicking the development roller.
8. Clean the development roller with a dry cloth.

Development

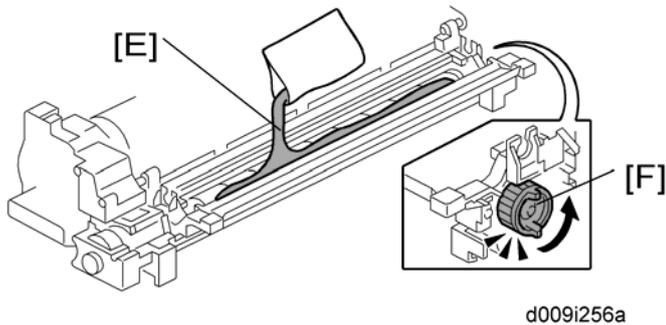

9. Pour approximately 1/3 of the developer [E] evenly along the length of the development unit.
10. Rotate the drive gear [F] to work the developer into the unit.
11. Repeat steps 8 and 9 until all toner is in the unit and level with the edges.
12. Re-install the development roller.

↓ Note

- Make sure that the seals at the both sides of the development roller are set inside the case after you re-install the development roller.

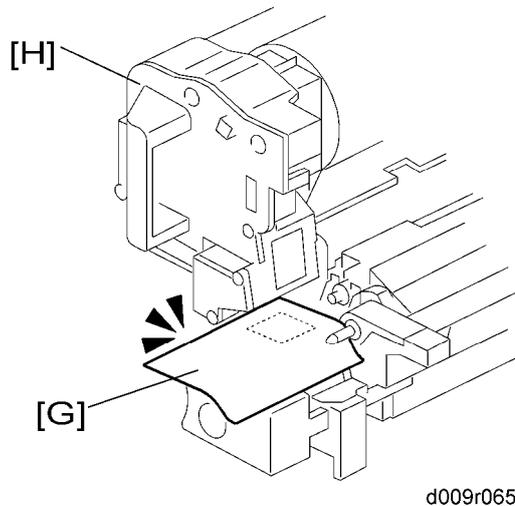

13. Place a piece of paper [G] over the toner entrance hole. This prevents used toner falling from the drum unit into the development unit during the TD sensor initial setting and interfering with the Vref setting (toner density reference voltage)
14. Secure the drum unit [H] to the development unit, to close the PCDU (🔩 x 2).
15. Install the PCDU in the machine and close the front and right doors.
16. Turn on the main power switch, and wait for the machine to warm up.
17. Do SP2801 to initialize the TD sensor and enter the developer lot number.
18. After performing the TD sensor initial setting, remove the sheet of paper from the PCDU.

4.8.4 TD SENSOR

1. PCDU (☛ p.4-32)
2. Empty all developer from the development unit. (☛ p.4-43)

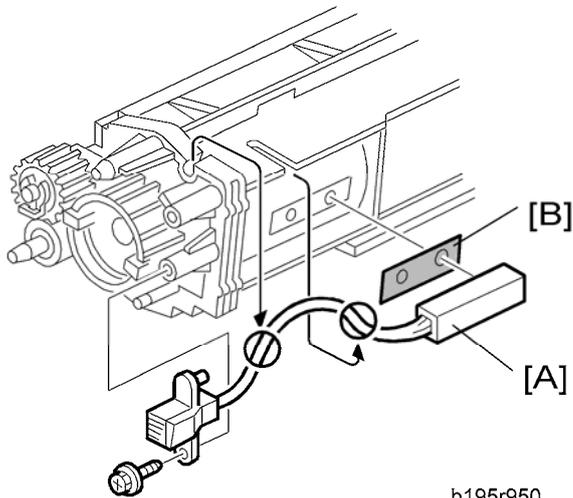

3. Seal
4. TD sensor [A] (☛ x1)

↓ Note

- The TD sensor is attached to the casing with double-sided tape [B]. Pry it off with the flat head of a screwdriver. Use fresh double-sided tape to re-attach the sensor.

5. Pour new developer into the development unit and perform the TD sensor initial setting using SP2-801.

↓ Note

- When performing the TD sensor initial setting, cover the toner entrance hole with a piece of paper.

4.9 TRANSFER

4.9.1 TRANSFER BELT UNIT

↓ Note

- To avoid exposing the drum to strong light, cover it with paper if the right cover will be open for a long period.

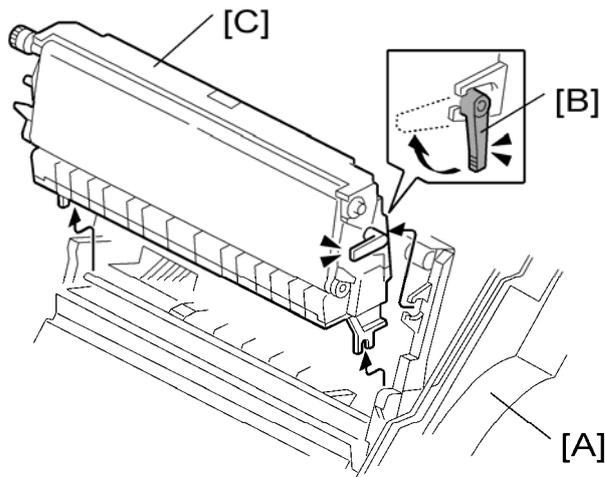

d009r025

1. Open the right door [A].
2. Release the lever [B].
3. Transfer belt unit [C]

↓ Note

- Avoid touching the transfer belt surface.

4.9.2 TRANSFER BELT

1. Transfer belt unit (☛ p.4-46)

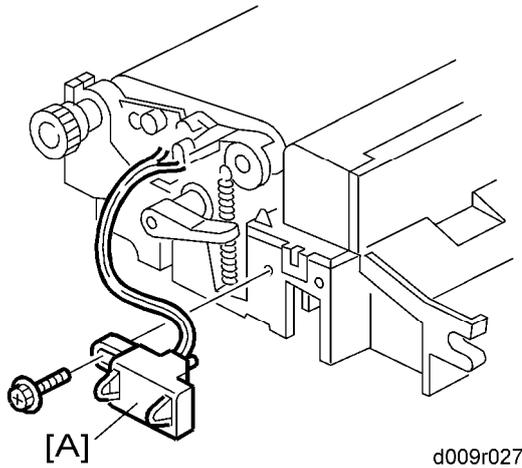

2. Connector [A] (☛ x 1)

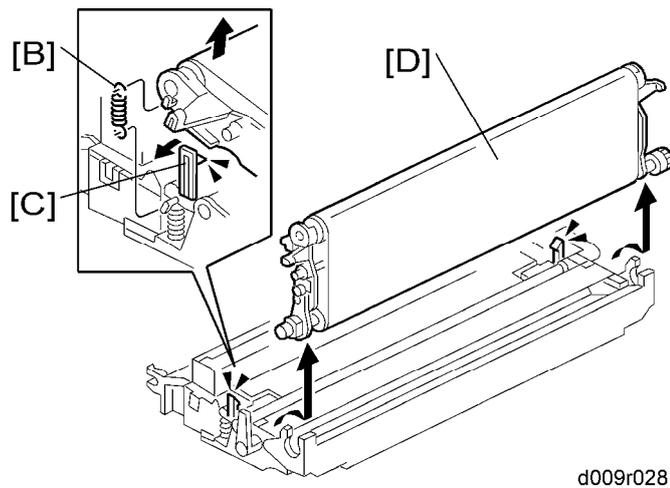

3. Remove the springs (front and rear) [B].
4. Release the hooks (front and rear) [C].
5. Transfer belt with rollers [D]

Transfer

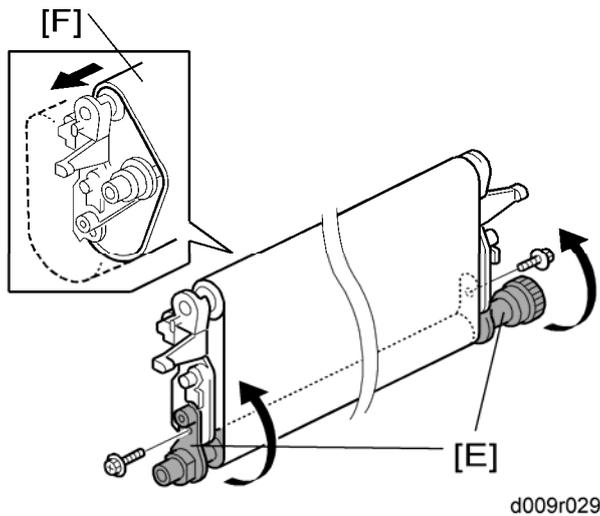

6. Lay the transfer belt with rollers on a flat clean surface, and fold the unit [E] to release the tension on the belt (⚙ x 2).

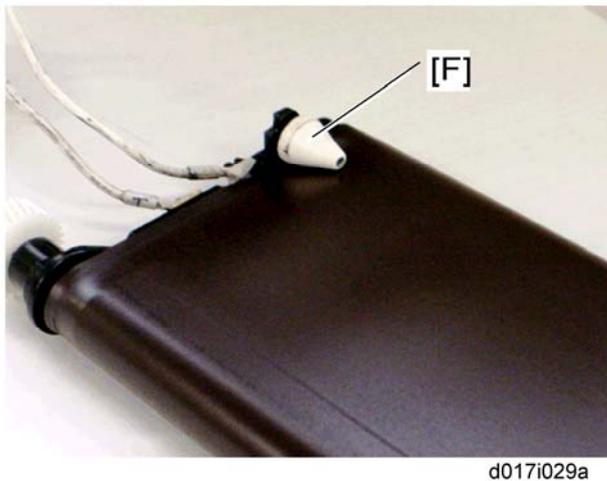

7. Transfer belt [F]

↓ Note

- Avoid touching the transfer belt surface.
- Before installing the new transfer belt, clean all the rollers and shafts with alcohol to prevent the belt from slipping.
- When reinstalling the transfer belt, make sure that the belt is under the pin [F].
- To avoid damaging the transfer belt during installation, manually turn the rollers and make sure that the new transfer belt is not running over the edges of any of the rollers.

4.9.3 TONER OVERFLOW SENSOR

1. Transfer belt unit (☞ p.4-46)

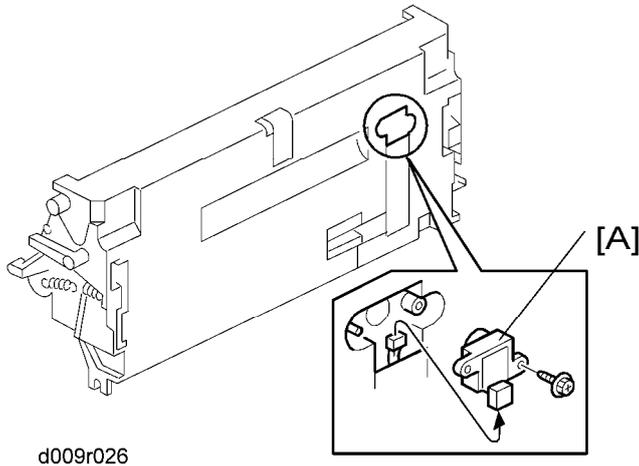

2. Toner overflow sensor [A] (☞ x 1, ☞ x 1)

4.9.4 TRANSFER BELT CLEANING BLADE

1. Transfer belt unit (☞ p.4-46)
2. Transfer belt (☞ p.4-47)

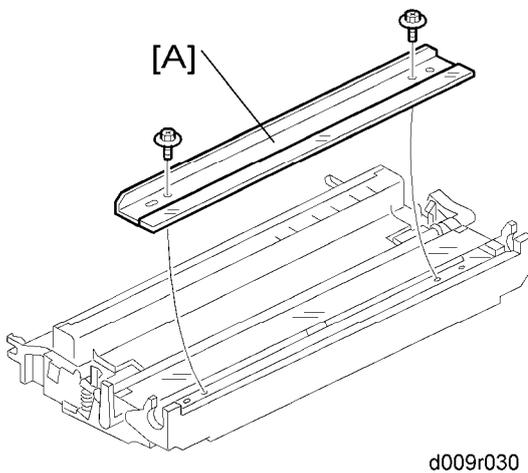

3. Transfer belt cleaning blade [A] (☞ x 2)

↓ Note

- Avoid touching the edge of the new blade. Check the new blade for dust or damage.

4.10 PAPER FEED

4.10.1 PAPER FEED UNIT

Tray 1 and Tray 2

1. Rear cover (🔧 p.4-4)
2. Right rear cover (🔧 p.4-5)
3. Duplex unit (🔧 p.4-70)
4. Pull out tray 1 and tray 2.

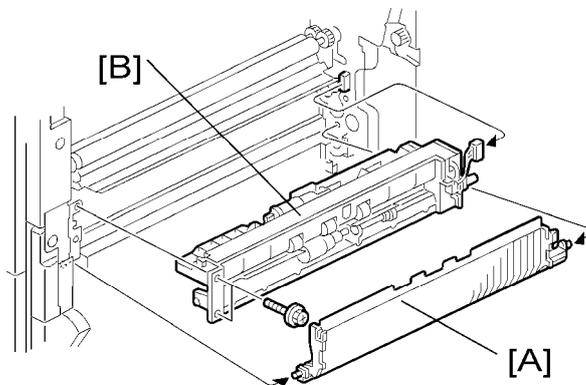

b222r138

5. Paper guide plate [A] (hook x 2)
6. Paper feed unit [B] (🔧 x 2, 📄 x 1)

4.10.2 PICK-UP, FEED AND SEPARATION ROLLERS

Tray 1 and Tray 2

1. Paper feed unit (☛ p.4-50)

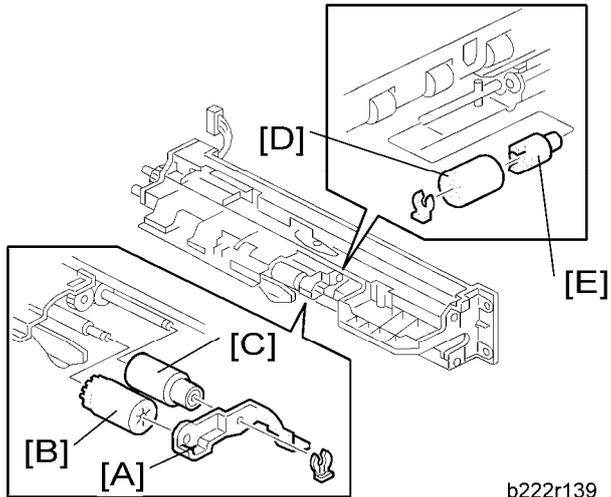

2. Roller holder [A] (☛ x 1)
3. Pick-up roller [B]
4. Feed roller [C]
5. Separation roller [D] and torque limiter [E] (☛ x 1)

4.10.3 TRAY LIFT MOTOR

1. Rear cover (🔧 p.4-4)

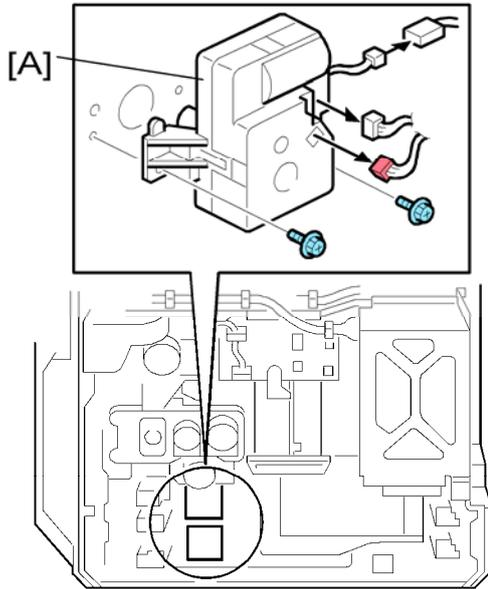

d009r013

2. Tray lift motor 1 or 2 [A] (🔧 x 2, 📦 x 3)

4.10.4 RELAY, TRAY LIFT, PAPER END AND PAPER FEED SENSORS

Tray 1 and Tray 2

1. Rear cover (☛ p.4-4)
2. Right rear cover (☛ p.4-5)
3. Duplex unit (☛ p.4-70)
4. Paper feed unit (☛ p.4-50)

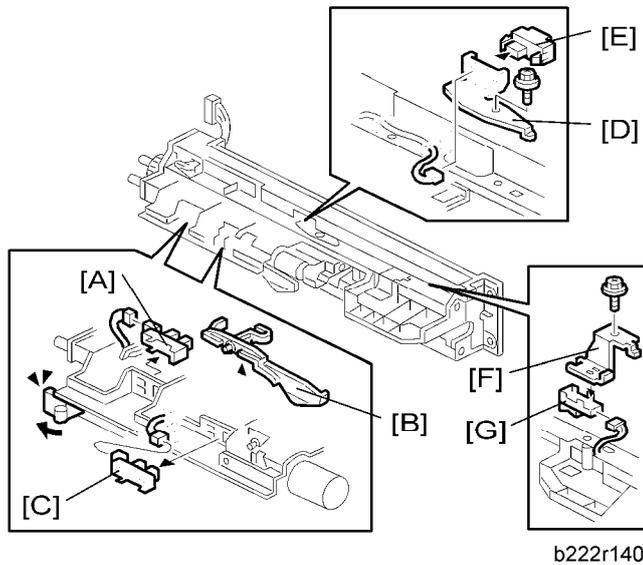

5. Tray lift sensor [A] (☛ x 1)
6. Paper end feeler [B] and paper end sensor [C] (hook, ☛ x 1 each)
7. Relay sensor bracket [D] (☛ x 1)
8. Relay sensor [E] (☛ x 1, hook)
9. Paper feed sensor bracket [F] (☛ x 1)
10. Paper feed sensor [G] (☛ x 1, hook)

4.10.5 REGISTRATION SENSOR

1. Rear cover (☛ p.4-4)
2. Right rear cover (☛ p.4-5)
3. Duplex unit (☛ p.4-70)
4. Paper feed unit for tray 1 (☛ p.4-50)
5. Paper Trays 1 and 2

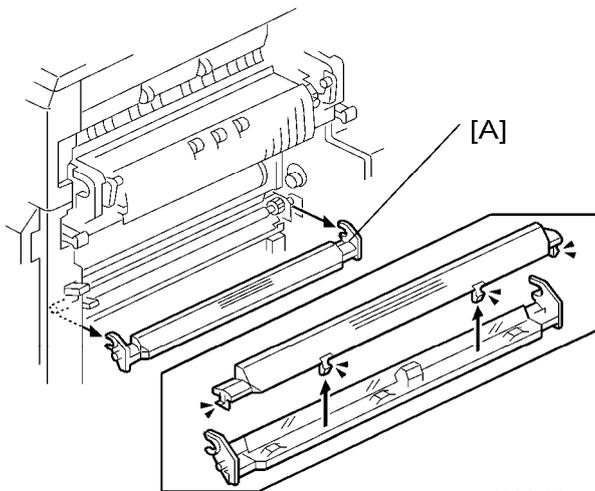

d009r024

6. Paper dust box [A]

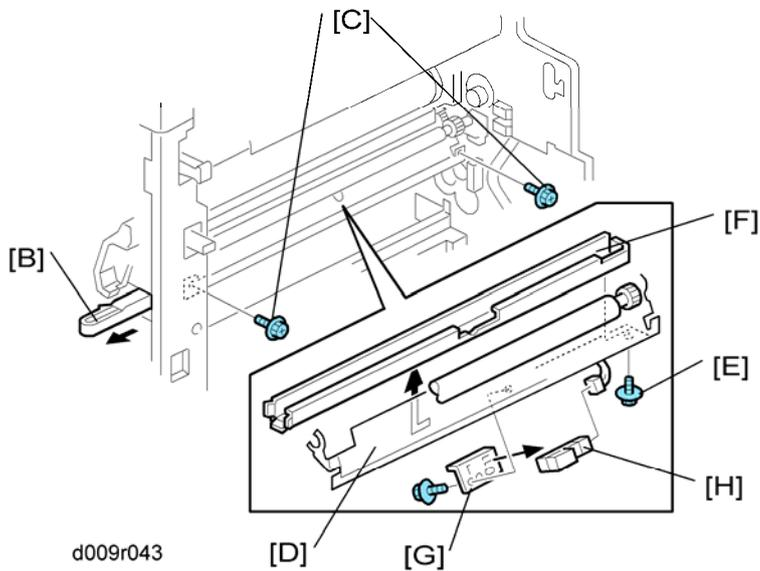

d009r043

7. Pull out the paper dust container [B].
8. Remove two screws [C].

 Note

- This makes the paper guide [D] tilt a little bit. Now you can access the screw [E].

9. Dust container rail [F]  [E] x 1)

10. Sensor bracket [G]  x 1)

 Note

- You can only access the screw on the sensor bracket from the inside (paper tray location) of the machine.

11. Registration sensor [H]  x 1, hooks)

Reinstall the registration sensor

It is very difficult to secure the sensor bracket to the frame. First attach the sensor bracket with tape temporarily.

4.11 FUSING

4.11.1 FUSING UNIT

⚠ CAUTION

- Turn off the main switch and wait until the fusing unit cools down before beginning any of the procedures in this section. The fusing unit can cause serious burns.

1. Turn off the main power switch.
2. Open the right door.

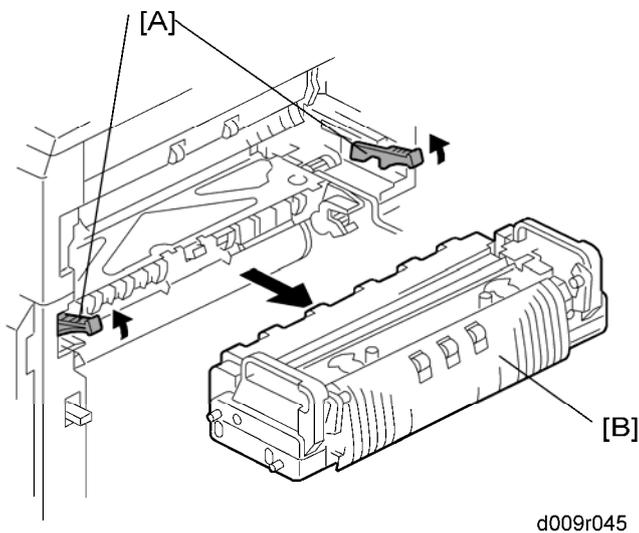

3. Pull up the lock levers [A].
4. Pull the fusing unit [B] until you hear a click.

↓ Note

- The lock levers lock the fusing unit again at this time to prevent the fusing unit from falling down.
5. Pull up the lock levers [A] again, and then remove the fusing unit [B].

4.11.2 WEB ROLLER UNIT

1. Fusing unit (☛ p.4-56)

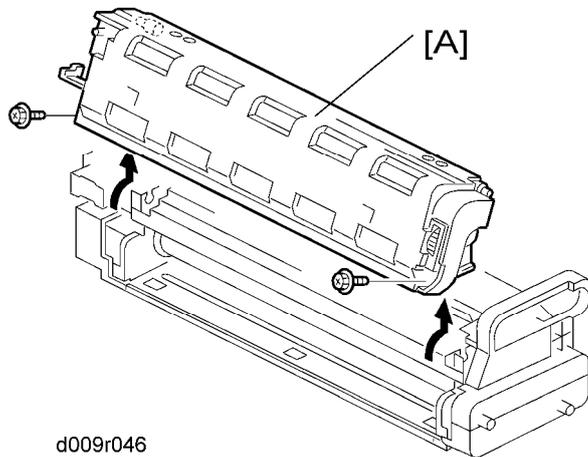

2. Web roller unit [A] (☛ x 2)

4.11.3 BRAKE PAD

1. Web roller unit (☛ p.4-57)

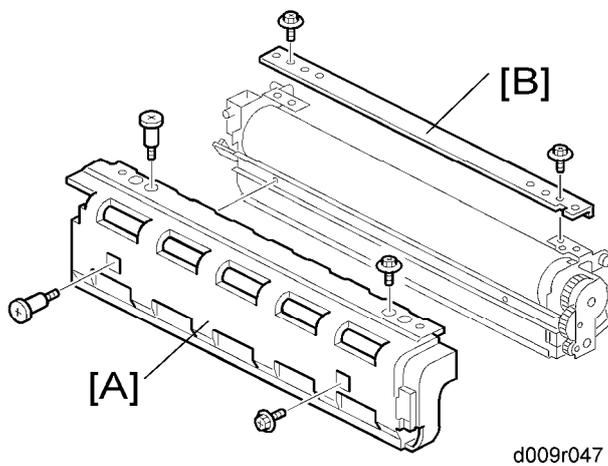

2. Web left cover [A] (front: ☛ x 2, rear: stepped screw x 2)
3. Web top frame [B] (☛ x 2)

Fusing

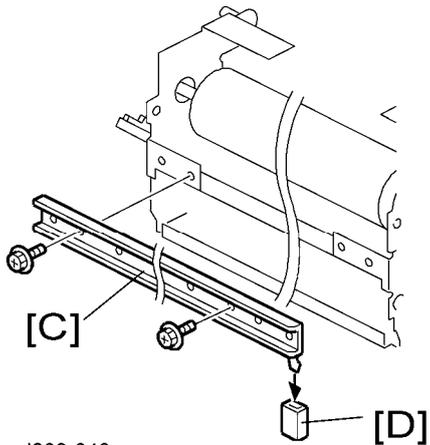

d009r048a

4. Web left frame [C] (🔩 x 2)
5. Brake pad [D]

4.11.4 WEB HOLDER ROLLER AND WEB ROLLERS

1. Web roller unit (🔩 p.4-57)
2. Web left cover (🔩 p.4-57)
3. Web top frame (🔩 p.4-57)
4. Web left frame (🔩 p.4-57)

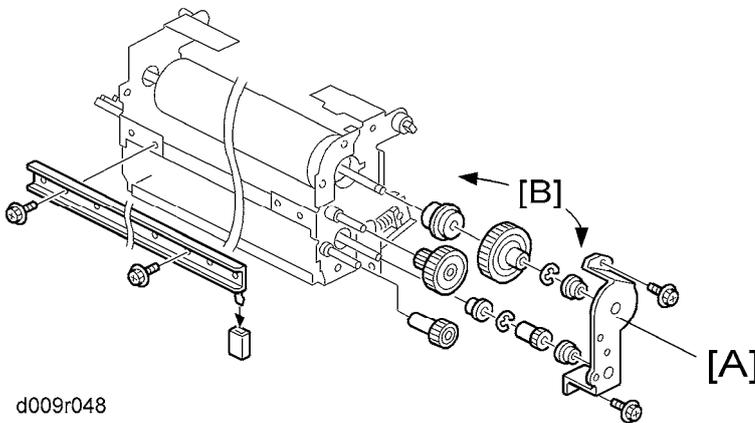

d009r048

5. Front gear bracket [A] (🔩 x 2)
6. All gears and bushings (rear side) [B] (Ⓒ x 2)

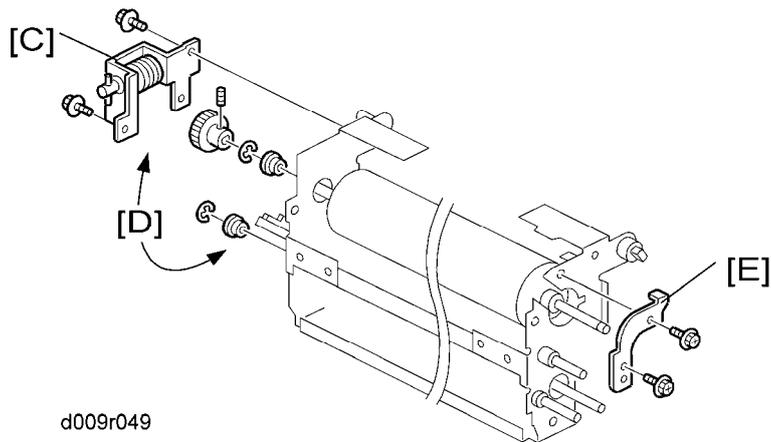

7. Rear gear bracket [C] (🔩 x 2)
8. All gear and bushings (rear side) [D] (Ⓒ x 2, spring x 1)
9. Front bracket [E] (🔩 x 2)

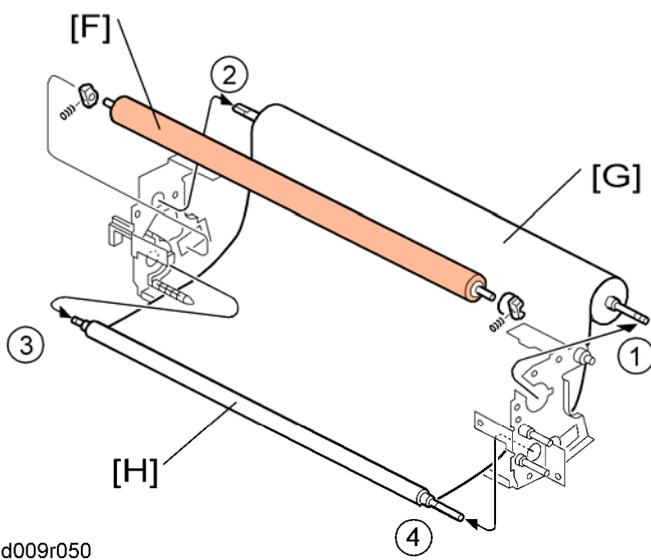

10. Web holder roller [F] (holder x 2, spring x 2)
11. Web take up roller [G] (① → ②)
12. Web supply roller [H] (③ → ④)

Fusing

Installing a new web holder roller

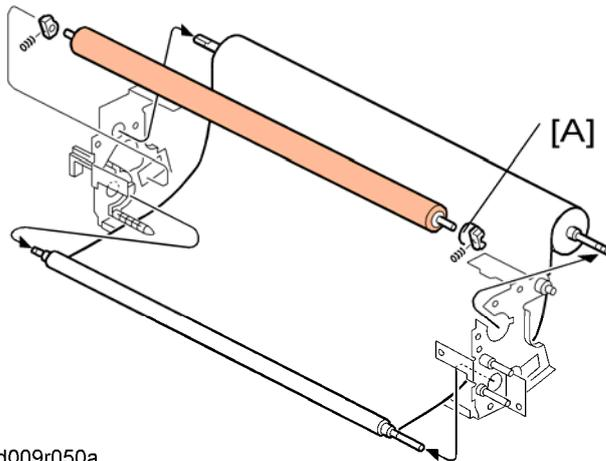

d009r050a

The holder [A] has a one-way clutch. Make sure that the holder [A] is set at the front side.

Installing new web rollers

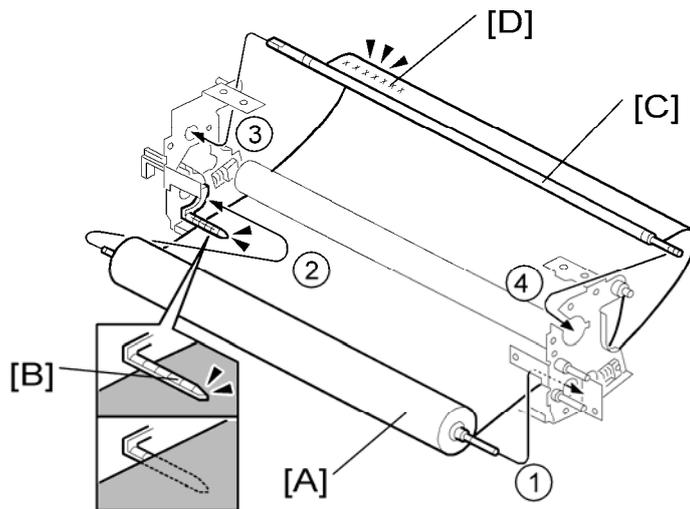

d009r051

1. Install the web supply roller [A] first (① → ②). Make sure that the web sheet is under the pin [B].
2. Install the web take up roller [C] (③ → ④). Make sure that the printed number [D] is outside the web take up roller.
3. Reinstall the rear gear bracket (🔧 p.4-58).
4. Reinstall the front and rear gears and bushings (🔧 p.4-58).
5. Reinstall the rear gear bracket (🔧 p.4-58).

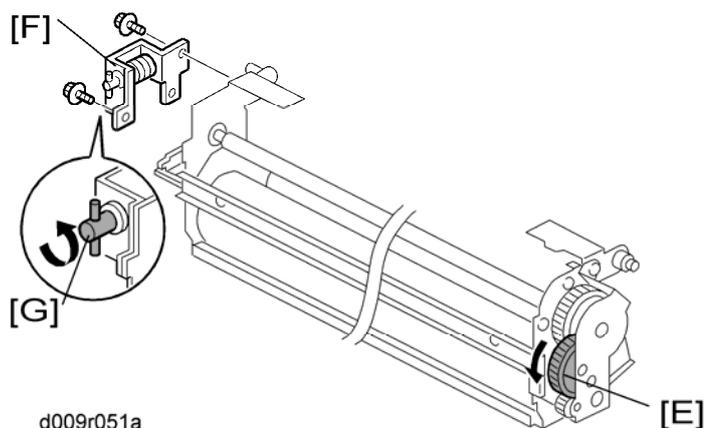

6. Turn the rear gear [E] in the arrow direction to remove the slack in the web sheet.
7. Reinstall the front gear bracket [F] (☛ p.4-58).
8. Turn the coupling [G] in the arrow direction to remove the slack in the web sheet.
9. Reinstall the web unit.
10. If you install a new cleaning web, reset SP 7806-008 (press "Execute" on the LCD).

4.11.5 PRESSURE ROLLER CLEANING ROLLER

1. Fusing unit (☛ p.4-56)

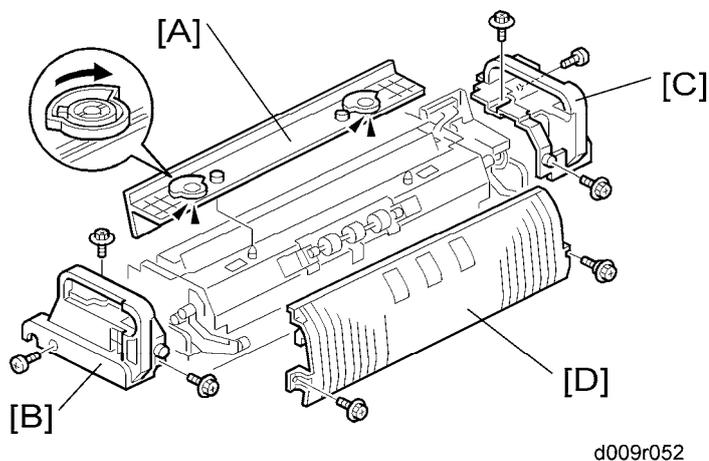

2. Fusing exit guide [A] (lock x 2)
3. Fusing front upper cover [B] (☛ x 3)
4. Fusing rear upper cover [C] (☛ x 3)
5. Fusing outer guide [D] (front: ☛ x 1, rear: stepped screw x 1)

Fusing

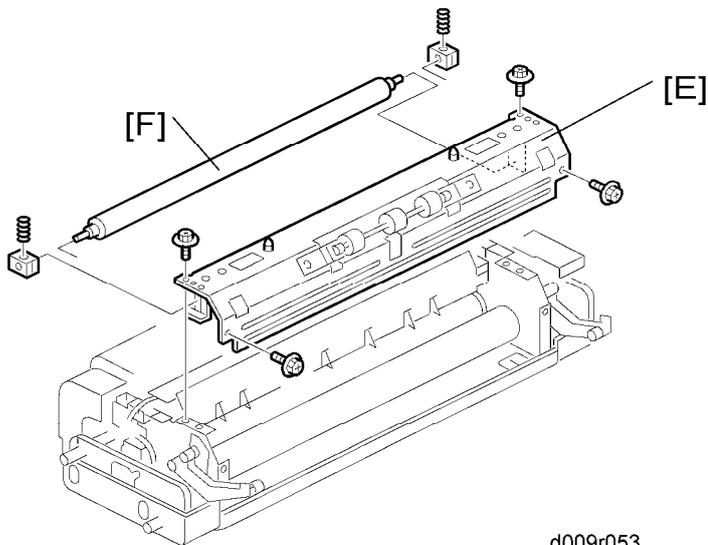

d009r053

6. Cleaning roller unit [E] (🔩 x 4)
7. Pressure roller cleaning roller [F] (spring x 2, holder x 2)

4.11.6 THERMOSTAT

1. Fusing unit (🔧 p.4-56)
2. Web roller unit (🔧 p.4-57)

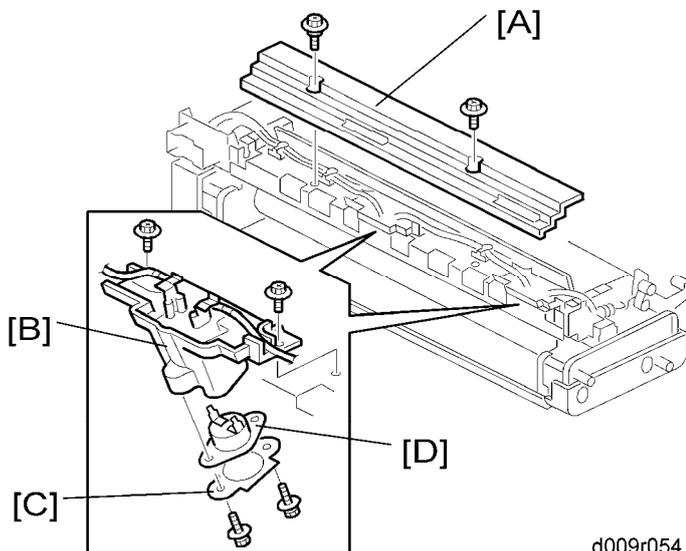

d009r054

3. Fusing top cover [A] (front: 🔩 x 1, rear: stepped screw x 1)
4. Thermostat holder [B] (🔩 x 2)
5. Thermostat cover [C] (🔩 x 2)
6. Thermostat [D] (terminal x 2)

4.11.7 THERMISTOR

1. Fusing unit (☛ p.4-56)
2. Web roller unit (☛ p.4-57)
3. Fusing top cover (☛ p.4-62)

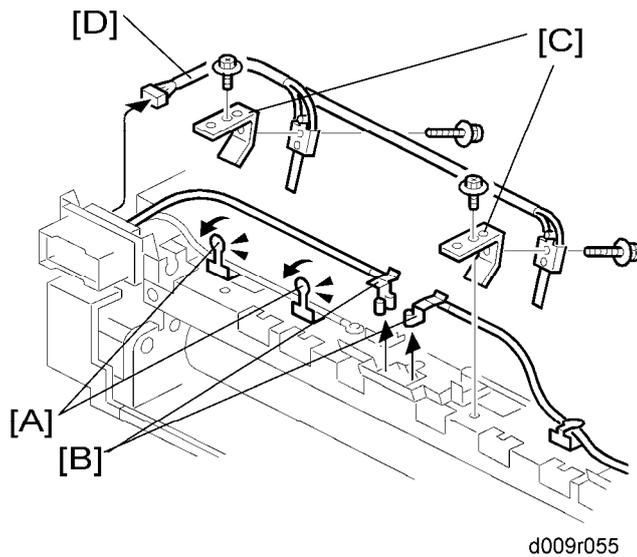

4. Pull the two tabs [A].
5. Disconnect the two terminals [B].
6. Sensor stays [C] (☛ x 1 each)
7. Thermistors [D] (☛ x 2, ☛ x 1)

Fusing

4.11.8 HOT ROLLER STRIPPERS

1. Fusing unit (☛ p.4-56)
2. Web roller unit (☛ p.4-57)
3. Fusing top cover (☛ p.4-62)

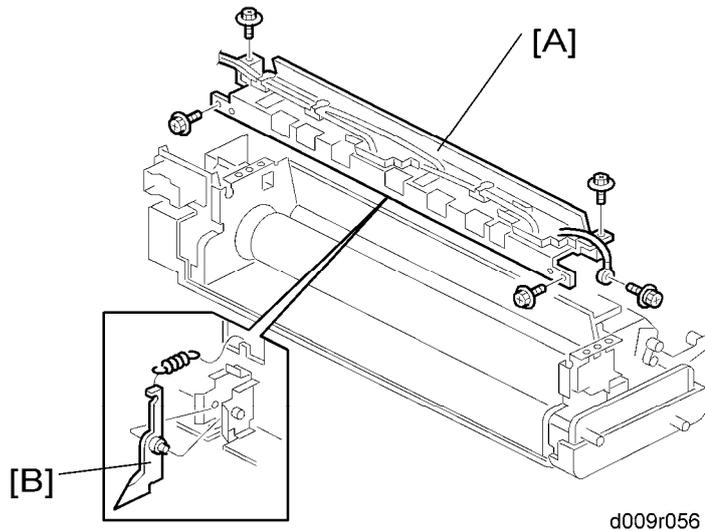

4. Fusing top frame [A] (☛ x 5)

↓ Note

- The cords on this frame are still connected to the fusing unit at this time. Be careful not to damage the cords when removing the hot roller stripper [B].

5. Hot roller stripper [B] (spring x 1)

4.11.9 FUSING LAMPS

1. Fusing unit (☛ p.4-56)
2. Web roller unit (☛ p.4-57)
3. Fusing top cover (☛ p.4-62)

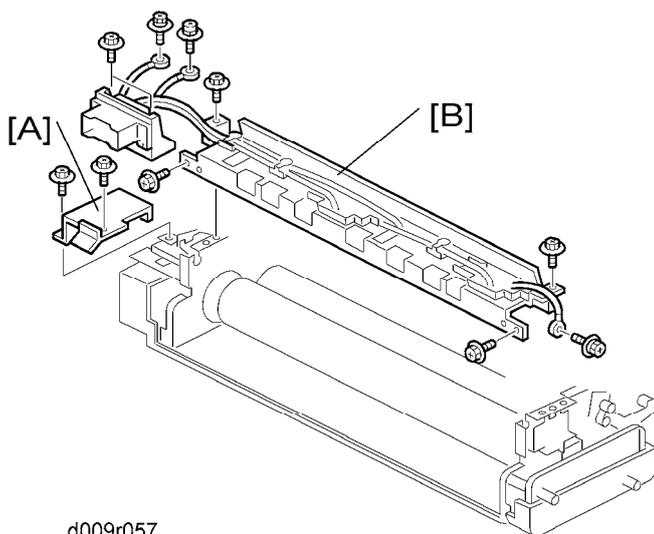

d009r057

4. Connector cover [A] (☛ x 2)
5. Fusing top frame with connector [B] (☛ x 9)

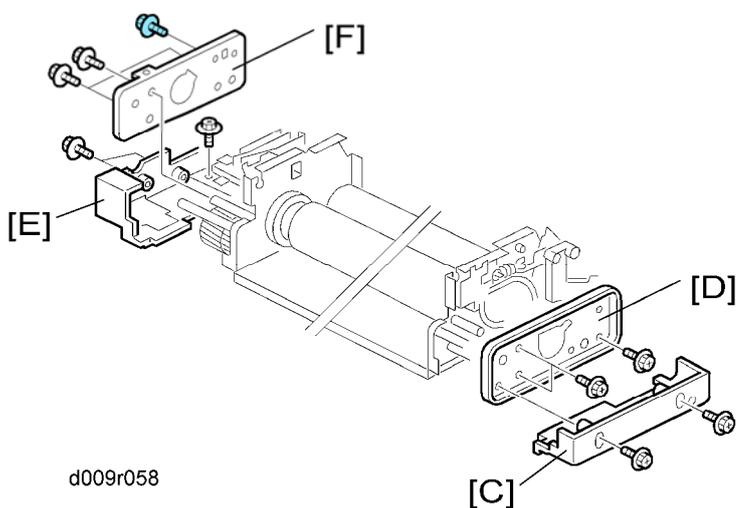

d009r058

6. Fusing front lower cover [C] (☛ x 2)
7. Fusing front frame [D] (☛ x 3)
8. Fusing rear lower cover [E] (☛ x 2)
9. Fusing rear frame [F] (☛ x 5)

Fusing

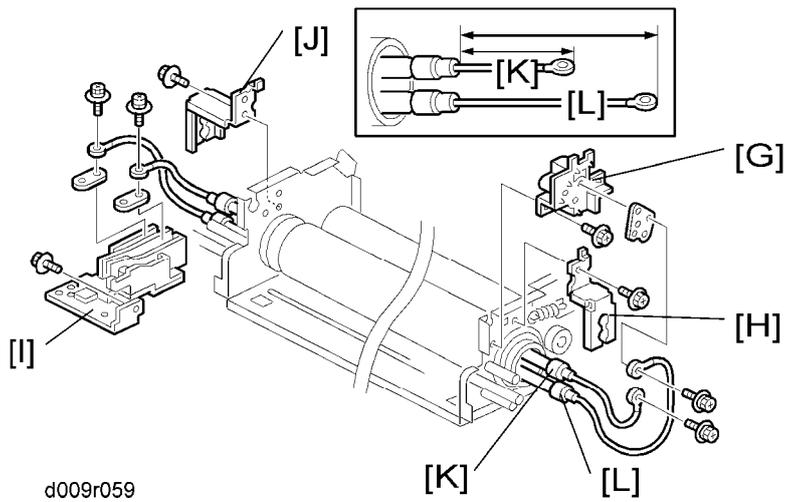

10. Terminal bracket [G] (🔩 x 4)
11. Front holder bracket [H] (🔩 x 1)
12. Terminal base [I] (🔩 x 3)
13. Rear holder bracket [J] (🔩 x 1)
14. Fusing lamp-Center (550W) [K]
15. Fusing lamp-End (750W) [L]

4.11.10 HOT ROLLER AND PRESSURE ROLLER

1. Fusing lamps-Center and End (🔩 p.4-65)

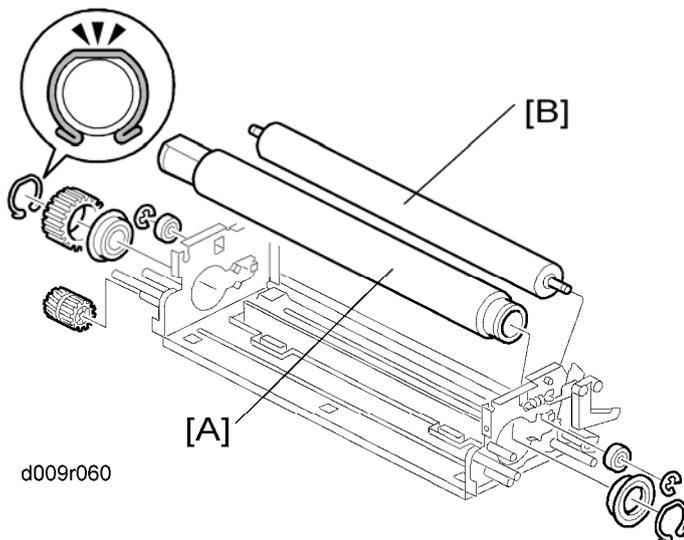

2. Hot roller [A] (snap ring x 2, gear x 2, bushing x 2)
3. Pressure roller [B] (🌀 x 2, bushing x 2)

4.12 PAPER EXIT

4.12.1 PAPER EXIT UNIT

1. Fusing unit (☛ p.4-56)
2. Fusing exhaust fan duct (☛ p.4-95)

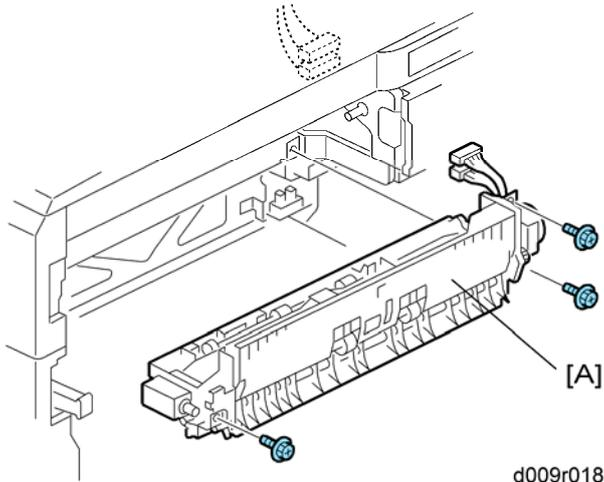

3. Paper exit unit [A] (☛ x 3, ☛ x 2)

4.12.2 FUSING EXIT, PAPER OVERFLOW, AND PAPER EXIT SENSORS

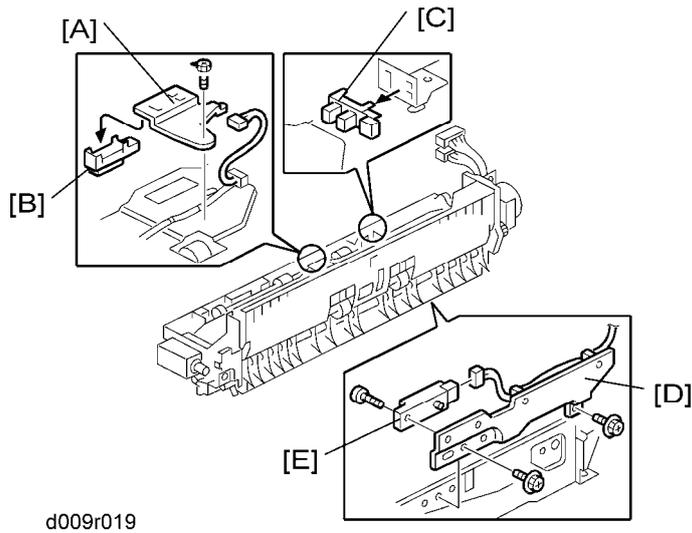

Paper Exit

Paper Exit Sensor

1. Paper exit unit (🔌 p.4-67)
2. Sensor bracket [A] (🔩 x 1)
3. Paper exit sensor [B] (🔌 x 1, hooks)

Paper Overflow Sensor

1. Paper exit unit (🔌 p.4-67)
2. Paper overflow sensor [C] (🔌 x 1, hooks)

Fusing Exit Sensor

1. Paper exit unit (🔌 p.4-67)
2. Sensor bracket [D] (🔩 x 2)
3. Fusing exit sensor [E] (🔌 x 1, 📌 x 1)

4.12.3 JUNCTION JAM SENSOR

1. Paper exit unit (🔌 p.4-67)

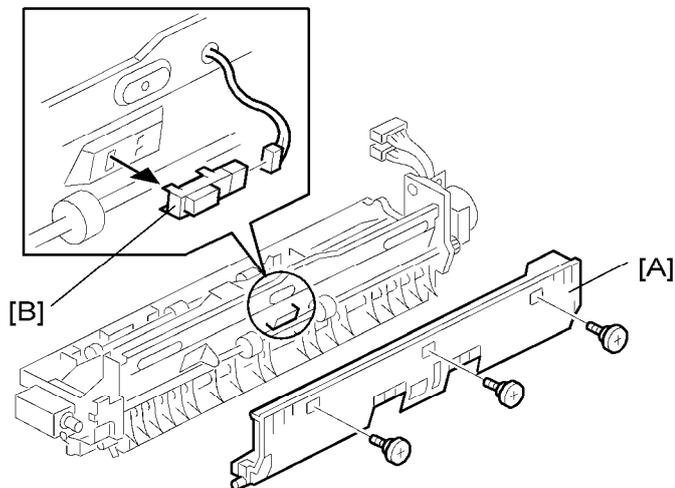

d009r020

2. Paper guide [A] (🔩 x 3)
3. Junction jam sensor [B] (🔌 x 1)

4.12.4 PAPER EXIT MOTOR

1. Paper exit unit (🔧 p.4-67)

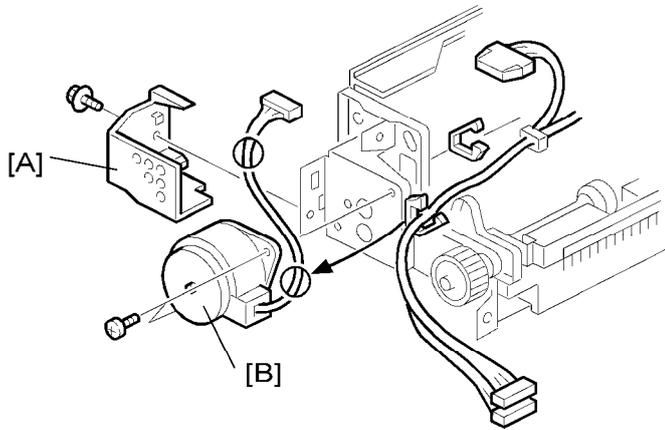

d009r021

2. Motor cover [A] (🔧 x 1)
3. Paper exit motor [B] (🔧 x 2, 🛠️ x 2, 🛠️ x 1)

Duplex

4.13 DUPLEX

4.13.1 DUPLEX UNIT

1. Rear cover (☛ p.4-4)
2. Right rear cover (☛ p.4-5)

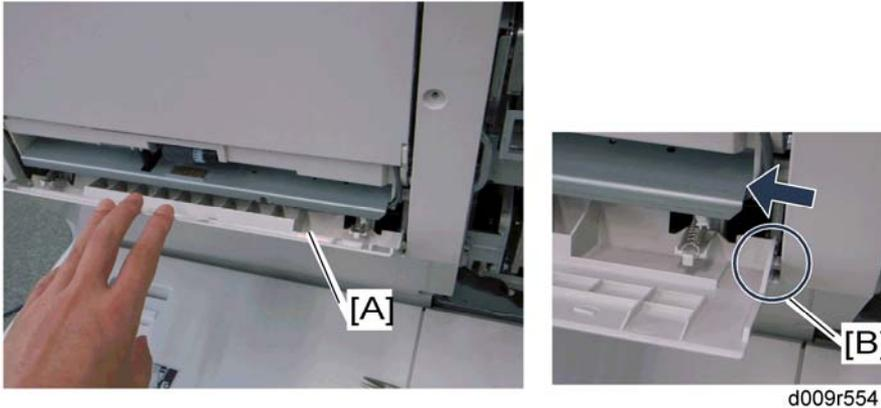

3. Open the lower door [A] at the duplex unit.
4. Release the tab [B] and remove the lower door (spring x 2).
5. Open the right door.

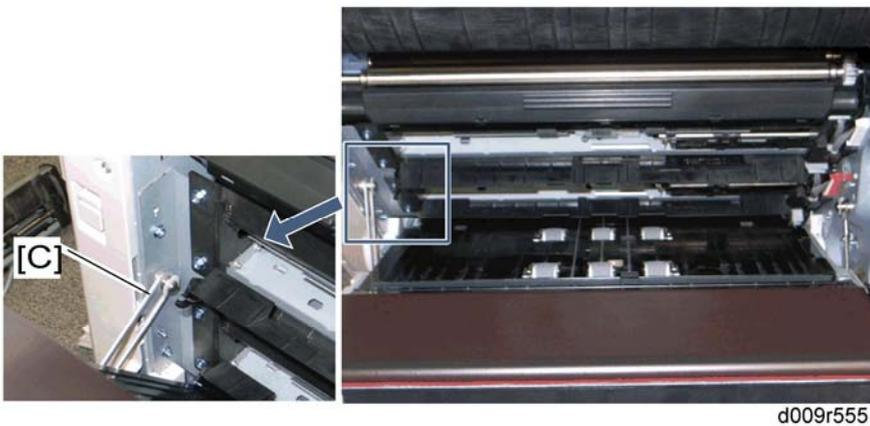

6. Release the front link [C] (☛ x 1).



d009r557

7. Keep the right door fully open.

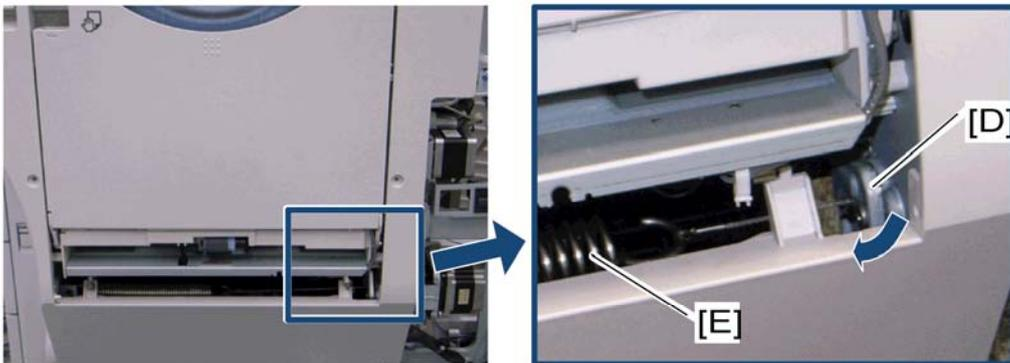

d009r556

8. Push up the duplex unit a little bit, while pressing the bracket [D] to lock the spring [E].

Note

- Do not let the duplex unit open fully before releasing the wire (step 9). Otherwise, the lock for the spring [E] is released.

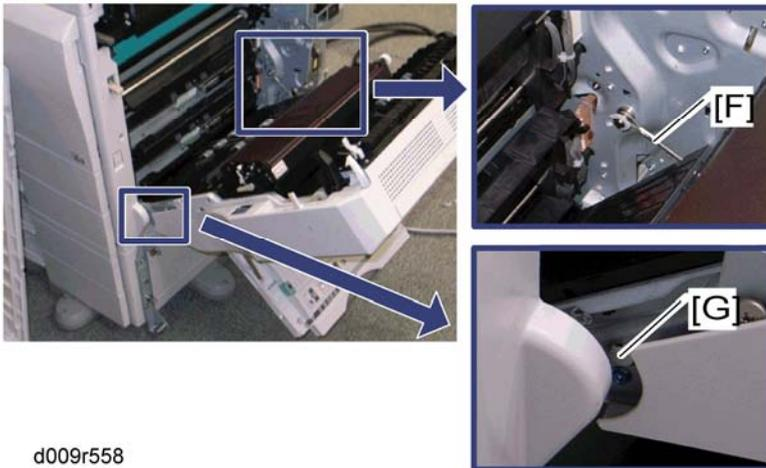

d009r558

9. Wire [F] (⌀ x 1)

Duplex

10. Push the projection [G].
11. Duplex unit ( x 3, ground cable x 1)

4.13.2 RIGHT DOOR COVER

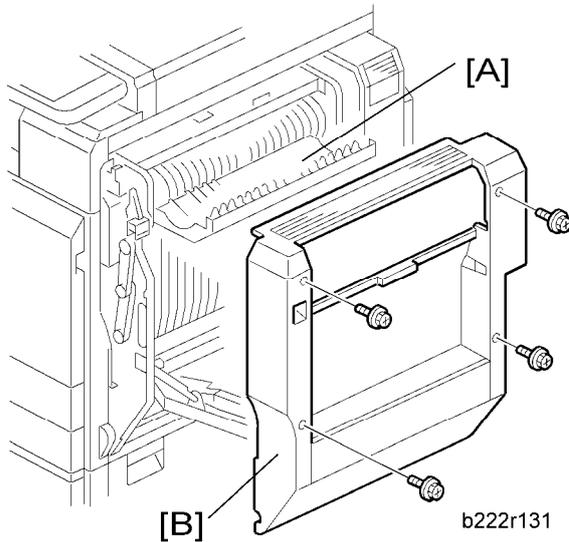

1. Open the duplex door [A] and by-pass tray.
2. Right door cover [B] ( x 4)

4.13.3 DUPLEX DOOR SENSOR

1. Right door cover ( p.4-70)
2. Open the right door.

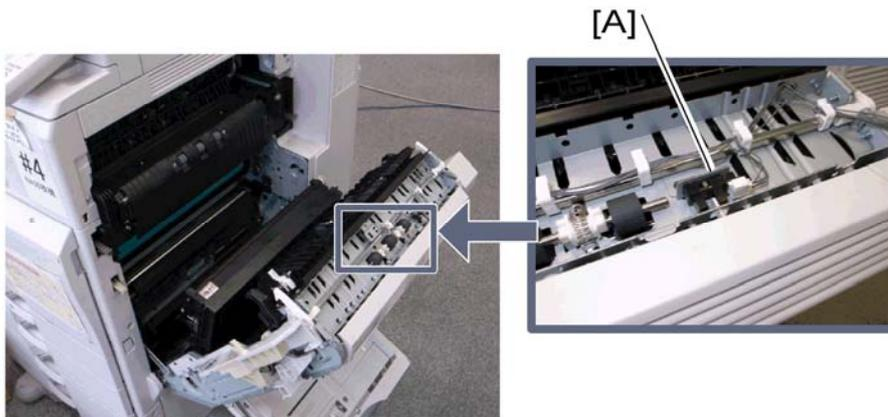

d009r599

3. Duplex door sensor [A] ( x 1, hook)

4.13.4 DUPLEX ENTRANCE SENSOR

1. Right door cover (☛ p.4-70)
2. Open the right door.

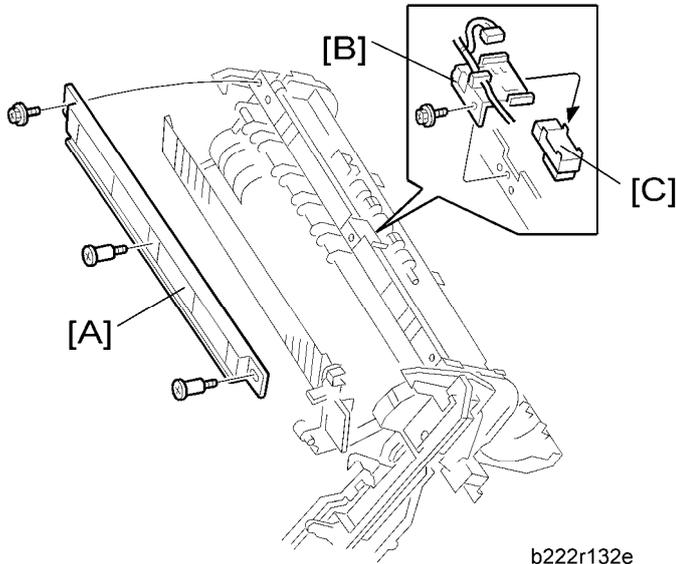

3. Duplex entrance guide [A] (☛ x1, stepped screw x 2)
4. Duplex entrance sensor bracket [B] (☛ x 1, ☛ x 1)
5. Duplex entrance sensor [C] (hooks)

4.13.5 DUPLEX EXIT SENSOR

1. Transfer belt unit (☛ p.4-46)

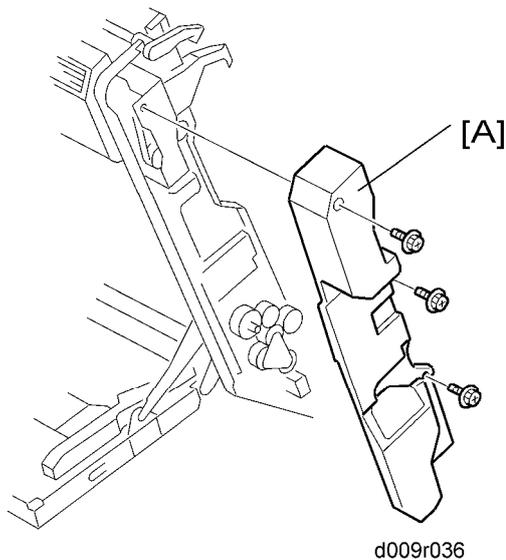

Duplex

2. Right door rear cover [A] (🔩 x 3)

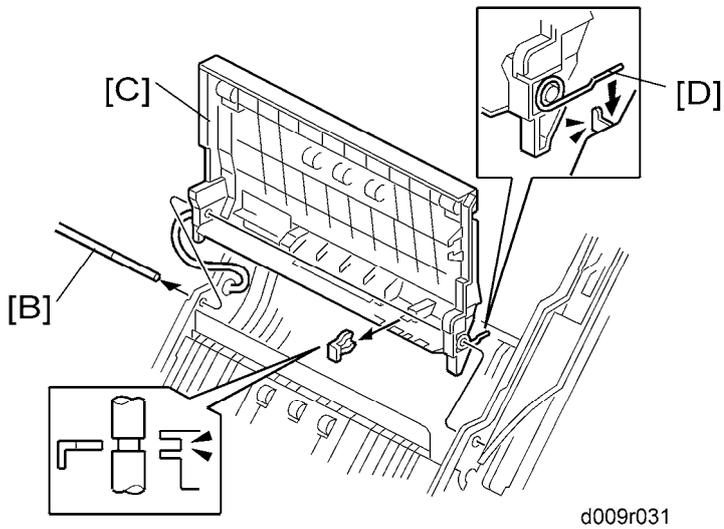

3. Remove the shaft [B] (🔩 x 1).
4. Transfer belt unit holder [C] (🔩 x 1, 📐 x 1)

↓ Note

- When re-installing the transfer belt unit holder, make sure that the spring [D] correctly hooks onto the frame.

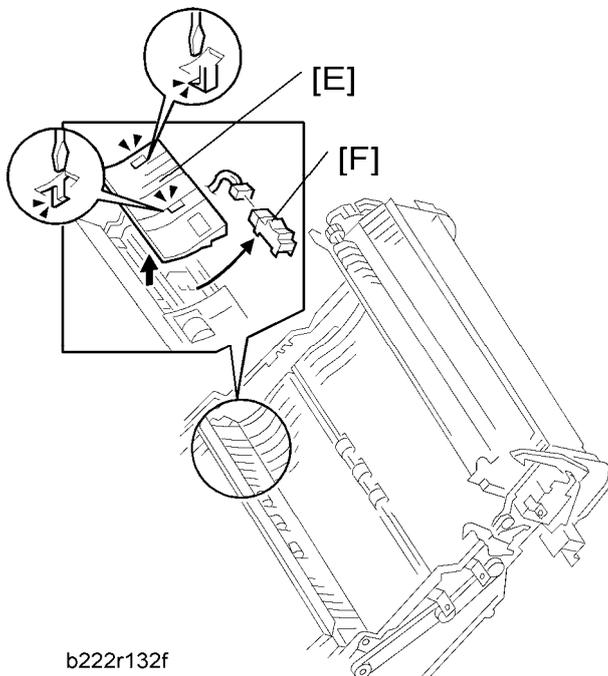

5. Guide plate [E] (two hooks)
6. Duplex exit sensor [F] (🔩 x 1, hooks)

4.13.6 DUPLEX/BY-PASS MOTOR

1. Rear cover (☛ p.4-4)

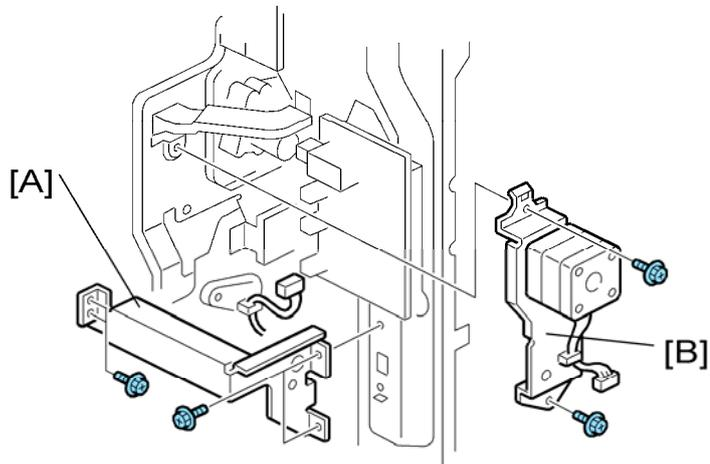

d009r034

2. Frame [A] (☛ x 4)
3. Duplex/By-pass motor bracket [B] (☛ x 2, ☛ x 1)

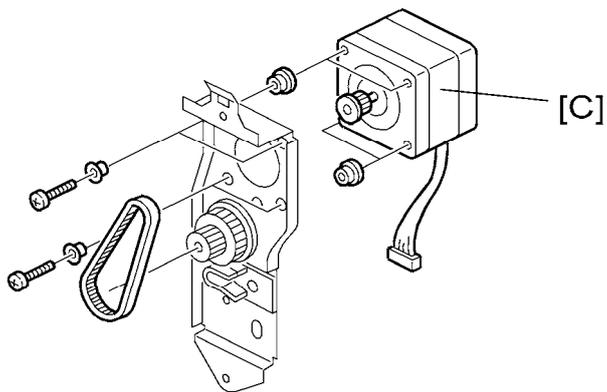

d009r035

4. Duplex/By-pass motor [C] (☛ x 4, bushing x 8, timing belt x 1)

Duplex

4.13.7 DUPLEX INVERTER MOTOR

1. Right door cover (☛ p.4-70)
2. Open the right door.

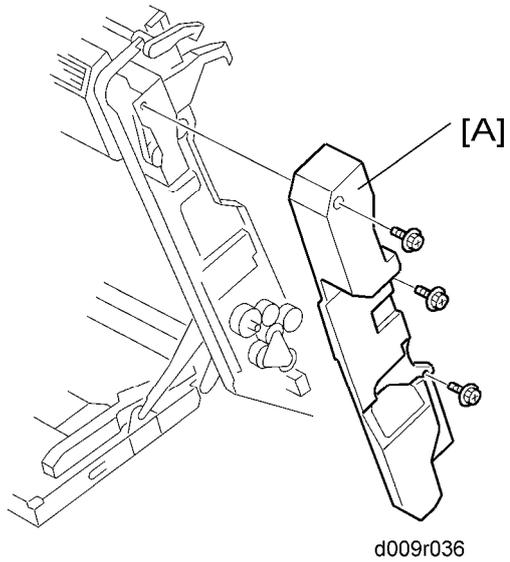

3. Right door rear cover [A] (☛ x 3)

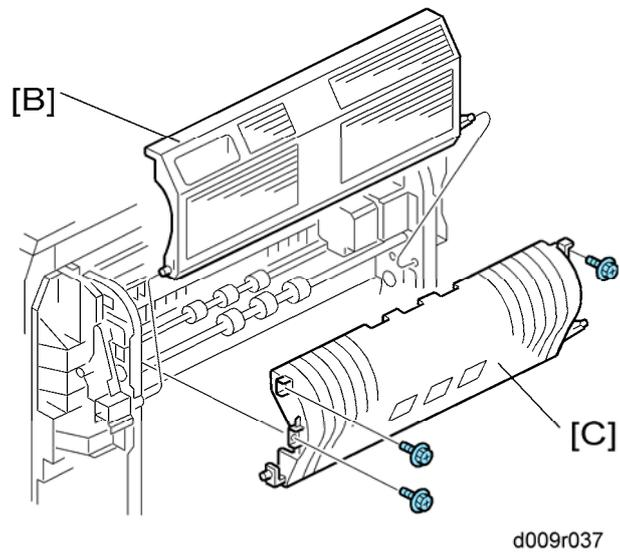

4. Duplex door [B]
5. Duplex guide plate [C] (☛ x 3)

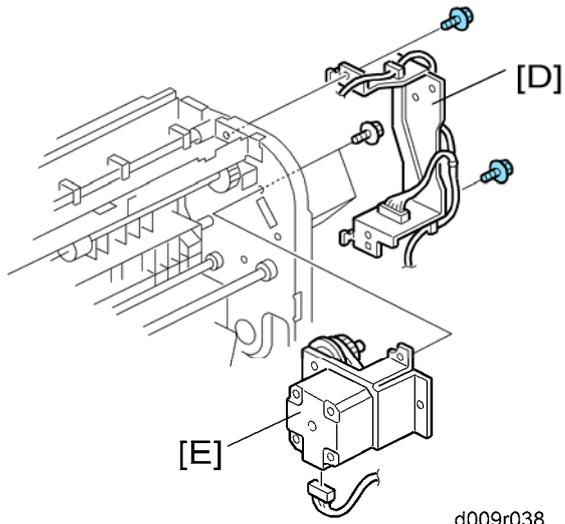

6. Bracket [D] (🔩 x 2)
7. Duplex inverter motor [E] (🔩 x 3, 📦 x 1)

4.14 BY-PASS

4.14.1 BY-PASS PAPER SIZE SENSOR

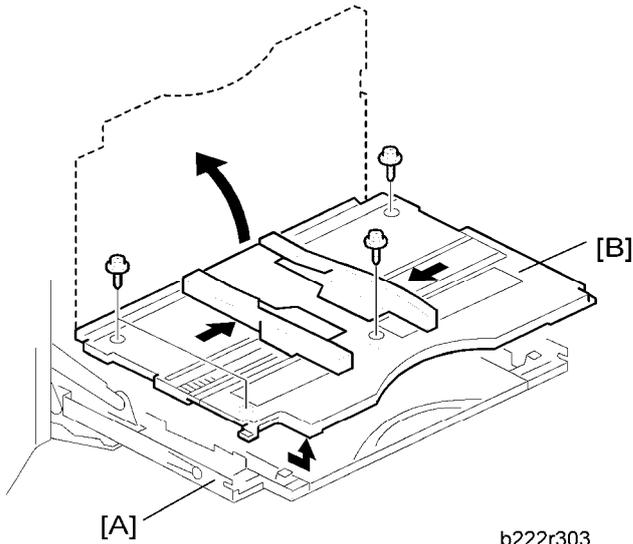

1. Open the by-pass tray [A].
2. Move the side fences to the center.
3. By-pass tray cover [B] (🔩 x 4)

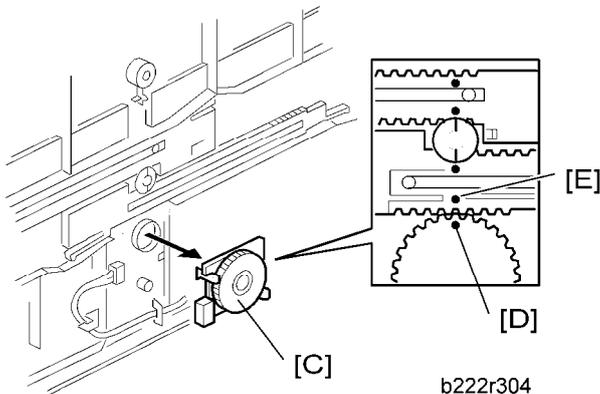

4. By-pass paper size sensor [C] (🔩 x 1)

When reinstalling the by-pass paper size sensor

1. Adjust the projection [E] of the left side fence bar (it must be centered).
2. Install the by-pass paper size sensor so that the hole [D] in this sensor faces the projection [E] of the left side fence bar.
3. Reassemble the copier.
4. Plug in and turn on the main power switch.

5. Check this switch operation with SP5803-024 (By-pass paper size < Input Check).

- Display on the LCD -

Paper Size	Display	Paper Size	Display
A3 SEF	00001110	A5 SEF	00001011
B4 SEF	00001100	B6 SEF	00000011
A4 SEF	00001101	A6 SEF	00000111
B5 SEF	00001001	Smaller A6 SEF	00001111

4.14.2 BY-PASS PAPER END SENSOR

1. Right door cover (🔩 p.4-72)

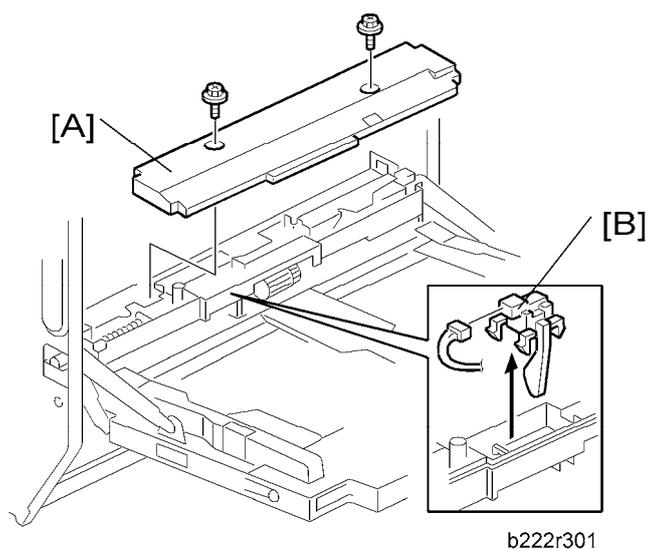

2. By-pass feed unit cover [A] (🔩 x 2).

3. By-pass paper end sensor [B] (🔩 x 1, hooks)

By-pass

4.14.3 BY-PASS PICK-UP, FEED AND SEPARATION ROLLER, TORQUE LIMITER

1. Right door cover (☛ p.4-72)
2. By-pass feed unit cover (☛ p.4-79)

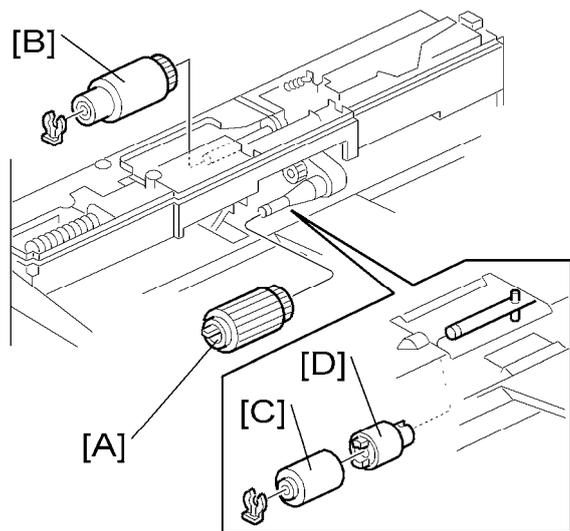

b222r302

3. By-pass pick-up roller [A] (hook)
4. By-pass feed roller [B] (☛ x 1)
5. By-pass separation roller [C] (☛ x 1)
6. Torque limiter [D]

4.14.4 BY-PASS FEED CLUTCH

1. Open the right door.
2. Right door rear cover (🔧 p.4-73)
3. Transfer belt unit (🔧 p.4-46)
4. Transfer belt unit holder (🔧 p.4-73)

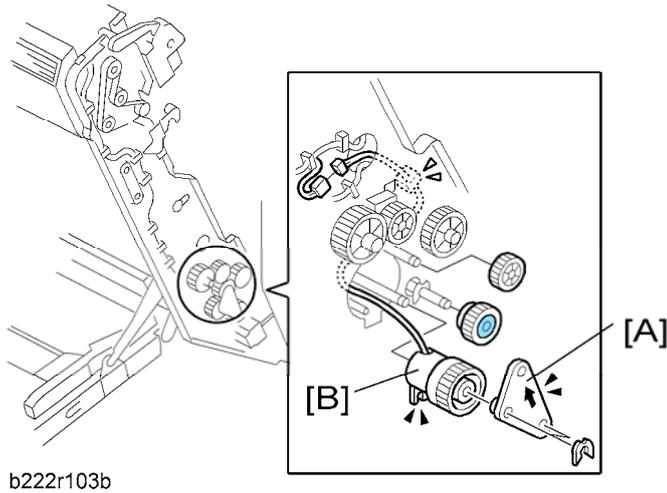

5. By-pass feed clutch holder [A] (🔧 x 2)
6. By-pass feed clutch [B] (🔧 x 1, 🔄 x 1)

4.15 DRIVE AREA

4.15.1 PAPER FEED CLUTCH

Tray 1 and Tray 2

1. Rear cover (☛ p.4-4)

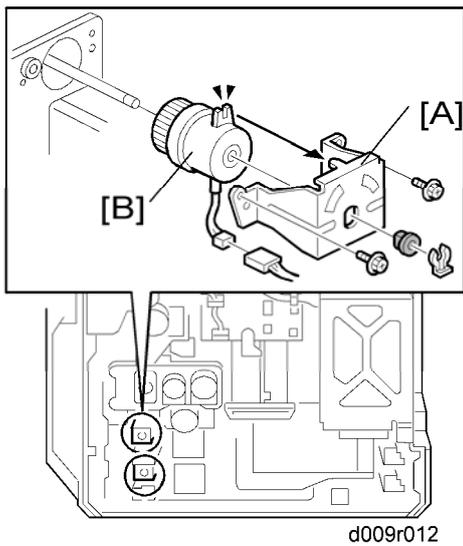

2. Clutch bracket [A] (☛ x 2, ☛ x 1, bushing x 1)
3. Paper feed clutch [B] (☛ x 1)

4.15.2 DEVELOPMENT PADDLE MOTOR

1. Rear cover (🔧 p.4-4)

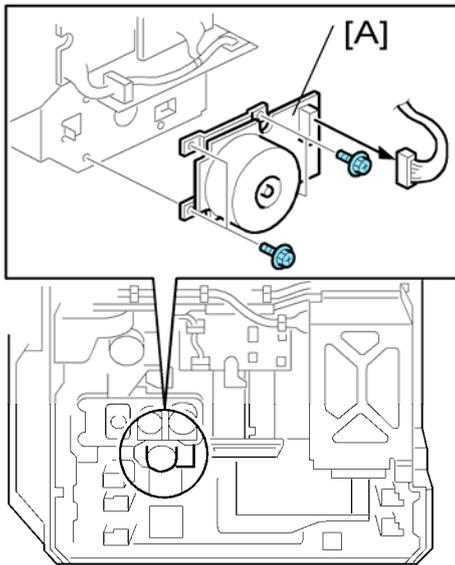

d009r014

2. Development paddle motor [A] (🔧 x 4, 📡 x 1)

4.15.3 TRANSFER/DEVELOPMENT MOTOR

1. Rear cover (🔧 p.4-4)

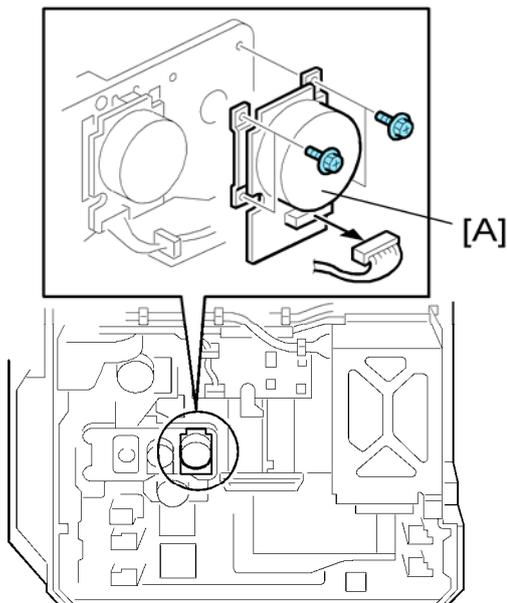

d009r015

2. Transfer/development motor [A] (🔧 x 4, 📡 x 1)

Drive Area

4.15.4 DRUM MOTOR

1. Rear cover (🔩 p.4-4)

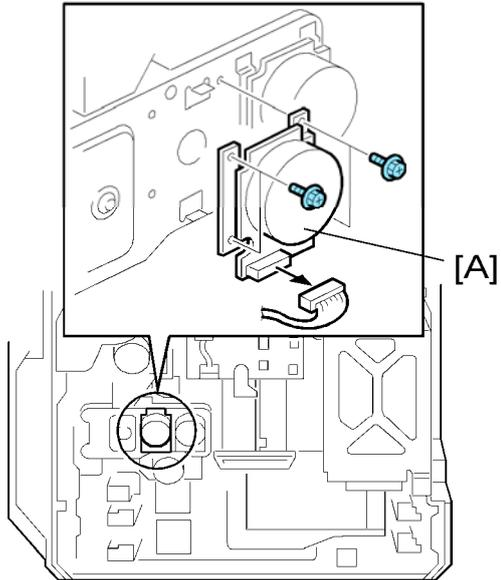

d009r016

2. Drum motor [A] (🔩 x 4, 🛠️ x 1)

4.15.5 FUSING MOTOR

1. Rear cover (🔩 p.4-4)

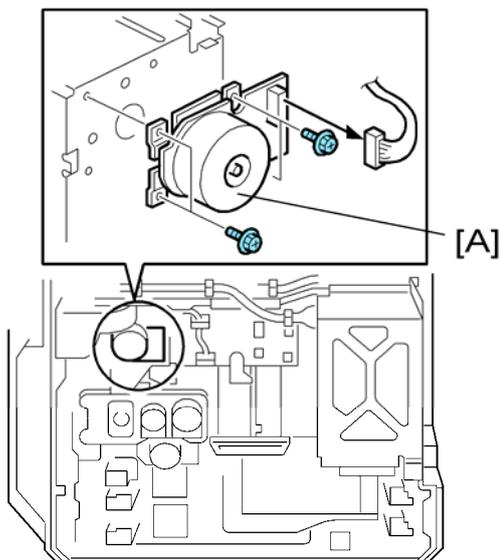

d009r017

2. Fusing motor [A] (🔩 x 4, 🛠️ x 1)

4.15.6 WEB MOTOR

1. Rear cover (🔧 p.4-4)

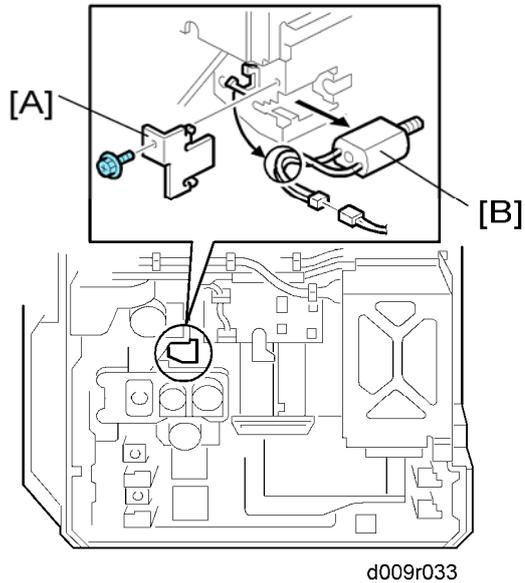

2. Bracket [A] (🔧 x 1, 📦 x 1)
3. Web motor [B] (📦 x 1, 📦 x 1)

4.15.7 PAPER FEED MOTOR

1. Rear cover (🔧 p.4-4)
2. Right rear cover (🔧 p.4-5)

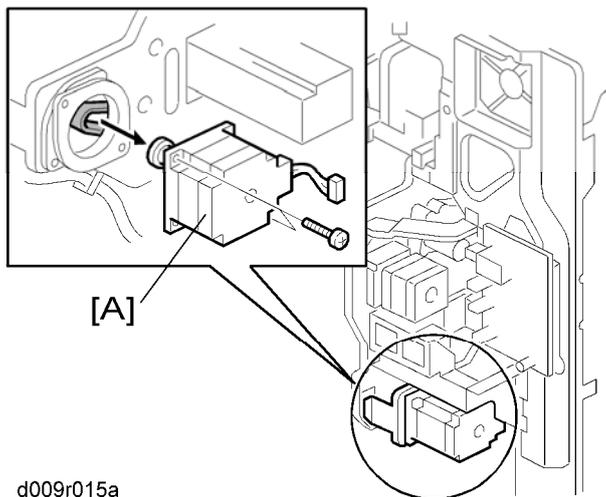

3. Paper feed motor [A] (🔧 x 2, 📦 x 1)

Drive Area

4.15.8 TRANSFER BELT CONTACT MOTOR

1. Rear cover (☛ p.4-4)
2. Right rear cover (☛ p.4-5)

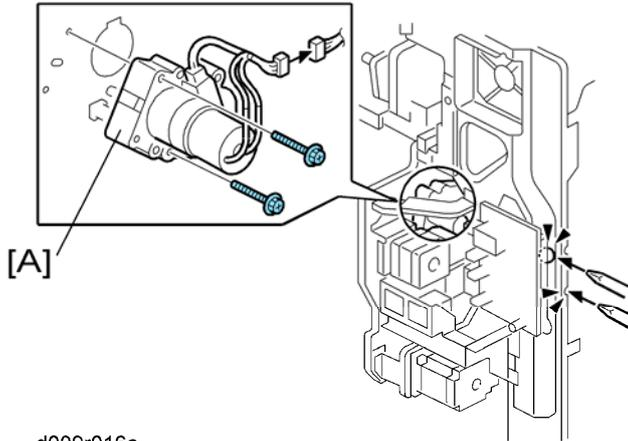

d009r016a

3. Transfer belt contact motor [A] (☛ x 2, ☛ x 1)

4.15.9 REGISTRATION MOTOR

1. Rear cover (☛ p.4-4)
2. Right rear cover (☛ p.4-5)

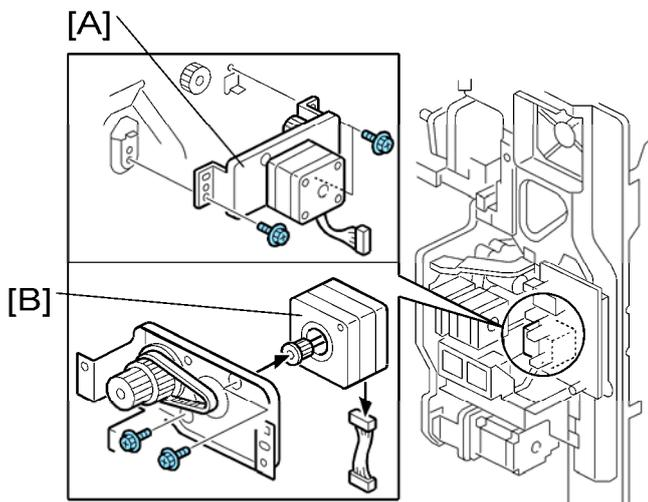

d009r017a

3. Registration motor bracket [A] (☛ x 3, ☛ x 1)
4. Registration motor [B] (☛ x 2, ☛ x 1)

4.15.10 TONER SUPPLY MOTOR

1. Left cover (🔧 p.4-4)
2. Upper inner cover (🔧 p.4-3)
3. Inner Tray (🔧 p.4-8)

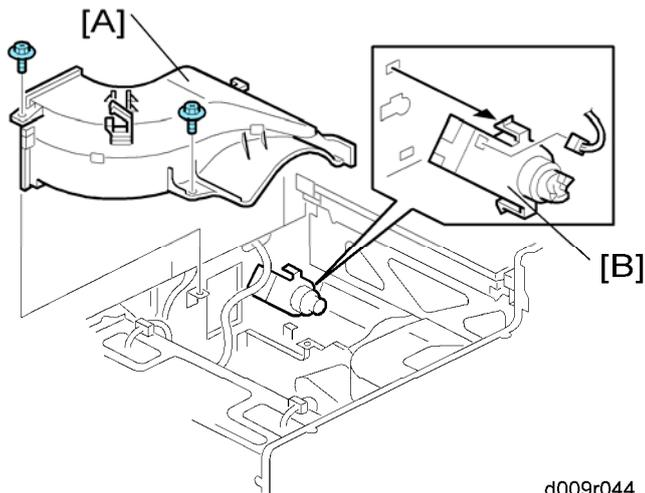

d009r044

4. Exhaust duct [A] (🔧 x 2)
5. Toner supply motor [B] (hooks, 🧰 x 1)

4.16 ELECTRICAL COMPONENTS

4.16.1 CONTROLLER UNIT

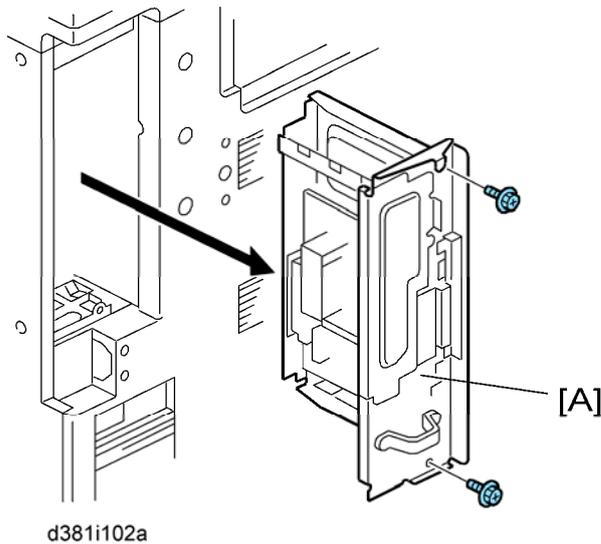

1. Controller unit [A] (🔩 x 2)

4.16.2 HDD UNIT (STANDARD FOR D011/D013/D091/D092)

Before replacing the HDD unit

Copy the address book data to an SD card from the HDD with **SP5846-051** if possible.

Replacement Procedure

1. Controller unit (☛ p.4-88)

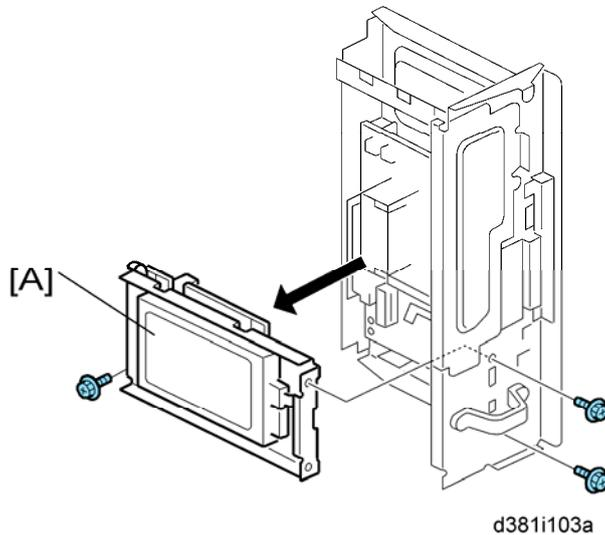

2. HDD unit [A] (☛ x 3)

After installing the new HDD unit

1. Do **SP5832-001** to format the hard disk.
2. Do **SP5853-001** to copy the preset stamp data from the firmware to the hard disk.
3. Do **SP5846-052** to copy back the address book to the hard disk from the SD card to which you have already copied the address book data if possible.
4. Turn the main power switch off/on.

Disposal of HDD Units

- Never remove an HDD unit from the work site without the consent of the client.
- If the customer has any concerns about the security of any information on the HDD, the HDD must remain with the customer for disposal or safe keeping.
- The HDD may contain proprietary or classified (Confidential, Secret) information. Specifically, the HDD contains document server documents and data stored in temporary files created automatically during copy job sorting and jam recovery. Such data is stored on the HDD in a special format so it cannot normally be read but can be recovered with illegal methods.

Reinstallation

- Explain to the customer that the following information stored on the HDD is lost when the HDD is replaced: document server documents, fixed stamps, document server address book

Electrical Components

- The address book and document server documents (if needed) must be input again.
- If the customer is using the Data Overwrite Security or the Data Encryption feature, these applications must be installed again. For more, see "Installation".
- If the customer is using the HDD Encryption Unit, the encryption key must be restored after replacing the HDD unit. For details, see the installation procedure for the HDD Encryption Unit.

4.16.3 CONTROLLER BOARD

CAUTION

- The battery on the control board can explode if replaced incorrectly.
- Dispose of the old battery in accordance with the instructions.

Before replacing the controller board in the model without HDD

When you replace the controller board in a model without a HDD, address book data can be copied from an old controller board to a new controller board using an SD card.

Copy the address book data to an SD card from the flash ROM on the controller board with **SP5846-051** if possible.

Replacement Procedure

1. Controller unit (☛ p.4-88)
2. HDD unit (if it has been installed.) (☛ p.4-88)

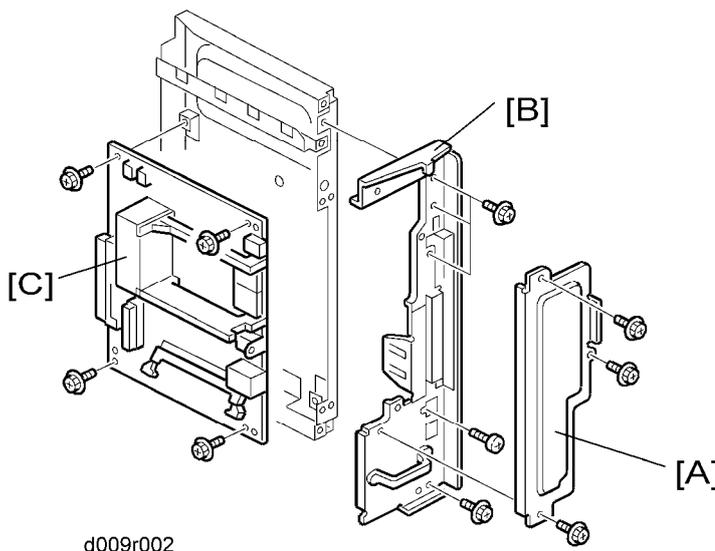

3. FCU cover [A] (☛ x 3)
4. Controller left bracket [B] (☛ x 5)
5. Controller board assembly [C] (☛ x 4, connector caps)

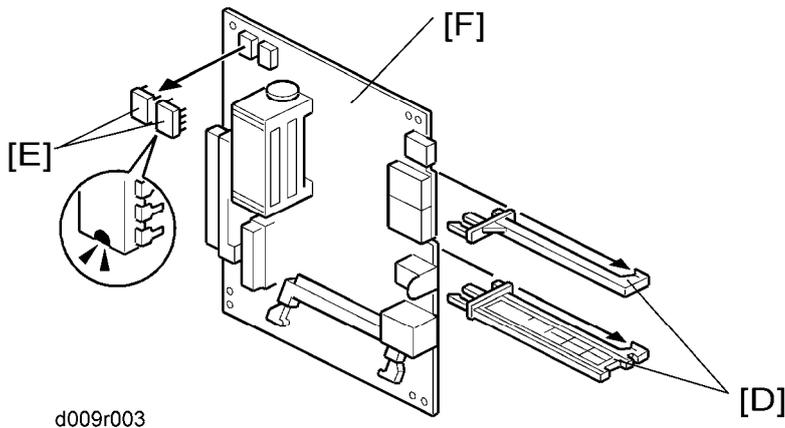

6. Interface rails [D] (hooks each)
7. NVRAMs [E]
8. DIMM-RAM (If it is installed.)
9. Controller board [F]

When installing the new controller board

1. Remove the NVRAMs from the old controller board.
2. Install them on the new controller board after you replace the controller board.
3. Replace the NVRAMs if the NVRAM on the old controller board is defective.

Note

- Make sure you print out the SMC reports ("SP Mode Data" and "Logging Data") before you replace the NVRAMs.

CAUTION

- Keep NVRAMs away from any objects that can cause static electricity. Static electricity can damage NVRAM data.
- Make sure the NVRAMs are correctly installed on the controller board.
- Make sure that the DIP-switch settings on the old controller board are the same for the new controller board. Do not change the DIP switches on the controller board in the field.

After installing the controller board

1. For a model without a HDD, do **SP5846-052** to copy back the address book to the flash ROM on the controller board from the SD card to which you have already copied the address book data if possible.
2. For a model in which the HDD encryption unit has been installed, restoring the encryption key is required. Refer to "Recovery from a Device Problem" in the

Electrical Components

installation procedure for "p.2-93 "HDD Encryption Unit".

3. Turn the main power switch off/on.

4.16.4 MOTHER BOARD

1. Rear cover (☛ p.4-4)
2. Controller unit (☛ p.4-88)

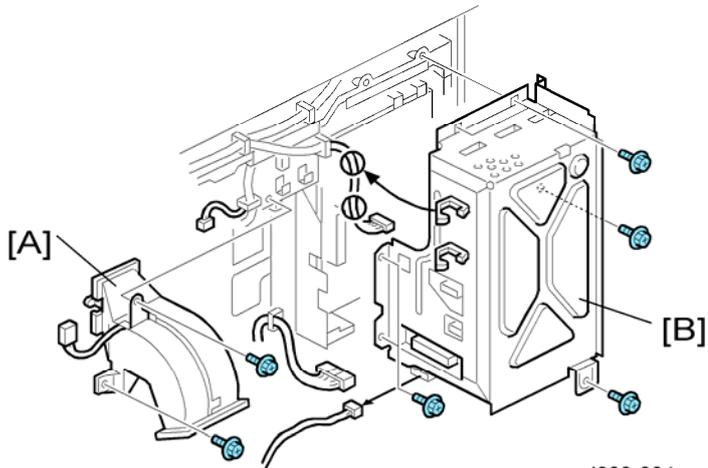

3. Exhaust fan duct [A] (☛ x 2, ☛ x 1)
4. Controller box [B] (☛ x 6, ☛ x 2, ☛ x 3)

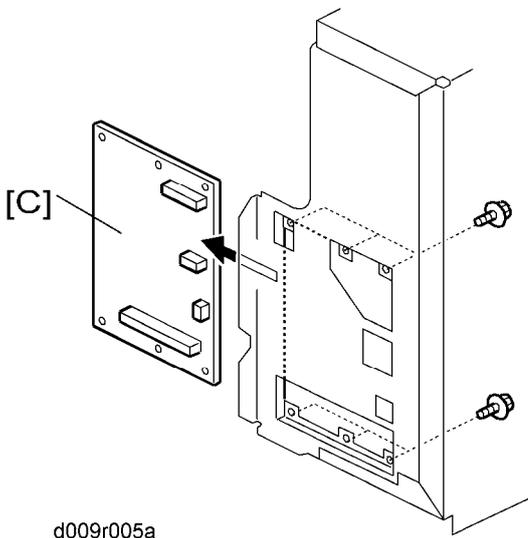

5. Mother board [C] (☛ x 6)

4.16.5 BICU

1. Controller box (🔧 p.4-92)

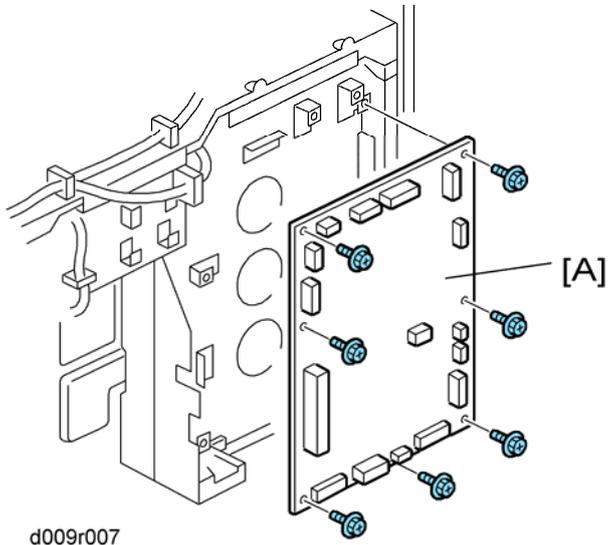

2. BICU[[A] (🔧 x 7, 📦 x all)

4.16.6 IOB

1. Rear cover (🔧 p.4-4)

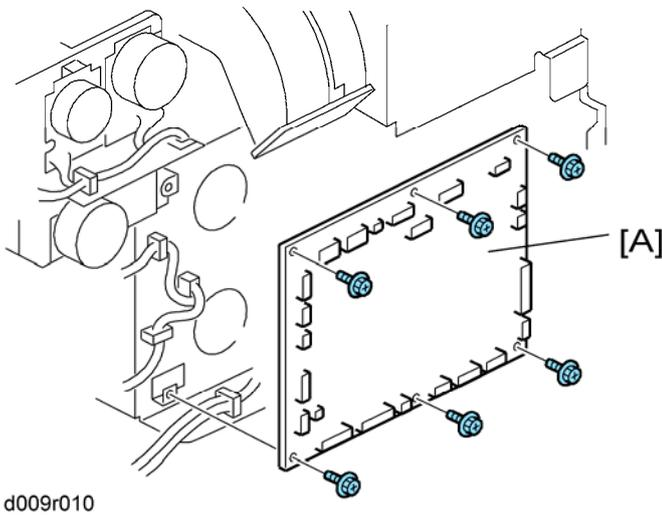

2. IOB [A] (🔧 x 6, 📦 x all)

Replacement
&
Adjustment

When installing a new IOB

★ Important

- The IOB is identical for the D009/D011/D012/D013. However, the DIP switches are set differently for each machine. Set the DIP switches on the new IOB board to the same settings as the old board.

1. Set the bit switches on the new IOB to the same settings as the old IOB.

4.16.7 PSU

1. Left cover (☛ p.4-4)

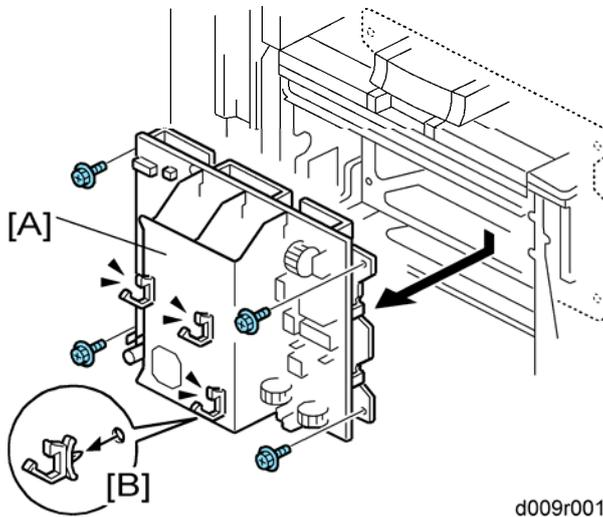

2. PSU [A] (☛ x 4, ☛ x all)
3. Three clamps [B] (These clamps will be used for the new PSU.)

4.16.8 HIGH VOLTAGE POWER SUPPLY BOARD

1. Rear cover (🔩 p.4-4)
2. Right rear cover (🔩 p.4-5)

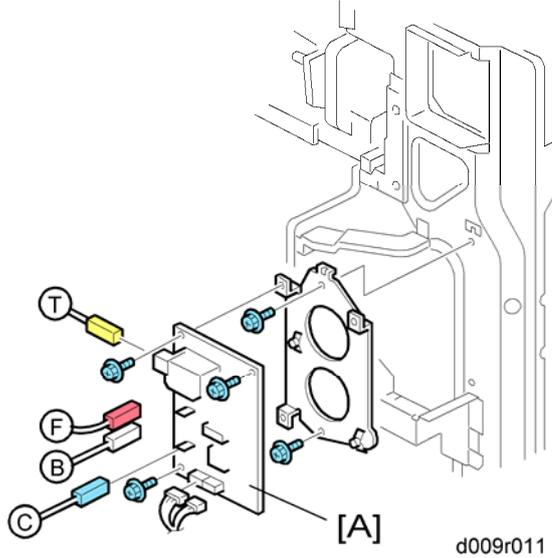

3. High voltage power supply board [A] (🔩 x 3, 📏 x all)

4.16.9 FUSING EXHAUST FAN

1. Rear cover (🔩 p.4-4)

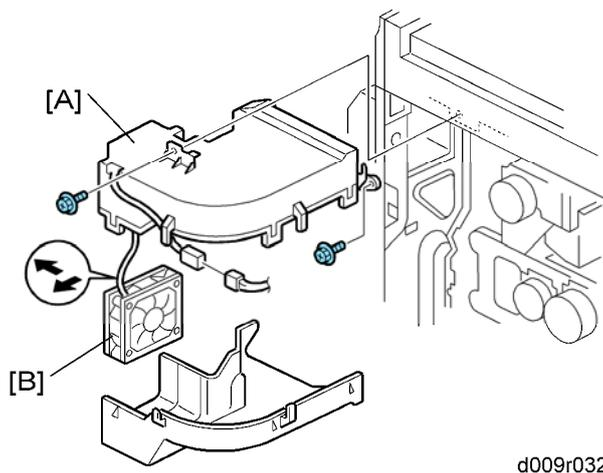

2. Fusing exhaust duct [A] (🔩 x 2, 📏 x 1)
3. Separate the duct (hooks).
4. Fusing exhaust fan [B]

When installing the fusing exhaust fan

Make sure that the fusing fan is installed with its decal facing the right side of the machine.

4.16.10 CONTROLLER FAN

1. Controller box (☛ p.4-92)

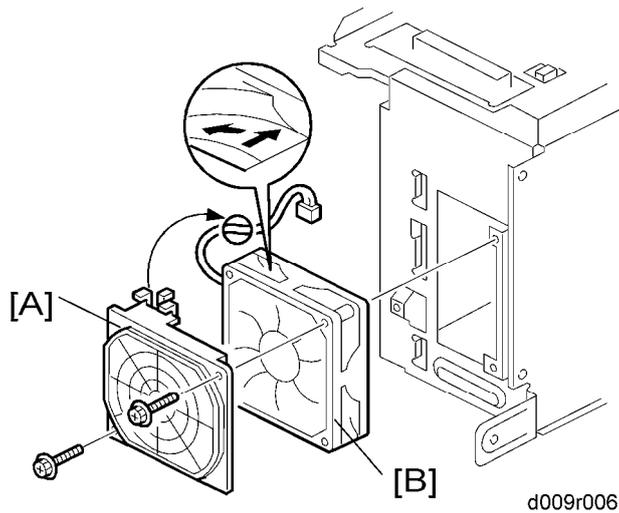

2. Fan cover [A] (☛ x 2)
3. Controller fan [B] (☛ x 1)

When installing the controller fan

Make sure that the controller fan is installed with its decal facing upward.

4.17 COPY ADJUSTMENTS

4.17.1 OVERVIEW

Perform these adjustments after replacing any of the following:

- Scanner Wire
- Lens Block/SBU Assembly
- Scanner Drive Motor
- Polygon Mirror Motor
- Paper Side Fence
- Memory All Clear

4.17.2 PRINTING

1. Make sure paper is installed correctly in each paper tray before you start these adjustments.
2. Use the Trimming Area Pattern (SP2-109-1, No. 14) to print the test pattern for the following procedures.

Registration - Leading Edge/Side-to-Side

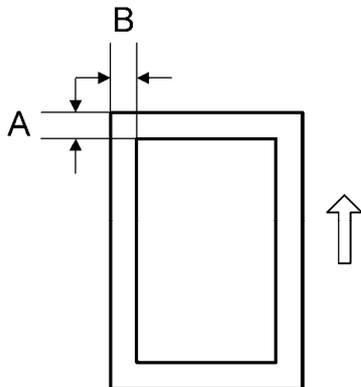

b195r827

1. Check the leading edge registration [A] for each paper type and paper feed station, and adjust it with following SP modes.

Copy Adjustments

	SP No.	Specification
Tray: Plain	SP1-001-1	0 ±9.0 mm
Tray: Thick 1	SP1-001-2	
Tray: Thick 2	SP1-001-3	
By-pass: Plain	SP1-001-4	
By-pass: Thick 1	SP1-001-5	
By-pass: Thick 2	SP1-001-6	
Duplex: Plain	SP1-001-7	
Duplex: Thick 1	SP1-001-8	

2. Check side-to-side registration [B] for each paper feed station, and adjust with the following SP modes.

	SP No.	Specification
By-pass	SP1-002-1	0 ±4.0 mm
Tray 1	SP1-002-2	
Tray 2	SP1-002-3	
Tray 3	SP1-002-4	
Tray 4	SP1-002-5	
LCT	SP1-002-6	
Duplex	SP1-002-7	

Blank Margin**Note**

- If the leading edge/side-to-side registration cannot be adjusted within specifications, adjust the leading/left side edge blank margin.

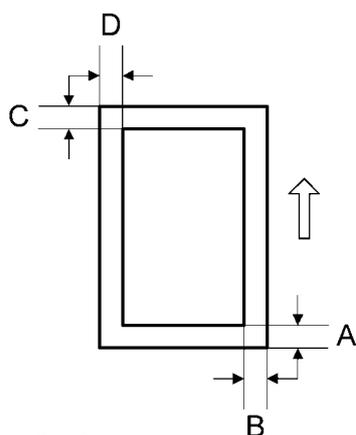

b195r828

1. Check the trailing edge [A], right edge [B], leading edge [C] and left edge [D] blank margins, and adjust them with the following SP modes.

	SP No.	Specification
Leading Edge	SP2-103-1	3.0 mm [0.0 to 9.0 mm]
Trailing Edge	SP2-103-2	
Left	SP2-103-3	2.0 mm [0.0 to 9.0 mm]
Right	SP2-103-4	
Duplex: Trailing Edge: L Size: Plain	SP2-103-5	1.0 mm [0.0 to 4.0 mm]
Duplex: Trailing Edge: M Size: Plain	SP2-103-6	0.8 mm [0.0 to 4.0 mm]
Duplex: Trailing Edge: S Size: Plain	SP2-103-7	0.6 mm [0.0 to 4.0 mm]
Duplex: Left: Plain	SP2-103-8	0.3 mm [0.0 to 1.5 mm]
Duplex: Right: Plain	SP2-103-9	

Copy Adjustments

	SP No.	Specification
Duplex: Trailing Edge: L Size: Thick	SP2-103-10	0.8 mm [0.0 to 4.0 mm]
Duplex: Trailing Edge: M Size: Thick	SP2-103-11	0.6 mm [0.0 to 4.0 mm]
Duplex: Trailing Edge: S Size: Thick	SP2-103-12	0.4 mm [0.0 to 4.0 mm]
Duplex: Left: Thick	SP2-103-13	0.1 mm [0.0 to 1.5 mm]
Duplex: Right: Thick	SP2-103-14	

- L Size: Paper length is 297.1 mm or more.
- M Size: Paper length is 216.1 to 297 mm
- S Size: Paper length is 216 mm or less.

Main Scan Magnification

1. Use SP2-109-001 no 5 (Grid Pattern) to print a single dot pattern.
2. Check magnification, and then SP2-102 (Magnification Adjustment Main Scan) to adjust magnification if required. Specification: $\pm 2\%$.

Parallelogram Image Adjustment

Do the following procedure if a parallelogram prints while adjusting the printing registration or printing margin using a trimming area pattern.

The following procedure should be done after adjusting the side-to-side registration for each paper tray station.

Use SP2-109-1 No. 14 (Trimming Area) to determine whether a parallelogram image appears. If the parallelogram pattern appears, perform the following procedure.

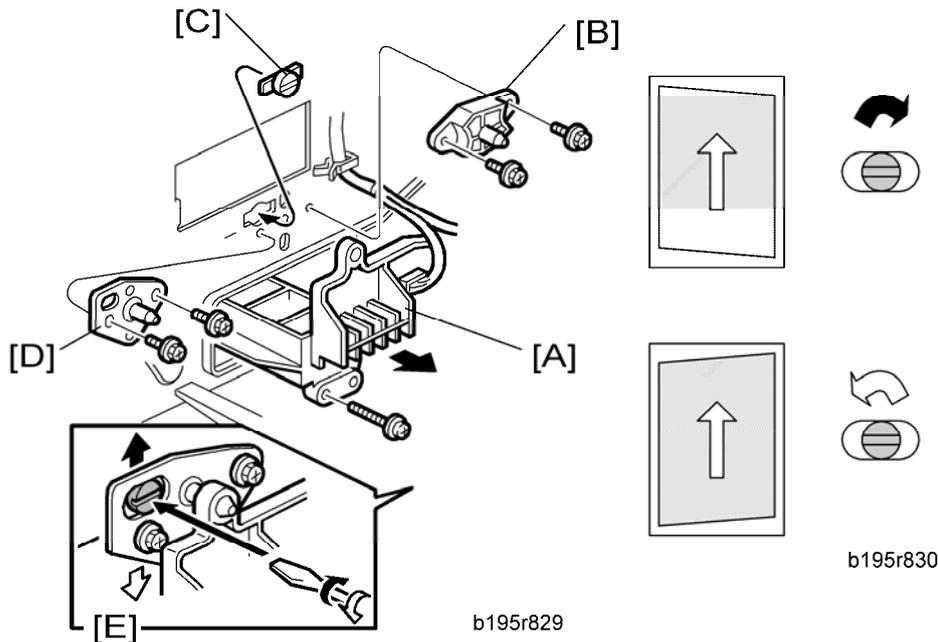

1. Laser unit [A]
2. Bracket [B] (x2)
3. Install adjustment cam [C] (P/N: A2309003).
4. Secure positioning pin [D] (P/N A2309004) with the two screws removed with the bracket [B]. Do not tighten the screws at this time.
5. To adjust the position of the laser unit [E]
 - 1) Adjust the laser unit position by turning the adjustment cam. (See the illustration above.)
 - 2) Tighten the adjustment bracket.
 - 3) Print the trimming area pattern to check the image. If the results are not satisfactory, repeat steps 5-1) to 5-3).

4.17.3 SCANNING

Before doing the following scanner adjustments, perform or check the printing registration/side-to-side adjustment and the blank margin adjustment.

↓ Note

- Use the S5S test chart to perform the following adjustments.

Copy Adjustments

Registration: Platen Mode

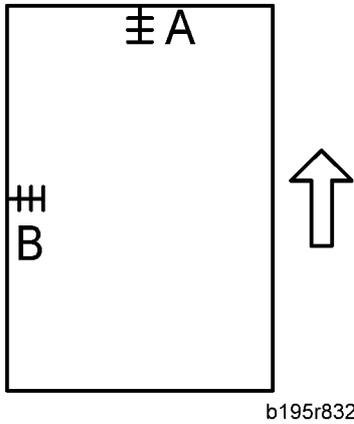

1. Place the test chart on the exposure glass and make a copy from one of the feed stations.
2. Check the leading edge [A] and side-to-side [B] registration, and adjust them with the following SP modes if necessary.

	SP No.	Specification
Leading Edge	SP4-010-1	0 ±2.0 mm
Side-to-side	SP4-011-1	0 ±2.5 mm

Magnification

Use the S5S test chart to perform the following adjustment.

Sub Scan Magnification

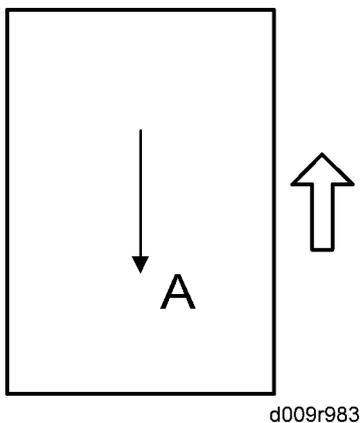

1. Place the test chart on the exposure glass and make a copy from one of the feed stations.
2. Check the magnification ratio. Use SP4-008 (Scanner Sub Scan Magnification) to adjust if necessary. Specification: $\pm 0.9\%$.

4.17.4 ADF IMAGE ADJUSTMENT

Registration

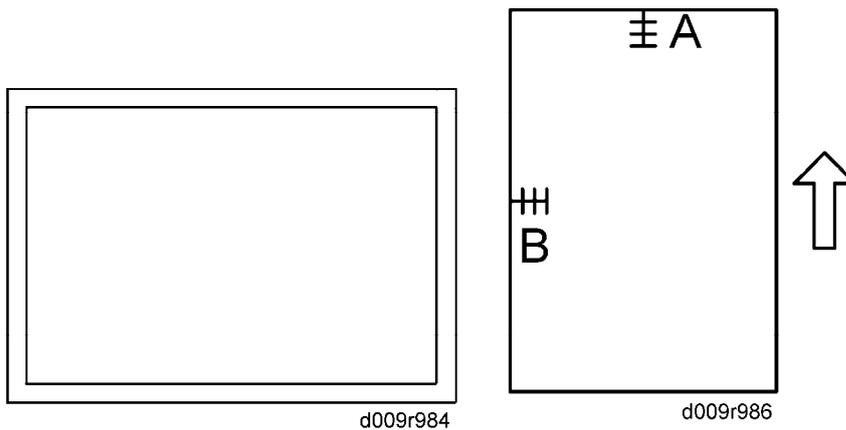

1. Make a temporary test chart as shown above using A3/DLT paper.
2. Place the temporary test chart on the ADF and make a copy from one of the feed stations.
3. Check the registration, and adjust using the following SP modes if necessary.

	SP No.	Specification
Side-to-side: 1st side	SP6-006-1	0.0 mm \pm 3 mm
Side-to-side: 2nd side	SP6-006-2	
Leading Edge	SP6-006-3	0.0 mm \pm 5 mm
Leading Edge: 1st side	SP6-006-5	0.0 mm \pm 3 mm
Leading Edge: 2nd side	SP6-006-6	0.0 mm \pm 2.5 mm
Trailing Erase edge:	SP6-006-7	0.0 mm \pm 10.0 mm

4.17.5 TOUCH SCREEN CALIBRATION

After clearing the memory, or if the touch panel detection function is not working correctly, follow this procedure to calibrate the touch screen.

Note

- Do not attempt to use items [2] to [7] on the Self-Diagnostic Menu. These items are for design use only.

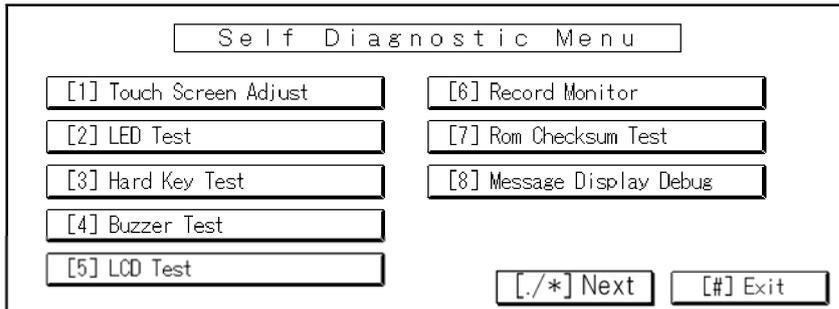

b195r834

- Press , "1", "9", "9", "3", and then press  5 times to open the Self-Diagnostics menu.
- On the touch screen press "Touch Screen Adjust" (or press "1").

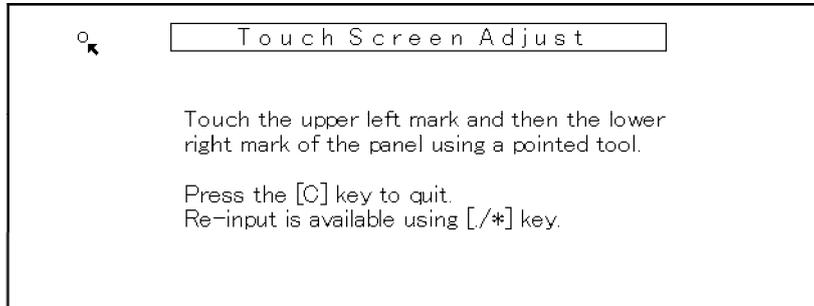

b195r9835

- Use a pointed (not sharp!) tool to press the upper left mark .
- Press the lower right mark  after it appears.
- Touch a few spots on the touch panel to confirm that the marker (+) appears exactly where the screen is touched.
If the + mark does not appear where the screen is touched, press Cancel and repeat from Step 2.
- When you are finished, press [#] OK on the screen (or press .
- Touch [#] Exit on the screen to close the Self-Diagnostic menu and save the calibration settings.

SERVICE TABLES

REVISION HISTORY		
Page	Date	Added/Updated/New
		None

5. SERVICE TABLES

5.1 SERVICE PROGRAM MODE

CAUTION

- Never turn off the main power switch when the power LED is lit or flashing. To avoid damaging the hard disk or memory, press the operation switch to switch the power off, wait for the power LED to go off, and then switch the main power switch off.

Note

- The main power LED lights or flashes while the platen cover or ARDF is open, while the main machine is communicating with a facsimile or the network server, or while the machine is accessing the hard disk or memory for reading or writing data.

5.1.1 SERVICE PROGRAM MODE OPERATION

The service program (SP) mode is used to check electrical data, change modes, and adjust values.

CAUTION

- Never turn off the main power switch when the power LED is lit or flashing. To avoid damaging the hard disk or memory, press the operation switch to switch the power off, wait for the power LED to go off, and then switch the main power switch off.

Service Mode Lock/Unlock

At locations where the machine contains sensitive data, the customer engineer cannot operate the machine until the Administrator turns the service mode lock off. This function makes sure that work on the machine is always done with the permission of the Administrator.

1. If you cannot go into the SP mode, ask the Administrator to log in with the User Tool and then set "Service Mode Lock" to OFF. After he or she logs in:
[User Tools] > System Settings > Administrator Tools > Service Mode Lock > OFF
 - This unlocks the machine and lets you get access to all the SP codes.
 - The service technician can do servicing on the machine and turn the machine off and on. It is not necessary to ask the Administrator to log in again each time the machine is turned on.
2. If you must use the printer bit switches, go into the SP mode and set **SP5169** to "1".
3. After machine servicing is completed:
 - Change **SP5169** from "1" to "0".
 - Turn the machine off and on.
 - Tell the administrator that you completed servicing the machine.
 - The administrator will then set the "Service Mode Lock" to ON.

5.1.2 SERVICE PROGRAM MODE TABLES

Please note these general changes in this section:

- Group 8(Data Log 2) is a new group of counters.
- Along with the addition of Group 8, many of the Group 7 counters have been removed.

Service Table Key

Notation	What it means
[range / default / step]	Example: [-9 to +9 / 0 / 0.1 mm step]. The setting can be adjusted in the range ± 9 , value reset to +3.0 after an NVRAM reset, and the value can be changed in 0.1 mm steps with each key press.
*	Value stored in NVRAM. After a RAM reset, this default value (factory setting) is restored.
MS	Monochrome Scanner Model: D009/D012
CS	Color Scanner Model: D011/D013/D091/D092
DFU	Denotes "Design or Factory Use". Do not change this value.
Japan only	The feature or item is for Japan only. Do not change this value.
D009/D011	40 cpm: D009/D011
D012/D013	50 cpm: D012/D013
D091	D091
D092	D092
SSP	This denotes a "Special Service Program" mode.

5.2 SERVICE PROGRAM MODE TABLES

5.2.1 SP TABLES

See "Appendices" for the following information:

- System SP Tables
- Printer SP Tables
- Scanner SP Tables

5.3 USING SP MODES

5.3.1 TEST PATTERN PRINTING

 Note

- Always print a test pattern to confirm correct operation of the machine.
1. Enter the SP mode and select SP2-109 (Printing) or SP4-417 (IPU).
 2. Enter the number for the test pattern that you want to print and press . (See the tables below.)
 3. When you are prompted to confirm your selection, press "OK". This selects the test pattern for printing.
 4. Press Copy Window to open the copy window and then select the settings for the test print (paper size, etc.)
 5. Press Start  twice. (Ignore the "Place Original" messages) to start the test print.
 6. Press SP Mode (highlighted) to return to the SP mode display.

Test Pattern Table (SP2-109-001: Printing test pattern)

No.	Test Pattern	No.	Test Pattern
0	None	13	Independent Pattern (4-dot)
1	Vertical Line (1-dot)	14	Trimming Area
2	Vertical Line (2-dot)	15	Hound's Tooth Check (Vertical)
3	Horizontal Line (1-dot)	16	Hound's Tooth Check (Horizontal)
4	Horizontal Line (2-dot)	17	Black Band (Horizontal)
5	Grid Vertical Line	18	Black Band (Vertical)
6	Grid Horizontal Line	19	Checker Flag Pattern
7	Grid Pattern Small	20	Grayscale (Vertical Margin)
8	Grid Pattern Large	21	Grayscale (Horizontal Margin)
9	Argyle Pattern Small	22	Two Beam Density Pattern
10	Argyle Pattern Large	23	Full Dot Pattern

Using SP Modes

No.	Test Pattern	No.	Test Pattern
11	Independent Pattern (1-dot)	24	All White Pattern
12	Independent Pattern (2-dot)		

Test Pattern Table: SP4-417-001 IPU Test Patterns

No.	Test Pattern	No.	Test Pattern
0	Scanned image	13	Grid pattern CMYK
1	Gradation main scan A	14	Color patch CMYK
2	Gradation main scan B	15	Gray pattern (1)
3	Gradation main scan C	16	Gray pattern (2)
4	Gradation main scan D	17	Gray Pattern (3)
5	Gradation sub scan (1)	18	Shading pattern
6	Grid pattern	19	Thin line pattern
7	Slant grid pattern	20	Scanned + Grid pattern
8	Gradation RGBCMYK	21	Scanned + Gray scale
9	UCR pattern	22	Scanned + Color patch
10	Color patch 16 (1)	23	Scanned + Slant Grid C
11	Color patch 16 (2)	24	Scanned + Slant Grid D
12	Color patch 64		

5.3.2 SMC PRINT OUT LISTS: SP5-990

1. Open SP mode 5-990 and select the number corresponding to the list that you wish to print.

SMC (System Parameter and Data Lists)	
1	All Data List
2	SP Mode Data List
3	UP Mode Data List
4	Logging Data List
5	Self-Diagnostics Results List
6	Non-Default
7	NIB Summary
8	NetFile Log
21	Copy UP Mode List
22	Scanner SP Mode List
23	Scanner UP Mode List

2. Press "Execute" on the touch panel.
3. Select "Single Face" or "Both Face".
4. After printing the list, press "Close" to return to the SP mode display.
5. Press Exit twice to close the SP Mode screen and return to copy mode.

5.3.3 NIP BAND WIDTH ADJUSTMENT: SP1-109

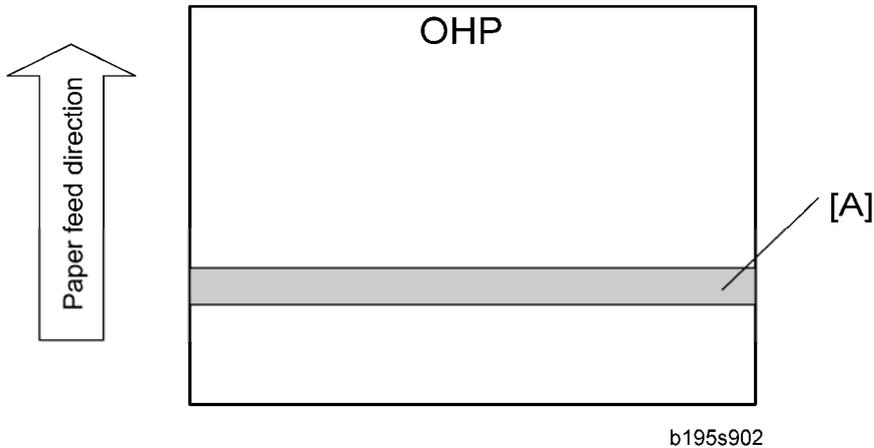

When paper wrinkling or image offset occurs, the pressure from the pressure roller can be adjusted by changing the position of the pressure springs. At this time, the nip bandwidth can also be checked with SP1-109.

1. Execute SP5-802 to perform a free run of about 50 sheets.
2. Open SP1-109-1, press \oplus , and then press Yes to confirm the selection.
3. Press Copy Window to return to the copy window.
4. Place an OHP sheet (A4/8.5" x 11" LEF) on the by-pass feed tray.
5. Press Start \odot twice. The OHP sheet stops in the fusing unit for about 10 seconds, then it exits automatically.
6. Check the nip bandwidth [A].

Note

- Check the nip bandwidth around the center of the OHP.

Nip band Specification: 7.0 \pm 0.5 mm

5.3.4 MEMORY CLEAR: SP5-801

Executing Memory All Clear resets all the settings stored in the NVRAM to their default settings except the following:

	Electrical total counter value
SP5-811-1:	Machine serial number
SP5-907:	Plug & Play Brand Name and Production Name Setting

1. Execute SP5-990 to print out all SMC Data Lists.
2. Open SP mode 5-801.
3. Press the number for the item that you want to initialize. The number you select determines which application is initialized. For example, press 1 if you want to initialize all modules or select the appropriate number from the table below.

5801-001	All Clear	Initializes items 2 to 15 below.
002	Engine Clear	Initializes all registration settings for the engine and copy process settings.
003	SCS	Initializes default system settings, SCS (System Control Service) settings, operation display coordinates, and ROM update information.
004	IMH Memory Clear	Initializes the image file system. (IMH: Image Memory Handler)
005	MCS	Initializes the automatic delete time setting for stored documents. (MCS: Memory Control Service)
006	Copier application	Initializes all copier application settings.
007	Fax application	Initializes the fax reset time, job login ID, all TX/RX settings, local storage file numbers, and off-hook timer.

Using SP Modes

008	Printer application	Initializes the printer defaults, programs registered, the printer SP bit switches, and the printer CSS counter.
009	Scanner application	Initializes the defaults for the scanner and all the scanner SP modes.
010	Web Service/Network application	Deletes the Netfile (NFA) management files and thumbnails, and initializes the Job login ID. Netfiles: Jobs to be printed from the document server using a PC and the DeskTopBinder software
011	NCS	Initializes the system defaults and interface settings (IP addresses also), the SmartNetMonitor for Admin settings, WebStatusMonitor settings, and the TELNET settings. (NCS: Network Control Service)
012	R-FAX	Initializes the job login ID, SmartNetMonitor for Admin, job history, and local storage file numbers.
014	Clear DCS Setting	Initializes the DCS (Delivery Control Service) settings.
015	Clear UCS Setting	Initializes the UCS (User Information Control Service) settings.
016	MIRS Setting	Initializes the MIRS (Machine Information Report Service) settings.
017	CCS	Initializes the CCS (Certification and Charge-control Service) settings.

018	SRM Clear	Initializes the SRM (System Resource Manager) settings.
019	LCS Clear	Initializes the LCS (Log Count Service) settings.
020	Web Uapli	
021	ECS	

4. Press Execute, and then follow the prompts on the display to complete the procedure.
5. Make sure that you perform the following settings:
 - Do the laser beam pitch adjustment (☛ p.4-29).
 - Do the printer and scanner registration and magnification adjustments (☛ p.4-97/ p.4-101).
 - Do the touch screen calibration (☛ p.4-104).
 - Referring to the SMC data lists, re-enter any values, which had been changed from their factory settings.
 - Do SP 3-001-2 (ID Sensor Initial Setting).
6. Check the copy quality and the paper path, and do any necessary adjustments.

5.3.5 SOFTWARE RESET

The software can be reboot when the machine hangs up. Use the following procedure. Turn the main power switch off and on.

-or-

Press and hold down   together for over 10 seconds. When the machine beeps once release both buttons. After "Now loading. Please wait" is displayed for a few seconds the copy window will open. The machine is ready for normal operation.

5.3.6 SYSTEM SETTINGS AND COPY SETTING RESET

System Setting Reset

The system settings in the UP mode can be reset to their defaults. Use the following procedure.

1. Press User Tools/Counter .
2. Hold down  and then press System Settings.

 Note

- You must press  first.

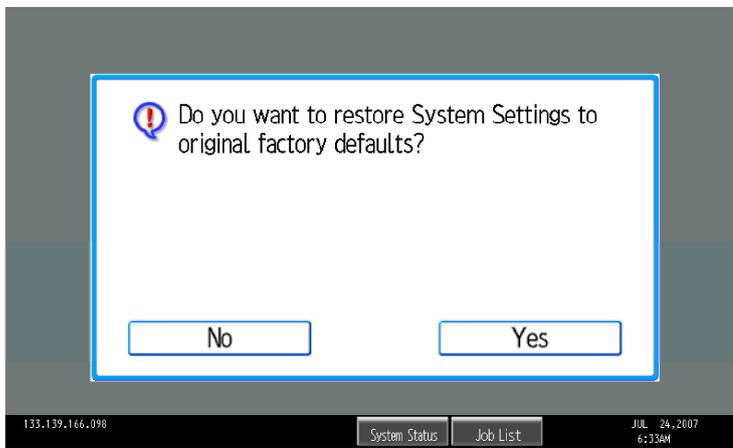

d009s903

3. When the message prompts you to confirm that you want to reset the system settings, press Yes.
4. When the message tells you that the settings have been reset, press Exit.

5.3.7 COPIER SETTING RESET

The copy settings in the UP mode can be reset to their defaults. Use the following procedure.

1. Press User Tools/Counter .
2. Hold down  and then press Copier/Document Server Settings.

 Note

- You must press  first.

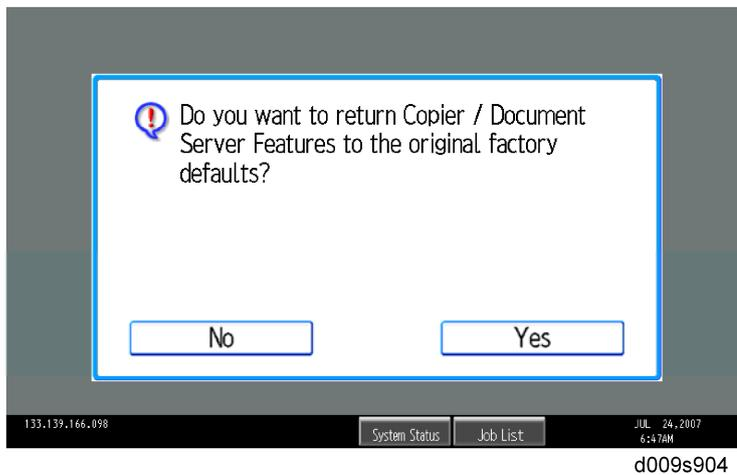

3. When the message prompts you to confirm that you want to reset the Copier Document Server settings, press "Yes".
4. When the message tells you that the settings have been reset, press "Exit".

5.4 UPDATING THE FIRMWARE

To update the firmware for this machine, you must have the new version of the firmware downloaded onto an SD (Secure Digital) Card. The SD Card is inserted into SD Card Slot 2 on the controller box.

5.4.1 BEFORE YOU BEGIN

An SD card is a precision device. Always observe the following precautions when you handle SD cards:

- Always switch the machine off before you insert an SD card. Never insert the SD card into the slot with the power on.
- Do not remove the SD card from the service slot after the power has been switched on.
- Never switch the machine off while the firmware is downloading from the SD card.
- Keep SD cards in a safe location where they are not exposed to high temperature, high humidity, or exposure to direct sunlight.
- Always handle SD cards with care. Do not bend or scratch them. Do not let the SD card get exposed to shock or vibration.
- Make sure that the write protection of an SD card is unlocked when you download an application to it. If not, downloading fails and a download error (e.g. Error Code 44) occurs during a firmware upgrade.

Keep the following points in mind when you use the firmware update software:

- "Upload" means to send data from the machine to the SD card. "Download" means to send data from the SD card to the machine.
- To select an item on the LCD, touch the appropriate button on the soft touch-screen of the LCD, or, press the appropriate number key on the 10-key pad of the operation panel. For example, when "Exit (0)" shows on the screen you can touch the Exit button on the screen, or, press the "0" button on the operation panel of the copier.
- Make sure that the machine is disconnected from the network to prevent a print job for arriving while the firmware update is in progress before you start the firmware update procedure.

5.4.2 UPDATING FIRMWARE

Preparation

1. If the SD card is blank, copy the entire "romdata" folder onto the SD card.
2. If the card already contains the "romdata" folder, copy the "D009" folder onto the card.

Note

- Do not put multiple machine firmware programs on the same SD card. Copy the only model firmware you want.

1. Stop all SDK applications if the VM card is installed (☛ p.2-93 "HDD Encryption Unit").
2. Turn the main power switch off.
3. Remove the slot cover (☛ x 1).
4. Remove the VM card from SD Card Slot 2 if it is installed.
5. Insert the SD card into SD Card Slot 2. Make sure the label on the SD card faces the rear side of the machine.
6. Slowly push the SD card into the slot so it locks in place. You will hear it click. Make sure the SD card locks in place.

Note

- To remove the SD, push it in to unlock the spring lock. Then release it so it pops out of the slot.
7. Disconnect the network cable from the copier if the machine is connected to a network.
 8. Switch the main power switch on. After about 45 seconds, the initial version update screen appears on the LCD in English.
 9. On the screen, touch the button or press the corresponding number key on the operation panel to select the item in the menu that you want to update.

ROM/NEW	What it means
ROM:	Tells you the number of the module and name of the version currently installed. The first line is the module number, the second line the version name.
NEW:	Tells you the number of the module and name version on the SD card. The first line is the module number, the second line the version name.

Updating the Firmware

↓ Note

- Controller, engine and operation panel firmware cannot be updated at the same time. It is recommended to update firmware modules one by one.

10. Touch "UpDate (#)" (or ) to start the update.

↓ Note

- While downloading is in progress, the LCD will display "Loading". When downloading has been completed, the panel will display "update done".
- For operation panel software, the Start key lights red while downloading is in progress, and then lights green again after downloading is completed.

11. The "Update is Done" message appears on the operation panel after completing the updating. The message differs depending on the firmware that has been updated.

12. Switch the copier main power switch off when you see the "Update is Done" message or follow the procedure that is displayed on the operation panel.

13. Press in the SD card to release it. Then remove it from the slot.

14. Switch the copier on for normal operation.

15. Error Messages

An error message shows in the first line if an error occurs during the download.

The error code consists of the letter "E" and a number. The example above shows error "E24" displayed. For details, refer to the Error Message Table. ( "Handling Firmware Update Errors" in this section)

Firmware Update Error

If a firmware update error occurs, this means the update was cancelled during the update because the module selected for update was not on the SD card.

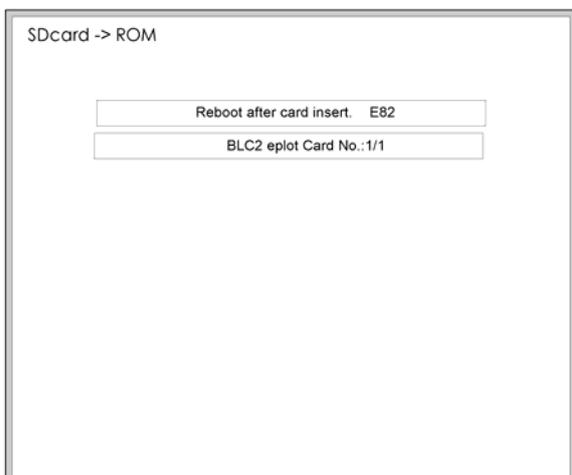

Recovery after Power Loss

If the ROM update is interrupted as a result of accidental loss of power while the firmware is updating, then the correct operation of the machine cannot be guaranteed after the machine is switched on again. If the ROM update does not complete successfully for any reason, then in order to ensure the correct operation of the machine, the ROM update error will continue to show until the ROM is updated successfully.

In this case, insert the card again and switch on the machine to continue the firmware download automatically from the card without the menu display.

5.4.3 HANDLING FIRMWARE UPDATE ERRORS

An error message shows in the first line if an error occurs during a download. The error code consists of the letter "E" and a number ("E20", for example).

Error Message Table

Code	Meaning	Solution
20	Cannot map logical address	Make sure the SD card is installed correctly, or use a different SD card.
21	Cannot access memory	HDD connection incorrect or replace HDD.
22	Cannot decompress compressed data	Incorrect ROM data on the SD card, or data is damaged.
23	Error occurred when ROM update program started	Controller program defective. If the second attempt fails, replace controller board.
24	SD card access error	Make sure the SD card is inserted correctly, or use a different SD card.
30	No HDD available for stamp data download	HDD connection incorrect or replace HDD.
31	Data incorrect for continuous download	Insert the SD card with the remaining data required for the download, the re-start the procedure.

Updating the Firmware

Code	Meaning	Solution
32	Data incorrect after download interrupted	Execute the recovery procedure for the intended module download, then repeat the installation procedure.
33	Incorrect SD card version	Incorrect ROM data on the SD card, or data is corrupted.
34	Module mismatch - Correct module is not on the SD card)	SD update data is incorrect. Acquire the correct data (Japan, Overseas, OEM, etc.) then install again.
35	Module mismatch – Module on SD card is not for this machine	SD update data is incorrect. The data on the SD card is for another machine. Acquire correct update data then install again.
36	Cannot write module – Cause other than E34, E35	SD update data is incorrect. The data on the SD card is for another machine. Acquire correct update data then install again.
40	Engine module download failed	Replace the update data for the module on the SD card and try again, or replace the BCU board.
42	Operation panel module download failed	Replace the update data for the module on the SD card and try again, or replace the LCDC.
43	Stamp data module download failed	Replace the update data for the module on the SD card and try again, or replace the hard disks.
44	Controller module download failed	Replace the update data for the module on the SD card and tray again, or replace controller board.
50	Electronic confirmation check failed	SD update data is incorrect. The data on the SD card is for another machine. Acquire correct update data then install again.

5.5 NVRAM DATA UPLOAD/DOWNLOAD

The content of the NVRAM can be uploaded to and downloaded from an SD card.

5.5.1 UPLOADING NVRAM DATA (SP5-824)

1. Turn off the main switch.
2. Remove the SD card cover (🔑 x 1).
3. Insert the SD card into SD card slot 2.
4. Turn on the main switch.
5. Execute SP5-824.
6. Press "1" to start uploading the NVRAM data.

5.5.2 DOWNLOADING NVRAM DATA (SP5-825)

The following data are not downloaded from the SD card:

- Total counter
 - C/O, P/O Counter
 - Dupelx, A3/DLT/Over 420 mm, Staple and Scanner application scanning counters (system settings).
 - Engine SP data
1. Stop all SDK applications if the VM card is installed (🖱️ p.2-93 "HDD Encryption Unit").
 2. Turn off the main switch.
 3. Remove the SD card cover [A].
 4. Remove the VM card from SD card slot 2 if it is installed.
 5. Plug the SD card [B] into SD card slot 2.
 6. Turn on the main switch.
 7. Execute SP5-825.
 8. Press "1" to start downloading the NVRAM data.

Note that the following errors could occur during downloading:

- If a card is not installed in the card slot and a message tells you that downloading cannot proceed, you cannot execute downloading, even by pressing "1".
- If the correct card for the NVRAM data is not inserted in the card slot, after you press "1" a message will tell you that downloading cannot proceed because the card is abnormal and the execution will halt.

5.6 SD CARD APPLI MOVE

5.6.1 OVERVIEW

The service program "SD Card Appli Move" (SP5-873) lets you to copy application programs from one SD card to another SD card.

Slot 1 and Slot 2 are used to store application programs. However you can move application programs from Slot 2 to Slot 1 with the following procedure.

If PostScript3 is not to be installed, the printer/scanner card in slot 1 has enough space for the other applications. Use the printer/scanner card as a destination card.

But if PostScript3 is to be installed, use the PostScript3 card as a destination card because moving the data from the PostScript3 card is not licensed from the maker of this software.

Use caution when you do the SD Card Appli Move procedure:

1. The data necessary for authentication is transferred with the application program from an SD card to another SD card. Authentication fails if you try to use the SD card after you copy the application program from one card to another card.
2. Do not use the SD card if it has been used by the user on the computer. Normal operation is not guaranteed when such an SD card is used.
3. Return the SD card to a customer for safekeeping place after you copy the application program from one card to another card. This is done for the following reasons:
 - The SD card can be the only proof that the user is licensed to use the application program.
 - You may need to check the SD card and its data to solve a problem in the future.
4. You cannot copy PostScript data to another SD card. You have to copy other data to the same SD card that stores PostScript data.

5.6.2 MOVE EXEC

The menu "Move Exec" (SP5-873-001) lets you copy application programs from the original SD card to another SD card.

★ Important

- Do not turn ON the write protect switch of the system SD card or application SD card on the machine. If the write protect switch is ON, a download error (e.g. Error Code 44) occurs during a firmware upgrade or application merge.
1. Turn the main switch off.
 2. Make sure that an SD card is in SD Card Slot 1. The application program is copied into this SD card.
 3. Insert the SD card (having stored the application program) to SD Card Slot 2. The application program is copied from this SD card.
 4. Turn the main switch on.
 5. Start the SP mode.
 6. Select SP5-873-001 "Move Exec."
 7. Follow the messages shown on the operation panel.
 8. Turn the main switch off.
 9. Remove the SD card from SD Card Slot 2.
 10. Turn the main switch on.
 11. Check that the application programs run normally.

5.6.3 UNDO EXEC

The menu "Undo Exec" (SP5-873-002) lets you copy back application programs from an SD card to the original SD card. You can use this program when, for example, you have mistakenly copied some programs by using Move Exec (SP5-873-001).

 **Important**

- Do not turn ON the write protect switch of the system SD card or application SD card on the machine. If the write protect switch is ON, a download error (e.g. Error Code 44) occurs during a firmware upgrade or application merge.

1. Turn the main switch off.
2. Insert the original SD card in SD Card Slot 2. The application program is copied back into this card.
3. Insert the SD card (having stored the application program) to SD Card Slot 1. The application program is copied back from this SD card.
4. Turn the main switch on.
5. Start the SP mode.
6. Select SP5-873-002 "Undo Exec."
7. Follow the messages shown on the operation panel.
8. Turn the main switch off.
9. Remove the SD card from SD Card Slot 2.

 **Note**

- This step assumes that the application programs in the SD card are used by the machine.
10. Turn the main switch on.
 11. Check that the application programs run normally.

5.7 SELF-DIAGNOSTIC MODE

5.7.1 SELF-DIAGNOSTIC MODE AT POWER ON

As soon as the main machine is powered on, the controller waits for the initial settings of the copy engine to take effect and then starts an independent self-diagnostic test program. The self-diagnostic test follows the path of the flow chart shown below and checks the CPU, memory, HDD, and so on. An SC code is displayed in the touch panel if the self-diagnostic program detects any malfunction or abnormal condition.

Self-Diagnostic Mode

5.7.2 SELF-DIAGNOSTIC TEST FLOW

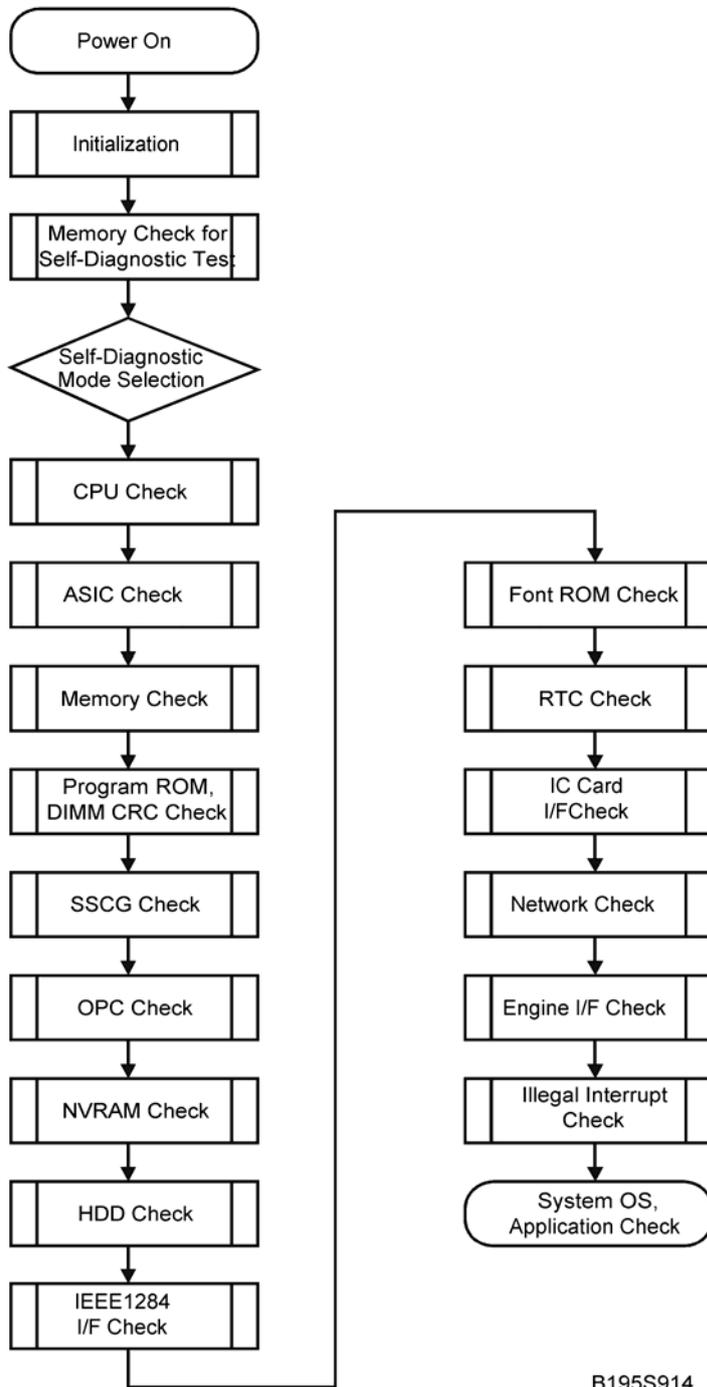

B195S914

5.7.3 DETAILED SELF-DIAGNOSTIC MODE

In addition to the self-diagnostic test initiated every time the main machine is powered on, you can set the machine in a more detailed diagnostic mode manually in order to test other components or conditions that are not tested during self-diagnosis after power on. The following device is required in order to put the machine in the detailed self-diagnosis mode.

No.	Name
G02119350	Parallel Loopback Connector

5.7.4 EXECUTING DETAILED SELF-DIAGNOSIS

Follow this procedure to execute detailed self-diagnosis.

1. Switch off the machine, and connect the parallel loopback device to the Centronics I/F port.
2. Hold down , press and hold down , and then while pressing both keys at the same time, switch on the machine.

You will see "Now Loading" on the touch-panel, and then you will see the results of the test.

A report is printed every time a detailed self-diagnostic test is executed, whether errors were detected or not.

5.8 USING THE DEBUG LOG

5.8.1 OVERVIEW

This machine provides a Save Debug Log feature that allows the Customer Engineer to save and retrieve error information for analysis.

Every time an error occurs, debug information is recorded in volatile memory but this information is lost when the machine is switched off and on.

To capture this debug information, the Save Debug Log feature provides two main features:

- Switching on the debug feature so error information is saved directly to the HDD for later retrieval.
- Copying the error information from the HDD to an SD card.

When a user is experiencing problems with the machine, follow the procedure below to set up the machine so the error information is saved automatically to the HDD. Then ask the user to reproduce the problem.

5.8.2 SWITCHING ON AND SETTING UP SAVE DEBUG LOG

The debug information cannot be saved until the "Save Debug Log" function has been switched on and a target has been selected.

1. Enter the SP mode.
2. Under "5857 Save Debug Log", press "1".

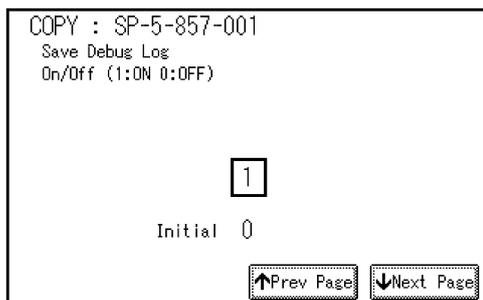

3. On the control panel keypad, press "1" then press # . This switches the Save Debug Log feature on.



- The default setting is "0" (OFF). This feature must be switched on in order for the debug information to be saved.
4. Next, select the target destination where the debug information will be saved. Under "5857 Save Debug Log", touch "2 Target", enter "2" with the operation panel key to select the hard disk as the target destination, then press # .

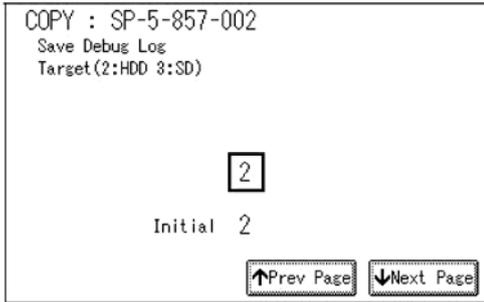

↓ Note

- Select "3 SD Card" to save the debug information directly to the SD card if it is inserted in the service slot.
5. Now touch "5858" and specify the events that you want to record in the debug log. SP5858 (Debug Save When) provides the following items for selection.

1	Engine SC Error	Saves data when an engine-related SC code is generated.
2	Controller SC Error	Saves debug data when a controller-related SC Code is generated.
3	Any SC Error	Saves data only for the SC code that you specify by entering code number.
4	Jam	Saves data for jams.

Service Tables

↓ Note

- More than one event can be selected.

Example 1: To Select Items 1, 2, 4

Touch the appropriate items(s). Press "ON" for each selection. This example shows "Engine SC Error" selected.

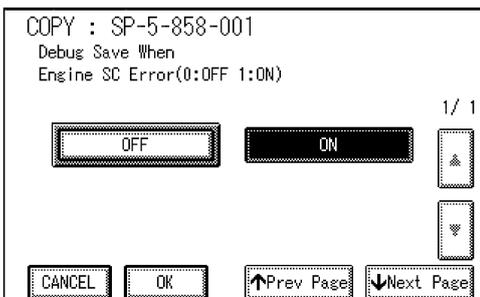

Example 2: To Specify an SC Code

Using the Debug Log

Touch "3 Any SC Error", enter the 3-digit SC code number with the control panel number keys, then press **#**. This example shows an entry for SC670.

COPY : SP-5-858-003
Debug Save When
Any SC Error

670

Initial 0

Prev Page Next Page

Note

- For details about SC code numbers, please refer to the SC tables in Section "4. Troubleshooting"

6. Next, select the one or more memory modules for reading and recording debug information. Touch "5859".

Under "5859" press the appropriate key item for the module that you want to record.

Enter the appropriate 4-digit number, then press **#**.

Note

- Refer to the two tables below for the 4-digit numbers to enter for each key.

The example below shows "Key 1" with "2222" entered.

COPY : SP-5-859-001
Debug Save Key No.
Key 1

2222

Initial 0

Prev Page Next Page

The following keys can be set with the corresponding numbers. (The initials in parentheses indicate the names of the modules.)

4-Digit Entries for Keys 1 to 10

Key No.	Copy	Printer	Scanner	Web
1	2222 (SCS)			
2	2223 (SRM)			
3	256 (IMH)			
4	1000 (ECS)			
5	1025 (MCS)			
6	4848(COPY)	4400 (GPS)	5375 (Scan)	5682 (NFA)
7	2224 (BCU)	4500 (PDL)	5682 (NFA)	6600 (WebDB)
8		4600 (GPS-PM)	3000 (NCS)	3300 (PTS)
9		2000 (NCS)	2000 (NCS)	6666 (WebSys)
10		2224 (BCU)		2000 (NCS)

 Note

- The default settings for Keys 1 to 10 are all zero ("0").

Key to Acronyms

Acronym	Meaning	Acronym	Meaning
ECS	Engine Control Service	NFA	Net File Application
GPS	GW Print Service	PDL	Printer Design Language
GSP-PM	GW Print Service – Print Module	PTS	Print Server
IMH	Image Memory Handler	SCS	System Control Service
MCS	Memory Control Service	SRM	System Resource Management
NCS	Network Control Service	WebDB	Web Document Box (Document Server)

The machine is now set to record the debugging information automatically on the HDD (the target selected with SP5-857-002) for the events that you selected SP5-858 and the memory modules selected with SP5-859.

Please keep the following important points in mind when you are doing this setting:

- Note that the number entries for Keys 1 to 5 are the same for the Copy, Printer, Scanner, and Web memory modules.
- The initial settings are all zero.
- These settings remain in effect until you change them. Be sure to check all the settings, especially the settings for Keys 6 to 10. To switch off a key setting, enter a zero for that key.
- You can select any number of keys from 1 to 10 (or all) by entering the corresponding 4-digit numbers from the table.
- You cannot mix settings for the groups (COPY, PRINTER, etc.) for 006 to 010. For example, if you want to create a PRINTER debug log you must select the settings from the 9 available selections for the "PRINTER" column only.
- One area of the disk is reserved to store the debug log. The size of this area is limited to 4 MB.

Retrieving the Debug Log from the HDD

1. Insert the SD card into service slot of the copier.
2. Enter the SP mode and execute SP5857 009 (Copy HDD to SD Card (Latest 4 MB) to write the debugging data to the SD card.

 **Note**

- The SD card can hold up to 4MB of data. If the debugging data is larger than 4MB, you can switch to another SD card.
3. Use a card reader to copy the file and send it for analysis to your local Ricoh representative by email, or just send the SD card by mail.

Recording Errors Manually

Since only SC errors and jams are recorded to the debug log automatically, for any other errors that occur while the customer engineer is not on site, please instruct customers to perform the following immediately after occurrence to save the debug data. Such problems would include a controller or panel freeze.

 **Note**

- In order to use this feature, the customer engineer must have previously switched on the Save Debug Feature (SP5857-001) and selected the hard disk as the save destination (SP5857-002).
1. When the error occurs, on the operation panel, press  (Clear Modes).
 2. On the control panel, enter "01" then hold down  for at least 3 sec. until the machine beeps then release. This saves the debug log to the hard disk for later retrieval with an SD card by the service representatives.
 3. Switch the machine off and on to resume operation.
The debug information for the error is saved on the hard disk so the service representatives can retrieve it on their next visit by copying it from the HDD to an SD card.

Dip Switches

5.9 DIP SWITCHES

5.9.1 I/O BOARD: DIP SW101

Location	Bit		
	6	7	8
Japan	ON	ON	OFF
North America	OFF	ON	OFF
Europe	ON	OFF	OFF
China	OFF	OFF	ON
Taiwan	OFF	ON	ON
Korea	ON	OFF	ON
Asia	ON	ON	ON

ON: Up, OFF: Down

TROUBLESHOOTING

REVISION HISTORY		
Page	Date	Added/Updated/New
		None

6. TROUBLESHOOTING

6.1 SERVICE CALL CONDITIONS

For "Service Call Conditions" information, see "Appendices".

6.2 ELECTRICAL COMPONENT DEFECTS

6.2.1 SENSORS

Component (Symbol)	CN	Condition	Symptom
Scanner Home Position (S1)	318-2 (SIO)	Open	SC121 is displayed.
		Shorted	SC120 is displayed.
Platen Cover (S2)	318-5 (SIO)	Open	APS and ARE do not function properly.
		Shorted	No symptom.
Original Width 1 (S3)	313-14 (SIO)	Open/ Shorted	CPU cannot detect the original size properly. APS and ARE do not function correctly.
Original Width 2 (S4)	313-11 (SIO)	Open/ Shorted	CPU cannot detect the original size properly. APS and ARE do not function correctly.
Original Length 1 (S5)	313-8 (SIO)	Open/ Shorted	CPU cannot detect the original size properly. APS and ARE do not function correctly.
Original Length-2 (S6)	313-5 (SIO)	Open Shorted	CPU cannot detect the original size properly. APS and ARE do not function correctly.
Original Length-3 (S7)	313-2 (SIO)	Open Shorted	CPU cannot detect the original size properly. APS and ARE do not function correctly.

Component (Symbol)	CN	Condition	Symptom
Fusing Entrance (S8)	208-8 (IOB)	Open	CPU cannot detect paper even a sheet of paper remains at the fusing unit.
		Shorted	CPU detects paper even a sheet of paper does not remain at the fusing unit.
ID (Image Density) (S9)	208-11 (IOB)	Open	SC350 is displayed after copying.
		Shorted	SC351 is displayed after copying.
Web End (S10)	208-16 (IOB)	Open	CPU detects the web end even the web is not used up.
		Shorted	CPU cannot detect the web end even the web is used up.
TD (Toner Density) (S11)	213-14 (IOB)	Open	The add toner indicator blinks even if there is toner in the development unit.
		Shorted	SC390 is displayed.
Toner Overflow (S13)	217-B15 (IOB)	Open	CPU cannot detect the toner overflow even the waste toner in the transfer belt unit is full.
		Shorted	CPU detects the toner overflow even the waste toner in the transfer belt unit is not full.
Duplex Entrance (S14)	217-A8 (IOB)	Open	Jam Z (Jam 26/27)
		Shorted	Jam Z (Jam 1)

Electrical Component Defects

Component (Symbol)	CN	Condition	Symptom
Duplex Cover (S15)	217-A11 (IOB)	Open	"Open Cover" is displayed
		Shorted	"Open cover" cannot be detected.
Duplex Exit (S16)	217-A14 (IOB)	Open	Jam Z (Jam 25)
		Shorted	Jam Z (Jam 1)
By-pass Paper End (S17)	217-B3 (IOB)	Open	The Paper End indicator lights even if paper is placed on the by-pass tray.
		Shorted	The Paper End indicator does not light even if there is no paper on the by-pass tray.
By-pass Paper Size (S18)	217-B9, 10,12,13 (IOB)	Open	Paper size error
		Shorted	
Paper Feed 1 (S9)	216-A4 (IOB)	Open/ Shorted	No symptom, but this may cause Jam A (Jam 11) and some pieces of paper are remaining at the paper feed unit when tray 1 is opened.
Relay 1 (S20)	216-A7 (IOB)	Open	Jam A (Jam 3, 11)
		Shorted	Jam A, B (Jam 1)
Paper End 1 (S21)	216-A10 (IOB)	Open	The Paper End indicator lights even if paper is placed in the paper tray 1.
		Shorted	The Paper End indicator does not light even if there is no paper in the paper tray 1.

Electrical Component Defects

Component (Symbol)	CN	Condition	Symptom
Tray Lift 1 (S22)	216-A13 (IOB)	Open/ Shorted	SC501 is displayed.
Paper Feed 2 (S23)	216-B4 (IOB)	Open/ Shorted	No symptom, but this may cause Jam A (Jam 12) and some pieces of paper are remaining at the paper feed unit when tray 2 is opened.
Relay 2 (S24)	216-B7 (IOB)	Open	Jam A (Jam 3, 11)
		Shorted	Jam A, B (Jam 1)
Paper End 2 (S25)	216-B10 (IOB)	Open	The Paper End indicator lights even if paper is placed in the paper tray 2.
		Shorted	The Paper End indicator does not light even if there is no paper in the paper tray 2.
Tray Lift 2 (S26)	216-B13 (IOB)	Open/ Shorted	SC502 is displayed.
Registration (S27)	209-2 (IOB)	Open	Jam A (Jam 8, 17)
		Shorted	Jam A, B (Jam 1)
Paper Size 1 (S28)	209-4,5,6,8 (IOB)	Open/ Shorted	Paper size error in tray 1
Paper Size 2 (S29)	209-9,10,11,13 (IOB)	Open/ Shorted	Paper size error in tray 2
Lower Paper Height 1 (S30)	210-4 (IOB)	Open/ Shorted	Remaining paper volume in tray 2 on the LCD is wrong.
Lower Paper Height 2 (S31)	210-7 (IOB)	Open/ Shorted	

Trouble-shooting

Electrical Component Defects

Component (Symbol)	CN	Condition	Symptom
Upper Paper Height 1 (S32)	210-12 (IOB)	Open/ Shorted	Remaining paper volume in tray 1 on the LCD is wrong.
Upper Paper Height 2 (S33)	210-15 (IOB)	Open/ Shorted	
Junction Jam (S34)	221-A10 (IOB)	Open/ Shorted	Jam C (Jam 24/64)
Paper Exit (S35)	221-B2 (IOB)	Open	Jam C (Jam 20)
		Shorted	Jam C (Jam 1)
Fusing Exit	221-B5	Open	Jam C (Jam 19)
		Shorted	Jam C (Jam 1)
Paper Overflow	221-B8	Open	Paper overflow message is not displayed when a paper overflow condition exists.
		Shorted	Paper overflow message is displayed when a paper overflow condition does not exist.

6.2.2 SWITCHES

Component (Symbol)	CN	Condition	Symptom
Main Power (SW1)	903-1,2 (PSU)	Open	The machine does not turn on.
		Shorted	The machine does not turn off.
Interlock 1 (SW2)	913-1 (PSU)	Open	"Doors/Covers Open" is displayed even if the front or right door is closed.
		Shorted	The LCD goes blank when the front or right door is opened.
Interlock 2 (SW3)	913-2 (PSU)	Open	"Open Cover" is displayed even if the front or right door is closed.
		Shorted	The LCD goes blank when the front or right door is opened.
Right Door (SW4)	221-B10 (IOB)	Open	"Open Cover" is displayed even if the right door is closed.
		Shorted	The LCD goes blank when the right door is opened.

6.3 BLOWN FUSE CONDITIONS

CAUTION

- Use a correct rating fuse for the fuse replacement. Never use a wrong rating fuse. If do so, the machine may be damaged.

Fuse	Rating		Symptom at power on
	115V	210 to 230V	
Power Supply Board			
FU21	6.3A / 125V	6.3A / 250V	SC 533 (Power to IOB)
FU22	6.3A / 125V	6.3A / 250V	SC 144-02 (Power to SIO)
FU23	10A / 125V	10A / 250V	"Open Cover" is displayed. (Power to Interlock Switch)
FU24	10A / 125V	10A / 250V	"Open Cover" is displayed. (Power to Interlock Switch)
FU25	6.3A / 125V	6.3A / 250V	Alert LED turns on and operation panel does not turn on. (Power to MB)
FU26	6.3A / 125V	6.3A / 250V	Stack paper in the optional paper feed unit or LCT is not detected. SC 503 is issued after opening and closing the tray 3 or 4. (Power to optional PFU or LCT)
FU27	6.3A / 250V	6.3 A / 250V	The machine does not detect a finisher. (Power to optional Finisher)
FU101	15A / 125V	8A / 250V	No response
FU102	12A / 125V	4A / 250V	No response

ENERGY SAVING

REVISION HISTORY		
Page	Date	Added/Updated/New
		None

7. ENERGY SAVING

7.1 ENERGY SAVE

7.1.1 ENERGY SAVER MODES

Customers should use energy saver modes properly, to save energy and protect the environment.

Power Consump.

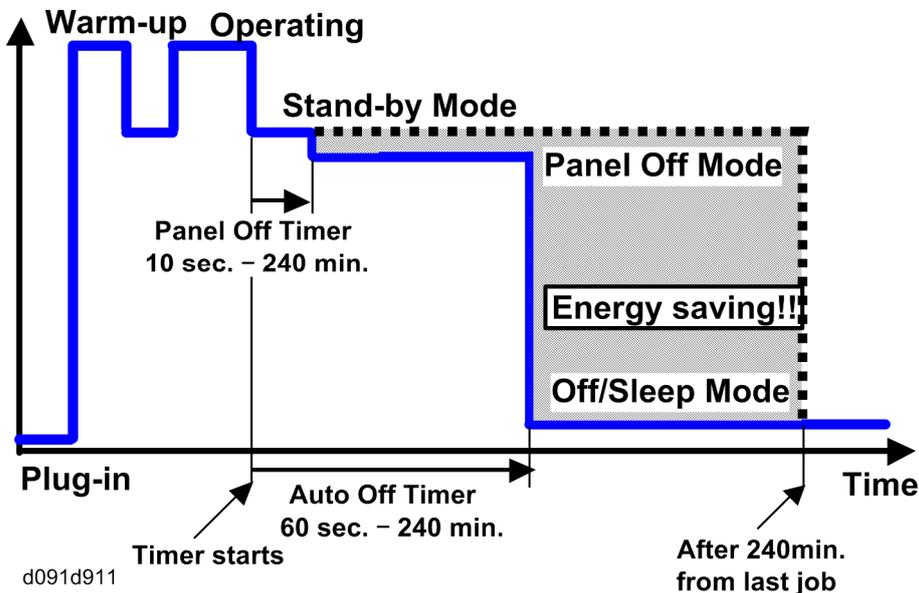

The area shaded grey in this diagram represents the amount of energy that is saved when the timers are at the default settings. If the timers are changed, then the energy saved will be different. For example, if the timers are all set to 240 min., the grey area will disappear, and no energy is saved before 240 min. expires.

Timer Settings

The user can set these timers with User Tools (System settings > Timer setting)

- Panel off timer (10 sec – 240 min): Panel Off Mode. Default setting: 1 minute
- Auto off timer (1 – 240 min): Off/Sleep Mode
Default settings: 1 minute

Normally, Panel Off timer < Auto Off timer. But, for example, if Auto Off timer < or = Panel Off timer, the machine goes immediately to Off mode when the Auto Off timer expires. It skips the Panel Off.

Energy Save

Example

- Panel off: 1 min.
- Auto Off: 1 min.
- The machine goes to Off mode after 1 minute. Panel Off and Low Power modes are not used.

Return to Stand-by Mode

Off/Sleep Mode

Recovery time.

- Max 10 sec. for D009/D011/D091
- Max 15 sec. for D012/D013/D092

Recommendation

We recommend that the default settings should be kept.

- If the customer requests that these settings should be changed, please explain that their energy costs could increase, and that they should consider the effects on the environment of extra energy use.
- If it is necessary to change the settings, please try to make sure that the Auto Off timer is not too long. Try with a shorter setting first, such as 30 min., then go to a longer one (such as 60 min.) if the customer is not satisfied.
- If the timers are all set to the maximum value, the machine will not begin saving energy until 240 minutes has expired after the last job. This means that after the customer has finished using the machine for the day, energy will be consumed that could otherwise be saved.
- If you change the settings, the energy consumed can be measured using SP8941, as explained below.

7.1.2 ENERGY SAVE EFFECTIVENESS

SP 8941 (Machine Status) keeps a record of the amount of time that the machine spends in each mode.

- 8941-001: Operating mode
- 8941-002: Standby mode
- 8941-003: Panel off mode
- 8941-004: Low power mode (not used in this machine)
- 8941-005: Off/sleep mode

With this data, and the power consumption values from the specifications, we can estimate the amount of energy that is used by the machine.

This should only be used as a reference value, because the power consumption specifications are measured in a controlled environment with a constant power supply.

To get an exact measurement at the customers site, a watt meter must be used to measure the actual energy consumed.

To use SP8941 to calculate the energy consumed:

- At the start of the measurement period, read the values of SP8941 001 to 005.
- At the end of the measurement period, read the values of SP8941 001 to 005 again.
- Find the amount of time spent in each mode (subtract the earlier measurement from the later measurement).
- Multiply this by the power consumption spec for each mode.
- Convert the result to kWh (kilowatt hours)

Here is an example calculation.

Energy Save

Machine Date	Power Consumption (W): Data: a	SP8941:Machine Status	Start Time: (min.) Data: b	End Time: (min.) Data: c	Time Differences (Data:b - Data: c) (min.) Data: d	Power Consumption (Data:a x Data:d) (Wmin.) Data: e
① Operating mode	1081.8	001: Operating Time	21089.0	21386.0	297.0	321294.6
② Ready mode (stand by)	214.0	002: Standby Time	306163.0	308046.0	1883.0	402962.0
③ Energy mode (Panel off)	214.0	003: Energy Save Time	71386.0	75111.0	3725.0	797150.0
④ Off/Sleep mode	7.0	005: Off mode Time	508776.0	520377.0	11601.0	81207.0
Total Time of Data: d (min.)					17506.0	
Total Time of Data: d/60min. (Hour)					291.77	
Total Power Consumption of Data: e (Wmin.)						1602613.60
Total Power Consumption of Data: e /60min./1000W (KWH)						26.71

7.2 PAPER SAVE

7.2.1 EFFECTIVENESS OF DUPLEX/COMBINE FUNCTION

Duplexing and the combine functions reduce the amount of paper used. This means that less energy overall is used for paper production, which improves the environment.

1. Duplex:

Reduce paper volume in half!



d062d102

2. Combine mode:

Reduce paper volume in half!

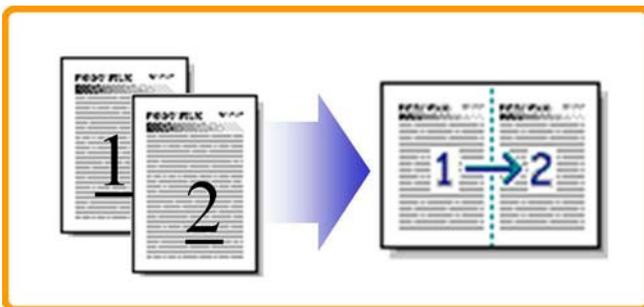

d062d100

Paper Save

3. Duplex + Combine:

Using both features together can further reduce paper volume by 3/4!

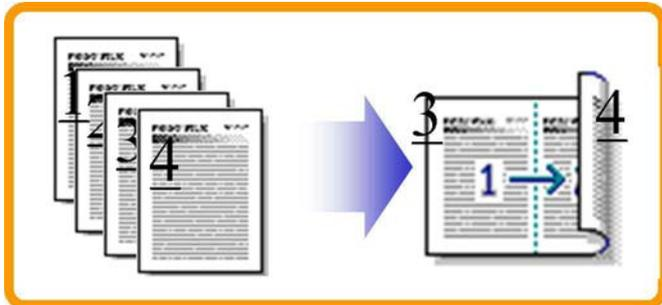

d062d101

To check the paper consumption, look at the total counter and the duplex counter.

The total counter counts all pages printed.

- For one duplex page, the total counter goes up by 2.
- For a duplex job of a three-page original, the total counter goes up by 3.

The duplex counter counts pages that have images on both sides.

- For one duplex page, the duplex counter goes up by 1.
- For a duplex job of a three-page original, the duplex counter will only increase by 1, even though two sheets are used.
- Total counter: SP 8581-001
- Duplex counter: SP 8411-001
- Single-sided with combine mode: SP 8421-004
- Duplex with combine mode: SP 8421-005

The following table shows paper savings and how the counters increase for some simple examples of single-sided and duplex jobs

Duplex mode:

Originals	Simplex Sheet used	Duplex Sheets used	Paper Saved	Total counter SP8501-001	Duplex counter SP8411-001
1	1	1	0	1	0
2	2	1	1	2	1
3	3	2	1	3	1
4	4	2	2	4	2
5	5	3	2	5	2
10	10	5	5	10	5
20	20	10	10	20	10

If combine mode is used, the total and duplex counters work in the same way as explained previously. The following table shows paper savings and how the counters increase for some simple examples of duplex/combine jobs.

2 in 1 mode:

Originals	Simplex Sheet used	Duplex Sheets used	Paper Saved	Total counter SP8501-001	Duplex counter SP8421-004
1	1	1	0	1	1
2	2	1	1	1	1
3	3	2	1	2	2
4	4	2	2	2	2
5	5	3	2	3	2
10	10	5	5	5	5
20	20	10	10	10	10

Paper Save

Duplex + 2 in 1 mode:

Originals	Simplex Sheet used	Duplex Sheets used	Paper Saved	Total counter SP8501-001	Duplex counter SP8421-005
1	1	1	0	1	1
2	2	1	1	1	1
3	3	1	2	2	2
4	4	1	3	2	2
5	5	2	3	3	3
6	6	2	4	3	3
7	7	2	5	4	4
8	8	2	6	4	4
9	9	3	6	5	5
10	10	3	7	5	5
11	11	3	8	6	6
12	12	3	9	6	6

D009/D011/D012/D013/D091/D092
SERVICE MANUAL APPENDICES

D009/D011/D012/ D013/D091/D092 APPENDICES

TABLE OF CONTENTS

1. APPENDIX: GENERAL SPECIFICATIONS	1-1
1.1 GENERAL SPECIFICATIONS	1-1
1.1.1 GENERAL.....	1-1
1.1.2 POWER CONSUMPTION.....	1-4
1.1.3 PRINTER CONTROLLER.....	1-5
1.1.4 SCANNER SPECIFICATIONS.....	1-6
1.2 OPTIONAL EQUIPMENT.....	1-7
1.2.1 ARDF	1-7
1.2.2 TWO-TRAY PAPER FEED UNIT	1-8
1.2.3 LCT 2000-SHEET	1-8
1.2.4 LCT 1200-SHEET	1-9
1.2.5 1-BIN TRAY UNIT	1-9
1.2.6 BRIDGE UNIT	1-10
1.2.7 1000-SHEET FINISHER	1-10
Upper Tray	1-10
Lower Tray	1-11
1.2.8 3000-SHEET FINISHER	1-12
1.2.9 2000-SHEET BOOKLET FINISHER	1-14
1.2.10 PUNCH UNIT FOR 2000/3000-SHEET (BOOKLET) FINISHER.....	1-17
1.2.11 USB SPECIFICATIONS	1-18
1.2.12 IEEE 802.11A/G, G	1-18
1.2.13 BLUETOOTH SPECIFICATIONS	1-18
2. APPENDIX: PM TABLES	2-1
2.1 PM TABLES.....	2-1
2.1.1 MAINFRAME	2-1
2.1.2 OPTIONS.....	2-7
ARDF	2-7
PFU	2-8

LCT	2-8
SR5020	2-8
2000/3000-Sheet (Booklet) Finisher	2-9
Bridge Unit.....	2-9
1-Bin Tray Unit	2-10

3. APPENDIX: SERVICE CALL CONDITIONS3-1

3.1 SERVICE CALL CONDITIONS.....	3-1
3.1.1 SUMMARY.....	3-1
3.1.2 SC CODE DESCRIPTIONS.....	3-2
SC Tables: SC1xx.....	3-3
SC Tables: SC2xx.....	3-7
SC Tables: SC3xx.....	3-9
SC Tables: SC4xx.....	3-13
SC Tables: SC5xx.....	3-14
SC Tables: SC6xx.....	3-23
SC Tables: SC7xx.....	3-30
SC Tables: SC8xx.....	3-39
SC Tables: SC9xx.....	3-57

4. APPENDIX: SERVICE PROGRAM MODE TABLES4-1

4.1 SYSTEM SP TABLE-1	4-1
4.1.1 SP1-XXX: FEED	4-1
4.2 SYSTEM SP TABLE-2.....	4-19
4.2.1 SP2-XXX: DRUM.....	4-19
4.3 SYSTEM SP TABLE-3.....	4-37
4.3.1 SP3-XXX: PROCESS	4-37
4.4 SYSTEM SP TABLE-4.....	4-40
4.4.1 SP4-XXX: SCANNER	4-40
4.5 SYSTEM SP TABLE-5.....	4-80
4.5.1 SP5-XXX: MODE	4-80
4.6 SYSTEM SP TABLE-6.....	4-153
4.6.1 SP6-XXX: PERIPHERALS.....	4-153
4.7 SYSTEM SP TABLE-7	4-165
4.7.1 SP7-XXX: DATA LOG.....	4-165
4.8 SYSTEM SP TABLE-8.....	4-184
4.8.1 SP8-XXX: DATA LOG 2.....	4-184

4.9 INPUT CHECK.....	4-236
4.9.1 COPIER	4-236
Table 1: Paper Height Sensor	4-239
Table 2: Paper Size Switch	4-240
Table 3: Paper Size (By-pass Table).....	4-241
APS Original Size Detection.....	4-242
4.9.2 OPTIONS.....	4-243
2000/3000-Sheet (Booklet) Finisher (B804, B805).....	4-243
1000-Sheet Finisher (B408)	4-247
4.10 OUTPUT CHECK	4-249
4.10.1 COPIER	4-249
4.10.2 1000-SHEET FINISHER (B408).....	4-255
4.10.3 2000/3000-SHEET (BOOKLET) FINISHER	4-256
4.11 PRINTER SERVICE TABLE.....	4-259
4.11.1 PRINTER SP TABLES	4-259
4.12 SCANNER SERVICE TABLE.....	4-266
4.12.1 SP TABLES.....	4-266

APPENDIX: GENERAL SPECIFICATIONS

REVISION HISTORY		
Page	Date	Added/Updated/New
		None

1. APPENDIX: GENERAL SPECIFICATIONS

1.1 GENERAL SPECIFICATIONS

1.1.1 GENERAL

Configuration	Desktop	
Copy Process	Dry electrostatic transfer system	
Original	Sheet/Book	
Original Size	Maximum A3/11" x 17"	
Copy Paper Size	Paper tray, Duplex:	A3/11" x 17" - A5 LEF
	By-pass tray:	12" x 18"/305 x 457.2 mm, A3/11" x 17" - A6 SEF
	Non-standard sizes:	Paper tray Width: 182 - 297 mm (7.2" - 11.7") Length: 210 mm - 431.8 mm (8.3" - 17.0") By-pass tray Width: 90 - 305 mm (3.6" - 12.1") Length: 148 - 457.2 mm (5.8" - 18.1")
Copy Paper Weight	Paper tray/ Duplex:	60 - 169 g/m ² (16 - 45 lb.)
	By-pass:	52 - 220 g/m ² (16 - 57 lb.)
Reproduction Ratios	7R5E:	Metric version (%): 400, 200, 141, 122, 115, 93, 82, 75, 71, 65, 50, 25 Inch version (%): 400, 200, 155, 129, 121, 93, 85, 78, 73, 65, 50, 25
	Zoom:	25 to 400% in 1% steps

General Specifications

Copying Speed	D009/D011 /D091	40 cpm A4, 81/2" x 11" LEF, 1-to-1 (ADF)
	D012/D013 /D092	50 cpm, A4, 81/2" x 11" LEF, 1-to-1 (ADF)
First Copy Time	D009/D011 /D091	4.1 s, 1st Tray, A4/81/2" x 11" LEF
	D012/D013 /D092	3.5 s, 1st Tray, A4/81/2" x 11" LEF
Warm-up Time	D009/D011 /D091	Less than 18.0 s (Basic), 15 s (MFP)
	D012/D013 /D092	Less than 18.0 s (Basic), 15 s (MFP)
Continuous Copy	1 to 999 (operation panel entry)	
Paper Capacity (without options)	1,200 sheets (550 sheets/tray x 2 with 100 sheets in the by-pass tray)	
Paper Capacity (with options)	4,400 sheets (550 sheets/tray x 2 with 100 sheets in the by-pass tray, 1200-sheet LCT and 2000-sheet LCT)	
Paper Output	A4, 81/2" x 11" and smaller:	500 sheets
	B4 and larger:	250 sheets
Power Source	North America:	120V/60 Hz, More than 12.5 A
	Europe/Asia:	220 – 240 V/50, 60 Hz, More than 6.8 A
	Taiwan	110V/60Hz
Dimensions (w x d x h)	Without ADF	670 mm x 677 mm x 760 mm (26.3" x 26.8" x 30.1")
	With ADF	670 mm x 677 mm x 910 mm (26.3" x 26.8" x 36.1")

Weight	EU	Less than 85 kg (187 lb.)		
	NA	Less than 97 kg (147 lb.)		
Resolution	600 dpi (Scanning and Printing)			
Gradation	256 levels (Scanning and Printing)			
Original Archive	More than 2,500 A4 pages for document server (ITU-T No. 4 Chart)			
Toner Replenishment	Cartridge exchange (630 g)			
Total Counter	Electric counter			
Noise Emission: Copying			Mainframe Only	Full System
	D009/D011 /D091		70 dB(A) or less	74 dB(A) or less
	D012/D013 /D092		72 dB(A) or less	76 dB(A) or less
Noise Emission: StandBy			Mainframe Only	Full System
	D009/D011 /D091		45 dB(A) or less	45 dB(A) or less
	D012/D013 /D092		48 dB(A) or less	48 dB(A) or less

General Specifications

1.1.2 POWER CONSUMPTION

	D009/D011//D091		D012/D013//D092	
Operating	NA	770 W	NA	777 W
	EU, Asia	812 W	EU, Asia	896 W
Ready Mode	NA	144 W	NA	148 W
	EU, Asia	143 W	EU, Asia	148 W
Panel Off	NA	104 W	NA	104 W
	EU, Asia	105 W	EU, Asia	105 W
Sleep Mode	NA	5.5 W	NA	5.5 W
	EU, Asia	D009/D011: 5.7 W D091: 5.3 W	EU, Asia	D012/D013: 5.6 W D092: 5.3 W
Maximum	Less than 1.44 kW (NA) Less than 1.5 kW (EU, Asia)		Less than 1.44 kW (NA) Less than 1.5 kW (EU, Asia)	

↓ Note

- The above measurements were made in accordance with ISO 7779.
- In the above "Panel Off" condition, the polygonal mirror motor is not rotating.

1.1.3 PRINTER CONTROLLER

Printing Speed:	D009/D012/D091: Maximum 40 ppm (A4/LT LEF) D011/D013/D092: Maximum 50 ppm (A4/LT LEF)	
Printer Languages:	PCL6/PCL5e PostScript 3 (Option) RPCS (Refined Printing Command Stream - an original Ricoh PDL, For D009/D011/D012/D013 only) IPDS	
Resolution (Driver):	RPCS	200/600 dpi For D009/D011/D012/D013 only
	PS3	300/600 dpi
	PCL5e	300/600 dpi
	PCL6	600 dpi
	IPDS	300/600 dpi
Resident Fonts:	PCL	45 fonts, International 13 fonts
	PS3	Option fonts PS3
Connectivity	Std.	Ethernet; (RJ-45 network port: 10Base-T/100Base-TX), USB 2.0
	Option	IEEE802.11a/g, g (Wireless LAN), Bluetooth, IEEE1284 (Centronics Parallel), Gigabit Ethernet
Network Protocols	TCP/IP, IPX/SPX, AppleTalk (Auto Switching)	
RAM:	Maximum MS model: 512 MB (Resident 256 MB + Additional 256 MB) CS model: 768 MB (Resident 512 MB + Additional 256 MB) Note: Additional 256 MB is required for all printer/scanner unit and printer units.	

General Specifications

1.1.4 SCANNER SPECIFICATIONS

Standard Scanner Resolution:	Main scan/Sub scan 600 dpi	
Scanning Speed	B/W Scanning; 61 ipm, E-mail/Scan-to-Folder/Network Delivery Scanner (A4 LEF, Text 200 dpi, MH Compression) Color Scanning; 31 ipm, E-mail/Scan-to-Folder/Network Delivery Scanner (A4 LEF, Text/Photo 200 dpi, Default Compression)	
Available scanning Resolution Range:	100 to 1200 dpi;	When used as a Network TWAIN scanner.
	100, 200, 300, 400, 600 dpi;	When used as a network delivery scanner, Scan-to-Folder, Scan-to-Email, or Document Server storage.
Grayscales:	8 bits/pixel	
Interface:	Ethernet 10/100BASE TX, Wireless LAN 802.11a/g, g	
Compression Method:	MH, MR, MMR (Binary Picture Processing) JPEG (Grayscale Processing) PDF (High Compression Processing): CS model only	
Video Memory Capacity:	MS model: 35 MB (A4/ Grayscale/ 600dpi) CS model: 109 MB (A4/ Full color/ 600dpi)	
Image Storage Capacity:	Number of originals per file: Maximum 1,000 pages Maximum of files: 3000 files	
Max. Storage on Doc. Svr.	9,000 pages (B&W (ITUT No. 1/200 dpi MMR)	

1.2 OPTIONAL EQUIPMENT

1.2.1 ARDF

Paper Size/Weight:	Simplex	Size	A3 to A5, DLT to HLT
		Weight	40 to 128 g/m ² (11 to 34 lb.)
	Duplex	Size	A3 to A5, DLT to HLT
		Weight	52 to 128 g/m ² (14 to 34 lb.)
Table Capacity:	100 sheets (81.4 g/m ² , 22 lb)		
Original Standard Position:	Rear left corner		
Separation:	Feed belt and separation roller		
Original Transport:	Roller transport		
Original Feed Order:	From the top original		
Supported Magnification Ratios:	Copy	-	32 to 200 %
	Fax	Color	32.6 to 200 %
		Black & white	48.9 to 200 %
Power Source:	DC 24V, 5V from the scanner unit		
Power Consumption:	Less than 60W		
Dimensions (W x D x H):	570 mm x 520 mm x 135 mm (22.4"x20.5"x5.3")		
Weight:	Less than 12kg (26.5 lb.)		

Optional Equipment

1.2.2 TWO-TRAY PAPER FEED UNIT

Paper Feed System:	FRR
Paper Height Detection:	5 steps (100%, 70%, 30%, 10% (Near end), and Empty)
Capacity:	550 sheets x 2 trays
Paper Weight:	60 to 169 g/m ² (16 to 45 lb.)
Paper Size:	A3 SEF to A5, DLT SEF to HLT
Power Source:	DC 24V, 5V (from the main frame)
Power Consumption:	Less than 50 W (Max.)/ Less than 35 W (Ave.)
Dimensions (W x D x H):	580 mm x 620 mm x 260 mm (22.8" x 24.4" x 10.2")
Weight:	26 kg (57.3 lb.)

1.2.3 LCT 2000-SHEET

Paper Size:	A4 LEF/LT LEF
Paper Weight:	60 g/m ² to 169 g/m ² , 16 lb. to 45 lb.
Tray Capacity:	2,000 sheets (80 g/m ² , 20lb.)
Remaining Paper Detection:	5 steps (100%, 70%, 30%, 10%, Empty): Right Tray 4 steps (100%, 70%, 30%, Empty): Left Tray
Power Source:	DC 24 V, 5 V (from copier/printer)
Power Consumption:	50 W (Max.)/30 W (Ave.)
Weight:	26 kg (57.3 lb.)
Size (W x D x H):	580 mm x 620 mm x 260 mm (22.8" x 24.4" x 10.2")

1.2.4 LCT 1200-SHEET

Paper Size:	A4 LEF/ LT LEF/ B5 LEF
Paper Weight:	60 g/m ² to 169 g/m ² , 16 lb to 45 lb
Tray Capacity:	1200 sheets (80 g/m ² , 20lb)
Remaining Paper Detection:	5 steps (100%, 75%, 30%, 10%, End)
Power Source:	24 Vdc, 5 Vdc (from copier/printer)
Power Consumption:	55 W (Max)/ 25 W (Ave.)
Weight:	14 kg (30.8 lb.)
Size (W x D x H):	348 mm x 540 mm x 290 mm (13.7" x 21.3" x 11.4")

1.2.5 1-BIN TRAY UNIT

Paper Size:	Standard Size: A3 /DLT to A6/ HLT SEF
Paper Weight:	60 to 169 g/m ² , 16 to 45 lb.
Tray Capacity:	125 sheets (80 g/m ² , 20 lb., A4)
Power Source:	DC 24 V, 5 V (from the copier)
Power Consumption:	Less than 1 W
Weight:	2 kg
Size (W x D x H):	465 mm x 440 mm x 219 mm (18.3"x17.3"x8.6")

Optional Equipment

1.2.6 BRIDGE UNIT

Paper Size:	Standard sizes A6 SEF to A3, HLT to DLT Non-standard sizes Width: 90 to 305 mm Length: 148 to 600 mm
Paper Weight:	52 g/m ² to 253 g/m ² , 16 lb. to 78 lb.
Power Source:	DC 24 V, 5 V (form the copier/printer)
Dimensions (W x D x H):	415 mm x 412 mm x 111 mm (16.3" x 16.2" x 4.4")
Weight	5 kg (11 lb.)

1.2.7 1000-SHEET FINISHER

Upper Tray

Paper Size:	A3 to A6 11" x 17" to 5.5" x 8.5"
Paper Weight:	60 to 157 g/m ² (16 to 42 lb.)
Paper Capacity:	250 sheets (A4 LEF/8.5" x 11" SEF or smaller) 50 sheets (A4, 8.5" x 11" or smaller) 30 sheets (B4, 8.5" x 14" or larger)

Lower Tray

Paper Size:	No staple mode: A3 to B5, DLT to HLT Staple mode: A3, B4, A4, B5, DLT to LT			
Paper Weight:	No staple mode: 60 to 157 g/m ² (16 to 42 lb) Staple mode: 64 to 90 g/m ² (17 to 24 lb)			
Stapler Capacity:	30 sheets (A3, B4, DLT, LG) 50 sheets (A4, B5 LEF, LT)			
Paper Capacity:	No staple mode: 1,000 sheets (A4/LT or smaller: 80 g/m ² , 20 lb.) 500 sheets (A3, B4, DLT, LG: 80 g/m ² , 20 lb.) Staple mode: (80 g/m ² , 20 lb., number of sets)			
	Set Size	2 to 9	10 to 50	
	Size		10 to 30	31 to 50
	A4/LT LEF B5 LEF	100	100 to 20	100 to 20
	A4/LT SEF	100	50 to 10	50 to 10
	A3, B4, DLT, LG	50	50 to 10	-
Staple positions:	1 Staple: 2 positions (Front, Rear) 2 Staples: 2 positions (Upper, Left)			
Staple Replenishment:	Cartridge (5,000 staples/cartridge)			
Power Source:	DC 24 V, 5 V (from the copier/printer)			
Power Consumption:	50 W			
Weight:	25 kg (55.2 lbs)			
Dimensions (W x D x H):	527 x 520 x 790 mm (20.8" x 20.5" x 31.1")			

Optional Equipment

1.2.8 3000-SHEET FINISHER

Finisher			
Dimension (w x d x h)	657 mm x 613 mm x 960 mm (25.9" x 24.1" x 37.8")		
Weight	Less than 54 kg (119 lb.) (no punch unit) Less than 56 kg (123.5 lb.) (with punch unit)		
Power Consumption	Less than 96 W		
Noise	Less than 75 db		
Configuration	Console type attached base-unit		
Power Source	From base-unit		
Proof Tray	Stack Capacity	250 sheets: A4, 8.5" x 11" or smaller 50 sheets: B4, 8.5" x 14 or larger	
	Paper Size	A5-A3 SEF, A6 SEF, A6 SEF 5.5" x 8.5"-11" x 17" SEF, 12" x 18" SEF	
	Paper Weight	52 g/m ² - 163 g/m ² (14 lb. - 43 lb.)	
Shift Tray	Stack Capacity	3,000 sheets	A4 LEF, 8.5" x 11" LEF
		1,500 sheets	A3 SEF, A4 SEF, B4 SEF, B5, 11" x 17" SEF, 8.5" x 14" SEF, 8.5" x 11" SEF, 12" x 18" SEF
		500 sheets	A5 LEF
		100 sheets	A5 SEF, B6 SEF, A6 SEF, 5.5" x 8.5" SEF
	Paper Size	A5 - A3 SEF, A6 SEF, B6 SEF, 5.5" x 8.5"- 11" x 17" SEF, 12" x 18" SEF	
	Paper Weight	52 g/m ² - 256 g/m ² (14 lb. - 68 lb.)	

Staples			
Paper Size		B5 - A3 8.5" x 11" - 11" x 17", 12" x 18"	
Paper Weight		64 g/m ² - 90 g/m ² (14 lb. - 24 lb.)	
Staple Position		Top, Bottom, 2 Staple, Top-slant	
Stapling Capacity	Same Paper Size	50 sheets	A4, 8.5" x 11" or smaller
		30 sheets	B4, 8.5" x 14" or larger
	Mixed Paper Size	30 sheets	A4 LEF + A3 SEF, B5 LEF + B4 SEF, 8.5" x11" LEF + 11" x 17" SEF

Staple Replenishment	Cartridge exchange / 5000 pins per cartridge		
Stapled Stack Capacity (same size)	Paper Size	Pages/Set	Sets
	A4 LEF, 8.5" x 11" LEF	20 - 50 pages	150 - 60 sets
		2 - 19 pages	150 sets
	A4 SEF, B5, 8.5" x 11" SEF	15 - 50 pages	100 - 30 sets
		2 - 14 pages	100 sets
	Others	15 - 30 pages	100 - 33 sets
2 - 14 pages		100 sets	
Stapled Stack Capacity (mixed sizes)	A4 LEF & A3 SEF, B5 LEF & B4 SEF, 8.5" x11" LEF & 11" x 17" SEF	2 - 30 pages	50 set

Optional Equipment

1.2.9 2000-SHEET BOOKLET FINISHER

Finisher			
Dimension W x D x H		657 mm x 613 mm x 960 mm (25.9 x 24.1 x 37.8")	
Weight		Less than 63 kg (138.6 lb.) (no punch unit) Less than 65 kg (143 lb.) (with punch unit)	
Power Consumption		Less than 96 W	
Noise		Less than 75 db	
Configuration		Console type attached base-unit	
Power Source		From base-unit	
Proof Tray	Stack Capacity	250 sheets: A4, 8.5" x 11" or smaller 50 sheets: B4, 8.5" x 14 or larger	
	Paper Size	A5 - A3 SEF, B6 SEF, A6 LEF 5.5" x 8.5" to 11" x 17" SEF, 12"x18" SEF	
	Paper Weight	52 g/m ² - 163 g/m ² (14 lb. - 43 lb.)	
Shift Tray	Stack Capacity	2,000 sheets	A4 LEF, 8.5" x 11" LEF
		1,000 sheets	A3 SEF, A4 SEF, B4 SEF, B5 11" x 17" SEF, 8.5" x 14" SEF, 8.5" x 11" SEF, 12"x18" SEF
		500 sheets	A5 LEF
		100 sheets	A5 SEF, B6 SEF, A6 SEF, 5.5" x 8.5" SEF
	Paper Size	A5 - A3 SEF, A6 SEF, B6 SEF 5.5" x 8.5" to 11" x 17" SEF, 12" x 18" SEF	
	Paper Weight	52 g/m ² - 256 g/m ² (14 lb. - 68 lb.)	

Staple			
Paper Size		B5-A3, 8.5" x 11" - 11" x 17", 12" x 18"	
Paper Weight		64 g/m ² - 90 g/m ² , 17 lb. Bond - 28 lb. Bond	
Staple Position		Top, Bottom, 2 Staple, Top-slant	
Staples Capacity	Same Paper Size	50 sheets	A4, 8.5" x 11" or smaller
		30 sheets	B4, 8.5" x 14" or larger
	Mixed Paper Size	30 sheets	A4 LEF & A3 SEF, B5 LEF & B4 SEF, 8.5" x 11" LEF & 11" x 17" SEF
	Booklet Stapling	15 sheets	A4 SEF, A3 SEF, B5 SEF, B4 SEF, 8.5" x 11" SEF, 8.5" x 14" SEF, 11" x 17" SEF, 12" x 18" SEF

Optional Equipment

Staple Replenishment		Corner staple	5,000 staples per cartridge
		Booklet staple	2,000 staples per cartridge
Corner Staple Capacity	Same Size	A4 LEF, 8.5" x 11" LEF	13 - 50 pages
			2 - 12 pages
		A4 SEF, B5, 8.5" x 11" SEF	10 - 50 pages
			2 - 9 pages
	Others	10 - 30 pages	
		2 - 9 pages	
Mixed Size	A4 LEF + A3 SEF B5 LEF + B4 SEF 8.5" x 11" LEF + 11" x 17" SEF	2 - 30 pages	
Booklet Staple Capacity	A4 SEF, A3 SEF, B5 SEF, B4 SEF 8.5" x 11" SEF, 8.5" x 14" SEF, 11" x 17" SEF 12" x 18" SEF		2 - 5 pages
			6 - 10 pages
			11 - 15 pages

1.2.10 PUNCH UNIT FOR 2000/3000-SHEET (BOOKLET) FINISHER

Available Punch Units		NA	2/3 holes switchable
		EU	2/4 holes switchable
		Scandinavia	4 holes
Punch Waste Replenishment		NA 2-holes	Up to 5,000 sheets
		NA 3-holes	Up to 5,000 sheets
		EU 2-holes	Up to 14,000 sheets
		EU 4-holes	Up to 7,000 sheets
		Scandinavia 4-holes	Up to 7,000 sheets
Paper Weight		52 g/m ² - 163 g/m ² , 14 lb Bond - 43 lb Bond	
Paper Sizes	NA 2-holes	SEF	A5 to A3, 5.5" x 8.5" to 11" x 17"
		LEF	A5 to A4, 5.5" x 8.5" , 8.5" x 11"
	NA 3-holes	SEF	A3, B4, 11" x 17"
		LEF	A4, B5, 8.5" x 11"
	EU 2-holes	SEF	A5 to A3, 5.5" x 8.5" to 11" x 17"
		LEF	A5 to A4, 5.5" x 8.5", 8.5" x 11"
	EU 4-holes	SEF	A3, B4, 11"x17"
		LEF	A4, B5, 8.5" x 11"
	Scandinavia 4-holes	SEF	A5 to A3, 5.5" x 8.5" to 11" x 17"
		LEF	A5 to A4, 5.5" x 8.5", 8.5" x 11"

Optional Equipment

1.2.11 USB SPECIFICATIONS

USB connectivity is built into the controller.

Interface	USB 2.0
Data rates	480 Mbps (high speed), 12 Mbps (full speed), 1.5 Mbps (low speed)
	High speed mode is only supported by USB 2.0.

1.2.12 IEEE 802.11A/G, G

Radiofrequency Band	802.11a: 5 GHz 802.11b: 2.4 GHz 802.11g: 2.4 GHz
Data Transfer Speed	802.11a: 54 Mbps 802.11b: 11 Mbps 802.11g: 54 Mbps
Security Standards	IEEE 802.11 WEP WPA/ WPA2 (IEEE 802.11i) Enterprise Mode

1.2.13 BLUETOOTH SPECIFICATIONS

Transmission Specifications	Based on Bluetooth V1.1
Data Transfer Speed	1 Mbps
Profile	Hard Copy Cable Replacement Profile (HCRP), Serial Port Profile (SPP), BIP
Distance Between Devices	10 m (The maximum distance when using outdoors, otherwise depends on the office environment.)

APPENDIX: PM TABLES

REVISION HISTORY		
Page	Date	Added/Updated/New
		None

2. APPENDIX: PM TABLES

2.1 PM TABLES

Amounts mentioned as the PM interval indicate the number of prints.

2.1.1 MAINFRAME

Symbol key: **C**: Clean, **R**: Replace, **L**: Lubricate, **I**: Inspect

	EM	160K	320K	800K	Note
Scanner/Optics					
Reflector		C			Optics cloth
1st Mirror		C			Optics cloth
2nd Mirror		C			Optics cloth
3rd Mirror		C			Optics cloth
Scanner Guide Rails		C			Do not use alcohol.
Exposure Glass	C	C			Cleaner
Toner Shield Glass	C	C			Dry cloth or cleaner
APS Sensor		C			Dry cloth
Exposure Glass (Sheet through)	C	C			Cleaner
Drum (OPC) Area					
OPC Drum	I	R			
Charge Roller		R			
Charge Roller Cleaning		R			

PM Tables

	EM	160K	320K	800K	Note
Roller					
Drum Cleaning Blade 1		R			
Quenching Lamp	C		C		Dry cloth
Pick-off Pawls		R			
Spurs	C	C			Dry cloth
ID Sensor	C	C			Perform SP3-001-2 after blower brush cleaning.
Cleaning Entrance Seal		C			Blower brush. Replace if required.
Side Seal		I			
Development Unit					
Development Drive Gears				C	Dry cloth
Development Filter		R			
Development filter: front		R			
Development filter: rear		R			
Developer		I	R		
Entrance Seal		I			
Side Seal		I			
Development Roller		C			Dry cloth

Paper Feed					
	EM	160K	320K	800K	Note
Registration Roller	I	C			Water
Idle Roller Dust Blade	I	C			Detach and tap gently on flat surface to empty. Blower brush.
Registration Roller Dust Blade	I	C			Blower brush.
Feed Rollers	I	C			Water
Pick-up Rollers	I	C			Water
Separation Rollers	I	C			Water
By-pass Feed Roller	I	C			Water
By-pass Pick-up Roller	I	C			Water
By-pass Separation Roller	I	C			Water
Paper Feed Guides	I	C			Dry cloth
Relay Rollers	I	C			Water
Bottom Plate Pad	I	C			Water
Bottom Plate Pad (By-pass feed)	I	C			Water
Registration Sensor	I	C			Blower brush
By-pass Feed Roller Gear	I	L			Silicone Grease G-501
Relay Sensors	I	C			Blower Brush
Paper Feed Sensors	I	C			Blower Brush

PM Tables

Duplex Unit					
	EM	160K	320K	800K	Note
Inverter Rollers		C			Water
Transport Rollers		C			Water
Entrance Sensor		C			Water
Exit Sensor		C			Water
Transfer Belt Unit					
Transfer Belt	C	R			Dry cloth. To prevent damage to the cleaning blade, always replace these items together.
Transfer Belt Cleaning Blade		R			
Transfer Belt Rollers		C			Dry cloth
Entrance Seal		C			Dry cloth
Transfer Entrance Guide	C	C			Dry cloth
Used Toner Tank	I	C			Empty the tank

Paper Exit					
	EM	160K	320K	800K	Note
Paper Exit Sensor	I	I			Blower brush
Junction Gate Jam sensor	I	C			Blower brush
Fusing Exit Sensor	I	I			Blower brush
Paper Exit Rollers	I	I			Water
Junction Transport Roller	I	I			Water
Paper Exit Guide	I	I			Water

↓ Note

- Due to their durability and extended service life, the feed rollers, separation rollers, and pick-up rollers of the mainframe, optional paper trays, and LCT are not replaced at PM.

*1: Lubricate the by-pass feed clutch gear with Silicone Grease G501 every P.M.

PM Tables

	EM	160K	320K	800K	Note
Fusing Unit and Paper Exit					
Fusing Entrance and Exit Guide Plates		C			Water or alcohol
Hot Roller		R			
Pressure Roller		R			
Fusing Thermistors		R			
Cleaning Roller Bushings		L			Grease: Barrierta JFE 55/2
Hot Roller Strippers			R		
Paper Exit Guide Ribs		C			Water or alcohol
Web Supply Roller		R			
Web Holder Roller			R		
Brake Pad			R		

2.1.2 OPTIONS

Amounts mentioned as the PM interval indicate the number of prints/ originals.

Symbol key: **C**: Clean, **R**: Replace, **L**: Lubricate, **I**: Inspect

ARDF

B802	EM	120K (Originals)	Note
ARDF (for originals)			
Pick-up Roller		R	Damp cloth; alcohol
Feed Belt		R	Damp cloth; alcohol
Separation Roller		R	Damp cloth; alcohol
Sensors	C		Blower brush
Platen Sheet Cover	C		Damp cloth; alcohol (Replace if required.)
White Plate	C		Dry or damp cloth
Drive Gear	L		Grease G501
Transport Roller	C		Damp cloth; alcohol
Exit Roller	C		Damp cloth; alcohol
Inverter Roller	C		Damp cloth; alcohol
Idle Rollers	C		Damp cloth; alcohol

PM Tables

PFU

D351	EM	150K	300K	450K	Note
Paper Feed Unit					
Relay Rollers		C			Dry or damp cloth
Bottom Plate Pad		C			Dry or damp cloth

LCT

D352	EM	150K	300K	450K	Note
LCT 2000-sheet					
Bottom Plate Pad		C			Dry or damp cloth

SR5020

B408	EM	150K	300K	450K	Note
1000-Sheet Finisher					
Rollers	C				Water or alcohol.
Discharge Brush	C	C			Dry cloth
Sensors	C				Blower brush
Jogger Fences	I	I			Replace if required.

2000/3000-Sheet (Booklet) Finisher

B804/B805	EM	Note
2000/3000-Sheet (Booklet) Finisher		
Rollers	C	Water or alcohol.
Discharge Brush	C	Dry cloth
Sensors	C	Blower brush
Jogger Fences	I	Replace if required.
Punch Unit		
Punch Chads	C	Discard chads.

Bridge Unit

D386	EM	Note
Bridge Unit		
Rollers	C	Dry or damp cloth
Copy Tray	C	Dry or damp cloth
Sensors	C	Blower brush

PM Tables

1-Bin Tray Unit

D389	EM	Note
1-Bin Tray Unit		
Rollers	C	Dry or damp cloth
Copy Tray	C	Dry or damp cloth
Sensors	C	Blower brush

APPENDIX: SERVICE CALL CONDITIONS

REVISION HISTORY		
Page	Date	Added/Updated/New
		None

3. APPENDIX: SERVICE CALL CONDITIONS

3.1 SERVICE CALL CONDITIONS

3.1.1 SUMMARY

There are 4 levels of service call conditions.

Level	Definition	Reset Procedure
A	To prevent damage to the machine, the main machine cannot be operated until the SC has been reset by a service representative (see the note below).	Enter SP mode, use SP 5810, touch [Execute], and then turn the main power switch off and on.
B	SCs that disable only the features that use the defective item. Although these SCs are not shown to the user under normal conditions, they are displayed on the operation panel only when the defective feature is selected.	Turn the operation switch or main switch off and on.
C	The SC history is updated. The machine can be operated as usual.	The SC will not be displayed. Only the SC history is updated.
D	Turning the main switch off then on resets SCs displayed on the operation panel. These are re-displayed if the error occurs again.	Turn the operation switch off and on. Also see below.

When a Level "D" SC code occurs

When a Level D SC occurs, a screen opens on the operation panel to tell the operator:

- An error occurred
- The job in progress will be erased
- The machine will reboot automatically after approximately 30 seconds.

The operator can wait until the machine reboots automatically or touch "Reset" on the screen to reset the machine immediately and go back to the copy screen.

Service Call Conditions

If the operator does not touch "Reset"

The next message tells the operator that the machine will reset automatically and that the previous job was lost and must be started again. After reading the message, the operator touches "Confirm" on the screen. The next screen shows the number and title of the SC code, and stops until the operator turns the machine off and on.

If the operator touches "Reset"

If the operator touches "Reset" to bypass the 30-second interval for the machine to reboot, the machine reboots immediately and the operation panel displays the copy screen.

Note

- Do not try to use the operation panel during an automatic reboot.
- If the Remote Service System is in use, the SC code is sent immediately to the Service Center.

3.1.2 SC CODE DESCRIPTIONS

Important

- If a problem concerns a circuit board, disconnect and reconnect the connectors and then test the machine. Often a loose or disconnected harness is the cause of the problem. Always do this before you decide to replace the PCB.
- If a motor lock error occurs, check the mechanical load before you decide to replace the motor or sensors.
- When a Level "A" or "B" SC occurs while in an SP mode, the machine cannot display the SC number. If this occurs, check the SC number after leaving the SP mode.
- The machine reboots automatically when the machine issues a Level "D" SC code. This is done for Level "D" SC codes only.

CAUTION

- Never turn off the main power switch when the power LED is lit or flashing. To avoid damaging the hard disk or memory, press the operation switch to switch the power off, wait for the power LED to go off, and then switch the main power switch off.

Note

- The main power LED lights or flashes while the platen cover or ARDF is open, while the main machine is communicating with a facsimile or the network server, or while the machine is accessing the hard disk or memory for reading or writing data.

SC Tables: SC1xx

101	D	Exposure lamp error
		-001: Shading at AGC -002: Shading at scanning <ul style="list-style-type: none"> ▪ The standard white level was not detected properly when scanning the white plate
		<ul style="list-style-type: none"> ▪ Exposure lamp defective ▪ Lamp stabilizer defective ▪ Exposure lamp connector defective ▪ Standard white plate dirty ▪ Scanner mirror or scanner lens out of position or dirty ▪ SBU defective ▪ BICU defective
		The peak white level is less than 64/255 digits (8 bits) when scanning the shading plate. (The shading data peak does not reach the specified threshold)

Appendix:
Service Call
Conditions

120	D	Scanner home position error 1
		The scanner home position sensor does not detect the "OFF" condition during initialization or copying.
		<ul style="list-style-type: none"> ▪ SIB (B/W), SIB (Color) or scanner drive motor defective ▪ Scanner motor defective ▪ Harness between SIB and scanner drive motor disconnected ▪ Harness between SIB and scanner drive motor power source disconnected ▪ Scanner HP sensor defective ▪ Harness between SIB and HP sensor disconnected ▪ Scanner wire, timing belt, pulley, or carriage defective ▪ BICU defective

Service Call Conditions

121	D	Scanner home position error 2
		The scanner home position sensor does not detect the "ON" condition during initialization or copying.
		<ul style="list-style-type: none"> ▪ SIB (B/W), SIB (Color) or scanner motor drive board defective ▪ Scanner motor defective ▪ Harness between SIB and scanner drive motor disconnected ▪ Harness between SIB and scanner drive motor power source disconnected ▪ Scanner HP sensor defective ▪ Harness between SIB and scanner HP sensor disconnected ▪ Scanner wire, timing belt, pulley, or carriage defective ▪ BICU defective

141	D	Black level detection error (Color Scanner model only)
		The black level cannot be adjusted within the target value during the zero clamp.
		<ul style="list-style-type: none"> ▪ Defective SBU ▪ BICU defective

142	D	White level detection error (Color Scanner model only)
		The white level cannot be adjusted within the target during auto gain control.
		<ul style="list-style-type: none"> ▪ Dirty exposure glass or optics section ▪ SBU board defective ▪ Exposure lamp defective ▪ Lamp stabilizer defective ▪ BICU defective

143	C	SBU auto adjust error (B/W Scanner model only)	
		<p>One of the following occurred:</p> <ul style="list-style-type: none"> ▪ When the machine was powered on, automatic adjustment of the SBU failed. ▪ Automatic white density adjustment failed when reading standard white plate. 	
		<ul style="list-style-type: none"> ▪ Exposure lamp defective ▪ Lamp stabilizer defective ▪ Lamp stabilizer connection loose, disconnected or damaged ▪ White plate mounting is incorrect or defective ▪ Scanner mirror or scanner lens out of position or dirty ▪ SBU, SCNB defective ▪ BICU defective ▪ Harness connections 	

144	D	-001: SBU connection error	
		<p>The SBU connection cannot be detected at power on or recovery from the energy save mode.</p>	<ul style="list-style-type: none"> ▪ Defective SBU ▪ Defective harness ▪ Defective detection port on the BICU
	D	-002: SBU serial communication error	
		<p>The power ON of the SBU is not detected.</p>	<ul style="list-style-type: none"> ▪ Defective SIO, SBU or SCNB ▪ Defective harness ▪ Defective detection port on the BICU
	D	-003: GASBU reset error	
		<p>The serial communication does not work.</p>	<ul style="list-style-type: none"> ▪ Defective SBU ▪ Defective detection circuit on the BICU ▪ Defective harness

Service Call Conditions

		-004: VERSION error	
	D	The serial communication does not work.	<ul style="list-style-type: none"> ▪ Defective SBU ▪ Defective detection circuit on the BICU ▪ Defective harness

		Scanner adjustment error (B/W Scanner model only)	
		During the SBU adjustment, the machine detects that the white level read from the white plate or paper is out of range. (SP4015)	
145	C	<ul style="list-style-type: none"> ▪ Exposure lamp defective ▪ Dirty white plate ▪ Incorrect position or width of white plate scanning (SP4015) ▪ BICU board defective ▪ SBU board defective 	

		BICU error	
		The error result of self-diagnostic by the ASIC on the BICU is detected.	
161	D	<ul style="list-style-type: none"> ▪ Defective BICU ▪ Defective connection between BICU and SBU 	

		Copy Data Security Unit error	
		The copy data security board is not detected when the copy data security function is set "ON" with the initial setting.	
		A device check error occurs when the copy data security function is set to "ON" with the initial setting.	
165	D	<ul style="list-style-type: none"> ▪ Incorrect installation of the copy data security board ▪ Defective copy data security board 	

SC Tables: SC2xx

202	D	Polygon motor error 1: ON timeout
		The polygon mirror motor does not reach the targeted operating speed within 10 sec. after turning on or changing speed
203	D	Polygon motor error 2: OFF timeout
		The polygon mirror motor does not leave the READY status within 3 sec. after the polygon motor switched off.
204	D	Polygon motor error 3: XSCRDY signal error
		The SCRDY_N signal remains HIGH for 200 ms while the LD unit is firing.
		<ul style="list-style-type: none"> ▪ Polygon motor/driver board harness loose or broken ▪ Polygon motor/driver board defective ▪ Laser optics unit defective ▪ BICU defective

220	D	Laser synchronizing detection error: start position LD0
		The laser synchronizing detection signal for the start position of the LDB is not output for two seconds after LDB unit turns on while the polygon motor is rotating normally
		<ul style="list-style-type: none"> ▪ The Copy Data Security Unit card not installed ▪ The Copy Data Security Unit card is installed, but it is not the correct type for the machine.

Appendix:
Service Call
Conditions

Service Call Conditions

221	D	Laser synchronizing detection error: start position LD1
		The laser synchronizing detection signal for the start position of the LDB is not output for two seconds after LDB unit turns on while the polygon motor is rotating normally.
		<ul style="list-style-type: none"> ▪ The Copy Data Security Unit card not installed ▪ The Copy Data Security Unit card is installed, but it is not the correct type for the machine.

230	D	FGATE ON error
		The FGATE signal does not assert within the prescribed time. (The BICU generates the FGATE signal and sends it to the LD unit when the registration sensor switches on.)
231	D	FGATE OFF error
		The FGATE signal does not assert within the prescribed time. (The BICU generates the FGATE signal and sends it to the LD unit when the registration sensor switches on.)
		<ul style="list-style-type: none"> ▪ BICU defective ▪ BICU, Controller board harness loose or broken ▪ Controller board defective.

240	C	LD error
		The BICU detected a problem at the LD unit.
		<ul style="list-style-type: none"> ▪ Worn-out LD ▪ Disconnected or broken harness of the LD.

SC Tables: SC3xx

302	D	Charge roller bias leak
		A charge roller bias leak signal was detected.
		<ul style="list-style-type: none"> ▪ Charge roller damaged ▪ High voltage supply board defective ▪ PCDU harness defective or disconnected

304	D	Charge roller bias correction leak
		The charge roller bias correction is performed twice even if the maximum charge roller bias (-2000V) is applied to the roller.
		<ul style="list-style-type: none"> ▪ ID sensor defective ▪ Worn charge roller ▪ Charge roller damaged

320	D	Development roller bias leak
		The development roller bias leak is detected for 60 ms after the high voltage has been supplied to the development unit.
		<ul style="list-style-type: none"> ▪ Development bias leak ▪ Broken harness ▪ Defective high voltage power supply, voltage supply ▪ Defective high voltage supply unit

Service Call Conditions

324	D	Development paddle motor error
		The machine detects a lock signal error from the development puddle motor for 2 seconds after the drum motor has turned on.
		<ul style="list-style-type: none"> ▪ Overload on the development puddle motor ▪ Defective development puddle motor ▪ Defective harness ▪ Defective IOB

350	D	ID sensor pattern test error
		<p>One of the following readings occurred 10 times in the ID sensor output when the ID sensor pattern was checked:</p> <ol style="list-style-type: none"> 1) $V_{sp} > 2.5V$ 2) $V_{sg} < 2.5V$ 3) $V_{sp} = 0V$ 4) $V_{sg} = 0V$
		<ul style="list-style-type: none"> ▪ ID sensor connector defective ▪ Poor ID sensor connector connection ▪ I/O board (IOB) defective ▪ Poor writing of ID sensor pattern on the drum ▪ High voltage supply board defective

351	D	ID sensor Vsg test error
		When the ID sensor was checked, the ID sensor output voltage is 5.0V while the LED current value is 0.
		<ul style="list-style-type: none"> ▪ ID sensor defective or dirty ▪ ID sensor connector defective ▪ Poor ID sensor connection ▪ I/O board (IOB) defective ▪ Scanning system defective ▪ High voltage supply board defective ▪ Defect at the ID sensor pattern writing area of the drum

355	C	Grayscale measurement error
		When the grayscale control result is the maximum and it does not operate correctly and these cases are detected 15 times.
		<ul style="list-style-type: none"> ▪ ID sensor defective or dirty ▪ The life of ID sensor or photo conductor ▪ Shield glass dirty

Appendix:
Service Call
Conditions

Service Call Conditions

360	D	TD sensor (Vt) error 1
		The following condition occurs thirty times consecutively during printing. Vt is less than 0.5V or 4.8V or more
		<ul style="list-style-type: none"> ▪ TD sensor disconnected ▪ Harness between TD sensor and PCDU defective ▪ Defective TD sensor.

372	D	TD sensor adjustment error
		Vts is less than 1.8V or 4.8V or more during TD sensor initialization.
		<ul style="list-style-type: none"> ▪ Heat seal not removed from a new developer pack ▪ TD harness sensor disconnected, loose or defective ▪ TD sensor defective ▪ Harness between TD sensor and drawer disconnected, defective

396	D	Drum motor error
		The machine detects a lock signal error from the drum motor for 2 seconds after the drum motor turned on.
		<ul style="list-style-type: none"> ▪ Overload on the motor ▪ Defective drum motor ▪ Defective harness ▪ Defective IOB

SC Tables: SC4xx

400	D	Vsg adjustment error
		Vsg is more than 4.2V or 3.8V or less when the machine adjusts Vsg value.
		<ul style="list-style-type: none"> ▪ Dirty or defective ID sensor ▪ Defective ID sensor shutter

440	D	Transfer belt bias error
		The feed back bias from the transfer belt is more than 4V for 60 msec while the transfer belt bias is output.
		The A/D conversion level is 20 or less for 60 msec.
		The PWM duty is 24% or more for 60 msec.
		<ul style="list-style-type: none"> ▪ Power pack broken ▪ Defective harness ▪ Disconnected connector

441	D	Transfer/Development motor error
		The machine detects a lock signal error from the transfer/development motor for 2 seconds after the transfer/development motor turned on.
		<ul style="list-style-type: none"> ▪ Overload on the motor ▪ Defective transfer/development motor ▪ Defective harness ▪ Defective IOB

Appendix:
Service Call
Conditions

Service Call Conditions

442	D	Transfer belt contact motor error
		The transfer belt HP sensor detects incorrect movement of the transfer belt after the transfer belt contact motor has turned on.
		<ul style="list-style-type: none"> ▪ Dirty transfer belt HP sensor ▪ Defective transfer belt contact motor ▪ Disconnected connector of the transfer belt HP sensor or motor ▪ Disconnected cable ▪ Defective IOB

SC Tables: SC5xx

501	B	1st tray lift malfunction
		The tray lift sensor is not activated after the tray lift motor has been on for 10 seconds. If the main power switch is turned on when the paper is already at the feed height, the paper height position is detected again. At this time, the tray lift sensor should de-activate within 1.5 sec after the paper bottom plate starts to drop. If it does not deactivate within 1.5 sec., a message will prompt the user to reset Tray 1. After two attempts to release the error by re-setting the paper tray, if this does not solve the problem then this SC is displayed.
		<ul style="list-style-type: none"> ▪ An obstruction (jammed paper, paper scraps, etc.) has blocked the motor drive and caused an overload. ▪ Tray lift sensor connection loose, disconnected, or damaged ▪ Tray lift sensor defective ▪ Tray lift motor connection loose, disconnected, or damaged ▪ Tray lift motor defective

502	B	2nd tray lift malfunction
		The tray lift sensor is not activated after the tray lift motor has been on for 10 seconds. If the main power switch is turned on when the paper is already at the feed height, the paper height position is detected again. At this time, the tray lift sensor should de-activate within 1.5 sec. after the paper bottom plate starts to drop. If it does not deactivate within 1.5 sec., a message will prompt the user to reset Tray 2. After two attempts to re-set the paper tray, if this does not solve the problem then this SC is displayed.
		<ul style="list-style-type: none"> ▪ An obstruction (jammed paper, paper scraps, etc.) has blocked the motor drive and caused an overload. ▪ Tray lift sensor connection loose, disconnected, or damaged ▪ Tray lift sensor defective ▪ Tray lift motor connection loose, disconnected, or damaged ▪ Tray lift motor defective

503		3rd tray lift malfunction (optional paper feed unit or LCT)
-1	B	<p>For the paper feed unit:</p> <ul style="list-style-type: none"> ▪ SC 503-01 occurs if the lift sensor does not turn on within 10 seconds after the tray lift motor has turned on. <p>For the LCT:</p> <ul style="list-style-type: none"> ▪ SC 503-01 occurs if the lift sensor does not turn on or turn off within 8 seconds after the tray lift motor has turned on to lift or lower the tray.
		<p>For the paper feed unit:</p> <ul style="list-style-type: none"> ▪ Defective tray lift motor or connector disconnection ▪ Defective lift sensor or connector disconnection <p>For the LCT:</p> <ul style="list-style-type: none"> ▪ Defective stack transport clutch or connector disconnection ▪ Defective tray motor or connector disconnection ▪ Defective end fence home position sensor or connector disconnection ▪ Defective upper limit sensor or connector disconnection ▪ Defective tray lift motor or connector disconnection

Service Call Conditions

-2	B	<p>This SC is generated if the following condition occurs 3 consecutive times.</p> <p>For the paper feed unit:</p> <ul style="list-style-type: none"> ▪ When the tray lowers, the tray lift sensor does not go off within 1.5 sec. <p>For the LCT:</p> <ul style="list-style-type: none"> ▪ When the main switch is turned on or when the LCT is set, if the end fence is not in its position (home position sensor ON), the tray lift motor stops. ▪ If the upper limit does not go off for 1.5 seconds even the tray lift motor turns on to lower the tray after the upper limit has been detected at power on.
		<p>For the paper feed unit:</p> <ul style="list-style-type: none"> ▪ Defective tray lift motor or connector disconnection ▪ Defective lift sensor or connector disconnection <p>For the LCT:</p> <ul style="list-style-type: none"> ▪ Defective stack transport clutch or connector disconnection ▪ Defective tray motor or connector disconnection ▪ Defective end fence home position sensor or connector disconnection

504		4th tray lift malfunction (optional paper feed unit)
-1	B	<p>For the paper feed unit:</p> <ul style="list-style-type: none"> ▪ When the tray lift motor turns on, the upper limit is not detected within 10 seconds. If this condition occurs three consecutive times, the SC is generated.
		<p>For the paper feed unit:</p> <ul style="list-style-type: none"> ▪ Defective tray lift motor or connector disconnection ▪ Defective lift sensor or connector disconnection
-2	B	<p>For the paper feed unit:</p> <p>When the tray lift motor is turned on, the upper limit is not detected within 10 seconds.</p> <p>If this condition occurs three consecutive times, the SC is generated.</p>
		<ul style="list-style-type: none"> ▪ Defective tray lift motor or connector disconnection ▪ Defective lift sensor or connector disconnection

505		5th tray lift malfunction (optional LCT)
-1	B	This SC is generated if the following condition occurs: <ul style="list-style-type: none"> ▪ When the tray lift sensor of the LCT 1200-sheet does not go on after the tray lift motor has turned on to lift the paper tray. ▪ When the tray lift sensor of the LCT 1200-sheet does not go off after the tray lift motor has turned on to lower the paper tray. ▪ When the tray lift sensor of the LCT 1200-sheet does not go on after the pick-up roller solenoid has turned on at power on.
		<ul style="list-style-type: none"> ▪ Tray lift motor defective or disconnected ▪ Tray lift sensor defective or disconnected
-2	B	Both tray lift sensor and lower limit sensor are turned on at the same time when the main power is turned on or the right door is closed.
		<ul style="list-style-type: none"> ▪ Tray lift motor defective or disconnected ▪ Tray lift sensor defective or disconnected ▪ Low limit sensor defective or disconnected

530	D	Fusing exhaust fan motor error
		The IOB does not receive the lock signal for 10 seconds after turning on the fusing exhaust fan.
		<ul style="list-style-type: none"> ▪ Defective fusing exhaust fan motor or connector disconnection ▪ Defective IOB ▪ Disconnected harness

531	D	Exhaust fan motor error
		The IOB does not receive the lock signal for 10 seconds after turning on the exhaust fan motor.
		<ul style="list-style-type: none"> ▪ Defective exhaust fan motor or connector disconnection. ▪ Defective IOB ▪ Disconnected harness

Service Call Conditions

532	D	Cooling fan motor error
		The machine does not detect the fan motor lock signal for 10 seconds after turning on the cooling fan motor.
		<ul style="list-style-type: none"> ▪ Defective cooling fan motor or connector disconnection. ▪ Disconnected harness ▪ Defective IOB

533	D	Paper exit cooling fan motor error
		The machine does not detect the fan motor lock signal for 10 seconds after turning on the paper exit cooling fan motor.
		<ul style="list-style-type: none"> ▪ Defective paper exit cooling fan motor or connector disconnection. ▪ Defective IOB ▪ Disconnected harness

540	D	Fusing motor error
		The IOB does not receive the lock signal for 2 seconds after turning on the fusing motor.
		<ul style="list-style-type: none"> ▪ Motor overload ▪ Defective fusing motor or connector disconnection. ▪ Defective IOB ▪ Disconnected harness

541	A	Fusing thermistor open (center)
		The thermistor (center) detects 0°C or less for 5 sec.
		<ul style="list-style-type: none"> ▪ Fusing thermistor disconnected ▪ Fusing thermistor connector defective

542	A	Fusing temperature warm-up error(center)
		<p>This SC is generated if the following condition occurs:</p> <ul style="list-style-type: none"> ▪ The thermistor (center) does not detect an 8°C increment in the fusing temperature for 7.5 sec. just after the fusing temperature reached 45°C. ▪ The temperature of the center thermistor does not reach the target temperature for 28 seconds after the fusing lamps turned on.
		<ul style="list-style-type: none"> ▪ Thermistor warped or broken

543	A	Fusing overheat error 1 (software detection)
		<p>A fusing temperature (at the center) of over 230°C (446°F) is detected for 1 second by the fusing thermistors at the center or at either end of the fusing roller.</p>
		<ul style="list-style-type: none"> ▪ Power supply unit defective ▪ I/O board (IOB) defective ▪ BICU defective ▪ TRIAC short on PSU (PSU defective)

544	A	Fusing overheat error 1 (hardware detection)
		<p>A fusing temperature (at the center) over 250°C is detected by the fusing temperature monitor circuit in the BICU board.</p>
		<ul style="list-style-type: none"> ▪ I/O board (IOB) defective ▪ BICU defective

545	A	Fusing lamp consecutive full power 1
		<p>After warm-up the fusing lamp remains at full power for 15 seconds without the hot roller rotating.</p>
		<ul style="list-style-type: none"> ▪ Disconnected or defective thermistors (center) ▪ Defective fusing lamp

Service Call Conditions

547	D	Zero cross error
		<ul style="list-style-type: none"> ▪ The zero cross signal is detected three times even though the heater relay is off when turning on the main power. ▪ The zero cross signal is not detected for 2 seconds even though the heater relay is on after turning on the main power or closing the front door. ▪ The detection error occurs twice or more in the 11 zero cross signal detections. This error is defined when the detected zero cross signal is less than 45.
		<ul style="list-style-type: none"> ▪ Defective fusing lamp relay ▪ Defective fusing lamp relay circuit ▪ Unstable power supply

551	A	Fusing thermistor open (end)
		The thermistor (end) detects 0°C or less for 5 sec.
		<ul style="list-style-type: none"> ▪ Fusing thermistor (end) disconnected ▪ Fusing thermistor (end) connector defective

552	A	Fusing temperature warm-up error (end)
		<p>This SC is generated if the following condition occurs:</p> <ul style="list-style-type: none"> ▪ The thermistor (end) does not detect an 8°C increment in the fusing temperature for 7.5 sec. just after the fusing temperature reached 45°C. ▪ The temperature of the end thermistor does not reach the target temperature for 31 seconds after the fusing lamps turned on.
		<ul style="list-style-type: none"> ▪ Thermistor warped or broken

553	A	Fusing overhear error 1 (software detection)
		A fusing temperature (at the end) of over 230°C (446°F) is detected for 1 second by the fusing thermistors at the center or at either end of the fusing roller.
		<ul style="list-style-type: none"> ▪ Power supply unit defective ▪ I/O board (IOB) defective ▪ BICU defective ▪ TRIAC short on PSU (PSU defective)

554	A	Fusing overhear error 1 (hardware detection)
		A fusing temperature (at the end) over 250°C is detected by the fusing temperature monitor circuit in the BICU board.
		<ul style="list-style-type: none"> ▪ I/O board (IOB) defective ▪ BICU defective

555	A	Fusing lamp consecutive full power 1
		After warm-up, the fusing lamp remains at full power for 15 seconds without the hot roller rotating.
		<ul style="list-style-type: none"> ▪ Disconnected or defective thermistors (ends) ▪ Defective fusing lamp

557	C	Zero cross frequency error
		When the zero cross signal is 66 or more and it is detected 10 times or more in 11 detections, the machine determines that input 60 Hz and SC557 occurs.
		<ul style="list-style-type: none"> ▪ Noise (High frequency)

Service Call Conditions

559	A	Fusing unit jam
		The fusing sensor detected a fusing unit paper late jam three times. The paper was late and the fusing exit sensor could not detect the paper three times.
		<ul style="list-style-type: none">▪ Remove the paper that is stopped in the fusing unit.▪ Check that the fusing unit is clean and has no obstacles in the paper feed path.▪ If the error persists, replace the fusing unit.

Important

- SC559 does not operate until SP1159 has been set to "1" (ON). This sets the machine to count the number of occurrences of paper late jams in the fusing unit. The default setting is "0" (OFF).
- SC559 is issued after the third occurrence of a paper late jam in the fusing unit. Once this SC has been issued, the machine cannot be used until the service technician removes the cause of the jam and restores it to normal operation.
- The jam counter is reset after a sheet of paper successfully passes the fusing exit sensor after the cause of the jam has been removed.

SC Tables: SC6xx

610	D	Mechanical counter error: BK
		This SC is only for NA models. The machine detects the mechanical counter error when SP5987-001 is set to "1".
		<ul style="list-style-type: none"> ▪ Disconnected mechanical counter ▪ Defective mechanical counter

620	B	Communication error between IOB and ADF
		After the ARDF is detected, the break signal occurs or communication timeout occurs.
		<ul style="list-style-type: none"> ▪ Incorrect installation of ARDF ▪ ARDF defective ▪ IOB board defective ▪ External noise

621	D	Communication timeout error between IOB and finisher or mailbox
		A break (low) signal is received from the finisher or the mailbox.
		<ul style="list-style-type: none"> ▪ Disconnected cable ▪ Defective IOB ▪ Defective main board in the peripherals

Service Call Conditions

622	D	Paper feed unit communication error
		While the IOB communicates with a peripheral, an SC code is displayed if one of following conditions occurs. <ul style="list-style-type: none"> ▪ The IOB receives the break signal which is generated by the peripheral only just after the main switch is turned on. ▪ The IOB receives the break signal which is generated by URAT.
		<ul style="list-style-type: none"> ▪ Defective main control board of the peripheral ▪ Defective BICU or IOB ▪ Disconnected peripheral

623	D	2nd Paper Bank communication error
		This SC is not issued for this machine. When a communication error signal between the 1st paper bank and 2nd paper bank is received.
		<ul style="list-style-type: none"> ▪ Loose connector

630	C	CSS communication error
		A communication error occurred during communication with the CSS.
		<ul style="list-style-type: none"> ▪ Communication line error

632	B	MF accounting device error 1
		The controller sends data to the accounting device, but the device does not respond. This occurs three times.
		<ul style="list-style-type: none"> ▪ Loose connection between the controller and the accounting device

633	B	MF accounting device error 2
		After communication is established, the controller receives the brake signal from the accounting device.
		<ul style="list-style-type: none"> ▪ Loose connection between the controller and the accounting device

634	B	MF accounting device error 3
		The accounting device sends the controller the report that indicates a backup RAM error has occurred.
		<ul style="list-style-type: none"> ▪ Defective controller of the MF accounting device ▪ Battery error

635	B	MF accounting device error 4
		The accounting device sends the controller the report that indicates the battery voltage error has occurred.
		<ul style="list-style-type: none"> ▪ Defective controller of the MF accounting device ▪ Battery error

636		IC Card Error
-01	D	External authentication module error
		This SC is generated if the external authentication is enabled and following condition occurs: <ul style="list-style-type: none"> ▪ No external authentication module ▪ SD card error or external authentication module broken ▪ No DESS module
		Version error
-02	D	The version of the external authentication module is not correct.
		<ul style="list-style-type: none"> ▪ Incorrect module version

Service Call Conditions

-99	D	Management area error
		The management number of the external authentication module exceeds the maximum limit.
		<ul style="list-style-type: none"> ▪ Software error

641	D	BICU communication error
		The BICU does not respond to the frame transmitted from the controller.
		<ul style="list-style-type: none"> ▪ Defective controller ▪ Detective BICU

650		Communication error of the remote service modem (Embedded RCG-M)
-001	B	Authentication error
		The authentication for the Embedded RCG-M fails at a dial up connection.
		<ul style="list-style-type: none"> ▪ Incorrect SP settings ▪ Disconnected telephone line ▪ Disconnected modem board <p>Check and set the correct user name (SP5816-156) and password (SP5816-157).</p>
-004	B	Incorrect modem setting
		Dial up fails due to the incorrect modem setting.
		<ul style="list-style-type: none"> ▪ Same as -001 <p>Check and set the correct AT command (SP5816-160).</p>
-005	-	Communication line error
		The supplied voltage is not sufficient due to a defective communication line or defective connection.
		<ul style="list-style-type: none"> ▪ Same as -001

		Consult with the user's local telephone company.
-011	-	Incorrect network setting
		Both the NIC and Embedded RCG-M are activated at the same time.
		<ul style="list-style-type: none"> ▪ Same as -001 Disable the NIC with SP5985-1.
-012	-	Modem board error
		The modem board does not work properly even though the setting of the modem board is installed with a dial up connection.
		<ul style="list-style-type: none"> ▪ Same as -001 1. Install the modem board. 2. Check and reset the modem board setting with SP5816. 3. Replace the modem board.

651	C	Incorrect dial up connection
		-001: Program parameter error
		-002: Program execution error
		An unexpected error occurs when the modem (Embedded RCG-M) tries to call the center with a dial up connection.
		<ul style="list-style-type: none"> ▪ Caused by a software bug

669	D	EEPROM error
		Retry of EEPROM communication fails three times after the machine has detected the EEPROM error.
		<ul style="list-style-type: none"> ▪ Caused by noise

Service Call Conditions

670	D	Engine startup error
		The BICU fails to respond with the prescribed time when the machine is turned on.
		<ul style="list-style-type: none"> ▪ Connections between BICU and controller board are loose, disconnected, or damaged <ol style="list-style-type: none"> 1. Replace the BICU 2. Replace the controller board

671	D	BICU error
		The model code from the BICU is not correct when the machine is turned on.
		Install the correct BICU for this model.

672	D	Controller-to-operation panel communication error at startup
		<ul style="list-style-type: none"> ▪ After the machine is powered on, the communication between the controller and the operation panel is not established, or communication with controller is interrupted after a normal startup. ▪ After startup reset of the operation panel, the attention code or the attention acknowledge code is not sent from the controller within 15 seconds. ▪ After the controller issues a command to check the communication line with the controller at 30-second intervals, the controller fails to respond twice.
		<ul style="list-style-type: none"> ▪ Controller stalled ▪ Controller board installed incorrectly ▪ Controller board defective ▪ Operation panel connector loose or defective ▪ The controller is not completely shutdown when you turn the main switch off. <p>Check the setting of SP5875-001. If the setting is set to "1 (OFF)", change it to "0 (ON)".</p>

687	D	Memory address (PER) command error
		<p>The BICU does not receive a memory address command from the controller for the prescribed time after the paper has reached the registration sensor.</p> <ul style="list-style-type: none"> ▪ Harness Disconnection at BICU ▪ Controller board loose or broken ▪ Defective BICU ▪ Defective Controller Board

Service Call Conditions

SC Tables: SC7xx

700	D	Original stopper HP error
		When the pick-up motor turns on clockwise, the original stopper HP sensor does not detect the home position of the original stopper.
		<ul style="list-style-type: none"> ▪ Defective original stopper HP sensor ▪ Defective pick-up motor ▪ Defective DF drive board

701	D	Pick-up roller HP error
		When the pick-up motor turns on counterclockwise, the pick-up roller HP sensor does not detect the home position of the pick-up roller.
		<ul style="list-style-type: none"> ▪ Defective pick-up roller HP sensor ▪ Defective pick-up motor ▪ Defective DF drive board

721	B	Finisher jogger motor error
		The jogger fences move out of the home position but the HP sensor output does not change within the specified number of pulses. The 1st failure issues an original jam message, and the 2nd failure issues this SC code.
		<ul style="list-style-type: none"> ▪ Jogger HP sensor disconnected, defective ▪ Jogger motor disconnected, defective ▪ Jogger motor overloaded due to obstruction ▪ Finisher main board and jogger motor

723	B	Stack feed-out motor error
		<ul style="list-style-type: none"> ▪ The stack feed-out HP sensor does not detect the home position of the stack feed-out belt 3000ms after the stack feed-out belt has moved to its home position. ▪ The stack feed-out HP sensor does not turn off 200 ms after the stack feed-out belt has moved from its home position. <p>The 1st detection failure causes a jam error, and the 2nd failure causes this SC code.</p>
		<ul style="list-style-type: none"> ▪ Defective stack feed-out HP sensor ▪ Overload on the stack feed-out motor ▪ Defective stack feed-out motor ▪ Defective main board ▪ Disconnected or defective harness

725	B	Finisher exit guide plate motor error
		<p>After moving away from the guide plate position sensor, the exit guide is not detected at the home position within the prescribed time.</p> <p>The 1st detection failure issues a jam error, and the 2nd failure issues this SC code.</p>
		<ul style="list-style-type: none"> ▪ Guide plate motor disconnected, defective ▪ Guide plate motor overloaded due to obstruction ▪ Guide plate position sensor disconnected, defective

Appendix:
Service Call
Conditions

Service Call Conditions

726	B	Shift jogger motor 1 error
		The side fence does not retract within the prescribed time after the shift jogger motor 1 switches on. The 1st detection failure issues a jam error, and the 2nd failure issues this SC code.
		<ul style="list-style-type: none"> ▪ Shift jogger motor 1 disconnected, defective ▪ Shift jogger motor 1 overloaded due to obstruction ▪ Shift jogger 1 HP sensor disconnected, defective

727	B	Shift jogger motor 2 error
		The side fence does not retract within the prescribed time after the shift jogger motor 2 switches on. The 1st detection failure issues a jam error, and the 2nd failure issues this SC code.
		<ul style="list-style-type: none"> ▪ Shift jogger motor 2 disconnected, defective ▪ Shift jogger motor 2 overloaded due to obstruction ▪ Shift jogger 2 HP sensor disconnected, defective

728	B	Shift jogger retraction motor error
		The side fences do not retract within the prescribed time after the retraction motor switches on. The 1st detection failure issues a jam error, and the 2nd failure issues this SC code.
		<ul style="list-style-type: none"> ▪ Shift jogger retraction motor broken ▪ Shift jogger retraction motor connection loose ▪ Shift jogger retraction motor overloaded ▪ Defective shift jogger retraction HP sensor

730	B	Finisher Tray 1 shift motor error
		The shift roller HP sensor of the upper tray does not activate within the prescribed time after the shift tray starts to move toward or away from the home position.
		The 1st detection failure issues a jam error, and the 2nd failure issues this SC code.
		<ul style="list-style-type: none"> ▪ Shift tray HP sensor of the upper tray disconnected, defective ▪ Shift tray motor of the upper tray disconnected, defective ▪ Shift tray motor of the upper tray overloaded due to obstruction

740	B	Finisher corner stapler motor error
		The 1st detection failure causes a jam error, and the 2nd failure causes this SC code.
		<p>For the 2000/3000-sheet (booklet) finisher</p> <ul style="list-style-type: none"> ▪ Staple movement is not finished after a certain time. <p>For the 1000-sheet finisher</p> <ul style="list-style-type: none"> ▪ The stapler motor does not switch off within the prescribed time after operating. ▪ The HP sensor of the staple unit does not detect the home position after the staple unit moves to its home position. ▪ The HP sensor of the staple unit detects the home position after the staple unit moves from its home position.
		<ul style="list-style-type: none"> ▪ Staple jam ▪ Motor overload ▪ Defective stapler motor

Appendix:
Service Call
Conditions

Service Call Conditions

741	B	Finisher corner stapler rotation motor error
		The stapler does not return to its home position within the specified time after stapling. The 1st detection failure causes a jam error, and the 2nd failure causes this SC code.
		<ul style="list-style-type: none"> ▪ Defective stapler rotation motor ▪ Overload to the stapler rotation motor ▪ Defective stapler rotation HP sensor

742	B	Finisher stapler movement motor error
		Staple movement is not finished within a certain time. The 1st detection failure causes a jam error, and the 2nd failure causes this SC code.
		<ul style="list-style-type: none"> ▪ Motor overload ▪ Loose connection of the stapler home position sensor ▪ Loose connection of the stapler movement motor ▪ Defective stapler home position sensor ▪ Defective stapler movement motor

743	B	Booklet stapler motor error 1
		The 1st detection failure causes a jam error, and the 2nd failure causes this SC code. For the 2000-sheet booklet finisher The front stapler unit saddle-stitch motor does not start operation within the specified time.
		<ul style="list-style-type: none"> ▪ Motor overload ▪ Loose connection of the front stapler motor ▪ Defective front stapler motor

744	B	Booklet staple motor error 2
		The 1st detection failure causes a jam error, and the 2nd failure causes this SC code. For the 2000-sheet booklet finisher
		The rear stapler unit saddle-stitch motor does not start operation within the specified time. <ul style="list-style-type: none"> ▪ Motor overload ▪ Loose connection of the rear stapler motor ▪ Defective rear stapler motor

750	B	1000/2000/3000-sheet (booklet) finisher: Tray lift motor error
		The 1st detection failure causes a jam error, and the 2nd failure causes this SC code. The upper tray paper height sensor does not change its status with the specified time after the tray raises or lowers.

753	B	Return roller motor error
		This occurs during the operation of the lower tray pressure motor
		<ul style="list-style-type: none"> ▪ Motor harness disconnected, loose, defective ▪ Motor overloaded ▪ Home position sensor harness disconnected, loose, defective ▪ Home position defective

Appendix:
Service Call
Conditions

Service Call Conditions

760	B	Finisher punch motor error
		The punch HP sensor is not activated within the specified time after the punch motor turned on. The 1st detection failure causes a jam error, and the 2nd failure causes this SC code.
		<ul style="list-style-type: none"> ▪ Punch HP sensor disconnected, defective ▪ Punch motor disconnected or defective ▪ Punch motor overload due to obstruction

761	B	Finisher folder plate motor error
		The folder plate moves but is not detected at the home position within the specified time. The 1st detection failure causes a jam error, and the 2nd failure causes this SC code.
		<ul style="list-style-type: none"> ▪ Folder plate HP sensor disconnected, defective ▪ Folder plate motor disconnected, defective ▪ Folder plate motor overloaded due to obstruction.

763	B	Punch movement motor error
		The punch unit moves but is not detected at the home position within the specified time. The 1st detection failure causes a jam error, and the 2nd failure causes this SC code.
		<ul style="list-style-type: none"> ▪ Motor harness disconnected, loose, defective ▪ Defective motor

764	B	Paper position sensor slide motor error
		The paper position sensor moves but is not detected at the home position within the specified time.
		The 1st detection failure causes a jam error, and the 2nd failure causes this SC code.
		<ul style="list-style-type: none"> ▪ Motor harness disconnected, loose, defective ▪ Defective motor

765	B	Folding unit bottom fence lift motor
		The folding unit bottom fence movement is not finished within a certain time.
		The 1st detection failure causes a jam error, and the 2nd failure causes this SC code.
		<ul style="list-style-type: none"> ▪ Motor harness loose, broken ▪ Motor drive obstructed ▪ Motor defective

766	B	Clamp roller retraction motor error
		The clamp roller movement is not finished within a certain time.
		The 1st detection failure causes a jam error, and the 2nd failure causes this SC code.
		<ul style="list-style-type: none"> ▪ Motor harness loose, broken ▪ Motor drive obstructed ▪ Motor defective

Service Call Conditions

767	B	Stack junction gate motor error
		The stack junction gate motor moves but the stack junction gate is not detected at its position within a specific time. The 1st detection failure causes a jam error, and the 2nd failure causes this SC code.
		<ul style="list-style-type: none"> ▪ Motor broken ▪ Motor connection loose ▪ Motor overloaded

770	B	Shift motor error
		The shift motor HP sensor does not detect any change for 1.86 seconds after the shift motor has turned on at power on or during its operation.
		<ul style="list-style-type: none"> ▪ Defective shift motor ▪ Defective shift motor HP sensor

791	D	Bridge unit error
		The machine recognizes the finisher, but does not recognize the bridge unit.
		<ul style="list-style-type: none"> ▪ Defective connector ▪ Broken harness

792	B	Finisher error
		The machine does not recognize the finisher, but recognizes the bridge unit.
		<ul style="list-style-type: none"> ▪ Defective connector ▪ Defective harness ▪ Incorrect installation

SC Tables: SC8xx

816	D	Energy save I/O sub-system error
		Energy saver sub-system detects an error.
		<ul style="list-style-type: none"> ▪ Defective controller board

817	D	Monitor Error
		This is a file detection and electronic file signature check error when the boot loader attempts to read the self-diagnostic module, system kernel, or root system files from the OS Flash ROM, or the items on the SD card in the controller slot are false or corrupted.
		<ul style="list-style-type: none"> ▪ OS Flash ROM data defective; change the controller firmware ▪ SD card data defective; use another SD card

Appendix:
Service Call
Conditions

Service Call Conditions

819	C	Fatal kernel error	
		Due to a control error, a RAM overflow occurred during system processing. One of the following messages was displayed on the operation panel.	
		0x6261	6261 6420 6469 7200 00 -> "bad dir"
		0x696e	0x69742064 -> "init died"
		0x766d	0x5f706167 -> "vm_pageout: VM is full"
		554C	UL (USB error)
		----	Error in the OS
		"init died", "vm_pageout: VM is full", "Cache Error"	
		<ul style="list-style-type: none"> ▪ System program defective ▪ Controller board defective ▪ Optional board defective ▪ Replace controller firmware 	

↓ Note

- For more details about this SC code error, execute SP5990 to print an SMC report so you can read the error code. The error code is not displayed on the operation panel.

820	CTL D	Self-diagnostics error: CPU [XXXX]: Detailed error code
[0001] to [06FF] [0801] to [4005]	<p>CPU error</p> <p>During the self-diagnostic, the controller CPU detects an error. There are 47 types of error code (0001 to 4005) depending on the cause of the error. The CPU detects an error and displays the specific error code with the program address where the error occurs.</p>	
	<ul style="list-style-type: none"> ▪ System firmware problem ▪ Defective controller 	
	<ol style="list-style-type: none"> 1. Turn the main switch off and on. 2. Reinstall the controller system firmware. 3. Replace the controller. <p>When the problem cannot be fixed with the above procedure, the following information displayed on the screen needs to be fed back to a technical support center.</p> <ul style="list-style-type: none"> ▪ SC code ▪ Detailed error code ▪ Program address 	
[0702] [0709] [070A]	CPU/Memory Error	
	<ul style="list-style-type: none"> ▪ System firmware problem ▪ Defective RAM-DIMM ▪ Defective controller 	
	<ol style="list-style-type: none"> 1. Reinstall the controller system software. 2. Replace the RAM-DIMM. 3. Replace the controller. 	

Service Call Conditions

821	D	Self-diagnostics error: ASIC [XXXX]: Detailed error code
[0B00]	ASIC error	
	The write-&-verify check error has occurred in the ASIC.	
	<ul style="list-style-type: none"> ▪ Defective ASIC device Replace the controller board.	
[0B06]	ASIC detection error	
	The I/O ASIC for system control is not detected.	
	<ul style="list-style-type: none"> ▪ Defective ASIC ▪ Defective North Bridge and PCI I/F Replace the controller board.	
[0D05]	Self-diagnosis error: ASIC	
	The CPU checks if the ASIC timer works correctly compared with the CPU timer. If the ASIC timer does not function in the specified range, this SC code is displayed.	
	<ul style="list-style-type: none"> ▪ System firmware problem ▪ Defective RAM-DIMM ▪ Defective controller Replace the controller board.	
[50A1]	Video bridge device (ASIC) error 1	
	The CPU does not detect the video bridge device.	
	<ul style="list-style-type: none"> ▪ Defective I/F between the video bridge device and controller 	
[50A2]	Video bridge device (ASIC) register error 1	
	The CPU detects the video bridge device, but detects error data from the video bridge device.	
	<ul style="list-style-type: none"> ▪ Defective I/F between the video bridge device and controller 	

↓ Note

- For more details about this SC code error, execute SP5990 to print an SMC report so you can read the error code. The error code is not displayed on the operation panel.

822	B	Self-diagnostic error: HDD
[3003]	Check performed only when HDD is installed:	
	<ul style="list-style-type: none"> ▪ HDD device busy for over 31 s. ▪ After a diagnostic command is set for the HDD, but the device remains busy for over 6 s. 	
[3004]	<ul style="list-style-type: none"> ▪ HDD defective ▪ HDD harness disconnected, defective ▪ Controller board defective 	
	No response to the self-diagnostic command from the ASIC to the HDDs.	
		<ul style="list-style-type: none"> ▪ HDD defective

823	B	Self-diagnostic error: NIB [XXXX]: Detailed error code
[6101]	<p>MAC address check sum error</p> <p>The result of the MAC address check sum does not match the check sum stored in ROM.</p>	
[6104]	<p>PHY IC error</p> <p>The PHY IC on the controller cannot be correctly recognized.</p>	
[6105]	<p>PHY IC loop-back error</p> <p>An error occurred during the loop-back test for the PHY IC on the controller.</p>	

Service Call Conditions

824	D	Self-diagnostic error : NVRAM
		NVRAM device does not exist, NVRAM device is damaged, or NVRAM socket damaged.
		<ul style="list-style-type: none"> ▪ NVRAM defective ▪ Controller board defective ▪ NVRAM backup battery exhausted ▪ NVRAM socket damaged

826	D	Self-diagnostic Error: RTC/optional NVRAM
[1501]		The one second counted by the RTC is different from the one second counted by the CPU on the controller.
		<ul style="list-style-type: none"> ▪ Defective the RTC device
[15FF]		The RTC device is not detected.
		<ul style="list-style-type: none"> ▪ Defective RTC device ▪ NVRAM without RTC installed ▪ Discharged backup battery

827	D	Self-diagnostic error: Standard SDRAM DIMM [XXXX]: Detailed error code
[0201]		Verification error
		Error detected during a write/verify check for the standard RAM (SDRAM DIMM).
		<ul style="list-style-type: none"> ▪ Loose connection ▪ Defective SDRAM DIMM ▪ Defective controller

828	D	Self-diagnostic error: ROM [XXXX]: Detailed error code
[0101]		<p>Check sum error 1</p> <ul style="list-style-type: none"> ▪ The boot monitor and OS program stored in the ROM DIMM is checked. If the check sum of the program is incorrect, this SC code is displayed.

829	D	Self-diagnostic error: Optional RAM [XXXX]: Detailed error code
[0301]		Verification error
		Error detected during a write/verify check for the optional RAM (SDRAM DIMM).
		<ul style="list-style-type: none"> ▪ Loose connection ▪ Defective SDRAM DIMM ▪ Defective controller
		<p>Turn the main switch off and on. Replace the SDRAM DIMM. Replace the controller.</p>
[0302]		Memory structure data error
		The memory structure data error for the optional RAM (SDRAM DIMM) is detected when the self-diagnostic is executed.
		<ul style="list-style-type: none"> ▪ Defective RAM DIMM ▪ Defective SPD ROM on RAM DIMM ▪ Defective 12C bus
		Replace the RAM DIMM.

Service Call Conditions

833	C	Self-diagnostic error 8: Engine I/F ASIC
[0F30] [0F31]		ASIC (Mandolin) for system control could not be detected. After the PCI configuration, the device ID for the ASIC could not be checked. Replace the IPU.
[0F41]		ASIC (Mandolin) for system control could not be detected. After the PCI configuration, the device ID for the ASIC could not be checked. Replace the IPU.
[50B1]		Could not initialize or read the bus connection. Check for loose connections at the mother board. Replace the IPU.
[50B2]		Value of the SSCG register is incorrect. Check for loose connections at the mother board. Replace the IPU.

835	C	Self-diagnostic error: Centronic device
[1102]		Loopback connector is connected but check results in an error. <ul style="list-style-type: none"> ▪ IEEE1284 connector error ▪ Centronic loopback connector defective Replace the controller board.
[110C]		Loopback connector is connected but check results in an error. <ul style="list-style-type: none"> ▪ ASIC device error ▪ IEEE1284 connector error ▪ Centronic loopback connector defective Replace the controller board.

[1120]	Centronic loopback connector is not connected for detailed self-diagnostic test.	
	<ul style="list-style-type: none"> ▪ Centronic loopback connector not connected correctly ▪ Centronic loopback connector defective ▪ ASIC device defective 	
	Replace the controller board.	

838	B	Self-diagnostic Error: Clock Generator
[2701]	A verify error occurred when setting data was read from the clock generator via the I2C bus.	
	<ul style="list-style-type: none"> ▪ Defective clock generator ▪ Defective I2C bus ▪ Defective I2C port on the CPU 	
	Replace the controller board.	

839	C	USB NAND Flash ROM error
[9101]	The ID of the USB NAND Flash ROM cannot be read.	
	<ul style="list-style-type: none"> ▪ Defective controller board 	
[9110]	The USB NAND Flash ROM controller is disconnected.	
	<ul style="list-style-type: none"> ▪ Defective controller board 	

851	B	IEEE 1394 I/F error
		Driver setting incorrect and cannot be used by the 1394 I/F.
		<p>Not supported by this machine</p> <ul style="list-style-type: none"> ▪ NIB (PHY), LINK module defective; change the Interface Board ▪ Controller board defective

Service Call Conditions

853	B	Wireless LAN Error 1
		During machine start-up, the machine can get access to the board that holds the wireless LAN, but not to the wireless LAN card (Bluetooth).
		<ul style="list-style-type: none"> ▪ Wireless LAN card missing (was removed)

854	B	Wireless LAN Error 2
		During machine operation, the machine can get access to the board that holds the wireless LAN, but not to the wireless LAN card (Bluetooth).
		<ul style="list-style-type: none"> ▪ Wireless LAN card missing (was removed)

855	B	Wireless LAN error 3
		An error is detected on the wireless LAN card (802.11a/g, g or Bluetooth).
		<ul style="list-style-type: none"> ▪ Wireless LAN card defective ▪ Wireless LAN card connection incorrect

856	B	Wireless LAN error 4
		An error was detected on the wireless LAN card (Bluetooth).
		<ul style="list-style-type: none"> ▪ Wireless LAN card defective ▪ PCI connector (to the mother board) loose

857	B	USB I/F Error
		The USB driver is not stable and caused an error.
		<ul style="list-style-type: none"> ▪ Bad USB card connection <p>Replace the controller board</p>

858	C	HDD Encryption unit error 1
		A serious error occurs when data is encrypted to update an encryption key with the HDD encryption unit.
	[0]	Encryption key acquisition error: The controller fails to get a new encryption key.
		<ul style="list-style-type: none"> ▪ Defective controller board Replace the controller board.
	[1]	Encryption key setting for HDD error: The controller fails to copy a new encryption key to the HDD.
		<ul style="list-style-type: none"> ▪ Defective SATA chip on the controller board Replace the controller board.
	[2]	NVRAM data encryption error 1: An error occurs while the NVRAM data is encrypted.
		<ul style="list-style-type: none"> ▪ Defective NVRAM on the controller board Replace the NVRAM.
	[30]	NVRAM data encryption error 2: An error occurs before the NVRAM data is encrypted.
		<ul style="list-style-type: none"> ▪ Defective controller board Replace the controller board.
	[31]	Other error: A serious error occurs while the data is encrypted.
		<ul style="list-style-type: none"> ▪ Same as SC991

Service Call Conditions

859	C	HDD Encryption unit error 2
		A serious error occurs when the HDD data is encrypted to update an encryption key with the HDD encryption unit.
[8]		HDD check error: The HDD is not correctly installed.
		<ul style="list-style-type: none"> ▪ No HDD installed ▪ Unformatted HDD ▪ The encryption key on the controller is different from the one on the HDD <ol style="list-style-type: none"> 1. Install the HDD correctly. 2. Initialize the HDD.
[9]		Power failure during the data encryption: The data encryption (NVRAM and HDD) has not been completed.
		<ul style="list-style-type: none"> ▪ Power failure during the data encryption Initialize the HDD.
[10]		Data read/write error: The DMAC error is detected twice or more.
		<ul style="list-style-type: none"> ▪ Same as SC863

860	B	HDD startup error at main power on
		<ul style="list-style-type: none"> ▪ HDD is connected but a driver error is detected. ▪ The driver does not respond with the HDD within 30 s.
		<ul style="list-style-type: none"> ▪ HDD is not initialized ▪ Label data is corrupted ▪ Defective HDD Initialize the HDD with SP5832-001.

861	D	HDD re-try failure
		At power on, the HDD is detected. Power supply to the HDD is interrupted after the system has entered the energy save mode, but after the HDD has been awakened from the energy save mode, it does not return to the ready status within 30 sec.
		<ul style="list-style-type: none"> ▪ Harness between HDD and controller board disconnected, defective ▪ HDD power connector disconnected ▪ HDD defective ▪ Controller board defective

862	D	Bad sector number error
		The number of bad sectors in the HDD (image data area) goes over 101.
		<ul style="list-style-type: none"> ▪ Defective HDD
		Format the HDD with SP5-832-002. Replace the HDD.

863	D	HDD data read failure
		The data written to the HDD cannot be read normally, due to bad sectors generated during operation.
		<ul style="list-style-type: none"> ▪ HDD defective <p>Note: If the bad sectors are generated at the image partition, the bad sector information is written to NVRAM, and the next time the HDD is accessed, these bad sectors will not be accessed for read/write operation.</p>

864	D	HDD data CRC error
		During HDD operation, the HDD cannot respond to a CRC error query. Data transfer does not execute normally while data is being written to the HDD.
		<ul style="list-style-type: none"> ▪ HDD defective

Service Call Conditions

865	D	HDD access error
		HDD responded to an error during operation for a condition other than those for SC863, 864.
		<ul style="list-style-type: none"> ▪ HDD defective.

866	B	SD card error 1: Confirmation
		The machine detects an electronic license error in the application on the SD card in the controller slot immediately after the machine is turned on. The program on the SD card contains electronic confirmation license data. If the program does not contain this license data, or if the result of the check shows that the license data in the program on the SD card is incorrect, then the checked program cannot execute and this SC code is displayed.
		<ul style="list-style-type: none"> ▪ Program missing from the SD card ▪ Download the correct program for the machine to the SD card

867	D	SD card error 2: SD card removed
		The SD card in the slot is removed while the machine is on.
		Insert the SD card, then turn the machine off and on.

868	D	SD card error 3: SC card access
		An error occurs while an SD card is used.
		<ul style="list-style-type: none"> ▪ SD card not inserted correctly ▪ SD card defective ▪ Controller board defective <p>Note: If you want to try to reformat the SC card, use SD Formatter Ver 1.1.</p>

870	B	Address book data error
		The address book data cannot be read from the HDD, SD card or flash ROM on the controller where it is stored, or the data read from the media is defective.
		<ul style="list-style-type: none"> ▪ Software defective: Turn the machine off/on. If this is not the solution for the problem, then replace the controller firmware. ▪ HDD defective.
		<p>More Details</p> <ul style="list-style-type: none"> ▪ Do SP5846-046 (Initialize All Setting & Addr Book) to reset all address book data. ▪ Reset the user information with SP5832-006 (HDD Formatting– User Information). ▪ Replace the HDDs.

872	B	HDD mail receive data error
		<ul style="list-style-type: none"> ▪ The machine detects that the HDD is not operating correctly at power on. ▪ The machine detects that the HDD is not operating correctly (can neither read nor write) while processing incoming email.
		<ul style="list-style-type: none"> ▪ HDD defective ▪ The machine is turned off while the HDD is being accessed. <p>Do SP5832-007 to format the mail RX data on the HDD.</p>

873	B	HDD mail send data error
		An error is detected on the HDD immediately after the machine has been turned on, or power has been turned off while the machine has used the HDD.
		<ol style="list-style-type: none"> 1. Do SP5832-008 (Format HDD – Mail TX Data) to initialize the HDD. 2. Replace the HDD

Service Call Conditions

874	D	Delete All error 1: HDD
		A data error is detected for the HDD/NVRAM after the Delete All option has been used. Note: The source of this error is the DataOverwriteSecurity Unit (D362) running from an SD card.
		<ol style="list-style-type: none"> 1. Turn the main switch off/on and try the operation again. 2. Install the DataOverwriteSecurity Unit again. For more, see "Installation". 3. HDD defective

875	D	Delete All error 2: Data area
		An error occurs while the machine deletes data from the HDD. Note: The source of this error is the DataOverwriteSecurity Unit (D362) running from an SD card.
		Turn the main switch off/on and try the operation again

876	CTL D	Log Data Error
		An error is detected in the handling of the log data at power on or during machine operation. This can be caused by switching the machine off while it is operating.
-001		Log Data Error 1
		<ul style="list-style-type: none"> ▪ Damaged log data file in the HDD <p>Initialize the HDD with SP5832-004.</p>
-002		Log Data Error 2
		<ul style="list-style-type: none"> ▪ HDD encryption unit not installed <ol style="list-style-type: none"> 1. Ask the customer's administrator to disable the HDD encryption setting with a user tool. 2. Install the HDD encryption unit.

876	CTLD	Log Data Error
		An error is detected in the handling of the log data at power on or during machine operation. This can be caused by switching the machine off while it is operating.
-003		Log Data Error 3
		<ul style="list-style-type: none"> ▪ Invalid log encryption key due to defective NVRAM data
		<ol style="list-style-type: none"> 1. Initialize the HDD with SP5832-004. 2. Ask the customer's administrator to disable the HDD encryption setting with a user tool.
-004		Log Data Error 4
		<ul style="list-style-type: none"> ▪ Unusual HDD encryption function due to defective NVRAM data
		Initialize the HDD with SP5832-004.
-005		Log Data Error 5
		<ul style="list-style-type: none"> ▪ Installed a NVRAM or HDD which was used in another machine
		<ol style="list-style-type: none"> 1. Reinstall the previous NVRAM or HDD. 2. Initialize the HDD with SP5832-004.
-099		Log Data Error 99
		<ul style="list-style-type: none"> ▪ Other than the above causes
		Ask your supervisor.

Service Call Conditions

877	B	HDD DataOverwriteSecurity SD card error
		The 'all delete' function cannot be executed but the DataOverwriteSecurity Unit (D362) is installed and activated.
		<ul style="list-style-type: none"> ▪ Defective SD card (D362) ▪ SD card (D362) not installed
		<ol style="list-style-type: none"> 1. Replace the NVRAM and then install the new SD card (D362). 2. Check and reinstall the SD card (D362).

878	D	TPM system authentication error
		The system firmware is not authenticated by TPM (security chip).
		<ul style="list-style-type: none"> ▪ Incorrect updating for the system firmware ▪ Defective flash ROM on the controller board
		Replace the controller board.

880	B	File Format Converter (MLB) error
		A request to get access to the MLB is not answered within the specified time.
		<ul style="list-style-type: none"> ▪ MLB defective, replace the MLB

SC Tables: SC9xx

900	D	Electrical total counter error
		The total counter contains something that is not a number.
		<ul style="list-style-type: none"> ▪ NVRAM incorrect type ▪ NVRAM defective ▪ NVRAM data scrambled ▪ Unexpected error from external source

920	B	Printer error 1
		An internal application error was detected and operation cannot continue.
		<ul style="list-style-type: none"> ▪ Software defective; turn the machine off/on, or change the controller firmware ▪ Insufficient memory

921	D	Printer font error
		A necessary font is not found in the SD card.
		<ul style="list-style-type: none"> ▪ A necessary font is not found in the SD card. ▪ The SD card data is corrupted.

925	B	Net File function error
		The NetFile file management on the HDD cannot be used, or a NetFile management file is corrupted and operation cannot continue. The HDDs are defective and they cannot be debugged or partitioned, so the Scan Router functions (delivery of received faxes, document capture, etc.), Web services, and other network functions cannot be used. HDD status codes are displayed below the SC code.
		<ul style="list-style-type: none"> ▪ Refer to the four procedures below (Recovery from SC 925).

Appendix:
Service Call
Conditions

Service Call Conditions

Here is a list of HDD status codes:

Display	Meaning
(-1)	HDD not connected
(-2)	HDD not ready
(-3)	No label
(-4)	Partition type incorrect
(-5)	Error returned during label read or check
(-6)	Error returned during label read or check
(-7)	"filesystem" repair failed
(-8)	"filesystem" mount failed
(-9)	Drive does not answer command
(-10)	Internal kernel error
(-11)	Size of drive is too small
(-12)	Specified partition does not exist
(-13)	Device file does not exist

Recovery from SC 925

Procedure 1

If the machine shows SC codes for HDD errors (SC860 to SC865) with SC 925, do the recovery procedures for SC860 to SC865.

Procedure 2

If the machine does not show one of the five HDD errors (SC860 to SC865), turn the machine power off and on. If this is not the solution for the problem, then initialize the NetFile partition on the HDD with SP5832-011 (HDD Formatting – Ridoc I/F).

NetFiles: Jobs printed from the document server using a PC and DeskTopBinder

- Before you initialize the NetFile partition on the HDD, tell the customer that:

- Received faxes on the delivery server will be erased
- All captured documents will be erased
- DeskTopBinder/Print Job Manager/Desk Top Editor job history will be erased
- Documents on the document server, and scanned documents, will not be erased.
- The first time that the network gets access to the machine, the management information must be configured again (this will use a lot of time).

Before you initialize the Netfile partition with SP5832-011, do these steps:

1. Go into the User Tools mode and do "Delivery Settings" to print all received fax documents that are scheduled for delivery. Then erase them.
2. In the User Tools mode, do Document Management> Batch Delete Transfer Documents.
3. Do SP5832-011, then turn the machine power off and on.

Procedure 3

If "Procedure 2" is not the solution for the problem, do SP5832-001 (HDD Formatting – All), then turn the machine power off and on.

SP5832-001 erases all document and address book data on the hard disks. Ask the customer before you do this SP code.

Procedure 4

If "Procedure 3" is not the solution for the problem, replace the HDD.

990	D	Software error 1
		The software performs an unexpected function and the program cannot continue.
		<ul style="list-style-type: none"> ▪ Software defective, re-boot
991	C	Software error 2
		The software performs an unexpected function. However, unlike SC990, recovery processing allows the program to continue.
		<ul style="list-style-type: none"> ▪ Software defective, re-boot

Service Call Conditions

In order to get more details about SC990 and SC991:

- 1) Execute SP7403 or print an SMC Report (SP5990) to read the history of the 10 most recent logged errors.
- 2) If you press the zero key on the operation panel with the SP selection menu displayed, you will see detailed information about the recently logged SC990 or SC991, including the software file name, line number, and so on.

 Note

- 1) is the recommended method, because another SC could write over the information for the previous SC.

992	D	Undefined error
		Defective software program
		<ul style="list-style-type: none"> ▪ An error undetectable by any other SC code occurred

994	C	Application Item Error
		The number of executed application items on the operation panel reach the maximum limit for the operation panel structure.
		<ul style="list-style-type: none"> ▪ Too much executed application items

995	D	Controller Board Mismatch
		The information on the controller board does not match that of the machine
		<ul style="list-style-type: none"> ▪ Wrong controller board installed

997	B	Software Error 3: Cannot select application function
		An application does not start after the user pushed the correct key on the operation panel.
		<ul style="list-style-type: none"> ▪ Software bug ▪ A RAM or DIMM option necessary for the application is not installed or not installed correctly.

998	D	Software Error 4: Application cannot start
		Register processing does not operate for an application within 60 s after the machine power is turned on. No applications start correctly, and all end abnormally.
		<ul style="list-style-type: none"> ▪ Software bug ▪ A RAM or DIMM option necessary for the application is not installed or not installed correctly.

Appendix:
Service Call
Conditions

APPENDIX:

SERVICE PROGRAM MODE TABLES

REVISION HISTORY		
Page	Date	Added/Updated/New
		None

4. APPENDIX: SERVICE PROGRAM MODE TABLES

4.1 SYSTEM SP TABLE-1

4.1.1 SP1-XXX: FEED

1001*	Leading Edge Registration:	
	Adjusts the leading edge registration by changing the registration clutch operation timing.	
001	Tray: Plain	[-9 to 9/ 0 / 0.1 mm step]
002	Tray: Thick 1	
003	Tray: Thick 2	
004	By-pass: Plain	
005	By-pass: Thick 1	
006	By-pass: Thick 2	
007	Duplex: Plain	
008	Duplex: Thick 1	

System SP Table-1

1002*	Side-to-Side Registration	
	Adjusts the side to side registration by changing the laser main scan start position for each mode.	
001	By-pass	[-4 to 4 / 0 / 0.1 mm step]
002	Tray 1	
003	Tray 2	
004	Tray 3	
005	Tray 4	
006	LCT	
007	Duplex	

1003*	Registration Buckle Adjustment	
	Adjusts the paper feed motor timing. Paper feed motor timing determines the amount of paper buckle at Registration. (A "+" setting causes more buckling.)	
001	Tray 1: Plain	[-9 to 5 / -4 / 1 mm step]
002	Tray 1: Thick 1	
003	Tray 1: Thick 2	
004	Tray 2, 3, 4: Plain	
005	Tray 2, 3, 4: Thick1	
006	Tray 2, 3, 4: Thick2	
007	By-pass: Plain	[-9 to 5 / -2 / 1 mm step]
008	By-pass: Thick 1	
009	By-pass: Thick 2	

System SP Table-1

010	Duplex: Plain	[-9 to 5 / -4 / 1 mm step]
011	Duplex: Thick 1	[-9 to 5 / -3 / 1 mm step]
012	LCT: Plain	[-9 to 5 / -4 / 1 mm step]
013	LCT: Thick1	
014	LCT: Thick2	

1007*	By-pass Paper Size Detection	
	Controls paper size detection for the by-pass feed table.	
001	Detection Timing	[-15 to 15 / 0 / 5 mm step]
002	LG Detection	[0 to 1 / 0 / 1] 0: LT SEF, 1: LG

1103*	Fusing Idling	
	Switches fusing idling on/off. When on, printing will not start until enough time has elapsed so the hot roller can reach optimum temperature. This ensures even heat on the hot roller. Switch on if fusing on the 1st and 2nd copies is incomplete (this may occur if the room is cold.). You must switch SP1103-1 ON before you set the fusing interval with SP1103-2.	
	001	Enable Fusing Idling
002	Interval	[0 to 60 / 30 / 1 sec.]

System SP Table-1

003	Idling Time at Every Job	<p>Sets the machine to fusing idling only for 30 sec. for every job (when the original is set on the ARDF, when the ARDF cover is opened, etc.) and the fusing unit has reached the reload temperature (optimum temperature for operation).</p> <p>[0 to 30 / 0 / 1 sec.]</p> <p>0: No idling done before a job.</p>
-----	--------------------------	--

1104*	Fusing Temperature Control	
	On-Off/Phase	
	<p>Selects the fusing temperature control method. After changing this setting, be sure to turn the machine off and on again with the main power switch to enable the new setting.</p> <p>[0 to 1 / 0 / 1]</p> <p>0: Normal (ON/OFF control). Allows full application from ac power supply to bring the hot roller up to the target fusing temperature then shuts off. Determines the on-time from the present temperature (detected by the thermistor on the hot roller) and the temperature of 1 cycle before.</p> <p>1: Phase (hysteresis) control. Sets the upper and lower limits for the temperature; at the lower temperature the fusing lamp is on and at the higher temperature the fusing lamp is off.</p> <p>Change this setting to "0" only if the user has excessive electrical noise or interference on the power supply line. Such interference can cause voltage to drop when power is applied using the ON/OFF control method. Interference can be caused by the general poor quality of the power supply lines, or if the machine is sharing a power supply with other electrical devices such as fluorescent lights. Before changing this setting, make sure that the machine is connected to a power supply not shared by other electrical equipment.</p> <p> Note</p> <ul style="list-style-type: none"> ▪ Selecting Phase control ("1") could cause the fusing temperature control board to emit low pitched noise 	

1105*	Fusing Temperature Adjustment	
	<p>Allows adjustment of the hot roller temperature at the center and ends of the roller for the quality or thickness of the paper. The hot roller in this machine has two fusing lamps: one heats the center of the roller, the other heats both ends. Each fusing lamp can be adjusted separately.</p> <p>The "re-load temperature" is the "print ready temperature". When the fusing temperature exceeds this setting, the machine can operate. Do not set up a re-load temperature (Re-load Temp. = Fusing. Temp – SP Value.) that is higher than the SP1-105-2 setting.</p>	
001	Roller Center	C1b/C1.5b: [100 to 170 / 140 / 1 deg] C1c/C1.5c: [100 to 170 / 150 / 1 deg]
	Adjusts the fusing temperature at the center of the hot roller.	
002	Roller Ends	C1b/C1.5b: [100 to 170 / 145 / 1 deg] C1c/C1.5c: [100 to 170 / 155 / 1 deg]
	Adjusts the fusing temperature at the ends of the hot roller.	
003	Re-load Temp. Minus: Roller Center	[0 to 60 / 0 / 1 deg]
	<p>Sets the reload temperature for the center of the hot roller. This setting depends on the target temperature.</p> <p>Reload temp. = Target Temp – This SP Setting</p> <p>↓ Note</p> <ul style="list-style-type: none"> Do not set a temperature that is higher than the setting for SP1105 1 (Roller Center: Trays) 	
004	Re-load Temp. Minus: Roller Ends	[0 to 60 / 0 / 1 deg]
	<p>Sets the reload temperature for the ends of the hot roller. This setting depends on the target temperature.</p> <p>Reload temp. = Target Temp – This SP Setting</p> <p>↓ Note</p> <ul style="list-style-type: none"> Do not set a temperature that is higher than the setting for SP1105 2 (Roller Ends: Trays) 	

System SP Table-1

005 to 022	The following SPs adjust the fusing temperature at the center or ends of the hot roller for each paper type.	
005	Roller Center: M-Thick	C1b/C1.5b: [100 to 170 / 145 / 1 deg] C1c/C1.5c: [100 to 170 / 155 / 1 deg]
006	Roller Ends: M-Thick	C1b/C1.5b: [100 to 170 / 150 / 1 deg] C1c/C1.5c: [100 to 170 / 160 / 1 deg]
007	Roller Center: Thick 1	[100 to 170 / 130 / 1 deg]
008	Roller Ends: Thick 1	
009	Roller Center: Thick 2	[100 to 170 / 150 / 1 deg]
010	Roller Ends: Thick 2	
011	Roller Center: Thin	C1b/C1.5b: [100 to 170 / 130 / 1 deg] C1c/C1.5c: [100 to 170 / 140 / 1 deg]
012	Roller Ends: Thin	C1b/C1.5b: [100 to 170 / 135 / 1 deg] C1c/C1.5c: [100 to 170 / 145 / 1 deg]
013	Roller Center: OHP: Plain	[100 to 170 / 150 / 1 deg]
014	Roller Ends: OHP: Plain	[100 to 170 / 155 / 1 deg]
015	Roller Center: OHP: Thick	
016	Roller Ends: OHP: Thick	[100 to 170 / 160 / 1 deg]
017	Roller Center: Special 1	C1b/C1.5b: [100 to 170 / 140 / 1 deg] C1c/C1.5c: [100 to 170 / 150 / 1 deg]
018	Roller Ends: Special 1	C1b/C1.5b: [100 to 170 / 145 / 1 deg] C1c/C1.5c: [100 to 170 / 155 / 1 deg]
019	Roller Center: Special 2	C1b/C1.5b: [100 to 170 / 140 / 1 deg] C1c/C1.5c: [100 to 170 / 150 / 1 deg]
020	Roller Ends: Special 2	C1b/C1.5b: [100 to 170 / 145 / 1 deg] C1c/C1.5c: [100 to 170 / 155 / 1 deg]

021	Roller Center: Special 3	C1b/C1.5b: [100 to 170 / 140 / 1 deg] C1c/C1.5c: [100 to 170 / 150 / 1 deg]
022	Roller Ends: Special 3	C1b/C1.5b: [100 to 170 / 145 / 1 deg] C1c/C1.5c: [100 to 170 / 155 / 1 deg]
023	Feed Waiting: Plain	<p>Turns the feed waiting mode on or off for each paper type.</p> <p>[0 to 1 / 0 / 1]</p> <p>0=Off, 1=On</p> <p>The paper waits at the registration roller until the fusing temperature reaches the prescribed temperature (adjustable with SP1105-028 to -37).</p> <p>If you enable this feature, also set SP 1105-38 to a convenient value for the customer.</p>
024	Feed Waiting: M-Thick	
025	Feed Waiting: Thick 1	
026	Feed Waiting: Thick 2	
027	Feed Waiting: Thin	
028	Feed Wait: Center Minus: Plain	
029	Feed Wait: Ends Minus: Plain	
030	Feed Wait: Center Minus: M-Thick	<p>Adjusts the offset value for each re-load temperature to exit the feed waiting mode.</p> <p>[0 to 60 / 0 / 1 deg]</p>
031	Feed Wait: Ends Minus: M-Thick	
032	Feed Wait: Center Minus: Thick 1	
033	Feed Wait: Ends Minus: Thick 1	
034	Feed Wait: Center Minus: Thick 2	
035	Feed Wait: Ends Minus: Thick 2	
036	Feed Wait: Center Minus: Thin	
037	Feed Wait: Ends Minus: Thin	

System SP Table-1

038	Feed Waiting: Maximum Time	<p>Sets the maximum feed waiting time. [0 to 30 / 0 / 1 sec]</p> <p>The paper is fed when the time specified with this SP has passed even though the fusing temperature has not reached the prescribed temperature.</p> <p>0: Disabled.</p>
-----	----------------------------	---

1106	Fusing Temperature Display	
001	Roller Center	<p>Displays the temperature of the fusing unit. [-20 to 250 / 0 / 1 deg]</p>
002	Roller Ends	
003	Machine Inside at Power On	<p>Displays the temperature inside the machine. [-20 to 250 / 0 / 1 deg]</p>
004	Machine Inside	

1109*	Fusing Nip Band Check	
	Checks the fusing nip band.	
001	Execution	
002	Idling Rotation Time	[0 to 120 / 60 / 1 sec]
	Specifies the fusing rotation time before executing SP1109-001.	
003	Pre-Idling Time	[5 to 30 / 10 / 1 sec]
	Specifies the time that the paper stops in the fusing unit for measuring the nip.	

1159	Fusing Jam Detection
	SC Code Display
	<p>[0 to 1 / 0 / 1] 0:OFF, 1:ON</p> <p>This SP setting determines whether SC559 is issued after three paper late jams occur in the fusing unit. After this SP code is turned on, a counter monitors the number of paper late jams that occur in the fusing unit. After the 3rd occurrence of a fusing jam, SC559 is issued and the machine cannot be used until the service technician releases the error.</p> <p> Note</p> <ul style="list-style-type: none"> Switching the machine off/on does not reset this jam counter. The counter is reset after the cause of the jam has been removed and a sheet of paper successfully passes the fusing exit sensor.

1801*	Motor Speed Adjustment	
	<p>Adjusts the speeds of each motor. Each step decreases or increases motor speed in 0.05% increments</p> <p>Regist: Registration motor, Feed: Feed motor, Duplex: Duplex/By-pass motor, Inverter: Duplex inverter motor, Exit: Paper exit motor, Bridge: Bridge unit drive motor, OpcMot: Drum motor, TransferMot: Transfer/Development Motor, FusingMot: Fusing motor, DevPuddleMot: Development Paddle motor</p>	
001	Regist: 90: Thick 2	[-2 to 2 / 0.4 / 0.05 %]
002	Regist: 154: Thick 1	
003	Regist: 180: Plain	
004	Regist: 230: Plain	
005	Feed: 90: Thick 2	[-2 to 2 / -0.4 / 0.05 %]
006	Feed: 154: Thick 1	

System SP Table-1

007	Feed: 180: Plain	[-2 to 2 / -1 / 0.05 %]
008	Feed: 230: Plain	
009	Duplex_CW: 90: Thick 2	[-4 to 4 / 0.4 / 0.1 %]
010	Duplex_CW: 154: Thick 1	
011	Duplex_CW: 180: Plain	[-4 to 4 / -2.3 / 0.1 %]
012	Duplex_CW: 230: Plain	
013	Duplex_CCW: 90: Thick 2	[-4 to 4 / 0.4 / 0.1 %]
014	Duplex_CCW: 154: Thick 1	
015	Duplex_CCW: 180: Plain	[-4 to 4 / -2.3 / 0.1 %]
016	Duplex_CCW: 230: Plain	
017	Inverter_CW: 90: Thick 2	[-4 to 4 / 0 / 0.1 %]
018	Inverter_CW: 154: Thick 1	
019	Inverter_CW: 180: Plain	
020	Inverter_CW: 230: Plain	
021	Inverter_CCW: 90: Thick 2	
022	Inverter_CCW: 154: Thick 1	
023	Inverter_CCW: 180: Plain	
024	Inverter_CCW: 230: Plain	
025	Exit_CW: 90: Thick 2	
026	Exit_CW: 154: Thick 1	
027	Exit_CW: 180: Plain	
028	Exit_CW: 230: Plain	
029	Bridge: 90: Thick 2	

System SP Table-1

030	Bridge: 154: Thick 1	
031	Bridge: 180: Plain	
032	Bridge: 230: Plain	
033	OpcMot:90	
034	OpcMot:154	
035	OpcMot:180	
036	OpcMot:230	
037	TransferMot:90	
038	TransferMot:154	
039	TransferMot:180	[-4 to 4 / 0 / 0.01 %]
040	TransferMot:230	
041	FusingMot:90	
042	FusingMot:154	
043	FusingMot:180	
044	FusingMot:230	
045	DevPuddleMot	[-4 to 4 / 0 / 0.1 %]

Appendix:
Service
Program
Mode Tables

System SP Table-1

1902	Cleaning Web Setting	
001	Web Consumption	[0 to 120 / 0 / 1 %]
	Displays the consumed amount of the web roll.	
002	Web Motor Interval	C1b/C1.5b: [3 to 130 / 8.4 / 0.1 sec] C1c/C1.5c: [3 to 130 / 6.7 / 0.1 sec]
	Adjusts the interval for web motor rotation.	
003	Web Motor Time	[0.3 to 10 / 4.2 / 0.1 sec]
	Adjusts the rotation time of the web motor.	
004	Web Near End Setting	C1b/C1.5b: EU [0 to 100 / 90 / 1 %] C1b/C1.5b: ASIA/NA [0 to 100 / 92 / 1 %] C1c/C1.5c: EU [0 to 100 / 90 / 1 %] C1c/C1.5c: ASIA/NA [0 to 100 / 92 / 1 %]
		Adjusts the threshold for web near end.
005	Web Motor Interval: Thick 1	[3 to 130 / 11.2 / 0.1 sec]
	Adjusts the interval for web motor rotation (thick 1).	
006	Web Motor Interval: Thick 2	[3 to 130 / 16.8 / 0.1 sec]
	Adjusts the interval for web motor rotation (thick 2).	
007	Paper Interval Time	[0 to 10 / 5 / 1 sec]
	Adjusts the threshold for paper feeding. When the time between trailing edge detection and leading edge detection is within the value of this setting, the machine determines that the paper is still being fed.	
008	Web Motor Setting: Web End	[0 to 60 / 27 / 1 sec]
	Adjusts the motor rotation time after the web end.	

009	Web Motor Rotation: Power On	[0 to 10 / 2 / 1 times]
	Adjusts the number of web motor rotations at the re-load state.	
010	Web Motor Interval: Pre-idle	[0 to 30 / 5 / 1 sec]
	Adjusts the motor waiting time after the fusing motor idling.	
011	Web Motor Rotation: Pre-idle	[0 to 10 / 2 / 1 times]
	Adjusts the number of web motor rotations at the fusing idling state.	

1903	Cleaning Web Setting	
001	Total Paper Counter	[0 to 999999999 / 0 / 1 sec]
	Displays the total paper feeding time.	
002	Total Web Motor Drive Time	[0 to 999999999 / 0 / 1 sec]
	Displays the total time of web motor rotation.	

1907	Paper Feed Timing Adj. (DFU)	
001	Feed Solenoid ON: Plain	[-10 to 40 / 0 / 2.5 mm]
002	Feed Solenoid ON: Thick	
003	Feed Solenoid OFF: Plain	[-10 to 10 / 0 / 1 mm]
004	Feed Solenoid OFF: Thick	
005	Feed Clutch ON: Plain	
006	Feed Clutch ON: Thick	
007	Stop Position before Inverter	
008	Stop Position after Inverter	

System SP Table-1

009	Re-Feed Stop Position		
010	By-pass Solenoid OFF	[0 to 40 / 0 / 1 mm]	
011	By-pass Solenoid ON	[0 to 1 / 1 / 1 mm]	
012	By-pass Feed Clutch ON		
013	Exit Roller: Shift: 180		
014	Exit Roller: Shift: 230		
015	Exit: Junction Solenoid ON		
016	Exit: Junction Solenoid OFF		[-10 to 10 / 0 / 1 mm]
017	Bridge: Junction Solenoid ON		
018	Bridge: Junction Solenoid OFF		
019	1-Bin: Junction Solenoid ON		
020	1-Bin: Junction Solenoid OFF		
021	Shift Motor ON		[-1 to 1 / 0 / 0.1 mm]

1908	Paper Bank Feed Timing Adj (DFU)	
001	Feed Clutch ON: Plain	[-10 to 10 / 0 / 1 mm]
002	Feed Clutch ON: Thick	

1916	CPM Down Setting	
	When this machine gets a sequence of coping/printing jobs, the machine uses CPM down mode to prevent the fusing temperature from becoming too low.	
001	Temp.: Plain	Adjusts the thresholds for each environmental condition (between Low and Medium). [10 to 23 / 17 / 1 deg]
002	Temp.: M-Thick	
003	Temp.: Thick 1	
004	Temp.: Thick 2	
005	Temp.: Thin	
006	ON/OFF: Low: Plain	Turns on or off the CPM down setting for each paper type and ambient temperature. [0 to 1 / 0 / 1] 0= Off, 1= On
007	ON/OFF: Low: M-Thick	
008	ON/OFF: Low: Thick 1	
009	ON/OFF: Low: Thick 2	
010	ON/OFF: Low: Thin	
011	ON/OFF: Medium: Plain	
012	ON/OFF: Medium: M-Thick	
013	ON/OFF: Medium: Thick 1	
014	ON/OFF: Medium: Thick 2	
015	ON/OFF: Medium: Thin	
016	Waiting Time: Low: Plain	Adjusts the threshold time to enter the CPM down mode. [0 to 180 / 60 / 1 sec] The machine determines whether the CPM down mode is activated or not
017	Waiting Time: Low: M-Thick	
018	Waiting Time: Low: Thick 1	
019	Waiting Time: Low: Thick 2	

System SP Table-1

020	Waiting Time: Low: Thin	after the time specified with these SPs has passed.
021	Waiting Time: Medium: Plain	
022	Waiting Time: Medium: M-Thick	
023	Waiting Time: Medium: Thick 1	
024	Waiting Time: Medium: Thick 2	
025	Waiting Time: Medium: Thin	
026	Temp.: Low: Plain	Adjusts the threshold temperature of the fusing unit to enter the CPM down mode. [100 to 200 / 120 / 1 deg] If the temperature of the fusing unit is less than the temperature specified with these SPs, the machine changes the CPM (adjustable with SP1916-36 to -45).
027	Temp.: Low: Plain	
028	Temp.: Low: Thick 1	
029	Temp.: Low: Thick 2	
030	Temp.: Low: Thin	
031	Temp.: Medium: Plain	
032	Temp.: Medium: M-Thick	
033	Temp.: Medium: Thick 1	
034	Temp.: Medium: Thick 2	
035	Temp.: Medium: Thin	
036	CPM: Low: Plain	Adjusts the CPM in the CPM down mode. C1b/C1.5b: [20 to 35 / 35 / 5 cpm] C1c/C1.5c: [20 to 45 / 45 / 5 cpm]
037	CPM: Low: M-Thick	Adjusts the CPM in the CPM down mode. C1b/C1.5b: [20 to 35 / 35 / 5 cpm] C1c/C1.5c: [20 to 45 / 45 / 5 cpm]

038	CPM: Low: Thick 1	Adjusts the CPM in the CPM down mode. C1b/C1.5b: [5 to 15 / 15 / 5 cpm] C1c/C1.5c: [5 to 25 / 25 / 5 cpm]
039	CPM: Low: Thick 2	Adjusts the CPM in the CPM down mode. [5 to 15 / 15 / 5 cpm]
040	CPM: Low: Thin	Adjusts the CPM in the CPM down mode. C1b/C1.5b: [20 to 35 / 35 / 5 cpm] C1c/C1.5c: [30 to 45 / 45 / 5 cpm]
041	CPM: Medium: Plain	
042	CPM: Medium: M-Thick	
043	CPM: Medium: Thick 1	Adjusts the CPM in the CPM down mode. C1b/C1.5b: [5 to 15 / 15 / 5 cpm] C1c/C1.5c: [5 to 25 / 25 / 5 cpm]
044	CPM: Medium: Thick 2	Adjusts the CPM in the CPM down mode. [5 to 15 / 15 / 5 cpm]
045	CPM: Medium: Thin	Adjusts the CPM in the CPM down mode. C1b/C1.5b: [20 to 35 / 35 / 5 cpm] C1c/C1.5c: [30 to 45 / 45 / 5 cpm]

System SP Table-1

1930	OnOff Time Adjust	
001	On Time Adjust	[0 to 100 / 40 / 10 msec]
	Adjusts the Off-On interval of the transfer belt contact motor. ("On" means that the transfer belt is in contact with the drum.)	
002	Off Time Adjust	[0 to 100 / 20 / 10 msec]
	Adjusts the On-Off interval of the transfer belt contact motor. ("Off" means that the transfer belt is away from the drum.)	
1950	Tray Lock at Jam	[0 or 1 / 0 / 1] 0= OFF, 1= ON
	Not used	

4.2 SYSTEM SP TABLE-2

4.2.1 SP2-XXX: DRUM

2001*	Charge Bias	
001	Setting (Copying)	[1000 to 2000 / 1500 / 10 V]
	Adjusts the voltage applied to the charge roller for copying.	
002	Setting (P Pattern)	[0 to 700 / 250 / 10 V]
	Adjusts the voltage applied to the charge roller when making the VSDP ID sensor pattern (for charge roller voltage correction). The actual charge roller voltage is this value plus the value of SP2001-1.	

2005*	Bias Control	
001	Bias Correction 1	[0.1 to 1 / 0.85 / 0.05 step]
	Adjusts the lower threshold value for the charge roller correction. When the value of VSDP/VSG is greater than this value, the charge roller voltage increases by 30 V (e.g., from –500 to –530).	
002	Bias Correction 2	[0.1 to 1 / 0.9 / 0.05 step]
	Adjusts the upper threshold value for the charge roller correction. When the value of VSDP/VSG is greater than this value, the charge roller voltage decreases by 30 V (absolute value).	
003	Bias Adjustment 1	[1000 to 2000 / 1500 / 10 vol]
	Adjusts the lower limit value for charge roller voltage correction.	
004	Bias Adjustment 2	[1000 to 2000 / 2000 / 10 vol]
	Adjusts the upper limit value for charge roller voltage correction.	

System SP Table-2

005	Bias Adjustment 3	[0 to 100 / 30 / 10 vol]
	Adjusts the correction voltage adjustment step size.	

2102*	Magnification Adjustment	
	Main Scan	[-2 to 2 / 0 / 0.1 %]
	Adjusts the magnification in the main scan direction for copy mode and printer mode. Press "Clear/Stop" key to toggle plus or minus.	

2103*	Erase Margin Adjustment	
	Adjusts the erase margin by deleting image data at the margins. L Size: 297.1 mm or more (length) M Size: 216.1 to 297 mm (length) S Size: 216 mm or less (length)	
	001	Leading Edge
	002	Trailing Edge
		[0 to 9 / 3 / 0.1mm]
003	Left	[0 to 9 / 2 / 0.1mm]
004	Right	
005	Duplex Trail.: L Size: Plain	[0 to 4 / 1 / 0.1mm]
006	Duplex Trail.: M Size: Plain	[0 to 4 / 0.8 / 0.1mm]
007	Duplex Trail.: S Size: Plain	[0 to 4 / 0.6 / 0.1mm]
008	Duplex Left: Plain	[0 to 1.5 / 0.3 / 0.1mm]
009	Duplex Right: Plain	
010	Duplex Trail.: L Size: Thick	[0 to 4 / 0.8 / 0.1mm]
011	Duplex Trail.: M Size: Thick	[0 to 4 / 0.6 / 0.1mm]
012	Duplex Trail.: S Size: Thick	[0 to 4 / 0.4 / 0.1mm]

013	Duplex Left: Thick	[0 to 1.5 / 0.1 / 0.1mm]
014	Duplex Right: Thick	

2105*	LD Power Adjustment	
	Adjusts the LD power for each mode. Each LD power setting is decided by the process control.	
001	LD1: Copy	[-50 to 79 / -24 (C1b/C1.5b), 5 (C1c/C1.5c) /1]
002	LD2: Copy	
003	LD1: Printer/Fax	[-50 to 79 / -44 (C1b/C1.5b), -25 (C1c/C1.5c)/1]
004	LD2: Printer/Fax	

2106*	POL REV TIME (Polygon motor rotation time)	
001	PRE TIME	[0 to 60 / 10 /1 sec]
	Adjusts the time of polygon motor rotation before a job. If this is set to "0", this SP is not activated.	
002	POST TIME	[0 to 60 / 0 /1 sec]
	Adjusts the time of the polygon motor rotation after a job. If this is set to "0", the polygon motor never switches off in standby mode. However, if the machine enters the energy saver mode, the polygon motor will ignore the zero setting and switch itself off.	

System SP Table-2

2109	Test Pattern	
001	Pattern Selection	[0 to 24 / 0 / 1] Test pattern of the GAVD
	0: None 1: Vertical Line (1 dot) 2: Vertical Line (2 dot) 3: Horizontal Line (1 dot) 4: Horizontal Line (2 dot) 5: Grid Vertical Line 6: Grid Horizontal Line 7: Grid pattern small 8: Grid Pattern Large 9: Argyle Pattern Small 10: Argyle Pattern Large 11: Independent pattern (1 dot) 12: Independent Pattern (2 dot)	13: Independent Pattern (3 dot) 14: Trimming Area 15: Hound's Tooth Check (Vertical) 16: Hound's Tooth Check (Horizontal) 17: Black Band (Horizontal) 18: Black band (Vertical) 19: Checker Flag Pattern 20: Grayscale (Vertical Margin) 21: Grayscale (Horizontal Margin) 22: Two Beam Density Pattern 23: Full Dot Pattern 24: All white Pattern
002	Density	[0 to 15 / 15 / 1] Set the density of the test pattern which is output in SP2109-001. This SP is not used for the Grayscale patterns.

2201*	Development Bias Adjustment	
001	Development Bias	[200 to 700 / 560 / 10V]
	Adjusts the development bias for copying. Use as a temporary measure to correct faint copies from an aging drum.	
002	ID Sensor Pattern	[200 to 700 / 400 / 10V]
	Adjusts the development bias for the ID sensor pattern for VSP	

2207	Forced Toner Supply	
	Forces the toner bottle to supply toner at 1-second intervals for up to 30 seconds. To start, press  .	

2208*	Toner Supply Mode	[0: Sensor, 1: pixel]
	<p>Selects the toner mode.</p> <p>If you select "1", SP2-209-002 should be set to its default value. Use image pixel count modes only as a temporary measure if the ID or TD sensor is defective.</p>	

2209*	Toner Supply Rate	
001	Toner Rate	[10 to 800 / 60 mg/s / 5 mg]
	<p>Sets the amount of toner supplied every second by the toner supply motor. The length of time the motor remains on is determined by the data read by the TD sensor and ID sensor.</p> <p>Increasing this value reduces the toner supply clutch on time. Use a lower value if the user tends to make lots of copies that have a high proportion of black.</p>	
002	Correction Data	[25 to 300 / 300 / 25]
	<p>Displays the toner supply correction coefficient (K). It can also be used to adjust K, but the value is changed again when VT is measured for the next copy.</p> <p>The toner supply rate depends on the amount of toner in the toner bottle. This change is corrected using this coefficient. This SP can be used to check the toner supply condition. The lower the value of K, the lower the toner density</p>	

Appendix:
Service
Program
Mode Tables

System SP Table-2

2210*	P Pattern Cycle	
	Sets the interval between ID sensor pattern prints.	
001*	Job Page Count	[0 to 200 / 10 / 1 sheet]
	Sets the interval between ID sensor pattern printing. For users that do not make many copies daily, set a smaller interval to compensate for the effects of seasonal and weather changes.	
002*	Forced Page Count	[2 to 999 / 100 / 1 sheet]
	Sets the interval between ID sensor pattern printing. Forces creation of the ID sensor pattern to prevent low density copies for customers who use the copier for long copy jobs.	

2213*	Toner End Setting	
	<p>Selects the detection type for toner end.</p> <p>[0 to 2 / 0 / 1 step]</p> <p>[0: 90 copies, 1: No copies, 2: 10 copies]</p> <p> Note</p> <ul style="list-style-type: none"> ▪ 90 copies: Toner end is determined if a low density image ($V_{ref} < V_t(10)$) is detected 90 times after toner near end. ▪ If "1" is selected, the machine stops printing when the TD sensor output drops below the prescribed level. ▪ Select 1 or 2 if the customer normally makes copies of very high density. 	

2220*	Vref Setting	
	<p>Adjusts the TD sensor reference voltage (Vref). Change this value after replacing the development unit with another development unit that contains toner.</p> <p>[1 to 5 / 4 / 0.01]</p> <ol style="list-style-type: none"> 1. Check the value of SP2-220 in both the machine containing the test unit and the machine that you are going to move it to. 2. Install the test development unit, and then input the VREF for this unit into SP2-220. 3. After the test, put back the old development unit, and change SP2-220 back to the original value. 	

2221*	Reverse Interval Drum, Transfer	[0 to 2000 / 0 / 100 sheets]
	<p>Adjusts the threshold for the reverse rotation of the drum and development/transfer motors. This helps the drum and transfer belt cleaning operations. This reverse rotation will interrupt a multiple printing job.</p>	

2223*	Vt Display	
001	Current	[0 to 5 / 4 / 0.01]
	Displays the TD sensor output voltage for the immediately previous copy.	
002	Average 10 copies	[0 to 5 / 4 / 0.01]
	Displays the average of the most recent TD sensor outputs (from the previous 10 copies).	
003	Rate of Change	[-10000 to 10000 / 0 / 1]
	Displays the rate of change in the TD sensor output.	

System SP Table-2

004	GAIN	[0 to 255 / 0 / 1]
	Displays the GAIN value used to calculate the on time for the toner supply motor.	
005	Image Pixel Count	[0 to 255 / 0 / 1]
	Displays the image pixel count.	
2228*	Developer Lot	
	Displays the lot number of the developer. (The lot number is embossed on the top edge of the developer pack.)	
2301*	Transfer Current Adjustment	
	If the transfer current of image area is set highly than normal, the print image is easily come out. If the leading transfer current is set as same, the black line is come out due to exfoliation leave.	
001	Image Area: 1st Side	[10 to 100 / 45 / 1 μ A]
	Adjusts the transfer current for printing the first side of the paper	
002	Image Area: 2nd Side	[10 to 100 / 40 / 1 μ A]
	Adjusts the transfer current for printing the second side of the paper	
003	Leading Edge: 1st Side	[10 to 100 / 20 / 1 μ A]
	Adjusts the transfer current for copying at leading edge the first side of the paper. Increase the current to separate the paper from the drum properly in high humidity and high temperature conditions.	

004	Leading Edge: 2nd Side	[10 to 100 / 20 / 1 μ A]
	<p>Adjusts the transfer current for copying at leading edge the second side of the paper.</p> <p>Increase the current to separate the paper from the drum properly in high humidity and high temperature conditions.</p>	
005	By-pass: Image Area	[10 to 100 / 45 / 1 μ A]
	<p>Adjusts the transfer current for copying from the by-pass tray.</p> <p>If the user normally feeds thicker paper from the bypass tray, use a higher setting.</p>	
006	By-pass: Leading Edge	[10 to 100 / 20 / 1 μ A]
	<p>Adjusts the transfer current for copying at the leading edge of paper fed from the by-pass tray.</p> <p>Increase the current to separate the paper from the drum properly in high humidity and high temperature conditions.</p>	
008	No Image Area	[10 to 100 / 15 / 1 μ A]
	Adjusts the transfer current for copying.	

2309*	Current: Paper Size Correction	
001	Paper Lower Width (a)	[1 to 150 / 150 / 1 mm]
	<p>Adjusts the lower paper width threshold for the transfer current, charge voltage, and development bias corrections.</p> <p>Use this SP when an image problem (e.g., insufficient toner transfer) occurs with a small width paper. If the paper width is smaller than this value, the transfer current will be multiplied by the factor in SP2-309-3 (paper tray) or SP2-309-5 (by-pass).</p>	

System SP Table-2

002	Paper Upper Width (b)	[151 to 296 / 216 / 1 mm]
	Adjusts the upper paper width threshold for the transfer current, charge voltage, and development bias corrections. As for SP2-309-1, but the factors are in SP2-309-4 (paper tray) and SP2-309-6 (by-pass).	
003	Paper Tray: Plain (alpha)	[1 to 3 / 1 / 0.1]
	Adjusts the transfer current correction coefficient used if the paper width is less than the setting of SP2-309-1.	
004	Paper Tray: Plain (beta)	[1 to 3 / 1 / 0.1]
	Adjusts the transfer current correction coefficient used if the paper width is less than the setting of SP2-309-2.	
005	By-pass: Plain (gamma)	[1 to 3 / 1.1 / 0.1]
	Adjusts the transfer current correction coefficient used if the paper width is less than the setting of SP2-309-1.	
006	By-pass: Plain (delta)	[1 to 3 / 1.1 / 0.1]
	Adjusts the transfer current correction coefficient used if the paper width is less than the setting of SP2-309-2.	
007	Paper Tray: Thick 1 (alpha)	[1 to 3 / 1 / 0.1]
008	Paper Tray: Thick 1 (beta)	
009	By-pass: Thick 1 (gamma)	[1 to 3 / 1.1 / 0.1]
010	By-pass: Thick 1 (delta)	
011	Paper Tray: Thick 2 (alpha)	[1 to 3 / 1.1 / 0.1]
012	Paper Tray: Thick 2 (beta)	
013	By-pass: Thick 2 (gamma)	[1 to 3 / 1.5 / 0.1]

014	By-pass: Thick 2 (delta)	
015	Paper Tray: M-Thick (alpha)	[1 to 3 / 1 / 0.1]
016	Paper Tray: M-Thick (beta)	
017	By-pass: M-Thick (gamma)	[1 to 3 / 1.1 / 0.1]
018	By-pass: M-Thick (delta)	
019	Paper Tray: Thin (alpha)	[1 to 3 / 1 / 0.1]
020	Paper Tray: Thin (beta)	
021	By-pass: Thin (gamma)	[1 to 3 / 1.1 / 0.1]
022	By-pass: Thin (delta)	
023	Paper Tray: Special 1 (alpha)	[1 to 3 / 1 / 0.1]
024	Paper Tray: Special 1 (beta)	
025	By-pass: Special 1 (gamma)	[1 to 3 / 1.1 / 0.1]
026	By-pass: Special 1 (delta)	
027	Paper Tray: Special 2 (alpha)	[1 to 3 / 1 / 0.1]
028	Paper Tray: Special 2 (beta)	
029	By-pass: Special 2 (gamma)	[1 to 3 / 1.1 / 0.1]
030	By-pass: Special 2 (delta)	
031	Paper Tray: Special 3 (alpha)	[1 to 3 / 1 / 0.1]
032	Paper Tray: Special 3 (beta)	
033	By-pass: Special 3 (gamma)	[1 to 3 / 1.1 / 0.1]
034	By-pass: Special 3 (delta)	

System SP Table-2

2801*	TD Sensor Initial Setting	Initialization
	<p>Performs the TD sensor initial setting and allows the service technician to enter the lot number of the developer. (The lot number is embossed on the edge of the developer package.) This SP mode controls the voltage applied to the TD sensor to make the TD sensor output about 3.0 V. Press "Execute" to start. After finishing this, the TD sensor output voltage is displayed.</p> <p>Use this mode only after installing the machine, changing the TD sensor, or adding new developer.</p>	

2802*	TD Sensor Manual Setting	
	Allows you to adjust the TD sensor output manually for the following.	
001	VTS	[1 to 5 / 4.78 / 0.01vol]
	<p>Adjusts the TD sensor output (VT).</p> <p>Change this value after replacing the development unit with another one that already contains toner. For example, when using a development unit from another machine for test purposes. To adjust VT, use a similar procedure as for SP2-220.</p>	
002	VTMAX	[1 to 5 / 4.78 / 0.01vol]
	Adjusts the maximum value for SP2802 1.	
003	VTMIN	[1 to 5 / 1 / 0.01vol]
	Adjusts the minimum value for SP2802 1.	

2805*	Process Setting	
	<p>Performs the developer initialization. Press "Execute" to start. This SP should be performed after doing SP2801 at installation and after replacing the drum.</p>	

2810	Grayscale Setting	
	Initializes the LD power setting. This SP should be done after replacing the drum.	

2812*	Drum Reverse Rotation (SSP)	
001	Reverse time	[0 to 9 / 4 / 1]
	Sets the reverse time of the drum motor after the end of a job.	
002	Interval time	[0 to 19 / 9 / 1]
	Sets the waiting time of the drum motor reverse after the end of a job.	

2912*	Transfer Reverse Rotation	
002	Interval	[0 to 10 / 3 / 1]
	Sets the reverse time of the transfer/development motor after the end of a job.	

2914*	Paper Setting	
001	C-alpha	[0 to 400 / 150 / 10vol]
	<p>Adjusts the charge roller voltage used when paper with a small width is fed from the by-pass tray. The paper width below which the correction starts depends on the value of SP2-309-1.</p> <p>Use this SP when an image problem (such as white spots at the center of black dots or breaks in thin black lines) occurs when paper with a small width is fed from the by-pass feed tray.</p>	

System SP Table-2

002	C-beta	[0 to 400 / 0 / 10vol]
	<p>Adjusts the charge roller voltage used when paper with a small width is fed from the by-pass tray. The paper width below which the correction starts depends on the value of SP2-309-2.</p> <p>Use this SP when an image problem (see 2-914-1) occurs when paper with a small width is fed from the by-pass feed tray.</p>	
003	B-gamma	[0 to 300 / 200 / 10vol]
	<p>Adjusts the development bias used when paper with a small width is fed from the by-pass tray. The paper width below which the correction starts depends on the value of SP2-309-1.</p> <p>Use this SP when an image problem (see 2-914-1) occurs when paper with a small width is fed from the by-pass feed tray.</p>	
004	B-delta	[0 to 300 / 50 / 10vol]
	<p>Adjusts the development bias used when paper with a small width is fed from the by-pass tray. The paper width below which the correction starts depends on the value of SP2-309-2.</p> <p>Use this SP when an image problem (see 2-914-1) occurs when paper with a small width is fed from the by-pass feed tray.</p>	
2960*	Toner Overflow Sensor	[0 = No, 1 = Yes]
	<p>Selects whether or not the toner overflow sensor is activated.</p>	

2964*	Transfer Cleaning Blade Forming (SSP)	
	<p>Applies a pattern of toner to the transfer belt at a defined interval between sheets on the transfer belt in order to reduce friction between the belt surface and the cleaning blade.</p> <p>Under conditions of high temperature and high humidity, the density control feature may reduce the amount of toner, which also reduces the amount of toner on the surface of the transfer belt. With less toner on the belt, the friction between the belt and the blade increases, and could cause the blade to bend or scour the surface of the belt.</p>	
001	0: OFF, 1: ON	[0 to 1 / 0 / 1]
002	Pattern Interval	[1 to 100 / 15 / 1 sheet]
003	Pattern Number	[1 to 3 / 1 / 1 line]
004	Pattern LD Power	[0 to 15 / 2 / 1]

2972*	Grayscale Limit (SSP)	
	<p>Controls the halftone density level to prevent deterioration of the OPC. The halftone density is detected by the ID sensor, and the machine adjusts the intensity of the LD beam according to the upper/lower limit setting.</p>	
001	Upper Limit	[0 to 100 / 58 (C1b/C1.5b), 63 (C1c/C1.5c) / 1vol]
	<p>Defines the upper limit for grayscale.</p> <p>A larger value allows a wider range of halftones at the pale end of the scale. If the image contains pale areas with fuzzy borders surrounded by dark areas, reduce this value to make the borders clearer.</p>	

System SP Table-2

002	Lower Limit	[0 to 100 / 52 (C1b/C1.5b) , 57 (C1c/C1.5c) / 1vol]
	<p>Defines the lower limit for grayscale. A smaller value allows a wider range of halftones at the dark end of the scale.</p>	

2973*	Grayscale Cycle (SSP)	[0 to 1000 / 100 / 10 sheets]
	<p>Set s the halftone operation interval in order to prevent deterioration of the OPC. If the number of copies exceeds this setting, at the end of the job, or if the door is opened and closed, charge correction is executed.</p>	

2974*	Image Density	
001	Adjustment Mode	[1 to 5 / 3 / 1]
	<p>Adjusts image density. Changing this setting adjusts development bias and ID sensor output voltage that in turn raises or lowers image density.</p>	

2975*	Near End Setting	
	Detection Time	[0 to 2000 / 0 / 10 sec]
	<p>Sets a time for toner supply motor rotation for issuing the toner near end warning on the operation panel. The time may need to be shorter for customers who run especially large print jobs (working at night, for example) to ensure earlier warning of the toner near end condition so toner out does not interrupt a long job.</p>	

2976*	Bottle Motor Time	
	<p>Displays the total ON time of the toner supply motor, calculated from when the toner bottle was replaced. Use this to check that the toner end count (SP2975) is working properly.</p> <p>When SP2975 is set to any value other than "0", this value is displayed when it matches the setting of SP2975. When SP2975 is set to "0", SP2976 is disabled. SP2976 is automatically set to zero by toner end recovery.)</p>	
	Time	[0 to 7,000,000 / 0 / 1 msec]

2977*	Toner End Status	
	Indicates the toner near end or end condition.	
001	Near End	<p>[0 to 10 / 0 / 1]</p> <p>0: Not detected</p> <p>1: Detected by SP2975-001</p> <p>2: $V_t(10) - V_{ref} > 0.2$ and $V_{sp} > 0.6$</p> <p>3: $V_t(10) - V_{ref} > 0.45$</p> <p>4: $0.45 > V_t(10) - V_{ref} > 0.2$ and toner end counter > 300</p> <p>5 to 10: Not used</p>
002	End	<p>[0 to 10 / 0 / 1]</p> <p>0: Not detected</p> <p>1: $V_{sp} > 2.0$</p> <p>2: Toner end counter > 90 when SP2213-001 is set to "0".</p> <p>3: Toner end counter < 90 and $V_t(10) > (V_{ref} + 0.3)$ when SP2213-001 is set to "0".</p> <p>4: When SP2213-001 is set to "2"</p> <p>5: $V_{sp} > 0.9$ when SP2213-001 is set to "2"</p> <p>6: Special order</p> <p>7 to 10: Not used</p>

System SP Table-2

2980*	Charge Counter	[0 to 1000000 / 0 / 1 sheets]
	<p>Set the number of pages to print after toner and carrier initialization before the charge input is increased to compensate for deterioration over time in the polarity of the carrier.</p> <p>The strength in the polarity of the carrier in the toner will eventually decrease and cause lower charge output. Setting the charge output to increase after a specified number of copies can compensate for this effect.</p>	

4.3 SYSTEM SP TABLE-3

4.3.1 SP3-XXX: PROCESS

3001*	P Sensor Setting	
001	Current	[0 to 43 / 13 / 0.1 mA]
	Allows you to reset the PWM of the ID sensor LED to avoid a service call error after clearing NVRAM or replacing the NVRAM. The PWM data is stored by executing SP-3001-2.	
002	ID Initialization	-
	Performs the ID sensor initial setting. ID sensor output for the bare drum (VSG) is adjusted automatically to 4.0 ±0.2 V. Press "Execute" to start. Perform this setting after replacing or cleaning the ID sensor, replacing the drum, or clearing NVRAM.	

3045*	Toner End Setting, ON/OFF	DFU
	[0 to 1 / 0 / 1] 0=Off, 1=On	

3103*	P Sensor Output	
	Displays the current VSG, VSP, VSDP, and grayscale control. If the P sensor does not detect the P pattern, "VSP = 5.0 V/VSG = 5.0 V" is displayed and an SC code is generated. If the P sensor does not detect the bare area of the drum, "VSP = 0.0 V/VSG = 0.0 V" is displayed and an SC code is generated.	
001	Vsg	[0 to 5 / 0 / 0.1]
002	Vsp	[0 to 5 / 0 / 0.1]

System SP Table-3

003	Vsdp	[0 to 5 / 0 / 0.1]
004	Vsm/Vsg	[0 to 5 / 0 / 0.1]

3902*	New PCU Detection (Not used)	
001	On/OFF Setting	[0 to 1 / 0 / 1] 0: On, 1: Off
	Turns on or off the new unit detection for the transfer belt unit and fusing unit.	

3905*	Hot Roller Stripper Cleaning	
	"Cleaning A": 15 sec. off/on cycle for the fusing motor. "Cleaning B": Off (45 sec.) and On (15 sec.) cycle for the fusing motor.	
001	1st Cleaning: Interval	
	Sets the threshold for the 1st cleaning mode. "Cleaning A" is done once. [0 to 5 / 5 / 1 sheets]	
002	1st Cleaning: Mode Setting	
	Sets the number of additional execution times of the 1st cleaning mode. [0 to 5 / 0 / 1 times]	
003	2nd Cleaning: Interval	
	Sets the threshold for the 2nd cleaning mode. "Cleaning A" is done twice. [6 to 49 / 30 / 1 sheets]	

004	2nd Cleaning: Mode Setting
	Sets the number of additional execution times of the 2nd cleaning mode. [0 to 5 / 0 / 1 times]
005	3rd Cleaning: Interval
	Sets the threshold for the 3rd cleaning mode. "Cleaning A" is done twice and "Cleaning B" is done "N" times. "N" is specified with SP3905-006. [50 to 999 / 100 / 1 sheets]
006	3rd Cleaning: Mode Setting
	Sets the number of execution times of the 3rd cleaning mode. [0 to 5 / 0 / 1 times]  Note <ul style="list-style-type: none"> ▪ All fans remain on during cleaning and then switch off 60sec after the cleaning cycle ends.
007	Cleaning Priority Setting
	[0 to 1 / 0 / 1 sheets] 0: Priority to printing (No job interruption) 1: Priority to cleaning (Job interruption)

4.4 SYSTEM SP TABLE-4

4.4.1 SP4-XXX: SCANNER

4008*	Scanner Sub Scan Magnification ADJ
	<p>Adjusts the magnification of the sub scan direction during scanning. Changing this value changes the scanner motor speed. Press  to toggle \pm.</p> <p>[-1 to 1 / 0 / 0.1%]</p>
4010*	Scanner Leading Edge Registration ADJ
	<p>Adjusts the leading edge registration for scanning. Press  to toggle \pm.</p> <p>[-2 to 2 / 0 / 0.1 mm]</p> <p>As you enter a negative value, the image moves toward the leading edge.</p>
4011*	Scanner Side-to-Side Registration ADJ
	<p>Adjusts side-to-side registration for scanning. Press  to toggle \pm.</p> <p>CS: [-2.5 to 2.5 / 0 / 0.1 mm]</p> <p>MS: [-4.2 to 4.2 / 0 / 0.1 mm]</p> <p>As you enter negative values, the image will disappear at the left, and as you enter positive values, the image will appear at the left.</p>

4012*	Scanner Erase Margin: Scale	
	Adjusts scanning margins for the leading and trailing edges (sub scan) and right and left edge (main scan).  Note <ul style="list-style-type: none"> ▪ Do not adjust unless the customer desires a scanner margin greater than the printer margin. ▪ These settings are adjusted to erase shadows caused by the gap between the original and the scale of the scanner unit. 	
001	Book: Leading Edge	[0 to 3 / 1 / 0.1 mm]
002	Book: Trailing Edge	[0 to 3 / 0 / 0.1 mm]
003	Book: Left	[0 to 3 / 1 / 0.1 mm]
004	Book: Right	[0 to 3 / 0 / 0.1 mm]
005	ADF: Leading Edge	[0 to 3 / 0 / 0.1 mm]
007	ADF: Right	[0 to 3 / 0 / 0.1 mm]
008	ADF: Left	[0 to 3 / 0 / 0.1 mm]

4013	Scanner Free Run	
	Performs a scanner free run with the exposure lamp on or off.	
001	Lamp: ON	[0 to 1 / 0 / 1]
002	Lamp: OFF	0=Off, 1=On

4014	Scanner Free Run	
001	HP Detection Enable	Scanner free run with HP sensor check.
002	HP Detection Disable	Scanner free run without HP sensor check.

System SP Table-4

4020*	ADF Scan Glass Dust Check
	This function checks the narrow scanning glass of the ADF for dust that can cause black lines in copies. If dust is detected a system banner message is displayed, but processing does not stop.
001	<p>Check On/Off Change</p> <p>Issues a warning if there is dust on the narrow scanning glass of the ADF when the original size is detected before a job starts. This function can detect dust on the white plate above the scanning glass, as well as dust on the glass. Sensitivity of the level of detection is adjusted with SP4020-2.</p> <p>[0 to 1 / 0 / 1]</p> <p>0: Off. No dust warning. 1: On. Dust warning. This warning does not stop the job.</p> <p> Note</p> <ul style="list-style-type: none"> ▪ Before switching this setting on, clean the ADF scanning glass and the white plate above the scanning glass.
002	<p>Detect Level</p> <p>Adjusts the sensitivity for dust detection on the ADF scanning glass. This SP is available only after SP4020-1 is switched on.</p> <p>[0 to 8 / 4 / 1]</p> <p>If you see black streaks in copies when no warning has been issued, raise the setting to increase the level of sensitivity. If warnings are issued when you see not black streaks in copies, lower the setting.</p> <p> Note</p> <ul style="list-style-type: none"> ▪ Dust that triggers a warning could move be removed from the glass by the originals in the feed path. If the dust is removed by passing originals, this is not detected and the warning remains on.
003	<p>Correction Level</p> <p>Selects the level of the sub scan line correction when using the ARDF.</p> <p>[0 to 4 / 0 / 1]</p> <p>0: OFF, 1: Weakest, 2: Weak, 3: Strong, 4: Strongest</p>

4301	APS Sensor Output Display	
	Displays a code that represents the original size detected by the original sensors. (p.4-236 "Input Check")	

4303*	APS A5/LT Size Detection	
	<p>Determines whether an original of non-standard size is detected as A5/HLT size by the APS sensor.</p> <p>0: No original 1: A5/HLT- lengthwise (SEF) 2:A5/HLT - Sideways (LEF)</p> <p>If "0" is selected, "Cannot detect original size" will be displayed.</p>	

4305	Original Size Detection	
	<p>[0 to 3 / 0 / 1 step]</p> <p>0: Normal Detection (the machine detects A4/LT size as A4 or LT, depending on the paper size setting)</p> <p>1: A4-sideways LT-Lengthwise 2: LT-sideways A4-Lenghtwise 3: 8K 16K</p>	

4400*	Scanner Erase Margin	
	These SPs set the area to be masked during platen (book) mode scanning.	
001	Book: Leading Edge	[0 to 3 / 0 / 0.1 mm]
002	Book: Trailing Edge	
003	Book: Left	
004	Book: Right	
005	ADF: Leading Edge	[0 to 3 / 2 / 0.1 mm]
007	ADF: Right	[0 to 3 / 0 / 0.1 mm]

System SP Table-4

008	ADF: Left	
-----	-----------	--

4417	IPU Test Pattern		
	Selects the IPU test Pattern.		
	Test Pattern Selection	[0 to 28 / 0 / 1]	
		0: Scanned image	15: Gray pattern (1)
		1: Gradation main scan A	16: Gray pattern (2)
		2: Gradation main scan B	17: Gray pattern (3)
		3: Gradation main scan C	18: Shading pattern
		4: Gradation main scan D	19: Thin line pattern
		5: Gradation sub scan (1)	20: Scanned + Grid pattern
		6: Grid pattern	21: Scanned + Grid scale
		7: Slant grid pattern	22: Scanned + Color patch
		8: Gradation K	23: Scanned + Slant Grid C
		9: Check pattern 16	24: Scanned + Slant Grid D
		10: Gray patch 16 (1)	25: Gray Scale 18 text
		11: Gray patch 16 (2)	26: Gray Scale 18 photo
12: Gray patch 64		27: Gray Scale 256 text	
13: Grid pattern (2)	28: Gray Scale 256 photo		
14: Color patch K			

4429*	ICI Output Selection	
001	Copy	Adjusts the density of the embedded message with the copy data security unit. [0 to 3 / 3 / 1] 3: Darkest density
002	Scanner	
003	Fax	

4450*	Scan Image Path Selection	
001	Black Reduction ON/OFF	[0 to 1 / 1 / 1] 0=OFF, 1=ON
	Uses or does not use the black reduction image path.	
002	SH ON/OFF	[0 to 1 / 0 / 1] 0=OFF, 1=ON
	Uses or does not use the shading image path.	

4460*	Digital AE Setting	
	Specifies the level of deleting the background in the ADS mode. You can adjust its level for each scanning method (platen, ADF).	
001	Lower Limit	CS: [0 to 1020 / 364 / 4 digit] MS: [0 to 1020 / 408 / 4 digit]
002	Background Level	[512 to 1535 / 972 / 1 digit]

System SP Table-4

4540*	Printer Vector Correction	
	This SP corrects the printer coverage of 12 hues (RY, YR, YG, etc. x 4 Colors [R, G, B, Option]) for a total of 48 parameters.	
001-004	RY Phase: Option/R/G/B	Specifies the printer vector correction value. [0 to 255 / 0 / 1]
005-008	YR Phase: Option/R/G/B	
009-012	YG Phase: Option/R/G/B	
013-016	GY Phase: Option/R/G/B	
017-020	GC Phase: Option/R/G/B	
021-024	CG Phase: Option/R/G/B	
025-028	CB Phase: Option/R/G/B	
029-032	BC Phase: Option/R/G/B	
033-036	BM Phase: Option/R/G/B	
037-040	MB Phase: Option/R/G/B	
041-040	MR Phase: Option/R/G/B	
045-048	RM Phase: Option/R/G/B	

4550*	Scanner: Text/Chart	
4551*	Scanner: Text	
4552*	Scanner: Text (Dropout Color)	
4553*	Scanner: Text/photo	
4554*	Scanner: Photo	
4565*	Scanner: Gray Scale	
4570*	Scanner: Color: Text/Photo	
4571*	Scanner: Color: Photo	
4572*	Scanner: Color: Auto Color	
-005	MTF: 0(Off), 1-15(High)	[0 to 15 / 8 / 1] 0: MTF OFF
	Sets the MTF level (Modulation Transfer Function) designed to improve image contrast. Set higher for stronger effect, lower for weaker effect.	
-006	Smoothing: 0(x1), 1-7(High)	[0 to 7 / 4 / 1]
	Use to remove "jaggies" if they appear. Set higher for smoother images.	
-007	Brightness: 1-255	[1 to 255 / 128 / 1]
	Set higher for darker, set lower for lighter.	
-008	Contrast: 1-255	[1 to 255 / 128 / 1]
	Set higher for more contrast, set lower for less contrast.	
-009	Ind. Dot Erase: 0(x1), 1-7(High)	[0 to 7 / 0 / 1]
	Sets the erasure level of Irregular Dots. Set higher for stronger effect, lower for weaker effect. 0: Not activated	

System SP Table-4

4580*	Fax: Text/Chart	
4581*	Fax: Text	
4582*	Fax: Text/Photo	
4583*	Fax: /Photo	
4584*	Fax: Original 1	
4585*	Fax: Original 2	
-005	MTF: 0(Off), 1-15(High)	[0 to 15 / 8 / 1] 0: MTF OFF
	Sets the MTF level (Modulation Transfer Function) designed to improve image contrast. Set higher for stronger effect, lower for weaker effect.	
-006	Smoothing: 0(x1), 1-7(High)	[0 to 7 / 4 / 1]
	Use to remove "jaggies" if they appear. Set higher for smoother images.	
-007	Brightness: 1-255	[1 to 255 / 128 / 1]
	Set higher for darker, set lower for lighter.	
-008	Contrast: 1-255	[1 to 255 / 128 / 1]
	Set higher for more contrast, set lower for less contrast.	
-009	Ind. Dot Erase: 0(x1), 1-7(High)	[0 to 7 / 0 / 1]
	Sets the erasure level of Irregular Dots. Set higher for stronger effect, lower for weaker effect. 0: Not activated	
4600	SBU Version	
	Displays the ID of the SBU.	

4602	Scanner Memory Access	
001	Scanner Memory Access	Enables the read and write check for the SBU registers.
002	Address Setting	Not used
003	Data Setting	

4603	AGC Execution	
002	HP Detection Enable	Executes the AGC with the scanner detection.
003	HP Detection Disable	Executes the AGC with the scanner detection.

4604	FGATE Open/Close	
	<p>Opens or closes the FGATE signal. This SP automatically returns to the default status (close) after exiting this SP.</p> <p>[0 to 1 / 0 / 1]</p> <p>0: OFF, 1: ON</p>	

4606	White Balance Target: R	
	<p>This value is the target value of red for the white level adjustment (CS model only).</p> <p>[0 to 1023 / 784 / 1 digit]</p>	

4607	White Balance Target: G	
001	<p>This value is the target value of green for the white level adjustment.</p> <p>CS: [1023 to 0 / 784 / 1 digit]</p> <p>MS: [1023 to 1 / 876 / 1 digit]</p>	

System SP Table-4

4608	White Balance Target: B (CS model only)	
	This value is the target value of blue for the white level adjustment. [1023 to 0 / 784 / 1 digit]	

4623	Black Level Rough/Fine Adj. Display (CS model only)	
001	Latest: RE Color	[0 to 255 / 128 / 1 digit]
	Displays the black offset value (rough adjustment) for the even green signal in the SBU (color printing speed).	
002	Latest: RO Color	[0 to 255 / 128 / 1 digit]
	Displays the black offset value (rough adjustment) for the odd green signal in the SBU (color printing speed).	
003	Latest: RE Color	[0 to 255 / 128 / 1 digit]
	Displays the black offset value (fine adjustment) for the even green signal in the SBU (color printing speed).	
004	Latest: RO Color	[0 to 255 / 128 / 1 digit]
	Displays the black offset value (fine adjustment) for the odd green signal in the SBU (color printing speed).	
005	Latest: RE B/W	[0 to 255 / 128 / 1 digit]
	Displays the black offset value (rough adjustment) for the even red signal in the SBU (black and white printing speed).	
006	Latest: RO B/W	[0 to 255 / 128 / 1 digit]
	Displays the black offset value (rough adjustment) for the odd red signal in the SBU (black and white printing speed).	

007	Latest: RE B/W	[0 to 255 / 128 / 1 digit]
	Displays the black offset value (fine adjustment) for the even red signal in the SBU (black and white printing speed).	
008	Latest: RO B/W	[0 to 255 / 128 / 1 digit]
	Displays the black offset value (fine adjustment) for the odd red signal in the SBU (black and white printing speed).	

 Note

- RE: Red Even signal, RO: Red Odd signal

4624	Black Level Rough/Fine Adj. Display (CS model only)	
001	Latest: GE Color	
	[0 to 255 / 128 / 1 digit]	Displays the black offset value (rough adjustment) for the even green signal in the SBU (color printing speed).
002	Latest: GO Color	
	[0 to 255 / 128 / 1 digit]	Displays the black offset value (rough adjustment) for the odd green signal in the SBU (color printing speed).
003	Latest: GE Color	
	[0 to 255 / 128 / 1 digit]	Displays the black offset value (fine adjustment) for the even green signal in the SBU (color printing speed).

System SP Table-4

004	Latest: GO Color
	[0 to 255 / 128 / 1 digit] Displays the black offset value (fine adjustment) for the odd green signal in the SBU (color printing speed).
005	Latest: GE B/W
	[0 to 255 / 128 / 1 digit] Displays the black offset value (rough adjustment) for the even green signal in the SBU (black and white printing speed).
006	Latest: GO B/W
	[0 to 255 / 128 / 1 digit] Displays the black offset value (rough adjustment) for the odd green signal in the SBU (black and white printing speed).
007	Latest: GE B/W
	[0 to 255 / 128 / 1 digit] Displays the black offset value (fine adjustment) for the even red signal in the SBU (black and white printing speed).
008	Latest: GO B/W
	[0 to 255 / 128 / 1 digit] Displays the black offset value (fine adjustment) for the odd green signal in the SBU (black and white printing speed).

 Note

- GE: Green Even signal, GO: Green Odd signal

4625	Black Level Rough/Fine Adj. Display (CS model only)
001	Latest: BE Color
	[0 to 255 / 128 / 1 digit] Displays the black offset value (rough adjustment) for the even blue signal in the SBU (color printing speed).
002	Latest: BO Color
	[0 to 255 / 128 / 1 digit] Displays the black offset value (rough adjustment) for the odd blue signal in the SBU (color printing speed).
003	Latest: BE Color
	[0 to 255 / 128 / 1 digit] Displays the black offset value (fine adjustment) for the even blue signal in the SBU (color printing speed).
004	Latest: BO Color
	[0 to 255 / 128 / 1 digit] Displays the black offset value (fine adjustment) for the odd blue signal in the SBU (color printing speed).
005	Latest: BE B/W
	[0 to 255 / 128 / 1 digit] Displays the black offset value (rough adjustment) for the even blue signal in the SBU (black and white printing speed).
006	Latest: BO B/W
	[0 to 255 / 128 / 1 digit] Displays the black offset value (rough adjustment) for the odd blue signal in the SBU (black and white printing speed).

System SP Table-4

007	Latest: BE B/W
	[0 to 255 / 128 / 1 digit] Displays the black offset value (fine adjustment) for the even blue signal in the SBU (black and white printing speed).
008	Latest: BO B/W
	[0 to 255 / 128 / 1 digit] Displays the black offset value (fine adjustment) for the odd blue signal in the SBU (black and white printing speed).

 Note

- BE: Blue Even signal, BO: Blue Odd signal

4628	Gain Adjustment Display (CS model only)	
	Displays the gain value of the amplifiers on the controller for Red. Only for the color scanner	
001	Latest: RE Color	[0 to 255 / 0 / 1 digit]
002	Latest: RO Color	
003	Latest: RE B/W	
004	Latest: RO B/W	

4629	Gain Adjustment Display	
	Displays the gain value of the amplifiers on the controller for Green. SP4629-003 and -004 are used only for the color scanner model.	
001	Latest: GE Color	[0 to 255 / 0 / 1 digit]
002	Latest: GO Color	
003	Latest: GE B/W	
004	Latest: GO B/W	

4630	Gain Adjustment Display (CS model only)	
	Displays the gain value of the amplifiers on the controller for Blue.	
001	Latest: BE Color	[0 to 255 / 0 / 1 digit]
002	Latest: BO Color	
003	Latest: BE B/W	
004	Latest: BO B/W	

4640	SBU: Black Level Loop (CS model only)	
	Displays the black level adjustment time for each mode. The black level adjustment is done twice. The 1st adjustment decides the reference value for the 2nd adjustment.	
001	Loop Count (1st): Color	[0 to 20 / 0 / 1]
002	Loop Count (1st): B/W	
003	Loop Count (2nd): Color	
004	Loop Count (2nd): B/W	

4641	SBU: White Level Loop	
	Displays the white level adjustment time for each mode.	
001	Loop Count: Color	[0 to 20 / 0 / 1]
002	Loop Count: B/W	

System SP Table-4

4646	SBU: Time-out Error	
	Displays the result of the AGC adjustment.	
001	Black Level Adjustment 1	[0 to 1 / 0 / 1]
002	Black Level Adjustment 2	0:OK, 1: AGC adjustment failure
003	White Level Adjustment	[0 x 0000 to 0 x 003F / 0 / 1 Hex]
	Bit 0: Gain adjustment error (even) Bit 1: Gain adjustment error (odd) Bit 2: White level error (RE) Bit 3: White level error (RO) Bit 4: White level error (BE) Bit 5: White level error (BO)	

4647	SBU Error	
	Displays the result of the SBU connection check.	
	Power-On	[0 to 1 / 0 / 1] 0: OK, 1: SBU connection check failure If the SBU connection check fails, SC144-001, -002 or -003 occurs.

4654*	Black Level 1: Rough/Fine Adj. Display (CS model only)
001	Previous: RE Color
	[0 to 255 / 112 / 1 digit] Displays the previous black offset value (rough adjustment) for the even red signal in the SBU (color printing speed).
002	Previous: RO Color
	[0 to 255 / 112 / 1 digit] Displays the previous black offset value (rough adjustment) for the odd red signal in the SBU (color printing speed).
003	Previous: RE Color
	[0 to 255 / 128 / 1 digit] Displays the previous black offset value (fine adjustment) for the even red signal in the SBU (color printing speed).
004	Previous: RO Color
	[0 to 255 / 128 / 1 digit] Displays the previous black offset value (fine adjustment) for the odd red signal in the SBU (color printing speed).
005	Previous: RE B/W
	[0 to 255 / 112 / 1 digit] Displays the previous black offset value (rough adjustment) for the even red signal in the SBU (black and white printing speed).
006	Previous: RO B/W
	[0 to 255 / 112 / 1 digit] Displays the previous black offset value (rough adjustment) for the odd red signal in the SBU (black and white printing speed).

System SP Table-4

007	Previous: RE B/W
	[0 to 255 / 128 / 1 digit] Displays the previous black offset value (fine adjustment) for the even red signal in the SBU (black and white printing speed).
008	Previous: RO B/W
	[0 to 255 / 128 / 1 digit] Displays the previous black offset value (fine adjustment) for the odd red signal in the SBU (black and white printing speed).

↓ None

- RE: Red Even signal, RO: Red Odd signal

4655*	Black Level 1: Rough/Fine Adj. Display (CS model only)
001	Previous: GE Color
	[0 to 255 / 112 / 1 digit] Displays the previous black offset value (rough adjustment) for the even green signal in the SBU (color printing speed).
002	Previous: GO Color
	[0 to 255 / 112 / 1 digit] Displays the previous black offset value (rough adjustment) for the odd green signal in the SBU (color printing speed).
003	Previous: GE Color
	[0 to 255 / 128 / 1 digit] Displays the previous black offset value (fine adjustment) for the even green signal in the SBU (color printing speed).

004	Previous: GO Color
	[0 to 255 / 128 / 1 digit] Displays the previous black offset value (fine adjustment) for the odd green signal in the SBU (color printing speed).
005	Previous: GE B/W
	[0 to 255 / 112 / 1 digit] Displays the previous black offset value (rough adjustment) for the even green signal in the SBU (black and white printing speed).
006	Previous: GO B/W
	[0 to 255 / 112 / 1 digit] Displays the previous black offset value (rough adjustment) for the odd green signal in the SBU (black and white printing speed).
007	Previous: GE B/W
	[0 to 255 / 128 / 1 digit] Displays the previous black offset value (fine adjustment) for the even green signal in the SBU (black and white printing speed).
008	Previous: GO B/W
	[0 to 255 / 128 / 1 digit] Displays the previous black offset value (fine adjustment) for the odd green signal in the SBU (black and white printing speed).

 Note

- GE: Green Even signal, GO: Green Odd signal

System SP Table-4

4656*	Black Level 1: Rough/Fine Adj. Display (CS model only)
001	Previous: BE Color
	[0 to 255 / 112 / 1 digit] Displays the previous black offset value (rough adjustment) for the even blue signal in the SBU (color printing speed).
002	Previous: BO Color
	[0 to 255 / 112 / 1 digit] Displays the previous black offset value (rough adjustment) for the odd blue signal in the SBU (color printing speed).
003	Previous: BE Color
	[0 to 255 / 128 / 1 digit] Displays the previous black offset value (fine adjustment) for the even blue signal in the SBU (color printing speed).
004	Previous: BO Color
	[0 to 255 / 128 / 1 digit] Displays the previous black offset value (fine adjustment) for the odd blue signal in the SBU (color printing speed).
005	Previous: BE B/W
	[0 to 255 / 112 / 1 digit] Displays the previous black offset value (rough adjustment) for the even blue signal in the SBU (black and white printing speed).
006	Previous: BO B/W
	[0 to 255 / 112 / 1 digit] Displays the previous black offset value (rough adjustment) for the odd blue signal in the SBU (black and white printing speed).

007	Previous: BE B/W
	[0 to 255 / 128 / 1 digit] Displays the previous black offset value (fine adjustment) for the even blue signal in the SBU (black and white printing speed).
008	Previous: BO B/W
	[0 to 255 / 128 / 1 digit] Displays the previous black offset value (fine adjustment) for the odd blue signal in the SBU (black and white printing speed).

↓ Note

- BE: Blue Even signal, BO: Blue Odd signal

4658	Gain Adjustment Display (CS model only)	
	Displays the previous gain value of the amplifiers on the controller for Red.	
001	Previous: RE Color	[0 255 / 64 / 1 digit]
002	Previous: RO Color	
003	Previous: RE B/W	
004	Previous: RO B/W	

4659	Gain Adjustment Display	
	Displays the previous gain value of the amplifiers on the controller for Green. SP4659-003 and -004 are used only for the color scanner model.	
001	Previous: GE Color	[0 255 / 64 / 1 digit]
002	Previous: GO Color	
003	Previous: GE B/W	
004	Previous: GO B/W	

System SP Table-4

4660	Gain Adjustment Display (CS model only)	
	Displays the previous gain value of the amplifiers on the controller for Blue.	
001	Previous: BE Color	[0 255 / 64 / 1 digit]
002	Previous: BO Color	
003	Previous: BE B/W	
004	Previous: BO B/W	

4661*	Black Level 2: Rough/Fine Adj. Display (CS model only)	
001	Before Previous: RE Color	[0 to 255 / 112 / 1 digit] Displays the previous 2nd black offset value (rough adjustment) for the even red signal in the SBU (color printing speed).
	002	
002	[0 to 255 / 112 / 1 digit]	Displays the previous 2nd black offset value (rough adjustment) for the odd red signal in the SBU (color printing speed).
	003	
003	[0 to 255 / 128 / 1 digit]	Displays the previous 2nd black offset value (fine adjustment) for the even red signal in the SBU (color printing speed).
	004	
004	[0 to 255 / 128 / 1 digit]	Displays the previous 2nd black offset value (fine adjustment) for the odd red signal in the SBU (color printing speed).

005	Before Previous: RE B/W
	[0 to 255 / 112 / 1 digit] Displays the previous 2nd black offset value (rough adjustment) for the even red signal in the SBU (black and white printing speed).
006	Before Previous: RO B/W
	[0 to 255 / 112 / 1 digit] Displays the previous 2nd black offset value (rough adjustment) for the odd red signal in the SBU (black and white printing speed).
007	Before Previous: RE B/W
	[0 to 255 / 128 / 1 digit] Displays the previous 2nd black offset value (fine adjustment) for the even red signal in the SBU (black and white printing speed).
008	Before Previous: RO B/W
	[0 to 255 / 128 / 1 digit] Displays the previous 2nd black offset value (fine adjustment) for the odd red signal in the SBU (black and white printing speed).

 Note

- RE: Red Even signal, RO: Red Odd signal

System SP Table-4

4662*	Black Level 2: Rough/Fine Adj. Display (CS model only)
001	Before Previous: GE Color
	[0 to 255 / 112 / 1 digit] Displays the previous 2nd black offset value (rough adjustment) for the even green signal in the SBU (color printing speed).
002	Before Previous: GO Color
	[0 to 255 / 112 / 1 digit] Displays the previous 2nd black offset value (rough adjustment) for the odd green signal in the SBU (color printing speed).
003	Before Previous: GE Color
	[0 to 255 / 128 / 1 digit] Displays the previous 2nd black offset value (fine adjustment) for the even green signal in the SBU (color printing speed).
004	Before Previous: GO Color
	[0 to 255 / 128 / 1 digit] Displays the previous 2nd black offset value (fine adjustment) for the odd green signal in the SBU (color printing speed).
005	Before Previous: GE B/W
	[0 to 255 / 112 / 1 digit] Displays the previous 2nd black offset value (rough adjustment) for the even green signal in the SBU (black and white printing speed).
006	Before Previous: GO B/W
	[0 to 255 / 112 / 1 digit] Displays the previous 2nd black offset value (rough adjustment) for the odd green signal in the SBU (black and white printing speed).

007	Before Previous: GE B/W
	[0 to 255 / 128 / 1 digit] Displays the previous 2nd black offset value (fine adjustment) for the even green signal in the SBU (black and white printing speed).
008	Before Previous: GO B/W
	[0 to 255 / 128 / 1 digit] Displays the previous 2nd black offset value (fine adjustment) for the odd green signal in the SBU (black and white printing speed).

↓ Note

- GE: Green Even signal, GO: Green Odd signal

4663*	Black Level 2: Rough/Fine Adj. Display (CS model only)
001	Before Previous: BE Color
	[0 to 255 / 112 / 1 digit] Displays the previous 2nd black offset value (rough adjustment) for the even blue signal in the SBU (color printing speed).
002	Before Previous: BO Color
	[0 to 255 / 112 / 1 digit] Displays the previous 2nd black offset value (rough adjustment) for the odd blue signal in the SBU (color printing speed).
003	Before Previous: BE Color
	[0 to 255 / 128 / 1 digit] Displays the previous 2nd black offset value (fine adjustment) for the even blue signal in the SBU (color printing speed).

System SP Table-4

004	Before Previous: BO Color
	[0 to 255 / 128 / 1 digit] Displays the previous 2nd black offset value (fine adjustment) for the odd blue signal in the SBU (color printing speed).
005	Before Previous: BE B/W
	[0 to 255 / 112 / 1 digit] Displays the previous 2nd black offset value (rough adjustment) for the even blue signal in the SBU (black and white printing speed).
006	Before Previous: BO B/W
	[0 to 255 / 112 / 1 digit] Displays the previous 2nd black offset value (rough adjustment) for the odd blue signal in the SBU (black and white printing speed).
007	Before Previous: BE B/W
	[0 to 255 / 128 / 1 digit] Displays the previous 2nd black offset value (fine adjustment) for the even blue signal in the SBU (black and white printing speed).
008	Before Previous: BO B/W
	[0 to 255 / 128 / 1 digit] Displays the previous 2nd black offset value (fine adjustment) for the odd blue signal in the SBU (black and white printing speed).

 Note

- BE: Blue Even signal, BO: Blue Odd signal

4673	Black Level 2: Rough/Fine Adj. Display (CS model only)
001	Factory Setting: RE Color
	[0 to 255 / 0 / 1 digit] Displays the factory setting value of the 2nd black offset level rough adjustment for the even red signal in the SBU (color printing speed).
002	Factory Setting: RO Color
	[0 to 255 / 0 / 1 digit] Displays the factory setting values of the 2nd black offset level rough adjustment for the odd red signal in the SBU (color printing speed).
003	Factory Setting: RE Color
	[0 to 255 / 0 / 1 digit] Displays the factory setting values of the 2nd black offset level fine adjustment for the even red signal in the SBU (color printing speed).
004	Factory Setting: RO Color
	[0 to 255 / 0 / 1 digit] Displays the factory setting values of the 2nd black offset level fine adjustment for the odd red signal in the SBU (color printing speed).
005	Factory Setting: RE B/W
	[0 to 255 / 0 / 1 digit] Displays the factory setting values of the 2nd black offset level rough adjustment for the even red signal in the SBU (black and white printing speed).
006	Factory Setting: RO B/W
	[0 to 255 / 0 / 1 digit] Displays the factory setting values of the 2nd black offset level rough adjustment for the odd red signal in the SBU (black and white printing speed).

System SP Table-4

007	Factory Setting: RE B/W
	[0 to 255 / 0 / 1 digit] Displays the factory setting values of the 2nd black offset level fine adjustment for the even red signal in the SBU (black and white printing speed).
008	Factory Setting: RE B/W
	[0 to 255 / 0 / 1 digit] Displays the factory setting values of the 2nd black offset level fine adjustment for the odd red signal in the SBU (black and white printing speed).

 Note

- RE: Red Even signal, RO: Red Odd signal

4674	Black Level 2: Rough/Fine Adj. Display (CS model only)
001	Factory Setting: GE Color
	[0 to 255 / 0 / 1 digit] Displays the factory setting value of the 2nd black offset level rough adjustment for the even green signal in the SBU (color printing speed).
002	Factory Setting: GO Color
	[0 to 255 / 0 / 1 digit] Displays the factory setting values of the 2nd black offset level rough adjustment for the odd green signal in the SBU (color printing speed).
003	Factory Setting: GE Color
	[0 to 255 / 0 / 1 digit] Displays the factory setting values of the 2nd black offset level fine adjustment for the even green signal in the SBU (color printing speed).

004	Factory Setting: GO Color
	[0 to 255 / 0 / 1 digit] Displays the factory setting values of the 2nd black offset level fine adjustment for the odd green signal in the SBU (color printing speed).
005	Factory Setting: GE B/W
	[0 to 255 / 0 / 1 digit] Displays the factory setting values of the 2nd black offset level rough adjustment for the even green signal in the SBU (black and white printing speed).
006	Factory Setting: GO B/W
	[0 to 255 / 0 / 1 digit] Displays the factory setting values of the 2nd black offset level rough adjustment for the odd green signal in the SBU (black and white printing speed).
007	Factory Setting: GE B/W
	[0 to 255 / 0 / 1 digit] Displays the factory setting values of the 2nd black offset level fine adjustment for the even green signal in the SBU (black and white printing speed).
008	Factory Setting: GE B/W
	[0 to 255 / 0 / 1 digit] Displays the factory setting values of the 2nd black offset level fine adjustment for the odd green signal in the SBU (black and white printing speed).

Appendix:
Service
Program
Mode Tables

 Note

- GE: Green Even signal, GO: Green Odd signal

System SP Table-4

4675	Black Level 2: Rough/Fine Adj. Display (CS model only)
001	Factory Setting: BE Color
	[0 to 255 / 0 / 1 digit] Displays the factory setting value of the 2nd black offset level rough adjustment for the even blue signal in the SBU (color printing speed).
002	Factory Setting: BO Color
	[0 to 255 / 0 / 1 digit] Displays the factory setting values of the 2nd black offset level rough adjustment for the odd blue signal in the SBU (color printing speed).
003	Factory Setting: BE Color
	[0 to 255 / 0 / 1 digit] Displays the factory setting values of the 2nd black offset level fine adjustment for the even blue signal in the SBU (color printing speed).
004	Factory Setting: BO Color
	[0 to 255 / 0 / 1 digit] Displays the factory setting values of the 2nd black offset level fine adjustment for the odd blue signal in the SBU (color printing speed).
005	Factory Setting: BE B/W
	[0 to 255 / 0 / 1 digit] Displays the factory setting values of the 2nd black offset level rough adjustment for the even blue signal in the SBU (black and white printing speed).
006	Factory Setting: BO B/W
	[0 to 255 / 0 / 1 digit] Displays the factory setting values of the 2nd black offset level rough adjustment for the odd blue signal in the SBU (black and white printing speed).

007	Factory Setting: BE B/W
	[0 to 255 / 0 / 1 digit] Displays the factory setting values of the 2nd black offset level fine adjustment for the even blue signal in the SBU (black and white printing speed).
008	Factory Setting: BE B/W
	[0 to 255 / 0 / 1 digit] Displays the factory setting values of the 2nd black offset level fine adjustment for the odd blue signal in the SBU (black and white printing speed).

↓ Note

- BE: Blue Even signal, BO: Blue Odd signal

4677	Gain Adjustment Display	
	Displays the factory setting values of the gain adjustment for Red. SP4677-003 and -004 are used only for the color scanner model.	
001	Factory Setting: RE Color	[0 255 / 0 / 1 digit]
002	Factory Setting: RO Color	
003	Factory Setting: RE B/W	
004	Factory Setting: RO B/W	

System SP Table-4

4678	Gain Adjustment Display	
	Displays the factory setting values of the gain adjustment for Green. SP4678-003 and -004 are used only for the color scanner model.	
001	Factory Setting: GE Color	[0 255 / 0 / 1 digit]
002	Factory Setting: GO Color	
003	Factory Setting: GE B/W	
004	Factory Setting: GO B/W	

4679	Gain Adjustment Display (CS model only)	
	Displays the factory setting values of the gain adjustment for Blue.	
001	Factory Setting: BE Color	[0 255 / 0 / 1 digit]
002	Factory Setting: BO Color	
003	Factory Setting: BE B/W	
004	Factory Setting: BO B/W	

4685*	Gray Balance Setting:	
	Adjusts the gray balance of the red signal for each scanning mode.	
001	R Book Scan	CS: [-512 to 511 / -32 / 1 digit]
002	R DF Scan	MS: [-512 to 511 / 25 / 1 digit]

4686*	Gray Balance Setting:	
	Adjusts the gray balance of the green signal for each scanning mode.	
001	G Book Scan	CS: [-512 to 511 / -7 / 1 digit] MS: [-512 to 511 / 25 / 1 digit]
002	G DF Scan	

4687*	Gray Balance Setting:	
	Adjusts the gray balance of the blue signal for each scanning mode.	
001	B Book Scan	CS: [-512 to 511 / -14 / 1 digit] MS: [-512 to 511 / 25 / 1 digit]
002	B DF Scan	

4688*	DF: Density Adjustment	
	Adjusts the white shading parameter when scanning an image with the ARDF. Adjusts the density level if the ID of outputs made in the DF and Platen mode is different.	
	[50 to 150 / 100 / 1 %]	

4690	White Peak Level	
	Displays the peak level of the white level scanning.	
001	RE	[0 to 1023 / 0 / 1 digit]
002	RO	
003	RE: BK	
004	RO: BK	

System SP Table-4

4691	White Peak Level	
	Displays the peak level of the white level scanning.	
001	GE	[0 to 1023 / 0 / 1 digit]
002	GO	
003	GE: BK	
004	GO: BK	

4692	White Peak Level	
	Displays the peak level of the white level scanning.	
001	BE	[0 to 1023 / 0 / 1 digit]
002	BO	
003	BE: BK	
004	BO: BK	

4693	Black Peak Level	
	Displays the peak level of the black level scanning.	
001	RE	[0 to 1023 / 0 / 1 digit]
002	RO	
003	RE: BK	
004	RO: BK	

4694	Black Peak Level	
	Display the peak level of the black level scanning.	
001	GE	[0 to 1023 / 0 / 1 digit]
002	GO	
003	GE: BK	
004	GO: BK	

4695	Black Peak Level	
	Display the peak level of the black level scanning.	
001	BE	[0 to 1023 / 0 / 1 digit]
002	BO	
003	BE: BK	
004	BO: BK	

4802	DF Shading Free Run	
001	Lamp ON	[0 to 1 / 0 / 1]
002	Lamp OFF	Executes the scanner free run of the shading movement with exposure lamp on or off. Press "OFF" to stop this free run. Otherwise, the free run continues.

4803*	Home Position Adjustment (DFU)	[-1 to 1 / 0 / 0.1 mm]
001	Adjusts the home position of the exposure lamp.	

System SP Table-4

4804*	Returning to Scanner HP	<p>Moves the exposure lamp a short distance and immediately returns it to its home position.</p> <p>Touch [Execute] > "Completed" > [Exit]</p>
-------	-------------------------	--

4806	Moving from Scanner HP	
	<p>Moves the exposure lamp a short distance away from the home position and stops.</p> <p>Touch [Execute] > "Completed" > [Exit]</p> <p>Do SP4804 to return the exposure lamp to its home position.</p> <p> Note</p> <ul style="list-style-type: none"> ▪ This SP is done before shipping the machine to another location. ▪ Cycling the machine power off/on also returns the exposure lamp to its home position. 	

4903*	Filter Setting	
	<p>This SP code sets the threshold value for independent dot erase. These adjustments are effective only for the "Custom Setting" original type. The "0" setting disables independent dot erase. A higher setting detects more spurious dots for erasing. However, this could erase dots in images that contain areas filled by dithering.</p>	
	001 Independent Dot Erase: Text/Photo	[0 to 7 / 0 / 1]
002 Independent Dot Erase: Generation Copy		

4905*	Dither Selection	<p>Changes the parameters for dithering.</p> <p>[0 to 255 / 0 / 1]</p>
-------	------------------	---

4907	SBU Test Pattern Change	
	<p>[0 to 255 / 0 / 1]</p> <p>0: Default (Scanning Image)</p> <p>1: Grid pattern</p> <p>2: Gradation main scan</p> <p>3: Gradation sub scan</p> <p>4 to 250: Default (Scanning Image)</p>	

4908*	Factory Setting Input	
001	Execution: ON/OFF	
	Copies the settings of the previous black level adjustment and gain adjustment to the factory settings.	
002	Execution Flag	[0 to 1 / 0 / 1]
	Displays the execution flag of the factory setting input. "1" means that the scanner settings have been adjusted at the factory.	

4918	Manual Gamma Adjustment (DFU)	
	<p>Adjusts the offset data of the printer gamma for black in Photo mode or Letter mode.</p> <p>Touch [Change] to open the printer gamma screen.</p> <p>Enter the manual gamma adjustment screen.</p>	

System SP Table-4

4991	IPU Image Pass [Path] Selection (RGB Frame Memory) DFU	
	Selects the image path. Enter the number to be selected using the 10-key pad. [0 to 11 / 2/ 1]	
	0	Scanner input RGB images
	1	Scanner I/F RGB images
	2	RGB images done by Shading correction (Shading ON, Black offset ON)
	3	Shading data
	4	Inner pattern data: Gray scale
	5	RGB images done by Line skipping correction
	6	RGB images done by Digital AE
	7	RGB images done by Vertical line correction
	8	RGB image done by Scanner gamma correction
	9	RGB image done by Filtering correction
	10	RGB images done by Full color ADS
	11	RGB image done by Color correction

4993*	Highlight Correction	
001	Sensitivity Selection	Selects the Highlight correction level. [0 to 9 / 4 / 1 /step] 0: weakest sensitivity 9: strongest sensitivity
002	Range Selection	Selects the Highlight correction level. [0 to 9 / 4 / 1 /step] 0: weakest skew correction, 9: strongest skew correction

4994*	Text/Photo Detection Level Adj.	
	Selects the definition level between Text and Photo for high compression PDF.	
	High Compression PDF Setting	[0 to 2 / 1 / 1] 0: Text priority 1: Normal 2: Photo priority

Appendix:
Service
Program
Mode Tables

4.5 SYSTEM SP TABLE-5

4.5.1 SP5-XXX: MODE

5024*	mm/inch Display Selection	0: Europe/Asia (mm) 1: North America (inch)
	Selects the unit of measurement. After selection, turn the main power switch off and on.	

5045*	Accounting Counter	
	Counter Method	
	Selects whether the printer counter is displayed on the LCD. [0 to 1 / 0 / 1] 0: Displays total counter only. 1: Displays both total counter and printer counter.	

5047*	Paper Display	
	Turns on or off the printed paper display on the LCD. [0 to 1 / 0 / 1] 0: Not displayed, 1: Displayed	

5055*	Display IP Address	
	Display or does not display the IP address on the LCD. [0 to 1 / 0 / 1] 0: OFF, 1: ON	

5056*	Coverage Counter Display
	Display or does not display the coverage counter on the LCD. [0 to 1 / 0 / 1] 0: Not displayed, 1: Displayed
5061*	Toner Remaining Icon Display
	Display or does not display the remaining toner display icon on the LCD. [0 to 1 / 0 / 1] 0: Not display, 1: Display
5104*	A3/DLT Double Count (SSP)
	Specifies whether the counter is doubled for A3/DLT. "Yes" counts except from the bypass tray. When "Yes" is selected, A3 and DLT paper are counted twice, that is A4 x2 and LT x2 respectively.
5112*	Non-Std. Paper Sel.
	Determines whether a non-standard paper size can be input for each tray (Tray 1 to 4) [0 or 1 / 1 / -] 0: OFF 1: ON

System SP Table-5

5113*	Optional Counter Type
001	Default Optional Counter Type
	<p>Selects the type of counter:</p> <p>0: None</p> <p>1: Key Card (RK3, 4) Japan only</p> <p>2: Key Card Down</p> <p>3: Pre-paid Card</p> <p>4: Coin Rack</p> <p>5: MF Key Card</p> <p>11: Exp. Key Card (Add)</p> <p>12: Exp. Key Card (Deduct)</p>
002	External Optional Counter Type
	<p>Enables the SDK application. This lets you select a number for the external device for user access control.</p> <p>Note: "SDK" refers to software on an SD card.</p> <p>[0 to 3 / 0 / 1]</p> <p>0: None</p> <p>1: Expansion Device 1</p> <p>2: Expansion Device 2</p> <p>3: Expansion Device 3</p>
5114*	Optional Counter I/F
001	MF Key Card Extension
	<p>Use this SP and change the setting to "1" only when the "5" (MF Key Card) is selected with SP5113-001.</p> <p>[0: Not installed/ 1: Installed (scanning accounting)]</p>

5118*	Disable Copying
	Temporarily denies access to the machine. Japan Only [0 to 1 / 0 / 1] 0: Release for normal operation [Default] 1: Prohibit access to machine
5120*	Mode Clear Opt. Counter Removal
	Selects if mode clear is done for an optional counter when an optional counter is removed. 0 : Yes. (Always mode clear) 1: StandBy. (Mode clear before/after a job) 2: No. (No mode clear)
5121*	Counter Up Timing
	Determines whether the optional key counter counts up at paper feed-in or at paper exit. [0 to 1 / 0 / 1] 0 : Feed, 1: Exit
5126*	F Size Original Setting
	Selects F size original setting. [0 to 2 / 0 / 1 step] 0: 8 1/2 x 13 (Foolscap) 1: 8 1/4 x 13 (Folio) 2: 8 x 13 (F)

System SP Table-5

5127*	APS Off Mode
	<p>Selects whether the APS function is enabled or disabled with the contact of a pre-paid card or coin lock.</p> <p>0: Disable (APS active) [Default], 1: Enable (APS not active)</p>
5131*	Paper Size Type Selection
	<p>Selects the paper size (type) for both originals and copy paper.</p> <p>[0 to 2 / - / 1 step]</p> <p>0: Japan, 1: North America, 2: Europe</p> <p>After changing the setting, turn the copier off and on. If the paper size of the archive files stored on the HDD is different, abnormal copies could result.</p>
5150	Bypass Length Setting
	<p>Sets up the by-pass tray for long paper.</p> <p>[0 to 1 / 0 / 1]</p> <p>0: Off [Default]</p> <p>1: On. Sets the tray for feeding paper up to 600 mm long.</p> <p>With this SP selected on, paper jams are not detected in the paper path.</p>
5162*	App. Switch Method
	<p>Determines whether the application screen is switched with a hardware switch or software switch.</p> <p>0: Soft Key Set</p> <p>1: Hard Key Set</p>

5167*	Fax Printing Mode at Optional Counter Off	
	<p>Enables or disables the automatic print out without an accounting device. This SP is used when the receiving fax is accounted for by an external accounting device.</p> <p>0: Automatic printing 1: No automatic printing</p>	

5169*	CE Login	
	<p>If you will change the printer bit switches, you must 'log in' to service mode with this SP before you go into the printer SP mode.</p> <p>[0 to 1 / 0 / 1]</p> <p>0: Off. Printer bit switches cannot be adjusted. 1: On. Printer bit switches can be adjusted.</p>	

5179*	By-pass Tray Paper Size Error	[0 to 1 / 0 / 1] 0= OFF, 1= ON
	<p>This SP determines whether a paper size error prompt appears when the machine detects the wrong paper size for the job and during feed from the by-pass tray.</p>	

5181*	Paper Size Setting	
	Adjusts the paper size for each tray. [0 to 1 / - / 1]	
001	Tray 1: 1	0: A4 LEF, 1: LT LEF
002	Tray 1: 2	0: A3, 1: DLT
003	Tray 1: 3	0: B4, 1: LG
004	Tray 1: 4	0: B5 LEF, 1: Exe LEF
005	Tray 2: 1	0: A4 LEF, 1: LT LEF
006	Tray 2: 2	0: A3, 1: DLT

System SP Table-5

007	Tray 2: 3	0: B4, 1: LG
008	Tray 2: 4	0: B5 LEF, 1: Exe LEF
009	Tray 3: 1 (Tandem)	0: A4 LEF, 1: LT LEF
010	Tray 3: 2	0: A3, 1: DLT
011	Tray 3: 3	0: B4, 1: LG
012	Tray 3: 4	0: B5 LEF, 1: Exe LEF
013	Tray 4: 1	0: A4 LEF, 1: LT LEF
014	Tray 4: 2	0: A3, 1: DLT
015	Tray 4: 3	0: B4, 1: LG
016	Tray 4: 4	0: B5 LEF, 1: Exe LEF
017	LCT	[0 to 2 / - / 1] 0: A4 LEF, 1: LT LEF, 2: B5 LEF

5186*	RK4 Setting (Japan only)
	<p>Enable or distance the prevention for RK4 (Accounting device) Disconnection. If the RK4 is disconnected for 10 seconds when this SP is set to "1 (Enable)", the machine automatically jams a sheet of paper and stops.</p> <p>[0 to 1 / 0 / 1]</p>

5188*	Copy Nv Version
	Displays the NV version on the controller.

5195*	Limitless SW
	DFU

5212*	Page Numbering	
003	Duplex Printout Left/Right Position	Horizontally positions the page numbers printed on both sides during duplexing. [-10 to 10/ 0 / 1 mm] 0 is center, minus is left, + is right.
004	Duplex Printout High/Low Position	Vertically positions the page numbers printed on both sides during duplexing. [-10 to 10/ 0 / 1 mm] 0 is center, minus is down, + is up.

5302*	Set Time	
002	Sets the time clock for the local time. This setting is done at the factory before delivery. The setting is GMT expressed in minutes. [-1440 to 1440 / - / 1 min.] Japan: +540 (Tokyo) NA: -300 (NY) EU: +60 (Paris) CH: +480 (Peking) TW: +480 (Taipei) AS: +480 (Hong Kong) KO: +540 (Korea)	

System SP Table-5

5307	Summer Time	
001	Setting	<p>[0 to 1 / 1 (NA/EU), 0 (ASIA) / 1 /step]</p> <p>0: Disabled</p> <p>1: Enabled</p>
	<p>Enables or disables the summer time mode.</p> <p> Note</p> <ul style="list-style-type: none"> Make sure that both SP5-307-3 and -4 are correctly set. Otherwise, this SP is not activated even if this SP is set to "1". 	
003	Rule Set (Start)	
	<p>Specifies the start setting for the summer time mode.</p> <p>There are 8 digits in this SP. For months 1 to 9, the "0" cannot be input in the first digit, so the eight-digit setting for -2 or -3 becomes a seven-digit setting.</p> <p>1st and 2nd digits: The month. [1 to 12]</p> <p>3rd digit: The week of the month. [1 to 5]</p> <p>4th digit: The day of the week. [0 to 6 = Sunday to Saturday]</p> <p>5th and 6th digits: The hour. [00 to 23]</p> <p>7th digit: The length of the advanced time. [0 to 9 / 1 hour /step]</p> <p>8th digit: The length of the advanced time. [0 to 5 / 10 minutes /step]</p> <p>For example: 3500010</p> <p>The timer is advanced by 1 hour at am 0:00 on the 5th Sunday in March.</p> <p>The digits are counted from the left.</p> <p>Make sure that SP5-307-1 is set to "1".</p>	

004	Rule Set (End)
	<p>Specifies the end setting for the summer time mode. There are 8 digits in this SP. 1st and 2nd digits: The month. [1 to 12] 3rd digit: The week of the month. [0 to 5] 4th digit: The day of the week. [0 to 7 = Sunday to Saturday] 5th and 6th digits: The hour. [00 to 23] The 7th and 8 digits must be set to "00". The digits are counted from the left. Make sure that SP5-307-1 is set to "1".</p>

5401*	Access Control (DFU)	
	This SP stores the settings that limit uses access to SDK application data.	
103	Default Document ACL	
	<p>Whenever a new login user is added to the address book in external certification mode (for Windows, LDAP, RDH), the default document ACL is updated according to this SP setting. [0 to 3 / 0 / 1] 0: View 1: Edit 2: Edit/Delete 3: Full control Note: This SP setting is ignored on a machine that is not using document server.</p>	
162	Extend Certification Detail	<p>Selects the log out type for the extend authentication device. Bit 0: Log-out without an IC card 0: Not allowed (default) 1: Allowed</p>
200	SDK1 Unique ID	"SDK" is the "Software Development

Appendix:
Service
Program
Mode Tables

System SP Table-5

201	SDK1 Certification Method	Kit". This data can be converted from SAS (VAS) when installed or uninstalled. (DFU)
210	SDK2 Unique ID	
211	SDK2 Certification Method	
220	SDK3 Unique ID	
221	SDK3 Certification Method	
230	SDK certification device	
240	Detail Option	<p>Enables or disables the log out confirmation option.</p> <p>Bit 0: Log out confirmation option 0: Enable (default), 1: Disable</p> <p>Selects the automatic log out time.</p> <p>Bit 1 and 2: Automatic log out timer reduction 00: 60 seconds (default), 01: 10 seconds, 10: 20 seconds, 11: 30 seconds</p>
5404	User Code Count Clear	Clears the counts of the user codes assigned by the key operator to restrict the use of the machine. Press [Execute] to clear.

5411*	LDAP Certification	
004	Easy Certification	Turns simple authentication on or off for LDAP. [0 to 1 / 1 / 1] 0: OFF 1: ON
005	Password Null Not Permit	This SP is enabled only when SP5411-4 is set to "1" (ON). [0 to 1 / 0 / 1] 0: Password null is not permitted. 1: Password null is permitted.

5413	Lock Setting	
001	Lockout On/Off	[0 to 1 / 0 / 1] 0: OFF, 1:ON
	Turns on or off the account lock for the local address book account.	
002	Lockout Threshold	[1 to 10 / 5 / 1]
	Sets the maximum trial times for accessing the address book account.	
003	Cancellation On/Off	[0 to 1 / 0 / 1] 0: OFF (Lockout is not cancelled.) 1: ON (Lockout is cancelled if a user ID and password are correctly entered after the lockout function has been executed and a specific time has passed.)
	Turns on or off the cancellation function of the account lockout.	
004	Cancellation Time	[1 to 9999 / 60 / 1 min]
	Sets the interval of the retry for accessing the local address book account after the lockout function has been executed. This setting is enabled only if SP5413-3 is set to "1" (ON).	
005	Counter Clear Time	Not Used

System SP Table-5

5414	Access Mitigation	
001	Mitigation ON / OFF	
	Permits or does not permit consecutive access to the machine with the same ID and password. [0 to 1 / 0 / 1] 0: OFF (Permitted) 1: ON (Not permitted)	
002	Mitigation Time	
	Sets the prohibiting time for consecutive access to the machine with the same ID and password. [0 to 60 / 15 / 1 min]	

5415*	Password Attack	
001	Permissible Number	[0 to 100 / 30 / 1 times]
	Sets the threshold number of attempts to attack the system with random passwords to gain illegal access to the system.	
002	Detect Time	[0 to 10 / 5 / 1 sec]
	Sets a detection time to count a password attack.	

5416*	Access Information	
001	Access User Max Num	[50 to 200 / 200 / 1]
	Sets the number of users for the access exclusion and password attack detection function.	
002	Access Password Num	[50 to 200 / 200 / 1]
	Sets the number of passwords for the access exclusion and password attack detection function.	

003	Monitor interval	[1 to 10 / 3 / 1 sec]
	Sets the interval of watching out for user information and passwords.	

5417	Access Attack	
001	Access Permissible number	[0 to 500 / 100 / 1]
	Sets a limit on access attempts to prevent password cracking.	
002	Access Detect Time	[10 to 30 / 10 / 1 sec]
	Sets a detection time to count password cracking.	
003	Productivity Fall Weight	[0 to 9 / 3 / 1 sec]
	Sets the wait time to slow down the speed of certification when an excessive number of access attempts have been detected.	
004	Attack Max Num	[50 to 200 / 200 / 1]
	Sets a limit on the number of requests received for certification in order to slow down the certification speed when an excessive number of access attempts have been detected.	

5420	User Authentication	
	<p>These settings should be done with the System Administrator.</p> <p> Note</p> <ul style="list-style-type: none"> These functions are enabled only after the user access feature has been enabled. 	
001	Copy	[0 or 1 / 0 / 1] 0: ON. 1: OFF Determines whether certification is required before a user can use the copy application.
011	Document Server	[0 or 1 / 0 / 1] 0: ON. 1: OFF Determines whether certification is required before a user can use the document server.

System SP Table-5

021	Fax	[0 or 1/ 0 / 1] 0: ON. 1: OFF Determines whether certification is required before a user can use the fax application.
031	Scanner	[0 or 1/ 0 / 1] 0: ON. 1: OFF Determines whether certification is required before a user can use the scanner application.
041	Printer	[0 or 1/ 0 / 1] 0: ON. 1: OFF Determines whether certification is required before a user can use the printer application.
051	SDK1	[0 or 1/ 0 / 1] 0: ON. 1: OFF Determines whether certification is required before a user can use the SDK application.
061	SDK2	
071	SDK3	

5481	Authentication Error Code	
	These SP codes determine how the authentication failures are displayed.	
001	System Log Disp	[0 or 1 / 0 / -] 0: OFF [Default], 1: ON Determines whether an error code appears in the system log after a user authentication failure occurs.
002	Panel Disp	[0 or 1 / 1 / 1] 0: OFF, 1: ON [Default] Determines whether an error code appears on the operation panel after a user authentication failure occurs.

5490	MF Key Card (Japan only)
	<p>Sets up operation of the machine with a keycard.</p> <p>[0 to 1 / 0 / 1]</p> <p>0: Disabled. Cancels operation without a user code.</p> <p>1: Enabled. Allows operation without a user code.</p>

5501*	PM Alarm
001	PM Alarm Interval
	<p>Sets the PM alarm interval.</p> <p>[0 to 9999 / 0 / 1 k copies/step]</p> <p>0: No PM alarm</p>
002	Original Count Alarm (DFU)
	<p>Selects whether the PM alarm for the number of scans is enabled or not.</p> <p>If this is "1", the PM alarm function is enabled.</p> <p>[0 = No / 1 = Yes]</p>

5504*	Jam Alarm
	<p>Sets the alarm to sound for the specified jam level (document misfeeds are not included).</p> <p>[0 to 3 / 3 / 1 step]</p> <p>0: Zero (Off)</p> <p>1: Low (2.5K jams)</p> <p>2: Medium (3K jams)</p> <p>3: High (6K jams)</p>

System SP Table-5

5505*	Error Alarm	
	<p>Sets the number of sheets to clear the error alarm counter.</p> <p>The error alarm counter counts "1" when any SC is detected. However, the error alarm counter decreases by "1" when an SC is not detected during a set number of copied sheets (for example, default 5000 (C1b) or 10000 (C1c) sheets). The error alarm occurs when the SC error alarm counter reaches "5".</p> <p>[0 to 255 / 50 (C1b/C1.5b), 100 (C1c/C1.5c) / 100 copies / step]</p>	

5507*	Supply Alarm	
001	Paper supply Alarm (0:Off 1:On)	<p>Switches the control call on/off for the paper supply. (DFU)</p> <p>0: Off, 1: On</p> <p>0: No alarm.</p> <p>1: Sets the alarm to sound for the specified number transfer sheets for each paper size (A3, A4, B4, B5, DLT, LG, LT, HLT)</p>
002	Staple Supply Alarm (0:Off 1:On)	<p>Switches the control call on/off for the stapler installed in the finisher. (DFU)</p> <p>0: Off, 1: On</p> <p>0: No alarm</p> <p>1: Alarm goes off for every 1K of staples used.</p>
003	Toner Supply Alarm (0:Off 1:On)	<p>Switches the control call on/off for the toner end. (DFU)</p> <p>0: Off, 1: On</p> <p>If you select "1" the alarm will sound when the copier detects toner end.</p>
128	Interval: Others	<p>The "Paper Supply Call Level: nn" SPs specify the paper control call interval for the referenced paper sizes. (DFU)</p> <p>[250 to 10000 / 1000 / 1 Step]</p>
132	Interval: A3	

133	Interval: A4	
134	Interval: A5	
141	Interval: B4	
142	Interval: B5	
160	Interval: DLT	
164	Interval: LG	
166	Interval: LT	
172	Interval: HLT	

5508	CC Call	
001	Jam Remains	Enables/disables initiating a call. [0 to 1 / 1 / 1] 0: Disable 1: Enable
002	Continuous Jams	
003	Continuous Door Open	
011	Jam Detection: Time Length	Sets the length of time to determine the length of an unattended paper jam. [3 to 30 / 10 / 1 minute]
012	Jam Detection Continuous Count	Sets the number of continuous paper jams required to initiate a call. [2 to 10 / 5 / 1 time]
013	Door Open: Time Length	Sets the length of time the remains opens to determine when to initiate a call. [3 to 30/ 10 / 1 minute]

System SP Table-5

	SC/Alarm Setting	
5515*	With @Remote in use, these SP codes can be set to issue an SC call when an SC error occurs. If this SP is switched off, the SC call is not issued when an SC error occurs.	
001	SC Call	[0 or 1 / 1 / 1] 0: OFF 1: ON
002	Service Parts Near End Call	
003	Service Parts End Call	
004	User Call	
006	Communication Information Test Call	[0 or 1 / 1 / 1] 0: OFF 1: ON
007	Machine Information Notice	
008	Alarm Notice	
009	Non Genuine Toner Alarm	
010	Supply Automatic Ordering Call	
011	Supply Management Report Call	
012	Jam/Door Open Call	

5801	Memory Clear	
	<p>Resets NVRAM data to the default settings. Before executing any of these SP codes, print an SMC Report.</p> <p>IMPORTANT NOTE:</p> <p>The following data stored in the NVRAM will not be saved on the SD Card when performing an NVRAM Data Upload (SP5824):</p> <ul style="list-style-type: none"> • Total count categories (SP7-003-***Copy Counter) • C/O P/O Counter (SP7-006-*** C/O, P/O Count Display) • Duplex, A3/DLT/Over 420mm, Stapler and Scanner application scanning counters(system settings). • Engine SP Data <p>Therefore, whenever an NVRAM Upload/Download is performed, make sure to print out the SP Data List before performing SP5801-001 (Memory Clear) or SP5801-002 (Memory Clear: Engine).</p>	
001	All Clear	Initializes items 2 to 15 below.
002	Engine Clear	Initializes all registration settings for the engine and copy process settings.
003	SCS	Initializes default system settings, SCS (System Control Service) settings, operation display coordinates, and ROM update information.
004	IMH Memory Clear	Initializes the image file system. (IMH: Image Memory Handler)
005	MCS	Initializes the automatic delete time setting for stored documents. (MCS: Memory Control Service)
006	Copier application	Initializes all copier application settings.
007	Fax application	Initializes the fax reset time, job login ID, all TX/RX settings, local storage file numbers, and off-hook timer.

System SP Table-5

008	Printer application	Initializes the printer defaults, programs registered, the printer SP bit switches, and the printer CSS counter.
009	Scanner application	Initializes the defaults for the scanner and all the scanner SP modes.
010	Web Service/Network application	Deletes the Netfile (NFA) management files and thumbnails, and initializes the Job login ID. Netfiles: Jobs to be printed from the document server using a PC and the DeskTopBinder software

011	NCS	Initializes the system defaults and interface settings (IP addresses also), the SmartDeviceMonitor for Admin settings, WebStatusMonitor settings, and the TELNET settings. (NCS: Network Control Service)
012	R-FAX	Initializes the job login ID, SmartDeviceMonitor for Admin, job history, and local storage file numbers.
014	Clear DCS Setting	Initializes the DCS (Delivery Control Service) settings.
015	Clear UCS Setting	Initializes the UCS (User Information Control Service) settings.
016	MIRS Setting	Initializes the MIRS (Machine Information Report Service) settings.
017	CCS	Initializes the CCS (Certification and Charge-control Service) settings.
018	SRM Memory Clear	Initializes the SRM (System Resource Manager) settings.
019	LCS Clear	Initializes the LCS (Log Count Service) settings.
020	Web Uapli	Initializes the web user application settings.
021	ECS	Initializes the ECS settings.

System SP Table-5

5802*	Free Run	
	<p>Performs a free run on the copier engine.</p> <p>The correct paper should be loaded in the 1st tray or 2nd tray, but paper is not fed.</p> <p>The main switch has to be turned off and on after using the free run mode for a test.</p>	
001	TRAY1:A4LEF	-
002	TRAY2:A3	-
003	TRAY2:A4SEF	-

5803	Input Check	
	<p>Displays the signals received from sensors and switches.</p> <p>( p.4-236 "Input Check")</p>	

5804	Output Check	
	<p>Turns on the electrical components individually for test purposes. ( p.4-249 "Output Check")</p>	

5810	SC Reset	
	Fusing SC Reset	<p>Resets all level A service call conditions, such as fusing errors. To clear the service call, touch "Execute" on the LCD, then turn the main power switch off/on.</p>

5811*	Machine No. Setting (DFU)	Code Set
	<p>This SP presents the screen used to enter the 11-digit number of the machine. The allowed entries are "A" to "Z" and "0" to "9". The setting is done at the factory, and should not be changed in the field.</p>	

5812*	Service Tel. No. Setting	
001	Service	Inputs the telephone number of the CE (displayed when a service call condition occurs.)
002	Facsimile	Use this to input the fax number of the CE printed on the Counter Report (UP mode).
003	Supply	Inputs the telephone number of the supplier displayed on the user mode screen.
004	Operation	Allows the service center contact telephone number to be displayed on the user mode screen.

5816	Remote Service	
	I/F Setting	
001		Selects the remote service setting. [0 to 2 / 2 / 1 /step] 0: Remote service off 1: CSS remote service on 2: @Remote service on
	CE Call	
002		Performs the CE Call at the start or end of the service. [0 or 1 / 0 / 1 /step] 0: Start of the service 1: End of the service NOTE: This SP is activated only when SP 5816-001 is set to "2".

System SP Table-5

	Function Flag
003	<p>Enables or disables the remote service function.</p> <p>[0 to 1 / 0 / 1 /step]</p> <p>0: Disabled, 1: Enabled</p> <p>NOTE: This SP setting is changed to "1" after @Remote registor has been completed.</p>
	SSL Disable
007	<p>Uses or does not use the RCG certification by SSL when calling the RCG.</p> <p>[0 to 1 / 0 / 1 /step]</p> <p>0: Uses the RCG certification</p> <p>1: Does no use the RCG certification</p>
	RCG Connect Timeout
008	<p>Specifies the connect timeout interval when calling the RCG.</p> <p>[1 to 90 / 30 / 1 second /step]</p>
	RCG Write Timeout
009	<p>Specifies the write timeout interval when calling the RCG.</p> <p>[1 to 100 / 60 / 1 second /step]</p>
	RCG Read Timeout
010	<p>Specifies the read timeout interval when calling the RCG.</p> <p>[1 to 100 / 60 / 1 second /step]</p>
	Port 80 Enable
011	<p>Enables/disables access via port 80 to the SOAP method.</p> <p>[0 or 1 / 0 / -]</p> <p>0: Disabled, 1: Enabled</p>

	RFU (Remote Firmware Update) Timing
013	<p>Selects the RFU timing.</p> <p>[0 or 1 / 1 / –]</p> <p>0: RFU is executed whenever update request is received.</p> <p>1: RFU is executed only when the machine is in the sleep mode.</p>
	RCG – C Registered
021	<p>This SP displays the Embedded RC Gate installation end flag.</p> <p>0: Installation not completed</p> <p>1: Installation completed</p>
	RCG – C Regist Detail
022	<p>This SP displays the Embedded RC Gate installation status.</p> <p>0: RCG device not registered</p> <p>1: RCG device registered</p> <p>2: Device registered</p>
	Connect Type (N/M)
023	<p>This SP displays and selects the Embedded RC Gate connection method.</p> <p>[0 or 1 / 0 / 1 /step</p> <p>0: Internet connection</p> <p>1: Dial-up connection</p>
	Cert. Expire Timing DFU
061	Proximity of the expiration of the certification.
	Use Proxy
062	This SP setting determines if the proxy server is used when the machine communicates with the service center.

System SP Table-5

063	<p>Proxy Host</p> <p>This SP sets the address of the proxy server used for communication between Embedded RC Gate-N and the gateway. Use this SP to set up or display the customer proxy server address. The address is necessary to set up Embedded RC Gate-N.</p> <p> Note</p> <ul style="list-style-type: none"> ▪ The address display is limited to 128 characters. Characters beyond the 128 character are ignored. ▪ This address is customer information and is not printed in the SMC report.
064	<p>Proxy Port Number</p> <p>This SP sets the port number of the proxy server used for communication between Embedded RC Gate-N and the gateway. This setting is necessary to set up Embedded RC Gate-N.</p> <p> Note</p> <ul style="list-style-type: none"> ▪ This port number is customer information and is not printed in the SMC report.
065	<p>Proxy User Name</p> <p>This SP sets the HTTP proxy certification user name.</p> <p> Note</p> <ul style="list-style-type: none"> ▪ The length of the name is limited to 31 characters. Any character beyond the 31st character is ignored. ▪ This name is customer information and is not printed in the SMC report.
066	<p>Proxy Password</p> <p>This SP sets the HTTP proxy certification password.</p> <p> Note</p> <ul style="list-style-type: none"> ▪ The length of the password is limited to 31 characters. Any character beyond the 31st character is ignored. ▪ This name is customer information and is not printed in the SMC report.

067	CERT: Up State	
	Displays the status of the certification update.	
	0	The certification used by Embedded RC Gate is set correctly.
	1	The certification request (setAuthKey) for update has been received from the GW URL and certification is presently being updated.
	2	The certification update is completed and the GW URL is being notified of the successful update.
	3	The certification update failed, and the GW URL is being notified of the failed update.
	4	The period of the certification has expired and new request for an update is being sent to the GW URL.
	11	A rescue update for certification has been issued and a rescue certification setting is in progress for the rescue GW connection.
	12	The rescue certification setting is completed and the GW URL is being notified of the certification update request.
	13	The notification of the request for certification update has completed successfully, and the system is waiting for the certification update request from the rescue GW URL.
	14	The notification of the certification request has been received from the rescue GW controller, and the certification is being stored.
15	The certification has been stored, and the GW URL is being notified of the successful completion of this event.	

System SP Table-5

	16	The storing of the certification has failed, and the GW URL is being notified of the failure of this event.
	17	The certification update request has been received from the GW URL, the GW URL was notified of the results of the update after it was completed, but a certification error has been received, and the rescue certification is being recorded.
	18	The rescue certification of No. 17 has been recorded, and the GW URL is being notified of the failure of the certification update.

068	CERT: Error	
	Displays a number code that describes the reason for the request for update of the certification.	
	0	Normal. There is no request for certification update in progress.
	1	Request for certification update in progress. The current certification has expired.
	2	An SSL error notification has been issued. Issued after the certification has expired.
	3	Notification of shift from a common authentication to an individual certification.
	4	Notification of a common certification without ID2.
	5	Notification that no certification was issued.
6	Notification that GW URL does not exist.	
069	CERT: Up ID	The ID of the request for certification.
083	Firmware Up Status	Displays the status of the firmware update.
084	Non-HDD Firm Up	This setting determines if the firmware can be updated, even without the HDD installed. 0: Not allowed update 1: Allowed update
085	Firm Up User Check	This SP setting determines if the operator can confirm the previous version of the firmware before the firmware update execution. If the option to confirm the previous version is selected, a notification is sent to the system manager and the firmware update is done with the firmware files from the URL.

System SP Table-5

086	Firmware Size	Allows the service technician to confirm the size of the firmware data files during the firmware update execution.
087	CERT: Macro Ver.	Displays the macro version of the @Remote certification.
088	CERT: PAC Ver.	Displays the PAC version of the @Remote certification.
089	CERT: ID2 Code	Displays ID2 for the @Remote certification. Spaces are displayed as underscores (_). Asterisks (*) indicate that no @Remote certification exists. "000000_____" indicates "Common certification".
090	CERT: Subject	Displays the common name of the @Remote certification subject. CN = the following 17 bytes. Spaces are displayed as underscores (_). Asterisks (*) indicate that no @Remote certification exists. "000000_____" indicates "Common certification".
091	CERT: Serial No.	Displays serial number for the @Remote certification. Asterisks (*) indicate that no @Remote certification exists.
092	CERT: Issuer	Displays the common name of the issuer of the @Remote certification. CN = the following 30 bytes. Asterisks (*) indicate that no @Remote certification exists.
093	CERT: Valid Start	Displays the start time of the period for which the current @Remote certification is enabled.

094	CERT: Valid End	Displays the end time of the period for which the current @Remote certification is enabled.
150	Selection Country	
	Not used	
151	Line Type Automatic Judgment	
	Not used	
152	Line Type Judgment Result	
	Not used	
153	Selection Dial/Push	
	Not used	
154	Outside Line/Outgoing Number	
	Not used	
156	Dial Up User Name	
	Not used	
157	Dial Up Password	
	Not used	
161	Local Phone Number	
	Not used	
162	Connection Timing Adjustment: Incoming	
	Not used	
163	Access Point	
	Not used	

System SP Table-5

164	Line Connecting		
	Not used		
173	Modem Serial Number	Not used	
174	Retransmission Limit		
	Not used		
187	FAX TX Priority	-	
	Not used		
200	Manual Polling	-	Not used
201	Regist: Status		
	<p>Displays a number that indicates the status of the @Remote service device.</p> <p>0: Neither the @Remote device nor Embedded RCG Gate is set.</p> <p>1: The Embedded RCG Gate is being set. Only Box registration is completed. In this status, @Remote device cannot communicate with this device.</p> <p>2: The Embedded RCG Gate is set. In this status, the @Remote device cannot communicate with this device.</p> <p>3: The @Remote device is being set. In this status the Embedded RCG Gate cannot be set.</p> <p>4: The @Remote module has not started.</p>		
202	Letter Number	Allows entry of the request number needed for the Embedded RCG Gate.	
203	Confirm Execute	Executes the confirmation request to the @Remote Gateway.	

204	Confirm Result	
	<p>Displays a number that indicates the result of the confirmation executed with SP5816-203.</p> <p>0: Succeeded 1: Confirmation number error 2: Registration in progress 3: Proxy error (proxy enabled) 4: Proxy error (proxy disabled) 5: Proxy error (Illegal user name or password) 6: Communication error 7: Certification update error 8: Other error 9: Confirmation executing</p>	
205	<p>Confirm Place</p> <p>Displays the result of the notification sent to the device from the Gateway in answer to the confirmation request. Displayed only when the result is registered at the Gateway.</p>	
206	Register Execute	Executes "Embedded RCG Registration".
207	<p>Register Result</p> <p>Displays a number that indicates the registration result.</p> <p>0: Succeeded 2: Registration in progress 3: Proxy error (proxy enabled) 4: Proxy error (proxy disabled) 5: Proxy error (Illegal user name or password) 6: Communication error 7: Certification update error 8: Other error 9: Registration executing</p>	

Appendix:
Service
Program
Mode Tables

System SP Table-5

208	Error Code		
	Displays a number that describes the error code that was issued when either SP5816-204 or SP5816-207 was executed.		
	Cause	Code	Meaning
	Illegal Modem Parameter	-11001	Chat parameter error
		-11002	Chat execution error
		-11003	Unexpected error
Operation Error, Incorrect Setting	-12002	Inquiry, registration attempted without acquiring device status.	
	-12003	Attempted registration without execution of an inquiry and no previous registration.	
	-12004	Attempted setting with illegal entries for certification and ID2.	
	-12005	@Remote communication is prohibited. The device has an Embedded RC gate-related problem.	
	-12006	A confirmation request was made after the confirmation had been already completed.	
	-12007	The request number used at registration was different from the one used at confirmation.	
	-12008	Update certification failed because mainframe was in use.	

		-2385	Attempted dial up overseas without the correct international prefix for the telephone number.
	Error Caused by Response from GW URL	-2387	Not supported at the Service Center
		-2389	Database out of service
		-2390	Program out of service
		-2391	Two registrations for same device
		-2392	Parameter error
		-2393	RCG device not managed
		-2394	Device not managed
		-2395	Box ID for RCG device is illegal
		-2396	Device ID for RCG device is illegal
		-2397	Incorrect ID2 format
		-2398	Incorrect request number format
209	Instl Clear	Releases the machine from its Embedded RCG Gate setup. NOTE: Turn off and on the main power switch after this setting has been changed.	
250	CommLog Print	Prints the communication log.	

System SP Table-5

5821*	Remote Service Address	
001	CSS PI Device Code	Sets the PI device code. After you change this setting, you must turn the machine off and on.
002	RCG IP Address	Sets the IP address of the RCG (Remote Communication Gate) destination for call processing at the remote service center. [00000000h to FFFFFFFFh / - / 1]

5824	NVRAM Data Upload	
	<p>Uploads the NVRAM data to an SD card. Push Execute.</p> <p>Note: When uploading data in this SP mode, the front door must be open.</p> <p>IMPORTANT NOTE:</p> <p>The following data stored in the NVRAM will not be saved on the SD Card when performing an NVRAM Data Upload (SP5824):</p> <ul style="list-style-type: none"> • Total count categories (SP7-003-***Copy Counter) • C/O P/O Counter (SP7-006-*** C/O, P/O Count Display) • Duplex, A3/DLT/Over 420mm, Stapler and Scanner application scanning counters(system settings). • Engine SP Data <p>Therefore, whenever an NVRAM Upload/Download is performed, make sure to print out the SP Data List before performing SP5801-001 (Memory Clear) or SP5801-002 (Memory Clear: Engine).</p>	

5825	NVRAM Data Download	
	<p>Downloads data from an SD card to the NVRAM in the machine. After downloading is completed, remove the card and turn the machine power off and on.</p>	

5828	Network Setting	
050	1284 Compatibility (Centro)	<p>Enables and disables bi-directional communication on the parallel connection between the machine and a computer.</p> <p>[0 to 1 / 1 / 1]</p> <p>0:Off, 1: On</p>
052	ECP (Centro)	<p>Disables and enables the ECP feature (1284 Mode) for data transfer.</p> <p>[0 to 1 / 1 / 1]</p> <p>0: Disabled, 1: Enabled</p>

System SP Table-5

065	Job Spooling	Switches the job spooling on and off. [0 to 1 / 0 / 1] 0: No spooling, 1: Spooling enabled	
066	Job Spooling Clear: Start Time	This SP determines whether the job interrupted at power off is resumed at the next power on. This SP operates only when SP5828-065 is set to "1". [0 to 1 / 1 / 1] 1: Resumes printing spooled job. 0: Clears spooled job.	
069	Job Spooling (Protocol)	This SP determines whether job spooling is enabled or disabled for each protocol. This is a 8-bit setting. [0 to 1 / 1 / 1] 0: No spooling, 1: Spooling enabled	
	0	LPR	4 BMLinks (Japan Only)
	1	FTP (Not Used)	5 DIPRINT
	2	IPP	6 Reserved (Not Used)
	3	SMB	7 Reserved (Not Used)
090	TELNET (0:OFF 1:ON)	Disables or enables Telnet operation. If this SP is disabled, the Telnet port is closed. [0 to 1 / 1 / 1] 0: Disable, 1: Enable	
091	Web (0:OFF 1:ON)	Disables or enables the Web operation. [0 to 1 / 1 / 1] 0: Disable, 1: Enable	

145	Active IPv6 Link Local Address	<p>This is the IPv6 local address referenced on the Ethernet or wireless LAN (802.11) in the format: "Link-Local address" + "Prefix Length"</p> <p>The IPv6 address consists of a total 128 bits configured in 8 blocks of 16 bits each. These notations can be abbreviated. See "Note: IPV6 Addresses " below this table.</p>
147	Active IPv6 Stateless Address 1	<p>These SPs are the IPv6 stateless addresses (1 to 5) referenced on the Ethernet or wireless LAN (802.11b) in the format: "Stateless Address" + "Prefix Length"</p> <p>The IPv6 address consists of a total 128 bits configured in 8 blocks of 16 bits each.</p>
149	Active IPv6 Stateless Address 2	
151	Active IPv6 Stateless Address 3	

System SP Table-5

153	Active IPv6 Stateless Address 4	
155	Active IPv6 Stateless Address 5	
156	IPv6 Manual Address	<p>This SP is the IPv6 manually set address referenced on the Ethernet or wireless LAN (802.11) in the format: "Manual Set Address" + "Prefix Length" The IPv6 address consists of a total 128 bits configured in 8 blocks of 16 bits each. These notations can be abbreviated. See "Note: IPV6 Addresses" below this table.</p>
	IPv6 Gateway	
158	<p>This SP is the IPv6 gateway address referenced on the Ethernet or wireless LAN (802.11). The IPv6 address consists of a total 128 bits configured in 8 blocks of 16 bits each. These notations can be abbreviated. See "Note: IPV6 Addresses" below this table.</p>	
<p>Note: IPV6 Addresses Ethernet and the Wireless LAN (802.11) reference the IPV6 "Link-Local address + Prefix Length". The IPV6 address consists of 128 bits divided into 8 blocks of 16 bits: aaaa:bbbb:cccc:dddd:eeee:ffff:gggg:hhhh: The prefix length is inserted at the 17th byte (Prefix Range: 0x0 to 0x80). The initial setting is 0x40 (64). For example, the data: "2001123456789012abcdef012345678940h" is expressed: "2001:1234:5678:9012:abcd:ef01:2345:6789": prefixlen 64 However, the actual IPV6 address display is abbreviated according to the following rules.</p>		
<p>Rules for Abbreviating IPV6 Addresses</p> <ol style="list-style-type: none"> The IPV6 address is expressed in hexadecimal delimited by colons (:) with the following characters: 0123456789abcdefABCDEF A colon is inserted as a delimiter every 4th hexadecimal character. fe80:0000:0000:0000:0207:40ff:0000:340e 		

<p>3. The notations can be abbreviated by eliminating zeros where the MSB and digits following the MSB are zero. The example in "2" above, then, becomes fe80:0:0:0207:40ff:0:340e</p> <p>4. Sections where only zeros exist can be abbreviated with double colons (::). This abbreviation can be done also where succeeding sections contain only zeros (but this can be done only at one point in the address). The example in "2" and "3" above then becomes: fe80::207:40ff:0:340e (only the first null sets zero digits are abbreviated as "::") -or- fe80:0:0:0:207:40ff::340e (only the last null set before "340e" is abbreviated as "::")</p>		
161	IPv6 Stateless Auto Setting	<p>Enable or disables the automatic setting for IPv6 stateless. [0 or 1 / 1 / 1] 1: Enable, 0: Disable</p>
236	Web Item visible	
	<p>Displays or does not display the Web system items. [0 x 0000 to 0 x ffff / 0 x ffff] 0: Not displayed, 1: Displayed bit0: Net RICOH bit1: Consumable Supplier bit2-15: Reserved (all)</p>	
237	Web shopping link visible	
	<p>Displays or does not display the link to Net RICOH on the top page and link page of the web system. [0 to 1 / 1 / 1] 0: Not display, 1:Display</p>	
238	Web supplies Link visible	
	<p>Displays or does not display the link to Consumable Supplier on the top page and link page of the web system. [0 to 1 / 1 / 1] 0: Not display, 1:Display</p>	
239	Web Link1 Name	

System SP Table-5

	This SP confirms or changes the URL1 name on the link page of the web system. The maximum characters for the URL name are 31 characters.	
240	Web URL	
	his SP confirms or changes the link to URL1 on the link page of the web system. The maximum characters for the URL are 127 characters.	
241	Web visible	
	Displays or does not display the link to URL1 on the top page of the web system. [0 to 1 / 1 / 1] 0: Not display, 1:Display	
242	Web Link2 Name	Same as "-239"
243	Web Link2 URL	Same as "-240"
244	Web Link2 visible	Same as "-241"

5831	Initial Setting Clear DFU	
002	Copier up application	
	Clears the initial setting of copier.	

5832	HDD Formatting	
	Enter the SP number for the partition to initialize, then press #. When the execution ends, cycle the machine off and on.	
001	HDD Formatting (All)	
002	HDD Formatting (IMH)	
003	HDD Formatting (Thumbnail)	
004	HDD Formatting (Job Log)	
005	HDD Formatting (Printer Fonts)	

006	HDD Formatting (User Info)
007	Mail RX Data
008	Mail TX Data
009	HDD Formatting (Data for Design)
010	HDD Formatting (Log)
011	HDD Formatting (Ridoc I/F) (for Ridoc Desk Top Binder)

5836*	Capture Setting	
001	Capture Function (0:Off 1:On)	
	<p>With this function disabled, the settings related to the capture feature cannot be initialized, displayed, or selected.</p> <p>[0 to 1 / 0 / 1]</p> <p>0: Disable, 1: Enable</p>	
002	Panel Setting	
	<p>Determines whether each capture related setting can be selected or updated from the initial system screen.</p> <p>[0 to 1 / 0 / 1]</p> <p>0: Disable, 1: Enable</p> <p>The setting for SP5836-001 has priority.</p>	
071	Reduction for Copy Color	<p>[0 to 3 / 2 / 1] (DFU)</p> <p>0:1, 1:1/2, 2:1/3, 3:1/4</p>
072	Reduction for Copy B&W Text	<p>[0 to 6 / 0 / 1]</p> <p>0:1, 1:1/2, 2:1/3, 3:1/4, 6:2/3</p>
073	Reduction for Copy B&W Other	<p>[0 to 6 / 0 / 1]</p> <p>0:1, 1:1/2, 2:1/3, 3:1/4, 6:2/3</p>

System SP Table-5

074	Reduction for Printer Color	[0 to 3 / 2 / 1] (DFU) 0:1, 1:1/2, 2:1/3, 3:1/4
075	Reduction for Printer B&W	[0 to 6 / 0 / 1] 0 1, 1:1/2, 2:1/3, 3:1/4, 6:2/3
076	Reduction for Printer B&W HQ	[0 to 3 / 0 / 1] 0:1, 1:1/2, 2:1/3, 3:1/4
081	Format for Copy Color	[0 to 3 / 0 / 1] (DFU) 0: JFIF/JPEG, 1: TIFF/MMR, 2: TIFF/MH, 3: TIFF/MR
082	Format for Copy B&W Text	[0 to 3 / 1 / 1] 0: JFIF/JPEG, 1: TIFF/MMR, 2: TIFF/MH, 3: TIFF/MR
083	Format Copy B&W Other	[0 to 3 / 1 / 1] 0: JFIF/JPEG, 1: TIFF/MMR, 2: TIFF/MH, 3: TIFF/MR
084	Format for Printer Color	[0 to 0 / 0 / 1] (DFU) 0: JFIF/JPEG, 1: TIFF/MMR, 2: TIFF/MH, 3: TIFF/MR
085	Format for Printer B&W	[0 to 3 / 1 / 1] 0: JFIF/JPEG, 1: TIFF/MMR, 2: TIFF/MH, 3: TIFF/MR
086	Format for Printer B&W HQ	[0 to 3 / 2 / 1] 0: JFIF/JPEG, 1: TIFF/MMR, 2: TIFF/MH, 3: TIFF/MR
091	Default for JPEG	[5 to 95 / 50 / 1]
	Sets the JPEG format default for documents sent to the document management server with the MLB, with JPEG selected as the format. Enabled only when optional File Format Converter (MLB: Media Link Board) is installed.	

5840*	IEEE 802.11	
006	Channel MAX	
	Sets the maximum range of the bandwidth for the wireless LAN. This bandwidth setting varies for different countries. [1 to 14 / 11 (NA), 13 (EU), 14 (JPN) / 1] JPN: 1 to 14, NA: 1 to 11, EU: 1 to 13	
007	Channel MIN	
	Sets the minimum range of the bandwidth for operation of the wireless LAN. This bandwidth setting varies for different countries. [1 to 14 / 1 / 1] JPN: 1 to 14, NA: 1 to 11, EU: 1 to 13	
008	Transmission speed	[0 x 00 to 0 x FF / 0 x FF to Auto / -]
	0 x FF to Auto [Default]	
	0 x 11 - 55M Fix	0 x 07 - 11M Fix
	0 x 10 - 48M Fix	0 x 05 - 5.5M Fix
	0 x 0F - 36M Fix	0 x 08 - 1M Fix
	0 x 0E - 18M Fix	0 x 13 - 0 x FE (reserved)
	0 x 0D - 12M Fix	0 x 12 - 72M (reserved)
	0 x 0B - 9M Fix 0 x 0A - 6M Fix	0 x 09 - 22M (reserved)
011	WEP Key Select	
	Selects the WEP key. Bit 1 and 0 00: Key1 , 01: Key2 (Reserved), 10: Key3 (Reserved), 11: Key4(Reserved) This SP is displayed only when the IEEE802.11 card is installed.	

System SP Table-5

	Fragment Thresh
042	Adjusts the fragment threshold for the IEEE802.11 card. [256 to 2346 / 2346 / 1] This SP is displayed only when the IEEE802.11 card is installed.
	11g CTS to self
043	Determines whether the CTS self function is turned on or off. [0 to 1 / 1 / 1] 0: Off, 1: On This SP is displayed only when the IEEE802.11 card is installed.
	11g Slot Time
044	Selects the slot time for IEEE802.11. [0 to 1 / 0 / 1] 0: 20 μ m, 1: 9 μ m This SP is displayed only when the IEEE802.11 card is installed.
	WPA Debug Lvl
045	Selects the debug level for WPA authentication application. [1 to 3 / 3 / 1] 1: Info, 2: warning, 3: error This SP is displayed only when the IEEE802.11 card is installed.

5841*	Supply Name Setting	
	Press the User Tools key. These names appear when the user presses the Inquiry button on the User Tools screen.	
001	Toner Name Setting: Black	
007	Org Stamp	
011	StapleStd1	
012	StapleStd2	Standard Staples for B804/B805
013	StapleStd3	Standard Staples for B408
014	StapleStd4	
021	StapleBind1	
022	StapleBind2	Booklet Staples for B804
023	StapleBind3	

System SP Table-5

5842*	GWWS Analysis (DFU)		
	This is a debugging tool. It sets the debugging output mode of each Net File process. Bit SW 0011 1111	Bit	Groups
		0	System & other groups (LSB)
		1	Capture related
		2	Certification related
		3	Address book related
		4	Machine management related
		5	Output related (printing, delivery)
	6	Repository related	
001	Setting 1	Default: 00000000 – do not change Netfiles: Jobs to be printed from the document server using a PC and the DeskTopBinder software	
002	Setting 2	Adjusts the debug program mode setting. Bit7: 5682 mmseg-log setting 0: Date/Hour/Minute/Second 1: Minute/Second/Msec. 0 to 6: Not used	

5844	USB
001	Transfer Rate
	Sets the speed for USB data transmission. [0 x 01 or 0 x 04 / 0 x 04 /-] 0 x 01 [Full Speed], 0 x 04 [Auto Change]
002	Vendor ID
	Sets the vendor ID: Initial Setting: 0x05A Ricoh Company [0x0000 to 0xFFFF/1] (DFU)
003	Product ID
	Sets the product ID. [0x0000 to 0xFFFF/1] (DFU)
004	Device Release No.
	Sets the device release number of the BCD (binary coded decimal) display. [0000 to 9999 / 100 / 1] (DFU) Enter as a decimal number. NCS converts the number to hexadecimal number recognized as the BCD.

System SP Table-5

5845*	Delivery Server Setting
	These are delivery server settings.
001	FTP Port No.
	[0 to 65535 / 3670 / 1]
002	IP Address (Primary)
	Use this SP to set the Scan Router Server address. The IP address under the transfer tab can be used with the initial system setting. [Range: 000.000.000.000 to 255.255.255.255]
006	Delivery Error Display Time
	Use this setting to set the length of time that the message is shown when a test error occurs during document transfer with the NetFile application and an external device. [0 to 999 / 300 / 1 sec]
008	IP Address (Secondary)
	Sets the IP address that is given to the computer that is the secondary delivery server for Scan Router. This SP lets you set only the IP address, and does not refer to the DNS setting. [Range: 000.000.000.000 to 255.255.255.255]
009	Delivery Server Model
	Lets you change the model of the delivery server that is registered by the I/O device. [0 to 4 / 0 / 1 step] 0: Unknown 1: SG1 Provided 2: SG1 Package 3: SG2 Provided 4: SG2 Package

	Delivery Svr. Capability	
010	<p>Changes the functions that the registered I/O device can do. [0 to 255 / 0 / 1 step]</p> <p>Bit7 = 1 Comment information exists Bit6 = 1 Direct specification of mail address possible Bit5 = 1 Mail RX confirmation setting possible Bit4 = 1 Address book automatic update function exists Bit3 = 1 Fax RX delivery function exists Bit2 = 1 Sender password function exists Bit1 = 1 Function to link MK-1 user and Sender exists Bit0 = 1 Sender specification required (if set to 1, Bit6 is set to "0")</p>	
	Delivery Svr.Capability (Ext)	
011	<p>These settings are for future use. They will let you increase the number of registered devices (in addition to those registered for SP5845 010). There are eight bits (Bit 0 to Bit 7). All are unused at this time.</p>	
013	Server Scheme (Primary)	
014	Server port Number (Primary)	[1 to 65535 / 80 / 1]
015	Server URL Path (Primary)	
016	Server Scheme (secondary)	
017	Server Port (Secondary)	[1 to 65535 / 80 / 1]
018	Server URL Path (Secondary)	
019	Capture Server Port Number	
020	Capture Server URL Path	[1 to 65535 / 80 / 1]
	Capture Server URL Path	
021	<p>These SPs (5845-013/014/015/016/017/018/019/020/021) listed above are used for the scan router program.</p>	

System SP Table-5

022	Rapid Sending Control	[0 to 1 / 0 / -] 0: Disable, 1: Enable
	Enables or disables the prevention function for the continuous data sending error.	

5846*	UCS Setting	
001	Machine ID (for Delivery Server)	
	Displays the unique device ID in use by the delivery server directory. The value is only displayed and cannot be changed. This ID is created from the NIC MAC or IEEE 1394 EUI. The ID is displayed as either 6-byte or 8-byte binary.	
002	Machine ID Clear (for Delivery Server)	
	Clears the unique ID of the device used as the name in the file transfer directory. Execute this SP if the connection of the device to the delivery server is unstable. After clearing the ID, the ID will be established again automatically by cycling the machine off and on.	
003	Maximum Entries	
	Changes the maximum number of entries that UCS can handle. [2000 to 20000 / 2000 / 1 step] If a value smaller than the present value is set, the UCS managed data is cleared, and the data (excluding user code information) is displayed.	
006	Delivery Server Retry Timer	
	Sets the interval for retry attempts when the delivery server fails to acquire the delivery server address book. [0 to 255 / 0 / 1 step] 0: No retries	

007	<p>Delivery Server Retry Times</p> <p>Sets the number of retry attempts when the delivery server fails to acquire the delivery server address book. [0 to 255 / 0 / 1step]</p>
008	<p>Delivery Server Maximum Entries</p> <p>Lets you set the maximum number of account entries and information about the users of the delivery server controlled by UCS. [2000 to 20000 / 2000 / 1 step]</p>
010	<p>LDAP Search Timeout</p> <p>Sets the length of the time-out for the search of the LDAP server. [1 to 255 / 60 /1 step]</p>
040	<p>Addr Book Migration (USB -> HDD)</p> <p>This SP moves the address book data from the SD card or flash ROM on the controller board to the HDD. You must cycle the machine off and on after executing this SP.</p> <ol style="list-style-type: none"> 1. Turn the machine off. 2. Install the HDD. 3. Turn the machine on. 4. Do SP5846 040. 5. Turn the machine off/on. <p> Note</p> <ul style="list-style-type: none"> ▪ Executing this SP overwrites any address book data already on the HDD with the data from the flash ROM on the controller board. ▪ We recommend that you back up all directory information to an SD card with SP5846-051 before you execute this SP. ▪ After the address book data is copied to HDD, all the address book data is deleted from the flash ROM. If the operation fails, the data is not erased from the flash ROM.

System SP Table-5

041	Fill Addr Acl Info.	
	<p>This SP must be executed immediately after installation of an HDD unit in a basic machine that previously had no HDD. The first time the machine is powered on with the new HDD installed, the system automatically takes the address book from the NVRAM and writes it onto the new HDD. However, the new address book on the HDD can be accessed only by the system administrator at this stage. Executing this SP by the service technician immediately after power on grants full address book access to all users.</p> <p>Procedure</p> <ol style="list-style-type: none"> 1. Turn the machine off. 2. Install the new HDD. 3. Turn the machine on. 4. The address book and its initial data are created on the HDD automatically. However, at this point the address book can be accessed by only the system administrator or key operator. 5. Enter the SP mode and do SP5846 041. After this SP executes successfully, any user can access the address book. 	
043	Addr Book Media	
	Displays the slot number where an address book data is in. [0 to 30 / - /1]	
	0: Unconfirmed 1: SD Slot 1 2: SD Slot 2 4: USB Flash ROM	20: HDD 30: Nothing
047	Initialize Local Address Book	
	Clears all of the address information from the local address book of a machine managed with UCS.	
048	Initialize Delivery Addr Book	
	Push [Execute] to delete all items (this does not include user codes) in the delivery address book that is controlled by UCS.	

049	Initialize LDAP Addr Book
	Push [Execute] to delete all items (this does not include user codes) in the LDAP address book that is controlled by UCS.
050	Initialize All Addr Book
	Clears everything (including users codes) in the directory information managed by UCS. However, the accounts and passwords of the system administrators are not deleted.
051	Backup All Addr Book
	Copies all directory information to the SD card. Do this SP before replacing the controller board or HDD. The operation may not succeed if the controller board or HDD is damaged.
052	Restore All Addr Book
	Copies back all directory information from the SD card to the flash ROM or HDD. Upload the address book from the old flash ROM or HDD with SP5846-51 before removing it. Do SP5846 52 after installing the new HDD.
053	Clear Backup Info.
	Deletes the address book uploaded from the SD card in the slot 2. Deletes only the files uploaded for that machine. This feature does not work if the card is write-protected. Note: After you do this SP, go out of the SP mode, turn the power off. Do not remove the SD card until the Power LED stops flashing.

System SP Table-5

060	Search Option	
	This SP uses bit switches to set up the fuzzy search options for the UCS local address book.	
	Bit	Meaning
	0	Checks both upper/lower case characters
	1	Japan Only
	2	
	3	
	4	--- Not Used ---
	5	--- Not Used ---
	6	--- Not Used ---
7	--- Not Used ---	
062	Complexity Option 1	
	<p>Use this SP to set the conditions for password entry to access the local address book. Specifically, this SP limits the password entry to upper case and sets the length of the password.</p> <p>[0 to 32 / 0 / 1step]</p> <p> Note</p> <ul style="list-style-type: none"> ▪ This SP does not normally require adjustment. ▪ This SP is enabled only after the system administrator has set up a group password policy to control access to the address book. 	

063	<p>Complexity Option 2</p> <p>Use this SP to set the conditions for password entry to access the local address book. Specifically, this SP limits the password entry to lower case and defines the length of the password.</p> <p>[0 to 32 / 0 / 1step]</p> <p> Note</p> <ul style="list-style-type: none"> ▪ This SP does not normally require adjustment. ▪ This SP is enabled only after the system administrator has set up a group password policy to control access to the address book.
064	<p>Complexity Option 3</p> <p>Use this SP to set the conditions for password entry to access the local address book. Specifically, this SP limits the password entry to numbers and defines the length of the password.</p> <p>[0 to 32 / 0 / 1step]</p> <p> Note</p> <ul style="list-style-type: none"> ▪ This SP does not normally require adjustment. ▪ This SP is enabled only after the system administrator has set up a group password policy to control access to the address book.
065	<p>Complexity Option 4</p> <p>Use this SP to set the conditions for password entry to access the local address book. Specifically, this SP limits the password entry to symbols and defines the length of the password.</p> <p>[0 to 32 / 0 / 1step]</p> <p> Note</p> <ul style="list-style-type: none"> ▪ This SP does not normally require adjustment. ▪ This SP is enabled only after the system administrator has set up a group password policy to control access to the address book.

System SP Table-5

	FTP Auth Port Setting
091	Sets the FTP port to get the delivery server address book that is used in the individual authorization mode. [0 to 65535 / 3671 / 1step]
	Encryption Start
094	Shows the status of the encryption function of the address book on the LDAP server. [0 to 255 / 1] No default

	Rep Resolution Reduction		
5847*	5847-2 through 5847-6 changes the default settings of image data sent externally by the Net File page reference function. 5847-21 sets the default for JPEG image quality of image files controlled by NetFile. "NetFile" refers to jobs to be printed from the document server with a PC and the DeskTopBinder software.		
002	Rate for Copy B&W Text	[0 to 6 / 0 / 1]	0: 1x 1: 1/2x 2: 1/3x 3: 1/4x 4: 1/5x 5: 1/8x 6: 2/3x1
003	Rate for Copy B&W Other	[0 to 6 / 0 / 1]	
005	Rate for Printer B&W	[0 to 6 / 0 / 1]	
	Network Quality Default for JPEG		
021	Sets the default value for the quality of JPEG images sent as NetFile pages. This function is available only with the MLB (Media Link Board) option installed. [5 to 95 / 50 / 1step]		

5848*	Web Service
-------	-------------

	5848-2 sets the 4-bit switch assignment for the access control setting. Setting of 0001 has no effect on access and delivery from Scan Router. 5848-100 sets the maximum size of images that can be downloaded. The default is equal to 1 gigabyte.	
002	Acc. Ctrl.: Repository (only Lower 4 Bits)	0000: No access control 0001: Denies access to DeskTop Binder.
003	Acc. Ctrl.: Doc. Svr. Print (Lower 4 Bits)	Switches access control on and off. 0000: OFF, 0001: ON
004	Acc. Ctrl.: User Directory (Lower 4 Bits)	
007	Acc. Ctrl Comm. Log Fax (Lower 4 Bits)	
009	Acc. Ctrl.: Job Control (Lower 4 Bits)	
011	Acc. Ctrl: Device Management (Lower 4 Bits)	
021	Acc. Ctrl: Delivery (Lower 4 Bits)	
022	Acc. Ctrl: User Administration (Lower 4 Bits)	
099	Repository: Download Image Setting	
100	Repository: Download Image Max. Size	Specified the max size of the image data that the machine can download/ [1 to 2048 / 2048 / 1 MB]
210	Setting: Log Type: Job 1	
	No information is available at this time.	
211	Setting: Log Type: Job 2	
	No information is available at this time.	
212	Setting: Log Type: Access	
	No information is available at this time.	
213	Setting: Primary Srv	

System SP Table-5

	No information is available at this time.
214	Setting: Secondary Srv
	No information is available at this time.
215	Setting: Start Time
	No information is available at this time.
216	Setting: Interval Time
	No information is available at this time.
217	Setting: Timing
	No information is available at this time.

5849	Installation Date	
	Displays or prints the installation date of the machine.	
001	Display	The "Counter Clear Day" has been changed to "Installation Date" or "Inst. Date".
002	Switch to Print	Determines whether the installation date is printed on the printout for the total counter. [0 to 1 / 1 / -] 0: OFF (No Print) 1: ON (Print)
003	Total Counter	When the total number of pages that are made reaches this value, the current date becomes the 'official' installation date for this machine. [0 to 99999999 / 0 / 1]

5850*	Address Book Function Japan Only
003	Replacement of Circuit Classification
	The machine is sold ready to use with a G3 line. This SP allows you to switch all at once to convert to G4 after you add a G4 line. Conversely, if for some reason the G4 line becomes unusable, you can easily switch back to G3.
5851*	Bluetooth
	Sets the operation mode for the Bluetooth Unit. Press either key. [0: Public] / [1: Private]
5853	Stamp Data Download
	Push [Execute] to download the fixed stamp data from the machine ROM onto the hard disk. Then these stamps can be used by the system. If this is not done, the user will not have access to the fixed stamps ("Confidential", "Secret", etc.). You must always execute this SP after replacing the HDD or after formatting the HDD. Always switch the machine off and on after executing this SP.
5856	Remote ROM Update
002	When set to "1" allows reception of firmware data via the local port (IEEE 1284) during a remote ROM update. This setting is reset to zero after the machine is cycled off and on. Allows the technician to upgrade the firmware using a parallel cable [0 to 1 / 0 / 1 step] 0: Not allowed 1: Allowed

System SP Table-5

5857	Save Debug Log
001	On/Off (1:ON 0:OFF)
	Switches on the debug log feature. The debug log cannot be captured until this feature is switched on. [0 to 1 / 0 / 1] 0: OFF, 1: ON
002	Target (2: HDD 3: SD)
	Selects the destination where the debugging information generated by the event selected by SP5858 will be stored if an error is generated [2 to 3 / 2 / 1] 2: HDD, 3: SD Card
005	Save to HDD
	Specifies the decimal key number of the log to be written to the hard disk.
006	Save to SD Card
	Specifies the decimal key number of the log to be written to the SD Card.
009	Copy HDD to SD Card (Latest 4 MB)
	Takes the most recent 4 MB of the log written to the hard disk and copies them to the SD Card. A unique file name is generated to avoid overwriting existing file names on the SD Card. Up to 4MB can be copied to an SD Card. 4 MB segments can be copied one by one to each SD Card.
010	Copy HDD to SD Card Latest 4 MB Any Key)
	Takes the log of the specified key from the log on the hard disk and copies it to the SD Card. A unique file name is generated to avoid overwriting existing file names on the SD Card. Up to 4 MB can be copied to an SD Card. 4 MB segments can be copied one by one to each SD Card. This SP does not execute if there is no log on the HDD with no key specified.

011	Erase HDD Debug Data
	Erases all debug logs on the HDD
012	Erase SD Card Debug Data
	Erases all debug logs on the SD Card. If the card contains only debugging files generated by an event specified by SP5858, the files are erased when SP5857 010 or 011 is executed. To enable this SP, the machine must be cycled off and on.
013	Free Space on SD Card
	Displays the amount of space available on the SD card.
014	Copy SD to SD (Latest 4MB)
	Copies the last 4MB of the log (written directly to the card from shared memory) onto an SD card.
015	Copy SD to SD (Latest 4MB Any Key)
	This SP copies the log on an SD card (the file that contains the information written directly from shared memory) to a log specified by key number.
016	Make HDD Debug
	This SP creates a 32 MB file to store a log on the HDD.
017	Make SD Debug
	This SP creates a 4 MB file to store a log on an SD card.

System SP Table-5

5858*	Debug Save When	
	These SPs select the content of the debugging information to be saved to the destination selected by SP5857-002. SP5858-003 stores one SC specified by number.	
001*	Engine SC Error (0:OFF 1:ON)	Stores SC codes generated by copier engine errors.
002*	Controller SC Error (0:OFF 1:ON)	Stores SC codes generated by GW controller errors.
003*	Any SC Error	[0 to 65535 / 0 / 1step]
004*	Jam (0:OFF 1:ON)	Stores jam errors.

5859*	Debug Log Save Function	
001	Key 1	These SPs allow you to set up to 10 keys for log files for functions that use common memory on the controller board. [-9999999 to 9999999 / - / 1]
002	Key 2	
003	Key 3	
004	Key 4	
005	Key 5	
006	Key 6	
007	Key 7	
008	Key 8	
009	Key 9	
010	Key 10	

5860*	SMTP/POP3/IMAP4
020	Partial Mail Receive Timeout
	[1 to 168 / 72 / 1 hour] Sets the amount of time to wait before saving a mail that breaks up during reception. The received mail is discarded if the remaining portion of the mail is not received during this prescribed time.
021	MDN Response RFC2298 Compliance
	Determines whether RFC2298 compliance is switched on for MDN reply mail. [0 to 1 / 1 / 1] 0: No, 1: Yes
022	SMTP Auth. From Field Replacement
	Determines whether the FROM item of the mail header is switched to the validated account after the SMTP server is validated. [0 to 1 / 0 / 1] 0: No. "From" item not switched. 1: Yes. "From" item switched.
025	SMTP Auth Direct Sending
	Select the authentication method for SMPT. Bit 0: LOGIN Bit 1: PLAIN Bit 2: CRAM_MD5 Bit 3: DIGEST_MD5 Bit 4 to Bit 7: Not Used  Note <ul style="list-style-type: none"> This SP is activated only when SMTP authentication is enabled by UP mode.

System SP Table-5

026	S/MIME: MIME Header Setting	
	Selects the MIME header type of an E-mail sent by S/MIME. [0 to 2 / 0 / 1] 0: Microsoft Outlook Express standard 1: Internet Draft standard 2: RFC standard	

5866	E-Mail Report	
001	Report Validity	Enables or disables the E-mail alert function. [0 or 1 / 0 / –] 0: Enabled, 1: Disabled
005	Add Date Field	Adds or does not add the date field to the header of the alert mail. [0 or 1 / 0 / –] 0: Not added, 1: Added

5870	Common Key Info Writing	
	Writes to flash ROM the common proof for validating the device for NRS specifications.	
	001	Writing
003	Initialize	These SPs are for future use and currently are not used.

5873	SD Card Appli. Move	
	Allows you to move applications from one SD card another. For more, see "SD Card Appli Move" in the chapter "System Maintenance (Main Chapters).	
001	Move Exec	Executes the move from one SD card to another.
002	Undo Exec	This is an undo function. It cancels the previous execution.

5875	SC Auto Reboot	
	<p>This SP determines whether the machine reboots automatically when an SC error occurs.</p> <p> Note</p> <ul style="list-style-type: none"> The reboot does not occur for Type A SC codes. 	
001	Reboot Setting	<p>[0 to 1 / 0 / 1]</p> <p>0: The machine reboots automatically when the machine issues an SC error and logs the SC error code. If the same SC occurs again, the machine does not reboot.</p> <p>1: The machine does not reboot when an SC error occurs.</p>
002	Reboot Type	<p>[0 to 1 / 0 / 1]</p> <p>0: Manual reboot, 1: Automatic reboot</p>

5878	Option Setup	
001	Data Overwrite Security	<p>Press [Execute] to initialize the Data Overwrite Security option for the copier. For more, see "DataOverwriteSecurity Unit" in the chapter "Installation".</p>
002	HDD Encryption	<p>Installs the HDD Encryption unit.</p>

5881	Fixed Phase Block Erasing	
	Detects the Fixed phrase.	

System SP Table-5

5885*	Set WIM Function	
020	DocSvr Acc Ctrl	<p>Allows or disallows the functions of web image monitor.</p> <p>0: OFF, 1: ON</p> <p>Bit:</p> <p>0: Forbid all document server access</p> <p>1: Forbid user mode access</p> <p>2: Forbid print function</p> <p>3: Forbid Fax</p> <p>4: Forbid scan sending</p> <p>5: Forbid download</p> <p>6: Forbid delete</p> <p>7: Forbid guest user</p>
50	DocSvr Format	
	<p>Selects the display type for the document box list.</p> <p>[0 to 2 / 0 / 1]</p> <p>0: Thumbnail, 1: Icon, 2: Details</p>	
51	DocSvr Trans	
	<p>Sets the number of documents to be displayed in the document box list.</p> <p>[5 to 20 / 10 / 1]</p>	
100	Set Signature	
	<p>[0 to 2 / 0 / 1/step]</p> <p>0: Signature for each e-mail</p> <p>1: Signature for all e-mails</p> <p>2: No signature</p>	
	<p>Selects whether the signature is added to the scanned documents with the WIM when they are transmitted by an e-mail.</p>	

101	Set Encryption	
	Determines whether the scanned documents with the WIM are encrypted when they are transmitted by an e-mail. [0 to 1 / 0 / 1] 0: Not encrypted, 1:Encryption	
200	Detect Mem Leak	Not used
201	DocSvr Timeout	Not used

5887	SD Get Counter	
	This SP determines whether the ROM can be updated.	
001	<p>This SP sends a text file to an SD card inserted in SD card Slot 2 (lower slot). The operation stores. The file is stored in a folder created in the root directory of the SD card called SD_COUNTER. The file is saved as a text file (*.txt) prefixed with the number of the machine.</p> <ol style="list-style-type: none"> 1. Insert the SD card in SD card Slot 2 (lower slot). 2. Select SP5887 then touch [EXECUTE]. Touch [Execute] in the message when you are prompted. 	

5888*	Personal Information Protect	
	<p>Selects the protection level for logs. [0 to 1 / 0 / 1] 0: No authentication, No protection for logs 1: No authentication, Protected logs (only an administrator can see the logs)</p>	

System SP Table-5

5907	Plug & Play Maker/Model Name	
	<p>Selects the brand name and the production name for Windows Plug & Play. This information is stored in the NVRAM. If the NVRAM is defective, these names should be registered again.</p> <p>After selecting, press the "Original Type" key and "#" key at the same time. When the setting is completed, the beeper sounds five times.</p>	
	<p>[0 to 23 / - / 1 step] FA</p> <p>0: RICOH Aficio MP 4000B 1: RICOH Aficio MP 4000 2: RICOH Aficio MP 5000B 3: RICOH Aficio MP 5000 4: SAVIN 9040b 5: SAVIN 9040 6: SAVIN 9050b 7: SAVIN 9050 8: Gestetner MP 4000B 9: Gestetner MP 4000 10: Gestetner MP 5000B 11: Gestetner MP 5000</p>	<p>↓</p> <p>12: LANIER MP 4000B/LD040B 13: LANIER MP 4000/LD040 14: LANIER MP 5000B/LD050B 15: LANIER MP 5000/LD050 16: NRG MP 4000B 17: NRG MP 4000 18: NRG MP 5000B 19: NRG MP 5000 20: infotec MP 4000B 21: infotec MP 4000 22 infotec MP 5000B 23 infotec MP 5000</p>
5913*	Switchover Permission Time	
002	Print Application Timer	[3 to 30 / 3 / 1 second step]
	<p>Sets the length of time to elapse before allowing another application to take control of the display when the application currently controlling the display is not operating because a key has not been pressed.</p>	

5967*	Switchover Permission Time	0: ON, 1: OFF
	Enable and disable the document server. This is a security measure that prevents image data from being left in the temporary area of the HDD. After changing this setting, you must switch the main switch off and on to enable the new setting.	

5974*	Cherry Server	
	Selects which version of the Scan Router application program, "Light" or "Full" (Professional) is installed. [0 or 1 / 0 / -] 0: Light 1: Full	

5985	Device Setting	
	The NIC and USB support features are built into the GW controller. Use this SP to enable and disable these features. In order to use the NIC and USB functions built into the controller board, these SP codes must be set to "1".	

001	On Board NIC	<p>[0 to 2 / 0 / 1 /step] 0: Disable, 1: Enable, 2: Function limitation When the "Function limitation" is set, "On board NIC" is limited only for the NRS or LDAP/NT authentication.</p> <p> Note</p> <ul style="list-style-type: none"> Other network applications than @Remote or LDAP/NT authentication are not available when this SP is set to "2". Even though you can change the initial settings of those network applications, the settings do not work
002	On Board USB	<p>[0 or 1 / 0 / 1/step] 0: Disable, 1: Enable</p>

System SP Table-5

5987*	Counter Falsification Prevention
	This SP detects that a mechanical counter device is removed. If it is detected, SC610 occurs. 0: OFF. 1: ON

5990	SP Print Mode	
001	All (Data List)	Prints out the SMC sheets.
002	SP (Mode Data List)	
003	User Program	
004	Logging Data	
005	Diagnostic Report	
006	Non-Default	
007	NIB Summary	
008	Capture Log	
021	Copier User Program	
022	Scanner SP	
023	Scanner User Program	

4.6 SYSTEM SP TABLE-6

4.6.1 SP6-XXX: PERIPHERALS

6006*	ADF Registration Adjust	
	Adjusts the side-to-side and leading edge registration for simplex and duplex original feeding in ARDF mode. Press  to toggle ±. SP6006-5 sets the maximum setting allowed for rear edge erase.	
001	Adjust Side-to-Side: 1st Side	[-3 to 3 / 0 / 0.1 mm / step]
002	Adjust Side-to-Side: 2nd Side	
003	Leading Edge	[-5 to 5 / 0 / 0.1 mm / step]
005	Leading Edge: 1st Side	[-3 to 3 / 0 / 0.1 mm / step]
006	Leading Edge: 2nd Side	[-2.5 to 2.5 / 0 / 0.1 mm / step]
007	Trailing Edge Erase	[-10 to 10 / 0 / 0.1 mm / step]

6007	ADF Input Check	
001	Original B5 Sensor	0: Paper not detected 1: Paper detected
002	Original A4 Sensor	
003	Original LG Sensor	
004	Original Width Sensor 1	
005	Original Width Sensor 2	
006	Original Width Sensor 3	
007	Original Width Sensor 4	
008	Original Width Sensor 5	
009	Original Set Sensor	

Appendix:
Service
Program
Mode Tables

System SP Table-6

010	Separation Sensor	
011	Skew Correction Sensor	
012	Interval Sensor	
013	Registration Sensor	
014	Exit Sensor	
015	Top Cover Sensor	0: ADF cover closed 1: ADF cover open
016	Lift Sensor	0: ADF closed 1: ADF open
017	Inverter Sensor	0: Paper not detected 1: Paper detected
018	Pick-up HP Sensor	0: HP (Pick-up roller: Up) 1: Not HP (Pick-up roller: Down)
019	Original Stopper HP Sensor	0: HP (Stopper: UP) 1: Not HP (Stopper: Down)

6008	ADF Output Check	
001	Pick-up Motor: Fwd	
002	Pick-up Motor: Rev	
003	Feed Motor: Fwd	
004	Feed Motor: Rev	
005	Transport Motor: Fwd	
007	Inverter Motor: Fwd	
008	Inverter Motor: Rev	
011	Junction Gate Solenoid	
012	Stamp Solenoid	

6009	ADF Free Run	
	Performs an ARDF free run in duplex mode. Press [ON] to start, press [OFF] to stop. Note: This is a general free run controlled from the copier.	
001	Free Run: Simplex	
002	Free Run: Duplex	
003	Free Run: Stamp	

6010*	ADF Stamp Position Adjustment	[-5 to 5 / 0 / 0.1 mm step]
	Adjusts the horizontal position of the stamp on the scanned originals.	

System SP Table-6

6016*	Original Size Detection Priority			
	Specifies the original size for a size detected by the original sensor, since original sensors cannot recognize all sizes.			
001	Original Size Detection Priority		[0 or 1 / 0 / -] 0: Setting 1 1: Setting 2	
		NA	Setting 1	Setting 2
			DLT SEF	Folio SEF 11" x 15"
			LG SEF	Foolscap SEF
			LT SEF	US EXE 8" x 10"
			LT LEF	US EXE LEF
		EU/ ASIA	DLT SEF	8K 267 x 390 mm
			LT SEF	16K 195 x 267 mm
			LT LEF	16K 267 x 195 mm
		6017*	Sheet Through Magnification	[-5 to 5 / 0 / 0.1% step]
Adjusts the magnification in the sub-scan direction for ADF mode. Use the key to toggle between + and - before entering the value				

6020*	Skew Correction Adjustment	
	Turns the original skew correction in the ARDF for all original sizes on or off. [0 to 1 / 0 / 1] 0: Off (only for small original sizes) 1: On (for all original sizes)	

6128	Punch Position: Sub Scan	
	Adjusts the punching position in the sub scan direction. (For B804/B805)	
001	2-Hole: DOM (Japan)	[-7.5 to 7.5 / 0 / 0.5 mm]
002	3-Hole: NA	
003	4-Hole: EU	
004	5-Hole: SCAN	
005	2-Hole: NA	
006	1-Hole: DOM (Japan)	

6129	Punch Position: Main Scan	
	Adjusts the punching position in the main scan direction. (For B804/B805)	
001	2-Hole: DOM (Japan)	[-2 to 2 / 0 / 0.4 mm]
002	3-Hole: NA	
003	4-Hole: EU	
004	4-Hole: SCAN	
005	2-Hole: NA	
006	1-Hole: DOM (Japan)	

System SP Table-6

6130*	Skew Correction: Buckle Adj.	
	Adjusts the paper buckle at the punch unit for each paper size. (For B804/B805)	
001	A3 SEF	[-5 to 5 / 0 / 0.25 mm]
002	B4 SEF	
003	A4 SEF	
004	A4 LEF	
005	B5 SEF	
006	B5 LEF	
007	DLT SEF	
008	LG SEF	
009	LT SEF	
010	LT LEF	
011	12" x 18"	
012	Other	

6131*	Skew Correction Control	
	Selects the skew correction control for each paper size. (For B804/B805)	
001	A3 SEF	[0 to 1 / 1 / 1 mm]
002	B4 SEF	
003	A4 SEF	
004	A4 LEF	
005	B5 SEF	

006	B5 LEF	
007	DLT SEF	
008	LG SEF	
009	LT SEF	
010	LT LEF	
011	12" x 18"	
012	Other	

6132*	Jogger Fence Fine Adj.	
	This SP adjusts the distance between the jogger fences and the sides of the stack on the finisher stapling tray in the (Booklet) Finisher B804/B805. The adjustment is done perpendicular to the direction of paper feed.	
001	A3 SEF	[-1.5 to 1.5 / 0 / 0.5 mm]
002	B4 SEF	
003	A4 SEF	
004	A4 LEF	
005	B5 SEF	
006	B5 LEF	
007	DLT SEF	
008	LG SEF	
009	LT SEF	
010	LT LEF	
011	12" x 18"	
012	Other	

System SP Table-6

6133*	Staple Position Adjustment	
	Adjusts the staple position for each finisher (B408/B804/B805). + Value: Moves the staple position to the rear side. - Value: Moves the staple position to the front side. [-3.5 to 3.5 / 0 / 1/step]	

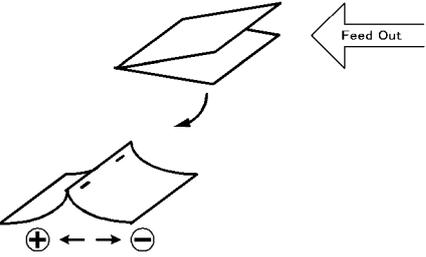
6134*	Saddle Stitch Position Adjustment	
	Use this SP to adjust the stapling position of the booklet stapler when paper is stapled and folded in the Booklet Finisher (B804).	
001	A3 SEF	[-3 to 3 / 0 / 0.2 mm] + Value: Shifts staple position toward the crease. - Value: Shifts staple position away from the crease 
002	B4 SEF	
003	A4 SEF	
004	B5 SEF	
005	DLT SEF	
006	LG SEF	
007	LT SEF	
008	12" x 18"	
009	Other	

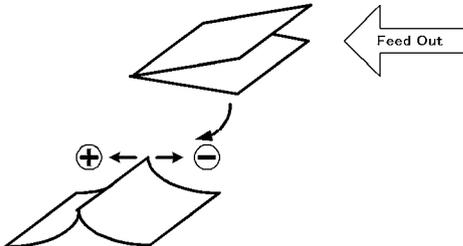
6135*	Folder Position Adj.	
	This SP corrects the folding position when paper is stapled and folded in the Booklet Finisher B804.	
001	A3 SEF	<p>[-3 to 3 / 0 / 0.2 mm]</p> <p>+ Value: Shifts staple position toward the crease.</p> <p>- Value: Shifts staple position away from the crease.</p> 
002	B4 SEF	
003	A4 SEF	
004	B5 SEF	
005	DLT SEF	
006	LG SEF	
007	LT SEF	
008	12" x 18"	
009	Other	

Appendix:
Service
Program
Mode Tables

6136*	Book Fold Repeat	
	Sets the number of times that folding is done in the Booklet Finisher B804. [2 to 30 / 2 / 1 time/step]	

System SP Table-6

6137	Finisher Free Run	
	These SPs are used only for the B408 or B793.	
001	Free Run 1	B408: Free run for stapling mode (without paper feeding). B793: Free run for paper edge stapling.
002	Free Run 2	B408: Free run for stapling mode and shift mode (without paper feeding). B793: Free run for booklet stapling.
003	Free Run 3	B408: Not used B793: Shipping free run. Simulates standby conditions during shipping.
004	Free Run 4	Not used

6139	FIN (KIN) INPUT Check	
	Display the signals received from sensors and switches of the (booklet) finisher. (B408) (☛ p.4-236 "Input Check")	

6140	FIN (EUP) INPUT Check	
	Display the signals received from sensors and switches of the (booklet) finisher. (B804/B805) (☛ p.4-236 "Input Check")	

6144	FIN (KIN) OUPUT Check	
	Display the signals received from sensors and switches of the (booklet) finisher. (B408) (☛ p.4-249 "Output Check")	

6145	FIN (EUP) OUPUT Check	
	Display the signals received from sensors and switches of the (booklet) finisher. (B804/B805) (🖨️ p.4-249 "Output Check")	

6148*	Jogger Fine Adjustment Not used	
001	A3 SEF	<p>This SP corrects the distance between the output jogger fence and the sides of the stack.</p> <p>+ Value:</p> <p>Increases the distance between the output jogger fence and the sides of the stack.</p> <p>- Value:</p> <p>Decreases the distance between the output jogger fences and the sides of the stack.</p> <p>[-1.5 to 1.5 / 0 / 0.5 mm]</p>
002	B4 SEF	
003	A4 SEF	
004	A4 LEF	
005	B5 LEF	
006	A5 LEF	
007	DLT SEF	
008	LG SEF	
009	LT SEF	
010	LT LEF	
011	HLT LEF	
012	Other	

6149*	Max. Pre-Stack Sheet	[0 to 3 / 3 / 1 sheets step]
	<p>This SP sets the number of sheets sent to the pre-stack tray.</p> <p>↓ Note</p> <ul style="list-style-type: none"> You may need to adjust this setting or switch it off when feeding thick or slick paper. 	

System SP Table-6

6150*	Jogger Control	[0 to 1 / 0 / 1] Not used
	This SP is for the output jogger control.	

6800	Sheet Conversion (Thick Paper)	
	Permits punching, including tab sheets. Note: Do not change this setting. [1 to 3 / 3 / 1 sheet] 1: 1 Sheet 2: 2 Sheets 3: 3 Sheets	

6910	Shading Control	
001	ON/OFF	[0 to 1 / 0 / 1] 0= OFF, 1= ON
	Enables or disables the shading adjustment for DF mode.	
002	Shading Interval: A	[0 to 60 / 3 / 1 sec] DFU
003	Shading Interval: B	[0 to 120 / 60 / 1] DFU

4.7 SYSTEM SP TABLE-7

4.7.1 SP7-XXX: DATA LOG

7401*	Total SC Counter	
	Displays the total number of service calls that have occurred.	

7403*	SC History	
001	Latest	Displays the most recent 10 service calls.
002	Latest 1	
003	Latest 2	
004	Latest 3	
005	Latest 4	
006	Latest 5	
007	Latest 6	
008	Latest 7	
009	Latest 8	
010	Latest 9	

7502*	Total Paper Jam Counter	
	Displays the total number of paper jams.	

7503*	Total Original Jam Counter	
	Displays the total number of original jams.	

System SP Table-7

13	Bank: Transport Sn 1: On
7504*	Total Jams Location
	These SPs display the total number of paper jams by location. A "Check-in" (paper late) error occurs when the paper fails to activate the sensor at the precise time. A "Check-out" ("paper lag") paper jam occurs when the paper remains at the sensor for longer than the prescribed time.
1	At power On
3	Tray 1: On
4	Tray 2: On
5	Tray 3: On
6	Tray 4: On
7	LCT: On
8	Bypass: On
9	Duplex: On
11	Vertical Transport 1: On
12	Vertical Transport 2: On
14	Bank: Transport Sn 2: On
17	Registration: On
19	Fusing Exit: On
20	Paper Exit: On
21	Bridge Exit On
22	Bridge Transport: On
24	Junction Gate Sensor: On
25	Duplex Exit: On

13	Bank: Transport Sn 1: On
26	Duplex Entrance: On (in)
27	Duplex Entrance: On (out)
51	Vertical Transport 1: Off
52	Vertical Transport 2: Off
53	Bank Transport 1: Off
54	Bank Transport 2: Off
57	Registration Sensor: Off
58	LCT Feed Sensor: Off
60	Paper Exit: Off
61	Bridge: Exit: Off
62	Bridge: Transport: Off
64	Junction Gate Sensor: Off
65	Duplex Exit: Off
66	Duplex Entrance: Off (in)
67	Duplex Entrance: Off (out)
100	Finisher Entrance: KIN
101	Finisher Shift: KIN
102	Finisher Staple: KIN
103	Finisher Exit: KIN
105	Finisher Tray Lift Motor: KIN
106	Finisher Jogger Motor: KIN
107	Finisher Shift Motor: KIN

System SP Table-7

13	Bank: Transport Sn 1: On
108	Finisher Staple Motor: KIN
109	Finisher Exit Motor: KIN
191	Finisher Entrance: EUP
192	Finisher Proof Exit: EUP
193	Finisher Shift Tray Exit: EUP
194	Finisher Staple Exit: EUP
195	Finisher Exit: EUP
198	Finisher Folder: EUP
199	Finisher Tray Motor: EUP
200	Finisher Jogger Motor: EUP
201	Finisher Shift Motor: EUP
202	Finisher Staple Moving Motor: EUP
203	Finisher Staple Motor: EUP
204	Finisher Folder Motor: EUP
206	Finisher Punch Motor:EUP

	Original Jam Location
7505	Displays the total number of original jams by location. These jams occur when the original does not activate the sensors. A Check-in ("paper late") error occurs when the paper fails to activate the sensor at the precise time. A Check-out ("paper lag") paper jam occurs when the paper remains at the sensor for longer than the prescribed time.
1	At Power: On
3	Separation Sensor: On

4	Skew Correction Sensor: On
5	Interval Sensor: On
6	Registration Sensor: On
7	Inverter Sensor: On
8	Original Exit Sensor: On
53	Separation Sensor: Off
54	Skew Correction Sensor: Off
55	Interval Sensor: Off
56	Registration Sensor: Off
57	Inverter Sensor: Off
58	Original Exit Sensor: Off

Appendix:
Service
Program
Mode Tables

7506*	Jam Count by Paper Size	
005	A4 LEF	Displays the total number of copy jams by paper size.
006	A5 LEF	
014	B5 LEF	
038	LT LEF	
044	HLT LEF	
132	A3 SEF	
133	A4 SEF	
134	A5 SEF	
141	B4 SEF	
142	B5 SEF	

System SP Table-7

160	DLT SEF	
164	LG SEF	
166	LT SEF	
172	HLT SEF	
255	Others	

7507*	Plotter Jam History				
7507 1	Last	<p>Displays the copy jam history (the most recent 10 jams)</p> <p>Sample Display:</p> <p>CODE:007</p> <p>SIZE:05h</p> <p>TOTAL:0000334</p> <p>DATE: Mon Mar 15 11:44:50 2000</p> <p>where:</p> <p>CODE is the SP7504-*** number (see above.</p> <p>SIZE is the ASAP paper size code in hex.</p> <p>TOTAL is the total jam error count (SP7502)</p> <p>DATE is the date the jams occurred.</p>			
7507 2	Latest 1				
7507 3	Latest 2				
7507 4	Latest 3				
7507 5	Latest 4				
7507 6	Latest 5				
7507 7	Latest 6				
7507 8	Latest 7				
7507 9	Latest 8				
7507 10	Latest 9				
Size	Code	Size	Code	Size	Code
A4 (S)	05	A3 (L)	84	DLT (L)	A0
A5 (S)	06	A4 (L)	85	LG (L)	A4
B5 (S)	0E	A5 (L)	86	LT (L)	A6
LT (S)	26	B4 (L)	8D	HLT (L)	AC
HLT (S)	2C	B5 (L)	8E	Others	FF

7508*	Original Jam History					
001	Last	Displays the original jam history (the most recent 10 jams). Sample Display: CODE:007 SIZE:05h TOTAL:0000334 DATE: Mon Mar 15 11:44:50 2000 where: CODE is the SP7505*** number (see above). SIZE is the ASAP paper size code in hex. TOTAL is the total jam error count (SP7503) DATE is the date the jams occurred.				
002	Last 1					
003	Last 2					
004	Last 3					
005	Last 4					
006	Last 5					
007	Last 6					
008	Last 7					
009	Last 8					
010	Last 9					
Size	Code	Size	Code	Size	Code	
A4 (S)	05	A3 (L)	84	DLT (L)	A0	
A5 (S)	06	A4 (L)	85	LG (L)	A4	
B5 (S)	0E	A5 (L)	86	LT (L)	A6	
LT (S)	26	B4 (L)	8D	HLT (L)	AC	
HLT (S)	2C	B5 (L)	8E	Others	FF	

Appendix:
 Service
 Program
 Mode Tables

7801	ROM No./Firmware Version
255	Displays the ROM number and firmware version numbers.

System SP Table-7

7803	PM Counter	
	Displays the PM counter since the last PM.	
001	Paper	[0 to 999999 / 0 / 1 page]
002	Page: PCD	[0 to 999999 / 0 / 1 page]
	Displays the PCD (Drum and Development unit) counter (pages)	
003	Page: Transfer	[0 to 999999 / 0 / 1 page]
	Displays the transfer unit counter (pages).	
004	Page: Fuser	[0 999999 / 0 / 1 page]
	Displays the fusing unit counter (pages).	
005	Rotation: PCU	[0 999999999 / 0 / 1 mm]
	Displays the PCD rotation counter (distance).	
006	Rotation: Transfer	[0 999999999 / 0 / 1 mm]
	Displays the transfer unit rotation counter (distance).	
007	Rotation: Fuser	[0 999999999 / 0 / 1 mm]
	Displays the fuser unit rotation counter (distance).	
008	Rotation(%): PCU	[0 255 / 0 / 1 %]
	Displays the PCD (%) rotation counter (Distance/PM).	
009	Rotation(%):Transfer	[0 255 / 0 / 1 %]
	Displays the transfer unit (%) rotation counter (distance/PM).	
010	Rotation(%):Fuser	[0 255 / 0 / 1 %]
	Displays the fuser unit (%) rotation counter (distance/PM).	
011	Rotation(%):Web	[0 255 / 0 / 1 %]

	Displays the web unit (%) rotation counter (distance/PM).	
7804	PM Counter	
	Resets the PM counter. To reset, press  .	
001	Paper	
	Resets the PM counter of the paper.	
002	Clear PCD	
	Resets the PM counter of the PCD (Drum and Development unit except developer).	
003	Clear Transfer	
	Resets the PM counter of the transfer unit.	
004	Clear Fuser	
	Resets the PM counter of the fuser unit.	
005	Clear Web	
	Reset the PM counter of the web unit.	
006	Clear All Clear	
	Resets all PM counter	

System SP Table-7

7805	Parts Counter	
001	Page: OPC	[0 to 999999 / 0 / 1 page]
	Displays the parts counter (pages) of the OPC.	
002	Page: Charge Roller	[0 to 999999 / 0 / 1 page]
	Displays the parts counter (pages) of the charge roller.	
003	Page: Developer	[0 to 999999 / 0 / 1 page]
	Displays the parts counter (pages) of the developer.	
004	Page: Belt Blade	[0 to 999999 / 0 / 1 page]
	Displays the parts counter (pages) of the transfer belt cleaning blade.	
005	Page: Heat Roller	[0 to 999999 / 0 / 1 page]
	Displays the parts counter (pages) of the hot roller.	
006	Page: Pressure Roller	[0 to 999999 / 0 / 1 page]
	Displays the parts counter (pages) of the pressure roller.	
007	Page: Cleaning Roller	[0 to 999999 / 0 / 1 page]
	Displays the parts counter (pages) of the cleaning roller.	
008	Page: Thermistor	[0 to 999999 / 0 / 1 page]
	Displays the parts counter (pages) of the thermistors.	
009	Page: Stripper	[0 to 999999 / 0 / 1 page]
	Displays the parts counter (pages) of the strippers.	
010	Rotation: OPC	[0 to 999999999 / 0 / 1 mm]
	Displays the parts counter (rotations) of the OPC.	
011	Rotation: Charge Roller	[0 to 999999999 / 0 / 1 mm]
	Displays the parts counter (rotations) of the charge roller.	

System SP Table-7

012	Rotation: Developer	[0 to 999999999 / 0 / 1 mm]
	Displays the parts counter (rotations) of the developer.	
013	Rotation: Belt Blade	[0 to 999999999 / 0 / 1 mm]
	Displays the parts counter (rotations) of the transfer belt, blade.	
014	Rotation: Heat Roller	[0 to 999999999 / 0 / 1 mm]
	Displays the parts counter (rotations) of the hot roller.	
015	Rotation: Pressure Roller	[0 to 999999999 / 0 / 1 mm]
	Displays the parts counter (rotations) of the pressure roller.	
016	Rotation: Cleaning Roller	[0 to 999999999 / 0 / 1 mm]
	Displays the parts counter (rotations) of the cleaning roller.	
017	Rotation: Thermistor	[0 to 999999999 / 0 / 1 mm]
	Displays the parts counter (rotations) of the thermistors.	
018	Rotation: Stripper	[0 to 999999999 / 0 / 1 mm]
	Displays the parts counter (rotations) of the strippers.	
019	Page(%): Web	[0 to 255 / 0 / 1 %]
	Displays the parts counter (rotations/PM %) of the cleaning web.	

System SP Table-7

7806	Counter Clear	
001	OPC	
	Resets the parts counter of the OPC.	
002	Charge Roller	
	Resets the parts counter of the charge roller.	
003	Developer	
	Resets the parts counter of the developer.	
004	Belt: Blade	
	Resets the parts counter of the transfer belt cleaning blade.	
005	Heat Roller	
	Resets the parts counter of the hot roller.	
006	Pressure Roller	
	Resets the parts counter of the pressure roller.	
007	Cleaning Roller	
	Resets the parts counter of the cleaning roller.	
008	Web	
	Resets the parts counter of the cleaning web.	
009	Thermistor	
	Resets the parts counter of the thermistors.	
010	Stripper	
	Resets the parts counter of the strippers.	
011	All Clear	
	Resets all parts counters.	

7807	SC/Jam Counter Reset	
	Resets the SC and jam counters. To reset, press Execute on the touch panel. This SP does not reset the jam history counters: SP7507, SP7508.	

7826	MF Error Counter Japan Only	
	Displays the number of counts requested of the card/key counter.	
001	Error Total	A request for the count total failed at power on. This error will occur if the device is installed but disconnected.
002	Error Staple	The request for a staple count failed at power on. This error will occur if the device is installed but disconnected.

7827	MF Error Counter Clear Japan Only	
	Press Execute to reset to 0 the values of SP7826. Japan Only	

7832	Self-Diagnose Result Display	
	Execute to open the "Self-Diagnostics Result Display" to view details about errors. Use the keys in the display on the touch-panel to scroll through all the information. If no errors have occurred, you will see the "No Error" message on the screen.	

7836	Total Memory Size	
	Displays the memory capacity of the controller system.	

System SP Table-7

7852	ADF Exposure Glass	
	Counts the number of occurrences (0 to 65,535) when dust was detected on the scanning glass of the ADF.	
001*	Dust Check Counter	Counts the occurrences. Counting is done only if SP4020-1 (ADF Scan Glass Dust Check) is switched on.
002*	Dust Check Clear Counter	Clears the count. Memory All Clear (SP5801) resets this counter to zero.

7853*	Replacement Counter	
001	PCD	[0 to 255 / 0 / 1]
	Displays the replacement counter of the PCD (Drum and Development unit).	
002	Transfer	[0 to 1 / 0 / 1]
	Displays the replacement counter of the transfer unit.	
003	Fuser	[0 to 1 / 0 / 1]
	Displays the replacement counter of the fusing unit.	
004	Web	[0 to 1 / 0 / 1]
	Displays the replacement counter of the cleaning web.	

7856* 1	Zero Cross	[0 to 255 / 60 / 1]
	Stores and displays the detected zero cross frequency of the main ac power supply from the wall socket.	

7901	Assert Info. DFU	
	These SP numbers display the results of the occurrence of the most recent SC code generated by the machine.	
001*	File Name	Module name
002*	Number of Lines	Number of the lines where error occurred.
003*	Location	Value

7906	Prev Counter	
001	Page: PCD	[0 999999 / 0 / 1 page]
	Displays the counter (pages) of the previous PCD	
002	Page: Transfer	[0 999999 / 0 / 1 page]
	Displays the previous counter (pages) of the previous transfer unit.	
003	Page: Fuser	[0 999999 / 0 / 1 page]
	Displays the previous counter (pages) of the previous fusing unit.	
004	Rotation: PCD	[0 999999999 / 0 / 1 mm]
	Displays the previous counter (rotations) of the previous PCD	
005	Rotation: Transfer	[0 999999999 / 0 / 1 mm]
	Displays the previous counter (rotations) of the previous transfer unit.	
006	Rotation: Fuser	[0 999999999 / 0 / 1 mm]
	Displays the previous counter (rotations/PM %) of the previous fusing unit.	
007	Rotation(%):PCD	[0 to 255 / 0 / 1 mm]
	Displays the previous counter (rotations/PM %) of the previous PCD	

System SP Table-7

008	Rotation(%):Transfer	[0 to 255 / 0 / 1 mm]
	Displays the previous counter (rotations/PM %) of the previous transfer unit.	
009	Rotation(%):Fuser	[0 to 255 / 0 / 1 mm]
	Displays the previous counter (rotations/PM %) of the previous fusing unit.	
010	Rotation(%):Web	[0 to 255 / 0 / 1 %]
	Displays the previous counter (rotations/PM %) of the previous cleaning web.	

7950	Replacement Date	
001	PCD	[0 to 1 / 0 / 1]
	Displays the replacement date of the PCD.	
002	Transfer	[0 to 1 / 0 / 1]
	Displays the replacement date of the transfer unit.	
003	Fuser	[0 to 1 / 0 / 1]
	Displays the replacement date of the fusing unit.	
004	Web	[0 to 1 / 0 / 1]
	Displays the replacement date of the web unit.	

7951	Remaining Counter	
001	PCD(Page)	[0 to 255 / 255 / 1 days]
	Displays the remaining counter (pages) of the PCD.	
002	Transfer(Page)	[0 to 255 / 255 / 1 days]
	Displays the remaining counter (pages) of the transfer unit.	
003	Fuser(Page)	[0 to 255 / 255 / 1 days]
	Displays the remaining counter (pages) of the fusing unit.	
005	PCD(Rotation)	[0 to 255 / 255 / 1 days]
	Displays the remaining counter (rotations) of the PCD.	
006	Transfer(Rotation)	[0 to 255 / 255 / 1 days]
	Displays the remaining counter (rotations) of the transfer unit.	
007	Fuser(Rotation)	[0 to 255 / 255 / 1 days]
	Displays the remaining counter (rotations) of the fusing unit.	
009	PCD (%)	[0 to 255 / 100 / 1 %]
	Displays the remaining counter (%) of the PCD.	
010	Transfer (%)	[0 to 255 / 100 / 1 %]
	Displays the remaining counter (%) of the transfer unit.	
011	Fuser (%)	[0 to 255 / 100 / 1 %]
	Displays the remaining counter (%) of the fusing unit.	
013	Web (%)	[0 to 255 / 100 / 1 %]
	Displays the remaining counter (%) of the cleaning web.	

System SP Table-7

7952	PM Yield Setting	
	Sets the each yield of the following.	
001	PCD(Page)	[0 to 99999999 / 160000 / 1 sheet]
	Sets the PM yield of the PCD (Pages).	
002	Transfer(Page)	[0 to 9999999 / 160000 / 1 sheet]
	Sets the PM yield of the transfer unit (Pages).	
003	Fuser(Page)	[0 to 9999999 / 160000 / 1 sheet]
	Sets the PM yield of the fusing unit (Pages).	
005	PCD(Rotation)	[0 to 999999999 / 199000 / 1 mm]
	Sets the PM yield of the PCD (Rotations).	
006	Transfer(Rotation)	[0 to 999999999 / 277000 / 1 mm]
	Sets the PM yield of the transfer unit (Rotations).	
007	Fuser(Rotation)	[0 to 999999999 / 54880000 / 1 mm]
	Sets the PM yield of the fusing unit (Rotations).	
009	Web (%)	[0 to 255 / 92 / 1 %]
	Sets the PM yield (%) of the web unit.	

7953	Operation Env Log	
001	T<10	[0 to 99999999 / 0 / 1 mm]
	Displays the PCU rotation distance in the environment: T<10°C	
002	10<=T<=17	[0 to 99999999 / 0 / 1 mm]
	Displays the PCU rotation distance in the environment: 10°C<=T<=17°C	
003	17<T<23	[0 to 99999999 / 0 / 1 mm]
	Displays the PCU rotation distance in the environment: 17<=T<=23	
004	23<=T<=27	[0 to 99999999 / 0 / 1 mm]
	Displays the PCU rotation distance of the environment: 23<=T<=27	
005	27<=T<=32	[0 to 99999999 / 0 / 1 mm]
	Displays the PCU rotation distance of the environment: 27<=T<=32	
006	32<T	[0 to 99999999 / 0 / 1 mm]
	Displays the PCU rotation distance of the environment: 32<T	
7954	Env Log Clear	
	Resets the environment logs (SP7953).	

4.8 SYSTEM SP TABLE-8

4.8.1 SP8-XXX: DATA LOG 2

Many of these counters are provided for features that are currently not available, such as sending color faxes, and so on. However, here are some Group 8codes that when used in combination with others, can provide useful information.

SP Numbers	What They Do
SP8211 to SP8216	The number of pages scanned to the document server.
SP8401 to SP8406	The number of pages printed from the document server
SP8691 to SP8696	The number of pages sent from the document server

Specifically, the following questions can be answered:

How is the document server actually being used?

What application is using the document server most frequently?

What data in the document server is being reused?

Most of the SPs in this group are prefixed with a letter that indicates the mode of operation (the mode of operation is referred to as an 'application'). Before reading the Group 8 Service Table, make sure that you understand what these prefixes mean.

Prefixes	What It Means	
T:	Total: (Grand Total).	Grand total of the items counted for all applications (C, F, P, etc.).
C:	Copy application.	Totals (pages, jobs, etc.) executed for each application when the job was not stored on the document server.
F:	Fax application.	
P:	Print application.	
S:	Scan application.	
L:	Local storage (document server)	Totals (jobs, pages, etc.) for the document server. The L: counters work differently case by case. Sometimes, they count jobs/pages stored on the document server; this can be in document server mode (from the document server window), or from another mode, such as from a printer driver or by pressing the Store File button in the Copy mode window. Sometimes, they include occasions when the user uses a file that is already on the document server. Each counter will be discussed case by case.
O:	Other applications (external network applications, for example)	Refers to network applications such as Web Image Monitor. Utilities developed with the SDK (Software Development Kit) will also be counted with this group in the future.

The Group 8 SP codes are limited to 17 characters, forced by the necessity of displaying them on the small LCDs of printers and faxes that also use these SPs. Read over the list of abbreviations below and refer to it again if you see the name of an SP that you do not understand.

Key for Abbreviations

System SP Table-8

Abbreviation	What It Means
/	"By", e.g. "T:Jobs/Apl" = Total Jobs "by" Application
>	More (2> "2 or more", 4> "4 or more")
AddBook	Address Book
Apl	Application
B/W	Black & White
Bk	Black
C	Cyan
ColCr	Color Create
ColMode	Color Mode
Comb	Combine
Comp	Compression
Deliv	Delivery
DesApl	Designated Application. The application (Copy, Fax, Scan, Print) used to store the job on the document server, for example.
Dev Counter	Development Count, no. of pages developed.
Dup, Duplex	Duplex, printing on both sides
Emul	Emulation
FC	Full Color
FIN	Post-print processing, i.e. finishing (punching, stapling, etc.)
Full Bleed	No Margins
GenCopy	Generation Copy Mode
GPC	Get Print Counter. For jobs 10 pages or less, this counter does

Abbreviation	What It Means
	not count up. For jobs larger than 10 pages, this counter counts up by the number that is in excess of 10 (e.g., for an 11-page job, the counter counts up 11-10 =1)
IFax	Internet Fax
ImgEdt	Image Edit performed on the original with the copier GUI, e.g. border removal, adding stamps, page numbers, etc.
K	Black (YMCK)
LS	Local Storage. Refers to the document server.
LSize	Large (paper) Size
Mag	Magnification
MC	One color (monochrome)
NRS	New Remote Service, which allows a service center to monitor machines remotely. "NRS" is used overseas, "CSS" is used in Japan.
Org	Original for scanning
OrgJam	Original Jam
Palm 2	Print Job Manager/Desk Top Editor: A pair of utilities that allows print jobs to be distributed evenly among the printers on the network, and allows files to moved around, combined, and converted to different formats.
PC	Personal Computer
PGS	Pages. A page is the total scanned surface of the original. Duplex pages count as two pages, and A3 simplex count as two pages if the A3/DLT counter SP is switched ON.
PJob	Print Jobs
Ppr	Paper

System SP Table-8

Abbreviation	What It Means
PrtJam	Printer (plotter) Jam
PrtPGS	Print Pages
R	Red (Toner Remaining). Applies to the wide format model A2 only. This machine is under development and currently not available.
Rez	Resolution
SC	Service Code (Error SC code displayed)
Scn	Scan
Sim, Simplex	Simplex, printing on 1 side.
S-to-Email	Scan-to-E-mail
SMC	SMC report printed with SP5990. All of the Group 8counters are recorded in the SMC report.
Svr	Server
TonEnd	Toner End
TonSave	Toner Save
TXJob	Send, Transmission
YMC	Yellow, Magenta, Cyan
YMCK	Yellow, Magenta, Cyan, Black

 Note

- All of the Group 8 SPs are reset with SP5 801-1 Memory All Clear.

8001	T:Total Jobs	<p>These SPs count the number of times each application is used to do a job. [0 to 9999999 / 0 / 1]</p> <p>Note: The L: counter is the total number of times the other applications are used to send a job to the document server, plus the number of times a file already on the document server is used.</p>
8002	C:Total Jobs	
8003	F:Total Jobs	
8004	P:Total Jobs	
8005	S:Total Jobs	
8006	L:Total Jobs	

- These SPs reveal the number of times an application is used, not the number of pages processed.
- When an application is opened for image input or output, this counts as one job.
- Interrupted jobs (paper jams, etc.) are counted, even though they do not finish.
- Only jobs executed by the customer are counted. Jobs executed by the customer engineer using the SP modes are not counted.
- When using secure printing (when a password is required to start the print job), the job is counted at the time when either "Delete Data" or "Specify Output" is specified.
- A job is counted as a fax job when the job is stored for sending.
- When a fax is received to fax memory, the F: counter increments but the L: counter does not (the document server is not used).
- A fax broadcast counts as one job for the F: counter (the fax destinations in the broadcast are not counted separately).
- A fax broadcast is counted only after all the faxes have been sent to their destinations. If one transmission generates an error, then the broadcast will not be counted until the transmission has been completed.
- A printed fax report counts as one job for the F: counter.
- The F: counter does not distinguish between fax sending or receiving.
- When a copy job on the document server is printed, SP8022 also increments, and when a print job stored on the document server is printed, SP8024 also increments.
- When an original is both copied and stored on the document server, the C: and L: counters both increment.
- When a print job is stored on the document server, only the L: counter increments.
- When the user presses the Document Server button to store the job on the document

System SP Table-8

server, only the L: counter increments.

- When the user enters document server mode and prints data stored on the document server, only the L: counter increments.
- When an image received from Palm 2 is received and stored, the L: counter increments.
- When the customer prints a report (user code list, for example), the O: counter increments. However, for fax reports and reports executed from the fax application, the F: counter increments.

8011	T:Jobs/LS	<p>These SPs count the number of jobs stored to the document server by each application, to reveal how local storage is being used for input.</p> <p>[0 to 9999999 / 0 / 1]</p> <p>The L: counter counts the number of jobs stored from within the document server mode screen at the operation panel.</p>
8012	C:Jobs/LS	
8013	F:Jobs/LS	
8014	P:Jobs/LS	
8015	S:Jobs/LS	
8016	L:Jobs/LS	
8017	O:Jobs/LS	

- When a scan job is sent to the document server, the S: counter increments. When you enter document server mode and then scan an original, the L: counter increments.
- When a print job is sent to the document server, the P: counter increments.
- When a network application sends data to the document server, the O: counter increments.
- When an image from Palm 2 is stored on the document server, the O: counter increments.
- When a fax is sent to the document server, the F: counter increments.

8021	T:Pjob/LS	<p>These SPs reveal how files printed from the document server were stored on the document server originally. [0 to 9999999 / 0 / 1]</p> <p>The L: counter counts the number of jobs stored from within the document server mode screen at the operation panel.</p>
8022	C:Pjob/LS	
8023	F:Pjob/LS	
8024	P:Pjob/LS	
8025	S:Pjob/LS	
8026	L:Pjob/LS	
8027	O:Pjob/LS	

- When a copy job stored on the document server is printed with another application, the C: counter increments.
- When an application like DeskTopBinder merges a copy job that was stored on the document server with a print job that was stored on the document server, the C: and P: counters both increment.
- When a job already on the document server is printed with another application, the L: counter increments.
- When a scanner job stored on the document server is printed with another application, the S: counter increments. If the original was scanned from within document server mode, then the L: counter increments.
- When images stored on the document server by a network application (including Palm 2), are printed with another application, the O: counter increments.
- When a copy job stored on the document server is printed with a network application (Web Image Monitor, for example), the C: counter increments.
- When a fax on the document server is printed, the F: counter increments.

System SP Table-8

8031	T:Pjob/DesApl	<p>These SPs reveal what applications were used to output documents from the document server.</p> <p>[0 to 9999999 / 0 / 1]</p> <p>The L: counter counts the number of jobs printed from within the document server mode screen at the operation panel.</p>
8032	C:Pjob/DesApl	
8033	F:Pjob/DesApl	
8034	P:Pjob/DesApl	
8035	S:Pjob/DesApl	
8036	L:Pjob/DesApl	
8037	O:Pjob/DesApl	

- When documents already stored on the document server are printed, the count for the application that started the print job is incremented.
- When the print job is started from a network application (Desk Top Binder, Web Image Monitor, etc.) the L: counter increments.

8041	T:TX Jobs/LS	<p>These SPs count the applications that stored files on the document server that were later accessed for transmission over the telephone line or over a network (attached to an e-mail, or as a fax image by I-Fax).</p> <p>[0 to 9999999 / 0 / 1]</p> <p>Note: Jobs merged for sending are counted separately.</p> <p>The L: counter counts the number of jobs scanned from within the document server mode screen at the operation panel.</p>
8042	C:TX Jobs/LS	
8043	F:TX Jobs/LS	
8044	P:TX Jobs/LS	
8045	S:TX Jobs/LS	
8046	L:TX Jobs/LS	
8047	O:TX Jobs/LS	

- When a stored copy job is sent from the document server, the C: counter increments.
- When images stored on the document server by a network application or Palm2 are sent as an e-mail, the O: counter increments.

8051	T:TX Jobs/DesApl	<p>These SPs count the applications used to send files from the document server over the telephone line or over a network (attached to an e-mail, or as a fax image by I-Fax). Jobs merged for sending are counted separately.</p> <p>[0 to 9999999 / 0 / 1]</p> <p>The L: counter counts the number of jobs sent from within the document server mode screen at the operation panel.</p>
8052	C:TX Jobs/DesApl	
8053	F:TX Jobs/DesApl	
8054	P:TX Jobs/DesApl	
8055	S:TX Jobs/DesApl	
8056	L:TX Jobs/DesApl	
8057	O:TX Jobs/DesApl	

- If the send is started from Desk Top Binder or Web Image Monitor, for example, then the O: counter increments.

8061	T:FIN Jobs	[0 to 9999999 / 0 / 1]
	These SPs total the finishing methods. The finishing method is specified by the application.	
8062	C:FIN Jobs	[0 to 9999999 / 0 / 1]
	These SPs total finishing methods for copy jobs only. The finishing method is specified by the application.	
8063	F:FIN Jobs	[0 to 9999999 / 0 / 1]
	<p>These SPs total finishing methods for fax jobs only. The finishing method is specified by the application.</p> <p>Note: Finishing features for fax jobs are not available at this time.</p>	
8064	P:FIN Jobs	[0 to 9999999 / 0 / 1]
	These SPs total finishing methods for print jobs only. The finishing method is specified by the application.	

System SP Table-8

8065	S:FIN Jobs		[0 to 9999999 / 0 / 1]
	These SPs total finishing methods for scan jobs only. The finishing method is specified by the application. Note: Finishing features for scan jobs are not available at this time.		
8066	L:FIN Jobs		[0 to 9999999 / 0 / 1]
	These SPs total finishing methods for jobs output from within the document server mode screen at the operation panel. The finishing method is specified from the print window within document server mode.		
8067	O:FIN Jobs		[0 to 9999999 / 0 / 1]
	These SPs total finishing methods for jobs executed by an external application, over the network. The finishing method is specified by the application.		
806x 1	Sort	Number of jobs started in Sort mode. When a stored copy job is set for Sort and then stored on the document server, the L: counter increments. (See SP8066 1)	
806x 2	Stack	Number of jobs started out of Sort mode.	
806x 3	Staple	Number of jobs started in Staple mode.	
806x 4	Booklet	Number of jobs started in Booklet mode. If the machine is in staple mode, the Staple counter also increments.	
806x 5	Z-Fold	Number of jobs started In any mode other than the Booklet mode and set for folding (Z-fold).	
806x 6	Punch	Number of jobs started in Punch mode. When Punch is set for a print job, the P: counter increments. (See SP8064 6.)	
806x 7	Other	Reserved. Not used.	

8071	T:Jobs/PGS	[0 to 9999999 / 0 / 1]	
	These SPs count the number of jobs broken down by the number of pages in the job, regardless of which application was used.		
8072	C:Jobs/PGS	[0 to 9999999 / 0 / 1]	
	These SPs count and calculate the number of copy jobs by size based on the number of pages in the job.		
8073	F:Jobs/PGS	[0 to 9999999 / 0 / 1]	
	These SPs count and calculate the number of fax jobs by size based on the number of pages in the job.		
8074	P:Jobs/PGS	[0 to 9999999 / 0 / 1]	
	These SPs count and calculate the number of print jobs by size based on the number of pages in the job.		
8075	S:Jobs/PGS	[0 to 9999999 / 0 / 1]	
	These SPs count and calculate the number of scan jobs by size based on the number of pages in the job.		
8076	L:Jobs/PGS	[0 to 9999999 / 0 / 1]	
	These SPs count and calculate the number of jobs printed from within the document server mode window at the operation panel, by the number of pages in the job.		
8077	O:Jobs/PGS	[0 to 9999999 / 0 / 1]	
	These SPs count and calculate the number of "Other" application jobs (Web Image Monitor, Palm 2, etc.) by size based on the number of pages in the job.		
807x 1	1 Page	807x 8	21to50 Pages
807x 2	2 Pages	807x 9	51to100 Pages
807x 3	3 Pages	807x 10	101to300 Pages

Appendix:
Service
Program
Mode Tables

System SP Table-8

807x 4	4 Pages	807x 11	301to500 Pages
807x 5	5 Pages	807x 12	501to700 Pages
807x 6	6 to10 Pages	807x 13	701to1000 Pages
807x 7	11to20 Pages	807x 14	1001to Pages

- For example: When a copy job stored on the document server is printed in document server mode, the appropriate L: counter (SP8076 0xx) increments.
- Printing a fax report counts as a job and increments the F: counter (SP 8073).
- Interrupted jobs (paper jam, etc.) are counted, even though they do not finish.
- If a job is paused and re-started, it counts as one job.
- If the finisher runs out of staples during a print and staple job, then the job is counted at the time the error occurs.
- For copy jobs (SP 8072) and scan jobs (SP 8075), the total is calculated by multiplying the number of sets of copies by the number of pages scanned. (One duplex page counts as 2.)
- The first test print and subsequent test prints to adjust settings are added to the number of pages of the copy job (SP 8072).
- When printing the first page of a job from within the document server screen, the page is counted.

8111	T:FAX TX Jobs		[0 to 9999999 / 0 / 1]
	These SPs count the total number of jobs (color or black-and-white) sent by fax, either directly or using a file stored on the document server, on a telephone line. Note: Color fax sending is not available at this time.		
001	B/W	Black TX	
8113	F:FAX TX Jobs		[0 to 9999999 / 0 / 1]
	These SPs count the total number of jobs (color or black-and-white) sent by fax directly on a telephone line. Note: Color fax sending is not available at this time.		
001	B/W	Black TX	

- These counters count jobs, not pages.
- This SP counts fax jobs sent over a telephone line with a fax application, including documents stored on the document server.
- If the mode is changed during the job, the job will count with the mode set when the job started.
- If the same document is faxed to both a public fax line and an I-Fax at a destination where both are available, then this counter increments, and the I-Fax counter (812x) also increments.
- The fax job is counted when the job is scanned for sending, not when the job is sent.

System SP Table-8

8121	T:IFAX TX Jobs		[0 to 9999999 / 0 / 1]
	These SPs count the total number of jobs (color or black-and-white) sent, either directly or using a file stored on the document server, as fax images using I-Fax. Note: Color fax sending is not available at this time.		
001	B/W	Black TX	
8123	F:IFAX TX Jobs		[0 to 9999999 / 0 / 1]
	These SPs count the number of jobs (color or black-and-white) sent (not stored on the document server), as fax images using I-Fax. Note: Color fax sending is not available at this time.		
001	B/W	Black TX	

- These counters count jobs, not pages.
- The counters for color are provided for future use; the color fax feature is not available at this time.
- The fax job is counted when the job is scanned for sending, not when the job is sent.

8131	T:S-to-Email Jobs		[0 to 9999999 / 0 / 1]
	These SPs count the total number of jobs scanned and attached to an e-mail, regardless of whether the document server was used or not.		
001	B/W	Black TX	
002	Color	Color TX / Only for D011, D013, D091 or D092	
003	ACS	Color TX / Only for D011, D013, D091 or D092	

8135	S:S-to-Email Jobs	
	These SPs count the number of jobs scanned and attached to an e-mail, without storing the original on the document server.	
001	B/W	Black TX
002	Color	Color TX / Only for D011, D013, D091 or D092
003	ACS	Color TX / Only for D011, D013, D091 or D092

- These counters count jobs, not pages.
- If the job is stored on the document server, after the job is stored it is determined to be color or black-and-white then counted.
- If the job is cancelled during scanning, or if the job is cancelled while the document is waiting to be sent, the job is not counted.
- If the job is cancelled during sending, it may or may not be counted, depending on what stage of the process had been reached when the job was cancelled.
- If several jobs are combined for sending to the Scan Router, Scan-to-Email, or Scan-to-PC, or if one job is sent to more than one destination. each send is counted separately. For example, if the same document is sent by Scan-to-Email as well as Scan-to-PC, then it is counted twice (once for Scan-to-Email and once for Scan-to-PC).

Appendix:
Service
Program
Mode Tables

8141	T:Deliv Jobs/Svr	[0 to 9999999 / 0 / 1]
	These SPs count the total number of jobs scanned and sent to a Scan Router server.	
001	B/W	Black Deliv
002	Color	Color Deliv / Only for D011, D013, D091 or D092
003	ACS	Color Deliv / Only for D011, D013, D091 or D092
8145	S:Deliv Jobs/Svr	
	These SPs count the number of jobs scanned and sent to a Scan Router server.	

System SP Table-8

001	B/W	Black Deliv
002	Color	Color Deliv / Only for D011, D013, D091 or D092
003	ACS	Color Deliv / Only for D011, D013, D091 or D092

- These counters count jobs, not pages.
- The jobs are counted even though the arrival and reception of the jobs at the Scan Router server cannot be confirmed.
- If even one color image is mixed with black-and-white images, then the job is counted as a "Color" job.
- If the job is cancelled during scanning, or if the job is cancelled while the document is waiting to be delivered, the job is not counted.
- If the job is cancelled during sending, it may or may not be counted, depending on what stage of the process had been reached when the job was cancelled.
- Even if several files are combined for sending, the transmission counts as one job.

8151	T:Deliv Jobs/PC		[0 to 9999999 / 0 / 1]
	These SPs count the total number of jobs scanned and sent to a folder on a PC (Scan-to-PC). Note: At the present time, 8151 and 8155 perform identical counts.		
001	B/W	Black Deliv	
002	Color	Color Deliv / Only for D011, D013, D091 or D092	
003	ACS	Color Deliv / Only for D011, D013, D091 or D092	
8155	S:Deliv Jobs/PC		
	These SPs count the total number of jobs scanned and sent with Scan-to-PC.		
001	B/W	Black Deliv	
002	Color	Color Deliv / Only for D011, D013, D091 or D092	
003	ACS	Color Deliv / Only for D011, D013, D091 or D092	

- These counters count jobs, not pages.
- If the job is cancelled during scanning, it is not counted.
- If the job is cancelled while it is waiting to be sent, the job is not counted.
- If the job is cancelled during sending, it may or may not be counted, depending on what stage of the process had been reached when the job was cancelled.
- Even if several files are combined for sending, the transmission counts as one job.

8161	T:PCFAX TX Jobs	These SPs count the number of PC Fax transmission jobs. A job is counted from when it is registered for sending, not when it is sent. [0 to 9999999 / 0 / 1] Note: At the present time, these counters perform identical counts.
8163	F:PCFAX TX Jobs	

- This counts fax jobs started from a PC using a PC fax application, and sending the data out to the destination from the PC through the copier.

8191	T:Total Scan PGS	These SPs count the pages scanned by each application that uses the scanner to scan images. [0 to 9999999 / 0 / 1]
8192	C:Total Scan PGS	
8193	F:Total Scan PGS	
8195	S:Total Scan PGS	
8196	L:Total Scan PGS	

System SP Table-8

- SP 8191 to 8196 count the number of scanned sides of pages, not the number of physical pages.
- These counters do not count reading user stamp data, or reading color charts to adjust color.
- Previews done with a scanner driver are not counted.
- A count is done only after all images of a job have been scanned.
- Scans made in SP mode are not counted.

Examples

- If 3 B5 pages and 1 A3 page are scanned with the scanner application but not stored, the S: count is 4.
- If both sides of 3 A4 sheets are copied and stored to the document server using the Store File button in the Copy mode window, the C: count is 6 and the L: count is 6.
- If both sides of 3 A4 sheets are copied but not stored, the C: count is 6.
- If you enter document server mode then scan 6 pages, the L: count is 6.

8201	T:LSize Scan PGS	[0 to 9999999 / 0 / 1]
8203	F Lsize Scan Pgs.	[0 to 9999999 / 0 / 1]
8205	S:LSize Scan PGS	[0 to 9999999 / 0 / 1]
	<p>These SP codes count the total number of large pages input with the scanner for scan jobs only. Large size paper (A3/DLT) scanned for fax transmission are not counted.</p> <p>Note: These counters are displayed in the SMC Report, and in the User Tools display..</p>	

8211	T:Scan PGS/LS	These SPs count the number of pages scanned into the document server . [0 to 9999999 / 0 / 1] The L: counter counts the number of pages stored from within the document server mode screen at the operation panel, and with the Store File button from within the Copy mode screen
8212	C:Scan PGS/LS	
8213	F:Scan PGS/LS	
8215	S:Scan PGS/LS	
8216	L:Scan PGS/LS	

- Reading user stamp data is not counted.
- If a job is cancelled, the pages output as far as the cancellation are counted.
- If the scanner application scans and stores 3 B5 sheets and 1 A4 sheet, the S: count is 4.
- If pages are copied but not stored on the document server, these counters do not change.
- If both sides of 3 A4 sheets are copied and stored to the document server, the C: count is 6 and the L: count is 6.
- If you enter document server mode then scan 6 pages, the L: count is 6.

System SP Table-8

8221	ADF Org Feeds	[0 to 9999999 / 0 / 1]
	These SPs count the number of pages fed through the ADF for front and back side scanning.	
001	Front	<p>Number of front sides fed for scanning:</p> <p>With an ADF that can scan both sides simultaneously, the Front side count is the same as the number of pages fed for either simplex or duplex scanning.</p> <p>With an ADF that cannot scan both sides simultaneously, the Front side count is the same as the number of pages fed for duplex front side scanning. (The front side is determined by which side the user loads face up.)</p>
002	Back	<p>Number of rear sides fed for scanning:</p> <p>With an ADF that can scan both sides simultaneously, the Back count is the same as the number of pages fed for duplex scanning.</p> <p>With an ADF that cannot scan both sides simultaneously, the Back count is the same as the number of pages fed for duplex rear-side scanning.</p>

- When 1 sheet is fed for duplex scanning the Front count is 1 and the Back count is 1.
- If a jam occurs during the job, recovery processing is not counted to avoid double counting. Also, the pages are not counted if the jam occurs before the first sheet is output.

8231	Scan PGS/Mode	[0 to 9999999 / 0 / 1]
	These SPs count the number of pages scanned by each ADF mode to determine the work load on the ADF.	
001	Large Volume	Selectable. Large copy jobs that cannot be loaded in the ADF at one time.
002	SADF	Selectable. Feeding pages one by one through the ADF.
003	Mixed Size	Selectable. Select "Mixed Sizes" on the operation panel.
004	Custom Size	Selectable. Originals of non-standard size.
005	Platen	Book mode. Raising the ADF and placing the original directly on the platen.
006	Simplex / Duplex	Selectable. Select "Simplex/Duplex" on the operation panel.

- If the scan mode is changed during the job, for example, if the user switches from ADF to Platen mode, the count is done for the last selected mode.
- The user cannot select mixed sizes or non-standard sizes with the fax application so if the original's page sizes are mixed or non-standard, these are not counted.
- If the user selects "Mixed Sizes" for copying in the platen mode, the Mixed Size count is enabled.
- In the SADF mode if the user copies 1 page in platen mode and then copies 2 pages with SADF, the Platen count is 1 and the SADF count is 3.

System SP Table-8

8241	T:Scan PGS/Org	[0 to 9999999 / 0 / 1]				
	These SPs count the total number of scanned pages by original type for all jobs, regardless of which application was used.					
8242	C:Scan PGS/Org	[0 to 9999999 / 0 / 1]				
	These SPs count the number of pages scanned by original type for Copy jobs.					
8243	F:Scan PGS/Org	[0 to 9999999 / 0 / 1]				
	These SPs count the number of pages scanned by original type for Fax jobs.					
8245	S:Scan PGS/Org	[0 to 9999999 / 0 / 1]				
	These SPs count the number of pages scanned by original type for Scan jobs.					
8246	L:Scan PGS/Org	[0 to 9999999 / 0 / 1]				
	These SPs count the number of pages scanned and stored from within the document server mode screen at the operation panel, and with the Store File button from within the Copy mode screen					
		8241	8242	8243	8245	8246
824x 1: Text		Yes	Yes	Yes	Yes	Yes
824x 2: Text/Photo		Yes	Yes	Yes	Yes	Yes
824x 3: Photo		Yes	Yes	Yes	Yes	Yes
824x 4: GenCopy, Pale		Yes	Yes	No	Yes	Yes
824x 5: Map		Yes	Yes	No	Yes	Yes
824x 6: Normal/Detail		Yes	No	Yes	No	No
824x 7: Fine/Super Fine		Yes	No	Yes	No	No
824x 8: Binary		Yes	No	No	Yes	No

824x 9: Grayscale	Yes	No	No	Yes	No
824x 11: Other	Yes	Yes	Yes	Yes	Yes

- If the scan mode is changed during the job, for example, if the user switches from ADF to Platen mode, the count is done for the last selected mode.

8251	T:Scan PGS/ImgEdt	<p>These SPs show how many times Image Edit features have been selected at the operation panel for each application. Some examples of these editing features are:</p> <p>Erase> Border Erase> Center Image Repeat Centering Positive/Negative [0 to 9999999 / 0 / 1]</p> <p>Note: The count totals the number of times the edit features have been used. A detailed breakdown of exactly which features have been used is not given.</p>
8252	C:Scan PGS/ImgEdt	
8255	S:Scan SGS/ImgEdt	
8256	L:Scan PGS/ImgEdt	
8257	O:Scan PGS/ImgEdt	

The L: counter counts the number of pages stored from within the document server mode screen at the operation panel, and with the Store File button from within the Copy mode screen.

8281	T:Scan PGS/TWAIN	<p>These SPs count the number of pages scanned using a TWAIN driver. These counters reveal how the TWAIN driver is used for delivery functions.</p> <p>[0 to 9999999 / 0 / 1]</p> <p>Note: At the present time, these counters perform identical counts.</p>
8285	S:Scan PGS/TWAIN	

System SP Table-8

8291	T:Scan PGS/Stamp	These SPs count the number of pages stamped with the stamp in the ADF unit. [0 to 9999999 / 0 / 1] The L: counter counts the number of pages stored from within the document server mode screen at the operation panel, and with the Store File button from within the Copy mode screen
8293	F:Scan PGS/Stamp	
8295	S:Scan PGS/Stamp	

8301	T:Scan PGS/Size	[0 to 9999999 / 0 / 1]
	These SPs count by size the total number of pages scanned by all applications. Use these totals to compare original page size (scanning) and output (printing) page size [SP 8-441].	
8302	C:Scan PGS/Size	[0 to 9999999 / 0 / 1]
	These SPs count by size the total number of pages scanned by the Copy application. Use these totals to compare original page size (scanning) and output (printing) page size [SP 8-442].	
8303	F:Scan PGS/Size	[0 to 9999999 / 0 / 1]
	These SPs count by size the total number of pages scanned by the Fax application. Use these totals to compare original page size (scanning) and output page size [SP 8-443].	
8305	S:Scan PGS/Size	[0 to 9999999 / 0 / 1]
	These SPs count by size the total number of pages scanned by the Scan application. Use these totals to compare original page size (scanning) and output page size [SP 8-445].	
8306	L:Scan PGS/Size	[0 to 9999999 / 0 / 1]
	These SPs count by size the total number of pages scanned and stored from within the document server mode screen at the operation panel, and with the Store File button from within the Copy mode screen. Use these totals to compare original page size (scanning) and output page size [SP	

	8-446].	
830x 1	A3	
830x 2	A4	
830x 3	A5	
830x 4	B4	
830x 5	B5	
830x 6	DLT	
830x 7	LG	
830x 8	LT	
830x 9	HLT	
830x 10	Full Bleed	
830x 254	Other (Standard)	
830x 255	Other (Custom)	

8311	T:Scan PGS/Rez	[0 to 9999999 / 0 / 1]
	These SPs count by resolution setting the total number of pages scanned by applications that can specify resolution settings.	
8315	S:Scan PGS/Rez	[0 to 9999999 / 0 / 1]
	These SPs count by resolution setting the total number of pages scanned by applications that can specify resolution settings. Note: At the present time, 8311 and 8315 perform identical counts.	
831x 1	1200dpi to	
831x 2	600dpito1199dpi	
831x 3	400dpito599dpi	
831x 4	200dpito399dpi	

System SP Table-8

831x 5	to199dpi	
--------	----------	--

- Copy resolution settings are fixed so they are not counted.
- The Fax application does not allow finely-adjusted resolution settings so no count is done for the Fax application.

8381	T:Total PrtPGS	<p>These SPs count the number of pages printed by the customer. The counter for the application used for storing the pages increments. [0 to 9999999 / 0 / 1]</p> <p>The L: counter counts the number of pages stored from within the document server mode screen at the operation panel. Pages stored with the Store File button from within the Copy mode screen go to the C: counter.</p>
8382	C:Total PrtPGS	
8383	F:Total PrtPGS	
8384	P:Total PrtPGS	
8385	S:Total PrtPGS	
8386	L:Total PrtPGS	
8387	O:Total PrtPGS	

- When the A3/DLT double count function is switched on with SP5104, 1 A3/DLT page is counted as 2.
- When several documents are merged for a print job, the number of pages stored are counted for the application that stored them.
- These counters are used primarily to calculate charges on use of the machine, so the following pages are not counted as printed pages:
 - Blank pages in a duplex printing job.
 - Blank pages inserted as document covers, chapter title sheets, and slip sheets.
 - Reports printed to confirm counts.
 - All reports done in the service mode (service summaries, engine maintenance reports, etc.)
 - Test prints for machine image adjustment.
 - Error notification reports.
 - Partially printed pages as the result of a copier jam.

8391	LSize PrtPGS	[0 to 9999999 / 0 / 1]
	<p>These SPs count pages printed on paper sizes A3/DLT and larger. Note: In addition to being displayed in the SMC Report, these counters are also displayed in the User Tools display on the copy machine.</p>	

8401	T:PrtPGS/LS	<p>These SPs count the number of pages printed from the document server. The counter for the application used to print the pages is incremented.</p> <p>The L: counter counts the number of jobs stored from within the document server mode screen at the operation panel.</p> <p>[0 to 9999999 / 0 / 1]</p>
8402	C:PrtPGS/LS	
8403	F:PrtPGS/LS	
8404	P:PrtPGS/LS	
8405	S:PrtPGS/LS	
8406	L:PrtPGS/LS	

- Print jobs done with Web Image Monitor and Desk Top Binder are added to the L: count.
- Fax jobs done with Web Image Monitor and Desk Top Binder are added to the F: count.

8411	Prints/Duplex	<p>This SP counts the amount of paper (front/back counted as 1 page) used for duplex printing. Last pages printed only on one side are not counted.</p> <p>[0 to 9999999 / 0 / 1]</p>
------	---------------	---

System SP Table-8

8421	T:PrtPGS/Dup Comb	[0 to 9999999 / 0 / 1]
	These SPs count by binding and combine, and n-Up settings the number of pages processed for printing. This is the total for all applications.	
8422	C:PrtPGS/Dup Comb	[0 to 9999999 / 0 / 1]
	These SPs count by binding and combine, and n-Up settings the number of pages processed for printing by the copier application.	
8423	F:PrtPGS/Dup Comb	[0 to 9999999 / 0 / 1]
	These SPs count by binding and combine, and n-Up settings the number of pages processed for printing by the fax application.	
8424	P:PrtPGS/Dup Comb	[0 to 9999999 / 0 / 1]
	These SPs count by binding and combine, and n-Up settings the number of pages processed for printing by the printer application.	
8425	S:PrtPGS/Dup Comb	[0 to 9999999 / 0 / 1]
	These SPs count by binding and combine, and n-Up settings the number of pages processed for printing by the scanner application.	
8426	L:PrtPGS/Dup Comb	[0 to 9999999 / 0 / 1]
	These SPs count by binding and combine, and n-Up settings the number of pages processed for printing from within the document server mode window at the operation panel.	
8427	O:PrtPGS/Dup Comb	[0 to 9999999 / 0 / 1]
	These SPs count by binding and combine, and n-Up settings the number of pages processed for printing by Other applications	
842x 1	Simplex> Duplex	
842x 2	Duplex> Duplex	
842x 3	Book> Duplex	

842x 4	Simplex Combine	
842x 5	Duplex Combine	
842x 6	2>	2 pages on 1 side (2-Up)
842x 7	4>	4 pages on 1 side (4-Up)
842x 8	6>	6 pages on 1 side (6-Up)
842x 9	8>	8pages on 1 side (8-Up)
842x 10	9>	9 pages on 1 side (9-Up)
842x 11	16>	16 pages on 1 side (16-Up)
842x 12	Booklet	
842x 13	Magazine	

- These counts (SP8421 to SP8427) are especially useful for customers who need to improve their compliance with ISO standards for the reduction of paper consumption.
- Pages that are only partially printed with the n-Up functions are counted as 1 page.
- Here is a summary of how the counters work for Booklet and Magazine modes:

System SP Table-8

Booklet		Magazine	
Original Pages	Count	Original Pages	Count
1	1	1	1
2	2	2	2
3	2	3	2
4	2	4	2
5	3	5	4
6	4	6	4
7	4	7	4
8	4	8	4

8431	T:PrtPGS/ImgEdt	[0 to 9999999 / 0 / 1]
	These SPs count the total number of pages output with the three features below, regardless of which application was used.	
8432	C:PrtPGS/ImgEdt	[0 to 9999999 / 0 / 1]
	These SPs count the total number of pages output with the three features below with the copy application.	
8434	P:PrtPGS/ImgEdt	[0 to 9999999 / 0 / 1]
	These SPs count the total number of pages output with the three features below with the print application.	

8436	L:PrtPGS/ImgEdt	[0 to 9999999 / 0 / 1]
	These SPs count the total number of pages output from within the document server mode window at the operation panel with the three features below.	
8437	O:PrtPGS/ImgEdt	[0 to 9999999 / 0 / 1]
	These SPs count the total number of pages output with the three features below with Other applications.	
843x 1	Cover/Slip Sheet	Total number of covers or slip sheets inserted. The count for a cover printed on both sides counts 2.
843x 2	Series/Book	The number of pages printed in series (one side) or printed as a book with booklet right/left pagination.
843x 3	User Stamp	The number of pages printed where stamps were applied, including page numbering and date stamping.

8441	T:PrtPGS/Ppr Size	[0 to 9999999 / 0 / 1]
	These SPs count by print paper size the number of pages printed by all applications.	
8442	C:PrtPGS/Ppr Size	[0 to 9999999 / 0 / 1]
	These SPs count by print paper size the number of pages printed by the copy application.	
8443	F:PrtPGS/Ppr Size	[0 to 9999999 / 0 / 1]
	These SPs count by print paper size the number of pages printed by the fax application.	
8444	P:PrtPGS/Ppr Size	[0 to 9999999 / 0 / 1]
	These SPs count by print paper size the number of pages printed by the printer application.	

System SP Table-8

8445	S:PrtPGS/Ppr Size	[0 to 9999999 / 0 / 1]
	These SPs count by print paper size the number of pages printed by the scanner application.	
8446	L:PrtPGS/Ppr Size	[0 to 9999999 / 0 / 1]
	These SPs count by print paper size the number of pages printed from within the document server mode window at the operation panel.	
8447	O:PrtPGS/Ppr Size	[0 to 9999999 / 0 / 1]
	These SPs count by print paper size the number of pages printed by Other applications.	
844x 1	A3	
844x 2	A4	
844x 3	A5	
844x 4	B4	
844x 5	B5	
844x 6	DLT	
844x 7	LG	
844x 8	LT	
844x 9	HLT	
844x 10	Full Bleed	
844x 254	Other (Standard)	
844x 255	Other (Custom)	

- These counters do not distinguish between LEF and SEF.

8451	PrtPGS/Ppr Tray		[0 to 9999999 / 0 / 1]
	These SPs count the number of sheets fed from each paper feed station.		
001	Bypass	Bypass Tray	
002	Tray 1	Copier	
003	Tray 2	Copier	
004	Tray 3	Paper Tray Unit (Option)	
005	Tray 4	Paper Tray Unit (Option)	
006	Tray 5	LCT (Option)	
007	Tray 6	Currently not used.	
008	Tray 7	Currently not used.	
009	Tray 8	Currently not used.	
010	Tray 9	Currently not used.	

8461	T:PrtPGS/Ppr Type		[0 to 9999999 / 0 / 1]
	<p>These SPs count by paper type the number pages printed by all applications.</p> <p>These counters are not the same as the PM counter. The PM counter is based on feed timing to accurately measure the service life of the feed rollers. However, these counts are based on output timing.</p> <p>Blank sheets (covers, chapter covers, slip sheets) are also counted.</p> <p>During duplex printing, pages printed on both sides count as 1, and a page printed on one side counts as 1.</p>		

Appendix:
Service
Program
Mode Tables

System SP Table-8

8462	C:PrtPGS/Ppr Type	[0 to 9999999 / 0 / 1]
	These SPs count by paper type the number pages printed by the copy application.	
8463	F:PrtPGS/Ppr Type	[0 to 9999999 / 0 / 1]
	These SPs count by paper type the number pages printed by the fax application.	
8464	P:PrtPGS/Ppr Type	[0 to 9999999 / 0 / 1]
	These SPs count by paper type the number pages printed by the printer application.	
8466	L:PrtPGS/Ppr Type	[0 to 9999999 / 0 / 1]
	These SPs count by paper type the number pages printed from within the document server mode window at the operation panel.	
846x 1	Normal	
846x 2	Recycled	
846x 3	Special	
846x 4	Thick	
846x 5	Normal (Back)	
846x 6	Thick (Back)	
846x 7	OHP	
846x 8	Other	

8471	PrtPGS/Mag	[0 to 9999999 / 0 / 1]
	These SPs count by magnification rate the number of pages printed.	
001	to 49%	
002	50% to 99%	
003	100%	
004	101% to 200%	
005	201% to	

- Counts are done for magnification adjusted for pages, not only on the operation panel but performed remotely with an external network application capable of performing magnification adjustment as well.
- Magnification adjustments done with printer drivers with PC applications such as Excel are also counted.
- Magnification adjustments done for adjustments after they have been stored on the document server are not counted.
- Magnification adjustments performed automatically during Auto Reduce/Enlarge copying are counted.
- The magnification rates of blank cover sheets, slip sheets, etc. are automatically assigned a rate of 100%.

8481	T:PrtPGS/TonSave
8484	P:PrtPGS/TonSave
	<p>These SPs count the number of pages printed with the Toner Save feature switched on.</p> <p>Note: These SPs return the same results as this SP is limited to the Print application.</p> <p>[0 to 9999999 / 0 / 1]</p>

System SP Table-8

8511	T:PrtPGS/Emul	[0 to 9999999 / 0 / 1]	
	These SPs count by printer emulation mode the total number of pages printed.		
8514	P:PrtPGS/Emul	[0 to 9999999 / 0 / 1]	
	These SPs count by printer emulation mode the total number of pages printed.		
001	RPCS		
002	RPDL		
003	PS3		
004	R98		
005	R16		
006	GL/GL2		
007	R55		
008	RTIFF		
009	PDF		
010	PCL5e/5c		
011	PCL XL		
012	IPDL-C		
013	BM-Links	Japan Only	
014	Other		

- SP8511 and SP8514 return the same results as they are both limited to the Print application.
- Print jobs output to the document server are not counted.

System SP Table-8

8521	T:PrtPGS/FIN	[0 to 9999999 / 0 / 1]
	These SPs count by finishing mode the total number of pages printed by all applications.	
8522	C:PrtPGS/FIN	[0 to 9999999 / 0 / 1]
	These SPs count by finishing mode the total number of pages printed by the Copy application.	
8523	F:PrtPGS/FIN	[0 to 9999999 / 0 / 1]
	These SPs count by finishing mode the total number of pages printed by the Fax application. Note: Print finishing options for received faxes are currently not available.	
8524	P:PrtPGS/FIN	[0 to 9999999 / 0 / 1]
	These SPs count by finishing mode the total number of pages printed by the Print application.	
8525	S:PrtPGS/FIN	[0 to 9999999 / 0 / 1]
	These SPs count by finishing mode the total number of pages printed by the Scanner application.	
8526	L:PrtPGS/FIN	[0 to 9999999 / 0 / 1]
	These SPs count by finishing mode the total number of pages printed from within the document server mode window at the operation panel.	
852x 1	Sort	
852x 2	Stack	
852x 3	Staple	
852x 4	Booklet	

System SP Table-8

852x 5	Z-Fold
852x 6	Punch
852x 7	Other

 Note

- If stapling is selected for finishing and the stack is too large for stapling, the unstapled pages are still counted.
- The counts for staple finishing are based on output to the staple tray, so jam recoveries are counted.

8531	Staples	This SP counts the amount of staples used by the machine. [0 to 9999999 / 0 / 1]
------	---------	---

8581	T: Counter	[0 to 9999999 / 0 / 1]
	<p>These SPs count the total output broken down by color output, regardless of the application used. In addition to being displayed in the SMC Report, these counters are also displayed in the User Tools display on the copy machine.</p> <p>Note: This SP is expanded for color MFP and color LP machines. For this machine, the count is done for black only.</p>	

8591	O: Counter	[0 to 9999999 / 0 / 1]
	<p>These SPs count the totals for A3/DLT paper use, number of duplex pages printed, and the number of staples used. These totals are for Other (O:) applications only.</p>	
001	A3/DLT	
002	Duplex	

8601	Coverage Counter		[0 to 9999999 / 0 / 1]
	These SPs count the total coverage for each color and printout pages for each printing mode.		
001	B/W		
011	B/W Printing Pages		

8631	T:FAX TX PGS		[0 to 9999999 / 0 / 1]
	These SPs count by color mode the number of pages sent by fax to a telephone number.		
001	B/W	Black TX	
8633	F:FAX TX PGS		[0 to 999999 / 0 / 1]
	These SPs count by color mode the number of pages sent by fax to a telephone number.		
002	B/W	Black TX	

Appendix:
Service
Program
Mode Tables

- If a document has color and black-and-white pages mixed, the pages are counted separately as B/W or Color.
- At the present time, this feature is provided for the Fax application only so SP8631 and SP8633 are the same.
- The counts include error pages.
- If a document is sent to more than one destination with a Group transmission, the count is done for each destination.
- Polling transmissions are counted but polling RX are not.
- Relay, memory, and confidential mailbox transmissions and are counted for each destination.

System SP Table-8

8641	T:FAX TX PGS		[0 to 9999999 / 0 / 1]
	These SPs count by color mode the number of pages sent by fax to as fax images using I-Fax.		
001	B/W	Black TX	
8643	F:FAX TX PGS		[0 o 9999999 / 0 / 1]
	These SPs count by color mode the number of pages sent by Fax as fax images using I-Fax.		
002	B/W	Black TX	

- If a document has color and black-and-white pages mixed, the pages are counted separately as B/W or Color.
- At the present time, this feature is provided for the Fax application only so SP8641 and SP8643 are the same.
- The counts include error pages.
- If a document is sent to more than one destination with a Group transmission, the count is done for each destination.
- Polling transmissions are counted but polling RX are not.
- Relay, memory, and confidential mailbox transmissions and are counted for each destination.

8651	T:S-to-Email PGS	[0 to 9999999 / 0 / 1]
	These SPs count by color mode the total number of pages attached to an e-mail for both the Scan and document server applications.	
001	B/W	
002	Color	
8655	S:S-to-Email PGS	[0 to 9999999 / 0 / 1]
	These SPs count by color mode the total number of pages attached to an e-mail for the Scan application only.	
001	B/W	
002	Color	

 Note

- The count for B/W and Color pages is done after the document is stored on the HDD. If the job is cancelled before it is stored, the pages are not counted.
- If Scan-to-Email is used to send a 10-page document to 5 addresses, the count is 10 (the pages are sent to the same SMTP server together).
- If Scan-to-PC is used to send a 10-page document to 5 folders, the count is 50 (the document is sent to each destination of the SMB/FTP server).
- Due to restrictions on some devices, if Scan-to-Email is used to send a 10-page document to a large number of destinations, the count may be divided and counted separately. For example, if a 10-page document is sent to 200 addresses, the count is 10 for the first 100 destinations and the count is also 10 for the second 100 destinations, for a total of 20).

System SP Table-8

8661	T:Deliv PGS/Svr	[0 to 9999999 / 0 / 1]
	These SPs count by color mode the total number of pages sent to a Scan Router server by both Scan and LS applications.	
001	B/W	
002	Color	
8665	S:Deliv PGS/Svr	[0 to 9999999 / 0 / 1]
	These SPs count by color mode the total number of pages sent to a Scan Router server by the Scan application.	
001	B/W	
002	Color	

 Note

- The B/W and Color counts are done after the document is stored on the HDD of the Scan Router server.
- If the job is canceled before storage on the Scan Router server finishes, the counts are not done.
- The count is executed even if regardless of confirmation of the arrival at the Scan Router server.

8671	T: Deliv PGS/PC	[0 to 9999999 / 0 / 1]
	These SPs count by color mode the total number of pages sent to a folder on a PC (Scan-to-PC) with the Scan and LS applications.	
001	B/W	
002	Color	
8675	S: Deliv PGS/PC	[0 to 9999999 / 0 / 1]
	These SPs count by color mode the total number of pages sent with Scan-to-PC with the Scan application.	
001	B/W	
002	Color	

8681	T:PCFAX TXPGS	These SPs count the number of pages sent by PC Fax. These SPs are provided for the Fax application only, so the counts for SP8681 and SP8683 are the same. [0 to 9999999 / 0 / 1]
8683	F:PCFAX TXPGS	

- This counts pages sent from a PC using a PC fax application, from the PC through the copier to the destination.
- When sending the same message to more than one place using broadcasting, the pages are only counted once. (For example, a 10-page fax is sent to location A and location B. The counter goes up by 10, not 20.)

System SP Table-8

8691	T:TX PGS/LS	<p>These SPs count the number of pages sent from the document server. The counter for the application that was used to store the pages is incremented.</p> <p>[0 to 9999999 / 0 / 1]</p> <p>The L: counter counts the number of pages stored from within the document server mode screen at the operation panel. Pages stored with the Store File button from within the Copy mode screen go to the C: counter.</p>
8692	C:TX PGS/LS	
8693	F:TX PGS/LS	
8694	P:TX PGS/LS	
8695	S:TX PGS/LS	
8696	L:TX PGS/LS	

 Note

- Print jobs done with Web Image Monitor and Desk Top Binder are added to the count.
- If several documents are merged for sending, the number of pages stored are counted for the application that stored them.
- When several documents are sent by a Fax broadcast, the F: count is done for the number of pages sent to each destination.

	TX PGS/Port	[0 to 9999999 / 0 / 1]
8701	<p>These SPs count the number of pages sent by the physical port used to send them. For example, if a 3-page original is sent to 4 destinations via ISDN G4, the count for ISDN (G3, G4) is 12.</p>	
001	PSTN-1	
002	PSTN-2	
003	PSTN-3	
004	ISDN (G3,G4)	
005	Network	

8711	T:Scan PGS/Comp	[0 to 9999999 / 0 / 1]	
	These SPs count the number of compressed pages scanned into the document server, counted by the formats listed below.		
001	JPEG/JPEG2000		
002	TIFF (Multi/Single)		
003	PDF		
004	Other		
005	High Compression PDF		

8715	S:Scan PGS/Comp	[0 to 9999999 / 0 / 1]	
	These SPs count the number of compressed pages scanned by the scan application, counted by the formats listed below.		
001	JPEG/JPEG2000		
002	TIFF (Multi/Single)		
003	PDF		
004	Other		
005	High Compression PDF		

Appendix:
Service
Program
Mode Tables

System SP Table-8

8741	RX PGS/Port	[0to9999999/ 0 / 1]	
	These SPs count the number of pages received by the physical port used to receive them.		
001	PSTN-1		
002	PSTN-2		
003	PSTN-3		
004	ISDN (G3,G4)		
005	Network		

8771	Dev Counter	[0to9999999/ 0 / 1]	
	<p>These SPs count the frequency of use (number of rotations of the development rollers) for black and other color toners.</p> <p>Note: For machines that do not support color, the Black toner count is the same as the Total count.</p>		

8781	Pixel Coverage Ratio		
	This SP displays the number of toner bottles used. The count is done based on the equivalent of 1,000 pages per bottle.		

8791	LS Memory Remain	<p>This SP displays the percent of space available on the document server for storing documents.</p> <p>[0 to 100 / 0 / 1]</p>	
------	------------------	--	--

8801	Toner Remain	[0 to 100 / 0 / 1]
	<p>This SP displays the percent of toner remaining for each color. This SP allows the user to check the toner supply at any time.</p> <p>Note:</p> <p>This precise method of measuring remaining toner supply (1% steps) is better than other machines in the market that can only measure in increments of 10 (10% steps).</p> <p>This SP is expanded for color MFP and color LP machines. For this machine, the count is done for black only.</p>	

8851	Toner Coverage 0-10%	[0 to 9999999 / 0 / 1]
	<p>These SPs count the percentage of dot coverage for black other color toners.</p>	
011	0 to 2%: BK	
021	3 to 4%: BK	
031	5 to 7%: BK	
041	8 to 10%: BK	

8861	Toner Coverage 11-20%	[0 to 9999999 / 0 / 1]	
	<p>These SPs count the percentage of dot coverage for black other color toners.</p>		
001	K	Black toner	Do not display for this machine.

System SP Table-8

8871	Toner Coverage 21-30%		[0 to 9999999 / 0 / 1]
	These SPs count the percentage of dot coverage for black other color toners.		
001	K	Black toner	Do not display for this machine.

8881	Toner Coverage 31 -%		[0 to 9999999 / 0 / 1]
	These SPs count the percentage of dot coverage for black other color toners.		
001	K	Black toner	Do not display for this machine.

8891	Printing PGS: Present Ink		[0 to 9999999 / 0 / 1]
	These SPs display the amount of the remaining current toner.		

8901	Printing PGS: Log: Latest 1		[0 to 9999999 / 0 / 1]
	These SPs display the amount of the remaining previous toner.		

8911	Printing PGS: Log: Latest 2		[0 to 9999999 / 0 / 1]
	These SPs display the amount of the remaining 2nd previous toner.		

8921	Toner Coverage Count Total		[0 to 9999999 / 0 / 1]
	Displays the total coverage and total printout number for each color.		
001	Coverage (%) BK		
011	Coverage (PGS) BK		

8941	Machine Status	[0 to 9999999 / 0 / 1]
	These SPs count the amount of time the machine spends in each operation mode. These SPs are useful for customers who need to investigate machine operation for improvement in their compliance with ISO Standards.	
001	Operation Time	Engine operation time. Does not include time while controller is saving data to HDD (while engine is not operating).
002	Standby Time	Engine not operating. Includes time while controller saves data to HDD. Does not include time spent in Energy Save, Low Power, or Off modes.
003	Energy Save Time	Includes time while the machine is performing background printing.
004	Low Power Time	Includes time in Energy Save mode with Engine on. Includes time while machine is performing background printing.
005	Off Mode Time	Includes time while machine is performing background printing. Does not include time machine remains powered off with the power switches.
006	SC	Total down time due to SC errors.
007	PrtJam	Total down time due to paper jams during printing.
008	OrgJam	Total down time due to original jams during scanning.
009	Supply PM Unit End	Total down time due to supply unit end.

System SP Table-8

8951	AddBook Register		
	These SPs count the number of events when the machine manages data registration.		
001	User Code	User code registrations.	[0 to 9999999 / 0 / 1]
002	Mail Address	Mail address registrations.	
003	Fax Destination	Fax destination registrations.	
004	Group	Group destination registrations.	
005	Transfer Request	Fax relay destination registrations for relay TX.	
006	F-Code	F-Code box registrations.	
007	Copy Program	Copy application registrations with the Program (job settings) feature.	[0 to 255 / 0 / 255]
008	Fax Program	Fax application registrations with the Program (job settings) feature.	
009	Printer Program	Printer application registrations with the Program (job settings) feature.	
010	Scanner Program	Scanner application registrations with the Program (job settings) feature.	

8999	Admin. Counter List	[0 to 9999999 / 0 / 1]
	Display the total coverage and total printout number for each color.	
001	Total	
003	Copy: BW	
007	Printer BW	
010	Fax Print: BW	
012	A3/DLT	
013	Duplex	
015	Coverage: BW (%)	
017	Coverage: BW Print Page (%)	
101	Transmission Total: Color	
102	Transmission Total: BW	
103	Fax Transmission	
104	Scanner Transmission: Color	
105	Scanner Transmission: BW	

4.9 INPUT CHECK

4.9.1 COPIER

When entering the Input Check mode, 8 digits display the result for a section. Each digit corresponds to a different device as shown in the table.

Bit No.	7	6	5	4	3	2	1	0
Result	0 or 1	0 or 1	0 or 1	0 or 1	0 or 1	0 or 1	0 or 1	0 or 1

5803	Input Check		
	Description	Reading	
		0	1
001	Tray 1: Paper Size Sensor	See the table 1 following this table.	
002	Tray 1: Tray Set Sensor	Set	Not set
003	Tray 1: Paper Lift Sensor	Not upper limit	Upper limit
004	Tray 1: Paper End Sensor	No paper	Paper remaining
005	Tray 1: Paper Height Sensor 1	See the table 2 following this table.	
006	Tray 1: Paper Height Sensor 2		
007	Tray 2: Paper Size Sensor	See the table 1 following this table.	
008	Tray 2: Tray Set Sensor	Set	Not set
009	Tray 2: Paper Lift Sensor	Not upper limit	Upper limit
010	Tray 2: Paper End Sensor	No paper	Paper remaining
011	Tray 2: Paper Height Sensor 1	See the table 2 following this table.	

012	Tray 2: Paper Height Sensor 2		
013	Tray 1: Paper Feed Sensor	Paper detected	No paper detected
014	Tray 2: Paper Feed Sensor	Paper detected	No paper detected
015	Tray 3: Paper Feed Sensor	Paper detected	No paper detected
016	Tray 4: Paper Feed Sensor	Paper detected	No paper detected
017	LCT: Paper Feed Sensor	No paper detected	Paper detected
018	Relay Sensor 1	Paper detected	No paper detected
019	Relay Sensor 2	Paper detected	No paper detected
020	Relay Sensor 3	No paper detected	Paper detected
021	Relay Sensor 4	No paper detected	Paper detected
022	Relay Sensor: LCT	No paper detected	Paper detected
023	By-pass: Paper End Sensor	Not end	Paper end
024	By-pass: Paper Size Sensor	See the table 3 following this table.	
025	Registration Sensor	Paper detected	No paper detected
026	Fusing Exit Sensor	No paper detected	Paper detected
027	Fusing Entrance Sensor	Paper detected	No paper detected
028	Junction Gate Relay Sensor	Paper detected	No paper detected
029	Exit Sensor	Paper detected	No paper detected
030	Paper Overflow Sensor	Not full	Full
031	Right Cover Open/Close	Close	Open
032	Duplex Unit Open/Close	Open	Close
033	Duplex Entrance Sensor	Paper detected	No paper detected
034	Duplex Exit Sensor	Paper detected	No paper detected

Input Check

035	Bank Right Cover Open/Close	Close	Open
036	Tray Cover Open/Close	Close	Open
037	LCT Set	Set	Not set
038	Bridge Exit Sensor	Paper detected	No paper detected
039	Bridge Relay Sensor	Paper detected	No paper detected
040	Bridge Unit Set Detection	Set	Not set
041	Bridge Right Guide Open/Close	Close	Open
042	Bridge Left Guide Open/Close	Close	Open
043	Transfer Belt Unit HP Sensor	Not HP	HP
046	Fusing Unit Set	Set (Bit1)	Not set (Bit1)
047	Toner Overflow Sensor	Not full	Full
048	Interlock Detection 1	Right or front door is open.	Right or front door is close.
049	Interlock Detection 2	Right or front door is open.	Right or front door is close.
050	Key Card Set	Set	Not set
051	Key Counter Set	Set	Not set
052	Mechanical Counter Set	Not set	set
053	1-Bin Unit Set	Set	Not set
054	1-Bin Unit: Paper Set	Paper detected	No paper detected
056	Dip Switch	-	-
057	Cleaning Web End	Not end	End
059	Shift Tray Set	Not set	Set
060	Shift Sensor	No paper detected	Paper detected

064	Shift Tray Sensor	Stay at rear	Stay at front
200	Scanner HP Sensor	Not HP	HP
201	Platen Cover Sensor	Open	Close

Table 1: Paper Height Sensor

0: Deactivated, 1: Activated (actuator inside sensor)

Remaining paper	Paper height sensor 1	Paper height sensor 2
Full	0	0
Nearly full	1	0
Near end	1	1
Almost empty	0	1

Input Check

Table 2: Paper Size Switch

Switch 1 is used for the tray set detection.

0: Pushed, 1: Not pushed

Models		Switch Location		
North America	Europe/Asia	4	3	2
11" x 17" SEF*1 (A3 SEF)	A3 SEF*1 (11" x 17" SEF)	0	0	1
8.5" x 14" SEF *2 (B4 SEF)	B4 SEF *2 (8.5" x 14" SEF)	0	0	0
A4 SEF	A4 SEF	1	1	0
8.5" x 11" SEF	8.5" x 11" SEF	1	1	1
B5 SEF	B5 SEF	0	1	1
11" x 8 1/2" LEF*3 (A4 LEF)	A4 LEF*3 (11" x 8 1/2" LEF)	1	0	0
10.5" x 7.25" LEF*4 (B5 LEF)	B5 LEF*4 (10.5" x 7.25" LEF)	0	1	0
A5 LEF	A5 LEF	1	0	1
<p>*1: The machine detects either 11" x 17" SEF or A3 SEF, depending on the setting of SP 5-181-002 (Tray 1) or -006 (Tray 2).</p> <p>*2: The machine detects either 8.5" x 14" SEF or B4 SEF, depending on the setting of SP 5-181-003 (Tray 1) or -007 (Tray 2).</p> <p>*3: The machine detects either 11" x 8 1/2" LEF or A4 LEF, depending on the setting of SP 5-181-001 (Tray 1) or -005 (Tray 2).</p> <p>*4: The machine detects either B5 LEF or 10.5" x 7.25" LEF, depending on the setting of SP 5-181-004 (Tray 1) or -008 (Tray 2)..</p>				

Table 3: Paper Size (By-pass Table)

0: Pushed, 1: Not pushed

Models		Bit No.			
North America	Europe/Asia	3	2	1	0
11" x 17" SEF*1 (11" x 8.5" LEF)	A3 SEF*1 (A4 LEF)	1	1	1	0
11" x 17" SEF*1 (11" x 8.5" LEF)	A3 SEF*1 (A4 LEF)	1	1	0	0
8.5" x 11" SEF*1 (8.5" x 11" SEF*2)	A4 SEF*1 (A5 LEF)	1	1	0	1
8.5" x 11" SEF*1 (8.5" x 11" SEF*2)	A4 SEF*1 (B5 LEF)	1	0	0	1
5.5" x 8.5" SEF	A5 SEF	1	0	1	1
5.5" x 8.5" SEF	A5 SEF	0	0	1	1
5.5" x 8.5" SEF	A6 SEF	0	1	1	1
5.5" x 8.5" SEF	A6 SEF	1	1	1	1

 **Note**

- *1: When the machine determines that the paper feed direction is "LEF", it considers that the paper size is bracketed size.

Input Check

APS Original Size Detection

Original Size		Length Sensor			Width Sensor		SP4-301 display
Metric version	Inch version	L3	L2	L1	W1	W2	
A3	11" x 17"	O	O	O	O	O	00011111
B4	10" x 14"	O	O	O	O	X	00011110
F4 8.5" x 13", 8.25" x 13", or 8" x 13" SP 5126 controls the size that is detected	8.5" x 14"	O	O	O	X	X	00011100
A4 LEF	8.5" x 11"	X	X	X	O	O	00000011
B5 LEF	-	X	X	X	O	X	00000010
A4 SEF	11" x 8.5"	X	O	O	X	X	00001100
B5 SEF	-	X	X	O	X	X	00000100
A5 LEF/ SEF	5.5" x 8.5", 8.5" x 5.5"	X	X	X	X	X	00000000

4.9.2 OPTIONS

2000/3000-Sheet (Booklet) Finisher (B804, B805)

6140	Bit	Description	Reading	
			0	1
001		Entrance Sensor	No paper detected	Paper detected
002		Proof Exit Sensor	No paper detected	Paper detected
003		Proof Full Detection Sensor	Not Full	Full
004		Trailing Edge Detection: Shift	No paper detected*1	Paper detected*1
005		Staple Exit Sensor	No paper detected	Paper detected
006		Shift HP Sensor	Not HP	HP
007		Shift Exit Sensor	No paper detected	Paper detected
008		Exit Guide Plate HP Sensor	Not HP	HP
009		Paper Detection Sensor: Staple	No paper detected	Paper detected
010		Paper Detection Sensor: Shift	No paper detected	Paper detected
011		Paper Full Sensor: 2000-Sheet	Not Full	Full
012		Oscillating Back Roller HP Sensor	Not HP	HP
013		Jogger HP Sensor	Not HP	HP
014		Exit Junction Gate HP Sensor	HP	Not HP
015		Staple Tray Paper Sensor	No paper detected	Paper detected
016		Staple Moving HP Sensor	Not HP	HP
017		Skew HP Sensor	Not HP	HP

Input Check

6140	Bit	Description	Reading	
			0	1
018		Limit SW	Not Limit	Limit
019		DOOR SW	Closed	Open
020		Stapler 1 Rotation	Not HP	HP
021		Staple Detection	No staple detected	Staple detected
022		Staple Leading Edge Detection	No staple detected	Staple detected
023		Punch Moving HP Sensor	Not HP	HP
024		Punch Registration HP Sensor	Not HP	HP
025		Punch Registration Detection Sensor	No paper detected	Paper detected
026		Punch Chad Full Sensor	Not Full	Full
027		Punch HP	Not HP	HP
028		Punch Selection DIPSW 1	See *1	
029		Punch Selection DiPSW 2	See *1	
030		Stack Junction Gate Open/Closed HP Sensor	Not HP	HP
031		Leading Edge Detection Sensor	No paper detected	Paper detected
032		Drive Roller HP Sensor	Not HP	HP
033		Arrival Sensor	No paper detected	Paper detected
034		Rear Edge Fence HP Sensor	Not HP	HP
035		Folder Cam HP Sensor	Not HP	HP
036		Folder Plate HP Sensor	Not HP	HP
037		Folder Pass Sensor	No paper detected	Paper detected

6140	Bit	Description	Reading	
			0	1
038		Saddle Full Sensor: Front	No paper detected*2	Paper detected*2
039		Saddle Full Sensor: Rear	No paper detected*2	Paper detected*2
040		Saddle Stitch Stapler 1 Rotation: Front	Not HP	HP
041		Saddle Stitch Detection: Front	No staple detected	Staple detected
042		Saddle Stitch Leading Edge Detection: Front	No staple detected	Staple detected
043		Saddle Stitch Stapler 1 Rotation: Rear	Not HP	HP
044		Saddle Stitch Detection: Rear	No staple detected	Staple detected
045		Saddle Stitch Leading Edge Detection: Rear	No staple detected	Staple detected
046		Full Sensor: 3000-Sheet	Not Full	Full
047		Exit Jogger HP Sensor: Front	Not used in the machine	
048		Exit Jogger HP Sensor: Rear	Not used in the machine	
049		Exit Jogger HP Sensor: Rear	Not used in the machine	

*1: Combination of DIP SW 1 and SW 2

Input Check

DIP SW 1	DIP SW 2	Punch Type
0	0	Japan
1	0	Europe
0	1	North America
1	1	North Europe

*2: Please refer to "Lower Tray (B804 Only)" in the Service Manual for the "2000/3000 (Booklet) Finisher".

1000-Sheet Finisher (B408)

6139	Bit	Description	Reading	
			0	1
001		Entrance Sensor	Paper detected	No paper detected
002		Shift Exit Sensor (Lower Tray Exit Sensor)	No paper detected	Paper detected
003		Staple Entrance Sensor (Stapler Tray Entrance Sensor)	Paper detected	No paper detected
004		Staple Moving HP Sensor (Stapler HP Sensor)	Not HP	HP
005		Jogger HP Sensor (Jogger Fence HP Sensor)	Not HP	HP
006		Stack Feed-out Belt HP Sensor	HP	Not HP
007		Staple Tray Paper Sensor	No paper detected	Paper detected
008		Staple Rotation Sensor (Staple Rotation HP Sensor)	Not HP	HP
009		Staple Sensor	Staple detected	No staple detected
010		Staple READY Detection	Staple detected	No staple detected
011		Exit Guide Plate HP (Exit Guide Plate HP Sensor)	Not HP	HP
012		Shift HP Sensor	Not HP	HP
013		Paper Sensor (Stack Height Sensor)	No output tray detected	Output tray detected

Input Check

6139	Bit	Description	Reading	
			0	1
014		Tray Lower Sensor (Lower Tray Lower Limit Sensor)	Lower limit	Not lower limit
015		Proof Full Sensor (Paper Limit Sensor)	Not full	Full

4.10 OUTPUT CHECK

4.10.1 COPIER

5804	Output Check	
001	Exit Motor: 350	Paper exit motor (Mainframe)
002	Exit Motor: 175	
003	Exit Motor: 230	
004	Exit Motor: 180	
005	Exit Motor: 154	
006	Exit Motor: 90	
007	Feed Motor: 300	Paper feed motor (Mainframe)
008	Feed Motor: 255	
009	Feed Motor: 230	
010	Feed Motor: 215	
011	Feed Motor: 180	
012	Feed Motor: 154	
013	Feed Motor: 90	Paper feed motor (Optional paper feed unit)
014	Bank: Feed Motor: 300	
015	Bank: Feed Motor: 255	
016	Bank: Feed Motor: 230	
017	Bank: Feed Motor: 215	
018	Bank: Feed Motor: 180	
019	Bank: Feed Motor: 154	

Output Check

5804	Output Check	
020	Bank: Feed Motor: 90	
021	LCT: Feed Motor: 300	Paper feed motor (Optional LCT)
022	LCT: Feed Motor: 255	
023	LCT: Feed Motor: 230	
024	LCT: Feed Motor: 215	
025	LCT: Feed Motor: 180	
026	LCT: Feed Motor: 154	
027	LCT: Feed Motor: 90	
028	Paper Feed Clutch 1	Paper feed clutch 1/2 (Mainframe)
029	Paper Feed Clutch 2	
030	Bank: Paper Feed Clutch 3	Paper feed clutch 3/4 (Optional paper feed unit)
031	Bank: Paper Feed Clutch 4	
032	LCT: Paper Feed Clutch	Paper feed clutch (Optional LCT)
033	Pick-up Solenoid 1	Pick-up Solenoid 1/2 (Mainframe)
034	Pick-up Solenoid 2	
035	Bank: Pick-up Solenoid 3	Pick-up Solenoid 3/4 (Optional paper feed unit)
036	Bank: Pick-up Solenoid 4	
037	LCT: Pick-up Solenoid	Pick-up Solenoid (LCT)
038	Tray Lift Motor 1: Up	
039	Tray Lift Motor 1: Down	
040	Tray Lift Motor 2: Up	
041	Tray Lift Motor 2: Down	

5804	Output Check	
042	Paper Tray Lock Solenoid	Not used
043	Bank: Paper Tray Lock Solenoid	Tray lock solenoid (Optional paper feed unit)
044	Registration Motor: 230	
045	Registration Motor: 180	
046	Registration Motor: 154	
047	Registration Motor: 90	
048	Exit: Junction Gate Solenoid	Junction gate 1 solenoid
049	Duplex: Inverter Gate Solenoid	Not used
050	Duplex Inverter Motor: Fwd: 230	
051	Duplex Inverter Motor: Fwd: 180	
052	Duplex Inverter Motor: Fwd: 154	
053	Duplex Inverter Motor: Fwd: 90	
054	Duplex Inverter Motor: Rev: 230	
055	Duplex Inverter Motor: Rev: 180	
056	Duplex Inverter Motor: Rev: 154	
057	Duplex Inverter Motor: Rev: 90	
058	Duplex/By-pass Motor: Fwd: 230	
059	Duplex/By-pass Motor: Fwd: 180	
060	Duplex/By-pass Motor: Fwd: 154	
061	Duplex/By-pass Motor: Fwd: 90	
062	Duplex/By-pass Motor: Rev: 230	
063	Duplex/By-pass Motor: Rev: 180	

Output Check

5804	Output Check	
064	Duplex/By-pass Motor: Rev: 154	
065	Duplex/By-pass Motor: Rev: 90	
066	By-pass Feed Clutch	-
067	By-pass Pick-up Solenoid	-
068	Bridge: Drive Motor: 230	Drive motor (Bridge unit)
069	Bridge: Drive Motor: 180	
070	Bridge: Drive Motor: 154	
071	Bridge: Drive Motor: 90	
072	Bridge: Junction Gate Solenoid	Junction Gate Solenoid (Bridge unit)
073	Bridge: Drive Motor: Reset	-
074	Bridge: Drive Motor: Enable	-
075	Bridge: Cooling Fan Motor	Not used
076	Transfer Belt Contact Motor	-
077	OPC Motor: 230	Drum motor
078	OPC Motor: 180	
079	OPC Motor: 154	
080	OPC Motor: 90	
081	Transfer/Development Motor: 230	-
082	Transfer/Development Motor: 180	
083	Transfer/Development Motor: 154	
084	Transfer/Development Motor: 90	
085	Fusing Motor: 230	-

Output Check

5804	Output Check	
086	Fusing Motor: 180	
087	Fusing Motor: 154	
088	Fusing Motor: 90	
089	Development Puddle Motor	-
090	PTL Control	-
091	Fusing Fan Motor: High	Fusing exhaust fan motor
092	Fusing Fan Motor: Low	
093	Exhaust Fan Motor: High	Exhaust fan motor
094	Exhaust Fan Motor: Low	
095	Duct Fan Motor	Cooling fan motor
096	Exit Fan Motor: High	Paper exit cooling fan motor
097	Exit Fan Motor: Low	
098	PSU Fan Motor	-
099	1-Bin Junction Gate Solenoid	Junction gate 2 solenoid (1-bin unit)
100	Polygon Motor: 230	
101	Polygon Motor: 180	
102	Polygon Motor: 154	
103	Polygon Motor: 90	
104	LD 1	-
105	LD 2	
106	Toner Bottle Motor: Fwd	Toner supply motor
107	Quenching Lamp	-

Appendix:
Service
Program
Mode Tables

Output Check

5804	Output Check	
108	Charge Bias	-
109	Development Bias	-
110	Transfer Belt Voltage	-
111	ID Sensor LED	-
115	Cleaning Web Motor	Web motor
116	Shift Tray Motor	Not used
117	CTL Cooling FAN	Controller fan
202	Scanner Lamp	-

4.10.2 1000-SHEET FINISHER (B408)

6144	Display	Description
6144 1	Relay Up Motor	Upper Transport Motor
6144 2	Relay Down Motor	Lower Transport Motor
6144 3	Exit Motor	-
6144 4	Proof Junction Gate SOL	Tray Junction Gate Solenoid
6144 5	Tray Up Motor	Lower Tray Lift Motor
6144 6	Jogger Motor	Jogger Fence Motor
6144 7	Staple Moving Motor	Stapler Motor
6144 8	Staple Motor	Stapler Hammer
6144 9	Staple Junction Gate SOL	Stapler Junction Gate Solenoid
6144 10	Positioning Roller Solenoid	Positioning Roller Solenoid
6144 11	Stack Feed-out Motor	-
6144 12	Shift Motor	-
6144 13	Exit Guide Plate Motor	-

Output Check

4.10.3 2000/3000-SHEET (BOOKLET) FINISHER

6145	Display	Description
6145 1	Entrance Motor	Finisher Entrance Motor
6145 2	Upper Feed Motor	Upper Transport Motor
6145 3	Lower Feed Motor	Lower Transport Motor
6145 4	Exit Motor	Upper/Proof Tray Exit Motor
6145 5	Knock Roller Motor	Clamp Roller Retraction Motor
6145 6	Shift Motor	Shift Roller Motor
6145 7	Exit Guide Plate Open/Close Motor	Exit Guide Plate Motor
6145 8	Tray Lift Motor	Upper Tray Lift Motor
6145 9	Oscillating Back Roller Motor	Stacking Sponge Roller Motor
6145 10	Jogger Motor	Jogger Fence Motor
6145 11	Stack Feed-out Motor	Feed Out Belt Motor
6145 12	Staple Moving Motor	Corner Stapler Movement Motor
6145 13	Staple Skew Motor	Corner Stapler Rotation Motor
6145 14	Staple Motor	Corner Stapler EH530

6145 15	Upper Junction Gate Solenoid	Proof Junction Gate Solenoid
6145 16	Lower Junction Gate Solenoid	Stapling Tray Junction Gate Solenoid
6145 17	Knock Solenoid	Stapling Edge Pressure Plate Solenoid
6145 18	Trailing Edge Hold Solenoid	Positioning Roller Solenoid
6145 19	Saddle Stitch Hold Solonoid	Booklet Pressure Roller Solenoid
6145 20	Stack Junction Gate Open/Close Motor	Stack Junction Gate Motor
6145 21	Trailing Edge Fence Moving Motor	Fold Unit Bottom Fence Lift Motor
6145 22	Saddle Stitch Staple Motor: Front	Booklet Stapler EH185R: Front
6145 23	Saddle Stitch Staple Motor: Rear	Booklet Stapler EH185R: Rear
6145 24	Folder Plate Motor	Fold Plate Motor
6145 25	Folder Roller Motor	Fold Roller Motor
6145 26	Drive Roller Oscillating Motor	Positioning Roller Motor

Output Check

6145 27	Punch Motor	Punch Drive Motor
6145 28	Punch Moving Motor	Punch Movement Motor
6145 29	Punch Registration Detection Motor	Paper Position Sensor Slide Motor
6145 30	Exit Jogger Motor: Front	-
6145 31	Exit Jogger Motor: Rear	-
6145 32	Exit Jogger Release Motor	-

4.11 PRINTER SERVICE TABLE

4.11.1 PRINTER SP TABLES

1001	Bit Switch			
001	Bit Switch 1		0	1
	bit 0	DFU	-	-
	bit 1	DFU	-	-
	bit 2	DFU	-	-
	bit 3	No I/O Timeout	0: Disable	1: Enable
		Enable: The MFP I/O Timeout setting will have no effect. I/O Timeouts will never occur.		
	bit 4	SD Card Save Mode	0: Disable	1: Enable
		Enable: Print jobs will be saved to an SD Card in the GW SD slot.		
	bit 5	DFU	-	-
	bit 6	DFU	-	-
bit 7	DFU	-	-	

Printer Service Table

1001	Bit Switch			
002	Bit Switch 2		0	1
	bit 0	DFU	-	-
	bit 1	DFU	-	-
	bit 2	Applying a collation Type	Shift Collate	Normal Collate
		<p>A collation type (shift or normal) will be applied to all jobs that do not already have a "Collate Type" configured.</p> <p> Note</p> <ul style="list-style-type: none"> If #5-0 is enabled, this Bit Switch has no effect. 		
	bit 3	[PCL5e/c,PS]: PDL Auto Switching	0: Enable	1: Disable
		<p>Disable: The MFPs ability to change the PDL processor mid-job. Some host systems submit jobs that contain both PS and PCL5e/c. If Auto PDL switching is disabled, these jobs will not be printed properly.</p>		
	bit 4	DFU	-	-
	bit 5	DFU	-	-
	bit 6	DFU	-	-
bit 7	DFU	-	-	

1001	Bit Switch			
003	Bit Switch 3		0	1
	bit 0	DFU	-	-
	bit 1	DFU	-	-
	bit 2	[PCL5e/c]: Legacy HP compatibility	0: Disable	1: Enable
		Enable: Uses the same left margin as older HP models such as HP4000/HP8000. In other words, the left margin defined in the job (usually "<ESC>*r0A") will be changed to "<ESC>*r1A"		
	bit 3	DFU	-	-
	bit 4	DFU	-	-
	bit 5	DFU	-	-
	bit 6	DFU	-	-
bit 7	DFU	-	-	

Appendix:
Service
Program
Mode Tables

1001	Bit Switch			
004	Bit Switch 4		0	1
	bit 0	DFU	-	-
bit 1	DFU	-	-	
bit 2	DFU	-	-	

Printer Service Table

bit 3	IPDS print-side reversal	0: Disable	1: Enable	
		If enabled, the simplex pages of IPDS jobs will be printed on the front side because of printing on the back side of the page. This might reduce printing speed.		
bit 4	DFU	-	-	
bit 5	DFU	-	-	
bit 6	DFU	-	-	
bit 7	DFU	-	-	

1001	Bit Switch			
005	Bit Switch 5		0	1
		Show "Collate Type", "Staple Type" and "Punch Type" buttons on the operation panel.	0: Disable	1: Enable
	bit 0	If enabled, users will be able to configure a Collate Type, Staple Type, and Punch Type from the operation panel. The available types will depend on the device and configured options. After enabling the function, the settings will appear under: "User Tools > Printer Features > System"		
	bit 1	DFU	-	-
	bit 2	Prevent SDK applications from altering the contents of a job.	0: Disable	1: Enable
		If this BitSw is enabled, SDK applications will not be able to alter print data. This is achieved by preventing SDK applications from accessing a module called the "GPS Filter". Note: The main purpose of this BitSw is for troubleshooting the effects of		

Printer Service Table

		SDK applications on data.		
	bit 3	[PS] PS Criteria	0: Pattern3	1: Pattern1
		Change the number of PS criterion used by the PS interpreter to determine whether a job is PS data or not. Pattern3: includes most PS commands. Pattern1: A small number of PS tags and headers		
	bit 4	Increase max number of the stored jobs to 1000 jobs.	0: Disable (100)	1: Enable (1000)
		Enable: Changes the maximum number of jobs that can be stored on the HDD via Job Type settings to 1000. The default is 100.		
	bit 5	DFU	-	-
	bit 6	DFU	-	-
	bit 7	DFU	-	-

Appendix:
Service
Program
Mode Tables

1001	Bit Switch			
006	Bit Switch 6		0	1
	bit 0 to 5	DFU	-	-
		PDL Auto Detection timeout of jobs submitted via USB or Parallel Port (IEEE 1284).	0: Disable (Immediately)	1: Enable (10 seconds)
	bit 6	To be used if PDL auto-detection fails. A failure of PDL autodetection doesn't necessarily mean that the job can't be printed. This bit switch tells the device whether to time-out immediately (default) upon failure or to wait 10 seconds.		
	bit 7	DFU	-	-

Printer Service Table

1001	Bit Switch		
007	Bit Switch 7 DFU	-	-

1001	Bit Switch		
008	Bit Switch 8	0	1
	bit 0 to 5	DFU	-
	bit 6	[PS]: Orientation Auto Detect Function	0: Enable 1: Disable
		Automatically chooses page orientations of PostScript jobs (Landscape or Portrait) based on the content.	
	bit 7	[PDF]: Orientation Auto Detect Function	0: Enable 1: Disable
		Automatically chooses page orientations of PDF jobs (Landscape or Portrait) based on the content.	

1003	Clear setting		
001	Initialize Printer System Initializes the settings in the printer feature settings of UP mode.		
003	Delete Program DFU		

1004	Print Summary		
	Touch [Execute] to print the printer summary sheets.		

Printer Service Table

1005	Display Version.
	Printer Application Version
	Displays the version of the controller firmware.

1006	Sample/Locked Print
	<p>This SP disables/enables use of the document server. [0 or 1/ 0 /1] 0: Enabled. Document server can be used. 1: Disabled. Document server cannot be used.</p>

4.12 SCANNER SERVICE TABLE

4.12.1 SP TABLES

SP	Number/Name	Function/[Setting]
1001	Scan NV Version	Displays the version of the scanner NV.
1004	Compression Type	Selects the compression type for binary picture processing. [1 to 3 / 1 / 1/step] 1: MH, 2: MR, 3: MMR
1005	Erase Margin	Creates an erase margin for all edges of the scanned image. If the machine has scanned the edge of the original, create a margin. [0 to 5 / 0 / 1 mm/step]
1009	Remote scan disable	Enables or disables the TWAIN function. [0 or 1 / 0 / -] 0: Enable, 1: Disable
1010	Non Display Clear Light PDF	Displays or does not display the clear light PDF function. [0 or 1 / 0 / -] 0: Display, 1: Not display
1011	Org Count Disp	Displays or does not display the original counter. [0 or 1 / 0 / -] 0: Not display, 1: Display
1012	User Info Release	Clears or does not clear a user information after a job. [0 or 1 / 1 / -] 0: Not clear, 1: Clear

Scanner Service Table

SP	Number/Name	Function/[Setting]
2021	Compression level (grayscale)	
	These SP codes set the compression ratio for the grayscale processing mode that can be selected with the notch settings on the operation panel. Range: 5 (lowest ratio) <-> 95 (highest ratio)	
1	Comp 1: 5 - 95	[5 to 95 / 20 / 1 /step]
2	Comp 2: 5 - 95	[5 to 95 / 40 / 1 /step]
3	Comp 3: 5 - 95	[5 to 95 / 65 / 1 /step]
4	Comp 4: 5 - 95	[5 to 95 / 80 / 1 /step]
5	Comp 5: 5 - 95	[5 to 95 / 95 / 1 /step]

2024*	[Compression ratio of ClearLight PDF]	
	Selects the compression ratio for clearlight PDF for the two settings that can be selected at the operation panel.	
1	Compression Ratio (Normal image)	[5 to 95 / 25 / 1 /step]
2	Compression Ratio (High comp image)	[5 to 95 / 20 / 1 /step]

1000-SHEET FINISHER B408

1000 SHEET FINISHER SR790 REVISION HISTORY		
Page	Date	Added/Updated/New
		None

1000-SHEET FINISHER B408

TABLE OF CONTENTS

1. REPLACEMENT AND ADJUSTMENT.....	1
1.1 MAIN PCB	1
1.2 STAPLER UNIT	2
1.3 MOTORS.....	3
1.3.1 SHIFT MOTOR	3
1.3.2 STAPLER MOTOR	3
1.3.3 UPPER TRANSPORT MOTOR AND EXIT MOTOR	4
1.3.4 LOWER TRANSPORT MOTOR	4
1.4 MOTORS AND SENSORS	5
1.4.1 PREPARATION	5
1.4.2 STACK HEIGHT SENSOR	6
1.4.3 STAPLER TRAY PAPER SENSOR.....	6
1.4.4 LOWER TRAY LIFT MOTOR	7
1.4.5 STACK FEED-OUT MOTOR	7
2. TROUBLESHOOTING	8
2.1 JAM DETECTION.....	8
3. SERVICE TABLES.....	9
3.1 DIP SWITCH SETTINGS.....	9
4. DETAILED DESCRIPTIONS.....	10
4.1 GENERAL LAYOUT	10
4.2 ELECTRICAL COMPONENT LAYOUT	11
4.3 ELECTRICAL COMPONENT DESCRIPTION	13
4.4 DRIVE LAYOUT	15
4.5 JUNCTION GATES	16
Upper Tray Mode	16
Sort/Stack Mode	16
Staple Mode.....	16
4.6 UPPER TRAY.....	17
4.7 LOWER TRAY UP/DOWN MECHANISMS.....	18
4.8 PAPER SHIFT MECHANISM	19
4.9 JOGGER UNIT PAPER POSITIONING MECHANISM.....	20
4.10 EXIT GUIDE PLATE	21
4.11 STAPLER MECHANISM.....	22
4.12 STAPLER UNIT MOVEMENT MECHANISM.....	23
4.13 PAPER FEED-OUT MECHANISM	24

1. REPLACEMENT AND ADJUSTMENT

⚠ CAUTION

Turn off the main power switch and unplug the machine before beginning any of the procedures in this section.

NOTE: This manual uses the following symbols.

 : See or Refer to
  : Screws
  : Connector
  : Clip ring
 : E-ring

1.1 MAIN PCB

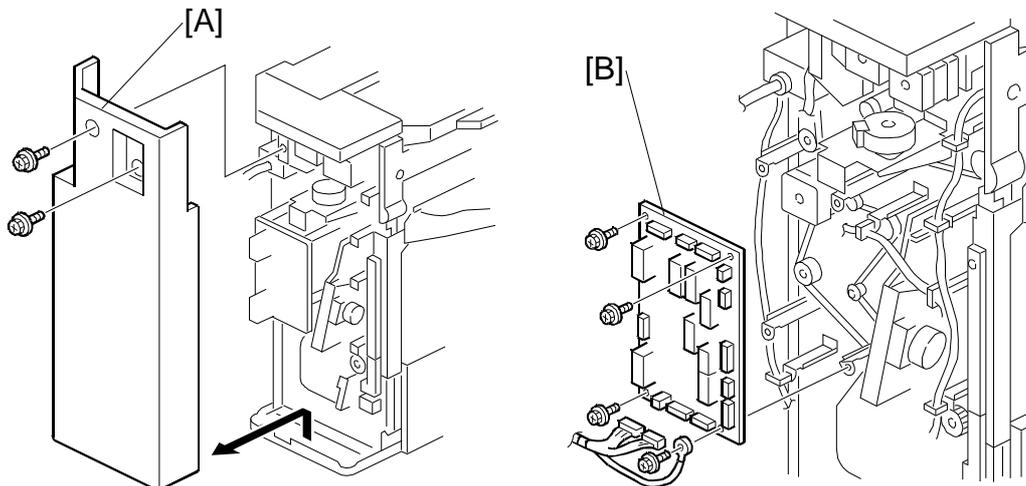

1. Rear cover [A] ( x 2)
2. Main PCB [B] ( x 4, All )

STAPLER UNIT

1.2 STAPLER UNIT

1. Side cover [A] (🔩 x 2)
2. Open exit guide plate [B]
3. Upper side cover [C] (🔩 x 2)

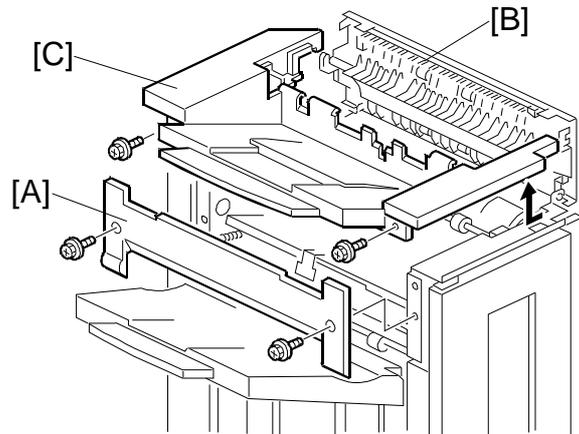

4. Front cover support plate [D] (🔩 x 1)
5. Front cover [E]
6. Front inner cover [F] (🔩 x 2)

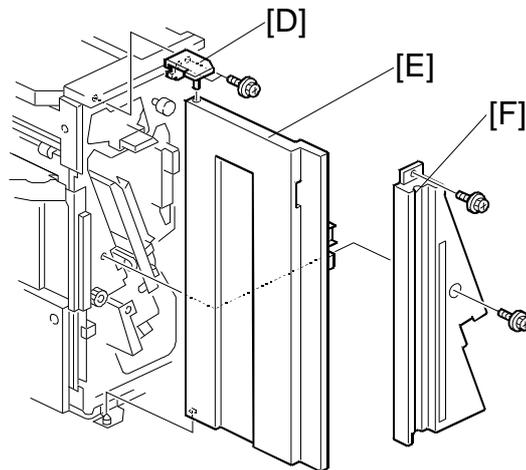

7. Harness [G]
8. Unhook the spring [H]
9. Turn the stapler unit [I] and take it out.
10. Bracket [J] (🔩 x 2)

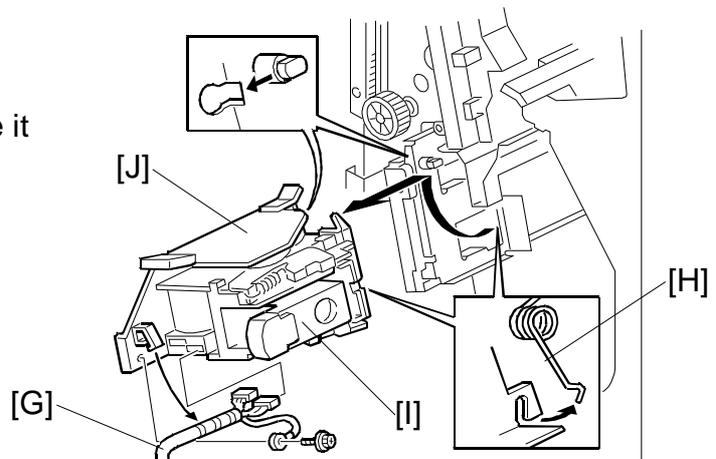

1.3 MOTORS

1.3.1 SHIFT MOTOR

1. Rear cover (🔩1.1)
2. Shift motor [A] (🔩 x 2, 📡 x 1)

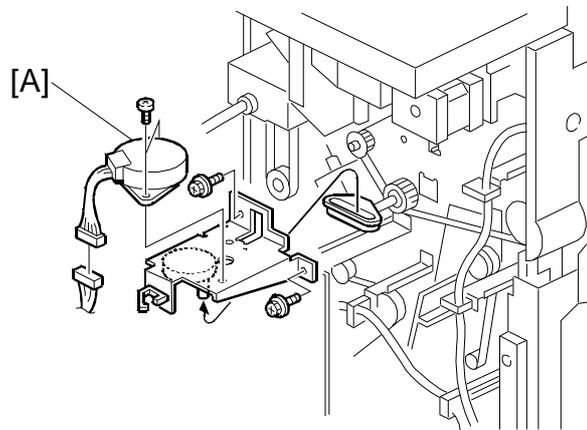

1.3.2 STAPLER MOTOR

1. Rear cover (🔩1.1)
2. Stapler motor [A] (🔩 x 2, 📡 x 1)

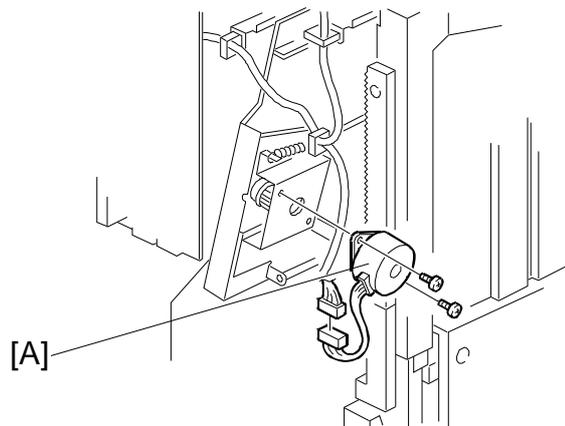

1000-Sheet
Finisher
B408

MOTORS

1.3.3 UPPER TRANSPORT MOTOR AND EXIT MOTOR

1. Rear cover (☛1.1)
2. Motor assembly [A] (🔩 x 4, 📡 x 2)
3. Upper transport motor [B] (🔩 x 4)
4. Exit motor [C] (🔩 x 4)

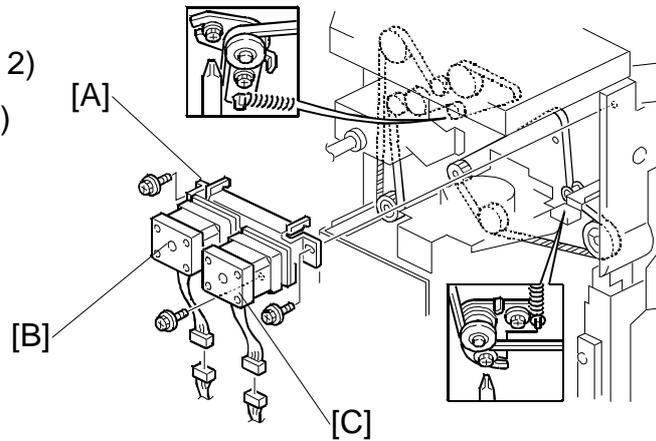

1.3.4 LOWER TRANSPORT MOTOR

1. Main PCB (☛1.1)
2. Lower transport motor [A] (🔩 x 2, 📡 x 1)

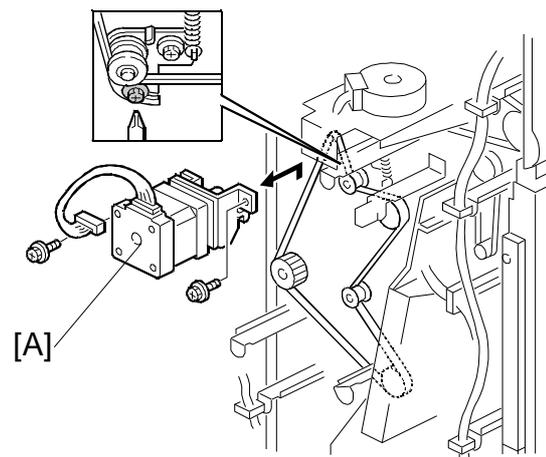

1.4 MOTORS AND SENSORS

1.4.1 PREPARATION

- 1. Front cover and inner cover (☛1.2)
- 2. Upper side cover [A] (🔩 x 2)
- 3. Upper tray [B] (🔩 x 1)

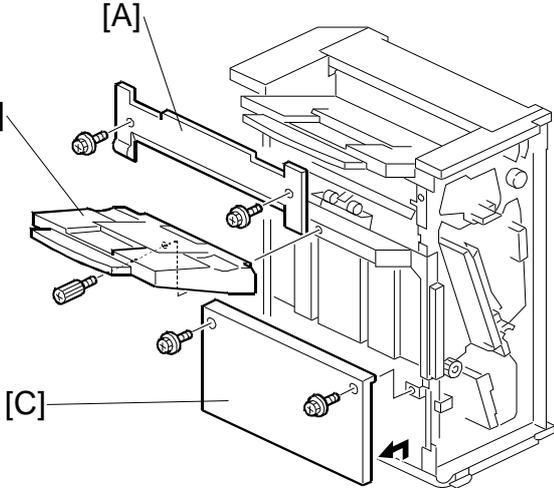

- 4. Lower side cover [C] (🔩 x 2)
- 5. Loosen the 2 screws [D].
- 6. Lower the lower tray guide plate [E].

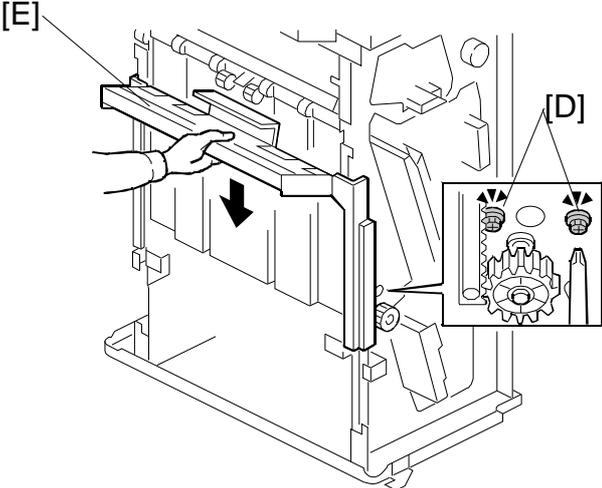

- 7. Guide plate [F] (🔩 x 4)

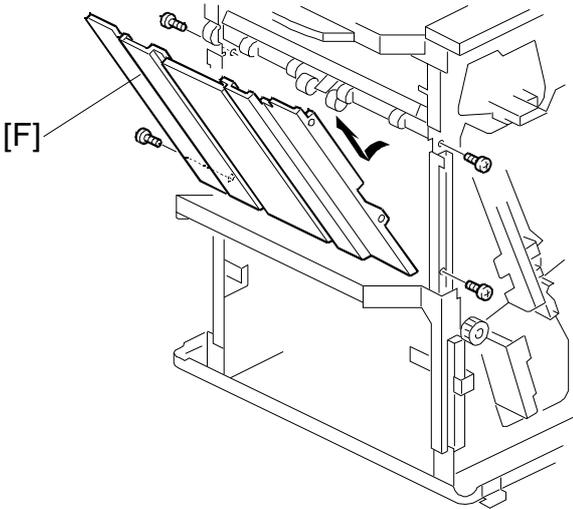

1000-Sheet
Finisher
B408

1.4.2 STACK HEIGHT SENSOR

1. Stack height sensor assembly [A] (🔧 x 1)
2. Stack height sensor [B] (🔌 x 1)

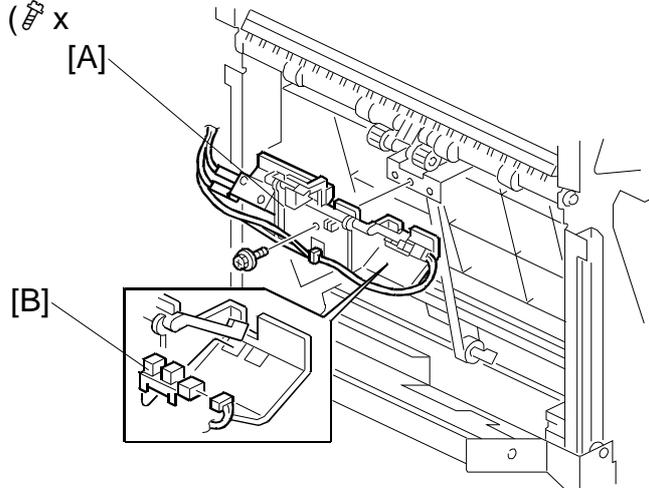

1.4.3 STAPLER TRAY PAPER SENSOR

1. Stapler tray paper sensor [A] (🔌 x 1)

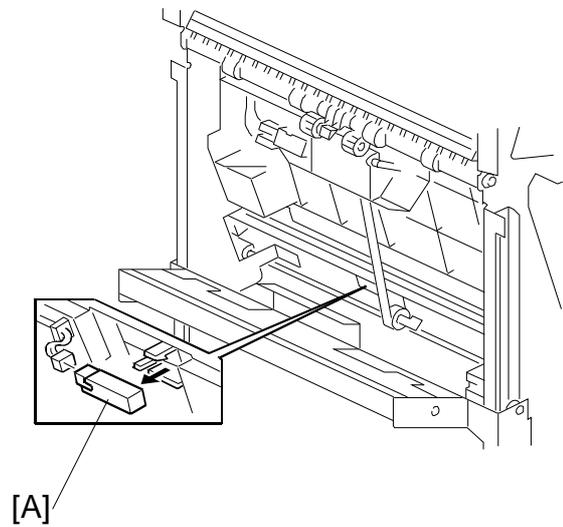

1.4.4 LOWER TRAY LIFT MOTOR

- 1. Lower tray lift motor [A] (⚙️ x 2, 📡 x 1)

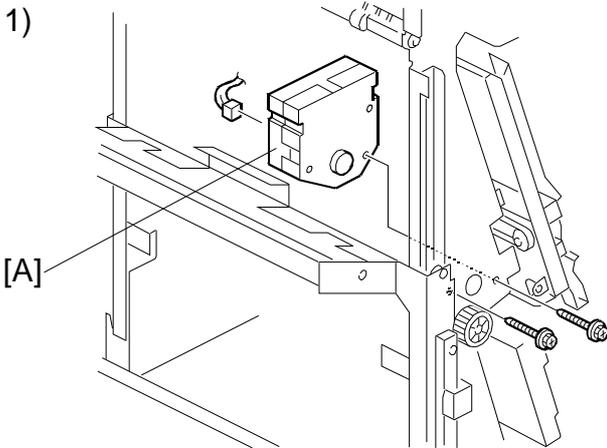

1.4.5 STACK FEED-OUT MOTOR

- 1. Stack feed-out motor [A] (⚙️ x 2, 📡 x 1)

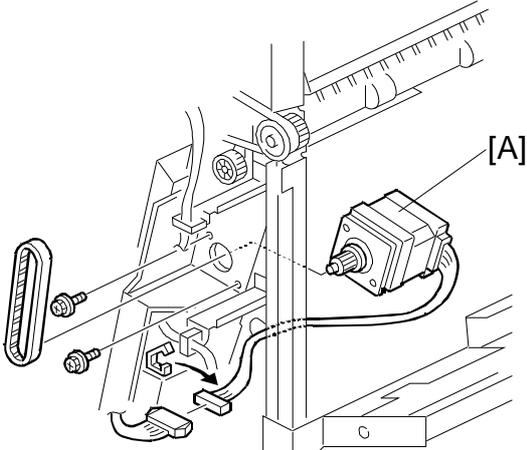

1000-Sheet
Finisher
B408

2. TROUBLESHOOTING

2.1 JAM DETECTION

Mode		Jam	Content
Shift	Staple		
✓	✓	Entrance sensor: On check	The entrance sensor does not turn on within the normal time after the main machine exit sensor turns on
✓	✓	Entrance sensor: Off check	The entrance sensor does not turn off within the normal time after it turns on.
✓		Lower tray exit sensor: On check	The lower tray exit sensor does not turn on within the normal time after the entrance sensor turns off.
✓		Tray exit sensor: Off check	The tray exit sensor does not turn off within the normal time after it turns on.
	✓	Stapler tray entrance sensor: On check	The stapler tray entrance sensor does not switch on within the normal time after the entrance sensor switched on.
	✓	Stapler tray entrance sensor: Off check	The staple tray entrance sensor does not turn off within the normal time after it turns on.
	✓	Lower tray exit sensor: On check	The lower exit sensor does not turn on after the feed-out pawl feeds out the outputs.
	✓	Lower tray exit sensor: Off check	The lower exit sensor turns on when the feed-out pawl returns to its home position after feeding out the outputs.

3. SERVICE TABLES

3.1 DIP SWITCH SETTINGS

The DIP switches should not be set to any combination other than those listed in the table below.

SW100		Description
1	2	
0	0	Normal operation mode (Default)
1	0	Packing mode.

- Before packing the machine, do the following: Set switch 1 to 1 then back to zero. The lower tray moves to the lowest position. Then turn off the main switch.
- After unpacking the machine, do the following: After turning the main switch back on, the lower tray returns to home position automatically.

4. DETAILED DESCRIPTIONS

4.1 GENERAL LAYOUT

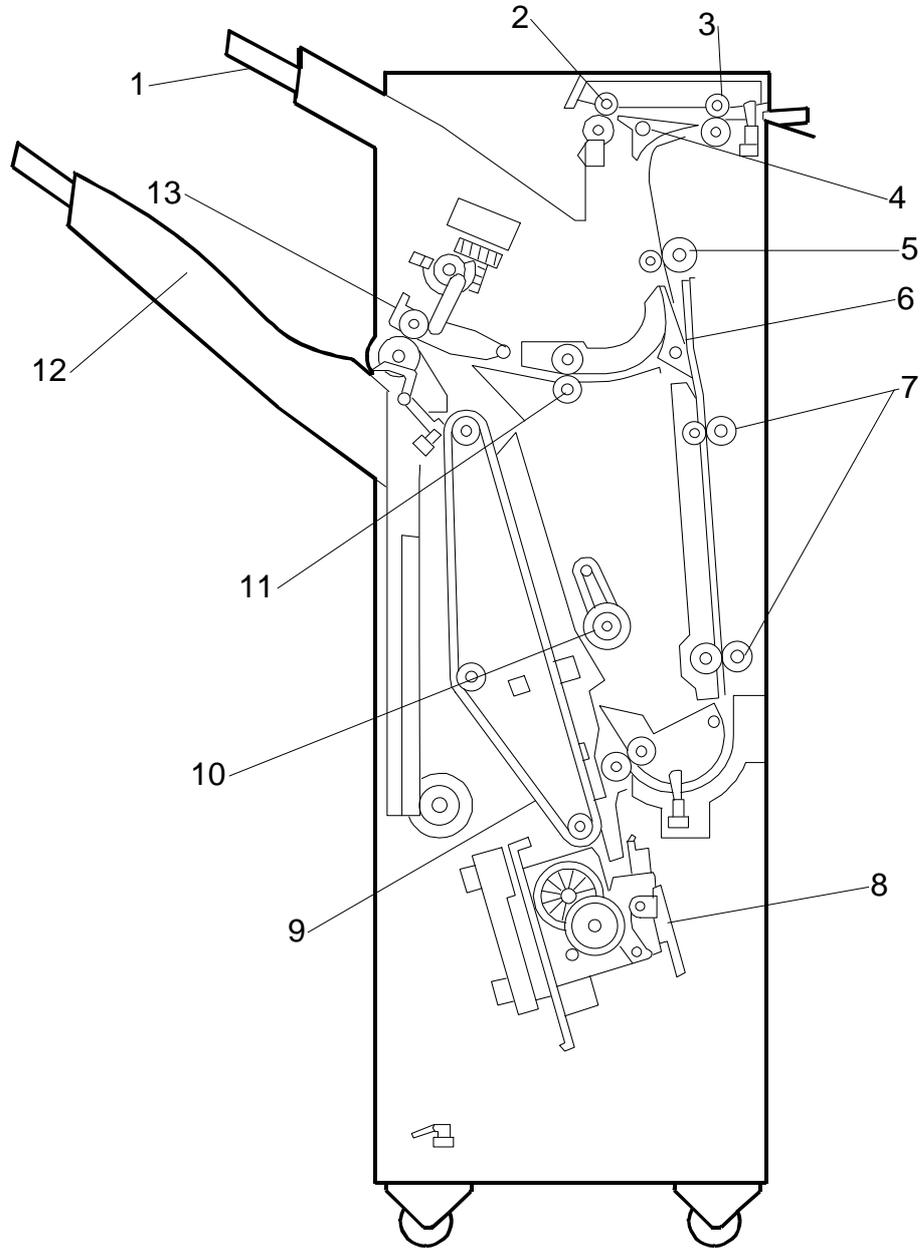

- | | |
|----------------------------|----------------------------|
| 1. Upper Tray | 8. Stapler |
| 2. Upper Tray Exit Roller | 9. Stack Feed-out Belt |
| 3. Entrance Roller | 10. Positioning Roller |
| 4. Tray Junction Gate | 11. Shift Roller |
| 5. Upper Transport Roller | 12. Lower Tray |
| 6. Stapler Junction Gate | 13. Lower Tray Exit Roller |
| 7. Lower Transport Rollers | |

4.2 ELECTRICAL COMPONENT LAYOUT

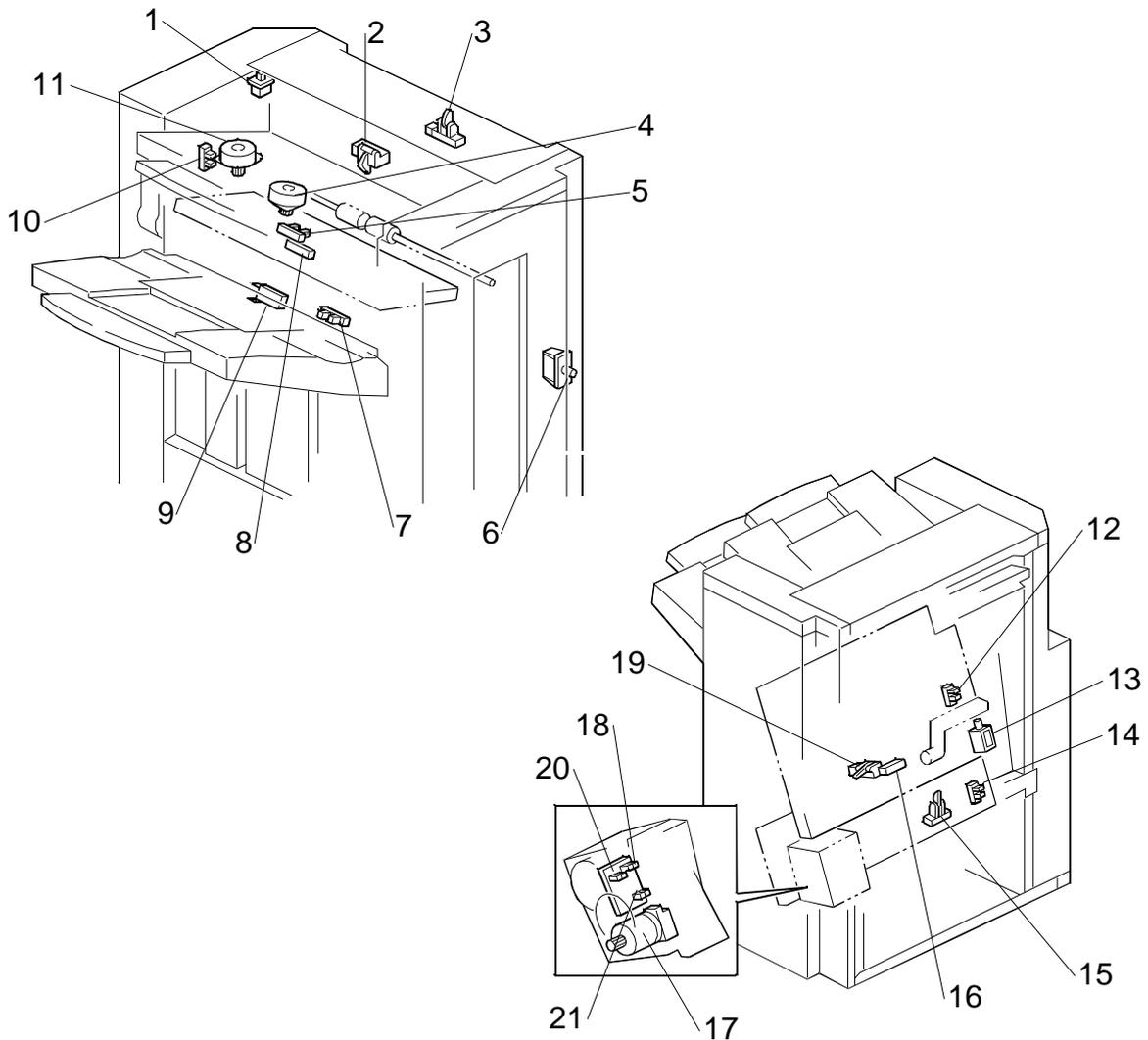

- | | |
|----------------------------------|-----------------------------------|
| 1. Upper Cover Switch | 12. Jogger Fence HP Sensor |
| 2. Paper Limit Sensor | 13. Positioning Roller Solenoid |
| 3. Entrance Sensor | 14. Stapler HP Sensor |
| 4. Exit Guide Plate Motor | 15. Stapler Tray Entrance Sensor |
| 5. Exit Guide Plate HP Sensor | 16. Stapler Tray Paper Sensor |
| 6. Front Door Safety Switch | 17. Stapler Hammer Motor |
| 7. Stack Height Sensor | 18. Staple Sheet Sensor |
| 8. Lower Tray Exit Sensor | 19. Stack Feed-out Belt HP Sensor |
| 9. Lower Tray Upper Limit Switch | 20. Stapler Rotation HP Sensor |
| 10. Shift HP Sensor | 21. Staple Sensor |
| 11. Shift Motor | |

ELECTRICAL COMPONENT LAYOUT

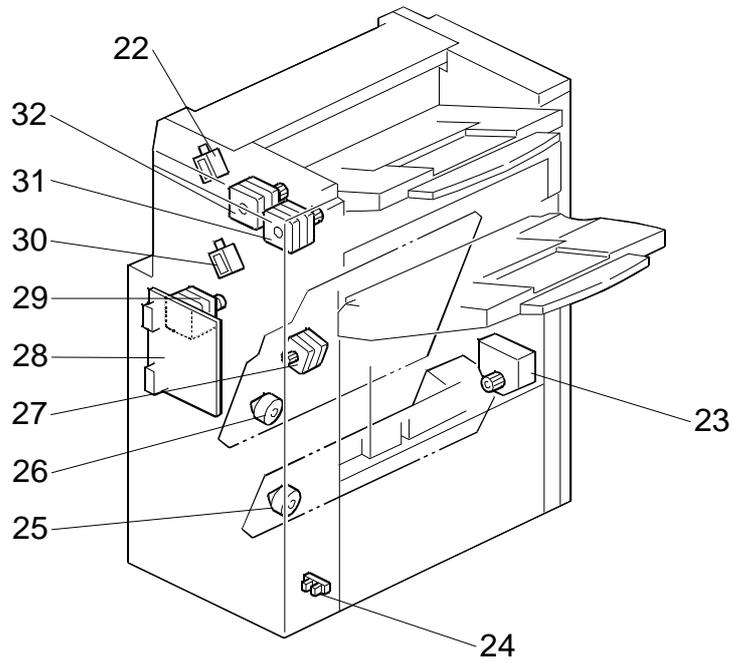

- 22. Tray Junction Gate Solenoid
- 23. Lower Tray Lift Motor
- 24. Lower Tray Lower Limit Sensor
- 25. Stapler Motor
- 26. Jogger Fence Motor
- 27. Stack Feed-out Motor
- 28. Main Board
- 29. Lower Transport Motor
- 30. Stapler Junction Gate Solenoid
- 31. Exit Motor
- 32. Upper Transport Motor

4.3 ELECTRICAL COMPONENT DESCRIPTION

Symbol	Name	Function	Index No.
Motors			
M1	Upper Transport	Drives the entrance roller and upper transport rollers.	32
M2	Lower Transport	Drives the lower transport rollers and the positioning roller.	29
M3	Jogger Fence	Drives the jogger fences.	26
M4	Staple Hammer	Drives the staple hammer.	17
M5	Stack Feed-out	Drives the stack feed-out belt.	27
M6	Exit Guide Plate	Opens and closes the exit guide plate.	4
M7	Exit	Drives the exit roller.	31
M8	Lower Tray Lift	Moves the lower tray up or down.	23
M9	Shift	Moves the shift roller from side to side.	11
M10	Stapler	Moves the stapler unit from side to side.	25
Sensors			
S1	Entrance	Detects copy paper entering the finisher and checks for misfeeds.	3
S2	Paper Limit	Detects when the paper stack height in the upper tray is at its limit.	2
S3	Jogger Fence HP	Detects when the jogger fence is at home position.	12
S4	Shift HP	Detects when the shift roller is at home position.	10
S5	Stack Feed-out Belt HP	Detects when the stack feed-out belt is at home position.	19
S6	Stapler HP	Detects when the stapler is at home position.	14
S7	Exit Guide Plate HP	Detects when the exit guide plate is at home position.	5
S8	Stapler Tray Entrance	Detects copy paper entering the stapler tray and checks for misfeeds.	15
S9	Lower Tray Exit	Checks for misfeeds.	8
S10	Stack Height	Detects the top of the copy paper stack.	7
S11	Lower Tray Lower Limit	Detects when the lower tray is at its lower limit position.	24
S12	Stapler Tray Paper	Detects when there is copy paper in the stapler tray.	16
S13	Staple Sheet	Detects the leading edge of the staple sheet.	18
S14	Stapler Rotation HP	Detects when the staple hammer is at home position.	20
S15	Staple	Detects whether there are staples in the staple cartridge.	21
Solenoids			
SOL1	Tray Junction Gate	Drives the tray junction gate.	22
SOL2	Stapler Junction Gate	Drives the stapler junction gate.	30

1000-Sheet
Finisher
B408

ELECTRICAL COMPONENT DESCRIPTION

Symbol	Name	Function	Index No.
SOL3	Positioning Roller	Moves the positioning roller.	13
Switches			
SW1	Lower Tray Upper Limit	Detects when the lower tray is at its upper limit position.	9
SW2	Front Door Safety	Cuts the dc power when the front door is opened.	6
SW3	Upper Cover	Cuts the dc power when the upper cover is opened.	1
PCBs			
PCB1	Main	Controls the finisher and communicates with the copier/printer.	28

4.4 DRIVE LAYOUT

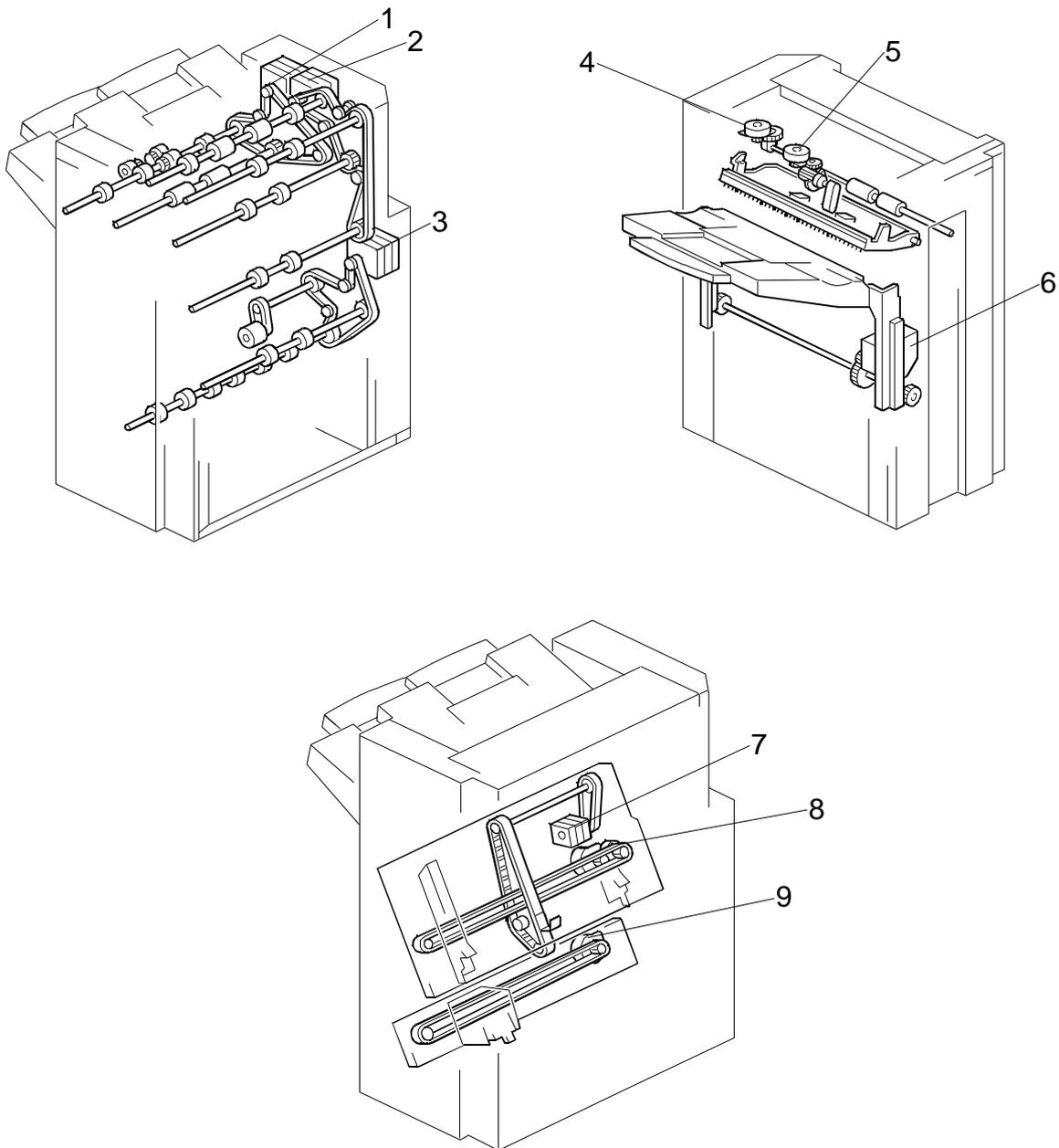

- 1. Exit Motor
- 2. Upper Transport Motor
- 3. Lower Transport Motor
- 4. Shift Motor
- 5. Exit Guide Plate Motor

- 6. Lower Tray Lift Motor
- 7. Stack Feed-out Motor
- 8. Jogger Motor
- 9. Stapler Motor

1000-Sheet
 Finisher
 B408

4.5 JUNCTION GATES

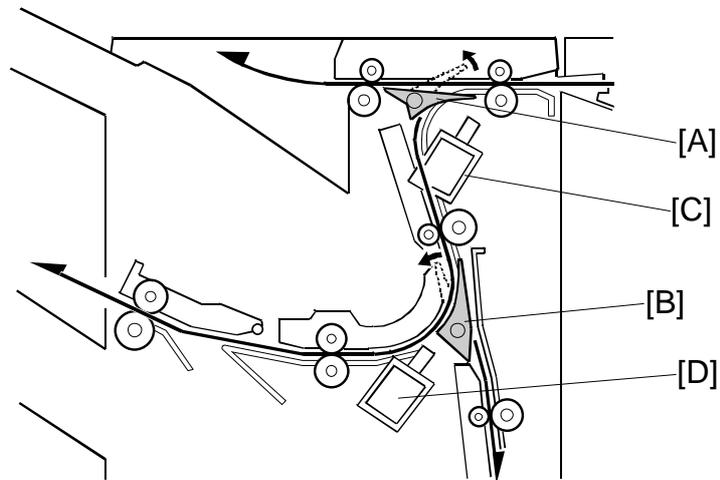

Depending on the finishing mode, the copies are directed up, straight through, or down by the combination of the tray junction gate [A] and stapler junction gate [B]. These gates are controlled by the tray junction gate solenoid [C] and stapler junction gate solenoid [D].

Upper Tray Mode

The tray junction gate solenoid remains off. The copies go up to the upper tray.

Sort/Stack Mode

The tray junction gate solenoid turns on and the stapler junction gate solenoid remains off. The copies are sent to the lower tray directly.

Staple Mode

The tray junction gate solenoid and the stapler junction gate solenoid both turn on. The copies go down to the jogger unit.

4.6 UPPER TRAY

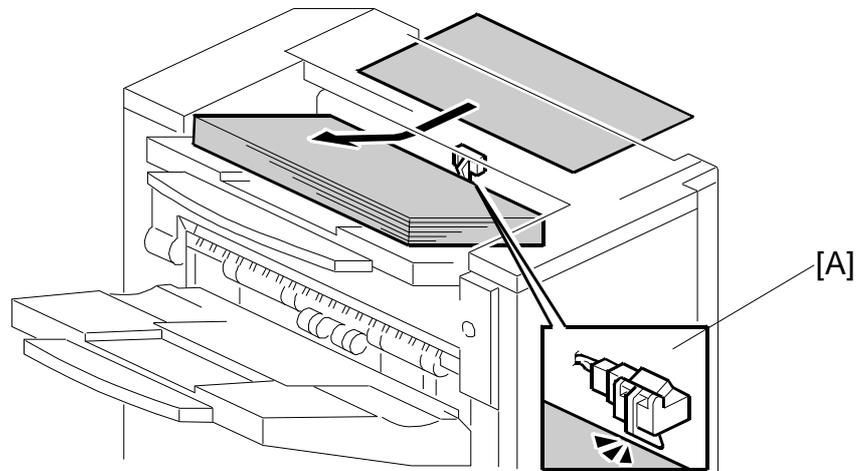

When the paper limit sensor [A] switches on during feed-out for each of three consecutive sheets of paper, paper overflow is detected.

1000-Sheet
Finisher
B408

4.7 LOWER TRAY UP/DOWN MECHANISMS

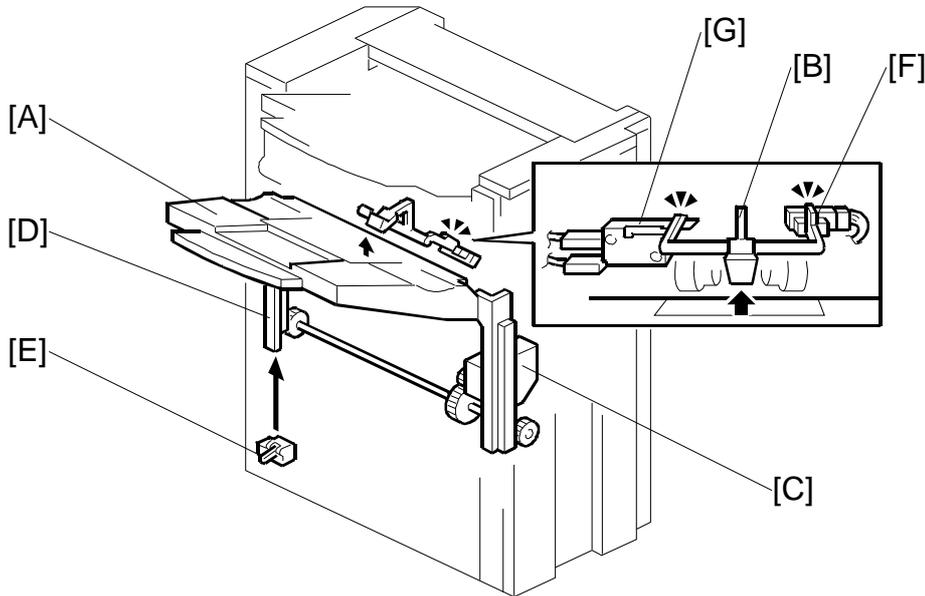

The vertical position of the lower tray [A] depends on the height of the copied paper stack on the lower tray. The stack height sensor feeler [B] contacts the top of the stack, and the lower tray lift motor [C] controls the tray height.

When the lower tray reaches its lowest possible position, the actuator [D] turns on the lower tray lower limit sensor [E], and copying stops.

Tray Up

When the copy paper on the tray is removed, the stack height sensor [F] turns off and the tray lifts up. Then, the tray stops when the sensor turns on again (the tray pushes up the feeler).

If the stack height sensor fails, the lower tray upper limit switch [G] detects the tray and stops the motor. This is a safety measure against stack height sensor failure.

Sort/Stack Mode (Tray Down)

Every five sheets of paper, the tray goes down until the sensor turns off again. Then, it goes up until the sensor is on again.

Staple Mode (Tray Down)

After a stapled copy is fed out, the tray goes up for 220 ms and stops for 300 ms. Then, it goes down for 1 second, waits for 500 ms, then goes up until the sensor turns on.

4.8 PAPER SHIFT MECHANISM

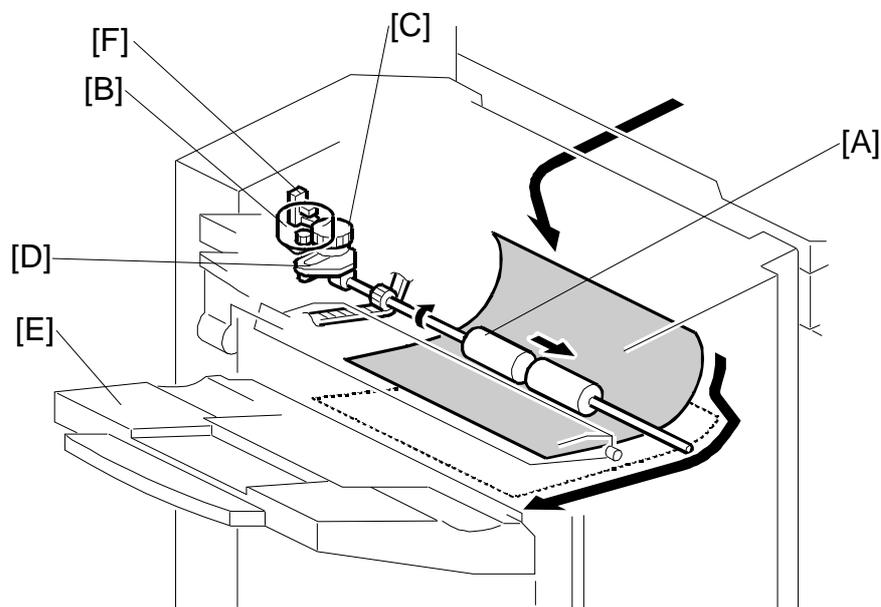

In the sort/stack mode, the shift roller [A] moves from side to side to separate the sets of copies.

The horizontal position of the shift roller is controlled by the shift motor [B] and the shift gear disk [C]. After the trailing edge of the copy passes the upper transport roller, the shift motor turns on, driving the shift gear disk and the link [D].

After the paper is delivered to the lower tray [E], the shift roller moves to its home position, which is detected by the shift HP sensor [F]. Then, when the trailing edge of the next copy passes the upper transport roller, the shift roller shifts again. This operation is done every sheet.

When the trailing edge of each page in the next set of copies passes the upper transport roller, the shift roller shifts in the opposite direction.

4.9 JOGGER UNIT PAPER POSITIONING MECHANISM

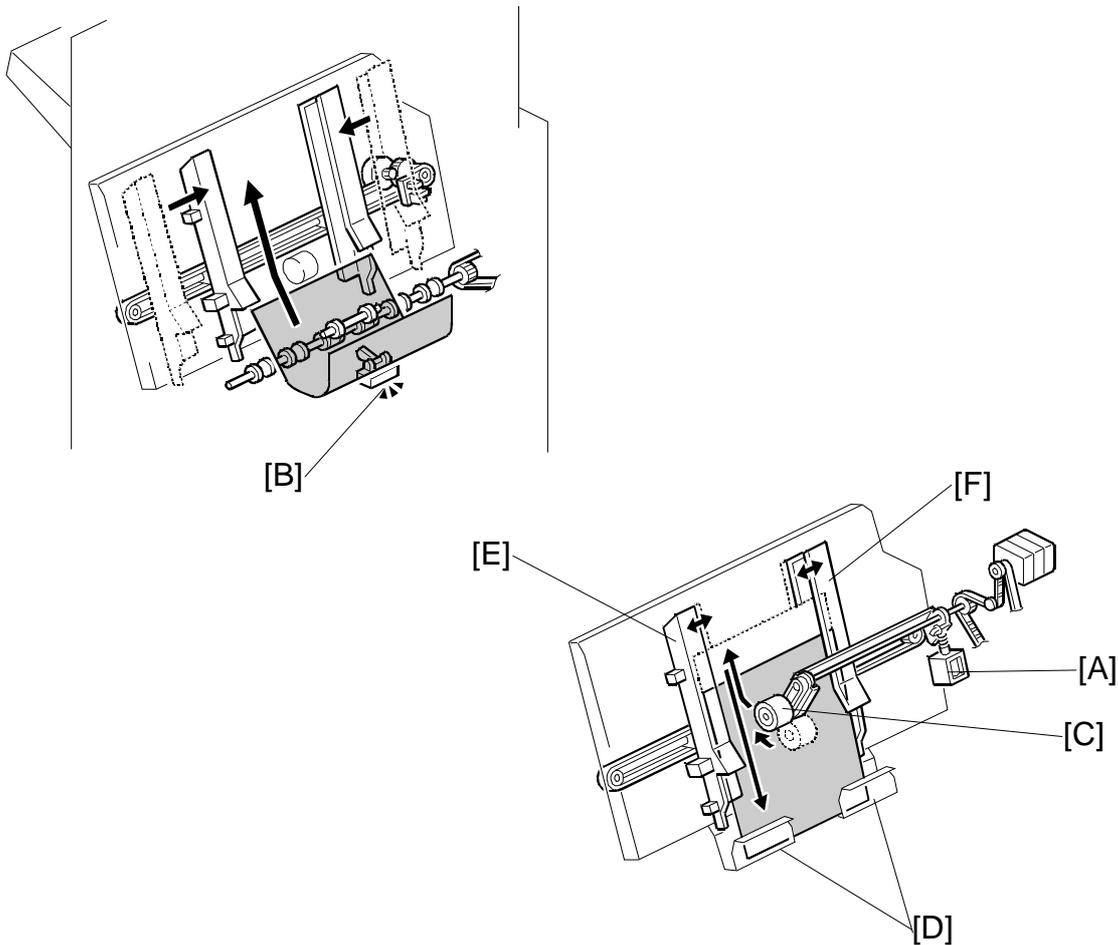

In staple mode, each sheet of copy paper is vertically and horizontally aligned when it arrives in the jogger unit.

For the vertical paper alignment, the positioning roller solenoid [A] turns on shortly after the stapler tray entrance sensor [B] turns off, and the positioning roller [C] pushes the copy against the bottom of the stack stopper [D].

For the horizontal paper alignment, the jogger front fence [E] and the rear fence [F] move to the waiting position, which is 18 mm away from the side of the paper. When aligning the paper vertically, the jogger fence moves in 14 mm from the waiting position. After the vertical position has been aligned, the jogger fence pushes the paper 4 mm against the rear fence to align the paper horizontally. Then the jogger fence moves back to the previous position.

4.10 EXIT GUIDE PLATE

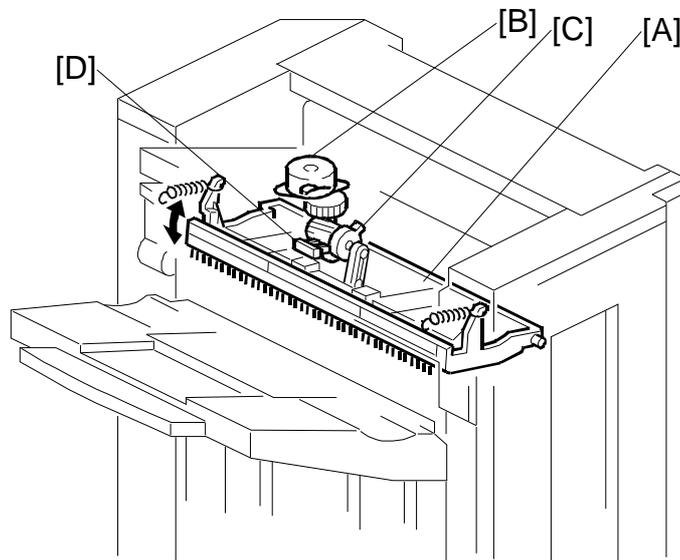

When stacking a large size of paper (such as A3, DLT) in the jogger unit, the leading edge of the paper reaches the exit rollers. To prevent the paper from running into the exit rollers and not being aligned correctly, the exit guide plate [A] is moved up to make a gap between the exit rollers. This operation is done for all paper sizes, but is only needed for the larger sizes.

The exit guide plate motor [B] and exit roller release cam [C] control the exit guide plate movement. When the exit guide plate motor starts, the cam turns and the exit guide plate moves up. When stapling is finished, the exit guide plate motor turns on again to close the exit guide plate. When the exit guide plate HP sensor [D] turns on, the motor stops.

1000-Sheet
Finisher
B408

4.11 STAPLER MECHANISM

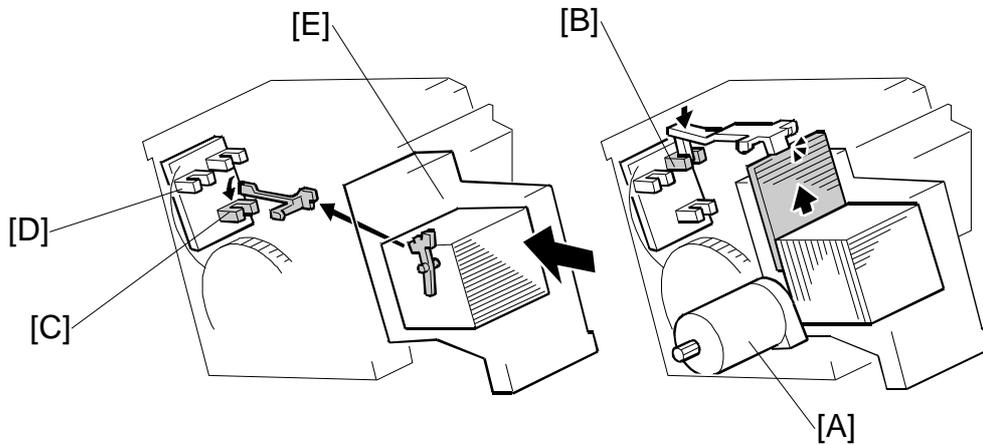

The staple hammer motor [A] drives the staple hammer.

The staple sheet sensor [B] detects the leading edge of the staple sheet at the stapling position to prevent the hammer from operating if there are no staples at the stapling position.

If there is no staple cartridge in the stapler unit or no staples in the staple cartridge, staple end is indicated on the operation panel. The stapler sensor [C] detects this.

The stapler rotation HP sensor [D] checks whether the staple hammer mechanism returns to home position after each stack has been stapled.

When excessive load is applied to the staple hammer motor, the copier detects a staple jam. When a staple jam has occurred, the jammed staple is inside the staple cartridge [E]. Therefore, the jammed staple can be removed easily after pulling out the staple cartridge.

4.12 STAPLER UNIT MOVEMENT MECHANISM

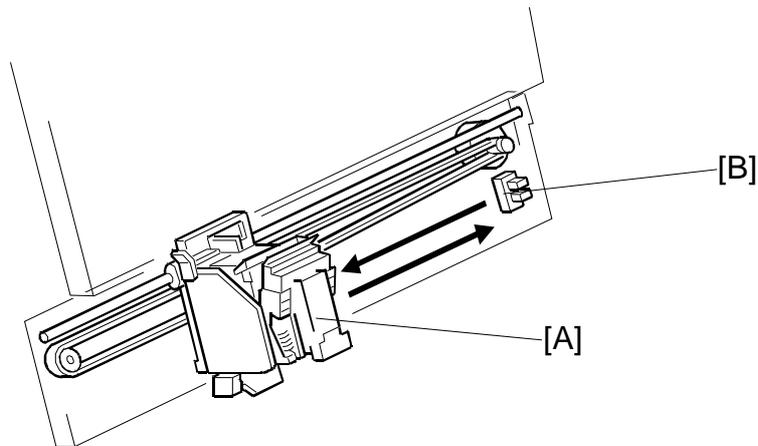

The stapler motor moves the stapler [A] from side to side. After the start key is pressed, the stapler moves from its home position to the stapling position.

If two-staple-position mode is selected, the stapler moves to the front stapling position first, then moves to the rear stapling position. However, for the next copy set, it staples in the reverse order (at the rear side first, then at the front side).

After the job is completed, the stapler moves back to its home position. The stapler HP sensor [B] detects this.

4.13 PAPER FEED-OUT MECHANISM

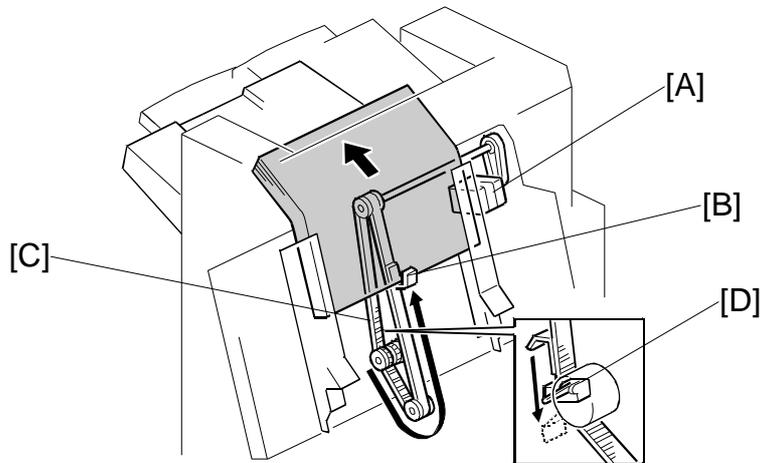

After the copies have been stapled, the stack feed-out motor [A] starts. The pawl [B] on the stack feed-out belt [C] transports the set of stapled copies up and feeds it to the shift roller. The shift roller takes over stack feed-out after the leading edge reaches this roller.

Just before the stapled stack passes through the lower tray exit sensor, the stack-feed-out motor turns off until the shift rollers have completely fed the stack out to the lower tray. Then, the stack-feed-out motor turns on again until the pawl [B] actuates the stack feed-out belt home position sensor [D].

**AUTO REVERSE DOCUMENT
FEEDER DF3010
B802**

REVISION HISTORY		
Page	Date	Added/Updated/New
		None

ARDF DF3010 B802

TABLE OF CONTENTS

1. REPLACEMENT AND ADJUSTMENT	1
1.1 COVERS AND TRAY	1
1.1.1 FRONT AND REAR COVER.....	1
1.1.2 ORIGINAL TRAY	1
1.2 DOCUMENT FEED COMPONENTS	3
1.2.1 PICK-UP ROLLER	3
1.2.2 FEED BELT.....	3
1.2.3 SEPARATION ROLLER.....	5
1.3 ELECTRICAL COMPONENTS	6
1.3.1 DF DRIVE BOARD.....	6
1.3.2 ORIGINAL LENGTH SENSORS AND TRAILING EDGE SENSOR.....	6
1.3.3 ORIGINAL SET, SEPARATION, SKEW CORRECTION AND SCANNING ENTRANCE SENSOR.....	7
1.3.4 ORIGINAL WIDTH SENSORS.....	8
1.3.5 REGISTRATION SENSOR	9
1.3.6 ORIGINAL EXIT SENSOR.....	9
1.3.7 DF POSITION SENSOR	10
1.3.8 COVER SENSOR	10
1.3.9 PICK-UP ROLLER HP AND ORIGINAL STOPPER HP SENSOR.....	11
1.3.10 STAMP SOLENOID.....	12
1.4 ORIGINAL FEED DRIVE.....	14
1.4.1 ADF FEED MOTOR	14
1.4.2 ADF INVERTER MOTOR	15
1.4.3 ADF TRANSPORT MOTOR.....	15
1.4.4 ADF PICK-UP MOTOR	15
2. DETAILED DESCRIPTIONS	17
2.1 COMPONENT LAYOUT	17
2.1.1 MECHANICAL COMPONENT LAYOUT	17
2.1.2 ELECTRICAL COMPONENT LAYOUT	18
2.1.3 DRIVE LAYOUT.....	21

2.2 BASIC OPERATION	23
2.2.1 ORIGINAL SIZE DETECTION	23
2.2.2 MIXED ORIGINAL SIZE MODE	25
2.2.3 PICK-UP AND SEPARATION	26
2.2.4 SKEW CORRECTION	27
2.2.5 SLIP DETECTION.....	28
2.2.6 ORIGINAL TRANSPORT AND EXIT	28
2.2.7 CONDITIONS FOR JAM DETECTION	30
3. SERVICE TABLES	31
3.1 DIP SWITCHES	31

Read This First

Safety and Symbols

Replacement Procedure Safety



- Turn off the main power switch and unplug the machine before beginning any of the replacement procedures in this manual.

Symbols Used in this Manual

This manual uses the following symbols.

: See or Refer to

: Screws

: Connector

: Clip ring

: E-ring

: Clamp

1. REPLACEMENT AND ADJUSTMENT

1.1 COVERS AND TRAY

1.1.1 FRONT AND REAR COVER

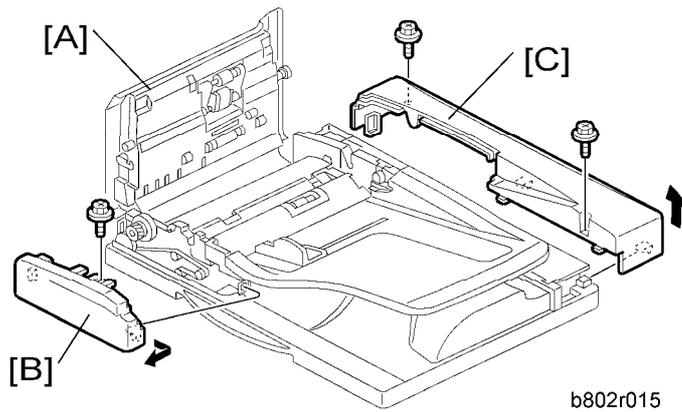

1. Open the left cover [A].
2. Front cover [B] (⚙ x 1, hook x 2)
3. Rear cover [C] (⚙ x 2, hook x 2)

1.1.2 ORIGINAL TRAY

1. Open the left cover.
2. Rear cover (☞ 1.1.1 "Front and Rear Cover")
3. Front cover (☞ 1.1.1 "Front and Rear Cover")

Covers and Tray

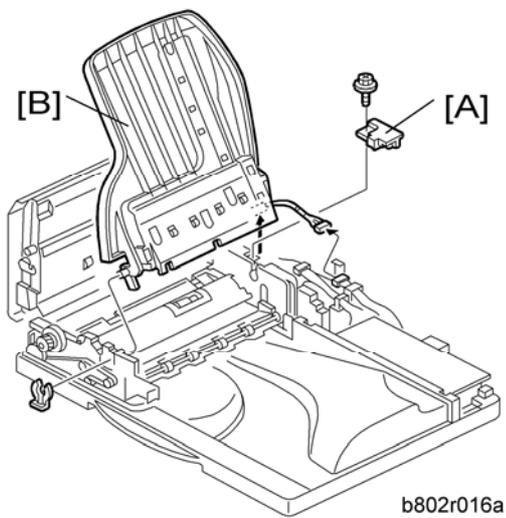

b802r016a

4. Pivot cover [A] (🔩 x 1)
5. Original tray [B] (🔩 x 1, 📏 x 1, 📏 x 2)

1.2 DOCUMENT FEED COMPONENTS

1.2.1 PICK-UP ROLLER

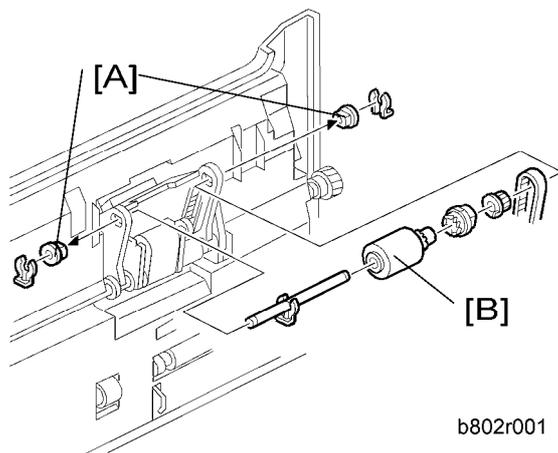

1. Open the left cover.
2. Bushings [A] (2 x 1 each)
3. Pick-up roller [B] (gear x 1, one-way gear x 1)

1.2.2 FEED BELT

1. Open the left cover.

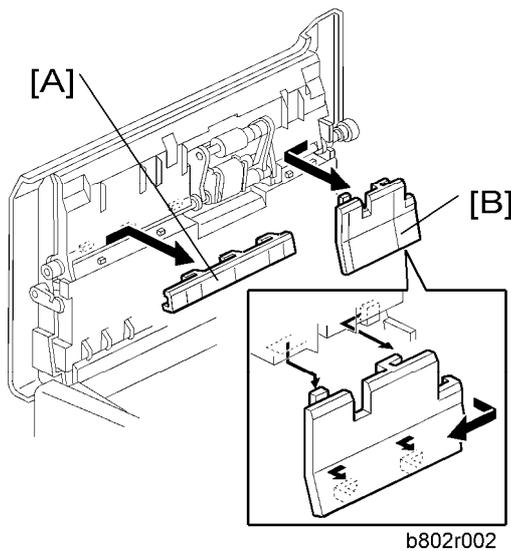

2. Front feed unit cover [A]
3. Rear feed unit cover [B] (hook x 2)

Document Feed Components

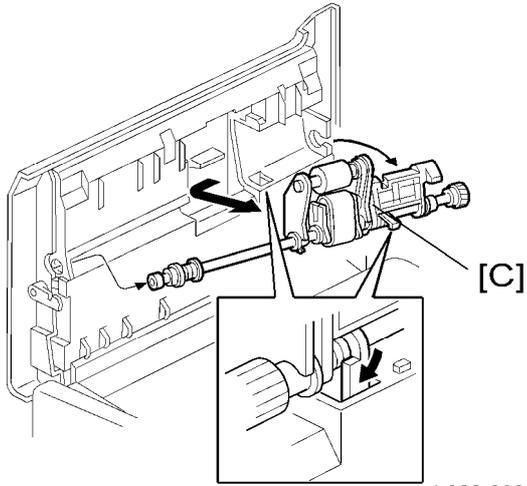

b802r003

4. Feed belt unit [C]

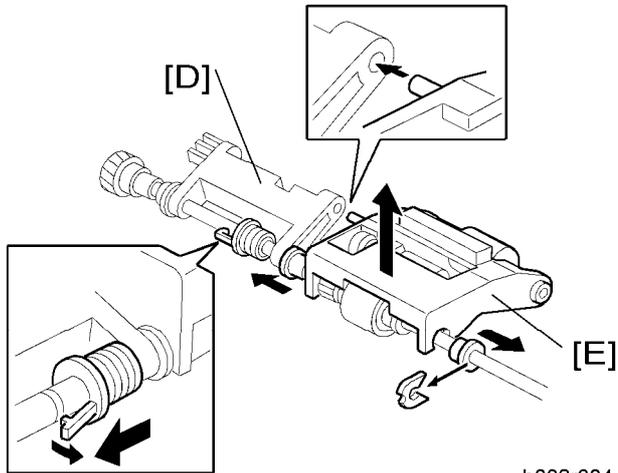

b802r004

5. Slide the tension plate [D] (hook)

6. Belt unit cover [E] (🔩 x 1)

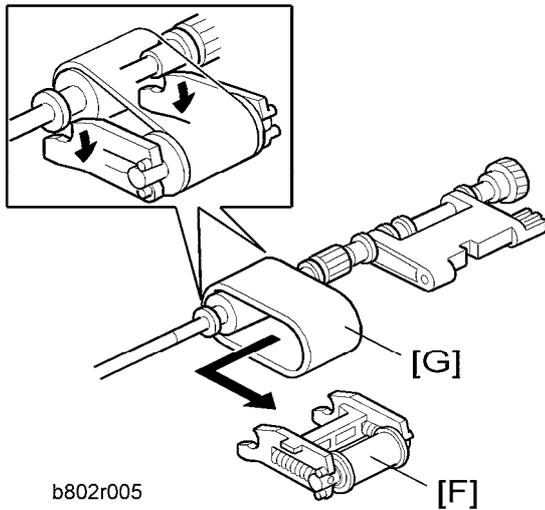

7. Belt tension unit [F]
8. Feed belt [G]

1.2.3 SEPARATION ROLLER

1. Open the left cover.

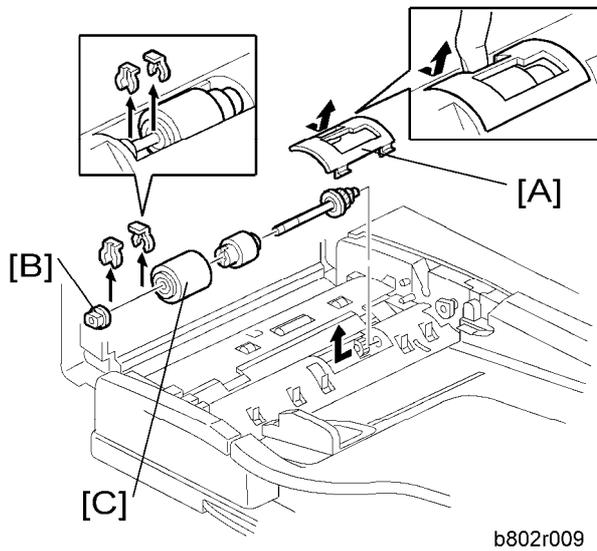

2. Separation roller cover [A]
3. Remove the bushing [B] (⌀ x 1).
4. Slide the separation roller shaft to the front side, and then remove it.
5. Separation roller [C] (⌀ x 1)

1.3 ELECTRICAL COMPONENTS

1.3.1 DF DRIVE BOARD

1. Rear cover (see 1.1.1 "Front and Rear Cover")

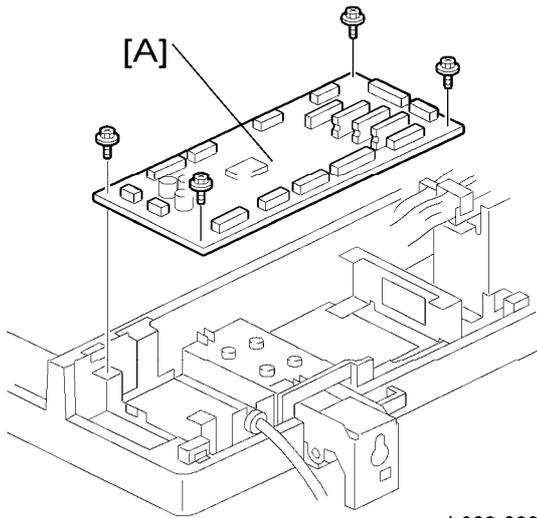

b802r023

2. DF drive board [A] (4 x 4, all screws)

1.3.2 ORIGINAL LENGTH SENSORS AND TRAILING EDGE SENSOR

1. Open the left cover.

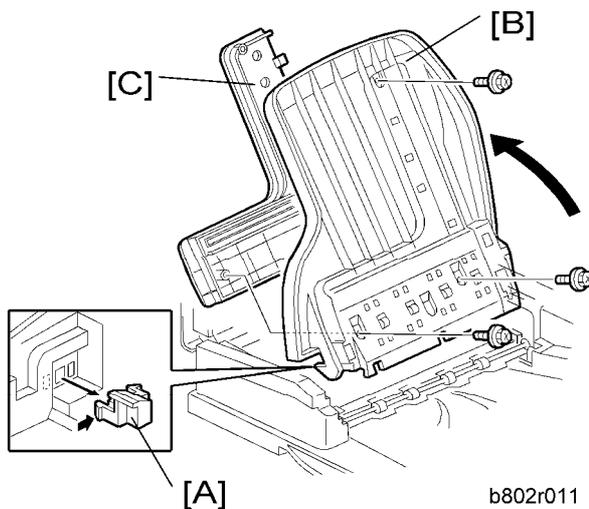

b802r011

2. Remove the tray stopper [A], while pushing the hook with a screw driver.

3. Open the original tray [B].
4. Original tray cover [C] (⌀ x 3)

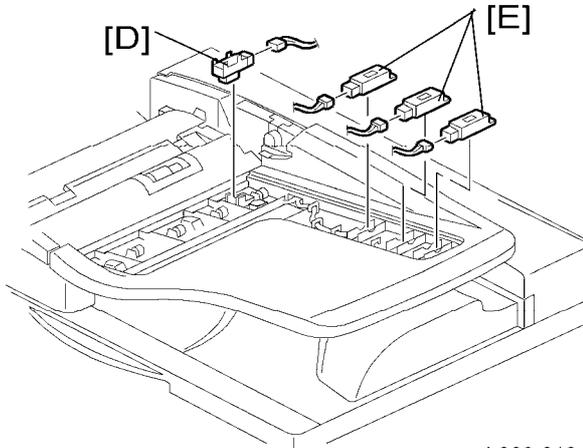

b802r012

5. Original trailing edge sensor [D] (⌀ x 1, hook)
6. Original length sensors [E] (⌀ x 1 each, hook)

1.3.3 ORIGINAL SET, SEPARATION, SKEW CORRECTION AND SCANNING ENTRANCE SENSOR

1. Open the left cover.

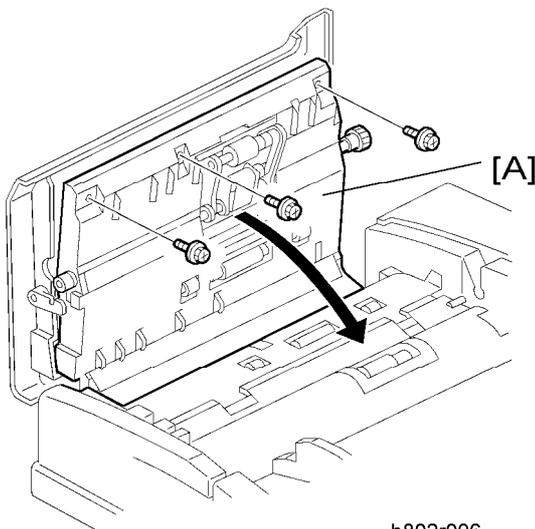

b802r006

2. Open the inner upper cover [A] (stepped screw x 3).

Electrical Components

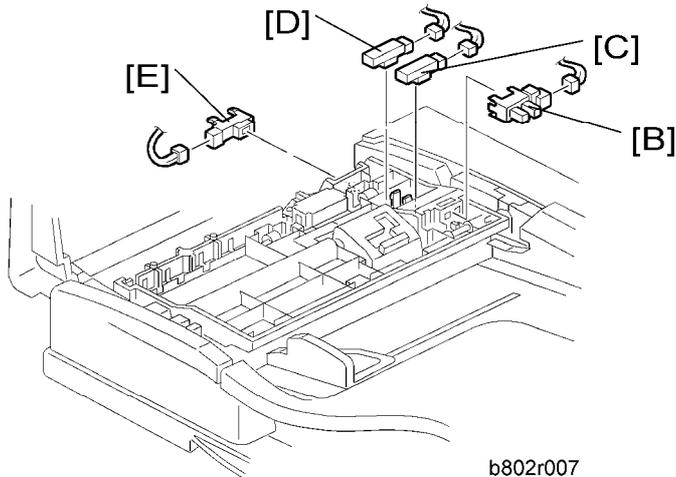

3. Original set sensor [B] (🔌 x 1, hook)
4. Separation sensor [C] (🔌 x 1, hook)
5. Skew correction sensor [D] (🔌 x 1, hook)
6. Scanning entrance sensor [E] (🔌 x 1, hook)

1.3.4 ORIGINAL WIDTH SENSORS

1. Open the left cover.
2. Open the inner upper cover (☛1.3.3" Original Set, Separation, Skew Correction and Registration Sensor").

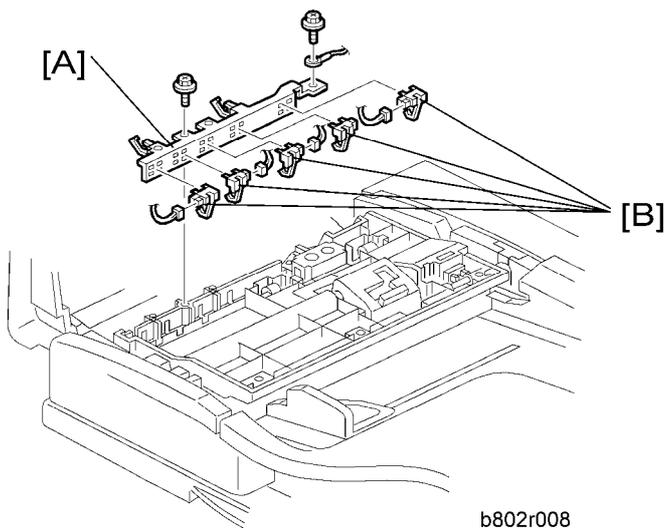

3. Original width sensor bracket [A] (🔩 x 2, ground cable x 1).
4. Original width sensors [B] (🔌 x 1 each, hook)

1.3.5 REGISTRATION SENSOR

1. Open the ARDF.

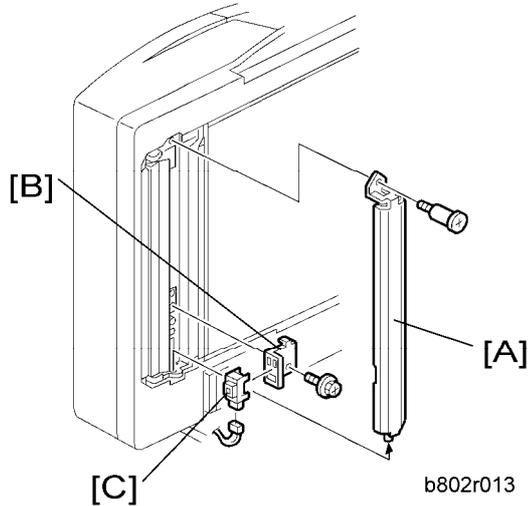

2. White plate [A] (stud screw x 1)
3. Registration sensor bracket [B] (⚙ x 1)
4. Registration sensor [C] (🔌 x 1)

1.3.6 ORIGINAL EXIT SENSOR

1. Open the left cover.

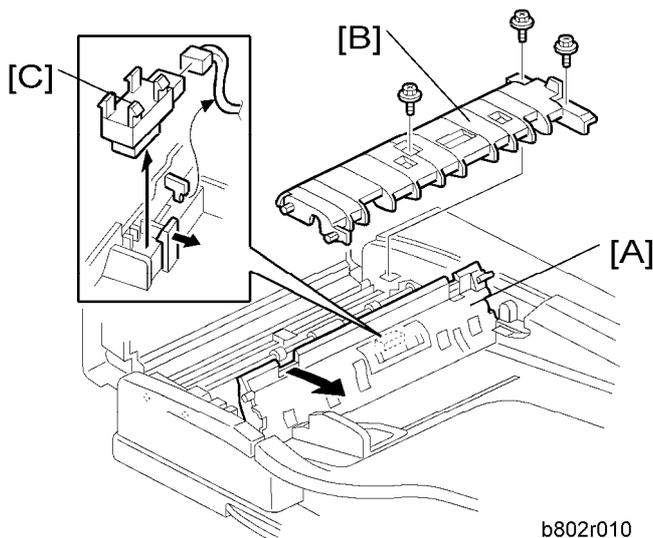

2. Open the feed-in guide plate [A].
3. Guide plate [B] (⚙ x 2, stepped screw x 1; front side)
4. Original exit sensor [C] (🔌 x 1, hook)

Electrical Components

1.3.7 DF POSITION SENSOR

1. Rear cover (☛1.1.1 "Front and Rear Cover")
2. ARDF drive board (☛1.3.1 "ARDF Drive Board")



3. DF position sensor bracket [A] (☛ x 1)

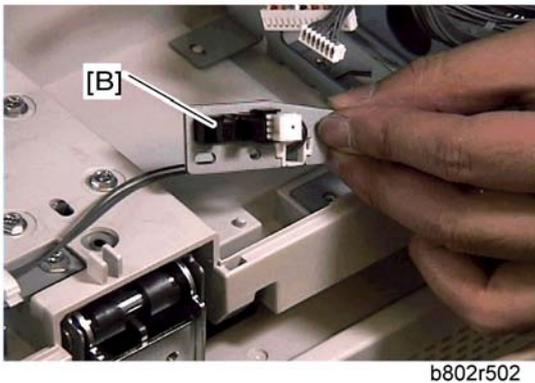

4. DF position sensor [B] (☛ x 1, hook)

1.3.8 COVER SENSOR

1. Open the left cover.
2. Rear cover (☛1.1.1 "Front and Rear Cover")

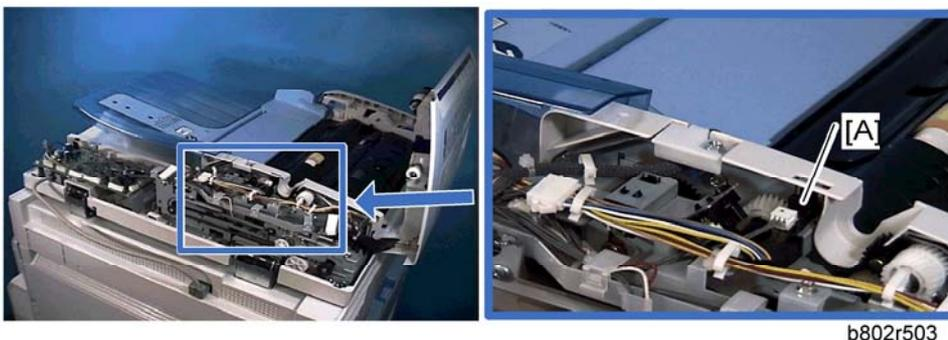

3. Cover sensor [A] (☛ x 1, hook)

1.3.9 PICK-UP ROLLER HP AND ORIGINAL STOPPER HP SENSOR

1. Open the left cover.
2. Rear cover (☛1.1.1 "Front and Rear Cover")

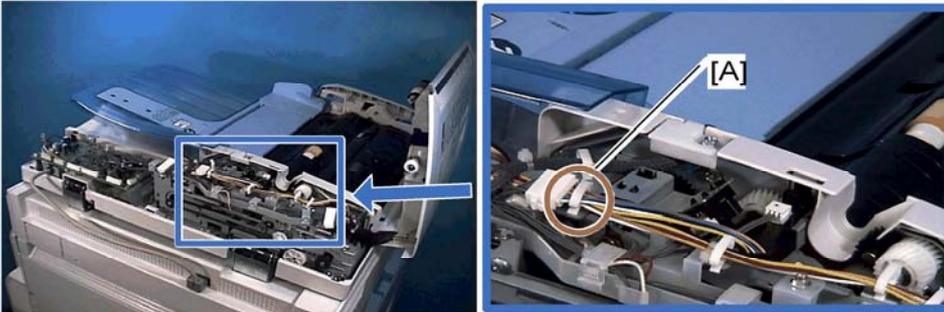

b802r504

3. Release the clamp [A] (☛x 1), and then slide the harnesses away.

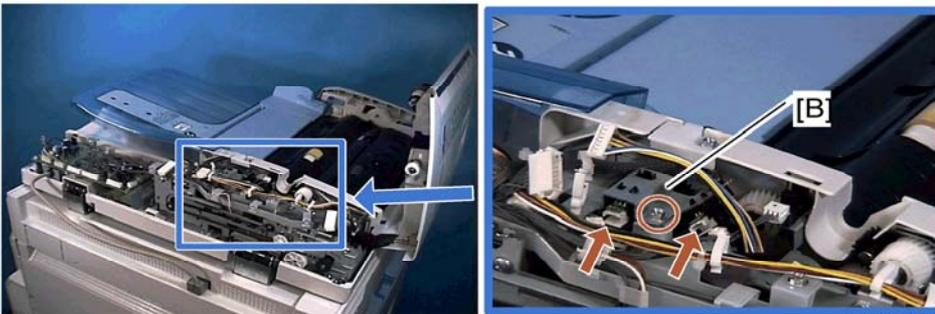

b802r505

4. Sensor bracket [B] (☛ x 1, ☛ x 2)

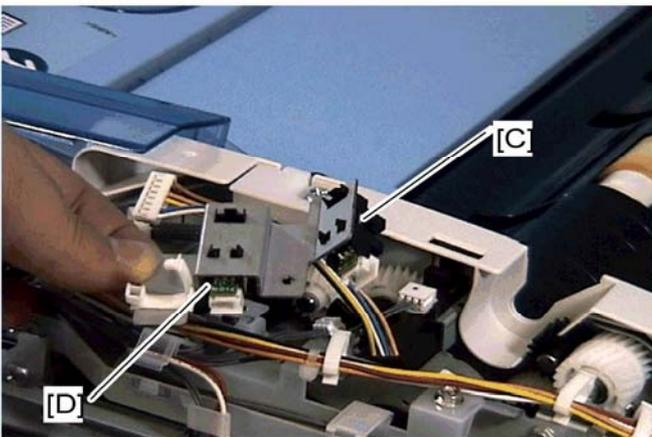

b802r506

5. Pick-up roller HP sensor [C] (hook)
6. Original stopper HP sensor [D] (hook)

1.3.10 STAMP SOLENOID

1. Open the left cover.

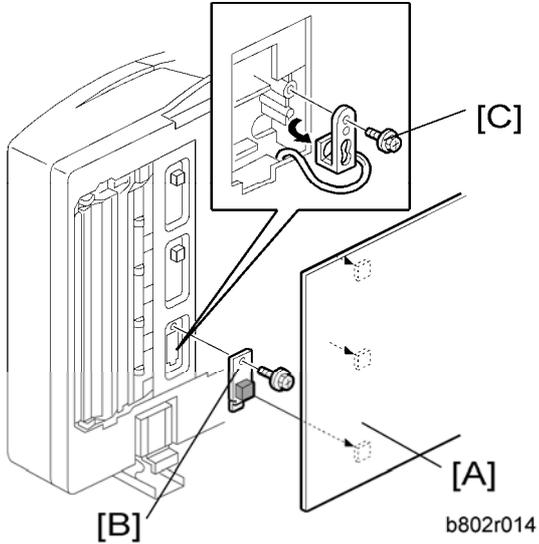

2. Remove the platen plate [A].
3. Stamp solenoid cover [B] (⚙ x 1)
4. Remove the screw [C] (⚙ x 1).

Note

- You cannot remove the stamp solenoid at this time.

5. Rear cover (☛1.1.1. "Front and Rear Cover")

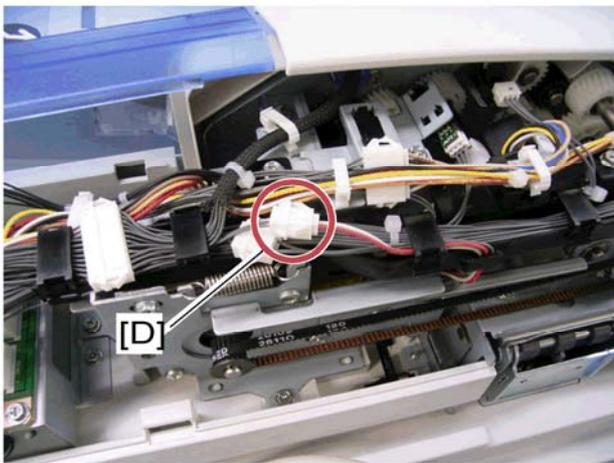

6. Disconnect the stamp solenoid harness [D].
7. ADF feed motor (☛1.4.1 "ADF Feed Motor")

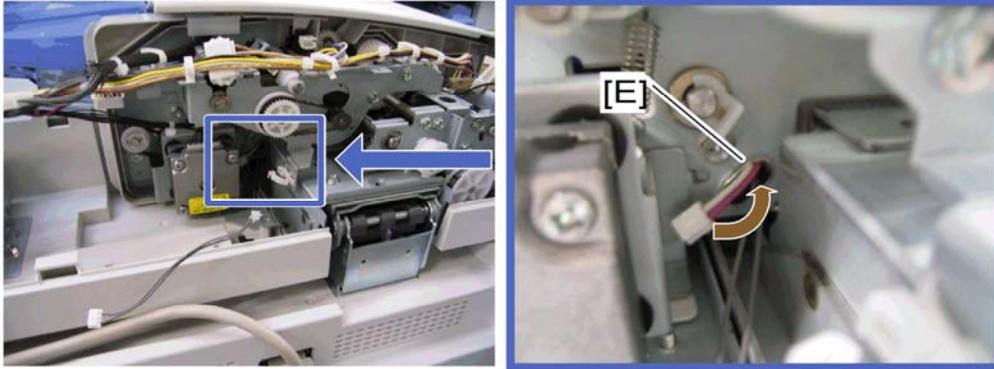

b802r508

8. Put the stamp solenoid harness into the cutout [E].

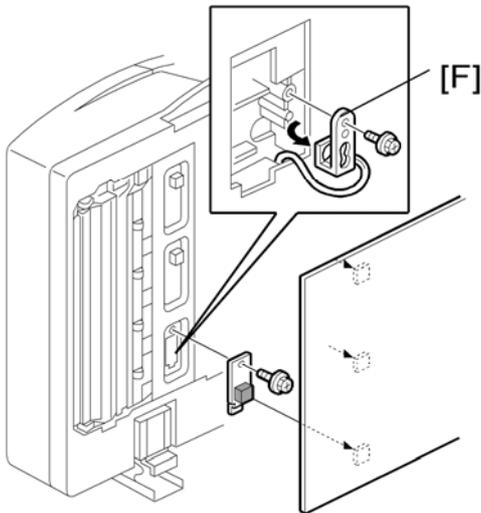

b802r014a

9. Pull out the stamp solenoid [F]

1.4 ORIGINAL FEED DRIVE

1.4.1 ADF FEED MOTOR

1. Rear cover (☛1.1.1 "Front and Rear Cover")

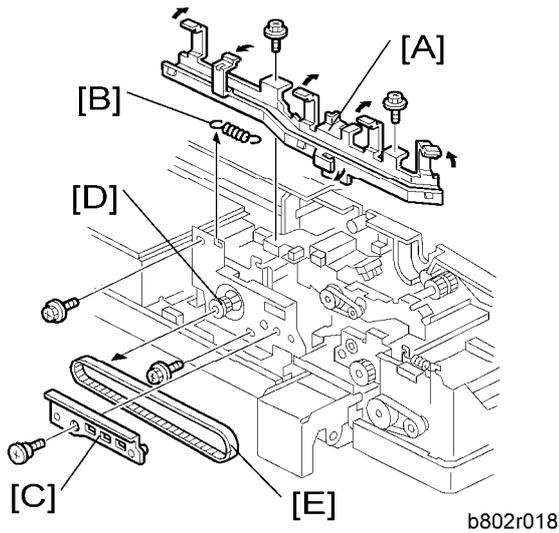

2. Harness guide [A] (☛ x 2, all ☛, all ☛s)
3. Remove the spring [B].
4. Stay bracket [C] (stepped screw x 1)
5. Slide the feed motor gear [D] to the left side (seen from the front of the machine), and then remove the timing belt [E].

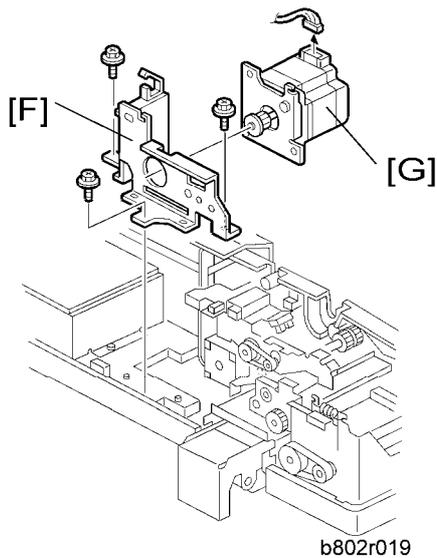

6. ADF feed motor bracket [F] (☛ x 3)
7. ADF feed motor [G] (☛ x 1)

1.4.2 ADF INVERTER MOTOR

1. ADF feed motor (●1.4.1 "ADF Feed Motor")

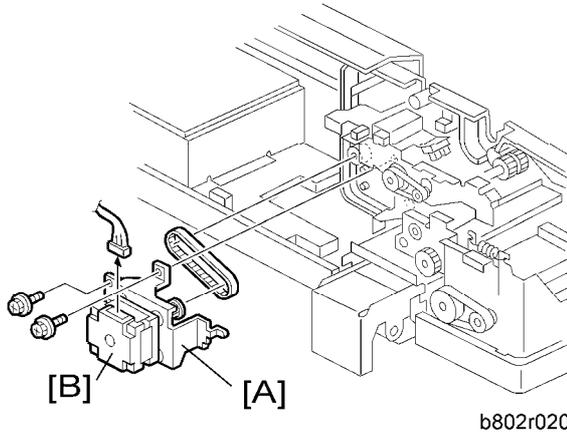

2. ADF inverter motor bracket [A] (⚙ x 2, ⚙ x 1, timing belt)
3. ADF inverter motor [B] (⚙ x 4)

1.4.3 ADF TRANSPORT MOTOR

1. Rear cover (●1.1.1 "Front and Rear Cover")

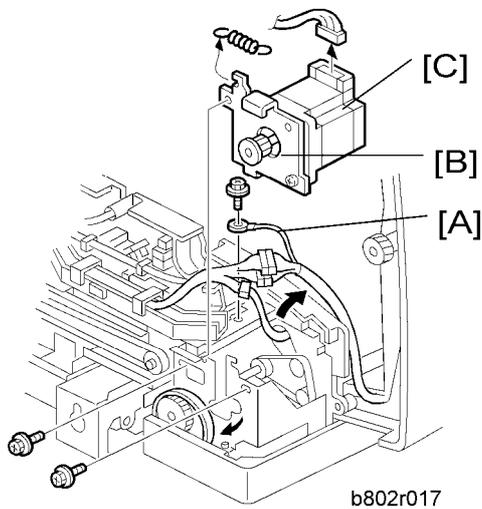

2. Ground cable [A] (⚙ x 1)
3. ADF transport motor bracket [B] (⚙ x 2, ⚙ x 1)
4. ADF transport motor [C] (⚙ x 2)

1.4.4 ADF PICK-UP MOTOR

1. Rear cover (●1.1.1 "Front and Rear Cover")

Original Feed Drive

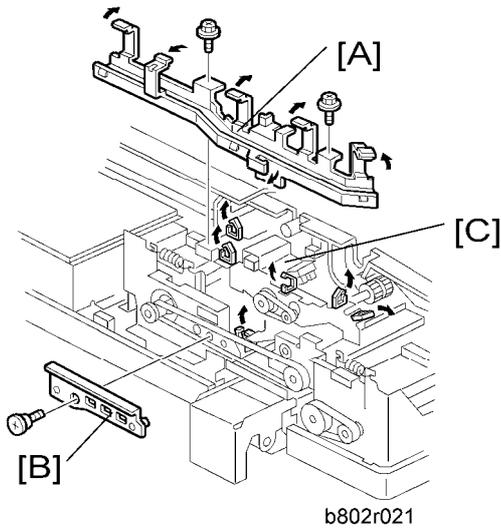

2. Harness guide [A] (⌀ x 2, all , all )
3. Stay bracket [B] (stepped screw x 1)
4. Release 6 clamps on the ADF pick-up motor bracket [C] ( x 6).

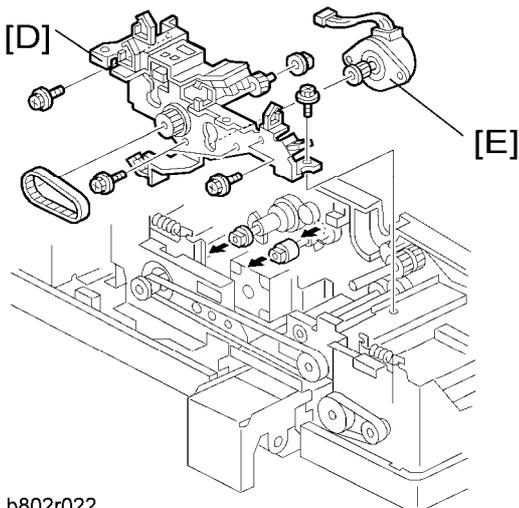

5. ADF pick-up motor bracket [D] (⌀ x 3,  x 1)
6. ADF pick-up motor [E] (⌀ x 2,  x 1, timing belt)

2. DETAILED DESCRIPTIONS

2.1 COMPONENT LAYOUT

2.1.1 MECHANICAL COMPONENT LAYOUT

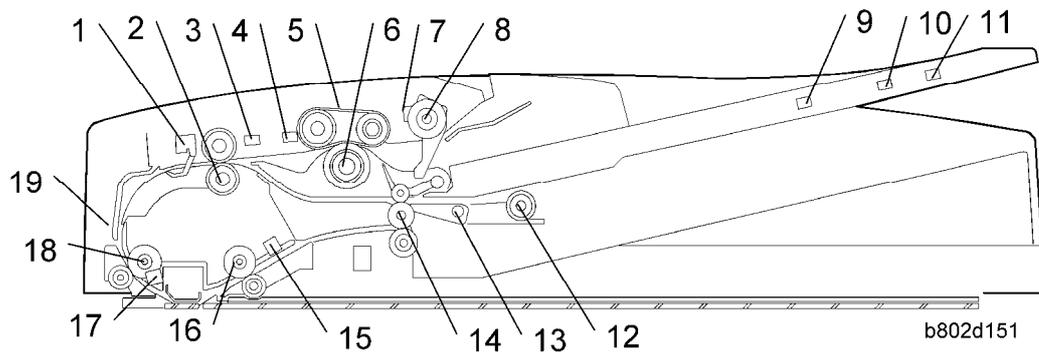

1. Original Width Sensor	11. Original Length Sensor 3
2. Skew Correction Roller	12. Inverter Roller
3. Skew Correction Sensor	13. Junction Gate
4. Separation Sensor	14. Exit Roller
5. Feed Belt	15. Original Exit Sensor
6. Separation Roller	16. Transport Roller
7. Original Set Sensor	17. Registration Sensor
8. Pick-up Roller	18. Registration Roller
9. Original Length Sensor 1	19. Scanning Entrance Sensor
10. Original Length Sensor 2	

2.1.2 ELECTRICAL COMPONENT LAYOUT

Sensors and Drive Components

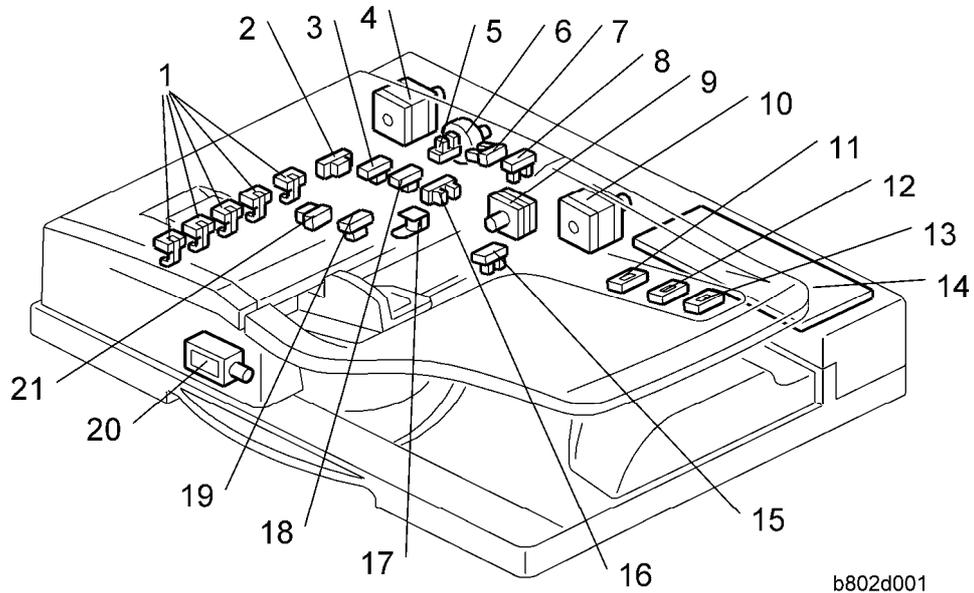

1. Original Width Sensors	12. Original Length Sensor 2
2. Scanning Entrance Sensor	13. Original Length Sensor 4
3. Skew Correction Sensor	14. DF Drive Board
4. ADF Transport Motor	15. Original Trailing Edge Sensor
5. Left Cover Sensor	16. Original Set Sensor
6. Pick-up Motor	17. Stamp Solenoid
7. Pick-up Roller HP Sensor	18. Separation Sensor
8. Original Stopper HP Sensor	19. Original Exit Sensor
9. ADF Inverter Motor	20. Junction Gate Solenoid
10. ADF Feed Motor	21. Registration Sensor
11. Original Length Sensor 1	

Electrical Component Descriptions

Name	Function	Index No.
Motors		
ADF Feed	Drives the feed belt, separation, pick-up, and reverse table rollers.	10
ADF Transport	Drives the transport and exit rollers	4
ADF Inverter	Drives the Inverter rollers	9
Pick-up Motor	Moves the pick-up roller up and down.	6
Sensors		
DF Position	Detects whether the DF is lifted or not.	
Skew Correction	Detects the leading edge of the original to turn off the DF feed and transport motors.	3
Registration	Detects the original exposure timing, and checks for original misfeeds.	21
Cover Sensor	Detects whether the feed-in cover is opened or not.	4
Original Width Sensor - S	Detects the original width - S.	1
Original Width Sensor - M	Detects the original width - M.	1
Original Width Sensor - L	Detects the original width - L.	1
Original Width Sensor - LL	Detects the original width - LL.	1
-	Detects the original length - S.	11

Component Layout

Original Length - M	Detects the original length - M.	12
Original Length - L	Detects the original length - L.	13
Original Set	Detects if an original is on the feed table.	16
Original Exit	Detects the leading edge of the original to turn on the junction gate solenoid and checks for original misfeeds. Detects the trailing edge of the original to turn off the transport and feed motor and junction gate solenoid. In single-sided mode, used to detect original misfeeds.	19
Original Trailing Edge Sensor	Detects the trailing edge of the last original to stop copy paper feed and to turn off the transport motor, and checks for original misfeeds.	15
Separation Sensor	The machine uses this sensor to check if the original has slipped during feed-in, to make sure that original feed starts at the correct time.	18
Solenoids		
Stamp	Energizes the stamper to mark the original.	17
Junction Gate	Opens and closes the junction gate.	20
PCBs		
DF Drive	Interfaces the sensor signals with the copier, and transfers the magnetic clutch, solenoid and motor drive signals from the copier.	14

2.1.3 DRIVE LAYOUT

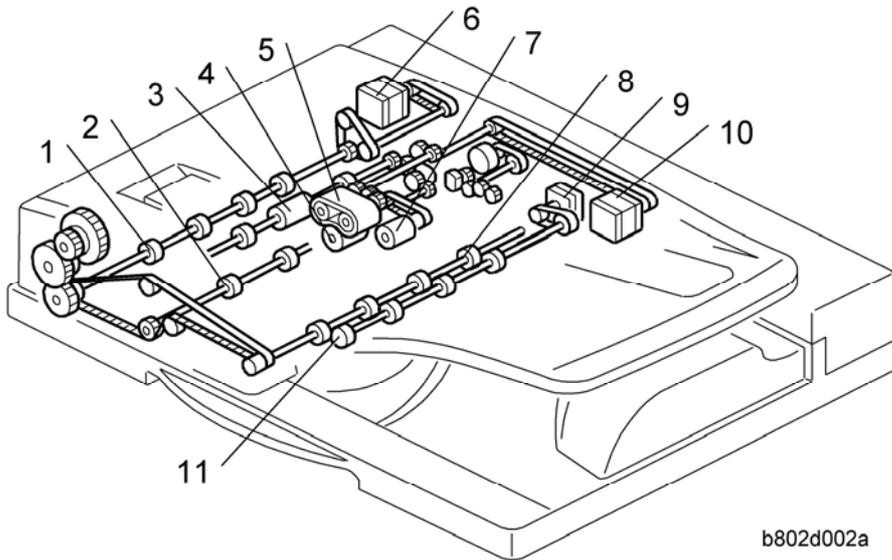

b802d002a

1. Registration Roller
2. Transport Roller
3. Skew Correction Roller
4. Separation Roller
5. Feed Belt
6. ADF Transport Motor
7. Pick-up Roller
8. Exit Roller
9. ADF Inverter Motor
10. ADF Feed Motor
11. Inverter Roller

Component Layout

ADF Feed Motor

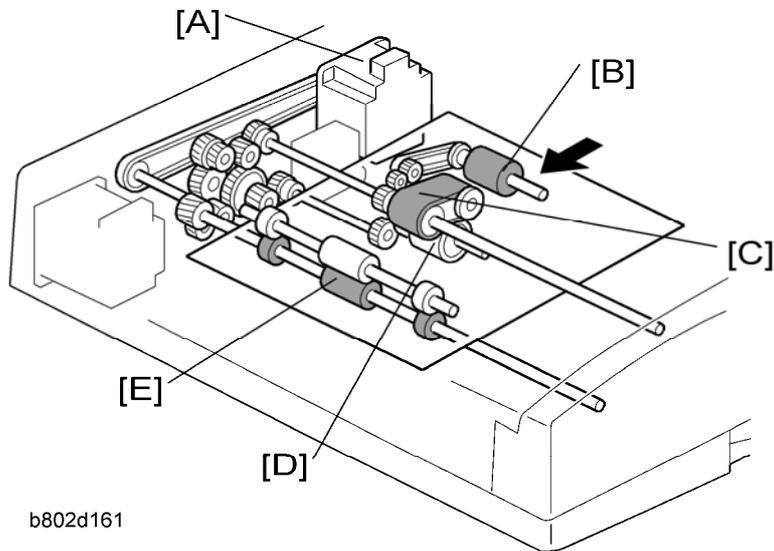

- ADF Feed Motor [A] drives the pick-up [B], feed belt [C], separation [D] and skew correction rollers [E].

ADF Transport Motor and ADF Inverter Motor

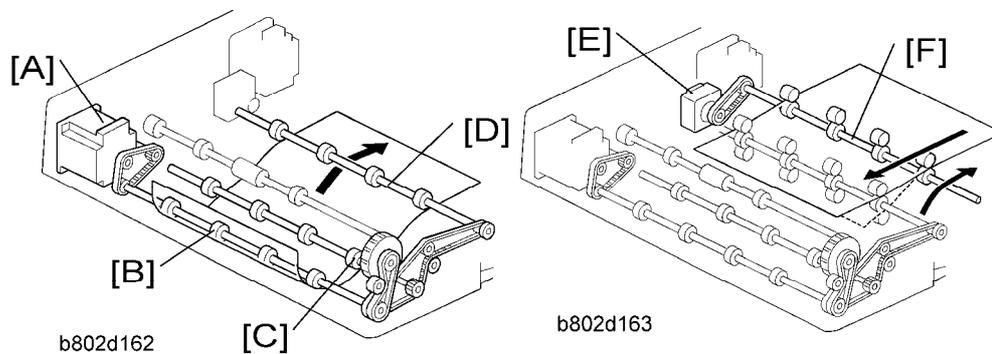

- ADF Transport Motor [A] drives the registration roller [B], transport roller [C] and exit roller [D].
- ADF Inverter Motor [E] drives the Inverter Roller [F].

2.2 BASIC OPERATION

2.2.1 ORIGINAL SIZE DETECTION

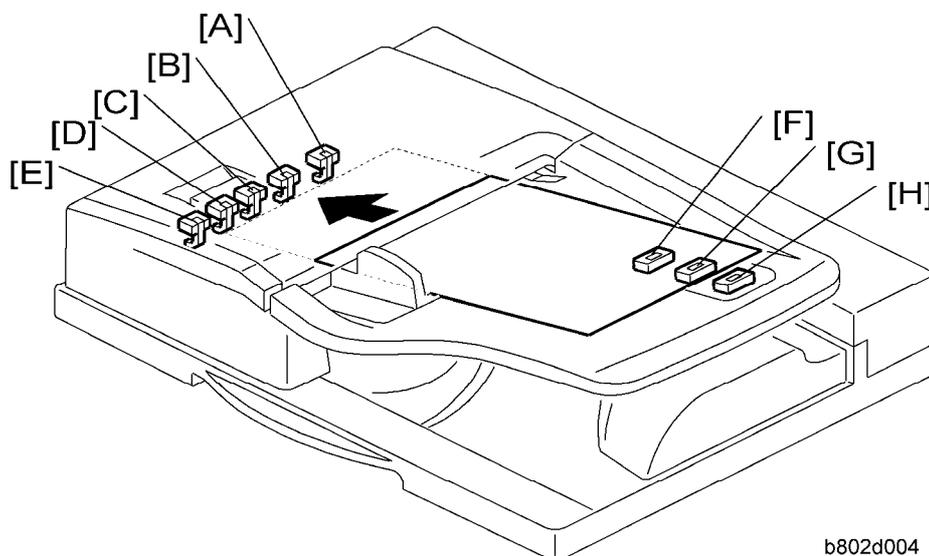

b802d004

The original size detection mechanism consists of the five original width sensors ([A]: Width Sensor SS, [B]: Width Sensor S, [C] Width Sensor M, [D]: Width Sensor L, [E]: Width Sensor LL) and three original length sensors ([F]: Length Sensor S, [G]: Length Sensor M, [H]: Length Sensor L). Based on the combined output of the length sensors and the width sensors, the machine can detect the size of the original. This integrated detection mechanism is detailed in the table below.

Size	Width Sensor					Length Sensor			Area	
	SS	S	M	L	LL	S	M	L	LT	A/B
A3/SEF (297 x 420)	ON	ON	ON	ON	ON	ON	ON	ON	O	O
B4/SEF (257 x 364)	ON	ON	ON	-	-	ON	ON	ON	-	O
A4/SEF (210 x 297)	ON	ON	-	-	-	ON	ON	-	O	O
A4/LEF (297 x 210)	ON	ON	ON	ON	ON	-	-	-	O	O
B5/SEF (182 x 257)	ON	-	-	-	-	ON	-	-	-	O

Basic Operation

B5/LEF (257 x 182)	ON	ON	ON	-	-	-	-	-	-	O
A5/SEF (148 x 210)	ON	-	-	-	-	-	-	-	-	O
A5/LEF (210 x 148)	ON	ON	-	-	-	-	-	-	-	O
11" x 17"/SEF (DLT)	ON	ON	ON	ON	-	ON	ON	ON	O ¹	O ⁵
11" x 15"/SEF	ON	ON	ON	ON	-	ON	ON	ON	● ¹	-
10" x 14"/SEF	ON	ON	ON	ON	ON	ON	ON	ON	O	-
8.5" x 14"/SEF (LG)	ON	ON	-	-	-	ON	ON	ON	O ²	-
8.5" x 13"/SEF (F4)	ON	ON	-	-	-	ON	ON	ON	● ²	O
8.25" x 13"/SEF	ON	ON	-	-	-	ON	ON	ON	-	-
8" x 13"/SEF (F)	ON	ON	-	-	-	ON	ON	ON	-	-
8.5" x 11"/SEF (LT)	ON	ON	-	-	-	ON	-	-	O ³	O ⁶
8.5" x 11"/LEF (LT)	ON	ON	ON	On	-	-	-	-	O ⁴	O ⁷
7.25" x 10.5"/SEF (US EXE)	ON	ON	-	-	-	ON	-	-	O	-
10.5" x 7.25"/SEF (US EXE)	ON	ON	ON	ON	-	-	-	-	● ⁴	-
10" x 8"/SEF	ON	ON	-	-	-	ON	-	-	● ³	-
5.5" x 8.5"/SEF (HLT)	-	-	-	-	-	-	-	-	O	-
5.5" x 8.5"/LEF (HLT)	ON	ON	-	-	-	-	-	-	O	-
267 mm x 390 mm	ON	ON	ON	ON	-	ON	ON	ON	-	● ⁵
195 mm x 267 mm	ON	ON	-	-	-	ON	-	-	-	● ⁶
267 mm x 195 mm	ON	ON	ON	ON	-	-	-	-	-	● ⁷

Symbols

O: Yes (Default), : Yes (Can select this with SP mode), ON: Paper present, LT: North America, A/B: Europe, Asia



- For "O/" mark, which has superscripted number, it is possible to change the original detection size with SP6-016. For example, instead of LT (O³), the machine can be set up to detect 10" x 8" (³).
- The F size can be selected with SP5-126. The default is 8.5" x 13"
- The machine cannot detect more than one size of original in the same job.

2.2.2 MIXED ORIGINAL SIZE MODE

This section explains what happens when the user selects mixed original size mode. Because this ARDF is a sheet-through document feeder, the method for original document width detection is the same as when the originals are the same size, but the document length detection method is different. Therefore, the scanning speed is slightly slower.

Document length detection

From when the skew correction sensor switches on until it switches off, the CPU counts the transport motor pulses. The number of pulses determines the length of the original.

Feed-in cycle

When the original size for the copy modes listed below cannot be determined, the image cannot be correctly scaled (reduced or enlarged) or processed until the original's length has been accurately detected. The length must be determined before the image is scanned.

Auto Reduce/Enlarge
Centering
Erase Center/Border
Booklet
Image Repeat

The originals follow this path:

1. Length detection → Scanning glass → Inverter table

Basic Operation

2. Inverter table → Scanning glass → Inverter table (restores the original order)
3. Inverter table → Scanning glass (image scanned) → Exit tray

Normal feed-in

In a copy mode other than those listed above, when the reduction/enlargement ratio has been determined, the originals are scanned normally. In order to store the scanned images, a large area of memory (the detected original width x 432 mm length) is prepared. Next, only the portion of the image up to the detected original length is read from memory and printed.

2.2.3 PICK-UP AND SEPARATION

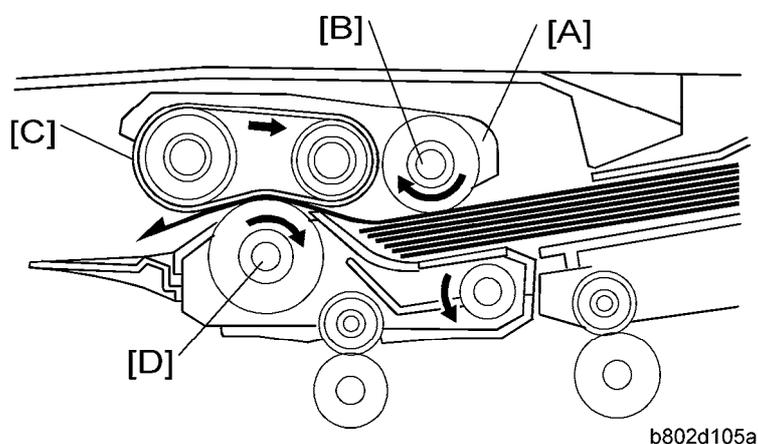

The original is set with the image facing up. The original pushes actuator and the original set sensor is activated.

After pressing the start button, the pick-up motor is activated and the original feed unit [A] moves down. At the same time, the ADF feed motor is activated and the pick-up roller [B] feeds original to the feed belt [C].

After being fed from feed belt [C], the topmost sheet is separated from the stack by the separation roller [D] and sent to the skew correction roller.

The mechanism is an FRR system, consisting of the original feed belt [C] and separation roller [D].

2.2.4 SKEW CORRECTION

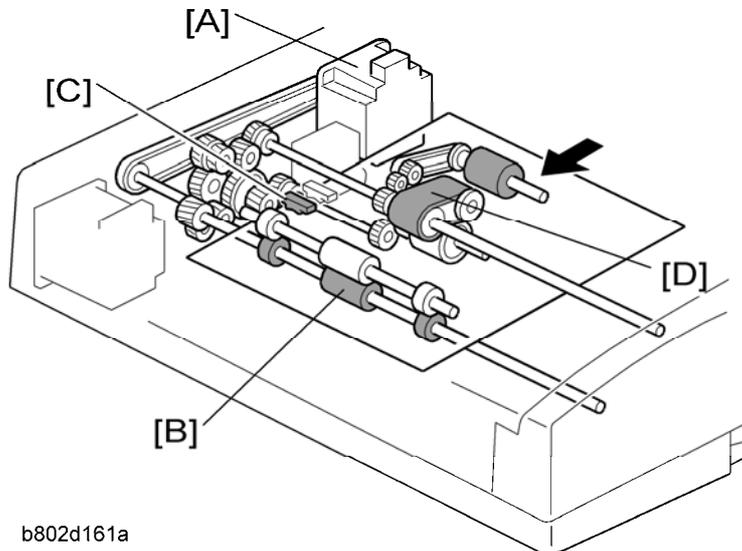

b802d161a

When an original is fed into the feeder, the feed motor [A] rotates forwards. At this time, the feed belt turns but the skew correction roller [B] does not, because these rollers have a one-way gear. (If the ADF feed motor rotates forward, the feed belt is moved. If the ADF feed motor rotates in reverse, the skew correction roller is moved.) As a result, when the leading edge of the paper gets to the skew correction roller, skew in the original is removed. A short time after the leading edge of the original turns on the skew correction sensor [C], the feed motor [A] turns off and rotates in reverse. At this time, the skew correction roller [B] and the feed belt [D] both turn, and original feed continues.

The registration roller also has the same skew correction mechanism, but only for small size originals (6, A5 or HLT). This function can be effective for all size paper with SP6-020-001.

2.2.5 SLIP DETECTION

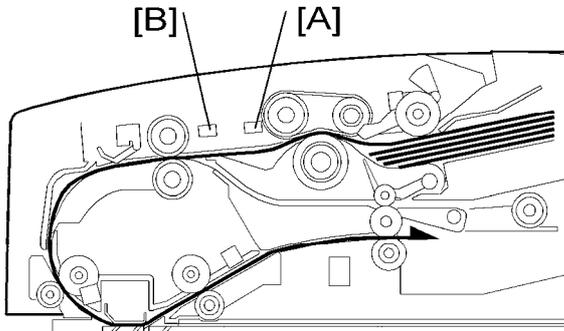

b802d152a

[A]: Separation sensor

[B]: Skew correction sensor

These two sensors are used to measure the amount of slippage and to correct for this.

The machine measures the time it takes for the original to get to the separation sensor [A] after the [Start] key is pressed.

- If the original arrives at the correct time, it feeds normally.
- If the original arrives late, the machine enters the slip mode.

In the slip mode, the machine measures the time for the leading edge of the original to move from the separation sensor to the skew correction sensor [B].

The machine uses this time to adjust the length of time that the entrance roller stays off to correct skew. This stops feed for enough time for the original to be in the correct position for feeding.

2.2.6 ORIGINAL TRANSPORT AND EXIT

Single-Sided Originals

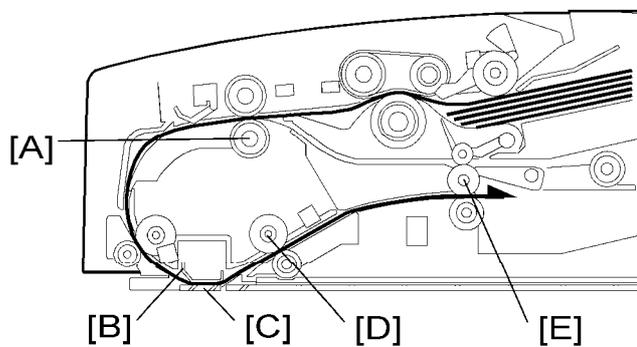

b802d152

The feed motor feeds the separated original to the skew correction roller [A] at maximum

speed. After skew correction, the feed and transport motors feed the original through the scanning area at a lower speed (the scanning area contains the original exposure guide [B] and DF exposure glass [C]). After scanning, the original is fed out by the transport roller [D] and exit roller [E].

Double-Sided Originals

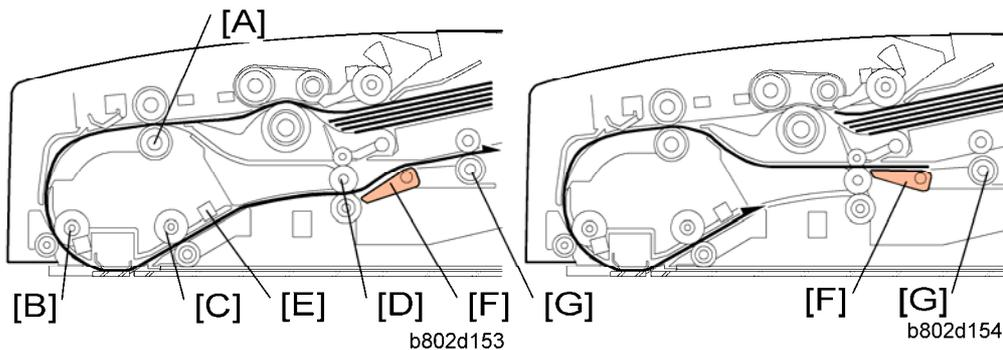

After skew correction, the ADF feed and transport motors drive the skew correction roller [A], registration roller [B], transport roller [C] and the exit roller [D]. The front side of the original is then scanned.

When the original exit sensor [E] detects the leading edge of the original, the junction gate solenoid is activated and the junction gate [F] opens. The original is then transported towards the inverter table.

Soon after the trailing edge of the original passes the exit sensor, the junction gate solenoid switches off and the junction gate [F] is closed. When the original has been fed onto the inverter table, the ADF inverter motor switches on. The original is then fed by the inverter roller [G], and then by the skew correction roller [A] and registration roller [B] to the scanning area (where the reverse side will be scanned).

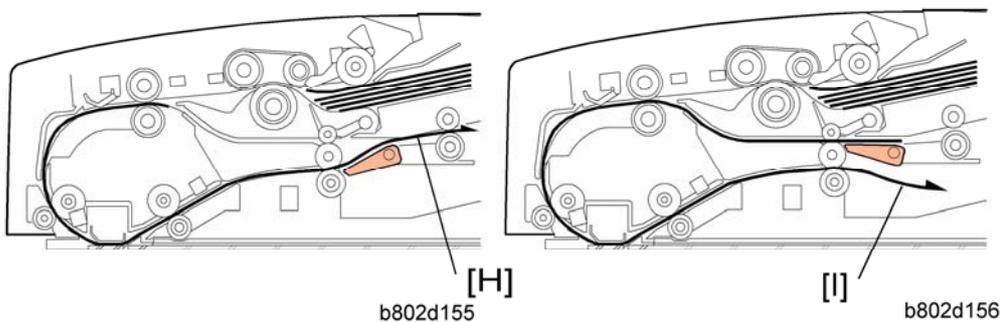

The original is then sent to the inverter table [H] again to be turned over. This is done so that the duplex copies will be properly stacked front side down in the exit tray [I] in the correct order.

Original Sensor

During one-to-one copying, copy paper is fed to the skew correction roller in advance

Basic Operation

(while the original is still being scanned), to increase the copy speed. The original set sensor monitors the stack of originals in the feeder, and detects when the trailing edge of the last page has been fed in. The main CPU then stops the copier from feeding an unwanted extra sheet of copy paper.

2.2.7 CONDITIONS FOR JAM DETECTION

Jam Mode	Detection Timing
Initial	When turning on the machine, the skew correction sensor, separation sensor, registration sensor or exit sensor detects an original.
	When the cover is closed or DF is down, the skew correction sensor, separation sensor, registration sensor or exit sensor detects an original.
	When the cover is opened or DF is lifted up, the skew correction sensor, separation sensor, registration sensor or exit sensor detects an original.
Sensor stays on too long	The skew correction sensor does not turn off even if the original was fed by the maximum length of the original + 150 mm after the skew correction sensor turned on.
	The registration sensor does not turn off even if the original was fed by its length x 1.5 after the registration sensor turned on.
	The exit sensor does not turn off even if the original was fed by its length x 1.5 after the exit sensor turned on.
Sensor does not come on	The separation sensor does not turn on even if the original was fed by transport path length x 1.5.
	The skew correction sensor does not turn on even if the original was fed by transport path length x 1.5.
	The registration sensor does not turn on even if the original was fed by transport path length x 1.5 after the skew correction sensor turned on.
	The exit sensor does not turn on even the original was fed by transport path length x 1.5 after the skew correction sensor turned on.

3. SERVICE TABLES

3.1 DIP SWITCHES

DIP-SW				Function
1	2	3	4	
0	0	0	0	Normal operating mode (Default)
0	0	0	1	Free run: With original: One-sided mode: 100% speed
0	0	1	0	Free run: With original: Two-sided mode: 100% speed
0	0	1	1	Free run: No original: One-sided mode: 100% speed
0	1	0	0	Free run: No original: Two-sided mode: 100% speed
0	1	0	1	Free run: With original: One-sided mode: 32% speed
0	1	1	0	Free run: With original: Two-sided mode: 32% speed
0	1	1	1	Free run: With original: One-sided mode: 70% speed
1	0	0	0	Free run: With original: Two-sided mode: 70% speed
1	0	0	1	Free run: With original: One-sided mode: 200% speed
1	0	1	0	Free run: With original: Two-sided mode: 200% speed
1	0	1	1	Transport Motor On
1	1	0	0	Feed Motor On
1	1	0	1	Transport Motor On with random mode
1	1	1	0	Feed Motor On with random mode
1	1	1	1	

**BOOKLET FINISHER & FINISHER
SR3020/SR3030/SR4010/SR4020
B804/B805/D373/D374**

REVISION HISTORY		
Page	Date	Added/Updated/New
		None

BOOKLET FINISHER SR3020/ FINISHER SR3030 B804/B805

TABLE OF CONTENTS

1. REPLACEMENT AND ADJUSTMENT	1
1.1 COVERS	1
1.1.1 EXTERIOR COVERS.....	1
1.1.2 UPPER TRAY, END FENCE.....	2
1.2 MAIN UNIT	3
1.2.1 UPPER TRAY LIMIT SENSOR, LIMIT SWITCH.....	3
1.2.2 POSITIONING ROLLER	4
1.2.3 PROOF TRAY EXIT SENSOR.....	4
1.2.4 UPPER TRAY HEIGHT SENSORS 1, 2	5
1.2.5 EXIT GUIDE PLATE, UPPER TRAY EXIT SENSOR.....	5
1.2.6 PROOF TRAY FULL SENSOR.....	6
1.2.7 FINISHER ENTRANCE SENSOR.....	7
1.2.8 PRE-STACK TRAY EXIT SENSOR.....	7
1.3 STAPLER UNIT.....	8
1.3.1 CORNER STAPLER	8
1.3.2 POSITIONING ROLLER	9
1.4 FOLD UNIT	10
1.4.1 FOLD UNIT	10
1.4.2 FOLD UNIT ENTRANCE SENSOR	12
1.4.3 FOLD UNIT EXIT SENSOR	12
1.4.4 STACK PRESENT SENSOR	13
1.4.5 FOLDING HORIZONTAL SKEW ADJUSTMENT (FOR B804 ONLY)	
14	
1.4.6 FOLD VERTICAL SKEW ADJUSTMENT (FOR B804 ONLY).....	17
1.5 BOOKLET STAPLER UNIT.....	19
1.5.1 BOOKLET STAPLER.....	19
1.5.2 BOOKLET STAPLER MOTOR.....	19
2. DETAILED SECTION DESCRIPTIONS	22
2.1 COMPONENT LAYOUT.....	22

2.1.1 GENERAL LAYOUT	22
2.1.2 ELECTRICAL COMPONENTS	24
2.1.3 SUMMARY OF ELECTRICAL COMPONENTS	28
2.1.4 DRIVE LAYOUT	38
2.2 JUNCTION GATES	40
2.2.1 PROOF MODE	40
2.2.2 SHIFT MODE	40
2.2.3 STAPLE MODE	41
2.3 PRE-STACKING	42
2.4 TRAY MOVEMENT MECHANISM	44
2.4.1 UPPER TRAY	44
2.4.2 LOWER TRAY (B804 ONLY)	46
2.5 CORNER STAPLING	49
2.5.1 STACKING AND JOGGING	49
2.5.2 STAPLER MOVEMENT	50
2.5.3 CORNER STAPLING	52
2.6 BOOKLET STAPLING (B804 ONLY)	53
2.6.1 BOOKLET PRESSURE MECHANISM	53
2.6.2 BOOKLET STAPLING AND FOLDING	54
2.6.3 BOOKLET STAPLING AND FOLDING MECHANISMS	60
2.7 UPPER TRAY OUTPUT	63
2.7.1 FEED OUT	63
2.7.2 FEED OUT STACKING	64
2.8 PUNCH UNIT B702 (FOR B804/B805)	65
2.8.1 OVERVIEW OF OPERATION	65
2.8.2 PUNCH MECHANISMS	67
2.8.3 PUNCH HOPPER MECHANISM	70
2.9 FINISHER JAM DETECTION	72

Read This First

Safety and Symbols

Replacement Procedure Safety



- Turn off the main power switch and unplug the machine before beginning any of the replacement procedures in this manual.

Symbols Used in this Manual

This manual uses the following symbols.

: See or Refer to

: Screws

: Connector

: Clip ring

: E-ring

1. REPLACEMENT AND ADJUSTMENT

1.1 COVERS

1.1.1 EXTERIOR COVERS

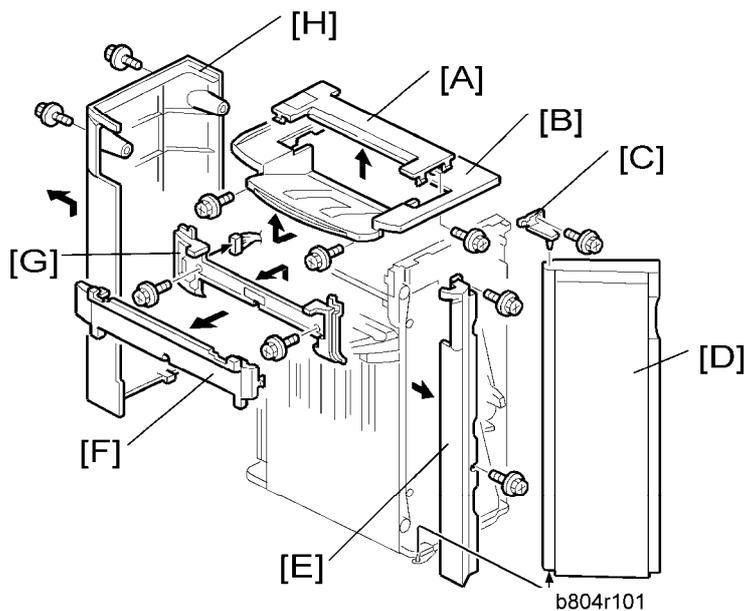

1. Open the front door [D].
2. Small upper cover [A] (🔩 x1)
3. Upper cover [B] (🔩 x2)
4. Front door bracket [C] (🔩 x1)
5. Front door [D]
6. Front left side cover [E] (🔩 x2)
7. Cover [F]
8. Paper exit cover [G] (🔩 x2)
9. Rear cover [H] (🔩 x2)

Booklet
Finisher/
Finisher
B804/B805

1.1.2 UPPER TRAY, END FENCE

1. Remove the rear cover. (* "Exterior Covers")

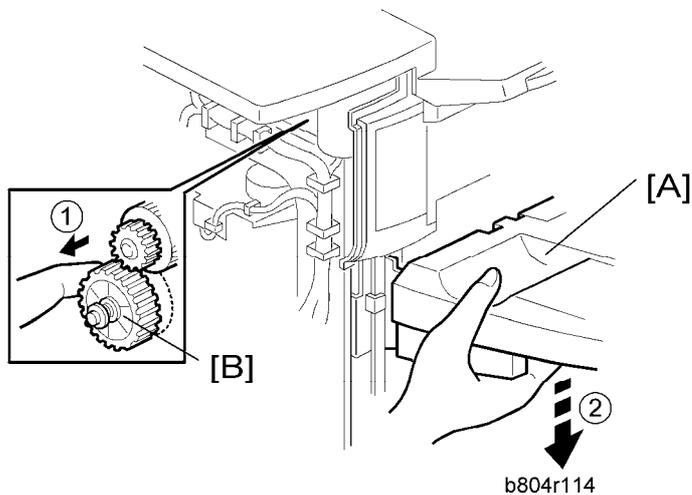

1. Support the tray [A] with your right hand.
2. Pull gear [B] toward you ① to release.
3. Slowly lower the tray ② until it stops.

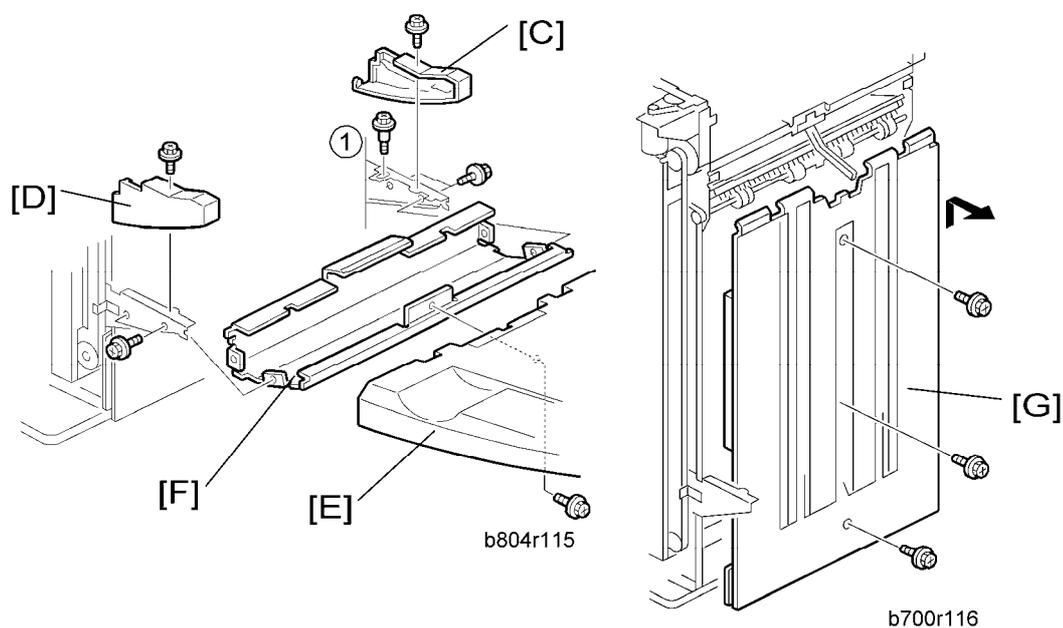

4. Front side cover [C] (⚙️ x1)
5. Rear side cover [D] (⚙️ x1)
6. Upper tray [E] (⚙️ x1)
7. Tray bracket [F] (⚙️ x4, ⚙️ x1 shoulder screw ①)
8. End Fence [G](⚙️ x3)

1.2 MAIN UNIT

1.2.1 UPPER TRAY LIMIT SENSOR, LIMIT SWITCH

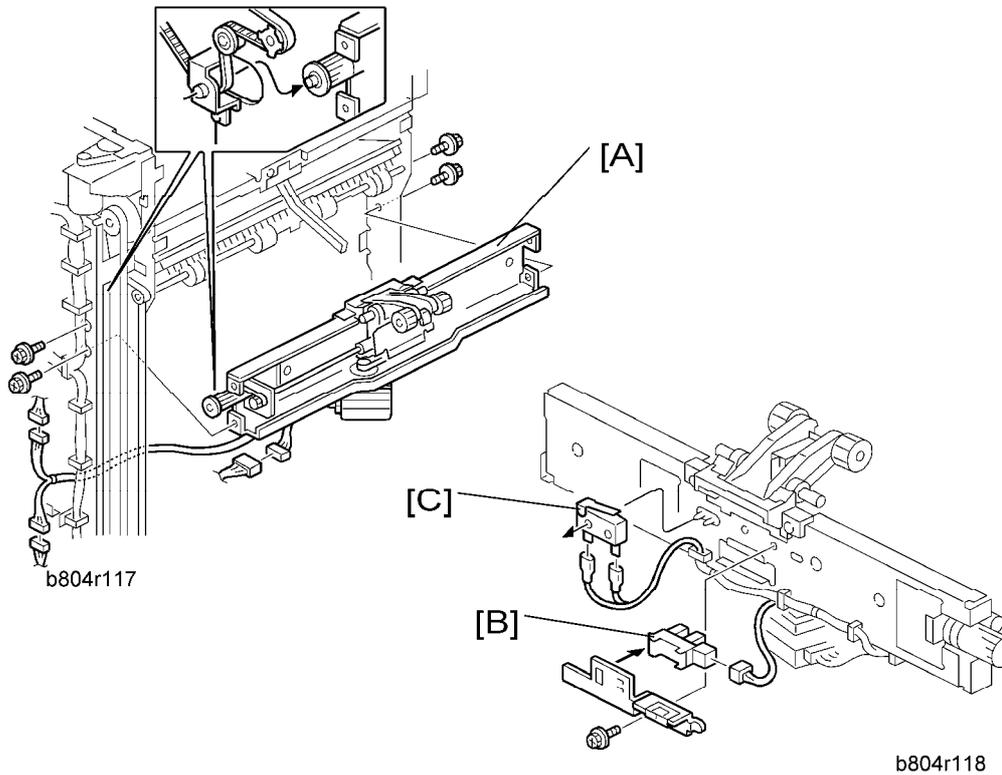

1. Front door, front left side cover, rear cover, upper cover (☛ "Exterior Cover")
2. End fence (☛ 1.1.2 "Upper Tray, End Fence")
3. Upper tray exit mechanism [A] (🔩 x4, 🛠️ x3)
4. Upper tray limit sensor [B] (🔩 x1, 🛠️ x1)
5. Upper tray limit switch [C] (🛠️ x2)

1.2.2 POSITIONING ROLLER

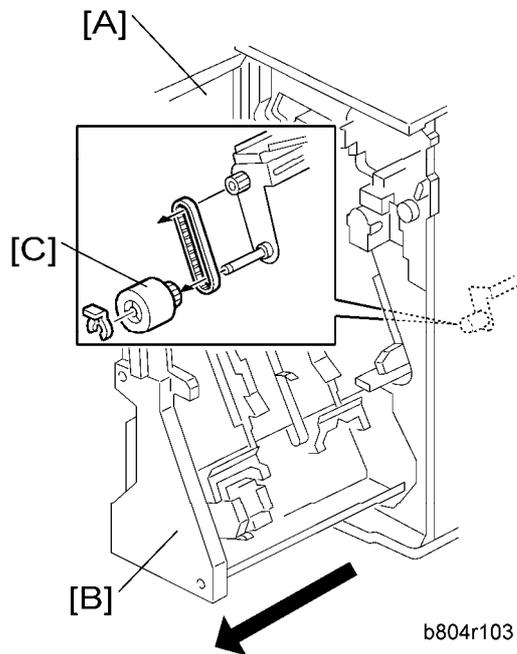

1. Open the front door [A].
2. Pull out the stapling unit [B].
3. Positioning roller [C] (⌚ x1, timing belt x1)

1.2.3 PROOF TRAY EXIT SENSOR

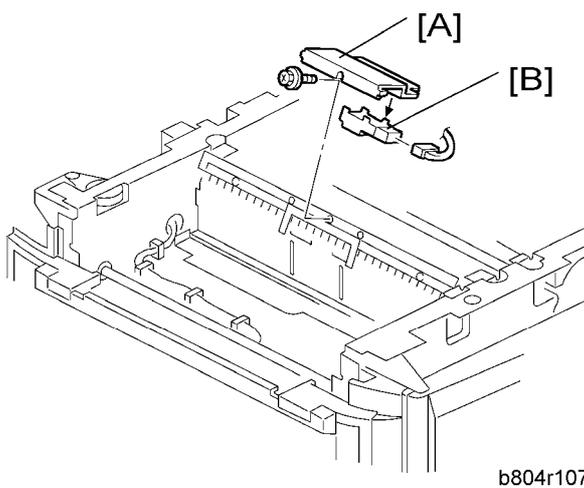

1. Small upper cover (☛1.1.1 "Exterior Cover")
2. Proof tray exit sensor bracket [A] (⌚ x1)

Main Unit

3. Proof tray exit sensor [B] (🔧 x1)

1.2.4 UPPER TRAY HEIGHT SENSORS 1, 2

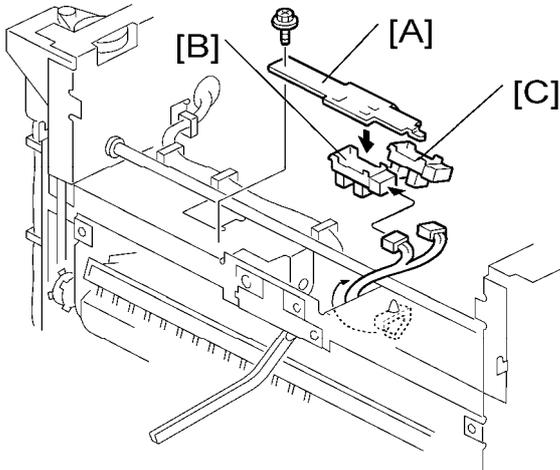

b804r108

1. Small upper cover, upper cover (🔧 1.1.1 "Exterior Cover")
2. Upper tray paper height sensor bracket [A] (🔧 x1)
3. Upper tray paper height sensor [B] – staple mode (S08) (🔧 x1)
4. Upper tray paper height sensor [C] – non-staple mode (S09) (🔧 x1)

Booklet
Finisher/
Finisher
B804/B805

1.2.5 EXIT GUIDE PLATE, UPPER TRAY EXIT SENSOR

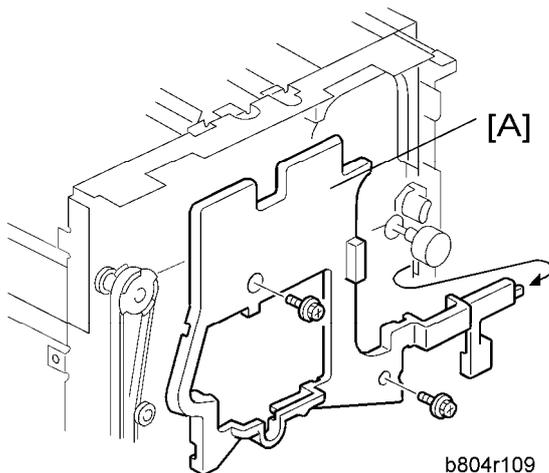

b804r109

1. Rear cover, Upper covers, Front door, Cover, Paper exit cover (🔧 1.1.1 "Exterior Cover")
2. Inner cover [A] (🔧 x2)

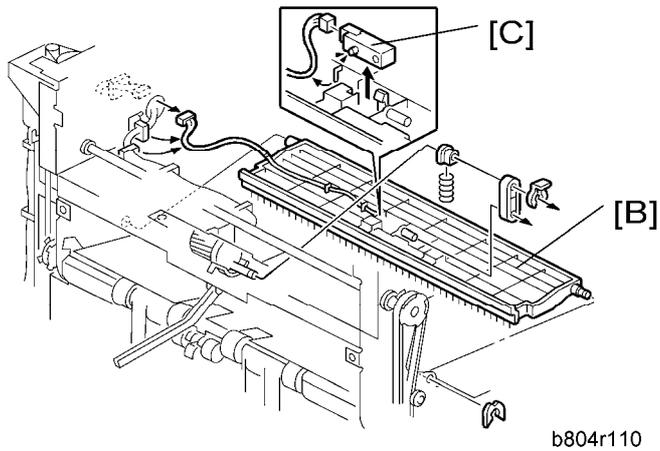

3. Exit guide plate [B] (⌘ x1, Link and spring, ⌘ x1, ⌘ x1)
4. Upper tray exit sensor [C] (S6) (⌘ x1)

1.2.6 PROOF TRAY FULL SENSOR

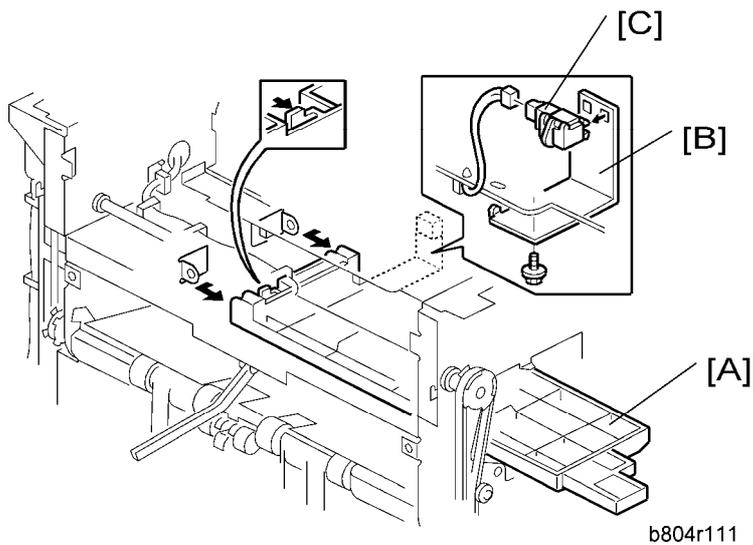

1. Exit guide plate. (☛1.2.5 "Exit Guide Plate, Upper Tray Exit Sensor")
2. Guide plate [A] (hook x 2)
3. Sensor bracket [B] (⌘ x1)
4. Proof tray full sensor [C] (S11) (⌘ x1)

1.2.7 FINISHER ENTRANCE SENSOR

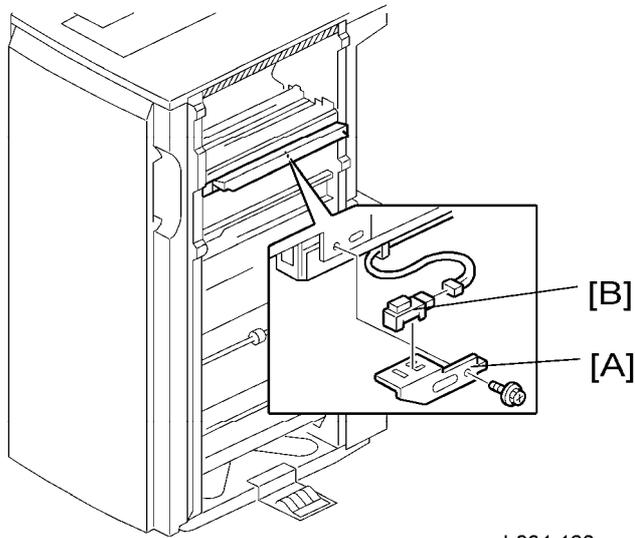

b804r133

1. Disconnect the finisher if it is connected to the copier.
2. Sensor bracket [A] (🔩 x1)
3. Finisher entrance sensor [B] (S1) (🔌 x1)

Booklet
Finisher/
Finisher
B804/B805

1.2.8 PRE-STACK TRAY EXIT SENSOR

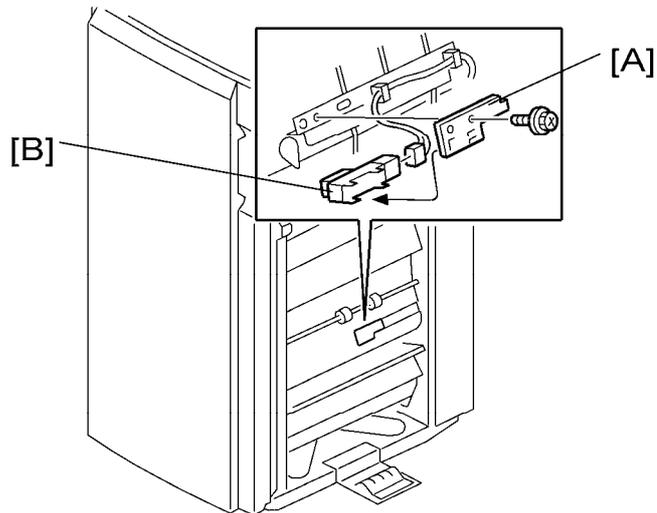

b804r102

1. Disconnect the finisher if it is connected to the copier.
2. Sensor bracket [A]
3. Pre-stack tray exit sensor [B] (S2)

1.3 STAPLER UNIT

1.3.1 CORNER STAPLER

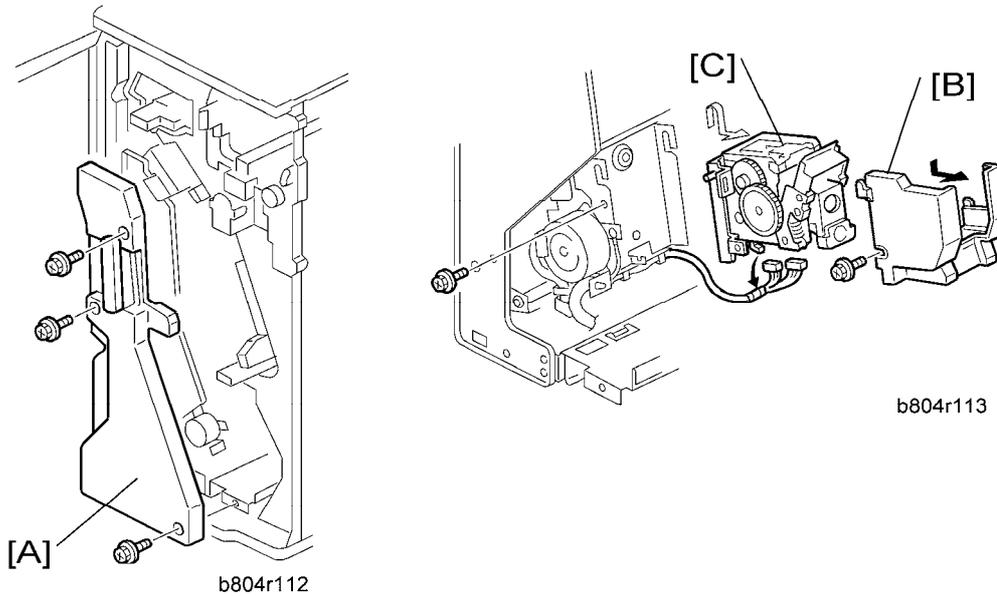

1. Open the front door.
2. Pull out the stapler unit.
3. Inner cover [A] (⌀ x3)
4. Stapler unit holder [B] (⌀ x1)
5. Corner stapler [C] (M20) (⌀ x1)

Stapler Unit

1.3.2 POSITIONING ROLLER

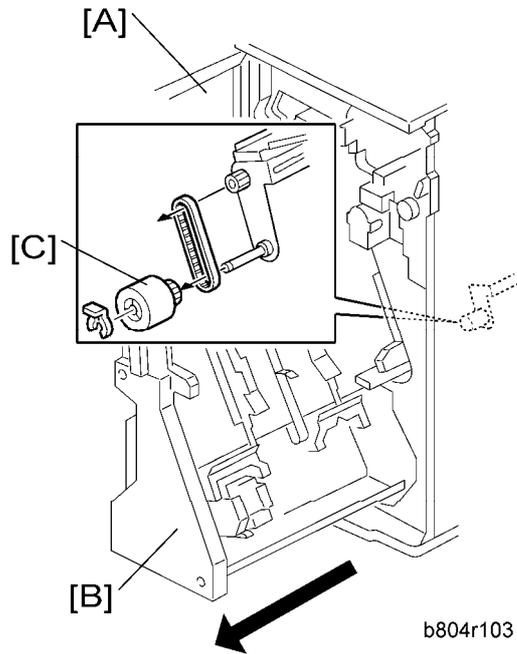

1. Open the front door [A].
2. Pull out the stapling unit [B].
3. Positioning roller [C] (⌀ x1, timing belt x1)

1.4 FOLD UNIT

1.4.1 FOLD UNIT

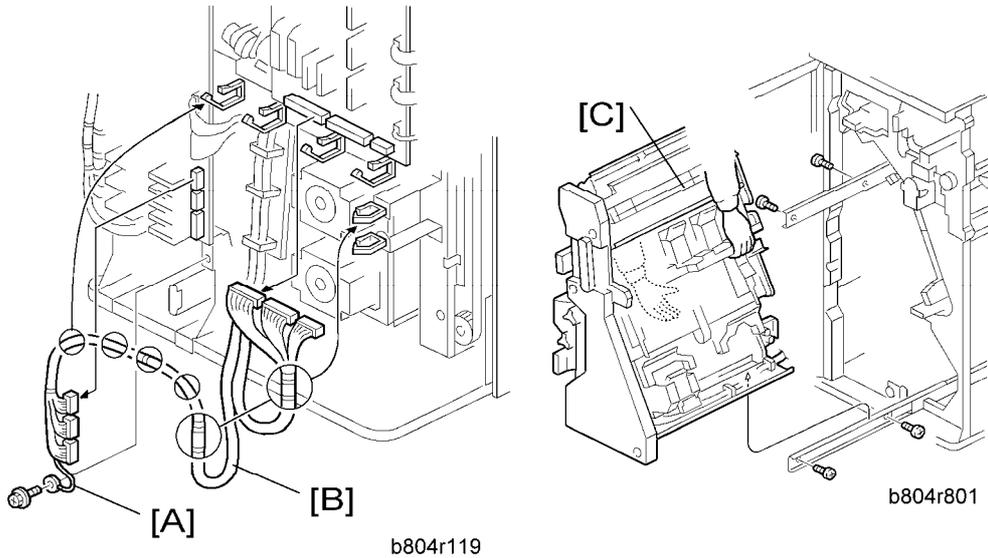

1. Remove the back cover (☛ 1.1.1 "Exterior Covers").
2. Open the front door.

⚠ CAUTION

- The stapler unit is heavy.

3. Ground cable [A] (🔩 x1)
4. Harness [B] (🔩 x6, 📎 x6)
5. Stapler unit [C] (🔩 x4)

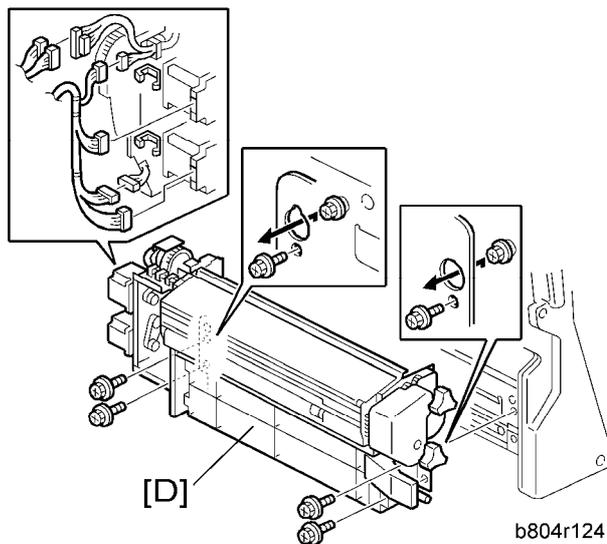

Fold Unit

Important

- Support the fold unit with your hand to prevent it from falling.

CAUTION

- The fold unit is heavy.

6. Folding unit [D] ( x4,  x2,  x6)

If you have replaced the folding unit:

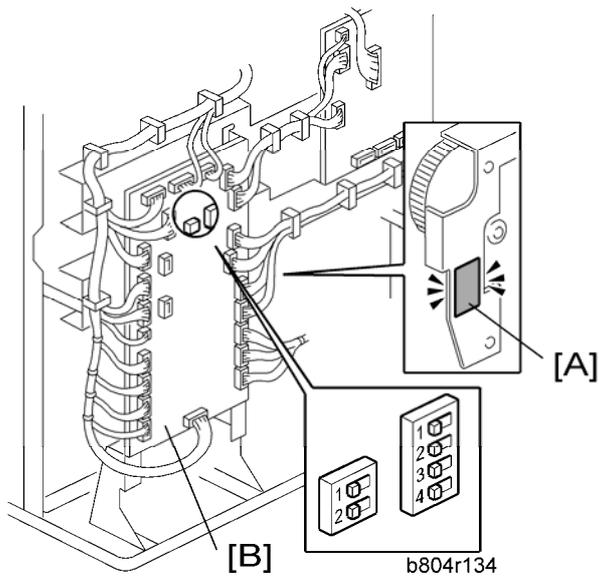

1. Read the DIP SW settings on the decal [A] attached to the back of the new folding unit.
2. Check the DIP SW settings on the main board [B] of the finisher.
3. If these settings are different, change these settings to match the settings printed on the decal attached to the folding unit.

Note

- Set DIP switches 1 to 4 (the switch set on the right). Do not touch the other DIP switches.

1.4.2 FOLD UNIT ENTRANCE SENSOR

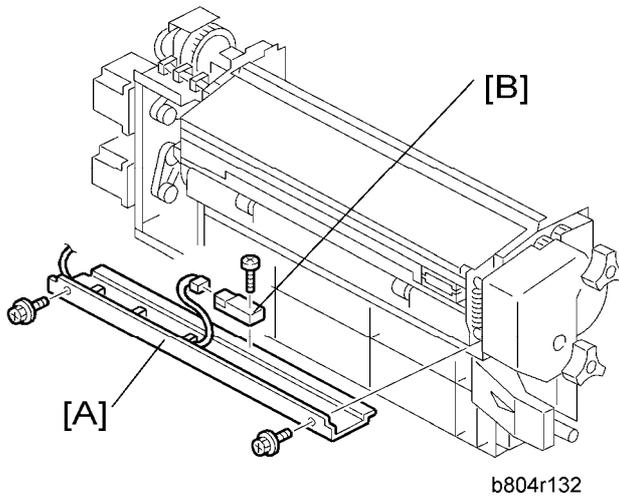

1. Pull out the stapler unit (☛1.3.2 "Positioning Roller").
2. Fold unit entrance sensor bracket [A] (🔩 x2)
3. Fold unit entrance sensor [B] (S26) (🔩 x1, 📌 x1)

1.4.3 FOLD UNIT EXIT SENSOR

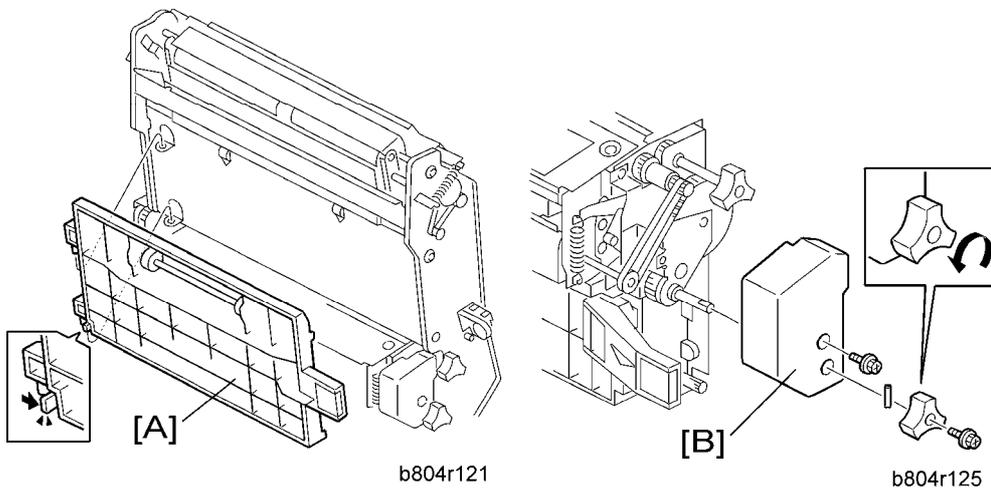

1. Open the front door.
2. Pull out the stapler unit (☛1.3.2 "Positioning Roller").
3. Fold unit vertical guide plate [A]
4. Fold unit inner cover [B] (🔩 x2, Spring pin x1)

Fold Unit

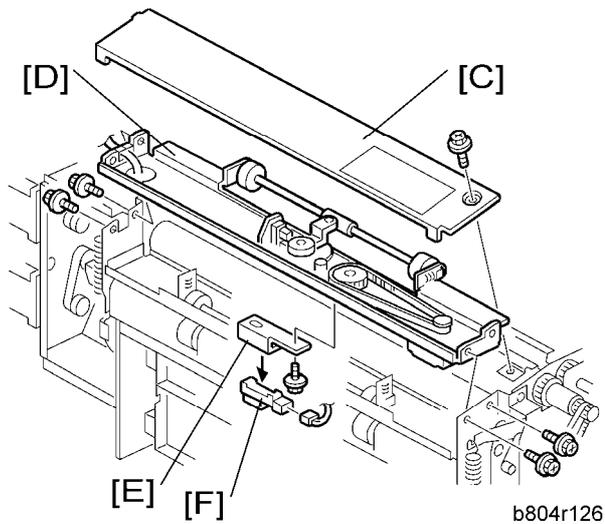

5. Fold unit upper cover [C] (🔩 x1)
6. Paper clamp mechanism [D] (🔩 x4)
7. Fold unit exit sensor bracket [E] (🔩 x1)
8. Fold unit exit sensor [F] (S31) (🔩 x1)

1.4.4 STACK PRESENT SENSOR

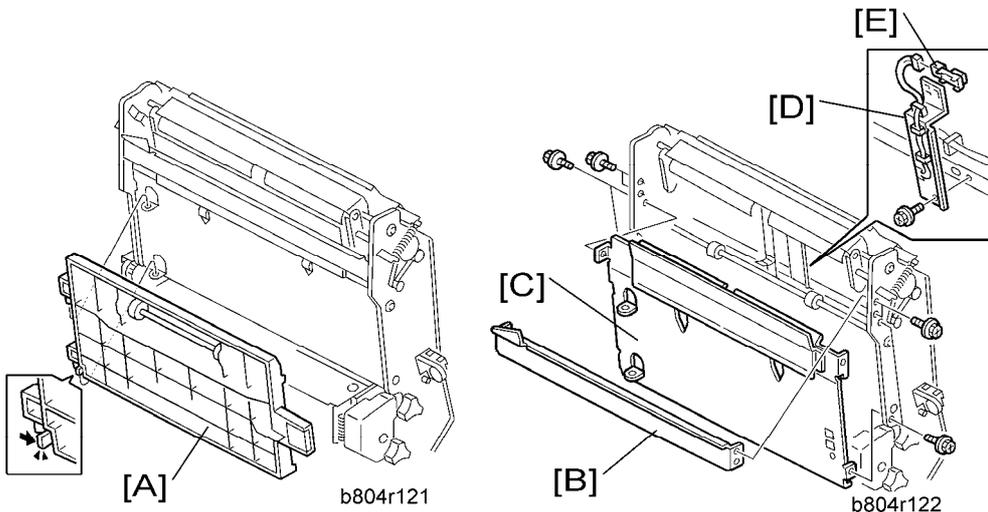

Important

- If you intend to correct the horizontal and vertical skew for the fold unit at the same time, do those adjustments first, then replace the sensor. (☞ 1.4.5 "Folding Horizontal Skew Adjustment" or "Fold Vertical Skew Adjustment")

1. Remove the stapler unit (☞ 1.4.1 "Fold Unit")

2. Guide plate [A].
3. Stay [B] (⚙️ x4)
4. Left plate [C] (⚙️ x4)
5. Sensor bracket [D] (⚙️ x1)
6. Stack present sensor [E] (S32) (⚙️ x1)

1.4.5 FOLDING HORIZONTAL SKEW ADJUSTMENT (FOR B804 ONLY)

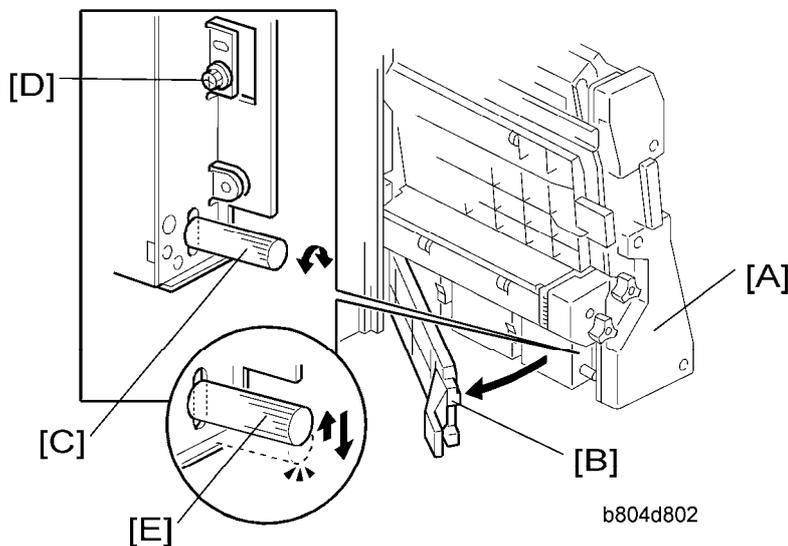

Important

- The fold unit is adjusted for optimum performance before the finisher is shipped from the factory. Do this adjustment only if the edges of folded booklets are not even.

1. Switch the copier on and enter the SP mode.
2. Europe, Asia: Use **SP6-134-001** (this is for A3 paper). North America: Use **SP6-134-005** (this is for DLT paper).

Note

- If the original setting of SP6-134-001 or -005 is not "0", then you must do the vertical skew adjustment (● 1.4.6 "Fold Vertical Skew Adjustment") after you finish this horizontal skew procedure.
3. Use the 10-key pad to input "-2" (mm) for the SP value. (Press **⊖/⊗** to enter the minus sign.)
 4. Press **[#]** then exit the SP mode.

Fold Unit

5. Open the front door and pull the stapler unit [A] out of the finisher.
6. Open the guide plate [B].
7. Loosen the adjustment screw [C] and then tighten until it stops. (Do not over tighten.)
8. Remove the lock screw [D].
9. Raise the tip [E] of the adjustment screw very slightly and allow it to descend under its own weight.

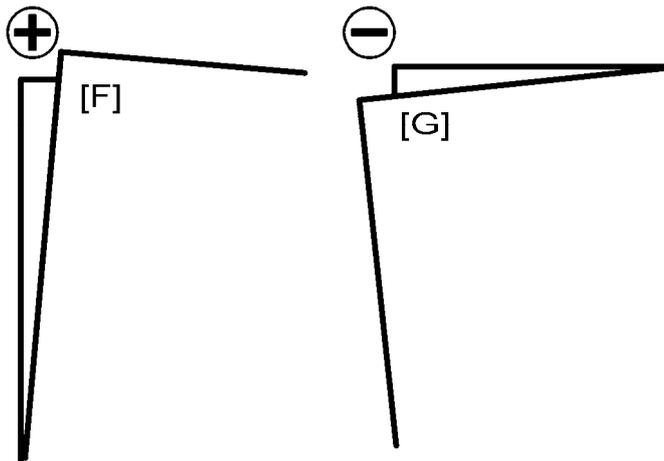

b804r901

10. Push the stapler unit into the finisher and close the front door.
11. Do a folding test.
 - Switch the copier on.
 - Put one page of A3 or DLT paper in the ARDF.
 - On the copier operation panel, select booklet stapling.
 - Press [Start]. One sheet is folded.
12. Remove the sheet from the lower tray.
13. Hold the folded sheet with the creased side pointing down and face-up (the same way that it came out of the finisher).
14. Referring to the diagram, determine if the skew is + [F] or - [G].

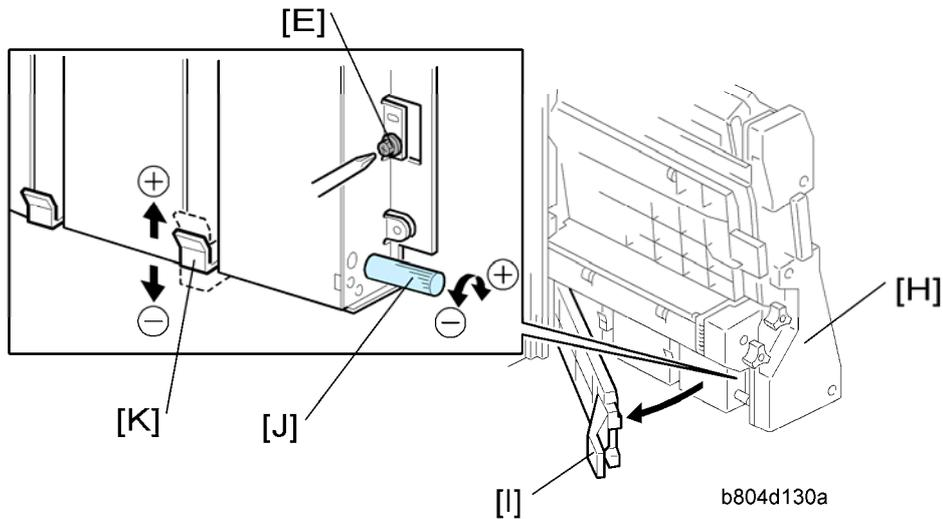

15. Open the front door of the finisher and pull the stapler unit [H] out.
16. Open the guide plate [I].
17. Turn the adjustment screw [J] to correct the amount of skew you measured from the test sheet.
 - For + skew [F], turn the adjustment screw (clockwise).
 - For – skew [G], turn the adjustment screw to the left (counter-clockwise).
 - Every click in the +/- direction adjusts the fold position by 0.1 mm by moving the bottom fence [K].
18. Raise the tip of the adjustment screw [J] and allow it to lower under its own weight.
19. Attach and tighten the lock screw [L].
20. Push the stapler unit into the machine, close the front door, then turn the copier on.
21. Europe, Asia: Do **SP6-134-001** (this is for A3 paper). North America: **Do SP6-134-005** (this is for DLT paper).
22. Reset it to "0".
23. Do the test again.
24. If the result is satisfactory, this completes the adjustment. -or- If some skew remains, repeat this adjustment.



- After doing this adjustment, adjust for vertical skew, if necessary. (See 1.4.6 "Fold Vertical Skew Adjustment")

1.4.6 FOLD VERTICAL SKEW ADJUSTMENT (FOR B804 ONLY)

Important

- The fold unit is adjusted for optimum performance before the finisher is shipped from the factory. Do this adjustment only if the edges of folded booklets are not even.
1. Switch the copier on.
 2. Do a folding test.
 - Switch the copier on.
 - Put one page of A3 or DLT paper in the ARDF.
 - On the copier operation panel, select booklet stapling.
 - Press [Start]. One sheet is folded.
 3. Hold the folded sheet with the creased side pointing down, and face-up (the same way that it came out of the finisher).

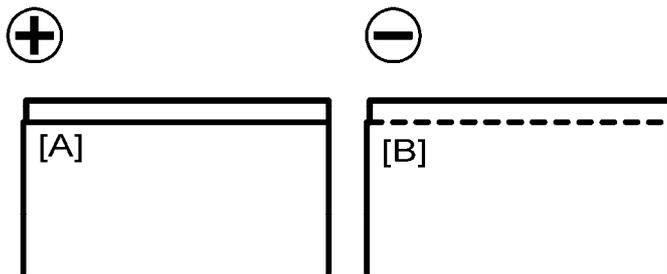

b804r902

4. Referring to the diagram, determine if the skew is positive [A] or negative [B].
5. Measure the amount of skew.
6. Enter the SP mode
 - Europe, Asia: Use **SP6-134-001** (this is for A3 paper).
 - North America: Use **SP6-134-005** (this is for DLT paper).
7. Enter one-half the measured amount of skew. Example: If the measure amount of skew is -1.2 mm, enter -0.6 mm

Note

- The range for measurement is -3.0 mm to +3.0 mm in 0.2 mm steps for every notch adjustment.
8. Exit the SP mode and do the test again (steps 2 to 5).
 9. Repeat this procedure until the skew is corrected.
- The illustration below shows the effects of +/- adjustment with SP6113. (The vertical arrows show the direction of paper feed.)

Fold Unit

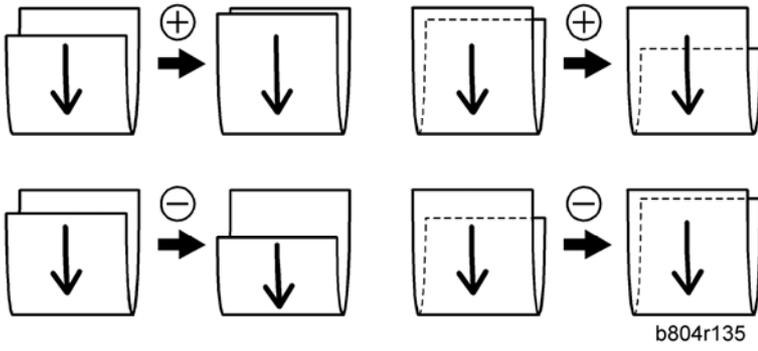

1.5 BOOKLET STAPLER UNIT

1.5.1 BOOKLET STAPLER

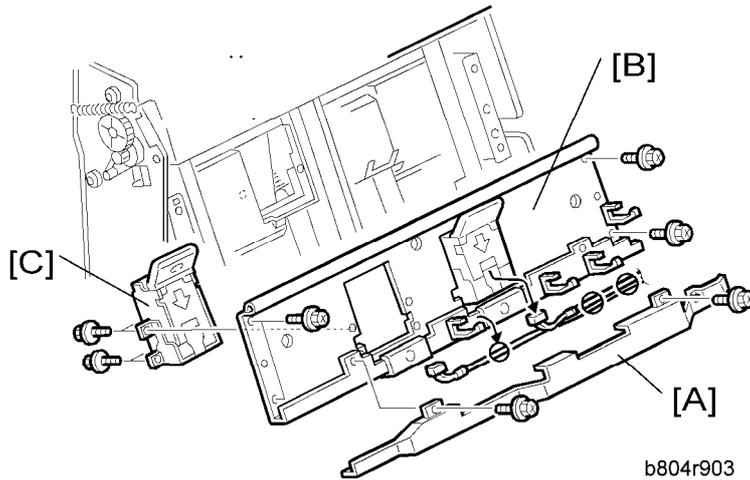

1. Open the front door.
2. Pull out the stapler unit (☛1.2.2 "Positioning Roller").
3. Harness cover [A] (🔩 x2)
4. Booklet stapler support stay [B] (🔩 x4, 📌 x2, ⬅️x4)
5. Stapler [C] (🔩 x4)

1.5.2 BOOKLET STAPLER MOTOR

1. Open the front door.
2. Remove the stapler unit. (☛1.4.1 "Fold Unit")

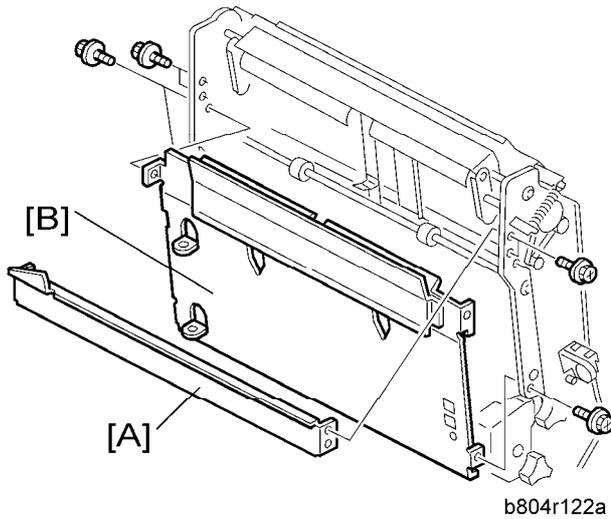

3. Stay [A] (⚙️ x4).
4. Left plate [B] (⚙️ x4)

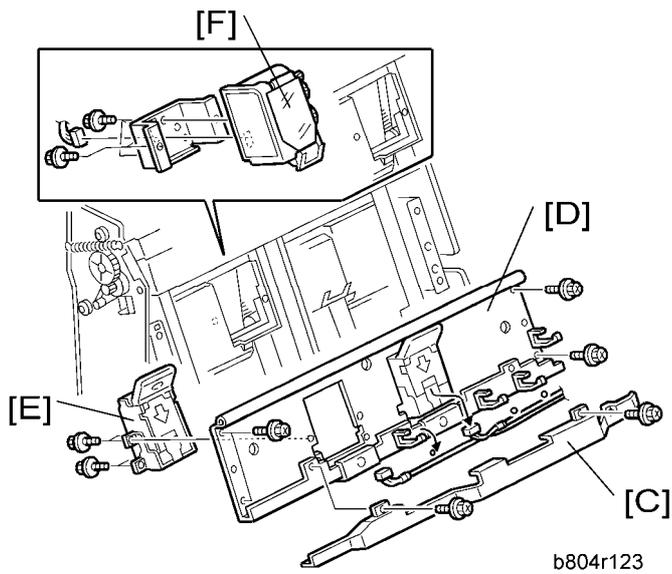

5. Harness cover [C] (⚙️ x2)
6. Booklet stapler support stay [D] (⚙️ x4, ⚙️ x2, ◀️x4)
7. Booklet stapler [E] (⚙️ x4)
8. Booklet stapler motor [F] (⚙️ x2, ⚙️ x1)

To Reattach the Booklet Stapler Motor

1. Reattach the booklet stapler motor.



- Do not tighten the screws.

Booklet Stapler Unit

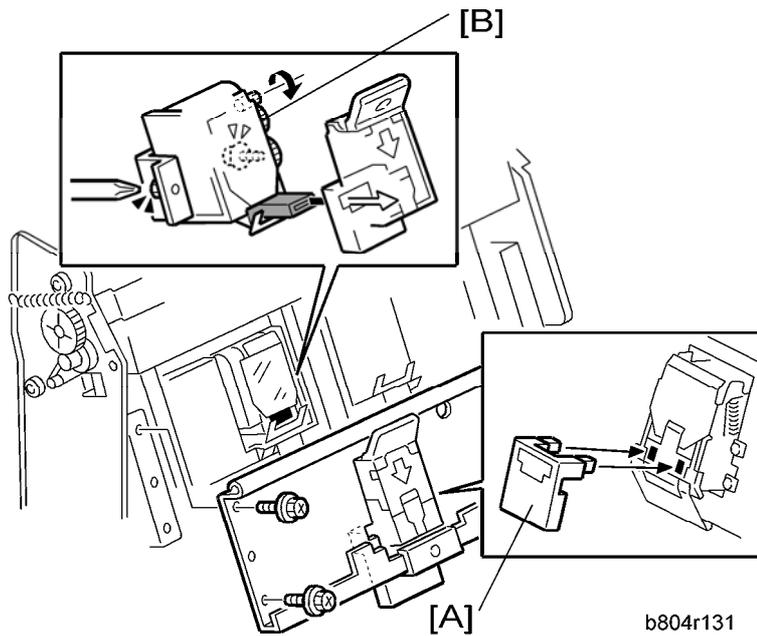

2. Attach the special tool [A] and reattach the booklet stapler stay.

Note

- This tool is included with the stapler spare part.
3. Turn the gear [B] with your finger until it stops.
 4. Tighten the screws to attach to the booklet stapler motor.
 5. Remove the stay again and remove the special tool.
 6. Reattach the booklet stapler stay.
 7. Push the stapler unit into the machine.

2. DETAILED SECTION DESCRIPTIONS

2.1 COMPONENT LAYOUT

2.1.1 GENERAL LAYOUT

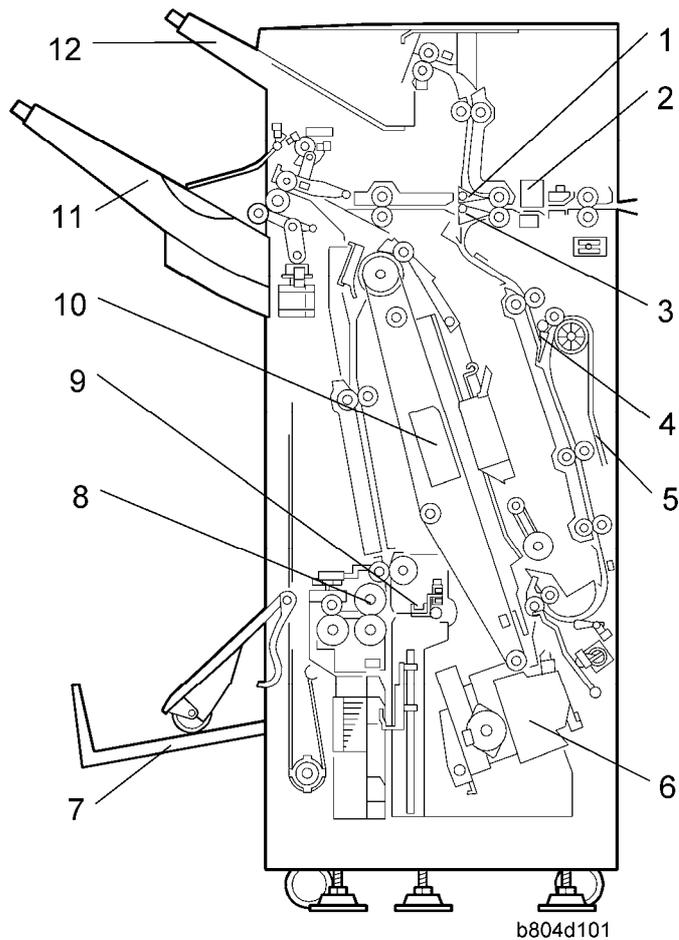

1. Proof Tray Junction Gate	7. Lower Tray (Booklet)* ¹
2. Punch Unit	8. Folder Rollers* ¹
3. Stapler Junction Gate	9. Folder Plate* ¹
4. Pre-Stack Junction Gate	10. Booklet Stapler* ¹
5. Pre-Stack Tray	11. Upper Tray (Shift)
6. Corner Stapler (M20)	12. Proof Tray

Component Layout

*1: B804 Only

Paper direction

The operation of the proof tray and stapler junction gates direct the flow of the paper once it enters the finisher:

Proof Junction Gate	Stapler Junction Gate	Paper Feeds
Closed	Closed	Paper feeds straight through
Open	Closed	Paper feeds to the proof tray
Closed	Open	Paper feeds to the staple tray

Proof tray

Copies are sent to the proof tray (12) when neither sorting nor stapling are selected for the job.

Upper tray

The upper tray (11) receives copies that are sorted and shifted and also receives copies that have been corner stapled. Corner stapling is provided on both the B804 and the B805.

Pre-stack tray

The pre-stack tray (5) has a switchback mechanism to increase the productivity of stapling. (2.3 "Pre-Stacking) Pre-stacking is done for corner stapling in the B804/B805 and for booklet stapling in the B804.

Lower tray

The lower tray (7) receives copies that have been center folded and stapled (booklet stapling). Booklet stapling is not provided on the B805.

2.1.2 ELECTRICAL COMPONENTS

Upper Area B804/B805

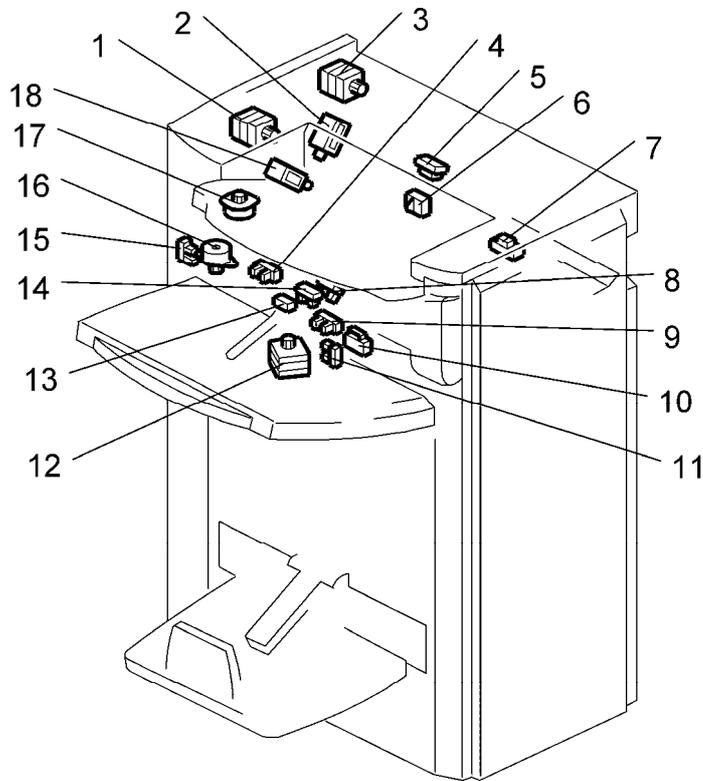

b804d201

1. Upper/Proof Exit Motor (M4)	10. Upper Tray Limit Switch (SW2)
2. Stapling Tray Junction Gate Solenoid (SOL2)	11. Stacking Roller HP Sensor (S13)
3. Upper Transport Motor (M2)	12. Stacking Sponge Roller Motor (M10)
4. Exit Guide Plate HP Sensor (S7)	13. Upper Tray Exit Sensor (S6)
5. Proof Tray Exit Sensor (S10)	14. Upper Tray Paper Height Sensor (S8) (Staple Mode)
6. Proof Tray Full Sensor (S11)	15. Shift Roller HP Sensor (S5)
7. Finisher Entrance Sensor (S1)	16. Shift Roller Motor (M18)
8. Upper Tray Paper Height Sensor (S9) (Non-Staple Mode)	17. Exit Guide Plate Motor (M19)
9. Upper Tray Limit Sensor (S12)	18. Proof Junction Gate Solenoid (SOL1)

Component Layout

Lower Area B804/B805

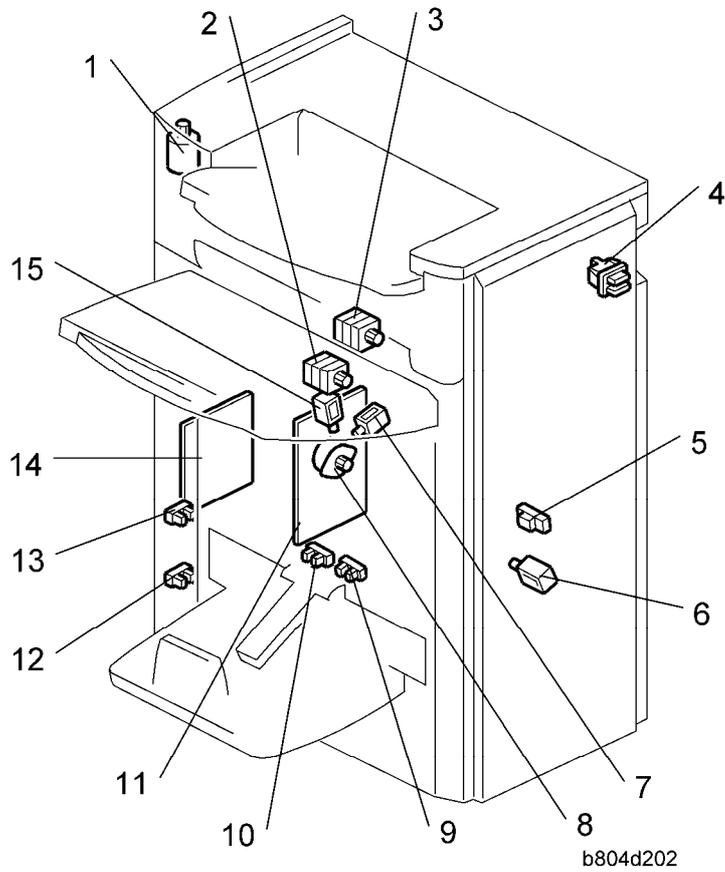

Booklet
Finisher/
Finisher
B804/B805

<p>1. Upper Tray Lift Motor (M21) 2. Lower Transport Motor (M3) 3. Entrance Motor (M1) 4. Front Door Safety Switch (SW1) 5. Pre-Stack Tray Exit Sensor (S2) 6. Stapling Edge Pressure Plate Solenoid (SOL4) 7. Positioning Roller Solenoid (SOL3)</p>	<p>8. Positioning Roller Motor (M14) 9. Lower Tray Full Sensor – Front (S34)^{*1} 10. Lower Tray Full Sensor – Rear (S33)^{*1} 11. Main Board (PCB1) 12. Upper Tray Full Sensor – (S20) ^{*2} 13. Upper Tray Full Sensor – (S19) 14. Booklet Stapler Board (PCB2)^{*1} 15. Booklet Pressure Roller Solenoid – (SOL5) ^{*1}</p>
---	--

^{*1}: B804 Only, ^{*2}: B805 Only

Punch Unit B702

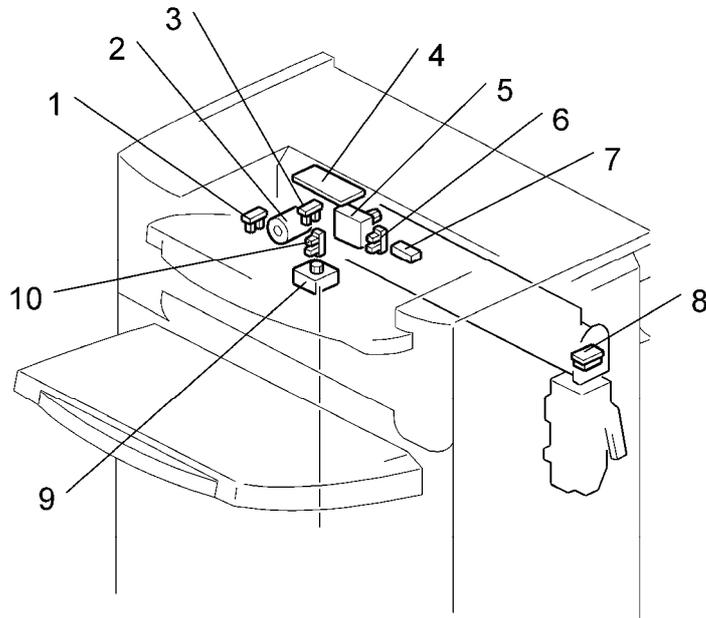

b804d203a

<ol style="list-style-type: none"> 1. Punch Encoder Sensor (S24) 2. Punch Drive Motor (M24) 3. Punch HP Sensor (S24) 4. Punch Unit Board (PCB3) 5. Paper Position Sensor Slide Motor (M7) 	<ol style="list-style-type: none"> 6. Paper Position Slide HP Sensor (S22) 7. Paper Position Sensor (S3) 8. Punch Hopper Full Sensor (S4) 9. Punch Movement Motor (M9) 10. Punch Movement HP Sensor (S21)
--	--

Component Layout

Stacker/Stapler - B804/B805

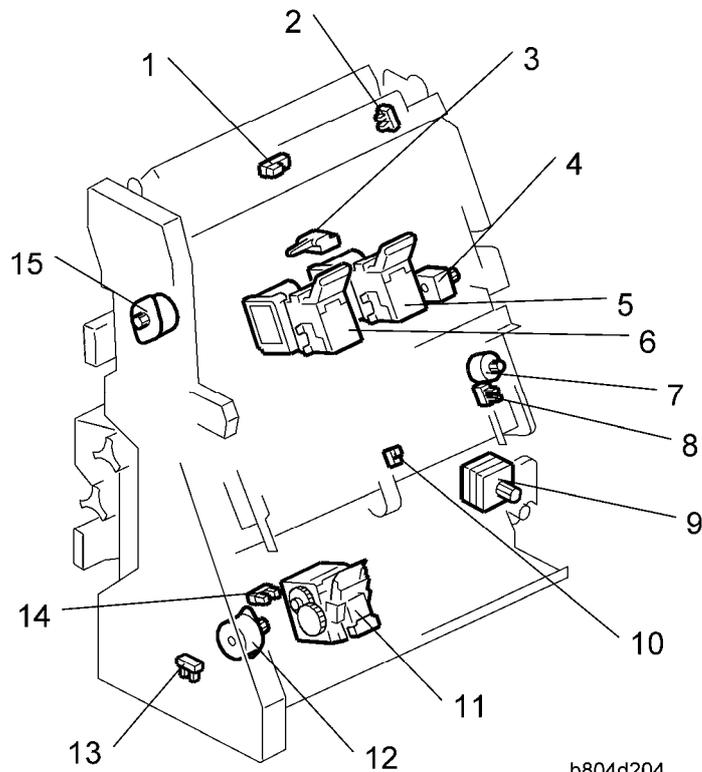

b804d204

Booklet
Finisher/
Finisher
B804/B805

1. Stack Present Sensor (S32)* ¹	7. Jogger Fence Motor (M15)
2. Stack Junction Gate HP Sensor (S27)* ¹	8. Jogger Fence HP Sensor (S15)
3. Stack Feed Out Belt HP Sensor (S16)	9. Corner Stapler Movement Motor (M6)
4. Feed Out Belt Motor (M5)	10. Stapling Tray Paper Sensor (S14)
5. Booklet Stapler EH185R – Rear (M23)* ¹	11. Corner Stapler EH530 (M20)
6. Booklet Stapler EH185R – Front (M22)* ¹	12. Corner Stapler Rotation Motor (M13)
	13. Corner Stapler HP Sensor (S17)
	14. Stapler Rotation HP Sensor (S18)
	15. Stack Junction Gate Motor (M17) * ¹

*¹: B804 Only

B804 Fold unit

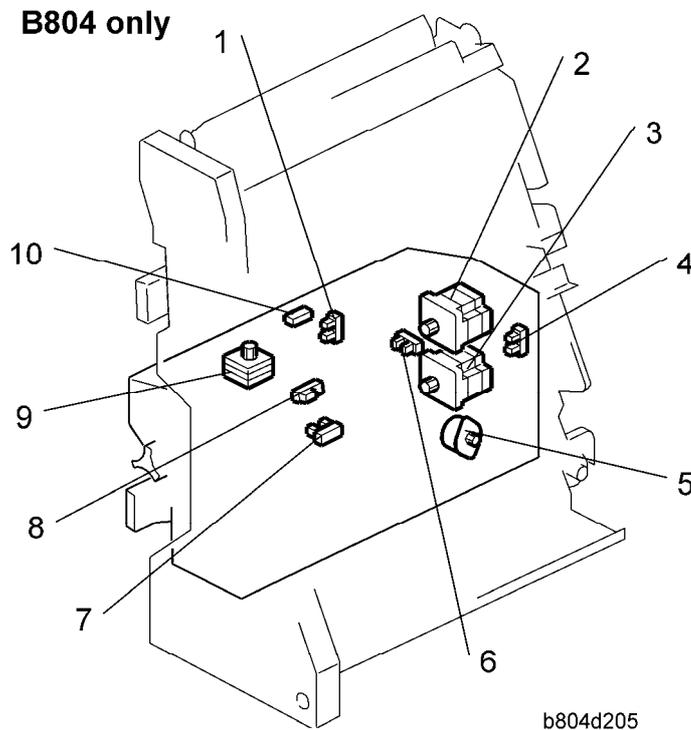

1. Clamp Roller HP Sensor (S25)	6. Fold Cam HP Sensor (S30)
2. Fold Roller Motor (M12)	7. Fold Bottom Fence HP Sensor (S28)
3. Fold Plate Motor (M11)	8. Fold Unit Entrance Sensor (S26)
4. Fold Plate HP Sensor (S29)	9. Clamp Roller Retraction Motor (M8)
5. Fold Unit Bottom Fence Lift Motor (M16)	10. Fold Unit Exit Sensor (S31)

2.1.3 SUMMARY OF ELECTRICAL COMPONENTS

Here is a general summary of all the electrical components of the B804/B805 finishers.

 **Note**

- In the table below a number that appears in bold text (**M8**, etc.) denotes a component that is on the 2000/3000 Sheet Finisher B804 only.

Component Layout

No.	Component	Function
Boards (PCB)		
PCB1	Main Board	The main board that controls the finisher
PCB2	Booklet Stapler Board	A separate board that controls booklet finishing.
PCB3	Punch Unit Board	The board that controls the punch unit.
Motors		
M1	Finisher Entrance Motor	Drives 1) the finisher entrance rollers, 2) and the punch waste transport belt of the punch unit.
M2	Upper Transport Motor	Drives the paper feed rollers that feed paper 1) to the proof tray, 2) straight-through to the upper tray, 3) the pre-stack tray entrance roller.
M3	Lower Transport Motor	Drives paper feed rollers forward and reverse in the pre-stack tray for the switchback, and drives the other rollers in the lower transport area.
M4	Upper/Proof Tray Exit Motor	Drives 1) proof tray exit rollers, 2) extension and retraction of the stacking sponge roller, 3) upper tray exit rollers.
M5	Feed Out Belt Motor	Drives the feed out belt that moves the stapled stacks out of the stapling tray after stapling.
M6	Corner Stapler Movement Motor	Moves the corner stapler horizontally on a steel rod to position the stapler at the stapling position at 1) the front, 2) the rear (straight stapling), 3) the rear (diagonal stapling), or 4) the front and rear for double stapling.
M7	Paper Position Sensor Slide Motor	Drives the movement of the paper position slide that holds the paper position sensor (S3) that detects the position of the paper.
M8	Clamp Roller Retraction Motor	Drives a large cam that alternately clamps and unclamps the clamp retraction roller, the idle roller of the clamp roller pair. When these rollers are clamped, they

No.	Component	Function
		are part of the paper feed path and feed the stack toward the bottom fence of the fold unit. When the idle roller is retracted, the stacks falls a very short distance (3 mm) onto the fold unit bottom fence below. These rollers remain unclamped while the bottom fence positions the stack for folding and while the stack is folded by the fold rollers.
M9	Punch Movement Motor	Drives the front/back movement of the punch unit to position it correctly for stapling the paper below.
M10	Stacking Sponge Roller Motor	Rotates the stacking roller that drags each sheet back against the end fence to jog the bottom of each sheet after feed out to the upper tray.
M11	Fold Plate Motor	Drives the fold plate that pushes the center of the stack into the nip of the fold rollers to start the fold.
M12	Fold Roller Motor	Rotates forward and drives the fold rollers that fold the stack and feed it out of the fold unit, reverses to feed the fold once more into the fold unit, and then rotates forward again to feed the fold out of the fold unit.
M13	Corner Stapler Rotation Motor	Swivels the corner stapler and positions it so the staple fires at an oblique angle at the rear corner of the paper stack.
M14	Positioning Roller Motor	Drives the positioning roller in the stapling tray.
M15	Jogger Fence Motor	Drives the jogger fences in the stapling tray to jog both sides of the stack before stapling.
M16	Fold Unit Bottom Fence Lift Motor	Raises the bottom fence and stops when the center of the vertical stack is opposite the edge of the horizontal fold blade. The distance for raising the blade is prescribed as one-half the size of the paper selected for the job. For large paper, (A3, B4) the bottom fence first

Component Layout

No.	Component	Function
		lowers the stack 10 mm below the fold position, and then raises it to the fold position.
M17	Stack Junction Gate Motor	Drives the large cam that operates the stack junction gate at the top of the stapling tray. When this gate is open, it directs the ascending stack to the upper tray if it has been corner stapled, or if it is closed the gate turns the booklet stapled stack down so it falls onto the bottom fence of the folding unit.
M18	Shift Roller Motor	Drives the shift roller that operates in shift mode to stagger document sets as they feed out to the upper tray (making them easier to separate).
M19	Exit Guide Plate Motor	Drives the mechanism that raises and lowers the exit guide plate.
M20	Corner Stapler EH530	This is the roving corner stapler, mounted on a steel rail that staples 1) at the front, 2) at the rear (straight staple), 3) at the rear (diagonal staple), and 4) front and rear (two staples).
M21	Upper Tray Lift Motor	Raises and lowers the upper tray during feed out to keep the tray at the optimum height until it is full.
M22	Booklet Stapler EH185R: Front	Booklet stapler. Staples paper stacks in the center before they are folded.
M23	Booklet Stapler EH185R: Rear	Booklet stapler. Staples paper stacks in the center before they are folded.
M24	Punch Drive Motor	Fires the punches that punch the holes in the paper.
Sensors		
S1	Finisher Entrance Sensor	Provides two functions: (1) Detects paper entering the finisher from the copier, and (2) Signals a jam if it detects paper at the entrance when the copier is switched on.

No.	Component	Function
S2	Pre-stack Tray Exit Sensor	Detects 1) paper fed from the pre-stack tray to the stapling tray, and detects 2) paper in the pre-stack when the copier is switched on. (This sensor performs no timing function. The entire flow of paper through the pre-stacking mechanism is controlled by motor pulse counts.)
S3	Paper Position Sensor	The photosensor that detects the edge of the paper and sends this information to the punch unit board where it is used to position the punch for punching the holes in the paper.
S4	Punch Hopper Full Sensor	1) A photosensor that detects and signals that the punch hopper is filled with punch waste and needs emptying, and 2) confirms the presence of the punch hopper and signals an error if it is missing or not installed completely.
S5	Shift Roller HP Sensor	Located near the shift roller motor, controls the front-to-back movement of the shift roller as shifts paper during straight-through feed.
S6	Upper Tray Exit Sensor	A flat, photo sensor located inside the guide plate, detects the leading edge and trailing edge of the paper as it feeds out to the upper tray during straight-through jobs (with and without stapling). When paper is fed to the upper tray, at the paper output slot this sensor signals an error when it detects (1) paper has failed to leave the paper exit (lag error), (2) detects paper has failed to arrive at the paper exit (late error), (3) detects paper is in the exit slot when the machine is turned on.
S7	Exit Guide Plate HP Sensor	Controls the vertical movement of the control exit guide . The guide plate is in the home position when the guide plate is down and the actuator interrupts the sensor gap.

Component Layout

No.	Component	Function
S8	Upper Tray Paper Height Sensor (Staple Mode)	This is the upper sensor of the upper/lower paper height sensor pair that controls the lift of the upper tray. This sensor detects the paper height of the stack in the upper tray when the copier is operating in the staple mode.
S9	Upper Tray Paper Height Sensor (Non-Staple Mode)	This is the lower sensor of the upper/lower paper height sensor pair that controls the lift of the upper tray. When the machine is switched on, the upper tray rises until the actuator on the tray triggers this sensor to switch off the upper tray lift motor.
S10	Proof Tray Exit Sensor	This sensor detects and times the feeding of paper to the proof tray. It also detects whether paper is present at the proof tray exit when the copier is switched on.
S11	Proof Tray Full Sensor	The top of the stack in the proof tray increases until it nudges the feeler of this sensor. The sensor then signals that the proof tray is full and the job halts until some paper is removed from the proof tray.
S12	Upper Tray Limit Sensor	<p>This sensor controls the position of the upper tray 1) during straight-through feed out, 2) during shift feed out, 3) when the machine is turned on. The machine obeys the signal of whichever sensor is actuated first.</p> <p>An actuator attached to an arm triggers this sensor. The tip of the same arm depresses the upper tray limit switch. If the sensor fails, the tip of the arm will activate the upper tray limit microswitch (SW2) and stop the lift of the upper tray.</p> <p>Note: When the machine is turned on, the upper tray position is controlled by either this sensor or the upper tray paper height sensor (S9).</p>
S13	Stacking Roller HP Sensor	Controls the forward and back motion of the stacking roller (a sponge roller) located at the output slot of the upper tray. The sponge roller drags each ejected sheet

No.	Component	Function
		back against the end fence of the upper tray to keep the bottom of the stack aligned.
S14	Stapling Tray Paper Sensor	A photo sensor that detects whether paper is in the stapling tray. When this sensor detects paper, the bottom fence motor raises or lowers the bottom fence to position the selected paper size for booklet stapling.
S15	Jogger Fence HP Sensor	Detects the home position of the jogger fences. When the actuator on the jogger fence interrupts this sensor, the jogger fence is in its home position and the jogger fence motor (M15) stops.
S16	Stack Feed-Out Belt HP Sensor	Controls the position of the stack feed-out pawl on the stack feed-out belt. Once the actuator on the feed belt nudges the feeler of this sensor near the top of the stapling unit, the feed out belt motor (M5) remains on for the time prescribed to position the pawl at the home position to catch the next stack.
S17	Corner Stapler HP Sensor	Located at the front the stapling tray and mounted above the steel rod where the corner stapler travels, this sensor detects the home position of the corner stapler. The corner stapler is in its home position when the actuator on the corner stapler unit interrupts this sensor.
S18	Stapler Rotation HP Sensor	Controls the angle of the position of the corner stapler during oblique stapling.
S19	Upper Tray Full Sensor (B804/B805)	<p>B804: When the actuator on the side of the upper fence enters the gap of this sensor, the sensor signals that the upper tray is at its lowest position (full) and stops the job.</p> <p>B805: One of two upper tray full sensors. This is the higher tray full sensor for A3 and other heavy paper. The other upper tray full sensor (20) is for lighter paper.</p>

Component Layout

No.	Component	Function
S20	Upper Tray Full Sensor (B805 only)	<p>B804: This sensor is not used on the booklet finisher. There is only one upper tray full sensor (S18).</p> <p>B805: One of two upper tray full sensors. This is the lower tray full sensor for A4 and smaller paper. The other upper tray full sensor (19) is for larger paper.</p>
S21	Punch Unit HP Sensor	Switches off the punch movement motor when the punch unit returns to its home position. Pulse counts determine where the punch unit pauses for punching and reversing.
S22	Paper Position Side HP Sensor	Controls the movement of the paper position detection unit. Switches on when the horizontal detection unit is at the home position (HP is the reference point).
S23	Punch HP Sensor	Detects the home position of the punch unit and controls the vertical movement of the punches when they fire.
S24	Punch Encoder Sensor	When the punch mode is selected for the job (2-hole, 3-hole, etc.), the machine controls the operation of the punch drive (M24) motor which drives a small encoder shaped like a notched wheel. This wheel is rotated forward and reverse precisely to select which punches are moved up and down during the punch stroke.
S25	Clamp Roller HP Sensor	Controls the movement of the clamp retraction roller (the idle roller of the clamp roller pair).
S26	Fold Unit Entrance Sensor	Detects 1) the leading edge of the stack during booklet stapling, and 2) also used to signal an alarm if a paper is detected at the entrance of the fold unit when the copier is turned on.
S27	Stack Junction Gate HP Sensor	Controls the opening and closing of the stack junction gate. Switches on when the stack junction gate is open and at the home position.

No.	Component	Function
S28	Fold Bottom Fence HP Sensor	Controls the movement of the bottom fence in the folding unit using pulse counts based on the size of the paper selected for the job to position the stack correctly for feeding.
S29	Fold Plate HP Sensor	Along with the fold plate cam HP sensor (S30) this sensor controls the movement of the fold plate . The fold plate has arrived at the home position when the edge of the plate enters the gap of this sensor.
S30	Fold Plate Cam HP Sensor	Along with the fold plate HP sensor (S29), this sensor controls the movement of the fold plate. The actuator mounted on the end of the roller that drives the folder plate forward and back makes three full rotations, i.e. the actuator passes the sensor gap twice and stops on the 3rd rotation and reverses. This accounts for the left and right movement of fold plate.
S31	Fold Unit Exit Sensor	1) Detects the folded edge of the stack as it feeds out from the nip of the fold rollers, stops the rollers, and reverses them so the fold feeds back into the nip, 2) when the folded booklet finally emerges from the nip of the fold rollers, detects the leading and trailing edge of the booklet to make sure that it feeds out correctly.
S32	Stack Present Sensor	This sensor determines whether there is paper at the turn junction gate when the machine is turned on. If a stack is present, this triggers a jam alert. (This sensor performs no dynamic function such as pulse counting, etc. It only detects whether paper is at the top of the folding unit when power its turned on.)
S33	Lower Tray Full Sensor - Rear	This rear sensor is the lower sensor of the lower tray full sensor pair. Two actuators are attached to the actuator arm that touches the top of stapled and folded booklets as they feed out. The on/off combinations of the two

Component Layout

No.	Component	Function
		sensors are used to detect when the tray is full and stop the job. (The lower tray is stationary. At tray full, the job halts until booklets are removed from the lower tray.)
S34	Lower Tray Full Sensor - Front	This front sensor is the higher sensor of the lower tray full sensor pair. Two actuators are attached to the actuator arm that touches the top of stapled and folded booklets as they feed out. The on/off combinations of the two sensors are used to detect when the tray is full and stop the job. (The lower tray is stationary. At tray full, the job halts until booklets are removed from the lower tray.)
Solenoids		
SOL1	Proof Junction Gate Solenoid	Opens and closes the proof tray junction gate. When the solenoid switches on, it opens the gate and paper is diverted to the proof tray. When this gate is closed, the paper goes straight to the upper tray. I
SOL2	Stapling Tray Junction Gate Solenoid	Directs paper to the stapling tray. When this solenoid is on, paper feeds straight through. When this solenoid is off, paper feeds to the stapler tray below.
SOL3	Positioning Roller Solenoid	Engages the stapler transport motor and the positioning roller of the stapling tray. The positioning roller pushes each sheet down against the bottom fence to align the bottom the stack for stapling. (The jogger fences align the sides.)
SOL4	Stapling Edge Pressure Plate Solenoid	Operates the pressure plate of the stapling unit. The pressure plate presses down the edge of stack in the stapling tray so it is tight for stapling.
SOL5	Booklet Pressure Roller Solenoid	When the paper stack in the stapling tray feeds to the folding unit, this solenoid turns on and operates the roller that pushes on the surface of the stack to flatten it.

No.	Component	Function
Switches		
SW1	Front Door Safety Switch	The safety switch cuts the dc power when the front door is opened.
SW2	Upper Tray Limit SW	A micro-switch cuts the power to the upper tray lift motor when the upper tray reaches its upper limit. This switch duplicates the function of the upper tray limit sensor (S12) and stops the upper tray if S12 fails.

2.1.4 DRIVE LAYOUT

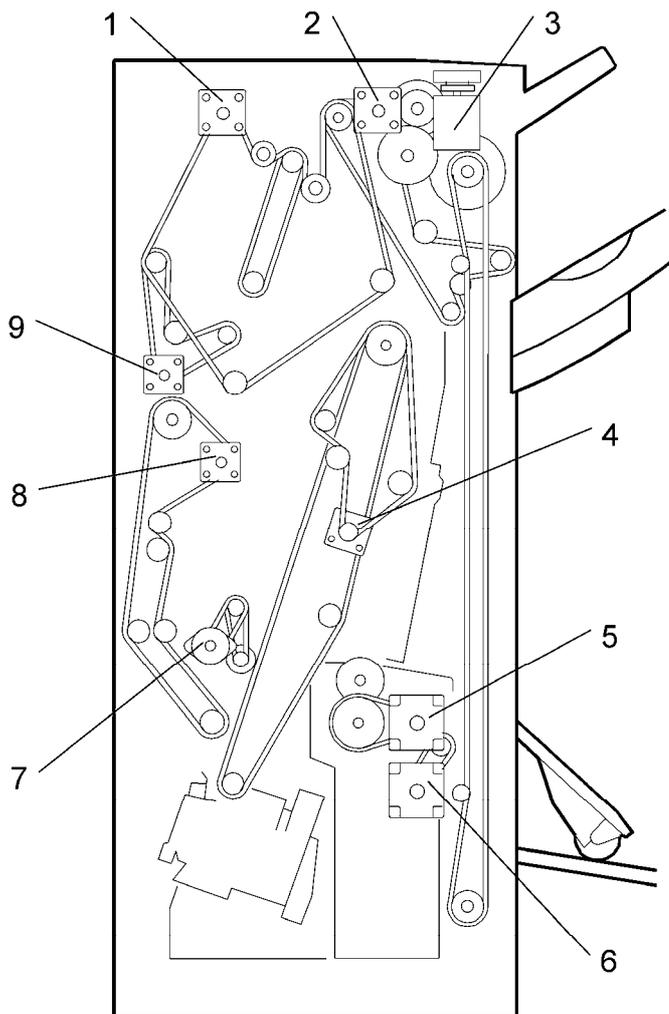

b804d206

Component Layout

<ol style="list-style-type: none">1. Upper Transport Motor (M2)2. Upper/Proof Exit Motor (M4)3. Upper Tray Lift Motor (M21)4. Feed-Out Belt Motor (M5)5. Fold Roller Motor*¹ (M12)	<ol style="list-style-type: none">6. Folder Plate Motor*¹ (M11)7. Positioning Roller Motor (M14)8. Lower Transport Motor (M3)9. Entrance Motor (M1)
---	---

*¹: B804 Only

2.2 JUNCTION GATES

The positions of the proof tray and staple tray junction gates determine the direction of paper feed after paper enters the finisher.

2.2.1 PROOF MODE

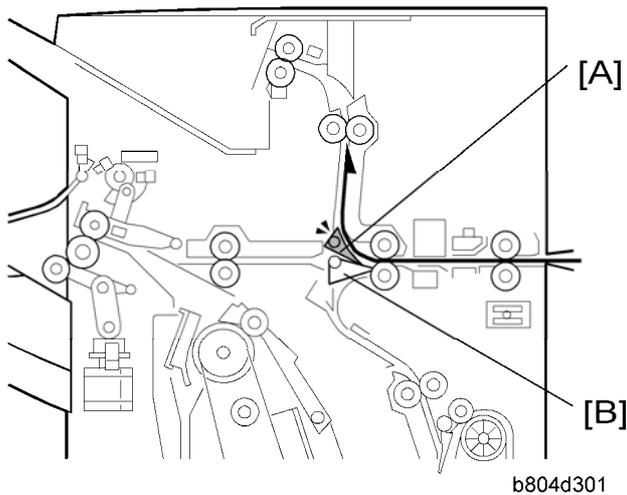

Proof tray junction gate [A] opens. Staple tray junction gate [B] remains closed. The proof tray junction gate directs paper to the proof tray above.

2.2.2 SHIFT MODE

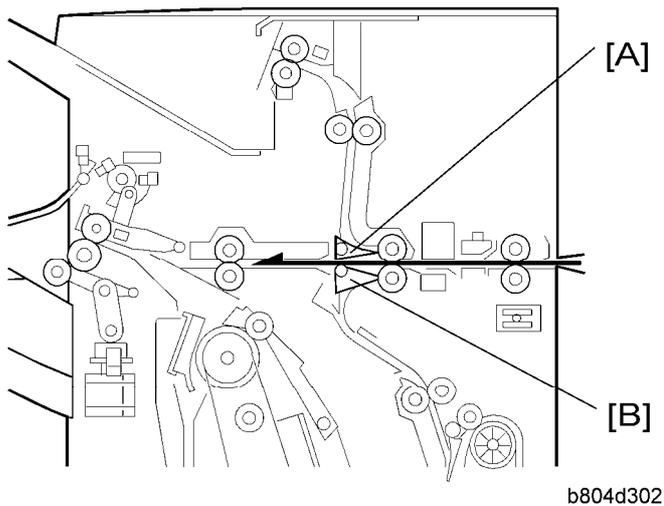

Proof tray junction gate [A] remains closed. Staple tray junction gate [B] remains closed. With both junction gates closed, the paper goes to the upper tray.

Junction Gates

2.2.3 STAPLE MODE

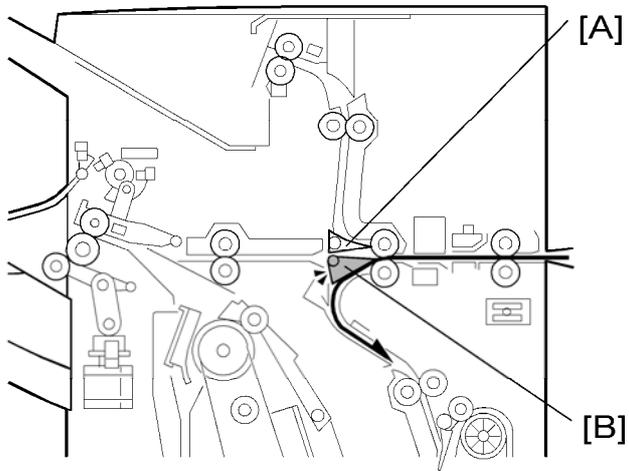

b804d303

Proof tray junction gate [A] remains closed. Staple tray junction gate [B] opens
The staple tray junction gate directs the paper to the staple tray below for jogging and stapling.

Booklet
Finisher/
Finisher
B804/B805

2.3 PRE-STACKING

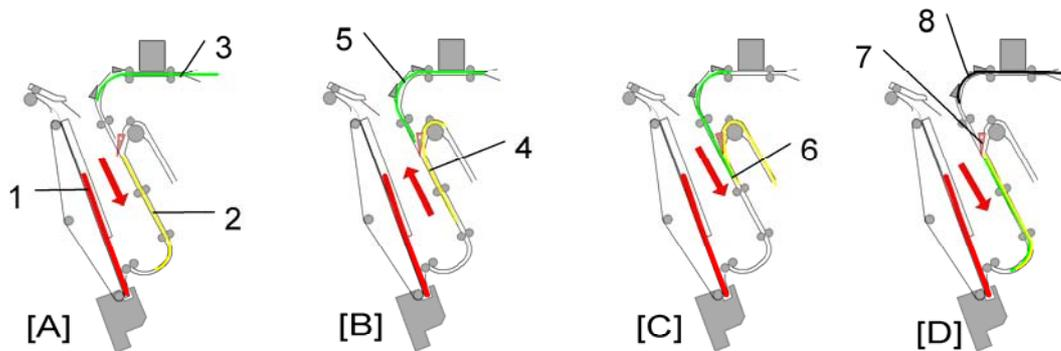

b804d992

This example describes what happens to Set 2 during the feed and stapling cycle of sets that contain three pages.

- [A]: While the Set 1 is being stapled in the staple tray [1], the 1st sheet of Set 2 [2] feeds to the pre-stack tray, and the 2nd sheet of Set 2 [3] enters the finisher.
- [B]: The pre-stack junction gate opens and the 1st sheet of Set 2 [4] switches back to the top of the pre-stack tray as the 2nd sheet of Set 2 [5] starts to descend.
- [C]: As the 2nd sheet of Set 2 continues to descend, the 1st sheet of Set 2 is fed from the pre-stack tray. At this time the leading edges [6] of both sheets are even.
- [D]: The trailing edges of the 1st and 2nd sheets of Set 2 pass the junction gate [7] as the 3rd sheet of Set 2 [8] enters the finisher.

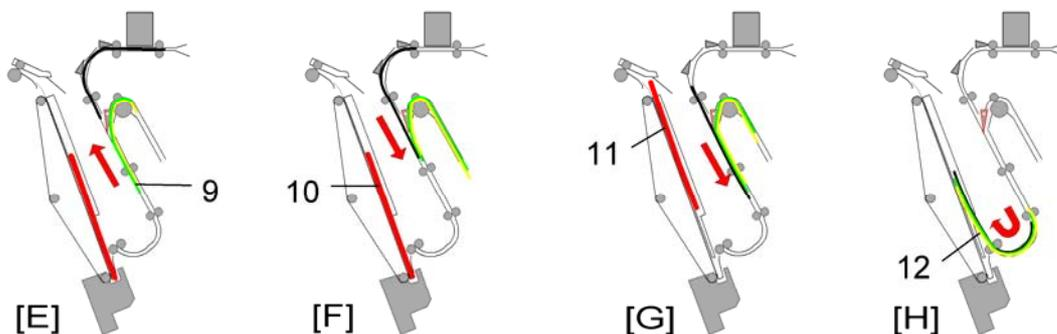

b804d993

- [E]: The 1st and 2nd sheets of Set 2 [9] switch back together into the top of the pre-stack and wait for the 3rd of Set 2 sheet to arrive.
- [F]: The stapling of Set 1 in the staple tray [10] is completed.
- [G]: Set 1 [11] exits the staple tray.
- [H]: The three sheets of Set 2 [12] feed together into the stapler tray for stapling.

Pre-stacking is only done for A4, B5, and LT paper.

Pre-Stacking

In one-staple mode, one sheet goes to the pre-stacking tray. Then two sheets go to the stapler tray at the same time.

In two-staple mode and booklet mode, three sheets go to the pre-stacking tray. Then four sheets go to the stapler tray at the same time.

2.4 TRAY MOVEMENT MECHANISM

2.4.1 UPPER TRAY

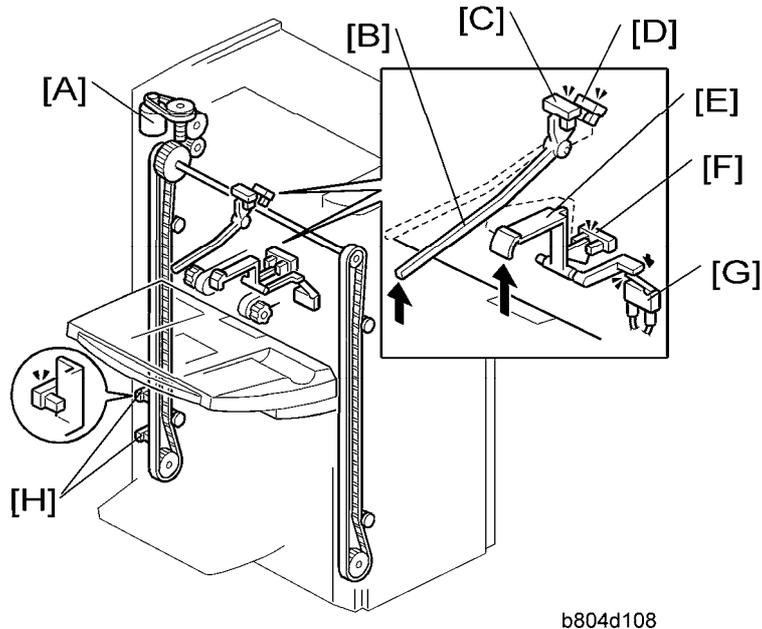

b804d108

[A]: Upper Tray Lift Motor

[B]: Upper Feeler

[C]: Upper Tray Paper Height Sensor 1 (Staple Mode)

[D]: Upper Tray Paper Height Sensor 2 (Non-Staple Mode)

[E]: Lower Feeler

[F]: Upper Tray Limit Sensor

[G]: Upper Tray Limit Switch

[H]: Upper Tray Full Sensors

Important

- The B804 (shown above) has only one upper tray full sensor (the higher sensor at [H]).
- The B805 has two upper tray full sensors (the upper and lower sensor at [H]). On the B805 the upper sensor detects tray full for heavier paper (A3, DLT, B4, LG, 12 x 18”), and the lower sensor detects tray full for lighter paper (A4, LT, etc.).
- The tray full capacity is 2,000 sheets (B804) for A4, LT and 3,000 sheets (B805) for

Tray Movement Mechanism

A4, LT.

Five sensors and one switch control the operation of the upper tray lift motor [A].

Upper Tray Raising and Lowering

Operation Mode	Sensors, Switch				Action
	[C]	[D]	[F]	[G]	
Standby (Non-Staple Mode)	OFF	OFF			Stops the lift motor at the standby position when the actuator of the upper feeler deactivates sensor [C] (when it is between sensors [C] and [D]). Note: Sensor [F] and switch [G] are used as backup if sensor [C] fails or if the upper tray is not attached.
Straight Through			ON		Non-staple mode operation: During operation, tray lift is controlled only by sensor [F]. When the actuator leaves sensor [F], the tray lowers until the actuator reactivates sensor [F].
Shift			ON		
Standby (Staple Mode)	ON				<p>Standby: The upper tray stops and waits for the paper output when the actuator activates sensor [C]. [D] is not used for staple mode</p> <p>Staple Mode Operation:</p> <ul style="list-style-type: none"> ▪ The upper tray lowers the prescribed distance immediately after the stack exits. ▪ The upper tray rises until the actuator activates sensor [C] and stops the tray lift motor (and the tray) to wait for the next set. ▪ Sensor [F] and switch [G] are used as backup if sensor [C] fails.

Booklet
Finisher/
Finisher
B804/B805

Tray Full

B804	When the actuator on the tray activates the upper tray full sensor [H] the tray lift motor [A] switches off. Operation resumes after some copies are removed from the tray. Upper Tray Capacity: 2,000 sheets (A4, LT)
B805	The operation of the upper tray full sensor is the same as the B804. Capacity: 1,500 sheets for A3, B4 or other large paper. An additional upper tray full sensor (below sensor [H]) allows more sheets to stack on the upper tray. Capacity: 3,000 sheets (A4, LT)

2.4.2 LOWER TRAY (B804 ONLY)

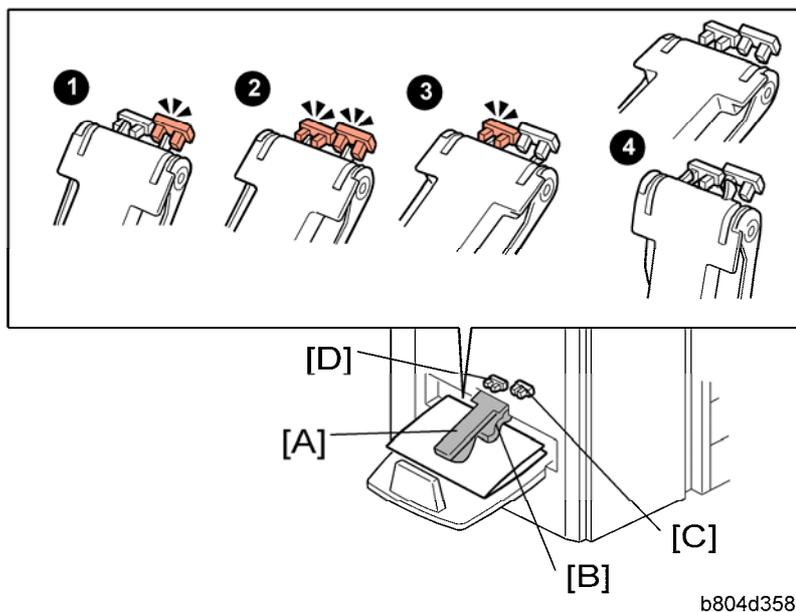

The lower tray sensor actuator arm [A] rests on the top of the stack of stapled booklets as they are output to the lower tray. A flap depressor [B] keeps the open ends of the booklets down.

The front lower tray full sensor (S34) [C] and rear lower tray full sensor (S33) [D] detect when the lower tray is full of booklets.

Important

- The front lower tray full sensor is mounted higher than the rear lower tray full sensor.
- The lower tray is stationary. When it becomes full, the stapling and folding job stops until booklets are removed from the tray.

Tray Movement Mechanism

- If the lower tray is not installed (this is detected if the front and rear sensors remain OFF), the machine will not operate in the booklet staple and fold mode. When booklet mode is selected, the tray full message appears on the operation panel.

The combinations of the two actuators and two sensors as the actuator arm rises determines the number of booklets that the lower tray can hold before the job stops.

The tray full detection depends on the size of the paper and the number of sheets in one stapled and folded booklet.

In the table below, the conditions (① Ready ② Full 1, ③ Full 2 ④ Full 3: See the illustration on the previous page) refer to the states of the sensors described on the previous page.

Condition	Front Sensor	Rear Sensor
Ready	ON	OFF
Full 1	ON	ON
Full 2	OFF	ON
Full 3 (or lower tray not installed)	OFF	OFF

Booklet
Finisher/
Finisher
B804/B805

In the tables below:

- "Sht" denotes "sheets in a stack".
- "Cnt" denotes "Count" (see below for an explanation).

After a booklet is feed out, the fold roller motor stops the exit roller. The machine then monitors the tray full sensors every 100 ms. The machine checks for a certain condition, based on the size of the paper and the number of sheets in the booklet.

An example is shown below. Tell the operators that the number of sheets that the lower tray can hold will vary greatly.

Lower Tray Full Condition Table

A3 (DLT)

	1 Sht	2 Sht	3 Sht	4 Sht	5 Sht	6 Sht	7 Sth	8 Sht	9 Sht	...
Full 1	3 Cnt	—	—	—	—	—	—	—	—	...
Full 2	—	5 Cnt	15 Cnt	—	—	—	—	—	—	...
Full 3	—	—	—	7 Cnt	13 Cnt	4 Cnt	2 Cnt	2 Cnt	2 Cnt	...

A4 (LT)

	1 Sht	2 Sht	3 Sht	4 Sht	5 Sht	6 Sht	7 Sth	8 Sht	9 Sht	...
Full1	16 Cnt	—	—	—	—	—	—	—	—	...
Full 2	—	10 Cnt	10 Cnt	15 Cnt	20 Cnt	15 Cnt	10 Cnt	8 Cnt	8 Cnt	...
Full 3	—	—	—							...

Examples:

After the copier makes a booklet with 1 sheet of A3/DLT paper, the machine checks every 100 ms for the 'Full 1' condition. If the Full 1 condition occurs 3 times, the machine detects that the tray is full.

After the copier makes a booklet with 5 sheets of A4/LT paper, the machine checks every 100 ms for the 'Full 2' condition. If the Full 2 condition occurs 20 times, the machine detects that the tray is full.

2.5 CORNER STAPLING

2.5.1 STACKING AND JOGGING

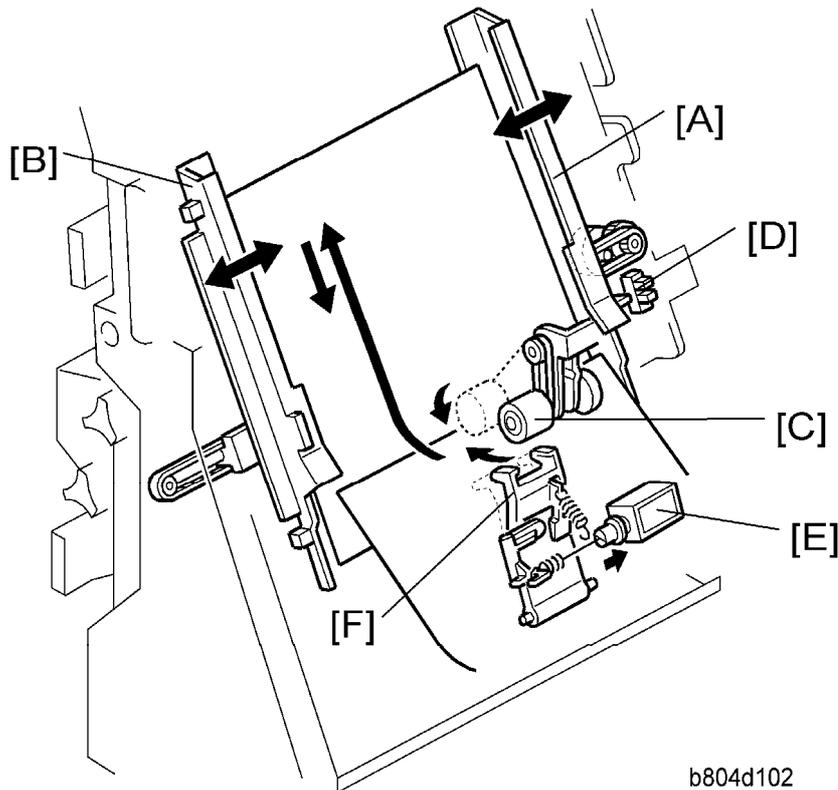

b804d102

- | |
|---|
| [A]: Jogger Fence Motor (M15) |
| [B]: Jogger Fences |
| [C]: Positioning Roller |
| [D]: Jogger Fence HP Sensor (S15) |
| [E]: Stapling Edge Pressure Plate Solenoid (SOL4) |
| [F]: Pressure Plate |

At the beginning of the job, the jogger fence motor (M15) [A] switches on and moves the jogger fences [B] to the standby position (7.5 mm from the sides of the selected paper size).

When each sheet passes the pre-stack tray exit sensor (S2) and enters the stapling tray:

- The jogger fence motor switches on and moves the jogger fences to within 5.5 mm of the sides of the selected paper size.
- The positioning roller solenoid (SOL3) switches on for the time prescribed for the paper

size. This pushes the positioning roller [C] onto the sheet and pushes it down onto bottom fence. This aligns the edge of the stack.

Next, the jogger fence motor:

- Switches on again and moves the jogger fences to within 2.6 mm of the sides of the stack to align the sides of the stack.
- Reverses and moves the fences to the standby position (7.5 mm away for the sides) and waits for the next sheet.
- The jogger fence HP sensor [D] switches off the jogger motor at the end of the job.

After the last sheet feeds:

- The stapling edge pressure plate solenoid [E] (SOL4) switches on and pushes the pressure plate [F] onto the stack to press down the edge for stapling.
- The corner stapler staples the stack.

2.5.2 STAPLER MOVEMENT

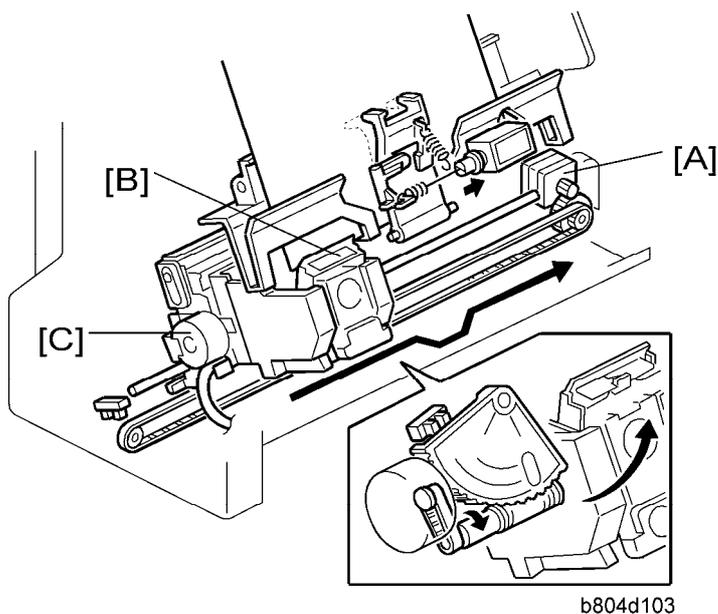

- | |
|---|
| <p>[A]: Stapler Movement Motor</p> <p>[B]: Stapler</p> <p>[C]: Stapler Rotation Motor</p> |
|---|

Corner Stapling

The stapler performs horizontal and rotational movement in each of the four staple modes:

- Front 1 staple
- Rear 1 staple
- Rear diagonal staple
- Rear/Front 2 staples

The stapler movement motor [A] drives a timing belt that moves stapler [B] left and right on its stainless steel rail.

The stapler rotation motor [C] rotates the stapler into position for diagonal stapling at the rear.

- The stapler movement motor switches on and moves the stapler the standby stapling position. (This is the stapling position for the paper size selected for the job.)
- The stapler movement motor switches off and the stapler waits for the signal to fire (or swivel and for diagonal stapling).

If the stack is to be stapled at two positions:

- The stapler movement motor moves the stapler to the front position and staples the front.
- The stapler movement motor moves the stapler to the rear and the stapler staples the rear.

If the stack is stapled at the rear with a diagonal staple, the staple moves to the rear. When it is time for stapling, the rotation motor rotates the stapler to the correct angle and holds the stapler in that position while the stapler fires.

The stapling positions can be fine adjusted with **SP6-133-001**.

2.5.3 CORNER STAPLING

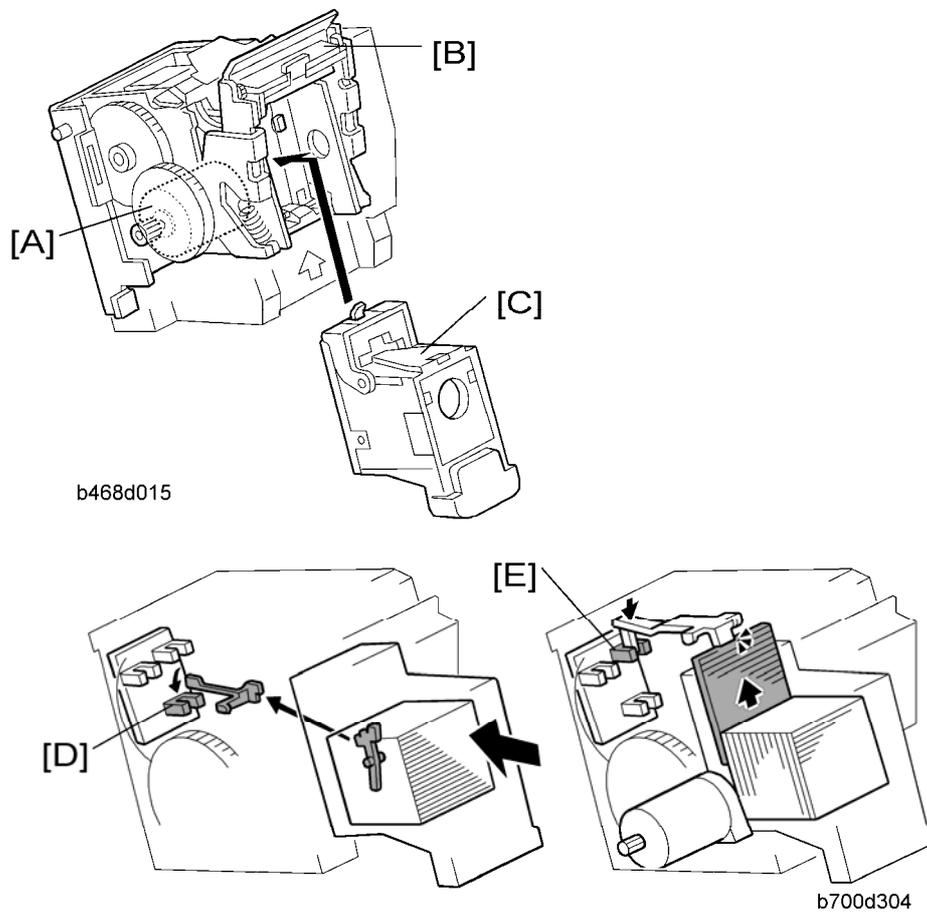

Staple firing is driven by the stapler motor [A] inside the stapler unit. The stapler hammer [B] fires the stapler [C].

The cartridge set sensor [D] detects the cartridge at the correct position.

The staple end sensor [E] detects the staple end condition.

2.6 BOOKLET STAPLING (B804 ONLY)

2.6.1 BOOKLET PRESSURE MECHANISM

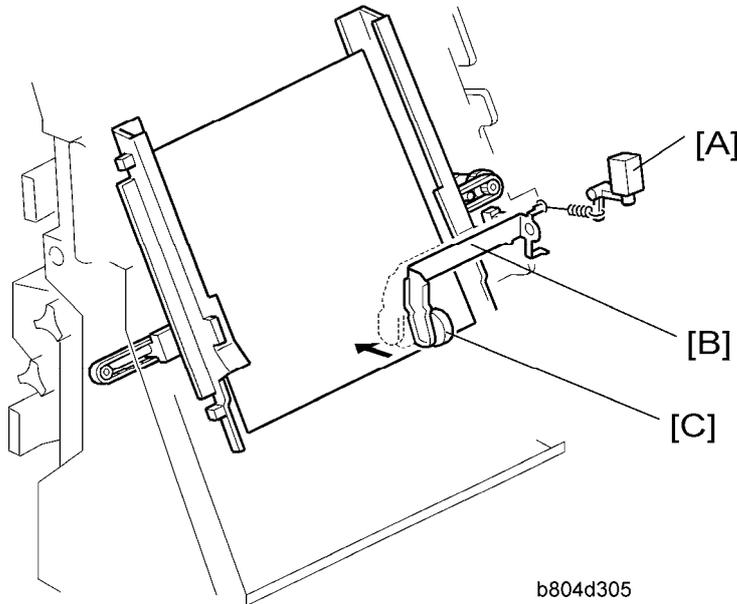

- [A]: Booklet Pressure Roller Solenoid (SOL5)
- [B]: Booklet Pressure Roller Arm
- [C]: Booklet Pressure Roller

As soon as the edges are aligned by the positioning roller and the jogger fences, the stack feed out belt moves.

In booklet mode, immediately after the edges are aligned by the positioning roller and jogger fences, the booklet pressure solenoid switches on and the booklet pressure roller presses down on the stack until booklet stapling is finished. This prevents the stack from shifting during stapling.

2.6.2 BOOKLET STAPLING AND FOLDING

Overview

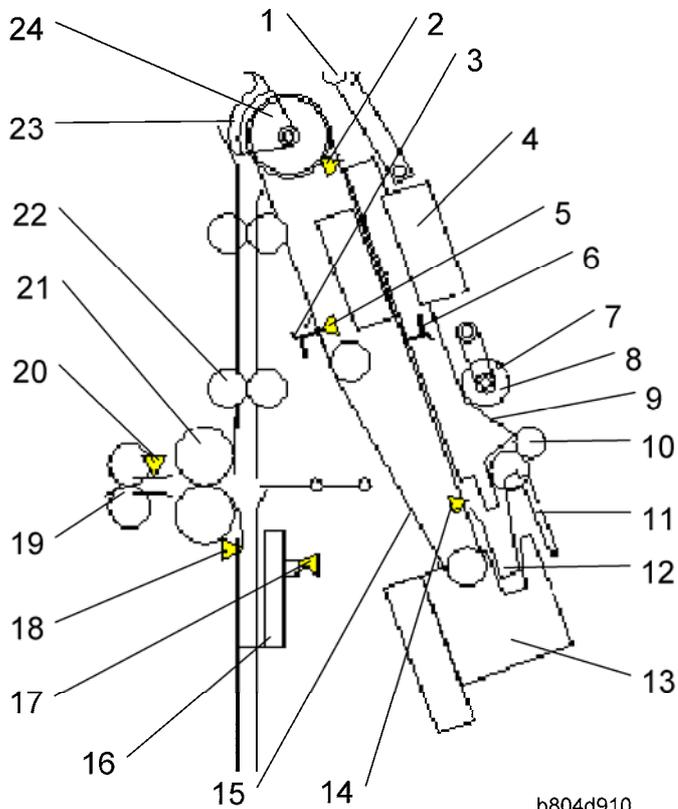

b804d910

1. Leading Edge Pressure Roller	13. Corner Stapler (M20)
2. Stack Present Sensor (S32)	14. Stapling Tray Paper Sensor (S14)
3. Feed Out Belt Pawl 1	15. Feed Out Belt
4. Booklet Staplers x2 (M22, M23)	16. Fold Unit Bottom Fence
5. Stack Feed Out Belt HP Sensor (S16)	17. Fold Bottom Fence HP Sensor (S28)
6. Feed Out Belt Pawl 2	18. Fold Unit Entrance Sensor (S26)
7. Positioning Roller	19. Fold Unit Exit Rollers x2
8. Booklet Pressure Roller (Rear)	20. Fold Unit Exit Sensor (S31)
9. Jogger Fences x2	21. Fold Rollers x2
10. Pre-Stack Exit Roller	22. Clamp Rollers x2
11. Pressure Plate	23. Stack Junction Gate
12. Stapling Tray Bottom Fence	24. Stack Transport Roller

Booklet Stapling (B804 Only)

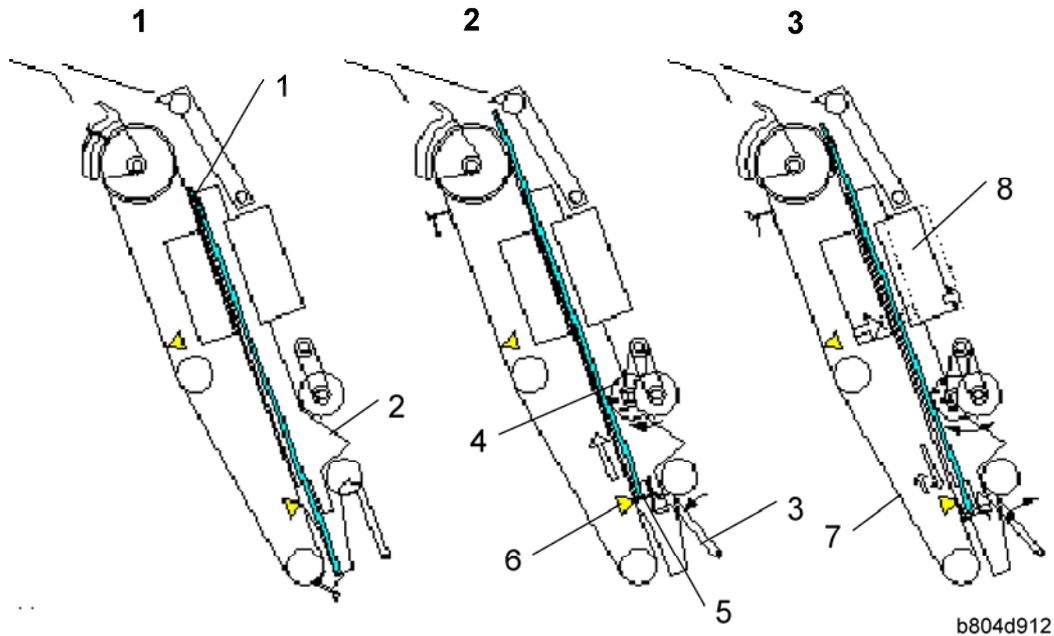

1:

The last sheet of the stack [1] enters the stapling tray. The jogger fences [2] jog the last sheet into position (based on the width of the selected paper size) and then retract and stop 1 mm away from the sides of the stack.

2:

The pressure plate [3] and booklet pressure roller [4] press down on the sheet. The stack feed out belt switches on and the pawl [5] on the feed out belt catches the bottom of the stack and raises it. The stapling tray sensor [6] detects the trailing edge of the paper stack.

3:

The feed out belt [7] raises the stack to the prescribed stapling position and stops. The jogger fences move to the sides of the stack and the booklet staplers [8] staple the stack.

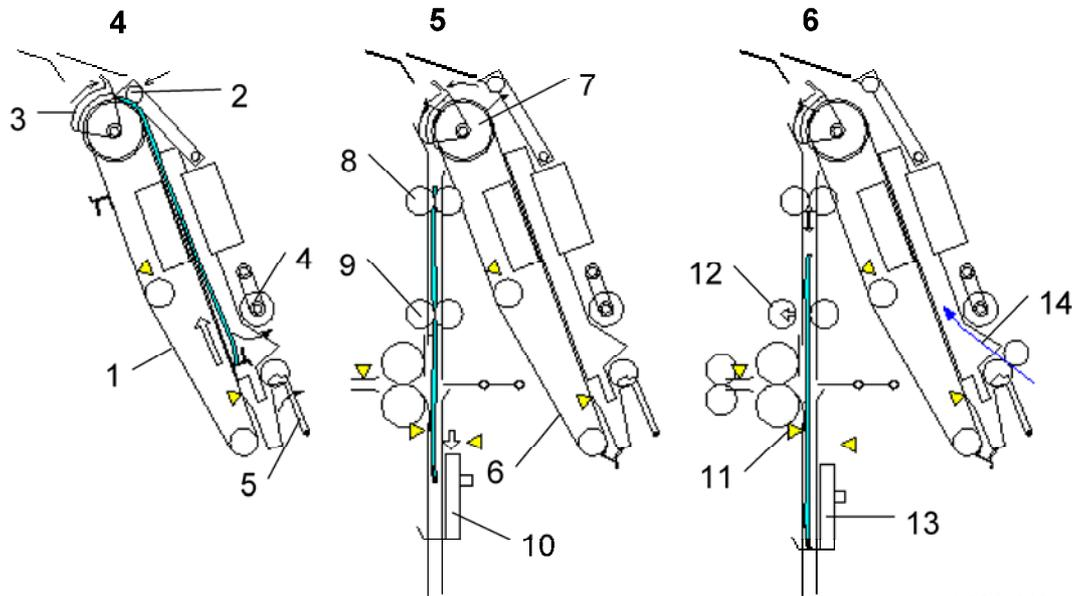

b804d913

4:

The jogger fences remain 1 mm away from the sides of the stack. The feed out belt [1] raises the stack until the top of the stack is 10 mm past the leading edge pressure roller [2] and stops. The leading edge pressure roller descends and applies pressure to the top of the stack. The stack junction gate [3] (normally open) closes. The pressure roller [4] and pressure plate [5] retract.

5:

The feed out belt [6], transport rollers [7], [8], and clamp rollers [9] rotate and feed the stack past the closed stack junction, over the top and down toward the bottom fence [10]. At the same time, the fold unit bottom fence descends from its home position and stops 10 mm below the fold position.

6:

The rollers feed the leading edge of the stack to within 3 mm of the stack stopper of the bottom fence [13]. The fold unit entrance sensor [11] detects the stack and opens the clamp rollers [12]. The stack drops 3 mm onto the fold unit bottom fence [13]. At this time, the first sheet [14] of the next stack feeds to the stapling tray.

Booklet Stapling (B804 Only)

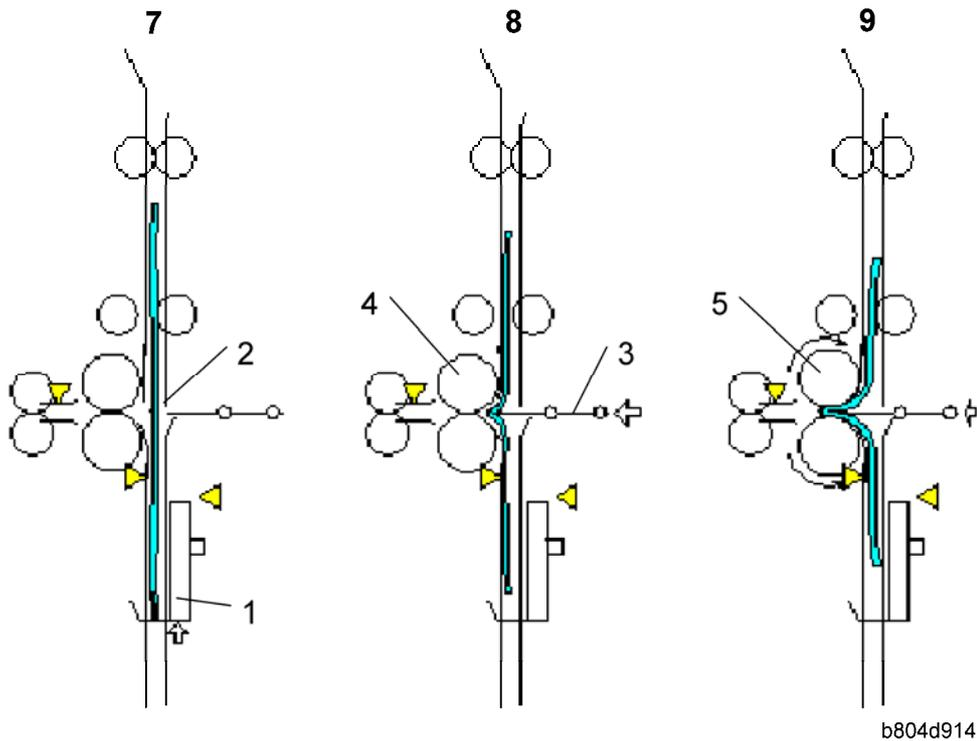

7:

The bottom fence [1] raises the stack to the prescribed fold position [2].

8:

The fold plate [3] moves to the left and advances 1/3 its maximum horizontal stroke and exerts 20 kg (44 lb.) of pressure at the fold rollers [4].

9:

With the fold plate pushing the stack into nip of the fold rollers [5], the fold rollers begin to rotate and fold the stack as it feeds out.

Booklet
Finisher/
Finisher
B804/B805

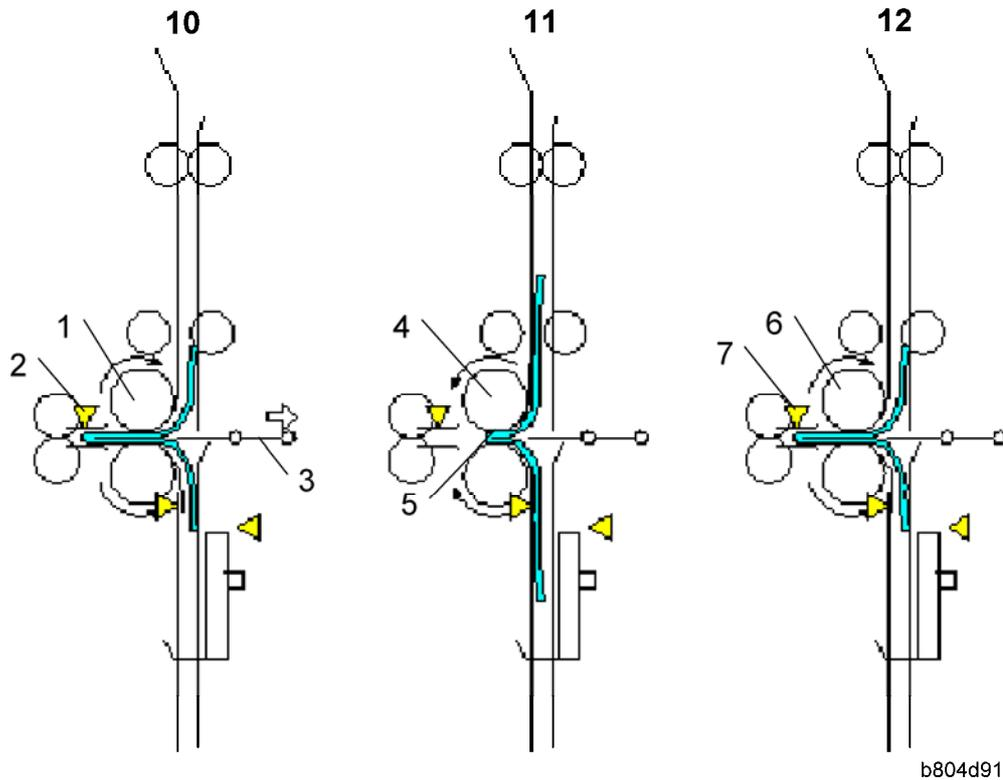

b804d915

10:

When the fold rollers [1] feed the stack 10 mm past the nip, the fold plate retracts until it no longer touches the stack. The fold unit exit sensor [2] detects the folded edge of the stack and stops the fold rollers.

11:

The rotation of the fold rollers [4] reverses and feeds the folded edge back until only 3 mm of the fold [5] remains at the nip.

12:

The fold rollers [6] rotate forward once again feed out. The fold unit exit sensor [7] once again detects the edge of the fold.



- You can do **SP6-136-001** to increase the sharpness of the fold. The number of forward and reverse feeds can be set in the range of 2 to 30. The machine repeats Steps 11 and 12. For more, please refer to Section "Service Tables".

Booklet Stapling (B804 Only)

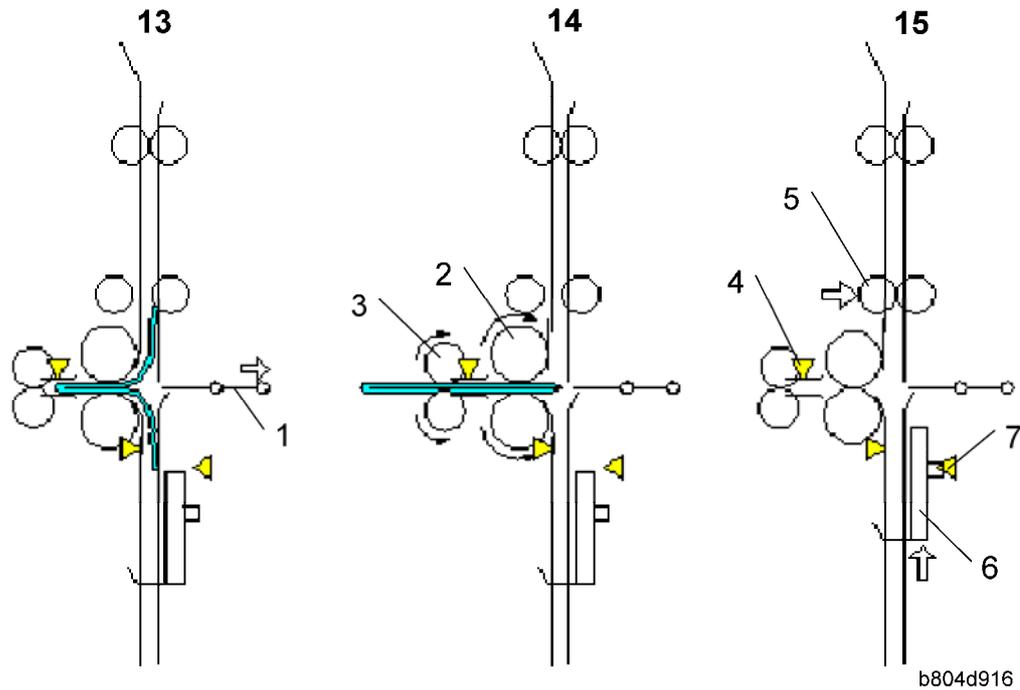

13:

With the feed of the stack halted, the fold plate [1] retracts. The fold plate HP sensor (not shown) detects the fold plate and stops it at its home position.

14:

The fold rollers [2] and fold unit exit rollers [3] begin to rotate together and feed out the folded booklet to the lower tray.

15:

Once the trailing edge of the stack passes the fold unit exit sensor [4], the clamp rollers [5] close to be ready to feed the next stack. The fold unit bottom fence [6] descends. The bottom fence HP sensor [7] stops the bottom fence when it detects the actuator on the bottom fence.

Booklet
Finisher/
Finisher
B804/B805

2.6.3 BOOKLET STAPLING AND FOLDING MECHANISMS

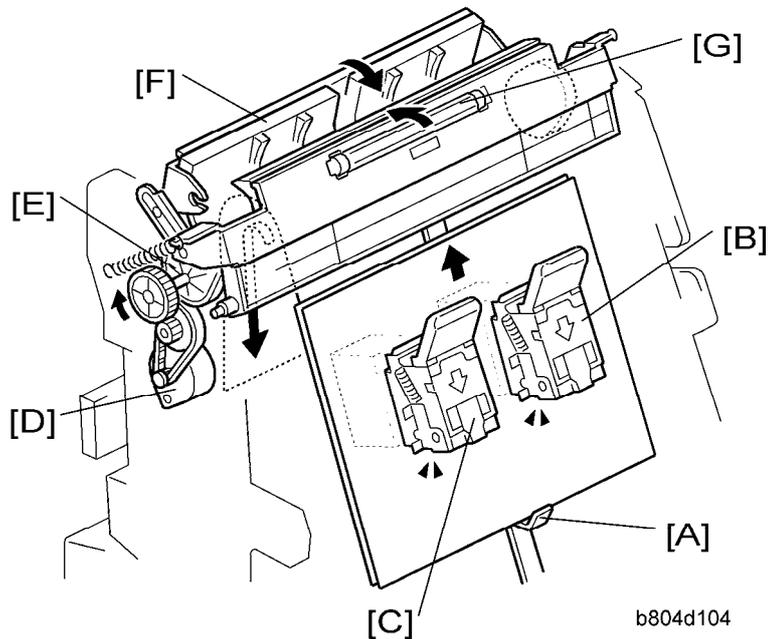

b804d104

Booklet Stapler

[A]: Feed Out Belt Pawl. Raises the stack to stapling position.

[B]: Booklet Stapler EH185R – Rear

[C]: Booklet Stapler EH185R – Front

Stack Junction Gate

[D]: Stack Junction Gate Motor. Drives a timing belt and stack junction gate cam.

[E]: Stack Junction Gate Cam. Opens and closes the stack junction gate.

[F]: Stack Junction Gate. The stack junction gate motor and stack junction gate cam close the stack junction gate. The feed out belt pawl raises the stapled stack and sends it over the top and down to the fold unit.

[G]: Leading Edge Pressure Roller. Presses down on the leading edge of the stack after booklet stapling.

Booklet Stapling (B804 Only)

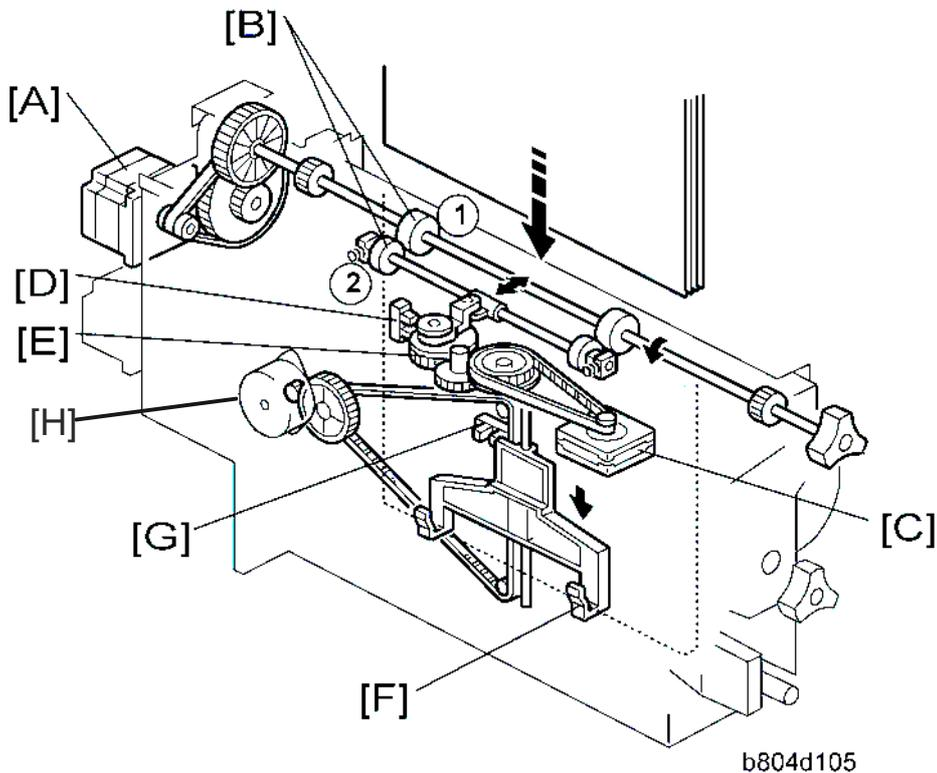

Clamp Roller

[A]: Fold Roller Motor. Drives the stationary clamp drive roller ① as well as the fold rollers (see next page).

[B]: Clamp Rollers.

① Clamp Roller – Drive. Rotated by the fold roller motor, this stationary roller feeds the stack down with the retracting roller closed.

② Clamp Roller – Retracting. Opened and closed by the retraction motor [C].

[C]: Clamp Roller Retraction Motor. Operates the clamp roller cam that retracts the retracting clamp roller. The clamp rollers feed the stack to within 3 mm of the bottom fence when closed and then open to drop the stack onto the bottom fence.

[D]: Clamp Roller HP Sensor. Controls the rotation of the clamp roller retraction motor and cam that open and close the retracting clamp roller.

[E]: Clamp Roller Cam. Forces open the spring loaded retracting clamp roller.

Bottom Fence

[F]: Bottom Fence. Raises the booklet stapled stack to the fold position.

[G]: Bottom Fence HP Sensor. Detects the actuator on the bottom fence and stops it at the home position after folding.

[H]: Bottom Fence Lift Motor. Raises the bottom fence and stapled stack to the fold position prescribed for the paper size.

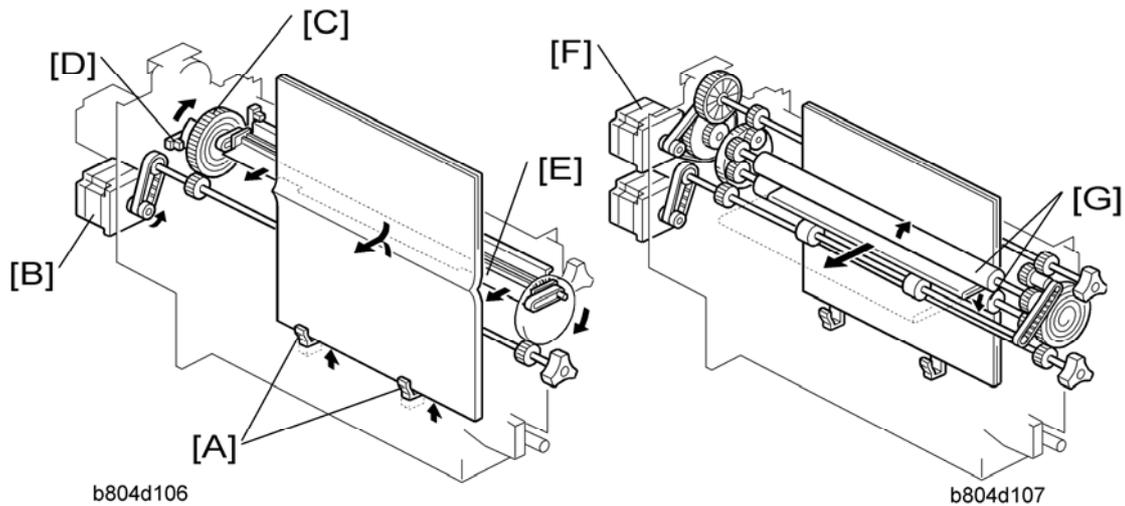

Fold Plate

[A]: Bottom Fence Stack Stoppers. Catches the stack after it is released by the clamp rollers.

[B]: Fold Plate Motor. Drives the timing belt and gears that move the fold plate.

[C]: Fold Plate Cam. Controls the movement of the fold plate to the left (into the nip of the fold rollers) and right (toward the fold plate home position).

[D]: Fold Plate HP Sensor. Controls operation of the fold plate motor.

[E]: Fold Plate. Moves left and pushes the stack into the nip of the fold rollers and then moves right to retract.

Fold Rollers

[F]: Fold Roller Motor. Drives forward to feed out the stack at the fold and then reverses to feed the fold in to sharpen the crease, and then drives forward again to feed out the folded stack. This reverse/forward cycle is done once.



- This cycle can be repeated by changing the setting of SP6114.

[G]: Fold Rollers. Driven by the fold roller motor, this roller pair feeds out the stack at its fold, reverses to feed in the stack to, and then feeds forward again (assisted by the fold unit exit rollers – not shown) to feed out the stack to the lower tray.

2.7 UPPER TRAY OUTPUT

2.7.1 FEED OUT

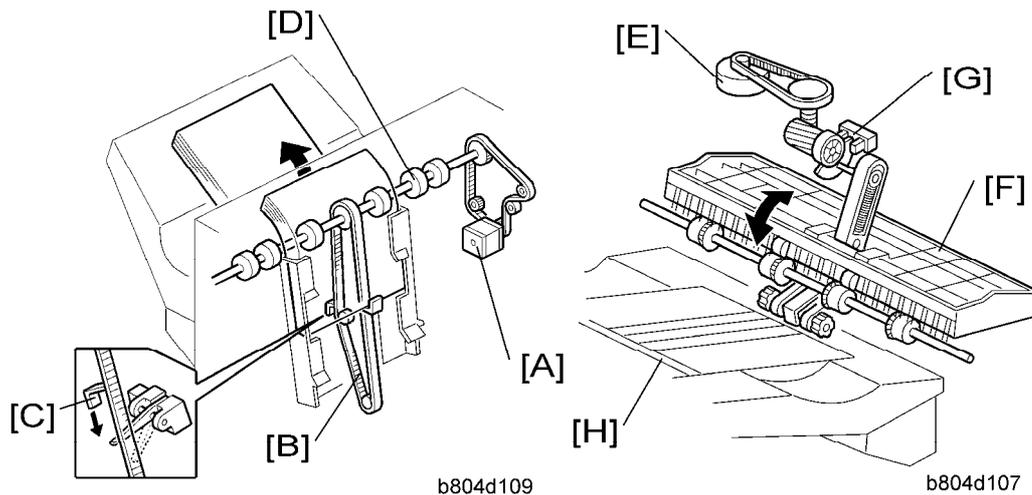

- [A]: Feed Out Belt Motor
- [B]: Stack Feed-Out Belt
- [C]: Pawl
- [D]: Exit Rollers
- [E]: Exit Guide Plate Motor
- [F]: Exit Guide Plate
- [G]: Exit Guide Plate HP Sensor
- [H]: Upper Tray

After the stack is stapled, the feed out belt motor [A] switches on and drives the feed out belt [B].

The pawl [C] attached to the feed out belt catches on the stack and lifts the stack toward the feed out slot.

The exit guide plate [F] remains open as the stack emerges at a prescribed distance away from the exit roller.

Next, the exit guide plate closes and the exit roller feeds the stack out.

The opening and closing of the exit guide plate is controlled by the rising and falling of a link driven by a rotating cam attached to the shaft of the exit guide plate motor [E].

The feed out belt motor stops 300 ms to prevent the stapled stack from rising too high.

Next, the feed out belt motor switches on again, then the pawl actuates its home position sensor and switches off the motor.

There are two output pawls on the feed out belt to improve the productivity of the feed out operation.

2.7.2 FEED OUT STACKING

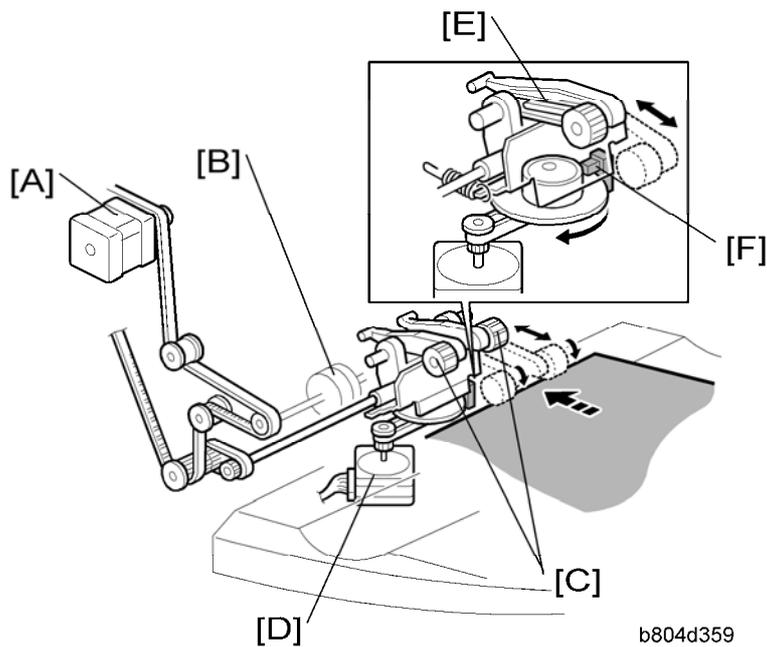

Upper/proof exit motor [A] drives feed roller [B] and stacking sponge roller [C].

Stacking sponge roller motor [D] moves the sponge roller forward and back with link [E].

The position of the stacking sponge roller [C] is controlled by the stacking sponge roller motor which is switched on and off by the stacking roller HP sensor [F].

2.8 PUNCH UNIT B702 (FOR B804/B805)

2.8.1 OVERVIEW OF OPERATION

Skew Correction before Punching

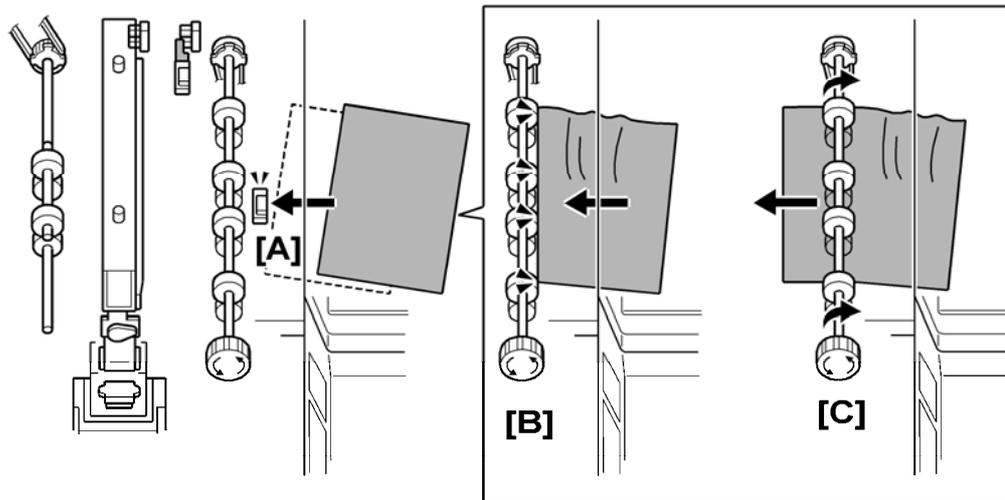

b804d351

This punch unit corrects for paper skew and then positions the punch unit to punch holes at the correct position. Each sheet is punched one at a time.

Paper feeds out of the copier. The finisher entrance sensor [A] detects the leading edge of the sheet.

The finisher entrance roller [B] stops rotating briefly while the copier exit rollers continue to rotate. This buckles the paper against the finisher entrance roller to correct skew. The finisher entrance roller [C] starts to rotate again and feeds the sheet into the finisher.

These SP codes adjust the skew operation in the punch unit:

- **SP6130.** This SP corrects the punch hole alignment. To do this, it corrects the skew of each sheet by adjusting the amount of time the finisher entrance roller remains off while the exit roller of the machine remains on. For more, see Section "Service Tables".
- **SP6131.** This SP determines whether the finisher entrance roller stops to correct skew when paper enters the finisher. You can use this SP to disable the skew correction. For more, see Section "Service Tables".

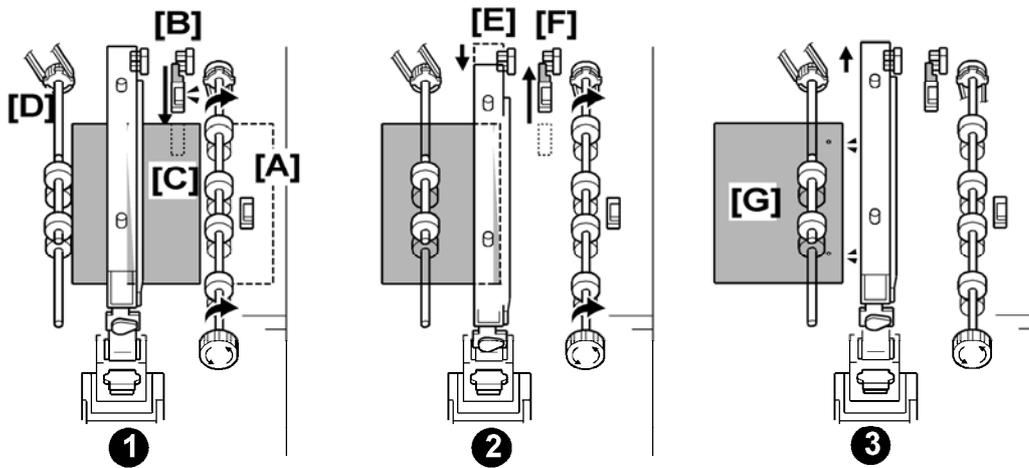
Punch Unit Position Correction

b804d352

These operations (skew correction before punching, and punch unit position correction) increase the accuracy of the punch alignment.

❶:

The trailing edge of the sheet passes the finisher entrance sensor [A].

The paper position slide unit [B] moves the paper position sensor [C] forward to the edge of the paper.

The paper position sensor detects the position of the paper edge and sends this information to the punch unit board. The machine uses the detected position of the paper edge to calculate the correct position for punching.

The upper transport motor switches on and rotates the feed rollers [D] the prescribed distance to position the paper under the punch unit.

❷:

Using the result of the position calculation, the punch unit control board moves the punch unit [E] to the adjusted punch position.

The paper position slide unit and its paper sensor, move back to the paper position slide home position sensor [F], and the punch unit fires the punches to make the holes.

❸:

The feed rollers [G] feed the punched paper out of the punch unit and into the paper path.

Punch Unit B702 (For B804/B805)

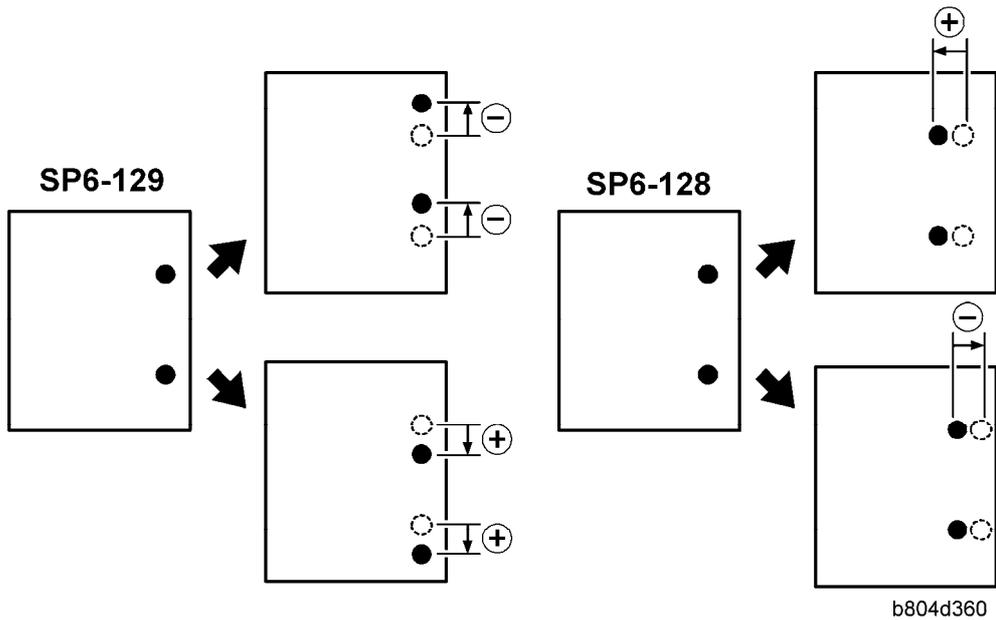

These SP codes adjust the punch hole alignment:

- **SP6-128** Adjusts the punch positions in the direction of paper feed.
- **SP6-129** Adjusts the punch position perpendicular to the direction of feed.

For more, see Section "Service Tables".

Booklet
Finisher/
Finisher
B804/B805

2.8.2 PUNCH MECHANISMS

Paper Position Detection

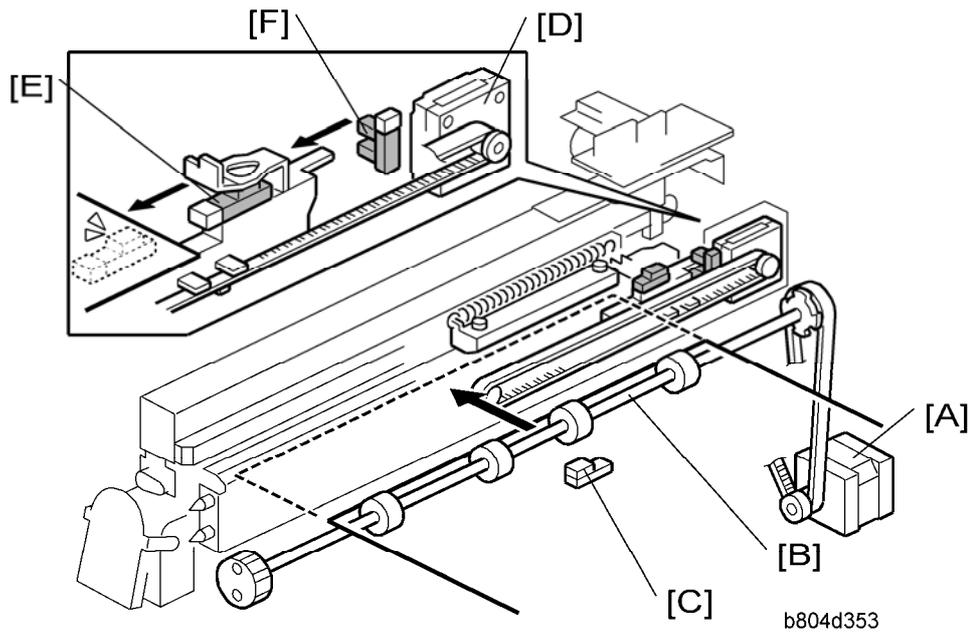

- [A]: Finisher Entrance Motor (M1)
- [B]: Finisher Entrance Roller
- [C]: Finisher Entrance Sensor (S1)
- [D]: Paper Position Sensor Slide Motor (M7)
- [E]: Paper Position Sensor (S27)
- [F]: Paper Position Sensor Slide HP Sensor (S22)

The finisher entrance motor (M1) [A] drives the finisher entrance rollers [B] that feed paper from the copier into the finisher. The finisher entrance sensor (S1) [C] detects paper when it enters the finisher, and detects paper jams.

The paper position slide sensor motor (M7) [D] extends and retracts the paper position slide that holds the paper position sensor (S27) [E]. The paper position sensor detects the position of the paper edge. The detected position of the paper is used to calculate and position the punch unit for punching.

The paper position slide HP sensor (S22) [F] detects the paper position slide when it retracts and stops the paper position slide motor so the slide stops at its home position.

Punch Unit Movement

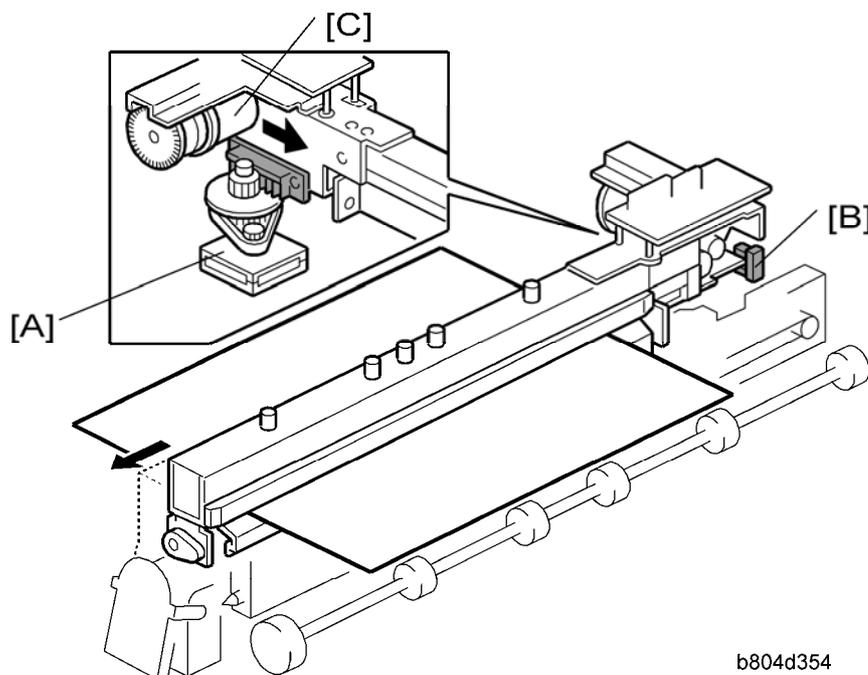

b804d354

Punch Unit B702 (For B804/B805)

- [A]: Punch Movement Motor (M9)
- [B]: Punch Movement HP Sensor (S21)
- [C]: Punch Drive Motor (M24)

The punch movement motor (M9) [A] extends and retracts the punch unit to position it at the correct position for punching.

The punch movement HP sensor (S21) [B] detects the position when it retracts, switches off the punch position movement motor, and stops the punch unit at its home position.

The punch drive motor (M24) [C] fires the punches that punch holes in the paper below.

Punch Selection and Firing

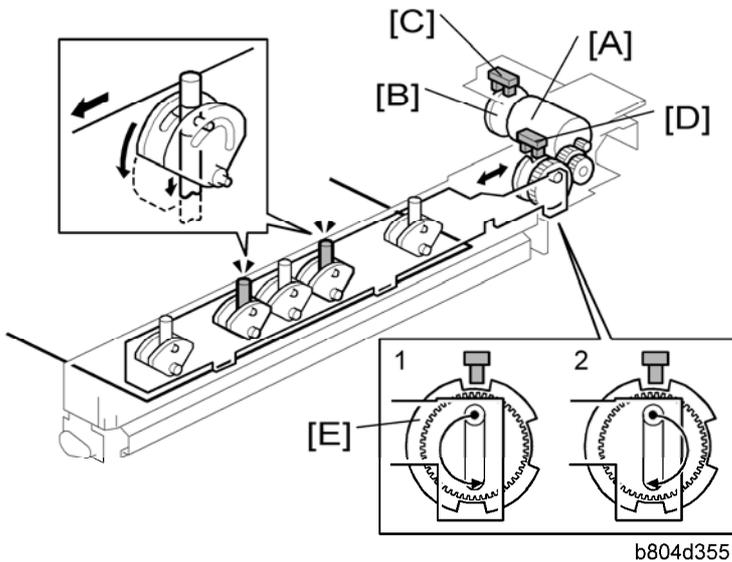

- [A]: Punch Drive Motor (M24)
- [B]: Punch Encoder Wheel
- [C]: Punch Encoder Sensor (S24)
- [D]: Punch HP Sensor (S23)

The punch drive motor (M24) [A] turns the small, notched encoder wheel [B] through the gap in the punch encoder sensor [C] (S24). The sensor output is used to control the punch timing.

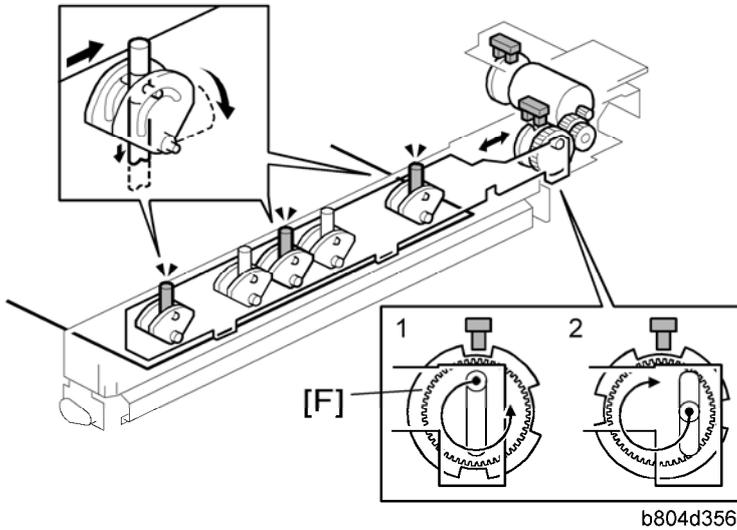

The timing for 2-hole punching [E] is different from 3-hole punching [F].

When the punch unit is at the punching position, the punch motor turns until the encoder detects the starting position for 2-hole or 3-hole punching.

- This is the '1' position in the diagrams (the top diagram is for 2-hole punching, and the bottom diagram is for 3-hole punching).

Then, the punch drive motor turns counter-clockwise to the '2' position. This movement punches the holes in the paper.

Then, the punch drive motor turns clockwise to the '1' position, to be ready for the next sheet of paper.

2.8.3 PUNCH HOPPER MECHANISM

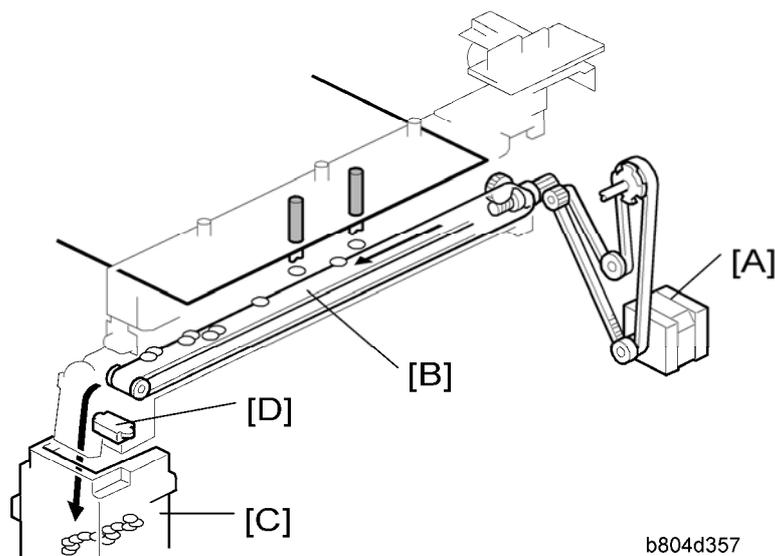

Punch Unit B702 (For B804/B805)

[A]: Finisher Entrance Motor (M1)
[B]: Punch Waste Belt
[C]: Punch Waste Hopper
[D]: Punch Hopper Full Sensor (S4)

The finisher entrance motor (M1) [A] drives the timing belt and gears that rotate the punch waste belt [B].

The punchouts fall from the punch unit onto the belt. The belt moves the punchouts to the front and dumps them in the punch waste hopper [C].

The punch hopper full sensor [D]:

- Signals that the hopper is full when it detects the top of the stack of punchouts that have collected in the hopper.
- It also detects when the punch hopper is set properly.

2.9 FINISHER JAM DETECTION

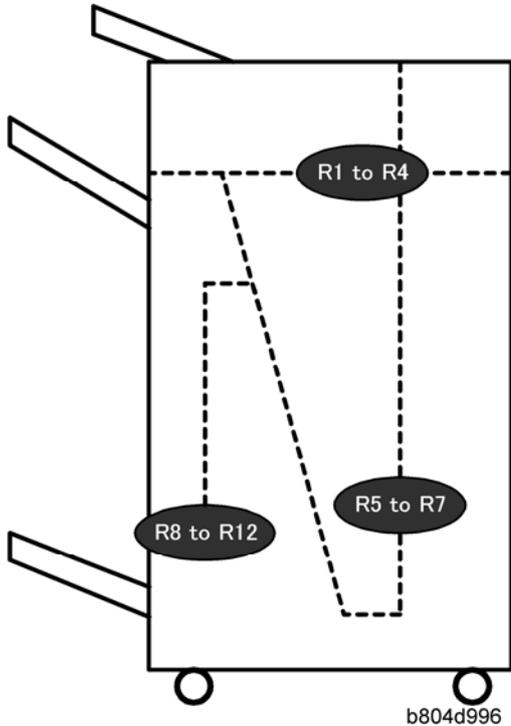

Display	Mode	Jam	What It Means
R1 to R3	Proof Shift Staple	Finisher entrance sensor late	After main machine exit sensor goes OFF, finisher entrance sensor does not go ON even after enough time to feed 450 mm.
		Finisher entrance sensor lag	After finisher entrance sensor goes ON, it does not go OFF after enough time to feed a sheet 1.5 times its length has elapsed.
R3	Proof	Proof exit sensor late	After finisher entrance sensor goes ON, proof exit sensor does not go ON even after enough time to feed 450 mm.
		Proof exit sensor lag	After finisher entrance sensor goes OFF, proof exit sensor does not go OFF even after enough time to feed 450 mm.

Finisher Jam Detection

Display	Mode	Jam	What It Means
R4	Shift	Upper tray exit sensor late	After finisher entrance sensor goes ON, upper tray exit sensor does not go ON even after enough time to feed 485 mm.
		Upper tray exit sensor lag	After finisher entrance sensor goes OFF, upper tray exit sensor does not go OFF even after enough time to feed 650 mm.
R5 to R7	Staple	Pre-stack tray exit sensor lag	After finisher entrance sensor goes ON, pre-stack tray exit sensor does not go ON even after enough time to feed 650 mm.
		Pre-stack tray exit sensor late	After finisher entrance sensor goes ON, pre-stack tray exit sensor does not go OFF even after enough time to feed 1650 mm.
R8 to R12	Booklet Staple (B700 Only)	Fold unit entrance sensor late (S26)	The fold unit entrance sensor goes not go ON after enough time has elapsed to feed 1.5 times the length of the stack after the leading edge of the stack reaches the stack present sensor (S32).
		Fold unit exit sensor late (S31)	The fold unit exit sensor does not go ON after enough time has elapsed for the stack to feed 1.5 times its length from the fold position.
		Fold unit exit sensor lag (S31)	After the fold unit exit sensor goes ON, it does not go OFF after enough time has elapsed to feed 442.9 mm.

Booklet
Finisher/
Finisher
B804/B805

SCANNER ACCESSIBILITY OPTION TYPE 4045 B838

REVISION HISTORY		
Page	Date	Added/Updated/New
All	10/08/2008	New Information – The entire B838 SM has been replaced.

SCANNER ACCESSIBILITY OPTION

TYPE 4045 B838

TABLE OF CONTENTS

1. SCANNER ACCESSIBILITY OPTION (B838)	1
1.1 INSTALLATION REQUIREMENTS.....	1
1.1.1 GENERAL REQUIREMENTS.....	1
1.1.2 SPECIFIC REQUIREMENTS.....	1
1.1.3 ACCESSORY CHECK.....	3
1.2 REMOVAL PROCEDURE FOR COVERS.....	5
1.3 REMOVAL PROCEDURE FOR SCANNER UNIT.....	7
1.4 CONNECTING PROCEDURE FOR SCANNER UNIT.....	9
1.5 CONNECTING PROCEDURE FOR OP PANEL.....	20
1.6 HARNESS BRACKET ATTACHMENT PROCEDURE.....	23
1.7 CONNECTING PROCEDURE FOR MAINFRAME.....	25
1.8 INSTALLATION FOR KEY COUNTER.....	31

Read This First

Safety and Symbols

Replacement Procedure Safety

CAUTION

- Turn OFF the main power switch and unplug the machine before beginning any of the replacement procedures in this manual.

Symbols Used in this Manual

This manual uses the following symbols.

: See or Refer to

: Screws

: Connector

: Clip ring

: E-ring

1. SCANNER ACCESSIBILITY OPTION (B838)

1.1 INSTALLATION REQUIREMENTS

1.1.1 GENERAL REQUIREMENTS

- Install the scanner on a solid base.
- Do not install the scanner in areas where the unit can fall down when the ADF cover is opened.
- Make sure you install the unit in area that allows easy access for operation.
- Ask the customer about their requirements before you install the unit.

1.1.2 SPECIFIC REQUIREMENTS

- The scanner cable should not touch the floor.
- The cables should not hang free where they can become entangled with other equipment or furniture such as a wheelchair.
- The unit should be positioned within 380 to 1220 mm (1.3 to 4 ft.) above the floor.

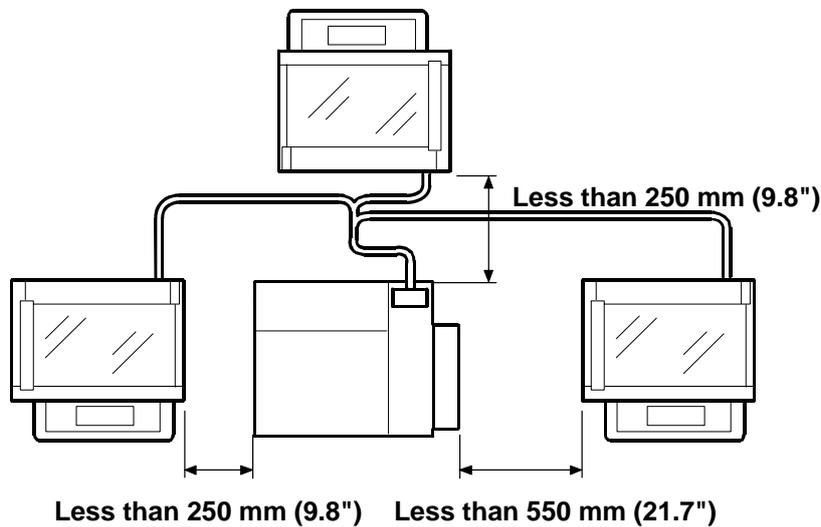

INSTALLATION REQUIREMENTS

- The scanner should be positioned as follows:
Within 250 mm (9.8") from the left and rear side of the main unit
Within 550 mm (21.7") from the right side of the main unit

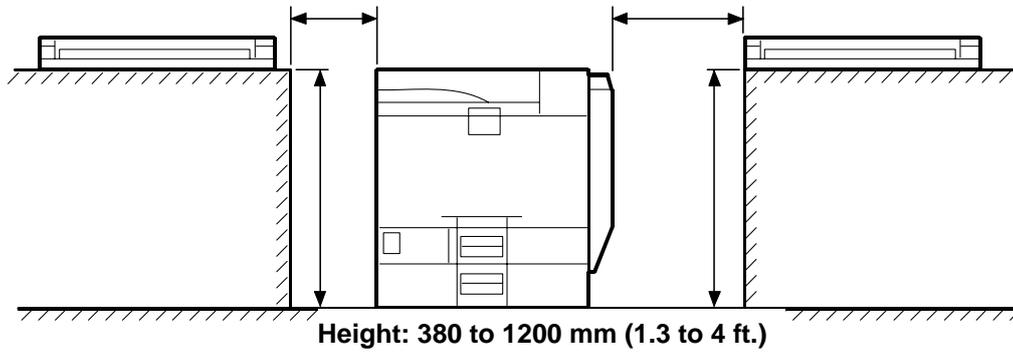

INSTALLATION REQUIREMENTS

1.1.3 ACCESSORY CHECK

Check the accessories and their quantities against the following list.

No.	Description	Q'ty
1	Top Rear Cover	1
2	Rear Bracket	1
3	Key Counter Bracket (only for installing key counter)	1
4	Left Scanner Stay	1
5	Right Bottom Plate	1
6	Left Bottom Plate	1
7	Left Stopper	1
8	Right Stopper	1
9	Cable Bracket Unit	1
10	Operation Panel Interface Board	1
11	MB Interface Board	1
12	Gasket - Scanner Frame	1
13	Gasket - Scanner Lens	1
14	Seal - Bottom	1
15	Ferrite Core	17
16	Shoulder Screw (only for installing key counter)	1
17	Adjuster	2
18	Spacer	2
19	Rubber Leg	3
20	Cap	3
21	Saddle Clamp	1
22	Clamp	1
23	Plate Clamp	4
24	Screw-Round: M4x8	2
25	Screw-Tapping: M3x8 (blue)	7
26	Screw-Round: M3x6	4
27	Screw 2-Tapping: M3x8	4
28	Screw-Tapping: M4x16	4
29	Screw-Tapping: M4x8	4
30	Screw-Tapping: M3x6	5
31	Screw-Tapping: M3x8	6
32	Left Bracket	1
33	Harness - MB	1
34	Harness - Operation Panel Board	1
35	Top Right Cover	1
36	Cable Bracket Cover	1

Scanner
Accessibility
Option
B838

INSTALLATION REQUIREMENTS

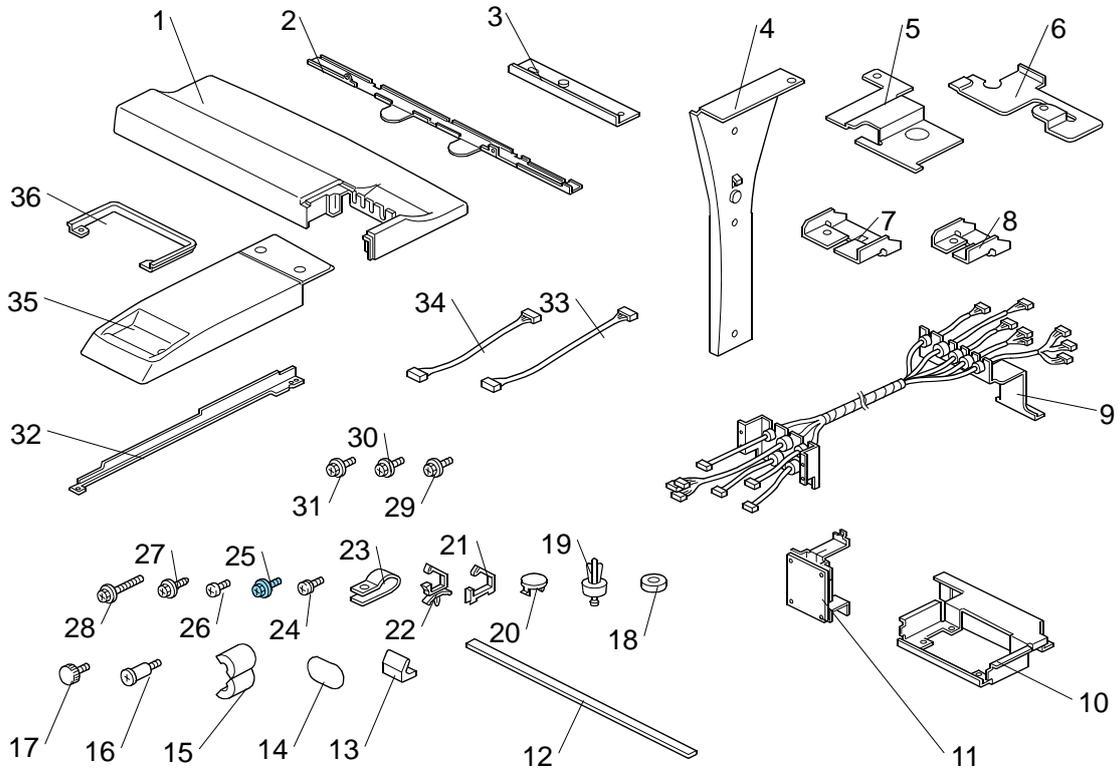

1.2 REMOVAL PROCEDURE FOR COVERS

1. Scanner left cover [1] (⚙️ x 2)
2. Slide the scanner rear cover [2] to the left side, and then remove it (⚙️ x 1, hook x 2).
3. Left rear cover [3] (⚙️ x 1)

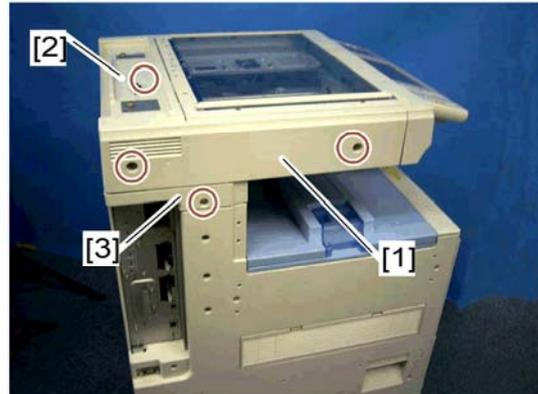

4. Left cover [4] (⚙️ x 6)

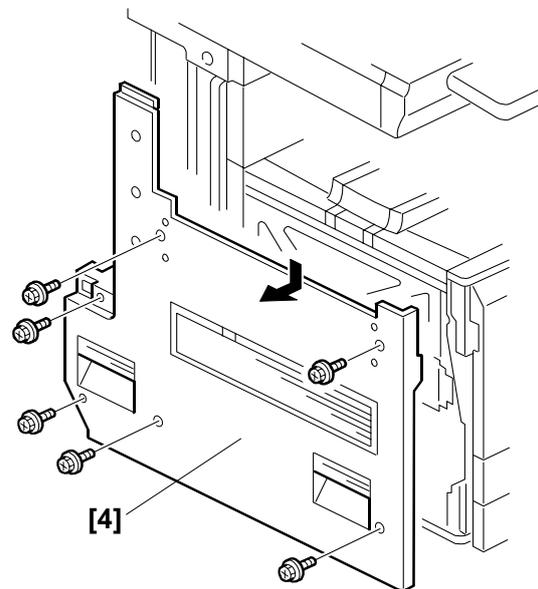

5. Scanner right cover [5] (⚙️ x 2)
6. Right top cover [6] (⚙️ x 1)
7. Open the right door [7].
8. Right rear cover [8] (⚙️ x 4)

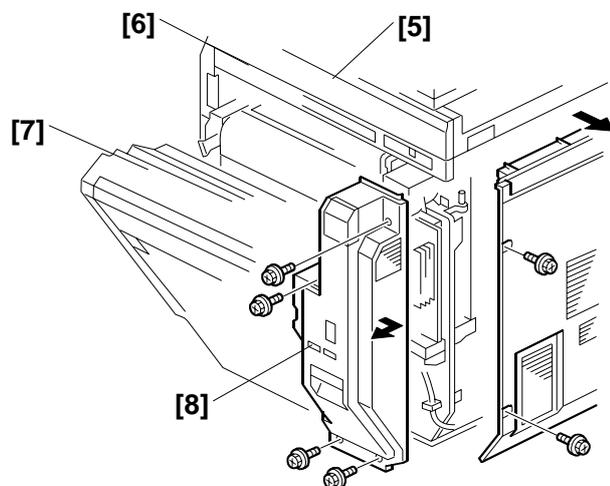

Scanner
Accessibility
Option
B838

Removal Procedure for Covers

- 9. Front right cover [9] (⚙️ x 1)
- 10. Operation panel with the scanner front cover [10] (⚙️ x 6; M3x3 bind screw x 2, M3x5 bind screw x 2 on the top of the scanner front cover, M3x8 tapping screw x 2 on the bottom of the scanner front cover)

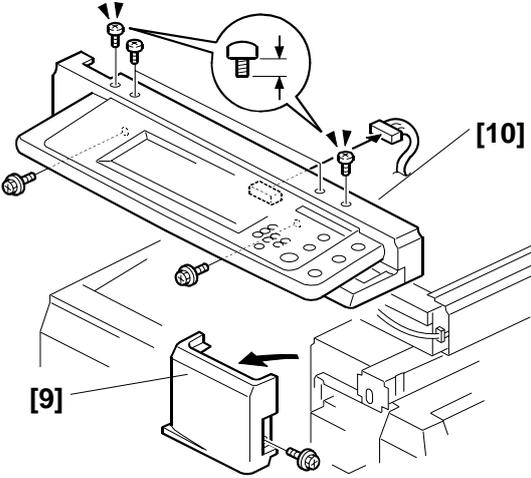

- 11. Scanner front cover [11] (⚙️ x 2)

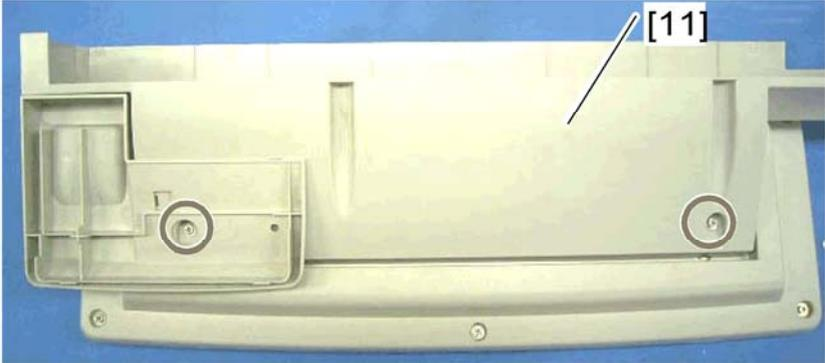

- 12. Rear cover [12] (⚙️ x 6)

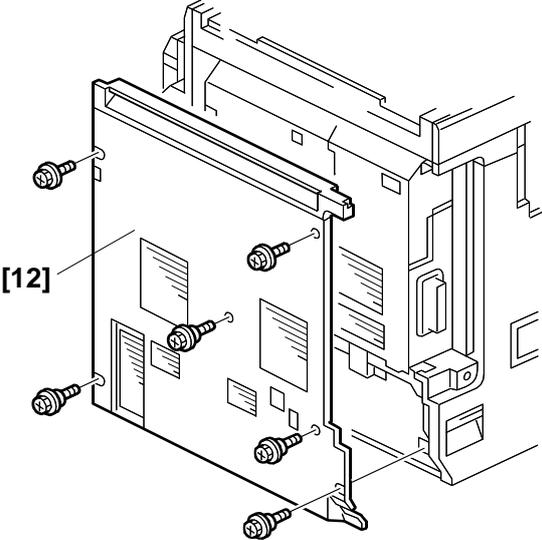

F

1.3 REMOVAL PROCEDURE FOR SCANNER UNIT

1. Controller box right cover [1]
( x 8)

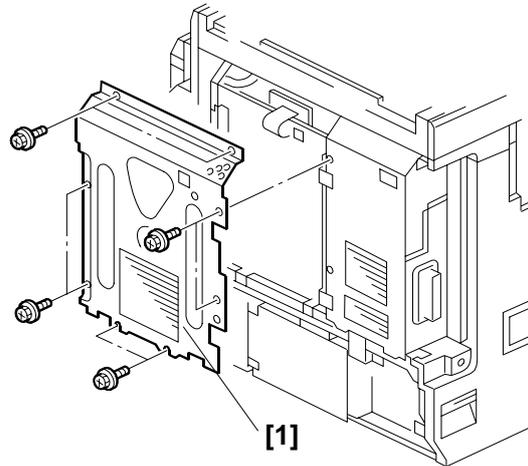

2. Remove the clamp plate [2] ( x 1).
3. Disconnect the scanner I/F cable [3] from the connector (CN509) on the IPU ( x 1, ground cable x 1).
4. Release the clamp [4].

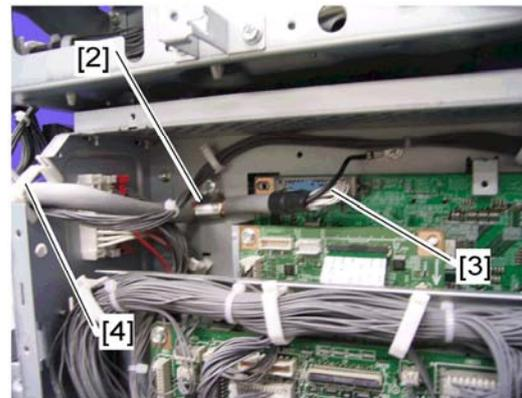

5. Disconnect the three connectors [5] on the controller box.

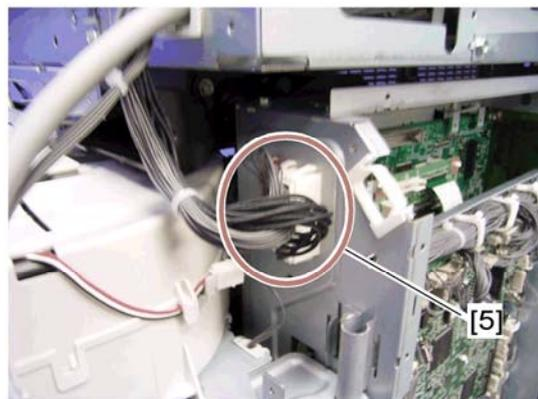

Removal Procedure for Scanner Unit

6. Scanner unit [6] (⚙️ x 5; right side x 2, left side x 3)

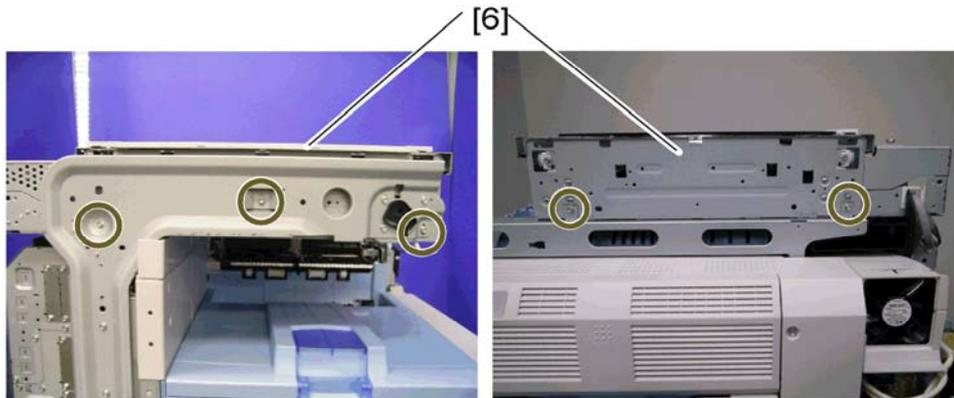

7. Scanner left stay [7] (⚙️ x 3)



1.4 CONNECTING PROCEDURE FOR SCANNER UNIT

1. Rear scale [1] (⌀ x 3; stepped screw)
2. Glass cover [2] (⌀ x 2; stepped screw)
3. Exposure glass with the left scale [3]

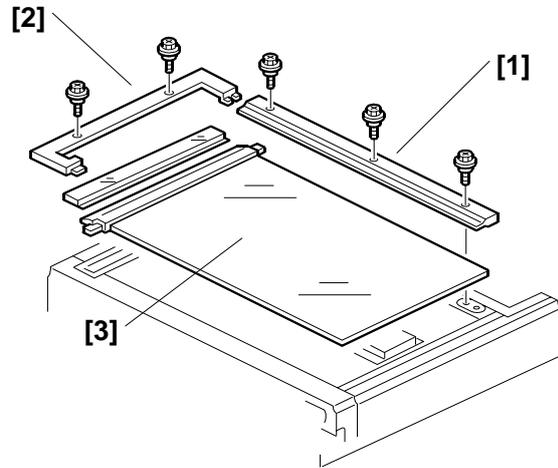

4. Disconnect the connectors [4] (CN312, CN318) from the SIO.
5. Disconnect the scanner HP sensor connector [5].
6. Scanner rear frame [6] (⌀ x 8)

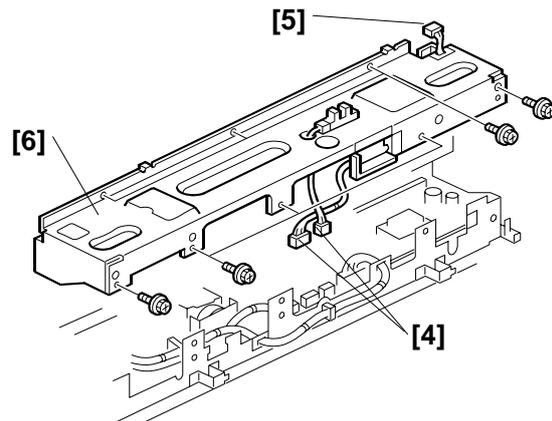

7. Release the clamps (⌀ x 7).



Connecting Procedure for Scanner Unit

8. Remove the clamp [7] for the scanner I/F cable (⚙️ x 1). This clamp will be used hereafter.

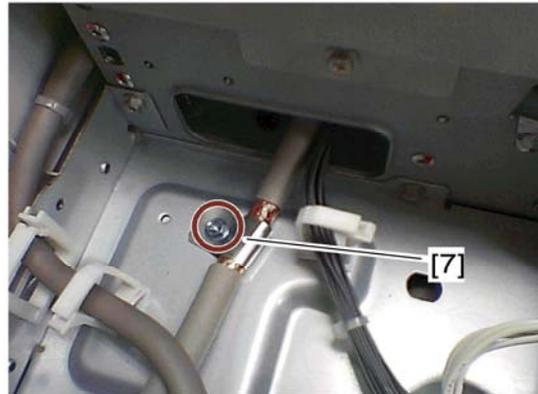

9. Disconnect the BICU interface harness [8] (CN310 on the SIO), and then remove it.
10. Disconnect the power supply harness [9] (CN311 on the SIO), and then remove it

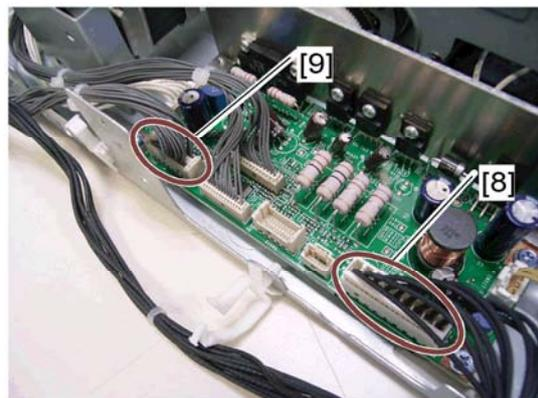

11. SBU cover [10] (⚙️ x 4)
12. SBU grounding plate [11] (⚙️ x 4)
13. SBU [12] (⚙️ x 4, ⚙️ x 2: 15 pins connector, 30 pins connector)

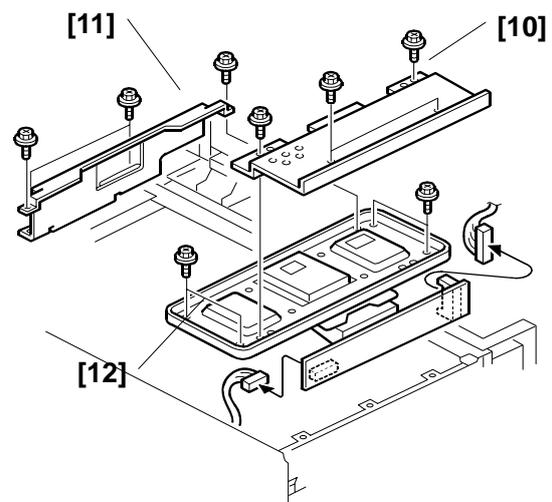

Connecting Procedure for Scanner Unit

14. Scanner I/F cable [13] (🔌 x 1, ground cable x 1)

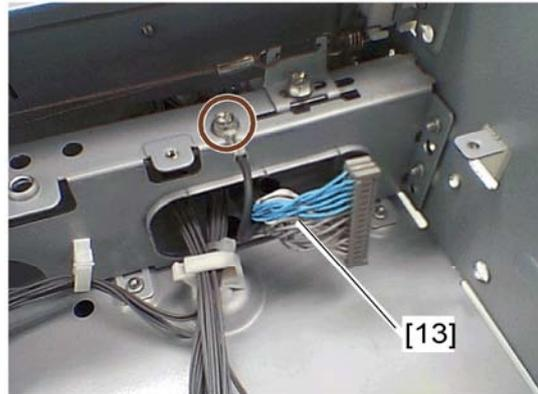

15. Operation panel I/F harness [14] (🔌 x 5)

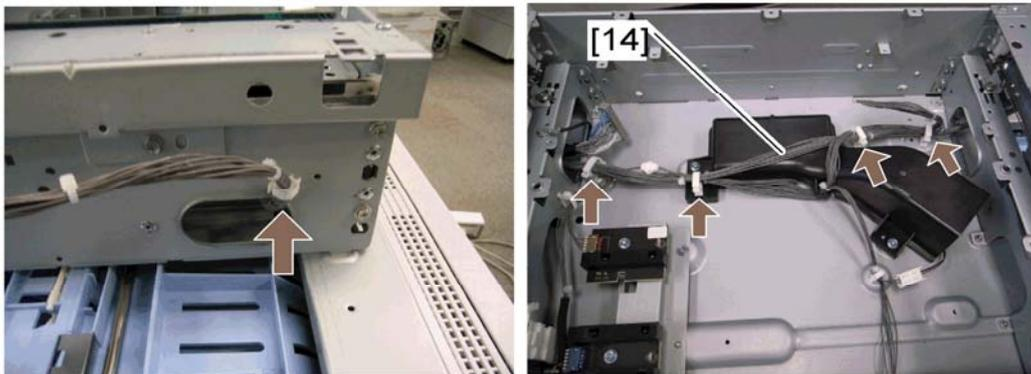

16. Scanner left stay [15] (🔌 x 2)

17. Move the scanner carriage [16] to the center position.

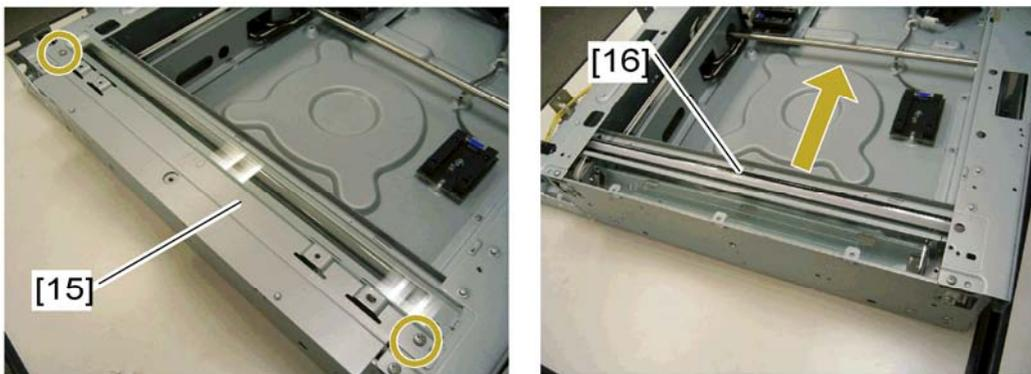

Scanner
Accessibility
Option
B838

18. Install the left bottom plate [17] in the place as shown (1 x 1; M3x6 blue screw).

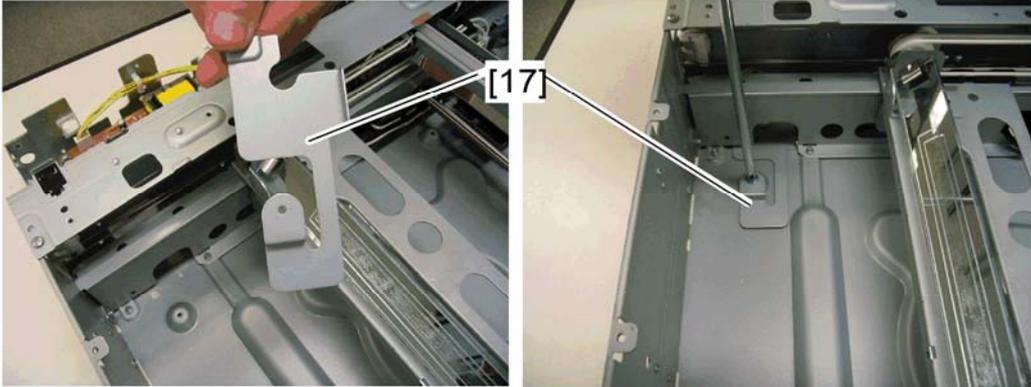

19. Install the right bottom plate [18] in the place as shown (1 x 1; M3x6 blue screw).

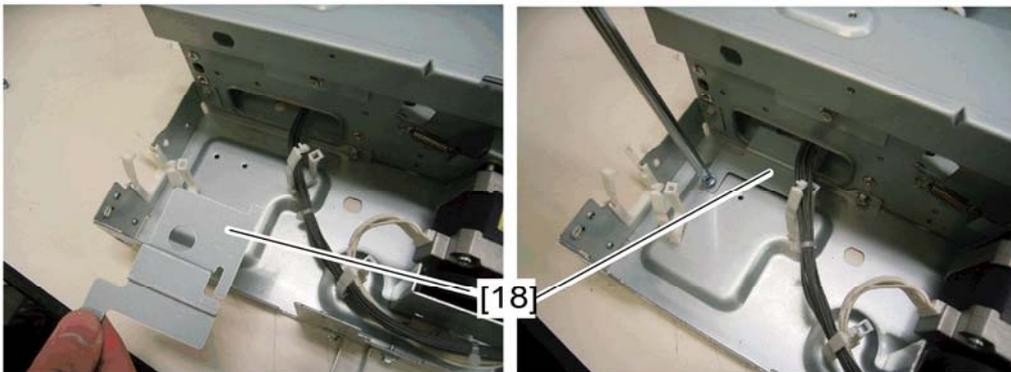

20. Install the three rubber legs [19] in the bottom of the scanner unit.

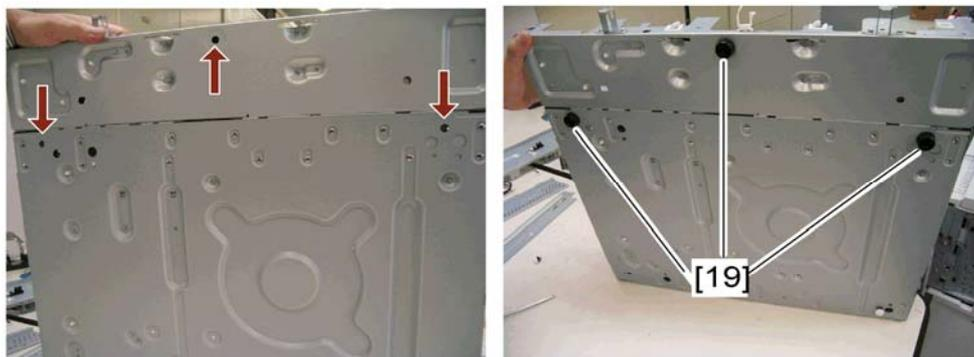

Connecting Procedure for Scanner Unit

21. Install the two spacers [20], adjusters [21] and seal [a] in the bottom [22] of the scanner unit.

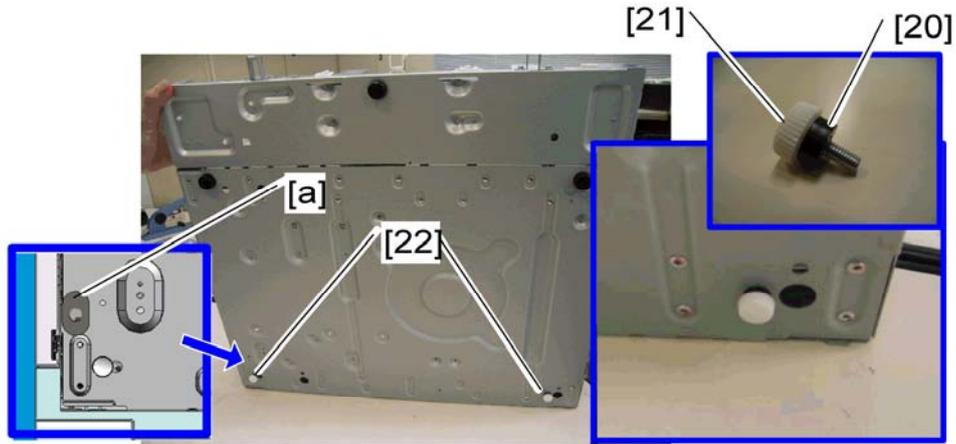

22. Move the scanner carriage [23] to its home position.

23. Reinstall the scanner left stay [24] (⌀ x 2).

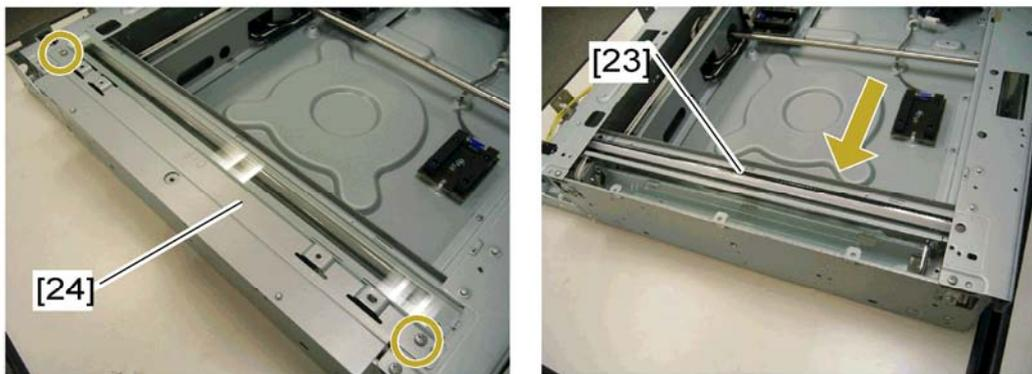

24. Install the rear bracket [25] to the outside of the scanner rear frame (🔩 x 2; M3x6 blue screw).

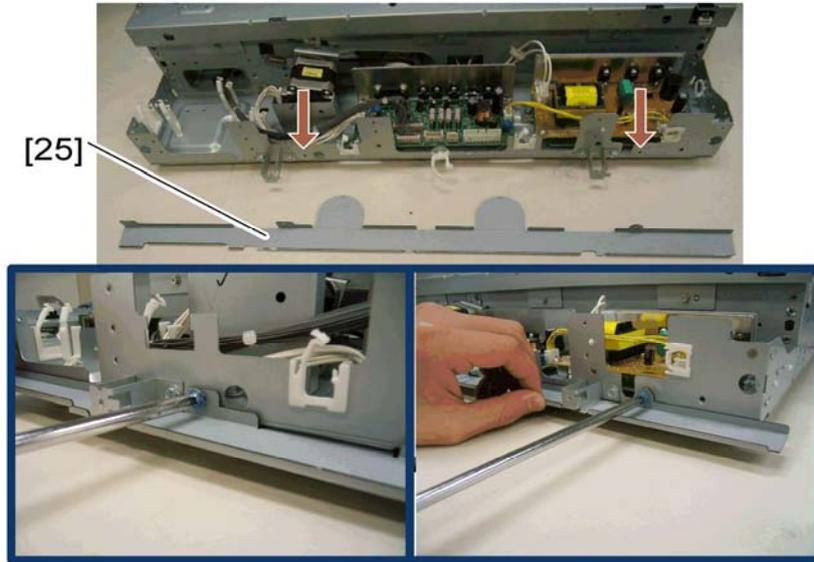

25. Install the left bracket [26] to the outside of the scanner left frame (🔩 x 2; M3x6 blue screw).

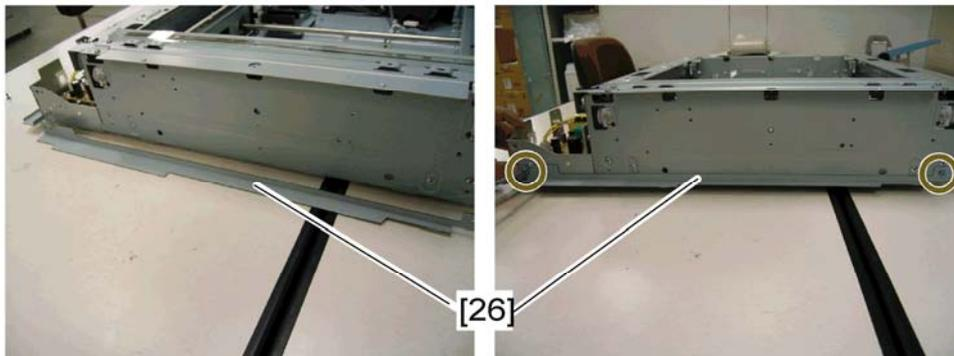

Connecting Procedure for Scanner Unit

26. Clean the inside of the scanner left frame with a cloth absorbing alcohol.
27. Attach the gasket [27] to the inside of the scanner left frame aligning with two projections [28].

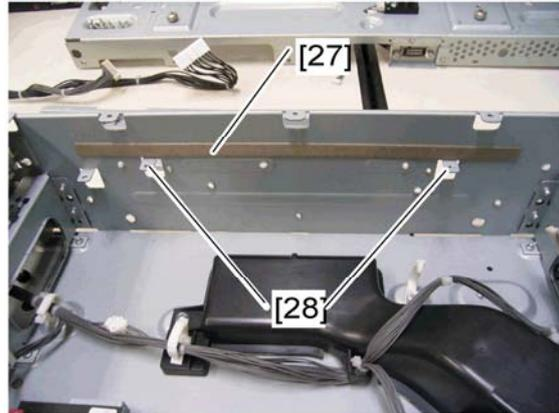

28. Clean the lens bracket with a cloth absorbing alcohol.
29. Attach the gasket [29] to the lens bracket as shown.

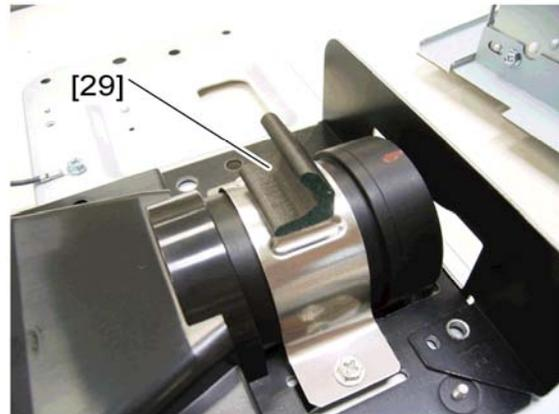

30. Attach the cable bracket [30] to the rear right of the scanner unit (⌀ x 4; screw-round M3x6).

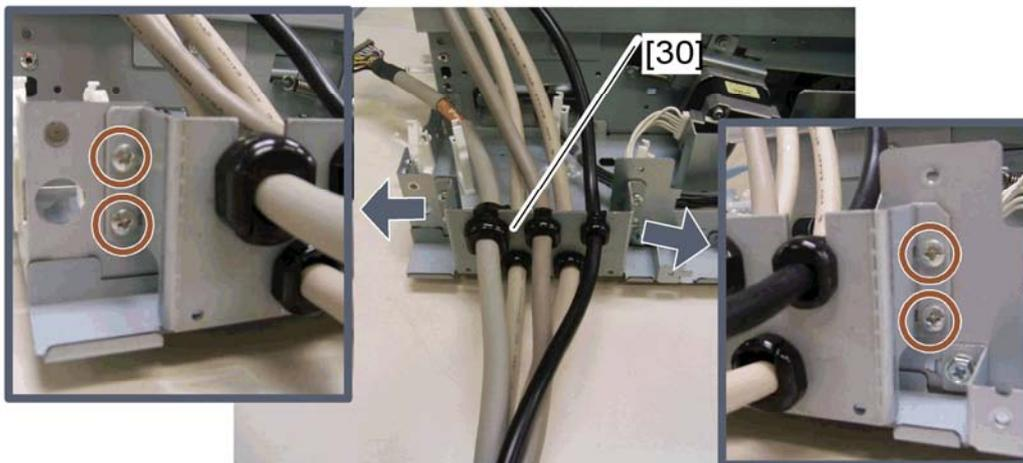

Connecting Procedure for Scanner Unit

31. Put the scanner I/F cable [31] through the cutout of the scanner rear frame.

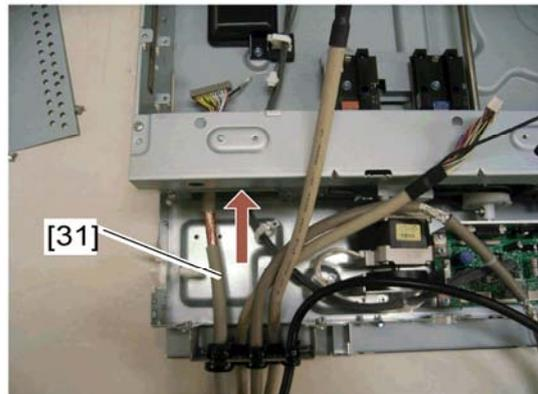

32. Reinstall the SBU [32] (⚙ x 4, 15 pins connector, 30 pins connector) and ground cable of the scanner I/F cable (⚙ x 1).
33. Reinstall the SBU grounding plate [33] (⚙ x 4).
34. Reinstall the SBU cover [34] (⚙ x 4).

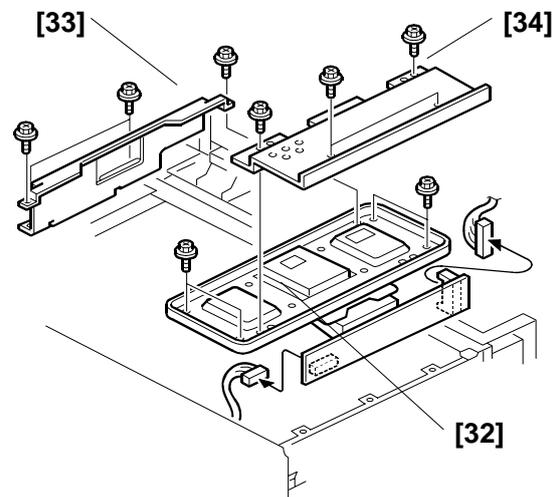

35. Remove the rap on the scanner I/F cable.
36. Attach the clamp [35] (this clamp is removed in step 8 in the "Connecting Procedure for Scanner Unit") to the scanner I/F cable and then secure it (⚙ x 1; M3x6 blue screw).

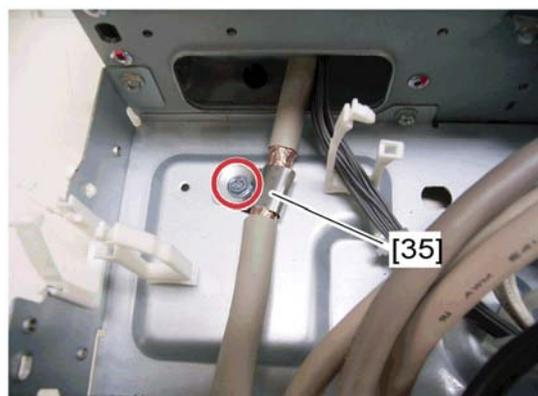

Connecting Procedure for Scanner Unit

37. Install the clamp [36] and saddle clamp [37] as shown (🔍 x 2).

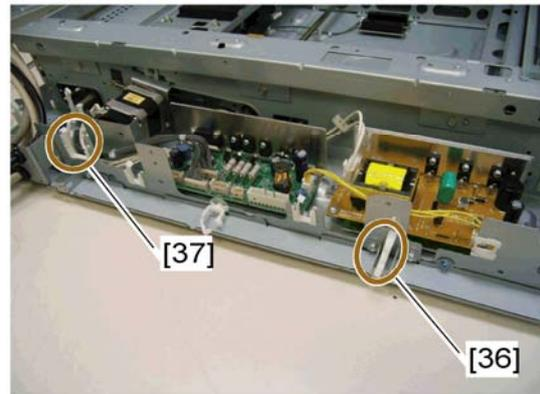

38. Route the operation panel I/F cable [38] and clamp it (🔍 x 2).

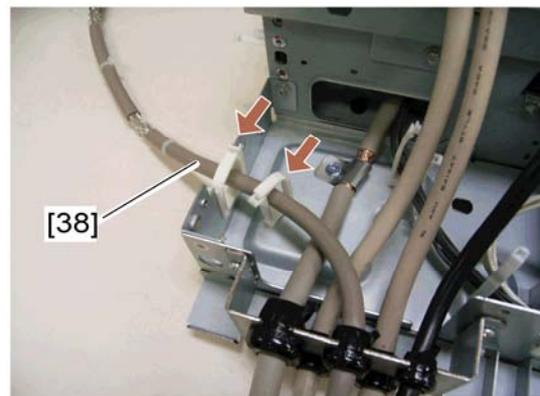

39. Route and connect the BICU interface cable [39] to CN311 on the SIO (🔍 x 1).

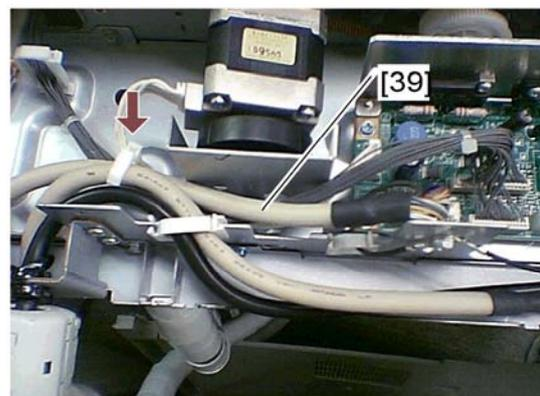

Scanner
Accessibility
Option
B838

Connecting Procedure for Scanner Unit

40. Route and connect the power supply cable [40] to CN310 on the SIO (🔧 x 4).
41. Secure two ground cables [41] (BICU interface cable and power supply cable) (🔧 x 1; M3x6 blue screw).

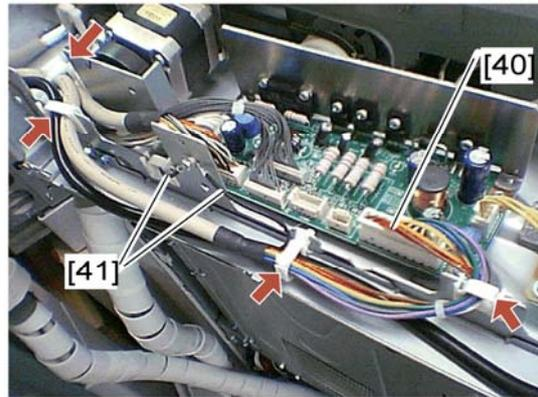

42. Route the heater relay cable [42] as shown and secure ground cable [43] (🔧 x 6, 🔧 x 1; screw-round M4x8).

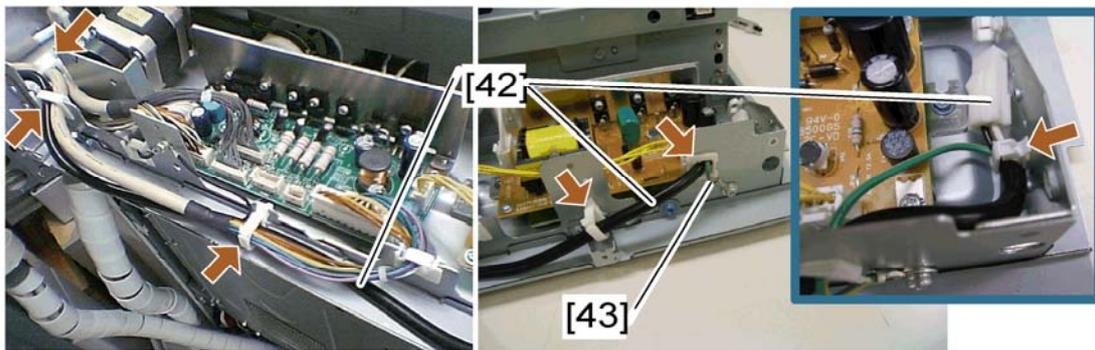

43. Reinstall the scanner rear frame [44] (🔧 x 8, 📏 x 2).
44. Connect the harness [45] to the scanner HP sensor.

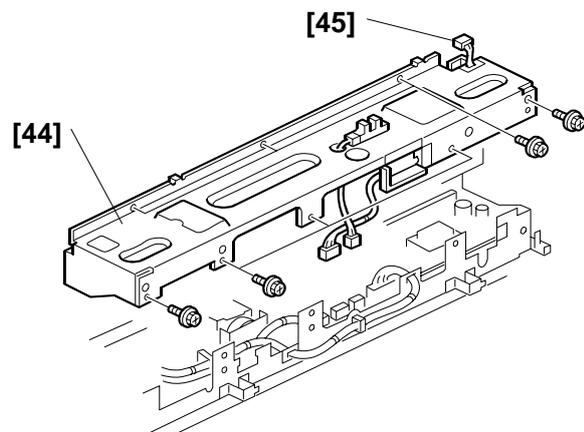

Connecting Procedure for Scanner Unit

45. Reinstall the exposure glass with left scale **[46]**.
46. Reinstall the glass cover **[47]** (stepped screw x 2).
47. Reinstall the rear scale **[48]** (stepped screw x 3).

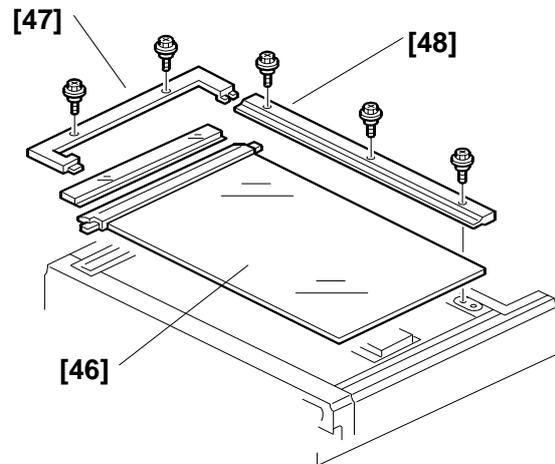

1.5 CONNECTING PROCEDURE FOR OP PANEL

1. Route and attach the operation panel I/F cable to the outside of the scanner right frame with four plate clamps (⌀ x 4; screw - tapping M3x8).

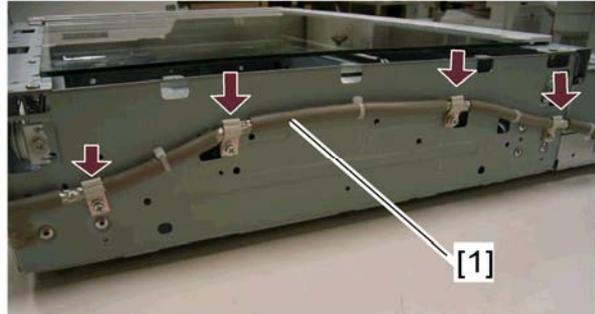

NOTE: Make sure that the operation panel I/F cable [A] does not cover the three cutouts [B].

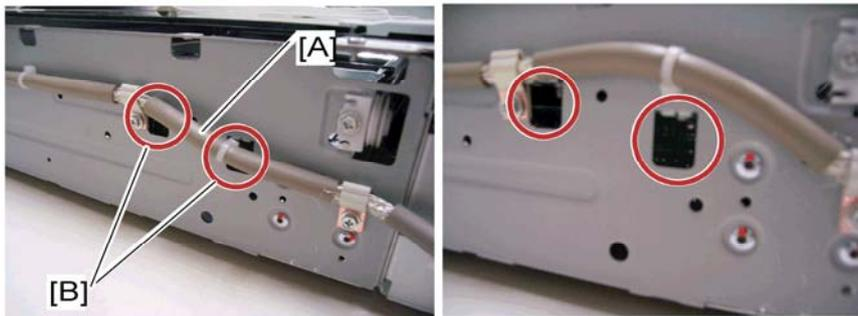

2. Connect the harness [2] to the operation panel interface board [3] as shown.



Connecting Procedure for Op Panel

3. Remove the two screws on the operation panel drive board [4].

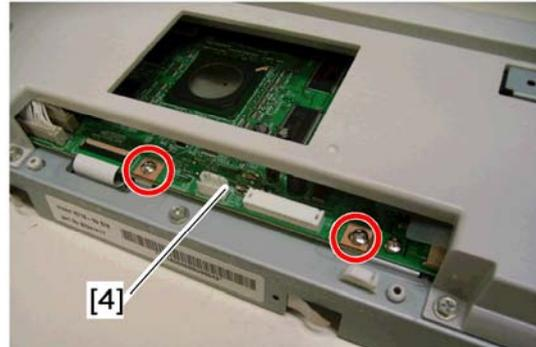

4. Attach the operation panel interface board [3] as shown (2 x 2; these are removed in step 3 in this procedure).
5. Connect the harness [2] to CN700 on the operation panel drive board and install the core [5] (RFC-8).

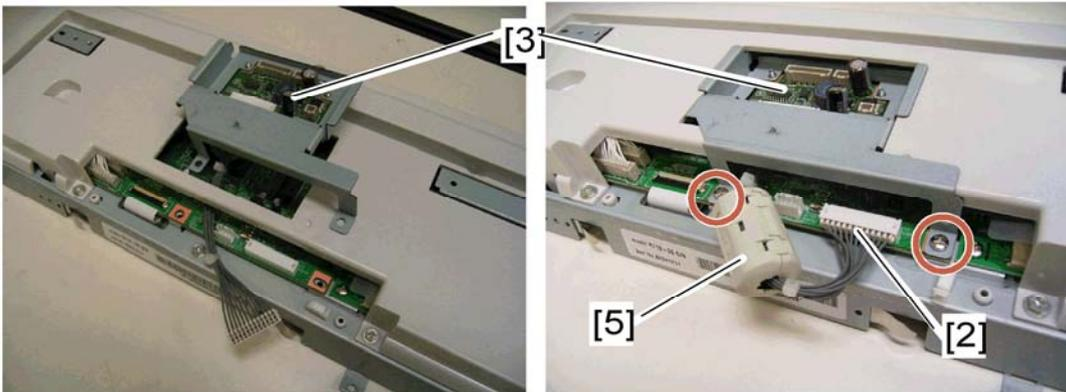

6. Put the operation panel I/F cable [6] through the scanner front cover [7].
7. Connect the three connectors [8] of the operation panel I/F cable to operation panel interface board.

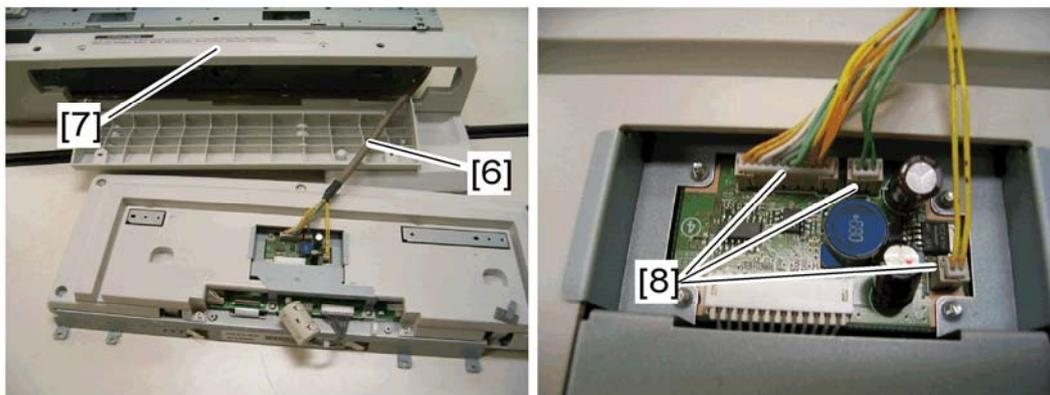

Scanner
Accessibility
Option
B838

Connecting Procedure for Op Panel

8. Remove the clip tray [9] from the scanner front cover [10].

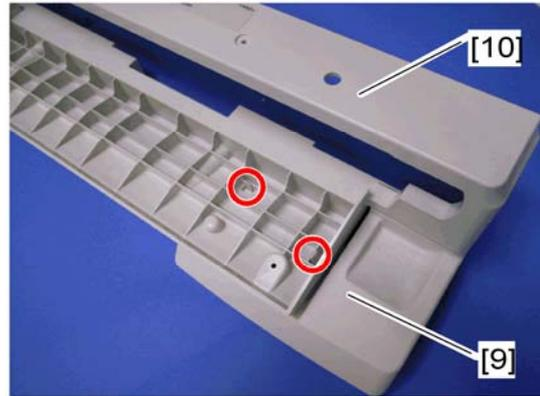

9. Attach the scanner front cover [11] to the operation panel (⚙ x 2).

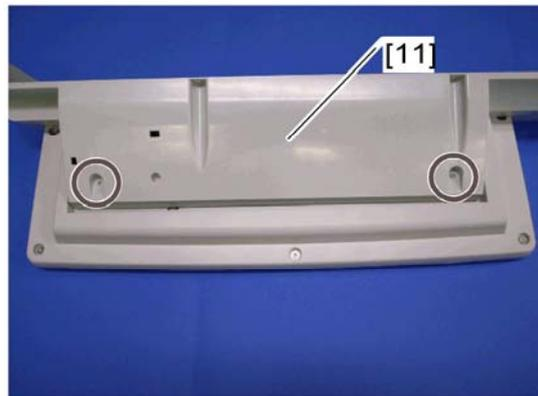

10. Reinstall the operation panel with the scanner front cover [12] in the scanner front frame (⚙ x 6; M3x3 bind screw x 2, M3x5 bind screw x 2 on the top of the scanner front cover, M3x8 tapping screw x 2 on the bottom of the scanner front cover).

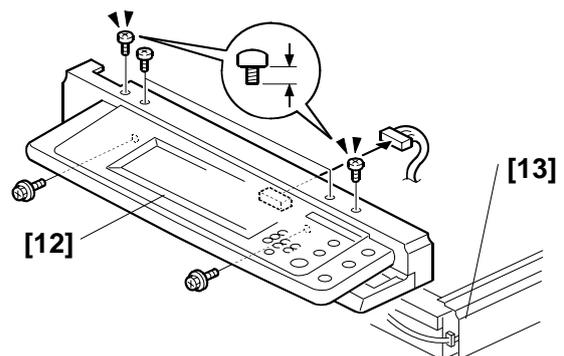

11. Reinstall the scanner right cover [13] (⚙ x 2).

1.6 HARNESS BRACKET ATTACHMENT PROCEDURE

1. Cut off the rear right [1] of the scanner top rear cover with a cutter.

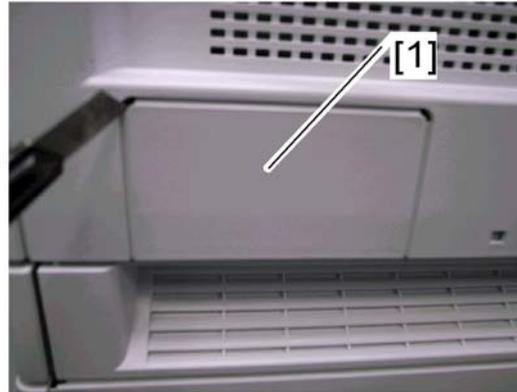

2. Reinstall the scanner top rear cover [2] (⚙️ x 1; M3x8 tapping screw).

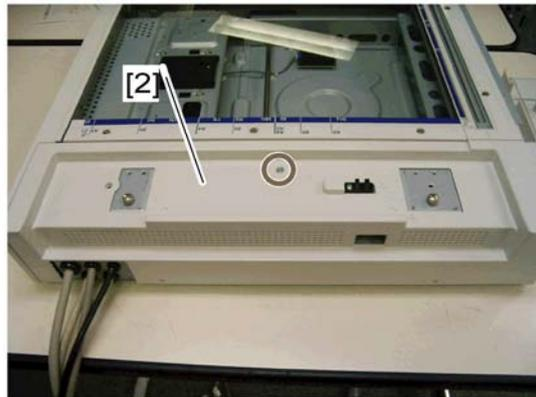

3. Install and attach the cable bracket cover [3] (⚙️ x 2; screw-tapping M3x8).

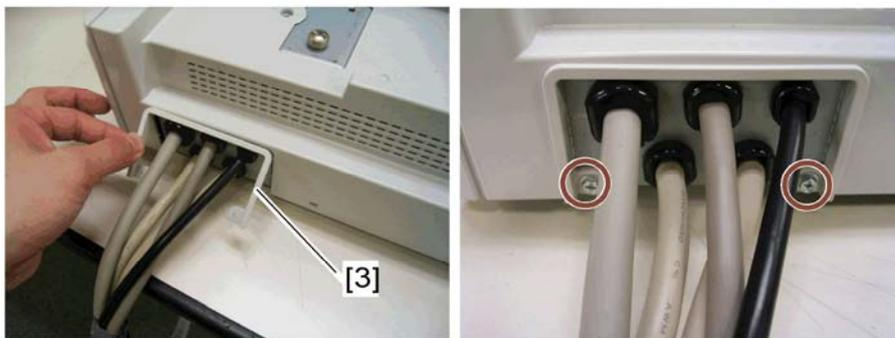

4. Reinstall the scanner left cover (⚙️ x 2).

Harness Bracket Attachment Procedure

5. Install the core [4] (RFC-9) to the operation panel I/F cable, ring core [5] (TFCM-41-27-16) to the bound cables and the cores [6] (RFC-13) to the other cables.

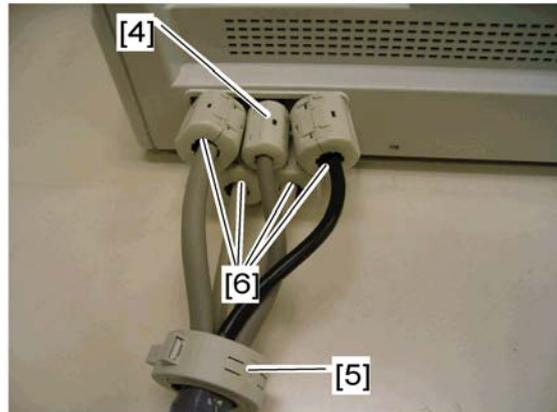

6. Install the ARDF [7] or platen cover on the scanner unit (stud screw x 2).

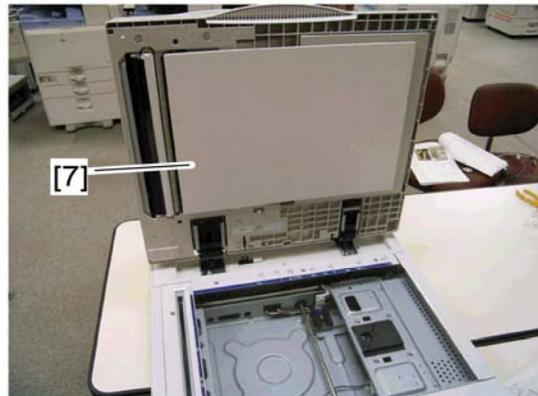

7. Connect the ARDF I/F cable [8] to the connector of the scanner unit.
8. Install the right and left stoppers [9] to the ARDF hinges (screw x 2 each; screw-tapping M3x16).

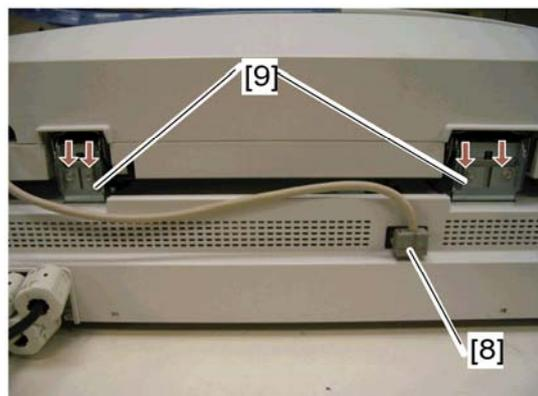

1.7 CONNECTING PROCEDURE FOR MAINFRAME

1. Controller box stay [1] (⚙ x 4)
2. Open the IOB bracket [2] (⚙ x 5, flat cable x 1, 𐄂 x 1).

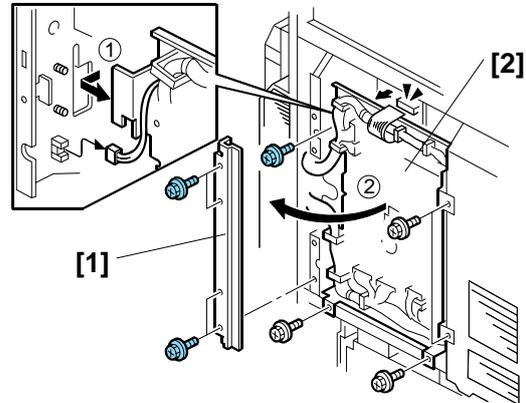

3. Install the core [3] (TFC16816) in the harness of CN510 (on the IPU) and the core [4] (RFC-8) in the harness of CN540 (on the MB).
4. Close the IOB bracket [2] (⚙ x 5, flat cable x 1, 𐄂 x 1).
5. Reinstall the controller box stay [1] (⚙ x 4).

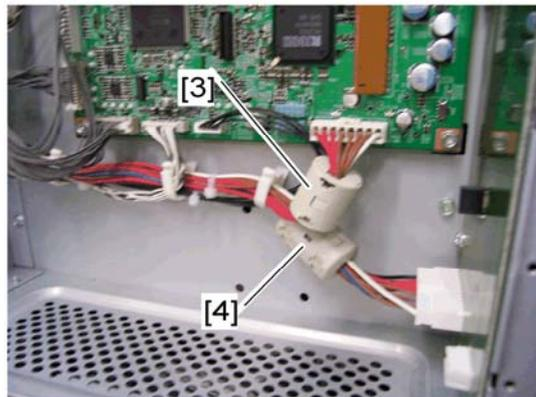

6. Install the core [5] (RFC-5) in the brown and red harnesses of CN201 (on the IOB).

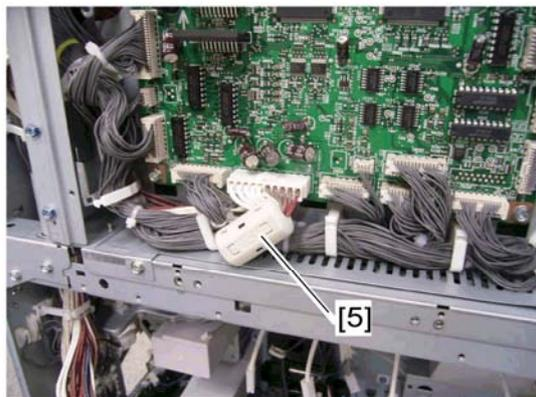

Connecting Procedure for Mainframe

7. Install the core [6] (RFC-13) in the power supply cables on the IH inverter.

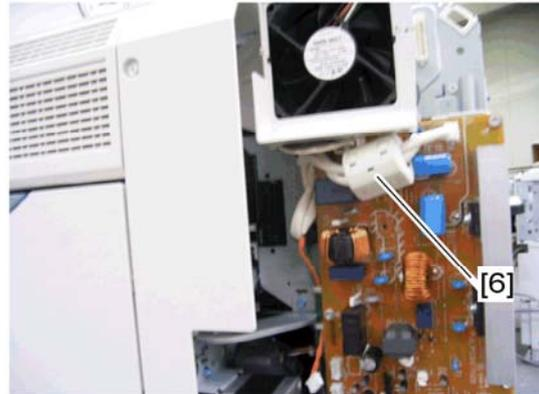

8. Install the cable bracket [7] in the rear frame of the mainframe (⌀ x 3; screw-tapping M3x6).

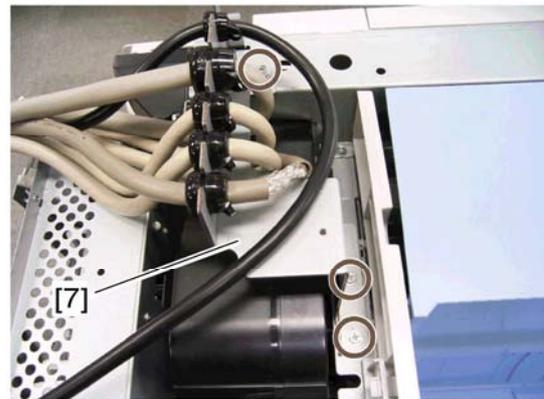

9. Route and connect the heater relay cable [8] to the heater cable [9] of the mainframe.

10. Secure the ground cable of the heater relay cable [10] (⌀ x 1; screw-round M4x8).

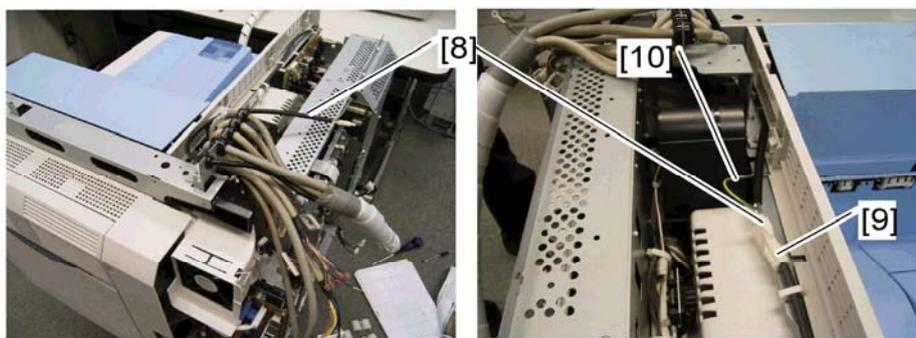

Connecting Procedure for Mainframe

11. Connect three connectors [11] to the outside of the controller box.
12. Secure the two ground cables [12] (⚙ x 1; screw-tapping M3x6).

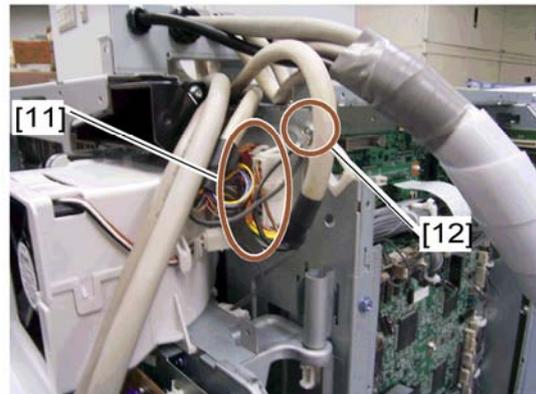

13. Route the scanner I/F cable [13] and connect it to CN509 (on the IPU) (⚙ x 1).
14. Secure the scanner I/F cable with the clamp [14] (⚙ x 1; M3x6 tapping screw) and the ground cable [15] (⚙ x 1; M3x6 tapping screw).
15. Remove the clamp [16].

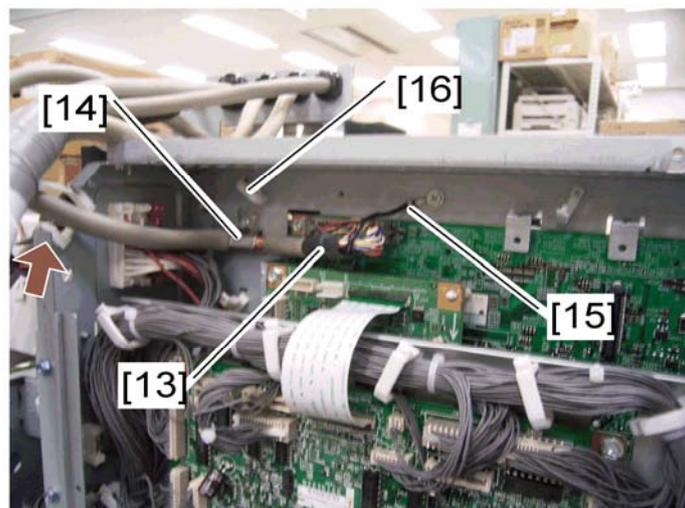

Scanner
Accessibility
Option
B838

16. Install the MB interface board [17] (x 1; screw-tapping M3x6).

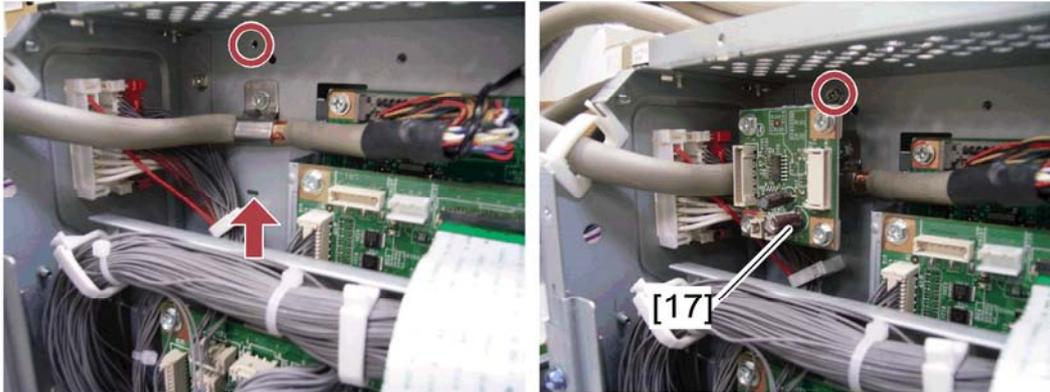

17. Install the core [18] (RFC-8) in between binds on the long relay harness [19].

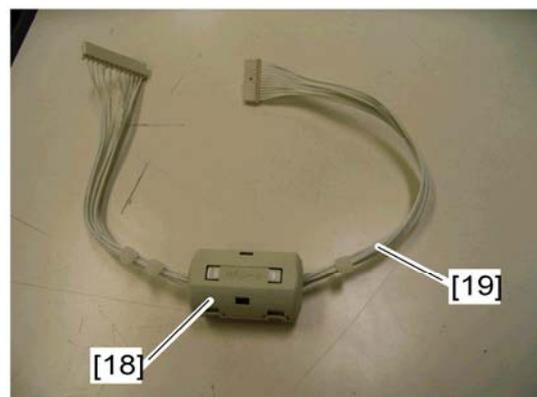

18. Route the long relay harness [20] with the connector, which has two binds, connecting to the MB and the connector, which has one bind, connecting to the MB interface board and clamp it between two binds (x 1).

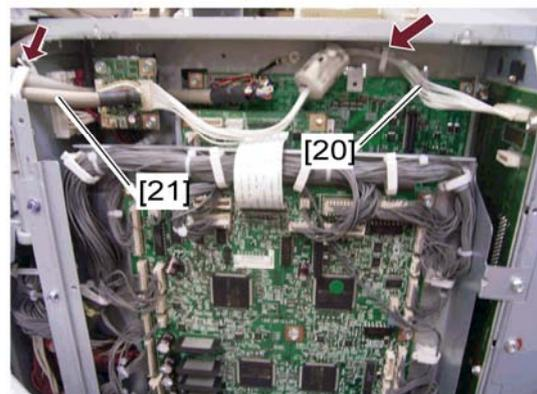

19. Connect the harness [20] to CN536 on the MB and other terminal to the CN1 on the MB interface board.
20. Connect the operation panel I/F cable [21] to the CN2, CN5 and CN6 on the MB interface board and clamp it (x 1).

Connecting Procedure for Mainframe

21. Reinstall the controller box right cover (🔩 x 8).
22. Install the left scanner stay [22] (🔩 x 2; M4x6 tapping screw) in the left side of the main machine.
23. Reinstall the left cover (🔩 x 6).
24. Reinstall the left rear cover (🔩 x 1).
25. Reinstall the right rear cover (🔩 x 4).
26. Close the right door.
27. Reinstall the right top cover (🔩 x 1).

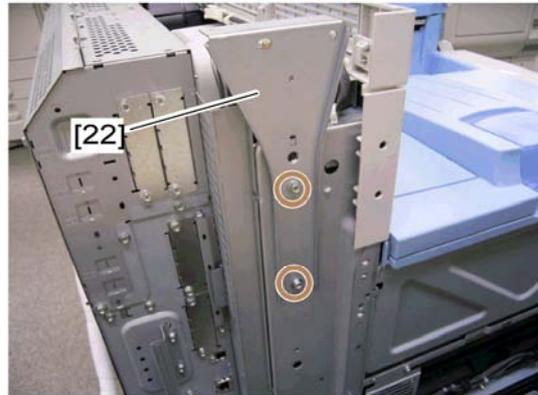

IMPORTANT: If you install the key counter, first refer to the "Installation for Key Counter".

28. Install the top rear cover [23] (🔩 x 2; screw-tapping M3x8).

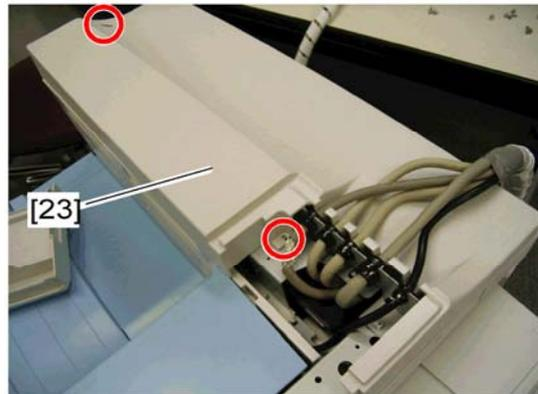

29. Install the top right cover [24] (🔩 x 3; screw-tapping M3x8).

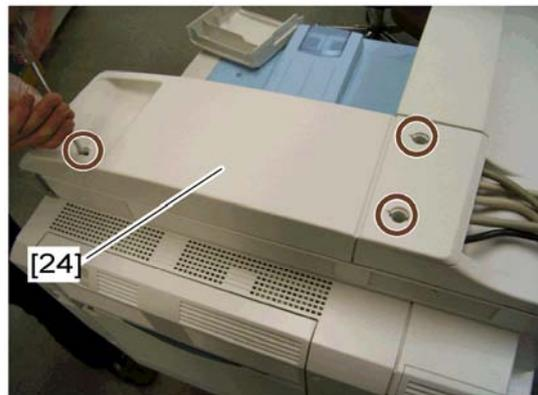

Connecting Procedure for Mainframe

30. Attach the three caps [25] to the screw holes on the top right cover.

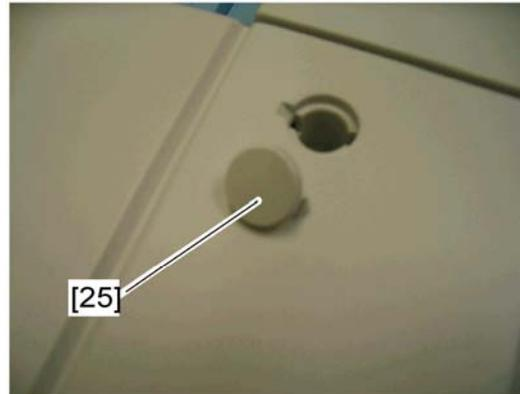

31. Install the ring core [26] (TFCM-41-27-16) to the bound cables and the cores [27] (RFC-13) to the other cables.

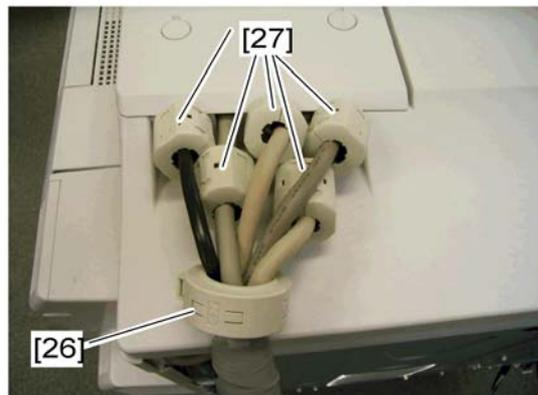

32. Install the cable cover [28] in the top rear cover.
33. Follow the "INSTALLATION REQUIREMENTS" to place the scanner accessibility unit for safety.
34. After installation, adjust the scanner image (☛ "Image Adjustment" > "Scanning" in the chapter "Replacement and Adjustment" of the Model B222/B224 SERVICE MANUAL)

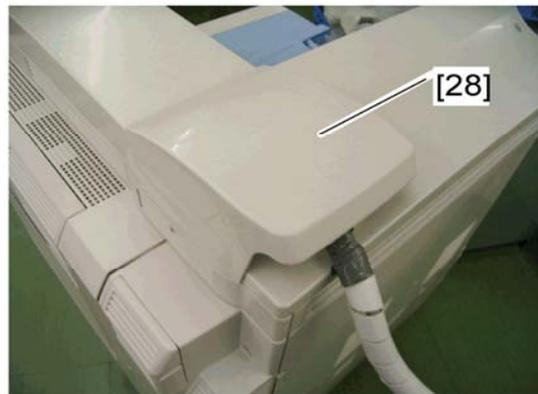

1.8 INSTALLATION FOR KEY COUNTER

1. Cut off and remove the parts [1] with a cutter.
2. Attach the key counter front bracket [2] and rear bracket [3] to the reverse side of the top right cover (⚙️ x 4; screw 2-tapping M3x8).

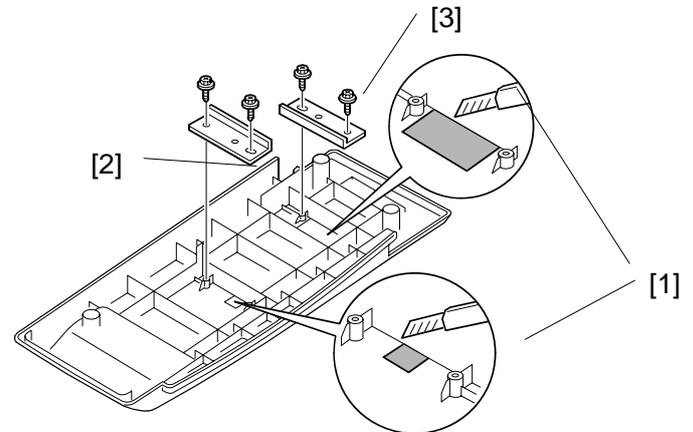

3. Put the key counter harness [4] into the machine.
4. Connect the key counter harness to the connector [5] of the right side of the controller box.

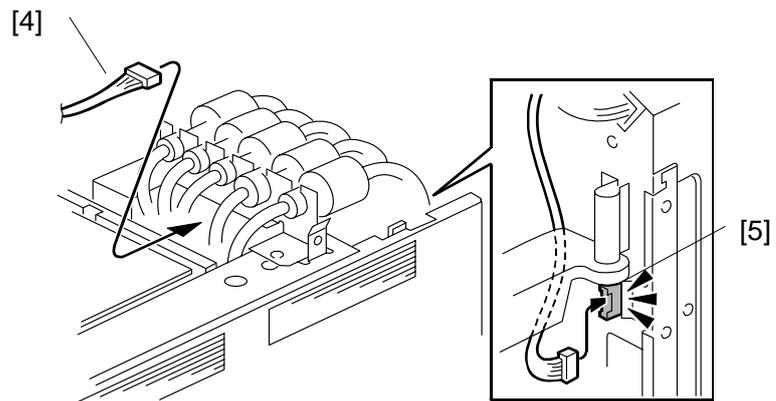

Scanner
Accessibility
Option
B838

5. Install the top rear cover (➡️ step 28 in "Connecting Procedure for Mainframe")

Installation for Key Counter

- 6. Put the key counter harness [6] through the cut out [7].
- 7. Install the top right cover in the machine and attach the caps to the screw holes (☛ steps 29 and 30 in "Connecting Procedure for Mainframe").
- 8. Install the shoulder screw [8].
- 9. Install the key counter [9] (⚙ x 1; screw-tapping M4x16, 📏 x 1).

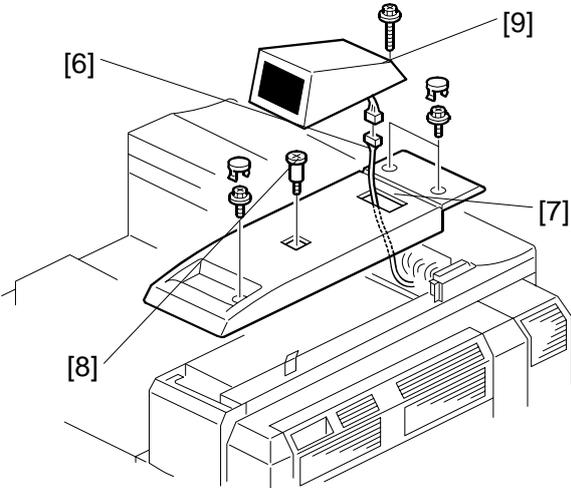

For details about installing the Key Counter, ☛ "Service Manual for B222/B224".

FAX OPTION TYPE 5000 D346

REVISION HISTORY		
Page	Date	Added/Updated/New
33	10/08/2009	Error Code 31-21 added.
145	01/30/2009	Updated Information – Service RAM Addresses

FAX OPTION TYPE 5000 (D346)

TABLE OF CONTENTS

1. INSTALLATION PROCEDURE	1
1.1 FAX OPTION INSTALLATION	1
1.1.1 COMPONENT CHECK	1
1.1.2 FAX OPTION INSTALLATION PROCEDURE	2
1.2 G3 INTERFACE BOARD INSTALLATION	5
1.2.1 COMPONENT CHECK	5
1.2.2 INSTALLATION: ONE G3 BOARD	6
1.2.3 INSTALLATION: TWO G3 BOARDS	7
1.3 FAX UNIT OPTIONS.....	9
1.3.1 MEMORY UNIT (G578)	9
1.3.2 HANDSET (B433)	9
2. REPLACEMENT AND ADJUSTMENT	12
2.1 FCU.....	12
3. TROUBLESHOOTING	13
3.1 ERROR CODES	13
3.2 IFAX TROUBLESHOOTING	34
3.3 IP-FAX TROUBLESHOOTING	37
3.3.1 IP-FAX TRANSMISSION	37
3.3.2 IP-FAX RECEPTION	40
4. SERVICE TABLE	44
4.1 BEFOREHAND	44
4.2 SERVICE TABLES.....	45
4.2.1 SP1-XXX (BIT SWITCHES)	45
4.2.2 SP2-XXX (RAM DATA)	46
4.2.3 SP3-XXX (TEL LINE SETTINGS)	47
4.2.4 SP4-XXX (ROM VERSIONS).....	49
4.2.5 SP5-XXX (INITIALIZING).....	50
4.2.6 SP6-XXX (REPORTS)	50
4.2.7 SP7-XXX (TEST MODES)	53
4.2.8 SP9-XXX (DESIGN SWITCH MODE).....	55

4.3 BIT SWITCHES.....	56
4.3.1 SYSTEM SWITCHES	57
4.3.2 I-FAX SWITCHES	69
4.3.3 PRINTER SWITCHES	76
4.3.4 COMMUNICATION SWITCHES	82
4.3.5 G3 SWITCHES	91
4.3.6 G3-2/3 SWITCHES	100
4.3.7 IP FAX SWITCHES.....	108
4.4 NCU PARAMETERS.....	117
4.5 DEDICATED TRANSMISSION PARAMETERS.....	133
4.5.1 PROGRAMMING PROCEDURE	133
4.5.2 PARAMETERS	133
4.6 SERVICE RAM ADDRESSES	141
5. DETAILS	151
5.1 OVERVIEW.....	151
5.2 BOARDS	152
5.2.1 FCU	152
5.2.2 MBU	153
5.2.3 SG3 BOARD	154
5.3 VIDEO DATA PATH.....	156
5.3.1 TRANSMISSION.....	156
5.3.2 RECEPTION	158
5.4 FAX COMMUNICATION FEATURES	159
5.4.1 MULTI-PORT	159
5.4.2 DOCUMENT SERVER.....	159
5.4.3 INTERNET MAIL COMMUNICATION.....	160
5.5 IP-FAX	170
5.5.1 WHAT IS IP-FAX?	170
6. SPECIFICATIONS.....	171
6.1 GENERAL SPECIFICATIONS	171
6.1.1 FCU	171
6.1.2 CAPABILITIES OF PROGRAMMABLE ITEMS	172
6.2 IFAX SPECIFICATIONS	174
6.3 IP-FAX SPECIFICATIONS.....	176
6.4 FAX UNIT CONFIGURATION.....	177

Read This First

Important Safety Notices

WARNING

- Never install telephone wiring during a lightning storm.
- Never install telephone jacks in wet locations unless the jack is specifically designed for wet locations.
- Never touch uninsulated telephone wires or terminals unless the telephone line has been disconnected at the network interface.
- Use caution when installing or modifying telephone lines.
- Avoid using a telephone (other than a cordless type) during an electrical storm. There may be a remote risk of electric shock from lightning.
- Do not use a telephone or cellular phone to report a gas leak in the vicinity of the leak.

CAUTION

- Before installing the fax unit, switch off the main switch, and disconnect the power cord.
- The fax unit contains a lithium battery. The danger of explosion exists if a battery of this type is incorrectly replaced. Replace only with the same or an equivalent type recommended by the manufacturer. Discard batteries in accordance with the manufacturer's instructions and local regulations.

Note

- **Note for Australia:**
- Unit must be connected to Telecommunication Network through a line cord which meets the requirements of ACA Technical Standard TS008.

Symbols and Abbreviations

Conventions Used in this Manual

This manual uses several symbols.

Symbol	What it means
	Refer to section number
	Screw
	Connector
	E-ring
	Clip ring
	Clamp

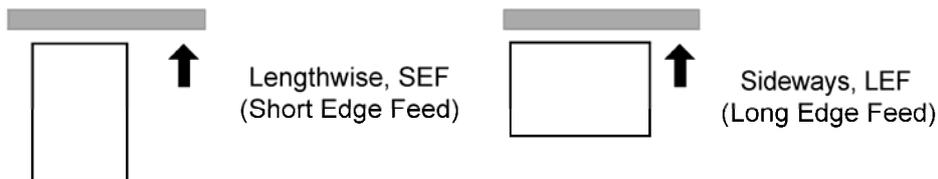

Cautions, Notes, etc.

The following headings provide special information:

WARNING

- Failure to obey warning information could result in serious injury or death.

CAUTION

- Obey these guidelines to ensure safe operation and prevent minor injuries.

Important

- Obey these guidelines to avoid problems such as misfeeds, damage to originals, loss of valuable data and to prevent damage to the machine.
- Always obey these guidelines to avoid serious problems such as misfeeds, damage to originals, loss of valuable data and to prevent damage to the machine. **bold** is added for emphasis.

Note

- This document provides tips and advice about how to best service the machine.

1. INSTALLATION PROCEDURE

1.1 FAX OPTION INSTALLATION

1.1.1 COMPONENT CHECK

Check the quantity and condition of the components against the following list.

No.	Description	Q'ty
1	FCU	1
2	Screw: M3x6	3
3	Handset Support Bracket (NA only)	1
4	Handset Bracket (NA only)	1
5	Telephone Cable (NA only)	1
6	Data Display Decal Sheet (20 languages)	2
7	FCC Decal (NA only)	1
8	Serial Number Decal	1
9	G3 Decal	1
10	Fax Keytop	2
11	Ferrite Core (EU only)	1

Fax Option Installation

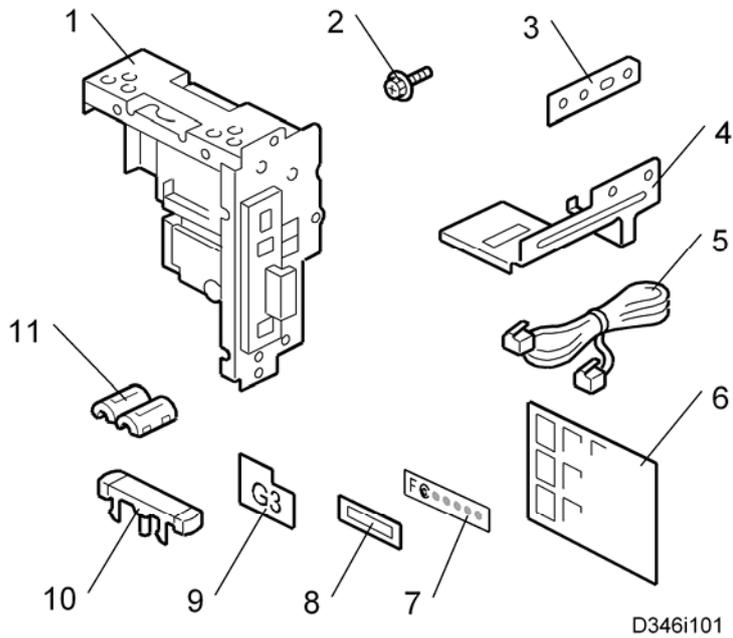

1.1.2 FAX OPTION INSTALLATION PROCEDURE

⚠ CAUTION

- Before installation:
- If there is a printer option in the machine, print out all data in the printer buffer.
- Push the operation switch to put the machine in standby mode. Make sure the power LED is off, turn the main switch off, and then disconnect the power cord and the network cable.
- The copier must be connected to a properly grounded socket outlet.

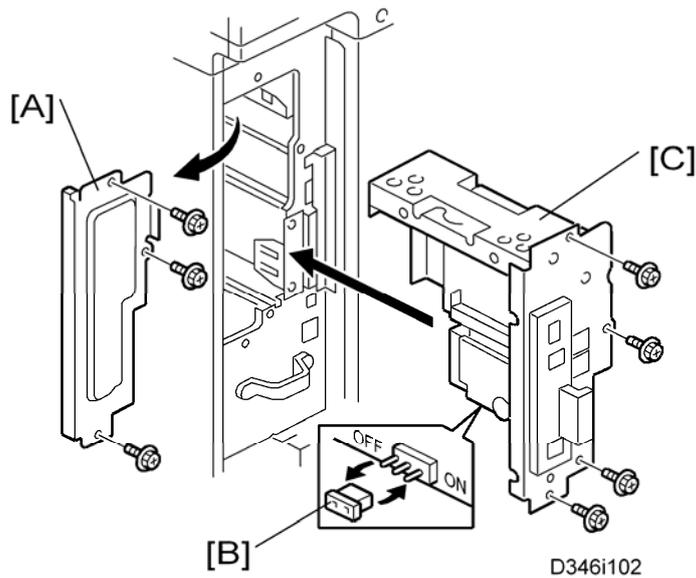

1. Attach the serial number decal near the serial number plate of the mainframe.
2. **For NA models**, attach the FCC decal near the serial number plate of the mainframe.
3. Remove the FCU cover [A] (⌀ x 3).
4. Press down the **MBU**.

↓ Note

- Make sure that the **MBU** is seated correctly. If not, SC672 occurs.

5. Remove the jumper [B] (set to OFF) and set it to ON.

↓ Note

- The machine may issue SC819, SC820 if the jumper is not set to "ON" correctly. (Sometimes these SC codes are not issued.)

6. Install the **FCU** [C] (⌀ x 4; use the three screws which were removed in step 3).

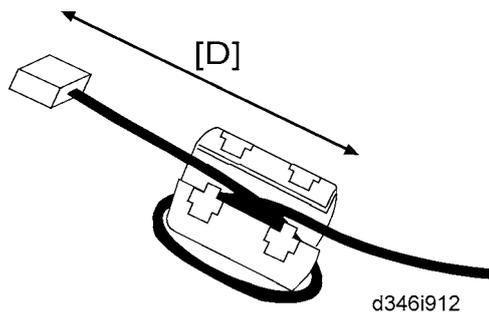

7. **For EU models**, attach the ferrite core to the telephone cord. The end of the ferrite core must be about 5 cm (2.1") [D] from the end of the cable.

Fax Option Installation

8. Connect the telephone cord to the "LINE 1" jack.

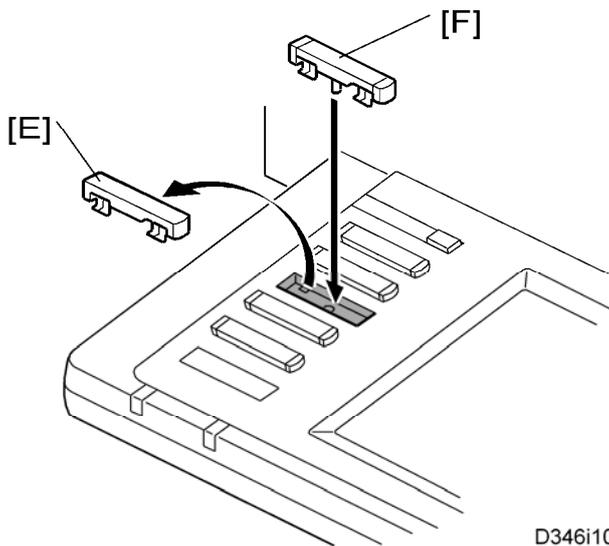

9. Remove dummy keytop [E] and replace it with the Fax keytop [F].

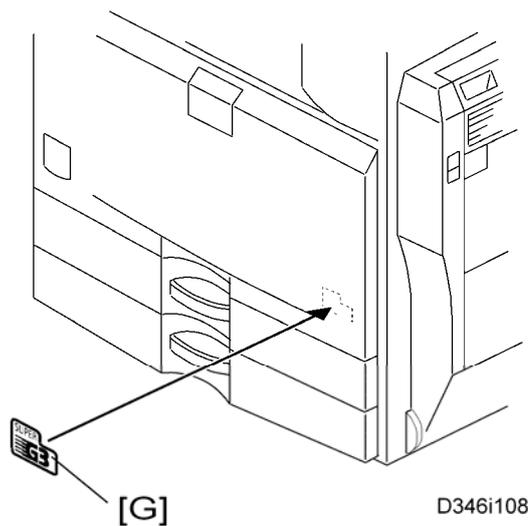

10. Attach the Super G3 decal [G].
11. Plug in the machine and turn on the main power switch.

★ Important

- After you turn the machine on, if you see a message that tells you the SRAM has been formatted due to a problem with SRAM, turn the machine off and on again to clear the message.
12. Enter the "User Tools" mode and set date and time.
 13. Do SP3102 in the fax SP mode and enter the serial number for the fax unit.

1.2 G3 INTERFACE BOARD INSTALLATION

1.2.1 COMPONENT CHECK

Check the quantity and condition of the components against the following list.

No.	Description	Q'ty
1	SG3 Interface Unit	1
2	Flat Cable	1
3	Screw: M3x6	3
4	Telephone Cable (NA only)	1
5	FCC Decal (NA only)	1

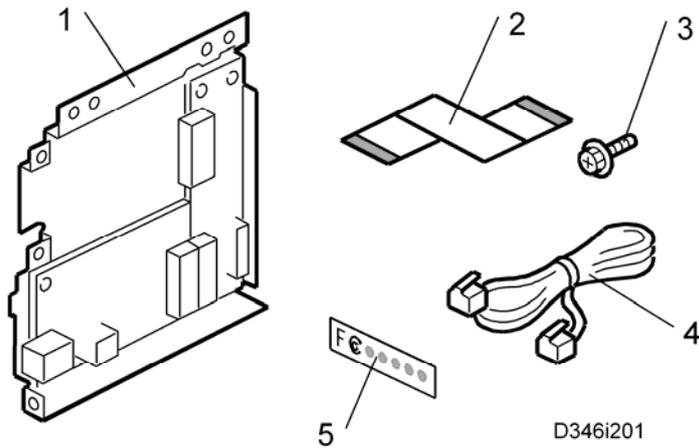

1.2.2 INSTALLATION: ONE G3 BOARD

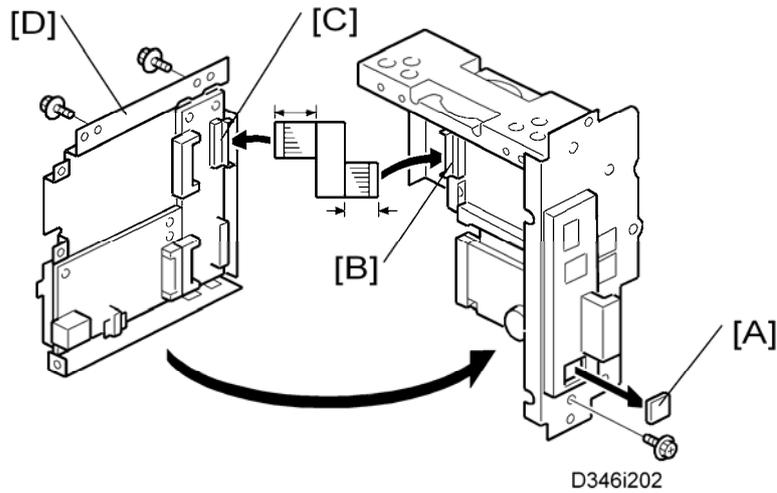

1. Remove the knockout (LINE 2) [A] with nippers from the FCU.
2. Attach one end (short length) of the flat cable to the connector [B] of the FCU board.
3. Attach the other end (long length) of the flat cable to the connector [C] of the CCUIF.
4. Attach the SG3 interface unit [D] (3 x).
5. Install the FCU in the machine (for details, refer to the installation procedure of the Fax Option Type 5000).
6. Connect the telephone cord to the LINE 2 jack.
7. Enter the service mode. Set bit 1 of communication switch 16 to "1" (SP1-104-023) for PSTN-2.
8. Turn the main switch off and on.
9. Print out the system parameter list. Then check that "G3" shows as an option.
10. Set up and program the items required for PSTN-2 communications.
11. Attach the FCC decal near the serial number plate of the mainframe.

1.2.3 INSTALLATION: TWO G3 BOARDS

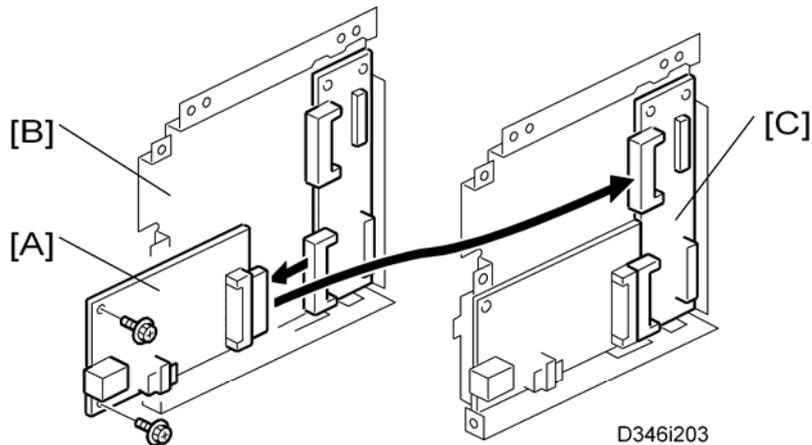

1. Remove the SG3 board [A] from the second SG3 interface unit [B] for the two-SG3 board installation (⚙ x 2).
2. Attach the SG3 board [A] to the interface board [C] of the first SG3 interface unit (⚙ x 2).

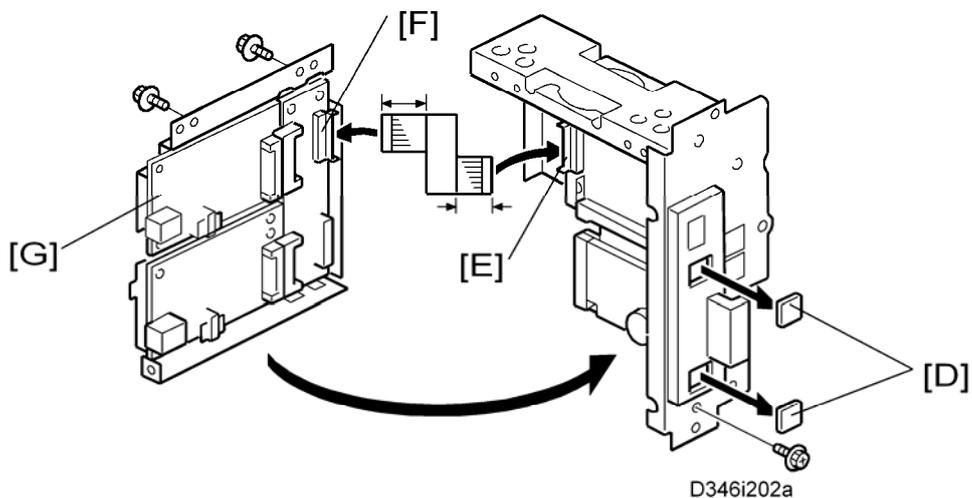

3. Remove the two knockouts [D].
4. Attach one end (short length) of the flat cable to the connector [E] of the FCU board.
5. Attach the other end (long length) of the flat cable to the connector [F] of the CCUIF.
6. Attach the SG3 interface unit [G] (⚙ x 3).
7. Install the FCU in the machine (for details, refer to the installation procedure of the Fax Option Type 5000).
8. Connect the telephone cord to the LINE 3 jack.
9. Enter the service mode. Set bit 3 of communication switch 16 to "1" (SP1-104-023) for PSTN-3.

G3 Interface Board Installation

10. Turn the main switch off and on.
11. Print out the system parameter list. Then check that "G3" shows as an option.
12. Set up and program the items required for PSTN-3 communications.
13. Attach the FCC decal near the serial number plate of the mainframe.

1.3 FAX UNIT OPTIONS

1.3.1 MEMORY UNIT (G578)

1. FCU (☛ "Installation Procedure" in the "Fax Unit (D346)")

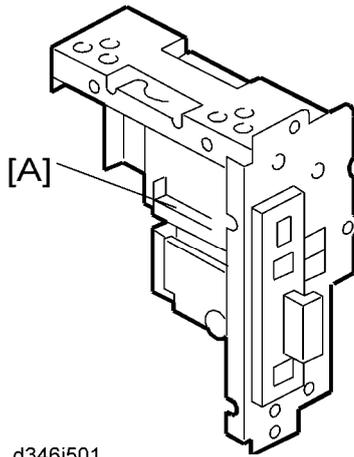

d346i501

2. Install the memory option in the memory slot [A].
3. Reassemble the machine.

1.3.2 HANDSET (B433)

↓ Note

- The optional handset is available for the U.S. version only.

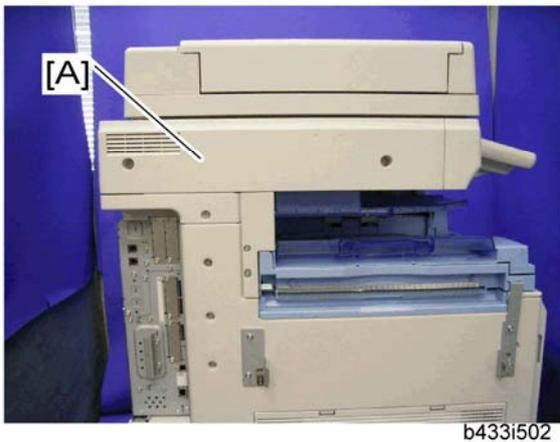

b433i502

1. Remove the scanner left cover [A] (☛ x 2).

Fax Unit Options

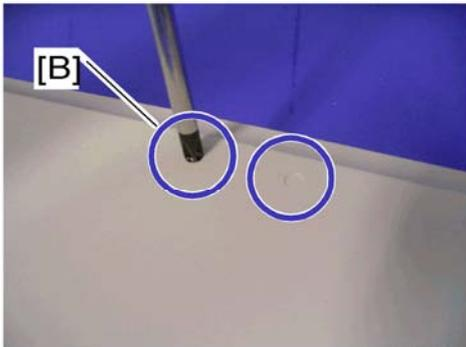

b433i503

2. Make two holes [B] in the scanner left cover.



- Drill a hole from the outside of the cover with a screwdriver.

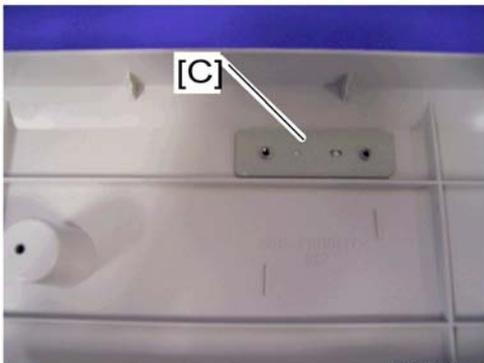

b433i504

3. Attach the handset support bracket [C] inside the scanner left cover.

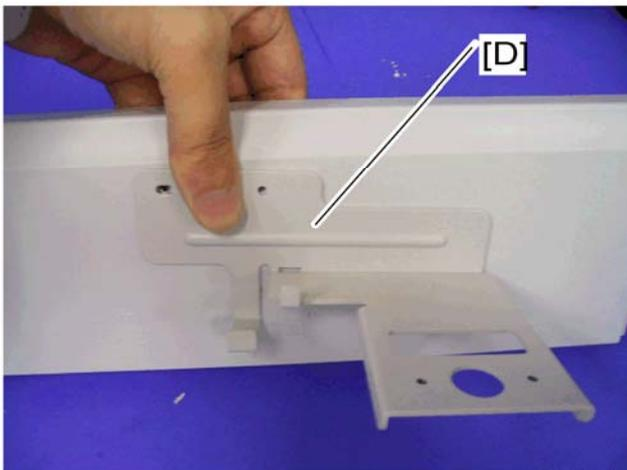

b433i505

4. Hold the handset bracket [D] and handset support bracket (set inside the scanner left cover).
5. Secure the handset bracket [D] (⌀ x 2).

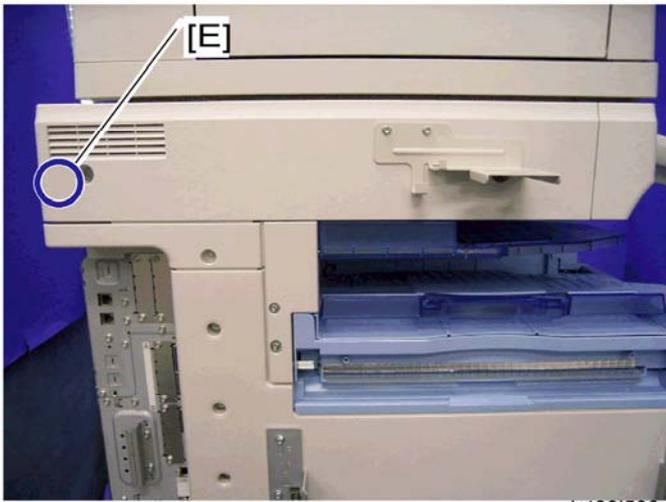

6. Install the scanner left cover on the machine.
7. Attach the clamp to the location [E].
8. Set the handset on the handset bracket.
9. Clamp the hand set cord.
10. Connect the handset cable to the "TEL" jack at the rear of the machine.

2. REPLACEMENT AND ADJUSTMENT

2.1 FCU

1. When you replace the FCU board, remove the MBU board from the old FCU board and install it on the new FCU board.
2. Set the correct date and time with the User Tools: User Tools > System Settings > Timer Setting > Set Date/Time.

 Note

- Do not turn off the battery switch (SW1).
- Do SP6101 in the Fax SP to print the system parameters, and check the settings.

3. TROUBLESHOOTING

3.1 ERROR CODES

If an error code occurs, retry the communication. If the same problem occurs, try to fix the problem as suggested below. Note that some error codes appear only in the error code display and on the service report.

Code	Meaning	Suggested Cause/Action
0-00	DIS/NSF not detected within 40 s of Start being pressed	<ul style="list-style-type: none"> ▪ Check the line connection. ▪ The machine at the other end may be incompatible. ▪ Replace the FCU. ▪ Check for DIS/NSF with an oscilloscope. ▪ If the rx signal is weak, there may be a bad line.
0-01	DCN received unexpectedly	<ul style="list-style-type: none"> ▪ The other party is out of paper or has a jammed printer. ▪ The other party pressed Stop during communication.
0-03	Incompatible modem at the other end	The other terminal is incompatible.
0-04	CFR or FTT not received after modem training	<ul style="list-style-type: none"> ▪ Check the line connection. ▪ Try changing the tx level and/or cable equalizer settings. ▪ Replace the FCU. ▪ The other terminal may be faulty; try sending to another machine. ▪ If the rx signal is weak or defective, there may be a bad line. <p>Cross reference Tx level - NCU Parameter 01 (PSTN)</p>

Error Codes

Code	Meaning	Suggested Cause/Action
		Cable equalizer - G3 Switch 07 (PSTN) Dedicated Tx parameters in Service Program Mode
0-05	Modem training fails even G3 shifts down to 2400 bps.	<ul style="list-style-type: none"> ▪ Check the line connection. ▪ Try adjusting the tx level and/or cable equalizer. ▪ Replace the FCU. ▪ Check for line problems. <p>Cross reference See error code 0-04.</p>
0-06	The other terminal did not reply to DCS	<ul style="list-style-type: none"> ▪ Check the line connection. ▪ Try adjusting the tx level and/or cable equalizer settings. ▪ Replace the FCU. ▪ The other end may be defective or incompatible; try sending to another machine. ▪ Check for line problems. <p>Cross reference See error code 0-04.</p>
0-07	No post-message response from the other end after a page was sent	<ul style="list-style-type: none"> ▪ Check the line connection. ▪ Replace the FCU. ▪ The other end may have jammed or run out of paper. ▪ The other end user may have disconnected the call. ▪ Check for a bad line. ▪ The other end may be defective; try sending to another machine.
0-08	The other end sent RTN or PIN after receiving a page, because there were too many errors	<ul style="list-style-type: none"> ▪ Check the line connection. ▪ Replace the FCU. ▪ The other end may have jammed, or run out of paper or memory space.

Code	Meaning	Suggested Cause/Action
		<ul style="list-style-type: none"> ▪ Try adjusting the tx level and/or cable equalizer settings. ▪ The other end may have a defective modem/FCU; try sending to another machine. ▪ Check for line problems and noise. <p>Cross reference</p> <ul style="list-style-type: none"> ▪ Tx level - NCU Parameter 01 (PSTN) ▪ Cable equalizer - G3 Switch 07 (PSTN) ▪ Dedicated Tx parameters in Service Program Mode
0-14	Non-standard post message response code received	<ul style="list-style-type: none"> ▪ Incompatible or defective remote terminal; try sending to another machine. ▪ Noisy line: resend. ▪ Try adjusting the tx level and/or cable equalizer settings. ▪ Replace the FCU. <p>Cross reference See error code 0-08.</p>
0-15	The other terminal is not capable of specific functions.	<p>The other terminal is not capable of accepting the following functions, or the other terminal's memory is full.</p> <ul style="list-style-type: none"> ▪ Confidential rx ▪ Transfer function ▪ SEP/SUB/PWD/SID
0-16	CFR or FTT not detected after modem training in confidential or transfer mode	<ul style="list-style-type: none"> ▪ Check the line connection. ▪ Replace the FCU. ▪ Try adjusting the tx level and/or cable equalizer settings. ▪ The other end may have disconnected, or it may be defective; try calling another machine. ▪ If the rx signal level is too low, there may be a

Error Codes

Code	Meaning	Suggested Cause/Action
		<p>line problem.</p> <p>Cross reference See error code 0-08.</p>
0-20	Facsimile data not received within 6 s of retraining	<ul style="list-style-type: none"> ▪ Check the line connection. ▪ Replace the FCU. ▪ Check for line problems. ▪ Try calling another fax machine. ▪ Try adjusting the reconstruction time for the first line and/or rx cable equalizer setting. <p>Cross reference Reconstruction time - G3 Switch 0A, bit 6 Rx cable equalizer - G3 Switch 07 (PSTN)</p>
0-21	EOL signal (end-of-line) from the other end not received within 5 s of the previous EOL signal	<ul style="list-style-type: none"> ▪ Check the connections between the FCU and line. ▪ Check for line noise or other line problems. ▪ Replace the FCU. ▪ The remote machine may be defective or may have disconnected. <p>Cross reference Maximum interval between EOLs and between ECM frames - G3 Bit Switch 0A, bit 4</p>
0-22	The signal from the other end was interrupted for more than the acceptable modem carrier drop time (default: 200 ms)	<ul style="list-style-type: none"> ▪ Check the line connection. ▪ Replace the FCU. ▪ Defective remote terminal. ▪ Check for line noise or other line problems. ▪ Try adjusting the acceptable modem carrier drop time. <p>Cross reference Acceptable modem carrier drop time - G3 Switch 0A, bits 0 and 1</p>
0-23	Too many errors during reception	<ul style="list-style-type: none"> ▪ Check the line connection. ▪ Replace the FCU.

Code	Meaning	Suggested Cause/Action
		<ul style="list-style-type: none"> ▪ Defective remote terminal. ▪ Check for line noise or other line problems. ▪ Try asking the other end to adjust their tx level. ▪ Try adjusting the rx cable equalizer setting and/or rx error criteria. <p>Cross reference Rx cable equalizer - G3 Switch 07 (PSTN) Rx error criteria - Communication Switch 02, bits 0 and 1</p>
0-30	The other terminal did not reply to NSS(A) in AI short protocol mode	<ul style="list-style-type: none"> ▪ Check the line connection. ▪ Try adjusting the tx level and/or cable equalizer settings. ▪ The other terminal may not be compatible. <p>Cross reference Dedicated tx parameters - Section 4</p>
0-32	The other terminal sent a DCS, which contained functions that the receiving machine cannot handle.	<ul style="list-style-type: none"> ▪ Check the protocol dump list. ▪ Ask the other party to contact the manufacturer.
0-33	The data reception (not ECM) is not completed within 10 minutes.	<ul style="list-style-type: none"> ▪ Check the line connection. ▪ The other terminal may have a defective modem/FCU.
0-52	Polarity changed during communication	<ul style="list-style-type: none"> ▪ Check the line connection. <p>Retry communication.</p>
0-55	FCU does not detect the SG3.	<ul style="list-style-type: none"> ▪ FCU firmware or board defective. ▪ SG3 firmware or board defective.
0-56	The stored message data exceeds the capacity of the mailbox in the SG3.	<ul style="list-style-type: none"> ▪ SG3 firmware or board defective.
0-70	The communication mode	<ul style="list-style-type: none"> ▪ The other terminal did not have a compatible

Error Codes

Code	Meaning	Suggested Cause/Action
	specified in CM/JM was not available (V.8 calling and called terminal)	communication mode (e.g., the other terminal was a V.34 data modem and not a fax modem.) <ul style="list-style-type: none"> A polling tx file was not ready at the other terminal when polling rx was initiated from the calling terminal.
0-74	The calling terminal fell back to T.30 mode, because it could not detect ANSam after sending CI.	<ul style="list-style-type: none"> The calling terminal could not detect ANSam due to noise, etc. ANSam was too short to detect. Check the line connection and condition. Try making a call to another V.8/V.34 fax.
0-75	The called terminal fell back to T.30 mode, because it could not detect a CM in response to ANSam (ANSam timeout).	<ul style="list-style-type: none"> The terminal could not detect ANSam. Check the line connection and condition. Try receiving a call from another V.8/V.34 fax.
0-76	The calling terminal fell back to T.30 mode, because it could not detect a JM in response to CM (CM timeout).	<ul style="list-style-type: none"> The called terminal could not detect a CM due to noise, etc. Check the line connection and condition. Try making a call to another V.8/V.34 fax.
0-77	The called terminal fell back to T.30 mode, because it could not detect a CJ in response to JM (JM timeout).	<ul style="list-style-type: none"> The calling terminal could not detect a JM due to noise, etc. A network that has narrow bandwidth cannot pass JM to the other end. Check the line connection and condition. Try receiving a call from another V.8/V.34 fax.
0-79	The called terminal detected CI while waiting for a V.21 signal.	<ul style="list-style-type: none"> Check for line noise or other line problems. If this error occurs, the called terminal falls back to T.30 mode.
0-80	The line was disconnected	<ul style="list-style-type: none"> The guard timer expired while starting

Code	Meaning	Suggested Cause/Action
	due to a timeout in V.34 phase 2 – line probing.	<p>these phases. Serious noise, narrow bandwidth, or low signal level can cause these errors.</p> <p>If these errors happen at the transmitting terminal:</p> <ul style="list-style-type: none"> ▪ Try making a call at a later time. ▪ Try using V.17 or a slower modem using dedicated tx parameters. ▪ Try increasing the tx level. ▪ Try adjusting the tx cable equalizer setting. <p>If these errors happen at the receiving terminal:</p> <ul style="list-style-type: none"> ▪ Try adjusting the rx cable equalizer setting. ▪ Try increasing the tx level. ▪ Try using V.17 or a slower modem if the same error is frequent when receiving from multiple senders.
0-81	The line was disconnected due to a timeout in V.34 phase 3 – equalizer training.	
0-82	The line was disconnected due to a timeout in the V.34 phase 4 – control channel start-up.	
0-83	The line was disconnected due to a timeout in the V.34 control channel restart sequence.	
0-84	The line was disconnected due to abnormal signaling in V.34 phase 4 – control channel start-up.	<ul style="list-style-type: none"> ▪ The signal did not stop within 10 s. ▪ Turn off the machine, then turn it back on. ▪ If the same error is frequent, replace the FCU.
0-85	The line was disconnected due to abnormal signaling in V.34 control channel restart.	<ul style="list-style-type: none"> ▪ The signal did not stop within 10 s. ▪ Turn off the machine, then turn it back on. ▪ If the same error is frequent, replace the FCU.
0-86	The line was disconnected because the other terminal requested a data rate using MPh that was not available in the currently selected symbol rate.	<ul style="list-style-type: none"> ▪ The other terminal was incompatible. ▪ Ask the other party to contact the manufacturer.
0-87	The control channel started	<ul style="list-style-type: none"> ▪ The receiving terminal restarted the control

Error Codes

Code	Meaning	Suggested Cause/Action
	after an unsuccessful primary channel.	<p>channel because data reception in the primary channel was not successful.</p> <ul style="list-style-type: none"> This does not result in an error communication.
0-88	The line was disconnected because PPR was transmitted/received 9 (default) times within the same ECM frame.	<ul style="list-style-type: none"> Try using a lower data rate at the start. Try adjusting the cable equalizer setting.
2-11	Only one V.21 connection flag was received	<ul style="list-style-type: none"> Replace the FCU.
2-12	Modem clock irregularity	<ul style="list-style-type: none"> Replace the FCU.
2-13	Modem initialization error	<ul style="list-style-type: none"> Turn off the machine, then turn it back on. Update the modem ROM. Replace the FCU.
2-23	JBIG compression or reconstruction error	<ul style="list-style-type: none"> Turn off the machine, then turn it back on.
2-24	JBIG ASIC error	<ul style="list-style-type: none"> Turn off the machine, then turn it back on.
2-25	JBIG data reconstruction error (BIH error)	<ul style="list-style-type: none"> JBIG data error Check the sender's JBIG function. Update the MBU ROM.
2-26	JBIG data reconstruction error (Float marker error)	
2-27	JBIG data reconstruction error (End marker error)	
2-28	JBIG data reconstruction error (Timeout)	
2-29	JBIG trailing edge maker error	<ul style="list-style-type: none"> FCU defective Check the destination device.

Code	Meaning	Suggested Cause/Action
2-50	The machine resets itself for a fatal FCU system error	<ul style="list-style-type: none"> If this is frequent, update the ROM, or replace the FCU.
2-51	The machine resets itself because of a fatal communication error	<ul style="list-style-type: none"> If this is frequent, update the ROM, or replace the FCU.
2-53	Snd msg() in the manual task is an error because the mailbox for the operation task is full.	<ul style="list-style-type: none"> The user did the same operation many times, and this gave too much load to the machine.
4-01	Line current was cut	<ul style="list-style-type: none"> Check the line connector. Check for line problems. Replace the FCU.
4-10	Communication failed because of an ID Code mismatch (Closed Network) or Tel. No./CSI mismatch (Protection against Wrong Connections)	<ul style="list-style-type: none"> Get the ID Codes the same and/or the CSIs programmed correctly, then resend. The machine at the other end may be defective.
5-10	DCR timer expired	<ul style="list-style-type: none"> Replace the FCU.
5-20	Storage impossible because of a lack of memory	<ul style="list-style-type: none"> Temporary memory shortage. Test the SAF memory.
5-21	Memory overflow	
5-23	Print data error when printing a substitute rx or confidential rx message	<ul style="list-style-type: none"> Test the SAF memory. Ask the other end to resend the message.
5-25	SAF file access error	<ul style="list-style-type: none"> Replace an SD card or HDD.

Error Codes

Code	Meaning	Suggested Cause/Action
		<ul style="list-style-type: none"> Replace the FCU.
6-00	G3 ECM - T1 time out during reception of facsimile data	<ul style="list-style-type: none"> Try adjusting the rx cable equalizer. Replace the FCU.
6-01	G3 ECM - no V.21 signal was received	
6-02	G3 ECM - EOR was received	
6-04	G3 ECM - RTC not detected	<ul style="list-style-type: none"> Check the line connection. Check for a bad line or defective remote terminal. Replace the FCU.
6-05	G3 ECM - facsimile data frame not received within 18 s of CFR, but there was no line fail	<ul style="list-style-type: none"> Check the line connection. Check for a bad line or defective remote terminal. Replace the FCU. Try adjusting the rx cable equalizer <p>Cross reference</p> <ul style="list-style-type: none"> Rx cable equalizer - G3 Switch 07 (PSTN)
6-06	G3 ECM - coding/decoding error	<ul style="list-style-type: none"> Defective FCU. The other terminal may be defective.
6-08	G3 ECM - PIP/PIN received in reply to PPS.NULL	<ul style="list-style-type: none"> The other end pressed Stop during communication. The other terminal may be defective.
6-09	G3 ECM - ERR received	<ul style="list-style-type: none"> Check for a noisy line. Adjust the tx levels of the communicating machines. See code 6-05.
6-10	G3 ECM - error frames still	<ul style="list-style-type: none"> Check for line noise.

Code	Meaning	Suggested Cause/Action
	received at the other end after all communication attempts at 2400 bps	<ul style="list-style-type: none"> ▪ Adjust the tx level (use NCU parameter 01 or the dedicated tx parameter for that address). ▪ Check the line connection. ▪ Defective remote terminal.
6-21	V.21 flag detected during high speed modem communication	<ul style="list-style-type: none"> ▪ The other terminal may be defective or incompatible.
6-22	The machine resets the sequence because of an abnormal handshake in the V.34 control channel	<ul style="list-style-type: none"> ▪ Check for line noise. ▪ If the same error occurs frequently, replace the FCU. ▪ Defective remote terminal.
6-99	V.21 signal not stopped within 6 s	<ul style="list-style-type: none"> ▪ Replace the FCU.
13-17	SIP user name registration error	<ul style="list-style-type: none"> ▪ Double registration of the SIP user name. ▪ Capacity for user-name registration in the SIP server is not sufficient.
13-18	SIP server access error	<ul style="list-style-type: none"> ▪ Incorrect initial setting for the SIP server. ▪ Defective SIP server.
13-24	SIP Authentication error	<ul style="list-style-type: none"> ▪ Registered password in the device does not match the password in the SIP server.
13-25	Network I/F setting error	<ul style="list-style-type: none"> ▪ IPV4 is not active in the active protocol setting. ▪ IP address of a device is not registered.
13-26	Network I/F setting error at power on	<ul style="list-style-type: none"> ▪ Active protocol setting does not match the I/F setting for SIP server. ▪ IP address of a device is not registered.
13-27	IP address setting error	<ul style="list-style-type: none"> ▪ IP address of a device is not registered.
14-00	SMTP Send Error	<ul style="list-style-type: none"> ▪ Error occurred during sending to the SMTP server. Occurs for any error other than 14-01 to 16. For example, the mail address of the

Error Codes

Code	Meaning	Suggested Cause/Action
		system administrator is not registered.
14-01	SMTP Connection Failed	<ul style="list-style-type: none"> ▪ Failed to connect to the SMTP server (timeout) because the server could not be found. ▪ The PC is not ready to transfer files. ▪ SMTP server not functioning correctly. ▪ The DNS IP address is not registered. ▪ Network not operating correctly. ▪ Destination folder selection not correct.
14-02	No Service by SMTP Service (421)	<ul style="list-style-type: none"> ▪ SMTP server operating incorrectly, or the destination for direct SMTP sending is not correct. ▪ Contact the system administrator and check that the SMTP server has the correct settings and operates correctly. ▪ Contact the system administrator for direct SMTP sending and check the sending destination.
14-03	Access to SMTP Server Denied (450)	<ul style="list-style-type: none"> ▪ Failed to access the SMTP server because the access is denied. ▪ SMTP server operating incorrectly. Contact the system administrator to determine if there is a problem with the SMTP server and to check that the SMTP server settings are correct. ▪ Folder send destination is incorrect. Contact the system administrator to determine that the SMTP server settings and path to the server are correct. ▪ Device settings incorrect. Confirm that the user name and password settings are correct. ▪ Direct SMTP destination incorrect. Contact the system administrator to determine if there is a

Code	Meaning	Suggested Cause/Action
		<p>problem at the destination at that the settings at the destination are correct.</p>
14-04	Access to SMTP Server Denied (550)	<ul style="list-style-type: none"> ▪ SMTP server operating incorrectly ▪ Direct SMTP sending not operating correctly
14-05	SMTP Server HDD Full (452)	<ul style="list-style-type: none"> ▪ Failed to access the SMTP server because the HDD on the server is full. ▪ Insufficient free space on the HDD of the SMTP server. Contact the system administrator and check the amount of space remaining on the SMTP server HDD. ▪ Insufficient free space on the HDD where the destination folder is located. Contact the system administrator and check the amount of space remaining on the HDD where the target folder is located. ▪ Insufficient free space on the HDD at the target destination for SMTP direct sending. Contact the system administrator and check the amount of space remaining on the target HDD.
14-06	User Not Found on SMTP Server (551)	<ul style="list-style-type: none"> ▪ The designated user does not exist. ▪ The designated user does not exist on the SMTP server. ▪ The designated address is not for use with direct SMTP sending.
14-07	Data Send to SMTP Server Failed (4XX)	<ul style="list-style-type: none"> ▪ Failed to access the SMTP server because the transmission failed. ▪ PC not operating correctly. ▪ SMTP server operating incorrectly ▪ Network not operating correctly. ▪ Destination folder setting incorrect. ▪ Direct SMTP sending not operating correctly.

Error Codes

Code	Meaning	Suggested Cause/Action
14-08	Data Send to SMTP Server Failed (5XX)	<ul style="list-style-type: none"> ▪ Failed to access the SMTP server because the transmission failed. ▪ SMTP server operating incorrectly ▪ Destination folder setting incorrect. ▪ Direct SMTP sending not operating correctly. ▪ Software application error.
14-09	Authorization Failed for Sending to SMTP Server	<ul style="list-style-type: none"> ▪ POP-Before-SMTP or SMTP authorization failed. ▪ Incorrect setting for file transfer
14-10	Addresses Exceeded	<ul style="list-style-type: none"> ▪ Number of broadcast addresses exceeded the limit for the SMTP server.
14-11	Buffer Full	<ul style="list-style-type: none"> ▪ The send buffer is full so the transmission could not be completed. Buffer is full due to using Scan-to-Email while the buffer is being used send mail at the same time.
14-12	Data Size Too Large	<ul style="list-style-type: none"> ▪ Transmission was cancelled because the detected size of the file was too large.
14-13	Send Cancelled	<ul style="list-style-type: none"> ▪ Processing is interrupted because the user pressed Stop.
14-14	Security Locked File Error	<ul style="list-style-type: none"> ▪ Update the software because of the defective software.
14-15	Mail Data Error	<ul style="list-style-type: none"> ▪ The transmitting a mail is interrupted via DCS due to the incorrect data. ▪ Update the software because of the defective software.
14-16	Maximum Division Number Error	<ul style="list-style-type: none"> ▪ When a mail is divided for the mail transmission and the division number of a mail are more than the specified number, the mail transmission is interrupted. ▪ Update the software because of the defective

Code	Meaning	Suggested Cause/Action
		software.
14-17	Incorrect Ticket	<ul style="list-style-type: none"> Update the software because of the defective software.
14-18	Access to MCS File Error	<ul style="list-style-type: none"> The access to MCS file is denied due to the no permission of access. Update the software because of the defective software.
⇒ 14-21	SMIME Sending Error	<ul style="list-style-type: none"> Make sure the user certificate or device certificate is registered correctly.
14-30	MCS File Creation Failed	<p>Failed to create the MCS file because:</p> <ul style="list-style-type: none"> The number of files created with other applications on the Document Server has exceeded the limit. HDD is full or not operating correctly. Software error.
14-31	UFS File Creation Failed	<p>UFS file could not be created:</p> <ul style="list-style-type: none"> Not enough space in UFS area to handle both Scan-to-Email and IFAX transmission. HDD full or not operating correctly. Software error.
14-32	Cancelled the Mail Due to Error Detected by NFAX	<ul style="list-style-type: none"> Error detected with NFAX and send was cancelled due to a software error.
14-33	No Mail Address For the Machine	<ul style="list-style-type: none"> Neither the mail address of the machine nor the mail address of the network administrator is registered.
14-34	Address designated in the domain for SMTP sending does not exist	<ul style="list-style-type: none"> Operational error in normal mail sending or direct SMTP sending. Check the address selected in the address book for SMTP sending. Check the domain selection.

			board
2	A	NVRAM read/write error	<ul style="list-style-type: none"> Replace the NVRAM
30	A	NVRAM error	<ul style="list-style-type: none"> Turn the machine power off/on If the error reoccurs, replace the controller board
31	A		<ul style="list-style-type: none"> See SC991

859	B	HDD data encryption error	
		Encryption of data on the hard disk failed.	
8	B	HDD check error	<ul style="list-style-type: none"> Format the HDD
6	B	Power loss during encryption	<ul style="list-style-type: none"> Format the HDD
10	B	Data read/write error	<ul style="list-style-type: none"> See SC863 below

860	B	HDD error 1	
		The hard disk connection is not detected because it is defective or has not been formatted	<ul style="list-style-type: none"> Cable between HDC and HDD loose or defective HDD power connector loose or defective HDD not formatted HDD defective Replace the controller board

861	B	HDD error 2	
		The HDD did not enter the ready status within 30 sec. after power on.	<ul style="list-style-type: none"> Cable between HDC and HDD loose or defective HDD power connector loose or defective HDD defective Replace the controller board

Code	Meaning	Suggested Cause/Action
		<p>server is not stored in the machine.</p> <ul style="list-style-type: none"> ▪ The DNS IP address is not registered. ▪ Network not operating correctly.
15-12	Authorization Error	<p>POP3/IMAP4 send authorization failed:</p> <ul style="list-style-type: none"> ▪ Incorrect IFAX user name or password. ▪ Access was attempted by another device, such as the PC. ▪ POP3/IMAP4 settings incorrect.
15-13	Receive Buffer Full	<ul style="list-style-type: none"> ▪ Occurs only during manual reception. Transmission cannot be received due to insufficient buffer space. The buffer is being used for mail send or Scan-to-Email.
15-14	Mail Header Format Error	<ul style="list-style-type: none"> ▪ The mail header is not standard format. For example, the Date line description is incorrect.
15-15	Mail Divide Error	<ul style="list-style-type: none"> ▪ The e-mail is not in standard format. There is no boundary between parts of the e-mail, including the header.
15-16	Mail Size Receive Error	<ul style="list-style-type: none"> ▪ The mail cannot be received because it is too large.
15-17	Receive Timeout	<ul style="list-style-type: none"> ▪ May occur during manual receiving only because the network is not operating correctly.
15-18	Incomplete Mail Received	<ul style="list-style-type: none"> ▪ Only one portion of the mail was received.
15-31	Final Destination for Transfer Request Reception Format Error	<ul style="list-style-type: none"> ▪ The format of the final destination for the transfer request was incorrect.
15-39	Send/Delivery Destination Error	<p>The transmission cannot be delivered to the final destination:</p> <ul style="list-style-type: none"> ▪ Destination file format is incorrect. ▪ Could not create the destination for the file

Code	Meaning	Suggested Cause/Action
		transmission.
15-41	SMTP Receive Error	<ul style="list-style-type: none"> Reception rejected because the transaction exceeded the limit for the "Auth. E-mail RX" setting.
15-42	Off Ramp Gateway Error	<ul style="list-style-type: none"> The delivery destination address was specified with Off Ramp Gateway OFF.
15-43	Address Format Error	<ul style="list-style-type: none"> Format error in the address of the Off Ramp Gateway.
15-44	Addresses Over	<ul style="list-style-type: none"> The number of addresses for the Off Ramp Gateway exceeded the limit of 30.
15-61	Attachment File Format Error	<ul style="list-style-type: none"> The attached file is not TIFF format.
15-62	TIFF File Compatibility Error	<p>Could not receive transmission due to:</p> <ul style="list-style-type: none"> Resolution error Image of resolution greater than 200 dpi without extended memory. Resolution is not supported. Page size error The page size was larger than A3. Compression error File was compressed with other than MH, MR, or MMR.
15-63	TIFF Parameter Error	<p>The TIFF file sent as the attachment could not be received because the TIFF header is incorrect:</p> <ul style="list-style-type: none"> The TIFF file attachment is a type not supported. The TIFF file attachment is corrupted. Software error.
15-64	TIFF Decompression Error	<p>The file received as an attachment caused the TIFF decompression error:</p>

Code	Meaning	Suggested Cause/Action
		<ul style="list-style-type: none"> ▪ The TIFF format of the attachment is corrupted. ▪ Software error.
15-71	Not Binary Image Data	<ul style="list-style-type: none"> ▪ The file could not be received because the attachment was not binary image data.
15-73	MDN Status Error	<ul style="list-style-type: none"> ▪ Could not find the Disposition line in the header of the Return Receipt, or there is a problem with the firmware.
15-74	MDN Message ID Error	<ul style="list-style-type: none"> ▪ Could not find the Original Message ID line in the header of the Return Receipt, or there is a problem with the firmware.
15-80	Mail Job Task Read Error	<ul style="list-style-type: none"> ▪ Could not receive the transmission because the destination buffer is full and the destination could not be created (this error may occur when receiving a transfer request or a request for notification of reception).
15-81	Repeated Destination Registration Error	<ul style="list-style-type: none"> ▪ Could not repeat receive the transmission because the destination buffer is full and the destination could not be created (this error may occur when receiving a transfer request or a request for notification of reception).
15-91	Send Registration Error	<p>Could not receive the file for transfer to the final destination:</p> <ul style="list-style-type: none"> ▪ The format of the final destination or the transfer destination is incorrect. ▪ Destinations are full so the final and transfer destinations could not be created.
15-92	Memory Overflow	<ul style="list-style-type: none"> ▪ Transmission could not be received because memory overflowed during the transaction.
15-93	Memory Access Error	<ul style="list-style-type: none"> ▪ Transaction could not complete due to a

Code	Meaning	Suggested Cause/Action
		malfunction of SAF memory.
15-94	Incorrect ID Code	<ul style="list-style-type: none"> ▪ The machine rejected an incoming e-mail for transfer request, because the ID code in the incoming e-mail did not match the ID code registered in the machine.
15-95	Transfer Station Function	<ul style="list-style-type: none"> ▪ The machine rejected an incoming e-mail for transfer because the transfer function was unavailable.
22-00	Original length exceeded the maximum scan length	<ul style="list-style-type: none"> ▪ Divide the original into more than one page. ▪ Check the resolution used for scanning. Lower the scan resolution if possible. ▪ Add optional page memory.
22-01	Memory overflow while receiving	<ul style="list-style-type: none"> ▪ Wait for the files in the queue to be sent. ▪ Delete unnecessary files from memory. ▪ Transfer the substitute reception files to an another fax machine, if the machine's printer is busy or out of order. ▪ Add an optional SAF memory card or hard disk.
22-02	Tx or rx job stalled due to line disconnection at the other end	<ul style="list-style-type: none"> ▪ The job started normally but did not finish normally; data may or may not have been received fully. ▪ Restart the machine.
22-04	The machine cannot store received data in the SAF	<ul style="list-style-type: none"> ▪ Update the ROM ▪ Replace the FCU.
22-05	No G3 parameter confirmation answer	<ul style="list-style-type: none"> ▪ Defective FCU board or firmware.
23-00	Data read timeout during construction	<ul style="list-style-type: none"> ▪ Restart the machine. ▪ Replace the FCU.



Code	Meaning	Suggested Cause/Action
25-00	The machine software resets itself after a fatal transmission error occurred	<ul style="list-style-type: none"> ▪ Update the ROM ▪ Replace the FCU.
31-21	LAN Fax Error	<ul style="list-style-type: none"> • It was cancelled received LAN Fax images during store the image to SAF of FCU. • The LAN Fax transmission of a message was cancelled by the LAN Fax driver.
F0-xx	V.34 modem error	<ul style="list-style-type: none"> ▪ Replace the FCU.
F6-xx	SG3 modem error	<ul style="list-style-type: none"> ▪ Update the SG3 modem ROM. ▪ Replace the SG3 board. ▪ Check for line noise or other line problems. ▪ Try communicating another V.8/V.34 fax.

3.2 IFAX TROUBLESHOOTING

Use the following procedures to determine whether the machine or another part of the network is causing the problem.

Communication Route	Item	Action [Remarks]
General LAN	1. Connection with the LAN	<ul style="list-style-type: none"> ▪ Check that the LAN cable is connected to the machine. ▪ Check that the LEDs on the hub are lit.
	2. LAN activity	Check that other devices connected to the LAN can communicate through the LAN.
Between IFAX and PC	1. Network settings on the PC	<ul style="list-style-type: none"> ▪ Check the network settings on the PC. [Is the IP address registered in the TCP/IP properties in the network setup correct? Check the IP address with the administrator of the network.]
	2. Check that PC can connect with the machine	<ul style="list-style-type: none"> ▪ Use the “ping” command on the PC to contact the machine. [At the MS-DOS prompt, type ping then the IP address of the machine, then press Enter.]
	3. LAN settings in the machine	<ul style="list-style-type: none"> ▪ Check the LAN parameters ▪ Check if there is an IP address conflict with other PCs. [Use the “Network” function in the User Tools. If there is an IP address conflict, inform the administrator.]
Between machine and e-mail server	1. LAN settings in the machine	<ul style="list-style-type: none"> ▪ Check the LAN parameters ▪ Check if there is an IP address conflict with other PCs. [Use the “Network” function in the User Tools. If there is an IP address conflict, inform the administrator.]

Communication Route	Item	Action [Remarks]
	2. E-mail account on the server	<ul style="list-style-type: none"> ▪ Make sure that the machine can log into the e-mail server. ▪ Check that the account and password stored in the server are the same as in the machine. [Ask the administrator to check.]
	3. E-mail server	<ul style="list-style-type: none"> ▪ Make sure that the client devices which have an account in the server can send/receive e-mail. [Ask the administrator to check. Send a test e-mail with the machine's own number as the destination. The machine receives the returned e-mail if the communication is performed successfully.]
Between e-mail server and internet	1. E-mail account on the Server	<ul style="list-style-type: none"> ▪ Make sure that the PC can log into the e-mail server. ▪ Check that the account and password stored in the server are the same as in the machine. [Ask the administrator to check.]
	2. E-mail server	<ul style="list-style-type: none"> ▪ Make sure that the client devices which have an account in the server can send/receive e-mail. [Ask the administrator to check. Send a test e-mail with the machine's own number as the destination. The machine receives the returned e-mail if the communication is performed successfully.]

IFAX Troubleshooting

	3. Destination e-mail address	<ul style="list-style-type: none"> ▪ Make sure that the e-mail address is actually used. ▪ Check that the e-mail address contains no incorrect characters such as spaces.
	4. Router settings	<ul style="list-style-type: none"> ▪ Use the “ping” command to contact the router. ▪ Check that other devices connected to the router can send data over the router. [Ask the administrator of the server to check.]
	5. Error message by e-mail from the network of the destination.	<ul style="list-style-type: none"> ▪ Check whether e-mail can be sent to another address on the same network, using the application e-mail software. ▪ Check the error e-mail message. [Inform the administrator of the LAN.]

3.3 IP-FAX TROUBLESHOOTING

3.3.1 IP-FAX TRANSMISSION

Cannot send by IP Address/Host Name

Check Point		Action
1	LAN cable connected?	Check the LAN cable connection.
2	Specified IP address/host name correct?	Check the IP address/host name.
3	Firewall/NAT is installed?	Cannot breach the firewall. Send by using another method (Fax, Internet Fax)
4	Transmission sent manually?	Manual sending not supported.
5	IP address of local machine registered?	Register the IP address.
6	Remote terminal port number setting other than 1720?	Send by specifying the port number.
7	Specified port number correct?	Confirm the port number of the remote fax.
8	DNS server registered when host name specified?	Contact the network administrator.
9	Remote fax a T.38 terminal?	Check whether the remote fax is a T38 terminal.
10	Remote fax switched off or busy?	Check that the remote fax is switched on.
11	Network bandwidth too narrow?	Request the network administrator to increase the bandwidth.
		Raise the delay level. IPFAX SW 01 Bit 0 to 3

IP-Fax Troubleshooting

		IP-Fax bandwidth is the same as the DCS speed. Set IP-Fax SW00 Bit 6 to 1.
12	Remote fax cancelled transmission?	Check whether the remote fax cancelled the transmission.

Cannot send via VoIP Gateway

Check Point		Action
1	LAN cable connected?	Check the LAN cable connection.
2	VoIP Gateway T.38 standard?	Contact the network administrator.
3	VoIP Gateway installed correctly?	Contact the network administrator.
4	VoIP Gateway power switched on?	Contact the network administrator.
5	Is the IP address/host name of the specified Gateway correct?	Check the IP address/host name.
6	Number of the specified fax correct?	Check the remote fax number.
7	Firewall/NAT is installed?	Cannot breach the firewall. Send by using another method (Fax, Internet Fax)
8	Transmission sent manually?	Manual sending not supported.
9	IP address of local fax registered?	Register the IP address.
10	DNS registered when host name specified?	Contact the network administrator.
11	Remote fax a G3 fax?	Check that the remote fax is a G3 fax.
12	G3 fax is connected to VoIP gateway?	Check that G3 fax is connected.
13	Remote G3 fax turned on?	Check that G3 fax is switched on.

14	Network bandwidth too narrow?	Request the network administrator to increase the bandwidth.
		Raise the network delay level. IPFAX SW 01 Bit 0 to 3
		IP-Fax bandwidth is the same as the DCS speed. Set IP-Fax SW00 Bit 6 to 1.

Cannot send by Alias Fax number.

Check Point		Action
1	LAN cable connected?	Check the LAN cable connection.
2	Number of specified Alias fax correct?	Confirm the Alias of the remote fax. Error Code: 13-14
3	Firewall/NAT installed?	Cannot breach the firewall. Send by using another method (Fax, Internet Fax)
4	Transmission sent manually?	Manual sending not supported.
5	Gatekeeper installed correctly?	Contact the network administrator.
6	Gatekeeper power switched on?	Contact the network administrator.
7	IP address/host name of Gatekeeper correct?	Check the IP address/host name.
8	DNS server registered when Gatekeeper host name specified?	Contact the network administrator.
9	Enable H.323 SW is set to on?	Check the settings. See User Parameter SW 34 Bit 0
10	IP address of local fax registered?	Register the IP address of the local fax.
11	Alias number of local fax registered?	Register the Alias number of the local

IP-Fax Troubleshooting

		fax.
12	Remote fax registered in Gatekeeper?	Contact the network administrator.
13	Remote fax a T.38 terminal?	Check whether the remote fax is a T38 terminal.
14	Remote fax switched off or busy?	Contact the network administrator.
15	Network bandwidth too narrow?	Request the system administrator to increase the bandwidth.
		Raise the delay level. IPFAX SW 01 Bit 0 to 3
		Lower the modem transmission baud rate. IPFAX SW 05
16	Remote fax cancelled transmission?	Check whether the remote fax cancelled the transmission.

3.3.2 IP-FAX RECEPTION

Cannot receive via IP Address/Host Name.

Check Point		Action
1	LAN cable connected?	Check the LAN cable connection.
2	Firewall/NAT is installed?	Cannot breach the firewall. Send by using another method (Fax, Internet Fax)
3	IP address of local fax registered?	Register the IP address.
4	Port number specified at remote sender fax (if required)?	Request the sender to specify the port number.
5	Specified port number correct (if required)?	Request the sender to check the port number.

6	DNS server registered when host name specified on sender side?	Contact the network administrator.  Note <ul style="list-style-type: none"> The sender machine displays this error code if the sender fax is a Ricoh model.
7	Network bandwidth too narrow?	Request the system administrator to increase the bandwidth.
		Lower the start modem reception baud rate on the receiving side. IPFAX SW06
8	Remote fax cancelled transmission?	Check whether the remote fax cancelled the transmission.

Cannot receive by VoIP Gateway.

Check Point		Action
1	LAN cable connected?	Check the LAN cable connection.
2	Firewall/NAT is installed?	Cannot breach the firewall. Request the remote fax to send by using another method (Fax, Internet Fax)
3	VoIP Gateway installed correctly?	Contact the network administrator.
4	VoIP Gateway power switched on?	Contact the network administrator.
5	IP address/host name of specified VoIP Gateway correct on sender's side?	Request the remote fax to check the IP address/host name.
6	DNS server registered when host name specified on sender side?	Contact the network administrator.
7	Network bandwidth too narrow?	Request the network administrator to increase the bandwidth.
8	G3 fax connected?	Check that G3 fax is connected.

IP-Fax Troubleshooting

9	G3 fax power switched on?	Check that G3 fax is switched on.
---	---------------------------	-----------------------------------

Cannot receive by Alias Fax number.

Check Point		Action
1	LAN cable connected?	Check the LAN cable connection.
2	Firewall/NAT is installed?	Cannot the breach firewall. Request the remote fax to send by using another method (Fax, Internet Fax)
3	Gatekeeper installed correctly?	Contact the network administrator.  Note <ul style="list-style-type: none"> The sender machine displays this error code when the sender fax is a Ricoh model.
4	Power to Gatekeeper switched on?	Contact the network administrator.  Note <ul style="list-style-type: none"> The sender machine displays this error code when the sender fax is a Ricoh model.
5	IP address/host name of Gatekeeper correct on the sender's side?	Request the sender to check the IP address/host name.  Note <ul style="list-style-type: none"> The sender machine displays this error code when the sender fax is a Ricoh model.
6	DNS server registered when Gatekeeper host name specified on sender's side?	Contact the network administrator.  Note <ul style="list-style-type: none"> The sender machine displays this error code when the sender fax is a Ricoh model.
7	Enable H.323 SW is set to on?	Request the sender to check the settings.

		<p>User Parameter SW 34 Bit 0</p> <p>↓ Note</p> <ul style="list-style-type: none"> Only if the remote sender fax is a Ricoh fax.
8	Local fax IP address registered?	Register the IP address.
9	Local fax Alias number registered?	Register the Alias number.
10	Network bandwidth too narrow?	Request the system administrator to increase the bandwidth.
		<p>Lower the start modem reception baud rate on the receiving side.</p> <p>IPFAX SW06</p>
11	Remote fax cancelled transmission?	Check whether the remote fax cancelled the transmission.
12	Local fax registered in Gatekeeper?	<p>Contact the network administrator.</p> <p>↓ Note</p> <ul style="list-style-type: none"> The sender machine displays this error code when the sender fax is a Ricoh model.

4. SERVICE TABLE

4.1 BEFOREHAND

CAUTION

- Never turn off the main power switch when the power LED is lit or flashing. To avoid damaging the hard disk or memory, press the operation power switch to switch the power off, wait for the power LED to go off, and then switch the main power switch off.

Note

- The main power LED () lights or flashes while the platen cover or ARDF is open, while the main machine is communicating with a facsimile or the network server, or while the machine is accessing the hard disk or memory for reading or writing data.

4.2 SERVICE TABLES

4.2.1 SP1-XXX (BIT SWITCHES)

☛ Bit Switches

1	Mode No.		Function
101	System Switch		
	001 – 032	00 – 1F	Change the bit switches for system settings for the fax option ☛ "Bit Switches"
102	Ifax Switch		
	001 – 016	00 – 0F	Change the bit switches for internet fax settings for the fax option ☛ "Bit Switches"
103	Printer Switch		
	001 – 016	00 – 0F	Change the bit switches for printer settings for the fax option ☛ "Bit Switches"
104	Communication Switch		
	001 – 032	00 – 1F	Change the bit switches for communication settings for the fax option ☛ "Bit Switches"
105	G3-1 Switch		
	001 – 016	00 – 0F	Change the bit switches for the protocol settings of the standard G3 board ☛ "Bit Switches"
106	G3-2 Switch		
	001 – 016	00 – 0F	Change the bit switches for the protocol settings of

Service Tables

			the optional G3 board ☛ "Bit Switches"
107	G3-3 Switch		
	001 – 016	00 – 0F	Change the bit switches for the protocol settings of the optional G3 board ☛ "Bit Switches"
108	G4 Internal Switch		
	001 – 032	00 – 1F	Not used (Do not change the bit switches)
109	G4 Parameter Switch		
	001 – 016	00 – 0F	Not used (Do not change the bit switches)
111	IP fax Switch		
	001 – 016	00 – 0F	Change the bit switches for optional IP fax parameters ☛ "Bit Switches"

4.2.2 SP2-XXX (RAM DATA)

2	Mode No.		Function
101	RAM Read/Write		
	001		Change RAM data for the fax board directly. ☛ "Service RAM Addresses"
102	Memory Dump		
	001	G3-1 Memory Dump	Print out RAM data for the fax board. ☛ "Service RAM Addresses"
	002	G3-2 Memory Dump	Print out RAM data for the optional SG3 board.
	003	G3-3 Memory	Print out RAM data for the optional SG3

		Dump	board.
	004	G4 Memory Dump	Not used
103	G3-1 NCU Parameters		
	001 – 023	CC, 01 – 22	NCU parameter settings for the standard G3 board. ➡ "NCU Parameters"
104	G3-2 NCU Parameters		
	001 – 023	CC, 01 – 22	NCU parameter settings for the optional G3 board. ➡ "NCU Parameters"
105	G3-3 NCU Parameters		
	001 – 023	CC, 01 – 22	NCU parameter settings for the optional G3 board. ➡ "NCU Parameters"

4.2.3 SP3-XXX (TEL LINE SETTINGS)

3	Mode No.	Function	
101	Service Station		
	001	Fax Number	Enter the fax number of the service station.
	002	Select Line	Select the line type.
102	Serial Number		
	000		Enter the fax unit's serial number.
103	PSTN-1 Port Settings		
	001	Select Line	Select the line type setting for the G3-1 line. If the machine is installed on a PABX line, select "PABX", "PABX(GND)" or "PABX(FLASH)".
	002	PSTN Access Number	Enter the PSTN access number for the G3-1 line.

Service Tables

	003	Memory Lock Disabled	Not used
104	PSTN-2 Port Settings		
	001	Select Line	Select the line setting for the G3-2 line. If the machine is installed on a PABX line, select "PABX", "PABX(GND)" or "PABX(FLASH)".
	002	PSTN Access Number	Enter the PSTN access number for the G3-2 line.
	003	Memory Lock Disabled	Not used
	004	Transmission Disabled	If you turn this SP on, the machine does not send any fax messages on the G3-2 line.
105	PSTN-3 Port Settings		
	001	Select Line	Select the line setting for the G3-3 line. If the machine is installed on a PABX line, select "PABX", "PABX(GND)" or "PABX(FLASH)".
	002	PSTN Access Number	Enter the PSTN access number for the G3-3 line.
	003	Memory Lock Disabled	Not used
	004	Transmission Disabled	If you turn this SP on, the machine does not send any fax messages on the G3-3 line.
106	ISDN Port Settings		
	001	Select Line	Not used (Do not change the settings.)
	002	PSTN Access Number	
	003	Memory Lock Disabled	

106	004	Transmission Disabled	
107	IPFAX Port Settings		
	001	H323 Port	Sets the H323 port number.
	002	SIP Port	Sets the SIP port number.
	003	RAS Port	Sets the RAS port number.
	004	Gatekeeper port	Sets the Gatekeeper port number.
	005	T.38 Port	Sets the T.38 port number.
	006	SIP Server Port	Sets the SIP port number.
	007	IPFAX Protocol Priority	Select "H323" or "SIP".
201	FAX SW		
	001 – 032	00 – 1F	

4.2.4 SP4-XXX (ROM VERSIONS)

4	Mode No.		Function
101	001	FCU ROM Version	Displays the FCU ROM version.
102	001	Error Codes	Displays the latest 64 fax error codes.
103	001	G3-1 ROM Version	Displays the G3-1 modem version.
104	001	G3-2 ROM Version	Displays the G3-2 modem version.
105	001	G3-3 ROM Version	Displays the G3-3 modem version.
106	001	G4 ROM Version	Not used (Do not change the settings.)
107	001	Charge ROM Version	Not used (Do not change the settings.)

4.2.5 SP5-XXX (INITIALIZING)

5	Mode No.	Function
101	Initialize SRAM	
	000	Initializes the bit switches and user parameters, user data in the SRAM, files in the SAF memory, and clock.
102	Erase All Files	
	000	Erases all files stored in the SAF memory.
103	Reset Bit Switches	
	000	Resets the bit switches and user parameters.
104	Factory setting	
	000	Resets the bit switches and user parameters, user data in the SRAM and files in the SAF memory.
105	Initialize All Bit Switches	
	000	Initializes all the current bit switch settings.
106	Initialize Security Bit Switches	
	000	Initializes only the security bit switches. If you select automatic output/display for the user parameter switches, the security settings are initialized.

4.2.6 SP6-XXX (REPORTS)

6	Mode No.	Function
101	System Parameter List	
	000	- Touch the "ON" button to print the system parameter list.

102	Service Monitor Report		
	000	-	Touch the "ON" button to print the service monitor report.
103	G3 Protocol Dump List		
	001	G3 All Communications	Prints the protocol dump list of all communications for all G3 lines.
	002	G3-1 (All Communications)	Prints the protocol dump list of all communications for the G3-1 line.
	003	G3-1 (1 Communication)	Prints the protocol dump list of the last communication for the G3-1 line.
	004	G3-2 (All Communications)	Prints the protocol dump list of all communications for the G3-2 line.
	005	G3-2 (1 Communication)	Prints the protocol dump list of the last communication for the G3-2 line.
	006	G3-3 (All Communications)	Prints the protocol dump list of all communications for the G3-3 line.
	007	G3-3 (1 Communication)	Prints the protocol dump list of the last communication for the G3-3 line.
104	G4 Protocol Dump List		
	001	Dch + Bch 1	Not used (Do not change the settings.)
	002	Dch	
	003	Bch 1 Link Layer	
	004	Dch Link Layer	
	005	Dch +Bch 2	
	006	Bch 2 Link Layer	
105	All Files print out		

Service Tables

	000	-	<p>Prints out all the user files in the SAF memory, including confidential messages.</p> <p>↓ Note</p> <ul style="list-style-type: none"> Do not use this function, unless the customer is having trouble printing confidential messages or recovering files stored using the memory lock feature.
106	Journal Print out		
	001	All Journals	The machine prints all the communication records on the report.
	002	Specified Date	The machine prints all communication records after the specified date.
107	Log List Print out		
	001	All log files	These log print out functions are for designer use only.
	002	Printer	
	003	SC/TRAP Stored	
	004	Decompression	
	005	Scanner	
	006	JOB/SAF	
	007	Reconstruction	
	008	JBIG	
	009	Fax Driver	
	010	G3CCU	
	011	Fax Job	
	012	CCU	

	013	Scanner Condition	
108	IP Protocol Dump List		
	001	All Communications	Prints the protocol dump list of all communications for the IP fax line.
	002	1 Communication	Prints the protocol dump list of the last communication for the IP fax line.

4.2.7 SP7-XXX (TEST MODES)

These are the test modes for PTT approval.

7	Function
101	G3-1 Modem Tests
102	G3-1 DTMF Tests
103	Ringer Test
104	G3-1 V34 (S2400baud)
105	G3-1 V34 (S2800baud)
106	G3-1 V34 (S3000baud)
107	G3-1 V34 (S3200baud)
108	G3-1 V34 (S3429baud)
109	Recorded Message Test
110	G3-2 Modem Tests
111	G3-2 DTMF Tests
112	G3-2 V34 (S2400baud)
113	G3-2 V34 (S2800baud)
114	G3-2 V34 (S3000baud)

Service Tables

115	G3-2 V34 (S3200baud)
116	G3-2 V34 (S3429baud)
117	G3-3 Modem Tests
118	G3-3 DTMF Tests
119	G3-3 V34 (S2400baud)
120	G3-3 V34 (S2800baud)
121	G3-3 V34 (S3000baud)
122	G3-3 V34 (S3200baud)
123	G3-3 V34 (S3429baud)
124	IG3-1 Modem Tests - Not used
125	IG3-1 DTMF Tests - Not used
126	IG3-1 V34 (S2400baud) - Not used
127	IG3-1 V34 (S2800baud) - Not used
128	IG3-1 V34 (S3000baud) - Not used
129	IG3-1 V34 (S3200baud) - Not used
130	IG3-1 V34 (S3429baud) - Not used
131	IG3-2 Modem Tests - Not used
132	IG3-2 DTMF Tests - Not used
133	IG3-2 V34 (S2400baud) - Not used
134	IG3-2 V34 (S2800baud) - Not used
135	IG3-2 V34 (S3000baud) - Not used
136	IG3-2 V34 (S3200baud) - Not used
137	IG3-2 V34 (S3429baud) - Not used

4.2.8 SP9-XXX (DESIGN SWITCH MODE)

9	Mode No.	Function
702	Design Switch	DFU

4.3 BIT SWITCHES

WARNING

- Do not adjust a bit switch or use a setting that is described as “Not used”, as this may cause the machine to malfunction or to operate in a manner that is not accepted by local regulations. Such bits are for use only in other areas, such as Japan.

Note

- Default settings for bit switches are not listed in this manual. Refer to the System Parameter List printed by the machine.

4.3.1 SYSTEM SWITCHES

System Switch 00 [SP No. 1-101-001]		
No	FUNCTION	COMMENTS
0	Dedicated transmission parameter programming 0: Disabled, 1: Enabled	Set this bit to 1 before changing any dedicated transmission parameters. Reset this bit to 0 after programming dedicated transmission parameters.
1	Not used	Do not change
2	Technical data printout on the Journal 0: OFF 1: ON	1: Instead of the personal name, the following data are listed on the Journal for each G3 communication.
	e.g. 0000 (1) // 32 (2) V34 (3) // 288 (4) // 264 (5) // L0100 (6) 03 (7) 04 (8) (1): EQM value (Line quality data). A larger number means more errors. (2): Symbol rate (V.34 only) (3): Final modem type used (4): Starting data rate (for example, 288 means 28.8 kbps) (5): Final data rate (6): Rx level (refer to the note after this table for how to read the rx level) (7): Total number of error lines that occurred during non-ECM reception. (8): Total number of burst error lines that occurred during non-ECM reception.	
	<p> Note</p> <ul style="list-style-type: none"> ▪ EQM and rx level are fixed at "FFFF" in tx mode. ▪ The seventh and eighth numbers are fixed at "00" for transmission records and ECM reception records. 	
	Rx level calculation Example: 0000 // 32 V34 // 288/264 // L 01 00 03 04 The four-digit hexadecimal value (N) after "L" indicates the rx level. The high byte is given first, followed by the low byte. Divide the decimal value of N by -16 to get the rx level. In the above example, the decimal value of N (= 0100 [H]) is 256.	

Bit Switches

	So, the actual rx level is $256/-16 = -16$ dB	
3	Not used	Do not change this setting.
4	Line error mark print 0: OFF, 1: ON (print)	When "1" is selected, a line error mark is printed on the printout if a line error occurs during reception.
5	G3/G4 communication parameter display 0: OFF 1: ON	This is a fault-finding aid. The LCD shows the key parameters (see below). This is normally disabled because it cancels the CSI display for the user. Be sure to reset this bit to 0 after testing.
6	Protocol dump list output after each communication 0: OFF 1: ON	This is only used for communication troubleshooting. It shows the content of the transmitted facsimile protocol signals. Always reset this bit to 0 after finishing testing. If system switch 09 bit 6 is at "1", the list is only printed if there was an error during the communication.
7	Not used	Do not change the setting.

System Switch 01 - Not used (Do not change the factory settings.)

System Switch 02 [SP No. 1-101-003]		
No	FUNCTION	COMMENTS
0-1	Not used	Do not change these settings.
2	Force after transmission stall 0: Off 1: On	With this setting on, the machine resets itself automatically if a transmission stalls and fails to complete the job.
3	Not used	Do not change these settings.

4	File retention time 0: Depends on User Parameter 24 [18(H)] 1: No limit (until the year 2126)	1: A file that had a communication error will not be erased unless the communication is successful.
5	Not used	Do not change this setting.
6-7	Memory read/write by RDS Bit 7: 0, Bit 6: 0 Always disabled Bit 7: 0, Bit 6: 1 User selectable Bit 7: 1, Bit 6: 0 User selectable Bit 7: 1, Bit 6: 1 Always enabled	(0,0): All RDS systems are always locked out. (0,1), (1,0): Normally, RDS systems are locked out, but the user can temporarily switch RDS on to allow RDS operations to take place. RDS will automatically be locked out again after a certain time, which is stored in System Switch 03. Note that if an RDS operation takes place, RDS will not switch off until this time limit has expired. (1,1): At any time, an RDS system can access the machine.

System Switch 03 [SP No. 1-101-004]		
No	FUNCTION	COMMENTS
0-7	Length of time that RDS is temporarily switched on when bits 6 and 7 of System Switch 02 are set to "User selectable"	00 - 99 hours (BCD). This setting is only valid if bits 6 and 7 of System Switch 02 are set to "User selectable". The default setting is 24 hours.

System Switch 04 [SP No. 1-101-005]		
No	FUNCTION	COMMENTS
0-2	Not used	Do not change these settings.
3	Printing dedicated tx parameters on Quick/Speed Dial Lists 0: OFF 1: ON	1: Each Quick/Speed dial number on the list is printed with the dedicated tx parameters.

Bit Switches

4-7	Not used	Do not change these settings.
-----	-----------------	-------------------------------

System Switch 05 - Not used (Do not change the factory settings.)
System Switch 06 - Not used (Do not change the factory settings.)
System Switch 07 - Not used (Do not change the factory settings.)
System Switch 08 - Not used (Do not change the factory settings.)

System Switch 09 [SP No. 1-101-010]		
No	FUNCTION	COMMENTS
0	Addition of image data from confidential transmissions on the transmission result report 0: OFF 1: ON	If this feature is enabled, the top half of the first page of confidential messages will be printed on transmission result reports.
1	Inclusion of communications on the Journal when no image data was exchanged. 0: Disabled 1: Enabled	0: Communications that reached phase C (message tx/rx) of the T.30 protocol are listed on the Journal. 1: Communications that reached phase A (call setup) of T.30 protocol are listed on the Journal. This will include telephone calls.
2	Automatic error report printout 0: Disabled 1: Enabled	0: Error reports will not be printed. 1: Error reports will be printed automatically after failed communications.
3	Printing of the error code on the error report 0: OFF 1: ON	1: Error codes are printed on the error reports.
4	Not used	Do not change this setting.
5	Power failure report 0: OFF 1: ON	1: A power failure report will be automatically printed after the power is switched on if a fax message disappeared from the memory when the

		power was turned off last.
6	<p>Conditions for printing the protocol dump list</p> <p>0: Print for all communications</p> <p>1: Print only when there is a communication error</p>	<p>This switch becomes effective only when system switch 00 bit 6 is set to 1.</p> <p>1: Set this bit to 1 when you wish to print a protocol dump list only for communications with errors.</p>
7	<p>Priority given to various types of remote terminal ID when printing reports</p> <p>0: RTI > CSI > Dial label > Tel. Number</p> <p>1: Dial label > Tel. number > RTI > CSI</p>	<p>This bit determines which set of priorities the machine uses when listing remote terminal names on reports.</p> <p>Dial Label: The name stored, by the user, for the Quick/Speed Dial number.</p>

System Switch 0A [SP No. 1-101-011]		
No	FUNCTION	COMMENTS
0	<p>Automatic port selection</p> <p>0: Disabled, 1: Enabled</p>	<p>When "1" is selected, a suitable port is automatically selected if the selected port is not used.</p>
1-3	Not used	Do not change these settings.
4	<p>Dialing on the ten-key pad when the external telephone is off-hook</p> <p>0: Disabled 1: Enabled</p>	<p>0: Prevents dialing from the ten-key pad while the external telephone is off-hook. Use this setting when the external telephone is not by the machine, or if a wireless telephone is connected as an external telephone.</p> <p>1: The user can dial on the machine's ten-key pad when the handset is off-hook.</p>
5	<p>On hook dial</p> <p>0: Disabled 1: Enabled</p>	<p>0: On hook dial is disabled.</p>

Bit Switches

System Switch 0B - Not used (Do not change the factory settings.)
System Switch 0C - Not used (Do not change the factory settings.)
System Switch 0D - Not used (Do not change the factory settings.)

System Switch 0E [SP No. 1-101-015]		
No	FUNCTION	COMMENTS
0-1	Not used	Do not change the settings.
2	Enable/disable for direct sending selection 0: Direct sending off 1: Direct sending on	Direct sending cannot operate when the capture function is on during sending. Setting this switch to "1" enables direct sending without capture. Setting this switch to "0" masks the direct sending function on the operation panel so it cannot be selected.
3	Action when the external handset goes off-hook 0: Manual tx and rx operation 1: Memory tx and rx operation (the display remains the same)	0: Manual tx and rx are possible while the external handset is off-hook. However, memory tx is not possible. 1: The display stays in standby mode even when the external handset is used, so that other people can use the machine for memory tx operation. Note that manual tx and rx are not possible with this setting.
4-7	Not used	Do not change these settings.

System Switch 0F [SP No. 1-101-016]			
No	FUNCTION	COMMENTS	
0-7	Country/area code for functional settings (Hex)	This country/area code determines the factory settings of bit switches and RAM addresses. However, it has no effect on the NCU parameter settings and communication parameter RAM	
	00: France		11: USA
	01: Germany		12: Asia

02: UK	12: Asia	addresses. Cross reference NCU country code: SP No. 2-103-001 for G3-1 SP No. 2-104-001 for G3-2 SP No. 2-105-001 for G3-3
03: Italy	13: Japan	
04: Austria	14: Hong Kong	
05: Belgium	15: South Africa	
06: Denmark	16: Australia	
07: Finland	17: New Zealand	
08: Ireland	18: Singapore	
09: Norway	19: Malaysia	
0A: Sweden	1A: China	
0B: Switzerland	1B: Formosa	
0C: Portugal	1C: Korea	
0D: Netherland	1D: Brazil	
0E: Spain	20: Turkey	
0F: Israel	21: Greece	
10: ---	22: Hungary	
11: USA	23: Czech	
24: Poland		

System Switch 10 [SP No. 1-101-017]		
No	FUNCTION	COMMENTS
0-7	Threshold memory level for parallel memory transmission	Threshold = N x 128 KB + 256 KB N can be between 00 - FF(H) Default setting: 02(H) = 512 KB

System Switch 11 [SP No. 1-101-018]
--

Bit Switches

No	FUNCTION	COMMENTS
0	TTI printing position 0: Superimposed on the page data 1: Printed before the data leading edge	Change this bit to 1 if the TTI overprints information that the customer considers to be important (G3 transmissions).
2	Not used	Do not change the factory settings.
3	TTI printing type 0: Address unit 1: File unit	TTI printing unit can be selected.
4-6	Not used	Do not change the factory settings.
7	Not used	Japan Only

System Switch 12 [SP No. 1-101-019]		
No	FUNCTION	COMMENTS
0-7	TTI printing position in the main scan direction	TTI: 08 to 92 (BCD) mm Input even numbers only. This setting determines the print start position for the TTI from the left edge of the paper. If the TTI is moved too far to the right, it may overwrite the file number which is on the top right of the page. On an A4 page, if the TTI is moved over by more than 50 mm, it may overwrite the page number.

System Switch 13 - Not used (do not change these settings)
System Switch 14 - Not used (do not change these settings)

System Switch 15 [SP No. 1-101-022]		
No	FUNCTION	COMMENTS

0	Not used	Do not change the settings.
1	Going into the Energy Saver mode automatically 0: Enabled 1: Disabled	1: The machine will restart from the Energy Saver mode quickly, because the +5V power supply is active even in the Energy Saver mode.
2-3	Not used	Do not change these settings.
4-5	Interval for preventing the machine from entering Energy Saver mode if there is a pending transmission file. Bit 5: 0, Bit 4: 0 1 min Bit 5: 0, Bit 4: 1 30 min Bit 5: 1, Bit 4: 0 1 hour Bit 5: 1, Bit 4: 1 24 hours	If there is a file waiting for transmission, the machine does not go to Energy Saver mode during the selected period. After transmitting the file, if there is no file waiting for transmission, the machine goes to the Energy Saver mode.
6-7	Not used	Do not change

System Switch 16 [SP No. 1-101-023]

No	FUNCTION	COMMENTS
0	Parallel Broadcasting 0: OFF 1: ON	1: The machine sends messages simultaneously using all available ports during broadcasting.
1	Priority setting for the G3 line. 0: PSTN-1 > PSTN-2 or 3 1: PSTN-2 or 3 > PSTN-1	This function allows the user to select the default G3 line type. The optional SG3 unit(s) are required to use the PSTN-2 or 3 setting.
4-7	Not used	Do not change these settings.

Bit Switches

System Switch 17 - Not used (do not change these settings)
System Switch 18 - Not used (do not change these settings)

System Switch 19 [SP No. 1-101-026]		
No	FUNCTION	COMMENTS
0-5	Not used	Do not change the settings.
6	Extended scanner page memory after memory option is installed 0: Disabled 1: Enabled	0: After installing the memory expansion option, the scanner page memory is extended to 4 MB from 2 MB. 1: If this bit is set to 1 after installing the memory expansion option, the scanner page memory is extended to 12 MB. But the SAF memory decreases to 18 MB.
7	Special Original mode 0: Disabled 1: Enabled	1: If the customer frequently wishes to transmit a form or letterhead which has a colored or printed background, change this bit to "1". "Original 1" and "Original 2" can be selected in addition to the "Text", "Text/Photo" and "Photo" modes.

System Switch 1A [SP No. 1-101-027]		
No.	FUNCTION	COMMENTS
0-7	LS RX memory remaining Threshold value setting	Sets a value of 4K. If the amount of memory remaining falls below 4K, documents received in memory are printed to create more space in memory. Initial value: 0x80 (512K) 00-FF (0-1020 KB: Hex)

System Switch 1B - Not used (do not change these settings)

System Switch 1C - Not used (do not change these settings)

System Switch 1D [SP No. 1-101-030]

No	FUNCTION	COMMENTS
0	RTI/CSI/CPS code display 0: ON 1: OFF	0: RTI, CSI, CPS codes are displayed on the top line of the LCD panel during communication. 1: Codes are switched off (no display)
1-7	Not used	Do not change these settings.

System Switch 1E [SP No. 1-101-031]

No	FUNCTION	COMMENTS
0	Communication after the Journal data storage area has become full 0: ON 1: OFF	0: When this switch is on and the journal history becomes full, the next report prints. If the journal history is not deleted, the next transmission cannot be received. This prevents overwriting communication records before the machine can print them. 1: If the buffer memory of the communication records for the Journal is full, fax communications are still possible. But the machine will overwrite the oldest communication records. Note: This setting is effective only when Automatic Journal printout is enabled but the machine cannot print the report (e.g., no paper).
1	Action when the SAF memory has become full during scanning 0: The current page is erased. 1: The entire file is erased.	0: If the SAF memory becomes full during scanning, the successfully scanned pages are transmitted. 1: If the SAF memory becomes full during scanning, the file is erased and no pages are transmitted. This bit switch is ignored for parallel memory

Bit Switches

		transmission.
2	RTI/CSI display priority 0: RTI 1: CSI	This bit determines which identifier, RTI or CSI, is displayed on the LCD while the machine is communicating in G3 non-standard mode.
3	File No. printing 0: Enabled 1: Disabled	1: File numbers are not printed on any reports.
4	Action when authorized reception is enabled but authorized RTIs/CSIs are not yet programmed 0: All fax reception is disabled 1: Faxes can be received if the sender has an RTI or CSI	If authorized reception is enabled but the user has stored no acceptable sender RTIs or CSIs, the machine will not be able to receive any fax messages. If the customer wishes to receive messages from any sender that includes an RTI or CSI, and to block messages from senders that do not include an RTI or CSI, change this bit to "1", then enable Authorized Reception. Otherwise, keep this bit at "0 (default setting)".
5-7	Not used	Do not change the settings

System Switch 1F [SP No. 1-101-032]		
No	FUNCTION	COMMENTS
0	Not used	Do not change the settings.
1	Report printout after an original jam during SAF storage or if the SAF memory fills up 0: Enabled 1: Disabled	0: When an original jams, or the SAF memory overflows during scanning, a report will be printed. Change this bit to "1" if the customer does not want to have a report in these cases. Memory tx – Memory storage report Parallel memory tx – Transmission result report
2	Not used	Do not change the settings.
3	Received fax print start timing	0: The machine prints each page immediately after

	(G3 reception) 0: After receiving each page 1: After receiving all pages	the machine receives it. 1: The machine prints the complete message after the machine receives all the pages in the memory.
5/6	Not used	Do not change the factory settings.
7	Action when a fax SC has occurred 0: Automatic reset 1: Fax unit stops	0: When the fax unit detects a fax SC code other than SC1201 and SC1207, the fax unit automatically resets itself. 1: When the fax unit detects any fax SC code, the fax unit stops. Cross Reference Fax SC codes - See "Troubleshooting"

4.3.2 I-FAX SWITCHES

I-fax Switch 00 [SP No. 1-102-001]		
No	FUNCTION	COMMENTS
	Original Width of TX Attachment File	This setting sets the maximum size of the original that the destination can receive. (Bits 3~7 are reserved for future use or not used.)
0	A4	0: Off (not selected), 1: On (selected) If more than one of these three bits is set to "1", the larger size has priority. For example, if both Bit 2 and Bit 1 are set to "1" then the maximum size is "A3" (Bit 2). When mail is sent, there is no negotiation with the receiving machine at the destination, so the sending machine cannot make a selection for the receiving capabilities (original width setting) of the receiving machine. The original width selected with this switch is used as the RX machine's original width setting, and the original is reduced to
1	B4	
2	A3	
3-6	Reserved	
7	Not used	

Bit Switches

		<p>this size before sending. The default is A4.</p> <p>If the width selected with this switch is higher than the receiving machine can accept, the machine detects this and this causes an error.</p>
--	--	---

I-fax Switch 01 [SP No. 1-102-002]		
No	FUNCTION	COMMENTS
	Original Line Resolution of TX Attachment File	These settings set the maximum resolution of the original that the destination can receive.
0	200x100 Standard	<p>0: Not selected 1: Selected</p> <p>If more than one of these three bits is set to "1", the higher resolution has priority. For example, if both Bit 0 and Bit 2 are set to "1" then the resolution is set for "Bit 2 200 x 400."</p>
1	200x200 Detail	
2	200x400 Fine	
3	300 x 300 Reserve	
4	400 x 400 Super Fine	
5	600 x 600 Reserve	
6	Reserve	
7	mm/inch	<p>This setting selects mm/inch conversion for mail transmission.</p> <p>0: Off (No conversion), 1: On (Conversion)</p> <p>When on (set to "1"), the machine converts millimeters to inches for sending mail.</p> <p>There is no switch for converting inches to millimeters.</p> <p>Unlike G3 fax transmissions which can negotiate between sender and receiver to determine the setting, mail cannot negotiate between terminals; the mm/inch selection is determined by the sender fax.</p> <p>When this switch is Off (0):</p> <p>Images scanned in inches are sent in inches.</p> <p>Images scanned in mm are sent in mm.</p> <p>Images received in inches are transmitted in inches.</p> <p>Images received in mm are transmitted in mm.</p>

	<p>When this switch is On (1):</p> <p>Images scanned in inches are sent in inches.</p> <p>Images scanned in mm are converted to inches.</p> <p>Images received in inches are transmitted in inches.</p> <p>Images received in mm are converted to inches.</p>
--	---

I-fax Switch 02 [SP No. 1-102-003]		
No	FUNCTION	COMMENTS
	RX Text Mail Header Processing	
		<p>This setting determines whether the header information is printed with text e-mails when they are received.</p> <p>0: Prints only text mail.</p> <p>1: Prints mail header information attached to text mail.</p> <p>When a text mail is received with this switch On (1), the "From" address and "Subject" address are printed as header information.</p> <p>When a mail with only binary data is received (a TIFF-F file, for example), this setting is ignored and no header is printed.</p>
1	Output from Attached Document at E-mail TX Error	
		<p>This setting determines whether only the first page or all pages of an e-mail attachment are printed at the sending station when a transmission error occurs. This allows the customer to see which documents have not reached their intended destinations if sent to the wrong e-mail addresses, for example.</p> <p>0: Prints 1st page only.</p> <p>1: Prints all pages.</p>
2-3	Text String for Return Receipt	
		<p>This setting determines the text string output for the Return Receipt that confirms the transmission was received normally at the destination.</p>
		<p>00: "Dispatched"</p> <p>Sends from PC mail a request for a Return Receipt. Receives the Return Receipt with "dispatched" in the 2nd part:</p> <p>Disposition: Automatic-action/MDN-send automatically; dispatched</p>

Bit Switches

	<p>The “dispatched” string is included in the Subject string.</p> <p>01: “Displayed”</p> <p>Sends from PC mail a request for a Return Receipt. Receives the Return Receipt with “displayed” in the 2nd part:</p> <p>Disposition: Automatic-action/MDN-send automatically; displayed</p> <p>The “displayed” string is included in the Subject string.</p> <p>10: Reserved</p> <p>11: Reserved</p> <p>A mail requesting a Return Receipt sent from an IFAX with this switch set to “00” (for “dispatched”) received by Microsoft Outlook 2000 may cause an error. If any setting other than “displayed” (01) causes a problem, change the setting to “01” to enable normal sending of the Return Receipt.</p>
4	<p>Media accept feature</p> <p>This setting adds or does not add the media accept feature to the answer mail to confirm a reception.</p> <p>0: Does not add the media accept feature to the answer mail</p> <p>1: Adds the media accept feature to the answer mail.</p> <p>Use this bit switch if a problem occurs when the machine receives an answer mail, which contains the media accept feature field.</p>
5-6	Not Used
7	<p>Image Resolution of RX Text Mail</p> <p>This setting determines the image resolution of the received mail.</p> <p>0: 200 x 200</p> <p>1: 400 x 400</p> <p>The “1” setting requires installation of the Function Upgrade Card in order to have enough SAF (Store and Forward) memory to receive images at 400 x 400 resolution.</p>

I-fax Switch 03 - Not used (do not change the settings) [SP No. 1-102-004]

I-fax Switch 04 [SP No. 1-102-005]

No	FUNCTION	COMMENTS
0	Subject for Delivery TX/Memory Transfer	<p>This setting determines whether the RTI/CSI registered on this machine or the RTI/CSI of the originator is used in the subject lines of transferred documents.</p> <p>0: Puts the RTI/CSI of the originator in the Subject line. If this is used, either the RTI or CSI is used. Only one of these can be received for use in the subject line.</p> <p>1: Puts the RTI/CSI registered on this machine in the Subject line.</p> <p>When this switch is used to transfer and deliver mail to a PC, the information in the Subject line that indicates where the transmission originated can be used to determine automatically the destination folder for each e-mail.</p>
1	Subject corresponding to mail post database	<p>0: Standard subject</p> <p>1: Mail post database subject</p> <p>The standard subject is replaced by the mail post database subject in the following three cases:</p> <ol style="list-style-type: none"> 1) When the service technician sets the service (software) switch. 2) When memory sending, delivery specified by F code or SMTP reception is done. 3) With relay broadcasting (1st stage without the Schmidt 4 function). <p> Note</p> <ul style="list-style-type: none"> ▪ This switch does not apply for condition 3) when the RX system is set up for memory sending, delivery by F-code, sending with SMTP RX and when operators are using FOL (to prevent problems when receiving transmissions).
2-7	Not Used	

I-fax Switch 05 [SP No. 1-102-006]		
No	FUNCTION	COMMENTS
0	Mail Addresses of SMTP Broadcast Recipients	<p>Determines whether the e-mail addresses of the destinations that receive transmissions broadcasted using SMTP protocol are recorded in the Journal.</p>

Bit Switches

	<p>For example: "1st destination + Total number of destinations: 9" in the Journal indicates a broadcast to 9 destinations. 0: Not recorded 1: Recorded</p>	
1	<p>I-Fax Automatic Re-dial Setting 0: OFF 1: ON</p>	<p>Determines whether the I-fax automatically redials when an error occurs.</p>
2-7	<p>Not Used</p>	

<p>I-fax Switch 06 - Not used (do not change the settings) [SP No. 1-102-007]</p>
<p>I-fax Switch 07 - Not used (do not change the settings) [SP No. 1-102-008]</p>

<p>I-fax Switch 08 [SP No. 1-102-009]</p>		
No	FUNCTION	COMMENTS
0-7	<p>Memory Threshold for POP Mail Reception</p>	<p>This setting determines the amount of SAF (Store and Forward) memory. (SAF stores fax messages to send later for transmission to more than one location, and also holds incoming messages if they cannot be printed.) When the amount of SAF memory available falls below this setting, mail can no longer be received; received mail is then stored on the mail server. 00-FF (0 to 1024 KB: HEX)</p> <p>↓ Note</p> <ul style="list-style-type: none"> The hexadecimal number you enter is multiplied by 4 KB to determine the amount of memory.

<p>I-fax Switch 09 [SP No. 1-102-010]</p>		
No	FUNCTION	COMMENTS

0-3	Not used	Do not change the settings
4-7	Restrict TX Retries	This setting determines the number of retries when connection and transmission fails due to errors. 01-F (1-15 Hex)

I-fax Switch 0A - Not used (do not change the settings) [SP No. 1-102-011]
I-fax Switch 0B - Not used (do not change the settings) [SP No. 1-102-012]
I-fax Switch 0C - Not used (do not change the settings) [SP No. 1-102-013]
I-fax Switch 0D - Not used (do not change the settings) [SP No. 1-102-014]
I-fax Switch 0E - Not used (do not change the settings) [SP No. 1-102-015]

I-fax Switch 0F [SP No. 1-102-016]		
No	FUNCTION	COMMENTS
0	Delivery Method for SMTP RX Files	
		This setting determines whether files received with SMTP protocol are delivered or output immediately. 0: Off. Files received via SMTP are output immediately without delivery. 1: On. Files received via SMTP are delivered immediately to their destinations.
1	Signature for the SMTP	
		This setting determines whether a signature is put on an e-mail via SMTP. 0: No signature 1: Signature
2		This setting determines whether an e-mail via SMTP is encrypted. 0: Not encrypted 1: Encrypted
3-7	Not used	

4.3.3 PRINTER SWITCHES

Printer Switch 00 [SP No. 1-103-001]		
No	FUNCTION	COMMENTS
0	Select page separation marks 0: OFF 1: ON	<p>0: If a 2 page RX transmission is split, [*] is printed in the bottom right corner of the 1st page and only a [2] is printed in the upper right corner of the 2nd page.</p> <p>1: If a 2 page RX transmission is split into two pages, for example, [*] [2] is printed in the bottom right corner of the 1st page and only a [2] is printed in the upper right corner of the 2nd page.</p> <p> Note</p> <ul style="list-style-type: none"> This helps the user to identify pages that have been split because the size of the paper is smaller than the size of the document received. (When A5 is used to print an A4 size document, for example.)
1	Repetition of data when the received page is longer than the printer paper 0: OFF 1: ON	<p>1: Default. 10 mm of the trailing edge of the previous page are repeated at the top of the next page.</p> <p>0: The next page continues from where the previous page stopped without any repeated text.</p>
2	Prints the date and time on received fax messages 0: OFF 1: ON	<p>This switch is only effective when user parameter 02 - bit 2 (printing the received date and time on received fax messages) is enabled.</p> <p>1: The machine prints the received and printed date and time at the bottom of each received page.</p>
3-7	Not used	Do not change the settings.

Printer Switch 01 [SP No. 1-103-002]		
No	FUNCTION	COMMENTS
0-2	Not used	Do not change the settings.
3-4	Maximum print width used in the setup protocol Bit 4: 0, Bit 3: 0 = Not used Bit 4: 0, Bit 3: 1 = A3 Bit 4: 1, Bit 3: 0 = B4 Bit 4: 1, Bit 3: 1 = A4	These bits are only effective when bit 7 of printer switch 01 is "1".
5-6	Not used	Do not change the settings.
7	Received message width restriction in the protocol signal to the sender 0: Disabled 1: Enabled	0: The machine informs the transmitting machine of the print width depending on the paper size available from the paper feed stations. Refer to the table on the next page for how the machine chooses the paper width used in the setup protocol (NSF/DIS). 1: The machine informs the transmitting machine of the fixed paper width which is specified by bits 3 and 4 above.

Printer Switch 02 [SP No. 1-103-003]		
No	FUNCTION	COMMENTS
0	1st paper feed station usage for fax printing 0: Enabled 1: Disabled	0: The paper feed station can be used to print fax messages and reports. 1: The specified paper feed station will not be used for printing fax messages and reports.
1	2nd paper feed station usage for fax printing 0: Enabled 1: Disabled	<div style="border: 1px solid blue; padding: 2px; display: inline-block;">  Note </div> <ul style="list-style-type: none"> ▪ Do not disable usage for a paper feed station which has been specified by User Parameter Switch 0F (15), or which is

Bit Switches

2	3rd paper feed station usage for fax printing 0: Enabled 1: Disabled	used for the Specified Cassette Selection feature.
3	4th paper feed station usage for fax printing 0: Enabled 1: Disabled	
4	LCT usage for fax printing 0: Enabled 1: Disabled	
5-7	Not used	Do not change the settings.

Printer Switch 03 [SP No. 1-103-004]		
No	FUNCTION	COMMENTS
0	Length reduction of received data 0: OFF 1: ON	0: Incoming pages are printed without length reduction. (Page separation threshold: Printer Switch 03, bits 4 to 7) 1: Incoming page length is reduced when printing. (Maximum reducible length: Printer Switches 04, bits 0 to 4)
1-3	Not used	Do not change the settings
4-7	Page separation setting when sub scan compression is forbidden 00-0F (0-15 mm: Hex) Default: 6 mm	Page separation threshold (with reduction disabled with switch 03-0 above). For example, if this setting is set to "10", and A4 is the selected paper size: If the received document is 10 mm or less longer than A4, then the 10 mm are cut and only 1 page prints. If the received document is 10 mm longer than A4,

		then the document is split into 2 pages.
--	--	--

Printer Switch 04						
SP No. 1-103-005						
No	FUNCTION			COMMENTS		
0-4	Maximum reducible length when length reduction is enabled with switch 03-0 above. $\langle \text{Maximum reducible length} \rangle = \langle \text{Paper length} \rangle + (N \times 5\text{mm})$ "N" is the decimal value of the binary setting of bits 0 to 4.					
	Bit 4	Bit 3	Bit 2	Bit 1	Bit 0	Setting
	0	0	0	0	0	0 mm
	0	0	0	0	1	5 mm
	0	0	1	0	0	20 mm
	1	1	1	1	1	155 mm
For A5 sideways and B5 sideways paper $\langle \text{Maximum reducible length} \rangle = \langle \text{Paper length} \rangle + 0.75 \times (N \times 5\text{mm})$						
5-6	Length of the duplicated image on the next page, when page separation has taken place. Bit 6: 0, Bit 5: 0 = 4 mm Bit 6: 1, Bit 5: 0 = 10 mm Bit 6: 0, Bit 5: 1 = 15 mm Bit 6: 1, Bit 5: 1 = Not used					
7	Not used.			Do not change the setting.		

Printer Switch 05 - Not used (do not change the settings)

Printer Switch 06 [SP No. 1-103-007]		
No	FUNCTION	COMMENTS

Bit Switches

0	<p>Printing while a paper cassette is pulled out, when the Just Size Printing feature is enabled.</p> <p>0: Printing will not start 1: Printing will start if another cassette has a suitable size of paper, based on the paper size selection priority tables.</p>	<p>Cross reference Just size printing on/off – User switch 05, bit 5</p>
1-7	Not used.	Do not change the settings.

Printer Switch 07 [SP No. 1-103-008]		
No	FUNCTION	COMMENTS
0-3	Not used.	Do not change the settings.
4	<p>List of destinations in the Communication Failure Report for broadcasting</p> <p>0: All destinations 1: Only destinations where communication failure occurred</p>	1: Only destinations where communication failure occurred are printed on the Communication Failure Report.
5-7	Not used.	Do not change the settings.

Printer Switch 08 - Not used (do not change the settings)
Printer Switch 09 - Not used (do not change the settings)
Printer Switch 0A - Not used (do not change the settings)

Printer Switch 0B - Not used (do not change the settings)
Printer Switch 0C - Not used (do not change the settings)

Printer Switch 0D - Not used (do not change the settings)

Printer Switch 0E [SP No. 1-103-015]		
No	FUNCTION	COMMENTS
0	Paper size selection priority 0: Width 1: Length	0: A paper size that has the same width as the received data is selected first. 1: A paper size which has enough length to print all the received lines without reduction is selected first.
1	Paper size selected for printing A4 width fax data 0: 8.5" x 11" size 1: A4 size	This switch determines which paper size is selected for printing A4 width fax data, when the machine has both A4 and 8.5" x 11" size paper.
2	Page separation 0: Enabled 1: Disabled	1: If all paper sizes in the machine require page separation to print a received fax message, the machine does not print the message (Substitute Reception is used). After a larger size of paper is set in a cassette, the machine automatically prints the fax message.
3-4	Printing the sample image on reports Bit 4: 0, Bit 3: 0 = The upper half only Bit 4: 0, Bit 3: 1 = 50% reduction in sub-scan only Bit 4: 1, Bit 3: 0 = Same size Bit 4: 1, Bit 3: 1 = Not used	"Same size" means the sample image is printed at 100%, even if page separation occurs. User Parameter Switch 19 (13H) bit 4 must be set to "0" to enable this switch. Refer to Detailed Section Descriptions for more on this feature.
5-6	Not used	Do not change the settings.
7	Equalizing the reduction ratio	0: When page separation has taken place, all the

Bit Switches

	among separated pages (Page Separation) 0: ON 1: OFF	pages are reduced with the same reduction ratio. 1: Only the last page is reduced to fit the selected paper size when page separation has taken place. Other pages are printed without reduction.
--	---	---

Printer Switch 0F [SP No. 1-103-016]		
No	FUNCTION	COMMENTS
0-1	Smoothing feature Bit 1: 0 Bit 0: 0 = OFF Bit 1: 0 Bit 0: 1 = OFF Bit 1: 1 Bit 0: 0 = ON Bit 1: 1 Bit 0: 1 = Not used	(0, 0) (0, 1): Disable smoothing if the machine receives halftone images from other manufacturers fax machines frequently.
2	Duplex printing 0: OFF 1: ON	1: The machine always prints received fax messages in duplex printing mode:
3	Binding direction for Duplex printing 0: Left binding 1: Top binding	0: Sets the binding for the left edge of the stack. 1: Sets the binding for the top of the stack.
4-7	Not used	Do not change the settings.

4.3.4 COMMUNICATION SWITCHES

Communication Switch 00 [SP No. 1-104-001]		
No	FUNCTION	COMMENTS
0-1	Compression modes available in receive mode Bit 1: 0 Bit 0: 0 = MH only Bit 1: 0 Bit 0: 1 = MH/MR Bit 1: 1 Bit 0: 0 = MH/MR/MMR	These bits determine the compression capabilities to be declared in phase B (handshaking) of the T.30 protocol.

	Bit 1: 1 Bit 0: 1 = MH/MR/MMR/JBIG	
2-3	Compression modes available in transmit mode Bit 3: 0 Bit 2: 0 = MH only Bit 3: 0 Bit 2: 1 = MH/MR Bit 3: 1 Bit 2: 0 = MH/MR/MMR Bit 3: 1 Bit 2: 1 = MH/MR/MMR/JBIG	These bits determine the compression capabilities to be used in the transmission and to be declared in phase B (handshaking) of the T.30 protocol.
4	Not used	Do not change the settings.
5	JBIG compression method: Reception 0: Only basic supported 1: Basic and optional both supported	Change the setting when communication problems occur using JBIG compression.
6	JBIG compression method: Transmission 0: Basic mode priority 1: Optional mode priority	Change the setting when communication problems occur using JBIG compression.
7	Closed network (reception) 0: Disabled 1: Enabled	1: Reception will not go ahead if the polling ID code of the remote terminal does not match the polling ID code of the local terminal. This function is only available in NSF/NSS mode.

Communication Switch 01 [SP No. 1-104-002]		
No	FUNCTION	COMMENTS
0	ECM 0: Off 1: On	If this bit is set to 0, ECM is switched off for all communications. In addition, V.8 protocol and JBIG compression are switched off automatically.
1	Not used	Do not change the settings.

Bit Switches

2-3	<p>Wrong connection prevention method</p> <p>Bit 3: 0, Bit 2: 0 = OFF</p> <p>Bit 3: 0, Bit 2: 1 = 8 digit CSI</p> <p>Bit 3: 1, Bit 2: 0 = 4 digit CSI</p> <p>Bit 3: 1, Bit 2: 1 = CSI/RTI</p>	<p>(0,1) - The machine will disconnect the line without sending a fax message, if the last 8 digits of the received CSI do not match the last 8 digits of the dialed telephone number. This does not work when manually dialed.</p> <p>(1,0) - The same as above, except that only the last 4 digits are compared.</p> <p>(1,1) - The machine will disconnect the line without sending a fax message, if the other end does not identify itself with an RTI or CSI.</p> <p>(0,0) - Nothing is checked; transmission will always go ahead.</p> <p> Note</p> <ul style="list-style-type: none"> This function does not work when dialing is done from the external telephone.
4-5	Not used	Do not change the setting.
6-7	<p>Maximum printable page length available</p> <p>Bit 7: 0 Bit 6: 0 = No limit</p> <p>Bit 7: 0 Bit 6: 1 = B4 (364 mm)</p> <p>Bit 7: 1 Bit 6: 0 = A4 (297 mm)</p> <p>Bit 7: 1 Bit 6: 1 = Not used</p>	The setting determined by these bits is informed to the transmitting terminal in the pre-message protocol exchange (in the DIS/NSF frames).

Communication Switch 02 [SP No. 1-104-003]						
No	FUNCTION	COMMENTS				
0	G3 Burst error threshold 0: Low 1: High	<p>If there are more consecutive error lines in the received page than the threshold, the machine will send a negative response. The Low and High threshold values depend on the sub-scan resolution, and are as follows.</p> <table border="1" data-bbox="711 1854 1353 2004"> <tr> <td data-bbox="711 1854 858 1926">100 dpi</td> <td data-bbox="858 1854 1353 1926">6(L) → 12(H)</td> </tr> <tr> <td data-bbox="711 1926 858 2004">200 dpi</td> <td data-bbox="858 1926 1353 2004">12(L) → 24(H)</td> </tr> </table>	100 dpi	6(L) → 12(H)	200 dpi	12(L) → 24(H)
100 dpi	6(L) → 12(H)					
200 dpi	12(L) → 24(H)					

		300 dpi	18(L) → 36(H)
		400 dpi	24(L) → 48(H)
1	Acceptable total error line ratio 0: 5% 1: 10%	If the error line ratio for a page exceeds the acceptable ratio, RTN will be sent to the other end.	
2	Treatment of pages received with errors during G3 reception 0: Deleted from memory without printing 1: Printed	0: Pages received with errors are not printed.	
3	Hang-up decision when a negative code (RTN or PIN) is received during G3 immediate transmission 0: No hang-up, 1: Hang-up	0: The next page will be sent even if RTN or PIN is received. 1: The machine will send DCN and hang up if it receives RTN or PIN. This bit is ignored for memory transmissions or if ECM is being used.	
4-7	Not used	Do not change the settings.	

Communication Switch 03 [SP No. 1-104-004]		
No	FUNCTION	COMMENTS
0-7	Maximum number of page retransmissions in a G3 memory transmission	00 - FF (Hex) times. This setting is not used if ECM is switched on. Default setting - 03(H)

Communication Switch 04 - Not used (do not change the settings)
Communication Switch 05 - Not used (do not change the settings)
Communication Switch 06 - Not used (do not change the settings)
Communication Switch 07 - Not used (do not change the settings)

Bit Switches

Communication Switch 08 - Not used (do not change the settings)

Communication Switch 09 [SP No. 1-104-010]		
No	FUNCTION	COMMENTS
0-7	IP-Fax dial interval setting	Adjusts the interval of the I-fax dialing. The interval of I-fax dialing is calculated by following formula. [Interval time = specified value with this switch x 0.2 msec]

Communication Switch 0A [SP No. 1-104-011]		
No	FUNCTION	COMMENTS
0	Point of resumption of memory transmission upon redialing 0: From the error page 1: From page 1	0: The transmission begins from the page where transmission failed the previous time. 1: Transmission begins from the first page, using normal memory transmission.
1-7	Not used	Do not change the settings.

Communication Switch 0B - Not used (do not change the settings)

Communication Switch 0C - Not used (do not change the settings)

Communication Switch 0D [SP No. 1-104-014]		
No	FUNCTION	COMMENTS
0-7	The available memory threshold, below which ringing detection (and therefore reception into memory) is disabled	00 to FF (Hex), unit = 4 kbytes (e.g., 06(H) = 24 kbytes) One page is about 24 kbytes. The machine refers to this setting before each fax reception. If the amount of remaining memory is below this threshold, the machine cannot receive

		any fax messages. If this setting is kept at 0, the machine will detect ringing signals and go into receive mode even if there is no memory available. This will result in communication failure.
--	--	--

Communication Switch 0E [SP No. 1-104-015]

No	FUNCTION	COMMENTS
0-7	Minimum interval between automatic dialing attempts	06 to FF (Hex), unit = 2 s (e.g., 06(H) = 12 s) This value is the minimum time that the machine waits before it dials the next destination.

Communication Switch 0F – Not used (do not change the settings.)**Communication Switch 10 [SP No. 1-104-017]**

No	FUNCTION	COMMENTS
0-7	Memory transmission: Maximum number of dialing attempts to the same destination	01 – FE (Hex) times

Communication Switch 11 – Not used (do not change the settings.)**Communication Switch 12 [SP No. 1-104-019]**

No	FUNCTION	COMMENTS
0-7	Memory transmission: Interval between dialing attempts to the same destination	01 – FF (Hex) minutes

Bit Switches

Communication Switch 13 – Not used (do not change the settings.)

Communication Switch 14 [SP No. 1-104-021]		
No	FUNCTION	COMMENTS
0	Inch-to-mm conversion during transmission 0: Disabled 1: Enabled	0: In immediate transmission, data scanned in inch format are transmitted without conversion. In memory transmission, data stored in the SAF memory in mm format are transmitted without conversion. Note: When storing the scanned data into SAF memory, the fax unit always converts the data into mm format. 1: The machine converts the scanned data or stored data in the SAF memory to the format which was specified in the set-up protocol (DIS/NSF) before transmission.
1-5	Not used	Do not change the factory settings.
6-7	Available unit of resolution in which fax messages are received Bit 7: 0, Bit 6: 0 = mm Bit 7: 0, Bit 6: 1 = inch Bit 7: 1, Bit 6: 0 = mm and inch (default) Bit 7: 1, Bit 6: 1 = Not used	For the best performance, do not change the factory settings. The setting determined by these bits is informed to the transmitting terminal in the pre-message protocol exchange (in the DIS/NSF frames).

Communication Switch 15 – Not used (do not change the settings)

Communication Switch 16 [SP No. 1-104-023]		
No	FUNCTION	COMMENTS
0	Not used	Do not change the factory settings.

1	Optional G3 unit (G3-2) 0: Off 1: On	Change this bit to "1" when installing the first optional G3 unit (G3-2).
2	Not used	Do not change the factory settings.
3	Optional G3 unit (G3-3) 0: Off 1: On	Change this bit to "1" when installing the second optional G3 unit (G3-3).
4-7	Not used	Do not change the factory settings.

Communication Switch 17 [SP No. 1-104-024]		
No	FUNCTION	COMMENTS
0	SEP reception 0: Disabled 1: Enabled	0: Polling transmission to another maker's machine using the SEP (Selective Polling) signal is disabled.
1	SUB reception 0: Disabled 1: Enabled	0: Confidential reception to another maker's machine using the SUB (Sub-address) signal is disabled.
2	PWD reception 0: Disabled 1: Enabled	0: Disables features that require PWD (Password) signal reception.
3-6	Not used	Do not change the factory settings.
7	Action when there is no box with an F-code that matches the received SUB code 0: Disconnect the line 1: Receive the message (using normal reception mode)	Change this setting when the customer requires.

Communication Switch 18 [SP No. 1-104-025]		
---	--	--

Bit Switches

No	FUNCTION	COMMENTS
0-4	Not used	Do not change the factory settings.
5	IP-Fax dial-in routing selection 0: Off 1: On	1: Transfers receiving data to each IP-Fax dial-in number. IP-Fax dial-in number is 4 digit-number.
6-7	Not used	Do not change the factory settings.

Communication Switch 19 - Not used (do not change the settings)
Communication Switch 1A - Not used (do not change the settings)

Communication Switch 1B [SP No. 1-104-028]		
No	FUNCTION	COMMENTS
0-7	Extension access code (0 to 7) to turn V.8 protocol On/Off 0: On 1: Off	If the PABX does not support V.8/V.34 protocol procedure, set this bit to "1" to disable V.8. Example: If "0" is the PSTN access code, set bit 0 to 1. When the machine detects "0" as the first dialed number, it automatically disables V.8 protocol. (Alternatively, if "3" is the PSTN access code, set bit 3 to 1.)

Communication Switch 1C [SP No. 1-104-029]		
No	FUNCTION	COMMENTS
0-1	Extension access code (8 and 9) to turn V.8 protocol On/Off 0: On 1: Off	Refer to communication switch 1B. Example: If "8" is the PSTN access code, set bit 0 to 1. When the machine detects "8" as the first dialed number, it automatically disables V.8 protocol. (If "9" is the PSTN access code, use bit 1.)
2-7	Not used	Do not change the settings.

Communication Switch 1D - Not used (do not change the settings)
Communication Switch 1E - Not used (do not change the settings)
Communication Switch 1F - Not used (do not change the settings)

4.3.5 G3 SWITCHES

G3 Switch 00 [SP No. 1-105-001]		
No	FUNCTION	COMMENTS
0 1	Monitor speaker during communication (tx and rx) Bit 1: 0, Bit 0: 0 = Disabled Bit 1: 0, Bit 0: 1 = Up to Phase B Bit 1: 1, Bit 0: 0 = All the time Bit 1: 1, Bit 0: 1 = Not used	(0, 0): The monitor speaker is disabled all through the communication. (0, 1): The monitor speaker is on up to phase B in the T.30 protocol. (1, 0): Used for testing. The monitor speaker is on all through the communication. Make sure that you reset these bits after testing.
2	Monitor speaker during memory transmission 0: Disabled 1: Enabled	1: The monitor speaker is enabled during memory transmission.
3-5	Not used	Do not change the settings.
6	G3 mode selection for direct line 0: Off 1: On	1: G3 communication through the direct line is enabled.
7	Not used	Do not change the settings.

G3 Switch 01 [SP No. 1-105-002]		
No	FUNCTION	COMMENTS

Bit Switches

0-1	Not used	Do not change the settings.
2-3	Not used	Do not change the settings.
4	DIS frame length 0: 10 bytes 1: 4 bytes	1: The bytes in the DIS frame after the 4th byte will not be transmitted (set to 1 if there are communication problems with PC-based faxes which cannot receive the extended DIS frames).
5	Not used	Do not change the setting.
6	Forbid CED/AMsam output 0: Off 1: On (Forbid output)	Do not change this setting (Default: 0: Off), unless communication problem is caused by a CED or ANSam transmission.
7	Not used	Do not change the setting.

G3 Switch 02 [SP No. 1-105-003]		
No	FUNCTION	COMMENTS
0	G3 protocol mode used 0: Standard and non-standard 1: Standard only	Change this bit to 1 only when the other end can only communicate with machines that send T.30-standard frames only. 1: Disables NSF/NSS signals (these are used in non-standard mode communication)
1-6	Not used	Do not change the settings.
7	Short preamble 0: Disabled 1: Enabled	Refer to Appendix B in the Group 3 Facsimile Manual for details about Short Preamble.

G3 Switch 03 [SP No. 1-105-004]		
No	FUNCTION	COMMENTS
0	DIS detection number (Echo countermeasure) 0: 1	0: The machine will hang up if it receives the same DIS frame twice. 1: Before sending DCS, the machine will wait for

	1: 2	the second DIS which is caused by echo on the line.
1	Not Used	Do not change the settings.
2	V.8 protocol 0: Disabled 1: Enabled	0: V.8/V.34 communications will not be possible. Note: Do not set to 0 unless the line condition is always bad enough to slow down the data rate to 14.4 kbps or lower.
3	ECM frame size 0: 256 bytes 1: 64 bytes	Keep this bit at "0" in most cases.
4	CTC transmission conditions 0: After one PPR signal received 1: After four PPR signals received (ITU-T standard)	0: When using ECM in non-standard (NSF/NSS) mode, the machine sends a CTC to drop back the modem rate after receiving a PPR, if the following condition is met in communications at 14.4, 12.0, 9.6, and 7.2 kbps. $\sqrt{N_{\text{Transmit}} \leq N_{\text{Resend}}}$ NTransmit- Number of transmitted frames NResend- Number of frames to be retransmitted 1: When using ECM, the machine sends a CTC to drop back the modem rate after receiving four PPRs. PPR, CTC: These are ECM protocol signals. This bit is not effective in V.34 communications.
5	Modem rate used for the next page after receiving a negative code (RTN or PIN) 0: No change 1: Fallback	1: The machine's tx modem rate will fall back before sending the next page if a negative code is received. This bit is ignored if ECM is being used.
6	Not Used	Do not change the settings
7	Select detection of reverse polarity in ringing	This switch is used to prevent reverse polarity in ringing on the phone line (applied to PSTN-G3

Bit Switches

	0: Off 1: On	ringing). Do not change this setting 0: No detection → Outside Japan 1: Detection → Inside Japan only
--	-----------------	---

G3 Switch 04 [SP No. 1-105-005]		
No	FUNCTION	COMMENTS
0-3	Training error detection threshold	0 - F (Hex); 0 - 15 bits If the number of error bits in the received TCF is below this threshold, the machine informs the sender that training has succeeded.
4-7	Not used	Do not change the settings.

G3 Switch 05 [SP No. 1-105-006]						
No	FUNCTION					COMMENTS
0-3	Initial Tx modem rate					These bits set the initial starting modem rate for transmission. Use the dedicated transmission parameters if you need to change this for specific receivers. If a modem rate 14.4 kbps or slower is selected, V.8 protocol should be disabled manually. Cross reference V.8 protocol on/off - G3 switch 03, bit2
	Bit 3	Bit 2	Bit 1	Bit 0	bps	
	0	0	0	1	2.4k	
	0	0	1	0	4.8k	
	0	0	1	1	7.2k	
	0	1	0	0	9.6k	
	0	1	0	1	12.0k	
	0	1	1	0	14.4k	
	0	1	1	1	16.8k	
	1	0	0	0	19.2k	
	1	0	0	1	21.6k	

	1	0	1	0	24.0k	
	1	0	1	1	26.4k	
	1	1	0	0	28.8k	
	1	1	0	1	31.2k	
	1	1	1	0	33.6k	
	Other settings - Not used					
4-5	Initial modem type for 9.6 k or 7.2 kbps. Bit 5: 0, Bit 4: 0 = V.29 Bit 5: 0, Bit 4: 1 = V.17 Bit 5: 1, Bit 4: 0 = V.34 Bit 5: 1, Bit 4: 1 = Not used					These bits set the initial modem type for 9.6 and 7.2 kbps, if the initial modem rate is set at these speeds.
6-7	Not used					Do not change the settings.

G3 Switch 06 [SP No. 1-105-007]						
No	FUNCTION					COMMENTS
0-3	Initial Rx modem rate					<ul style="list-style-type: none"> ▪ These bits set the initial starting modem rate for reception. ▪ Use a lower setting if high speeds pose problems during reception. ▪ If a modem rate 14.4 kbps or slower is selected, V.8 protocol should be disabled manually. Cross reference: V.8 protocol on/off - G3 switch 03, bit2
	Bit 3	Bit 2	Bit 1	Bit 0	bps	
	0	0	0	1	2.4k	
	0	0	1	0	4.8k	
	0	0	1	1	7.2k	
	0	1	0	0	9.6k	
	0	1	0	1	12.0k	
	0	1	1	0	14.4k	
	0	1	1	1	16.8k	

Bit Switches

	1	0	0	0	19.2k	
	1	0	0	1	21.6k	
	1	0	1	0	24.0k	
	1	0	1	1	26.4k	
	1	1	0	0	28.8k	
	1	1	0	1	31.2k	
	1	1	1	0	33.6k	
Other settings - Not used						
4-7	Modem types available for reception					<ul style="list-style-type: none"> The setting of these bits is used to inform the transmitting terminal of the available modem type for the machine in receive mode. If V.34 is not selected, V.8 protocol must be disabled manually. <p>Cross reference: V.8 protocol on/off - G3 switch 03, bit2</p>
	Bit 7	Bit 6	Bit 5	Bit 4	Setting	
	0	0	0	1	V.27ter	
	0	0	1	0	V.27ter,V.29	
	0	0	1	1	V.27ter, V.29, V.33	
	0	1	0	0	V.27ter, V.29, V.17/V.33	
0	1	0	1	V.27ter, V.29, V.17/V33, V.34		
Other settings - Not used						

G3 Switch 07 [SP No. 1-105-008]		
No	FUNCTION	COMMENTS
0-1	PSTN cable equalizer	Use a higher setting if there is signal loss at higher

	<p>(tx mode: Internal)</p> <p>Bit 1: 0, Bit 0: 0 = None</p> <p>Bit 1: 0, Bit 0: 1 = Low</p> <p>Bit 1: 1, Bit 0: 0 = Medium</p> <p>Bit 1: 1, Bit 0: 1 = High</p>	<p>frequencies because of the length of wire between the modem and the telephone exchange.</p> <p>Use the dedicated transmission parameters for specific receivers.</p> <p>Also, try using the cable equalizer if one or more of the following symptoms occurs.</p> <p>Communication error</p> <p>Modem rate fallback occurs frequently.</p> <p> Note</p> <ul style="list-style-type: none"> This setting is not effective in V.34 communications.
2-3	<p>PSTN cable equalizer (rx mode: Internal)</p> <p>Bit 3: 0, Bit 2: 0 = None</p> <p>Bit 3: 0, Bit 2: 1 = Low</p> <p>Bit 3: 1, Bit 2: 0 = Medium</p> <p>Bit 3: 1, Bit 2: 1 = High</p>	<p>Use a higher setting if there is signal loss at higher frequencies because of the length of wire between the modem and the telephone exchange.</p> <p>Also, try using the cable equalizer if one or more of the following symptoms occurs.</p> <p>Communication error with error codes such as 0-20, 0-23, etc.</p> <p>Modem rate fallback occurs frequently.</p> <p> Note</p> <ul style="list-style-type: none"> This setting is not effective in V.34 communications.
4	<p>PSTN cable equalizer (V.8/V.17 rx mode: External)</p> <p>0: Disabled</p> <p>1: Enabled</p>	<p>Keep this bit at "1".</p>
5	<p>Not used</p>	<p>Do not change the settings.</p>
6	<p>Parameter selection for dial tone detection</p> <p>0: Normal parameter</p> <p>1: Specific parameter</p>	<p>0: This uses the fixed table in the ROM for dial tone detection.</p> <p>1: This uses the specific parameter adjusted with SRAM (69ECBEH - 69ECDEH). Select this if the dial tone cannot be detected when the "Normal parameter: 0" is selected.</p>

Bit Switches

7	Not used	Do not change the settings.
---	-----------------	-----------------------------

G3 Switch 08 - Not used (do not change the settings)
G3 Switch 09 - Not used (do not change the settings)

G3 Switch 0A [SP No. 1-105-011]		
No	FUNCTION	COMMENTS
0-1	Maximum allowable carrier drop during image data reception Bit 1: 0, Bit 0: 0 = 200 (ms) Bit 1: 0, Bit 0: 1 = 400 (ms) Bit 1: 1, Bit 0: 0 = 800 (ms) Bit 1: 1, Bit 0: 1 = Not used	These bits set the acceptable modem carrier drop time. Try using a longer setting if error code 0-22 is frequent.
2	Select cancellation of high-speed RX if carrier signal lost while receiving 0: Off 1: On	This switch setting determines if high-speed receiving ends if the carrier signal is lost when receiving during non-ECM mode
3	Not used	Do not change the settings
4	Maximum allowable frame interval during image data reception. 0: 5 s 1: 13 s	This bit set the maximum interval between EOL (end-of-line) signals and the maximum interval between ECM frames from the other end. Try using a longer setting if error code 0-21 is frequent.
5	Not used	Do not change the settings.
6	Reconstruction time for the first line in receive mode	When the sending terminal is controlled by a computer, there may be a delay in receiving page

	0: 6 s 1: 12 s	data after the local machine accepts set-up data and sends CFR. This is outside the T.30 recommendation. But, if this delay occurs, set this bit to 1 to give the sending machine more time to send data. Refer to error code 0-20. ITU-T T.30 recommendation: The first line should come within 5 s of CFR.
7	Not used	Do not change the settings.

G3 Switch 0B - Not used (do not change the settings).
G3 Switch 0C - Not used (do not change the settings)
G3 Switch 0D - Not used (do not change the settings).

G3 Switch 0E [SP No 1-105-015]		
0-7	Set CNG send time interval Some machines on the receiving side may not be able to automatically switch the 3-second CNG interval.	
	High order bit	3000-2250ms: 3000-50xNms 3000 – 50 x Nms 0F (3000 ms) ≤ N ≤ FF (2250 ms)
	Low order bit	00-0E(3000-3700ms: 3000+50xNms 3000 – 50 x Nms 0F (3000 ms) ≤ N ≤ 0F (3700 ms)

G3 Switch 0F [SP No. 1-105-016]		
No	FUNCTION	COMMENTS
0	Alarm when an error occurred in Phase C or later 0: Disabled 1: Enabled	If the customer wants to hear an alarm after each error communication, change this bit to "1".

Bit Switches

1	Alarm when the handset is off-hook at the end of communication 0: Disabled 1: Enabled	If the customer wants to hear an alarm if the handset is off-hook at the end of fax communication, change this bit to "1".
2/3	Not used	Do not change the settings.
4	Sidaa manual calibration setting 0: Off 1: On	1: manually calibrates for communication with a line, whose current change occurs such as an optical fiber line.
5-7	Not used	Do not change the settings.

4.3.6 G3-2/3 SWITCHES

These switches require an optional G3 interface unit.

G3-3 switches are the same as for G3-2 switches.

G3-2 Switch 00 [SP No. 1-106-001]		
No	FUNCTION	COMMENTS
0-1	Monitor speaker during communication (tx and rx) Bit 1: 0, Bit 0: 0 = Disabled Bit 1: 0, Bit 0: 1 = Up to Phase B Bit 1: 1, Bit 0: 0 = All the time Bit 1: 1, Bit 0: 1 = Not used	(0, 0): The monitor speaker is disabled all through the communication. (0, 1): The monitor speaker is on up to phase B in the T.30 protocol. (1, 0): Used for testing. The monitor speaker is on all through the communication. Make sure that you reset these bits after testing.
2	Monitor speaker during memory transmission 0: Disabled 1: Enabled	1: The monitor speaker is enabled during memory transmission.
3-7	Not used	Do not change the settings.

G3-2 Switch 01 [SP No. 1-106-002]		
No	FUNCTION	COMMENTS
0-3	Not used	Do not change the settings.
4	DIS frame length 0: 10 bytes, 1: 4 bytes	1: The bytes in the DIS frame after the 4th byte will not be transmitted (set to 1 if there are communication problems with PC-based faxes which cannot receive the extended DIS frames).
5	Not used	Do not change the setting.
6	CED/ANSam transmission 0: Disabled 1: Enabled	Do not change this setting, unless the communication problem is caused by the CED/ANSam transmission.
7	Not used	Do not change the setting.

G3-2 Switch 02 [SP No. 1-106-003]		
No	FUNCTION	COMMENTS
0	G3 protocol mode used 0: Standard and non-standard 1: Standard only	Change this bit to 1 only when the other end can only communicate with machines that send T.30-standard frames only. 1: Disables NSF/NSS signals (these are used in non-standard mode communication)
1-4	Not used	Do not change the settings.
5	Use of modem rate history for transmission using Quick/Speed Dials 0: Disabled 1: Enabled	0: Communications using Quick/Speed Dials always start from the highest modem rate. 1: The machine refers to the modem rate history for communications with the same machine when determining the most suitable rate for the current communication.
6	Not used	Do not change the settings.
7	Short preamble	Refer to Appendix B in the Group 3 Facsimile

Bit Switches

	0: Disabled, 1: Enabled	Manual for details about Short Preamble.
--	-------------------------	--

G3-2 Switch 03 [SP No. 1-106-004]		
No	FUNCTION	COMMENTS
0	DIS detection number (Echo countermeasure) 0: 1 1: 2	0: The machine will hang up if it receives the same DIS frame twice. 1: Before sending DCS, the machine will wait for the second DIS which is caused by echo on the line.
1	Not used	Do not change the settings.
2	V.8 protocol 0: Disabled 1: Enabled	0: V.8/V.34 communications will not be possible.  Note <ul style="list-style-type: none"> Do not set to 0 unless the line condition is always bad enough to slow down the data rate to 14.4 kbps or lower.
3	ECM frame size 0: 256 bytes 1: 64 bytes	Keep this bit at "0" in most cases.
4	CTC transmission conditions 0: After one PPR signal received 1: After four PPR signals received (ITU-T standard)	0: When using ECM in non-standard (NSF/NSS) mode, the machine sends a CTC to drop back the modem rate after receiving a PPR, if the following condition is met in communications at 14.4, 12.0, 9.6, and 7.2 kbps. $\sqrt{N_{\text{Transmit}} \leq N_{\text{Resend}}}$ <p>N_{Transmit}- Number of transmitted frames N_{Resend}- Number of frames to be retransmitted</p> 1: When using ECM, the machine sends a CTC to drop back the modem rate after receiving four PPRs.

		PPR, CTC: These are ECM protocol signals. This bit is not effective in V.34 communications.
5	Modem rate used for the next page after receiving a negative code (RTN or PIN) 0: No change, 1: Fallback	1: The machine's tx modem rate will fall back before sending the next page if a negative code is received. This bit is ignored if ECM is being used.
6	Not used	Do not change the settings.
7	Not used	Do not change the settings.

G3-2 Switch 04 [SP No. 1-106-005]		
No	FUNCTION	COMMENTS
0-3	Training error detection threshold	0 - F (Hex); 0 - 15 bits If the number of error bits in the received TCF is below this threshold, the machine informs the sender that training has succeeded.
4-7	Not used	Do not change the settings.

G3-2 Switch 05 [SP No. 1-106-006]						
No	FUNCTION					COMMENTS
0-3	Initial Tx modem rate					These bits set the initial starting modem rate for transmission. Use the dedicated transmission parameters if you need to change this for specific receivers. If a modem rate 14.4 kbps or slower is selected, V.8 protocol should be disabled manually. Cross reference V.8 protocol on/off - G3 switch 03, bit2
	Bit 3	Bit 2	Bit 1	Bit 0	bps	
	0	0	0	1	2.4k	
	0	0	1	0	4.8k	
	0	0	1	1	7.2k	
	0	1	0	0	9.6k	
	0	1	0	1	12.0k	

Bit Switches

	0	1	1	0	14.4k	
	0	1	1	1	16.8k	
	1	0	0	0	19.2k	
	1	0	0	1	21.6k	
	1	0	1	0	24.0k	
	1	0	1	1	26.4k	
	1	1	0	0	28.8k	
	1	1	0	1	31.2k	
	1	1	1	0	33.6k	
	Other settings - Not used					
4-5	Initial modem type for 9.6 k or 7.2 kbps. Bit 5: 0, Bit 4: 0 = V.29 Bit 5: 0, Bit 4: 1 = V.17 Bit 5: 1, Bit 4: 0 = V.34 Bit 5: 1, Bit 4: 1 = Not used					These bits set the initial modem type for 9.6 and 7.2 kbps, if the initial modem rate is set at these speeds.
6-7	Not used					Do not change the settings.

G3-2 Switch 06 [SP No. 1-106-007]						
No	FUNCTION					COMMENTS
0-3	Initial Rx modem rate					<ul style="list-style-type: none"> ▪ These bits set the initial starting modem rate for reception. ▪ Use a lower setting if high speeds pose problems during reception. ▪ If a modem rate 14.4 kbps or slower is selected, V.8 protocol should be disabled manually.
	Bit 3	Bit 2	Bit 1	Bit 0	bps	
	0	0	0	1	2.4k	
	0	0	1	0	4.8k	
	0	0	1	1	7.2k	

	0	1	0	0	9.6k	<p>Cross reference: V.8 protocol on/off - G3 switch 03, bit2</p>
	0	1	0	1	12.0k	
	0	1	1	0	14.4k	
	0	1	1	1	16.8k	
	1	0	0	0	19.2k	
	1	0	0	1	21.6k	
	1	0	1	0	24.0k	
	1	0	1	1	26.4k	
	1	1	0	0	28.8k	
	1	1	0	1	31.2k	
	1	1	1	0	33.6k	
	Other settings - Not used					
4-7	Modem types available for reception					<ul style="list-style-type: none"> The setting of these bits is used to inform the transmitting terminal of the available modem type for the machine in receive mode. If V.34 is not selected, V.8 protocol must be disabled manually. <p>Cross reference: V.8 protocol on/off - G3 switch 03, bit2</p>
	Bit 7	Bit 6	Bit 5	Bit 4	Setting	
	0	0	0	1	V.27ter	
	0	0	1	0	V.27ter,V.29	
	0	0	1	1	V.27ter, V.29, V.33	
	0	1	0	0	V.27ter, V.29, V.17/V.33	
	0	1	0	1	V.27ter, V.29, V.17/V33, V.34	

Bit Switches

	Other settings - Not used	
--	----------------------------------	--

G3-2 Switch 07 [SP No. 1-106-008]		
No	FUNCTION	COMMENTS
0-1	PSTN cable equalizer (tx mode: Internal) Bit 1: 0, Bit 0: 0 = None Bit 1: 0, Bit 0: 1 = Low Bit 1: 1, Bit 0: 0 = Medium Bit 1: 1, Bit 0: 1 = High	Use a higher setting if there is signal loss at higher frequencies because of the length of wire between the modem and the telephone exchange. Use the dedicated transmission parameters for specific receivers. Also, try using the cable equalizer if one or more of the following symptoms occurs. Communication error Modem rate fallback occurs frequently. <div style="border: 1px solid blue; padding: 2px; display: inline-block; margin-top: 5px;"> ↓ Note </div> <ul style="list-style-type: none"> ▪ This setting is not effective in V.34 communications.
2-3	PSTN cable equalizer (rx mode: Internal) Bit 3: 0, Bit 2: 0 = None Bit 3: 0, Bit 2: 1 = Low Bit 3: 1, Bit 2: 0 = Medium Bit 3: 1, Bit 2: 1 = High	Use a higher setting if there is signal loss at higher frequencies because of the length of wire between the modem and the telephone exchange. Also, try using the cable equalizer if one or more of the following symptoms occurs. Communication error with error codes such as 0-20, 0-23, etc. Modem rate fallback occurs frequently. <div style="border: 1px solid blue; padding: 2px; display: inline-block; margin-top: 5px;"> ↓ Note </div> <ul style="list-style-type: none"> ▪ This setting is not effective in V.34 communications.
4	PSTN cable equalizer (V.8/V.17 rx mode: External) 0: Disabled 1: Enabled	Keep this bit at "1".
5	Not used	Do not change the settings.

6	Parameter selection for dial tone detection 0: Normal parameter 1: Specific parameter	0: This uses the fixed table in the ROM for dial tone detection. 1: This uses the specific parameter adjusted with SRAM (69ECBEH - 69ECDEH). Select this if the dial tone cannot be detected when the "Normal parameter: 0" is selected.
7	Not used	Do not change the settings.

G3-2 Switch 08 - Not used (do not change the settings)

G3-2 Switch 09 - Not used (do not change the settings)

G3-2 Switch 0A [SP No. 1-106-011]

No	FUNCTION	COMMENTS
0-1	Maximum allowable carrier drop during image data reception Bit 1: 0, Bit 0: 0 = 200 (ms) Bit 1: 0, Bit 0: 1 = 400 (ms) Bit 1: 1, Bit 0: 0 = 800 (ms) Bit 1: 1, Bit 0: 1 = Not used	These bits set the acceptable modem carrier drop time. Try using a longer setting if error code 0-22 is frequent.
2	Select cancellation of high-speed RX if carrier signal lost while receiving 0: Off 1: On	This switch setting determines if high-speed receiving ends if the carrier signal is lost when receiving during non-ECM mode
3	Not used	Do not change the settings
4	Maximum allowable frame interval during image data reception. 0: 5 s 1: 13 s	This bit set the maximum interval between EOL (end-of-line) signals and the maximum interval between ECM frames from the other end. Try using a longer setting if error code 0-21 is frequent.

Bit Switches

5	Not used	Do not change the settings.
6	Reconstruction time for the first line in receive mode 0: 6 s 1: 12 s	When the sending terminal is controlled by a computer, there may be a delay in receiving page data after the local machine accepts set-up data and sends CFR. This is outside the T.30 recommendation. But, if this delay occurs, set this bit to 1 to give the sending machine more time to send data. Refer to error code 0-20. ITU-T T.30 recommendation: The first line should come within 5 s of CFR.
7	Not used	Do not change the settings.

G3-2 Switch 0B - Not used (do not change the settings.)

G3-2 Switch 0C - Not used (do not change the settings.)

4.3.7 IP FAX SWITCHES

IP Fax Switch 00 [SP No. 1-111-001]		
No.	FUNCTION	COMMENTS
0	Not used	Do not change this setting.
1	IP Fax Transport 0: TCP, 1: UDP	Selects TCP or UDP protocol for IP-Fax
2	IP Fax single port selection 0: OFF, 1: ON (enable)	Selects single data port.
3	IP Fax double ports (single data port) selection 0: OFF, 1: ON (enable)	Selects whether IP-Fax uses a double port.
4	IP Fax Gatekeeper	Enables/disables the communication via the

	0: OFF, 1: ON (enable)	gatekeeper for IP-Fax.
5	IP Fax T30 bit signal reverse 0: LSB first, 1: MSB first	Reverses the T30 bit signal.
6	IP Fax max bit rate setting 0: Not affected, 1: Affected	When "0" is selected, the max bit rate does not affect the value of the DIS/DCS. When "1" is selected, the max bit rate affects the value of the DIS/DCS.
7	IP Fax received telephone number confirmation 0: No confirmation, 1: Confirmation	When "0" is selected, fax data is received without checking the telephone number. When "1" is selected, fax data is received only when confirming that the telephone number from the sender matches the registered telephone number in this machine. If this confirmation fails, the line is disconnected.

IP-Fax Switch 01						
No.	FUNCTION					COMMENTS
0-3	Select IP FAX Delay Level					Raise the level by selecting a higher setting if too many transmission errors are occurring on the network. If TCP/UDP is enabled on the network, raise this setting on the T.30 machine. Increasing the delay time allows the recovery of more lost packets. If only UDP is enabled, increase the number of redundant packets. Level 1~2: 3 Redundant packets Level 3: 4 Redundant packets
	Bit3	Bit2	Bit1	Bit0	Setting	
	0	0	0	0	Level 0	
	0	0	0	1	Level 1	
	0	0	1	0	Level 2	
	0	0	1	1	Level 3	
4-7	IP Fax preamble wait time setting					Selects the preamble wait time. [00 to 0f] There are 16 values in this 4-bit binary

Bit Switches

		<p>switch combination.</p> <p>Waiting time: set value level x 100 ms</p> <p>Max: 0f (1500 ms) Min: 00 (No wait time)</p> <p>The default is "0000" (00H).</p>
--	--	--

IP Fax Switch 02 [SP No. 1-111-003]		
No.	FUNCTION	COMMENTS
0	<p>IP Fax bit signal reverse setting</p> <p>0: Maker code setting</p> <p>1: Internal bit switch setting</p>	<p>When "0" is selected, the bit signal reverse method is decided by the maker code.</p> <p>When "1" is selected, the bit signal reverse method is decided by the internal bit switch.</p> <p>(When communicating between IP Fax devices, LSB first is selected.)</p>
1	<p>IP Fax transmission speed setting</p> <p>0: Modem speed</p> <p>1: No limitation</p>	<p>Selects the transmit speed for IP Fax communication.</p>
2	<p>SIP transport setting</p> <p>0: TCP</p> <p>1: UDP</p>	<p>This bit switch sets the transport that has priority for receiving IP Fax data.</p> <p>This function is activated only when the sender has both TCP and UDP.</p>
3	<p>CCM connection</p> <p>0: No CCM connection</p> <p>1: CCM connection</p>	<p>When "1" is selected, only the connection call message with H.323 or no tunneled H.245 is transmitted via CCM.</p>
4	<p>Message reception selection from non-registered SIP server</p> <p>0: Answer</p> <p>1: Not answer</p>	<p>0: This answers the INVITE message from the SIP server not registered for the machine.</p> <p>1: This does not receive the INVITE message from the SIP server not registered for the machine and send a refusal message.</p>
5	<p>ECM communication setting</p> <p>0: No limit for image compression</p>	<p>0: This does not limit the type of the image compression with ECM communication.</p>

	1: Limit for image compression	1: When the other end machine is Cisco, this permits the image compression other than JBIG or MMR with ECM communication.
6-7	Not used	Do not change these settings.

IP Fax Switch 03 [SP No. 1-111-004]		
No.	FUNCTION	COMMENTS
0	Effective field limitation for G3 standard function information 0: OFF, 1: 4byte (DIS)	Limits the effective field for standard G3 function information.
1	Switching between G3 standard and G3 non standard 0: Enable switching 1: G3 standard only	Enables/disables switching between G3 standard and G3 non-standard.
2	Not used.	Do not change this setting.
3	ECM frame size selection at transmitting 0: 256byte, 1: 64byte	Selects the ECM frame size for sending.
4	DIS detection times for echo prevention 0: 1 time, 1: 2 times	Sets the number of times for DIS to detect echoes.
5	CTC transmission selection 0: PPRx1 1: PPRx4	When "0" is selected, the transmission condition is decided by error frame numbers. When "1" is selected, the transmission condition is based on the ITU-T method.
6	Shift down setting at receiving negative code 0: OFF, 1: ON	Selects whether to shift down when negative codes are received.
7	Not used	Do not change this setting.

Bit Switches

IP Fax Switch 04 [SP No. 1-111-005]		
No.	FUNCTION	COMMENTS
0	TCF error threshold	Sets the TCF error threshold level. [00 to 0f] The default is "1111" (0fH).
1		
2		
3		
4-7	Not used	Do not change these settings.

IP Fax Switch 05 [SP No. 1-111-006]						
No.	FUNCTION				COMMENTS	
0-3	Modem bit rate setting for transmission				Sets the modem bit rate for transmission. The default is "0110" (14.4K bps).	
	Bit 3	Bit 2	Bit 1	Bit 0		
	0	0	0	1		2400 bps
	0	0	1	1		4800 bps
	0	0	1	1		7200 bps
	0	1	0	0		9600 bps
	0	1	0	1		12.0 Kbps
	0	1	1	0		14.4 Kbps
	0	1	1	1		16.8 Kbps
	1	0	0	0		19.2 Kbps
	1	0	0	1		21.6 Kbps
	1	0	1	0		24.0 Kbps

	1	0	1	1	26.4 Kbps
	1	1	0	0	28.8 Kbps
	1	1	0	1	31.2 Kbps
	1	1	1	0	33.6 Kbps
4-5	<p>Modem setting for transmission Sets the modem for transmission. The default is "00" (V29). Bit 5: 0, Bit 4: 0 = V29 Bit 5: 0, Bit 4: 1 = V17 Bit 5: 1, Bit 4: 0 = V34* Bit 5: 1, Bit 4: 1 = Not used *V34 is not supported for IP-Fax communication.</p>				
6-7	Not used		Do not change these settings.		

IP Fax Switch 06 [SP No. 1-111-007]					
No.	FUNCTION			COMMENTS	
0-3	Modem bit rate setting for reception Sets the modem bit rate for reception. The default is "0110" (14.4K bps).				
	Bit 3	Bit 2	Bit 1	Bit 0	
	0	0	0	1	2400 bps
	0	0	1	0	4800 bps
	0	0	1	1	7200 bps
	0	1	0	0	9600 bps
	0	1	0	1	12.0 Kbps
	0	1	1	0	14.4 Kbps
	0	1	1	1	16.8 Kbps

Bit Switches

	1	0	0	0	19.2 Kbps
	1	0	0	1	21.6 Kbps
	1	0	1	0	24.0 Kbps
	1	0	1	1	26.4 Kbps
	1	1	0	0	28.8 Kbps
	1	1	0	1	31.2 Kbps
	1	1	1	0	33.6 Kbps
4-7	Modem setting for reception Sets the modem type for reception. The default is "0100" (V27ter, V29, V17).				
	Bit 7	Bit 6	Bit 5	Bit 4	
	0	0	0	1	V27ter
	0	0	1	0	V27ter, V29
	0	0	1	1	V27ter, V29, V33 (invalid)
	0	1	0	0	V27ter, V29, V17
	0	1	0	1	V27ter, V29, V17, V34*
	*V34 is not supported for IP-Fax communication.				

IP Fax Switch 07 [SP No. 1-111-008]		
No.	FUNCTION	COMMENTS
0	TSI information 0: Not added, 1: Added	Adds or does not add TSI information to NSS(S).
1	DCN transmission setting at T1	Transmits or does not transmit DCN at T1

	timeout 0: Not transmitted, 1: Transmitted	timeout.
2	Not used	Do not change this setting.
3	Hang up setting at DIS reception disabled 0: No hang up 1: Hang up after transmitting DCN	Sets whether the machine disconnects after DIS reception.
4	Number of times for training 0: 1 time, 1: 2 times	Selects the number of times training is done at the same bit rate.
5	Space CSI transmission setting at no CSI registration 0: Not transmitted, 1: Transmitted	When "0" is selected, frame data is enabled. When "1" is selected, the transmitted data is all spaces.
6-7	Not used	Do not change these settings.

IP Fax Switch 08 [SP No. 1-111-009]		
No.	FUNCTION	COMMENTS
0-1	T1 timer adjustment Adjusts the T1 timer. The default is "00" (35 seconds). Bit 1: 0, Bit 0: 0 = 35 sec Bit 1: 0, Bit 0: 1 = 40 sec Bit 1: 1, Bit 0: 0 = 50 sec Bit 1: 1, Bit 0: 1 = 60 sec	-
2-3	T4 timer adjustment Adjust the T4 timer. The default is "00" (3 seconds). Bit 3: 0, Bit 2: 0 = 3 sec Bit 3: 0, Bit 2: 1 = 3.5 sec Bit 3: 1, Bit 2: 0 = 4 sec Bit 3: 1, Bit 2: 1 = 5 sec	-

Bit Switches

4-5	<p>T0 timer adjustment</p> <p>Bit 5: 0, Bit 4: 0 = 75 sec</p> <p>Bit 5: 0, Bit 4: 1 = 120 sec</p> <p>Bit 5: 1, Bit 4: 0 = 180 sec</p> <p>Bit 5: 1, Bit 4: 1 = 240 sec</p>	<p>Adjusts the fail safe timer. This timer sets the interval between "setup" data transmission and T.38 phase decision. If your destination return is late on the network or G3 fax return is late, adjust the longer interval timer.</p> <p>The default is "00" (75 seconds).</p>
6-7	Not used	Do not change these settings.

IP Fax Switch 09 [SP No. 1-111-010]		
No.	FUNCTION	COMMENTS
0	<p>Network I/F setting for SIP connection</p> <p>0: IPv4</p> <p>1: IPv6.</p>	<p>Selects the connection type (IPV4 or IPV6) to connect the SIP server.</p>
1	<p>Network I/F setting for Fax communication</p> <p>0: Same setting as SIP server connection</p> <p>1: Automatic setting</p>	<p>0: The I/F setting for Fax communication follows the setting for SIP server connection.</p> <p>1: The negotiation between the SIP server and the device decides whether IPv4 or IPv6 is used for I/F setting for Fax communication.</p>
2	<p>Record-route setting</p> <p>0: Disable</p> <p>1: Enable</p>	<p>0: Disables the record-route function of the SIP server.</p> <p>1: Enables the record-route function of the SIP server.</p>

4.4 NCU PARAMETERS

The following tables give the RAM addresses and the parameter calculation units that the machine uses for ringing signal detection and automatic dialing. The factory settings for each country are also given. Most of these must be changed by RAM read/write (SP2-102), but some can be changed using NCU Parameter programming (SP2-103, 104 and 105); if SP2-103, 104 and 105 can be used, this will be indicated in the Remarks column. The RAM is programmed in hex code unless (BCD) is included in the Unit column.

Note

- The following addresses describe settings for the standard NCU.
- Change the fourth digit from “5” to “6” (e.g. 680500 to 680600) for the settings for the first optional G3 interface unit and from “5” to “7” (e.g. 680700) for the settings for the second optional G3 interface unit.

Address	Function					
680500	Country/Area code for NCU parameters					
	Use the Hex value to program the country/area code directly into this address, or use the decimal value to program it using SP2-103-001					
	Country /Area	Decimal	Hex	Country /Area	Decimal	Hex
	France	00	00	USA	17	11
	Germany	01	01	Asia	18	12
	UK	02	02	Hong Kong	20	14
	Italy	03	03	South Africa	21	15
	Austria	04	04	Australia	22	16
	Belgium	05	05	New Zealand	26	17
	Denmark	06	06	Singapore	24	18
	Finland	07	07	Malaysia	25	19
	Ireland	08	08	China	26	1A
	Norway	09	09	Taiwan	27	1B

NCU Parameters

Address	Function					
	Sweden	10	0A	Korea	28	1C
	Switzerland	11	0B	Turkey	32	20
	Portugal	12	0C	Greece	33	21
	Holland	13	0D	Hungary	34	22
	Spain	14	0E	Czech	35	23
	Israel	15	0F	Poland	36	24

Address	Function	Unit	Remarks
680501	Line current detection time	20 ms	Line current detection is disabled. Line current is not detected if 680501 contains FF.
680502	Line current wait time		
680503	Line current drop detect time		
680504	PSTN dial tone frequency upper limit (high byte)	Hz (BCD)	If both addresses contain FF(H), tone detection is disabled.
680505	PSTN dial tone frequency upper limit (low byte)		
680506	PSTN dial tone frequency lower limit (high byte)	Hz (BCD)	If both addresses contain FF(H), tone detection is disabled.
680507	PSTN dial tone frequency lower limit (low byte)		
680508	PSTN dial tone detection time	20 ms	If 680508 contains FF(H), the machine pauses for the pause time (address 68050D / 68050E). Italy: See Note 2.
680509	PSTN dial tone reset time (LOW)		
68050A	PSTN dial tone reset time (HIGH)		
68050B	PSTN dial tone continuous tone time		

Address	Function	Unit	Remarks
68050C	PSTN dial tone permissible drop time		
68050D	PSTN wait interval (LOW)		
68050E	PSTN wait interval (HIGH)		-
68050F	PSTN ring-back tone detection time	20 ms	Detection is disabled if this contains FF.
680510	PSTN ring-back tone off detection time	20 ms	-
680511	PSTN detection time for silent period after ring-back tone detected (LOW)	20 ms	-
680512	PSTN detection time for silent period after ring-back tone detected (HIGH)	20 ms	-
680513	PSTN busy tone frequency upper limit (high byte)	Hz (BCD)	If both addresses contain FF(H), tone detection is disabled.
680514	PSTN busy tone frequency upper limit (low byte)		
680515	PSTN busy tone frequency lower limit (high byte)	Hz (BCD)	If both addresses contain FF(H), tone detection is disabled.
680516	PSTN busy tone frequency lower limit (low byte)		
680517	PABX dial tone frequency upper limit (high byte)	Hz (BCD)	If both addresses contain FF(H), tone detection is disabled.
680518	PABX dial tone frequency upper limit (low byte)		
680519	PABX dial tone frequency lower	Hz (BCD)	If both addresses

NCU Parameters

Address	Function	Unit	Remarks
	limit (high byte)		contain FF(H), tone detection is disabled.
68051A	PABX dial tone frequency lower limit (low byte)		
68051B	PABX dial tone detection time	20 ms	If 68051B contains FF, the machine pauses for the pause time (680520 / 680521).
68051C	PABX dial tone reset time (LOW)		
68051D	PABX dial tone reset time (HIGH)		
68051E	PABX dial tone continuous tone time		
68051F	PABX dial tone permissible drop time		
680520	PABX wait interval (LOW)		
680521	PABX wait interval (HIGH)		-
680522	PABX ringback tone detection time	20 ms	If both addresses contain FF(H), tone detection is disabled.
680523	PABX ringback tone off detection time	20 ms	
680524	PABX detection time for silent period after ringback tone detected (LOW)	20 ms	If both addresses contain FF(H), tone detection is disabled.
680525	PABX detection time for silent period after ringback tone detected (HIGH)	20 ms	
680526	PABX busy tone frequency upper limit (high byte)	Hz (BCD)	If both addresses contain FF(H), tone detection is disabled.
680527	PABX busy tone frequency upper limit (low byte)		
680528	PABX busy tone frequency lower	Hz (BCD)	If both addresses

Address	Function	Unit	Remarks
	limit (high byte)		contain FF(H), tone detection is disabled.
680529	PABX busy tone frequency lower limit (low byte)		
68052A	Busy tone ON time: range 1	20 ms	-
68052B	Busy tone OFF time: range 1		
68052C	Busy tone ON time: range 2		
68052D	Busy tone OFF time: range 2		
68052E	Busy tone ON time: range 3		
68052F	Busy tone OFF time: range 3	20 ms	
680530	Busy tone ON time: range 4		
680531	Busy tone OFF time: range 4		
680532	Busy tone continuous tone detection time		
680533	<p>Busy tone signal state time tolerance for all ranges, and number of cycles required for detection (a setting of 4 cycles means that ON-OFF-ON or OFF-ON-OFF must be detected twice).</p> <p>Tolerance (±)</p> <p>Bit 1: 0, Bit 0: 0 = 75% Bits 2 and 3 must always be kept at 0.</p> <p>Bit 1: 0, Bit 0: 0 = 50% Bits 2 and 3 must always be kept at 0.</p> <p>Bit 1: 0, Bit 0: 0 = 25%</p> <p>Bit 1: 0, Bit 0: 0 = 12.5%</p> <p>Bits 7, 6, 5, 4 - number of cycles required for cadence detection</p>		
680534	International dial tone frequency upper limit (high byte)	Hz (BCD)	If both addresses contain FF(H), tone detection is disabled.
680535	International dial tone frequency upper limit (low byte)		
680536	International dial tone frequency	Hz (BCD)	If both addresses

NCU Parameters

Address	Function	Unit	Remarks
	lower limit (high byte)		contain FF(H), tone detection is disabled.
680537	International dial tone frequency lower limit (low byte)		
680538	International dial tone detection time	20 ms	If 680538 contains FF, the machine pauses for the pause time (68053D / 68053E). Belgium: See Note 2.
680539	International dial tone reset time (LOW)		
68053A	International dial tone reset time (HIGH)		
68053B	International dial tone continuous tone time		
68053C	International dial tone permissible drop time		
68053D	International dial wait interval (LOW)		
68053E	International dial wait interval (HIGH)		
68053F	Country dial tone upper frequency limit (HIGH)	Hz (BCD)	If both addresses contain FF(H), tone detection is disabled.
680540	Country dial tone upper frequency limit (LOW)		
680541	Country dial tone lower frequency limit (HIGH)		If both addresses contain FF(H), tone detection is disabled.
680542	Country dial tone lower frequency limit (LOW)		
680543	Country dial tone detection time	20 ms	If 680543 contains FF, the machine pauses for
680544	Country dial tone reset time (LOW)		

Address	Function	Unit	Remarks
680545	Country dial tone reset time (HIGH)		the pause time (680548 / 680549).
680546	Country dial tone continuous tone time	-	-
680547	Country dial tone permissible drop time	20 ms	-
680548	Country dial wait interval (LOW)		
680549	Country dial wait interval (HIGH)		
68054A	Time between opening or closing the DO relay and opening the OHD1 relay	1 ms	See Notes 3, 6 and 8. SP2-103-012 (parameter 11).
68054B	Break time for pulse dialing	1 ms	See Note 3. SP2-103-013 (parameter 12).
68054C	Make time for pulse dialing	1 ms	See Note 3. SP2-103-014 (parameter 13).
68054D	Time between final OHD1 relay closure and DO relay opening or closing	1 ms	See Notes 3, 6 and 8. SP2-103-015 (parameter 14). This parameter is only valid in Europe.
68054E	Minimum pause between dialed digits (pulse dial mode)	20 ms	See Note 3 and 8. SP2-103-016 (parameter 15).
68054F	Time waited when a pause is entered at the operation panel		SP2-103-017 (parameter 16). See Note 3.

NCU Parameters

Address	Function	Unit	Remarks
680550	DTMF tone on time	1 ms	SP2-103-018 (parameter 17).
680551	DTMF tone off time		SP2-103-019 (parameter 18).
680552	Tone attenuation level of DTMF signals while dialing	-N x 0.5 -3.5 dBm	SP2-103-020 (parameter 19). See Note 5.
680553	Tone attenuation value difference between high frequency tone and low frequency tone in DTMF signals	-dBm x 0.5	SP2-103-021 (parameter 20). The setting must be less than -5dBm, and should not exceed the setting at 680552h above. See Note 5.
680554	PSTN: DTMF tone attenuation level after dialling	-N x 0.5 -3.5 dBm	SP2-103-022 (parameter 21). See Note 5.
680555	ISDN: DTMF tone attenuation level after dialling	-dBm x 0.5	See Note 5
680556	Not used	-	Do not change the settings.
680557	Time between 68054Dh (NCU parameter 14) and 68054Eh (NCU parameter 15)	1 ms	This parameter takes effect when the country code is set to France.
680558	Not used	-	Do not change the setting.
680559	Grounding time (ground start mode)	20 ms	The Gs relay is closed for this interval.
68055A	Break time (flash start mode)	1 ms	The OHDI relay is open

Address	Function	Unit	Remarks
			for this interval.
68055B	International dial access code (High)	BCD	For a code of 100: 68055B - F1 68055C - 00
68055C	International dial access code (Low)		
68055D	PSTN access pause time	20 ms	This time is waited for each pause input after the PSTN access code. If this address contains FF[H], the pause time stored in address 68054F is used. Do not set a number more than 7 in the UK.
68055E	Progress tone detection level, and cadence detection enable flags	Bit 7: 0, Bit 6: 0, Bit 5: 0 = -25.0 dBm Bit 7: 0, Bit 6: 0, Bit 5: 1 = -35.0 dBm Bit 7: 0, Bit 6: 1, Bit 5: 0 = -30.0 dBm Bit 7: 1, Bit 6: 0, Bit 5: 0 = -40.0 dBm Bit 7: 1, Bit 6: 1, Bit 5: 0 = -49.0 dBm Bits 2, 0 - See Note 2.	
68055F To 680564	Not used	-	Do not change the settings.
680565	Long distance call prefix (HIGH)	BCD	For a code of 0: 680565 – FF 680566 - FF
680566	Long distance call prefix (LOW)	BCD	
680567 to 680571	Not used	-	Do not change the settings.
680572	Acceptable ringing signal frequency: range 1, upper limit	1000/ N (Hz).	SP2-103-003 (parameter 02).

NCU Parameters

Address	Function	Unit	Remarks
680573	Acceptable ringing signal frequency: range 1, lower limit		SP2-103-004 (parameter 03).
680574	Acceptable ringing signal frequency: range 2, upper limit		SP2-103-005 (parameter 04).
680575	Acceptable ringing signal frequency: range 2, lower limit		SP2-103-006 (parameter 05).
680576	Number of rings until a call is detected	1	SP2-103-007 (parameter 06). The setting must not be zero.
680577	Minimum required length of the first ring	20 ms	See Note 4. SP2-103-008 (parameter 07).
680578	Minimum required length of the second and subsequent rings	20 ms	SP2-103-009 (parameter 08).
680579	Ringing signal detection reset time (LOW)	20 ms	SP2-103-010 (parameter 09).
68057A	Ringing signal detection reset time (HIGH)		SP2-103-011 (parameter 10).
68057B to 680580	Not used	-	Do not change the settings.
680581	Interval between dialing the last digit and switching the Oh relay over to the external telephone when dialing from the operation panel in handset mode.	20 ms	Factory setting: 500 ms
680582	Bits 0 and 1 - Handset off-hook detection time Bit 1:0, Bit 0: 0 = 200 ms		-

Address	Function	Unit	Remarks
	Bit 1:0, Bit 0: 1 = 800 ms Other Not used Bits 2 and 3 - Handset on-hook detection time Bit 3: 0, Bit 2: 0 = 200 ms Bit 3: 0, Bit 2: 1 = 800 ms Other Not used Bits 4 to 7 - Not used		
680583 To 6805A0	Not used	-	Do not change the settings.
6805A1	Acceptable CED detection frequency upper limit (high byte)	BCD (Hz)	If both addresses contain FF(H), tone detection is disabled.
6805A2	Acceptable CED detection frequency upper limit (low byte)		
6805A3	Acceptable CED detection frequency lower limit (high byte)	BCD (Hz)	If both addresses contain FF(H), tone detection is disabled.
6805A4	Acceptable CED detection frequency lower limit (low byte)		
6805A5	CED detection time	20 ms ± 20 ms	Factory setting: 200 ms
6805A6	Acceptable CNG detection frequency upper limit (high byte)	BCD (Hz)	If both addresses contain FF(H), tone detection is disabled.
6805A7	Acceptable CNG detection frequency upper limit (low byte)		
6805A8	Acceptable CNG detection frequency lower limit (high byte)	BCD (Hz)	If both addresses contain FF(H), tone detection is disabled.
6805A9	Acceptable CNG detection frequency lower limit (low byte)		

NCU Parameters

Address	Function	Unit	Remarks
6805AA	Not used	-	Do not change the setting.
6805AB	CNG on time	20 ms	Factory setting: 500 ms
6805AC	CNG off time	20 ms	Factory setting: 3000 ms
6805AD	Number of CNG cycles required for detection	-	The data is coded in the same way as address 680533.
6805AE	Not used	-	Do not change the settings.
6805AF	Acceptable AI short protocol tone (800Hz) detection frequency upper limit (high byte)	Hz (BCD)	If both addresses contain FF(H), tone detection is disabled.
6805B0	Acceptable AI short protocol tone (800Hz) detection frequency upper limit (low byte)		
6805B1	Acceptable AI short protocol tone (800Hz) detection frequency lower limit (high byte)	Hz(BCD)	If both addresses contain FF(H), tone detection is disabled.
6805B2	Acceptable AI short protocol tone (800Hz) detection frequency lower limit (low byte)		
6805B3	Detection time for 800 Hz AI short protocol tone	20 ms	Factory setting: 360 ms
6805B4	PSTN: Tx level from the modem	-N – 3 dBm	SP2-103-002 (parameter 01).
6805B5	PSTN: 1100 Hz tone transmission level	- N 6805B4 - 0.5N 6805B5 –3.5 (dB) See Note 7.	
6805B6	PSTN: 2100 Hz tone transmission	- N6805B4 - 0.5N 6805B6 –3 (dB)	

Address	Function	Unit	Remarks
	level	See Note 7.	
6805B7	PABX: Tx level from the modem	- dBm	
6805B8	PABX: 1100 Hz tone transmission level	- N 6805B7 - 0.5N 6805B8 (dB)	
6805B9	PABX: 2100 Hz tone transmission level	- N 6805B7 - 0.5N 6805B9 (dB)	
6805BD	Modem turn-on level (incoming signal detection level)	-37-0.5N (dBm)	
6805BE to 6805C6	Not used	-	Do not change the settings.
6805C7	Bits 0 to 3 – Not used Bit 4 = V.34 protocol dump 0: Simple, 1: Detailed (default) Bits 5 to 7 – Not used.		
6805C8 to 6805D9	Not used	-	Do not change the settings.
6805DA	T.30 T1 timer	1 s	
6805E0 bit 3	Maximum wait time for post message	0: 12 s 1: 30 s	1: Maximum wait time for post message (EOP/EOM/MPS) can be changed to 30 s. Change this bit to “1” if communication errors occur frequently during V.17 reception.
6805E3	Voltage setting to detect off-hook for voltage/DP detection for an externally connected line.	0: Auto 1: Fixed V	Do not change these settings

NCU Parameters

Address	Function					Unit	Remarks	
	Here is a summary of the fixed voltage settings (1: Fixed) for an externally connected line.							
	Bit 7	Bit 6	Bit 5	Bit 4	-			
	0	0	0	0	Not used			
	0	0	0	1	2.75 V			
	0	0	1	0	5.5 V			
	1	0	0	0	22 V			
	1	1	1	1	41.25 V			
6805E4	Bit 1 sets the level of the call signal, Bit 3 sets the call signal impedance			Bit 1	0	RT=0 (Low)	-	
					1	RT=1 (High)		
				Bit 3	0	RZ=0 (High)		
					1	RZ=1 (Composite)		
6805E5	Bit 0 sets the ring detection method, Bit 1 sets the ring detection method when fixed.			Bit 0	0	Auto	If any setting is changed, select a setting that is higher than the default setting.	
					1	Fixed		
				Bit 1	0	Use RDTP		
					1	Use RDTN		
	Here is a summary of the voltages for the detection of off-hook for DP detection.							
	Bit 7	Bit 6	Bit 5	Bit 4	-			
	0	0	0	0	Not used			
	0	0	0	1	2.75 V			
	0	0	1	0	5.5 V			

Address	Function				Unit	Remarks
	1	0	0	0	22 V	
	1	1	1	1	41.25 V	

NOTES

1. If a setting is not required, store FF in the address.
2. Italy and Belgium only
 RAM address 68055E: the lower four bits have the following meaning.
 Bit 2 - 1: International dial tone cadence detection enabled (Belgium)
 Bit 1 - Not used
 Bit 0 - 1: PSTN dial tone cadence detection enabled (Italy)

 If bit 0 or bit 2 is set to 1, the functions of the following RAM addresses are changed.
 680508 (if bit 0 = 1) or 680538 (if bit 2 = 1): tolerance for on or off state duration (%), and number of cycles required for detection, coded as in address 680533.
 68050B (if bit 0 = 1) or 68053B (if bit 2 = 1): on time, hex code (unit = 20 ms)
 68050C (if bit 0 = 1) or 68053C (if bit 2 = 1): off time, hex code (unit = 20 ms)
3. Pulse dial parameters (addresses 68054A to 68054F) are the values for 10 pps. If 20 pps is used, the machine automatically compensates.
4. The first ring may not be detected until 1 to 2.5 wavelengths after the time specified by this parameter.
5. The calculated level must be between 0 and 10.
 The attenuation levels calculated from RAM data are:
 High frequency tone:
 - $-0.5 \times N_{680552/680554} - 3.5$ dBm
 - $-0.5 \times N_{680555}$ dBm
 Low frequency tone:
 - $-0.5 \times (N_{680552/680554} + N_{680553}) - 3.5$ dBm
 - $-0.5 \times (N_{680555} + N_{680553})$ dBm

Note

 - N_{680552} , for example, means the value stored in address 680552(H)
6. 68054A: Europe - Between Ds opening and Di opening, France - Between Ds closing and Di opening
 68054D: Europe - Between Ds closing and Di closing, France - Between Ds opening

NCU Parameters

and Di closing

7. Tone signals which frequency is lower than 1500Hz (e.g., 800Hz tone for AI short protocol) refer to the setting at 6805B5h. Tones which frequency is higher than 1500Hz refer to the setting at 6805B6h.
8. 68054A, 68054D, 68054E: The actual inter-digit pause (pulse dial mode) is the sum of the period specified by the RAM addresses 68054A, 68054D, and 68054E.

4.5 DEDICATED TRANSMISSION PARAMETERS

There are two sets of transmission parameters: Fax and E-mail

Each Quick Dial Key and Speed Dial Code has eight bytes of programmable parameters allocated to it. If transmissions to a particular machine often experience problems, store that terminal's fax number as a Quick Dial or Speed Dial, and adjust the parameters allocated to that number.

The programming procedure will be explained first. Then, the eight bytes will be described.

4.5.1 PROGRAMMING PROCEDURE

1. Set the bit 0 of System Bit Switch 00 to 1.
2. Enter Address Book Management mode ([User Tools]> System Settings> Key Operator> Address Book Management).
3. Select the address book that you want to program.
4. For the fax parameter, select "Fax Dest.", for the E-mail parameter, select "E-mail", then press "Start". Make sure that the LED of the Start button lights green.
5. The settings for the switch 00 are now displayed. Press the bit number that you wish to change.
6. To scroll through the parameter switches, either:
7. Select the next switch: press "Next" or Select the previous switch: "Prev." until the correct switch is displayed. Then go back to step 6.
8. After the setting is changed, press "OK".
9. After finishing, reset bit 0 of System Bit Switch 00 to 0.

4.5.2 PARAMETERS

Fax Parameters

The initial settings of the following fax parameters are all FF(H) - all the parameters are disabled.

Switch 00
FUNCTION AND COMMENTS
ITU-T T1 time (for PSTN G3 mode) If the connection time to a particular terminal is longer than the NCU parameter setting, adjust this byte. The T1 time is the value stored in this byte (in hex code), multiplied by 1

Dedicated Transmission Parameters

second.

Range:

0 to 120 s (00h to 78h)

FFh - The local NCU parameter factory setting is used.

Do not program a value between 79h and FEh.

Switch 01							
No	FUNCTION					COMMENTS	
0-4	Tx level					<p>If communication with a particular remote terminal often contains errors, the signal level may be inappropriate. Adjust the Tx level for communications with that terminal until the results are better.</p> <p>If the setting is "Disabled", the NCU parameter 01 setting is used.</p> <p>↓ Note</p> <ul style="list-style-type: none"> Do not use settings other than listed on the left. 	
	Bit4	Bit3	Bit2	Bit1	Bit0		
	0	0	0	0	0		0
	0	0	0	0	1		-1
	0	0	0	1	0		-2
	0	0	0	1	1		-3
	0	0	1	0	0		-4
	↓	↓	↓	↓	↓		↓
	0	1	1	1	1		-15
	1	1	1	1	1		Disabled
5-7	<p>Cable equalizer</p> <p>Bit 7: 0, Bit 6: 0, Bit 5: 0 = None</p> <p>Bit 7: 0, Bit 6: 0, Bit 5: 1 = Low</p> <p>Bit 7: 0, Bit 6: 1, Bit 5: 0 = Medium</p> <p>Bit 7: 0, Bit 6: 1, Bit 5: 1 = High</p> <p>Bit 7: 1, Bit 6: 1, Bit 5: 1 = Disabled</p>					<p>Use a higher setting if there is signal loss at higher frequencies because of the length of wire between the modem and the telephone exchange when calling the number stored in this Quick/Speed Dial.</p> <p>Also, try using the cable equalizer if one or more of the following symptoms occurs.</p> <p>Communication error with error codes such as 0-20, 0-23, etc.</p>	

Dedicated Transmission Parameters

		<p>Modem rate fallback occurs frequently.</p> <p>↓ Note</p> <ul style="list-style-type: none"> Do not use settings other than listed on the left. <p>If the setting is “Disabled”, the bit switch setting is used.</p>
--	--	---

Switch 02						
No	FUNCTION					COMMENTS
0-3	Initial Tx modem rate					<p>If training with a particular remote terminal always takes too long, the initial modem rate may be too high. Reduce the initial Tx modem rate using these bits.</p> <p>For the settings 14.4 or kbps slower, Switch 04 bit 4 must be changed to 0.</p> <p>↓ Note</p> <ul style="list-style-type: none"> Do not use settings other than listed on the left. If the setting is “Disabled”, the bit switch setting is used.
	Bit3	Bit2	Bit1	Bit0	bps	
	0	0	0	0	Not used	
	0	0	0	1	2400	
	0	0	1	0	4800	
	0	0	1	1	7200	
	0	1	0	0	9600	
	0	1	0	1	12000	
	0	1	1	0	14400	
	0	1	1	1	16800	
	1	0	0	0	19200	
	1	0	0	1	21600	
	1	0	1	0	24000	
	1	0	1	1	26400	
	1	1	0	0	28800	
1	1	0	1	31200		

Dedicated Transmission Parameters

	1	1	1	0	33600	
	1	1	1	1	Disabled	
	Other settings: Not used					
4-7	Not used					Do not change the settings.

Switch 03		
No	FUNCTION	COMMENTS
0-1	Inch-mm conversion before tx Bit 1: 0, Bit 0: 0 = Inch-mm conversion available Bit 1: 0, Bit 0: 1 = Inch only Bit 1: 1, Bit 0: 0 = Not used Bit 1: 1, Bit 0: 1 = Disabled	The machine uses inch-based resolutions for scanning. If "inch only" is selected, the printed copy may be slightly distorted at the other end if that machine uses mm-based resolutions. If the setting is "Disabled", the bit switch setting is used.
2-3	DIS/NSF detection method Bit 3: 0, Bit 2: 0 = First DIS or NSF Bit 3: 0, Bit 2: 1 = Second DIS or NSF Bit 3: 1, Bit 2: 0 = Not used Bit 3: 1, Bit 2: 1 = Disabled	(0, 1): Use this setting if echoes on the line are interfering with the set-up protocol at the start of transmission. The machine will then wait for the second DIS or NSF before sending DCS or NSS. If the setting is "Disabled", the bit switch setting is used.
4	V.8 protocol 0: Off 1: Disabled	If transmissions to a specific destination always end at a lower modem rate (14,400 bps or lower), disable V.8 protocol so as not to use V.34 protocol. 0: V.34 communication will not be possible. If the setting is "Disabled", the bit switch setting is used.
5	Compression modes available in transmit mode 0: MH only 1: Disabled	This bit determines the capabilities that are informed to the other terminal during transmission. If the setting is "Disabled", the bit switch setting is used.

6-7	ECM during transmission Bit 7: 0, Bit 6: 0 = Off Bit 7: 0, Bit 6: 1 = On Bit 7: 1, Bit 6: 0 = Not used Bit 7: 1, Bit 6: 1 = Disabled	For example, if ECM is switched on but is not wanted when sending to a particular terminal, use the (0, 0) setting. ↓ Note <ul style="list-style-type: none"> ▪ V.8/V.34 protocol and JBIG compression are automatically disabled if ECM is disabled. ▪ If the setting is “Disabled”, the bit switch setting is used.
-----	--	--

Switch 04 - Not used (do not change the settings)
Switch 05 - Not used (do not change the settings)
Switch 06 - Not used (do not change the settings)
Switch 07 - Not used (do not change the settings)
Switch 08 - Not used (do not change the settings)
Switch 09 - Not used (do not change the settings)

E-mail Parameters

The initial settings of the following e-mail parameters are all "0" (all parameters disabled).

Switch 00		
No	FUNCTION	COMMENTS
0	MH Compression mode for e-mail attachments 0: Off 1: On	Switches MH compression on and off for files attached to e-mails for sending.
1	MR Compression mode for e-mail attachments 0: Off 1: On	Switches MR compression on and off for files attached to e-mails for sending.

Dedicated Transmission Parameters

2	MMR Compression mode for e-mail attachments 0: Off 1: On	Switches MMR compression on and off for files attached to e-mails for sending.
3-6	Not used	Do not change these settings.
7	Designates the bits to reference for compression method of e-mail attachments 0: Registered (Bit 0 to 6) 1: No registration.	The "0" selection (default) references the settings for Bits 00, 01, 02 above. The "1" selection ignores the selections of Bits 00, 01, 02.

Switch 01		
No	FUNCTION	COMMENTS
0	Original width of e-mail attachment: A4 0: Off 1: On	Sets the original width of the e-mail attachment as A4.
1	Original width of e-mail attachment: B4 0: Off 1: On	Sets the original width of the e-mail attachment as B4.
2	Original width of e-mail attachment: A3 0: Off 1: On	Sets the original width of the e-mail attachment as A3.
3-6	Not used	Do not change these settings.
7	Designates the bits to reference for original size of e-mail attachments 0: Registered (Bit 0 to 6)	The "0" selection (default) references the settings for Bits 00, 01, 02 above. The "1" selection ignores the selections of Bits 00, 01, 02.

	1: No registration.	
--	---------------------	--

Switch 02		
No	FUNCTION	COMMENTS
0	Line resolution of e-mail attachment: 200 x 100 0: Off 1: On	Sets the line resolution of the e-mail attachment as 200 x100.
1	Line resolution of e-mail attachment: 200 x 200 0: Off 1: On	Sets the line resolution of the e-mail attachment as 200 x 200.
2	Line resolution of e-mail attachment: 200 x 400 0: Off 1: On	Sets the line resolution of the e-mail attachment as 200 x 400.
3	Not used	Do not change these settings.
4	Line resolution of e-mail attachment: 400 x 400 0: Off 1: On	Sets the line resolution of the e-mail attachment as 400 x 400.
5-6	Not used	Do not change these settings.
7	Designates the bits to reference for original size of e-mail attachments 0: Registered (Bit 0 to 6) 1: No registration.	The "0" selection (default) references the settings for Bits 00, 01, 02, 04 above. The "1" selection ignores the selections of Bits 00, 01, 02, 04.

Switch 03 - Not used (do not change the settings)
--

Dedicated Transmission Parameters

Switch 04		
No	FUNCTION	COMMENTS
0	Full mode address selection 0: Full mode address 1: No full mode (simple mode)	If the other ends have the addresses, which have the full mode function flag ("0"), this machine determines them as full mode standard machines. <ul style="list-style-type: none"> ▪ This machine attaches the "demand of reception confirmation" to a message when transmitting. ▪ This machine updates the reception capability to the address book when receiving.
1-7	Not used	Do not change these settings.

Switch 05		
No	FUNCTION	COMMENTS
0	Direct transmission selection to SMTP server 0: ON 1: OFF	Allows or does not allow the direct transmission to SMTP server.
1-7	Not used	Do not change these settings.

Switch 06 - Not used (do not change the settings)
Switch 07 - Not used (do not change the settings)
Switch 08 - Not used (do not change the settings)
Switch 09 - Not used (do not change the settings)

4.6 SERVICE RAM ADDRESSES

CAUTION

- Do not change the settings which are marked as “Not used” or “Read only.”

680001 to 680004(H) - ROM version (Read only)

680001(H) - Revision number (BCD)

680002(H) - Year (BCD)

680003(H) - Month (BCD)

680004(H) - Day (BCD)

680006 to 680015(H) - Machine's serial number (16 digits - ASCII)

680018(H) - Total program checksum (low)

680019(H) - Total program checksum (high)

680020 to 68003F(H) - System bit switches

680050 to 68005F(H) - Printer bit switches

680060 to 68007F(H) - Communication bit switches

680080 to 68008F(H) - G3 bit switches

680090 to 68009F(H) - G3-2 bit switches: Not used

6800A0 to 6800AF(H) - G3-3 bit switches: Not used

6800D0(H) - User parameter switch 00 (SWUER_00) : Not used

6800D1(H) - User parameter switch 01 (SWUSR_01) : Not used

6800D2(H) - User parameter switch 02 (SWUSR_02)

Bit 0: Forwarding mark printing on forwarded messages 0: Disabled, 1: Enabled

Bit 1: Center mark printing on received copies

(This switch is not printed on the user parameter list.)

0: Disabled, 1: Enabled

Bit 2: Reception time printing

(This switch is not printed on the user parameter list.)

0: Disabled, 1: Enabled

Bit 3: TSI print on received messages 0: Disabled, 1: Enabled

Bit 4: Checkered mark printing

(This switch is not printed on the user parameter list.)

0: Disabled, 1: Enabled

Bit 5: Not used

Bit 6: Not used

Bit 7: Not used

6800D3(H) - User parameter switch 03 (SWUSR_03: Automatic report printout)

Service RAM Addresses

Bit 0: Transmission result report (memory transmissions) 0: Off, 1: On

Bit 1: Not used

Bit 2: Memory storage report 0: Off, 1: On

Bit 3: Polling reserve report (polling reception) 0: Off, 1: On

Bit 4: Polling result report (polling reception) 0: Off, 1: On

Bit 5: Transmission result report (immediate transmissions) 0: Off, 1: On

Bit 6: Not used

Bit 7: Journal 0: Off, 1: On

6800D4(H) - User parameter switch 04 (SWUSR_04: Automatic report printout)

Bit 0: Not used

Bit 1: Automatic communication failure report and transfer result report output 0: Off, 1: On

Bits 2 to 3: Not used

Bit 4: Indicates the parties 0: Not indicated, 1: Indicated

Bit 5: Include sender's name on reports 0: Off, 1: On

Bit 6: Not used

Bit 7: Inclusion of a sample image on reports 0: Off, 1: On

6800D5(H) - User parameter switch 05 (SWUSR_05)

Bit 0: Substitute reception when the base copier is in an SC condition

0: Enabled, 1: Disabled

Bits 1 and 2: Condition for substitute rx when the machine cannot print messages (Paper end, toner end, jam, and during night mode)

Bit 2: 0, Bit 1: 0 = The machine receives all the fax messages.

Bit 2: 0, Bit 1: 1 = The machine receives the fax messages with RTI or CSI.

Bit 2: 1, Bit 1: 0 = The machine receives the fax messages with the same ID code.

Bit 2: 1, Bit 1: 1 = The machine does not receive anything.

Bit 3: Not used

Bit 4: Not used

Bit 5: Just size printing 0: Off, 1: On

Bit 6: Not used

Bit 7: Add paper display when a cassette is empty 0: Off, 1: On

6800D6(H) - User parameter switch 06 (SWUSR_06): Not used

6800D7(H) - User parameter switch 07 (SWUSR_07)

Bit 0 Ringing 0: Off, 1: On

Bit 1: Automatic answering message 0: Off, 1: On

Bit 2: Parallel memory transmission 0: Off, 1: On

Bits 3 and 4: Not used

Bit 5: Remote control 0: Off, 1: On

Bits 6 and 7: Not used

6800D8(H) - User parameter switch 08 (SWUSR_08)

Bits 0 and 1: Not used.

Bit 2: Authorized reception

0: Only faxes from senders whose RTIs/CSIs are specified for this feature are accepted.

1: Only faxes from senders whose RTIs/CSIs are not specified for this feature are accepted.

Bits 3 to 7: Not used.

6800D9(H) - User parameter switch 09 (SWUSR_09): Not used

6800DA(H) - User parameter switch 10 (SWUSR_0A)

Bits 0 to 2: Not used

Bit 3: Page reduction 0: Off, 1: On

Bits 4 and 5: Not used

Bit 6: Use both e-mail notification and printed reports to confirm the transmission results 0: Off, 1: On

Bit 7: Not used

6800DB(H) - User parameter switch 11 (SWUSR_0B)

Bits 0 and 1: Not used

Bit 2: White original detection 0: Off, 1: On (alarm and alert message on the LCD)

Bit 3: Receive rejection for 1300 Hz transmission 0: Off (receive), 1: On (not receive)

Bit 5: Not used

Bit 6: Printout of messages received while acting as a forwarding station 0: Off, 1: On

Bit 7: Not used

6800DC(H) - User parameter switch 12 (SWUSR_0C): Not used

6800DD(H) - User parameter switch 13 (SWUSR_0D): Not used

6800DE(H) - User parameter switch 14 (SWUSR_0E)

Bit 0: Message printout while the machine is in Night Printing mode 0: On, 1: Off

Bit 1: Maximum document length detection 0: Double letter, 1: Longer than double-letter (well log) – up to 1,200 mm

Bit 2: Not used

Bit 3: Fax mode settings, such as resolution, before a mode key (Copy/Fax/Printer/Scanner) is pressed 0: Not cleared, 1: Cleared

Bits 4 to 6: Not used

Bit 7: Not used

6800DF(H) - User parameter switch 15 (SWUSR_0F)

Service RAM Addresses

(This switch is not printed on the user parameter list.)

Bits 0, 1 and 2: Cassette for fax printout

Bit 2: 0, Bit 1: 0, Bit 0: 1 = 1st paper feed station

Bit 2: 0, Bit 1: 1, Bit 0: 0 = 2nd paper feed station

Bit 2: 0, Bit 1: 1, Bit 0: 1 = 3rd paper feed station

Bit 2: 1, Bit 1: 0, Bit 0: 0 = 4th paper feed station

Bit 2: 1, Bit 1: 0, Bit 0: 1 = LCT

Other settings Not used

Bits 3 and 4: Not used

Bit 5: Using the cassette specified by bits 0, 1 and 2 above only 0: On, 1: Off

Bits 6 and 7: Not used

6800E0(H) – User parameter switch 16 (SWUSR_10)

(This switch is not printed on the user parameter list.)

Bits 0 and 1: Not used

Bit 2: Paper size selection priority for an A4 size fax message when A4/LT size paper is not available. 0: A3 has priority, 1: B4 has priority

Bits 3 to 7: Not used

6800E1(H) – User parameter switch 17 (SWUSR_11)

Bit 0: Not used

Bit 1: Not used

Bit 2: Inclusion of the “Add” button when a sequence of Quick/Speed dials is selected for broadcasting 0:Not needed, 1: Needed

Bits 3 to 6: Not used

Bit 7: Press “Start” key without an original when using the on hook dial or the external telephone,

0: displays “Cannot detect original size”. 1: Receives fax messages.

6800E2(H) - User parameter switch 18 (SWUSR_12)

Bit 0: TTI date 0: Off, 1: On

Bit 1: TTI sender 0: Off, 1: On

Bit 2: TTI file number 0: Off, 1: On

Bit 3: TTI page number 0: Off, 1: On

Bits 4 to 6: Not used

Bit 7: Japan only

6800E3(H) - User parameter switch 19 (SWUSR_13)

Bit 0: Not used

Bit 1: Journal format

0: The Journal is separated into transmissions and receptions

1: The Journal is separated into G3-1, G3-2, and G3-3 communications

Bit 2: Not used

Bit 3: 90° image rotation during B5 portrait Tx (This switch is not printed on the user parameter list.) 0: Off, 1: On

Bit 4: Reduction of sample images on reports to 50% in the main scan and sub-scan directions. (This switch is not printed on the user parameter list.) 0: Technician adjustment (printer switch 0E bits 3 and 4), 1: 50% reduction

Bit 5: Use of A5 size paper for reports (This switch is not printed on the user parameter list.) 0: Off, 1: On

Bits 6 and 7: Not used

6800E4(H) - User parameter switch 20 (SWUSR_14)

Bit 0: Automatic printing of the LAN fax result report 0: Off, 1: On

Bit 1: Not used.

Bits 2 to 5: Store documents in memory which could not be printed from PC fax (LAN fax) driver

Bit 5	Bit 4	Bit 3	Bit 2	Setting
0	0	0	0	0 min.
0	0	0	1	1 min.
↓	↓	↓	↓	↓
1	1	1	0	14 min.
1	1	1	1	15 min.

Bits 6 and 7: Not used.

6800E5(H) - User parameter switch 21 (SWUSR_15)

Bit 0: Print results of sending reception notice request message 0: Disabled (print only when error occurs), 1: Enabled

Bit 1: Respond to e-mail reception acknowledgment request 0: Disabled, 1: Enabled

Bit 2: Not used

⇒ Bit 3: File format for forwarded folders and E-Mail 0: TIFF, 1:PDF

Bit 4: Transmit Journal by E-mail 0: Disabled, 1: Enabled

Bit 5: Not used

Service RAM Addresses

Bit 6: Network error display 0: Displayed, 1: Not displayed

Bit 7: Transmit error mail notification 0: Enabled, 1: Disabled

6800E6(H) - User parameter switch 22 (SWUSR_16)

(This switch is not printed on the user parameter list.)

Bit 0: Dial tone detection (PSTN 1) 0: Disabled, 1: Enabled

Bits 1 to 7: Not used

6800E7(H) - User parameter switch 23 (SWUSR_17): Not used

6800E8(H) - User parameter switch 24 (SWUSR_18): Not used

6800E9(H) - User parameter switch 25 (SWUSR_19)

Bit 0: Not used

Bit 1: Reception mode switch timer 0: Off, 1: On (switching Fax or Fax/Tel)

Bit 2: Mode priority switch 0: Fax first, 1: Tel first

Bit 3: Dial in function (Japan Only)

Bit 4: RDS operation 0: Not acceptable, 1: Acceptable for the limit specified by system switch 03



- This bit is only effective when RDS operation can be selected by the user (see system switch 02).

Bits 5 to 7: Not used

6800EA(H) and 6800EB(H) - User parameter switches 26 and 27 (SWUSR_1A and 1B):

Not used

6800EC(H) - User parameter switch 28(SWUSR_1C)

Xxxxx

6800ED(H) - User parameter switch 29(SWUSR_1D)

xxxxxx

6800EE(H) and 6800EF(H) - User parameter switches 30 and 31 (SWUSR_1E and 1F):

Not used

6800F0(H) - User parameter switch 32 (SWUSR_20)

Bit 0: Quotation priority for a destination when there is no destination of the specified type

0: Paper output priority = Priority order: 1. IP-fax destination, 2. Fax Number, 3. E-mail address, 4. Folder

1: Electric putout order = Priority order: 1. E-mail address, 2. Folder, 3. IP-fax destination, 4. Fax number

Bits 1 to 7: Not used

6800F1(H) - User parameter switch 33 (SWUSR_21): Not used

6800F2(H) - User parameter switch 34 (SWUSR_22)

Bit 0: Gatekeeper server used with IP-Fax 0: Disabled, 1: Enabled

Bit 1: SIP server used with IP-Fax 0: Disabled, 1: Enabled

Bits 2 to 7: Not used

680100 to 68010F(H) - G4 Parameter Switches – Not used

680110 to 68012F(H) - G4 Internal Switches – Not used

680130 to 68016F(H) - Service Switches

680170 to 68017F(H) - IFAX Switches

680180 to 68018F(H) - IP-FAX Switches

680190 to 6801AF(H) - Service station's fax number (SP3-101)

6801B0 to 6801B9(H) - Own fax PABX extension number

6801BA to 6801C3(H) - Own fax number (PSTN) – Not used

6801C4 to 6801D7(H) - Own fax number (ISDN G4) – Not used

6801D8 to 6801E3(H) - The first subscriber number (ISDN G3) – Not used

6801E4 to 6801EF(H) - The second subscriber number (ISDN G3) – Not used

6801F0 to 6801FB(H) - The first subscriber number (ISDN G4) – Not used

6801FC to 680207(H) - The second subscriber number (ISDN G4) – Not used

680208 to 68021B(H) - PSTN-1 RTI (Max. 20 characters - ASCII) - See the following note.

68021C to 68022F(H) - PSTN-2 RTI (Max. 20 characters - ASCII) - Not used

680230 to 680246(H) - PSTN-3 RTI (Max. 20 characters - ASCII) - Not used

680247 to 680286(H) - TTI 1 (Max. 64 characters - ASCII) - See the following note.

680287 to 6802C6(H) - TTI 2 (Max. 64 characters - ASCII) - Not used

6802C7 to 680306(H) - TTI 3 (Max. 64 characters - ASCII) - Not used

680307 to 68031A(H) - PSTN-1 CSI (Max. 20 characters - ASCII)

68031B to 68032E(H) - PSTN-2 CSI (Max.20 characters - ASCII) - Not used

68032F to 680342(H) - PSTN-3 CSI (Max.20 characters - ASCII) - Not used

680343(H) - Number of PSTN-1 CSI characters (Hex)

680344(H) - Number of PSTN-2 CSI characters (Hex) - Not used

680345(H) - Number of PSTN-3 CSI characters (Hex) - Not used



- If the number of characters is less than the maximum (20 for RTI, 64 for TTI), add a stop code (00[H]) after the last character.

680380 to 680387(H) - Last power off time (Read only)

680380(H) - 01(H) - 24-hour clock, 00(H) - 12-hour clock (AM), 02(H) - 12-hour clock (PM)

680381(H) - Year (BCD)

680382(H) - Month (BCD)

680383(H) - Day (BCD)

Service RAM Addresses

680384(H) – Hour

680385(H) – Minute

680386(H) – Second

680387(H) - 00: Monday, 01: Tuesday, 02: Wednesday, /// , 06: Sunday

680394(H) - Optional equipment (Read only – Do not change the settings)

Bit 0: Page Memory 0: Not installed, 1: Installed

Bit 1: SAF Memory 0: Not installed, 1: Installed

Bits 2 to 7; Not used

680395(H) - Optional equipment (Read only – Do not change the settings)

Bits 0 to 3: Not used

Bit 4: G3-2 0: Not installed, 1: Installed

Bit 5: G3-3 0: Not installed, 1: Installed

Bit 6 and 7: Not used

680406 to 68040A – Option G3 board (G3-2) ROM information (Read only)

680406(H) - Suffix (BCD)

680407(H) - Version (BCD)

680408(H) - Year (BCD)

680409(H) - Month (BCD)

68040A(H) - Day (BCD)

68040B to 68040F – Option G3 board (G3-3) ROM information (Read only)

68040B(H) - Suffix (BCD)

68040C(H) - Version (BCD)

68040D(H) - Year (BCD)

68040E(H) - Month (BCD)

68040F(H) - Day (BCD)

680410(H) - G3-1 Modem ROM version (Read only)

680412(H) - G3-2 Modem ROM version (Read only)

680414(H) - G3-3 Modem ROM version (Read only)

680420(H) - Number of multiple sets print (Read only)

680476(H) - Time for economy transmission (hour in 24h clock format - BCD)

680477(H) - Time for economy transmission (minute - BCD)

680492(H) - Transmission monitor volume 00 - 07(H)

680493(H) - Reception monitor volume 00 - 07(H)

680494(H) - On-hook monitor volume 00 - 07(H)

680495(H) - Dialing monitor volume 00 - 07(H)

680496(H) - Buzzer volume 00 - 07(H)

- 680497(H)** - Beeper volume 00 - 07(H)
6804A8(H) - Machine code (Check ram 4)
688E8E to 68918D(H) - SIP server address (Read only)
 688E8E(H) - Proxy server - Main (Max. 128 characters - ASCII)
 688F0E(H) - Proxy server - Sub (Max. 128 characters - ASCII)
 688F8E(H) - Redirect server - Main (Max. 128 characters - ASCII)
 68900E(H) - Redirect server - Sub (Max. 128 characters - ASCII)
 68908E(H) - Registrar server - Main (Max. 128 characters - ASCII)
 68910E(H) - Registrar server - Sub (Max. 128 characters - ASCII)
68918E(H) - Gatekeeper server address - Main (Max. 128 characters - ASCII)
68920E(H) - Gatekeeper server address - Sub (Max. 128 characters - ASCII)
68928E(H) - Arias Number (Max. 128 characters - ASCII)
68930E(H) - SIP user name (Max. 128 characters - ASCII)
68938E(H) - **SIP digest authentication password** (Max. 128 characters - ASCII)
68940E(H) - Gateway address information (Max. 7100 characters - ASCII)
68AFCA(H) - Stand-by port number for H.232 connection
68AFCCH) - Stand-by port number for SIP connection
68AFCE(H) - RAS port number
68AFD0(H) - Gatekeeper port number
68AFD2(H) - Port number of data waiting for T.38
68AFD4(H) - Port number of SIP server
68AFD6(H) - Priority for SIP and H.323 0: H.323, 1: SIP
68AFD7(H) - SIP function 0: Disabled, 1: Enabled
68AFD8(H) - H.323 function 0: Disabled, 1: Enabled
68AFD9(H) - **SIP digest authentication function** 0: Disabled, 1: Enabled
68AFDA(H) - **IP-Fax backup data** 00 - 600 (H)
69ECBE(H) - 69ECDE(H) - **Dial tone detection parameter** (Max. 11 x 3 lines)

69ECBE(H)	Dial tone frequency upper limit (high byte)	Hz (BCD)
69ECBF(H)	Dial tone frequency upper limit (low byte)	
69ECC0(H)	Dial tone frequency lower limit (high byte)	Hz (BCD)
69ECC1(H)	Dial tone frequency lower limit (low byte)	
69ECC2(H)	Dial tone detection time	(x 20 ms)

Service RAM Addresses

69ECC3(H)	Dial tone reset time (low)	(x 20 ms)
69ECC4(H)	Dial tone reset time (high)	
69ECC5(H)	Dial tone continuous tone time	(x 20 ms)
69ECC6(H)	Dial tone permissible drop time	(x 20 ms)
69ECC7(H)	Wait interval (low)	(x 20 ms)
69ECC8(H)	Wait interval (high)	

Default values

	NA	EU	Asia, Finland
Dial tone frequency upper limit	650 Hz	650 Hz	650 Hz
Dial tone frequency lower limit	360 Hz	360 Hz	360 Hz
Dial tone detection time	2000 ms	540 ms	1000 ms
Dial tone reset time	10 s	10 s	10 s
Dial tone continuous tone time	2000 ms	2000 ms	2000 ms
Dial tone permissible drop time	340 ms	300 ms	340 ms
Wait interval	4000 ms	4000 ms	4000 ms

5. DETAILS

5.1 OVERVIEW

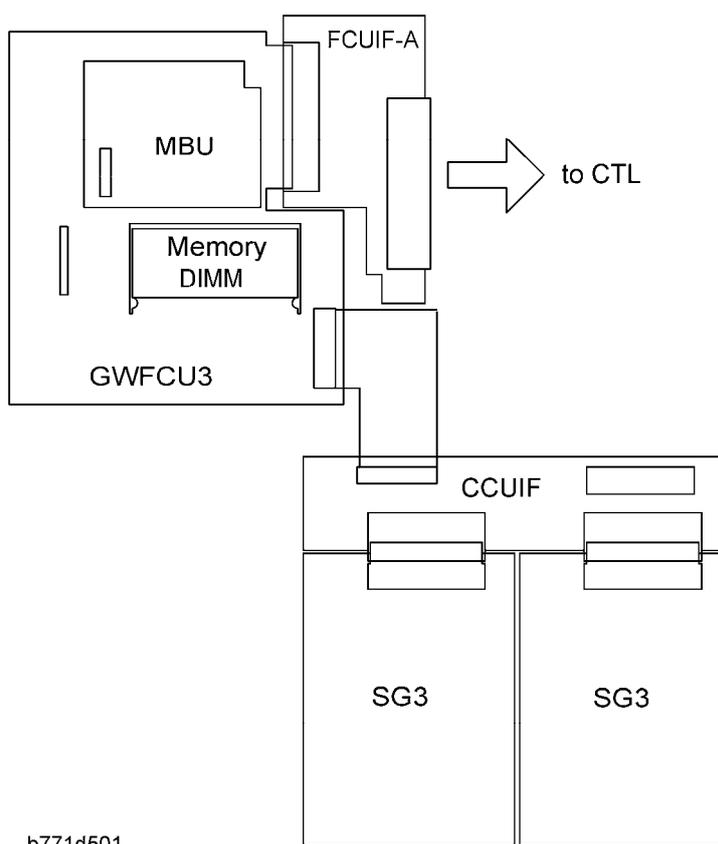

b771d501

The basic fax unit consists of two PCBs: an FCU and an MBU.

The FCU controls all the fax communications and fax features, in cooperation with the controller board. The MBU contains the ROM and SRAM. Also, the FCU has an NCU circuit.

Fax Options:

1. Extra G3 Interface option: This provides one more analog line interface. This allows full dual access. Two extra G3 interface options can be installed.
2. Memory Expansion: This expands the SAF memory and the page memory (used for image rotation); without this expansion, the page memory is not big enough for image rotation at 400 dpi, so transmission at 400 dpi is not possible.

5.2 BOARDS

5.2.1 FCU

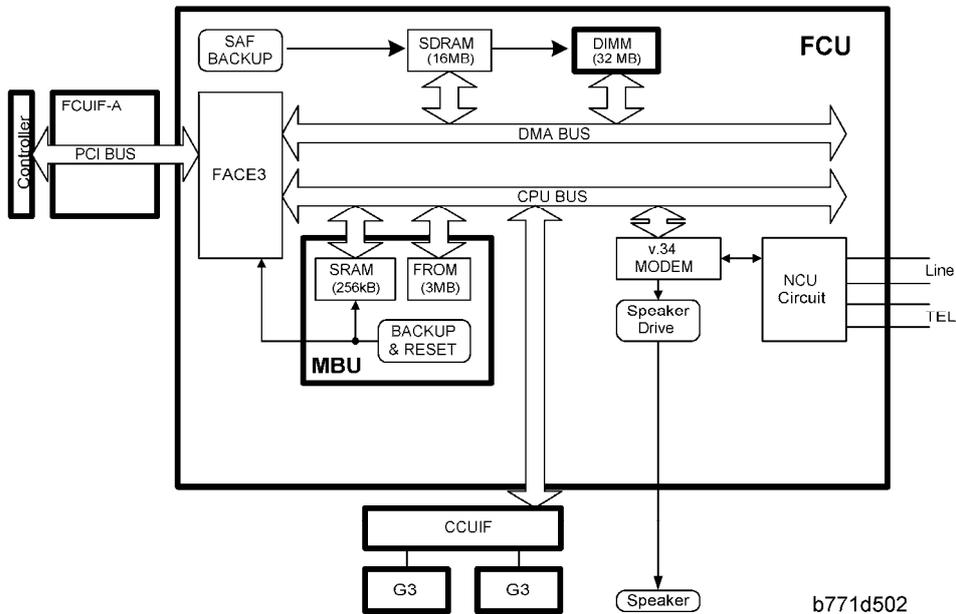

The FCU (Facsimile Control Unit) controls fax communications, the video interface to the base copier's engine, and all the fax options.

FACE3 (Fax Application Control Engine)

- CPU
- Data compression and reconstruction (DCR)
- DMA control
- Clock generation
- DRAM backup control

Modem (FAME)

- V.34, V33, V17, V.29, V.27ter, V.21, and V.8

DRAM

- The 16 MB of DRAM is shared as follows.
 - SAF memory: 4MB
 - Working memory: 8MB
 - Page memory: 4MB
- The SAF memory is backed up by a rechargeable battery.

Memory Back-up

- A Rechargeable battery backs up the SAF memory (DRAM) for 1 hour.

5.2.2 MBU

On this board, the flash ROM contains the FCU firmware, and the SRAM contains the system data and user parameters. Even if the FCU is changed, the system data and user parameters are kept on the MBU board.

ROM

- 3MB flash ROMs for system software storage
2MB (16bit x 1MB) + 1MB (16bit x 512K)

SRAM

- The 256KB SRAM for system and user parameter storage is backed up by a lithium battery.

Memory Back-up

- A lithium battery backs up the system parameters and programmed items in the SRAM, in case the base copier's main switch is turned off.

Switches

Item	Description
SW1	Switches the SRAM backup battery on/off.

5.2.3 SG3 BOARD

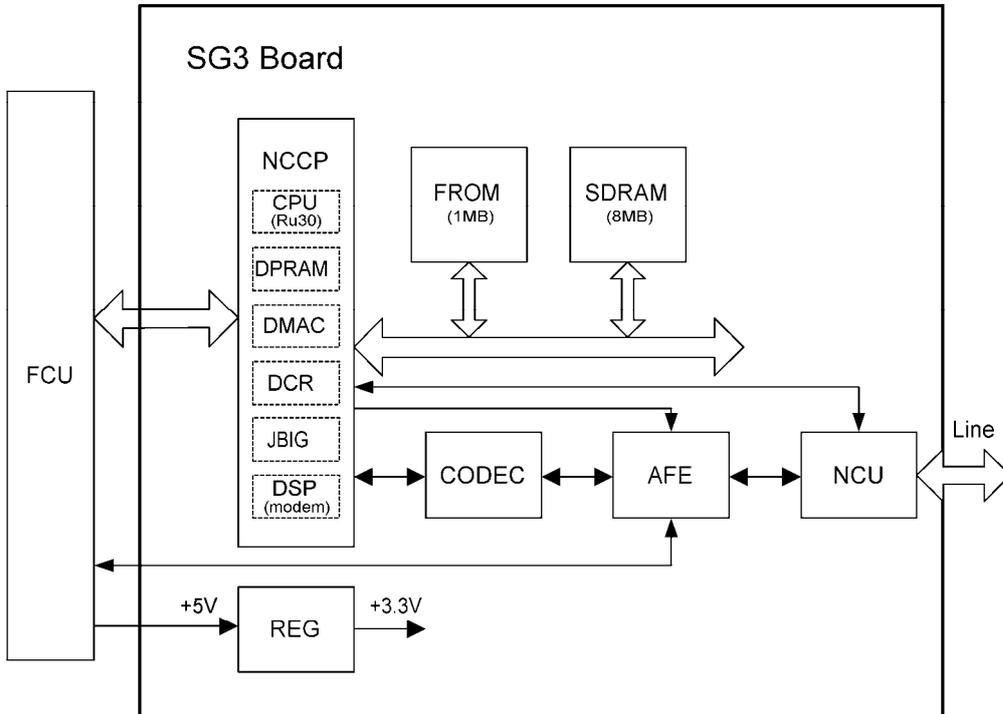

The SG3 board allows up to three simultaneous communications when used in combination with the FCU and optional G3 boards. The NCU is on the same board as the common SG-3 board. This makes the total board structure smaller. But, the specifications of the SG3 board do not change.

NCCP (New Communication Control Processor)

- Controls the SG3 board.
- CPU (RU30)
- DPRAM (Dual Port RAM): Handshaking with the FCU is done through this block.
- DMA controller
- JBIG
- DSP V34 modem (RL5T892): Includes the DTMF Receiver function
- DCR for MH, MR, MMR, and JBIG compression and decompression

FROM

- 1Mbyte flash ROM for SG3 software storage and modem software storage

SDRAM

- 4Mbyte DRAM shared between ECM buffer, line buffer, and working memory

AFE (Analog Front End)

- Analog processing

CODEC (COder-DECoder)

- A/D & D/A conversions for modem

REG

- Generates +3.3 V from the +5V from the FCU

5.3 VIDEO DATA PATH

5.3.1 TRANSMISSION

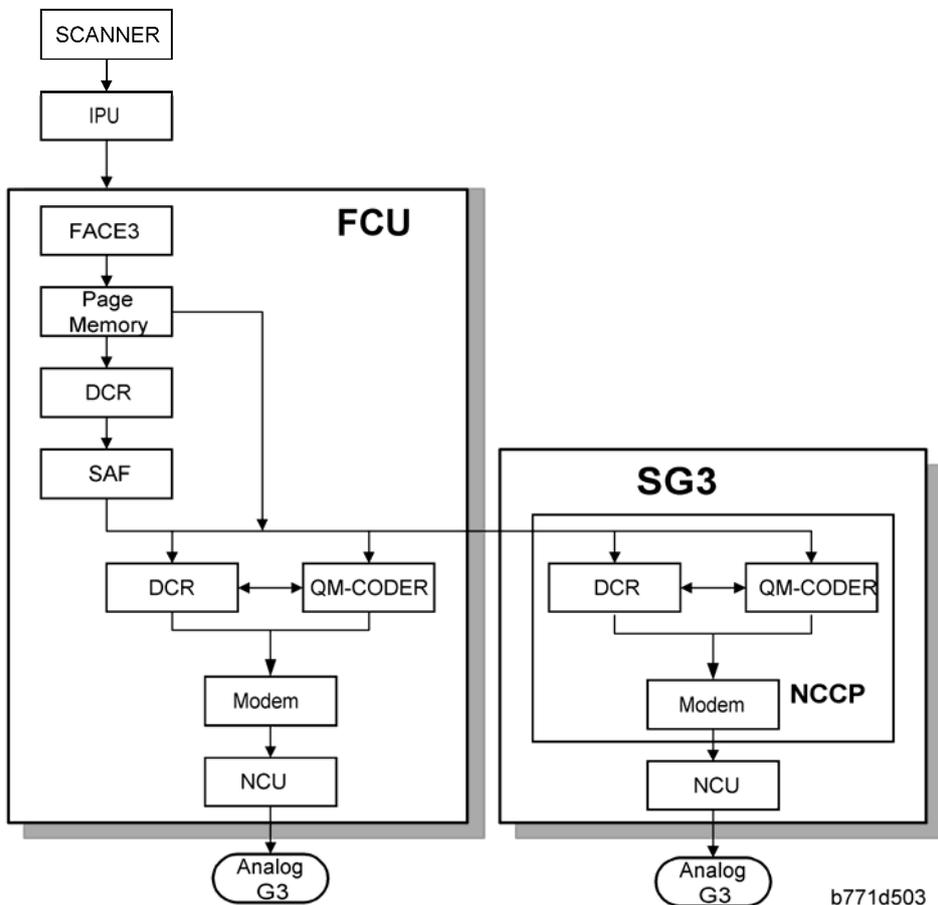

Memory Transmission and Parallel Memory Transmission

The base copier's scanner scans the original at the selected resolution in inch format. The IPU processes the data and transfers it to the FCU.

Note

- When scanning a fax original, the IPU uses the MTF, independent dot erase and thresholding parameter settings programmed in the fax unit's scanner bit switches, not the copier's SP modes.

Then, the FCU converts the data to mm format, and compresses the data in MMR or raw format to store it in the SAF memory. If image rotation will be done, the image is rotated in page memory before compression.

At the time of transmission, the FCU decompresses the stored data, then re-compresses and/or reduces the data if necessary for transmission. The NCU transmits the data to the

line.

Immediate Transmission

The base copier's scanner scans the original at the resolution agreed with the receiving terminal. The IPU video processes the data and transfers it to the FCU.



- When scanning a fax original, the IPU uses the MTF, independent dot erase and thresholding parameter settings programmed in the fax unit's scanner bit switches, not the copier's SP modes.

Then the FCU stores the data in page memory, and compresses the data for transmission. The NCU transmits the data to the line.

JBIG Transmission

- **Memory transmission:** If the receiver has JBIG compression, the data goes from the DCR to the QM-Coder. Then the NCU transmits the data to the line. When an optional G3 unit (SG3) is installed and PSTN2 is selected as the line type, JBIG compression is available, but only for the PSTN-2 line.
- **Immediate transmission:** If the receiver has JBIG compression, the data goes from the page memory to the QM-Coder. Then the NCU transmits the data to the line. When an optional G3 unit (SG3) is installed and PSTN2 is selected as the line type, JBIG compression is available, but only for the PSTN-2 line.

Adjustments

Priority for the line used for G3 transmissions (PSTN 1/PSTN 2 or 3): System switch 16 bit

1

5.3.2 RECEPTION

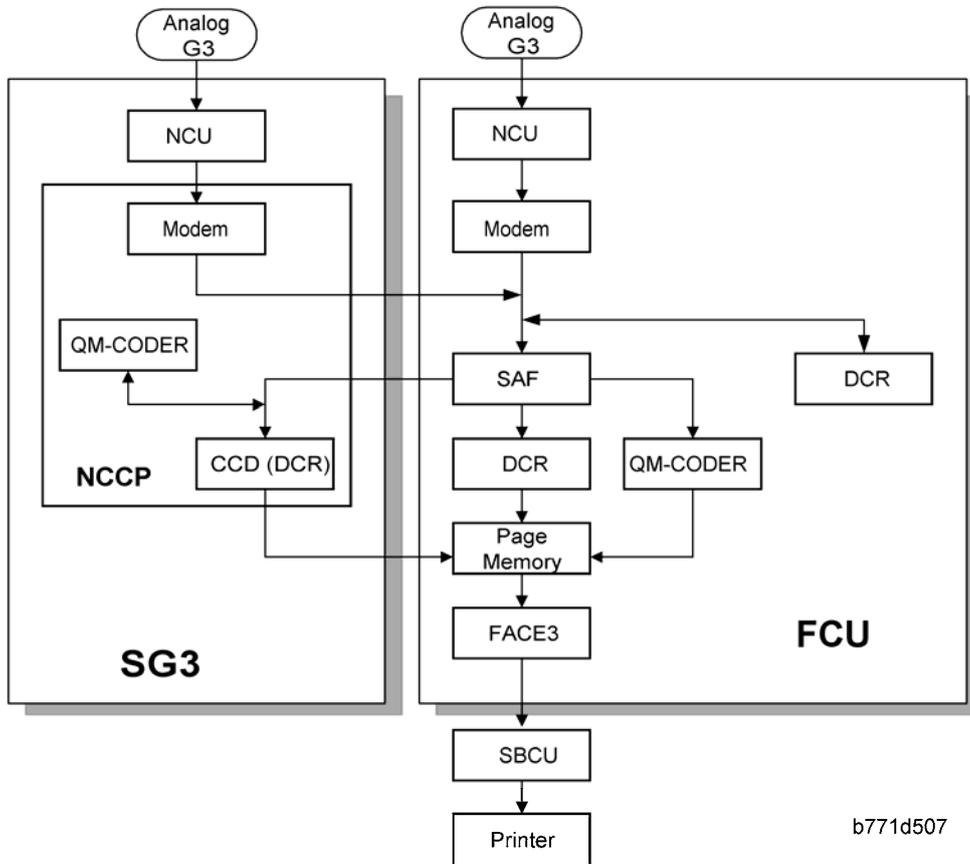

First, the FCU stores the incoming data from either an analog line to the SAF memory. (The data goes to the FACE3 at the same time, and is checked for error lines/frames.)

The FCU then decompresses the data and transfers it to page memory. If image rotation will be done, the image is rotated in the page memory. The data is transferred to the IPU. If the optional G3 unit is installed, the line that the message comes in on depends on the telephone number dialled by the other party (the optional G3 unit has a different telephone number from the main fax board).

JBIG Reception

When data compressed with JBIG comes in on PSTN-1 (the standard analog line), the data is sent to the QM-CODER for decompression. Then the data is stored in the page memory, and transferred to the IPU.

When data compressed with JBIG comes in on PSTN-2 (optional extra analog line), the data is sent to the QM-CODER on the SG3 board for decompression.

5.4 FAX COMMUNICATION FEATURES

5.4.1 MULTI-PORT

When the optional extra G3 Interface Unit is installed, communication can take place at the same time through the two or three lines at once.

Option	Available Line Type	Available protocol Combinations
Standard only	PSTN	G3
Extra G3 Interface Unit (single)	PSTN + PSTN	G3 + G3
Extra G3 Interface Unit (double)	PSTN + PSTN +PSTN	G3 + G3 +G3

5.4.2 DOCUMENT SERVER

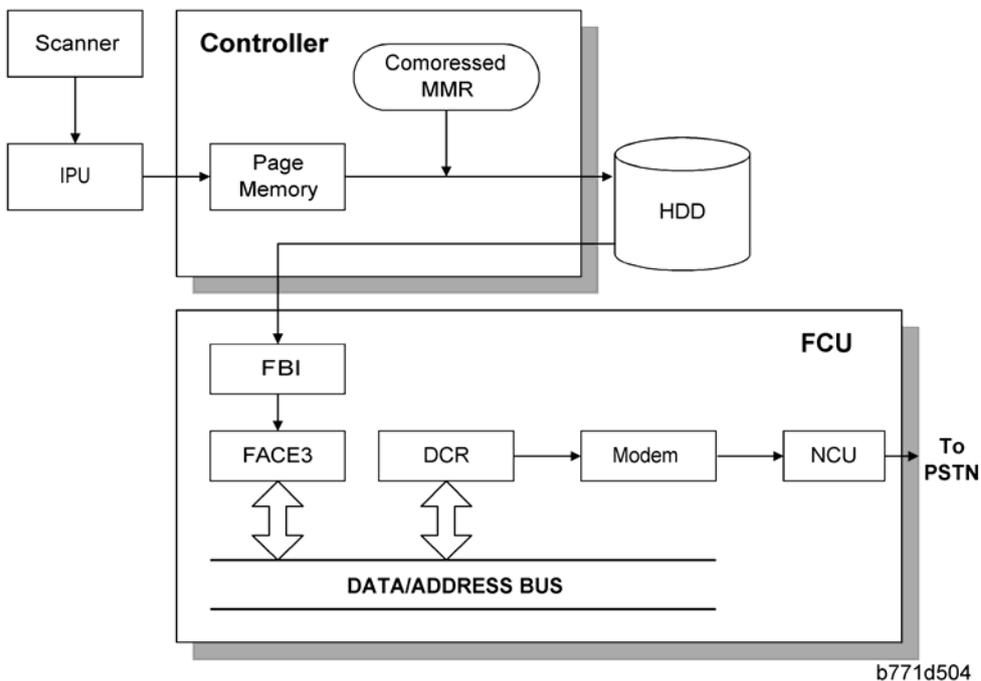

The base copier's scanner scans the original at the selected resolution. The IPU video processes the data and transfers it to the controller board.

Then the controller stores the data in the page memory for the copier function, and

Fax Communication Features

compresses the data in MMR (by software) to store it in the HDD. If image rotation will be done, the image is rotated in the page memory before compression.

For transmission, the stored image data is transferred to the FCU. The FCU decompresses the image data, then recompresses and/or reduces the data if necessary for transmission. the NCU transmits the data to the line.

The documents can be stored in the HDD (Document Server) from the fax application. The stored documents in the document sever can be used for the fax transmission in many times. More than one document and the scanned document can be combined into one file and then the file can be transmitted.

- When using the document server, the SAF memory is not used.
- The document is compressed with MMR and stored.
- Up to 9,000 pages can be stored. (1 file: Up to 1,000 pages) from the fax application.
- Only stored documents from the fax application can be transmitted.
- Scanned documents are given a name automatically, such as "FAX001". But it is possible to change the file name, user name and password.
- Up to 30 files can be selected at once.

↓ Note

- The compression method of the fax application is different from the copy application. The storing time is longer than the copier storing.
- When selecting "Print 1st page", the stored document will be reduced to A4 size.

5.4.3 INTERNET MAIL COMMUNICATION

Mail Transmission

This machine supports T.37 full mode. (ITU-, RFC232). The difference between T.37 simple mode and full mode is as follows.

Function	T.37 Simple Mode	T.37 Full Mode
Resolution	200 x 100 200 x 200	200 x100 200 x 200 200 x 400 400 x 400 (if available)
RX Paper Width	A4	A4, B4, A3
RX Data Compression Method	MH	MH (default), MR, MMR,

Signals	Image data transmission only	Image data transmission, exchange of capability information between the two terminals, and acknowledgement of receipt of fax messages
---------	------------------------------	---

Data Formats

The scanned data is converted into a TIFF-F formatted file.

The fields of the e-mail and their contents are as follows:

Field	Content
From	Mail address of the sender
Reply To	Destination requested for reply
To	Mail address of the destination
Bcc	Backup mail address
Subject	From CSI or RTI (Fax Message No. xxxx)
Content Type	Multipart/mixed Attached files: image/tiff
Content Transfer Encoding	Base 64, 7-bit, 8-bit, Quoted Printable
Message Body	MIME-converted TIFF-F (MIME standards specify how files are attached to e-mail messages)

Direct SMTP Transmission

Internet Fax documents can be sent directly to their destinations without going through the SMTP server. (Internet Faxes normally transmit via the SMTP server.)

For example:

e-mail address:	gts@ricoh.co.jp
-----------------	-----------------

Fax Communication Features

SMTP server address:	gts.abcd.com
----------------------	--------------

In this case this feature destination e-mail address (gts@ricoh.co.jp) is read as the SMTP server address "gts.abcd.com" and the transmissions bypass the SMTP server.

Selectable Options

These options are available for selection:

- With the default settings, the scan resolution can be either standard or detail. Inch-mm conversion before TX depends on IFAX SW01 Bit 7. Detail resolution will be used if Super Fine resolution is selected, unless Fine resolution is enabled with IFAX SW01.
- The requirements for originals (document size, scan width, and memory capacity) are the same as for G3 fax memory TX.
- The default compression is TIFF-F format.
- IFAX SW00: Acceptable paper widths for sending
- IFAX SW09: Maximum number of attempts to the same destination

Secure Internet Transmission

- SMTP Authentication: User Tools> System Settings> File Transfer> SMTP Authentication
- POP Before SMTP: User Tools> System Settings> File Transfer> POP Before SMTP

Mail Reception

This machine supports three types of e-mail reception:

- POP3 (Post Office Protocol Ver. 3.)
- IMAP4 (Internet Messaging Access Protocol)
- SMTP (Simple Mail Transfer Protocol)

For details: Core Technology Manual – Facsimile Processes – Faxing from a PC – Internet/LAN Fax Boards – Mail Reception

POP3/IMAP4 Mail Reception Procedure

The machine automatically picks up e-mail from the server at an interval which is adjustable in the range 2 to 1440 min. in 1-minute steps: User Tools> System Settings> File Transfer> E-mail Reception Interval

SMTP Reception

- The IFAX must be registered as an SMTP server in the MX record of the DNS server, and the address of the received mail must specify the IFAX.
- Enable SMTP reception: User Tools> System Settings> File Transfer> Reception

Protocol

Even if the MX record on the DNS server includes the IFAX, mail cannot be received with SMTP until SMTP reception is enabled:

However, if SMTP reception is selected and the machine is not registered in the MX record of the DNS server, then either IMAP4 or POP3 is used, depending on the setting: User Tools> System Settings> File Transfer> Reception Protocol

Mail Delivery Conditions: Transferring Mail Received With SMTP

1. The machine must be set up for SMTP mail delivery: User Tools> Facsimile Features> E-mail Settings> SMTP RX File Delivery Settings
2. If the user wishes to limit this feature so that the machine will only deliver mail from designated senders, the machine's "Auth. E-mail RX" feature must be set (User Tools> Facsimile Features> E-mail Settings> SMTP RX File Delivery Settings).
3. If the "SMTP RX File Delivery Setting" is set to 0 to prohibit SMTP receiving, and if there is mail designated for delivery, then the machine responds with an error. (User Tools> Facsimile Features> E-mail Settings> SMTP RX File Delivery Settings)
4. If the quick dial, speed dial, or group dial entry is incorrect, the mail transmission is lost, and the IFAX issues an error to the SMTP server and outputs an error report.

Auth. E-mail RX

In order to limit access to mail delivery with IFAX, the addresses of senders must be limited using the Access Limit Entry. Only one entry can be registered.

1. Access Limit Entry

For example, to limit access to @IFAX.ricoh.co.jp:

gts@IFAX.ricoh.co.jp	Matches and is delivered.
gts@IFAX.abcde.co.jp	Does not match and is not delivered.
IFAX@ricoh.co.jp	Does not match and is not delivered.

2. Conditions

- The length of the Access Limit Entry is limited to 127 characters.
- If the Access Limit Entry address and the mail address of the incoming mail do not match, the incoming mail is discarded and not delivered, and the SMTP server responds with an error. However, in this case an error report is not output.
- If the Access Limit Entry address is not registered, and if the incoming mail specifies a delivery destination, then the mail is delivered unconditionally.

Handling Mail Reception Errors

Abnormal files

When an error of this type occurs, the machine stops receiving and commands the server to erase the message. Then the machine prints an error report and sends information about the error by e-mail to the sender address (specified in the “From” or “Reply-to” field of the message). If there is an incomplete received message in the machine memory, it will be erased.

The machine prints an error message when it fails to send the receive error notification after a certain number of attempts.

The following types of files are judged to be abnormal if one or more of the following are detected:

1. Unsupported MIME headers.
Supported types of MIME header

Header	Supported Types
Content-Type	Multipart/mixed, text/plain, message/rfc822 Image/tiff
Charset	US-ASCII, ISO 8859 X. Other types cannot be handled, and some garbage may appear in the data.
Content-Transfer-Encoding	Base 64, 7-bit, 8-bit, Quoted Printable

2. MIME decoding errors
3. File format not recognized as TIFF-F format
4. Resolution, document size, or compression type cannot be accepted

Remaining SAF Capacity Error

The machine calls the server but does not receive e-mail if the remaining SAF capacity is less than a certain value (the value depends on IFAX Switch 08. The e-mail will be received when the SAF capacity increases (for example, after substitute reception files have been printed). The error handling method for this type of error is the same as for “Abnormal files”. If the capacity of the SAF memory drops to zero during reception, the machine operates in the same way as when receiving an abnormal file (refer to “Abnormal files” above).

Secure Internet Reception

To enable password encryption and higher level security: User Tools> System Settings> File Transfer> POP3/IMAP4 Settings> Encryption (set to “On”)

Transfer Request: Request By Mail

For details: Core Technology Manual – Facsimile Processes – Faxing from a PC – Internet/LAN Fax Boards – Transfer Request

The fields of the e-mail and their contents are as follows:

Field	Content
From	E-mail address of the requesting terminal
To	Destination address (Transfer Station address)
Bcc	Blind carbon copy
Subject	From TSI (Fax Message No. xxxx)
Content-Type	Multipart/mixed Text/Plain (for a text part), image/tiff (for attached files)
Content-Transfer-Encoding	Base 64, 7-Bit, 8-bit, Quoted Printable
Mail body (text part)	RELAY-ID:-: xxxx (xxxx: 4 digits for an ID code) RELAY: #01#*X#**01....
Message body	MIME-converted TIFF-F.

E-Mail Options (Sub TX Mode)

The following features are available as options for mail sending: entering a subject, designating the level of importance, confirming reception of the mail.

Subject and Level of Importance

You can enter a subject message with: Sub TX Mode> E-mail Options

The Subject entry for the mail being sent is limited to 64 characters. The subject can also be prefixed with an “Urgent” or “High” notation.

How the Subject Differs According to Mail Type

Mail Type	①	②	③
Subject	---	Entry Condition	Fax Message No.

Fax Communication Features

Entry				
No Subject Entry		1. "CSI" ("RTI")	+ File No.	
		2. "RTI"		CSI not registered
		3. "CSI"		RTI not registered
		4. None		CSI, RTI not registered
Confirmation of Reception	From	1. "CSI" ("RTI")	Normal: Return Receipt (dispatched). You can select "displayed" with IFAX SW02 Bits 2 and 3.	
		2. "RTI"		CSI not registered
		3. "CSI"	RTI not registered	Error: Return Receipt (processed/error)
		4. None	CSI, RTI not registered	
Mail delivery, memory transfer, SMTP receiving and delivery	From	RTI or CSI of the station designated for delivery	Mail delivery	
		RTI or CSI of sender	Mail sending from G3 memory	
		Mail address of sender	Memory sending	
		Mail address of sender	SMTP receiving and delivery (Off Ramp Gateway)	
Mail error notification	---	Error Message No. xxxx From CSI (RTI)		

Items ① ② ③ of the table above are in the Subject.

Subjects Displayed on the PC

Sender	Date	Size	Subject
Substation 2	04/25/2002	1,513	Parts List
Substation 2	04/26/2002	1,147	Specifications
Main Station	05/09/2002	33,551	[Urgent] Memo 2041
		21,624,288	

b771d505

E-mail Messages

After entering the subject, you can enter a message with:

Sub TX Mode> E-mail Options

An e-mail message (up to 5 lines) can be pre-registered with: User Tools> System Settings> File Transfer> Program/Change/Delete E-mail Message

Limitations on Entries

Item	Maximum
Number of Lines	5 lines
Line Length	80 characters
Name Length	20 characters

Message Disposition Notification (MDN)

For details: Core Technology Manual – Facsimile Processes – Faxing from a PC – Internet/LAN Fax Boards – E-mail Options

The network system administrator can confirm whether a sent mail has been received correctly or not. This function is enabled only when "I-FAX switch 02 Bit 4" is set to "1" This confirmation is done in four steps.

1. Send request for confirmation of mail reception. To enable or disable this request (known as MDN):
2. Sub TX Mode> E-mail Options
3. Mail reception (receive confirmation request)
4. Send confirmation of mail reception
5. Receive confirmation of mail reception

The other party’s machine will not respond to the request unless the two conditions below are met:

- The other party’s machine must be set up to respond to the confirmation request.

Fax Communication Features

- The other party's machine must support MDN (Message Disposition Notification).
- Setting up the Receiving Party -

The receiving party will respond to the confirmation request if:

1. The "Disposition Notification To" field is in the received mail header (automatically inserted in the 4th line in the upper table on the previous page, if MDN is enabled), and
2. Sending the disposition notification must be enabled (User Parameter Setting SW21 (15 [H]) Bit 1 for this model). The content of the response is as follows:

Normal reception:	"Return Receipt (dispatched)" in the Subject line
IFAX SW02 (Bit 2, 3)	"Return Receipt (displayed)" in the Subject line
Error:	"Return Receipt (processed/error)" in the Subject line

Handling Reports

1. Sending a Request for a Return Receipt by Mail
After the mail sender transmits a request for a return receipt, the mail sender's journal is annotated with two hyphens (--) in the Result column and a "Q" in the Mode column.
2. Mail Receipt (Request for Receipt Confirmation) and Sending Mail Receipt Response
After the mail receiver sends a response to the request for a return receipt, the mail receiver's journal is annotated with two hyphens (--) in the Result column and an "A" in the Mode column.
3. Receiving the Return Receipt Mail
 - After the mail sender receives a return receipt, the information in the mail sender's journal about the receipt request is replaced, i.e. the journal is annotated with "OK" in the Result column.
 - When the return receipt reports an error, the journal is annotated with an "E" in the Result column.
 - The arrival of the return receipt is not recorded in the journal as a separate communication. Its arrival is only reported by the presence of "OK" or "E" in the Result column.
 - If the mail address used by the sender specifies a mailing list (i.e., a Group destination; the machine sends the mail to more than one location. See "How to set up Mail Delivery"), the Result column of the Journal is updated every time a return receipt is received. For example, if the mailing list was to 5 destinations, the Result column indicates the result of the communication with the 5th destination

only. The results of the communications to the first 4 destinations are not shown. Exceptions: If one of the communications had an error, the Result column will indicate E, even if subsequent communications were OK.

If two of the communications had an error, the Journal will indicate the destination for the first error only.

Report Sample

DATE	TIME	ADDRESS	RESULT	MODE	TIME	PAGE
MAY. 5	10:15	fuser_01@domlg. ricoh. co.		Mail SM	0'09"	2
	10:16	fuser_01@domlg. ricoh. co.		Mail SMQ	0'05"	1
	10:17	s_tadashi@domlg. ricoh. co.		Mail SMQ	0'09"	2
	10:19	m_masataka@domlg. ricoh. co.	OK	Mail SMA	0'05"	1
			--			

b771d506

IP-Fax

5.5 IP-FAX

5.5.1 WHAT IS IP-FAX?

For details: Core Technology Manual – Facsimile Processes – Faxing from a PC – Internet/LAN Fax Boards – IP-FAX

T.38 Packet Format

TCP is selected by default for this machine, but you can change this to UDP with IPFAX

SW 00 Bit 1.

UDP Related Switches

IP-Fax Switch 01						
No.	FUNCTION					COMMENTS
0-3	Select IP FAX Delay Level					Raise the level by selecting a higher setting if too many transmission errors are occurring on the network.
	Bit3	Bit2	Bit1	Bit0	Setting	
	0	0	0	0	Level 0	If TCP/UDP is enabled on the network, raise this setting on the T.30 machine. Increasing the delay time allows the recovery of more lost packets.
	0	0	0	1	Level 1	
	0	0	1	0	Level 2	
	0	0	1	1	Level 3	If only UDP is enabled, increase the number of redundant packets.
					Level 1~2: 3 Redundant packets Level 3: 4 Redundant packets	

Settings

User parameter switch 34 (22[H]), bit 0

IP-Fax Gate Keeper usage 0: No, 1: Yes

IP Fax Switches: Various IP-FAX settings (see the bit switch table)

6. SPECIFICATIONS

6.1 GENERAL SPECIFICATIONS

6.1.1 FCU

Type:	Desktop type transceiver
Circuit:	PSTN (max. 3ch.) PBX
Connection:	Direct couple
Original Size:	Book (Face down) Maximum Length: 432 mm [17 ins] Maximum Width: 297 mm [11.7 ins] ARDF (Face up) (Single-sided document) Length: 128 - 1200 mm [5.0 - 47.2 ins] Width: 105 - 297 mm [4.1 - 11.7 inch] (Double-sided document) Length: 128 - 432 mm [5.0 - 17 inch] Width: 105 - 297 mm [4.1 - 11.7 inch]
Scanning Method:	Flat bed, with CCD
Resolution:	G3 8 x 3.85 lines/mm (Standard) 8 x 7.7 lines/mm (Detail) 8 x 15.4 line/mm (Fine) See Note 1 16 x 15.4 line/mm (Super Fine) See Note 1 200 x 100 dpi (Standard) 200 x 200 dpi (Detail) 400 x 400 dpi (Super Fine) See Note 1 ↓ Note <ul style="list-style-type: none"> ▪ Optional Expansion Memory required

General Specifications

Transmission Time:	G3: 3 s at 28800 bps; Measured with G3 ECM using memory for an ITU-T #1 test document (Slerexe letter) at standard resolution
Data Compression:	MH, MR, MMR, JBIG
Protocol:	Group 3 with ECM
Modulation:	V.34, V.33, V.17 (TCM), V.29 (QAM), V.27ter (PHM), V.8, V.21 (FM)
Data Rate:	G3: 33600/31200/28800/26400/24000/21600/19200/16800/14400/12000/9600/7200/4800/2400 bps Automatic fallback
I/O Rate:	With ECM: 0 ms/line Without ECM: 2.5, 5, 10, 20, or 40 ms/line
Memory Capacity:	ECM: 128 KB SAF Standard: 4 MB With optional Expansion Memory: 28 MB (4 MB+ 24 MB) Page Memory Standard: 4 MB (Print: 2 MB + Scanner: 2 MB) With optional Expansion Memory: 12 MB (4 MB + 8 MB) (Print 8 MB + Scanner: 4 MB)

6.1.2 CAPABILITIES OF PROGRAMMABLE ITEMS

The following table shows the capabilities of each programmable items.

Item	Standard
Quick Dial	2000
Groups	100
Destination per Group	500
Destinations dialed from the ten-key pad overall	500

Programs	100
Auto Document	6
Communication records for Journal stored in the memory	200
Specific Senders	30

The following table shows how the capabilities of the document memory will change after the Expansion Memory are installed.

	Without the Expansion Memory	With the Expansion Memory
Memory Transmission file	400	400
Maximum number of page for memory transmission	1000	1000
Memory capacity for memory transmission (Note1)	320	2240

↓ Note

- Measured using an ITU-T #1 test document (Slerexe letter) at the standard resolution, the auto image density mode and the Text mode.

6.2 IFAX SPECIFICATIONS

Connectivity:	Local area network Ethernet 100base-Tx/10base-T IEEE1394 (IP over 1394) IEEE802.11b (wireless LAN)
Resolution:	Main scan: 400 dpi, 200 dpi Sub scan: 400 dpi, 200 dpi, 100 dpi  Note <ul style="list-style-type: none"> ▪ To use 400 dpi, IFAX SW01 Bit 4 must be set to “1”.
Transmission Time:	1 s (through a LAN to the server) Condition: ITU-T #1 test document (Selerexe Letter) MTF correction: OFF TTI: None Resolution: 200 x 100 dpi Communication speed: 10 Mbps Correspondent device: E-mail server Line conditions: No terminal access
Document Size:	Maximum message width is A4/LT.  Note <ul style="list-style-type: none"> ▪ To use B4 and A3 width, IFAX SW00 Bit 1 (B4) and/or Bit 2 (A3) must be set to “1”.
E-mail File Format:	Single/multi-part MIME conversion Image: TIFF-F (MH, MR, MMR)
Protocol:	Transmission: SMTP, TCP/IP Reception: POP3, SMTP, IMAP4, TCP/IP
Data Rate:	100 Mbps(100base-Tx) 10 Mbps (10base-T)

Authentication Method:	SMTP-AUTH POP before SMTP A-POP
Remark:	The machine must be set up as an e-mail client before installation. Any client PCs connected to the machine through a LAN must also be e-mail clients, or some features will not work (e.g. Autorouting).

6.3 IP-FAX SPECIFICATIONS

Network:	Local Area Network Ethernet/10base-T, 100base-TX IEEE1394 (IP over 1394) IEEE802.11b (wireless LAN)
Scan line density:	8 x 3.85 lines/mm, 200x100dpi (standard character), 8 x 7.7lines/mm, 200x200dpi (detail character), 8 x 15.4lines/mm (fine character: optional expansion memory required), 16 x 15.4lines/mm, 400x400dpi (super fine character: optional expansion memory required)
Original size:	Maximum A3 or 11"x 17" (DLT)
Maximum scanning size:	Standard: A3, 297mm x 432mm Irregular: 297mm x 1200mm
Transmission protocol:	Recommended: T.38 Annex protocol, TCP, UDP/IP communication
Compatible machines:	IP-Fax compatible machines
IP-Fax transmission function:	Specify IP address and send fax to an IP-Fax compatible fax through a network. Also capable of sending fax from a G3 fax connected to the public telephone lines via a VoIP gateway.
IP-Fax reception function:	Receive a fax sent from an IP-Fax compatible fax through a network. Also capable of receiving fax from a G3 fax connected the public telephone lines via a VoIP gateway.

6.4 FAX UNIT CONFIGURATION

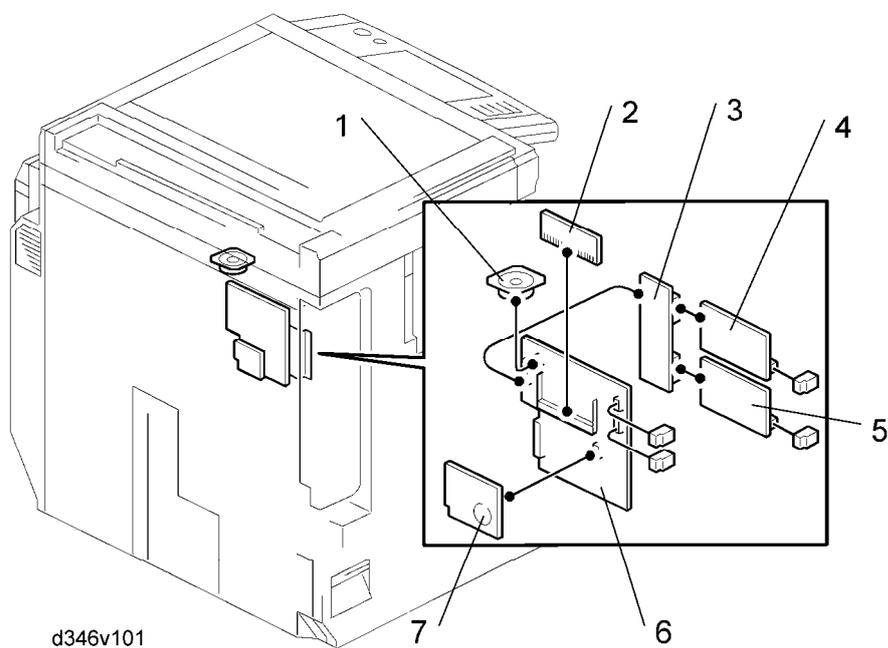

d346v101

Component	Code	No.	Remarks
MBU	D346	7	Included with fax unit
FCU		6	
Speaker		1	
Expansion Memory	G578	2	Optional
CCU I/F Board	D346	3	Optional
SG3 Board		4	
SG3 Board	D346	5	Optional
Handset Type 1018	B433	-	NA only. Also used with Ap-C1

PAPER FEED UNIT PB3040 D351

REVISION HISTORY		
Page	Date	Added/Updated/New
		None

PAPER FEED UNIT PB3040 (D351)

TABLE OF CONTENTS

1. REPLACEMENT AND ADJUSTMENT	1
1.1 REAR COVER	1
1.2 MOTORS AND CLUTCHES	2
1.2.1 LIFT MOTORS.....	2
1.2.2 UPPER AND LOWER PAPER FEED CLUTCHES.....	2
1.2.3 PAPER FEED MOTOR.....	3
1.3 MAIN BOARD	4
1.4 LIFT, PAPER END, AND RELAY SENSORS	5
1.5 PAPER FEED UNIT	6
1.6 PICK-UP, PAPER FEED AND SEPARATION ROLLERS.....	7
2. DETAILS	8
2.1 COMPONENT LAYOUT	8
2.1.1 MECHANICAL COMPONENT LAYOUT	8
2.1.2 ELECTRICAL COMPONENT LAYOUT	9
2.2 PAPER FEED	10
2.3 PAPER SIZE DETECTION	11
2.4 REVERSE ROLLER AND PICK-UP ROLLER RELEASE	13
2.5 PAPER HEIGHT AND END DETECTION.....	14
2.5.1 PAPER HEIGHT DETECTION.....	14
2.5.2 PAPER END AND BOTTOM PLATE	15
2.6 PAPER LIFT	16

Read This First

Safety and Symbols

Replacement Procedure Safety

CAUTION

- Turn off the main power switch and unplug the machine before beginning any of the replacement procedures in this manual.

Symbols Used in this Manual

This manual uses the following symbols.

: See or Refer to

: Screws

: Connector

: Clip ring

: E-ring

1. REPLACEMENT AND ADJUSTMENT

1.1 REAR COVER

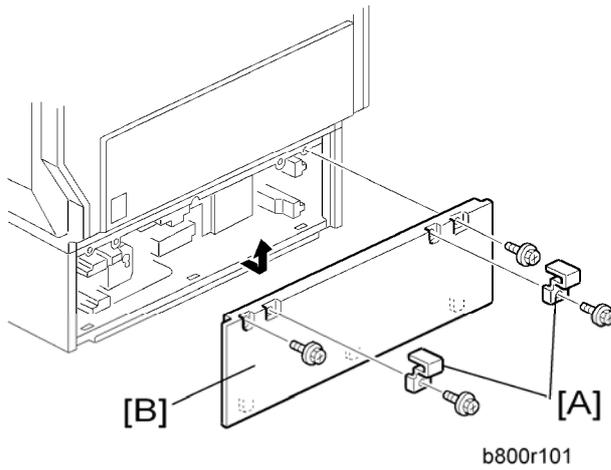

1. Securing brackets [A] (1 x 1 each)
2. Rear cover [B] (1 x 2)

Paper Feed
Unit PB3040
D351

1.2 MOTORS AND CLUTCHES

1.2.1 LIFT MOTORS

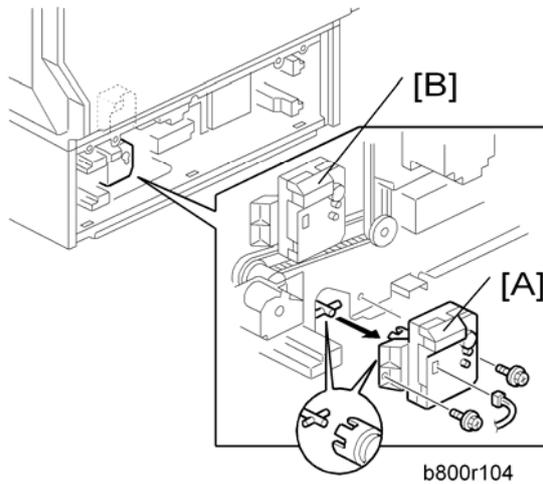

1. Rear cover (➔ "Rear Cover")
2. Lift motors [A][B] (⚙️ x 2, ⚙️ x 1 each)

1.2.2 UPPER AND LOWER PAPER FEED CLUTCHES

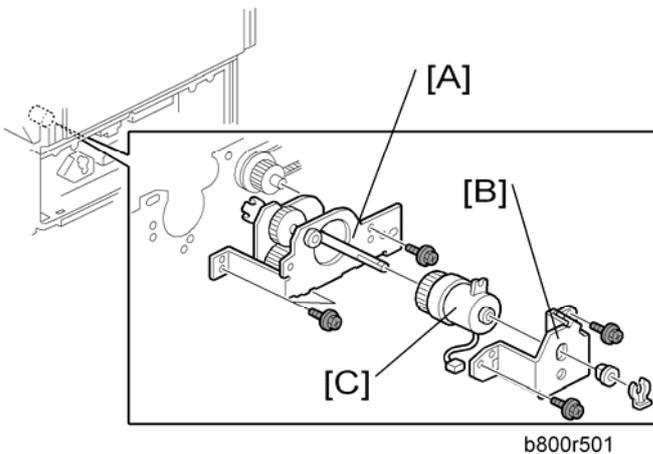

1. Rear cover (➔ "Rear Cover")
2. Upper paper feed gear unit [A] (⚙️ x 3, ⚙️ x 1)
3. Upper paper feed clutch bracket [B] (⌘ x 1, ⚙️ x 2, bushing x 1)
4. Upper paper feed clutch [C]

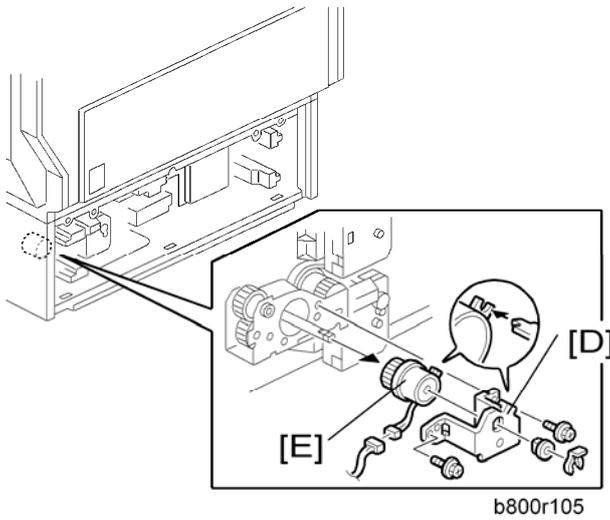

5. Lower paper feed clutch bracket [D] (⌘ x 1, bushing x 1, ⚙ x 2)
6. Lower paper feed clutch [E] (⚙ x 1)

1.2.3 PAPER FEED MOTOR

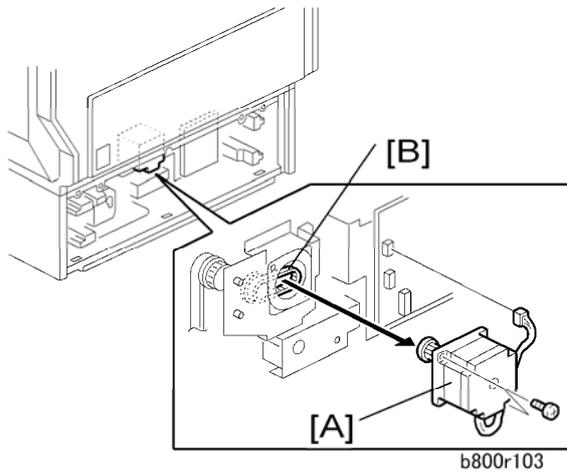

1. Rear cover (➡ "Rear Cover")
2. Paper feed motor [A] (⚙ x 1, ⚙ x 2)

↓ Note

- When installing the paper feed motor, make sure that the gear of the paper feed motor holds the timing belt [B].

1.3 MAIN BOARD

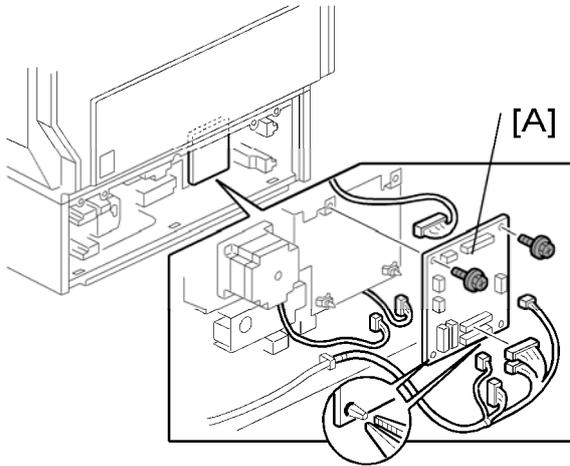

1. Rear cover (➔ "Rear Cover")
2. Main board [A] (All s,  x 2, snap pin x 2)

1.4 LIFT, PAPER END, AND RELAY SENSORS

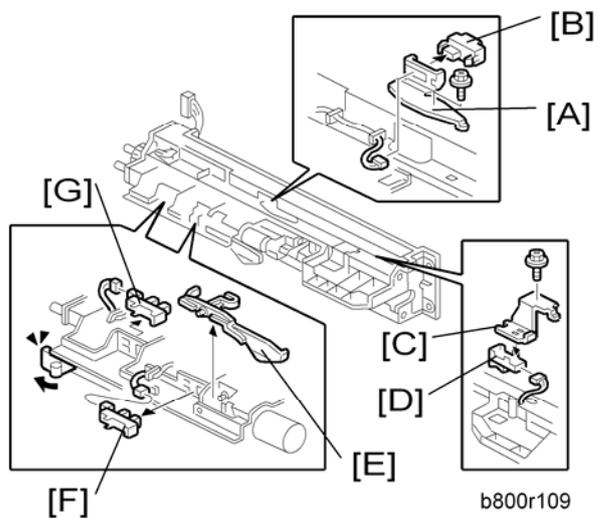

1. Paper feed unit (➡ "Paper Feed Unit")
2. Vertical transport sensor bracket [A] (🔩 x 1)
3. Vertical transport sensor [B] (🔩 x 1)
4. Paper feed sensor bracket [C] (🔩 x 1)
5. Paper feed sensor [D] (🔩 x 1)
6. Paper end sensor filler [E]
7. Paper end sensor [F] (🔩 x 1)
8. Lift sensor [G] (🔩 x 1)

1.5 PAPER FEED UNIT

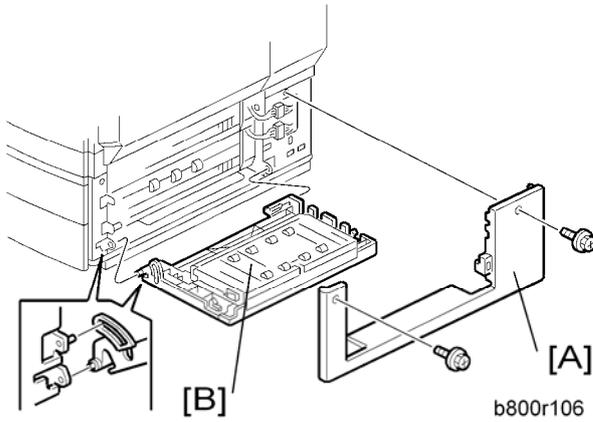

1. Right cover [A] (⚙ x 2)
2. Vertical transport guide [B] of the paper feed unit

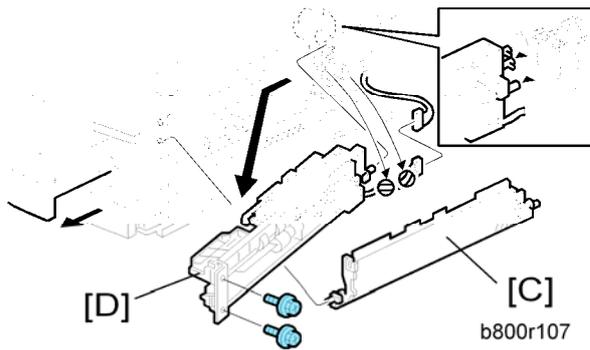

1. Pull the tray 3 (or 4).
2. Paper guide [C]
3. Paper feed unit [D] (⚙ x 2, ⚙ x 1, ⚙ x 2)

When replacing the paper feed unit of tray 4, do the same.

1.6 PICK-UP, PAPER FEED AND SEPARATION ROLLERS

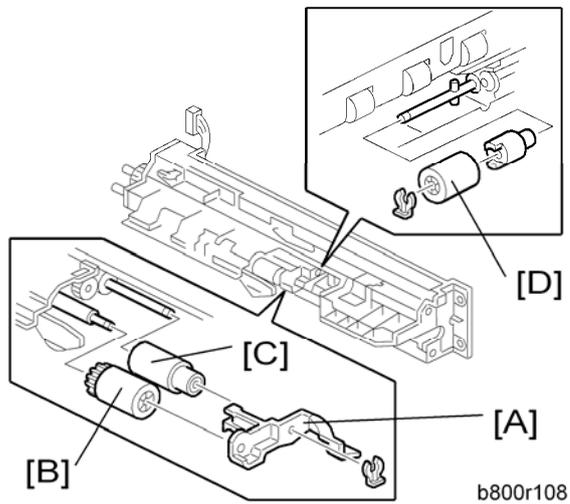

1. Paper feed unit (➡ "Paper Feed Unit)
2. Roller holder [A] (☞ x 1)
3. Pick-up roller [B]
4. Paper feed roller [C]
5. Separation roller [D] (☞ x 1)

2. DETAILS

2.1 COMPONENT LAYOUT

2.1.1 MECHANICAL COMPONENT LAYOUT

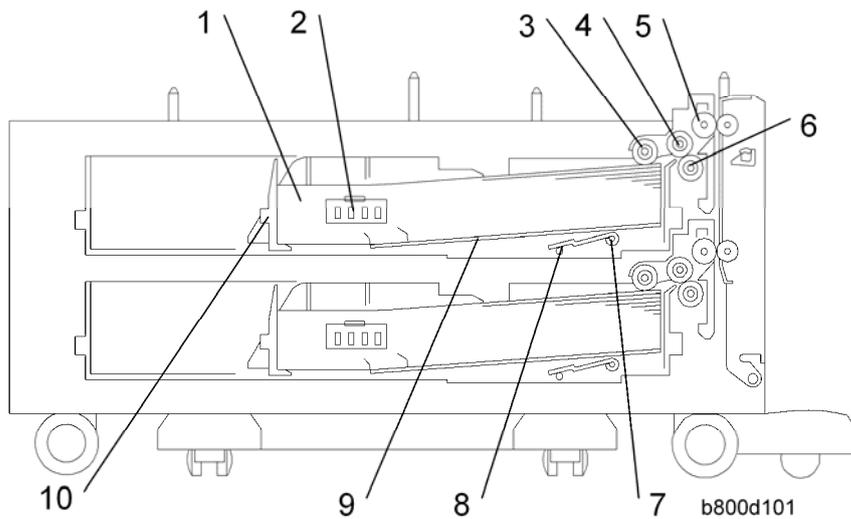

1. Upper tray	6. Separation roller
2. Paper size switch: Upper tray	7. Tray lift arm
3. Pick-up roller: Upper tray	8. Lift arm shaft
4. Paper feed roller	9. Bottom plate
5. Vertical transport roller	10. End plate

 Note

- Listed above are the components of tray 1 (upper tray). Tray 2 (lower tray) has the same components as tray 1.

2.1.2 ELECTRICAL COMPONENT LAYOUT

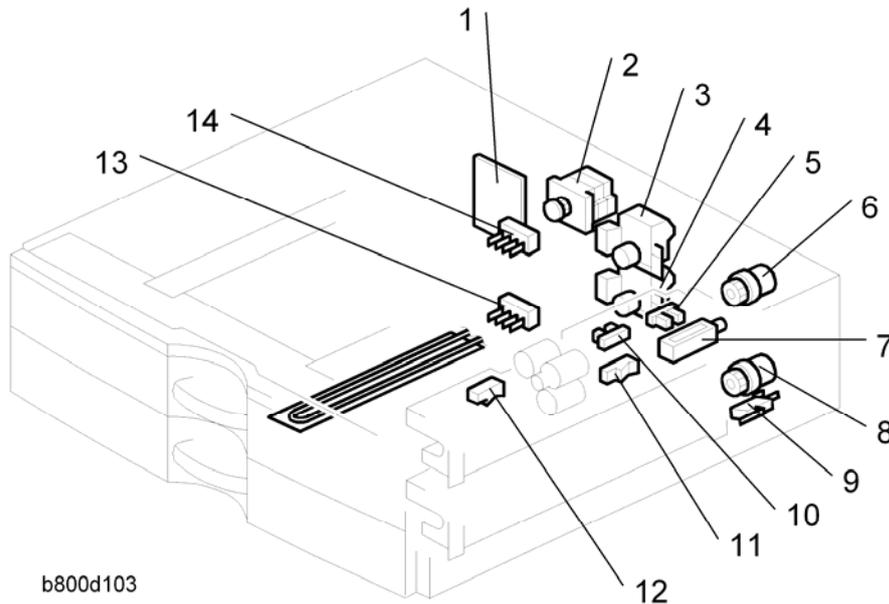

Paper Feed
Unit PB3040
D351

1. Main board	8. Lower paper feed clutch
2. Feed motor	9. Vertical transport guide switch
3. Upper tray lift motor	10. Paper end sensor
4. Lower tray lift motor	11. Vertical transport sensor 1
5. Upper lift sensor	12. Paper feed sensor
6. Upper paper feed clutch	13. Paper size switch: Lower tray
7. Pick-up solenoid	14. Paper size switch: Upper tray

Note

- Listed above are the components of tray 1 (upper tray), except for the right cover switch and anti-condensation heater (there is only one each of these for the entire unit). Tray 2 (lower tray) has the same components as tray 1.

2.2 PAPER FEED

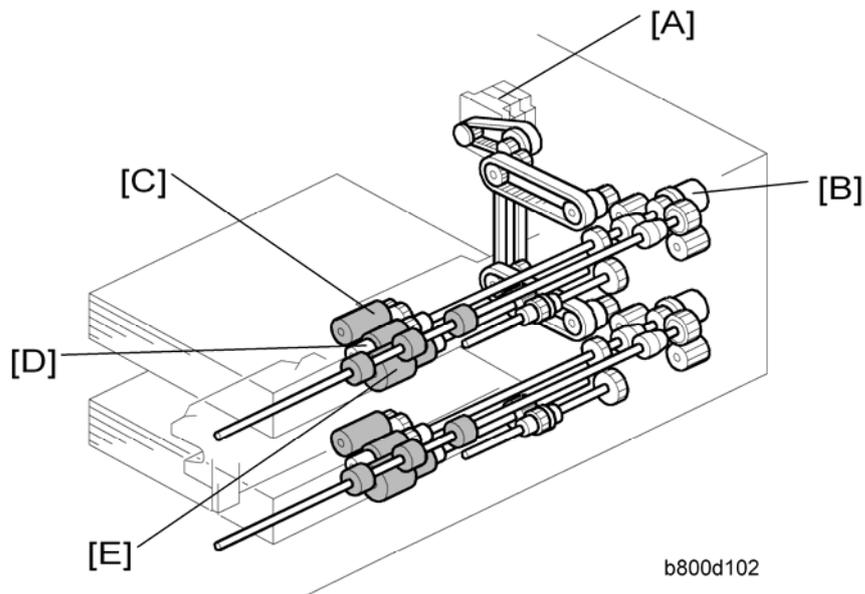

Paper Feed Mechanism:

An FRR (feed and reverse roller) feed mechanism is used (➔ "Paper Feed Methods" in the Core Technology Manual).

Drive Path:

Tray 3 (upper tray) and tray 4 (lower tray) have identical paper feed systems. The feed motor [A] drives all the rollers in the unit. The paper feed clutch [B] controls the pick-up roller [C], paper feed roller [D], and separation roller [E].

2.3 PAPER SIZE DETECTION

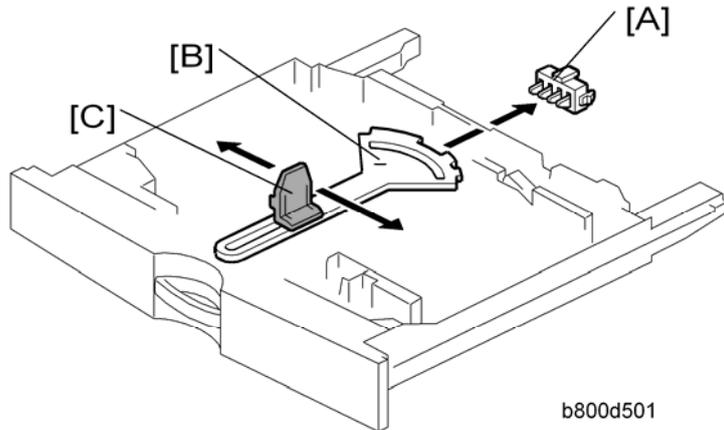

There are four paper size switches [A] working in combination. Switch 1 (right end) is for tray set detection. The other three switches detect the paper size as shown in the table below. The actuator [B] is moved by the end plate [C].

0: Not pushed, 1: Pushed

Models		Switch Location		
North America	Europe/Asia	SW4	SW3	SW2
DLT (A3) SEF*1	A3 (DLT) SEF*1	1	1	0
LG (B4) SEF*2	B4 (LG) SEF*2	1	1	1
A4 SEF	A4 SEF	0	0	1
B5 SEF	B5 SEF	0	0	0
LT (A4) LEF*3	A4 (LT) LEF*3	0	1	1
B5 (Exe) LEF*4	B5 (Exe) LEF*4	1	0	1
A5 LEF	A5 LEF	0	1	0

Note

- *1: Detects either DLT SEF or A3 SEF, depending on the setting of SP5-181-7 or 11.
- *2: Detects either LG SEF or B4 SEF, depending on the setting of SP5-181-8 or 12.

Paper Size Detection

- *3: Detects either LT LEF or A4 LEF, depending on the setting of SP5-181-6 or 10.
- *4: Detects either Exe LEF or B5 LEF, depending on the setting of SP5-181-9 or 13

The machine disables paper feed from a tray if the paper size cannot be detected (if the paper size actuator is broken or no tray is installed).

For non-standard paper sizes, if they are not visible on the user tool screen for selecting paper sizes, then set SP 5-112 to 1. If the user selects one of these sizes, auto paper size selection is disabled.

2.4 REVERSE ROLLER AND PICK-UP ROLLER RELEASE

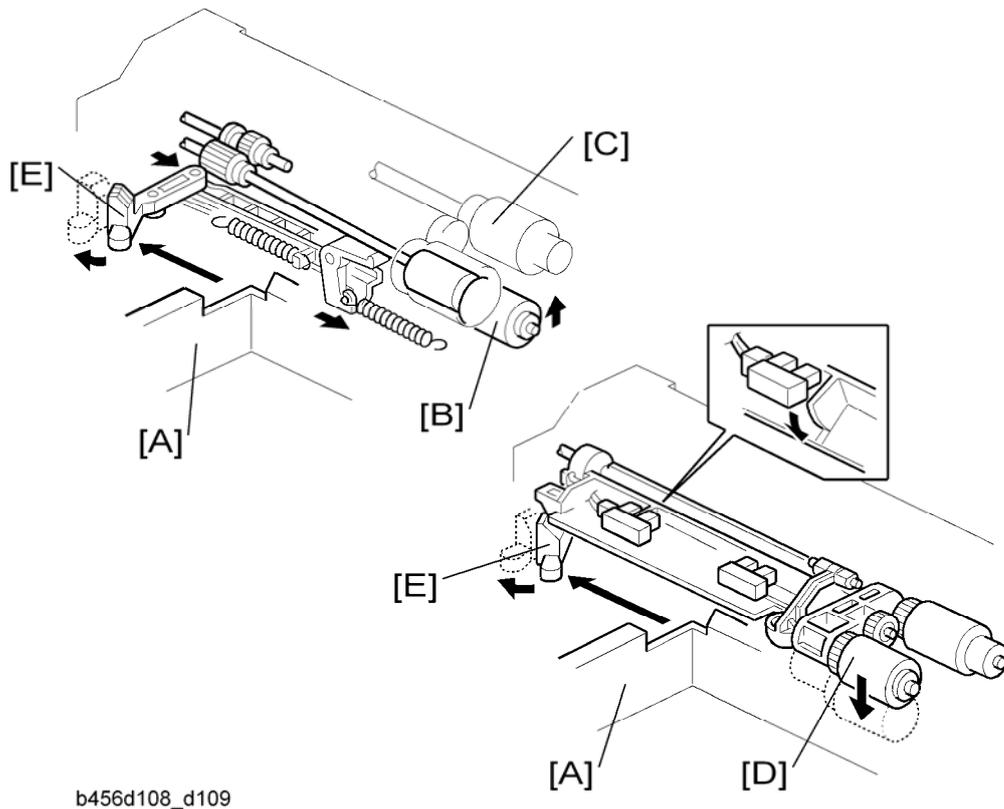

The pick-up roller and separation roller release the paper when it is not being fed. This helps remove jammed paper easily.

When the paper tray [A] is not in the machine, the separation roller [B] is away from the paper feed roller [C] and the pick-up roller stays in its upper position.

When the paper tray is pushed into the machine, it pushes the release lever [E]. This causes the pick-up roller [D] to go down into contact with the top sheet of paper, and causes the reverse roller [B] to move up and contact the paper feed roller.

2.5 PAPER HEIGHT AND END DETECTION

2.5.1 PAPER HEIGHT DETECTION

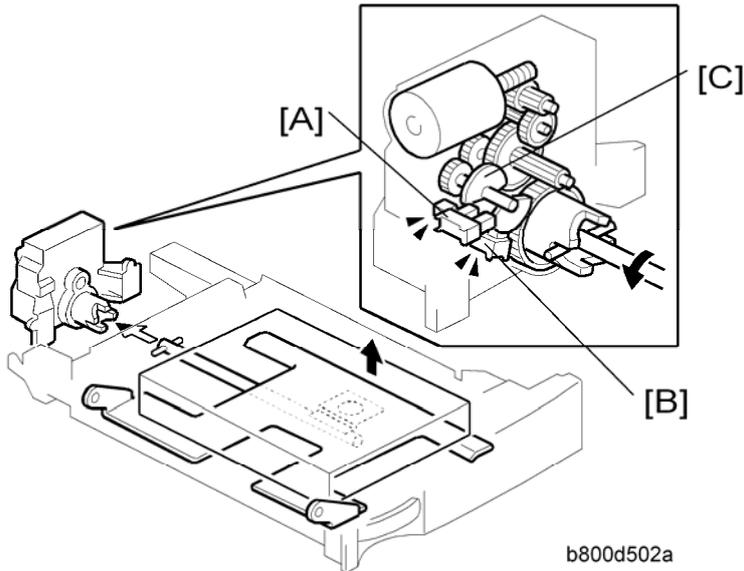

Two paper height sensors [A] [B] and actuator [C] are built into the paper tray lift motor. The paper height sensors, detect the amount of paper in the tray.

The actuator [C] has two semicircles, and it is engaged with the lift arm shaft via gears. The paper height sensors detect the paper size depending on the position of the two semicircles. The list shown below shows the detection combination of the two sensors.

The paper remaining status bar is displayed in the tray selection icon on the LCD.

Remaining paper	Paper height sensor 1 [A]	Paper height sensor 2 [B]
100% (Status bar x 4)	OFF	OFF
70% (Status bar x 3)	ON	OFF
30% (Status bar x 2)	ON	ON
10% (Status bar x 1)	OFF	ON

OFF: No actuator

2.5.2 PAPER END AND BOTTOM PLATE

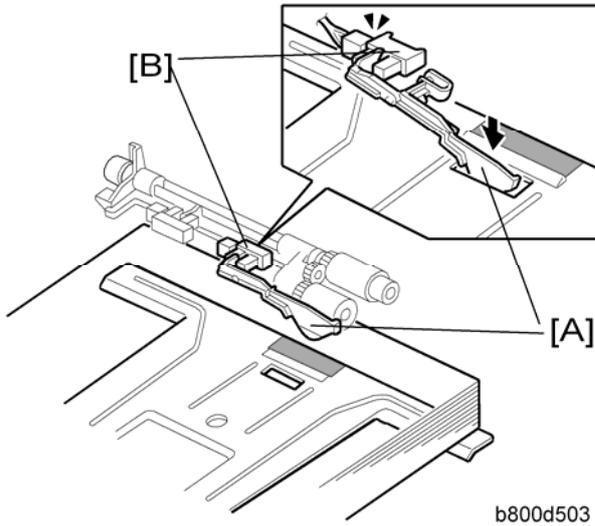

The paper stack raises the paper end feeler [A] and the paper end sensor [B] deactivates if there is some paper in the paper tray.

When the paper tray runs out of paper, the paper end feeler [A] drops into the cutout in the tray bottom plate. At this time the paper end sensor [B] activates

2.6 PAPER LIFT

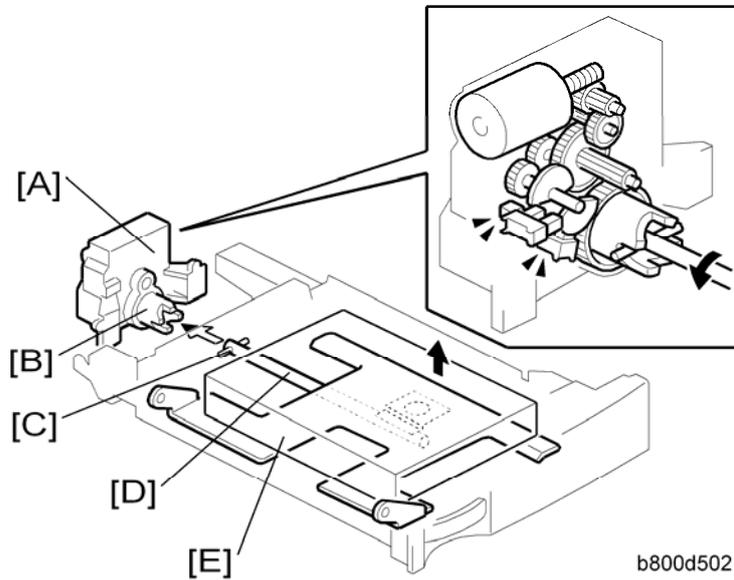

When the machine detects that a tray has been placed in the machine, the tray lift motor [A] rotates and the coupling gear [B] on the tray lift motor engages the pin [C] on the lift arm shaft [D]. Then the tray lift arm lifts the tray bottom plate [E] until the paper lift sensor for the tray detects that the top of the stack is at the paper feed position.

When the tray is removed from the machine, the connection between the coupling gear and lift arm shaft is disengaged, and the tray bottom plate lowers.

LCIT PB3050 D352

REVISION HISTORY		
Page	Date	Added/Updated/New
		None

LCIT PB3050 (D352)

TABLE OF CONTENTS

1. REPLACEMENT AND ADJUSTMENT	1
1.1 LEFT AND RIGHT TRAY	1
1.2 SENSORS	2
1.2.1 PAPER HEIGHT SENSORS ON THE PAPER STORAGE SIDE	2
1.2.2 END FENCE HP SENSOR/PAPER END SENSOR 2	2
1.3 CHANGING THE TRAY SIZE	3
1.4 MAIN BOARD	4
1.5 CLUTCHES.....	5
1.5.1 STACK TRANSPORT CLUTCH	5
1.5.2 PAPER FEED CLUTCH.....	5
1.6 PAPER FEED UNIT	6
1.7 MOTORS	7
1.7.1 TRAY LIFT MOTOR.....	7
1.7.2 TRAY MOTOR	8
1.8 PICK-UP, FEED AND SEPARATION ROLLERS.....	9
1.9 PAPER FEED, PAPER END, LIFT AND RELAY SENSORS.....	10
1.10 PAPER FEED.....	11
2. DETAILS	12
2.1 COMPONENT LAYOUT	12
2.1.1 MECHANICAL COMPONENT LAYOUT	12
2.1.2 ELECTRICAL COMPONENT LAYOUT	13
2.1.3 ELECTRICAL COMPONENT DESCRIPTIONS.....	14
2.2 SEPARATION ROLLER AND PICK-UP ROLLER RELEASE	16
2.3 TRAY LIFT	17
2.4 PAPER AMOUNT DETECTION.....	18
2.5 PAPER END DETECTION (PAPER FEED SIDE)	19
2.6 PAPER STACK TRANSPORT	20

Read This First

Safety and Symbols

Replacement Procedure Safety

CAUTION

- Turn off the main power switch and unplug the machine before beginning any of the replacement procedures in this manual.

Symbols Used in this Manual

This manual uses the following symbols.

: See or Refer to

: Screws

: Connector

: Clip ring

: E-ring

1. REPLACEMENT AND ADJUSTMENT

1.1 LEFT AND RIGHT TRAY

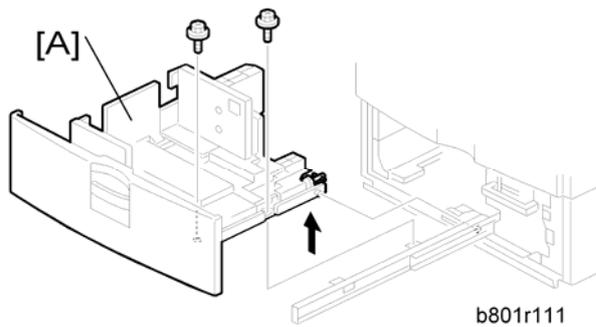

1. Pull the LCT drawer.

↓ Note

- If the right tray comes up with the left tray, push the right tray into the LCT.

2. Left tray [A] (⌀x 2)

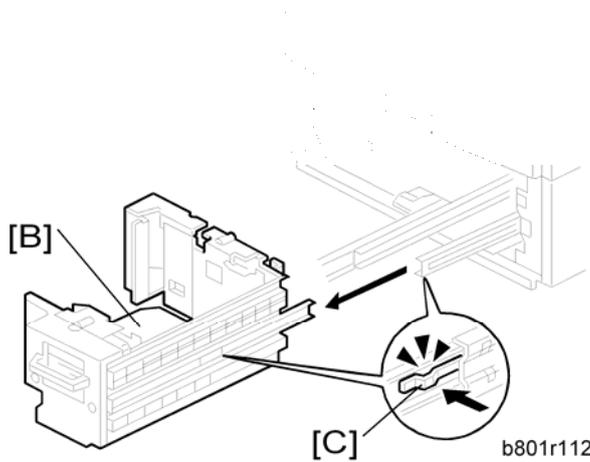

3. Remove the right tray [B] while pressing down the stopper [C].

↓ Note

- When reinstalling the tray, set the tray on the guide rail and carefully push the tray in, making sure to keep the tray level.

1.2 SENSORS

1.2.1 PAPER HEIGHT SENSORS ON THE PAPER STORAGE SIDE

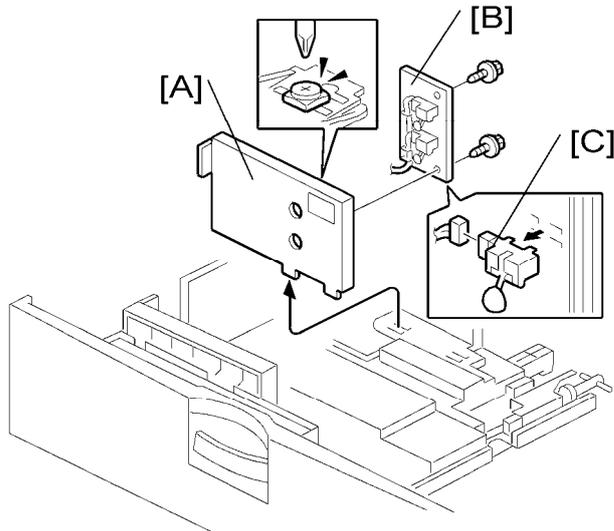

1. Tray (➡ "Left and Right Tray")
2. Rear fence [A] (🔩 x 1)
3. Rear fence bracket [B] (🔩 x 2)
4. Paper height sensors [C] (🔌 x 1 each)

1.2.2 END FENCE HP SENSOR/PAPER END SENSOR 2

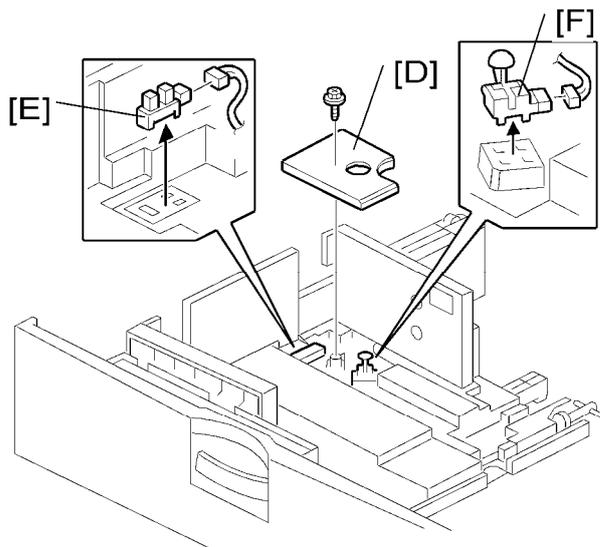

1. Bottom cover [D] (🔩 x 1)
2. End fence HP sensor [E] (🔌 x 1)
3. Paper end sensor 2 (paper storage side) [F] (🔌 x 1)

1.3 CHANGING THE TRAY SIZE

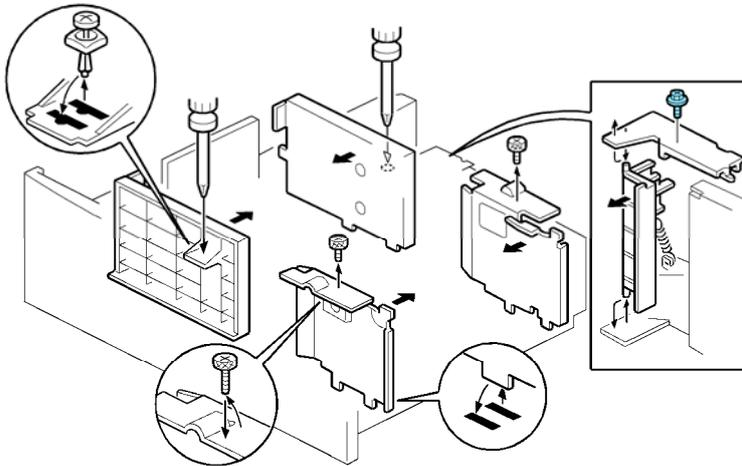

1. Remove the fence screws (⌀x 5).
2. Change the position of the fences.

↓ Note

- Before fastening the screws, set paper in the tray.

Main Board

1.4 MAIN BOARD

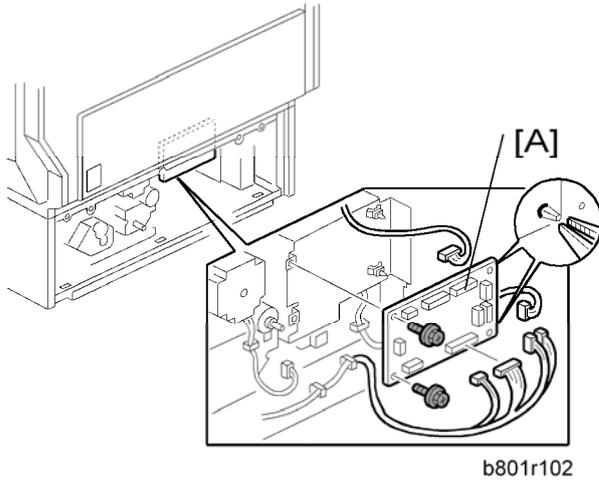

1. Rear cover (➔ "Tray Lift Motor")
2. Main board [A] (All s,  x 2, snap x 2)

1.5 CLUTCHES

1.5.1 STACK TRANSPORT CLUTCH

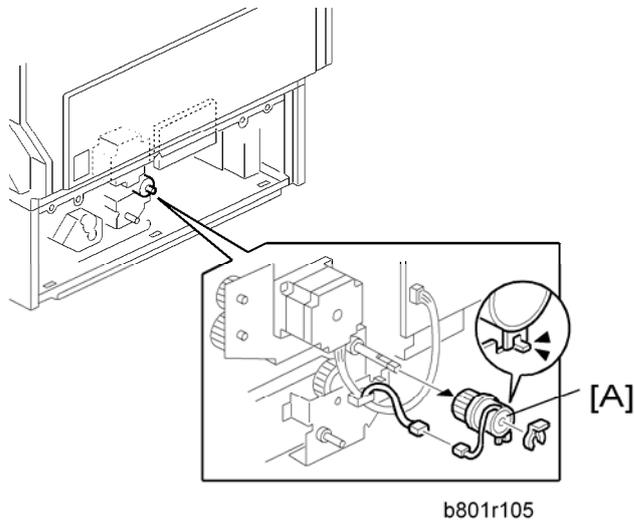

1. Rear cover (➔ "Tray Lift Motor")
2. Stack transport clutch [A] (⚙️ x 1, ⚙️ x 1)

1.5.2 PAPER FEED CLUTCH

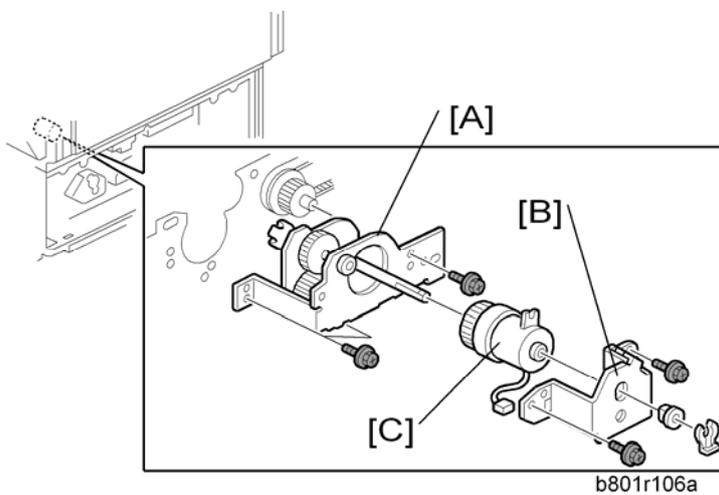

1. Rear cover (➔ "Tray Lift Motor")
2. Paper feed gear unit [A] (⚙️ x 3, ⚙️ x 1)
3. Paper feed clutch bracket [B] (⚙️ x 1, ⚙️ x 2, bushing x 1)
4. Paper feed clutch [C]

1.6 PAPER FEED UNIT

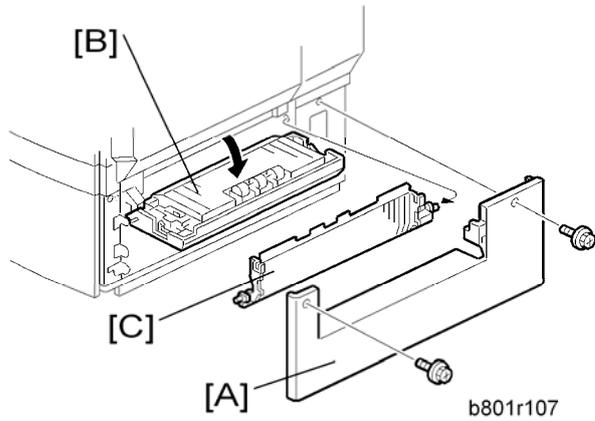

1. Right cover [A]
2. Open the vertical guide plate [B]
3. Guide plate [C]

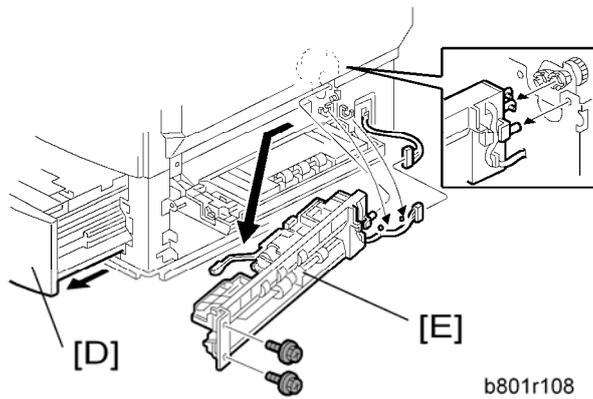

4. Pull the LCT drawer [D].
5. Paper feed unit [E] (🔧 x 2, 📄 x 1)

1.7 MOTORS

1.7.1 TRAY LIFT MOTOR

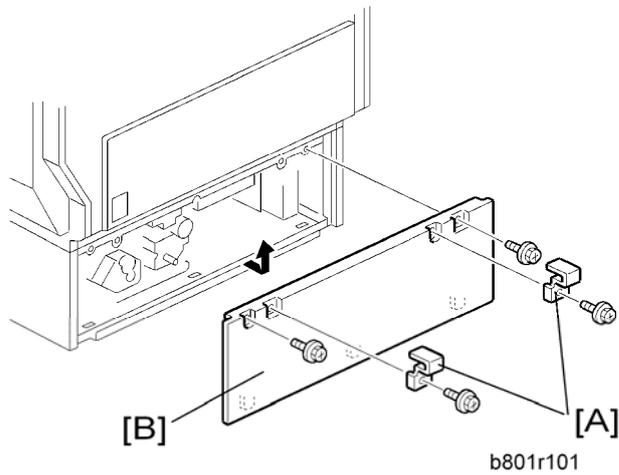

1. Securing brackets [A] (⌘ x 1 each)
2. Rear cover [B] (⌘ x 2)

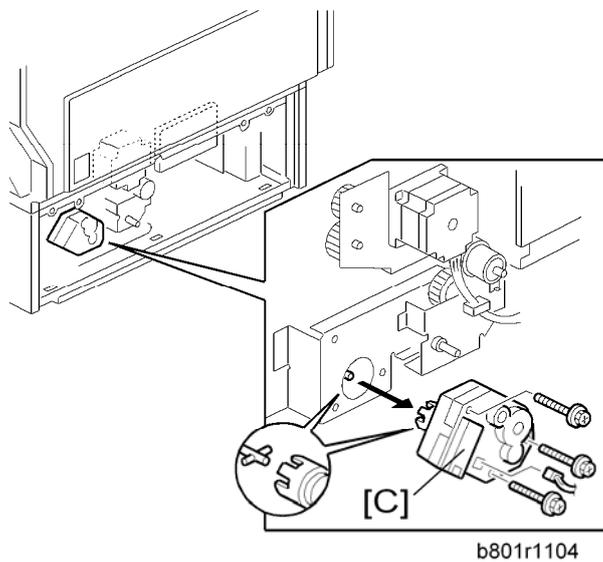

3. Tray lift motor [C] (⌘ x 1, ⌘ x 3)

Motors

1.7.2 TRAY MOTOR

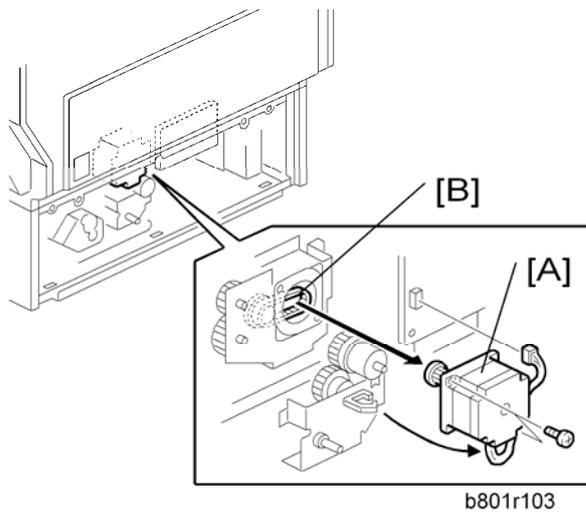

1. Rear cover (➡ "Tray Lift Motor")
2. Tray motor [A] (⚙️ x 1, 🔩 x 2)

Note

- When installing the tray motor, make sure that the gear of the tray motor holds the timing belt [B].

1.8 PICK-UP, FEED AND SEPARATION ROLLERS

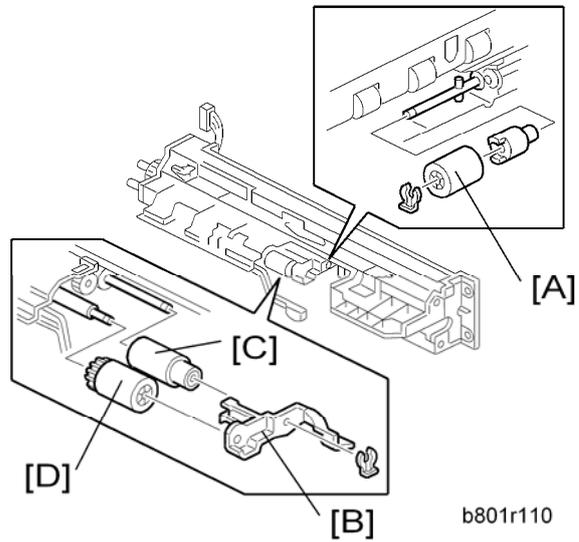

1. Paper feed unit (➔ "Paper Feed Unit")
2. Separation roller [A] (Ⓜ x 1)
3. Roller holder [B] (Ⓜ x 1)
4. Feed roller [C] and pick-up roller [D]

1.9 PAPER FEED, PAPER END, LIFT AND RELAY SENSORS

SENSORS

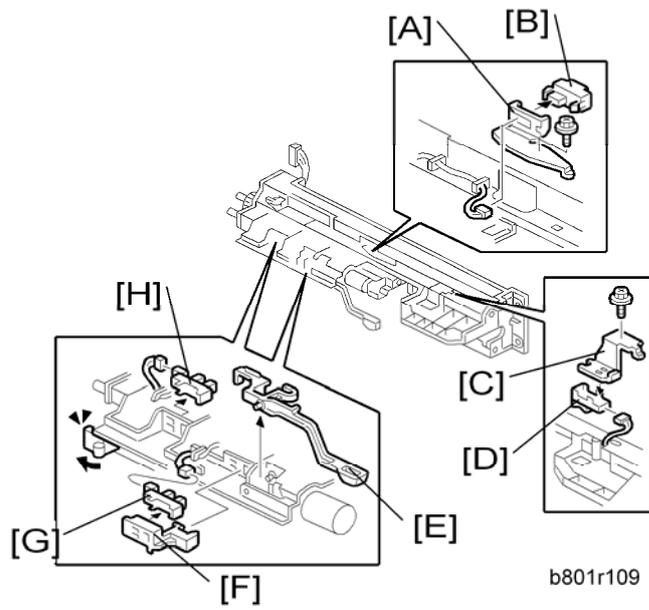

1. Paper feed unit (➡ "Paper Feed Unit")
2. Vertical transport sensor bracket [A] (🔩 x 1, 📏 x 1)
3. Relay sensor [B]
4. Paper feed sensor bracket [C]
5. Paper feed sensor [D]
6. Paper end feeler [E]
7. Paper end sensor holder [F] (hook x 3)
8. Paper end sensor [G] (📏 x 1, hook x 3)
9. Lift sensor [H] (📏 x 1, hook x 3)

1.10 PAPER FEED

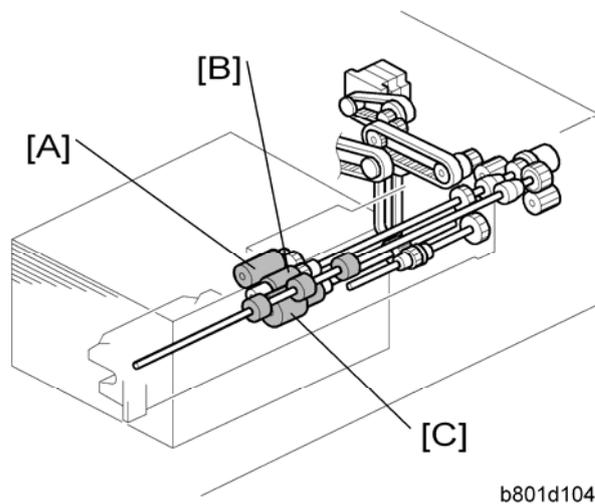

This products uses an FRR type paper feed mechanism.

The paper feed unit consists of the pick-up roller [A], paper feed roller [B], separation roller [C], and relay rollers.

There is a torque limiter in the back of the separation roller (ferrite powder type).

2. DETAILS

2.1 COMPONENT LAYOUT

2.1.1 MECHANICAL COMPONENT LAYOUT

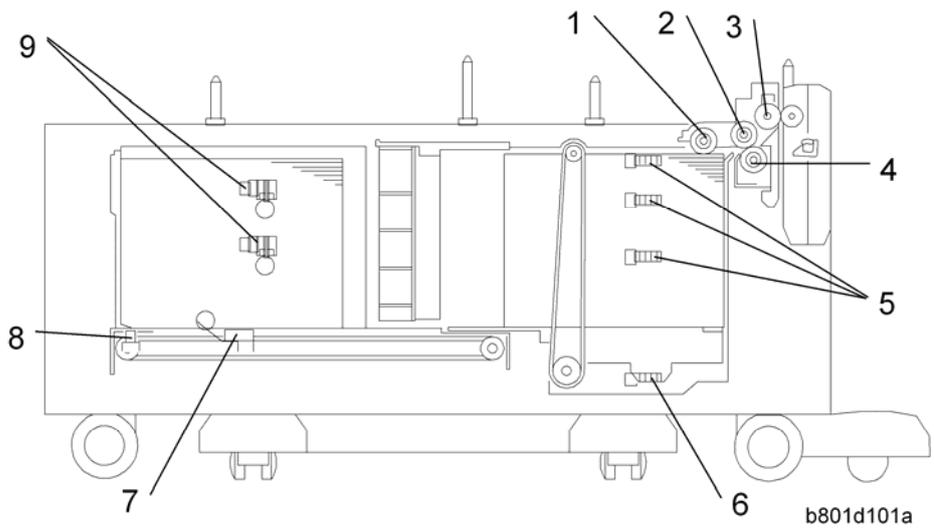

1. Pick-up Roller	6. Lower Limit Sensor
2. Paper Feed Roller	7. Paper End Sensor 2
3. Relay Sensor	8. End Fence HP Sensor
4. Separation Roller	9. Paper Height Sensors 4, 5
5. Paper Height Sensors 1, 2, 3	

2.1.2 ELECTRICAL COMPONENT LAYOUT

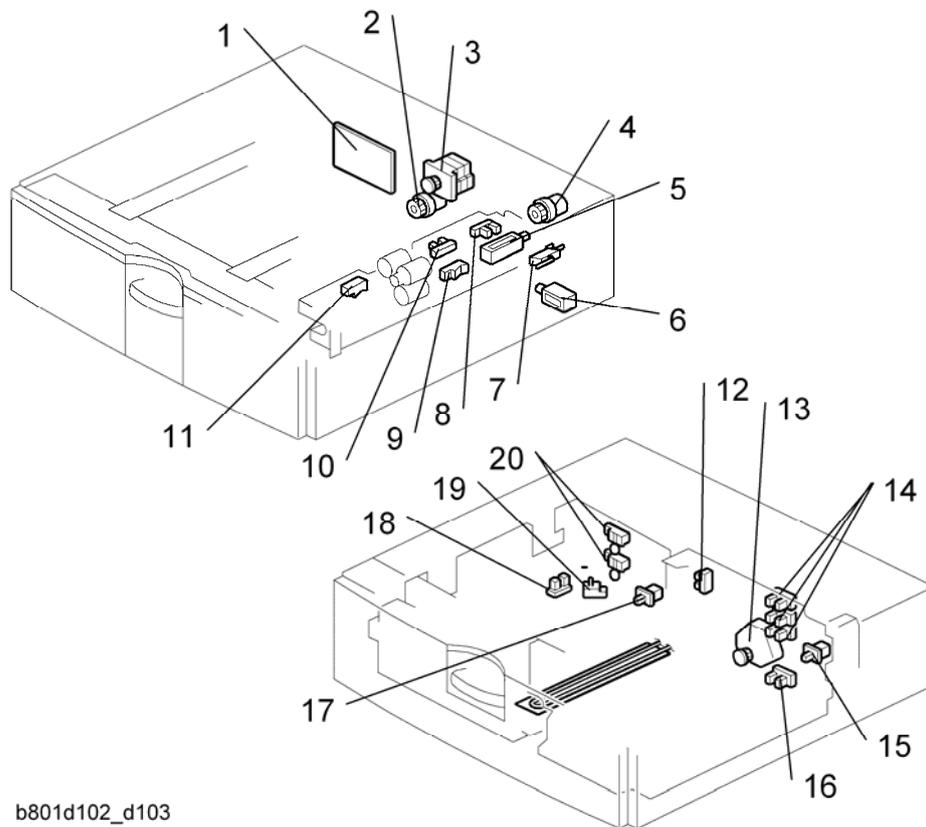

b801d102_d103

1. Main board	11. Paper feed sensors
2. Stack transport clutch	12. Side fence sensor
3. Tray motor	13. Tray lift motor
4. Paper feed clutch	14. Paper height sensor 1, 2, 3
5. Pick-up solenoid	15. Tray set switch
6. Right tray lock solenoid	16. Lower limit sensor
7. Vertical guide switch	17. Left tray set switch
8. Lift sensor	18. End fence HP sensor
9. Relay sensor	19. Paper end sensor 2
10. Paper end sensor 1	20. Paper height sensors 4, 5

2.1.3 ELECTRICAL COMPONENT DESCRIPTIONS

Symbol	Name	Function	Index No.
Motors			
M1	Tray	Drives all rollers.	3
M2	Tray Lift	Drives the paper tray up or down.	13
Sensors			
S1	Paper Feed Sensor	Detects whether the paper is jammed at LCT.	11
S2	Relay	Detects the copy paper coming to the relay roller and checks for misfeeds.	9
S3	Paper End 1 (paper feed side)	Informs the copier/printer when the paper in the right side (paper feed side) of the tray has been used up. If there is a paper stack in the left side (paper storage side), this is moved into the paper feed side. If there is no paper stack in the left side, paper end is indicated.	10
S4	Lift	Detects when the paper is at the correct paper feed height.	8
S5-S7	Paper Height 1, 2, 3	Detects the amount of paper remaining in the right side of the tray.	14
S8	Lower Limit	Detects when the tray is completely lowered, to stop the LCT motor.	16
S9	End Fence HP	Detects when the left fence is at its home position	18
S10	Side Fence	Detects whether the side fence is open or closed. (The fence opens when the	12

Component Layout

Symbol	Name	Function	Index No.
		left-tray paper stack is moving to the paper feed side.)	
S11	Paper End 2 (paper storage side)	Informs the copier/printer when there is no paper in the left side (paper storage side) of the tray.	19
S12 S13	Paper Height 4, 5	Detects the amount of paper remaining in the left side of the tray.	20
Switches			
SW1	Vertical Guide	Detects whether the right cover is open.	7
SW2	Tray Set Switch	Detects whether the tray is correctly set.	15
SW3	Left Tray Set Switch	Detects whether the left tray is correctly set.	17
Magnetic Clutches			
MC1	Paper Feed	Drives the paper feed roller.	4
MC2	Stack Transport	Drives the rear fence of the paper storage side.	2
Solenoids			
SOL1	Pick-up	Pushes the pick-up roller up or down.	5
SOL2	Tray Lock	Locks or unlocks the right tray.	6
PCBs			
PCB1	Main	Controls the LCT and communicates with the copier/printer.	1

LCT PB3050
D352

2.2 SEPARATION ROLLER AND PICK-UP ROLLER RELEASE

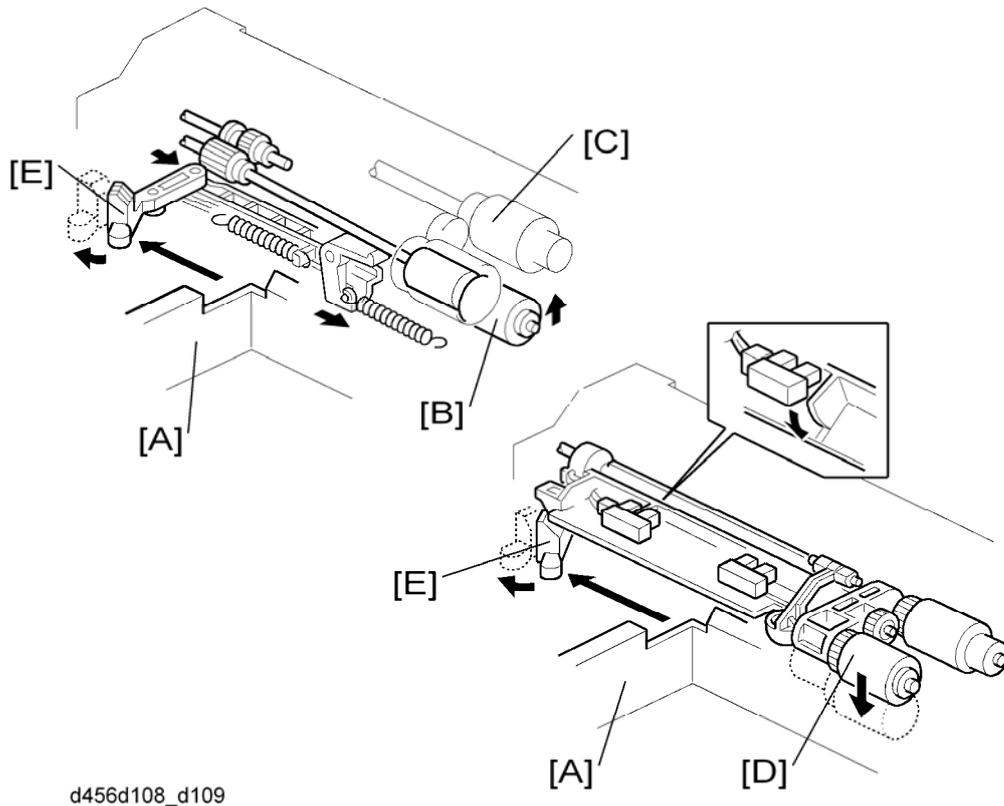

To prevent the paper from being torn when pulling out the paper feed tray, the separation and pick-up rollers release automatically.

When the paper tray [A] is not inside the machine, the separation roller [B] is away from the paper feed roller [C], and the pick-up roller [D] stays in the upper position.

When the paper tray is set into the machine, it pushes the release lever [E]. This causes the pick-up roller [D] to go down into contact with the top sheet of paper and the separation roller [B] to move up and contact the paper feed roller.

2.3 TRAY LIFT

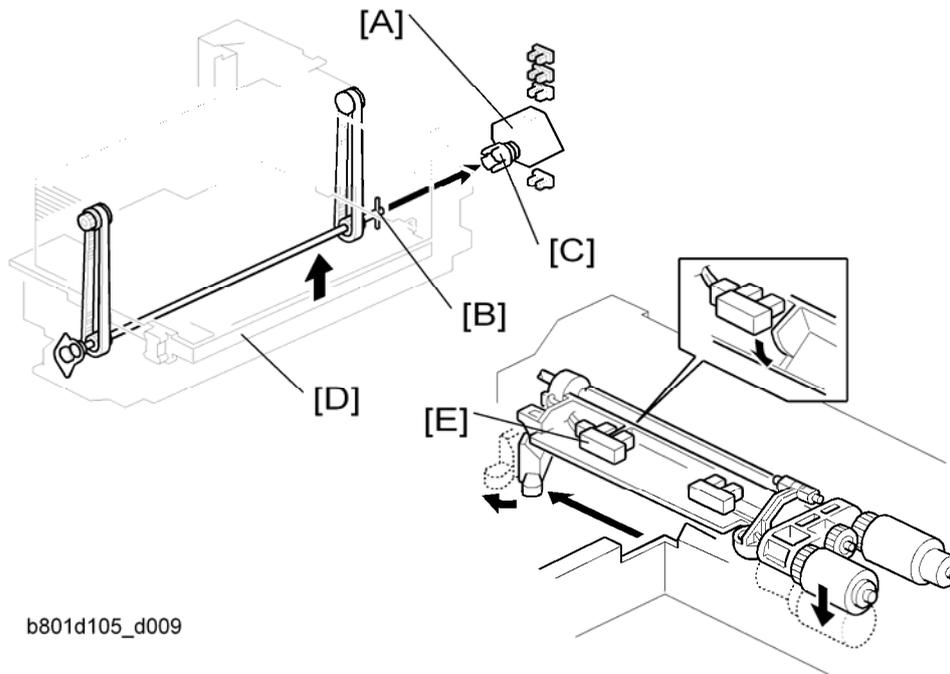

b801d105_d009

When the paper feed tray is put in the machine, the tray switch on the back turns on and the tray lift motor [A] starts. The base plate lift shaft [B] is coupled to the lift motor at the shaft [C], so the base plate [D] of the tray is lifted. After a short while, the top of the paper stack contacts the pick-up roller and lifts it up. Then the motor stops lifting the plate when the upper limit sensor actuator enters the sensor (➔ "Electrical Component Layout").

When paper in the tray is used up, the pick-up roller is gradually lowered, and the actuator leaves the lift sensor [E]. When this happens, the lift motor begins turning again. The tray will then be lifted until the actuator enters the upper limit sensor again).

When the tray is removed from the copier, the coupling between the lift motor [A] and base plate lift shaft [B] is broken and the base plate goes into a controlled free fall (using a damper to slow the fall and prevent damage).

2.4 PAPER AMOUNT DETECTION

The table lists the sensors that are used to detect the amount of remaining paper.

Right Tray (Paper feed side)

- Paper end sensor 1
- Paper height sensor 1 to 3

Left Tray (Paper storage side)

- Paper height sensor 4 and 5
- Paper end sensor 2

Right Tray

Amount of paper	Paper Height Sensor			Paper End Sensor	Display No. of Line
	1	2	3		
100%	OFF	OFF	OFF	ON	4
70%	OFF	OFF	ON	ON	3
30%	OFF	ON	-	ON	2
10%	ON	-	-	ON	1
Paper End	-	-	-	OFF	0

Left Tray

Amount of paper	Paper Height Sensor		Paper End Sensor	Display No. of Line
	4	5		
100%	OFF	OFF	OFF	4
70%	ON	OFF	OFF	3
30%	ON	ON	OFF	2
Paper End	ON	ON	ON	0

2.5 PAPER END DETECTION (PAPER FEED SIDE)

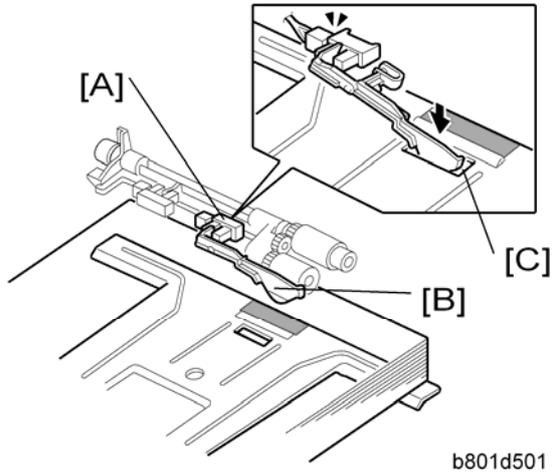

The paper end sensor 1 [A] detects when copy paper in the paper feed side runs out. When there is paper in the tray, the paper pushes up the feeler [B] and the actuator enters the sensor. When paper runs out, the feeler drops in to cutout [C] and the actuator leaves the sensor, and the machine detects that there is no paper in the tray.

2.6 PAPER STACK TRANSPORT

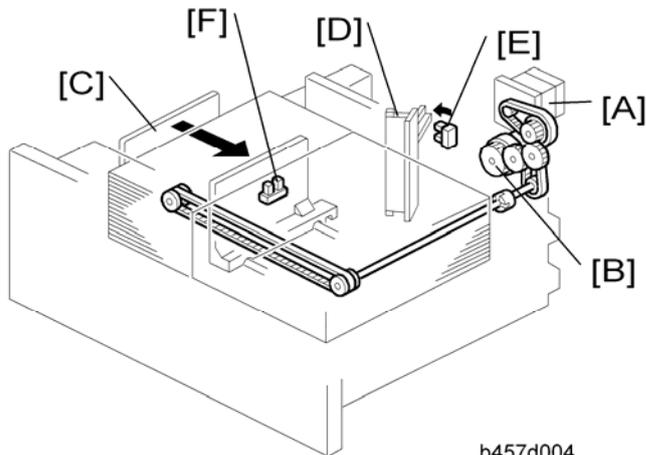

When the paper in the paper feed side is used up, the tray motor [A] and stack transport clutch [B] turn on. Then the end fence [C] moves the stack of paper from the paper storage side to the paper feed side.

 Note

- During paper feed, the stack transport clutch (☛ "Electrical Component Layout") does not switch on, so drive from the tray motor only transfers to the relay roller and not to the fence mechanism.

While the stack is in motion, it pushes the side fence [D] aside, and the side fence sensor [E] detects that the fence is open.

After the stack has been moved all the way across, a spring in the side fence moves the side fence back, and the side fence sensor detects that the fence is closed. Then, the tray motor reverses until end fence home position sensor [F] is deactivated.

1200-SHEET LCIT RT3000 D353

REVISION HISTORY		
Page	Date	Added/Updated/New
		None

1200-SHEET LCIT RT3000(D353)

TABLE OF CONTENTS

1. REPLACEMENT AND ADJUSTMENT	1
1.1 COVERS	1
1.1.1 REAR COVER	1
1.1.2 RIGHT DOOR	1
1.1.3 FRONT AND TOP COVERS	2
1.2 PAPER FEED	3
1.2.1 PICK-UP, PAPER FEED AND SEPARATION ROLLERS	3
1.3 DRIVE	4
1.3.1 PAPER FEED CLUTCH	4
1.3.2 PAPER FEED MOTOR	4
1.3.3 TRAY LIFT MOTOR	5
1.4 ELECTRICAL COMPONENTS	6
1.4.1 MAIN BOARD	6
1.4.2 LCT SET SWITCHES	6
1.4.3 DOWN SWITCH	7
1.4.4 PAPER FEED, PAPER END, TRAY LIFT AND RELAY SENSORS	7
1.4.5 STACK SENSOR	9
1.5 SIDE FENCE POSITION CHANGE	10
2. DETAILS	11
2.1 COMPONENT LAYOUT	11
2.1.1 COMPONENT LAYOUT	11
2.1.2 ELECTRICAL COMPONENT LAYOUT	12
2.1.3 ELECTRICAL COMPONENT DESCRIPTIONS	12
2.1.4 DRIVE LAYOUT	15
2.2 PAPER FEED	16
2.2.1 PAPER FEED MECHANISM	16
2.2.2 TRAY LIFT MECHANISM	17
2.2.3 PAPER HEIGHT AND END DETECTION	18

Read This First

Safety and Symbols

Replacement Procedure Safety

CAUTION

- Turn off the main power switch and unplug the machine before beginning any of the replacement procedures in this manual.

Symbols Used in this Manual

This manual uses the following symbols.

: See or Refer to

: Screws

: Connector

: Clip ring

: E-ring

: Clamp

1. REPLACEMENT AND ADJUSTMENT

1.1 COVERS

1.1.1 REAR COVER

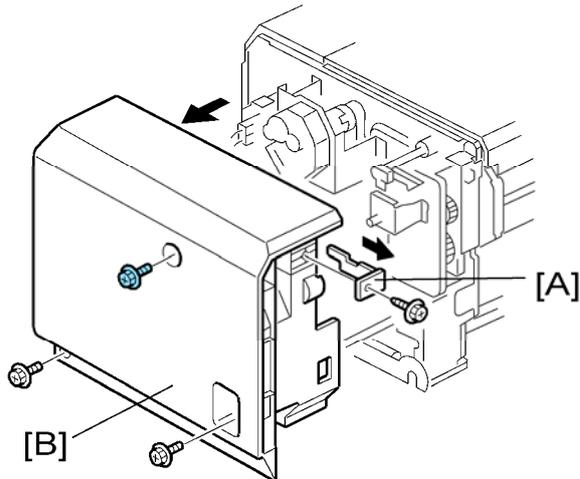

d353r102

1. Cover [A] (🔩 x 1)
2. Rear cover [B] (🔩 x 3)

1.1.2 RIGHT DOOR

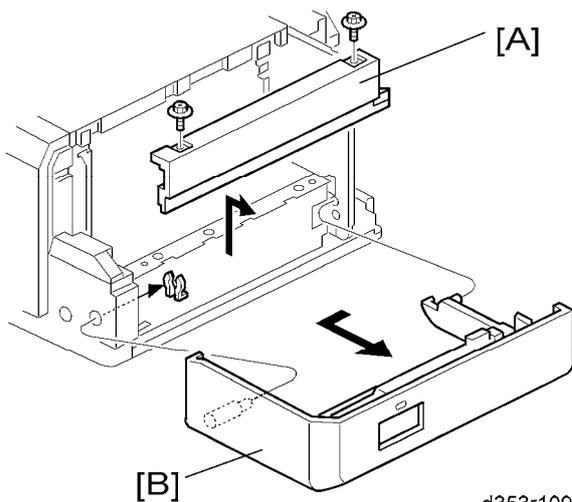

d353r109

1. Right lower cover [A] (🔩 x 2)
2. Right door [B] (🚪 x 1)

Covers

1.1.3 FRONT AND TOP COVERS

1. Right door (→ p.1 "Rear Cover")

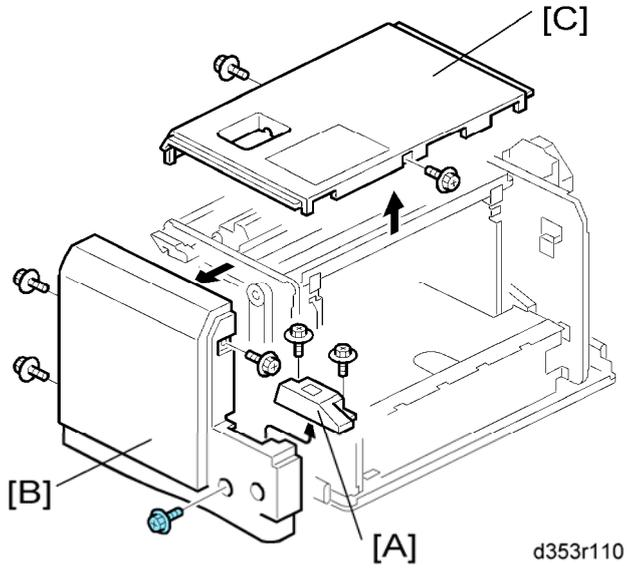

2. Switch cover [A] (⚙ x 2)
3. Front cover [B] (⚙ x 4)
4. Top cover [C] (⚙ x 2)

1.2 PAPER FEED

1.2.1 PICK-UP, PAPER FEED AND SEPARATION ROLLERS

1. Open the right door.

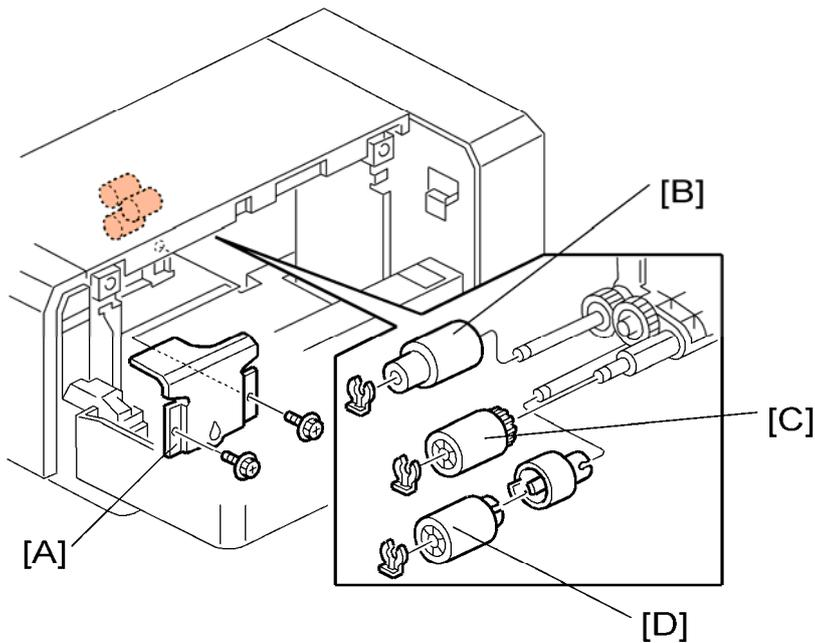

d353r101

2. Sensor bracket [A] (🔩 x 2)
3. Rollers [B], [C], [D] (🌀 x 1 each)
 - [B]: Paper feed roller
 - [C]: Pick-up roller
 - [D]: Separation roller

Drive

1.3 DRIVE

1.3.1 PAPER FEED CLUTCH

1. Rear cover (→ p.1 "Rear Cover")

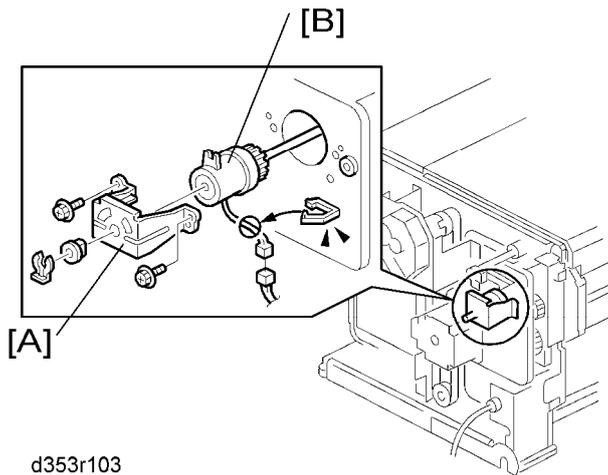

2. Bracket [A] (⌘ x 1, ⚙ x 2, bushing x 1)
3. Paper feed clutch [B] (⚙ x 1, ⌘ x 1)

1.3.2 PAPER FEED MOTOR

1. Rear cover (→ p.1 "Rear Cover")

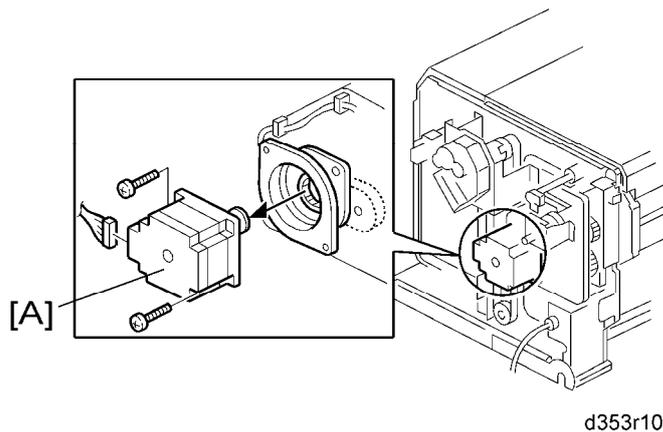

1. Paper feed motor [A] (⚙ x 2)

1.3.3 TRAY LIFT MOTOR

1. Rear cover (→ p.1 "Rear Cover")

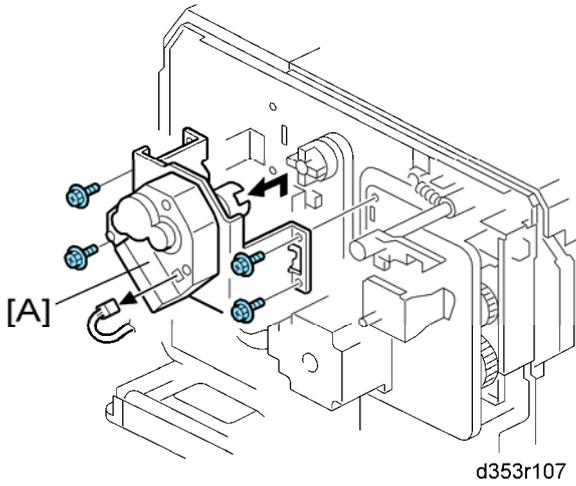

2. Tray lift motor unit [A] (⚙️ x 4, 📁 x 1)

1200 Sheet
LCT RT3000
D353

1.4 ELECTRICAL COMPONENTS

1.4.1 MAIN BOARD

1. Rear cover (↪ p.1 "Rear Cover")

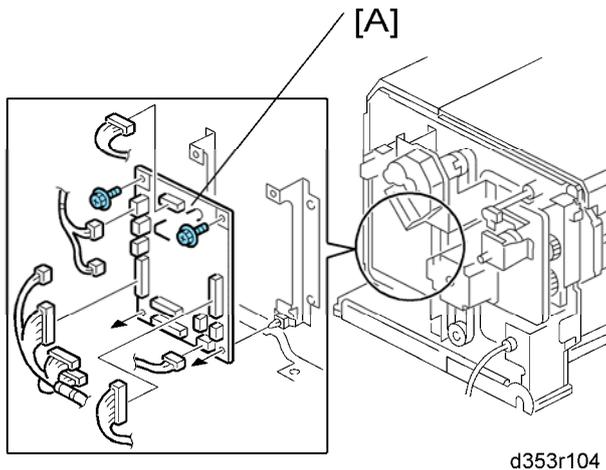

d353r104

2. Main board (⚙ x 2, all ⚙'s)

1.4.2 LCT SET SWITCHES

Rear

1. Rear cover (↪ p.1 "Rear Cover")

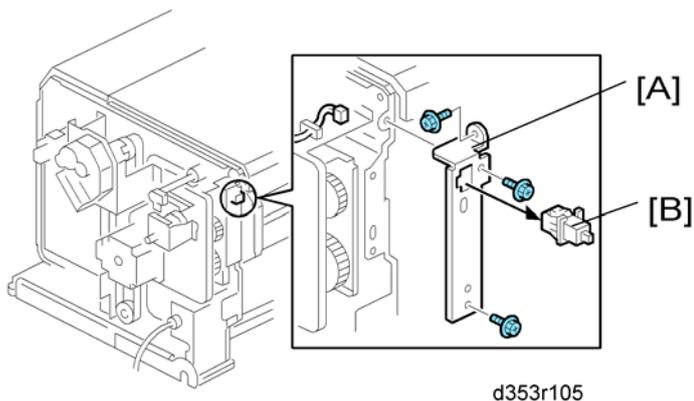

d353r105

2. Switch bracket [A] (⚙ x 3)
3. Rear LCT set switch [B]

Front

1. Front cover (↪ p.2 "Front and Top Covers")

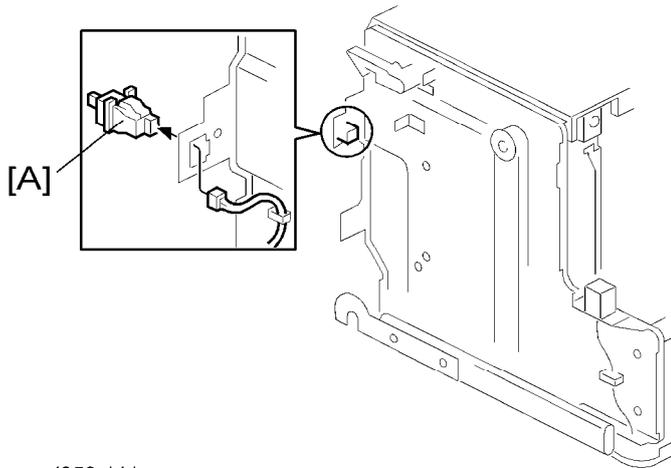

d353r111

2. Front LCT set switch [A] (☞ x 1)

1.4.3 DOWN SWITCH

1. Front cover (☞ p.2 "Front and Top Covers")

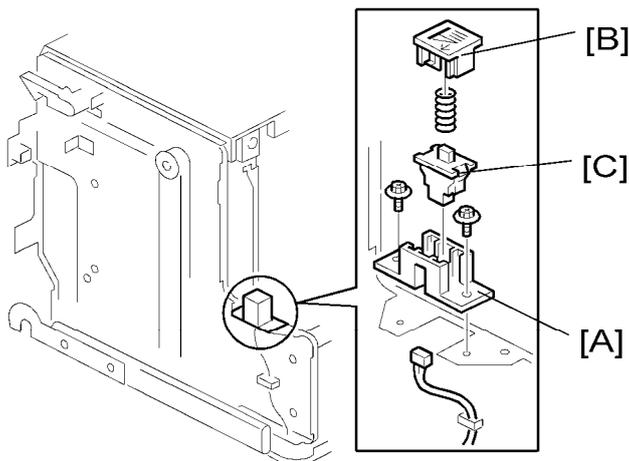

d353r112

2. Switch base [A] (☞ x 2, ☞ x 1)
3. Down button [B] (spring x 1)
4. Down switch [C] (hook)

1.4.4 PAPER FEED, PAPER END, TRAY LIFT AND RELAY SENSORS

1. Front cover (☞ p.2 "Front and Top Covers")
2. Top Cover (☞ Front and Top Covers)

1200 Sheet
LCT RT3000
D353

Electrical Components

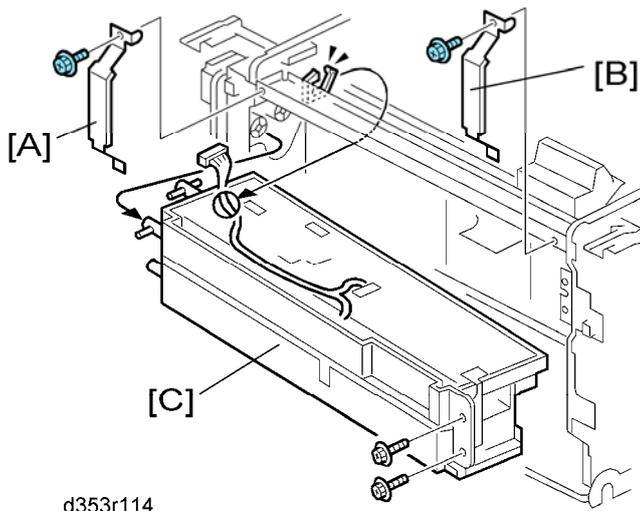

d353r114

3. Rear ground plate [A] (⚙️ x 1)
4. Front ground plate [B] (⚙️ x 1)
5. Paper feed unit [C] (⚙️ x 2, 📄 x 1, 📄 x 1)

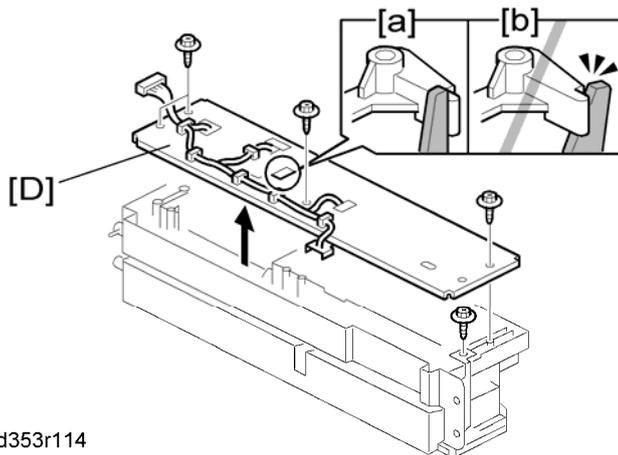

d353r114

6. Paper feed unit cover [D] (⚙️ x 5, 📄 x 1)

⚠️ Note

- Before you re-install the paper feed unit cover, make sure that the pick-up solenoid holds the pick-up roller lever ([a]: correct, [b]: incorrect) and the pick-up roller works properly.

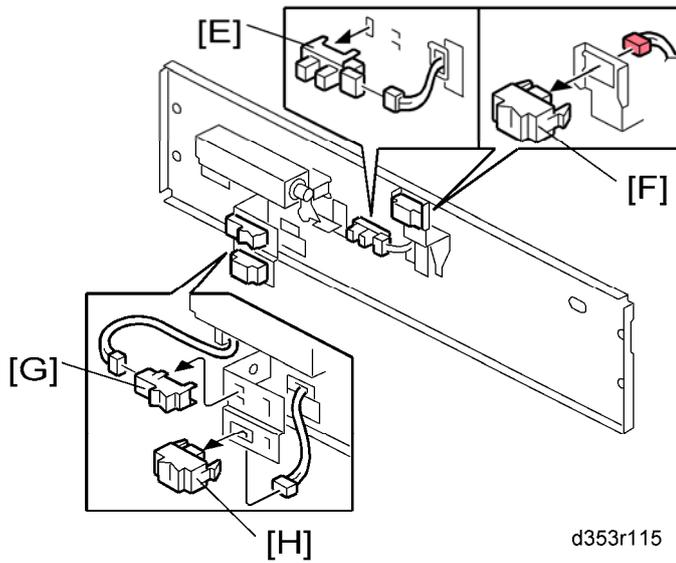

7. Sensors [E], [F], [G], [H] (☞ x 1, hooks each)

[E]: Tray lift sensor

[F]: Relay sensor

[G]: Paper feed sensor

[H]: Paper end sensor

1.4.5 STACK SENSOR

1. Open the right door
2. Paper feed unit (☛ p.7 "Paper Feed, Paper End, Tray Lift and Relay Sensors")

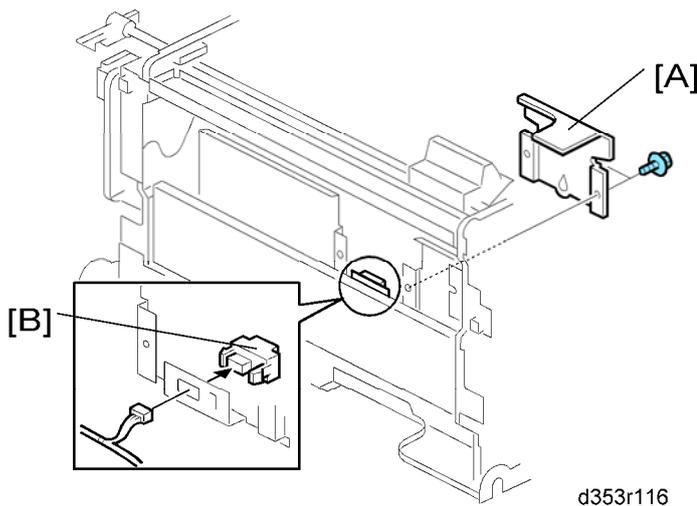

3. Sensor bracket [A] (☛ x 2)

4. Stack sensor [B] (☞ x 1)

1.5 SIDE FENCE POSITION CHANGE

1. Open the right door of the LCT.
2. Push the down switch to lower the tray bottom plate until it reaches its lowest position.

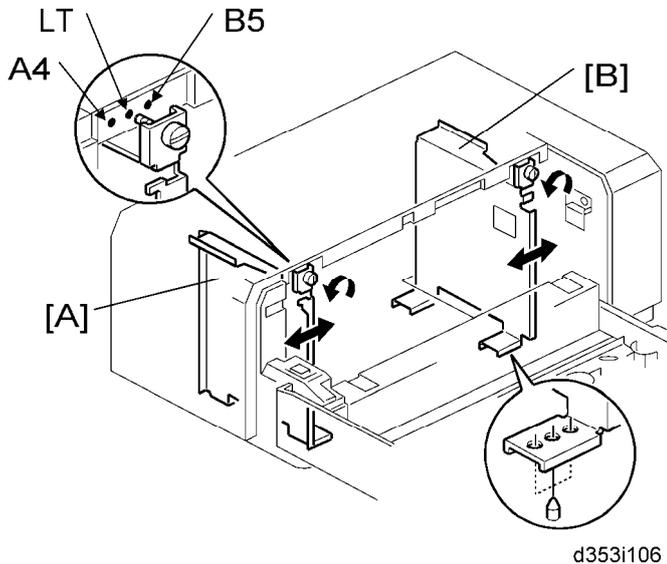

3. Remove the front and rear side fences [A, B] (⌀ x 1 each).
4. Install the side fences in the correct position (A4 LEF/ LT LEF/ B5 LEF).

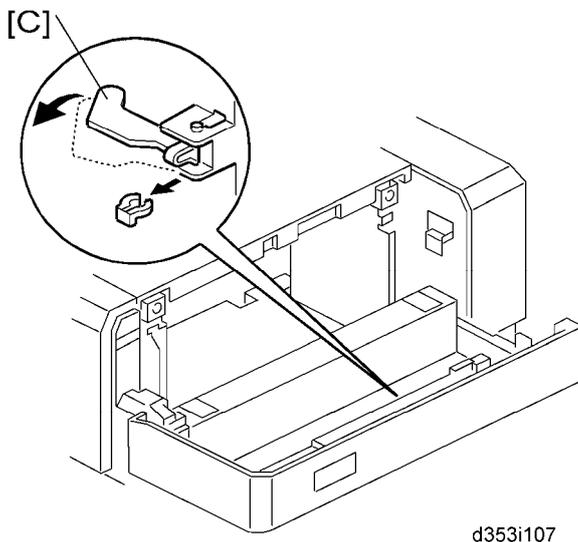

5. Pull the end fence [C] for B5 size paper as shown (⌀ x 1) if the the side fences are adjusted for B5 size paper.
6. Close the right door.
7. Turn on the main power switch, and then go into the SP mode.
8. Input the correct paper size for the 1200-sheet LCT with SP5181-017.

2. DETAILS

2.1 COMPONENT LAYOUT

2.1.1 COMPONENT LAYOUT

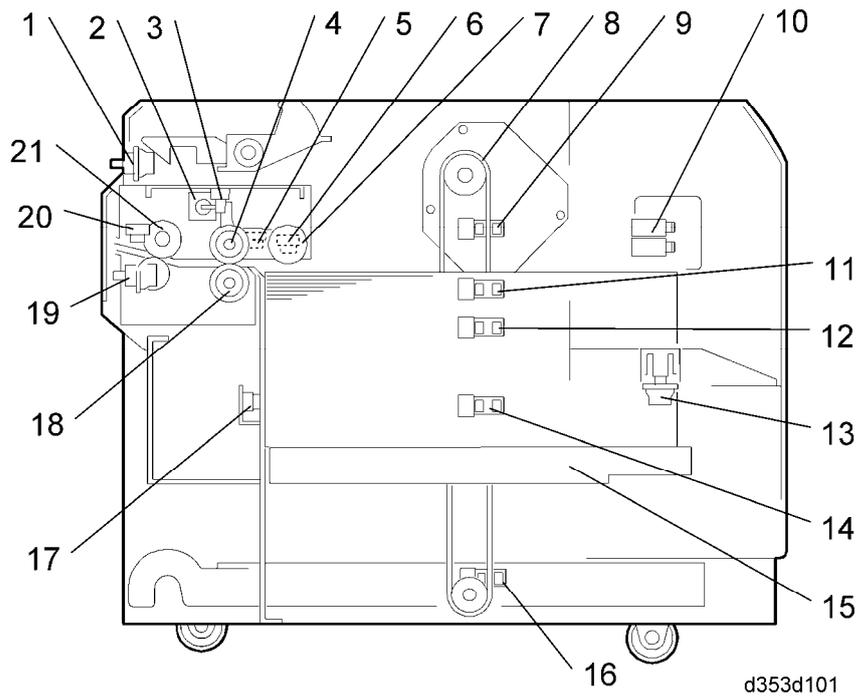

1200 Sheet
LCT RT3000
D353

<ul style="list-style-type: none"> 1. Rear LCT Set Switch 2. Pick-up Roller Solenoid 3. Tray Lift Sensor 4. Paper Feed Roller 5. Paper Feed Sensor 6. Paper End Sensor 7. Pick-up Roller 8. Tray Lift Motor 9. Paper Height Sensor 1 10. Interlock Switches 11. Paper Height Sensor 2 	<ul style="list-style-type: none"> 12. Sub Paper Height Sensor 13. Tray Down Switch 14. Paper Height Sensor 3 15. Paper Tray 16. Lower Limit Sensor 17. Stack Sensor 18. Separation Roller 19. Front LCT Set Switch 20. Relay Sensor 5 21. Relay Roller
--	---

Component Layout

2.1.2 ELECTRICAL COMPONENT LAYOUT

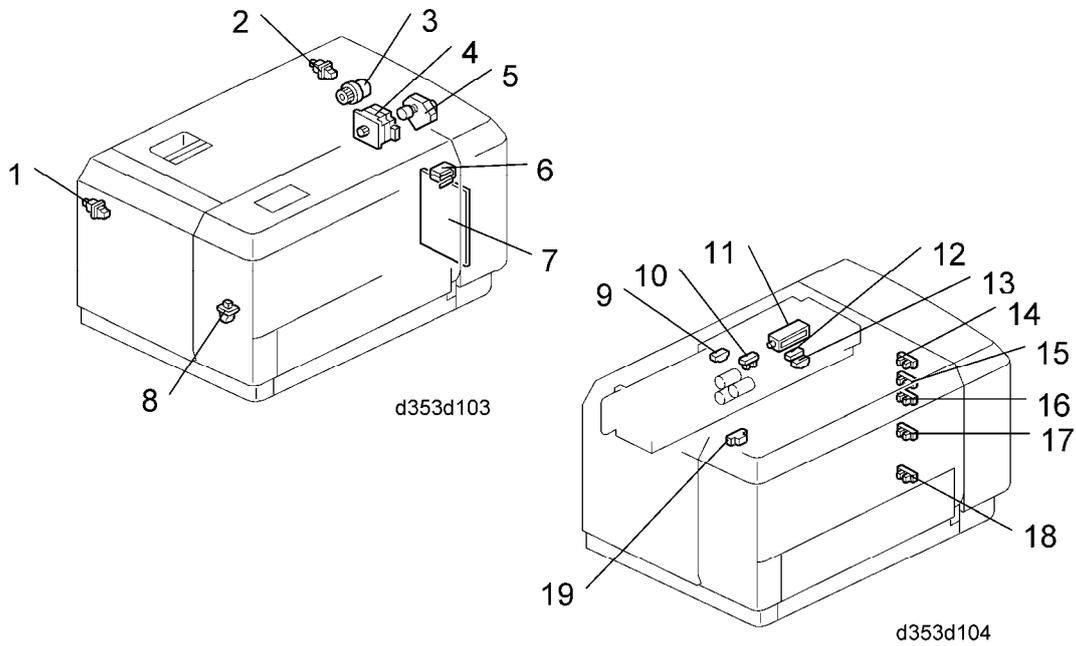

<ul style="list-style-type: none"> 1. Front LCT Set Switch 2. Rear LCT Set Switch 3. Paper Feed Clutch 4. Paper Feed Motor 5. Tray Lift Motor 6. Interlock Switches 7. Main Board 8. Tray Down Switch 9. Relay Sensor 10. Tray Lift Sensor 	<ul style="list-style-type: none"> 11. Pick-up Roller Solenoid 12. Paper Feed Sensor 13. Paper End Sensor 14. Paper Height Sensor 1 15. Paper Height Sensor 2 16. Sub Paper Height Sensor 17. Paper Height Sensor 3 18. Lower Limit Sensor 19. Stack Sensor
--	--

2.1.3 ELECTRICAL COMPONENT DESCRIPTIONS

Symbol	Name	Function	Index No.
Motors			
M1	Paper Feed	Drives all rollers.	4

Symbol	Name	Function	Index No.
M2	Tray Lift	Drives the paper tray up or down.	5
Sensors			
S1	Paper Feed	Detects whether the paper is jammed at the LCT.	12
S2	Relay	Detects the copy paper coming to the relay roller and checks for misfeeds.	9
S3	Paper End	Informs the mainframe when the paper in the tray has been used up and indicates paper end.	13
S4	Tray Lift	Detects when the paper is at the correct paper feed height.	10
S5	Paper Height 1	Detects the amount of paper remaining in the tray.	14
S6	Paper Height 2		15
S7	Sub Paper Height		16
S8	Paper Height 3		17
S9	Lower Limit	Detects when the tray is completely lowered, to stop the tray lift motor.	18
S10	Stack	Detects a) when the tray has moved down to the paper supply position after paper end, to stop the tray lift motor or b) when the top of the paper stack has moved down to the paper supply position, to stop the tray lift motor after the down switch has been pressed.	19

Component Layout

Symbol	Name	Function	Index No.
Switches			
SW1	Right Door	Detects whether the right door is open and starts to drive the tray lift motor.	6
SW2	Front LCT Set	Detects whether the LCT is correctly set.	1
SW3	Rear LCT Set	Detects whether the LCT is correctly set.	2
SW4	Down	Lowers the tray to the paper supply position if pressed.	8
Magnetic Clutches			
MC1	Paper Feed	Drives the paper feed unit.	3
Solenoids			
SOL1	Pick-up	Pushes the pick-up roller up or down.	11
PCBs			
PCB1	Main	Controls the LCT and communicates with the copier/printer.	7

2.1.4 DRIVE LAYOUT

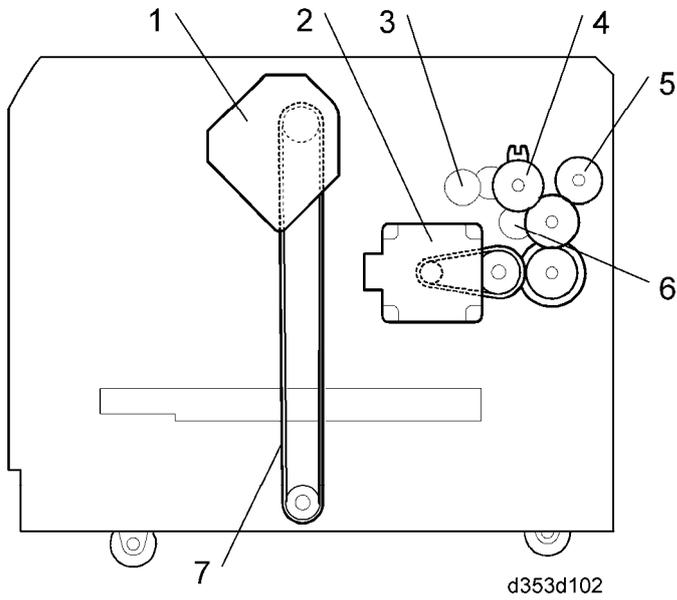

1. Tray Lift Motor	5. Relay Roller
2. Paper Feed Motor	6. Separation Roller
3. Pick-up Roller	7. Tray Drive Belt
4. Paper Feed Clutch	

1200 Sheet
LCT RT3000
D353

2.2 PAPER FEED

2.2.1 PAPER FEED MECHANISM

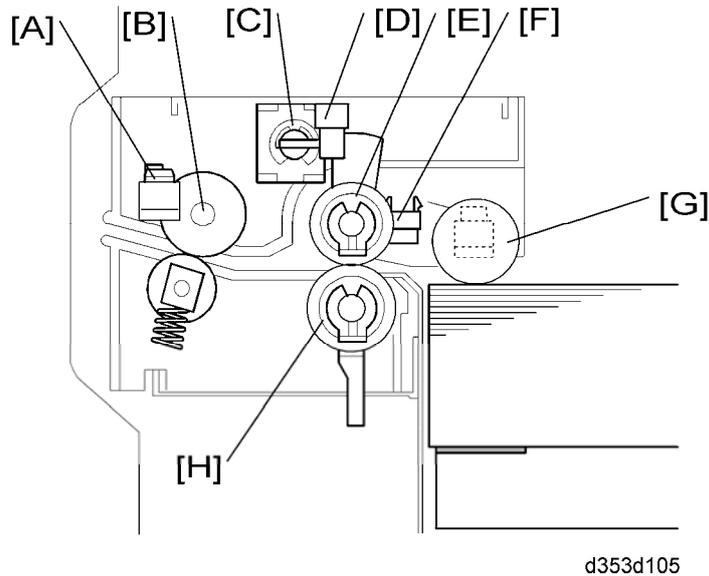

This machine uses the FRR paper feed system (paper feed roller [E], separation roller [H], pick-up roller [G]).

When the right door is closed, the tray lift motor raises the tray to the position where the top of the paper stack in the tray interrupts the tray lift sensor [D]. The paper feed motor switches on, then the pick-up solenoid [C] switches off and the pick-up roller drops onto the top of the stack of paper. The paper feed clutch transfers drive to the paper feed roller [E], pick-up roller [G] and separation roller [H].

The rotating pick-up roller lowers and feeds the first sheet when it contacts the top of the stack.

The separation roller [H], in contact with the feed roller, only allows one sheet out of the tray.

As soon as the paper feed sensor [F] detects the leading edge of the paper, it switches off the pick-up solenoid which raises the pick-up roller. The feed roller feeds the sheet to the registration roller in the main machine through the relay roller [B].

This process is repeated for each sheet.

The paper feed sensor [F] detects "JAM7" and the relay sensor [A] detects "JAM58".

2.2.2 TRAY LIFT MECHANISM

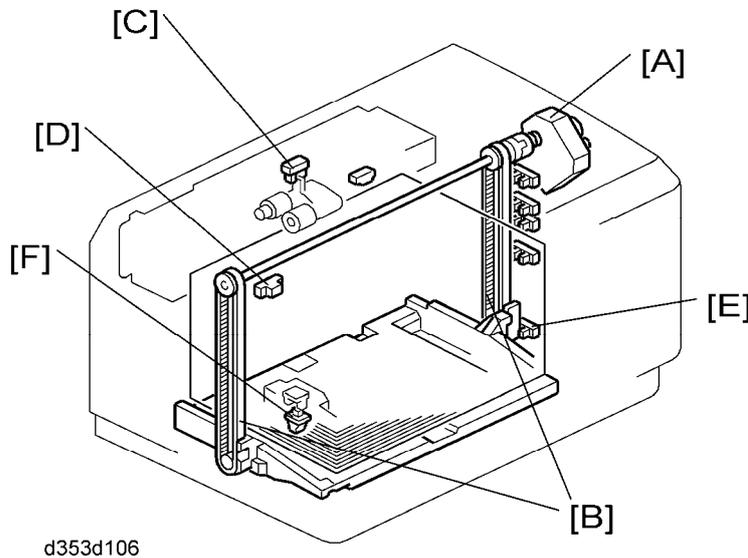

The lift motor [A] controls the vertical position of the tray through the timing belts [B].

Tray lifting conditions

When the tray lift sensor [C] turns off in the following conditions, the tray lift motor raises the tray bottom plate until the tray lift sensor [C] turns on again.

- Just after the main switch is turned on
- During copying
- Just after the tray cover is closed
- Just after leaving the energy saving mode

Tray lowering conditions (Paper supply position)

In the following conditions, the tray lift motor lowers the tray until the stack sensor [D] turns on (this is the correct tray position for supplying paper).

- Just after the paper end sensor turns on
- Just after the down switch is pressed by the user

Tray lowering conditions (Full-down position)

In the following condition, the tray lift motor lowers the tray until the lower limit sensor [E] turns on (this is the correct tray position for adding 500 sheets of paper after installing the first stack of paper in the LCT tray).

- Just after the down switch [F] is pressed for 3 seconds or more when the tray is at the paper supply position.

2.2.3 PAPER HEIGHT AND END DETECTION

Paper Height

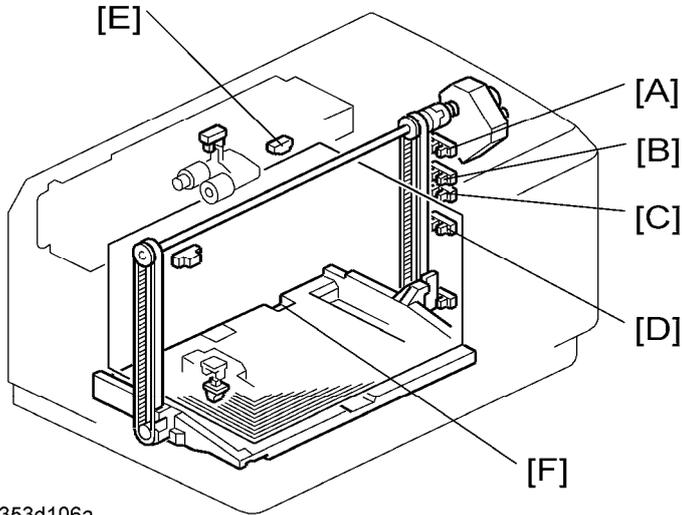

d353d106a

The amount of the paper in the tray is detected by combination of high (1)/low (0) outputs from three sensors (paper height sensor 1 [A], 2 [B], 3 [D] and sub paper height sensor [C]).

Amount of paper	PH S-1	PH S-2	PH S-3	Sub PH S	Indicator on the operation panel
100%	0	0	0	0	Four lines
70%	0	0	1	-	Three lines
	0	0	0	1	
30%	0	1	-	-	Two lines
10%	1	-	-	-	One line
End	-	-	-	-	No line

0: No interruption (low), 1: Interruption (high), -: No checking

PH S: Paper Height Sensor

Paper End

The paper end sensor [E] monitors the light reflected by each sheet on top of the stack.

When the last sheet feeds, the cutout [F] is exposed, and the paper end sensor receives no reflected light from below because there is no paper. As a result, this signals paper end.

**PRINTER/SCANNER OPTION
TYPE 5000
D381**

REVISION HISTORY		
Page	Date	Added/Updated/New
		None

PRINTER/SCANNER OPTION

TYPE 5000(D381)

TABLE OF CONTENTS

1. INSTALLATION	1
1.1 OVERVIEW.....	1
1.1.1 PRINTER/SCANNER OPTIONS.....	1
1.1.2 OTHER OPTIONS	1
1.1.3 BOARD, SD CARD SLOTS	2
1.2 PRINTER AND P/S OPTIONS.....	5
1.2.1 OVERVIEW.....	5
1.2.2 KIT CONTENTS.....	6
1.2.3 PRINTER/SCANNER INSTALLATION	8
1.2.4 PRINTER ENHANCE, SCANNER ENHANCE OPTIONS.....	10
1.2.5 APPLICATION MERGE	12
1.3 OTHER OPTIONS	14
1.3.1 OVERVIEW.....	14
1.3.2 POSTSCRIPT 3.....	15
1.3.3 FILE FORMAT CONVERTER.....	16
1.3.4 IEEE1284.....	16
1.3.5 IEEE 802.11A/G, G (WIRELESS LAN)	17
1.3.6 BLUETOOTH	20
1.3.7 GIGABIT ETHERNET AND USB2.0	21
1.3.8 CHECK ALL CONNECTIONS.....	22
2. SERVICE TABLES.....	23
2.1 PRINTER SERVICE TABLE	23
2.1.1 SP TABLES	23
2.2 SCANNER SERVICE TABLE	24
2.2.1 SP TABLES	24
3. DETAILED SECTION DESCRIPTIONS.....	26
3.1 OVERVIEW.....	26
3.1.1 PRINTER FEATURES	26

3.1.2 SCANNER FEATURES	27
4. SPECIFICATIONS.....	29
4.1 PRINTER CONTROLLER SPECIFICATIONS	29
4.1.1 PRINTER CONTROLLER.....	29
4.1.2 USB SPECIFICATIONS.....	30
4.1.3 IEEE 802.11A/G, G.....	30
4.1.4 BLUETOOTH SPECIFICATIONS	30
4.1.5 SCANNER SPECIFICATIONS.....	31
4.2 SOFTWARE ACCESSORIES.....	32
4.2.1 PRINTER	32
4.2.2 PRINTER DRIVERS	32
4.2.3 UTILITY SOFTWARE	32
4.2.4 SCANNER	33

Read This First

Safety and Symbols

Conventions Used in this Manual

This manual uses several symbols.

➔: See or Refer to

🔩: Screws

🔌: Connector

🔗: Clip ring

Ⓢ: E-ring

🔧: Clamp

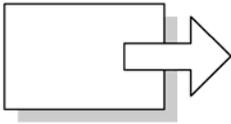

Short Edge Feed (SEF)

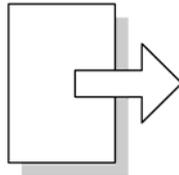

Long Edge Feed (LEF)

Cautions, Notes, etc.

The following headings provide special information:

WARNING

- Failure to obey warning information could result in serious injury or death.

CAUTION

- Obey these guidelines to ensure safe operation and prevent minor injuries.

Important

- Obey these guidelines to avoid problems such as misfeeds, damage to originals, loss of valuable data and to prevent damage to the machine.

Note

- This information provides tips and advice about how to best service the machine.

1. INSTALLATION

1.1 OVERVIEW

This section describes the installation procedures for printer, scanner, and other options for D009/D012 series machines.

1.1.1 PRINTER/SCANNER OPTIONS

The options listed in the table below are for D009/D012 machines only.

No.	Item	SD Card Slot	Merge Options
D381	Printer/Scanner Unit Type 5000	1	DOS
D381	Printer Unit Type 5000	1	DOS, Scanner Enhance
D381	RPCS Printer Unit Type 5000	1	DOS, Scanner Enhance Printer Enhance
D381	Printer Enhance Option Type 5000	Merge: 2 → 1	
D381	Scanner Enhance Option Type 5000	Merge: 2 → 1	

Printer/
Scanner
Option
D381

1.1.2 OTHER OPTIONS

The options listed in the table below are used in both D009/D012 series machines as well as D011/D013 series machines.

No.	Item	Slots
D377	File Format Converter Type E	Board Slot. Only one of these boards can be installed at one time.
G381	Gigabit Ethernet Type 7300	
B826	Bluetooth Interface Unit Type 3245	

Overview

No.	Item	Slots
D377	IEEE 802.11a/g, g Interface Unit Type J	
B679	IEEE 1284 Interface Board Type A	
D381	PostScript3 Unit Type 5000	SD card slot 1
D362	Data Overwrite Security Unit Type I	SD card slot 1, or merge to SD Slot 1
D377	HDD Encryption Unit Type A	SD card slot 2 (Install, then remove)
D377	Browser Unit Type D	SD card slot 2 (Install, then remove)
D377	VM Card Type F	SD card slot 2
D362	Memory Unit Type G 256 MB	Controller Board

Note

- For more details about merging applications from SD card slot 2 to 1, see "Printer Enhance, Scanner Enhance Options" in this chapter.

1.1.3 BOARD, SD CARD SLOTS

The machine controller box has one board slot and two SD card slots. Make sure that each board and SD card is put in the correct slot.

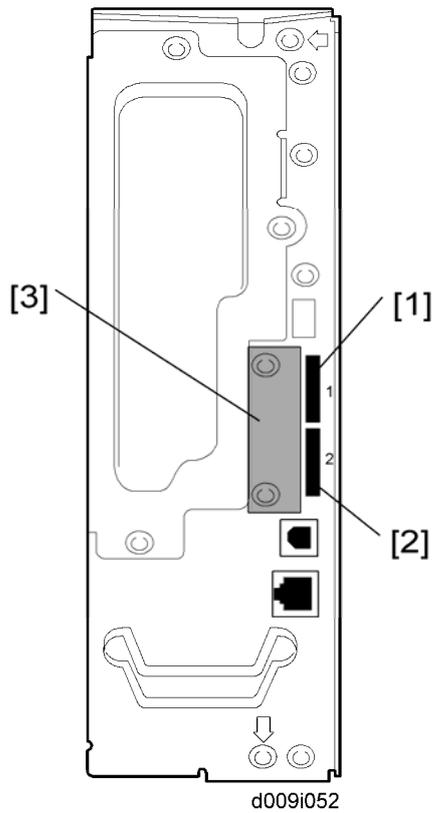

Printer/
Scanner
Option
D381

The names of the slots for the board and SD cards are embossed on the face of the controller plate.

SD Slot 1, Slot 2

Slot	SD Card
[1]	RPCS Printer Unit Printer Unit Printer/Scanner Unit Data Overwrite Security PostScript3
[2]	<ul style="list-style-type: none"> ▪ Service slot for firmware version updates ▪ Installing the optional browser unit, VM card or HDD encryption unit ▪ Moving applications to an SD card in slot 1 ▪ Downloading/uploading NVRAM contents

Overview

Board Slot

Slot	Board
[3]	<ul style="list-style-type: none">▪ File Format Converter (MLB): D377▪ Bluetooth Interface Unit: B826▪ IEEE 802.11a/g, g: D377▪ IEEE 1284 Interface Board: B679▪ Gigabit Ethernet: G381

Note

- Only one of these boards can be installed at one time.

1.2 PRINTER AND P/S OPTIONS

1.2.1 OVERVIEW

This section describes the installation of the following items:

- RPCS Printer Unit
- Printer Unit
- Printer/Scanner Unit
- 256 Memory. Optional memory is required for each unit.
- Printer Enhance Option
- Scanner Enhance Option

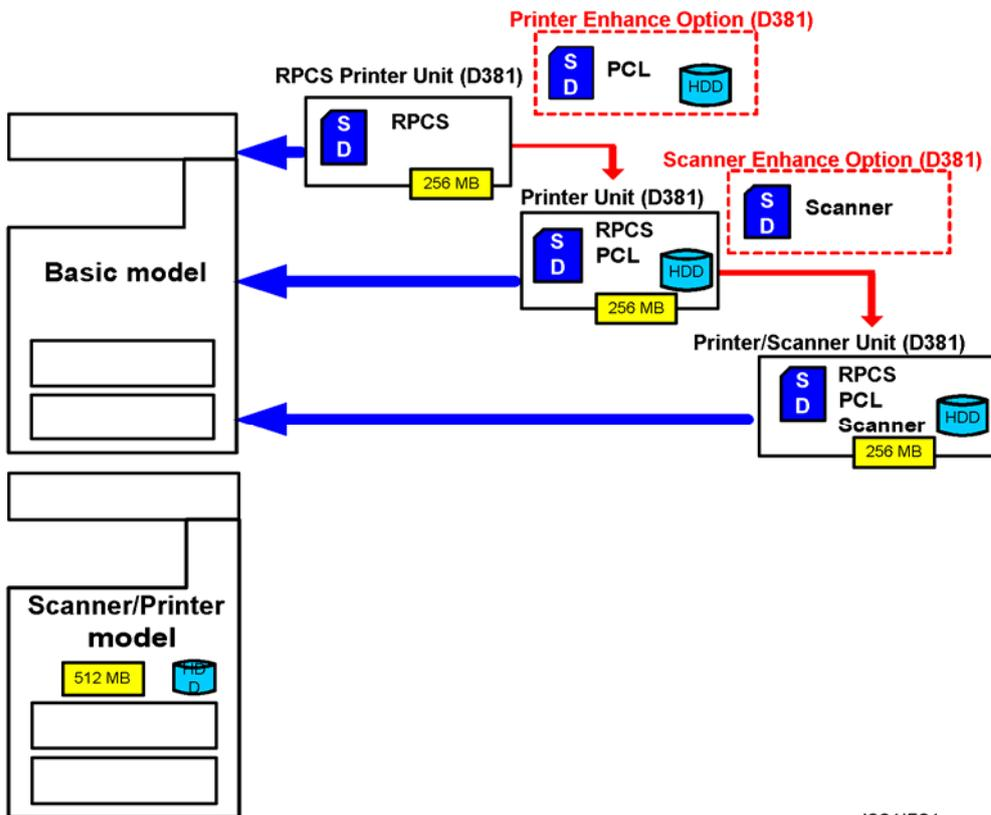

d381i501

Three Main Units

- **RPCS Printer Unit Type 5000:**
For customers who require only basic copying and printing and the RPCS printer language. The 256 MB memory is required.
- **Printer Unit Type 5000:**
For customers who do not require the extended scanning features but need more printing capability (both RPCS and PCL printer languages are provided). The 256 MB

Printer and P/S Options

memory is required.

- **Printer/Scanner Unit Type 5000:**

For customers who require the full range of DS features (advanced scanning and printing features such as "scan-to" solutions, virtual mailboxes, PCL, etc.). The 256 MB memory unit is required.

Separate Options

There are two separate options not provided with the kits: 256 MB memory and PS3.

- **256 MB memory:**

Not provided with any option. However, every unit (RPCS, Printer Unit, P/S unit) requires installation of the 256 MB memory.

- **PostScript 3 Unit:**

The PS3 option can be used with the RPCS Unit, the Printer Unit, or the Printer/Scanner Unit.

Enhance Options

There are two enhance options:

- **Printer Enhance Option Type 5000:**

Updates the RPCS unit by adding PCL.

- **Scanner Enhance Option Type 5000:**

Updates the RPCS unit or Printer Unit by adding the advanced scanning features.

1.2.2 KIT CONTENTS

Check the accessories and their quantities against the list below and the illustration on the next page. This is a common list for all the kits.

Common Accessory Table

This common accessory table lists all the items of the following units and options for the D009/D012 Series machines:

- RPCS: RPCS Printer Unit
- PU: Printer Unit
- P/S: Printer/Scanner Unit
- PEO: Printer Enhance Unit
- SEO: Scanner Enhance Unit

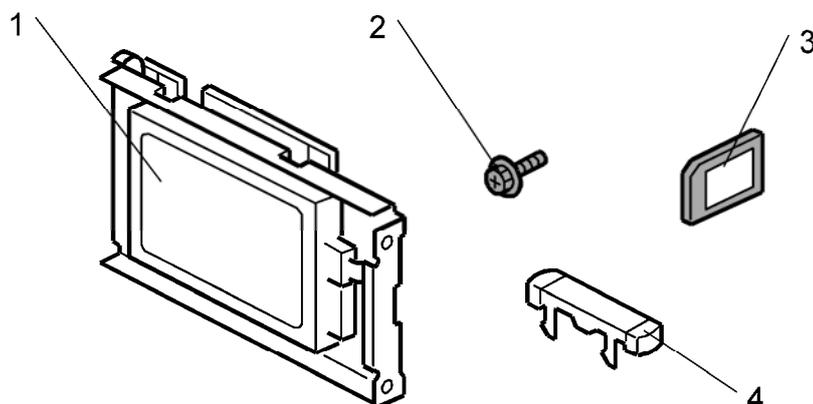

d381i101a

No.	Description	Q'ty	Kit Contents				
			RPCS	PU	P/S	PEO	SEO
	256 MB Memory* ¹	-	No	No	No	No	No
1	HDD Unit	1	No	Yes	Yes	Yes	No
2	Screw	3	No	Yes	Yes	Yes	No
3	SD Card	1	Yes	Yes	Yes	Yes	Yes
4	Keytop Set: NA* ²	1	Yes	Yes	Yes	Yes	Yes
	Keytop Set: EU* ²	1	Yes	Yes	Yes	Yes	Yes

Printer/
Scanner
Option
D381

*1: The 256 Memory is a separate option and it is not provided in the kits. However, one memory unit is required for the installation of every print unit.

*2: The number of keytops provided varies:

Kit	Keytops			
	Copy	Document Server	Printer	Scanner
RPCS Unit	1		1	
Printer Unit	1	1	1	

Printer and P/S Options

Kit	Keytops			
	Copy	Document Server	Printer	Scanner
Printer/Scanner Unit	1	1	1	1
Printer Enhance Unit		1		
Scanner Enhance Unit				1

1.2.3 PRINTER/SCANNER INSTALLATION

CAUTION

- Turn off the main power switch and disconnect the power supply cord.

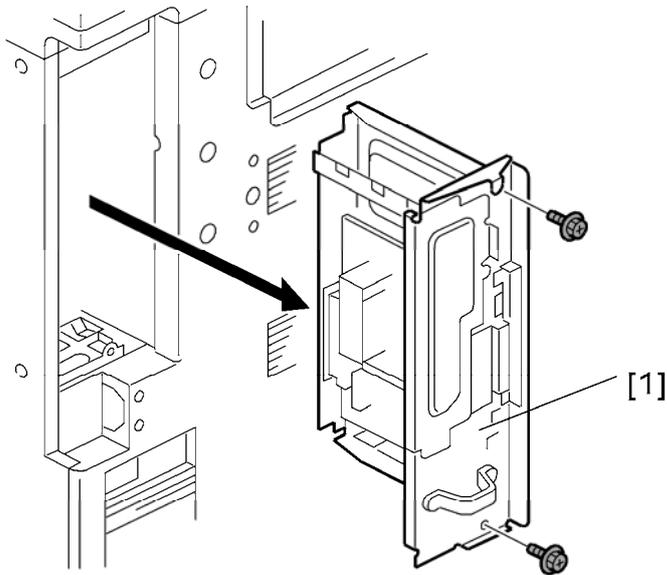

d381i102

1. Remove the controller board [1] ( x 2).

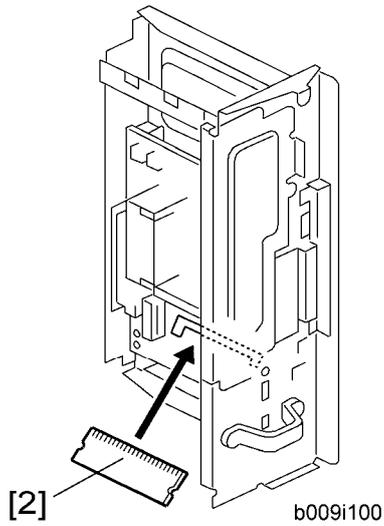

2. Install the 256 MB memory DIMM [2].
3. Install a hard disk (except RPCS Printer Kit). (➔ HDD Installation in the Service Manual of the Model AL-C1)
4. Reinstall the controller board.

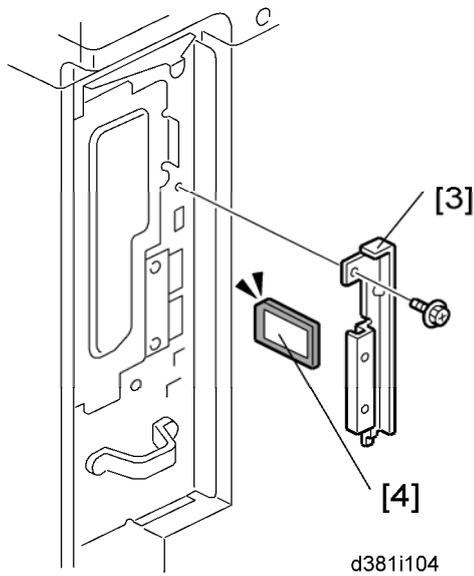

5. Remove the SD card slot cover [3] (⚙️x1).
6. Insert the Printer/Scanner SD card [4] in SD card slot 1.
7. Reattach the cover.
8. Connect the LAN cable to the "NIC" connection.
9. Connect the USB cable to the "USB" connection.

Printer/
Scanner
Option
D381

Printer and P/S Options

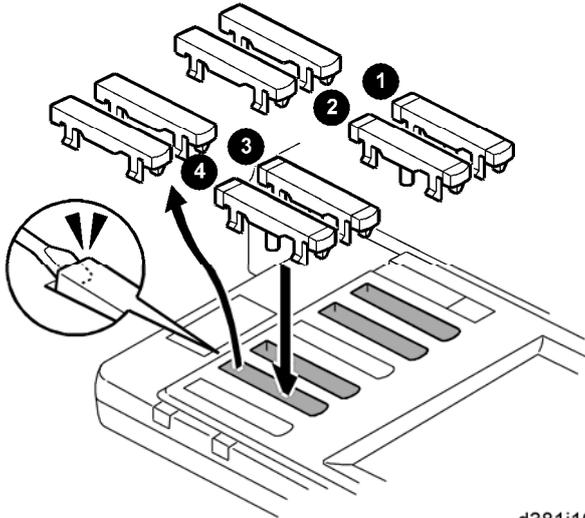

d381i105

10. Remove the 1st, 2nd, 4th, and 5th blank key tops.

Note

- The 3rd blank keytop from the top is reserved for the "Fax" keytop. Do not remove it at this time.

11. Replace the blank keytops:

- ① Copy
- ② Document Server
- ③ Printer
- ④ Scanner

12. Connect the machine's power cord and turn the main power switch on.

13. Enable the NIB and/or USB function.

- To enable the NIB function, enter the SP mode and set SP5985-001 (On Board NIC) to "1" (Enable).
- To enable the USB function, enter the SP mode and set SP5985-002 (On Board USB) to "1" (Enable).

1.2.4 PRINTER ENHANCE, SCANNER ENHANCE OPTIONS

Accessory Check

Refer to the "Common Accessory Table" in this chapter.

Installation (Application Merge)

The installation of the printer enhance option and scanner enhance option are done with **SP5873-001 (Application Move)**.

Note

- If you are going to update the RPCS unit with both the printer and scanner

enhance options, the order of execution is not important.

1. Turn off the copier.
2. Remove the cover (🔧 x1).
3. Confirm that the RPCS Unit or Printer Unit SD card is in SD card Slot 1.
4. Put the option SD Card (Printer Enhance Option or Scanner Enhance Option) in SD card slot 2.
5. Open the front door.
6. Turn the copier on.
7. Go into the SP mode and select **SP5873-001**.
8. Touch "Execute".
9. Read the instructions on the display and touch "Execute" to start.
10. When the display tells you copying is completed, touch "Exit", then turn the copier off.
11. Remove the option SD card from slot 2.
12. Turn the copier on.
13. Go into the User Tools mode and confirm that update was successful.
14. User Tools> System Settings> Administrator Tools> Firmware Version> Next
15. Turn the copier off again, then reattach the cover.
16. Return the copied SD card to the customer for safekeeping, or tape it to the faceplate of the controller.

To undo an option update

1. Turn the main switch off.
2. Confirm that the RPCS Unit or Printer Unit SD card is in SD card Slot 1.
3. Put the original option SD card (Printer Enhance Option or Scanner Enhance Option) in SD card slot 2.
4. Turn the main switch on.
5. Go into the SP mode and do **SP5873-002** (Undo Exec).
6. Follow the messages on the operation panel to complete the procedure.
7. Turn the main switch off.
8. Remove the option SD card from Slot 2.
9. Turn the main switch on.
10. Go into the User Tools mode and confirm that undo was successful.
User Tools> System Settings> Administrator Tools> Firmware Version> Next
11. Turn the copier off again, then reattach the cover.

Important Notes about SD Cards

Here are some basic rules about merging applications on SD cards.

Printer and P/S Options

- The data necessary for authentication is transferred with the application program to the target SD card.
- The SD card is the only evidence that the customer is licensed to use the application program. The service technician may occasionally need to check the SD card and its data to solve problems. SD cards must be stored in a safe location at the work site.
- Once the merge is completed, the SD card from which the application was copied cannot be used again, but the customer must keep the card to serve as proof of purchase.
- An SD card from which an application has been moved to another SD card can be restored to full operation with **SP5873-002** (Undo).
- Before storing the card from which an application has been copied, label it carefully so that you can identify it easily if you need to do the undo procedure later.

1.2.5 APPLICATION MERGE

This machine has two SD card slots only. However, more than two optional applications are supplied for this machine. Always keep SD card slot 2 vacant for servicing (except VM Card Type F). Because of this, SD card merge is required if a customer wants to use many applications.

Consider the following limitations when you try to merge SD cards.

- PostScript3 cannot be moved to the other SD card.
- The destination SD card should have the largest memory size of all the application SD cards. Refer to the following table for the memory size of each SD card.

SD Card Options	SD Card Size	Module Size
Printer/Scanner Unit Type 5000	32 MB	9.3 MB
RPCS Printer Unit Type 5000	32 MB	6.3 MB
Printer Unit Type 5000	32 MB	8.3 MB
Printer Enhance Option Type 5000	16 MB	4 MB
Scanner Enhance Option Type 5000	16 MB	3 MB
DataOverwriteSecurity Unit Type I	16 MB	4 MB
PostScript3 Unit Type 5000	64 MB	14.6 MB

Case 1: PostScript3 is not installed

Merge all applications which the customer wants to use into one SD card (Destination Card).



- The destination card should have the largest memory size of all the application SD cards.
- The VM Card Type F cannot be merged, nor moved to another SD card. This card must be installed in slot 2.

Case 2: PostScript3 is installed

Merge all applications which the customer wants to use into the PostScript3 SD card.

1.3 OTHER OPTIONS

1.3.1 OVERVIEW

This machine has a board slot for optional I/F connection and two SD card slots for applications.

After you install an option, check that the machine can recognize it (➔ “Check All Connections” at the end of this section).

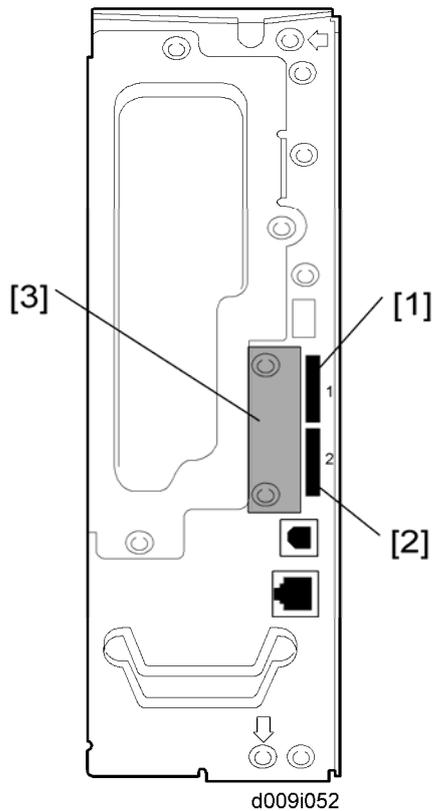

Board Slot

- This slot [3] is used for one of the optional board connections (only one can be installed): IEEE1284, IEEE802.11a/g, g (Wireless LAN), Bluetooth, Gigabit Ethernet, or File Format Converter.

SD Card Slots

- Slot 1 [1] is used for PostScript3 or Data Overview Security Unit.
- Slot 2 [2] is used for installing the VM Card, HDD Encryption Unit, Browser Unit or for service use

1.3.2 POSTSCRIPT 3

CAUTION

- Unplug the main machine power cord before you do the following procedure.

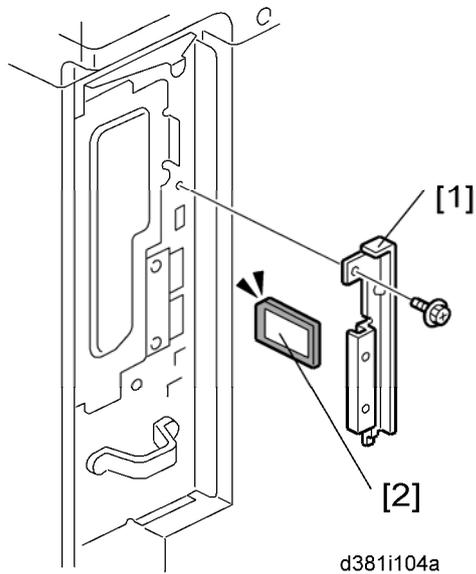

1. Remove the slot cover [1] (🔩 x 1).
2. Turn the SD-card label face [2] to the rear of the machine. Then push it slowly into slot 1 until you hear a click.
3. Attach the slot cover [1] (🔩 x 1).

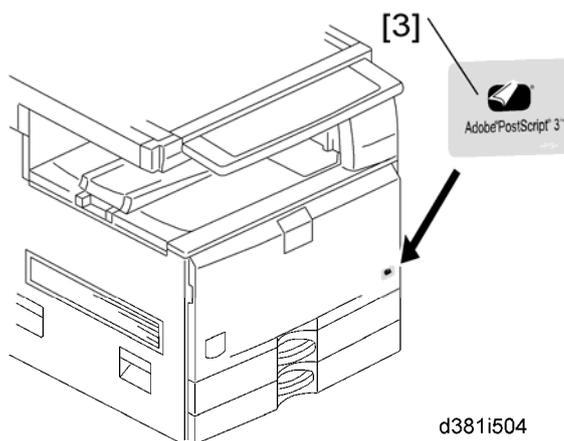

4. Attach the "Adobe PostScript 3" decal [3] to the front door.
5. Make sure that the machine can recognize the option (➡ "Check All Connections" at the end of this section).

1.3.3 FILE FORMAT CONVERTER

⚠ CAUTION

- Unplug the main machine power cord before you do the following procedure.

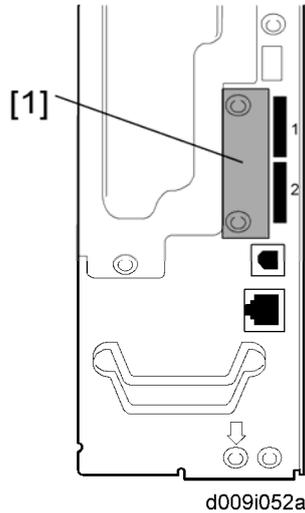

1. Remove the slot cover [1] from the board slot (⚠ x 2).
2. Install the file format converter into the board slot, and then fasten it with screws.
3. Plug in and turn on the main power switch.
4. Check or set the following SP codes with the values shown below.

SP No.	Title	Setting
SP5-836-001	Capture Function (0:Off 1:On)	"1"
SP5-836-002	Panel Setting	"0"

5. Check the operation.
6. Make sure that the machine can recognize the option (➡ "Check All Connections" at the end of this section).

1.3.4 IEEE1284

Installation Procedure

⚠ CAUTION

- Unplug the main machine power cord before you do the following procedure.

You can only install one of the following network interfaces at one time: (IEEE 802.11a/g, g (Wireless LAN), IEEE1284, Bluetooth).

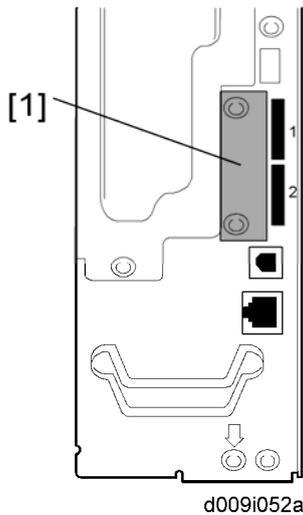

1. Remove the slot cover [1] from the board slot (⚙ x 2).
2. Install the interface board (Knob-screw x 2) into the board slot.
3. Make sure that the machine can recognize the option (see "Check All Connections" at the end of this section).

1.3.5 IEEE 802.11A/G, G (WIRELESS LAN)

Installation Procedure

⚠ CAUTION

- Unplug the main machine power cord before you do the following procedure.

You can only install one of the following network interfaces at one time: (IEEE 802.11a/g, g (Wireless LAN), IEEE1284, Bluetooth).

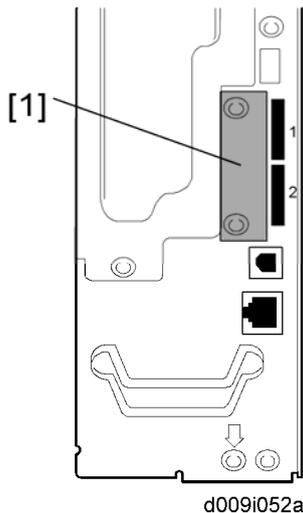

1. Remove the slot cover [1] from the board slot (⚙ x 2).
2. Install the wireless LAN board (Knob-screw x 2) into the board slot.
3. Make sure that the machine can recognize the option (see 'Check All Connections' at

Other Options

the end of this section).

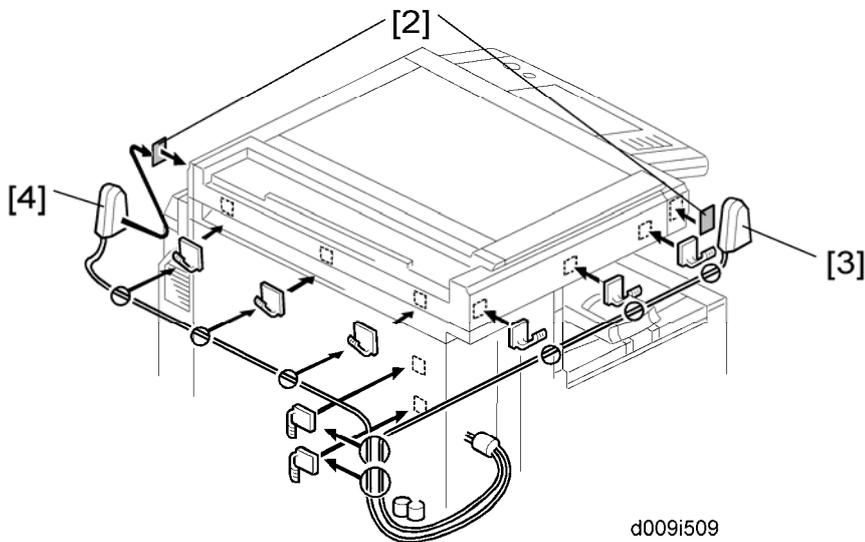

d009i509

4. Peel off the double-sided tapes on the Velcro fasteners [2], and then attach them [2] at the front left and rear right of the machine.
5. Attach the "ANT1" (having a black ferrite core) to the front left of the machine.
6. Attach the "ANT2" (having a white ferrite core) to the rear right of the machine.

↓ Note

- "ANT1" is a transmission/reception antenna and "ANT2" is a reception antenna. Do not attach them at the wrong places.

7. Attach the clamps as shown above.
8. Wire the cables and clamp them (🔗 x 8).

↓ Note

- Make sure that the cables are not slack. Keep them wired tightly along the covers.

You may have to move the machine if the reception is not clear.

- Make sure that the machine is not located near an appliance or any type of equipment that generates strong magnetic fields.
- Put the machine as close as possible to the access point.

UP Mode Settings for Wireless LAN

Enter the UP mode. Then do the procedure below to perform the initial interface settings for IEEE 802.11a/g, g. These settings take effect every time the machine is powered on.

↓ Note

- You cannot use the wireless LAN if you use Ethernet.
1. Press the "User Tools/Counter" key.
 2. On the touch panel, press "System Settings".

↓ Note

- The Network I/F (default: Ethernet) must be set for either Ethernet or wireless LAN.
3. Select "Interface Settings".
 4. Press "Wireless LAN". Only the wireless LAN options show.
 5. Communication Mode. Select either "802.11 Ad hoc", "Ad hoc" or "Infrastructure".
 6. SSID Setting. Enter the SSID setting. (The setting is case sensitive.)
 7. Channel. You need this setting when Ad Hoc Mode is selected.
Range: 1 to 14 (default: 11)

↓ Note

- The allowed range for the channel settings may vary for different countries.
8. WEP (Encryption) Setting. The WEP (Wired Equivalent Privacy) setting is designed to protect wireless data transmission. The same WEP key is required on the receiving side in order to unlock encoded data. There are 64 bit and 128 bit WEP keys.

WEP:

Selects "Active" or "Inactive". ("Inactive" is default.)

Range of Allowed Settings:

64 bit: 10 characters

128 bit: 26 characters

9. Transmission Speed. Press the Next button to show more settings. Then select the transmission speed for the mode: Auto, 11 Mbps, 5.5 Mbps, 2 Mbps, 1 Mbps (default: Auto). This setting should match the distance between the closest machine or access point. This depends on which mode is selected.

↓ Note

- For the Ad Hoc Mode, this is the distance between the machine and the closest PC in the network. For the Infrastructure Mode, this is the distance between the machine and the closest access point.
- 11 Mbps: 140 m (153 yd.)
 5.5 Mbps: 200 m (219 yd.)
 2 Mbps: 270 m (295 yd.)
 1 Mbps: 400 m (437 yd.)
10. Press "Return to Default" to initialize the wireless LAN settings.
Press "Yes" to initialize the following settings:
 - Transmission mode
 - Channel
 - Transmission Speed

Other Options

- WEP
- SSID
- WEP Key

SP Mode Settings for IEEE 802.11a/g, g Wireless LAN

The following SP commands and UP modes can be set for IEEE 802.11a/g, g.

SP No.	Name	Function
5840-006	Channel MAX	Sets the maximum range of the channel settings for the country.
5840-007	Channel MIN	Sets the minimum range of the channels settings allowed for your country.
5840-011	WEP Key Select	Used to select the WEP key (Default: 00).
UP mode	Name	Function
	SSID	Used to confirm the current SSID setting.
WEP Key	Used to confirm the current WEP key setting.	
WEP Mode	Used to show the maximum length of the string that can be used for the WEP Key entry.	

1.3.6 BLUETOOTH

CAUTION

- Unplug the main machine power cord before you do the following procedure.

You can only install one of the following network interfaces at one time: (IEEE 802.11a/g, g (Wireless LAN), IEEE1284, IEEE1394, Bluetooth).

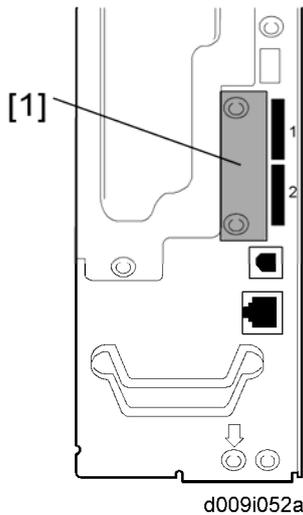

1. Remove the slot cover [1] from the board Slot (⚙ x 2).
2. Install the Bluetooth board (Knob-screw x 2) into the board slot.
3. Insert the Bluetooth card into the Bluetooth card adaptor.
4. Attach the antenna cap to the Bluetooth card.
5. Install the Bluetooth card adaptor into the Bluetooth board.
6. Make sure that the machine can recognize the option (see "Check All Connections" at the end of this section).

Printer/
Scanner
Option
D381

1.3.7 GIGABIT ETHERNET AND USB2.0

⚠ CAUTION

- Unplug the main machine power cord before you do the following procedure.

You can only install one of the following network interfaces at one time: (IEEE 802.11a/g, g (Wireless LAN), IEEE1284, IEEE1394, Bluetooth).

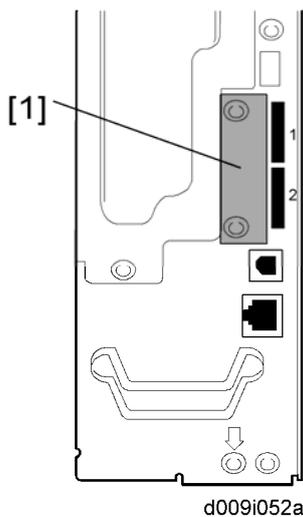

1. Remove the slot cover [1] from the board slot (⚙ x 2).

Other Options

2. Insert the Gigabit Ethernet Board into the I/F slot and fasten it with the screws.
3. Print a configuration page to confirm that the machine recognizes the installed board for USB2.0:
 - User Tools > Printer Features > List/Test Print > Configuration Page

1.3.8 CHECK ALL CONNECTIONS

Plug in the power cord. Then turn on the main switch.

Enter the printer user mode. Then print the configuration page.

User Tools > Printer Settings > List Test Print > Config. Page

All installed options are shown in the "System Reference" column.

2. SERVICE TABLES

2.1 PRINTER SERVICE TABLE

2.1.1 SP TABLES

P	Number/Bit SW		Initial	
1001	Bit Switch			
	001	Bit SW 1	00H	Adjusts the bit switch settings. Note: These bit switches are currently not used
	002	Bit SW 2	00H	
	003	Bit SW 3	00H	
	004	Bit SW 4	00H	
	005	Bit SW 5	00H	
	006	Bit SW 6	00H	
	007	Bit SW 7	00H	
	008	Bit SW 8	00H	

1003	Clear setting		
	001	Initialize Printer System	Initializes the settings in the printer feature settings of UP mode.
	003	Delete Program	DFU
1004	Print Summary		Prints the printer summary sheet.
1005	Display Version		Displays the version of the controller firmware.
1006	Sample/Proof Print		[0 or 1 / 0 / -] 0: Link with Doc. Server 1: Enable

2.2 SCANNER SERVICE TABLE

2.2.1 SP TABLES

SP	Number/Name	Function/[Setting]
1001	Scan NV Version	Displays the version of the scanner NV.
1004	Compression Type	Selects the compression type for binary picture processing. [1 to 3 / 1 / 1/step] 1: MH, 2: MR, 3: MMR
1005	Erase Margin	Creates an erase margin for all edges of the scanned image. If the machine has scanned the edge of the original, create a margin. [0 to 5 / 0 / 1 mm/step]
1009	Remote scan disable	Enables or disables the TWAIN function. [0 or 1 / 0 / -] 0: Enable, 1: Disable
1010	Non Display Clear Light PDF	Displays or does not display the clear light PDF function. [0 or 1 / 0 / -] 0: Display, 1: Not display
1011	Org Count Disp	Displays or does not display the original counter. [0 or 1 / 0 / -] 0: Not display, 1: Display
1012	User Info Release	Clears or does not clear a user information after a job. [0 or 1 / 1 / -] 0: Not clear, 1: Clear

Scanner Service Table

SP	Number/Name	Function/[Setting]
2021	Compression level (grayscale)	
	These SP codes set the compression ratio for the grayscale processing mode that can be selected with the notch settings on the operation panel. Range: 5 (lowest ratio) ↔ 95 (highest ratio)	
1	Comp 1: 5 - 95	[5 to 95 / 20 / 1 /step]
2	Comp 2: 5 - 95	[5 to 95 / 40 / 1 /step]
3	Comp 3: 5 - 95	[5 to 95 / 65 / 1 /step]
4	Comp 4: 5 - 95	[5 to 95 / 80 / 1 /step]
5	Comp 5: 5 - 95	[5 to 95 / 95 / 1 /step]

2024*	[Compression ratio of ClearLight PDF]	
	Selects the compression ratio for clearlight PDF for the two settings that can be selected at the operation panel.	
1	Compression Ratio (Normal image)	[5 to 95 / 25 / 1 /step]
2	Compression Ratio (High comp image)	[5 to 95 / 20 / 1 /step]

Printer/
Scanner
Option
D381

3. DETAILED SECTION DESCRIPTIONS

3.1 OVERVIEW

3.1.1 PRINTER FEATURES

Function	A-C4.5	AL-C1
Sample Print	Yes	Yes
Locked Print	Yes	Yes
Hold Print	Yes	Yes
Stored Print	Yes	Yes
Store and Print	Yes	Yes
PDF Direct Print	Yes	Yes
Bonjour (Rendez-vous)	Yes	Yes
Windows Active Directory	Yes	Yes
PictBridge	No	No
DDNS Support	Yes	Yes
Mail to Print	No	Yes
PCL resident font	Yes	Yes
Tray-Parameter Change from WebImageMonitor	No	Yes
Imposition Settings	No	No
Creep Adjustment	No	No
Crop Mark	No	No
Mobile Driver	Yes	Yes

Function	A-C4.5	AL-C1
Windows Vista	Yes	Yes
Wireless LAN interface option	Yes	Yes
IPv6	Yes	Yes
Black Over Print	-	-
CLP Simulation	-	-

3.1.2 SCANNER FEATURES

Function	A-C4.5	AL-C1
Scan to E-mail	Yes	Yes
E-mail message attached	Yes	Yes
Subject attached	Yes	Yes
SMTP Auth	Yes	Yes
POP before SMTP	Yes	Yes
Scan to SMB	Yes	Yes
Scan to FTP	Yes	Yes
Scan to URL	Yes	Yes
Scan to NCP	Yes	Yes
Scanned file naming	Yes	Yes
Reference # Setting	Yes	Yes
Scan file type selection	Yes	Yes
Single TIFF	Yes	Yes
Single JPEG (Gray Scale)	Yes	Yes

Overview

Function	A-C4.5	AL-C1
Single PDF	Yes	Yes
Single High Compression PDF	Yes	Yes
Multi page TIFF/PDF	Yes	Yes
Multi page High Compression PDF	Yes	Yes
LDAP Support	Yes	Yes
Email Address search	Yes	Yes
FAX address search	Yes	Yes
Preview before transmission (TX Preview)	No	Yes
PDF Encryption	No	Yes
Drop out Color Send	No	Yes
Twain Scan	Yes	Yes

4. SPECIFICATIONS

4.1 PRINTER CONTROLLER SPECIFICATIONS

4.1.1 PRINTER CONTROLLER

Printing Speed:	D009/D012: Maximum 40 ppm (A4/LT LEF) D011/D013: Maximum 50 ppm (A4/LT LEF)	
Printer Languages:	PCLXL/PCL5e PostScript 3 (Option) RPCS (Refined Printing Command Stream - an original Ricoh PDL)	
Resolution (Driver):	RPCS	200/600 dpi
	PS3	300/600 dpi
	PCL5e	300/600 dpi
	PCLXL	300/600 dpi
Resident Fonts:	PCL	TrueType: 10, Intellifont: 35, International: 13
	PS3	Option fonts PS3
Connectivity	Std.	Ethernet; (RJ-45 network port: 10Base-T/100Base-TX), USB 2.0
	Option	IEEE802.11a/g, g (Wireless LAN), Bluetooth, IEEE1284 (Centronics Parallel), Gigabit Ethernet
Network Protocols	TCP/IP, IPX/SPX, AppleTalk (Auto Switching)	
RAM:	Maximum MS model: 512 MB (Resident 256 MB + Additional 256 MB) CS model: 768 MB (Resident 512 MB + Additional 256 MB) Note: Additional 256 MB is required for all printer/scanner unit and printer units.	

4.1.2 USB SPECIFICATIONS

USB connectivity is built into the controller.

Interface	USB 2.0
Data rates	480 Mbps (high speed), 12 Mbps (full speed), 1.5 Mbps (low speed)
	High speed mode is only supported by USB 2.0.

4.1.3 IEEE 802.11A/G, G

Radiofrequency Band	802.11a: 5 GHz 802.11b: 2.4 GHz 802.11g: 2.4 GHz
Data Transfer Speed	802.11a: 54 Mbps 802.11b: 11 Mbps 802.11g: 54 Mbps
Security Standards	IEEE 802.11 WEP WPA/ WPA2 (IEEE 802.11i) Enterprise Mode

4.1.4 BLUETOOTH SPECIFICATIONS

Transmission Specifications	Based on Bluetooth V1.1
Data Transfer Speed	1 Mbps
Profile	Hard Copy Cable Replacement Profile (HCRP), Serial Port Profile (SPP), BIP
Distance Between Devices	10 m (The maximum distance when using outdoors, otherwise depends on the office environment.)

4.1.5 SCANNER SPECIFICATIONS

Standard Scanner Resolution:	Main scan/Sub scan 600 dpi	
Scanning Speed	B/W Scanning; 61 ipm, E-mail/Scan-to-Folder/Network Delivery Scanner (A4 LEF, Text 200 dpi, MH Compression) Color Scanning; 31 ipm, E-mail/Scan-to-Folder/Network Delivery Scanner (A4 LEF, Text/Photo 200 dpi, Default Compression)	
Available scanning Resolution Range:	100 to 1200 dpi;	When used as a Network TWAIN scanner.
	100, 200, 300, 400, 600 dpi;	When used as a network delivery scanner, Scan-to-Folder, Scan-to-Email, or Document Server storage.
Grayscales:	8 bits/pixel	
Interface:	Ethernet 10/100BASE TX, Wireless LAN 802.11a/g, g	
Compression Method:	MH, MR, MMR (Binary Picture Processing) JPEG (Grayscale Processing) PDF (High Compression Processing): MS model only	
Video Memory Capacity:	MS model: 35 MB (A4/ Grayscale/ 600dpi) MS model: 109 MB (A4/ Full color/ 600dpi)	
Image Storage Capacity:	Number of originals per file: Maximum 1,000 pages Maximum of files: 3000 files	
Max. Storage on Doc. Svr.	9,000 pages (B&W (ITUT No. 1/200 dpi MMR)	

4.2 SOFTWARE ACCESSORIES

4.2.1 PRINTER

The printer drivers and utility software are provided on one CD-ROM. An auto-run installer allows you to select which components to install.

4.2.2 PRINTER DRIVERS

Printer Language	Windows 95/98/Me	Windows NT4.0	Windows 2000, XP, Server 2003/Vista	MacOS8.6 to 9.x, MacOSX10.1 or later
PCL 6	Yes	Yes	Yes	No
PCL 5e	Yes	Yes	Yes	No
PS3	Yes	Yes	Yes	Yes
RPCS	Yes	Yes	Yes	No

Note

- The printer drivers for Windows NT 4.0 are only for the Intel x86 platform. There is no Windows NT 4.0 printer driver for the PowerPC, Alpha, or MIPS platforms.
- The PS3 drivers are all genuine AdobePS drivers, except for Windows 2000/XP/Server 2003/Vista, which uses Microsoft PS. A PPD file for each operating system is provided with the driver.

4.2.3 UTILITY SOFTWARE

Software	Description
Agfa Monotype Font Manager 2000 (Win 95/98/Me, NT4, 2000)	A font management utility with screen fonts for the printer.
Smart Device Monitor for Admin (Win 95/98/Me, NT4, 2000/XP/Server 2003/Vista)	A printer management utility for network administrators. NIB setup utilities are also available.

DeskTopBinder – SmartDeviceMonitor for Client (Win 95/98/Me, NT4, 2000/XP/Server 2003/ Vista)	A printer management utility for client users. Peer-to-peer printing utility and parallel/recovery printing functions are included.
LAN-Fax M7 Driver (Win 95/98/Me, NT4, 2000/XP)	This driver allows use of the LAN-Fax functions by installing the LAN-Fax driver, Address Book, and LAN-Fax Cover Sheet Editor.
PS Utility for Mac	This software provides several convenient functions for printing from Macintosh clients.
Acrobat Reader	A utility that allows reading PDF files.

4.2.4 SCANNER

The scanner driver and utility software are provided on one CD-ROM.

Scanner Driver

- Network Twain Driver for Win95/98/Me/NT4/2000/XP/Server 2003/Vista

Scanner Utilities

- DeskTopBinder Lite for 2000/XP/Server 2003

BRIDGE UNIT BU3030 D386

REVISION HISTORY		
Page	Date	Added/Updated/New
		None

BRIDGE UNIT BU3030 (D386)

TABLE OF CONTENTS

1. REPLACEMENT AND ADJUSTMENT	1
1.1 BRIDGE UNIT CONTROL BOARD	1
1.2 BRIDGE UNIT DRIVE MOTOR.....	2
1.3 TRAY EXIT SENSOR	3
1.4 RELAY SENSOR	4
2. DETAILS	5
2.1 MECHANICAL COMPONENT LAYOUT	5
2.2 DRIVE LAYOUT.....	6
2.3 ELECTRICAL COMPONENT LAYOUT	7
2.4 ELECTRICAL COMPONENT DESCRIPTION	8
2.5 JUNCTION GATE MECHANISM	9

Read This First

Safety and Symbols

Replacement Procedure Safety

CAUTION

- Turn off the main power switch and unplug the machine before beginning any of the replacement procedures in this manual.

When taking apart the bridge unit, first take the unit out of the copier.

Symbols Used in this Manual

This manual uses the following symbols.

: See or Refer to

: Screws

: Connector

: Clip ring

: E-ring

1. REPLACEMENT AND ADJUSTMENT

1.1 BRIDGE UNIT CONTROL BOARD

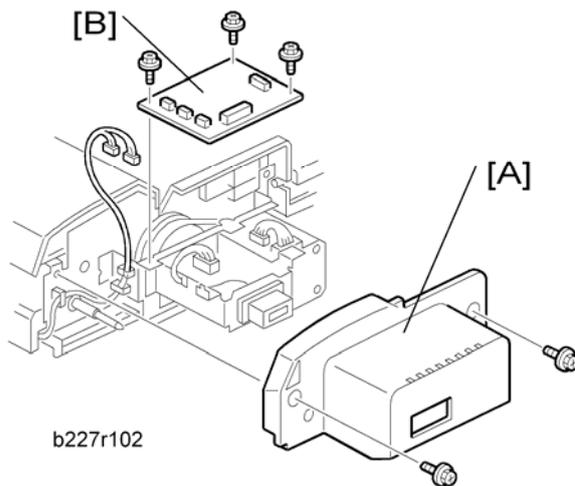

1. Bridge unit (➔ "Installation Procedure" in the base copier manual)
2. Rear cover [A] (🔩 x 2)
3. Bridge unit control board [B] (🔩 x 3, 📏 x 4)

1.2 BRIDGE UNIT DRIVE MOTOR

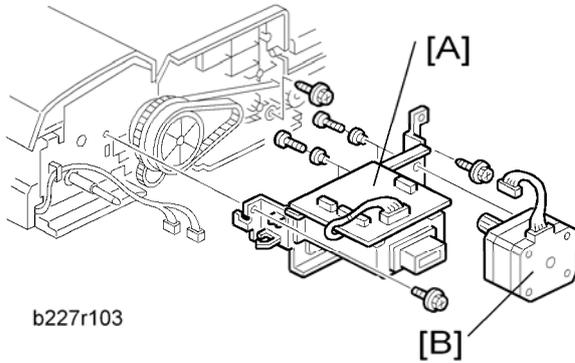

1. Bridge unit (➔ "Installation Procedure" in the base copier manual)
2. Rear cover (➔ "Bridge Unit Control Board")
3. Bracket [A] (⚙ x 3, 🛠 x 2)
4. Bridge unit drive motor [B] (⚙ x 4, 🛠 x 1)

1.3 TRAY EXIT SENSOR

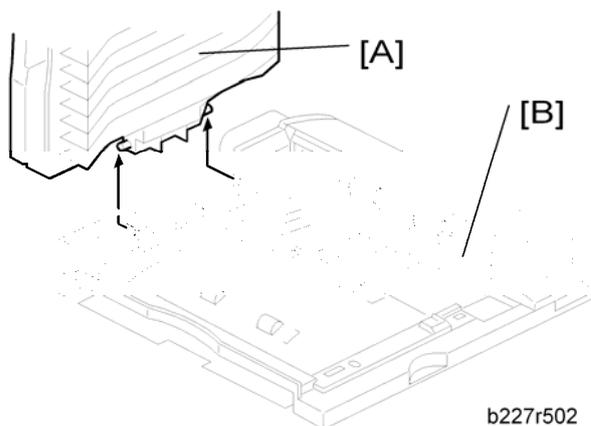

1. Bridge unit (➔ "Installation Procedure" in the base copier manual)
2. Rear cover (➔ "Bridge Unit Control Board")
3. Paper tray [A]
4. Exit guide [B] (🔩 x 1)

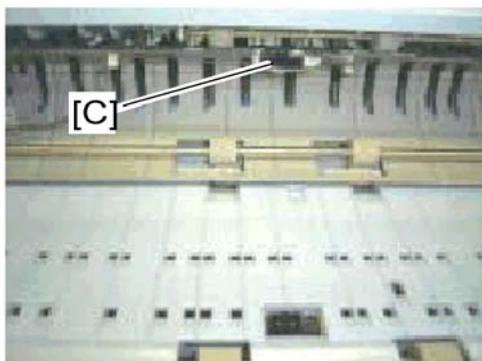

5. Tray exit sensor [C] (🔩 x 1)

Relay Sensor

1.4 RELAY SENSOR

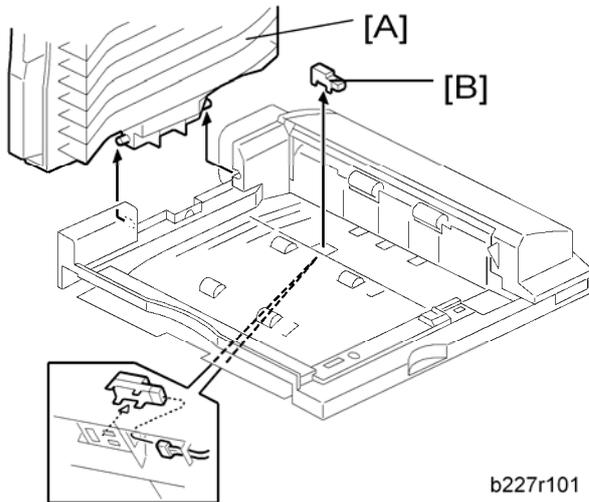

b227r101

1. Bridge unit (➔ "Installation Procedure" in the base copier manual)
2. Paper tray [A]
3. Relay sensor [B] (☞ x 1)

2. DETAILS

2.1 MECHANICAL COMPONENT LAYOUT

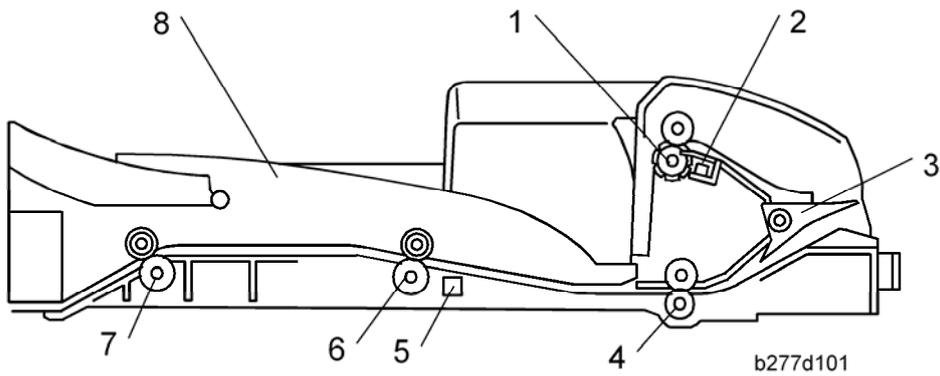

1. Upper Exit Roller	5. Relay Sensor
2. Tray Exit Sensor	6. 2nd Transport Roller
3. Junction Gate	7. Left Exit Roller
4. 1st Transport Roller	8. Paper Tray

2.2 DRIVE LAYOUT

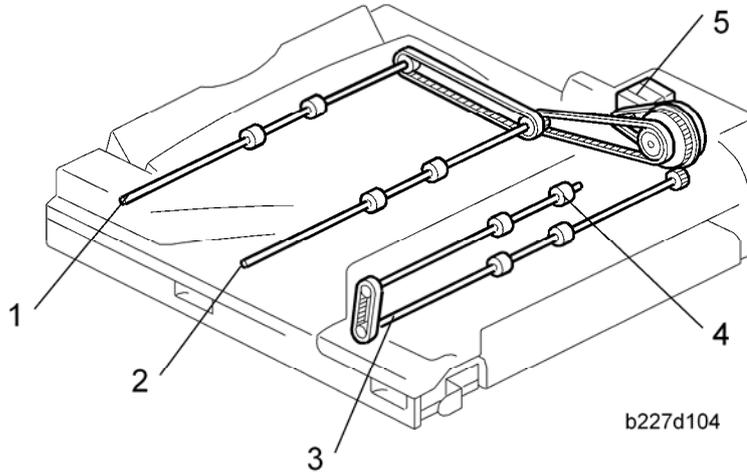

1. Left Exit Roller
2. 2nd Transport Roller
3. 1st Transport Roller
4. Upper Exit Roller
5. Bridge Unit Drive Motor

2.3 ELECTRICAL COMPONENT LAYOUT

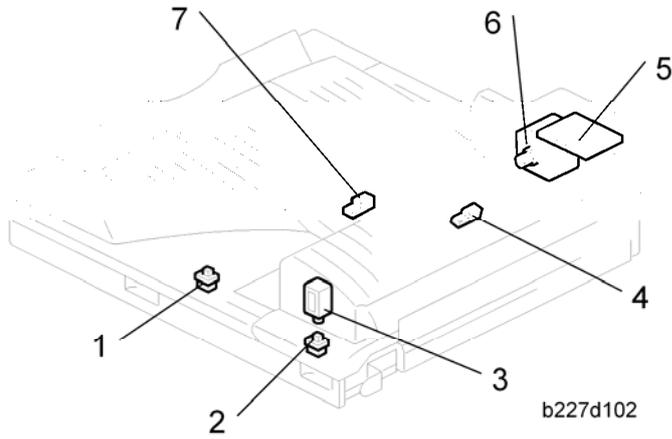

1. Left Guide Switch
2. Right Guide Switch
3. Junction Gate Solenoid
4. Tray Exit Sensor
5. Bridge Unit Control Board
6. Bridge Unit Drive Motor
7. Relay Sensor

2.4 ELECTRICAL COMPONENT DESCRIPTION

Symbol	Name	Function	Index No.
Motors			
M1	Drive Motor	Drives the bridge unit.	6
Sensors			
S1	Tray Exit	Checks for misfeeds.	4
S2	Relay	Checks for misfeeds.	7
Switches			
SW2	Right Guide	Detects when the right guide is opened.	2
SW3	Left Guide	Detects when the left guide is opened.	1
Solenoids			
SOL1	Junction Gate	Moves the junction gate to direct the paper to the upper tray (on top of the bridge unit) or to the finisher.	3
PCBs			
PCB1	Bridge Unit Control Board	Controls the bridge unit.	5

2.5 JUNCTION GATE MECHANISM

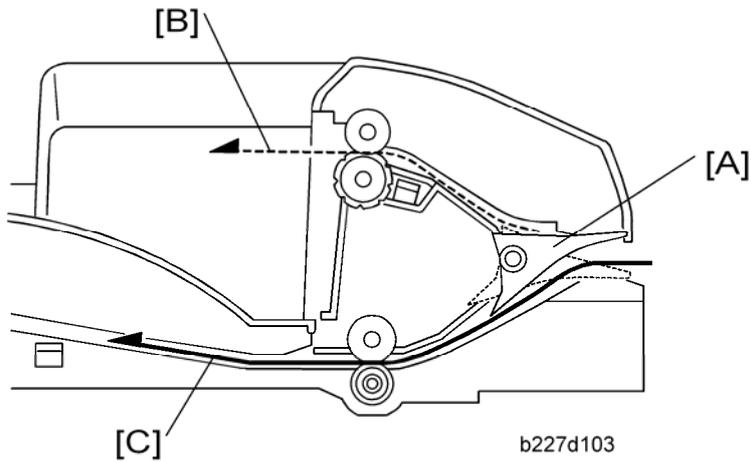

The junction gate [A] directs any paper reaching the bridge unit to either the upper tray (on top of the bridge unit) or to the finisher, depending on which has been selected.

If the junction gate solenoid has been activated, the junction gate [A] points downward and directs the paper to the upper tray [B] (dotted line path in illustration). When the solenoid is off, the junction gate points upward and the paper is fed out to the finisher [C] by the transport and left exit rollers (solid line).

1 BIN TRAY BN3040 D389

REVISION HISTORY		
Page	Date	Added/Updated/New
		None

1 BIN TRAY BN3040 (D389)

TABLE OF CONTENTS

1. REPLACEMENT AND ADJUSTMENT	1
1.1 ELECTRICAL COMPONENTS	1
1.1.1 PAPER SENSOR.....	1
1.1.2 1-BIN CONTROL BOARD.....	2
2. DETAILS	3
2.1 COMPONENT LAYOUT	3
2.1.1 MECHANICAL COMPONENT LAYOUT	3
2.1.2 ELECTRICAL COMPONENT LAYOUT	3
2.1.3 ELECTRICAL COMPONENT DESCRIPTIONS.....	4
2.2 BASIC OPERATION	5

Read This First

Safety and Symbols

Replacement Procedure Safety

CAUTION

- Turn off the main power switch and unplug the machine before beginning any of the replacement procedures in this manual.

Symbols Used in this Manual

This manual uses the following symbols.

: See or Refer to

: Screws

: Connector

: Clip ring

: E-ring

1. REPLACEMENT AND ADJUSTMENT

1.1 ELECTRICAL COMPONENTS

1.1.1 PAPER SENSOR

1. 1-bin-tray (🔩 x 2; M3 x 16)

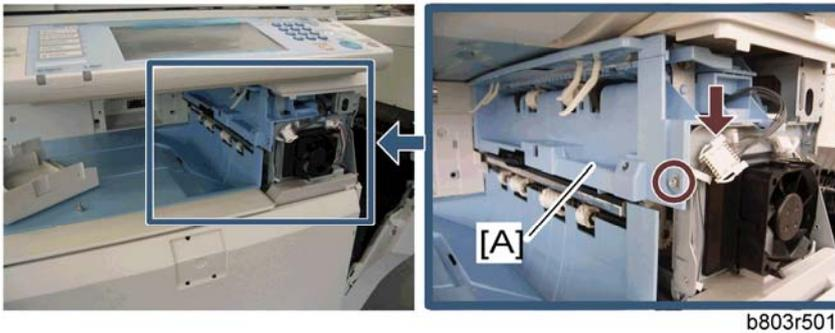

2. 1-bin sorter unit [A]

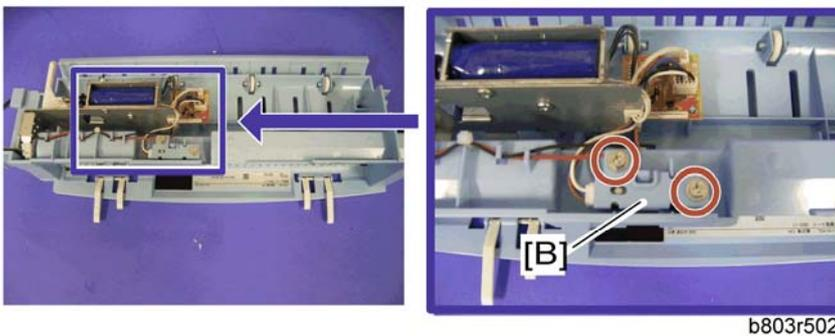

3. Paper sensor cover [B] (🔩 x 2)

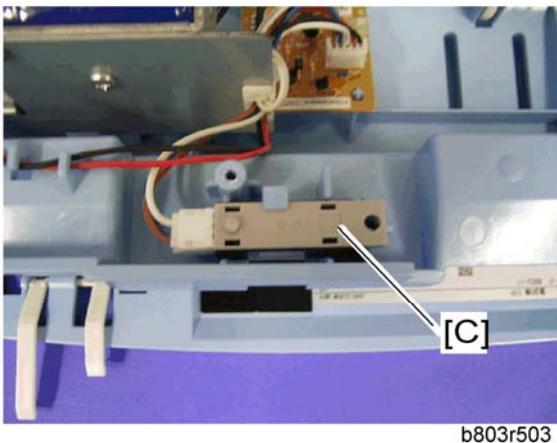

4. Paper sensor [C] (🔩 x 1, hook)

1 Bin Tray
BN3040
D389

Electrical Components

1.1.2 1-BIN CONTROL BOARD

1. 1-bin tray
2. 1-bin sorter unit (↔ "Paper Sensor")

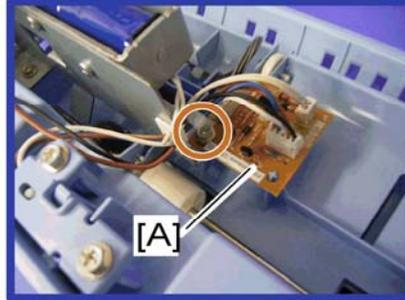
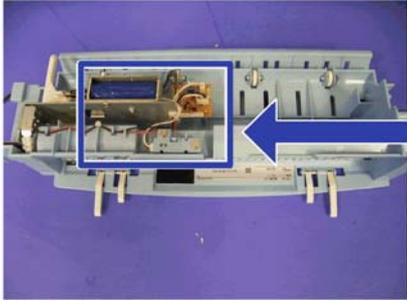

b803r504

3. 1-bin control board [A] (☞ x 1, ☞ x 3)

2. DETAILS

2.1 COMPONENT LAYOUT

2.1.1 MECHANICAL COMPONENT LAYOUT

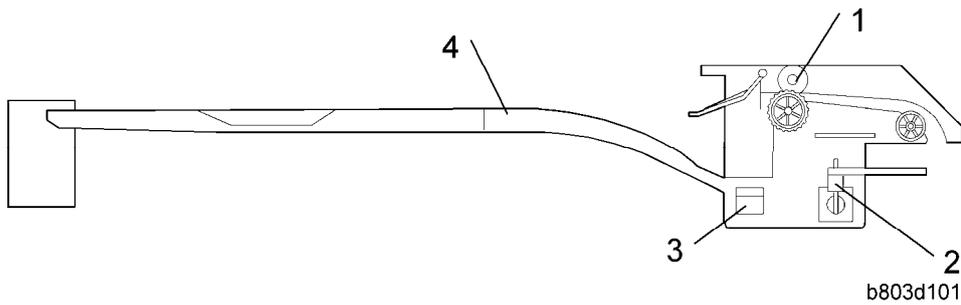

1. Exit Roller
2. Junction Gate 2* Solenoid
3. Paper Sensor
4. Paper Tray

* Junction Gate 2 is located in the main frame.

2.1.2 ELECTRICAL COMPONENT LAYOUT

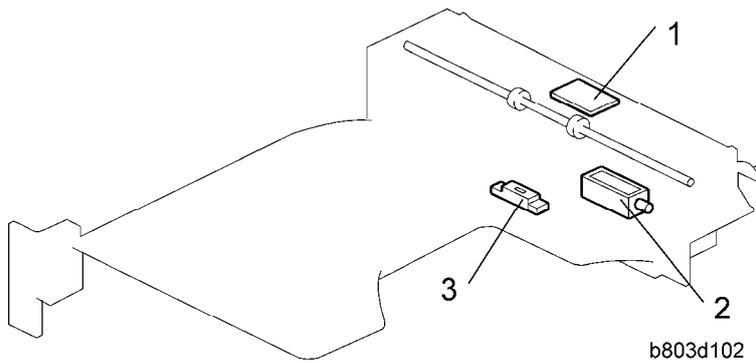

1. 1-bin Control Board
2. Junction Gate 2 Solenoid
3. Paper Sensor

2.1.3 ELECTRICAL COMPONENT DESCRIPTIONS

Symbol	Name	Function	Index No.
Sensor			
S1	Paper	Detects whether there is paper on the tray.	3
Solenoid			
SOL1	Junction Gate 2 Solenoid	Controls junction gate 2 in the main frame.	2
PCB			
PCB1	1-bin Control Board	Controls the junction gate 2 solenoid and the LED that indicates when there is paper in the tray.	1

2.2 BASIC OPERATION

At the appropriate time after the leading edge of the first sheet of copy paper reaches the copier's registration roller, the junction gate 2 solenoid turns on to switch junction gate 2 in the main frame to direct the paper to the 1-bin paper tray.

The junction gate 2 solenoid turns off at the appropriate time after the paper is directed to the 1-bin paper tray.

The paper sensor turns on when there is paper in the tray, and the paper indicator turns on. The tray can be opened for easier jam removal by swinging the tray to the left.