

OKIDATA
an OKI AMERICA company

Pacemark 3410

Service Handbook

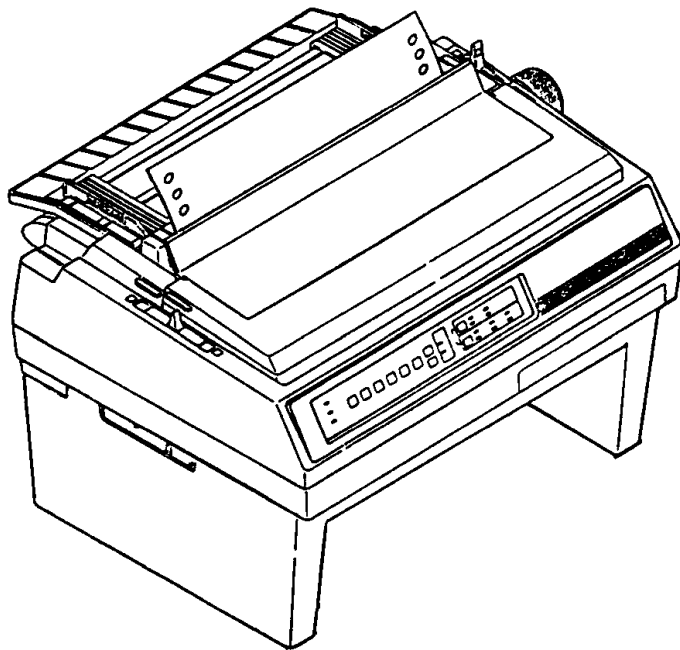

OKI

P/N 59249702

Pacemark 3410
Service Handbook

This document may not be reproduced without the written permission of the Okidata[®] Technical Training Group. Every effort has been made to ensure the accuracy of the information contained in this training course. Okidata is not responsible for errors beyond its control.

© 1994 by Okidata All rights reserved.

First Edition January, 1992

P/N 59249701

Second Edition October, 1994

P/N 59249702

Written and produced by the Okidata Technical Training Group

Please address any comments on this publication to:

Technical Training Group

Okidata

532 Fellowship Road

Mount Laurel, NJ 08054-3499

Fax Number: (609) 235-2600, ext. 7034

Okilink Login Name: Technical Training

OKIDATA is a registered trademark of Oki Electric Industry Company, Ltd.; marques deposede de Oki Electric Industry Company, Ltd.; marca registrada, Oki Electric Industry Company, Ltd.

MICROLINE is a trademark of Oki Electric Industry Company, Ltd.

PACEMARK is a trademark of Oki Electric Industry Company, Ltd.

IBM and Proprinter are registered trademarks of International Business Machines Corporation.

Centronics is a registered trademark of the Centronics Corporation

Epson and Epson FX are registered trademarks of Seiko Epson Corporation

Table of Contents

COURSE ADMINISTRATION:

OVERVIEW	i-1
RECOMMENDATIONS	i-2
INFORMATION UPDATES.....	i-3
NOTICES.....	i-3
WHERE TO SEND TESTING MATERIALS	i-4
MISSING ITEMS OR MISSING PAGES.....	i-5
Missing Items	i-5
Missing Pages	i-5
COURSE PATH	i-6
SERVICE TRAINING.....	i-7
ON-SITE SERVICE SUPPORT AGREEMENT	i-11
General Information.....	i-11
Where to Send the Agreement	i-11
SERVICE AUTHORIZATION	i-12
General Information.....	i-12
Where to Send Your Test Materials.....	i-12
On-Site Service Support Agreement: Pacemark 3410.....	i-14
Answer Sheet: Pacemark 3410	i-15
Certification Test: Pacemark 3410.....	i-16
Course Critique: Pacemark 3410	i-27

SECTION ONE: SPECIFICATIONS

1.1	OVERVIEW	1-1
	1.1.01 General Information.....	1-1
1.2	PHYSICAL SPECIFICATIONS	1-2
	1.2.01 Printer Dimensions.....	1-2
	1.2.02 Printer Weight.....	1-2

1.3	POWER REQUIREMENTS.....	1-2
1.3.01	Input Power.....	1-2
1.3.02	Power Consumption.....	1-2
1.4	ENVIRONMENTAL CONDITIONS.....	1-3
1.4.01	Acoustic Rating.....	1-3
1.4.02	Altitude	1-3
1.4.03	Ambient Temperature and Relative Humidity.....	1-3
1.5	AGENCY APPROVALS.....	1-3
1.5.01	Listings.....	1-3
1.6	OPERATIONAL SPECIFICATIONS.....	1-4
1.6.01	Character Matrix Sizes.....	1-4
1.6.02	Characters Per Line.....	1-4
1.6.03	Character Pitches	1-4
1.6.04	Character Sets	1-4
1.6.05	Emulations	1-5
1.6.06	Fonts.....	1-5
	Standard	1-5
1.6.07	Front Panel Switches.....	1-6
1.6.08	Graphics Resolution.....	1-6
1.6.09	Interface Methods	1-6
	Standard	1-6
	Optional.....	1-6
1.6.10	Line Feed Increments.....	1-6
1.6.11	Line Feed Time	1-6
1.6.12	Menu Mode.....	1-7
1.6.13	Paper Feed Methods.....	1-7
1.6.14	Paper Feed Paths	1-7
1.6.15	Paper Loading	1-7
1.6.16	Paper Out Detection.....	1-7
1.6.17	Paper Tear Capabilities	1-8
1.6.18	Print Method	1-8
	Printhead Type	1-8
	General Information.....	1-8
	Overheat Protection	1-8
1.6.19	Print Modes	1-8
1.6.20	Print Speeds	1-8

1.7	PAPER SPECIFICATIONS	1-9
1.7.01	Types.....	1-9
	Card Stock.....	1-9
	Continuous Form	1-9
	Cut Sheet.....	1-10
	Envelopes.....	1-10
	Labels.....	1-11
	Transparency.....	1-11
1.7.02	Length.....	1-12
1.7.03	Number of Copies.....	1-13
1.7.04	Thickness.....	1-13
1.7.05	Weight.....	1-13
1.7.06	Width.....	1-13
1.8	MEMORY SPECIFICATIONS.....	1-14
1.8.01	EEPROM.....	1-14
1.8.02	RAM.....	1-14
1.8.03	ROM.....	1-14
1.9	CONSUMABLES.....	1-14
1.9.01	Ribbon.....	1-14
1.10	OPTIONS.....	1-15
1.10.01	Cut Sheet Feeders.....	1-15
1.10.02	Pull Tractor with Acoustic Cover.....	1-15
1.10.03	Microline/Pacemark Emulation Chip Set.....	1-15
1.10.04	Printer Stands.....	1-15
1.10.05	Twin-ax / Co-ax.....	1-15
1.11	RELIABILITY.....	1-16
1.11.01	Mean Time Before Failure (MTBF).....	1-16
1.11.02	Mean Time To Repair (MTTR).....	1-16
1.11.03	Printer Life.....	1-16
1.11.04	Printhead Life.....	1-16
1.11.05	Ribbon Life.....	1-16
1.11.06	Warranty (Limited).....	1-16
1.11.07	Service.....	1-16

SECTION TWO: PRINCIPLES OF OPERATION

2.1	ELECTRICAL OPERATION.....	2-1
2.1.01	General Information.....	2-1
2.1.02	Microprocessor (MPU) and Peripheral Circuits	2-2
	Microprocessor	2-2
	Program ROM for the MPU	2-2
	DRAM.....	2-2
	EEPROM	2-2
	Interface/Motor Control LSI.....	2-3
	Space Motor Enable / Speed Control.....	2-3
	Line Feed Motor Phasing Control.....	2-3
	Bail Motor Phasing Control	2-3
	Dot ON Timing signal generation.....	2-3
	Printhead / Bottom Tractor Feed Control LSI	2-3
	Printhead Drive Control	2-3
2.1.03	Initialization	2-4
	Block Diagram	2-5
2.1.04	Interface Control	2-6
	Parallel Interface	2-6
	RS232-C Serial Interface	2-7
2.1.05	Printhead Drive Circuit	2-8
2.1.06	Spacing Drive Circuit	2-8
2.1.07	Line Feed Circuit	2-9
2.1.08	Alarm Circuits.....	2-10
	Fault Alarm Circuit (in Power Supply Unit).....	2-10
	Printhead Overheat Alarm Circuit	2-10
	Cover Open Alarm Circuit.....	2-10
2.1.09	Paper End Detection Circuit	2-10
2.1.10	Power Supply	2-11
	Voltage / Signal Table	2-11
2.2	MECHANICAL OPERATION	2-12
2.2.01	Printhead Mechanism.....	2-12
	Head Gap Adjusting.....	2-12
2.2.02	Spacing Mechanism.....	2-14
	Spacing Operation.....	2-14
2.2.03	Ribbon Drive Mechanism	2-15
	Ribbon Cartridge.....	2-15
	Ribbon Feed Operation	2-15

2.2.04	Paper Feed Mechanism	2-16
	Friction (Sheet) Feed.....	2-16
	Tractor (Continuous) Feed.....	2-16
2.2.05	Paper-End Detection Mechanism	2-17
	Friction Feed (Cut-Sheet) Paper-End.....	2-17
	Continuous (Bottom) Feed Paper-End.....	2-17
	Continuous (Rear) Feed Paper-End	2-17
2.2.06	Automatic Paper Loading	2-18
	Cut-Sheet Paper	2-18
	Continuous Sheet (Rear Feed) SASF.....	2-18
2.2.07	Paper Park Feature	2-19

SECTION THREE: MAINTENANCE

3.1	OVERVIEW	3-1
	3.1.01 General Information.....	3-1
	3.1.02 Maintenance Items	3-2
	3.1.03 Maintenance Precautions	3-3
3.2	DISASSEMBLY/ASSEMBLY PROCEDURES	3-5
	General Information.....	3-5
	3.2.01 Printhead (with Preliminary Items).....	3-6
	3.2.02 Ribbon Protector Assembly	3-8
	3.2.03 Upper Cover Assembly.....	3-10
	3.2.04 Operator Panel	3-12
	3.2.05 Interface Connector Board.....	3-14
	3.2.06 Main Logic (CBNP) Board.....	3-16
	3.2.07 Printer Mechanism	3-18
	3.2.08 Power Supply Unit.....	3-20
	3.2.09 Printer Unit.....	3-22
	3.2.10 BTFD PCB.....	3-24
	3.2.11 Tension Spring	3-26
	3.2.12 Bottom Push Mechanism and Front Door Assembly	3-28
	3.2.13 Drive Pulley and Belt.....	3-30
	3.2.14 Tractor Assembly (BTF).....	3-32
	3.2.15 Line Feed Motor (BTF)	3-34
	3.2.16 Platen Assembly.....	3-36
	3.2.17 Paper Pressure Guide.....	3-38
	3.2.18 Line Feed Motor Assembly	3-40
	3.2.19 Ribbon Cartridge Bracket	3-42
	3.2.20 Fan Assembly.....	3-44
	3.2.21 Head Cable Assembly.....	3-46

3.2.22	Carriage and Carriage Shaft.....	3-48
3.2.23	Ribbon Feed Assembly	3-50
3.2.24	Space Motor Assembly	3-52
3.2.25	Space Belt	3-54
3.2.26	Sensor Board (LPRW)	3-56
3.2.27	Bail Motor/Gear Assembly	3-58
3.2.28	Paper Bail Assembly.....	3-60
3.2.29	Rear Feed Tractor Assembly	3-62
3.2.30	Printhead Gap/Release Lever Microswitches	3-64
3.2.31	Release Lever / Gear Assemblies	3-66
3.3	PRINTER ADJUSTMENTS	3-69
3.3.01	General Information.....	3-69
3.3.02	Printhead Gap.....	3-70
	General Information.....	3-70
	Procedure	3-72
	Setup Phase (Steps 1 - 6)	3-72
	Printhead Gap Modification Phase (Steps 7 - 9).....	3-72
	Parallel Adjustment Phase (Steps 10 - 12).....	3-72
	Check Phase (Steps 13 - 16)	3-72
	Diagram.....	3-73
	Microswitch 2 Modification	3-74
	General Information.....	3-74
	Procedure	3-74
	Verification	3-75
	Read Me First.....	3-76
	90 Day On-Site Warranty Extension	3-77
3.3.02	Line Feed Belt Tension.....	3-78
3.3.03	Key Combinations	3-81
	Table	3-81
3.3.04	Menu Operation	3-82
	General Description	3-82
	Menu Mode.....	3-82
	Printing the Menu	3-83
	Reset Menu to Factory Defaults	3-84
	Reset Menu and Top of Form to Factory Defaults	3-84
	Limited Operation.....	3-85
	Menu Settings	3-86
3.3.05	Top Of Form	3-93
	General Information.....	3-93
	Setting Top of Form.....	3-93
	Reset Top of Form and Menu to Factory Defaults	3-93

3.3.06	Paper Park	3-95
	General Information	3-95
	Procedure: Continuous Feed to Single Sheet	3-95
	Procedure: Single Sheet to Continuous Feed	3-95
3.3.07	Forms Tear Off	3-96
	General Information	3-96
	Setting	3-97
	Using	3-97
	Checking Top of Form with Form Tear Off Activated	3-97
3.3.08	Resets	3-99
	Reset Menu to Factory Defaults	3-99
	Reset Menu and Top of Form to Factory Defaults	3-99
3.4	CLEANING	3-100
3.4.01	General Information	3-100
	Table of Cleaning Locations	3-101
	Diagram of Cleaning Locations	3-101
3.5	LUBRICATION	3-103
3.5.01	General Information	3-103
3.5.02	Areas Not Lubricated	3-104
3.5.03	Lubrication Diagrams	3-105
	Right and Left Sides of Printer	3-105
	Carriage Shaft	3-106
	Ribbon Feed Assembly	3-106
	Space Motor Assembly	3-107
	Tractor Feed Assembly	3-107
3.6	SHIPPING INSTRUCTIONS	3-108
3.6.01	Return for Service	3-108
3.6.02	All Other Returns	3-109

SECTION FOUR: FAILURE ANALYSIS

4.1	OVERVIEW	4-1
4.1.01	Introduction	4-1
4.1.02	Printer Serial Number Identification	4-3
4.2	REPORTING PROBLEMS	4-4
4.2.01	General Information	4-4
4.2.02	Problem Lists	4-4

4.2.03	Reporting Methods.....	4-5
	Okilink II.....	4-5
	Course Critique.....	4-5
	Fax Number.....	4-5
	Mailing Address.....	4-5
	Information Provided.....	4-5
4.3	TROUBLESHOOTING UPDATES.....	4-6
4.3.01	General Information.....	4-6
4.3.02	Okilink II.....	4-6
4.3.03	Faxable Facts.....	4-6
4.3.04	Technical Service Bulletins.....	4-6
4.4	TROUBLESHOOTING TIPS.....	4-7
4.4.01	Preliminary Checks.....	4-7
4.4.02	Problem Categories.....	4-8
	ALARM Lamp Blinks (Fatal Errors).....	4-8
	Operational Errors.....	4-8
	ALARM Lamp Lights (Paper End/Jam Conditions).....	4-8
4.4.03	START HERE Flowchart.....	4-9
4.4.04	Tips for Preventing Image Problems.....	4-10
4.4.05	Common Problems.....	4-11
4.5	ABNORMAL OUTPUT.....	4-14
4.5.01	Output Samples.....	4-14
	Light Print on the Entire Page.....	4-15
	Uneven Print Density.....	4-15
	Smearred Print.....	4-15
	Inconsistent Line Feed.....	4-15
	Drifting Margin.....	4-15
4.6	FAULT ALARMS.....	4-17
4.6.01	Error Indications.....	4-17
4.7	REPAIR ANALYSIS PROCEDURES (RAPs).....	4-18
4.7.01	Using the RAPs.....	4-18
4.7.02	RAP Index.....	4-19
	RAP 01: Power Lamp Does Not Light.....	4-20
	RAP 02: Spacing Error.....	4-22
	RAP 03: Head Homing Error.....	4-24
	RAP 04: Bail Homing Error.....	4-26
	RAP 05: Ribbon Feed Problem.....	4-27
	RAP 06: Wrong Character, Character Omission or Dot Omission.....	4-28
	RAP 07: Line Feed Problem.....	4-30

	RAP 08: Malfunction of Operator Panel Switch	4-31
	RAP 09: Data Receiving Failure.....	4-32
	Parallel	4-32
	Serial	4-33
	RAP 10: ALARM Lamp ON	4-35
	RAP 11: Bottom Tractor Feed Unit (BTFU) Problem.....	4-36
4.8	PRINTER TESTS	4-39
4.8.01	Rolling ASCII Test	4-39
	General Information	4-39
	Procedure	4-40
	Sample.....	4-41
4.8.02	Font Sample Test	4-42
	General Information	4-42
	Procedure	4-42
	Sample.....	4-43
4.8.03	Serial Interface Diagnostic.....	4-44
	General Information.....	4-44
	Procedure	4-44
	Serial Cable Information.....	4-45
	Serial Interface Signal Requirements.....	4-45
4.8.04	Hexadecimal Dump	4-46
	General Information.....	4-46
	Example	4-46
	Procedure	4-46
4.9	RESISTANCE CHECKS.....	4-47
4.9.01	General Description	4-47
	Layout Diagram	4-48
4.9.02	Printhead	4-49
4.9.03	Line Feed Motor	4-49
4.9.04	Space Motor	4-50
4.9.05	Bail Motor.....	4-50

APPENDIX A: BOARD DIAGRAMS

A.1	OVERVIEW	A-1
	A.1.01 General Information.....	A-1
A.2	INDEX TO CHARTS	A-2
	A.2.01 Main Logic Board (CBNP).....	A-4
	A.2.02 Power Supply Board	A-6
	A.2.03 Interface Board (HKTY).....	A-8

A.2.04	Sensor Board (LPRW)	A-10
A.2.05	Operator Panel Board (OPML)	A-12
A.2.06	Bottom Tractor Feed Unit Board (BTFD)	A-14

APPENDIX B: ILLUSTRATED PARTS LISTING

B.1	OVERVIEW	B-1
B.1.01	General Information	B-1
	Format	B-2
	Current Part Numbers	B-3
B.1.02	Definition of Terms	B-4
	Assemblies	B-4
	Blank	B-4
	Consumable	B-4
	Document	B-4
	Drivers	B-4
	Firmware	B-4
	Option	B-4
	Option RSPL	B-4
	RSPL	B-4
	Technical Service Bulletins	B-5
B.1.03	Parts Ordering Information	B-6
	Service Center Reference Guide	B-6
	Placing a Parts Order	B-7
B.2	CHARTS	B-8
B.2.01	Printer	B-10
B.2.02	Upper Cover Assembly	B-12
B.2.03	Printer Unit	B-14
B.2.04	Operator Panel Assembly	B-16
B.2.05	Carriage Assembly	B-18
B.2.06	Printer Mechanism (1 of 2)	B-20
B.2.07	Printer Mechanism (2 of 2)	B-22
B.2.08	Bottom Tractor Feed Unit	B-24
B.2.09	Options	B-26
B.2.10	Pull Tractor Unit (Option)	B-28
B.2.11	Packing Materials	B-30
B.2.12	Consumables	B-32
B.2.13	Documentation	B-34

COURSE ADMINISTRATION

OVERVIEW

Okidata developed this course in order to provide the information necessary to install and maintain the Pacemark 3410. Upon successful completion of this training course, you will be able to do the following.

- Install and operate the product
- Locate the major assemblies of the product
- Identify fault indications
- Perform corrective and preventive maintenance

The Service Handbook is the primary reference manual for this course. You cannot, however, successfully complete this course by referring only to this manual. Take the time to familiarize yourself with all of the documentation in the training kit. This additional information will greatly simplify working with the product.

Okidata's Technical Training Program is designed to build a knowledgeable and efficient service and support group for Okidata products.

One step in becoming an Authorized Okidata Service Center is obtaining a training kit for the appropriate product. This acquisition allows the Dealership to have reference materials available during service jobs. Having, and using, these reference materials will minimize the time and money spent on repairs.

Technicians complete Certification Tests as part of Okidata's Authorization process. Testing familiarizes the technician with the product and reference materials.

This training course provides *assembly level* repair information to the field technician. No attempt is made to provide basic training in being a technician. This kit strives to train a technician to service the product. Okidata views service technicians as representatives of Okidata. Through this course, Okidata seeks to provide the means and the motivation that will make good service a reality.

Remember

Component level servicing is provided only at Okidata Service Repair Depots!

RECOMMENDATIONS

Prerequisites

Before beginning this course, you should know the following concepts.

Have an understanding of basic electronics

Be familiar with electrostatic principles

Be familiar with dot matrix technology and protocol

Be familiar with the proper procedures for handling circuit boards, Read Only Memory (ROM), and Random Access Memory (RAM)

Be able to use basic tools

Be able to use a digital multimeter (DMM)

Equipment

The following equipment is recommended for the successful completion of this training course.

Pacemark 3410 (optional)

Tools (optional - refer to Module Three of the Service Handbook)

Personal Computer (for Okilink II connection)

Modem (for Okilink II connection)

Communications Software (for Okilink II connection)

Telephone (for Faxable Facts connection)

Facsimile Machine (for Faxable Facts connection)

Video Cassette Player (for viewing videotape)

Video Monitor (for viewing videotape)

Documentation

You should have access to the following documentation while completing this course.

Okidata Service Center Reference Guide

Service Handbook

Printer Handbook

Service Videotape

INFORMATION UPDATES

Every effort has been made to ensure the accuracy of the information contained in this training course. Okidata is not responsible for errors beyond its control.

Technical updates are made available to authorized Service Centers through the Technical Service Bulletins (TSBs / Okidata's Monthly Technical Mail). The TSBs are distributed via Okidata's Bulletin Board, Okilink II.

Additions and corrections to the training materials are available in the Training Section of Okilink II. Please sign on and check this section before beginning this course.

For information on using Okilink II, please refer to the Service Center Reference Guide.

NOTICES

Pay attention to all notices that appear throughout this training course. They are for your safety! Here are the definitions of the notices.

NOTE:

This notice refers to supplemental information.

CAUTION:

Deviation from the listed procedures may result in damage to the product.

WARNING:

Deviation from the listed procedures may result in personal injury.

WHERE TO SEND TESTING MATERIALS

Refer to the Okidata Service Center Reference Guide for where to send the test materials.

The Okidata Service Center Reference Guide is sent to your dealership along with the Okidata Service Contract materials. It is available from Okidata Dealer Service. It is also available through Okilink II.

MISSING ITEMS OR MISSING PAGES

Missing Items

When you receive the training kit, you *MUST* verify that the kit contains the items listed on the Read Me First sheet.

If any items are missing, please contact Okidata Logistics at the appropriate number listed below.

Facsimile 1-609-424-7423

Voice 1-800-727-8654

You must provide the following information.

- Okidata Authorization Number (Dealer Number)
- Okidata Customer Number
- Order Acknowledgment Number (on the invoice)
- Part Number of kit

Missing Pages

If you find that *pages* are missing from any item in this kit, please contact Okidata Technical Training.

Please FAX your request or use Okilink II.

Fax Number: (609) 235-2600, ext. 7034

Okilink Login Name: Technical Training

You must provide the following information.

- Okidata Authorization Number (Dealer Number)
- Part Number of document with missing pages
- Name of document with missing pages
- Page numbers of missing pages

If it is the Service Handbook, be sure to specify the section (i, 1, 2, 3, 4, a, or b).

- Your facsimile number (with area code)

COURSE PATH

This Course Administration directs you through the training package. Each section covers a different part of the training. Tasks within each section direct you to the portions of the training materials that cover the subject you are studying.

When you have completed one section, move on to the next. You must achieve a score of 80% or greater on your Certification Test to successfully complete this course.

You must return your completed Certification Test Answer Sheet and Course Critique to Okidata within 30 days after the kit is received by your Dealership. If multiple technicians are training at your Dealership, only one technician must complete the testing during the 30 days.

DO NOT STAPLE THE ANSWER SHEET TO THE COURSE CRITIQUE!

Be sure to make a copy of the Answer Sheet for your records.

Your Answer Sheet will be corrected within two days after it is received by Okidata. If you achieve a score of 80% or higher, you will receive a Certificate of Training. The Dealership you work for will become an Authorized Service Center for the products covered in this training package.

Service Authorization is approved once Okidata processes the Answer Sheet. The Certificate of Training will be mailed to you after the Answer Sheet is corrected.

You and your Dealership are responsible for returning the Answer Sheet and Course Critique within 30 days after receiving the training kit. Okidata strongly urges you to keep track of the date you return your Answer Sheet and Course Critique. Certification and Authorization are processed within two days after Okidata receives the testing materials. A certificate for successful completion of the training program will be sent to you within 21 days. If authorization is not updated within two days or a certificate received within 21 days, contact Okidata Dealer Service.

Proceed through each section and perform the assigned tasks.

Learn from the Course and Good Luck!

SERVICE TRAINING

Requirements

You will need the following items.

- Service Center Reference Guide
- Service Handbook
- User's Documentation
- Service Videotape
- Video Cassette Player and Monitor

Service Training is divided into the following six sections.

- General Description
- Installation
- Principles of Operation
- Failure Analysis
- Appendices
- Maintenance
 - Disassembly/Assembly
 - Adjustments and Service Checks
 - Cleaning
 - Lubrication
 - Packing for Shipment

General Description

This section describes the features and specifications of the printers.

Assigned Tasks

- Read Section 1 of the Service Handbook.

Installation

In this section, you will install the unit. You will also perform various tests.

Assigned Tasks

- Review the Printer Handbook
- If a product is available, perform the tests listed below. Refer to Section 4 of the Service Handbook.

Rolling ASCII

Font Test

Principles of Operation

This section describes the function of the major assemblies from an electrical and mechanical perspective.

Assigned Tasks

- Read Section 2 of the Service Handbook.

Failure Analysis

This section covers the methods used to identify and correct problems with the unit.

Assigned Tasks

- Read Section 4 of the Service Handbook.
- Study the Board Diagrams in Appendix A of the Service Handbook.
- Check Okilink II for additional troubleshooting information. Refer to the Service Center Reference Guide for information on accessing Okilink II.

Appendices A and B

Appendices A and B contain charts, illustrations, and an illustrated parts list to support you in servicing the product.

Appendix A

Appendix A contains information about the printed circuit boards (PCBs). This appendix includes reference charts which present data regarding function, firmware, fuses, jumpers, sensors, switches, and test points. An illustration of each board is also included.

Appendix B

Appendix B is an illustrated parts listing of the product. This listing is cross-referenced to Section 3 of the Service Handbook.

Assigned Tasks

- Look through Appendix A and Appendix B in the Service Handbook.

Maintenance

Disassembly / Assembly

Assigned Tasks

- Read Section 3.2 of the Service Handbook.
- View the videotape.

CAUTION:

Okidata does not recommend performing the disassembly / assembly procedures on a product which is operating normally. Therefore, you are not required to perform the disassembly / assembly procedures to complete this training.

Adjustments and Service Checks

This section explains the adjustments performed after parts replacement. Hardware replacement may require adjustments to firmware settings. This section also explains viewing and resetting counters.

Assigned Tasks

- Read Section 3.3 of the Service Handbook.
- Perform the procedures listed in Section 3.3 of the Service Handbook.

Cleaning

Assigned Tasks

- Read Section 3.4 of the Service Handbook.

Lubrication

Assigned Tasks

- Read Section 3.5 of the Service Handbook.

Shipping Instructions

Assigned Tasks

- Read Section 3.6 of the Service Handbook.

ON-SITE SERVICE SUPPORT AGREEMENT

General Information

IMPORTANT NOTICE

MANAGEMENT SIGNATURE REQUIRED

Okidata requires that a Dealership authorized as a Warranty Repair Center for the Pacemark 3410 *MUST* agree to perform on-site customer repair service for the product.

An officer of the dealership must sign the On-Site Service Support Agreement (a copy is provided in this training kit). The signature indicates that the Dealership agrees to perform on-site service support and realizes that this performance is a factor in becoming and remaining warranty authorized for the Pacemark 3410 Printer.

The On-Site Service Support Agreement in this section is the only copy of this item you will receive.

DO NOT WRITE ON THIS ITEM!

PHOTOCOPY IT!

Use the photocopy to complete the process.

The information provided on this Agreement is used to update your Dealership's Okidata Service Warranty Profile.

MAKE ALL RESPONSES COMPLETE AND LEGIBLE!

Make a copy of the completed On-Site Service Support Agreement for your records.

Where to Send the Agreement

Refer to the Okidata Service Center Reference Guide for where to send the agreement.

The Okidata Service Center Reference Guide is sent to your dealership along with the Okidata Service Contract materials. It is available from Okidata Dealer Service. It is also available through Okilink II.

SERVICE AUTHORIZATION

General Information

Read through the instructions for completing the testing process before you begin.

This section contains the On-Site Service Support Agreement, Answer Sheet, Certification Test, and Course Critique for this service training package. These are the only copies of these items you will receive.

DO NOT WRITE ON THESE ITEMS!

PHOTOCOPY EACH ITEM!

Use the photocopies to complete the testing process. Photocopy the Certification Test, Answer Sheet, and Course Critique as required for each technician being trained.

The information provided on the Answer Sheet and Course Critique is used to update your Dealership's Okidata Service Warranty Profile and to process your Certificate of Training. The critique information is used to respond to your questions regarding this training package.

MAKE YOUR RESPONSES COMPLETE AND LEGIBLE!

Feel free to reference the training material as you answer the test questions.

Every attempt has been made to test your knowledge of the product and your ability to use the reference materials in this kit. No attempt has been made to write "trick questions".

If you have a question about a specific test question or answer, please bring it to the attention of Okidata Technical Training. Refer to the Service Center Reference Guide for information on contacting Okidata Technical Training.

In order to improve the quality of future training courses, Okidata welcomes your evaluation of this training program. Please complete the course critique for this training course.

Before returning your completed testing materials, photocopy your completed Answer Sheet for your records.

DO NOT ATTACH ANYTHING TO THE ANSWER SHEET!

Where to Send Your Test Materials

Refer to the Okidata Service Center Reference Guide for where to send the test materials.

The Okidata Service Center Reference Guide is sent to your dealership along with the Okidata Service Contract materials. It is available from Okidata Dealer Service. It is also available through Okilink II.

Certification Test

Requirements

You must achieve a score of 80% or greater on your Certification Test to successfully complete this course.

You will need the following items.

Service Handbook

User's Documentation

#2 Lead Pencil

Assigned Tasks

- Read through all instructions *BEFORE* completing the testing process.
- Photocopy the Certification Test and Answer Sheet provided in this kit. Use the photocopies to complete the testing process.
- Complete the top section of the Answer Sheet. Make your responses legible.
- Answer the Certification Test Questions by filling in the appropriate circle on the Answer Sheet. Use a Number 2 pencil and completely fill in the selected circle.

DO NOT ATTACH ANYTHING TO THE ANSWER SHEET!

- Make a copy of the completed Answer Sheet for your records.

Course Critique

Requirements

You will need the following items.

Your photocopy of the Course Critique

Assigned Tasks

- Complete the Course Critique.
- Return the Answer Sheet and Course Critique to Okidata Dealer Service.

DO NOT ATTACH ANYTHING TO THE ANSWER SHEET!

DATE ITEMS RETURNED TO OKIDATA: _____

On-Site Service Support Agreement: Pacemark 3410

IMPORTANT NOTICE

MANAGEMENT SIGNATURE REQUIRED BELOW

As stated when your company first ordered this training kit, to become authorized as a Warranty Repair Center, and receive labor reimbursements for warranty service, as well as all other benefits associated with warranty authorization, your dealership must agree to, and be able to perform, on-site customer repair service for the Pacemark 3410.

Your signature below, states that you agree to perform on-site service support and realize that this performance is a factor in becoming and remaining warranty authorized for the Pacemark 3410 Printer.

Dealer Code: _____ Today's Date: _____

Name: _____

Title: _____

Signature: _____

Company: _____

Company's Address: _____

City: _____

State/Province: _____

Zip/Postal Code: _____

Country: _____

Phone #: _____ Fax #: _____

Answer Sheet: Pacemark 3410

Section 1

Dealer Code: _____ Today's Date: _____

Technician's Name: _____

Company: _____

Company's Address: _____

City: _____

State/Province: _____

Zip/Postal Code: _____

Country: _____

Phone #: _____ Fax #: _____

If your Dealership uses Okilink II, please provide your Dealership's Login Name.

First: _____ Last: _____

Section 2

	<u>A</u>	<u>B</u>	<u>C</u>	<u>D</u>		<u>A</u>	<u>B</u>	<u>C</u>	<u>D</u>
1.	O	O	O	O	11.	O	O	O	O
2.	O	O	O	O	12.	O	O	O	O
3.	O	O	O	O	13.	O	O	O	O
4.	O	O	O	O	14.	O	O	O	O
5.	O	O	O	O	15.	O	O	O	O
6.	O	O	O	O	16.	O	O	O	O
7.	O	O	O	O	17.	O	O	O	O
8.	O	O	O	O	18.	O	O	O	O
9.	O	O	O	O	19.	O	O	O	O
10.	O	O	O	O	20.	O	O	O	O

Certification Test: Pacemark 3410

1. When installing the tractor assembly (BTF), you should
 - A. synchronize the tractors by aligning the synchronization marks.
 - B. position the left tractor assembly to the left of the metal tab.
 - C. Both A and B
 - D. Neither A nor B

2. You suspect that the print data (being received from the computer) is corrupted. To determine if the printer is receiving corrupt data, you should place the printer into Hexadecimal Dump Mode.
 - A. True
 - B. False

3. You *MUST* use continuous feed paper to print the continuous print test (rolling ASCII) and font sample test.
 - A. True
 - B. False

4. According to Appendix A in the Service Handbook, the 10.0 Amp fuse on the power supply board is
 - A. not soldered in.
 - B. soldered in.
 - C. accessible without removing the printer cover.
 - D. accessible by removing the printer cover.

5. The part numbers of the line feed motor used for in *BOTH* the top and bottom line feed assemblies are identical.
- A. True
 - B. False
6. The Operator Panel Function Item in the printer menu is set to LIMITED OPERATION. In order to return the operator panel to full operation,
- A. power off the unit. Then, press and hold LINE FEED on power up.
 - B. power off the unit. Then, press and hold FORM FEED on power up.
 - C. deselect the printer. Then, press and hold both PRINT QUALITY and CHARACTER PITCH at the same time. Once in menu mode, reset the OPERATOR PANEL FUNCTION item to FULL OPERATION.
 - D. power off the unit. Then, press and hold both PRINT QUALITY and CHARACTER PITCH at the same time on power up. Once in menu mode, reset the OPERATOR PANEL FUNCTION item to FULL OPERATION.

7. When the printhead temperature reaches approximately 115 degrees Celsius, the printer will begin unidirectional printing. If the temperature continues to increase (125 degrees Celsius), printing stops until the printhead cools down, then printing resumes.

A. True

B. False

8. In order to feed cardstock through the printer, Okidata recommends

A. using the optional pull tractor.

B. feeding from the bottom tractor feed unit.

C. using the CSF-3001.

D. feeding through the rear push tractor only.

9. In order to perform a Serial Interface Diagnostic Test, you should
1. place a DB-25P Loopback Test Connector on the serial port.
 2. press and hold PARK during power ON.
 3. press and hold LINE FEED during power ON.
 4. change the menu setting for SERIAL I/F DIAGNOSTIC TEST to YES.
- A. 1
- B. 1 and 2
- C. 1 and 3
- D. 1 and 4
10. According to Appendix A in the Service Handbook, the main logic board contains which of the following?
- A. One 3.5 Amp fuse (F1)
 - B. Test Points for (+38vdc, +5vdc, +8vdc, -8vdc)
 - C. Jumper plug S2
 - D. All of the above

11. PAPER END (when the release lever is in the continuous [tractor] feed position) is detected by the photosensor located on the paper pressure guide.
- A. True
 - B. False
12. A customer states that the printer occasionally switches from bi-directional to uni-directional printing while printing a particular job. The printer then stops printing for a while. Printing resumes without warning. What is the most probable cause?
- A. The main logic board is defective.
 - B. The printhead is overheating.
 - C. The ribbon is incorrectly installed.
 - D. The printer is out of paper.

13. You are using narrow (9 1/2 inch wide) continuous feed paper in the *BOTTOM* tractor feed unit. Before running the Rolling ASCII test, you should do which of the following?
- A. Verify that the menu setting for Top Feed, Paper Width is 8 inches, not 13.6.
 - B. Verify that the menu setting for Bottom Feed, Paper Width is 8 inches, not 13.6.
 - C. Verify that the menu setting for Rear Feed, Paper Width is 8 inches, not 13.6.
 - D. The menu setting for all feeds' page width doesn't matter.
14. Your customer has complained of "light print". This could be caused by which of the following?
- 1. A defective space motor.
 - 2. A ribbon past its service life.
 - 3. An incorrect printhead gap setting.
 - 4. A printhead temperature of 100 degrees Celsius.
- A. 1 and 3
 - B. 2 and 4
 - C. 1 and 4
 - D. 2 and 3

15. According to Section 3 in the Service Handbook, you should use the ribbon cartridge bracket, paper chute, and guide shaft for handholds when lifting the printer mechanism during disassembly.

A. True

B. False

16. The +8 vdc from the Power Supply is used

A. as a locking voltage for the line feed motor.

B. to fire the printwires.

C. as a TTL Logic "1" throughout the printer.

D. as power for the Operator Panel LEDs.

17. The Pacemark 3410 is displaying a Fault Alarm Condition.
The ALARM lamp is flashing.
The 15 cpi lamp is lit.
The GOTHIC lamp is lit.

The recommended action is to

- A. replace the main logic board.
 - B. go to RAP 03.
 - C. replace the power supply unit.
 - D. go to RAP 04.
18. If the rear feed tractor assembly is correctly installed,
- A. the upper center guide will move with difficulty.
 - B. the tractors will be synchronized.
 - C. the left tractor assembly will be positioned between the two guide tabs.
 - D. All of the above

19. You have identified a printer failure as a ribbon feed problem. You are using RAP 05 to troubleshoot. After removing the ribbon cartridge, you find that the ribbon feed knob does not rotate smoothly. Your next action should be to
- A. replace the ribbon feed assembly.
 - B. ensure the lock mechanism on the ribbon has been disengaged.
 - C. replace the ribbon cartridge.
 - D. replace the main logic board.
20. Whenever the printhead is replaced, the printhead gap adjustment must be performed.
- A. True
 - B. False

This page was intentionally left blank.

Course Critique: Pacemark 3410

Dealer Code: _____ Today's Date: _____

Technician's Name: _____

Company: _____

Company's Address: _____

City: _____

State/Province: _____

Zip/Postal Code: _____

Country: _____

Phone #: _____ Fax #: _____

1. Have you completed other Okidata Self-Study Service Training packages?

Yes _____ No _____

2. Please rate this course.

Excellent _____ Below Average _____
Above Average _____ Poor _____
Average _____

3. Does your Dealership use Okilink II?

Yes _____ No _____

If yes, please provide your Dealership's Login Name.

First Name: _____

Last Name: _____

**SECTION ONE
SPECIFICATIONS**

1.1 OVERVIEW

1.1.01 General Information

The Pacemark 3410 is a high speed, dot matrix printer, which utilizes a 9 pin printhead.

The printer is capable of emulating the IBM Proprinter or the Epson FX printers.

The Pacemark 3410 comes standard with both an RS232-C Serial Interface and a Centronics Parallel Interface. Also standard is the bottom push tractor feed unit.

1.2 PHYSICAL SPECIFICATIONS

1.2.01 Printer Dimensions

NOTE:

Dimensions include the bottom feed unit.

Width: 25.5 inches (54.0 centimeters)

Depth: 19 inches (48.3 centimeters)

Height: 15 inches (20.3 centimeters)

1.2.02 Printer Weight

63 pounds (25.4 kilograms)

United Parcel Service (UPS) shippable

1.3 POWER REQUIREMENTS

1.3.01 Input Power

Input Voltage

120 VAC +5.5%, -15%

220/240 +10%, -10%

Frequency

50/60 hz. +/-2%

1.3.02 Power Consumption

Operating: 75 W

Idle: 30 W

1.4 ENVIRONMENTAL CONDITIONS

1.4.01 Acoustic Rating

58.5 dBa

1.4.02 Altitude

10,000 feet (3,048 meters)

1.4.03 Ambient Temperature and Relative Humidity

In Operation

41 to to 95 degrees Fahrenheit (5 to 35 degrees Celsius)

@ 20% - 80% Relative Humidity

In Storage

14 to to 122 degrees Fahrenheit (-10 to 50 degrees Celsius)

@ 5% - 95% Relative Humidity

1.5 AGENCY APPROVALS

1.5.01 Listings

North America

FCC Class B

UL 478 (Office Machines and Business Equipment)

CSA 22.2 (220)

1.6 OPERATIONAL SPECIFICATIONS

1.6.01 Character Matrix Sizes

Print Mode	Horizontal	Vertical
Near Letter Quality	24	17
Utility	12	9
High Speed Draft	9	9

1.6.02 Characters Per Line

136 Characters @ 10 cpi
163 Characters @ 12 cpi
204 Characters @ 15 cpi
233 Characters @ 17.1 cpi
272 Characters @ 20 cpi

1.6.03 Character Pitches

10, 12, 15, 17.1, 20

1.6.04 Character Sets

Standard ASCII
Epson Character Set I
Epson Character Set II
IBM Character Set I
IBM Character Set II
IBM ALL (Proprinter) Character Set
Foreign Language Substitution (International Characters)
Line Graphics
Code Pages: 850, 863

1.6.05 Emulations

NOTE:

The Plug-in Chip Set for Microline/Pacemark Emulation is installed by a technician.

Resident

Epson FX-1050

IBM Proprinter III

Optional Plug-in Chip Set

Microline/Pacemark

1.6.06 Fonts

Standard

Near Letter Quality

Courier

Gothic

Proportional

Draft

Utility

High Speed Draft

Custom Characters

Barcode

Code 128 (ABC)

Code 3 of 9

EAN 8

EAN 13

Interleaved 2 of 5

POSTNET

UPC-A

UPC-E

1.6.07 Front Panel Switches

Select	Paper Park
Menu Mode	Pitch Selection
Line Feed	Print Quality Selection
Form Feed	Tear
Top of Form	Micro Feed Up / Down

1.6.08 Graphics Resolution

Maximum: 240 x 216 dots per inch (dpi)

1.6.09 Interface Methods

Standard

Centronics Parallel Interface

RS232-C Serial Interface (19.2 KB)

Optional

Twin-ax or Co-ax

Available from a third party vendor. Call 1-800-OKIDATA [1-800-654-3282] for more information.

1.6.10 Line Feed Increments

1/6" (Selected through the Menu)

1/8" (Selected through the Menu)

n/72"

n/144"

n/216"

1.6.11 Line Feed Time

10.0 Inches Per Second (IPS) slew rate (when Printhead Gap Lever is set at 1 or 2)

6 IPS slew rate (when Printhead Gap Lever is set at 3 or 4)

5 IPS slew rate (when Printhead Gap Lever is set at 5 through 9)

1.6.12 Menu Mode

Print: Prints the entire menu.

Group: Selects Group Function

Item: Selects Item

Set: Selects Item Value

Exit: Exits Menu Mode, Enters Select

1.6.13 Paper Feed Methods

Built-in Push Tractor (Bottom)

Built-in Push Tractor (Rear)

Friction Feed (Top)

Bottom Push Tractor Feed Unit

Optional Pull Tractor (Bottom / Rear)

Optional Cut Sheet Feeders (Single and Dual Bin)

1.6.14 Paper Feed Paths

Bottom Feed

Rear Feed

Top Feed

Special Features

Paper Park

Automatic Paper Loading

Forms Tear Off

1.6.15 Paper Loading

Auto Bail Arm for Auto Loading

1.6.16 Paper Out Detection

Distance from end of paper

Rear Feed: 2.30 inches (58.42 mm)

Bottom Feed: .94 inches (23.88 mm)

Cut Sheet: .93 inches (23.62 mm)

1.6.17 Paper Tear Capabilities

Form Tear-Zero Tear

Metal Tear Bar

1.6.18 Print Method

Printhead Type

General Information

Impact, Dot Matrix

Staggered, 9 pin, stored energy printhead

0.36 mm diameter pins

Installed by Service Technician

The Printhead Gap Adjustment must be performed when the printhead is replaced.

Overheat Protection

When the printhead temperature reaches 115 degrees Celsius, the printer stops bi-directional printing. Uni-directional printing begins.

If the temperature continues to rise (125° Celsius), printing stops.

Printing will resume when the printhead temperature drops below 115 degrees Celsius.

1.6.19 Print Modes

Near Letter Quality (NLQ)

Utility

High Speed Draft

1.6.20 Print Speeds

Pitch	High Speed Draft	Utility	Near Letter Quality
10 cpi	550 cps	417 cps	104 cps
12 cpi	550 cps	417 cps	104 cps
15 cpi	550 cps	417 cps	104 cps
17.1 cpi	550 cps	417 cps	104 cps
20 cpi	550 cps	417 cps	104 cps

cpi - Characters Per Inch

cps - Characters Per Second

1.7 PAPER SPECIFICATIONS

1.7.01 Types

Card Stock

Weight:	120 lbs. (450 g/m ²)	Maximum
Width:	5 to 14 inches (12.7 to 35.6 centimeters)	
Length:	3 to 17 inches (7.62 to 43.18 centimeters)	
Thickness:	.02 inches (0.5 millimeters)	
Paper Feed Path:	Bottom	
Head Gap Lever Setting:	8 - 9	

Continuous Form

Weight:		
Single Part	12 - 24 lb. (45 to 90 g/m ²)	
Multi-Part, Carbonless	9 - 11 lb. (35 to 40 g/m ²)	
Multi-Part, Interleaf Paper Carbon	10 - 12 lb. (38 to 45 g/m ²) 9 lb. (35 g/m ²)	
Width:	3 to 16 inches (76.2 to 406.4 millimeters)	
Length:	3 to 17 inches (7.62 to 43.18 centimeters)	
Thickness:	0.014 inches (0.36 millimeters)	Rear Feed
	0.02 inches (0.5 millimeters)	Bottom Feed
Paper Feed Path:	Rear or Bottom	
Head Gap Lever Setting:	1	Single Part 12 - 15 lb. (45 to 56 g/m ²)
	1 - 2	Single Part 20 - 24 lb. (75 to 90 g/m ²)
	2 - 3	Two Part
	3 - 4	Three Part
	5	Four Part
	6	Five Part
	7	Six Part

Cut Sheet

Weight:	12 to 24 lbs. (45 to 90 g/m ²)
Width:	7.2 to 14.3 inches (18.3 to 36.3 centimeters)
Length:	3 to 17 inches (7.62 to 43.18 centimeters)
Thickness:	0.014 inches (0.325 millimeters) Maximum
Paper Feed Path:	Top
Head Gap Lever Setting:	1 12 - 15 lb. (45 to 56 g/m ²) 1 - 2 20 - 24 lb. (75 to 90 g/m ²)

Envelopes

Weight:	24 lbs. (90 g/m ²) Maximum
Size:	
Single Feed	
Minimum:	6.5 x 3.6 inches (16.5 x 9.1 centimeters)
Maximum:	9.5 x 4.1 inches (24.1 x 10.4 centimeters)
Continuous	
Non-overlap type	
Thickness:	.014 inches (.325 millimeters) Maximum
Paper Feed Path:	Bottom
Head Gap Lever Setting:	5 - 9

Labels

Weight:	N/A
Width:	3 to 16 inches (7.62 to 40.64 centimeters)
Length:	3 to 17 inches (7.62 to 43.18 centimeters)
Thickness:	.011 inches (0.28 mm) Maximum (including backing)
Paper Feed Path:	Bottom
Head Gap Lever Setting:	3 - 4

Transparency*NOTE:*

Roller marks may mar the transparency under high temperature / high humidity conditions.

Weight:	12 to 24 lbs. (45 to 90 g/m ²)
Width:	7.2 to 14.3 inches (18.3 to 36.3 centimeters)
Length:	3 to 17 inches (7.62 to 43.18 centimeters)
Thickness:	0.14 inches (0.36 millimeters)
Paper Feed Path:	Top
Head Gap Lever Setting:	1 12 - 15 lb. 1 - 2 20 - 24 lb.

1.7.02 Length

NOTE:

The recommended length is specific to paper type.

Rear Feed

Minimum 3 inches (7.62 centimeters)

Maximum 17 inches (43.18 centimeters)

Bottom Feed

Minimum 3 inches (7.62 centimeters)

Maximum 17 inches (43.18 centimeters)

Top Feed

Minimum 3 inches (7.62 centimeters)

Maximum 17 inches (43.18 centimeters)

1.7.03 Number of Copies

Original + 5 Interleaf

Original + 7 Carbonless

Original + 3 Cut Sheet (top edge must be glued tight)

1.7.04 Thickness

0.014 inches / 0.36 mm Maximum Thickness, Rear Feed

0.020 inches / 0.50 mm Maximum Thickness, Bottom Feed

1.7.05 Weight

NOTE:

The recommended weight is specific to paper type.

Minimum: 9 lb. (35 g/m²)

Maximum: 24 lb. (90 g/m²)

1.7.06 Width

NOTE:

The recommended width is specific to paper type.

Minimum: 3 inches

Maximum: 16 inches

1.8 MEMORY SPECIFICATIONS

1.8.01 EEPROM

Internal Control, Menu = 256 bits

1.8.02 RAM

Total RAM = 64 Kbytes

Print Buffer = 28 Kbytes

DLL Buffer = 0 to 31 Kbytes

1.8.03 ROM

Resident: Program ROM = 256 Kbytes

1.9 CONSUMABLES

1.9.01 Ribbon

Black Cartridge

Type: Nylon Fabric

Ribbon Life: Approximately 7.5 million characters

1.10 OPTIONS

1.10.01 Cut Sheet Feeders

CSF 3001 Single Bin

and

CSF 3002 Dual Bin

14 inches wide

User installable

Sheet Capacity

170 sheets of 16 lb.

100 sheets 24 lb.

Paper Width

7.2 to 8.5 inches (18.3 to 21.6 centimeters)

Paper Length

10.1 to 14 inches (25.7 to 35.6 centimeters)

1.10.02 Pull Tractor with Acoustic Cover

Use with bottom feed for continuous forms, labels, and / or invoices.

1.10.03 Microline/Pacemark Emulation Chip Set

Technician installable

1.10.04 Printer Stands

Available through a Third Party Vendor.

For more information, please call

800-749-2258 (Pacemark ONLY)

800-827-2672 (all printers)

1.10.05 Twin-ax / Co-ax

Available through a Third Party Vendor.

For more information, please call 508-777-7957.

1.11 RELIABILITY

1.11.01 Mean Time Before Failure (MTBF)

Approximately 8,000 hours @ 25% Duty Cycle, 35% Page Density

Approximately 2,000 hours @ 100% Duty Cycle

1.11.02 Mean Time To Repair (MTTR)

Approximately 15 minutes @ major sub-assembly level

1.11.03 Printer Life

Approximately 16,000 Hours @ 25% Duty Cycle, 35% Page Density

1.11.04 Printhead Life

Approximately 200,000,000 characters (average)

@ 10 cpi Draft Mode @ 25% Duty Cycle, 35% Page Density

1.11.05 Ribbon Life

Approximately 7.5 million characters

1.11.06 Warranty (Limited)

One year parts, labor, printhead

1.11.07 Service

90 days, on-site

SECTION TWO
PRINCIPLES OF OPERATION

2.1 ELECTRICAL OPERATION

2.1.01 General Information

The main logic board consists of the microprocessor, its peripheral LSI circuits, ROM, DRAM and the drive circuits. The voltages for the main logic board are supplied by the power supply unit. The voltages for the various electrical components (motors, sensors, etc.) are distributed from the main logic board.

2.1.02 Microprocessor (MPU) and Peripheral Circuits

Microprocessor

Q3: M67X640V1

The MicroProcessor Unit (MPU) is the nucleus of the control circuit. Various peripheral circuits operate under program control of this microprocessor. The MPU (Q3) controls all aspects of printer operation.

Program ROM for the MPU

Q4: 27C202K

This 2Mbit Read Only Memory (ROM) contains the control program for the printer. The MPU operates under program control.

This ROM also stores the resident character fonts.

DRAM

Q10 and Q11

The Dynamic Random Access Memory (RAM) chips, each consisting of 64 K x 4 bits, are used as the Command Buffer, Receive Buffer and Print Buffer.

The total buffer size is 64 K x 8 bits. The RAM speed is 120 ns.

EEPROM

Q14: 93C06N

This 256-bit serial Electrically Erasable and Programmable Read Only Memory (EEPROM) stores the menu data and initial settings for the LSI circuits.

Interface/Motor Control LSI

Q5: B562 13497

This LSI controls the following functions listed below.

Space Motor Enable / Speed Control

To obtain the carriage speed instructed by the microprocessor, Q5 uses the signals SP - Phase A and SP - Phase B, derived from space motor movement to generate the pulse width timing and overdrive time.

Line Feed Motor Phasing Control

To turn the line feed motor in the proper direction, this LSI sends motor drive signals (properly phased) to the line feed driver (TRA4).

Bail Motor Phasing Control

To turn the bail motor in the proper direction, this LSI sends motor drive signals (properly phased) to the bail driver (TRA3).

Dot ON Timing signal generation

Q5 uses the signals SP - Phase A and SP - Phase B, derived from space motor movement, to produce the signal IPT. This signal (IPT) is used to enable the print wires at the desired carriage position.

Printhead / Bottom Tractor Feed Control LSI

Q2: B563 12597

This LSI enables the printhead drivers and is the interface between the bottom tractor feed unit (BTFD PCB) and the MPU.

The functions of this LSI are described below.

Printhead Drive Control

Printhead drive correction modifies the drive time under the following circumstances:

Drive time correction for drive voltage fluctuations

Drive time correction for head gap setting.

Bottom tractor feed unit control

2.1.03 Initialization

The printer is initialized whenever it is powered ON or when the I-PRIME signal is received from the host at the parallel interface.

The initialization process is performed as listed below.

1. The reset circuit sends the RST-P signal to the MPU and LSIs.
2. ROM program execution starts with the mode setting of Q2 and Q5.
3. ROM and RAM are checked for errors.
4. RAM is initialized.
5. Bail and carriage homing is performed.
6. The interface signals (output level of ACK, BUSY, etc.) are set.
7. The SELECT lamp is turned ON.
8. The printer signals the host computer that it is ready to receive data.

Block Diagram

Block Diagram

Q5 is one LSI performing Interface Control and Motor Control Functions. Therefore, it is shown in two locations.

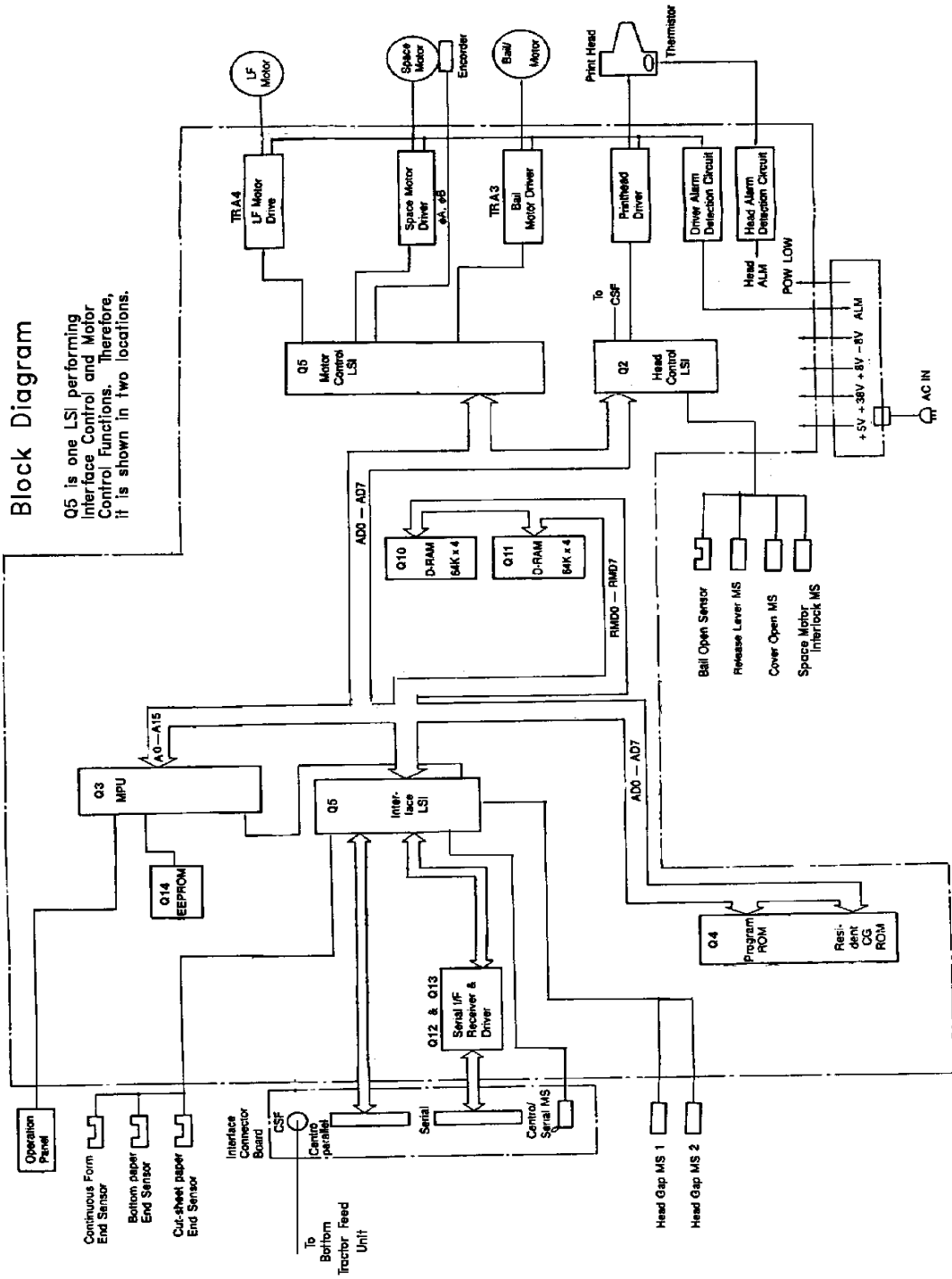

2-A.pcx

2.1.04 Interface Control

The printer is capable of serial or parallel operation. The desired interface method is selected by sliding the interface cover to expose the desired connector. When this is done, the interface select switch is turned ON or OFF to inform the Interface/Motor Control LSI (Q5: B562 13497) of the selected interface.

Parallel Interface

When the interface select switch is turned OFF, the parallel interface is selected and Q5 is in the parallel interface mode.

The data from the interface is received through connector (CN-1) and Q5 latches this data in sync with the STB signal.

The BUSY signal is turned ON as the data is processed. When processing is completed, the BUSY signal is turned OFF and an ACK signal is sent to the host to request more data.

The BUSY signal is also turned ON when the printer is not able to receive data (the Print Buffer is full, the printer is deselected or an error condition exists).

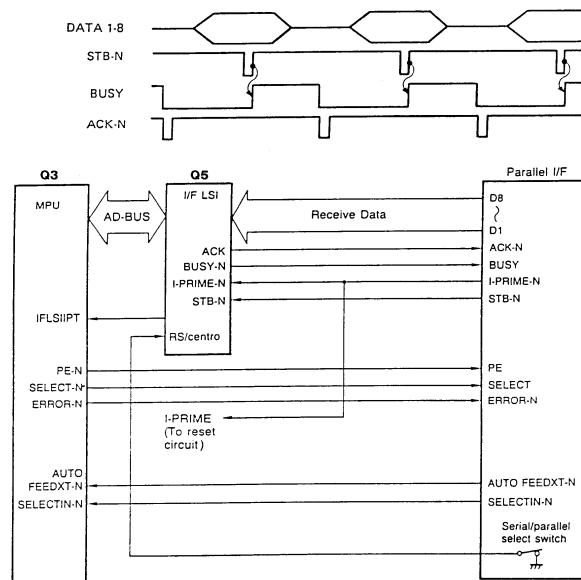

2-B.pcx

RS232-C Serial Interface

When the interface select switch is turned ON, the serial interface is selected and Q5 is in the serial interface mode.

The RS232-C interface signals (DSR, CTS, CD and RD) are converted to TTL levels by the line receiver (Q13) and input to Q5 where the serial data is converted to parallel data.

The interface signals (DTR, RTS, SSD and TD) output from Q5 are converted from TTL levels to RS232-C levels by the line driver (Q12) and sent to the serial interface connector.

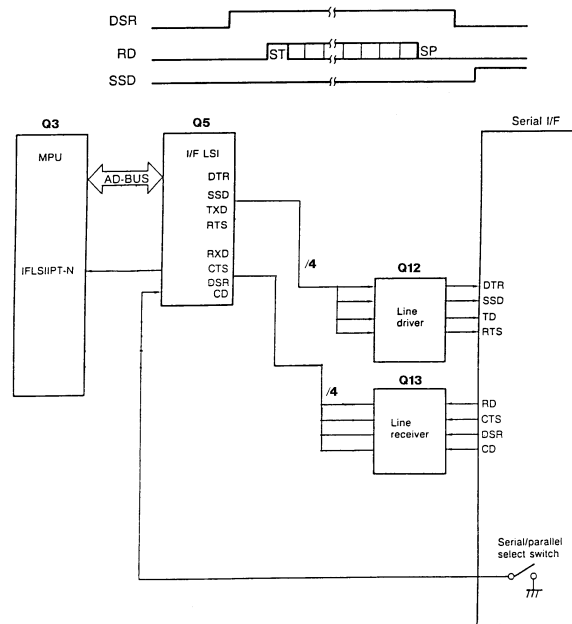

2-C.pcx

2.1.05 Printhead Drive Circuit

This circuit is used to drive the 9 print wires. The signals HD01 through HD09 from Q2 are used to enable the individual wire drivers (TRA1 and TRA2). TRA1 drives Pins 1, 2, 6 and 7. TRA2 drives Pins 3, 4, 8 and 9. TR7 drives Pin 5. The HD ON signal enables the drive circuit when printing is desired. The head drive duration is determined by an RC integrating circuit which modifies the HD ON pulsewidth. The pulsewidth of the HD ON signal varies with the number of pins being driven. The drive time is increased as a greater number of pins are driven, but decreased as less pins are to be driven. The drive time is also increased if the head gap lever is placed in positions 3 through 9. The RC circuit is also used to compensate for the fluctuation of drive voltage (+38vdc).

2.1.06 Spacing Drive Circuit

After receiving a spacing command from the MPU (Q3), the Interface/Motor Control LSI (Q5) outputs the SPFWD signal to run the DC motor in the forward direction, or the SPRVS signal to run the DC motor in the reverse direction. This is a fixed pulsewidth signal.

To control the motor speed, Q5 varies the pulse duty cycle according to feedback received from the space motor. As the space motor rotates, the SPSP Board (inside the motor housing) generates feedback pulse signals SPφA and SPφB. Q5 detects the edge pulses from these signals and divides the frequency to output the IPT signal for use in printhead dot timing.

The space motor interlock switch (located at the left side of the shield plate) disables the space motor drive signals whenever the printer cover is open.

Fuse F1 (3.5 amperes) protects the +38vdc space motor power circuit, should an overdrive condition exist.

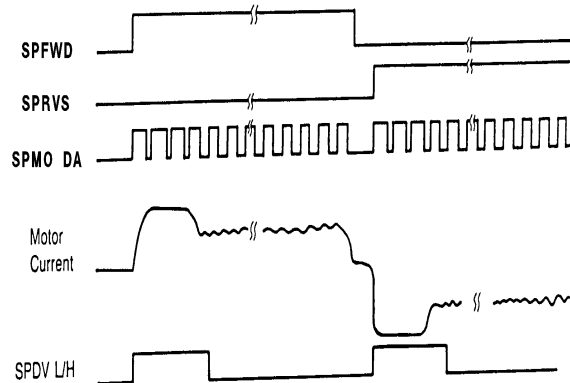

2-D.pcx

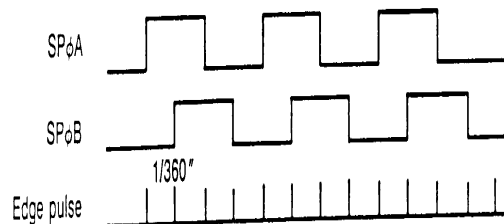

2-E.pcx

2.1.07 Line Feed Circuit

Whenever it is in a stopped position, the line feed motor shaft is held stationary by +8vdc, which is enabled by the LFCHOP Signal from Q2. The holding current is approximately 30 ma.

During a line feed operation, the line feed motor is driven by +38 vdc in accordance with the LFOVDV signal. The signals LF - Phase 01 and LF - Phase 04 establish the proper phase relationship for driving the motor. However, the line feed motor uses Phase 1 - 4.

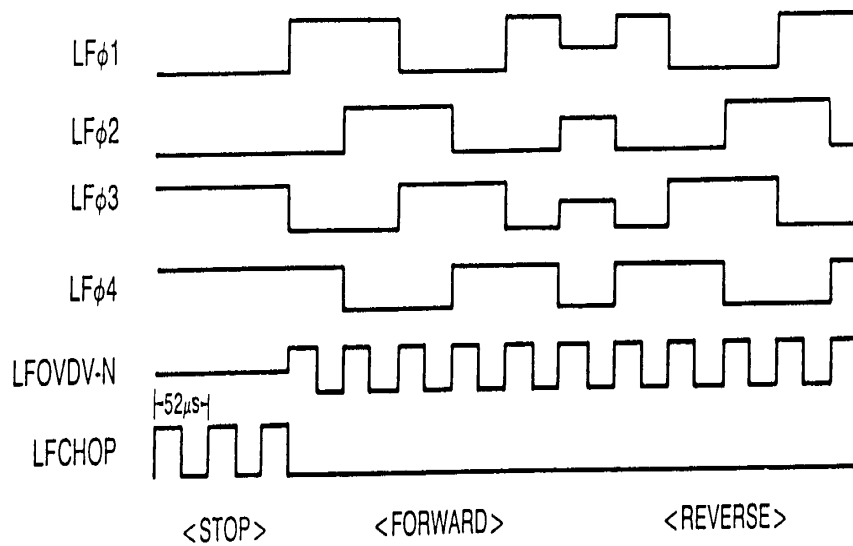

2-F.pcx

2.1.08 Alarm Circuits

Fault Alarm Circuit (in Power Supply Unit)

This protective circuit turns off the power supply when a fault occurs in the printhead, line feed, or bail motor drive circuits, thus preventing secondary component failure.

To accomplish this, the circuit monitors the overdrive signal of each drive circuit. If the duration of any drive circuit exceeds a predetermined length of time, the appropriate signal (EVN COM, ODD COM, LF COM or BM COM) will be sent to the fault alarm circuit. The fault alarm circuit generates the ALM signal which causes the power supply to turn all DC power OFF.

Printhead Overheat Alarm Circuit

In order to protect the printhead coils, this circuit monitors the printhead temperature by using a thermistor contained in the printhead. The CPU senses this circuit every time a line is printed.

When printing, the printhead temperature will increase. If the head temperature reaches approximately 115° Celsius, a head overheat ALARM 1 is generated. When ALARM 1 is detected by the MPU, the printer will begin unidirectional printing. If the printhead temperature increases to 125° Celsius, ALARM 2 is generated and printing is halted until the head temperature decreases. When the head temperature returns below the ALARM 1 threshold, printing is resumed.

Cover Open Alarm Circuit

When the front access cover is opened, the CVOPEN-N signal is sent to the MPU from the cover interlock microswitch. The MPU will halt printing immediately and light the ALARM Lamp.

2.1.09 Paper End Detection Circuit

NOTE:

Paper End is also known as paper out

Whenever the release lever is in the Tractor (Continuous) Feed position, paper end is detected by the microswitch on the push tractor (*rear feed*) or the paper end sensor on the sensor board (*bottom feed*).

Whenever the release lever is in the Friction (Sheet) Feed position, Paper End is detected by a photosensor (*top feed*) located in the paper pressure guide.

When the printer detects an out of paper condition, the PEN (Paper End) signal goes low, the printing is stopped and the ALARM LAMP is turned ON.

2.1.10 Power Supply

This switching power supply converts the AC input voltage to +5vdc, +/-8vdc and +38 vdc for use throughout the printer.

Voltage / Signal Table

Voltage/Signal	Purpose
+5 vdc	IC logic Levels - LED Drive Voltage
+8 vdc	Serial Interface logic Levels - Line Feed Motor Locking Voltage
-8 vdc	Serial Interface logic Levels
+38 vdc	Printhead, Space Motor, Line Feed Motor, Bail Motor Drive Voltage
POW ALM	Output from the Power Supply in the event of an abnormal temperature rise in the power supply unit or an overcurrent condition of the +38 vdc. The main logic board suppresses this condition by temporarily suspending printing. If the condition does not change, the main logic board will enable the FAN ALARM. Refer to Section 4 - Failure Analysis
ALM	Input from the main logic board upon detection of an overdrive condition in the printhead, line feed motor or bail motor drive circuits. Upon detecting this signal, the power supply disables the +38 vdc output.

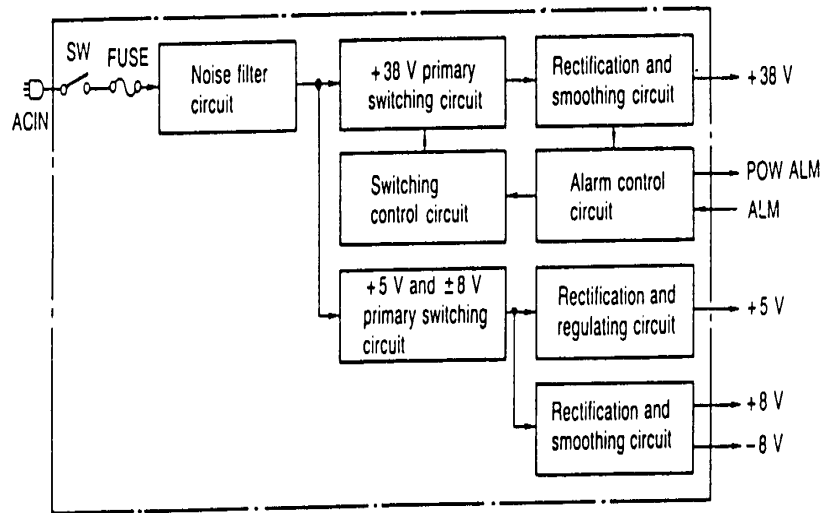

2-J.pcx

2.2 MECHANICAL OPERATION

2.2.01 Printhead Mechanism

The printer uses a highly efficient stored energy type printhead. Power is not consumed until the printwires are activated, thereby extending the printhead life to approximately 200 million characters.

The printhead uses 9 printwires in two columns. Each wire is welded to an armature. Behind this armature is a spacer ring.

Each of the 9 printwire armatures has a permanent magnet behind it. The magnets attract the armatures, pulling the printwires into the wire guide, thus keeping the wires inside the printhead. A coil is wrapped around each of the permanent magnets.

When a dot is to be printed, current is passed through the appropriate coil. This creates an electromagnetic field which counters the magnetic field of the permanent magnet. The armature can then spring forward and the print wire (which is attached to the armature) strikes the ribbon and imprints a dot on the paper.

When current is removed from the coil, the magnetic field of the permanent magnet attracts the armature, causing the printwire to retract into the wire guide once again.

The printhead consists of the parts listed below.

- Wire Guide

- Print Wires

- Armature Assembly

- Spacer

- Permanent Magnet Assembly

- Thermistor: used to monitor the printhead temperature

- Printed Circuit board with Coils

Head Gap Adjusting

The head gap adjusting mechanism modifies the gap between the platen and printhead. This is accomplished by moving the adjusting lever on the right side of the printer mechanism. When the lever is moved, the carriage shaft rotates. Since the carriage shaft is attached to the printer mechanism through eccentric collars, turning the carriage shaft, changes the distance between the platen and the printhead.

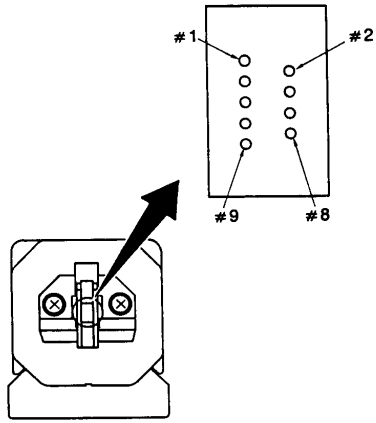

2-2.pcx

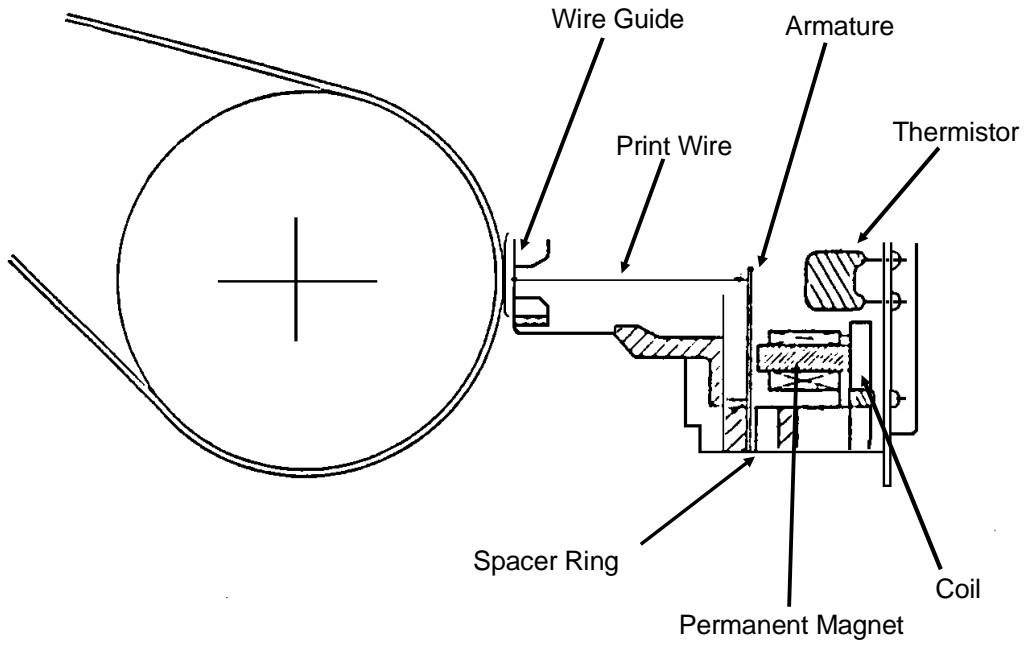

2-3.pcx

2.2.02 Spacing Mechanism

Spacing is performed when the servo motor drives the carriage along the carriage shaft, parallel to the platen.

The spacing mechanism consists of the following items.

DC (Servo) Motor

Idle Pulley

Carriage Shaft

Carriage Frame

Space Belt

Spacing Operation

The carriage containing the printhead moves parallel to the platen along the carriage shaft. Power from the space motor is transferred via the space belt, which is attached to the bottom of the carriage. The carriage is designed to move 1.6 inches when the servo motor performs one rotation.

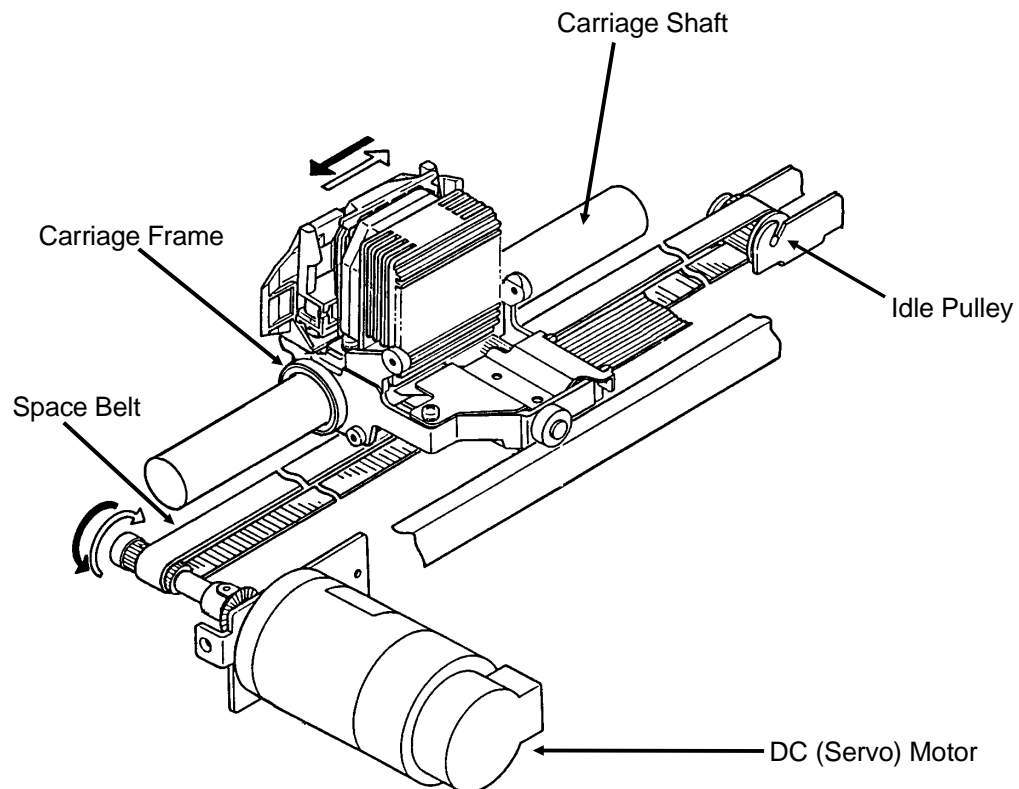

2-4.pcx

2.2.03 Ribbon Drive Mechanism

The ribbon drive mechanism moves the ribbon in synchronization with the space motor operation.

The ribbon drive mechanism consists of the items listed below.

Ribbon Drive Assembly

Ribbon Cartridge

Ribbon Cartridge

An endless ribbon with a single direction feed is used. Ink is supplied from an ink tank, which is contained in the ribbon cartridge.

Ribbon Feed Operation

The rotation of the space motor is transmitted to the drive gear in the ribbon cartridge through the ribbon feed gear assembly, thereby feeding the ink ribbon.

The feed direction of the ribbon is maintained by switching the rotational direction of the gears in the ribbon drive assembly. This ensures unidirectional ribbon movement when bi-directional printing is used.

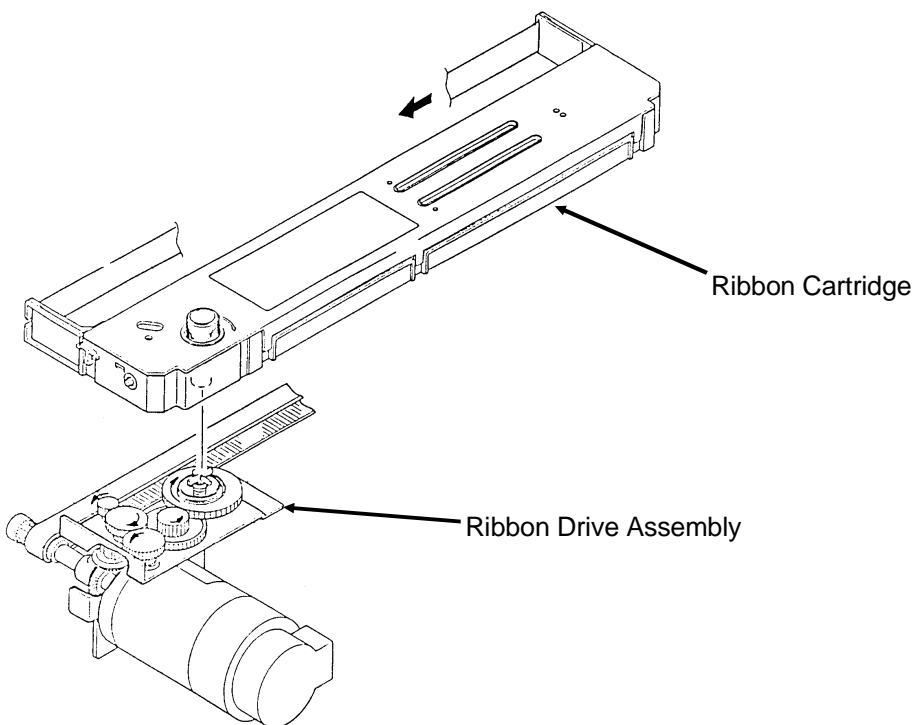

2-5.pcx

2.2.04 Paper Feed Mechanism

Paper feeding is performed by turning the platen and the tractors, which are driven by the line feed pulse motor.

The paper feed mechanism consists of the items listed below.

Line Feed (Pulse) Motor with gears

Idle Gear

Change Spring

Change Gear

Platen

Push Tractor Assembly

Bottom Tractor Feed Unit

Paper Pressure Guide

Friction (Sheet) Feed

When the release lever is set to the SHEET FEED position, the change gear is disengaged from the tractor gear. At the same time, the release lever applies pressure to push the pressure rollers against the platen, allowing paper to be fed.

A photosensor located in the paper pressure guide detects PAPER END.

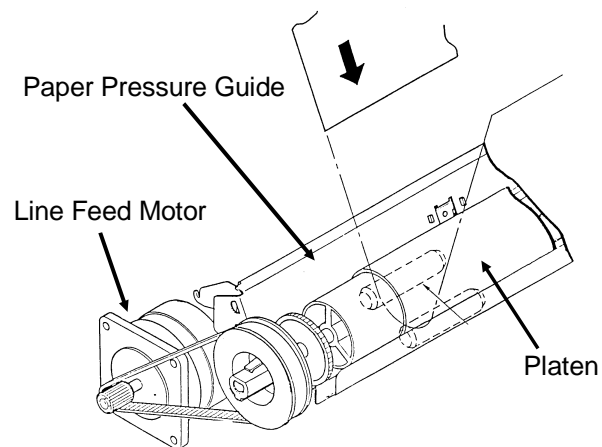

2-7.pcx

Tractor (Continuous) Feed

When the Release Lever is set to the TRACTOR FEED position, the release lever allows the reset spring to push the change gear toward the tractor gear. At the same time, the release lever pushes the pressure rollers away from the platen, allowing paper to be fed by the tractors.

The microswitch on the push tractor (rear feed) and the paper end sensor on the sensor board (bottom feed) detect PAPER END.

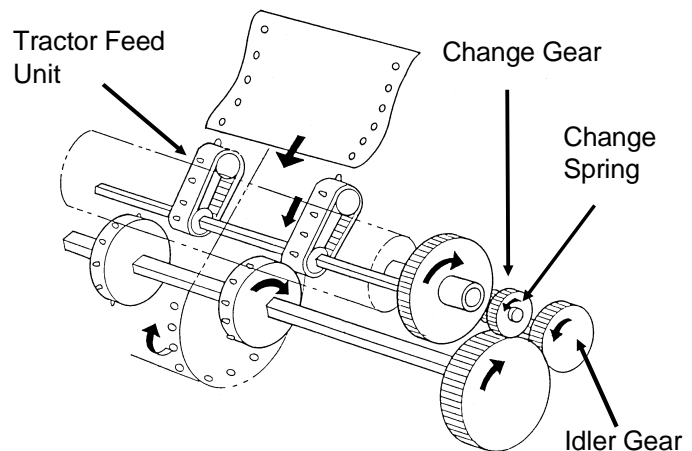

2-8.pcx

2.2.05 Paper-End Detection Mechanism

Friction Feed (Cut-Sheet) Paper-End

When the Release Lever is in the SHEET FEED Position, the photosensor located in the Paper Pressure Guide is active. If sheet paper is installed, the paper is detected by the sensor and the sensor is turned ON. When the printer is out of sheet paper, the sensor is turned OFF indicating a paper-end condition.

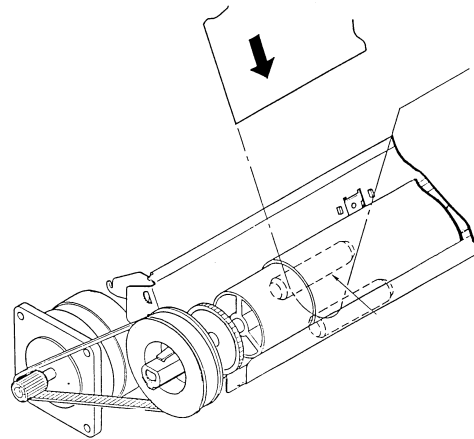

Continuous (Bottom) Feed Paper-End

(Also used with Bottom Tractor Feed Unit)

When the Release Lever is in the TRACTOR FEED Position, the switch on the left Push Tractor and the Paper-End sensor on the sensor board are active. If paper is detected by either of these sensors, paper-end is inhibited.

When bottom feed paper is installed, it moves the bottom paper-end lever to turn the sensor ON. When a paper out condition exists, the lever blocks the sensor, indicating a paper-end condition.

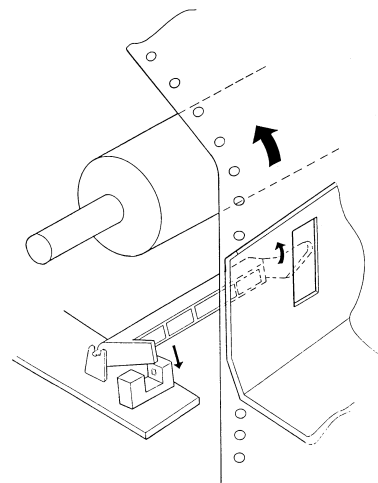

2-7.pcx

Continuous (Rear) Feed Paper-End

When the Release Lever is in the TRACTOR FEED Position, the switch on the left Push Tractor and the Paper-End sensor on the sensor board are active. If paper is detected by either of these sensors, Paper-End is inhibited.

When rear feed paper is installed, pressure is placed on the microswitch, located in the left push tractor. Since the switch is turned ON, paper is detected.

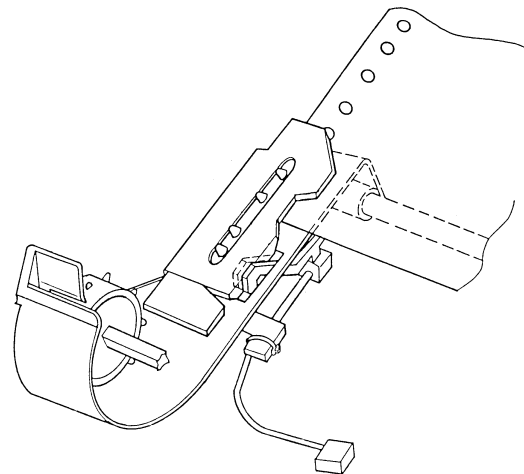

2-13.pcx

2-12.pcx

2.2.06 Automatic Paper Loading

Automatic Paper Loading is used to consistently set the print start position when using cut-sheet or continuous sheet paper. The autoloading procedures for each type of paper follow.

Cut-Sheet Paper

1. Push the paper release lever to the cut-sheet position.
2. Insert the paper from behind the platen.
3. Press the FORM FEED switch.
4. The paper bail will automatically open.
5. The line feed operation will load the paper.
6. The paper bail will automatically close.

NOTE:

If the paper does not move, the Auto-Load motion becomes invalid and is treated like an ordinary paper-end condition.

Continuous Sheet (Rear Feed) SASF

1. Push the paper release lever to the continuous sheet side (front of printer).
2. Insert the paper into the push tractor. The white guide line on the left tractor **MUST** be visible.
3. Press the FORM FEED switch.
4. The paper bail will automatically open.
5. The line feed operation will load the paper.
6. The paper bail will automatically close.

NOTE:

If the paper does not move, the auto-load motion becomes invalid and is treated like an ordinary paper-end condition.

2.2.07 Paper Park Feature

Occasionally, the user will want to print on cut-sheet paper, and continuous feed paper is loaded in the printer. Rather than unloading the continuous feed paper, the operator can use the paper park feature. Paper Park retracts the continuous feed paper until a paper-end condition exists or until 14 inches of paper has been retracted. The continuous feed paper remains on the push tractor (or bottom tractor feed unit), but out of the printing path. This allows cut-sheet paper to be loaded. Once the cut-sheet printing is complete, the continuous feed paper is reloaded.

CAUTION:

Do not attempt to PARK labels or more than one sheet of paper

This page was intentionally left blank.

SECTION THREE
MAINTENANCE

3.1 OVERVIEW

3.1.01 General Information

This section lists the parts replacement, adjustment, cleaning, lubrication, and shipping procedures.

Disassembly should not be performed unless absolutely necessary. **NEVER** perform disassembly on a malfunctioning unit until you have followed the failure analysis procedures in Section Four of this Service Handbook.

Follow the procedures listed in *Adjustments and Service Settings*. Adjustments may be required when either consumables or parts are replaced. Failure to perform these procedures could result in unnecessary service calls.

Cleaning procedures must be performed correctly if high print quality is to be achieved.

3.1.02 Maintenance Items

The following items are required to service the unit.

- #1 Phillips Screwdriver (with magnetic tip, 10 inch shaft)
- #2 Phillips Screwdriver (with magnetic tip, 6 inch shaft)
- #3 Phillips Screwdriver (with magnetic tip)
- Straight-slot Screwdriver (1/4 inch)
- Needle Nose Pliers (4 inch)
- Diagonal Cutters
- Tension Gauge (capable of measuring 1 pound of pressure)
- 7 mm open-ended wrench
- Ruler (capable of measuring 1/16 inch increments)
- 3/32 inch socket with driver
- Feeler Gauge
- Paper Clip (used for Microswitch 2 modification)
- Digital Multimeter
- Shop Vacuum
- Cloth (soft and lint-free)
- All-Purpose Cleaner
- Machine Oil
- Graphite Based Lubricant
- Contact Kleen (Okidata P/N 51802301)

3.1.03 Maintenance Precautions

1. Do not disassemble the unit if it is operating normally.
2. Before starting disassembly and assembly, always power OFF the unit and detach the AC power cord.
3. Detach the interface cable, if installed.
4. Do not remove parts unnecessarily. Try to keep disassembly to a minimum.
5. Use the recommended maintenance tools.
6. When disassembling, follow the listed sequence. Failure to follow the correct sequence may result in damaged parts.
7. Since screws, collars and other small parts are easily lost, they should be temporarily attached to the original positions.
8. When handling circuit boards use extreme care. Integrated circuits (microprocessors, ROM, and RAM) can be destroyed by static electricity.
9. Do not place printed circuit boards directly on conductive surfaces.
10. Follow the recommended procedures when replacing assemblies and units.
11. Perform the printhead gap adjustment when any of the items listed below occur.
 - Print Quality is darker on one side of the document.
 - Parts / Assemblies are replaced.
 - Printhead (3.2.01)
 - Platen Assembly (3.2.16)
 - Carriage Shaft (3.2.22)

This page was intentionally left blank.

3.2 DISASSEMBLY/ASSEMBLY PROCEDURES

General Information

This section contains the printer disassembly procedures. Only the removal procedures are explained here. Reverse the procedure for the installation.

At the bottom of each procedure is a listing of the parts covered in that procedure. The Okidata part number, item description, comment (RSPL, Option, Consumable) and cross-reference to Appendix B is provided for each part. Items included in the Recommended Spare Parts List are indicated by the acronym RSPL. N/A will appear where a part number is not available.

<input type="checkbox"/> Part Number	Item Description	Comment	Appendix B Reference
---	---------------------	---------	-------------------------

This Service Handbook lists the disassembly procedures for major components of the unit. Okidata DOES NOT recommend disassembling a unit which is operating normally. If you decide to perform disassembly during this training, Okidata recommends that you perform *only* the disassembly procedures for RSPL items. All other procedures are provided to assist you in identifying parts. It is not likely that you will perform these procedures while servicing the unit.

Be sure to read all notes, cautions, and warnings, as they contain important information regarding disassembly / assembly.

3.2.01 Printhead (with Preliminary Items)

WARNING:

The printhead will be HOT immediately after printing.

1. Open the printer access cover (1).
2. Remove the ribbon cartridge (2).
3. Set the head gap adjusting lever (3) to the range '9' position.
4. Lift and remove the ribbon guide (4) from the two posts.
5. Remove the two printhead mounting screws (5).
6. Disconnect the printhead (6) from the connector by lifting.

NOTES:

Installation

Push the printhead towards the platen (in the direction of Arrow A).

Perform the printhead gap adjustment. Refer to Section 3.3

<input type="checkbox"/>	P/N 50215701	Cover: Access	RSPL	B.2.02
<input type="checkbox"/>	P/N 50090301	Printhead: Assembly	RSPL	B.2.03
<input type="checkbox"/>	P/N 52105801	Ribbon Cartridge	Consumable	B.2.03, B.2.12
<input type="checkbox"/>	P/N 56609701	Cord: AC (120V)	RSPL	B.2.03
<input type="checkbox"/>	P/N 56624101	Cord: AC (220V) (ML) Right Angle	Option	B.2.03
<input type="checkbox"/>	P/N 53062601	Guide: Ribbon Assembly	RSPL	B.2.05

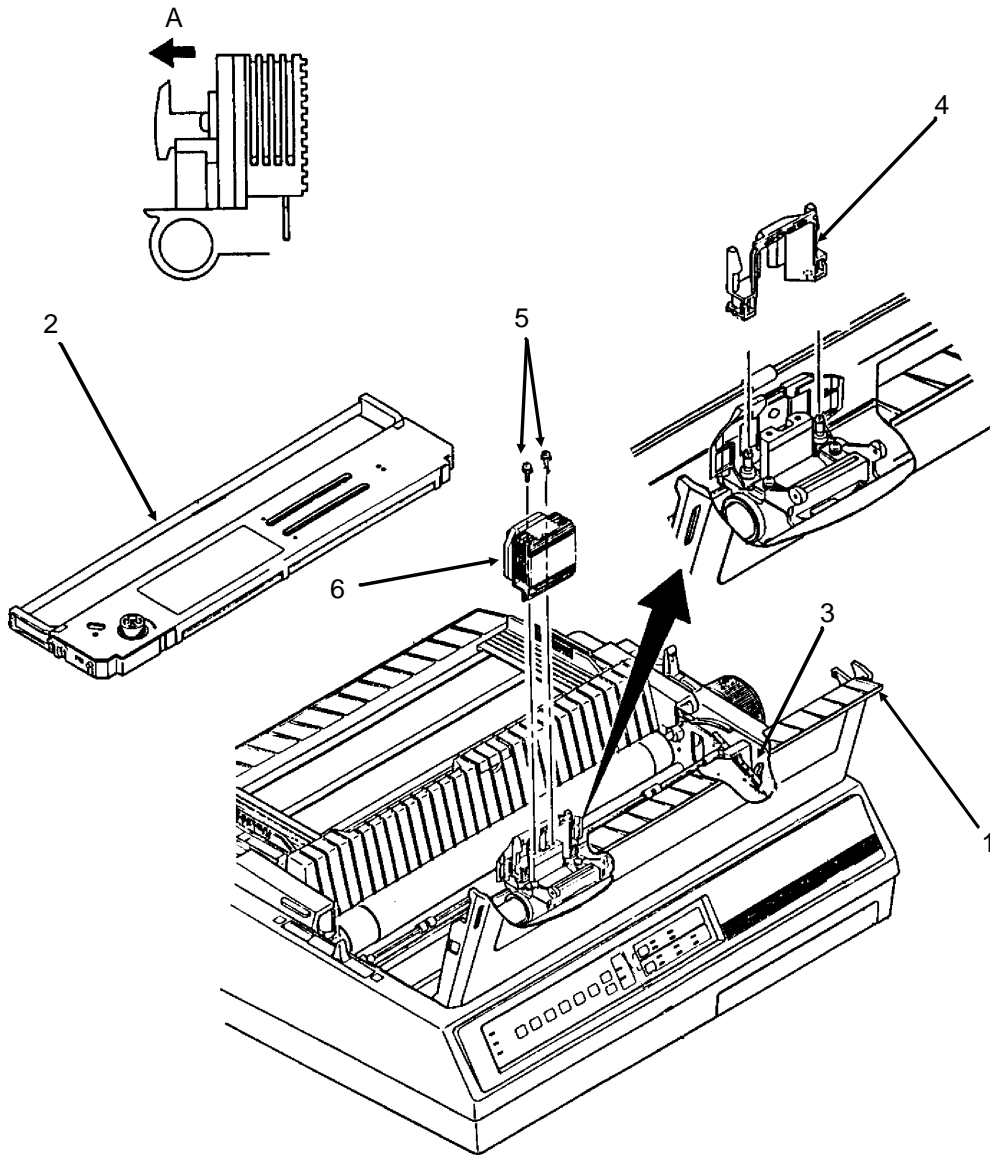

3-2-01.pcx

3.2.02 Ribbon Protector Assembly

1. Open the printer access cover.
2. Remove the ribbon cartridge.
3. Set the head gap adjusting lever to the range '9' position.
4. Lift and remove the ribbon guide from the two posts.
5. Remove the two mounting screws (1) and detach the ribbon protector (2) by lifting.

<input type="checkbox"/>	P/N 50316701	Screw: Ribbon Protector (Post)	RSPL	B.2.05
<input type="checkbox"/>	P/N 53062701	Protector: Ribbon Assembly	RSPL	B.2.05

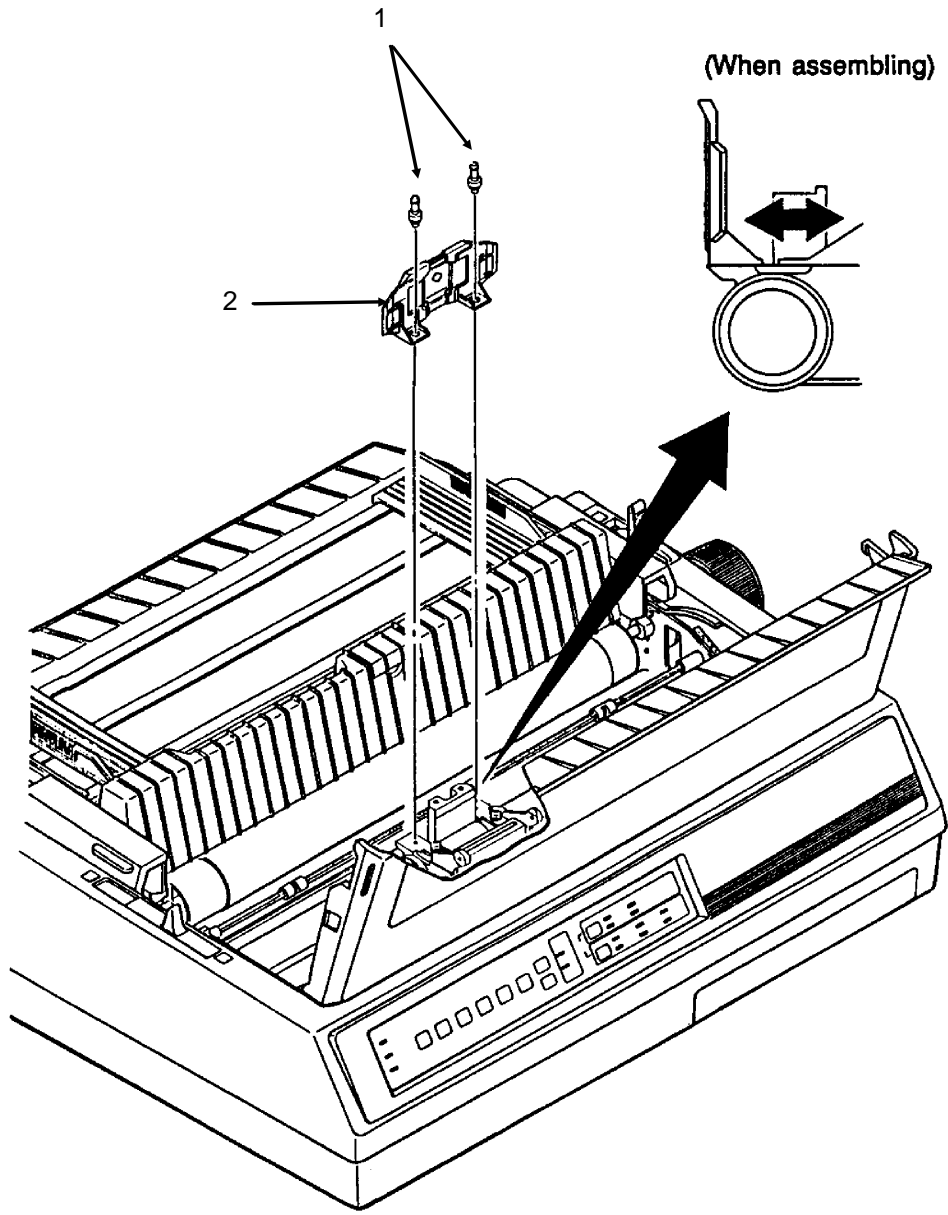

3-2-02.pcx

3.2.03 Upper Cover Assembly

1. Detach the platen knob (1).
2. Pull the release lever (2) toward the front of the printer.
3. Remove the two cover mounting screws (3), located at the rear of the printer.
4. Lift the sheet separator (4).
5. Open the bail arm (5).
6. Grasp the pull-up roller assembly (6), then lift and rotate it towards the back of the printer.
7. Close the bail arm.
8. Lower the sheet separator.
9. Lift the upper cover assembly (7) at the rear of printer. Rotate the assembly towards the front of the printer, disengaging the cover from the four claws (8) at the front of the printer.

CAUTION:

When installing the upper cover assembly, move the bail arm lever towards the back of the printer and move the release lever towards the front of the printer. Then, check that the paper bail moves properly.

<input type="checkbox"/>	P/N 50212431	Cover: Middle (PM3410)	RSPL	B.2.02
<input type="checkbox"/>	P/N 50215801	Cover: Rear (Assembly)	RSPL	B.2.02
<input type="checkbox"/>	P/N 50215901	Pull-Up Roller Assembly	RSPL	B.2.02
<input type="checkbox"/>	P/N 50215901	Pull-Up Roller Assembly	RSPL	B.2.03
<input type="checkbox"/>	P/N 53478601	Knob: Platen	RSPL	B.2.03
<input type="checkbox"/>	P/N 50910505	Spring: Cover Open	RSPL	B.2.04

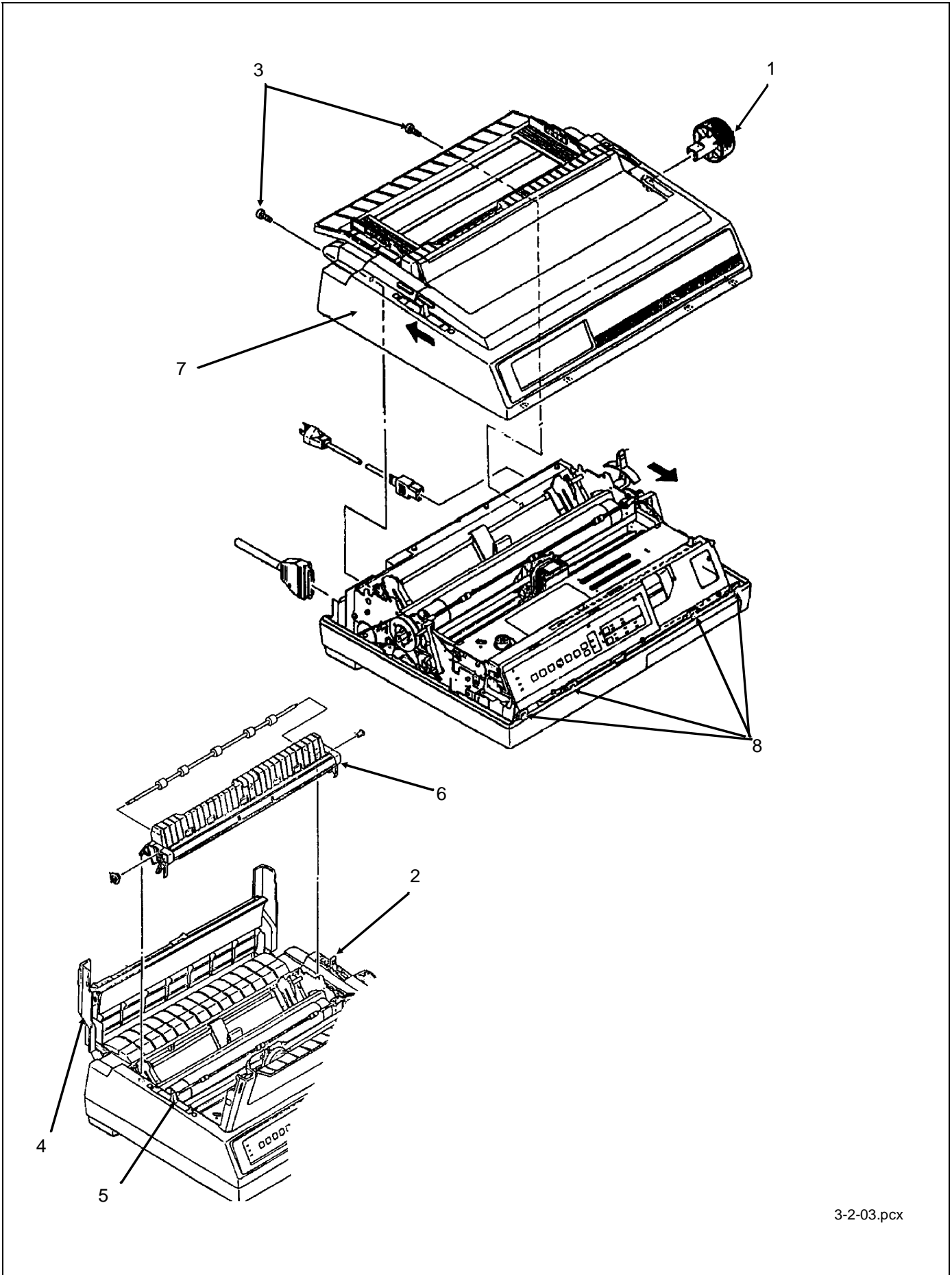

3-2-03.pcx

3.2.04 Operator Panel

1. Remove the upper cover assembly (3.2.03)
2. Disconnect the operator panel cable (1) from CN10 (2) on the control board.
3. Remove the two mounting screws (3).
4. Detach the operator panel assembly by moving it upward, and then pulling toward the front of the printer, detaching the four claws.
5. Release the ten claws.
6. Detach the operator panel (4) from the operator panel holder (5).

<input type="checkbox"/>	P/N 53553401	Panel: Operator (PM3410)	RSPL	B.2.04
<input type="checkbox"/>	P/N 55061401	PCB: OPML Operation Panel	RSPL	B.2.04
<input type="checkbox"/>	P/N 56628402	Cable: Op Panel (PM3410)	RSPL	B.2.04

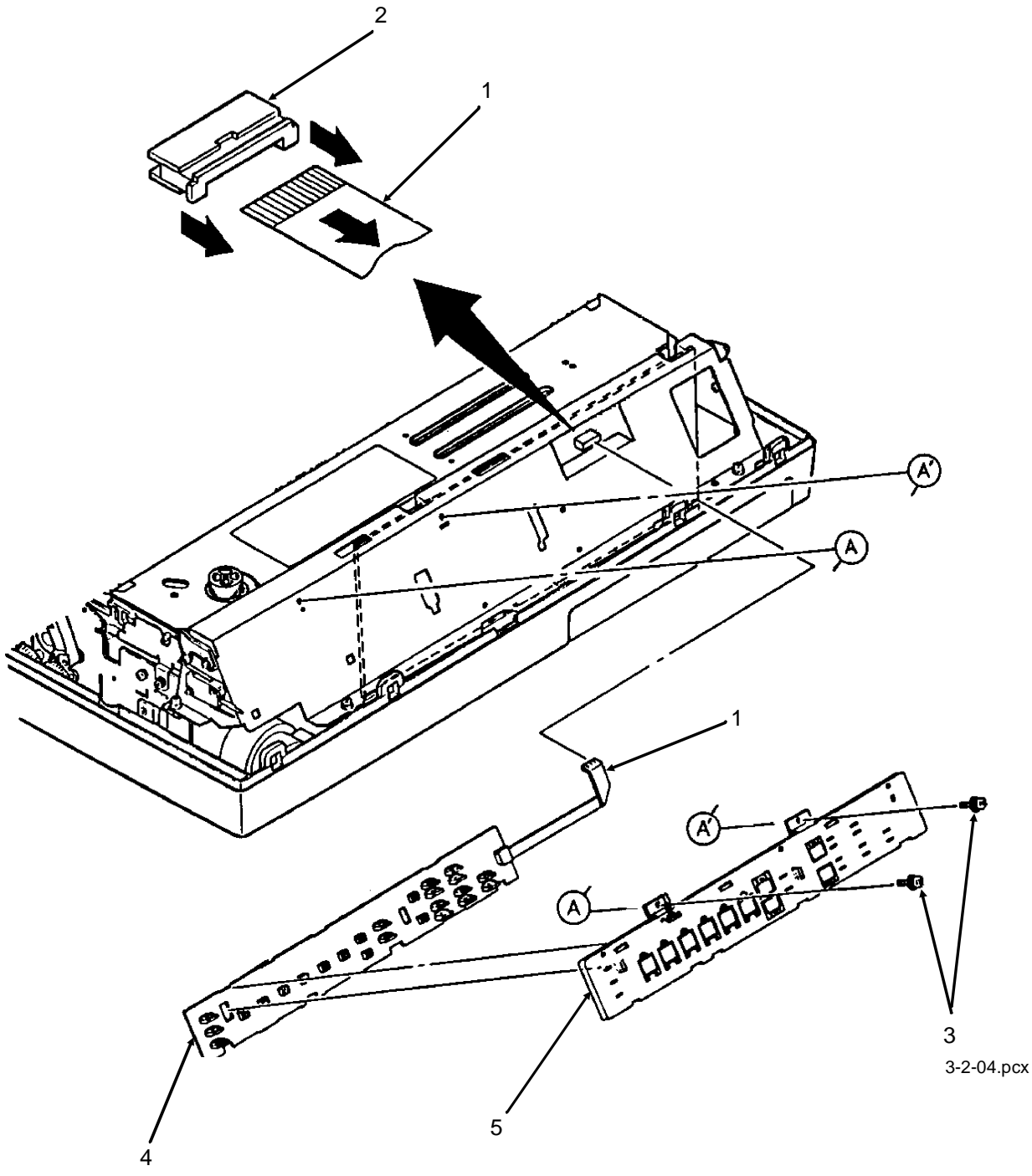

3-2-04.pcx

3.2.05 Interface Connector Board

NOTE:

To allow easier access to the mounting screw and cables, configure the interface connector board to use the serial interface connector.

1. Remove the upper cover assembly (3.2.03).
2. Disconnect connectors CN101 (1), CN102 (2), and CN103 (3).
3. Remove the two mounting screws (4) and detach the interface connector board (5) by lifting.

NOTE:

After assembly, configure the interface connector board for the desired type of interface.

P/N 55061711 PCB: HKTY Interface Connector Assembly RSPL B.2.03

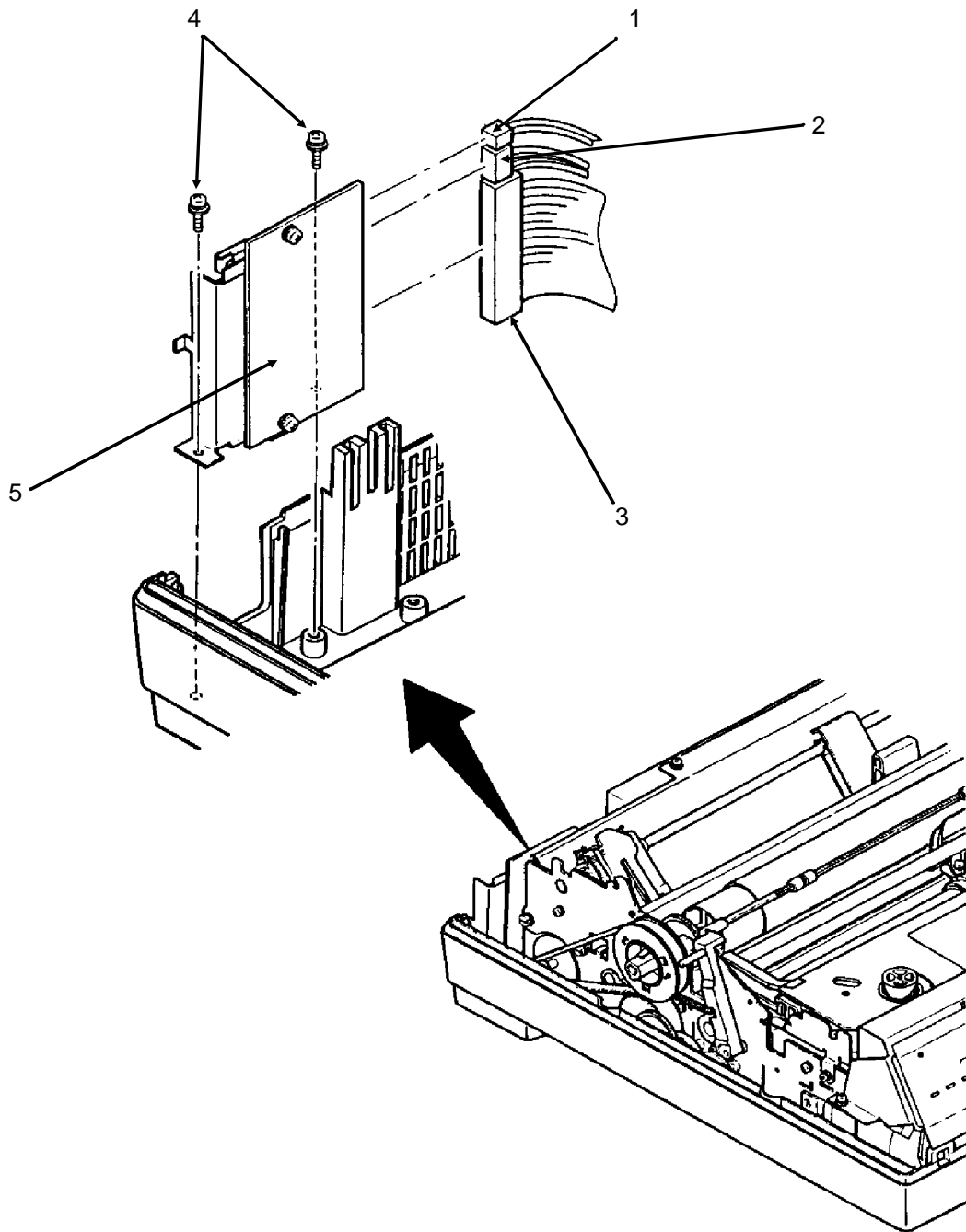

3-2-05.pcx

3.2.06 Main Logic (CBNP) Board

1. Remove the upper cover assembly. (3.2.03)
2. Remove the ribbon cartridge.
3. Release the lock of connector CN10 (1) and detach the operator panel cable (2).
4. Remove the five shield cover mounting screws (3).
5. While slightly lifting the shield cover (4), detach connectors CN11 (5) and CN12 (6) from the main logic board.
6. Remove the shield cover.
7. Detach the connectors CN1, CN2, CN3, CN5, CN6, CN7, CN8, and CN9 (7).
8. Loosen the mounting screw (8).
9. Remove the main logic board (9).

CAUTION:

When assembling the printer, follow these instructions.

1. Do not allow cables to get caught under the main logic board.
2. Insert the main logic board into the groove in the base tray (10).
3. Fit the main logic board into the groove (11) in the shield cover, then secure the shield cover.

<input type="checkbox"/>	P/N 55061611	PCB: CPNB Main Logic (w/o ROM)	RSPL	B.2.03
<input type="checkbox"/>	P/N 55934601	IC: EEPROM NM93C06N-NW	RSPL	B.2.03
<input type="checkbox"/>	P/N 56212601	Switch: Interlock (Assy)	RSPL	B.2.04

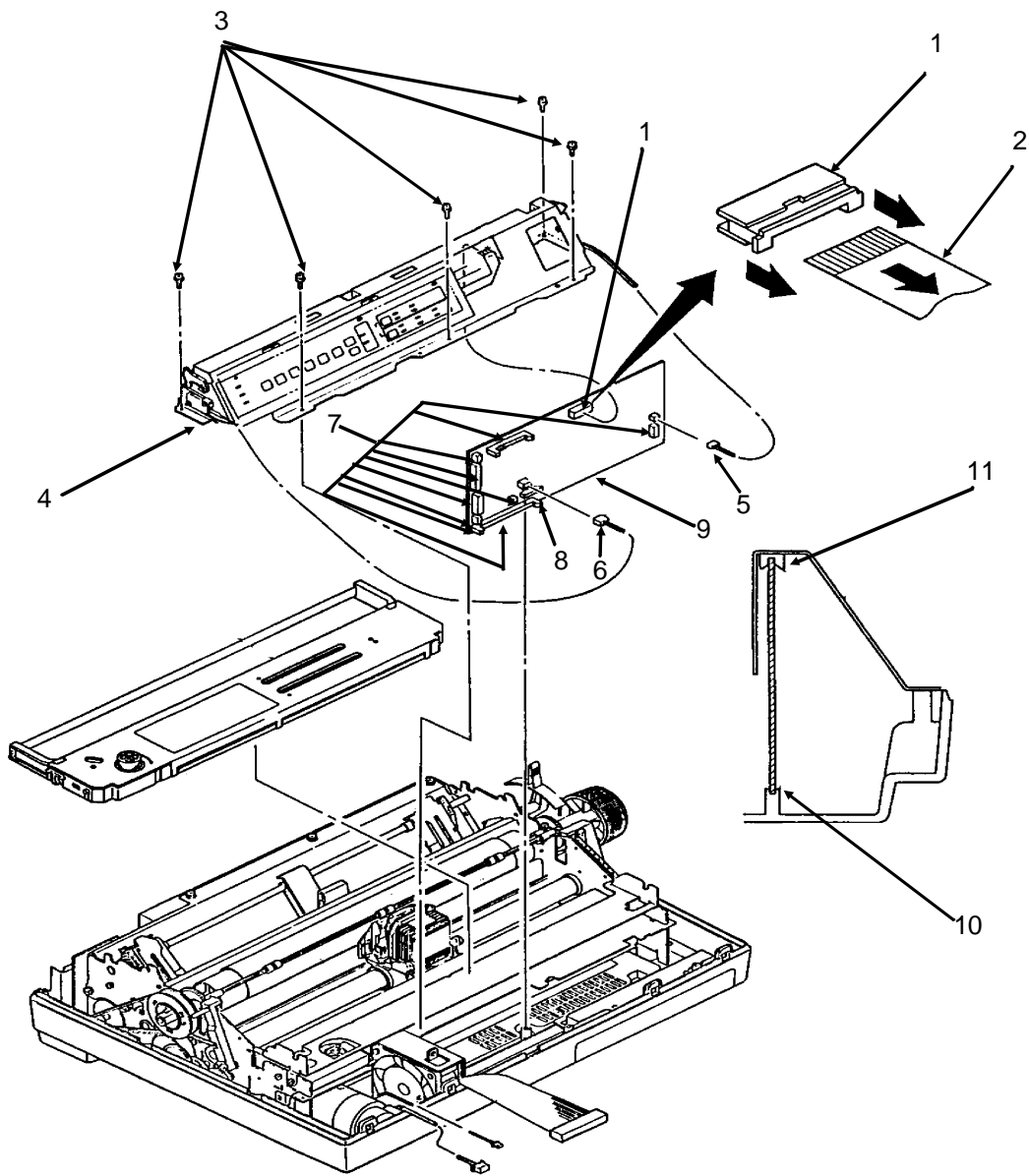

3-2-06.pcx

3.2.07 Printer Mechanism

1. Remove the main logic board (3.2.06).
2. Detach connectors CN102 (1) and CN103 (2) from the interface connector board (3).
3. Remove the three mounting screws (4) at the rear of the printer mechanism (5).
4. Remove the three mounting screws and brackets (6). There are two on the left side of the printer mechanism and one on the right side.

CAUTION:

Do not grasp the ribbon cartridge bracket, paper chute, or the guide shaft of the sheet feeder assembly when lifting the printer during the next step.

5. Grasp the printer mechanism near the line feed motor (Position A).
6. While holding at position A, also grasp the printer mechanism (Position B).

CAUTION:

DO NOT GRASP THE RIBBON CARTRIDGE BRACKET -- IT WILL BEND.

7. Lift and remove the printer mechanism.

NOTE:

When assembling the printer, do not allow cables to get caught under the printer mechanism.

<input type="checkbox"/>	P/N 56614101	Cord: Power Connection (9 Pin)	RSPL	B.2.03
<input type="checkbox"/>	P/N 56614801	Cord: Power Connection (13 Pin)	RSPL	B.2.03
<input type="checkbox"/>	P/N 56614901	Cable: I/F (Internal) [I/F-Main Brd 50 Pin]	RSPL	B.2.03

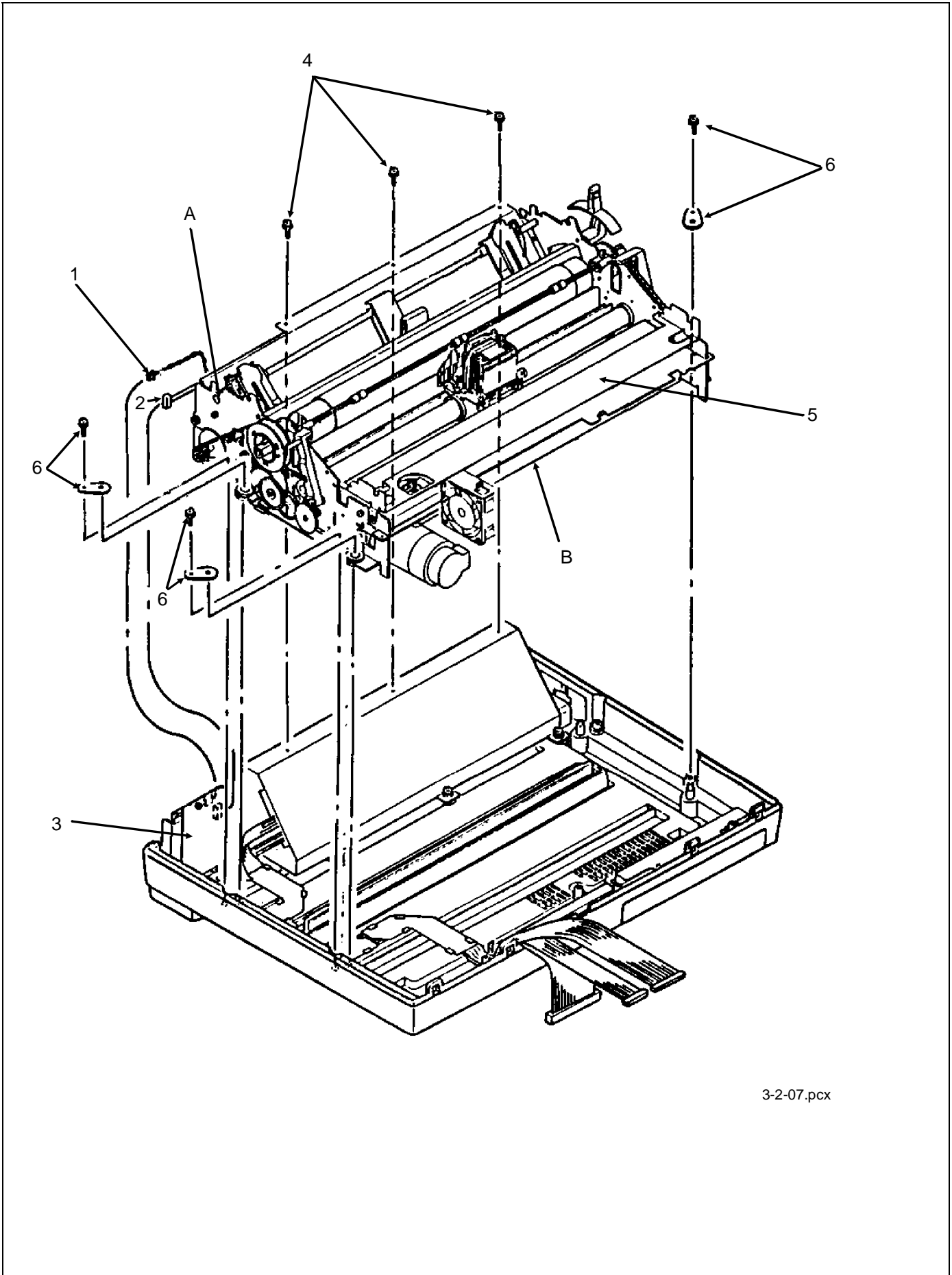

3-2-07.pcx

3.2.08 Power Supply Unit

1. Remove the printer mechanism (3.2.07).
2. Disconnect the two cables (1) from the left side of the power supply unit (2).
3. Remove the four power supply mounting screws (3).
4. To remove the power supply unit:

Rotate the left side of the power supply unit towards the front of the printer.

Lift the power supply unit to disengage the power switch (4), AC receptacle (5) and the tabs (6).

CAUTION:

Be careful not to damage the cables with the power supply unit mounting bracket (7). This bracket is located at the left/rear of the power supply unit.

<input type="checkbox"/>	P/N 56406302	Power Supply Assembly (220/240 V)	Option	B.2.03
<input type="checkbox"/>	P/N 56411201	Power Supply Assembly (120 V)	RSPL	B.2.03

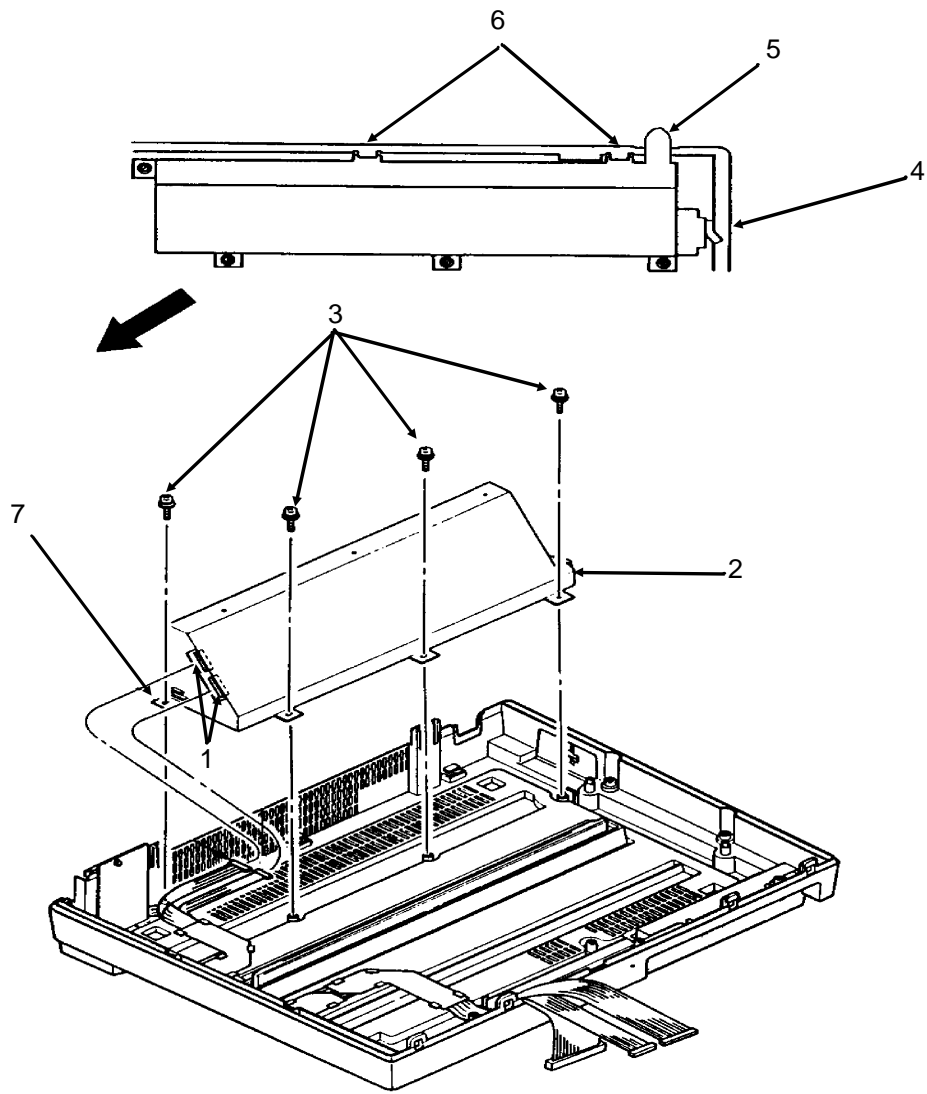

3-2-08.pcx

3.2.09 Printer Unit

1. Detach the DIN connector (1).
2. Lift the printer unit (2) from the bottom tractor feed unit (3).

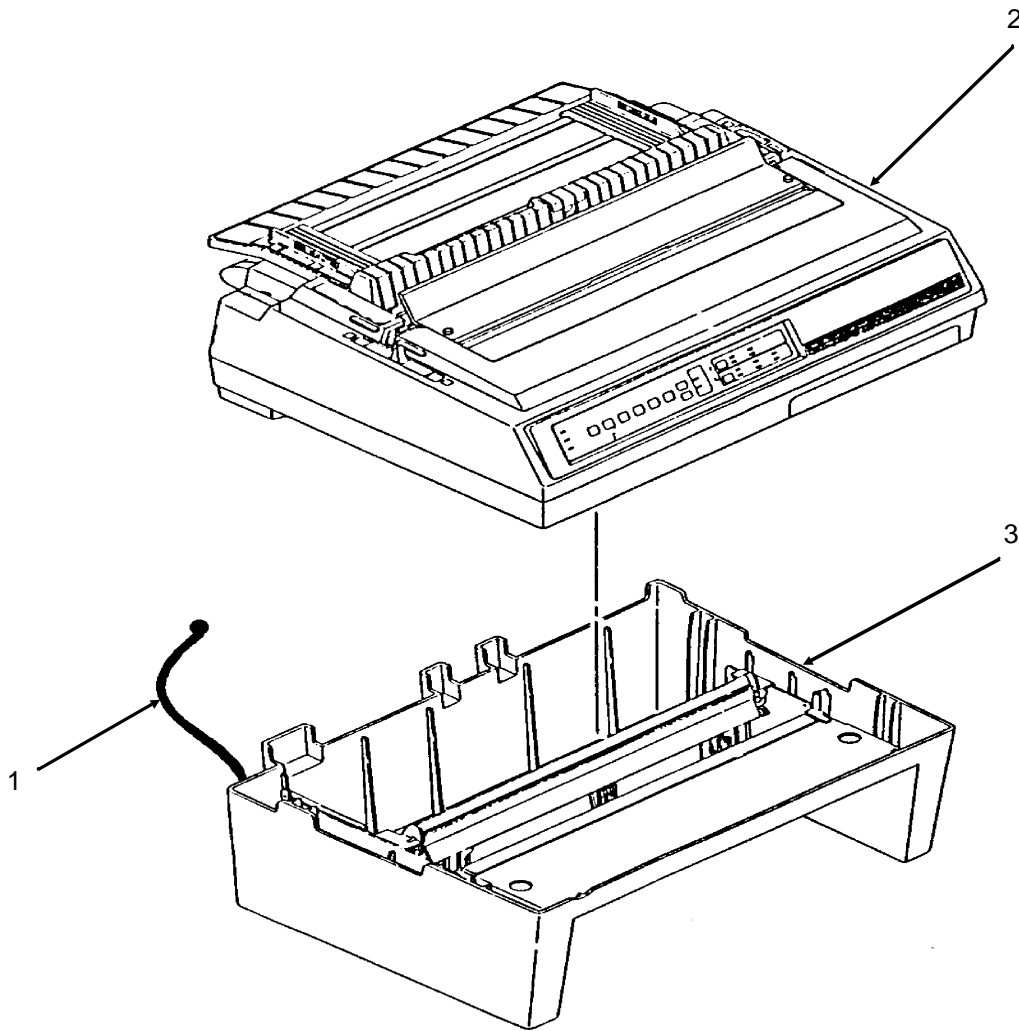

3-2-09.pcx

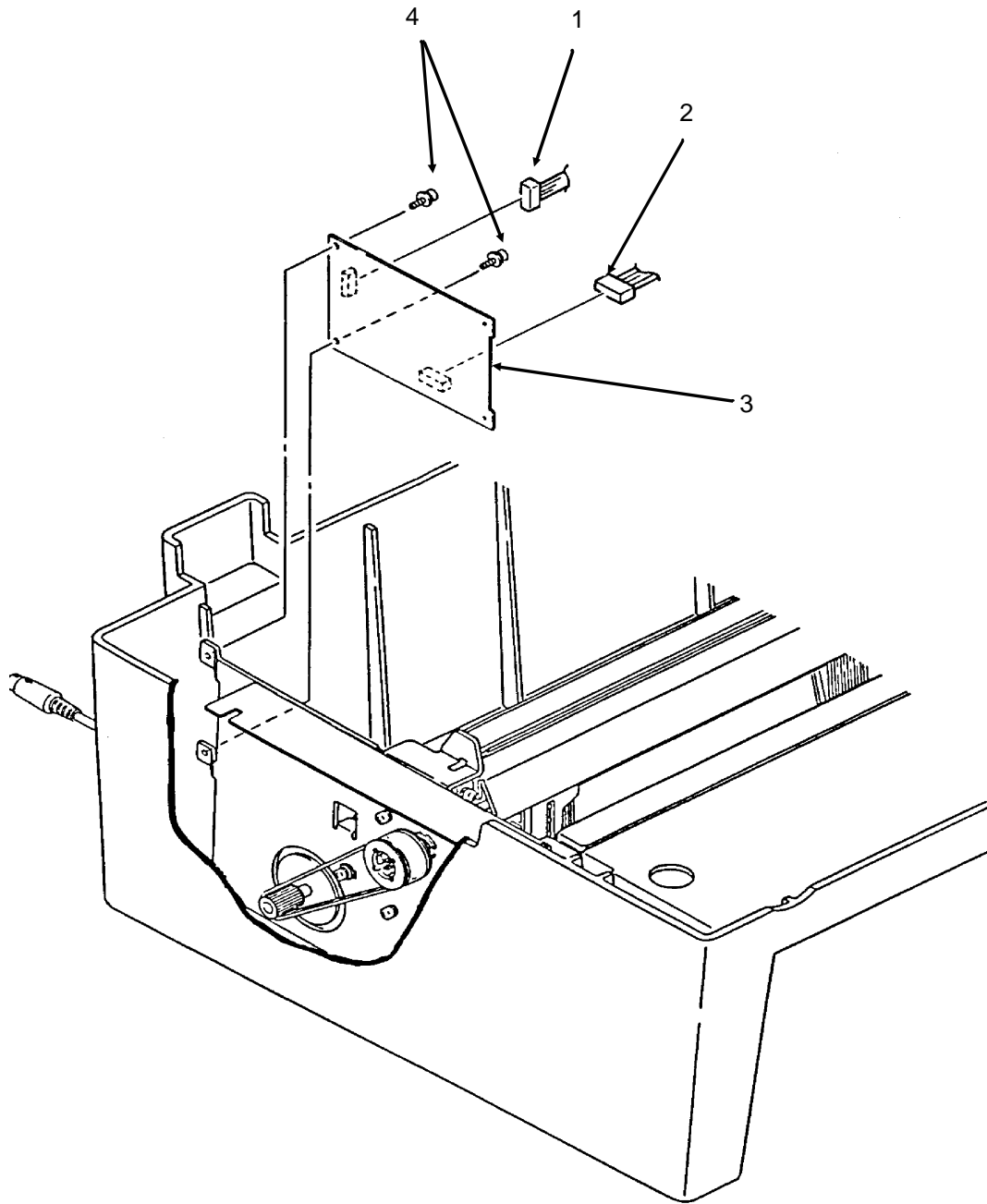

3-2-10.pcx

3.2.11 Tension Spring

1. Remove the printer unit (3.2.09).
2. Raise the front door assembly (1).
3. Detach the tension spring (2) from the upper plate (3).
4. Detach the tension spring from the front door assembly.

P/N 50922001 Spring: (BTF)

RSPL

B.2.08

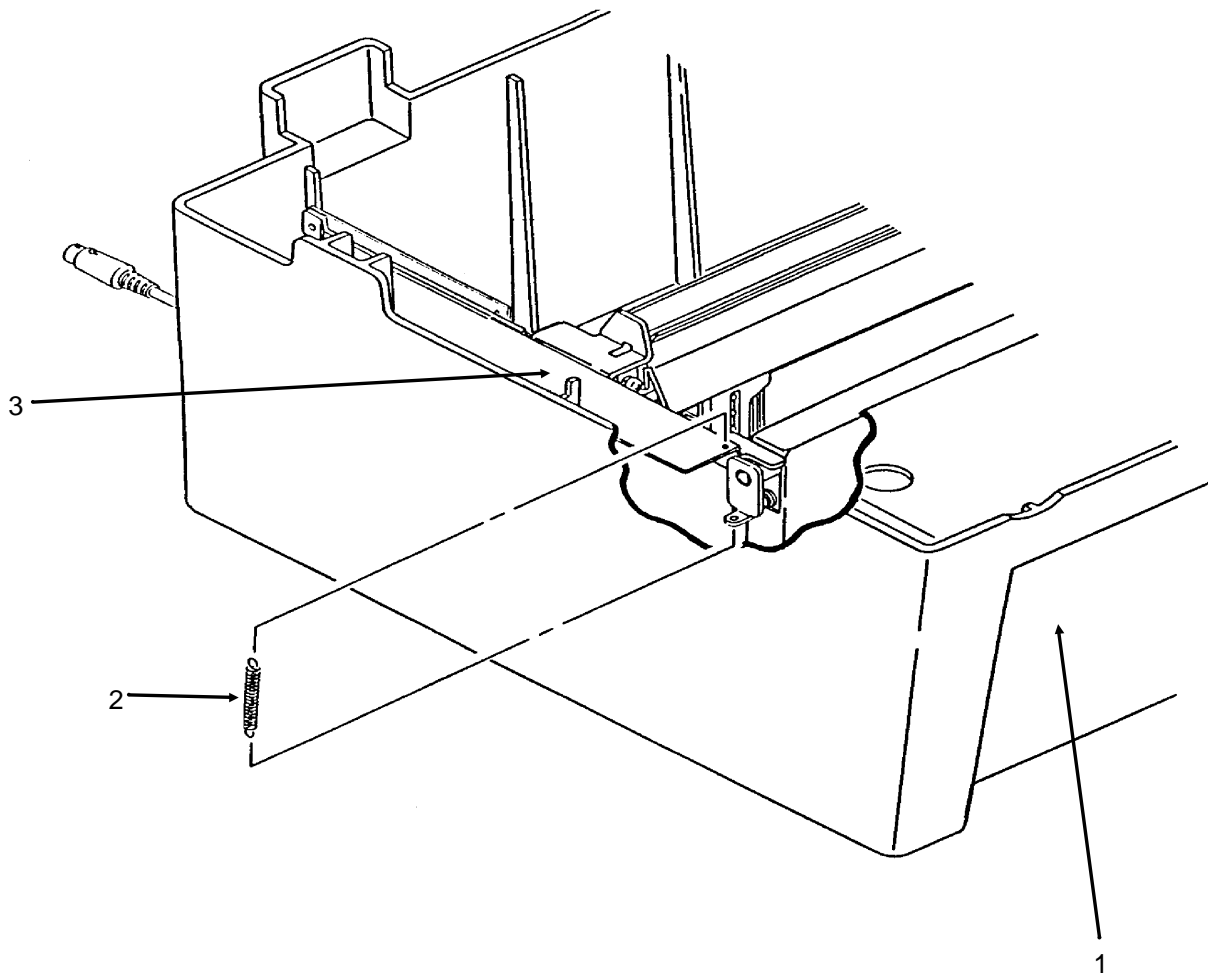

3-2-11.pcx

3.2.12 Bottom Push Mechanism and Front Door Assembly

1. Remove the printer unit (3.2.09).
2. Remove the tension spring (3.2.11).
3. Detach connector CN1 (1) on the BTFD PCB (2).
4. Remove the four screws (3).
5. Remove the bottom push mechanism (4).
6. Remove the front door assembly (5).

P/N 53063701 Door: Front (Assembly) (BTF) RSPL B.2.08

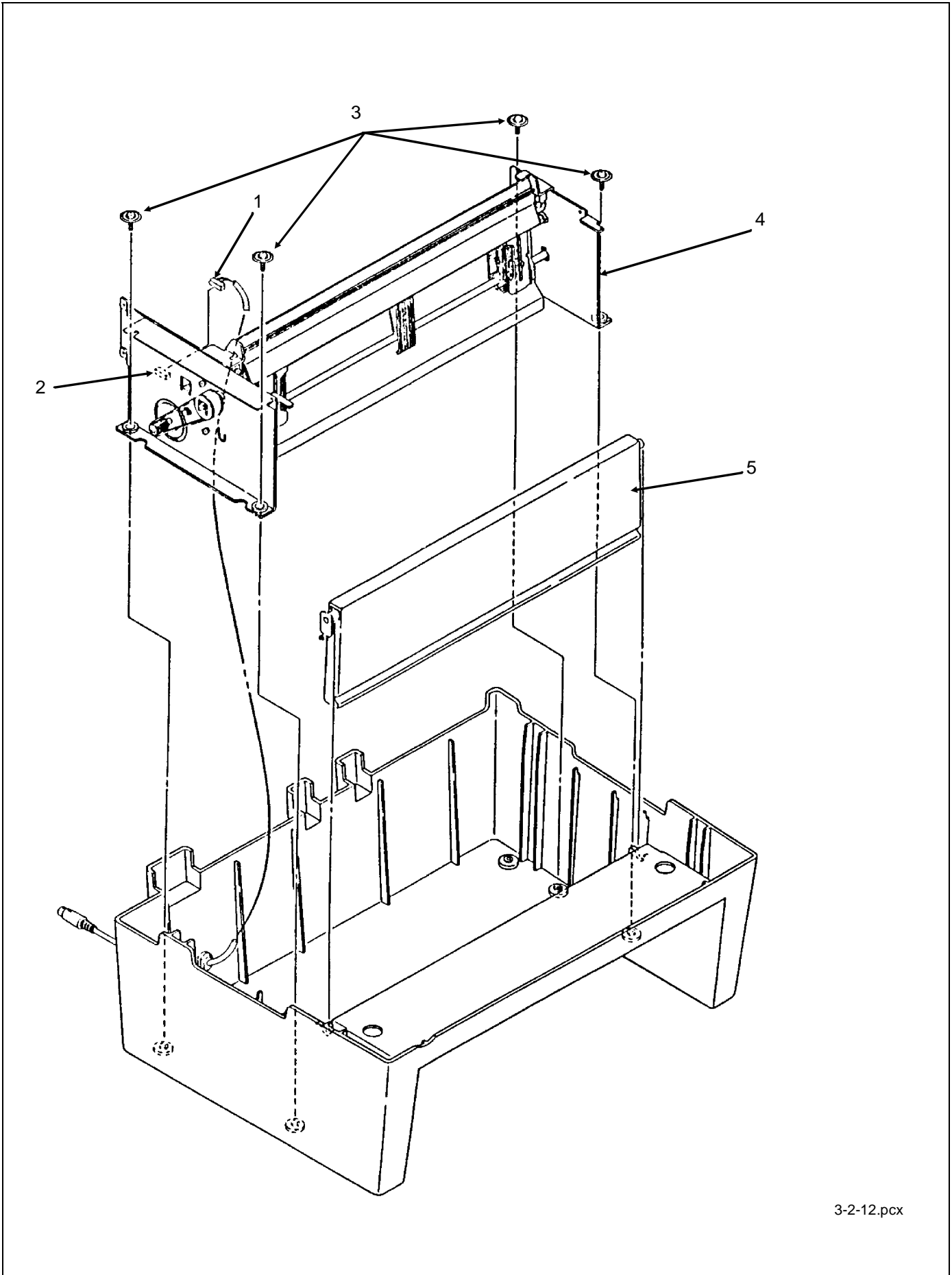

3-2-12.pcx

3.2.13 Drive Pulley and Belt

1. Remove the printer unit (3.2.09).
2. Remove the tension spring (3.2.11).
3. Remove the bottom push mechanism (3.2.12).
4. Loosen the two motor screws (1).
5. Push the motor (2) in the direction of Arrow A, to loosen the belt (3).
6. Remove the belt.
7. Pry open the claws in the center of the pulley, then remove the drive pulley (4) from the tractor feed drive shaft (5).

NOTES:

The drive pulley has two parts. Disassembly of the drive pulley is not required during this procedure.

Once the drive pulley has been removed, be sure that the tractor feed drive shaft is not removed. If you remove the tractor feed drive shaft, the left or right tractors will lose the synchronization between the pin feeds.

When assembling, perform the belt tension adjustment (3.3.02).

<input type="checkbox"/>	P/N 51226901	Pulley: Drive (BTF)	RSPL	B.2.08
<input type="checkbox"/>	P/N 51304501	Belt: Line Feed (BTF) Mini-Pitch [120 teeth]	RSPL	B.2.08

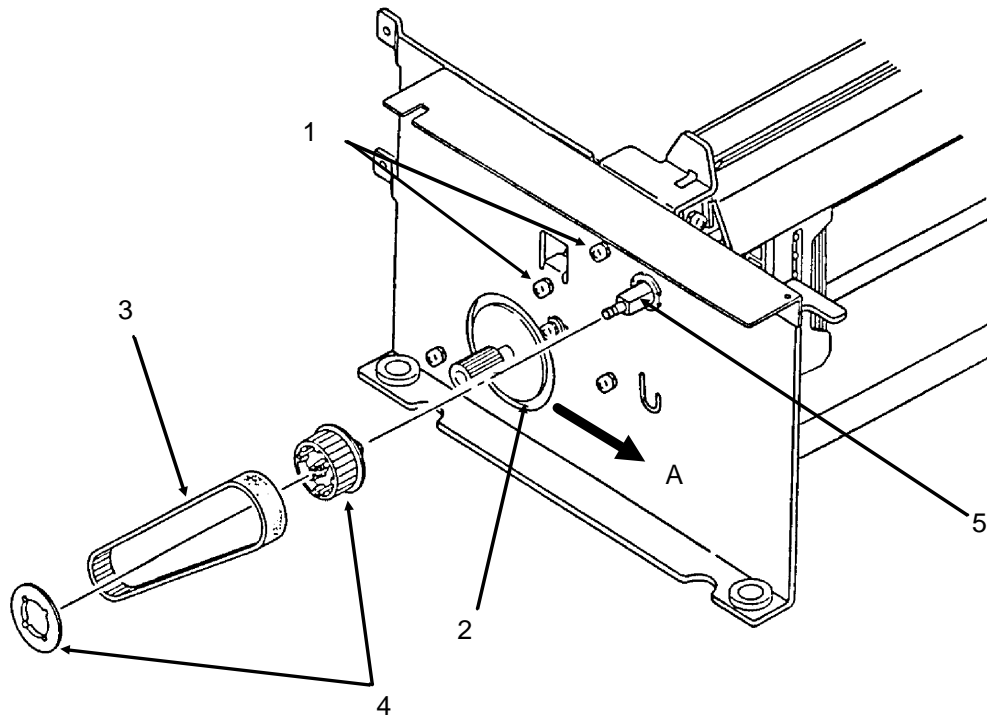

3-2-13.pcx

3.2.14 Tractor Assembly (BTF)

NOTE:

On each side frame, the tractor drive shaft passes through a plastic bushing. These bushings should remain in the frame. However, if a bushing must be removed, press the bushing's claw which can be accessed from the inside of the side frame.

1. Remove the drive pulley (3.2.13).
2. Remove the tractor drive shaft (1) by sliding it to the right.
3. Rotate the tops of both the left (2) and right (3) tractor assemblies and the sheet guide (not shown) in the direction of Arrow A.
4. Lift the left side of the drive roller (4) and remove the drive roller, tractor assemblies, and sheet guide.

NOTES:

The sheet guide may be removed without disassembling the drive shaft.

When installing the tractor assemblies, take the following precautions:

Make sure that the tractors are synchronized by aligning the synchronization marks (5).

The left tractor assembly must be positioned to the left of the metal tab.

<input type="checkbox"/>	P/N 50057401	Left Tractor Assembly	RSPL	B.2.08
<input type="checkbox"/>	P/N 50057501	Right Tractor Assembly	RSPL	B.2.08
<input type="checkbox"/>	P/N 51002201	Guide: Sheet (BTF)	RSPL	B.2.08
<input type="checkbox"/>	P/N 53340401	Roller: Drive (BTF)	RSPL	B.2.08

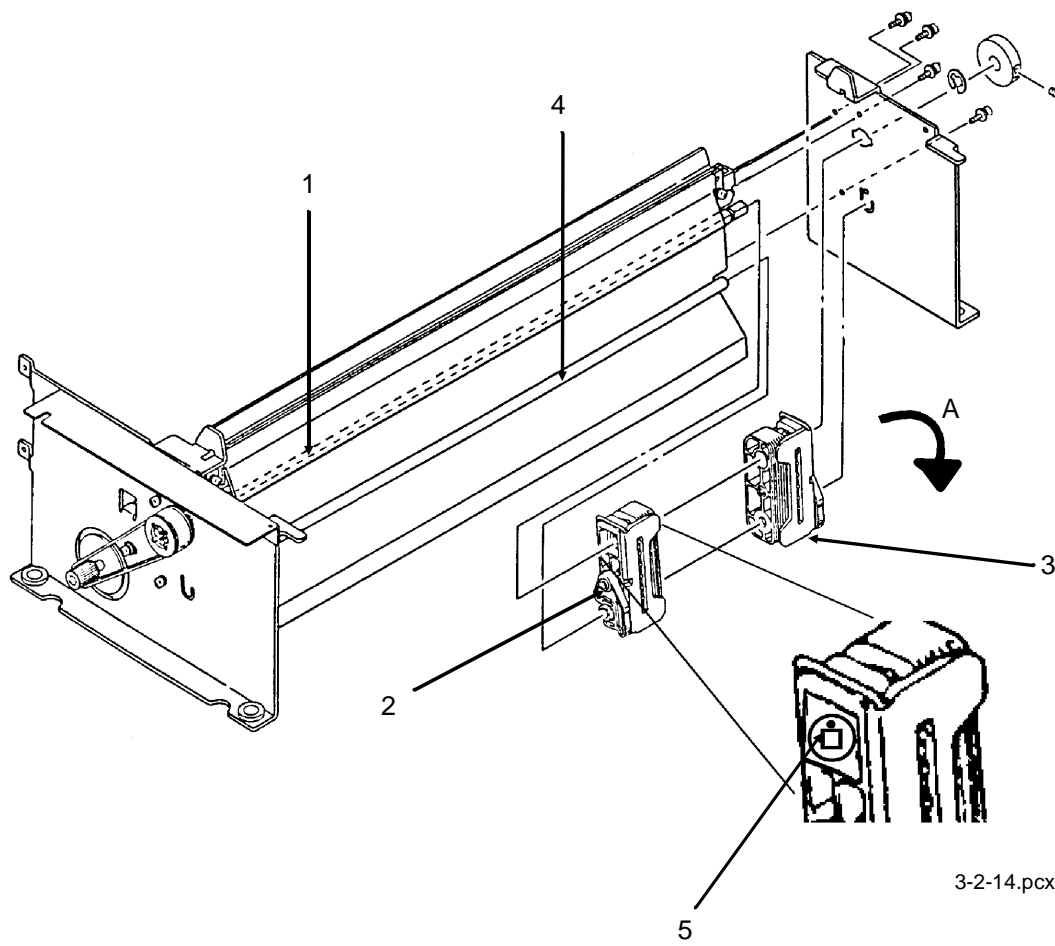

3.2.15 Line Feed Motor (BTF)

1. Remove the bottom push mechanism (3.2.12).
2. Remove the two screws (1).
3. Remove the line feed motor (2).

NOTE:

When installing the line feed motor, the harness should be oriented towards the top.

This line feed motor is used in two different places: the bottom push unit and the printer unit.

P/N 56509401 Motor: Line Feed (BTF) RSPL B.2.08

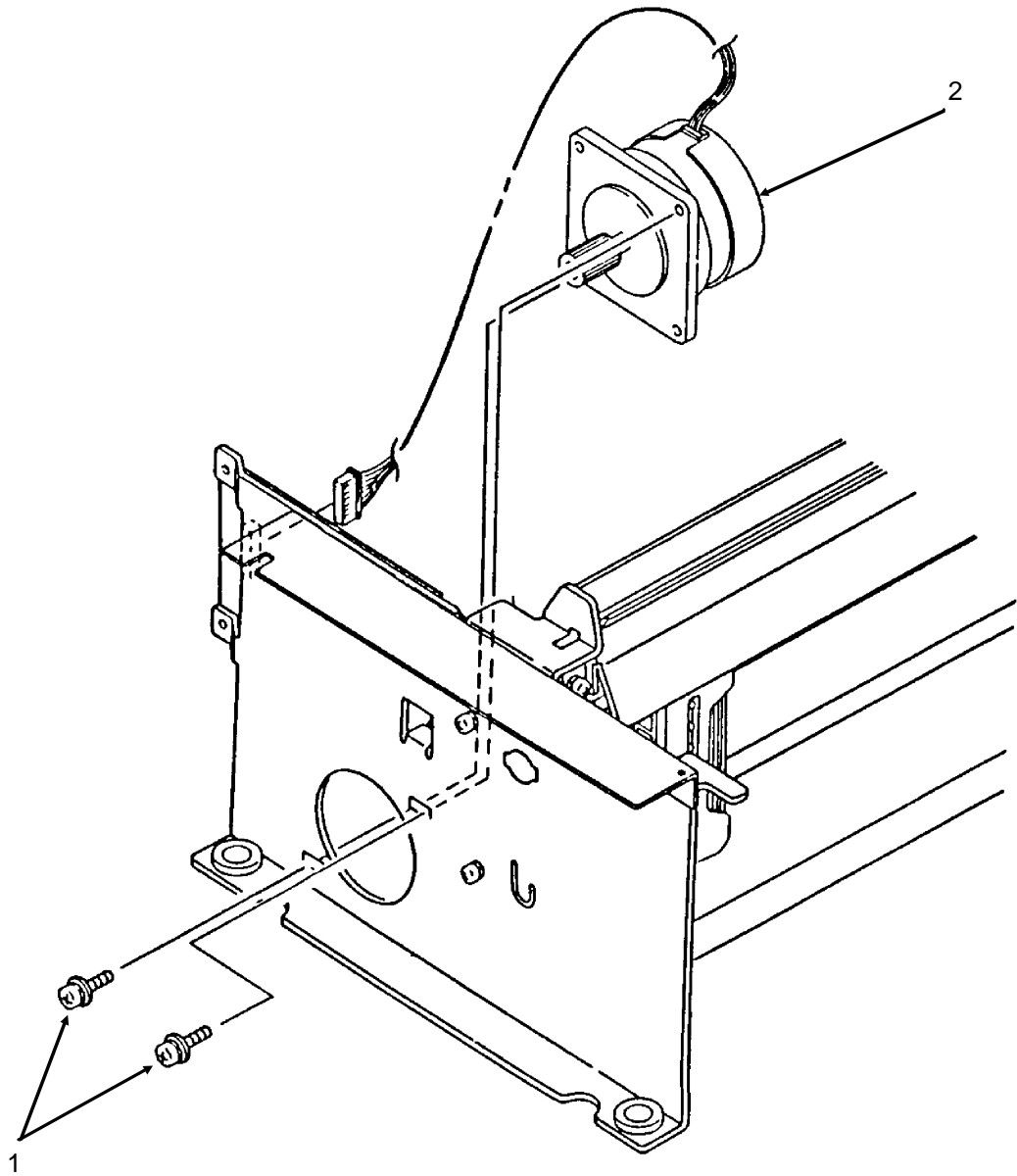

3-2-15.pcx

3.2.16 Platen Assembly

1. Remove the printer mechanism (3.2.07).
2. Loosen the three 7 mm line feed motor mounting bolts (1).
3. Move the line feed motor (2) closer to the platen (3) and detach the line feed drive belt (4).
4. Remove the E-ring, washer, spring and idle gear (5).
5. Remove the screw and detach the gear pulley, washer and bushing (6).
6. Remove the screw and detach the gear and bushing (7).
7. Push in the platen lever (8), lift the bail and remove the platen.

NOTE:

*Perform the line feed belt tension adjustment after replacing the line feed drive belt.
Refer to Section 3.3*

Perform the printhead gap adjustment after installing the platen. Refer to Section 3.3.

<input type="checkbox"/>	P/N 50054101	Platen: (Assembly)	RSPL	B.2.06
<input type="checkbox"/>	P/N 51214501	Gear: Platen "A"	RSPL	B.2.06
<input type="checkbox"/>	P/N 51226801	Pulley: Platen	RSPL	B.2.06
<input type="checkbox"/>	P/N 51304401	Belt: Mini Pitch (Line Feed)	RSPL	B.2.06

OLD

<input type="checkbox"/>	P/N 50910305	Spring: Idle Gear
--------------------------	--------------	-------------------

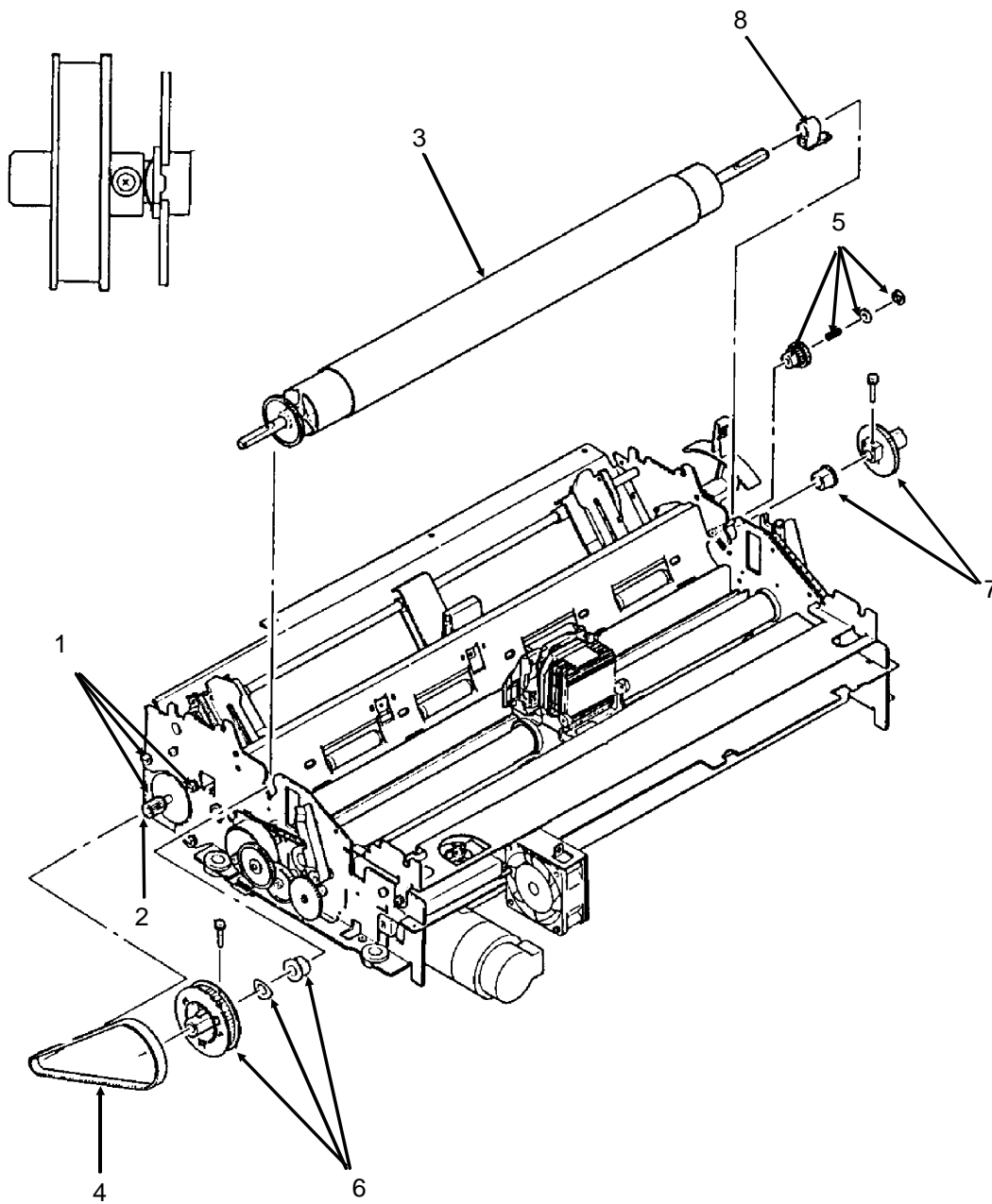

3-2-16.pcx

3.2.17 Paper Pressure Guide.

1. Remove the platen assembly (3.2.16)
2. Remove the two paper chute springs (1) located on each side of the paper pressure guide (2).
3. Remove the screw (3), located on the left side frame of the printer mechanism, directly under the upper tractor shaft.
4. Remove the release lever detent spring (4) located on the right side frame of the printer mechanism.
5. Separate the claws and remove the release lever (5).
6. Remove the paper pressure bar (6) by sliding it to the right.
7. Using needle-nose pliers, squeeze the nylon latch (7) to release the paper out sensor wire harness (8).
8. Detach the cable from CN1 of the sensor board (9).
9. Lift the paper pressure guide and remove it.

<input type="checkbox"/>	P/N 50907502	Spring: (Paper Chute)	RSPL	B.2.06
<input type="checkbox"/>	P/N 50910201	Spring: Detent (Release Lever)	RSPL	B.2.06
<input type="checkbox"/>	P/N 53478706	Lever: Release	RSPL	B.2.06
<input type="checkbox"/>	P/N 53478801	Block: Release Lever Guide	RSPL	B.2.06
<input type="checkbox"/>	P/N 56625001	Cable: Cut Sheet Sensor Assembly	RSPL	B.2.06

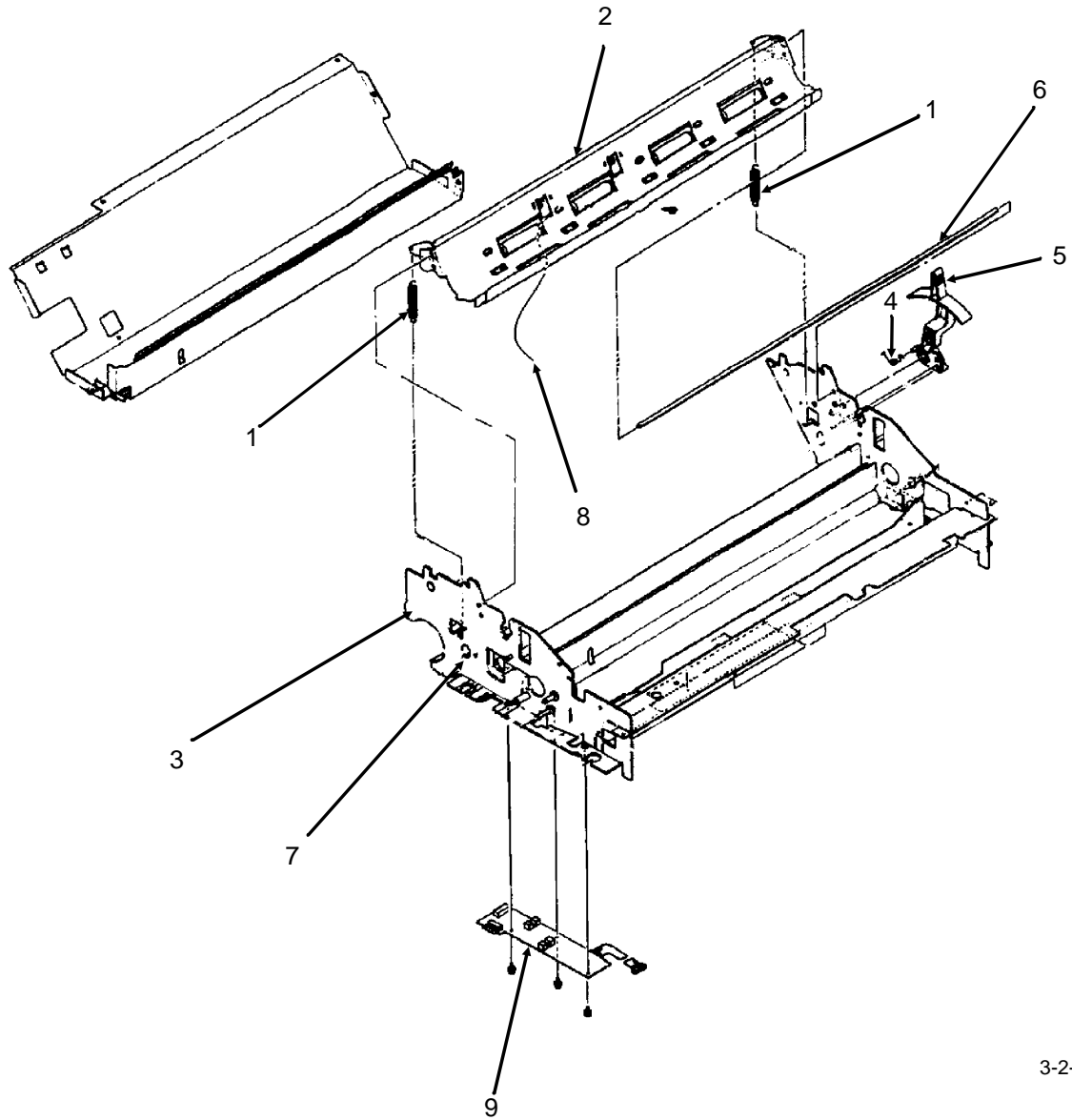

3-2-17.pcx

3.2.18 Line Feed Motor Assembly

1. Remove the printer mechanism (3.2.07)
2. Remove the three mounting bolts and washers (1), then remove the line feed motor(2).

NOTES:

When installing the line feed motor, the cable should be positioned toward the top.

Adjust the line feed belt tension (3.3.02) after installing the line feed motor.

This line feed motor is used in two different places: the bottom push unit and the printer unit.

P/N 56509401 Motor: Line Feed (BTF) RSPL B.2.06

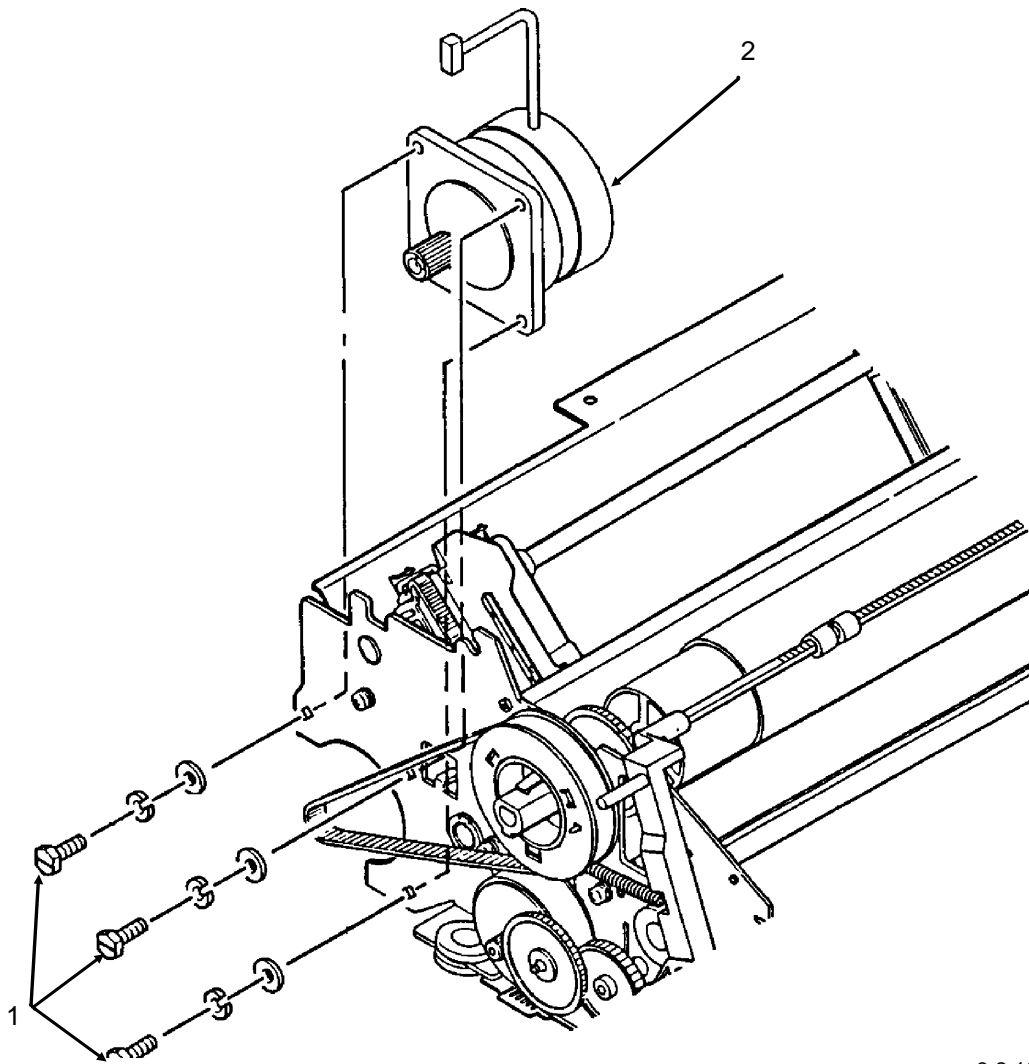

3-2-18.pcx

3.2.19 Ribbon Cartridge Bracket

1. Remove the printer mechanism (3.2.07)
2. Remove the two ribbon cartridge bracket mounting screws (1).
3. Remove the ribbon cartridge bracket (2).

NOTE:

When assembling, the tabs (3) on each side of the ribbon cartridge bracket must slide into the slots on the printer mechanism.

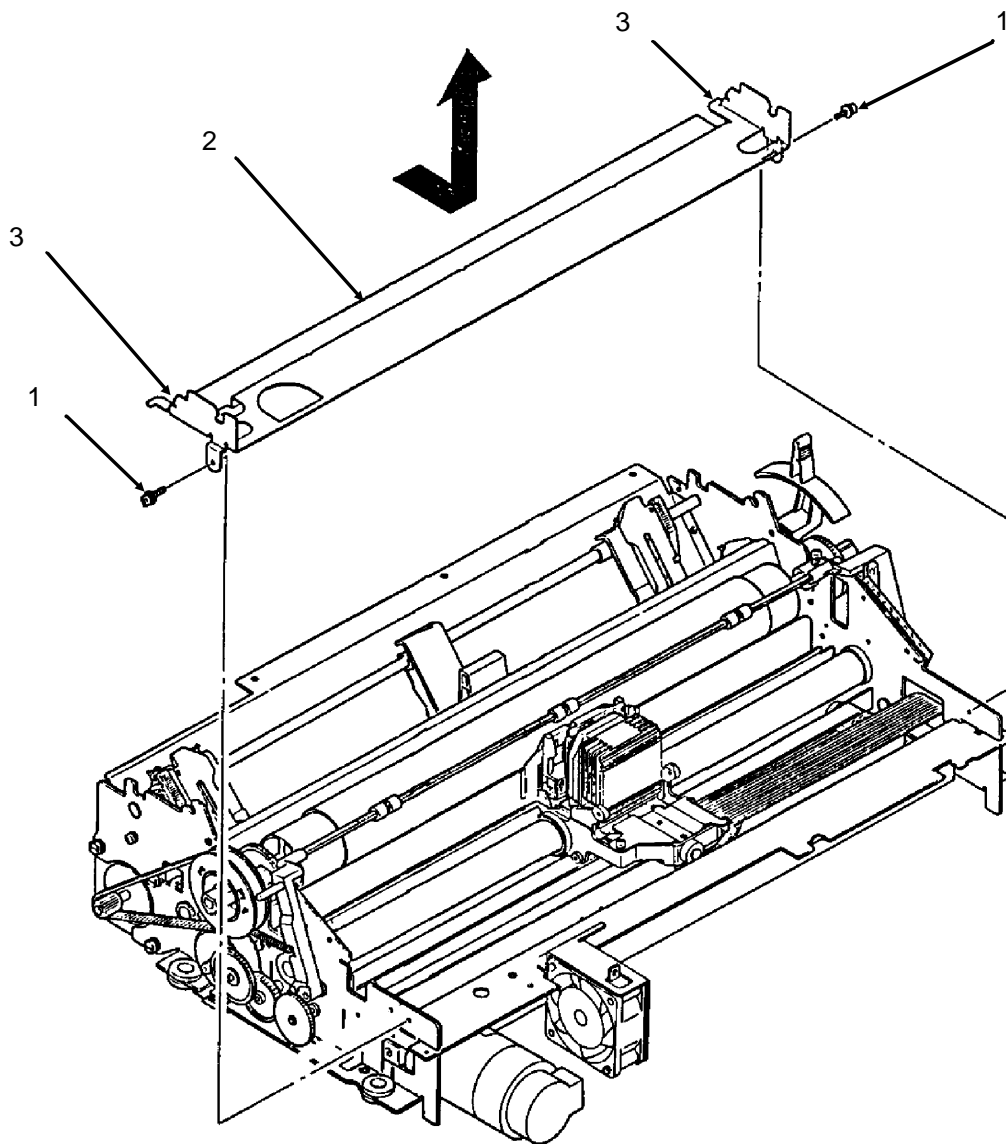

3-2-19.pcx

3.2.20 Fan Assembly

1. Remove the ribbon cartridge bracket (3.2.19).
2. Using needle-nose pliers, squeeze the nylon latch (1) to release the space motor wire harness.
3. Remove the two fan mounting screws (2).
4. Remove the fan (3).

P/N 56509501 Fan: Cooling

RSPL

B.2.03

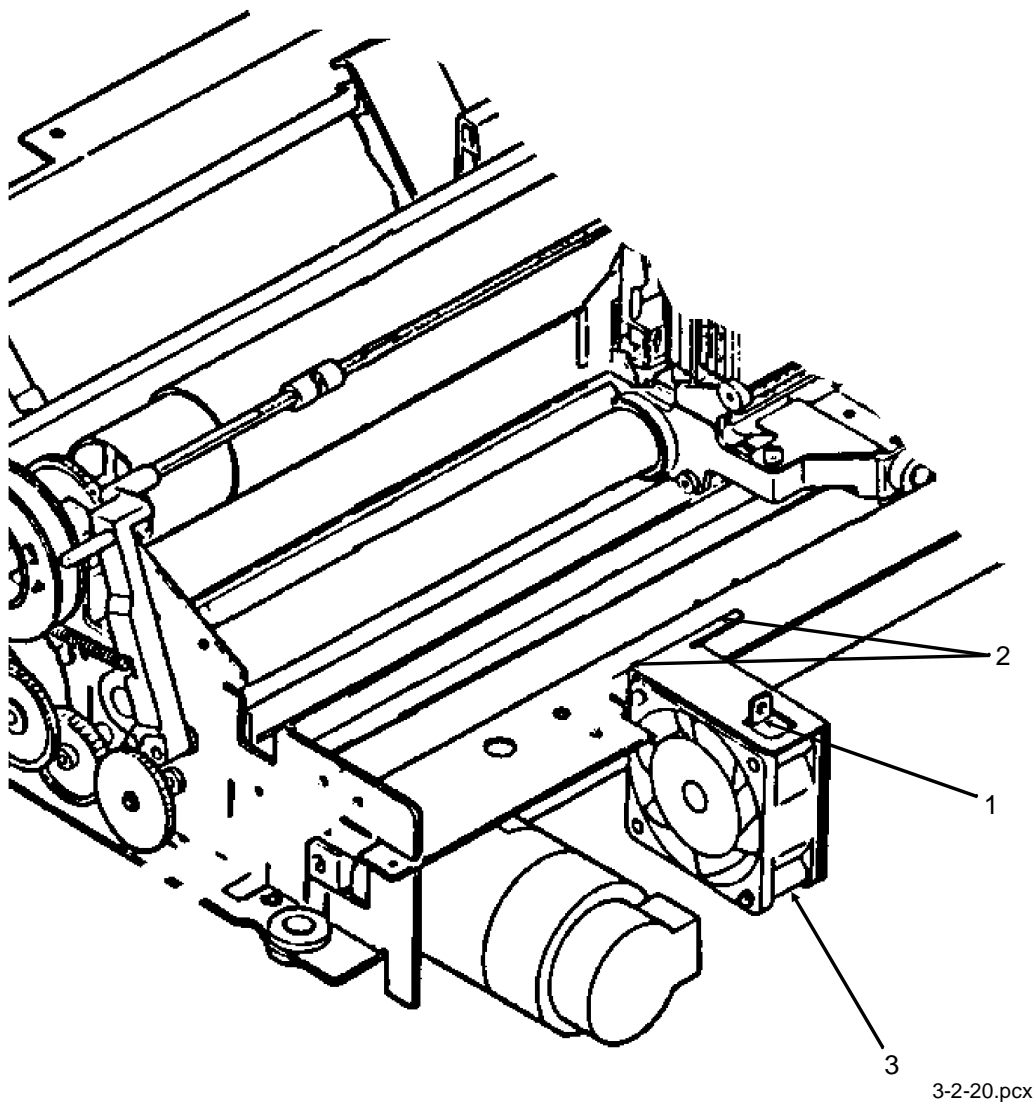

3-2-20.pcx

3.2.21 Head Cable Assembly

1. Detach the printhead (3.2.01)
2. Remove the ribbon cartridge bracket (3.2.19).
3. Loosen the two mounting screws (1), detach the tabs from the frame and remove the cable holder (2). The tabs must be accessed from the bottom of the printer mechanism.
4. Remove the mounting screw (3) and detach the connector clamp (4).
5. Detach the head cable connector (5) from the carriage frame (6).
6. Slide the carriage to the left side frame. While lifting the front end of the printer mechanism, remove the head cable assembly (7) by pulling downward.

P/N 56624901 Cable: Head Assembly

RSPL

B.2.05

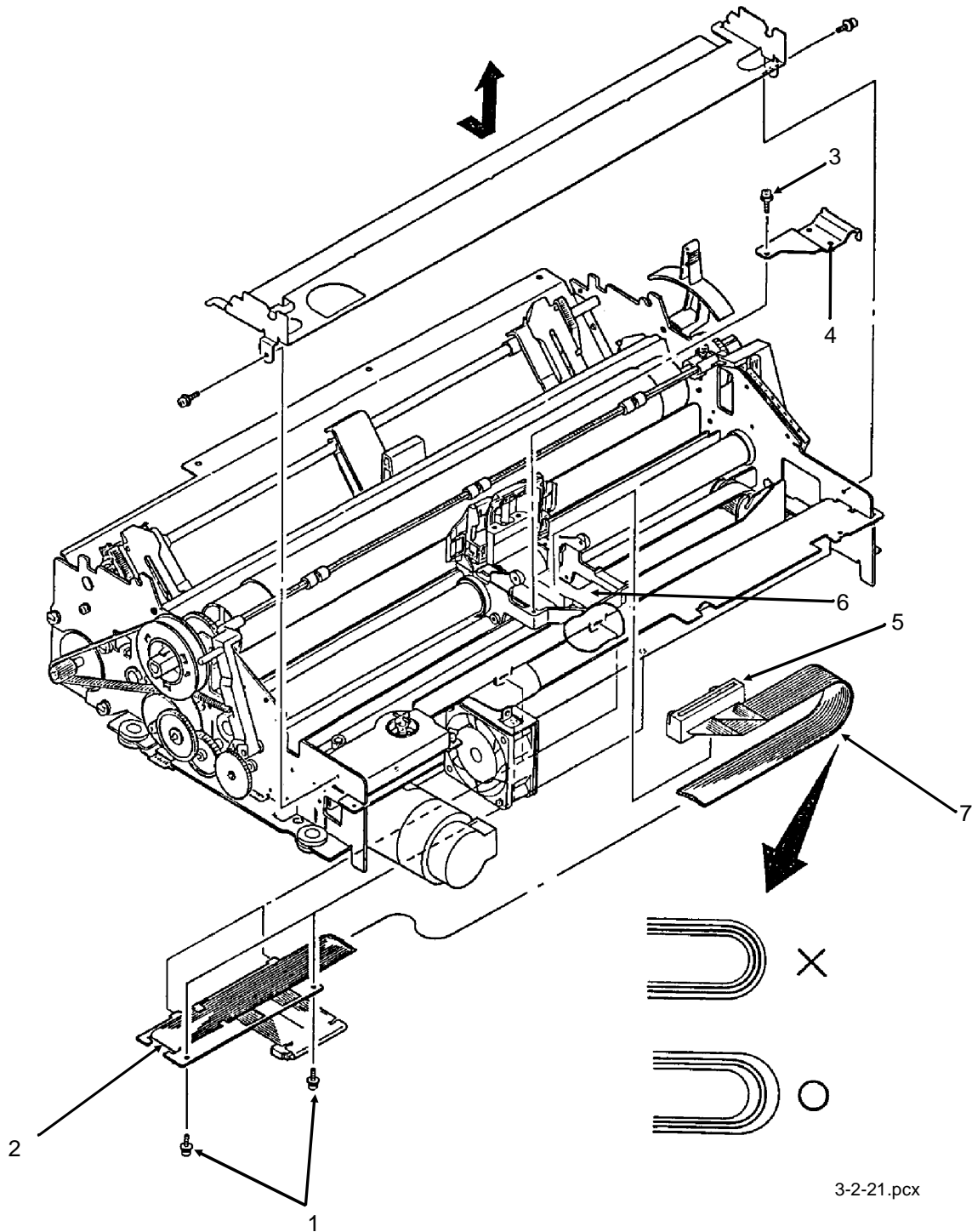

3-2-21.pcx

3.2.22 Carriage and Carriage Shaft

1. Remove the head cable assembly (3.2.21)
2. Loosen the slider mounting screw (1) and push it towards the back of the printer.
3. Remove the belt clamp mounting screw (2) and detach the belt clamp (3).
4. Loosen the screw (4) and detach the left printhead gap adjusting collar (5).

NOTE:

The protrusions on the collar face the outside of the printer.

5. Remove the screw and detach the blue printhead gap adjusting lever (not shown).
6. Loosen the screw (6) and detach the right printhead gap adjusting collar (7).
7. Pull the two rubber carriage bumpers (8) from the carriage shaft (9).
8. Slide the carriage shaft to the right and remove the shaft and the carriage assembly (10).

NOTES:

Installation

Be sure that the larger extension at the end of the carriage shaft is positioned to the right.

Perform the printhead gap adjustment after installing this assembly. Refer to Section 3.3.

<input type="checkbox"/>	P/N 53340501	Carriage: (Assembly)	RSPL	B.2.05
<input type="checkbox"/>	P/N 50706701	Collar: Eccentric (with Screw)	RSPL	B.2.06
<input type="checkbox"/>	P/N 51112101	Shaft: Carriage	RSPL	B.2.06
<input type="checkbox"/>	P/N 53063801	Bracket: Printhead Gap Indicator	RSPL	B.2.06
<input type="checkbox"/>	P/N 53478401	Lever: Adjust	RSPL	B.2.06

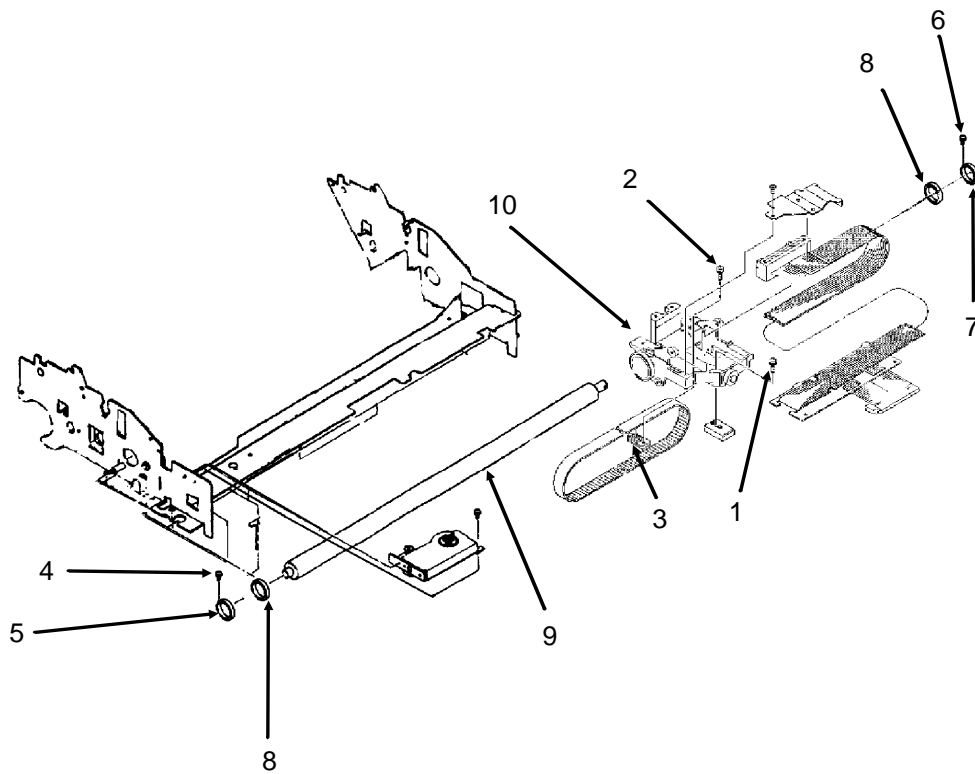

3-2-22.pcx

3.2.23 Ribbon Feed Assembly

1. Remove the ribbon cartridge bracket (3.2.19).
2. Remove the two mounting screws (1) and detach the ribbon feed assembly (2).

NOTE:

When assembling, install the ribbon drive assembly so that the gear backlash (3) is at a minimum.

P/N 50054301 Assembly: Ribbon Feed RSPL B.2.06

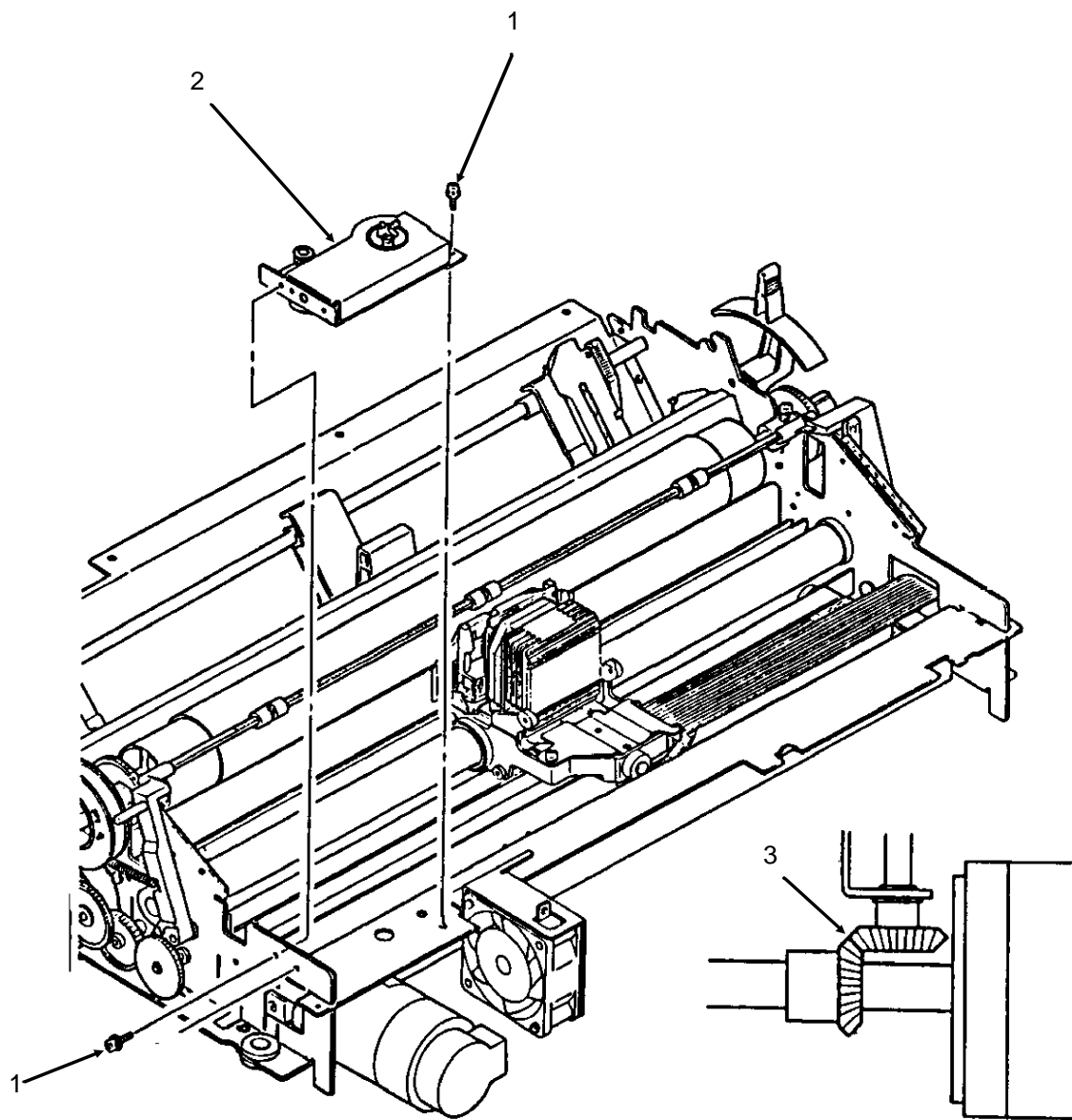

3-2-23.pcx

3.2.24 Space Motor Assembly

1. Remove the ribbon feed assembly (3.2.23).
2. Loosen the two belt pulley bracket mounting screws (1). While pushing the belt pulley bracket to the left (A), temporarily tighten the two screws. This will ease the tension on the space belt.
3. Remove the three space motor mounting screws (2).
4. Remove the space motor (3) by pulling toward the front of the printer.

P/N 56506204 Motor: Space

RSPL

B.2.06

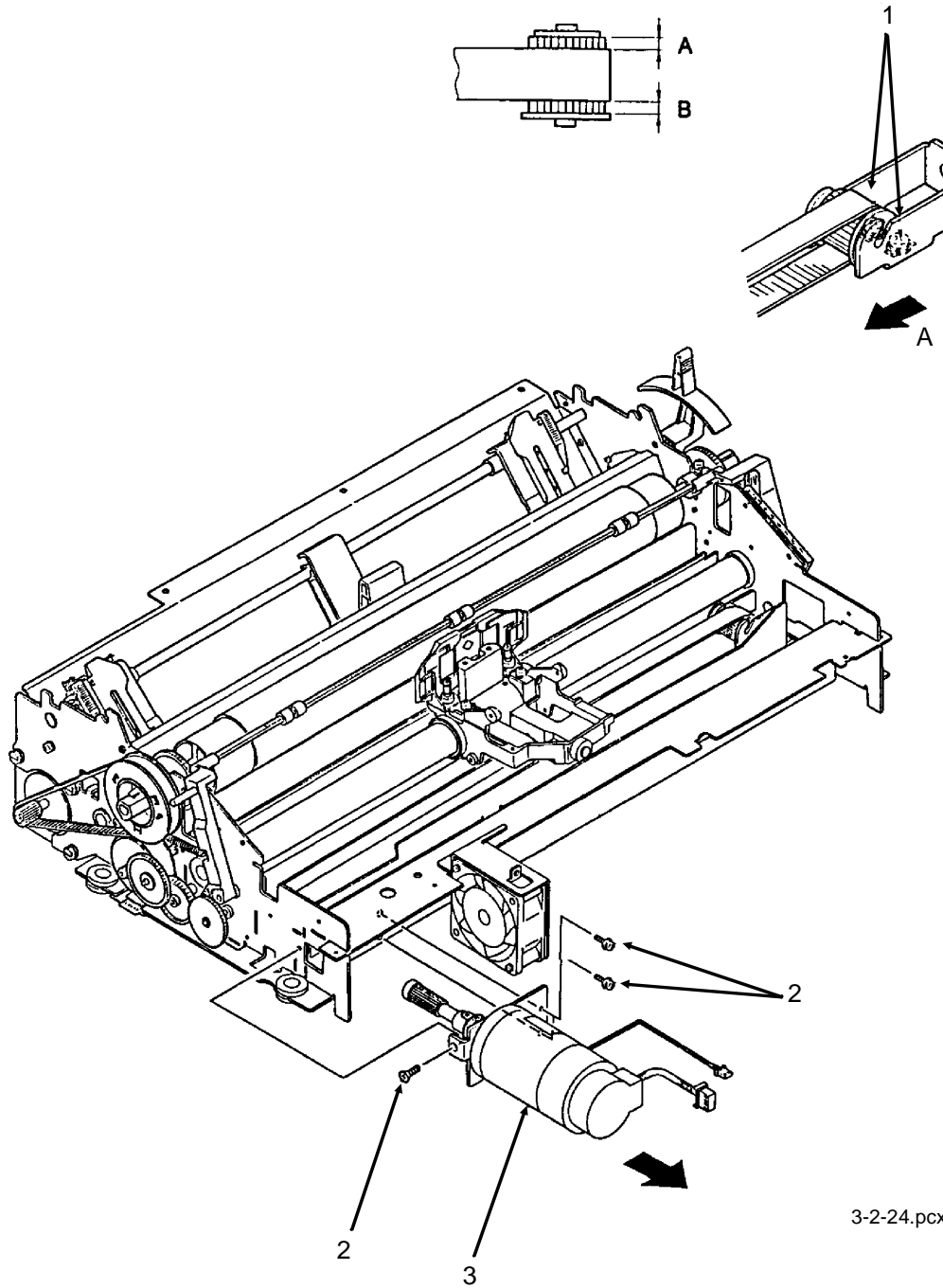

3.2.25 Space Belt

1. Remove the printhead (3.2.01)
2. Remove the space motor assembly (3.2.24)
3. Remove the mounting screw and detach the connector clamp (1). Detach the head cable assembly (2) from the carriage.
4. Remove the mounting screw (3) and detach the belt clamp (4).
5. Remove the belt pulley (5) from the bracket (6) and detach the space belt (7).

<input type="checkbox"/>	P/N 50702301	Belt Clamp		B.2.05
<input type="checkbox"/>	P/N 51303101	Belt: Mini Pitch (Spacing)	RSPL	B.2.05

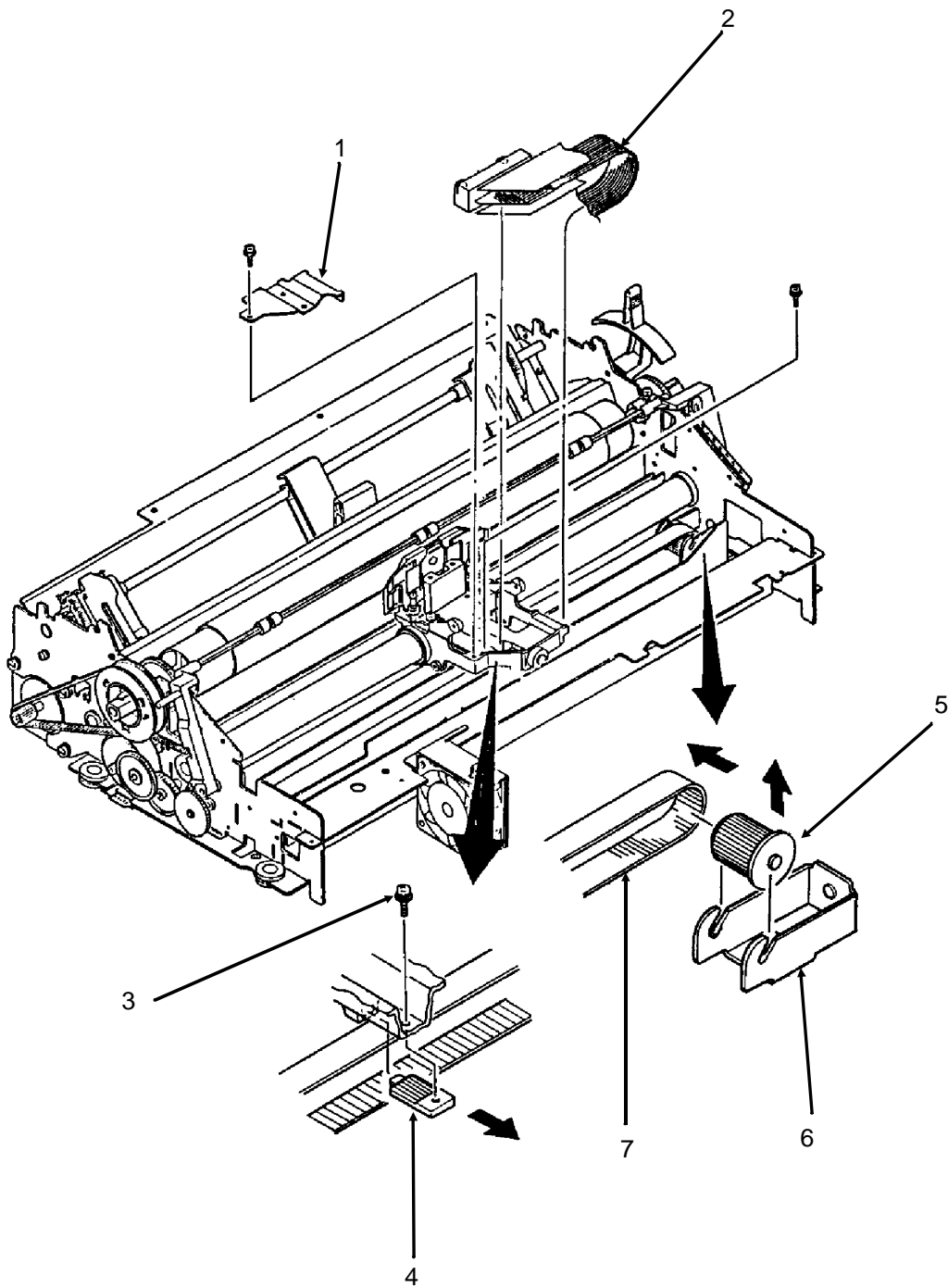

3-2-25.pcx

3.2.26 Sensor Board (LPRW)

1. Remove the printer mechanism (3.2.07).
2. Disconnect connectors CN1 and CN2 (1) from the sensor board (2).
3. Raise the front of the printer mechanism.
4. Remove the three sensor board mounting screws (3).
5. Disconnect connector CN3 (4) and detach the sensor board.

<input type="checkbox"/>	P/N 55061501	PCB: LPRW Sensor	RSPL	B.2.06
<input type="checkbox"/>	P/N 56616804	Cable: Sensor Board Connection	RSPL	B.2.06

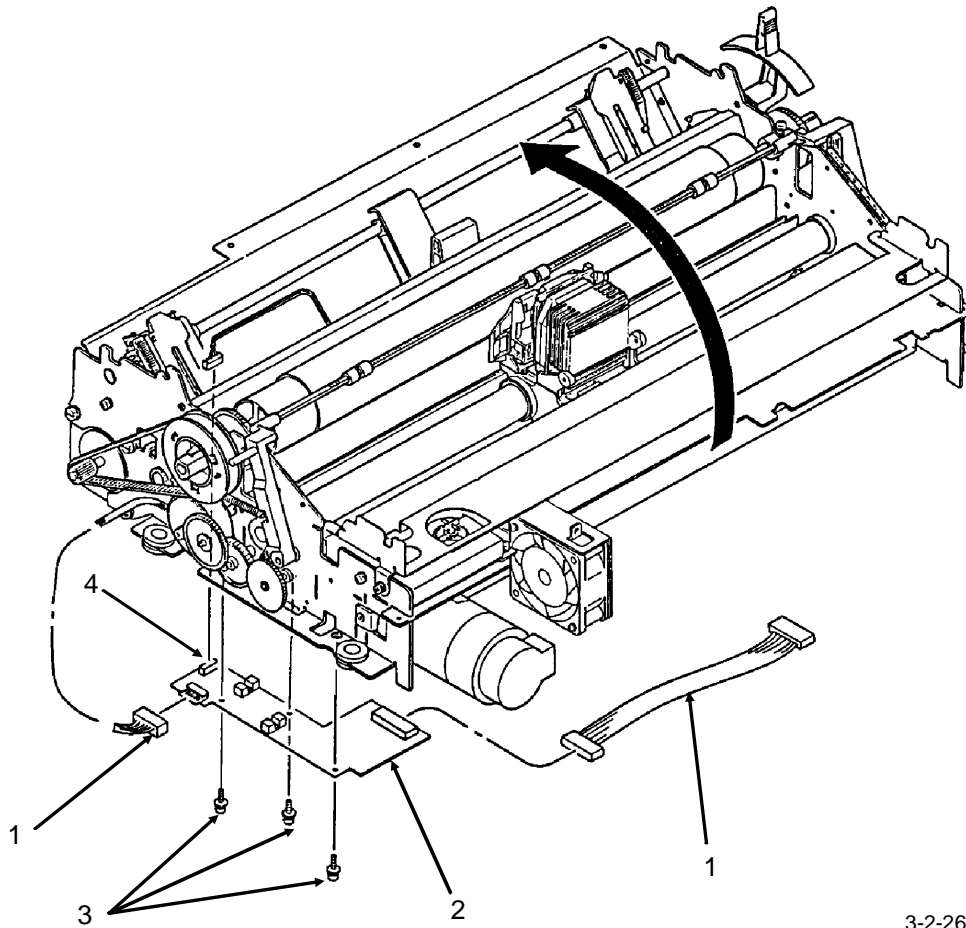

3-2-26.pcx

3.2.27 Bail Motor/Gear Assembly

1. Remove the printer mechanism (3.2.07).
2. Disconnect connector CN2 (1).
3. Remove the two mounting screws (2) and detach the bail motor/gear assembly (3).

NOTE:

When assembling, install the bail/ribbon motor assembly so that the gear backlash is at a minimum.

P/N 56506301 Motor: Step (Bail Arm) Assembly RSPL B.2.06

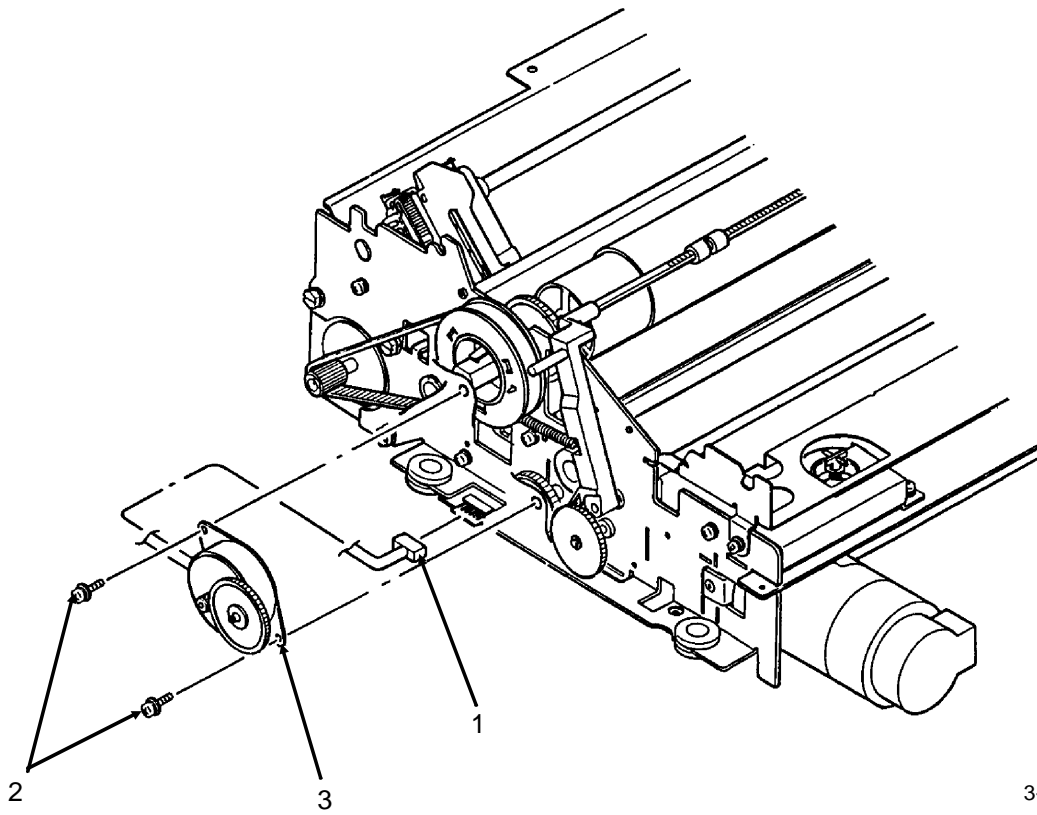

3-2-27.pcx

3.2.28 Paper Bail Assembly

1. Remove the printer mechanism (3.2.07).
2. Remove the bail motor / ribbon gear assembly (3.2.27).
3. Detach the paper bail springs (1).

NOTE:

The right and left bail arm springs are different; be careful to install them properly.

4. Remove the idler gear (2).
5. Detach the “E” snap ring and remove the bail open cam (3).
6. Detach the “E” snap ring (4) and remove the left bail arm (5) from the paper bail bar (6) by pulling toward the left.
7. Remove the right bail arm (7) by pulling toward the right while expanding the clamps (8).
8. Detach the right bail arm from the paper bail bar.

<input type="checkbox"/>	P/N 50054401	Assembly: Indicator Shaft	RSPL	B.2.07
<input type="checkbox"/>	P/N 50910701	Spring: Bail Arm (Left)	RSPL	B.2.07
<input type="checkbox"/>	P/N 50910801	Spring: Bail Arm (Right)	RSPL	B.2.07
<input type="checkbox"/>	P/N 51210201	Gear: Idle (Bail Arm)	RSPL	B.2.07
<input type="checkbox"/>	P/N 51214701	Cam: Bail Open	RSPL	B.2.07
<input type="checkbox"/>	P/N 53478501	Bail Arm (Left)	RSPL	B.2.07
<input type="checkbox"/>	P/N 53478502	Bail Arm (Right)	RSPL	B.2.07

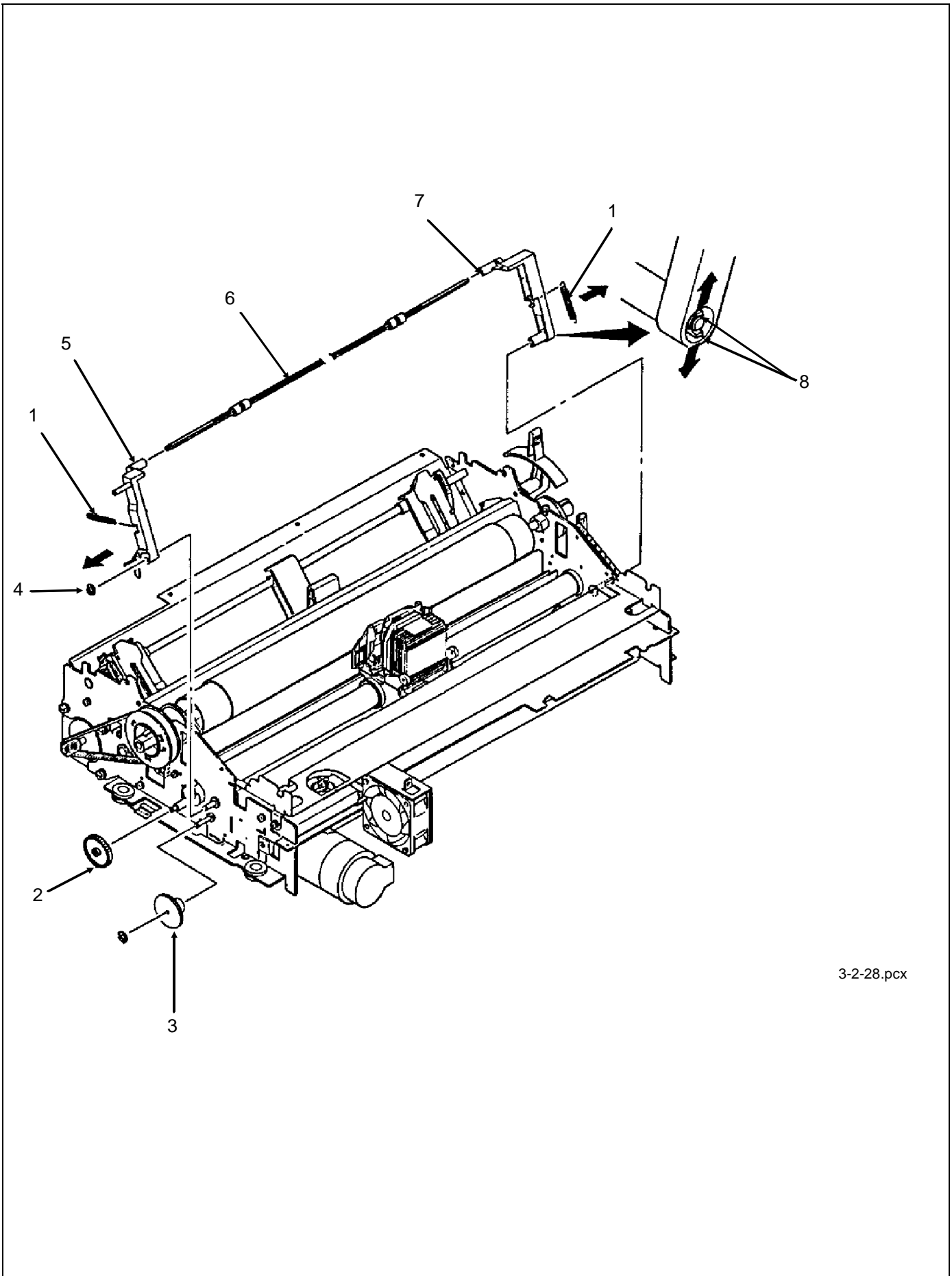

3-2-28.pcx

3.2.29 Rear Feed Tractor Assembly

1. Remove the printer mechanism (3.2.07).
2. Remove the lower center guide (1).
3. Separate the claws (2) and remove the two drive gears from the right side of the printer mechanism (3A - Drive Gear A and 3B - Drive Gear B).
4. Using a needle nose pliers, remove the nylon cable clamp (4).
5. Slide the upper drive shaft (5) to the left and remove it.
6. Slide the lower drive shaft (6) to the left and remove it.
7. Remove the upper center guide (7), being careful not to lose the friction ring (8).
8. Lift and remove the push tractor assemblies (9) and locking shaft (10).

NOTES:

To remove the tractors , raise the lock levers and slide the tractors off.

When installing the push tractor assembly, take the following precautions:

9. First, install the friction ring in the upper center guide. If the upper center guide moves easily along the locking shaft, you must rotate the friction ring 45 degrees, using a standard screwdriver (11).
10. Check the installation; if the guide moves with difficulty, it is properly installed.
11. Make sure that the tractors are synchronized by aligning the synchronization marks in the same direction.
12. Make sure that the guide holes (12) in the tractor drive gears face the same direction.
13. The groove of the upper center guide must be positioned behind the paper pressure guide (13).
14. The left tractor assembly must be positioned between the two guide tabs (14).

<input type="checkbox"/>	P/N 50054501	Tractor: Push (Left) Assembly	RSPL	B.2.07
<input type="checkbox"/>	P/N 50054601	Tractor: Push (Right) Assembly	RSPL	B.2.07
<input type="checkbox"/>	P/N 51002301	Friction: Piece	RSPL	B.2.07
<input type="checkbox"/>	P/N 51002401	Guide: Center - Upper	RSPL	B.2.07
<input type="checkbox"/>	P/N 51002501	Guide: Center Lower A	RSPL	B.2.07
<input type="checkbox"/>	P/N 51002601	Guide: Center Lower B	RSPL	B.2.07

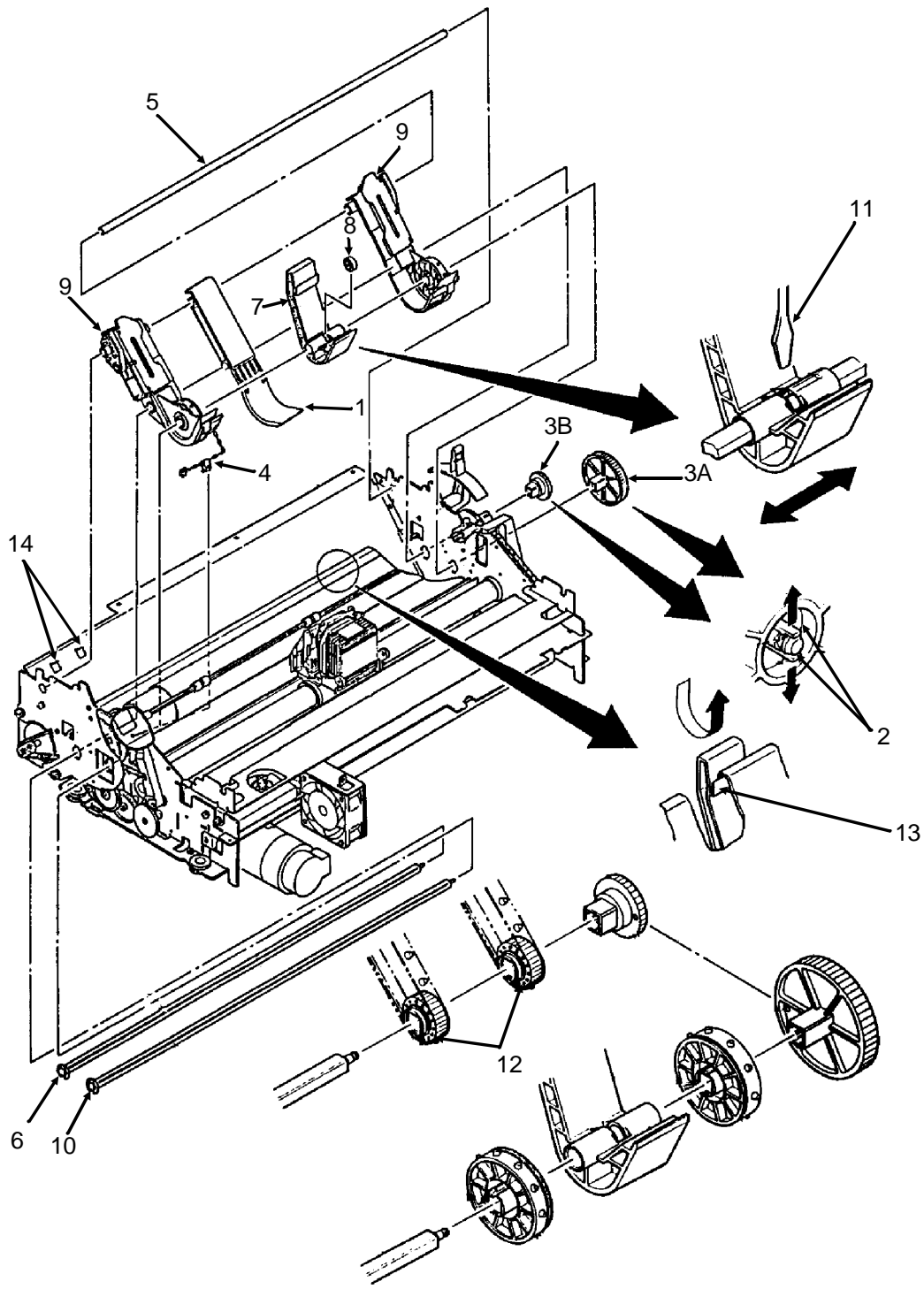

3-2-29.pcx

3.2.30 Printhead Gap/Release Lever Microswitches

1. Remove the printer mechanism (3.2.07).
2. Remove the mounting screw to remove the release lever microswitch (1).
3. Push down on the mounting tab and detach the upper printhead gap microswitch (2).
4. Push down on the mounting tab and detach the lower printhead gap microswitch (3).
5. Using a needle nose pliers, detach the nylon cable clamp (4) and remove the harness and switches from the printer mechanism.

NOTES:

The harness connector must be detached from the main logic board.

Refer to the Microswitch 2 Modification procedure in Section 3.3 - Adjustments.

<input type="checkbox"/>	P/N 56209901	Switch: Micro (Adj & Rel Lever)	RSPL	B.2.07
<input type="checkbox"/>	P/N 56624801	Cable: Micro Switch Assembly (Adj & Rel Lever)	RSPL	B.2.07
<input type="checkbox"/>	P/N 56614301	Cable: Micro Switch (Cover Open)	RSPL	B.2.04

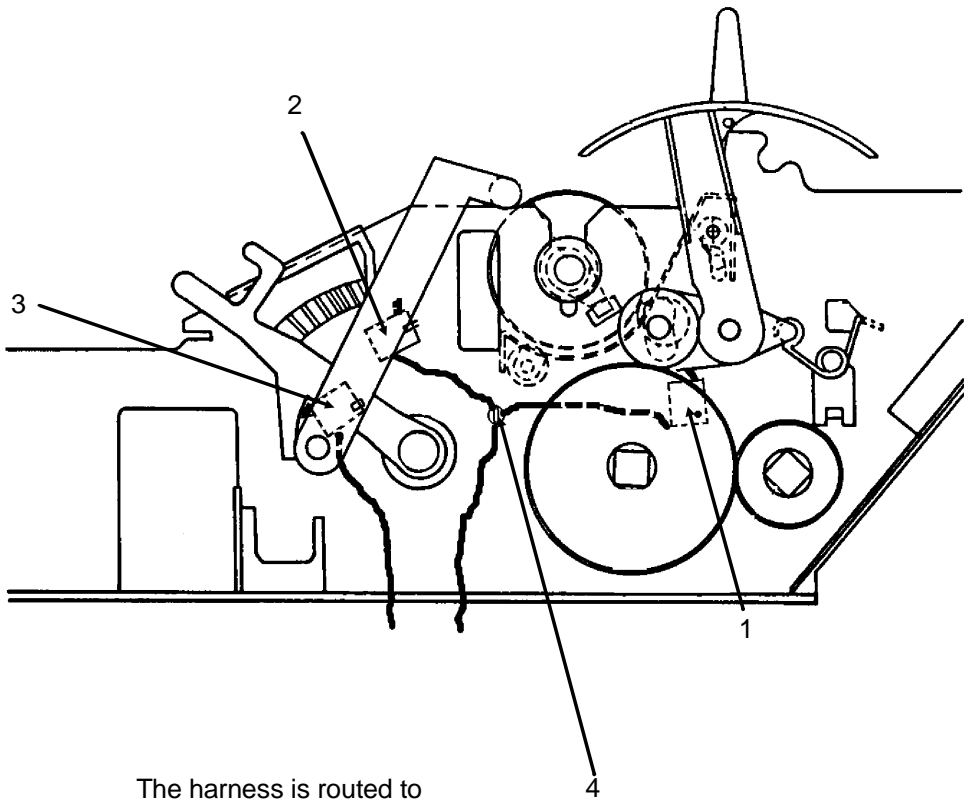

3-2-30.pcx

The harness is routed to the main logic board.

3.2.31 Release Lever / Gear Assemblies

6. Remove the printer mechanism (3.2.07).

NOTE:

Before performing the next step, place the release lever toward the front of the printer. This will remove tension from the detent spring.

7. Detach the E-Ring, washer and spring, then remove the idle gear (1).
8. Remove the (Release Lever) detent spring (2).
9. Pry open the center claws and slide the release lever (3) from the printer mechanism.
10. Pry open the center claws then remove drive gear A (large gear) (4).
11. Pry open the center claws then remove drive gear B (small gear) (5).

<input type="checkbox"/>	P/N 50910305	Spring: Idle Gear	RSPL	B.2.07
<input type="checkbox"/>	P/N 51214201	Gear: Drive A	RSPL	B.2.07
<input type="checkbox"/>	P/N 51214301	Gear: Drive B	RSPL	B.2.07
<input type="checkbox"/>	P/N 51214401	Gear: Idle (Release Lever)	RSPL	B.2.07
<input type="checkbox"/>	P/N 53478706	Lever: Release	RSPL	B.2.06
<input type="checkbox"/>	P/N 50910201	Spring: Detent (Release Lever)	RSPL	B.2.06

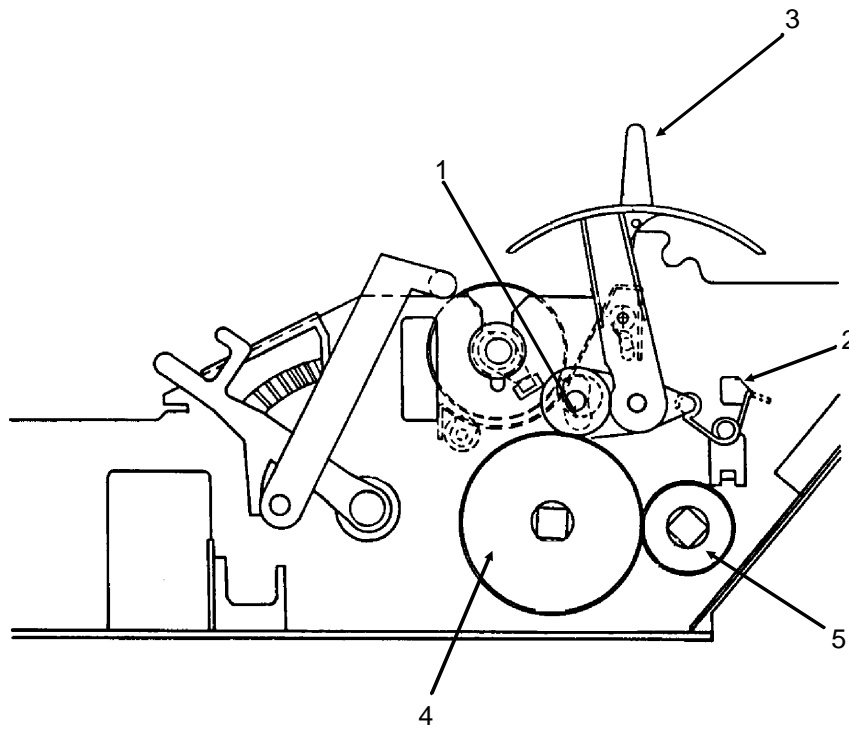

3-2-31.pcx

This page was intentionally left blank.

3.3 PRINTER ADJUSTMENTS

3.3.01 General Information

This section contains the procedures for performing adjustments on the printer. These procedures may be required when replacing either consumables or parts. The disassembly / assembly procedures list the required adjustment and refer you to this section. Failure to perform these procedures may result in unnecessary service calls.

3.3.02 Printhead Gap

NOTES:

*The information in this section is also covered in Technical Service Bulletin 1603.
A Pacemark 3410 Replacement Printhead Kit includes the items listed below.*

Technical Service Bulletin 1603

Read Me First Card

Head Gap Lever Adjustment Sticker

90 Day Warranty Extension Card

General Information

Before performing this adjustment, always verify that the printhead is properly installed.

The printhead gap adjustment should be performed when the following occur.

- Print quality is darker on one side of the document.
- Parts / Assemblies are replaced.

Printhead Assembly (3.2.01)

Platen Assembly (3.2.16)

Carriage Shaft (3.2.22)

The printhead gap should measure .014 +/- .002 inches (0.35 +/- 0.05 millimeters).

This adjustment has four phases.

1. Setup Phase (Steps 1 - 6)

The cover is removed and the printhead is placed at a known reference point.

2. Printhead Gap Modification Phase (Steps 7 - 9)

The distance between the printhead and the platen at the left (line feed motor) side of the platen is modified by rotating the left eccentric collar. Rotating the eccentric collar varies the position of the carriage shaft relative to the platen.

3. Parallel Adjustment Phase (Steps 10 - 12)

The right eccentric collar is rotated to ensure that the printhead moves parallel to the platen (at the correct gap setting).

4. Check Phase (Steps 13 - 16)

This phase verifies that the Parallel Adjustment Phase did not affect the Printhead Gap Modification Phase.

Procedure

NOTE:

The printhead gap must measure .014 +/- .002 inches (0.35 +/- 0.05 millimeters).

Setup Phase (Steps 1 - 6)

1. Remove the ribbon cartridge and ribbon guide (3.2.01).
2. Remove the ribbon protector (3.2.02).
3. Remove the upper cover (3.2.03).
4. Set the printhead gap lever to position 1.
5. Set the release lever to the CUT SHEET ("OPEN") position.
6. Loosen the left and right eccentric collar mounting screws.

Printhead Gap Modification Phase (Steps 7 - 9)

7. Move the printhead to the left side of the platen.
8. Rotate the left eccentric collar until the correct gap is obtained.
9. Move the printhead to the right side of the platen.

Parallel Adjustment Phase (Steps 10 - 12)

10. Rotate the right eccentric collar until the correct gap is obtained.
11. Move the printhead to the left side of the platen.
12. Recheck the gap, rotating the left eccentric collar as necessary.

Check Phase (Steps 13 - 16)

13. Move the printhead to the right side of the platen.
14. Check the gap, rotating the right eccentric collar as necessary.
15. Repeat Steps 11 - 14 until the the correct gap is obtained at each side of the platen.
16. Move the printhead to the center of the platen and check the gap.
17. When the correct gap has been attained, tighten the left and right eccentric collar mounting screws.
18. Install the upper cover, the ribbon protector, ribbon guide and the ribbon cartridge.

NOTE:

When installing the printhead, push it towards the platen. This ensures a correct fit between the printhead and stopper. Then, tighten the printhead screws.

Diagram

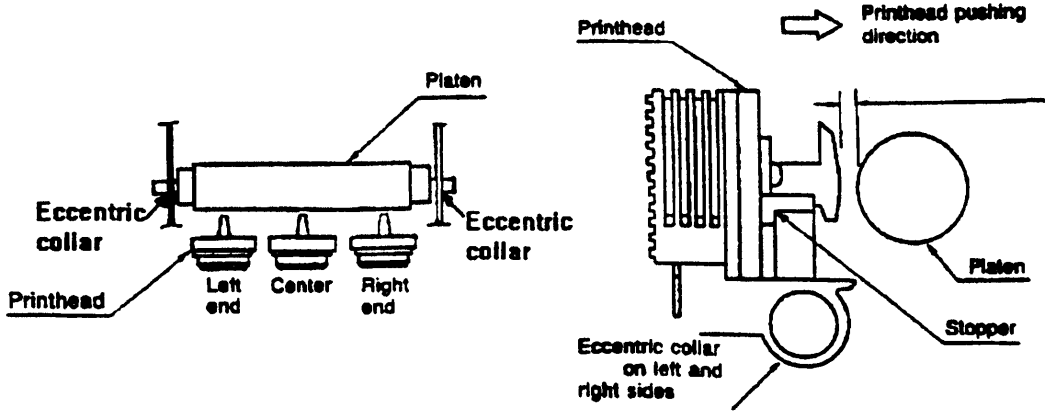

3-3-01c.pcx

Microswitch 2 Modification

NOTES:

The information in this section is also covered in Technical Service Bulletin 1603.

A Pacemark 3410 Replacement Printhead Kit includes the items listed below.

TSB 1603

Read Me First Card

Head Gap Lever Adjustment Sticker

90 Day Warranty Extension Card

General Information

Modifying Microswitch 2 will reduce drive time and increase printhead life.

Perform this modification when a replacement printhead is installed.

Procedure

1. Remove the upper cover. (3.2.03)
2. Locate the blue head gap lever.
3. Set the blue head gap lever to Position 1.
4. Locate the two microswitches on the right side (platen knob) of the printer. The microswitch below the head gap lever is Microswitch 2.
5. Make a paper clip into a hook.
6. Insert the paper clip hook into the small hole on the microswitch arm.

CAUTION:

The paper clip hook will keep the arm from falling into the printer during the next step.

7. Hold the paper clip and carefully cut the arm of Microswitch 2 at its base.
8. Discard the cut arm.

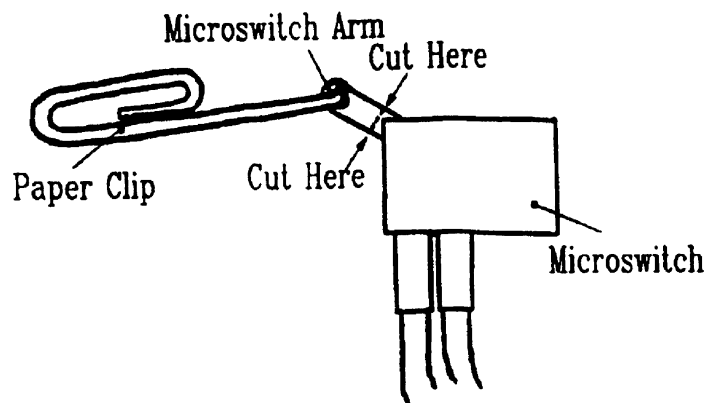

3-3-01b.pcx

Verification

To verify that Microswitch 2 has been disabled, follow this procedure.

1. Set the head gap lever to position 5 or above.
2. Attach an ohmmeter to pins 5 and 6 of connector CN9 on the main control board.
3. Verify that the switch is closed.
4. Set the head gap lever to the proper setting for the paper (thickness) being used.
5. Replace the upper cover.
6. Place the Head Gap Lever Adjustment Sticker on the tear bar of the access cover.
7. Fill out the Customer Warranty Extension Card (if applicable).

Read Me First

The Read Me First Sheet in the Pacemark 3410 Replacement Printhead Kit reads as follows.

When changing paper paths or paper type, be sure to adjust the printhead gap lever. This blue lever is located on the right hand side of the printer. Failure to correctly adjust this lever could result in damage to the printhead.

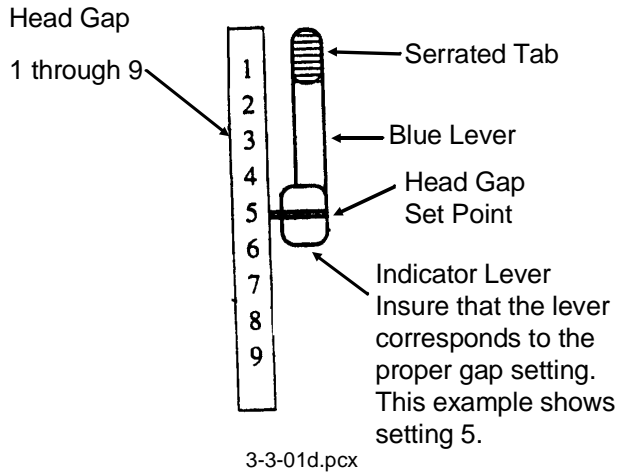

Paper	Setting
12 - 14 lb. paper	1
Labels	3 - 4
Envelopes	5 - 9
Forms (w/carbon)	
Two-part	2 - 3
Three-part	3 - 4
Four-part	5
Five-part	6
Six-part	7

90 Day On-Site Warranty Extension

The 90 Day On-Site Warranty Extension in the Pacemark 3410 Replacement Printhead Kit reads as follows.

This document entitles the owner an extension of the initial 90 day on-site warranty.

The extension will cover any printhead repair performed within the first 90 days after the date of purchase and extend the warranty for 90 days from the date of the printhead repair.

Any Authorized Pacemark 3410 Okidata Repair Center will honor this extension when properly dated and signed by a certified repair technician. Please retain this for your records.

Date of Purchase: _____ Printer Serial Number _____

Date of Printhead Repair _____ 90 Day Extension Expiration Date _____

Authorized Okidata Repair Center _____ Dealer Number _____

Technician Name _____ Technician Signature _____

Customer's Name and Address _____

ODA P/N 58084801

3.3.02 Line Feed Belt Tension

1. Loosen the three line feed motor mounting bolts (1).
2. Using a tension gauge, apply .5 pounds of pressure at Point A.

NOTE:

Rotate the platen pulley at least once before making the adjustment

3. Adjust the line feed motor (2) position to obtain a $\frac{1}{16}$ inch deflection as shown.
4. Tighten the three mounting bolts.

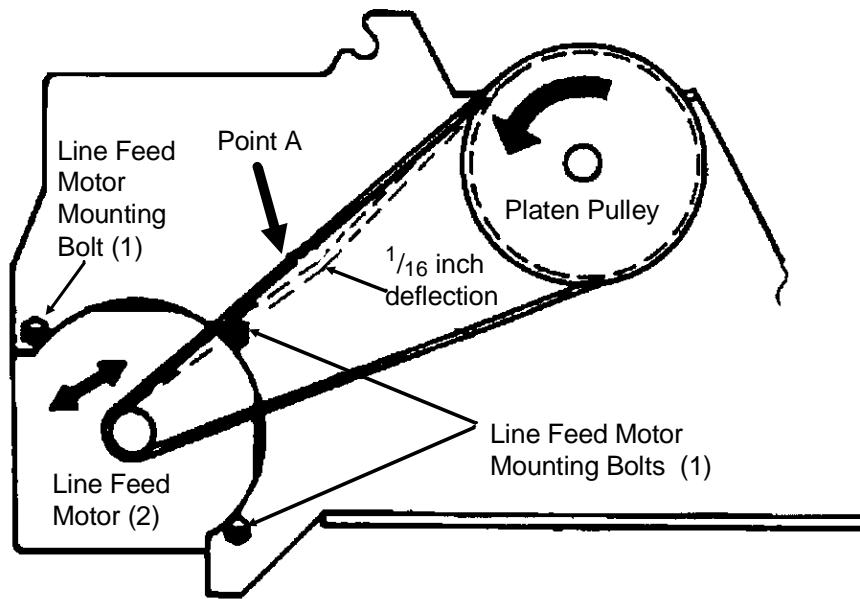

3-3-02.pcx

This page was intentionally left blank.

3.3.03 Key Combinations

Table

Key Combination	Function
PRINT QUALITY + CHARACTER PITCH (Either during ON-LINE or or hold during power ON)	Menu Mode
SELECT + FORM FEED (Hold during power ON)	Activates Hexadecimal Dump Mode
SELECT + LINE FEED (Hold during power ON)	Resets Printer Menu to factory defaults
SELECT + TOP OF FORM (Hold during power ON)	Resets Printer Menu and Top of Form to factory defaults
LINE FEED (Hold during power ON)	Activate Font Test To end Font Test, press SELECT
FORM FEED (Hold during power ON)	Activate Rolling ASCII Test To end Rolling ASCII Test, press SELECT

3.3.04 Menu Operation

General Description

The Menu is used to customize the printer's settings and features.

The Menu is made up of a number of groups.

Each group has a list of items.

Each item has several settings.

Menu Mode

To enter Menu Mode, follow this procedure.

1. Verify that continuous feed paper is installed.
2. Verify that the ribbon is correctly installed.
3. Verify that the width of the installed paper matches the paper width menu setting.
4. Press PRINT QUALITY and CHARACTER PITCH at the same time to place the printer in Menu Mode.

When in Menu Mode, the functions printed *below* the operator panels switches are active.

5. Press GROUP until the desired Group prints.
6. Press ITEM until the desired Item prints.
7. Press SET until the desired setting prints.
8. Press EXIT to save the change and exit Menu Mode.

Printing the Menu

Printing the Menu provides a reference of current settings.

This will help you move through the menu.

Okidata **STRONGLY RECOMMENDS** printing the Menu *before* resetting the Menu to factory defaults.

To print the Menu, follow this procedure.

1. Verify that continuous feed paper is installed.
2. Verify that the ribbon is correctly installed.
3. Verify that the width of the installed paper matches the paper width menu setting.
4. Power ON the printer.
5. Press and hold PRINT QUALITY and CHARACTER PITCH at the same time to place the printer in Menu Mode.

When in Menu Mode, the functions printed *below* the operator panels switches are active.

6. Press PRINT.
7. The Menu will print.
8. Press EXIT to exit Menu Mode.

Reset Menu to Factory Defaults

To reset the Menu to Factory Defaults, follow this procedure.

1. Before resetting the Menu, Okidata **STRONGLY RECOMMENDS** printing the Menu.

Printing the Menu provides a reference of customized settings.

When the Menu is reset, all customized setting are LOST.

2. Power OFF the printer.
3. Press and hold SELECT and LINE FEED while powering ON the printer.

Reset Menu and Top of Form to Factory Defaults

To reset the Menu and the Top of Form to Factory Defaults, follow this procedure.

1. Before resetting the Menu, Okidata **STRONGLY RECOMMENDS** printing the Menu.

Printing the Menu provides a reference of customized settings.

When the Menu is reset, all customized setting are LOST.

2. Power OFF the printer.
3. Press and hold SELECT and TOP OF FORM while powering ON the printer.

Limited Operation

In the Printer Menu, the fifth item in the Set-Up Group is Operator Panel Function.

The settings for this Item are Full Operation and Limited Operation. The factory default is Full Operation.

A system manager may use this feature to maintain proper print settings if the printer is part of a customized system or if the printer is used by different operators.

When the Printer Menu is set to Limited Operation, the TOP OF FORM, MICRO FEED UP/DOWN, PRINT QUALITY, and PITCH switches of the operator panel DO NOT work. Menu Mode CANNOT be accessed.

To change from LIMITED OPERATION to FULL OPERATION, follow this procedure.

1. Verify that continuous feed paper is installed.
2. Verify that the ribbon is correctly installed.
3. Verify that the width of the installed paper matches the paper width menu setting.
4. Power OFF the printer.
5. Press and hold PRINT QUALITY and CHARACTER PITCH while powering ON the printer to place the printer in Menu Mode.

When in Menu Mode, the functions printed *below* the operator panels switches are active.

6. Press GROUP until Set-Up prints.
7. Press ITEM until Operator Panel Function prints.
8. Press SET until FULL OPERATION prints.
9. Press EXIT to exit Menu Mode.

Menu Settings

Factory default settings are printed in ***Bold Italic***.

Except as indicated, the menu for the Epson/IBM model is the same as the menu for the ML/Pacemark model.

Group	Item	Setting	Notes
Printer Mode	Emulation Mode (Epson/IBM)	<i>Epson FX</i> , IBM PPR	Refer to the Printer Handbook
	Emulation Mode (ML/Pacemark)	<i>Microline</i> Pacemark 2410	Refer to the Printer Handbook
Font	Print Mode	<i>Utility</i> , NLQ Courier, NLQ Gothic, HSD	
	Pitch (Epson / IBM)	<i>10</i> , 12, 15, 17.1, 20 cpi	
	Pitch (ML / Pacemark)	<i>10</i> , 12, 15, 17.1, 20 cpi	Proportional spacing is a separate menu item in the ML/Pacemark menu.
	Style	<i>Normal</i> , Italics	
	Size	<i>Single</i> , Double	Double is double width and height
Symbol Sets	Character Set	<i>Set I</i> , Set II	These are standard IBM character sets.
	Language Set	<i>American</i> , French, German, British, Danish I, Swedish, Italian, Spanish I, Japanese, Norwegian, Danish II, Spanish II, Latin American, French Canadian, Dutch, Publisher	These sets contain special characters used in foreign languages. The Publisher set includes special printing symbols.
	Zero Character	<i>Slashed</i> , Unslashed	Use slashed zero to distinguish from the capital letter O.
	Code Page	<i>USA</i> , Canada French, Multilingual, Portugal, Norway	Matches the character set to the computer display character set. Refer to a DOS manual.

Factory default settings are printed in ***Bold Italic***.

Except as indicated, the menu for the Epson/IBM model is the same as the menu for the ML/Pacemark model.

Group	Item	Setting	Notes
The next three groups set parameters for each of the paper paths independently. When changing from one path to another, the parameters also automatically change.			
Rear Feed	Line Spacing	6 , 8 LPI	Sets the distance between line in lines per inch.
	Form Tear Off	OFF , 500 mS, 1 sec, 2 sec	Activate the form tear off feature by selecting a time for the printer to wait after data before advancing the page to tear-off. If the software pauses during printing, print registration may be disrupted. Select a longer time or deactivate this feature. Refer to the Printer Handbook.
	Skip Over Perforation	No , Yes	When set to YES, the printer advances the paper 1 inch (when reaching the bottom of the page) to the next top of form. Use ONLY for unformatted listings or programs that don't format the page.
	Page Width	13.6" , 8"	The 8" setting emulates a narrow carriage printer. If 8.5" paper is always used, choose this setting to prevent printing on the platen.
	Page Length	11" , 11 2/3", 12", 14", 17", 3", 3.5" 4", 5.5", 6", 7", 8", 8.5"	

Factory default settings are printed in ***Bold Italic***.

Except as indicated, the menu for the Epson/IBM model is the same as the menu for the ML/Pacemark model.

Group	Item	Setting	Notes
Bottom Feed	Line Spacing	6, 8 LPI	Sets the distance between line in lines per inch.
	Form Tear Off	<i>OFF</i> , 500 mS, 1 sec, 2 sec	Activate the form tear off feature by selecting a time for the printer to wait after data before advancing the page to tear-off. If the software pauses during printing, print registration may be disrupted. Select a longer time or deactivate this feature. Refer to the Printer Handbook.
	Skip Over Perforation	No , Yes	When set to YES, the printer advances the paper 1 inch (when reaching the bottom of the page) to the next top of form. Use ONLY for unformatted listings or programs that don't format the page.
	Page Width	13.6" , 8"	The 8" setting emulates a narrow carriage printer. If 8.5" paper is always used, choose this setting to prevent printing on the platen.
	Page Length	11" , 11 2/3", 12", 14", 17", 3", 3.5" 4", 5.5", 6", 7", 8", 8.5"	

Factory default settings are printed in ***Bold Italic***.

Except as indicated, the menu for the Epson/IBM model is the same as the menu for the ML/Pacemark model.

Group	Item	Setting	Notes
Top Feed	Line Spacing	6, 8 LPI	Sets the distance between line in lines per inch.
	Skip Over Perforation	No, Yes	When set to YES, the printer advances the paper 1 inch (when reaching the bottom of the page) to the next top of form. Use ONLY for unformatted listings or programs that don't format the page.
	Page Width	13.6", 8"	The 8" setting emulates a narrow carriage printer. If 8.5" paper is always used, choose this setting to prevent printing on the platen.
	Page Length	11", 11 2/3", 12", 14", 17", 3", 3.5" 4", 5.5", 6", 7", 8", 8.5"	

Factory default settings are printed in ***Bold Italic***.

Except as indicated, the menu for the Epson/IBM model is the same as the menu for the ML/Pacemark model.

Group	Item	Setting	Notes
Set-Up	Graphics	<i>Bi-directional</i> , Unidirectional	Bi-directional prints from left to right, then right to left. It is faster, but may cause registration problems. Unidirectional prints from left to right ONLY . It is more precise, but slower.
	Max. Receive Buffer	1 Line, 4K, <i>16K</i> , 28K	Specifies the amount of the printer's buffer used to store data.
	Paper Out Override	No , Yes	A sensor stops printing about 1 inch from the bottom of a single page. Changing this setting to YES allows printing to occur closer to the bottom edge of the paper.
	Print Registration	0.25 mm Right, 0.20 mm Right, 0.15 mm Right, 0.10 mm Right, 0.05 mm Right, 0.00 mm , 0.05 mm Left, 0.10 mm Left, 0.15 mm Left, 0.20 mm Left, 0.25 mm Left	Adjusts the vertical registration in graphics. The best setting may vary from one software package to another.

Factory default settings are printed in ***Bold Italic***.

Except as indicated, the menu for the Epson/IBM model is the same as the menu for the ML/Pacemark model.

Group	Item	Setting	Notes
Set-Up (continued)	Operator Panel Function	<i>Full Operation</i> Limited Operation	Changing this setting to Limited Operation deactivates the menu mode and these control panel buttons: TOP OF FORM, MICRO FEED UP/DOWN, PRINT QUALITY, and PITCH. This is used in situations where several people are using the printer. To restore to full operation, power OFF the printer. Press and hold PRINT QUALITY and PITCH while powering ON the printer. The printer will be in Menu Mode. Change this setting to FULL OPERATION.
	Reset Inhibit	No , Yes	Changing this to Yes prevents a reset signal from the computer from resetting the printer to its defaults.
	Print Suppress Effective	Yes, No	Determines whether the DC3 code causes the printer to ignore data until a DC1 code is received.
	Auto LF	No , Yes	
	Auto CR (IBM only)	No , Yes	
	CSF Bin Select	<i>Bin 1</i> , Bin 2	Only available when the dual bin cut sheet feeder (CSF 3002) is installed. Determines which bin is active.
	SI Select Pitch (10 cpi - IBM ONLY)	<i>17.1</i> , 15 cpi	Sets the pitch of condensed mode from 10 cpi using the SI code.
	SI Select Pitch (12 cpi - IBM ONLY)	<i>20</i> , 12 cpi	Sets the pitch of condensed mode from 12 cpi using the SI code.
	Time Out Print (Epson/IBM)	<i>Valid</i> , Invalid	When set to Valid, contents of the buffer will print when additional data is not received for a predetermined amount of time.
	Auto Select	No , Yes	
Sensor Disable	No , Yes		

Factory default settings are printed in ***Bold Italic***.

Except as indicated, the menu for the Epson/IBM model is the same as the menu for the ML/Pacemark model.

Group	Item	Setting	Notes
Parallel I/F	I-Prime	<i>Buffer Print</i> , Line End, Invalid	Buffer Print = I-Prime makes printer print contents of buffer. Line End = I-Prime makes printer print to the end of the current line. Invalid = I-Prime the signal is ignored.
	Pin 18	<i>+5</i> , 0 V	Determines whether voltage is supplied to pin 18.
	Auto Feed XT (Epson / IBM)	<i>Invalid</i> , Valid	Epson Emulation Some interface cables are wired so that the XT signal always causes an automatic line feed. The <i>Invalid</i> setting eliminates this. Use the <i>Valid</i> setting if the system uses the XT signal for automatic line feed.
Serial I/F	Parity	<i>None</i> , Odd, Even	
	Serial Data 7 or 8 Bits	<i>8 Bits</i> , 7 Bits	
	Protocol	<i>Ready/Busy</i> , X-ON/X-OFF	
	Diagnostic Test	<i>No</i> , Yes	Set to Yes to run the serial interface diagnostic test. To restore to full operation, power OFF the printer. Press and hold PRINT QUALITY and PITCH and power ON the printer. This will place the printer in Menu Mode. Then, change this setting to NO for normal operation.
	Busy Line	<i>SSD-</i> , SSD+, DTR, RTS	
	Baud Rate	19200, <i>9600</i> , 4800, 2400, 1200, 600, 300 bps	
	DSR Signal	<i>Valid</i> , Invalid	
	DTR Signal	<i>Ready on Power Up</i> , Ready on Select	
	Busy Time	<i>200 mS</i> , 1 sec	

3.3.05 Top Of Form

General Information

The Top of Form is the place on the page where printing starts.

When the printer advances to the next page, it stops at the top of form.

The Pacemark 3410 can store a different top of form position for the three standard paper feed paths (top, rear, and bottom).

Setting Top of Form

The same procedure is used for all three paper paths.

1. Load paper into the printer by pressing FORM FEED.
2. Set the Top of Form position.

The red line on the plastic ribbon shield marks the base of the printing line. Use this as your guide when setting the Top of Form.

To increase the space between the top edge of the paper and the print start position (advance the paper), press and hold TOP OF FORM while pressing MICRO FEED up.

To decrease the space between the top edge of the paper and the print start position (retract the paper), press and hold TOP OF FORM while pressing MICRO FEED down.

3. Release TOP OF FORM. The position you set in Step 2 is registered in the printer's memory.

Reset Top of Form and Menu to Factory Defaults

To reset the Top of Form and the Menu to Factory Defaults, follow this procedure.

1. Before resetting the Menu, Okidata **STRONGLY RECOMMENDS** printing the Menu.

Printing the Menu provides a reference of customized settings.

When the Menu is reset, all customized settings are LOST.

2. Power OFF the printer.
3. Press and hold SELECT and TOP OF FORM while powering ON the printer.

This page was intentionally left blank.

3.3.06 Paper Park

General Information

Paper park allows the user to print using single sheet pages without removing continuous forms from the printer.

Procedure: Continuous Feed to Single Sheet

1. Remove any printed pages from the printer.
2. Press PARK to retract the continuous forms paper from the paper path.
3. Move the paper lever to the Single Sheet position.
4. Load the single sheet paper.

Procedure: Single Sheet to Continuous Feed

1. Remove any single sheet pages from the printer.
2. Move the paper lever to the Continuous Forms position (rear feed).
3. Leave the paper lever at the Single Sheet position for bottom feed.
4. Lower the paper support.
5. Press FORM FEED to load the continuous forms paper into the printer.

3.3.07 Forms Tear Off

General Information

This feature allows a printed page (rear feed or bottom feed, continuous form) to be torn off without wasting paper or adjusting the printer.

Forms Tear Off advances the paper from the initial printing position to the tear off position. The top of the page (perforation) will be even with the tear bar. The tear bar is located under the clear top of the access cover.

Paper will remain in the tear off position until the printer receives data. Then, the paper is retracted to the initial print position.

When printing stops, the paper will advance to the tear off position.

NOTE:

If the software package being used "pauses" while sending data to the printer, Forms Tear Off may be activated (if it is enabled through the Menu). The pause must be for two or more seconds. No data is lost. Uneven print registration will occur due to the paper movement. If the problem occurs, deactivate Forms Tear Off through the Menu.

Do NOT use Forms Tear Off with labels or multi-part forms.

Remember to activate the Form Tear Off for the paper path you are using (rear feed or bottom feed).

Setting

1. Verify that continuous feed paper is installed.
2. Verify that the ribbon is correctly installed.
3. Verify that the width of the installed paper matches the paper width menu setting.
4. Press PRINT QUALITY and CHARACTER PITCH at the same time to place the printer in Menu Mode.

When in Menu Mode, the functions printed *below* the operator panels switches are active.

5. Press GROUP until the desired Group prints (Rear Feed or Bottom Feed).
6. Press ITEM until the desired Item prints (Form Tear Off)
7. Press SET until the desired setting prints (Off, 500 mS, 1 sec, 2 sec).
8. Press EXIT to save the change and exit Menu Mode.

Using

1. Load paper.
2. Press FORM FEED
3. The paper will advance past the start print position (Top of Form) to the tear bar position.
4. The paper stays in this position until the printer receives data. Then, the paper will be retracted to the appropriate Top of Form position.
5. A few seconds after printing stops, the paper advances to the tear bar position.

Checking Top of Form with Form Tear Off Activated

1. Load paper.
2. Press and *hold* TEAR. When you release TEAR, the paper will return to the tear off position.
3. The paper will retract to the Top of Form position.
4. Release TEAR.
5. The paper advances to the tear bar position.

This page was intentionally left blank.

3.3.08 Resets

Reset Menu to Factory Defaults

To reset the Menu to Factory Defaults, follow this procedure.

1. Before resetting the Menu, Okidata **STRONGLY RECOMMENDS** printing the Menu.

Printing the Menu provides a reference of customized settings.

When the Menu is reset, all customized setting are LOST.

2. Power OFF the printer.
3. Press and hold SELECT and LINE FEED while powering ON the printer.

Reset Menu and Top of Form to Factory Defaults

To reset the Menu and the Top of Form to Factory Defaults, follow this procedure.

1. Before resetting the Menu, Okidata **STRONGLY RECOMMENDS** printing the Menu.

Printing the Menu provides a reference of customized settings.

When the Menu is reset, all customized setting are LOST.

2. Power OFF the printer.
3. Press and hold SELECT and TOP OF FORM while powering ON the printer.

3.4 CLEANING

WARNING:

When cleaning the printer, turn the power switch OFF and remove the AC power cable from the printer of AC outlet.

3.4.01 General Information

An accumulation of paper dust is the most frequent cause of print quality problems in a dot matrix printer. Small pieces of paper can cause paper jams. A dirty platen will smudge paper. It is important to clean the printer regularly, paying particular attention to the printhead area and paper paths.

If the lubrication procedures are not performed properly, the printer will require more frequent cleaning. Excess lubricant attracts dust and accumulations build up quickly.

Keeping the covers in place and performing the cleaning procedures correctly will help ensure the highest quality printer output.

1. Cleaning Interval: Every six months or 300 Operating Hours
2. Cleaning Tools
 - Lint free cloth
 - Soft cloth
 - Vacuum cleaner
 - Platen cleaner
 - Long cotton swabs
 - All Purpose Cleaner

Table of Cleaning Locations

Follow this chart when cleaning the printer.

Areas to be Cleaned	Action to be Taken
Printer Mechanism	Vacuum paper dust
Carriage Shaft	Wipe clean with lint-free cloth
Slide Bar	Wipe clean with lint-free cloth
Ribbon Protector	Use a dry cotton swab to remove ink residue
Single Sheet Sensor	Wipe with dry cotton swab
Carriage Guide Bearing	Wipe clean with lint-free cloth
Bottom Paper-End Sensor	Wipe with dry cotton swab
Paper Bail Sensor	Wipe with dry cotton swab
Platen	Wipe clean with Okidata Platen Cleaner Pad
Printer Cover	Clean with soft cloth and all-purpose cleaner

Diagram of Cleaning Locations

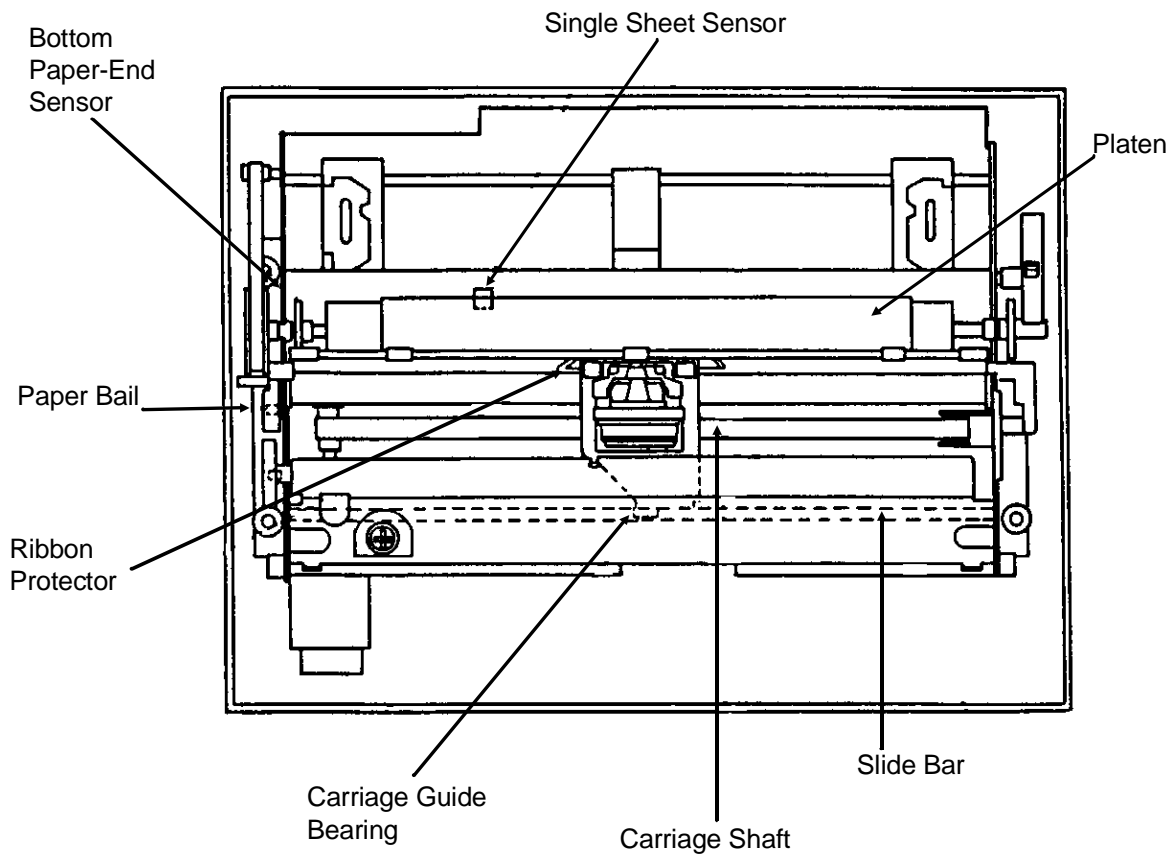

3-4-01.pcx

This page was intentionally left blank.

3.5 LUBRICATION

3.5.01 General Information

If the lubrication procedures are not performed properly, the printer will require more frequent cleaning. Excess lubricant attracts dust and accumulations build up quickly. An accumulation of paper dust is the most frequent cause of print quality problems in a dot matrix printer.

1. Lubricating Interval

Every 600 hours (or Annually).

2. Types of Lubricant

Machine Oil (or equivalent) [MO]

Graphite Based Lubricant (or equivalent) [GL]

3. Amount of Lubricant

Amount "A"

Apply oil liberally

Large amount of graphite lubricant

Amount "B"

Apply three to four drops of oil

Medium amount of graphite lubricant

Amount "C"

Apply one drop of oil

Small amount of graphite lubricant

4. Recommended Lubrication Points

The following pages have illustrations of the recommended lubrication points. The type of lubricant (MO or GL) is followed by the recommended amount (A,B, or C).

3.5.02 Areas Not Lubricated

Area	Reason
Ink Ribbon	Produces Blurred Print Images
Sensors	Attracts Dust - Blocks Sensors
Platen Assembly (Rubber Face)	Stains Paper
Sheet Feeder Assembly	Stains Paper
Mini-pitch Belt	Deterioration and Stretching of Rubber
Mini-pitch Belt Pulley Tooth Face	Deterioration and Stretching of Rubber
Head Cable Assembly	Electrical Problems
Printhead	Malfunction

3.5.03 Lubrication Diagrams

Right and Left Sides of Printer

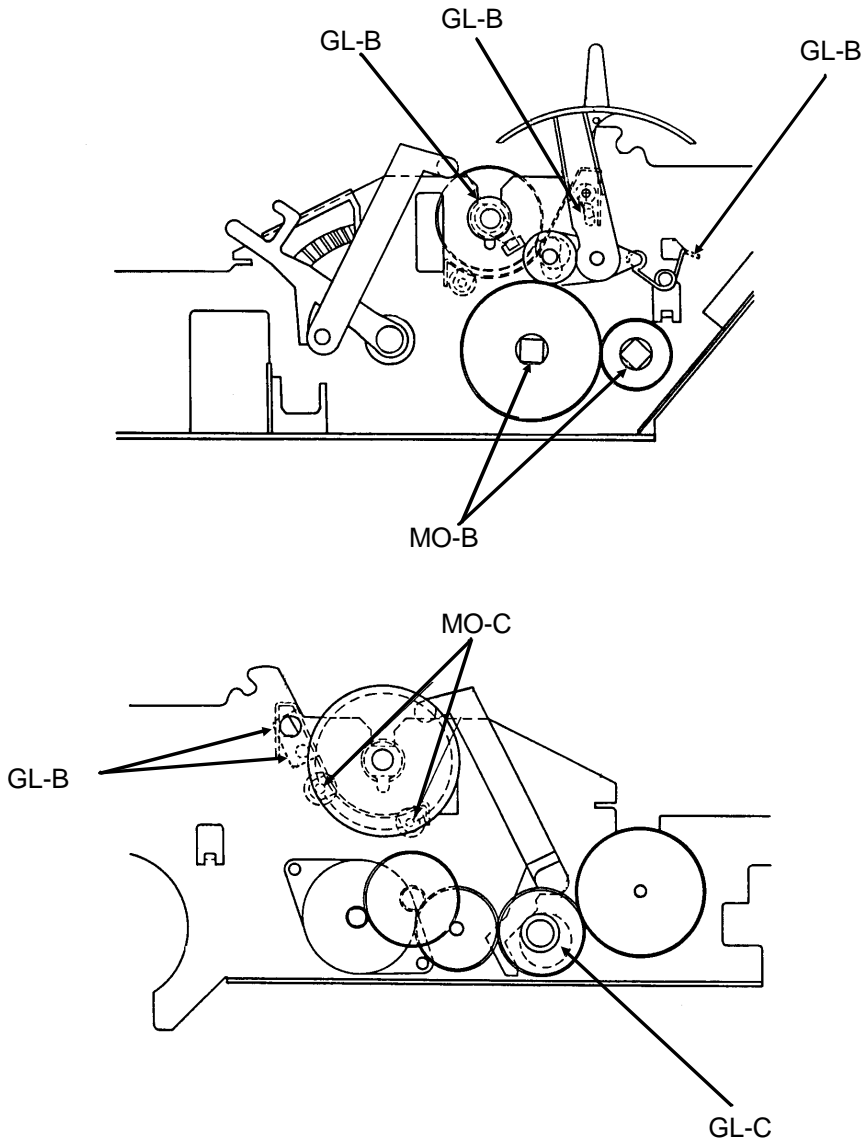

3-5-01.pcx

Carriage Shaft

(Viewed from the top)

To lubricate the carriage shaft, apply a small amount of oil to a clean lint-free cloth and wipe the carriage shaft. Then, using a dry portion of the cloth, wipe the residual oil from the carriage shaft.

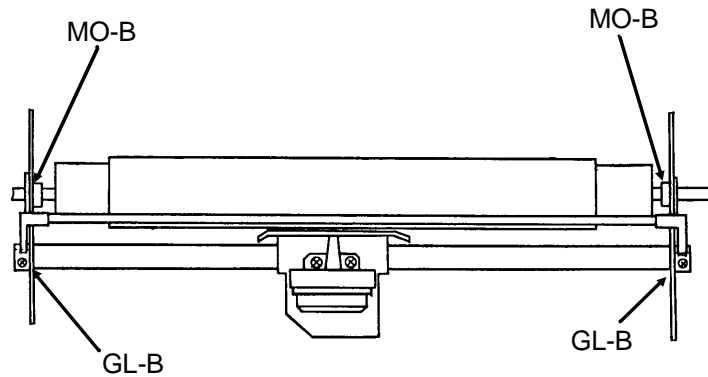

3-5-02.pcx

Ribbon Feed Assembly

(Viewed from the top)

Apply GL-B to the teeth of the six gears

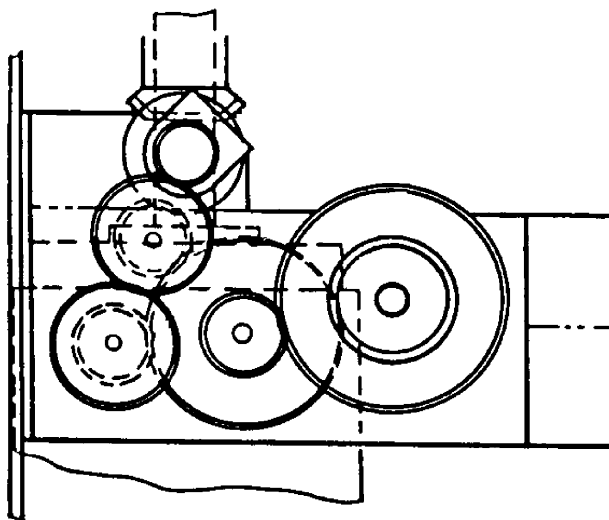

3-5-03.pcx

Space Motor Assembly

(Viewed from the front of the printer)

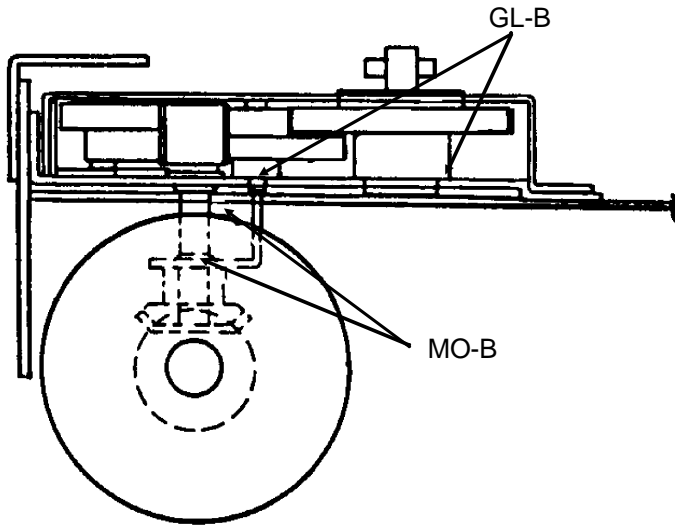

3-5-03.pcx

Tractor Feed Assembly

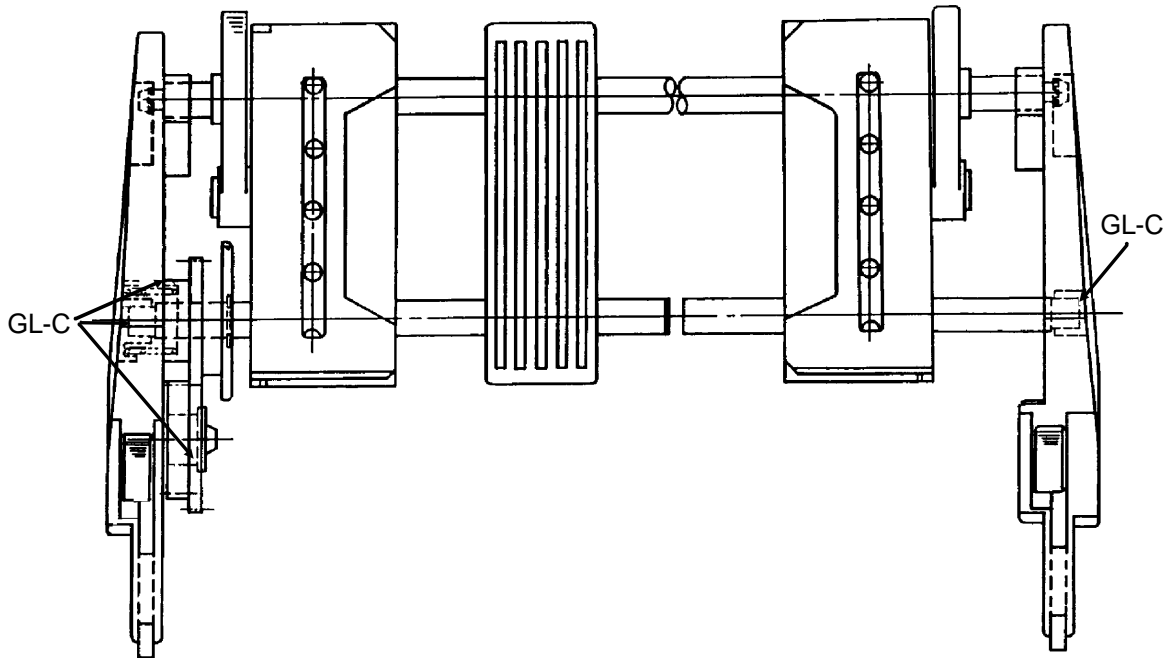

3-5-04.pcx

3.6 SHIPPING INSTRUCTIONS

3.6.01 Return for Service

CAUTION:

When shipping the printer, use the original packaging to prevent damage.

Be sure to secure the printhead so it will not move during shipment.

1. Locate the original packaging or order replacement packaging from Okidata. (Refer to Appendix B)
2. Make sure the printhead is secured so it will not move during shipment.
3. Remove the platen knob. Be sure to place it in the shipping container.
4. Pack the unit, using the materials from Step 1.

3.6.02 All Other Returns

CAUTION:

The product MUST be returned in the original packaging.

The product MUST be returned with ALL originally supplied factory items.

Be sure to secure the printhead so it will not move during shipment.

1. Locate the original packaging or order replacement packaging from Okidata. (Refer to Appendix B)
2. Locate the originally supplied factory items.
(Refer to *Setting Up* in the Printer Handbook)
3. Make sure the printhead is secured so it will not move during shipment.
4. Pack the unit, using the materials from Step 1.

This page was intentionally left blank.

SECTION FOUR
FAILURE ANALYSIS

4.1 OVERVIEW

4.1.01 Introduction

This section is used to isolate problems to the assembly level. Application problems and detection of faulty components on the printed circuit boards are NOT addressed.

When troubleshooting a defective unit, follow these steps.

1. Refer to Section 4.3, which explains where to check for updates to the troubleshooting information.
2. Section 4.4 contains tips on preventing problems, as well as a list of common problems.
3. Section 4.5 shows samples of abnormal outputs.
4. Section 4.6 provides tables of error messages.
5. Section 4.7 contains the Repair Analysis Procedures (RAPs). Each RAP will ask you questions or require you to make observations. The answers to these questions and the results of your observations determine your next course of action. Use the RAP Index to identify which RAP should be used to resolve the problem with the machine.
6. Section 4.8 provides the procedures for various printer tests.
7. Section 4.9 lists the resistance check points.
8. Section 4.2 lists methods for reporting problems. If you encounter a situation that is NOT addressed by the documentation in this kit, please report the problem to Okidata, using one of the methods listed.

Refer to the Service Center Reference Guide for information on contacting Okidata.

This page was intentionally left blank.

4.1.02 Printer Serial Number Identification

To identify the revision level of a printer, record the serial number from the back of the printer. Refer to the following to decode the serial number.

Example Printer Serial Number: 401A0154693

Date Code 401 (4 = year. 01 = month)

Revision A

Serial Number 0154693

4.2 REPORTING PROBLEMS

4.2.01 General Information

Okidata strives to provide accurate and detailed service information through its training materials. The Technical Training Group realizes that service technicians have valuable experience, knowledge, and opinions. Okidata strongly encourages you to report any problems you may encounter when using the materials of this training kit. Please be as specific and detailed as possible. Your comments, suggestions, and criticisms are used to update and revise training kits.

You should reference the training materials when servicing Okidata products. Most problems can be solved by using the information provided in the training materials. If you encounter a situation that cannot be solved, please let Okidata know.

Refer to the Service Center Reference Guide for information on contacting Okidata.

4.2.02 Problem Lists

Technicians frequently request a list of common problems specific to a product. Technical Training Kits are written before a product is shipped to customers. Therefore, such information is NOT available when a product is first released.

However, Okidata wants to respond to these requests. Okilink II provides round-table discussions on technical problems. Errors and corrections in the training materials are listed in the Training Section of Okilink II. The Technical Service Bulletins (also known as Okidata's Monthly Mail) are available via Okilink II. Situations that are NOT addressed in the reference documentation, technical service bulletins, or round-tables may be reported to the Dealer Service and Support Engineers (Contact Technical Support) or the Technical Training Group. You will receive a response to your message within one business day.

The information on Okilink II is the most accurate and up-to-date technical information available from Okidata. This is only possible with your assistance. By reporting your suggestions, concerns, and problems, Okidata can provide the best possible information.

Your cooperation is greatly appreciated. Thank you for your help!

4.2.03 Reporting Methods

Okilink II

You may use Okilink II to report your findings. Refer to the Service Center Reference Guide for information on using Okilink II.

Course Critique

Use the Course Critique to report any problems you find as you are completing the self-paced training.

Fax Number

If you wish to fax your response, please use the numbers listed in the Service Center Reference Guide.

Mailing Address

If you respond by mail, please use the appropriate address listed in the Service Center Reference Guide.

Information Provided

Please provide the following information when reporting problems.

Okidata Dealer Number

Technician's Name

Company Name

Company's Address (Street, City, State/Province, ZIP / Postal Code, Country)

Telephone and Fax Numbers (with area / country access codes)

Product Name

Unit's Serial Number

Firmware Revision Level

Description of Problem

Document Name (with page number or procedure) with error or problem.

4.3 TROUBLESHOOTING UPDATES

4.3.01 General Information

Okidata distributes updated troubleshooting information in three ways.

Okilink II

Faxable Facts

Technical Service Bulletins

4.3.02 Okilink II

Okilink II is Okidata's Bulletin Board Service. This service is available to all Okidata Certified Service Technicians. Okilink II provides troubleshooting and service information. Technicians can download files, ask questions of Okidata's technical support personnel, and participate in round table discussions about Okidata products and services. Technical Service Bulletins, Recommended Spare Parts Lists, Printer Drivers, Product Specifications, and Service Training Information are also available.

Refer to the Service Center Reference Guide for information on accessing Okilink II.

4.3.03 Faxable Facts

Okidata's Faxable Facts is an automated fax document retrieval system. It is maintained by Okidata's Customer Information Center. Answers to common questions about Okidata products are available through Faxable Facts.

Refer to the Service Center Reference Guide for information on accessing Faxable Facts.

4.3.04 Technical Service Bulletins

Okidata's Technical Service Bulletins (TSBs) contain technical information developed after product release. Firmware updates, part number changes, and procedural changes are some of the subjects covered by these bulletins. The TSBs are distributed through Okilink II.

Refer to the Service Center Reference Guide for information on accessing Okilink II.

4.4 TROUBLESHOOTING TIPS

4.4.01 Preliminary Checks

1. Is the product being operated under the proper ambient conditions?
2. Does the paper being used meet the specifications for this product?
3. Has the ribbon been replaced as recommended?
4. Has the ribbon been installed properly?
5. Is an Okidata ribbon being used?
6. Is the printhead gap correctly set?

4.4.02 Problem Categories

There are three categories of problems that you might encounter when servicing the printer.

ALARM Lamp Blinks (Fatal Errors)

The following can cause the ALARM lamp to blink.

- Open Bail Arm
- Jammed Paper
- Printhead Cannot Move
- Other Fatal Error

When the ALARM Lamp is blinking, check the items listed below.

1. Close the bail arm.
2. Check for a paper jam.
3. Verify that the printhead moves freely.
4. Record the status of the ALARM, PRINT QUALITY, and CHARACTER PITCH Lamps.
5. Refer to the Alarm Lamp Codes Table. (Section 4.6)
6. Locate the error.
7. Perform the designated corrective action.

Operational Errors

An Operational Error is usually not accompanied by an ALARM Lamp.

Refer to the Start Here Flowchart (Section 4.4.03) and perform the corrective action.

ALARM Lamp Lights (Paper End/Jam Conditions)

A solid ALARM Lamp usually indicates a cover open, paper jam or paper-end (out of paper) condition.

4.4.03 START HERE Flowchart

START

Does the failure occur immediately after the unit is powered ON?

YES Which of the following resembles the problem?

Power is not supplied to the printer

Refer to RAP 01

No spacing operation

Refer to RAP 02

ALARM lamp is blinking

Refer to Section 4.6

NO The problem occurs during printing.

Refer to the RAP Index - Section 4.7

4.4.04 Tips for Preventing Image Problems

1. Make sure that the ribbon is not "dried out". If the printer output is faded, install a new ribbon, then print another sample.
2. Make sure that the paper you are using is within specifications. Paper specifications can be found in Section 1 of this Service Handbook.
3. Always place the Head Gap Lever in the position appropriate for the paper that you are using.

4.4.05 Common Problems

1. Nothing happens when the printer is powered ON.

Make sure the printer is plugged in.

Check the power cord connection to the printer and the outlet.

If a power strip is being used, make sure the strip is powered ON.

2. The ALARM lamp is lit.

The printer may be out of paper or the paper may have jammed. The SEL lamp will not light. After loading paper, press the SEL switch.

If the ALARM lamp does not go out after paper is loaded, refer to Section 4.5 of this Service Handbook.

3. The printer does not print when the computer sends it data.

The printer may be deselected. Make sure that the SEL lamp is lit. If it is not, press the SEL switch.

4. The paper keeps jamming.

Verify that the top of form is set so that the paper is held in place by the bail bar. If the top edge of the page is below the bail, it will catch on the bail as it advances. Do not use the FORM FEED switch to load paper into the printer.

If the paper does jam, power OFF the printer. Carefully back the paper out of the paper path by using the platen knob. Remove any shreds of paper from the paper path.

5. The printer suddenly changes to unidirectional printing. It then stops printing completely. The MENU light is flashing.

This indicates a Printhead Overheat Condition. When the printer prints for a long period of time, heat will build up in the printhead. When the printhead temperature reaches approximately 115 degrees Celsius, the printer will print unidirectionally. If the temperature continues to rise, printing will stop until the printhead cools. Printing will resume after the printhead cools.

6. Static electricity causes the paper to stick.

In cold, dry weather, static charges can build up on continuous-form paper. This can make the paper cling to the paper separator. If this problem occurs during high-volume printing jobs, try moving the single sheet paper guides on the separator together so that the paper rests on the guides rather than on the separator itself.

7. Files do not print the way the printer menu and front panel are set.

Before sending a file to a printer, many word processors send an initialization string. This string contains codes that reset the printer to a default set of features. Otherwise, the printer might print using features set for a previous job. The codes will override panel or menu settings.

Check the word processor's manual to see if the initialization string can be modified. If so, remove any codes that interfere with the printer's settings.

To set the printer to ignore the reset code, follow this procedure.

1. Verify that the printer is loaded with paper and that the ribbon and printhead are installed.
2. Verify that the printer is powered ON.
3. Press PRINT QUALITY and CHARACTER PITCH to enter Menu Mode.
4. The first Group/Item/Setting will print.
5. Press GROUP until SET UP prints.
6. Press ITEM until RESET INHIBIT prints.
7. Press SET until YES prints.
8. Press EXIT to exit the Menu Mode.

This will stop the reset code from resetting the printer, but other codes in the initialization string may still override the printer Menu and / or front panel settings.

8. Output is missing dots.

Check the headgap setting. Move the head gap lever to a lower setting.

Settings 1, 2, and 3 are for one or two part forms.

Settings 3, 4, and 5 are for three or four part forms.

Settings 6 - 9 are for envelopes and extra-thick paper.

Perform the Printhead Gap Adjustment. Refer to Section 3.3 of this Service Handbook for details.

Refer to RAP 03.

9. Strange symbols and incorrect fonts appear during a print run.

The printer driver does not agree with the emulation selected for the printer.

OR

Incorrect printer commands are embedded within the software.

To check the selected emulation, follow this procedure.

1. Verify that the printer is loaded with paper and that the ribbon and printhead are installed.
2. Verify that the printer is powered ON.
3. Press PRINT QUALITY and CHARACTER PITCH to enter Menu Mode.
4. A line will print, indicating the emulation selected.
5. Press SET to change the emulation.
6. Press SELECT to exit Menu Mode.

If the emulation is correct, check the software documentation on how to select a printer driver. Verify that the selected driver is correct for the emulation. Refer to the Printer Handbook. Drivers near the top of the list are more compatible with the printer than drivers near the bottom of the list. If the software does NOT offer any driver on the list, check with the software manufacturer to see if additional drivers have been added since the software was purchased.

Verify that any embedded commands in the software have been correctly entered.

10. TOP OF FORM, MICRO FEED UP / DOWN, PRINT QUALITY, and CHARACTER PITCH (on the operator panel) do not work.

The Operator Panel Function Item in the Printer Menu can be set to enable (FULL OPERATION) or disable (LIMITED OPERATION) these features. If the printer is part of a customized system or if it is used by different operators, a system manager may be using this feature to maintain proper print settings.

To activate these switches, power OFF the printer. Press and hold PRINT QUALITY and CHARACTER PITCH while powering ON the printer. Follow the normal menu procedures to set the Operator Panel Function Item to FULL OPERATION.

4.5 ABNORMAL OUTPUT

4.5.01 Output Samples

Light Print on the Entire Page

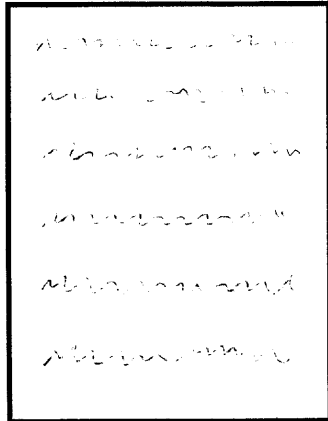

Uneven Print Density

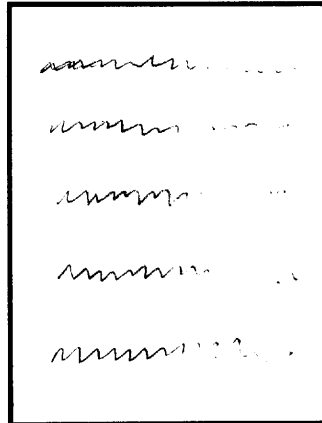

Smearred Print

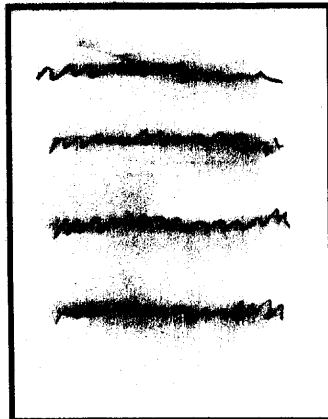

Inconsistent Line Feed

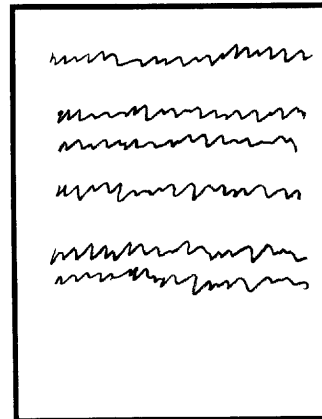

Drifting Margin

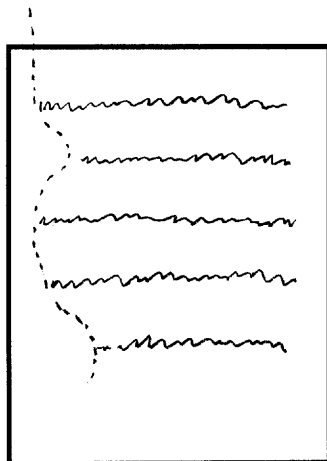

4-5-01.pcx

Light Print on the Entire Page

Possible Causes:

1. Ribbon is "dried out". Replace the ribbon.
2. Head gap lever is in the incorrect position. Place the lever in correct position.
3. Paper is not within specification. Refer to Section One for paper specification.

Uneven Print Density

Possible Causes:

1. Printhead gap not within specification. Perform the printhead gap adjustment.
2. Defective platen. Replace the platen.

Smearred Print

Possible Causes:

1. Head gap lever is in the incorrect position. Place the lever in correct position.
2. Paper is not within specification. Refer to Section One for paper specification.
3. Ribbon protector is missing or broken. Replace the ribbon protector.

Inconsistent Line Feed

Possible Causes:

1. Power OFF the printer. Turn the platen knob. The platen should rotate smoothly. If it does not, remove the cause of the binding.
2. Make sure that the line feed belt tension is within specification. If it is not, tighten the line feed belt.
3. Defective line feed motor. Replace the line feed motor.

Drifting Margin

Possible Causes:

1. Power OFF the printer. Move the carriage assembly. The carriage should move smoothly. If it does not, remove the cause of the binding.
2. Make sure that the space belt tension is within specification. If it is not, tighten the belt.

This page was intentionally left blank.

4.6 FAULT ALARMS

4.6.01 Error Indications

ALARM Lamp Status	Character Pitch Lamp	Print Quality Lamp	Description of Error	Recommended Action
ON	N/A	N/A	Cover Open Switch	Close access cover Replace cover open switch Replace main logic board
ON	N/A	N/A	Paper End	Install paper Go to RAP 10
Flashing	10	Gothic	Spacing Error	Go to RAP 02
Flashing	12	Gothic	Head Homing Error	Go to RAP 03
Flashing	15	Gothic	Bail Homing Error	Go to RAP 04
Flashing	17	Gothic	Carriage Position Sensing Alarm	Go to RAP 03.
Flashing	20	Gothic	Fan Alarm	Replace the power supply unit.
Flashing	PROP	Gothic	Power Down Alarm See Note 1	Go to RAP 03 Replace the power supply unit.
Flashing	10 and PROP	Gothic	Head Thermistor Alarm	Replace the printhead.
Flashing	10	None	Firmware MSG Alarm	Replace the firmware. Replace the main logic board.
Flashing	12	None	Firmware OVERRUN Alarm	Replace the firmware. Replace the main logic board.
Flashing	10	HSD	(CPU) RAM Alarm	Replace the main logic board.
Flashing	12	HSD	NMI Alarm	Replace the main logic board.
Flashing	15	HSD	Watch Dog Timer Alarm	Replace the main logic board.
Flashing	17	HSD	Break Alarm	Replace the main logic board.
Flashing	10	Utility	Program ROM Alarm	Replace the firmware. Replace the main logic board.
Flashing	12	Utility	EEPROM Alarm	Replace the EEPROM. Replace the main logic board.
Flashing	15	Utility	External RAM Alarm	Replace the RAM. Replace the main logic board.

NOTE 1:

The + 38 vdc drive voltage has dropped below + 30 vdc.

4.7 REPAIR ANALYSIS PROCEDURES (RAPs)

4.7.01 Using the RAPs

When using the Repair Analysis Procedures, follow these steps.

1. Go to the RAP Index.
2. Find the RAP which is associated with the printer's problem.
3. Go to the appropriate RAP.
4. All RAPs begin with a START statement, followed by questions or another type of statement.

4.7.02 RAP Index

RAP Number	Description
01	Power Lamp Does Not Light
02	Spacing Error
03	Head Homing Error
04	Bail Homing Error
05	Ribbon Feed Problem
06	Wrong Character, Character Omission or Dot Omission
07	Line Feed Problem
08	Malfunction of Operator Panel Switch
09	Data Receiving Failure
10	Alarm Lamp ON
11	Bottom Tractor Unit Feed Error

RAP 01: Power Lamp Does Not Light

START

Is the AC cable connected to an AC outlet and the printer?

NO Connect the AC cable.

Is the problem resolved?

YES End of procedure.

NO Go to the next step listed below.

YES Is fuse F1 on the power supply unit open?

YES Replace fuse F1.

Does fuse open again?

YES Go to A.

NO Is the problem resolved?

YES End of procedure.

NO Contact Technical Support.

NO Are the + 5 vdc and + 38 vdc present on the main logic board?

For + 5 vdc, check between Pin 24 of Q5 and the power bar.

For + 38 vdc, check both ends of Capacitor C4.

NO Are connectors CN3 and CN7 attached to the main logic board?

NO Attach the connectors.

Is the problem resolved?

YES End of procedure.

NO Go to the next step listed below.

YES Go to A.

YES Replace the main logic board.

Is the problem resolved?

YES End of procedure.

NO Go to A.

A

Replace the power supply unit or connection cable.

Is the problem resolved?

YES End of procedure.

NO Contact Technical Support.

RAP 02: Spacing Error

START

Is the carriage assembly binding or jammed?

YES Remove the cause of the carriage jam.

Is the problem resolved?

YES End of procedure.

NO Go to the next step listed below.

NO Replace the Program ROM on the main logic board.

Is the problem resolved?

YES End of procedure.

NO Is fuse F1 on the main logic board open?

NO Go to A.

YES Replace fuse F1.

Is the problem resolved?

YES End of procedure.

NO Go to A.

A

Is +38vdc present on the main logic board? Check at both ends of Capacitor C4.

YES Are the cables to CN3 and CN7 on the main logic board connected correctly?

NO Correctly connect them.

YES Replace the power supply unit or connection cable.

Is the problem resolved?

YES End of procedure.

NO Go to the next step listed below.

NO Are the cables to CN1 and CN5 on the main logic board connected correctly?

NO Correctly connect them.

YES Replace the main logic board.

Is the problem resolved?

YES End of procedure.

NO Replace the space motor.

Is the problem resolved?

YES End of procedure.

NO Contact Technical Support.

RAP 03: Head Homing Error

START.

Is +38vdc present on the main logic board? Check at both ends of Capacitor C4.

NO Check for an open fuse on the main logic board.

Are the cables from CN3 and CN7 on the main logic board correctly connected to the power supply unit?

YES Replace the power supply unit.

NO Connect them correctly.

Is the problem resolved?

YES End of procedure.

NO Go to the next step listed below.

YES Make sure that connector CN1 on the main logic board is correctly installed.

Is the problem resolved?

YES End of procedure.

NO Power OFF the printer and manually move the carriage.
Does it move smoothly?

YES Replace the main logic board.

Is the problem resolved?

YES End of procedure.

NO Replace the space motor.

Is the problem resolved?

YES End of procedure.

NO Contact Technical Support.

NO Is there any paper scrap or dirt on the spacing mechanism?

YES Remove the obstruction.

NO Remove the ribbon cartridge.

Does the carriage move smoothly?

YES Replace the ribbon cartridge.

NO Replace the ribbon feed assembly.

Is the problem resolved?

YES End of procedure.

NO Replace the space motor.

Is the problem resolved?

YES End of procedure.

NO Contact Technical Support.

RAP 04: Bail Homing Error

START.

Manually rotate the bail open gear counterclockwise.

Does it rotate smoothly?

NO Remove all obstructions from the bail motor gear, idle gear, and bail open gear.
Check the meshing of each of the following. Replace defective items.

Bail Motor Gear

Idle Gear

Bail Open Gear

YES Is the cable to CN4 on the main logic board connected correctly?

NO Connect it correctly.

YES Are the cables to CN2 and CN3 on the sensor board connected correctly?

NO Connect them correctly.

YES Is there dirt or dust on any of the sensors on the sensor board?

YES Clean the sensors.

NO Is the bail arm lever damaged?

YES Replace the bail arm lever.

NO Replace the main logic board.

Is the problem resolved?

YES End of procedure.

NO Replace the sensor board.

Is the problem resolved?

YES End of procedure.

NO Replace the bail motor.

Is the problem resolved?

YES End of procedure.

NO Contact Technical Support.

RAP 05: Ribbon Feed Problem

START.

Remove the ribbon cartridge.

Rotate the ribbon cartridge ribbon feed knob.

Does it rotate smoothly?

NO Has the lock mechanism on the ribbon been disengaged?

YES Replace the ribbon cartridge.

NO Disengage the lock mechanism.

YES Replace the ribbon. Slide the carriage from the the left to the right.

Does the ribbon feed shaft rotate?

NO Replace the ribbon feed assembly.

YES Verify that the ribbon feed shaft is correctly engaged with the ribbon feed roller of the ribbon cartridge.

RAP 06: Wrong Character, Character Omission or Dot Omission

START.

Are the cables to CN2 and CN6 on the main logic board connected correctly?

NO Connect them correctly.

Is the problem resolved?

YES End of procedure.

NO Go to the next step listed below.

YES Is the cable to CN101 on the interface connector board connected correctly?

NO Connect it correctly.

Is the problem resolved?

YES End of procedure.

NO Go to A.

A

YES Is the interface cable connected correctly?

NO Connect it correctly.

YES Are the + 8 vdc output voltages supplied by the main logic board?
Check at pin 6 of connector CN7.

NO Are the cables to CN3 and CN7 on the main logic board properly connected
to the power supply unit?

NO Connect them correctly.

YES Replace the Power Supply Unit.

YES Replace the printhead.

Is the problem resolved?

YES End of procedure.

NO Replace the Program and Slave ROMs.

Is the problem resolved?

YES End of procedure.

NO Are the cables connected to CN2 and CN6 on the main logic board
damaged?

YES Replace the cables.

NO Check the following MENU Settings related to the interface:

Baud Rate

Character Format

Protocol

BUSY Signal output selection

RAP 07: Line Feed Problem

START.

Place the release lever in the cut-sheet feed position.

Manually rotate the platen knob.

Does it rotate smoothly?

YES Place the release lever in the tractor feed position.

Rotate the platen knob.

Does it smoothly rotate?

NO Check the synchronization of the push tractor assemblies.

Replace the right or left push tractor, as necessary.

YES Go to A.

NO Replace the line feed motor.

A

Is the cable to CN6 on the main logic board connected correctly?

NO Connect it correctly.

YES Is the cable to CN101 on the interface connector board connected correctly?

NO Connect it correctly.

YES Is the cable to CN102 on the interface connector board connected correctly?

NO Connect it correctly.

YES Replace the main logic board.

Is the problem resolved?

YES End of procedure

NO Replace the line feed motor.

RAP 08: Malfunction of Operator Panel Switch

START.

Is the cable to CN1 on the operator panel connected correctly?

NO Connect it correctly.

YES Is the cable to CN10 on the operator panel connected correctly?

NO Connect it correctly.

YES Replace the operator panel circuit board.

Is the problem resolved?

YES End of procedure

NO Replace the operator panel holder.

Is the problem resolved?

YES End of procedure

NO Replace the main logic board.

RAP 09: Data Receiving Failure

START.

Is the SELECT lamp flashing?

YES Set the menu to ignore DC3.

NO Is the ALARM lamp ON?

YES Go to RAP 10.

NO Is the SELECT lamp ON?

NO Set the printer ON LINE.

YES Is the interface cable connected correctly?

NO Correctly connect the cable.

YES Is cable CN101 on the interface connector board connected correctly?

NO Correctly connect the cable.

YES Is cable CN6 on the operator panel connected correctly?

NO Correctly connect the cable.

YES If parallel, go to Parallel
If serial, go to Serial.

Parallel

Replace the Program ROMs on the main logic board. Is the problem resolved?

YES End of procedure.

NO Replace the main logic board.

Is the problem resolved?

YES End of procedure.

NO Replace the interface connector board.

Is the problem resolved?

YES End of procedure.

NO Replace the cable connected to CN6 on the main logic board.

Is the problem resolved?

YES End of procedure.

NO Contact Technical Support.

Serial

Correctly set the interface menu parameters.

Is the problem resolved?

YES End of procedure.

NO Are +/- 8 vdc present at the main logic board?
Check + 8 vdc at Pin 6 of cable CN7.
Check - 8 vdc at Pin 7 of cable CN7.

NO Replace the power supply unit.

YES Replace the Program ROMs on the main logic board.

Is the problem resolved?

YES End of procedure.

NO Replace the main logic board.

Is the problem resolved?

YES End of procedure.

NO Replace the interface connector board.

Is the problem resolved?

YES End of procedure.

NO Replace the cable connected to CN6 on the main logic board.

Is the problem resolved?

YES End of procedure.

NO Contact Technical Support.

This page was intentionally left blank.

RAP 10: ALARM Lamp ON

START.

Remove the front access cover.

Override the space motor interlock switch (left side).

Power ON the unit while overriding the cover open switch (right side).

Does the ALARM lamp light?

NO Correctly connect cable CN13 on the main logic board.
Check the alignment between the front access cover and the cover open switch.
Replace the cover open microswitch/cable assembly.

YES Is the paper properly installed?

NO Install the paper properly.

YES Does the continuous form end microswitch function correctly?

NO Correctly connect CN103 on the interface connector board.
Replace the sheet feeder assembly.

YES Does the single sheet end sensor function correctly?

NO Check that there is no dirt or dust on the sensor surface.
Correctly connect CN1 on the sensor board.
Replace the sensor cable assembly.

YES Does the bottom feed paper end sensor function correctly?

NO Check that there is no dirt or dust on the sensor on the sensor board.
Correctly connect cable CN4 on the main logic board.
Replace the sensor board.

YES Does the release lever microswitch function correctly?

NO Correctly connect cable CN9 on the main main logic board.
Replace the release lever microswitch and cable assembly.

YES Replace the main logic board.

RAP 11: Bottom Tractor Feed Unit (BTFU) Problem

START.

Is the BTFU cable attached to the CSF connector?

NO Connect the cable.

YES Is the release lever in the cut sheet position?

NO Place the release lever in the cut sheet position.

YES Does the paper feed properly?

YES End of procedure.

NO Does the paper move at all?

NO Replace the BTFD board.

Is the problem resolved?

YES End of procedure.

NO Replace the bottom feed unit motor.

Is the problem resolved?

YES End of procedure.

NO Replace the main logic board.

YES Go to A.

A

Does the paper jam?

YES Clear the paper path.

Is the problem resolved?

YES End of procedure.

NO Replace the bottom feed unit motor.

Is the problem resolved?

YES End of procedure.

NO Replace the bottom tractor assembly.

NO Is paper skewed?

YES Properly install the paper.

Is problem resolved?

YES End of procedure.

NO Replace the bottom tractor assembly.

NO Contact Technical Support.

This page was intentionally left blank.

4.8 PRINTER TESTS

4.8.01 Rolling ASCII Test

CAUTION:

Select the correct paper width setting in the Printer Menu for the paper feed path. Using 9.5 inch paper in a path set for 13.6 inch paper will cause this test to be printed on the right side of the platen. This could destroy the printhead or platen.

This test will not run unless continuous feed paper is installed in the printer.

General Information

The Rolling ASCII Test will continually print the ASCII Character Set (shifting the characters one position to the right on subsequent lines).

If the characters appear lighter towards either margin, check the printhead gap adjustment.

If the print is light across the entire page, check the setting of the printhead gap adjusting lever. If the lever is in the correct position, this problem could be caused if the printer is using an old ribbon, or by an incorrect printhead gap adjustment.

The header contains information which can be helpful when servicing the printer.

Printer Model

Character Set

Firmware Part Number (Current part numbers are available through Okilink II)

Emulation

Firmware / Character Generator Revision Level

Procedure

To perform the Rolling ASCII Test, follow this procedure.

1. Verify that continuous feed paper is installed.
2. Verify that the ribbon is correctly installed.
3. Verify that the width of the installed paper matches the paper width menu setting.
4. Power OFF the printer.
5. Press FORM FEED as you power ON the printer.
6. The Test will run until one of the following situations occur.
 - A. The technician presses SELECT.
 - B. A Paper End condition is encountered.

4.8.02 Font Sample Test

NOTE:

This test will not run unless continuous feed paper is installed in the printer.

General Information

The Font Sample Test print samples of fonts at various character pitches.

This test will not run unless continuous feed paper is installed in the printer.

The header contains information which can be helpful when servicing the printer.

Printer Model

Character Set

Firmware Part Number (Current part numbers are available through Okilink II)

Emulation

Firmware / Character Generator Revision Level

Procedure

To perform the Font Sample Test, follow this procedure.

1. Verify that continuous feed paper is installed.
2. Verify that the ribbon is correctly installed.
3. Verify that the width of the installed paper matches the paper width menu setting.
4. Power OFF the printer.
5. Press LINE FEED as you power ON the printer.
6. The test will print.
7. To stop the test (at any time), press SELECT.
8. When the two page test is complete, the SELECT lamp will turn OFF.
9. Press SELECT to place the printer ON-LINE.

Sample

```

PM 3410 EI A F/W 01.18 YR4089-3008
CS 01.11

HSD 10CPI
!@#%&'()*+,-./0123456789:;<=>?@ABCDEFGHIJKLMN
PQRSTUVWXYZ[\]^_`abcdefghijklmnopqrstuvwxyz{|}~
123456789:;<=>?@ABCDEFGHIJKLMN
PQRSTUVWXYZ[\]^_`abcdefghijklmnopqrstuvwxyz{|}~
123456789:;<=>?@ABCDEFGHIJKLMN
PQRSTUVWXYZ[\]^_`abcdefghijklmnopqrstuvwxyz{|}~

HSD 12CPI
!@#%&'()*+,-./0123456789:;<=>?@ABCDEFGHIJKLMN
PQRSTUVWXYZ[\]^_`abcdefghijklmnopqrstuvwxyz{|}~
123456789:;<=>?@ABCDEFGHIJKLMN
PQRSTUVWXYZ[\]^_`abcdefghijklmnopqrstuvwxyz{|}~
123456789:;<=>?@ABCDEFGHIJKLMN
PQRSTUVWXYZ[\]^_`abcdefghijklmnopqrstuvwxyz{|}~

HSD 17CPI
!@#%&'()*+,-./0123456789:;<=>?@ABCDEFGHIJKLMN
PQRSTUVWXYZ[\]^_`abcdefghijklmnopqrstuvwxyz{|}~
123456789:;<=>?@ABCDEFGHIJKLMN
PQRSTUVWXYZ[\]^_`abcdefghijklmnopqrstuvwxyz{|}~
123456789:;<=>?@ABCDEFGHIJKLMN
PQRSTUVWXYZ[\]^_`abcdefghijklmnopqrstuvwxyz{|}~

UTL 10CPI
!@#%&'()*+,-./0123456789:;<=>?@ABCDEFGHIJKLMN
PQRSTUVWXYZ[\]^_`abcdefghijklmnopqrstuvwxyz{|}~
123456789:;<=>?@ABCDEFGHIJKLMN
PQRSTUVWXYZ[\]^_`abcdefghijklmnopqrstuvwxyz{|}~
123456789:;<=>?@ABCDEFGHIJKLMN
PQRSTUVWXYZ[\]^_`abcdefghijklmnopqrstuvwxyz{|}~

UTL 12CPI
!@#%&'()*+,-./0123456789:;<=>?@ABCDEFGHIJKLMN
PQRSTUVWXYZ[\]^_`abcdefghijklmnopqrstuvwxyz{|}~
123456789:;<=>?@ABCDEFGHIJKLMN
PQRSTUVWXYZ[\]^_`abcdefghijklmnopqrstuvwxyz{|}~
123456789:;<=>?@ABCDEFGHIJKLMN
PQRSTUVWXYZ[\]^_`abcdefghijklmnopqrstuvwxyz{|}~

UTL 17CPI
!@#%&'()*+,-./0123456789:;<=>?@ABCDEFGHIJKLMN
PQRSTUVWXYZ[\]^_`abcdefghijklmnopqrstuvwxyz{|}~
123456789:;<=>?@ABCDEFGHIJKLMN
PQRSTUVWXYZ[\]^_`abcdefghijklmnopqrstuvwxyz{|}~
123456789:;<=>?@ABCDEFGHIJKLMN
PQRSTUVWXYZ[\]^_`abcdefghijklmnopqrstuvwxyz{|}~

NLG 10CPI
!@#%&'()*+,-./0123456789:;<=>?@ABCDEFGHIJKLMN
PQRSTUVWXYZ[\]^_`abcdefghijklmnopqrstuvwxyz{|}~
123456789:;<=>?@ABCDEFGHIJKLMN
PQRSTUVWXYZ[\]^_`abcdefghijklmnopqrstuvwxyz{|}~
123456789:;<=>?@ABCDEFGHIJKLMN
PQRSTUVWXYZ[\]^_`abcdefghijklmnopqrstuvwxyz{|}~

NLG 12CPI
!@#%&'()*+,-./0123456789:;<=>?@ABCDEFGHIJKLMN
PQRSTUVWXYZ[\]^_`abcdefghijklmnopqrstuvwxyz{|}~
123456789:;<=>?@ABCDEFGHIJKLMN
PQRSTUVWXYZ[\]^_`abcdefghijklmnopqrstuvwxyz{|}~
123456789:;<=>?@ABCDEFGHIJKLMN
PQRSTUVWXYZ[\]^_`abcdefghijklmnopqrstuvwxyz{|}~

NLG 10CPI DOUBLE WIDTH/HIGHT
!@#%&'()*+,-./0123456789:;<=>?@ABCDEFGHI
HIJKLMN
PQRSTUVWXYZ[\]^_`abcdefghijklmnopqrstuvwxyz{|}~

```

4-5-01a.pcx

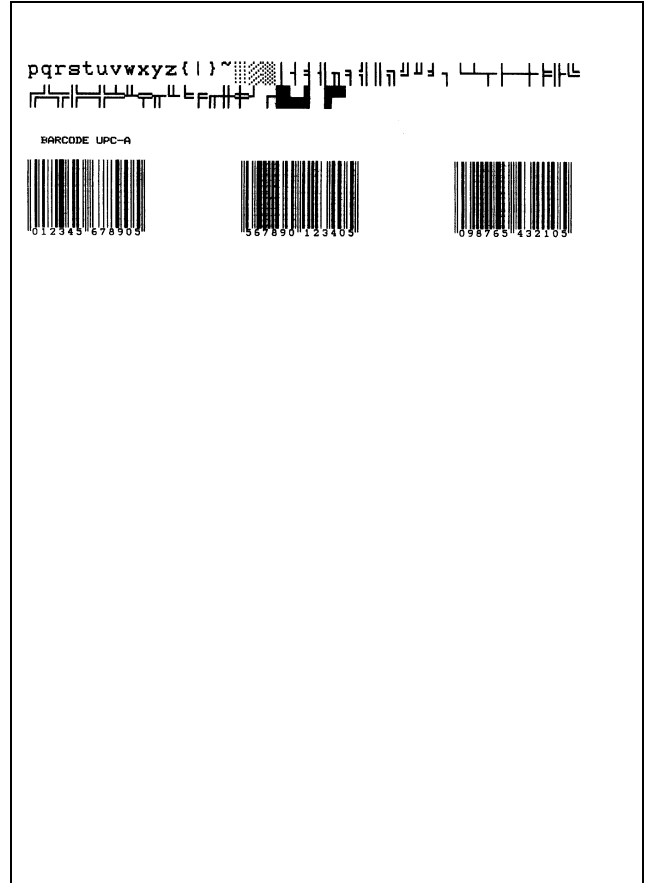

4-5-01b.pcx

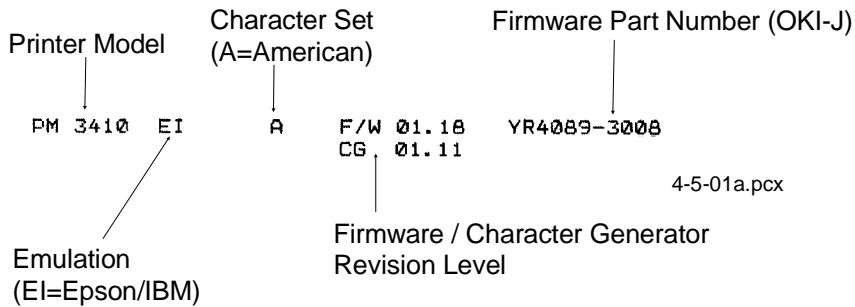

4.8.03 Serial Interface Diagnostic

General Information

The Serial Interface Diagnostic is used to verify the proper operation of the serial port and its associated circuitry.

Procedure

To perform the Serial Interface Diagnostic, follow this procedure.

1. Verify that continuous feed paper is installed.
2. Verify that the ribbon is correctly installed.
3. Verify that the width of the installed paper matches the paper width menu setting.
4. Select the serial interface on the interface board.
5. Place a DB-25P Loopback Test Connector on the serial port. Refer to the diagram for the correct configuration.

6. Press PRINT QUALITY and CHARACTER PITCH at the same time to place the printer in Menu Mode.

When in Menu Mode, the functions printed *below* the operator panels switches are active.

7. Press GROUP until Serial I/F prints.
8. Press ITEM until Diagnostic Test prints.
9. Press SET until YES prints.
10. Press EXIT to save the change and exit Menu Mode.
11. The Serial Interface Diagnostic will begin.
12. If this diagnostic fails, go to RAP 09.T
13. To return the printer to normal operation, reset the Menu.
14. Follow steps 6, 7, and 8.
15. Follow step 9, but press SET until NO prints.

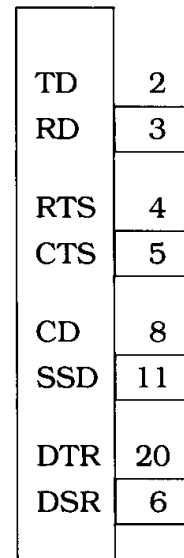

RS232-C (DB 25P Plug)

4-05-03.pcx

Serial Cable Information

The information in this section will help you make a serial cable to connect between the printer and computer.

Refer to the computer documentation to determine the cable requirements on the computers end.

The Pacemark 3410 has the following cable requirements.

- Shielded, RS-232C cable
- UL and CSA approved
- No more than 50 feet long
- Cannon DB-25P plug (or equivalent) with 25 pins
- Cannon DB-C2-J9 (or equivalent) connector shell

Serial Interface Signal Requirements

Pin	Signal	Symbol	Direction	Description
1	Protective Ground	PG	Ground	Connected to the printer frame
2	Transmit Data	TD	From Printer	Serial data transmitted to the system
3	Receive Data	RD	To Printer	Serial data received by the printer
4	Request to Send	RTS	From Printer	Always set to low (mark)
6	Data Set Ready	DSR	From Printer	Indicates that data can be sent
7	Signal Ground	SG	Ground	Ground
11	Supervisory Send Data	SSD	From Printer	Indicates that the printer is not ready to receive data
20	Data Terminal Ready	DTR	From Printer	Indicates that the printer is not ready to receive data

4.8.04 Hexadecimal Dump

General Information

Hexadecimal Dump Mode allows you to test the data being sent from the computer to the printer.

When the printer is in Hexadecimal Dump Mode, all data received (including text and printer commands) will be printed in both hexadecimal and ASCII format.

NOTE:

In ASCII format, all non-printable characters are represented by a period.

Example

Below is a line of BASIC code.

```
LPRINT CHR$(27) ;"0";CHR$(30);"This is an example of hexadecimal dump."
```

Below is the same line as it would appear in Hexadecimal Dump Mode.

1B 30 1E 54 68 69 73 20 69 73 20 61 6E 20 65 78 .0.	This is an ex
61 6D 70 6C 65 20 66 20 61 20 68 65 78 61 64	ample of a hexad
65 63 69 6D 61 6C 20 64 75 6D 70 2E 0D 0A	ecimal dump

Procedure

1. Verify that paper is loaded.
2. Verify that the ribbon is installed.
3. Power OFF the printer.
4. Press and hold SELECT and FORM FEED while powering ON the printer.
5. The printer will print the line shown below.

```
HEX DATA DUMP
```

6. The printer is ready to receive data in the Hexadecimal Dump Mode.
7. Send data to the printer.
8. To exit Hexadecimal Dump Mode, power OFF the printer.

4.9 RESISTANCE CHECKS

4.9.01 General Description

The charts on the following pages provide information needed to determine if the printhead and motors used in the printer are defective.

Layout Diagram

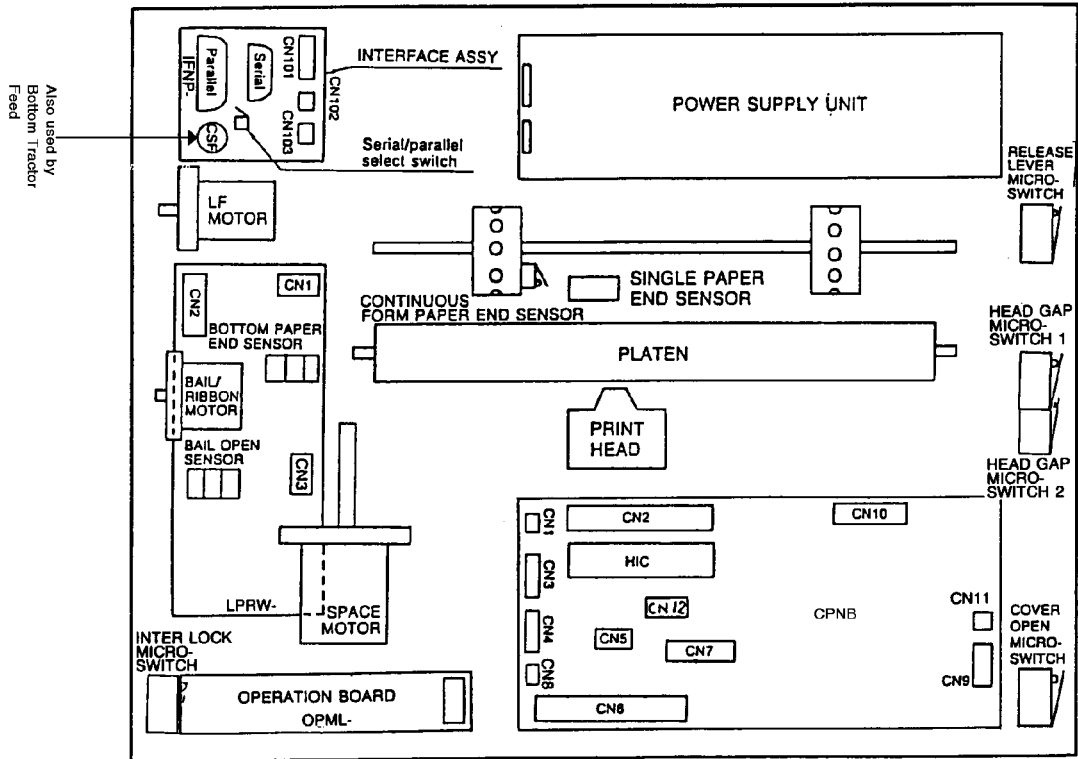

4-6-01a.pcx

4.9.02 Printhead

The resistance of each coil should be approximately 4.5 ohms.

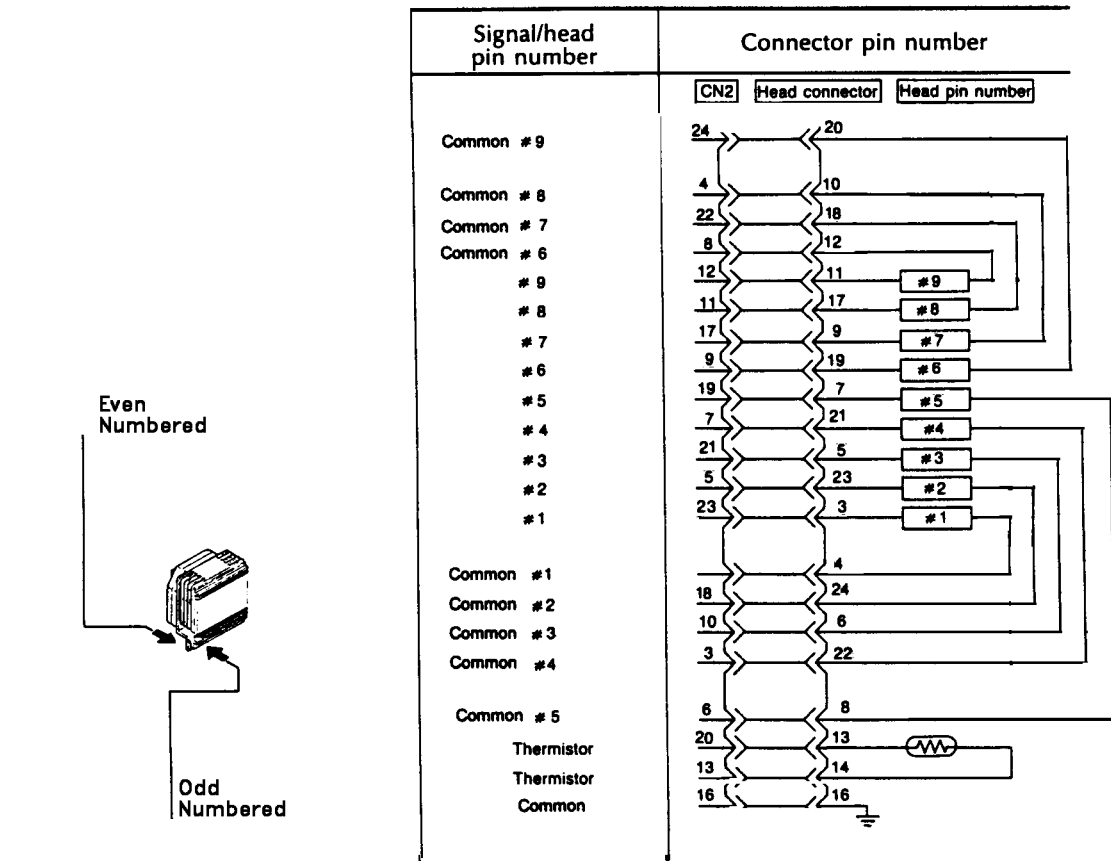

4-6-01b.pcx

4.9.03 Line Feed Motor

The resistance of each winding should be approximately 5.6 ohms.

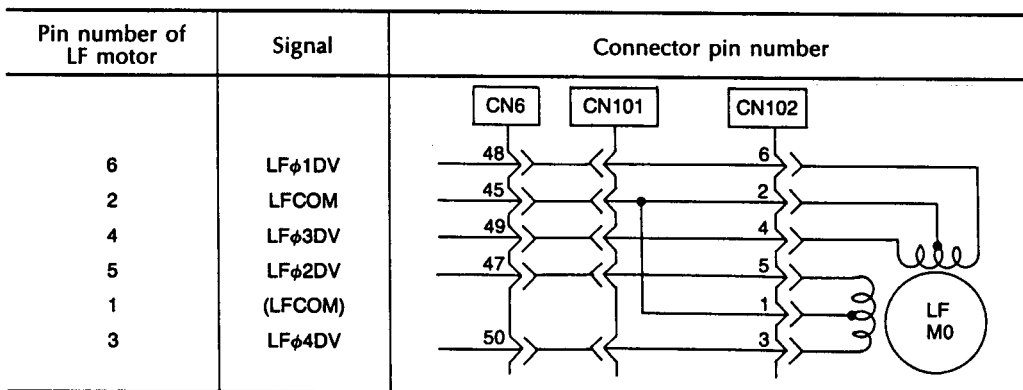

4-6-01c.pcx

4.9.04 Space Motor

The resistance of each winding should be approximately 11.4 ohms.

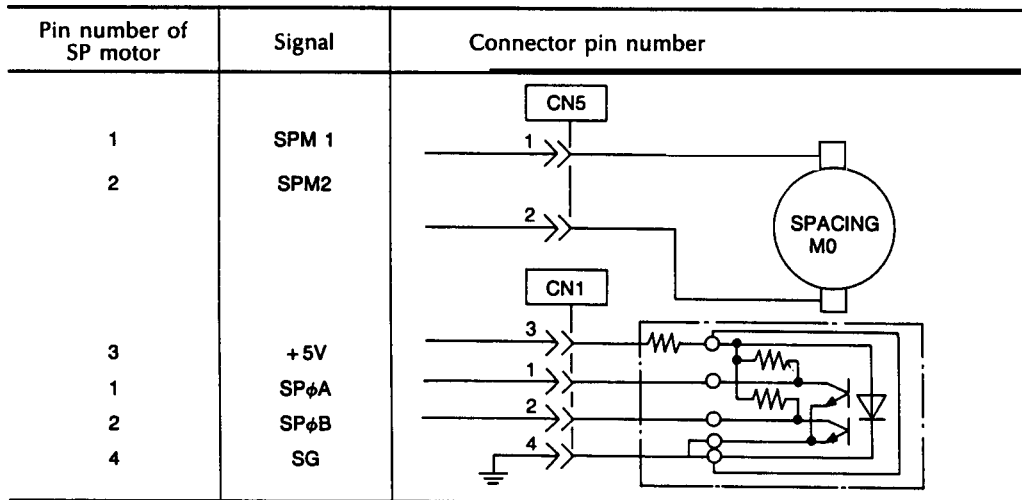

4-6-01d.pcx

4.9.05 Bail Motor

The resistance of each winding should be approximately 34 ohms.

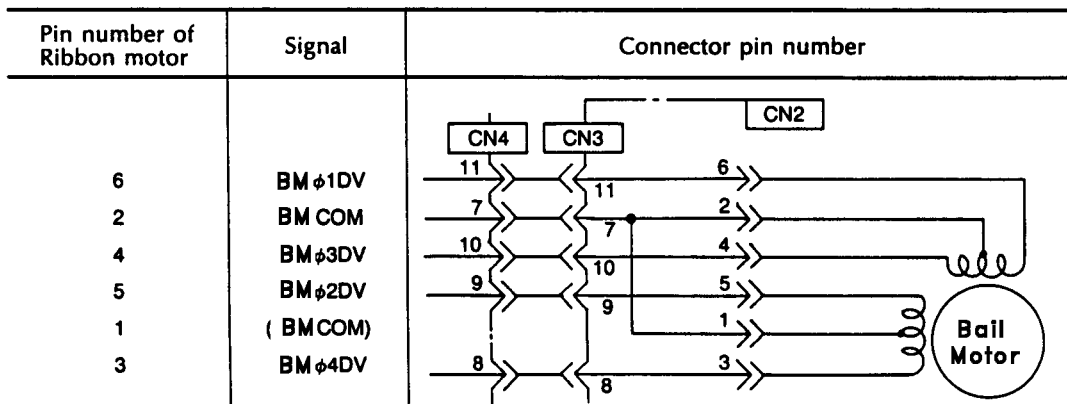

4-6-01e.pcx

APPENDIX A
BOARD DIAGRAMS

A.1 OVERVIEW

A.1.01 General Information

This section describes the characteristics of the printed circuit boards in the printer.

The following areas are covered.

Firmware

Fuses

Jumpers

Sensors

Switches

Test Points

Where an item is not applicable, the word *NONE* will be listed.

A.2 INDEX TO CHARTS

Description	Board Designation	Section
Main Logic Board	CBNP	A.2.01
Power Supply Board	(part of Power Supply Assembly)	A.2.02
Interface Board	HKTY	A.2.03
Sensor Board	LPRW	A.2.04
Operator Panel Board	OPML	A.2.05
Bottom Tractor Feed Board	BTFD	A.2.06

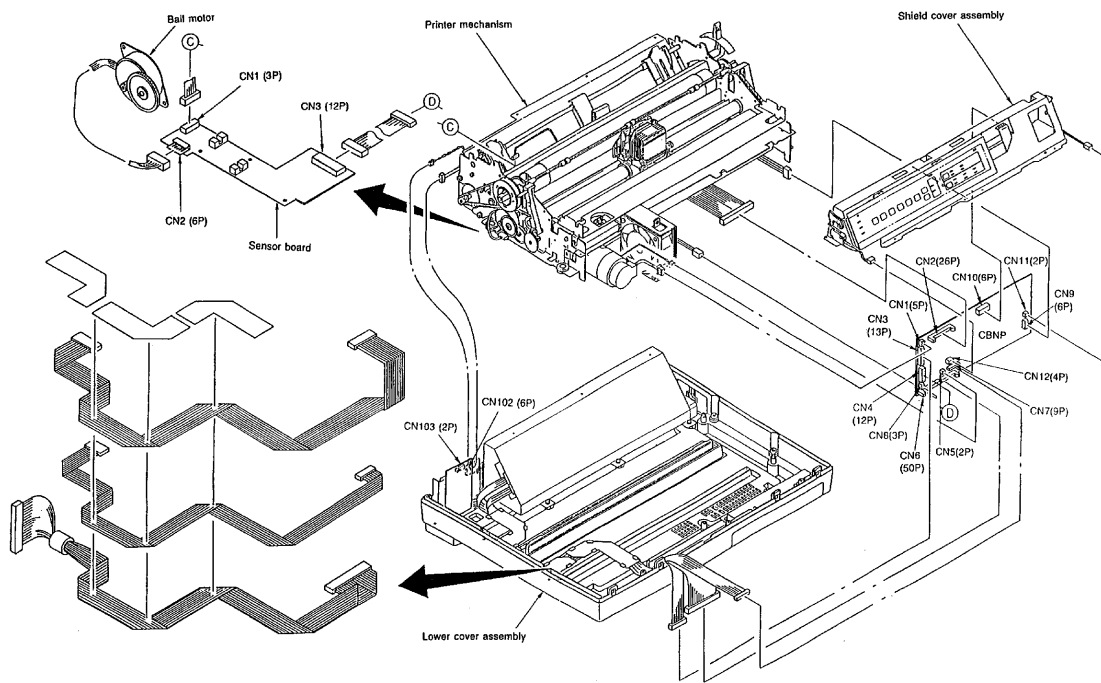

A-2-00.pcx

A.2.01 Main Logic Board (CBNP)

Firmware

Q4 - Program ROM

Fuses

F1 3.5 amp 125V

Jumpers

S2: SHORTED - Pacemark Emulation ROM Installed

Sensors

NONE

Switches

NONE

Test Points

+ 38vdc

Printhead, SP Motor, LF Motor and Bail Motor drive voltage.

Check on both ends of Capacitor C4.

+ 5vdc

Integrated Circuit Logic / LED drive voltage.

Check between pin 24 of Q5 and the power bar.

+ 8vdc

Line feed motor holding voltage and serial interface line voltage.

Check on Pin 6 of Connector CN7.

- 8vdc

Serial interface line voltage.

Check on Pin 7 of Connector CN7.

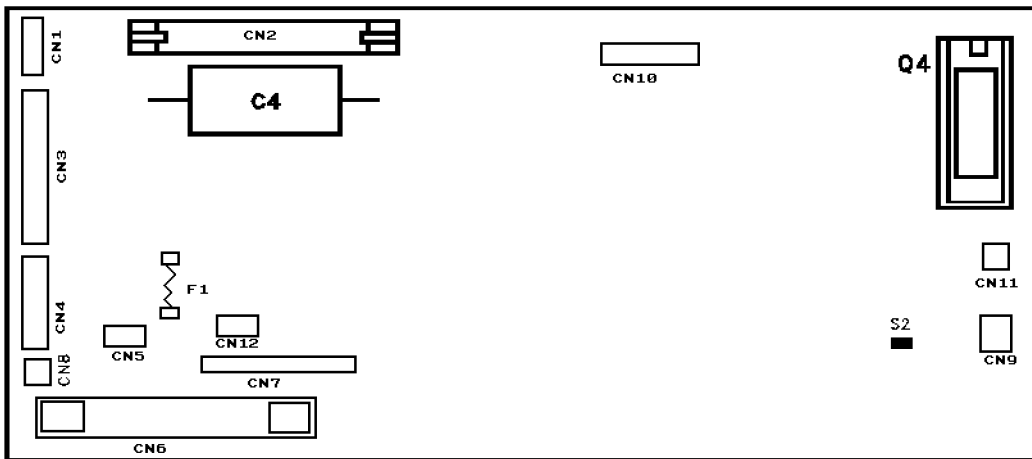

A-2-01.pcx

A.2.02 Power Supply Board

Firmware

NONE

Fuses

F1: 10.0 Amp 125V (Soldered in)

Jumpers

NONE

Sensors

NONE

Switches

NONE

Test Points

CN - 1

Pin 6: +38vdc

CN - 2

Pin 6: +8vdc

Pin 7: -8vdc

Pin 4: +5vdc

Pin 2: Signal Ground

Pin 3: Signal Ground

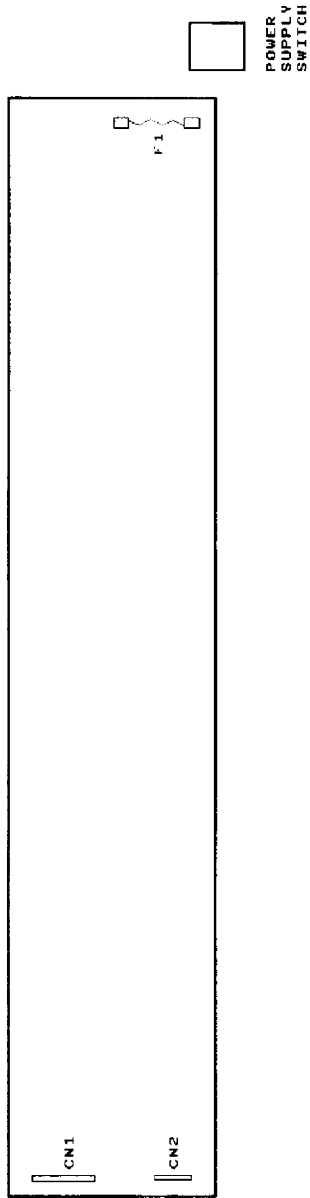

A-2-02.pcx

A.2.03 Interface Board (HKTY)

Firmware

NONE

Fuses

NONE

Jumpers

NONE

Sensors

NONE

Switches

SW101 - This switch toggles when either serial or parallel interface is selected

Test Points

NONE

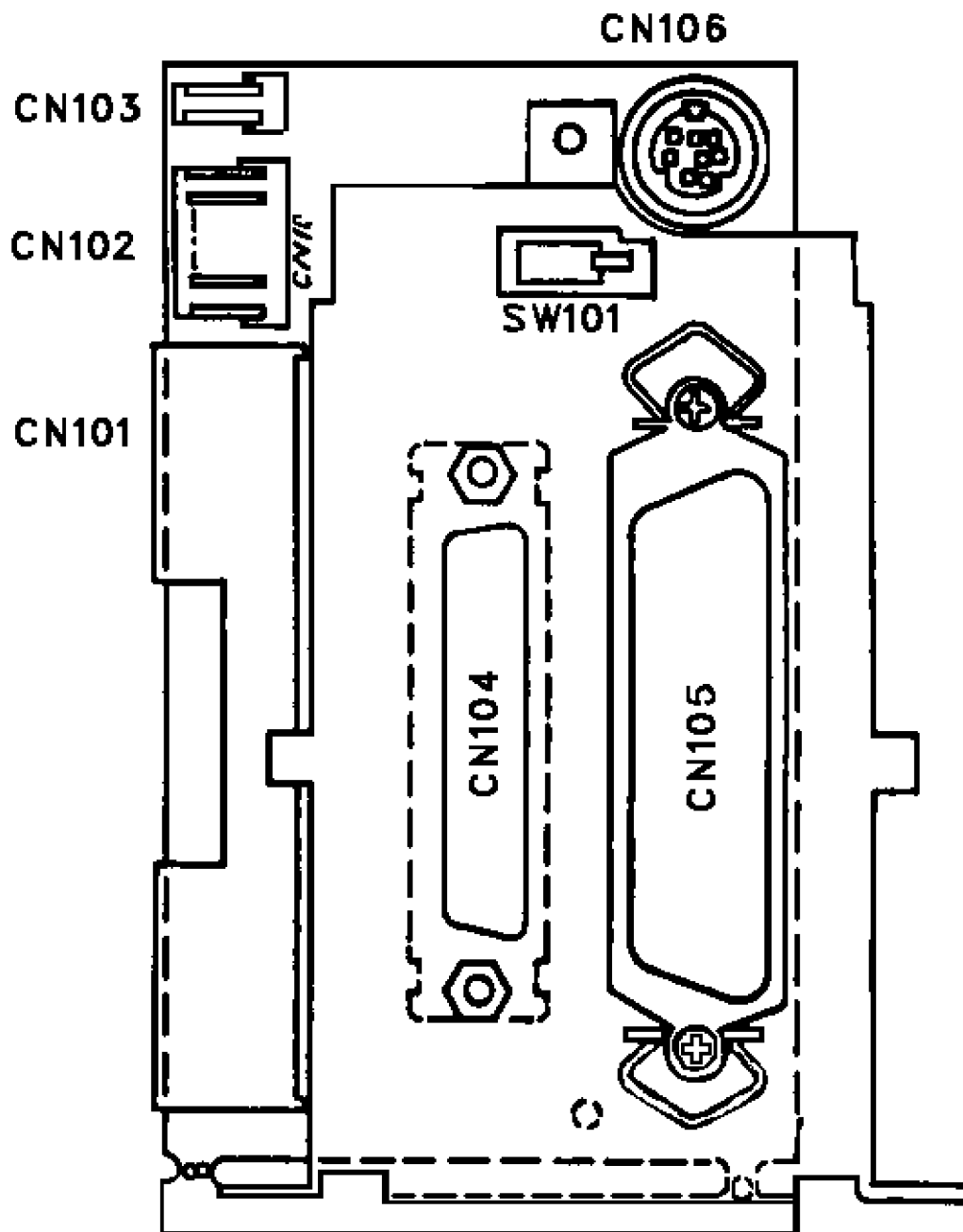

A-2-03.pcx

A.2.04 Sensor Board (LPRW)

Firmware

NONE

Fuses

NONE

Jumpers

NONE

Sensors

Bottom Paper Sensor

Bail Arm Sensor

CN1 - Connector for Friction Feed Paper Photosensor located on the Paper Pressure Guide

Switches

NONE

Test Points

NONE

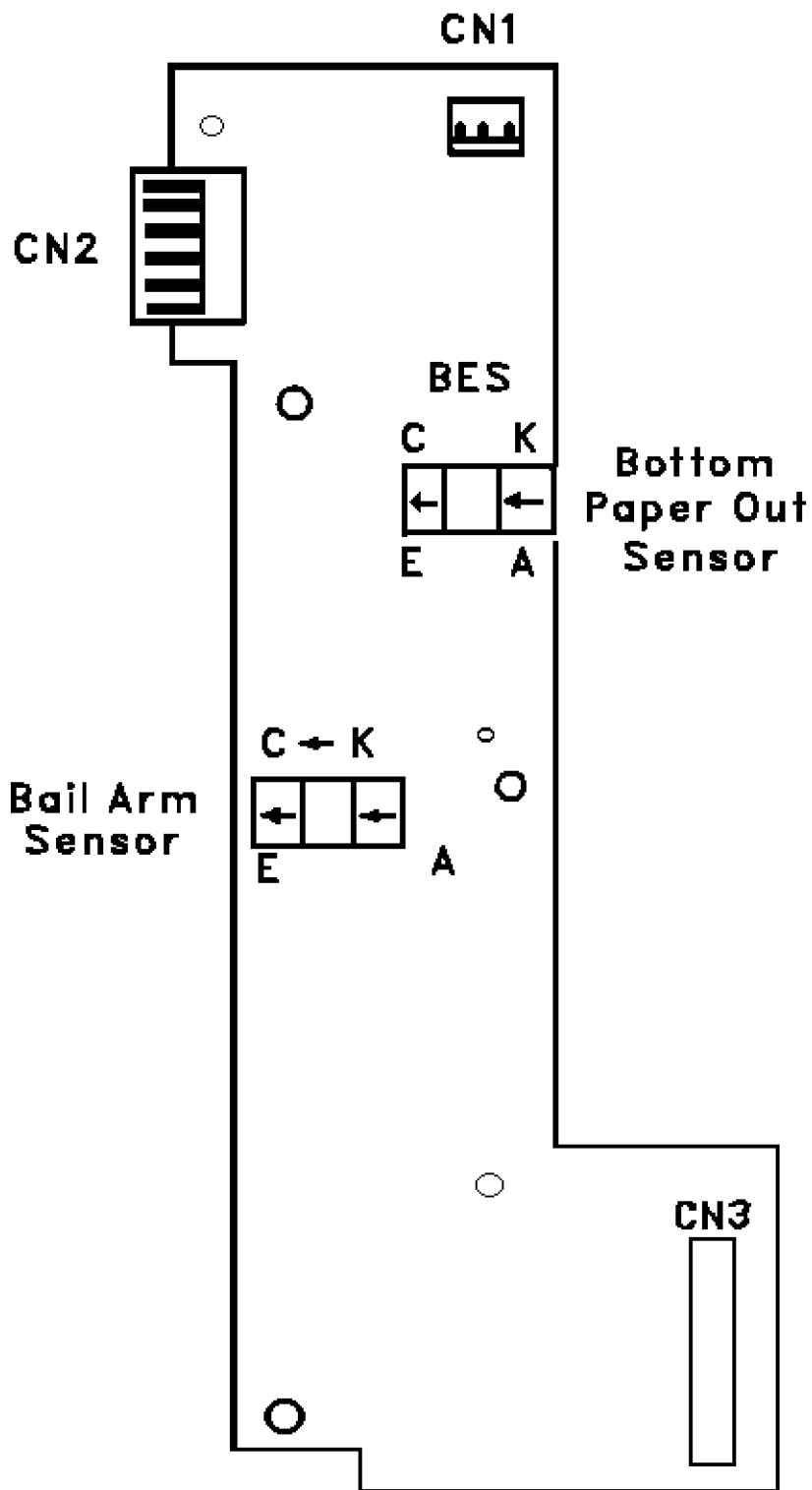

A-2-04.pcx

A.2.05 Operator Panel Board (OPML)

Firmware

NONE

Fuses

NONE

Jumpers

NONE

Sensors

NONE

Switches

10 momentary contact membrane switches which control the following functions:

Select/Deselect

Line Feed

Form Feed

Paper Tear

Paper Park

Top of Form Set

MicroFeed Up

MicroFeed Down

Print Quality

Character Pitch

Test Points

NONE

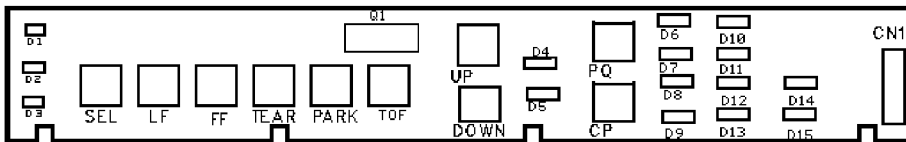

A-2-05.pcx

A.2.06 Bottom Tractor Feed Unit Board (BTFD)

Firmware

NONE

Fuses

F1 2.5 amp 125V (Protection for the +38vdc Motor Drive Circuit)

Jumpers

NONE

Sensors

NONE

Switches

NONE

Test Points

NONE

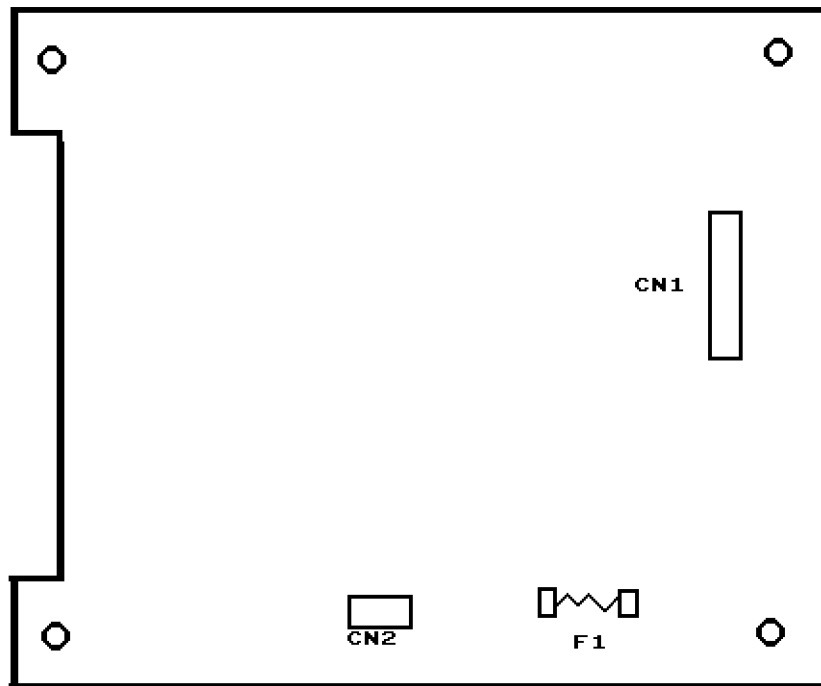

A-2-06.pcx

This page was intentionally left blank.

APPENDIX B
ILLUSTRATED PARTS LISTING

B.1 OVERVIEW

B.1.01 General Information

This appendix will assist you in identifying the assemblies and parts of the product.

Use Section Four (Failure Analysis) to determine the defective part(s).

Locate the part and its part number in this section.

Appendix B is cross-referenced to Section Three (Maintenance).

Format

The format for this appendix is a series of tables with diagrams. The tables contain the item reference number, the Okidata and Oki-Japan (Oki-J) part numbers, the part description, a comments section, and the disassembly procedure.

Item	Okidata P/N Oki-J P/N	Description	Comments Refer to B.1.02	Disassembly Procedure
------	--------------------------	-------------	-----------------------------	--------------------------

Items with the comments RSPL (Recommended Spare Parts List), Consumable, Document, or Option are available from Okidata. Items without these comments are usually not stocked.

Some items are only available as assemblies. Every effort has been made to clearly indicate which items are in assemblies and which are not.

N/A will appear where a part number is not available.

Current Part Numbers

Please refer to either of the following resources for current part numbers and pricing.

- Okidata's Electronic Bulletin Board (Okilink II) contains current part numbers, prices, and recommended stocking levels for each item listed as a recommended spare part. For instructions on accessing Okilink II, refer to the Service Center Reference Guide.
- Okidata's Faxable Facts is an automated fax document retrieval system. Part numbers and pricing are available through Faxable Facts. For instructions on accessing Faxable Facts, refer to the Service Center Reference Guide.

REMEMBER

Current part numbers, recommended stocking levels, and pricing information are available through Okilink II and Faxable Facts. Refer to the Service Center Reference Guide for information on accessing these resources.

B.1.02 Definition of Terms

Assemblies

Assemblies are parts grouped under a single description and/or part number. Generally, individual items in an assembly are not available from Okidata.

Assemblies are surrounded by broken line boxes in the diagrams.

Assemblies will say "Includes xx xx" under the *Comments* section of the tables.

Parts in assemblies will say "Part of xx" under the *Comments* section of the tables.

Blank

Okidata does not recommend stocking this item. This item should be purchased on an **As Required Basis** *only*.

The availability of this item is *NOT* guaranteed by Okidata.

Consumable

A consumable is a supply item which has a specified life and must be periodically replaced. It is purchased and installed by the end user. Okidata machines are designed to work *exclusively* with Okidata consumables. By using genuine Okidata consumable products, the investment made in the equipment is protected.

Document

A document is a printed item which supports the service and marketing of a product. Various documents are available from Okidata.

Drivers

Printer drivers are updated frequently. Please refer to Okilink II for the latest printer driver information.

Firmware

Firmware is revised frequently. Please refer to Okilink II for the latest firmware information.

Option

An option is a part/assembly which is added to a product. The option expands the product's functionality. An option may or may not be installed by the end user. Instructions for installation accompany each option.

Option RSPL

Okidata recommends that this part/assembly be on hand for servicing installed options.

RSPL

Okidata recommends that this part/assembly be on hand for servicing.

Technical Service Bulletins

Technical Service Bulletins (TSBs) are also referred to as Okidata's monthly mail.

The TSBs contain the latest information on firmware revisions, procedure changes, and technical information updates.

Okidata distributes the TSBs through Okilink II. The TSBs are issued monthly.

B.1.03 Parts Ordering Information

Service Center Reference Guide

When a technician has successfully completed a Service Training Course for a product and the Dealer has become Service Authorized, an information package is provided to the Dealer. The Okidata Service Center Reference Guide outlines the following items.

- Responsibilities of Okidata Service Centers
- Spare parts and consumables information
- Procedures for warranty repairs
- Product Training, Certification, and Authorization
- Product Support information
- Okidata Depot information and services
- Third Party Service information
- Information about Okidata's Customer Information Center
- Okidata Service and Support telephone numbers.

The Service Center Reference Guide contains the procedures to follow for ordering parts. Please *read, understand, and follow* these procedures. Service Authorization for a specific product *must* be obtained before a Dealer can submit warranty claims.

Direct questions regarding the Service Center Reference Guide to Okidata Dealer Service. Refer to the Service Center Reference Guide for information on contacting Okidata.

Placing a Parts Order

All authorized Okidata resellers may order spare parts and consumables for Okidata products. Orders are placed through Okidata's Logistics Department.

Please refer to your Service Center Reference Guide for details on ordering parts.

You should have the following information available *before* you place your order.

- Okidata Dealer Authorization Number
- Okidata Customer Number
- Your Purchase Order Number
- Okidata Part Number(s)

Use this Appendix, Okilink II, Faxable Facts, or contact Okidata Technical Support to find the correct part number. Refer to the Service Center Reference Guide for information on contacting Okidata.

B.2 CHARTS

Below is an index to the illustrated parts breakdown charts.

Description	Section
Printer	B.2.01
Upper Cover Assembly	B.2.02
Printer Unit	B.2.03
Operator Panel Assembly	B.2.04
Carriage Assembly	B.2.05
Printer Mechanism (1 of 2)	B.2.06
Printer Mechanism (2 of 2)	B.2.07
Bottom Tractor Feed Unit	B.2.08
Options	B.2.09
Pull Tractor Unit	B.2.10
Packing Materials	B.2.11
Consumables	B.2.12
Documentation	B.2.13

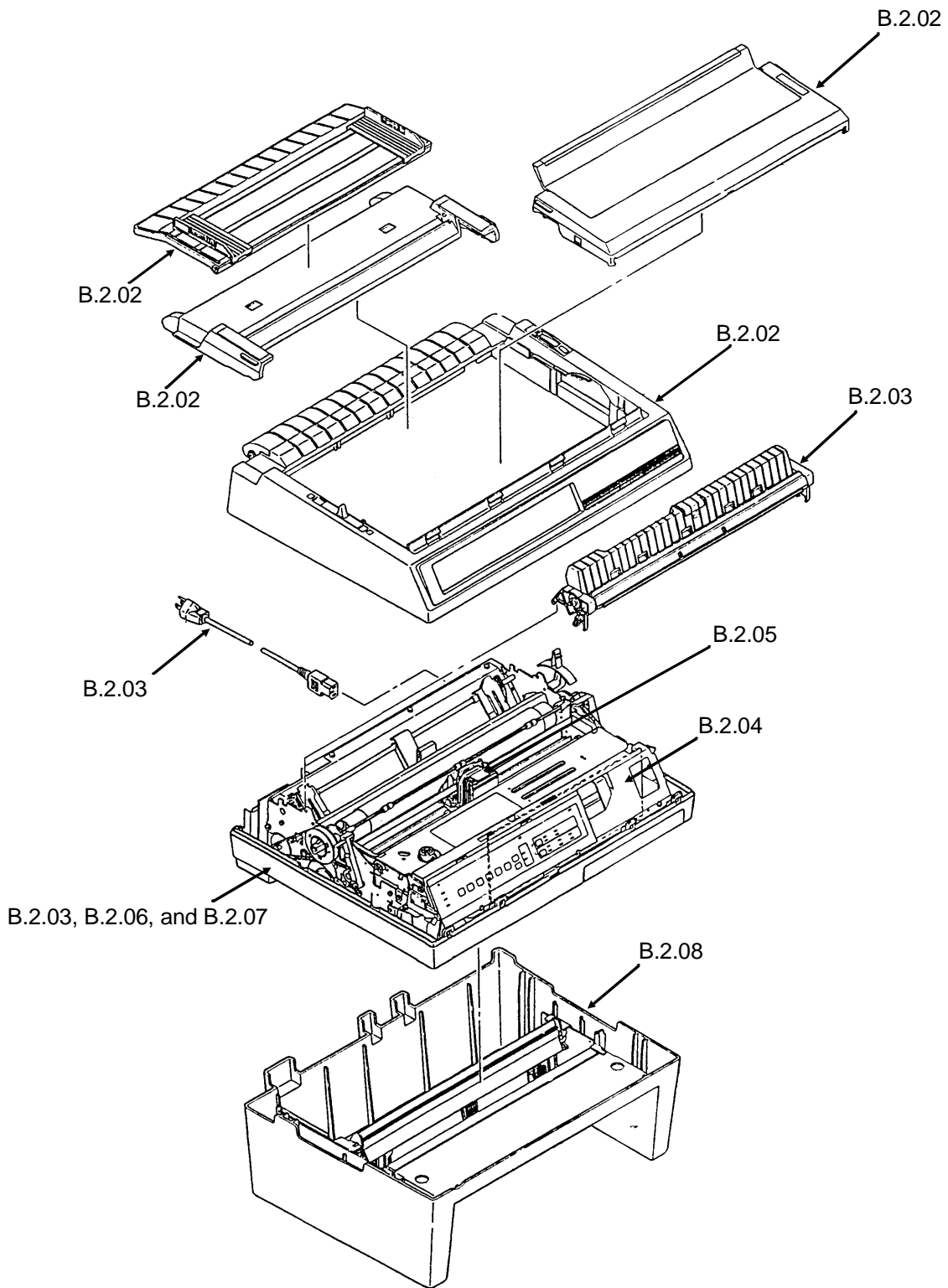

B-2-00.pcx

B.2.01 Printer

Part numbers are subject to change. Refer to Okilink II for current part numbers and pricing information.

Item	Okidata P/N Oki-J P/N	Description	Comments	Disassembly Procedure
1	61800801 N/A	Printer: Parallel / Serial 120 V Epson / IBM Compatible		N/A
1	61800802 N/A	Printer: Parallel / Serial 220/240 V Epson / IBM Compatible		N/A

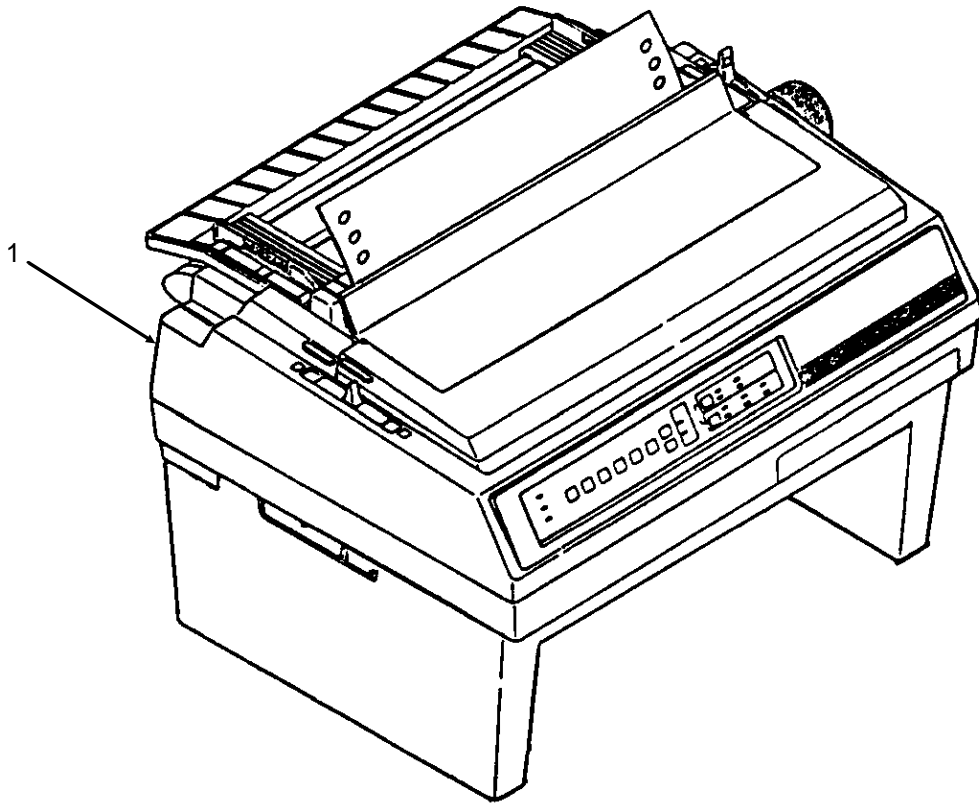

B-2-30.pcx

B.2.02 Upper Cover Assembly

Part numbers are subject to change. Refer to Okilink II for current part numbers and pricing information.

Item	Okidata P/N Oki-J P/N	Description	Comments	Disassembly Procedure
1	50215701 1PA4049-5837G1	Cover: Access	RSPL	3.2.01
2	50212431 2PA4016-4723G31	Cover: Middle (PM3410)	RSPL	3.2.03
3	50215801 1PA4094-5841G1	Cover: Rear (Assembly)	RSPL	3.2.03
4	50215901 4YA4043-4280G1	Pull-Up Roller Assembly	RSPL	3.2.03

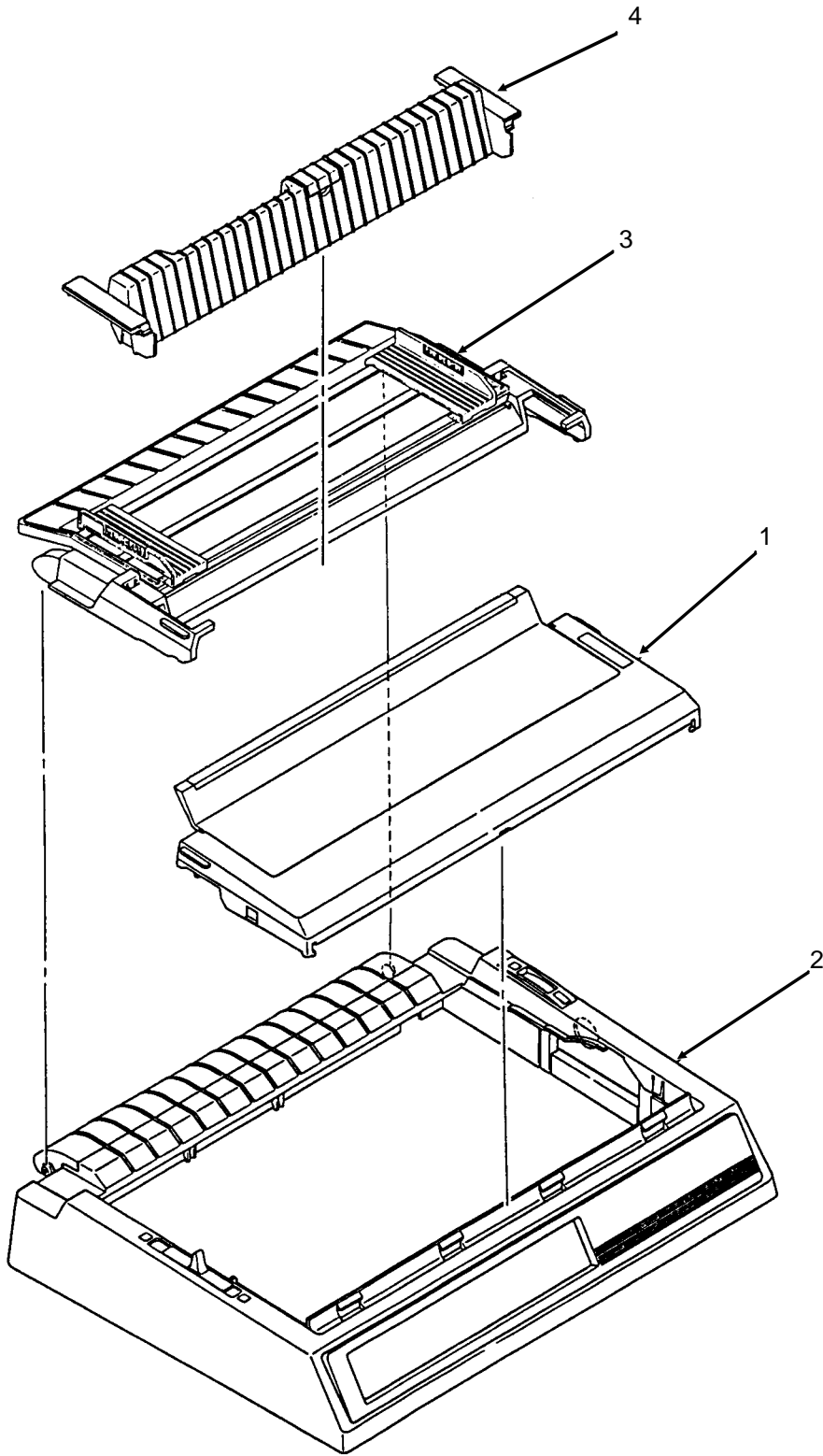

B-2-01.pcx

B.2.03 Printer Unit

Part numbers are subject to change. Refer to Okilink II for current part numbers and pricing information.

Item	Okidata P/N Oki-J P/N	Description	Comments	Disassembly Procedure
1	56609701 3YS4011-1315P1	Cord: AC (120V)	RSPL	3.2.01
2	56624101 3YS4011-1265P1	Cord: AC (220V) (ML) Right Angle	Option	3.2.01
3	52105801 N/A	Ribbon Cartridge	Consumable	3.2.01
4	50090301 4YA4023-1501G1	Printhead: Assembly	RSPL	3.2.01
5	53478601 3PP4043-2501P1	Knob: Platen	RSPL	3.2.03
6	55061711 4YA4042-1510G11	PCB: HKTY Interface Connector Assembly	RSPL	3.2.05
7	55061611 4YA4042-1509G11	PCB: CPNB Main Logic (w/o ROM)	RSPL	3.2.06
8	55934601 816A8022M0000	IC: EEPROM NM93C06N-NW	RSPL	3.2.06
9	56614901 3YS4011-2710G1	Cable: I/F (Internal) [I/F-Main Brd 50 Pin]	RSPL	3.2.07
10	56614101 4YS4011-6295G1	Cord: Power Connection (9 Pin)	RSPL	3.2.07
11	56614801 4YS4011-6253G3	Cord: Power Connection (13 Pin)	RSPL	3.2.07
12	56411201 4YB4049-1709P1	Power Supply Assembly (120 V)	RSPL	3.2.08
12	56406302 4YB4049-1278P2	Power Supply Assembly (220/240 V)	Option	3.2.08
13	56509501 4YX4043-4219G1	Fan: Cooling	RSPL	3.2.20
14*	51007701 3PB4043-4357P1	Guide: Bottom (Mylar)	RSPL	N/A
15*	51007601 4PB4043-2579P1	Guide: Cut Sheet (Mylar)	RSPL	N/A
16*	51007801 4PB4043-4331P1	Guide: Bottom Plate (Mylar)	RSPL	N/A
17	51007901 3PB4043-4227P1	Guide: Bottom Rear Guide (Mylar) Base	RSPL	N/A
18	50212604 2PA4016-4722G4	Cover: Acoustic (Pull Tractor)	Option RSPL	N/A
19	50215901 4YA4043-4280G1	Pull-Up Roller Assembly	RSPL	3.2.03

* Items 14, 15, and 16 are in the same location.

Item 14, Bottom Guide (Mylar) is the largest mylar sheet.

Item 15, Cut Sheet Guide (Mylar) is the smallest mylar sheet.

Item 16, Bottom Guide Plate (Mylar) is the mylar sheet which extends from the bottom of the printer mechanism.

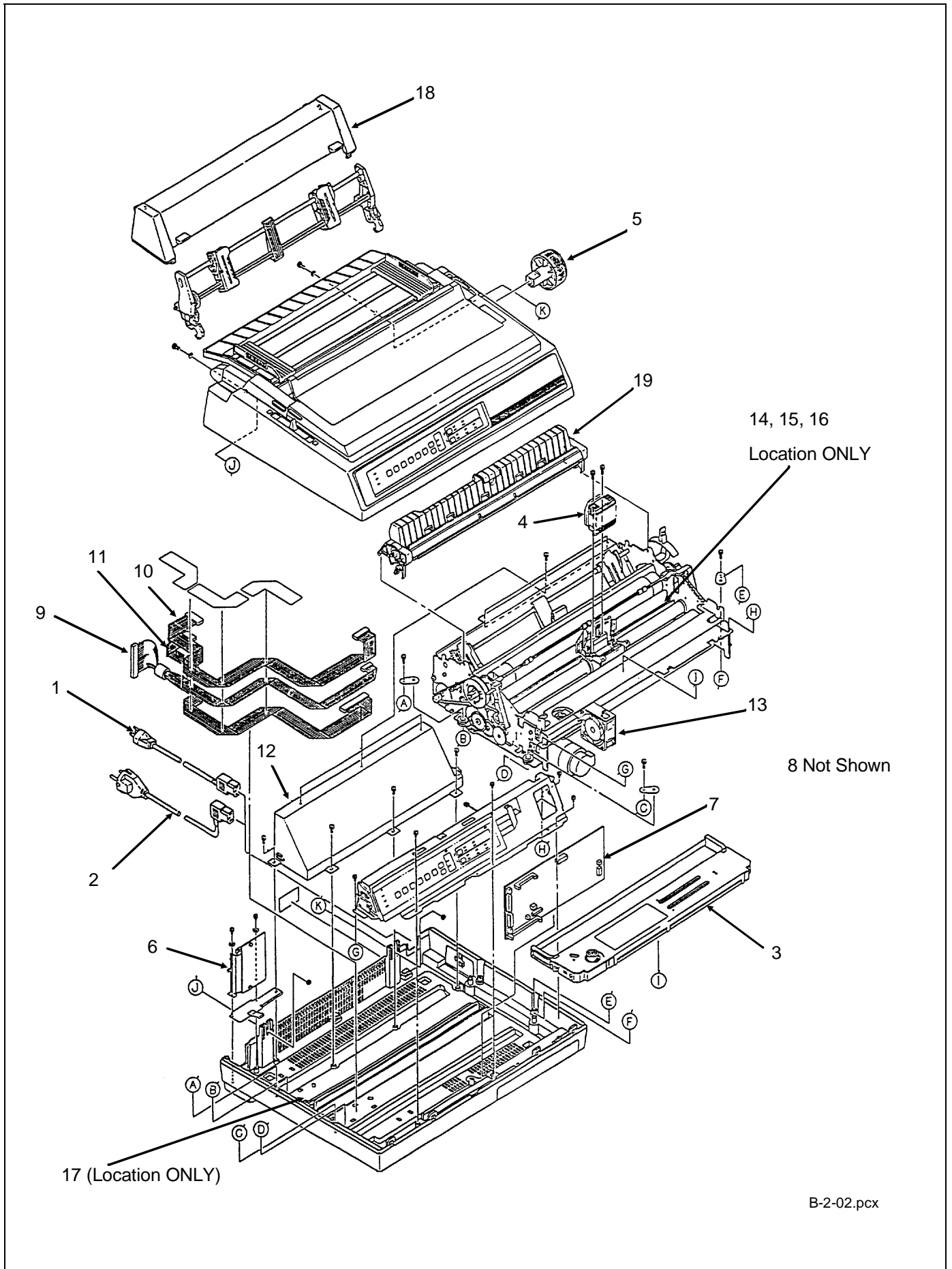

B-2-02.pcx

B.2.04 Operator Panel Assembly

Part numbers are subject to change. Refer to Okilink II for current part numbers and pricing information.

Item	Okidata P/N Oki-J P/N	Description	Comments	Disassembly Procedure
1	50910505 4LB-192200-5	Spring: Cover Open	RSPL	3.2.03
2	56614301 4YX4043-2759G1	Cable: Micro Switch (Cover Open)	RSPL	3.2.30
3	55061401 4YA4042-1511G1	PCB: OPML Operation Panel	RSPL	3.2.04
4	53553401 3PP4043-4339G1	Panel: Operator (PM3410)	RSPL	3.2.04
5	56628402 4LP-5466-36	Cable: Op Panel (PM3410)	RSPL	3.2.04
6	56212601 3YX4043-4228G1	Switch: Interlock (Assy)	RSPL	3.2.06

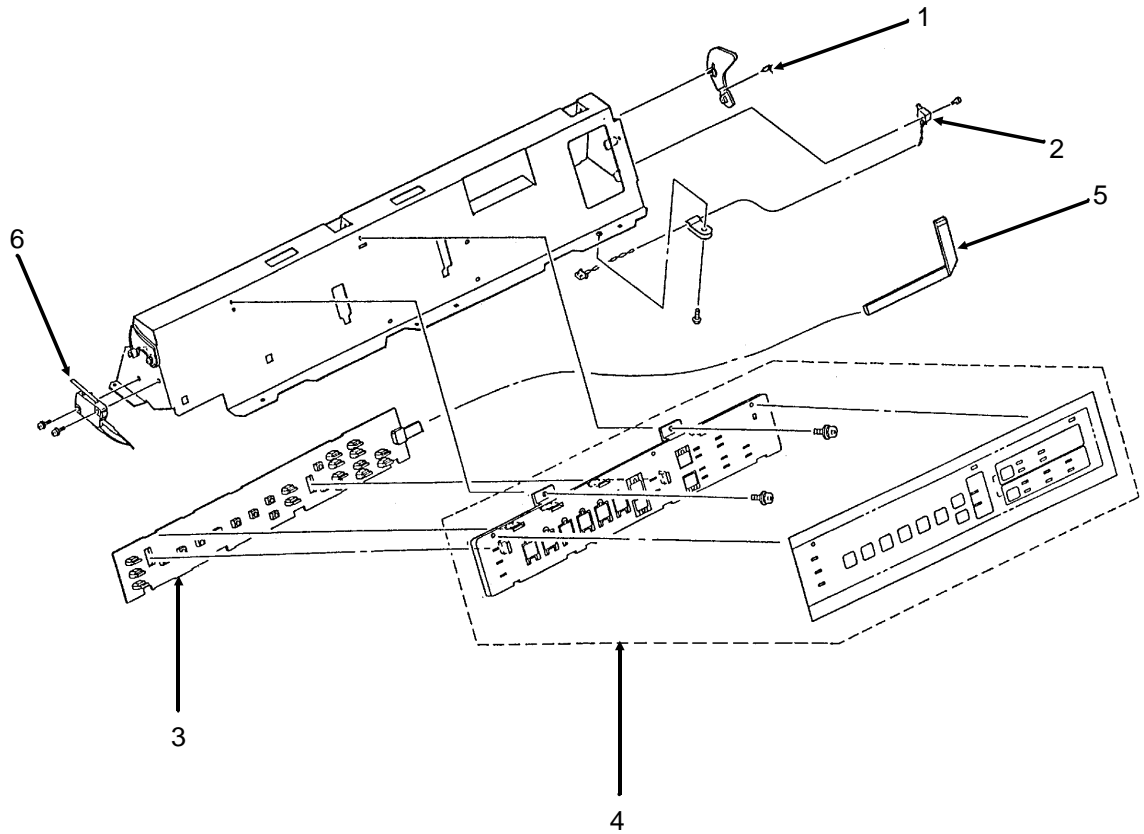

B-2-03.pcx

B.2.05 Carriage Assembly

Part numbers are subject to change. Refer to Okilink II for current part numbers and pricing information.

Item	Okidata P/N Oki-J P/N	Description	Comments	Disassembly Procedure
1	53062601 4PP4043-4241G1	Guide: Ribbon Assembly	RSPL	3.2.01
2	53062701 4PA4043-4235G1	Protector: Ribbon Assembly	RSPL	3.2.02
3	50316701 4PP4043-4243P1	Screw: Ribbon Protector (Post)	RSPL	3.2.02
4	56624901 3YX4043-4232G1	Cable: Head Assembly	RSPL	3.2.21
5	53340501 2YX4043-4230G1	Carriage: (Assembly)	RSPL	3.2.22
6	51303101 4PB4044-1492P3	Belt: Mini Pitch (Spacing)	RSPL	3.2.25
7	50702301 N/A	Belt Clamp		3.2.25

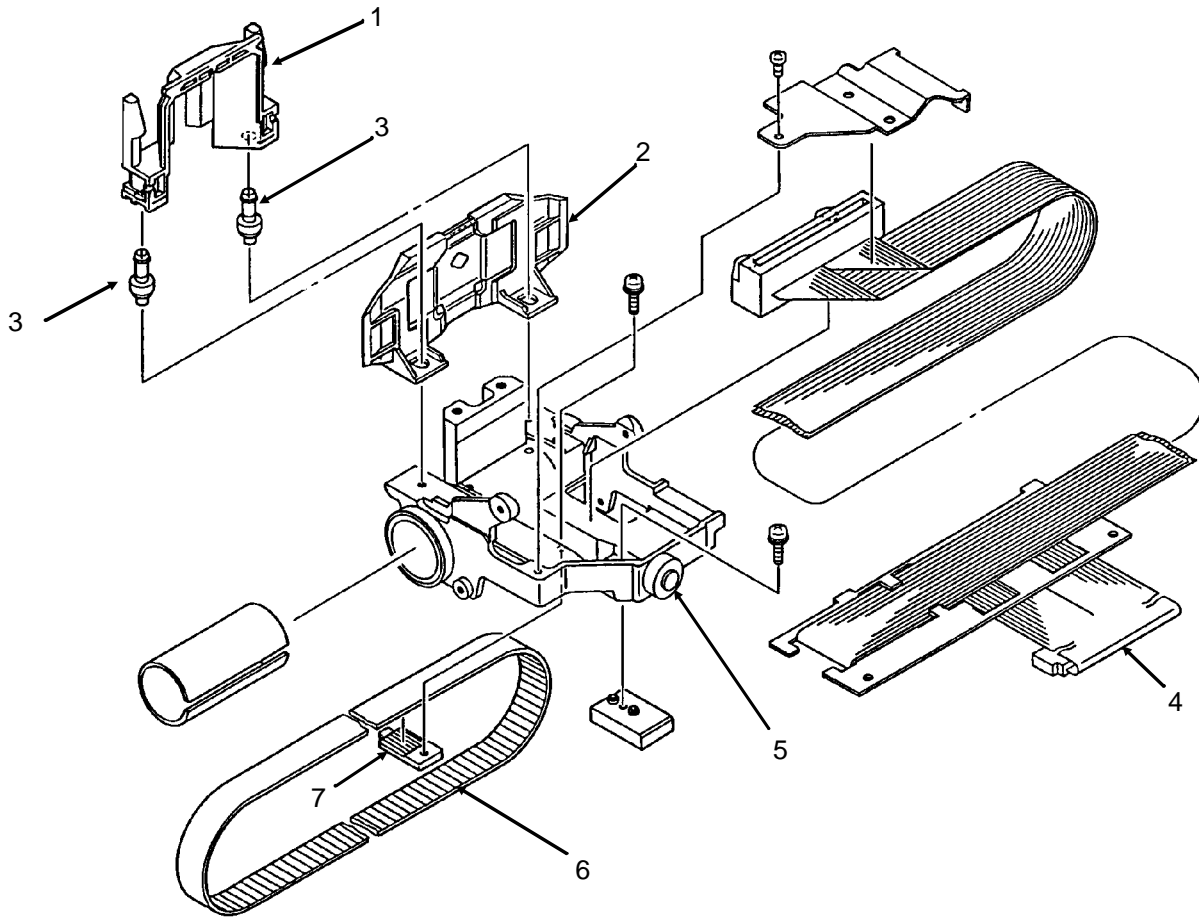

B-2-04.pcx

B.2.06 Printer Mechanism (1 of 2)

Part numbers are subject to change. Refer to Okilink II for current part numbers and pricing information.

Item	Okidata P/N Oki-J P/N	Description	Comments	Disassembly Procedure
1	50054101 4PA4043-2556G1	Platen: (Assembly)	RSPL	3.2.16
2	51304401 4LP1313-313	Belt: Mini Pitch (Line Feed)	RSPL	3.2.16
3	51226801 3PP4043-4246P1	Pulley: Platen	RSPL	3.2.16
4	51214501 3PP4043-2466P1	Gear: Platen "A"	RSPL	3.2.16
5	53478706 3PP4043-2459P6	Lever: Release	RSPL	3.2.17, 31
6	56625001 4YX4043-2571G1	Cable: Cut Sheet Sensor Assembly	RSPL	3.2.17
7	53478801 4PP4043-2460P1	Block: Release Lever Guide	RSPL	3.2.17
8	50910201 4PB4043-2754P1	Spring: Detent (Release Lever)	RSPL	3.2.17, 31
9	50907502 4LB-193400-1	Spring: (Paper Chute)	RSPL	3.2.17
10 *	56509401 3PB4043-4249P1	Motor: Line Feed (BTF)	RSPL	3.2.18
11	51112101 4PB4043-4348P1	Shaft: Carriage	RSPL	3.2.22
12	50706701 4PP4043-4226P1	Collar: Eccentric (with Screw)	RSPL	3.2.22
13	53478401 3PP4043-2504P1	Lever: Adjust	RSPL	3.2.22
14	53063801 3PP4043-4224P1	Bracket: Printhead Gap Indicator	RSPL	3.2.22
15	50054301 4PA4043-2584G1	Assembly: Ribbon Feed	RSPL	3.2.23
16	56506204 3YX4043-2550G4	Motor: Space	RSPL	3.2.24
17	55061501 4YA4042-1512G1	PCB: LPRW Sensor	RSPL	3.2.26
18	56616804 4YS4011-4311P4	Cable: Sensor Board Connection	RSPL	3.2.26
19	56506301 3PB4043-2601P1	Motor: Step (Bail Arm) Assembly	RSPL	3.2.27

* This line feed motor is used in two different places: the bottom push unit and the printer unit.

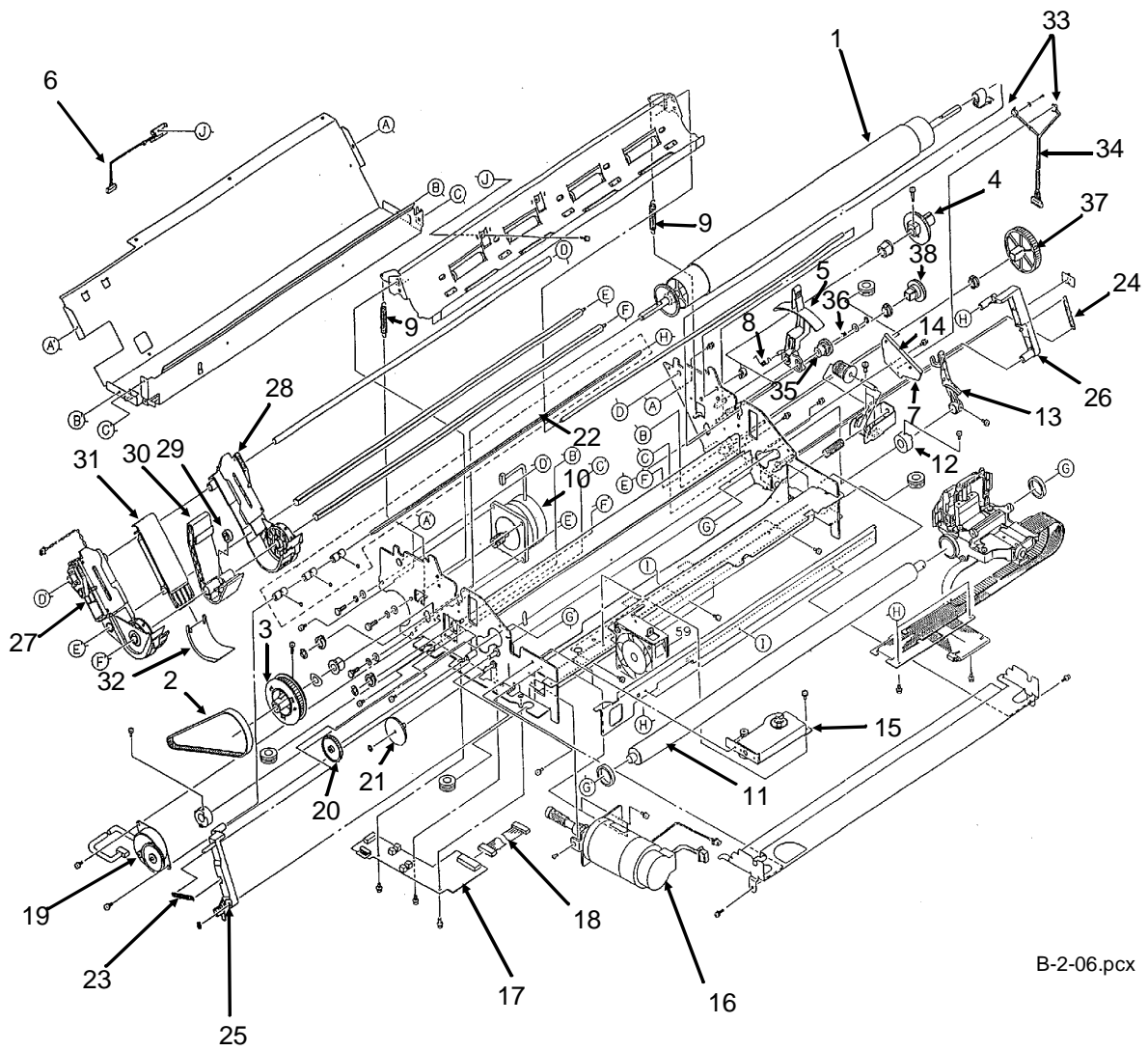

B-2-06.pcx

B.2.07 Printer Mechanism (2 of 2)

Part numbers are subject to change. Refer to Okilink II for current part numbers and pricing information.

Item	Okidata P/N Oki-J P/N	Description	Comments	Disassembly Procedure
20	51210201 5LR-193134-1	Gear: Idle (Bail Arm)	RSPL	3.2.28
21	51214701 3PP4043-2764P1	Cam: Bail Open	RSPL	3.2.28
22	50054401 4PA4043-2711G1	Assembly: Indicator Shaft	RSPL	3.2.28
23	50910701 4PP4043-2628P1	Spring: Bail Arm (Left)	RSPL	3.2.28
24	50910801 4LB-193100-2	Spring: Bail Arm (Right)	RSPL	3.2.28
25	53478501 3PP4043-2509P1	Bail Arm (Left)	RSPL	3.2.28
26	53478502 3PP4043-2510P1	Bail Arm (Right)	RSPL	3.2.28
27	50054501 3YX4043-2561G1	Tractor: Push (Left) Assembly	RSPL	3.2.29
28	50054601 3PA4043-2562G1	Tractor: Push (Right) Assembly	RSPL	3.2.29
29	51002301 4PP4043-2451P1	Friction: Piece	RSPL	3.2.29
30	51002401 3PP4043-2452P1	Guide: Center - Upper	RSPL	3.2.29
31	51002501 3PP4043-2453P1	Guide: Center Lower A	RSPL	3.2.29
32	51002601 3PP4043-2454P1	Guide: Center Lower B	RSPL	3.2.29
33	56209901 4YX4043-2784G1	Switch: Micro (Adj & Rel Lever)	RSPL	3.2.30
34	56624801 3PB4043-4204P1	Cable: Micro Switch Assembly (Adj & Rel Lever)	RSPL	3.2.30
35	51214401 4PP4043-2458P1	Gear: Idle (Release Lever)	RSPL	3.2.31
36	50910305 4LB-190600-6	Spring: Idle Gear	RSPL	3.2.31
37	51214201 4PP4043-2456P1	Gear: Drive A	RSPL	3.2.31
38	51214301 4PP4043-2457P1	Gear: Drive B	RSPL	3.2.31

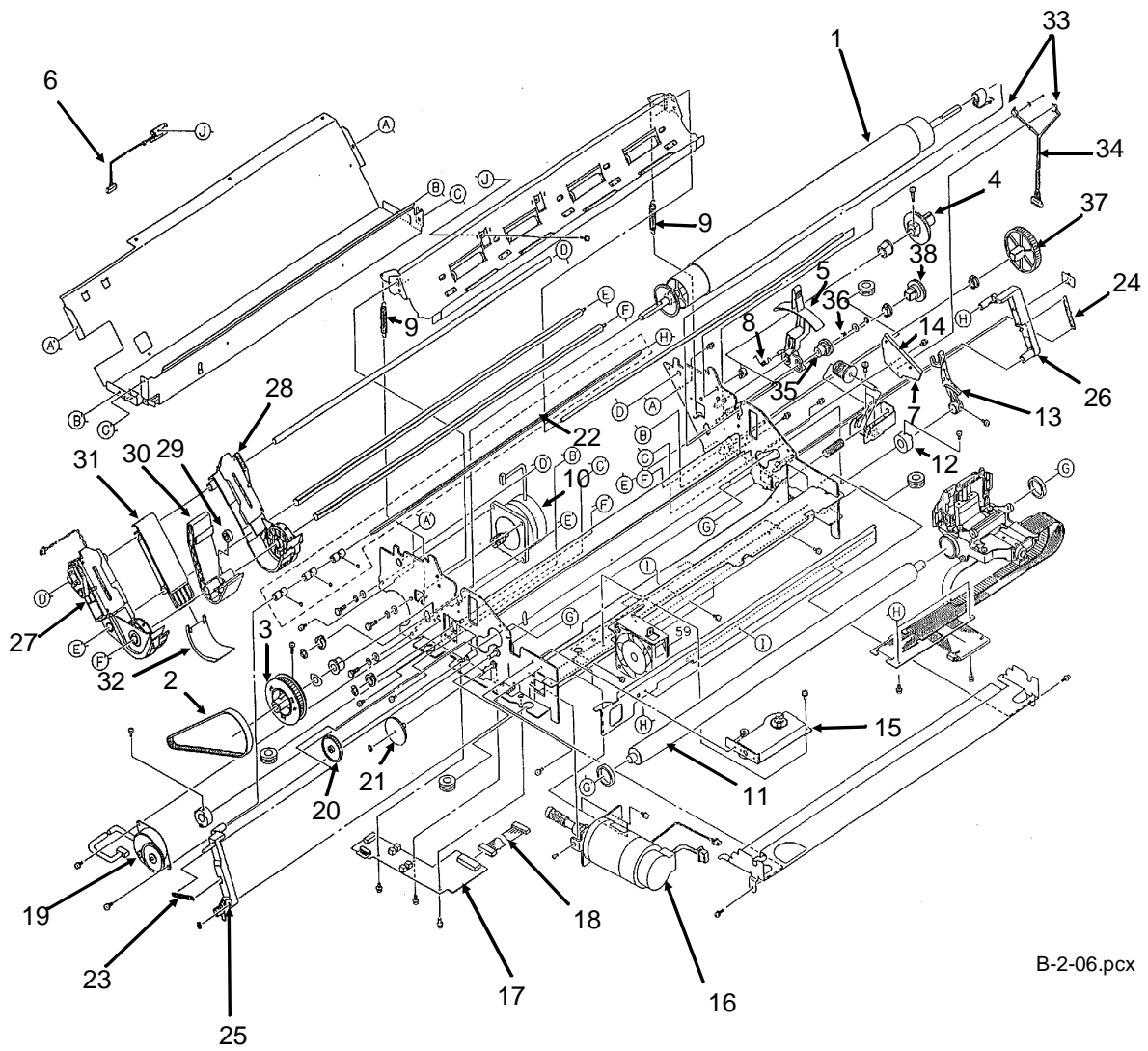

B-2-06.pcx

B.2.08 Bottom Tractor Feed Unit

Part numbers are subject to change. Refer to Okilink II for current part numbers and pricing information.

Item	Okidata P/N Oki-J P/N	Description	Comments	Disassembly Procedure
1	55066101 4YA4042-1513G1	PCB: BTFD (BTF)	RSPL	3.2.10
2	50922001 4PP4043-4300P1	Spring: (BTF)	RSPL	3.2.11
3	53063701 3PA4094-6159G1	Door: Front (Assembly) (BTF)	RSPL	3.2.12
4	51304501 4LP-1313-59	Belt: Line Feed (BTF) Mini-Pitch [120 teeth]	RSPL	3.2.13
5	51226901 4PP4043-4283P1	Pulley: Drive (BTF)	RSPL	3.2.13
6	51002201 4PP4025-2653P1	Guide: Sheet (BTF)	RSPL	3.2.14
7	53340401 3PB4043-4272P1	Roller: Drive (BTF)	RSPL	3.2.14
8	50057401 4PA4043-2684G2	Left Tractor Assembly	RSPL	3.2.14
9	50057501 4PA4043-2685G2	Right Tractor Assembly	RSPL	3.2.14
10 *	56509401 3PB4043-4249P1	Motor: Line Feed (BTF)	RSPL	3.2.15

* This line feed motor is used in two different places: the bottom push unit and the printer unit.

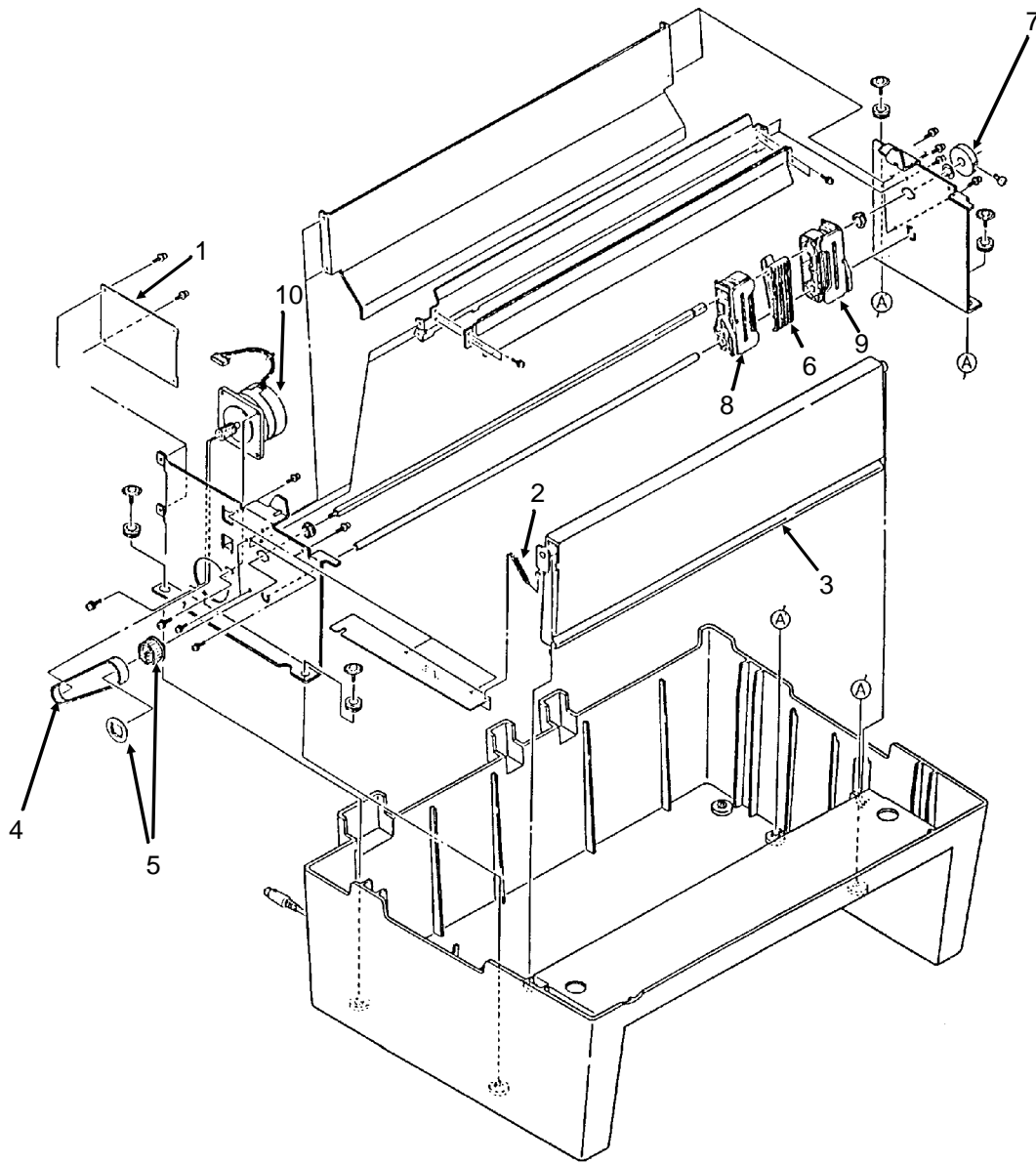

B-2-07.pcx

B.2.09 Options

Part numbers are subject to change. Refer to Okilink II for current part numbers and pricing information.

Item	Okidata P/N Oki-J P/N	Description	Comments	Disassembly Procedure
1	70010601 N/A	Cut Sheet Feeder 3001 Single Bin	Option	N/A
2	70010701 N/A	Cut Sheet Feeder 3002 Dual Bin	Option	N/A
3	70011701 N/A	Pull Tractor Kit	Option	N/A
4	70022001 N/A	Microline / Pacemark Emulation Chip Set	Option	N/A
5	56406302 4YB4049-1278P2	Power Supply Assembly (220/240 V)	Option	N/A
6	56624101 3YS4011-1265P1	Cord: AC (220 V) (ML) Right Angle	Option	N/A
7	50212604 2PA4016-4722G4	Cover: Acoustic (Pull Tractor)	Option RSPL	N/A
8 *	N/A N/A	Printer Stand	Option Third Party	N/A
9 **	N/A N/A	Twin-ax / Co-ax	Option Third Party	N/A

* Call

1-800-749-2258 (Third Party Vendor - Pacemark 3410 stands ONLY)

1-800-827-2672 (Third Party Vendor - all printer stands)

** Call 1-508-777-7957 (Third Party Vendor) for more information.

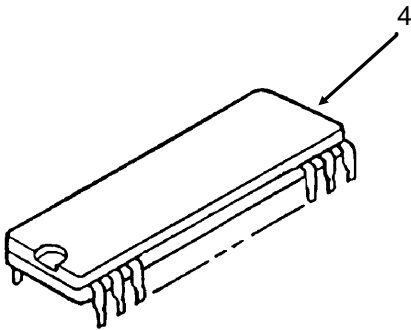
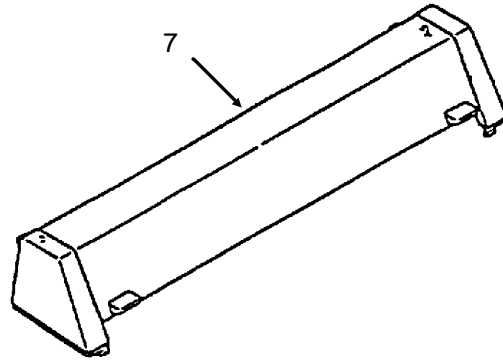
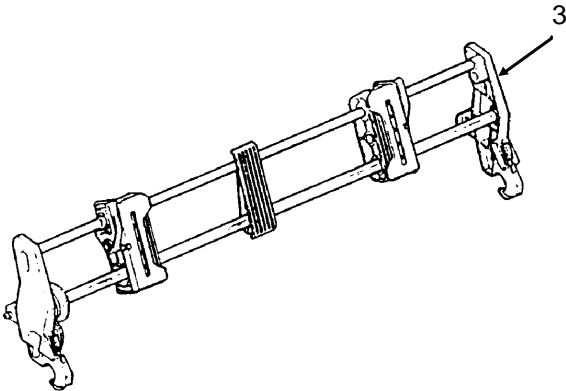
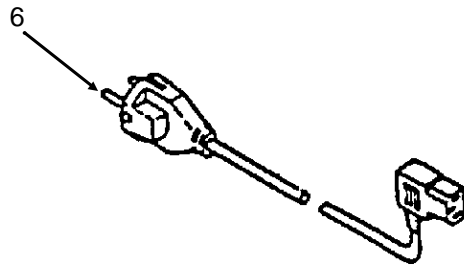
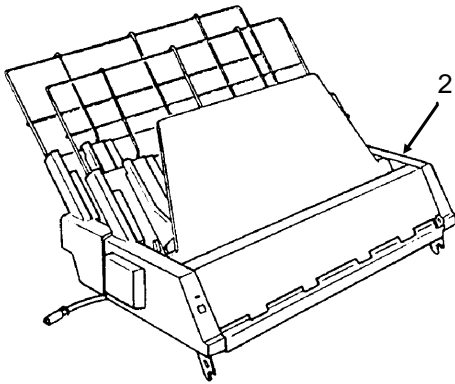
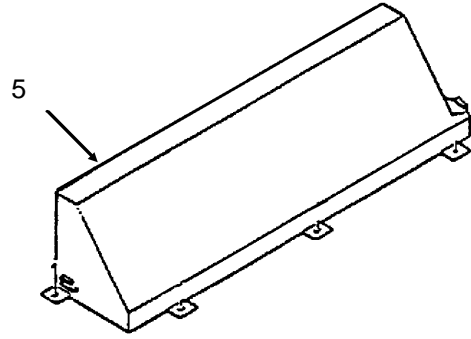
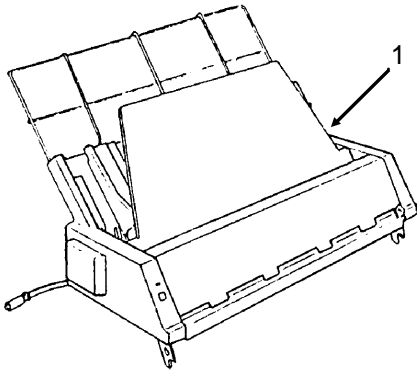

8 Not shown

9 Not shown

B-2-20.pcx

B.2.10 Pull Tractor Unit (Option)

Part numbers are subject to change. Refer to Okilink II for current part numbers and pricing information.

Item	Okidata P/N Oki-J P/N	Description	Comments	Disassembly Procedure
1	50057401 4PA4043-2684G1	Tractor: Pin (Left)	Option RSPL	N/A
2	50057501 4PA4043-2685G1	Tractor: Pin (Right)	Option RSPL	N/A

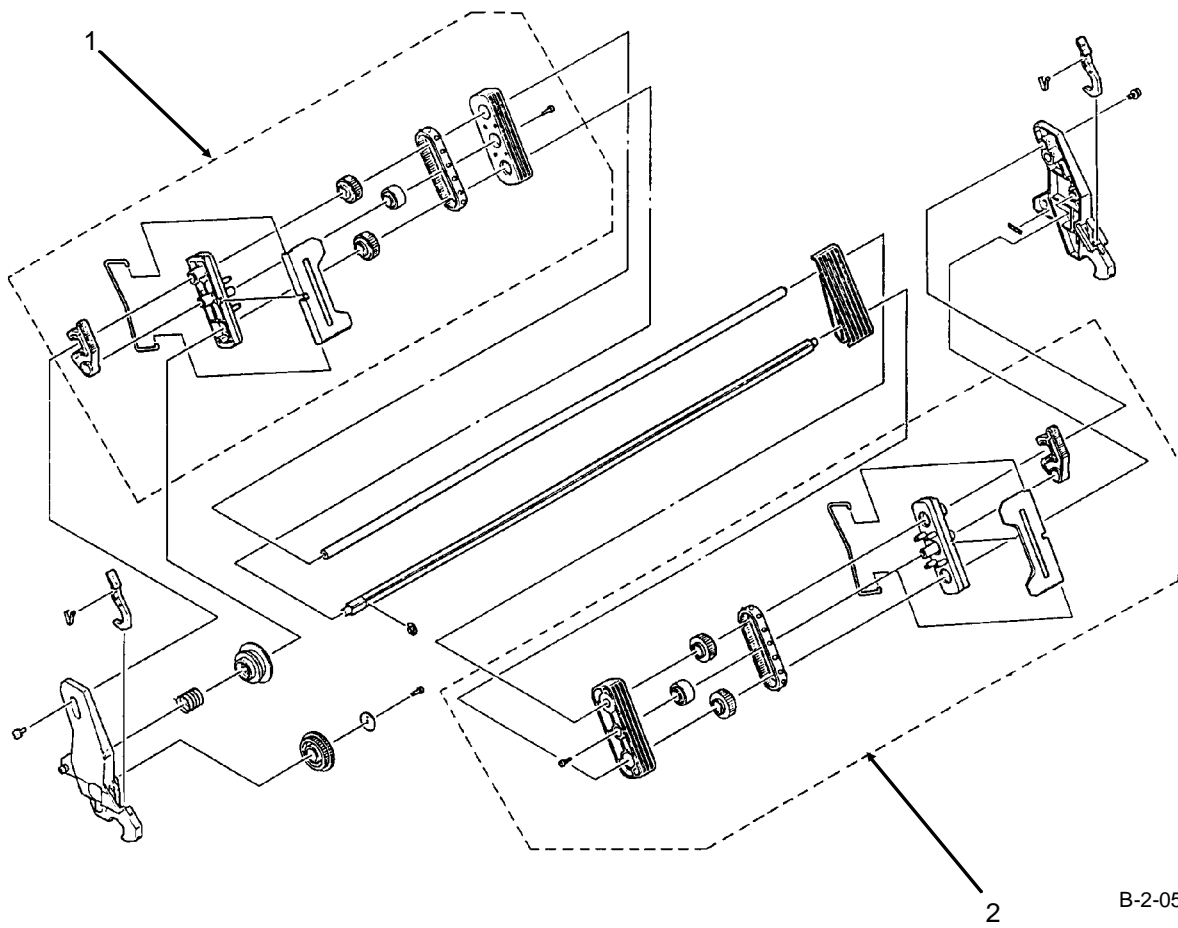

B-2-05.pcx

B.2.11 Packing Materials

Part numbers are subject to change. Refer to Okilink II for current part numbers and pricing information.

Item	Okidata P/N Oki-J P/N	Description	Comments	Disassembly Procedure
1	53532501 N/A	Foam: Spacer		N/A
2	53532002 N/A	Box: Spare (PM3410 / 393 / 395)	RSPL	N/A
2	53556401 N/A	Box: PM3410 Printer (Production)	RSPL	N/A
3	53528901 N/A	End Cap - Right	RSPL	
4	53528902 N/A	End Cap - Left	RSPL	N/A
5	53460215 N/A	Overpack Assembly		N/A
6	53556801 4PP4083-2820P14	Box: Bottom Tractor (PM3410)	RSPL	N/A
7	53556901 3PP4043-4332P1	Cap: End 1 Set (BTF) (PM3410)	RSPL	N/A

1, 5, 6, and 7
Not shown

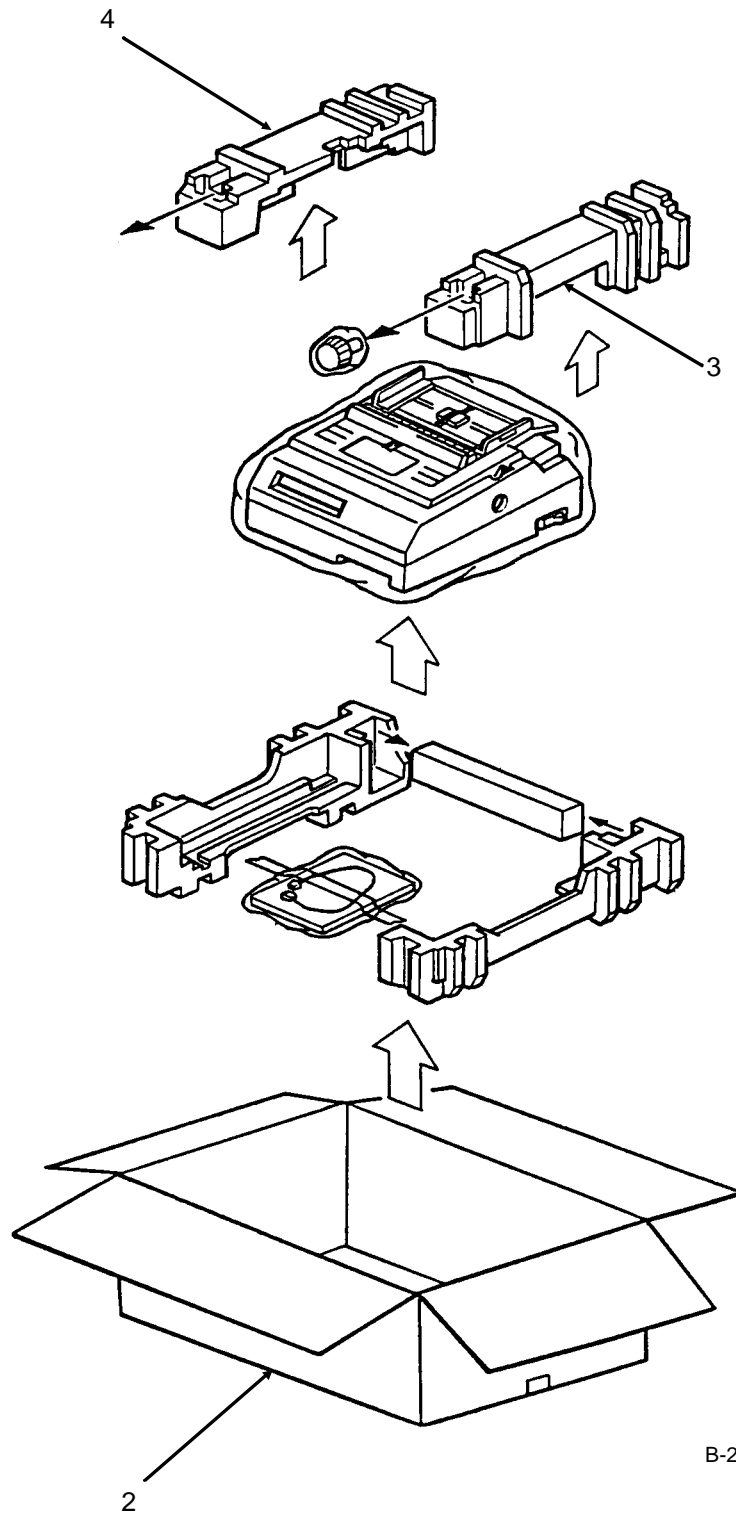

B-2-08.pcx

B.2.12 Consumables

Part numbers are subject to change. Refer to Okilink II for current part numbers and pricing information.

Item	Okidata P/N Oki-J P/N	Description	Comments	Disassembly Procedure
1	52105801 N/A	Ribbon Cartridge	Consumable	3.2.01

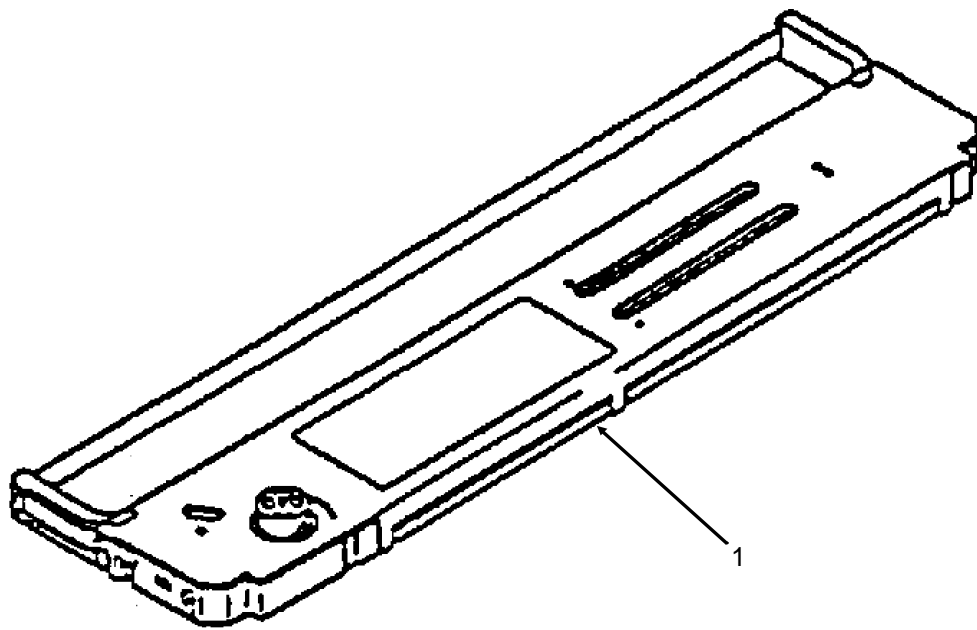

B-2-10.pcx

B.2.13 Documentation

Part numbers are subject to change. Refer to Okilink II for current part numbers and pricing information.

Item	Okidata P/N Oki-J P/N	Description	Comments	Disassembly Procedure
1A #	58224101 N/A	Kit: Pacemark 3410 Serv Train	Document	N/A
1B #	58224102 N/A	Kit: Pacemark 3410 Serv Train	Document	N/A
2	59249701 N/A	Handbook: Pacemark 3410 Service	Document Part of 01 kit	N/A
2	59249702 N/A	Handbook: Pacemark 3410 Service	Document Part of 02 kit	N/A
3	59249101 N/A	Handbook: Pacemark 3410 Printer	Document Part of 01 kit	N/A
3	59249102 N/A	Handbook: Pacemark 3410 Printer	Document	N/A
3	59249103 N/A	Handbook: Pacemark 3410 Printer	Document	N/A
3	59249104 N/A	Handbook: Pacemark 3410 Printer	Document Part of 02 kit	N/A
4	59250001 N/A	Manual: Maintenance	Document	N/A
4	59250002 N/A	Manual: Maintenance	Document	N/A
5	N/A N/A	Okidata Service Center Reference Guide	Document	N/A
6	53547501 N/A	Okidata Support 3-Ring Binder	Document	N/A
7	58067201 N/A	ABCD Warranty Claim Forms (Pkg of 20)	Document	N/A
8	58052401 N/A	Warranty Summary Forms (Pkg of 20)	Document	N/A
9	N/A N/A	Printer Drivers	Refer to Okilink	N/A
10	N/A N/A	Product Updates	Document Refer to Okilink	N/A
11	N/A N/A	Recommended Spare Parts List	Document Refer to Okilink	N/A
12	N/A N/A	Software	Refer to Okilink	N/A
13	N/A N/A	Technical Service Bulletins	Document Refer to Okilink	N/A
14	N/A N/A	Troubleshooting Manual	Document	N/A
15 *	N/A N/A	Marketing Literature	Document	N/A
16 **	N/A N/A	Okidata Marketing Literature Order Form	Document	N/A

Item	Okidata P/N Oki-J P/N	Description	Comments	Disassembly Procedure
1A #	58224101 N/A	Kit: Pacemark 3410 Serv Train	Document	N/A
	52053201 N/A	Label: Pacemark 3410 Kit	Part of 01 kit	N/A
	58075401 N/A	Envelope: Administration	Part of 01 kit	N/A
	58075501 N/A	Letter: Cover	Part of 01 kit	N/A
	59249601 N/A	Guide: Training	Part of 01 kit	N/A
	58076101 N/A	Material: Printhead Gap Adjustment	Part of 01 kit	N/A
	58075601 N/A	Test: Certification	Part of 01 kit	N/A
	58075701 N/A	Sheet: Test Answer	Part of 01 kit	N/A
	58075801 N/A	Critique: Course	Part of 01 kit	N/A
	58075901 N/A	Envelope: Pre-Printed Return	Part of 01 kit	N/A
2	59249701 N/A	Handbook: Pacemark 3410 Service	Part of 01 kit	N/A
	59249801 N/A	Documentation: User's	Part of 01 kit	N/A
	57517901 N/A	Video: Pacemark 3410 Service Training	Part of 01 kit	N/A
	52053202 N/A	Label: Pacemark 3410 Video Case	Part of 01 kit	N/A
	52053203 N/A	Label: Pacemark 3410 Video (Front)	Part of 01 kit	N/A
	52053204 N/A	Label: Pacemark 3410 Video (Spine)	Part of 01 kit	N/A
	57517101 N/A	Case: Red Vinyl Video	Part of 01 kit	N/A
	53533001 N/A	Box: Storage	Part of 01 kit	N/A
1B #	58224102 N/A	Kit: Pacemark 3410 Serv Train	Document	N/A
	52053205 N/A	Label: Pacemark 3410 Kit	Part of 02 kit	N/A
	58075502 N/A	Sheet: Read Me First	Part of 02 kit	N/A
2	59249702 N/A	Handbook: Pacemark 3410 Service	Part of 02 kit	N/A
3	59249104 N/A	Handbook: Pacemark 3410 Printer	Part of 02 kit	N/A
	57517902 N/A	Video: Pacemark 3410 Service Training	Part of 02 kit	N/A
	52053204 N/A	Label: Pacemark 3410 Video (Spine)	Part of 02 kit	N/A

* To order Marketing Literature, complete an Okidata Marketing Literature Order Form. Fax the completed form to Okidata Marketing Communications.

** Obtain this form by faxing a request to Okidata Marketing Communications. Refer to the Service Center Reference Guide for information on contacting Okidata.

See the following pages

58224101 Pacemark 3410 Service Training Kit

This kit was replaced by P/N 58224102.

Items in the training kit (except for the Printer Handbook) are NOT available separately.

Includes

52053201 Label: Pacemark 3410 Kit

58075401 Envelope: Administration

Includes

58075501 Letter: Cover

59249601 Guide: Training

58076101 Material: Printhead Gap Adjustment

58075601 Test: Certification

58075701 Sheet: Test Answer

58075801 Critique: Course

58075901 Envelope: Pre-Printed Return

59249701 Handbook: Pacemark 3410 Service

59249801 Documentation: User's

Includes

59249101 Handbook: Pacemark 3410 Printer

57517901 Video: Pacemark 3410 Service Training

52053202 Label: Pacemark 3410 Video Case

52053203 Label: Pacemark 3410 Video (Front)

52053204 Label: Pacemark 3410 Video (Spine)

57517101 Case: Red Vinyl Video

53533001 Box: Storage

58224102 Pacemark 3410 Service Training Kit

This kit replaces P/N 58224101.

Items in the training kit (except for the Printer Handbook) are NOT available separately.

Includes

- 52053205 Label: Pacemark 3410 Kit
- 58075502 Sheet: Read Me First
- 59249702 Handbook: Pacemark 3410 Service
- 59249104 Handbook: Pacemark 3410 Printer
- 57517902 Video: Pacemark 3410 Service Training
- 52053204 Label: Pacemark 3410 Video (Spine)

This page was intentionally left blank.



Pacemark 3410 Service Handbook

P/N 59249702