OKIDATA[®]
Service Manual

ML390/ML391
Dot Matrix Printers

Adobe Acrobat printable reference
copy of the OKIDATA Service Training Manual.
09/17/97

Note: This Adobe Acrobat version of the Okidata Service Training Manual was built with the pictures rendered at 300 dpi, which is ideal for printing, but does not view on most displays well.

Table of Contents	Page
Service Guide ML390/391	
0 About This Manual	
Front Cover	1
Manual Copyright	2
1 Product Specifications	
1.1 General Description - General Information	3
....1.1.02 Compatibility - Microline 390/391 vs. Microline 390/391-Plus	4
1.2 Product Specifications	5
1.3 Paper Specifications	6
1.4 Physical Specifications	7
1.5 Power Requirements	8
1.6 Environmental Requirements	9
1.7 Agency Approvals	10
1.8 Options	11
1.9 Consumables	12
1.10 Memory Specifications	13
1.11 Reliability Specifications	14
2 Principles of Operation	
2.1 Printer Overview - General Information	15
....2.1.02 Compatibility - Microline 390/391 vs. Microline 390/391-Plus	16
2.2 Circuit Board Description	17
....Block Diagram (Microline 390/391)	18
....Block Diagram (Microline 390/391-Plus)	19
2.3 Electrical Operation - Initialization	20
....2.3.02 Interface Control	21
....2.3.03 Print Head Drive Circuit	22
....2.3.04 Spacing Operation	23
....2.3.05 Line Feed	24
....2.3.06 Alarm Circuits	25
2.4 Mechanical Principles Of Operation - Printhead	26
....2.4.02 Space Mechanism / Operation	27
.....Head Gap Adjusting Mechanism	28
.....Head Gap Adjusting Mechanism - Diagram 1	29
.....Head Gap Adjusting Mechanism - Diagram 2	30
....2.4.03 Ribbon Drive Mechanism / Operation	31
....2.4.04 Paper Feed Mechanism	32
....2.4.05 Paper-End Detection Mechanism	33
....2.4.06 Semi-Automatic Sheet Feeder (SASF) Operation	34
....2.4.07 Release Lever Operation	35
3 Maintenance & Disassembly	
3.1 Maintenance - General Information	36

Table of Contents

Page

....3.1.02 Maintenance Tools	37
....3.1.03 Maintenance Precautions	38
3.2 Disassembly/Assembly Procedures	39
....3.2.01 Preliminary Items	40
....3.2.02 Separator Assembly	41
....3.2.03 Printhead Assembly	42
....3.2.04 Upper Cover Assembly	43
....3.2.05 Operator Panel Assembly	44
....3.2.06 Control Board - Revs A and B	45
.....Control Board - Rev C	46
....3.2.07 IC Card (B) Panel	47
....3.2.08 Transformer - Revs A and B	48
.....Transformer - Rev C	49
....3.2.09 Filter Assembly	50
....3.2.10 Power Supply Board - Revs A and B	51
.....Power Supply Board - Rev C	52
....3.2.11 Power Interconnect Module / Cable Guide - Revs A and B	53
.....Power Interconnect Module / Cable Guide - Rev C	54
....3.2.12 Indicator Assembly (Bail Bar Assembly)	55
....3.2.13 Head Cable Access Cover and Connection Board (SRBS)	56
....3.2.14 Ribbon Feed Gear Assembly	57
....3.2.15 Space Motor Assembly	58
....3.2.16 Carriage Frame Assembly	59
....3.2.17 Space Rack	60
....3.2.18 Guide Rail	61
....3.2.19 Platen Assembly	62
....3.2.20 Line Feed Motor and Gear - Line Feed Motor	63
.....Line Feed Motor and Gear - Line Feed Motor Gear	64
....3.2.21 Line Feed Motor Interconnect Module	65
....3.2.22 Reset Spring, Change Gear, and Idler Gear	66
....3.2.23 Release Lever	67
....3.2.24 Paper Pressure Guide	68
....3.2.25 Pressure Roller Assembly	69
....3.2.26 Tractor Assembly	70
....3.2.27 Sensor Lever	71
....3.2.28 Paper End (B) Lever	72
....3.2.29 Main Chassis Assembly	73
3.3 Adjustments - General Information	74
....3.3.01 Printhead Gap Adjustment	75
3.4 Cleaning	76
3.5 Lubrication	77

4 Failure & Repair Analysis

Table of Contents

Page

4.1 Overview - Introduction	78
....4.1.02 Compatibility - Microline 390/391 vs. Microline 390/391-Plus	79
4.2 Troubleshooting Updates	80
4.3 Reporting Problems	81
4.4 Troubleshooting Tips	82
4.5 Fault Alarms	83
4.6 Repair Analysis Procedures - Using The RAPS	84
....4.6.02 RAP Index	85
....4.6.03 Troubleshooting Cautions	86
.....RAP 01: Operator Panel Lamps Do Not Light	87
.....RAP 02: Abnormal Spacing	88
.....RAP 03: Wrong or Missing Characters / Dots on Output	89
.....RAP 04: Line Feed Problems	90
.....RAP 05: Malfunction of Operator Panel Switch(es)	91
.....RAP 06: Parallel Interface Does Not Receive Data	92
.....RAP 07: Serial Interface Does Not Receive Data	93
4.7 Hexadecimal Dump	94
4.8 Resistance / Service Checks - Index To Charts	95
....4.8.02 Interconnect Diagrams - Microline 390/391 - Rev. A and B	96
.....Interconnect Diagrams - Microline 390/391 - Rev C	97
.....Interconnect Diagrams - Microline 390/391 - Plus	98
....4.8.03 Printhead	99
....4.8.04 Space Motor	100
....4.8.05 Line Feed Motor	101
....4.8.06 Operator Panel Board	102
....4.8.07 Control Board	103
4.9 Printer Tests - General Information	104
....4.9.02 Rolling ASCII Print Test	105
....4.9.03 Font Sample Test	106
....4.9.04 Serial Interface Loopback Test	107
4.10 Menu Operation	108
4.11 Top Of Form	109
4.12 Paper Park	110
4.13 Forms Tear Off	111
A Board Diagrams	
A.1 Board Reference Charts - General Information	112
....A.1.02 Compatibility - Microline 390/391 vs. Microline 390/391-Plus	113
A.2 Index To Charts - Microline 390/391: Rev A And B	114
....Index To Charts - Microline 390/391: Rev C	115
....Index To Charts - Microline 390/391 - Plus	116
....A.2.01 Control Board (SKRB) - Rev A and B	117

Table of Contents

Page

....A.2.02 Control Board (SKRA) - Rev C and "Plus" Printers	118
....A.2.03 Power Supply (PAII) - Rev A and B	119
....A.2.04 Power Supply (SUII) - Rev C and "Plus" Printers	120
....A.2.05 Filter Assembly	121
....A.2.06 Operator Panel (LXSP) - Microline 390/391	122
....A.2.07 Operator Panel (LXSP-5) - Microline 390/391-Plus	123
....A.2.08 Interconnect Board (SRBS)	124
....A.2.09 RS232-C Serial Interface (LXHI)	125
B Illustrated Parts Listing	
B.1 Illustrated Parts Listing - General Information	126
....B.1.02 Definitions of Terms	127
....B.1.03 Compatibility - Microline 390/391 vs. Microline 390/391-Plus	128
....B.1.04 Parts Ordering Information	129
B.2 Charts - Index	130
....B.2.01 Covers	131
....B.2.02 Electrical Components - Rev A and B	132
....B.2.03 Electrical Components - Rev C	133
....B.2.04 Printer Mechanism - Rev A and B (1 of 2)	134
....B.2.05 Printer Mechanism - Rev A and B (2 of 2)	135
....B.2.06 Printer Mechanism - Rev C (1 of 2)	136
....B.2.07 Printer Mechanism - Rev C (2 of 2)	137
....B.2.08 Operator Panel	138
....B.2.09 Carriage Assembly	139
....B.2.10 Tractor Assembly	140
....B.2.11 Options	141
....B.2.12 Consumables	142
....B.2.13 Packaging	143
....B.2.14 Documentation	144



Service Guide ML390/391

Chapter 0 About This Manual

This document may not be reproduced without written permission of the Okidata ® Technical Training Group. Every effort has been made to ensure the accuracy of the information contained in this training course. Okidata is not responsible for errors beyond our control.

© 1994 by Okidata All rights reserved.

First Edition April, 1994

Written and produced by the Okidata Technical Training Group

Please address any comments on this publication to:

Technical Training Group

Okidata

532 Fellowship Road

Mount Laurel, NJ 08054-3499

Fax Number: (609) 235-2600, ext. 7034

Okilink Login Name: Technical Training

OKIDATA is a registered trademark of Oki Electric Industry Company, Ltd.; marques deposee de Oki Electric Industry Company, Ltd.; marca registrada, Oki Electric Industry Company, Ltd.

Microline is a registered trademark of Oki Electric Industry Company, Ltd.

Centronics is a registered trademark of Centronics Inc.

IBM is a registered trademark of International Business Machines, Inc.

Proprinter is a registered trademark of International Business Machines, Inc.

Copyright 1997, Okidata, Division of OKI America, Inc. All rights reserved. See the OKIDATA Business Partner Exchange (BPX) for any updates to this material. (<http://bpx.okidata.com>)

1.1 GENERAL DESCRIPTION

1.1.01 General Information

The Microline 390, Microline 391, Microline 390-Plus, and 391-Plus are twenty-four pin, dot matrix printers. These printers provide Epson LQ and IBM Proprinter emulations, which are selected through the Printer Menu.

The major difference between the Microline 390/390-Plus and Microline 391/391-Plus is the width of each printer. The Microline 390/390-Plus can handle 80 print columns (at 10 CPI). The Microline 391/391-Plus can print up to 136 columns (at 10 CPI).

The standard interface is a Centronics parallel and an optional RS232-C serial interface can be installed. The optional serial interface can transfer data at speeds up to 19.2K baud.

Both printers feature an enhanced operator panel which provides access to the following capabilities.

- Menu Selection
- Quiet Mode
- Printer Tests
- Paper Park
- Print Characteristics
- Standard Printer Controls

1.1.02 Compatibility - Microline 390/391 vs. Microline 390/391-Plus

The differences between the Microline 390/391 and Microline 390/391-Plus printers are listed below.

Hardware Differences

- Operator Panel
- Operator Board
- Character Generator Programmable Read Only Memory (CGROM)
- Programmable Read Only Memory (PROM)
- Middle Cover

Operational Differences

- "Plus" printers have more resident fonts.
- In the "Plus" printers, data in the receive buffer is printed upon receipt, without having to wait for a line terminator character (CR/LF or FF).
- In the "Plus" printers, the DC1/DC3 Acknowledge/Ignore, Receive Buffer Size, and RESET inhibit can be controlled through the printers Menu.

Serial Number Revision Levels

Microline 390/391

A

Rev A units are original production units. An interconnect module connects the power supply board to the main control board.

B

Rev B units are retrofitted to include a modified interconnect module, which prevents corrosion.

C

These units have a cable connection between the power supply board and the main control board. The cable connection wire replaces the interconnect module.

Microline 390/391-Plus

Revision levels do NOT apply to the "Plus" printers.

NOTE:

Please refer to the parts lists for parts differentiation. Please be sure of the parts you need before ordering to avoid confusion and incorrect parts orders.

Printer Serial Number Identification

There are three serial number revision levels for the printers. Hardware differences exist between levels. To identify the revision level of a printer, record the serial number from the back of the printer. Refer to the following to decode the serial number.

Example Printer Serial Number: 401A0154693

Date Code 401 (4 = year. 01 = month)

Revision A

Serial Number 0154693

Compatibility Chart

Item	Okidata P/N	Purpose / Function of Item	Printer Serial Number Revision Level				
			390/391A	390/391B	390/391C	390+	391+
Main Control Board							
SKRA Board	55045401	Main Control Board	Yes	Yes	No	No	No
SKRB Board	55038702	Main Control Board	Yes	Yes	Yes	No	No
SKRA-3 Board	55045403	Main Control Board	Yes	Yes	Yes	Yes	Yes
Power Supply Board							
PAII Board	55038801	Power Supply Board	Yes	Yes	No	No	No
SUII Board	55047401	Power Supply Board	Yes	Yes	Yes	Yes	Yes
Operator Panel Assembly							

Panel: Operator Assembly	5006960 1	Operato r Panel Assemb ly (390/39 1)	Yes	Yes	Yes	No	No
Panel: Operator Assembly	5006961 0	Operato r Panel Assemb ly (390/39 1-Plus)	No	No	No	Yes	Yes
PCB: LXSP	5504560 1	Operato r Panel Board (390/39 1)	Yes	Yes	Yes	No	No
PCB: LXSP-5	5503860 5	Operato r Panel Board (390/39 1-Plus)	No	No	No	Yes	Yes
Transfor mer							
120 Volt XFRMR	5640720 1	Transfo rmer (390 and 390-Plu s)	Yes	Yes	Yes	Yes	Yes
120 Volt XFRMR	5640720 2	Transfo rmer (391 and 391-Plu s)	Yes	Yes	Yes	Yes	Yes
220 Volt XFRMR	5640780 1	Transfo rmer (390 and 390-Plu s)	Yes	Yes	Yes	Yes	No

220 Volt XFRMR	56407802	Transformer (391 and 391-Pluses)	Yes	Yes	Yes	No	Yes
Interconnect Module							
Interconnect Module	55328301	Connects power supply board to main board	Yes	Yes	No	No	No
Cable							
Cable	56616802	Connects power supply board to main board	No	No	Yes	Yes	Yes
Cable Guide							
Cable Guide	51003801	Holds cable in place	No	No	Yes	Yes	Yes
Covers							
Cover	53488301	Middle Cover (390)	Yes	Yes	Yes	No	No
Cover	53488401	Middle Cover (391)	Yes	Yes	Yes	No	No

Cover	5348831 6	Middle Cover (390-Plu s)	No	No	No	Yes	No
Cover	5348842 2	Middle Cover (391-Plu s)	No	No	No	No	Yes
Chassis							
Chassis	5006110 1	Chassis : Main (390 and 390-Plu s)	Yes	Yes	Yes	Yes	No
Chassis	5006120 1	Chassis : Main (391 and 391-Plu s)	Yes	Yes	Yes	No	Yes

Copyright 1997, Okidata, Division of OKI America, Inc. All rights reserved. See the OKIDATA Business Partner Exchange (BPX) for any updates to this material. (<http://bpx.okidata.com>)

1.2 PRODUCT SPECIFICATIONS

1.2.01 Print Method

- Impact Dot Matrix

Number of Print Wires: 24

Print Wire Diameter: .0079 inch (.2 mm)

1.2.02 Print Modes

- Utility
- Letter Quality (LQ)

1.2.03 Character Pitches

- 10 CPI
- 12 CPI
- 15 CPI
- 17.1 CPI
- 20 CPI
- Proportional

1.2.04 Character Sets

- Standard ASCII
- Epson Character Set
- IBM Character Set I
- IBM Character Set II
- IBM Proprinter Compatible Character Set
- Foreign Language Substitution
- Line Graphics

NOTES:

Characters Per Inch = cpi Characters Per Second = cps Dots Per Inch = dpi

Character Sets are selected through the Menu

1.2.05 Resident Fonts

Microline 390/391

- Courier
- Utility

NOTE:

Additional fonts can be accessed by using an optional font card.

Microline 390/391-Plus

- Courier
- Roman
- Swiss
- Orator
- Gothic
- Prestige
- Utility

NOTE:

Additional fonts can be accessed by using an optional font card.

The "Plus" printers can access Down Line Loadable (DLL) fonts.

1.2.06 Print Speed

Print Mode	Character Pitch				
	10 cpi	12 cpi	15 cpi	17.1cpi	20 cpi
Utility	225 cps	270 cps	168.6 cps	192.9 cps	225 cps
LQ	75 cps	90 cps	112.5	128.6 cps	150 cps

1.2.07 Print Resolution

Print Mode	Character Pitch				
	10 cpi	12 cpi	15 cpi	17.1cpi	20 cpi
Utility	120 dpi	120 dpi	240 dpi	240 dpi	240 dpi
LQ	360 dpi	360 dpi	360 dpi	360 dpi	360 dpi

1.2.08 Character Matrix Sizes

Print Mode	Matrix Size	Characters Per Inch
Utility	9 X 7	All sizes
LQ	17 X 13	10 and 12 cpi
LQ	15 X 18	15 17.1 and 20 cpi

1.2.09 Characters Per Line

	10 CPI	12 CPI	15 CPI	17.1 CPI	20 CPI
390/390-Plus	80	96	120	137	160
391/391-Plus	136	163	204	233	272

1.2.10 Paper Feed Specification

Available Paper Paths

- Rear
- Top
- Bottom Feed

NOTE:

Bottom Feed requires the use of the optional pull tractor

Line Feed Increments

- 1/6", 1/8", n/60", n/180", n/216" and n/360".

Line Feed Timing

- 70 ms @ 6 lines per inch
- Slew Rate: 3.75 inches per second (Continuous Feed Paper)

1.2.11 Interface Specifications

- Centronics Parallel (Standard)
- RS232C Serial (Optional)

NOTE:

Interface cables are sold separately.

A shielded cable is required. Twisted-pair wires are recommended for noise protection.

Parallel interface cables should be no more than 16.4 feet (5 m) in length.

Copyright 1997, Okidata, Division of OKI America, Inc. All rights reserved. See the OKIDATA Business Partner Exchange (BPX) for any updates to this material. (<http://bpx.okidata.com>)

1.3 PAPER SPECIFICATIONS

1.3.01 Width

- Microline 390/390-Plus

Minimum: 3 inches (76.2 mm)

Maximum: 10 inches (254 mm)

- Microline 391/391-Plus

Minimum: 3 inches (76.2 mm)

Maximum: 16 inches (406.4 mm)

1.3.02 Single Part Forms

- Weight

Minimum: 12 pound (45 g/m²)

Maximum: 24 pound (90 g/m²)

1.3.03 Multipart Forms - Carbon Lined or Pressure Sensitive

- Weight

Minimum: 9 pound (35 g/m²)

Maximum: 11 pound (40 g/m²)

- Thickness

Maximum: 0.014 inches (0.356 mm)

- Number of Copies

Original plus three copies

1.3.04 Multipart - Interleaf

- Weight

Paper

Minimum: 10 pound (38 g/m²)

Maximum: 12 pound (45 g/m²)

Carbon

Maximum: 9 pound (35 g/m²)

- Thickness

Maximum: 0.014 inches (0.356 mm)

- Number of Copies

Original plus three copies

1.3.05 Cut Sheets (Single Part ONLY)

- Friction Feed

Weight

Minimum: 12 pound (45 g/m²)

Maximum: 24 pound (90 g/m²)

- Cut Sheet Feeder 3000

Weight

Minimum: 16 pound

Maximum: 24 pound (90 g/m²)

1.3.06 Envelopes (Individual)

- Weight

Maximum: 24 pound maximum (90 g/m²)

- Thickness

Maximum: 0.016 inches (0.41 mm)

- Dimensions

6 1/2 inches x 3 5/8 inches

8 7/8 inches x 3 7/8 inches

9 1/2 inches x 4 1/8 inches

1.3.07 Envelopes (Continuous)

NOTES:

Continuous Feed Envelopes should be used ONLY with bottom feed.

- Weight

Maximum: 24 pound (90 g/m²)

- Thickness

Maximum: 0.014 inches (0.36 mm)

- Width

Minimum: 3 inches (76.2 mm)

Maximum: 10 inches (354 mm)

1.3.08 Card Stock

NOTES:

Card Stock should be used ONLY with bottom feed.

Set the head gap adjusting lever for optimum printing performance.

- Weight

Maximum: 100 pound (150 g/m²)

- Thickness

Maximum: 0.008 inches (0.20 mm)

· Dimensions

Maximum: 5 inches x 8 inches

1.3.09 Labels

NOTES:

Labels should be used ONLY with bottom feed.

Do NOT use fabric labels.

Do NOT print on the edge or perforation of the label.

· Carrier Width

Maximum: 8.5 inches (216 mm) Microline 390/390-Plus

Maximum: 15 inches (381 mm) Microline 391/391-Plus

· Thickness

Maximum: 0.011 inches (0.28 mm)

1.3.10 Transparencies

· Thickness

Maximum: 0.004 inches (0.10 mm)

· Dimensions

Maximum: 8.5 inches wide x 11 inches long (216 mm x 260 mm)

Copyright 1997, Okidata, Division of OKI America, Inc. All rights reserved. See the OKIDATA Business Partner Exchange (BPX) for any updates to this material. (<http://bpx.okidata.com>)

1.4 PHYSICAL SPECIFICATIONS**1.4.01 Printer Dimensions**

The printer dimensions do not include the platen knob, acoustic cover, or paper separator.

Product	Height	Width	Depth
390/390-Plus	4.6"	15.7"	13.6"
391/391-Plus	4.6"	21.7"	13.6"

1.4.02 Weight

· Microline 390/390-Plus

18.5 pounds

· Microline 391/391-Plus

22.3 pounds

1.5 POWER REQUIREMENTS

1.5.01 Input Power Requirements

- Single Phase AC
 - Voltage
- 120 VAC +5.5%, -15%

or

220/240 VAC +5.5%, -10%

- Frequency
- 50/60 Hz +/- 2%

1.5.02 Power Consumption

- Operating: 110 VA
 - Idle: 40 VA
-

Copyright 1997, Okidata, Division of OKI America, Inc. All rights reserved. See the OKIDATA Business Partner Exchange (BPX) for any updates to this material. (<http://bpx.okidata.com>)

1.6 ENVIRONMENTAL REQUIREMENTS

1.6.01 Temperature

- Operating
41 through 104 degrees Fahrenheit (5 to 40 degrees Celsius)
- Non-Operating
14 through 109.4 degrees Fahrenheit (-10 to 43 degrees Celsius)
- Storage
-40 through 158 degrees Fahrenheit (-40 to 70 degrees Celsius)

1.6.02 Relative Humidity

- Operating
20% to 90%
- Non-Operating
5% to 95%
- Storage
5% to 95%

1.6.03 Acoustic Specifications

- Standard Operation
57 dba
- Quiet Mode
52 dba



1.7 AGENCY APPROVALS

1.7.01 Listings

- UL Standard No. 478, Ver. 5
- CSA Standard C22.2 No. 220
- FCC Part 15, Subject J, Class B

Copyright 1997, Okidata, Division of OKI America, Inc. All rights reserved. See the OKIDATA Business Partner Exchange (BPX) for any updates to this material. (<http://bpx.okidata.com>)

1.8 OPTIONS**1.8.01 Font Card**

- Prestige Elite
- Letter Gothic

1.8.02 Pull Tractor with Acoustic Cover**1.8.03 Cut Sheet Feeder with Access Cover (CSF-3000A)****1.8.04 Super-Speed RS232-C Serial Interface Board****1.8.05 Memory Expansion Card (Microline 390/391-Plus ONLY)**

- 32 Kbytes Character Buffer
-

Copyright 1997, Okidata, Division of OKI America, Inc. All rights reserved. See the OKIDATA Business Partner Exchange (BPX) for any updates to this material. (<http://bpx.okidata.com>)



1.9 CONSUMABLES

1.9.01 Cartridge Ribbon

- Black
- 2 million character ribbon life
- Re-inking cartridge

Copyright 1997, Okidata, Division of OKI America, Inc. All rights reserved. See the OKIDATA Business Partner Exchange (BPX) for any updates to this material. (<http://bpx.okidata.com>)

1.10 MEMORY SPECIFICATIONS

1.10.01 DRAM

- 60 Kbytes

1.10.02 Working RAM

- 15.3 Kbytes

1.10.03 Print Buffer

- 3.5 Kbytes

1.10.04 Image Buffer

- 13.2 Kbytes

1.10.05 Receive Buffer

- Epson Mode: 28 Kbytes
- IBM Mode: 16 Kbytes

1.10.06 Memory Expansion Card (Option)

- 32 Kbytes Character Buffer
- Microline 390/391-Plus ONLY

1.11 RELIABILITY SPECIFICATIONS

1.11.01 Mean Time Between Failures (MTBF)

- 5000 hrs @ 25% duty cycle, 35% page density

1.11.02 Mean Time To Repair (MTTR)

- 15 minutes @ major sub-assembly level

1.11.03 Printer Life

- 12,000 hrs @ 25% duty cycle, 35% page density

1.11.04 Ribbon Life

- 2 million characters

1.11.05 Printhead Life

- 200 million characters in 10 cpi utility print quality. 35% page density and 25% duty cycle

2.1 PRINTER OVERVIEW

2.1.01 General Information

This section describes the operation of the printer. It is divided into three parts.

- Circuit Board Description

The major components of the main controller board are described and functional descriptions of the operator panel board and power supply are provided. Some signal names are listed with a (-N) after them. This means that the signal is "active" or ON when it is a logic "0". This is also indicated by a line over the signal name (I-PRIME).

- Electrical Operation

This section views the printer functions from an electrical perspective.

- Mechanical Operation

This section views the printer functions from a mechanical perspective.

2.1.02 Compatibility - Microline 390/391 vs. Microline 390/391-Plus

The differences between the Microline 390/391 and Microline 390/391-Plus printers are listed below.

Hardware Differences

- Operator Panel
- Operator Board
- Character Generator Programmable Read Only Memory (CGROM)
- Programmable Read Only Memory (PROM)
- Middle Cover

Operational Differences

- "Plus" printers have more resident fonts.
- In the "Plus" printers, data in the receive buffer is printed upon receipt, without having to wait for a line terminator character (CR/LF or FF).
- In the "Plus" printers, the DC1/DC3 Acknowledge/Ignore, Receive Buffer Size, and RESET inhibit can be controlled through the printers Menu.

Serial Number Revision Levels

Microline 390/391

A

Rev A units are original production units. An interconnect module connects the power supply board to the main control board.

B

Rev B units are retrofitted to include a modified interconnect module, which prevents corrosion.

C

These units have a cable connection between the power supply board and the main control board. The cable connection wire replaces the interconnect module.

Microline 390/391-Plus

Revision levels do NOT apply to the "Plus" printers.

NOTE:

Please refer to the parts lists for parts differentiation. Please be sure of the parts you need before ordering to avoid confusion and incorrect parts orders.

Printer Serial Number Identification

There are three serial number revision levels for the printers. Hardware differences exist between levels. To identify the revision level of a printer, record the serial number from the back of the printer. Refer to the following to decode the serial number.

Example Printer Serial Number: 401A0154693

Date Code 401 (4 = year. 01 = month)

Revision A

Serial Number 0154693

Compatibility Chart

Item	Okidata P/N	Purpose / Function of Item	Printer Serial Number Revision Level				
			390/391A	390/391B	390/391C	390+	391+
Main Control Board							
SKRA Board	55045401	Main Control Board	Yes	Yes	No	No	No
SKRB Board	55038702	Main Control Board	Yes	Yes	Yes	No	No
SKRA-3 Board	55045403	Main Control Board	Yes	Yes	Yes	Yes	Yes
Power Supply Board							
PAII Board	55038801	Power Supply Board	Yes	Yes	No	No	No
SUII Board	55047401	Power Supply Board	Yes	Yes	Yes	Yes	Yes
Operator Panel Assembly							

Panel: Operator Assembly	50069601	Operator Panel Assembly (390/391)	Yes	Yes	Yes	No	No
Panel: Operator Assembly	50069610	Operator Panel Assembly (390/391- Plus)	No	No	No	Yes	Yes
PCB: LXSP	55045601	Operator Panel Board (390/391)	Yes	Yes	Yes	No	No
PCB: LXSP-5	55038605	Operator Panel Board (390/391- Plus)	No	No	No	Yes	Yes
Transfor mer							
120 Volt XFRMR	56407201	Transfor mer (390 and 390-Plus)	Yes	Yes	Yes	Yes	Yes
120 Volt XFRMR	56407202	Transfor mer (391 and 391-Plus)	Yes	Yes	Yes	Yes	Yes
220 Volt XFRMR	56407801	Transfor mer (390 and 390-Plus)	Yes	Yes	Yes	Yes	No
220 Volt XFRMR	56407802	Transfor mer (391 and 391-Plus)	Yes	Yes	Yes	No	Yes
Intercon nect Module							

Interconnect Module	55328301	Connects power supply board to main board	Yes	Yes	No	No	No
Cable							
Cable	56616802	Connects power supply board to main board	No	No	Yes	Yes	Yes
Cable Guide							
Cable Guide	51003801	Holds cable in place	No	No	Yes	Yes	Yes
Covers							
Cover	53488301	Middle Cover (390)	Yes	Yes	Yes	No	No
Cover	53488401	Middle Cover (391)	Yes	Yes	Yes	No	No
Cover	53488316	Middle Cover (390-Plus)	No	No	No	Yes	No
Cover	53488422	Middle Cover (391-Plus)	No	No	No	No	Yes
Chassis							
Chassis	50061101	Chassis: Main (390 and 390-Plus)	Yes	Yes	Yes	Yes	No

Chassis	50061201	Chassis: Main (391 and 391-Plus)	Yes	Yes	Yes	No	Yes
---------	----------	---	-----	-----	-----	----	-----

Copyright 1997, Okidata, Division of OKI America, Inc. All rights reserved. See the OKIDATA Business Partner Exchange (BPX) for any updates to this material. (<http://bpx.okidata.com>)

2.2 CIRCUIT BOARD DESCRIPTION

2.2.01 Operator Panel Board

The operator panel board contains switches and LEDs which allow the end user to control and monitor the printers operation. For specific information on the capabilities and use of the operator panel, please refer to *Operation* in the Setup Guides or *Chapter 1: Front Panel Control* in the Reference Guides.

2.2.02 Power Supply

The power supply consists of a power transformer, filter board and a DC power supply board. The AC input voltage is stepped down to 8.6 VAC, 46 VAC and 10 VAC by the power transformer. These AC voltages are converted into + 5 vdc, + 8 vdc, and + 40 vdc by the power supply board for use throughout the printer.

Power Transformer

If the transformer temperature rises above a pre-determined level, the built-in temperature fuse opens to prevent damage to components in the printer. Once this fuse opens, the transformer **MUST** be replaced.

Filter Board

The power switch, line fuse, and line filter are mounted on the filter board.

Power Supply Board

This board transforms AC voltages into + 5 vdc, + 8 vdc and + 40 vdc for use throughout the printer.

2.2.03 Control Board

Microprocessor

The microprocessor is the nucleus of the control circuitry. All peripheral circuits operate under the control of the microprocessor.

For the Rev A, B, and C printers, the microprocessor is Q8 - 80C154.

Program Read Only Memory (ROM)

The printers control program is stored in the Program ROM. The microprocessor operates under the control of this program.

For the Rev A, B, and C printers, the Program ROM is Q12 - 128 kilobytes.

Random Access Memory (RAM)

The RAM stores the following information.

- Data to be printed (Receive Buffer)
- All character fonts

Q1 and Q2 provide 64 kbytes of RAM. The battery backup retains data when power is removed.

Character Generator Read Only Memory (CGROM)

This stores the resident character fonts.

Q5 (128 kbytes) is the CGROM.

Electrically Erasable and Programmable Read Only Memory (EEPROM)

Menu data is stored in Q9 (256 bit), the EEPROM.

Large Scale Integrated Circuitry (LSI)

Q6 - MSM6990

This is an external interface and motor control LSI. It performs the following functions.

External Interface Controller

Parallel Interface Control

This circuit supplies signals used by the Centronics parallel interface.

Serial Interface Control

This circuit supplies signals used by the RS 232-C serial interface.

I/O Ports

Control signals are sent in response to commands input from the microprocessor. The input port is used to read information on the printers condition.

Address Latch

It latches the low order eight bits of the address bus (A0 to A7). These bits are used as addresses for read/write operations with peripheral devices.

Motor Controller

Spacing Motor Control

This function accelerates and decelerates the spacing motor in accordance with commands from the microprocessor and controls the spacing motor speed in various printing modes. Motor speed and direction are determined by monitoring the signals PHASE A and PHASE B, which are provided by the encoder on the spacing motor.

DOT Timing Generation

This function generates the DOT-ON signal (IPT), which synchronizes the print wire firing in accordance with the signals PHASE A and PHASE B. This timing information is also sent to the microprocessor.

Q6 - MSM79H048, MSM79H097

This LSI controls the functions listed below.

Direct Memory Access (DMA) Control

Transfers data between the ROM and RAM or between RAMs independent of the microprocessor.

Printhead Drive Control

Drive pulses are produced for printwire drive timing using the signal IPT as a trigger. IPT is generated from the signals PHASE A and PHASE B (which are produced by the spacing motor). The pulse width (drive time) of IPT varies with the number of printwires to be fired. The duration of IPT is preset by the microprocessor.

Print Data Transfer Control

Controls the serial transfer of print data. Print data is transferred from the print buffer to a register in this LSI in synchronization with the IPT signal (provided by the MSM6990 LSI). The data stored in this register will be transferred serially to the head drive circuits.

Line Feed Microstep Control

Controls incremental stepping of the line feed motor.

Memory Interface

This expands the memory space for ROMs and RAMs connected to this LSI. Up to 368 kbytes of memory may be accessed.

Dynamic RAM (D-RAM) Refresh

CAS is used to refresh the D-RAMs before the RAS refresh method is used.

Copyright 1997, Okidata, Division of OKI America, Inc. All rights reserved. See the OKIDATA Business Partner Exchange (BPX) for any updates to this material. (<http://bpx.okidata.com>)



Service Guide ML390/391

Chapter 2 Principles of Operation

Block Diagram (Microline 390/391)

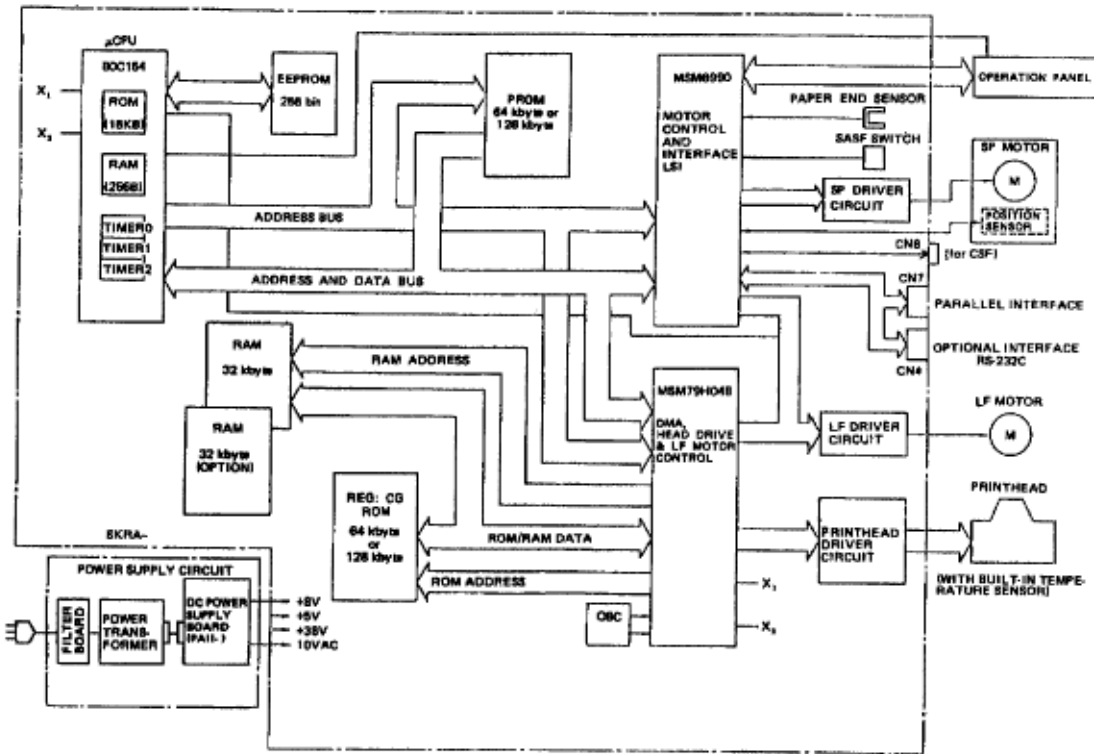

Copyright 1997, Okidata, Division of OKI America, Inc. All rights reserved. See the OKIDATA Business Partner Exchange (BPX) for any updates to this material. (<http://bpx.okidata.com>)



Service Guide ML390/391

Chapter 2 Principles of Operation

Block Diagram (Microline 390/391-Plus)

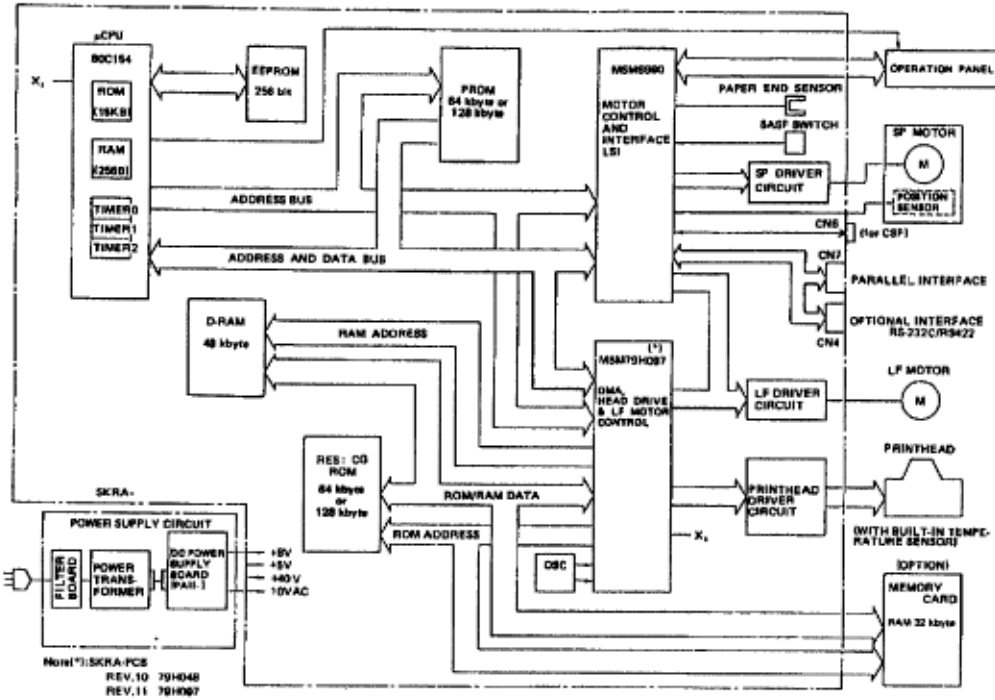

Copyright 1997, Okidata, Division of OKI America, Inc. All rights reserved. See the OKIDATA Business Partner Exchange (BPX) for any updates to this material. (<http://bpx.okidata.com>)

2.3 ELECTRICAL OPERATION

2.3.01 Initialization

Initialization occurs whenever the printer is powered ON or when the signal I-PRIME is received at the parallel interface.

The initialization sequence is as follows.

- Q6, Q8, and Q11 are reset.
 - The operating modes of Q6, Q8, and Q11 are set.
 - Memory (ROM and RAM) is checked.
 - RAM is initialized.
 - Carriage homing is performed. The carriage will move to the left until it contacts the left frame.
 - The program establishes the interface signals (ACK, BUSY) and the SEL lamp lights.
-

2.3.02 Interface Control

Parallel Interface

Data from the host is input through connector CN7 to the interface LSI Q11.

The interface LSI latches this input data in synchronization with the STB-N signal. The BUSY signal is active while this data is being processed. When processing is complete, the BUSY signal is turned OFF, and an ACK-N is sent to the host (to request more data).

The BUSY signal is also sent to the host whenever the printer is incapable of receiving data.

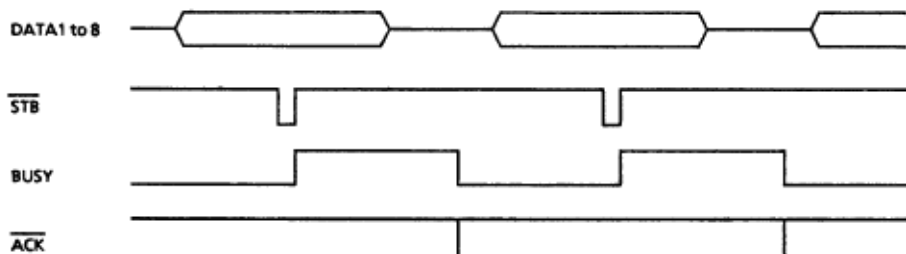

2.3.03 Print Head Drive Circuit

This circuit drives the printhead coils (1 through 24) using the HD DV signal, along with the twenty-four HD DATA signals. The pulsewidth of HD DV determines the pin drive time. The pin drive time increases as the number of pins to be driven increases. The pins are driven in synchronization with the signal IPT, which is derived from the timing encoder (PHASE A and PHASE B) on the space motor.

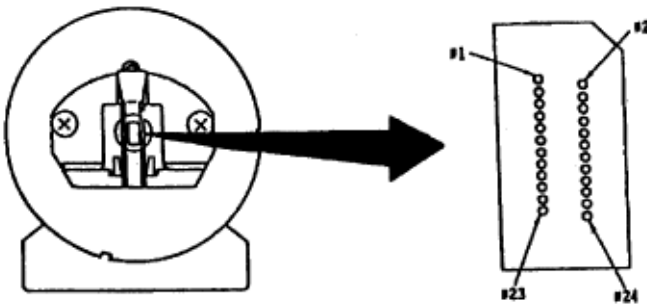

2.3.04 Spacing Operation

Spacing Motor Control

The motor control LSI produces the spacing motor phase signals SP-U, SP-V, SP-W and the overdrive signal SPD-A in accordance with spacing commands from the microprocessor.

The SPD-A signal is a fixed period pulse signal whose pulsewidth is controlled by the program. This signal is used to control motor drive time.

The signal SP ON/OFF is used at acceleration/deceleration, when a large amount torque is required.

The motor driver (MTDV) drives the space motor in accordance with the SPD-A and SP ON/OFF signals. Pins 9 and 11 of the MTDV are the protection circuits against over voltage and over current.

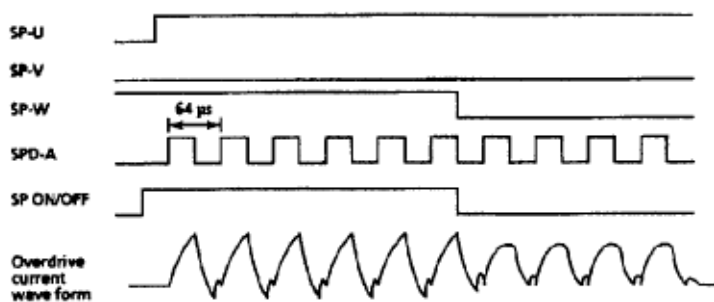

Spacing Motor Encoder Disk / Photosensor

As the spacing motor is driven, the signals PHASE-A and PHASE-B are generated by the photosensor / encoder disk (which is mounted to the spacing motor).

The motor control LSI divides the frequency of these signals in accordance with the selected print pitch. The LSI generates the IPT-N signal, which provides dot-on timing and carriage position detection.

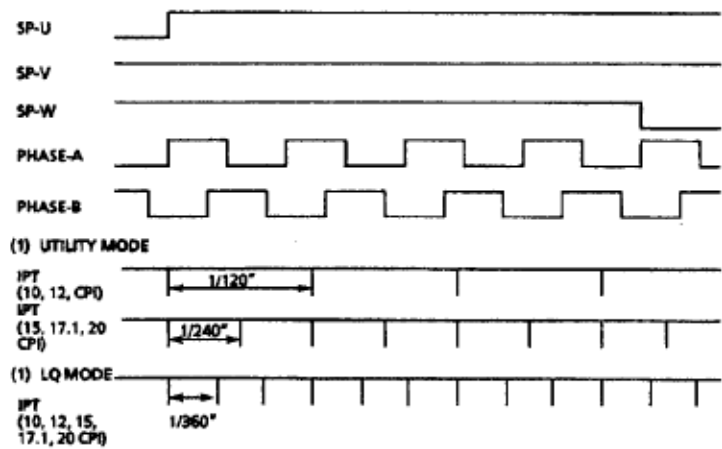

Copyright 1997, Okidata, Division of OKI America, Inc. All rights reserved. See the OKIDATA Business Partner Exchange (BPX) for any updates to this material. (<http://bpx.okidata.com>)

2.3.05 Line Feed

During a line feed operation, the line feed motor is driven by the phase signals LFPHA and LFPHB, in synchronization with the signal LFOVD.

When it is not being driven, the line feed motor is held in place by the LF HOLD signal.

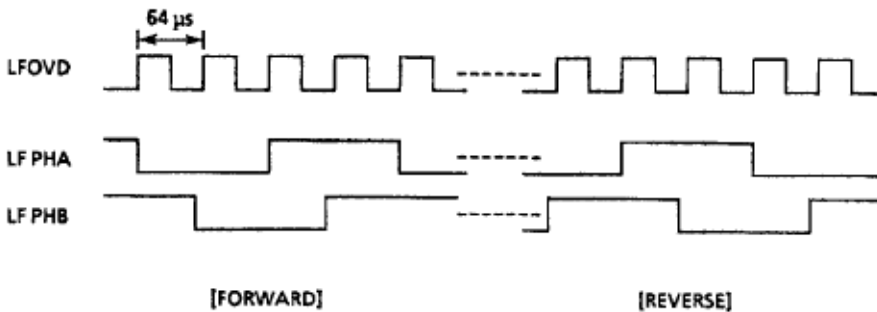

2.3.06 Alarm Circuits

Drive Circuit Fault Alarm Circuit

This is a protective circuit which causes the AC line fuse to open when a fault occurs in the printhead drive circuit, the spacing motor drive circuit, or the line feed drive circuit. The fault alarm circuit monitors the drive time of each of these circuits and produces the ALM signal if any drive time exceeds its specified value. The ALM signal activates SCR ON, which causes the secondary coil (40 volts) of the transformer to short-circuit. This creates an over-current condition, which causes the AC line fuse to open.

Head Overheat Alarm Circuit

The printhead contains a built-in thermistor (rated at 130 degrees Celsius). The thermistor monitors the printhead temperature.

Printhead temperature rises when the unit is printing. When the temperature of the printhead rises, the resistance of the thermistor decreases and the potential falls at the negative input of comparator Q7. Q7 is located on the main controller board.

When printhead temperature reaches approximately 90 degrees Celsius, this comparator output inverts, causing the HEAD TEMP signal to be sent to the motor control LSI. The unit prints unidirectionally.

When printhead temperature reaches approximately 130 degrees Celsius, the thermistor sends a signal to the main control board, generating the HEAD OVERHEAT alarm. Printing stops when this alarm is detected (A BUSY signal is sent to the host computer. Data remains in the print buffer as long as power is supplied to the printer). This allows the printhead temperature to fall. When the printhead temperature falls below the alarm detection level, printing is resumed (the BUSY signal to the host computer becomes inactive).

Paper End Detection Circuit

When the printer runs out of paper, the photosensor on the main control board is deactivated. This causes the signal PAPER END-N to become low. This signal is fed to pin 55 of the motor control LSI (Q11 on the main control board). Printing stops and the ALARM lamp lights.

2.4 MECHANICAL PRINCIPLES OF OPERATION

2.4.01 Printhead

Operation

The printhead used by the printer is a highly efficient, stored-energy type. Power is not consumed until the pins are activated. Printhead life is approximately 200 million characters.

The printhead is designed with twenty-four pins, vertically aligned. Each pin is welded to an armature ring. Behind the armature ring is a spacer ring.

Each armature has a permanent magnet behind it. The magnet attracts the armature, keeping the pin inside the printhead. Because of the spacer ring behind the armature ring, the armature is attracted toward the permanent magnet at an angle. A coil is wrapped around each permanent magnet.

When a dot is printed, current passes through the coil, creating a magnetic field which counters the magnetic field of the permanent magnet. The armature and pin spring forward. A dot is printed on the paper.

When current is removed from the coil, the magnetic field of the permanent magnet attracts the armature. The pin is retracted into the printhead.

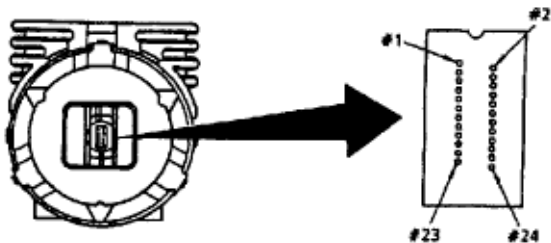

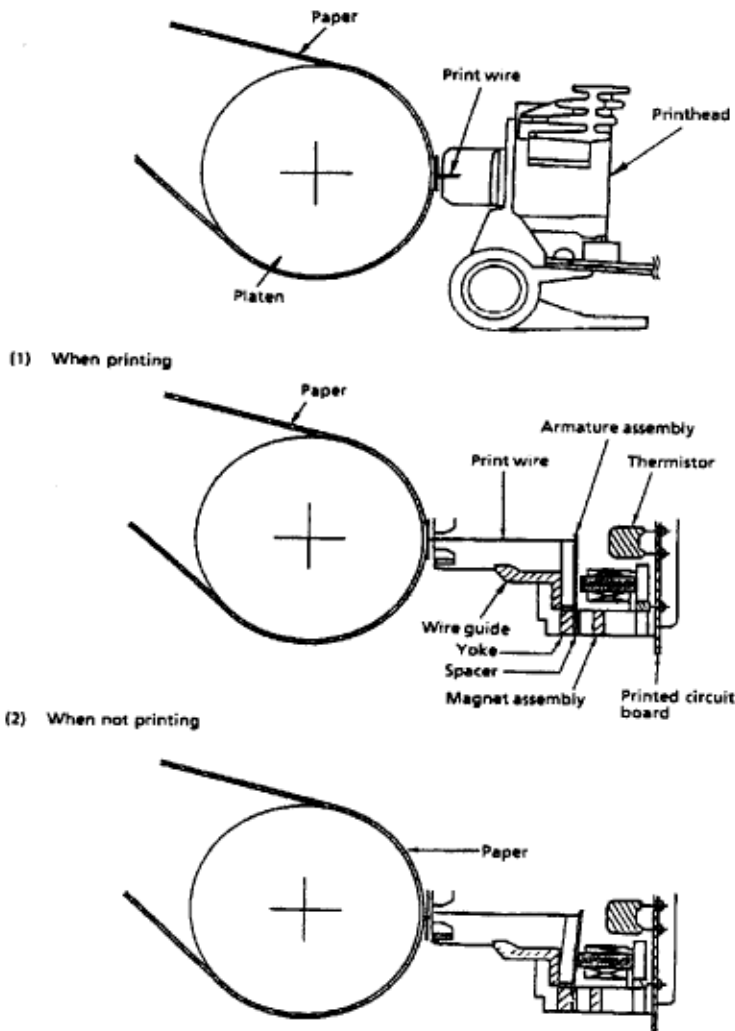

Overheat Condition

The printhead contains a built-in thermistor (rated at 130 degrees Celsius). The thermistor monitors the printhead temperature.

Printhead temperature rises when the unit is printing. When the temperature of the printhead rises, the resistance of the thermistor decreases and the potential falls at the negative input of comparator Q7. Q7 is located on the main controller board.

When printhead temperature reaches approximately 90 degrees Celsius, this comparator output inverts, causing the HEAD TEMP signal to be sent to the motor control LSI. The unit prints unidirectionally.

When printhead temperature reaches approximately 130 degrees Celsius, the thermistor sends a signal to the main control board, generating the HEAD OVERHEAT alarm. Printing stops when this alarm is detected (A BUSY signal is sent to the host computer. Data remains in the print buffer as long as power is supplied to the printer). This allows the printhead temperature to fall. When the printhead temperature falls below the alarm detection level, printing is resumed (the BUSY signal to the host computer becomes inactive).

Partner Exchange (BPX) for any updates to this material. (<http://bpx.okidata.com>)

2.4.02 Space Mechanism / Operation

The spacing operation is performed by applying power to the DC spacing motor. This drives the carriage frame along the carriage shaft, space rack, and guide rail. The carriage shaft, space rack, and guide rail are parallel to the platen.

The spacing motor assembly consists of the following items.

- DC Motor / Gear
- Carriage Frame
- Carriage Shaft
- Space Rack
- Encoder Disk Sensor
- Encoder Disk
- Guide Rail

Spacing Operation

The printhead and spacing motor are mounted on the carriage frame. The carriage frame moves along the carriage shaft, space rack, and guide rail. The carriage shaft, space rack, and guide rail are parallel to the platen. As the spacing motor rotates counterclockwise, the carriage frame is driven to the right.

When the spacing motor rotates one turn, the carriage frame moves 0.8 inch (20.32 mm).

Motor rotation turns the encoder disk. The timing windows on the disk then pass through the encoder disk sensor. The position of the carriage frame is obtained by counting the pulses generated by the encoder disk sensor as the disk turns.

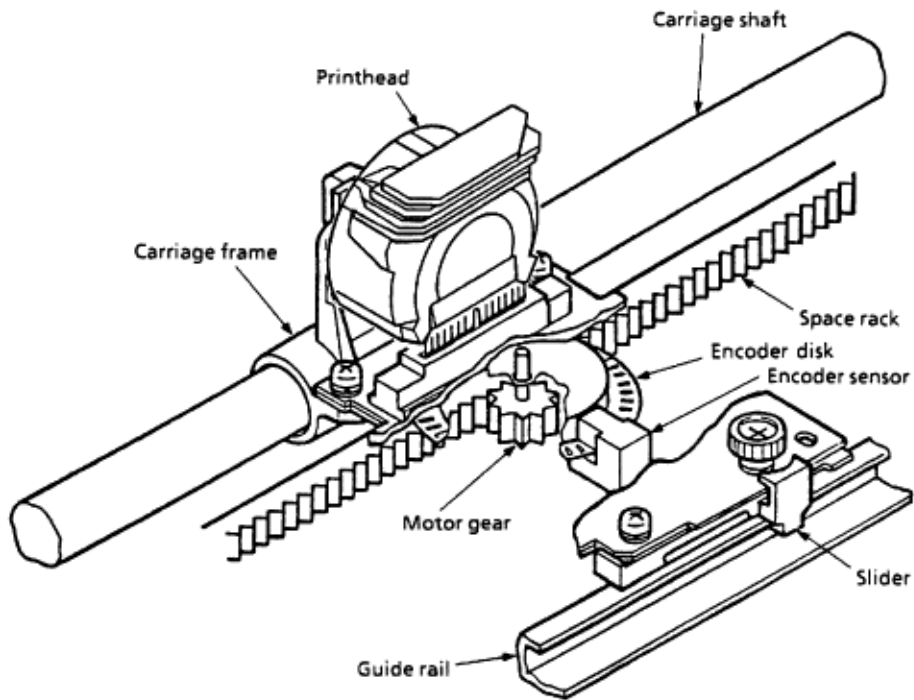

Copyright 1997, Okidata, Division of OKI America, Inc. All rights reserved. See the OKIDATA Business Partner Exchange (BPX) for any updates to this material. (<http://bpx.okidata.com>)

Head Gap Adjusting Mechanism

The head gap adjusting mechanism adjusts the gap between the platen and printhead by changing the tilt angle of the carriage frame. This is accomplished by using the adjusting lever.

Moving the adjusting lever rotates the adjusting screw. The adjusting screw is interlocked with the lever via a gear. Rotating the adjusting screw changes the angle of tilt for the carriage frame. The printhead is mounted vertically on the carriage frame. Changing the angle of tilt for the carriage frame moves the printhead closer to, or farther away from, the platen.

The adjusting cam is used to compensate for differences in the printhead gap when measured at the left and right sides of the platen. Rotating the adjusting cam changes the height of the guide rail. The height of the guide rail helps determine the distance between the printhead and platen, when measured at the right end of the platen.

Turning the adjusting cam to the RIGHT will lower the right side of the guide rail. This causes the printhead gap (on the right side of the platen) to increase.

Turning the adjusting cam to the LEFT will raise the right side of the guide rail. This causes the printhead gap (on the right side of the platen) to decrease.

The adjusting lever determines the head gap setting.

Setting 1 is for one or two part forms.

Setting 2 is for three or four part forms.

Settings 3, 4, and 5 are for envelopes and extra-thick paper.

When the adjusting lever is set to position 3, 4, or 5, the distance between the printhead and platen increases. The electrical contact (attached to the carriage cover) touches a contact pad on the spacing motor circuit board. This reduces printing speed. Slower speeds ensure adequate printing pressure.

Refer to Section 3.3 for further details on the Printhead Gap Adjustment .



Service Guide ML390/391
Chapter 2 Principles of Operation



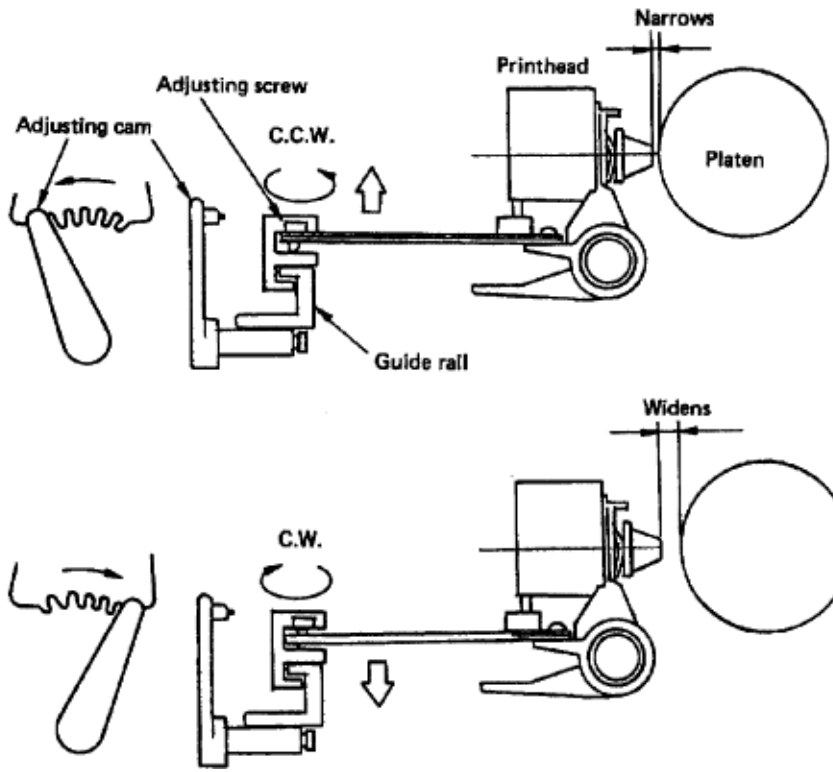
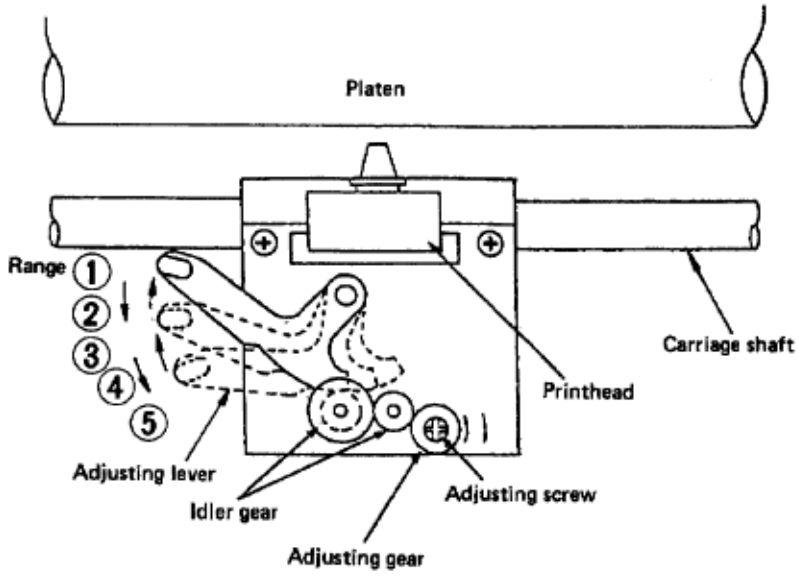

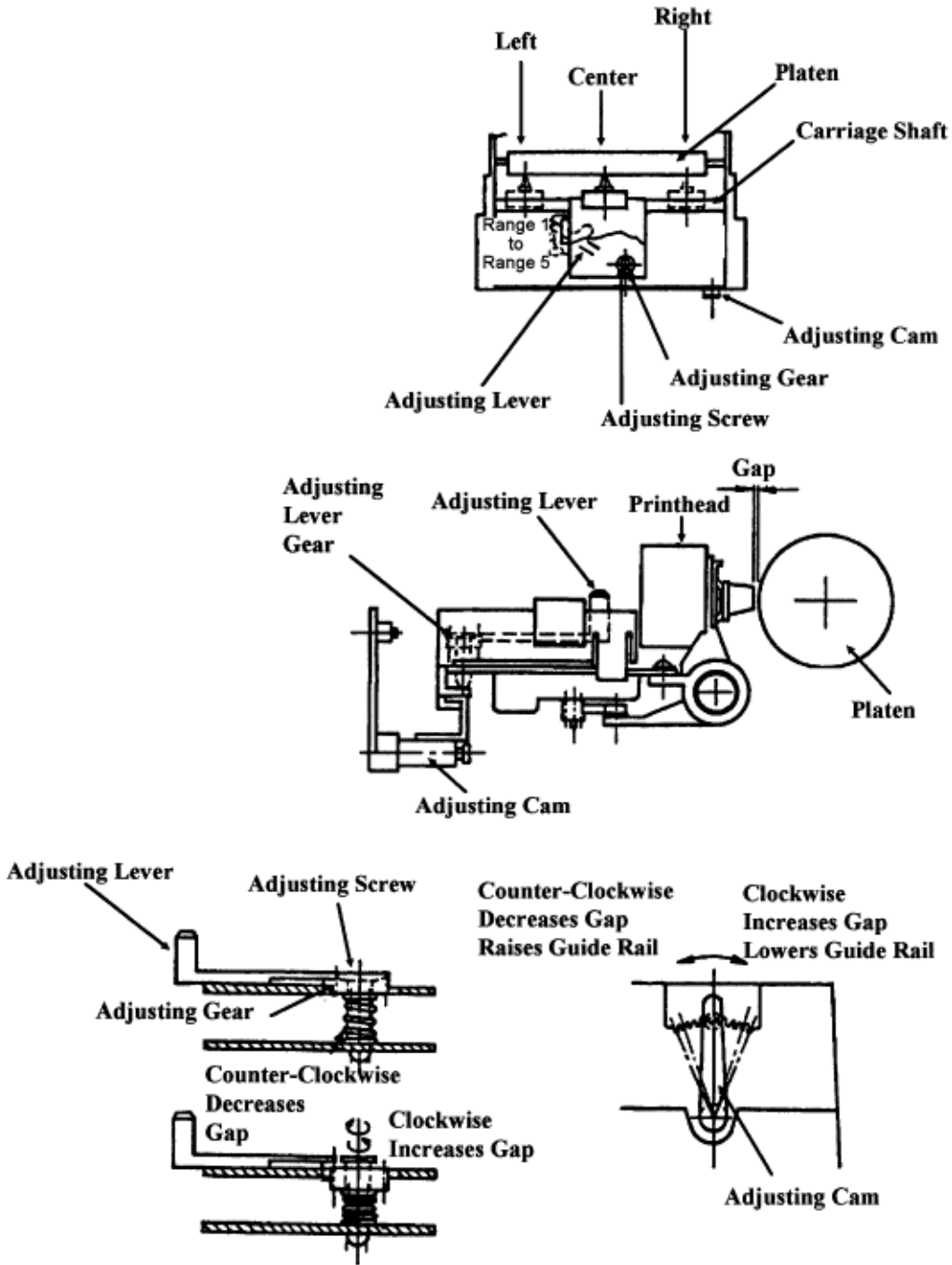

2.4.03 Ribbon Drive Mechanism / Operation

NOTE:

The ribbon drive gear assembly is secured to the top of the spacing motor assembly by the four claw tabs.

The ribbon drive mechanism drives the ribbon in sync with the spacing operation. The mechanism is driven by the spacing motor.

The ribbon drive mechanism consists of the following items.

- Ribbon Drive Gear Assembly
- Ribbon Gear

The gear is attached to the spacing motor.

- Ribbon Cartridge

Ribbon Cartridge

A uni-directional feed, continuous ribbon is used. The ribbon is replenished by a built-in ink tank in the ribbon cartridge.

Ribbon Feed Operation

As the spacing motor rotates, the ribbon gear (on the spacing motor shaft) turns the drive gear in the ribbon cartridge via the ribbon drive gear assembly. As a result, the ribbon is moved.

In bi-directional printing, the ribbon gear rotational direction reverses each time the direction of the carriage movement reverses. In this case, the gears in the ribbon drive gear assembly move the position of an intermediate idler gear, causing the ribbon to feed in one direction.

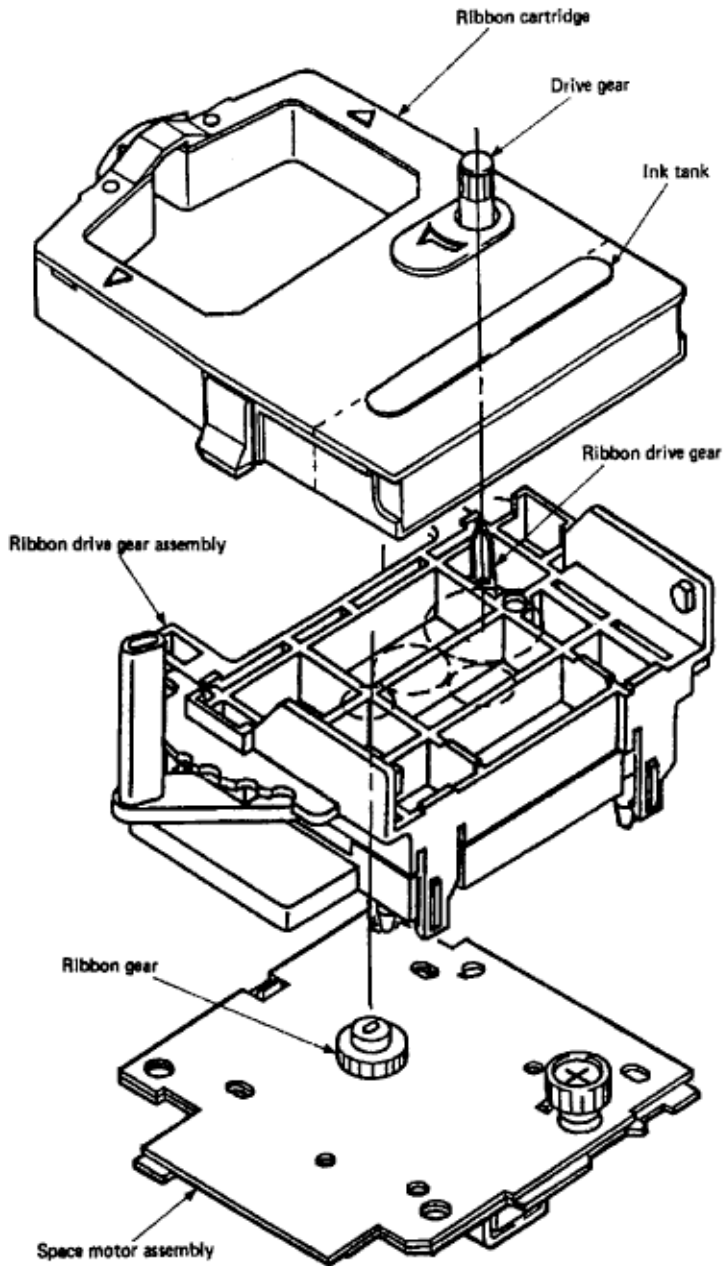

Copyright 1997, Okidata, Division of OKI America, Inc. All rights reserved. See the OKIDATA Business Partner Exchange (BPX) for any updates to this material. (<http://bpx.okidata.com>)

2.4.04 Paper Feed Mechanism

The paper feed mechanism consists of the following items.

- Line Feed Motor (with drive gear)
- Reduction Gear
- Platen
- Push Tractor Unit
- Pressure Rollers (friction feed rollers)
- Pull Tractor Unit (optional)

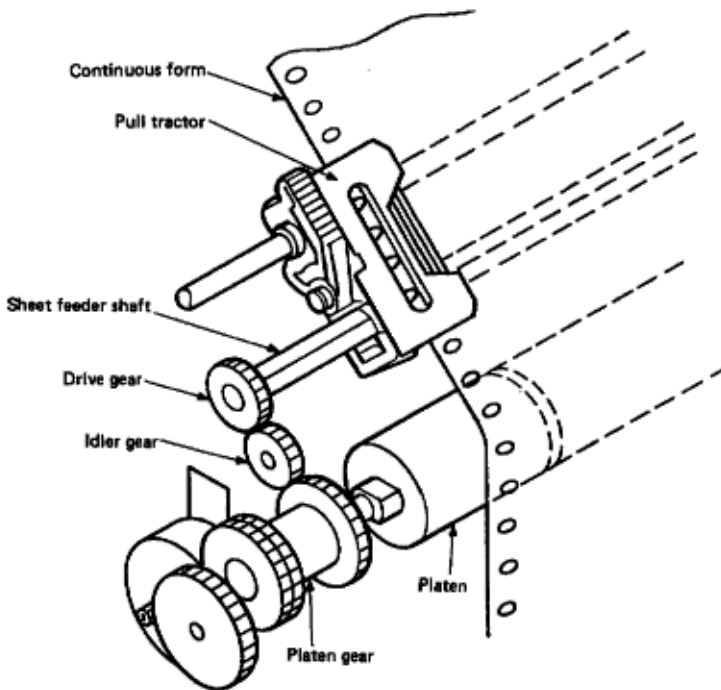

Paper Feed Operation

The line feed motor is mounted on the left side frame of the printer. It drives the platen via the reduction gear. If the optional tractor unit is installed, platen rotation is transmitted through the idle gear to the tractor unit.

The paper feed mechanism is designed so when the stepper motor rotates 48 steps (360 degrees), paper is fed 0.17 inch (4.23 mm).

Friction Feed

When the release lever is set to the friction feed position, the release lever disengages the change gear from the tractor gear. At the same time, the release lever applies pressure to push the pressure rollers against the platen, allowing paper to be fed.

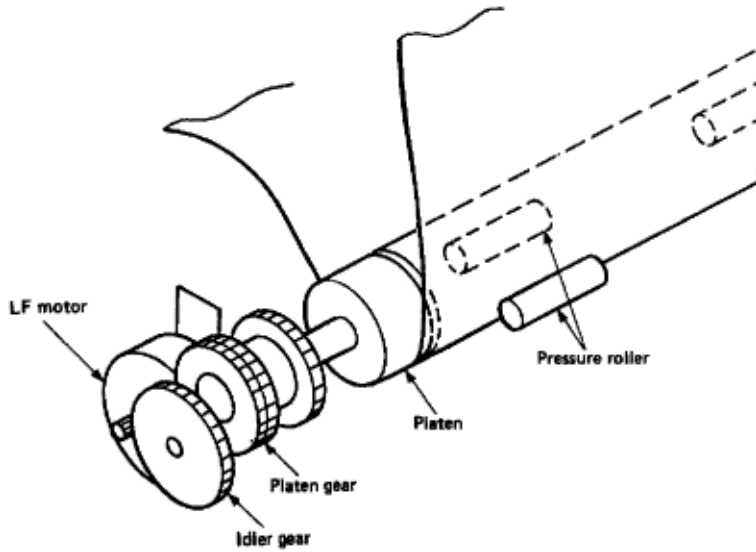

Tractor Feed

When the release lever is set to the tractor feed position, the release lever allows the reset spring to push the change gear toward the tractor gear. At the same time, the release lever pushes the pressure rollers away from the platen, which allows paper to be fed by the push tractor.

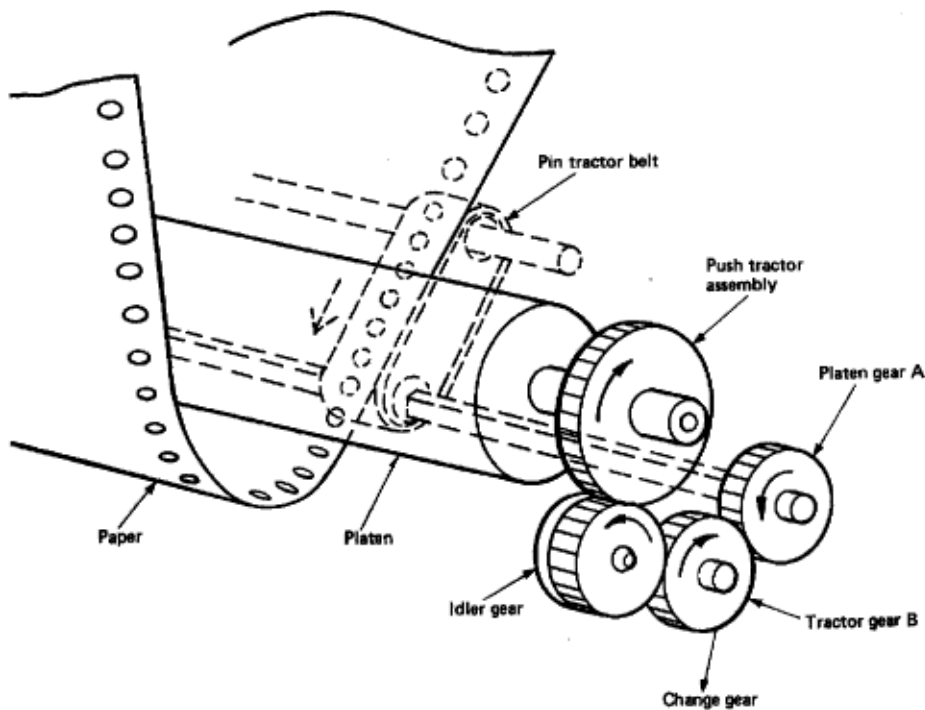

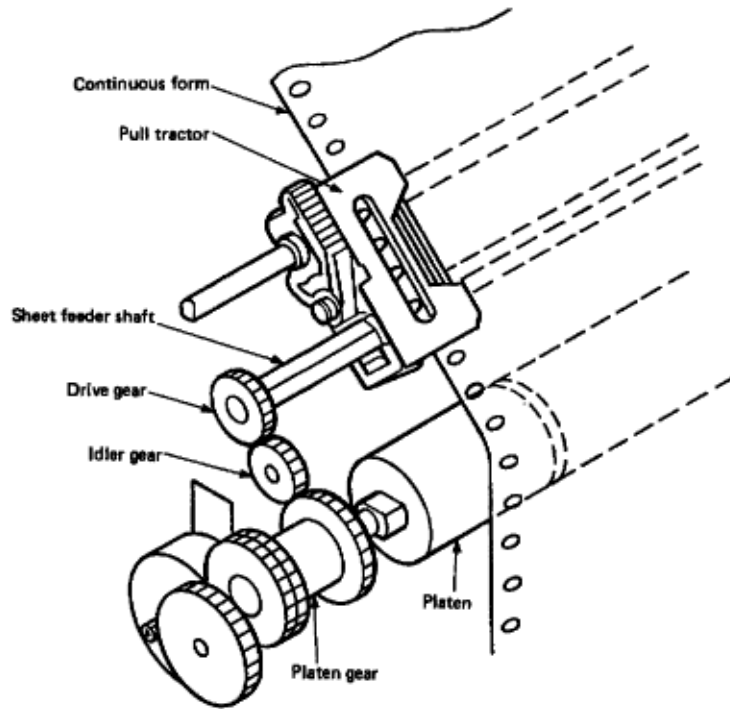

Copyright 1997, Okidata, Division of OKI America, Inc. All rights reserved. See the OKIDATA Business Partner Exchange (BPX) for any updates to this material. (<http://bpx.okidata.com>)

2.4.05 Paper-End Detection Mechanism

Rear Paper Feed

When paper is installed in the printer, it prevents the paper-end lever (Tip A) from falling into the groove of the paper chute and platen. This activates the paper-end sensor.

When the printer runs out of paper, the paper-end lever falls into the groove of the paper chute. The rear part of the paper-end lever deactivates the paper-end sensor. An out-of-paper condition is detected.

Paper-end is detected when the end of the remaining paper is about 1 inch (25.4 mm) from the printhead position.

Bottom Paper Feed

Paper installed in the printer contacts the paper-end lever (Tip B). The paper prevents the bottom paper-end lever from falling into the slot in the bottom paper guide. This causes the rear part of the paper-end lever to activate the paper-end sensor.

When the printer runs out of paper, the tip of the bottom paper-end lever falls into the hole in the bottom paper guide. The rear part of the paper-end lever activates the paper-end sensor. An out-of-paper condition is detected.

Paper-end is detected when the end of the remaining paper is about 1 inch (25.4 mm) from the printhead position.

Cut-Sheet Paper Feed

Paper installed in the printer prevents the paper-end lever (Tip C) from falling into the groove of the paper chute. The paper-end sensor is activated.

When paper is removed, the paper-end lever falls into the groove of the paper chute. The rear part of the paper-end lever deactivates the paper-end sensor. An out-of-paper condition is detected.

Paper-end is detected when the end of the remaining paper is about 1 inch (25.4 mm) from the printhead position.

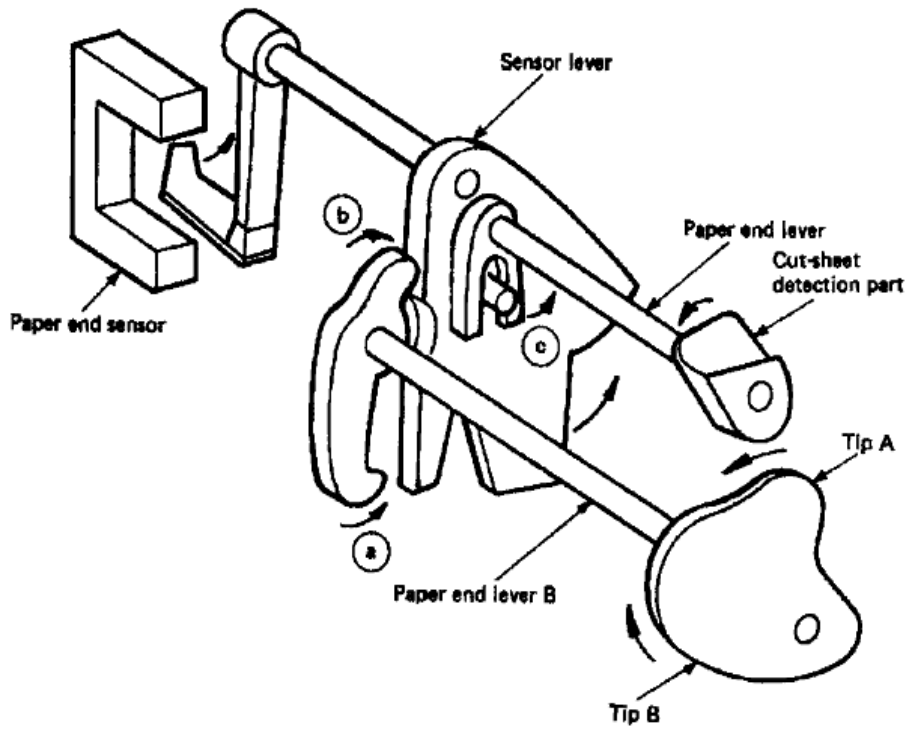

Copyright 1997, Okidata, Division of OKI America, Inc. All rights reserved. See the OKIDATA Business Partner Exchange (BPX) for any updates to this material. (<http://bpx.okidata.com>)

2.4.06 Semi-Automatic Sheet Feeder (SASF) Operation

When the paper release lever is set for friction feed paper, opening the bail arm causes the SASF switch to close. The line feed motor feeds two inches of paper. SASF motion stops after two inches of paper feed motion and paper-end is detected.

SASF should be used for loading tractor feed paper. Okidata recommends using SASF instead of pressing FORM FEED. Since the paper bail is opened for SASF, there is less chance of jamming.

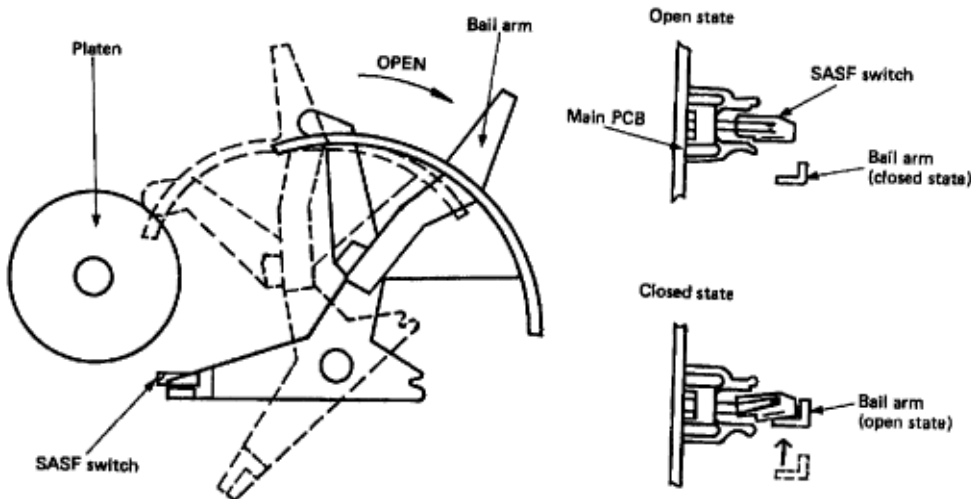

2.4.07 Release Lever Operation

The release lever (on the power switch side of the printer) sets the unit for continuous or cut-sheet feeding.

Cut-Sheet

The release lever is pushed back (towards the rear of the printer).

When the release lever is set for cut-sheet feeding, the change gear moves out (in the direction of arrow A). The pin tractor becomes inoperative, because power is not transmitted from the platen gear (through the idler and change gears) to the tractor gear.

Cut-sheets are fed by the rotation of the platen.

Continuous

The release lever is pushed forward (towards the front of the printer).

When the release lever is set for continuous feeding, the reset spring presses the change gear in (in the direction of arrow B). The pin tractor operates, because power is transmitted from the platen gear (through the idler and change gears) to the tractor gear.

Continuous feeding is due to the rotation of the pin feeds, not the rotation of the platen.

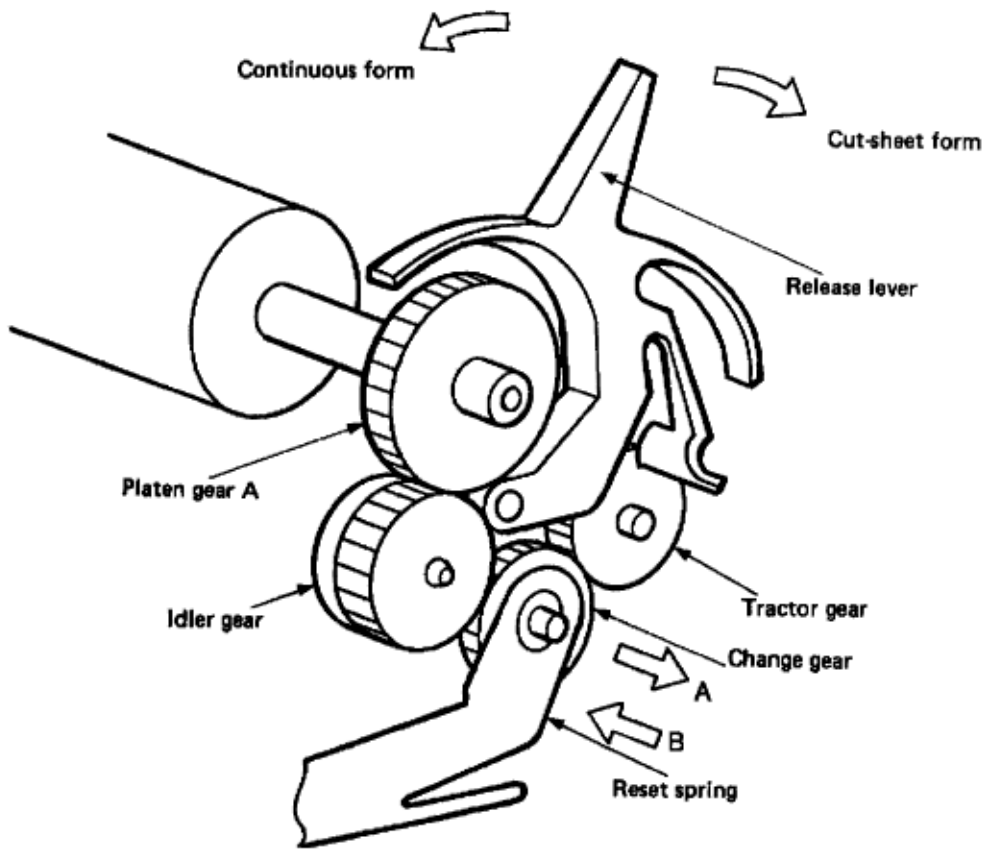

Copyright 1997, Okidata, Division of OKI America, Inc. All rights reserved. See the OKIDATA Business Partner Exchange (BPX) for any updates to this material. (<http://bpx.okidata.com>)

3.1 MAINTENANCE

3.1.01 General Information

This section lists the parts replacement, adjustment, cleaning, and lubrication procedures.

Disassembly should not be performed unless absolutely necessary. **NEVER** perform disassembly on a malfunctioning unit until you have followed the failure analysis procedures in Section Four of this Service Handbook.

Follow the procedures listed in *Adjustments and Service Settings*. Adjustments may be required when either consumables or parts are replaced. Failure to perform these procedures could result in unnecessary service calls.

Cleaning procedures must be performed correctly if high print quality is to be achieved.

Copyright 1997, Okidata, Division of OKI America, Inc. All rights reserved. See the OKIDATA Business Partner Exchange (BPX) for any updates to this material. (<http://bpx.okidata.com>)

3.1.02 Maintenance Tools

The following tools are required to service the unit.

- #2 Phillips Screwdriver (with magnetic tip)
 - Straight-slot Screwdriver
 - Needle Nose Pliers (4 Inch)
 - Rubber Band (used during removal of upper cover)
 - Cutters
 - Feeler Gauge
 - Large, straightened Paper Clip (used during printhead gap adjustment)
 - Digital Multimeter
 - Shop Vacuum
 - Cloth (soft and lint-free)
 - Cotton Swabs
 - All-purpose Cleaner
 - Platen Cleaner
 - Contact Kleen (P/N 51802301)
 - Grease (Dow Corning BR2 or equivalent)
 - Machine Oil
-



Service Guide ML390/391

Chapter 3 Maintenance & Disassembly

3.1.03 Maintenance Precautions

- Do NOT disassemble the unit if it is operating normally.
- Before starting disassembly and assembly, always power OFF the unit and detach the power cord.
- Detach the interface cable, if installed.
- Do not remove parts unnecessarily. Try to keep disassembly to a minimum.
- Use the recommended maintenance tools.
- When disassembling, follow the listed sequence. Failure to follow the correct sequence may result in damaged parts.
- Screws, collars and other small parts are easily lost. Temporarily attach these parts to their original positions.
- When handling circuit boards use extreme care. Integrated circuits (microprocessors, ROM, and RAM) can be destroyed by static electricity.
- Do not place printed circuit boards directly on conductive surfaces.
- Follow the recommended procedures when replacing assemblies and units.
- Perform the Printhead Gap Adjustment ([Refer to Section 3.3](#) ) when the following occur.

Print quality is darker on either side of the document.

The following parts are replaced.

Space Motor Assembly ([Refer to Section 3.2.15](#) )

Carriage Shaft ([Refer to Section 3.2.16](#) )

Guide Rail ([Refer to Section 3.2.18](#) )

3.2 DISASSEMBLY/ASSEMBLY PROCEDURES

General Information

This section contains the printer disassembly procedures. Only the removal procedures are explained. Reverse the procedure for the installation.

This Service Handbook lists the disassembly procedures for major components of the unit. Okidata does NOT recommend disassembling a unit which is operating normally. If you decide to perform disassembly during this training, Okidata recommends that you perform *only* the disassembly procedures for RSPL items. All other procedures are provided to assist you in identifying parts. It is not likely that you will perform these procedures while servicing the product.

Read all notes, cautions, and warnings. They contain important information regarding assembly/disassembly.

At the bottom of each procedure is a listing of the parts covered in that procedure. The Okidata part number, item description, applicable product, comment (RSPL, Option, Consumable), serial number revision level, and the cross-reference(s) to Appendix B are provided for each part. Items included in the Recommended Spare Parts List are indicated by the acronym RSPL. N/A appears where a part number is not available.

Part Item Product Comment Revision App. B Number Description Reference

Below is an explanation of the terms found in the Product Field of the parts list.

390

This part is found ONLY in the Microline 390 printer.

391

This part is found ONLY in the Microline 391 printer.

390 +

This part is found ONLY in the Microline 390-Plus printer.

391 +

This part is found ONLY in the Microline 391-Plus printer.

Both

This part is found in both the Microline 390 and 391 printers.

Both +

This part is found in both the Microline 390 and 391-Plus printers.

Both 90

This part is found in both the Microline 390 and Microline 390-Plus printers.

Both 91

This part is found in both the Microline 391 and Microline 391-Plus printers.

All

This part is found in the Microline 390, Microline 391, Microline 390-Plus, and Microline 391-Plus printers.

Compatibility - Microline 390/391 vs. Microline 390/391-Plus

The differences between the Microline 390/391 and Microline 390/391-Plus printers are listed below.

Hardware Differences

- Operator Panel
- Operator Board
- Character Generator Programmable Read Only Memory (CGROM)
- Programmable Read Only Memory (PROM)
- Middle Cover

Operational Differences

- "Plus" printers have more resident fonts.
- In the "Plus" printers, data in the receive buffer is printed upon receipt, without having to wait for a line terminator character (CR/LF or FF).
- In the "Plus" printers, the DC1/DC3 Acknowledge/Ignore, Receive Buffer Size, and RESET inhibit can be controlled through the printers Menu.

Serial Number Revision Levels

Microline 390/391

A

Rev A units are original production units. An interconnect module connects the power supply board to the main control board.

B

Rev B units are retrofitted to include a modified interconnect module, which prevents corrosion.

C

These units have a cable connection between the power supply board and the main control board. The cable connection wire replaces the interconnect module.

Microline 390/391-Plus

Revision levels do NOT apply to the "Plus" printers.

NOTE:

Please refer to the parts lists for parts differentiation. Please be sure of the parts you need before ordering to avoid confusion and incorrect parts orders.

Printer Serial Number Identification

There are three serial number revision levels for the printers. Hardware differences exist between levels. To identify the revision level of a printer, record the serial number from the back of the printer. Refer to the following to decode the serial number.

Example Printer Serial Number: 401A0154693

Date Code 401 (4 = year. 01 = month)

Revision A

Serial Number 0154693

Compatibility Chart

Item	Okidata P/N	Purpose / Function of Item	Printer Serial Number Revision Level				
			390/391A	390/391B	390/391C	390+	391+
Main Control Board							
SKRA Board	55045401	Main Control Board	Yes	Yes	No	No	No
SKRB Board	55038702	Main Control Board	Yes	Yes	Yes	No	No
SKRA-3 Board	55045403	Main Control Board	Yes	Yes	Yes	Yes	Yes
Power Supply Board							
PAII Board	55038801	Power Supply Board	Yes	Yes	No	No	No
SUII Board	55047401	Power Supply Board	Yes	Yes	Yes	Yes	Yes
Operator Panel Assembly							
Panel: Operator Assembly	50069601	Operator Panel Assembly (390/391)	Yes	Yes	Yes	No	No

Panel: Operator Assembly	50069610	Operator Panel Assembly (390/391- Plus)	No	No	No	Yes	Yes
PCB: LXSP	55045601	Operator Panel Board (390/391)	Yes	Yes	Yes	No	No
PCB: LXSP-5	55038605	Operator Panel Board (390/391- Plus)	No	No	No	Yes	Yes
Transfor mer							
120 Volt XFRMR	56407201	Transfor mer (390 and 390-Plus)	Yes	Yes	Yes	Yes	Yes
120 Volt XFRMR	56407202	Transfor mer (391 and 391-Plus)	Yes	Yes	Yes	Yes	Yes
220 Volt XFRMR	56407801	Transfor mer (390 and 390-Plus)	Yes	Yes	Yes	Yes	No
220 Volt XFRMR	56407802	Transfor mer (391 and 391-Plus)	Yes	Yes	Yes	No	Yes
Interconn ect Module							
Interconn ect Module	55328301	Connects power supply board to main board	Yes	Yes	No	No	No



Cable							
Cable	56616802	Connects power supply board to main board	No	No	Yes	Yes	Yes
Cable Guide							
Cable Guide	51003801	Holds cable in place	No	No	Yes	Yes	Yes
Covers							
Cover	53488301	Middle Cover (390)	Yes	Yes	Yes	No	No
Cover	53488401	Middle Cover (391)	Yes	Yes	Yes	No	No
Cover	53488316	Middle Cover (390-Plus)	No	No	No	Yes	No
Cover	53488422	Middle Cover (391-Plus)	No	No	No	No	Yes
Chassis							
Chassis	50061101	Chassis: Main (390 and 390-Plus)	Yes	Yes	Yes	Yes	No
Chassis	50061201	Chassis: Main (391 and 391-Plus)	Yes	Yes	Yes	No	Yes

Copyright 1997, Okidata, Division of OKI America, Inc. All rights reserved. See the OKIDATA Business Partner Exchange (BPX) for any updates to this material. (<http://bpx.okidata.com>)

3.2.01 Preliminary Items

- Press the AC switch (1 shows location) and power OFF the printer.
- Remove the paper, if installed.
- Detach the AC power cord (2).
- Detach the interface cable (3), if installed.

P/N 56609701 Cord: AC 120 V All RSPL A B C [B.2.02](#) , [B.2.03](#) 

P/N 56610801 Cord: AC (220 V) (ML Series) All Option RSPL A B C [B.2.02](#) , [B.2.03](#) 

P/N 56616501 Cord: AC 240 V All Option A B C [B.2.02](#) , [B.2.03](#) 

P/N 56624101 Cord: AC 220 V (ML) All Option A B C [B.2.02](#) , [B.2.03](#)  Right Angle

P/N 70000803 Kit: Parallel Interface Both Option A B C D N/A PlugnPlay Accessory

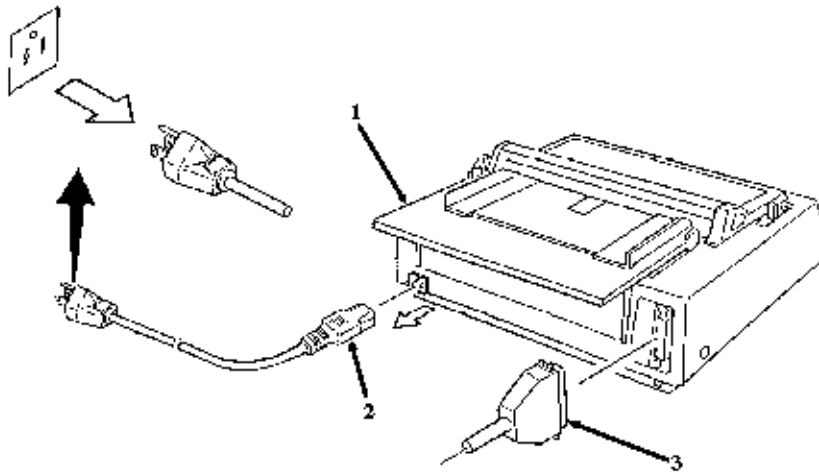

3.2.02 Separator Assembly

CAUTION:

To avoid damaging the ribbon protector, slide the printhead towards the center of the printer before removing the separator assembly.

· **Perform this procedure: 3.2.01** .

- Open the access cover (1).
- Move the paper bail lever (2) toward the front of the printer.
- While pressing the release latches (3), tilt the separator assembly (4) toward the rear of the printer to release it from the platen shaft (5).
- Remove the separator assembly.

NOTES:

The Rev A and B units used a metal ruler guide instead of the plastic separator assembly.

The metal ruler guide is no longer available.

To remove the metal ruler guide, follow this procedure.



Open the access cover.

Move the paper bail lever toward the front of the printer.

Squeeze the retaining clips and tilt the ruler guide towards the rear of the printer.

Remove the ruler guide.

P/N 50069801 Separator: Assembly (Narrow) Both 90 RSPL A B C [B.2.04](#) , [B.2.06](#) 

P/N 50069901 Separator: Assembly (Wide) Both 91 RSPL A B C [B.2.04](#) , [B.2.06](#) 

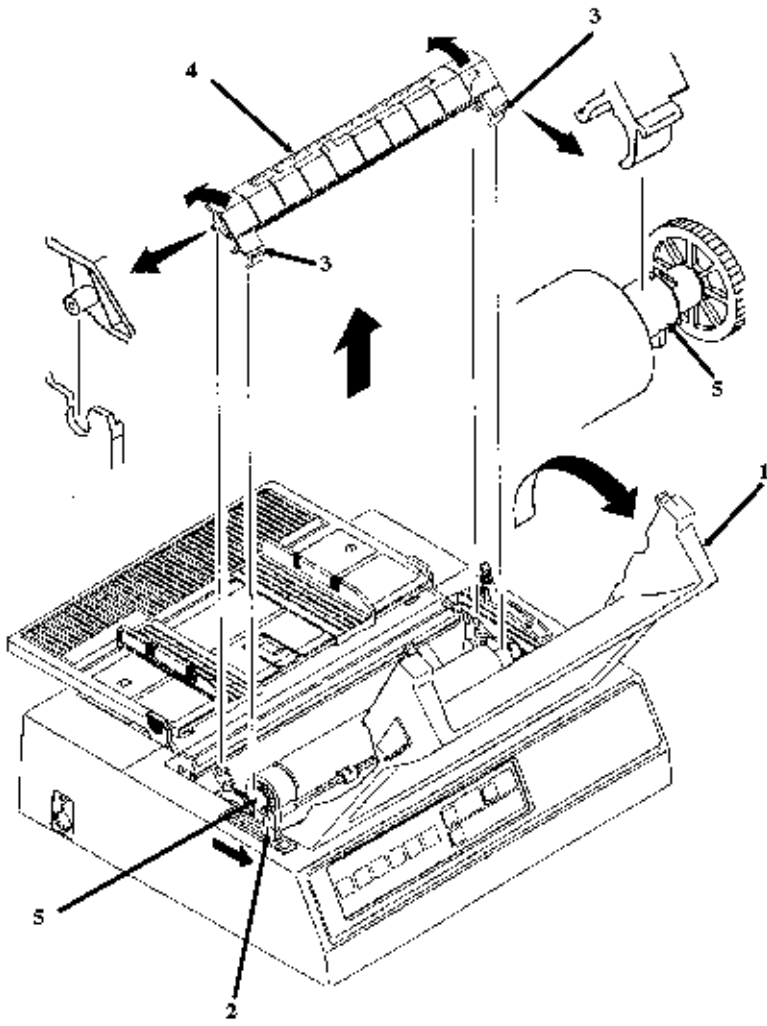

Copyright 1997, Okidata, Division of OKI America, Inc. All rights reserved. See the OKIDATA Business Partner Exchange (BPX) for any updates to this material. (<http://bpx.okidata.com>)

3.2.03 Printhead Assembly

WARNING:



The printhead will be hot immediately after printing. Allow the printhead to cool before handling.

· **Perform this procedure: 3.2.01** .

- Open the access cover (1).
- Remove the ribbon cartridge (2).
- Move the printhead mounting clamp (3) in the direction of arrow A to unlock the printhead (4).
- Lift and remove the printhead from the carriage frame (5).

NOTE:

When installing the printhead, push the printhead towards the platen.

P/N 50062201 Printhead: (Assembly) All RSPL A B C **B.2.02** , **B.2.03** 

P/N 52104001 Ribbon All Consumable A B C **B.2.12** 

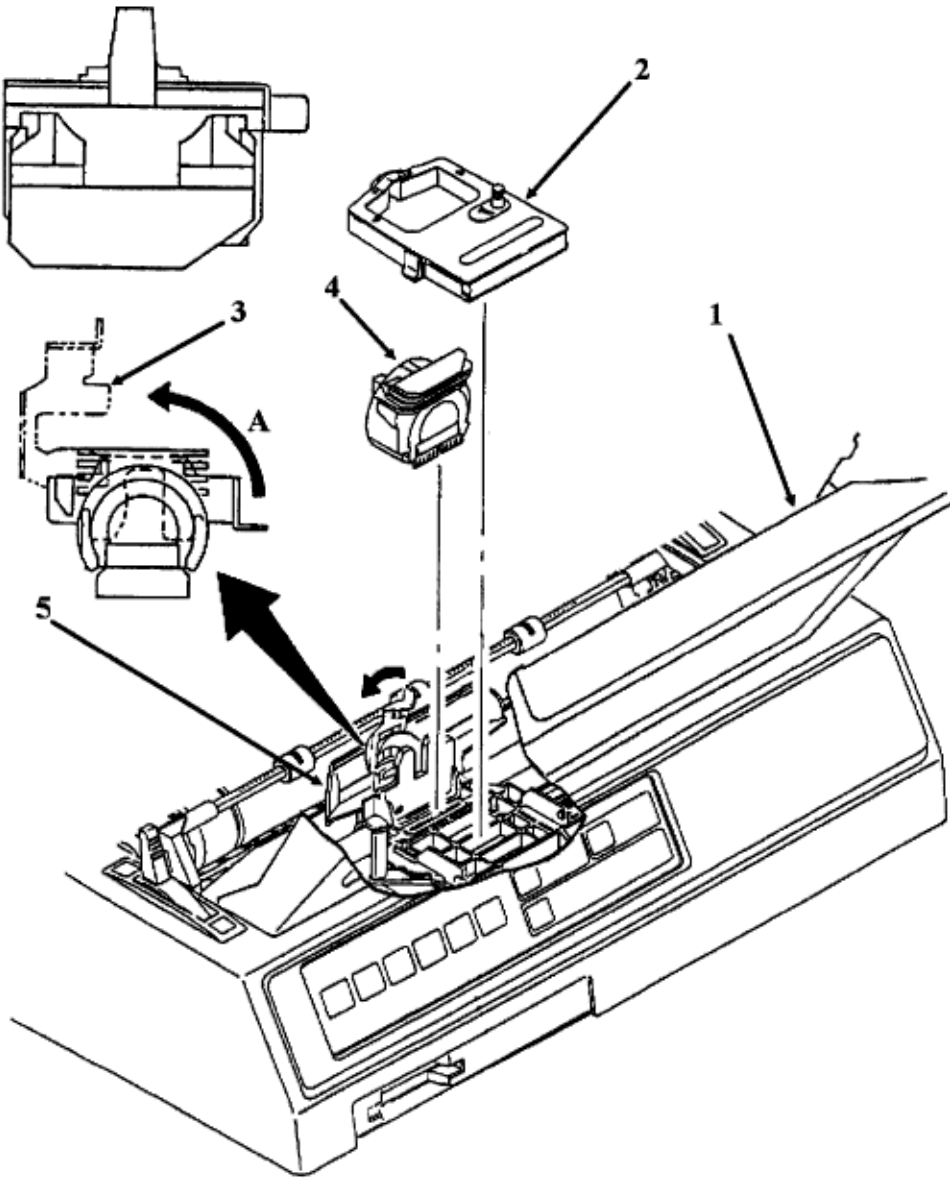

Copyright 1997, Okidata, Division of OKI America, Inc. All rights reserved. See the OKIDATA Business Partner Exchange (BPX) for any updates to this material. (<http://bpx.okidata.com>)

3.2.04 Upper Cover Assembly

· **Perform this procedure: 3.2.01** .

- Wrap a rubber band around the wire extensions of the interface connector. This pulls the extensions in and avoids damage when the cover is removed. (Not shown).
- Detach the platen knob (1).
- Insert a flat-blade screwdriver through the slots (2) and disengage the claws of the cover. The Microline 390 and Microline 390-Plus have three slots. The Microline 391 and Microline 391-Plus have five slots.
- Lift the front of the upper cover assembly (3) and remove the assembly.
- The upper cover assembly contains the access cover assembly (4), the sheet separator assembly (5), the rear cover (6), and the middle cover (7)

CAUTION:

Do NOT rotate the access cover past the vertical when removing it. The tab extensions can break.

Before installing the cover, move the bail arm lever towards the back of the printer and move the release lever towards the front of the printer.

After installation, verify that the cover is correctly seated in the front slots. The cover will warp if it is incorrectly installed. Check that the paper bail moves properly.

When cleaning, refer to Section 3.4 of this Service Handbook .

P/N 51901101 Knob: Platen All RSPL A B C **B.2.02** , **B.2.03** 

P/N 50060701 Cover: Access (Assembly) Both 90 RSPL A B C **B.2.01** 

P/N 50060801 Cover: Access (Assembly) Both 91 RSPL A B C **B.2.01** 

P/N 50060901 Separator: Sheet (Assembly) Both 90 RSPL A B C **B.2.01** 

P/N 50061001 Separator: Sheet (Assembly) Both 91 RSPL A B C **B.2.01** 

P/N 53488501 Frame: Rear Cover Both 90 RSPL A B C **B.2.01** 

P/N 53488601 Frame: Rear Cover Both 91 RSPL A B C **B.2.01** 

P/N 53488301 Cover: Middle (ML390) 390 RSPL A B C **B.2.01** 

P/N 53488316 Cover: Middle (ML390+) 390+ RSPL A B C **B.2.01** 

P/N 53488401 Cover: Middle (ML391) 391 RSPL A B C **B.2.01** 

P/N 53488422 Cover: Middle (ML391+) 391+ RSPL A B C **B.2.01** 

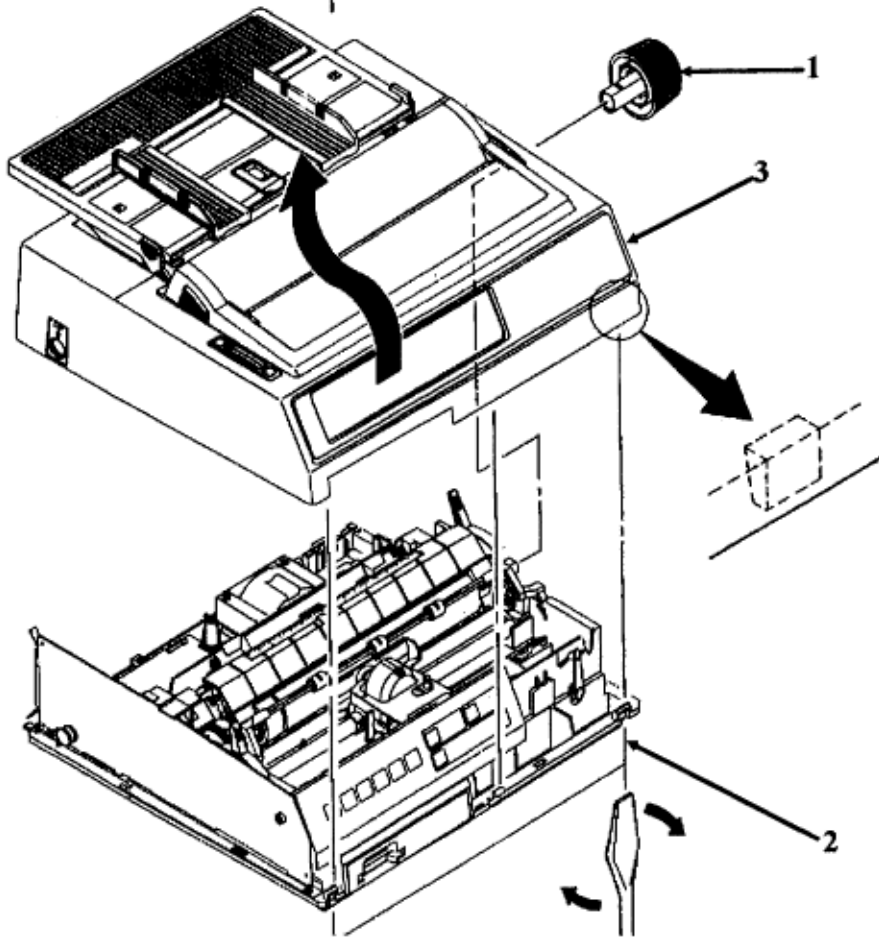
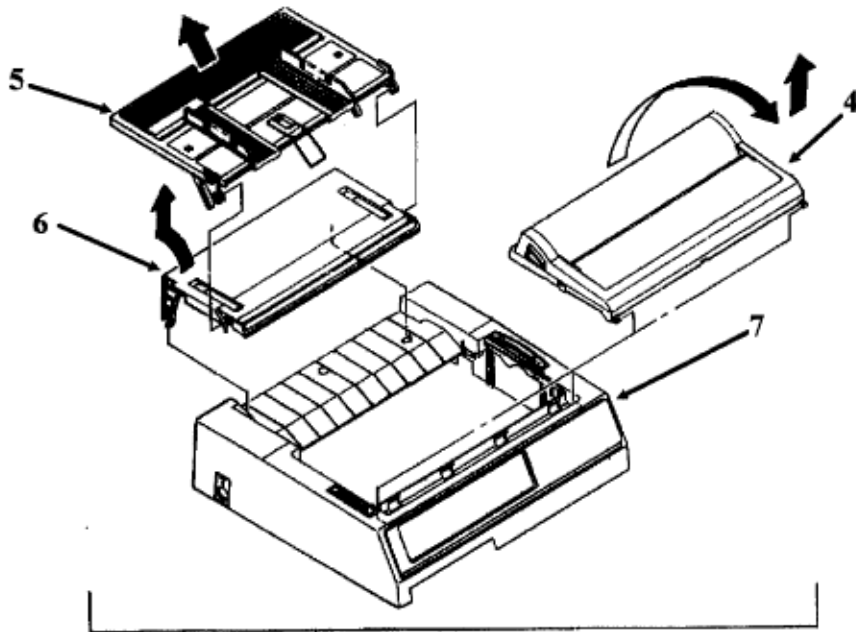

Copyright 1997, Okidata, Division of OKI America, Inc. All rights reserved. See the OKIDATA Business Partner Exchange (BPX) for any updates to this material. (<http://bpx.okidata.com>)

3.2.05 Operator Panel Assembly

NOTE:

The operator panel assembly and board for the Microline 390 and 391 printers are NOT compatible with the Microline 390-Plus and 391-Plus operator panel assembly and board.

· **Perform this procedure: 3.2.01**  **3.2.04** .

· Release the claws (1) and remove the operator panel assembly (2) from the chassis (3). As the operator panel assembly is removed, it must be detached from the connector (4) on the control board (5).

· Release the eight claws (6) and remove the operator board (7) from the bezel (8).

P/N 50069601 Panel: Operation w/Frame Both RSPL A B C **B.2.08**  (Assembly)

P/N 50069610 Panel: Operator Both+ RSPL A B C **B.2.08** 

P/N 55038605 PCB: LXSP-5 (Operator Panel) Both+ RSPL **B.2.08** 

P/N 55045601 PCB: LXSP (Operator PCB) Both RSPL A B C **B.2.08** 

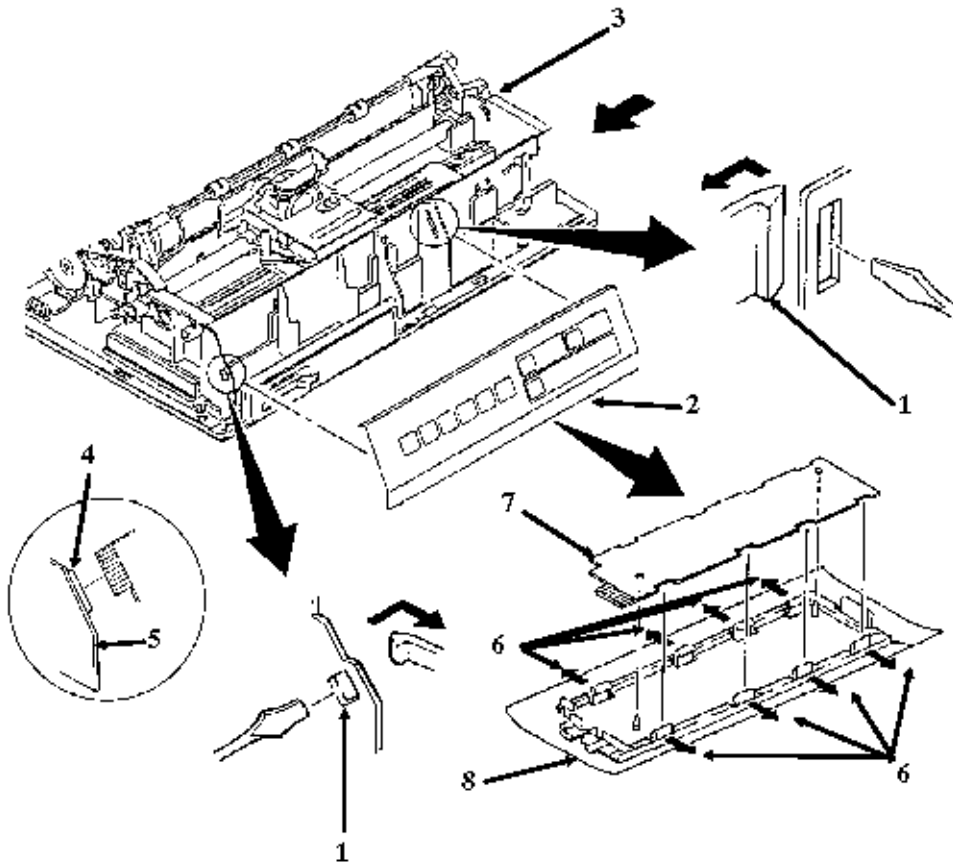

Copyright 1997, Okidata, Division of OKI America, Inc. All rights reserved. See the OKIDATA Business Partner Exchange (BPX) for any updates to this material. (<http://bpx.okidata.com>)



Service Guide ML390/391

Chapter 3 Maintenance & Disassembly

3.2.06 Control Board



Rev A and B

CAUTION:

Check the contacts between the power interconnect module, the control board, and the power supply board (Rev A and B units ONLY). Clean the contacts if dirty. If contacts are bent or broken, replace the module. Proper inspection and cleaning of the power interconnect module contacts can eliminate a false diagnosis of a failed control board or power supply board.

Check the contacts and connections of the control board. If good contact is not made at all connections and ground points, false diagnosis will occur.



Refer to Appendix A for detailed information regarding the differences between the Rev A, B, and C control boards.



- **Perform this procedure:** [3.2.01](#) , [3.2.04](#) , [3.2.05](#) .
- Turn the locking post (1) 90 degrees clockwise to unlock it.
- Lift the locking claw (2) and pull the control board (3) away from the chassis.
- Tilt the control board 45 degrees and remove it.

NOTES:

When installing, verify that correct contacts are made at these points: Guides (A and B), Power Interconnect Module (C), Linefeed Motor Interconnect Module (D), Sensor Lever (E), and Printhead Cable Connector (F).

The sensor lever must be positioned in the paper end sensor. If the lever is not correctly positioned, the ALARM lamp will light and the unit will not automatically load paper or receive data.

P/N 55923901 IC: CU EEPROM 391 390+ RSPL [B.2.02](#) , [B.2.03](#) 

P/N 55938101 IC: CU EEPROM ER59256 390 391+ RSPL [B.2.02](#) , [B.2.03](#) 

P/N 50704301 Clamp: PCB All RSPL A B C [B.2.02](#) , [B.2.03](#) 

P/N 55045403 PCB: SKRA-3 w/o ROM All RSPL A B C [B.2.02](#) , [B.2.03](#)  Control Board

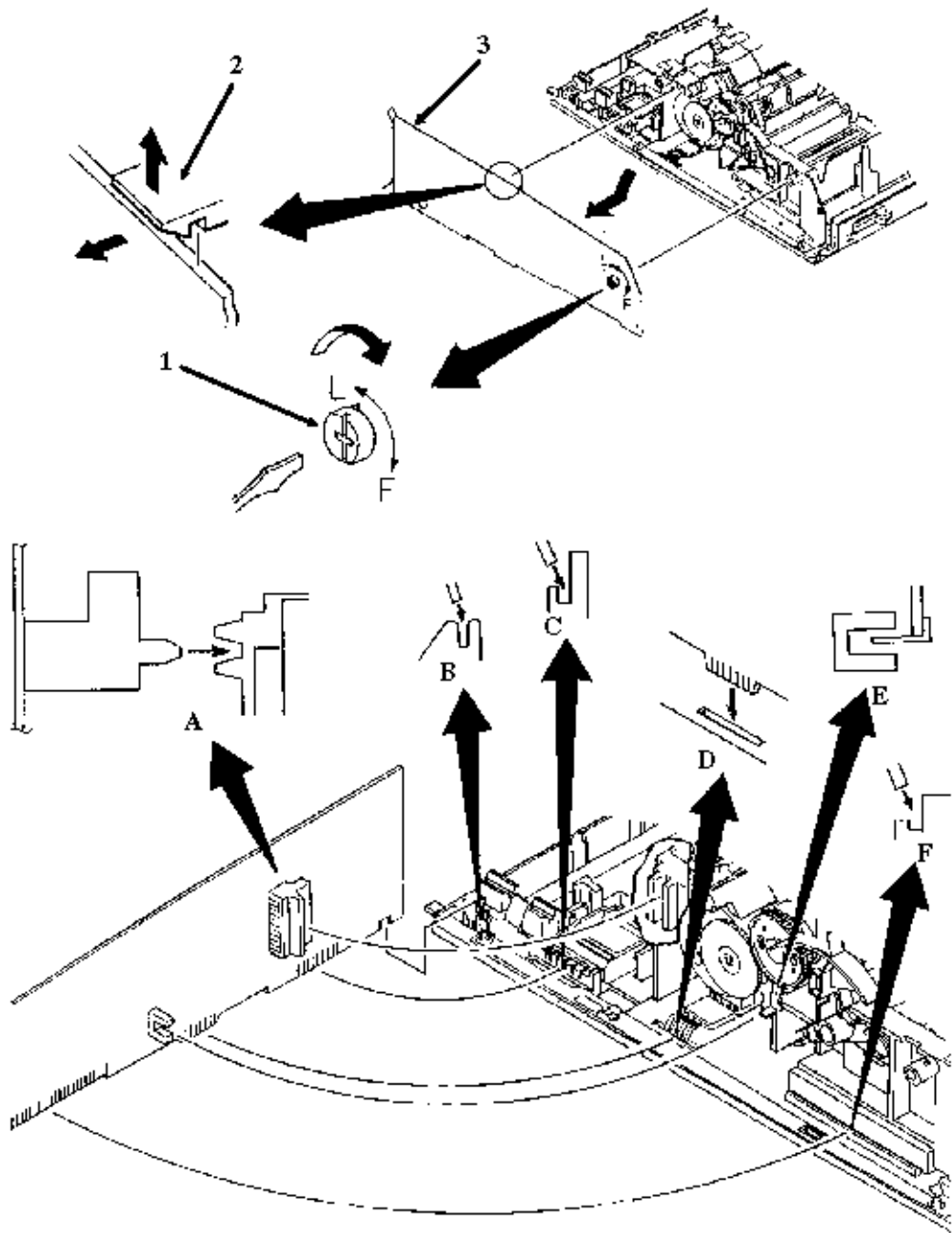

P/N 50605501 Lock: Board Screw All RSPL A B C [B.2.02](#) , [B.2.03](#) 



Copyright 1997, Okidata, Division of OKI America, Inc. All rights reserved. See the OKIDATA Business Partner Exchange (BPX) for any updates to this material. (<http://bpx.okidata.com>)

Rev C**CAUTION:**

Check the contacts and connections of the control board. If good contact is not made at all connections and ground points, false diagnosis will occur.

- **Perform this procedure:** [3.2.01](#) , [3.2.04](#) , [3.2.05](#) .
- Turn the locking post (1) 90 degrees clockwise to unlock it.
- Lift the locking claw (2) and pull the control board (3) away from the chassis.
- Detach the cable from the connector (4).
- Tilt the control board 45 degrees and remove it.

NOTE:

When installing, verify that correct contacts are made at these points.



Guides (A and B)



Linefeed Motor Interconnect Module (C)

Sensor Lever (D)

Printhead Cable Connector (E)

The sensor lever must be positioned in the paper end sensor. If the lever is not correctly positioned, the ALARM lamp will light and the unit will not automatically load paper or receive data.

P/N 55923901 IC: CU EEPROM 391 390+ RSPL [B.2.02](#) , [B.2.03](#) 

P/N 55938101 IC: CU EEPROM ER59256 390 391+ RSPL [B.2.02](#) , [B.2.03](#) 

P/N 50704301 Clamp: PCB All RSPL A B C [B.2.02](#) , [B.2.03](#) 

P/N 55045403 PCB: SKRA-3 w/o ROM All RSPL A B C [B.2.02](#) , [B.2.03](#)  Control Board

P/N 50605501 Lock: Board Screw All RSPL A B C [B.2.02](#) , [B.2.03](#) 

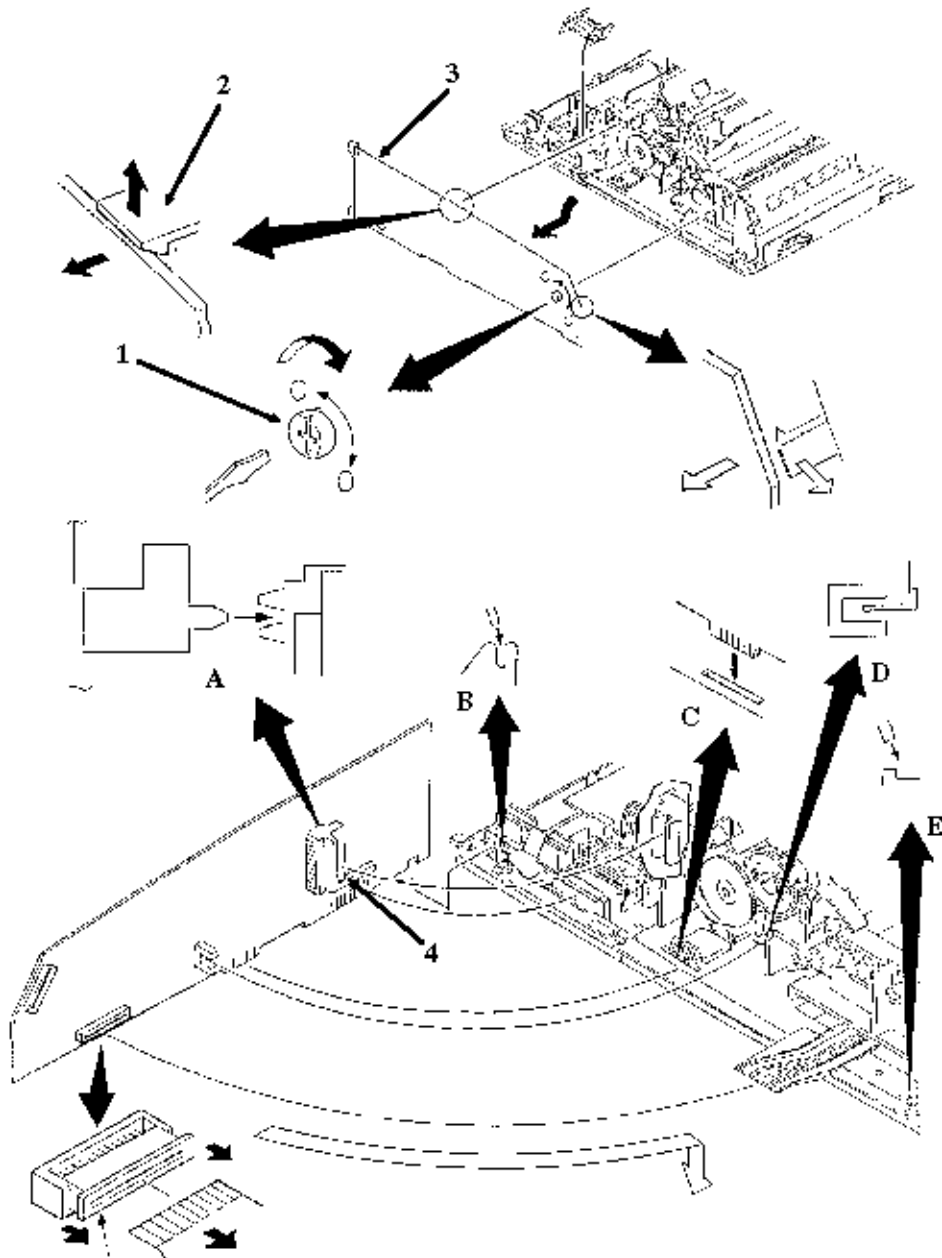

Copyright 1997, Okidata, Division of OKI America, Inc. All rights reserved. See the OKIDATA Business Partner Exchange (BPX) for any updates to this material. (<http://bpx.okidata.com>)

3.2.07 IC Card (B) Panel

· Perform this procedure: [3.2.01](#), [3.2.04](#).

· Insert a flat-blade screwdriver at the bottom of the chassis (1) and push up on the two claws (2) of the IC card (B) panel (3) to release the panel.

· Pull the panel in the direction of arrow A and remove the panel.

P/N 53490301 Panel: IC Card (B) All RSPL A B C [B.2.04](#), [B.2.06](#)

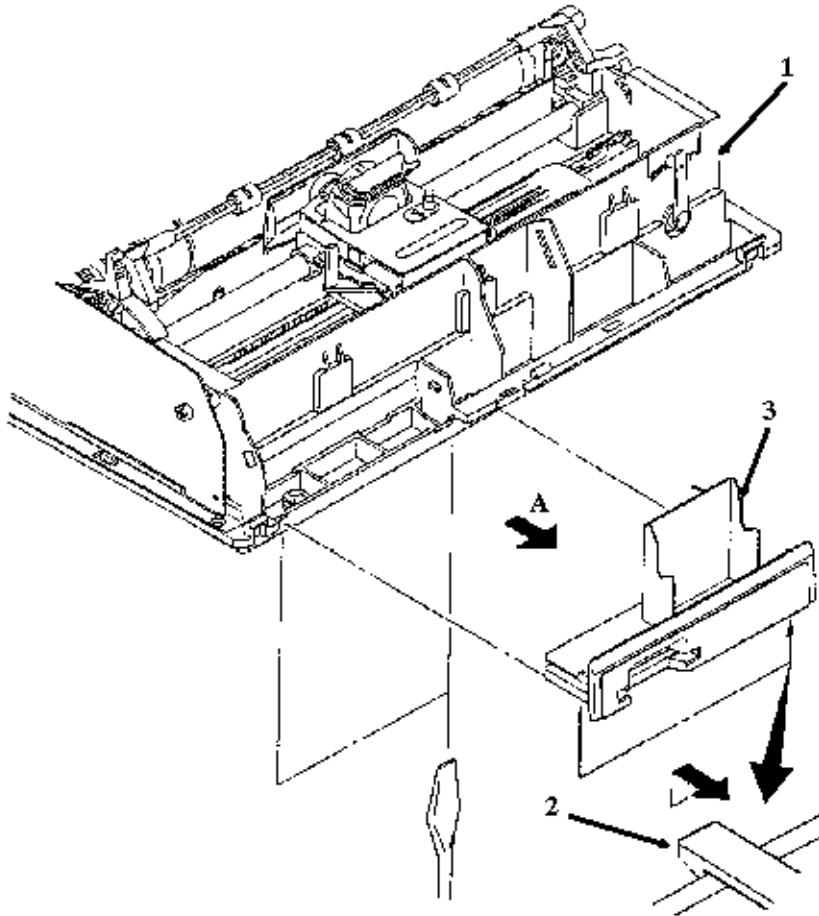



3.2.08 Transformer

Revs A and B

NOTE:

*The transformer contains a built-in temperature fuse. Once the fuse opens, the transformer **MUST** be replaced.*

The transformer shown in the diagram is the Rev A and B transformer. This unit has been replaced by the Rev C unit, shown on the following pages.

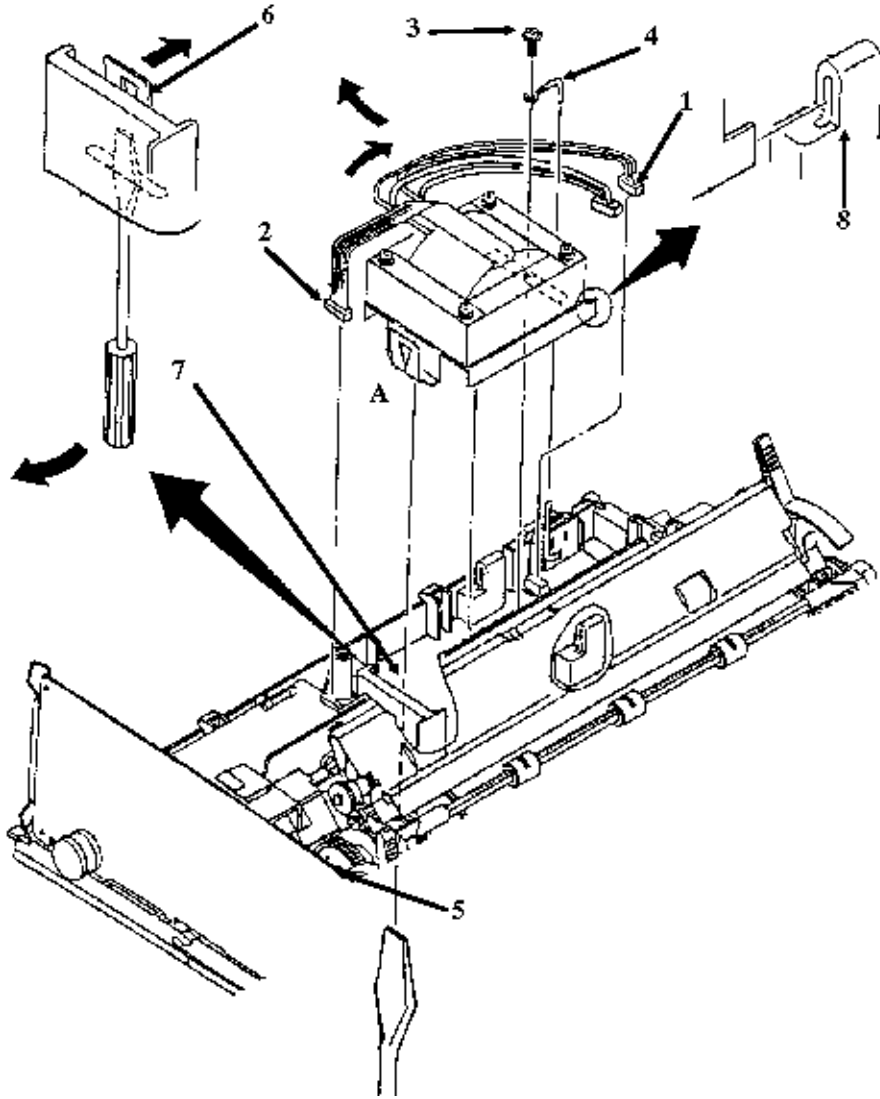

- **Perform this procedure: 3.2.01** , **3.2.04** .
- Disconnect the cable (1) from the filter assembly.
- Disconnect the cable (2) from the power supply board.
- Remove the screw (3) and detach the grounding wire (4).
- Insert a straight-slot screwdriver into the chassis from the bottom. (5 shows location)
- Push the lock spring (6) on the transformer and detach the lock spring from transformer clamp A (7).
- Lift the A side of the transformer and detach it from the transformer clamp B (8).







Copyright 1997, Okidata, Division of OKI America, Inc. All rights reserved. See the OKIDATA Business Partner Exchange (BPX) for any updates to this material. (<http://bpx.okidata.com>)



Rev C**NOTE:**

The transformer contains a built-in temperature fuse. Once the fuse opens, the transformer MUST be replaced.

- **Perform this procedure: 3.2.01** , **3.2.04** .
- Disconnect the cable (1) from the filter assembly.
- Disconnect the cable (2) from the power supply board.
- Remove the screw (3) and detach the grounding wire (4).
- Insert a straight-slot screwdriver into the chassis from the bottom. (5 shows location)
- Push the lock spring (6) on the transformer and detach the lock spring from transformer clamp A (7).
- Lift the A side of the transformer and detach it from the transformer clamp B (8).

P/N 56407201 Transformer: 120 V Both 90 RSPL A B C **B.2.02** , **B.2.03** 

P/N 56407202 Transformer: 120 V Both 91 RSPL A B C **B.2.02** , **B.2.03** 



P/N 56407801 Transformer: 220/240 V Both 90 Option RSPL A B C **B.2.02** , **B.2.03** 

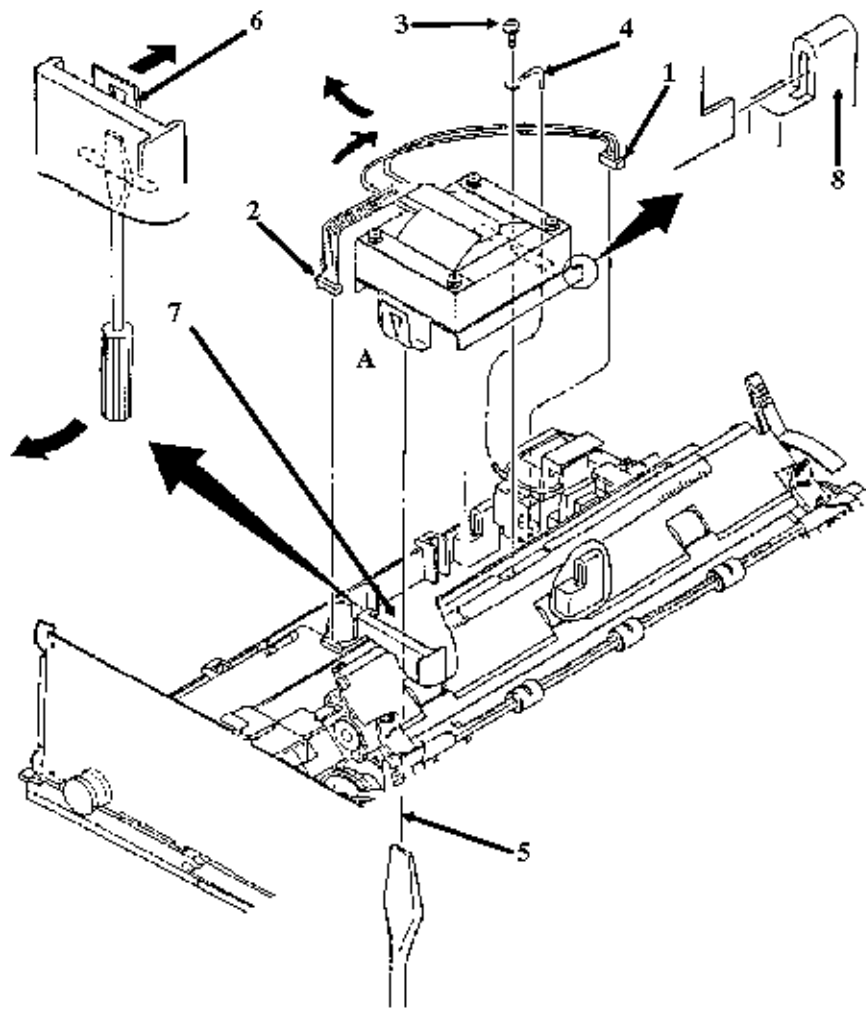

P/N 56407802 Transformer: 220/240 V Both 91 Option RSPL A B C **B.2.02** , **B.2.03** 





Copyright 1997, Okidata, Division of OKI America, Inc. All rights reserved. See the OKIDATA Business Partner Exchange (BPX) for any updates to this material. (<http://bpx.okidata.com>)

3.2.09 Filter Assembly

- Perform these procedures: [3.2.01](#) , [3.2.04](#) .
- Working from the bottom of the chassis, push on and release the claw (1) of the filter assembly (2).
- Lift the AC connector (3) and the AC power switch (4) from the two guides on the main frame.
- Remove the filter assembly.
- The filter assembly contains a fuse (5).

P/N 55503101 Filter: (Assembly) AC 120V All RSPL A B C [B.2.02](#) , [B.2.03](#) 

P/N 55503102 Filter: 220/240 V (Assembly) All Option A B C [B.2.02](#) , [B.2.03](#) 

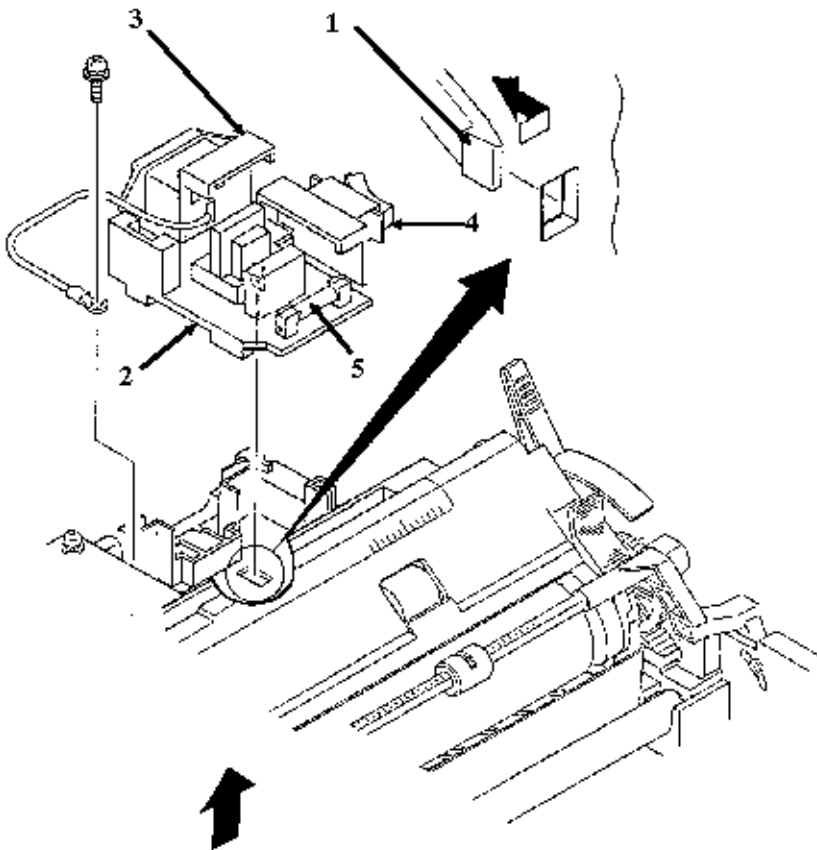



Partner Exchange (BPX) for any updates to this material. (<http://bpx.okidata.com>)

3.2.10 Power Supply Board



Revs A and B

NOTE:

Refer to Appendix A for more information on this board.

- Perform these procedures: [3.2.01](#) , [3.2.04](#) .
- Push the board clamp claw (1) in the direction of arrow A.
- Lift the B side of the power supply board (2).
- Detach the C side of the power supply board from the power interconnect module (3).
- The power supply board contains a fuse (4).

P/N 55047401 PCB: SUII (Power Supply) All RSPL A B C [B.2.02](#) , [B.2.03](#) 

P/N 55047406 PCB: SUII-6 (220/24V) Option A B C [B.2.02](#) , [B.2.03](#)  (Power Supply)

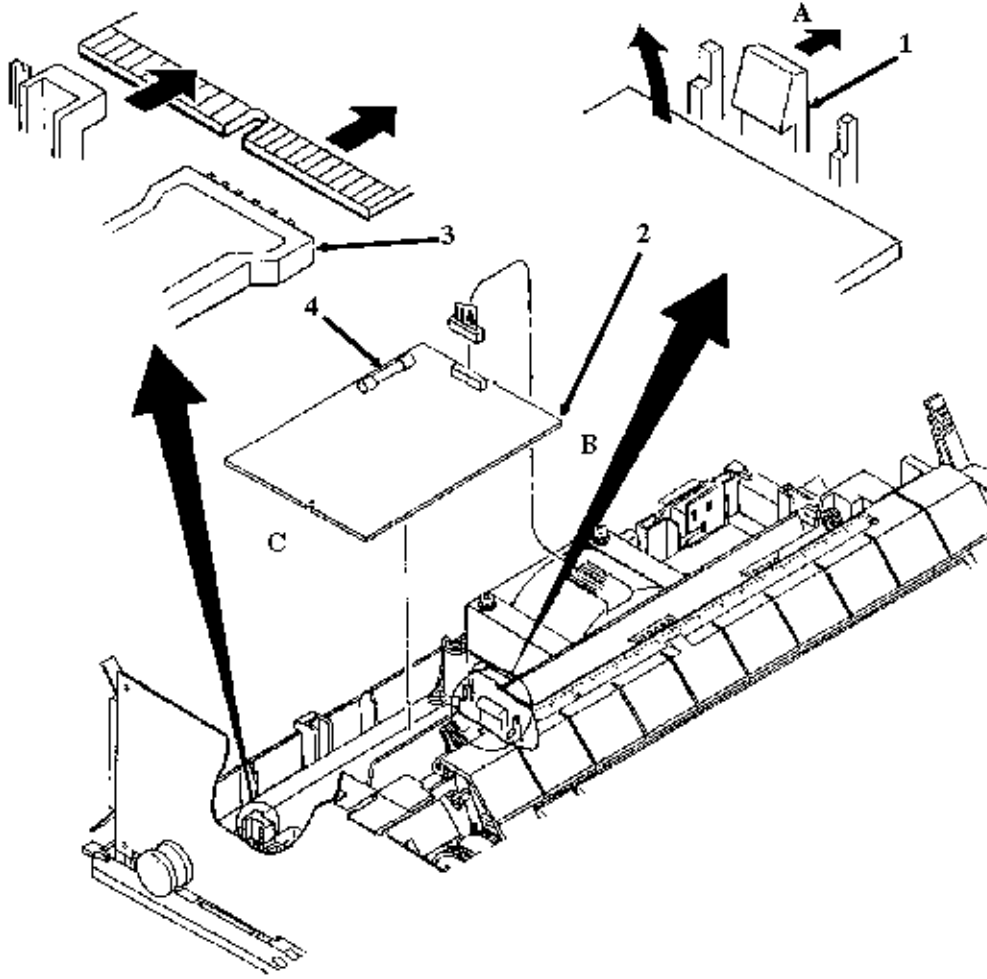

P/N 56616802 Cable: Power Supply All RSPL C [B.2.02](#) , [B.2.03](#)  -Nylon Connector





Copyright 1997, Okidata, Division of OKI America, Inc. All rights reserved. See the OKIDATA Business Partner Exchange (BPX) for any updates to this material. (<http://bpx.okidata.com>)

Rev C**NOTE:**

Refer to Appendix A for more information on this board.

- Perform these procedures: [3.2.01](#) , [3.2.04](#) .
- Push the board clamp claw (1) in the direction of arrow A.
- Lift the B side of the power supply board (2).
- Detach the cable from the connector (3).
- The power supply board contains a fuse (4).

P/N 55047401 PCB: SUII (Power Supply) All RSPL A B C [B.2.02](#) , [B.2.03](#) 

P/N 55047406 PCB: SUII-6 (220/24V) Option A B C [B.2.02](#) , [B.2.03](#)  (Power Supply)

P/N 56616802 Cable: Power Supply All RSPL C [B.2.02](#) , [B.2.03](#)  -Nylon Connector

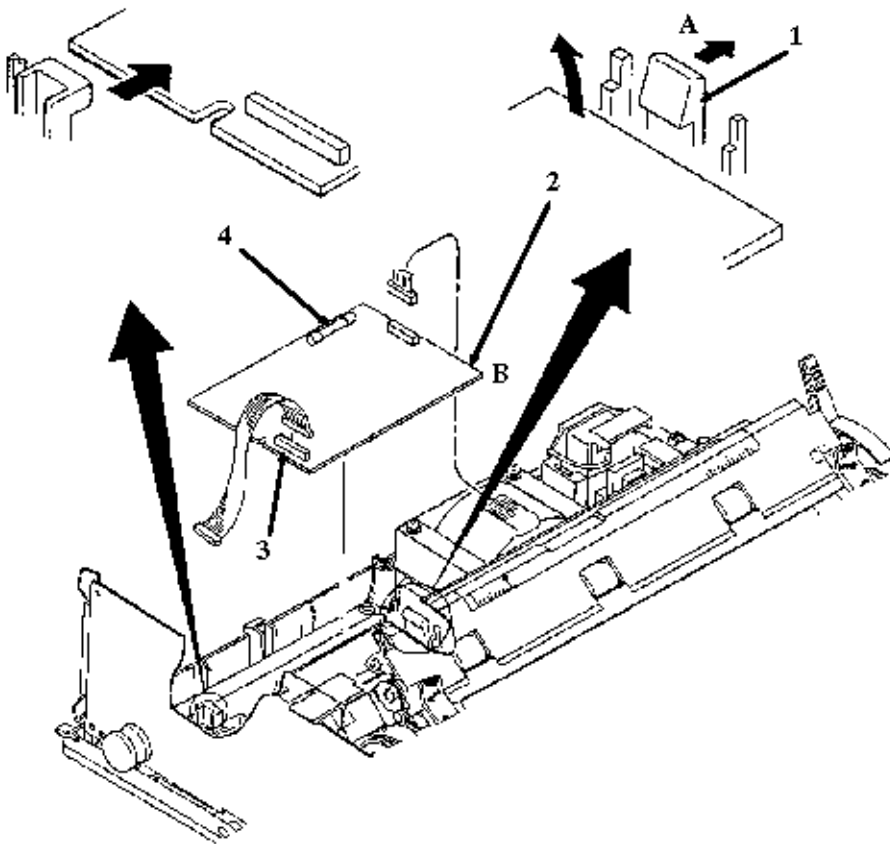

Copyright 1997, Okidata, Division of OKI America, Inc. All rights reserved. See the OKIDATA Business Partner Exchange (BPX) for any updates to this material. (<http://bpx.okidata.com>)

3.2.11 Power Interconnect Module / Cable Guide



Revs A and B

NOTES:

The Rev A and B printers do NOT have a cable guide.

The Rev C printers do NOT have a power interconnect module.

Rev C printers have a cable guide.

- Perform these procedures: [3.2.01](#) , [3.2.04](#) .
- Use a straight-slot screwdriver to release the claws (1) from the chassis clamps (2).
- Remove the power interconnect module (3).

P/N 53328301 Module: Power Interconnect Both RSPL A B [B.2.04](#) 

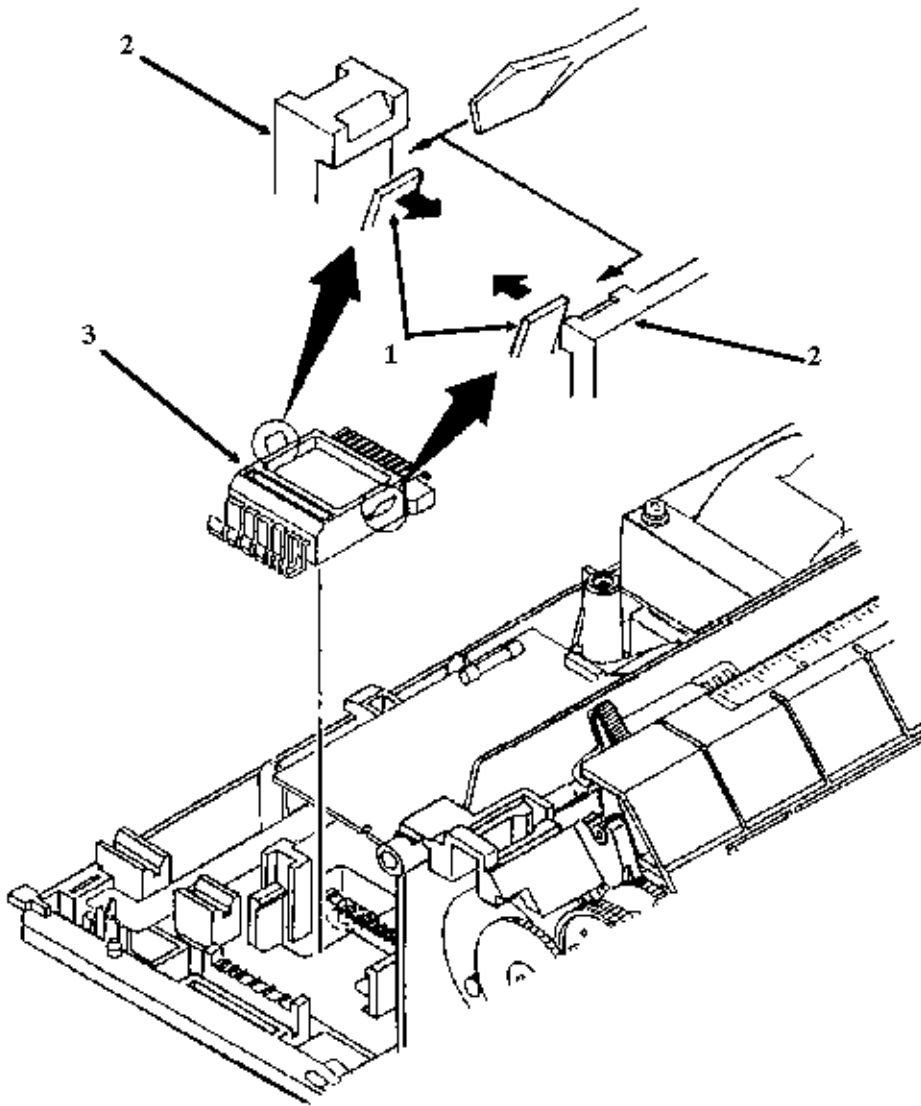



Copyright 1997, Okidata, Division of OKI America, Inc. All rights reserved. See the OKIDATA Business Partner Exchange (BPX) for any updates to this material. (<http://bpx.okidata.com>)

Rev C*NOTES:*

The Rev A and B printers do NOT have a cable guide.

The Rev C printers do NOT have a power interconnect module.

Rev C printers have a cable guide.



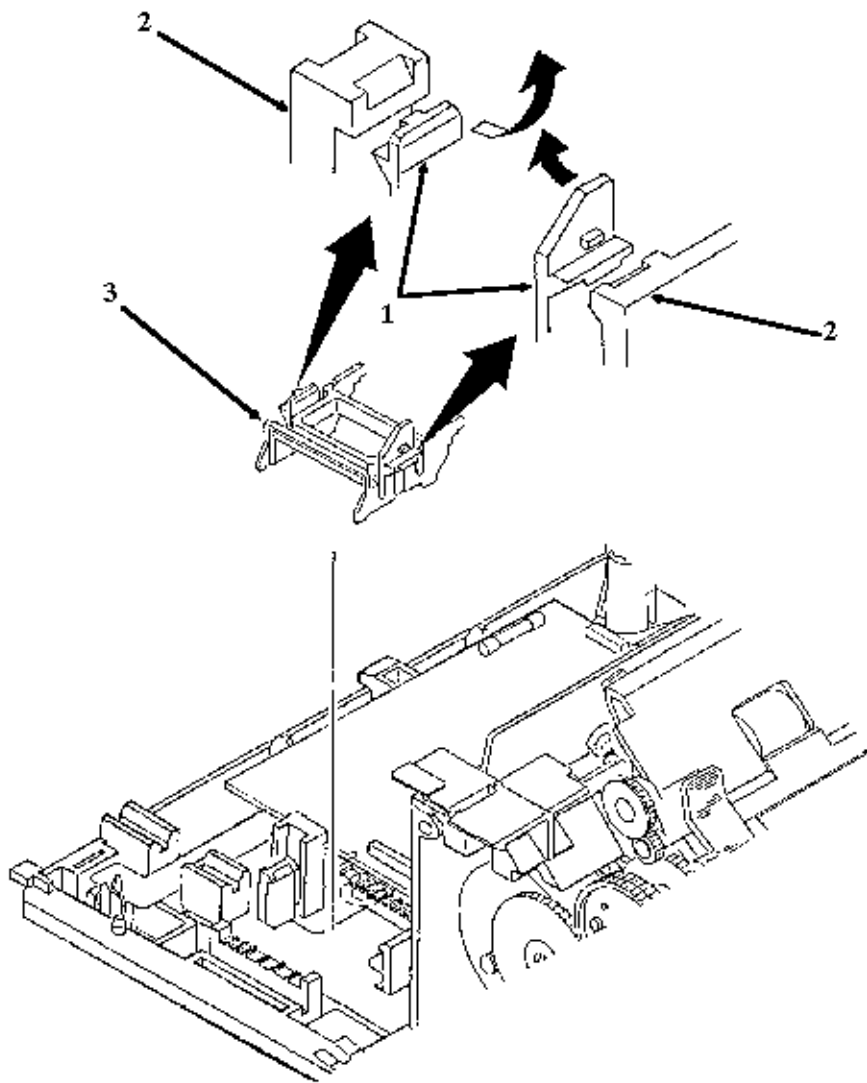

- Perform these procedures: [3.2.01](#) , [3.2.04](#) .
- Use a straight-slot screwdriver to release the claws (1) from the chassis clamps (2).
- Remove the cable guide (3).



P/N 51003801 Guide: Cable All RSPL C [B.2.06](#) 





Copyright 1997, Okidata, Division of OKI America, Inc. All rights reserved. See the OKIDATA Business Partner Exchange (BPX) for any updates to this material. (<http://bpx.okidata.com>)

3.2.12 Indicator Assembly (Bail Bar Assembly)

- Perform these procedures: [3.2.01](#) , [3.2.04](#) , [3.2.05](#) , [3.2.06](#) .
- Use needle-nose pliers to remove the left bail arm spring (1).
- Release the claw (2) and detach the left bail arm (3) from the bail bar (4).
- Pull the left bail arm through the guide hole (5) in the chassis and remove the arm.
- Detach the bail bar from the right bail arm (6).
- Use needle-nose pliers to remove the right bail arm spring (7).
- Release the claw (8) and detach the right bail arm from the bail bar.
- Pull the right bail arm through the guide hole (9) in the chassis and remove the arm.

P/N 50911801 Spring: Bail Arm (L) All RSPL A B C [B.2.04](#) , [B.2.06](#) 

P/N 53489301 Bail Arm (L) All RSPL A B C [B.2.04](#) , [B.2.06](#) 

P/N 50911701 Spring: Bail Arm (R) All RSPL A B C [B.2.04](#) , [B.2.06](#) 

P/N 53489201 Bail Arm (R) All RSPL A B C [B.2.04](#) , [B.2.06](#) 

P/N 50061501 Indicator (Assembly) Both 90 RSPL A B C [B.2.04](#) , [B.2.06](#) 

P/N 50061502 Indicator (Assembly) Both 91 RSPL A B C [B.2.04](#) , [B.2.06](#) 

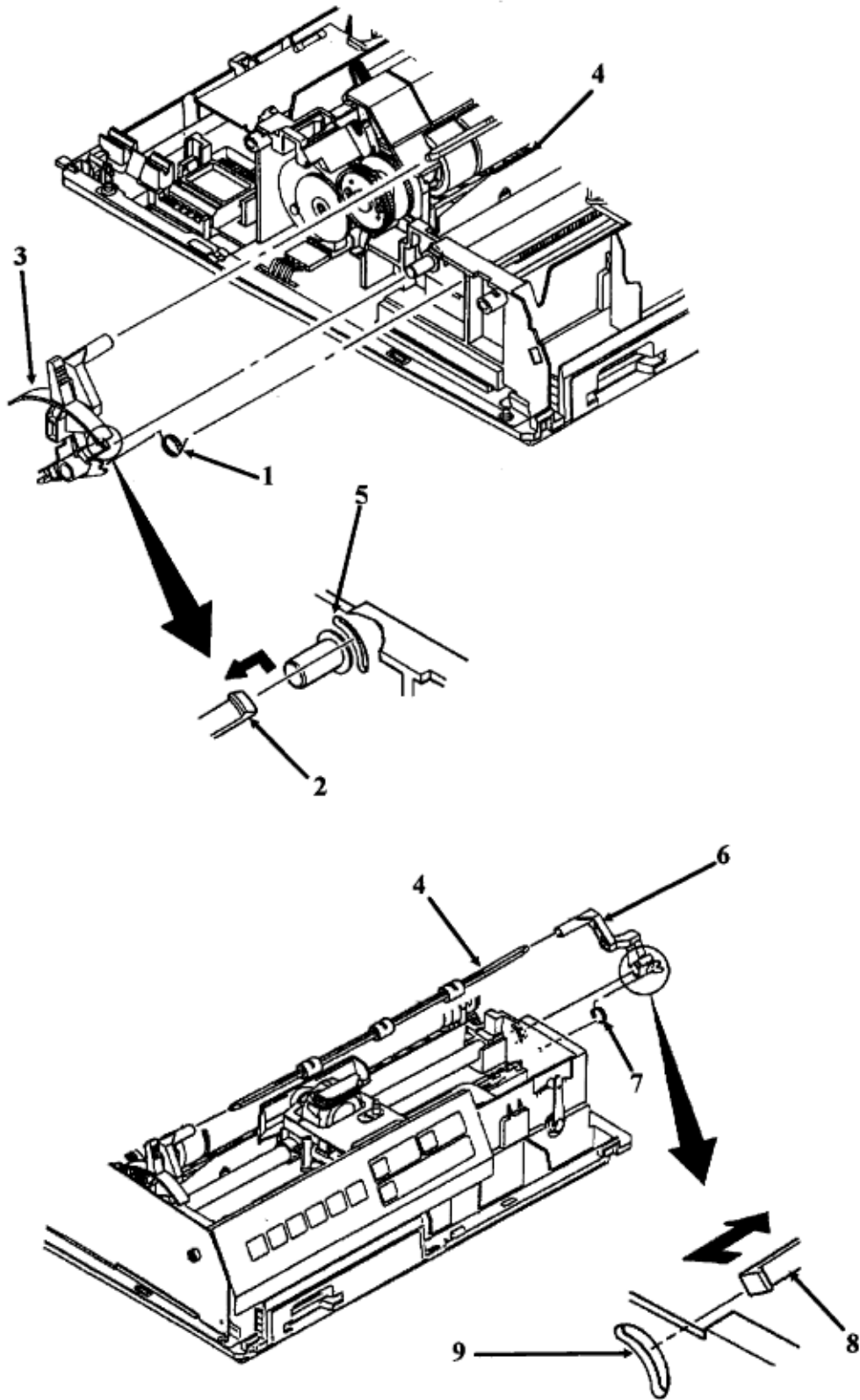





Partner Exchange (BPX) for any updates to this material. (<http://bpx.okidata.com>)

3.2.13 Head Cable Access Cover and Connection Board (SRBS)

NOTE:

Remove this cover to provide access when connecting the head cable to the control board.

- Perform these procedures: [3.2.01](#) , [3.2.04](#) , [3.2.05](#) , [3.2.06](#) .
- Slide the carriage frame (1) in the direction of arrow A.
- Pull the connector (2) in the direction of arrow B and remove the connector.
- Release the clamp (3) and detach the head cable (4).
- Release the two claws (5) and remove the head cable access cover (6). The claws are accessed from the bottom of the printer.
- Pull the board (7) in the direction of arrow B to detach it from the claws (8).
- Remove the board.

P/N 56723801 Conn: Connection AKT-60 All RSPL [B.2.04](#) 

P/N 50062301 Cover: Head Cable Access All RSPL A B C [B.2.04](#), [B.2.06](#) 

P/N 55038501 PCB: SRBS All RSPL [B.2.04](#)  (Connection Board)

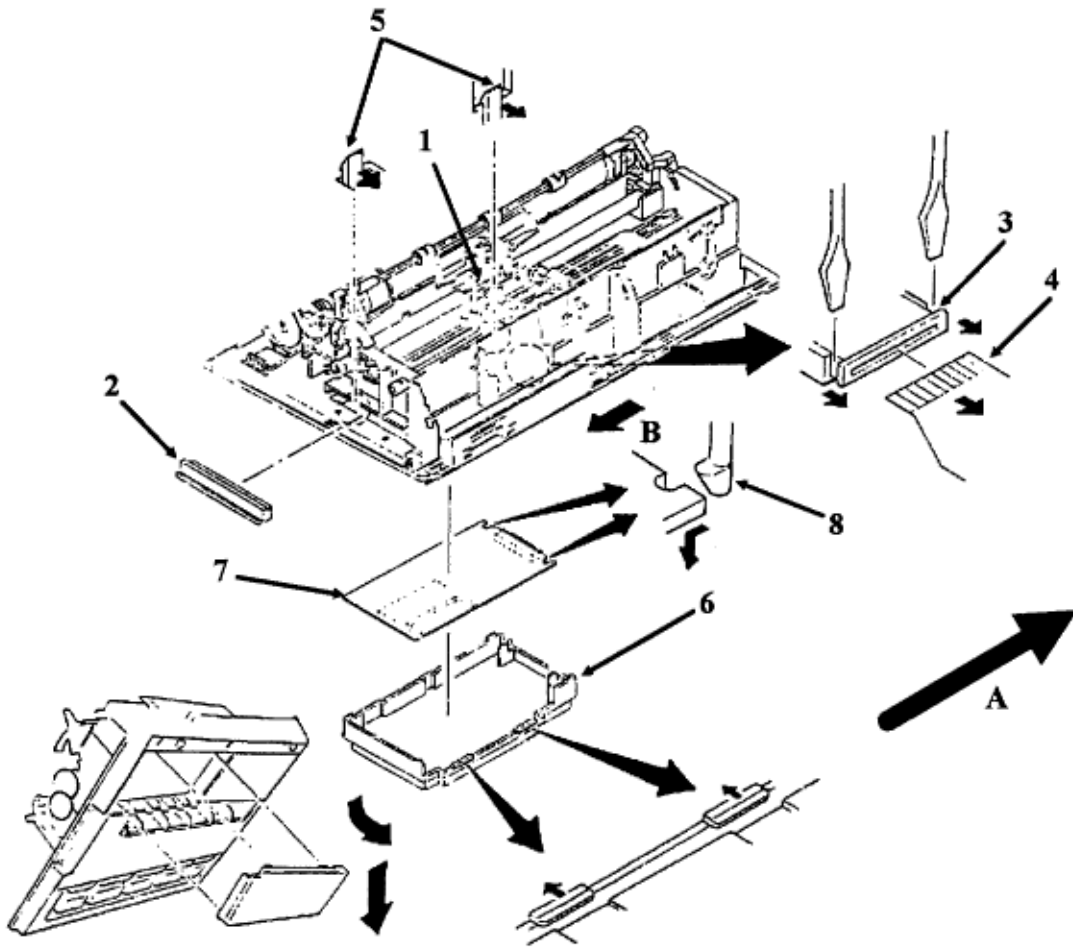



Copyright 1997, Okidata, Division of OKI America, Inc. All rights reserved. See the OKIDATA Business Partner Exchange (BPX) for any updates to this material. (<http://bpx.okidata.com>)

3.2.14 Ribbon Feed Gear Assembly

CAUTION:

When handling the head cable, do NOT bend the cable at sharp angles or you may damage it.

- Perform these procedures: [3.2.01](#) , [3.2.04](#) .
- Remove the ribbon (1).
- Insert a straight-slot screwdriver through the access slots and release the two front claws (2) and the two rear claws (3) of the ribbon feed gear assembly (4).
- Lift and remove the assembly.
- Detach the head cable (5), the cable clamp (not shown) and the contact pressure rubber (6) from the assembly.

NOTE:*Lubrication*

When lubricating, refer to Section 3.5 of this Service Handbook .

P/N 50061401 Gear: Ribbon Feed (Assembly) All RSPL A B C [B.2.09](#) .

P/N 56615403 Cable: Head (Flexible) Both 90 RSPL A B C [B.2.09](#) .

P/N 56615404 Cable: Head (Flexible) Both 91 RSPL A B C [B.2.09](#) .

P/N 51706501 Rubber: Contact Pressure Both RSPL A B C [B.2.09](#) .

P/N 53526701 Rubber: Contact Pressure Both+ RSPL A B C [B.2.09](#) .

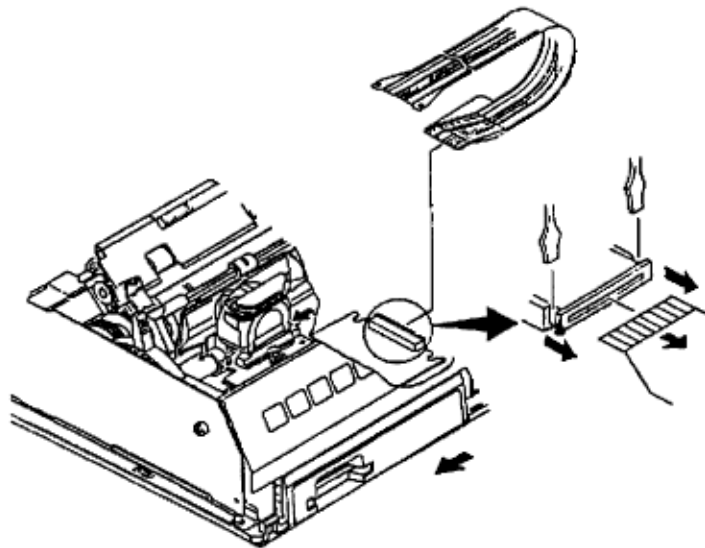
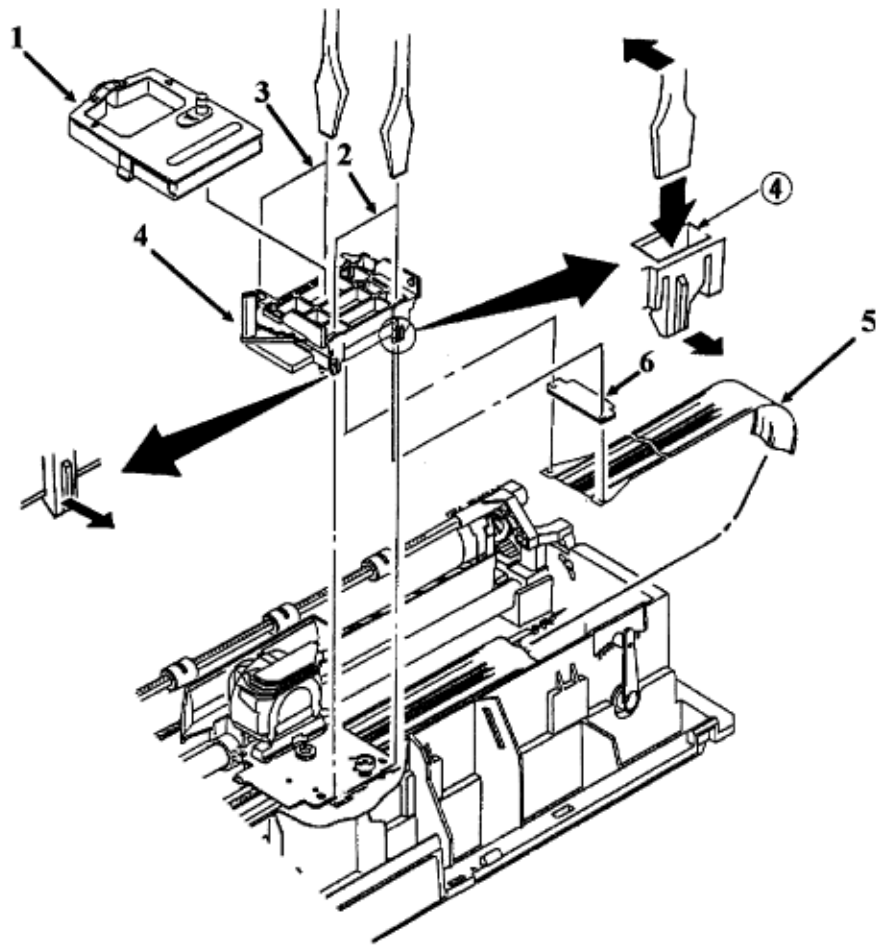

Copyright 1997, Okidata, Division of OKI America, Inc. All rights reserved. See the OKIDATA Business Partner Exchange (BPX) for any updates to this material. (<http://bpx.okidata.com>)

3.2.15 Space Motor Assembly

- Perform these procedures: [3.2.01](#), [3.2.03](#), [3.2.04](#), [3.2.14](#).
- Note the position of the connector (1). During assembly, the connectors orientation is critical for correct printhead operation.
- Detach the connector.
- Remove the three mounting screws (2).
- Remove the space motor assembly (3). Be careful not to lose the slider (4).

NOTES:

Installation

Do not touch the contacts of the assembly.

Position the slider first.

The contact side of the head cable faces down when the carriage cable is inserted into the connector on the space motor assembly.

Work the cable from side to side until it is fully seated in the connector. No contacts should be visible.

Perform the printhead gap adjustment after installing this assembly. [Refer to Section 3.3 of this Service Handbook for details](#).

Cleaning

When cleaning, refer to Section 3.4 of this Service Handbook.

Lubricating

When lubricating, refer to Section 3.5 of this Service Handbook.

P/N 51001801 Guide: Space Motor (Slider) All RSPL A B C [B.2.09](#).



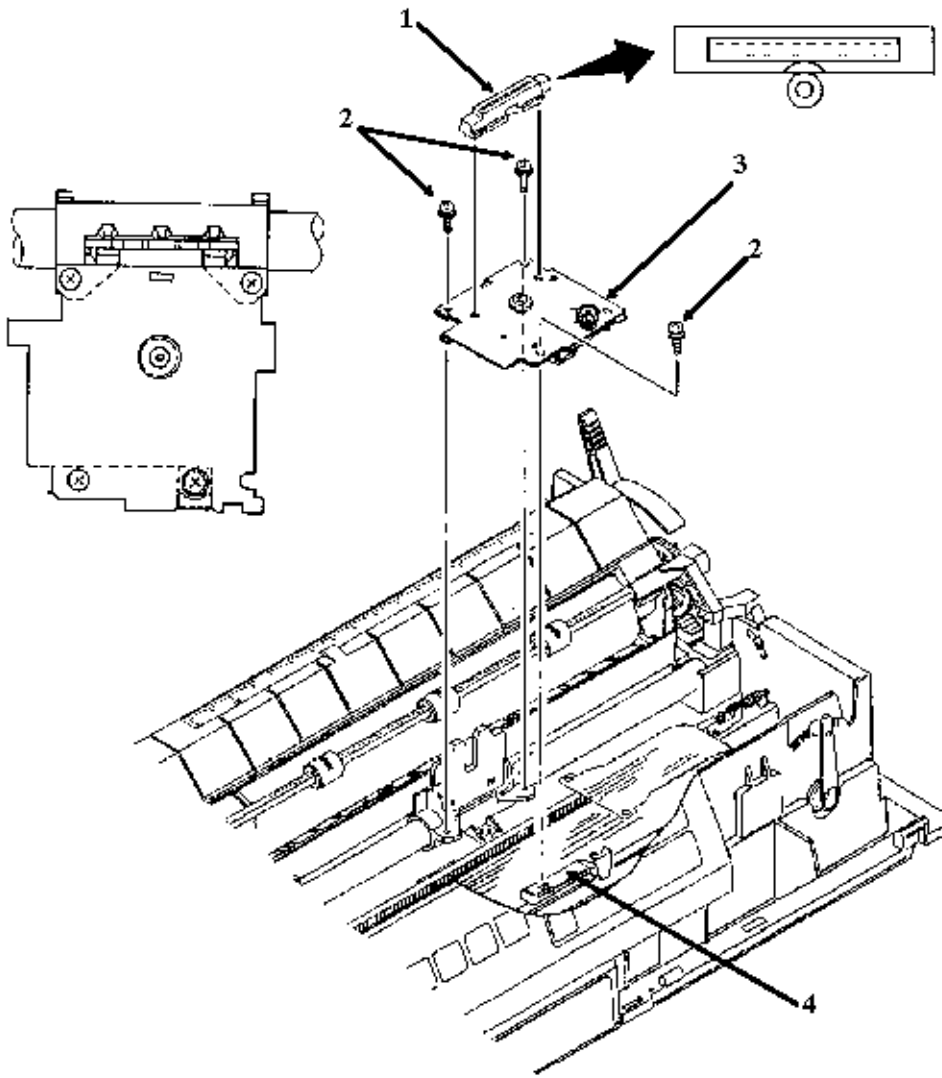

P/N 56719201 Connector: Head All RSPL A B C [B.2.09](#).

P/N 56507104 Motor: Space (Assembly) All RSPL A B C [B.2.09](#).



Copyright 1997, Okidata, Division of OKI America, Inc. All rights reserved. See the OKIDATA Business Partner Exchange (BPX) for any updates to this material. (<http://bpx.okidata.com>)

3.2.16 Carriage Frame Assembly

- Perform these procedures: [3.2.01](#) , [3.2.03](#) , [3.2.04](#) , [3.2.14](#) , [3.2.15](#) .
- Detach the head clamp (1).
- Use a flat-blade screwdriver to release the tabs of the ribbon protector (2).
- Remove the ribbon protector.
- Push the carriage shaft clamp (3) in the direction of arrow A.
- Lift the carriage shaft (4) at position B.
- Remove the carriage shaft from the guide hole by pulling at position C.
- Remove the carriage shaft, with the carriage frame (5).
- Slide the carriage frame off the carriage shaft.

NOTES:

Installation



Perform the printhead gap adjustment after installing this assembly. [Refer to Section 3.3 of this Service Handbook for details](#) .



Cleaning

[When cleaning, refer to Section 3.4 of this Service Handbook](#) .

Lubrication

[When lubricating, refer to Section 3.5 of this Service Handbook](#) .

P/N 51109401 Shaft: Carriage Both 90 RSPL A B C [B.2.04](#) , [B.2.06](#) 

P/N 51109402 Shaft: Carriage Both 91 RSPL A B C [B.2.04](#) , [B.2.06](#) 

P/N 50702901 Clamp: Head All RSPL A B C [B.2.09](#) 



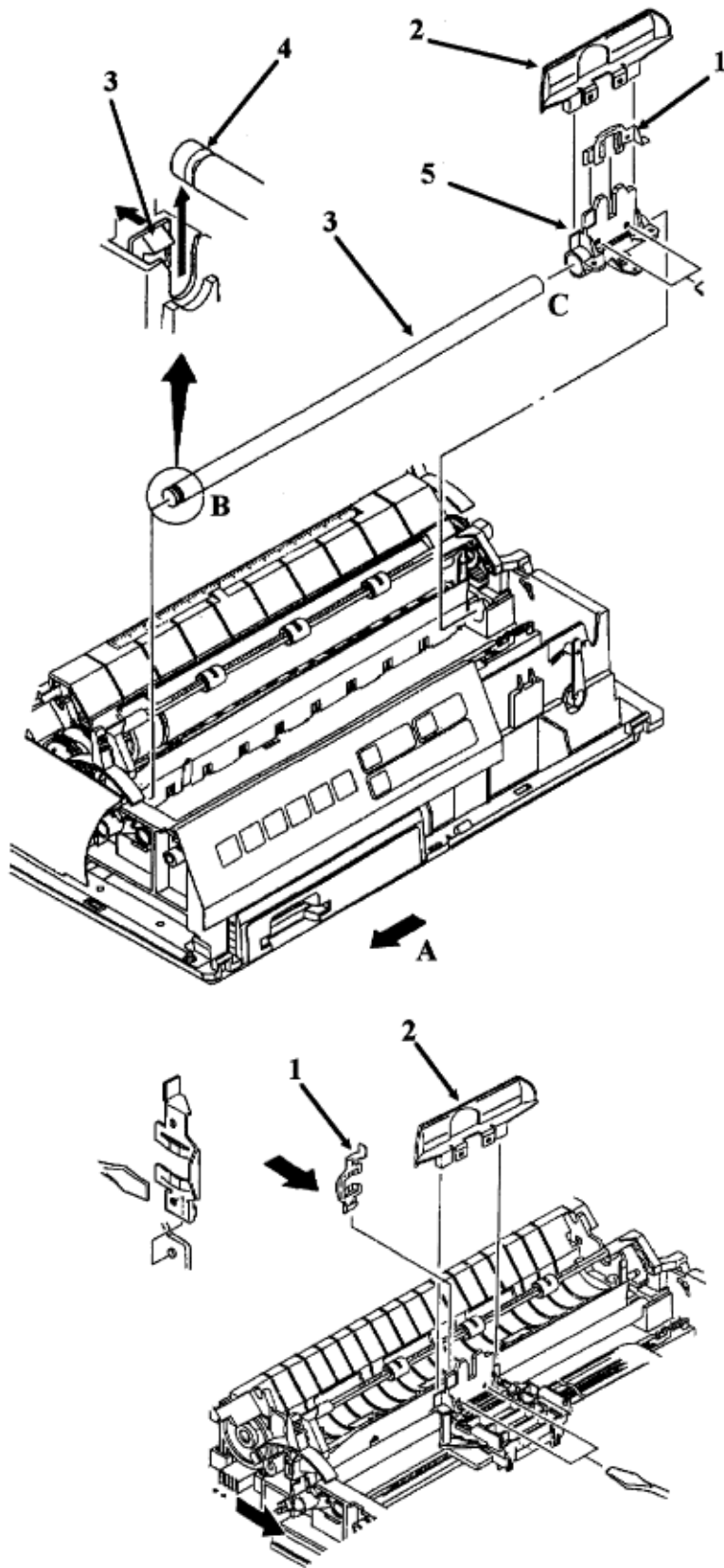

P/N 53490401 Frame: Carriage (Assembly) All RSPL A B C [B.2.09](#) 

P/N 53056201 Protector: Ribbon All RSPL A B C [B.2.09](#) 



Copyright 1997, Okidata, Division of OKI America, Inc. All rights reserved. See the OKIDATA Business Partner Exchange (BPX) for any updates to this material. (<http://bpx.okidata.com>)

3.2.17 Space Rack

- Perform these procedures: [3.2.01](#) , [3.2.04](#) , [3.2.14](#) , [3.2.15](#) .
- Remove the tension spring (1).
- Release the claw (2) from the hole (3) in the chassis.
- Pull the space rack (4) in the direction of arrow A.
- Remove the space rack.

NOTES:

Installation

Fully seat the two guide pins (5).



Cleaning



When cleaning, refer to Section 3.4 of this Service Handbook .

CAUTION:

Lubrication

Do NOT lubricate the space rack. Lubricating the space rack will attract dust. If enough dust accumulates on the space rack, printing problems will occur.

P/N 53489401 Rack: Space Both 90 RSPL A B C [B.2.04](#) , [B.2.06](#) 



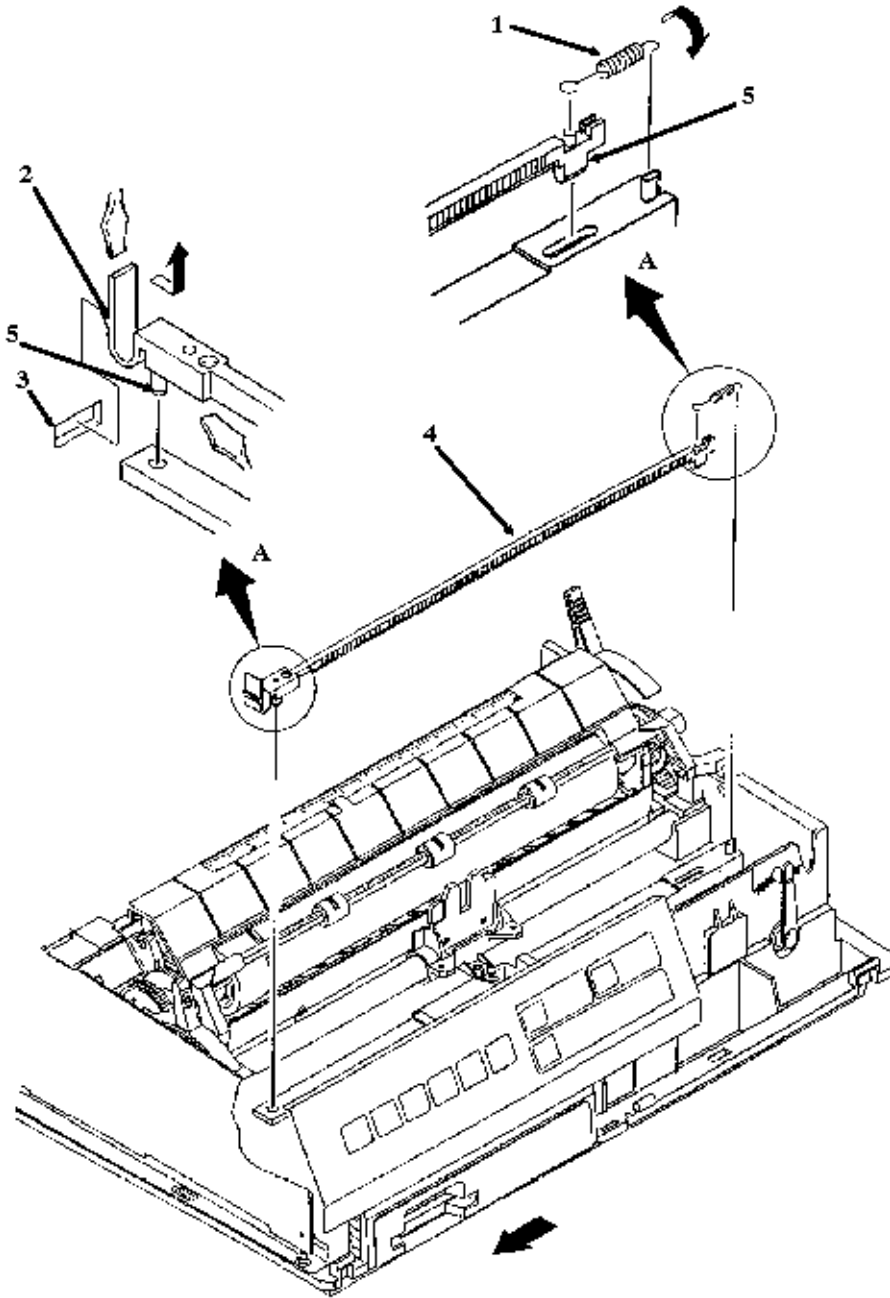

P/N 53489402 Rack: Space Both 91 RSPL A B C [B.2.04](#) , [B.2.06](#) 

P/N 50911901 Spring: Tension All RSPL A B C [B.2.04](#) , [B.2.06](#) 





Copyright 1997, Okidata, Division of OKI America, Inc. All rights reserved. See the OKIDATA Business Partner Exchange (BPX) for any updates to this material. (<http://bpx.okidata.com>)



3.2.18 Guide Rail

- Perform these procedures: [3.2.01](#) , [3.2.04](#) , [3.2.14](#) , [3.2.15](#) .
- Pull the adjusting cam (1) out and rotate it to the horizontal position.
- Release the adjusting cam from the guide (2) in the chassis and remove the cam.
- Push the claw (3) in the direction of arrow A to disengage the guide rail (4) at position B.
- Pull the guide rail in the direction of arrow C to release it from the guide (5) in the chassis.
- Lift and remove the guide rail.

NOTE:

After installing the guide rail, check the printhead gap adjustment. Refer to Section 3.3 of this Service Handbook .

P/N 51002101 Rail: Guide Both 90 RSPL A B C [B.2.04](#) , [B.2.06](#) 

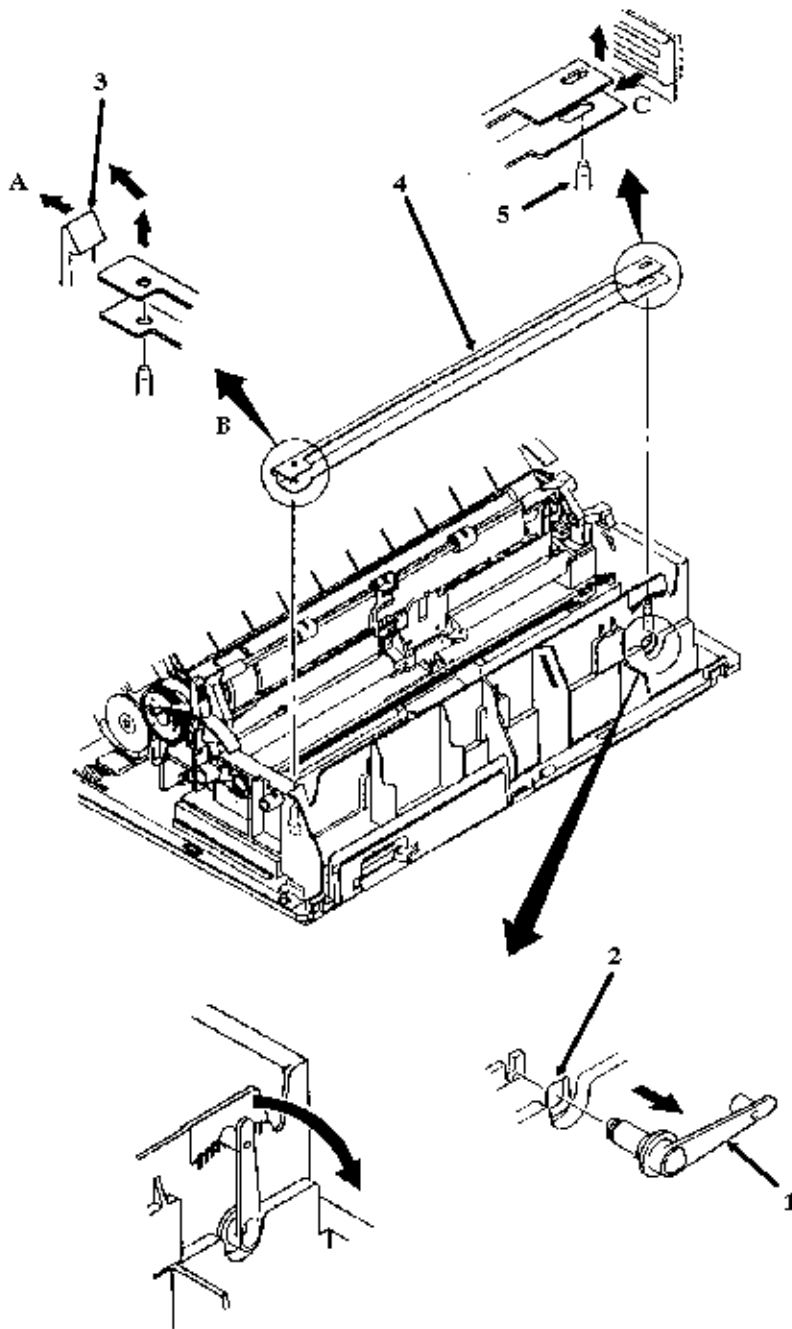

P/N 51002102 Rail: Guide Both 91 RSPL A B C [B.2.04](#) , [B.2.06](#) 

P/N 51216201 Cam: Adjust All RSPL A B C [B.2.04](#) , [B.2.06](#) 



Copyright 1997, Okidata, Division of OKI America, Inc. All rights reserved. See the OKIDATA Business Partner Exchange (BPX) for any updates to this material. (<http://bpx.okidata.com>)

3.2.19 Platen Assembly

- Perform these procedures: [3.2.01](#) , [3.2.02](#) , [3.2.04](#) .
- Push the release lever (1) to the rear of the printer.
- Pull the platen lock levers (2) in the direction of arrow A.
- Rotate the lock levers in the direction of arrow B. This releases the platen assembly (3) from the chassis.
- Lift and remove the platen assembly.

NOTES:

Installation

Before installation, turn the bias gear (4) towards the front of the printer as far as it will go.

Set the platen assembly into place.

Verify that the bias gear securely engages the line feed motor gear.

Secure the two lock levers.

Set the release lever to OPEN (front) and check that the groove of the paper chute firmly engages with the groove of the main chassis.

Cleaning



When cleaning, refer to Section 3.4 of this Service Handbook .

Lubrication

When lubricating, refer to Section 3.5 of this Service Handbook .

Do NOT lubricate the line feed motor gear. Lubricant will cause the gear to disintegrate.

P/N 50061305 Platen: (Assembly) Both 90 RSPL A B C [B.2.04](#) , [B.2.06](#) 

P/N 50061306 Platen: (Assembly) Both 91 RSPL A B C [B.2.04](#) , [B.2.06](#) 

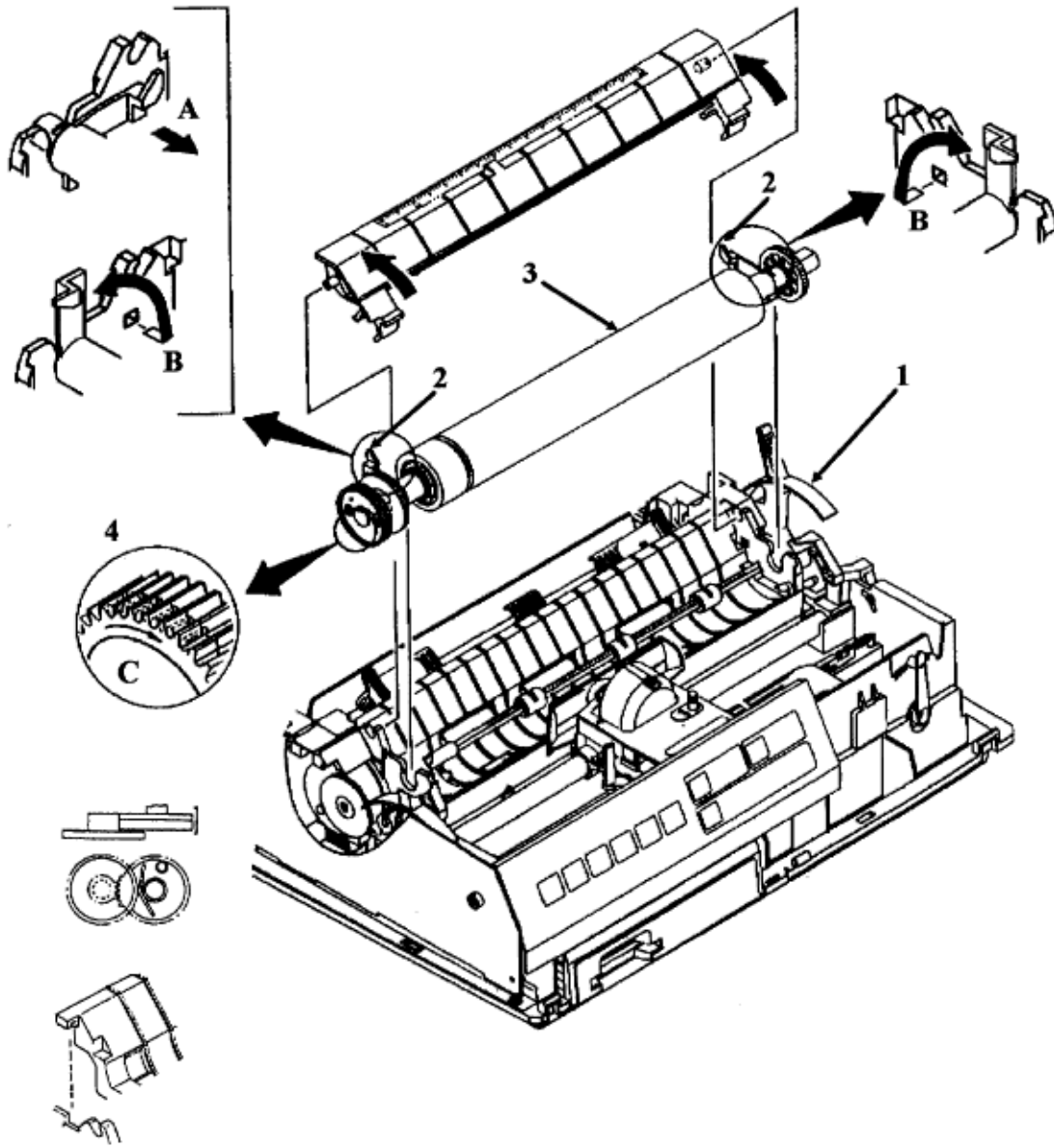

Copyright 1997, Okidata, Division of OKI America, Inc. All rights reserved. See the OKIDATA Business Partner Exchange (BPX) for any updates to this material. (<http://bpx.okidata.com>)







3.2.20 Line Feed Motor and Gear

Line Feed Motor

NOTES:

Use care when performing this procedure. The plastic claws will break if too much pressure is applied.

*If the line feed motor gear breaks or becomes worn, it is not necessary to replace the entire line feed motor assembly. The gear (6) can be replaced without removing the line feed motor assembly. However, the platen assembly **MUST** be removed. The line feed idle gear should be removed **ONLY** if it must be replaced. The claws will break when the gear is removed. A new gear must be installed.*

- Perform these procedures: [3.2.01](#) , [3.2.02](#) , [3.2.04](#) , [3.2.05](#) , [3.2.06](#) , [3.2.19](#) .
- Remove the left bail arm.
- Use a straight slot screwdriver to remove the clip (1).
- Use a straight slot screwdriver to open the lock levers (2) and push the bracket (3) of the line feed motor (4) in the direction of arrow A.
- Remove the line feed motor from the guides (5).

CAUTION:

Installation

If the line feed motor assembly is not correctly installed, excessive wear of the platen gears will occur.

Verify that the tabs are not bent. If the tabs are bent, straighten them. The assembly will not seat if the tabs are bent. If the assembly is not seated correctly, the gears will not correctly align.

Rotate the bias gear towards the front of the printer as far as the gear will turn. This aligns the bias gear with the platen gear.

Set the platen assembly in place, securely engaging the idler gear with the platen gears.

Lock the line feed motor assembly into position. Verify that the tabs are not bent.

P/N 56507003 Motor: Line Feed All RSPL A B C [B.2.05](#) , [B.2.07](#) 

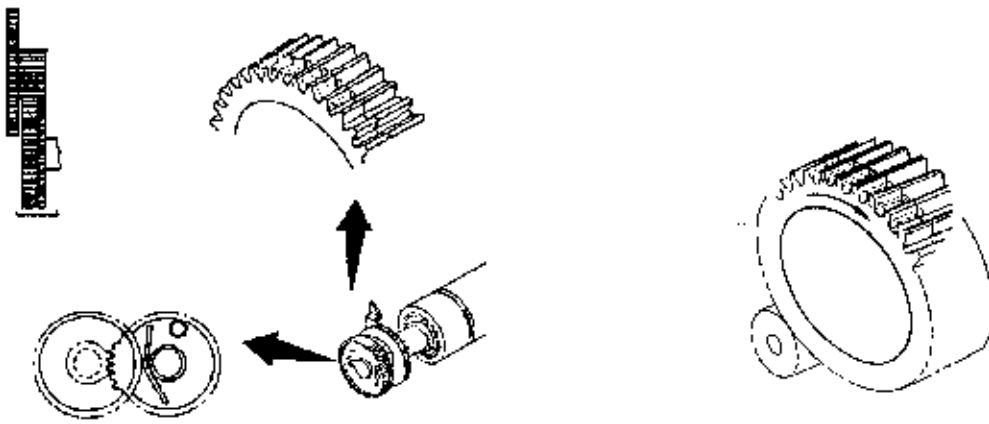
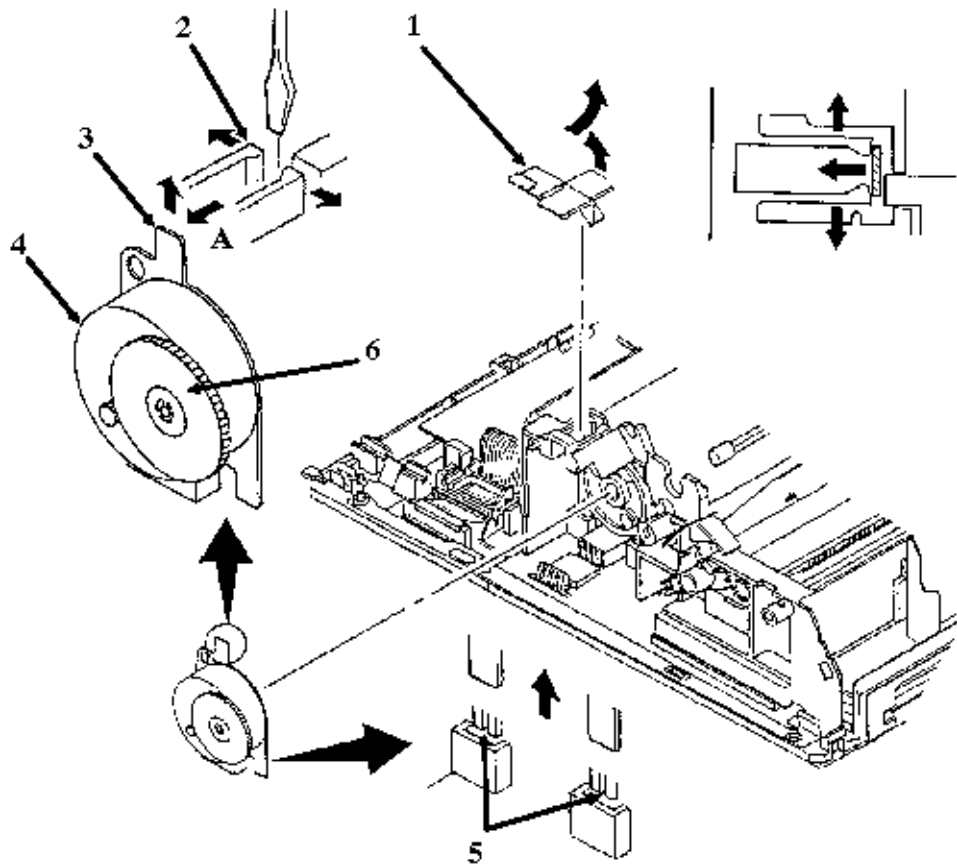

Copyright 1997, Okidata, Division of OKI America, Inc. All rights reserved. See the OKIDATA Business Partner Exchange (BPX) for any updates to this material. (<http://bpx.okidata.com>)









Service Guide ML390/391

Chapter 3 Maintenance & Disassembly

Line Feed Motor Gear

NOTES:

*If the line feed motor gear breaks or becomes worn, it is not necessary to replace the entire line feed motor assembly. The gear can be replaced without removing the line feed motor assembly. However, the platen assembly **MUST** be removed. The line feed idle gear should be removed **ONLY** if it must be replaced. The claws will break when the gear is removed. A new gear must be installed.*

- Perform these procedures: [3.2.01](#) , [3.2.02](#) , [3.2.04](#) , [3.2.05](#) , [3.2.06](#) , [3.2.19](#) .
- Remove the left bail arm.
- Use a small cutting pliers to cut the three claws (1) that secure the line feed motor gear (2) to the support shaft (3).
- Remove the gear and cut claws.
- Apply one drop of machine oil to the support shaft.
- Slide the new gear onto the support shaft.
- Lock the three claws of the gear into the groove of the shaft.
- Rotate the bias gear towards the front of the printer as far as the gear will turn. This aligns the bias gear with the platen gear.
- Set the platen assembly in place, securely engaging the line feed motor gear with the platen gears.

CAUTION:

If the claws do not lock into the groove of the support shaft, the gear will "walk" off the shaft during use. Verify that the line feed motor gear and line feed motor assembly are correctly installed. Verify that the line feed motor gear and the platen gears are correctly aligned. Incorrect installation and alignment will cause line feed motor gear breakage and wearing.

Do NOT apply lubricant to the teeth of the line feed motor gear. Grease causes the plastic to break down, resulting in premature wear of the gear teeth.

P/N 51219001 Gear: Line Feed Motor All RSPL A B C [B.2.05](#) , [B.2.07](#) 

P/N 58217901 Field Change Order 7677A Kit Both A B Contains a strengthened line feed motor gear and installation instructions. **ONLY** Rev A and Rev B printers require this FCO.

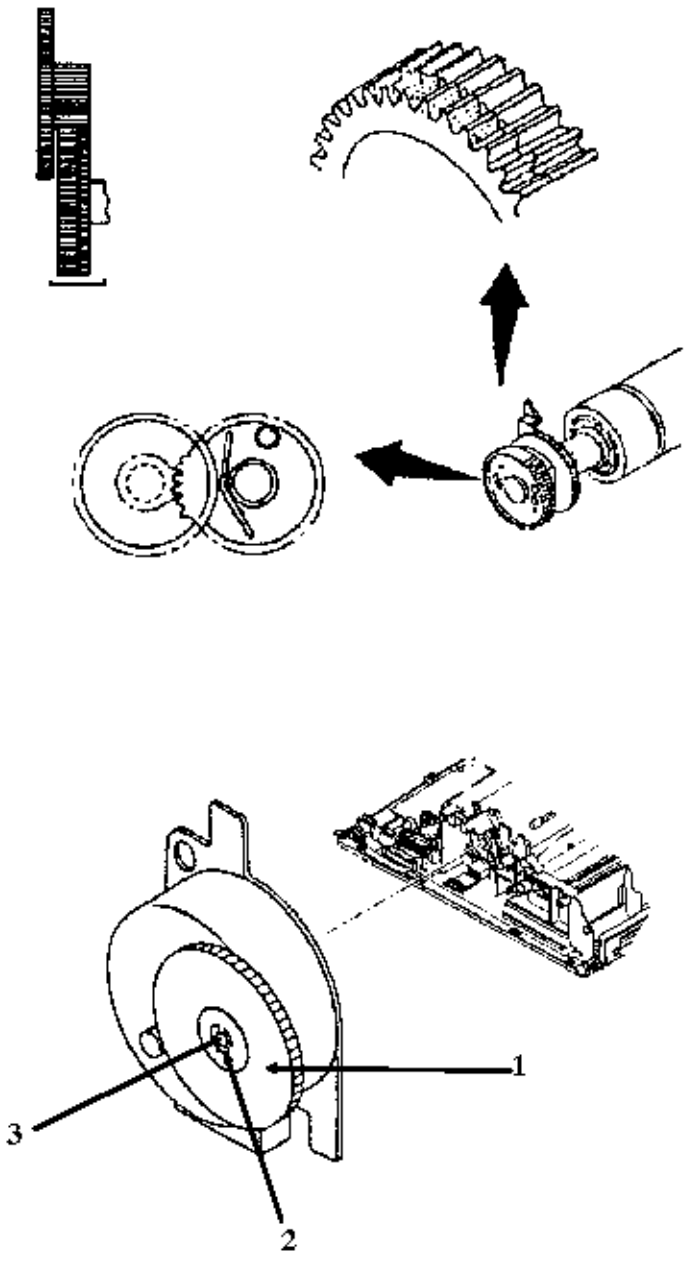

Copyright 1997, Okidata, Division of OKI America, Inc. All rights reserved. See the OKIDATA Business Partner Exchange (BPX) for any updates to this material. (<http://bpx.okidata.com>)



3.2.21 Line Feed Motor Interconnect Module

NOTE:

Use care when performing this procedure. The plastic extension will break if too much pressure is applied.

· Perform these procedures: [3.2.01](#) , [3.2.02](#) , [3.2.04](#) , [3.2.05](#) , [3.2.06](#) , [3.2.20](#) .

· Insert a straight-slot screwdriver between the line feed motor interconnect module (1) and the chassis. Then, carefully pry the module from the two guide holes (2).

P/N 53328401 Module: LF Motor Interconnect All RSPL A B C [B.2.05](#) , [B.2.07](#) 

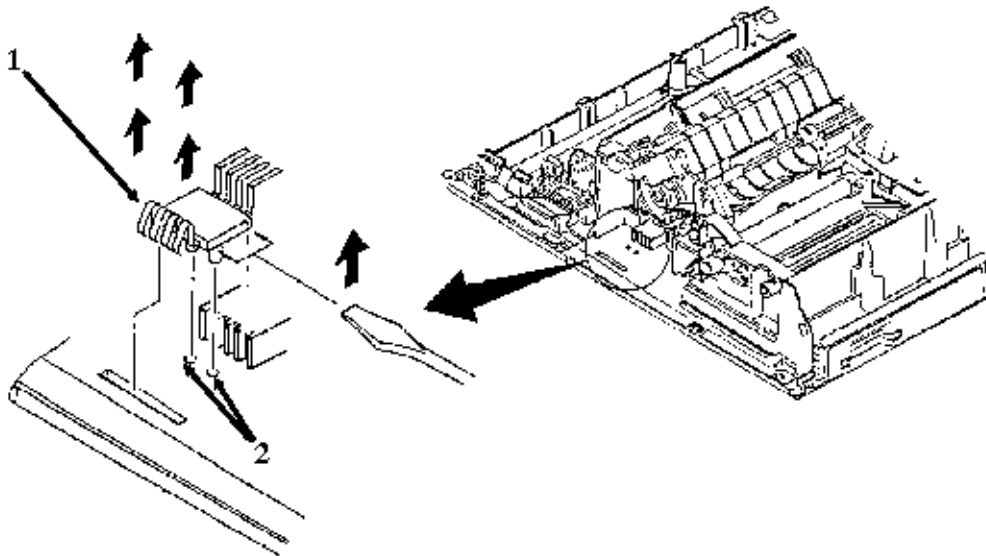



3.2.22 Reset Spring, Change Gear, and Idler Gear

CAUTION:

Please read through this entire procedure before performing it.

Do NOT press against the vertical extension of the reset spring at any time during this procedure.

Firm pressure will release the reset spring, NOT brute force.

- Perform these procedures: [3.2.01](#) , [3.2.02](#) , [3.2.04](#) .
- Use a flat-blade screwdriver to press down at position A of the reset spring (1).
- Slide the spring out in the direction of arrow B.
- Detach the change gear (2).
- Detach the idler gear (3).

NOTE:

Lubrication

When lubricating, refer to Section 3.5 of this Service Handbook .

Parts Replacement

The Kit: Idler/Change Gear (ML300) includes the change and idler gears. Order this kit when replacing these parts.

P/N 50912001 Spring: Reset All RSPL A B C [B.2.05](#) , [B.2.07](#) 

P/N 58227501 Kit: Idler/Change Gear All RSPL A B C [B.2.05](#) , [B.2.07](#)  (ML300) *Includes the Change Gear and the Idler Gear*

P/N 51216001 Idler Gear Both A B C D [B.2.07](#) , [B.2.09](#) , [B.2.11](#)  *Included in the Idler/Change Gear Kit*

P/N 51215901 Change Gear Both A B C D [B.2.07](#) , [B.2.09](#) , [B.2.11](#)  *Included in the Idler/Change Gear Kit*

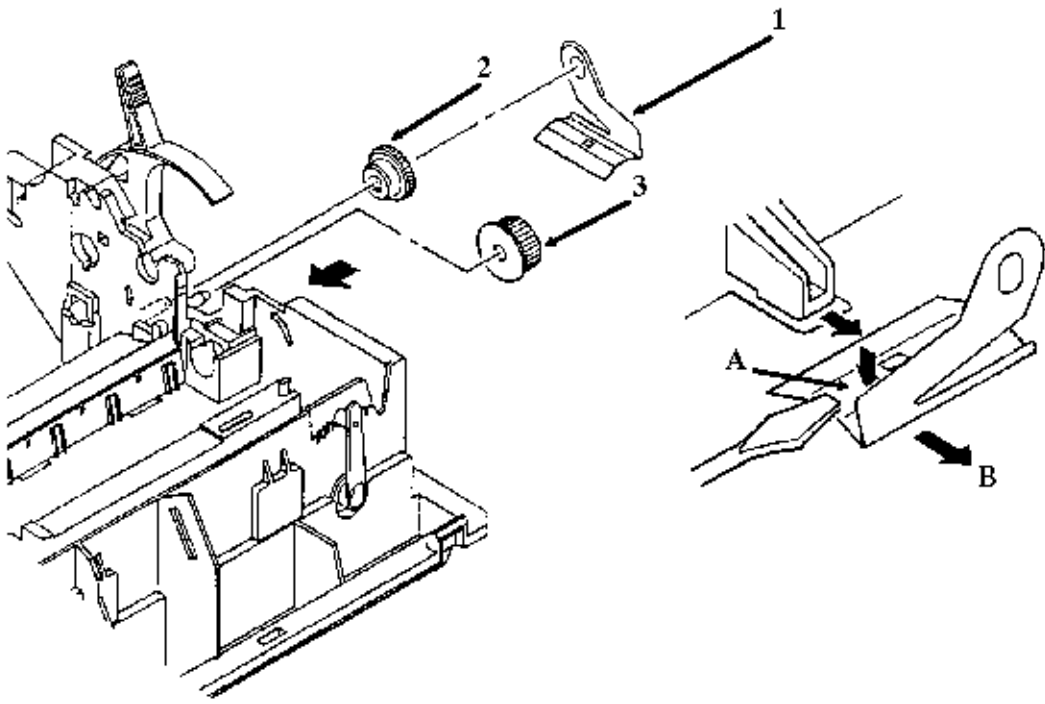

Copyright 1997, Okidata, Division of OKI America, Inc. All rights reserved. See the OKIDATA Business Partner Exchange (BPX) for any updates to this material. (<http://bpx.okidata.com>)



3.2.23 Release Lever

- Perform these procedures: [3.2.01](#), [3.2.02](#), [3.2.04](#), [3.2.22](#)
- Release the claw (1) from the guide (2) in the chassis.
- Pull the release lever (3) in the direction of arrow A and remove the lever.

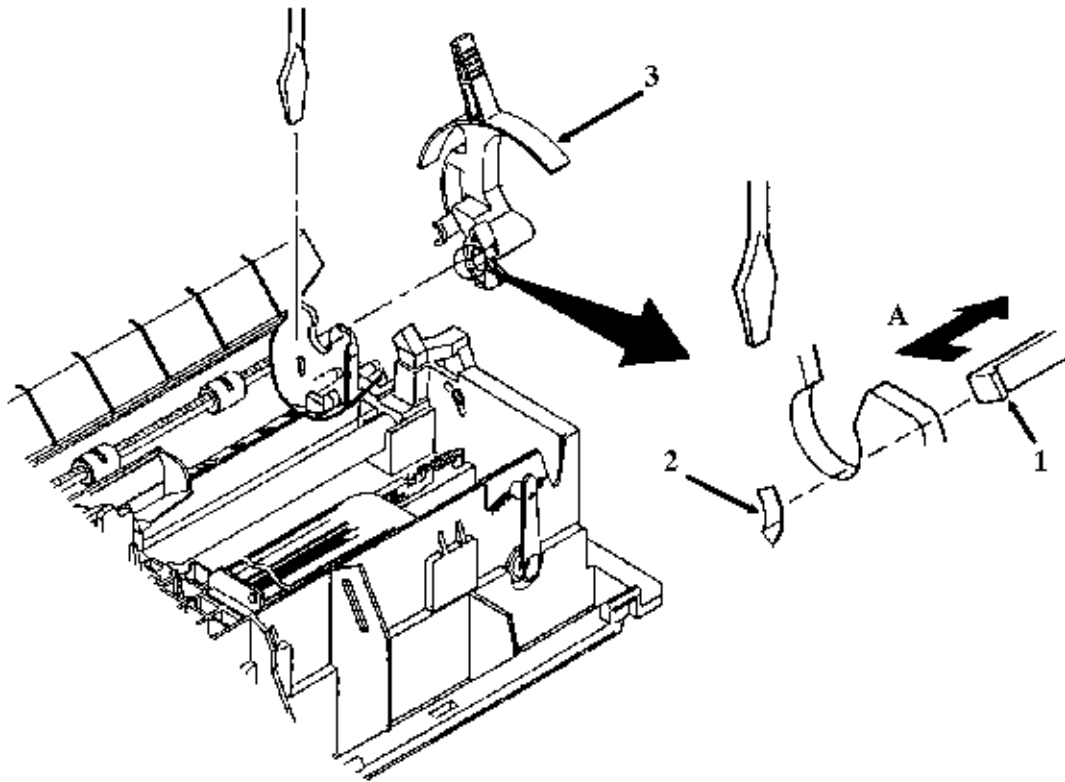
P/N 53489501 Lever: Release All RSPL A B C [B.2.05](#), [B.2.07](#)



3.2.24 Paper Pressure Guide

- Perform these procedures: [3.2.01](#) , [3.2.02](#) .
- Use a straight-slot screwdriver to detach the coupling holes (1) of the support spring (2) from the projections (3) on the main chassis. (Microline 391-Plus ONLY)
- Work from left to right and use a straight-slot screwdriver to detach the coupling holes (4) from the projections (5) on the chassis.
- Remove the paper pressure guide (6).

NOTE:

When installing the paper pressure guide, be sure to fit it into the projections (5) and guide plates (7) at the same time.



The Microline 390 / 390-Plus has five coupling holes and ten guide plates.

The Microline 391 / 391-Plus has seven coupling holes and thirteen guide plates.

P/N 50911501 Guide: Paper Pressure Both 90 RSPL A B C [B.2.05](#) , [B.2.07](#) 

P/N 50911601 Spring: Release 391 RSPL A B [B.2.05](#) 



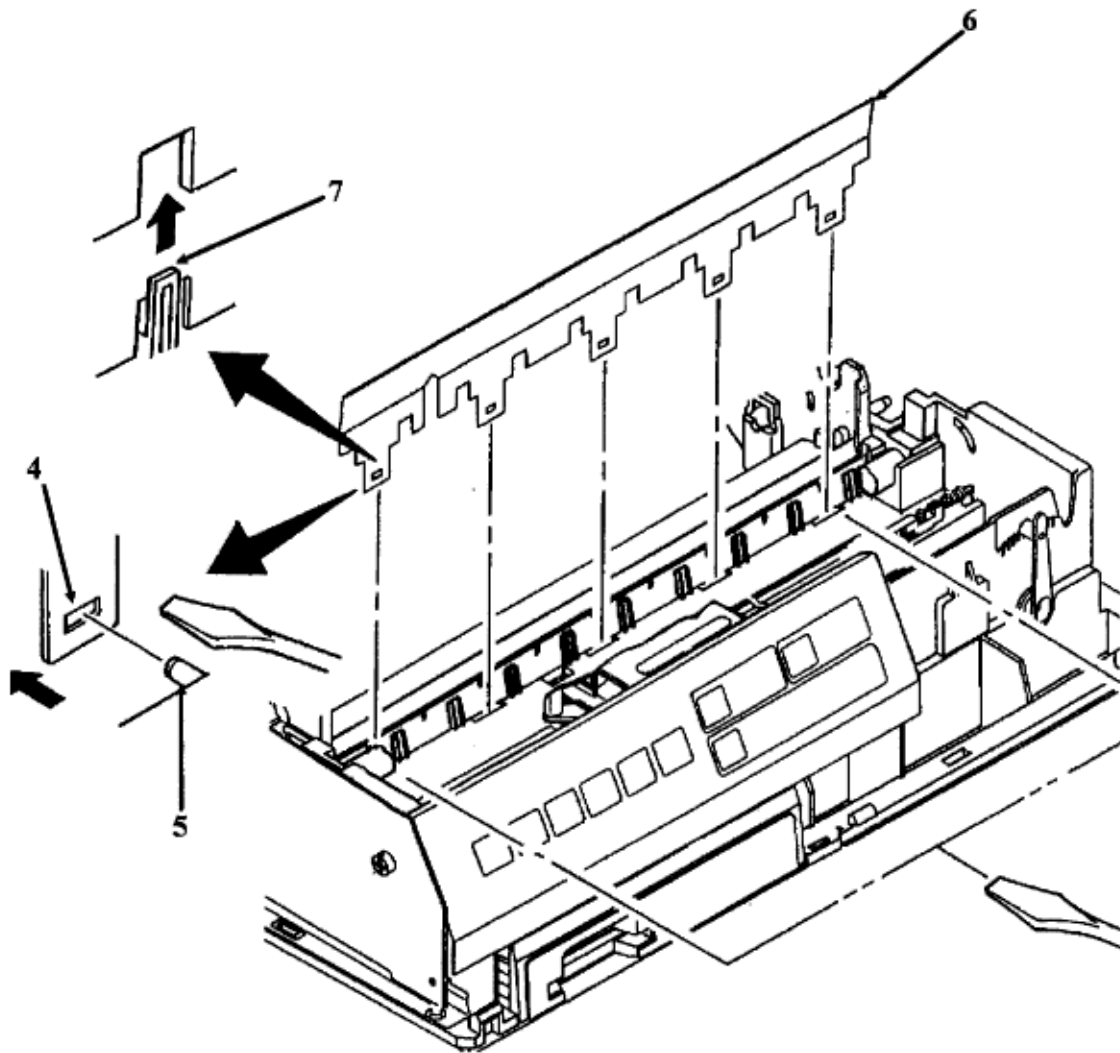
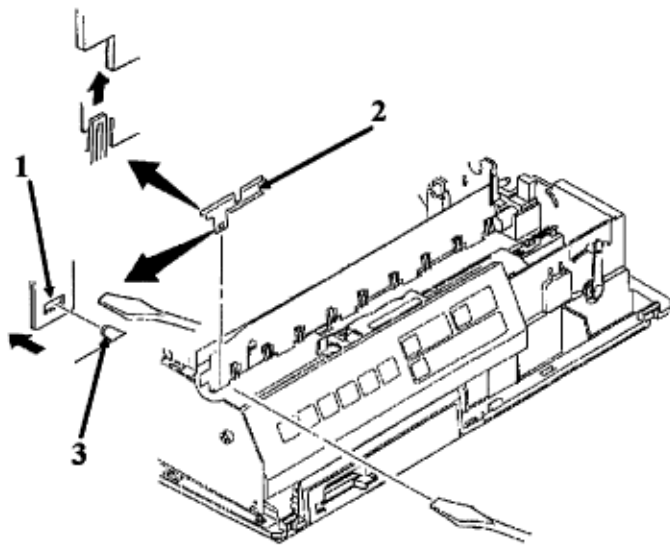

P/N 50911602 Guide: Paper Pressure Both 91 RSPL C [B.2.05](#) , [B.2.07](#) 

P/N 50913901 Spring: Support 391+ RSPL A B C [B.2.05](#) , [B.2.07](#) 



Copyright 1997, Okidata, Division of OKI America, Inc. All rights reserved. See the OKIDATA Business Partner Exchange (BPX) for any updates to this material. (<http://bpx.okidata.com>)

3.2.25 Pressure Roller Assembly

- Perform these procedures: [3.2.01](#) , [3.2.02](#)  , [3.2.04](#) , [3.2.22](#) , [3.2.23](#)  .
- Remove the paper chute (1).
- Turn the release link (2) as shown in View A so the spine (3) is aligned with the slot (4) in the guide hole.
- Slide the release link off the pressure roller assembly (5).
- Remove the pressure roller assembly by sliding it through the guide hole (6).



NOTES:



Installation



Attach the paper end lever (7) to the shaft of the sensor lever (8). Refer to View B for the correct position. If the paper end lever is incorrectly positioned, paper jams / no paper-end indications will occur.



Position the tab of the paper chute firmly with the groove of the main frame.

Engage the cut-sheet paper end lever (attached to the bottom of the paper chute) to the bottom paper end lever (under the main frame). Then, install the paper chute.

P/N 50061801 Chute: Paper (Assembly) Both 90 RSPL A B C [B.2.05](#) , [B.2.07](#) 

P/N 50061901 Chute: Paper (Assembly) Both 91 RSPL A B C [B.2.05](#) , [B.2.07](#) 

P/N 50061601 Roller: Pressure (Assembly) Both 90 RSPL A B C [B.2.05](#) , [B.2.07](#) 

P/N 50061701 Roller: Pressure (Assembly) Both 91 RSPL A B C [B.2.05](#) , [B.2.07](#) 

P/N 53489601 Link: Release All RSPL A B C [B.2.05](#) , [B.2.07](#) 

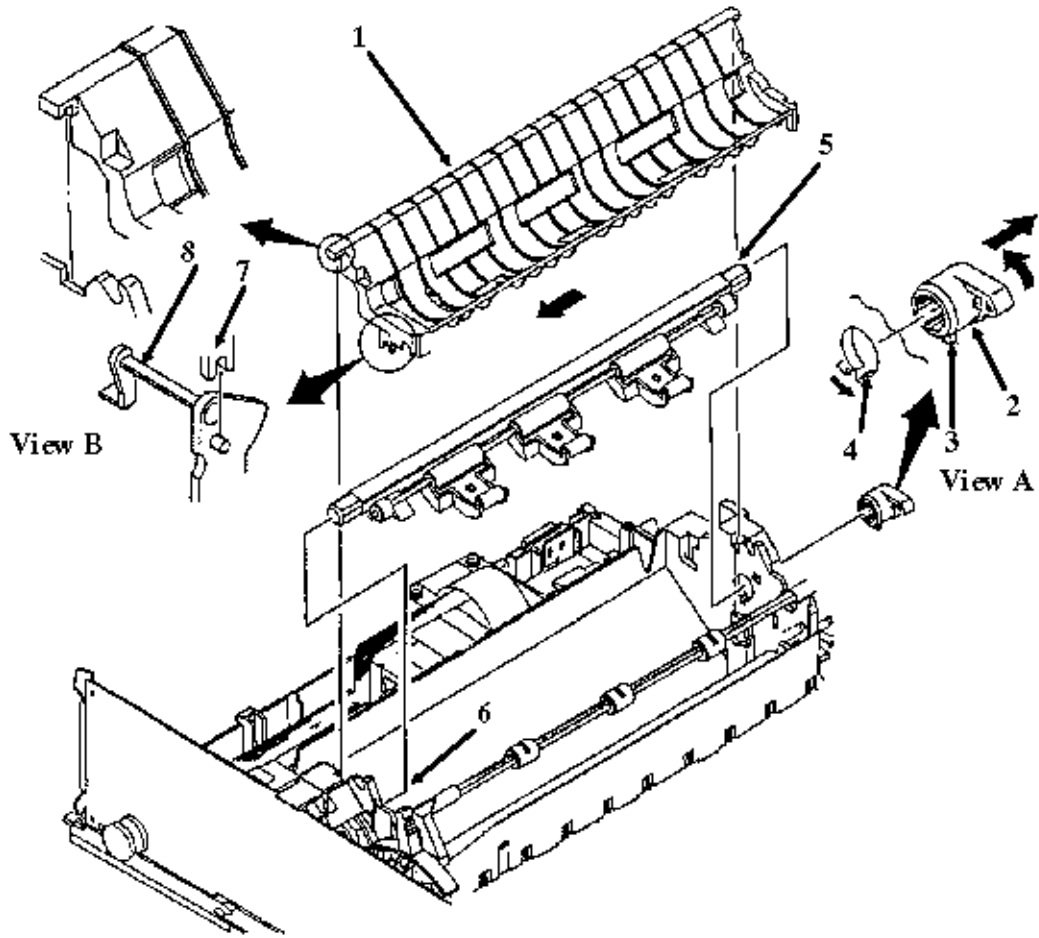





Copyright 1997, Okidata, Division of OKI America, Inc. All rights reserved. See the OKIDATA Business Partner Exchange (BPX) for any updates to this material. (<http://bpx.okidata.com>)

3.2.26 Tractor Assembly

NOTE:

Horizontal movement of the left tractor is restricted by a stopper on the lower cover.

- Perform these procedures: [3.2.01](#) , [3.2.02](#) , [3.2.04](#) , [3.2.22](#) , [3.2.25](#) .
- Use a needle nose pliers to release the claw (1) of the tractor gear (2) from the groove (3) in the lower tractor feed shaft (4). The lower tractor feed shaft is square.
- Remove the tractor gear.
- Lift the lower tractor feed shaft above the guide (5).
- Slide the lower tractor feed shaft in the direction of arrow B until the C side is free of the guide hole (6).
- Lift the upper tractor feed shaft (7) above the guide (8). The upper tractor feed shaft is round.
- Remove the tractor assembly (9).
- Raise the lock levers (10) on the left (11) and right (12) tractor assemblies.
- Remove the left tractor assembly, the sheet guide (13), and the right tractor assembly.

NOTES:

Installation

The tractors must be synchronized. The pins (14) on the left and right tractors must be aligned when installed. Also, verify that the guide holes (15) in the tractor drive gears are facing the same direction.

The left tractor assembly must be positioned to the left (line feed motor side) of the plastic tab and ground plate. This limits movement and correctly positions the paper against the paper end sensor.

When lubricating, refer to Section 3.5 of this Service Handbook .

RSPL A B C B.2.10

P/N 51216101 Gear: Tractor All RSPL A B C B. [B.2.05](#) , [B.2.07](#) 

P/N 50062101 Frame: Tractor (L) Assembly All RSPL A B C [B.2.10](#) 

P/N 50062001 Frame: Tractor (R) Assembly All RSPL A B C [B.2.10](#) 

P/N 51109501 Shaft: Drive Both 90 RSPL A B C [B.2.10](#) 

P/N 51109502 Shaft: Drive Both 91 RSPL A B C [B.2.10](#) 

P/N 51109602 Shaft: Lock 391 RSPL A B C [B.2.10](#) 

P/N 51111201 Shaft: Lock Both 90 RSPL A B C [B.2.10](#) 

P/N 51111202 Shaft: Lock 391+ RSPL A B C [B.2.10](#) 

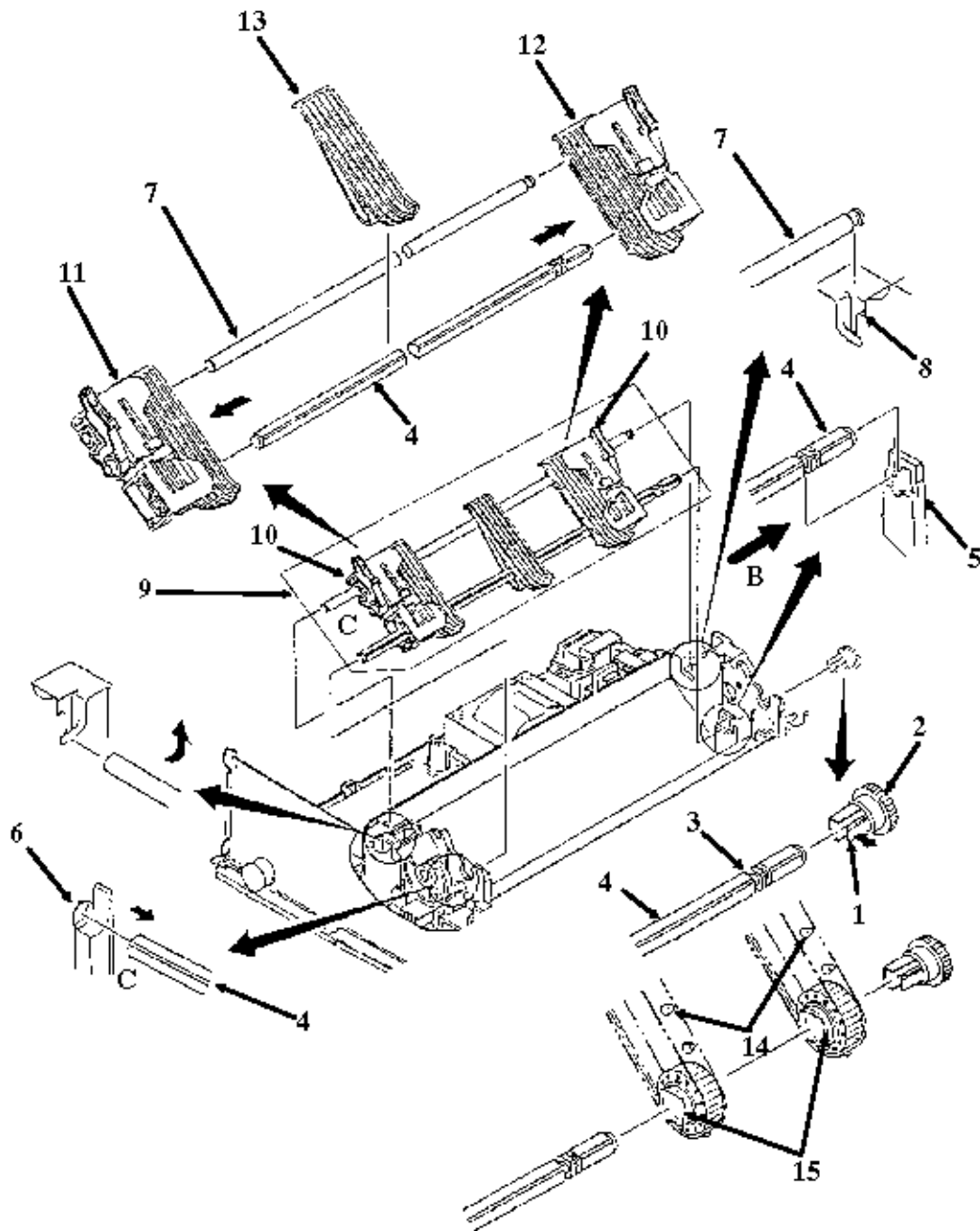

Copyright 1997, Okidata, Division of OKI America, Inc. All rights reserved. See the OKIDATA Business Partner Exchange (BPX) for any updates to this material. (<http://bpx.okidata.com>)

3.2.27 Sensor Lever

· Perform these procedures: [3.2.01](#), [3.2.02](#), [3.2.04](#), [3.2.05](#), [3.2.06](#), [3.2.20](#), [3.2.22](#), [3.2.25](#), [3.2.26](#).

- Turn the sensor lever (1) clockwise until it is horizontal.
- Lift the sensor lever from the shaft bearing (2).
- Work the sensor lever from the guide hole (3) in the chassis and remove the lever.

P/N 53489001 Lever: Sensor All RSPL A B C [B.2.05](#), [B.2.07](#)

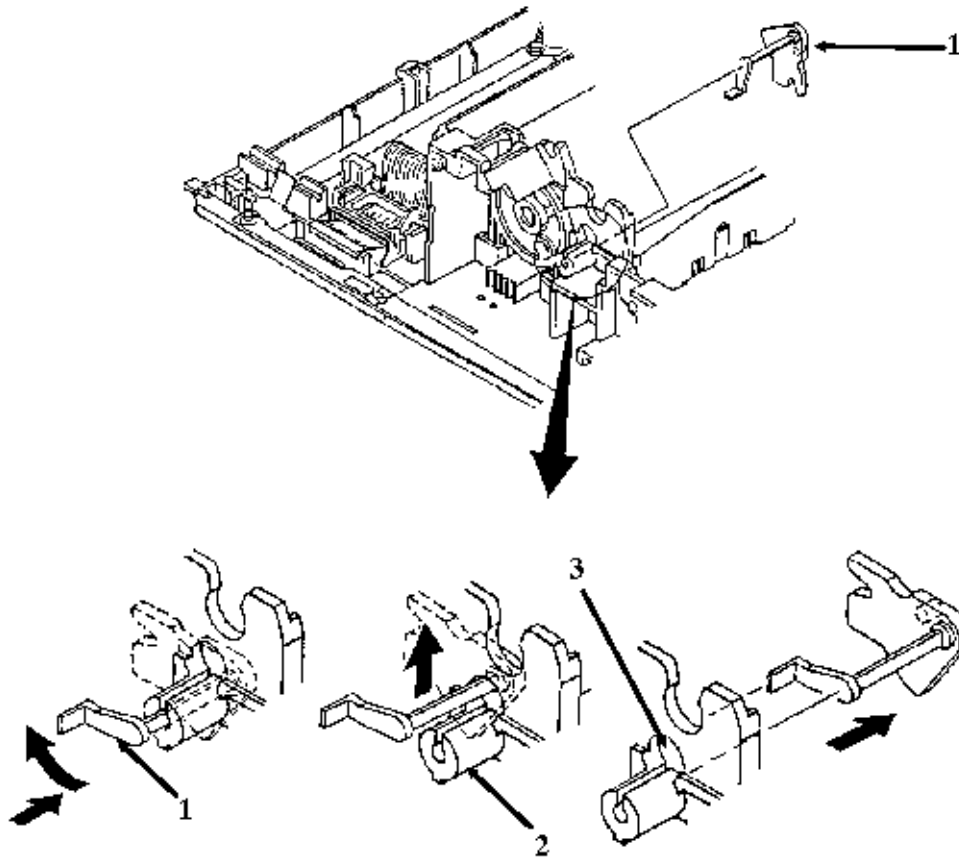

3.2.28 Paper End (B) Lever

NOTE:

The paper end lever guide is accessed from the bottom of the printer.

· Perform these procedures: [3.2.01](#) , [3.2.02](#) , [3.2.04](#) , [3.2.05](#) , [3.2.06](#) , [3.2.20](#), [3.2.22](#) , [3.2.25](#) , [3.2.26](#) , [3.2.27](#) .

· While pushing on the six claws (1), detach the sensor cover (2). Four of the six claws are visible in the illustration.

· Lift the paper end (B) lever (3) from the chassis.

P/N 53488901 Lever: Paper End (B) Both 90 RSPL A B C [B.2.05](#) , [B.2.07](#) 

P/N 53488902 Lever: Paper End (B) Both 91 RSPL A B C [B.2.05](#) , [B.2.07](#) 

P/N 53489101 Cover: Sensor All RSPL A B C [B.2.05](#) , [B.2.07](#) 

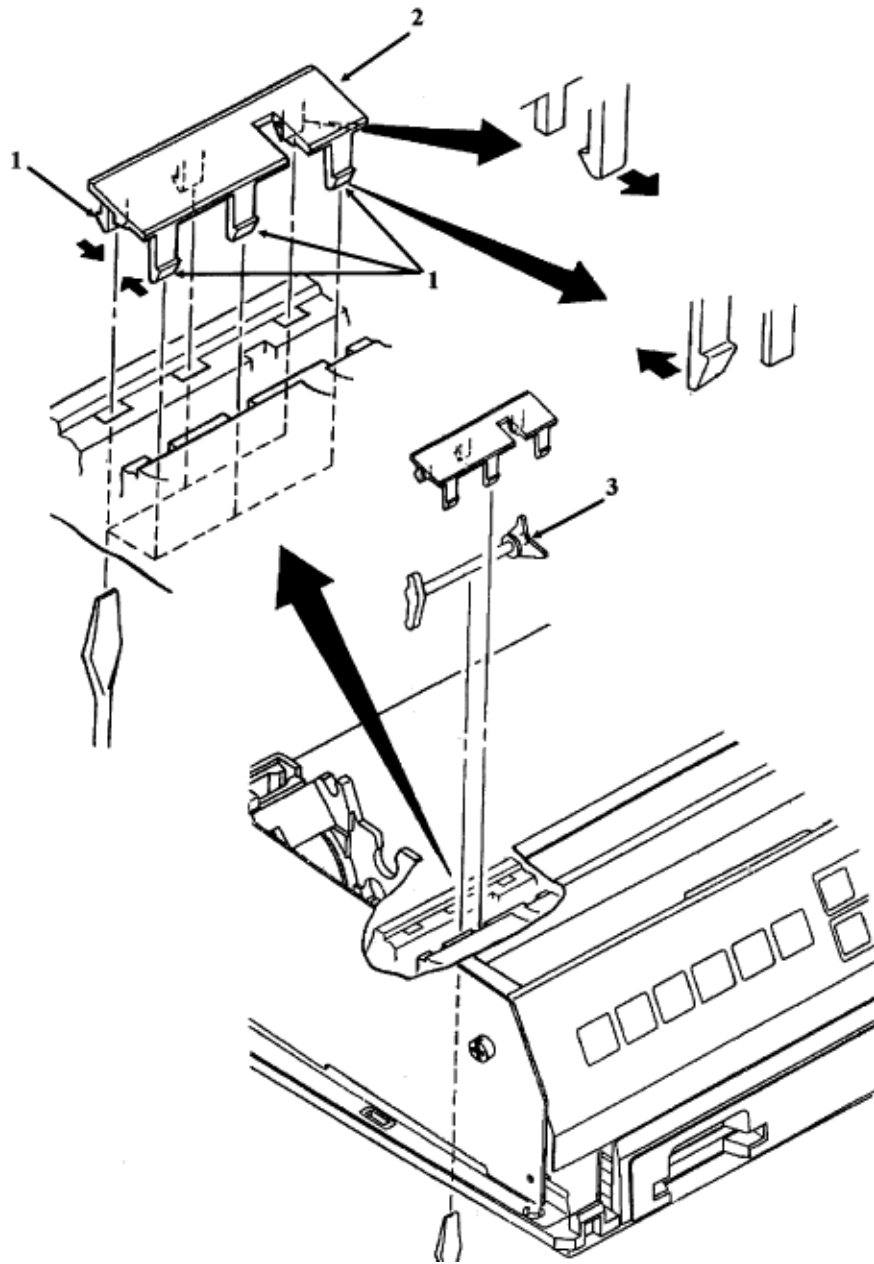

Copyright 1997, Okidata, Division of OKI America, Inc. All rights reserved. See the OKIDATA Business Partner Exchange (BPX) for any updates to this material. (<http://bpx.okidata.com>)

3.2.29 Main Chassis Assembly

· All disassembly procedures must be carried out to reach the main chassis assembly (1).

P/N 50061101 Chassis: Main (Assembly) Both 90 RSPL A B C [B.2.05](#), [B.2.07](#)

P/N 50061201 Chassis: Main (Assembly) Both 91 RSPL A B C [B.2.05](#), [B.2.07](#)

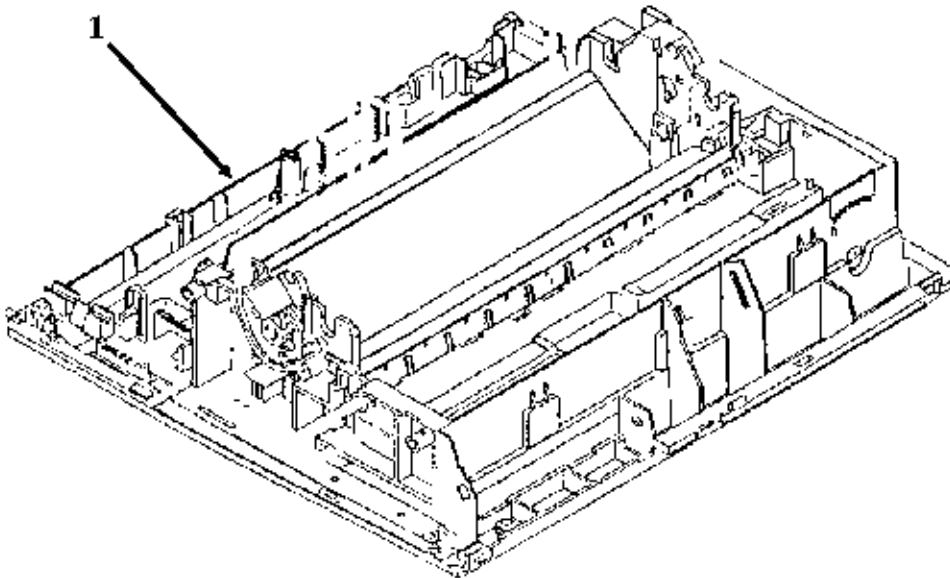

2 2 00 000

3.3 ADJUSTMENTS

General Information

This section contains the procedure for performing the adjustment on the Microline 390, Microline 391, Microline 390-Plus, and Microline 391-Plus printers. This procedure may be required when replacing either consumables or parts. The disassembly / assembly procedures list the required adjustment and refer you to this section. Failure to perform these procedures may result in unnecessary service calls.

Copyright 1997, Okidata, Division of OKI America, Inc. All rights reserved. See the OKIDATA Business Partner Exchange (BPX) for any updates to this material. (<http://bpx.okidata.com>)

3.3.01 Printhead Gap Adjustment

Before performing this adjustment, always verify that the printhead is properly installed.

The printhead gap should measure:

0.016 inch, + / - 0.002 inch (0.41 mm, + / - 0.05 mm)

The printhead gap adjustment procedure should be performed when the following occur.

- Print quality is darker on either side of the document.
- Parts /Assemblies are replaced.

Space Motor Assembly (3.2.15)

Carriage Shaft (3.2.16)

Guide Rail (3.2.18)

This adjustment has four phases.

- Setup Phase (Steps 1-6)

The cover is removed and the printhead is placed at a known reference point.

- Printhead Gap Modification Phase (Steps 7-9)

The distance between the printhead and the platen at the left (line feed motor) side of the platen is modified by turning the adjust screw. Turning the adjust screw varies the vertical position of the space motor.

- Parallel Adjustment Phase (Steps 10 - 12)

The adjust cam lever is moved to ensure that the printhead moves parallel to the platen.

- Verification Phase (Steps 13 - 14)

This phase verifies that the Parallel Adjustment Phase did not affect the Printhead Gap Modification Phase.

To adjust the printhead gap, follow this procedure.

1. Remove the upper cover.
2. Move the change lever to the rear paper feed position.
3. Place the paper bail bar in the OPEN position.
4. Set the adjusting lever to Position 1.
5. Place the adjust cam in the vertical position.
6. Slide the carriage assembly to the left (line feed motor) side of the platen.
7. Use a feeler gauge to check the printhead gap. The printhead gap must measure:
0.016 inch, + / - 0.002 inch (0.41 mm, + / - 0.05 mm)
8. Use a straightened paper clip to press down on the adjusting gear. This separates the gear from the

adjusting lever. Keep pressing down on the adjusting gear while performing Step 9.

9. Use a small phillips screwdriver to turn the adjusting screw.

Turn the adjusting screw CLOCKWISE to increase the gap.

Turn the adjusting screw COUNTER-CLOCKWISE to decrease the gap.

The printhead gap must measure:

0.016 inch, + / - 0.002 inch (0.41 mm, + / - 0.05 mm)

10. Slide the carriage assembly to the right (platen knob) side of the platen.

11. Use a feeler gauge to check the printhead gap. The printhead gap must measure:

0.016 inch, + / - 0.002 inch (0.41 mm, + / - 0.05 mm)

12. If the gap measurements are different between the left and right positions, turn the adjust cam. Turning the adjust cam adjusts the height of the ruler guide.

Turn CLOCKWISE to increase the printhead gap. The guide rail is lowered.

Turn COUNTER-CLOCKWISE to decrease the gap. The guide rail is raised.

13. Check the printhead gap at the left, right, and center of the platen.

14. If the printhead gap is not the same in all three positions, return to Step 6.

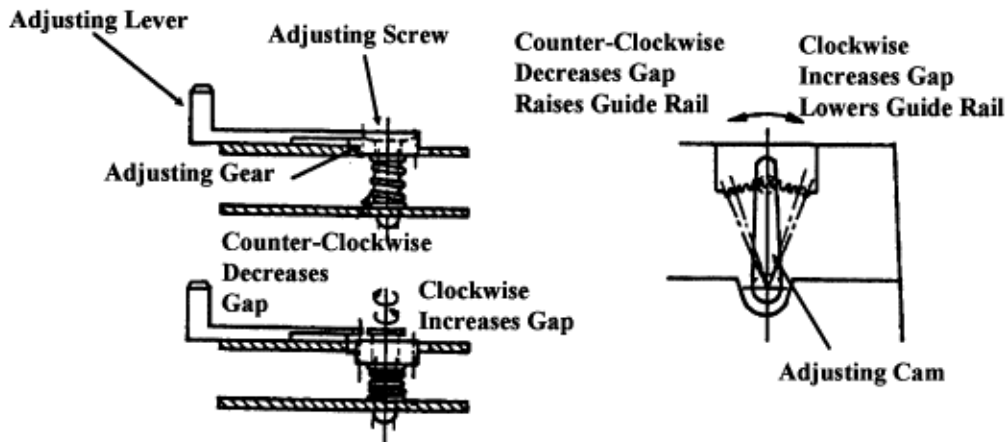
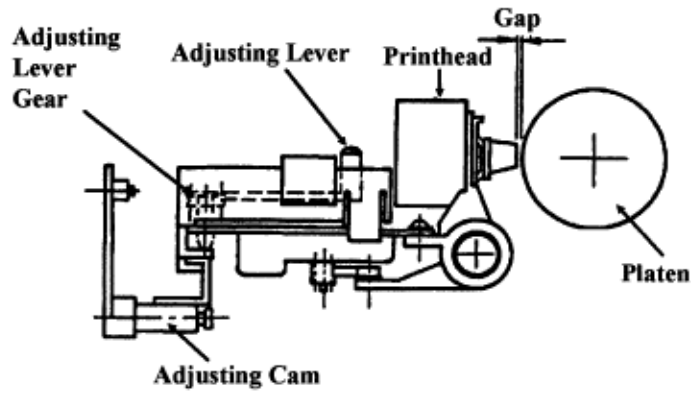
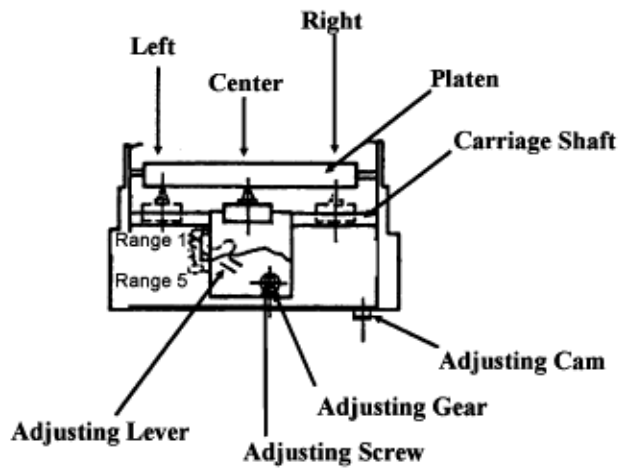

Copyright 1997, Okidata, Division of OKI America, Inc. All rights reserved. See the OKIDATA Business Partner Exchange (BPX) for any updates to this material. (<http://bpx.okidata.com>)

3.4 CLEANING

WARNING:

Power OFF the printer before cleaning it.

3.4.01 General Information

An accumulation of paper dust is the most frequent cause of print quality problems in a dot matrix printer. Small pieces of paper can cause paper jams. A dirty platen will smudge paper. It is important to clean the printer regularly, paying particular attention to the printhead area and paper paths.

If the lubrication procedures are not performed properly, the printer will require more frequent cleaning. Excessive lubricant attracts dust and accumulations build up quickly.

Keeping the covers in place and performing the cleaning procedures correctly will help ensure the highest quality printer output.

3.4.02 Cleaning Schedule

Routine inspection and cleaning should be performed as listed below.

- Every six months

or

- 300 hours of operation

3.4.03 Cleaning Tools

- Soft, Lint-free Cloth

- Cotton Swab

- All-purpose Cleaner







- Platen Cleaner

- Vacuum Cleaner

- Contact Kleen (P/N 51802301)

3.4.04 Areas to be Cleaned

Areas To Be Cleaned	Disassembly Procedure	Tools	Description Of Cleaning
Paper Feed Paths and Pins	N/A	Vacuum Cloth All-purpose cleaner	Remove any paper particles. Wipe or vacuum all dirt dust etc.

Ribbon Protector	3.2.03 	Cotton swab All-purpose cleaner	Remove ink residue
Covers	3.2.04 	Cloth All-purpose cleaner	Clean all covers with the all-purpose cleaner and cloth.
Carriage Shaft	3.2.16 	Cloth All-purpose cleaner	Remove any paper particles. Wipe or vacuum all dirt dust etc.
Area Around Carriage Shaft	3.2.16 	Vacuum Cloth All-purpose cleaner	Remove any paper particles. Wipe or vacuum all dirt dust etc.
Space Rack	3.2.17 	Vacuum Cloth	Remove any paper particles. Wipe or vacuum all dirt dust etc.
Paper-End Sensor	3.2.28 	Vacuum Cloth	Wipe or vacuum any accumulated dust from the sensor.
Platen	3.2.29 	Cloth Platen Cleaner	Wipe the surface of the platen with platen cleaner.

Copyright 1997, Okidata, Division of OKI America, Inc. All rights reserved. See the OKIDATA Business Partner Exchange (BPX) for any updates to this material. (<http://bpx.okidata.com>)

3.5 LUBRICATION

3.5.01 General Information

If the lubrication procedures are not performed properly, the printer will require more frequent cleaning. Excessive lubricant attracts dust and accumulations build up quickly. An accumulation of paper dust is the most frequent cause of print quality problems in a dot matrix printer.

3.5.02 Lubrication Schedule

Routine inspection and lubrication should be performed as listed below.

- Every six months
- or
- 300 hours of operation
- or
- When a part on the lubrication schedule is replaced

3.5.03 Lubrication Types

- Grease (Dow Corning BR2 or equivalent)
- Machine Oil (10 - 30 weight)

3.5.04 Lubrication Amounts









Do NOT over-lubricate the printer. Operational problems are caused by excess lubricant. The excess lubricant causes dust to accumulate. These accumulations can jam gears or cause print problems.

The Lubrication Chart will direct you to use the following amounts of lubricant.

- Medium
- Oil: three to four drops
- Grease: thin coating (approximately 0.15 inch)
- Small
- Oil: one drop
- Grease: extremely thin coating (approximately 0.008 inch)

3.5.05 Lubrication Table

Lubrication Point	Disassembly Procedure	Lubricant	Amount	Notes
-------------------	-----------------------	-----------	--------	-------

Ribbon Drive Assembly (Visible bearings of gears)	3.2.14 	Machine Oil	Small	Do NOT lubricate the teeth of the gears. Do NOT disassemble the case.
Space Motor Assembly Contact between the space motor assembly gear and the space rack.	3.2.15 	Machine Oil	Small	Turn the assembly over to access the point. Do not over-lubricate. Do NOT place lubricant directly on the space rack.
Carriage Shaft	3.2.16 	Machine Oil	Small	Place a small amount on the surface of the carriage shaft. Wipe with a soft lint-free cloth.
Platen Assembly Contact point between the bias gear and the platen gear.	3.2.19 	Machine Oil	Small	
Idle Gear Bearing	3.2.22 	Grease	Medium	
Change Lever Bearing and pivot point	3.2.22 	Grease	Medium	
Pressure Spring Pivot point of the release cam. Holders on the pressure spring. Bearing of the front release arm.	3.2.22 	Grease	Medium	
Tractor Gear Bearing	3.2.26 	Grease	Medium	
Lower Tractor Feed Shaft Contact points with main chassis	3.2.26 	Grease	Medium	

3.5.06 Areas Not Lubricated

WARNING

Do NOT allow lubricant to contact the following areas. Poor print quality will result.

- Ribbon Cartridge
 - Printhead
 - Platen Surface (Rubber Face)
 - Pressure Roller (Rubber Face)
 - Tractor Pins
 - Space Motor Board
 - Electrical Contacts and Connections
 - Space Rack
 - Head Cable
 - Microswitches
 - Pressure Rollers (on Bail Bar)
-

Copyright 1997, Okidata, Division of OKI America, Inc. All rights reserved. See the OKIDATA Business Partner Exchange (BPX) for any updates to this material. (<http://bpx.okidata.com>)

4.1 OVERVIEW

4.1.01 Introduction

This section is used to isolate problems to the assembly level. Application problems and detection of faulty components on the printed circuit boards are not addressed.

When troubleshooting a defective unit, refer first to Section 4.4  of this Service Handbook. This section contains tips on preventing problems as well as a list of common problems.

Next, refer to Section 4.6. Repair Analysis Procedures  (RAPs) will ask you questions or require you to make observations. The answers to these questions and the results of your observations determine your next course of action. Use the RAP Index to identify which RAP should be used to resolve the problem with the machine.

If you encounter a situation that is not addressed by the documentation in this kit, please report the problem to Okidata. Send your report to the Okidata Technical Training Group. Refer to the Service Center Reference Guide for information on contacting Okidata.

The following information is provided to detect and analyze failures.

- Okilink II, Faxable Facts, Technical Service Bulletins
- Troubleshooting Tips / Common Problems
- Fault Alarms
- Repair Analysis Procedures
- Hexadecimal Dump
- Resistance / Service Checks
- Tests
- Menu Operation
- Top of Form
- Paper Park

4.1.02 Compatibility - Microline 390/391 vs. Microline 390/391-Plus

The differences between the Microline 390/391 and Microline 390/391-Plus printers are listed below.

Hardware Differences

- Operator Panel
- Operator Board
- Character Generator Programmable Read Only Memory (CGROM)
- Programmable Read Only Memory (PROM)
- Middle Cover

Operational Differences

- "Plus" printers have more resident fonts.
- In the "Plus" printers, data in the receive buffer is printed upon receipt, without having to wait for a line terminator character (CR/LF or FF).
- In the "Plus" printers, the DC1/DC3 Acknowledge/Ignore, Receive Buffer Size, and RESET inhibit can be controlled through the printers Menu.

Serial Number Revision Levels

Microline 390/391

A

Rev A units are original production units. An interconnect module connects the power supply board to the main control board.

B

Rev B units are retrofitted to include a modified interconnect module, which prevents corrosion.

C

These units have a cable connection between the power supply board and the main control board. The cable connection wire replaces the interconnect module.

Microline 390/391-Plus

Revision levels do NOT apply to the "Plus" printers.

NOTE:

Please refer to the parts lists for parts differentiation. Please be sure of the parts you need before ordering to avoid confusion and incorrect parts orders.

Printer Serial Number Identification

There are three serial number revision levels for the printers. Hardware differences exist between levels. To identify the revision level of a printer, record the serial number from the back of the printer. Refer to the following to decode the serial number.

Example Printer Serial Number: 401A0154693

Date Code 401 (4 = year. 01 = month)

Revision A

Serial Number 0154693

Compatibility Chart

Item	Okidata P/N	Purpose / Function of Item	Printer Serial Number Revision Level				
			390/391A	390/391B	390/391C	390+	391+
Main Control Board							
SKRA Board	55045401	Main Control Board	Yes	Yes	No	No	No
SKRB Board	55038702	Main Control Board	Yes	Yes	Yes	No	No
SKRA-3 Board	55045403	Main Control Board	Yes	Yes	Yes	Yes	Yes
Power Supply Board							
PAII Board	55038801	Power Supply Board	Yes	Yes	No	No	No
SUII Board	55047401	Power Supply Board	Yes	Yes	Yes	Yes	Yes
Operator Panel Assembly							

Panel: Operator Assembly	50069601	Operator Panel Assembly (390/391)	Yes	Yes	Yes	No	No
Panel: Operator Assembly	50069610	Operator Panel Assembly (390/391- Plus)	No	No	No	Yes	Yes
PCB: LXSP	55045601	Operator Panel Board (390/391)	Yes	Yes	Yes	No	No
PCB: LXSP-5	55038605	Operator Panel Board (390/391- Plus)	No	No	No	Yes	Yes
Transfor mer							
120 Volt XFRMR	56407201	Transfor mer (390 and 390-Plus)	Yes	Yes	Yes	Yes	Yes
120 Volt XFRMR	56407202	Transfor mer (391 and 391-Plus)	Yes	Yes	Yes	Yes	Yes
220 Volt XFRMR	56407801	Transfor mer (390 and 390-Plus)	Yes	Yes	Yes	Yes	No
220 Volt XFRMR	56407802	Transfor mer (391 and 391-Plus)	Yes	Yes	Yes	No	Yes
Intercon nect Module							

Interconnect Module	55328301	Connects power supply board to main board	Yes	Yes	No	No	No
Cable							
Cable	56616802	Connects power supply board to main board	No	No	Yes	Yes	Yes
Cable Guide							
Cable Guide	51003801	Holds cable in place	No	No	Yes	Yes	Yes
Covers							
Cover	53488301	Middle Cover (390)	Yes	Yes	Yes	No	No
Cover	53488401	Middle Cover (391)	Yes	Yes	Yes	No	No
Cover	53488316	Middle Cover (390-Plus)	No	No	No	Yes	No
Cover	53488422	Middle Cover (391-Plus)	No	No	No	No	Yes
Chassis							
Chassis	50061101	Chassis: Main (390 and 390-Plus)	Yes	Yes	Yes	Yes	No

Chassis	50061201	Chassis: Main (391 and 391-Plus)	Yes	Yes	Yes	No	Yes
---------	----------	---	-----	-----	-----	----	-----

Copyright 1997, Okidata, Division of OKI America, Inc. All rights reserved. See the OKIDATA Business Partner Exchange (BPX) for any updates to this material. (<http://bpx.okidata.com>)

4.2 TROUBLESHOOTING UPDATES

4.2.01 General Information

Okidata distributes updated troubleshooting information in three ways.

- Okilink II
- Faxable Facts
- Technical Service Bulletins

4.2.02 Okilink II

Okilink II is Okidata's Bulletin Board Service. This service is available to all Okidata Certified Service Technicians. Okilink II provides troubleshooting and service information. Technicians can download files, ask questions of Okidatas technical support personnel, and participate in round table discussions about Okidata products and services. Technical Service Bulletins, Recommended Spare Parts Lists, Printer Drivers, Product Specifications, and Service Training Information are also available.

Refer to the Service Center Reference Guide for information on accessing Okilink II.

4.2.03 Faxable Facts

Okidatas Faxable Facts is an automated fax document retrieval system. It is maintained by Okidatas Customer Information Center. Answers to common questions about Okidata products are available through Faxable Facts.

Refer to the Service Center Reference Guide for information on accessing Faxable Facts.

4.2.04 Technical Service Bulletins

Okidatas Technical Service Bulletins (TSBs) contain technical information developed after product release. Firmware updates, part number changes, and procedural changes are some of the subjects covered by these bulletins. The TSBs are distributed through Okilink II.

Refer to the Service Center Reference Guide for information on accessing Okilink II.

4.3 REPORTING PROBLEMS

4.3.01 General Information

Okidata strives to provide accurate and detailed service information through its training materials. The Technical Training Group realizes that service technicians have valuable experience, knowledge, and opinions. Okidata strongly encourages you to report any problems you may encounter when using the materials of this training kit. Please be as specific and detailed as possible. Your comments, suggestions, and criticisms are used to update and revise training kits.

You should reference the training materials when servicing Okidata products. Most problems can be solved by using the information provided in the training materials. If you encounter a situation that cannot be solved, please let Okidata know.

Refer to the Service Center Reference Guide for information on contacting Okidata.

4.3.02 Problem Lists

Technicians frequently request a list of common problems specific to a product. Technical Training Kits are written before a product is shipped to customers. Therefore, such information is not available when a product is first released.

However, Okidata wants to respond to these requests. Okilink II provides round-table discussions on technical problems. Errors and corrections in the training materials are listed in the Training Section of Okilink II. The Technical Service Bulletins (also known as Okidata's Monthly Mail) are available via Okilink II. Situations that are not addressed in the reference documentation, technical service bulletins, or round tables may be reported to the Dealer Service and Support Engineers (DSSEs) or the Technical Training Group. You will receive a response to your message within one business day.

The information on Okilink II is the most accurate and up-to-date technical information available from Okidata. This is only possible with your assistance. By reporting your suggestions, concerns, and problems, Okidata can provide the best possible information.

Your cooperation is greatly appreciated. Thank you for your help!

4.3.03 Reporting Methods

Okilink II

You may use Okilink II to report your findings. Refer to the Service Center Reference Guide for information on using Okilink II.

Course Critique

Use the Course Critique to report any problems you find as you are completing the self-paced training.

Fax Number

If you wish to fax your response, please use the numbers listed in the Service Center Reference Guide.

Mailing Address

If you respond by mail, please use the appropriate address listed in the Service Center Reference Guide.

Information Provided

Please provide the following information when reporting problems.

- Okidata Dealer Number
- Technicians Name
- Company Name
- Company's Address (Street, City, State/Province, ZIP / Postal Code, Country)
- Telephone and Fax Numbers (with area / country access codes)
- Product Name
- Units Serial Number
- Firmware Revision Level
- Description of Problem
- Document Name (with page number or procedure) with error or problem.

Copyright 1997, Okidata, Division of OKI America, Inc. All rights reserved. See the OKIDATA Business Partner Exchange (BPX) for any updates to this material. (<http://bpx.okidata.com>)

4.4 TROUBLESHOOTING TIPS

4.4.01 Preliminary Checks

- Is the product being operated under the proper ambient conditions?
- Does the paper being used meet the specifications for this product?
- Has the ribbon been replaced as recommended?
- Has the ribbon been installed properly?
- Is an Okidata ribbon being used?
- Is the printhead gap correctly set?
- Check the contacts between the power interconnect module, the control board, and the power supply board (Rev A and B units ONLY). Clean the contacts if dirty. If contacts are bent or broken, replace the module. Proper inspection and cleaning of the power interconnect module contacts can eliminate a false diagnosis of a failed control board or power supply board.
- Check the contacts and connections of the control board. If good contact is not made at all connections and ground points, false diagnosis will occur.

4.4.02 Common Problems

- Nothing happens when the printer is powered ON.

Make sure the printer is plugged in.

Check the power cord connection to the printer and the outlet.

If a power strip is being used, make sure the strip is powered ON.

- The ALARM lamp is lit.

The printer may be out of paper or the paper may have jammed. The SEL lamp will not light. After loading paper, press the SEL switch.

If the ALARM lamp does not go out after paper is loaded, [refer to Section 4.5 !\[\]\(0d7ca0919e6c47bbd874bfa0189fe22e_img.jpg\) of this Service Handbook.](#)

- The printer does not print when the computer sends it data.

The printer may be deselected. Make sure that the SEL lamp is lit. If it is not, press the SEL switch.

- The paper keeps jamming.

Verify that the top of form is set so that the paper is held in place by the bail bar. If the top edge of the page is below the bail, it will catch on the bail as it advances. Do not use the FORM FEED switch to load paper into the printer.

If the paper does jam, power OFF the printer. Carefully back the paper out of the paper path by using the platen knob. Remove any shreds of paper from the paper path.

- The printer suddenly changes to unidirectional printing. It then stops printing completely. The MENU light is flashing.

This indicates a Printhead Overheat Condition. When the printer prints for a long period of time, heat will build up in the printhead. When the printhead temperature reaches approximately 90 degrees Celsius, the printer will print unidirectionally. If the temperature reaches approximately 130 degrees Celsius, printing will stop until the printhead cools. Printing will resume after the printhead cools.

- Output is missing dots.

Check the headgap setting. Move the head gap lever to a lower setting.

Setting 1 is for one or two part forms.

Setting 2 is for three or four part forms.

Settings 3, 4, and 5 are for envelopes and extra-thick paper.

Perform the Printhead Gap Adjustment. Refer to Section 3.3  of this Service Handbook for details.

Refer to RAP 03 .

- Files do not print the way the printer menu and front panel are set.

Before sending a file to a printer, many word processors send an initialization string. This string contains codes that reset the printer to a default set of features. Otherwise, the printer might print using features set for a previous job. The codes will override panel or menu settings. Check the word processors manual to see if the initialization string can be modified. If so, remove any codes that interfere with the printers settings.

- The PRINT QUALITY, CHARACTER PITCH, and MODE switches do not work.

The Operator Panel Functions Item in the Printer Menu can be set to enable (FULL OPERATION) or disable (LIMITED OPERATION) these features. If the printer is part of a customized system or if it is used by different operators, a system manager may be using this feature to maintain proper print settings.

To activate these switches, power OFF the printer. Press and hold MODE while powering ON the printer. Follow the normal menu procedures to set the Operator Panel Functions Item to FULL OPERATION.

- Static electricity causes the paper to stick.

In cold, dry weather, static charges can build up on continuous-form paper. This can make the paper cling to the paper separator. If this problem occurs during high-volume printing jobs, try moving the single sheet paper guides on the separator together so that the paper rests on the guides rather than on the separator itself.

Copyright 1997, Okidata, Division of OKI America, Inc. All rights reserved. See the OKIDATA Business Partner Exchange (BPX) for any updates to this material. (<http://bpx.okidata.com>)



Service Guide ML390/391

Chapter 4 Failure & Repair Analysis

4.5 FAULT ALARMS

4.5.01 General Information

The operator panel is used to display printer modes and error conditions. The table below shows the operator panel display and the mode or condition it matches.

Printer Modes

Microline 390/391

ALARM Lamp Status	SELECT Lamp Status	MENU Lamp Status	Printer Mode	Status	Description
OFF	ON	N/A	Normal Operation	On-Line	The printer is ready to receive data and to print.
OFF	ON	N/A	Normal Operation	Hex Dump	The printer is in Hex Dump Mode. Refer to Section 4.7
OFF	OFF	N/A	Normal Operation	Off-Line	The printer will NOT receive data or print.
OFF	OFF	ON	Normal Operation	Menu Mode	The operator may view or change the menu settings.
ON	OFF	N/A	Operator Alarm	Paper End	Printer is out of paper.
ON	OFF	N/A	Operator Alarm	Paper Jam	SASF paper jam
ON	OFF	N/A	Operator Alarm	CSF Paper Jam	Paper jam or paper end with CSF installed.
OFF	BLINK	N/A	Operator Alarm	Print Suppress	The printer has received a PRINT SUPPRESS code from the computer.

BLINK	OFF	N/A	Fault Alarm	Refer to the Fault Alarm Conditions Table Microline 390/391	Refer to the Fault Alarm Conditions Table Microline 390/391
-------	-----	-----	-------------	---	---

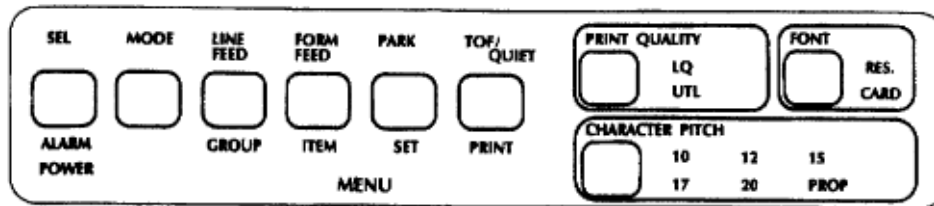

Microline 390/391-Plus

ALARM Lamp Status	SELECT Lamp Status	MENU Lamp Status	Printer Mode	Status	Description
OFF	ON	N/A	Normal Operation	On-Line	The printer is ready to receive data and to print.
OFF	ON	N/A	Normal Operation	Hex Dump	The printer is in Hex Dump Mode. Refer to Section 4.7
OFF	OFF	N/A	Normal Operation	Off-Line	The printer will NOT receive data or print.
OFF	OFF	ON	Normal Operation	Menu Mode	The operator may view or change the menu settings.
ON	OFF	N/A	Operator Alarm	Paper End	Printer is out of paper.
ON	OFF	N/A	Operator Alarm	Paper Jam	The paper has jammed.
ON	OFF	N/A	Operator Alarm	CSF Paper Jam	Paper jam or paper end with CSF installed.

OFF	BLINK	N/A	Operator Alarm	Print Suppress	The printer has received a PRINT SUPPRESS code from the computer.
BLINK	OFF	N/A	Fault Alarm	Refer to the Fault Alarm Conditions Table Microline 390/391-Plus	Refer to the Fault Alarm Conditions Table Microline 390/391-Plus

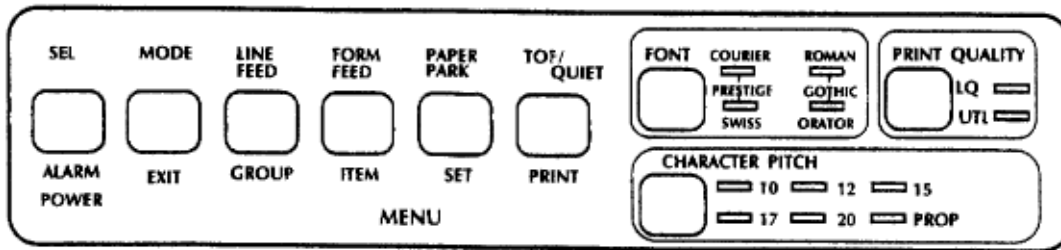

Fault Alarm Conditions

Microline 390/391

CAUTION:

Check the contacts between the power interconnect module, the control board, and the power supply board (Rev A and B units ONLY). Clean the contacts if dirty. If contacts are bent or broken, replace the module. Proper inspection and cleaning of the power interconnect module contacts can eliminate a false diagnosis of a failed control board or power supply board.

Check the contacts and connections of the control board. If good contact is not made at all connections and ground points, false diagnosis will occur.

ALARM Lamp Status	10	12	15	17	20	L Q	UTI L	RE S	CAR D	Error Condition	Action
Blinking	ON					ON				MPU Internal ROM Error	Replace the main control board.
Blinking		ON				ON				Program ROM Error	1. Replace the ROM.

											2.Replace the main control board.
Blinking		O N					ON			EEPROM Error	1.Replace the EEPROM.
											2.Replace the main control board.
Blinking		O N						ON		Resident CG Error	Replace the main control board.
Blinking		O N							ON	Cartridge CG Error	1.Reinsert the font card.
											2.Replace the font card.
											3.Replace the main control board.
Blinking				O N		O N				Head Homing Error	Refer to RAP 02.
Blinking				O N			ON			Spacing Error	Refer to RAP 02.
Blinking					O N			ON		Resident CG Release	Replace the main control board.
Blinking					O N				ON	Cartridge CG Release	1.Reinsert the font card.
											2.Replace the font card.
											3.Replace the main control board.

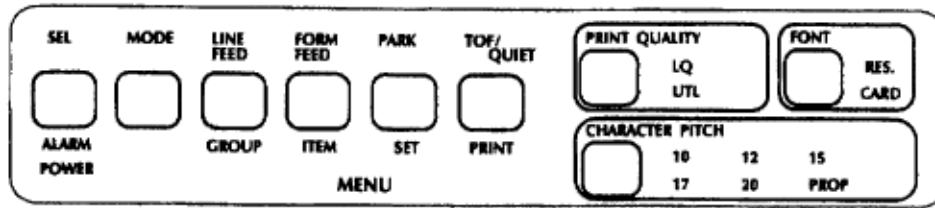

Microline 390/391-Plus

CAUTION:

Check the contacts and connections of the control board. If good contact is not made at all connections and ground points, false diagnosis will occur.

ALARM Lamp Status	10	12	15	17	20	PR OP	Courie r	Roma n	Helv ette	Orator	Error Condi tion	Action
Blinking	ON						ON				Internal RAM Error	Replace the main control board.
Blinking	ON								ON		Serial I/F Connection Error	1.Reinstall the serial interface.
												2.Replace the serial i/f.
												3.Replace the main control board.
Blinking	ON									ON	Serial I/F Time Out Error	1.Replace the serial i/f.
												2.Replace the main control board.
Blinking		ON					ON				Progra m ROM Error	1.Replace the ROM.

												2. Replace the main control board.
Blinking		ON								ON	Cartridge CG Error	1. Reinstall the font card.
												2. Replace the font card.
												3. Replace the main control board.
Blinking		ON								ON	Resident CG Error	Replace the main control board.
Blinking			ON				ON				External RAM Error	1. Reinsert the RAM card.
												2. Replace the RAM card.
												3. Replace the main control board.
Blinking			ON							ON	RAM Card Error	1. Reinsert the RAM card.
												2. Replace the RAM card.
												3. Replace the main control board.
Blinking				ON			ON				Head Homing Error	Refer to RAP 02.
Blinking				ON				ON			Spacing Error	Refer to RAP 02.

Blinking				ON			ON	ON			Print Overrun	1. Replace the serial interface.
												2. Replace the main control board.
Blinking					ON				ON		Resident CG Error	
Blinking					ON					ON	Cartridge CG Release	
Blinking						ON	ON				Print End Response Error	Replace the main control board.
Blinking						ON		ON			Call Put	Replace the main control board.
Blinking						ON		ON	ON		Call Get	Replace the main control board.
Blinking						ON	ON	ON			HPC / LPC FIFO	Replace the main control board.

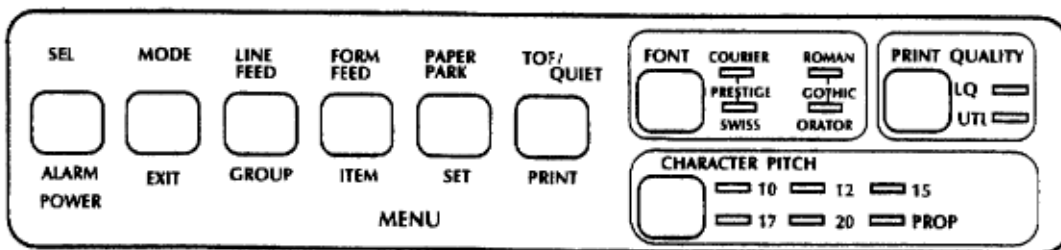

Copyright 1997, Okidata, Division of OKI America, Inc. All rights reserved. See the OKIDATA Business Partner Exchange (BPX) for any updates to this material. (<http://bpx.okidata.com>)

4.6 REPAIR ANALYSIS PROCEDURES

4.6.01 Using the RAPs

When using the Repair Analysis Procedures, follow these steps.

- Use the RAP INDEX to find the RAP associated with the printers problem.
 - Go to the appropriate RAP.
 - All of the RAPs will begin with a START Statement, followed by questions or another type of statement.
 - If the RAPs do not lead you to the cause of a problem, please report this to Okidata. [Refer to Section 4.3 for further details](#) .
-

Copyright 1997, Okidata, Division of OKI America, Inc. All rights reserved. See the OKIDATA Business Partner Exchange (BPX) for any updates to this material. (<http://bpx.okidata.com>)

4.6.02 RAP Index

RAP Number	Description
01	Operator Panel Lamps Do Not Light
02	Abnormal Spacing
03	Wrong or Missing Characters / Dots on Output
04	Line Feed Problems
05	Malfunction of Operator Panel Switch(es)
06	Parallel Interface Does Not Receive Data
07	Serial Interface Does Not Receive Data

4.6.03 Troubleshooting Cautions

Power Interconnect Module

Check the contacts between the power interconnect module, the control board, and the power supply board (Rev A and B units ONLY). Clean the contacts if dirty. If contacts are bent or broken, replace the module. Proper inspection and cleaning of the power interconnect module contacts can eliminate a false diagnosis of a failed control board or power supply board.

Control Board

Check the contacts and connections of the control board. If good contact is not made at all connections and ground points, false diagnosis will occur.

Copyright 1997, Okidata, Division of OKI America, Inc. All rights reserved. See the OKIDATA Business Partner Exchange (BPX) for any updates to this material. (<http://bpx.okidata.com>)

RAP 01: Operator Panel Lamps Do Not Light

START

Are the AC cables connected correctly?

NO Connect the AC cables correctly.

Is the problem resolved?

YES End of procedure.

NO Go to A

YES Go to A

A

Check the AC fuse on the primary side of the filter assembly. Is it open?

YES Replace the fuse

Is the problem resolved?

YES End of procedure.

NO Go to B

NO Go to B

B

Verify that the fuse holder is making proper contact with the fuse. Remove the fuse from the holder. Gently squeeze both sides of the holder slightly towards each other. Reinsert the fuse. Is the problem resolved?

YES End of procedure.

NO Are + 5 vdc and + 40 vdc supplied to the control board?

+ 5 vdc Take the voltage reading between Pin 6 and Pin 9 of CN2 on the power supply board.

+ 40 vdc Take the voltage reading between Pin 1 and Pin 5 of CN2 on the power supply board. Meter should read + 40 vdc.

YES Replace the control board.

YES End of procedure.

NO Go to C

NO Go to C

C

Check the fuse on the power supply board. Is it open?

YES Replace the fuse.

Is the problem resolved?

YES End of procedure.

NO Go to D

NO Go to D

D

Are the control board contacts and the power supply board contacts properly made?

NO Properly make the contacts.

Is the problem resolved?

YES End of procedure.

NO Go to E

YES Go to E

E

Replace the connector between the power supply board and the control board.

Is the problem resolved?

YES End of procedure.

NO Replace the power supply board.

Is the problem resolved?

YES End of procedure.

NO Contact Technical Support.

RAP 02: Abnormal Spacing**START**

Check the movement (Steps A and B) of the carriage assembly.

A

Does the assembly vibrate back and forth in the same location or does it move sharply to the left or right end of the carriage shaft?

YES Replace the control board.

Is the problem resolved?

YES End of procedure.

NO Go to the next step listed below.

NO Clean the contacts between the carriage cable and the space motor contacts.

Is the problem resolved?

YES End of procedure.

NO Go to B.

B

Is the carriage assembly jammed?

YES Clean the teeth of the space motor and the space rack.

Is the problem resolved?

YES End of procedure.

NO Go to C

NO Go to C

C

Are + 5 vdc and + 40 vdc being supplied to the control board?

+ 5 vdc Voltage is read between Pin 6 and Pin 9 of CN2 on the power supply board.

+ 40 vdc Voltage is read between Pin 1 and Pin 5 of CN2 on the power supply board.

YES Replace the control board.

YES End of procedure.

NO Go to D

NO Go to D

D

Are the power supply board and the control board connected properly?

YES Replace the power supply board.

Is the problem resolved?

YES End of procedure.

NO Go to the next step listed below.

NO Reseat the power supply board, the control board, and the connection between the two boards.

Is the problem resolved?

YES End of procedure.

NO Go to E.

E

Is the carriage cable properly inserted into CN2 of the control board?

NO Properly insert the cable.

Is the problem resolved?

YES End of procedure.

NO Go to the next step listed below.

YES Replace the control board.

Is the problem resolved?

YES End of procedure.

NO Replace the space motor.

Is the problem resolved?

YES End of procedure.

NO Contact Technical Support.

Copyright 1997, Okidata, Division of OKI America, Inc. All rights reserved. See the OKIDATA Business Partner Exchange (BPX) for any updates to this material. (<http://bpx.okidata.com>)

RAP 03: Wrong or Missing Characters / Dots on Output

START

Is the head cable correctly inserted into CN2 of the control board?

NO Correctly insert the cable.

Is the problem resolved?

YES End of procedure.

NO Go to the next step listed below.

YES Is the head cable correctly inserted into CN1 of the connection board?

NO Correctly insert the cable.

Is the problem resolved?

YES End of procedure.

NO Go to the next step listed below.

YES Go to the next step listed below.

YES Replace the printhead.

Is the problem resolved?

YES End of procedure.

NO Replace the control board.

Is the problem resolved?

YES End of procedure.

NO Go to A.

A

Are the contacts between the space motor and the carriage cable properly made?

YES Replace the space motor.

Is the problem resolved?

YES End of procedure.

NO Go to the next step listed below.

NO Reseat the carriage cable and the space motor assembly.

Is the problem resolved?

YES End of procedure.

NO Contact Technical Support.

Copyright 1997, Okidata, Division of OKI America, Inc. All rights reserved. See the OKIDATA Business Partner Exchange (BPX) for any updates to this material. (<http://bpx.okidata.com>)

RAP 04: Line Feed Problems

NOTE:

Before performing this RAP, check the following.

1. Is the head gap correctly set for the type of paper being used?
2. Remove the printhead. Examine the pins. Do they appear damaged? If so, replace the printhead.

START

Manually rotate the platen knob. Does it rotate smoothly?

YES Go to A.

NO Set the release lever to OPEN. Manually rotate the platen knob. Does it rotate smoothly?

NO Go to A.

YES Check the following in the order given below. Check the operation of the platen knob before moving between steps.

1. Check the paper feed path setting.
2. Clean the platen gear, idle gear, and drive gear.
3. Verify that the platen gear, idle gear, and drive gear are correctly meshing.
4. Verify that the left and right push tractor assemblies are correctly installed.
5. Verify that the left and right push tractor assemblies are correctly operating. Replace if necessary.

Is the problem resolved?

YES End of procedure.

NO Go to A.

A

Are the connection plate and the line feed motor making correct contact?

YES Is the connection plate making correct contact with the control board?

YES Replace the control board.

Is the problem resolved?

YES End of procedure.

NO Replace the line feed motor.

Is the problem resolved?

YES End of procedure.

NO Contact Technical Support.

NO Replace the line feed motor.

Is the problem resolved?

YES End of procedure.

NO Contact Technical Support.

NO Correct the contact.

Is the problem resolved?

YES End of procedure.

NO Contact Technical Support.

Copyright 1997, Okidata, Division of OKI America, Inc. All rights reserved. See the OKIDATA Business Partner Exchange (BPX) for any updates to this material. (<http://bpx.okidata.com>)

RAP 05: Malfunction of Operator Panel Switch(es)

START

Is the operator panel board correctly connected to CN1 of the control board?

YES Replace the operator panel assembly.

Is the problem resolved?

YES End of procedure.

NO Replace the control board.

Is the problem resolved?

YES End of procedure.

NO Contact Technical Support.

NO Correctly make the connection.

Is the problem resolved?

YES End of procedure.

NO Replace the control board.

Is the problem resolved?

YES End of procedure.

NO Contact Technical Support.

RAP 06: Parallel Interface Does Not Receive Data

START

Is the SELECT lamp lit?

NO Press the SELECT button to place the printer in Select Mode. The SELECT lamp will be lit when the printer is in Select Mode.

Is the problem resolved?

YES End of procedure.

NO Go to the next step listed below.

YES Check the interface cable. Is it correctly connected?

YES Replace the cable with a cable known to work.

Is the problem resolved?

YES End of procedure.

NO Replace the control board.

Is the problem resolved?

YES End of procedure.

NO Call Technical Support.

NO Correctly connect the cable.

Is the problem resolved?

YES End of procedure.

NO Replace the control board.

Is the problem resolved?

YES End of procedure.

NO Call Technical Support.

RAP 07: Serial Interface Does Not Receive Data

NOTE:

Before performing the procedures of this RAP, make sure that the correct protocols are selected. Print the Menu to check protocol settings. For information on printing the Menu, refer to Section 4.10 of this Service Handbook.

START

Is the serial interface cable correctly connected to both the serial interface board and the host computer?

NO Correctly connect the cable.

Is the problem resolved?

YES End of procedure.

NO Go to the next step listed below.

YES Replace the serial interface cable with a cable proven to work. Is the problem resolved?

YES Replace the cable.

NO Perform the Serial Loopback Test. Refer to Section 4.9 of this Service Handbook.

Do the memory buffer and interface tests pass?

NO Replace the serial interface board.

Is the problem resolved?

YES End of procedure.

NO Go to the next step listed below.

YES Check the connection between the serial interface board and the control board. Is the serial interface board properly inserted into CN3 of the control board?

YES End of procedure.

NO Replace the control board.

Is the problem resolved?

YES End of procedure.

NO Contact Technical Support.

4.7 HEXADECIMAL DUMP

4.7.01 General Information

Hexadecimal dump mode allows you to check the data sent from the computer to the printer. All data sent to the printer, including test and printer commands, will print in both hexadecimal and ASCII format. In the ASCII format, all non-printable codes will be represented by a period.

4.7.02 Procedure

To place the printer in hexadecimal dump mode, follow this procedure.

- Power OFF the printer.
- Press and hold SEL while powering ON the printer.
- The printer will remain in hexadecimal dump mode until it is powered OFF.

4.7.03 Sample

Here is a line of BASIC code.

```
LPRINT CHR$(27) ;"0";CHR$(30) ;"This is an example of a hexadecimal dump."
```

In hexadecimal dump mode, the BASIC code line would print as follows.

This is an example of a hexadecimal dump.

```
1B 30 1E 54 68 69 73 20 69 73 20 61 6E 20 65 78 .0.
```

```
61 6D 70 6C 65 20 6F 66 20 61 20 68 65 78 61 64
```

```
65 63 69 6D 61 6C 20 64 75 6D 70 2E 0D 0A . .
```

Appendix C of the Reference Guide contains tables of hexadecimal codes and ASCII characters.

4.8 RESISTANCE / SERVICE CHECKS

4.8.01 Index to Charts

The following resistance charts are included in this section.

- Interconnect Diagram

Microline 390/391

Rev A and B

Rev C

Microline 390/391-Plus

- Printhead
- Space Motor

- Line Feed Motor

- Control Board

Microline 390/391

Rev A and B

Rev C

Microline 390/391-Plus

- Operator Panel Board
-

4.8.02 Interconnect Diagrams

Microline 390/391 - Rev. A and B

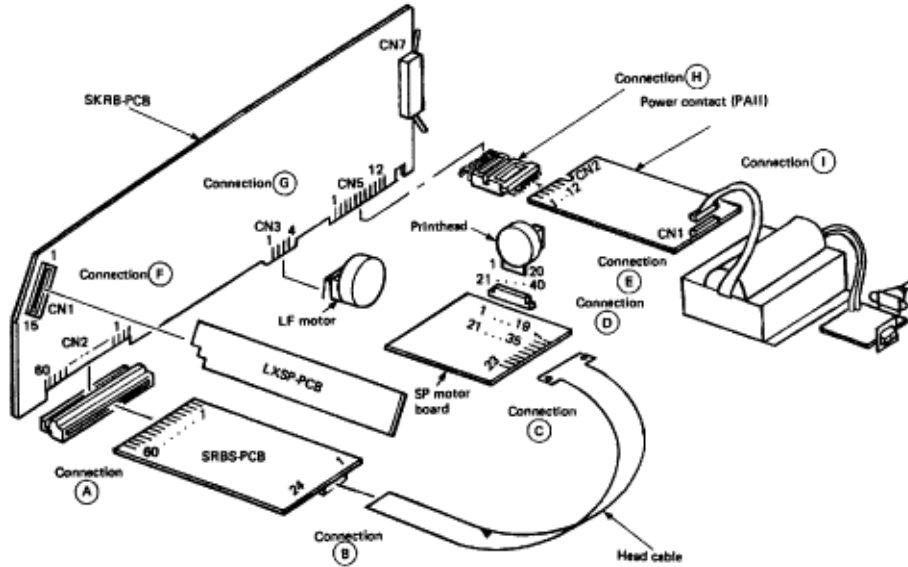

Copyright 1997, Okidata, Division of OKI America, Inc. All rights reserved. See the OKIDATA Business Partner Exchange (BPX) for any updates to this material. (<http://bpx.okidata.com>)

Microline 390/391 - Rev C

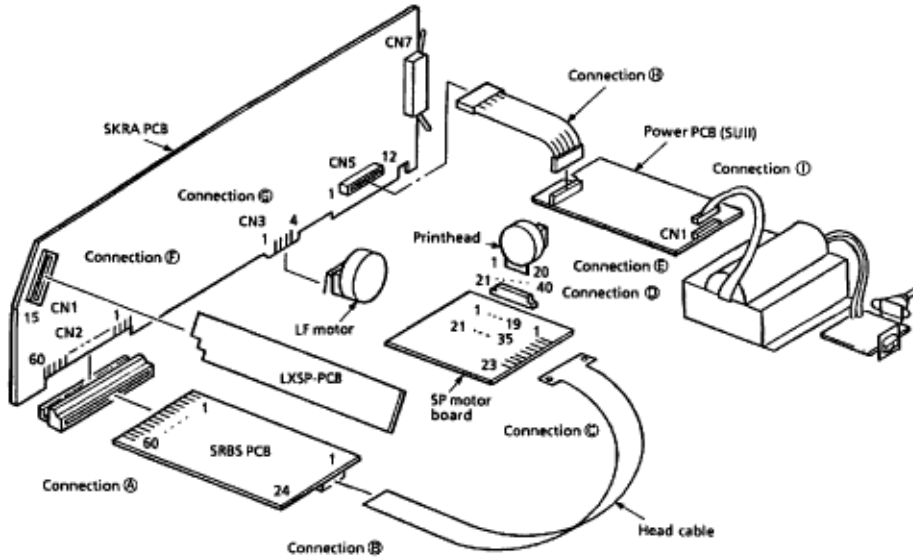

Copyright 1997, Okidata, Division of OKI America, Inc. All rights reserved. See the OKIDATA Business Partner Exchange (BPX) for any updates to this material. (<http://bpx.okidata.com>)

Microline 390/391-Plus

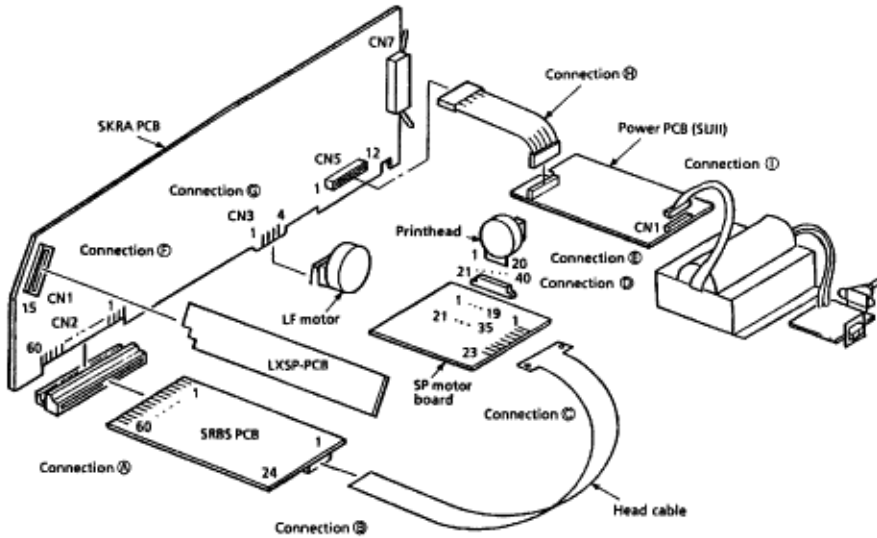

Copyright 1997, Okidata, Division of OKI America, Inc. All rights reserved. See the OKIDATA Business Partner Exchange (BPX) for any updates to this material. (<http://bpx.okidata.com>)

4.8.03 Printhead

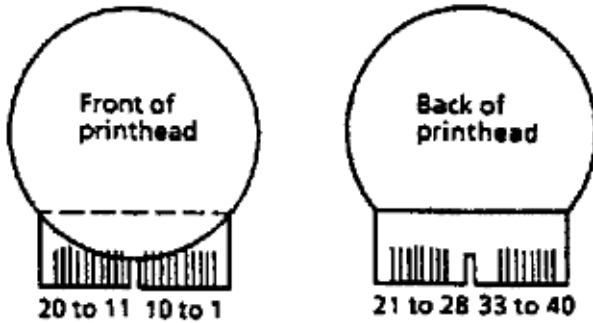

Name	Signal Name	Connection (Refer to Interconnect Diagram)					Coil Resistance	Figure
		A	B	C	D	E		
Print head	Odd En	2 3	13 15	13				Pins on front of printhead
	Even En	2 3	13 15	15				
	Headgap	7	2	2				
	Odd Common	8 - 12	3 - 6	5 6	14 15 30 31			
	Even Common	8 - 12	3 - 6	3 4	6 7	26 27		
	TSD	14	10	10	20			
	S Clock	15	11	11				
	S Data	17	14	14				

	40 V	1	23	22				
	0 V	16	12	12				
	5 V	18	16	16	26			
	EP	21 - 25	19-2 2	19-2 2				
	Pin 1				19	19	Approx . 18.3 ohms	Pins on back of printhead
	Pin 2				2	2		
	Pin 3				18	18		
	Pin 4				3	3		
	Pin 5				35	39		
	Pin 6				22	22		
	Pin 7				34	38		
	Pin 8				23	23		
	Pin 9				17	17		
	Pin 10				4	4		
	Pin 11				16	16		
	Pin 12				5	5		
	Pin 13				33	33		
	Pin 14				24	24		
	Pin 15				32	32		
	Pin 16				25	25		
	Pin 17				13	13		
	Pin 18				8	8		
	Pin 19				12	23		
	Pin 20				9	9		
	Pin 21				11	11		
	Pin 22				10	10		
	Pin 23				29	29		

	Pin 24				28	28		
--	--------	--	--	--	----	----	--	--

Copyright 1997, Okidata, Division of OKI America, Inc. All rights reserved. See the OKIDATA Business Partner Exchange (BPX) for any updates to this material. (<http://bpx.okidata.com>)



Service Guide ML390/391

Chapter 4 Failure & Repair Analysis

4.8.04 Space Motor

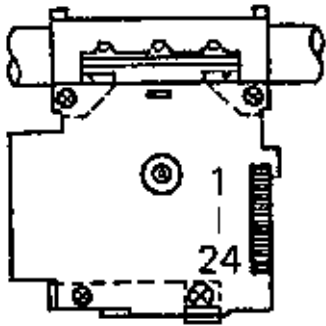

Name	Signal Name	Connection (Refer to Interconnect Diagram)			Coil Resistance
		A	B	C	
Space Motor	U	5	7	7	Approx. 21 ohms
	V	13	8	8	
	W	4	9	9	
	Phase A	20	18	18	
	Phase B	19	17	17	

4.8.05 Line Feed Motor

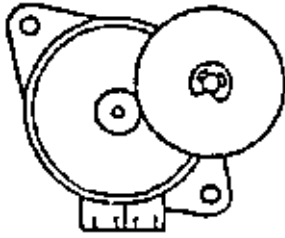

4 - 1

Name	Signal Name	Connection (Refer to Interconnect Diagram)	Coil Resistance
Line Feed Motor	Phase 1	2	
		1	
	Phase 2	3	
		4	

4.8.06 Operator Panel Board

Name	Signal Name	Connection (Refer to Interconnect Diagram)
		F
Op Panel	SEL	3
	MODE	4
	LF	5
	FF	6
	PARK	7
	TOF	13
	PRINT	10
	FONT	11
	CHAR	12
	SD CLK	14
	SD	2
	+ 5 V	1,15
	0 V	8,9

4.8.07 Control Board

Name	Signal Name	Connection (Refer to Interconnect Diagram)
		H
Control Board CN5	+ 40 V	1, 3
	EP	4, 5
	+ 5 V	6, 7
	0 V	8, 9
	+ 8 V	10
	AC 10 V	11
	ALM	12

4.9 PRINTER TESTS

4.9.01 General Information

There are three tests which can be run for the unit.

- Rolling ASCII Print Test
- Font Sample Test
- Serial Interface Loopback Test

The Rolling ASCII Print and Font Sample Tests are used to determine if the printer is operating properly. The Serial Interface Loopback Test is used to test proper operation of the Serial Interface Board.

Copyright 1997, Okidata, Division of OKI America, Inc. All rights reserved. See the OKIDATA Business Partner Exchange (BPX) for any updates to this material. (<http://bpx.okidata.com>)

4.9.02 Rolling ASCII Print Test

General Information

The Rolling ASCII Print Test produces a continuous printout of all 96 ASCII characters in a rolling pattern. The type style set in the printer menu will be utilized.

Use the Rolling ASCII Test to check the following.

- Print Quality

Across the entire length of a line

Down the entire page

- Line Spacing
- Character Formation

At the top of the printout, you will see the Printer Model, Emulation, Country Code, and Firmware Revision Level.

CAUTION:

If 13.6 inch Paper Width is selected in the menu, and you run this test with 8.5 inch wide paper loaded, the test will print on the platen. This may damage the platen, ribbon, and printhead. Set the paper width to 8.5 inches before running this test.

Procedure

- Verify that the printer is loaded with paper and that the paper is the correct width.
- Power OFF the printer.
- Press and hold the TOF/QUIET switch while powering ON the printer. If the printer is powered on and the Rolling ASCII Test does not start, you may have released the switch too soon.
- To stop the Rolling ASCII Test, press MODE switch or power OFF the printer.

Sample

Printer Model
 Emulation
 Country Code
 Firmware Revision Level

ML390+ ET A F/W 00.24 YR4077-1137
 RES 01.10 YR4077-1138

```

!""$%&'()*+,-./0123456789:;<=>?@ABCDEFGHIJKLMN0PQRSTUVWXYZ[\]^_`'abcdefghijklmnop
!""$%&'()*+,-./0123456789:;<=>?@ABCDEFGHIJKLMN0PQRSTUVWXYZ[\]^_`'abcdefghijklmnop
""$%&'()*+,-./0123456789:;<=>?@ABCDEFGHIJKLMN0PQRSTUVWXYZ[\]^_`'abcdefghijklmnop
#$%&'()*+,-./0123456789:;<=>?@ABCDEFGHIJKLMN0PQRSTUVWXYZ[\]^_`'abcdefghijklmnop
%&'()*+,-./0123456789:;<=>?@ABCDEFGHIJKLMN0PQRSTUVWXYZ[\]^_`'abcdefghijklmnopqr
&'()*+,-./0123456789:;<=>?@ABCDEFGHIJKLMN0PQRSTUVWXYZ[\]^_`'abcdefghijklmnopqrst
'()*+,-./0123456789:;<=>?@ABCDEFGHIJKLMN0PQRSTUVWXYZ[\]^_`'abcdefghijklmnopqrstu
()*+,-./0123456789:;<=>?@ABCDEFGHIJKLMN0PQRSTUVWXYZ[\]^_`'abcdefghijklmnopqrstuv
)"+,-./0123456789:;<=>?@ABCDEFGHIJKLMN0PQRSTUVWXYZ[\]^_`'abcdefghijklmnopqrstuvx
"+,-./0123456789:;<=>?@ABCDEFGHIJKLMN0PQRSTUVWXYZ[\]^_`'abcdefghijklmnopqrstuvxy
  
```

Copyright 1997, Okidata, Division of OKI America, Inc. All rights reserved. See the OKIDATA Business Partner Exchange (BPX) for any updates to this material. (<http://bpx.okidata.com>)

4.9.03 Font Sample Test

General Information

This test will print samples of the available fonts.

At the top of the printout, you will see the Printer Model, Emulation, Country Code, Interface, and Firmware Revision Level.

CAUTION:

If 13.6 inch Paper Width is selected in the menu, and you run this test with 8.5 inch wide paper loaded, the test will print on the platen. This may damage the platen, ribbon, and printhead. Set the paper width to 8.5 inches before running this test.

Procedure

- Verify that the printer is loaded with paper.
- Power OFF the printer.
- Press and hold the LINE FEED switch while powering ON the printer. If the font sample test does not print after you power ON the printer, you may have released the LINE FEED switch too soon.
- This is a two page test. The printer will stop after printing the pages. If you want to stop the test before it is complete, press the MODE switch or power OFF the printer.

Sample

NOTE:

Only a portion of the test is shown.

Printer Model

Emulation

Country Code

Interface Selected

Firmware Revision Level

ML390+

IB

A

P

F/W 01.13
RES 01.11

YR4084-1314

LQ-ROMAN 10 CPI

```
!"#$%&'()*+,-./0123456789:;<=>?@ABCDEFGHIJKLMNQRSTU VWXYZ[\]^_`abcdefghijklmnop  
qrstuvwxyz{|}~ !"#$%&'()*+,-./0123456789:;<=>?@ABCDEF GHIJKLMNQRSTU VWXYZ[\]^_  
abcdefghijklmnopqr stuvwxyz{|}~
```

LQ-ROMAN PROPORTIONAL

```
!"#$%&'()*+,-./0123456789:;<=>?@ABCDEFGHIJKLMNQRSTU VWXYZ [\]^_`abcdefghijklmnopqr stuvwxyz{  
|}~ !"#$%&'()*+,-./0123456789:;<=>?@ABCDEFGHIJKLMNQRSTU VWX Z[\]^_`abcdefghijklmnopqr stuvwxy  
z{|}~
```

LQ-SWISS 10 CPI

```
!"#$%&'()*+,-./0123456789:;<=>?@ABCDEFGHIJKLMNQRSTU VWXYZ[\]^_`abcdefghijklmnop  
qrstuvwxyz{|}~ !"#$%&'()*+,-./0123456789:;<=>?@ABCDEF GHIJKLMNQRSTU VWXYZ[\]^_  
abcdefghijklmnopqr stuvwxyz{|}~
```

LQ-SWISS PROPORTIONAL

```
!"#$%&'()*+,-./0123456789:;<=>?@ABCDEFGHIJKLMNQRSTU VWXYZ [\]^_`abcdefghijklmnopqr stuvwxyz{  
|}~ !"#$%&'()*+,-./0123456789:;<=>?@ABCDEFGHIJKLMNQRSTU VWX Z[\]^_`abcdefghijklmnopqr stuvwxy  
z{|}~
```

LQ-COURIER 10 CPI

```
!"#$%&'()*+,-./0123456789:;<=>?@ABCDEFGHIJKLMNQRSTU VWXYZ[\]^_`abcdefghijklmnop  
qrstuvwxyz{|}~ !"#$%&'()*+,-./0123456789:;<=>?@ABCDEF GHIJKLMNQRSTU VWXYZ[\]^_  
abcdefghijklmnopqr stuvwxyz{|}~
```

LQ-COURIER 12 CPI

```
!"#$%&'()*+,-./0123456789:;<=>?@ABCDEFGHIJKLMNQRSTU VWXYZ[\]^_`abcdefghijklmnopqr stuvwxyz{  
|}~ !"#$%&'()*+,-./0123456789:;<=>?@ABCDEFGHIJKLMNQRSTU VWXYZ[\]^_`abcdefghijklmnopqr stuvwxyz{  
|}~ !"#$%&'()*+,-./0123456789:;<=>?@ABCDEFGHIJKLMNQRSTU VWXYZ[\]^_`abcdefghijklmnopqr stuvwxyz{  
|}~
```

LQ-ORATOR 10 CPI

```
!"#$%&'()*+,-./0123456789:;<=>?@ABCDEFGHIJKLMNQRSTU VWXYZ[\]^_`ABCDEFGHIJKLMNO  
PQRSTUVWXYZ{|}~ !"#$%&'()*+,-./0123456789:;<=>?@ABCDEF GHIJKLMNQRSTU VWXYZ[\]^_  
ABCDEFGHIJKLMNQRSTU VWXYZ{|}~
```

LQ-ORATOR 12 CPI

```
!"#$%&'()*+,-./0123456789:;<=>?@ABCDEFGHIJKLMNQRSTU VWXYZ[\]^_`ABCDEFGHIJKLMNO  
PQRSTUVWXYZ{|}~ !"#$%&'()*+,-./0123456789:;<=>?@ABCDEFGHIJKLMNQRSTU VWXYZ[\]^_  
ABCDEFGHIJKLMNQRSTU VWXYZ{|}~ !"#$%&'()*+,-./0123456789:;<=>?@ABCDEFGHIJKLMNQRSTU VWXYZ[\]^_  
ABCDEFGHIJKLMNQRSTU VWXYZ{|}~
```

LQ-12 CPI

```
!"#$%&'()*+,-./0123456789:;<=>?@ABCDEFGHIJKLMNQRSTU VWXYZ[\]^_`abcdefghijklmnopqr stuvwxyz{  
|}~ !"#$%&'()*+,-./0123456789:;<=>?@ABCDEFGHIJKLMNQRSTU VWXYZ[\]^_`abcdefghijklmnopqr stuvwxyz{  
|}~
```

4.9.04 Serial Interface Loopback Test

NOTE:

Attach a serial loopback test connector to the printers serial port to run this test.

General Information

The Serial Interface Loopback Test checks the operation of the serial interface board.

Procedure

- Verify that the ribbon and paper are installed.
- Power ON the printer.
- Press MODE. The SEL light will go out and the MENU lamp will light.

When the MENU lamp is lit, the functions printed BELOW the operator panel switches are activated.

- Press GROUP until you access the desired group (Serial Interface). Each time you press GROUP, the printer will print the current group.
- Press ITEM until you access the desired item (Diagnostic Test).
- Press SET until you access the desired setting (YES).
- Press MODE to record the changes and return to Print Mode. The MENU lamp will go out and the SEL lamp will light.
- Power OFF the printer.
- Attach the loopback test connector to the printers serial port.

- Verify that continuous feed paper is installed.
- Power ON the printer.
- The message LOOP TEST will print.
- The memory buffer size will print.
- The test checks the memory function of the memory buffer.

OK will print if the memory check passes.

BAD will print if the memory check fails.

- One of the following messages will print next.

I/F Good

If the message **I/F GOOD** prints, no problems were found.

I/F BAD

If the message **I/F BAD** prints, a problem was found.

- Hexadecimal characters 20 through 7F are transmitted through the transmit data (TD) line.

- The receive data (RD) line receives the characters.
- The message buffer stores the characters.
- The data prints.
- The test runs until the SELECT switch is pressed or the printer is powered OFF.
- To restore the printer to normal operation, power OFF the printer.
- Press and hold the MODE switch while powering ON the printer. The printer will be in Menu Mode.
- Press GROUP until you access the desired group (Serial Interface). Each time you press GROUP, the printer will print the current group.
- Press ITEM until you access the desired item (Diagnostic Test).
- Press SET until you access the desired setting (NO).
- Press MODE to record the changes and return to Print Mode. The MENU lamp will go out and the SEL lamp will light.

Serial Loopback Plug Diagram

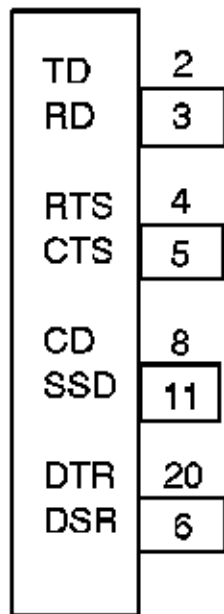

RS232-C (DB 25P Plug)

4.10 MENU OPERATION

4.10.01 General Information

The end user can customize printer features by changing menu settings. These settings are automatically activated when the printer is powered ON.

Selections made in Menu Mode are stored in the printers permanent memory. They will stay in effect, even when the printer is powered OFF. However, they can be changed through software commands, the front panel, and by resetting the menu. Changes made by software commands or the front panel are canceled when the printer is powered OFF.

Refer to *Chapter 2* of the Setup Guide or Appendix B of the *Reference Guide* for information regarding the menu.

4.10.02 Limited Operation

In the Printer Menu, the sixth item in the General Control Group is Operator Panel functions. The settings for this item are Full Operation and Limited Operation. A system manager may use this feature to maintain proper print settings if the printer is part of a customized system or if it is used by different operators.

When the Printer Menu is set to Limited Operation, the FONT, PRINT QUALITY, CHARACTER PITCH, and MODE switches of the operator panel do not work.

To change from LIMITED OPERATION to FULL OPERATION, follow this procedure.

- Verify that the ribbon and paper are installed.
- Power OFF the printer.
- Press and hold MODE while powering ON the printer.
- Follow the normal menu procedures to set the Operator Panel Functions Item to FULL OPERATION.

4.10.03 Printing the Menu

- Verify that the ribbon and paper are installed.
- Power ON the printer.
- Press MODE. The SEL light will go out and the MENU lamp will light.
- Press PRINT. The menu will print.

4.10.04 Modifying the Menu

- Verify that the ribbon and paper are installed.
- Power ON the printer.
- Press MODE. The SEL light will go out and the MENU lamp will light.

When the MENU lamp is lit, the functions printed BELOW the operator panel switches are activated.

- Press GROUP. The first line of the menu will print.

FONT Print Mode Utility

(GROUP) (ITEM) (Current SETting)

- Press GROUP until you reach the desired group.
- Press ITEM until you access the desired item of a group.
- Press SET until you access the desired setting for an item.
- Press EXIT/MODE to record the changes and return to Print Mode. The MENU lamp will go out and the SEL lamp will light.

4.10.05 Resetting to Factory Defaults

CAUTION:

Always print the menu before resetting to factory defaults. All customized information will be lost once the menu has been reset.

The Menu will be reset to factory default settings. Refer to Chapter 2 of the Setup Guide or Appendix B of the Reference Guide for these settings.

Menu

- Power OFF the printer.
- Press and hold the MODE and SELECT switches while powering ON the printer.

Menu and Top of Form

- Power OFF the printer.
- Press and hold the PARK and TOF/QUIET switches while powering ON the printer.

Copyright 1997, Okidata, Division of OKI America, Inc. All rights reserved. See the OKIDATA Business Partner Exchange (BPX) for any updates to this material. (<http://bpx.okidata.com>)

4.11 TOP OF FORM

4.11.01 General Information

Top of Form sets the print start position for the printer. It is adjustable in increments of 1/360 of an inch. The amount of adjustment is limited to avoid paper jams.

4.11.02 Procedure

Continuous Feed / Single Sheet

- Verify that the ribbon and paper are installed.
- Power ON the printer.
- Press SEL until the SEL lamp goes out. The printer is deselected.
- Press and hold TOF/Quiet. While doing this, press either of the switches listed below.

FORM FEED increases the Top of Form. The paper is advanced.

LINE FEED decreases the Top of Form. The paper is retracted.

The lower red line on the ribbon protector shows the baseline of the current printing position. Use this when positioning the Top of Form.

- The Top of Form is automatically saved in the printers static memory. Powering OFF the unit will NOT change the Top of Form. You must reset the Top of Form to change it.

NOTE:

The bail must hold the paper in place. If the top of the page is set below the bail, the paper will catch on the bail and a paper jam will occur.

4.11.03 Reset to Factory Defaults

Top of Form

- Verify that the ribbon and paper are installed.
- Power ON the printer.
- Press PAPER PARK to park the paper.
- Press TOF / QUIET.
- Open the bail lever to advance the paper.

Top of Form and Menu

- Verify that the ribbon and paper are installed.
 - Power OFF the printer.
 - Press PARK and TOF / QUIET while powering ON the printer.
-

4.12 PAPER PARK

4.12.01 General Information

Paper Park allows single sheet paper to be printed without removing continuous feed paper from the printer.

4.12.02 Procedure

- Remove any printed pages.
- Press PARK. The continuous feed paper will retract from the paper path. The ALARM lamp will light and the SEL lamp will go out.
- Move the paper lever to the Single Sheet Setting. This is towards the back of the printer.
- Open the access cover.
- Push the guide wire back into its locked position on the paper separator.
- Raise the separator to its upright position.
- Set a sheet of paper on the separator and adjust the guides. The guides should barely touch the edges of the paper. Be sure to position the left edge of the paper even with the reference mark on the separator.
- Pull the bail lever forward. The paper will advance.
- Push the bail lever back.
- Adjust the Top of Form (if necessary). Refer to Section 4.11.
- Print.

To return to continuous feed paper printing, perform the following.

- Remove any printed pages.
- Set the paper lever to continuous feed. This is towards the front of the printer.
- Pull the bail lever forward. The paper will advance.
- Push the bail lever back.
- Adjust the Top of Form (if necessary). Refer to Section 4.11.
- The unit is ready to print.

4.13 FORMS TEAR OFF

4.13.01 General Information

This feature allows a printed page (rear feed, continuous form) to be torn off without wasting paper or adjusting the printer.

Forms Tear Off advances the paper from the initial printing position to the tear off position. The top of the page (perforation) will be even with the tear bar. The tear bar is located under the clear top of the access cover.

Paper will remain in the tear off position until the printer receives data. Then, the paper is retracted to the initial print position.

When printing stops, the paper will advance to the tear off position.

NOTE:

If the software package being used "pauses" while sending data to the printer, Forms Tear Off may be activated (if it is enabled through the Menu). The pause must be for two or more seconds. No data is lost. Uneven print registration may occur due to the paper movement. If the problem occurs, deactivate Forms Tear Off through the Menu.

Do NOT use Forms Tear Off with labels or multi-part forms.

4.13.02 Procedure

- Verify that the ribbon and paper are installed.
- Power ON the printer.
- Press MODE. The SEL light will go out and the MENU lamp will light.

When the MENU lamp is lit, the functions printed BELOW the operator panel switches are activated.

- Press GROUP. The first line of the menu will print.

FONT Print Mode Utility

(GROUP) (ITEM) (Current SETting)

- Press GROUP until you access VERTICAL CONTROL.
- Press ITEM until you access FORMS TEAR OFF.
- Press SET until you access 500 ms.
- Press MODE to record the changes and return to Print Mode. The MENU lamp will go out and the SEL lamp will light.
- Press SEL until the SEL lamp goes out. The printer is deselected.
- Press and hold TOF/Quiet. While doing this, press either of the switches listed below.

FORM FEED increases the Top of Form. The paper is advanced.

LINE FEED decreases the Top of Form. The paper is retracted.

The lower red line on the ribbon protector shows the baseline of the current printing position. Use this when positioning the Top of Form.

The Top of Form is automatically saved in the printers static memory. Powering OFF the unit will NOT change the Top of Form. You must reset the Top of Form to change it.

- Release TOF/Quiet. The paper advances from the initial print position to the tear off position.

To check the initial print position, perform the following procedure.

- Press SEL until the SEL lamp goes out. The printer is deselected.
- Press and hold TOF/Quiet. The paper will retract to the initial print position.
- Release TOF/Quiet. The paper will advance to the forms tear off position.

Copyright 1997, Okidata, Division of OKI America, Inc. All rights reserved. See the OKIDATA Business Partner Exchange (BPX) for any updates to this material. (<http://bpx.okidata.com>)

A.1 BOARD REFERENCE CHARTS

A.1.01 General Information

This section describes the characteristics of the printed circuit boards used in the Microline 390/391 and Microline 390/391-Plus printers. The following areas are covered.

- Function
- Firmware
- Fuses
- Jumpers
- Switches
- Sensors
- Test Points

Where an item is not applicable, the word *NONE* will be listed.

Copyright 1997, Okidata, Division of OKI America, Inc. All rights reserved. See the OKIDATA Business Partner Exchange (BPX) for any updates to this material. (<http://bpx.okidata.com>)

A.1.02 Compatibility - Microline 390/391 vs. Microline 390/391-Plus

The differences between the Microline 390/391 and Microline 390/391-Plus printers are listed below.

Hardware Differences

- Operator Panel
- Operator Board
- Character Generator Programmable Read Only Memory (CGROM)
- Programmable Read Only Memory (PROM)
- Middle Cover

Operational Differences

- "Plus" printers have more resident fonts.
- In the "Plus" printers, data in the receive buffer is printed upon receipt, without having to wait for a line terminator character (CR/LF or FF).
- In the "Plus" printers, the DC1/DC3 Acknowledge/Ignore, Receive Buffer Size, and RESET inhibit can be controlled through the printers Menu.

Serial Number Revision Levels

Microline 390/391

A

Rev A units are original production units. An interconnect module connects the power supply board to the main control board.

B

Rev B units are retrofitted to include a modified interconnect module, which prevents corrosion.

C

These units have a cable connection between the power supply board and the main control board. The cable connection wire replaces the interconnect module.

Microline 390/391-Plus

Revision levels do NOT apply to the "Plus" printers.

NOTE:

Please refer to the parts lists for parts differentiation. Please be sure of the parts you need before ordering to avoid confusion and incorrect parts orders.

Printer Serial Number Identification

There are three serial number revision levels for the printers. Hardware differences exist between levels. To identify the revision level of a printer, record the serial number from the back of the printer. Refer to the following to decode the serial number.

Example Printer Serial Number: 401A0154693

Date Code 401 (4 = year. 01 = month)

Revision A

Serial Number 0154693

Compatibility Chart

Item	Okidata P/N	Purpose / Function of Item	Printer Serial Number Revision Level				
			390/391A	390/391B	390/391C	390+	391+
Main Control Board							
SKRA Board	55045401	Main Control Board	Yes	Yes	No	No	No
SKRB Board	55038702	Main Control Board	Yes	Yes	Yes	No	No
SKRA-3 Board	55045403	Main Control Board	Yes	Yes	Yes	Yes	Yes
Power Supply Board							
PAII Board	55038801	Power Supply Board	Yes	Yes	No	No	No
SUII Board	55047401	Power Supply Board	Yes	Yes	Yes	Yes	Yes







Operator Panel Assembly							
Panel: Operator Assembly	50069601	Operator Panel Assembly (390/391)	Yes	Yes	Yes	No	No
Panel: Operator Assembly	50069610	Operator Panel Assembly (390/391-Plus)	No	No	No	Yes	Yes
PCB: LXSP	55045601	Operator Panel Board (390/391)	Yes	Yes	Yes	No	No
PCB: LXSP-5	55038605	Operator Panel Board (390/391-Plus)	No	No	No	Yes	Yes
Transformer							
120 Volt XFRMR	56407201	Transformer (390 and 390-Plus)	Yes	Yes	Yes	Yes	Yes
120 Volt XFRMR	56407202	Transformer (391 and 391-Plus)	Yes	Yes	Yes	Yes	Yes
220 Volt XFRMR	56407801	Transformer (390 and 390-Plus)	Yes	Yes	Yes	Yes	No
220 Volt XFRMR	56407802	Transformer (391 and 391-Plus)	Yes	Yes	Yes	No	Yes
Interconnect Module							

Interconnect Module	55328301	Connects power supply board to main board	Yes	Yes	No	No	No
Cable							
Cable	56616802	Connects power supply board to main board	No	No	Yes	Yes	Yes
Cable Guide							
Cable Guide	51003801	Holds cable in place	No	No	Yes	Yes	Yes
Covers							
Cover	53488301	Middle Cover (390)	Yes	Yes	Yes	No	No
Cover	53488401	Middle Cover (391)	Yes	Yes	Yes	No	No
Cover	53488316	Middle Cover (390-Plus)	No	No	No	Yes	No
Cover	53488422	Middle Cover (391-Plus)	No	No	No	No	Yes
Chassis							
Chassis	50061101	Chassis: Main (390 and 390-Plus)	Yes	Yes	Yes	Yes	No
Chassis	50061201	Chassis: Main (391 and 391-Plus)	Yes	Yes	Yes	No	Yes

Copyright 1997, Okidata, Division of OKI America, Inc. All rights reserved. See the OKIDATA Business Partner Exchange (BPX) for any updates to this material. (<http://bpx.okidata.com>)

A.2 INDEX TO CHARTS

Microline 390/391: Rev A and B

Description	Board Designation	Section
Control Board	SKRA or SKRB	A.2.01  , A.2.02 
Power Supply	PAII	A.2.03 
Filter Assembly	N/A	A.2.05 
Operator Panel	LXSP	A.2.06 
Interconnect Board	SRBS	A.2.08 
RS232-C Serial Interface	LXHI	A.2.09 

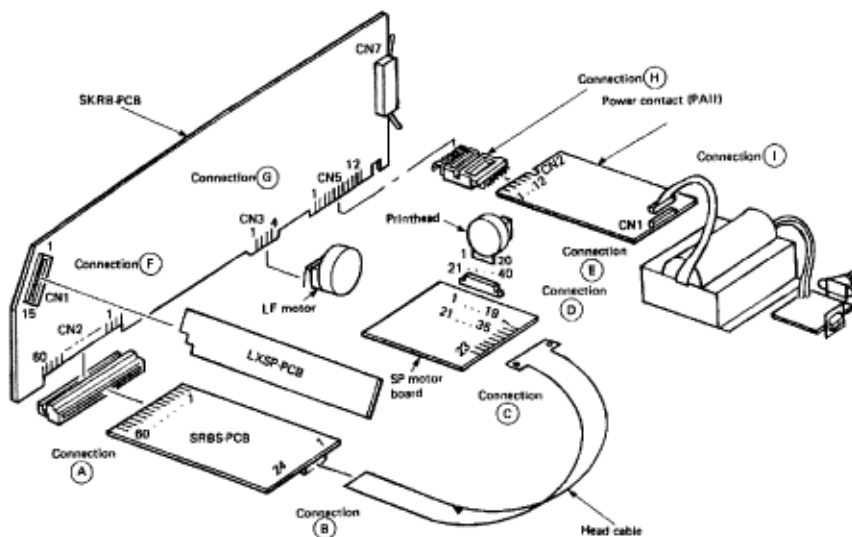



Service Guide ML390/391

Chapter A Board Diagrams

Microline 390/391: Rev C

Description	Board Designation	Section
Control Board	SKRA-3	A.2.02
Power Supply	SUII	A.2.04
Filter Assembly	N/A	A.2.05
Operator Panel	LXSP	A.2.06
Interconnect Board	SRBS	A.2.08
RS232-C Serial Interface	LXHI	A.2.09

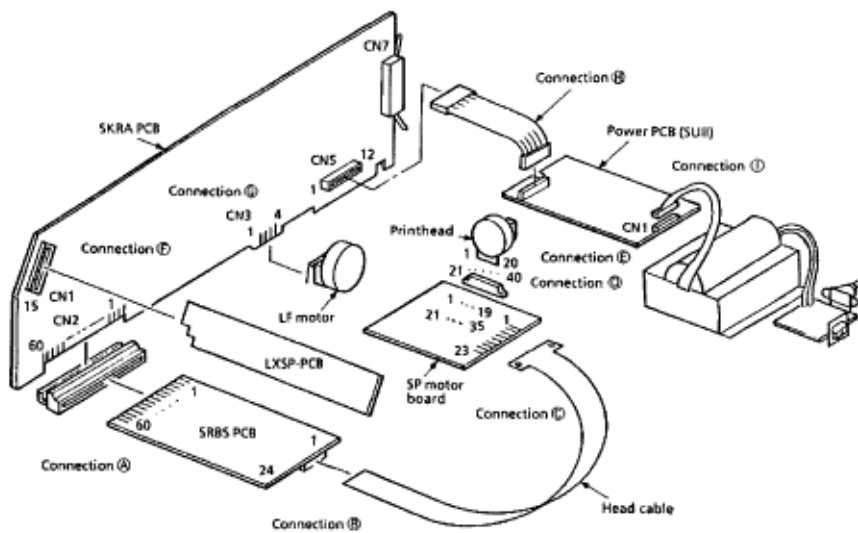

Copyright 1997, Okidata, Division of OKI America, Inc. All rights reserved. See the OKIDATA Business Partner Exchange (BPX) for any updates to this material. (<http://bpx.okidata.com>)



Service Guide ML390/391

Chapter A Board Diagrams

Microline 390/391-Plus

Description	Board Designation	Section
Control Board	SKRB	A.2.02
Power Supply	SUII	A.2.04
Filter Assembly	N/A	A.2.05
Operator Panel	LXSP-5	A.2.07
Interconnect Board	SRBS	A.2.08
RS232-C Serial Interface	LXHI	A.2.09

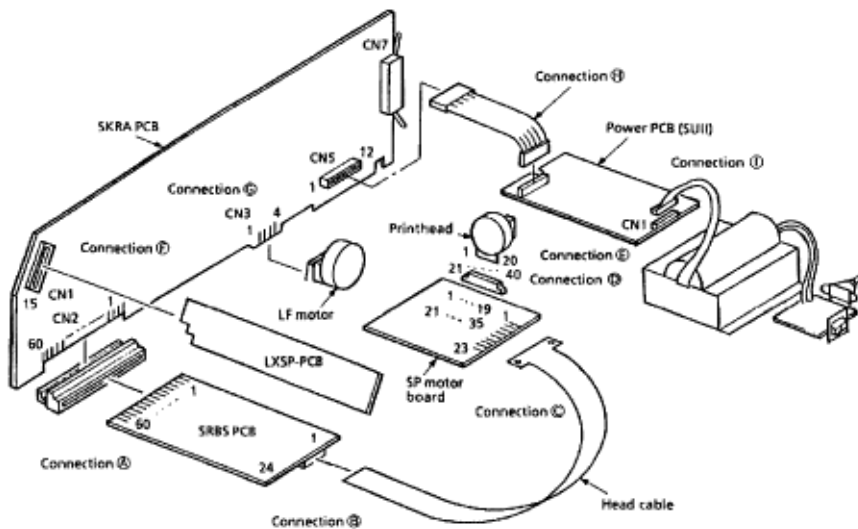

Copyright 1997, Okidata, Division of OKI America, Inc. All rights reserved. See the OKIDATA Business Partner Exchange (BPX) for any updates to this material. (<http://bpx.okidata.com>)

A.2.01 Control Board (SKRB) - Rev A and B**Function**

The control board contains the microprocessor and its peripheral circuits. The drive circuits, paper end sensor, and the interface connector are on this board. The 3.25 V lithium battery on this board provides power to the EEPROM. This allows Menu Data to be retained when power is removed from the printer.

Firmware

Q5 and Q12

Fuses

Rev 1 and 2

F1: Thermal Fuse (The fuse is located on Q10.)

Rev 3 and up

F1: Inline Thermal Fuse

Jumpers

SP1 Q5 ROM Selection

Side A 512 kbyte

Side B 1 Mbyte

SP2 I-Prime (Host Reset) Selection

Side A I-Prime active with negative strobe

Side B I-Prime active with positive strobe

SP3 Auto Feed Select

Side A Auto Feed disabled.

Side B Auto Feed enabled.

SP4 Selection of application of +5 vdc to pin 18 of the parallel interface connector

Side A + 5 vdc applied

Side B + 5 vdc not applied

Sensors

Paper End

Switches

SASF

Test Points

Refer to the diagram

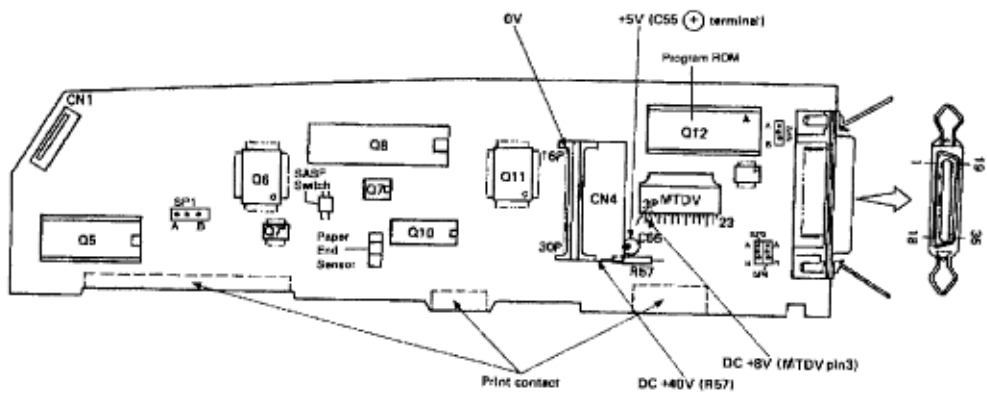

Copyright 1997, Okidata, Division of OKI America, Inc. All rights reserved. See the OKIDATA Business Partner Exchange (BPX) for any updates to this material. (<http://bpx.okidata.com>)

A.2.02 Control Board (SKRA) - Rev C and "Plus" Printers**Function**

The control board contains the microprocessor and its peripheral circuits. The drive circuits, paper end sensor, and the interface connector are on this board. The 3.25 V lithium battery on this board provides power to the EEPROM. This allows Menu Data to be retained when power is removed from the printer.

Firmware

Q5 and Q12

Fuses

F1: Inline Fuse

Jumpers

SP1 Q5 ROM Selection

Side A 512 kbyte

Side B 1 Mbyte

SP2 I-Prime (Host Reset) Selection

Side A I-Prime active with negative strobe

Side B I-Prime active with positive strobe

SP3 Auto Feed Select

Side A Auto Feed disabled.

Side B Auto Feed enabled.

SP4 Selection of application of +5 vdc to pin 18 of the parallel interface connector

Side A + 5 vdc applied

Side B + 5 vdc not applied

Sensors

Paper End

Switches

SASF

Test Points

Refer to the diagram.

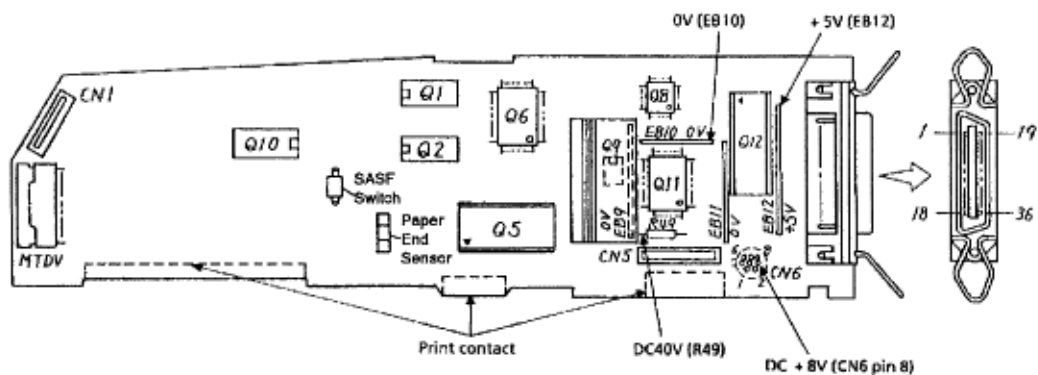

Copyright 1997, Okidata, Division of OKI America, Inc. All rights reserved. See the OKIDATA Business Partner Exchange (BPX) for any updates to this material. (<http://bpx.okidata.com>)

A.2.03 Power Supply (PAII) - Rev A and B**Function**

This board converts and regulates the AC voltage input to DC voltage and supplies the DC voltage to the control board.

Firmware

NONE

Fuses

F1 2.0 amp / 250 VAC

Jumpers

NONE

Sensors

NONE

Switches

NONE

Test Points

CN2: Pin 1 + 40 vdc

CN2: Pin 6 + 5 vdc

CN2: Pin 10 + 8 vdc

Notes

CN1: connection from Transformer

CN2: connection to Power Interconnect Module

RV-1

This is a variable resistor.

It is used to adjust the space motor drive circuit.

The adjustment is set at the factory.

The power supply board (PAII) was used in both the Microline 390/391 and Microline 320/321 printers. The adjustment for RV1 is very different for the two series. When installing a replacement power supply board, verify that RV-1 is properly adjusted for the series printers it is being installed in.

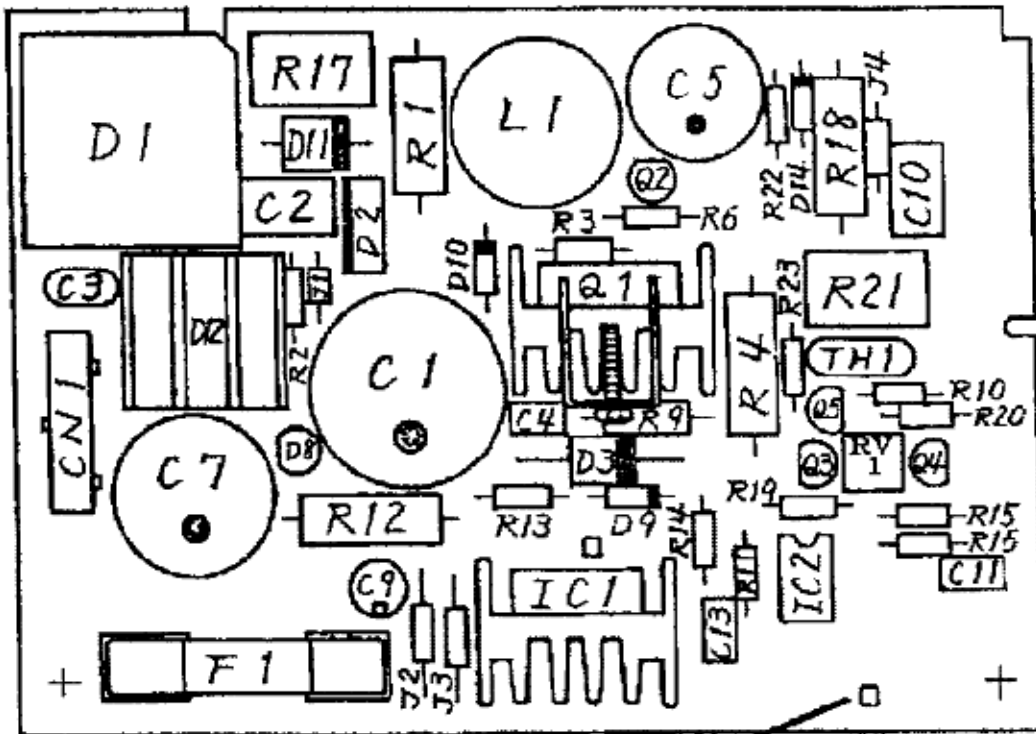
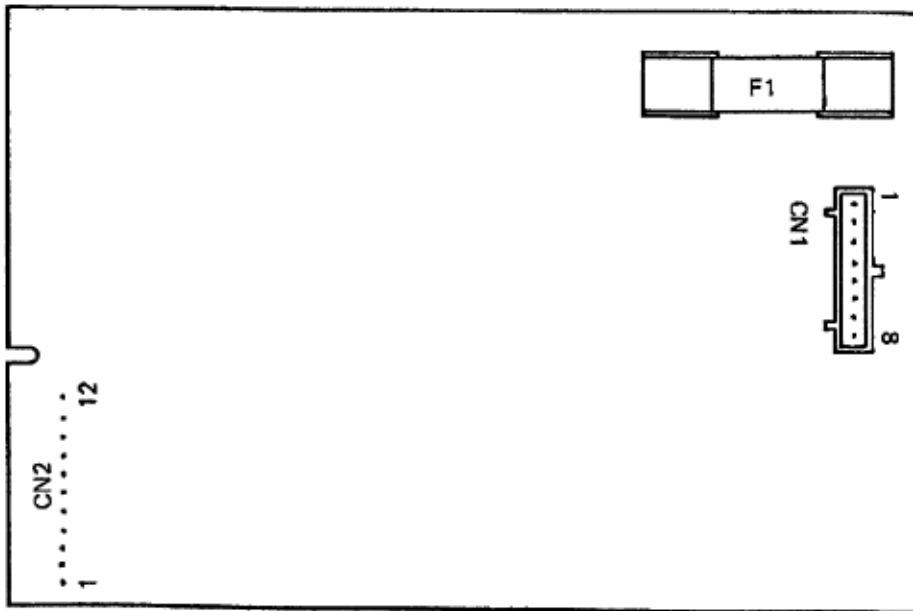

ML320/321 - 2 is stamped here
 ML300/301 - Blank

ML320/321
Setting for RV1

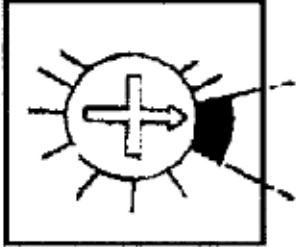

ML390/391
Setting for RV1

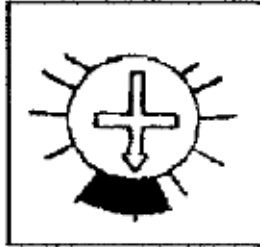

Copyright 1997, Okidata, Division of OKI America, Inc. All rights reserved. See the OKIDATA Business Partner Exchange (BPX) for any updates to this material. (<http://bpx.okidata.com>)

A.2.04 Power Supply (SUII) - Rev C and "Plus" Printers**Function**

This board converts and regulates the AC voltage input to DC voltage and supplies the DC voltage to the control board.

Firmware

NONE

Fuses

F1 2.0 amp / 250 VAC

Jumpers

NONE

Sensors

NONE

Switches

NONE

Test Points

CN2: Pin 1 + 40 vdc

CN2: Pin 6 + 5 vdc

CN2: Pin 8 + 8 vdc

Notes

CN1 connection from Transformer

CN2 connection to Power Interconnect Module

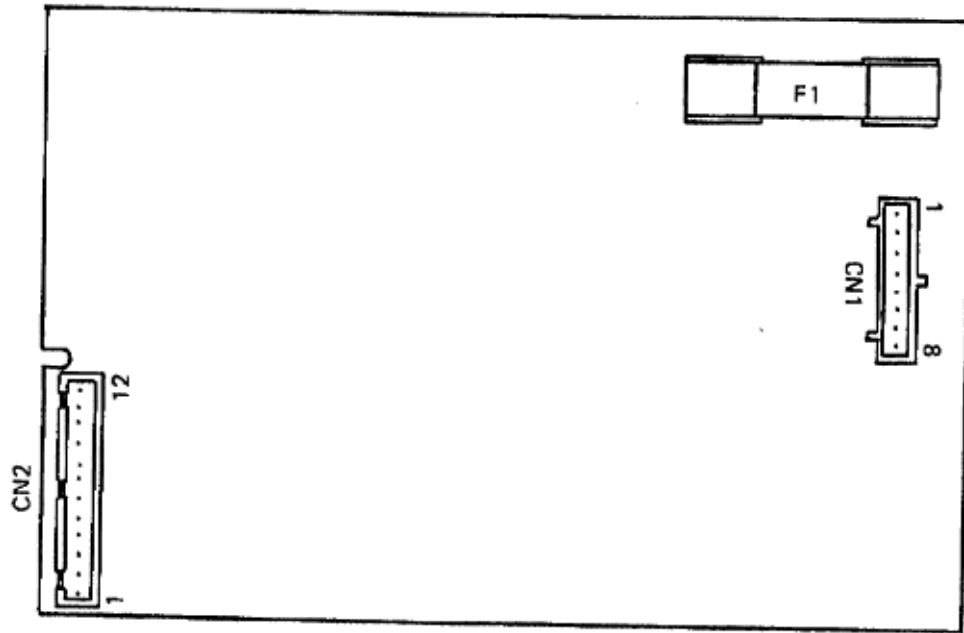

Copyright 1997, Okidata, Division of OKI America, Inc. All rights reserved. See the OKIDATA Business Partner Exchange (BPX) for any updates to this material. (<http://bpx.okidata.com>)

A.2.05 Filter Assembly**Function**

This assembly filters out AC line noise. Its fuse will open when a fault occurs in the printhead drive circuit, the space motor drive circuit, or any of their peripheral circuits. This prevents component failure.

Firmware

NONE

Fuses

F1 (also known as the AC fuse)

5 amp (250 V)

Jumpers

NONE

Sensors

NONE

Switches

Power ON/OFF

Test Points

NONE

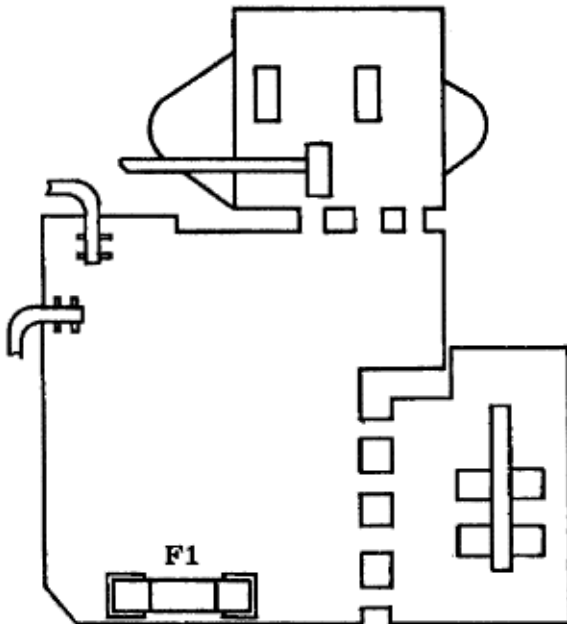

Copyright 1997, Okidata, Division of OKI America, Inc. All rights reserved. See the OKIDATA Business Partner Exchange (BPX) for any updates to this material. (<http://bpx.okidata.com>)



Service Guide ML390/391

Chapter A Board Diagrams

A.2.06 Operator Panel (LXSP) - Microline 390/391

Function

The operator panel is the interface between the operator and the printer.

Firmware

NONE

Fuses

NONE

Jumpers

NONE

Sensors

NONE

Switches

Refer to diagram

Test Points

NONE

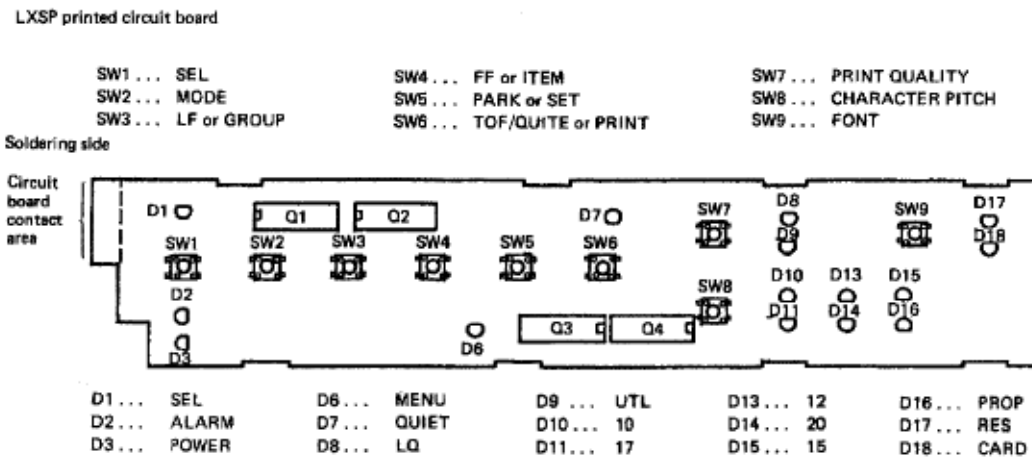



Service Guide ML390/391

Chapter A Board Diagrams

A.2.07 Operator Panel (LXSP-5) - Microline 390/391-Plus

Function

The operator panel is the interface between the operator and the printer.

Firmware

NONE

Fuses

NONE

Jumpers

NONE

Sensors

NONE

Switches

Refer to diagram

Test Points

NONE

LXSP printed circuit board

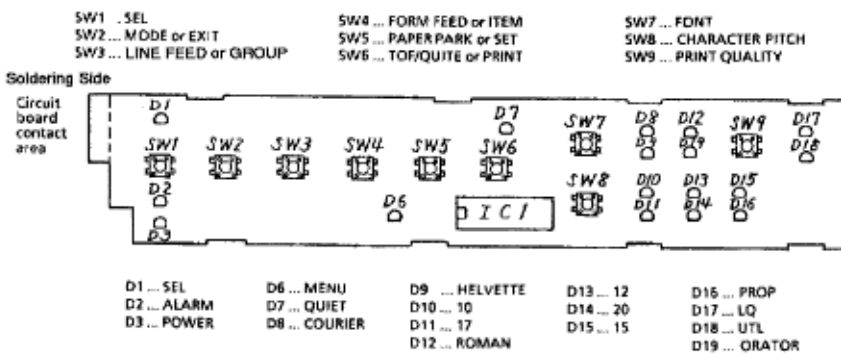



Service Guide ML390/391

Chapter A Board Diagrams

A.2.08 Interconnect Board (SRBS)

Function

This board is the connection between the font card, the control board, and the space motor.

Firmware

NONE

Fuses

NONE

Jumpers

NONE

Sensors

NONE

Switches

NONE

Test Points

NONE

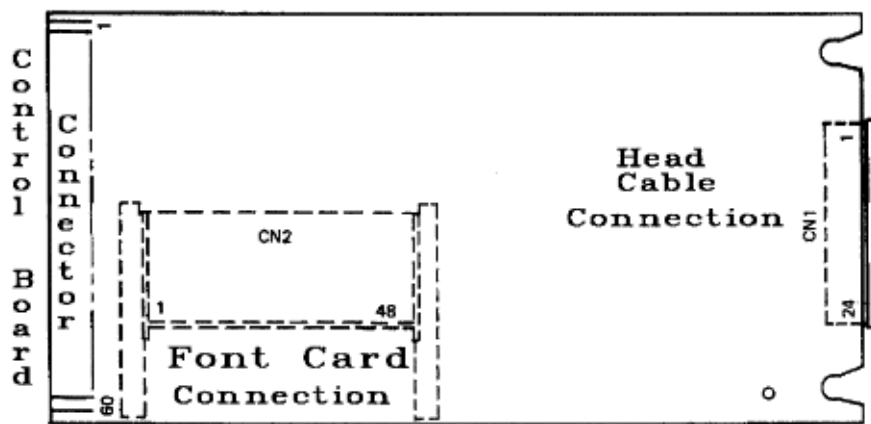

SRBS-PCB (connection board)

A.2.09 RS232-C Serial Interface (LXHI)**Function**

This board permits the serial transport of data to and from the printer. It is capable of transferring data at speeds up to 19.2 K Baud. Interface parameters (such as baud rate and word length) are selected through the printer menu.

Firmware**ROM**

Version 1 Q8: 1 megabyte ROM. Contains the serial interface control program.

Version 2 None

RAM

Versions 1 and 2 8 kilobytes, Static RAM Receive Buffer

Processor

Version 1 Q3 M80C31F

Version 2 Q3 M80C51F

Fuses

NONE

Jumpers

Version 1 SP1 Side A Q8 has ROM installed

Version 2 SP1 Side B CPU Masked ROM is utilized

Sensors

NONE

Switches

NONE

Test Points

NONE

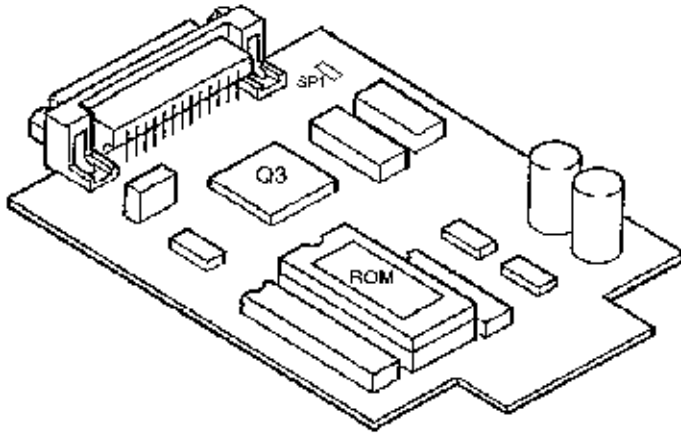

Copyright 1997, Okidata, Division of OKI America, Inc. All rights reserved. See the OKIDATA Business Partner Exchange (BPX) for any updates to this material. (<http://bpx.okidata.com>)

B.1 ILLUSTRATED PARTS LISTING

B.1.01 General Information

This appendix will assist you in identifying the assemblies and parts of the printers. Once you have used Section Four (Failure Analysis) to find a defective part, you can locate the part number in this section. This appendix is cross-referenced to Section Three (Maintenance) to assist you in servicing the printers.

The format for this appendix is a series of tables with diagrams. The table contains the item reference number, the Okidata and Oki-Japan (Oki-J) part numbers, the part description, a comments section, and the disassembly procedure. Items with the comment RSPL (Recommended Spare Parts List), Consumable, or Option are available from Okidata. Items without these comments are usually not stocked. Also note that some items are only available as assemblies. Every effort has been made to clearly indicate which items are in assemblies and which are not.

N/A will appear where a part number is not available.

Please read the Definition of Terms in the following section carefully. It is important that you understand the different types of classifications and their availability.

Please refer to the following resources for current part numbers and pricing.

- Okidata's Bulletin Board (Okilink II) contains current part numbers, prices, and recommended stocking levels for each item listed as a recommended spare part. For instructions on accessing Okilink II, refer to the Service Center Reference Guide.
- Okidata's Faxable Facts is an automated fax document retrieval system. Part numbers and pricing are available through Faxable Facts. For instructions on accessing Faxable Facts, refer to the Service Center Reference Guide.
- Okidatas Technical Information Group is a telephone support line reserved for Authorized Dealers. Part numbers and pricing are available through Technical Information. For instructions on accessing Technical Information, refer to the Service Center Reference Guide.

REMEMBER

Current part numbers, recommended stocking levels, and pricing information are available through Okilink II, Faxable Facts, and Technical Information. Refer to the Service Center Reference Guide for information on accessing these resources.

B.1.02 Definitions of Terms

RSPL

Okidata recommends that this part/assembly be on hand for servicing.

Consumable

A consumable is a supply item which has a specified life and needs to be replaced periodically. It is purchased and installed by the end user. Okidata machines are designed to work *exclusively* with Okidata consumables. By using genuine Okidata consumable products, the investment made in the equipment will be protected.

Option

An option is a part/assembly which is added to a product and expands the products functionality. An option may or may not be installed by the end-user. Instructions for installation accompany each option.

Option RSPL

Okidata recommends that this part/assembly be on hand for servicing installed options.

Document

A document is a printed item which supports the service and marketing of a product. Various documents are available from Okidata.

Blank

Okidata does not recommend stocking this item. This item should be purchased on an **As Required Basis** *only*. The availability of this item is NOT guaranteed by Okidata.

390

This part is found **ONLY** in the Microline 390 printer.

391

This part is found **ONLY** in the Microline 391 printer.

390 +

This part is found **ONLY** in the Microline 390-Plus printer.

391 +

This part is found **ONLY** in the Microline 391-Plus printer.

Both

This part is found in both the Microline 390 and 391 printers.

Both +

This part is found in both the Microline 390 and 391-Plus printers.

Both 90

This part is found in both the Microline 390 and Microline 390-Plus printers.

Both 91

This part is found in both the Microline 391 and Microline 391-Plus printers.

All

This part is found in the Microline 390, Microline 391, Microline 390-Plus, and Microline 391-Plus printers.

Copyright 1997, Okidata, Division of OKI America, Inc. All rights reserved. See the OKIDATA Business Partner Exchange (BPX) for any updates to this material. (<http://bpx.okidata.com>)

B.1.03 Compatibility - Microline 390/391 vs. Microline 390/391-Plus

The differences between the Microline 390/391 and Microline 390/391-Plus printers are listed below.

Hardware Differences

- Operator Panel
- Operator Board
- Character Generator Programmable Read Only Memory (CGROM)
- Programmable Read Only Memory (PROM)
- Middle Cover

Operational Differences

- "Plus" printers have more resident fonts.
- In the "Plus" printers, data in the receive buffer is printed upon receipt, without having to wait for a line terminator character (CR/LF or FF).
- In the "Plus" printers, the DC1/DC3 Acknowledge/Ignore, Receive Buffer Size, and RESET inhibit can be controlled through the printers Menu.

Serial Number Revision Levels

Microline 390/391

A

Rev A units are original production units. An interconnect module connects the power supply board to the main control board.

B

Rev B units are retrofitted to include a modified interconnect module, which prevents corrosion.

C

These units have a cable connection between the power supply board and the main control board. The cable connection wire replaces the interconnect module.

Microline 390/391-Plus

Revision levels do NOT apply to the "Plus" printers.

NOTE:

Please refer to the parts lists for parts differentiation. Please be sure of the parts you need before ordering to avoid confusion and incorrect parts orders.

Printer Serial Number Identification

There are three serial number revision levels for the printers. Hardware differences exist between levels. To identify the revision level of a printer, record the serial number from the back of the printer. Refer to the following to decode the serial number.

Example Printer Serial Number: 401A0154693

Date Code 401 (4 = year. 01 = month)

Revision A

Serial Number 0154693

Compatibility Chart

Item	Okidata P/N	Purpose / Function of Item	Printer Serial Number Revision Level				
			390/391 A	390/391 B	390/391 C	390 +	391+
Main Control Board							
SKRA Board	55045401	Main Control Board	Yes	Yes	No	No	No
SKRB Board	55038702	Main Control Board	Yes	Yes	No	No	No
SKRA-3 Board	55045403	Main Control Board	Yes	Yes	Yes	Yes	Yes
Power Supply Board							
PAII Board	55038801	Power Supply Board	Yes	Yes	No	No	No
SUII Board	55047401	Power Supply Board	Yes	Yes	Yes	Yes	Yes
Operator Panel Assembly							

Panel: Operator Assembly	50069601	Operator Panel Assembly (390/391)	Yes	Yes	Yes	No	No
Panel: Operator Assembly	50069610	Operator Panel Assembly (390/391-Plus)	No	No	No	Yes	Yes
PCB: LXSP	55045601	Operator Panel Board (390/391)	Yes	Yes	Yes	No	No
PCB: LXSP-5	55038605	Operator Panel Board (390/391-Plus)	No	No	No	Yes	Yes
Transfor mer							
120 Volt XFRMR	56407201	Transformer (390 and 390-Plus)	Yes	Yes	Yes	Yes	Yes
120 Volt XFRMR	56407202	Transformer (391 and 391-Plus)	Yes	Yes	Yes	Yes	Yes
220 Volt XFRMR	56407801	Transformer (390 and 390-Plus)	Yes	Yes	Yes	Yes	No
220 Volt XFRMR	56407802	Transformer (391 and 391-Plus)	Yes	Yes	Yes	No	Yes
Intercon nect Module							
Interconn ect Module	55328301	Connects power supply board to main board	Yes	Yes	No	No	No
Cable							

Cable	56616802	Connects power supply board to main board	No	No	Yes	Yes	Yes
Cable Guide							
Cable Guide	51003801	Holds cable in place	No	No	Yes	Yes	Yes
Covers							
Cover	53488301	Middle Cover (390)	Yes	Yes	Yes	No	No
Cover	53488401	Middle Cover (391)	Yes	Yes	Yes	No	No
Cover	53488316	Middle Cover (390-Plus)	No	No	No	Yes	No
Cover	53488422	Middle Cover (391-Plus)	No	No	No	No	Yes
Chassis							
Chassis	50061101	Chassis: Main (390 and 390-Plus)	Yes	Yes	Yes	Yes	No
Chassis	50061201	Chassis: Main (391 and 391-Plus)	Yes	Yes	Yes	No	Yes

B.1.04 Parts Ordering Information

General Information

All authorized Okidata Dealers may order spare parts and consumables for Okidata products. Orders are placed through Okidata's Logistics Department.

When a technician has successfully completed a product certification course and the Dealer has become service authorized, an information package will be provided to the Dealer. The Okidata Service Center Reference Guide outlines the following.

- Responsibilities of Okidata Service Centers
- Spare parts and consumables information
- Procedures for warranty repairs
- Product training, certification, and authorization
- Product support information
- Okidata depot information and services
- Third party service information
- Information about Okidata's Customer Information Center
- Okidata service and support telephone numbers.

The Service Center Reference Guide contains detailed procedures to follow when ordering parts. Please *read, understand, and follow* these procedures. Service authorization for a specific product *must* be obtained before a Dealer can submit warranty claims.

Questions regarding the Service Center Reference Guide should be directed to Okidata Dealer Service.

Placing a Parts Order

Please refer to the Service Center Reference Guide for details on ordering parts.















The following information **MUST** be available *before* an order is placed.

- Okidata Dealer Authorization Number
- Purchase Order number
- Serial Number / Revision Level of the printer(s)
- Okidata Part Number(s)

Use this Appendix, Okilink II, Faxable Facts, or Technical Information to find the correct part number. Refer to the Service Center Reference Guide for information on contacting Okidata.

B.2 CHARTS







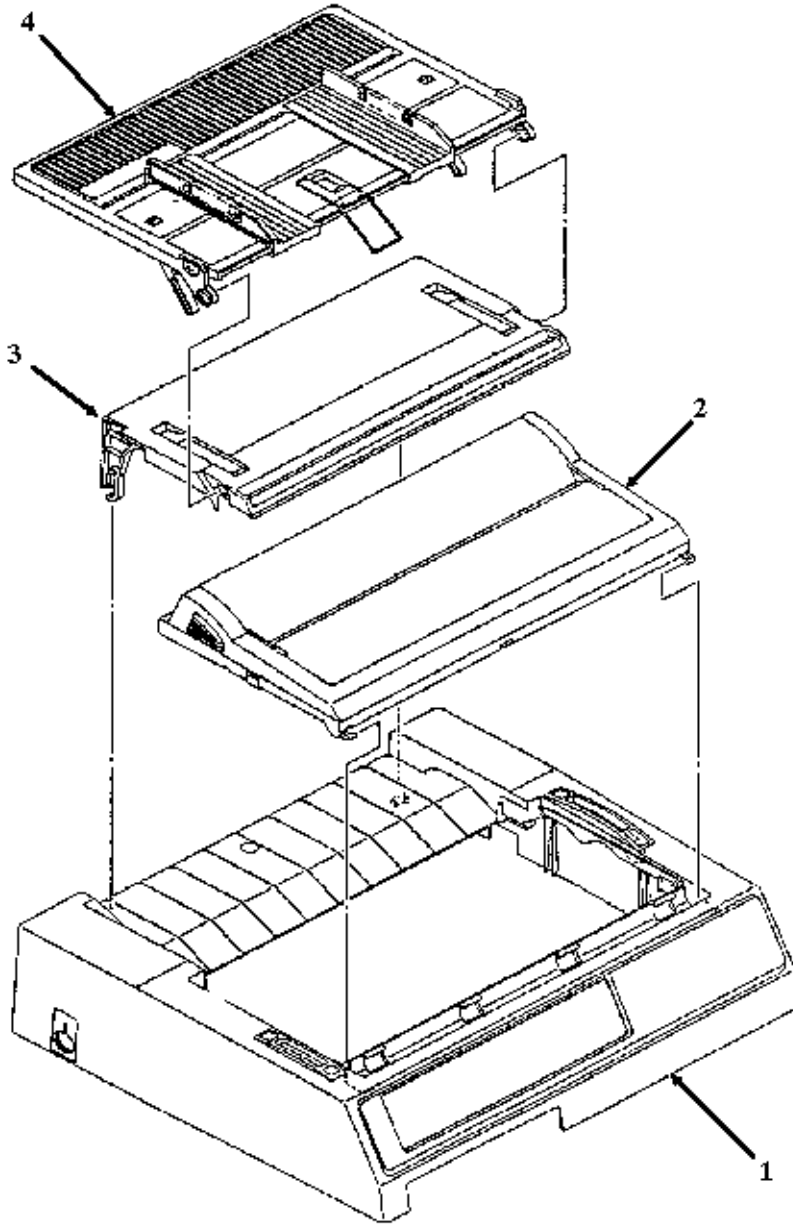

Below is an index to the illustrated parts breakdown charts.

Description	Section
Covers	B.2.01 
Electrical Components - Rev A and B	B.2.02 
Electrical Components - Rev C	B.2.03 
Printer Mechanism - Rev A and B (1 of 2)	B.2.04 
Printer Mechanism - Rev A and B (2 of 2)	B.2.05 
Printer Mechanism - Rev C (1 of 2)	B.2.06 
Printer Mechanism - Rev C (2 of 2)	B.2.07 
Operator Panel Assembly	B.2.08 
Carriage Assembly	B.2.09 
Tractor Assembly	B.2.10 
Options	B.2.11 
Consumables	B.2.12 
Packaging	B.2.13 
Documentation	B.2.14 

B.2.01 Covers

Part numbers are subject to change. [Refer to Section B.1.01](#)  for finding current information.











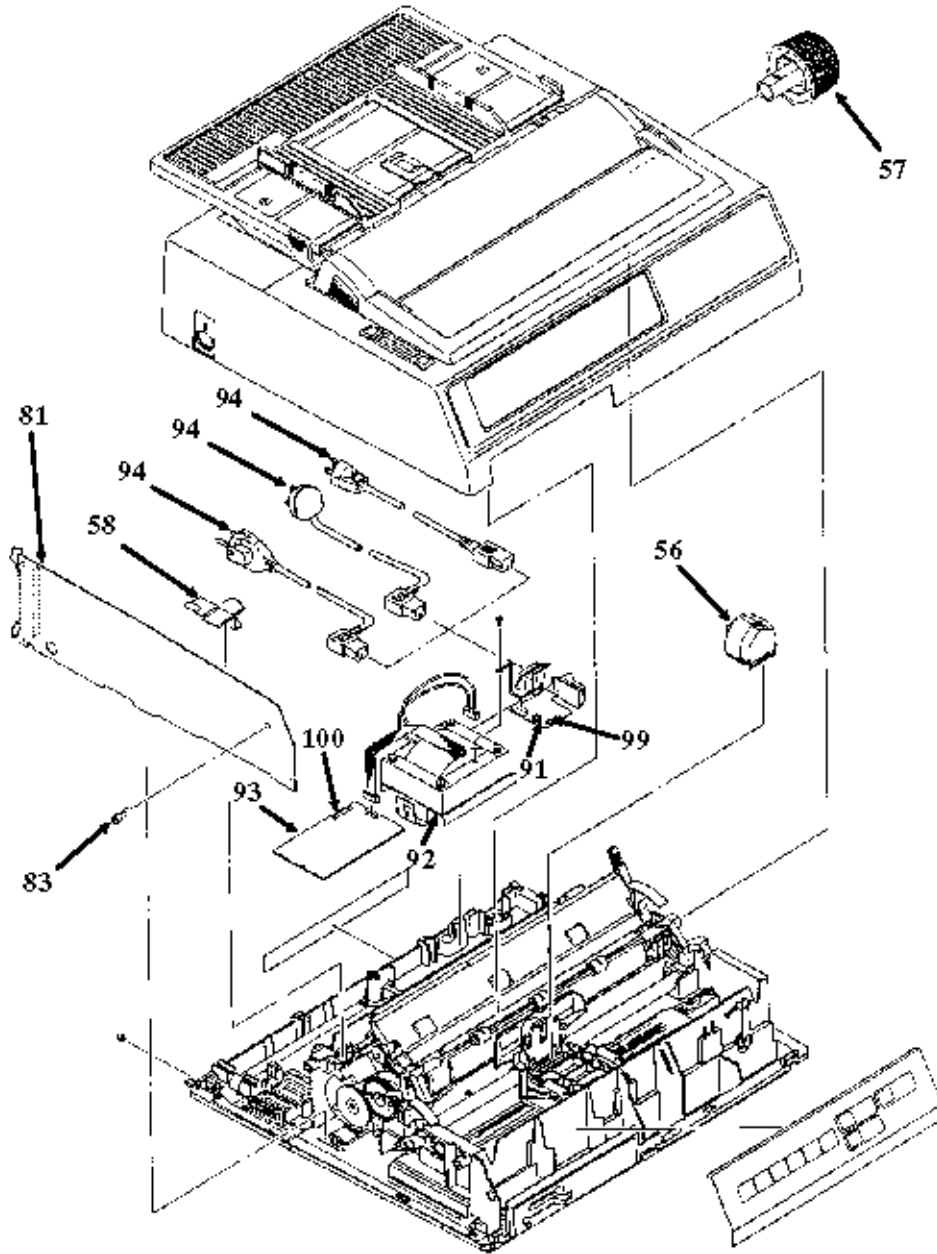









Item	Okidata P/N Oki-J P/N	Description	Product	Comments Refer to B.1.02 	Disassembly Procedure	Serial No. Rev. Letter
1	53488301 1PP4016-6557P1	Cover: Middle (ML390)	390	RSPL	3.2.04 	A B C
1	53488316 1PP4016-6557P16	Cover: Middle (ML390+)	390+	RSPL	3.2.04 	A B C
1	53488401 1PP4016-6558P1	Cover: Middle (ML391)	391	RSPL	3.2.04 	A B C
1	53488422 1PP4016-6558P22	Cover: Middle (ML391+)	391+	RSPL	3.2.04 	A B C
2	50060701 2PA4016-6559G1	Cover: Access (Assembly)	Both 90	RSPL	3.2.04 	A B C
2	50060801 2PA4016-6560G1	Cover: Access (Assembly)	Both 91	RSPL	3.2.04 	A B C
3	53488501 1PP4016-6567P1	Frame: Rear Cover	Both 90	RSPL	3.2.04 	A B C
3	53488601 1PP4016-6568P1	Frame: Rear Cover	Both 91	RSPL	3.2.04 	A B C
4	50060901 1PA4016-6569G1	Separator: Sheet (Assembly)	Both 90	RSPL	3.2.04 	A B C
4	50061001 1PA4016-6570G1	Separator: Sheet (Assembly)	Both 91	RSPL	3.2.04 	A B C



Copyright 1997, Okidata, Division of OKI America, Inc. All rights reserved. See the OKIDATA Business Partner Exchange (BPX) for any updates to this material. (<http://bpx.okidata.com>)

B.2.02 Electrical Components - Rev A and B

Part numbers are subject to change. [Refer to Section B.1.01](#) for finding current information.



Item	Okidata P/N Oki-J P/N	Description	Product	Comments Refer to B.1.02 	Disassembly Procedure	Serial No. Rev. Letter
94	56609701 3YS4011-1315P1	Cord: AC 120 V	All	RSPL	3.2.01 	A B C
94	56610801 3YS4011-1052P1	Cord: AC (220 V) (ML Series)	All	Option RSPL	3.2.01 	A B C
94	56616501 3YS4011-1292P1	Cord: AC 240V	All	Option	3.2.01 	A B C
94	56624101 3YS4011-1265P1	Cord: AC 220 V (ML) Right Angle	All	Option	3.2.01 	A B C
56	50062201 4YA4023-2011G1	Printhead: (Assembly)	All	RSPL	3.2.03 	A B C
57	51901101 3PP4025-2871P1	Knob: Platen	All	RSPL	3.2.04 	A B C
58	50704301 3PA4025-2896P1	Clamp: PCB	All	RSPL	3.2.06 	A B C
81	55045403 4YA4021-1052G103	PCB: SKRA-3 w/o ROM (Cntl Board)	All	RSPL	3.2.06 	A B C
83	50605501 4PP4025-2870P1	Lock: Board Screw	All	RSPL	3.2.06 	A B C
92	56407201 4YB4056-8300P1	Transformer: 120 V	Both 90	RSPL	3.2.08 	A B C
92	56407202 4YB4056-8300P2	Transformer: 120 V	Both 91	RSPL	3.2.08 	A B C
92	56407801 4YB4056-8348P1	Transformer: 220/240 V	Both 90	Option RSPL	3.2.08 	A B C
92	56407802 4YB4056-8348P2	Transformer: 220/240 V	Both 91	Option RSPL	3.2.08 	A B C
91	55503101 4YX4056-3477G1	Filter: (Assembly) AC 120V	All	RSPL	3.2.09 	A B C
91	55503102 4YX4056-3477G2	Filter: 220/240 V (Assembly)	All	Option	3.2.09 	A B C
93	55047401 3YU5057-3311G1	PCB: SU11 (Power Supply)	All	RSPL	3.2.10 	A B C



93	55047406 3YU5057-3311G6	PCB: SU11-6 (220/24V) (Pwr Supp)		Option	3.2.10 	A B C
	55923901	IC: CU EEPROM MSM16811RS- NW	391 390+	RSPL	3.2.06 	
	55938101 816A8003M001	IC: CU EEPROM ER59256	390 391+	RSPL	3.2.06 	
	56302001 540A2052M2502	Fuse: 5A Glass MGC-5 (Toyo)	Both	Option RSPL		
	56302101 540A2065N2202	Fuse: Glass 2 amp 250V	Both	Option		A B C
	56302601 540A2044S2322	Fuse: 3.15 Amp	Both	Option RSPL		
	56304602 FP-21107-2	Fuse: 2 Amp 250 V	Both+	RSPL		
	56304603 FP-21107-3	Fuse: 5 Amp 250 V	Both+	RSPL		
	56304702 FP-21108-2	Fuse: 2 Amp 250 V	Both+	Option RSPL		

Copyright 1997, Okidata, Division of OKI America, Inc. All rights reserved. See the OKIDATA Business Partner Exchange (BPX) for any updates to this material. (<http://bpx.okidata.com>)

B.2.03 Electrical Components - Rev C

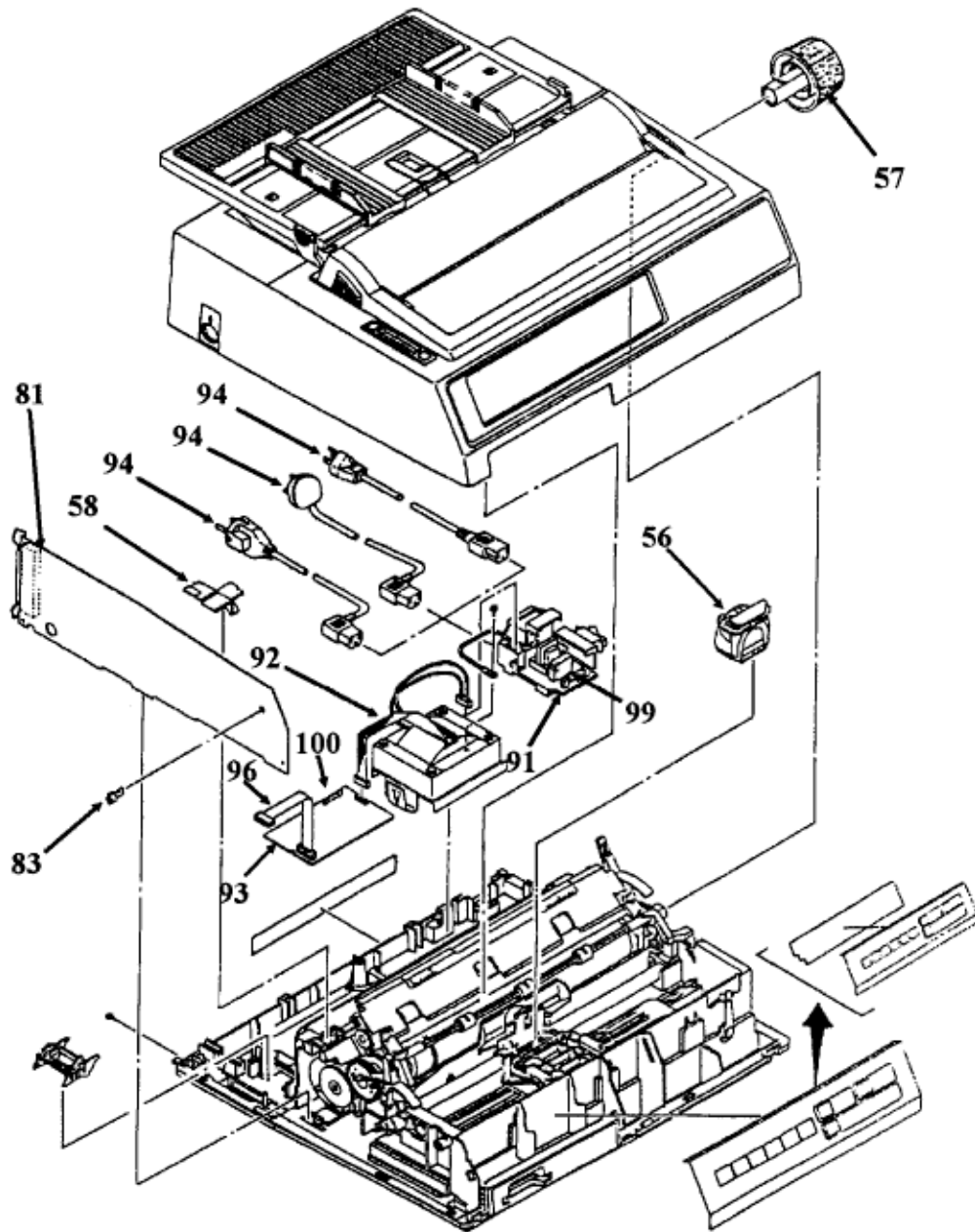
Part numbers are subject to change. [Refer to Section B.1.01 !\[\]\(d3fb9f94af8b26d1c844efa9a98805b0_img.jpg\) for finding current information.](#)



Item	Okidata P/N Oki-J P/N	Description	Product	Comments Refer to B.1.02 	Disassembly Procedure	Serial No. Rev. Letter
94	56609701 3YS4011-1315P1	Cord: AC 120 V	All	RSPL	3.2.01 	A B C

94	56610801 3YS4011-1052P1	Cord: AC (220 V) (ML Series)	All	Option RSPL	3.2.01 	A B C
94	56616501 3YS4011-1292P1	Cord: AC 240V	All	Option	3.2.01 	A B C
94	56624101 3YS4011-1265P1	Cord: AC 220 V (ML) Right Angle	All	Option	3.2.01 	A B C
56	50062201 4YA4023-2011G1	Printhead: (Assembly)	All	RSPL	3.2.03 	A B C
57	51901101 3PP4025-2871P1	Knob: Platen	All	RSPL	3.2.04 	A B C
58	50704301 3PA4025-2896P1	Clamp: PCB	All	RSPL	3.2.06 	A B C
81	55045403 4YA4021-1052G1 03	PCB: SKRA-3 w/o ROM (Cntl Board)	All	RSPL	3.2.06 	A B C
83	50605501 4PP4025-2870P1	Lock: Board Screw	All	RSPL	3.2.06 	A B C
92	56407201 4YB4056-8300P1	Transformer: 120 V	Both 90	RSPL	3.2.08 	A B C
92	56407202 4YB4056-8300P2	Transformer: 120 V	Both 91	RSPL	3.2.08 	A B C
92	56407801 4YB4056-8348P1	Transformer: 220/240 V	Both 90	Option RSPL	3.2.08 	A B C
92	56407802 4YB4056-8348P2	Transformer: 220/240 V	Both 91	Option RSPL	3.2.08 	A B C
91	55503101 4YX4056-3477G1	Filter: (Assembly) AC 120V	All	RSPL	3.2.09 	A B C
91	55503102 4YX4056-3477G2	Filter: 220/240 V (Assembly)	All	Option	3.2.09 	A B C
93	55047401 3YU5057-3311G1	PCB: SUII (Power Supply)	All	RSPL	3.2.10 	A B C
93	55047406 3YU5057-3311G6	PCB: SUII-6 (220/24V) (Pwr Supp)		Option	3.2.10 	A B C
	55923901	IC: CU EEPROM MSM16811RS- NW	391 390+	RSPL	3.2.06 	

	55938101 816A8003M001	IC: CU EEPROM ER59256	390 391+	RSPL	3.2.06 	
	56302001 540A2052M2502	Fuse: 5A Glass MGC-5 (Toyo)	Both	Option RSPL		
	56302101 540A2065N2202	Fuse: Glass 2 amp 250V	Both	Option		A B C
	56302601 540A2044S2322	Fuse: 3.15 Amp	Both	Option RSPL		
	56304602 FP-21107-2	Fuse: 2 Amp 250 V	Both+	RSPL		
	56304603 FP-21107-3	Fuse: 5 Amp 250 V	Both+	RSPL		
	56304702 FP-21108-2	Fuse: 2 Amp 250 V	Both+	Option RSPL		



Copyright 1997, Okidata, Division of OKI America, Inc. All rights reserved. See the OKIDATA Business Partner Exchange (BPX) for any updates to this material. (<http://bpx.okidata.com>)

B.2.04 Printer Mechanism - Rev A and B (1 of 2)

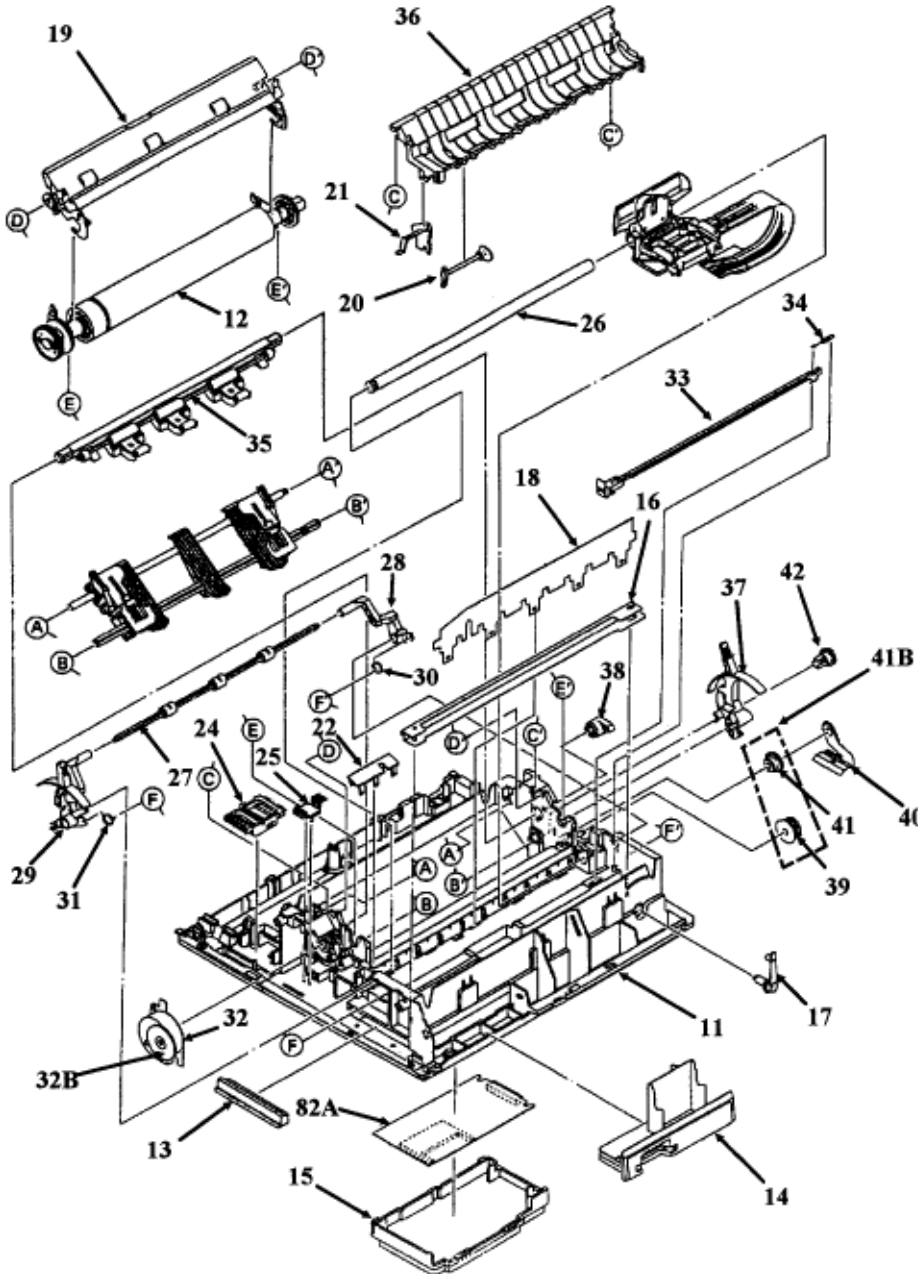
Part numbers are subject to change. [Refer to Section B.1.01](#) for finding current information.



Item	Okidata P/N Oki-J P/N	Description	Product	Comments Refer to B.1.02 📄	Disassembly Procedure	Serial No. Rev. Letter
94	56609701 3YS4011-1315P1	Cord: AC 120 V	All	RSPL	3.2.01 📄	A B C
94	56610801 3YS4011-1052P1	Cord: AC (220 V) (ML Series)	All	Option RSPL	3.2.01 📄	A B C
94	56616501 3YS4011-1292P1	Cord: AC 240 V	All	Option	3.2.01 📄	A B C
94	56624101 3YS4011-1265P1	Cord: AC 220 V (ML) Right Angle	All	Option	3.2.01 📄	A B C
56	50062201 4YA4023-2011G1	Printhead: (Assembly)	All	RSPL	3.2.03 📄	A B C
57	51901101 3PP4025-2871P1	Knob: Platen	All	RSPL	3.2.04 📄	A B C
58	50704301 3PA4025-2896P1	Clamp: PCB	All	RSPL	3.2.06 📄	A B C
81	55045403 4YA4021-1052G103	PCB: SKRA-3 w/o ROM (Cntl Board)	All	RSPL	3.2.06 📄	A B C
83	50605501 4PP4025-2870P1	Lock: Board Screw	All	RSPL	3.2.06 📄	A B C
92	56407201 4YB4056-8300P1	Transformer: 120 V	Both 90	RSPL	3.2.08 📄	A B C
92	56407202 4YB4056-8300P2	Transformer: 120 V	Both 91	RSPL	3.2.08 📄	A B C
92	56407801 4YB4056-8348P1	Transformer: 220/240 V	Both 90	Option RSPL	3.2.08 📄	A B C
92	56407802 4YB4056-8348P2	Transformer: 220/240 V	Both 91	Option RSPL	3.2.08 📄	A B C
91	55503101 4YX4056-3477G1	Filter: (Assembly) AC 120V	All	RSPL	3.2.09 📄	A B C
91	55503102 4YX4056-3477G2	Filter: 220/240 V (Assembly)	All	Option	3.2.09 📄	A B C
93	55047401 3YU5057-3311G1	PCB: SUII (Power Supply)	All	RSPL	3.2.10 📄	A B C









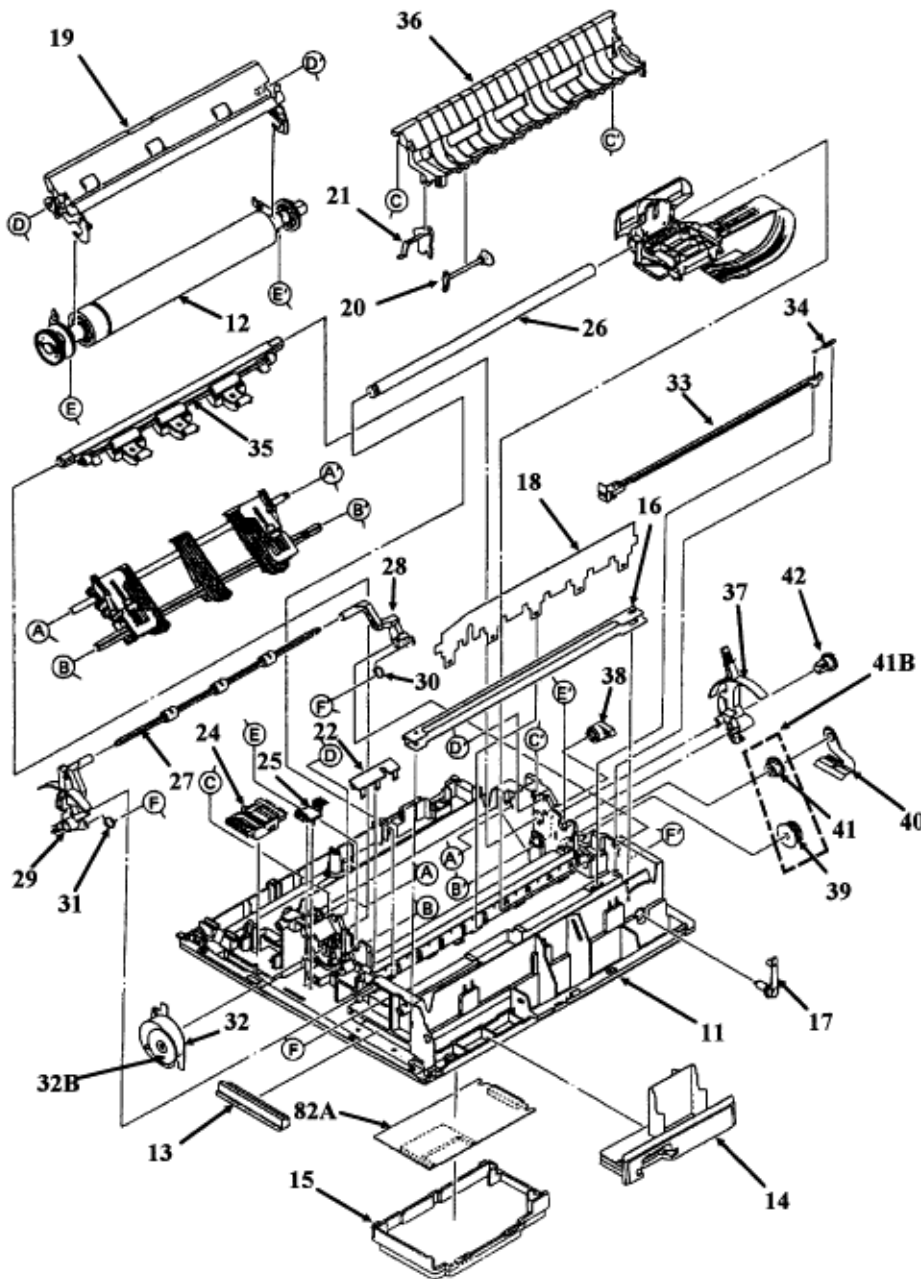



93	55047406 3YU5057-3311G6	PCB: SU11-6 (220/24V) (Pwr Supp)		Option	3.2.10 	A B C
	55923901	IC: CU EEPROM MSM16811RS-N W	391 390+	RSPL	3.2.06 	
	55938101 816A8003M001	IC: CU EEPROM ER59256	390 391+	RSPL	3.2.06 	
	56302001 540A2052M2502	Fuse: 5A Glass MGC-5 (Toyo)	Both	Option RSPL		
	56302101 540A2065N2202	Fuse: Glass 2 amp 250V	Both	Option		A B C
	56302601 540A2044S2322	Fuse: 3.15 Amp	Both	Option RSPL		
	56304602 FP-21107-2	Fuse: 2 Amp 250 V	Both+	RSPL		
	56304603 FP-21107-3	Fuse: 5 Amp 250 V	Both+	RSPL		
	56304702 FP-21108-2	Fuse: 2 Amp 250 V	Both+	Option RSPL		
96	56616802 4YS4011-4311P2	Cable: Power Supply-Nylon Connector	All	RSPL	3.2.10	C











Copyright 1997, Okidata, Division of OKI America, Inc. All rights reserved. See the OKIDATA Business Partner Exchange (BPX) for any updates to this material. (<http://bpx.okidata.com>)

B.2.05 Printer Mechanism - Rev A and B (2 of 2)

Part numbers are subject to change. [Refer to Section B.1.01](#) for finding current information.



Item	Okidata P/N Oki-J P/N	Description	Product	<u>Comments Refer to B.1.02</u> 	Disassembly Procedure	Serial No. Rev. Letter
19	50069801 3PA4025-2963G 1	Separator: Assembly (Narrow)	Both 90	RSPL	3.2.02 	A B C
19	50069901 3PA4025-2978G 1	Separator: Assembly (Wide)	Both 91	RSPL	3.2.02 	A B C
14	53490301 2PP4025-2805P 1	Panel: IC Card (B)	All	RSPL	3.2.07 	A B C
24	53328301 3PB4025-2911P 1	Module: Power Interconnect	Both	RSPL	3.2.11 	A B
27	50061501 4PA4025-2838G 1	Indicator (Assembly)	Both 90	RSPL	3.2.12 	A B C
27	50061502 4PA4025-2838G 2	Indicator (Assembly)	Both 91	RSPL	3.2.12 	A B C
28	53489201 3PP4025-2840P 1	Bail Arm (R)	All	RSPL	3.2.12 	A B C
29	53489301 3PP4025-2841P 1	Bail Arm (L)	All	RSPL	3.2.12 	A B C
30	50911701 4PB4025-2842P 1	Spring: Bail Arm (R)	All	RSPL	3.2.12 	A B C
31	50911801 4PB4025-2843P 1	Spring: Bail Arm (L)	All	RSPL	3.2.12 	A B C
15	50062301 3PA4025-2806G 1	Cover: Head Cable Access	All	RSPL	3.2.13 	A B C
82 A	55038501 4YA4021-1049G 1	PCB: SRBS (Connection Board)	All	RSPL	3.2.13 	

13	56723801 224A1152P0600	Conn: Connection AKT-60	All	RSPL	3.2.13 	
26	51109401 4PP4025-2837P 1	Shaft: Carriage	Both 90	RSPL	3.2.16 	A B C
26	51109402 4PP4025-2837P 2	Shaft: Carriage	Both 91	RSPL	3.2.16 	A B C
33	53489401 3PP4025-2845P 1	Rack: Space	Both 90	RSPL	3.2.17 	A B C
33	53489402 3PP4025-2845P 2	Rack: Space	Both 91	RSPL	3.2.17 	A B C
34	50911901 4PB4025-2873P 1	Spring: Tension	All	RSPL	3.2.17 	A B C
16	51002101 3PP4025-2809P 1	Rail: Guide	Both 90	RSPL	3.2.18 	A B C
16	51002102 3PP4025-2809P 2	Rail: Guide	Both 91	RSPL	3.2.18 	A B C
17	51216201 4PP4025-2810P 1	Cam: Adjust	All	RSPL	3.2.18 	A B C
12	50061305 3PA4025-2811G 5	Platen: (Assembly)	Both 90	RSPL	3.2.19 	A B C
12	50061306 3PA4025-2811G 6	Platen: (Assembly)	Both 91	RSPL	3.2.19 	A B C

Item	Okidata P/N Oki-J P/N	Description	Product	Comments Refer to B.1.02 	Disassembly Procedure	Serial No. Rev. Letter
32 B	51219001 3PB4055-2440P1	Gear: Line Feed Motor	All	RSPL	3.2.20 	A B C
32	56507003 3PB4025-2844P3	Motor: Line Feed	All	RSPL	3.2.20 	A B C
25	53328401 3PP4025-2874P1	Module: LF Motor Interconnect	All	RSPL	3.2.21 	A B C
41 B	58227501 N/A	Kit: Idler/Change Gear (ML300)	All	RSPL Inc. 39 and 41	3.2.22 	A B C
39	51216001 4PP4025-2868P1	Idler Gear	All		3.2.22 	A B C
41	51215901 4PP4025-2866P1	Change Gear	All		3.2.22 	A B C
40	50912001 4PP4025-2867P1	Spring: Reset	All	RSPL	3.2.22 	A B C
37	53489501 3PP4025-2852P1	Lever: Release	All	RSPL	3.2.23 	A B C
18	50911501 3PP4025-2819P1	Guide: Paper Pressure	Both 90	RSPL	3.2.24 	A B C
18	50911601 3PP4025-2905P1	Spring: Release	391	RSPL	3.2.24 	A B
18	50911602	Guide: Paper Pressure	Both 91	RSPL	3.2.24 	C
95	50913901 3PP4025-3161P1	Spring: Support	391+	RSPL	3.2.24 	A B C
36	50061801 3PA4025-2853G1	Chute: Paper (Assembly)	Both 90	RSPL	3.2.25 	A B C
36	50061901 3PA4025-2915G1	Chute: Paper (Assembly)	Both 91	RSPL	3.2.25 	A B C
38	53489601 4PP4025-2881P1	Link: Release	All	RSPL	3.2.25 	A B C
35	50061601 3PA4025-2846G1	Roller: Pressure (Assembly)	Both 90	RSPL	3.2.25 	A B C







35	50061701 3PA4025-2908G1	Roller: Pressure (Assembly)	Both 91	RSPL	3.2.25 	A B C
42	51216101 4PP4025-2869P1	Gear: Tractor	All	RSPL	3.2.26 	A B C
21	53489001 3PP4025-2826P1	Lever: Sensor	All	RSPL	3.2.27 	A B C
20	53488901 3PP4025-2825P1	Lever: Paper End (B)	Both 90	RSPL	3.2.28 	A B C
20	53488902 3PP4025-2825P2	Lever: Paper End (B)	Both 91	RSPL	3.2.28 	A B C
22	53489101 3PP4025-2827P1	Cover: Sensor	All	RSPL	3.2.28 	A B C
11	50061101 3PA4025-2802G1	Chassis: Main (Assembly)	Both 90	RSPL	3.2.29 	A B C
11	50061201 3PA4025-2902G1	Chassis: Main (Assembly)	Both 91	RSPL	3.2.29 	A B C

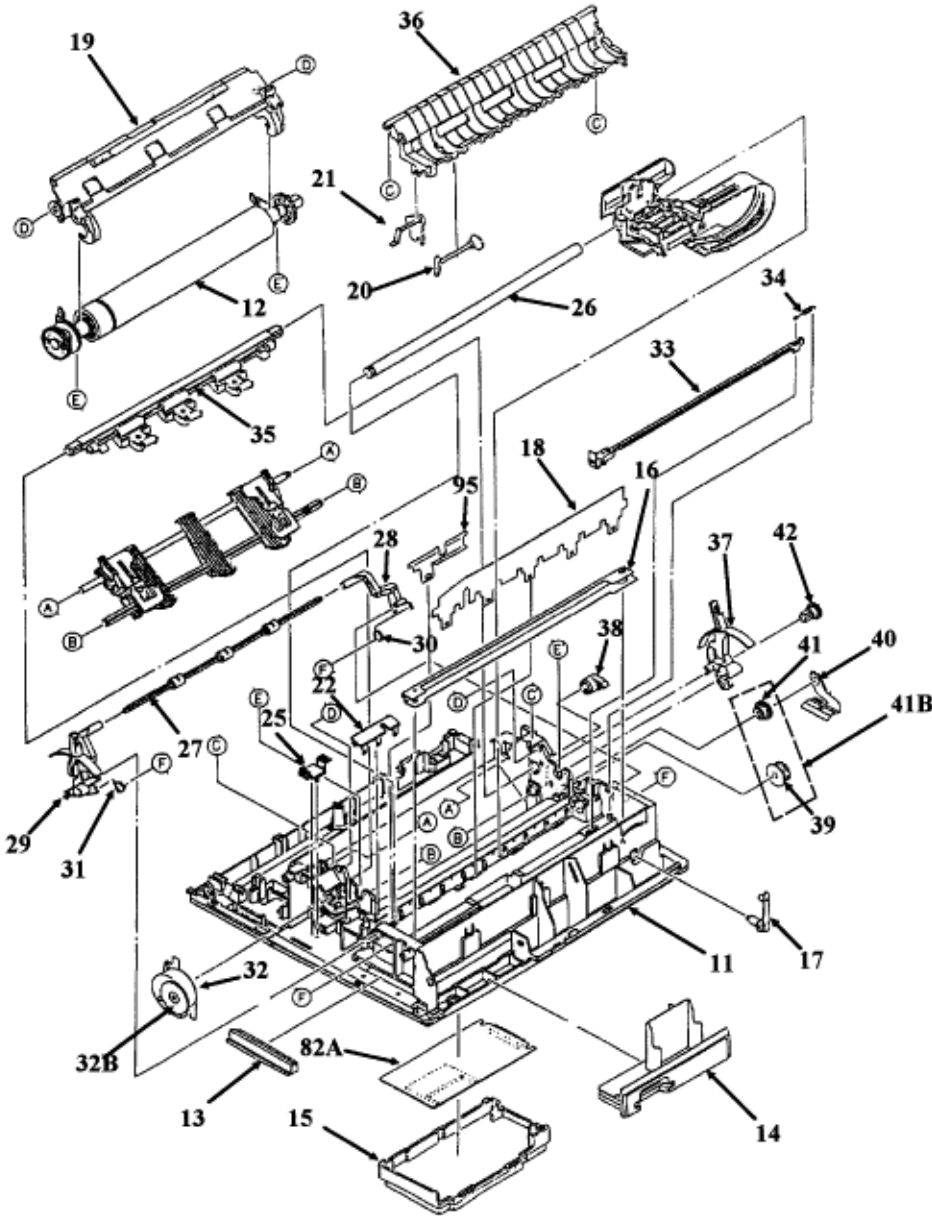

Copyright 1997, Okidata, Division of OKI America, Inc. All rights reserved. See the OKIDATA Business Partner Exchange (BPX) for any updates to this material. (<http://bpx.okidata.com>)

B.2.07 Printer Mechanism - Rev C (2 of 2)

Part numbers are subject to change. [Refer to Section B.1.01](#) for finding current information.



Item	Okidata P/N Oki-J P/N	Description	Product	Comments Refer to B.1.02 	Disassembly Procedure	Serial No. Rev. Letter
19	50069801 3PA4025-2963G 1	Separator: Assembly (Narrow)	Both 90	RSPL	3.2.02 	A B C
19	50069901 3PA4025-2978G 1	Separator: Assembly (Wide)	Both 91	RSPL	3.2.02 	A B C
14	53490301 2PP4025-2805P 1	Panel: IC Card (B)	All	RSPL	3.2.07 	A B C
24	51003801 4PB4025-3180P 1	Guide: Cable	All	RSPL	3.2.11 	C
27	50061501 4PA4025-2838G 1	Indicator (Assembly)	Both 90	RSPL	3.2.12 	A B C
27	50061502 4PA4025-2838G 2	Indicator (Assembly)	Both 91	RSPL	3.2.12 	A B C
28	53489201 3PP4025-2840P 1	Bail Arm (R)	All	RSPL	3.2.12 	A B C
29	53489301 3PP4025-2841P 1	Bail Arm (L)	All	RSPL	3.2.12 	A B C
30	50911701 4PB4025-2842P 1	Spring: Bail Arm (R)	All	RSPL	3.2.12 	A B C
31	50911801 4PB4025-2843P 1	Spring: Bail Arm (L)	All	RSPL	3.2.12 	A B C
15	50062301 3PA4025-2806G 1	Cover: Head Cable Access	All	RSPL	3.2.13 	A B C
26	51109401 4PP4025-2837P 1	Shaft: Carriage	Both 90	RSPL	3.2.16 	A B C
26	51109402 4PP4025-2837P 2	Shaft: Carriage	Both 91	RSPL	3.2.16 	A B C

33	53489401 3PP4025-2845P 1	Rack: Space	Both 90	RSPL	3.2.17 	A B C
33	53489402 3PP4025-2845P 2	Rack: Space	Both 91	RSPL	3.2.17 	A B C
34	50911901 4PB4025-2873P 1	Spring: Tension	All	RSPL	3.2.17 	A B C
16	51002101 3PP4025-2809P 1	Rail: Guide	Both 90	RSPL	3.2.18 	A B C
16	51002102 3PP4025-2809P 2	Rail: Guide	Both 91	RSPL	3.2.18 	A B C
17	51216201 4PP4025-2810P 1	Cam: Adjust	All	RSPL	3.2.18 	A B C
12	50061305 3PA4025-2811G 5	Platen: (Assembly)	Both 90	RSPL	3.2.19 	A B C
12	50061306 3PA4025-2811G 6	Platen: (Assembly)	Both 91	RSPL	3.2.19 	A B C

Copyright 1997, Okidata, Division of OKI America, Inc. All rights reserved. See the OKIDATA Business Partner Exchange (BPX) for any updates to this material. (<http://bpx.okidata.com>)



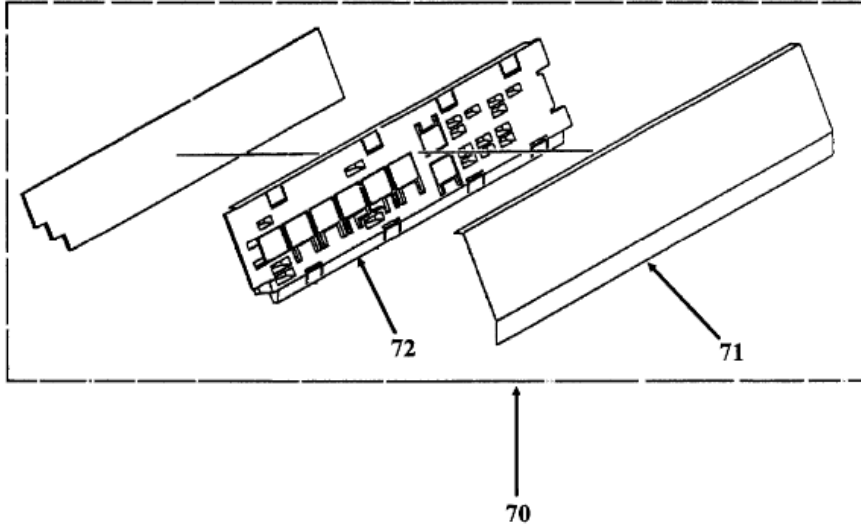

B.2.08 Operator Panel

Part numbers are subject to change. [Refer to Section B.1.01](#) for finding current information.



Item	Okidata P/N Oki-J P/N	Description	Product	Comments Refer to B.1.02	Disassembly Procedure	Serial No. Rev. Letter
32 B	51219001 3PB4055-2440P 1	Gear: Line Feed Motor	All	RSPL	3.2.20	A B C
32	56507003 3PB4025-2844P 3	Motor: Line Feed	All	RSPL	3.2.20	A B C
25	53328401 3PP4025-2874P 1	Module: LF Motor Interconnect	All	RSPL	3.2.21	A B C
41 B	58227501 N/A	Kit: Idler/Change Gear (ML300)	All	RSPL Inc. 39 and 41	3.2.22	A B C
39	51216001 4PP4025-2868P 1	Idler Gear	All		3.2.22	A B C

41	51215901 4PP4025-2866P 1	Change Gear	All		3.2.22 	A B C
40	50912001 4PP4025-2867P 1	Spring: Reset	All	RSPL	3.2.22 	A B C
37	53489501 3PP4025-2852P 1	Lever: Release	All	RSPL	3.2.23 	A B C
18	50911501 3PP4025-2819P 1	Guide: Paper Pressure	Both 90	RSPL	3.2.24 	A B C
18	50911602 3PP4025-2905P 1	Guide: Paper Pressure	Both 91	RSPL	3.2.24 	C
95	50913901 3PP4025-3161P 1	Spring: Support	391+	RSPL	3.2.24 	A B C
36	50061801 3PA4025-2853G 1	Chute: Paper (Assembly)	Both 90	RSPL	3.2.25 	A B C
36	50061901 3PA4025-2915G 1	Chute: Paper (Assembly)	Both 91	RSPL	3.2.25 	A B C
38	53489601 4PP4025-2881P 1	Link: Release	All	RSPL	3.2.25 	A B C
35	50061601 3PA4025-2846G 1	Roller: Pressure (Assembly)	Both 90	RSPL	3.2.25 	A B C
35	50061701 3PA4025-2908G 1	Roller: Pressure (Assembly)	Both 91	RSPL	3.2.25 	A B C
42	51216101 4PP4025-2869P 1	Gear: Tractor	All	RSPL	3.2.26 	A B C
21	53489001 3PP4025-2826P 1	Lever: Sensor	All	RSPL	3.2.27 	A B C
20	53488901 3PP4025-2825P 1	Lever: Paper End (B)	Both 90	RSPL	3.2.28 	A B C

20	53488902 3PP4025-2825P 2	Lever: Paper End (B)	Both 91	RSPL	3.2.28 	A B C
22	53489101 3PP4025-2827P 1	Cover: Sensor	All	RSPL	3.2.28 	A B C
11	50061101 3PA4025-2802G 1	Chassis: Main (Assembly)	Both 90	RSPL	3.2.29 	A B C
11	50061201 3PA4025-2902G 1	Chassis: Main (Assembly)	Both 91	RSPL	3.2.29 	A B C

NOTE:

The Microline 390/391 operator panel is shown.

Copyright 1997, Okidata, Division of OKI America, Inc. All rights reserved. See the OKIDATA Business Partner Exchange (BPX) for any updates to this material. (<http://bpx.okidata.com>)

B.2.09 Carriage Assembly

Part numbers are subject to change. [Refer to Section B.1.01](#) for finding current information.

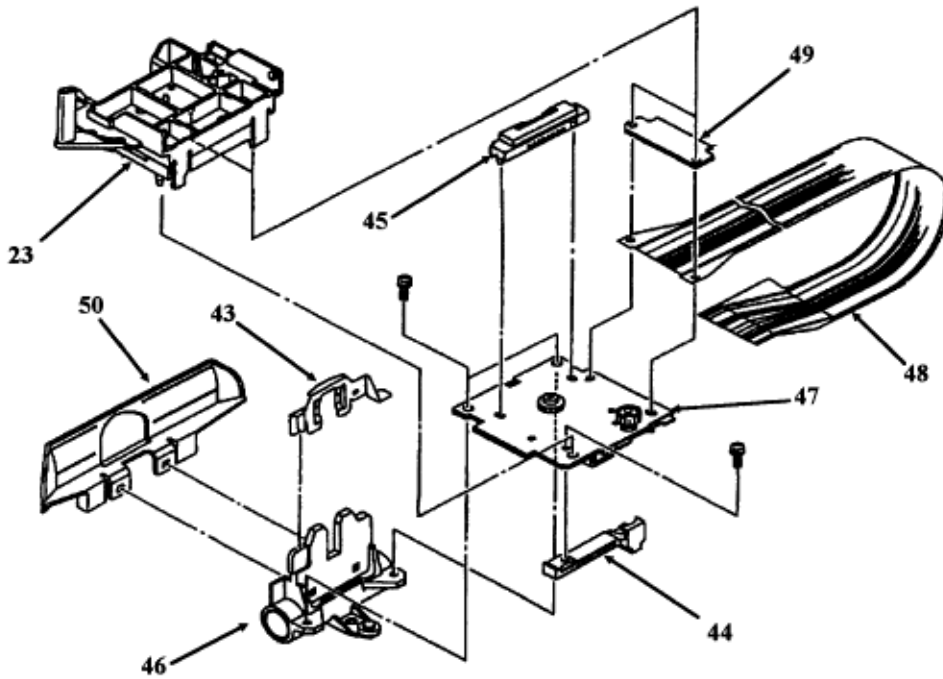

Item	Okidata P/N Oki-J P/N	Description	Product	Comments Refer to B.1.02	Disassembly Procedure	Serial No. Rev. Letter
70	50069601 3PP4025-3114G 1	Panel: Operation w/Frame (Assembly)	Both	RSPL	3.2.05	A B C
71	50069610 3PP4025-3114G 10	Panel: Operator	Both+	RSPL	3.2.05	A B C
72	55045601 4YA4021-1074P 1	PCB: LXSP (Operator PCB)	Both	RSPL	3.2.05	A B C

72	55038605 4YA4021-1048G 5	PCB: LXSP-5 (Operator Panel)	Both+	RSPL	3.2.05 	
----	--------------------------------	---------------------------------------	-------	------	--	--

Copyright 1997, Okidata, Division of OKI America, Inc. All rights reserved. See the OKIDATA Business Partner Exchange (BPX) for any updates to this material. (<http://bpx.okidata.com>)

B.2.10 Tractor Assembly

Part numbers are subject to change. [Refer to Section B.1.01](#) for finding current information.

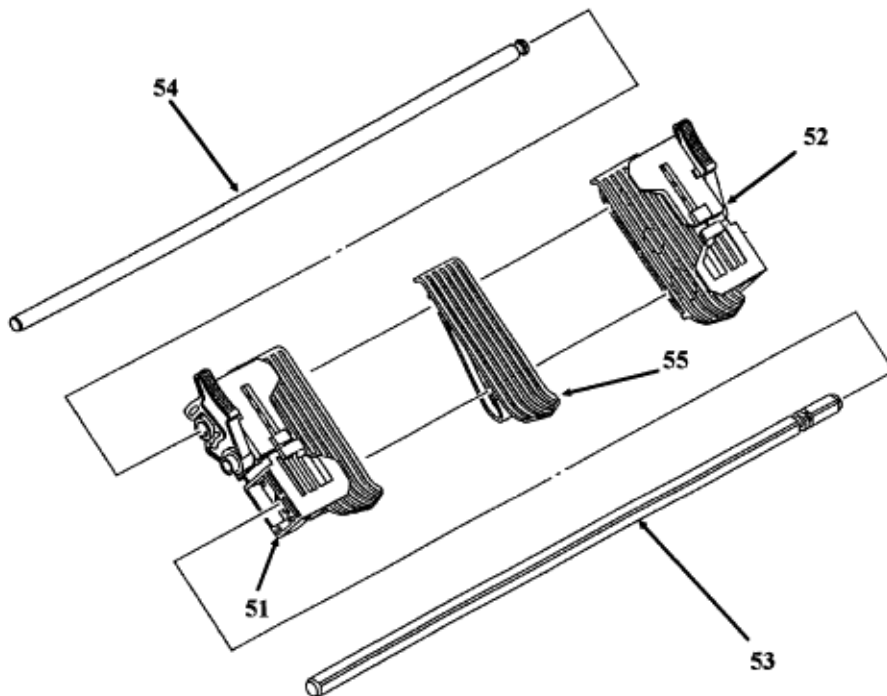

Item	Okidata P/N Oki-J P/N	Description	Product	Comments Refer to B.1.02	Disassembly Procedure	Serial No. Rev. Letter
23	50061401 4PA4025-2832G 1	Gear: Ribbon Feed (Assembly)	All	RSPL	3.2.14	A B C
48	56615403 2PU4007-1095P 3	Cable: Head (Flexible)	Both 90	RSPL	3.2.14	A B C
48	56615404 2PU4007-1095P 4	Cable: Head (Flexible)	Both 91	RSPL	3.2.14	A B C

49	51706501 4PP4025-2690P 1	Rubber: Contact Pressure	Both	RSPL	3.2.14 	A B C
49	53526701 4PP4025-2960P 1	Rubber: Contact Pressure	Both+	RSPL	3.2.14 	A B C
44	51001801 4PB4025-1088P 1	Guide: Space Motor (Slider)	All	RSPL	3.2.15 	A B C
45	56719201 3PB4025-1241P 1	Connector: Head	All	RSPL	3.2.15 	A B C
47	56507104 4YX4025-2052G 4	Motor: Space (Assembly)	All	RSPL	3.2.15 	A B C
46	53490401 4PB4025-2829G 1	Frame: Carriage (Assembly)	All	RSPL	3.2.16 	A B C
43	50702901 4PP4025-1048P 1	Clamp: Head	All	RSPL	3.2.16 	A B C
50	53056201 3PP4025-2836P 1	Protector: Ribbon	All	RSPL	3.2.16 	A B C

Copyright 1997, Okidata, Division of OKI America, Inc. All rights reserved. See the OKIDATA Business Partner Exchange (BPX) for any updates to this material. (<http://bpx.okidata.com>)

B.2.11 Options

Part numbers are subject to change. [Refer to Section B.1.01](#)  for finding current information.

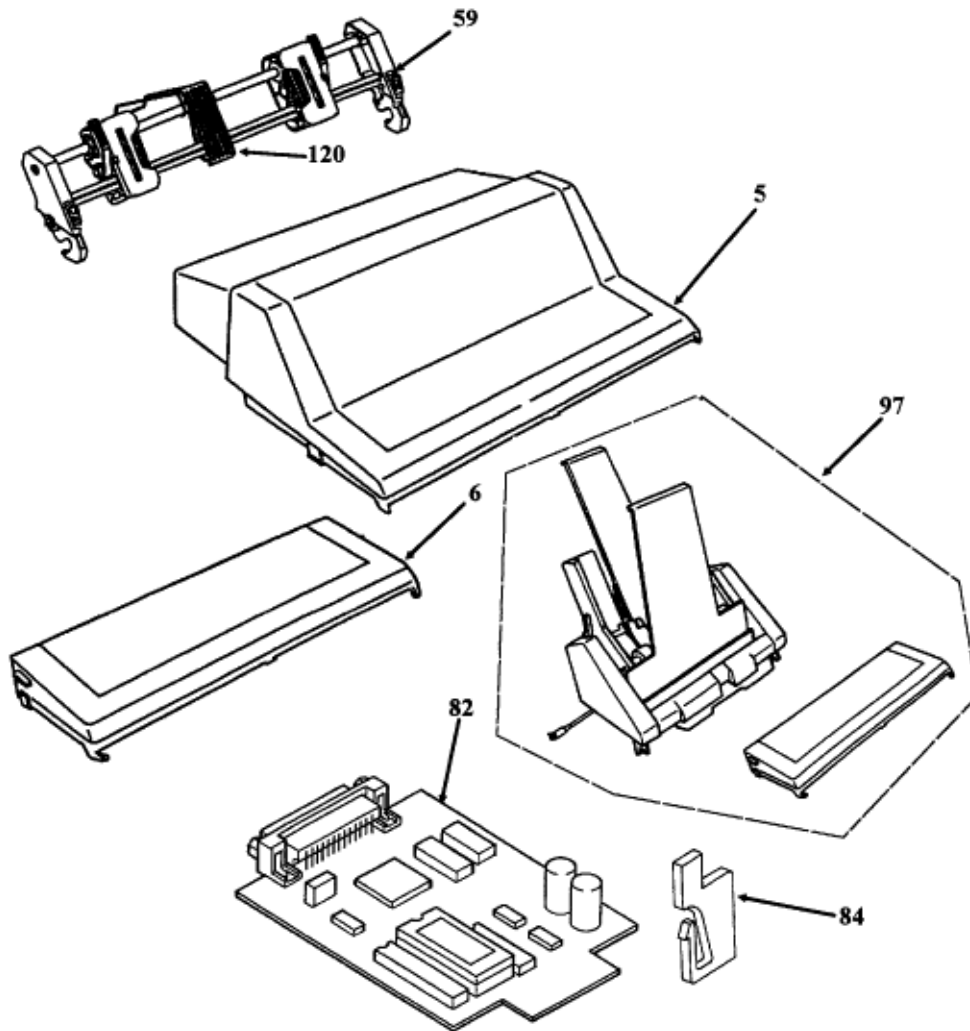

Item	Okidata P/N Oki-J P/N	Description	Product	Comments Refer to B.1.02 	Disassembly Procedure	Serial No. Rev. Letter

51	50062101 4PA4025-2861G1	Frame: Tractor (L) Assembly	All	RSPL	3.2.26 	A B C
52	50062001 4PA4025-2855G1	Frame: Tractor (R) Assembly	All	RSPL	3.2.26 	A B C
53	51109501 4PP4025-2864P1	Shaft: Drive	Both 90	RSPL	3.2.26 	A B C
53	51109502 4PP4025-2864P2	Shaft: Drive	Both 91	RSPL	3.2.26 	A B C
54	51111201 4PP4025-2831P1	Shaft: Lock	Both 90	RSPL	3.2.26 	A B C
54	51109602 4PP4025-2865P2	Shaft: Lock	391	RSPL	3.2.26 	A B C
54	51111202 4PP4025-2831P2	Shaft: Lock	391+	RSPL	3.2.26 	A B C
55	51004901 3PP4025-2927P1	Sheet Guide	All	RSPL	3.2.26 	A B C

Copyright 1997, Okidata, Division of OKI America, Inc. All rights reserved. See the OKIDATA Business Partner Exchange (BPX) for any updates to this material. (<http://bpx.okidata.com>)

B.2.12 Consumables

Part numbers are subject to change. [Refer to Section B.1.01](#) for finding current information.

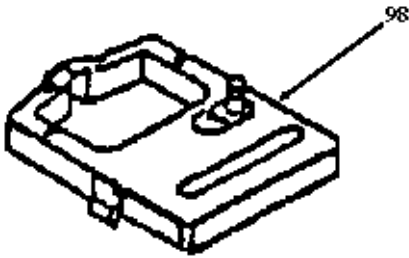

Item	Okidata P/N Oki-J P/N	Description	Product	Comments Refer to B.1.02	Disassembly Procedure	Serial No. Rev. Letter
5	53493201 2PP4016-6865G 1	Cover: Acoustic (Tractor Option)	Both 90	Option RSPL	N/A	A B C
5	53494201 2PP4016-6866G 1	Cover: Acoustic (Tractor Option)	Both 91	Option RSPL	N/A	A B C
6	53494301 2PP4016-6867G 1	Cover: Acoustic (CSF Option)	Both 90	Option RSPL	N/A	A B C
6	53494401 2PP4016-6868G 1	Cover: Acoustic (CSF Option)	Both 91	Option RSPL	N/A	A B C
59	70012501 N/A	Pull Tractor Assembly Kit	Both 90	Option	N/A	A B C
59	70012601 N/A	Pull Tractor Assembly Kit	Both 91	Option	N/A	A B C
97	70012701 N/A	CSF-3000A (Cut Sheet Feeder)	All	Option	N/A	A B C



82	55038901 4YA4021-1050G 002	PCB: LXHI (RS232-C)	All	Option RSPL	N/A	A B C
84	50803801 4PP4025-2887P 1	Clip: Interface Lock	All	Option RSPL	N/A	A B C
120	51002201 4PP4025-2653P 1	Guide: Sheet (BTF)	All	Option	N/A	A B C

Copyright 1997, Okidata, Division of OKI America, Inc. All rights reserved. See the OKIDATA Business Partner Exchange (BPX) for any updates to this material. (<http://bpx.okidata.com>)

B.2.13 Packaging

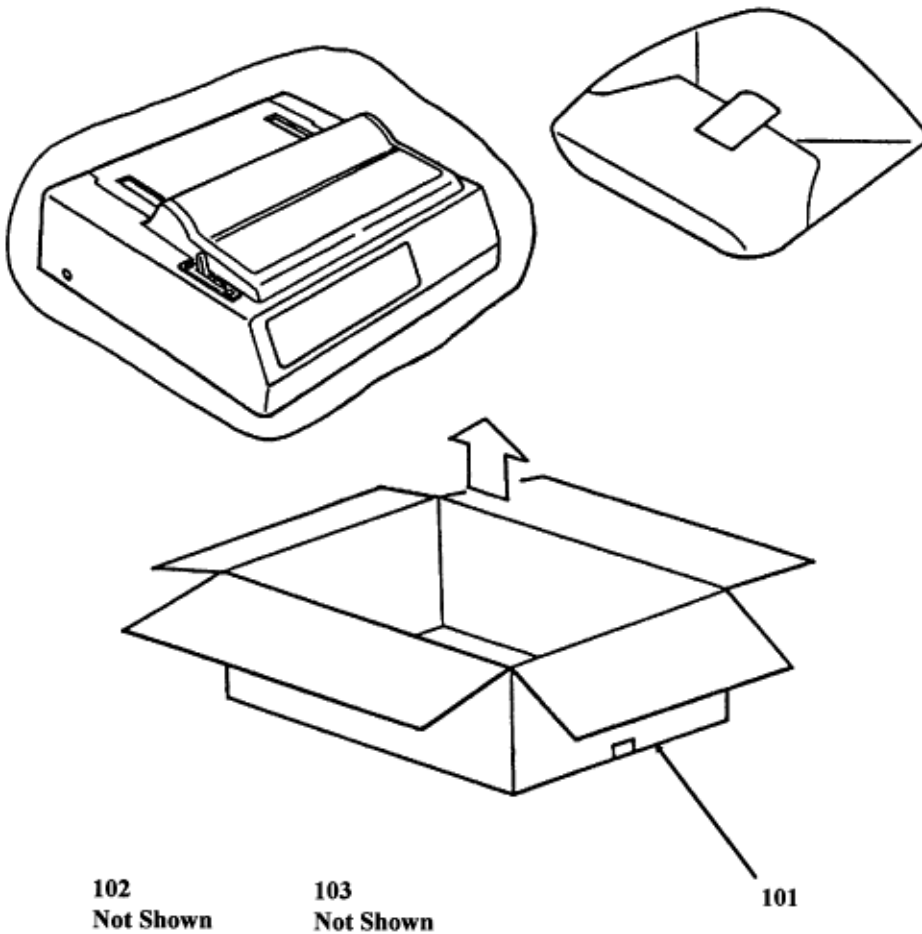
Part numbers are subject to change. [Refer to Section B.1.01](#)  for finding current information.



Item	Okidata P/N Oki-J P/N	Description	Product	<u>Comments Refer to</u> B.1.02 	Disassembly Procedure	Serial No. Rev. Letter
98	52104001 N/A	Ribbon	All	Consumable	3.2.03 	A B C

Copyright 1997, Okidata, Division of OKI America, Inc. All rights reserved. See the OKIDATA Business Partner Exchange (BPX) for any updates to this material. (<http://bpx.okidata.com>)



Service Guide ML390/391

Chapter B Illustrated Parts Listing

B.2.14 Documentation

Part numbers are subject to change. [Refer to Section B.1.01](#)  for finding current information.

Item	Okidata P/N Oki-J P/N	Description	Product	Comments Refer to B.1.02 	Disassembly Procedure	Serial No. Rev. Letter
101	53496601 N/A	Box (ML390)	390		N/A	
101	53496602 N/A	Box (ML390+)	390+		N/A	
101	53496701 N/A	Box (ML391)	391		N/A	
101	53496702 N/A	Box (ML391+)	391+		N/A	
102	53495501 N/A	End Cap L	All		N/A	
103	53495502 N/A	End Cap R	All		N/A	

* To order Microline 390/391 and Microline 390/391-Plus Marketing Literature, complete an Okidata Marketing Literature Order Form. Fax the completed form to Okidata Marketing Communications.

** An Okidata Marketing Literature Order Form can be obtained by faxing your request to Okidata Marketing Communications. Refer to the Service Center Reference Guide for information on contacting Okidata.