

# ML320/321 Turbo Maintenance Manual For Rev "I0" and Higher

022811D

## **Copyright © 2008 by Oki Data. All Rights Reserved**

---

Oki Data America's, Inc. ("Oki Data"), authorizes you to view, copy, and print documents published by Oki Data for noncommercial use within your organization only. In consideration of this authorization, you agree and acknowledge that any copy of these documents shall retain all copyright and proprietary rights contained herein. Each document published by Oki Data may contain additional copyright information and proprietary notification relating to that individual document.

Nothing contained herein shall be construed as conferring by estoppel, implication or otherwise any license or right under any patent or trademark of Oki Data, Oki Electric Industry Co., Ltd. ("Oki Electric"), or any third party. Except as provided above nothing contained herein shall be construed as conferring any license or right under any Oki Data copyright.

Oki Data has taken care to insure that the information which follows is complete, accurate and up-to-date. However, Oki Data assumes no responsibility for errors or omissions which may occur. All the information provided is subject to change from time to time at the sole discretion of Oki Data.

All publications may include technical inaccuracies or typographical errors. We reserve the right to make periodic changes, additions, and deletions to publications without notice.

The most up-to-date drivers and manuals are available from the web site:

<http://www.okiprintingsolutions.com>

## PREFACE

This maintenance manual describes how to maintain the Microline 320/321Turbo, Microline 3320/3321 printer in the field.

This manual is for customer engineers.

For further information, refer to the Users Manual for handling or operating the equipment.

The relation between the destination point and the model name of this printer is as follows.

Destintion point

For OEL	Microline 3320/3321
For other	Microline 320/321 Turbo

# CONTENTS

<b>1.</b>	<b>CONFIGURATION .....</b>	<b>6</b>
1.1.	Standard Printer Configuration .....	6
1.2	Options .....	7
<b>2.</b>	<b>THEORY OF OPERATION .....</b>	<b>9</b>
2.1	Electrical Operation .....	9
2.1.1	Summary .....	9
2.1.2	Microprocessor and the Peripheral Circuit .....	9
2.1.3	Initialization .....	15
2.1.4	Parallel Interface Control .....	16
2.1.5	Universal Serial Bus (USB) (at USB Ver.) .....	17
2.1.6	Print Control .....	19
2.1.7	SP/LF Motor Control .....	21
2.1.8	Operation Panel .....	23
2.1.9	Alarm Circuit .....	25
2.1.10	Power Supply Circuit .....	27
2.2	Mechanical Operation .....	28
2.2.1	Printhead Mechanism and Operation (See Figure 2-2.) .....	28
2.2.2	Spacing Operation (See Figure 2-4.) .....	31
2.2.3	Head Gap Adjusting (See Figure 2-5.) .....	32
2.2.4	Ribbon Drive (See Figure 2-6.) .....	34
2.2.5	Paper Feed Operation .....	35
2.2.6	Paper Detection Mechanism (See Figure 2-15.) .....	45
2.2.7	Automatic Sheet Feed .....	47
2.2.8	Paper Park Function (Continuous paper) .....	49
<b>3.</b>	<b>ASSEMBLY/DISASSEMBLY .....</b>	<b>50</b>
3.1	Precaution for Parts Replacement .....	50
3.2	Service Tools .....	51
3.3	Disassembly/Reassembly Procedure .....	52
3.3.1	Printhead .....	54
3.3.2	Ribbon Protector .....	55
3.3.3	Pull-up Roller Assy .....	56
3.3.4	Upper Cover Assy, Access Cover Assy and Sheet Guide Assy .....	57
3.3.5	Gear Case Assy .....	58
3.3.6	PC Connector .....	59
3.3.7	Space Motor, Guide Roller Assy .....	60
3.3.8	Space Rack .....	61
3.3.9	Carriage Cable .....	62
3.3.10	Backup Roller Holder Assy .....	63
3.3.11	Platen Assy .....	64
3.3.12.1	Driver Board (DVE/DVF) (at USB Ver.) .....	65
3.3.12.2	Driver Board (SDF) (at non USB Ver.) .....	66
3.3.13	LF Motor .....	67
3.3.14	Operation Panel PCB (LEOP) .....	68
3.3.15	Control/Power Supply Board (AOE/AOU/AOO) .....	69
3.3.16	Transformer Assy .....	70
3.3.17	Change Lever and Gears .....	71
3.3.18	Carriage Shaft .....	72
3.3.19	Paper Pan .....	73
3.3.20	Rear Tractor Assy .....	74

3.3.21	Rear Pressure Assy .....	75
3.3.22	Switch Lever .....	76
<b>4.</b>	<b>ADJUSTMENT .....</b>	<b>77</b>
<b>5.</b>	<b>CLEANING AND LUBRICATION .....</b>	<b>85</b>
5.1	Cleaning .....	85
5.2	Lubrication .....	86
<b>6.</b>	<b>TROUBLESHOOTING AND REPAIR .....</b>	<b>94</b>
6.1	Items to Check Before Repair .....	94
6.2	Troubleshooting Table .....	94
6.3	Lamp Display .....	95
6.4	Connection Circuit Check for Printhead and SP/LF Motor .....	99
6.5	Troubleshooting flow chart .....	101
	<b>APPENDIX A PCB LAYOUT .....</b>	<b>113</b>
	<b>APPENDIX B RS-232C SERIAL INTERFACE BOARD (OPTION).....</b>	<b>115</b>

# 1. CONFIGURATION

## 1.1. Standard Printer Configuration

This printer consists of the following assemblies:

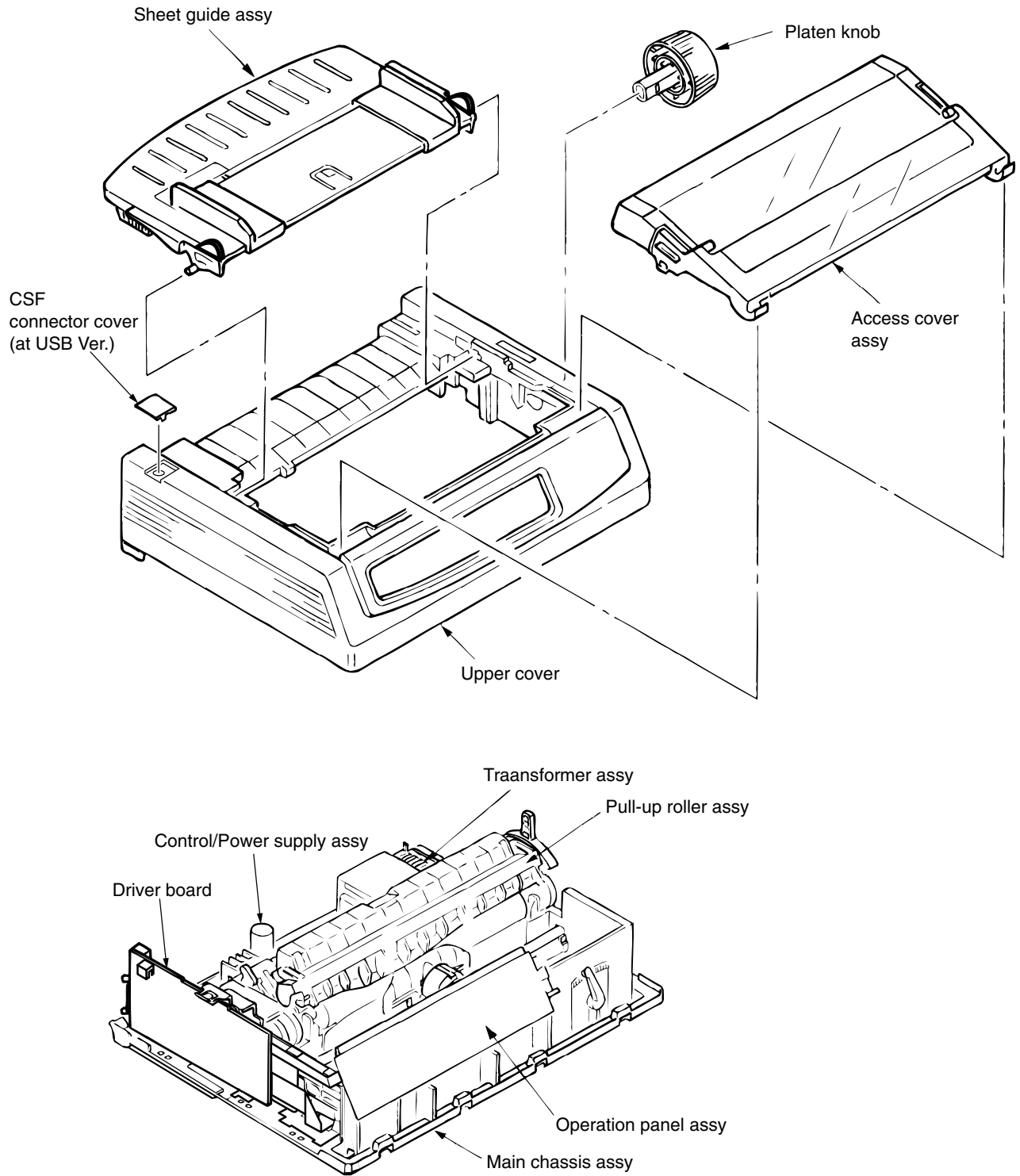
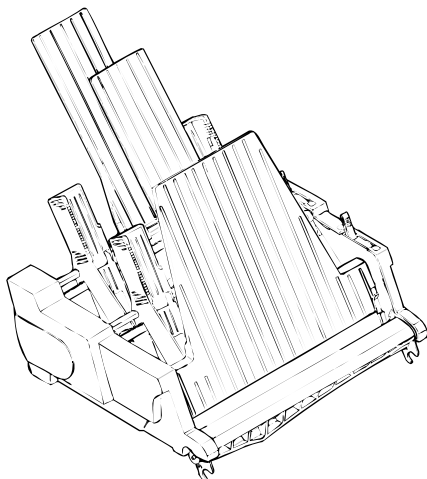

Figure 1-1 Configuration

## 1.2 Options

- (1) Cut sheet feeder unit (CSF)  
(Narrow and wide versions available)

Dual-bin CSF



Single-bin CSF

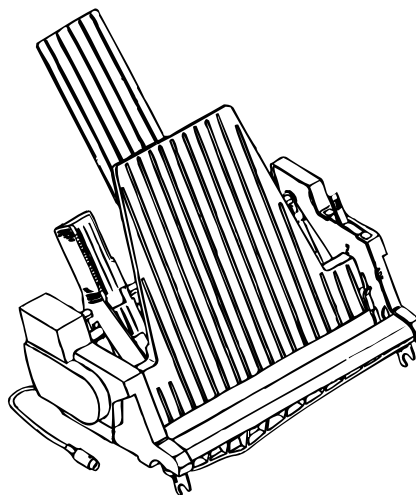

Attachment assy

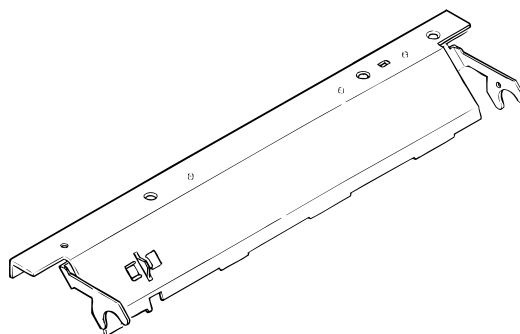

- (2) Pull-tractor assy

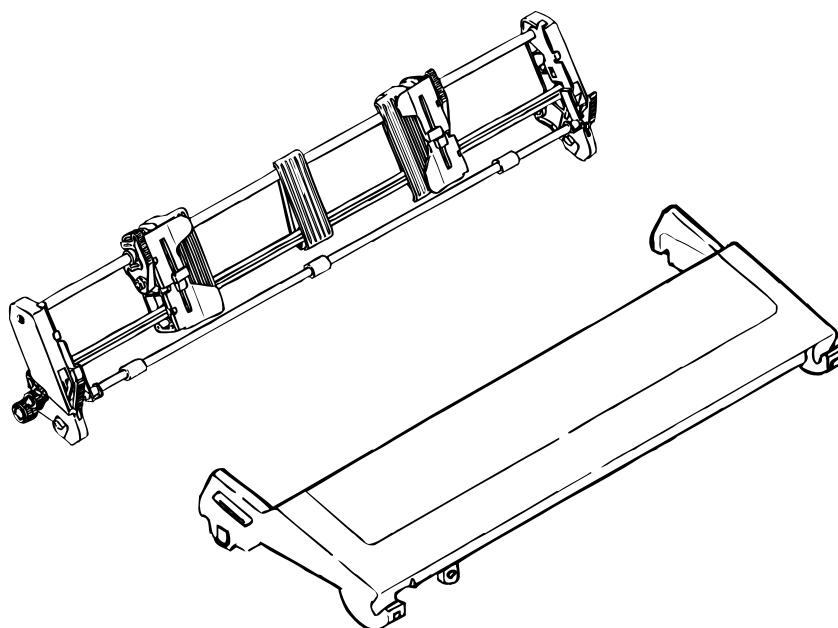

(3) Bottom push tractor unit

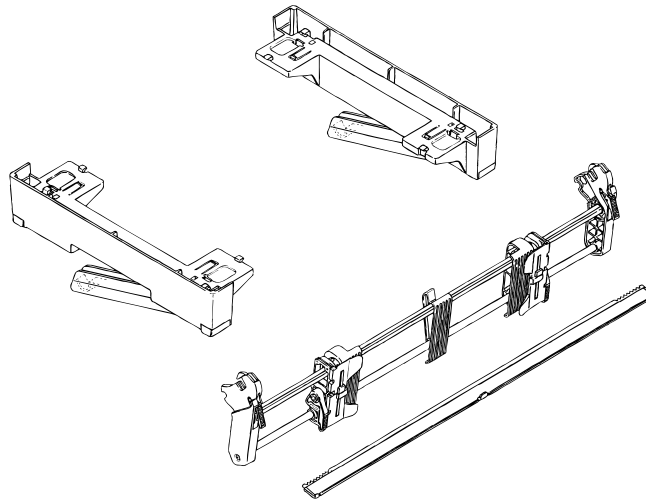

(4) Roll paper stand (Narrow only)

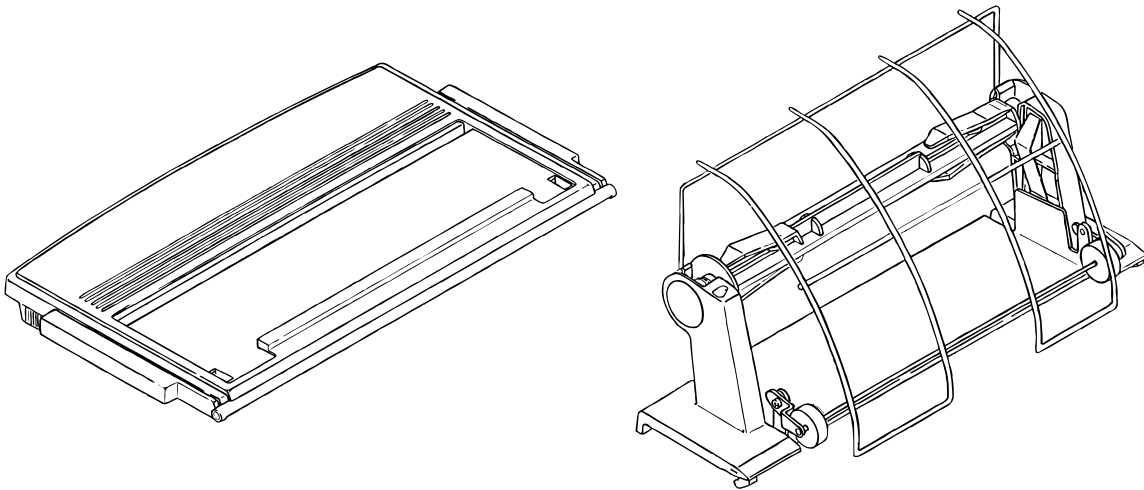

(5) Option I/F Board

- RS232C
- RS422A
- Current Loop
- NIC (Network version only)

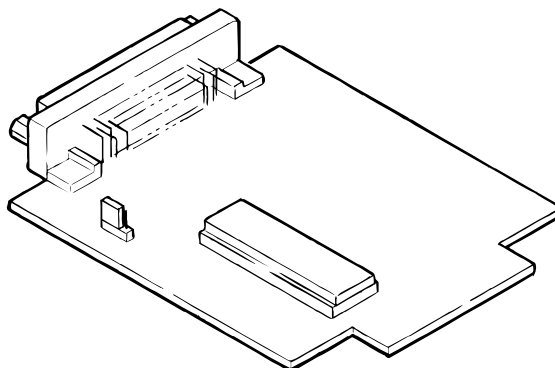



## 2. THEORY OF OPERATION

### 2.1 Electrical Operation

The electrical operation of the printer circuit is described in this section.

#### 2.1.1 Summary

Fig. 2-1 shows the block diagram of the printer.

The control board is made up of the microprocessors, peripheral circuits, drive circuits, sensors and interface connectors.

The power to the control board is supplied by the power board through the connector cord.

The power to other electrical parts is also distributed through the connectors within the control board.

#### 2.1.2 Microprocessor and the Peripheral Circuit

##### (1) Microprocessor (67X640)

This processor is a CMOS single-chip computer with integrated peripheral device functions and a 16 bit MPU core, all OKI original architecture.

The processor has a 20 bit address bus and a 16 bit data bus.

It is capable of accessing up to 4M bit program memory and 128K bytes of data memory.

The following characteristics are also provided:

- Built-in type data memory of 512 bytes
- 8-bit 4-channel A/D converter × 1
- 16-bit automatic reload timer × 2
- 8-bit serial port × 2
- 8-bit parallel port × 3 (bitwise I/O specification available)

And others.

The function of this microprocessor is to provide a central mechanism for the entire printer by executing the control program through the LSI and driver circuits.

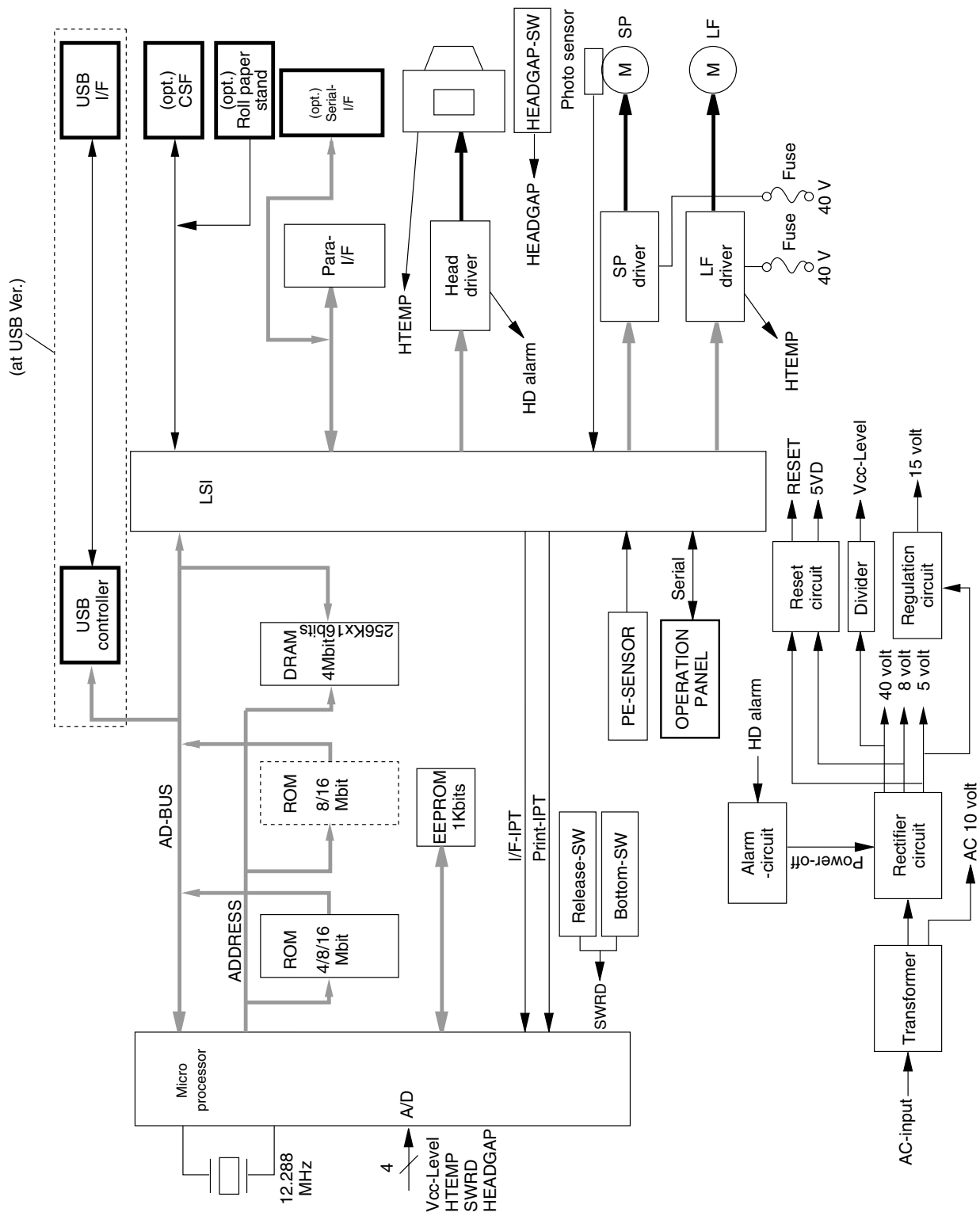

Figure 2-1

(2) Program ROM

This is a 256K/512K/1024K × 16 bits (4/8/16M bit) MASK ROM or FLASH ROM with the control program for the printer stored. The MPU executes instructions under this program.

The program ROM is assigned to the program memory area of the MPU and is fetched by the PSEN signal of the MPU.

The following shows the operation of the memory access.

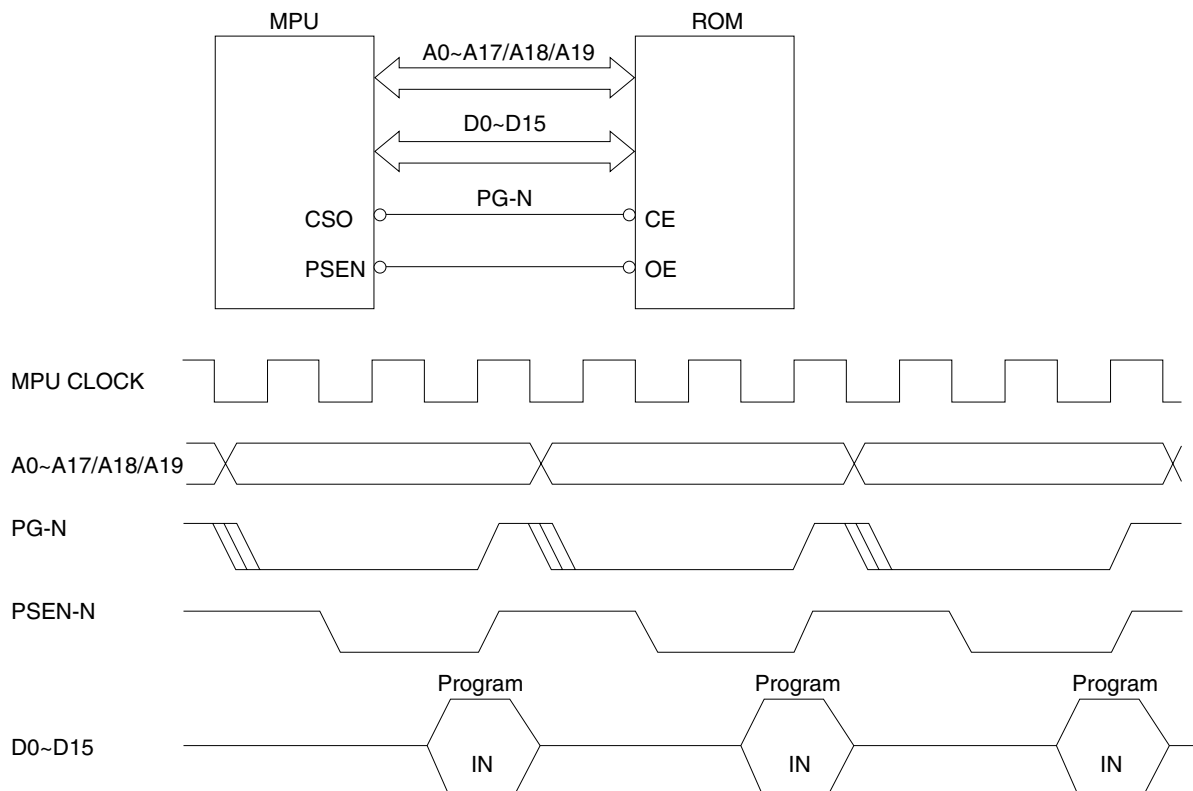

(3) RAM

The RAM is CMOS dynamic RAM with 256K × 16bits (4Mbit), and used as buffers (such as receiving buffer, printing buffer, DLL buffer and working buffer).

The following shows the examples of the memory access operation.

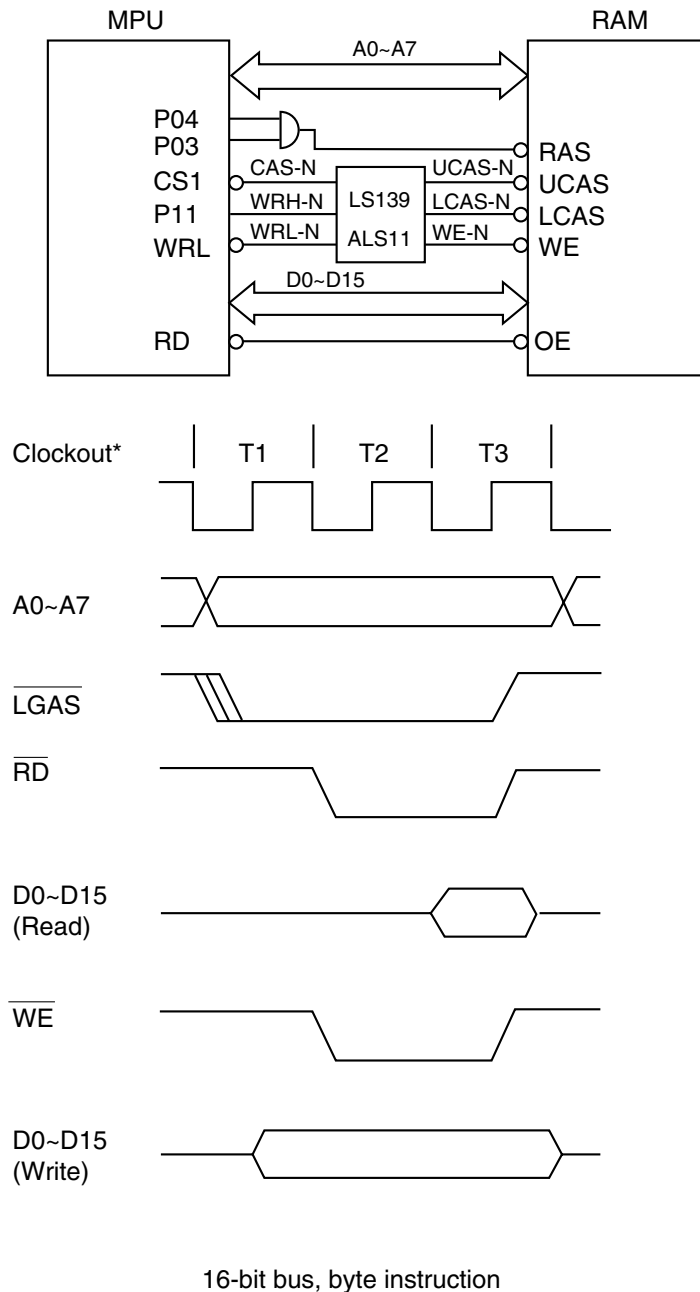

\* Clockout is provided when the original excitation is selected.

(4) EEPROM

The EEPROM is a CMOS serial I/O type memory which is capable of electrically erasing and writing 1,024 bits.

The EEPROM contains menu data.

The following shows the memory access operation.

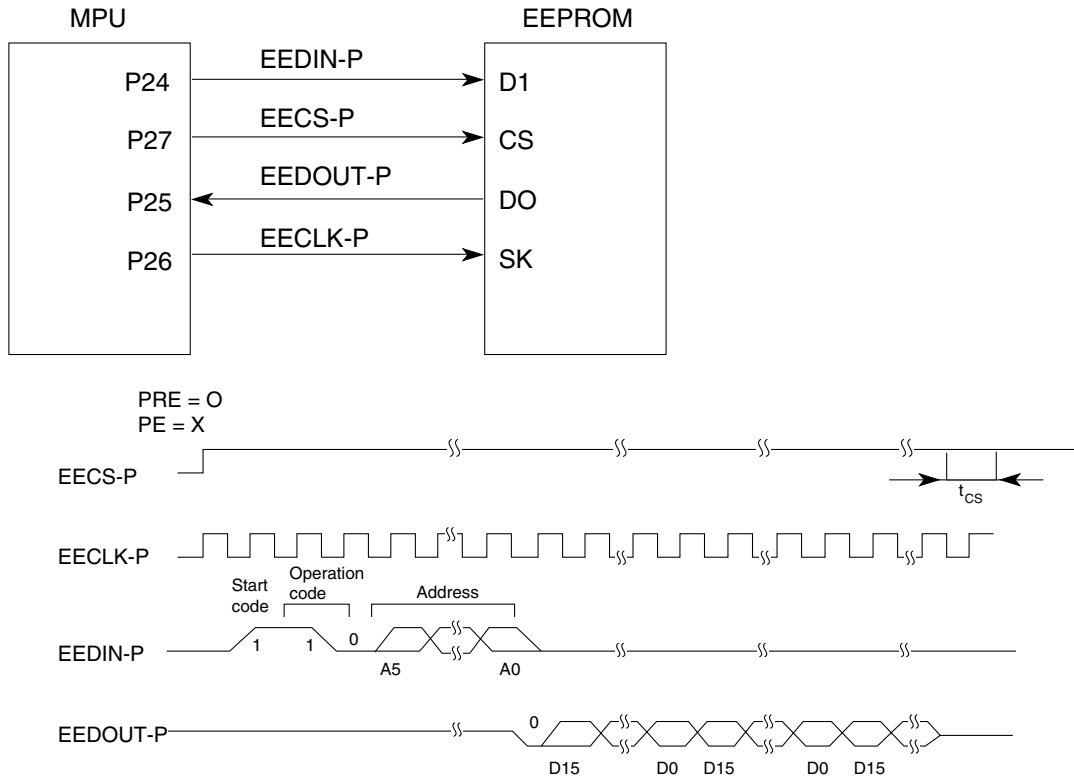

Read cycle timing (READ)

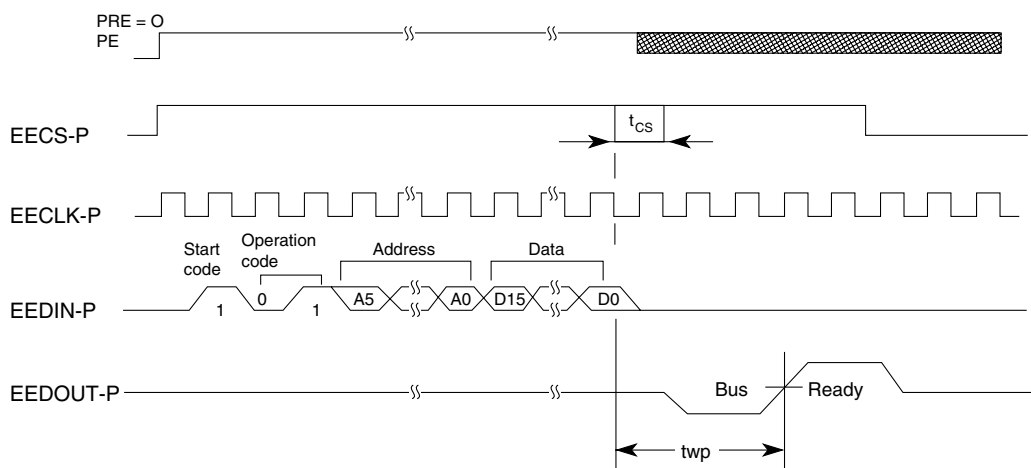

Write cycle timing (WRITE)

(5) LSI

This LSI detects and controls the SP motor speeds by monitoring the two phase sensor signals obtained from the DC motors and modifying the excitation phases as appropriate.

This LSI is connected in multiplex to the MPU.

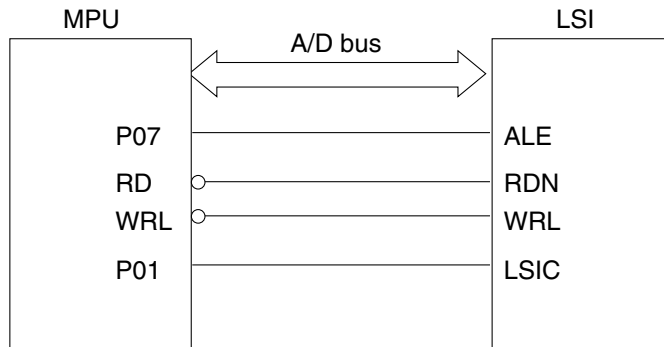

\* Clockout is provided when the original excitation is selected.

### 2.1.3 Initialization

This printer is initialized when the power is turned on or when the I-PRIME-N signal is input from the host side via the parallel interface.

For the initializing operation, the RST-N signal is first output from the reset circuit to reset the MPUs and LSIs. When resetting ends, the program starts and the LSIs are reset by MPU via LSIRST-N. Reset operation by I-PRIME starts program to initialize, but does not reset the MPU.

The program here sets the mode of the LSI including the MPU, checks the memories (ROMs and RAMs) and, after USB I/F control LSI initialization and USB I/F bus opening, performs carriage homing operation and LF motor phase setting.

Finally, the program establishes the interface signals (P-I/F: ACK-P signal sending, and S-I/F: BUSY-N signal off) and lights the SELECT lamp to inform the ready state for receiving to the host side and ends the initialize operation.

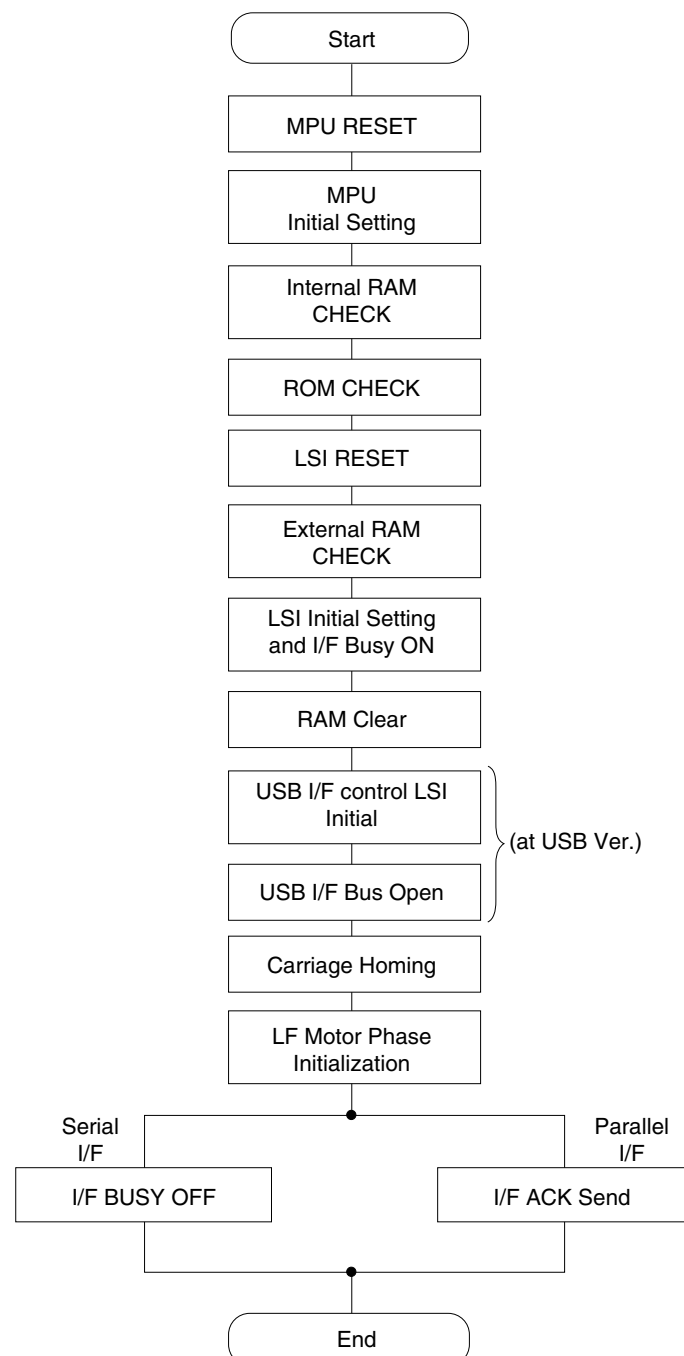

### 2.1.4 Parallel Interface Control

The parallel data input from the host to the interfaced LSI is latched to its internal register at the falling edge of the STROBE-N signal.

At the same time, the LSI sets the BUSY signal to the high level to inform the host that the data is being processed, and outputs the RXD signal to inform the MPU of data reception. The data is read upon receiving the RD-N signal from the MPU.

When the data processing ends, the BUSY signal is set to off and the ACK-N signal is sent to request the next data. When reception is impossible because the buffer is full, the BUSY signal is sent to request stopping of data transmission.

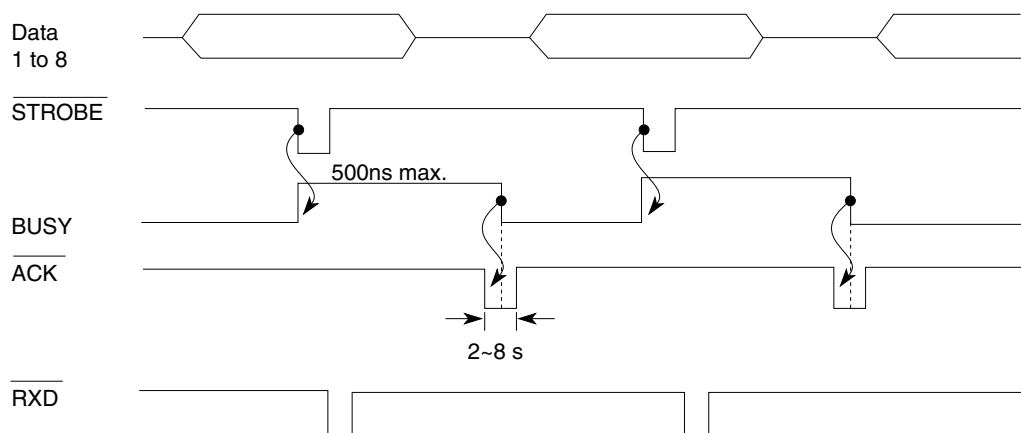
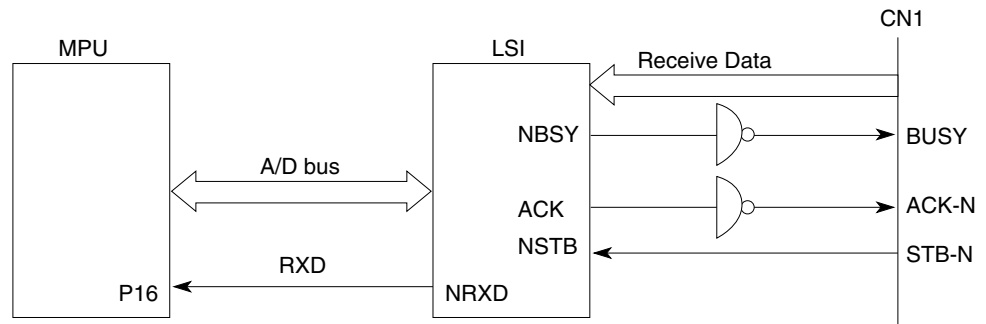



2.1.5 Universal Serial Bus (USB) (at USB Ver.)

Universal Serial Bus Specification Revision 1.0 compliance.

1) Connector

- Printer Side : "B" Receptacle (Upstream Input to the USB Device)
- Cable Side : Series "B" Plug

2) Cable

- Cable Length : Approx 1.8m (A cable must be met USB Spec Rev 1.1 for normal operation)

**Note:** Cable is not supplied.

3) Table of USB I / F signals

Contact Number	Signal Name	Typical Wiring Assignment
1	Vbus	Red
2	D -	White
3	D +	Green
4	GND	Black
Shell	Shield	Drain Wire

4) Connector pin arrangement

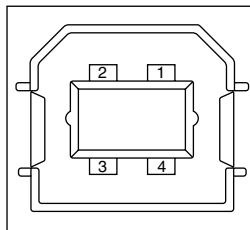

5) Mode & Class of Device

- Full - speed Driver
- Self - powered Device

6) Data Signaling Rate

- Full - speed function - 12Mb/s  $\pm$  0.25%(2500ppm)

7) Receive Buffer

- 2044K Bytes

8) Interface circuit

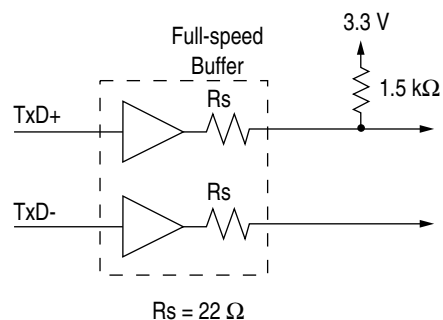

## 9) Signal Level

## • Input / Output Level

Parameter	Symbol	Min.	Max.	Units
Input Levels :				
High (driven)	V <sub>IH</sub>	2.0		V
High (floating)	V <sub>IHZ</sub>	2.7	3.6	V
Low	V <sub>IL</sub>		0.8	V
Output Levels :				
Low	OL	0.0	0.3	V
High (driven)	OH	2.8	3.6	V
Output Signal Crossover Voltage	V <sub>CRS</sub>	1.3	2.0	V

### 2.1.6 Print Control

Print data is transmitted as parallel data (HEAD1~HEAD9) from LSI to print head. LSI generates print timing and drive time.

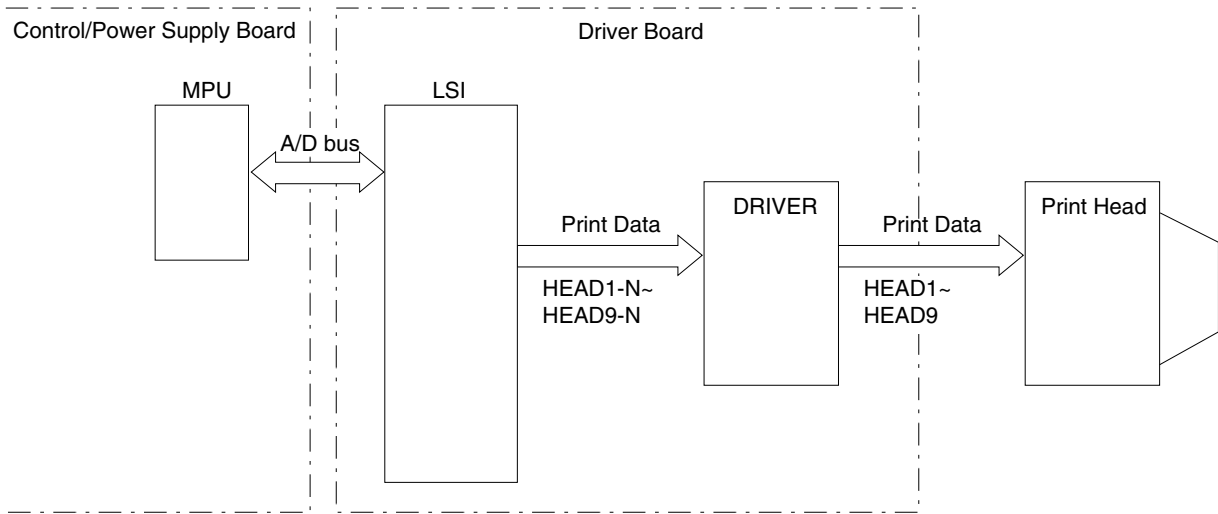

**HEAD DRIVE TIMING CHART**

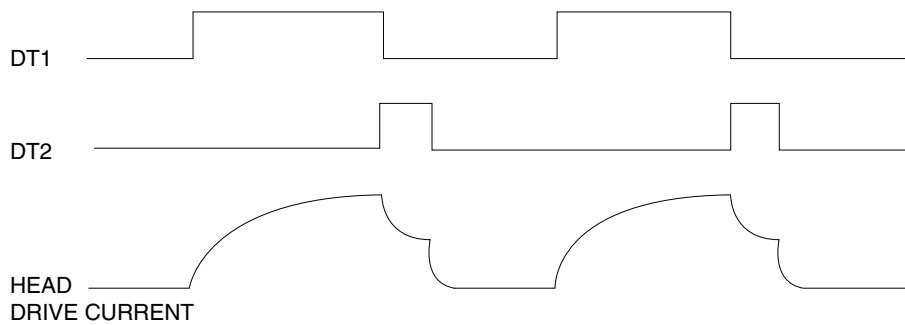

Print Compensation Control

The print compensation can be made as shown below:

- (a) Voltage compensation (See 2.1.8 "Alarm Circuit.")
- (b) Temperature compensation (See 2.1.8 "Alarm Circuit.")
- (c) Pin stroke compensation

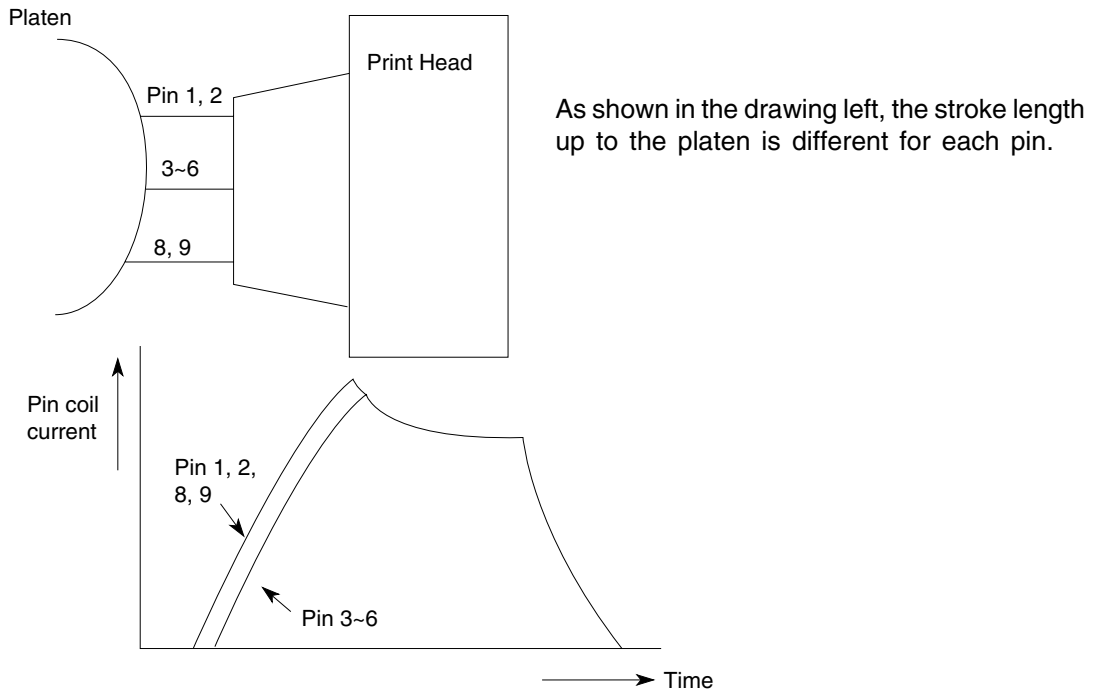

- (d) Simultaneous Compensation of the number of impact pins

The MPU is provided with the compensation table for each pin to make necessary compensation.

Number of impact pins	Few ←————→ Many
Drive time	Short ←————→ Long

- (e) Print mode compensation

According to the thickness of the printing medium, the print mode is compensated as shown in the table below:

Head Gap Range	1	2	3	4	5
Print speed	100%	95%	85%	85%	80%
Drive time	Short ←————→ Long				

→ (Drive time lengthens at each step.)

## 2.1.7 SP/LF Motor Control

### (1) Space motor control

The SP motor driver (ECN30105) drives the three-phase brushless motor based on the phase signal (SPU, SPV and SPW) and the speed instruction data from the LSI. The MPU can identify the current speed of the space motor by measuring through the LSI the pulse length of the output ( $\phi A$ ,  $\phi B$ ) of the slit encoder included in the space motor.

By comparing the target speed for each print mode with the actual current speed to change the speed instruction data, the motor speed is accelerated or decelerated to maintain the specified speed for each print mode.

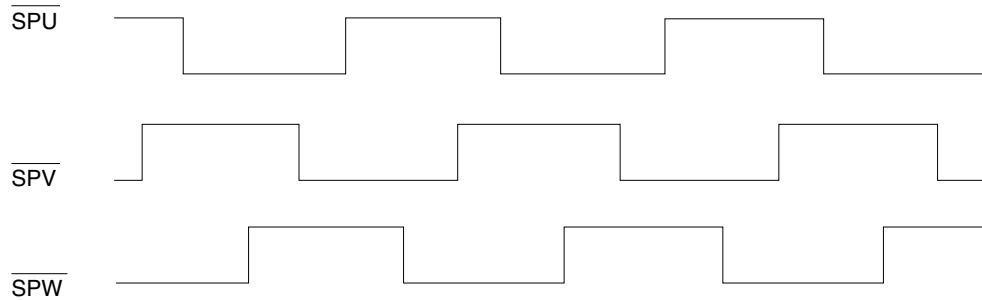

SP truth table

HALL			OUTPUT		
AMP	INPUT		U	V	W
$\overline{SPU}$	$\overline{SPV}$	$\overline{SPW}$			
H	L	H	L	H	OPEN
H	L	L	L	OPEN	H
H	H	L	OPEN	L	H
L	H	L	H	L	OPEN
L	H	H	H	OPEN	L
L	L	H	OPEN	H	L

(2) Encoder disk

In the operation of the spacing motor, the PHASE-A and PHASE-B signals are generated when the encoder disk interrupts the photo sensor.

The LSI divides these edge pulse signals in accordance with the print pitch, and sends the IPT signal to provide dot-on timing and carriage position detection timing.

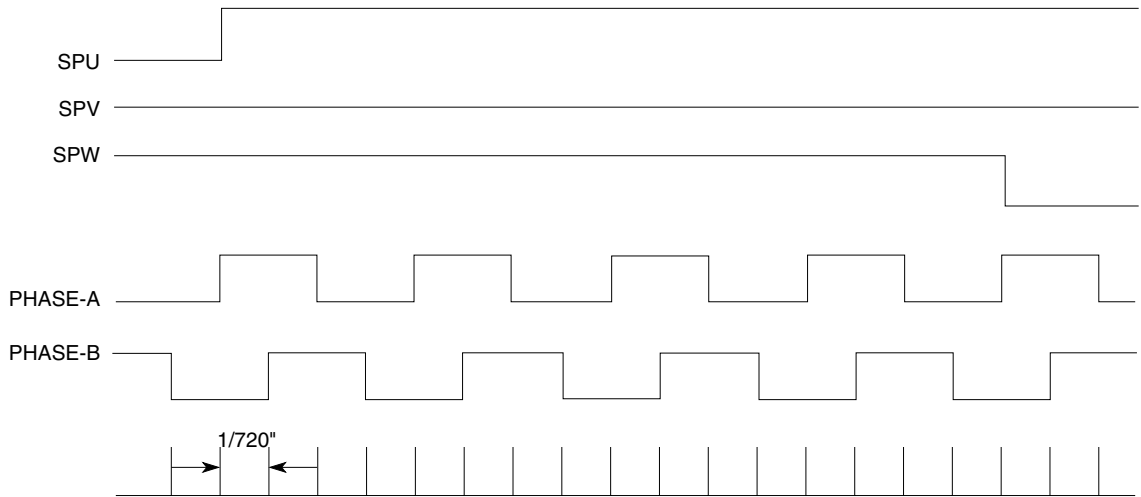

• UTILITY MODE

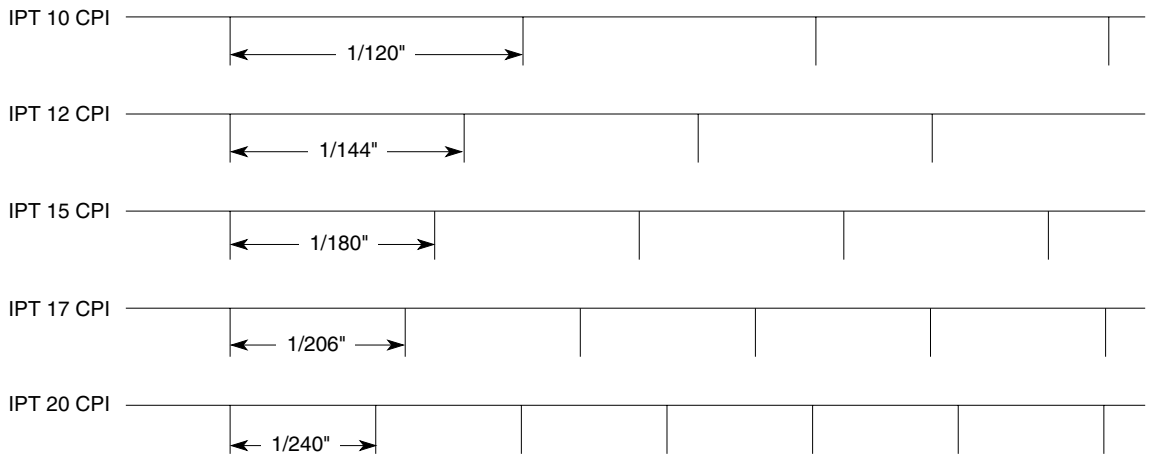

(3) LF motor control

The LF motor driver (MTD2005F) drives the LF motor in two-phase or 1-2 phase bipolar, based on the phase changeover data and the output current data from the LSI.

The data from the LSI is processed by a specific register contained in the LF motor driver to measure the overdrive time and to change the phase.

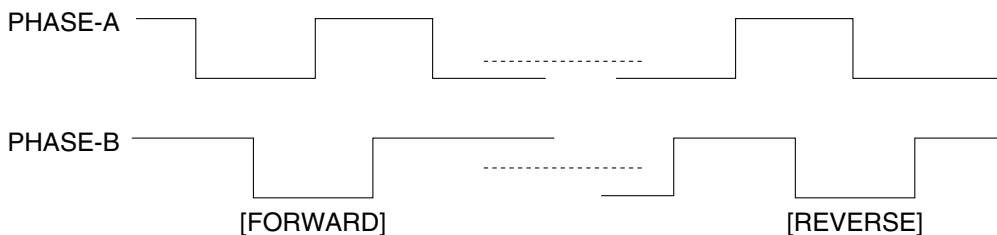

### 2.1.8 Operation Panel

The clock synchronization OPCLK of LSI is used to input the switch data and output the LED data through the operation panel control LSI (IC1: BU6152S).

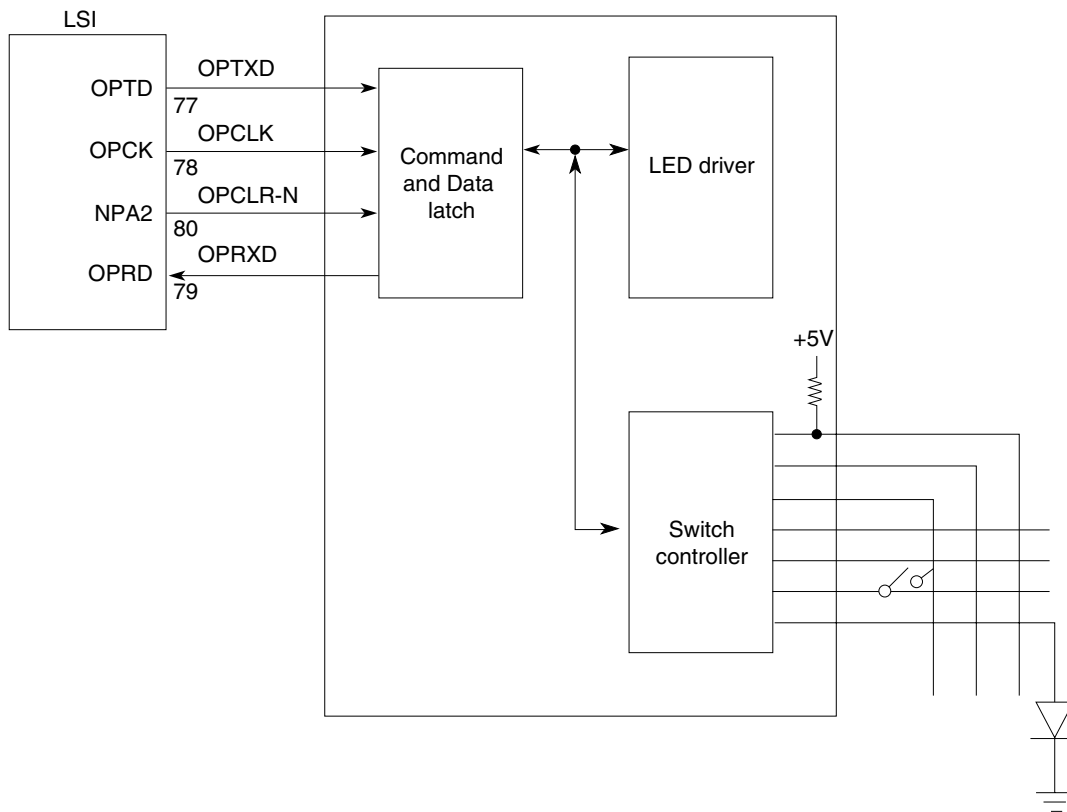

A 2-byte (15 bits + 1 even parity bit) command (OPTXD) is transmitted to the LSI (BU6152S) in synchronization with the OPCLK signal. The LSI decodes this command and when it is found to be legal, returns a 2-byte command response back to the LSI which includes data on Switch information, LED status, receive command ACK/NAK and 1 odd parity bit.

Any transmission errors found cause the command to be reissued after the transmission of the OPCLR-N signal.

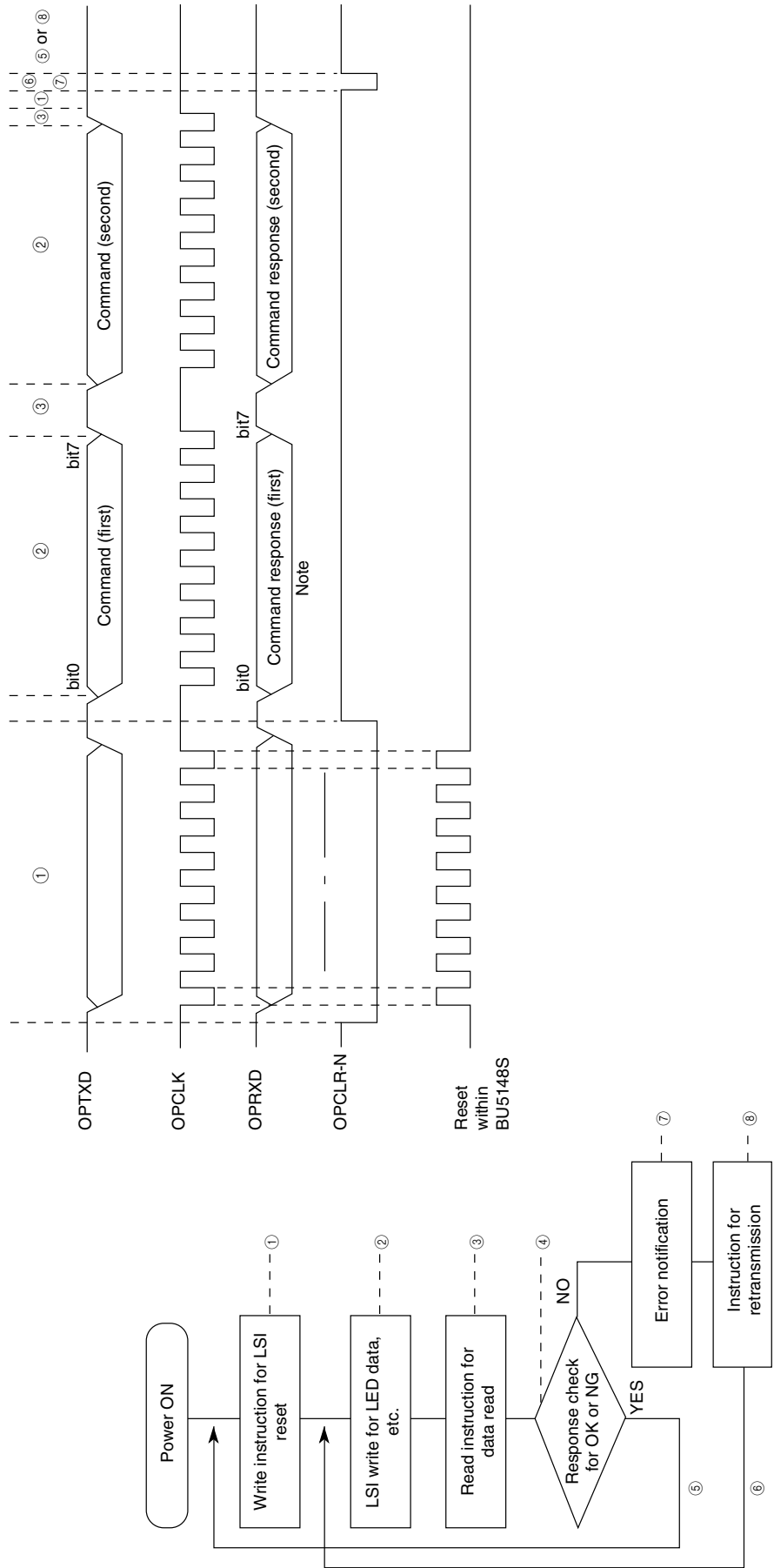

**Note:** From the illustration above, you can see that the command and the command response are output at the same time. This is because the bit 0 to bit 3 of OPRXD are fixed so that the response can be returned before decoding the command.



2.1.9 Alarm Circuit

(1) Head drive time alarm circuit

This circuit monitors the drive time using the HDALM signal interlocked with the overdrive signal of each drive circuit.

If the drive time of any drive circuit exceeds the specified time, the drive fault alarm circuit sends an ALARM-N signal to turn on the SCR (SO).

This cause the secondary coil (40V) of the transformer to be short-circuited, causing an overcurrent to flow through the primary coil and making the AC fuse (transformer assy) open.

(2) Alarm processing when DC power is low.

+ 40V is converted into the POWLEV signal (0V to +5V) by Ra and Rb and input into the A/D port of the MPU to control the drive time and the print speed (pass number) of the head.

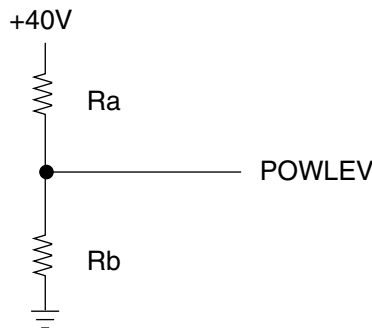

(a) Head drive time

The head drive time is lengthened to compensate for the amount of voltage drop by monitoring the POWLEV signal once every 500 μ sec. to control and maintain the impact necessary for each printing pin at the fixed value.

(b) Print speed

Voltage, +40V	Pass number	Print speed
38V or more	1 Pass	100%
25V to 37V	1 Pass	100~30%
25V or less	1 Pass	30%

(3) Head overheat alarm

The voltage of the output TSD signal of the thermistors, one of which is contained in the print head and the other in the print head driver, is monitored by the CPU/AD port to control the voltage

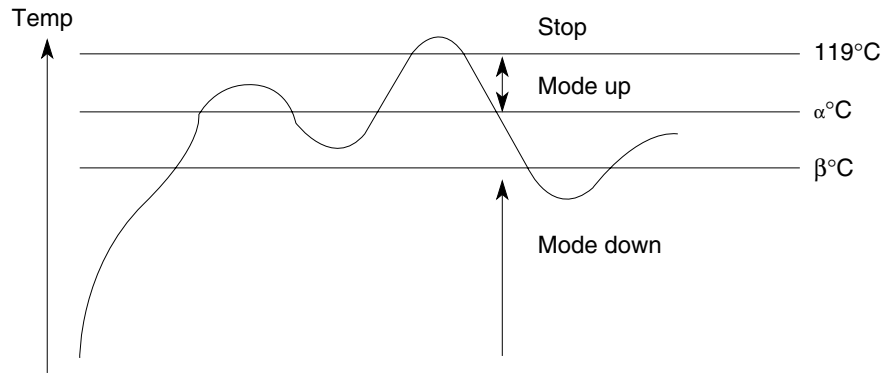

Mode and print control

Mode	Speed	Pass	Direction	
1	100%	1	Bi	
2	85%	1	Bi	
3	70%	1	Bi	
4	55%	1	Bi	
5	40%	1	Bi	
6	30%	1	Bi	1.5 Sec Stop
(7)	Stop			

- When the temperature is between  $\alpha^{\circ}\text{C}$  and  $119^{\circ}\text{C}$ , the mode switches sequentially to higher level. When the temperature falls below  $\beta^{\circ}\text{C}$ , the mode switches to lower level.
- When the temperature exceeds  $119^{\circ}\text{C}$ , printing will stop.
- When temperature gradient is steep, higher mode shall be specified directly.

### 2.1.10 Power Supply Circuit

This power supply circuit supplies the +5VDC, +8VDC, +40VDC, 10VAC.

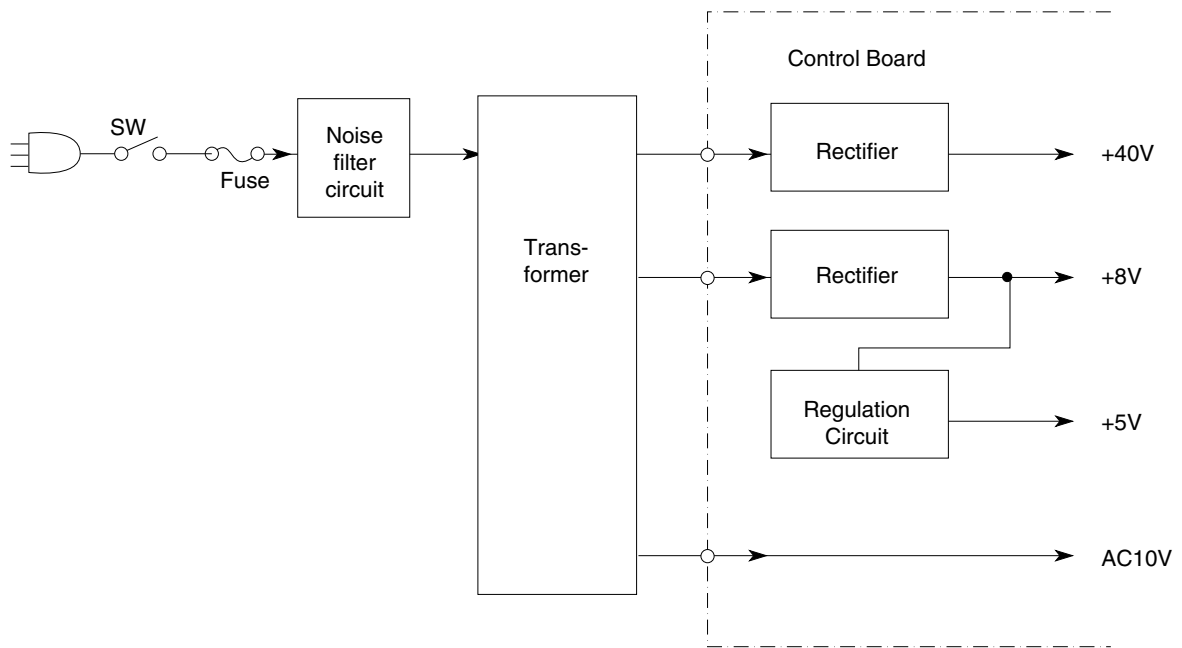

The uses of output voltages and signals are described below.

Voltage/signal	Use
+5V	Logic IC/LED drive voltage
+8V	Serial interface line voltage
+ 40V	Printhead, LF motor drive voltage, SP motor drive voltage
AC 10V	Option board

## 2.2 Mechanical Operation

### 2.2.1 Printhead Mechanism and Operation (See Figure 2-2.)

The printhead is a spring charged 9-pin driving head using a permanent magnet. It is attached to the carriage, which moves in parallel with the platen. Electrically, this unit is connected to the control circuits through the control board.

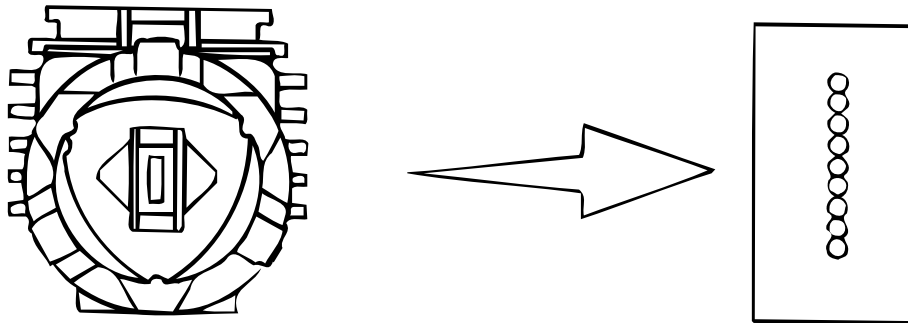

**Figure 2-2 Arrangement of the head pins  
View from the tip of the printhead**

(1) The printhead configuration:

The printhead is composed of the following parts:

- (a) Wire guide
- (b) Spring assembly (Wire, Armature, Spring, Yoke, Spacer)
- (c) Magnet assembly (Magnet, core, coil, Yoke)
- (d) Printed circuit board
- (e) Fin

(2) Operation of printhead (See Figure 2-3.)

- (a) When the printhead is idle, the armature is attracted by a permanent magnet and the spring fixing the armature is compressed. The print wires fixed to each armature are thus concealed under the wire guide.
- (b) When a signal for a character to be printed is detected, a current flows through the coil. When the coil is activated, the magnetic flux (caused by the permanent magnet between the armature and the core) is canceled to eliminate the attraction force. The armature is driven in the direction of the platen by the force of the armature spring. The print wire fixed to the armature protrudes from the tip of the wire guide, strikes the paper through the ribbon and prints a dot on the paper.
- (c) After the character has been printed, the armature is magnetically attracted again and the print wires are again concealed under the wire guide.

A thermistor in the printhead prevents burning caused by over-heating of the coil during extended continuous bi-directional printing. When the temperature of the coil exceeds a pre-determined limit (about 119°C) the control circuit detects a thermistor signal. Printing will then be intermittent or stop completely until the coil temperature falls below the limit value.

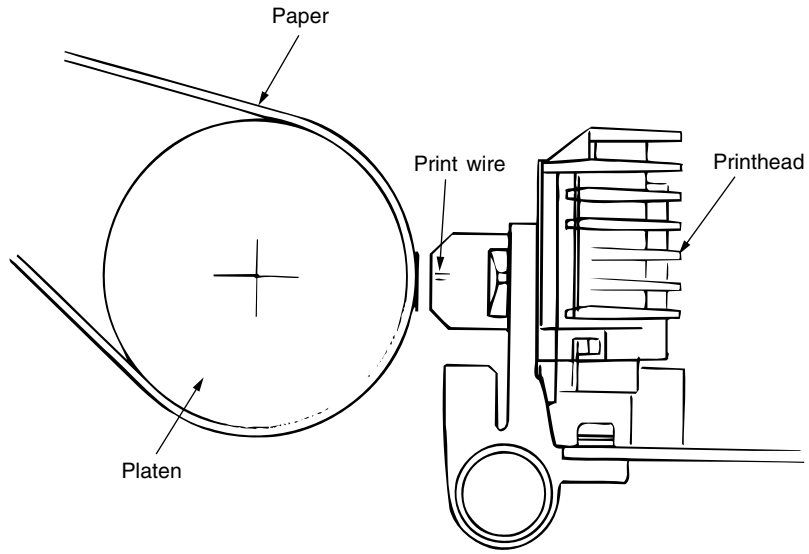

(1) When printing

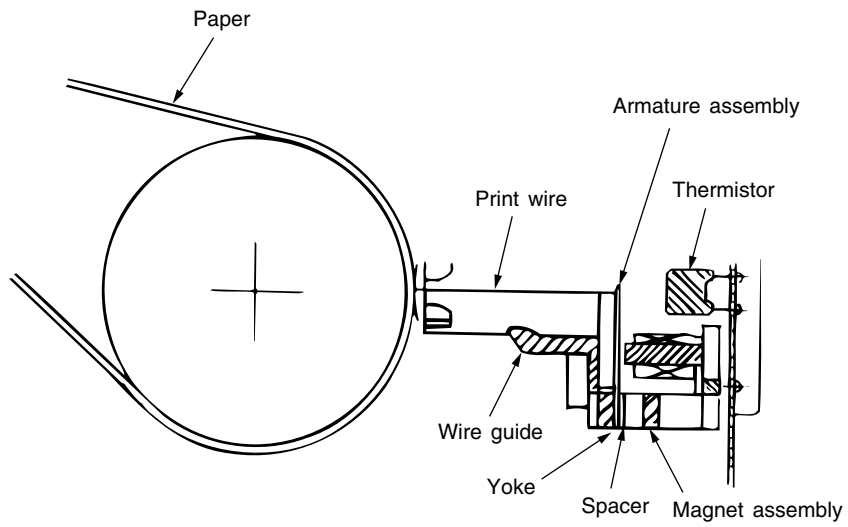

(2) When not printing

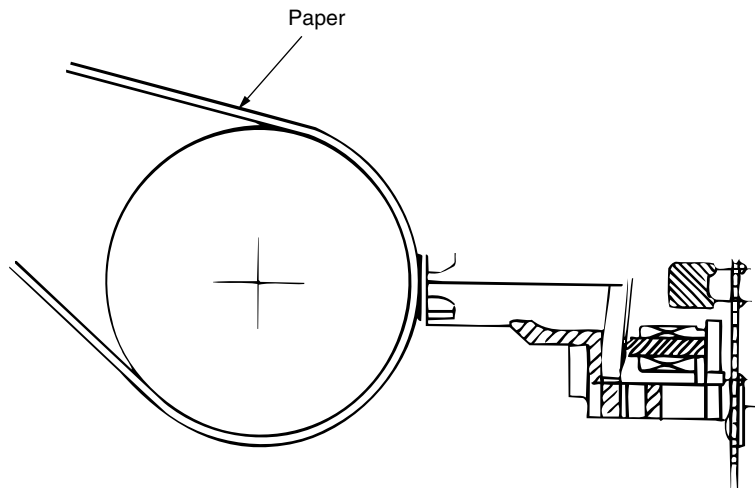

Figure 2-3

## 2.2.2 Spacing Operation (See Figure 2-4.)

The spacing mechanism consists of a carriage shaft mounted in parallel with the platen, and a carriage frame that moves along the shaft. It is driven by a DC motor mounted on the bottom of the carriage frame. Items included in the spacing mechanism are as follows:

- (a) DC motor with motor gear
  - (b) Carriage frame (stationary yoke and motor driver board included)
  - (c) Carriage shaft
  - (d) Space rack
  - (e) Sensor
  - (f) Encoder disk
- (1) Spacing operation

The carriage frame, on which the printhead and space motor are mounted, moves along the carriage shaft in parallel with the platen. When the spacing motor rotates counterclockwise, the driving force is transmitted to the motor gear. As the motor gear rotates, the carriage moves from left to right.

Mechanically, it is designed in such a way that for every revolution of the DC motor, the carriage frame moves 0.8 inch (20.32 mm).

At the same time the encoder disk rotates together with the motor and passes the sensor. The position of the carriage frame can be determined by counting the interrupts detected by the sensor.

In the same way, the rotation of the space motor can be recognized and controlled by measuring the cycle of interrupts detected by the sensor.

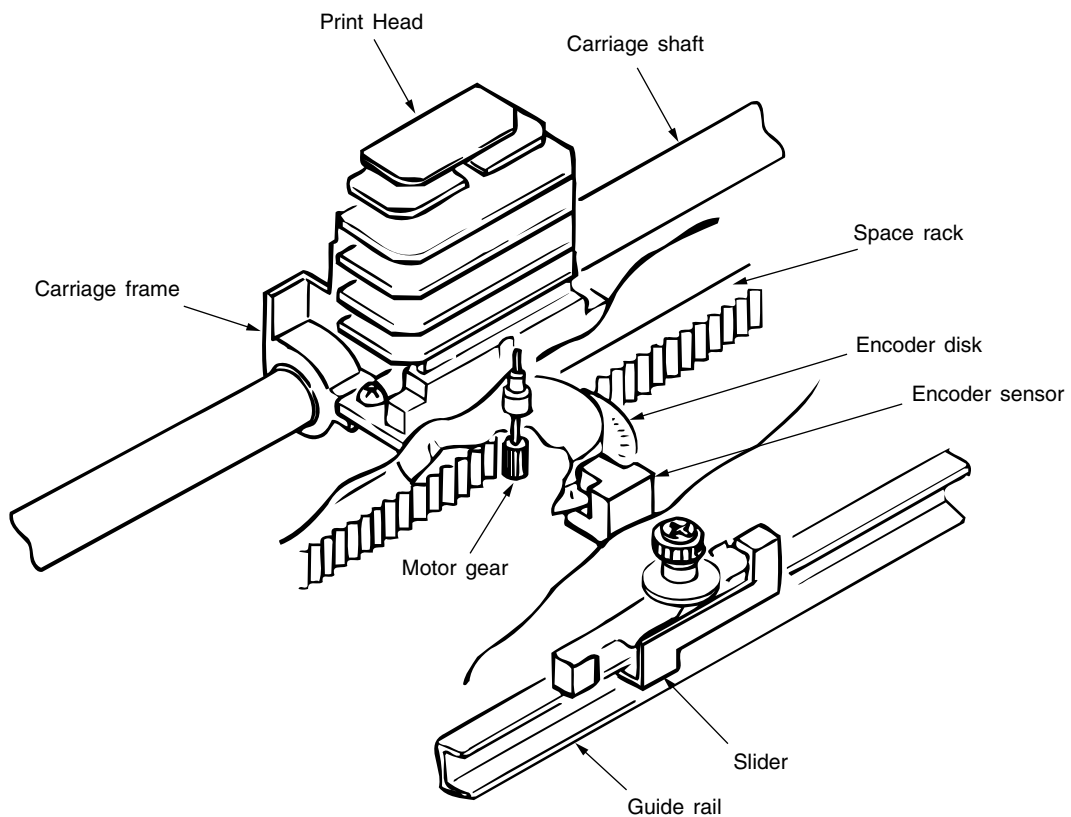

Figure 2-4

### 2.2.3 Head Gap Adjusting (See Figure 2-5.)

The head gap adjusting lever moves back and forth to tilt the carriage frame, altering the gap between the printhead and the platen.

The adjusting screw, which is connected to the adjusting gear rotates when the adjusting lever is moved creating a fine gap adjustment. If the adjusting gear is pushed down, the adjusting screw can be turned with a screw driver to change the coarse gap adjustment.

When the adjusting lever is set to range ② ~ ⑤ the contact which is attached to the under side of the carriage cover will connect with the contact of the space motor PC board. The printer will reduce the printing speed automatically to ensure that adequate printing pressure is maintained for multipart paper.

And, the adjusting cam adjusts the headgap toward left and right side in accordance with the guide rail up and down as a position of the left end of it.



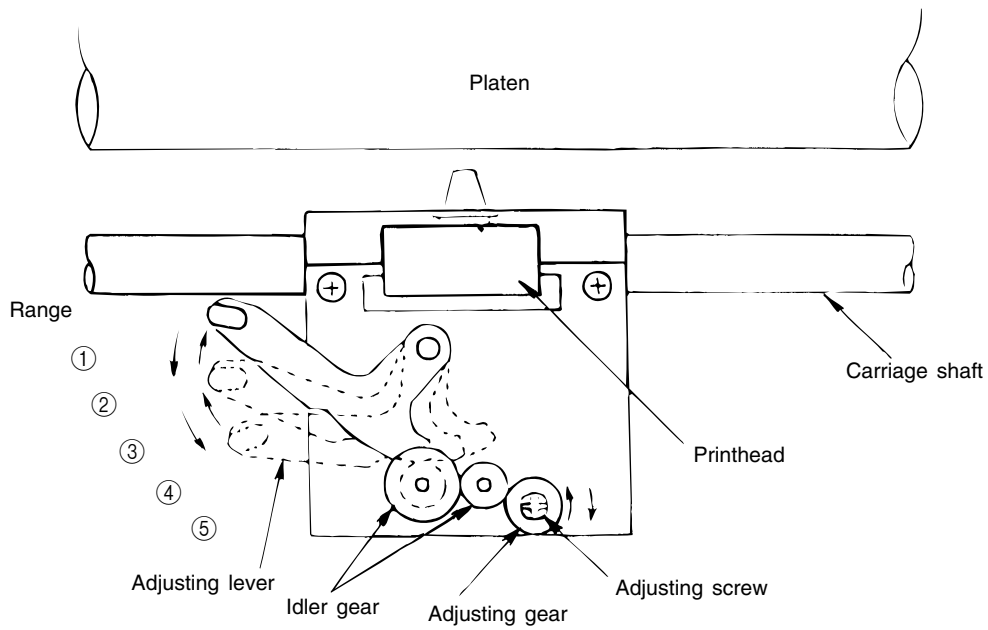

Range from ⑤ to ①

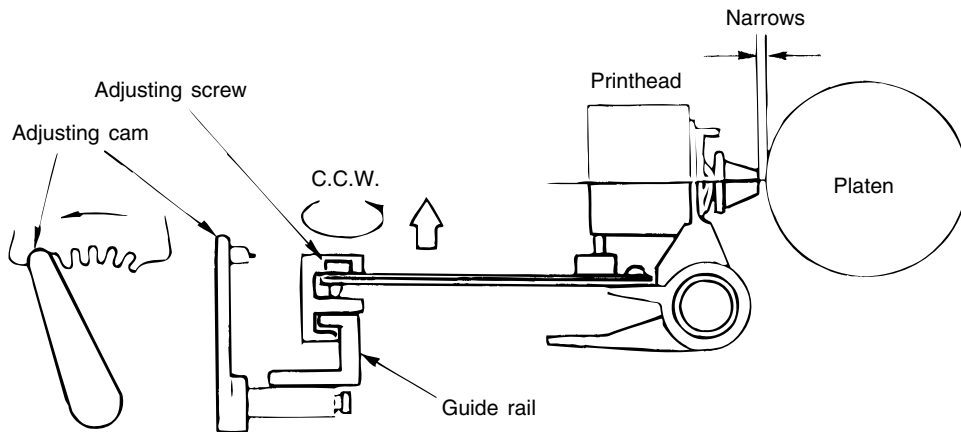

Range from ① to ⑤

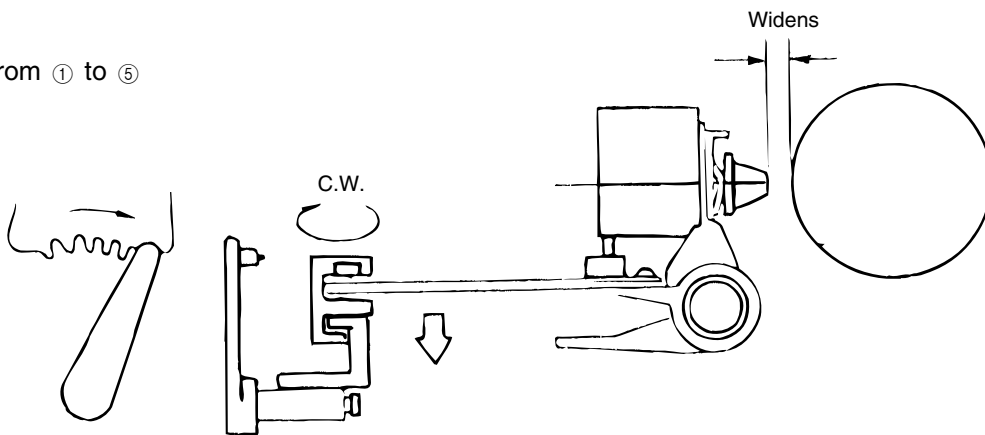

Figure 2-5

## 2.2.4 Ribbon Drive (See Figure 2-6.)

The ribbon driver mechanism moves the ribbon in synchronization with the space motor operation.

The ribbon drive mechanism consist of the following items:

- (a) Ribbon drive gear assembly
  - (b) Ribbon gear (space motor)
  - (c) Ribbon cartridge
- (1) Ribbon cartridge

An endless ribbon with a single direction feed is used. Ink is supplied from an ink tank, which is built in to the ribbon cartridge.

- (2) Ribbon feed operation

When the space motor is activated, the ribbon gear rotates. The rotation is transmitted via the ribbon drive gear assembly to the drive gear in the ribbon cartridge, thus moving the ribbon.

The feed direction of the ribbon is maintained by switching the rotational direction of the gears in the ribbon drive gear assembly. This ensures ribbon movement when bidirectional printing is used.

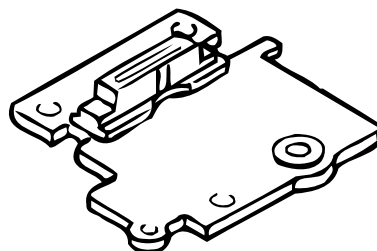
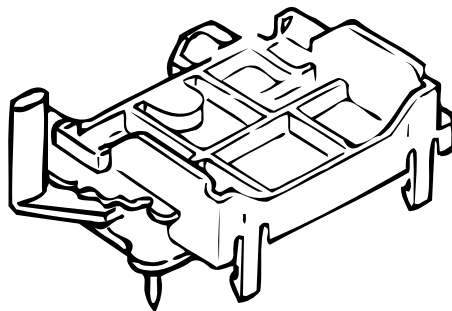
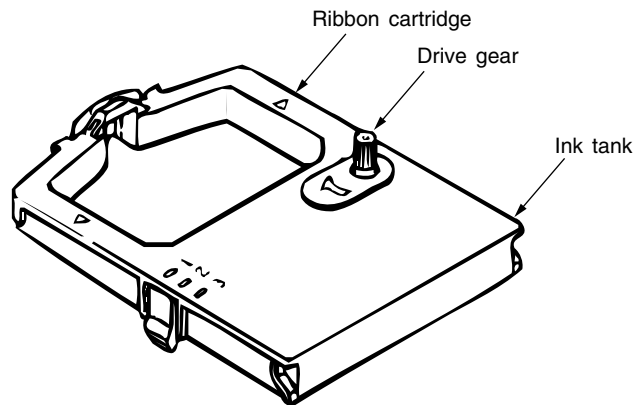

Figure 2-6

### 2.2.5 Paper Feed Operation

Feeding of the paper is performed by turning the platen and the pin tractor, which is driven by the LF pulse motor.

Item of the paper feed mechanism are as follows:

- (a) Pulse motor with gears
- (b) Decelerating gear
- (c) Platen
- (d) Tractor feed unit
- (e) Pressure roller

## (1) Cut sheet and continuous sheet switching mechanism (See Figure 2-8.)

Three different paper paths can be selected and set by the change lever.

(a) **TOP** (for cut sheet)

When the cut sheet is used in the manual mode or fed by the CSF (option), set the change lever at the position marked TOP.

## [Operation]

The driving force of the platen gear (R) is transmitted to the idle gear by setting the change lever to the TOP position. However, this causes the idle gear to be disengaged from the change gear, leaving it free.

At this time, the pressure rollers (at the rear and the front) are pressed securely to the platen to feed the cut sheet. At the same time, the switch lever positions between the rear switch and bottom switch, to confirm to the control board that you are in the cut sheet mode.

In the cut sheet mode, the control board automatically feeds the sheet up to the print start position after pausing for the wait time stored in the menu.

(b) **REAR** (Continuous sheet from push tractor)

When the change lever is set to REAR position, the change gear is engaged with the idle gear and the tractor gear to transmit the rotation of the platen to the push tractor shaft, and the continuous sheet is fed from the push tractor.

At the same time, the switch lever turns on the rear switch, to confirm to the control board that you are in the continuous sheet mode.

(c) **BOTTOM** (Continuous sheet from bottom feeder) (option)

When the change lever is set in the **BOTTOM** position, the rotation of the platen is transmitted to the drive gear of the bottom tractor feed unit through the idle gear to feed the sheet which has been set in the bottom tractor feed.

At the same time, the switch lever turns on the bottom switch, to confirm to the control board that you are in the continuous sheet mode.

## Correlation in Mechanism

Mechanism Lever Position	Rear Switch	Bottom Switch	Idle Gear	Change Gear	Tractor Gear	Sheet Insertion
TOP	OFF	OFF	Rotate	Stop	Stop	Manual/ automatic  CSF: Operation SW or instruction
REAR	ON	OFF	Rotate	Rotate	Rotate	• Operation SW or • instruction
BOTTOM	OFF	ON	Rotate	Rotate	Stop	• Operation SW or • instruction

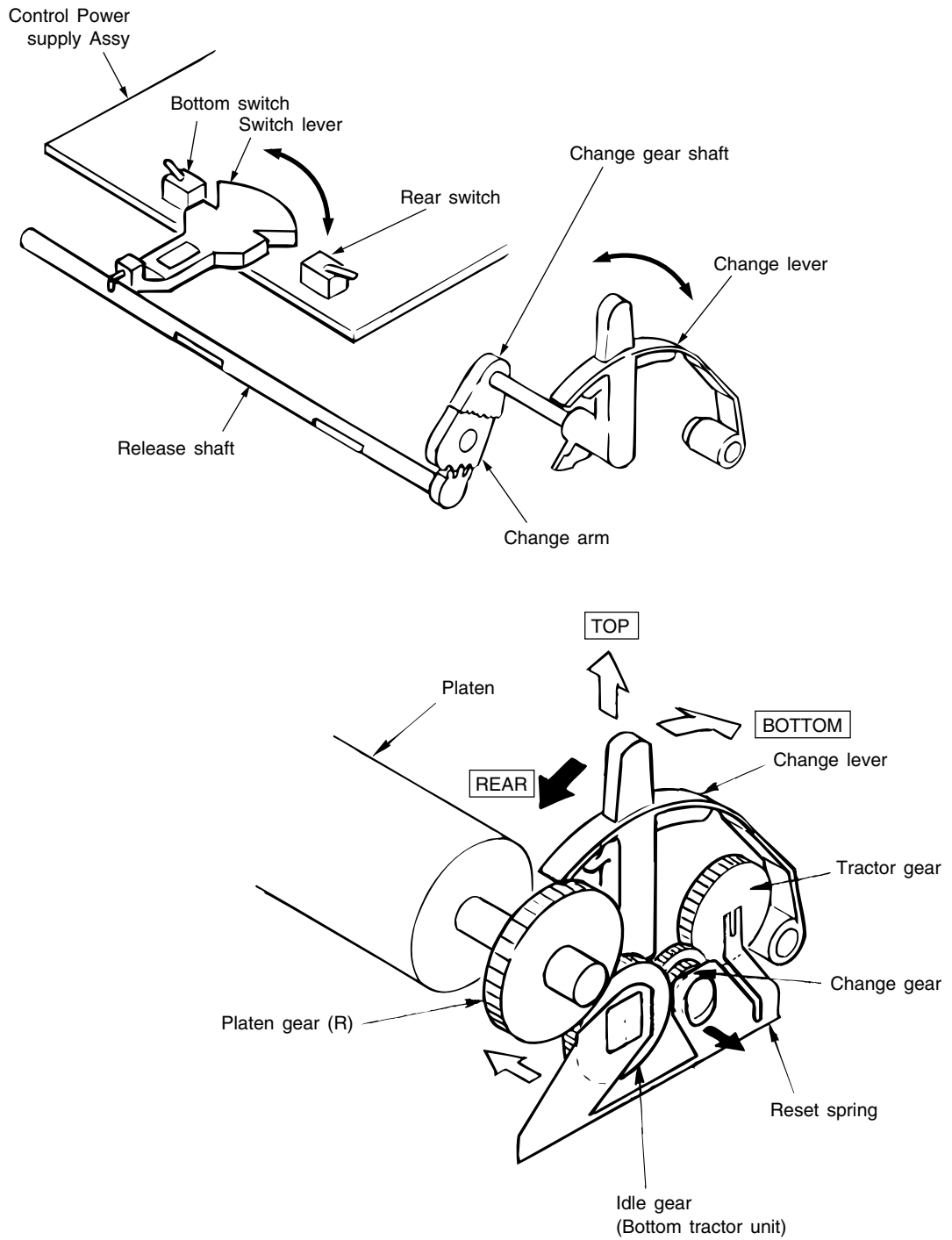

Figure 2-8

(2) Cut-sheet feeder operation (See Figure 2-9.)

The pulse motor used for the paper feed mechanism is mounted on the left of the frame, and the rotation of the motor is transmitted through decelerating gears (LF idle gear, platen gear) to the platen. When using cut-sheet paper, the change lever must be in the **TOP** position to grab the paper, while disengaging the push tractor.

When the change lever is set to the **TOP** position, the cut sheet is automatically fed in up to the print start position after pausing for the wait time stored in the menu.

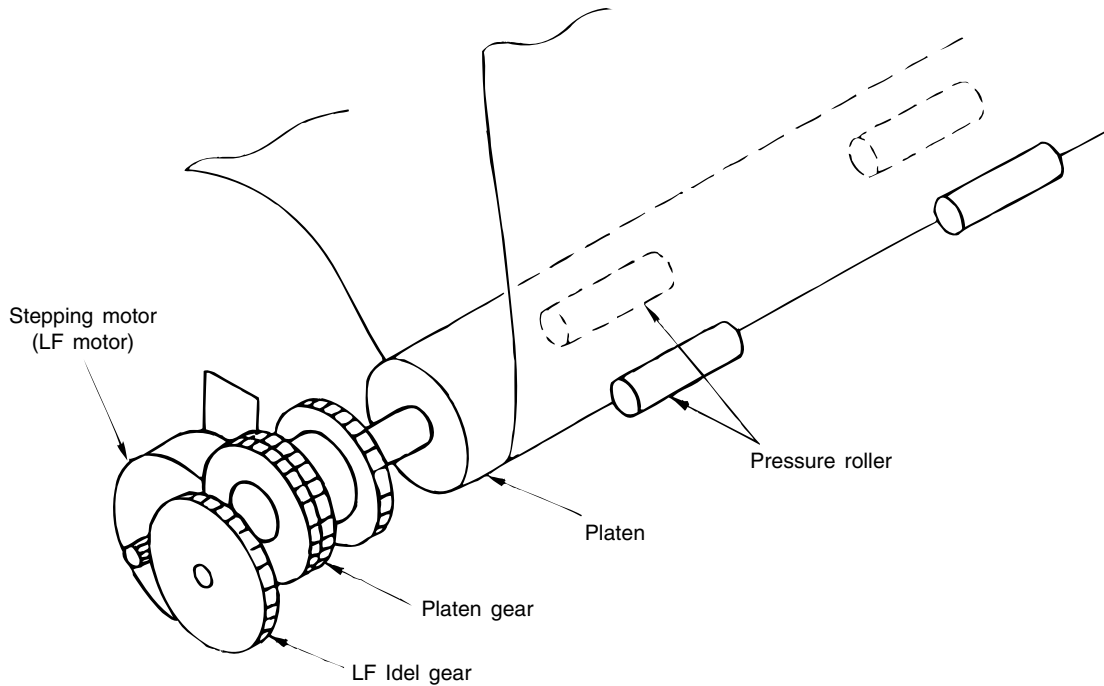

Figure 2-9

(3) Continuous paper feed operation (Rear) (See Figure 2-10.)

The force transmitted to the platen, rotates the tractor gear through platen gear, the idler gear and the change gear. The rotation of the tractor gear makes the pin tractor belt rotate through a sheet feeder shaft, feeding the continuous paper.

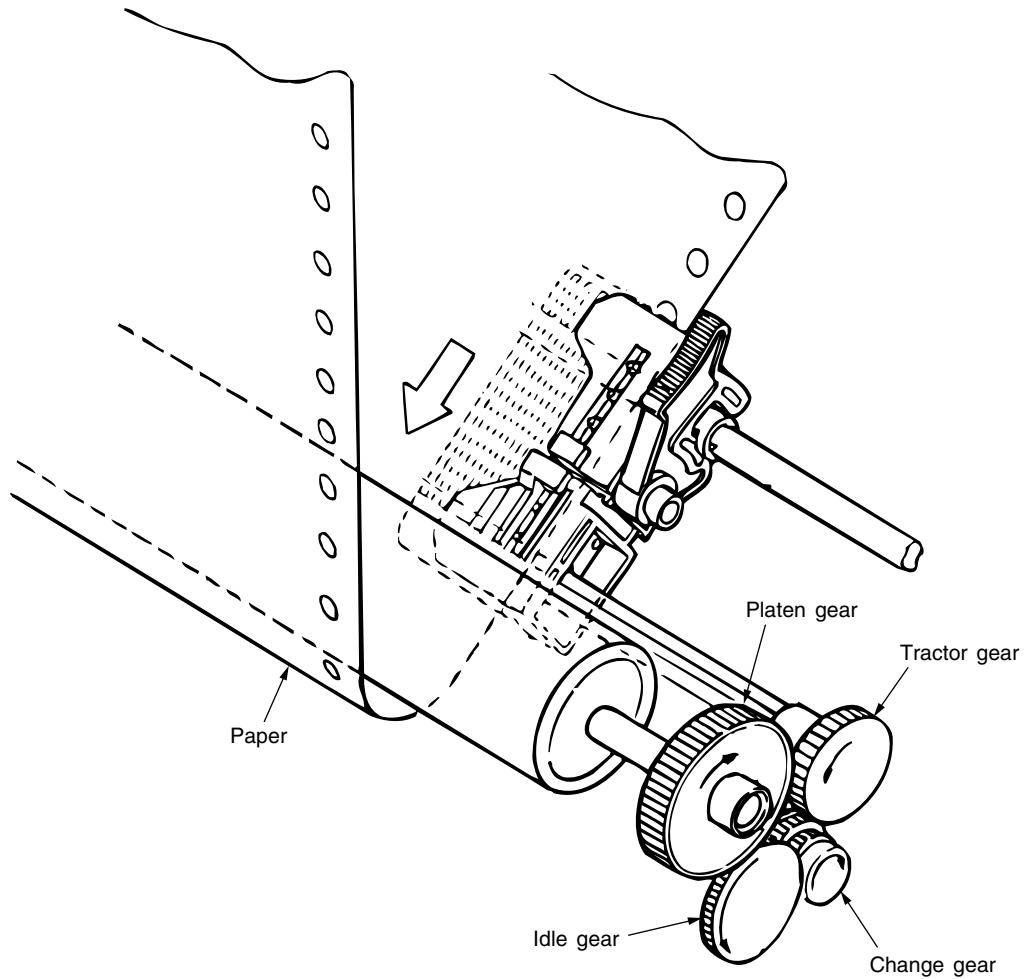

Figure 2-10

## (4) Push and pull tractor mechanism (Option) (See Figure 2-11).

This mechanism consist of an optional pull tractor and a standard push tractor mechanism. This mechanism can perform forward and reverse feed by setting continuous sheets to the push tractor and pull tractor.

The rotation of the platen is transmitted to the push tractor and the pull tractor. Sheets are fed by these two tractors at the same time.

To remove slack from the sheets, set the sheets according to the following procedure when using the push and pull tractors.

- ① Set the change lever to the **REAR** position (setting the sheets to the push tractor to feed).
- ② Set the paper, which is fed in front of the platen, to the pull tractor.
- ③ Set the change lever to the **TOP** position and feed paper using the platen knob.
- ④ If paper slack is removed, set the change lever to the **REAR** position.

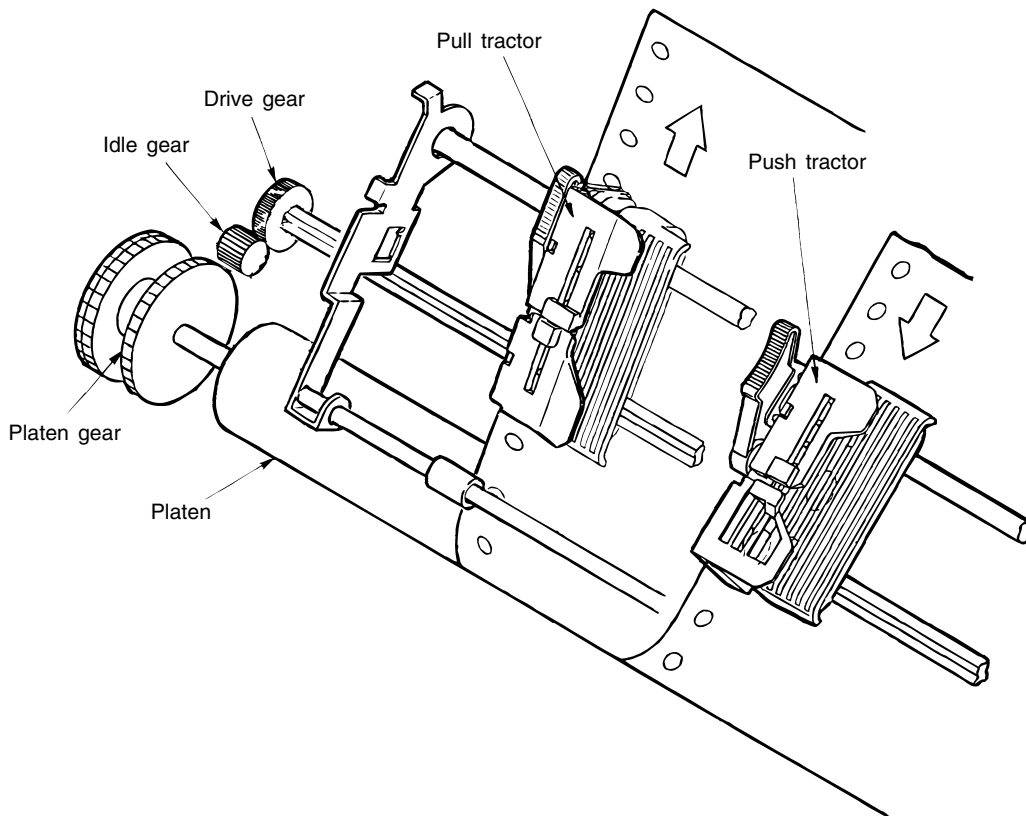

**Figure 2-11**



## (5) Pull tractor mechanism (option) (See Figure 2-12.)

Bottom feed of continuous sheets is possible only when an optional pull tractor unit is installed.

The rotation of the platen is transmitted to the idle gear of the pull tractor unit through the platen gear at the left end of the platen. The rotation of the idle gear is transmitted to the drive gear, and continuous sheet forms are fed by the pull tractor being rotated through the sheet feeder shaft.

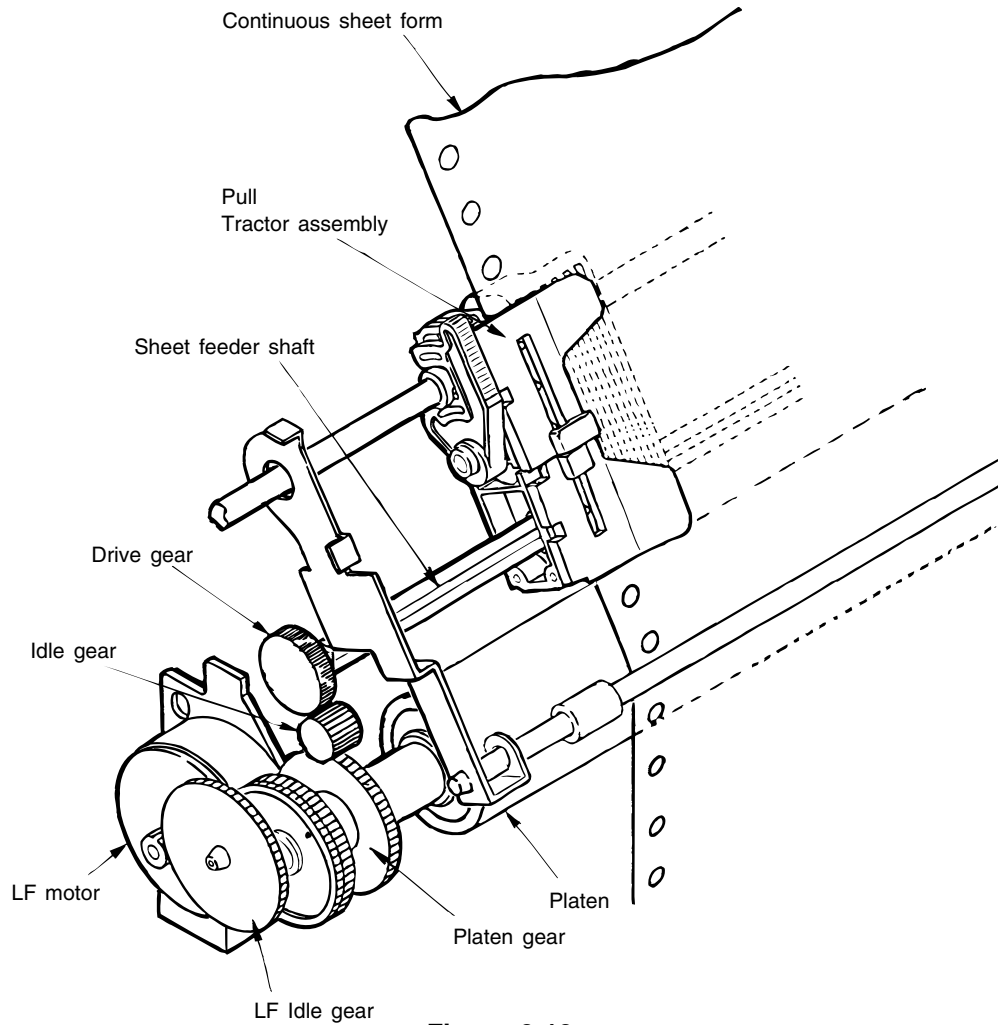

**Figure 2-12**

(6) Bottom push feed operation (Option) (See Figure 2-13.)

The bottom push feed of the continuous sheet is possible only when the bottom tractor feed unit is installed.

When the platen rotates, the rotational force of the platen is transmitted through the tractor idle gear and the tractor change gear to the tractor drive gear of the bottom push tractor, and the sheet of paper is fed in to the print start position.

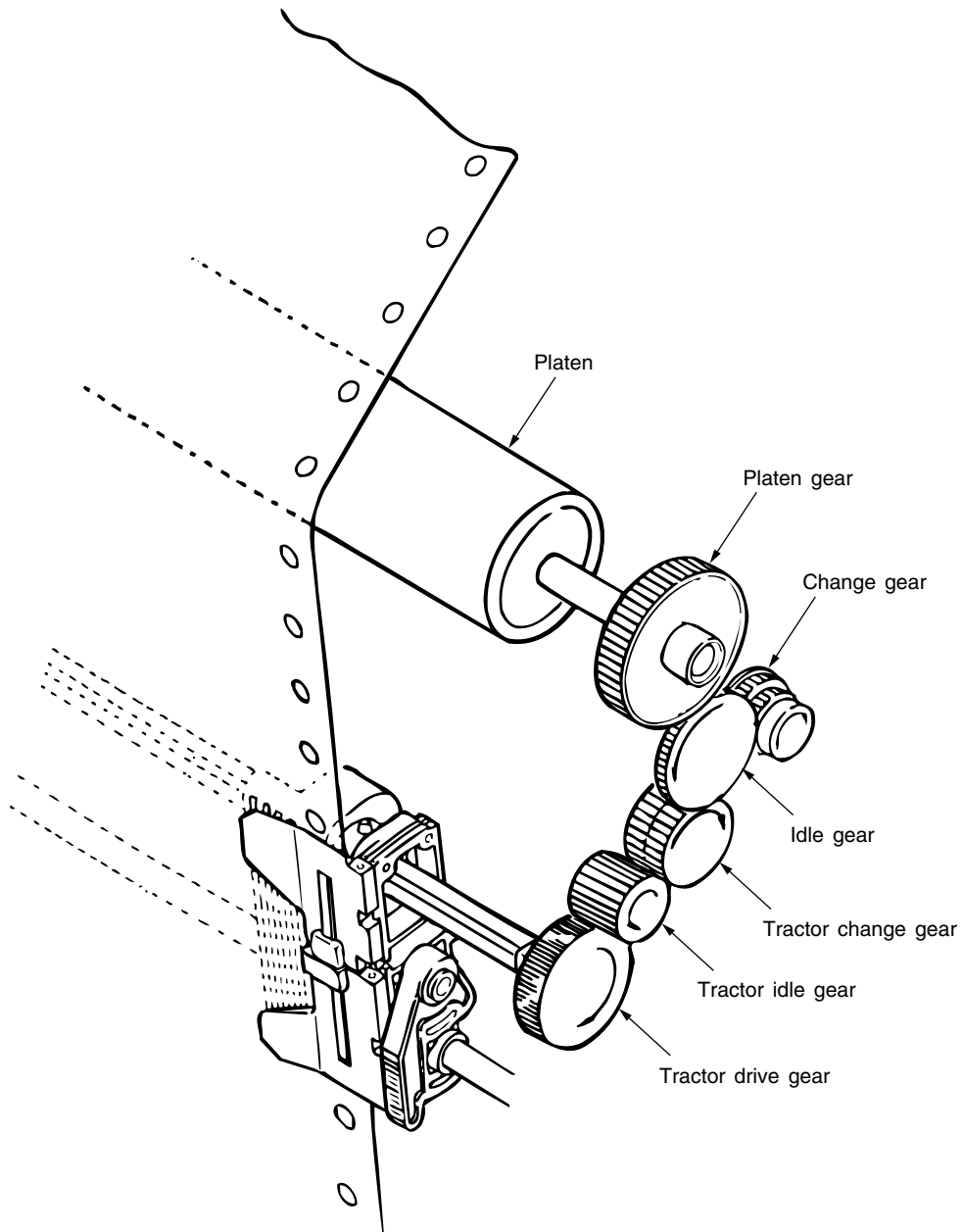

Figure 2-13

## (7) Paper clamp mechanism (See Figure 2-14.)

When setting the change lever to the **BOTTOM**, **TOP** or **REAR** position, the operation of the front release gear arm changes according to the position of the release cam. And at the same time, the position of the cam installed to the front release gear shaft changes, and the open and close of the pressure roller.

Position of change lever	Open or close of front pressure roller	Open or close of rear pressure roller
BOTTOM	OPEN	OPEN
TOP	CLOSE	CLOSE
REAR	OPEN	OPEN

TOP

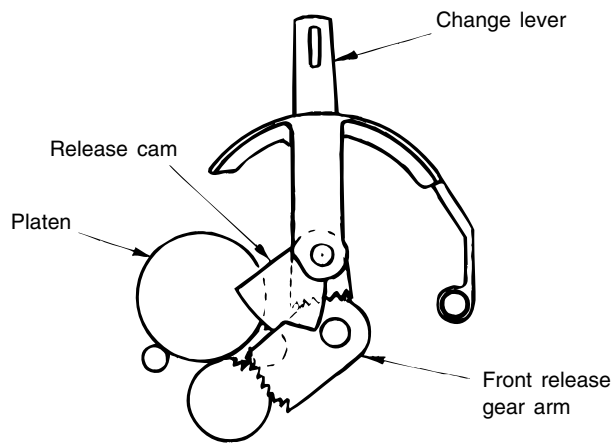

BOTTOM

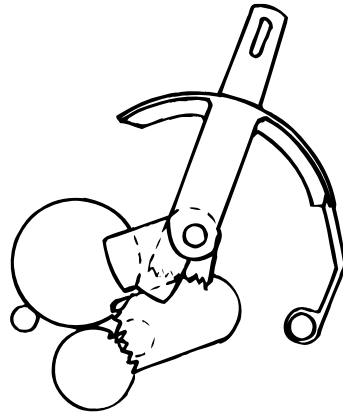

REAR

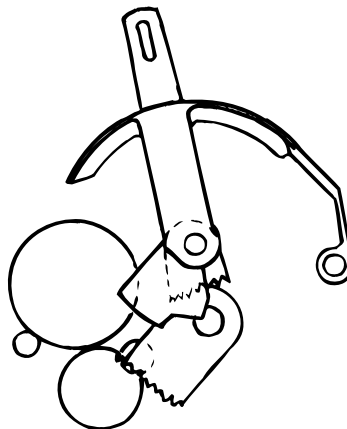

Figure 2-14

## 2.2.6 Paper Detection Mechanism (See Figure 2-15.)

### (1) Cut sheet detection

When the cut sheet is inserted, the point A is pushed backward and the paper near end lever B rotates counterclockwise (CCW).

At this time, the rear sensor lever rotates counterclockwise (CCW), the rear sensor lever and pulls out of the rear and top paper end sensor to detect that the sheet is provided.

The procedure for the paper end is made in the reverse order, that is, its detection is performed when the paper end sensor is blocked.

### (2) Rear feed detection

When the sheet is fed from the push tractor, the point B is pushed to the front side and the paper near end lever A rotates clockwise (CW). At this time, the rear sensor lever rotates counterclockwise (CCW), and pulls out of the rear and top paper end sensor to detect that the sheet is provided.

The procedure for the paper end is made in the reverse order, that is, its detection is performed when the rear sensor lever intercepts the sensor.

### (3) Bottom feed detection

When the sheet is fed from the bottom, the point C rotates clockwise (CW). When the bottom sensor lever rotates clockwise (CW), it pulls out of the bottom paper end sensor to detect that the sheet is provided.

The procedure for the paper end is made in the reverse order, that is, its detection is performed when the bottom sensor lever intercepts the sensor.

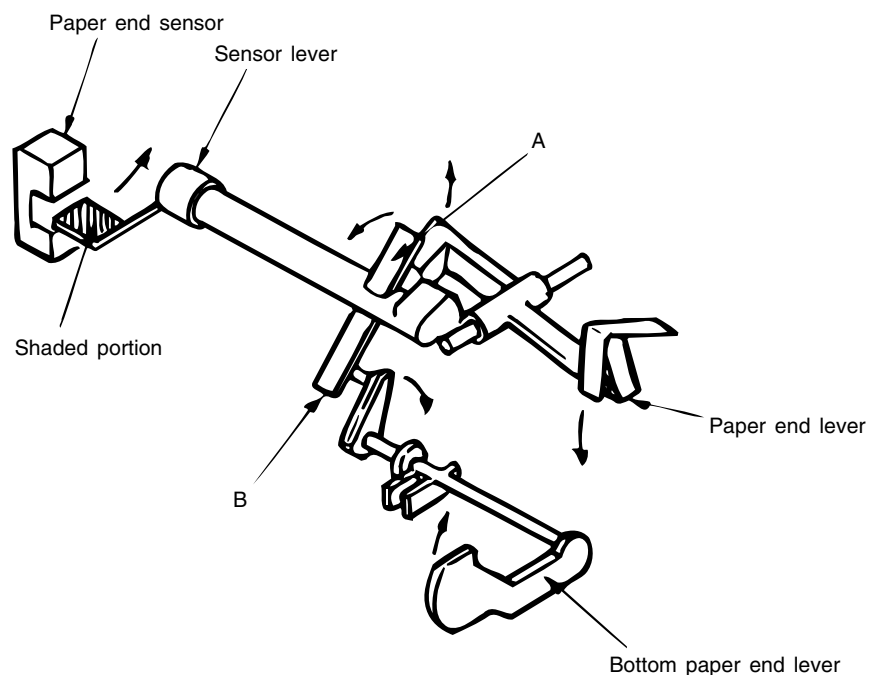

Figure 2-15

(4) Top line print mechanism (See Figure 2-16.)

The front edge of the sheet is protected by the ribbon protector so that it can stop at a position just near to the print head (0 tear off position) to start printing at the front end of the sheet, without causing the sheet to crumple or curl up.

The printing starts at the front end of the sheet, and continues uni-directionally until the front end of the sheet gets to the inside of the pull up roller cover.

After that, that printing continues bi-directionally.

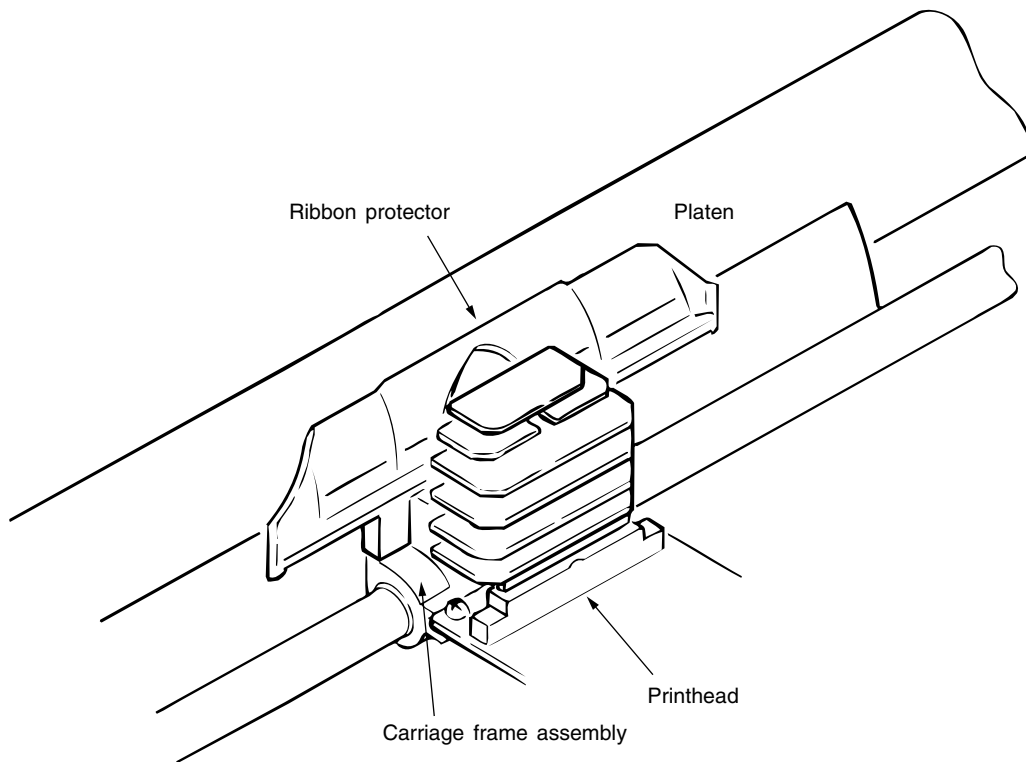

Figure 2-16

## 2.2.7 Automatic Sheet Feed

This function is used to feed in the sheet automatically up to the print start position when the cut sheet or the continuous sheet is used.

[Operational procedure]

### (1) When using the cut sheet

- 1) Set the change lever to the **TOP** position. (See Figure 2-17.)
- 2) Insert a sheet of paper between the platen and the paper shoot.
- 3) After the lapse of time selected by the "wait time" in the menu, the LF motor starts its operation to feed the sheet of paper up to the print position.
- 4) When the default is selected, the sheet of paper is feed in up to the position 0.35 inches (first dot position) from the upper end of the sheet. However, the 0 tear off mechanism allows the printing at the front end of the sheet by changing the TOF position.

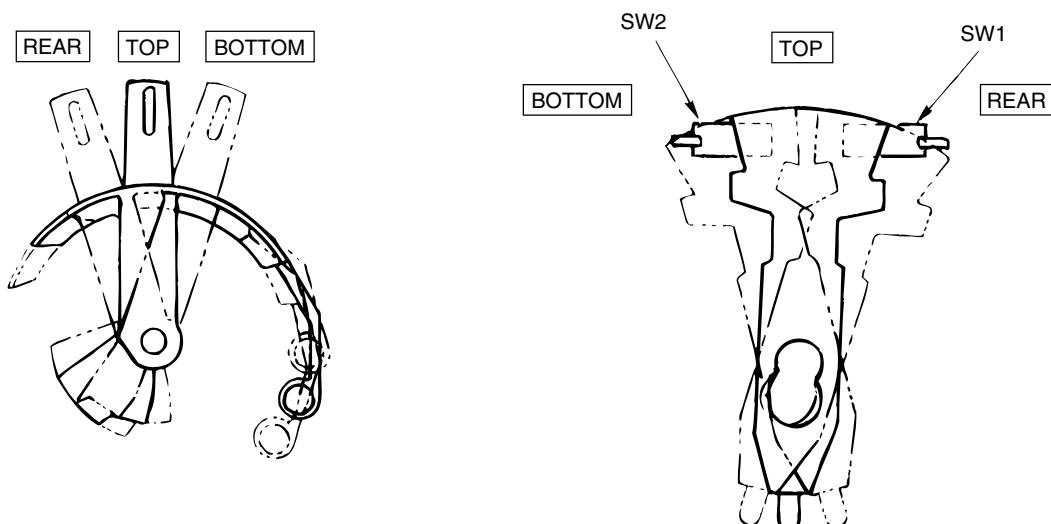
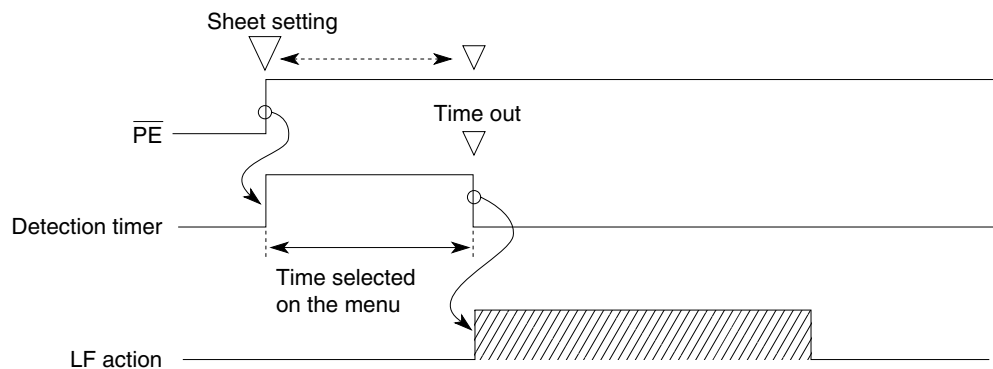
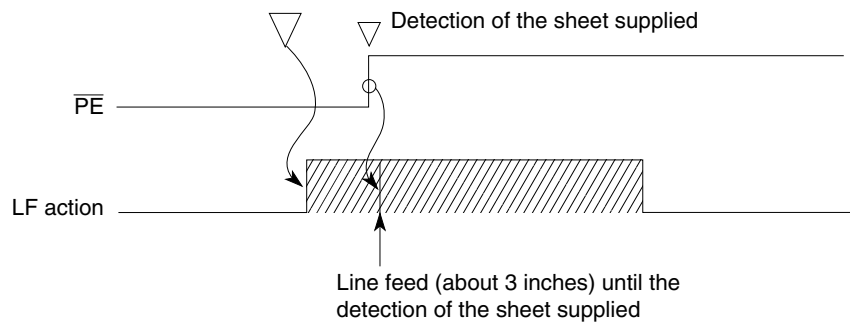

Figure 2-17

## (2) When using the continuous paper

- 1) Set the change lever either to the rear side or the bottom side position. (See Figure 2-17.)
- 2) Set a sheet of paper either to the push tractor or the bottom tractor.
- 3) Press the "FF/LOAD" switch.
- 4) The LF motor starts its operation to feed the paper up to the print start position.
- 5) The paper is fed in up to the TOF position (Factory default: 0.35 inches from the top).

Push down the "FF/LOAD" switch.



When the "FF/LOAD" switch is pushed down, the LF motor feeds in the sheet about 3 inches. When the LF motor completes the operation and the sheet has not been fed in, the feeding operating operation becomes, ineffective, thus resulting in the feeding jam.



### 2.2.8 Paper Park Function (Continuous paper)

Continuous sheets which have been inserted can be reversed automatically by using the "PARK" button on the operation panel.

- 1) Press the "PARK" button on the operation panel.
- 2) Reverse LF is started and paper is fed in reverse until paper end occurs or 19 inches maximum have been fed.
- 3) The paper is fed in reverse, to leave the paper on the push-tractor or bottom-tractor.

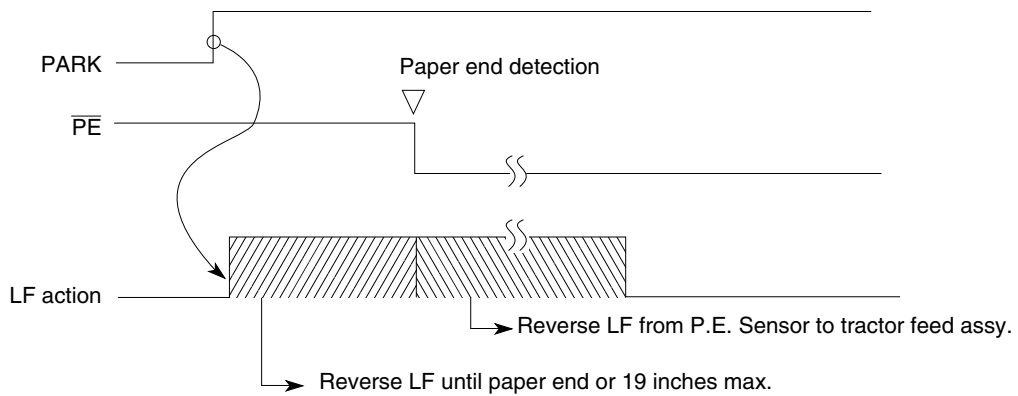

Alarm LED lights up when P.E. is not detected after 19 inches reverse feeding.

Operator can press SEL key to turn off the ALARM LED then press PARK key to continue park function.

This operation is required when the length of paper for parking is more than 19 inches.

### 3. ASSEMBLY/DISASSEMBLY

This section explains the procedures for removing and installing various assemblies and units in the field.

Description is mainly limited to the removal procedure; installation should basically be performed in the reverse sequence of the removal procedure.

#### 3.1 Precaution for Parts Replacement

- (1) Remove the AC cable and the interface cable before disassembling or assembling.
  - (a) Turn off the AC power switch. Remove the AC input plug of the AC cable from the receptacle. Remove the AC cable from the inlet on the printer (only 200V).

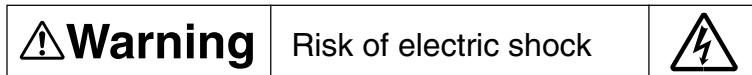

There is a risk of electric shock during replacement of the power supply.

Use insulating gloves or avoid direct contact with any conducting part of the power supply, and caution should be exercised during replacement.

The capacitor may take one minute to complete discharge after the AC cable is unplugged. Also, there is a possibility that the capacitor doesn't discharge because of a breakage of the PCB, etc., so remember the possibility of electric shock to avoid electric shock.

- (b) To connect the AC cable again, connect it to the inlet on the printer (only 200V) first, then insert the AC input plug into a receptacle.

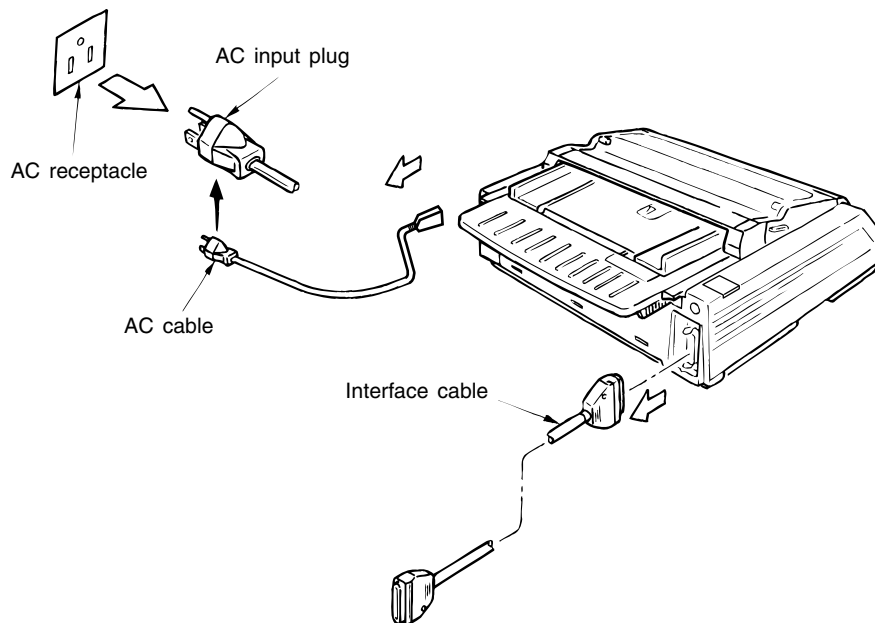







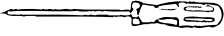

- (2) Do not disassemble the printer as long as it is operating normally.
- (3) Do not remove unnecessary parts, and limit the disassembly area as much as possible.
- (4) Use the designated service tools.
- (5) Carry out disassembly in the prescribed sequence; otherwise, damage to the parts may result.
- (6) It is advisable to temporarily install screws, snap rings and other small parts in their original positions to avoid losing them.
- (7) Whenever handling the microprocessors, ROM, RAM IC chips and boards, do not use gloves which may cause static electricity.
- (8) Do not place the printed circuit board directly on the equipment or on the floor.
- (9) If adjustment is specified in the middle of installation, follow the instructions.

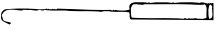
### 3.2 Service Tools

Table 3.1 lists the tools necessary for replacing printed circuit boards and parts of units in the field.

**Table 3.1 Service tools**

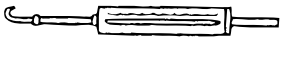
No.	Service Tool		Q'ty	Use	Remarks
1		No. 1-100 Phillips screwdriver	1	Screws 2.6 mm	
2		No. 2-200 Phillips screwdriver	1	Screws 3-5 mm	
3		No. 3-100 screwdriver	1		
4		Spring hook	1		
5		J-YX4025-83335-3	1	Head gap adjustment	
6		Volt/ohmmeter	1		
7		Feeler gauge	1	Head gap adjustment	
8		Pliers	1		
9		No. 5 nippers	1		
10		1.1 lbs (500 g) bar pressure gauge	1		

### 3.3 Disassembly/Reassembly Procedure

This section explains the assembly replacement procedures according to the following disassembly system.

[Parts Layout]

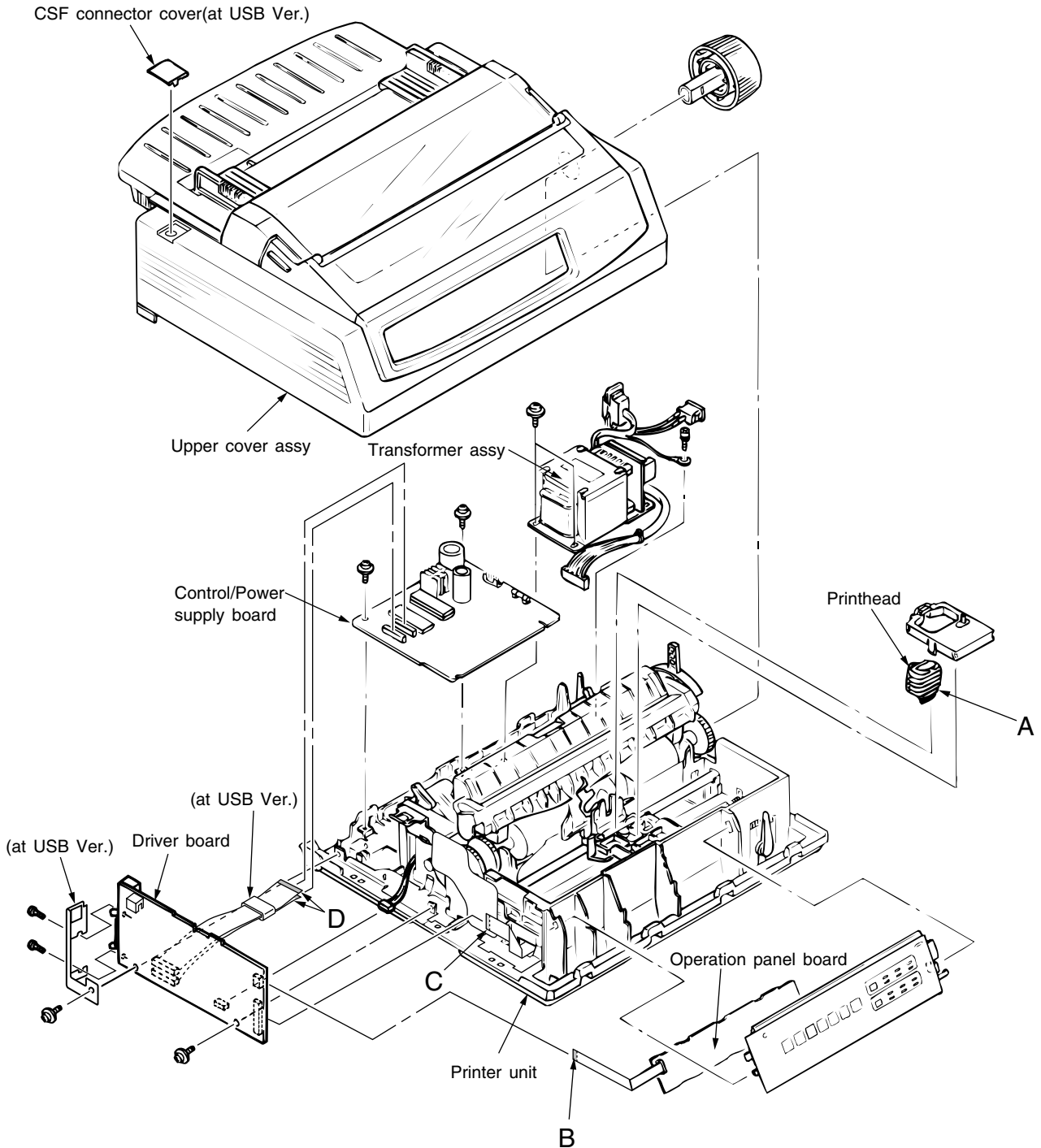
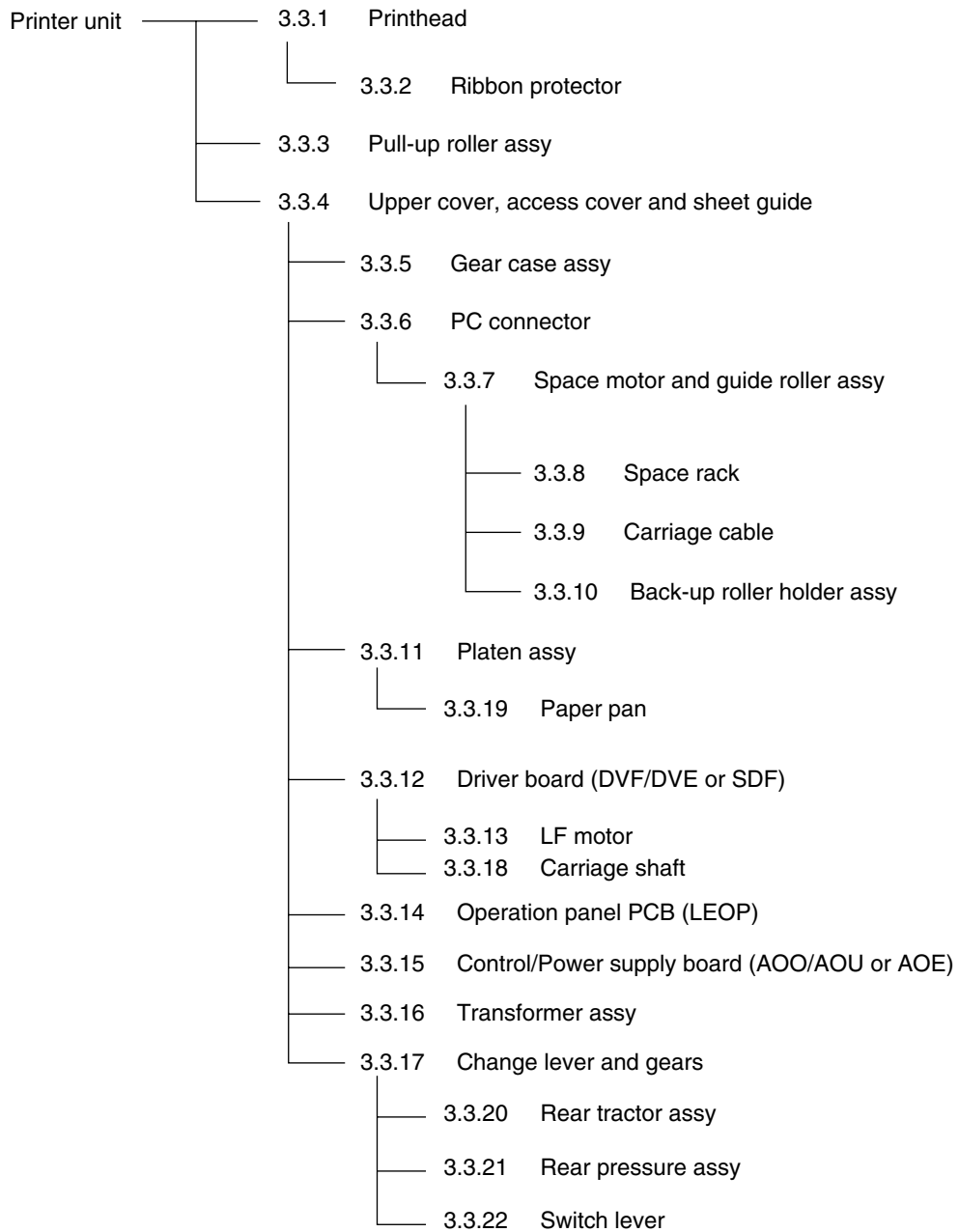

Figure 3-1 Printer unit

## [How to Change Parts]

This section explains how to change parts and assemblies appearing in the disassembly diagram below.



### 3.3.1 Printhead

- (1) Open the access over.
- (2) Pull up and rotate the head clamp ① to unclamp the printhead ② as shown fig. 3.3.1.
- (3) Disconnect the printhead ② from PC connector ③.
- (4) To install, follow the removal steps in the reverse order.

#### Notes on installation:

- (1) Insert the printhead ② into the PC connector ③ while pushing it against the carriage frame ④.
- (2) The head clamp ① must surely be sandwiched between printhead ② and carriage frame ④ as shown fig. 3.3.2.
- (3) Be sure to check the gap between platen and printhead (see 4).
- (4) Be careful not to touch the print head while it is very hot.
- (5) Make sure that there is not any dust or oil on the connector contact section A. If it is found, wipe it off by alcohol.

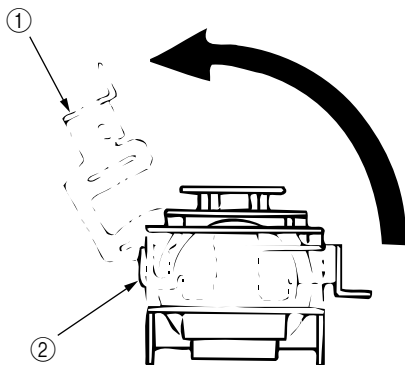

Figure 3.3.1

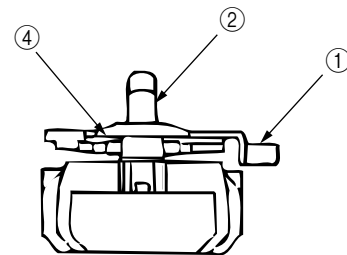
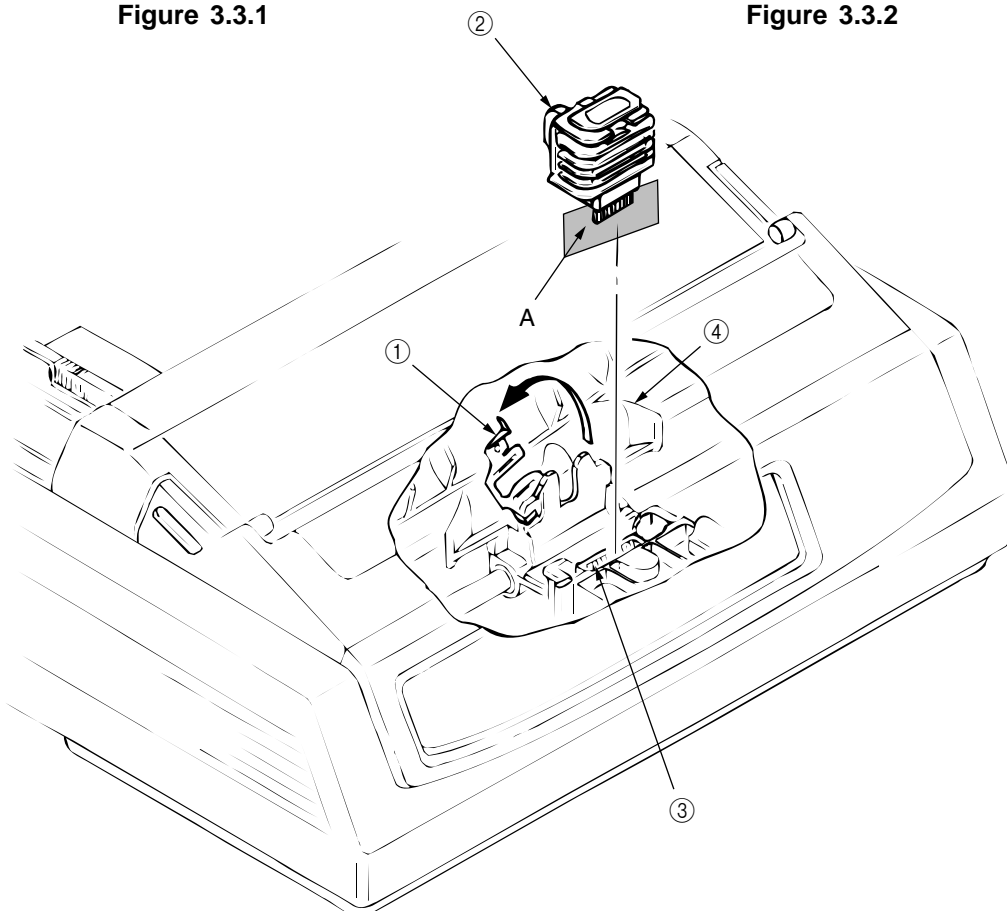
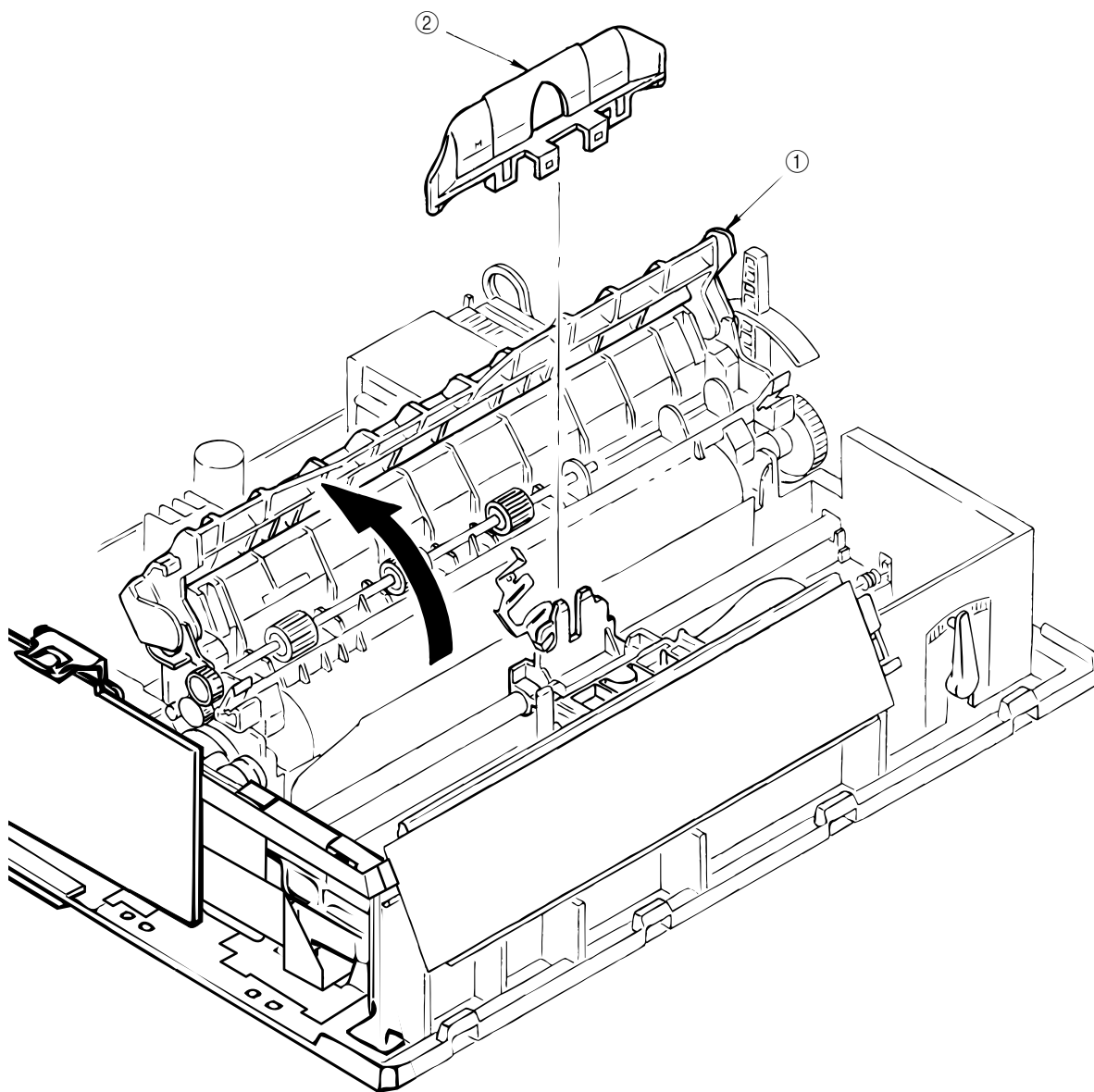

Figure 3.3.2



### 3.3.2 Ribbon Protector

- (1) Remove the printhead (see 3.3.1).
- (2) Open the pull-up roller cover ①.
- (3) Raise and remove the ribbon protector ②.
- (4) To install, follow the removal steps in the reverse order.



### 3.3.3 Pull-up Roller Assy

- (1) Open the access cover ①.
- (2) Lift up the sheet guide Assy ④ to remove.
- (3) Tilting the pull-up roller Assy ② toward the front, remove from the shaft of platen Assy ③.
- (4) To install, follow the removal steps in the reverse order.

**Note:** Remove the sheet guide Assy ④ before installing or removing the pull-up roller Assy ②.

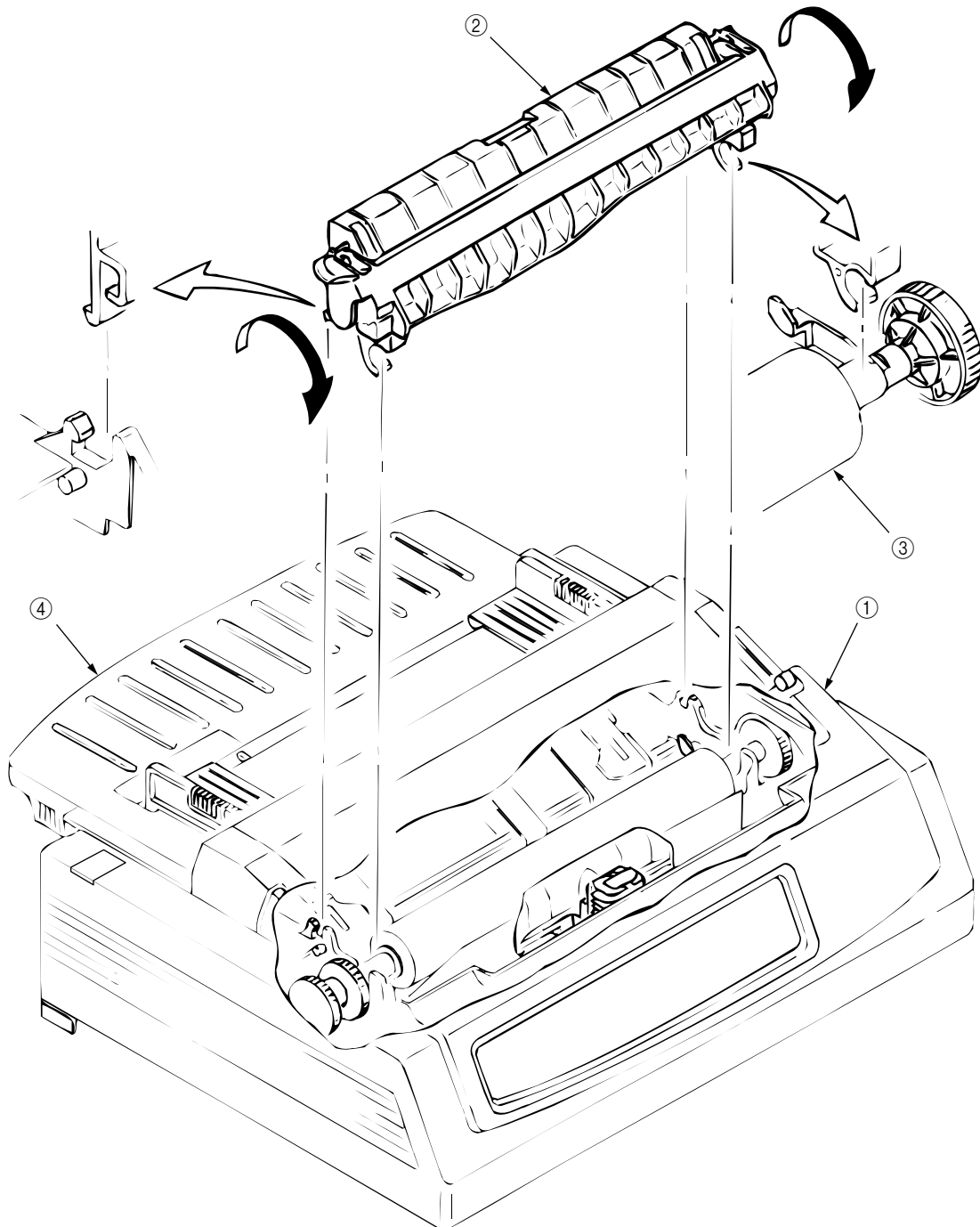



### 3.3.4 Upper Cover Assy, Access Cover Assy and Sheet Guide Assy

- (1) Pull off the platen knob ①.
- (2) Turn the change lever ② toward the bottom position.
- (3) Insert a flat-blade screwdriver into grooves (5 places) (4 places for narrow type) of frame and twist to disengage claws of upper cover ③.
- (4) Raise the front side of upper cover Assy ③ and shift toward the rear to disengage claws (6 places) (5 places for narrow type) of frame.
- (5) Raise the upper cover Assy ③ to remove.
- (6) Open the access cover Assy ④ toward the front to remove.
- (7) Lift up the sheet guide Assy ⑤ to remove.
- (8) To install, follow the removal steps in the reverse order.

Remark on assembly:

Match the posts ①A at the both sides of the Sheet Guide ⑤ with the arrow marks on the upper cover. Push the Guide into the Cover.

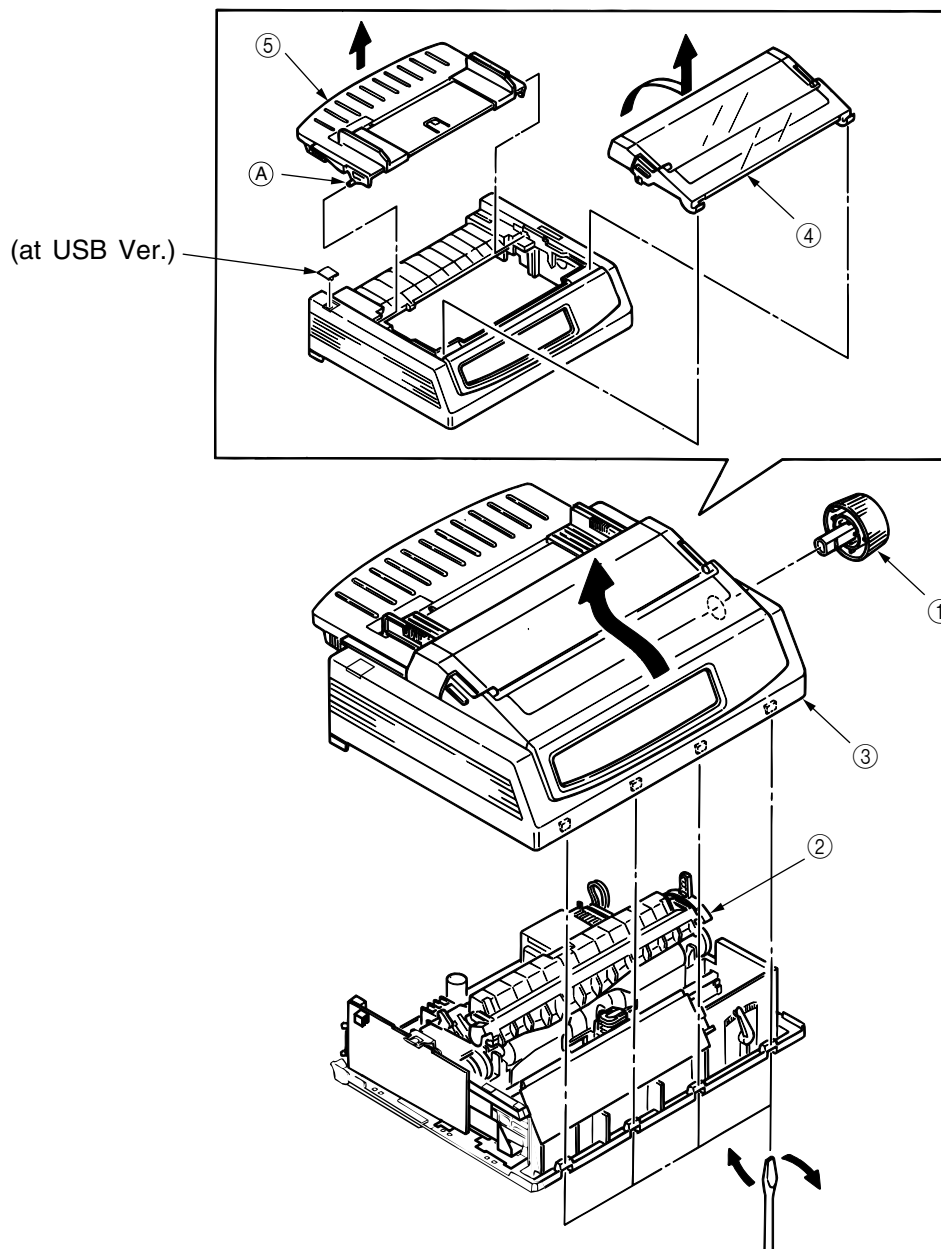

### 3.3.5 Gear Case Assy

- (1) Remove the printhead (see 3.31).
- (2) Remove the upper cover (see 3.3.4 (1) – (5)).
- (3) Move the carriage Assy to right hand side, remove two screws ①, then the space motor ②.
- (4) Disconnect a carriage cable.
- (5) Disengage claws (4 places).  
Using a flat-blade screwdriver, push to widen the claw for easy disengagement.
- (6) Remove the gear case Assy ③ in upper direction and release the carriage cable from the cable clamp of the gear case Assy.
- (7) To install, follow the removal steps in the reverse order.

Note on installation:

- (1) To assemble, align the direction of the SP motor axis ④ with the Gear Hole of the Gear Case Assy.
- (2) Be sure to check, and adjust if necessary, the gap between platen and printhead (see 4-1).

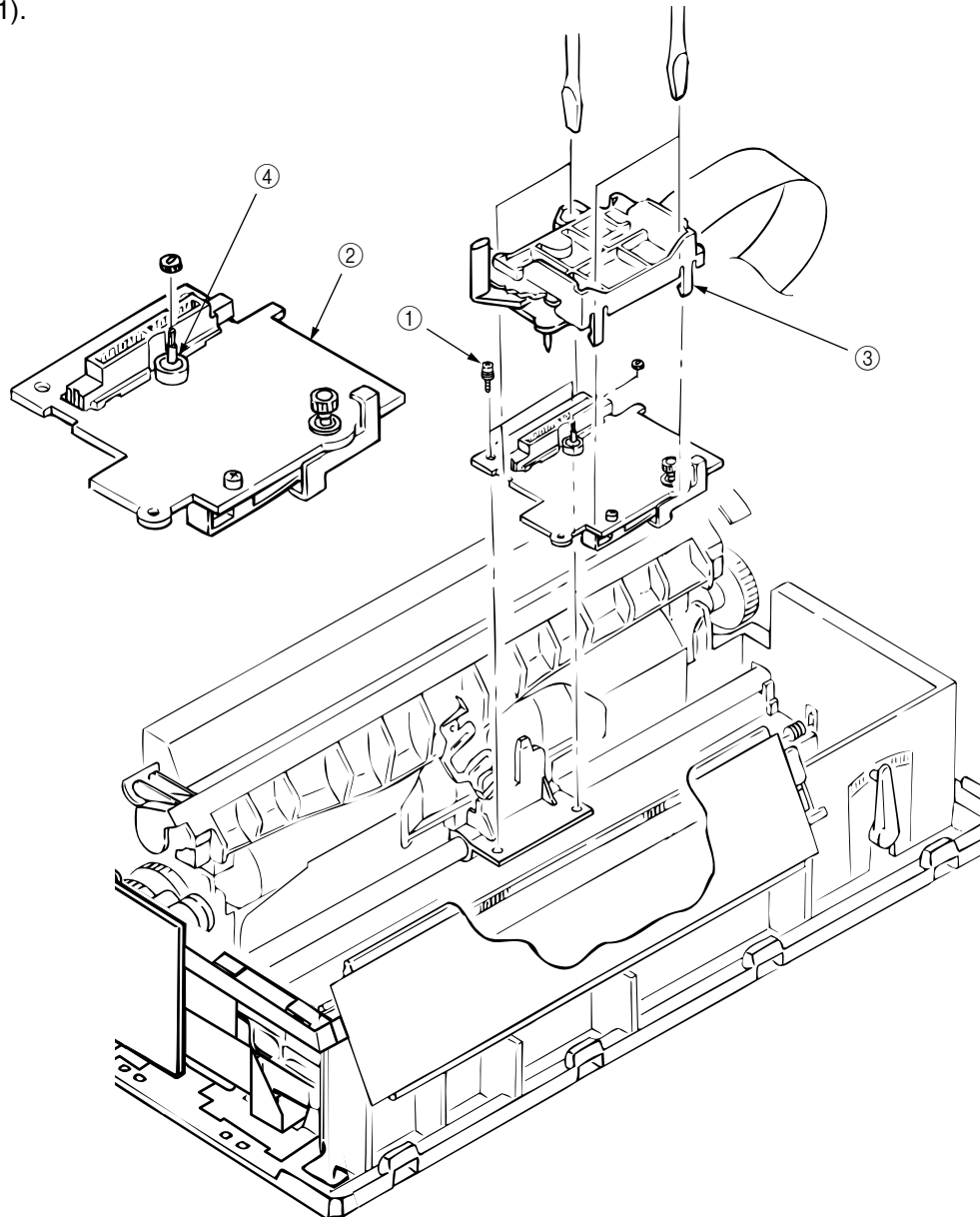

### 3.3.6 PC Connector

- (1) Remove the printhead (see 3.3.1).
- (2) Remove the upper cover (see 3.3.4 (1) – (5)).
- (3) Remove the gear case Assy (see 3.3.5).
- (4) Remove the PC connector ① from the space motor Assy ②.
- (5) To install, follow the removal steps in the reverse order.

#### Note on installation:

- (1) Do not touch the space motor ② or terminals of PC connector ①. Also, take care to avoid dust or foreign matters.
- (2) After installation, check and adjust the gap between platen and printhead (see 4-1).
- (3) Make sure that there is not any dust or oil on the connector contact section A. If it is found, wipe it off by alcohol.

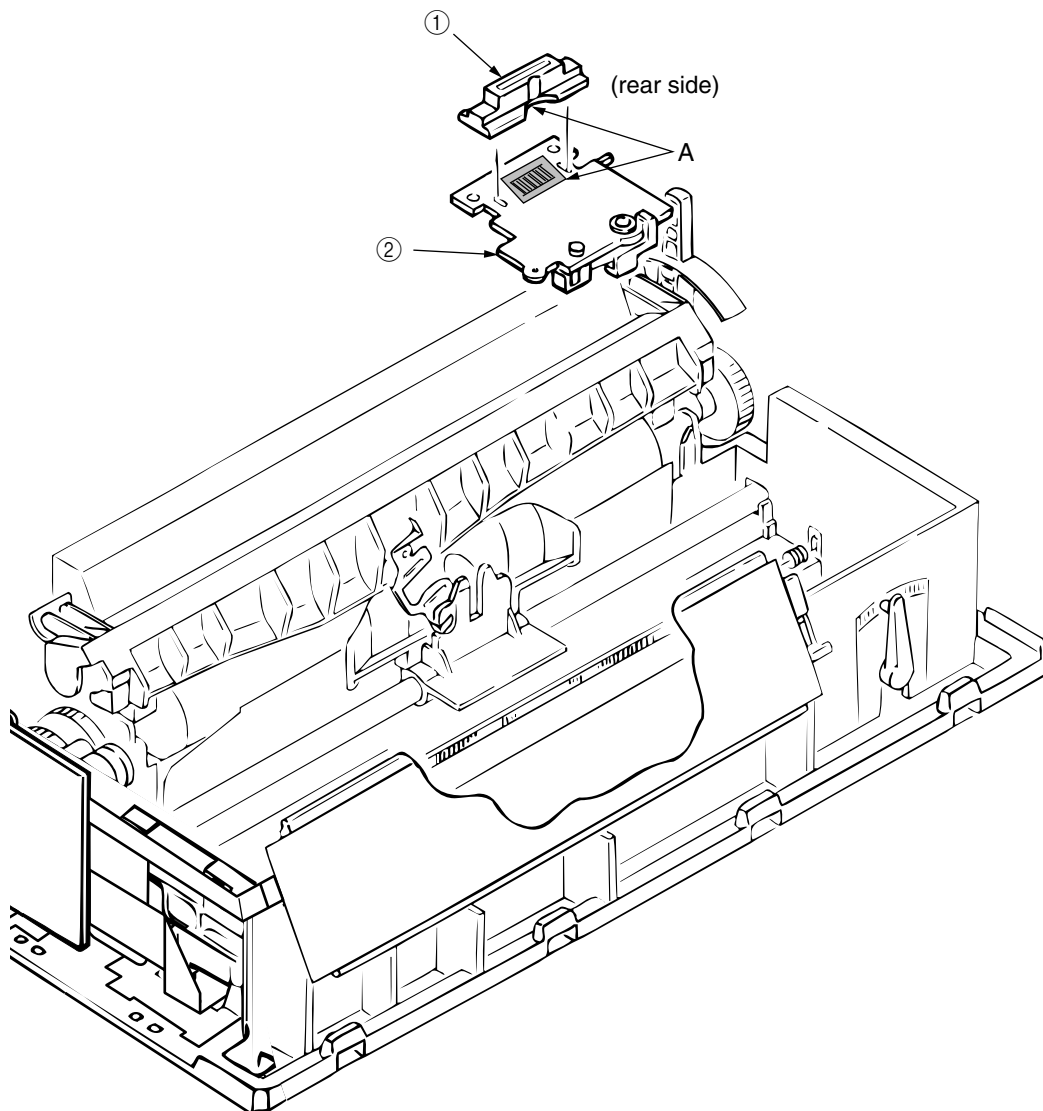

### 3.3.7 Space Motor, Guide Roller Assy

- (1) Remove the printhead (see 3.3.1).
- (2) Remove the upper cover (see 3.3.4 (1) – (5)).
- (3) Remove the gear case Assy (see 3.3.5).
- (4) Remove the PC connector (see 3.3.6).
- (5) Remove screw ②, then the guide roller Assy ③ from the space motor ①.
- (6) To install, follow the removal steps in the reverse order.

#### Notes on installation:

- (1) Do not touch the terminals of space motor ①. Also, take care to avoid dust or foreign matters.
- (2) When installing the guide roller Assy ③, push portions A and B against the space motor ①.
- (3) When installing the space motor ①, align the face C with carriage frame ④ and push portion D against the frame.
- (4) After installation, check and adjust the gap between platen and printhead (see 4-1).

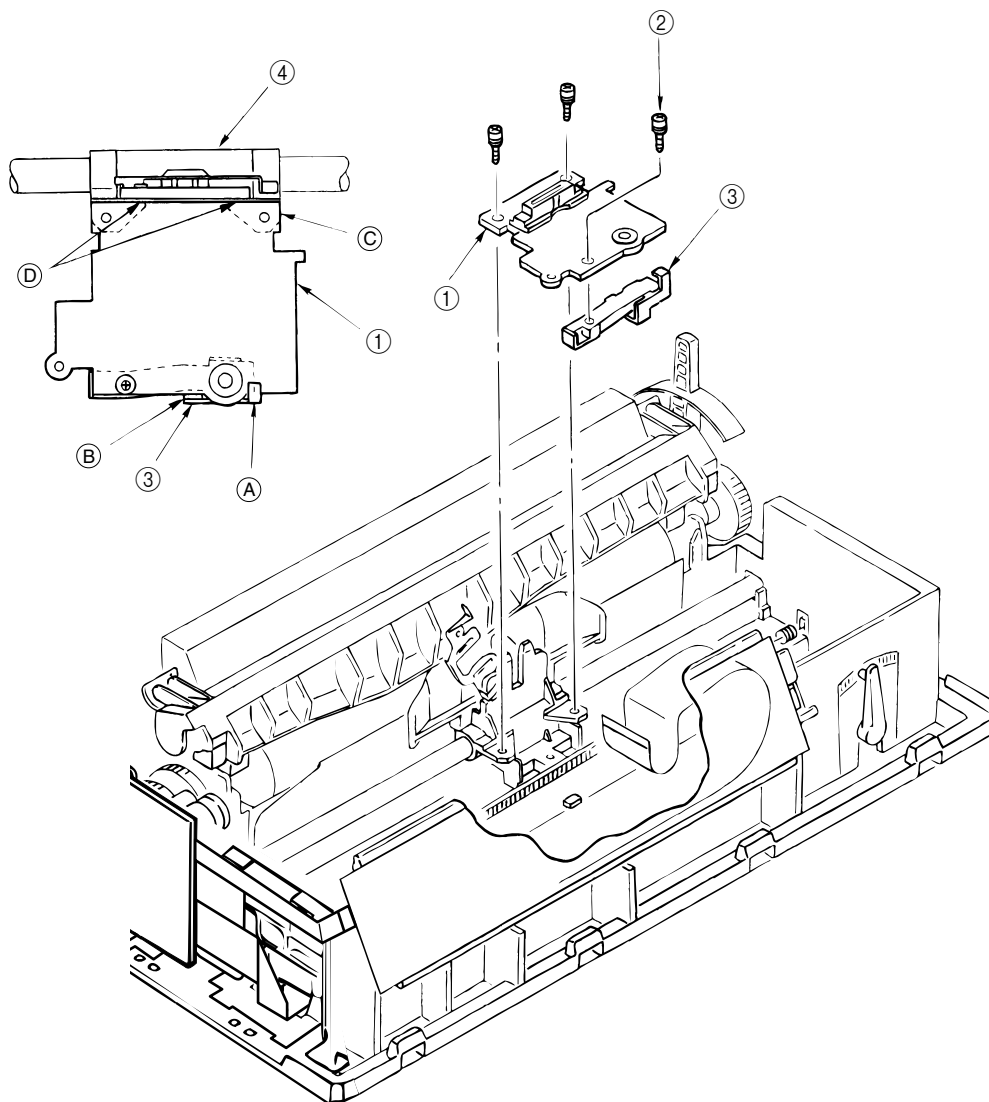

### 3.3.8 Space Rack

- (1) Remove the printhead (see 3.3.1).
- (2) Remove the upper cover (see 3.3.4 (1) – (5)).
- (3) Remove the gear case Assy (see 3.3.5).
- (4) Remove the space motor (see 3.3.7).
- (5) Remove the spring ①.
- (6) Disengage the claw on left side of space rack ② from the frame, and remove the space rack ② in upper direction.
- (7) To install, follow the removal steps in the reverse order.

Note on installation:

- (1) After installation, check and adjust the gap between platen and printhead (see 4-1).

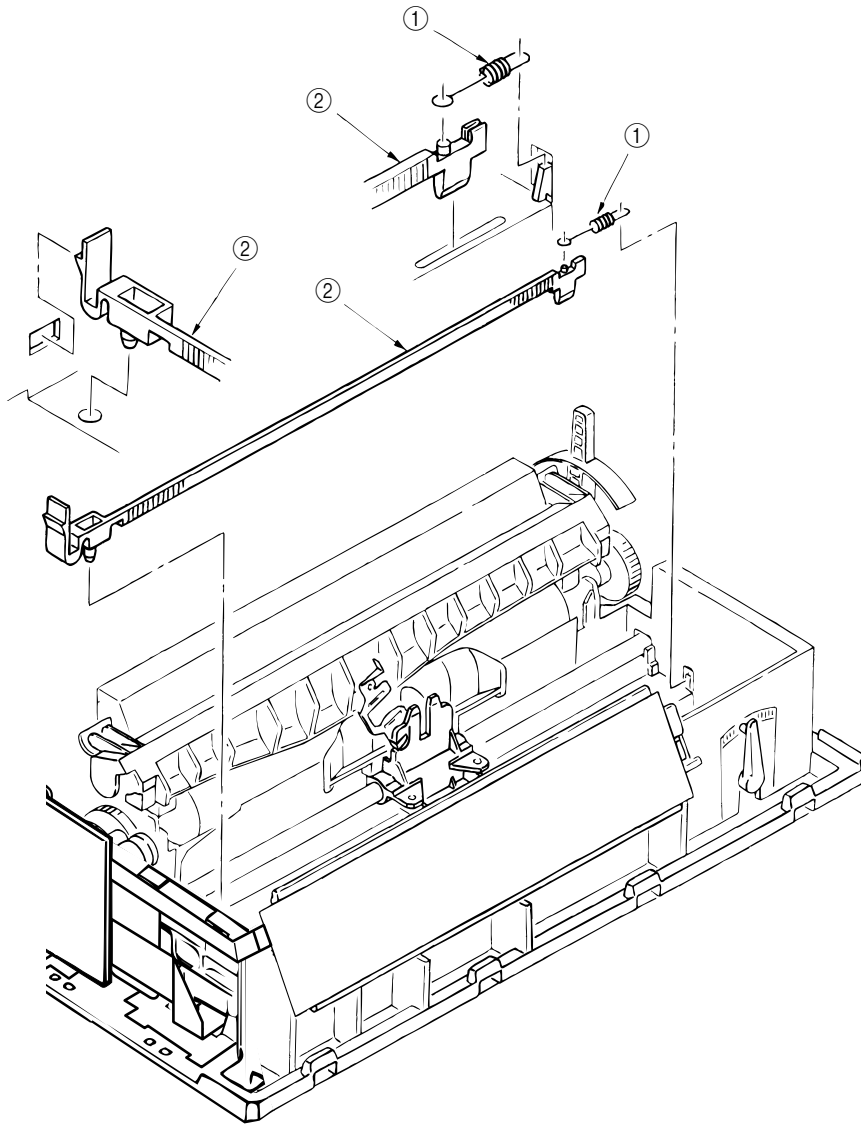

### 3.3.9 Carriage Cable

- (1) Remove the printhead (see 3.3.1).
- (2) Remove the upper cover (see 3.3.4 (1) – (5)).
- (3) Remove the gear case Assy (see 3.3.5).
- (4) Remove the space motor (see 3.3.7).
- (5) Remove the space rack (3.3.8).
- (6) Remove two screws ①, release the driver board ② by lifting clamp ⑧, and disconnect cable from connector ③, ④, ⑤, ⑥.
- (7) Remove carriage cable ⑦ from fasteners on frame.
- (8) To install, follow the removal steps in the reverse order.

#### Note on installation:

- (1) Take care not to fold the carriage cable ⑦ during installation. Curve slightly the carriage cable ⑦ when assembling into the fasteners.
- (2) Make sure that the paper end lever ⑩ will not contact the Paper end Sensor ⑨ when mounting the Driver Board.
- (3) Make sure that there is not any dust or oil on the connector contact sections A to D. If it is found, wipe it off by alcohol.
- (4) Butt and attach the drive board ② to the E sections (2 places) of the convex of the main chassis.

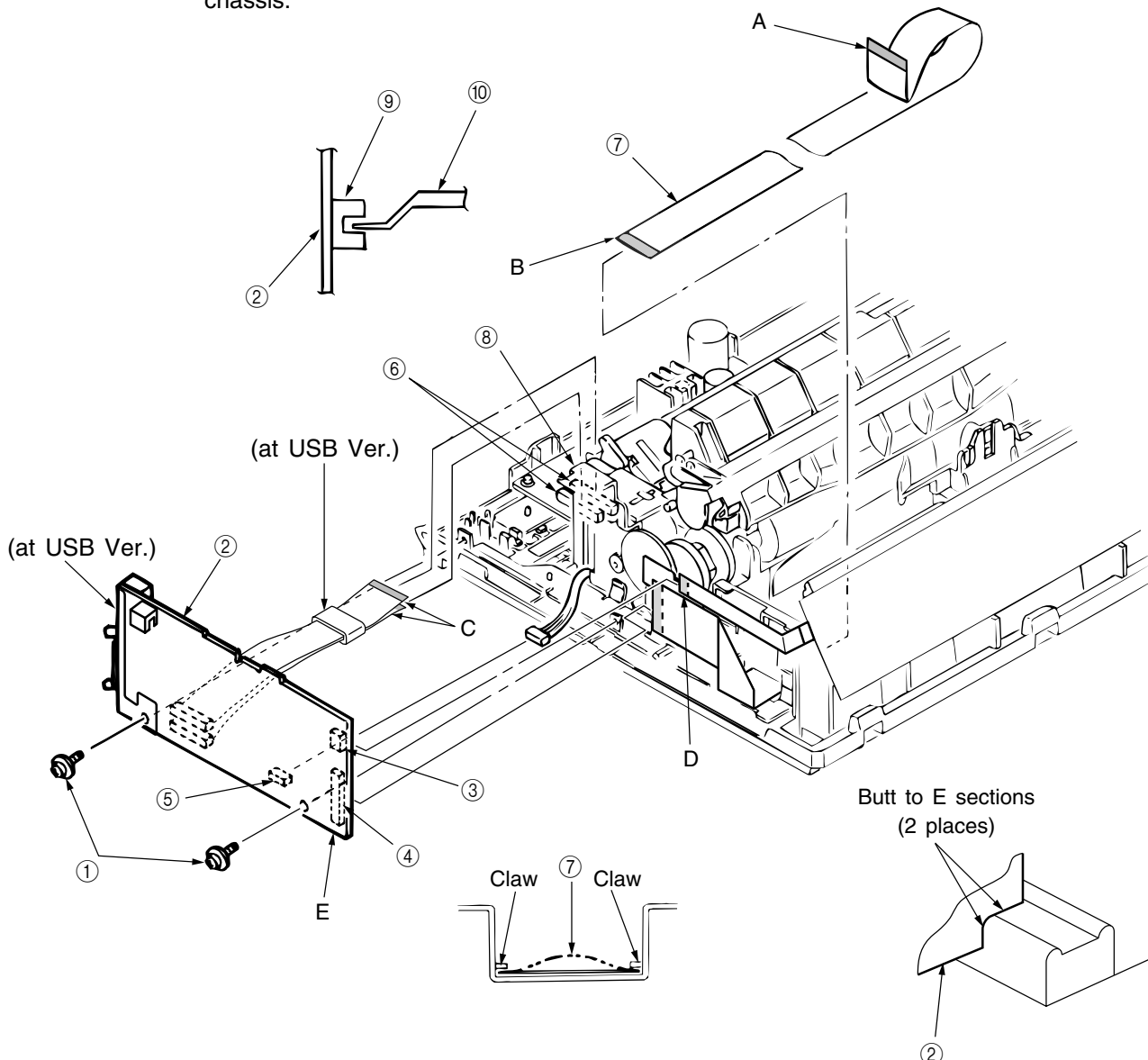

### 3.3.10 Backup Roller Holder Assy

- (1) Remove the printhead (see 3.3.1),
- (2) Remove the upper cover (see 3.3.4 (1) – (5)).
- (3) Remove the gear case Assy (see 3.3.5).
- (4) Remove the space motor (see 3.3.7).
- (5) Remove the backup roller spring ②.

Disengage claws (2 places) of roller holder from the carriage frame ①, and remove the backup roller holder assy ③.

- (6) To install, follow the removal steps in the reverse order.

**Note:** Small round hole with metal tip on back up roller holder assy ③ should be facing up when installing.

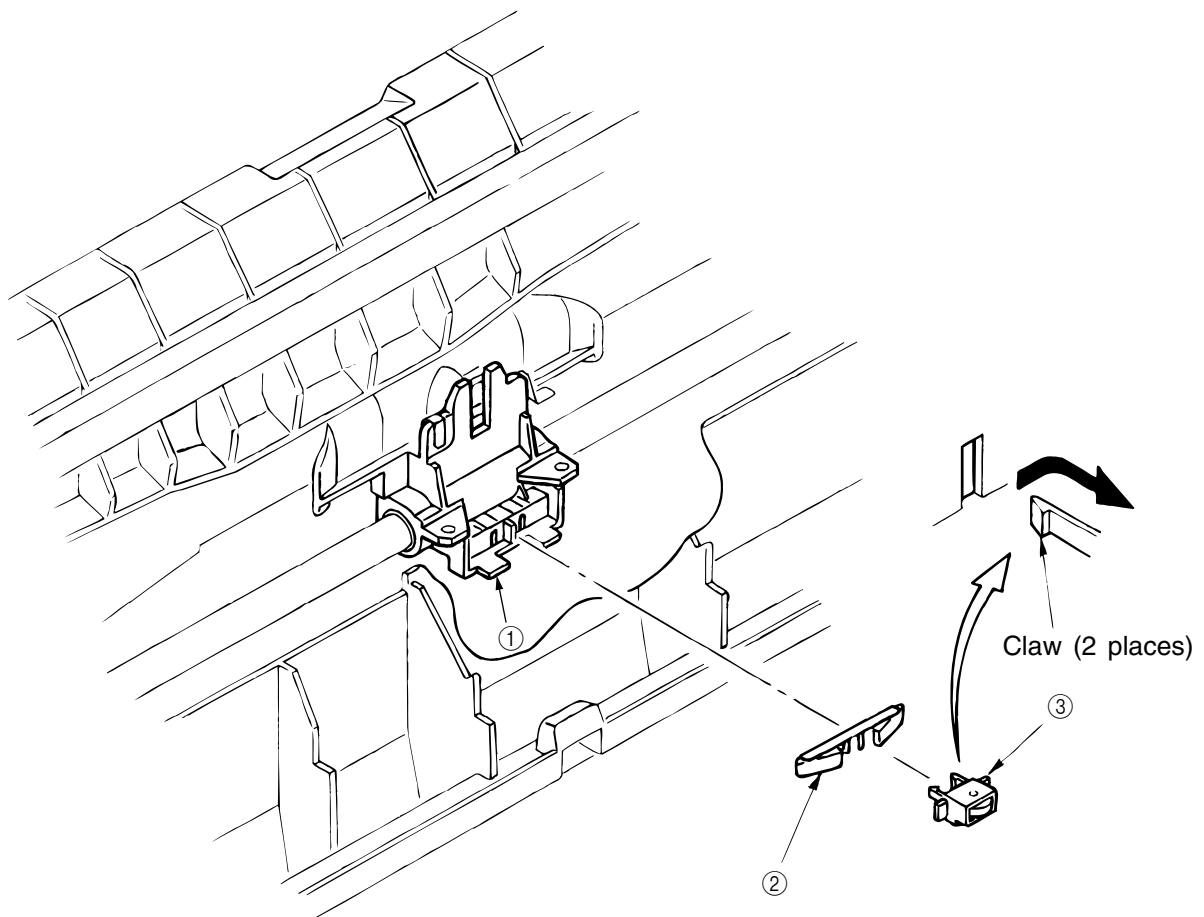

### 3.3.11 Platen Assy

- (1) Remove the printhead (see 3.3.1).
- (2) Remove the ribbon protector (see 3.3.2).
- (3) Remove the pull-up roller Assy (see 3.3.3).
- (4) Remove the upper cover (see 3.3.1 (1) – (5)).
- (5) Turn the change lever ① to the bottom position.
- (6) Push in the lock levers ② on both sides to unlock from the frame, then rotate them upward by 90°.
- (7) Remove the platen Assy ④ from base frame.
- (8) To install, follow the removal steps in the reverse order.

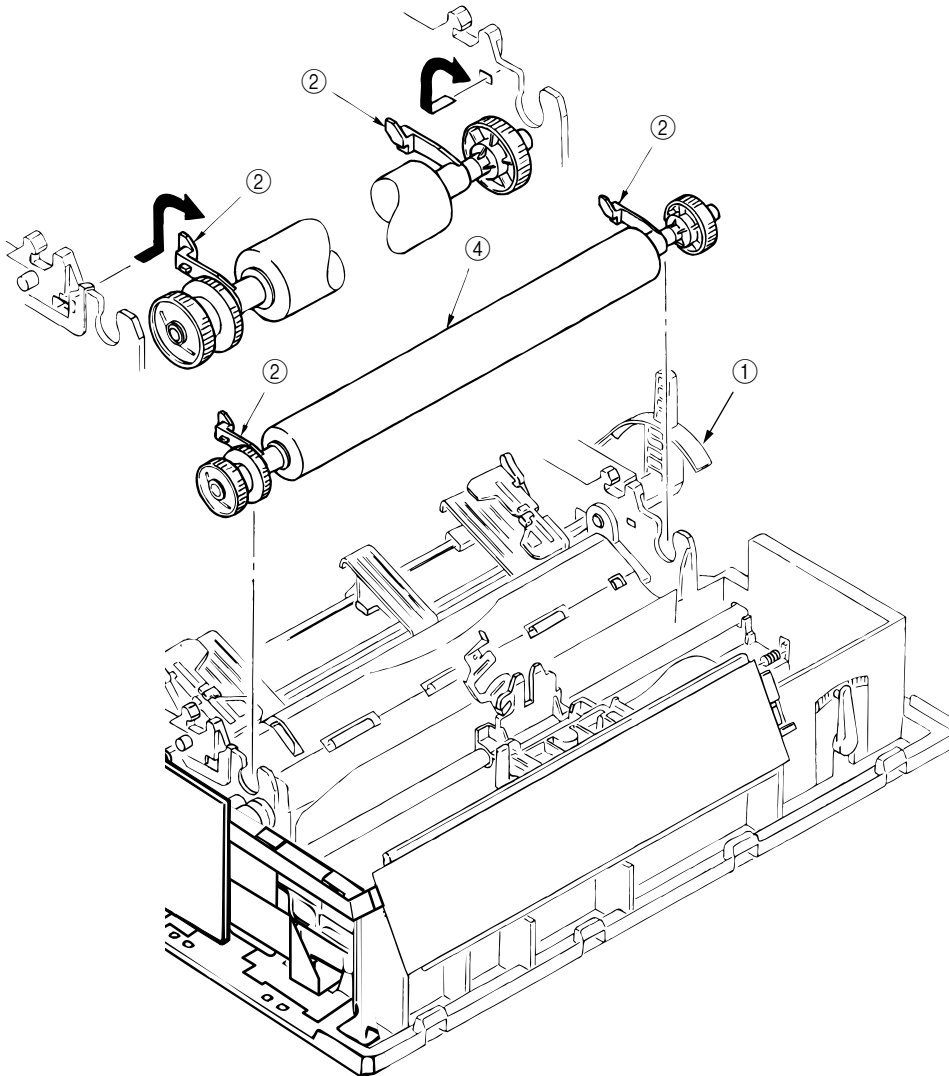



### 3.3.12.1 Driver Board (DVE/DVF) (at USB Ver.)

- (1) Remove the upper cover (see 3.3.4 (1) – (5)).
- (2) Remove two screws ① and remove two screws ⑤, and release the driver board ② and Plate I/F ⑥ by lifting clamp ④.
- (3) Disconnect all cables from driver board ②.
- (4) To install, follow the removal steps in the reverse order.

Note on installation:

- (1) Insert one sensor lever ③ between sensor when installing the driver board ②.
- (2) Butt and attach the drive board ② to the E sections (2 places) of the convex of the main chassis.

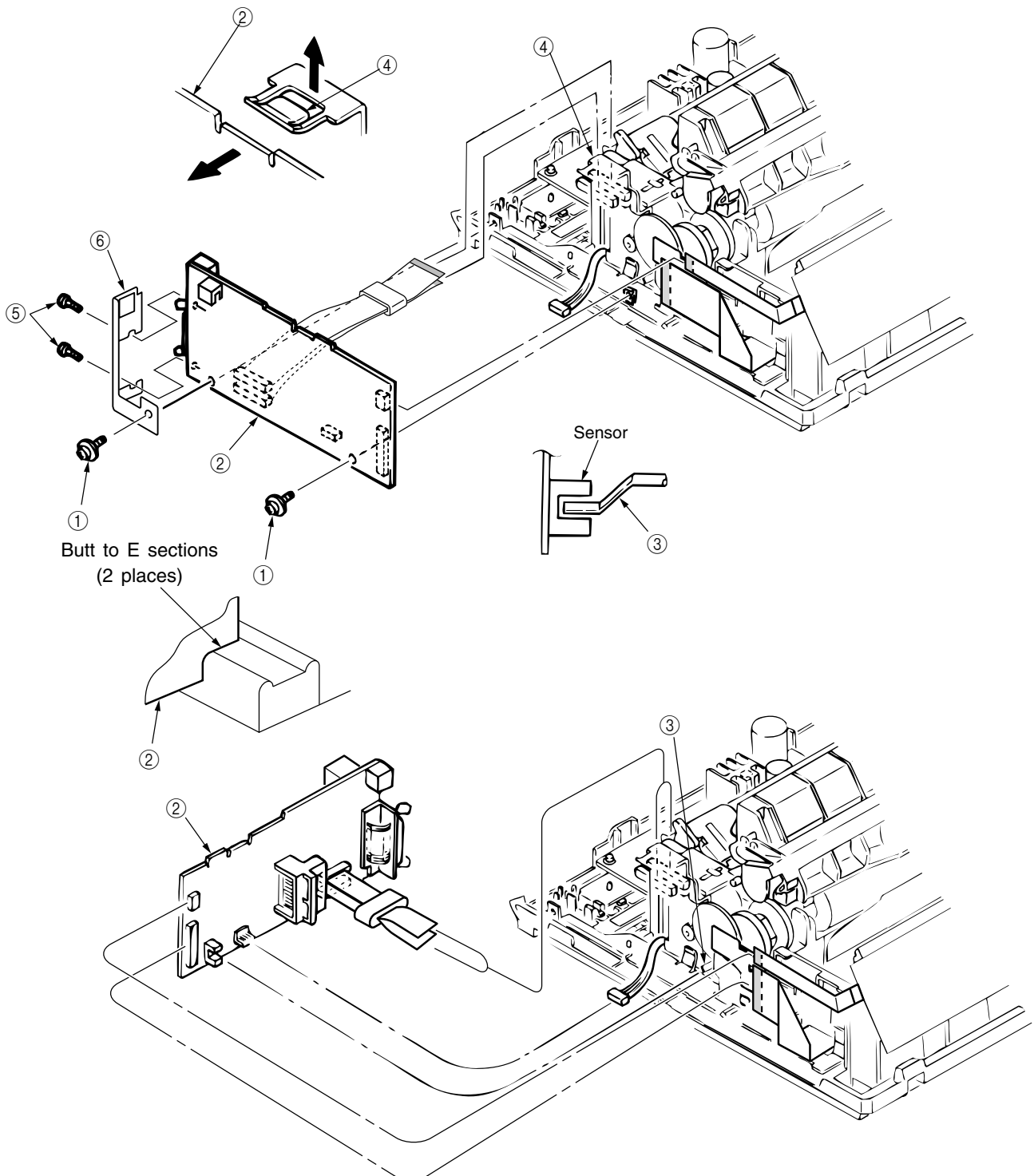

3.3.12.2 Driver Board (SDF) (at non USB Ver.)

- (1) Remove the upper cover (see 3.3.4 (1) – (5)).
- (2) Remove two screws ①, and release the driver board ② and PCB sheet ⑤ by lifting clamp ④.
- (3) Disconnect all cables from driver board ②.
- (4) To install, follow the removal steps in the reverse order.

Note on installation:

- (1) Insert one sensor lever ③ between sensor when installing the driver board ②.

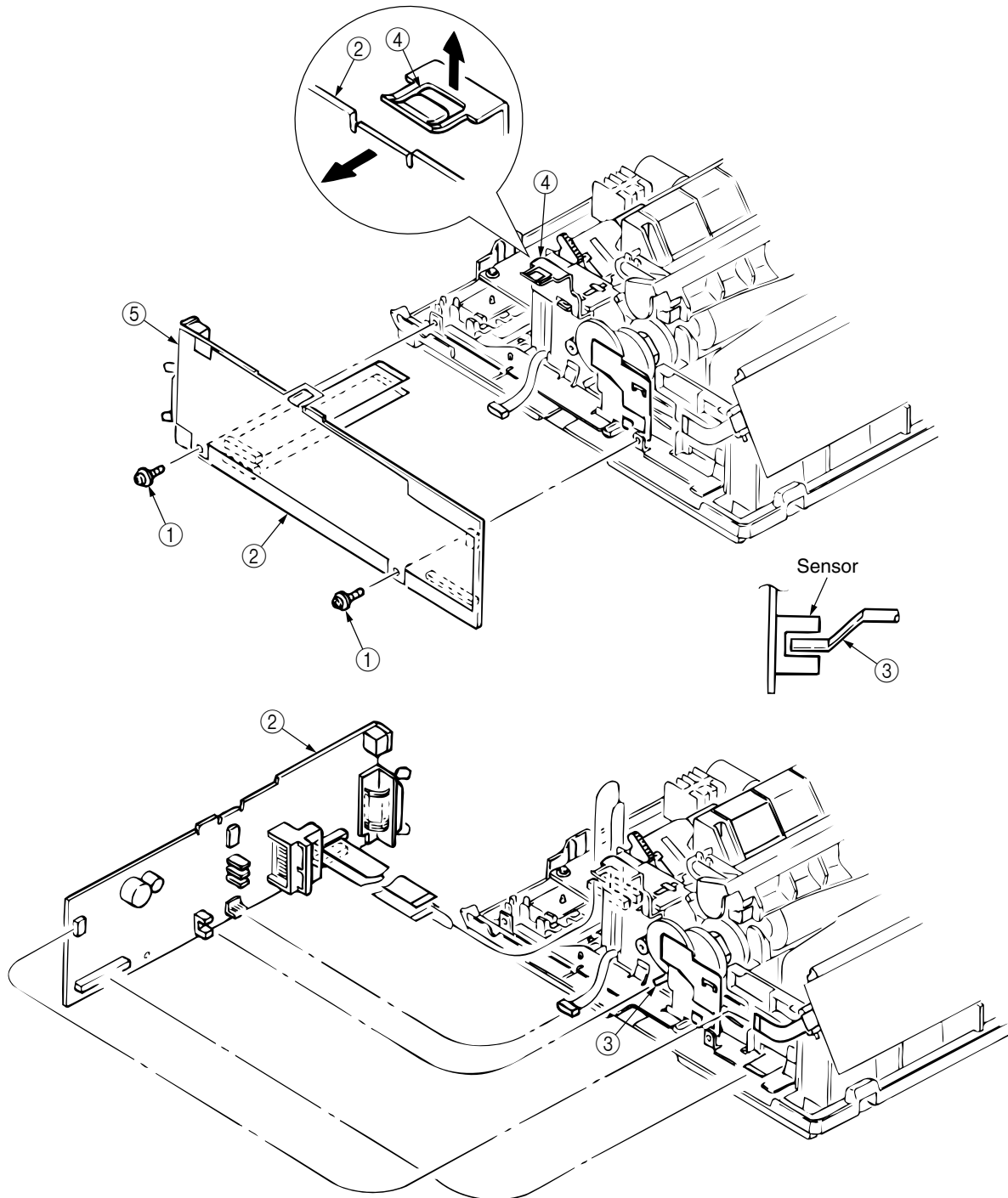

### 3.3.13 LF Motor

- (1) Remove the printhead (see 3.3.1).
- (2) Remove the ribbon protector (see 3.3.2).
- (3) Remove the pull-up roller Assy (see 3.3.3).
- (4) Remove the upper cover (see 3.3.4 (1) – (5)).
- (5) Remove the platen Assy (see 3.3.11).
- (6) Remove the driver board (see 3.3.12).
- (7) Remove the left FG plate ①.
- (8) Release the lock A to remove the LF motor ②.
- (9) To install, follow the removal steps in the reverse order.

Remark on assembly:

- (1) Press the LF Motor Cable with a portion ① of the Motor Plate.

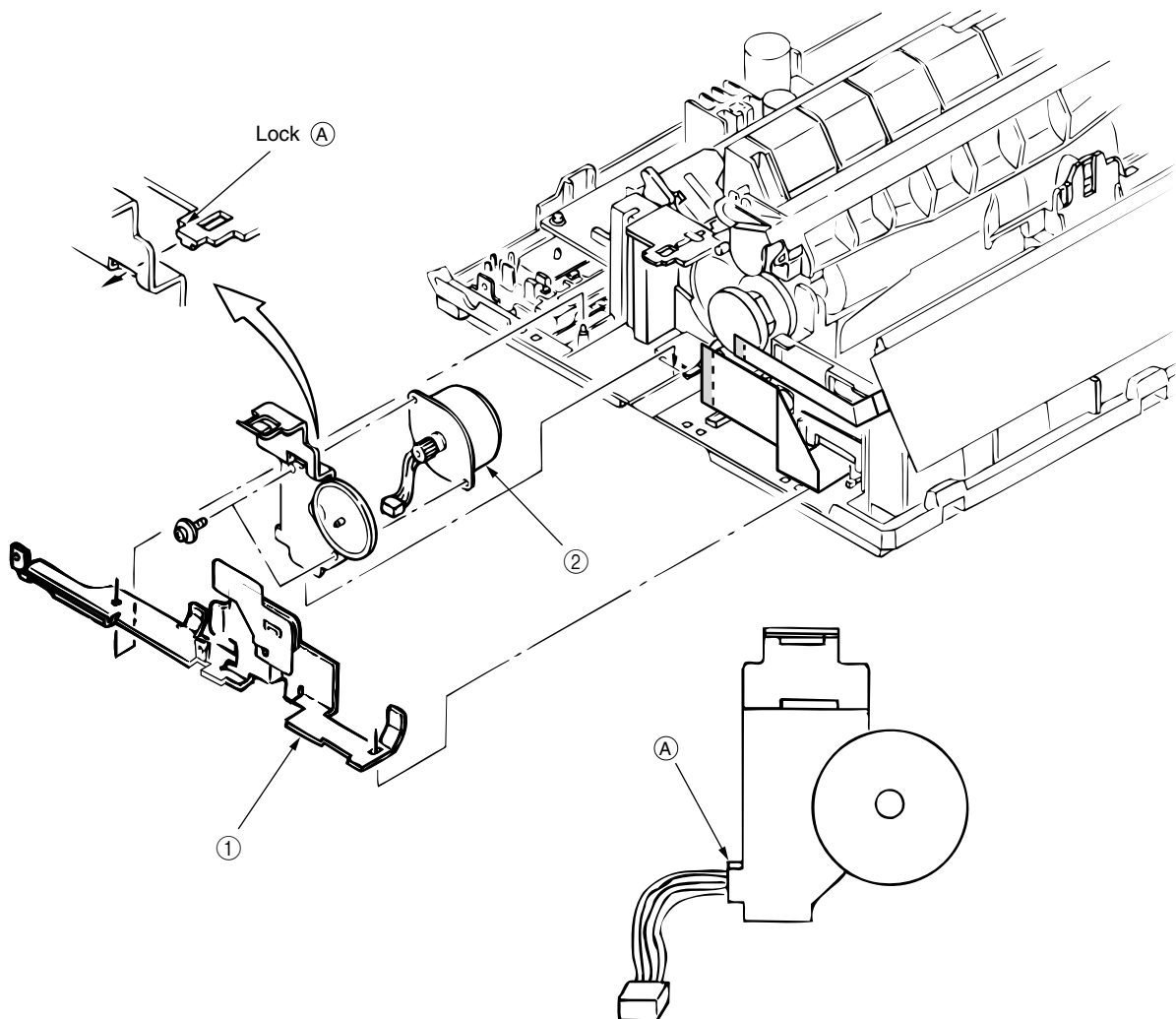

### 3.3.14 Operation Panel PCB (LEOP)

- (1) Remove the upper cover (see 3.3.4 (1) – (5)).
- (2) Disconnect the cable ① from connector ③ of Driver board ②.
- (3) Disengage claws on both sides from the frame, and remove the operation panel ④.
- (4) Open claws (8 places) and remove the operation panel PCB ⑤ from the operation panel ④.
- (5) To install, follow the removal steps in the reverse order.

#### Notes on installation

- (1) Make sure that there is not any dust or oil on the connector contact section A. If it is found, wipe it off by alcohol.

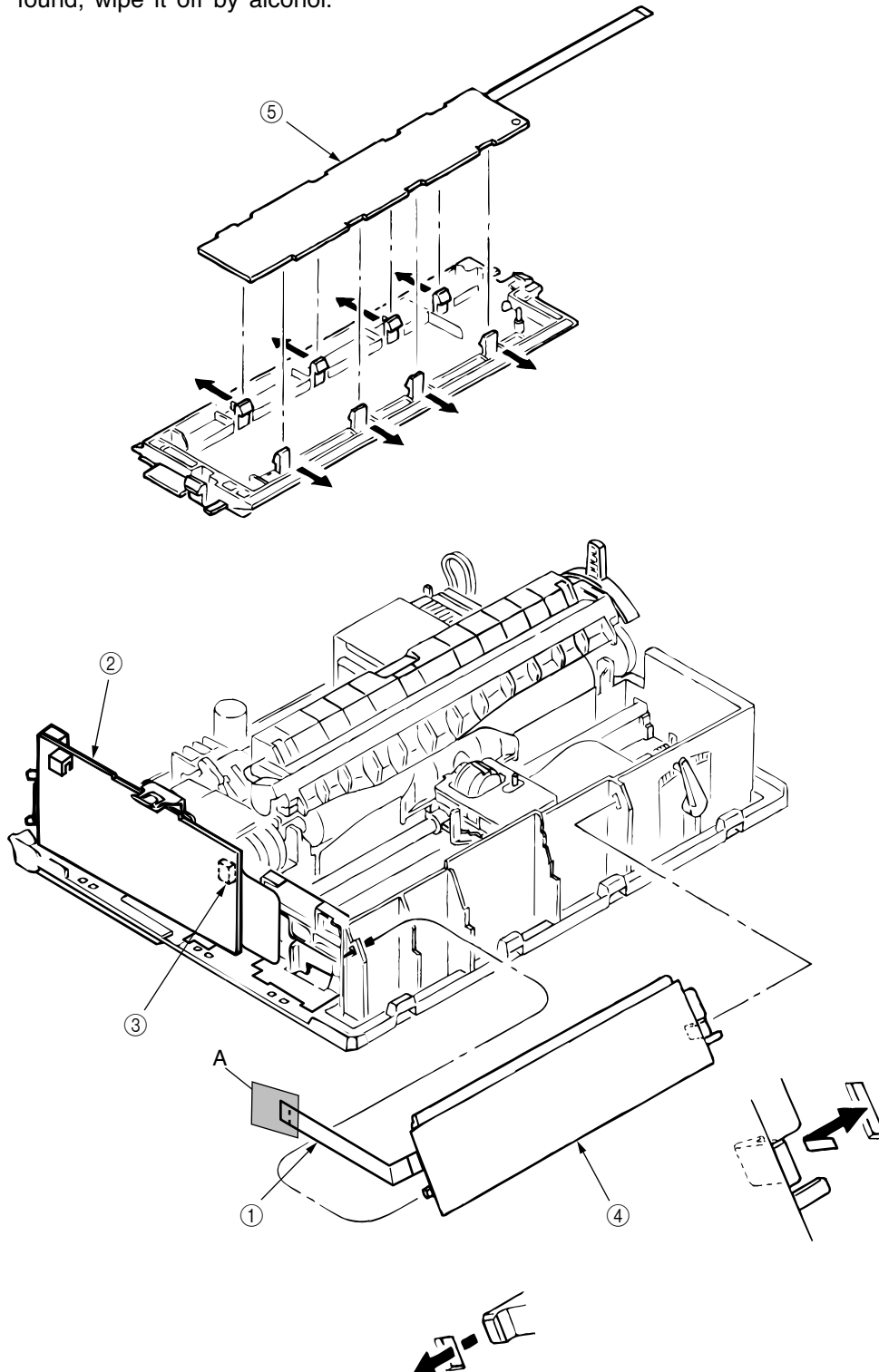

## 3.3.15 Control/Power Supply Board (AOE/AOU/AOO)

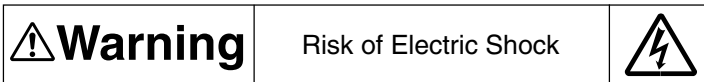

There is a risk of electric shock during replacement of the power supply.

Use insulating gloves or avoid direct contact with any conducting part of the power supply, and caution should be exercised during replacement.

The capacitor may take one minute to complete discharge after the AC cable is unplugged. Also, there is a possibility that the capacitor doesn't discharge because of a breakage of the PCB, etc., so remember the possibility of electric shock to avoid electric shock.

- (1) Remove the upper cover (see 3.3.4 (1) – (5)).
- (2) Disconnect two flexible cable ③ from the connector ② the Control/Power Supply Board ①.
- (3) Remove the cable ⑤ from the connector ④ on the Control/Power Supply board ①.
- (4) Remove two screws ⑥, and remove the Control/Power Supply Board ①.
- (5) To install, follow the removal steps in the reverse order.

Remark on assembly:

- (1) To mount the Control/Power Supply Board, set the change lever to the top position so that the Switch Lever ⑦ will not hooked on the microswitches ⑧.

Notes on installation

- (1) Make sure that there is not any dust or oil on the connector contact section A. If it is found, wipe it off by alcohol.

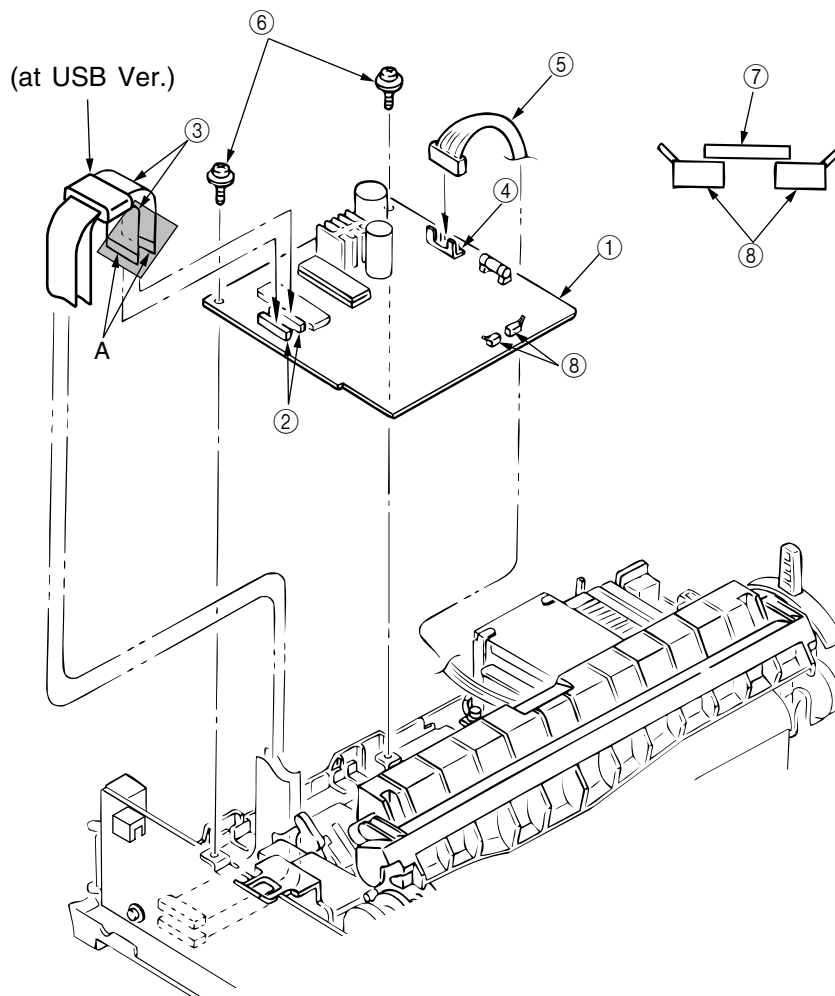

### 3.3.16 Transformer Assy

- (1) Remove the upper cover (see 3.3.4 (1) – (5)).
- (2) Remove AC inlet ① and AC switch ② from the frame guide.
- (3) Disconnect the cable ③ from the connector ④ on the Control/Power Supply Board ⑤.
- (4) Remove a screw ⑥ and disconnect ground cable ⑦.
- (5) Remove two screws ⑧ and shift the transformer Assy ⑨ to the left and remove it.

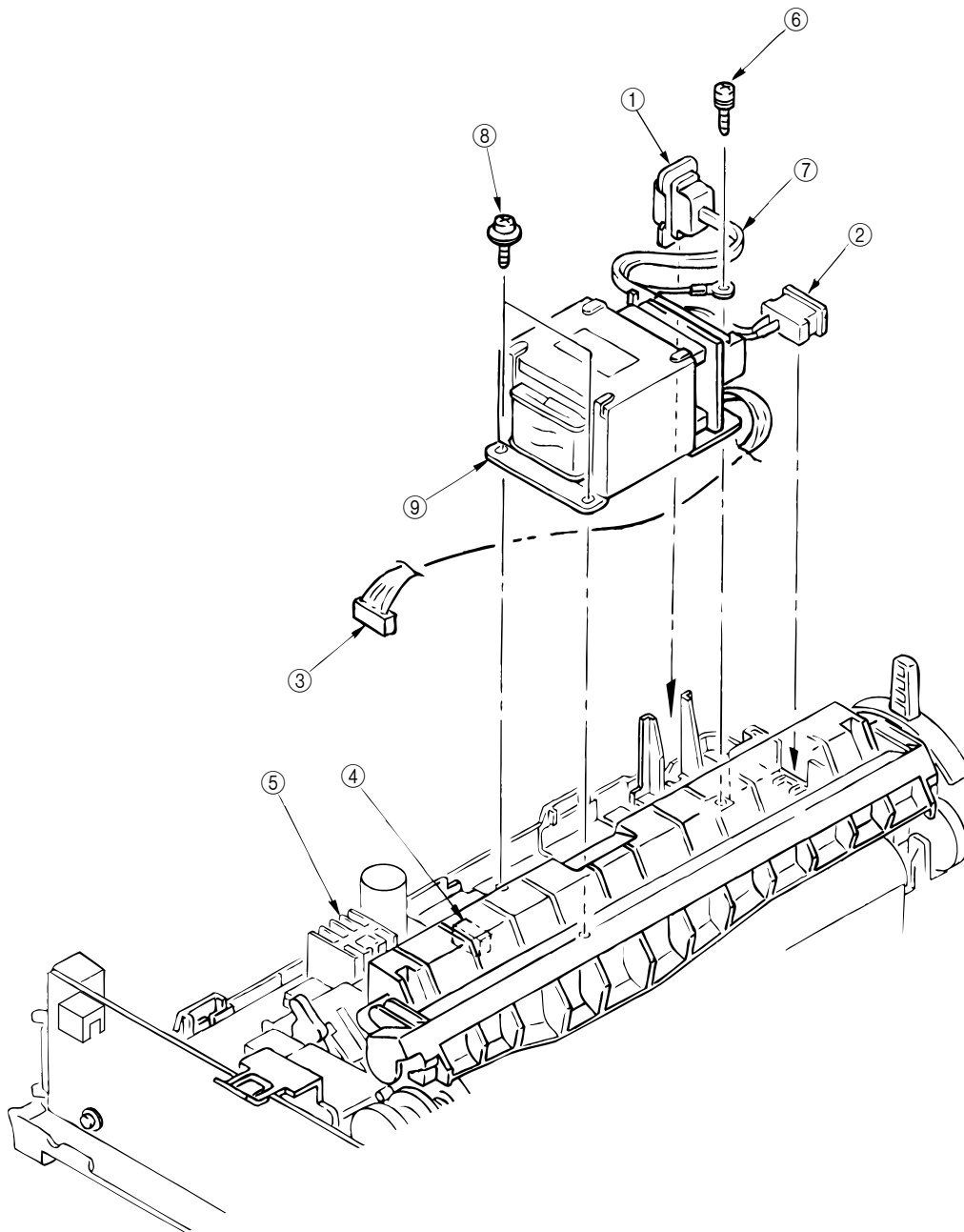

### 3.3.17 Change Lever and Gears

- (1) Remove the upper cover (see 3.3.4 (1) – (5)).
- (2) Remove the reset spring ①, then remove the idle gear ②, the tractor gear ④ and the change gear ⑤.
- (3) Push back the protrusion of the Change Gear Shaft ⑥ with a flatblade screw driver to remove the change lever ③.
- (4) To perform mounting, follow the reverse procedure of removal.

Remark on assembly:

- (1) To insert the change lever into the Change Gear Shaft ⑥, match the flat surface (D cut).

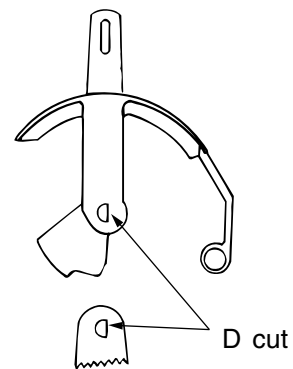
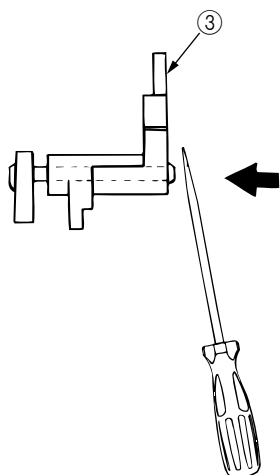
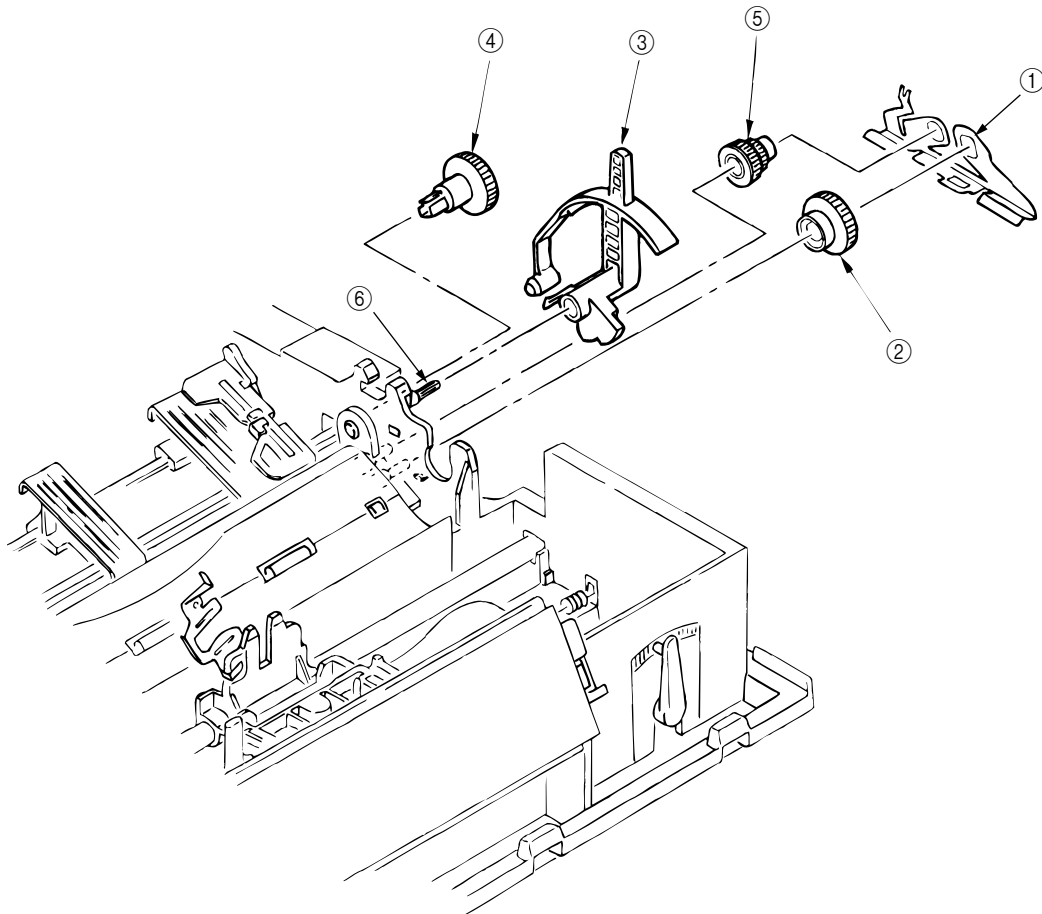

### 3.3.18 Carriage Shaft

- (1) Remove the printhead (see 3.3.1).
- (2) Remove the upper cover (see 3.3.4 (1) – (5)).
- (3) Remove the driver board (see 3.3.12).  
Remove the FG plate (L) ②.
- (4) Slide the carriage shaft ① to the left side (in the direction of the arrow) to remove.
- (5) To perform mounting, follow the reverse procedure of removal.

Note on installation:

- (1) After installation, check and adjust the gap between platen and printhead (see 4-1).

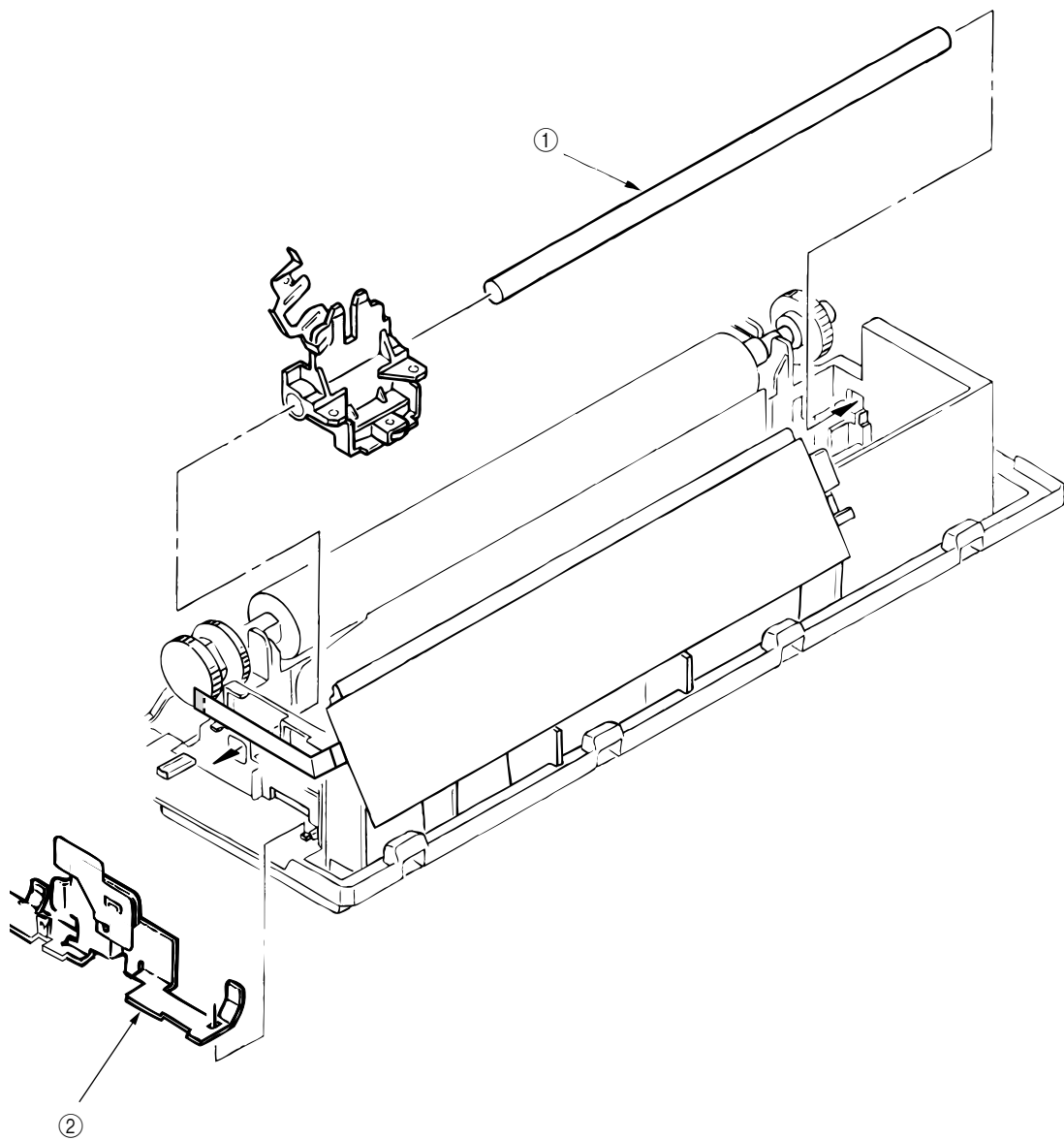



### 3.3.19 Paper Pan

- (1) Remove the printhead (see 3.3.1).
- (2) Remove the ribbon protector (see 3.3.2).
- (3) Remove the pull-up roller assy (see 3.3.2).
- (4) Remove the upper cover assy (see 3.3.4 (1) – (5)).
- (5) Remove the platen assy (see 3.3.11).
- (6) Release claws **A**.
- (7) Lift up the paper chute assy **1** and remove.
- (8) To perform mounting, follow the reverse procedure of removal.

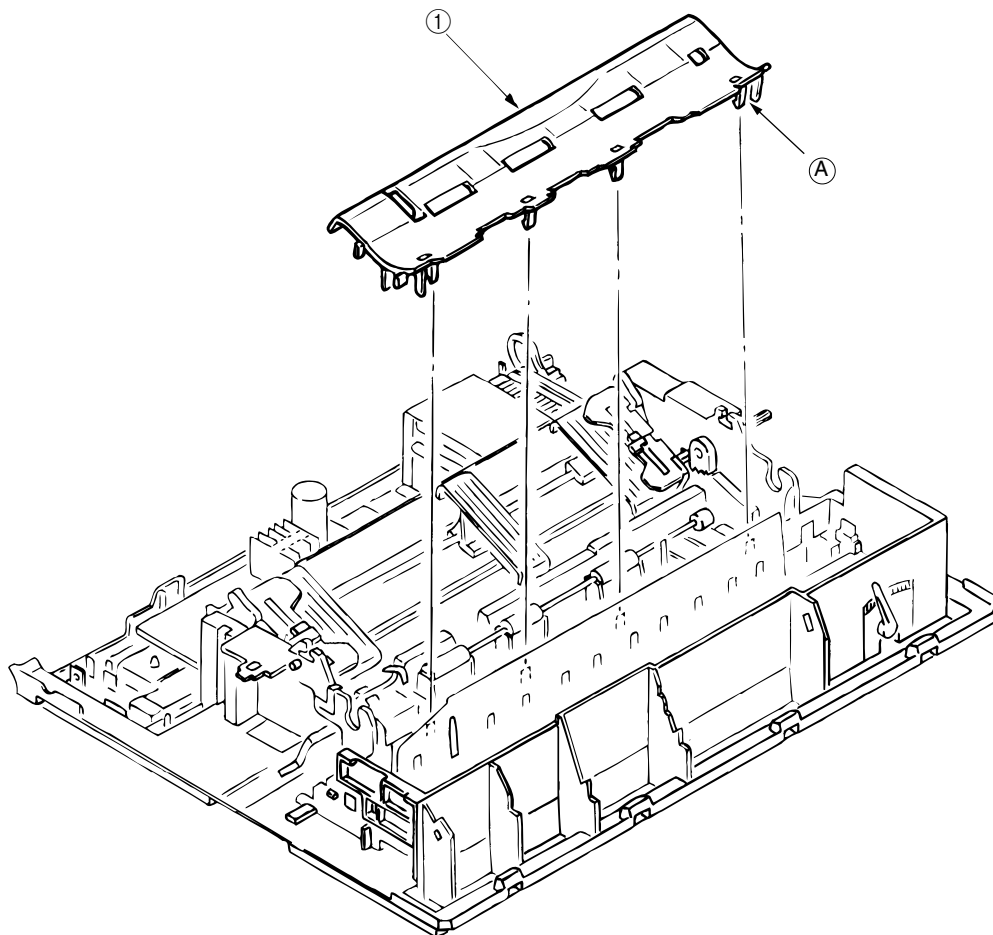

### 3.3.20 Rear Tractor Assy

- (1) Remove the printhead (see 3.3.1).
- (2) Remove the ribbon protector (see 3.3.2).
- (3) Remove the pull-up roller assy (see 3.3.3)
- (4) Remove the upper cover (see 3.3.4 (1) – (5)).
- (5) Remove the reset spring (see 3.3.17 (3))
- (6) Remove the tractor gear ①.
- (7) Shift the drive shaft ② to the right side to remove (in the direction of the arrow).
- (8) To perform mounting, follow the reverse procedure of removal.

Remark on assembly:

- (1) When the Tractor Assy (L) ③ (R) ④ have been detached from the Drive Shaft, align the protrusions ⑤ of the Pin Tractor Wheels to the same direction before assembly.

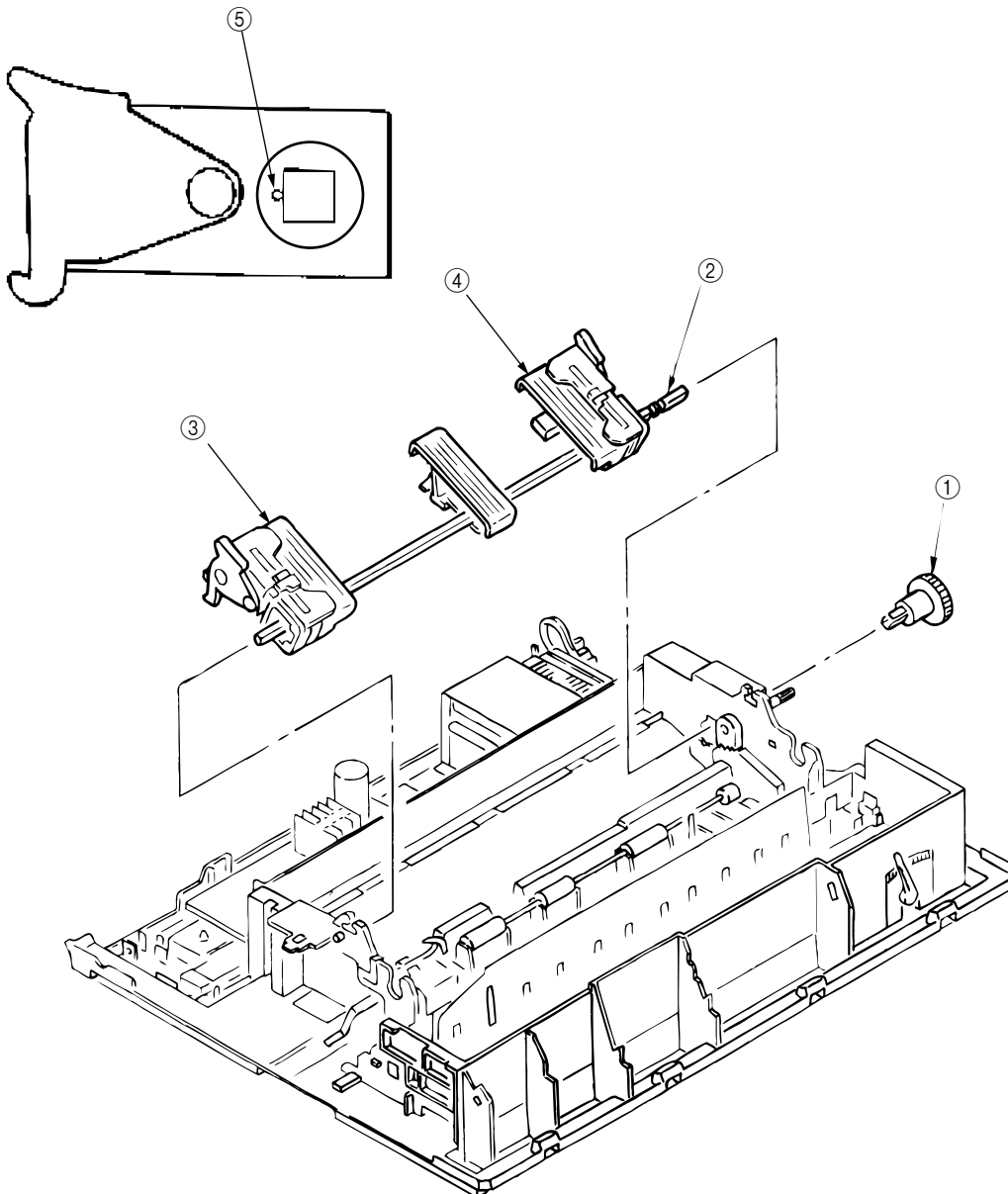

### 3.3.21 Rear Pressure Assy

- (1) Remove the upper cover (see 3.3.4 (1) – (5)).
- (2) Remove the change lever and gears (see 3.3.17).
- (3) Remove the paper pan (see 3.3.19).
- (4) Remove the rear pressure roller ①.
- (5) Rotate the release shaft ② and move it to the left to detach the release shaft ②.

Match the Main Frame Rib A with the protrusion B of the Release Shaft.

- (6) Remove rear pressure SP assy ③.
- (7) To install, follow the removal step in the reverse order.

**Note:** (1) At mounting release shaft ②, pay attention to the gear engagement of release shaft ②, change arm lever ⑥, change gear shaft ⑦.

(2) There are 5 Rear pressure Spring Assemblies. Use two pieces which have larger spring diameter on the right side. Use three remaining pieces on the left side (for Wide Printer).

(3) Make sure that the Release Shaft ② will be on top of the Support spring ④.

(4) To assemble the Release Shaft ②, make sure that the protrusion of the switch lever ⑤ is in the U groove of the Release Shaft ②.

#### Note on installation

- (1) Install the support spring ④ below the rear pressure roller ①.

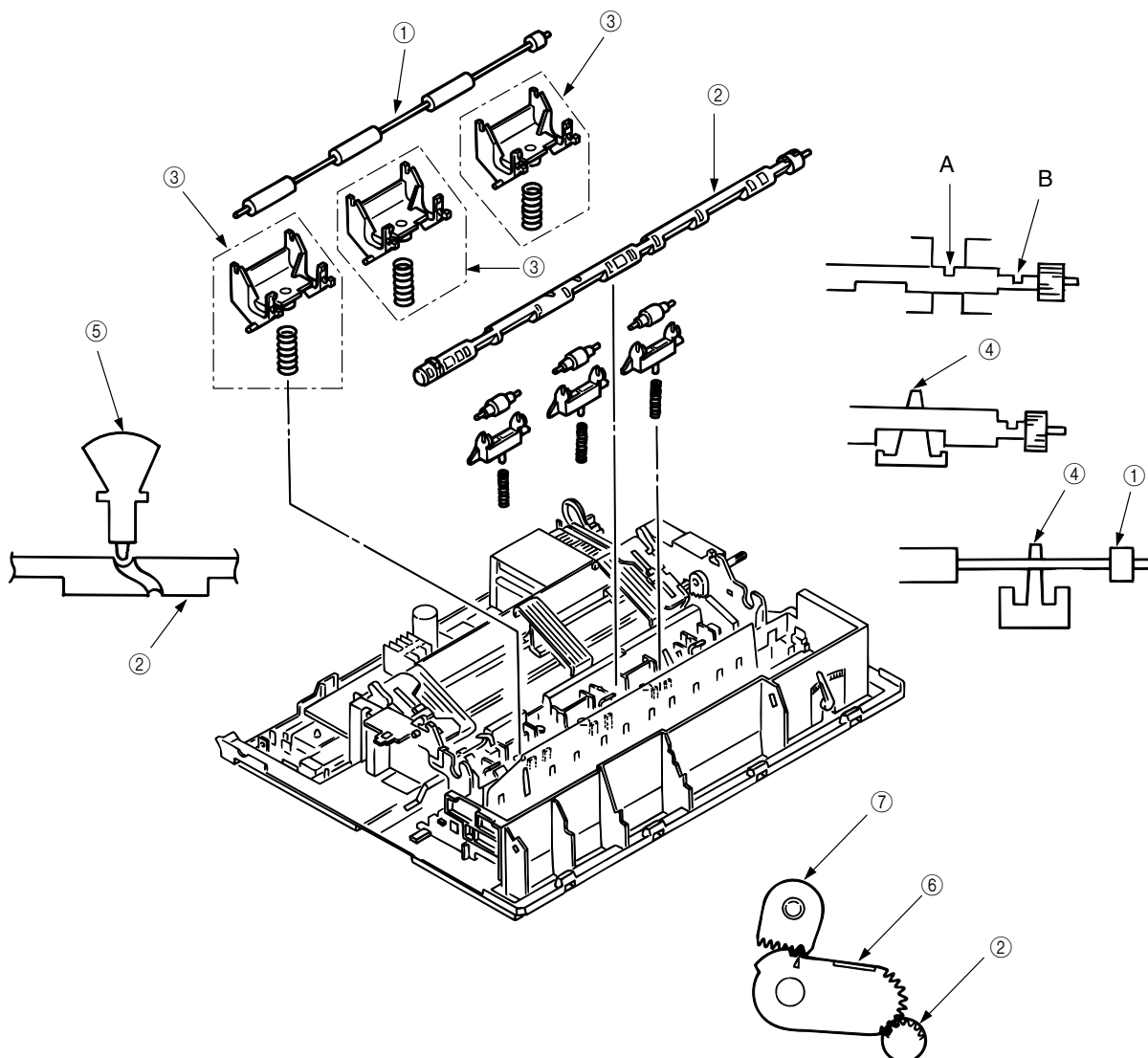

### 3.3.22 Switch Lever

- (1) Remove the upper cover (see 3.3.4 (1) – (5)).
- (2) Remove the change lever and gears (see 3.3.17).
- (3) Remove the paper pan (see 3.3.19).
- (4) Remove the rear pressure assy (see 3.3.21).
- (5) Pull the Switch Lever toward you and remove it upward.
- (6) To install, follow the removal step in the reverse order.

Remark on assembly:

- (1) At the time of the Switch Lever assembly, make sure that the Micro switch on the Main Board works properly.

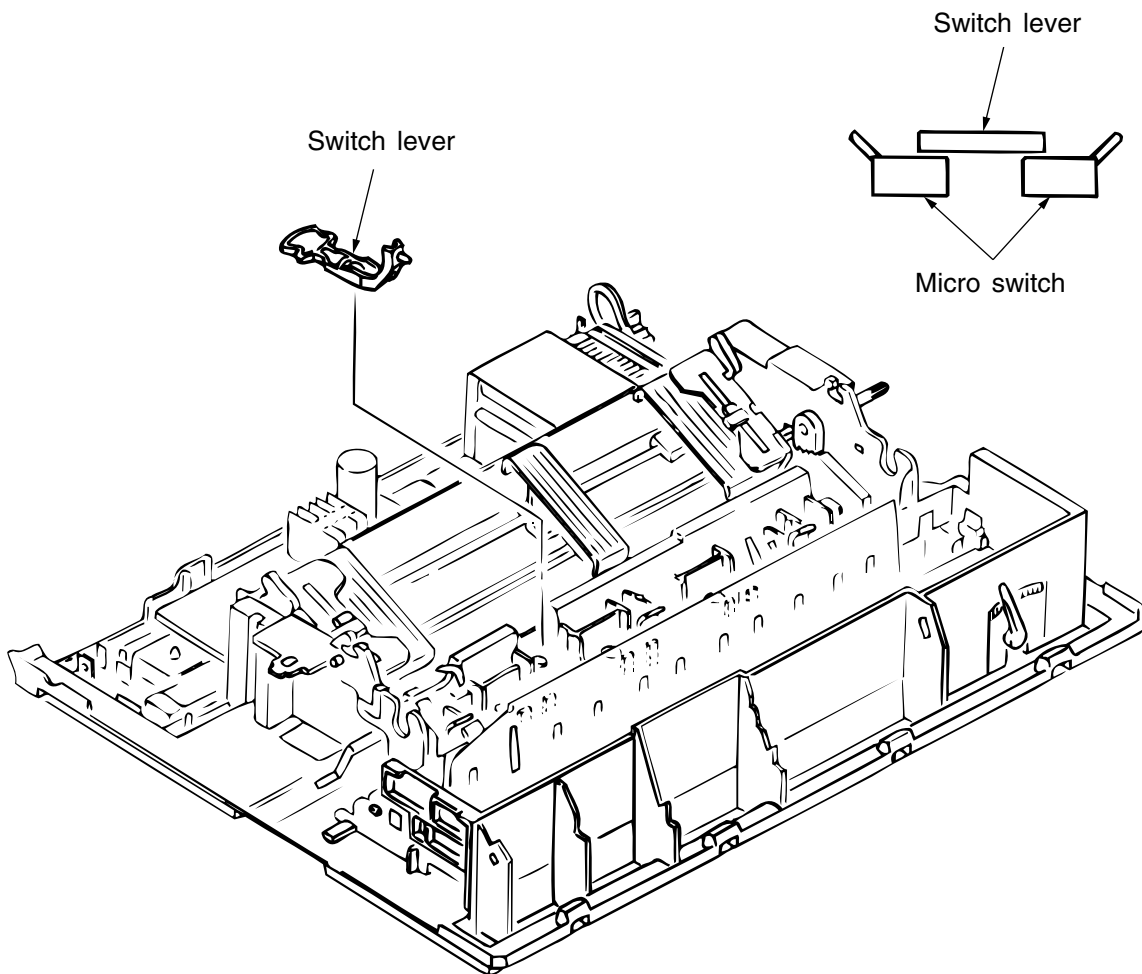

## 4. ADJUSTMENT

- (1) Be sure to carry out this adjustment with the printer mechanism mounted on the lower cover.
- (2) Be sure to carry out this adjustment operation on a level and highly rigid work table (flatness: less than 0.039 inch or 1 mm) so as to minimize adjustment error.

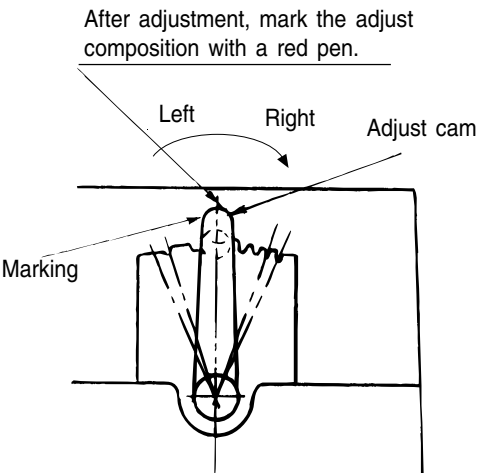
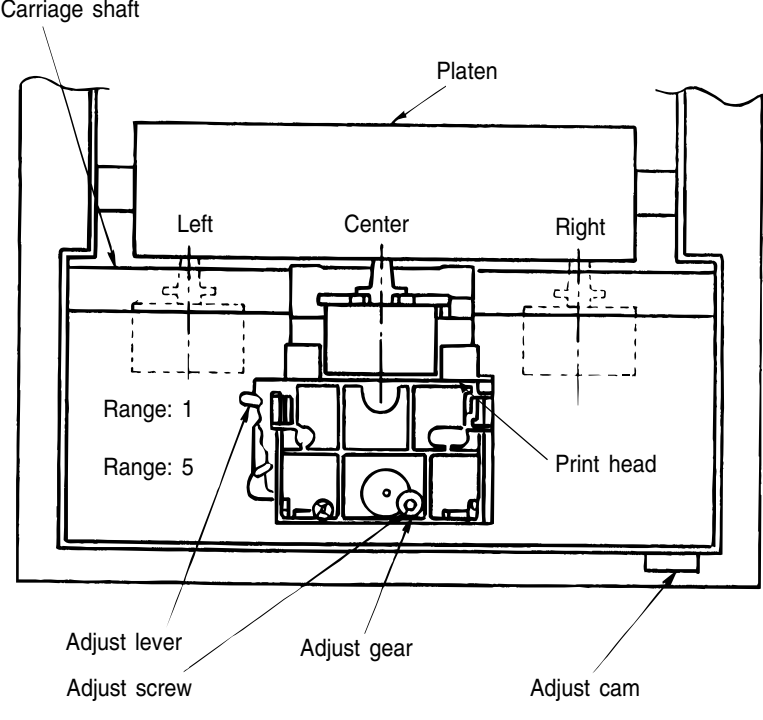
No.	Item	Specification	Drawing	Adjustment method
4-1-1	<p>Gap between the platen and the print head</p> <p>1) Parallelism adjustment</p>	<p>Variation of value at the left, the center and the right shall be less than 0.02 mm</p>	<p>After adjustment, mark the adjust composition with a red pen.</p> 	<p>It shall be measured at 3 points: the left end, the center and the right end of the platen.</p> <p>Adjustment method</p> <p>(1) Gap between the platen and the print head at the left end and the right end shall be adjusted by rotating the adjust cam.</p>
	<p>2) Initial adjustment</p>	<p><math>0.41 \pm 0.03</math> mm</p>		<p>(2) Set the adjust lever at the Range: 1. Press the adjust gear downward (in direction A) to push the adjust gear and the adjust gear out of mesh.</p> <p>(3) Adjust the gap by rotating the adjust screw in direction B or C while the adjust lever and the adjust gear are disengaged.</p> <p>(4) After adjustment, mark the adjust cam position with a red pen.</p>

No.	Item	Specification	Drawing	Adjustment method
				<p>Note 1) The head gap shall be measured with the change lever set to rear position.</p> <p>Note 2) The head gap shall be measured positioning the platen gear (R) crawl on the top.</p> <p>Note 3) Move the adjust screw in clockwise direction (in direction B) to measure.</p>
4-1-2	Measure variation of gap when range is changed.	Gap = 0.71 ± 0.05 at the range 5.		

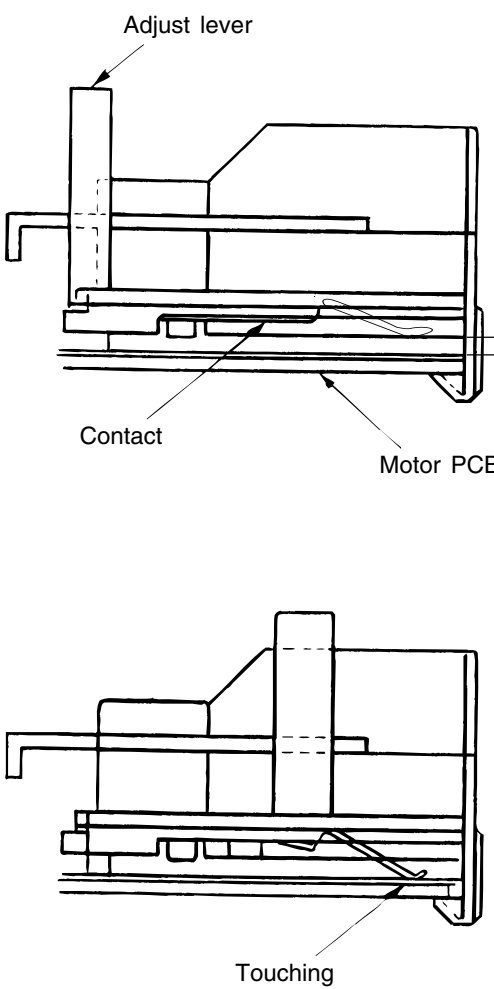
No.	Item	Specification	Drawing	Adjustment method
	Gap between the contact and the monitor	0.3mm or more	 <p>The drawing consists of two cross-sectional views of a mechanical assembly. The top view shows an 'Adjust lever' on the left, a 'Contact' in the middle, and a 'Motor PCB' on the right. A dimension line between the contact and the motor PCB is labeled '0.3mm or more'. The bottom view shows the 'Adjust lever' moved to a different position, causing the 'Contact' to touch the 'Motor PCB', which is labeled 'Touching'.</p>	<p>Confirm followings.</p> <p>Make sure that the gap between the contact and the motor PCB is 0.3 mm or more.</p> <p>At the time of printing test, make sure that the contact touches the motor PCB and it becomes reduced speed mode when the adjust lever is set to range 2 and 4.</p>

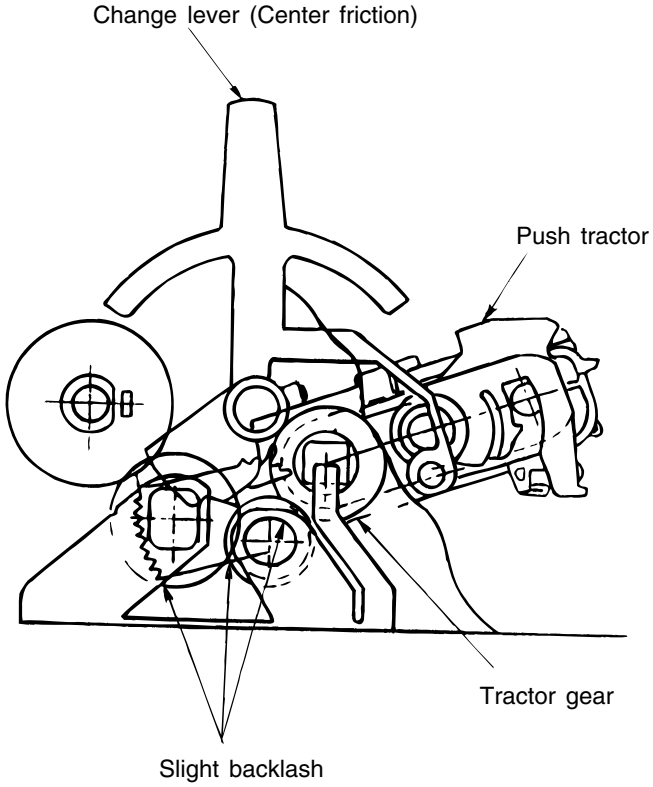

No.	Item	Specification	Drawing	Adjustment method
4-2	Gap between the platen and the paper pan	1±0.5		<p>Confirm followings.</p> <p>(1) When the change lever is set at Friction position, the gap between the platen and the paper pan at the rear side shall be 1±0.5mm.</p> <p>(2) When the change lever is set at Rear or Bottom position, the gap between the platen and the paper pan at the front side shall be 1±0.5 mm.</p>
4-3	Gap between the platen and the pressure roller			<p>Confirm followings.</p> <p>(1) When the change lever is set at Friction position, all the pressure rollers shall be pressed to the platen.</p> <p>(2) When the change lever is set at Rear or Bottom position, the gap between the platen and the pressure roller at the rear side shall be 3mm. The front pressure rollers shall be pressed to the platen.</p>

No.	Item	Specification	Drawing	Adjustment method
4-4-1	Rotation of the push tractor			<p>To confirm:</p> <p>The tractor gear shall rotate smoothly when the change lever is set at Friction position.</p>
4-4-2	Backlash between gears	Approx. 0.05 to 0.11 mm		<p>To confirm:</p> <p>There shall be slight backlash between gears to allow smooth rotation of gears. (Backlash 0.05 to 0.11 mm)</p>

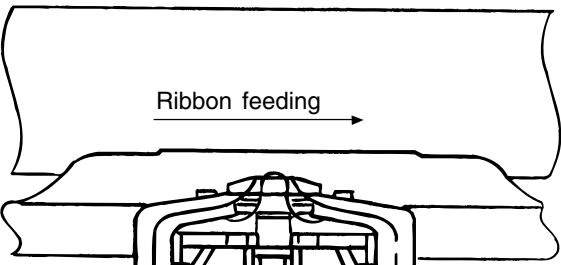
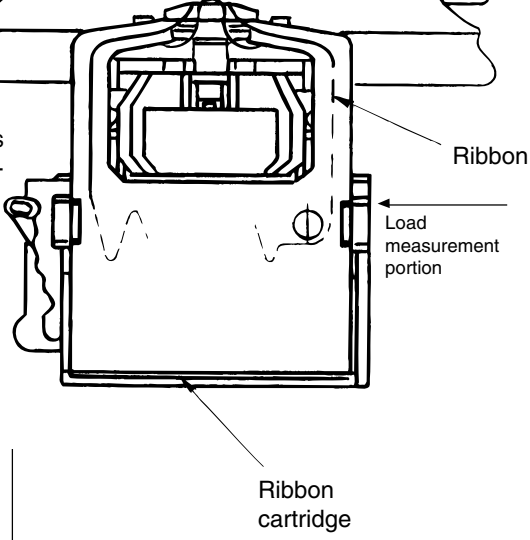
No.	Item	Specification	Drawing	Adjustment method
4-5-1	Ribbon feed			<p>To confirm: Ribbon shall be fed smoothly when the carriage is moved from side to side.</p>
4-5-2	Running load to spacing mechanism	250g or less without a ribbon cartridge		<p>To confirm: Make sure that the power is turned off at the time of measurement.</p>

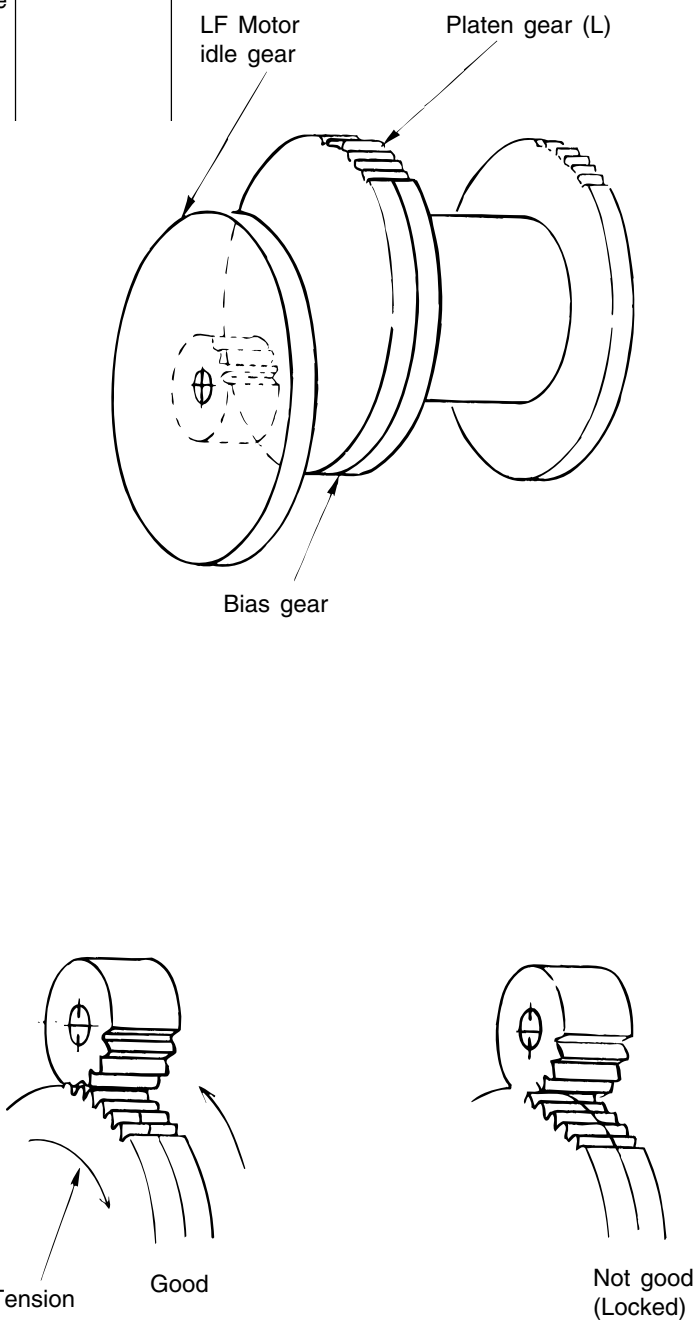
No.	Item	Specification	Drawing	Adjustment method
4-6	Engagement of the double gear and the LF motor idle gear of the Platen Assy.		 <p>The drawing shows three gears: the LF Motor idle gear on the left, the Platen gear (L) in the middle, and the Bias gear on the right. The LF Motor idle gear and Platen gear (L) are in mesh. The Bias gear is also in mesh with the Platen gear (L). The bias gear and the platen gear shall be staggered by one teeth as shown in the drawing.</p> <p>Below the main drawing are two smaller diagrams illustrating the correct and incorrect engagement states:</p> <ul style="list-style-type: none"> <li><b>Good:</b> Shows the LF Motor idle gear and Platen gear (L) in mesh. An arrow labeled "Tension" points to the mesh area.</li> <li><b>Not good (Locked):</b> Shows the LF Motor idle gear and Platen gear (L) in mesh, but the bias gear is not in mesh with the platen gear, causing the assembly to lock.</li> </ul>	<p>To confirm:</p> <p>The idle gear of the LF motor and the platen gear (L) and the bias gear of the platen shall be in mesh in such way that the platen gear (L) and the bias gear rotate against each other to pinch the teeth of idle gear.</p> <p>The idle gear stays in mesh with the platen gear (L) and the bias gear and not locked. The bias gear and the platen gear shall be staggered by one teeth as shown in the drawing.</p>

## 5. CLEANING AND LUBRICATION

### 5.1 Cleaning

#### [Cautions]

1. Be sure to turn OFF the AC POWER switch before cleaning. Remove the AC power cord from the printer.
2. Avoid dust inside the printer mechanism when cleaning.
3. If a lubricated part has been cleaned, be sure to apply lubricating oil to that portion after cleaning.

#### (1) Cleaning time

When the equipment operating time has reached six months or 300 hours, whichever comes first.

#### (2) Cleaning tools

Dry cloth (soft cloth such as gauze), vacuum cleaner

#### (3) Places to be cleaned

Table 5.1 lists the places to be cleaned:

**Table 5.1**

Place to be cleaned	Cleaning procedure
Carriage shaft and the vicinity Paper travel surface	Remove paper waste and wipe off stain, dust, ribbon waste. etc.

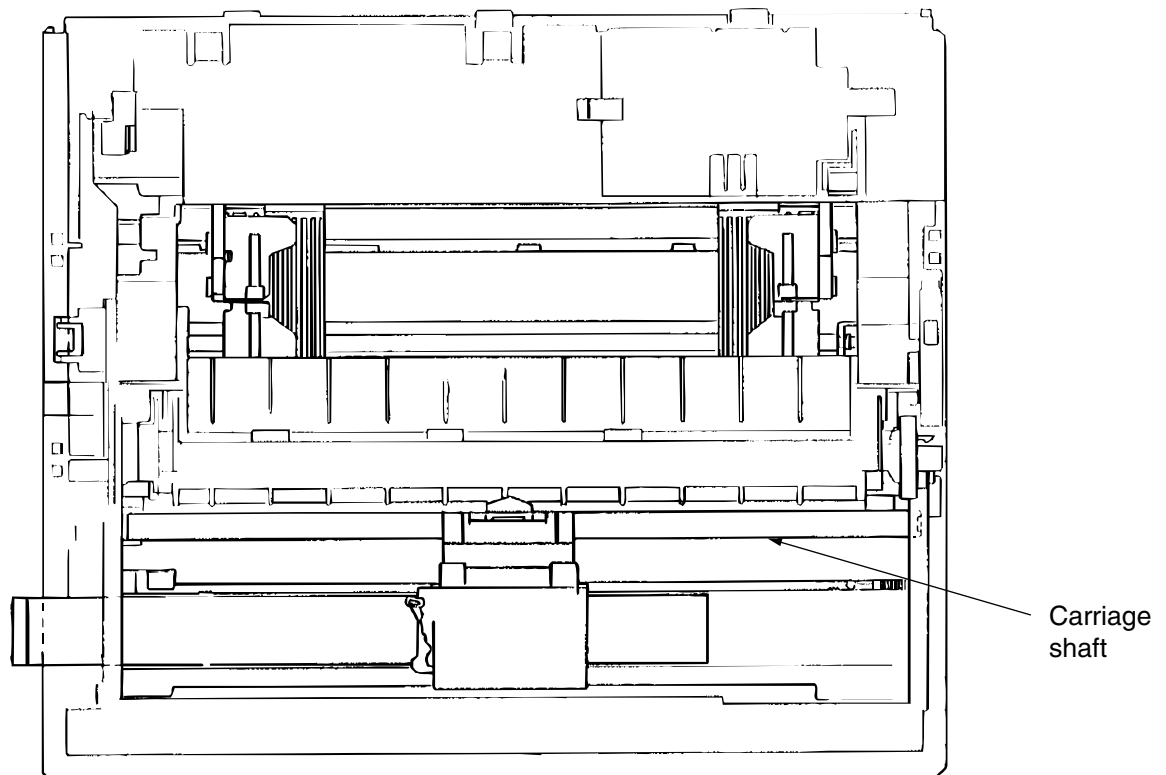



## 5.2 Lubrication

This printer is designed to be maintenance free and requires no lubrication during normal operation. However it is necessary to apply lubricant in case the printer is disassembled, reassembled, cleaned or parts have been changed.

### (1) Cleaning time

Remarks:

- 1) Turn off the power before cleaning.
- 2) Make sure that paper dust will not fall inside of the machine.
  - Cleaning period:  
6 months of operation or 300 hours of operation, whichever the earlier.
  - Cleaning points:
    - Carriage shaft and surroundings:  Remove paper and ribbon dust.
    - Paper path:  Clean stains and dusts.
    - Paper End Sensor  Remove the dust on the Sensor.

### (2) Lubricant

- Pan motor oil (or equivalent): PM
- Molicort (or equivalent): EM-30L

### (3) Amount of lubricant

- Medium amount A : Apply three to four drops of oil, or 0.008 inch (0.2 mm) thick grease.
- Small amount B : Apply one drop of oil (0.006±0.002 g)

### (4) Areas to Avoid

No.	Do not lubricate	Reason	Remarks
1	Platen assembly (rubber face)	To prevent stained paper and illegal paper feed.	Pay attention not to put the grease on the rubber face of the pressure roller.
2	Pressure roller (rubber face)	To prevent stained paper	
3	Carriage shaft	To stabilize carriage traveling load	
4	Ink ribbon image	To prevent blurring of print	
5	Pin tractor	To prevent stained paper	
6	Flexible cable and crack	To prevent loose connection	
7	Motor PCB	To prevent loose connection	
8	Connector terminals	To prevent loose connection	

(5) Lubrication point

1. Ribbon feed gear Assy.

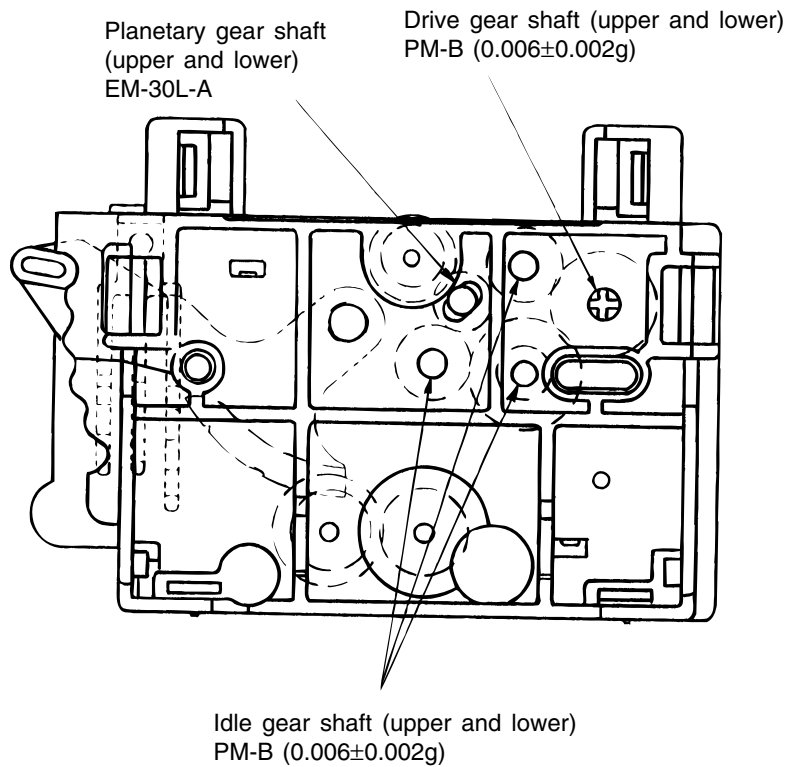

2. Space rack

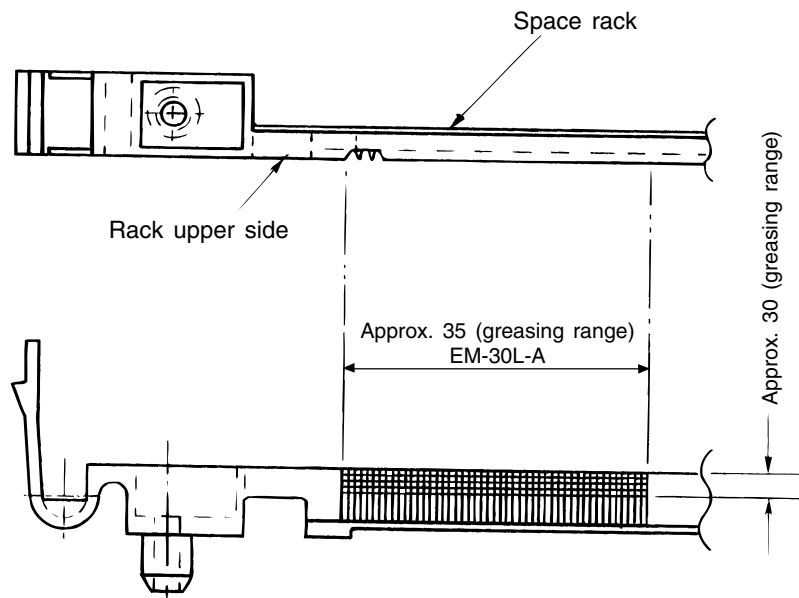

3. Platen Assy.

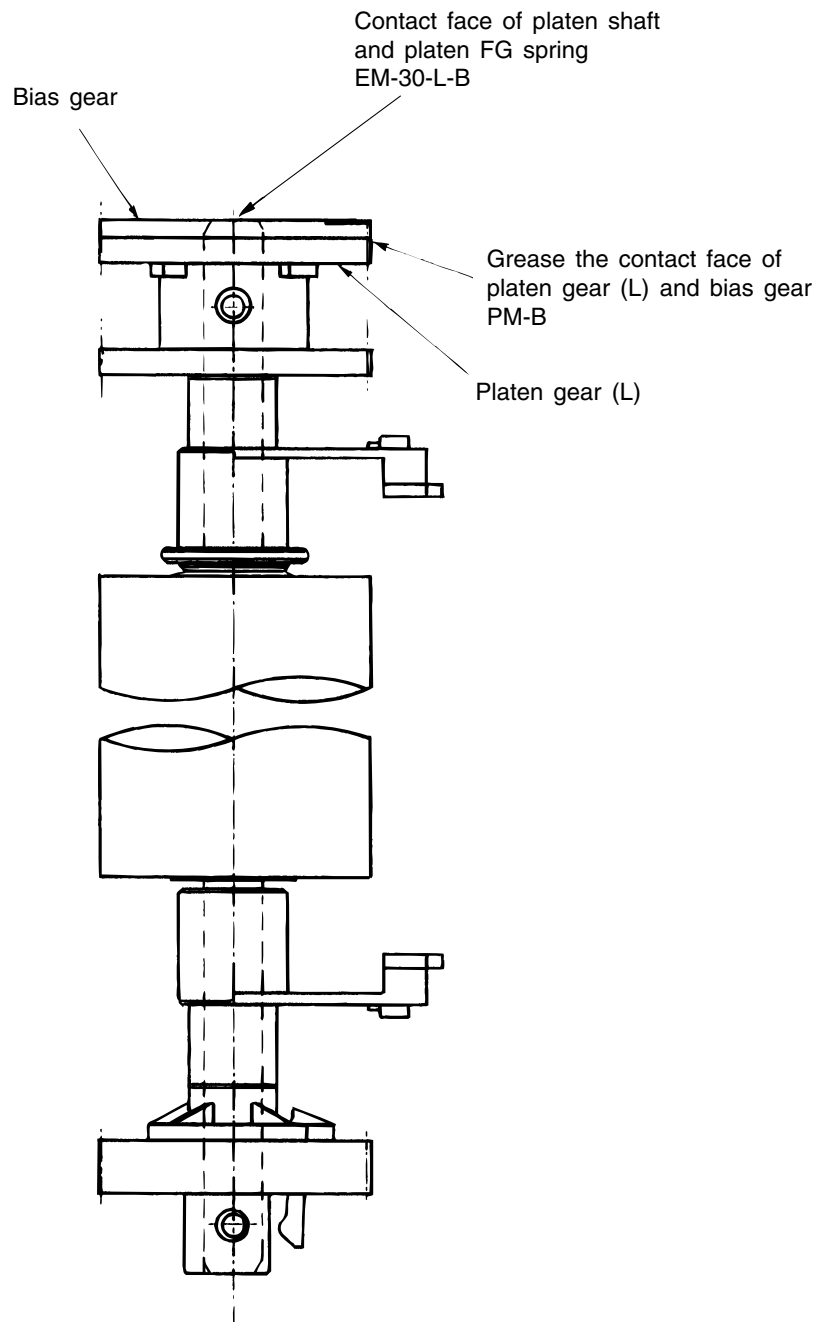



4. Tractor driving mechanism

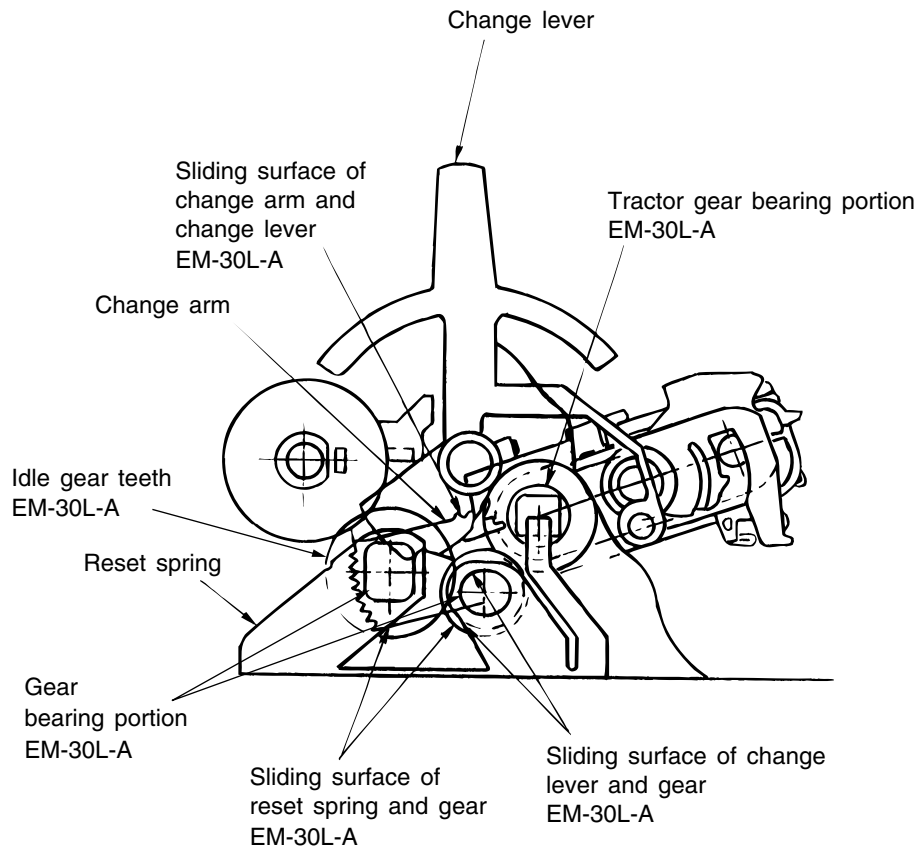

5. Tractor drive shaft

Sliding surface of FG spring and drive shaft end EM-30L-A

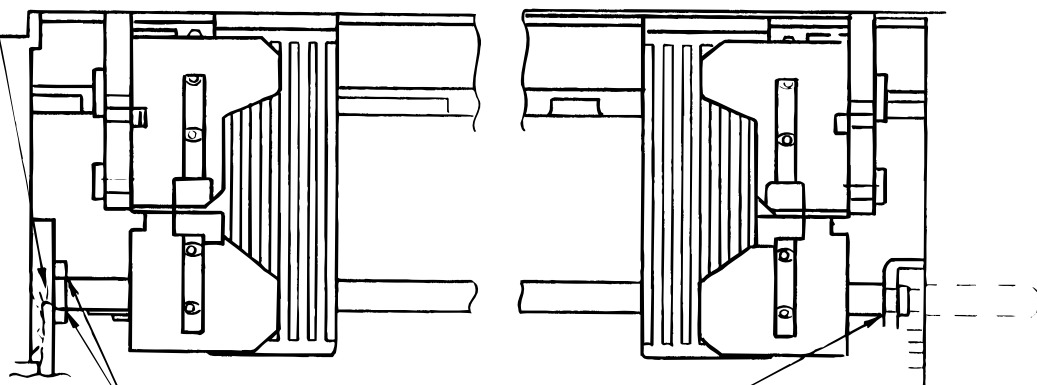

Drive shaft bearing portion EM-30L-A



A-A Arrow view

6. Pressure roller

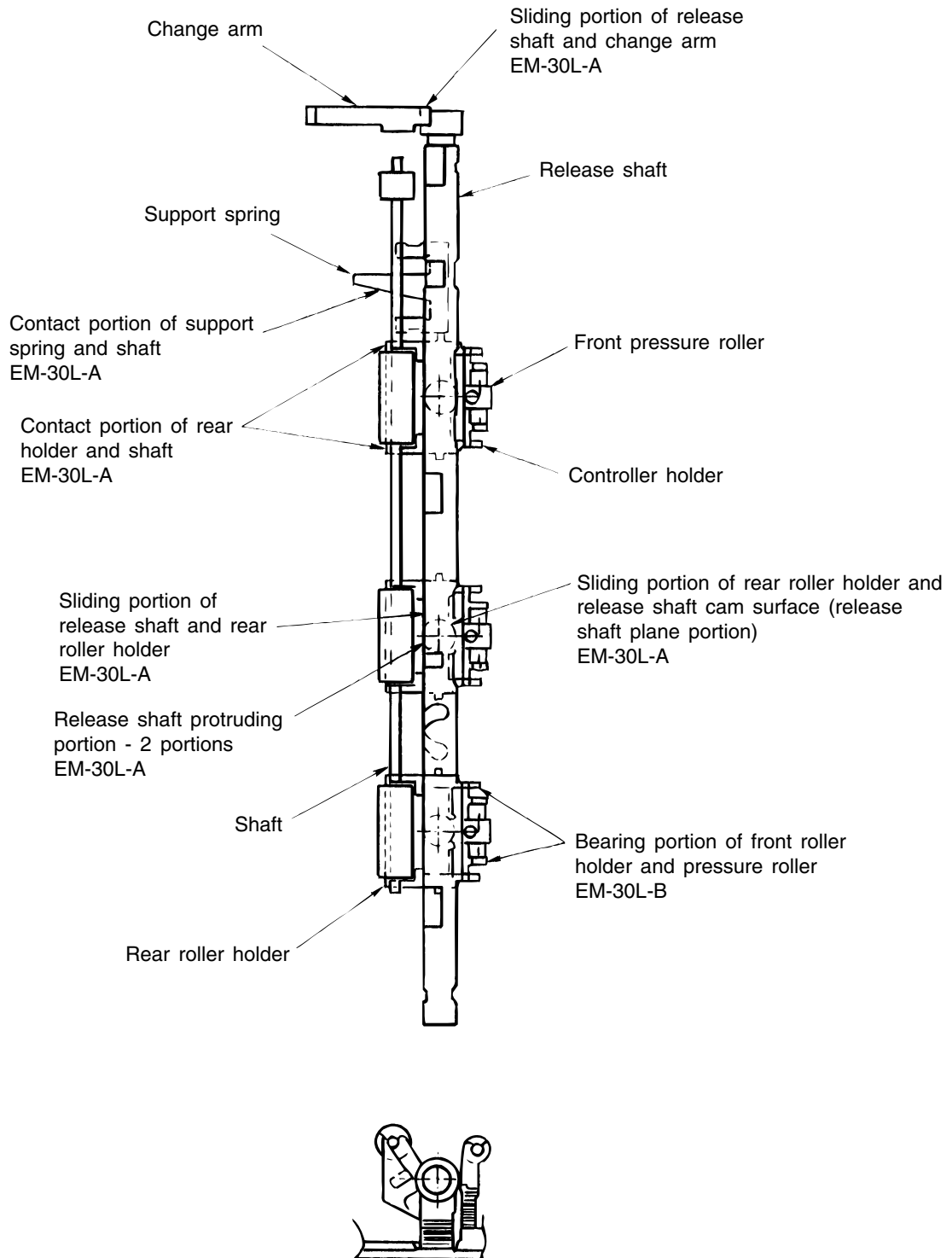

7. Pull up roller Assy.

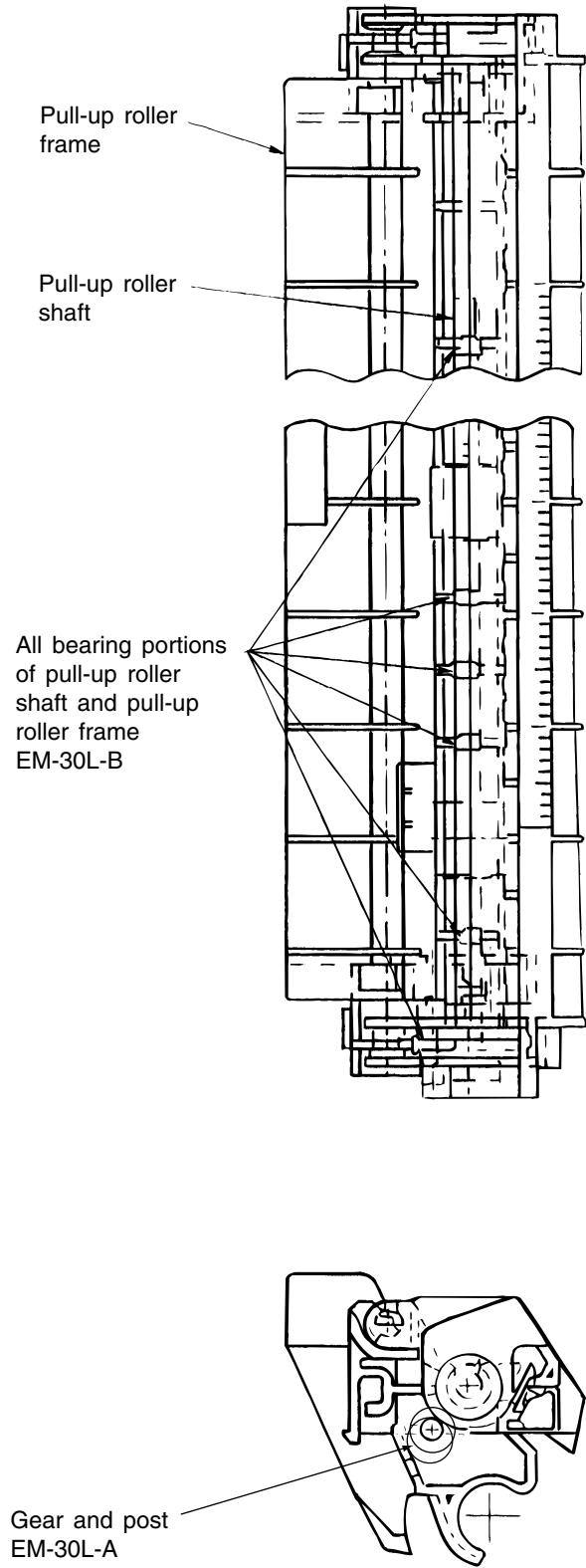

8. Main chassis Assy.

Grease portion (N: 3 portions, W: 5 portions) rear side  
EM-30L-A

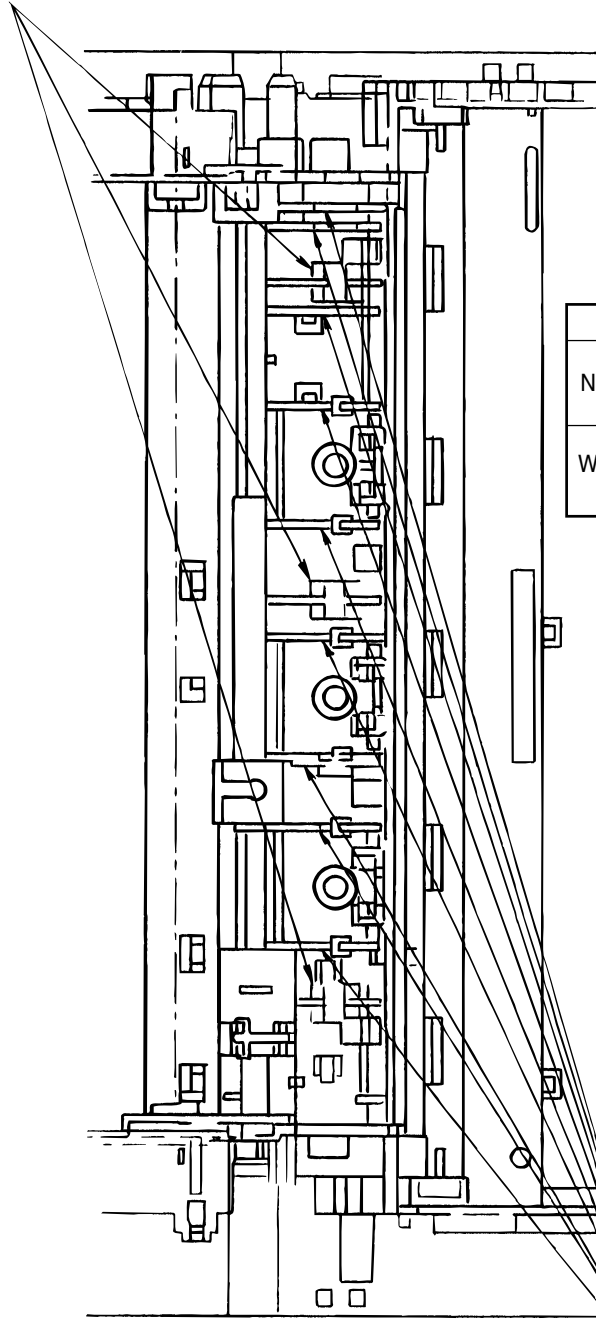

	Models	Destination apoint
N	ML3320	OEL
	ML320Turbo	Other
W	ML3321	OEL
	ML321Turbo	Other

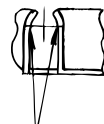

Grease portion

Grease portion at rib  
(N: 9 portions W: 13 portions)  
EM-30L-A

9. Carriage Assy.

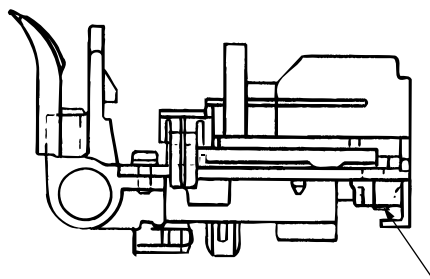

NK2-10-SUS Bearing portion  
of guide roller  
EM-30L-B

## 6. TROUBLESHOOTING AND REPAIR

### 6.1 Items to Check Before Repair

- (1) Check the inspection items specified in the instruction manual.
- (2) Find out as many details of the trouble as possible from the customer.
- (3) Inspect in the conditions as close as possible to those at the time the trouble occurred.
- (4) Proceed with the repair as follows:  
 Check the trouble status according to Table 6.1 for the details of the trouble. Then, locate the trouble position according to the detailed flowchart.
- (5) Carry out a thorough test after the repair to check for correct functioning.

### 6.2 Troubleshooting Table

**Table 6.1**

Status	Trouble Contents	Troubleshooting Flowchart No.	Surmise of Trouble
Trouble upon power on	• Power is not supplied.	①	Control/Power Supply Board, Driver Board, Transformer Assy.
	• No spacing operation	②	Space Motor, Carriage Cable, Printhead.
	• Homing does not end normally.	③	Space Motor, Carriage Cable, Control/Power Supply Board, Driver Board, Spacing Mechanism
Trouble during printing	• Paper jam while paper insertion	④	Pressure Roller Mechanism, Pull Up Roller Cover.
	• Smearing/Missing dots	⑤	Printhead, Driver Board, Space Motor, Carriage Cable
	• Faint or dark print	⑥	Printhead, Ribbon Feed Assembly, Driver Board
	• Ribbon feed trouble	⑦	Ribbon Feed Assembly, Space Motor, Driver Board
	• Line feed trouble	⑧	LF Motor, Platen Assy, LF Mechanism, Driver Board
	• Malfunction of switch on operation panel	⑨	Operation Panel, Driver Board
	• Data receiving failure	⑩	Driver Board, (I/F Board), I/F Cable, Menu Setting

### 6.3 Lamp Display

#### (1) Printer mode display

**Table 6.2**

ALARM CATEGORY	ALARM	LED CONDITION					CONTENTS	TROUBLE SHOOTING
		ALARM	SEL	MENU	10CPI	15CPI		
OPERATOR ALARM	Paper end alarm	ON	OFF				From, cut sheet or bottom paper end	Set New paper.
	Paper change lever alarm	ON	OFF		BLINK 1	OFF	Change lever is set to TOP position while paper is already inserted from rear or bottom.	<ul style="list-style-type: none"> <li>Set the lever to specified position.</li> <li>Check rear sensor lever.</li> <li>Replace Control Board</li> </ul>
	Paper jam alarm	ON	OFF		OFF	BLINK 1	<ul style="list-style-type: none"> <li>Cut sheet could not be ejected.</li> <li>Cut sheet could not be fed properly</li> </ul>	<ul style="list-style-type: none"> <li>Remove the paper or check feed Mechanism</li> <li>Press SEL key.</li> </ul>
	Print Head thermal alarm	OFF		BLINK 1			Print head temperature exceeds 119°C	<ul style="list-style-type: none"> <li>Wait until it is cooled.</li> <li>Replace P.H. or Driver Board</li> </ul>
	Space motor thermal alarm	OFF		BLINK 1			Temperature of space motor exceeds specified value.	<ul style="list-style-type: none"> <li>It is recovered automatically</li> <li>Replace SP motor or Driver Board</li> </ul>
FATAL ALARM		BLINK 2	OFF	OFF	See Table 6.3		Hardware Alarm has occurred.	See Table 6.3.

**Note:**

BLINK1 : 400ms ON, 400ms OFF

BLINK2 : 200ms ON, 200ms OFF

— : LED is kept in Current Condition (no change)

#### (2) Fault alarm display

When the printer detects any of the various alarm states, the information is displayed as shown below on the operation panel. The alarm is specified by lamp combination of PRINT QUALITY and CHARACTER PITCH. (See Table 6.3 for details.)

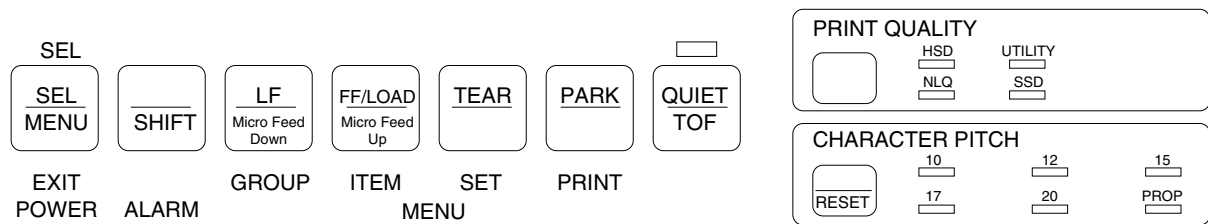

**Figure 6-1**

(3) Fatal Alarm

Table 6.3 (1/2)

ALARM CATEGORY	ALARM	LED DISPLAY										REMARKS	TROUBLESHOOTING		
		ALARM	10	12	15	17	20	PROP	HSD	UJL	NLQ				
MAIN CONTROL ALARM	MPU internal RAM alarm	⊙	○											Read/write error	Replace Control/Power Supply Board
	Program ROM alarm	⊙		○										Check sum error	Replace ROM or Control/Power Supply Board
	RAM on Control Board alarm	⊙					○							Read/write error	Replace Control/Power Supply Board
	EEPROM alarm	⊙		○									○	No reaction when MPU reads data	Replace Control/Power Supply Board
FIRMWARE DETECTION ALARM	WDT (Watch Dog Timeout) alarm	⊙				○								MPU is locked up and it ios reset after 65ms.	Turn the power OFF and ON or replace Control/Power Supply Board
	NMI signal alarm	⊙				○								NMI port of MPU is kept low level.	Turn the power OFF and ON or replace Control/Power Supply Board
	BRK instruction alarm	⊙				○						○		FFFF data is detected due to MPU locked up.	Replace ROM or Control/Power Supply Board
SERIAL INTERFACE ALARM	MPU internal RAM alarm	⊙	○											Read/write error	Replace I/F Board
	ROM alarm	⊙			○									Check sum error	Replace ROM on I/F board or I/F Board
	RAM on I/F board alarm	⊙					○							Read/write error	Replace I/F Board
	I/F not mounted	⊙		○										No reaction from serial I/F board	Replace I/F Board or Control Board.

⊙ : LED Blink (200ms ON, 200ms OFF)  
 ○ : LED Lights up



Table 6.3 (2/2)

ALARM CATEGORY	ALARM	LED DISPLAY										REMARKS	TROUBLESHOOTING			
		ALARM	10	12	15	17	20	PROP	HSD	UTL	NLQ					
SPACING ALARM	Spacing alarm	◎							○			○			Space IPT is not occurred within in specified timing.	<ul style="list-style-type: none"> <li>• Replace space motor.</li> <li>• Replace P.H. cable.</li> <li>• Replace Control/Power Supply Board</li> </ul>
	Print Head homing alarm	◎										○			Print head does not reach to the home position.	<ul style="list-style-type: none"> <li>• Check the mechanisms if load is too much.</li> </ul>
PRINT HEAD ALARM	Print Head A/D alarm	◎	○							○					Thermister is open, short with 0V or short with +5V.	<ul style="list-style-type: none"> <li>• Check the P.H. connection.</li> <li>• Replace Print Head.</li> <li>• Replace P.H. cable.</li> <li>• Replace Control/Power Supply Board</li> </ul>
	Print Head Gap A/D alarm	◎	○										○		Print Head Gap Signal open	<ul style="list-style-type: none"> <li>• Replace P.H. cable.</li> <li>• Replace Space Motor Assy.</li> <li>• Replace Control/Power Supply Board</li> </ul>

◎ : LED Blink (200ms ON, 200ms OFF)  
○ : LED Lights up

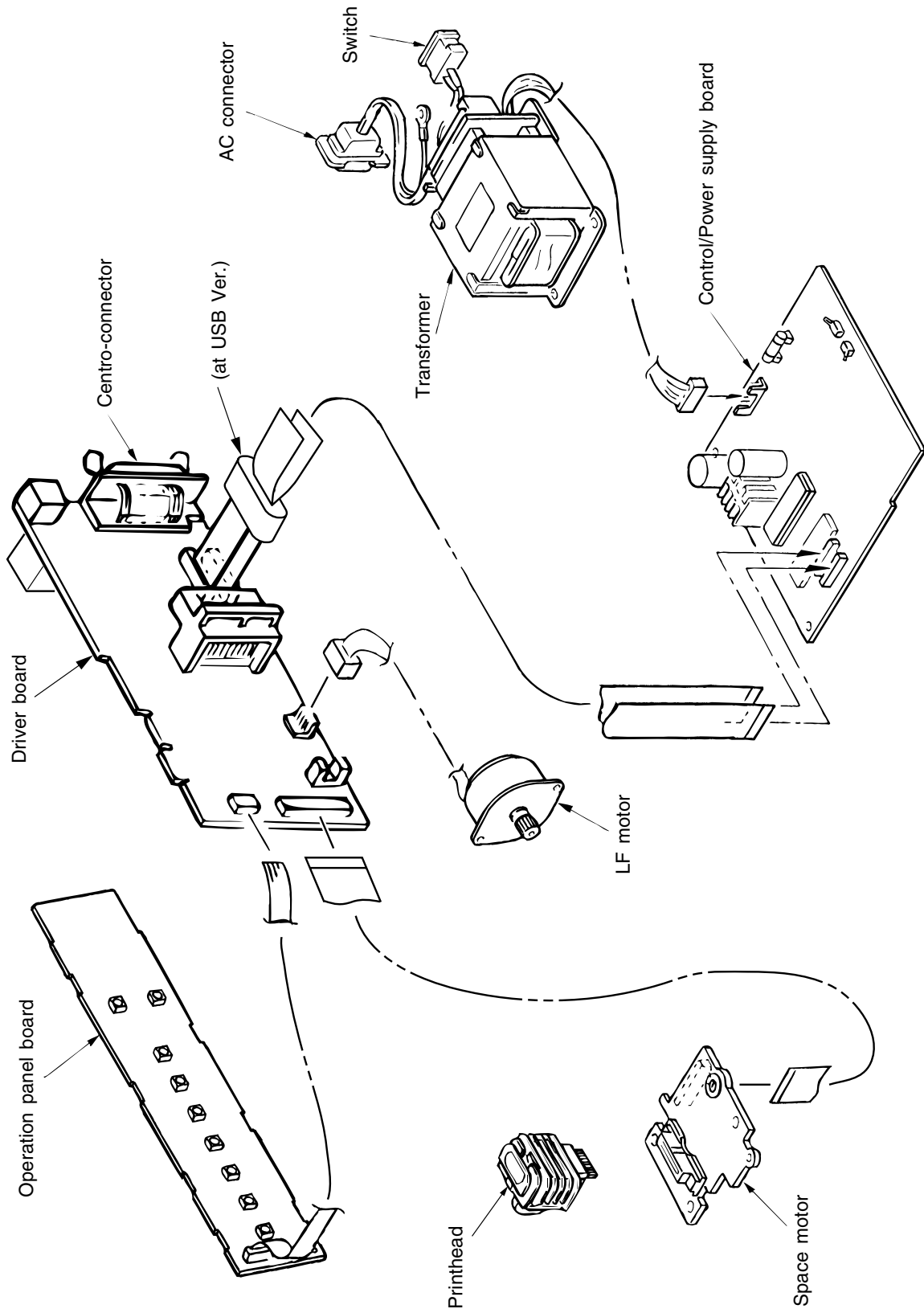

### 6.4 Connection Circuit Check for Printhead and SP/LF Motor

#### (1) Printhead

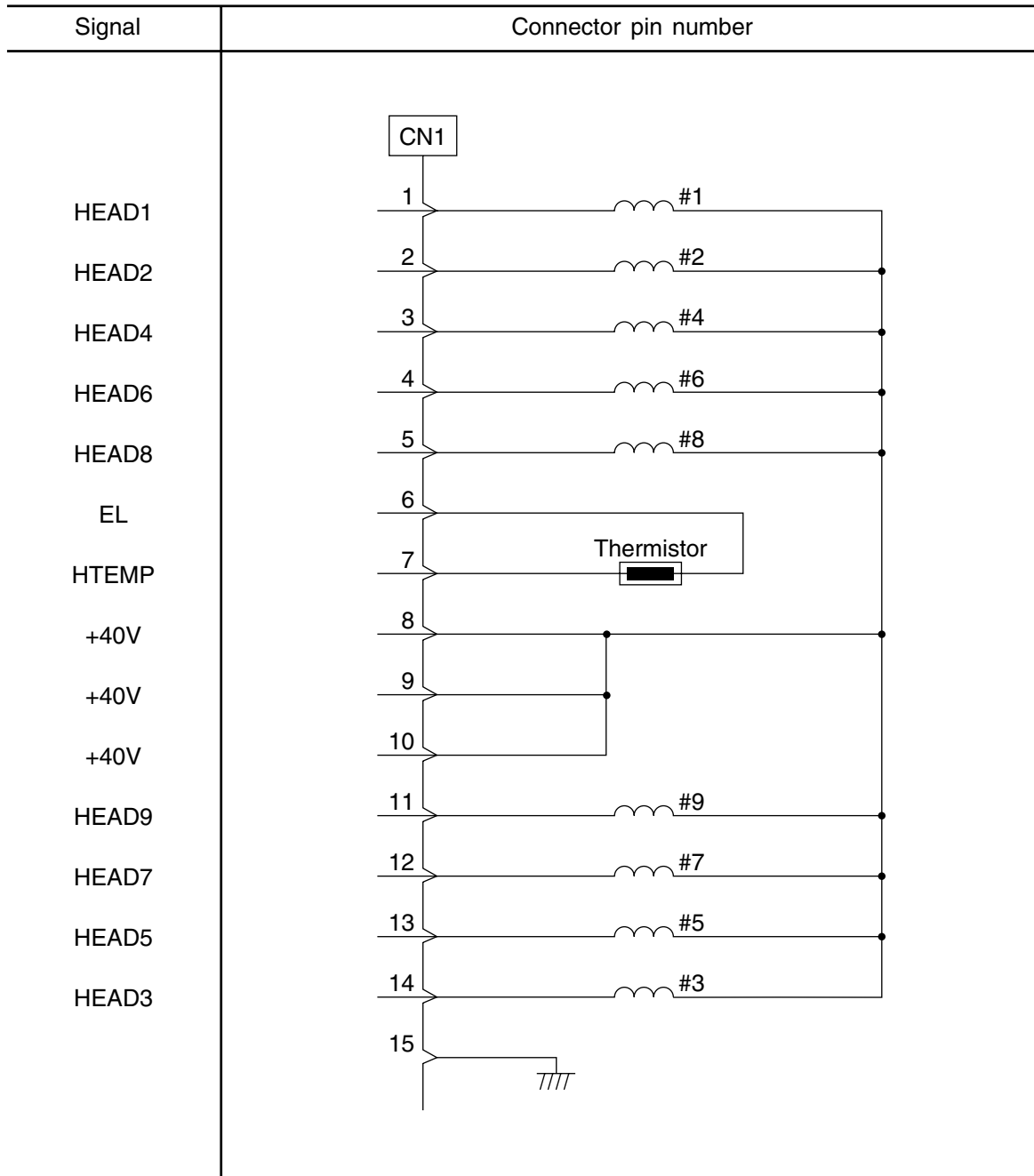

(2) Line Feed Motor

Resistance of each coil should be about 10.4Ω.

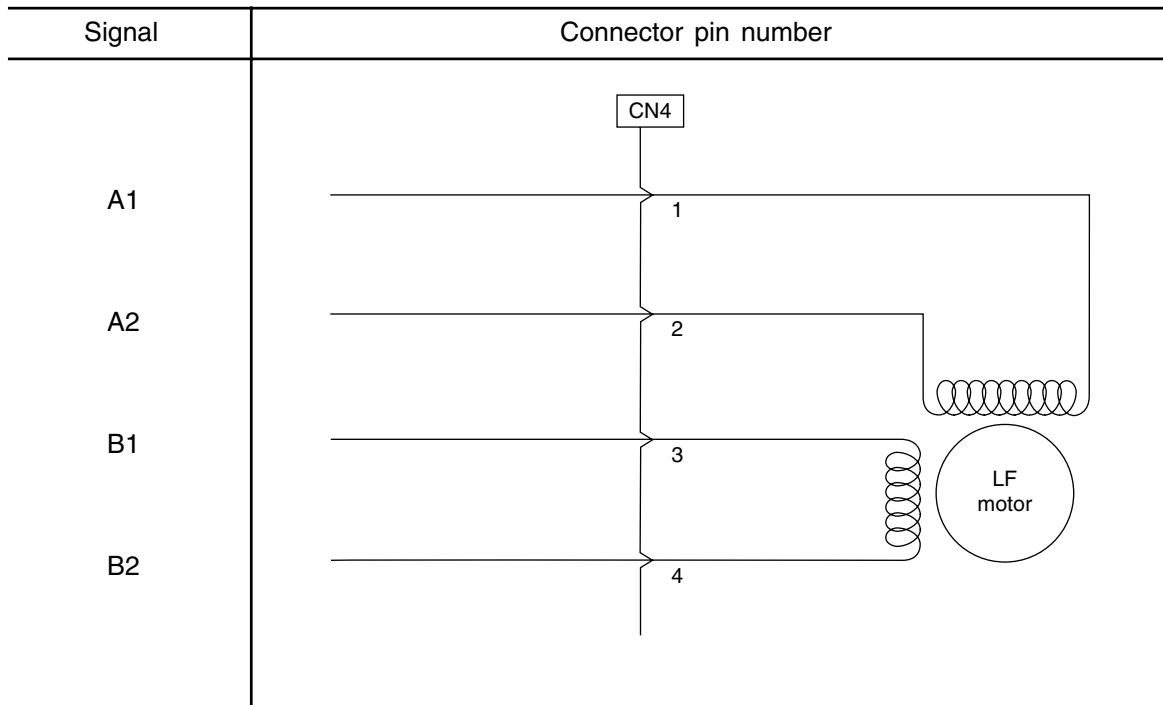

(3) Space Motor

Resistance of each coil should be about 18.4Ω.

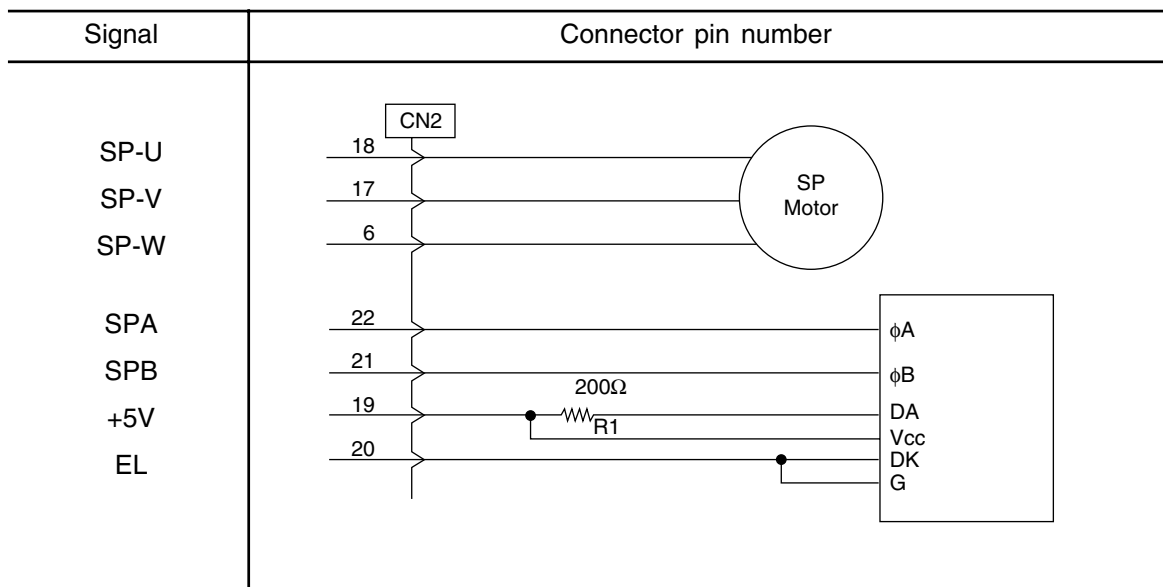

## 6.5 Troubleshooting flow chart

① Power is not supplied.

- Is the AC cable connected correctly?

Yes No

- Connect the AC cable correctly.

- Is fuse F1 on the transformer assy/or F1 on the control/power supply board blown?

No Yes

- Replace fuse (with same type and rating).
- Remedied?

No Yes

- End

- Does DC + 8V out?

No Yes

- Remove Printhead. (Turn power off, then on.)
- Remedied?

No Yes

- End

- Replace carriage cable or ribbon feed mechanism.

- Remedied?

No Yes

- End

- Replace Control/Power supply board.

- Remove CN3 on Driver board.

- Measure for any short circuits between + 5V, + 40V, + 8V, 0V (EL or EP).

- Any short circuit?

No Yes



- No Yes
- ↓
- Replace Driver board.
  - Replace Transformer assy.
  - Remedied?

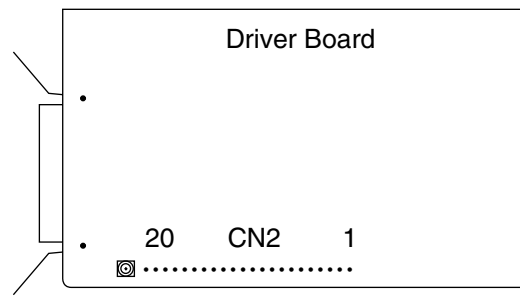

- No Yes
- ↓
- End
  - Replace Control/Power supply board.

Pin No.	20	19	18	17	16	15	14	13	10	9	8	7	6	5
Signal	+8V	EP (F.G)			+40V			AC 10V	EL (0V)		+5V			

## ② No spacing operation (The alarm LED Blinks)

- Is carriage assembly binding or jammed?

No      Yes

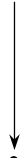

- Check around space motor to repair the mechanism of space rack, back up roller, ribbon feed mechanism, and carriage frame etc.

- Replace Space motor assy.

- Remedied?

No      Yes

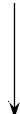

- End

- Replace Driver board.

- Remedied?

No      Yes

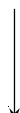

- End

- Replace Carriage cable.

③ Homing does not end normally

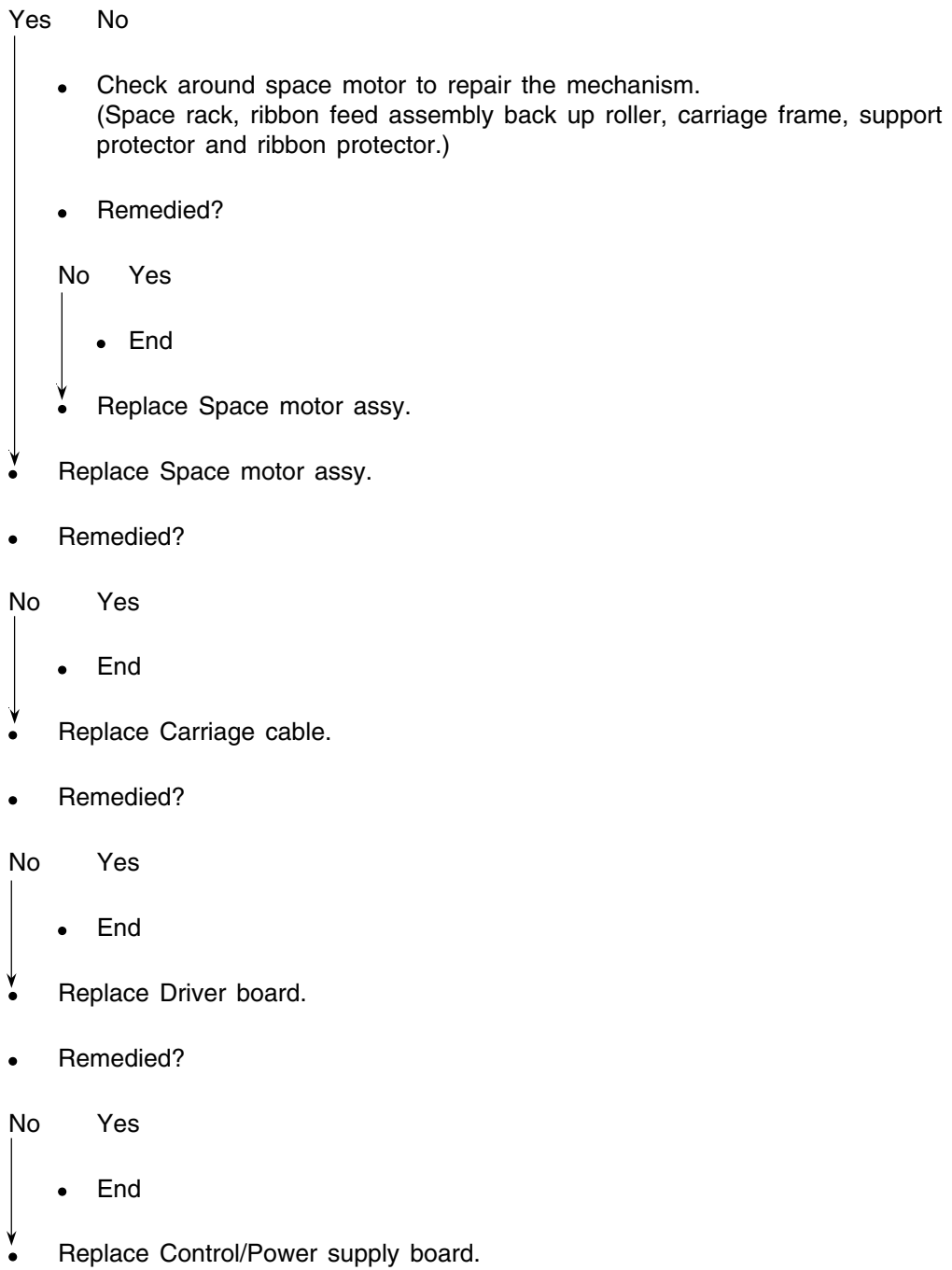



## ④ Paper jam while paper insertion

Jam 1

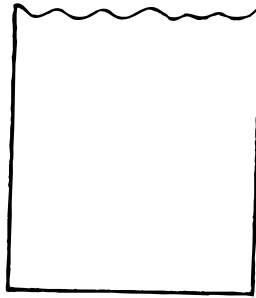

- Check the ribbon protector.
- Check the pull up roller cover is closed properly.

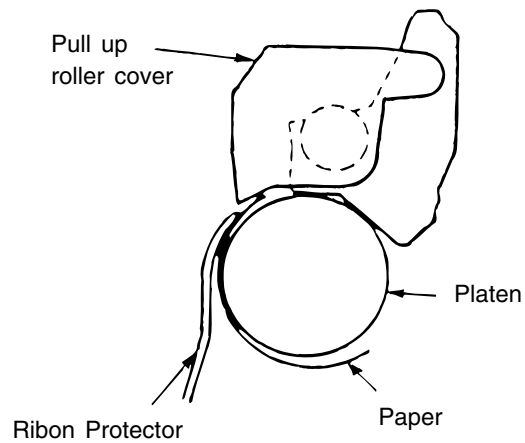

Jam 2 (wrinkled paper)

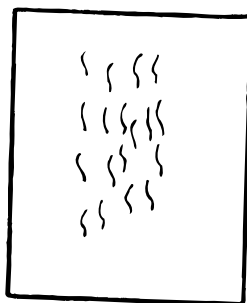

- Check around pressure roller mechanism.
  - Front pressure springs are narrow: 3 pcs; wide: 5 pcs) mounted properly or not.
  - Tension of all of front pressure rollers is properly.
  - Make sure of the fitting position of change gear shaft, change arm shaft and release shaft are correct.

## ⑤ Smearing/missing dots

- Does ALARM LED blink and display alarm?

No      Yes



- See Tables 6.2 and 6.3 for troubleshooting information.

- Replace Printhead.

- Remedied?

No      Yes



- End

- Replace Driver board.

- Remedied?

No      Yes



- End

- Replace Carriage cable or Space motor assy.

## ⑥ Faint or dark print

- Is the print head gap set properly?

Yes    No



- Adjust the printhead gap (see section 5).
- Remedied?

No    Yes



- End

- Replace Printhead.

- Remedied?

No    Yes



- End

- Replace Driver board.

- Remedied?

No    Yes



- End

- Replace Ribbon feed mechanism.

## ⑦ Ribbon feed trouble

- Remove the ribbon cartridge.
- Move carriage to left and right.
- Does the ribbon drive shaft rotate?

No      Yes



- Change Ribbon cartridge.
- Remove Ribbon feed mechanism.
- Move carriage to left and right.
- Does the ribbon drive shaft rotate?

No      Yes



- Replace Ribbon feed mechanism.
- Replace Space motor assy.

⑧ Line feed trouble

- Turn the power off, and rotate the platen manually.
- Does the platen rotate smoothly?

Yes    No

- Is the platen gear (L) broken?

No    Yes

- Replace Platen assembly.

- Is the LF motor idle gear broken?

No    Yes

- Replace the LF motor assembly or LF idle gear.

- Is the platen gear (R), idle gear or change gear broken?

No    Yes

- Replace the gear.

- Set change lever to the rear position.

- Does the platen rotate smoothly?

No    Yes

- Replace Tractor feed assembly.

- Replace LF motor assembly.

- Replace LF motor assembly.

- Remedied?

No    Yes

- End

- Replace Driver board.

## ⑨ Malfunction of switch on operation panel

- Is the CN1 of Operation panel connected to the CN3 on the driver board?

Yes    No



- Connect the cable properly.
- Replace Operation panel board.
- Remedied?

No    Yes



- End
- Replace Driver board.



10-2 (RS232C I/F)

Printer I/F pin assignment.

TXD	2 pin,
RXD	3 pin,
SSD	11 pin,
DTR	20 pin,
DSR	6 pin.

• Is the correct cable used?

Yes      No



- Change I/F cable.

• Is ALARM LED blinking?

No      Yes



- See tables 6.2 and 6.3 for the troubleshooting.
- Make sure of the parameters for RS232C in the menu are correct.

- Baud rate
- Bit length
- Parity
- Protocol
- Busy signal and its polarity

• Remedied?

No      Yes



- End
- Is + 8V supplied on Driver board?

Yes      No



- Remove RS232C I/F Board.
- Is the + 8V supplied on the Driver board?

No      Yes



- Replace RS232C I/F board.
- Replace Driver board.



- Replace RS232C board.

• Remedied?

No      Yes



- End
- Replace Driver board.

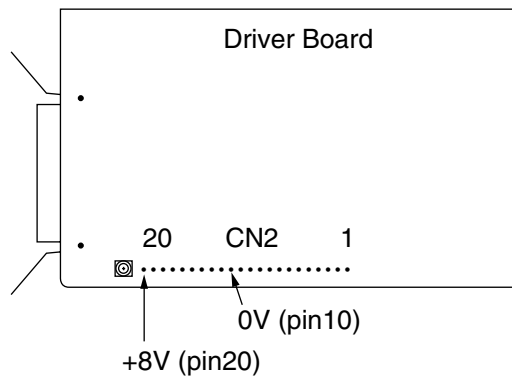



# APPENDIX A PCB LAYOUT

## PCB list

- (1) Circuit board AOE/AOU/AOO (Control/Power Supply)
- (2) Circuit board DVE/DVF or SDF (Driver)
- (3) Circuit board LEOP (Operation Panel)

- (1) Control/Power Supply Board (AOE/AOU/AOO)  
(AOE)

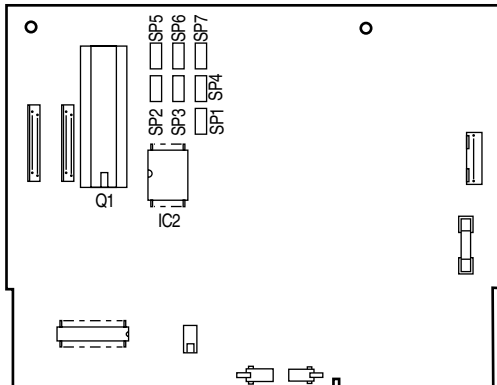

Short Plug	Setting	Destination Point		
		OEL	ODA	INT
SP1 1 [ ] [ ] [ ] 3	NOMOUNT 1 - 2: Normal 2 - 3: Change Program			<input type="radio"/>
SP2 1 [ ] [ ] [ ] 3	NOMOUNT 1 - 2: Normal 2 - 3: Change Program	<input type="radio"/>	<input type="radio"/>	<input type="radio"/>
SP3 1 [ ] [ ] [ ] 3	NOMOUNT 1 - 2: To use program Rom of IC2 2 - 3: To use program Rom of Q1	<input type="radio"/>	<input type="radio"/>	<input type="radio"/>
SP4 1 [ ] [ ] [ ] 3	NOMOUNT 1 - 2: Normal 2 - 3: Change Program	<input type="radio"/>	<input type="radio"/>	<input type="radio"/>
SP5 1 [ ] [ ] [ ] 3	NOMOUNT 1 - 2: Normal 2 - 3: Change Program	<input type="radio"/>	<input type="radio"/>	<input type="radio"/>
SP6 1 [ ] [ ] [ ] 3	NOMOUNT 1 - 2: Normal 2 - 3: Change Program	<input type="radio"/>	<input type="radio"/>	<input type="radio"/>
SP7 1 [ ] [ ] [ ] 3	NOMOUNT 1 - 2: Normal 2 - 3: Change Program	<input type="radio"/>	<input type="radio"/>	<input type="radio"/>

## (AOU)

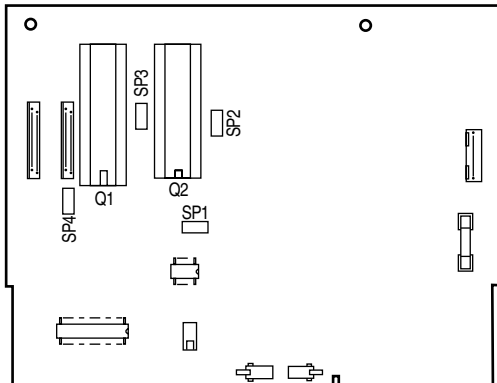

Short Plug	Setting	Default				
		OEL	ODA	INT	ADP	BANAMEX
SP1 1 [ ] [ ] [ ] 3	NOMOUNT 1 - 2: 4Mbit ROM of Q2 2 - 3: 1M/2Mbit ROM of Q2	*1	*1	*1	*1	*1
SP2 1 [ ] [ ] [ ] 3	NOMOUNT 1 - 2: To use program ROM of Q1 2 - 3: To use program ROM of Q2	*1	*1	*1	*1	*1
SP3 1 [ ] [ ] [ ] 3	NOMOUNT 1 - 2: To use CGROM of Q2 2 - 3: To use CGROM of Q1	<input type="radio"/>	<input type="radio"/>	<input type="radio"/>	<input type="radio"/>	<input type="radio"/>
SP4 1 [ ] [ ] [ ] 3	NOMOUNT 1 - 2: 32 Mbit CGROM of Q1 2 - 3: 8 M/16 Mbit CGROM of Q1	<input type="radio"/>	<input type="radio"/>	<input type="radio"/>	<input type="radio"/>	<input type="radio"/>

\*Note : \*1 is LINK WIRE

## (AOO)

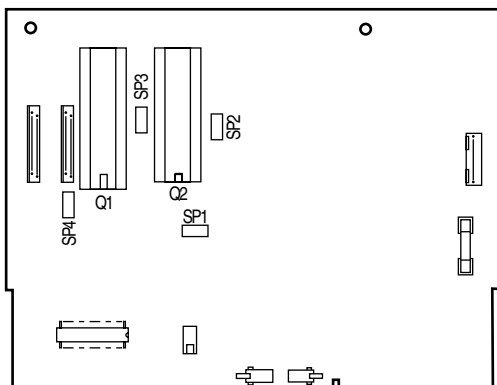

Short Plug	Setting	Default	
		RUSSIA	HASAR
SP1 1 [ ] [ ] [ ] 3	NOMOUNT 1 - 2: 4Mbit ROM of Q2 2 - 3: 1M/2Mbit ROM of Q2	*1	*1
SP2 1 [ ] [ ] [ ] 3	NOMOUNT 1 - 2: To use program ROM of Q1 2 - 3: To use program ROM of Q2	*1	*1
SP3 1 [ ] [ ] [ ] 3	NOMOUNT 1 - 2: To use CGROM of Q2 2 - 3: To use CGROM of Q1	<input type="radio"/>	<input type="radio"/>
SP4 1 [ ] [ ] [ ] 3	NOMOUNT 1 - 2: 32 Mbit CGROM of Q1 2 - 3: 8 M/16 Mbit CGROM of Q1	<input type="radio"/>	<input type="radio"/>

\*Note : \*1 is LINK WIRE

(2) Driver Board (DVE/DVF or SDF)

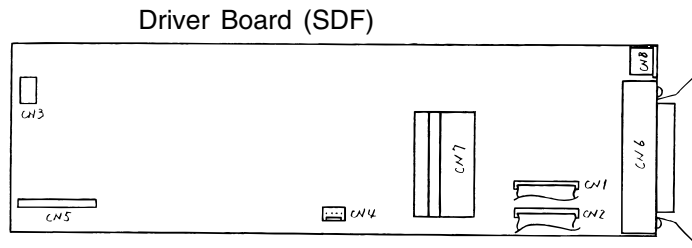
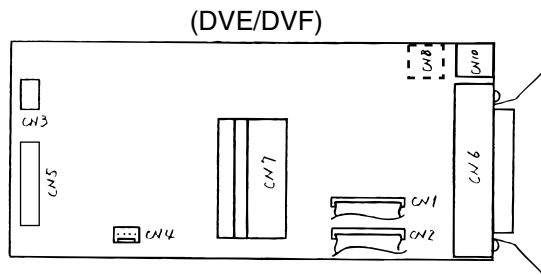

(3) Operation Panel Board (LEOP)

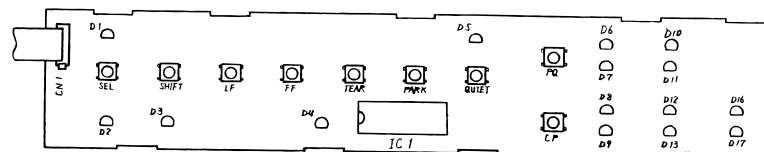

## APPENDIX B RS-232C SERIAL INTERFACE BOARD (OPTION)

### 1. GENERAL

This section describes the operation of the RS-232C Serial Interface board installed in the Printer as an option using a start-stop synchronization and serial communications circuit. This serial interface board is capable of transmitting and receiving simultaneously at speeds up to 19,200 bits per second. Two protocols are available: printer Ready/Busy and X-ON/X-OFF modes.

### 2. OPERATION DESCRIPTION

#### 2.1 Element Description

(1) 80C51 with MASK ROM

An eight-bit microprocessor controller that controls the following:

- (a.) Serial interface protocol and data transfer through a serial port.
- (b.) Message buffer.
- (c.) Transmission of parallel data to the printer.

(2) SN75189

An RS-232C standard line receiver

(3) SN75188

An RS-232C standard line driver.

(4) 2764

An 8 kbyte ROM that contains the serial interface control program.

(5) HM6264

An 8192-byte static RAM used as a message buffer.

#### 2.2 Circuit Description

A block diagram is shown in Figure B-2-1.

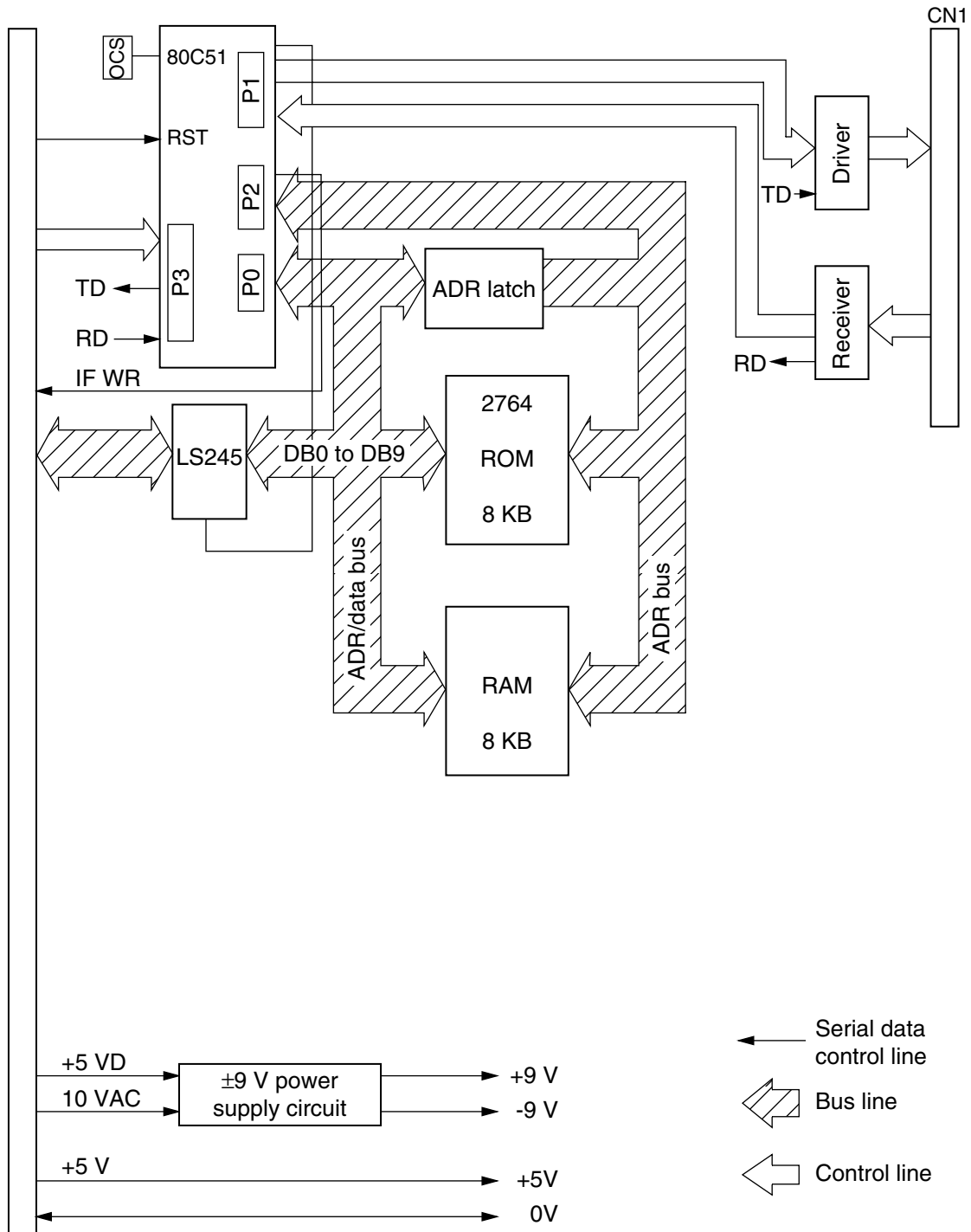

Figure B-2-1 Block Diagram

### 2.2.1 Operation at power on

After power is turned on, an RST OUT signal is sent from the printer control board to reset the printer. When the reset is canceled, the 80C51 CPU performs initialization. Initialization consists of setting the 80C51 timer, and setting the serial mode.

### 2.2.2. RS-232C interface

The DTR, SSD, TD and RTS signals output by the 80C51 are converted to RS-232C signals by line driver SN75188 and sent to the interface.

In addition, signals DSR, CTS, CD, and RD on the RS232C interface are converted to TTL level by line receiver SN75189 and input to the 80C51.

## 2.3 Communication Procedure Flowchart

### 2.3.1 Mode (a)

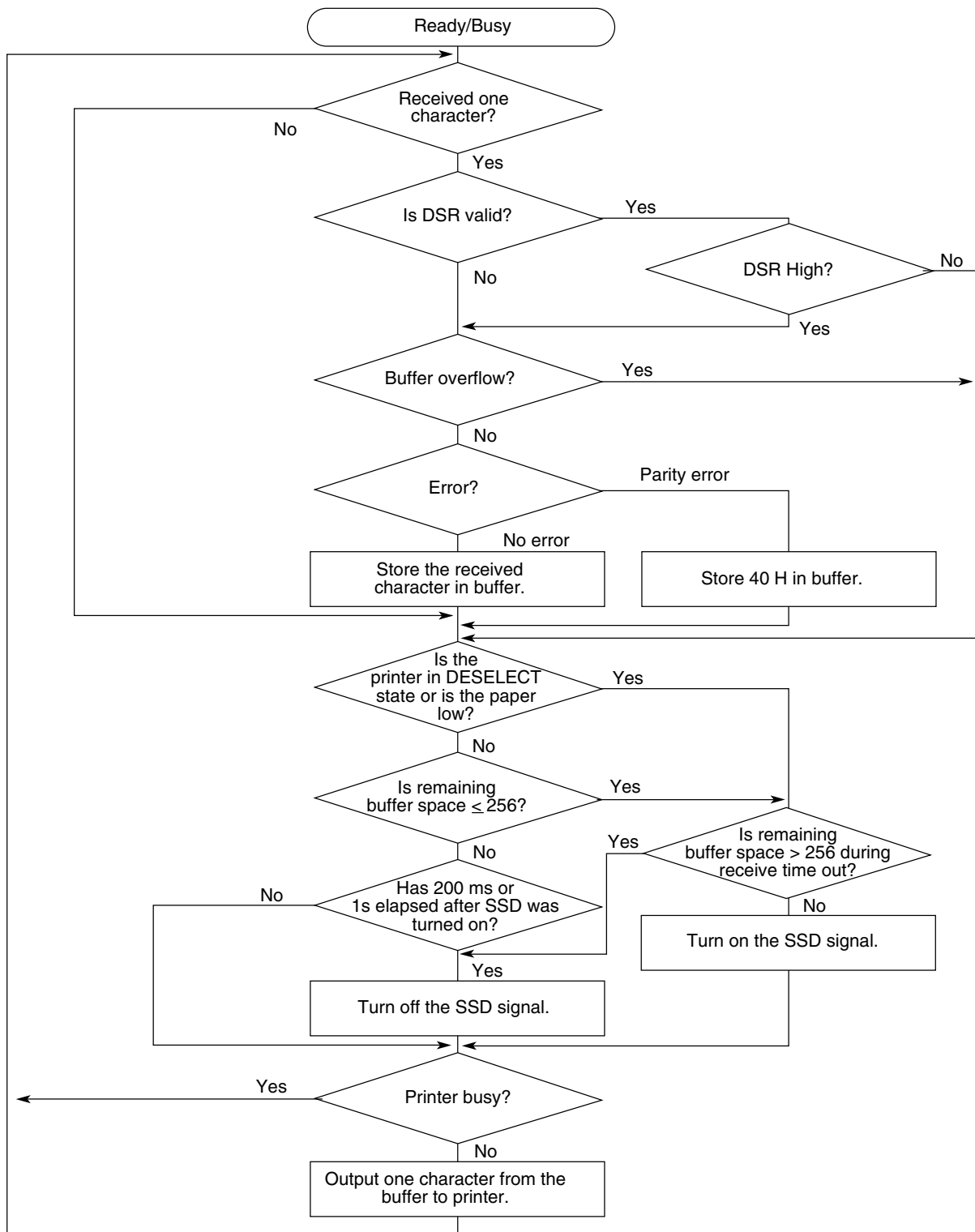

Figure B-2-2

2.3.2 Mode ②

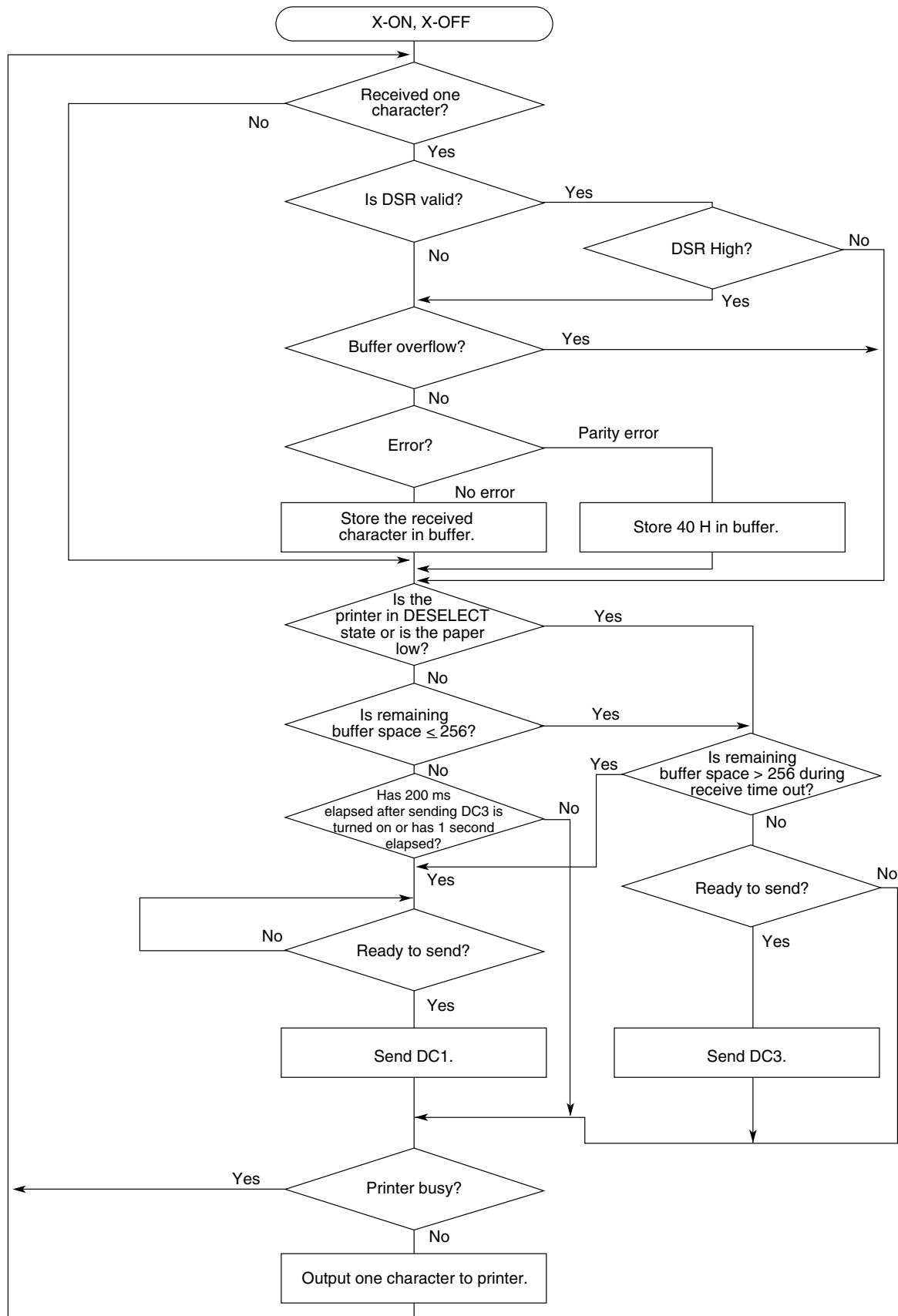

Figure B-2-3

### 3. TROUBLESHOOTING FLOWCHART

#### 3.1 Before Repairing a Fault

Before servicing the printer, ask the customer in what situation the trouble occurred and record the response.

Before starting troubleshooting, operate the printer in the same situation as that at the time of trouble occurrence to see if the same trouble occurs again. If not, perform the printers self test and thoroughly test the printers functionality. If the trouble is reproducible proceed to the troubleshooting section.

#### 3.2 Troubleshooting

- (1) The data is not received using a serial interface.
  - (2) Using a serial interface, the print data is omitted or the print operation is not performed.
- ① The data is not received using a serial interface.

(A protocol is set to READY/BUSY state, and BUSY LINE is in SSD + state.)

- Is the OSC oscillation waveform as specified in Figure B-3-1?

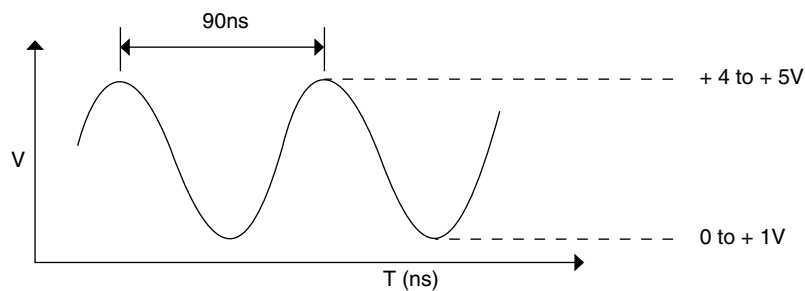

**Figure B-3-1**

- No Replace the OSC.

- Yes Is a RST signal in Q3 is as specified in Figure B-3-2?

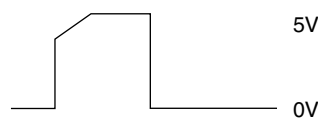

**Figure B-3-2**

- No Check the RST circuit on the Control/Power Supply board.

Ⓐ



(A)

• Yes Are ALE,  $\overline{\text{PSEN}}$ ,  $\overline{\text{RD}}$ ,  $\overline{\text{WR}}$ , signals as specified in Figure B-3-3?

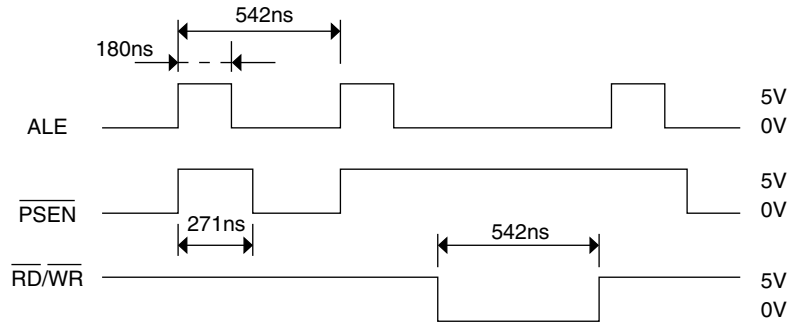

Figure B-3-3

• No Replace the Q3.  
 • Yes Are (T1)  $\overline{\text{SELECT}}$  and (INT0)  $\overline{\text{BUSY}}$  signals low level?

• No Check Q12 on the Driver board.

• Yes Are +9V and -9V input to Q1?

• No Replace defective component in +9/-9 volt control circuit.

• Yes Is pin 1 SSD signal of Q3 High level?

• No Replace the Q3.

• Yes Is pin 11 SSD of Q1 low level?

• No Replace the Q1 or the CN1?

• Yes Is the RxD of Q3 as specified in Figure B-3-4?

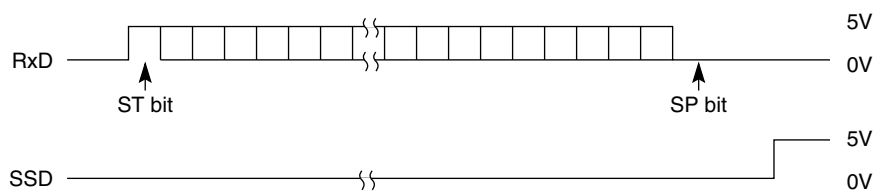

Figure B-3-4

• No Replace the Q2.

• Yes Replace the Q3.

② In receiving by serial interface, printing data is omitted or printing operation is not performed.

• Are RxD and SSD of Q3 as specified in Figure B-3-4?

- No Replace the Q2.

• Yes Are,  $\overline{WR}$ , and BUS signals of Q3 pin 3 as specified in Figure B-3-5?

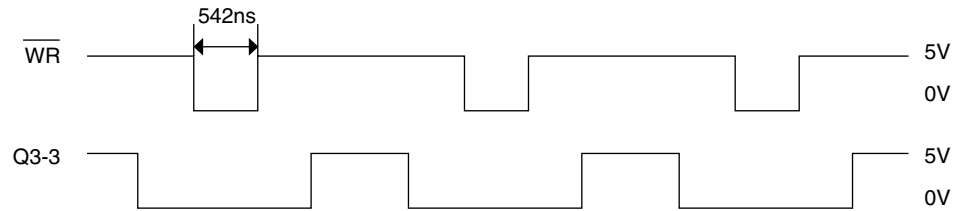

**Figure B-3-5**

- No Replace the Q3.

• Yes Is the level of a BUS signals at Q7 pins 2-9 the same as that of DB0-7 when  $\overline{WR}$  signal is started?

- No Replace the Q7.

• Yes Is 4 pin of Q6 identical to  $\overline{WR}$  signal in Figure B-3-5?

- No Replace the Q6.

• Yes Check Q12 on the Driver board.

### 3.3 Local Test

#### 3.3.1 Circuit test mode

##### 3.3.1.1 Setting

- (1) Diagnostic test (set by menu)
- (2) Test connector

Connect the test connector shown in Figure B-3-6 to the interface connector

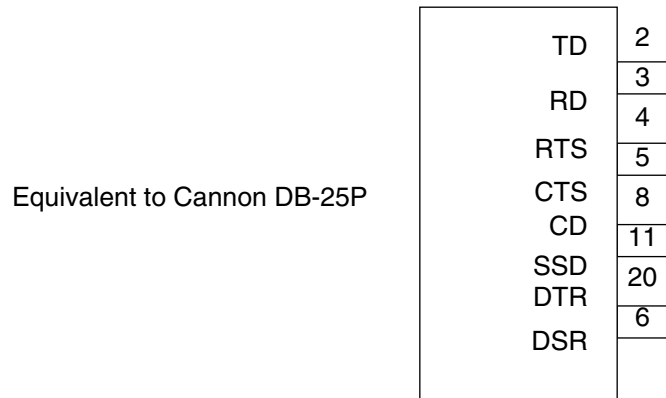

**Figure B-3-6 Test Connector Connection Diagram**

##### 3.3.1.2 Function

After the settings outlined in Section 3.3.1.1 are completed and power is turned on, the serial interface checks the message buffer memory and interface driver/receiver circuit. It then prints characters.

To start and stop this test, push the SEL switch on the front of the printer.

Details of this test are explained on the following.

- (1) The program revision using two numerical characters is printed.
- (2) "LOOP TEST" is printed.
- (3) Memory is checked for the message buffer.
- (4) Prints "OK" is printed if the memory check is OK and "BAD" is printed if the memory check fails.
- (5) Output level to DTR, RTS, and SSD signals is dropped low. If DSR, CTS, or CD signals is High, "IF BAD" is printed. If DSR, CTS, and CD signals are all Low, "IF OK" is printed.
- (6) Output level to DTR, RTS, and SSD signals is raised high. If DSR, CTS, or CD signals is Low, "IF BAD" is printed. If DSR, CTS, and CD signals are all High, "IF OK" is printed.
- (7) Transmits characters codes from 20H to 7FH is transmitted by SD signal. At the same time, characters are received by the RD signal and stored in the message buffer.
- (8) The characters that were stored in the message buffer as indicated in (7) are printed.
- (9) Steps (1) through (8) are repeated until test is interrupted.