

**Job Separator
MJ-5006
Maintenance Manual**

060114A

Trademarks

- FLOIL is a registered trademark of Kanto Kasei Ltd. CORPORATION
- Mylar is a registered trademark of DuPont Teijin Films U.S. Limited Partnership.
- Molykote is a registered trademark of Dow Corning Corporation.
- Other company names and product names in this manual are the trademarks of their respective companies.

GENERAL PRECAUTIONS FOR INSTALLATION/SERVICING/ MAINTENANCE

The installation and service shall be done by a qualified service technician.

1. When installing the Job Separator MJ-5006 to the equipment, be sure to follow the instructions described in the "Unpacking/Set-Up Procedure for the MJ-5006" booklet which comes with each unit of the MJ-5006.
2. The MJ-5006 should be installed by an authorized/qualified person.
3. Before starting installation, servicing or maintenance work, be sure to turn off and unplug the equipment first.
4. Be sure to fix and plug in the power cable securely after the installation so that no one trips over it.
5. The equipment shall be installed near the socket outlet and shall be accessible.
6. Unplug the power cable and clean the area around the prongs of the plug and socket outlet once a year or more. A fire may occur when dust lies on this area.
7. When parts are disassembled, reassembly is basically the reverse of disassembly unless otherwise noted in this manual or other related materials. Be careful not to reassemble small parts such as screws, washers, pins, E-rings, toothed washers to the wrong places.
8. Basically, the machine should not be operated with any parts removed or disassembled.
9. Delicate parts for preventing safety hazard problems (such as breakers, thermofuses, fuses, door switches, sensors, etc. if any) should be handled/installed/adjusted correctly.
10. Use suitable measuring instruments and tools.
11. During servicing or maintenance work, be sure to check the nameplate and other cautionary labels (if any) to see if they are clean and firmly stuck. If not, take appropriate actions.
12. The PC board must be stored in an anti-electrostatic bag and handled carefully using a wristband, because the ICs on it may be damaged due to static electricity. Before using the wrist band, pull out the power cord plug of the equipment and make sure that there is no uninsulated charged objects in the vicinity.
13. For the recovery and disposal of used MJ-5006, consumable parts and packing materials, follow the relevant local regulations/rules.
14. After completing installation, servicing and maintenance of the MJ-5006, return the MJ-5006 to its original state, and check operation.

CONTENTS

1. SPECIFICATIONS.....	1-1
2. GENERAL DESCRIPTION.....	2-1
2.1 External Appearance and Name of Each Part	2-1
2.2 Layout of Electrical Parts	2-1
3. CIRCUIT DESCRIPTION.....	3-1
3.1 Harness Connection Diagram	3-1
3.2 Meaning of Signals.....	3-1
4. DISASSEMBLY AND REPLACEMENT.....	4-1

1. SPECIFICATIONS

Function	Stacker tray with full detection sensor
Loading capacity	25 mm (Approx. 150 sheets: 80 g/m ² (21.3 lb. Bond))
Dimensions	Stacker tray: 426 (W) × 377 (D) × 152 (H) mm 16.77 (W) × 14.84 (D) × 5.98 (H) inch Sensor unit: 171 (W) × 208 (D) × 150 (H) mm 6.73 (W) × 8.19 (D) × 5.91 (H) inch
Weight	Approx. 1.5 kg (3.3 lb.)
Power supply	5 VDC (supplied from the equipment)

2. GENERAL DESCRIPTION

2.1 External Appearance and Name of Each Part

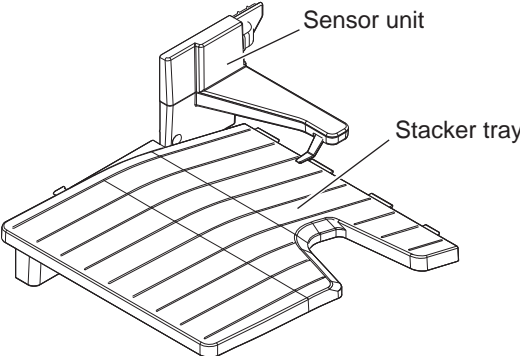

Fig. 2-1

2.2 Layout of Electrical Parts

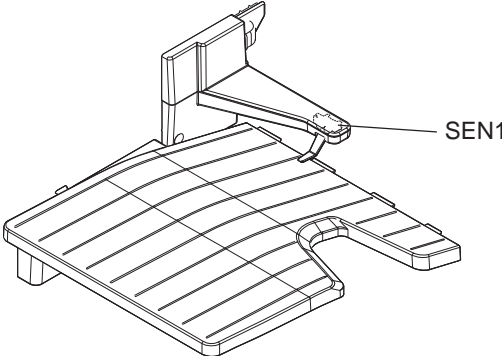

Fig. 2-2

Symbol	Name	Function
SEN1	Full detection sensor	Detects the limit number of sheets in the tray. Tray full is detected when the tray is full of paper. To clear the tray full, remove paper from the tray.

3. CIRCUIT DESCRIPTION

3.1 Harness Connection Diagram

ES9465 MFP/ES9475 MFP

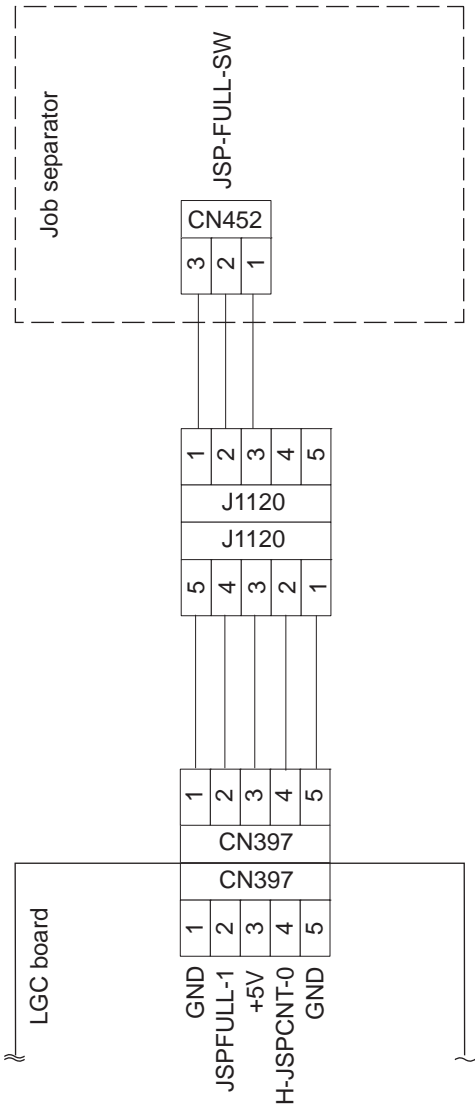

Fig. 3-1

3.2 Meaning of Signals

Signal Name	Name	Function	Status	Remarks
JSPFULL-1	Full detection sensor	Detects the limit number of sheets	High: Paper full	Photo sensor

4. DISASSEMBLY AND REPLACEMENT

[A] Sensor unit

- (1) Release 1 hook and take off the stacker tray.

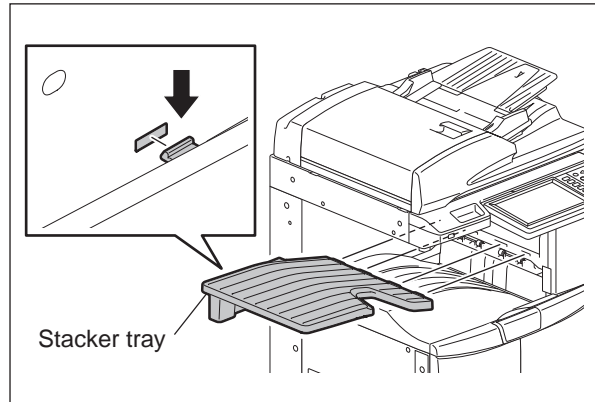

Fig. 4-1

- (2) Remove 2 screws and take off the connector cover.

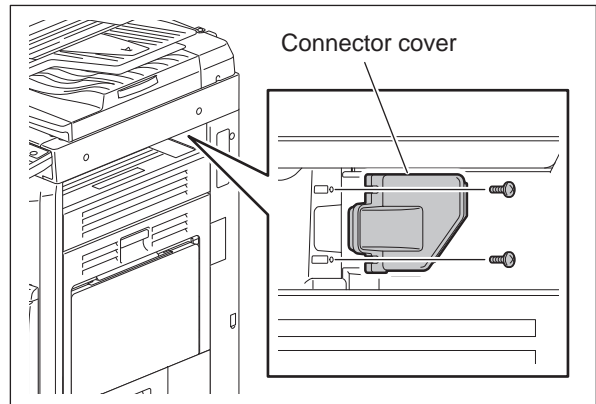

Fig. 4-2

- (3) Pull the handle and open the ADU.

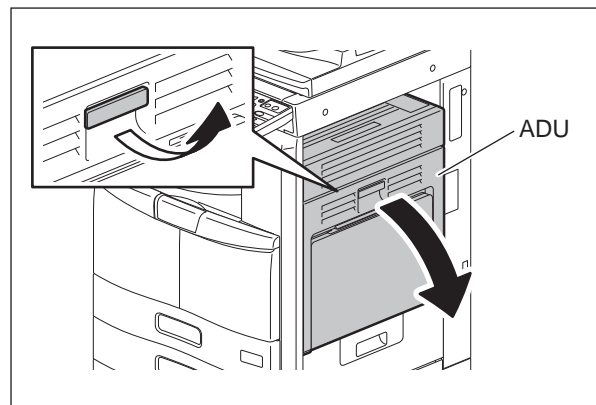

Fig. 4-3

- (4) Remove 1 screw and take off the connecting port cover.

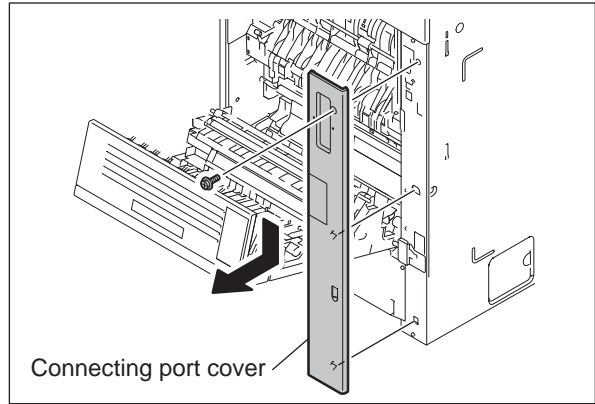

Fig. 4-4

- (5) Take off the right rear cover.

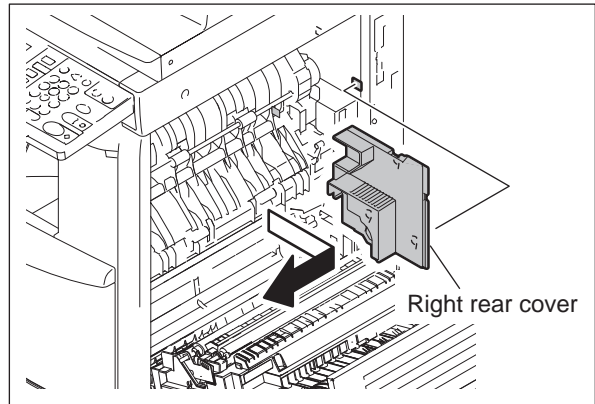

Fig. 4-5

- (6) Detach the connector.

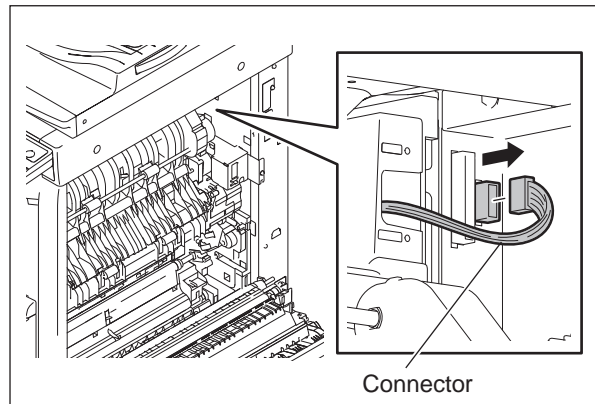

Fig. 4-6

(7) Close the ADU.

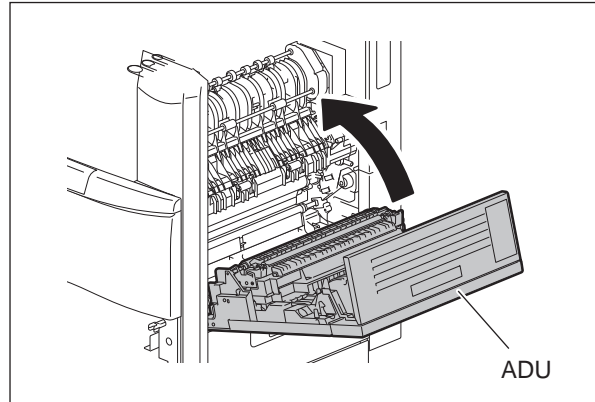

Fig. 4-7

(8) Remove 2 screws and take off the sensor unit.

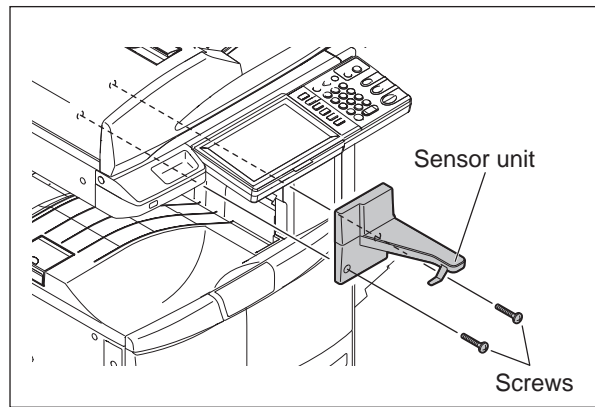

Fig. 4-8

[B] Full detection sensor

- (1) Remove the sensor unit.
📖 P.4-1 "[A] Sensor unit"
- (2) Remove 2 screws and take off the top cover.

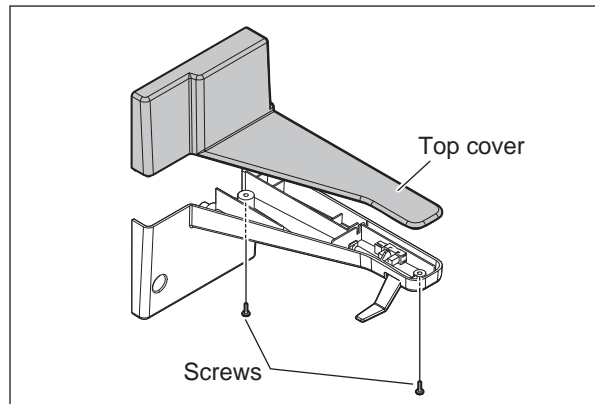

Fig. 4-9

- (3) Release hooks and take off the actuator.

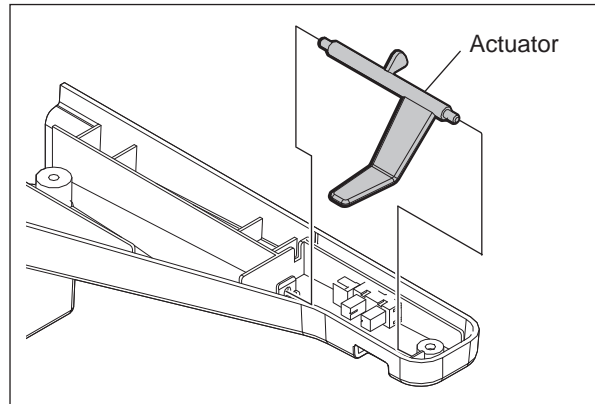

Fig. 4-10

- (4) Release the latch, remove the full detection sensor, and then disconnect 1 connector.

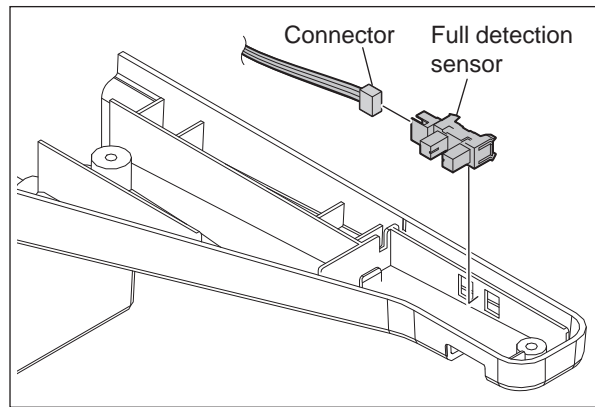

Fig. 4-11

