

**MC770 / MC780
MPS3537mc / MPS4242mc
GD-1340 FAX Unit
Maintenance Manual**

060313A

Document Revision History

Rev.No.	Date	Corrected items			Person in charge
		No.	Page	Description of change	
1	2013-04-10			ISSUE	P2E1 T. Asaba

TRADEMARKS

- The official name of Windows XP is Microsoft Windows XP Operating System.
- The official name of Windows 7 is Microsoft Windows 7 Operating System.
- The official name of Windows 8 is Microsoft Windows 8 Operating System.
- Microsoft, Windows, Windows NT, Windows Vista and the brand names and product names of other Microsoft products are trademarks or registered trademarks of Microsoft Corporation in the U.S. and/or other countries.
- Apple, AppleTalk, Macintosh, and Mac are trademarks of Apple Inc. in the U.S. and other countries.
- PostScript is a trademark of Adobe Systems Incorporated.
- NOVELL, NetWare, and NDS are trademarks or registered trademarks of Novell, Inc.
- Other company names and product names in this manual are the trademarks of their respective companies.

© 2013 OKI DATA CORPORATION All rights reserved

Under the copyright laws, this manual cannot be reproduced in any form without prior written permission of OKI DATA CORPORATION.

GENERAL PRECAUTIONS REGARDING THE SERVICE FOR GD-1340

The installation and service shall be done by a qualified service technician.

1) Transportation/Installation

- When transporting/installing the equipment, employ two or more persons and be sure to hold the positions as shown in the figure. The equipment is quite heavy and weighs approximately 60 kg (132.27 lb.) (including the finisher), therefore pay full attention when handling it.

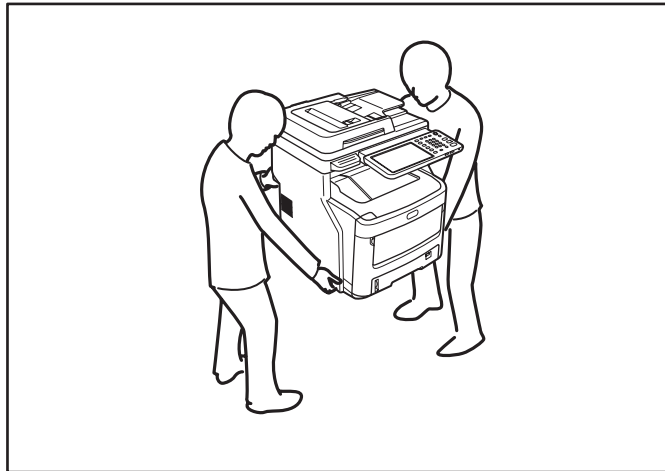

- Be sure not to hold the movable parts or units (e.g. the control panel, ADU or RADF) when transporting the equipment.
- Be sure to use a dedicated outlet with AC 110 V / 13.2 A, 115 V or 127 V / 12 A, 220-240 V / 8 A for its power source.
- The equipment must be grounded for safety.
- Select a suitable place for installation. Avoid excessive heat, high humidity, dust, vibration and direct sunlight.
- To insure adequate working space for the copying operation, keep a minimum clearance of 20 cm (8") on the left, 20 cm (8") on the right and 60 cm (24") on the rear.
- The equipment shall be installed near the socket outlet and shall be accessible.
- Be sure to fix and plug in the power cable securely after the installation so that no one trips over it.
- If the caster is installed, lock the casters after setting up the product.

2) General Precautions at Service

- Be sure to turn the power OFF and unplug the power cable during service (except for the service should be done with the power turned ON).
- Unplug the power cable and clean the area around the prongs of the plug and socket outlet once a year or more. A fire may occur when dust lies on this area.
- When the parts are disassembled, reassembly is the reverse of disassembly unless otherwise noted in this manual or other related documents. Be careful not to install small parts such as screws, washers, pins, E-rings, star washers in the wrong places.
- Basically, the equipment should not be operated with any parts removed or disassembled.

- The PC board must be stored in an anti-electrostatic bag and handled carefully using a wristband since the ICs on it may be damaged due to static electricity.

Caution : Before using the wristband, unplug the power cable of the equipment and make sure that there are no charged objects which are not insulated in the vicinity.

- Be sure not to touch high-temperature sections such as the fuser unit and areas around them.
- Be sure not to touch high-voltage sections such as the chargers, transfer belt, developer, high-voltage transformer and power supply unit. Especially, the board of these components should not be touched since the electric charge may remain in the capacitors, etc. on them even after the power is turned OFF.
- Make sure that the equipment will not operate before touching potentially dangerous places (e.g. rotating/operating sections such as gears, belts pulleys and fans).
- Be careful when removing the covers since there might be the parts with very sharp edges underneath.
- When servicing the equipment with the power turned ON, be sure not to touch live sections and rotating/operating sections.
- Use designated jigs and tools.
- Use recommended measuring instruments or equivalents.
- Return the equipment to the original state and check the operation when the service is finished.
- Be very careful to treat the touch panel gently and never hit it. Breaking the surface could cause malfunctions.

3) Important Service Parts for Safety

- The door switch, fuse, thermostat, thermistor, IC-RAMs including lithium batteries, etc. are particularly important for safety. Be sure to handle/install them properly. If these parts are short-circuited and their functions become ineffective, they may result in fatal accidents such as burnout. Do not allow a short-circuit or do not use the parts not recommended by OKI DATA Corporation.

4) Cautionary Labels

- During servicing, be sure to check the rating plate and cautionary labels such as “Unplug the power cable during service”, “CAUTION. HOT”, “CAUTION. HIGH VOLTAGE”, etc. to see if there is any dirt on their surface and if they are properly stuck to the equipment.

5) Disposal of the Equipment, Supplies, Packing Materials, Used Batteries and IC-RAMs

- Regarding the recovery and disposal of the equipment, supplies, packing materials, used batteries and IC-RAMs including lithium batteries, follow the relevant local regulations or rules.

Caution:

Dispose of used batteries and IC-RAMs including lithium batteries according to this manual.

Attention:

Se débarrasser de batteries et IC-RAMs usés y compris les batteries en lithium selon ce manuel.

Vorsicht:

Entsorgung der gebrauchten Batterien und IC-RAMs (inclusive der Lithium-Batterie) nach diesem Handbuch

CONTENTS

1. SPECIFICATIONS AND OUTLINE OF SYSTEM.....	1-1
1.1 FAX Options.....	1-1
1.2 Specifications.....	1-2
1.3 Features.....	1-5
1.4 Accessories and Parts	1-7
1.5 Options	1-8
1.6 System List	1-9
1.7 Overview.....	1-10
1.8 Layout of PC Boards.....	1-11
2. LED-RELATED FUNCTIONS	2-1
2.1 Recording Mode	2-1
2.2 Recording Paper Selection Algorithm and Printing Algorithm	2-2
2.2.1 Recording paper selection algorithm.....	2-2
2.2.2 Printing algorithm.....	2-2
2.2.3 Setting for the split recording.....	2-6
2.3 Recording Paper and Function	2-7
2.3.1 Table of the recording paper selection modes.....	2-7
2.3.2 Others.....	2-7
2.4 Energy saver functions.....	2-8
2.5 Memory Reception.....	2-10
3. DIALING/COMMUNICATION CONTROL.....	3-1
3.1 Circuit Connection and Procedure to Change Mode.....	3-1
3.1.1 Dial call-up transmission to a telephone circuit	3-1
3.1.2 Selection of the communication mode	3-2
3.1.3 Procedure to select the transmission mode	3-2
3.2 Signaling System Diagram and Signal Forms.....	3-3
3.2.1 Circuit control signals.....	3-3
3.2.2 Communication with the binary signals.....	3-4
3.2.3 V.8/V.34 communication sequence	3-13
3.3 FAX Automatic Switching.....	3-26
3.3.1 General functions.....	3-26
3.3.2 TEL mode	3-26
3.3.3 FAX mode.....	3-26
3.3.4 TEL/FAX mode	3-26
4. ELECTRICAL CIRCUITS	4-1
4.1 Configuration.....	4-1
4.2 Description of Circuits	4-2
4.2.1 Configuration	4-2
4.2.2 Line path switching control circuit.....	4-4
4.2.3 Dial pulse generation circuit	4-6
4.2.4 Line current detection circuit.....	4-8
4.2.5 CI detection circuit.....	4-10
4.2.6 Line monitor circuit.....	4-12
5. INSTALLATION.....	5-1
5.1 Explanation to the Users.....	5-1

1. SPECIFICATIONS AND OUTLINE OF SYSTEM

1.1 FAX Options

Equipments can be used as a FAX by installing the FAX unit.

Some options can be added when the FAX unit is installed or to extend the FAX functions.

 P. 1-8 "1.5 Options"

1.2 Specifications

1) Main +system

- Type
Desktop type transceiver
- Operation
Transmission Manual/Automatic
Reception Manual/Automatic

2) Scanner

<Scanning density> []: at rotation transmission

- Horizontal direction
16 lines/mm, 8 lines/mm
[15.4 lines/mm, 7.7 lines/mm, 3.85 lines/mm]
- Vertical direction
15.4 lines/mm, 7.7 lines/mm, 3.85 lines/mm
[16 lines/mm, 8 lines/mm]
- Combination
U-Fine: 16 x 15.4 lines/mm [15.4 x 16 lines/mm]
Semi-U-Fine: 8 x 15.4 lines/mm [15.4 x 8 lines/mm]

Note:

Operation from the panel is automatically converted at the receiving capability of “U-Fine” combination.

Fine: 8 x 7.7 lines/mm [7.7 x 8 lines/mm]

Normal: 8 x 3.85 lines/mm [3.85 x 8 lines/mm]

- Effective scanning area

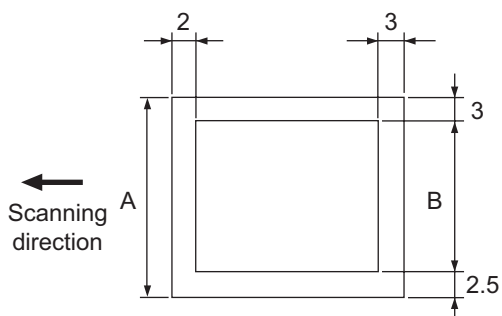

(Mechanical system error ± 2 mm included)

Fig.1-1

(mm)

Original size	A	B
A4	210	204.5
FOLIO	330	324.5
LT	216	210.5
LG	355.6	350.1

3) Transmission system

Circuits to be used: Subscriber line/FAX communication network (G3)

- Calling automatic transmission (including the sequential multi-address transmission)
- Calling automatic reception (polling reception)
- Called automatic transmission (polling transmission)
- Called automatic reception
- Calling manual transmission
- Calling manual reception
- Called manual transmission
- Called manual reception

Communication mode

High-speed mode (Original procedure mode)

G3 mode

ECM (Error Correction Mode)

Circuit carrier link equalization function

Embedded

Output level

-16 dBm to -8 dBm (The setting can be changed by "1 dB".)

Input level

-43 dBm to 0 dBm

(Level -55 dBm or lower cannot be detected)

Specifications of the communication mode

	High-speed mode (Original procedure mode)	G3 mode	ECM
Horizontal scanning density	8 dots/mm 300 dpi (Reception only) 16 dots/mm	Same as on the left	Same as on the left
Vertical scanning density	3.85 lines/mm 7.7 lines/mm 300 dpi (Reception only) 15.4 lines/mm	Same as on the left	Same as on the left
Encoding system	MH/MR/MMR/JBIG	MH/MR	MH/MR/MMR/JBIG
Minimum transmission time for 1 line	2.5 ms	Same as on the left	Same as on the left
Transmission speed (image signal) and modulation method	14.4 k/12 k/9600 7200/4800/2400 bps Conformance to V.17/V.29/V.27 ter	Same as on the left	33.6 k/31.2 k/28.8 k/ 26.4 k/24 k/21.6 k/ 19.2 k/16.8 k/14.4 k/ 12 k/9600/7200/ 4800/2400 bps
Control signal	300 bps V.21	Same as on the left	2400/1200/600/ 300 bps V.34/V.8/V.21
Procedure to control the transmission	Original procedure	T.30 conformance	Same as on the left

4) Recording paper

- Recording method
Electrophotographic recording method by LED
- Horizontal printing density
24 lines/mm (96 lines/mm with the smoothing processing)
[23.1 lines/mm (92.4 lines/mm with the smoothing processing)]
- Vertical printing density
23.1 lines/mm (24 lines/mm with the smoothing processing)
- Recording paper size and the effective printing area

Unit: mm (inch)

Paper size	Dimension (width x length)	Printing area
A5	148 x 210	143.8 x 205.8
B5	182 x 257	177.8 x 252.8
A4	210 x 297	205.8 x 292.8
FOLIO	210 x 330	205.8 x 325.8
ST	139.7 x 216 (5.5 x 8.5)	135.5 x 211.8
LT	216 x 279.4 (8.5 x 11)	211.8 x 275.2
Legal 13"	216 x 330 (8.5 x 13)	211.8 x 325.8
Legal 13.5"	216 x 343 (8.5 x 13.5)	211.8 x 338.8
Legal 14"	216 x 356 (8.5 x 14)	211.8 x 351.8

1.3 Features

- High-speed transmission
33.6 Kbps high speed modem
Original high-speed communication modes EX and HS
JBIG encoding system
- Dual Access
 - FAX transmission
There are two types of FAX transmission: Page-by-page direct transmission and memory transmission that all pages are stored in the memory before being transmitted.
 - FAX reception
Basically, all pages are input in the memory before being output. This reduces the time that the FAX communication occupies the machine, making Dual Access between the copying/faxing and printing operation possible.

Namely, the followings are possible:

- Memory input during the memory transmission
 - Memory input during the memory reception
 - Copying during the memory transmission
 - Reception during the copying
 - Reception during the memory output
 - Reception during the list output
- LED printing on plain paper
Printing is made on the standard size paper (A5, B5, A4, FOLIO, ST, LT, Legal 13", Legal 13.5", Legal 14") with the LED system.
 - Gradation
256 tones, error diffusion method
 - Memory communication function
Image data can be stored in the HDD. In the delayed transmission, image data read from an original are stored in the memory, then sent when the specified time comes.
Other memory functions: multi transmission, memory reception, ECM communication, etc.
 - Smoothing
The smoothing process is applied to the received images so that they are changed from 8 × 3.85, 8 × 7.7, 8 × 15.4 or 16 × 15.4 to 24 × 92.4 (equivalent to 600 × 2400dpi), then printed out.
 - Editing function
Duplex transmission and duplex printing are possible.
 - FAX data file storage capacity
1GB (for transmission and reception)
- Note:**
For hard drivers, GB means 1 billion bytes.
- Phone Book (400 addresses(1,000 addresses when the HDD is installed))
Up to 400 addresses can be registered in the Phone Book using the large LCD control panel.
 - Multi-address transmission function
Data are sent to multiple addresses (400 destinations) in sequence in a single operation.
There are three ways to choose/enter the address.

- Choose from the Phone Book (up to 400 destinations)
- Direct dialing (up to 400 destinations)
- Mix operation (Phone Book, Direct dialing, Group destinations: up to 400 destinations)
- Memory reception function
When the recording paper has run out or a paper jam has occurred, the memory receives and stores the data.
- Auto-dialing function
 - Delayed dialing
Documents are transmitted automatically to the preset number at the preset time.
 - Redialing
When the receiving side is busy during the automatic dialing, the machine keeps dialing at a fixed interval for a specified number of times.
- Receiving tone/completion tone
Sound notifies that the reception of a FAX document or printing of a received document has been completed.
- List output
The following data stored in the RAM can be printed out
 - Phone book information
 - Function list
 - Transmission journal
 - Reception journal
 - Memory transmission report
 - Power failure list etc.
- Power saver mode
During hours in which the reception amount is small, the weekly timer works to shut off the main power and the heater power to save power consumption.
- Tray selection
It is possible to choose a tray on to whose paper the received images are to be printed.

1.4 Accessories and Parts

The following accessories and parts come with the FAX unit:

Accessory	GD-1340
Modular cord (2 m)	1 pc.
Unpacking instruction	1 set

Parts	GD-1340
Fax unit	1 pc.
SG3 label	1 pc.
FCC Part 68 label (U.S.A.) / IC label (Canada): NA only	
Telepermit label (New Zealand): AU only	
Screw	4 pc.

* Apply the each label to the specified positions following the Unpacking/Setup Instruction

1.5 Options

Extends the FAX functions when the FAX unit is installed.

Option	Function	MC760/MC770/MC780
Finisher	Sorts out documents to be output for the FAX/copying operation	45372301 (MJ-1038)

1.6 System List

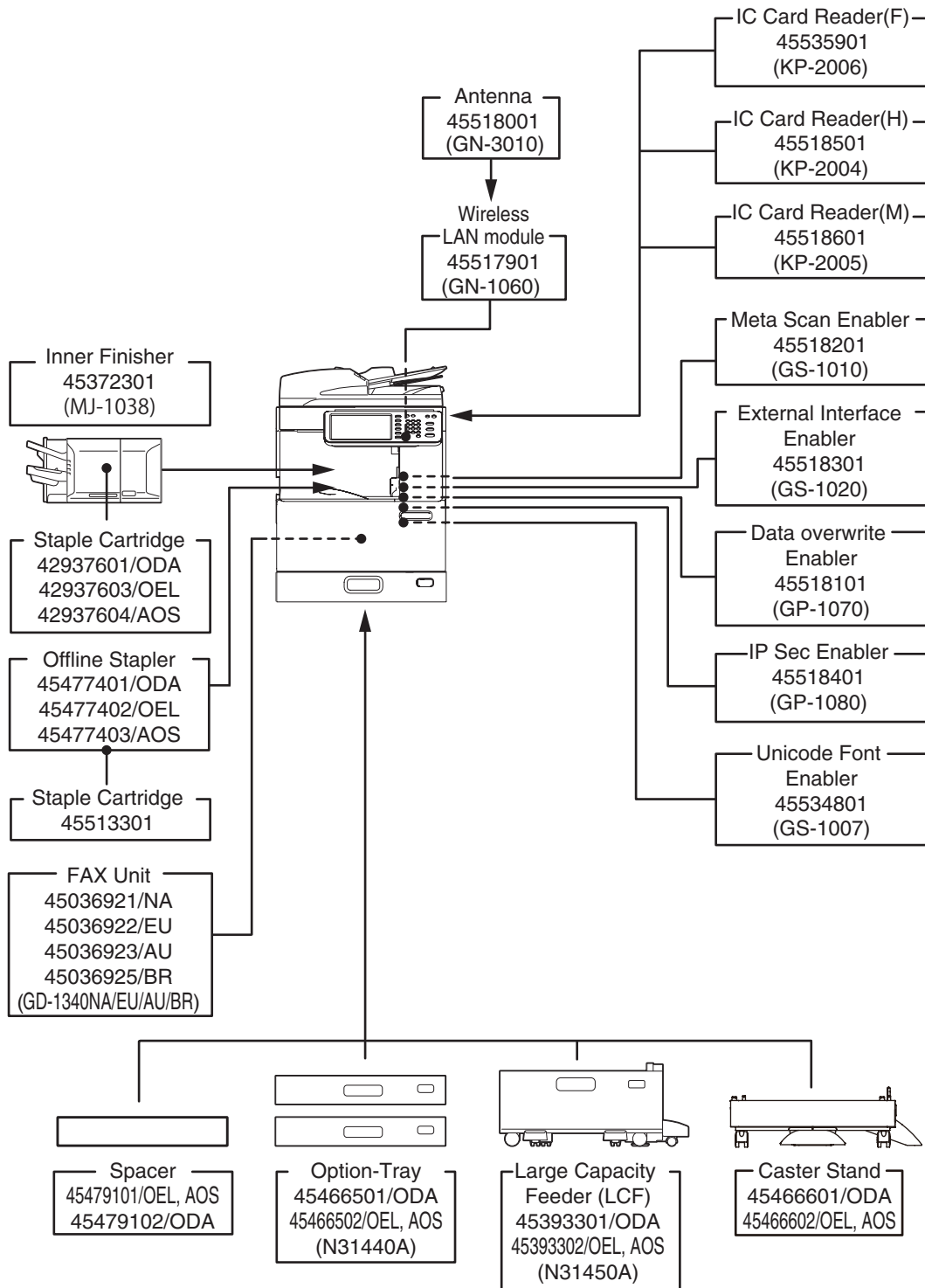

Note:

The antenna (GN-3010) is necessary to enable the wireless LAN module (GN-1060).

1.7 Overview

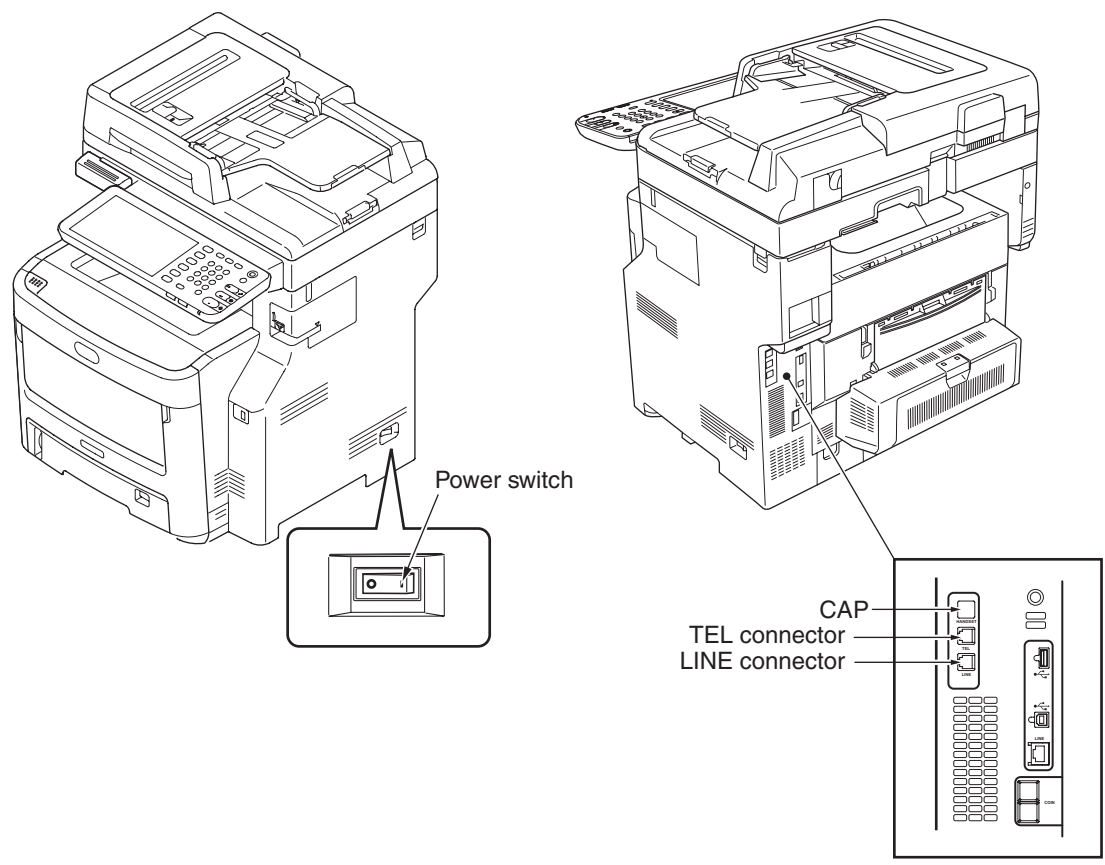

Fig. 1-3



Fig. 1-4

1.8 Layout of PC Boards

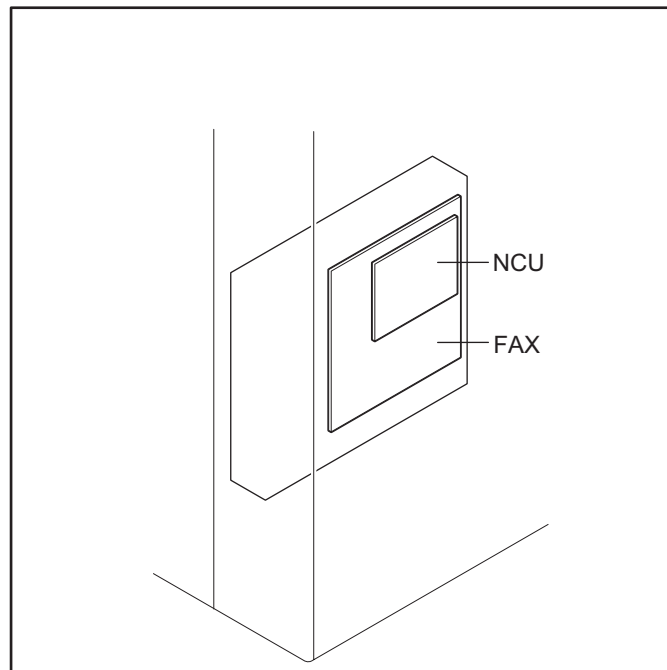

Fig. 1-5 Rear side of the equipment

Symbol	Name	Function
FAX	FAX board	Controls the FAX function
NCU	NCU board	Control the line of telephone

2. LED-RELATED FUNCTIONS

2.1 Recording Mode

This machine offers various printing modes such as the selection of the applicable recording paper and the recording method, etc. to meet users' needs. To take full advantage of these features, it is important to understand the concepts of the recording paper selection algorithm and printing algorithm as described in 2. 2.

2.2 Recording Paper Selection Algorithm and Printing Algorithm

Before printing the received image, the preset settings are evaluated in the order of the following 1) and 2), and the printing is performed based on the result.

1) Recording paper selection algorithm

- Basically, the received image is printed on a sheet of paper of the same size as the original.

However, if this size is not available, this algorithm determines on which size of recording paper the output should be made. (Actual Size Mode/Free Mode)

2) Printing algorithm

- Determines how the received image is to be printed. (Discard printing/Vertical reduction printing/ Regular size reduction printing/Split printing)

2.2.1 Recording paper selection algorithm

It is possible to distinguish the size of each received image (A5, B5, A4, FOLIO, ST, LT, Legal 13", Legal 13.5", Legal 14"). Basically, recording paper of the same size as the original is used for printing. If recording paper of the size is not available, this algorithm selects paper of another size according to the setting in the Setting Mode.

1) Actual Size Mode (13-517: 0)

- Printing is performed when regular size reduction is not applied to the received image.

2) Free Mode (13-517: 1)

- Printing is performed on any available recording paper.

2.2.2 Printing algorithm

Recording paper has its effective printing area. Even if the size of the original paper and the recording paper are the same, the length of the original is normally longer.

This means that the received image would be divided onto two sheets. To prevent this, the printing algorithm works as described in the following pages.

Discard / Vertical reduction / Regular size reduction / Split printing flow chart

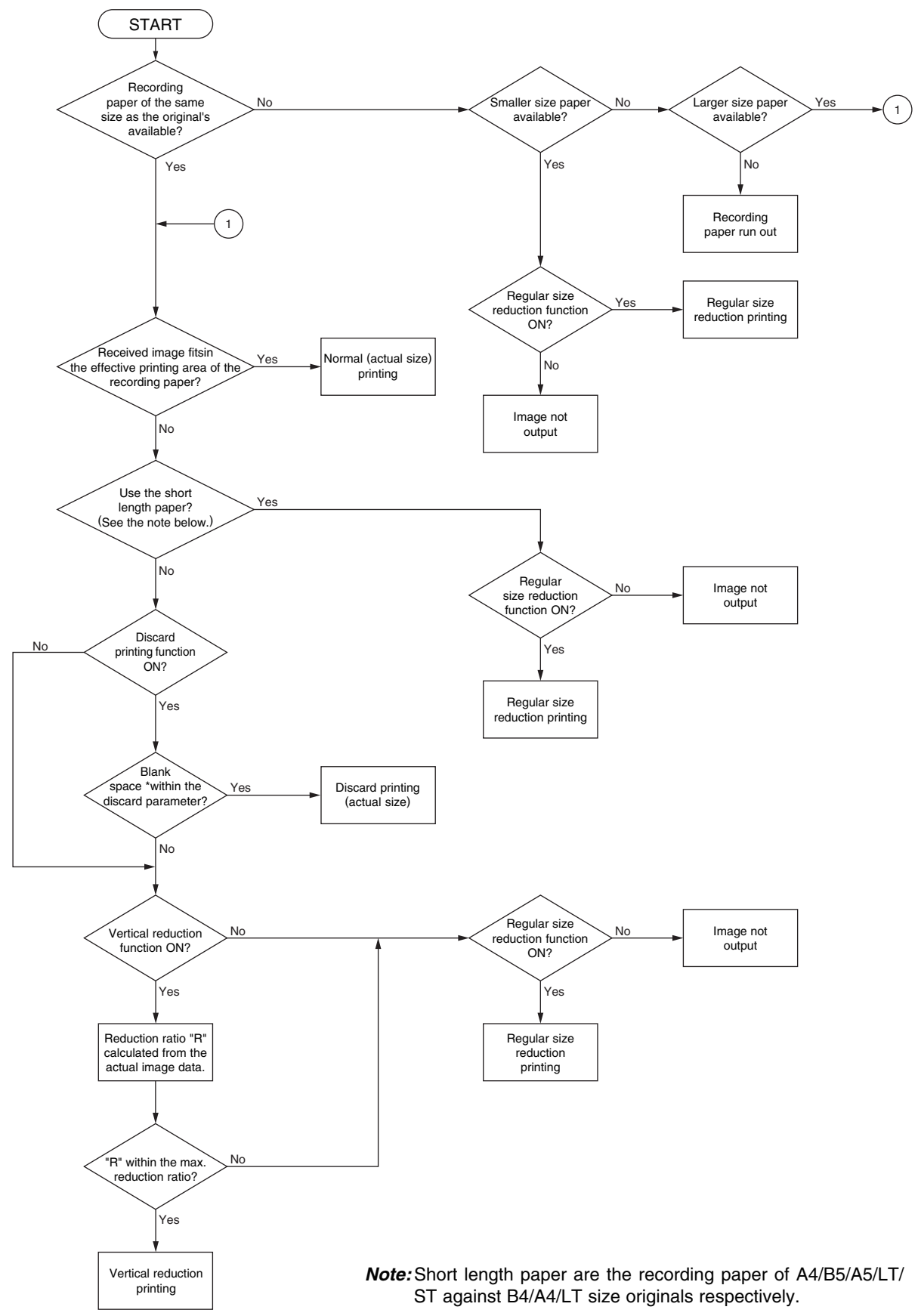

Note: Short length paper are the recording paper of A4/B5/A5/LT/ST against B4/A4/LT size originals respectively.

1) Discard printing

- Since the trailing edge area of the original is normally blank, this blank area is cut off to allow the image fit in one sheet in this mode. Image reduction is not performed.
 - Maximum discarding amount:
 - 0 mm: Discard not performed
 - 10 mm: Corresponding to the inside the TTI
 - 18 mm: Corresponding to the outside the TTI 1
 - 22 mm: Corresponding to the outside the TTI 2
 - 34 mm: A4 → LT conversion
- (TTI: Transmission Terminal Identifier)

When the discard function is ON (13-378:1):

Actual size recording is performed with no vertical reduction nor division. The original image is recorded as it is. Namely, the data exceeding the effective printing area are discarded.

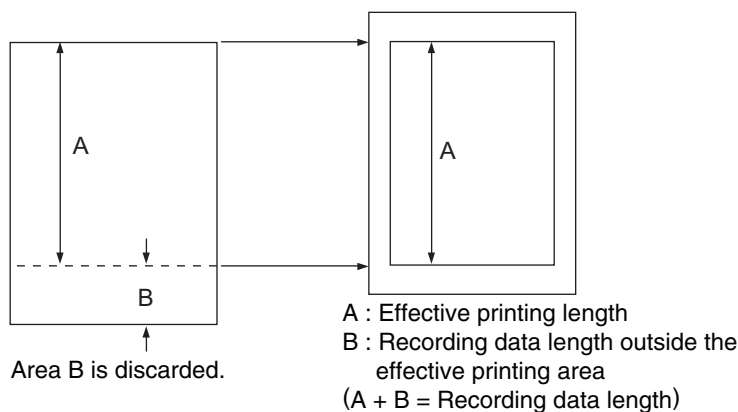

Discard parameter (13-375: 0 to 4)

The following parameters are available:

Discard function	Length of B (Discard parameter)	Set value
OFF	0 mm	0
ON	10 mm	1
	18 mm	2
	22 mm	3
	34 mm	4

Reference : These parameters should be set by the service technician (in the FAX Function Mode).

2) Vertical reduction printing (13-377: 0)

- The recording data length is reduced so that the image fits in the recording paper. The data can be reduced up to 90/75%, and the machine automatically selects the appropriate ratio.

3) Regular size reduction printing (13-517: 1)

- When the discard and vertical reduction printing cannot be applied to the received image, and any of the combinations B4 → A4, B4 → B5, B4 → A5, A4 → B5, A4 → A5, COMP → LT, COMP → ST, LT → ST, FOLIO → B5, FOLIO → A5 is satisfied, the regular size reduction printing is performed.

In case that the recording data length is within the effective printing length A, but the recording paper of the same size as the original's or larger size is not available;

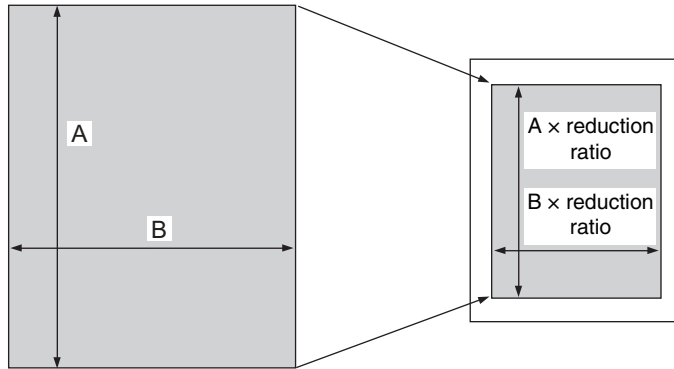

B4 → A4, B4 → B5, B4 → A5, A4 → B5,
 A4 → A5, COMP → LT, COMP → ST,
 LT → ST, FOLIO → B5, FOLIO → A5

Fig. 2-2

In case that the recording data length exceeds the effective printing length A, the vertical reduction printing is not applicable and larger size recording paper is not available;

(In the following example, A4/LT original was sent but the recording length exceeds A4 size and the data do not fit in A4/LT even if the vertical reduction is performed. The reduction B4 → A4 is applied in this case.)

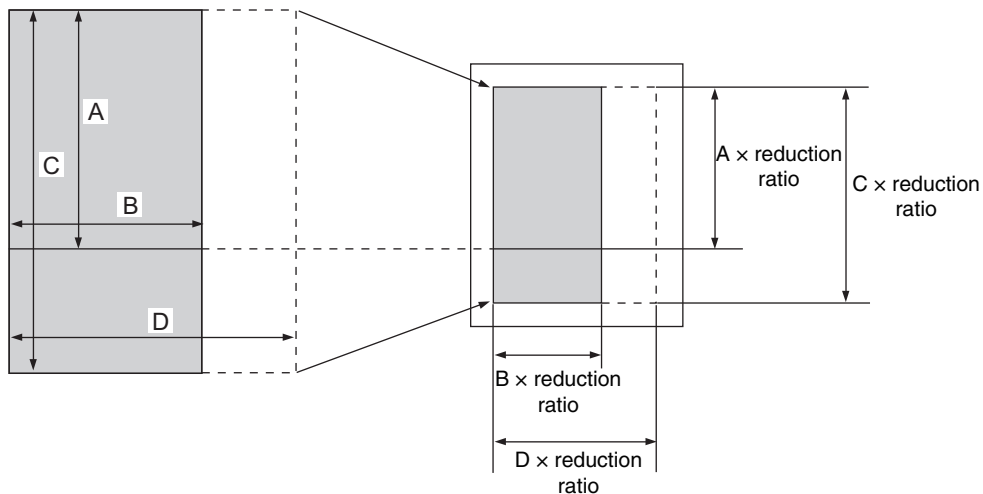

Fig. 2-3

4) Split printing

When the recording data do not fit in a recording paper even if vertical reduction is performed for the recording data length (the recording data length is exceeding the effective printing length of the largest recording paper in the tray installed in the machine), the recording data are divided onto two sheets while vertical reduction is performed.

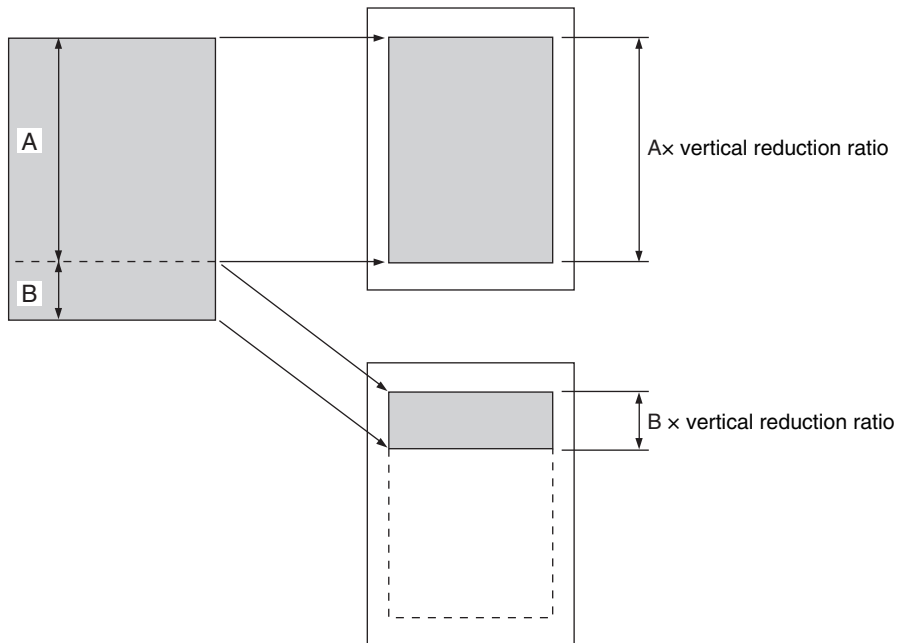

Fig. 2-4

2.2.3 Setting for the split recording

1) Split recording onto A4/B5/A5/LT/ST

Set as to whether split recording onto the short length paper (A4/B5/A5/LT/ST) is to be performed or not.

When this function is disabled, split recording for B4/A4/LT data onto A4/B5/A5/LT/ST recording paper is not performed.

2.3 Recording Paper and Function

The size of the recording paper on which the received image data are printed is determined according to the presence/absence of the recording paper and the above-mentioned function settings. Relation between the recording paper size and the function settings is described in this section.

2.3.1 Table of the recording paper selection modes

<Selection of recording paper: in case the recording data length do not exceed the effective recording length of the recording paper>

		Recording data size						
		A4	B5	A5	LT	LG	ST	FOLIO
Priority	1	A4	B5	A5	LT	LG	ST	FOLIO
						*3		
	2	FOLIO	A4 *1	A4	LG *2, *3	LT *1	LT	A4 *1
	3	B5 *1	FOLIO *1	FOLIO	COMP *2		LG *3	B5 *1
4	A5 *1	A5 *1	B5 *2	ST *1				

*1: Can be used when the regular size reduction function is ON (when it is OFF, the data are stored in the memory.)

*2: When the data are output in the primary scanning direction, it is printed in the center of the recording paper.

*3: The recording paper is selected in the following order: Legal 14", Legal 13.5", Legal 13".

2.3.2 Others

- 1) For the users with the TTI outside setting, it is recommended to set the discard parameter to 18 mm.

2.4 Energy saver functions

The equipment has the following energy saver functions.

- Weekly timer

By using this function, the users automatically have the equipment go to the Sleep mode during a specified period of time such as night time.

The users can set the "ON" timer for the starting time and "OFF" timer for the closing time for the desired day of the week so that the equipment turns itself ON and OFF.

If the users do not want to put the equipment into the Sleep mode for an entire day, make settings for the desired day of the week as follows:

[ON]: 0:00/[OFF]:24:00

The equipment does not go into the Sleep mode for an entire day, which is activated by the weekly function.

However, the equipment automatically goes into the Sleep mode according to the time value set for [Auto Sleep mode], if it is left inactive for a certain period of time.

- Auto Power Save mode

By using this function, the users automatically have the equipment go to the Power Save mode when it is left inactive for a certain period of time.

In the Power Save mode, the fuser unit can be shut off and then the LCD display goes to blue.

When a FAX is received via the FAX unit or a job is received via USB or Network in the Power Save mode, the equipment turns ON automatically.

By pressing the [START] button, it also turns ON. The [Power Save] button and each function button are also valid.

The users can set the desired period of time that it waits for the Power Save mode.

Item	How to enter the mode	Timer setting	How to cancel the mode
Power Save mode	Automatically	Can be set in th ADMIN SETTING menu ([Admin] -> [General] -> [Power Save])	Returns to the default screen in the following cases: - By receiving FAX document - By receiving a job via USB or Network - By pressing the [START] button or the [Power Save] button Returns to the each function screen by pressing each function button.

• Auto Sleep mode

By using this function, the users automatically have the equipment go to the Sleep mode when it is left inactive for a certain period of time.

Pressing the [Power Save] button also has the equipment go to Sleep mode.

In the Sleep mode, the fuser unit, main power and power supply for the control panel can be shut off and the LCD display turns OFF.

However the equipment remains a small amount of power supply to check the signals to turn on itself automatically.

When a FAX is received via the FAX unit or a job is received via USB or Network in the Sleep mode, the equipment turns ON automatically.

By pressing the [ON/OFF] button, it also turns ON.

The users can set the desired period of time that the equipment waits for the Sleep mode.

When the equipment goes to the Sleep mode, the Power Save LED usually turns OFF.

However it may not enter the Sleep mode completely in the following cases and the Power Save LED stays ON:

- A particular option is installed. (Wireless LAN module)
- The IPsec function is enabled.
- IEEE 802.1X authentication is enabled.
- IPv6 is enabled and the IPv6 address is set other than manually
- POP3 client setting is enabled.
- A particular network protocol is enabled. (AppleTalk, IPX/SPX)

Item	How to entre the mode	Timer setting	How to cancel the mode
Auto Sleep mode	Automatically or by pressing the [Power Save] button	Can be set in th ADMIN SETTING menu ([Admin] -> [General] -> [Power Save])	Returns to the default screen in the following cases: - By receiving FAX document - By receiveing a job via USB or Network - By pressing the [ON/OFF] button when the Power Save LED is OFF - By pressing the [Power Save] button or the [START] button when the Power Save LED is ON.

By changing the SLEEP MODE setting, the users can control the behavior of the equipment when it is left inactive for a certain period of time.

SLEEP MODE	Description
POWER OFF	When a certain period of time is left, the equipment turns off the main power completely. It will not turn on automatically even when it receives a FAX or a job via USB or Network. Pressing the [ON/OFF] button is required to turn it on. Weekly timer does not work when it is in POWER OFF.
AUTO	The equipment goes to the SLEEP mode or POWER OFF when a certain period of time is left. This depends on the conditions. When the equipment is connected via Network or the FAX board is installed, it goes to Sleep mode. Otherwise it goes to POWER OFF.
SLEEP	The equipment goes to the SLEEP mode when a certain period of time is left.

2.5 Memory Reception

Basically, the receiving FAX data are once stored in the HDD, then the data are printed out after the reception process is finished.

The memory reception is performed until the 1GB HDD (for transmission and reception) becomes full.

3. DIALING/COMMUNICATION CONTROL

3.1 Circuit Connection and Procedure to Change Mode

3.1.1 Dial call-up transmission to a telephone circuit

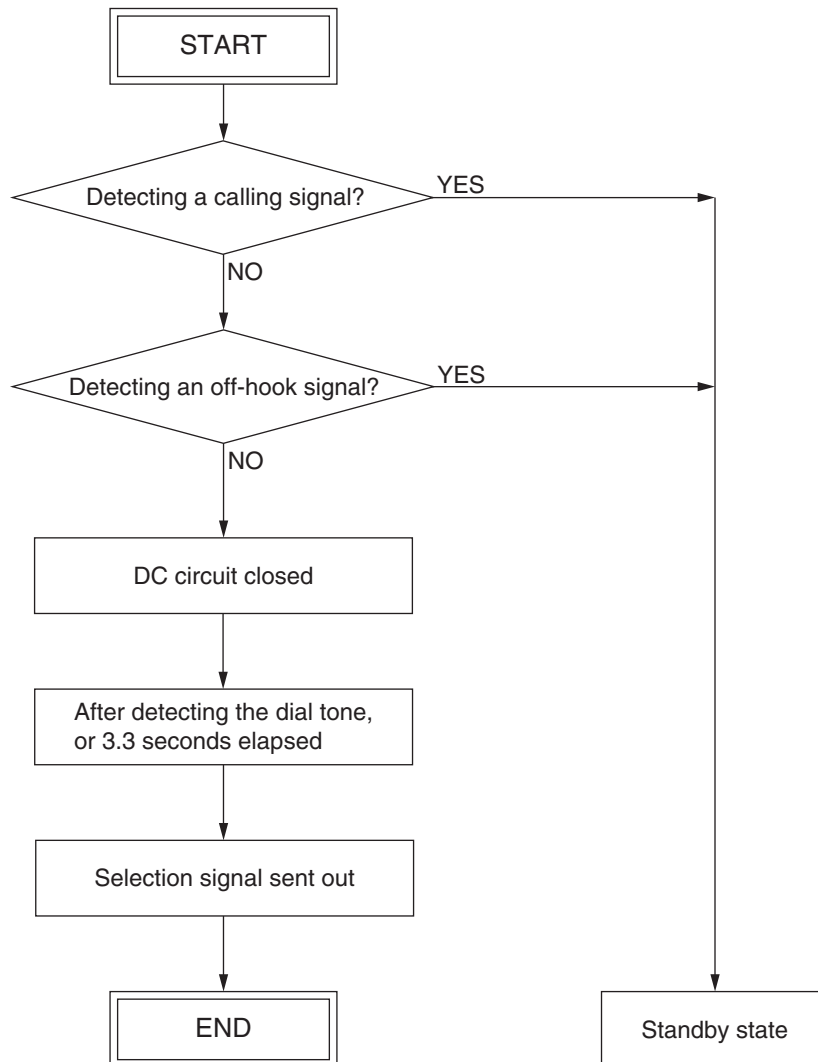

3.1.2 Selection of the communication mode

This machine has three types of communication mode. The mode to be used is determined according to the combination of the types of the circuits and communication and available function of the other side's machine.

	Communication mode		
	Original procedure	ECM	G3
Telephone circuit	○	○	○

3.1.3 Procedure to select the transmission mode

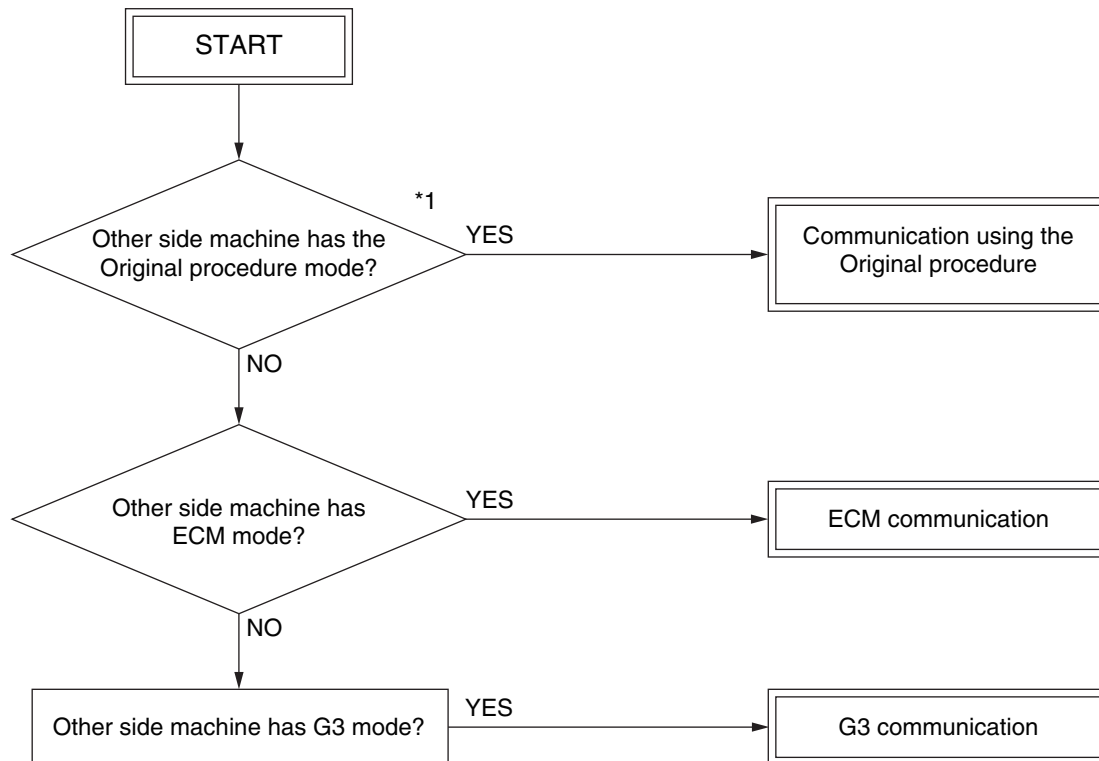

*1: This step is only checked when the other side machine has CRP2 (+ CRP1) or when the transmission is started by the CRP calling. (The first transmission to the other side with CRP1 only is performed in the ECM mode.)

3.2 Signaling System Diagram and Signal Forms

3.2.1 Circuit control signals

The following circuit control signals are used in the binary and tonal procedures.

- Circuit control signals

CED	Called station identification Indicates that the sender is a FAX machine in the automatic called mode. (*1)
CNG	Calling tone Indicates that the sender is a FAX machine in the automatic calling mode. (*1)

*1: This signal can be sent manually.

- Signal form

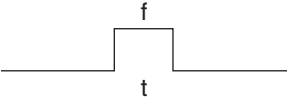
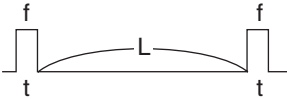
Signal name	Signal form	Signal form
CED		f: 2100 ±15 Hz t: 2.6 - 4.0 sec
CNG		f: 1100 ±38 Hz t: 0.5 sec ±15% (L: 3 sec)

3.2.2 Communication with the binary signals

In the original procedure/G3 modes, communication is performed with the binary procedure as follows.

(1) Binary procedure

- Transmission and reception in the original procedure/G3 modes

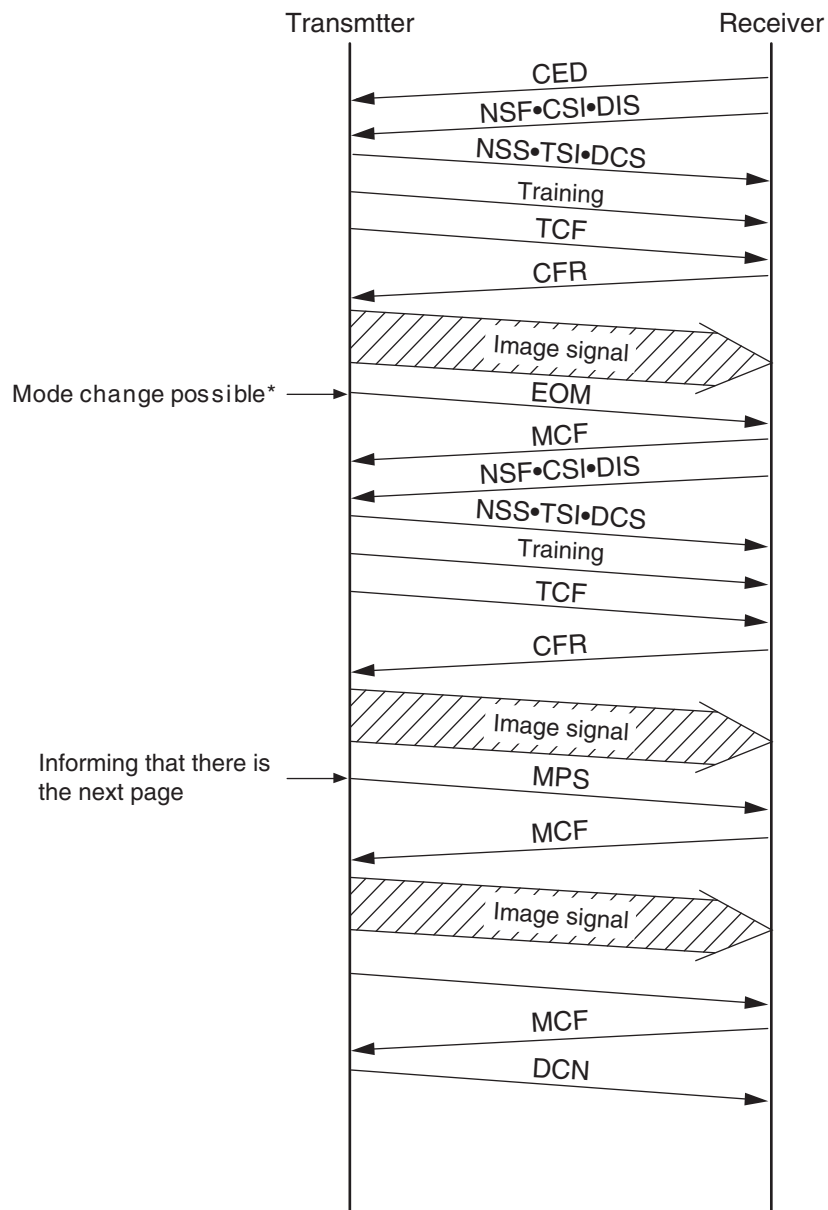

Fig. 3-1

* Mode change is possible only for the original set manually.

- Transmission and reception in the ECM mode

ECM (Error Correction Mode) conforms to T.30.

When an error has occurred to the received image data, the receiving station informs the sending station of the occurrence of the error, and the sending station sends the image data again.

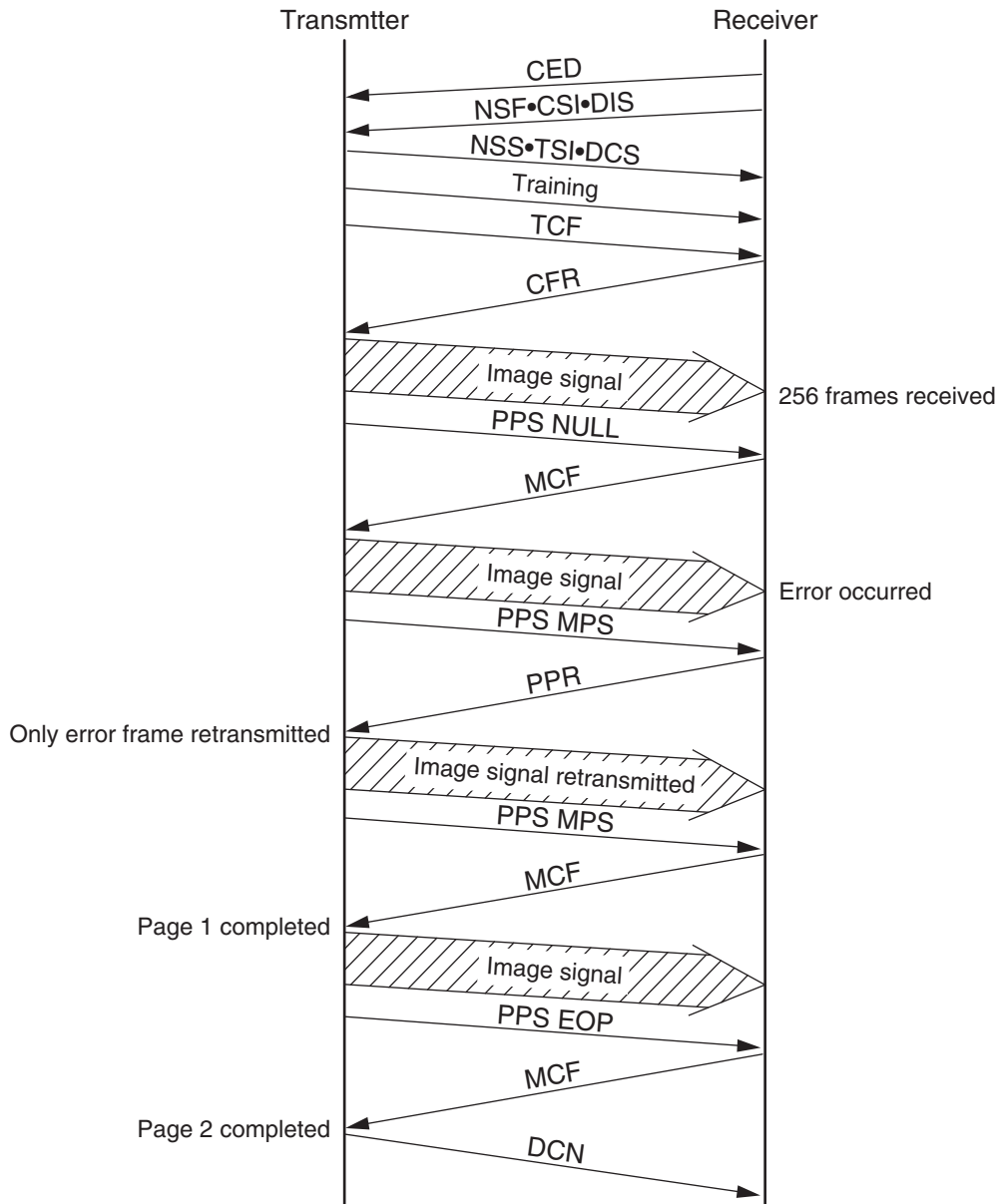

Fig. 3-2

- Cancellation during the transmission

If the [STOP] button is pressed during the direct transmission or memory input, the display to confirm the cancellation appears. The communication is finished normally regardless of the presence/absence of the next page or mode changes by pressing the [STOP] button.

If the [STOP] button is pressed anytime except during the transmission of the image data, DCN is forcibly sent to terminate the communication.

Press the [JOB STATUS] button, and select the transmission job to cancel, then press the [CANCEL] button on the LCD display to cancel the memory transmission or polling transmission.

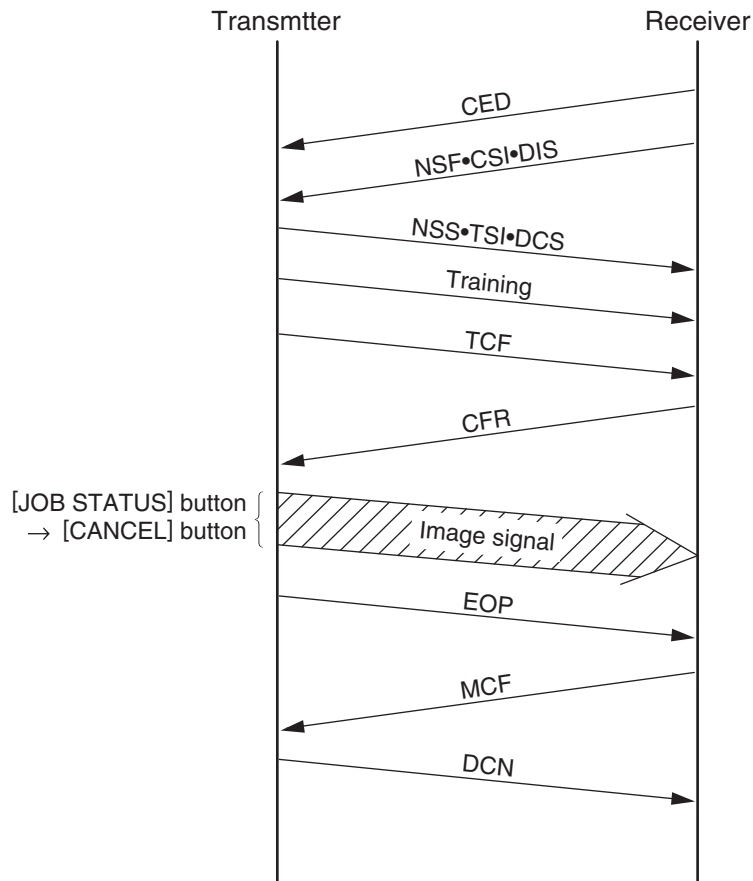

Fig. 3-3

(2) Binary signals

NSF	Non-Standard Facility Informs that the receiving station (machine) has a non-standard facility.
NSC	Non-Standard Facility Command Command to transmit using the non-standard facility which is selected corresponding to NSF (i.e., Polling etc.).
NSS	Non-Standard Facility Setup Command to transmit using the non-standard facility which is selected corresponding to NSF or NSC.
CSI	Called Subscriber Identification Provides the telephone number of the called station. Used to check the identity of the called station.
CIG	Calling Subscriber Identification Provides the telephone number of the calling station. Used to check the identity of the calling station (Polling, etc.).
TSI	Transmitting Station Identification Provides the telephone number of transmitting station. Used to check the identity of the transmitting station.
DIS	Digital Identification Signal Informs that the receiving station (machine) has a standard facility (G3/G2).
DTC	Digital Transmit Command Command to transmit using the standard facility which is selected corresponding to DIS (i.e., Polling, etc.).
DCS	Digital Command Signal Commands to transmit using the standard facility which is selected corresponding to DIS or DTC.
SUB	Sub-address Indicates that the FIF information is a sub-address in the domain on the call-in side.
SEP	Select Polling Indicates that the FIF information is a sub-address for the polling mode.
PWD	Password Indicates that the FIF information is a password for the polling mode in a reception. Indicates that the FIF information is a password for transmission in a transmission.
CFR	Confirmation of Reception Informs that the FAX is ready to receive data.
FTT	Failure to Train Informs that the TCF signal has not received correctly and requests the re-training.
EOM	End of Message Informs that the the 1st page has been transmitted and there is the next page; command to return to the beginning of the phase B.
MPS	Multi-page Signal Informs that the 1st page has been transmitted and there is the next page; command to return to the beginning of the phase C.
EOP	End of Procedure Informs that a document has been transmitted and there is no more pages.
MCF	Message Confirmation A reply to MPS, EOM or EOP; informing that image signals have been received correctly and the FAX is ready to receive data.
RTN	Retrain Negative Informs that a document has not been received correctly; requests for the retraining or phase synchronization to receive the next page.

PIP	Procedure Interrupt Positive Informs that the image signals have been received correctly and requests the operator's reply by telephone or to return to the beginning of the phase B to continue the communication (i.e., CALL Request, etc.).
PIN	Procedure Interrupt Negative Informs that the image signals have not been received correctly and requests for operator's reply by telephone or to return to the beginning of the phase B to continue the communication.
PRI-EOM	Procedure Interrupt EOM Command similar to EOM. Operation by operator is necessary.
PRI-MPS	Procedure Interrupt MPS Command similar to MPS. Operation by operator is necessary.
PRI-EOP	Procedure Interrupt EOP Command similar to EOP. Operation by operator is necessary.
DCN	Disconnect Command to disconnect the FAX line and to connect the telephone line. Reply from the other side is not necessary.
RR	Receive Ready Informs that the FAX is ready to receive documents and requests for data to set the reception mode. (ECM mode)
RNR	Receive Not Ready Informs that the FAX is not in the receivable state. (ECM mode)
PPR	Partial Page Request Informs that a part of page (ECM block) has not been received correctly. The number of the frame needs to be corrected is informed by the FIF. (EC mode)
PPS	Partial Page Signal Informs that a part of page (ECM block) or one page has been transmitted. (EC mode)
CTC	Continue to Correct Replies to the 4th PPR which requests to correct the image signal; informs that the transmitting station will continue to correct the frame data. (ECM mode)
CTR	Response for Continue to Correct Replies to CTC and informs that the receiving station has received and accepted the CTC. (EC mode)
EOR	End of Retransmission Informs that the transmitting station has completed the correction of the error frame data (binary signal) of the previous ECM block. (ECM mode)
ERR	Response for End Retransmission Replies to EOR and requests to transmit the image signal of the next ECM block. (ECM mode)
RTP	Retrain Positive Informs that the message has been received completely and that the subsequent message can be continued after receiving the synchronization signal and CFR signal.
CRP	Command Repeat Requests to resend all the commands including optional frames because the preceding command has been received incorrectly.

(3) Frame structure of binary signals

Each binary signal frame is comprised of the following sequence and fields. However, some binary signals do not have the FIF field inserted.

F	F	A	C	FCF	FIF	FCS	F
---	---	---	---	-----	-----	-----	---

Preamble

- F : Flag sequence
Indicates the start or end of a frame. Also establishes the frame synchronization.
- A : Address field
Informs the address.
- C : Control field
Informs if this frame is the last one in this procedure.
- FCF : FAX control field
Informs the type of the binary signal.
- FIF : FAX information field
Informs FAX information such as the functions.
- FCS : Frame check sequence
Checks if there was any error in the transmission from A to FIF.

- Format of F, A and C

	Format							
	b ₁	b ₂	b ₃	b ₄	b ₅	b ₆	b ₇	b ₈
F	0	1	1	1	1	1	1	0
A	1	1	1	1	1	1	1	1
C	1	1	0	0	X	0	0	0

* When this frame is the last frame, X = 1.

- FCF format of each binary signal

Binary signal	Format							
	b1	b2	b3	b4	b5	b6	b7	b8
NSF	0	0	0	0	0	1	0	0
NSC	1	0	0	0	0	1	0	0
NSS	×	1	0	0	0	1	0	0
CSI	0	0	0	0	0	0	1	0
CIG	1	0	0	0	0	0	1	0
TSI	×	1	0	0	0	0	1	0
DIS	0	0	0	0	0	0	0	1
DTC	1	0	0	0	0	0	0	1
DCS	×	1	0	0	0	0	0	1
SUB	×	1	0	0	0	0	1	1
SEP	1	0	0	0	0	1	0	1
PWD(Rx)	1	0	0	0	0	0	1	1
PWD(Tx)	×	1	0	0	0	1	0	1
CFR	×	0	1	0	0	0	0	1
FTT	×	0	1	0	0	0	1	0
EOM	×	1	1	1	0	0	0	1
MPS	×	1	1	1	0	0	1	0
EOP	×	1	1	1	0	1	0	0
MCF	×	0	1	1	0	0	0	1
RTN	×	0	1	1	0	0	1	0
PIP	×	0	1	1	0	1	0	1
PIN	×	0	1	1	0	1	0	0
PRI-EOM	×	1	1	1	1	0	0	1
PRI-MPS	×	1	1	1	1	0	1	0
PRI-EOP	×	1	1	1	1	1	0	0
DCN	×	1	0	1	1	1	1	1
RR	×	1	1	1	0	1	1	0
RNR	×	0	1	1	0	1	1	1
PPR	×	0	1	1	1	1	0	1
PPS	×	1	1	1	1	1	0	1
CTC	×	1	0	0	1	0	0	0
CTR	×	0	1	0	0	0	1	1
EOR	×	1	1	1	0	0	1	1
ERR	×	0	1	1	1	0	0	0
RTP	×	0	1	1	0	0	1	1
CRP	×	1	0	1	1	1	0	0

- × = 1 for the station which received DIS.
- × = 0 for the station which received a response signal to DIS.

(4) Training

The training is performed in the binary procedure to surely transmit the image signals.

- Training signal

The training signal is transmitted following the DCS signal at the modem speed specified by the DCS signal. Responding to this training signal, the receiving side adjusts the auto-equalizer.

- Format of the training signal

- 14.4 Kbps, 12 Kbps

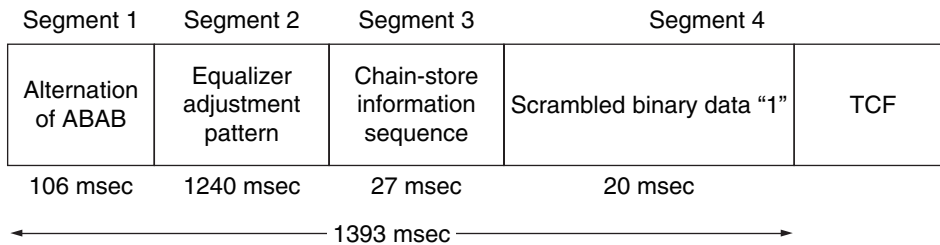

Fig. 3-4

- 9600 bps, 7200 bps

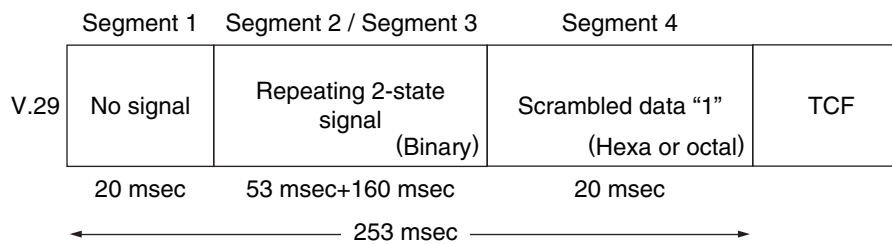

Fig. 3-5

- 4800 bps, 2400 bps

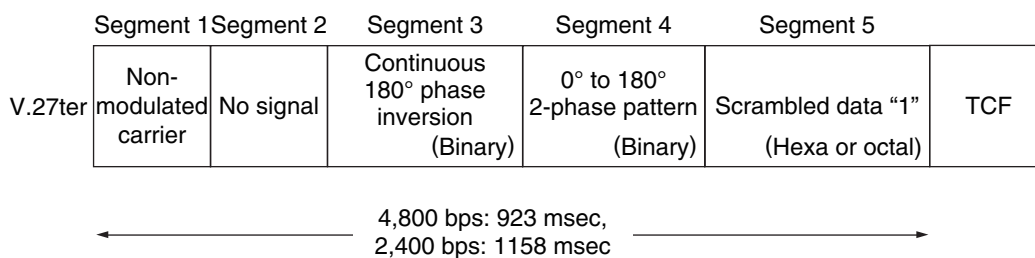

Fig. 3-6

- TCF signal

An error may occur in the image data if the training is not performed correctly. The transmitting side sends a TCF signal and checks if any error occurs in image data before the image data communication to follow. When the receiving side detects an error in the TCF signal, it transmits an FTT signal to the transmitting side to request the retraining. When there is no error, the receiving side transmits a CFR signal.

The TCF signal transmits all zeros for 1.5 seconds at the same modem speed as that for the training signal.

3.2.3 V.8/V.34 communication sequence

1) Outline

- V.8 is performed as a startup procedure to switch to V.34. V.8 can connect an existing facsimile machine to the equipment using a data modem or other V-series modems. The V.34 modem has a modem circuit previously recommended, allowing it to be also connected to the existing modems while they are upper compatible.
- New technologies such as the pre-emphasis technology *1 and the probing technology *2 are fully used. The pre-emphasis technology *1 not only speeds up the modulation, but also gains the S/N ratio. The probing technology examines the line characteristics and optimizes the modem for the line condition. Therefore, not only do these technologies speed up the transmission momentarily, but also the average speed of the process during the data transmission is increased.
- For V.8 and the pre/post-FAX transmission for V.34, the procedure is speeded up by the full duplex communication.
- Following 14 types of the image transmission speed are available: *3
33.6 kbps/31.2 kbps/28.8 kbps/26.4 kbps/24.0 kbps/21.6 kbps/19.2 kbps/16.8 kbps/14.4 kbps/12.0 kbps/9.6 kbps/7.2 kbps/4.8 kbps/2.4 kbps
- The modulating speed (baud rate) *4 can be selected from 2,400, 3,000, 3,200 symbol/sec (mandatory), or 2,743, 2,800, 3,429 symbol/sec (option). The data rate can be set more accurately than the conventional modem.

*1: A signal is sent while raising the output level in the high-frequency band in which the noise is relatively loud.

*2: Tone signal called "Probing Tone" is sent for the receiver to examine the line characteristics of the line.

*3: In the ITU-T Recommendation, it is described as "data rate". "Image transmission speed" is the same as "data rate".

*4: In the ITU-T Recommendation, it is described as "symbol speed". The "Symbol rate", "Modulating speed", and "Baud rate" are the same thing. This machine cannot realize the speed of 2,743 symbol/sec.

Notes:

1. ECM is used in the V.34 procedure. If the setting for the ECM transmission/reception of the user data is set to "Not performed", the V.8 procedure is not performed and the procedure is not switched to V.34. V.17 or lower is selected in this case.
2. When the transmission/reception speed is set to 14.4 kbps or slower, the V.8 procedure is not performed, and V.17 or lower is selected.
3. See "Late start (P3-20)" to move to the V. 8/V.34 procedure after starting with the V.21 procedure.
4. After the V.34 procedure is started, the fallback for the V.34 procedure is performed. However, the fallback for the V.17 mode or lower mode is not performed.

2) Standard procedure

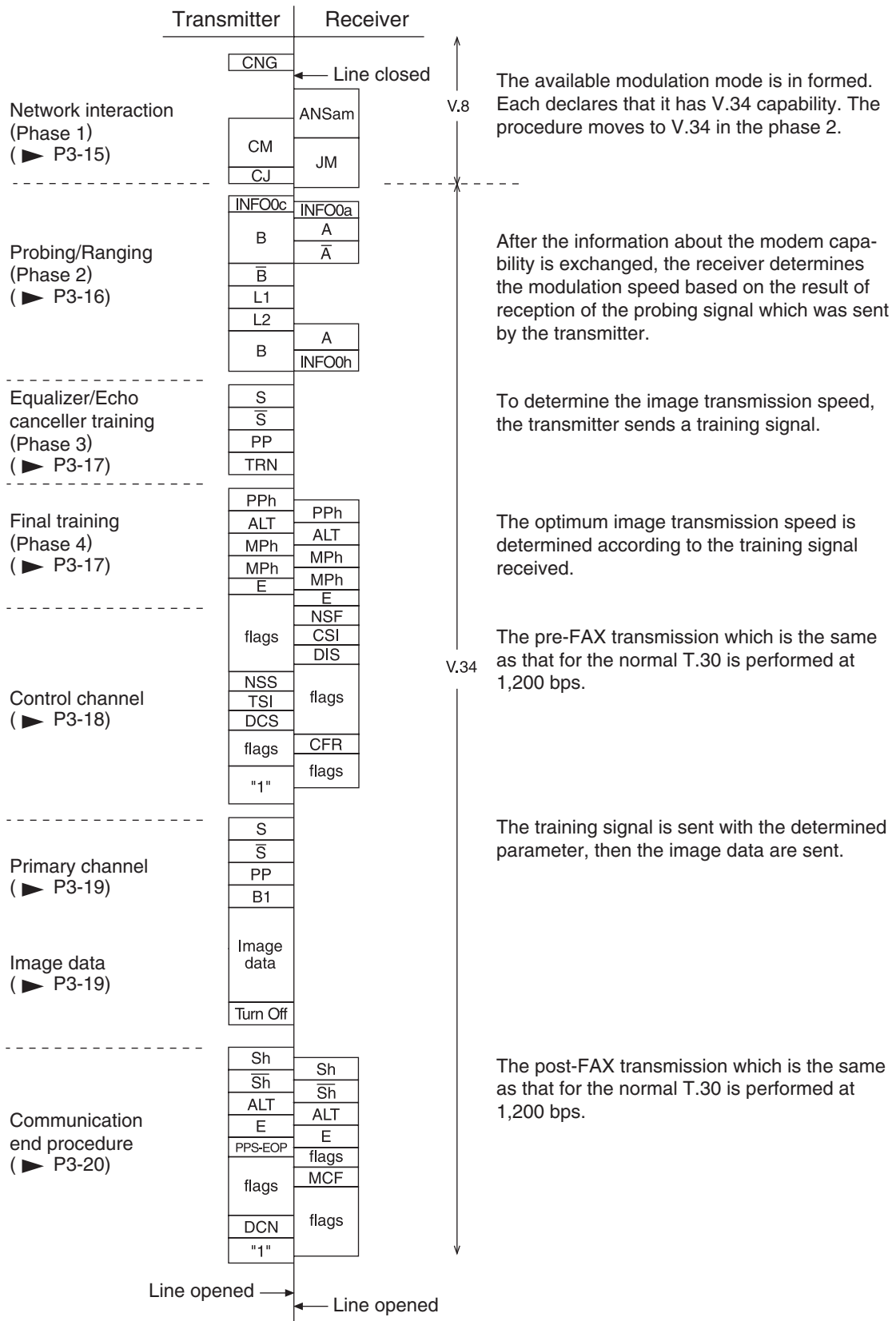

Fig. 3-7

- Network interaction (Phase 1)

The V.8 procedure is performed as the startup procedure for the V.34 high-speed modem. In the V.8 procedure, mainly the optimum modulation method (V series modem mode) that can be operated between the transmitter and receiver is determined.

Transmitter

Signal name	Abbreviation	Function	Remarks
Calling tone	CNG	1100 Hz tone signal specified by T.30 indicating the sender is a FAX machine in the automatic calling mode.	-
Call Menu signal	CM	Mainly indicates an available modulation method such as V.21, V.27ter, V.29, V.17, V.34, etc.	Modulated by V.21 (L) *1. Transmission rate: 300 bps
CM terminator	CJ	Indicates the detection of the JM signal or the termination of CM signal.	Modulated by V.21 (L) *1. Transmission rate: 300 bps
Call Indicator signal	CI	Indicates the general communication functions. It is sent when the V.8 procedure is restarted.	For the late start only. (P3-20) Modulated by V.21 (L) *1. Transmission rate: 300 bps

Receiver

Signal name	Abbreviation	Function	Remarks
Answer amplitude tone	ANSam	2100 Hz tone signal amplitude-modulated to 15 Hz.	Tone equivalent to CED of the conventional machine.
Joint Menu signal	JM	Indicates the terminal type such as a FAX machine. Response to a CM sent from the transmitter and informs available modulation method.	Modulated by V.21 (H) *1. Transmission rate: 300 bps

*1 V.21 (L)Low frequency channel defined by the V.21 recommendation 1,080±100 Hz (980 Hz: 1, 1,180 Hz: 0)

V.21 (H)High frequency channel defined by the V.21 recommendation 1,750±100 Hz (1,650 Hz: 1, 1,850 Hz: 0)

- Probing/Ranging (Phase 2)

Examines the line characteristics and sets the parameters for the modulation related items such as the modulating speed.

Transmitter

Signal name	Abbreviation	Function	Remarks
INFO sequence	INFO0c	Informs the modem capability such as modulating speed and frequency transmission capability (two frequency bands (high and low) used to examine the line characteristics), and requests for adjusting.	Transmission rate: 600 bps
Tone B	B	Synchronization between the modems by 1200 Hz tone signal	\bar{B} is a signal that shifts the phase B 180°.
Tone \bar{B}	\bar{B}		
Line probing signal L1	L1	Tone signal to analyze the line characteristics by probing	Probing is to examine the line characteristics. Tone signal between 150 Hz and 3,750 Hz in units of 150 Hz
Line probing signal L2	L2		

Receiver

Signal name	Abbreviation	Function	Remarks
INFO sequence	INFO0a	Informs the modem capability such as the modulating speed and frequency transmission capability.	Transmission rate: 600 bps
Tone A	A	Synchronization between the modems by 2,400 Hz tone signal	\bar{A} is a signal that shifts the phase A 180°.
Tone \bar{A}	\bar{A}		
INFO sequence	INFO0h	Based on the analysis of the line probing signal sent from the transmitter, it informs the pre-emphasis filter and modulating speed to be used for the data transmission.	Transmission rate: 600 bps

- Equalizer and echo canceller training (Phase 3)

Training (adjustment) is performed according to the parameters set in the phase 2 to optimize the filters such as an equalizer.

Transmitter

Signal name	Abbreviation	Function	Remarks
S signal	S	Short training	\bar{S} is a signal made as the result of phase transition of S.
\bar{S} signal	\bar{S}		
PP signal	PP	Used by the modem of the receiver to train the equalizer.	
TRN signal	TRN	Used by the receiver to determine the transmission rate.	

- Final training (Phase 4)

The settings such as the maximum value for the data rate, selection of the trellis encoder, and data rate which can be supported are made in this phase.

Transmitter/receiver

Signal name	Abbreviation	Function	Remarks
PPh signal	PPh	Used by the modem of the other side to train the equalizer.	
ALT signal	ALT	-	
Modulation parameter	MPh	Informs the parameters used for the image transmission such as maximum data signal rate and type of the trellis coding/pre-coding.	
E sequence	E	-	20 bit sequence of "1"s in binary

- Control channel

The conventional T.30 procedure is performed. The transmission rate is 1200 bps.

Transmitter

Signal name	Abbreviation	Function	Remarks
Flag	flags	Maintains the synchronization.	7E (H)
Non-standard facilities setting	NSS	Receives an NSF sent from the receiver. It selects the available mode from the received NSF, and specifies the mode for the reception.	
Transmitting Subscriber ID	TSI	Informs the telephone number of the transmitter.	
Digital Command Signal	DCS	Specifies the mode that can be used for the communication.	
-	1	Declares to switch to the high- speed procedure.	"1" is sent continuously.

Receiver

Signal name	Abbreviation	Function	Remarks
Non-Standard Facilities	NSF	Informs the presence of the facilities other than those recommended by ITU-T, abbreviated user names, and manufacturer codes, etc.	
Called Subscriber ID	CSI	Informs the telephone number of the receiver.	
Digital Identification Signal	DIS	Informs the standard facilities recommended by ITU-T.	
Flag	flags	Maintains the synchronization.	7E (H)
Confirmation for Reception	CFR	Informs that the training of the modem is completed, and the receiver is ready to receive the image signal.	

Reference : In the control channel, the frequency of the signals to be sent is different between the transmission and reception. The signal echoed back has never been misidentified as a signal sent from the other side. Therefore, this channel is not influenced by signals echoed back.

- Primary channel

The training is performed according to the parameters set in the phase 4. The transmission rate is 1,200 bps.

Transmitter

Signal name	Abbreviation	Function	Remarks
S signal	S	Short training	\bar{S} is a signal that makes a transition from phase S.
\bar{S} signal	\bar{S}		
PP signal	PP	Used by the modem of the receiver to train the equalizer.	
B1 sequence	B1	Scrambled data frame to be sent when the startup process is completed	

- Image data

Image data are sent.

Transmitter

Signal name	Abbreviation	Function	Remarks
Image data	Image data	Encoded image data	
-	Turn off	-	Scrambled 1 is sent for 35 ms.

- Communication end procedure

This procedure is to terminate the communication. The transmission rate is 1,200 bps.

Transmitter

Signal name	Abbreviation	Function	Remarks
Sh signal	Sh	Short training	
$\overline{\text{Sh}}$ signal	$\overline{\text{Sh}}$		
ALT signal	ALT	-	
E sequence	E	-	
End of procedure signal	PPS-EOP	The transmission of one page is completed.	
Flag	flags	Maintains the synchronization.	7E (H)
Disconnection signal	DCN	Informs to disconnect the line.	

Receiver

Signal name	Abbreviation	Function	Remarks
Sh signal	Sh	Short training	
$\overline{\text{Sh}}$ signal	$\overline{\text{Sh}}$		
ALT signal	ALT	-	
E sequence	E	-	
Flag	flags	Maintains the synchronization.	7E (H)
Message confirmation	MCF	Indicates that the image signal is received normally, and the receiver is ready to receive the next page.	

3) Example of protocol

The signals shaded in the following figure are the most important signals in the procedure.

- Late start

The receiver cannot detect CM signal while it is sending the ANSam signal. Therefore, it sends a DIS signal to inform the availability of V.8 support. The transmitter sends a CI signal that causes the receiver to send another ANSam signal which makes the receiver move to the V.8 procedure.

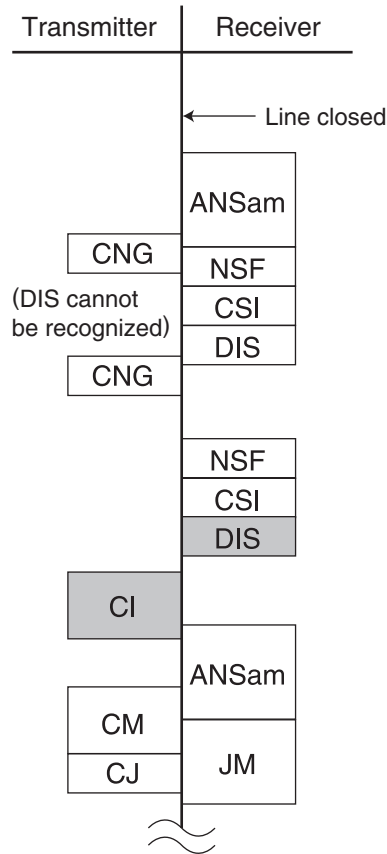

Fig. 3-8

- Multi-page sequence

In the same manner as the T.30 procedure, the transmitter sends a PPS-MPS signal after sending the image data. The receiver sends an MCF signal and moves to the next page transmission.

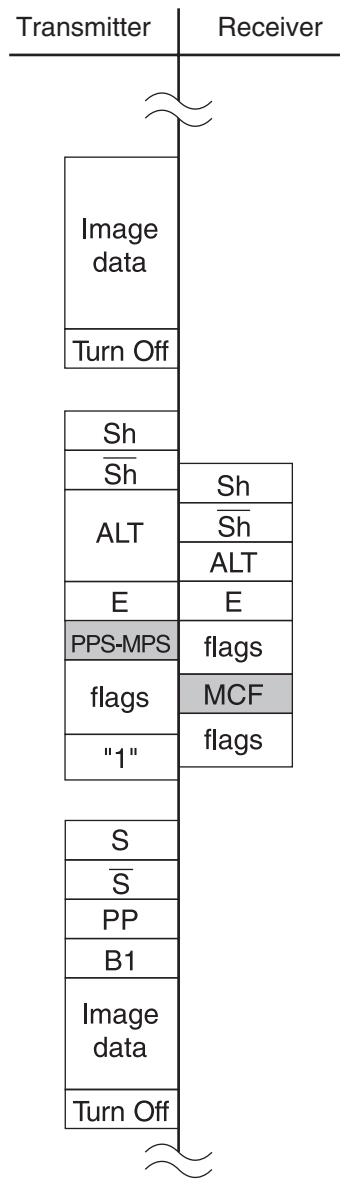

Fig. 3-9

- Mode change

The transmitter and receiver send a PPS-EOM signal and an MCF signal respectively. Then the receiver and transmitter send a DIS signal and a DCS signal respectively to change the mode.

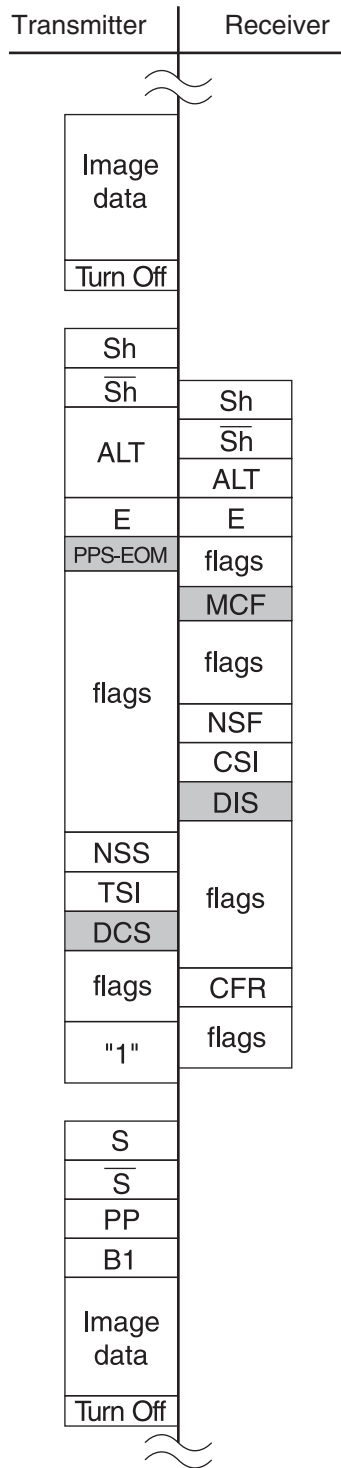

Fig. 3-10

- Change of the image transmission speed by the receiver
 The receiver sends a PPh signal responding to an Sh signal sent from the transmitter. Then, the image transmission speed is determined according to the MPh sequence sent from the both modems.

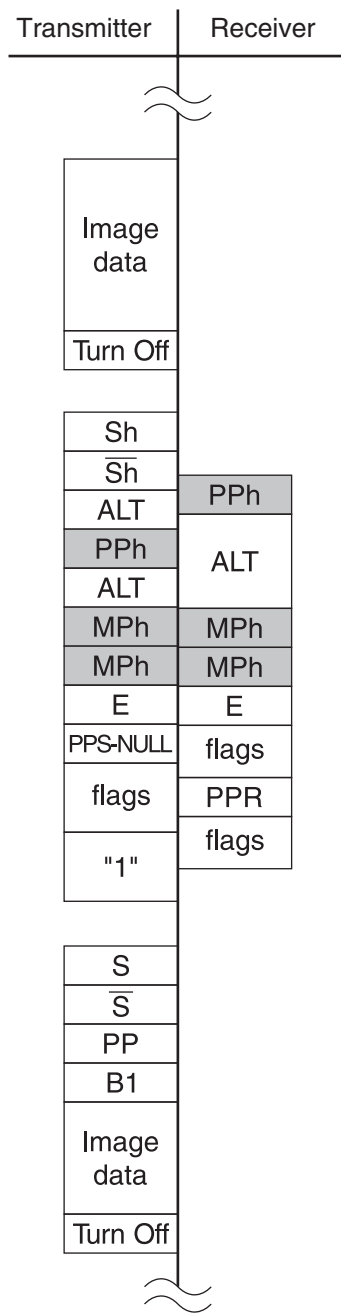

Fig. 3-11

- Change of the image transmission speed by the transmitter
 The transmitter sends a PPh signal after sending the image data. The receiver returns a PPh signal. Then, the image transmission speed is determined according to the MPh sequence sent from the both modems.

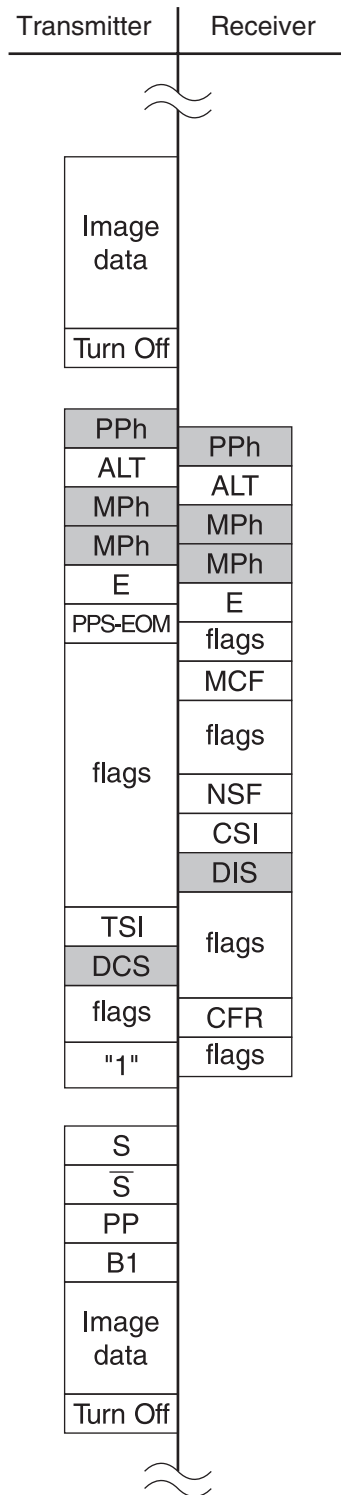

Fig. 3-12

3.3 FAX Automatic Switching

3.3.1 General functions

There are three types of setting for the FAX Auto-Switching Mode Selection: TEL Mode, FAX Mode and TEL/FAX Mode.

TEL/FAX mode setting	No-ringing receiving (Terminal setting: None)	Remote (DP/MF/Manual)	Pseudo ring (Terminal setting: None)
TEL	Off	Available	Non-use
FAX	On	Non-use	Non-use
TEL/FAX	On	Available	Available

3.3.2 TEL mode

This mode is selected to prioritize telephone communication when the frequency of the fax reception is low.

When it is selected, the automatic FAX reception function does not work. Therefore, when a calling signal comes from the exchange, the telephone continues ringing until the operator picks up the handset.

When the caller is communicating with the FAX mode, the operator has to perform manual reception including remote operation.

3.3.3 FAX mode

This mode is selected when the telephone line is used only for FAX communication.

When it is selected and the calling signal comes from the exchange, FAX reception starts automatically without having the telephone ring.

In this mode, a calling number can be set up to 15 times in the self-diagnosis setting "CI detection counter" (13-372 and 607).

3.3.4 TEL/FAX mode

Note : For the setting procedure of the TEL/FAX mode, refer to the User's Manual Advanced Guide.

This mode is selected when one telephone line is used for both the TEL and FAX communications. When it is selected and a calling signal comes from the exchange, the operation starts without having the telephone ring. Then the TEL/FAX simultaneous monitoring process starts to monitor the FAX signal (CNG, 1300 Hz, CRP) from the caller. After approx. 2 seconds have passed from the closing of the line a pseudo ring-back tone is transmitted to the circuit side, and the calling-on state is notified to the sender.

If the operator does not pick up the handset within the specified range, the FAX reception starts to correspond to the manual transmission of the sender. If it is not manual transmission, the operator of the sender breaks the connection.

For the outline of the operation, refer to the processing flow on the next page.

<Appended figure>
TEL/FAX

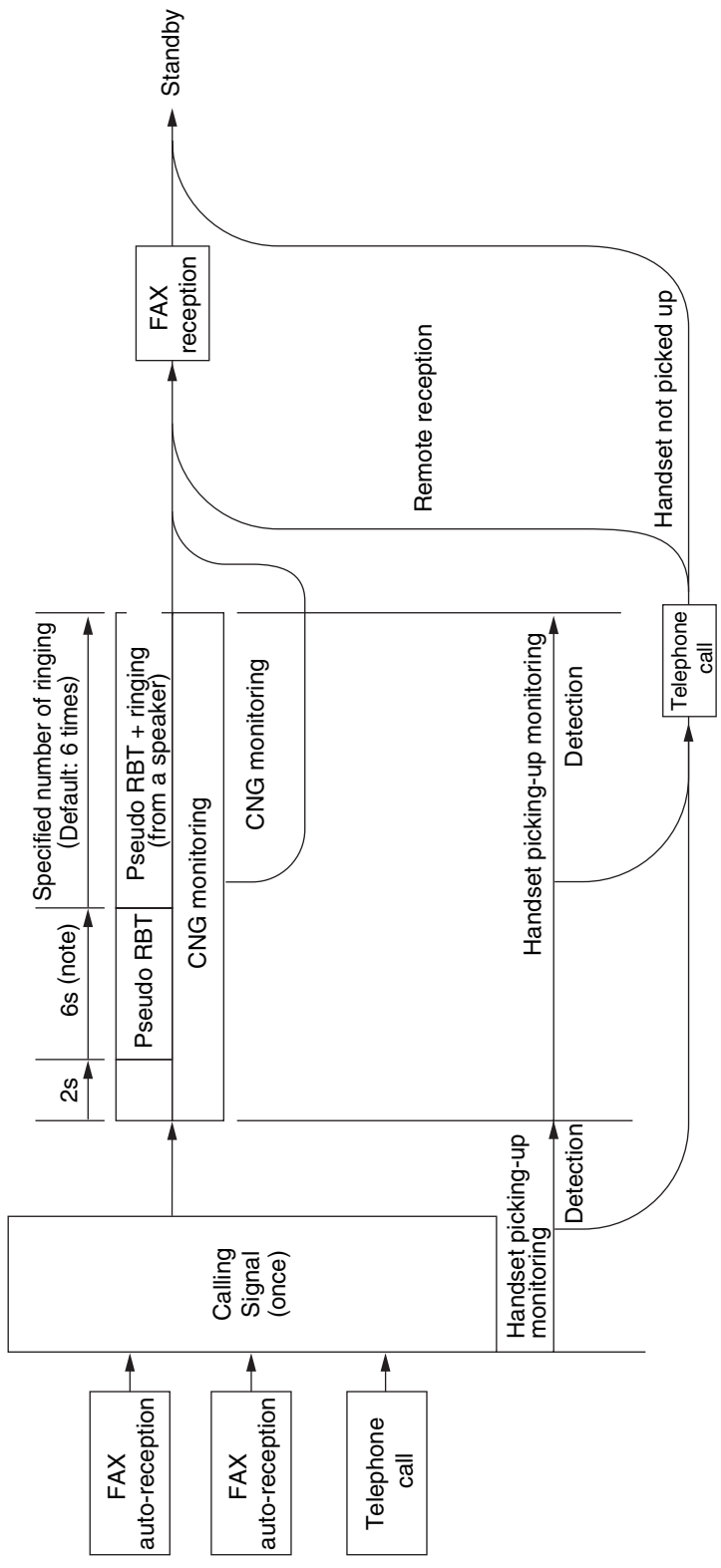

Fig. 3-13

Note:
The timer is paused if the time passed does not reach the specified number of rings during the CNG detection.
The FAX reception is started by your pressing the [START] button when the handset is picked up.

- Pseudo ring volume setting (05-9850)
Sets the ringing volume of the telephone (pseudo ring) from the speaker.
Pseudo bell sound waveform

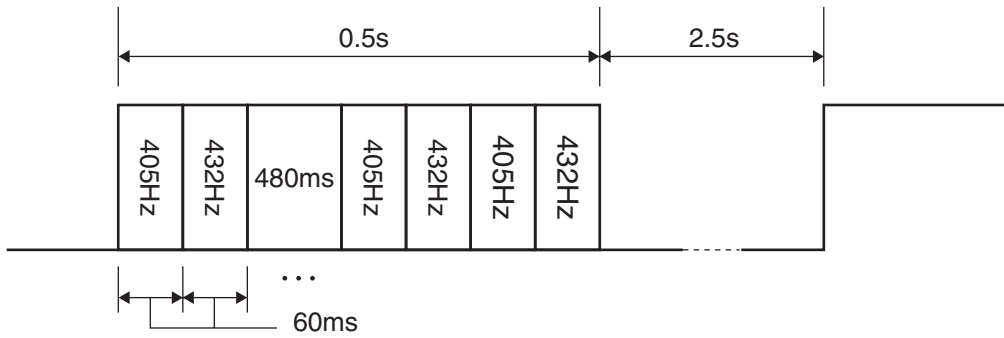

Fig. 3-14

- Pseudo ring-back tone waveform selection (13-722)
The waveform can be selected either of the following (a) or (b).

Waveform (a): Alternate transmission with 2 frequency-wave

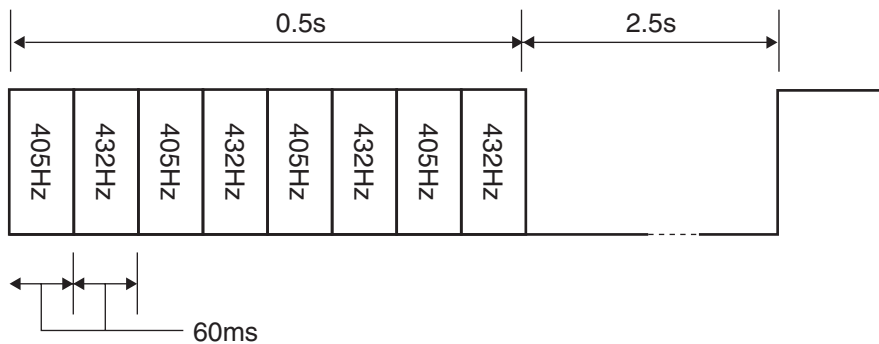

Fig. 3-15

Waveform (b): Single tone

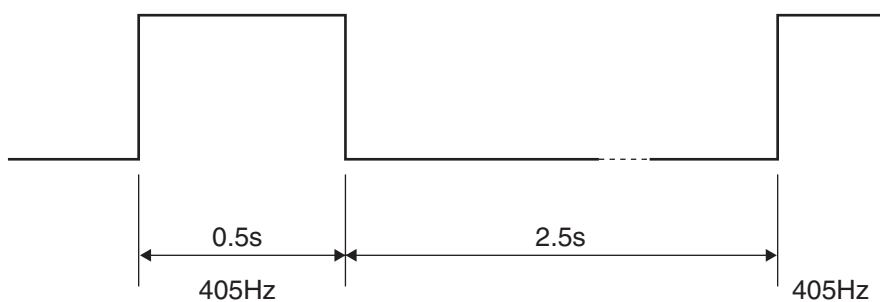

Fig. 3-16

- ATT setting when RBT is transmitted (13-723):
Default: -15 dB (-10 to -15 dBm)
- CNG detection (13-725)
CNG is detected with a modem. 2.5 seconds (during non-transmission) of the ring-back tone waveform is used as the tone detection mode.
The following is the combination of the frequency wave settings to avoid an incorrect detection.
 - 1100 ± 38 Hz: Default
 - 1100 ± 30 Hz
 - 1100 ± 24 Hz

<CNG detection determination method>

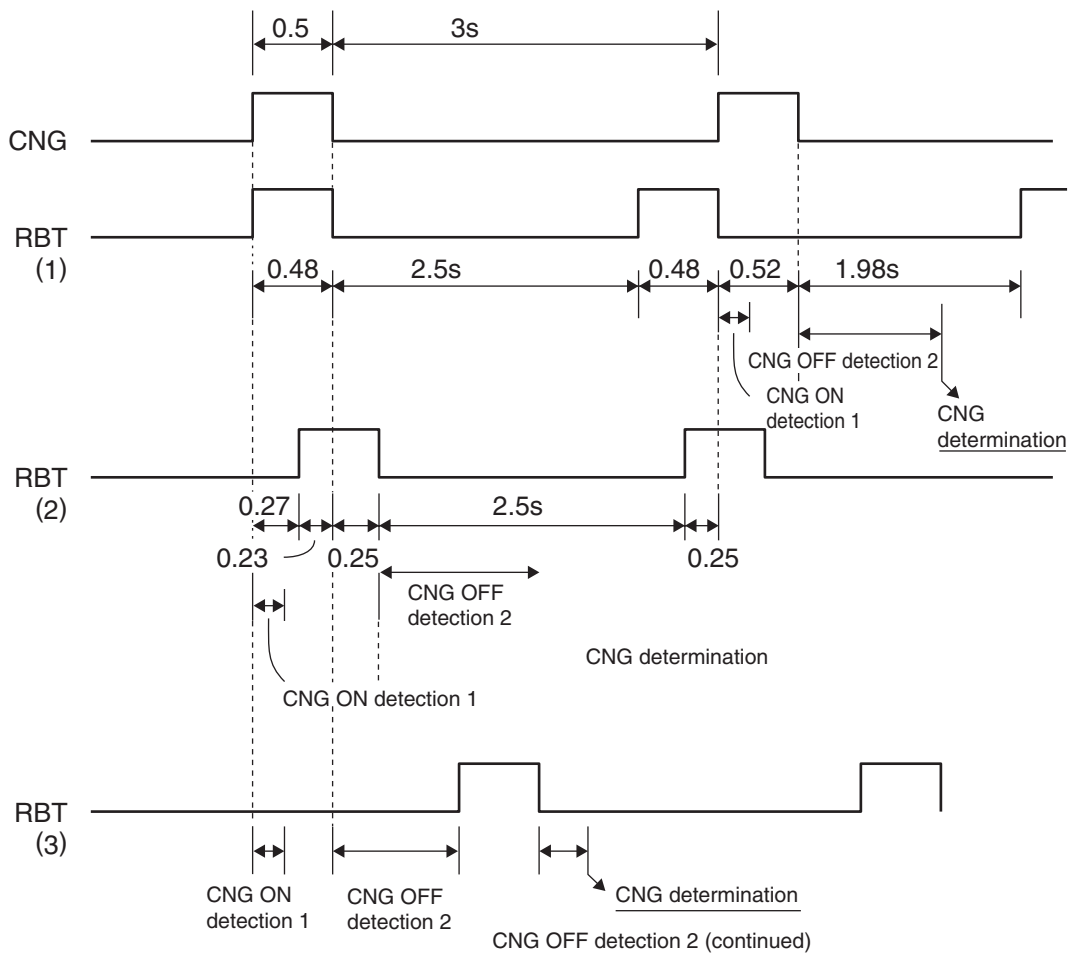

Fig. 3-17

- As indicated in the above figure, 1 CNG time is determined after the CNG ON detection time T1 (175 ms) and CNG OFF detection time T2 (350 ms) have passed, and one more cycle of their detection time has passed sequentially.
- The interruption time for RBT transmission is not counted.

- Number of detection determination setting (13-726)
Checks the duration time of between ON and OFF to avoid sound misdetection, and counts 1 detection time when the period between ON and OFF has been determined.
Sets the number of detections to be determined after 1 or 2 times have been counted. (Default: 1)
- Pseudo ring transmission function setting (13-724)
 - Default value of number of setting
 - $T1 (35s) - 2 - 6 - 3 = 24s$
 - $24/3 = 8 \text{ times}$
 - Due to this, "6" should be set as the default value.
 - Up to 15 times are available to be set. (More than 10 times is unnecessary in practice.)

4. ELECTRICAL CIRCUITS

4.1 Configuration

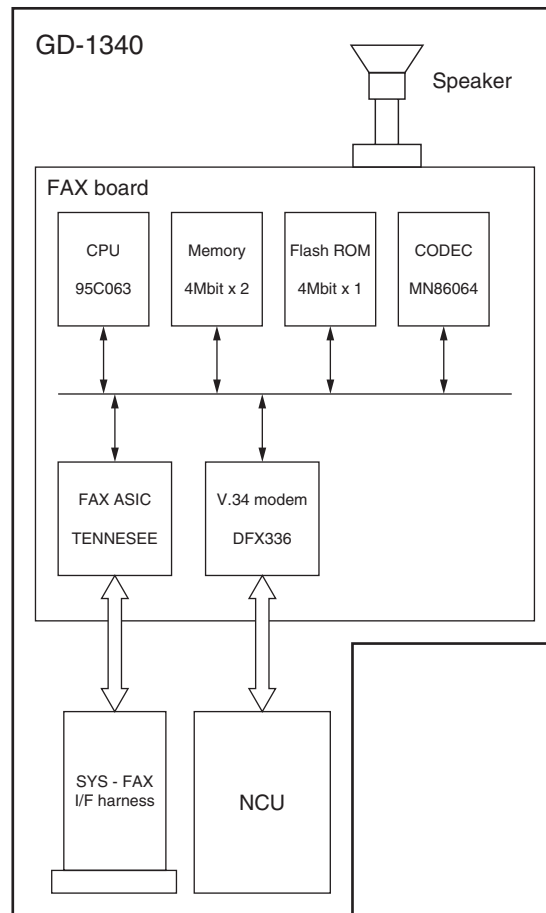

Fig. 4-1

4.2 Description of Circuits

4.2.1 Configuration

This section describes the function of each circuit.

The NCU board consists of the transformer, relay, analog switch and other peripheral devices. It controls switching of the line path, generates the dial pulses, detects the line current and ring signal, and monitors the line.

The NCU board is connected to CN501 on the FAX board.

NA models

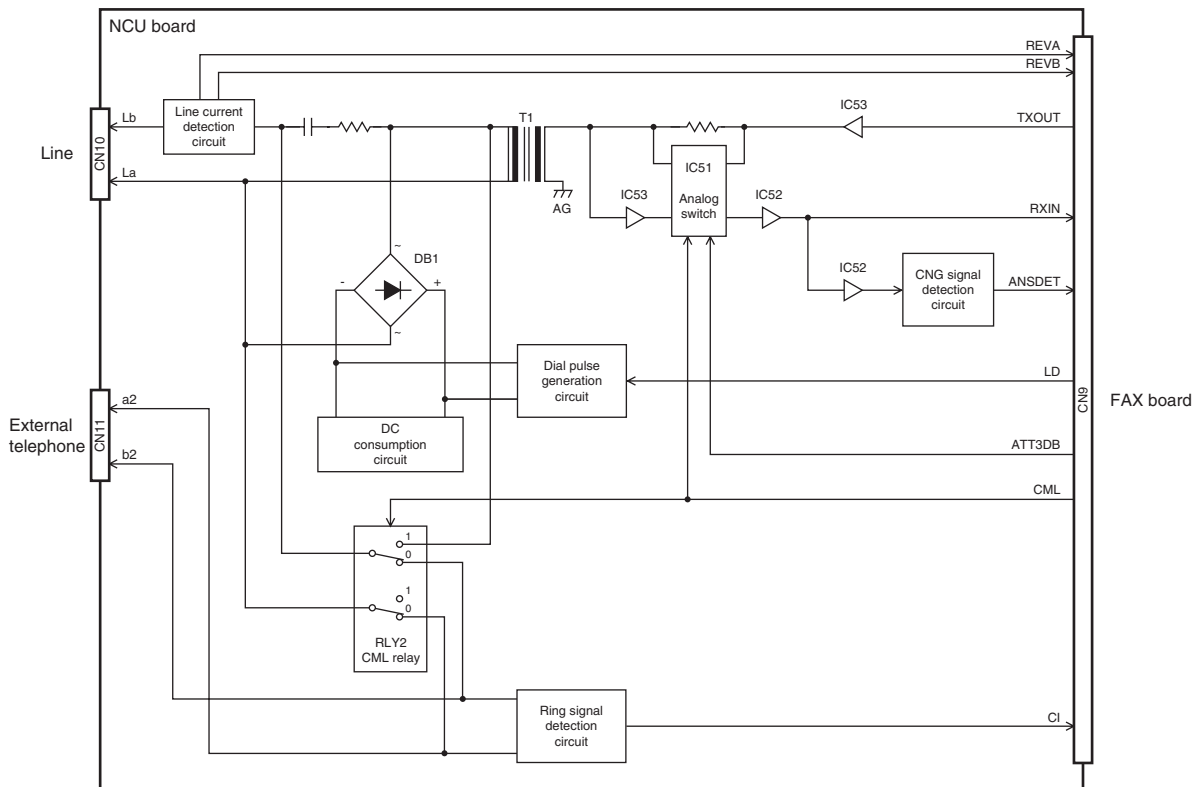

Fig. 4-2

EU/AU/BR models

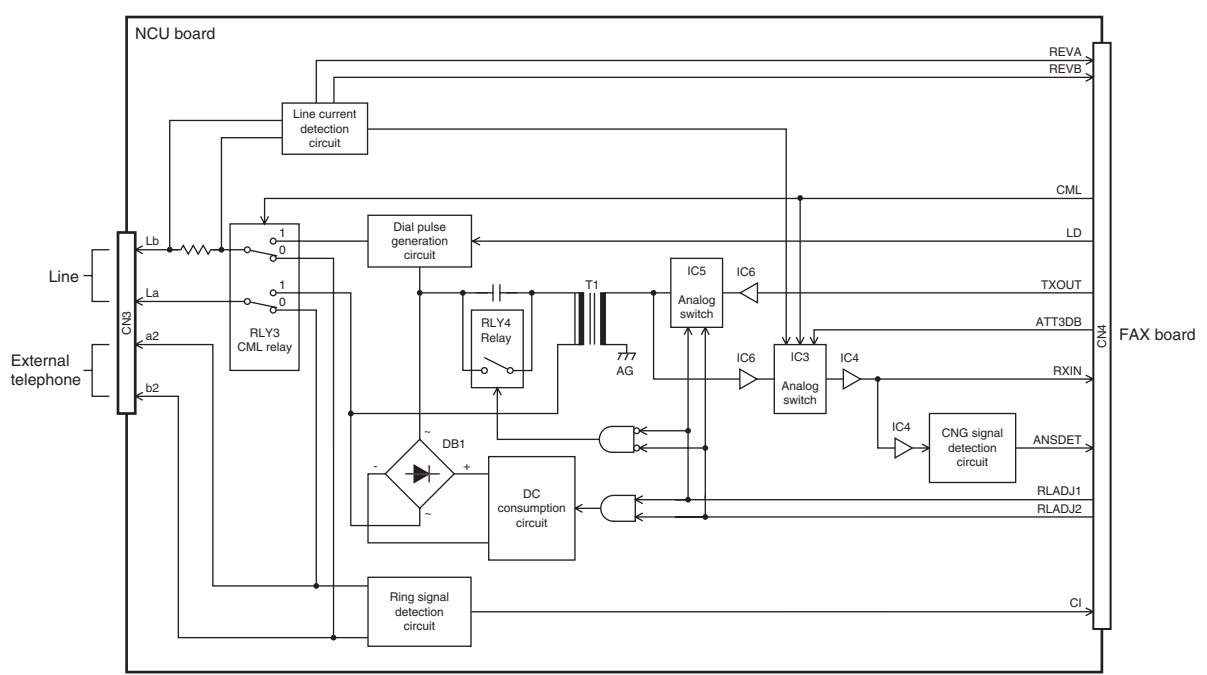

Fig. 4-3

4.2.2 Line path switching control circuit

NA models

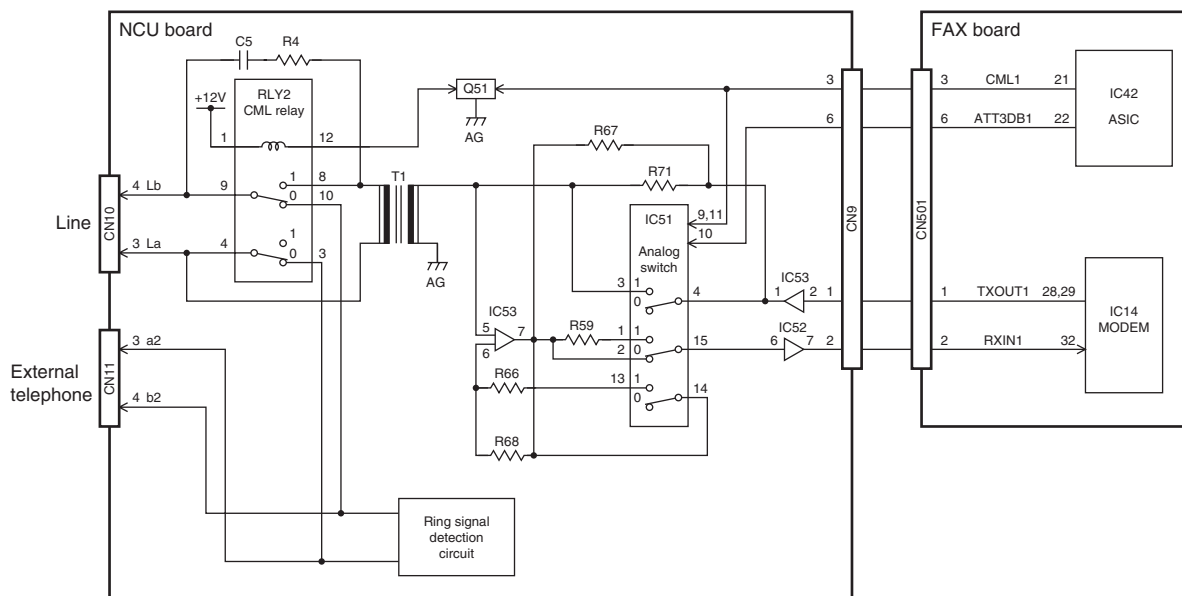

Fig. 4-4

The line path switching control circuit consists of the CML relay (RLY2) and analog switch (IC51) on the NCU board, the ASIC (IC42) on the FAX board and the other peripheral devices.

The CML relay is switched according to the CML1 signal output from the ASIC on the FAX board. When the CML1 signal goes HIGH, Q51 comes on to turn ON the CML relay.

The analog switch is switched according to the CML1 signal and ATT3DB1 signal. When the CML1 signal or ATT3DB1 signal goes HIGH, the analog switch is turned ON.

Turning ON the CML relay and analog switch allow the MODEM to be connected to the line.

Signal Name	Type	Active	Description	Destination
CML1	O	H	CML Relay Control Signal	RLY2, IC51
ATT3DB1	O	H	Attenuator Control Signal	IC51

EU/AU/BR models

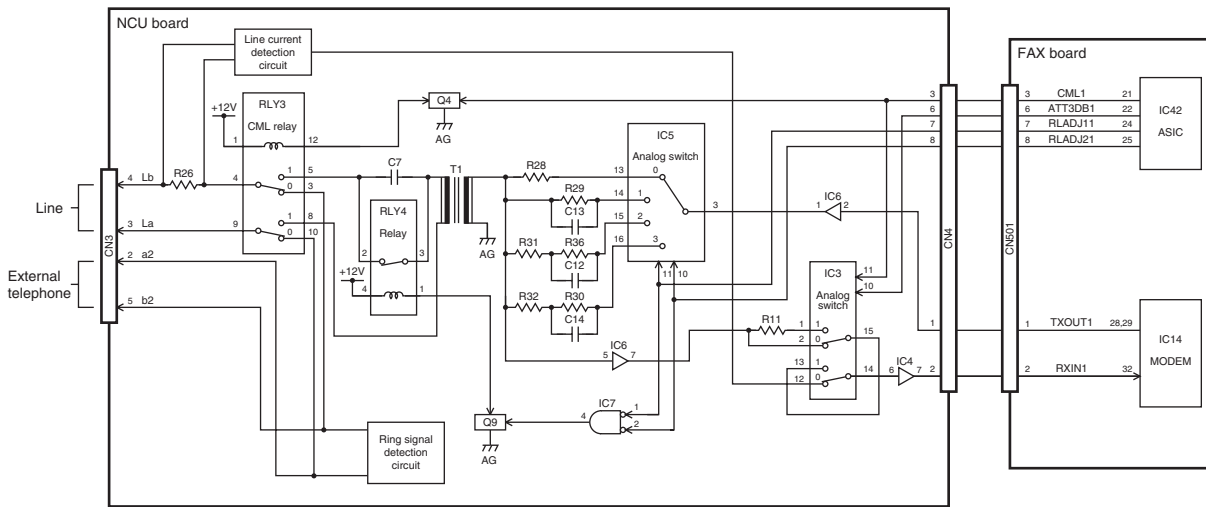

Fig. 4-5

The line path switching control circuit consists of the CML relay (RLY3) and analog switch (IC3, IC5) on the NCU board, the ASIC (IC42) on the FAX board, and the other peripheral devices. It changes the path for the FAX send/receive signals and connects it to each control circuit.

The CML relay is switched according to the CML1 signal output from the ASIC on the FAX board. When the CML1 signal goes HIGH, Q4 comes on to turn ON the CML relay.

The analog switch (IC3) is switched according to the CML1 signal and ATT3DB1 signal. When the CML1 signal or ATT3DB1 signal goes HIGH, the analog switch is turned ON.

The analog switch (IC5) is switched according to the RLADJ11 and RLADJ12 signals. The analog switch is switched according to the states of the RLADJ11 and RLADJ21 signals. Turning ON the CML relay and analog switch allow the MODEM to be connected to the line.

Signal Name	Type	Active	Description	Destination
CML1	O	H	CML Relay Control Signal	RLY3, IC3
ATT3DB1	O	H	Attenuator Control Signal	IC3
RLADJ11, 21	O	H	Return Loss Adjustment Signal	IC5

4.2.3 Dial pulse generation circuit

NA models

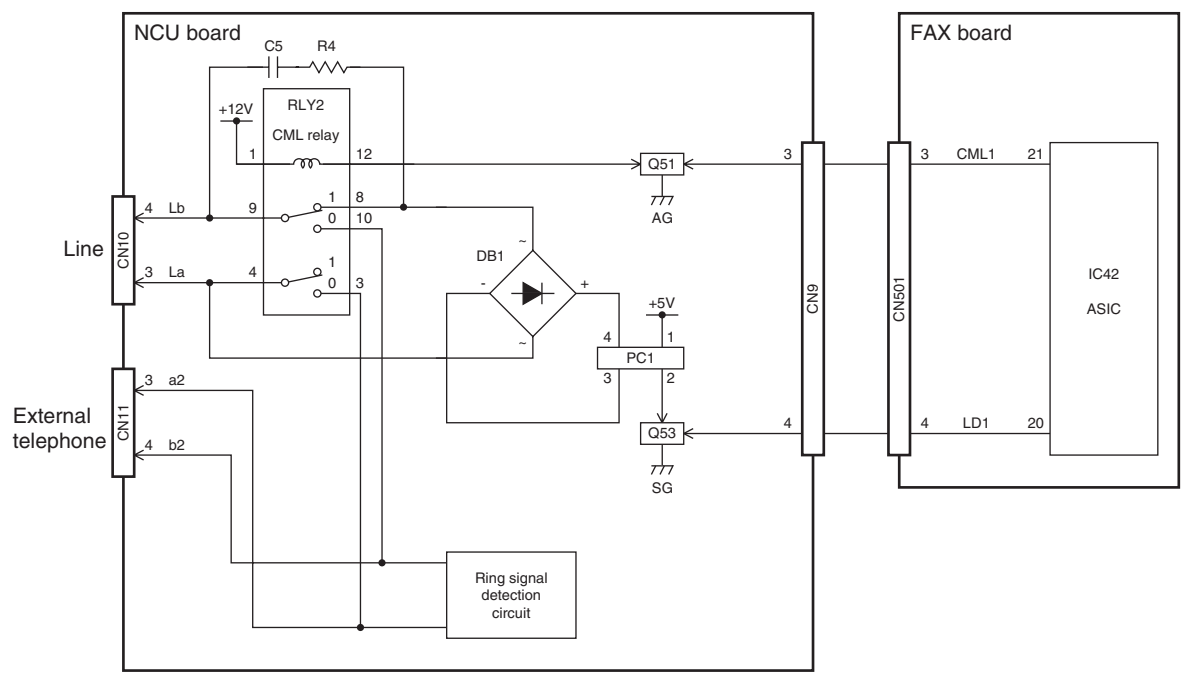

Fig. 4-6

The dial pulse generation circuit consists of the diode bridge (DB1), photocoupler (PC1), the ASIC (IC42) on the FAX board and the other peripheral devices. It generates the dial pulses in the FAX transmission and dialing to the outside.

The ASIC makes the CML1 signal become HIGH to connect the line to the MODEM side. To generate the dial pulse, the ASIC makes the LD1 signal become HIGH to turn ON Q53. This allows the photocoupler to come on and the current flows through the DB1 to send the dial pulses to the line.

Signal Name	Type	Active	Description	Destination
LD1	O	H	Dial Pulse Generation Signal	Q53

EU/AU/BR models

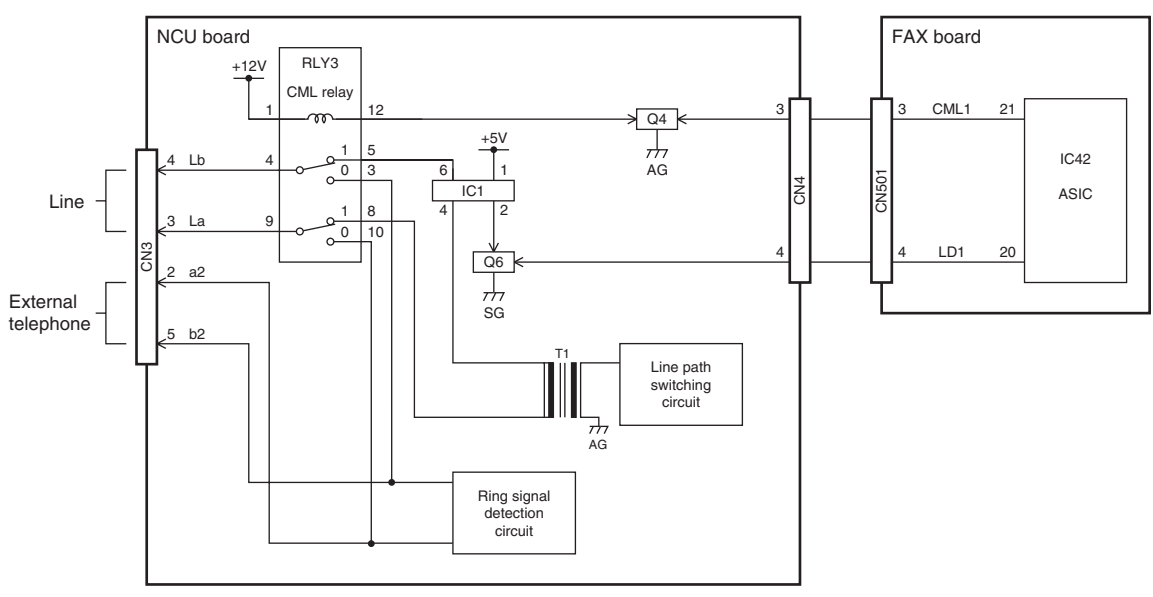

Fig. 4-7

The dial pulse generation circuit consists of the photocoupler (IC1), the ASIC (IC42) on the FAX board and the other peripheral devices. It generates the dial pulses in the FAX transmission and dialing to the outside.

The ASIC makes the CML1 signal become HIGH to connect the line to the MODEM side. To generate the dial pulses, the ASIC makes the LD1 signal become HIGH to turn ON Q6. This allows the photocoupler to come on and the current flows through the line for sending a dial attempt.

Signal Name	Type	Active	Description	Destination
LD1	O	H	Dial Pulse Generation Signal	Q6

4.2.4 Line current detection circuit

NA models

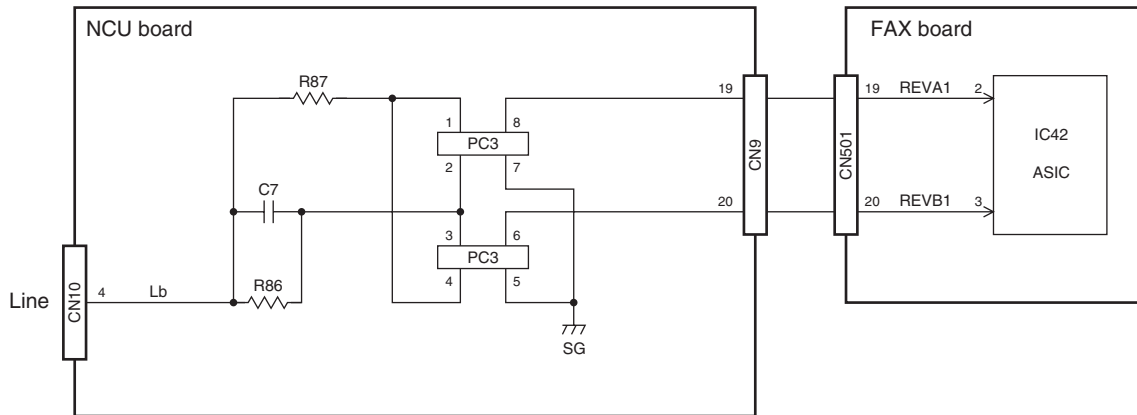

Fig. 4-8

The line current detection circuit consists of the photocoupler (PC3), ASIC (IC42) on the FAX board and the other peripheral devices. It detects a dial tone and the hook status of the external telephone from the current flowing through the line.

When a dial tone is input from the telephone line, current flows through the line and the photocoupler is repeatedly turned ON/OFF. This allows the REVA1 and REVB1 to be the pulse signals and input to the ASIC, then the dial tone is detected.

When the handset is lifted from the external telephone, current also flows through the line and the photocoupler is turned ON/OFF, then the off-hook state is detected.

Signal Name	Type	Active	Description	Destination
REVA1	I	-	Current Detection Signal	IC42
REVB1	I	-	Reverse Current Detection Signal	IC42

EU/AU/BR models

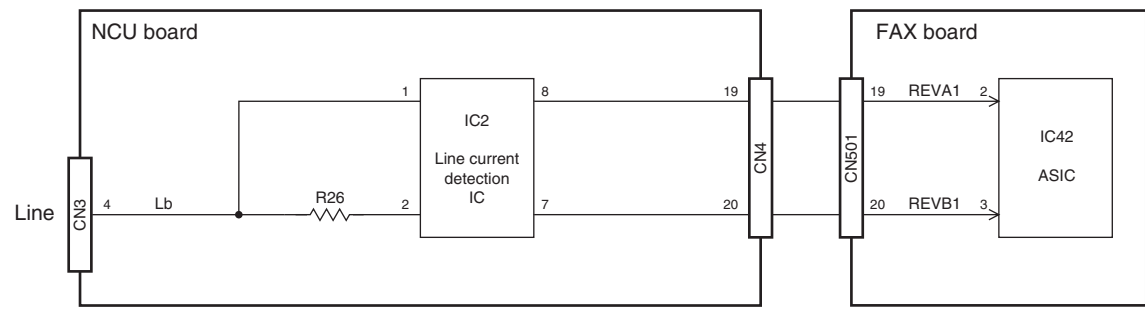

Fig. 4-9

The line current detection circuit consists of the line current detection IC (IC2), ASIC (IC42) on the FAX board, and the other peripheral devices. It detects a dial tone and the hook status of the external telephone from the current flowing through the line.

When a dial tone is input from the telephone line, current flows through the line. The line current detection IC sends REVA1 and REVB1 to the ASIC as pulse signals. This allows a dial tone to be detected.

Signal Name	Type	Active	Description	Destination
REVA1	I	-	Current Detection Signal	IC42
REVB1	I	-	Current Reverse Current Detection Signal	IC42

4.2.5 CI detection circuit

NA models

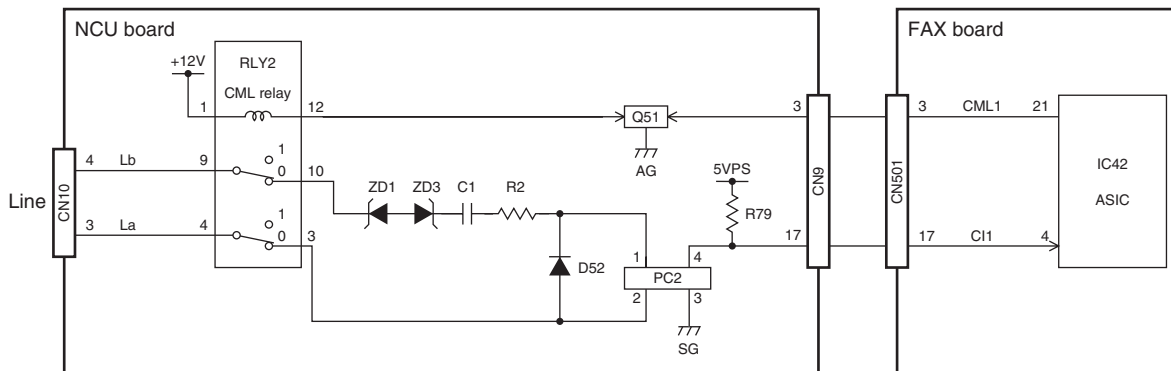

Fig. 4-10

The CI detection circuit consists of the photocoupler (PC2), ASIC (IC42) on the FAX board and the other peripheral devices to detect a ring signal input from the telephone line.

The ASIC makes the CML1 signal become LOW to connect the CI detection circuit to the telephone line.

When a ring signal is input from the telephone line, the photocoupler is repeatedly turned ON/OFF. This allows the C11 signal to become a pulse signal and input to the ASIC on the FAX board, thereby detecting the ring signal.

Signal Name	Type	Active	Description	Destination
C11	I	-	CI Detect Signal	IC42

EU/AU/BR models

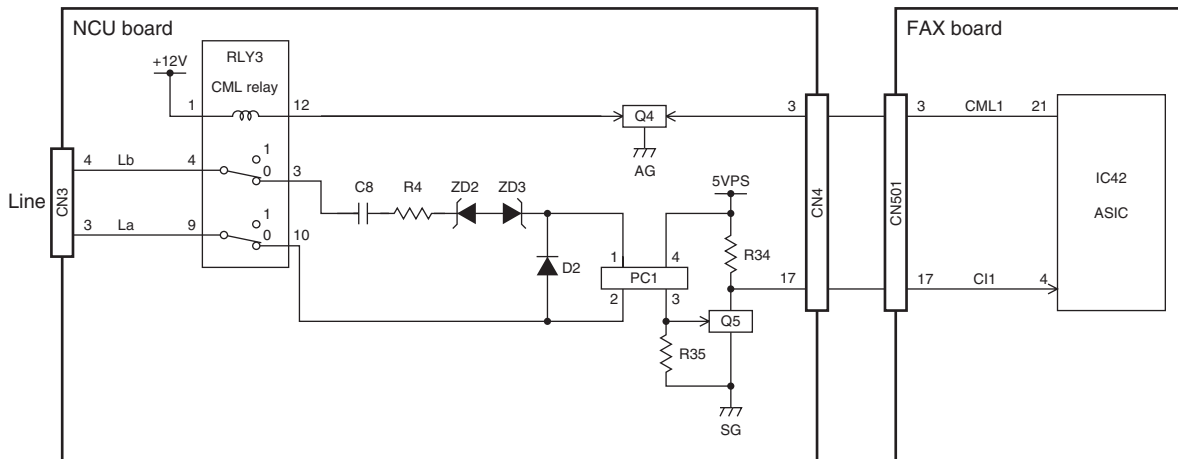

Fig. 4-11

The CI detection circuit consists of the photocoupler (PC1), ASIC (IC42) on the FAX board and other peripheral devices to detect a ring signal input from the telephone line.

The ASIC makes the CML1 signal become LOW to connect the CI detection circuit to the line. When a ring signal is input from the telephone line, the photocoupler is repeatedly turned ON/OFF. This allows Q5 to be turned ON/OFF and the CI1 signal to become a pulse signal and input to the ASIC on the FAX board, thereby detecting the ring signal.

Signal Name	Type	Active	Description	Destination
CI1	I	-	Line 1 CI Detection Signal	IC42

4.2.6 Line monitor circuit

NA models

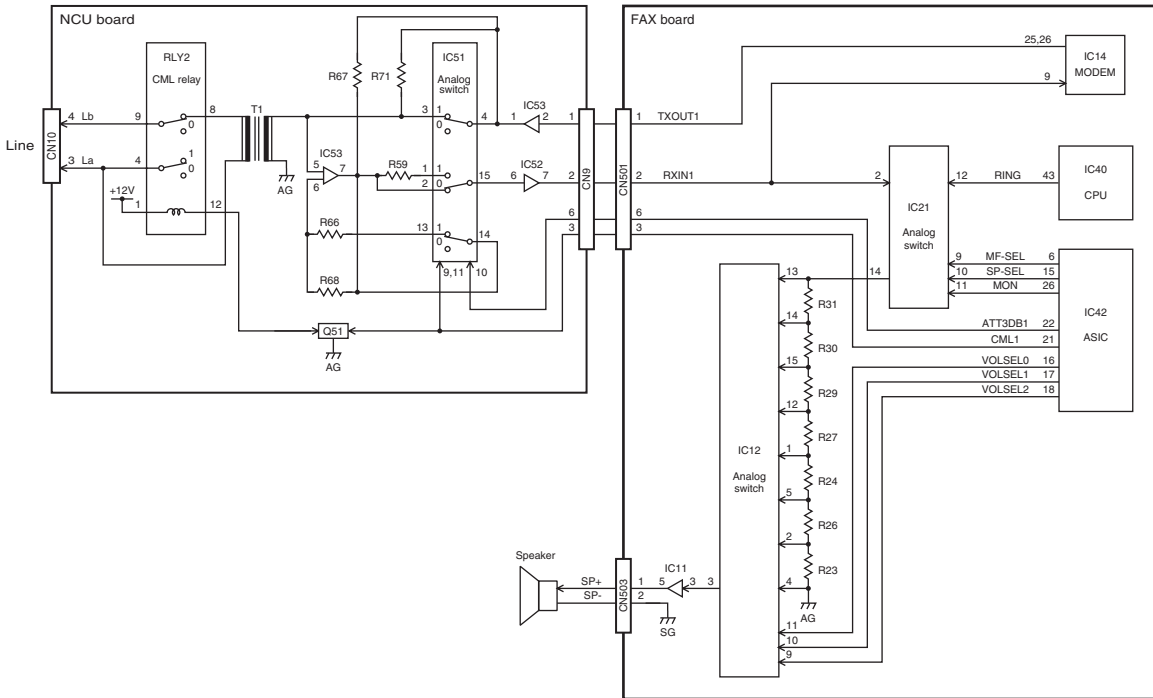

Fig. 4-12

EU/AU/BR models

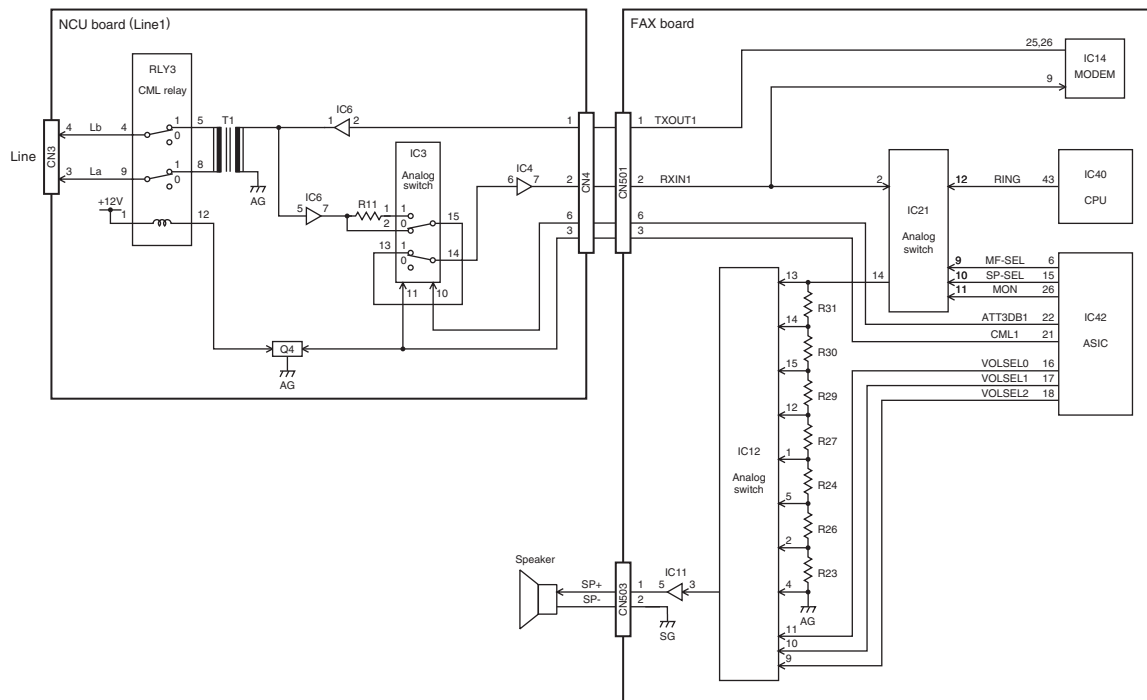

Fig. 4-13

The line monitor circuit consists of the CML relay (NA: RLY2, EU/AU: RLY3), analog switch (NA/TW: IC51, EU/AU/AS/C: IC3), the ASIC (IC42) and analog switches (IC21, IC12) on the FAX board, and other peripheral devices. It switches the telephone line path using the analog switch and monitors the line status and ringer signal in the FAX transmission and reception using the speaker connected to CN503 on the FAX board. It also switches the analog switch to output a buzzer tone from the speaker.

The signal to be monitored is selected by switching the analog switch (IC21) according to SP-SEL signal and MON signal which are output from the ASIC.

To monitor the line during the transmission and reception, the ASIC makes the CML1 signal become HIGH to switch the analog switch and connect the line to the MODEM side.

For the line path switching control, refer to P. 4-4 "4.2.2 Line path switching control circuit".

The relation between the signal levels and monitoring signals is as follows.

Monitoring signal	SP-SEL	MON
LINE Monitor	LOW	HIGH
Ringer/Alarm	-	LOW

The monitoring signal selected by IC21 is input to the analog switch (IC12) to select the output sound volume. The sound volume is selected by switching IC12 according to the VOLSEL0-2 signals output from the ASIC and selecting an input resistance for the monitoring signal.

The relation between the signals and sound volume is as follows.

Sound volume	VOLSEL2	VOLSEL1	VOLSEL0
Max. (7)	LOW	LOW	LOW
(6)	LOW	LOW	HIGH
(5)	LOW	HIGH	LOW
(4)	LOW	HIGH	HIGH
(3)	HIGH	LOW	LOW
(2)	HIGH	LOW	HIGH
Min. (1)	HIGH	HIGH	LOW
Silent (0)	HIGH	HIGH	HIGH

The monitoring signal whose volume is controlled by IC12 is amplified by the OP amplifier (IC11), then output to the speaker.

Signal Name	Type	Active	Description	Destination
SP-SEL	O	H	Line/Tone Selection Signal	IC21
MON	O	H	Ring/Tone Selection Signal	IC21
VOLSEL0-2	O	H	Speaker Volume Control Signals 0-2	IC12

5. INSTALLATION

5.1 Explanation to the Users

After installing the FAX unit, explain the following items to the user using the Operator's Manual. With the underlined items, actually demonstrate the operation.

Items to be explained

- Switches and control panel
 - Summary of the control panel (FAX functions)
 - After power is turned OFF, image data are kept in HDD.
- How to set originals
 - Acceptable original size and scanning width
 - How to insert originals:
Multiple originals placed on the RADF are scanned from the first page.
 - Unacceptable originals
 - How to set the mode (image quality) and density (contrast)
- Transmission method
 - Manual transmission
 - Monitor dialing
 - Direct dialing (with the digital keys)
 - Phone book dialing
 - Delayed transmission
 - Multi transmission
 - Redialing
- Recording paper size
 - Recording paper size
 - How to change the recording paper size
- Automatic/manual reception
 - How to switch the automatic and manual reception
 - How the machine works and how to operate it when a FAX is received in these modes
- Other functions
 - Memory reception (with the power kept ON)
 - How to set the power saving mode
- Polling
 - Polling operation
 - How to operate the polling reception and transmission
 - How the multi-polling reception works and how to operate it
- How to register addresses
 - How to register new addresses in the Phone Book
 - How to correct or erase the contents of the Phone Book
 - Group registration in the phone book for the multi-transmission or multi-polling
- How to output lists
 - How to output the TRANSMISSION JOURNAL and RECEPTION JOURNAL