

**MC770 / MC770+ / MC780 / MC780+**

**MPS3537mc / MPS3537mc+**

**MPS4242mc / MPS4242mc+**

# **Maintenance Manual**

**(1 of 2) Printer Unit**

072116H

## Copyright Information

---

Copyright © 2016 by Oki Data. All Rights Reserved

## Disclaimer

---

Every effort has been made to ensure that the information in this document is complete, accurate, and up-to-date. The manufacturer assumes no responsibility for the results of errors beyond its control. The manufacturer also cannot guarantee that changes in software and equipment made by other manufacturers and referred to in this guide will not affect the applicability of the information in it. Mention of software products manufactured by other companies does not necessarily constitute endorsement by the manufacturer.

While all reasonable efforts have been made to make this document as accurate and helpful as possible, we make no warranty of any kind, expressed or implied, as to the accuracy or completeness of the information contained herein.

The most up-to-date drivers and manuals are available from the web site:  
<http://www.okiprintingsolutions.com>

# PREFACE

This manual provides an overview of method for maintaining the MC760/MC770/MC780. This manual is intended for maintenance staff. For more information about how to operate the MC760/MC770/MC780, please refer to User 's manual.

- Note!**
- Manual may be revised and updated at any time without notice.
  - Unexpected mistakes may exist in the manual.  
OKI will not assume any responsibility whatsoever for damage to the equipment repaired/adjusted/changed by the user etc with this manual.
  - The parts used for this printer may be damaged when handling inappropriately. We strongly recommend maintaining this machine by our registration maintenance staff.
  - Please operate the machine after removing static electricity.

## **Warning**



Risk of explosion if battery is replaced by an incorrect type.  
Battery of the printer need not to be replaced. Do not touch the battery.  
Replace the whole board to replace the CU board.  
In the case of replacing batteries at board repairs, replace with the specified type ones. Installation of another type batteries may result in explosion.  
Caution for used batteries are as follows; do not recharge, force open, heat or dispose of in fire.

# Index

<b>1. Configuration</b> .....	<b>6</b>		
1.1 System configuration.....	7		
1.2 The Configuration of printer.....	8		
1.3 Optional parts.....	9		
1.4 Specifications.....	10		
1.5 Specification of interface.....	18		
1.5.1 Specification of USB interface.....	18		
1.5.1.1 General of USB interface.....	18		
1.5.1.2 Connector and cable of USB interface.....	18		
1.5.1.3 USB interface signal.....	18		
1.5.2 Specification of network interface.....	19		
1.5.2.1 General of network interface.....	19		
1.5.2.2 Connector and cable of network interface.....	19		
1.5.2.3 Signal of network interface.....	19		
1.5.3 Telephone Line Interface Specification.....	20		
1.5.3.1 Outline of telephone Line Interface.....	20		
1.5.3.2 Telephone Line Interface Connector and Cable.....	20		
1.5.3.3 Telephone Line Interface signal.....	20		
1.5.4 USB Host Interface.....	20		
1.5.4.1 Outline of USB Host Interface.....	20		
1.5.4.2 USB Host Interface Connector.....	20		
1.5.4.3 USB Host Interface Signal.....	20		
1.5.5 Specification of ACC interface.....	21		
<b>2. Operating instructions</b> .....	<b>22</b>		
2.1 Electrophotographic processing mechanism.....	23		
2.2 Printing process.....	27		
2.3 Image Scanning process.....	38		
2.3.1 Structure and process of RADF.....	38		
2.3.1.1 Cross-section view.....	38		
2.3.1.2 Electrical configuration.....	38		
2.3.1.3 Fundamental operations.....	39		
2.3.1.4 Document detection.....	42		
2.3.1.5 Jam detection.....	43		
2.3.2 Document table structure.....	43		
2.3.2.1 Overview.....	43		
2.3.2.2 Exposure block.....	44		
2.3.2.3 Carriage-Assy drive mechanism.....	44		
<b>3. Set up</b> .....	<b>45</b>		
3.1 Notes and precautions.....	46		
3.2 Unpack method.....	47		
3.3 Setting method.....	48		
3.4 List of equipments and accessories.....	49		
3.5 Assembling method.....	50		
3.5.1 Assemble the main body of the MFP.....	50		
3.5.2 Cable connect.....	57		
3.5.3 Optional part installation and confirmation.....	59		
3.6 Setting content print (Configuration).....	64		
3.7 Connecting method.....	65		
3.8 User used Paper confirmation.....	69		
<b>4. Component replacement</b> .....	<b>70</b>		
4.1 Precautions on component replacement.....	71		
4.2 Method of component replacement.....	73		
4.2.1 Belt unit.....	73		
4.2.2 Fuser unit.....	74		
4.2.3 Right side cover.....	74		
4.2.4 Left side cover.....	75		
4.2.5 Scanner unit.....	75		
4.2.6 Faceup tray.....	76		
4.2.7 Rear cover.....	76		
4.2.8 LED Assy/ LED Assy spring.....	77		
4.2.9 CU/PU PCB/Low voltage power supply.....	77		
4.2.10 Stay-R.....	79		
4.2.11 Plate-Board-R Assy/Guide-Cable Power Low.....	79		
4.2.12 Top cover Assy.....	80		
4.2.13 Top cover.....	81		
4.2.14 Frame Assy Top Front.....	81		

4.2.15	Board MFH .....	82
4.2.16	Hopping motor/ Fuse motor .....	83
4.2.17	Guide eject Assy/ Color regist Assy/ Board-IBY .....	84
4.2.18	FAN(Fuser) / Belt motor/ High-voltage board/ Cover open switch .....	85
4.2.19	MPT Assy .....	85
4.2.20	Cover Assy front/ Board-RSF/MPT hopping roller/ Frame Assy separator/ Feeder Assy regist .....	86
4.2.21	Plate-Driver/ Shaft-Liftup/ Hopping cover .....	87
4.2.22	Plate-Assy-Side R/ Plate-Assy-Side L .....	88
4.2.23	Feed roller .....	88
4.2.24	Eject sensor/Micro-SW .....	89
4.2.25	Antenna (for wireless model only) .....	89
4.2.26	Finisher (MC780dnf only) .....	90
4.2.27	Stapler (MC780dn only) .....	91
4.2.28	Tray-Assy-Document/Cover-ADF-R .....	92
4.2.29	ADF-unit .....	93
4.2.30	Sheet-document / Paper-weight-Assy / Spring-PW-ADF .....	94
4.2.31	Hinge-Assy-L / Hinge-Assy-R .....	95
4.2.32	ADF-Assy .....	95
4.2.33	Guide-Retard / Roller / Motor / Clutch / Solenoid / Photo-sensor .....	96
4.2.34	Cover-Assy-Top-ADF .....	97
4.2.35	Frame-Assy-Hopping-ADF .....	98
4.2.36	Guide-Assy-Retard .....	99
4.2.37	Flatbed-Unit .....	99
4.2.38	Frame-assy-FB .....	100
4.3	Check the Scanner Mech Level and SU FW version .....	101
4.4	Oiling spots .....	102

**5. Maintenance Menu ..... 113**

5.1	Maintenance Utility .....	114
5.2	Maintenance menu functions .....	115
5.2.1	Self-diagnostic mode .....	115
5.2.1.1	Operation panel .....	115
5.2.1.2	Ordinary self-diagnostic mode (level 1) .....	117
5.2.1.3	Switch scan test .....	118
5.2.1.4	Motor clutch test .....	120
5.2.1.5	Test print .....	122
5.2.1.6	Color registration correction test .....	126
5.2.1.7	Density correction test .....	127

5.2.1.8	Consumable item counter display .....	129
5.2.1.9	Number of print copies counter display .....	130
5.2.1.10	Switching between the Factory mode and the Shipping mode .....	130
5.2.1.11	Self-diagnostic function setting .....	131
5.2.1.12	LED head serial number display .....	132
5.2.1.13	NVRAM parameter setting .....	132
5.2.2	How to enter the Scanner Maintenance Menu .....	133
5.3	Setups upon completion of part replacement .....	135
5.3.1	Precautions when replacing the PU board .....	135
5.4	Density control manual setting .....	137

**6. Periodic Maintenance..... 138**

6.1	Cleaning .....	139
6.2	How to clean the LED lens array .....	140
6.3	How to clean the pickup roller .....	142
6.4	How to clean the paper feed rollers for MP Tray .....	143
6.5	How to clean the rollers in the ADF .....	144
6.6	How to clean the document rollers in the ADF .....	145
6.7	How to clean the document glass .....	146
6.8	How to clean inside of MFP .....	147

**7. Troubleshooting and repair procedure ..... 149**

7.1	Before starting the repair work .....	150
7.2	Confirmation items before taking corrective action against abnormalities .....	150
7.3	Precautions when taking corrective action against abnormality .....	150
7.4	Preparation for troubleshooting .....	150
7.5	Troubleshooting method .....	151
7.5.1	Error code list .....	151
7.5.2	Printer error troubleshooting .....	154
7.5.3	Scanner error troubleshooting .....	160
7.5.4	Preparation for troubleshooting .....	162
7.5.5	Troubleshooting the abnormal images .....	199
7.6	Fuse check .....	206
7.7	Paper cassette switches versus Paper size correspondence table .....	207

**8. Connection diagrams..... 208**

8.1	Resistance value check .....	209
8.2	Parts location .....	214

# 1. Configuration

---

1.1 System configuration .....	7
1.2 The Configuration of printer.....	8
1.3 Optional parts .....	9
1.4 Specifications .....	10
1.5 Specification of interface.....	18

# 1.1 System configuration

Figure 1-1 represents the system configuration of the printer.

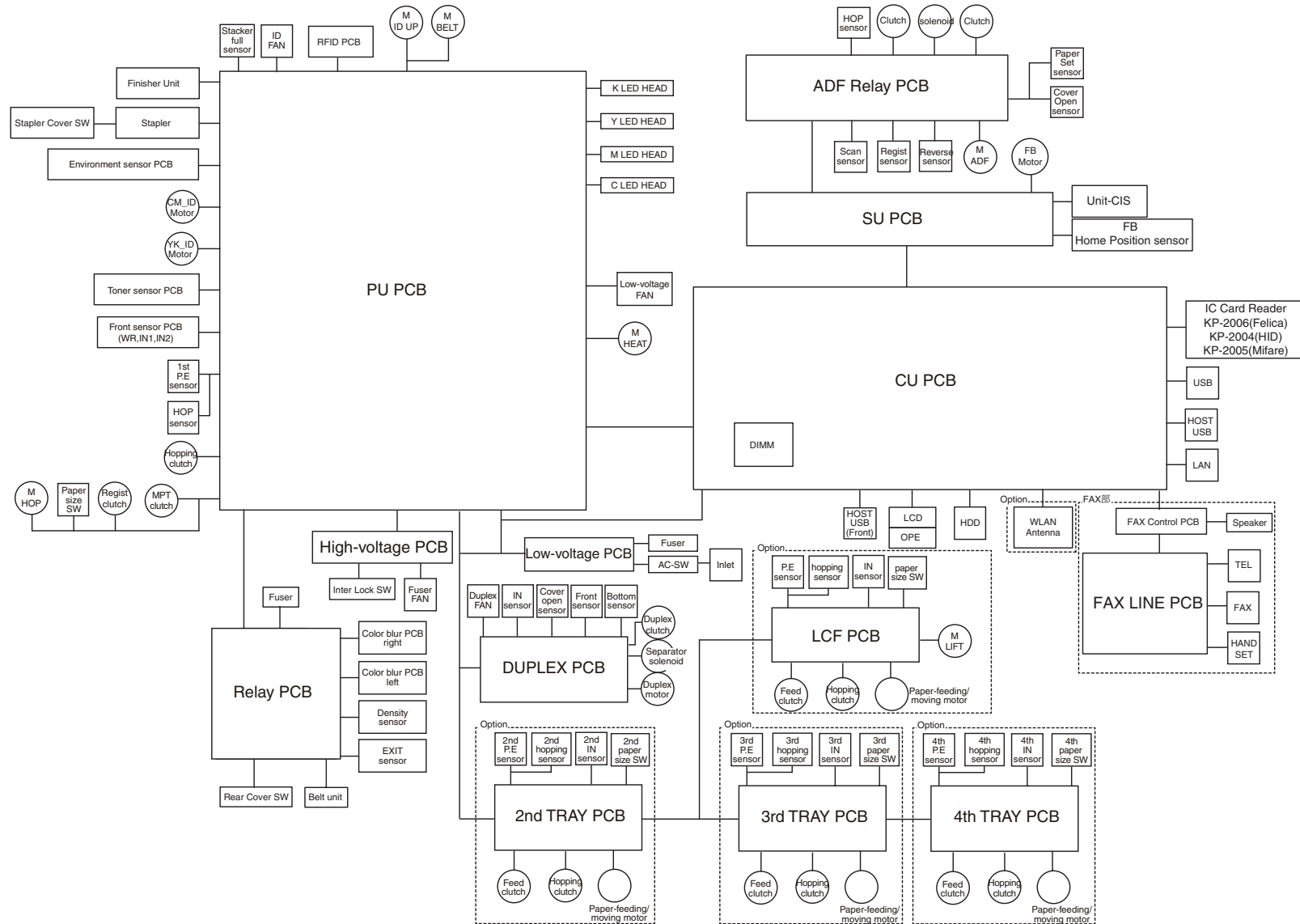

Fig1-1

## 1.2 The Configuration of printer

The parts in the MC760/MC770/MC780 are shown as below.

- Electrophotography process mechanism
- Paper feed path
- Control part (CU part/ PU part/ FAX Unit)
- Operator panel
- Power part (High-voltage part/low-voltage part)

The Configuration of the MFP is shown in Fig 1-2.

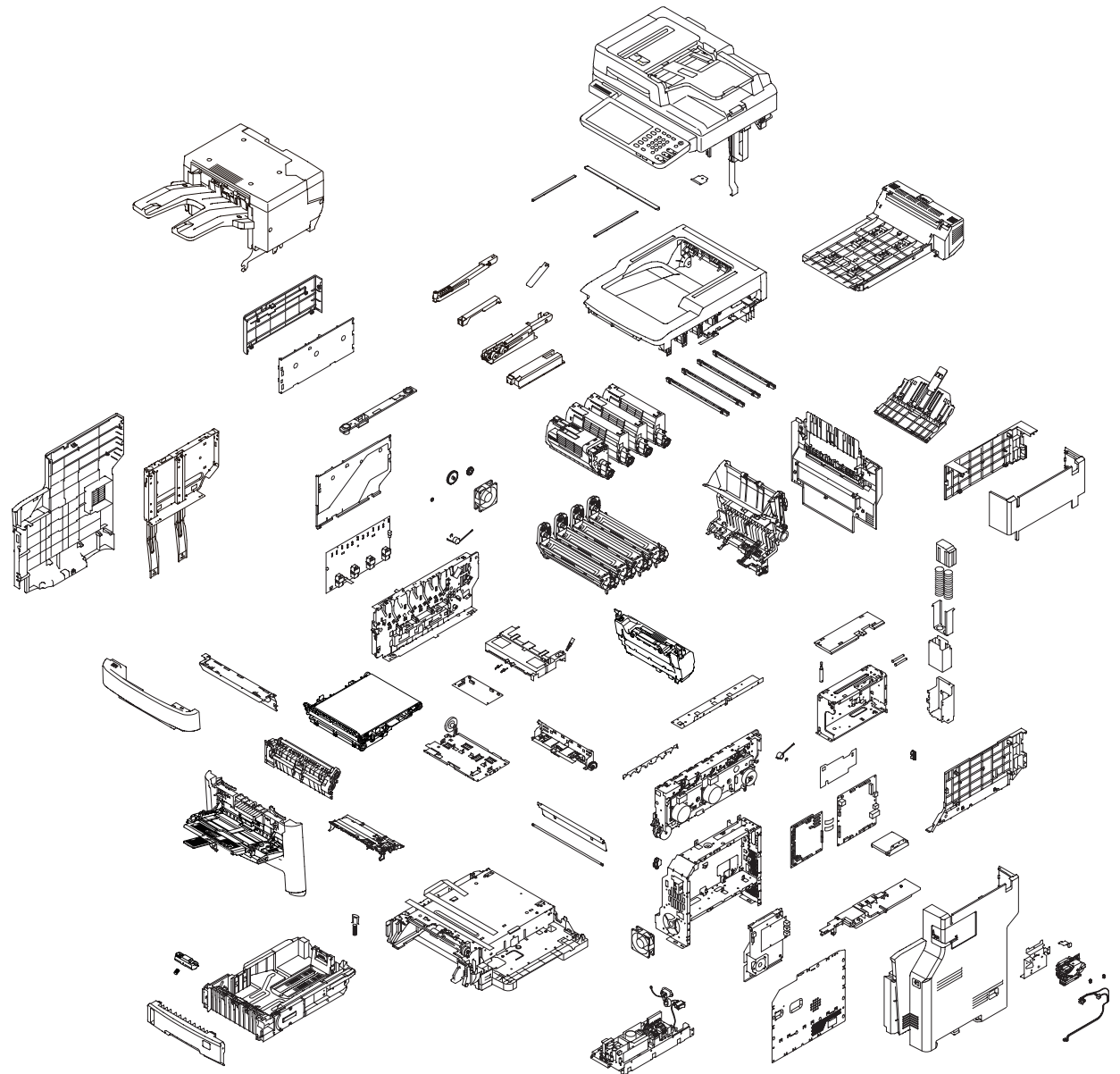

Fig 1-2



# 1.3 Optional parts

The optional parts for this printer are shown as below.

- (1) Optional tray(second tray/ third tray/fourth tray\*)  
\*fourth tray:not support for Finisher model

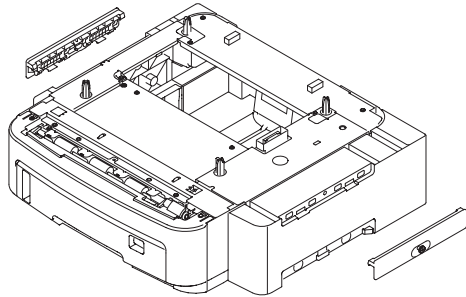

- (2) Spacer

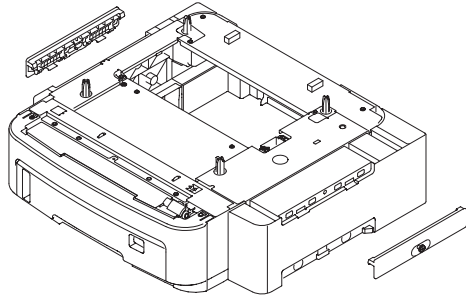

- (3) Caster Stand

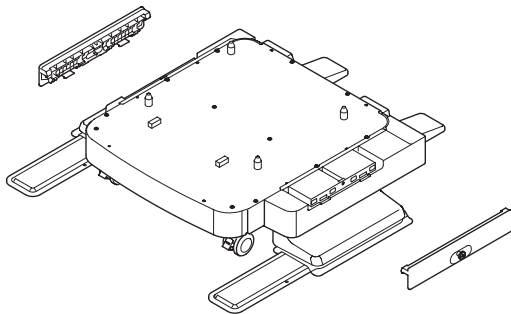

- (4) LCF

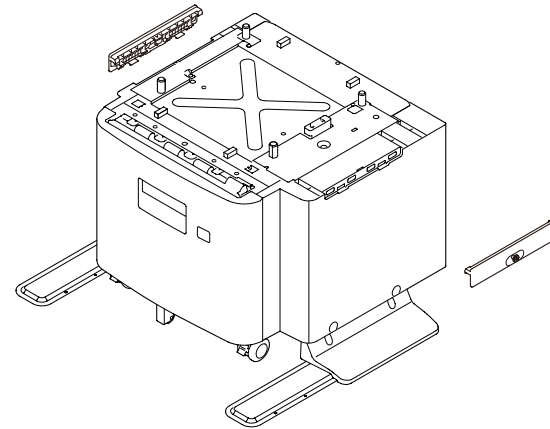

## 1.4 Specifications

### Fundamental specifications

Category	Item	MC760	MC770	MC780
Outside dimensions	Width	522mm		
	Depth	604mm		
	Height	675mm (Finisher model:811mm)		
Weight		Approx. 50kg (Finisher model:60kg)		
CPU CU	APM86190			
RAM CU	Resident	2 GB		
	Option	N/A		
ROM CU	Program	8MB		
Control Panel	LCD	9 inch WVGA color touch panel Size:198.0 mm(W) x 111.7 mm(H) Resolution:800dot x 480dot		
	Hard Keys	Ten key, start key, stop key, power key, ENERGY SAVER KEY and others		
	Qwerty keyboard	No		
Operation sound	Operating	55dB(A) (Sound pressure level)	57dB(A) (Sound pressure level)	
		Standby		
	Power save mode	Inaudible		
Power consumption	Power input	110-127VAC (Range 99-140VAC) 220-240VAC (Range 198-264VAC)		
	Sleep mode	1.5W (no FAX model) 2.0W (FAX model)		
	Power save mode	60W		
	Idle	130W		
	Typical operation	800W		
	Peak	1500W		

Category	Item	MC760	MC770	MC780
Operating environment (temperature)	During operation	10 °C to 32 °C, 17 °C to 27 °C (Full color print quality assurance temperature)		
	During non-operation	0°C - 43°C, Power OFF		
	During storage (Maximum one year)	-10°C to 43°C, with drum and toners		
	During transportation (Maximum one month)	-30°C - 50°C, with drum, without toners		
	During transportation (Maximum one month)	-30°C to 50°C, with drum and toners		
Operating environment (humidity)	During operation	20% - 80%, 50% - 70% (Full color print quality assurance humidity), Maximum wet-bulb temperature 25°C		
	During non-operation	10% - 90%, Maximum wet-bulb temperature 26.8°C, power OFF		
	During storage	10% - 90%, Maximum wet-bulb temperature 35°C		
	During transportation	10% - 90%, Maximum wet-bulb temperature 40°C		
Emulation	Standard	PCL5e/PCL5c/PCL6/PS3 emulation/ PDF emulation/XPS		
	Emulation switch	Automatic		
Others	USB-IF logo	Yes		
	Windows logo	Yes		
	Operations on UPS	Operations on UPS (uninterruptible power supply) are not guaranteed. Do not use UPS.		
CPU SU	Core	ARM9		
RAM SU	Resident	256 MB		
	Option	None		
ROM SU	Program	4MB		

### Printer section specifications

Category	Item	MC760	MC770	MC780	
Print width	Print width	A4 horizontal			
Engine speed (A4/LT)	Monochrome	28/30ppm	36/37ppm	40/42ppm	
	Duplex Mono	22/23ppm	27/28ppm	32/33ppm	
	Color	28/30ppm	34/35ppm	40/42ppm	
	Duplex Color	22/23ppm	25/26ppm	32/33ppm	
First print out time (A4) *Printer is not in low temperature(<16°C)	Monochrome	TBD	8 sec	8 sec	
	Color	TBD	9 sec	8 sec	
Warm-up time	From Power On with calibrations	Less than 60sec			
	From Power save	Less than 35sec			
Resolution	LED head	600 x 600 dpi			
	Maximum input resolution	600 x 1200dpi			
	Output resolution	True 600x600dpi x 5bit True 600x1200dpi x 1bit (for PS only)			
Life	Printer life	600K page or 5 years			
	Maximum Monthly Print Volume when Continuous Print	100K(under specific condition) 60K(under all condition)			
	MTBF	6,000H (Reference only)			
	MPBF	45K			
	MTTR	Less than 20 min.			
	Toner life (ISO/IEC 19798)	Starter toner (supplied)	C, M, Y, K : 4.8K		
		Standard	C,M,Y:6K,K:8K		
		High-Capacity	No	C,M,Y:11.5K,K:15K	
	Image drum life	Simplex	Continuous:40K (Target) 3P/J:30K 1P/J:18K		
		Duplex	Continuous:34K 3 sheets/J(6P/J):23.1K 1 sheets/J(2P/J):13.9K		

Category	Item	MC760	MC770	MC780
Life	Transfer belt life	60,000 pages		
	Fuser life	60,000 pages		
Paper handling	1st Tray	530 sheets of 80g/m <sup>2</sup> (70Kg) plain paper		
	Multi purpose tray	100 sheets of 80g/m <sup>2</sup> (70Kg) plain paper 10 envelopes		
	2nd/3rd/4th Tray Option	530 sheets of 80g/m <sup>2</sup> (70Kg) plain paper		
	LCF	2,000 sheets of 80g/m <sup>2</sup> (70Kg) plain paper		
	Paper output capability	Face up:Approx.100 sheets of 80g/m <sup>2</sup> (70Kg) plain paper Face down:Approx.500 sheets of 80g/m <sup>2</sup> (70Kg) plain paper (Finisher model:Approx.100 sheets of 80g/m <sup>2</sup> (70Kg) plain paper) Finisher : Approx.500 sheets of 80g/m <sup>2</sup> (70Kg) plain paper		
Paper size	1st/2nd/3rd/4th tray	A4,A5,B5,Letter,Legal13/13.5/14,Executive,8.5"SQ,Folio,China16K(195x270), Custom size(Width:148-216mm Length:210-356mm)		
	LCF	A4,Letter,Legal13/13.5/14		
	Multi purpose tray	A4,A5,A6,B5,Letter,Legal13/13.5/14, Executive,Statement,8.5"SQ,Folio,China 16K(195x270),Com-9,Com-10, Cyou3,Cyou4,B6Half,C5,DL,Monarch, IndexCard(3x5inch), PhotoSize(4x6inch/5x7inch), CustomSize(Width:64-216mm x Length:127-1321mm, (When length is over 356mm, width is 210-216mm)), Banner up to 52"		
	Duplex	A4,A5,B5,Letter,Legal13/13.5/14,Executive,Statement,8.5"SQ,Folio,China16K(195x270),Custom size(Width:148-216mm Length:210-356mm)		

Category	Item	MC760	MC770	MC780
Minimum paper size	1st/2nd/3rd/4th tray	5.8" x 8.3" (148 x 210mm : A5)		
	LCF	8.5"x11"(210x297mm : A4)		
	Multi purpose tray	3" x 5" (Index Card), 64 x 182mm (B6 Half)		
	Duplex	5.5"x8.3"(139.7 x 210mm)		
Paper thickness	1st/2nd/3rd/4th tray LCF	64 – 220 g/m <sup>2</sup>		
	MPT	64 – 250 g/m <sup>2</sup>		
	Duplex	64 – 220 g/m <sup>2</sup>		
Status switch/sensor	Paper Empty	Yes		
	Paper Low	No		
	MPT Paper End	No		
	Toner Low	Yes		
	Cover Open	Yes		
	Fuser Temperature	Yes		
	Paper Size Detect (Tray)	Yes		
	Paper Size Detect (MPT)	No		
	Stacker Full	Yes (Face-down)		
	Paper Thickness Detect	No		
	Continuouse Roll Paper Sag detection	No		
	Fonts	PCL Roman (Bitmap)	No	
PCL Roman (Scalable)		80 fonts		
PCL Heisei (Scalable)		No		
PS Roman (Scalable)		138 fonts		
PS Heisei (Scalable)		No		
Barcode computational		Yes (by font download)		

## Scanner section specifications

Item		
Scanner type		Legal size flatbed with RADF
Image sensor		Color CIS
Light source		LED
Optical resolution		600dpi
Input level (A/D conversion)		48 bit
Output level		24 bit
Document size	Flat bed	Max:8.5"x14" (215.9x355.6mm) Min:No limitation
	ADF	Max:8.5"x14" (215.9x355.6mm) Min:4.13"x5.8" (105x148mm)
Document thickness	Flat bed	20mm
	RADF	16~28lb (60~105g/m <sup>2</sup> )
Maximum scanning range	Flat bed	Maximum 215.9x355.6mm
	RADF	4.13 x 5.8~8.5x 14in (105 x 148~215.9x355.6mm)
Scanning speed (A4/Letter,simplex)		Color : up to 40ipm (Less than 300dpi) up to 25ipm (400 / 600dpi) Mono: up to 40ipm(300/400/600dpi)
Warm-up time		Less than 1 sec.
Life	MTBF	6,000H (Reference only)
	MTTR	Less than 20 min.
Attachment file format		Color : JPEG, TIFF(multi/single page), PDF(multi/single page), Slim PDF, Secure PDF, XPS(multi/single page) ACS : TIFF(multi/single page), PDF(multi/single page), XPS(multi/single page) Grayscale : JPEG, TIFF(multi/single page), PDF(multi/single page), Slim PDF, Secure PDF, XPS(multi/single page) Mono : TIFF(multi/single page), PDF(multi/single page), XPS(multi/single page)
Supported driver		Scanner driver (Network), Fax Modem driver (Windows only)

## Network specifications

Item	
Connection	10Base-T/100Base-TX/1000Base-T
Communication protocol	TCP/IP V4, TCP/IP V6, NetBIOS over TCP, Ether Talk, NetWare, LPR, Port9100, IPP, FTP, WSD-print, SMTP, POP3, HTTP, SNMPv1, SNMPv3, DHCP, DNS, DDNS, WINS, SLP, Bonjour, SNTP
Supported browser	Microsoft Internet Explorer Ver. 6.0 or higher Safari 4.0 or higher Firefox 3.5 or higher

## Copy function

Categories		Specs
Copy Resolution		Scan: 300x300dpi / 300x600dpi / 600x600dpi Print: 600x600dpi / 600x1200dpi
Document Size	Flatbed/RADF	A4, A5, A6, B5, Executive, Letter, Legal13, Legal13.5, Legal14, Folio
Number of Copies		1 to 999 pages
Collate(Sort)		Yes (No. of page is depend on HDD capacity)
Zoom (Auto is supported)	Custom	25 ~ 400%, to scale by 1%.
	Preset	No (Original size / Tray size selection works as preset scaling))
Edge Erase		2~50mm (increments of 1mm) 0.1~2.0 inch (increments of 0.1 inch)
Margin shift		0 ~ ±25 mm 0.0~±1.0 inch (1mm/Step)
N-up	Document pages	2-up,4-up
ID Card Copy		Yes (by template)
Repeat Copy		Yes (max 8 times)
Poster Copy		No
Document Direction		Portrait,Landscape
Duplex Copy		Yes (1 to 2, 2 to 1, 2 to 2)
Binding Position		Long edge, Short edge
Mixed Size		Yes (Letter/Legal13,Letter/Legal13.5,Letter/Legal14, A4/Folio)
Job build scanning		Yes
Banner Copy		No
Color/Mono		Selected by User by Menu setting
Copy image quality adjustment		Background removal, Density(Auto/Manual), Contrast, Saturation, Hue

### Fax specification

Category	Item	MC770	MC780
General Function	Compatibility	ITU-T G3	
	Applicable Network	PSTN, PBX	
	Country Code	Yes (26 Countries)	
	Transmission Ability	Letter / Legal	
	Reception Ability	Letter /unlimited	
	Fax Resolution	8 x 3.85 dots/mm, 8x 7.7 dots/mm, 8 x 15.4dots/mm, 16 x 15.4 dots/mm, 300 x 300 dots/inch	
	Contrast Control	Auto or manual (11 Level)	
	Send Fax from RADF (duplex document)	Yes	
	Mixed Reading For ADF/FBS	No	
	Auto reduction printing of the FAX	No	
	Fixed reduction printing of the FAX	Yes (90%)	
	Page division print	Yes	
	Maximum Modem Speed	33.6kbps	
	Dual Access	Yes	
	ECM	Yes	
	Coding Scheme	MH, MR, MMR, JBIG	
	Transmission time	Approx. 3 seconds	
	Memory Capacity	1GB	
	Image Battery Back Up	Yes (HDD)	

Category	Item	MC770	MC780
Communication Function	Realtime Tx	Yes	
	Instant Dial Tx (Quick Memory TX)	No	
	Realtime Page Print Reception	No	
	Memory Tx/Rx	Yes	
	Relay Broadcast (OKI Mode)	No	
	Confidential Tx/Rx (OKI Mode)	No	
	Bulletin Poll (OKI Mode)	No	
	F Code Bulletin Poll	Yes	
	F Code Confidential	Yes	
	F Code Routing	Yes	
	Delayed Transmission	Yes	
	Broadcast	Yes (400 stations)	
	Delayed Broadcast	Yes	
	Page Retransmission	No	
	Rotation TX	No	
	Rotation RX	No	
	Fax Forwarding (FAX to FAX)	Yes	
	Fax Forwarding To Email	Yes (by on-ramp gateway function)	
	PC-FAX	Yes (Tx only)	

Category	Item	MC770	MC780
Security Function	Junk Fax Protection	No	
	Memory Only Reception	Yes (High security mode)	
	ID Check TX	No	
	Double input for dialing number	Yes (can be switched by service person)	
	Access Control	Yes	
Telephone & Convenience Function	External handset	No	
	Dialing by Ten key	Yes	
	One touch Dial	No	
	Speed Dial	Yes (3000 Locations)	
	Group Dial	Yes (200 Groups)	
	Automatic Alternate Selecting Call	No	
	Auto Redial	Yes	
	Manual Redial	No	
	On-Hook Dial by HOOK key	Yes (with monitor key)	
	Chain Dial	Yes	
	Automatic Pause-signal insertion	No	
	Auto Rx	Yes	
	Manual Rx	Yes	
	FAX/TEL Automatic Switching	Yes	
	ANS/FAX Automatic Switching	No	
	Remote RX	Yes	
	Sender ID	Yes	
	Personal ID	No	
	Session No.	Yes	
	TSI Time Date print	Yes	
Acoustic Monitor	Yes		

Category	Item	MC770	MC780
Fax Local Print Function	Activity Report	Yes (Transmission /Reception Journal)	
	Message Confirmation Report (Single Location)	Yes (Transmission Report)	
	Message Confirmation Report with top of document (Single Location)	Yes (Transmission Report)	
	Message Confirmation Report(Broadcast)	Yes	
	Broadcast Entry Report	No	
	Speed Dial List	Yes (Phone Book List)	
	Fax Configuration List	Yes	
	Protocol Dump Print	Yes	
	Power Down Report	No	



## Internet Fax

Category	Item	MC760	MC770	MC780	
General Function	Compatibility	T.37 (Simple Mode) T.37 (Direct SMTP Mode)* *by Service Code Setting			
	Transmission Ability	Letter / Legal			
	Reception Ability	Letter /unlimited			
	Fax Resolution	8 x 3.85 dots/mm, 8x 7.7 dots/mm 16 x 15.4 dots/mm (Direct SMTP mode only)			
	Contrast Control	Auto or manual (11 Level)			
	Send Fax from RADF (duplex document)	Yes			
	Mixed Reading For ADF/FBS	Yes			
	Auto reduction printing of the FAX	No			
	Fixed reduction printing of the FAX	No			
	Page division print	No			
	Dual Access	Yes			
	Coding Scheme	MH			
	Attachment file format	Tiff-S Only Tiff-F (only A3, B4 & A4)* *Direct SMTP Mode Only"			
	Memory Capacity	1GB (HDD model)			
	Image Battery Back Up	Yes (HDD)			
	Communication Function	Memory Tx/Rx	Yes		
		Delayed Transmission	No		
Broadcast		Yes			
Delayed Broadcast		No			
Rotation TX		No			
Rotation RX		No			
Fax Forwarding		Yes (send to network folder/E-mail/Internet-Fax/Analog-Fax)			
PC-FAX		Yes			

Category	Item	MC760	MC770	MC780
Security Function	Junk Fax Protection	No		
	Memory Only Reception	No		
	ID Check TX	No		
	Double input for dialing number	No		
	Access Control	Yes		
Telephone & Convenience Function	Dialing by keyboard	Yes		
	One touch Dial	No		
	Speed Dial	Yes		
	Group Dial	No		
	Sender ID	No		
	Personal ID	No		
	TSI Time Date print	No		
Fax Local Print Function	Activity Report	Yes		
	Message Confirmation Report (Single Location)	Yes		
	Message Confirmation Report with top of document (Single Location)	Yes		
	Error Report	Yes		
	Message Confirmation Report (Broadcast)	No		
	Broadcast Entry Report	No		
	Speed Dial List	Yes		
	Power Down Report	No		

## 1.5 Specification of interface

### 1.5.1 Specification of USB interface

#### 1.5.1.1 General of USB interface

- (1) Spec.  
USB (Support Hi speed USB )
- (2) Transmission mode  
Full speed (Maximum 12Mbps 0.25%)  
High speed(Maximum 480Mbps 0.05%)
- (3) Power control  
Self power device

#### 1.5.1.2 Connector and cable of USB interface

- (1) Connector
  - Printer side: B Receptacle (female)  
Up-stream port  
UBB-4R-D14C-4D(LF)(SN) (JST Mfg. Co.,Ltd) or equivalent

Connector pins array

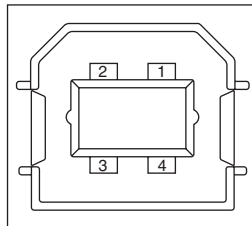

- Cable side: B plug(male)

#### (2) Cable

The length of the cable: the cable of less than 5m with USB 2.0 spec.  
(Less than 2m is recommended)  
(Please use the shielded wire for the cable.)

#### 1.5.1.3 USB interface signal

	Signal name	Function
1	Vbus	Power (+5V)
2	D-	For data transmission
3	D+	For data transmission
4	GND	Signal Ground
Shell	Shield	

## 1.5.2 Specification of network interface

### 1.5.2.1 General of network interface

#### Spec.

##### Network Protocol

TCP/IP sepc. Network layer

ARP, IP, ICMP, IPv6, IPSec

Transfer layer

TCP, UDP

Application layer

LPR, Port9100, FTP, HTTP, HTTPS, IPP, SNMPv1/v3, TELENET, DHCP/BOOTP, DNS, DDNS, WINS, UPnP, Bonjour, SNTP, SMTP, POP, Windows Rally (WSD Print, LLTD).

NBT/NetBEUI: SMB, NetBIOS, NetBIOS over TCP

Netware: Remote printer mode(Maximum 8 print sever )

Print sever mode (Maximum 8 files sever: 32 queue)

For encrypted password (when it is print sever mode)

NetWare6J/5J/4.1J (NDS, bindery)

SNMP

EtherTalk: ELAP, AARP, DDP, AEP, NBP, ZIP, RTMP, ATP, PAP

IEEE802.1X: EAP-TLS, PEAP

### 1.5.2.2 Connector and cable of network interface

#### (1) Connector

1000BASE-T/100BASE-TX/10BASE-T

(Auto switch, cannot be used simultaneously)

Connector pins array

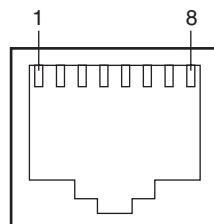

#### (2) Cable

Non-shield twisted-pair cable with RJ-45 connector

(Category 6 is recommended)

### 1.5.2.3 Signal of network interface

#### (1) 10/100Base-T

Pin No.	Signal name	Direction	Function
1	TXD+	FROM PRINTER	Transmission data +
2	TXD-	FROM PRINTER	Transmission data -
3	RXD+	TO PRINTER	Receive data +
4	-	-	Not use
5	-	-	Not use
6	RXD-	TO PRINTER	Receive data -
7	-	-	Not use
8	-	-	Not use

#### (2) 1000Base-T

Pin No.	Signal name	Direction	Function
1	TRD+(0)	bi-direction	Data0+ transmission and reception
2	TRD-(0)	↑	Data0-transmission and reception
3	TRD+(1)	↑	Data1+ transmission and reception
4	TRD+(2)	↑	Data2+ transmission and reception
5	TRD-(2)	↑	Data2-transmission and reception
6	TRD-(1)	↑	Data1- transmission and reception
7	TRD+(3)	↑	Data3+ transmission and reception
8	TRD-(3)	↑	Data3-transmission and reception

### 1.5.3 Telephone Line Interface Specification

#### 1.5.3.1 Outline of telephone Line Interface

The machine will reliably communicate with distant stations over voice-level telephone line.

#### 1.5.3.2 Telephone Line Interface Connector and Cable

Connector Type : RJ-11

Cable Type : TEL Cable (With RJ-11 plug)

Connector contact arrangement

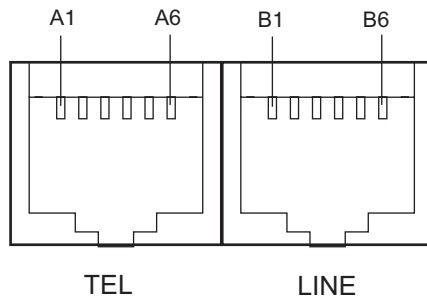

#### 1.5.3.3 Telephone Line Interface signal

	Contact No.	Functions
TEL	A1	Unspecified
	A2	Unspecified
	A3	TCP
	A4	TCP
	A5	Unspecified
	A6	Unspecified
LINE	B1	Unspecified
	B2	Unspecified
	B3	TCP
	B4	TCP
	B5	Unspecified
	B6	Unspecified

TCP : Terminal Connection Point

### 1.5.4 USB Host Interface

#### 1.5.4.1 Outline of USB Host Interface

- (1) Basic Specification  
USB
- (2) Transmission Mode  
Hi Speed (480Mbps±0.05% max.)
- (3) Supply Power  
Max. 500mA
- (4) Connection devices  
USB memory

#### 1.5.4.2 USB Host Interface Connector

USB A plug connector

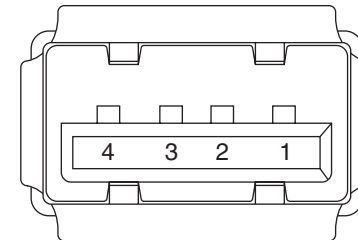

Connector pin arrangement

#### 1.5.4.3 USB Host Interface Signal

	Name of Signal	Function
1	Vbus	Power Supply (+5V)(red)
2	D -	Data transmission (white)
3	D +	Data transmission (green)
4	GND	Single ground (black)
Shell	Shield	

### 1.5.5 Specification of ACC interface

#### 1) Connector

Printer side: USB A receptacle (female)

Downstream port

UBA-4R-D14C2-4D(LF)(SN) (JST Mfg. Co.,Ltd) or equivalent

Cable side: USB A plug (male)

#### 2) Interface signals

Contact No.	Signal Name	Function
1	VBUS	Power supply(+5V)
2	D-	For data transfer
3	D+	For data transfer
4	GND	Signal ground Shell
Shell	Shield	Shield

#### 3) Conector pin arrangement

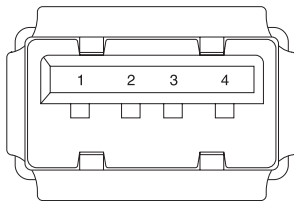

#### 4) Connecting device Card reader (Option)

# 2. Operating instructions

---

2.1	Electrophotographic processing mechanism .....	23
2.2	Printing process .....	27
2.3	Image Scanning process .....	38

## 2.1 Electrophotographic processing mechanism

### (1) Electrophotographic processing

The general of Electrophotography process is described as below.

#### 1. Charging

The voltage is impressed to CH roller, and the surface of OPC drum is electrified.

#### 2. Exposure

LED head irradiates light to the image signal on the surface of the electrified OPC drum. The electricity of the irradiated part on the surface of the OPC drum is attenuated by changing in light intensity, the electrostatic latent image is formed on the surface of the OPC drum.

#### 3. Development

The electrified toner adheres to the electrostatic latent image of the OPC drum by electrostatic force, and the image is developed on the surface of the OPC drum.

#### 4. Transfer

The paper is overlapped on the surface of the OPC drum, and the electricity is generated on the back of the paper by transfer roller, the toner image is transcribed to the paper.

#### 5. Fusing

Heat and pressure are applied to the toner image on the paper in order to make it fusing.

#### 6. Drum cleaning

The drum cleaning blade removes the toner left on the OPC drum after transfer.

#### 7. Electricity removal

The electric potential left on the drum is removed.

#### 8. Belt cleaning

The belt cleaning blade removes the toner left on the belt.

### (2) Charging

The voltage is impressed to the charging roller in contact with the surface of OPC drum, and the surface of OPC drum is minus charged.

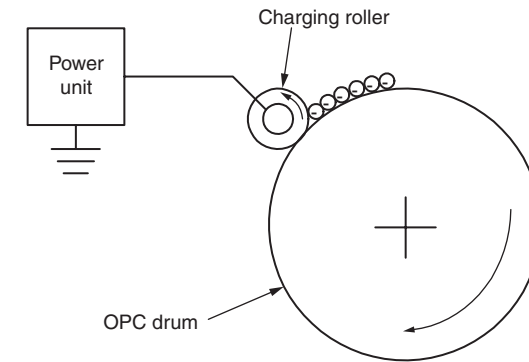

### (3) Exposure

The light generated from LED head is irradiated onto the surface of the electrified OPC drum. The electricity of the irradiated part on the surface of the OPC drum is attenuated by changing in light intensity, the electrostatic latent image is formed on the surface of the OPC drum.

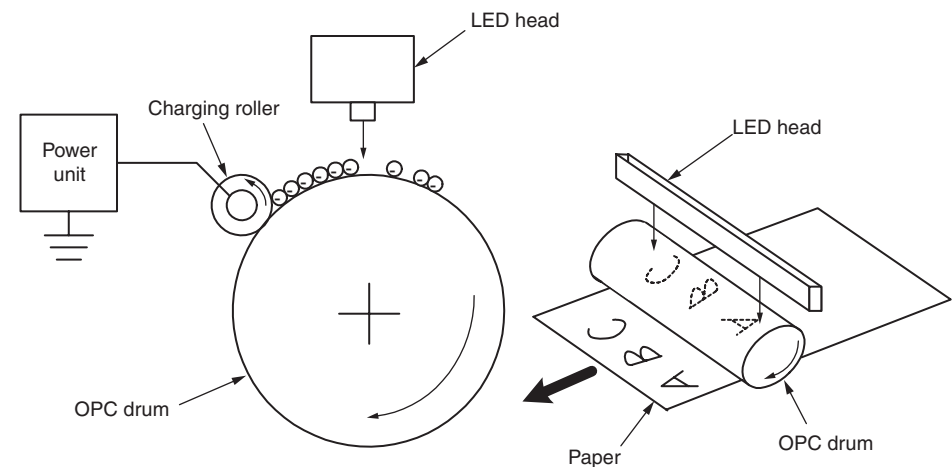

(4) Development

The toner adheres to the electrostatic latent image on the surface of the drum, and the electrostatic latent image is changed into the toner image.

1. The sponge roller makes the toner adhere to the developing roller.

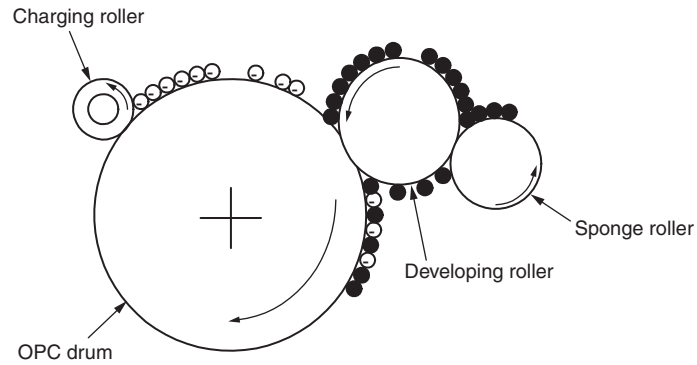

2. The electrostatic latent image on the surface of the OPC drum surface is visualized by toner.

(5) Transfer

The paper is overlapped on the surface of the OPC drum, and the electricity is generated on the back of the paper by transfer roller.

When high voltage is impressed from the power supply to the transfer roller, the electricity induced in the transfer roller is moved to the surface of the paper via contact surface, and the toner is drawn from the surface of the OPC drum to the surface of the paper.

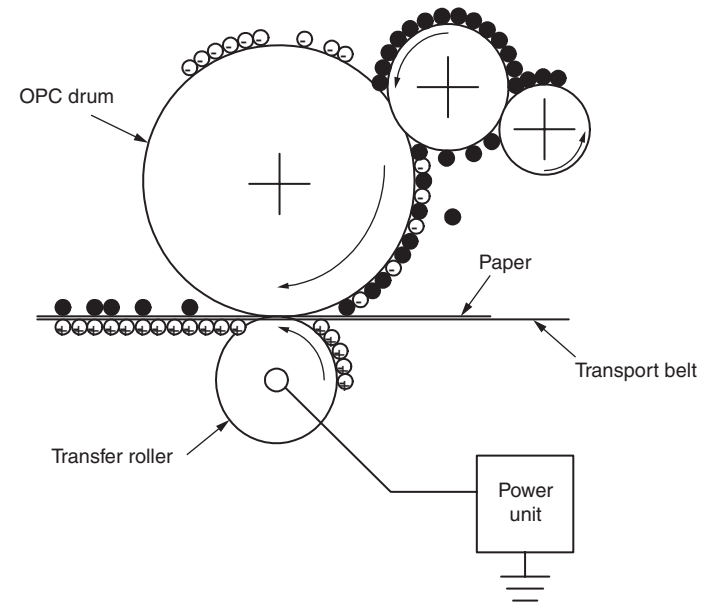



(6) Fusing

When the paper passes through the heat roller and backup roller unit, heat and pressure are applied to the toner image on the paper and the toner is fused onto the paper.

The halogen lamps of 800W and 400W are built in heat roller. The backup roller without built-in halogen lamp is heated by the heat transmission from the heat roller. The fusing temperature is controlled by the temperature detected by the thermistor that is not in contacting with the surface of the heat roller. On the other hand, the temperature detected by the thermistor rubbing the surface of backup roller is used for controlling the fusing temperature under specified conditions. Furthermore, a thermostat is used to limit the temperature rise, if the temperature rise of heat roller exceeds a set point, the thermostat would be open and the voltage supply to the heater would be cut off. The backup roller unit is pressed on the heat roller by the spring on both sides.

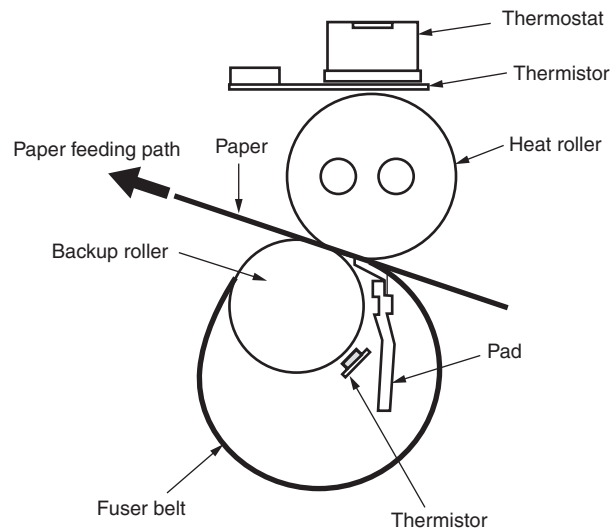

(7) Drum cleaning

The Unfused toner left on the OPC drum is cleaned up by the drum cleaning blade, and all residual toner is collected in the waste toner area of the toner cartridge.

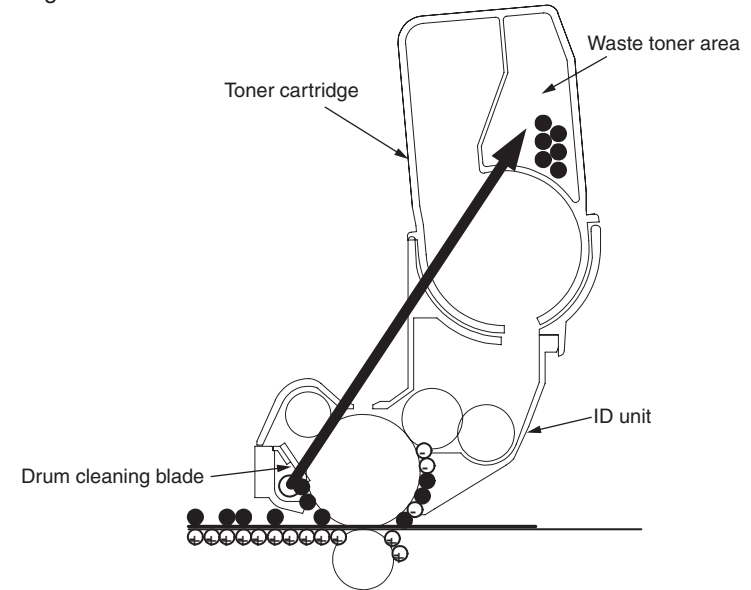

(8) Electricity removal

The electricity on the surface of the OPC drum is attenuated by irradiating the light to the surface of the OPC drum after transfer.

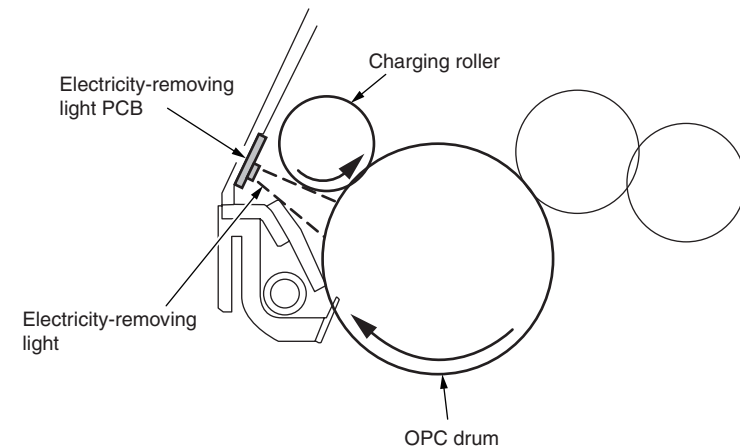

(9) Belt cleaning

The toner left on the transport belt is cleaned up by the belt cleaning blade, and all residual toner is collected in the waste toner box of the transport belt unit.

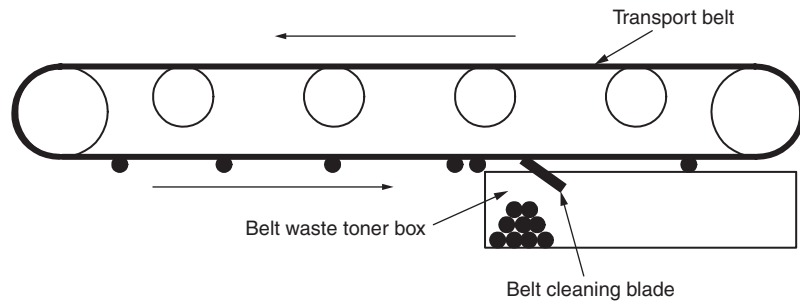

## 2.2 Printing process

The paper fed from tray 1 or tray 2, tray.3 is transferred by feeder roller, resister roller L, and transfer roller. It is transferred by MPT paper feed roller and resister roller U when the paper is fed from MPT. After that, the paper on the belt passes through the electrophotography process of KYMC, and sequentially the unfused toner image is generated on the paper. And then, the toner is fused by heat and pressure when it is passed through the fuse unit. After fusing, the paper is delivered to the faceup or facedown stacker by utilization of different delivery methods by opening or closing the faceup stacker.

The operation of single-sided printing is described as above. The operation of duplex printing is described as below.

As for the duplex print, the paper passed the fuse unit after initially back printing is drawn into the Duplex unit by separator DUP. The paper entered into the paper reversing path is transferred from the paper reversing path to the inside of Duplex by reverse operation of reversal roller. The paper passed over the inside of Duplex is fed from paper feed path of Duplex by the transfer roller set in the transfer path of Duplex inside, which is shared with the same paper feed path from the tray. The following operation is same as single-sided printing with paper feeding from the tray.

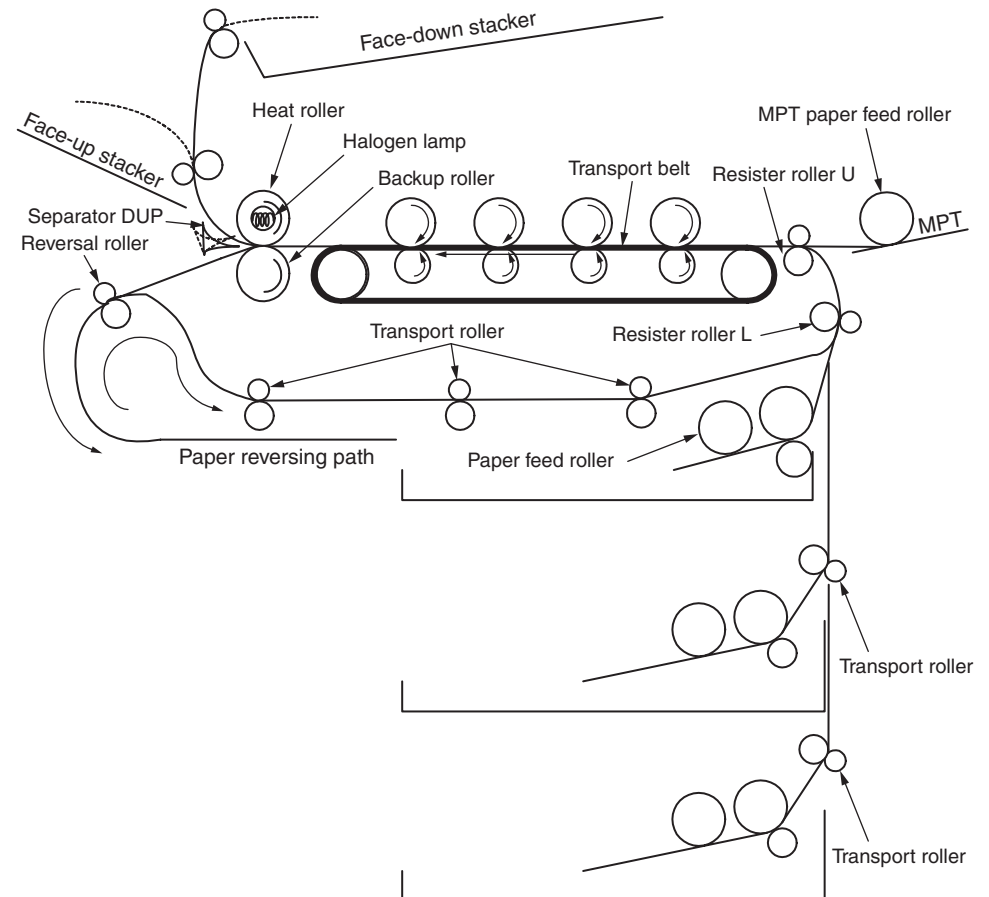

(1) Paper feeding from 1st tray

1. As figure 2-1 shows, a feed motor runs clockwise, a feed clutch engages and paper is fed (a feed roller rotates when the feed clutch engages).
2. After turning on an IN1 sensor, the paper is fed further a determined length until it touches a registration roller L (this corrects skews of the paper).
3. As figure 2-2 shows, a registration clutch engages and the registration roller L feeds paper (the registration roller L rotates when the registration clutch engages).

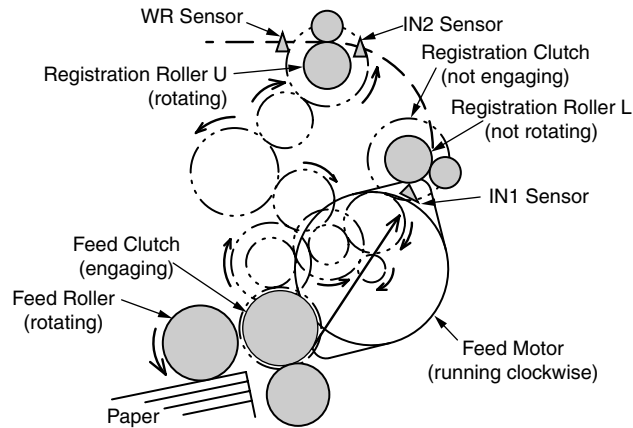

Figure 2-1

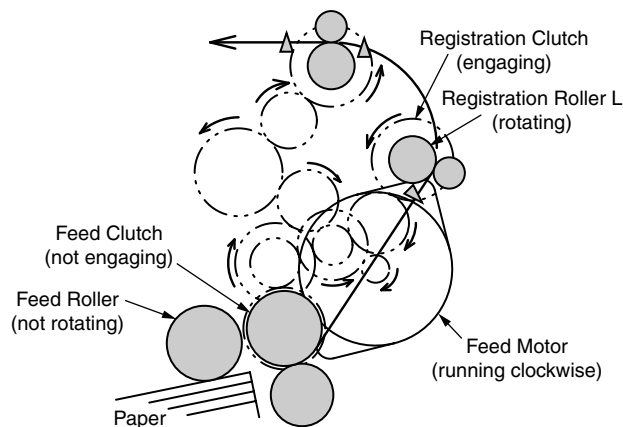

Figure 2-2

(2) Paper feeding from MPT

1. As figure 2-3 shows, a feed motor runs counterclockwise, an MPT clutch engages and paper is fed (an MPT feed roller rotates when the MPT clutch engages).
2. After turning on an IN2 sensor, the paper is fed further a determined length until it touches a registration roller U (this corrects skews of the paper).
3. As figure 2-4 shows, the feed motor runs clockwise and the registration roller U feeds the paper (the registration roller U rotates when the feed motor runs clockwise).

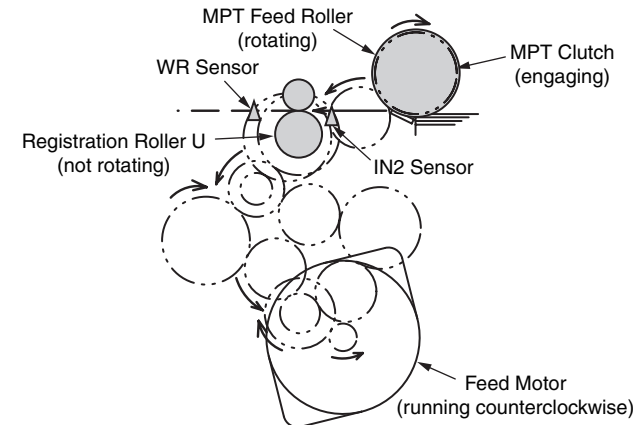

Figure 2-3

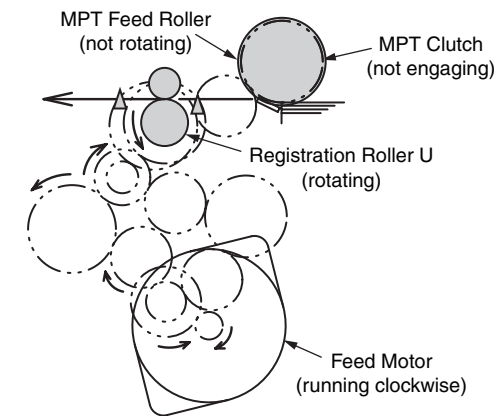

Figure 2-4

## (3) Transport belt

1. When the transport belt motor is rotated in the direction of the arrow, the transport belt is driven. As for the belt unit, a transfer roller is set over under each color drum. The belt is caught and installed between the transfer roller and drum.

As for the transport belt and transfer roller, if the specified voltage is impressed, the paper on the transport belt would be delivered to the fuser unit while transcribing the toner image on each color drum.

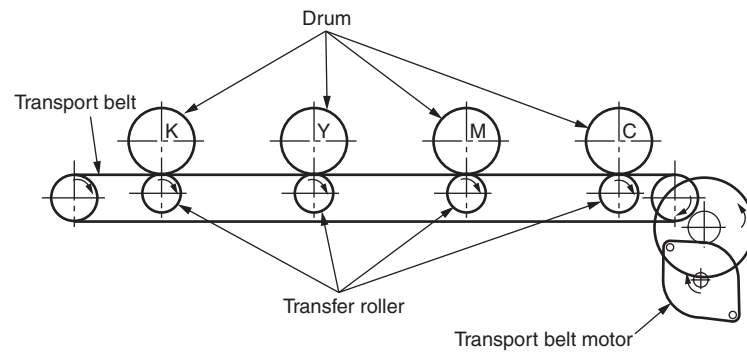

Figure 2-5

(4) Updown operation of ID unit

1. The up and down operation of the ID unit is done by driving the liftup motor.
2. Fig. 2-6 shows the operation of each ID unit when color printing. When the liftup motor is rotated (counter clockwise), the liftup link slides to left, and each ID unit is in DOWN condition as shown in Fig. 2-6. Under this condition, the color printing is available.
3. Fig. 2-7 shows the operation of each ID unit when mono printing. When the liftup motor is rotated (clockwise), the liftup link slides to right, and each ID unit (except K-ID unit) is in UP condition as shown in Fig. 2-7. Under this condition, the mono printing is available.

The operation of each ID unit when color printing

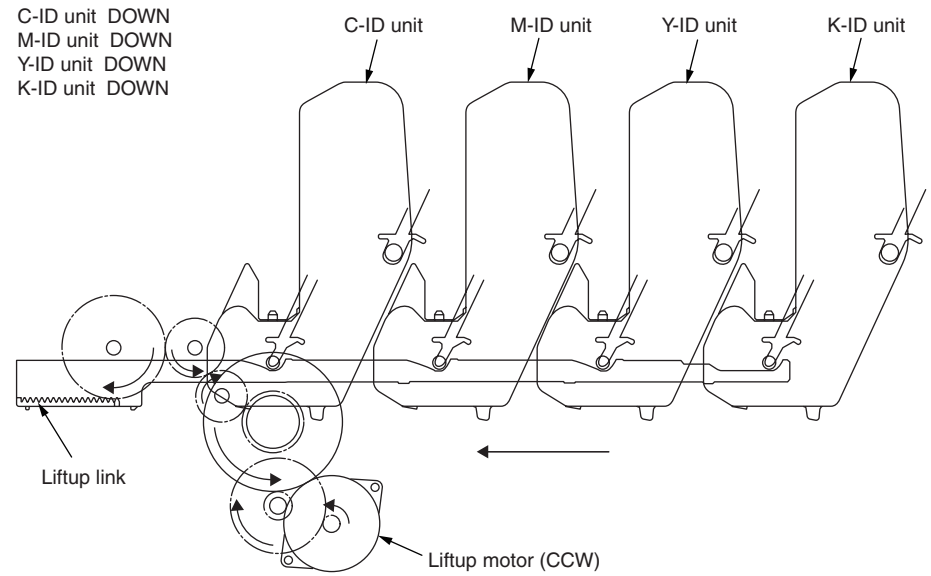

Figure 2-6

The operation of each ID unit when mono printing

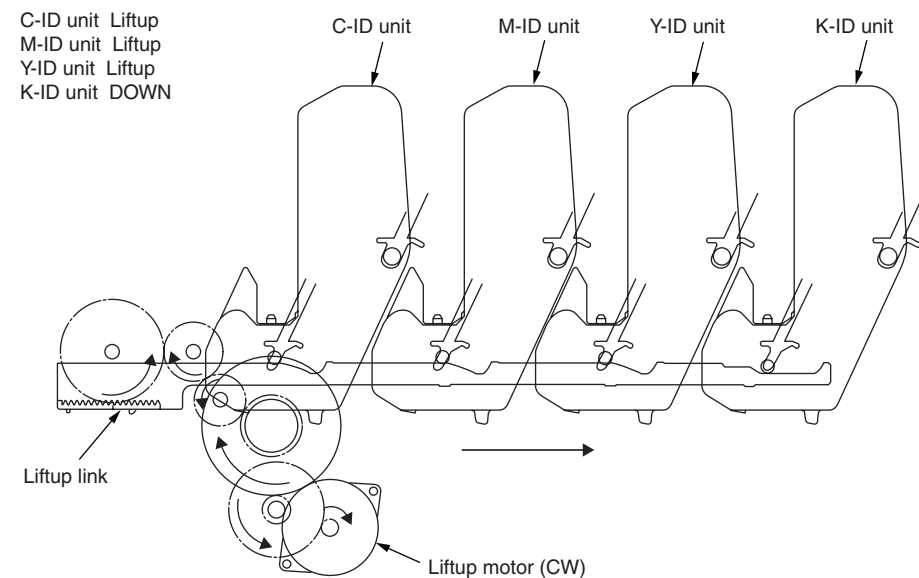

Figure 2-7

(5) Fuse unit and paper delivery

1. The fuse unit and the eject roller are driven by the DC motor as shown in Fig. 2-8. When the fuse motor is rotated (counter clockwise), the heat roller will begin to rotate. The heat roller makes the toner image fused to the paper by heat and pressure.
2. The paper exits while the eject roller rotates.

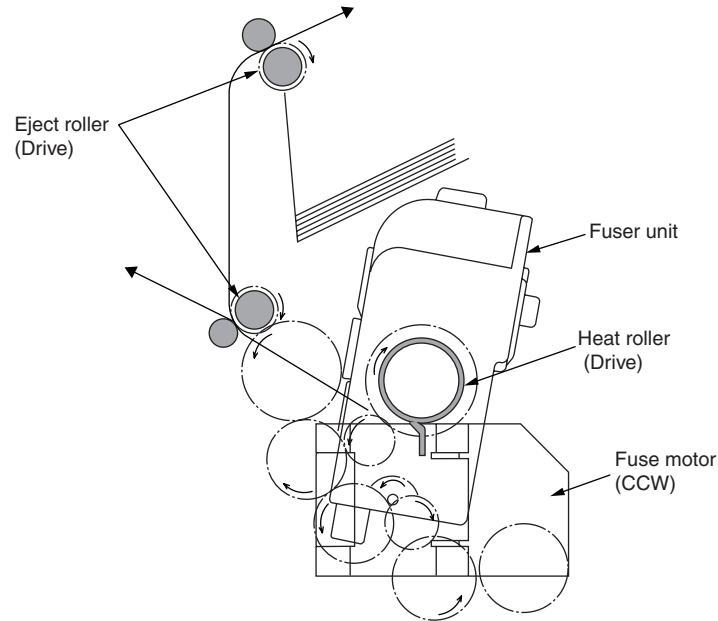

Figure 2-8

(6) Cover open operation of color blur sensor and density sensor

1. As shown in Fig. 2-9, when the fuse motor is rotated (clockwise), the cover open gear is operated and the cover of color blur sensor and density sensor is open.
2. When the fuse motor is rotated (counter clockwise) in the opposite direction, the cover open gear is moved out of engagement and the cover of color blur sensor and density sensor is close.

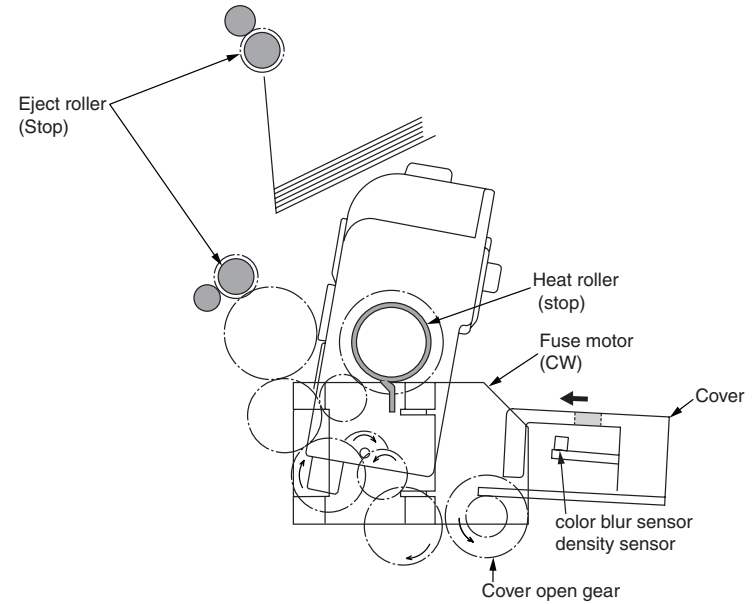

Figure 2-9

## General of color blur correction

The color blur correction is operated by reading the pattern for correction printed on the belt with a sensor set in the sensor shutter under the belt unit.

The pattern is detected by this sensor, and the correction is operated.

### Color blur correction auto-start timing

- When the power is on
- When the cover is closed after the cover is opened once
- When more than 400 copies are printed or when more than 6 hours have elapsed since the last print
- The Sleep mode has no color blur correction auto-start timings.

The amount of toner of the pattern, the toner left on the sensor and the open-close trouble of the shutter etc. may lead to correction error. However, as the error message may not display even if the error is occurred, it is necessary to perform the color registration correction test (see 5.2.1.6) by the utilization of the self-diagnostic mode and confirm the error display.

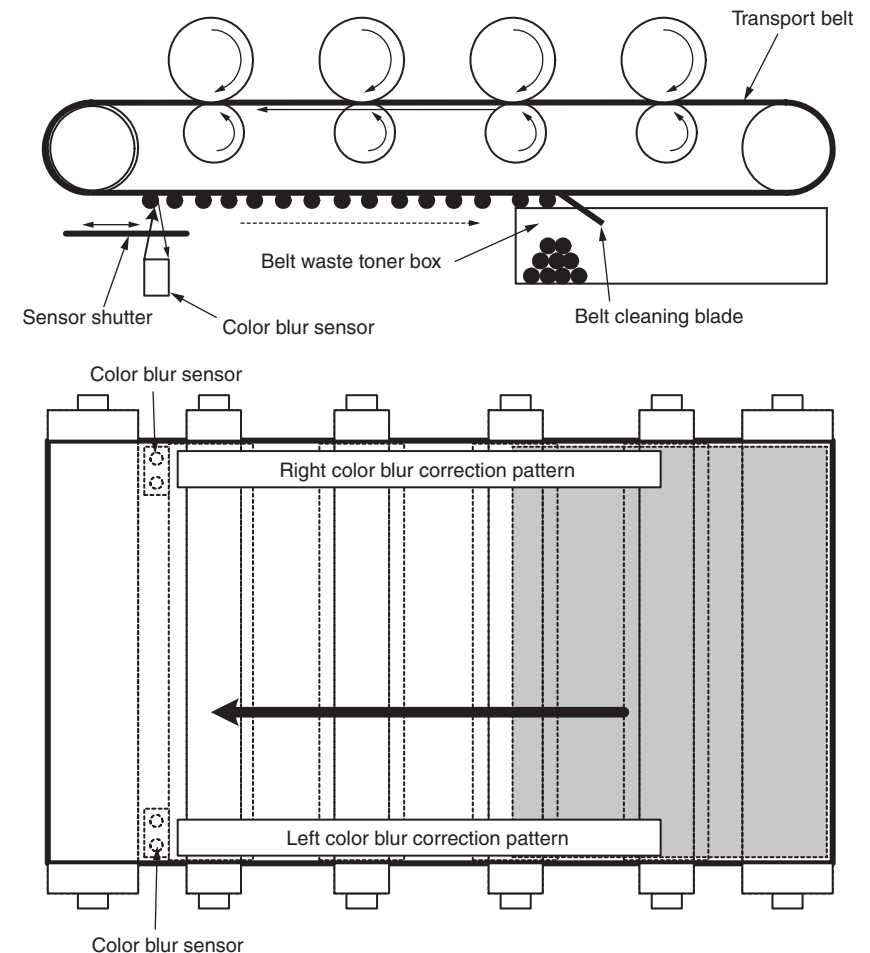



### Error-confirming method and Error-solving method

Use the color registration correction test in self-diagnostic mode to confirm the error. (See 5.2.1.6)

#### Error solving method

- CALIBRATION(L or R), DYNAMICRANGE(L or R)
  - Check 1: When the above display appears, please check the connection of sensor cable (FFC).  
When the connection is abnormal, please set it properly.
  - Check 2: Please check if the surface of the sensor is dirty with the toner and paper melts etc.
  - Check 3: Please confirm if the open and close operation of sensor shutter is normal by utilization of MOTOR&CLUTCH TEST in self-diagnostic mode.  
Exchange the shutter unit when the open and close operation is in trouble.

If there are no problems in check 1, 2, and 3, please check the circuit.

Please exchange the color adjust sensor PCB, relay PCB, PU PCB, and the cable one by one, and then check if the error is displayed.

- BELT REFLX ERR
  - Check 4: When this display appears, please check the cleaning of the toner left on the surface of the belt after finishing the above-mentioned check 1, 2, and 3. Remove the belt unit, and rotate the left inboard drive gear. Please confirm that the surface of the belt is cleaned completely.  
When the residual toner left on the surface of the belt could not be cleaned completely even if the drive gear is rotated, please exchange the belt unit.
- (Y or M or C) LEFT, (Y or M or C) RIGHT, (Y or M or C) HORIZONTAL
  - Check 5: When the above display appears, please confirm if the toner of NG color is empty.  
Please exchange the toner cartridge as required.
- See section 7 “Heavy color registration error(7.5.5.(6))” about the other errors.

## General of the density correction

The density correction is operated by reading the pattern for correction printed on the belt with a sensor set in the sensor shutter under the belt unit.

### Density correction auto-start timing

- The environment is remarkably different from last time when the power is on.
- When one or more ID count among the four ID count show the status of new part, at the power on
- The ID count value exceeds 500-count from last operation.
- When one or more UD is replaced with the new ID.
- When the belt is replaced with the new belt
- When toner cartridge is replace due to Toner Low, or Toner Empty so that Toner Low or Toner Empty has disappeared

The amount of toner of the pattern, the toner dirt and the open-close trouble of the shutter etc. may lead to correction error.

However, as the error message may not display even if the error is occurred, it is necessary to perform the density correction (see 5.3.1.7) by the utilization of the self-diagnostic mode and confirm the error display.

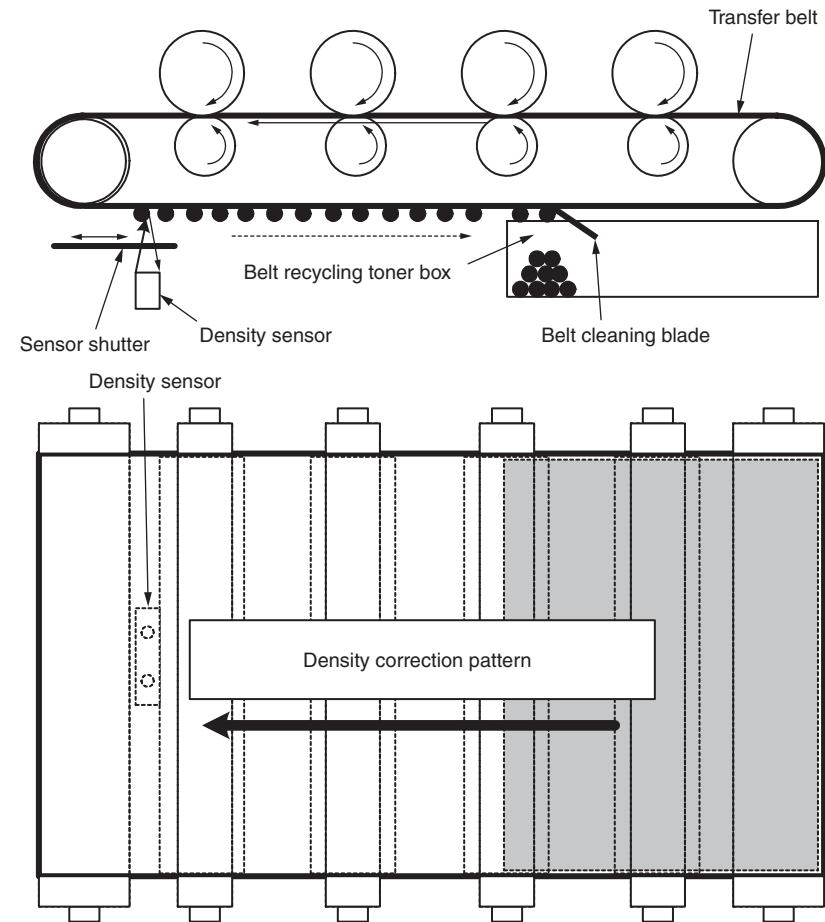

### Error-confirming method and Error-solving method

Use the density correction test function in self-diagnostic mode to confirm the error.

(See 5.3.1.7)

### Error solving method

- CALIBRATION ERR, DENS SENSOR ERR

Check 1: When the above display appears, please check the connection of sensor cable.

When the connection is abnormal, please set it properly.

Check 2: Please check if the surface of the sensor is dirty with the toner and paper melts etc.

Please wipe the dirt off if the sensor is dirty.

If there are no problems in check 1, 2, and 3, please check the circuit.

Please exchange the density sensor, relay PCB, PU PCB, and the cable one by one, and then check if the error is displayed.

- DENS SHUTTER ERR

Check 3: Please confirm if the open and close operation of sensor shutter is normal by utilization of MOTOR&CLUTCH TEST in self-diagnostic mode.

Exchange the shutter unit when the open and close operation is in trouble.

- DENS ID ERR

Check 4: Remove the ID unit, and confirm if the toner abnormally leaves on the surface of the drum.

Exchange LED head (Focus control). Or exchange the ID unit.

When a new ID unit is tried to use, please set the fuse keep mode of the maintenance menu.

### Toner sensor detection principle

Toner low is detected by the toner sensor (reflect sensor) installed in the equipment. The light board is installed in ID, and its rotation is synchronized with the mixing of toner. Toner low is detected by time for the light board passed toner sensor. Moreover, the shutter is installed in ID. Toner cartridge set properly by the lever of toner cartridge and synchronized toner sensor can be detected.

The following problems may lead to abnormal detection and the toner sensor error is occurred.

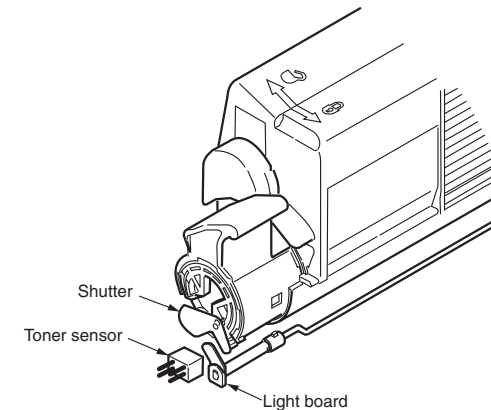

### Toner count principle

After the image data is transformed into binary data which can be printed by the printer, the data is counted as print dot number by LSI. The amount of the used toner is calculated from this count value, and the residual amount is displayed on the menu.

Toner LOW detection (residual amount display on LCD) by the toner sensor is to detect a certain amount of the reduction of the toner left in ID.

### The principle of ID counter, belt counter, fuse counter

**ID counter :** when 3 pieces of A4 paper are continuously printed, one third of the rotation of the drum is set as one count.

**Belt counter :** when 3 pieces of A4 paper are continuously printed, one third of the rotation of the drum is assumed as one count.

**Fuse counter :** The length of paper of legal 13 inch is set as nominal value.

If the length of paper is less than this nominal value, it is assumed as one count. If the length of paper is more than this nominal value, the counted number is determined by the times of legal 13 inch.

(The number after decimal point is rounded up.)

## Counter spec

	Total printed page number	MPT printed page number	Tray 1 printed page number	Tray 2 printed page number	Tray 3 printed page number	Tray 4 printed page number	Color-printed page number	Mono-printed page number
Description	Total printed page number	Hopping page number from MPT	Hopping page number from Tray1	Hopping page number from Tray2	Hopping page number from Tray3	Hopping page number from Tray4	Printed page number by color-printing	Printed page number by mono-printing
Count method A4 conversion or size independence	Count up after passing the writing sensor	Count up if MPF(MPT) hopping is finished	Count up if Tray1 hopping is finished	Count up if Tray2 hopping is finished	Count up if Tray3 hopping is finished	Count up if Tray4 hopping is finished	The page number is counted up by detecting the paper passing the fuser in color-printing mode after the job is finished. (1*) The value is A4/Letter value. Please refer to A4/ Letter conversion table (P37).	The page number is counted up by detecting the paper passing the fuser in mono-printing mode after the job is finished. (1*) The value is A4/Letter value. Please refer to A4/ Letter conversion table (P37).
Operation when paper jammed	Cannot count when paper feeding (hopping) jam and feed jam are occurred. It can count except the above-mentioned jam. As total printed page number is counted up when the front end of the page passes the writing sensor, according to the jam type, the feeding jam (380) is also included in the limits for counted.						Cannot count if the jam is occurred before the paper passes the fuser. It can count if the jam is occurred after the paper passes the fuser.	
Operation for Duplex	Front/Back count(+2)	Only front count (+1)					Double count If the color page and mono page exist together, the color printing page number would be plus 1 and the mono printing page number would be plus 1.	
Reset condition	None	None					1) When "Format Flash ROM" of system maintenance menu is performed. 2) When CU PCB is replaced. 3) When MENU RESET of system maintenance menu is performed.	
Value storage destination	PU	PU	PU	PU	PU	PU	CU	CU
Menu/MenuMap output	○ (*2)	○	○	○	○	○	○	○
EngineMenuMap output	○	○ (*3)	○ (*3)	○ (*3)	○ (*3)	○ (*3)	-	-

\*1. Count cannot be updated if the power is turned off when the jam is occurred.

\*2. In the initial state MenuMap output is not available. It is possible to switch in the system maintenance menu.

\*3. EngineMenuMap output divides into Engine Menu Print (the first page) and Engine EEPROM Dump Print (the last page), however, the number of paper fed from each tray is output only to the latter one (DUMP display only).

## A4/Letter conversion table

The paper is counted up as this sheet.

Paper size	Simplex	Duplex
LETTER	1	2
EXECUTIVE	1	2
LEGAL14	1	2
LEGAL13.5	1	2
LEGAL13	1	2
A4	1	2
A5	1	2
A6	1	-
B5	1	2
COM-9	1	-
COM-10	1	-
MONARCH	1	-
DL	1	-
C5	1	-
CUSTOM LENGTH $\leq$ 210mm	1	2
CUSTOM 210mm < LENGTH $\leq$ 899mm	2	4
CUSTOM 900mm $\leq$ LENGTH	4	-

## 2.3 Image Scanning process

### 2.3.1 Structure and process of RADF

#### 2.3.1.1 Cross-section view

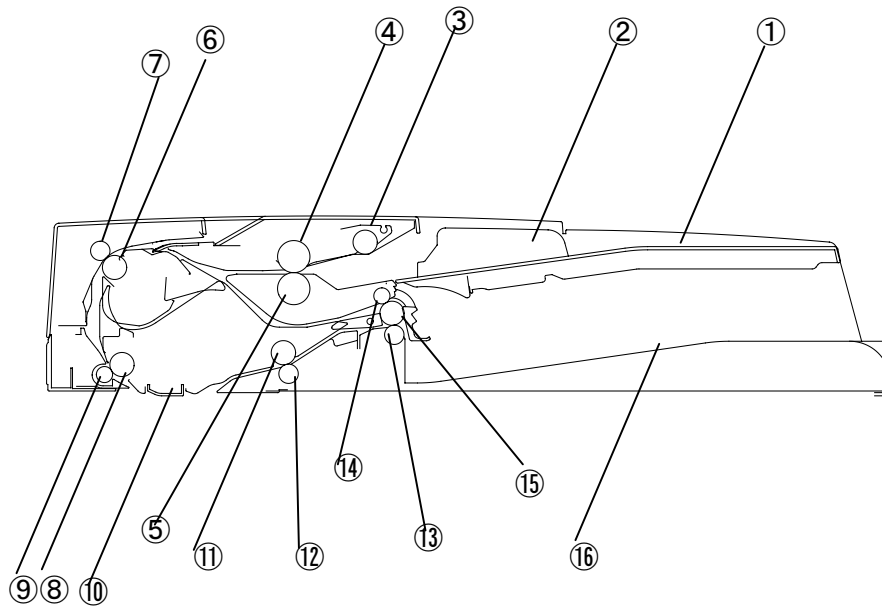

- |                   |                      |
|-------------------|----------------------|
| ① Paper tray      | ⑨ Pressure roller    |
| ② Paper guide     | ⑩ Paper holder       |
| ③ Pick-up roller  | ⑪ Scan roller        |
| ④ Feed roller     | ⑫ Pinch roller       |
| ⑤ Retard roller   | ⑬ Exit roller        |
| ⑥ Transfer roller | ⑭ Upper pinch roller |
| ⑦ Pinch roller    | ⑮ Lower pinch roller |
| ⑧ Regist roller   | ⑯ Paper stocker      |

#### 2.3.1.2 Electrical configuration

##### Electrical circuit configuration

This Scanner is controlled by the SU board(7SU).

The ASIC mounted on the SU board(7SU) control the DC load devices such as motor, solenoid and clutch via the ADF Relation board(7RL), in dependance of the sensor signals and control signals from the CU board not to be shown in the below figure.

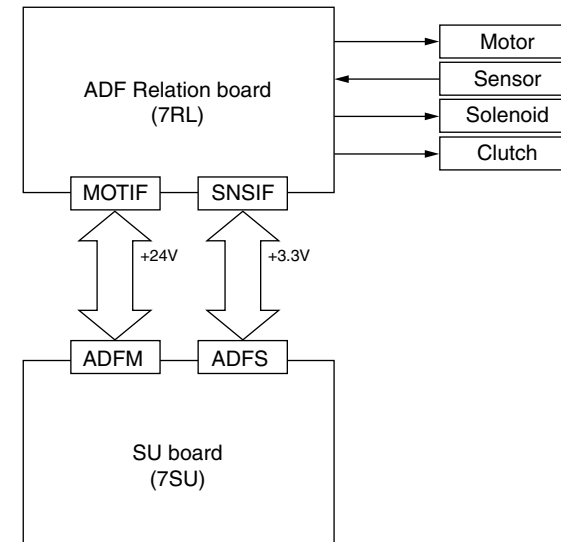

### 2.3.1.3 Fundamental operations

#### Drive force transmission diagram

The MFP is a document feed device of skim reading only.

Drive force diagram of the MFP is shown below.

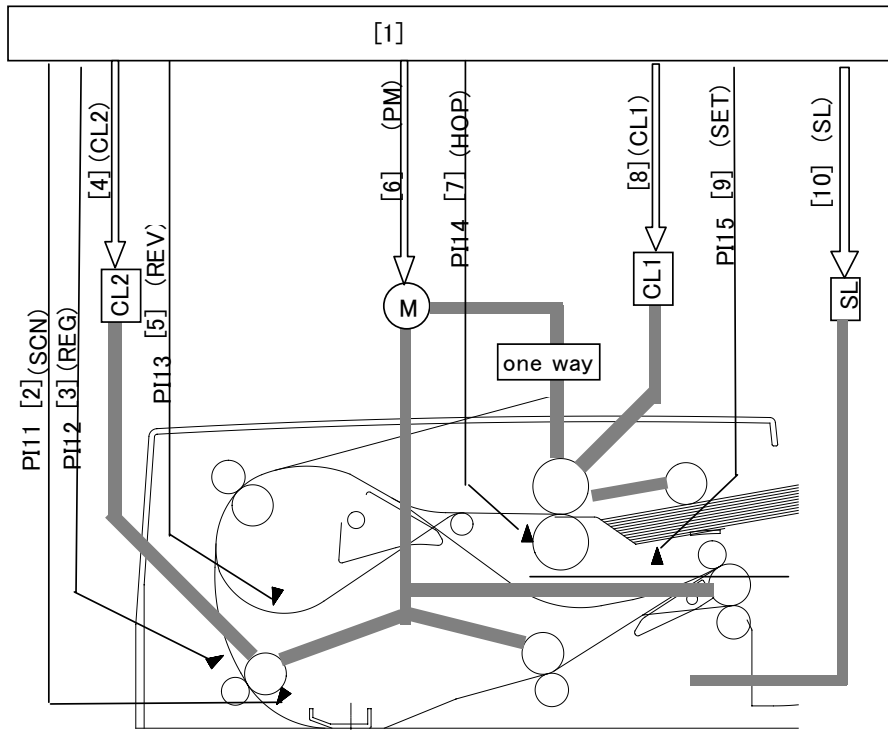

- [1] ADF Relation board(7RL)
- [2] Document detection signal
- [3] Document detection signal
- [4] Regist clutch signal
- [5] Document detection signal
- [6] Feed and transport motor drive signal
- [7] Document set signal
- [8] Feed clutch signal
- [9] Document set signal
- [10] Gear change solenoid signal

#### Overview of operation modes

There are four operation modes that are executed by the MFP. The respective operation modes are executed in accordance with the instructions given by the connected equipment to implement the print operation.

Name of the operation modes, the overview of the operation and the corresponding print modes are shown in the following table.

Name of the operation modes	Overview of the operation	Supporting print modes
[1] Normal direction feed paper/Unload paper	Document is fed and scanned. Upon completion of scan, document is unloaded as it is.	Single-sided document → Single-sided print Single-sided document → Both-sided print (This operation is performed in both cases when documents of same width and different width are used.)
[2] Normal direction feed paper/ Inverted unload paper	Document is fed and scanned. Upon completion of scan, document is inverted and unloaded.	Both-sided document → Both-sided print Both-sided document → single-sided print (This operation is performed in both cases when documents of same width and different width are used.)

### Normal direction feed paper and unload paper (single-sided document → single sided print) operation

Outline of document flow is shown below.

Supplement : When a single-sided document is selected, this operation is performed regardless of the same size mixed documents or different sizes mixed documents.

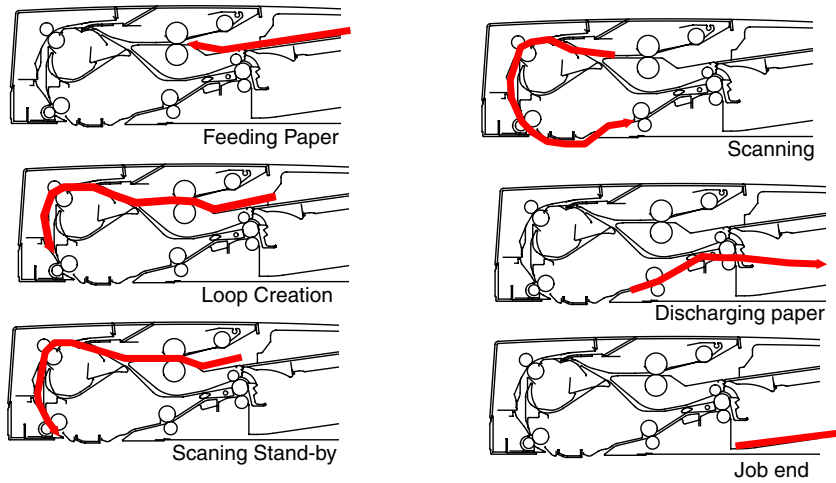



### Normal direction feed paper/Inverted unloading of paper (both-sided document → both sided print) operation

Outline of document flow is shown below.

Supplement : When a both-sided document is selected, this operation is performed regardless of the same size mixed documents or different sizes mixed documents.

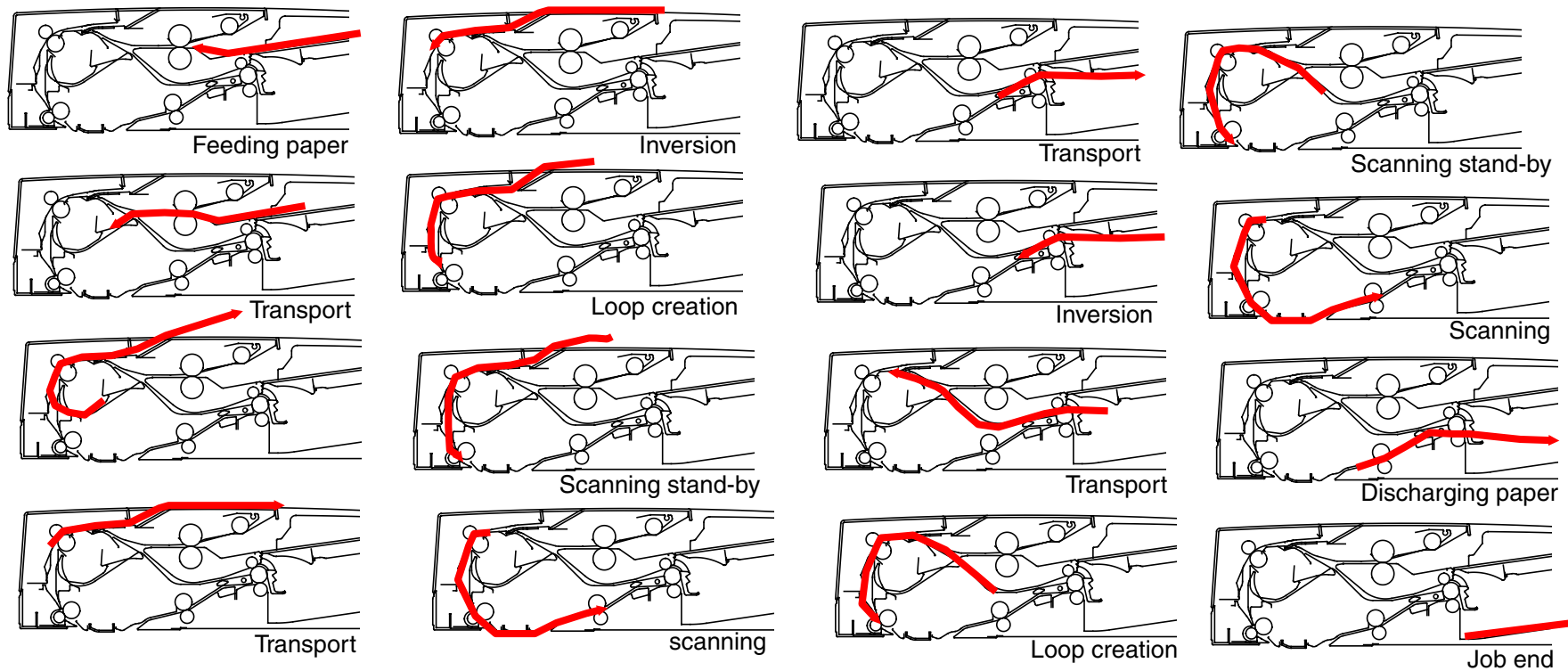

### 2.3.1.4 Document detection

#### Document present/absent detection

Document present/absent detection on the document tray is performed by document set sensor (PI15). When a document is placed on the document tray, the detection lever moves together with the light-shielding plate so that photo interrupter that has been passing the light, shut down the light. Thus, the document set sensor (PI15) issues the document detection signal (SET) telling that a document is set, to the connected equipment via the ADF Relation board(7RL).

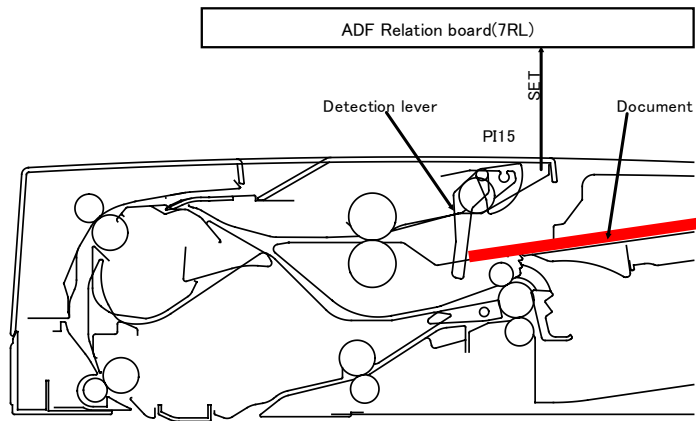

#### Detection of final document

The document set sensor (PI15) detect if the document that has started of the final document has passed the set sensor lever, the detection lever moves together with the light-shielding plate so that the photo interrupter that has been shutting down the light, passes the light. Thus, the document set sensor (PI15) issues the document set detection signal (SET). Telling that the document under feeding is the final document, to the connected equipment via the ADF Relation board(7RL).

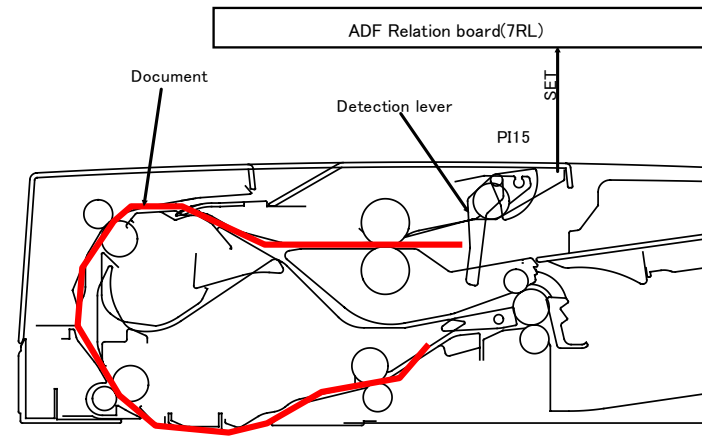

### 2.3.1.5 Jam detection

Document jam is detected by the sensors shown in the illustration. Check timing of the document jam detection has already been memorized in the ROM of the sensor main PCB beforehand so that jam occurrence can be judged from the information if a document exits or not, at the corresponding sensor block.

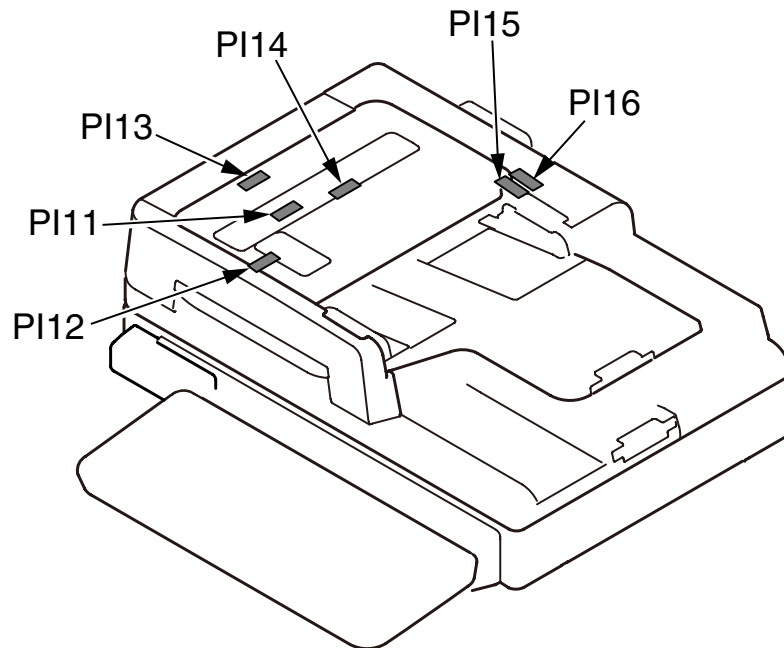

- PI11 : Scan sensor
- PI12 : Regist sensor
- PI13 : Reverse sensor
- PI14 : Hopping sensor
- PI15 : Document set sensor
- PI16 : Cover open/close sensor

### 2.3.2 Document table structure

#### 2.3.2.1 Overview

Flatbed unit consist of Cover-Top-Assy, Frame-Bottom-Assy, Carriage-Assy and Flatbed drive block.

The lamp (LED) is located on top of the Carriage-Assy. The light imadiated by the lamp (LED) rodrenze in this order and reaches the CMOS Sensor.

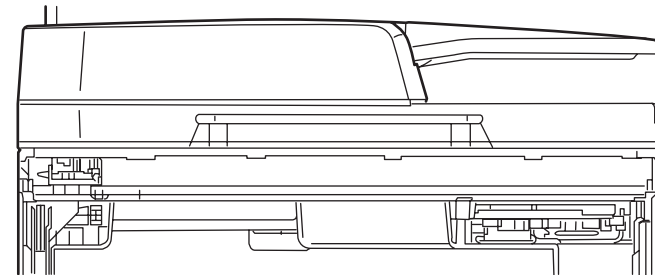

### 2.3.2.2 Exposure block

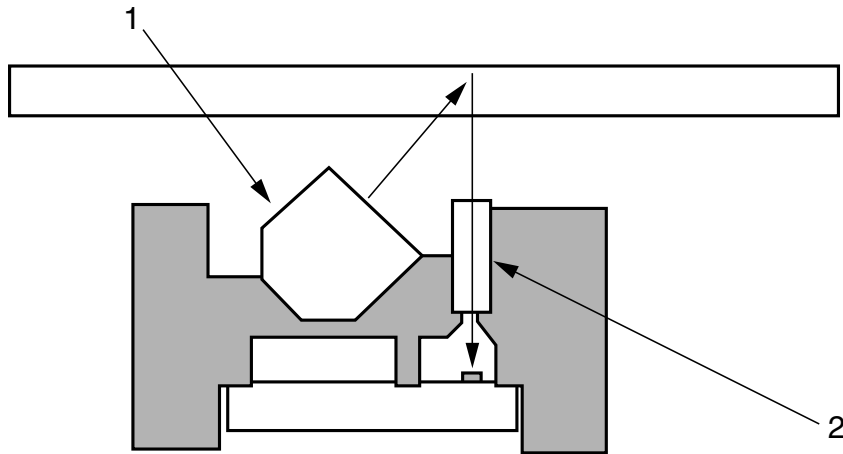

1. Lamp

LED(R,G,B) is used to irradiate light to document

2. Rod lens

The reflected light from document is again reflected to the CMOS sensor

### 2.3.2.3 Carriage-Assy drive mechanism

#### Carriage-Assy drive mechanism

Carriage-Assy performs the function of irradiating the lamp light uniformly over a document while moving its position.

The carriage-Assy is driven by a belt which is driven by the FB motor. Scanner moves at the scan speed corresponding to the respective magnification ratios that are set with reference to the standard scanning speed.

Home position of the carriage-Assy is the position where the home sensor is located. The home position is the reference position of the scanning operation.

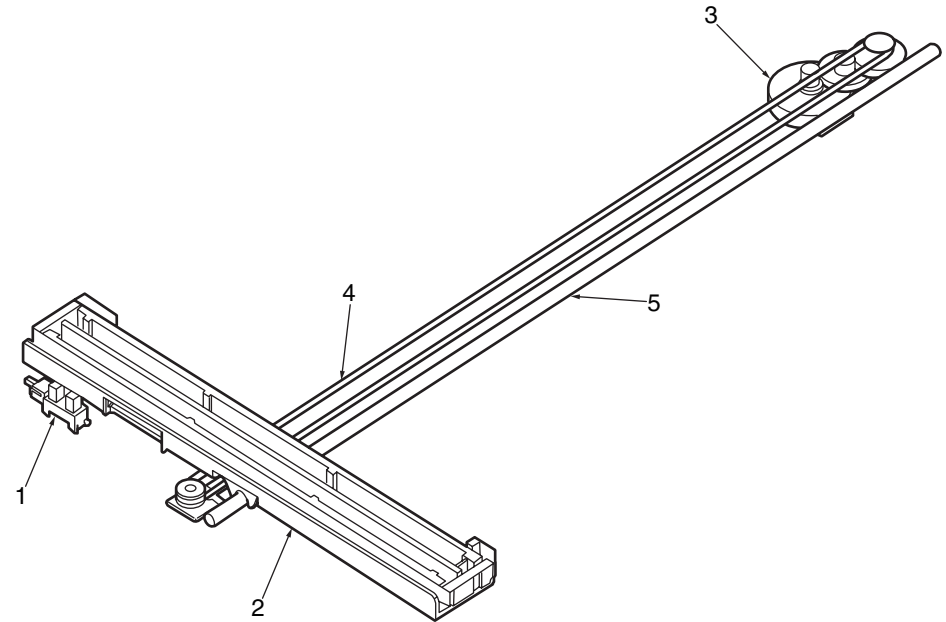

1	Home Sensor
2	Carriage Assy
3	FB Motor
4	Belt
5	Shaft

# 3. Set up

---

3.1	Notes and precautions.....	46
3.2	Unpack method .....	47
3.3	Setting method .....	48
3.4	List of equipments and accessories .....	49
3.5	Assembling method .....	50
3.6	Setting content print (Configuration).....	64
3.7	Connecting method .....	65
3.8	User used Paper confirmation .....	69

## 3.1 Notes and precautions

### Warning

- Do not set it in any high-temperature locations or near any heat sources.
- Do not set it in a place where the chemical reaction may occur (laboratory etc.).
- Do not set it near any liquid that may ignite such as alcohol and thinner.
- Do not keep it out of reach of children.
- Do not place it on an unstable or uneven surface (unstable table and slanting place, etc.).
- Do not put it in direct sunshine. And do not put it in a moist or dusty place.
- Do not set it in wet or corrosive environment.
- Do not set it in a place where may cause vibration.
- If the MFP is dropped down or the cover is damaged, please pull out the power plug from the outlet and contact the customer center.  
This may cause an electric shock, fire, injury.
- Please read this manual carefully before connecting the power supply cable, printer cable, ground cable.  
This may cause fire.
- Do not insert any foreign objects into the vent hole.  
This may cause an electric shock, fire, injury.
- Do not put a vessel(s) filled with water on the MFP.  
This may cause an electric shock, fire.
- Do not touch the fuser unit when you open the cover of the MFP.  
It is hot and could cause burns.
- Do not throw the toner cartridge, the image drum cartridge into the fire.  
It may cause burns due to dust explosion.
- Do not use inflammable sprays near the MFP.  
It may cause fire because some parts in the MFP may become very hot.
- If the cover becomes abnormally hot, smoke rises, it smells strange or it sounds abnormal, please pull out the power plug from the outlet and contact the customer center.  
It may cause fire.

### Warning

- If the liquid such as water enters the MFP, please pull out the power plug from the outlet and contact the customer center. It may cause fire.
- If you drop the foreign objects such as clip in the MFP, please pull out the power plug from the outlet and take the foreign objects out.  
This may cause an electric shock, fire, injury.
- Do not disassemble the MFP unless following the correct procedure written in the manual. This may cause an electric shock, fire, injury.

### Caution

- Do not set it in a place where the vent hole of the MFP is blocked.
- Do not set it directly on heavy wool or shag carpet.
- Do not place it in locations of poor ventilation such as enclosed areas.
- Give particular attention to adequate ventilation care when using it continuously in a narrow room for a long time.
- Do not place it close to strong magnetic fields and noise source.
- Do not place it next to the monitor and television.
- Hold tightly the both sides of the MFP when you move the MFP.
- Because the weight of the MFP is approximately 60kg (in a state of packing), it needs more than two adults to lift it up.
- Do not come close to the paper exit part while printing.  
This may cause injury.

Please explain the safety precautions about installation and handling with showing the all precautions in user's manual to customer. Especially, the details about power supply cable and the ground cable must be explained completely.

## 3.2 Unpack method

**Warning** Personal injuries may occur. 

Because the weight of the MFP is approximately 60kg(71kg:Finisher model) (in a state of packing), it needs more than three adults to lift it up.

- Take out the gripe on each side as shown in the following figure, and lift the cardboard box up.

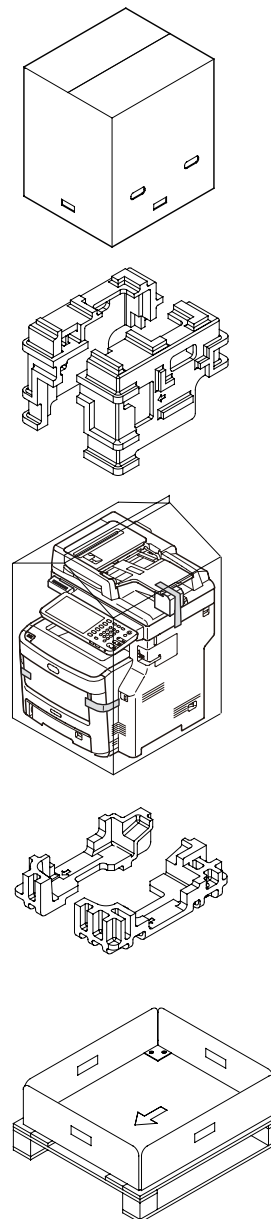
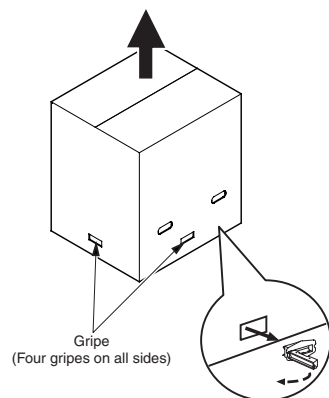

## 3.3 Setting method

- Set the MFP under these conditions.
  - Surrounding environment: 10~32°C
  - Surrounding humidity: 20~80%RH (Relative humidity)
  - Highest wet bulb temperature: 25°C
- Protect the MFP from dew formation.
- Use the humidifier or the static electricity prevention mats etc. when setting the MFP in the environment where the humidity is 30% or less.

### Set space

- The flat desk should be wide enough to put the MFP on.
- Ensure that there is enough room around the MFP for proper ventilation.

Plan view

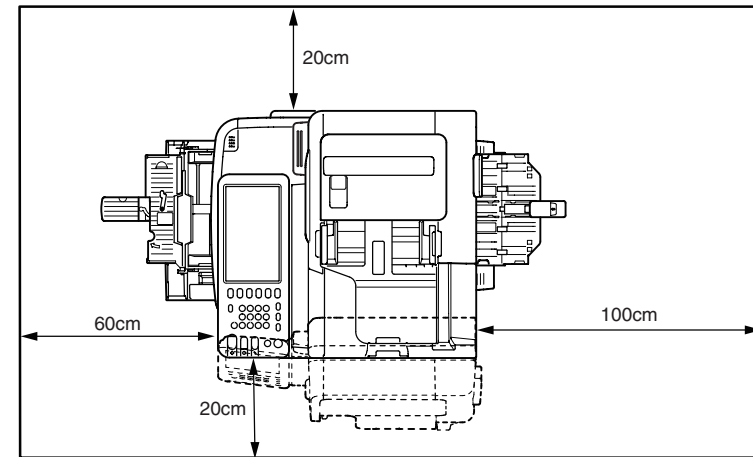

Side view

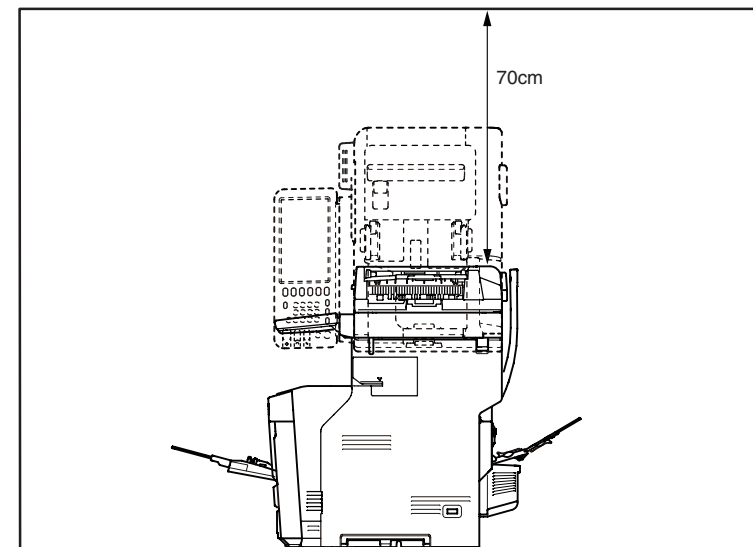



## 3.4 List of equipments and accessories

- Make sure that the appearance of the equipment is not damaged or dirty etc.
- Make sure that the following accessories are supplied with your MFP.
- If you are missing any of these accessories, contact your customer service department immediately.

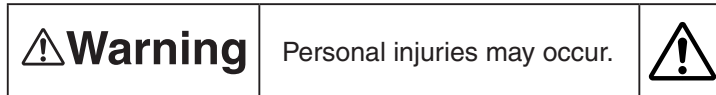

Because the weight of the MFP body is approximately 50kg (60kg in a state of packing), it needs more than three adults to lift it up.

- MFP (Body)

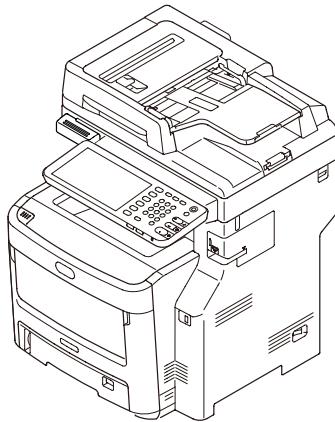

- Image drum cartridge (1 Cyan, 1 the magenta, 1 yellow, and 1 black) (mounted in the MFP)

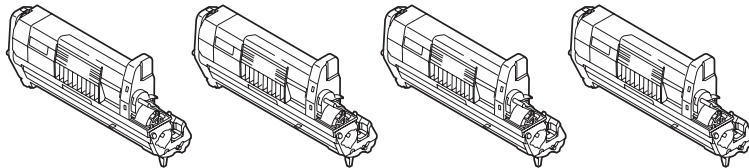

Explain to the customer that the toner cartridge and the image drum cartridge can be separated.

- Printer software DVD-ROM
- Power supply cord
- Guarantee card and user registration card
- User's manual (Setup)
- User's manual (DVD-ROM)
- TEL Cable

- Notes!**
- The printer cable is not included.
  - MFP's starter cartridge for a color cannot be reinstalled in it once replaced with an empty consumable toner cartridge for the color.

## 3.5 Assembling method

### 3.5.1 Assemble the main body of the MFP

Remove the protective materials.

- (1) Peel off the desiccant and the protection tape (three places) and pad on the MFP.

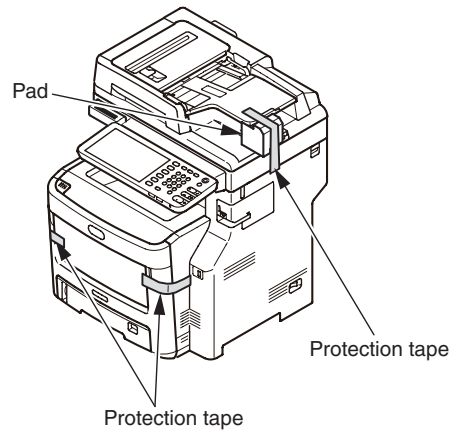

- (2) Peel off the paper on the front of MFP.

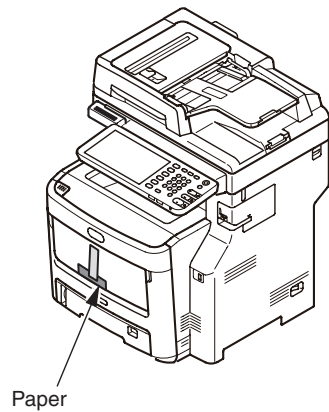

- (3) Peel off the protection tape (5 places) on the back of the MFP.

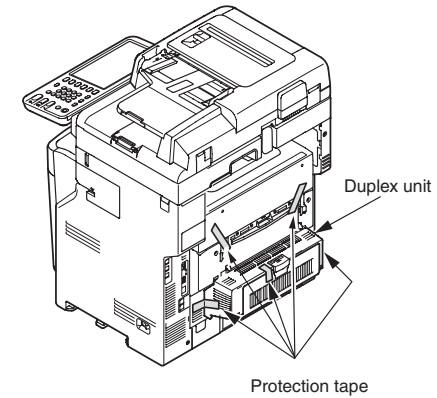

- (4) Confirm that the Duplex unit is fixed tightly.

- (5) Open the ADF and peel off the protection tape (4 places) and sheet(2 places).

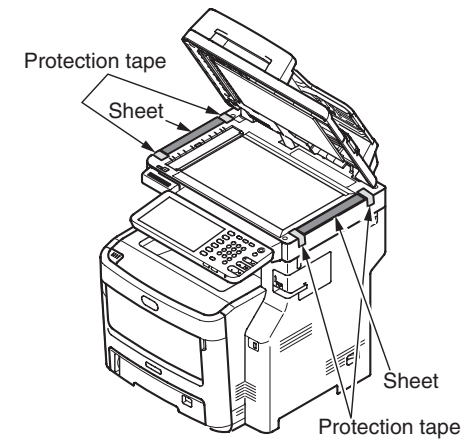

(6) Open the scanner and press down the OPEN button, and open the top cover.

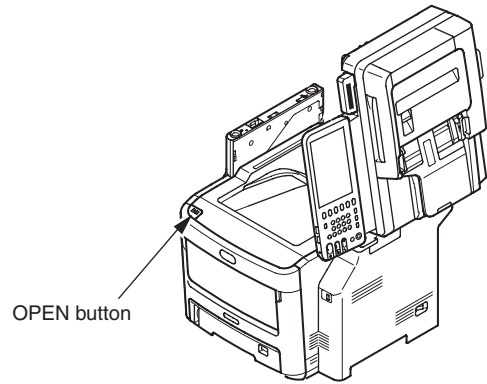

(7) Remove the stopper (orange) when pressing down the lever of the fuser unit (blue) in the direction of arrow ①.

**Note!** If you do not use the MFP for a long time or transport it, please use the stopper. Please keep it carefully.

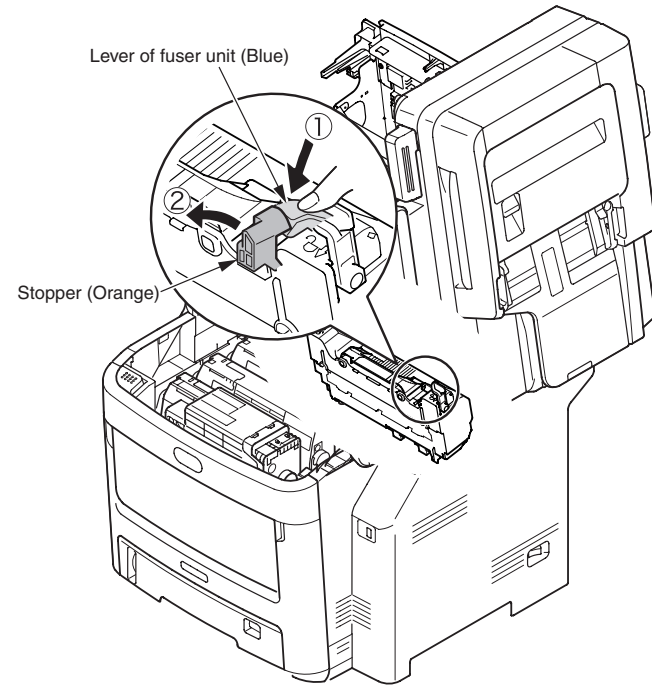

## Set the image drum cartridge.

- (1) Take the image drum cartridge (four) out slowly.

- Note!**
- The image drum (green cylinder) is very fragile. Please pay special attention to handling it.
  - Do not expose the image drum cartridge to direct sunshine and strong light (about 1500 lux). And do not expose it to room light for more than 5 minutes.

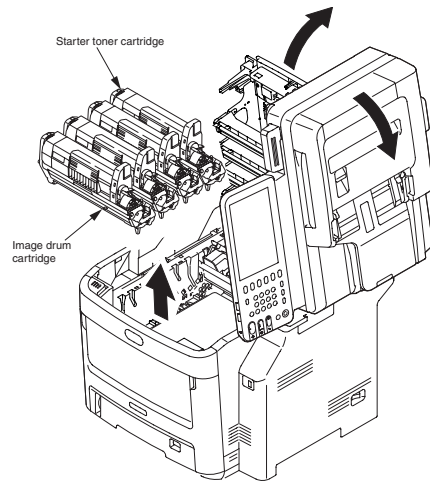

- (2) Put the image drum cartridge on the newspaper etc, peel off the tape of protection sheet and pull it out in the direction of the arrow.

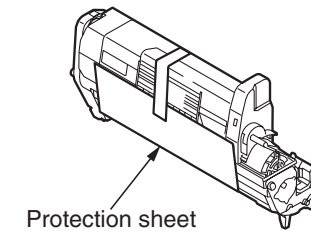

- (3) Remove all protection sheets from the image drum cartridge.

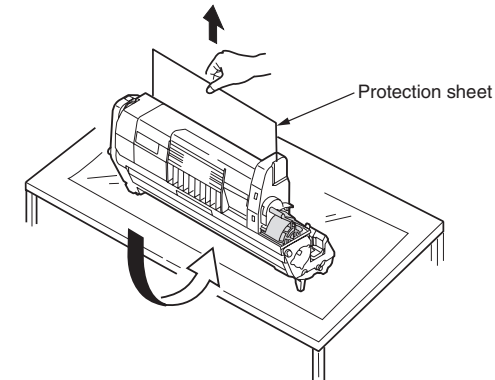

(4) Return the image drum cartridge back to the MFP.

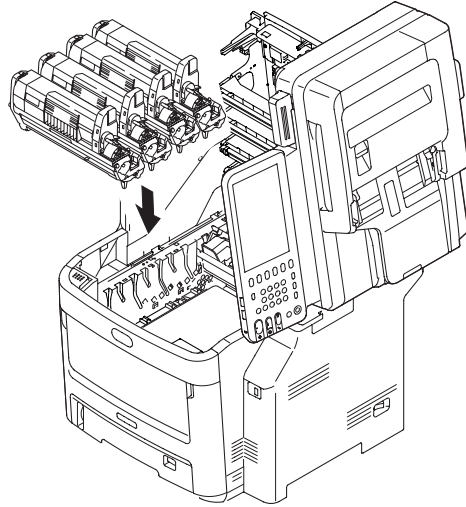

(5) Turn the lever of each starter toner cartridge in the direction of the arrow.  
(Four levers)

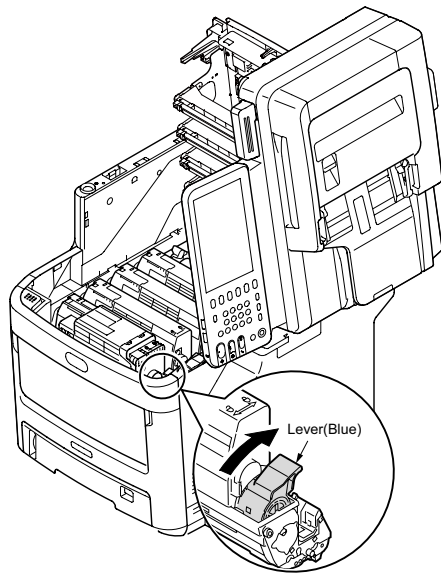

(6) Close the top cover and scanner.

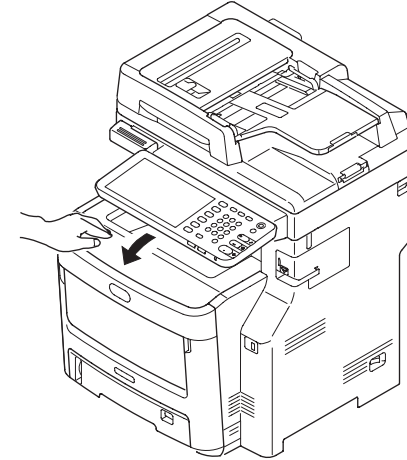

**Note!** If the message of [%COLOR% Waste Toner Full.Replace Toner.] on the control panel doesn't disappear indefinitely, please make sure that the lever of the toner cartridge is fully moved in the direction of the arrow.



## Set the paper in multi-paper tray.

- (1) Open the multi-paper tray, and open the paper supporter.

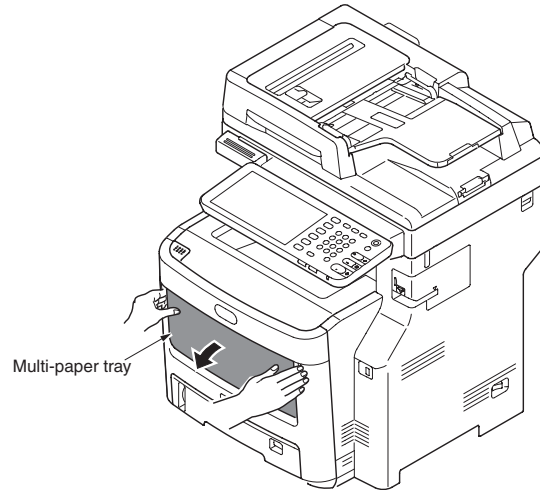

- (2) Match the manual insertion guide to the size of the paper.  
 (3) Flex the paper back and forth. Straighten the edges on a level surface.

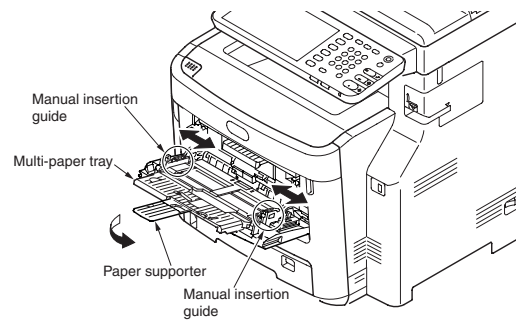

- (4) Place the printed side facing up, and insert the paper along the manual insertion guide straightly until bumping up.

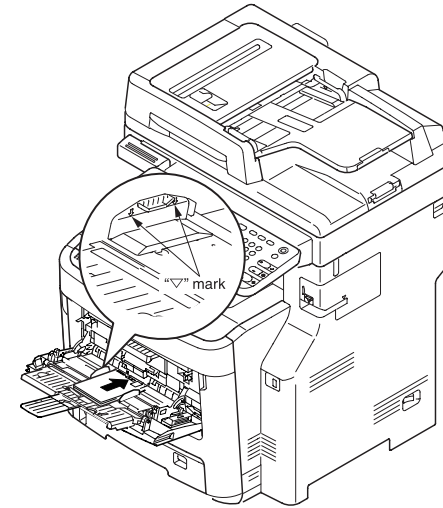

**Note!** Set papers so that paper should not exceed the "▽" mark. (100 sheets of paper with ream weight of 70 kg or 10 envelopes)

- (5) Press down the set button.

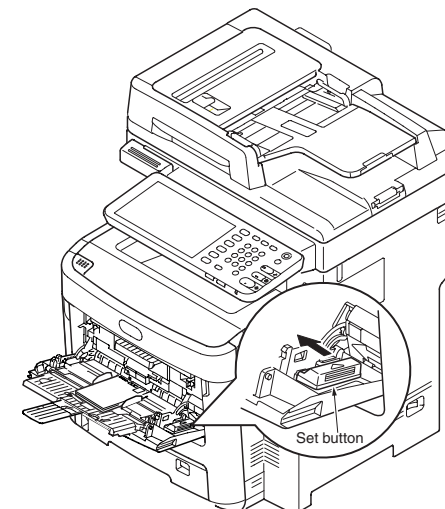

## Loading Documents on the ADF

- (1) Load your documents face up on the ADF.

If your documents are portrait, load them with the top edge of the documents in first.

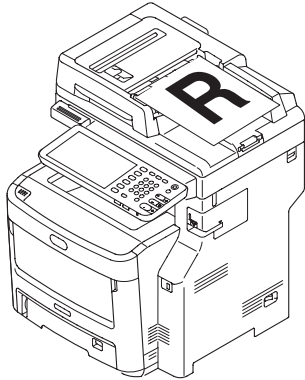

If your documents are landscape, load them with the left edge of the documents in first.

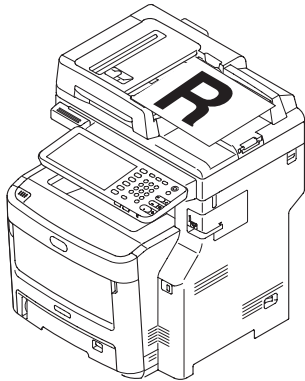

- (2) Adjust the document guides to the width of your documents.

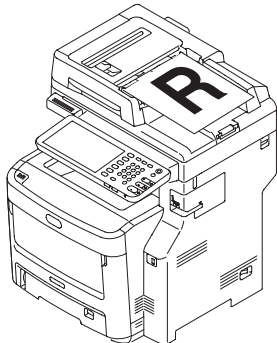

## Loading Documents on the Document Glass

- (1) Lift and open the document glass cover.

- (2) Place a document face down on the document glass.

If your document is portrait, align its top edge to the upper-left corner of the glass.

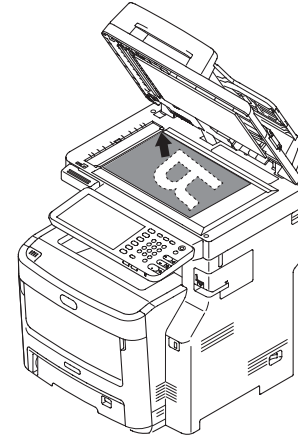

If your document is landscape, align its right edge to the upper-left corner of the glass.

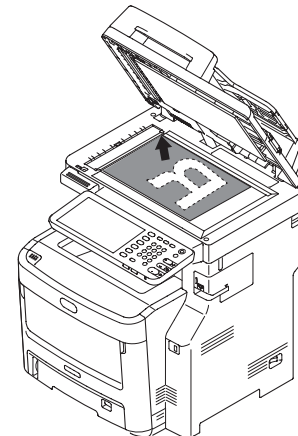

- (3) Close the document glass cover gently.

**Note!** If you want to use [N-in-1], [Sort] or [DuplexCopy] functions, change the [Document Direction] setting according to the direction of your document to get the output you want. The default setting is [Portrait].



## 3.5.2 Cable connect

### Power condition

- Keep the following items.
  - AC voltage : 100V ±10%/110~127V ± 10%/220~240V ± 10%
  - Frequency of the power supply : 50Hz or 60Hz ± 2%
- Use the voltage adjusting transformer etc. when the power supply is unstable.
- The maximum power consumption of this MFP is 1,500W. Confirm the power supply can provide enough power.
- The operation with UPS (uninterruptible power supplies) is not guaranteed. Explain to the customers that do not use UPS (uninterruptible power supplies).

#### **Warning**

It may cause an electric shock, fire.



- Installation and removal of the power supply cord and the ground cable must be performed after pressing down the power switch to OFF.
- Please connect the ground cable with a specified ground terminal. Please contact the dealer if you cannot get it.
- Be careful not to connect it with the lightning rod, the water pipe, the gas pipe, and the earth of the telephone wire.
- Connection of the ground terminal must be performed before inserting the power plug into the power outlet. And, removal of the ground terminal must be performed after pulling the power plug out of the power outlet.
- Please hold the power plug to disconnect or plug in the power supply cord.
- Please insert the power plug firmly into the outlet.
- Do not pull out or plug in the power plug with wet hands.
- Do not locate the MFP in a place where the cord may be abused by persons walking on, and do not place the heavy objects on the power cord.
- Do not use the power supply cord that is bundled or connect the power supply with an extension cord.
- Do not use a damaged power supply cord.
- Do not use a multiple outlet extension cord.
- Please connect this MFP into an outlet different from that to which other electric products is connected. Especially, the operation of the MFP might be affected by the electrical noise when the MFP is connected simultaneously with the air-conditioner, the copier and shredder etc. Please use the noise filter or the noise cut-off transformer sold at the market if you have to connect the MFP into a same outlet.
- Please use the attached power cord and insert it into the outlet directly. Do not use an unspecified power cord.
- Do not use an extension cable. Please use a cable that is more than 15A current rating if you have to use an extension cable.
- If the extension cord is used, the MFP might operate abnormally by the decrease of AC voltage.
- Do not unplug the power cord or switch off the power during printing.
- Please unplug the power cord if you do not use the MFP for a long time (long vacation or travel etc).
- Do not use the attached power cord of this MFP to the other electric products.

Explain completely the connection of the power supply cable and the ground cable with showing the user's manual to customer.

### Connect the power cord.

**Note!** Confirm that the power switch is turned to OFF "O".

- (1) Insert the power cord into the MFP.

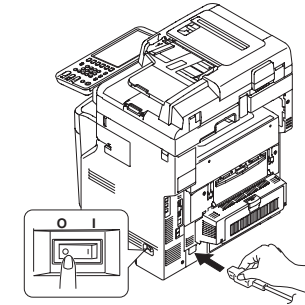

- (2) Insert the power plug into the outlet.

### Press down the power switch to ON (|).

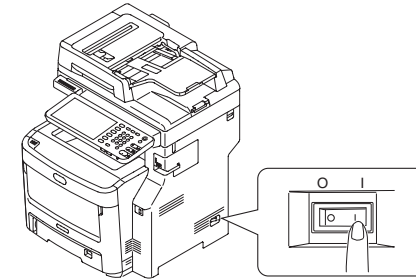

If the MFP is completely started up, the message "Ready To Print" would be displayed on the control panel shown as follows.

**Note!** When the MFP is getting cold, it may lead to error if the power is turned on. (Error number CE52,C41D,C466). At this time, please turn off the power and wait for a while, and then turn on the power again.

## Turn the power off.

**Note!** If you turn off the power without properly shutting down, it may cause damage to the MFP. Please follow the following procedure to turn the power off.

- (1) Press the  [POWER] button until a “pip” sound is heard.

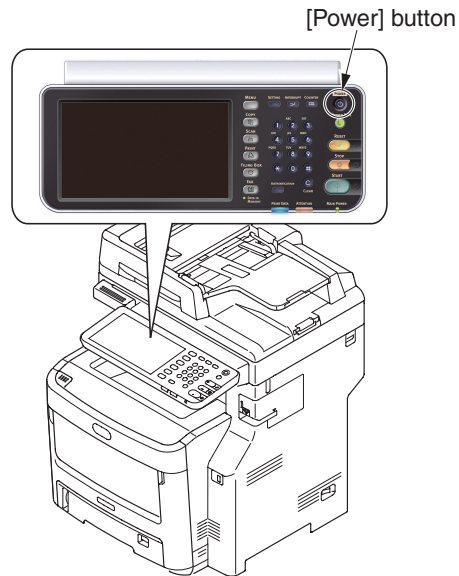

- (2) When the screen above disappears, turn OFF "O" the power switch.

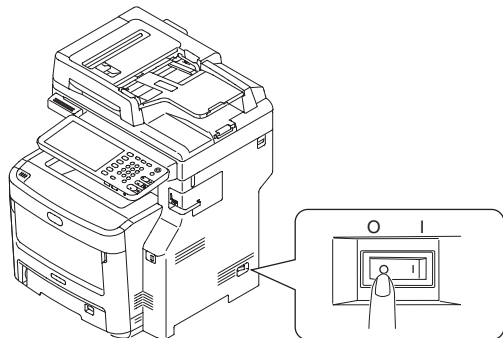

## When do not use the MFP for long time

Please explain to the customer about the following items.

Unplug the power cord if you do not use the MFP for a long time (long vacation or travel etc).

Install the stopper to the fuser.

**Note!** •Remove the power plug out of the power outlet.

•Even if the power plug of this MFP is pulled out for a long time (four weeks or more), the functional problems will not be caused easily. However, please explain to the customer that the deterioration of consumable such as toners and the image drums is not guaranteed.

### 3.5.3 Optional part installation and confirmation

#### (1) Installation of the optional tray unit (second/ third/ fourth tray/ LCF)

**Notes!** • Fourth tray : not support for Finisher model

It is a traditional paper tray for adding paper into MFP.

**Second/ third/ fourth tray** : 530 pieces of 70kg paper can be set. Using it with a standard paper cassette and a multi-purpose tray can print 2220 pieces of pages continuously.

**LCF** : 2000 pieces of 70kg paper can be set. Using it with a standard paper cassette and a multi-purpose tray and a second tray can print 3160 pieces of pages continuously. (Finisher model can not be used with the second tray and LCF)

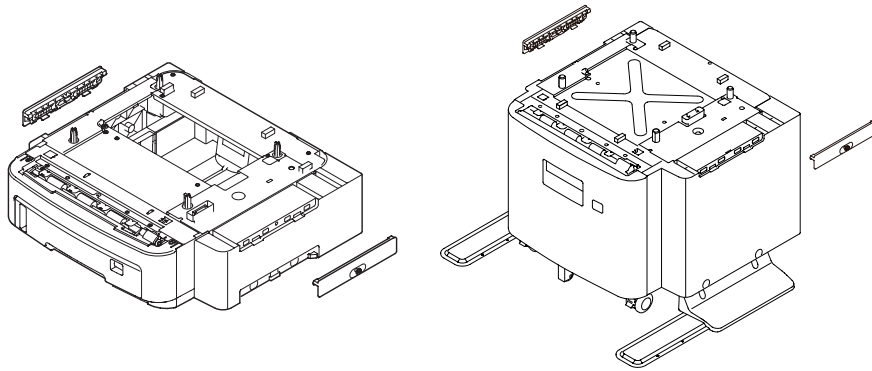

<second/ third/ fourth tray>

<LCF>

(1)-1. Turn the MFP power to OFF and pull out the power cord from the outlet.

Turn the power off with following the procedure in chapter 3.5.2 [Turn the power off.].

**Notes!** • If you turn off the power without properly shutting down, it may cause damage to the MFP. Please operate the [Shutdown Menu].  
• It may cause damage to the MFP, if you install the optional tray with power ON.

(1)-2. Install the optional tray unit to the MFP.

**Note!** Because the weight of the MFP body is approximately 50kg, it needs more than three adults to lift it up.

- ① Match the tab into the hole in the bottom of the MFP.
- ② Put the MFP on the optional tray unit slowly.
- ③ Attach the joint(2 places) to optional tray unit and screw up.

Remove it following the steps 1-2 in reverse order.

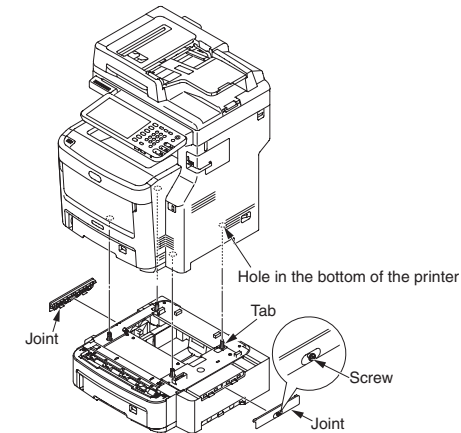

**Note!** When you install two or more optional trays to the MFP, set the optional tray directly on top of the other optional tray, and then put them on the MFP.

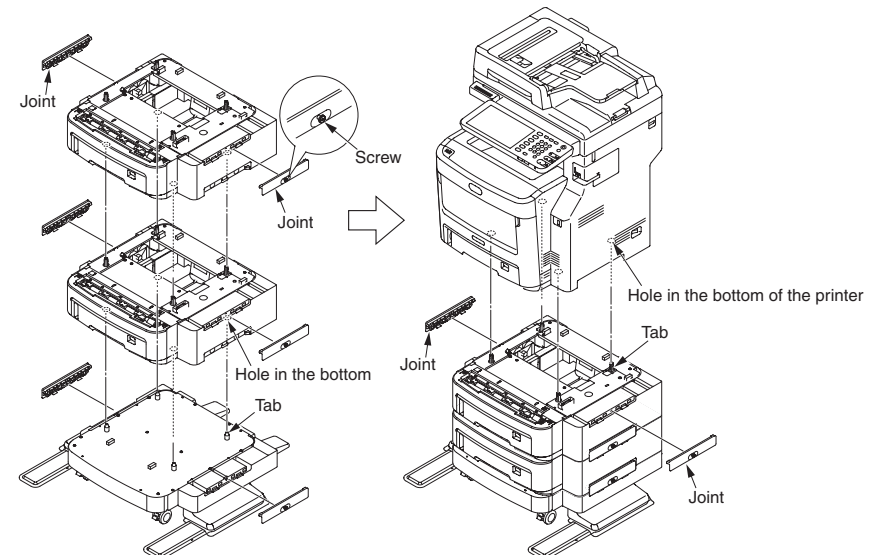

(1)-3. Connect the power cord and printer cable to the MFP and turn the power on.

**Note!** If the message [C56B] or [C56C] or [C56D] is displayed, reinstall the optional tray unit.

(1)-4. Print the setting content and confirm if the option tray unit is installed properly.

- ① Print the setting content with following the procedure in chapter 3.6.
- ② Confirm the content of [tray 2] or [tray 3] is display in header part.

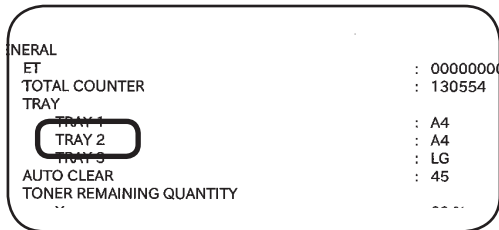

**Note!** If the content of [tray 2] or [tray 3] is not displayed, reinstall the second tray unit.

(1)-5. Set the number of tray by the printer driver.

<For MC760/MC770/MC780>

The printer driver setup for recognizing the option tray unit is required.

If the printer driver is not set up, please set up the printer driver completely referring to the user's manual (Setup) firstly, and then finish the following setting procedure.

**Note!** The authority of the computer administrator is required.

For Windows PCL/PS/XPS printer driver

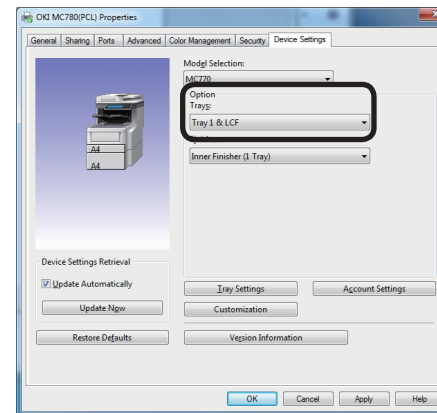

(For Windows XP)

- ① For Windows Vista, click on [start] => [control panel] => [printer].  
For Windows XP, click on [start] => [control panel] => [printer and other hardware] => [printers and faxes].  
For WindowsServer 2003, click on [start] => [printers and faxes].  
For Windows 2000, click on [start] => [Settings] => [printers].
- ② Click [OKI MC780\*1(\*2)] icon with right-click button on your mouse and choose [Properties].
- ③ Choose "Update Now" button in "Device Settings" tab. For USB connection, input the optional tray number in "Option" manually.
- ④ Click [OK].

\*1: Different of model name

\*2: PCL or PS XPS (printer driver type)

### For Mac OS X

When the optional device has been added into in Mac OS X before installing the printer driver, the device information is gotten automatically. However, if the printer is connected by [IP print] and [Bonjour], the device information could not be gotten automatically.

If the printer is connected by [AppleTalk], the device information could also not be gotten automatically when the optional device has been added into in Mac OS X before installing the printer driver.

Please finish the following setting procedure for above.

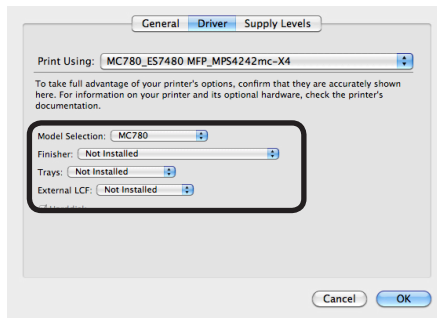

- ① Open System Preferences and click [Print & Scan].
- ② Select [OKI-MC780], click [Options & Supplies].
- ③ Click [Driver].
- ④ Set the following options.
  - Model Selection - Choose this for using your model.
  - Finisher
    - Not Installed — Select this if a finisher is not installed.
    - Inner Finisher (1 Tray) — Select this when the Inner Finisher is installed.

#### Notes!

- Even if you choose [Not Installed] for the Finisher option during print settings, the finisher options such as stapling can be selected. If you select the finisher options for printing but the finisher is not installed, finisher settings will be ignored and printing will be performed correctly.

#### • Trays

##### Tray 1

Select this when the tray 1 is installed.

##### Tray 1 and LCF

Select this when the tray 1 and LCF are installed.

##### Tray 1 and 2

Select this when the tray 1 and 2 are installed.

##### Tray 1, 2 and 3

Select this when the tray 1, 2 and 3 are installed.

##### Tray1, 2, 3 and 4

Select this when the tray 1, 2, 3 and 4 are installed.

##### Tray 1, 2 and LCF

Select this when the tray 1,2 and LCF are installed.

- ⑤ Click [OK].

<For e-STUDIO287CS/347CS/407CS>

The printer driver setup for recognizing the option drawer unit is required.

If the printer driver is not set up, please set up the printer driver completely referring to the user's manual (Setup) firstly, and then finish the following setting procedure.

**Note!** The authority of the computer administrator is required.

For TOSHIBA Universal Printer 2/ Universal PS3/ Universal XPS printer driver

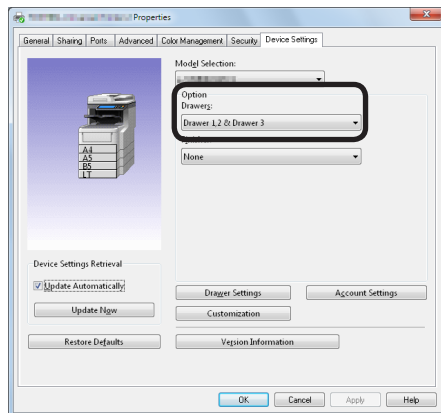

(For Windows XP)

① For Windows Vista, click on [start] => [control panel] => [printer].

For Windows XP, click on [start] => [control panel] => [printer and other hardware] => [printers and Faxes].

For WindowsServer 2003, click on [start] => [printers and faxes].

② Click [TOSHIBA Universal Printer 2\*1] icon with right-click button on your mouse and choose [Printer properties].

③ Choose "Update Now" button in "Device Settings" tab. For USB connection, input the optional tray number in "Option" manually.

④ Click [OK].

\*1: TOSHIBA Universal PS3 or TOSHIBA Universal XPS(printer driver type)

### For Mac OS X

When the optional device has been added into in Mac OS X before installing the printer driver, the device information is gotten automatically. However, if the printer is connected by [IP print] and [Bonjour], the device information could not be gotten automatically.

If the printer is connected by [AppleTalk], the device information could also not be gotten automatically when the optional device has been added into in Mac OS X before installing the printer driver.

Please finish the following setting procedure for above.

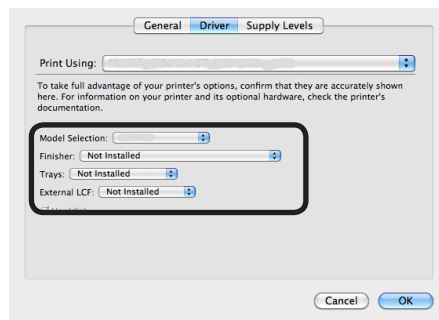

- ① Open System Preferences and click [Print & Scan].
- ② Select [TOSHIBA e-STUDIO407CS], click [Options & Supplies].
- ③ Click [Driver].
- ④ Set the following options.
  - Model Selection - Choose this for using your model.
  - Finisher
    - Not Installed — Select this if a finisher is not installed.
    - Inner Finisher (1 Tray) — Select this when the Inner Finisher is installed.

#### Notes!

- Even if you choose [Not Installed] for the Finisher option during print settings, the finisher options such as stapling can be selected. If you select the finisher options for printing but the finisher is not installed, finisher settings will be ignored and printing will be performed correctly.

#### • Drawers

##### Drawer 1

Select this when the drawer 1 is installed.

##### Drawer 1 and 2

Select this when the drawer 1 and 2 are installed.

##### Drawer 1, 2 and 3

Select this when the drawer 1, 2 and 3 are installed.

##### Drawer1, 2, 3 and 4

Select this when the drawer 1, 2, 3 and 4 are installed.

- ⑤ Click [OK].

## 3.6 Setting content print (Configuration)

To confirm the MFP operates normally, please print the [Configuration].

- (1) Set A4 paper in tray.
- (2) Press the **SETTING** button of display.
- (3) Press the **LIST** button of display.
- (4) Press down the **FUNCTION** button of display.

**Memo** When printing the network setting information ,enter the administrator menu.

- (1) Press the **SETTING** button of display.
- (2) Press the **ADMIN** tab of display.
- (3) Press the **PASSWORD** button of display.
- (4) Input the password.
- (5) Press the **LIST/REPORT** button of display.
- (6) Press the **LIST** button of display.
- (7) Press down the **NIC CONFIGURATION PAGE** button of display.

(sample)

```

FUNCTION LIST
S/N          : BA3C123456          TIME      : 15-01-2013 09:41
F/W Ver.    : 0280SYW1108
M-ROM Ver.  : 00.00.32
S-ROM Ver.  : to..5

GENERAL
ET           : 00000000070610170f100000000008
TOTAL COUNTER      : 3778
MAIN / PAGE MEMORY SIZE : 2048 MB / 512 MB
TRAY
TRAY 1           : A4
AUTO CLEAR       : 45
POWER SAVE
WEEKLY TIMER
TIMER SUNDAY     : 00:00:00 24:00:00
TIMER MONDAY     : 00:00:00 24:00:00
TIMER TUESDAY    : 00:00:00 24:00:00
TIMER WEDNESDAY  : 00:00:00 24:00:00
TIMER THURSDAY   : 00:00:00 24:00:00
TIMER FRIDAY     : 00:00:00 24:00:00
TIMER SATURDAY   : 00:00:00 24:00:00
ENABLE WEEKLY TIMER : DISABLE
AUTO POWER SAVE  : 60
SLEEP TIMER      : 60
SLEEP MODE       : SLEEP
DAYLIGHT SAVINGS TIME
ENABLE DAYLIGHT SAVINGS TIME : ENABLE
OFFSET           : +1:00
START DATE       : Mar LAST Sun 02:00
END DATE         : Oct LAST Sun 03:00
DATA CLONING FUNCTION : ENABLE
USB DIRECT PRINT : ENABLE
FUNCTIONS
SAVE AS LOCAL HDD : ENABLE
E-FILING          : ENABLE
EMAIL SEND        : ENABLE
SAVE AS FTP        : ENABLE
SAVE AS FTPS      : ENABLE
SAVE TO USB MEDIA : ENABLE
SAVE AS SMB        : ENABLE
SAVE AS NETWARE   : ENABLE
INTERNET FAX SEND : ENABLE
FAX SEND          : ENABLE
WEB SERVICES SCAN : ENABLE
TWIN SCANNING     : ENABLE
SCAN TO EXTERNAL CONTROLLER : ENABLE
NETWORK FAX       : ENABLE
NETWORK INTERNET FAX : ENABLE
LONG FILE NAME SETTING
LONG FILE NAME EXPRESSION (DISPLAY) : NON-ABBREVIATION
JOB SKIP CONTROL  : DISABLE
ENABLE JOB SKIP CONTROL : DISABLE
ADDRESS BOOK RESTRICTION BY ADMIN : NO RESTRICTION
CONFIDENTIALLY SETTING
DOCUMENT NAME     : DISABLE
POP-UP
PAPER MISFEED RECOVERY : ENABLE

```



## 3.7 Connecting method

### <USB connection>

**Note!** Please refer to user's manual for operation environment.

### Prepare for USB cable

- Notes!**
- The printer cable is not included. Provide the USB2.0 cable for special user.
  - When connecting the cable in [Hi-Speed] mode of USB 2.0, please use the USB cable with Hi-Speed spec.
  - Select the USB cable of less than 5m. It is recommended to use the USB cable of less than 2m.

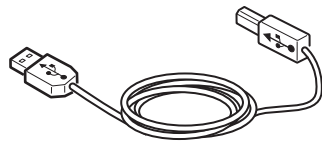

### Turn the MFP and computer OFF.

**Memo** Although USB cable can plug-and-play with computer and MFP power on, after this the setup of printer driver and USB driver may be required. Here the MFP is turned off to plug-and-play the USB cable.

### Connect the computer to the MFP.

- (1) Insert the USB cable into the USB interface connector of MFP.
- (2) Insert the USB cable into the USB interface connector of computer.

**Note!** Do not insert the USB cable into the network interface connector. It may cause trouble.

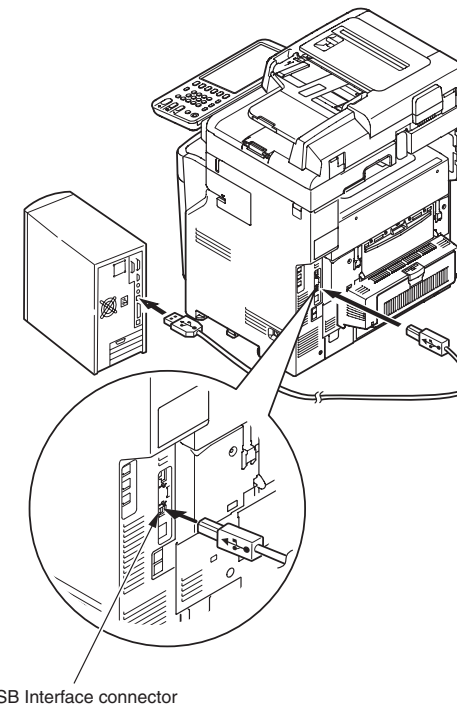

**Memo** Please refer to user's manual for setup of printer driver.

### < Ethernet cable connection >

**Note!** Refer to user's manual for operation environment.

#### Prepare for Ethernet cable

**Note!** The Ethernet cable and Hub is not included in MFP.  
Provide the Ethernet cable and Hub for special user.

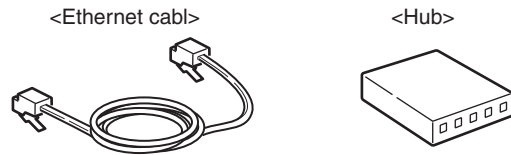

Turn the MFP and computer OFF.

Connect the computer to the MFP.

- (1) Insert the Ethernet cable into the network interface connector of MFP.
- (2) Insert the Ethernet cable into Hub.

**Memo** Refer to user's manual for setup of printer driver.

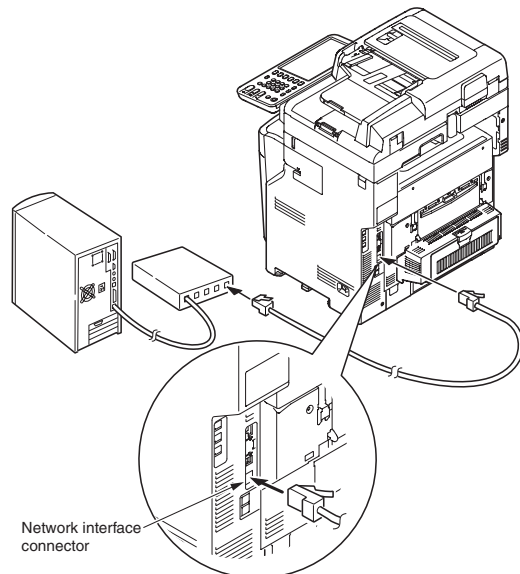

### < Telephone line cable connection >

Connection of the telephone line cable is different in each country and location. Connect the MFP to suit to the environment of each installation location using the following diagram as reference.

- Note!**
- The MFP cannot be connected to the ISDN line. Terminal adapter is required for ISDN line connection.
  - Be sure to use the supplied telephone line cable. Use of any telephone line cable other than what is supplied causes malfunction.

1. Connect the MFP to suit to the environment of each installation location.

#### To connect to public telephone line

(To use the MFP as the fax machine (without connecting telephone line to the MFP))

Connect the telephone line cable to [LINE connector] of the MFP.

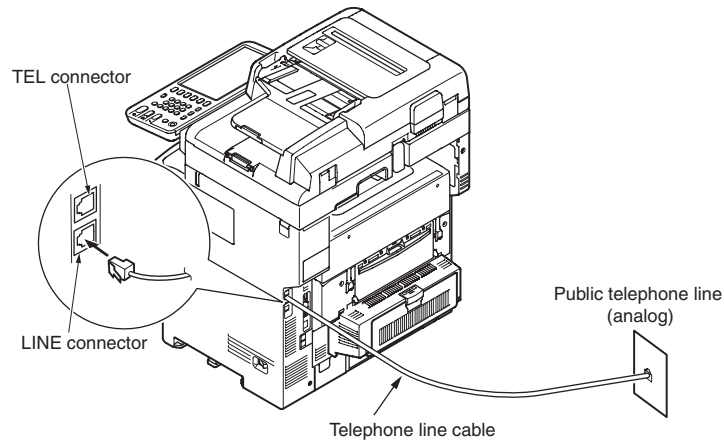

#### To connect to public telephone line

(To connect to the telephone of the MFP)

Connect the telephone cable that is connected to the public telephone line (analog) to the [LINE connector] of the MFP.

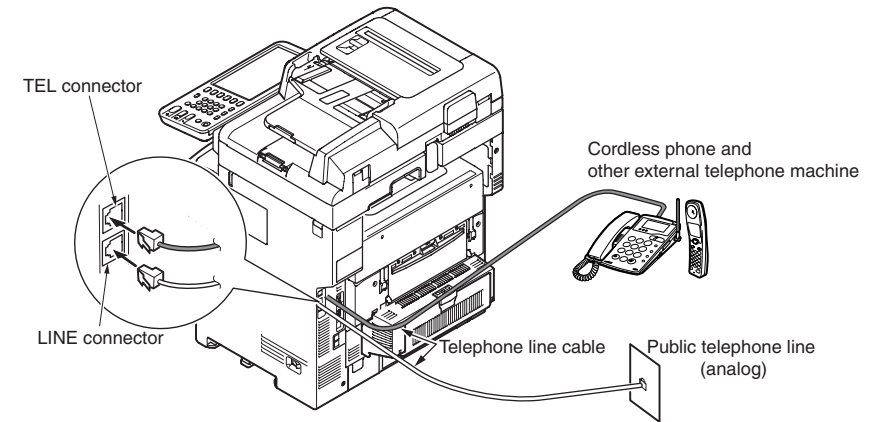

#### To connect to the ADSL environment

Connect the telephone cable that is connected to the ADSL modem to the [LINE connector] of the MFP. Connect the external telephone machine to the [TEL connector] of the MFP.

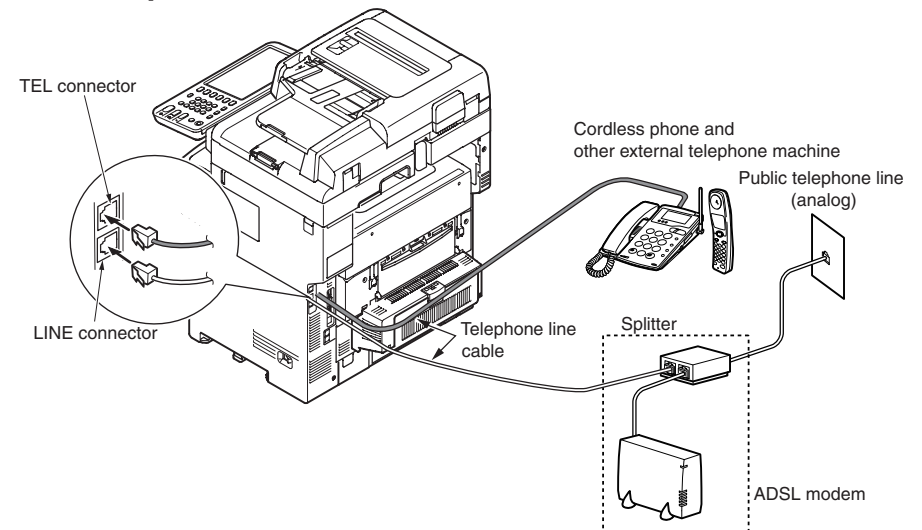

### To connect to the Optical fiber (IP telephone)

Connect the telephone cable that is connected to the Optical fiber (IP telephone) to the [LINE connector] of the MFP. Connect the external telephone machine to the [TEL connector] of the MFP

**Note!** • When using the Super G3 communication, check that the communication quality of provider is guaranteed.

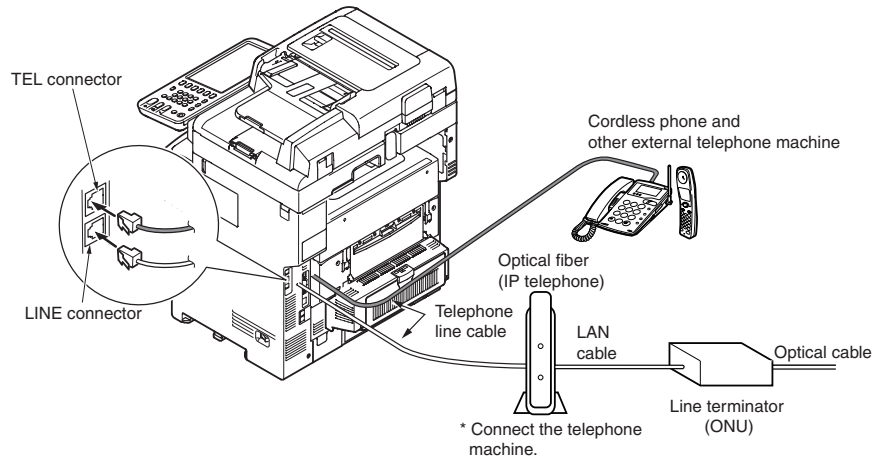

### To connect the MFP to CS tuner or digital TV

Connect the telephone cable that is connected to the public telephone line (analog) to the [LINE selector] of the MFP.

Connect the telephone cable that is connected to the CS tuner or digital TV to the [LINE connector] of the MFP.

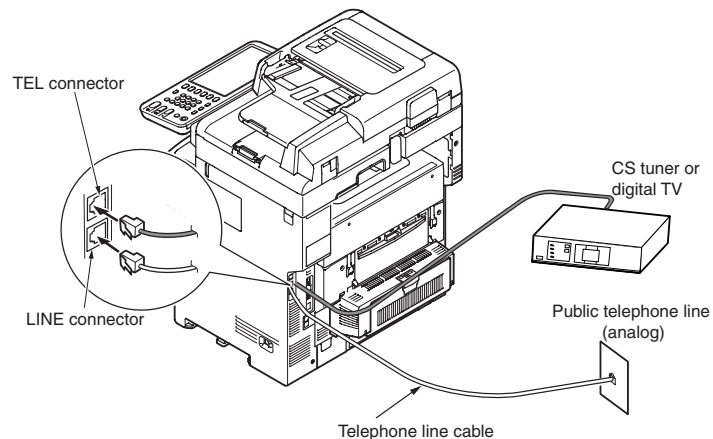

### To connect to the telephone switch board (PBX), home telephone, or business phone

Connect the telephone cable that is connected to the public telephone line (analog) to the [LINE connector] of the MFP.

Connect the telephone cable that is connected to the PBX and other control system to the [TEL connector] .

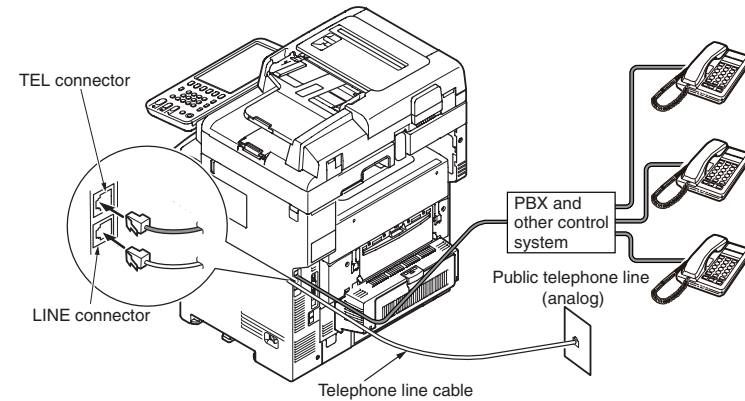

### To connect to the private phone system

Connect the telephone cable that is connected to the PBX and other control system to the [LINE connector] .

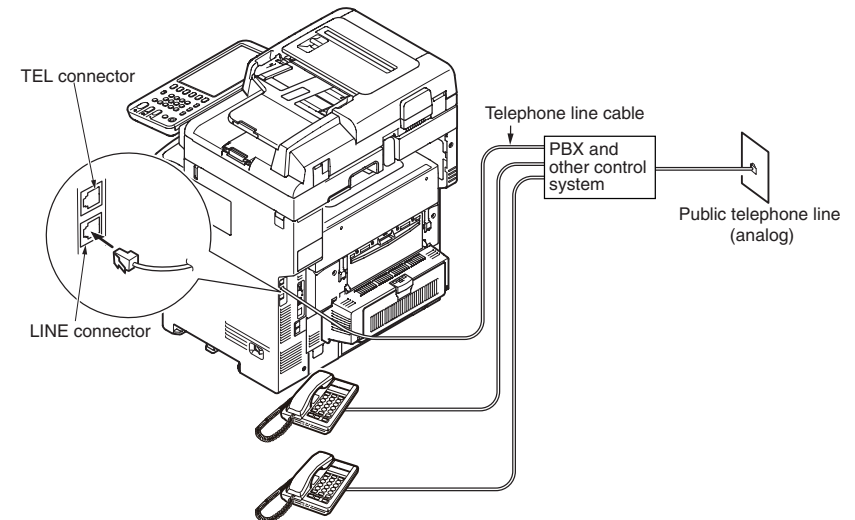

## 3.8 User used Paper confirmation

Load the paper used by user, set the media type/weight, print the setting content/demo, and confirm if the toner is chipped off.

Type	Thickness	settings of control panel	[Paper Type] settings of printer driver*1
		Paper Type	
Plain paper*2	55~64kg (64~74g/m <sup>2</sup> )	PLAIN(THIN)	PLAIN(THIN)
	65~77kg (75~90g/m <sup>2</sup> )	PLAIN	PLAIN
	78~90kg (91~105g/m <sup>2</sup> )	THICK1	THICK1
	91~103kg (106~120g/m <sup>2</sup> )	THICK2	THICK2
	104~162kg (121~188g/m <sup>2</sup> )	THICK3	THICK3
	163~189kg (189~220g/m <sup>2</sup> )	THICK4	THICK4
	190~215kg (221~250g/m <sup>2</sup> )	THICK5	THICK5
Post card	—	—	—
Envelope	—	Envelope1~4	Envelope1~4
Label paper	Less than 0.1~0.17mm	SPECIAL1	SPECIAL1
	0.17~0.2mm	SPECIAL2	SPECIAL2

\*1 : The Type of paper could be set by control panel and printer driver. The settings set by printed driver have priority. When [Paper feed method] is selected as [Auto select] or [Paper thickness] is set as [print setting] in the printer driver, the print operation is set by control panel.

\*2 : The thickness of the paper for duplex printing is 55~189kg (64~220g/m<sup>2</sup>).

**Memo** If the Paper Type is set except [PLAIN(THIN)] or [PLAIN], the print speed would be reduced.

# 4. Component replacement

---

In this chapter, the procedures for replacement of part and assembly and unit are described.

The replacement procedure is described by removal of the parts. Please install the new parts with following the replacement procedure in reverse order.

The parts (such as ① , ② )shown in this manual are different from the parts used in the Disassembly for Maintenance figure (4537600TL) and RSPL (45376001TR).

4.1	Precautions on component replacement .....	71
4.2	Method of component replacement .....	73
4.3	Check the Scanner Mech Level and SU FW version.....	101
4.4	Oiling spots.....	102

## 4.1 Precautions on component replacement

(1) Remove the AC cord and the interface cable before replacing the parts.

(a) Remove the AC cord according to the following procedure.

- ① Switch the power switch of printer off "O".
- ② Disconnect the AC insertion plug of the AC power cord from the AC power source.
- ③ Disconnect the earth wire from the earth terminal of the AC power source outlet.
- ④ Disconnect the AC cord and the interface cable with the printer.



There is a risk of electric shock during replacement of the low voltage power supply. Use insulating gloves or avoid direct contact with any conducting part of the power supply, and caution should be exercised during replacement.

The capacitor may take one minute to complete discharge after the AC cord is unplugged. Also, there is a possibility that the capacitor doesn't discharge because of a breakage of the PCB, etc., so remember the possibility of electric shock to avoid electric shock.

(b) Reconnect the printer according to the following procedure.

- ① Connect the AC cord and the interface cable with the printer.
- ② Connect the earth wire to the earth terminal of the AC power source outlet.
- ③ Connect the AC power cord insertion plug to the AC power source outlet.
- ④ Switch the power switch of printer on "I".

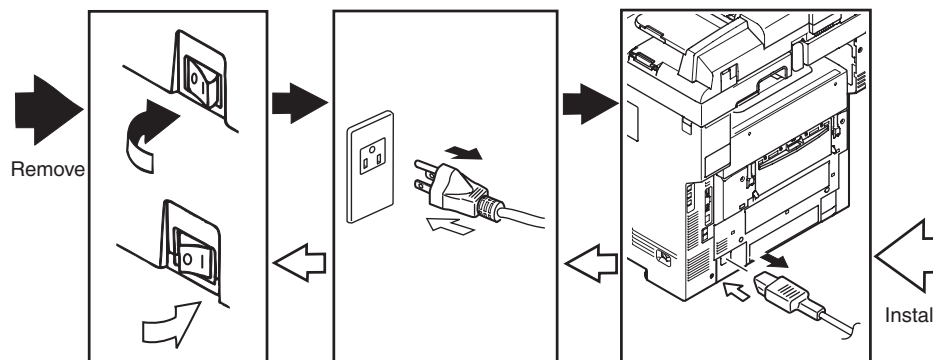

(2) Do not disassemble it if the printer works normally.

(3) Disassemble it as required. Do not remove the part that is not shown in the replacement procedure.

(4) Please use the specified maintenance tool.

(5) Disassemble it according to the proper procedure. It may cause damage to the parts if disassemble it without following the proper procedure.

(6) As the small parts such as the screws are lost easily, please fix them to the original position temporarily.

(7) Do not use gloves that may cause static electricity easily when handling IC and the circuit board such as microprocessor, ROM, and RAM.









(8) Do not put the PCB on the device and the floor directly.

(9) Do not work for a long time with the printer with the top cover open, and an image drum unit installed in it.

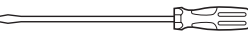
[Maintenance tool]

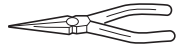
The required tools for replacing the PCB and the unit are shown in Table 4-1-1.

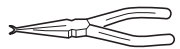
Table 4-1-1 Maintenance tools



No.	Maintenance tools	Amount	Purpose	Note
1	 No. 2-200 ⊕ Magnetic driver	1	3 - 5mm Screw	
2	 No. 3-100 Driver	1		
3	 No. 5-200 Driver	1		
4	 Digital multimeter	1		
5	 Combination pliers	1		
6	 Handy cleaner (the type corresponds to the toner)	1		Refer to the following note.
7	 E Ring pliers	1	For E ring detaching	
8	 USB memory device <b>(Note)</b>	1	FW Update	Refer to "6.1 Removal and Installation of Boards/HDD" in the Software Guide.

**(Note)** Refer to "8.2 FIRMWARE UPDATING" in the Software Guide according to the conditions for USB memory device

**Note!** Use the specified cleaner corresponding to the toner. It may cause a fire when using a general-purpose cleaner.

The required tools for using the maintenance utility are shown in Table 4-1-2.

Table 4-1-2 required tools

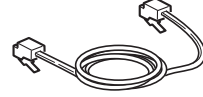
No.	Maintenance tools	Amount	Purpose	Note
1	 Notebook Please install the maintenance utility.	1		Refer to the chapter 5.2 for the maintenance utility.
2	 USB cable	1		
3	 Ethernet cable (Cross cable)	1		



## 4.2 Method of component replacement

In this chapter, the replacement of parts and assemblies is described by the disassemble figures.

### 4.2.1 Belt unit

- (1) Open the scanner and top cover.
- (2) Remove the ID unit ①.

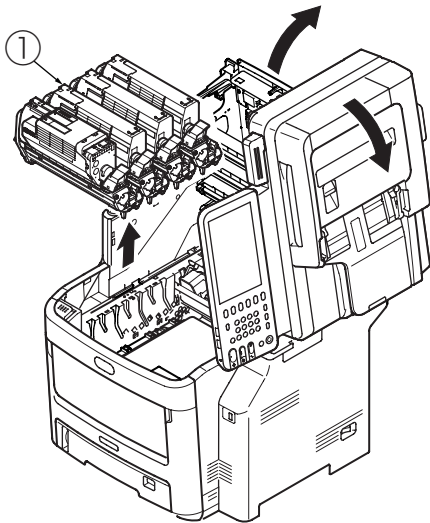

**Note!** Cover the removed image drum cartridge with black paper.

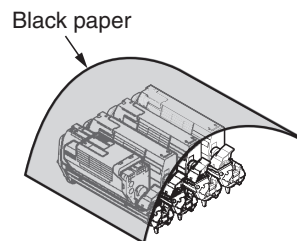

- (3) Rotate the lock lever (blue, 2 places) of the belt unit ② in the direction of arrow , and hold the lever (blue) to remove the belt unit.

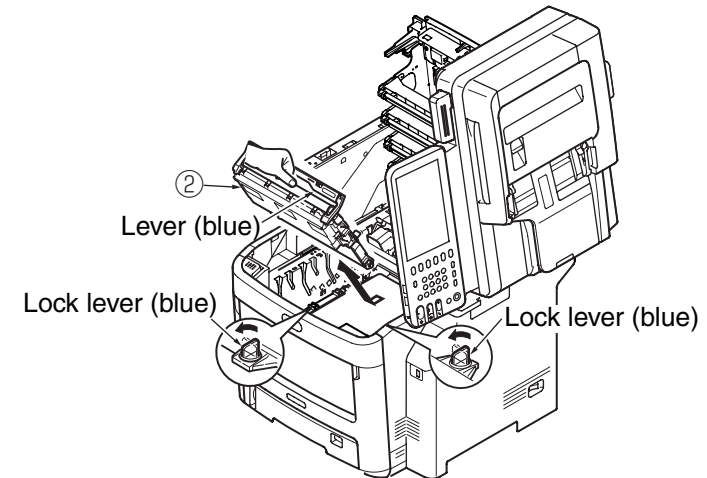

### 4.2.2 Fuser unit

- (1) Open the scanner and top cover.
- (2) Push up the fix lever of fuser unit in the direction of arrow, and remove the fuser unit ①.

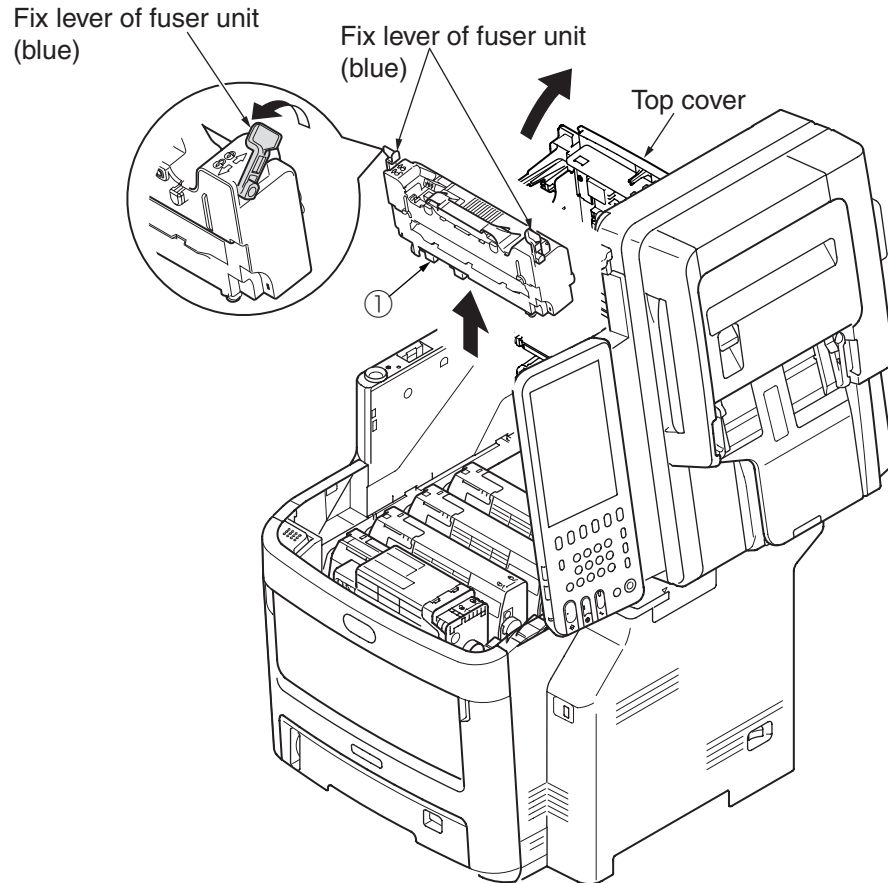

### 4.2.3 Right side cover

- (1) Open the scanner and top cover.
- (2) Loose the two screws (silver, No:42920408) ① and two screws (black, No:42932710) ②.
- (3) Release 5 claws.
- (4) Close the scanner and top cover. And open the feeder unit.
- (5) Remove the right side cover ③.

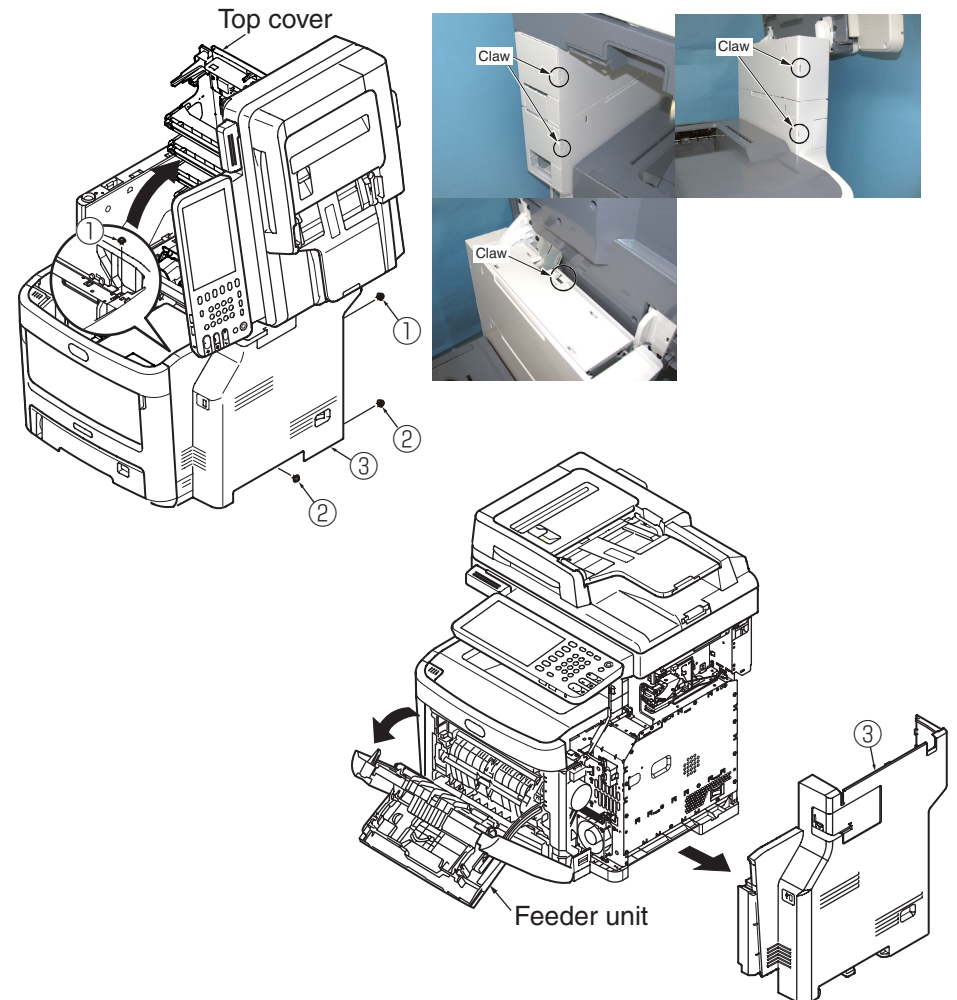

### 4.2.4 Left side cover

- (1) Open the scanner and top cover.
- (2) Open the feeder unit.
- (3) Remove the claw ①, and remove the Feeder-Unit without disconnecting the cable.
- (4) Remove the two screws (silver, No:42920408) ② and the screw (black, No:42932710) ③, and take off the claws and remove the left side cover ④.

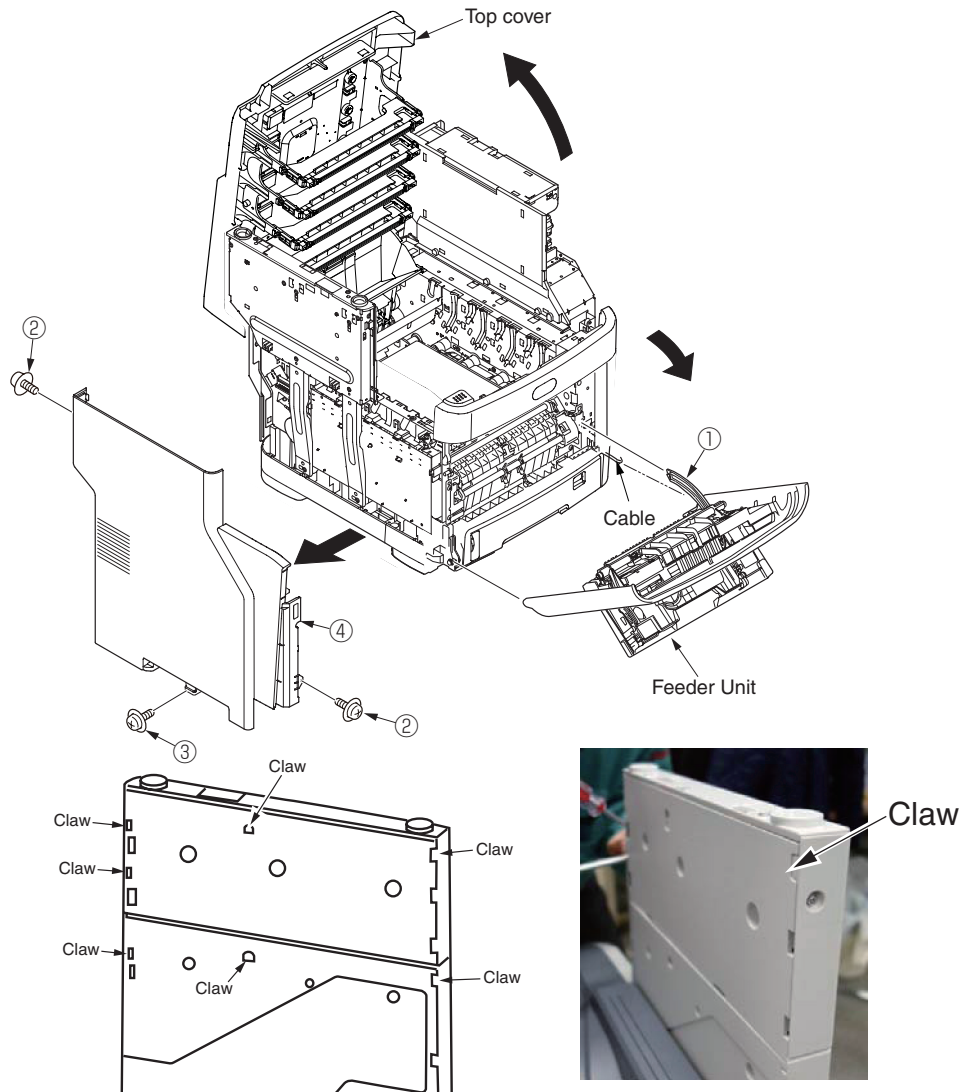

### 4.2.5 Scanner unit

- (1) Open the scanner and top cover.
- (2) Remove the right side cover. (See section 4.2.3)
- (3) Remove the Cover-Side(R-Top) ①.
- (4) Remove the Plate-Shield ②.
- (5) Remove the all connector of the scanner.
- (6) Remove the three E type stop rings ③ and two shafts ⑤, and remove the scanner ④ by lift the fulcrum.

**Note!** Pay attention to the scanner don't drop.

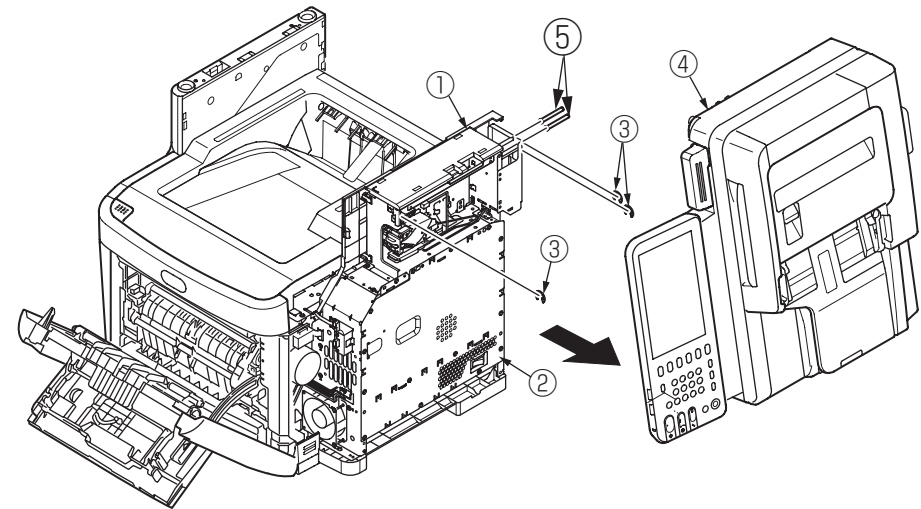

### 4.2.6 Faceup tray

- (1) Draw out the Duplex unit ①.
- (2) Open the faceup tray ② in the direction of arrow, and unlock the left and right pins while bending. Remove the faceup tray ②.

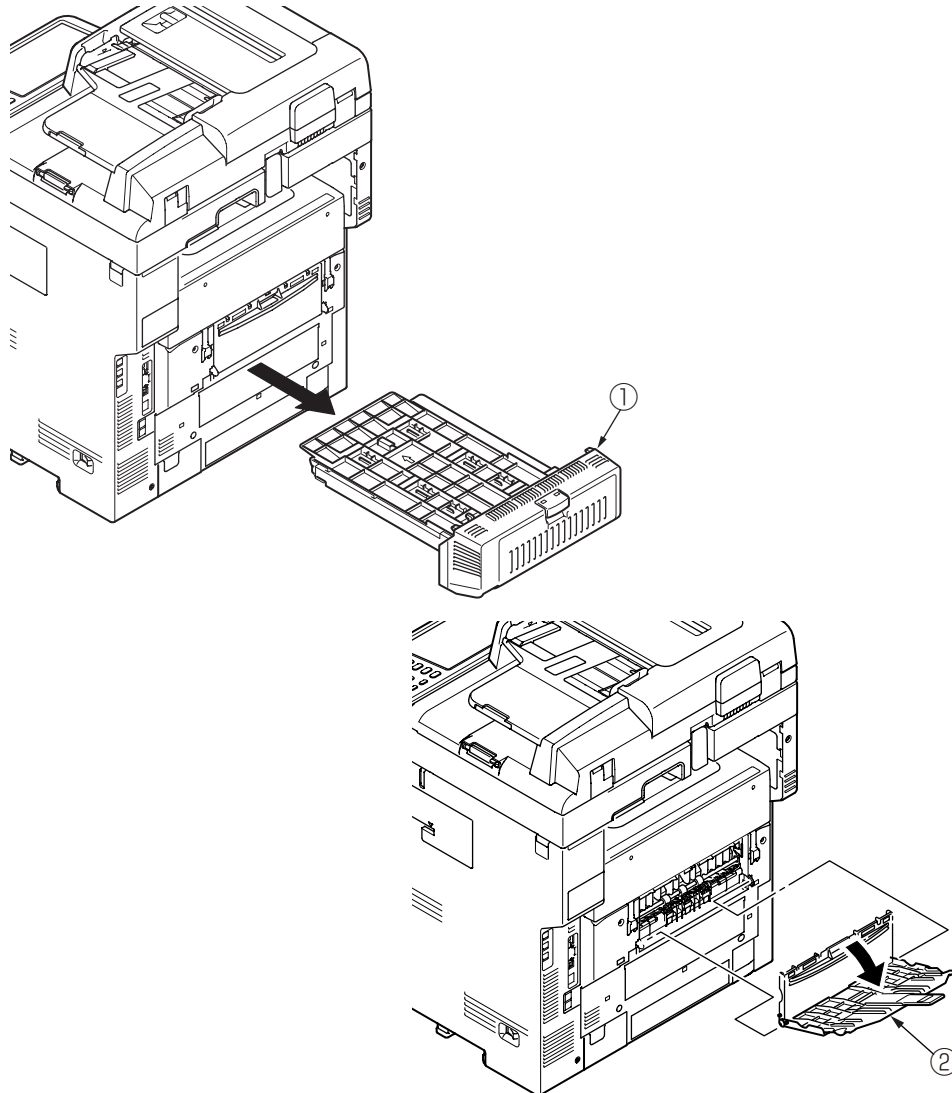

### 4.2.7 Rear cover

- (1) Open the faceup tray.
- (2) Remove the two screws (silver, No:42920406) ①.
- (3) As shown in fig 2, insert the flat-blade screwdriver into the hole A to disengage the claw A (2 place).
- (4) Disengage the claw B (2 places) and pull the upper side of the rear cover ② in the direction of A.
- (5) As shown in fig 3, push the lower side of the rear cover ② in the direction of B, and disengage the claw C (3 places) to remove the rear cover ②.

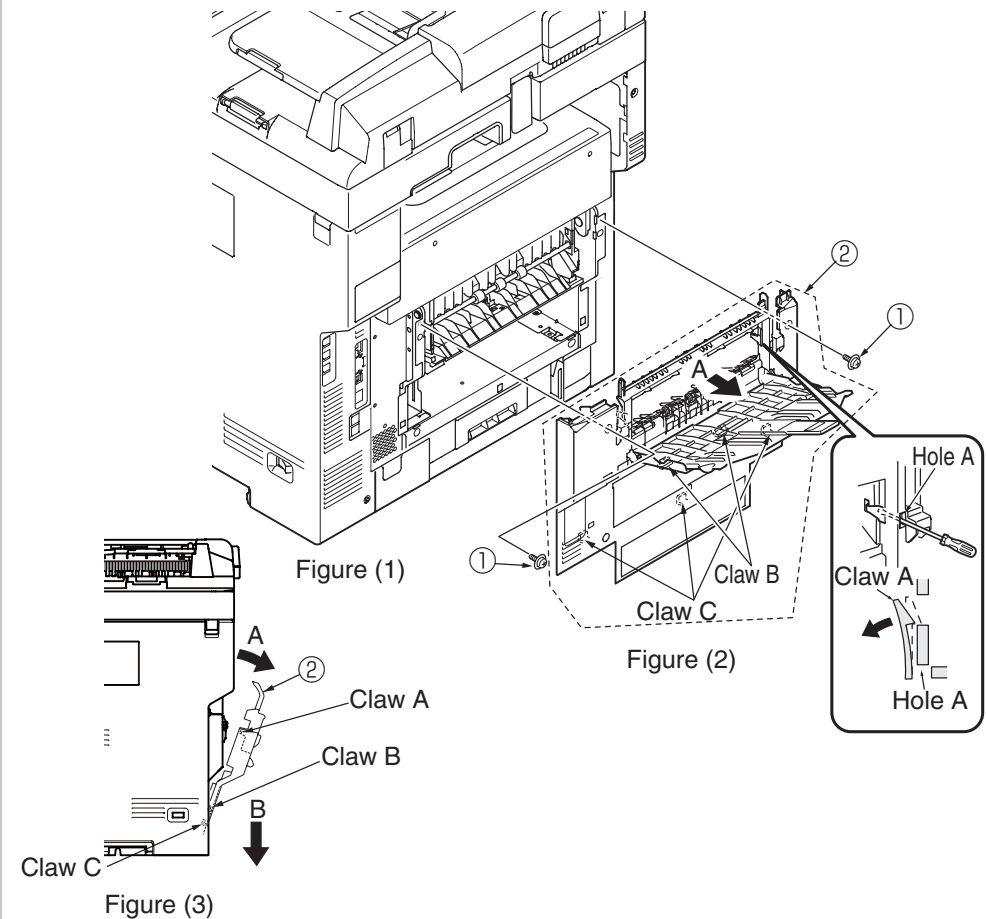

### 4.2.8 LED Assy/ LED Assy spring

- (1) Open the scanner and top cover.
  - (2) After removing the cable, as shown in fig 2, push the LED assy ① tightly in the direction of arrow. Take the hook A out firstly, and then take the hook B out, at last remove the LED assy.
- (At this time, the two springs ② is removed with LED Assy ① .)

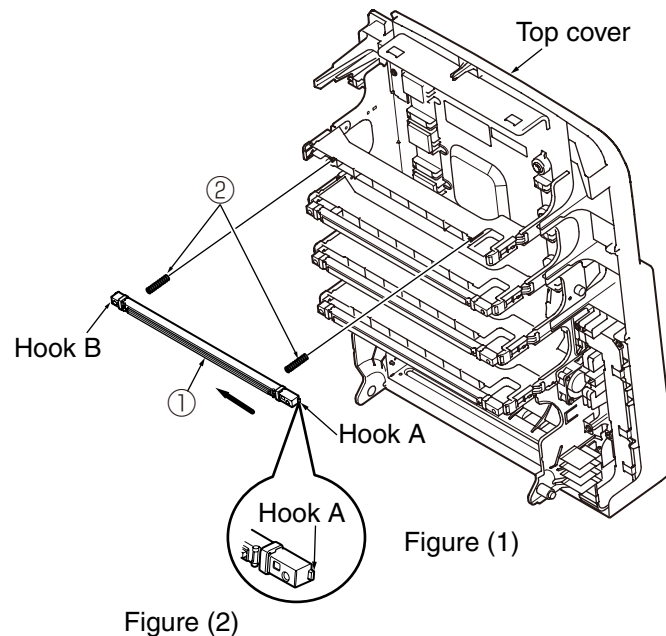

### 4.2.9 CU PCB/PU PCB/Low voltage power supply



There is a risk of electric shock during replacement of the low voltage power supply.

Use insulating gloves or avoid direct contact with any conducting part of the power supply, and caution should be exercised during replacement.

The capacitor may take one minute to complete discharge after the AC cord is unplugged. Also, there is a possibility that the capacitor doesn't discharge because of a breakage of the PCB, etc., so remember the possibility of electric shock to avoid electric shock.

- (1) Open the scanner and top cover.
- (2) Remove the right side cover. (See section 4.2.3)
- (3) Remove the eight screws (silver, No:42920406) ① to take out the plate-shield ② by dislocate to upper.
- (4) Remove the four screws (silver, No:42920406) ③ and all cables, and take the the FAX Unit ④ out.
- (5) Remove the eight screws (silver, No:42920406) ⑤ and two screws (silver, No:42920706) ⑥ and all cables, and take the CU PCB ⑦ out.
- (6) Remove the two screws (silver, No:42920406) ⑧ and all cables, and take the PU PCB ⑨ and Film Board ⑩ out.
- (7) Remove the two screws (silver, No:42920406) ⑪ and all cables, and take the Low voltage power supply ⑫ out.

- Note!**
- To attach the head cable, insert the end of the film-FG inside the plate-side-R, preventing from touching the edge of the plate-side-R.
  - Low-voltage power supply ⑫ and AC Inlet Assy should be replaced together. (The pair of low-voltage power supply and AC Inlet Assy meets the safety standards.)
  - When replace the PU PCB, collect information of the MFP, by using Maintenance Utility, before remove the PU PCB. (To see 5.3.1 "Precautions when replacing the PU board"). And replace the CU PCB or SRAM PCB, to see "Maintenance Manual (Software Guide)"

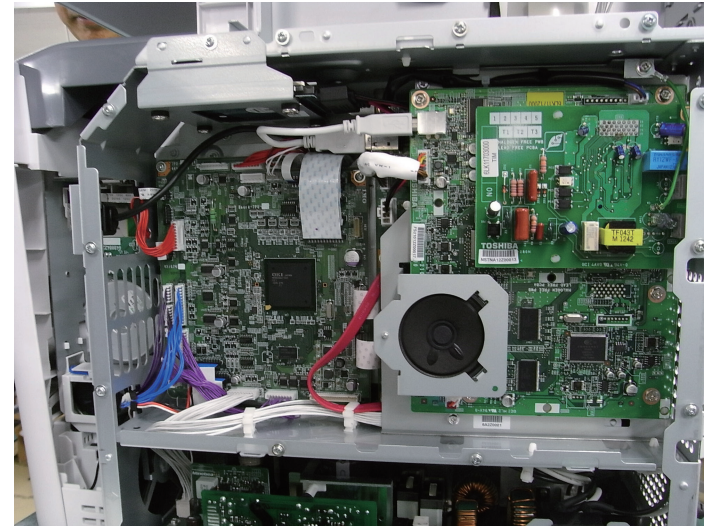
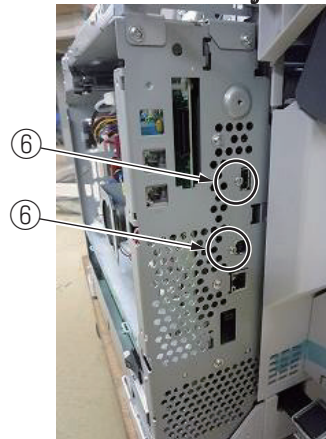
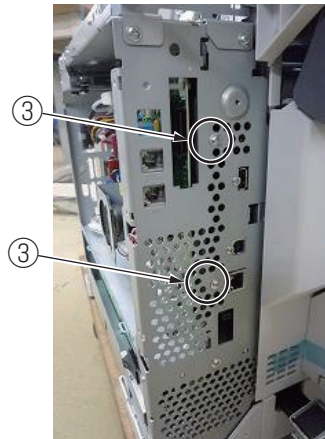
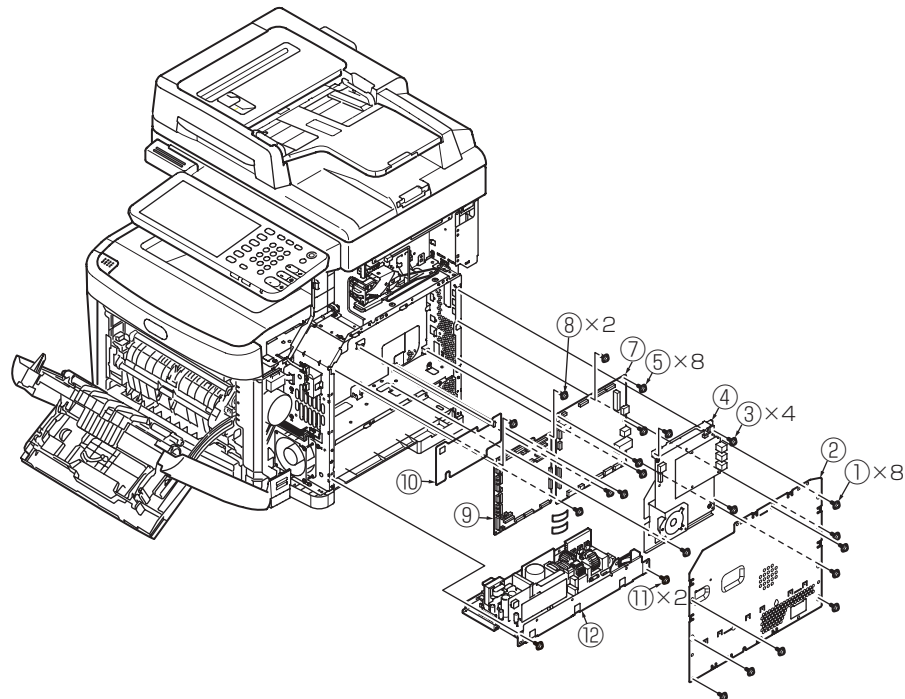

CU PCB

PU PCB

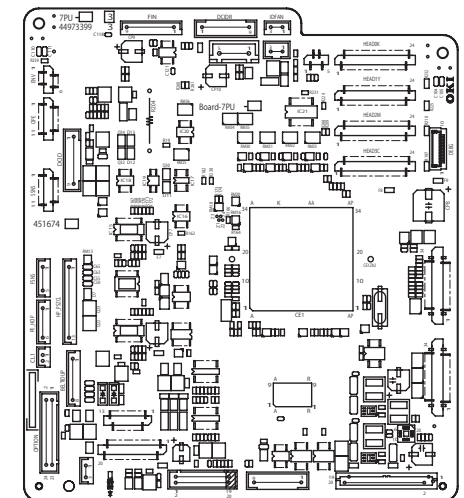
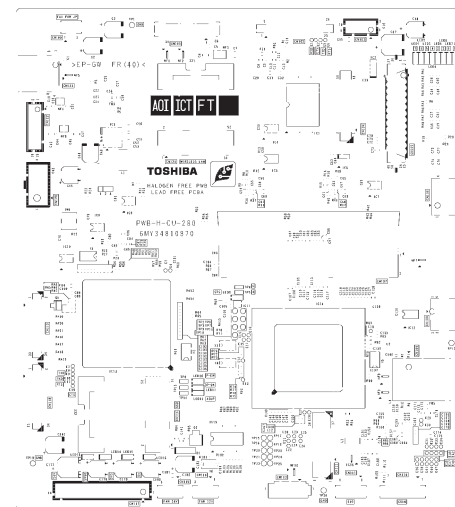

### 4.2.10 Stay-R

- (1) Remove the right side cover. (See section 4.2.3)
- (2) Remove the Scanner.
- (3) Remove the soft-absorber ① and cover side(R-Inner) ② .
- (4) Remove the seven screws (silver,No:42920406) ③ and remove the Stay-R ④ .

**Note!** When assemble the scanner, assemble the soft-absorber correct position and close the scanner.(Frame and soft-absorber break may occur)

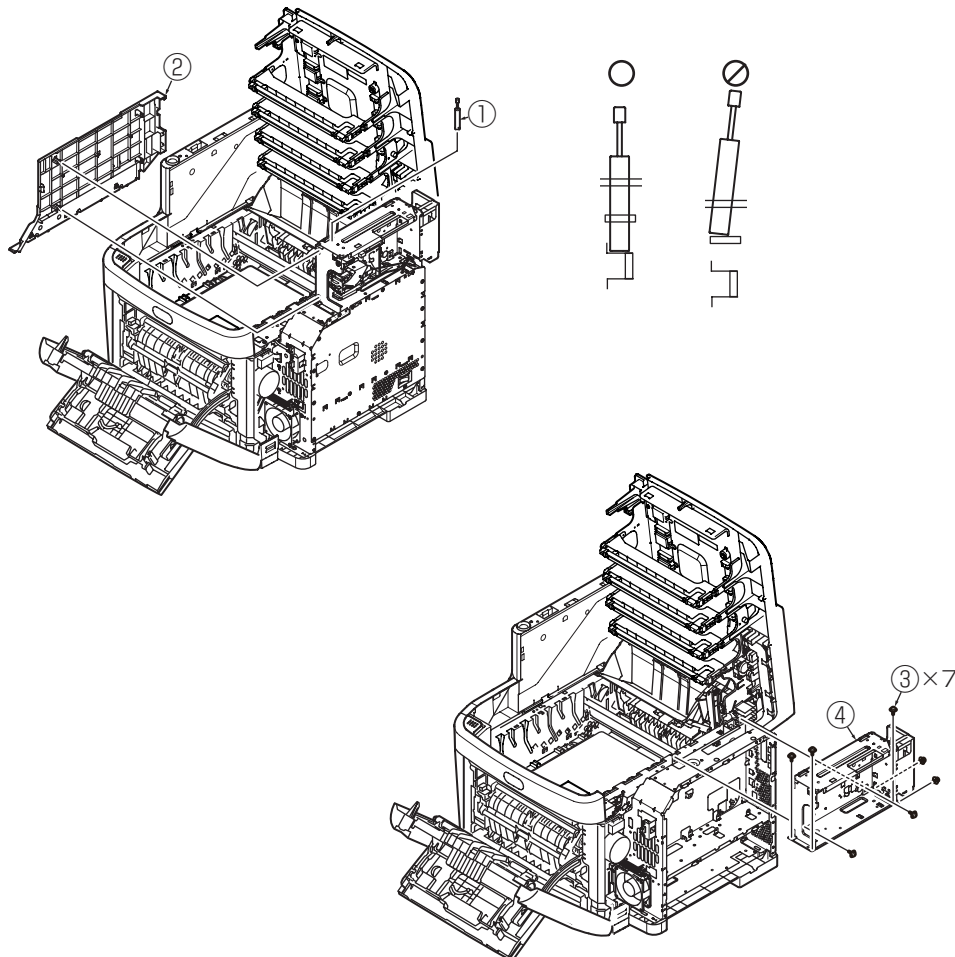

### 4.2.11 Plate-Board-R Assy/Guide-Cable Power Low

- (1) Remove the right side cover. (See section 4.2.3)
- (2) Remove the stay-R Assy. (See section 4.2.10)
- (3) Remove the rear cover. (See section 4.2.7)
- (4) Remove the plate shield and take CU PCB and PU PCB out. (See section 4.2.9)
- (5) Remove the eight screws (silver, No:42920406) ① ,remove the two screws (black,No:42932708) ② and remove the Plate-Board-R-Assy ③ .
- (6) Remove the Guide-Cable Power Low ④ .

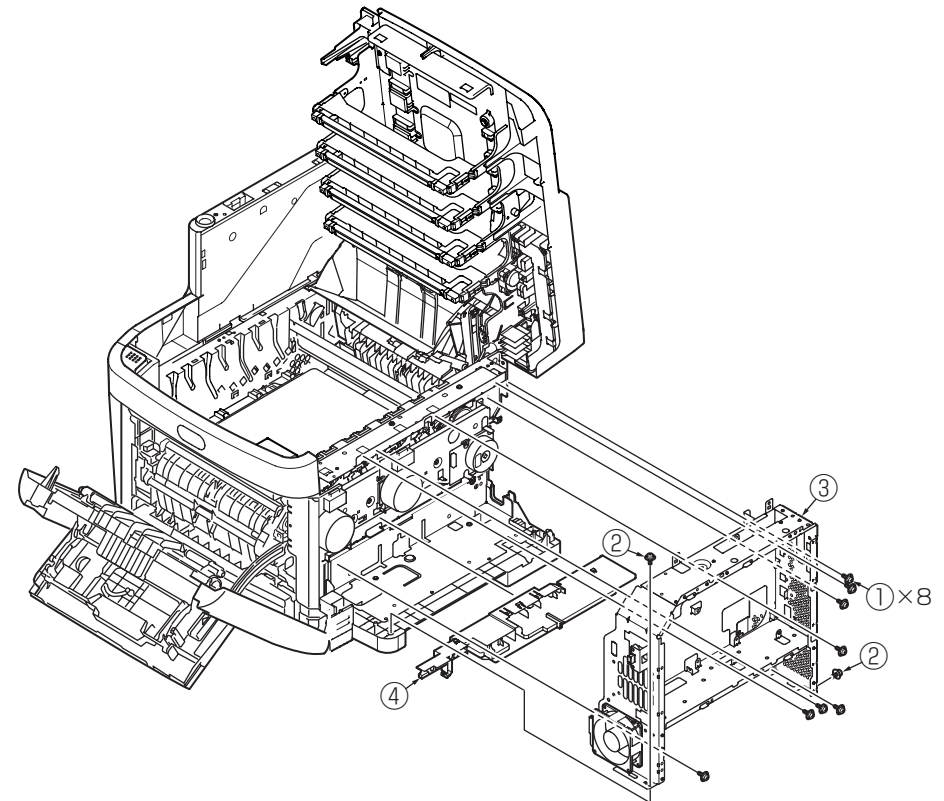

## 4.2.12 Top cover Assy

- (1) Remove the right side cover. (See section 4.2.3)
- (2) Remove the left side cover. (See section 4.2.4)
- (3) Remove the rear cover. (See section 4.2.7)
- (4) Remove the plate shield and take CU PCB and PU PCB out. (See section 4.2.9)
- (5) Remove the connectors of the stack full sensor cable and ID-FAN cable, remove the connector and the hanging RFID cable ① .
- (6) Remove the two screws (silver,No:42920406) ② and remove Head-cable-Assy with alumi-laminate-Film.
- (7) Remove two E type stop rings ③ and two torsion springs ④ , and remove the top cover Assy ⑤ .

- Notes!**
- Perform the following RFID circuit behavior check after replacement of the top cover assy:
    - By executing RFID COLOR for the switch scan test described in 5.3.1.3, check that the printer can display UID \*\*H for each of cyan, magenta, yellow and black with nonempty consumable cyan, magenta, yellow and black toner cartridges installed in it. The printer cannot detect the UID usage for a color with a starter toner cartridge installed for the color.
    - MFP's starter cartridge for a color cannot be reinstalled in it once replaced with an empty consumable toner cartridge for the color.
    - Don't open the Top cover over 90° or more.

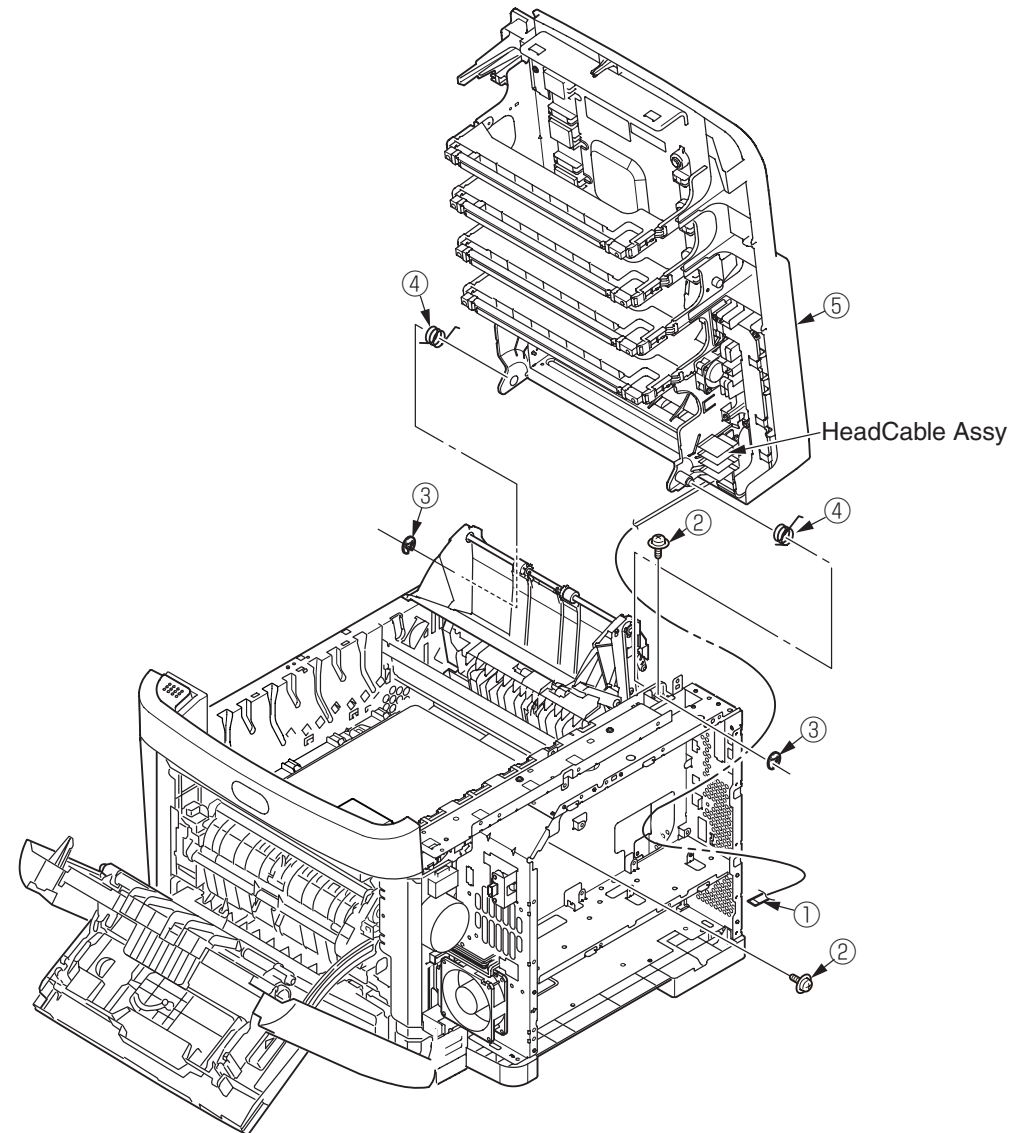



### 4.2.13 Top cover

- (1) Remove the top cover Assy. (See section 4.2.12)
- (2) Remove fifteen screws(black, No:42932708) ①, and remove the top cover ②.
- (3) Remove the screw (silver, No:42920406) ③, remove the two screws(silver,No:42920420) ④ and remove the Head Cable ⑤.

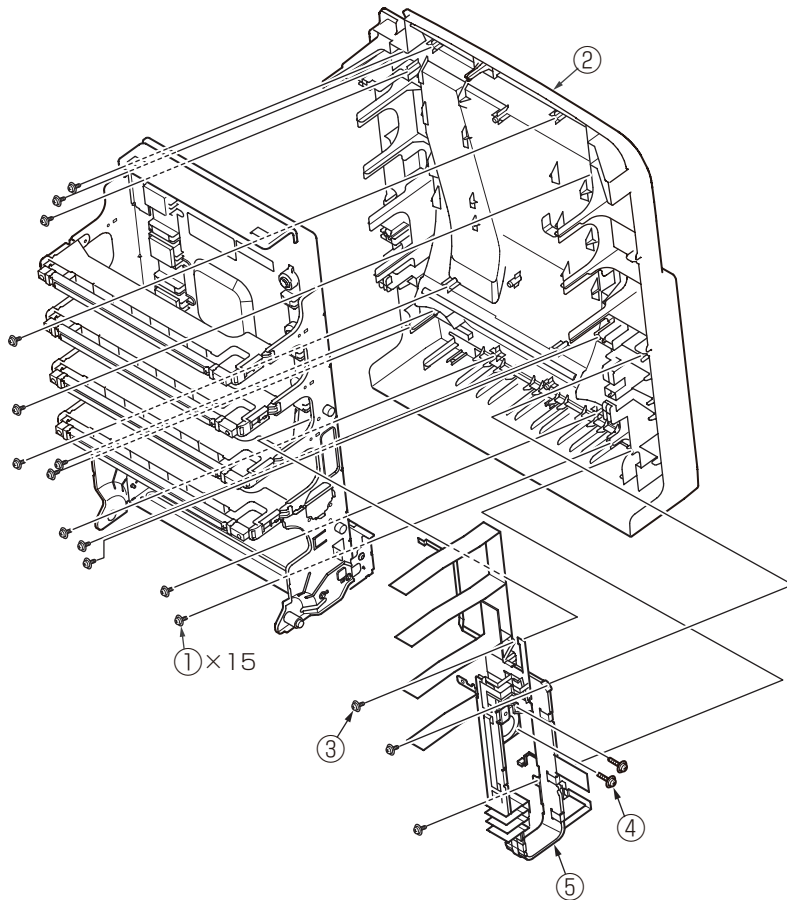

### 4.2.14 Frame Assy Top Front

- (1) Remove the right side cover. (See section 4.2.3)
- (2) Remove the plate shield. (See section 4.2.9)
- (3) Remove the connector of Frame Assy Top Front.
- (4) Remove the two screws (silver, No:42920406) ①, disengage the claws(3 places) on the Frame Assy Top Front ②, and remove the Frame Assy Top Front ②.

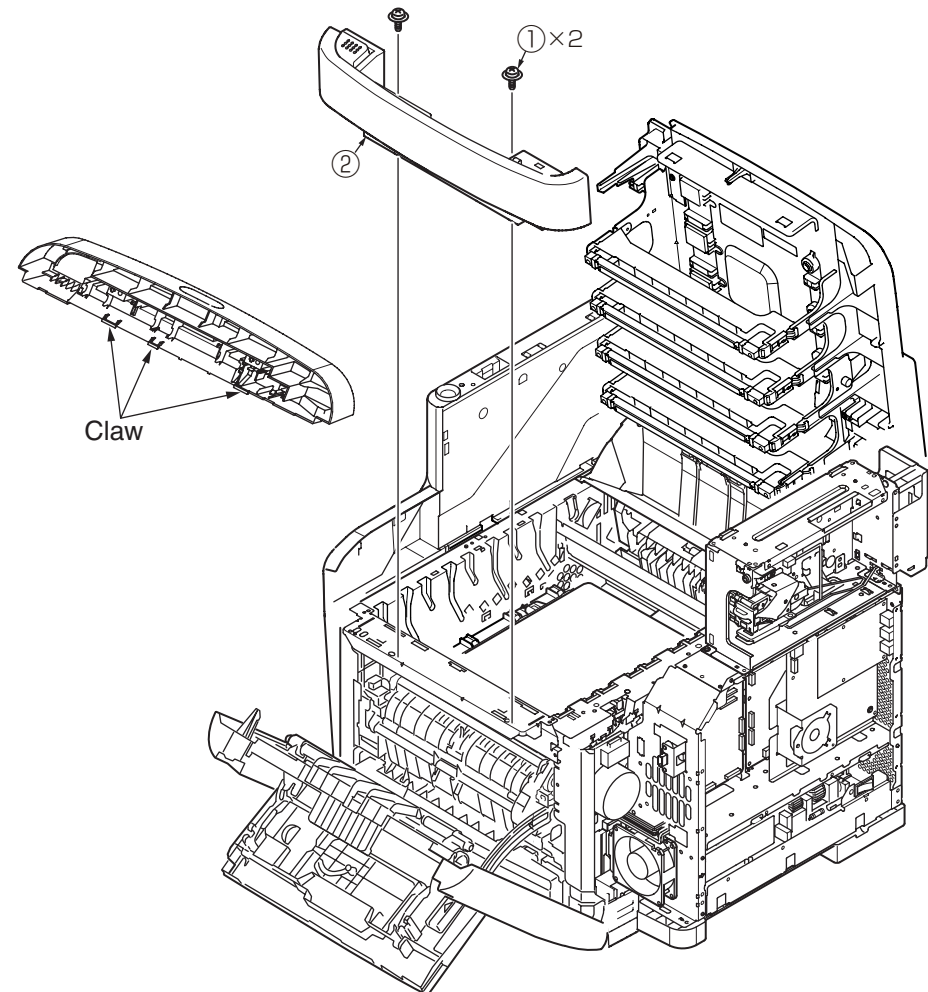

## 4.2.15 Board MFH

- (1) Remove the Frame Assy Top Front. (See section 4.2.14)
- (2) Disengage the claws(2 places) on the of Board MFH ① and remove the Board MFH ① .

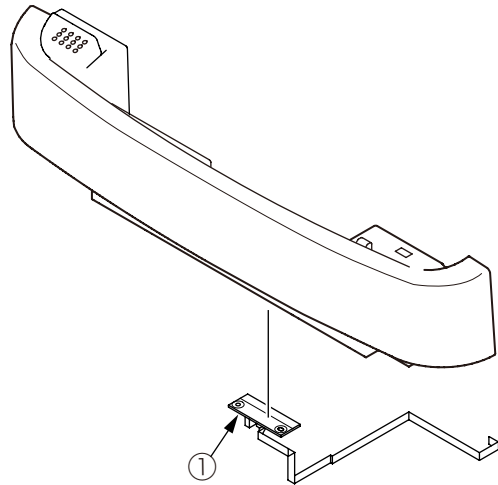

## 4.2.16 Hopping motor/ Fuse motor/Low voltage FAN/ID Motor

- (1) Open the scanner and top cover.
- (2) Remove the plate shield and take CU PCB and PU PCB out. (See section 4.2.9)
- (3) Remove the two screws ① (silver, No:42920428) and connector, and take the low voltage FAN ② out.
- (4) Disengage the claw D (2 places) and claw E, and remove the motor cover ③ .
- (5) Remove the two screws ④ (silver, No:42920406) and connector, and take the hopping motor ⑤ out.
- (6) Remove the three screws ⑥ (silver, No:42920406) and connector, and take the fuse motor ⑦ out.
- (7) Remove the three screws ⑧ (silver, No:42920406) and connector, and take the ID motor ⑨ out (2 places).

**Notes!** • Be careful to install the low voltage FAN ② in the proper direction.

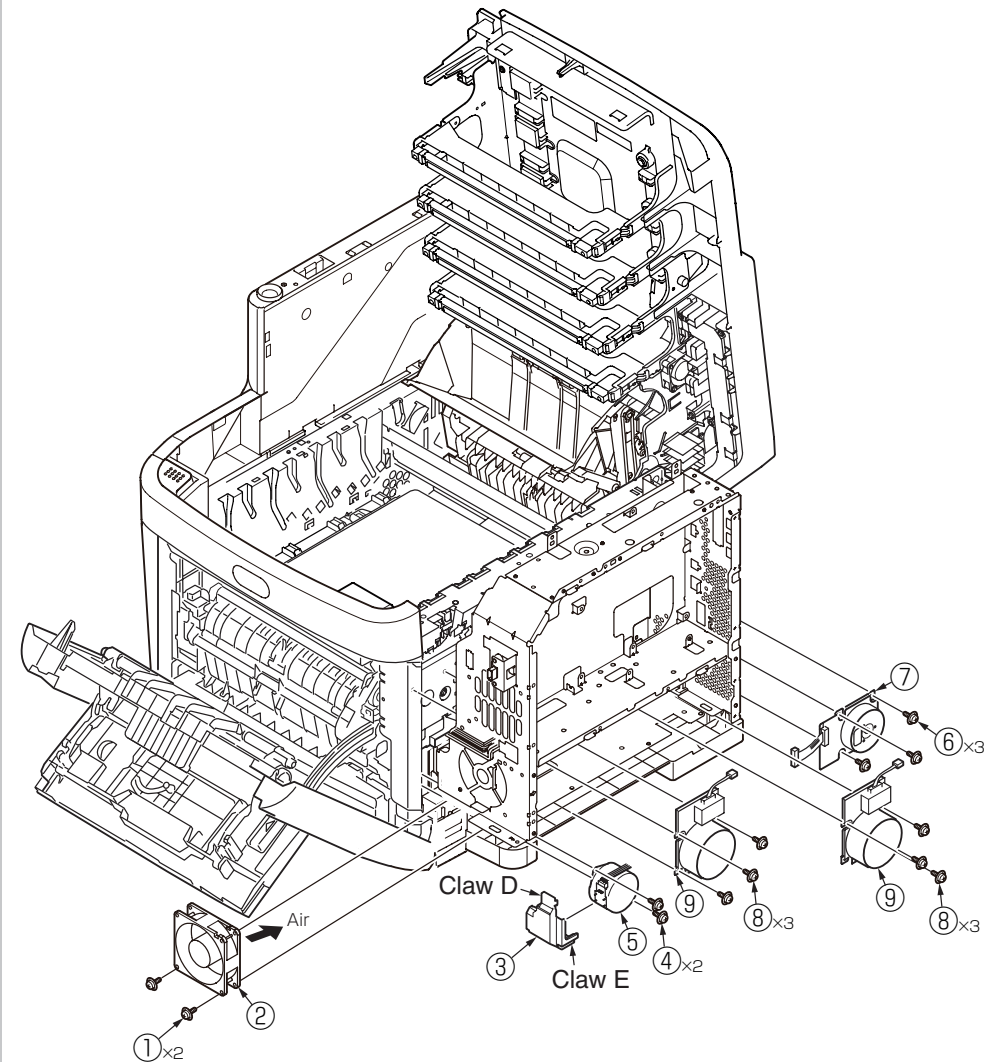

### 4.2.17 Guide eject Assy/ Color regist Assy/ Board-IBY

- (1) Remove the left side cover, right side cover, rear cover, top cover Assy. (See section 4.2.4, 4.2.3, 4.2.7, 4.2.12)
- (2) Remove CU PCB and PU PCB and low-voltage power supply. (See section 4.2.9)
- (3) Remove the connector of belt thermistor(it connect the High-voltage PCB), remove the two torsion springs ①, and disengage four claws (4 places) by minus driver, remove the cover driver ②.
- (4) Remove the screws (silver, No:42920406) ③ and connectors (7 places), remove the Board-IBY ④.
- (5) Remove the two screws (silver, No:42920406) ⑤ and remove the color regist Assy ⑥.
- (6) Remove the three screws (silver, No:42920406) ⑦, remove the cable ⑧ of fuse I/F connector from clamp, and slide the claw of cable guide ⑨ to disengage, remove the guide eject Assy ⑩.

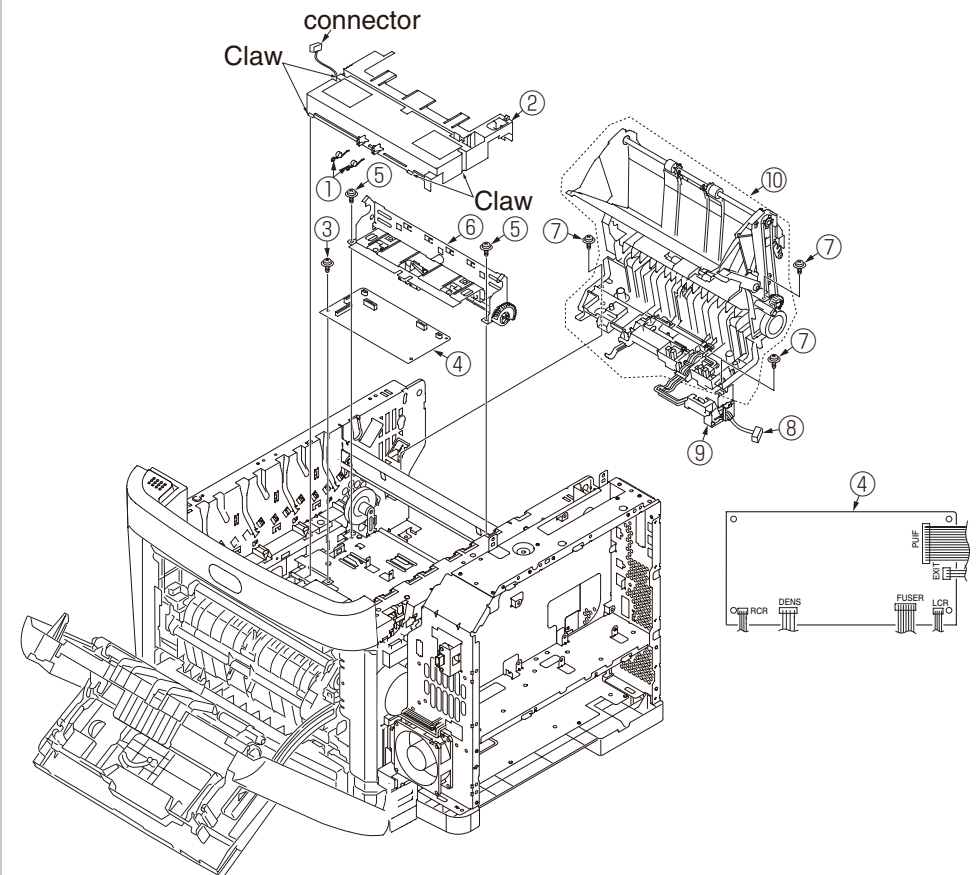
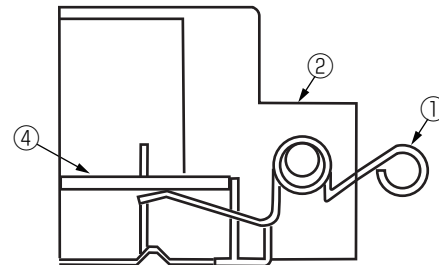
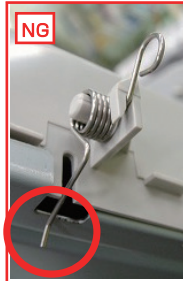

### 4.2.18 FAN(Fuser) / Belt motor/ High-voltage board/ Cover open switch

- (1) Remove the left side cover. (See section 4.2.4)
- (2) Remove the six screws ① (silver, No:42920406) and remove the Stay(L-Beam) ②.
- (3) Remove the screw ③ (silver, No:42920406) and connector, and remove the belt motor ④.
- (4) Remove the connector, and rotate the FAN (Fuser) ⑤ clockwise to remove.
- (5) Remove the connector and disengage the claw A (2 places), and remove the cover open switch ⑥.
- (6) Remove the 2 screws ⑦ (silver, No:42920406 and black, No:42932708) and connectors (2 places), and disengage the claw B (7 places). Remove the high-voltage power supply ⑧.

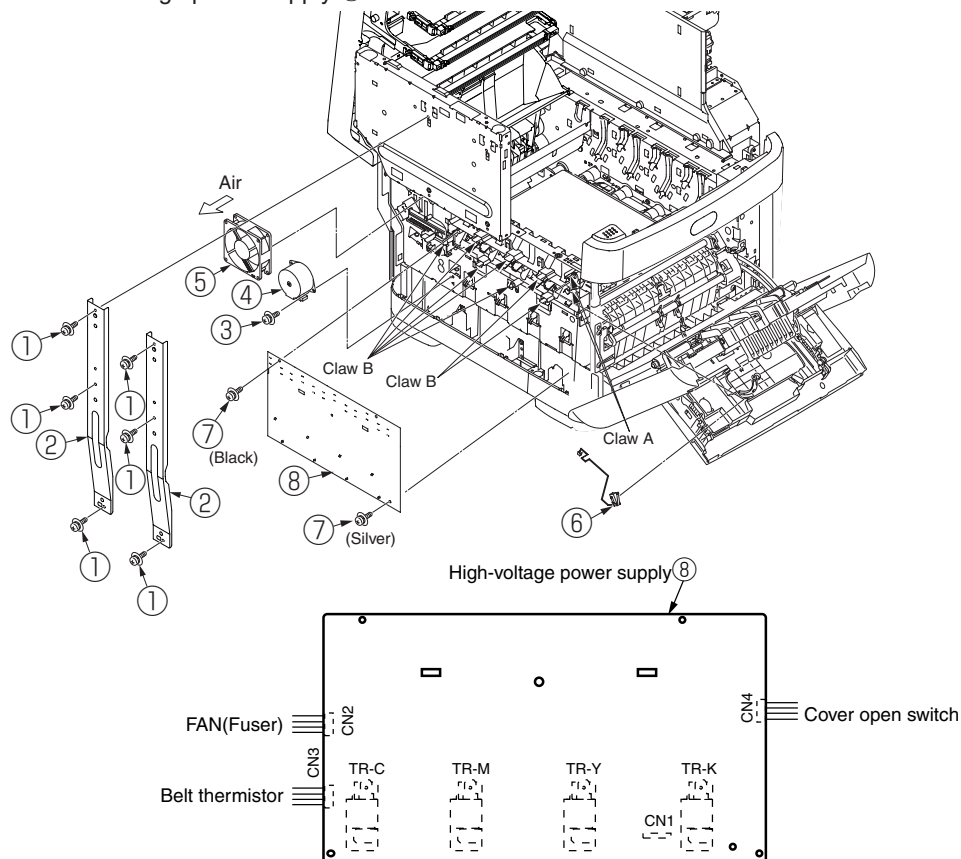

### 4.2.19 MPT Assy

- (1) Open the MPT Assy ①.
- (2) Remove the stoppers (2 places) while pushing the arms (2 places) on MPT Assy ① outside, pull the supporters (2 places) in the direction of the arrow and remove them, and remove the MPT Assy ①.

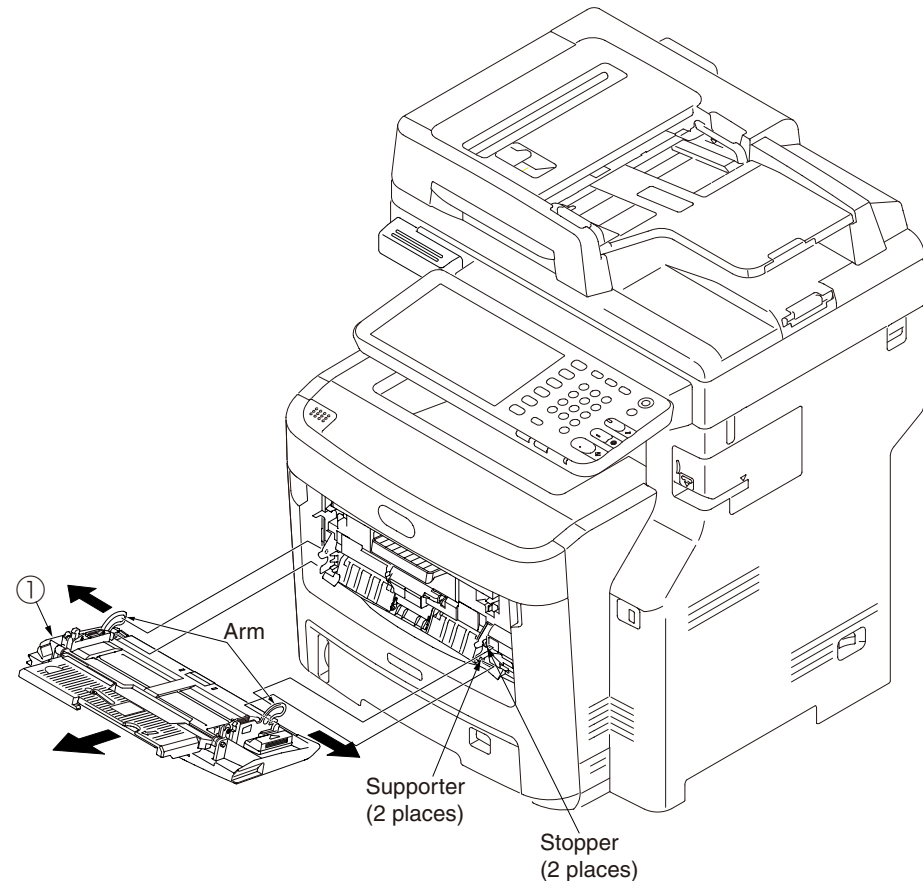



### 4.2.21 Plate-Driver/ Shaft-Liftup/ Hopping cover

- (1) Remove the left side cover, right side cover, rear cover, top cover unit, feeder Assy regist. (See section 4.2.4, 4.2.3, 4.2.7, 4.2.12, 4.2.20)
- (2) Remove CU PCB and PU PCB. (See section 4.2.9)
- (3) Remove the guide cable Power Low, low-voltage power supply. (See section 4.2.11,4.2.9)
- (4) Remove the cover driver, Board-IBY, color regist Assy, eject Assy. (See section 4.2.17)
- (5) Remove the two screws (silver, No:42920406) ①, and remove the plate driver ②.
- (6) Remove the the connector of 2nd Tray and remove hopping cover ③.
- (7) Remove the FAN(Fuser). (See section 4.2.18)
- (8) Remove the latches (2 places) and remove the gear ④, remove the E Ring (RE3-SK), remove the latch and remove the gear ⑤ and remove the E Ring (RE3-SK)of beside the Plate-Assy-Side-R and shaft ⑥.
- (9) Remove the Board ⑦.
- (10) Remove the two screws (silver, No:42920406) ⑧, and remove the Plate-Heat ⑨.

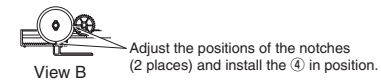
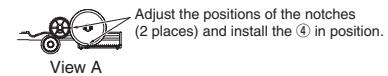
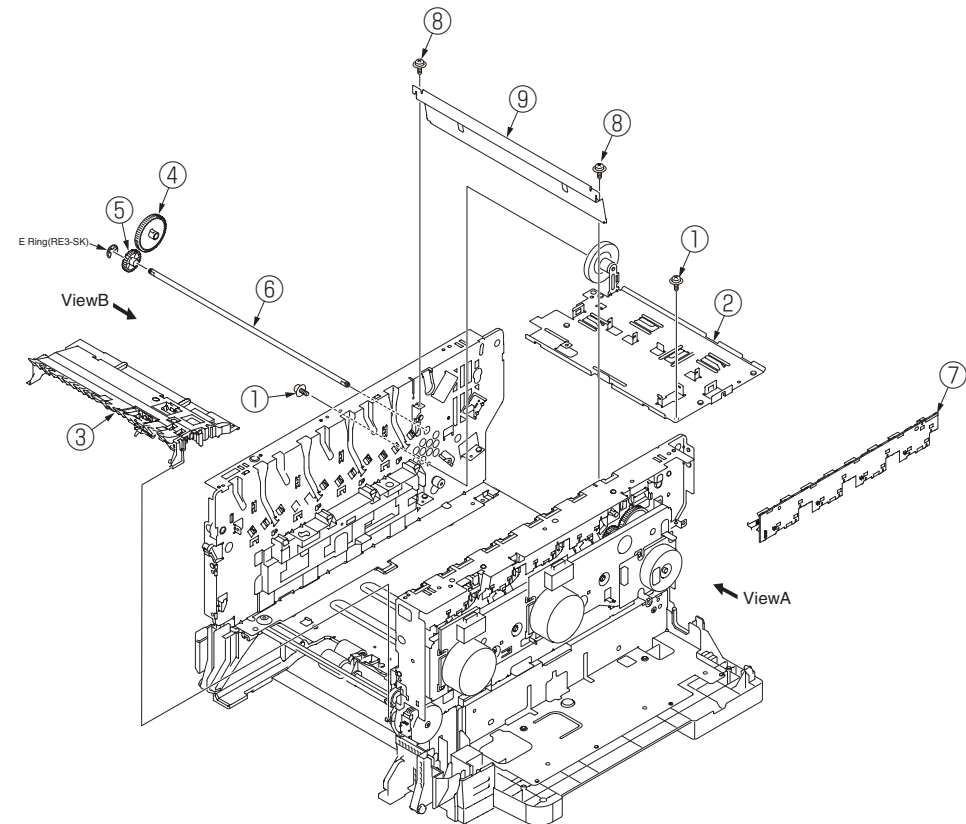

### 4.2.22 Plate-Assy-Side R/ Plate-Assy-Side L

- (1) Remove the plate driver, shaft-Liftup. (See section 4.2.21)
- (2) Remove the three screws (silver, No:42920406) ① and remove the Plate-Assy-Side R ②.
- (3) Remove the two screws (silver, No:42920406) ③ and remove the Plate-Assy-Side L ④.

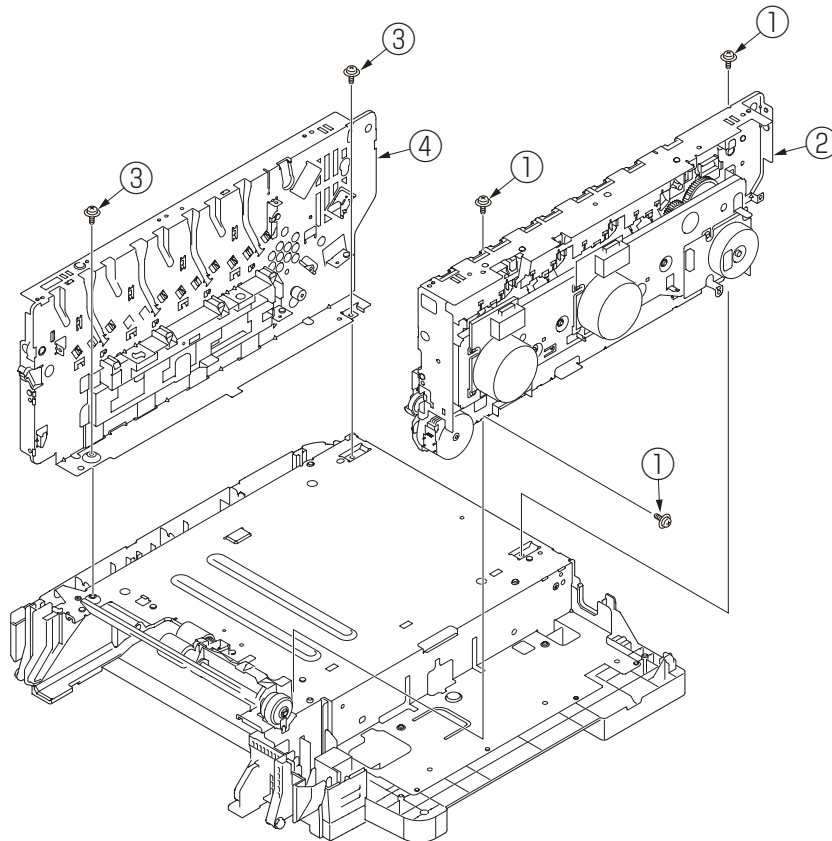

### 4.2.23 Feed roller

- (1) Remove the cassette.
- (2) Remove the latch and remove the feed roller (2 pieces) ①.

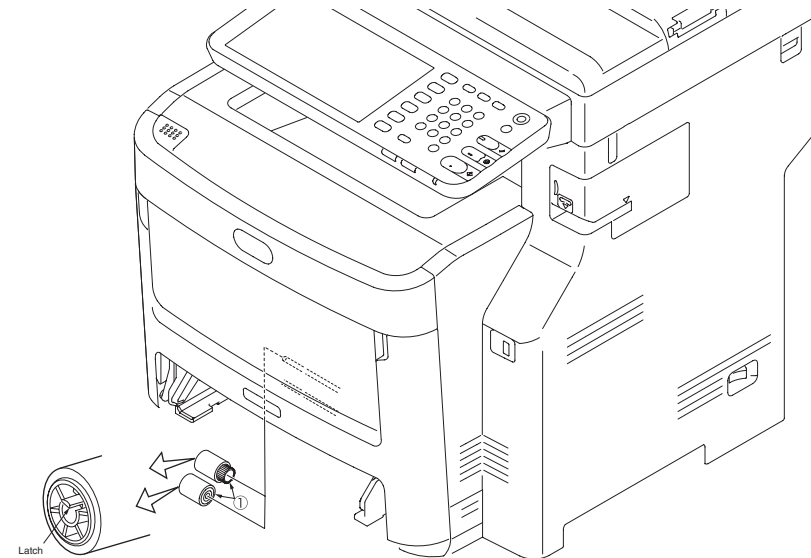



### 4.2.24 Eject sensor/Micro-SW

- (1) Remove the eject Assy. (See section 4.2.17)
- (2) Disengage the claws (2 places), and disassemble the Assy into guide eject lower ① and guide eject upper ② .
- (3) Remove the lever eject sensor ③ and spring-SNS(F/R) ④ and eject sensor ⑤ .
- (4) Remove the micro-SW ⑥ and cable ⑦ .

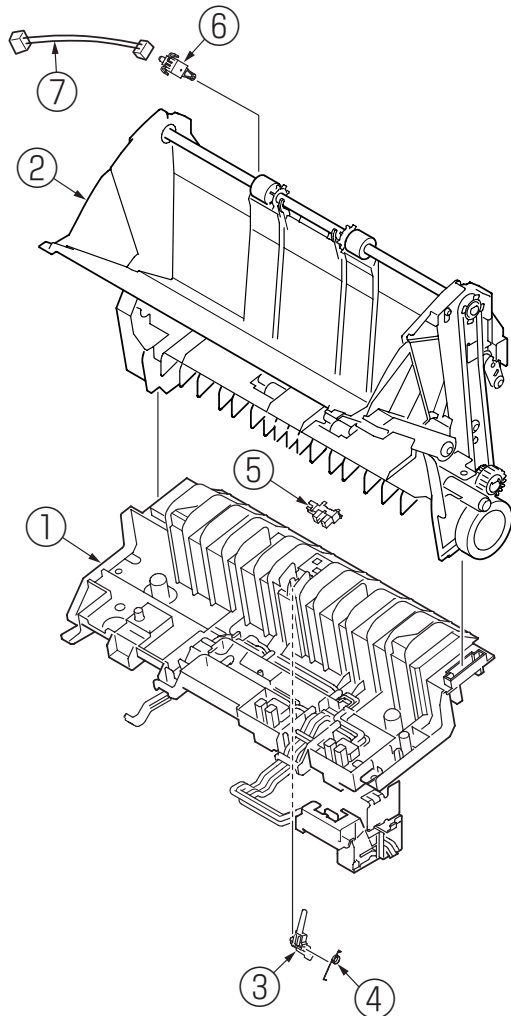

### 4.2.25 Antenna (for wireless model only)

- (1) Remove the FAX Unit. (See section 4.2.9)
- (2) Remove the two clamp-cable and core and disconnect the connector.
- (3) Remove the screw (silver, No:42920408) ① .
- (4) Remove the Antenna ② .

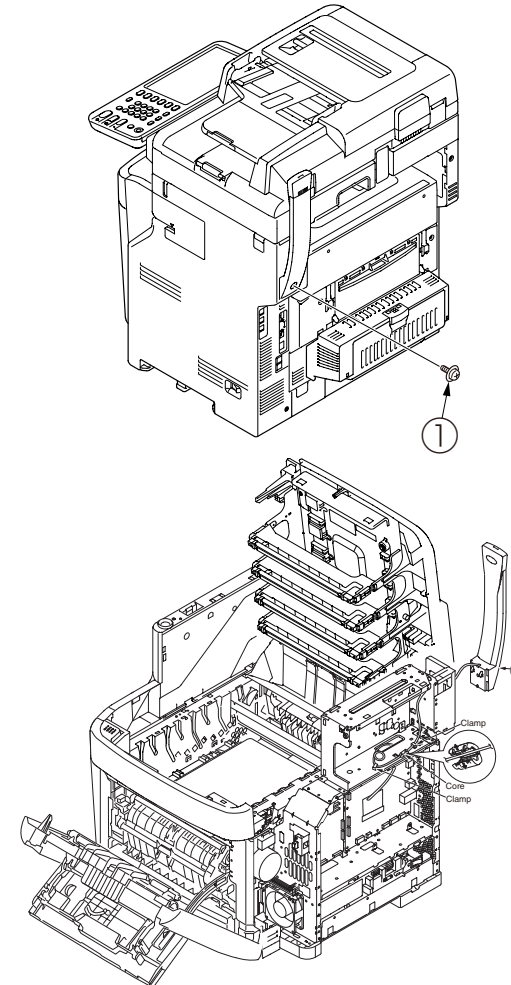

### 4.2.26 Finisher (MC780dnf only)

- (1) Open the Scanner and remove the two screws ① .
- (2) Remove the cover connector ② by push the tab.
- (3) Disconnect the connector and remove the finisher unit ③ by pull at rear.

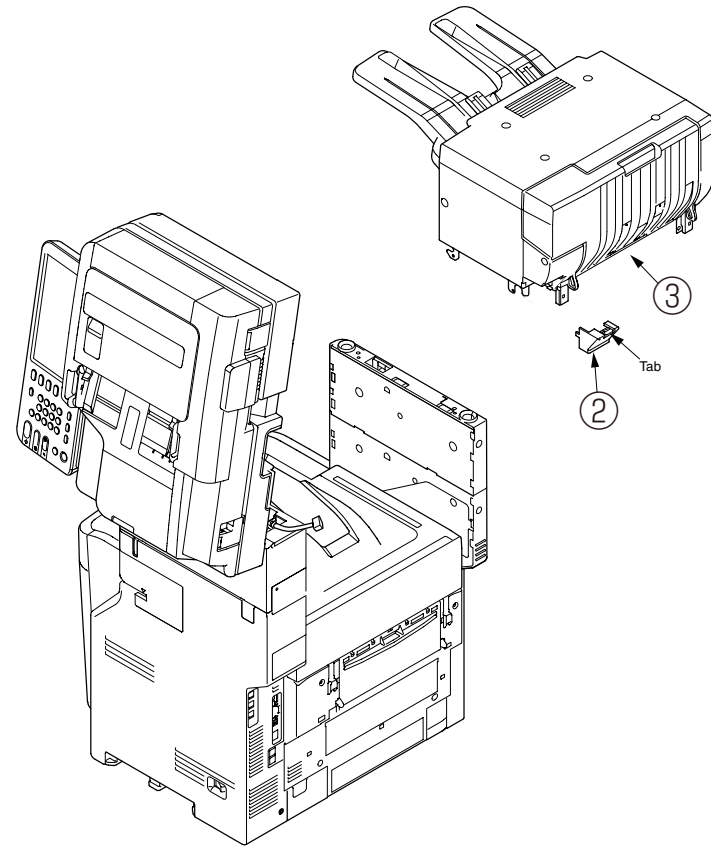
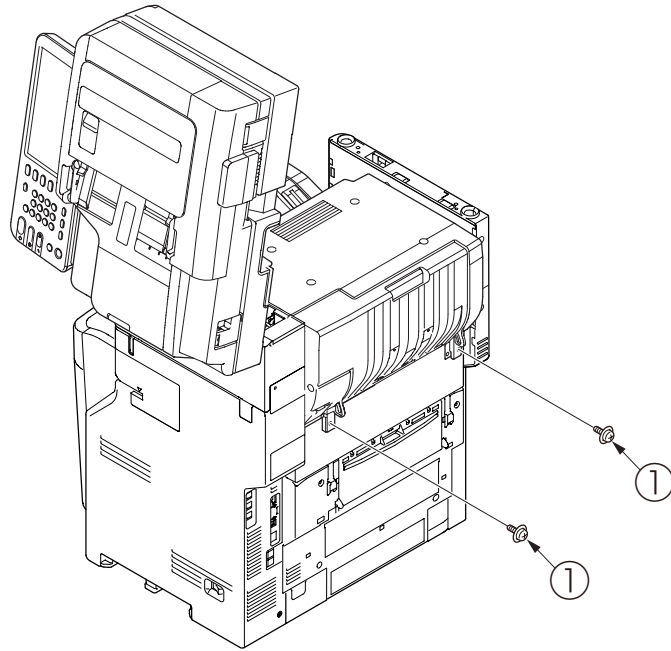

## 4.2.27 Stapler (MC780dn only)

- (1) Remove the plate shield. (See section 4.2.9).
- (2) Remove the two screws (silver, No:42920406) ① and remove the Staple ② .

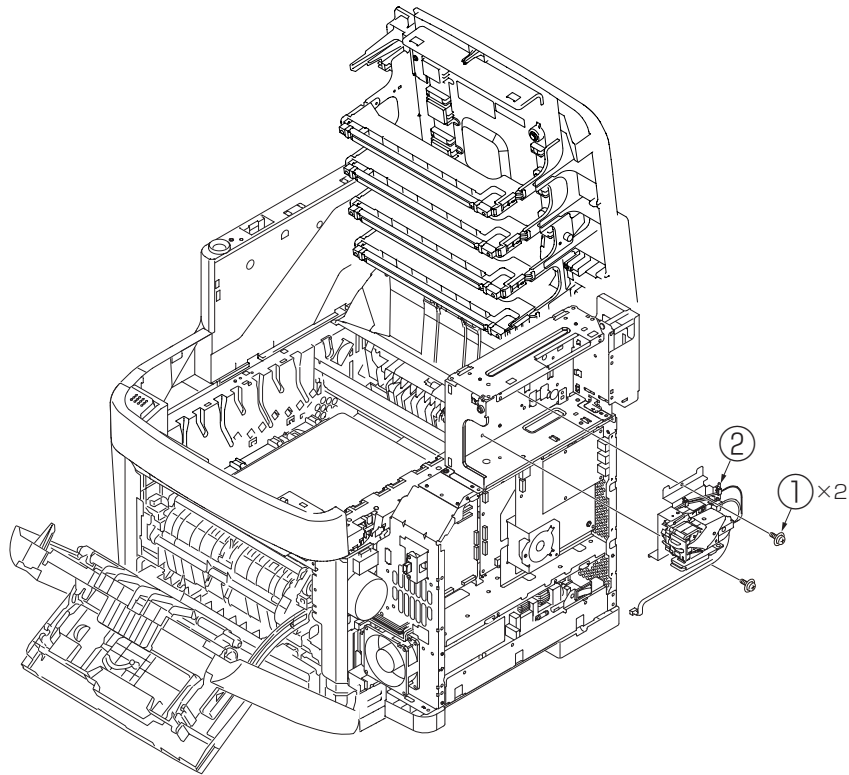

### 4.2.28 Tray-Assy-Document/Cover-ADF-R

- (1) Open the Cover-Assy-top-ADF.
- (2) Remove the Tray-Assy-Document ① by pull it in the direction arrow.

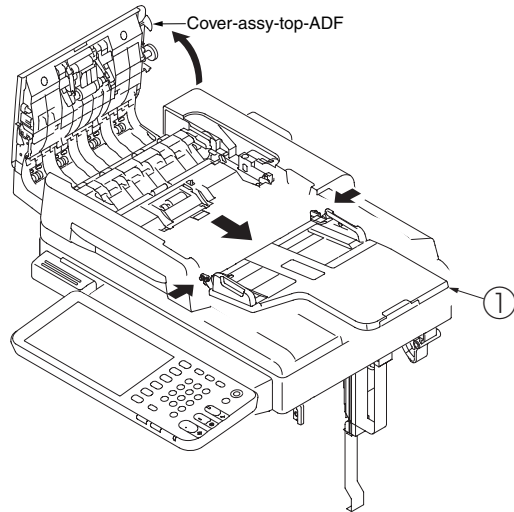

- (3) Open the ADF-unit while pushing the portion B, and push the claw of cover-ADF-R ②.

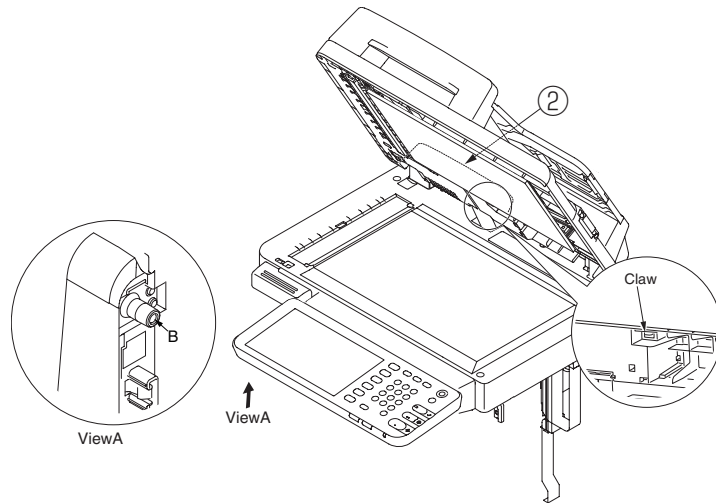

- (4) Push the portion A. (Concurrent to push the (3) )

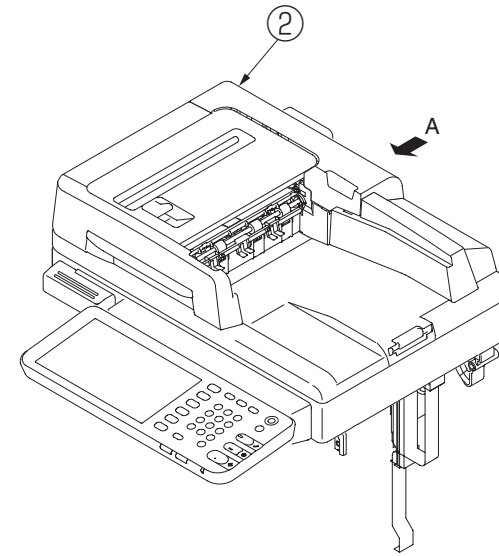

- (5) Remove the cover-ADF-R ② in the direction of the arrow.

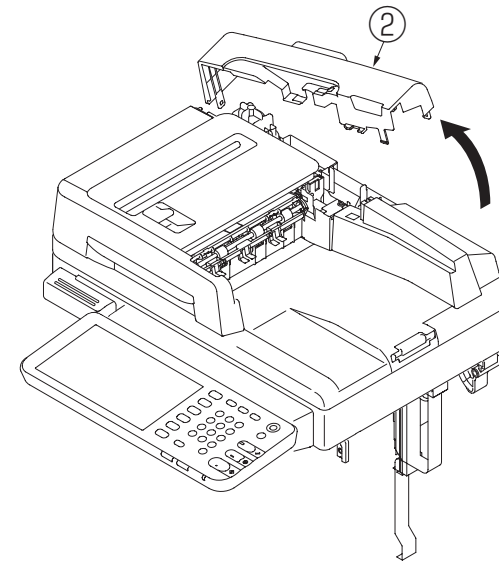

### 4.2.29 ADF-unit

- (1) Remove the cover-ADF-R. (See 4.2.24)
- (2) Detach a connector ① from the ADF relation board(7RL), and remove the screw (silver, No:42920406) ② and FG cable.

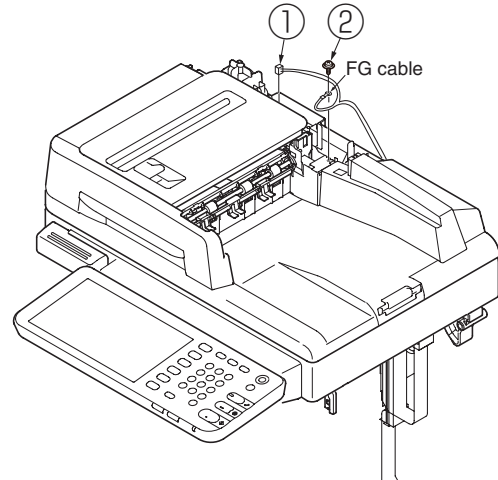

- (3) Open the ADF-unit ③ while pushing the portion B and remove the clamp cable.

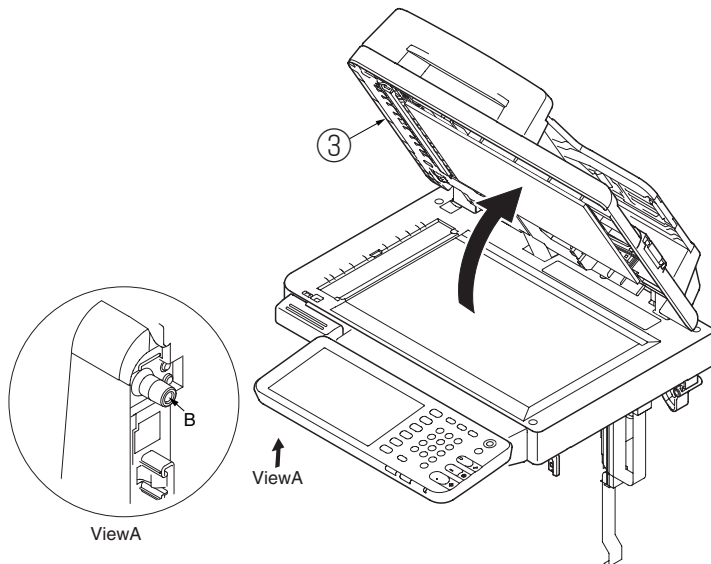

- (4) Remove the ADF-unit ③ by insert the flat-blade screwdriver to gap between ADF-unit ③ and flatbed-unit with pull the cables out of the Frame-Base(ADF) and Hinge.

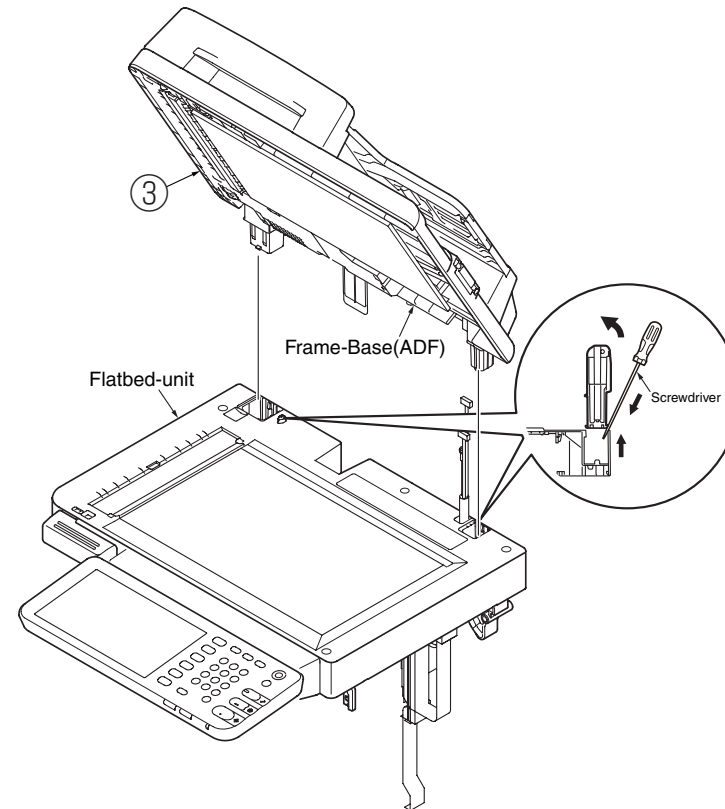

### 4.2.30 Sheet-document / Paper-weight-Assy / Spring-PW-ADF

- (1) Open the ADF-unit.
- (2) Remove the sheet-document ① .
- (3) Remove two claws to remove the paper-weight-assy ② and two spring-PW-ADF ③ .

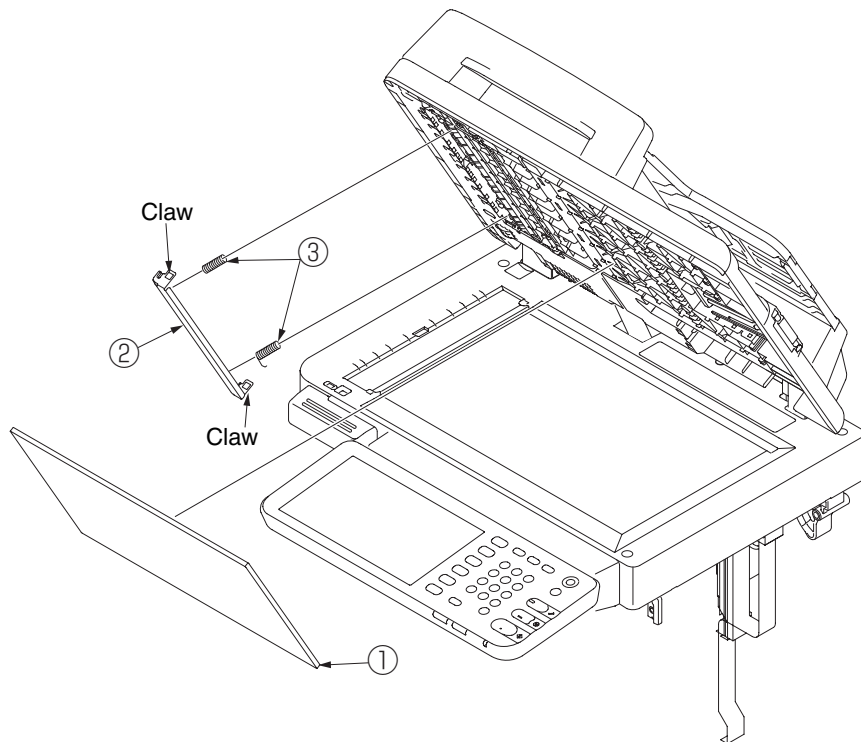

#### <Attention of affix the sheet-document>

- (1) Degrease the affix area of ADF-unit.
- (2) Remove the peeling-off sheet.
- (3) Set the sheet-document ① (see the figure below).
- (4) Close the ADF-unit.

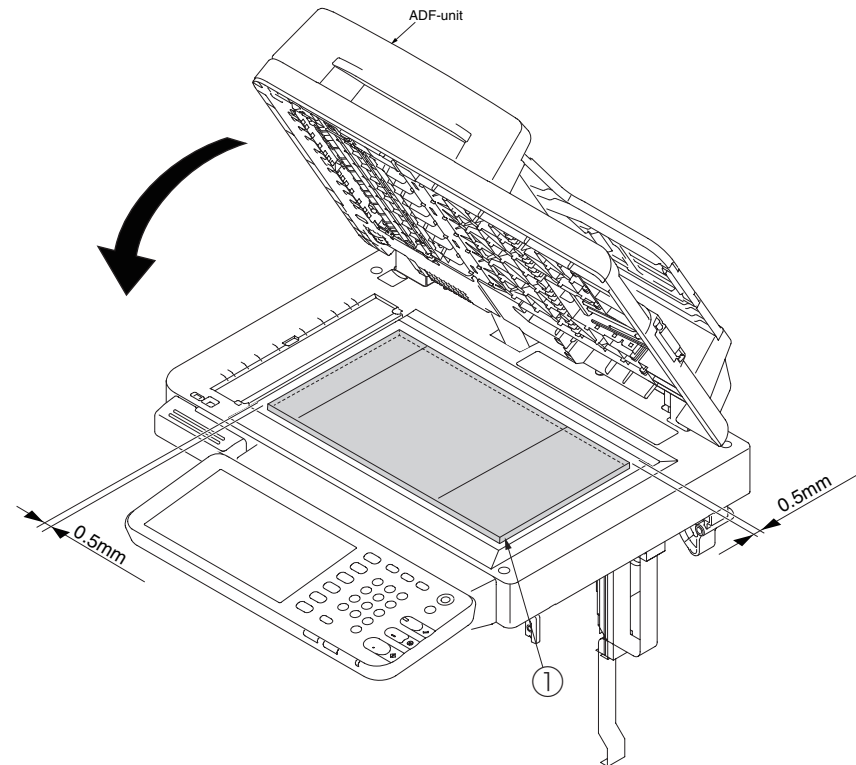

### 4.2.31 Hinge-Assy-L / Hinge-Assy-R

- (1) Remove the three screws (black, No:42932708) ① and remove the hinge-Assy-R ②.
- (2) Remove the three screws (black, No:42932708) ③ and remove the hinge-Assy-L ④.

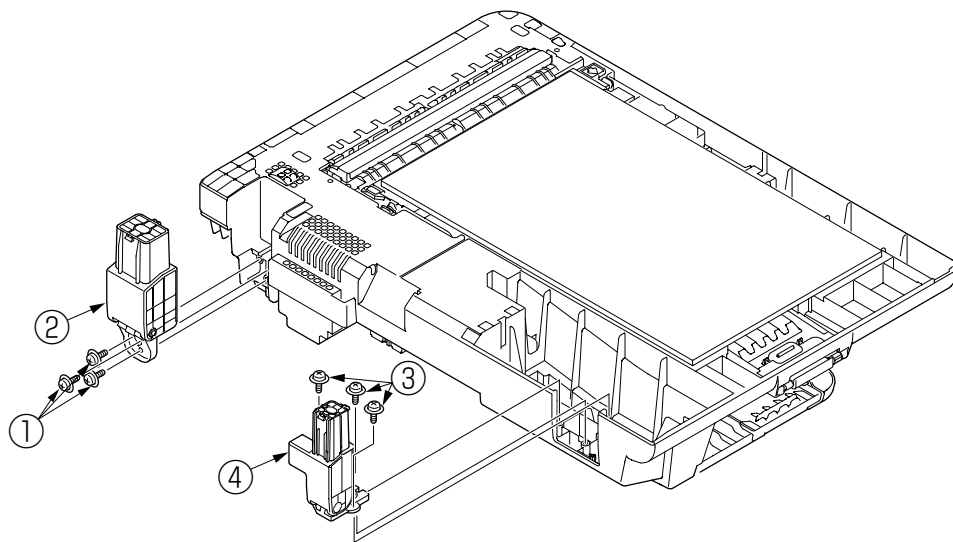

### 4.2.32 ADF-Assy

- (1) Remove the screw (silver, No:42920406) ① and remove the ADF board(7RL) ②.
- (2) Remove the four screws (black, No:42932706) ③ and remove the ADF-assy ④.

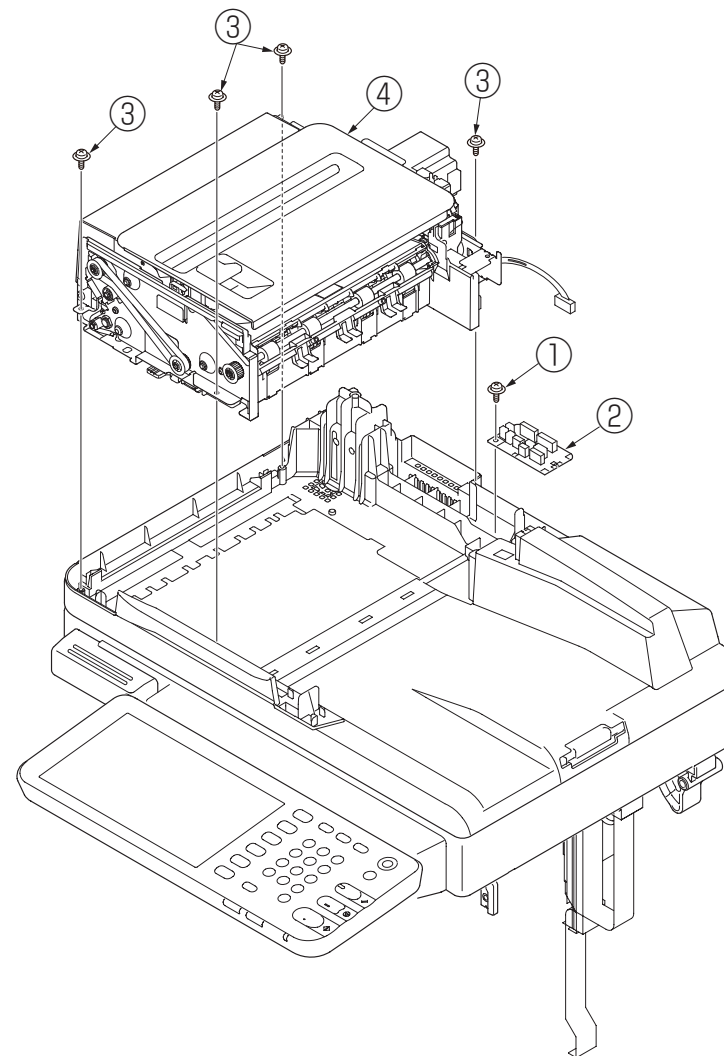

### 4.2.33 Guide-Retard / Roller / Motor / Clutch / Solenoid/ Photo-sensor

- (1) Pull and remove Guide-Cable-ADF ① .
- (2) Remove the E-type retaining ring ② and remove the clutch ③ .
- (3) Remove the three screws (silver, No:42920406) ④ and remove the plate-motor-ADF ⑤ .
- (4) Remove the two screws (silver, No:42920406) ⑥ and remove the motor-pulse-belt ⑦ from ⑤ .
- (5) Remove the E-type retaining ring ⑧ and remove the clutch ⑨ .
- (6) Open the Cover-Assy-Top-ADF ⑩, and warp around a post to Arrow A to remove Cover-Assy-Top-ADF ⑩ .
- (7) Disconnect a cable, and warp around post to Arrow B to remove the Guide-Retard-A ⑪ .
- (8) Remove the Guide Separator Hop ⑫ .
- (9) Remove the three screws (black, No:42932708) ⑬ and Plate-Drive ⑭ .
- (10) Remove the Feed roller ⑮ .
- (11) Remove two screws (silver, No:42938104) ⑯ and remove the solenoid ⑰ .
- (12) Warp around post to Arrow C to remove Guide-B ⑱ .
- (13) Warp around post to Arrow E to remove Guide-Separator ⑲ .
- (14) Disconnect all cables and warp around post to Arrow D to remove the Guide-Assy-C ⑳ and remove ㉑ .
- (15) Warp around post to Arrow F to remove the Guide-Assy-D ㉒ and remove the photo-sensor ㉓ .
- (16) Warp around post to Arrow G to remove the Guide-Retard and the Guide-Exit-Lower ㉔ and remove photo-sensor ㉕ .

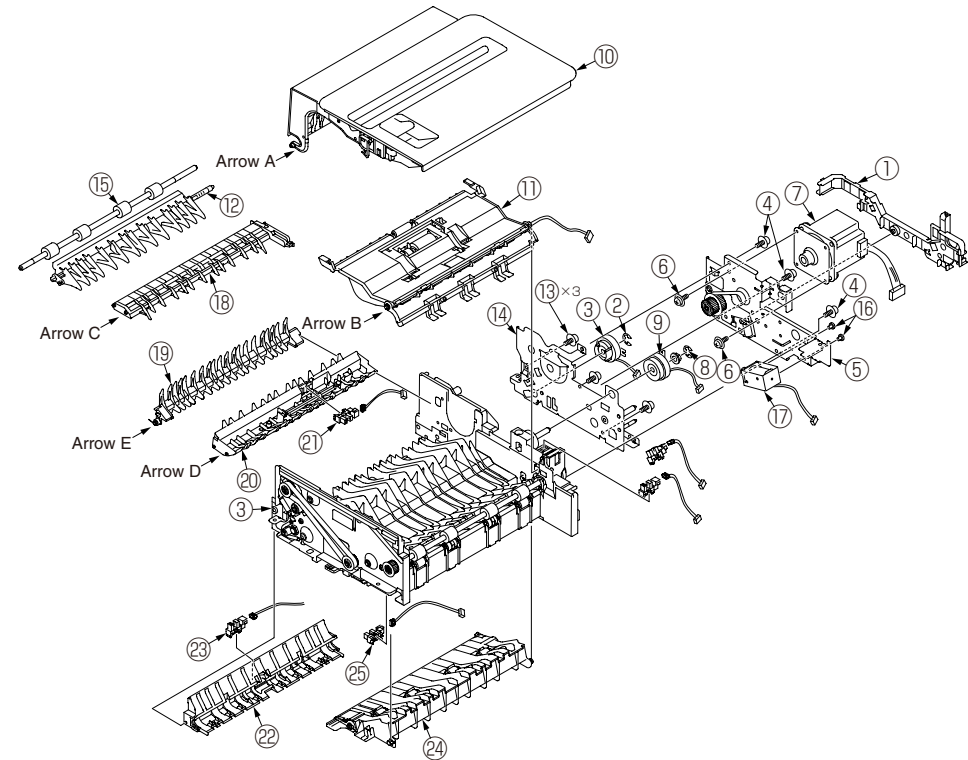



### 4.2.34 Cover-Assy-Top-ADF

- (1) Remove the ① with reference to 4.2.35.
- (2) Remove the four screws (black, No:42932708) ② and remove the Guide-Assy-Top(A) ③.
- (3) Remove the Piece-Lock(Pickup) ④ ,Gear-Shaft-Hopping ⑤ ,Lever-SNS-Set ⑥ ,Spring-Lock(ADF-Top) ⑦ ,Lever-Lock(ADF) ⑧ ,Guide-Separator-Top ⑨ from Guide-Top(A) ③.

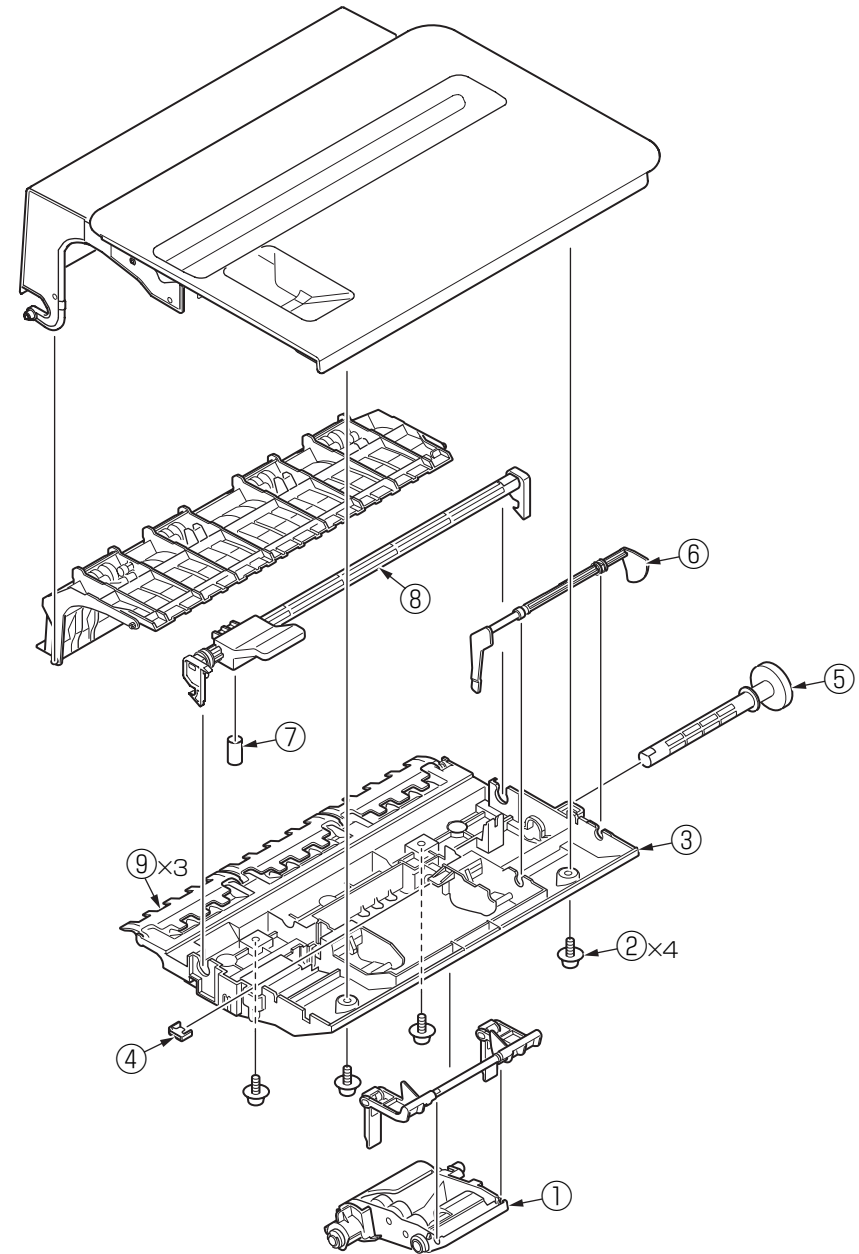

### 4.2.35 Frame-Assy-Hopping-ADF

- (1) Open the ADF-Cover and remove from the ADF-Unit.

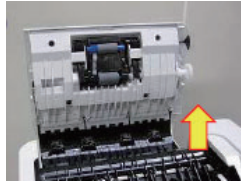

- (2) Remove a latch in the bottom of the gear. (Open it in the bottom)



- (3) Remove the gear to the arrow direction.



- (4) Pick up the Hopping-Assy and draw it slowly toward.



- (5) When draw it, be careful about left lower catches.



- (6) Remove the Hopping-Assy.



- (7) Remove the Spring-Lock(Pickup) ① from Frame-Pickup ② by turn an A part of Spring-Lock(Pickup) ① in the arrow direction and take it off the ditch B.

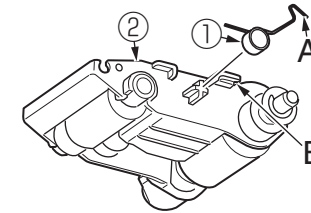

#### <Assembling procedure of the Frame-Assy-Hopping-ADF>

- (1) Set a gate of the Hopping-Assy like a figure.

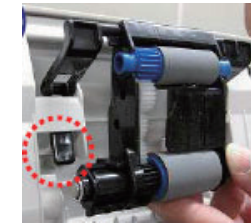

- (2) When set it, be careful about left lower portion.



- (3) Be careful when set the gear for D-cut.

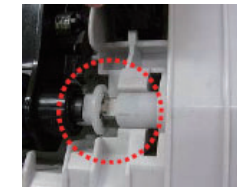

- (4) Set the gear and set to ADF-Unit.

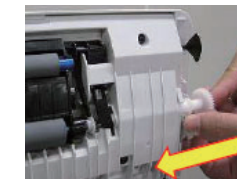

### 4.2.36 Guide-Assy-Retard

- (1) Remove the eight claws and remove the Guide-Retard(sub) ① .
- (2) Remove the Cover-Retard(ADF) ② .
- (3) Remove the Frame-Assy Retard ③ and remove the spring Retard ④ .
- (4) Remove the Lever-Hopping ⑤ and the spring-Hopping ⑥ .
- (5) Remove the Photo-coupler ⑦ and remove the cable (conn cord AMP3P-JST4P) ⑧ .

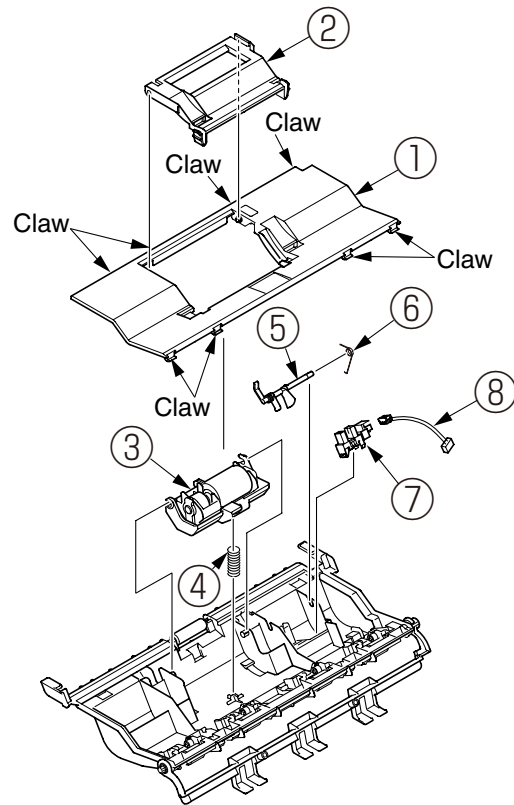

### 4.2.37 Flatbed-Unit

- (1) Remove the five screws (black, No:42932706) ① and remove the cover-Bottom ② .
- (2) Remove the screw (silver, No:42920406) ③ and remove the plate-stopper(OP) ④ .
- (3) Remove the two screws (black, No:PB4083-5670P013) ⑤ and remove the cover-OP ⑥ .
- (4) Remove the screw (black, No:42932708) ⑦ and remove the Handle-scanner(S) ⑧ .
- (5) Rotate the OP-panel-unit ⑨ 90 degrees.
- (6) Remove the two screws (silver, No:42920406) ⑩ .
- (7) Remove the screw (silver, No:42920406) ⑪ and remove the clamp-cable ⑫ and remove the OP-panel-unit ⑨ .

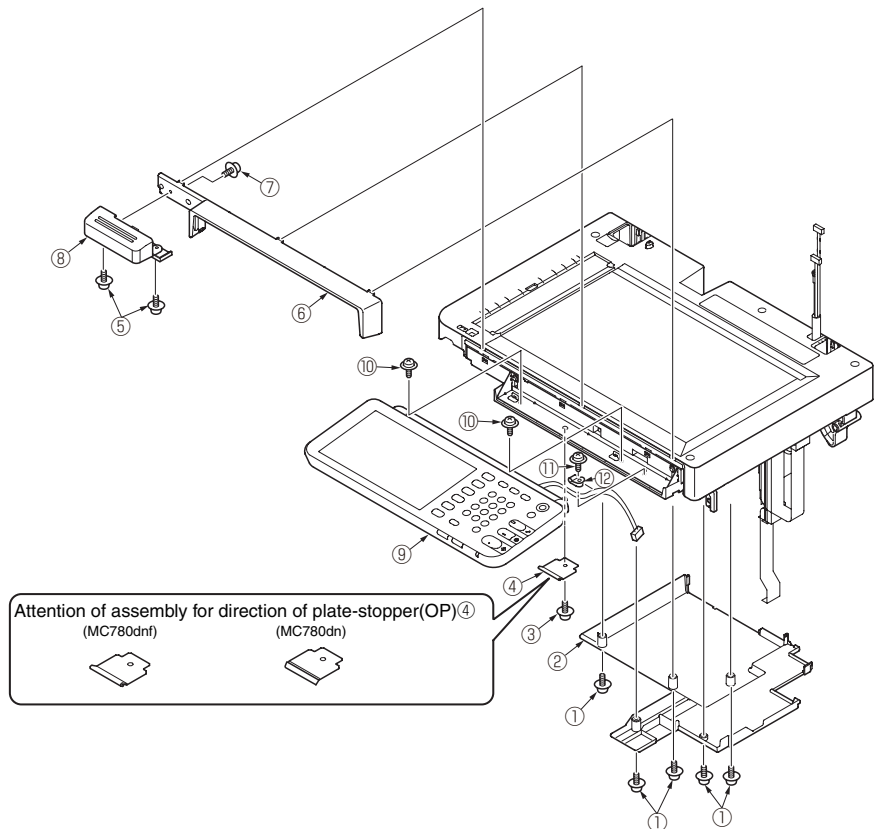

### 4.2.38 Frame-assy-FB

- (1) Remove the five screws (silver, No:42920406) ① and remove the five screws (black, No:42932706) ② .
- (2) And remove the plate-shield-SU ③ .
- (3) Remove the all SU-board cables.
- (4) Remove the five screws (silver, No:42920406) ④ and remove the SU-board ⑤ .
- (5) Remove the screw (black, No:42932706) ⑥ .
- (6) Pull core ⑦ (GFPC-31-12 (1051015C0004)) out of FFC cable.
- (7) Remove the FFC cable (20706FWR1.-24-520) ⑧ .
- (8) Remove the four screws (black, No:42932710) ⑨ and Film-FG(SCN-PR) ⑩ .
- (9) Remove the cover-hinge (L) ⑪ and the Plate-Hinge-L(Caulking) ⑫ .
- (10) Remove the seven screws (black, No:PB4083-5670P013) ⑬ and remove the cam-hinge ⑭ .
- (11) Remove the screw (black, No:42932706) ⑮ and the two screws (black, No:PB4083-5670P013) ⑯ .
- (12) Remove the cover-assy-LF ⑰ .

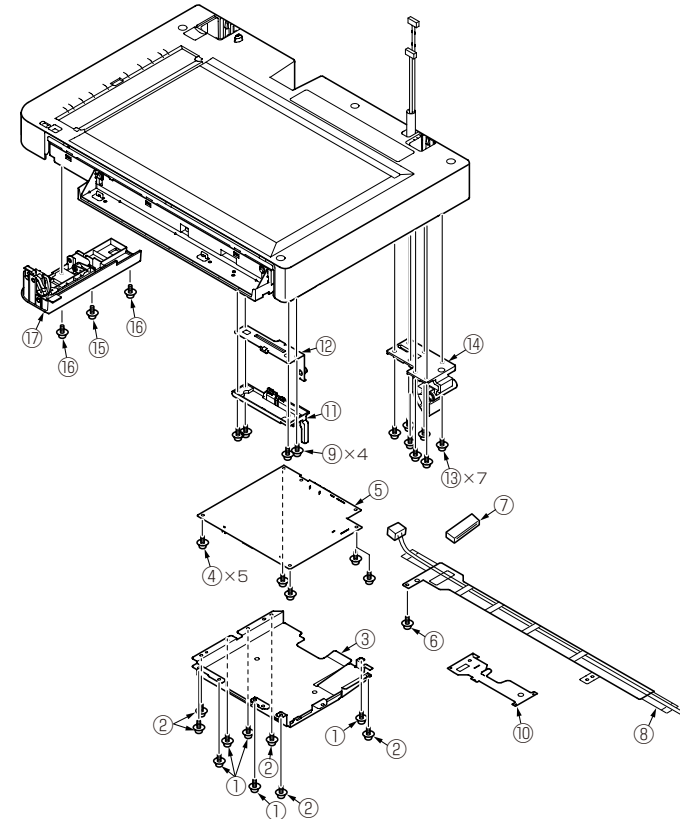

#### <Attention of assembly for FFC>

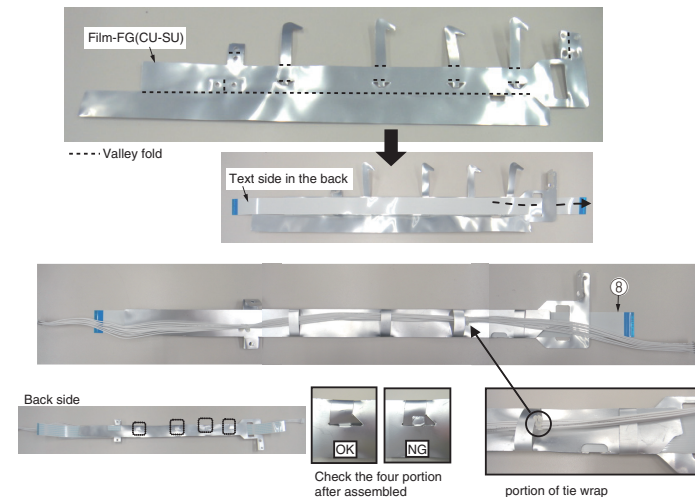

### 4.3 Check the Scanner Mech Level and SU FW version

When replacement the ADF Unit or ADF Assy or SU board, to check the Mech Level.

Open the ADF and see the Mark following figure and table.

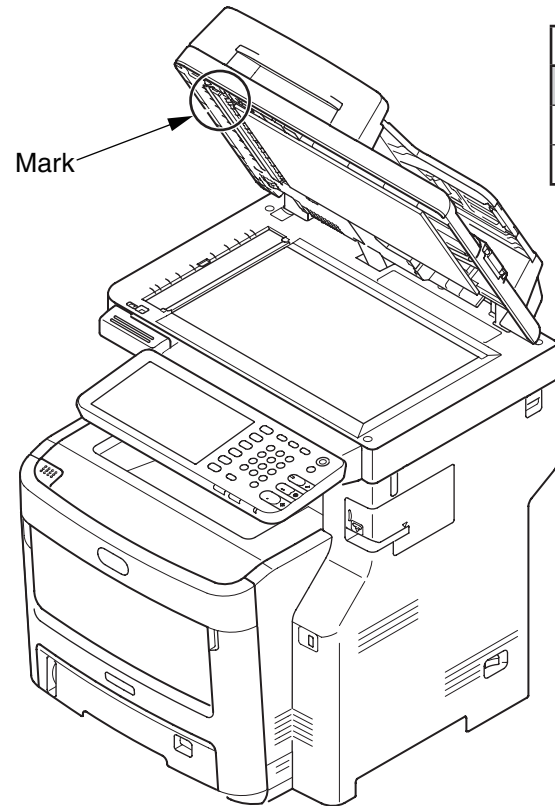

Mech Level	Mark
1	▲
2	■

Mech Level and SU FW version table

Mech Level	Mark	SU FW version
1	▲	01.07 or more
2	■	TBD

## 4.4 Oiling spots

This chapter shows the oiling spots. Do not oil the other spots that are not shown here.

It is not necessary to inject the machine-oil during disassembling. However, please add the specified oil when you wipe the oil off.

### Oiling operation

(1) Oil type and name

EM-30LP:MOLYKOTE

EM-D110:MOLYKOTE

HP-300: MOLYKOTE

PM: Pan motor oil 10W-40 or ZOA 10W-30

(2) Grease limit sample

Class	S	A	B	C	D	E	F
Amount of grease (cc)	0.0005	0.003	0.005	0.01	0.03	0.05	0.1
W(mm)	1.24	2.25	2.67	3.37	4.86	5.76	7.26
Sample	•	•	•	•	•	•	•

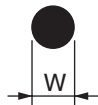

① 44259301PA Gear Assy.-HP

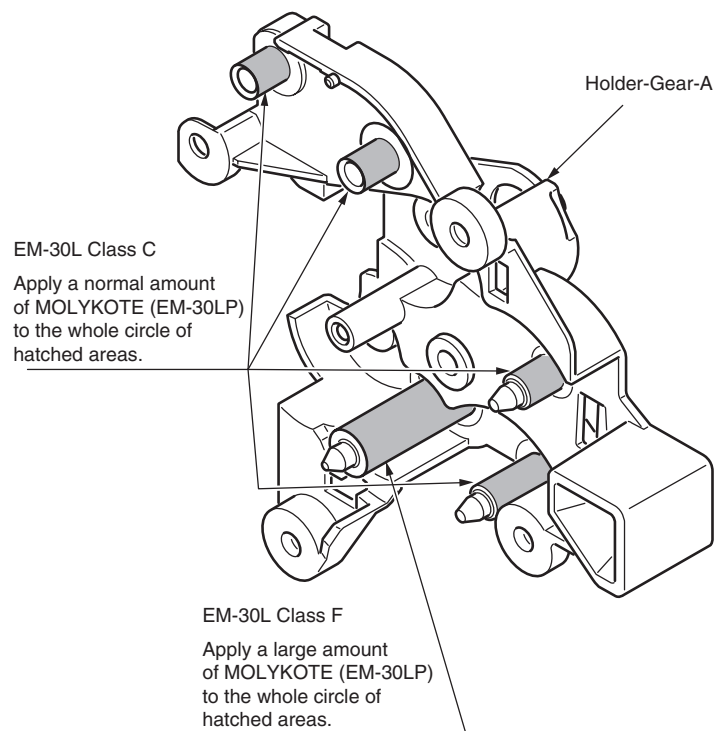

② -1 44259102PA Plate-Assy.-Side R

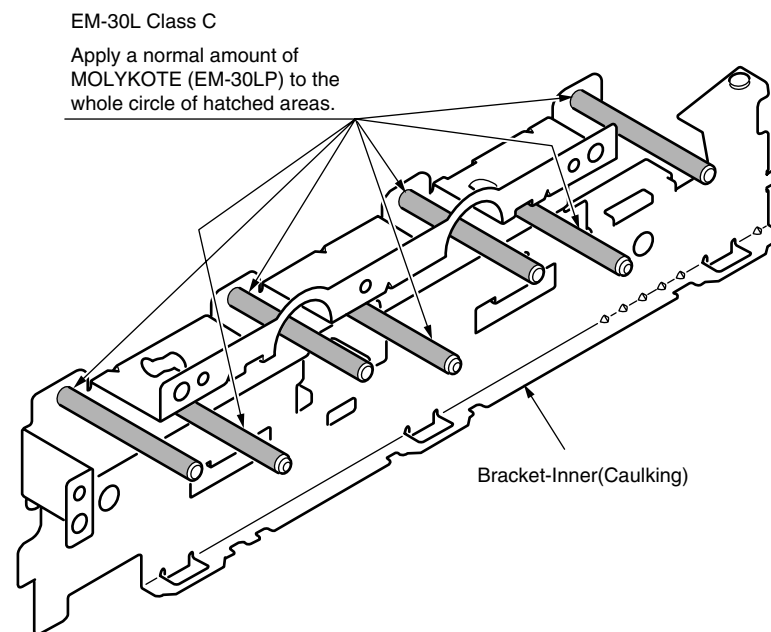

② -2 44259102PA Plate-Assy.-Side R

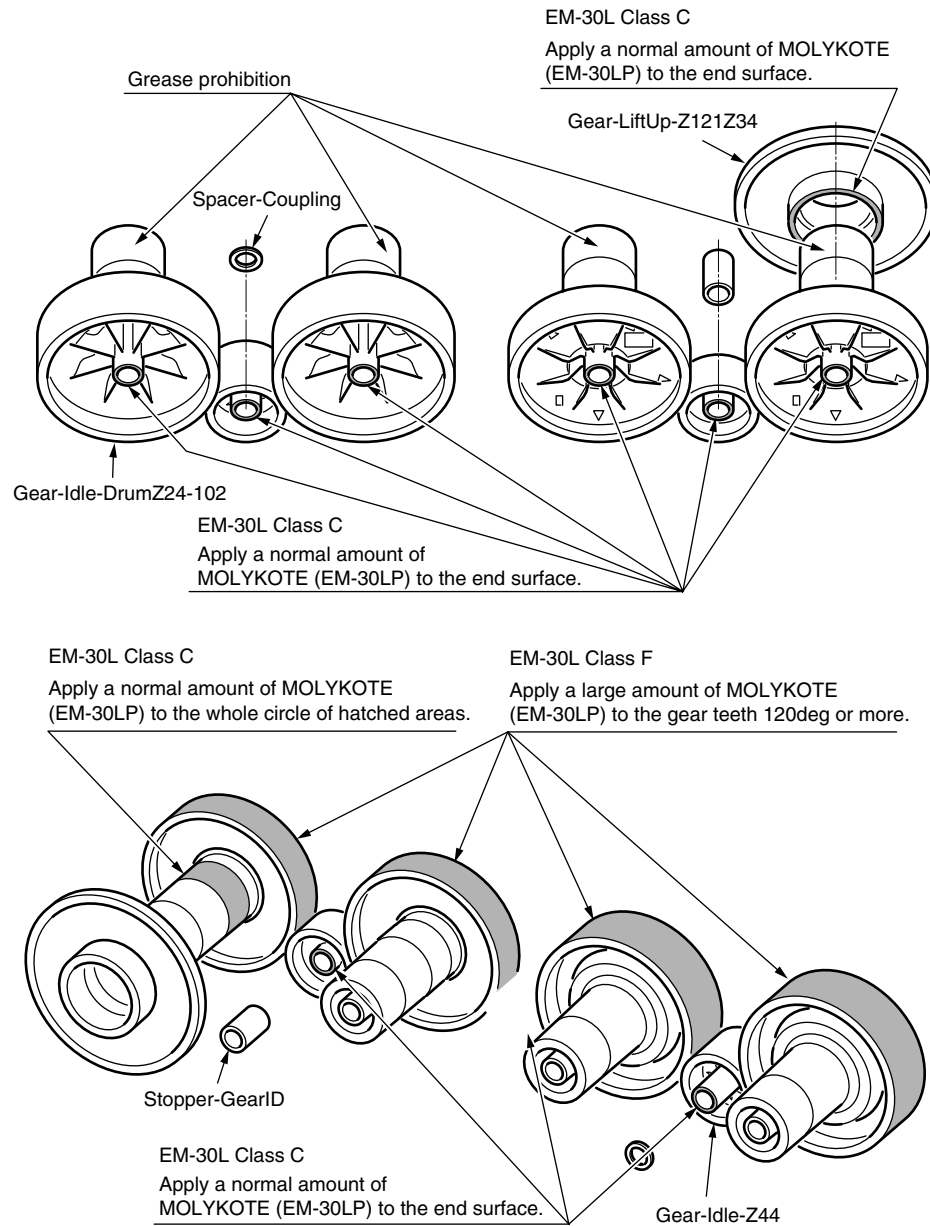

② -3 44259101PA Plate-Assy.-Side R

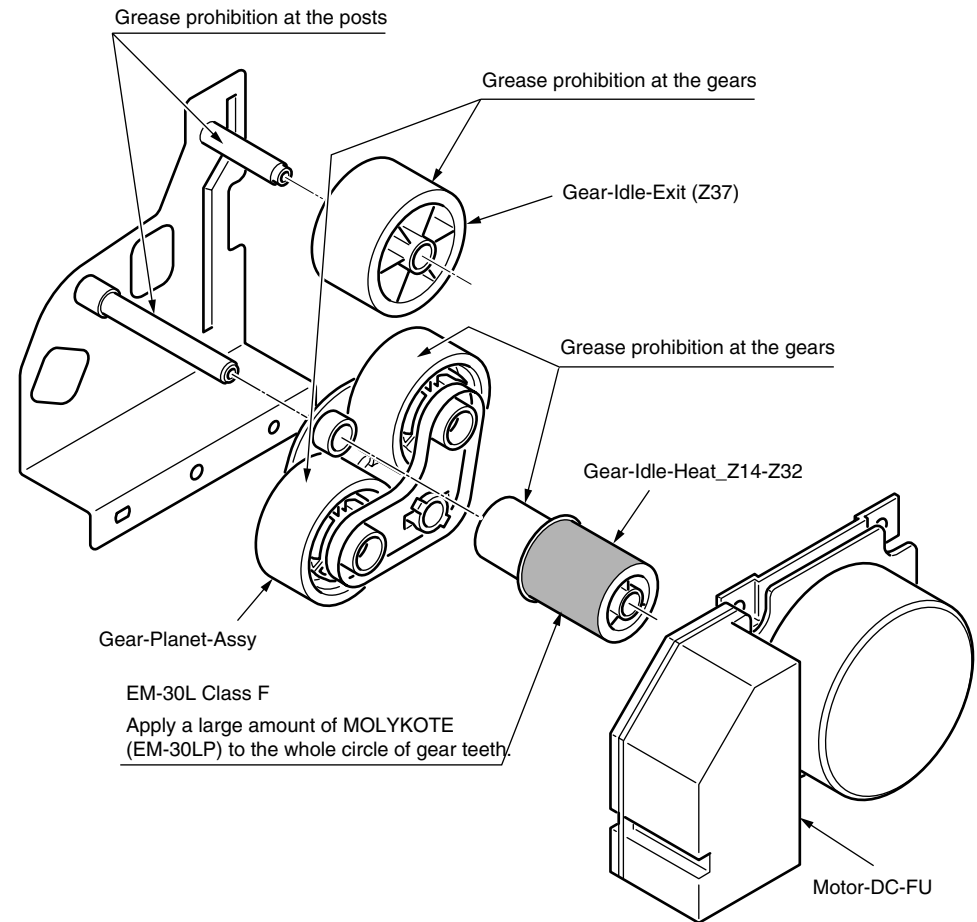



② -4 44259101PA Plate-Assy.-Side R

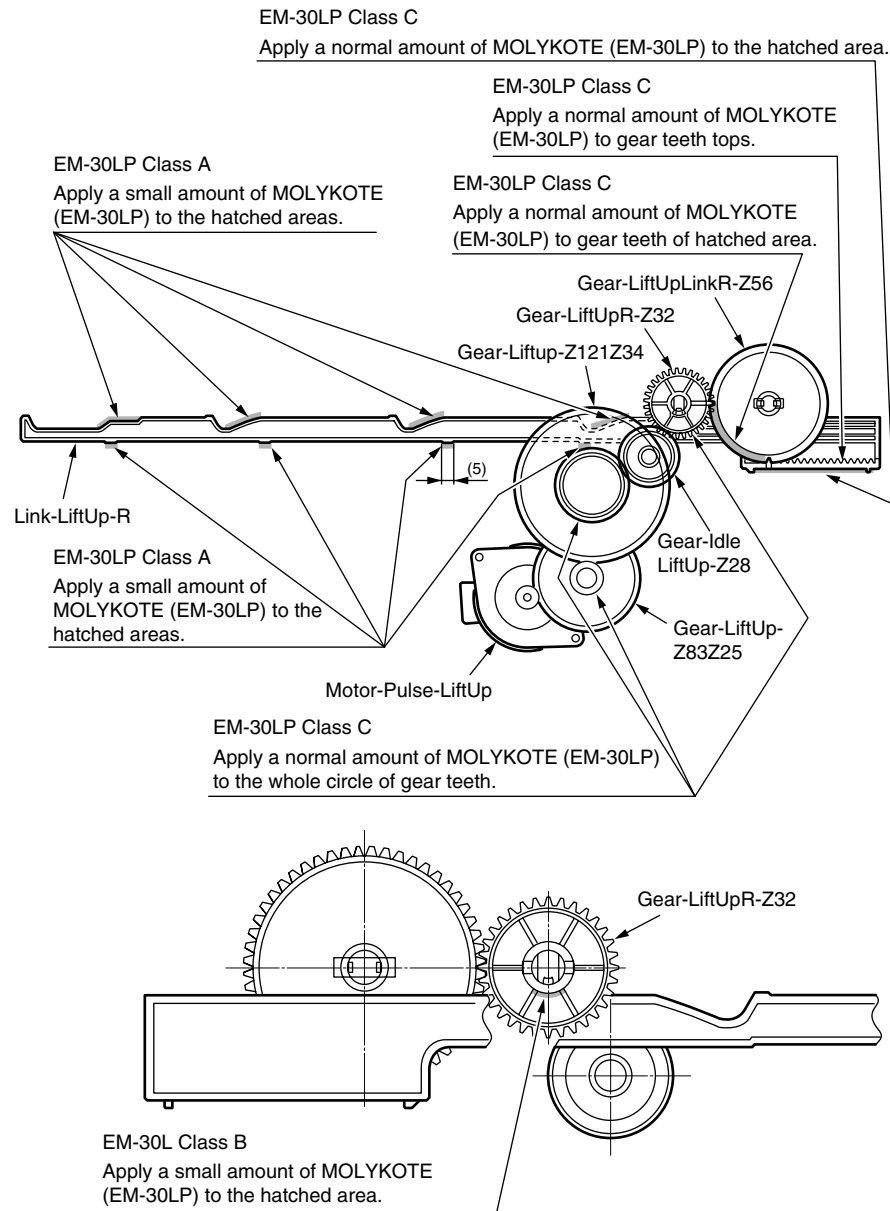

② -5 44259101PA Plate-Assy.-Side R

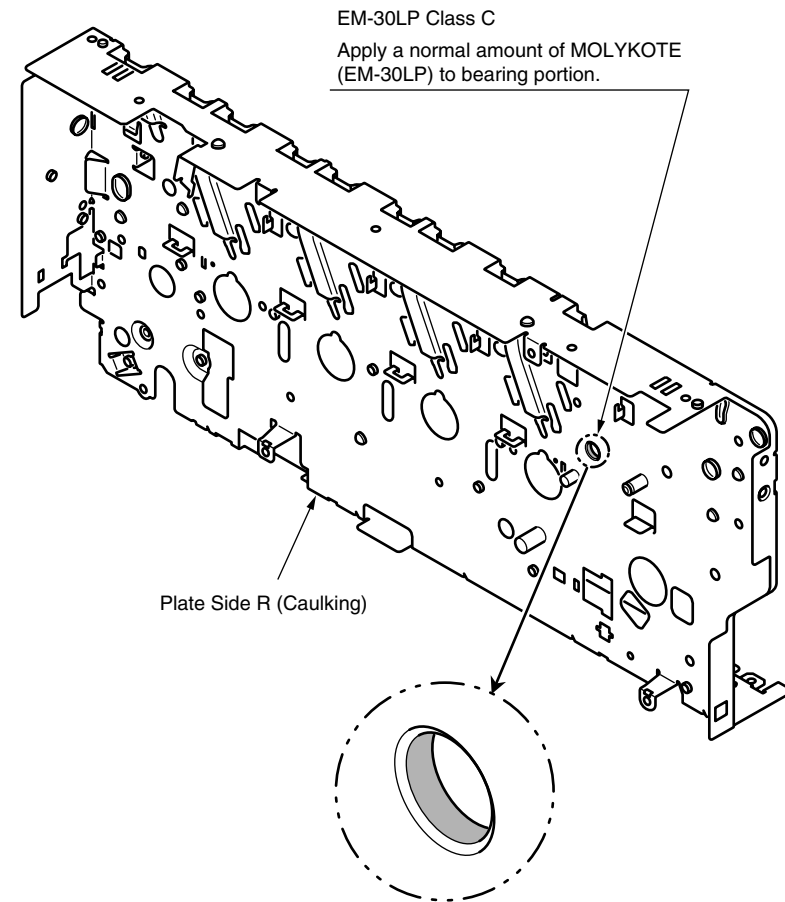

③ 43074904PA Plate-Assy.-Side-L

EM-30LP Class C

Apply a normal amount of MOLYKOTE (EM-30LP) to the gear tooth tops.

EM-30LP Class A

Apply a small amount of MOLYKOTE (EM-30LP) to the hatched areas.

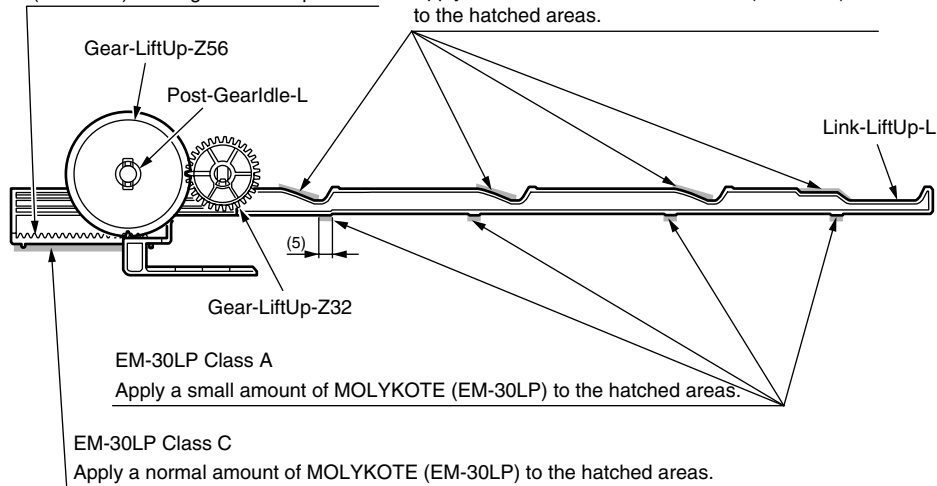

EM-30LP Class C  
Apply a normal amount of MOLYKOTE (EM-30LP) to the hatched areas.

EM-30LP Class C

Apply a normal amount of MOLYKOTE (EM-30LP) to the hatched areas.

EM-30LP Class B

Apply a small amount of MOLYKOTE (EM-30LP) to the hatched areas.

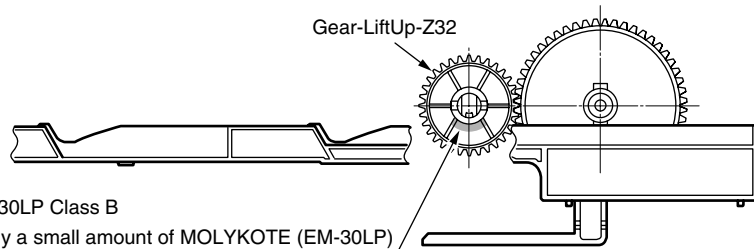

④ 42071401PA Holder Assy.-Regist-L

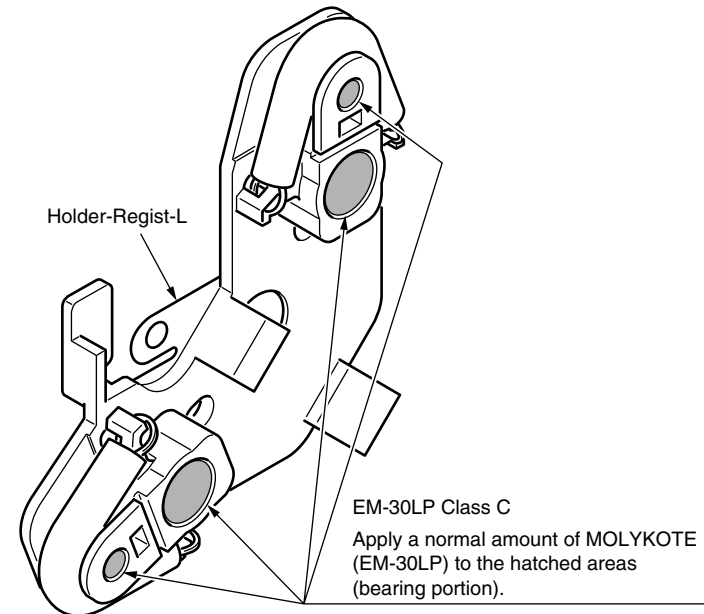

EM-30LP Class C

Apply a normal amount of MOLYKOTE (EM-30LP) to the hatched areas (bearing portion).

⑤ 44261901PA Feeder Assy.-Regist

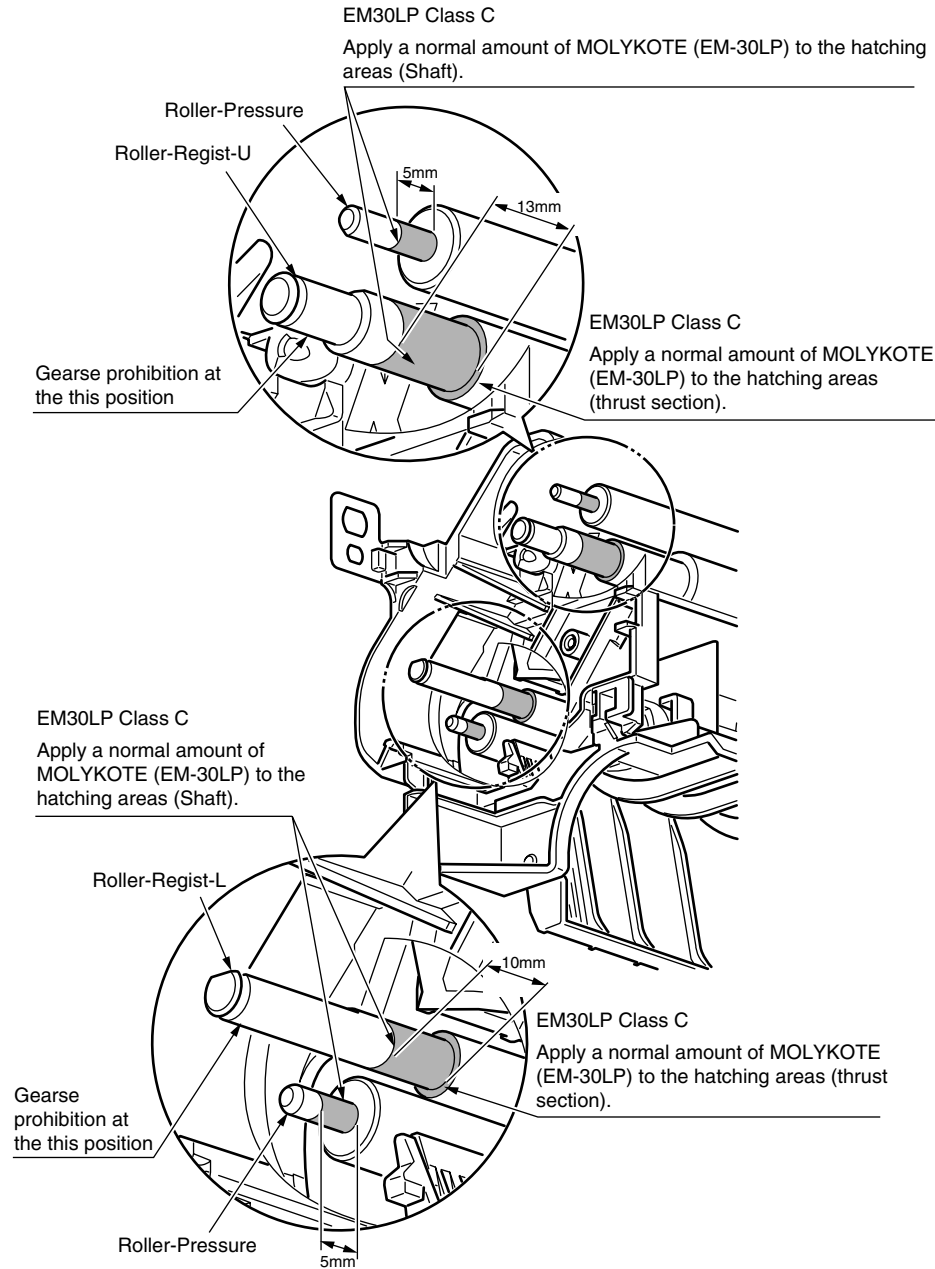

⑥ 44286901PA Fuser-Assy

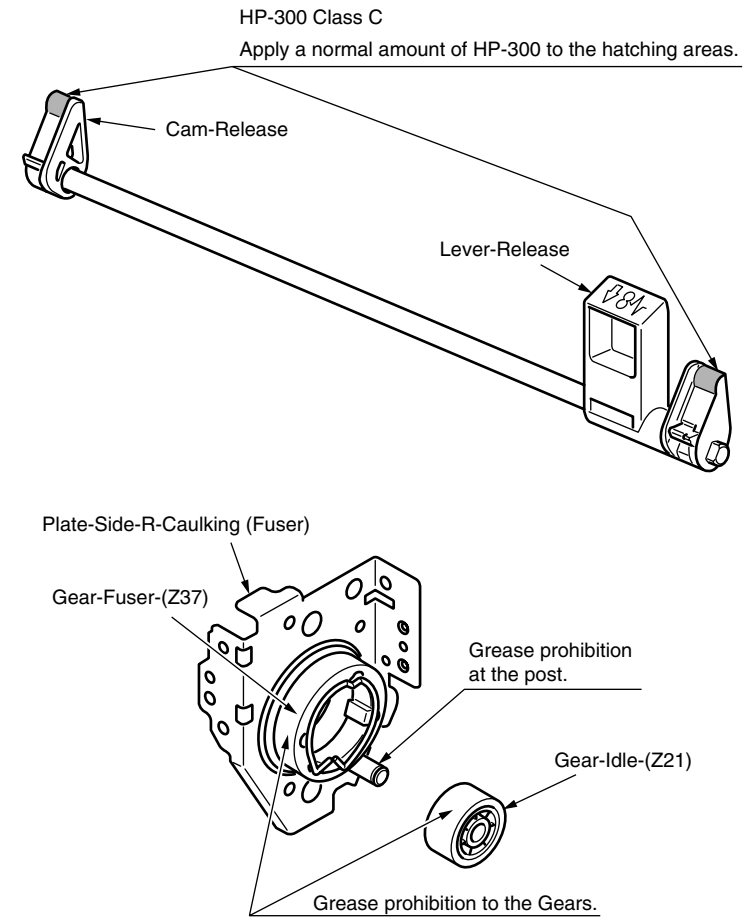

⑦ 45269001PA Guide-Assy.-Eject-U

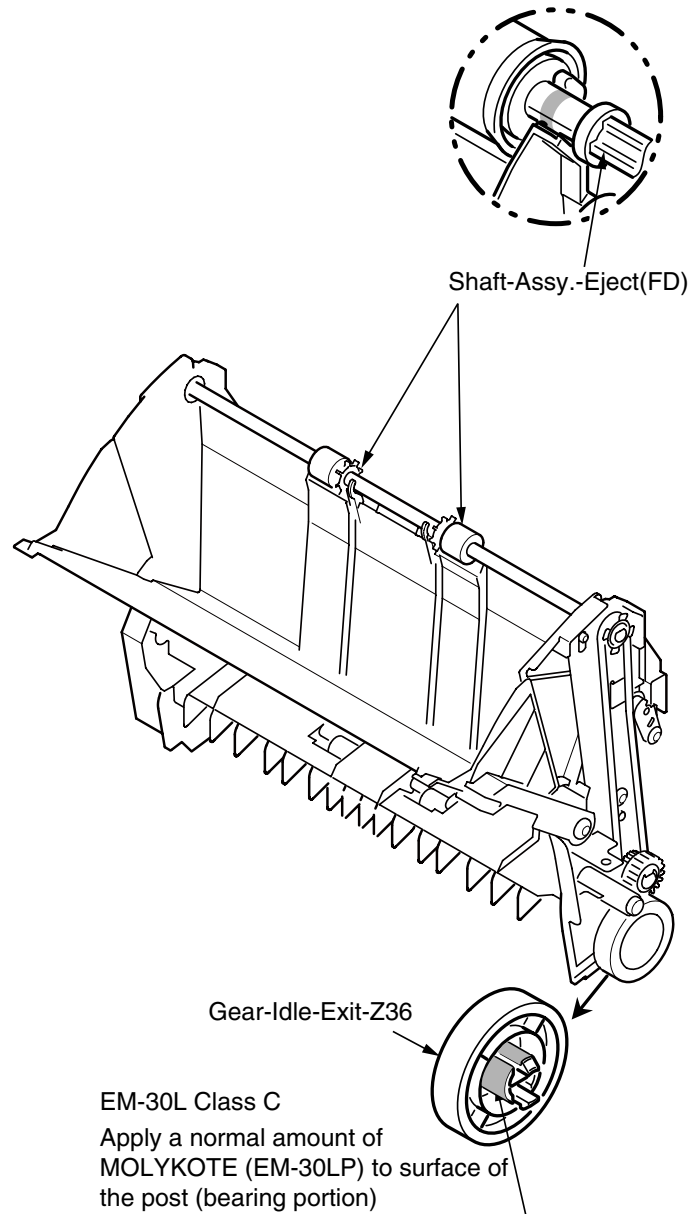

⑧-1 44257901PA Printer Unit-FX757

EM-30LP Class C

Apply a normal amount of MOLYKOTE (EM-30LP) to the tips of terminal.

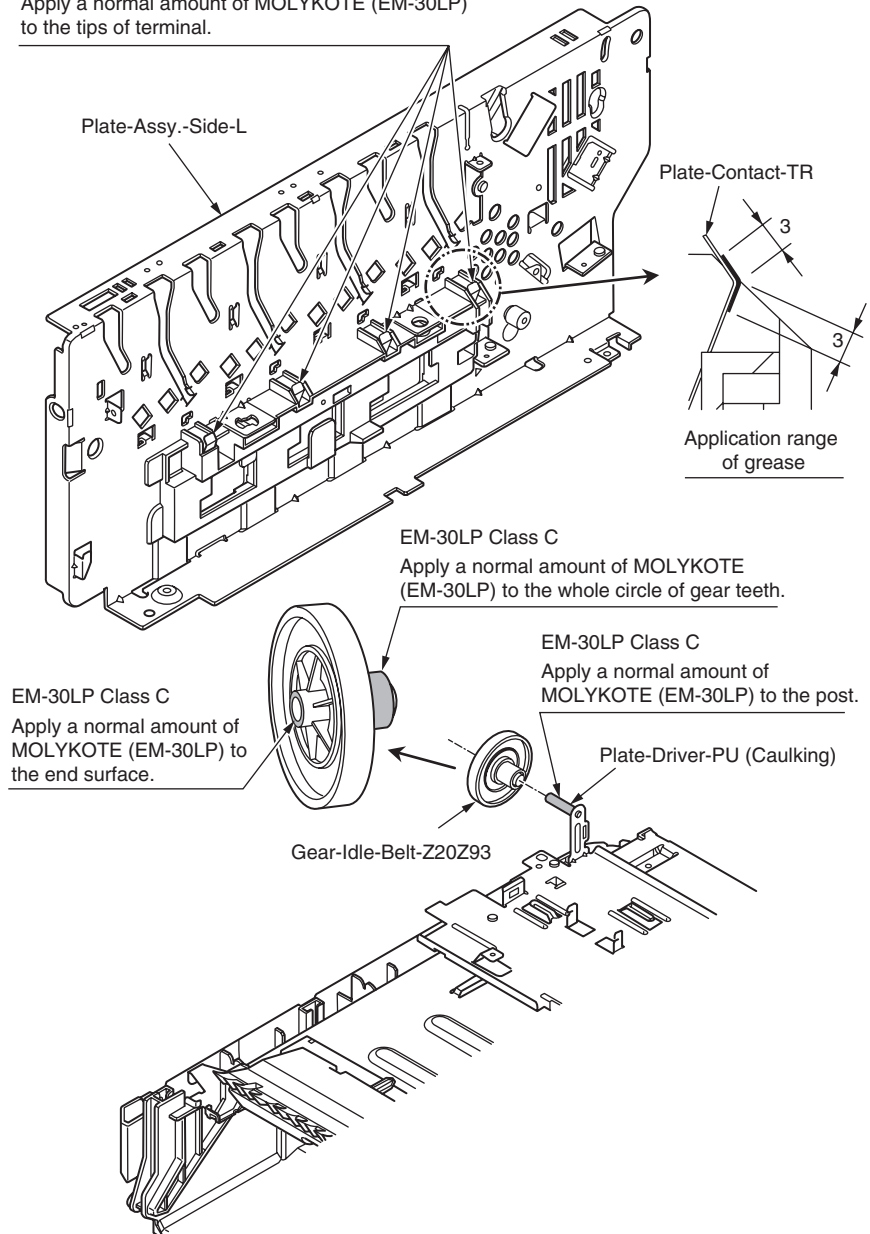

⑧-2 44257901PA Printer Unit-FX757

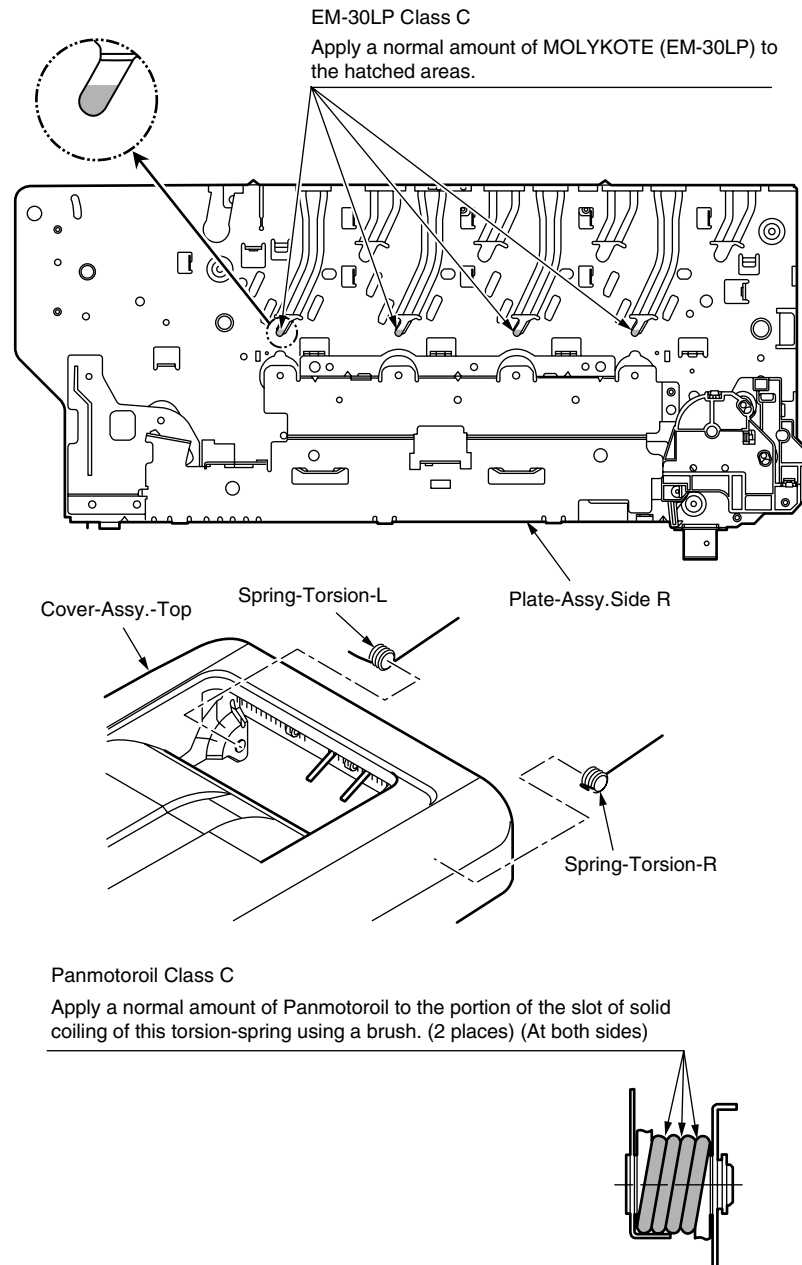

⑨ 44342001PA Belt-Assy

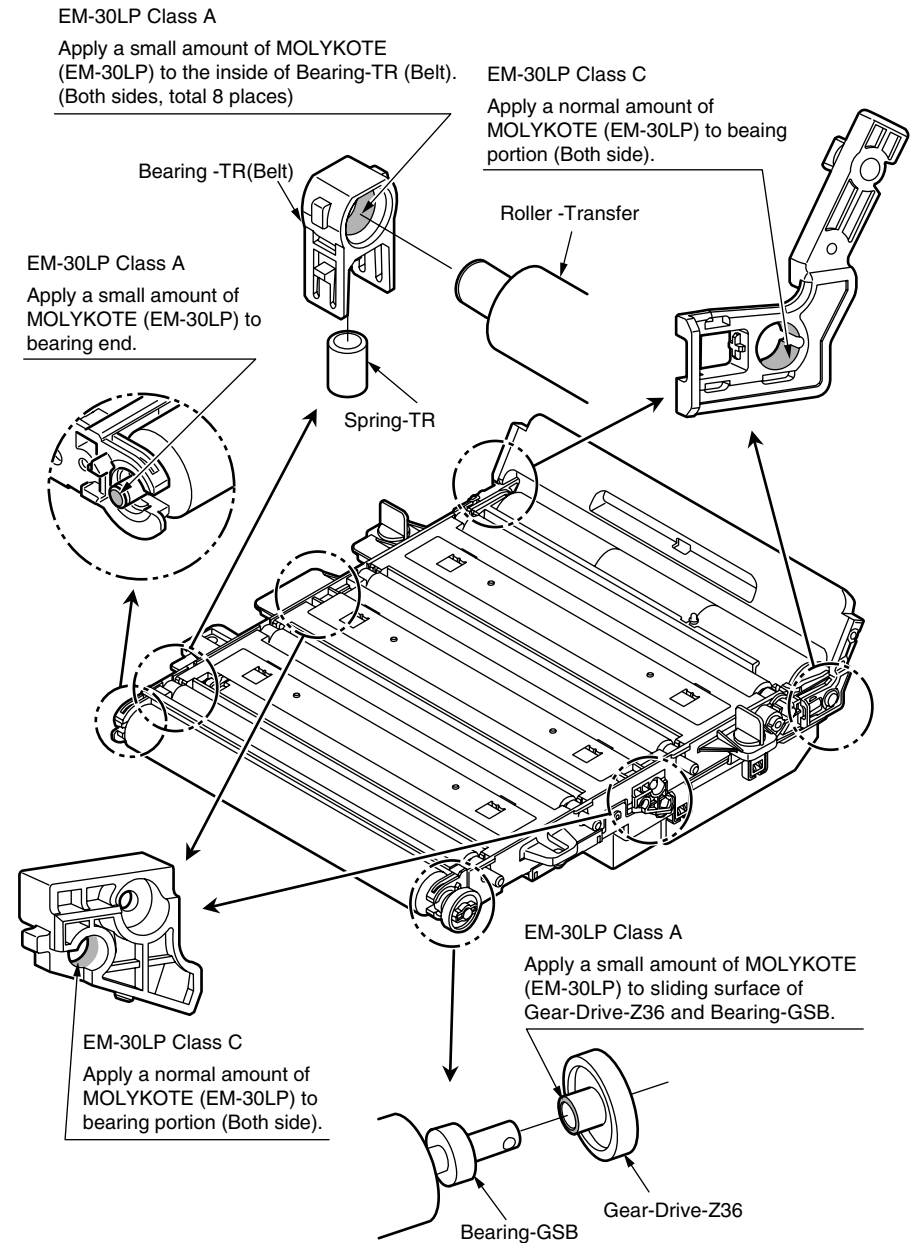

⑩ 43917501PA Sensor Assy. -Color Regist

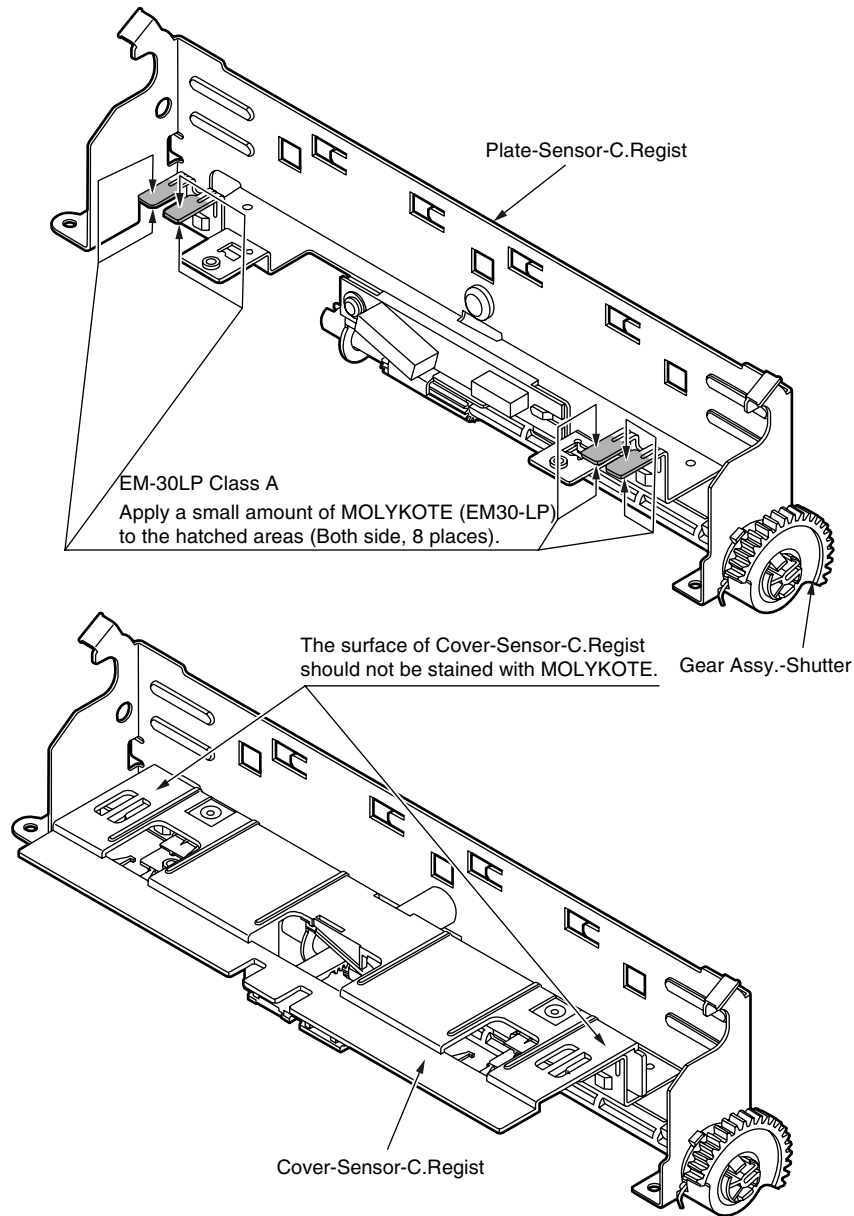

⑪ 43081301PA Roller-Assy. -Idle(FD)

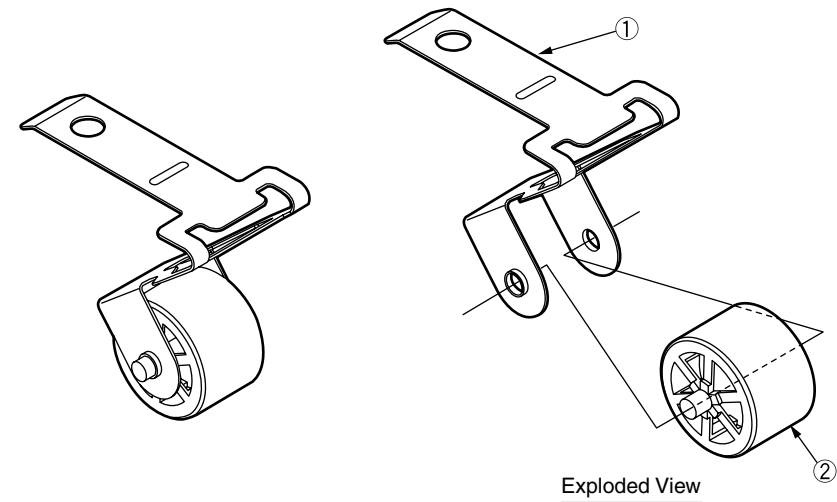

Method of amount grease

EM-30LP Class S  
Before ② assemble to ①, apply a minimum amount of  
MOLYKOTE (EM-30LP) to the sliding portions of ① and ②  
(the hatched areas).

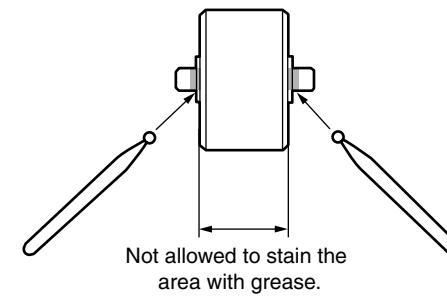

⑫ 43301601PA Roller-Assy. -BIAS(FU)C

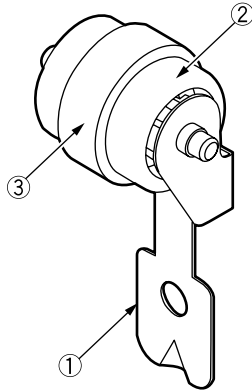

Method of amount grease

EM-30LP Class S

After ③ assemble to ②, apply a minimum amount of MOLYKOTE (EM-30LP) to the sliding portions of ① and ② (the hatched areas).

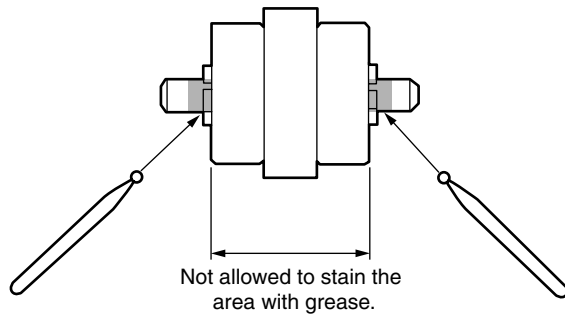

⑬-1 43894903PA Cassette-Assy-FX757

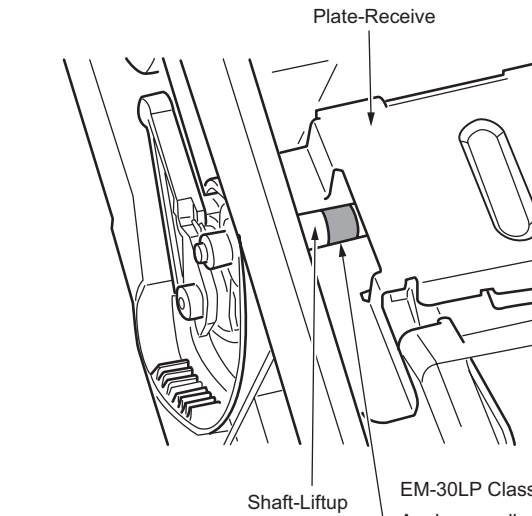

EM-30LP Class B

Apply a small amount of MOLYKOTE (EM-30LP) to sliding portions of sheet metal and shaft (the hatched area).

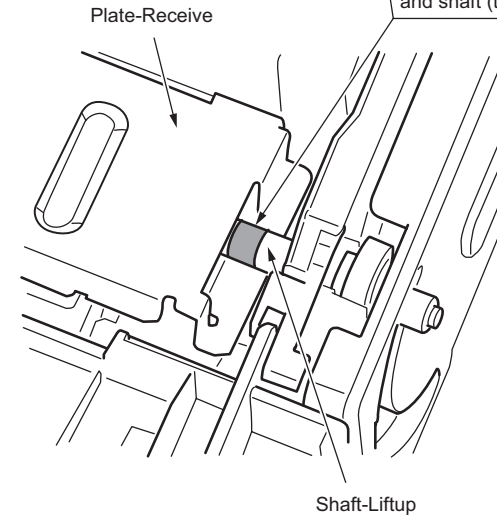

⑬-2 43894903PA Cassette-Assy-FX757

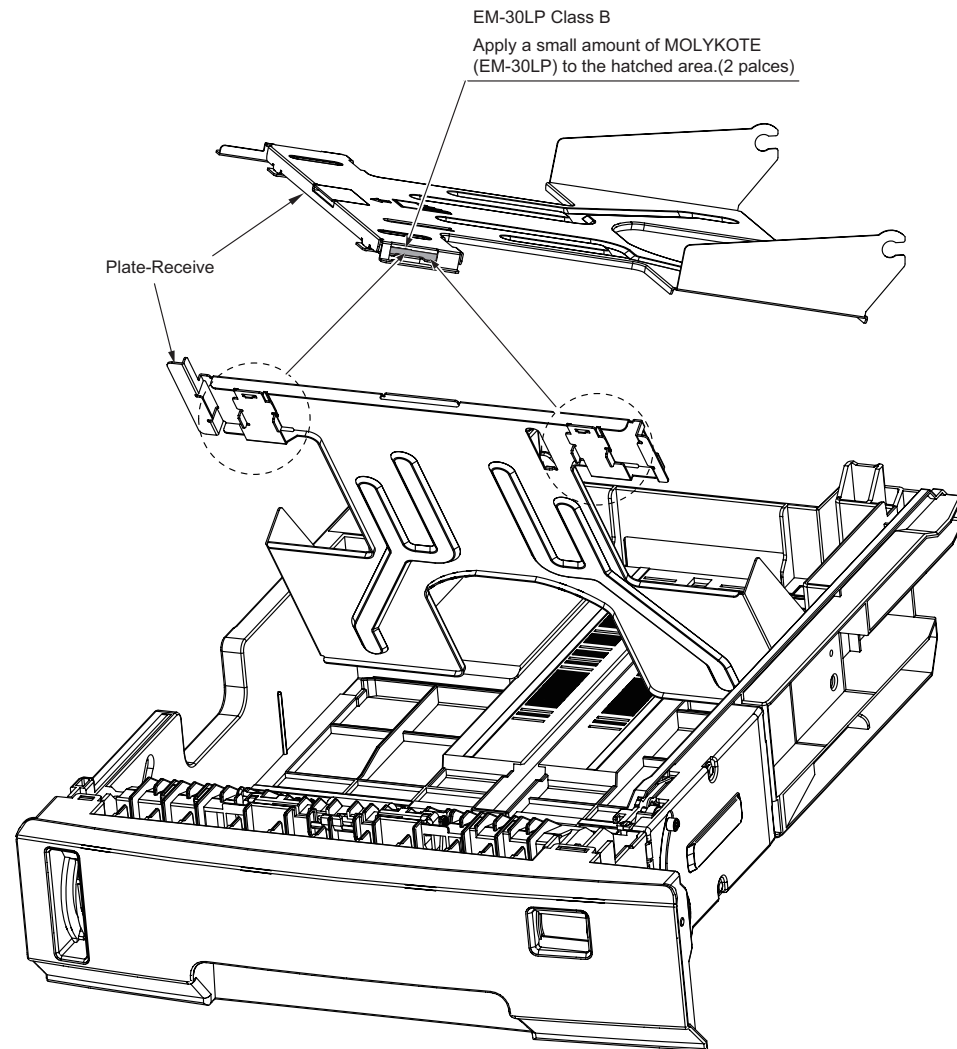

⑭ 4537xxxxYA Scanner-Hinge

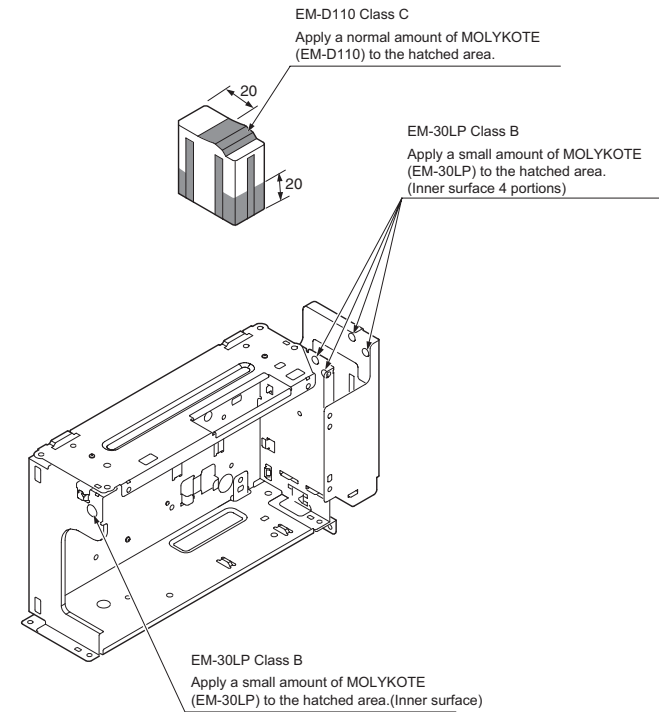



# 5. Maintenance Menu

---

Adjustment of this printer can be performed from the Maintenance Utilities by entering the corresponding menu from the keyboard of the operator panel.

This printer contains the maintenance menu in addition to the normal operation menus. Select an appropriate menu in accordance with the objective of adjustment.

5.1	System maintenance menu (for maintenance engineer) .....	114
5.2	Maintenance menu functions.....	115
5.3	Setups upon completion of part replacement.....	135
5.4	Density control manual setting .....	137

## 5.1 Maintenance Utility

The adjustments described in table 5-1 should be made by using Maintenance Utility.

The following details the utility:

- (1) Maintenance Utility Operating Manuals:  
42678817FU02 Rev 4 or higher(English)
- (2) Maintenance Utility program:

Applicable operating system	File name	Part number
Windows 2000/XP/Vista/7 (English)	MuWin.zip	42678817FW01 Rev. 1.41.0.1700 or higher

Table 5-1: Adjustment options in Maintenance Utility

	Option	Adjustment	Section in Maintenance Utility Operating Manual	Operation from operator panel (section in this maintenance manual)
1	Board replacement	Copies information in the EEPROM in the PU PCB. Purpose: To copy the above data onto a PU PCB with which to replace the PU PCB for a maintenance purpose.	2.4.1.1.1	Unavailable
2	Serial number setting	Rewrites the serial number recorded in the PU PCB. Purpose: To configure a maintenance replacement PU PCB onto which the PU PCB information cannot be copied with the board replacement function (e.g. due to an interface error).	2.4.1.1.2.3	Unavailable

	Option	Adjustment	Section in Maintenance Utility Operating Manual	Operation from operator panel (section in this maintenance manual)
3	Factory/Shipping mode	Switches between the Factory and Shipping modes. Purpose: To configure a maintenance replacement PU PCB onto which the PU PCB information cannot be copied with the board replacement function (e.g. due to an interface error). The maintenance board is put to the Factory mode usually by default and, by using this function, must be set to the Shipping mode.	2.4.1.1.2.4	5.2.1.10
4	Board option setup information	Checks serial number information and the Factory/Shipping mode.	2.4.1.1.5	Unavailable
5	Send to file	Send the specify file.	2.4.1.2.1	Unavailable

**Note:** Do not operate or set options added with 'Never use this option,' or a malfunction is potentially caused.

## 5.2 Maintenance menu functions

### 5.2.1 Self-diagnostic mode

This section describes the self-diagnostic LEVEL 0 and LEVEL 1 respectively.

#### 5.2.1.1 Operation panel

The following description on operating the self-diagnostic is premised on the operation panel layout as shown below.



Self-diagnostic mode layout (overall)

(1) How to select the menu items

- XXXXX Menu items can be selected directly.
- XXXXX Menu items can be selected by pressing either [2] or [8] key.

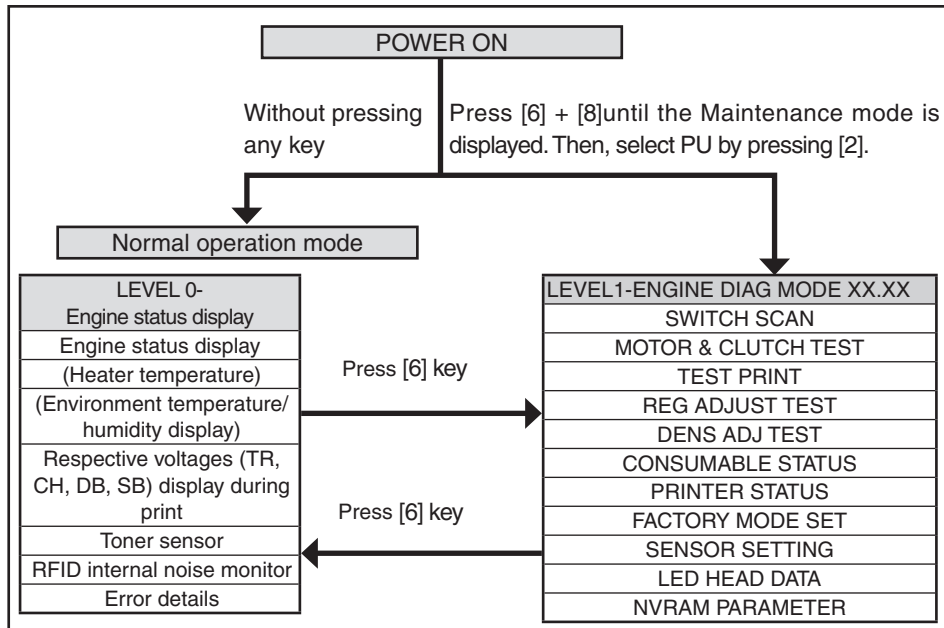

LEVEL0

(1) How to select the menu items

- XXXX Menu items can be selected by pressing of [4] or [ \* ], or by pressing of [2] or [8].
- XXXX Menu items can be selected by pressing either [2] or [8] key. Pressing of [4] returns the screen to the menu item selection screen.

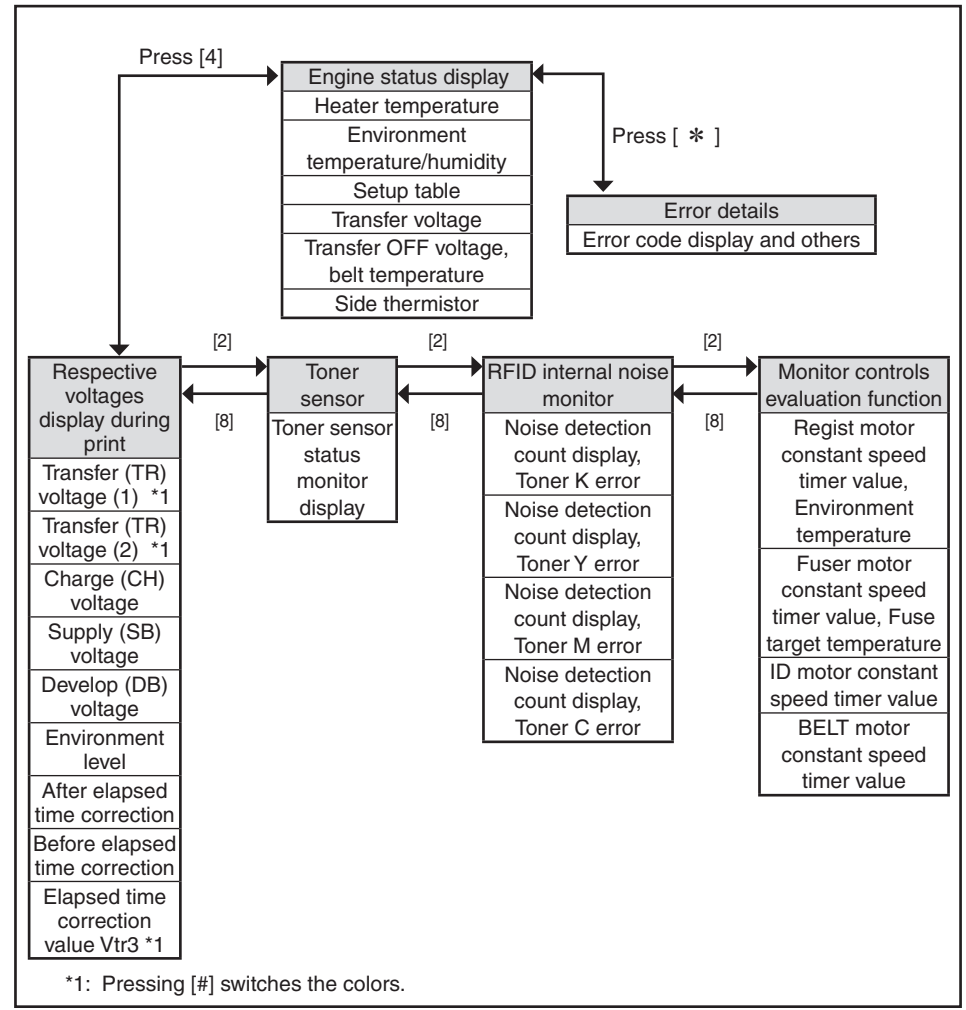

\*1: Pressing [#] switches the colors.

LEVEL1

(1) How to select the menu items

XXXXXX Menu items can be selected by pressing either [2] or [8] key, and executed by pressing [6].

XXXXXX Menu items can be entered by pressing of [6] or [4], and can be selected by pressing of [2] or [8].

The test can be executed by pressing [6], and can be exited by pressing [4].

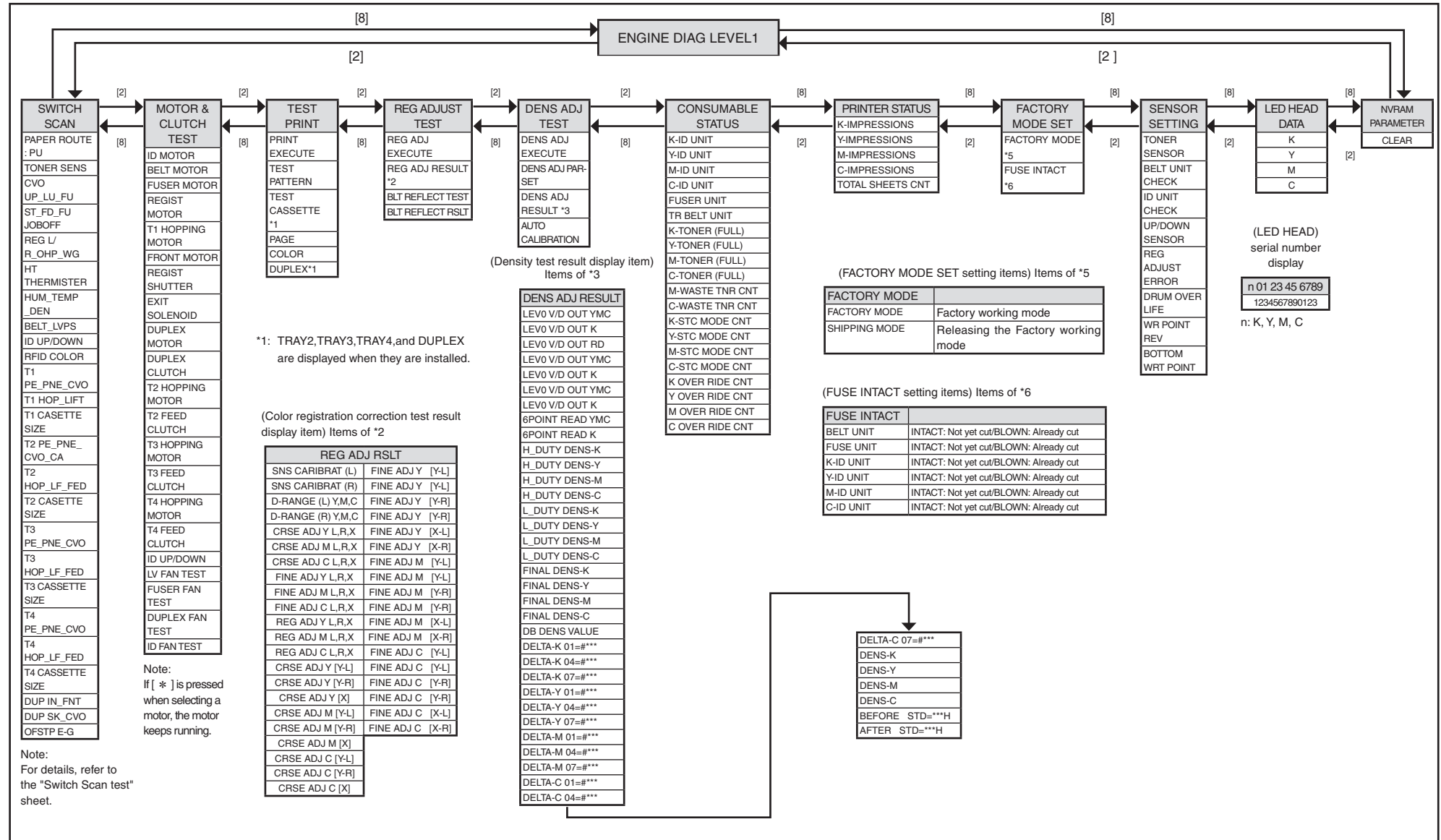

### 5.2.1.2 Ordinary self-diagnostic mode (level 1)

Menu items of the ordinary self-diagnostic mode are shown below.

	Item	Self-diagnostic menu	Adjustment contents	Maintenance utilities
1	Switch scan test	SWITCH SCAN	Entry sensor check and switch check	No.18
2	Motor clutch test	MOTOR&CLTCH TEST	Motor and clutch operation test	No.19
3	Test print execution	TEST PRINT	PU built-in test pattern print	Operation from the maintenance utilities cannot be made.
4	Color registration correction test	REG ADJUST TEST	Color registration mechanism check	No.20
5	Density correction test	DENS ADJ TEST	Density correction mechanism check	No.21
6	Consumable item counter display	CONSUMABLE STATUS	Consumable items consumption status display	No.23
7	Consumable item accumulative counter display	PRINTER STATUS	Consumable items accumulative consumption status display	No.23
8	Factory/Shipping mode selection	FACTORY MODE SET	Switching between the Factory mode and the Shipping mode	No.3, No.24
9	FUSE status check		Respective FUSEs status display	No.24
10	Engine parameter setting	SENSOR SETTING	Valid/Invalid setups of error detection by various sensors	No.25
11	LED Head serial number display	LED HEAD DATA	Display of LED head serial number	Use of this menu item is prohibited
12	NVRAM parameter setting	NVRAM PARAMETER	Do not use this item	Use of this menu item is prohibited

#### 5.2.1.2.1 How to enter the self-diagnostic mode (level 1)

1. While pressing the [6] and [8] keys, simultaneously, turn on the power to enter the Maintenance mode.

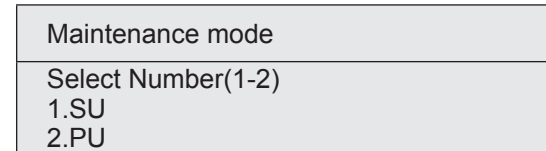

2. Select the PU by press the [2] key, display "DIAGNOSTIC MODE".

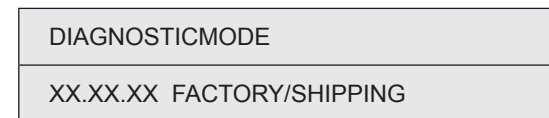

3. XXX.XX.XX of the message "DIAGNOSTIC MODE XX.XX.XX" that is displayed on the LCD display area indicates the PU firmware version number. The FACTORY WORKING MODE setup value is displayed in the right of the lower row. S-MODE of "SHIPPING" is displayed normally.
4. Press the [2] key or [8] key to advance to the desired step of each self-diagnostic menu. (The menu items rotate when either the [2] key or [8] key is pressed.)

#### 5.2.1.2.2 How to exit the self-diagnostic mode

1. Turn off the power once and back on 10 seconds later.

### 5.2.1.3 Switch scan test

This self-diagnostic menu is used to check the entry sensor and the switch.

1. Enter the self-diagnostic mode (level 1) and press the [2], [8] key until "SWITCH SCAN" is displayed in the upper row of the display area. (Pressing the [2] key increments the test item and pressing the [8] key decrements the test item.) Press [6] when displayed "SWITCH SCAN"

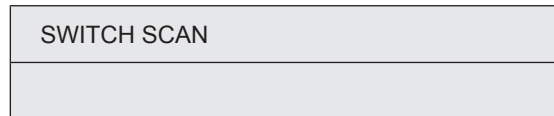

2. Press either the [2] or [8] key until the desired menu item corresponding to the unit to be tested in Table 5-2 is displayed in the lower row of the display area. (Pressing the [2] key increments the test item and pressing the [8] key decrements the test item.)
3. Pressing the [6] key starts the test. Name and present status of the corresponding unit are displayed.

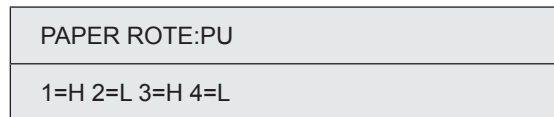

Activate the respective units. (Figure 5-1) Status of the respective units are displayed on the corresponding areas of the LCD display. (Display changes depending on each sensor. Refer to Table 5-2 for details.)

4. Press the [#] key to return to the status of step 2.
5. Repeat steps 2 to 4 as required.
6. Press the [4] key to exit the test. (Returns to the status of step 1.)

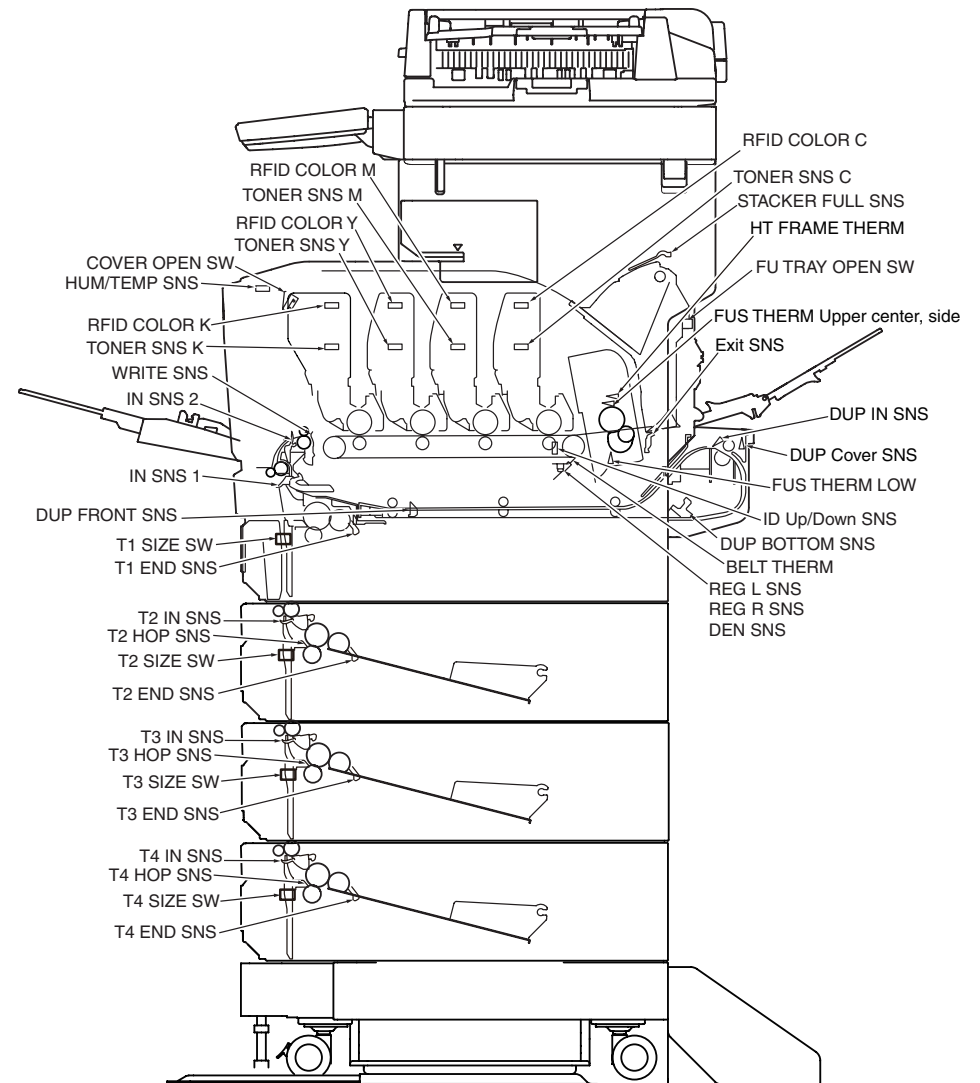

Figure 5-1 Switch and sensor location diagram

Table 5-2 SWITCH SCAN details

<Item having no function> Asterisk mark (\*) is displayed in the lower row of display area.

\* 1: "L" is displayed when the cover is opened.

Display area, upper row	1		2		3		4	
	Details	Display area, lower row	Details	Display area, lower row	Details	Display area, lower row	Details	Display area, lower row
PAPER ROUTE : PU	Entrance sensor 1	H: No paper L: Paper exists	Entrance sensor 2	H: No paper L: Paper exists	Write sensor	H: No paper L: Paper exists	Exit sensor	H: No paper L: Paper exists
TONER SENS	Toner sensor K	H: Light is interrupted L: Reflected	Toner sensor Y	H: Light is interrupted L: Reflected	Toner sensor M	H: Light is interrupted L: Reflected	Toner sensor C	H: Light is interrupted L: Reflected
CVO UP_LU_FU	Cover open switch	H: Close L: Open						
ST_FD_FU JOBOFF	Stacker down sensor	H: No paper L: Paper exists						
REG L/R_OHP_WG	Color registration sensor L	AD value: ***H	Color registration sensor R	AD value: ***H				
HT THERMISTER	Fuser thermistor, upper sensor	AD value: ***H	Fuser thermistor, lower sensor	AD value: ***H	Fuser thermistor, upper sensor, side	AD value: ***H	Heater frame thermistor	AD value: ***H
HUM_TEMP_DEN	Humidity sensor	AD value: ***H	Temperature sensor	AD value: ***H	Density sensor (k)	AD value: ***H	Density sensor (YMC)	AD value: ***H
BELT_LVPS	Belt thermistor	AD value: ***H	Power thermistor	AD value: ***H				
ID UP/DOWN							ID UpDown Sns	H: Down L: Up
RFID COLOR*1	RFID antenna K	UID: ***H	RFID antenna Y	UID: ***H	RFID antenna M	UID: ***H	RFID antenna C	UID: ***H
T1 PE_PNE_CVO	Tray 1 paper end sensor	H: No paper L: Paper exists						
T1 HOP_LIFT	Tray 1 Hopping Sns	H: No paper L: Paper exists						
T1 CASSETTE SIZE*1	Size setting switch 1	Port level H, L	Size setting switch 2	Port level H, L	Size setting switch 3	Port level H, L	Size setting switch 4	Port level H, L
T2 PE_PNE_CVO_CA	Tray 2 paper end sensor	H: No paper L: Paper exists						
T2 HOP_LF_FED	2nd-Hopping Sns	H: No paper L: Paper exists			Tray 2 entrance sensor	H: No paper L: Paper exists		
T2 CASSETTE SIZE*1	Size setting switch 1	Port level H, L	Size setting switch 2	Port level H, L	Size setting switch 3	Port level H, L	Size setting switch 4	Port level H, L
T3 PE_PNE_CVO	Tray 3 paper end sensor	H: No paper L: Paper exists						
T3 HOP_LF_FED	3rd-Hopping Sns	H: No paper L: Paper exists			Tray 3 entrance sensor	H: No paper L: Paper exists		
T3 CASSETTE SIZE	Size setting switch 1	Port level H, L	Size setting switch 2	Port level H, L	Size setting switch 3	Port level H, L	Size setting switch 4	Port level H, L
T4 PE_PNE_CVO	Tray 4 paper end sensor	H: No paper L: Paper exists						
T4 HOP_LF_FED	4th-Hopping Sns	H: No paper L: Paper exists			Tray 4 entrance sensor	H: No paper L: Paper exists		
T4 CASSETTE SIZE	Size setting switch 1	Port level H, L	Size setting switch 2	Port level H, L	Size setting switch 3	Port level H, L	Size setting switch 4	Port level H, L
DUP_IN_RA_FNT	Duplex (2-sided printing) entrance sensor	H: No paper L: Paper exists			Duplex (2-sided printing) front sensor	H: Paper exists L: No paper		
DUP_SK_CVO	Duplex (2-sided printing) bottom sensor	H: No paper L: Paper exists	Duplex (2-sided printing) cover sensor	H: Close L: Open				
OFSTP E-G	Stapler install signal	H: No installed L: Installed	Stapler error signal	H: Normal L: Abnormal				

### 5.2.1.4 Motor clutch test

This self-diagnostic menu is used to test the motor and clutch.

1. Enter the self-diagnostic mode (level 1) and press the [2], [8] key until "MOTOR&CLUTCH TEST" is displayed in the upper row of the display area.

(Pressing the [2] key increments the test item and pressing the [8] key decrements the test item.)

Press the [6] key when "MOTOR&CLUTCH TEST" is displayed.

2. Press either the [2] or [8] key until the desired menu item corresponding to the unit to be tested in Table 5-3 is displayed in the lower row of the display area. (Pressing the [2] key increments the test item and pressing the [8] key decrements the test item.)

MOTOR & CLUTCH TEST
ID MOTOR

3. Pressing the [6] key starts the test. The unit name starts flashing and the corresponding unit is activated for 10 seconds. (Refer to Figure 5-2.)

**Note!** After the corresponding unit has activated for 10 seconds, it returns to the status of step2, and is re-activated when the corresponding switch is pressed.

- The clutch solenoid repeats turning on and off during the normal print drive. (If a clutch solenoid cannot be activated independently, the motor is driven at the same time.) \* "ID UP/DOWN" keeps activated until the [#] key is pressed.
- If [ \* ] is pressed when selecting a motor, the motor keeps running.

4. When the [#] key is pressed, the corresponding unit stops activating. (Display of the corresponding unit keeps displayed.)
5. Repeat steps 2 to 4 as required.
6. Pressing the [4] key terminates the test. (Returns to the status of step 1.)

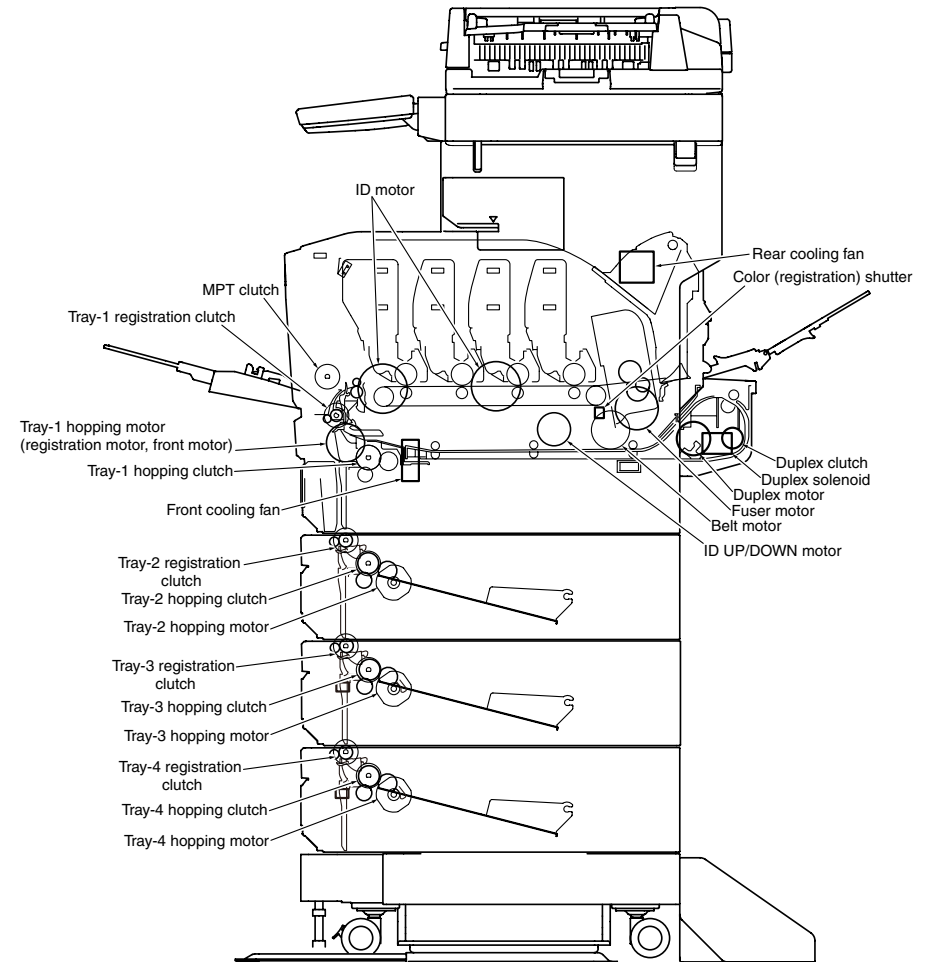

Figure 5-2



Table 5-3

Unit name display	Drive restriction condition	Remarks
ID MOTOR	To be driven when all of the ID (K/Y/M/C) are removed.	-
BELT MOTOR	To be driven when all of the ID (K/Y/M/C) are removed.	-
FUSER_RLS	-	-
REGIST MOTOR	-	-
T1 HOPPING MOTOR	-	-
FRONT MOTOR	-	-
REGIST SHUTTER	-	-
EXIT SOLENOID	-	-
DUPLEX MOTOR	-	-
DUPLEX CLUTCH	-	-
T2 HOPPING MOTOR	-	OPTION
T2 FEED CLUTCH	-	OPTION
T3 HOPPING MOTOR	-	OPTION
T3 FEED CLUTCH	-	OPTION
T4 HOPPING MOTOR	-	OPTION
T4 FEED CLUTCH	-	OPTION
ID UP/DOWN	TOP/FRONT cover closed status	-
LV FAN TEST	-	-
FUSER FAN TEST	-	-
DUPLEX FAN TEST	-	OPTION
ID FAN TEST	-	-

**Note!** Display while ID Up/Down execution is in progress

MOTOR & CLUTCH TEST
ID UP/DOWN     ***

\*\*\* Number of times of execution

Display when the REGIST SHUTTER [ \* ] key is pressed

MOTOR & CLUTCH TEST
SHT                ***

\*\*\* Number of times of execution

### 5.2.1.5 Test print

This self-diagnostic menu is used to print the test pattern that is built inside PU. Other test patterns are stored in the controller.

This test print cannot be used to check the print quality.

Diagnosis for the abnormal print image should be performed in accordance with section 7.

1. Enter the self-diagnostic mode (level 1) and keep pressing the [2], [8] key until "TEST PRINT" is displayed in the upper row of the display area. Then, press the [6] key. (Pressing the [2] key increments the test item and pressing the [8] key decrements the test item.)
2. The setting items that can be applied to the test print only is displayed in the lower row of display area. Keep pressing the [2], [8] key until the desired menu item is displayed. (Pressing the [2] key increments the test item and pressing the [8] key decrements the test item.) (If all setting items need no entry [Default setting], go to step 5.)
3. Keep pressing the [2], [8] key, and press the [6] key at the menu item set by step 2. Then, the setting item is displayed in the upper row of display area, and the setting value is displayed in the lower row of display area.

Pressing the [2] key increments the setting value. Pressing the [2] key decrements the setting value. (The setting value that is displayed at last is applied.) Pressing the [4] key determines the entry value, and returns to step 2. Repeat step 3 as required.

TEST PATTERN
1

Display	Setting value	Function
PRINT EXECUTE	–	Pressing the [6] key starts print/Pressing the [#] key terminates print. (In units of page)
TEST PATTERN	0	0: White paper print 1~9: Refer to next page. (Pattern print)
TEST CASSETTE	TRAY1	Selecting source of paper supply. If the TRAY 2 is not installed, TRAY2 is not displayed. If the TRAY 3 is not installed, TRAY3 is not displayed. If the TRAY 4 is not installed, TRAY4 is not displayed.
	TRAY2	
	TRAY3	
	TRAY4	
	MFP	
PAGE	0000	Setting number of the test print copies
COLOR	ON	Selecting either color/monochrome print * When ON is specified, ON/OFF setting for each color becomes available.
	OFF	
DUPLEX	2 PAGES STACK	Duplex (2-sided) print is performed by the stack of two sheets of paper. Selecting OFF for duplex (2-sided) print. Duplex (1-sided) print is performed by the stack of one sheet of paper.
	OFF	
	1PAGES STACK	

- is the initial default value. The menu item that is set here is valid in this menu item only. (The setting item is not saved in EEPROM.)

**Note!** PAGE setting

Pressing the [2] key or the [8] key shifts the digit. Pressing the [ \* ] key increments the setting value. Pressing the [2] key increments the setting value. If print is executed while the number of print copies remains in "0000", printing will continue infinitely.

COLOR setting

When the [6] key is pressed while ON is set, the following contents are displayed on the panel.

Print setting for each color

Pressing the [2] key or the [8] key shifts the setting. Pressing the [ \* ] key or the [#], the ON/OFF switchover will be set. Pressing the [4] key returns the panel display.

COLOR	→	Y:ON M:ON
ON		C:ON K:ON

- While the message "PRINT EXECUTE" that is set by the operation specified in step 2 is being displayed, press the [6] key and the test print is executed with the setting value that has been set by steps 2 and 3.

Pressing the [#] key stops the test print.

If any alarm that is shown in the following details column is issued at startup of test print or while test print is in progress, the test print is interrupted. (For error details, refer to section 5.2.2.14 Panel display details. However, the comment to be displayed is different in the case of the PU test print.)

Panel display	Details
STACKER FULL	Stacker full
PAPER END SELECTED TRAY	No paper
DUPLEX UNIT IS NOT INSTALLED	DUPLEX is not installed
SELECTED TRAY IS NOT INSTALLED	Selected tray is not installed.
REMOVE PAPER OUT OF DUPLEX	DUPLEX internal error
INSTALL CASSETTE TRAY OPEN	Cassette removal

Print pattern (It cannot be used for checking PQ.)

0..... White paper print

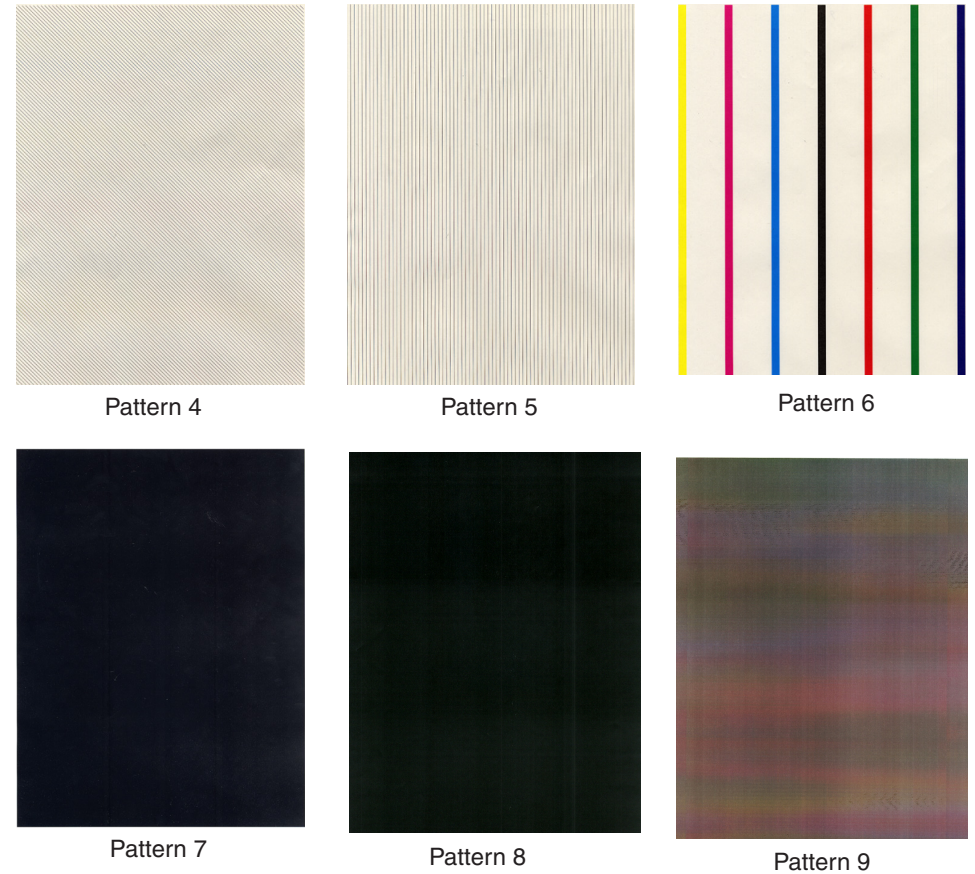
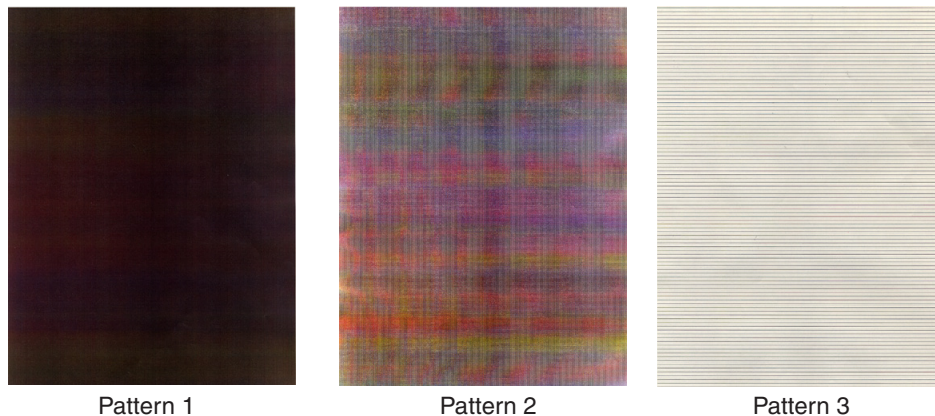

**Note!** If the solid print (pattern 7) among the local print function is selected and printed with the setting of 100% each color, offset occurs. To prevent print from this trouble, the print setting of each color should be made in accordance with the instruction specified in step 5.3.2.5-3 when performing the sold print, and number of print colors should be two colors or less.

- During printing, the following messages are displayed.

P=***
W=***

P : Number of test print copies (unit: copies)  
W : Print waiting time (unit: second)

- Displays are switched by pressing the [2] key.

T=*** U=***[###]
H=***%L=***[###]

U : \*\*\* = Upper heater temperature measurement value [unit:°C]  
[\*\*\*] = Print execution target temperature [unit:°C]  
L : \*\*\* = Lower heater temperature measurement value [unit:°C]  
[###] = Lower thermistor read-out AD value [unit: HEX]  
T : Environment temperature measurement value [unit:°C]  
H : Environment humidity measurement value [unit: %]

- Displays are switched by pressing the [2] key.

KTR=*.** YTR=*.**
MTR=*.** CTR=*.**

YTR, MTR, CTR and KTR indicate the transfer voltage setting value for each color (unit: KV)

- Displays are switched by pressing the [2] key.

KR=*.** YR=*.**
MR=*.** CR=*.**

KR : BLACK transfer roller resistance value [unit: uA]  
YR : YELLOW transfer roller resistance value [unit: uA]  
MR : MAGENTA transfer roller resistance value [unit: uA]  
CR : CYAN transfer roller resistance value [unit: uA]

- Displays are switched by pressing the [2] key.

ETMP=***UTMP=***
REG=****EXT=***

ETMP : Hopping motor constant speed correction parameter  
(environment temperature) [unit: DEC]  
UTMP : Fuser motor constant speed correction parameter  
(fuse target temperature) [unit: DEC]  
REG : Hopping motor constant speed timer value (I/O setting value)  
[unit: HEX]  
EXT : Fuse motor constant speed timer value (I/O setting value) [unit: HEX]

- Displays are switched by pressing the [2] key.

ID=****

KID, YID, MID and CID are the constant speed timer value of the respective ID motors (I/O setting value) [unit: HEX]

- Displays are switched by pressing the [2] key.

BELT=****
FRM [***] ( xxx )

BELT : Hopping motor constant speed timer value (I/O setting value) [unit: HEX]  
FRM : [\*\*\*] = Frame thermistor read-out AD value [unit: HEX]  
(XXX) = Frame temperature [unit: °C]

- Displays are switched by pressing the [2] key.

DB:k**y**m**c**

DB : Develop voltage setting table ID number [unit: HEX]

- Displays are switched by pressing the [2] key.

TR1:k**y**m**c**
TR2:k**y**m**c**

TR1 : Transfer voltage parameter VTR1 table ID number [unit: HEX]

TR2 : Transfer voltage parameter VTR2 table ID number [unit: HEX]

- Displays are switched by pressing the [2] key.

TROFF:**
BELT xxx(***)

TROFF : Transfer OFF voltage setting table ID number [unit: HEX]

BELT : XXX = Belt thermistor read-out AD value [unit: HEX]

\*\*\* Belt temperature [unit: °C]

5. Repeat steps 2 to 4 as required.
6. Pressing the CANCEL key terminates the test. (Returns to the status of step 1.)

### 5.2.1.6 Color registration correction test

This self-diagnostic menu item is used for the color registration error adjustment and to investigate cause of the error of a printer.

If the color registration error is recognized by the color registration correction test, correct it by following section 2 "General of color blur correction" and section 7 "Heavy color registration error(7.5.5.(6))".

1. Enter the self-diagnostic mode (level 1) and keep pressing the [2] or [8] key until the following message is displayed.

REG ADJUST TEST

2. When the [6] key is pressed, the following message is displayed. Keep pressing the [2] or [8] key until the target item is displayed.

REG ADJUST TEST
REG ADJ EXECUTE

3. When the [6] key is pressed, test of the item that is displayed on the panel is executed.

<<During execution of REG ADJ EXECUTE>>

- ① The color registration correction test is executed. (The [DATA] lamp flashes.)
- ② When the test is complete, the test result (OK or error name) is displayed in the upper row of the display area, and \*\*\*\*RESULT is displayed in the lower row of the display area

OK
REG ADJ RESULT

When the [2] key is pressed, the test results are displayed by incrementing them.

When the [8] key is pressed, the test results are displayed by decrementing them.

Pressing the [4] key returns the screen to the state of step 2.

**Remarks** The following message is displayed during initialization, when the cover is opened and during alarm.

NG
REG ADJ RESULT

- ③ When the [#] key is pressed while test is in progress (while the [DATA] lamp is lighting), the screen returns to the state of step 2.

<<During execution of REG ADJ RESULT>>

The same as the key operations of step 2. During execution of REG ADJ EXECUTE.

<<During execution of BLT REFLECT TEST>>

- ① The color registration correction test is executed.  
(The [DATA] lamp flashes.)
- ② When the test is complete, the test result (OK or error name) is displayed in the upper row of the display area, and \*\*\*\*RESULT is displayed in the lower row of the display area

OK
BLT REFLECT RSLT

When the [2] key is pressed, the test results are displayed by incrementing them.

When the [8] key is pressed, the test results are displayed by decrementing them.

Pressing the [4] key returns the screen to the state of step 2.

- ③ When the [#] key is pressed while test is in progress (while the [DATA] lamp is lighting), the screen returns to the state of step 2.

<<During execution of BLT REFLECT RSLT>>

The same as the key operations of step ②. During execution of BLT REFLECT TEST.

**Remarks** The following message is displayed during initialization, when the cover is opened and during alarm.

NG
REG REFLECT RSLT

4. Repeat steps 2 and 3 as required.
5. Pressing the [4] terminates the test. (Returns to the status of step 1.)

Color registration correction test items

Display	Details
REG ADJ EXECUTE	Executing the color registration correction
REG ADJ RESULT	Referring to result of the color registration correction
BLT REFLECT TEST	Executing judgment of GOOD/BAD of reflectance rate of color registration correction belt
BLT REFLECT RSLT	Referring to result of the judgment of GOOD/BAD of reflectance rate of color registration correction belt.

### 5.2.1.7 Density correction test

This self-diagnostic menu item is used to test the density correction function of a printer, and to refer to result of the test execution.

At the same time, GOOD/BAD of the density correction function is judged by executing this test.

If an error is issued, correct it by following section 2 "Density correction method overview".

1. Enter the self-diagnostic mode (level 1) and keep pressing the [2] or [8] key until the following message is displayed.

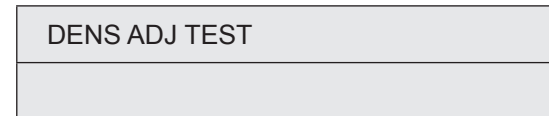

2. When the [6] key is pressed, the following message is displayed. Keep pressing the [2] or [8] key until the target item is displayed.

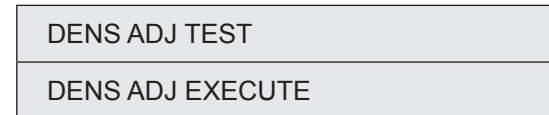

3. When the [6] key is pressed, test of the item that is displayed on the panel is executed.

<<During execution of REG ADJ EXECUTE>>

- ① The density correction test is executed. (The [DATA] lamp flashes.)
- ② When the test is complete, the test result (OK or error name) is displayed in the upper row of the display area, and \*\*\*\*RESULT is displayed in the lower row of the display area

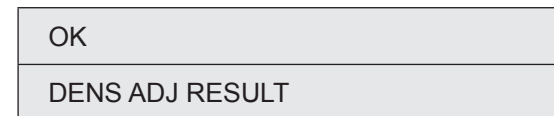

[When the [2] key is pressed, the test results are displayed by incrementing them.

When the [8] key is pressed, the test results are displayed by decrementing them.

Pressing the [4] key returns the screen to the state of step 2.

- ③ When the [#] key is pressed while test is in progress (while the [DATA] lamp is lighting), the screen returns to the state of step 2.

<<During execution of DENS ADJ RESULT>>

The same as the key operations of step 2. During execution of DENS ADJ EXECUTE.

<<During execution of DENS ADJ PAR - SET>>

Setup of the density correction parameter is displayed.

<<During execution of AUTO CALIBRATION>>

- ① The automatic setting of the density sensor sensitivity correction value is executed. (The [DATA] lamp flashes.)
- ② When the test is complete, the test result (OK or error name) is displayed in the upper row of the display area, and \*\*\*\*RESULT is displayed in the lower row of the display area

OK
DENS ADJ RESULT

When the [2] key is pressed, the test results are displayed by incrementing them.  
 When the [8] key is pressed, the test results are displayed by decrementing them.

Pressing the [4] key returns the screen to the state of step 2.

- ③ When the [#] key is pressed while test is in progress (while the [DATA] lamp is lighting), the screen returns to the state of step 2.

**Remarks** The following message is displayed during initialization, when the cover is opened and during alarm.

NG
DENS ADJ RESULT

- 4. Repeat step 3 as required.

- 5. Pressing the [4] key terminates the test. (Returns to the status of step 1.)

Density correction test items

Display	Details
DENS ADJ EXECUTE	Executing the density correction
DENS ADJ PAR-SET	Setting the control values with respect to the automatic density correction
DENS ADJ RESULT	Referring to result of the density correction
AUTO CALIBRATION	Automatic setting of the density sensor sensitivity correction value



### 5.2.1.8 Consumable item counter display

This self-diagnostic menu is used to display the consumption status of the consumable items.

1. Enter the ordinary self-diagnostic mode and press the [2] , [8] key until "CONSUMABLE STATUS" is displayed in the display area. (Pressing the [2] key increments the test item and pressing the [8] key decrements the test item.) Press the [6] key when "CONSUMABLE STATUS" is displayed in the display area.
2. When the [2] , [8] key is pressed, consumption statuses of the consumable items are displayed in order. (Pressing the [ \* ] or [#] key is invalid.)
3. Pressing the [4] key terminates the test. (Returns to the status of step 1.)

Display area, upper row	Display area, lower row	Format	Unit	Details
K-ID UNIT	*****IMAGES	DEC	Images	Number of rotations from the time when the ID UNITS of respective colors are installed up to the present time is displayed after converting them to the units of A4 3Page/Job.
Y-ID UNIT	*****IMAGES	DEC	Images	
M-ID UNIT	*****IMAGES	DEC	Images	
C-ID UNIT	*****IMAGES	DEC	Images	
FUSER UNIT	*****PRINTS	DEC	Prints	Number of copies from the time of installation of a new fuser unit up to the present time is displayed.
TR BELT UNIT	*****IMAGES	DEC	Images	Number of copies from the time of installation of a new belt unit up to the present time is displayed.
K-TONER (FULL)	*****%	DEC	%	Amount of consumption of the respective toners is displayed.
Y-TONER (FULL)	*****%	DEC	%	
M-TONER (FULL)	*****%	DEC	%	
C-TONER (FULL)	*****%	DEC	%	
M-WASTE TNR CNT	*****TIMES	DEC	Times	Amount of waste toner is displayed. * When the times reaches 32 times or more, the waste toner full is issued.
C-WASTE TNR CNT	*****TIMES	DEC	Times	

Display area, upper row	Display area, lower row	Format	Unit	Details
K-STC MODE CNT	*****TIMES	DEC	Times	Number of print dot counts of the toner of the respective colors are displayed. (Accumulative value since start of the system operation.)
Y-STC MODE CNT	*****TIMES	DEC	Times	
M-STC MODE CNT	*****TIMES	DEC	Times	
C-STC MODE CNT	*****TIMES	DEC	Times	
K OVER RIDE CNT	*****TIMES	DEC	Times	Number of times of continues of the toner cartridge of the respective colors are displayed.
Y OVER RIDE CNT	*****TIMES	DEC	Times	
M OVER RIDE CNT	*****TIMES	DEC	Times	
C OVER RIDE CNT	*****TIMES	DEC	Times	

### 5.2.1.9 Number of print copies counter display

This self-diagnostic menu is used to display status of the number of copies of a printer.

1. Enter the ordinary self-diagnostic mode and press the [2] key, [8] key until "PRINTER STATUS" is displayed in the display area. (Pressing the [2]key increments the test item and pressing the [8] key decrements the test item.)
2. When the [2], [8] key is pressed, statuses of the number of print copies are displayed in order.(Pressing the [ \* ] or [#] key is invalid.)
3. Pressing the [4] key terminates the test. (Returns to the status of step 1.)

Display area, upper row	Display area, lower row	Format	Unit	Details
K-IMPRESSIONS	*****PRINTS	DEC	Prints	Number of print copies of the respective colors are displayed.
Y-IMPRESSIONS	*****PRINTS	DEC	Prints	
M-IMPRESSIONS	*****PRINTS	DEC	Prints	
C-IMPRESSIONS	*****PRINTS	DEC	Prints	
TOTAL SHEET CNT	*****PRINTS	DEC	Prints	Total number of print copies are displayed.

### 5.2.1.10 Switching between the Factory mode and the Shipping mode

This self-diagnostic menu item is used to switch between the Factory mode and the Shipping mode. To use for confirm of cause consumables or maintenance parts. Invalidation the fuse cut mode, when Factory mode.

1. Enter the self-diagnostic mode (level 1) and keep pressing the [2] or [8] key until the following message is displayed.

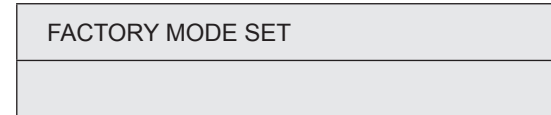

2. When the [6] key is pressed, the following message is displayed. Keep pressing the [2] or [8] key until the target item (refer to the following table) is displayed.

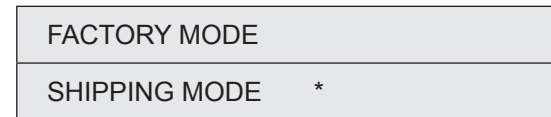

3. While the desired item to set is being displayed, press the [6] key that enables selection of the setting values.
4. While the desired setting value is being displayed, press the [6] key that registers the displayed value in EEPROM. (Returns to the status of step 2.)
5. Repeat steps 2 to 4 as required.
6. Pressing the [4] key terminates the test. (Returns to the status of step 1.)

Display	Setting value	Function
FACTORY MODE	FACTORY MODE	Sets the Factory working mode (fuse cut invalid mode).
	SHIPPING MODE	Releases the Factory working mode to make the fuse cut function valid.
FUSE INTACT  Note: ***** indicates INTACT or BLOWN.	BELT UNIT *****	Checks the fuse status of the transport belt unit.
	FUSE UNIT *****	Checks the fuse status of the fuser unit.
	K-ID UNIT *****	Checks the fuse status of the K-1D unit.
	Y-ID UNIT *****	Checks the fuse status of the Y-1D unit.
	M-ID UNIT *****	Checks the fuse status of the M-1D unit.
	C-ID UNIT *****	Checks the fuse status of the C-1D unit.

### 5.2.1.11 Self-diagnostic function setting

This self-diagnostic menu is used to set valid/invalid of the error detection by the various sensors.

The error detection can be made invalid or valid for locating source of abnormality. However, this menu item requires expert knowledge to set among the engine operations. Handle this menu item with utmost care.

Be sure to return the setting to the default setting upon completion of usage of this item.

1. Enter the self-diagnostic mode (level 1) and keep pressing the [2] or [8] key until the following message is displayed.

SENSOR SETTING

2. When the [6] key is pressed, the following message is displayed. Keep pressing the [2] or [8] key until the target item (refer to the table below) is displayed.

TONER SENSOR
ENABLE *

3. When the [6] key is pressed, the following message is displayed.  
Pressing the [2] key increments the setting value.  
Pressing the [8] key decrements the setting value.
4. While the desired setting value is being displayed, press the [6] key that registers the displayed value in EEPROM. (Returns to the status of step 2.)
5. Repeat steps 2 to 4 as required.
6. Pressing the [4] key terminates (except the status of step 4) the setting. (Returns to the status of step 1.)

Display	Setting value	Operation at the setting value	Function
TONER SENSOR	ENABLE	Detects	Valid/Invalid of toner sensor operation
	DISABLE	Not to detect	
BELT UNIT CHECK	ENABLE	Checks	Valid/Invalid of belt installation check operation
	DISABLE	Not to check	

Display	Setting value	Operation at the setting value	Function
ID UNIT CHECK	ENABLE	Checks	Valid/Invalid of ID installation check operation
	DISABLE	Not to check	
REG ADJUST ERROR	ENABLE	Stops	Valid/Invalid of error stop by the color registration detection value
	DISABLE	Not to stop	
DRUM OVER LIFE	STOP	Not to continue	Setting of valid/invalid of continuance when drum comes to end of its life
	CONTINUANCE	To continue	
WR POINT REV TBL=**H± *.***mm	00H~FFH	Correction value	The correction value is added to the existing write-down position.
BOTTOM WRT POINT TBL=**H± *.***mm	00H~FFH	Cut value	Amount of cut at the rear end of a paper is set.

Hatched portion: Default is shown

### 5.2.1.12 LED head serial number display

This self-diagnostic menu item is used to check whether the downloaded LED head data matches the serial number of the actual LED head.

1. Enter the self-diagnostic mode (level 1) and press the [2], [8] key until "LED HEAD DATA" is displayed in the upper row of the display area. (Pressing the [2] key increments the test item and pressing the [8] key decrements the test item.) Press the [6] key when "LED HEAD DATA" is displayed in the display area.
2. When the [2] key or the [8] key is pressed, serial numbers of the K/Y/M/C LED head data are displayed in order.
3. Pressing the [4] key terminates the test. (Returns to the status of step 1.)

K ** ** ** **
xxxxxxxxxxxxx

\*\* \*\* \*\* \*\*: Rev number

xxxxxxxxxxxxx: serial number

### 5.2.1.13 NVRAM parameter setting

Do not use this menu item.

## 5.2.2 How to enter the Scanner Maintenance Menu

- (1) Press the [6] key & [8] key when the MFP power is turned on.
- (2) Press the [1] key when the "Select Number" is displayed.

Maintenance mode
Select Number(1-2)
1.SU
2.PU

### Basic key assignment in the Scanner Maintenance Menu

↑ move	[2] key
← move	[4] key
→ move	[6] key
↓ move	[8] key
cancel	[#] key
confirm	[*] key

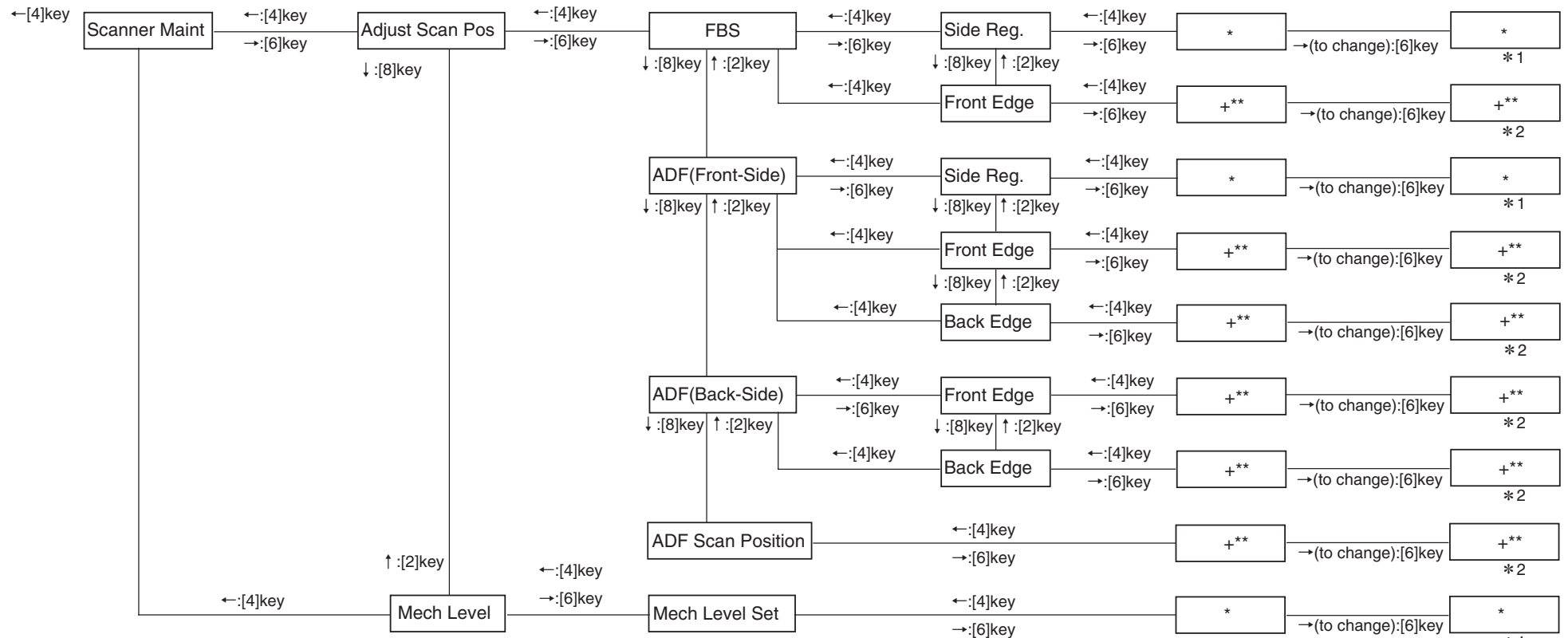

\* 1 decrement:[2]key,increment:[8]key,cancel:[#]key,confirm:[\*]key

\* 2 ←digit move:[4]key,→digit move:[6]key,decrement:[2]key,increment:[8]key,cancel:[#]key,confirm:[\*]key

(3) Display "Scanner Maint" as the Scanner Maintenance Menu show below.

Item1	Item2	Item3	Item4	Value (Step)	Default value ODA	Default value OEL	Default value JP	Notes	
Scanner Maint	Adjust Scan Pos	FBS	Side Reg.	+42 ~ 0	0	0	0	Adjust the scanning start position of main scanning direction when book scanning.	
			Front Edge	+30 ~ -30	0	0	0	During book scanning, add a value for the basic value (= 5 mm) when reading the shadow of the front edge of the document. Adjust in intervals of one step = 4/600 dpi (=0.17 mm).	
		ADF (Front-side)	Side Reg.	+42 ~ 0	+21	+21	+21	Adjust the scanning start position of main scanning direction when ADF scanning.	
			Front Edge	+30 ~ -40	0	0	0	When reading a document from the ADF, add a value for the basic value when reading the shadow of the front edge of the document. To skip the front edge of the document, add a negative value. Increase or decrease the number of motor pulses from detection by the sensor of the front edge of the media until actual reading starts. Adjust in intervals of one step = 4/600 dpi (= 0.17 mm).	
			Back Edge	+30 ~ -40	0	0	0	When reading a document from the ADF, add a value for the basic value when skipping the back edge of the document. To read the shadow of the back edge of the document, add a negative value. Increase or decrease the number of motor pulses from detection by the sensor of the back edge of the media until actual reading ends. Adjust in intervals of one step = 4/600 dpi (= 0.17 mm).	
		ADF (Back-side)	Front Edge	+30 ~ -40	0	0	0	When reading a document from the ADF, add a value for the basic value when reading the shadow of the front edge of the document. To skip the front edge of the document, add a negative value. Increase or decrease the number of motor pulses from detection by the sensor of the front edge of the media until actual reading starts. Adjust in intervals of one step = 4/600 dpi (= 0.17 mm).	
			Back Edge	+30 ~ -40	0	0	0	When reading a document from the ADF, add a value for the basic value when skipping the back edge of the document. To read the shadow of the back edge of the document, add a negative value. Increase or decrease the number of motor pulses from detection by the sensor of the back edge of the media until actual reading ends. Adjust in intervals of one step = 4/600 dpi (= 0.17 mm).	
			Adjust ADF Scan Pos		+30 ~ -30	0	0	0	Set the CIS reading position of the ADF for the focusing standard. Adjust in intervals of one step = 4/600 dpi (= 0.17 mm). This is correlated to adjustment of the ADF front edge position.
		Mech Level	Mech Level Set		0 ~ 1	0	0	0	Setting the Scanner Mech Level. Default value is 1. Setting proper value of scanner mech level, when shipping. To check the Mech Level, according to the section 4.3

## 5.3 Setups upon completion of part replacement

The adjustments that are required upon completion of part replacement are described below.

Replacement parts	Adjustment contents
LED head      See note.	Not required
Drum cartridges (Y, M, C, K)	Not required
Fuser unit	Not required
Belt unit	Not required
PU board	5.3.1 Copying the EEPROM information and utilities are required.
SU board	Not required
CU board	Refer to "6.1 Removal and Installation of PC Boards/HDD" in the Software Guide.
HDD	
SRAM board	

**Note!** Refer to the Software Guide for the removal and installation procedures of the CU board, HDD, and SRAM board <for CU board>.

### 5.3.1 Precautions when replacing the PU board

1. When access to the EEPROM of the board to remove is possible. (When the SERVICE CALL 104 [Engine EEPROM Error] is not displayed:)
  - (1) Obtain the EEPROM information from the board to remove, by using the board replacement function (Maintenance Utilities Operation Manual section 2.4.1.1.9 Board replacement function) of the Maintenance Utilities, and save in the hard disk of PC temporarily.
  - (2) Copy the EEPROM information that has been saved in the hard disk of PC by step (1), into the EEPROM of the new replacement board by using the Board replacement function (Maintenance Utilities Operation Manual section 2.4.1.1.9 Board replacement function) of the Maintenance Utilities.

**Note!** When obtaining and copying the EEPROM information by using the Maintenance Utilities, set the printer into the "Forced ONLINE mode"

2. When access to the EEPROM of the board to remove is impossible.

If the SERVICE CALL 104 [Engine EEPROM Error] is displayed on the operator panel with the board to remove, or is EEPROM data cannot be read-out, perform the following procedure by using the Maintenance Utilities.

(1) Setting the serial number information (Maintenance Utilities Operation Manual section 2.4.1.1.10.3)

The SAP serial number is applied to printer. The SAP serial number is displayed in the top-most row of the serial number label. Its number indicates the production place with 2 digits, manufacture date with 2 digits, serial number (sequential number) with 6 digits and revision number with 2 digits totaling 12 digits number.

- Select PU Serial Number for the printer serial number, and Show Only Serial Number for the output mode.
- The PU serial number is the 10 digits number excluding the revision number of 2 digits among the 12 digits SAP serial number.
- Perform the above setting by using the Maintenance Utilities section “2.4.1.1.10 Board setting function” – section “2.4.1.1.10.3 Serial number information setting”.
- To specify the PU serial number, enter the 11 digits number after adding “0” (Zero in single-byte character) at the top. (Be careful that the read-out data shows the 10 digits number.)  
Enter the 11 digit number by adding “0” (Zero in single-byte character) before the 10 digit number excluding the revision 2 digits that is shown in conceptual drawing of “Serial number information setting” screen as shown below.

- The PU serial number is output to the System/Serial Number column of the  
Enter the 11 digit number after adding “0” (zero in single-byte character) before the 10 digit number. (Enter “OAE01234567”.)

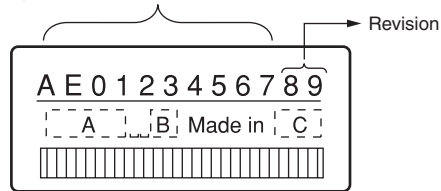

Serial number label conceptual drawing

Configuration. Therefore, confirmation upon completion of rewriting the PU serial number can be performed by printing the Configuration.

(2) Switching to the Shipping mode (Maintenance Utilities Operation Manual

section 2.4.1.1.10.4)

When the board is replaced with the new board, the new board has been set in the Factory working mode. Therefore, it should be switched to the Shipping mode.

- Switch the mode by using the Maintenance Utilities section “2.4.1.1.10 Board setting function” – section “2.4.1.1.10.4 Factory/Shipping mode” screen.

**Note!** Note that replacing the PU board with a new one without copying information onto the new one from the board’s EEPROM clears information about the lives of units of the printer, including the belt, toner and image drums, causing errors in managing these lives on the printer until the units are replaced. The counts cleared with such PU board replacement are as shown in the list below and chapter 2 Counter Specifications. When the units are replaced with new ones, their respective counts except for Total Sheets Fed are cleared, the errors being corrected.

Item	Contents	Count contents
Fuser unit	Fuser unit life count	Number of print copies after the new fuser unit is installed, after the data is converted to equivalent number of A4 size paper counts.
Belt unit	Belt unit life count	Number of print copies after the new belt unit is installed, after the data is converted to equivalent number of A4 size paper counts.
ID unit : Black ID unit : Yellow ID unit : Magenta ID unit : Cyan	Life count of respective ID units	Number of print copies after the new ID unit is installed, after the data is converted to equivalent number of A4 size paper counts.
Total number of papers fed	Printer life count	Total number of papers fed
Print : Black Print : Yellow Print : Magenta Print : Cyan	Number of print copies of each ID	Number of print copies after the new ID unit is installed.



## 5.4 Density control manual setting

---

When a printer is shipped from the factory, the automatic density correction mode has been set in "Automatic". If a printer is used after the density correction mode is set to "Manual", density may change during usage of a printer. Actions to be taken when density is not normal.

**Note!** Perform the followings while a printer is in the still state. Do not perform the followings during warm-up.

- (1) Press the [2] or [8] key several times until the [Calibration] is displayed. Then, press the [6] key.
- (2) Press the [2] or [8] key to display [Adjust Density/Execute].
- (3) Press the [6] key.

The automatic density correction starts.

# 6. Periodic Maintenance

---

6.1	Cleaning .....	139
6.2	How to clean the LED lens array .....	140
6.3	How to clean the pickup roller.....	142
6.4	How to clean the paper feed rollers for MP Tray .....	143
6.5	How to clean the rollers in the ADF .....	144
6.6	How to clean the document rollers in the ADF .....	145
6.7	How to clean the document glass.....	146
6.8	How to clean inside of MFP .....	147

## 6.1 Cleaning

---

Clean inside and outside of the MFP with clean dry cleaning cloth and small vacuum cleaner (hand cleaner) as required.

**Note!** Be careful not to touch the image drum terminals, the LED lens array and the LED head connectors.

## 6.2 How to clean the LED lens array

If the white banding, white stripe (white drop-out, light printing) in the vertical direction occurs on the print surface, clean the LED lens array.

White banding, white stripe  
(white drop-out, light printing)

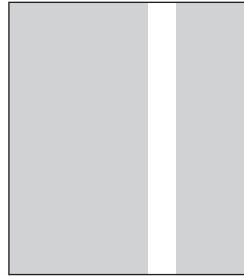

### Perform cleaning of the LED head.

If any light print or white banding is recognized or if print character becomes blurred, clean the LED head as described below.

- (1) Turn off the power of the MFP.

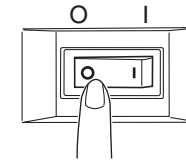

- (2) Open the scanner and press down the OPEN button to open the top cover.

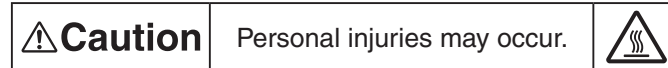

The fuser unit gets very hot. Do not touch the fuser unit.

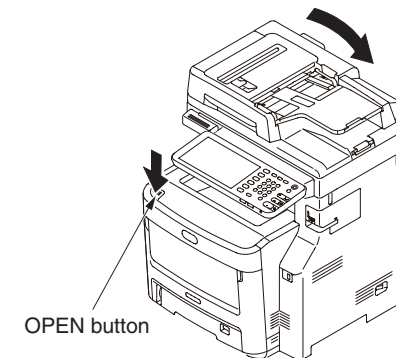

- (3) Wipe the lens surface (at the four positions) of the LED head with soft tissue paper gently and lightly.

**Note!** · Do not use the solvents such as methyl alcohol or thinner for cleaning the LED head lens because they can damage the LED head.  
· When use OA cleaner, wipe out authenticity.

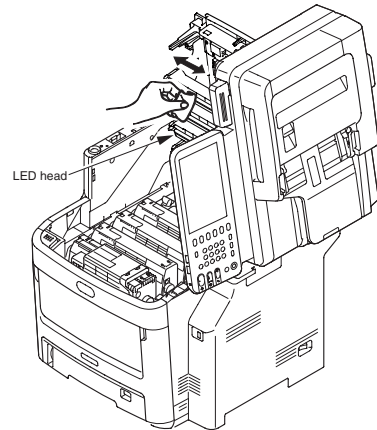

- (4) Close the top cover.

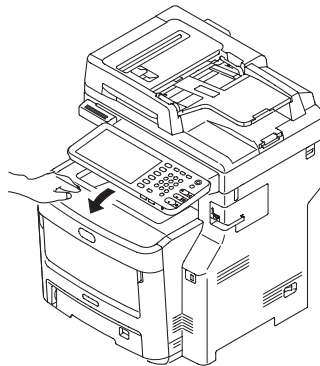

## 6.3 How to clean the pickup roller

If the vertical banding in the vertical direction occurs on the print surface, clean the pickup roller.

**Note!** Be sure to use a soft cloth or the like for cleaning the pickup roller. Otherwise, the roller surface can be damaged.

### Perform cleaning of the feed roller and the separation roller.

Perform this cleaning when the error code [Open Cassette/Paper Jam/Tray1/Please see HELP for details] occurs frequently.

- (1) Draw out the paper tray.
- (2) Clean the 2 feed rollers with a clean cloth stringently wrung out of clean water.

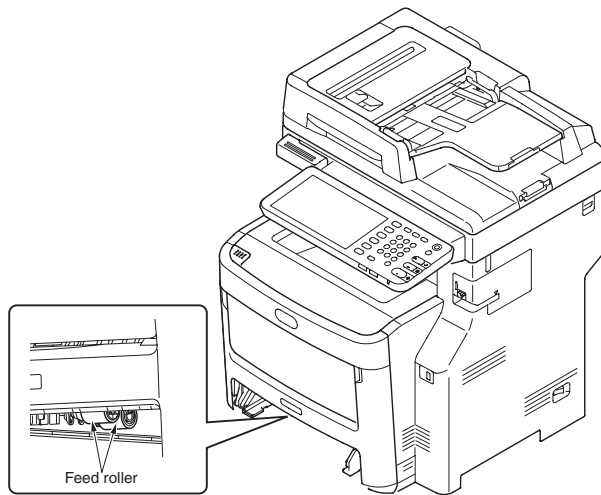

- (3) Clean the separation roller of the paper tray with a clean cloth wrung out stringently of clean water.

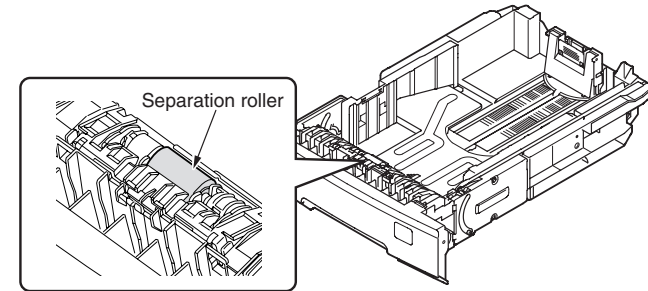

- Note!**
- Clean the second tray (option) in the same manner when the error code [Open Cassette/Paper Jam/Tray2/Please see HELP for details] occurs frequently.
  - Clean the feeder roller of the multi-purpose tray in the same manner when the error code [Open Cover/Paper Jam/Front Cover/Please see HELP for details] occurs frequently.

## 6.4 How to clean the paper feed rollers for MP Tray

(1) Open the MP tray.

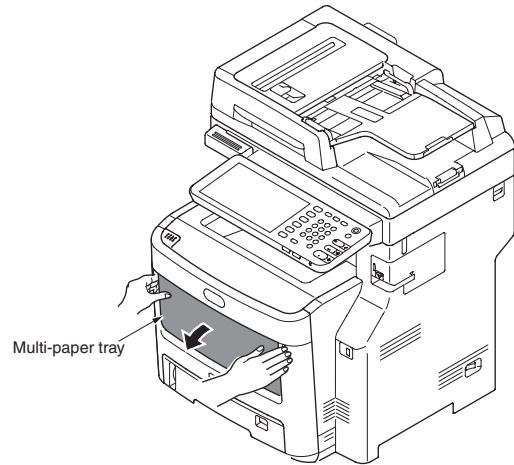

(2) While pressing the tab of the paper feed roller cover to the right, open the cover.

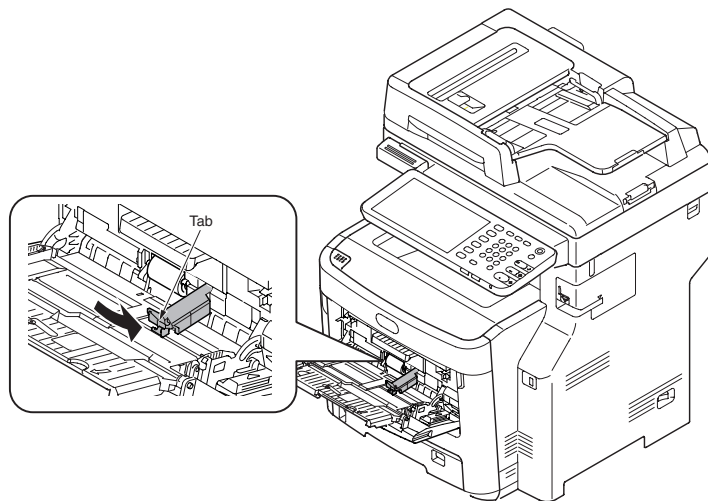

(3) Wipe the paper feed roller with a soft cloth lightly moistened with water.

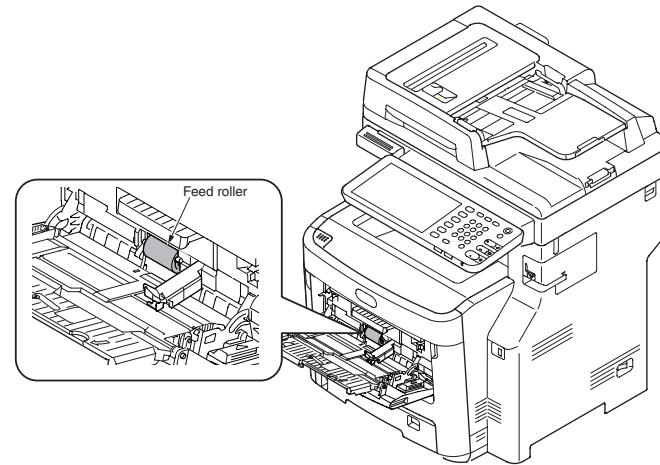

(4) Close the cover of the paper feed roller.

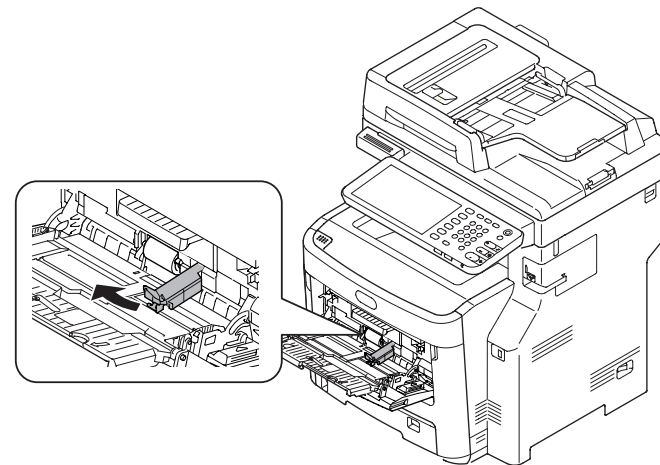

(5) Close the MP tray.

## 6.5 How to clean the rollers in the ADF

If the document feeding rollers in the ADF are contaminated with ink, toner particles or paper dust, documents and outputs get dirty and a paper jam may occur. To prevent this, it is recommended to clean the rollers once a month.

- (1) Turn off the power of MFP.
- (2) Open the ADF cover.

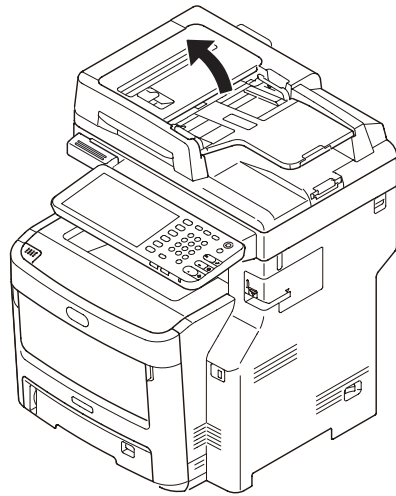

- (3) Open the Roller cover.

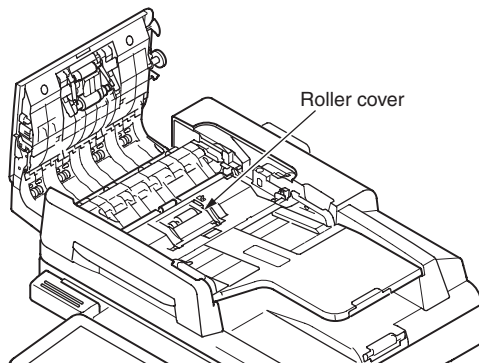

- (4) Wipe the document feeding rollers with a soft cloth lightly moistened with water. Wipe the whole surface of the roller while turning it with your hand.

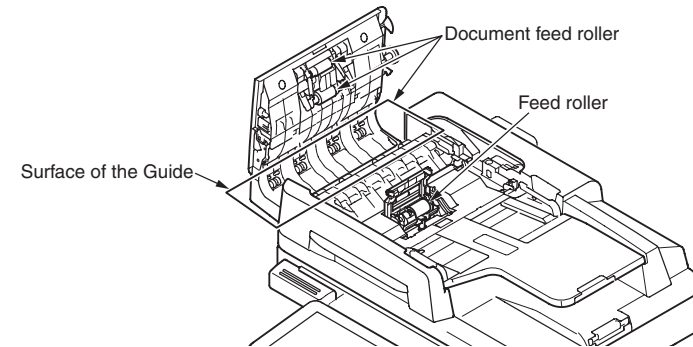

**Note!** If the rollers get too dirty, wipe them with a soft cloth lightly moistened with neutral detergent, and then wipe it again with a soft cloth lightly moistened with water.

- (5) Open the inner Cover and wipe the rollers with a soft cloth lightly moistened with water.

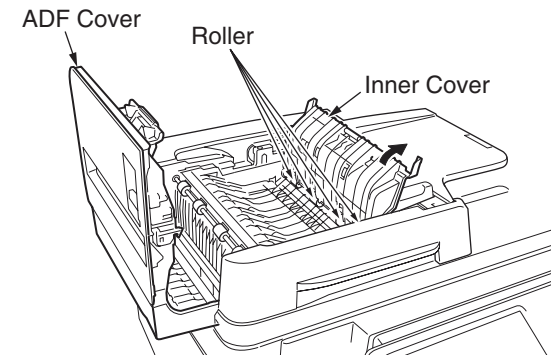

- (6) Close the Roller cover and ADF Cover.



## 6.6 How to clean the document rollers in the ADF

(1) Open the document glass cover.



(2) Pull lever and open the document hold pad.

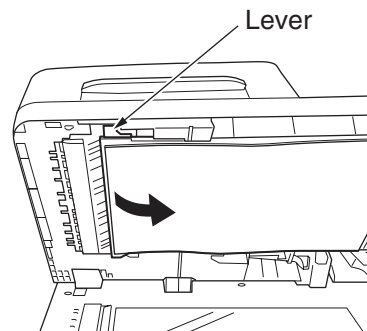

(3) Wipe the rollers with a soft cloth lightly moistened with water.

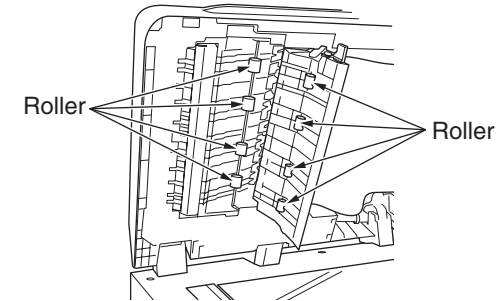

(4) Return the document hold pad.

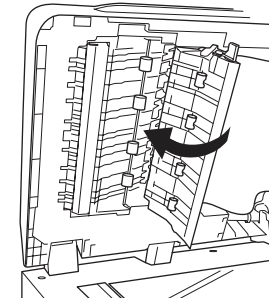

(5) Close the document glass cover.

## 6.7 How to clean the document glass

---

It is recommended to clean the document glass once a month to maintain image quality of the printouts.

- (1) Open the document glass cover.
- (2) Wipe the document holding pad, document glass and ADF document glass surface with a soft cloth lightly moistened with water.

**⚠ Caution** Do not use benzine, thinners or alcohol as a cleaning agent. They may damage the plastic parts of the MFP.

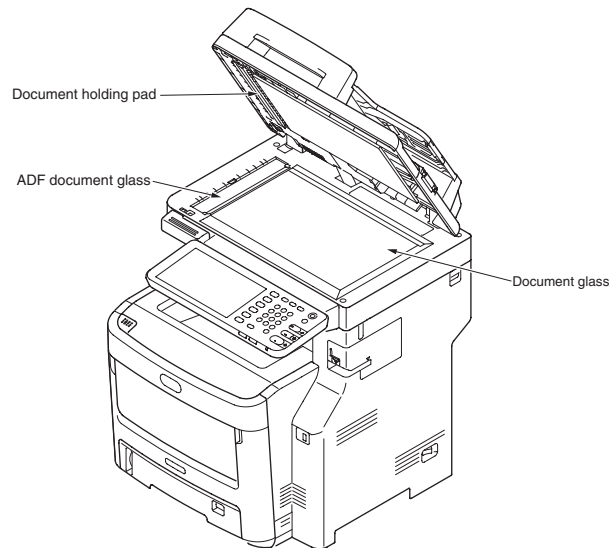

- (3) Close the document glass cover.

## 6.8 How to clean inside of MFP

### Clean inside of the MFP.

Toner can adhere to the metal shaft located in between the fuser and the cyan image drum cartridge depending on the print patter. Perform cleaning of inside of the MFP if toner has adhered to the metal shaft.

- (1) Turn off the power of the MFP.

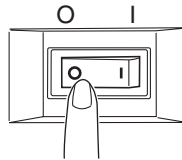

- (2) Open the scanner and press down the OPEN to open the top cover.

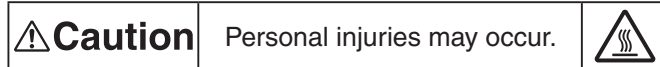

The fuser unit gets very hot. Do not touch the fuser unit.

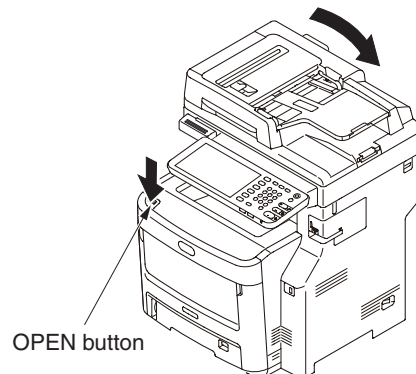

- (3) Remove the image drum cartridge.

1. Remove the four image drum cartridges and place them on a flat workbench.
2. Cover the removed image drum cartridge with a black paper.

- Note!**
- The image drum (green tubular portion) is highly inherently-brittle. Be very careful when handling it.
  - Be very careful not to expose the image drum to direct sun light or intense light (light of approx. 1500 lux or more). Do not leave it under the normal illumination even indoor for 5 minutes or longer.)

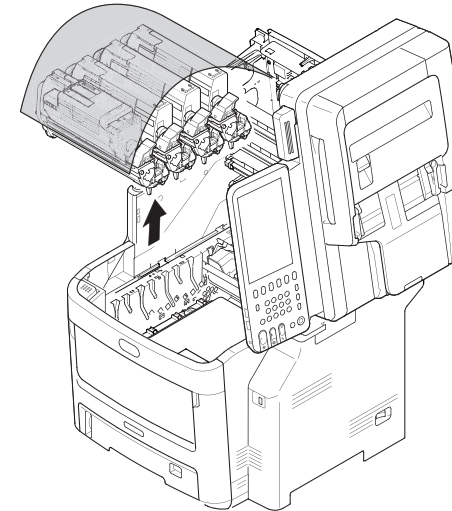

- (4) Remove the fuser unit.

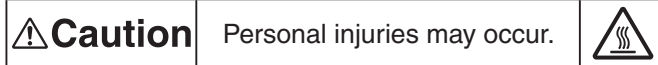

The fuser unit gets very hot. Be very careful not to touch the fuser unit with your hands.

If it got hot, stop the work and wait until it cools down. After it has cooled down, start the following steps.

1. Raise the fuser unit lock levers (two levers shown in blue) in the direction shown by the arrow.
2. Hold the handle of the fuser unit and remove it.

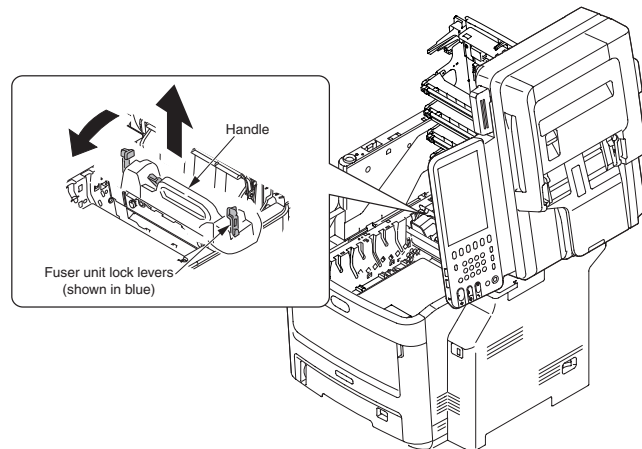

- (5) Clean the metal shaft with soft clean cloth or soft tissue paper.

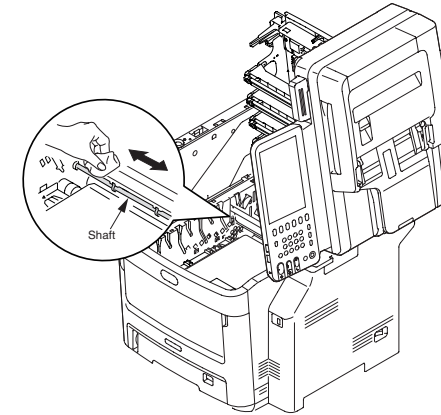

- (6) Install the fuser unit.

For the detailed procedure, refer to the User's Manual – Setup Guide "Replacing fuser unit".

- (7) Return the four image drum cartridges to the MFP gently and carefully.
- (8) Close the top cover.

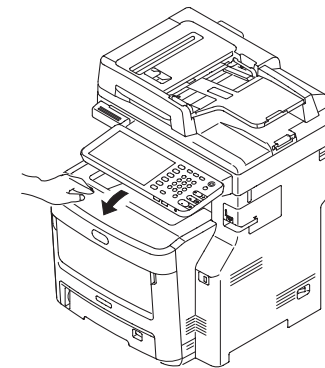

# 7. Troubleshooting and repair procedure

---

7.1	Before starting the repair work .....	150
7.2	Confirmation items before taking corrective action against abnormalities .....	150
7.3	Precautions when taking corrective action against abnormality	150
7.4	Preparation for troubleshooting .....	150
7.5	Troubleshooting method .....	151
7.6	Fuse check .....	206
7.7	Paper cassette switches versus Paper size correspondence table .....	207

## 7.1 Before starting the repair work

---

- (1) Confirm the basic check/inspection points described in User's Manual.
- (2) Get the information/status from client at the time when the trouble has occurred as much in details as possible
- (3) Create the status close to the user's status when the trouble has occurred, and inspect a printer in that status.

## 7.2 Confirmation items before taking corrective action against abnormalities

---

- (1) Is the usage environment of a printer normal?
- (2) Are the consumable items (toner, drum cartridge) replaced normally?
- (3) Is the print media (paper) normal? Refer to Specifications – Paper in User's Manual.
- (4) Is the drum cartridge installed normally?

## 7.3 Precautions when taking corrective action against abnormality

---

- (1) Do not touch the OPC drum surface with your hand or any foreign materials.
- (2) Do not expose the OPC drum to the direct sunlight.
- (3) The fuser unit will be hot. Do not touch.
- (4) Do not expose the image drum to any light for 5 minutes or longer under the normal room temperature.

## 7.4 Preparation for troubleshooting

---

- (1) Display on the Operator Panel  
Error status of this printer is displayed on the LCD (Liquid crystal display) of the Operator Panel.  
Take appropriate troubleshooting action in accordance with the message displayed on the LCD.

## 7.5 Troubleshooting method

When a trouble occurs in this printer, perform troubleshooting by following the steps described below.

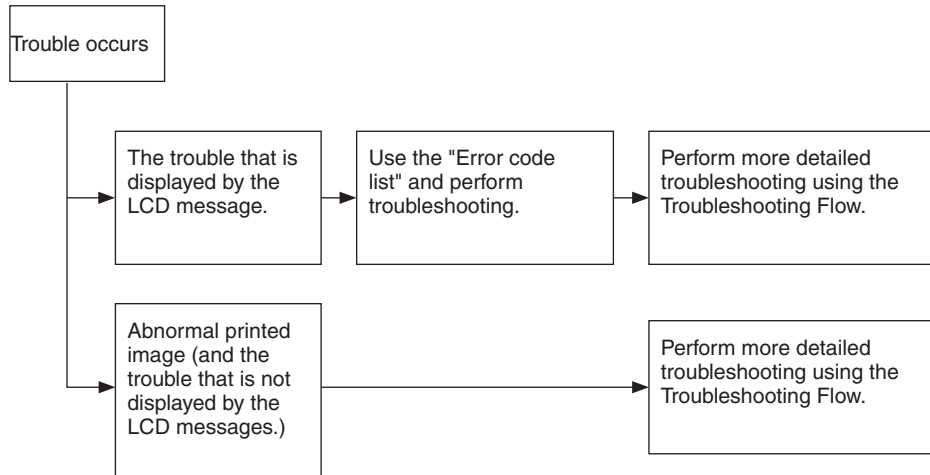

### 7.5.1 Error code list

**Note!** For the error codes not described in this manual, refer to the Software Guide.

Error Code	Details
3DE1	Black image drum life (The toner empty error is occurred after the image drum reached its life.)
3DE2	Cyan image drum life (The toner empty error is occurred after the image drum reached its life.)
3DE3	Magenta image drum life (The toner empty error is occurred after the image drum reached its life.)
3DE4	Yellow image drum life (The toner empty error is occurred after the image drum reached its life.)
C020	Drum motor lock error
C0A1	Fan Motor Error1(Fuser cooling Fan)
C0A2	Fan Motor Error2(Poert supply cooling Fan)
C0A5	Fan Motor Error5(Engine Fan Motor Error)
C0A6	Fan Motor Error6(Duplex Fan Motor Error)
C1DA	LCF unit detect error 1
C1DB	LCF unit detect error 2
C260	Ramp error
C270	Scanner error - carriage home position sensor not turning off
C280	Scanner error - carriage home position sensor not turning on
C291	Scanner error - carriage home position error
C37A	Belt thermister shortened error
C37B	Belt thermister open error
C37C	Belt thermister temperature high
C37D	Belt thermister temperature low
C383	Black toner sensor error
C393	Cyan toner sensor error
C3A3	Magenta toner sensor error
C3B3	Yellow toner sensor error
C3E2	Belt unit fuse cut error
C3EA	Yellow image drum fuse cut error
C3EB	Magenta image drum fuse cut error
C3EC	Cyan image drum fuse cut error
C3ED	Black image drum fuse cut error
C41A	Upper thermistor short error
C41B	Upper thermistor circuit open error
C41C	Lower thermistor short error
C41D	Lower thermistor circuit open error
C41E	Compensation thermistor shortened error
C446	Upper heater temperature low
C449	Upper heater temperature high
C44A	Thermistor slope Error
C466	Lower heater low temperature
C468	Lower heater temperature high
C46A	Compensation heater temperature high

Error Code	Details
C46B	Compensation heater temperature low
C4C0	Fuser unit fuse cut error
C4E3	Fuser motor lock error
C4FA	Paper rolled around fuser
C56A	Duplex Unit I/F Error
C56B	Tray2 Unit I/F Error
C56C	Tray3 Unit I/F Error
C56D	Tray4 unit I/F error
C56E	LCF Unit I/F Error
C5A1	Engine EEPROM error
C5A2	Duplex software error
C5A3	Tray2 software error
C5A4	Tray3 software error
C5A5	Engine software error
C5A6	Tray4 software error
C5A7	LCF Software Error
C5B0	Duplex clock adjust error
C5B2	Tray2 clock adjust error
C5B3	Tray3 clock adjust error
C5B4	Tray4 clock adjust error
C5B5	LCF Clock Adjust Error
C901	Scanner system initializing error
C91A	Engine Error5
C91B	Engine Error4
C91C	Engine Error2
C91D	Engine Error1
C921	AC voltage zero-crossing error
C940	Engine control error
C96A	Power supply LSI error
C9A0	Detect offline stapler error
CE50	Temperature sensor abnormality
CE51	Humidity sensor abnormality
CE52	Sensor dewed error (Humidity Sensor Wet Error)
CE7A	Drum up/down error
CE82	Yellow LED head missing
CE83	Magenta LED head missing
CE84	Cyan LED head missing
CE85	Black LED head missing
CF10	Finisher error
D102	MPTray paper empty
D108	LCF Liftup error
D109	LCF Capacity over
D201	Front cover open
D21D	Top cover open
D21E	Duplex unit cover open
D301	Black toner is empty
D302	Cyan toner is empty

Error Code	Details
D303	Magenta toner is empty
D304	Yellow toner is empty
D30D	Waste toner full (Cyan)
D30E	Waste toner full (Magenta)
D30F	Waste toner full (Belt)
D311	Non genuin toner (Black)
D312	Non genuin toner (Cyan)
D313	Non genuin toner (Magenta)
D314	Non genuin toner (Yellow)
D321	Black toner is near empty
D322	Cyan toner is near empty
D323	Magenta toner is near empty
D324	Yellow toner is near empty
D331	Incompatible toner (Black) → Black Toner Protected Region
D332	Incompatible toner (Cyan) → Cyan Toner Protected Region
D333	Incompatible toner (Magenta) → Magenta Toner Protected Region
D334	Incompatible toner (Yellow) → Yellow Toner Protected Region
D335	Incompatible toner (Black) → Black Toner Group Mismatch Error
D336	Incompatible toner (Cyan) → Cyan Toner Group Mismatch Error
D337	Incompatible toner (Magenta) → Magenta Toner Group Mismatch Error
D338	Incompatible toner (Yellow) → Yellow Toner Group Mismatch Error
D345	Black image drum life
D346	Cyan image drum life
D347	Magenta image drum life
D348	Yellow image drum life
D34F	Printer unit life
D361	Standard Bin (Face Down Bin) Full
D371	Toner sensor error (Black)
D372	Toner sensor error (Cyan)
D373	Toner sensor error (Magenta)
D374	Toner sensor error (Yellow)
D381	Toner region mismatch error (Black)
D382	Toner region mismatch error (Cyan)
D383	Toner region mismatch error (Magenta)
D384	Toner region mismatch error (Yellow)
D3B1	Improper Black lock lever position
D3B2	Improper Cyan lock lever position
D3B3	Improper Magenta lock lever position
D3B4	Improper Yellow lock lever position
D3C1	Black toner cartridge not installed
D3C2	Cyan toner cartridge not installed
D3C3	Magenta toner cartridge not installed
D3D1	Fuser unit life
D3D4	Belt unit life
D401	Tray1 missing (cassette missing)
D402	Tray2 missing (cassette missing)
D403	Tray3 missing (cassette missing)



Error Code	Details
D404	Tray4 missing (cassette missing)
D518	Yellow toner cartridge not installed
D901	Black drum missing
D902	Cyan drum missing
D903	Magenta drum missing
D904	Yellow drum missing
D910	Duplex unit pulled out
D920	Fuser unit missing
D930	Belt unit missing
E010	Paper transport jam
E01A	Paper Transport (remained paper)
E01B	Fuser jam
E020	Paper exti jam
E02A	Paper Exit (remained paper)
E061	Tray1 check paper size error
E062	Tray2 check paper size error
E063	Tray3 check paper size error
E064	Tray4 check paper size error
E065	MP Tray check paper size error
E066	LCF paper size setting error
E110	Duplex feed jam
E120	MPT feed jam
E130	Tray1 feed jam
E13A	Tray1 paper remaining
E140	Tray2 feed jam
E14A	Tray2 paper remaining
E150	Tray3 feed jam
E15A	Tray3 paper remaining
E160	Tray4 feed jam
E16A	Tray4 paper remaining
E190	LCF Paper feed jam
E19A	Detect the LCF paper remain
E202	Paper feed jam
E20A	Paper Feed (remained paper)
E400	Face Up Cover Jam (OPJAM2 #3)
E520	Duplex transport jam
E52A	Duplex Transport (remained paper)
E570	Duplex entry jam
E57A	Duplex entry (remained paper)
E580	Duplex reversal jam
E58A	Duplex reversal (remained paper)
E711	RADF JAM - Hopping
E712	RADF JAM - paper not reaching the registration sensor
E713	RADF JAM - Reverse
E714	RADF JAM - feed signal reception JAM
E715	RADF JAM - hopping sensor of reversal
E721	RADF JAM - scan sensor

Error Code	Details
E722	RADF JAM - too long paper detect
E723	RADF JAM - too short paper detect
E724	RADF JAM - remained scan sensor
E725	RADF JAM - too short margin between paper
E726	RADF JAM - illegal sensor detect (duplex)
E727	RADF JAM - illegal sensor detect
E728	RADF JAM - chattering (sensor)
E741	RADF JAM - too long paper detect (duplex)
E742	RADF JAM - too short paper detect (duplex)
E743	RADF JAM - forward reversal regist sensor
E744	RADF JAM - backword reversal regist sensor
E778	RADF JAM - remained paper detect
E779	RADF JAM - paper set sensor
E870	RADF open JAM
F031	Duplex version Error
F032	Tray2 version Error
F033	Tray3 version Error
F034	Tray4 version error
F035	LCF Version Error
F03A	Black tag version mismatch
F03B	Yellow tag version mismatch
F03C	Magenta tag version mismatch
F03D	Cyan tag version mismatch
F041	Excessive optional tray detected
F042	Toners duplicated by color
F070	Communication error between System-CPU and Engine-CPU
F071	Incompatible firmware combination between System-CPU and Engine-CPU
F072	Flash ROM abnormality
F073	Incompatible Specversion error
F090	SRAM abnormality on the SYS board
F100	HDD format error
F101	HDD uncounted
F102	HDD start error
F103	HDD transfer timeout
F104	HDD data error
F105	HDD other error
F110	Communication error between System-CPU and Scanner-CPU
F111	Scanner response abnormality
F112	Communication error between System-CPU and Scanner-CPU detected by Scanner-CPU
F113	Scanner software error
F114	Scanner CPU exception
F120	Database damaged
F350	Slog board abnormality
F400	CPU fan abnormality

### 7.5.2 Printer error troubleshooting

Error code	Cause	Error details		Remedial measure
C5A1	Read/write error of the engine EEPROM is detected.	Does this error recur?	Yes	Turn off the power of the printer and back on. Replace the PU board.
C940	Engine control logic has an error.	Does this error recur?	Yes	Turn off the power of the printer and back on. Replace the PU board.
F031	Duplex unit for other model is detected.	Is the Duplex unit for that specific model installed?	No	Install the correct duplex unit.
F032	2nd tray for other model is detected /LCF unsupported firmware	Is the 2nd tray for that specific model installed? LCF unsupported firmware(before the PU:v00.01.02) and LCF installed ?	No Yes	Install the correct 2nd tray. Update the PU firmware which supported LCF(after v00.01.08) (Refer the DVD is attached with LCF)
F033	3rd tray for other model is detected /LCF unsupported firmware	Is the 3rd tray for that specific model installed? LCF unsupported firmware(before the PU:v00.01.02) and LCF installed ?	No Yes	Install the correct 3rd tray. Update the PU firmware which supported LCF(after v00.01.08) (Refer the DVD is attached with LCF)
C96A	High voltage power supply interface error.	Is the cable connecting the PU board to the high voltage unit connected normally? Have you checked defective contact of contactor points?	No Yes No	Re-connect them normally. Check for defective contact of the high voltage system. Replace the high voltage power supply.
C0A2	Low voltage power supply fan error	Is the fan (bottom right of the front) of the low voltage power supply block working?  Is the fan connector connected normally?	No Yes No Yes	Check for sure connection of the fan connector. Replace the PU board. Replace the fan motor.

Error code	Cause	Error details		Remedial measure
CE51	Environment humidity is abnormal./ Humidity sensor is not connected.	Does this error recur?	Yes	Turn off the power of the printer and back on. Replace the Board MFH.
CE50	Environment temperature is abnormal.	Does this error recur?	Yes	Turn off the power of the printer and back on. Replace the Board MFH.
CE52	Dew condensation of the printer is detected.	This error can easily occur when a printer is brought in to indoor from outdoor. Leave the printer for 2 hours or half day under room temperature, and turn on the power again. Does this error recur?	Yes	After leaving a printer under room temperature, turn on the power again. Replace the Board MFH.
C0A1	Fuser exhaust fan error	Is the fan connector connected normally?  Does this error recur?	No Yes No	Re-connect it normally. Replace the fan motor. Replace the PU board.
C0A5	ID cooling fan error	Is the fan connector connected normally?  Does this error recur?	No Yes No	Re-connect it normally. Replace the fan motor. Replace the PU board.
C0A6	Duplex FAN Alarm Caution	Fan error inside the Duplex unit.  Does the error recur when the power is turned off once and back on?  Does the error recur when the power is turned off once and back on?	Yes Yes	Check if the Duplex unit is installed normally or not. Check if the fans are installed normally or not.  Replace the fan.

Error code	Cause	Error details		Remedial measure
CE82~ CE85	LED head detection error (CE82=Y, CE83=M, CE84=C, CE85=K)	Is the LED head connected normally?  Is the LED HEAD fuse brown? Does this error recur?	No Yes Yes No Yes	Install the LED head unit normally. Check the LED HEAD fuse. After checking fuse Turn on the power again. For the method of checking the LED head unit fuse, refer to section 7.6.
CE7A	ID Up/Down position detection error	Is the ID unit caught by anything when it is removed and re-installed?  Does this error recur?	Yes No Yes	Re-install the ID unit. Turn on the power again. Replace the high voltage power supply.
C3EA~ C3ED	The ID unit fuse has blown out. (C3EA=Y, C3EB=M, C3EC=C, C3ED=K)	Is the ID unit installed normally? Does this error recur? Does the printer recover from the error when the PU/PRZ board is replaced?	No Yes Yes No	Re-install the ID unit. Turn on the power again. After checking for the sure connection of the cable between PRZ board and PU board, replace the PRZ board. Replace the PU board.
C3E2	The fuse has blown out.	Is the belt unit connected normally?  Does this error recur?	No Yes Yes	Re-install the belt unit. Turn on the power again. After checking for the sure cable connection, replace the PU or Board IBY.
C4C0	The fuse has blown out.	Is the fuser unit installed normally?  Does this error recur?	No Yes Yes	After cleaning the connecting connector of the fuser unit, re-install the fuser unit. Turn on the power again. After checking for the sure cable connection, replace the PU or Board IBY.

Error code	Cause	Error details		Remedial measure
C3B3~ C383	Toner sensor detection error. (C3B3=Y, C3A3=M, C393=C, C383=K) This error does not occur with the default settings.	Is the toner cartridge installed?  Is the lock lever of the toner set?  Does this error recur?	No No Yes	Install the toner cartridge. Rotate the lock lever of toner to the lock position. Turn on the power again. Replace the toner sensor assembly.
C44A	Thermistor Slope Error	Is the error message displayed? Does this error recur?	Yes	Turn on the power again. After leaving a printer for 30 minutes, turn on the power again.
C41E	Compensation Thermistor Error	Is the error message displayed? Does this error recur?	Yes	Turn on the power again. After leaving a printer for 30 minutes, turn on the power again.
C41A C41B	Short-circuit or open-circuit of fuser thermistor is detected.	Does this error recur?	Yes	Turn on the power again. Replace the fuser unit.
C449 C446	The fuser thermistor has detected an abnormal temperature (high temperature or low temperature.)	Does this error recur?  Does this error recur?	Yes Yes	Turn on the power again. Replace the fuser unit. Replace the low voltage power supply unit.
C41C	The backup roller thermistor is detected of its short-circuit. (At high temperature)	Does this error recur?	Yes	Turn on the power again. Replace the fuser unit.
C41D	The backup roller thermistor is detected of its open-circuit. (At low temperature)	Does this error recur?	Yes	Turn on the power again. Replace the fuser unit.

Error code	Cause	Error details		Remedial measure
C468 C466	The backup roller thermistor has detected an abnormal temperature (high temperature or low temperature.)	Does this error recur?  Does this error recur?	Yes  Yes	Turn on the power again. Replace the fuser unit. Replace the low voltage power supply unit.
C56A C56B C56C C56D	Option unit I/F error (C56A=Duplex Unit, C56B=2nd Tray, C56C=3rd Tray C56D=4th Tray)	Does this error recur?  Does this error recur?	Yes  Yes	Turn on the power again. Check for sure connection of the connectors. Replace the option unit.
C56E		When LCF is setting, Tray2 Unit I/F Error or Tray3 Unit I/F Error is report from PU. Interchange the error to LCF Unit I/F Error by CU. Occur:When communication has dropped off.		Turn on the power again.
C91D	RFID Reader not Installed	RFID read device error  Does this error recur?	Yes  Yes	Check for normal connection of the RFID R/W board. Replace the RFID R/W. Replace the PU board.
C91A C91B C91C	RFID reader I/F error	Interface error with the RFID reader is detected. 01: Communication error between the RFID reader and the engine circuit boards. 02: Error in the wireless circuit of the RFID reader 03: Communication error between the RFID reader and the toner cartridge. 04: Error is detected in the RFID toner cartridge. (In more than 4)		01: Same as the error no. C91D 02: Replace the RFID R/W board. 03: Check for normal connection of the antenna cable. 04: Check if quantity of the toner cartridge is correct or not.

Error code	Cause	Error details		Remedial measure
C37A~ C37D	Abnormal temperature of belt  C37A: Short-circuit C37B: Open circuit C37C: High temperature C37D: Low temperature	Is the cable from belt thermistor to the high voltage board connected normally?  Does this error recur?	No Yes  No	Re-connect the cables normally. Turn on the power again. Replace the belt thermistor.
C020	Image drum lock error	The ID does not rotate normally.  Does the error display recur when the power is turned off once and back on?	  Yes Yes	Check if the ID is installed normally or not. Replace the ID unit. Replace the ID motor.
C4E3	Fuser motor lock error	Fuser does not rotate normally.  Does this error recur?	  Yes Yes	Check if the fuser is installed normally or not. Replace the fuser. Replace the fuser motor.
C4FA	Media wrapped around the fuser error	Media has wrapped around the fuser.		Turn off the power. Replace the fuser.
C5B2 C5B3 C5B4	Tray-2/3/4 CPU clock frequency error	C5B2=2nd Tray C5B3=3rd Tray C5B4=4th Tray		Replace the Tray board GOH-11.
C5B5		When LCF is setting, Tray2 Clock Adjust Error or Tray3 Clock Adjust Error is report from PU. Interchange the error to LCF Clock Adjust Error by CU.		Replace the Tray board
F041	Over than available setting number tray detection error	Over than available setting number tray is installed.		Remove the available setting number tray.

Error code	Cause	Error details	Remedial measure
F042	Error due to detection of the toner cartridges of the same color	Two or more toner cartridges of the same color are detected.	Install the cartridge of the specified in the specified position.
F03A~F03D	Detection of an unsupported toner cartridge	An unsupported toner cartridge has been detected. F03A:Black toner cartridge position F03B:Yellow toner cartridge position F03C:Magenta toner cartridge position F03D:Cyan toner cartridge position	Replace it with an appropriate toner cartridge.
C1DA C1DB		LCF unit detect error 1 LCF unit detect error 2	Replace the LCF Unit Board
C46A C46B		Compensation Heater Temp high Compensation Heater Temp Low	Turn on the power,after 30min.
C5A2		Duplex Software Error	Replace the Duplex Unit
C5A3		Tray3 Software Error	Change the Tray3 Board(GOH)
C5A4		Tray2 Software Error	Change the Tray2 Board(GOH)
C5A5		Software Error	Change the PU Board
C5A6		Tray4 Software Error	Change the Tray4 Board(GOH)
C5A7		When LCF is setting,Tray2 software Error or Tray3 software Error is report from PU. Interchange the error to LCF Software Error by CU. Occur:Detect flash memory software error of Tray.	Undetected flash memory software error of Tray3.
C5B0		Duplex Clock Adjust Error	Change the Duplex Unit
C9A0		Offline stapler error	Change the offline stapler

Error code	Cause	Error details	Remedial measure
D108		When LCF can not Lift up.	Set the Paper of the LCF Tray again.
D109		Detect the paper capacity is over.	Set the Paper of the LCF Tray again.
E010 E020 E570		Indicates that jam has occurred in the paper path. Error E010 : Transport Error E020 : Exit Error E570 : Duplex Entry	Take out the jammed paper.
E01A		Occur jam and Paper on the Transport Path	Take out the jammed paper. Change the Feeder-Assy.-Regist. Change the PU board.
E01B		Occur jam around Fuser Unit	Take out the jammed paper. Change the sensor Lever. Change the PU board.
E02A		Occur jam and Paper on the Exit Path	Take out the jammed paper. Change the sensor Lever. Change the PU board.
E061 E062 E063 E064 E065		Tray1 check paper size error Tray2 check paper size error Tray3 check paper size error Tray4 check paper size error MP Tray check paper size error	Change the paper size or change the paper in Tray.
E066		Occur:Difference between the actual paper size of LCF and realization of engine.	Match the paper size between the paper size of LCF and setting of engine.
E110		Indicates that jam has occurred in the vicinity of Duplex unit. Error E110 : Misfeed from Duplex	

Error code	Cause	Error details	Remedial measure
E120		Indicates that jam has occurred during feeding paper from the MP tray. Error E120: MP Tray	
E130		Occur jam with the Tray1	Take out the jammed paper. Change the Board-RSF. Change the Feeder-Assy.-Regist. Change the PU board.
E13A		Tray1 paper remaining	Take out the jammed paper. Change the Board-RSF. Change the Feeder-Assy.-Regist. Change the PU board.
E140		Occur jam with the Tray2	Take out the jammed paper. Change the Frame Assy-Hop. Change the Tray2 board(GOH).
E14A		Occur jam and Paper on the Tray2	Take out the jammed paper. Change the Frame Assy-Hop. Change the Tray2 board(GOH).
E150		Occur jam with the Tray3	Take out the jammed paper. Change the Frame Assy-Hop. Change the Tray3 board(GOH).
E15A		Occur jam and Paper on the Tray3	Take out the jammed paper. Change the Frame Assy-Hop. Change the Tray3 board(GOH).

Error code	Cause	Error details	Remedial measure
E160		Occur jam with the Tray4	Take out the jammed paper. Change the Frame Assy-Hop. Change the Tray4 board(GOH).
E16A		Occur jam and Paper on the Tray3	Take out the jammed paper. Change the Frame Assy-Hop. Change the Tray4 board(GOH).
E190		Paper feed jam at LCF	Take out the jammed paper. Change the Frame Assy-Hop. Change the GOI-board.
E19A		Receive paper remain information of Tray2 or Tray3, and notice remain paper by CU when LCF is setting.	Take out the jammed paper.
E202		Paper feed jam	Take out the jammed paper. Change the Board-RSF. Change the Feeder-Assy.-Regist. Change the PU board.
E20A		Occur jam and Paper on the Feed Path	Take out the jammed paper. Change the Board-RSF. Change the Feeder-Assy.-Regist. Change the PU board.
E400		Face Up Cover Jam	Change the sensor Lever. Change the cable. Change the relay board or PU board.
E52A		Occur Duplex jam and Paper on the Transport Path	Take out the jammed paper. Change the Duplex Unit.

Error code	Cause	Error details	Remedial measure
E57A		Occur Duplex jam and Paper on the Entry Path	Take out the jammed paper. Change the Duplex Unit.
E580 E520		Indicates that jam has occurred in the vicinity of Duplex unit. Error E580 : Duplex Reversal Error E520 : Duplex Input	Take out the jammed paper. Change the Duplex Unit.
E58A		Occur Duplex jam and Paper on the Reversal Path	Take out the jammed paper. Change the Duplex Unit.
C921		AC voltage zero-crossing error	Check the AC voltage. Change the Low-voltage board or PU board.
F034		Tray4 version error	Change the Tray4 board(GOH)
F035		Notice the Version Error of Tray2 or Tray3 and setting LCF Version Error by CU.	Install the correct LCF Unit.
F070		CU-PU communication error	Change the PU board
F071		CU-PU firmware incompatible combination	Change the PU board
F072		PU Flash Error	Change the PU board
F073		Request to print from incompatible specversion	Change the PU board

- Note!** · Service calls C41E error, C41B error, C41D error, C37C error and C37D error; These errors can occur when the printer temperature is below 0 °C. Turn on the power again after the printer temperature has increased.
- Service call C9A0 error can release temporary, by restart the MFP with stapler cover open.

### 7.5.3 Scanner error troubleshooting

System Spec.				
Code	Category	Cause	Error details	Measure
E711	Error	ADF document jam	Jam due to non-arrival at the hopping sensor – After paper feeding is started, the hopping sensor does not become active. (Simplex and Duplex)	Open the ADF cover, remove every jammed document from the paper feed path, and close the ADF cover.
E712	Error	ADF document jam	Jam due to non-arrival at the regist paper sensor – After feeding for a simplex document scan is started, the regist paper sensor does not become active. (Simplex)	Open the ADF cover, remove every jammed document from the paper feed path, and close the ADF cover.
E713	Error	ADF document jam	Jam due to non-arrival at the reverse paper sensor – After feeding for a duplex document scan is started, the reverse paper sensor does not become active. (Duplex)	Open the ADF cover, remove every jammed document from the paper feed path, and close the ADF cover.
E714	Error	ADF document jam	Jam due to document removal – In the middle of feeding for a simplex document scan, the document set sensor becomes inactive. (Simplex and Duplex)	Open the ADF cover, remove every jammed document from the paper feed path, and close the ADF cover.
E715	Error	ADF document jam	Activation of the hopping sensor at document reversal – The hopping sensor becomes active when the reverse paper sensor is inactive. Multi-feed of documents is detected. (Duplex)	Open the ADF cover, remove every jammed document from the paper feed path, and close the ADF cover.
E778	Error	ADF document jam	Remaining document detection at power on – A sensor other than the document set sensor becomes active when the power is turned on or the cover is opened and closed during operation.	Open the ADF cover, remove every jammed document from the paper feed path, and close the ADF cover.
E779	Error	ADF document jam	Activation of only the document set sensor – Only the document set sensor becomes active at initialization of the ADF stopper gate.	Open the ADF cover, remove every jammed document from the paper feed path, and close the ADF cover.
E721	Error	ADF document jam	Jam due to non-arrival at the scan sensor – Although the fed document is transferred to a certain distance, the scan sensor does not become active. (Simplex and Duplex)	Open the ADF cover, remove every jammed document from the paper feed path, and close the ADF cover.

System Spec.				
Code	Category	Cause	Error details	Measure
E722	Error	ADF document jam	Regist paper sensor stuck jam/detection of out-of-spec oversized documents – Once the regist paper sensor becomes active, it does not become inactive when the fed document is transferred to the distance exceeding the maximum page size. (Simplex and Duplex)	Open the ADF cover, remove every jammed document from the paper feed path, and close the ADF cover.
E723	Error	ADF document jam	Detection of out-of-spec undersized documents – Once the regist paper sensor becomes active, it becomes inactive before the fed document is transferred by the distance equal to the minimum page size. (Simplex and Duplex)	Open the ADF cover, remove every jammed document from the paper feed path, and close the ADF cover.
E724	Error	ADF document jam	Scan sensor stuck jam – The scan sensor does not become inactive even when the fed document is transferred by 60mm after the regist paper sensor becomes inactive. (Simplex and Duplex)	Open the ADF cover, remove every jammed document from the paper feed path, and close the ADF cover.
E725	Error	ADF document jam	Detection of a too little space between documents – Before the document is transferred by 31mm after the regist paper sensor becomes inactive, the sensor becomes active. Detection of a too little space between the documents. (Simplex)	Open the ADF cover, remove every jammed document from the paper feed path, and close the ADF cover.
E726	Error	ADF document jam	Activation of the reverse paper sensor for the documents not to be reversed – Switching to the first separator is not carried out normally causing activation of the reverse paper sensor. (Simplex and Duplex) <ul style="list-style-type: none"> <li>• The reverse paper sensor becomes active in feeding of a simplex document.</li> <li>• The reverse paper sensor becomes active between reversal to the back and activation of the regist paper sensor.</li> </ul>	Open the ADF cover, remove every jammed document from the paper feed path, and close the ADF cover.
E727	Error	ADF document jam	Activation of a sensor at an unintended timing – The scan sensor, regist paper sensor, hopping sensor or reverse paper sensor becomes active at an unintended timing. (Simplex and Duplex)	Open the ADF cover, remove every jammed document from the paper feed path, and close the ADF cover.



System Spec.				
Code	Category	Cause	Error details	Measure
E728	Error	ADF document jam	Detection of chattering of a sensor – Chattering of a sensor is detected. Once a sensor becomes active, the sensor becomes inactive in 18mm feeding of the document. Then the inactive sensor becomes active in the next 18mm feeding. (Simplex and Duplex)	Open the ADF cover, remove every jammed document from the paper feed path, and close the ADF cover.
E741	Error	ADF document jam	Reverse paper sensor stuck jam/ detection of out-of-spec oversized documents – The reverse paper sensor does not become inactive when the document is transferred to the distance exceeding the maximum page size. (Duplex)	Open the ADF cover, remove every jammed document from the paper feed path, and close the ADF cover.
E742	Error	ADF document jam	Detection of out-of-spec undersized documents – The reverse paper sensor becomes inactive before the document is transferred by the distance equal to the minimum page size. (Duplex)	Open the ADF cover, remove every jammed document from the paper feed path, and close the ADF cover.
E743	Error	ADF document jam	Non-arrival at the regist paper sensor at reversing to the front – After reversing to the front, the regist paper sensor does not become active in a lapse of a certain period of time. (Duplex)	Open the ADF cover, remove every jammed document from the paper feed path, and close the ADF cover.
E744	Error	ADF document jam	Non-arrival at the regist paper sensor at reversing to the back – When the document is transferred following reversal to the back, the regist paper sensor does not become active. (Duplex)	Open the ADF cover, remove every jammed document from the paper feed path, and close the ADF cover.
E870	Error	ADF document jam	ADF open jam – A document jam is caused by opening of the ADF while the RADF is operating.	Remove every jammed document from the paper feed path, and close the ADF cover.
C260	ServiceCall	Scanner lamp error	Lamp error – Exposure adjustment has failed.	Power cycle the unit. If the power cycle does not work to recover from the error, the unit needs repair. The CIS may be damaged.
C270	ServiceCall	Scanner home position error	The home position sensor does not become inactive in the designated period of time – The carriage does not move from the home position in the designated period of time.	Power cycle the unit. If the power cycle does not work to recover from the error, the unit needs repair. The possible cause is the damage of the home position sensor, the belt that moves CIS, or the FB motor.

System Spec.				
Code	Category	Cause	Error details	Measure
C280	ServiceCall	Scanner home position error	The home position sensor does not become active in the designated period of time – The carriage does not reach the home position in the designated period of time. The sensor malfunctions.	Power cycle the unit. If the power cycle does not work to recover from the error, the unit needs repair. The possible cause is the damage of the home position sensor, the belt that moves CIS, or the FB motor.
C291	ServiceCall	Scan position detect error	Scan position detect error – The black edge is not detected in scanning.	Power cycle the unit and retry to scan. If the error occurs again in the next scan, the unit needs repair. The calibration sheet may not be installed properly.
none	Error	ADF cover open	ADF cover open	Close the ADF cover.
none	Warning/Error	Scanner carriage warning	Carriage warning – The carriage does not return to the home position after the scan. This error may occur when a user presses the document hard against the FB to scan.	Perform the recovery procedure according to the guidance.
F110	ServiceCall	Communication error between system CPU and Scanner CPU	System CPU - Scanner CPU communication error	If the error occurs frequently, check for the proper connection between the CU PCB and the SU PCB.
F111	ServiceCall	Scanner response anomaly	Scanner response anomaly	The SU PCB, the scanner or the scanner firmware may have some problems.
F112	ServiceCall	Controller response anomaly	CU-PU communication error detected by the scanner	If the error occurs frequently, check for the proper connection between the CU PCB and the SU PCB.
F113	ServiceCall	Scanner CPU exception	Anomalous program on the scanner side	The SU PCB, the scanner or the scanner firmware may have some problems.
F114	ServiceCall	Scanner CPU exception	CPU exception on the scanner side	The SU PCB, the scanner or the scanner firmware may have some problems.

## 7.5.4 Preparation for troubleshooting

(1) LCD display error .....	163	(9) Paper size error (error code E061, E062, E063, E064, E065) .....	187
(1-1) LCD does not display anything. ....	163	(9-1) Jam occurs when paper end is located near the IN1 sensor. ....	187
(1-2) Error messages related to Operator Panel are displayed. ....	163	(10) ID unit Up/Down error (Service call CE7A) .....	188
(2) Abnormal operations of printer after the power is turned on .....	164	(10-1) Error occurs during the Up movement of the ID unit .....	188
(2-1) Any operation does not start at all. ....	164	(10-2) Error occurs during the Down movement of the ID unit .....	188
(2-2) Abnormal sound is heard. ....	164	(11) Fuser unit error (error C41A,C41B,C449,C446,C41C,C41D,C468,C466) .....	189
(2-3) Bad odors are generated. ....	165	(11-1) Error occurs immediately after the power is turned on. ....	189
(2-4) Rise-up time is slow. ....	165	(11-2) Error occurs approx. 1 minute after the power is turned on. ....	189
(3) Paper feed jam (error code E130: 1st tray) .....	176	(12) Motor fan error (error code C0A2, C0A1, C0A5, C0A6).....	190
(3-1) Jam occurs immediately after the power is turned on. (1st tray).....	176	(12-1) The low voltage power supply fan does not rotate immediately	
(3-2) Jam occurs immediately after the paper feed is started. (1st tray) .....	176	after the power is turned on. ....	190
(4) Feed jam (error code E202) .....	178	(12-2) Duplex fan does not rotate during the Duplex printing. ....	190
(4-1) Jam occurs immediately after the power is turned on.....	178	(12-3) All fans of the printer do not rotate.....	190
(4-2) Jam occurs immediately after the paper feed is started. ....	178	(13) Print speed is slow. (Performance is low.) .....	191
(5) Paper feed jam (error code E120: Multipurpose tray) .....	179	(13-1) Print speed decreases. ....	191
(5-1) Jam occurs immediately after the power is turned on.		(14) Option unit cannot be recognized.....	191
(Multipurpose tray).....	179	(14-1) Duplex unit cannot be recognized.....	191
(5-2) Jam occurs immediately after paper feed is started.		(14-2) Option try unit cannot be recognized. ....	191
(Multipurpose tray).....	180	(14-3) LCF unit cannot be recognized.....	192
(6) Paper running jam (error code E010).....	181	(15) LED head cannot be recognized. (error code CE82, CE83, CE84, CE85) .....	193
(6-1) Jam occurs immediately after the power is turned on.....	181	(15-1) Service call CE82 to CE85 (LED HEAD Missing).....	193
(6-2) Jam occurs immediately after a paper is taken into printer.....	181	(16) Toner cartridge cannot be recognized. (error code C3B3,C3A3,C393,C383) ....	194
(6-3) Jam occurs in the middle of paper running path.....	182	(16-1) Error caused by the consumable items.....	194
(6-4) Jam occurs immediately after paper has reached the fuser. ....	183	(16-2) Error caused by the toner sensor .....	194
(7) Paper unloading jam (error code E020) .....	183	(16-3) Error caused by the defective mechanism.....	195
(7-1) Paper unloading jam occurs immediately after the power is turned on. ....	181	(17) Fuse cut error (error codes C3EA,C3EB,C3EC,C3ED,,C3E2,C4C0) .....	195
(7-2) Paper unloading jam occurs after a paper is taken into printer.....	184	(17-1) Fuse cut error .....	195
(7-3) Paper unloading jam occurs in the middle of paper running path. ....	185	(18) Humidity sensor error (error code CE51) .....	196
(8) Two-sided printing jam (error code: E580, E520, E110, E510, E570).....	185	(18-1) Humidity sensor error .....	196
(8-1) Two-sided printing jam occurs immediately after the power is turned on..	185	(19) LCF Paper feed jam (error code E190) .....	196
(8-2) Two-sided printing jam occurs during taking in the paper		(19-1) Jam occurs immediately after the power is turned on .....	196
into Duplex unit. ....	186	(19-2) Jam occurs immediately after the paper feed is started .....	197
(8-3) Two-sided printing jam occurs in the process of reversing paper.....	186	(20) Wiring diagram .....	198
(8-4) Two-sided printing jam occurs during transporting paper			
inside the Duplex unit.....	187		
(8-5) Paper is not supplied from the Duplex unit to the regist roller.....	187		

**Note!** When replacing the PU board, read the EEPROM chip contents of the old board first, and copy them to the new board upon completion of the replacement. (Refer to section 5.4.1 Precautions when replacing the engine control board.)

7.5.4. (1) LCD display error

**Memo** For the numbers from ① through ③④ after name of the respective connectors, refer to section 7.5.4 (19) "Wiring diagram".

(1-1) LCD does not display anything.

Check item	Check work	Action to be taken at NG
(1-1-1) Check		
CU board		Replace CU board.
(1-1-2) Check the system connection		
Connection between the low voltage power supply unit and the CU board.	Check if the cable from the low voltage power supply to the POWER connector ⑦ of the CU board is normally connected or not. Check if the connector is connected only in the half-way or not, and check if the connector is inserted in slanted angle or not.	Re-connect the cable normally.
Cable assembly connecting the low voltage power supply unit and the CU/PU board.	Check if the cable is half-open circuit. Check if sheath of the cable has not peeled off or not. Check if the cable assembly is defective such as internal wires are disconnected or not.	Replace the cable with the normal cable. <b>Note!</b>
Connection between the CU board and Operator Panel	Check if the cable is connected to the OPE connector ③④ of the CU board normally or not. Check if the connector is connected in the half-way only or not, and check if the connector is inserted in a slanted angle or not.	Re-connect the cable normally.
Connecting the CU board and the Operator Panel board	Check if the cable has open circuit or not with VOM. Check if sheath of the cable has not peeled off or not by visual inspection.	Replace the OPE unit

Check item	Check work	Action to be taken at NG
(1-1-3) Check the peripherals of the power supplies		
Primary AC power source that is connected to the printer.	Check the supplied voltage of the AC power source.	Supply the AC power.
5V power that is supplied to the CU/PU board.	Check for the 5V power supply at PU ⑦ :Pin-11,13 CU ⑦ :Pin-1,2,3 of the POWER connector of the CU/PU board.	Replace the low voltage power supply.
(1-1-4) Check that power supply circuit has no short-circuit.		
5V power and 24V power that are supplied to the CU/PU board.	Check that power supply circuit has no short-circuit at the POWER connector ⑦ of the CU board. The follow voltage must appear respectively. PU ⑦ Pin 1,2,3,4:24V Pin 5,6,7,8:0VP Pin 9,10:0VL Pin 11,13:5V CU ⑦ Pin 1,2,3:5V Pin 4,5,6:0VL Pin 10,11:0VP Pin 12,13:24V If any voltage does not appear and short-circuit is detected, locate the source of the short-circuit as follows: Disconnect the cables that are connected to the CU board one cable after another until location of the short-circuit is found out.	Replace the part causing short-circuit.

(1-2) Error messages related to Operator Panel are displayed.

Check item	Check work	Action to be taken at NG
(1-2-1) Error message		
Error message	Check the error contents by referring to the Error Message List.	Follow the instruction.

7.5.4. (2) Abnormal operations of printer after the power is turned on

(2-1) Any operation does not start at all.

Check item	Check work	Action to be taken at NG
<b>(2-1-1) Check the peripherals of the power supplies</b>		
Primary AC power source that is connected to the printer.	Check the supplied voltage of the AC power source.	Supply the AC power.
5V power and 24V power that are supplied to the CU/PU board.	Check the power supply voltages at the POWER connector ⑦ of the CU/PU board. The follow voltage must appear respectively. PU ⑦ Pin 1,2,3,4:24V Pin 5,6,7,8:0VP Pin 9,10:0VL Pin 11,13:5V CU ⑦ Pin 1,2,3:5V Pin 4,5,6:0VL Pin 10,11:0VP Pin 12,13:24V	Replace the low voltage power supply.
<b>(2-1-2) Check the system connection</b>		
Connection condition of Operator Panel	Check contents of (1-1). Any operation of a printer will not start until the Operator Panel is detected and is started of its operation.	Follow the contents of (1-1).

(2-2) Abnormal sound is heard.

Check item	Check work	Action to be taken at NG
<b>(2-2-1) Check loss of synchronization of motor (Driver error)</b>		
Operating conditions of the respective motors	Check if operations of the respective motors are normal or not by using the self-diagnostic mode. Check if any load exists or not. "Buzzer" sound when an error occurs.	Replace the PU board.
Condition of the motor cable	Check for normal wiring conditions of the respective motors. Perform the visual check and measure resistance at open circuit with VOM as follows. Remove the motor cable at the board end. Measure resistance between the respective pins of the removed cable and FG with VOM.	Replace the motor cable. Re-connect the cable for normal conditions.
<b>(2-2-2) Check loss of synchronization of motor (Abnormal load of the consumable item)</b>		
Operating conditions of the respective motors	Check if operations of the respective motors are normal or not by using the self-diagnostic mode. Check if any load exists or not. "Buzzer" sound when an error occurs.	Replace the corresponding consumable item. If any attempt of using new part as a trial is going to be made, be sure to use the System Maintenance Menu FUSE KEEP MODE.

Check item	Check work	Action to be taken at NG
(2-2-3) Check the jumping phenomena of gear tooth. (Abnormal load of the consumable item)		
Operating conditions of the respective motors	Check if operations of the respective motors are normal or not by using the self-diagnostic mode. Check if any load exists or not. "Buzz buzz" sound is generated when an error occurs.	Replace the corresponding consumable item. If any attempt of using new part as a trial is going to be made, be sure to use the System Maintenance Menu FUSE KEEP MODE.
Installation condition of each consumable item	Check by visual inspection if the respective consumable items are installed in their normal positions in which gears of the consumable items engage accurately or not.	Replace an appropriate mechanical part as required, or adjust or repair
(2-2-4) Check the wiring conditions of cables		
Wiring conditions of the cables in the vicinity of the respective cooling fans	Check if the cable contacts with the fan blade because wiring conditions of the cables near fan is poor or not. "Clap, clap" sound is generated when an error occurs.	Correct the wiring conditions of the cable.
(2-2-5) Check installation condition of mechanical parts		
Check the installation conditions of the partition plate under the CU/PU boards.	Remove the CU/PU board, and inspect the installation conditions of the partition plate by visual inspection.	If they are not hooked on the normal specified positions, correct them.

(2-3) Bad odors are generated.

Check item	Check work	Action to be taken at NG
(2-3-1) Locating the exact position of generating bad odor		
Fuser unit	Remove the fuser unit and check the odor.	Implement section (2-3-2).
Low voltage power supply unit	Remove the low voltage power supply unit and check the odor.	Replace the low voltage power supply unit
(2-3-2) Check conditions of the fuser unit		
Life count of fuser unit	Check the life count of the fuser unit by using the self-diagnostic mode.	The fuser close to the new fuser unit smells some odors.
Check that no foreign material exists in fuser unit.	Check that no foreign materials such as paper are stuck inside of the fuser unit.	Remove the foreign material.

(2-4) Rise-up time is slow.

Check item	Check work	Action to be taken at NG
(2-4-1) Check the fuser unit		
Halogen lamp	Check that 120V or 230V is shown on the label on the rear of the fuser unit. (120V:ODA,230V:ODA/OEL)	Replace the fuser unit.

(3) Paper Jams

When paper jams occur or paper remains in the printer, "Paper Jam", or "Paper Remain" is displayed on the operation panel.

A method to remove the paper is displayed, remove the paper in the printer according to [Handling].

In addition, A method to remove paper is also described in the reference page at the right table.



Message to be displayed	Reference page
Open Cassette Paper Jam [Tray Name]	Page 167
Open Cassette Paper Remain [Tray Name]	
Open Cover Paper Jam Front Cover	Page 168
Open Cover Paper Remain Front Cover	
Open Cover Paper Jam Top Cover	Page 169
Open Cover Paper Remain Top Cover	
Check Duplex Unit Paper Jam	Page 171
Check Duplex Unit Paper Remain	

JAM location of occurrence outline chart

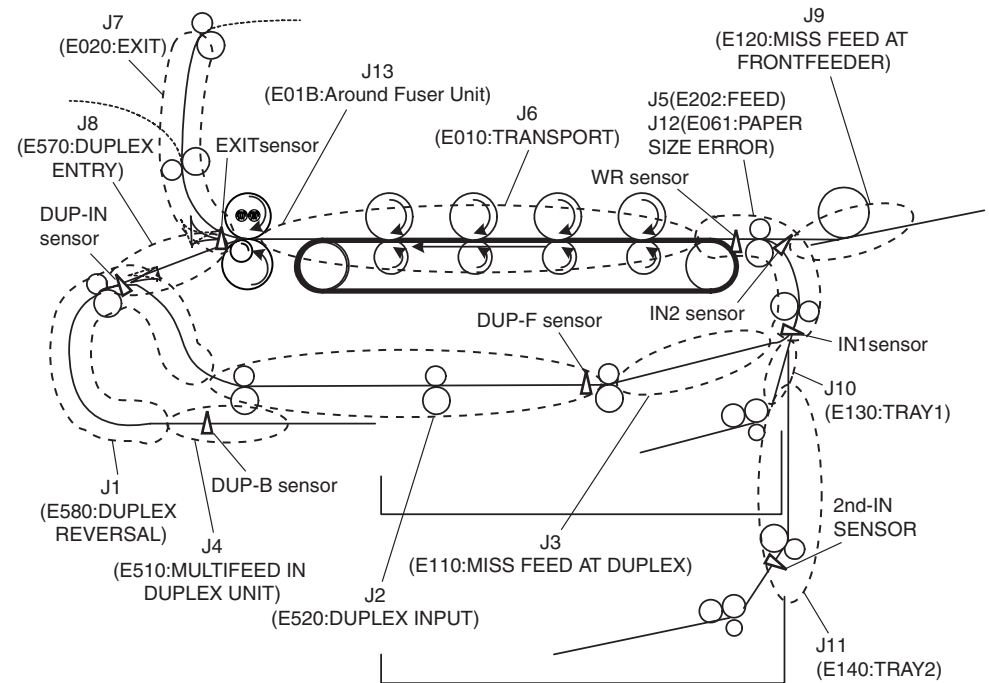

Open Cassette  
Paper Remain  
[Tray Name]

Open Cassette  
Paper Jam  
[Tray Name]

When the above messages are displayed.  
Tray1 is applied here as an example.

(1) Pull the displayed tray.

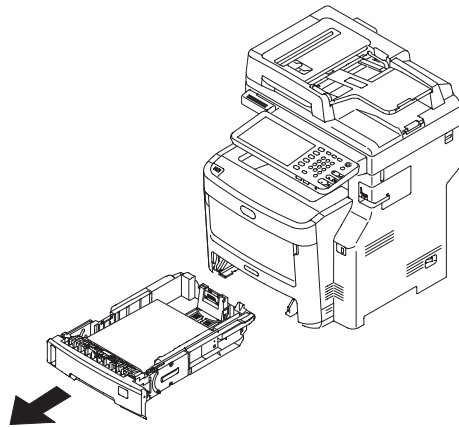

(2) Remove paper.

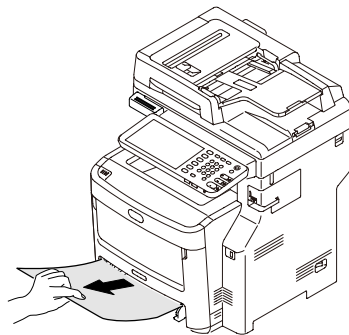

(3) Return the tray to the printer.

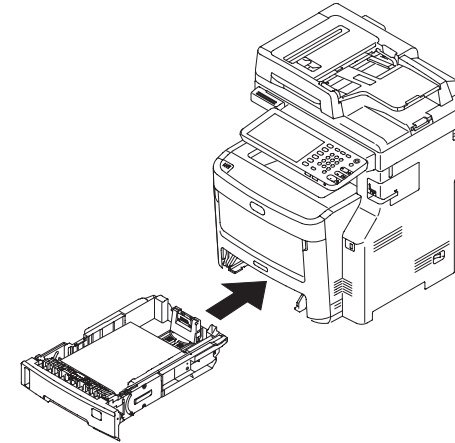

(4) Open and close the scanner and top cover.

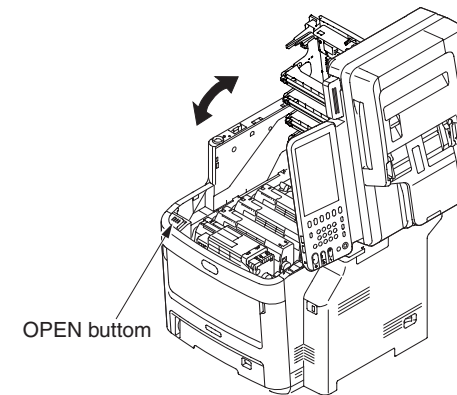

Open Cover  
Paper Remain  
Front Cover

Open Cover  
Paper Jam  
Front Cover

When the above messages are displayed.

- (1) Open the multipurpose tray.

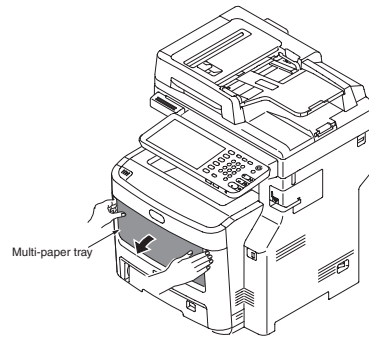

- (2) Push up the center handle (blue), to open the front cover.

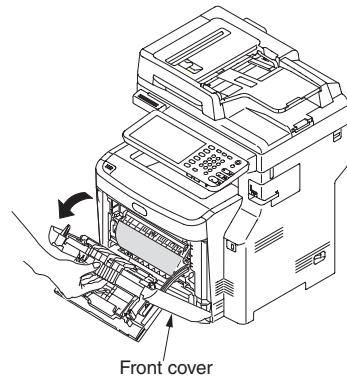

- (3) Slowly pull out the jammed paper.

- ① If you see the top edge of paper
- ② If you do not see the top edge of paper

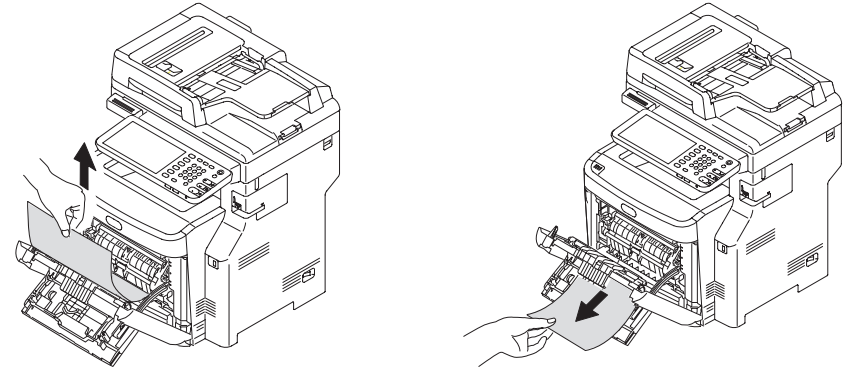

- (4) Close the front cover.

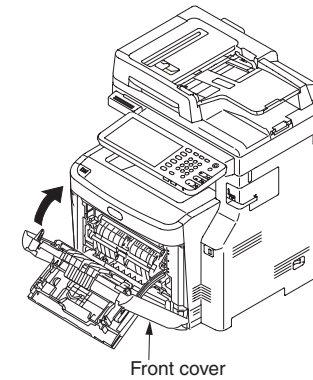

- (5) Close the multipurpose tray.

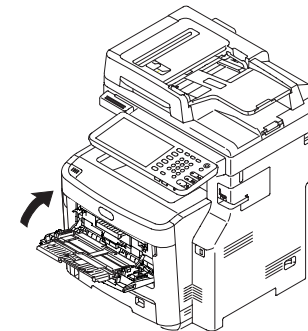



Open Cover  
Paper Remain  
Top Cover

Open Cover  
Paper Jam  
Top Cover

When the above messages are displayed.

- (1) Open the top cover.

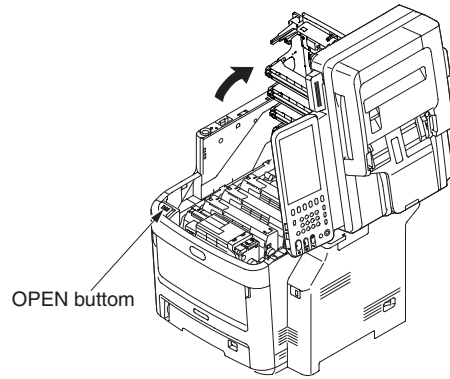

- (2) Touch the screw or plate with a hand to discharge static.

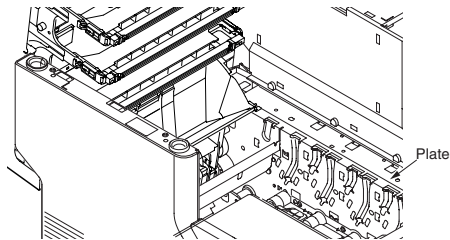

- (3) Uninstall the four image drum cartridges and put them on a flat table.

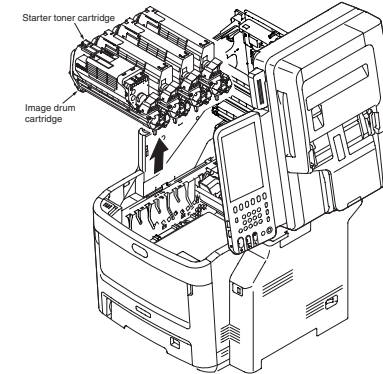

- (4) Cover the uninstalled image drum cartridges with black paper.

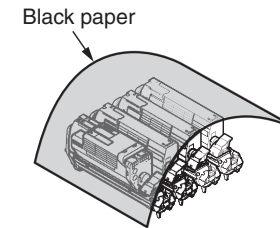

- (5) (a) If you see the top edge of paper  
Pull up the jammed paper slowly.

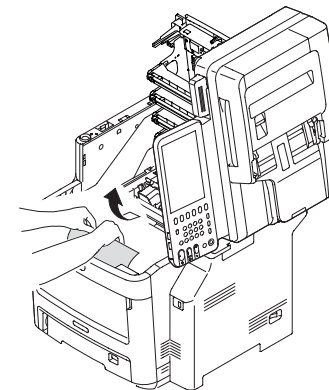

(b) If you do not see the top edge of paper

Pull up the jammed paper slowly while pushing the jam release lever of the fuser unit.

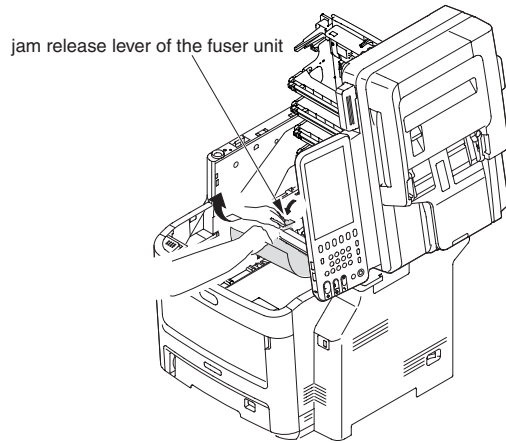

(c) If paper is jammed in the fuser unit

Pull the lock levers (2 levers) of the fuser unit to remove the fuser unit.

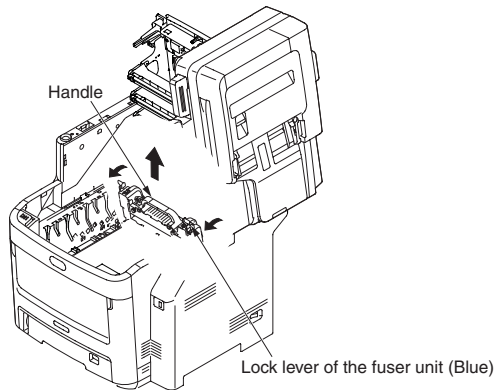

Pull the jammed paper to the front side while pressing the jam release lever.

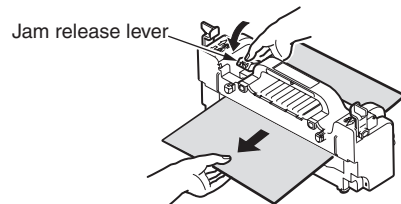

Set the fuser unit in the printer body and fold backward the lock lever (2 levers).

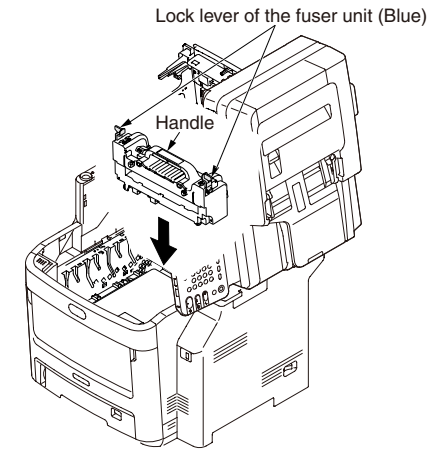

(6) Set four image drums in the printer.

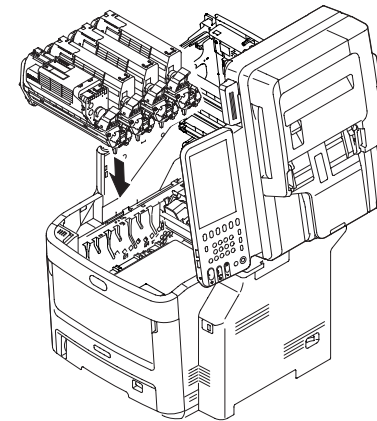

(7) Close the top cover.

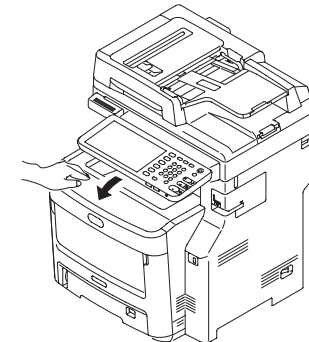

Check Duplex Unit  
Paper Remain

Check Duplex Unit  
Paper Jam

When the above messages are displayed.

- (1) Hold and press down the jam release lever of the Duplex unit to open the Duplex unit cover.

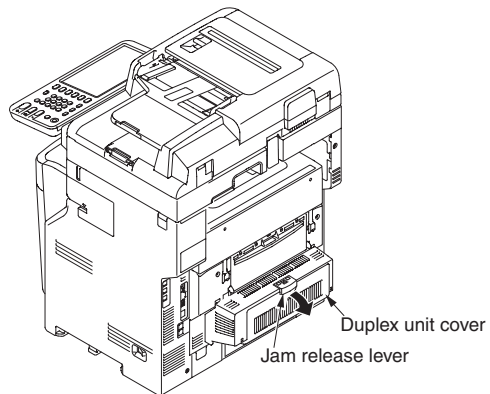

- (2) Release jammed paper.

If you do not see the paper, by closing the Duplex unit cover, the paper is automatically outputted.

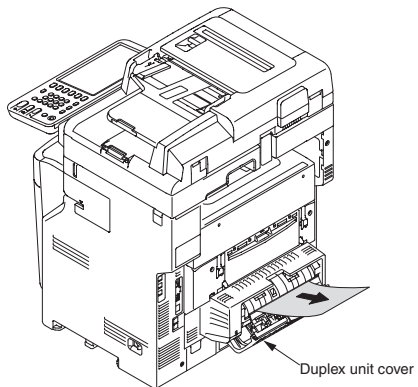

- (3) Close the Duplex unit cover.

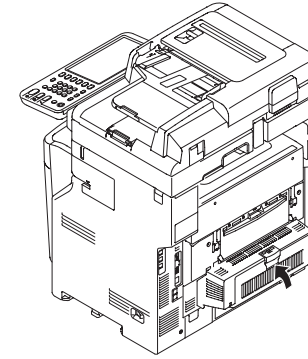

If jam occur the Inner Finisher(MC780dnf only)

(1) Open the Scanner.

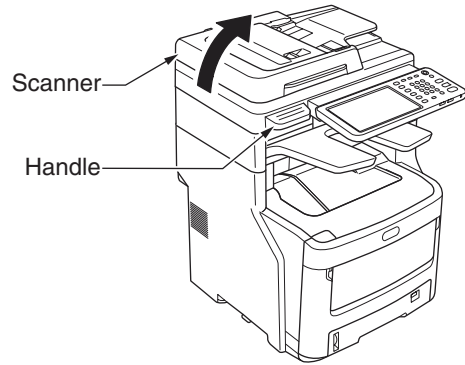

(2) Open the Finisher cover.

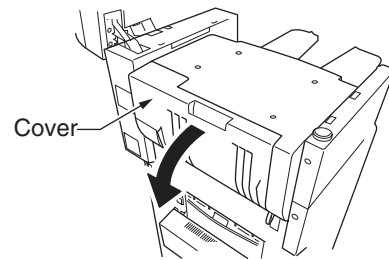

(3) Release jammed paper.

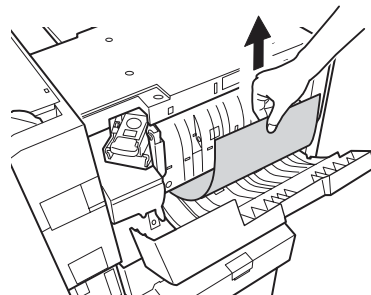

(4) Close the Finisher cover.

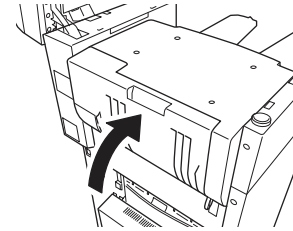

(5) Return the Scanner.

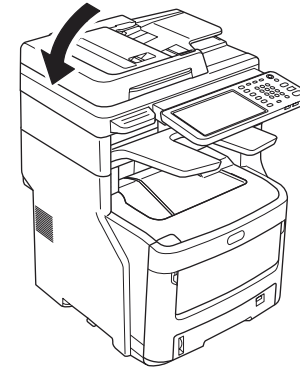

## Document Jam

### In the Duplex Paper Path

- (1) While opening the ADF cover, pull out the document from the duplex paper path.

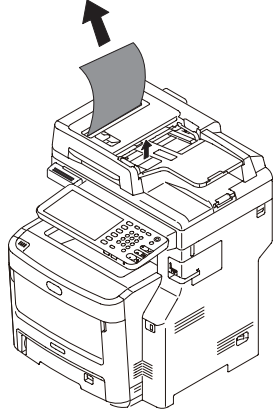

### Inside the ADF

- (1) Remove any documents from the document tray.
- (2) Open the ADF cover.

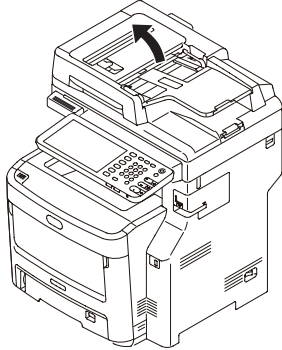

- (3) Hold jammed document by the top edge, and gently pull it out.

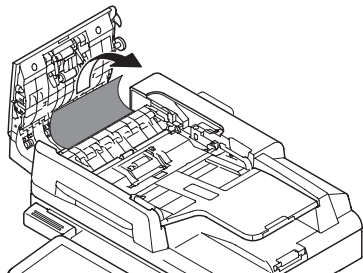

If the edge of the document can be seen under the paper guide, lift the paper guide and then pull out the document.

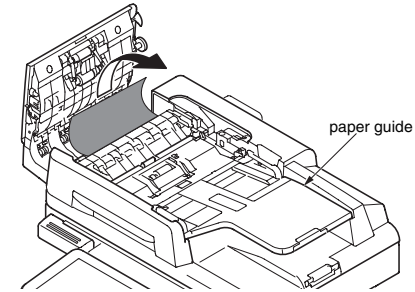

If the edge of the document cannot be seen in the ADF, lift the document tray and then pull out the document.

Pull down the document tray.

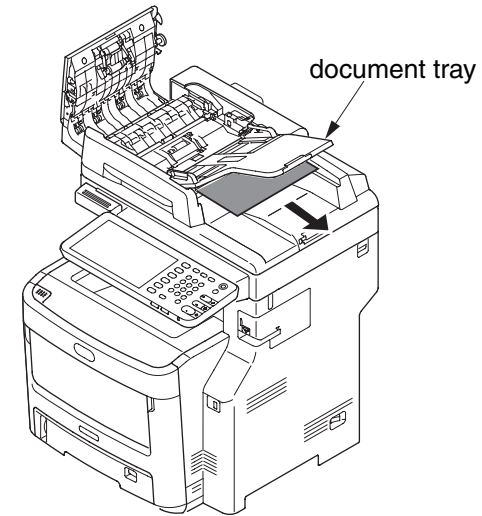

- (4) Close the ADF cover.

If jam occur the Staple in the Inner Finisher(MC780dnf only)

(1) Open the Scanner.

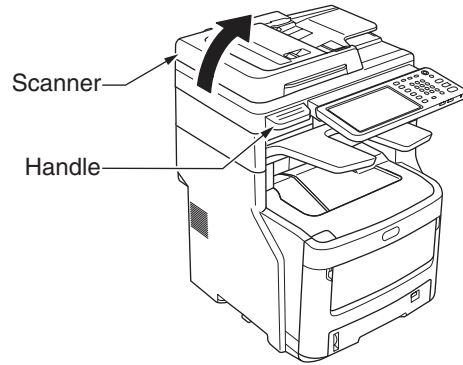

(2) Open the Finisher cover.

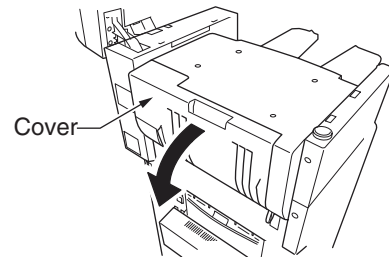

(3) Remove the Cartridge.

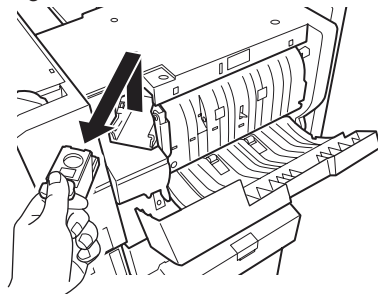

(4) Pull down the guide, pay attention to staple.

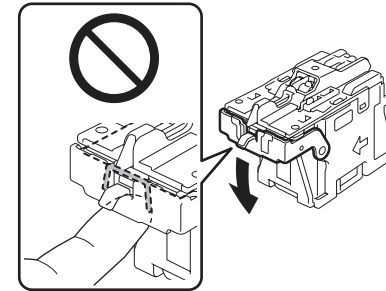

(5) Remove the staple sheet of the top.

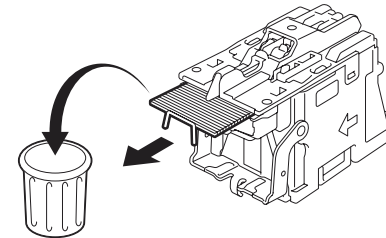

(6) Return to the guide.

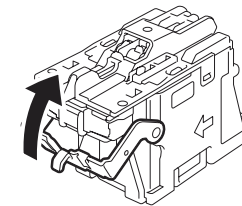

(7) Return to the Cartridge.

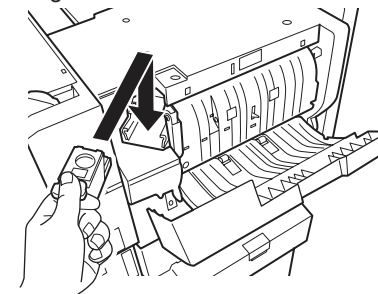

(8) Close the Finisher cover.

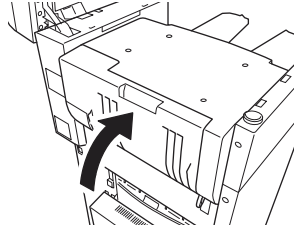

(9) Return to the Scanner.

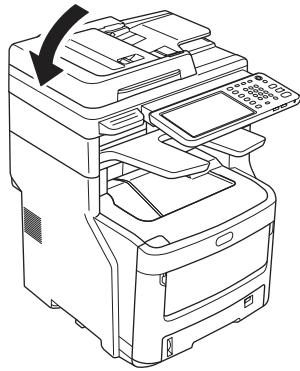

If jam occur the Staple in the Offline stapler(MC780dn only)

(1) Open the offline stapler cover.

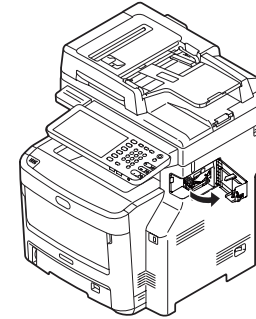

(2) Remove the cartridge and remove the staple.

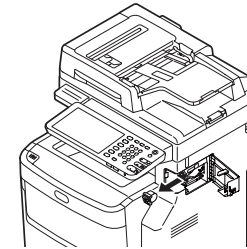

(3) Return the cartridge.

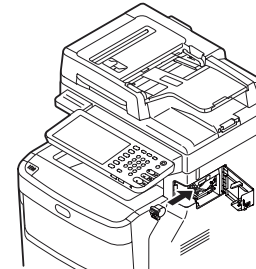

(4) Close the offline stapler cover.

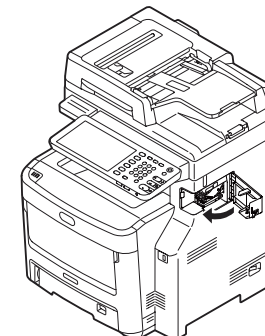

7.5.4. (3) Paper feed jam (error code E130: 1st tray)

(3-1) Jam occurs immediately after the power is turned on. (1st tray)

Check item	Check work	Action to be taken at NG
<b>(3-1-1) Check condition of the paper running path</b>		
Paper running path of the front unit	Open the front cover check if paper is not jammed in the paper running path.	Remove the jammed paper.
Check the paper guide of 1st Tray	Open the 1st Tray and check the paper guide position	Set the paper guide to correct position
<b>(3-1-2) Check condition of the mechanical parts</b>		
Check the sensor levers of the paper entrance sensor 1 and the paper entrance sensor 2.	Check if shape and movement of the sensor levers have any abnormality or not.	Replace the sensor lever with the good sensor lever.
<b>(3-1-3) Check condition of electrical parts</b>		
Check the detection condition of the sensor signal.	Confirm that the sensor signals are normally detected by using the Maintenance Menu SWITCH SCAN function.	Replace either the PU board or the front sensor board (RSF PCB) or connection cable.
Check output signal level of the paper entrance sensor 1 and that of the paper entrance sensor 2.	Check for the following signals at the FSNS connector ⑬ of the PU board. Pin-4: Paper entrance sensor 1 Pin-3: Paper entrance sensor 2 Confirm that the above signal levels change when the sensor lever is operated.	Replace the front sensor board (RSF PCB)
Check the power voltages supplied to the front sensor board (RSF PCB)	Check the 5V power at the FSNS connector ⑬ of the front sensor board (RSF PCB). Pin-1: 5V power supply Pin-5: 0VL	Replace the connection cable.

(3-2) Jam occurs immediately after the paper feed is started. (1st tray)

Check item	Check work	Action to be taken at NG
<b>(3-2-1) Check condition of the paper running path</b>		
Paper running path of the front unit	Check if paper is jammed or not in the paper running path.	Remove the jammed paper.
Check the paper guide of 1st Tray	Open the 1st Tray and check the paper guide position	Set the paper guide to correct position
<b>(3-2-2) Check condition of the mechanical parts</b>		
Check the sensor levers of the paper entrance sensor 1 and the paper entrance sensor 2.	Check if shape and movement of the sensor levers have any abnormality or not.	Replace the sensor with the good sensor lever.
Check the separator assemblies of the feed roller, the pickup roller and the tray.	Check if any foreign materials such as paper dust on the surface of the feed roller or of the pickup roller or not.	Remove the foreign material.
	Check if the feed roller or the pickup roller has worn out or not.	Replace the separator assemblies of the feed roller, pickup roller and tray.
<b>(3-2-3) Motor operation check</b>		
Paper feed motor	Confirm that the paper feed motor works normally by using the Motor & Clutch Test of the self-diagnostic mode.	Replace the PU board or the paper feed motor.
Paper feed motor driver	Remove the HP_PSZCL connector ⑨ of the PU board and check the followings at the connector side. Several MΩ between pin-1 – FG. Several MΩ between pin-2 – FG. Several MΩ between pin-3 – FG. Several MΩ between pin-4 – FG.	Replace the PU board.



Check item	Check work	Action to be taken at NG
(3-2-4) Check the system connection		
Paper feed motor drive cable	Check the connection condition of the cable. Check if the connector is connected in the half-way only or not, and check if the connector is inserted in a slanted angle or not. Check also that cables are assembled without any abnormality.	Replace the cable with the good cable that normalizes the connection condition.
Paper feed motor drive cable	Check that any cable is not pinched during assembling of the printer. Remove the HP_PSZCL connector ⑨ of the PU board and check the followings at the cable side. Short circuit between pin-1 – FG Short circuit between pin-2 – FG Short circuit between pin-3 – FG Short circuit between pin-4 – FG	Replace the cable with the good cable that normalizes the connection condition.
Paper feed motor	Remove the HP_PSZCL connector ⑨ of the PU board and check that approx. 3.4Ω can be measured between pin-1 -pin-2 at the cable end, and that approx. 5Ω can be measured between pin-3 -pin-4 respectively.	Replace the paper feed motor.
(3-2-5) Solenoid operation check		
Paper feed clutch	Confirm that the paper feed clutch or regist clutch works normally by using the Motor & Clutch Test of the self-diagnostic mode. Remove the metal plate from the right side of a printer so that the clutch becomes visible. Then, check operation of the clutch.	Replace the PU board, or replace the paper feed clutch or regist clutch.

Check item	Check work	Action to be taken at NG
(3-2-6) Check the system connection		
Paper feed clutch cable	Check the connection condition of the cable. Check if the connector is connected in the half-way only or not, and check if the connector is inserted in a slanted angle or not. Check also that cables are assembled without any abnormality.	Replace the cable with the good cable that normalizes the connection condition.
Paper feed clutch cable	Check that any cable is not pinched during assembling of the printer. Remove the CL1 connector ⑩ of the PU board and check the followings at the cable side. Short circuit between pin-1 – FG Remove the CL1 connector ⑩ of the PU board and check that approx. 240Ω can be measured between pin-1 and pin-2.	Replace the solenoid and re-assemble the printer correctly.

7.5.4. (4) Feed jam (error code E202)

(4-1) Jam occurs immediately after the power is turned on.

Check item	Check work	Action to be taken at NG
<b>(4-1-1) Check condition of the paper running path</b>		
Paper running path of the front unit	Open the front cover check if paper is not jammed in the paper running path.	Remove the jammed paper.
Check the paper guide of 1st Tray	Open the 1st Tray and check the paper guide position	Set the paper guide to correct position
<b>(4-1-2) Check condition of the mechanical parts</b>		
Check the sensor levers of the paper entrance sensor 1, that of the paper entrance sensor 2 and that of the WR sensor.	Check if shape and movement of the sensor levers have any abnormality or not.	Replace the sensor with the good sensor lever.
<b>(4-1-3) Check condition of electrical parts</b>		
Check the detection condition of the sensor signal.	Confirm that the sensor signals are normally detected by using the Maintenance Menu SWITCH SCAN function.	Replace either the PU board or the front sensor board (RSF PCB) or connection cable.
Check the output signal levels of the paper entrance sensor 1, that of the paper entrance sensor 2 and that of the WR sensor.	Check for the following signals at the FSNS connector ⑬ of the PU board. Pin-4: Paper entrance sensor 1 Pin-3: Paper entrance sensor 2 Pin-2: WR sensor Confirm that the above signal levels change when the sensor lever is operated.	Replace the front sensor board (RSF PCB)
Check the power voltages supplied to the front sensor board (RSF PCB)	Check the 5V power at the FSNS connector ⑬ of the front sensor board (RSF PCB). Pin-1: 5V power supply Pin-5: 0VL	Replace the connection cable.

(4-2) Jam occurs immediately after the paper feed is started.

Check item	Check work	Action to be taken at NG
<b>(4-2-1) Check condition of the paper running path</b>		
Paper running path of the front unit	Check if paper is jammed or not in the paper running path.	Remove the jammed paper.
Check the paper guide of 1st Tray	Open the 1st Tray and check the paper guide position	Set the paper guide to correct position
<b>(4-2-2) Check condition of the mechanical parts</b>		
Check the sensor levers of the paper entrance sensor 1, that of the paper entrance sensor 2 and that of the WR sensor.	Check if shape and movement of the sensor levers have any abnormality or not.	Replace the sensor with the good sensor lever.
<b>(4-2-3) Motor operation check</b>		
Paper feed motor	Confirm that the paper feed motor works normally by using the Motor & Clutch Test of the self-diagnostic mode.	Replace the PU board, or replace the paper feed motor.
Paper feed motor driver	Remove the HP_PSZCL connector ⑨ of the PU board and check the followings at the connector side. Several MΩ between pin-1 – FG Several MΩ between pin-2 – FG Several MΩ between pin-3 – FG Several MΩ between pin-4 – FG	Replace the PU board.

Check item	Check work	Action to be taken at NG
(4-2-4) Check the system connection		
Paper feed motor drive cable	Check the connection condition of the cable. Check if the connector is connected in the half-way only or not, and check if the connector is inserted in a slanted angle or not. Check also that cables are assembled without any abnormality.	Replace the cable with the good cable that normalizes the connection condition.
Paper feed motor drive cable	Check that any cable is not pinched during assembling of the printer. Remove the HP_PSZCL connector ⑨ of the PU board and check the followings at the cable side. Short circuit between pin-1 – FG Short circuit between pin-2 – FG Short circuit between pin-3 – FG Short circuit between pin-4 – FG	Replace the cable with the good cable that normalizes the connection condition.
Paper feed motor	Remove the HP_PSZCL connector ⑨ of the PU board and check that approx. 3.4Ω can be measured between pin-1 -pin-2 at the cable end, and that approx. 5Ω can be measured between pin-3 -pin-4 respectively.	Replace the paper feed motor.

7.5.4. (5) Paper feed jam (error code E120: Multipurpose tray)

(5-1) Jam occurs immediately after the power is turned on. (Multipurpose tray)

Check item	Check work	Action to be taken at NG
(5-1-1) Check condition of the paper running path		
Paper running path of the multipurpose tray	Check if paper is jammed or not in the paper running path.	Remove the jammed paper.
Check the paper guide of multipurpose tray	Open the multipurpose tray and check the paper guide position	Set the paper guide to correct position
(5-1-2) Check condition of the mechanical parts		
Check the sensor levers of the paper entrance sensor 2 and the WR sensor.	Check if shape and movement of the sensor levers have any abnormality or not.	Replace the sensor with the good sensor lever.
(5-1-3) Check condition of electrical parts		
Check the detection condition of the sensor signal.	Confirm that the sensor signals are normally detected by using the SWITCH SCAN function of the self-diagnostic mode.	Replace either the PU board or the front sensor board (RSF PCB) or connection cable.
Check the sensor output signal level of the paper entrance sensor 2 and the WR sensor.	Check for the following signals at the FSNS connector ⑬ of the PU board. Pin-2: WR sensor Pin-3: Paper entrance sensor 2 Confirm that the above signal levels change when the sensor lever is operated.	Replace the front sensor board (RSF PCB)
Check the power voltages supplied to the front sensor board (RSF PCB)	Check the 5V power at the CN connector ⑱ of the front sensor board (RSF PCB). Pin-1: 5V power supply Pin-5: 0VL	Replace the connection cable.

(5-2) Jam occurs immediately after paper feed is started. (Multipurpose tray)

Check item	Check work	Action to be taken at NG
<b>(5-2-1) Check condition of the paper running path</b>		
Paper running path of the multipurpose tray	Check if paper is jammed or not in the paper running path.	Remove the jammed paper.
Sheet Receive of the multipurpose tray	Confirm that the Sheet Receive has moved up normally. Confirm that the support spindle and spring of the Sheet Receive have been installed in the specified positions normally.	Correct installation of the above parts so that the Sheet Receive moves up to the specified position normally.
Check the paper guide of multipurpose tray	Open the multipurpose tray and check the paper guide position	Set the paper guide to correct position
<b>(5-2-2) Check condition of the mechanical parts</b>		
Check the sensor levers of the paper entrance sensor 2 and the WR sensor.	Check if shape and movement of the sensor levers have any abnormality or not.	Replace the sensor with the good sensor lever.
Planetary gear for paper feed control	Rotate the paper feed motor (FRONT MOTOR) using the Motor & Clutch Test of the self-diagnostic mode, and confirm that both of the two planetary gears rotate at the bottom position. (The planetary gear box can be located because it is the white molded block that is located on the right side when the front cover is opened.)	Replace the planetary gear box
Front cover	Confirm that the locks in the right and left of the front cover are locked normally.	Replace the front cover assembly
Check the feed roller and the pickup roller.	Check if any foreign materials such as paper dust on the surface of the feed roller or of the pickup roller or not.	Remove the foreign material.
	Check if the feed roller has worn out or not.	Replace the feed roller.

Check item	Check work	Action to be taken at NG
<b>(5-2-3) Motor operation check</b>		
Paper feed motor	Confirm that the paper feed motor works normally by using the Motor & Clutch Test of the self-diagnostic mode.	Replace the PU board, or replace the paper feed motor.
Paper feed motor driver	Remove the HP_PSZCL connector ⑨ of the PU board and check the followings at the connector side. Several MΩ between pin-1 – FG Several MΩ between pin-2 – FG Several MΩ between pin-3 – FG Several MΩ between pin-4 – FG	Replace the PU board.
<b>(5-2-4) Check the system connection</b>		
Paper feed motor drive cable	Check the connection condition of the cable. Check if the connector is connected in the half-way only or not, and check if the connector is inserted in a slanted angle or not. Check also that cables are assembled without any abnormality.	Replace the cable with the good cable that normalizes the connection condition.
Paper feed motor drive cable	Check that any cable is not pinched during assembling of the printer. Remove the HP_PSZCL connector ⑨ of the PU board and check the followings at the cable side. Short circuit between pin-1 – FG Short circuit between pin-2 – FG Short circuit between pin-3 – FG Short circuit between pin-4 – FG	Replace the cable with the good cable that normalizes the connection condition.
Paper feed motor	Remove the HP_PSZCL connector ⑨ of the PU board and check that approx. 3.4Ω can be measured between pin-1 -pin-2, and that approx. 5Ω can be measured between pin-3 -pin-4 respectively.	Replace the paper feed motor.

7.5.4. (6) Paper running jam (error code E010)

(6-1) Jam occurs immediately after the power is turned on.

Check item	Check work	Action to be taken at NG
(6-1-1) Check condition of the running path.		
Paper running path of the front unit	Check if paper is jammed or not in the paper running path.	Remove the jammed paper.
(6-1-2) Check condition of the mechanical parts		
Check the sensor lever of the WR sensor.	Check if shape and movement of the sensor levers have any abnormality or not.	Replace the sensor lever with the good sensor lever.
(6-1-3) Check condition of electrical parts		
Check the detection condition of the sensor signal.	Confirm that the sensor signals are normally detected by using the SWITCH SCAN function of the self-diagnostic mode.	Replace either the PU board or the front sensor board (RSF PCB) or connection cable.
Check the sensor lever of the WR sensor.	Check for the following signals at the FSNS connector ⑬ of the PU board. Pin-2: WR sensor Confirm that the above signal levels change when the sensor lever is operated.	Replace the front sensor board (RSF PCB)
Check the power voltages supplied to the front sensor board (RSF PCB)	Check the 5V power at the CN connector ⑱ of the front sensor board (RSF PCB). Pin-1: 5V power supply Pin-5: 0V	Replace the connection cable.

(6-2) Jam occurs immediately after a paper is taken into printer.

Check item	Check work	Action to be taken at NG
(6-2-1) Check condition of the paper running path		
Paper running path on the belt.	Remove the ID unit and check if paper is jammed or not in the paper running path.	Remove the jammed paper.
(6-2-2) Check condition of the mechanical parts		
Check the sensor lever of the WR sensor.	Check if shape and movement of the sensor levers have any abnormality or not.	Replace the sensor lever with the good sensor lever.
(6-2-3) Motor operation check		
Paper feed motor driver, belt motor driver and ID motor	Confirm that the paper feed motor, belt motor and ID motor work normally by using the Motor & Clutch Test of the self-diagnostic mode. Check if any load exists or not.	Replace the PU board, or replace the defective motor among paper feed motor, belt motor and ID motor, or replace the ID unit or belt unit. If any attempt of using new ID unit or new belt unit as a trial is going to be made, be sure to use the System Maintenance Menu FUSE KEEP MODE.
Paper feed motor, belt motor	Remove the BELT ID UP connector ② of the PU board and check the followings at the connector side. Several MΩ between pin-5 – FG Several MΩ between pin-6 – FG Several MΩ between pin-7 – FG Several MΩ between pin-8 – FG Remove the HP_PSZCL connector ⑨ of the PU board and check the followings at the connector side. Several MΩ between pin-1 – FG Several MΩ between pin-2 – FG Several MΩ between pin-3 – FG Several MΩ between pin-4 – FG	Replace either paper feed motor, belt motor or PU board.

Check item	Check work	Action to be taken at NG
(6-2-4) Check the system connection		
Paper feed motor drive cable, ID motor drive cable, belt motor drive cable, ID Up motor drive cable, fuser motor drive cable	Check the connection condition of the cables. PU board HP_PSZCL connector ⑨, DC ID connector ①, DCHEAT connector ③, BELT ID UP connector ②, RELAY connector ⑥. Check if the connector is connected in the half-way only or not, and check if the connector is inserted in a slanted angle or not. Check also that cables are assembled without any abnormality.	Normalize the connection condition. Replace the cable with the normal cable.
Paper feed motor drive cable, ID motor drive cable, belt motor drive cable, ID Up motor drive cable	Check that any cable is not pinched during assembling of the printer. Remove the BELT ID UP connector ② of the PU board and check the followings at the connector side. Short circuit between pin-1 – FG Short circuit between pin-2 – FG Short circuit between pin-3 – FG Short circuit between pin-4 – FG Short circuit between pin-5 – FG Short circuit between pin-6 – FG Short circuit between pin-7 – FG Short circuit between pin-8 – FG Remove the HP_PSZCL connector ⑨ of the PU board and check the followings at the cable side. Short circuit between pin-1 – FG Short circuit between pin-2 – FG Short circuit between pin-3 – FG Short circuit between pin-4 – FG	Replace the cable with the good cable that normalizes the connection condition.
Paper feed motor, belt motor, ID Up motor	Remove the respective connectors from the board, and confirm that the following resistance exists between the corresponding pins, at the cable side. PU board HP_PSZCL connector ⑨ Between pin-1 - pin-2 Approx. 3.4Ω or approx. 5Ω. Between pin-3 - pin-4 Approx. 3.4Ω or approx. 5Ω. PU board BELT ID UP connector ② Between pin-1 - pin-2 Approx. 6.1Ω or approx. 8.5Ω. Between pin-3 - pin-4 Approx. 6.1Ω or approx. 8.5Ω. Between pin-5 - pin-6 Approx. 3.4Ω or approx. 5Ω. Between pin-7 - pin-8 Approx. 3.4Ω or approx. 5Ω.	Replace paper feed motor, belt motor, ID Up motor.

(6-3) Jam occurs in the middle of paper running path.

Check item	Check work	Action to be taken at NG
(6-3-1) Motor operation check		
Paper feed motor driver, belt motor driver and ID motor	Confirm that the paper feed motor, belt motor and ID motor work normally by using the Motor & Clutch Test of the self-diagnostic mode. Check if any load exists or not.	Replace the PU board, or replace the defective motor among paper feed motor, belt motor and ID motor, or replace the ID unit or belt unit. If any attempt of using new ID unit or new belt unit as a trial is going to be made, be sure to use the System Maintenance Menu FUSE KEEP MODE.
Paper feed motor, belt motor	Remove the BELT ID UP connector ② of the PU board and check the followings at the connector side. Several MΩ between pin-5 – FG Several MΩ between pin-6 – FG Several MΩ between pin-7 – FG Several MΩ between pin-8 – FG Remove the HP_PSZCL connector ⑨ of the PU board and check the followings at the connector side. Several MΩ between pin-1 – FG Several MΩ between pin-2 – FG Several MΩ between pin-3 – FG Several MΩ between pin-4 – FG	Replace either paper feed motor, belt motor or PU board.

(6-4) Jam occurs immediately after paper has reached the fuser.

Check item	Check work	Action to be taken at NG
<b>(6-4-1) Motor operation check</b>		
Fuser motor	Confirm that the fuser motor works normally by using the Motor & Clutch Test of the self-diagnostic mode. Check if any load exists or not.	Replace the PU board. Replace the fuser motor. Replace the fuser unit. If any attempt of using new fuser unit as a trial is going to be made, be sure to use the System Maintenance Menu FUSE KEEP MODE.
<b>(6-4-2) Temperature control of the roller rotation speed</b>		
Heat roller detected temperature	Check the detected temperature of the heat roller using the self-diagnostic mode. Is abnormally high temperature or abnormally temperature detected?	Replace fuser unit, or relay board (IBY PCB) or the PU board. If any attempt of using new fuser unit as a trial is going to be made, be sure to use the System Maintenance Menu FUSE KEEP MODE.
<b>(6-4-3) Check the installation condition of fuser unit</b>		
Fuser unit	Check that the fuser unit is installed normally. (Is it pushed in down to the bottom-most point?)	Install the fuser unit correctly in a printer.

7.5.4. (7) Paper unloading jam (error code E020)

(7-1) Paper unloading jam occurs immediately after the power is turned on.

Check item	Check work	Action to be taken at NG
<b>(7-1-1) Check condition of the paper running path</b>		
Paper running path of the paper unloading unit	Check if paper is jammed or not in the paper running path.	Remove the jammed paper.
<b>(7-1-2) Check condition of the mechanical parts</b>		
Check the sensor lever of the paper exit sensor.	Check if shape and movement of the sensor levers have any abnormality or not.	Replace the sensor lever with the good sensor lever.
<b>(7-1-3) Check condition of electrical parts</b>		
Check the detection condition of the sensor signal.	Confirm that the sensor signals are normally detected by using the SWITCH SCAN function of the self-diagnostic mode.	Replace the PU board or EXIT sensor or its cable or its connection cable.
Check the output signal level of the EXIT sensor.	Check for the following signals at the RELAY connector ⑥ of the PU board. Pin-9: EXIT sensor Confirm that the above signal levels change when the sensor lever is operated.	Replace the EXIT sensor.
Check the power voltages supplied to the relay board.	Check the 5V power voltage at the EXIT connector ② of the relay board. Pin-1: 5V power supply Pin-3: 0VL	Replace the connection cable.

Check item	Check work	Action to be taken at NG
(7-1-4) Check the system connection		
Signal cable for relay board, EXIT sensor cable	Check that FFC is normally inserted at the RELAY connector ⑥ of the PU board and at the PU/CU IF connector ⑳. Check that the relay board and the EXIT sensor are normally connected.	Normalize the connection condition.
Signal cable for relay board, EXIT sensor cable	Confirm that the cables are not pinched, sheathes are not peeled off, and they are assembled normally.	Replace the connecting cable and normalize the assembled condition.

(7-2) Paper unloading jam occurs after a paper is taken into printer.

Check item	Check work	Action to be taken at NG
(7-2-1) Check condition of the paper running path		
Face Up Stacker Cover	Confirm that it is either fully opened or fully closed	Eliminate any in-between condition of the cover between the fully open position and fully closed position.
Duplex pull-in gate	Confirm that the Duplex pull-in gate works normally by using the Motor & Clutch Test of the self-diagnostic mode. Is it set to the paper unloading side normally?	Replace the Duplex pull-in gate or the Duplex solenoid
Rear panel	Check that the installation condition of the rear panel hampers smooth movement of a paper in the paper running path, or not.	Remove the rear panel and re-install it.
Paper running path of unloading unit	Check that any mechanical load does not exist that hampers the smooth movement of paper in the paper running path of the paper unloading unit, by the visual inspection. Check if the paper unloading motor becomes difficult to rotate or not.	Correct the portion that becomes mechanical load.

Check item	Check work	Action to be taken at NG
(7-2-2) Check condition of the mechanical parts		
Sensor lever of the paper exit sensor	Check if shape and movement of the sensor levers have any abnormality or not.	Replace the sensor lever with the good sensor lever.
(7-2-3) Motor operation check		
Fuser motor	Confirm that the fuser motor works normally by using the Motor & Clutch Test of the self-diagnostic mode. Check if any load exists or not.	Replace the PU board or fuser motor or fuser unit. If any attempt of using new fuser unit as a trial is going to be made, be sure to use the System Maintenance Menu FUSE KEEP MODE.
(7-2-4) Check the system connection		
Fuser motor drive cable	Check the connection condition of the cables. PU board DCHEAT connector ③, Check if the connector is connected in the half-way only or not, and check if the connector is inserted in a slanted angle or not. Check also that cables are assembled without any abnormality.	Replace the cable with the good cable that normalizes the connection condition.
Fuser motor		Replace the fuser motor.



(7-3) Paper unloading jam occurs in the middle of paper running path.

Check item	Check work	Action to be taken at NG
(7-3-1) Motor operation check		
Fuser motor	Confirm that the fuser motor works normally by using the Motor & Clutch Test of the self-diagnostic mode. Check if any load exists or not.	Replace the PU board or fuser motor or fuser unit. If any attempt of using new fuser unit as a trial is going to be made, be sure to use the System Maintenance Menu FUSE KEEP MODE.

7.5.4. (8) Two-sided printing jam (error code: E580, E520, E110, E570)

(8-1) Two-sided printing jam occurs immediately after the power is turned on.

Check item	Check work	Action to be taken at NG
(8-1-1) Check condition of the paper running path		
Paper running path of the Duplex unit	Check if paper is jammed or not in the paper running path. Open the front cover and check if any paper remains in the Duplex feeder or not. Open the rear cover and check if any paper remains in the paper reversing path or not. Remove the Duplex unit. Check if any paper exists in the Duplex insertion slot or not. Open the cover of the Duplex paper running path and check if any paper remains inside of the Duplex unit.	Remove the jammed paper.
(8-1-2) Check condition of the mechanical parts		
Check the sensor levers of the respective sensors of the Duplex unit.	Check if shape and movement of the sensor levers have any abnormality or not.	Replace the Duplexunit.
(8-1-3) Check condition of electrical parts		
Check the detection condition of the sensor signal.	Confirm that the sensor signals are normally detected by using the SWITCH SCAN function of the self-diagnostic mode. For all sensors except the Dup-IN sensor, check the detection condition of the respective sensor in the two status: One is the status in which paper remains inside the Duplex unit. The other is the status in which paper is removed from the Duplex unit.	Replace the Duplexunit.

(8-2) Two-sided printing jam occurs during taking in the paper into Duplex unit.

Check item	Check work	Action to be taken at NG
<b>(8-2-1) Solenoid operation check</b>		
Duplex solenoid	Confirm that the Duplex solenoid works normally by using the Motor & Clutch Test of the self-diagnostic mode.	Replace the Duplexunit.
Separator DUP (Paper unloading/ DUP paper taking-in switching gate located immediately after the fuser unit)	Check visually movement of the gate by using the Motor & Clutch Test of the self-diagnostic mode. (EXIT SOLENOID) Check if movement is unsmooth or not, if amount of open/close is abnormal or not.	Replace the Duplexunit.
ON/OFF timing of the Duplex solenoid	While the cover is in the opened state, perform the test print and confirm if the timing to open the separator DUP is correct or not.	Replace the WR sensor lever or solenoid.
<b>(8-2-2) Sensor lever operation check</b>		
Dup-IN sensor lever	Open the rear cover. Touch the Dup-IN sensor lever to check if its movement is unsmooth or not.	Replace the Duplexunit.
DUP-IN sensor	Confirm that the sensor signals are normally detected by using the SWITCH SCAN function of the self-diagnostic mode.	Replace the Duplexunit.
<b>(8-2-3) Check condition of the paper running path</b>		
Paper inverting transport path	Check that any foreign materials such as paper chip or blue do not exist that hampers the smooth movement of paper in the paper inverting transport path.	Remove the foreign material.

Check item	Check work	Action to be taken at NG
<b>(8-2-4) Motor operation check</b>		
Duplex motor	Confirm that the Duplex solenoid works normally by using the Motor & Clutch Test of the self-diagnostic mode. Open the rear cover and check rotation of the roller.	Replace the Duplexunit.
Duplex pull-in/reversing roller and its pinch roller	Check if the pull-in/reversing roller of the Duplex unit contacts or not with the pinch roller of the cover side when the Duplex rear cover is closed. (Does the pinch roller rotate when the roller is rotating?)	Replace the Duplexunit.

(8-3) Two-sided printing jam occurs in the process of reversing paper.

Check item	Check work	Action to be taken at NG
<b>(8-3-1) Sensor lever operation check</b>		
Dup-IN sensor lever	Open the rear cover. Touch the Dup-IN sensor lever to check if its movement is unsmooth or not.	Replace the Duplexunit.
DUP-IN sensor	Confirm that the sensor signals are normally detected by using the SWITCH SCAN function of the self-diagnostic mode.	Replace the Duplexunit.
<b>(8-3-2) Motor operation check</b>		
Duplex motor	Check if the paper reversing operation is started or not by visual inspection when viewing through slit of the rear cover. If the paper reversing operation is not started, check if movement of the planetary gear inside the Duplex unit is unsmooth or not.	Replace the Duplexunit.

(8-4) Two-sided printing jam occurs during transporting paper inside the Duplex unit.

Check item	Check work	Action to be taken at NG
(8-4-1) Sensor lever operation check		
Dup-R, Dup-F sensor lever	Remove the Duplex unit and check movement of the sensor lever.	Replace the Duplexunit.
(8-4-2) Sensor check		
Check the detection condition of the sensor signal	Confirm that the sensor signals are normally detected by using the SWITCH SCAN function of the self-diagnostic mode. For all sensors except the Dup-IN sensor, check the detection condition of the respective sensor in the two status: One is the status in which paper remains inside the Duplex unit. The other is the status in which paper is removed from the Duplex unit.	Replace the Duplexunit.

(8-5) Paper is not supplied from the Duplex unit to the regist roller.

Check item	Check work	Action to be taken at NG
(8-5-1) Clutch operation check		
Duplex clutch	Confirm that the Duplex clutch works normally by using the Motor & Clutch Test of the self-diagnostic mode. Confirm it by listening to the sound.	Replace the Duplexunit.

7.5.4. (9) Paper size error (error code E061, E062, E063, E064, E065)

(9-1) Jam occurs when paper end is located near the IN1 sensor.

Check item	Check work	Action to be taken at NG
(9-1-1) Check paper feed condition		
Multifeed of papers	Open the front cover and check if multifeed of papers occurs or not.	If the multifeed occurs again after the jammed paper is removed, replace the flap of the tray in use.
Paper size	Does the paper size specified for print match the paper size of paper stuck in the tray.	Change the specified paper size or size of paper inside the tray.
Paper entrance sensor 1	Check if shape and movement of the sensor levers have any abnormality or not.	Replace the sensor lever with the good sensor lever.

7.5.4. (10) ID unit Up/Down error (Service call CE7A)

(10-1) Error occurs during the Up movement of the ID unit

Check item	Check work	Action to be taken at NG
<b>(10-1-1) Check the mechanical load during the Up movement</b>		
Mechanical load during installation and removal of the ID unit	Check if abnormal heavy load is applied when removing the ID unit.	IReplace the ID unit, or replace the right/left side plate. If any attempt of using new ID unit as a trial is going to be made, be sure to use the System Maintenance Menu FUSE KEEP MODE.
Greasing to the right and left Up/Down link levers	Check if the slant surface of the link lever is coated by grease or not.	Apply grease.
Assembled condition of the right and left Up/Down link levers	Check if any part exists or not in the vicinity of link lever, that hampers movement of the link lever.	Assemble them correctly.
<b>(10-1-2) Up/Down mechanism</b>		
Assembled condition of the peripheral mechanism of the link lever	Is the mechanism assembled so that the link lever is connected to the planetary driving gear?	Assemble them correctly.
Right and left link levers	Check if the link lever is set in the correct position that enables the specified engagement of gears. (Check if the link lever is set in the wrong position that results in the wrong engagement of gears by several teeth.)	Assemble them correctly.

Check item	Check work	Action to be taken at NG
<b>(10-1-3) Sensor check</b>		
Up/Down sensor lever (unified structure with the left link lever)	Check if shape and movement of the sensor levers have any abnormality or not.	Replace the left link lever.
Up/Down sensor	Confirm that the sensor signals are normally detected by using the SWITCH SCAN function of the self-diagnostic mode. Check if the SCAN state changes or not when the incoming light is interrupted/passed by using a piece of paper or the like for the transparent type sensor.	Replace the high voltage board.

(10-2) Error occurs during the Down movement of the ID unit

Check item	Check work	Action to be taken at NG
<b>(10-2-1) Check the mechanical load during the Down movement</b>		
Mechanical load during installation and removal of the ID unit	Check if abnormal heavy load is applied when removing the ID unit.	Replace the ID unit, or replace the right/left side plate.
Greasing to the right and left Up/Down link levers	Check if the slant surface of the link lever is coated by grease or not.	Apply grease.
Assembled condition of the right and left Up/Down link levers	Check if any part exists or not in the vicinity of link lever, that hampers movement of the link lever.	Assemble them correctly.

7.5.4. (11) Fuser unit error (error C41A,C41B,C449,C446,C41C,C41D,C468,C466)

(11-1) Error occurs immediately after the power is turned on.

Check item	Check work	Action to be taken at NG
(11-1-1) Thermistor is defective Note)		
Upper thermistor, lower thermistor, frame thermistor	Check the respective thermistors if they are shorted or opened internally. Check the resistance value at the connector pins in the bottom of the fuser unit. (Refer to section 8.1 Resistance check (fuser unit).)	Replace the fuser unit. If any attempt of using new fuser unit as a trial is going to be made, be sure to use the System Maintenance Menu FUSE KEEP MODE.
Installed condition of fuser unit.	Check if the fuser nit is pressed in until the connector in the bottom of the fuser unit is surely connected.	Re-set the fuser unit.

**Note!** Service calls C41B error and C41D error can occur when the printer temperature is below 0°C. Turn on the power again after the printer temperature has increased.

(11-2) Error occurs approx. 1 minute after the power is turned on.

Check item	Check work	Action to be taken at NG
(11-2-1) Temperature increase of fuser unit		
Thermostat, halogen lamp	Heater of the fuser unit is controlled of its temperature. Check if the fuser unit gets hot or not by touching it with hands. If the fuser unit temperature does not increase and remains cold, check that the resistance between pin-1 and pin-6 of connector A, and that in between pin-1 and pin-6 of connector B of the two connectors is in the range of several ohms to several ten ohms respectively. (Refer to section 8.1 Resistance value (fuser unit).)	Replace the fuser unit. If any attempt of using new fuser unit as a trial is going to be made, be sure to use the System Maintenance Menu FUSE KEEP MODE.

Check item	Check work	Action to be taken at NG
(11-2-2) Temperature increase of fuser unit		
Installation position of the upper thermistor	Check if the upper thermistor is installed in the far position from the specified position or not causing detection of the lower temperature than the actual temperature of fuser unit. Remove the heater cover, and check warpage of sensor by visual inspection.	Replace the fuser unit. If any attempt of using new fuser unit as a trial is going to be made, be sure to use the System Maintenance Menu FUSE KEEP MODE.
Installation position of the lower thermistor	The lower thermistor must be installed while contacting with the fuser unit. Check if the lower thermistor is installed in the far position from the specified position or not causing detection of the lower temperature than the actual temperature of fuser unit.	Replace the fuser unit. If any attempt of using new fuser unit as a trial is going to be made, be sure to use the System Maintenance Menu FUSE KEEP MODE.
(11-2-3) AC power input to the halogen lamp		
AC power voltage from the low voltage power supply	Check if the AC voltage for heater is normally supplied or not. Power supply CN2 connector ②, between pin-1 and pin-2, and between pin-3 and pin-4.	Replace the low voltage power supply.
Heater ON signal that is output from PU to the low voltage power supply	Check that the heater ON signal goes active at the warming up timing, or not. "L" active while ON. Power connector ⑦ of the PU board, between pin-14 and pin-16.	Replace the PU board.

7.5.4. (12) Motor fan error (error code C0A2, C0A1, C0A5, C0A6)

(12-1) The low voltage power supply fan does not rotate immediately after the power is turned on.

Check item	Check work	Action to be taken at NG
(12-1-1) Cable connection condition and wiring condition		
Cable connection condition and wiring condition of the low voltage power supply fan and those of the fuser fan	Check if the connectors are connected normally or not. Check if extra length of the cables does not touch the fan blade or not.	Correct the connection condition of the connectors. Correct the cable wiring route. Replace the fan.

(12-2) Duplex fan does not rotate during the Duplex printing.

Check item	Check work	Action to be taken at NG
(12-1-2) Cable connection condition and wiring condition		
Cable connection condition and wiring condition of the Duplex fan	Check if the connectors are connected normally or not. Check if extra length of the cables does not touch the fan blade or not.	Correct the connection condition of the connectors. Correct the cable wiring route. Replace the Duplexunit.
24V fuse F501 of the Duplex board (GOH-10 PCB)	Check if the fuse F501 has blown out or not.	Replace the Duplexunit.
24V power supplied to the Duplex board (GOH-10 PCB).	Check if the fuse F1 and F4 of the PU board has blown out or not.	Replace the PU board.

(12-3) All fans of the printer do not rotate.

Check item	Check work	Action to be taken at NG
(12-3-1) 24V power supply		
PU board fuses	Check if the fuse F5 and F8 are not open-circuit or not.	Replace the PU board.
24V power that is supplied to the PU board.	Check the power supply voltages at the POWER connector ⑦ of the PU board. The follow voltage must appear respectively. PU ⑦ Pin 1,2,3,4:24V Pin 5,6,7,8:0VP	Replace the low voltage power supply.

7.5.4. (13) Print speed is slow. (Performance is low.)

(13-1) Print speed decreases.

Check item	Check work	Action to be taken at NG
(13-1-2) Media Weight setting		
Media Weight that is specified for the print	Check if the wrong Media Weight has been specified or not.	Correct the Media Weight.

7.5.4. (14) Option unit cannot be recognized.

(14-1) Duplex unit cannot be recognized.

Check item	Check work	Action to be taken at NG
(14-1-1) Duplex board		
Duplex unit	Check if the Duplex unit of MC7xx specification is being used or not.	Replace the Duplex unit.
(14-1-2) Check the system connection		
Check the system connection from the PU board to the Duplex board (GOH-10 PCB).	Check that the cable between the PU board option connector ⑩ to the Duplex board is normally connected.	Correct the connections.
Square connector connecting the Duplex unit to the printer.	Check if any foreign material exists in the connecting portion of the square connector.	Remove the foreign material.
Square connector connecting the Duplex unit to the printer.	Is the terminals of the square connector damaged?	Replace the connector.
(14-1-3) Check the control signals.		
Check the control signal that is output from the PU board to the Duplex board (GOH-10 PCB).	Check the control signal that is output from the PU board option connector ⑩. Pin-6: TXD (PU → DUP) Pin-4: RXD (DUP → PU)	Replace the PU board.

(14-2) Option try unit cannot be recognized.

Check item	Check work	Action to be taken at NG
(14-2-1) Option try board		
Option try unit	Check if the option try unit of MC7xx specification is being used or not.	Replace the option tray unit.

Check item	Check work	Action to be taken at NG
(14-2-2) Check the system connection		
Check the system connection from the PU board to the option tray board (GOH-11 PCB).	Check that the cable between the PU board option connector ⑩ to the option tray board is normally connected.	Correct the connections.
Square connector connecting the option tray unit to the printer.	Check if any foreign material exists in the connecting portion of the square connector.	Remove the foreign material.
Square connector connecting the option tray unit to the printer.	Is the terminals of the square connector damaged?	Replace the connector.
(14-2-3) Check the control signals.		
Check the control signal that is output from the PU board to the option tray board (GOH-11 PCB).	Check the control signal that is output from the PU board option connector ⑩. Pin-5: TXD (PU → 2nd) Pin-3: RXD (2nd → PU)	Replace the PU board.

(14-3) LCF unit cannot be recognized.

Check item	Check work	Action to be taken at NG
(14-3-1) LCF board		
LCF unit	Check if the LCF unit of MC7xx specification is being used or not.	Replace the LCF unit.
(14-3-2) Check the system connection		
Check the system connection from the PU board to the LCF board (GOI PCB).	Check that the cable between the PU board option connector ⑩ to the LCF board is normally connected.	Correct the connections.
Square connector connecting the LCF unit to the printer.	Check if any foreign material exists in the connecting portion of the square connector.	Remove the foreign material.
Square connector connecting the LCF to the printer.	Is the terminals of the square connector damaged?	Replace the connector.
(14-3-3) Check the control signals.		
Check the control signal that is output from the PU board to the LCF board (GOI PCB).	Check the control signal that is output from the PU board option connector ⑩. Pin-5: TXD (PU → LCF) Pin-3: RXD (LCF → PU)	Replace the PU board.



7.5.4. (15) LED head cannot be recognized. (error code CE82, CE83, CE84, CE85)

(15-1) Service call CE82 to CE85 (LED HEAD Missing)

Check item	Check work	Action to be taken at NG
(15-1-1) Check the system connection		
Connecting condition at the PU board connector and at the head connector.	Check the connecting condition of the FFC by the visual inspection.	Correct the connection to the normal connecting condition.
Head FFC	Remove the head FFC from the printer. Check if any open-circuit or peeling-off of sheath has occurred or not throughout the cable.	Replace the head FFC or the PU board.
Conduction of the fuse on the PU board.	Check that 5V appears across the capacitor CP8. (Refer to section 7.6.) Check if the fuses F8 and F9 are not open-circuit or not.	Replace the PU board.

## 7.5.4. (16) Toner cartridge cannot be recognized. (error code C3B3,C3A3,C393,C383)

## (16-1) Error caused by the consumable items.

Check item	Check work	Action to be taken at NG
(16-1-1) Consumable items installation condition		
ID unit and toner cartridge	Check that the ID unit is installed in the normal position. Check that the lock lever of the toner cartridge is locked.	Correct the installation to the normal installation condition.

## (16-2) Error caused by the toner sensor

Check item	Check work	Action to be taken at NG
(16-2-1) Toner sensor condition		
Toner sensor	Is the receptor of the toner sensor stained?	Wipe off the stain from the toner sensor.
Toner sensor	Confirm that the toner sensor works normally by using the SWITCH SCAN function of the self-diagnostic mode. Place a white paper in front of the toner sensor, and check if the SCAN state changes or not.	Replace the toner sensor board, or the PU board, or the FFC between the toner sensor board and the PU board.

**Note!** Toner sensor operation check method using the SWITCH SCAN function of the self-diagnostic mode.

## (1) How to check operation of the toner sensor at the printer side.

- Status change of the toner sensor can be checked from the Operator Panel using the self-diagnostic mode. First, switch the display to the Operator Panel display. For the method of switching the display to the Operator Panel display, refer to section 5.3.2.3 Switch Scan Test
- Remove the ID unit and the toner cartridge (TC) from a printer. There is a window inside a printer opposing the ID side when viewed from the front of a printer. The toner sensor is located inside the window.
- Place a white paper 3 mm away from the sensor window. The white paper should be placed in the manner of opposing the toner sensor.
- When light is reflected by a white paper so that incident light falls on the toner sensor, the Operator Panel display shows "L". When the paper is moved so that any light is not reflected by the paper so that the incident light does not reach the toner sensor, "H" is displayed on the Operator Panel.
- If the Operator Panel display toggles between "H" <-> "L" as a paper is flipped in front of the toner sensor, it indicates that the toner sensor and the related system of the printer are working normally.

## Action to be taken at NG

- Clean surface of the toner sensor to remove the stains due to residual toner and paper dust.
- Check the connection condition of the FFC cable at the PU board and at the toner sensor board (PRZ).
- Perform the operation check again. If the situation is not improved and remains unchanged, replace the PU board or the toner sensor board (PRZ).

## (2) How to check operation of the toner sensor at the toner cartridge (TC) side

- To the position where the toner sensor is confirmed to be operating normally in the printer itself by the above paragraph (1), install the TC and the ID unit to check operations by observing display on the Operator Panel.
- If the ID unit works normally, the display on the Operator Panel will toggle between "H" <-> "L" in synchronism with movement of the silver reflector plate that is located on the side of the ID.

## Action to be taken at NG

- Check operation condition of the respective ID motors by using the Motor & Clutch Test of the self-diagnostic mode.
- Clean surface of the silver reflector plate on the side of ID to remove stains. (Stain due to toner or paper dust)
- Replace the TC of different color and the ID unit as a pair.

If a satisfactory operation is attained by using the a pair of TC of different color and the ID unit, replace the TC or replace the ID unit.

(16-3) Error caused by the defective mechanism

Check item	Check work	Action to be taken at NG
<b>(16-3-1) Mechanical load applied to the ID unit</b>		
ID unit	Check if a heavy mechanical load is being applied to the ID unit due to breakage of the waster toner belt, or not.	Replace the ID unit. If any attempt of using new ID unit as a trial is going to be made, be sure to use the System Maintenance Menu FUSE KEEP MODE.
<b>(16-3-2) Motor operating condition</b>		
ID motor	Confirm that the respective ID motors work normally or not by using the Motor & Clutch Test of the self-diagnostic mode. Check if any extra load exists or not.	Replace the PU board or the ID motor.

7.5.4. (17) Fuse cut error (error codes C3EA,C3EB,C3EC,C3ED,C3E2,C4C0)

(17-1) Fuse cut error

Check item	Check work	Action to be taken at NG
<b>(17-1-1) Check the system connection</b>		
FFC connecting the PU board and the toner sensor board (PRZ PCB)	Check if the connector is connected in the half-way only or not, and is inserted in a slanted angle or not at the SSNS connector ⑮ of the PU board, and at the SSNS connector ⑯ of the toner sensor board (PRZ PCB). Check if FFC has open-circuit of sheath of the FFC has not peeled off or not.	Connect the FFC normally. Alternately, replace the FFC.
<b>(17-1-2) Fuse cut circuit</b>		
PU board	Upon completion of the system connection check, turn off the power once and back on. The, check if the error occurs or not.	Replace the PU board.

7.5.4. (18) Humidity sensor error (error code CE51)

(18-1) Humidity sensor error

Check item	Check work	Action to be taken at NG
<b>(18-1-1) Check the system connection</b>		
Connection between the PU board and Environment sensor Board MFH	Check if the 6-conductor FFC is connected to the ENV connector ⑭ of the PU board normally or not. Check if the 6-conductor FFC is connected to the CN connector ⑰ of the Board MFH normally or not. Check if the connector is connected in the half-way only or not, and check if the connector is inserted in a slanted angle or not.	Re-connect the cable normally.
FFC connecting the PU board and the Operator Panel board	Check for open-circuit with VOM. Check that peeling off of sheath does not occur in any cables by visual inspection.	Replace the FFC with the normal FFC.
<b>(18-1-2) Environment condition</b>		
Sharp change of environment condition	Is the environment condition changed sharply from a low temperature environment to a high environment condition within a short time? (Example is such a case that a printer is moved from storage condition of a cold area in winter to an office environment.)	Leave a printer for around one hour in the new environment to get used to the new environment. After that, turn on the power again. Before turn on the power, touch the metal panel of the controller panel and the metal plate inside a printer to feel temperature increase inside a printer with human hands. After confirmation that the printer temperature has increased close to the room temperature, turn on the power again.

7.5.4. (19) LCF Paper feed jam (error code E190)

(19-1) LCF paper feed jam occurs immediately after the power is turned on.

Check item	Check work	Action to be taken at NG
<b>(19-1-1) Check condition of the paper running path</b>		
Paper running path of the LCF Unit	Open the Paper cassette of LCF and check if paper is not jammed in the paper running path.	Remove the jammed paper.
Paper running path of the front unit	Open the front cover and check if paper is not jammed in the paper running path.	Remove the jammed paper.
<b>(19-1-2) Check condition of the mechanical parts</b>		
Check the sensor lever of LCF Hopping Sensor and that of LCF In Sensor.	Check if shape and movement of the sensor levers have any abnormality or not.	Replace the sensor with the good sensor lever.
Check the LCF Hopping Sensor and the LCF In Sensor.	Check if the photosensors are installed certainly.	Install the photosensor certainly.
<b>(19-1-3) Check condition of the electrical parts</b>		
Check the detection condition of the sensor signal on the LCF Hopping Sensor and the LCF In Sensor.	Confirm that the sensor signals are normally detected by using the Maintenance Menu SWITCH SCAN function.	Replace either the LCF board or the connection cable.
Check the connector of the connection cable.	Confirm that the connectors of the connection cable are jointed surely.	Joint the connectors surely.

(19-2) LCF paper feed jam occurs immediately after the paper feed is started.

Check item	Check work	Action to be taken at NG
<b>(19-2-1) Check condition of the paper running path</b>		
Paper running path of the LCF Unit	Open the Paper cassette of LCF and check if paper is not jammed in the paper running path.	Remove the jammed paper.
Paper guide of 1st Tray	Open the 1st Tray and check the paper guide position.	Set the paper guide of 1st Tray to correct position.
Paper guide of 2nd Tray (when 2nd Tray is set)	Open the 2nd Tray and check the paper guide position.	Set the paper guide of 2nd Tray to correct position.
Paper running path of the front unit	Open the front cover and check if paper is not jammed in the paper running path.	Remove the jammed paper.
<b>(19-2-2) Check condition of the mechanical parts</b>		
Check the sensor lever of LCF Hopping Sensor and that of LCF In Sensor.	Check if shape and movement of the sensor levers have any abnormality or not.	Replace the sensor with the good sensor lever.
Check the LCF Hopping Sensor and the LCF In Sensor.	Check if the photosensors are installed certainly.	Install the photosensor certainly.
Check the feed roller with gear, the pickup roller with no gear and the separation roller of the paper cassette.	Check if any foreign materials such as paper dust on the surface of the feed roller with gear or the pickup roller with no gear or the separation roller or not.	Remove the foreign material.
	Check if the feed roller with gear or the pickup roller with no gear or the separation roller have worn out or not.	Replace the feed roller with gear or the pickup roller with no gear or the separation roller.
<b>(19-2-3) Check condition of the electrical parts</b>		
LCF paper feed motor	Confirm that the paper feed motor works normally by using the Motor & Clutch Test of the self-diagnostic mode.	Replace the LCF board, or replace the LCF paper feed motor.

Check item	Check work	Action to be taken at NG
<b>(19-2-4) Check condition of the electrical parts</b>		
Check the LCF paper feed motor driver	Remove the MOTOR connector of the LCF board and check the followings at the connector side. Several MΩ between pin-1 - FG Several MΩ between pin-2 - FG Several MΩ between pin-3 - FG Several MΩ between pin-4 - FG	Replace the LCF board.
<b>(19-2-5) Check the connection system</b>		
LCF paper feed motor drive cable connection	Check the connection condition of the cable. Check if the connector is connected in the halfway only or not, and check if the connector is inserted in a slanted angle or not. Check also with eyes that cables are assembled without any abnormality.	Normalizes the connection condition. Replace the cable with the good cable.
LCF paper feed motor drive cable bite	Check that any cable is not bitten during assembling of the LCF unit. Remove the MOTOR connector of the LCF board and check the followings at the cable side. Short circuit between pin-1 - FG Short circuit between pin-2 - FG Short circuit between pin-3 - FG Short circuit between pin-4 - FG	Replace the cable with the good cable that normalizes the connection condition.
LCF paper feed motor	Remove the MOTOR connector of the LCF board and check that approx. 2.8kΩ can be each measured between pin-1 -pin-2, and between pin-3 -pin-4.	Replace the paper feed motor.
<b>(19-2-6) Clutch operation check</b>		
LCF paper feed clutch	Confirm that the paper feed clutch or regist clutch works normally by using the MOTOR & Clutch Test of the self-diagnostic mode.	Replace the LCF board, or replace the paper feed clutch or the regist clutch.
LCF paper feed clutch cable	Check the connection condition of the cable. Check if the connector is connected in the halfway only or not, and check if the connector is inserted in a slanted angle or not. Check also with eyes that cables are assembled without any abnormality.	Normalizes the connection condition. Replace the cable with the good cable.
LCF paper feed clutch cable bite	Check that any cable is not bitten during assembling of the LCF unit. Remove the CL1 connector or the CL2 connector of the LCF board and check the followings at the cable side. Short circuit between pin-1 - FG Remove the CL1 connector or the CL2 connector of the LCF board and check that approx. 240Ω can be measured between pin-1 and pin-2.	Replace the clutch and reassemble the LCF correctly.

7.5.4. (20) Wiring diagram

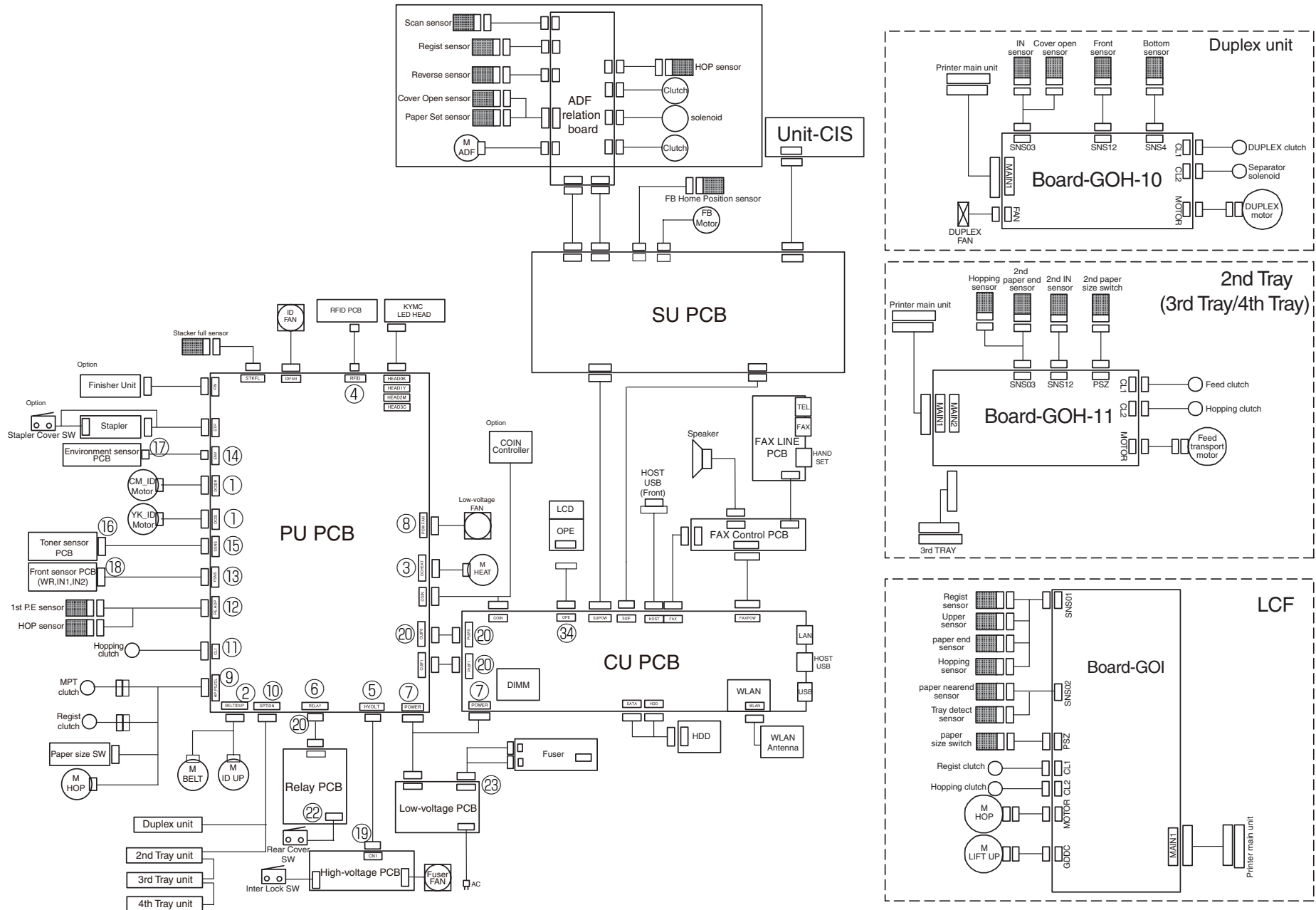

### 7.5.5 Troubleshooting the abnormal images

- (1) Color has faded-out and blurred entirely. (Refer to Figure 7-2A.) .....200
  - (1-1) Color are faded-out and blurred. ....200
- (2) Stain on white print (Refer to Figure 7-2B.) .....201
  - (2-1) Stain on white print (Partial stain) .....201
  - (2-2) Stain on white print (overall stain).....201
- (3) White print (Refer to Figure 7-2C.).....202
  - (3-1) White print over entire page.....202
- (4) Black banding/black streaking in vertical direction .....203
  - (4-1) Thin vertical line (with color) (Refer to Figure 7-2D.) .....203
  - (4-2) Thin vertical line (without color) (Refer to Figure 7-2F.) .....203
- (5) Cyclic abnormality (Refer to Figure 7-2E.) .....203
  - (5-1) Cyclic abnormality occurs in vertical direction .....203
- (6) Heavy color registration error .....204
  - (6-1) Display of the message "Color adjustment is in progress" appears only short time. ....204
  - (6-2) Though REG ADJUST TEST of engine maintenance function is ok, color blur occurs .....204
  - (6-3) Though REG ADJUST TEST of engine maintenance function is NG .....204
- (7) Entirely black print.....205
  - (7-1) All black print over entire page.....205

**Note!** When an attempt is going to be made to replace the PU board, read data contents of the EEPROM chip from the old PU board beforehand, and copy the data contents into the new board after the new PU board is installed.

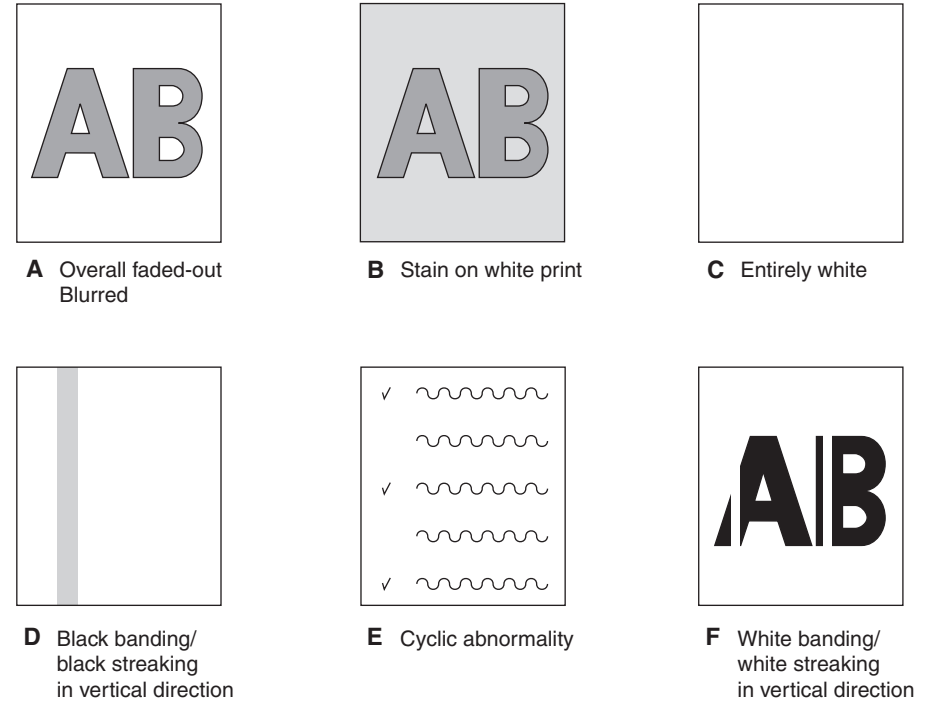

Figure 7-2

7.5.5.(1) Color has faded-out and blurred entirely. (Refer to Figure 7-2A.)

(1-1) Color are faded-out and blurred.

Check item	Check work	Action to be taken at NG
<b>(1-1-1) Toner</b>		
Remaining amount of toner	Check if the message "Prepare toner replacement." or "Replace the toner." appears or not.	Replace toner cartridge with new one.
Tape attached to the toner cartridge opening slot	Check to see that the tape attached to the toner cartridge opening slot has been peeled off.	Move the toner cartridge lever to CLOSE position and remove tape from opening slot.
<b>(1-1-2) LED head</b>		
Lens of the LED head	Check if surface of the lens of the LED head is stained or not by toner and paper dust.	Clean the lens with soft tissue paper.
Mounting condition of LED head	Check that the LED head is mounted on the LED head holder correctly. Check that the right and left tension springs are normally installed.	Correct for normal condition.
<b>(1-1-3) Print media</b>		
Media type	Check to see that the print media which is used for printing is not a specially thick media, and driver setting.	Use the normal paper.
<b>(1-1-4) High voltage terminal</b>		
ID unit terminal	Check that the high voltage terminal of the ID unit is contacting with the Contact Assembly normally by visual inspection. (Refer to Figure 7-3.)	Replace the ID unit or correct the high voltage terminal. If any attempt of using new ID unit as a trial is going to be made, be sure to use the System Maintenance Menu FUSE KEEP MODE.

Check item	Check work	Action to be taken at NG
<b>(1-1-5) ID unit installation condition</b>		
ID unit DOWN position (Defective transfer)	Move the ID unit in and out with hand to confirm that any abnormal mechanical load does not exist, and the ID unit can be moved down to the DOWN position normally. If a piece of paper is inserted in between drum and belt, if top end of the paper can enter easily, it is NG (No Good).	Check the U-shaped groove of the side plate for any abnormality. If repair is found impossible, replace the equipment.



7.5.5.(2) Stain on white print (Refer to Figure 7-2B.)

(2-1) Stain on white print (Partial stain)

Check item	Check work	Action to be taken at NG
<b>(2-1-1) ID unit</b>		
Exposure of drum to light	Is the drum left in a circumstance in which drum surface is exposed to direct light for a long time?	Replace the ID unit. If any attempt of using new ID unit as a trial is going to be made, be sure to use the System Maintenance Menu FUSE KEEP MODE.
Leakage of toner	Does toner leak out from either ID unit or from toner cartridge?	Replace the ID unit or toner cartridge. If any attempt of using new ID unit as a trial is going to be made, be sure to use the System Maintenance Menu FUSE KEEP MODE.
<b>(2-1-2) Fuser unit</b>		
Offset toner of the fuser unit	Check if the offset toner of the previous printing is left adhered on the fuser unit or not, by visual inspection.	Repeat blind printing using unwanted media until offset toner is created on print media. Alternately replace the fuser unit. If any attempt of using new fuser unit as a trial is going to be made, be sure to use the System Maintenance Menu FUSE KEEP MODE.

(2-2) Stain on white print (overall stain)

Check item	Check work	Action to be taken at NG
<b>(2-2-1) Print media</b>		
Type of print media	Check to see that the print media which is used for printing is not a specially thin media.	Use the normal paper.
<b>(2-2-2) High voltage terminal</b>		
ID unit terminal	Check that the high voltage terminal of the ID unit is contacting with the Contact Assembly normally by visual inspection. (Refer to Figure 7-3.)	Replace the ID unit or correct the high voltage terminal. If any attempt of using new ID unit as a trial is going to be made, be sure to use the System Maintenance Menu FUSE KEEP MODE.

7.5.5.(3) White print (Refer to Figure 7-2C.)

(3-1) White print over entire page

Check item	Check work	Action to be taken at NG
(3-1-1) Toner condition		
Remaining amount of toner	Confirm that sufficient amount of toner remains inside the toner cartridge.	Replace the toner cartridge.
(3-1-2) Exposure condition to light		
LED head	Confirm that the LED head is positioned in the normal position where the LED head opposes again the drum when the cover is closed. Check that no obstacle exists in front of the LED head, that hampers light emission from the illuminating surface of the LED head.	Correct the installation condition of the LED head.
Connecting condition of the LED head	Check that the LED head is normally connected.	Replace the LED head.
Drum shaft	Check that the drum shaft keeps contacting with the right and left side plates normally.	Replace the ID unit. If any attempt of using new ID unit as a trial is going to be made, be sure to use the System Maintenance Menu FUSE KEEP MODE.
F8,F9 fuse on the PU board	Measure resistance of F8,F9. 1 ohm or less: Normal Higher than 1 ohm: NG	Replace the PU board

Check item	Check work	Action to be taken at NG
(3-1-3) High voltage terminal		
ID unit terminal	Check that the high voltage terminal of the ID unit is contacting with the Contact Assembly normally by visual inspection. (Refer to Figure 7-3.)	Replace the ID unit or correct the high voltage terminal. If any attempt of using new ID unit as a trial is going to be made, be sure to use the System Maintenance Menu FUSE KEEP MODE.

7.5.5.(4) Black banding/black streaking in vertical direction

(4-1) Thin vertical line (with color) (Refer to Figure 7-2D.)

Check item	Check work	Action to be taken at NG
<b>(4-1-1) ID unit condition</b>		
Filming of the ID unit	Is print attempted without toner?	Replace toner cartridge with new one. If replacement does not solve the problem, replace the ID unit. If any attempt of using new ID unit as a trial is going to be made, be sure to use the System Maintenance Menu FUSE KEEP MODE.

(4-2) Thin vertical line (without color) (Refer to Figure 7-2F.)

Check item	Check work	Action to be taken at NG
<b>(4-2-1) LED head condition</b>		
LED head	Is any foreign material attached on the light emitting surface of the cell fox lens of the LED head?	Remove the foreign material.
<b>(4-2-2) Condition of paper running path</b>		
Paper running path	Check that any burr that may scatter the unfused toner on the paper running path does not exist.	Remove the burr.

7.5.5.(5) Cyclic abnormality (Refer to Figure 7-2E.)

(5-1) Cyclic abnormality occurs in vertical direction

Check item	Check work	Action to be taken at NG
<b>(5-1-1) Cycle</b>		
Image drum	Check that the cycle is 94.3 mm.	Replace the ID unit*1
Developing roller	Check that the cycle is 39.7 mm.	Replace the ID unit
Toner feed roller	Check that the cycle is 58.4 mm.	Replace the ID unit
Charge roller	Check that the cycle is 37.7 mm.	Replace the ID unit
Roller on top of fuser	Check that the cycle is 90.5mm.	Replace the fuser unit.*2
Fuser belt	Check that the cycle is 96.3 mm.	Replace the fuser unit.*2
Transfer roller	Check that the cycle is 50.3 mm.	Replace the belt unit.*3
		If any attempt of using new consumable item as a trial is going to be made, be sure to use the System Maintenance Menu FUSE KEEP MODE.

\*1:If stains could see on the Image drum, wipe the Image drum with a soft cloth lightly. If stains could not wipe with a dry cloth, dust a few toner on the cloth. Do not use the cloth moistened with water or alcohol. It is possible that damage to Image drum. Confirm the printing quality after cleaning.If occur abnormal images, change to new image drum.

\*2:If stains could see on the Fuser rollers and belt, wipe the rollers and belt with a soft cloth lightly when Fuser unit is cool.Confirm the printing quality after cleaning.If occur abnormal images, change to new Fuser Unit.

\*3:If stains could see on the Transfer belt, wipe the Transfer belt with a soft cloth lightly.Confirm the printing quality after cleaning.If occur abnormal images, change to new Belt unit.

## 7.5.5.(6) Heavy color registration error

(6-1) Display of the message "Color adjustment is in progress" appears only short time.

Check item	Check work	Action to be taken at NG
(6-1-1) Result of color registration error correction		
Color registration error correction time (If a printer is normal, it is approx. 40 seconds.)	Use the self-diagnostic mode and execute the REG ADJUST TEST. Check the result. Error is issued but is not displayed on the ON LINE display.	Replace the sensor that causes the error. Clean the sensor to remove stain. Replace the shutter. Replace the PU board.
(6-1-2) Toner		
Remaining amount of toner	Check if the message "Prepare toner replacement." or "Replace the toner." appears or not.	Replace toner cartridge with new one.
(6-1-3) Color registration error detection sensor		
Sensor is dirty	Is toner or paper dust attached to the sensor?	Clean the sensor to remove stain
(6-1-4) Color registration error detection sensor shutter		
Shutter operation is faulty	Check the shutter operation by the self-diagnostic mode	Replace the shutter or tune the mechanism

(6-2) Though the color registration correction test(REG ADJUST TEST) in self-diagnostic mode is ok, color blur occurs

Check item	Check work	Action to be taken at NG
(6-2-1) Paper feed system		
Paper feed system of the paper running path	Check if any obstacle exists in the paper feeding path, that hampers smooth paper run.	Remove the obstacle

(6-3) Though the color registration correction test(REG ADJUST TEST) in self-diagnostic mode is NG.

Check item	Check work	Action to be taken at NG
(6-3-1) Result of color registration error correction		
Result of color registration error correction	Use the self-diagnostic mode and execute the REG ADJUST TEST. Check the result.	Retry the REG ADJUST TEST.
(6-3-2) LED Head		
Set position of the LED Head	Adjust the position of the LED Heads.	Retry the REG ADJUST TEST.
(6-3-3) ID unit		
Set position of the ID unit	Remove and set the ID units.	Retry the REG ADJUST TEST.
(6-3-4) Transfer belt unit		
Set position of the Transfer belt unit	Remove and set the Transfer belt unit.	Retry the REG ADJUST TEST.
Defectiveness of the Transfer belt unit	Replace the Transfer belt unit.	Retry the REG ADJUST TEST.

7.5.5.(7) Entirely black print

(7-1) All black print over entire page

Check item	Check work	Action to be taken at NG
<b>(7-1-1) High voltage contacting condition</b>		
CH terminal	Check that the terminal coming from the printer body contacts with the high voltage terminal that is located on the left side of the ID unit when viewed from the top by visual inspection.	Replace the terminal of printer side.
CH terminal	Check that the high voltage terminal keeps the normal contacting condition on the high voltage board. Open the left cover and remove the high voltage board. Then, check that the terminal is not installed in the abnormal installation condition.	Correct the installation condition of the terminal to the normal condition.
ID unit terminal	Check that the high voltage terminal of the ID unit is contacting with the Contact Assembly normally by visual inspection. (Refer to Figure 7-3.)	Replace the ID unit or replace the high voltage board or correct the high voltage terminal. If any attempt of using new ID unit as a trial is going to be made, be sure to use the System Maintenance Menu FUSE KEEP MODE.
<b>(7-1-2) High voltage output condition</b>		
CH output	If high voltage probe is available as a maintenance tool, open the left cover, and check the CH output with the high voltage probe from the soldering side of the high voltage board. (The high voltage probe is not an ordinary maintenance tool.)	Replace the high voltage board.

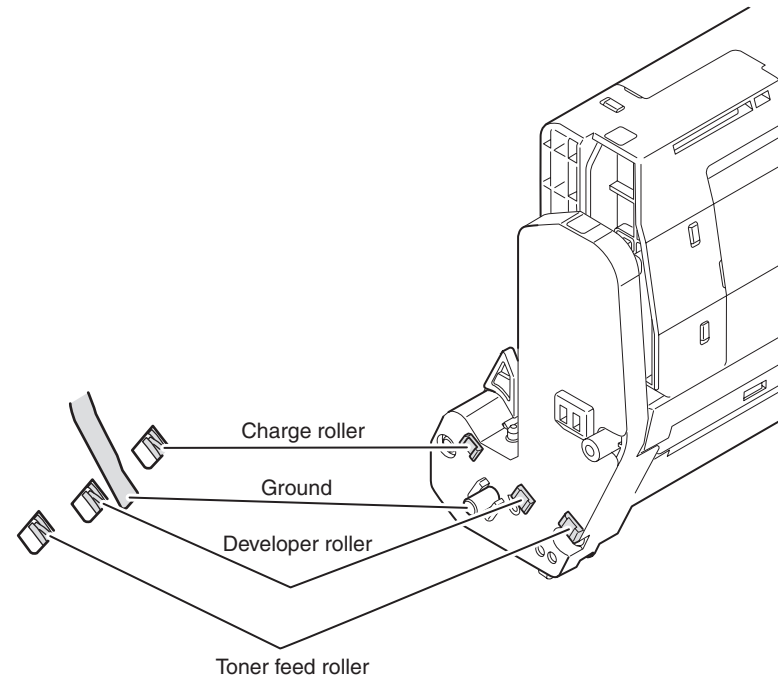

Figure 7-3

## 7.6 Fuse check

If the following error is issued, check the corresponding fuse of the PU/SU control board and high voltage power supply board.

(Refer to Table 7-6.)

Table 7-6 Fuse error

Fuse Name	Error Description		Insert Point	Resistance	
	When booting	After boot up			
PU board	F1	No error. LCD displays warning Up.	Scanner,copy,printer not work	Duplex,2nd/3rd/4th tray +24V	Less than 1 Ω
	F2	It repeats boot start	↑	3.3V DC power	
	F4	It remains the boot screen	↑	Duplex,2nd/3rd tray +5V	
	F5	S/C:C0A2	↑	Interlock,low power supply, Fuser fan	
	F6	No error, Boot normaly	↑	Hopping clutch,pulse motor	
	F7	S/C:C05A	↑	clutch,ID FAN,+24V	
	F8	S/C:CE82	↑	LED Head +3.3V	
	F9	No error	Scanner works normally. printer:miss-print(white paper)	LED Head +5V	
	F10	No error	Scanner ,copy,printer works normally	Stapler +24V	
	SU board	F1	No error	ADF not work, Flatbed scanner works normally	
F2		Attention lamp turns on. 3 beeps sound. Booting looks normally, but it does not work.	Scanner,copy,printer not work	Flatbed motor,Clutch,solenoid	
F3		It remains the boot screen.	↑	SU Controller	

## 7.7 Paper cassette switches versus Paper size correspondence table

(1)TRAY1~4

Dial display size	Bit No.			
	1	2	3	4
TRAY1~4				
Cassette: none	H	H	H	H
Legal 14"	H	L	H	L
Legal 13.5"	H	L	H	H
Legal 13"	L	L	L	H
Letter	L	L	L	L
Executive	L	L	H	L
Blank	L	L	L	L
Folio	H	H	L	L
A4	L	H	L	L
B5	L	H	H	L
A5	H	H	H	L
Not used	L	L	H	H
Not used	L	H	L	H
Not used	H	H	L	H
Not used	H	L	L	H
Not used	L	H	H	H
Not used	H	L	L	L

\* When switch is pressed: Low

(2)LCF

Dial display size	Bit No.			
	1	2	3	4
LCF				
Cassette:none	H	H	H	H
Legal 13.5"	H	L	H	L
Blank	H	L	H	H
Legal 13"	L	L	L	H
Blank	L	L	L	L
Letter	L	L	H	L
Blank	L	L	L	L
A4	H	H	L	L
Blank	L	H	L	L
Legal 14"	L	H	H	L
Blank	H	H	H	L
Not used	L	L	H	H
Not used	L	H	L	H
Not used	H	H	L	H
Not used	H	L	L	H
Not used	L	H	H	H
Not used	H	L	L	L

\*When switch is pressed : Low

# 8. Connection diagrams

---

8.1 Resistance value check .....	209
8.2 Parts location .....	214

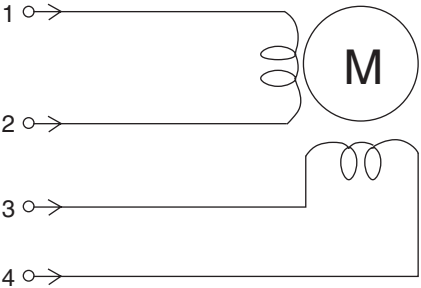
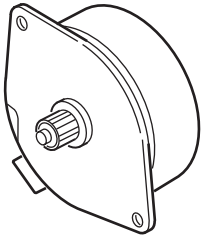
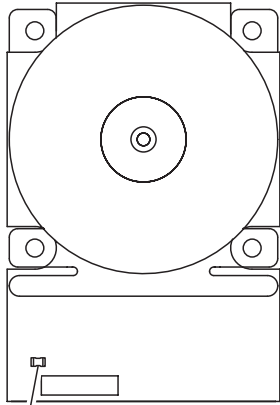
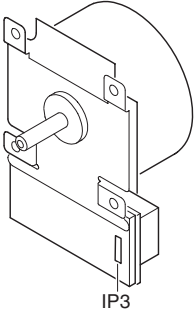

## 8.1 Resistance value check

Unit	Electrical circuit diagram, connection	Part outside view	Resistance value
<p>Transport belt motor</p>			<p>Between pin-1 and pin-2: 3.4Ω Between pin-3 and pin-4: 3.4Ω</p>
<p>ID motor</p>	 <p>IP2</p>	 <p>IP3</p>	<p>Across both ends of IP2 and IP3: 1Ω or less</p>

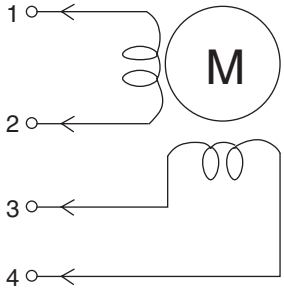
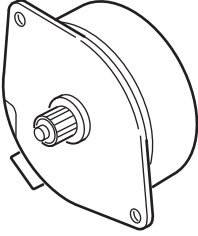
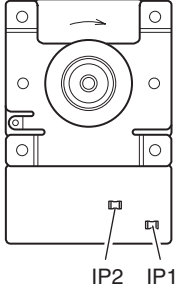
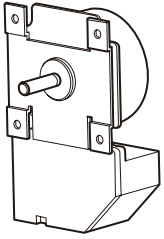
Unit	Electrical circuit diagram, connection	Part outside view	Resistance value
ID up/down motor			<p>Between pin-1 and pin-2: 6.1Ω                      Between pin-3 and pin-4: 6.1Ω</p>
Fuser unit motor			<p>Across both ends of IP1 and IP2: 1Ω or less</p>

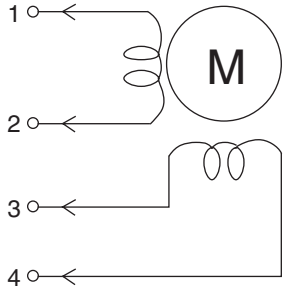
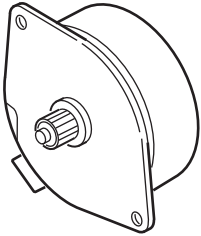
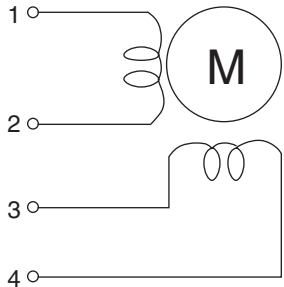
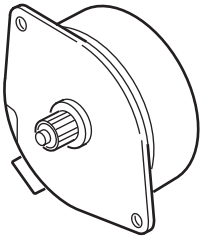
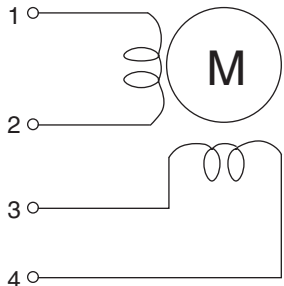
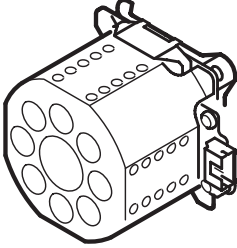
Unit	Electrical circuit diagram, connection	Part outside view	Resistance value
Feed motor			<p>Between pin-1 and pin-2: 3.4Ω Between pin-3 and pin-4: 3.4Ω</p>
Both-sided print motor			<p>Between pin-1 and pin-2: 3.2Ω Between pin-3 and pin-4: 3.2Ω</p>
2nd / 3rd/ 4th tray feed motor			<p>Between pin-1 and pin-2: 2.8Ω Between pin-3 and pin-4: 2.8Ω</p>

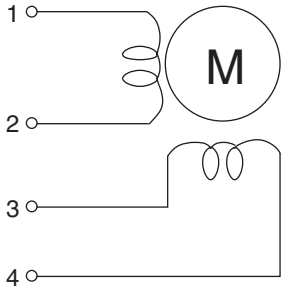
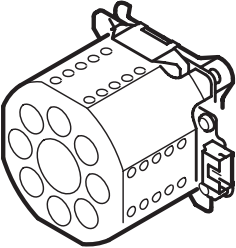
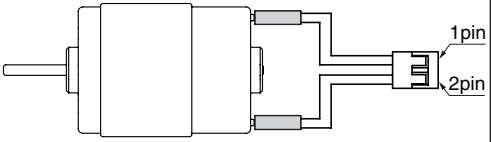
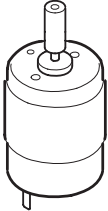
Unit	Electrical circuit diagram, connection	Part outside view	Resistance value
LCF Hopping Motor			<p>Between pin-1 and pin-2: 2.8Ω                      Between pin-3 and pin-4: 2.8Ω</p>
LCF Liftup Motor			<p>Between pin-1 and pin-2: 17 ~ 23Ω</p>

Unit	Electrical circuit diagram, connection	Part outside view	Resistance value
Fuser unit	<p>Upper roller heater #1          (B) - 6</p> <p>Upper roller heater #2          (A) - 6</p> <p>Thermostat          (B) - 1          (A) - 1</p> <p>Upper thermistor          (B) - 4          (B) - 5</p> <p>Lower thermistor          (A) - 2          (A) - 3</p> <p>Frame thermistor          (B) - 2          (B) - 3</p> <p>(A) - 4</p> <p>(A) - 5          Fuse</p>	<p>(A) 2 3 4 5          (+) [ ] (+)          (-) (-)          1 6</p> <p>(B) 2 3 4 5          (+) [ ] (+)          (-) (-)          1 6</p>	<p>Between pins (A)-1 and (A)-6: Several ohms to several ten ohms          Between pins (B)-1 and (B)-6: Several ohms to several ten ohms          Between pins (B)-4 and (B)-5: Approx. 590kΩ to 5338kΩ (0 to 93°C)          Between pins (A)-2 and (A)-3: Approx. 104.5kΩ to 806.5kΩ (0 to 43°C)          Between pins (B)-2 and (B)-3: Approx. 104.5kΩ to 806.5kΩ (0 to 43°C)          Between pins (A)-4 and (A)-5: Open</p>

# 8.2 Parts location

## (1) CU PCB

Component side

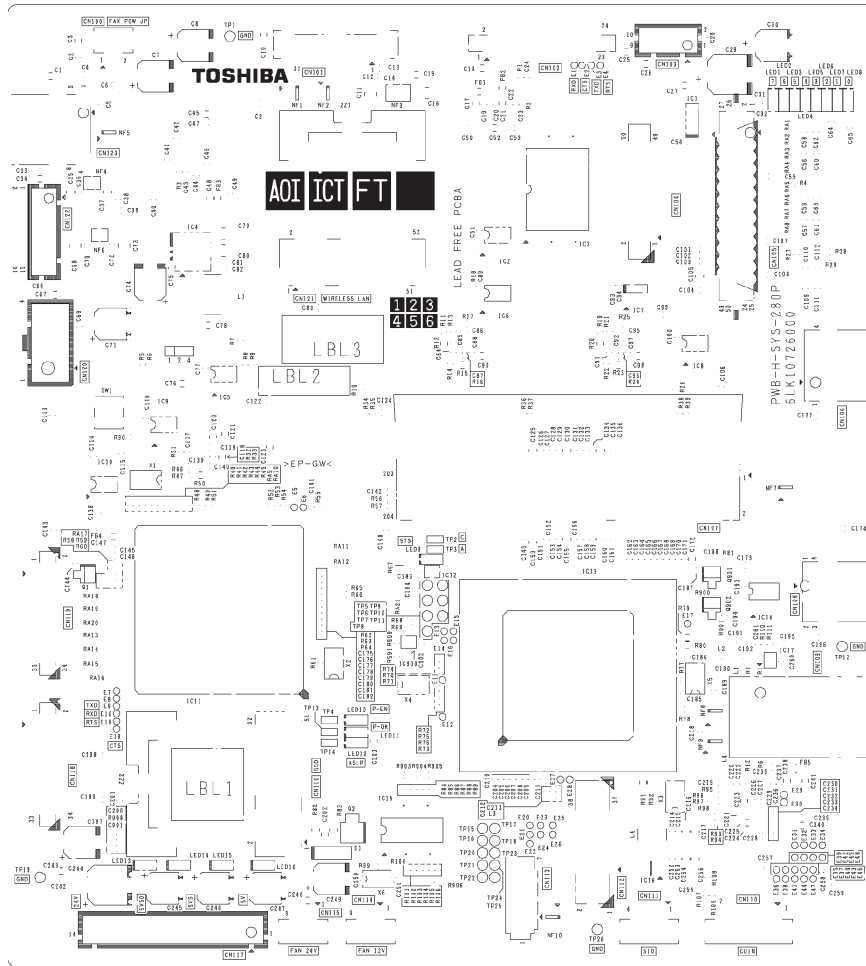

Soldering side

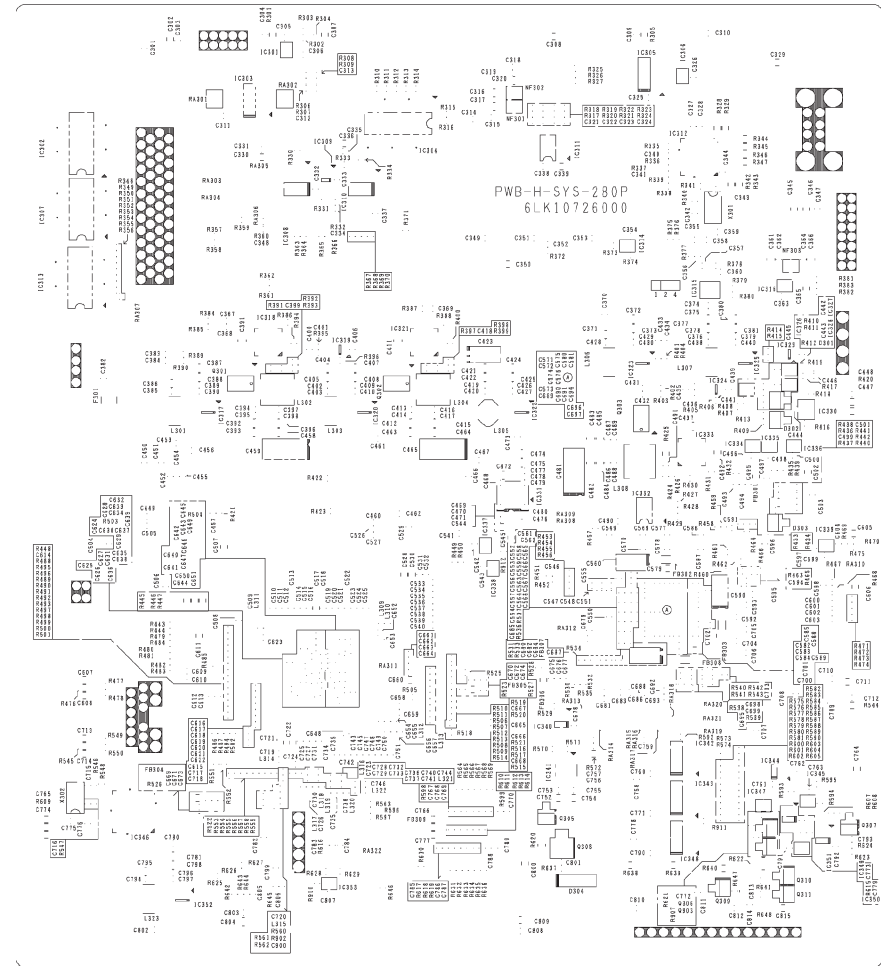

(2) PU PCB

Component side

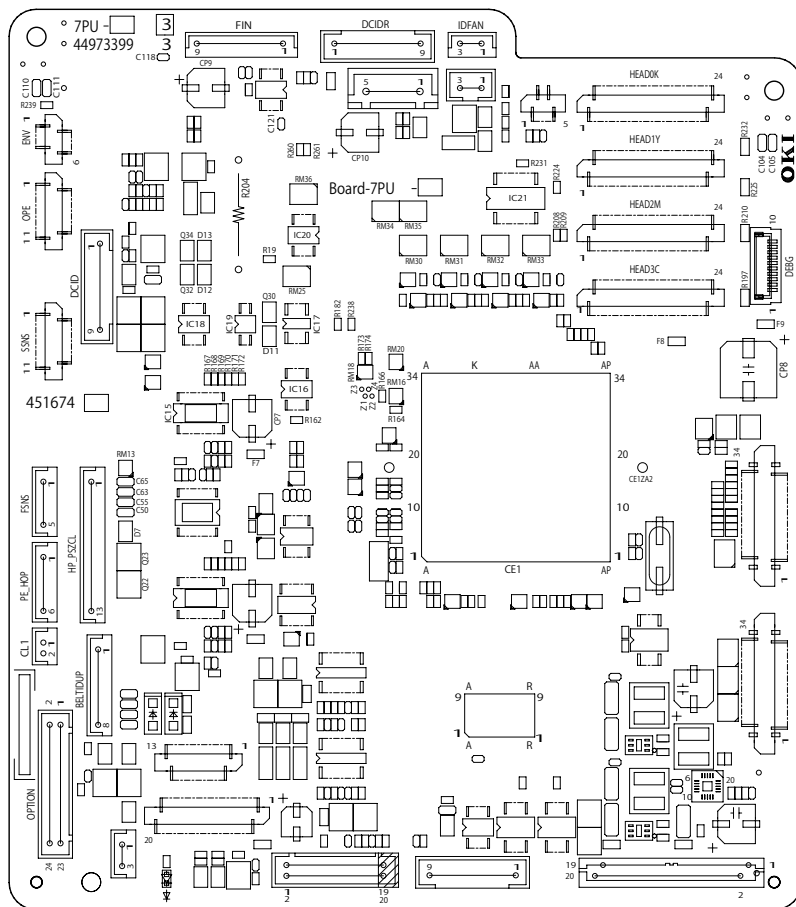

Soldering side

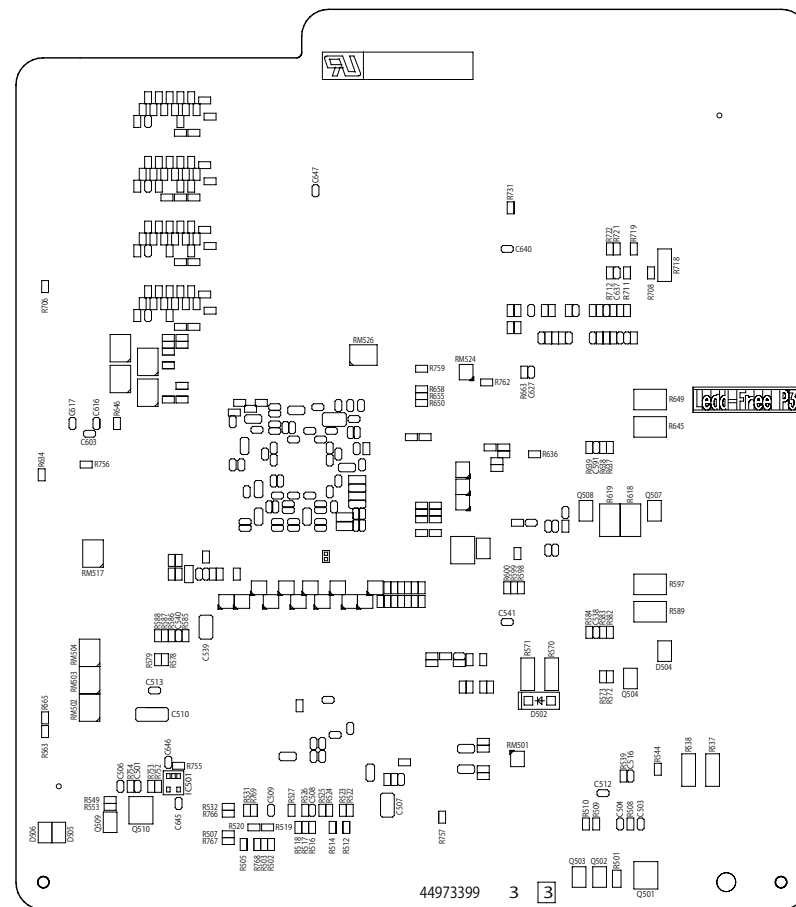

(3) Relay PCB

Component side

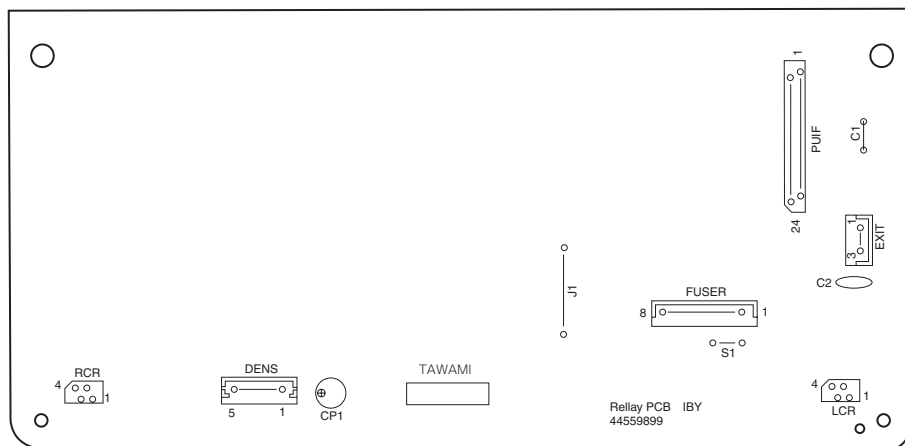

Soldering side

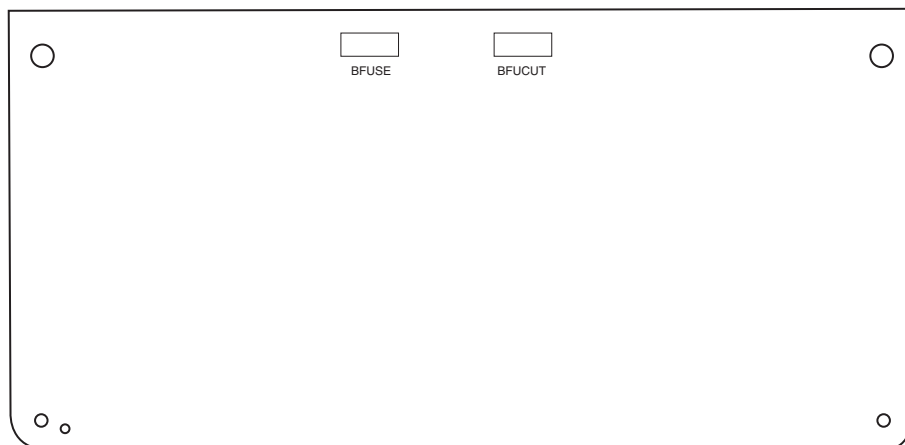



(4) Duplex Print Control PCB

Component side

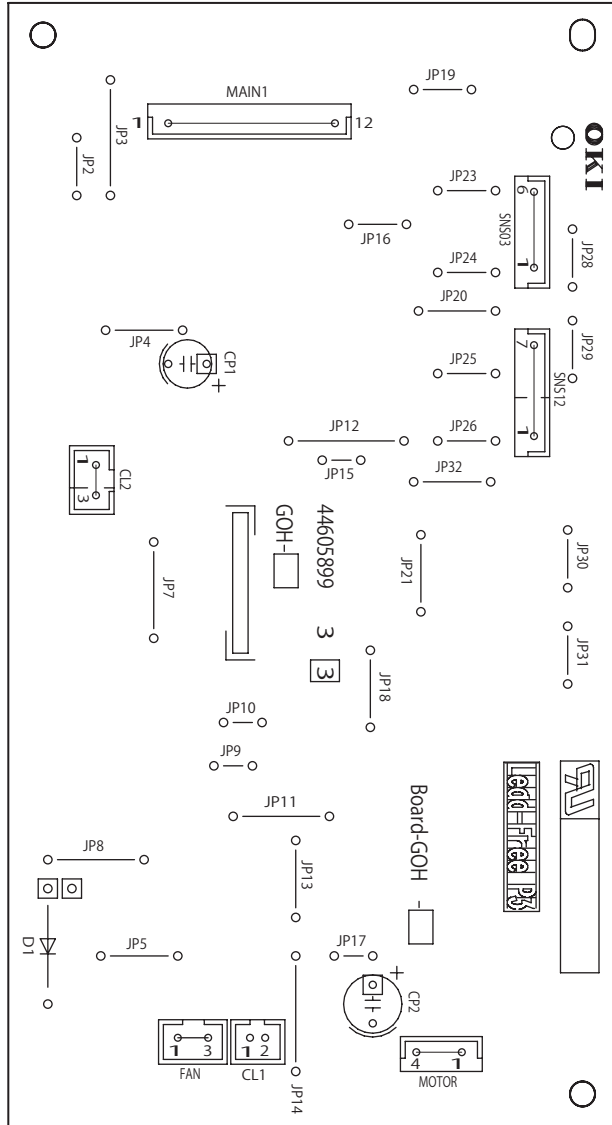

Soldering side

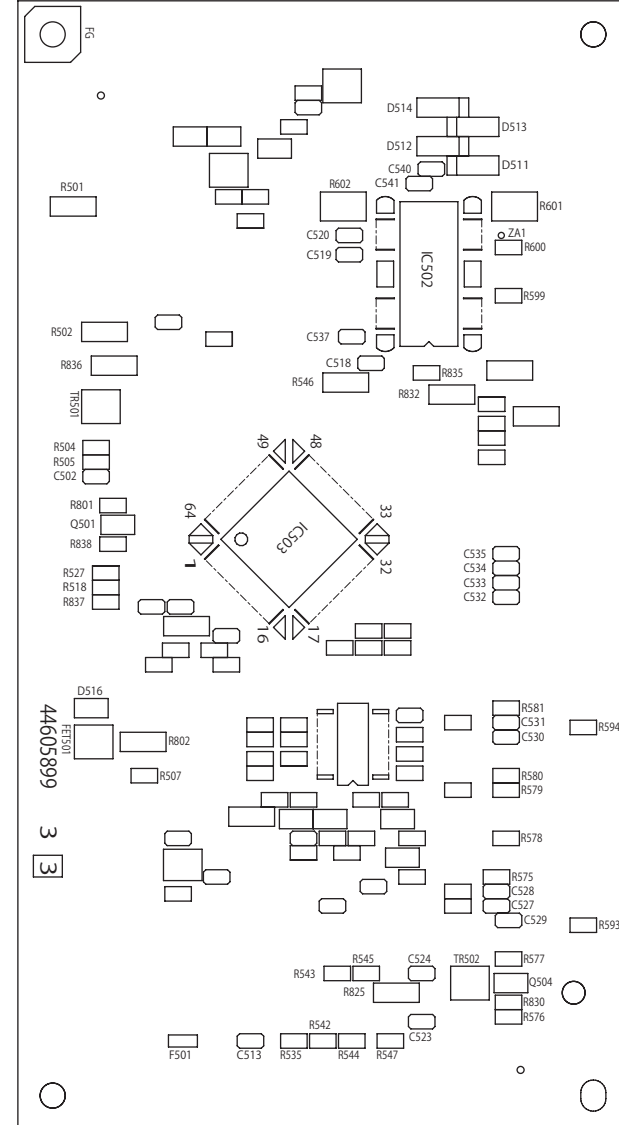

(5) Second Tray Control PCB

Component side

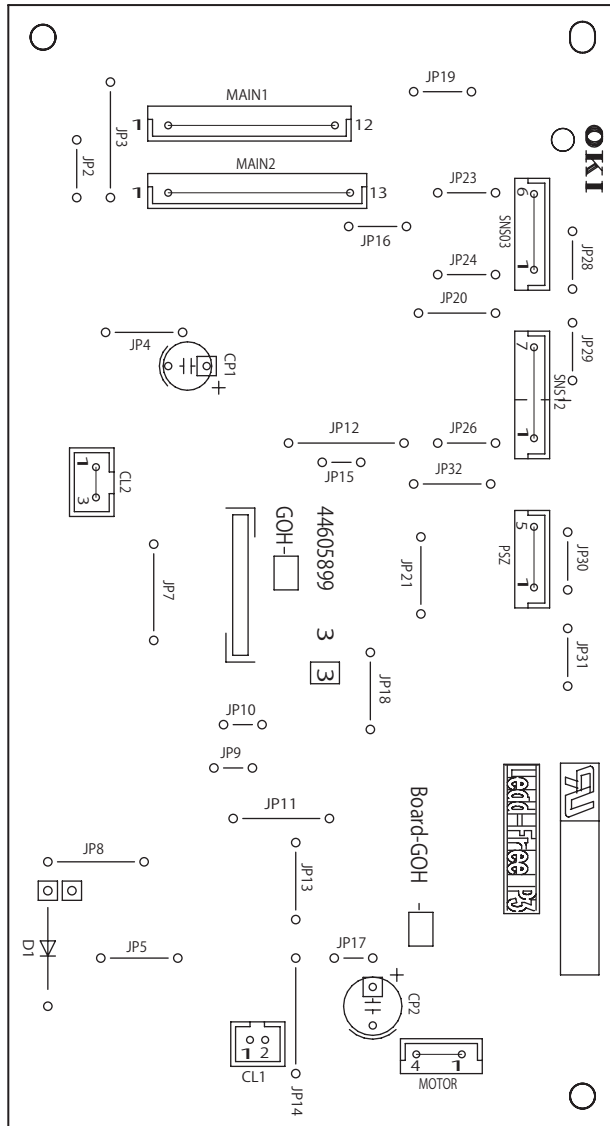

Soldering side

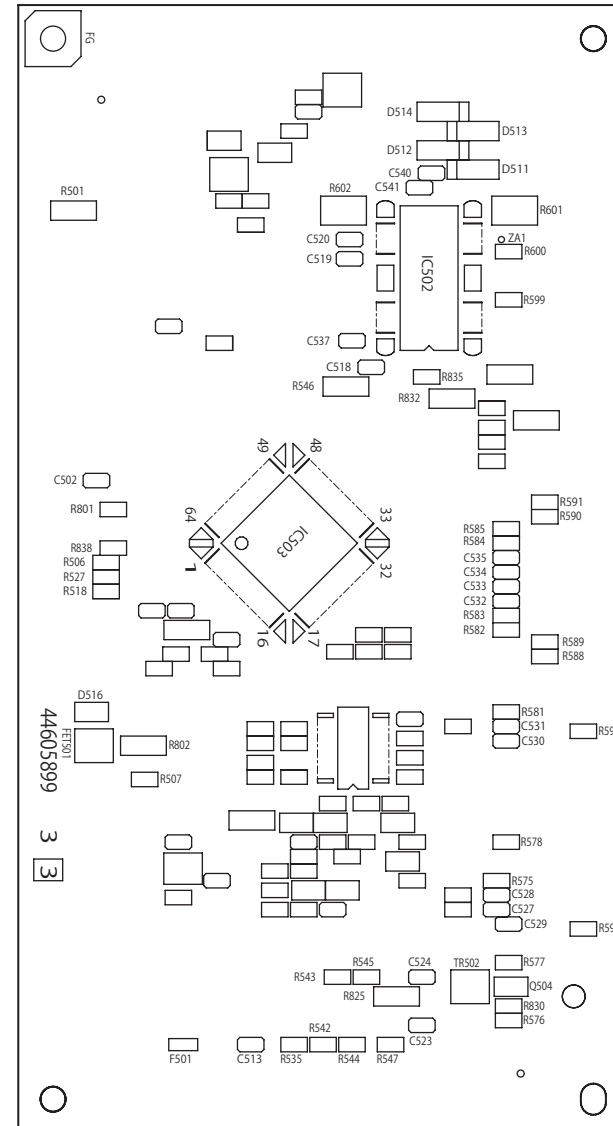

(6) Toner Low Sensor PCB

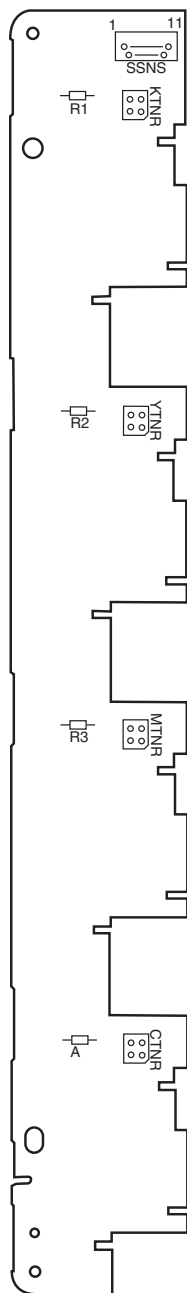

(7) Entrance Sensor PCB

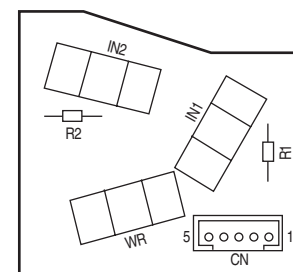

(8) Color Adjustment Sensor PCB

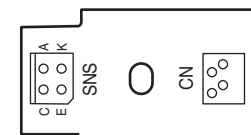

(9) High-Voltage Power Supply PCB

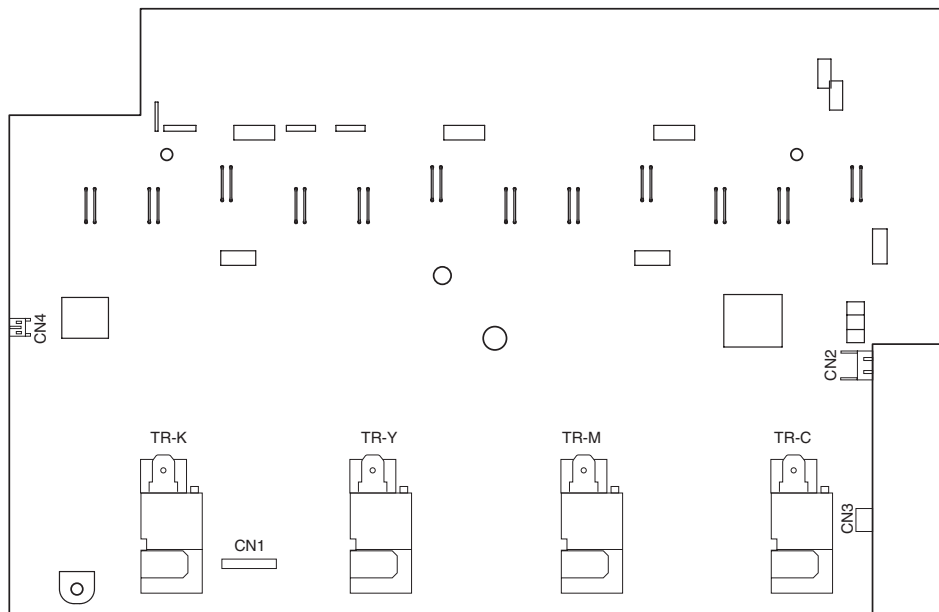

(10) Low-Voltage Power Supply PCB

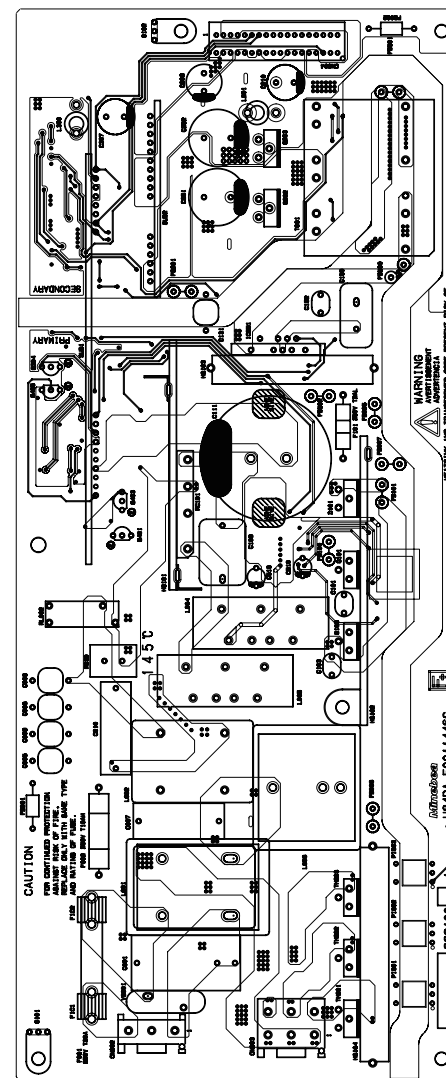

(11) ID unit

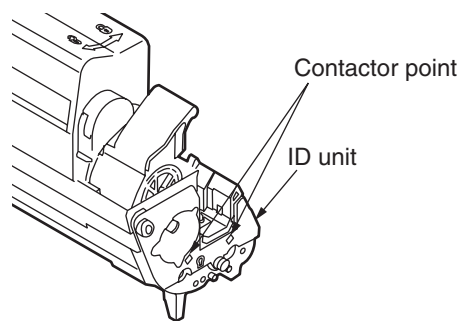
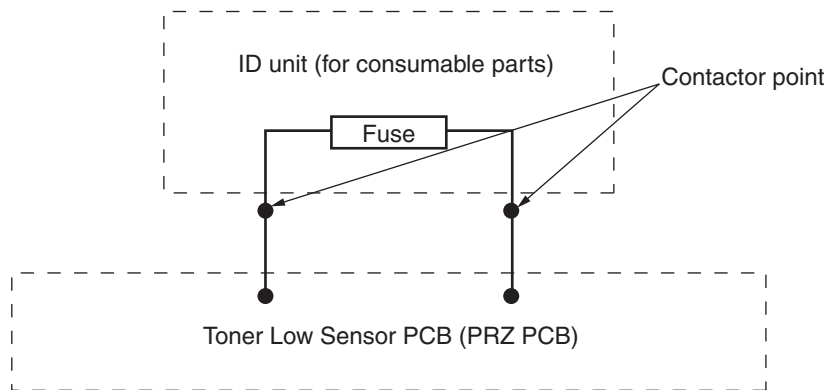

(12) Transfer belt unit

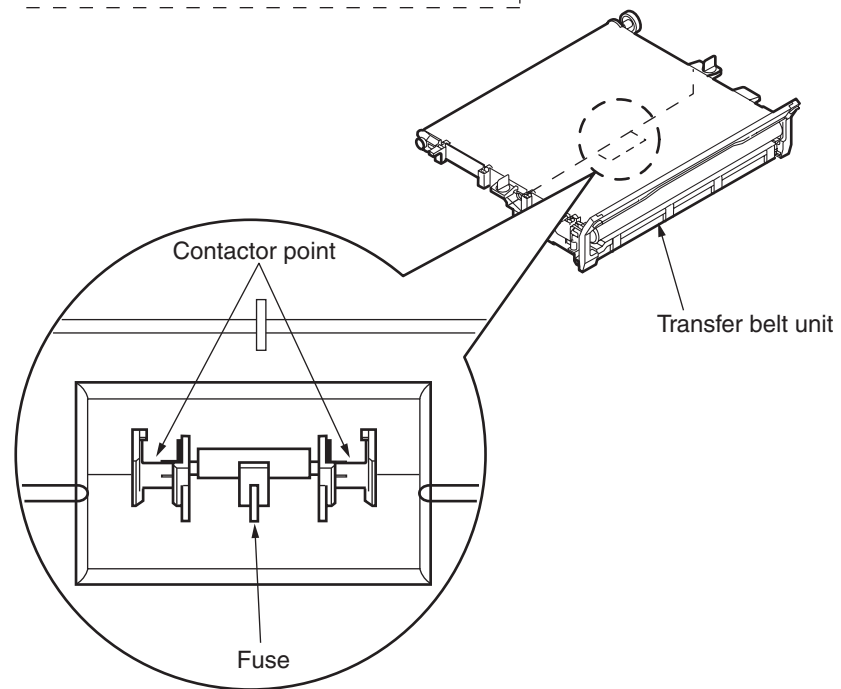
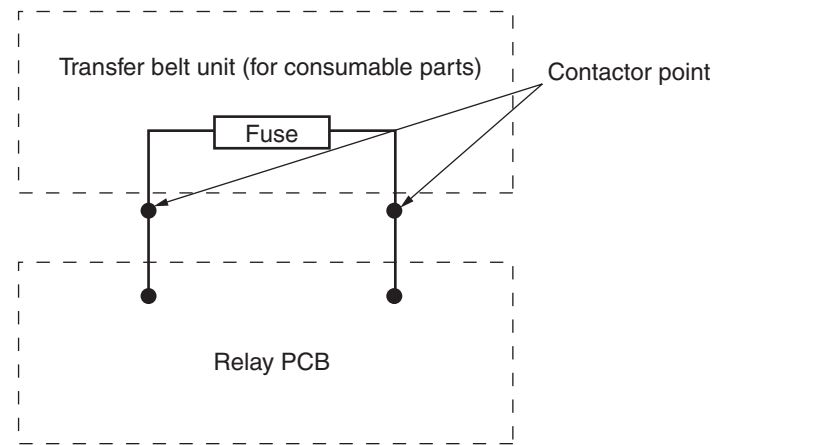

(13)SU Board

Component side

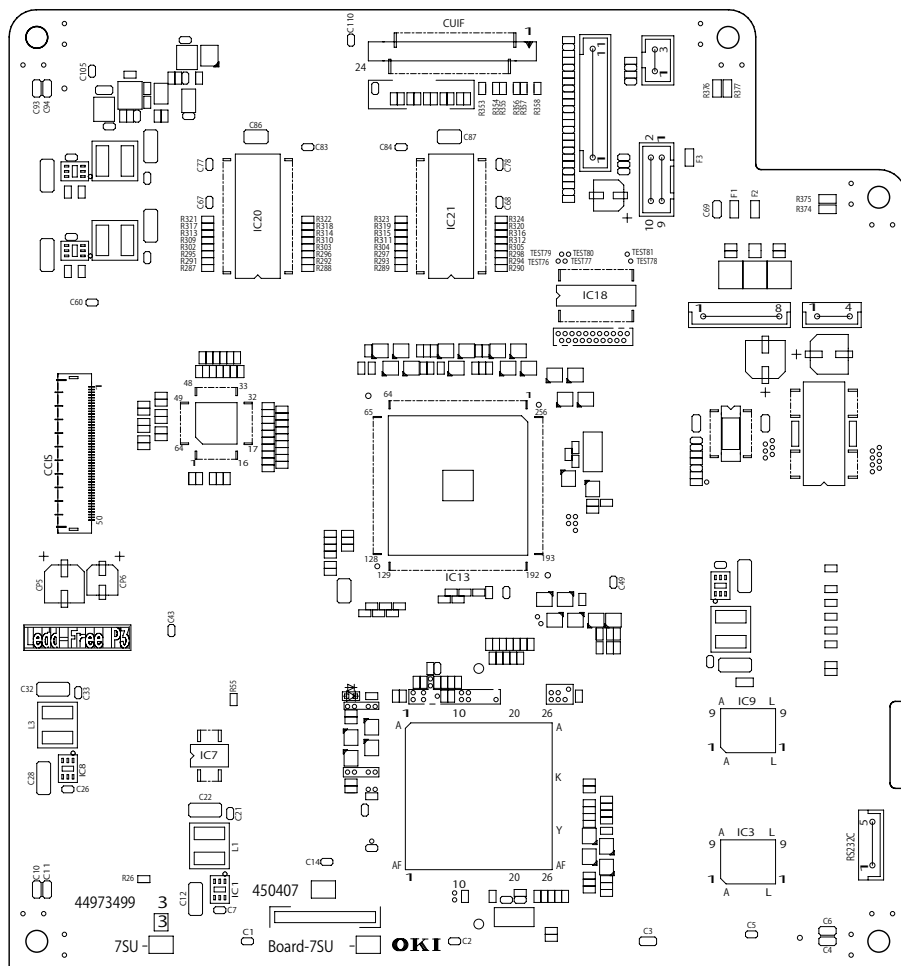

Soldering side

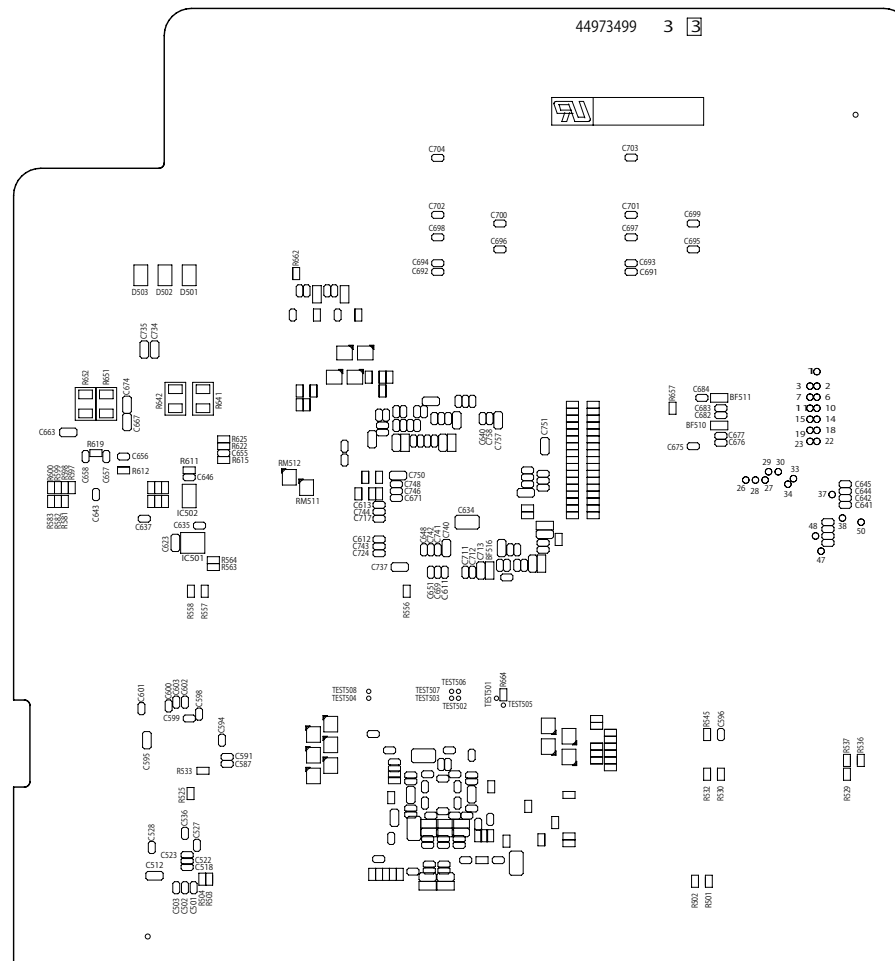

(14) Environment SNS

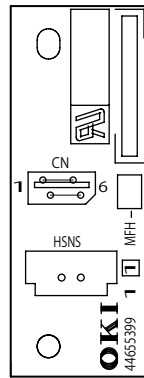

(15) ADF relation board

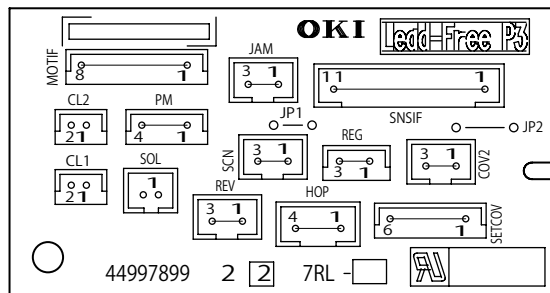

(16) LCF PCB

Component side

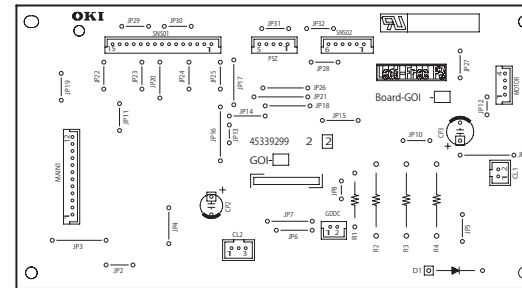

Soldering side

