

MC760 / MC770 / MC780 /
MB760dn / MB770dnf / B721dn / B731dn
LCF Unit

Maintenance Manual

102213A

Copyright Information

Copyright © 2013 by Oki Data. All Rights Reserved

Disclaimer

Every effort has been made to ensure that the information in this document is complete, accurate, and up-to-date. The manufacturer assumes no responsibility for the results of errors beyond its control. The manufacturer also cannot guarantee that changes in software and equipment made by other manufacturers and referred to in this guide will not affect the applicability of the information in it. Mention of software products manufactured by other companies does not necessarily constitute endorsement by the manufacturer.

While all reasonable efforts have been made to make this document as accurate and helpful as possible, we make no warranty of any kind, expressed or implied, as to the accuracy or completeness of the information contained herein.

The most up-to-date drivers and manuals are available from the web site:
<http://www.okiprintingsolutions.com>

PREFACE

This manual explains the maintenance methods of LCF unit optionally installed in the MC760/MC770/MC780/MB760dn/MB770dnf/B721dn/B731dn.

This manual is prepared for the maintenance person. In regard to the handling methods of MC760/MC770/MC780/MB760dn/MB770dnf/B721dn/B731dn, please refer to the User's Manual.

- Note!**
- Contents of this manual is subject to change without notice.
 - While all reasonable efforts have been made to make this document as accurate and helpful as possible, we make no warranty of any kind, expressed or implied, as to the accuracy of the information contained herein. Oki Data assumes no responsibility to the damages caused or claimed to have been caused by the user as a result of repair, adjustment and/or change using this manual.
 - Parts of this product are delicate and can be damaged unless properly handled. We strongly recommend the user to maintain the product at the hand of the registered maintenance person of our company
 - Before starting the maintenance work, please neutralize the static electricity.

1. REPLACEMENT OF PARTS

This chapter describes the procedures of the field replacement of parts, assemblies and units. The procedures are to detach them. Reverse the procedures to attach them.

The reference part numbers used in this manual (such as ① and ②) do not identical to the part numbers in the maintenance disassembly configuration diagram (45393301TL) and RSPL (45393301TR) for the manual.

1.1 Notes on replacement of parts	5
1.2 Part replacement procedure	7

1.1 Notes on replacement of parts

- (1) Prior to replacing a part, unplug the AC cord and the interface cable.
 - (a) Be sure to use the following procedure to unplug the AC cord:
 - ① Turn off the printer [the power switch to the off (O) position].
 - ② Pull out the AC plug of the AC cord from the AC power source.
 - ③ Unplug the AC cord and the interface cable.

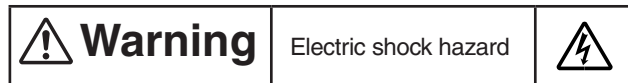

When replacing the low-voltage power supply, electric shock may occur. Wear insulated gloves, or be careful not to touch the conductors or terminals of the power supply directly. After the AC cord is unplugged, the capacitor may take about one minute to discharge completely or, due to PCB breakdown, could not discharge. Use caution about electric shock.

- (b) Always use the following procedure to reconnect the printer:
 - ① Connect the AC cord and the interface cable to the printer.
 - ② Insert the AC plug into the AC power source.
 - ③ Turn on the printer [the power switch to the on (I) position].

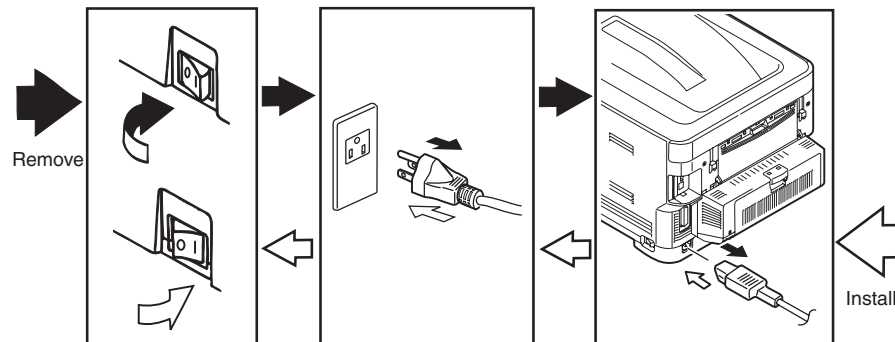

- (2) Do not disassemble the printer so long as it operates properly.
- (3) Minimize disassembly. Do not detach parts not shown in the part replacement procedure.
- (4) Use the replacement tools specified.
- (5) Conduct disassembly in the order instructed, or part damage may occur.
- (6) Removed small parts, such as screws or collars, should be tentatively installed in their original positions.
- (7) Do not use static-prone gloves when handling integrated circuits (ICs), including microprocessors, and ROM and RAM chips, or circuit boards.
- (8) Do not place printed-circuit boards (PCBs) directly on the printer or a floor.



Maintenance Tools:

Table 1-1-1 shows the tools necessary to replace printed-circuit boards and units:

Table 1-1-1: Maintenance Tools

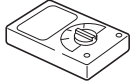
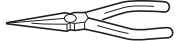
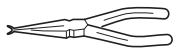
No.	Maintenance Tool	Quantity	Use	Remarks
1	 Phillips screwdriver with magnetic tip, No. 2-200	1	3- to 5-mm screws	
2	 Screwdriver No. 3-100	1		
3	 Digital multimeter	1		
4	 Pliers	1		
5	 E-ring pliers	1	E-shaped ring removal	

1.2 Part replacement procedure

This section describes the procedure for replacing the parts and assemblies shown in the disassembly diagrams below.

1.2.1 Board-GOI,Frame.Assy-Hop etc

- (1) Remove the Screw (silver,No:41723901) ① and remove the Joint ② (2 places),and remove the LCF Unit ③ from the MFP.
(This procedure unnecessary for B721/B731)
- (2) Draw out the Cassette ④ from LCF Unit.

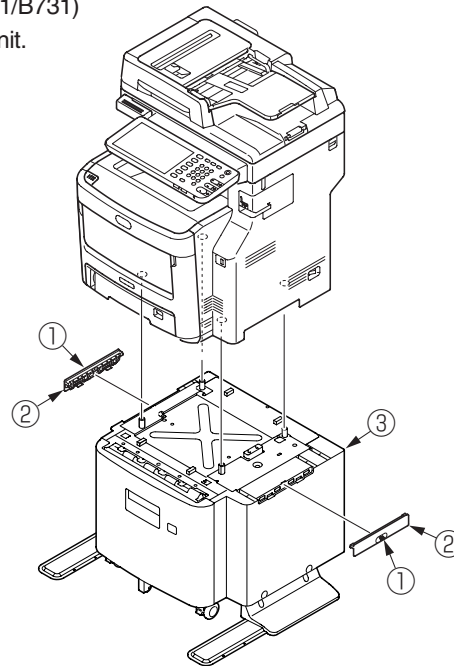

- (3) Remove the ten screws (silver,No:42920408) ⑤ and remove the Cover-Side(L) ⑥ ,Cover-Side(R) ⑦ .
(If the LCF for B721/B731, remove the four screws)
- (4) Remove the four screws (silver,No:42920408) ⑧ and remove the Plate-Joint(L) ⑨ ,Plate-Joint(R) ⑩ .
(This procedure unnecessary for B721/B731)
- (5) Remove the three screws (silver,No:42920406) ⑪ and two screws (black,No:44883906) ⑫ and remove the Plate-Top ⑬ .
(If the LCF for B721/B731, remove the seven screws (silver,No:42920406) and two screws (black,No:44883906))

- (6) Remove all cables ⑮ and connectors from the Board ⑭ .
- (7) Remove the two screws (black,No:44883906) ⑯ and remove the Board-GOI ⑭ .
- (8) Remove the two screws (silver,No:42920406) ⑰ and remove the Plate-Front ⑱ .
- (9) Remove the four screws (black,No:44883906) ⑲ and remove the Frame.Assy-Hop ⑳ .
- (10) Remove the two screws (silver,No:43497603) ㉑ and remove the Connector ㉒ .
- (11) Remove the Claw and remove the Switch ㉓ .
- (12) Remove the four screws (black,No:44883906) ㉔ and remove the Liftup-Motor-Assy ㉕ . Remove the two screws(silver,PSW2W2.6-5C) ㉖ and remove the motor ㉗ .

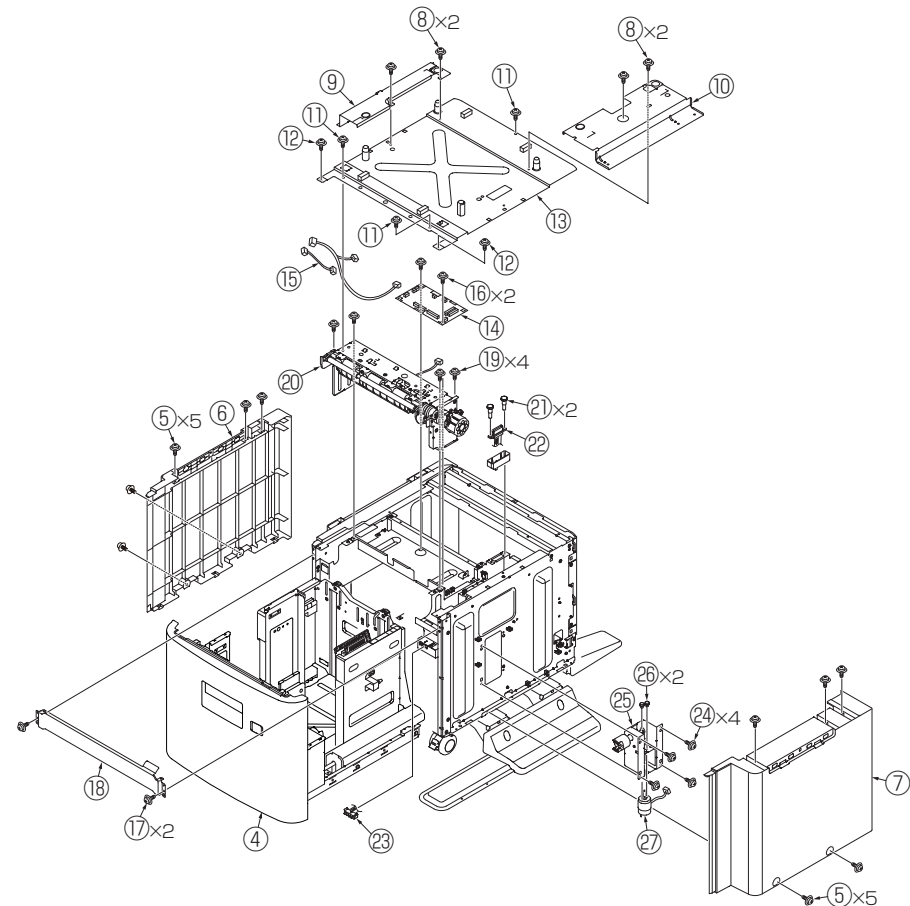

1.2.3 Caster etc

- (1) Draw out the Casstte ① ,remove the six screws (silver, D4-6HH) ② and remove the Cassette ① from LCF Unit.
- (2) Remove the six screws (silver, D4-6HH) ③ and remove the Slide-Rail ④ .
(2 places)
- (3) Remove the three screws (silver, No:42920406) ⑤ and remove the Cover-Front(LCF) ⑥ .
- (4) Remove the four screws (silver, No:42920406) ⑦ and Caster-Assy-Tray ⑧ .
- (5) Remove the twelve screws (silver, No:42937208) ⑨ and remove the two Casters(with lock) ⑩ and remove the two Casters(without lock) ⑪ . (Pay attention to the position of caster, when assembling.)
- (6) Remove the four screws (silver, No:42937210) ⑫ and remove the Cover-Leg-Side ⑬ .(2 places)
- (7) Remove the four screws (silver, No:42937210) ⑭ and remove the Plate-Leg-Assy ⑮ .(2 places)
- (8) Remove the six screws (silver, No:42937210) ⑯ and remove the Leg-Rear ⑰ .
(2 places)

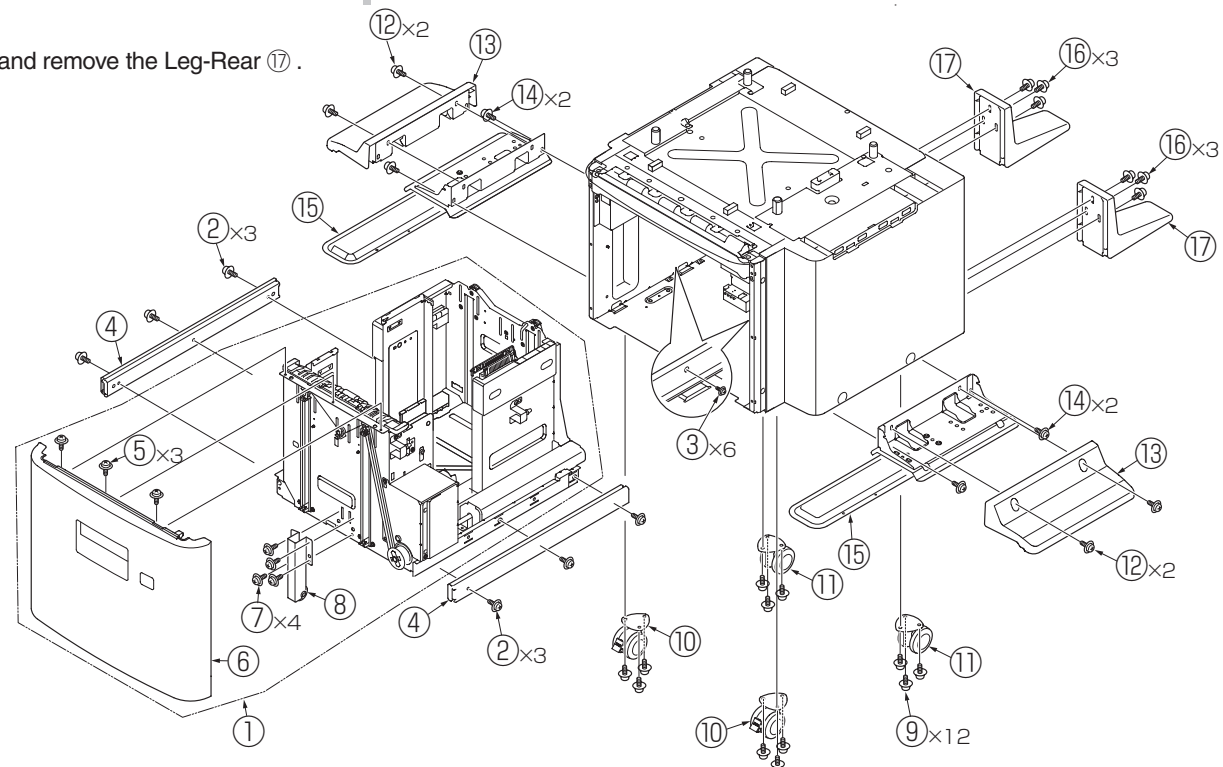

1.2.4 Pickup roller

If the hopping jam occurs frequently, to change the pickup roller and separation roller.

Model name : RS-C4B

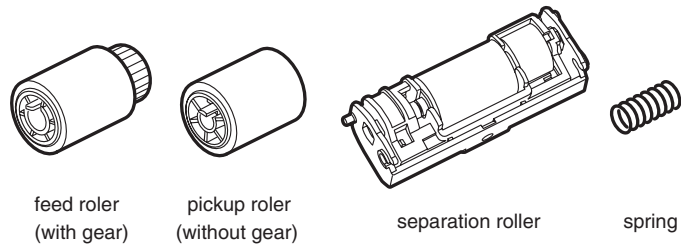

Notes! • If change the roller, to change all rollers.

(1) Draw out the paper tray after the power off the printer.

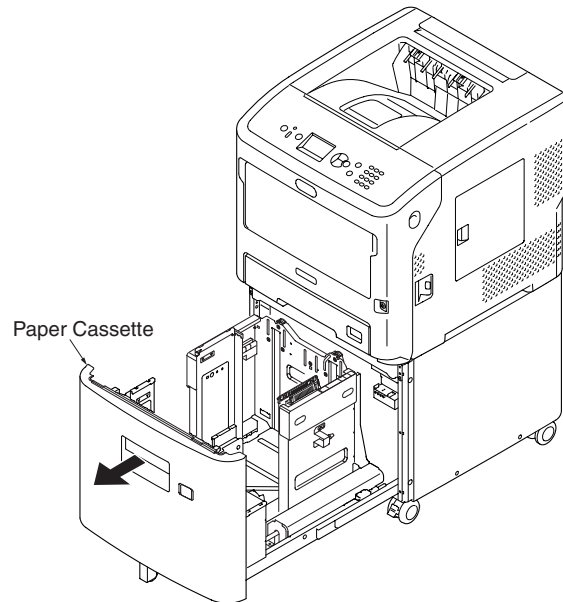

(2) Remove the latch and remove the roller ①, ②

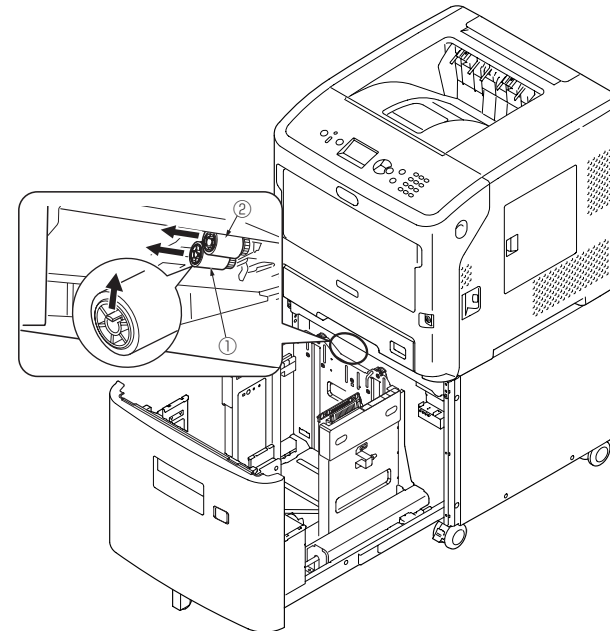

(3) Put the new roller (with gear) ① to the shaft.

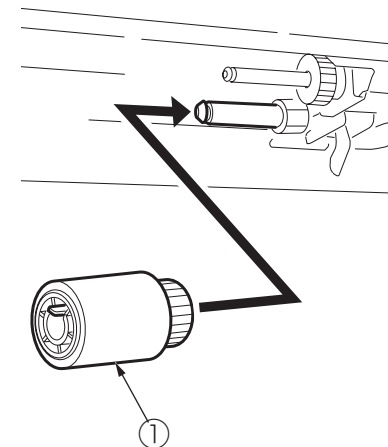

(4) Put the new roller (with gear) ② to the shaft.

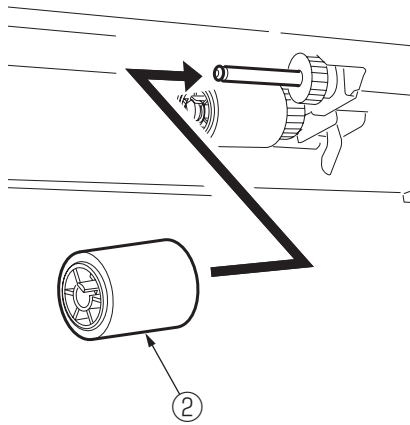

(5) Check the roller.

(6) Push the claws of cover and open the cover.

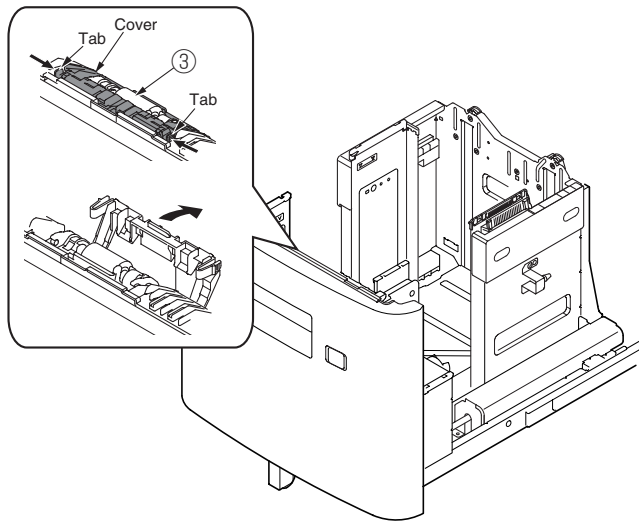

(7) Remove the Retard Roller ③ and spring ④ .

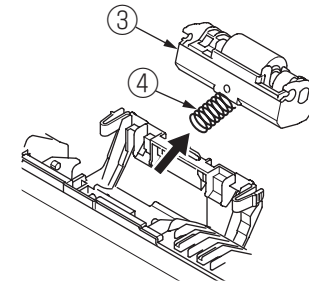

(8) Assemble the spring ④ to the new Retard Roller ③ .

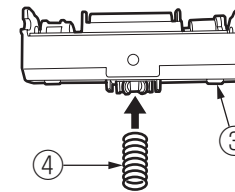

(9) Set the spring ④ of the Retard Roller ③ to the mark of the cassette.

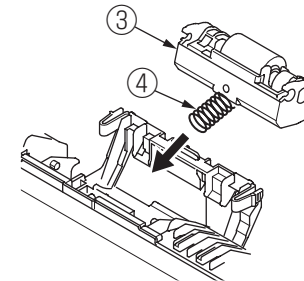

(10)Set the position groove of Retard Roller ③ to boss of Cassette.

Notes! Don't assemble the groove and boss this procedure.

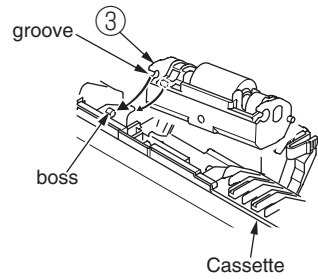

(11) Assemble the Retard Roller ③ to push the Retard Roller ③ to Cassette, and push up front side.

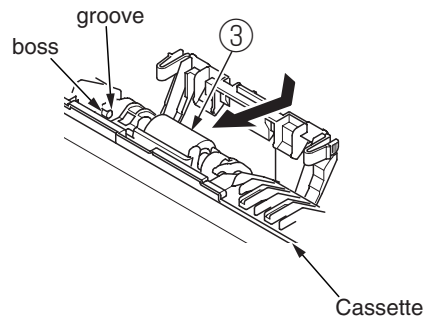

(12) Close the Cover.

Notes!To assemble again, if the cover cannot close.

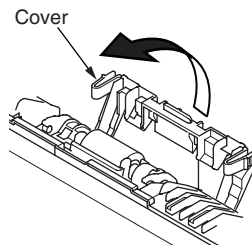

(13) To push around the cover, and check the Retard Roller moving up and down.

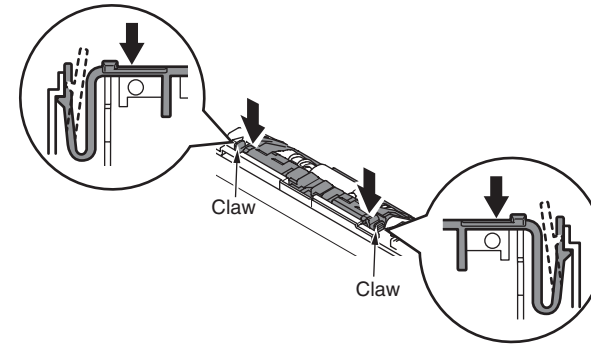

(14) Return to the cassette to LCF.