

**MB461 / MB471 / MB491 /
MB491+ / MPS4200mb
Maintenance Manual**

021312A

Document Revision History

Rev. No.	Date	Changed items			Person in charge
		No.	Page	Description of change	
1	2011-11-11			Issue	TD123 Takashi Kobayashi
2	2012-02-03			Addition of MB441/451/451w/471w	NHE11 Takashi Kobayashi

Rev. No.	Date	Changed items			Person in charge
		No.	Page	Description of change	

PREFACE

This manual explains the maintenance methods of Multi- Function Printer(MFP).The target model is as follows.

MB441/MB451/MB451w/MB461/MB471/MB471w/MB491/ES4161/ES4191

This manual is prepared for the maintenance person. In regard to the handling methods of these MFP, please refer to the User's Manual.

The description of a derivation model is omitted at this manual. Please substitute for a derivation model to each typical model as a following correlation table.

Correlation table of each model

Model	
Derivation	Typical
ES4161 / MB441	MB461
MB451	MB471
MB451w	MB471w
ES4191	MB491

Refer to the 1-4 specifications for the difference in each model.

- Note!**
- Contents of this manual is subject to change without notice.
 - While all reasonable efforts have been made to make this document as accurate and helpful as possible, we make no warranty of any kind, expressed or implied, as to the accuracy of the information contained herein. Oki Data assumes no responsibility to the damages caused or claimed to have been caused by the user as a result of repair, adjustment and/or change using this manual.
 - Parts of this product are delicate and can be damaged unless properly handled. We strongly recommend the user to maintain the product at the hand of the registered maintenance person of our company
 - Before starting the maintenance work, please neutralize the static electricity.

Warning



Risk of explosion if battery is replaced by an incorrect type.

Battery of the printer need not to be replaced. Do not touch the battery.

Replace the whole board to replace the SU board (MHE).

In the case of replacing batteries at board repairs, replace with the specified type ones. Installation of another type batteries may result in explosion.

Caution for used batteries are as follows; do not recharge, force open, heat or dispose of in fire.

CONTENTS

1. CONFIGURATION	1-1	2.3 Toner entrance detection	2-9
1.1 System configuration	1-2	2.3.1 Toner sensor detection principle	2-9
1.2 Structure of MFP	1-3	2.3.2 Toner count principle	2-9
1.3 Offer of Options	1-4	2.4 Image Scanning process	2-10
1.4 Specifications	1-5	2.4.1 Structure and process of RADF	2-10
1.5 Interface specifications	1-23	2.4.1.1 Cross-section view	2-10
1.5.1 USB Interface Specification.....	1-23	2.4.1.2 Electrical configuration	2-10
1.5.1.1 Outline of USB Interface.....	1-23	2.4.1.3 Fundamental operations.....	2-11
1.5.1.2 USB Interface Connector and Cable	1-23	2.4.1.4 Document detection	2-14
1.5.1.3 USB Interface Signal	1-23	2.4.1.5 Jam detection	2-15
1.5.2 Network Interface Specification.....	1-24	2.4.2 Document table structure	2-15
1.5.2.1 Outline of Network Interface.....	1-24	2.4.2.1 Overview	2-15
1.5.2.2 Network Interface Connector and Cable	1-24	2.4.2.2 Exposure block.....	2-16
1.5.2.3 Network Interface Signal	1-24	2.4.2.3 Carriage-Assy drive mechanism	2-16
1.5.3 Telephone Line Interface Specification (MB471/MB471w/MB491)	1-25	3. MFP INSTALLATION	3-1
1.5.3.1 Outline of telephone Line Interface	1-25	3.1 Precautions and Prohibition	3-2
1.5.3.2 Telephone Line Interface Connector and Cable	1-25	3.2 MFP Unpacking Procedure	3-3
1.5.3.3 Telephone Line Interface signal.....	1-25	3.3 MFP Installation Instructions	3-4
1.5.4 USB Host Interface.....	1-25	3.4 Packed Units and Attachments	3-5
1.5.4.1 Outline of USB Host Interface	1-25	3.5 Assembly Procedure	3-6
1.5.4.2 USB Host Interface Connector	1-25	3.5.1 MFP Main Body	3-6
1.5.4.3 USB Host Interface Signal.....	1-25	3.5.2 Power Cable Connection.....	3-14
1.5.5 Wireless LAN Interface(MB451w/MB471w)	1-26	3.5.3 Installation of Optional Components	3-16
1.5.5.1 Outline of Wireless LAN	1-26	3.5.3.1 Second Tray Unit	3-16
2. OPERATIONAL EXPLANATION	2-1	3.5.3.2 FDI Interface Kit (for MB491 only)	3-20
2.1 Electrophotographic process mechanism	2-2	3.6 Configuration Page Print.....	3-22
2.2 Printing process	2-6	3.7 Network Information Print	3-24

3.8	Connection Procedures	3-25	4.2.9	Plate Stay L / Plate Assy Stay R	4-30
3.9	Checking of User Paper	3-29	4.2.10	LED Head	4-31
4.	REPLACEMENT OF PARTS	4-1	4.2.11	Frame-Assy-TR	4-31
4.1	Notes on replacement of parts	4-2	4.2.12	Duplex Belt Assy	4-32
4.2	Part replacement procedure	4-4	4.2.13	DC Motor	4-32
4.2.1	Cover Side (L)	4-4	4.2.14	Hopping Clutch / MPT Clutch / Regist Clutch	4-34
4.2.2	Cover Side(R) / SD Card	4-5	4.2.15	HV-Board / Motor-FAN	4-37
4.2.3	Board 98M	4-6	4.2.16	Cover Assy Stacker	4-38
4.2.4	PWR unit	4-7	4.2.17	Stacker Cover	4-40
4.2.5	Cover Stay(R) / Cover Stay(L)	4-9	4.2.18	Fuser Assy	4-41
4.2.6	Cover Front (Top)	4-10	4.2.19	MPT Assy, Manual Assy	4-44
4.2.7	SW Assy	4-11	4.2.20	Cover Assy Rear	4-45
4.2.8	Scanner unit	4-12	4.2.21	Guide Eject Lower Assy	4-48
4.2.8.1	Tray-assy-document / Cover-ADF-R-assy	4-14	4.2.22	Eject Motor	4-49
4.2.8.2	ADF-unit	4-15	4.2.23	Plate Side R Assy / Plate Side L Assy / Front Assy	4-50
4.2.8.3	Sheet-document / Paper-weight-assy / Spring-PW-ADF	4-16	4.2.24	Plate Side L Assy	4-51
4.2.8.4	Hinge-assy-L / Hinge-assy-R	4-17	4.2.25	Plate Side R Assy	4-52
4.2.8.5	Cover-ADF-F / Guide-assy-exit-sub / ADF-assy / ADF board (MHD)	4-18	4.2.26	Front Assy	4-53
4.2.8.6	Cover-assy-top-ADF / Guide-assy / Roller / Motor / Clutch / Solenoid	4-20	4.2.27	Roller Feed Assy	4-53
4.2.8.7	Guide-A-sub / Frame-assy-separator / Spring-separator / Rubber-friction	4-21	4.2.28	Lever In Sensor / Lever WR Sensor / Photo Interrupter	4-54
4.2.8.8	Cable (ADF-Rev SNS)	4-21	4.2.29	Paper feeding roller (Roller-Pick-Up, Roller-Feed-NOW, Roller-Assy-MPT)	4-55
4.2.8.9	Cable (ADF-Reg SNS)	4-22	4.2.30	Frame-Assy-Retard, Spring-Retard	4-57
4.2.8.10	Frame-assy-OP	4-22	4.2.31	W-LAN Board (for MB471w only)	4-58
4.2.8.11	Frame-OP-panel / OPE board (Except MB461/ES4161)	4-23	5.	LUBRICATION POINT	5-1
4.2.8.12	Frame-OP-panel / OPE board (MB461/ES4161)	4-24	5.1	Lubrication point	5-2
4.2.8.13	LCD-assy	4-25	5.1.1	Printer	5-3
4.2.8.14	Frame-assy-FB	4-26	5.1.2	Scanner	5-11
4.2.8.15	How to remove Battery (SU Board MHE)	4-28	6.	MAINTENANCE MENUS	6-1
4.2.8.16	Frame-assy-hopping-ADF	4-29	6.1	Maintenance Menu	6-2
			6.2	Service Bit Menu	6-9
			6.3	Maintenance Utility	6-10

6.3.1 Maintenance Utility	6-10	8.1 Precautions prior to repair.....	8-2
6.4 Self-diagnostic mode	6-12	8.2 Items to be checked prior to taking action on abnormal images.....	8-2
6.4.1 Operator Panel	6-12	8.3 Precautions when taking action on abnormal images	8-2
6.4.2 Ordinary self-diagnostic mode (level 1).....	6-15	8.4 Preparations for troubleshooting	8-2
6.4.2.1 Entering self-diagnostic mode (level 1)	6-15	8.5 Troubleshooting method.....	8-3
6.4.2.2 Exiting self-diagnostic mode.....	6-15	8.5.1 LCD messages list	8-3
6.4.2.3 Switch scan test	6-16	8.5.2 Service Call List	8-32
6.4.2.4 Motor clutch test.....	6-18	8.5.3 Fax Error List.....	8-36
6.4.2.5 Test print.....	6-20	8.5.4 Email/Internet FAX/FAX Server Error List	8-37
6.4.2.6 Consumable item counter display	6-23	8.5.5 Preparing for troubleshooting	8-38
6.4.2.7 Number of print copies counter display	6-23	8.5.6 Print Troubleshooting.....	8-65
6.4.2.8 Switching between the Factory mode and the Shipping mode	6-24	8.5.7 Response after Flash compulsive initialization.....	8-70
6.4.2.9 Self-diagnostic function setting.....	6-24	8.5.8 Copy Image Abnormality Error Troubleshooting.....	8-70
6.4.2.10 LED head serial number display	6-25	8.5.9 Network Troubleshooting	8-71
6.4.2.11 NVRAM parameter setting	6-25	8.5.10 Wireless Troubleshooting	8-72
6.4.3 Adjustment at part replacement	6-26	8.6 Fuse Checking	8-73
6.4.3.1 EEPROM data upload / download method.....	6-26		
6.5 Switch pressing function when power supply is turned on.....	6-27	9. CONNECTION DIAGRAMS	9-1
6.6 Settings after Parts Replacement	6-28	9.1 Check of resistance values	9-2
6.6.1 Notes on CU/PU board (98M) replacement	6-28	9.2 Layout of parts	9-4
6.6.2 Notes on SU board (MHE)/Scanner Unit replacement	6-31	9.3 Firmware Information	9-11
7. REGULAR MAINTENANCE	7-1	9.3.1 ROM control numbers	9-11
7.1 Periodic Maintenance	7-2	9.3.2 Instruction of FW update	9-11
7.1.1 Periodic Replacement Parts.....	7-2	9.3.3 Checking and indication of the revision number.....	9-12
7.1.2 Cleaning	7-2	9.3.4 Stamp of maintenance board indication.....	9-12
7.1.3 Cleaning of LED lens array	7-2		
7.1.4 Cleaning the Feed rollers and the Retard roller	7-3	10. APPENDIX	10-1
7.2 Cleaning Rollers in the ADF	7-4	10.1 List of Initialized range.....	10-2
7.3 Cleaning the Document Glass	7-5	10.2 Maintenance Manual for Second Tray unit	10-9
8. TROUBLESHOOTING PROCEDURES	8-1	10.2.1 Overview	10-9
		10.2.1.1 Function.....	10-9

10.2.1.2 Exterior and Parts Name	10-9
10.2.2 Description for Operation of Second Tray unit	1010
10.2.3 Part Replacement	10-11
10.2.3.1 Precautions on replacing parts	10-11
10.2.3.2 Arrangement of Parts	10-12
10.2.3.3 How to Replace Parts	10-13
10.2.4 Cleaning of Paper Feed Roller and Separation Roller	10-19
10.2.5 Procedure for Troubleshooting	10-20
10.2.5.1 Precautions for Troubleshooting	10-20
10.2.5.2 Preparation before Troubleshooting	10-20
10.2.6 Connection Diagram	10-21
10.2.6.1 Connection diagram	10-21
10.2.6.2 Board Arrangement	10-21

1. CONFIGURATION

1.1 System configuration	1-2
1.2 Structure of MFP	1-3
1.3 Offer of Options	1-4
1.4 Specifications	1-5
1.5 Interface specifications	1-23

1.2 Structure of MFP

The insides of multi function printers are composed of the following parts.

- Scanner part
- Electronic photography process part
- Paper path
- Control part (CU part/PU part)
- Power supply parts (high voltage part/low voltage part)

Figure 1-2 shows the composition of the MFP.

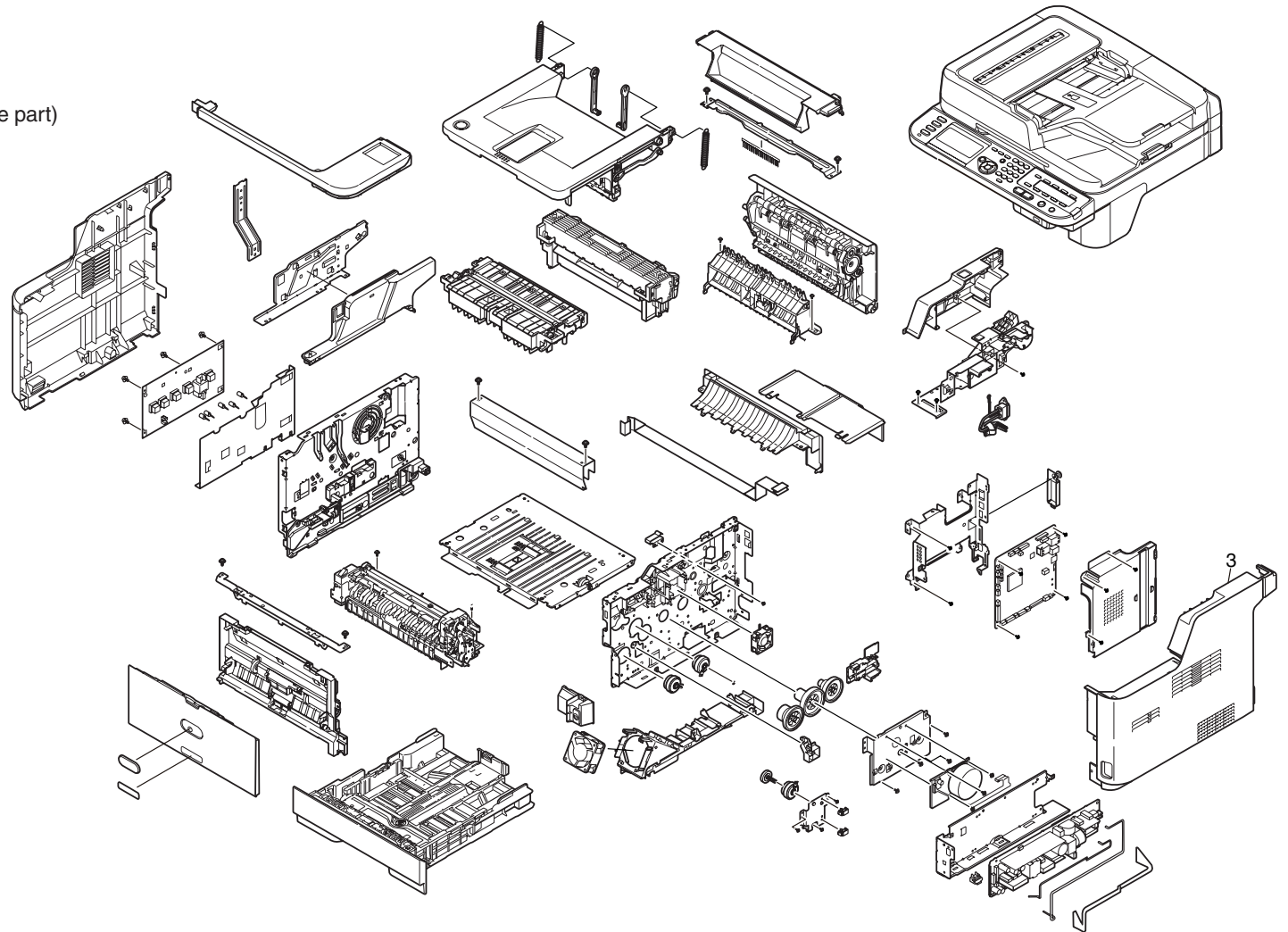
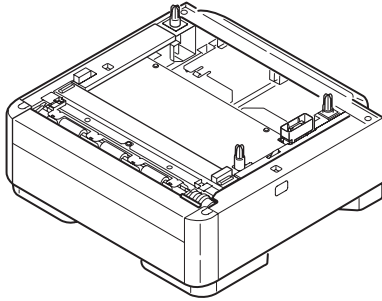

Figure 1-2

1.3 Offer of Options

This product can be installed with the following option.

- (1) Second Tray Unit



- (2) FDI Interface Kit (for MB491 only)

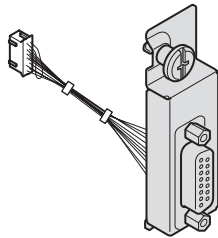

1.4 Specifications

Fundamental specifications

Category	Item		EDT (Entry Desk Top) model		MB461/ ES4161	MB471/ MB471w	MB491/ ES4191
			MB441	MB451/ MB451w			
Printer	Engine speed	A4/Letter, simplex	29 ppm		33/35 ppm		40/42 ppm
	Resolution	Max. resolution	2400 x 600dpi	600 x 600dpi	2400 x 600dpi	1200 x 1200dpi	
	Input tray	1st Tray	250 sheets (<80gsm)				
		2nd Tray	N/A		530 sheets (<80gsm) Option		
		MP Tray	Single sheet manual feed slot	100 sheets (<80gsm) 10 envelopes	Single sheet manual feed slot	100 sheets (<80gsm) 10 envelopes	
	Auto Duplex	Yes (Standard)					
	Toner Life (ISO19752)	Starter	1K		2K		
		Standard	1.5K		4K/3K (OEL)		
		High-Yield	2.5K		7K	7K/12K	
	Image Drum*	Life:Continuous 36K, 3P/J 25K, 1P/J 14.5K		Life:Continuous 44K, 3P/J 30K, 1P/J 17.5K			
RAM	Standard	256M Bytes					
	Option	N/A					
Emulation	Standard	PCL6	PCL6 / Post-Script3	PCL6	PCL6 / PostScript3		
	Option	N/A					
Scanner	Type	Flat Bed + RADF					
	Resolution	Max.	600 x 600dpi				
	Copy speed	A4, 1to1, High Speed	29cpm		33cpm		38cpm
Operation Panel	LCD	320 x 128dot Graphic panel w/ Back light					
	QWERTY	N/A			✓	✓	

*Image Drum for EDT model is included starter toner.

Category	Item	MB441/ MB461/ ES4161	MB451/ MB471	MB451w/ MB471w	MB491/ ES4191
Interface	USB2.0	✓	✓	✓	✓
	Ethernet	✓	✓	✓	✓
	Wireless LAN	N/A	N/A	✓	N/A
	Parallel	N/A	N/A	N/A	N/A
	Facsimile	N/A	✓	✓	✓
	USB Memory	✓	✓	✓	✓
	FDI	N/A	N/A	N/A	✓ (Option)
SD Memory Card		N/A	N/A	N/A	4GBytes
Dimensions (mm)		W x D x H 427 x 425 x 455			
Weight (kg)		20			
Power consumption	Power input	110-127VAC (Range 99-140VAC) 220-240VAC (Range 198-264VAC)			
	Sleep mode	3W			
	Power save mode	14W		18W	14W
	Idle	80W			
	Typical operation	540W	580W		610W
	Peak	950W			
	OFF mode	0.5W			
Operating environment (temperature)	During operation	10 °C to 32 °C, 17 °C to 27 °C (Print quality assurance temperature)			
	During non-operation	0°C - 43°C, Power OFF			
	During storage (Maximum one year)	-10°C to 43°C, with drum and toners			
	During transportation (Maximum one month)	-29°C to 50°C, with drum and toners			

Category	Item	MB441/ MB461/ ES4161	MB451/ MB471	MB451w/ MB471w	MB491/ ES4191
Operating environment (humidity)	During operation	20% - 80%, 50% - 70% (Print quality assurance humidity), Maximum wet-bulb temperature 25°C			
	During non-operation	10% - 90%, Maximum wet-bulb temperature 26.8°C, power OFF			
	During storage	10% - 90%, Maximum wet-bulb temperature 35°C			
	During transportation	10% - 90%, Maximum wet-bulb temperature 40°C			
Others	USB-IF logo	Yes			
	Windows logo	Yes			
	Operations on UPS	Operations on UPS (uninterruptible power supply) are not guaranteed. Do not use UPS.			

Printer section specifications

Category	Item	MB461/ ES4161	MB471	MB471w	MB491/ ES4191
Print width	Print width	A4 horizontal			
Engine speed	A4/Letter, simplex	33/35ppm			40/42ppm
	Duplex	17ppm			20ppm
First print out time (A4)	Standard Tray	5 sec			5 sec
	Second Tray	6 sec			6 sec
Warm-up time	From Power On	Approx. 60sec *1: Warm-up Time may change depending on a network environment.			
	From Power save	Approx. 25sec			
Resolution	LED head	600 dpi	1200 dpi		
	Max resolution	2400 x 600dpi	1200 x 1200dpi		
	Echono mode	Toner save by low brightness			
Life	Printer life	200K prints or 5year			
	AMPV (Average Monthly Print Volume)	3.3K/M			
	Image drum life	Continuous	44K		
		3P/J	30K		
		1P/J	17.5K		
Paper handling	Feed paper capacity (1st tray)	250 sheets of 80g/m ² (68Kg) plain paper, 25mm or less in total thickness			
	Feed paper capacity (manual feeder)	Single Sheet manual feed slot	100 sheets (<80gsm) 10 envelopes		
	2nd Tray Option	530 sheets (<80gsm)			
	Paper unloading	Face down: Approx. 150 sheets of 75g/m ² (65Kg) plain paper			

Category	Item	MB461/ ES4161	MB471	MB471w	MB491/ ES4191
Paper size	1st/2nd tray	A4, A5, A6, B5, Letter, Legal 13, Legal 13.5, Legal 14, Executive, 16K (184 x 260mm), 16K (195 x 270mm), 16K (197 x 273mm), Statement, Custom : A6 and Custom cannot be used in tray 2.			
	Multi purpose tray	A4, A5, A6, B5, Letter, Legal13, Legal13.5, Legal14, Executive, Statement, 16K (184 x 260mm), 16K (195 x 270mm), 16K (197 x 273mm), Custom, COM-9 Envelope, COM-10 Envelope, Monarch Envelope, DL Envelope, C5 Envelope, C6 Envelope			
	Duplex	Legal 14", Letter, A4, Legal 13", Legal 13.5", Executive and B5. (A5 is not supported due to short length)			
	Custom	86 x 140 ~ 216 x 1321			
Minimum paper size	Tray 1	4.1" x 5.8" (105 x 148mm : A6),			
	Tray 2 (option)	5.5" x 8.3" (148.5 x 210mm : A5)			
	MPT	3" x 5" (76.2mm x 127mm) Short Edge feed			
	Duplex	7.2" x 10.1" (182 x 257mm : B5)			
Paper thickness	Tray 1	16 to 32 lb (60 to 120g/m ²)			
	Tray 2 (option)	16 to 32 lb (60 to 120g/m ²)			
	MPT	16 to 43 lb (60 to 160g/m ²)			
	Duplex	16 to 32 lb (60 to 120g/m ²)			
Status switch/sensor	Paper out	Yes			
	Paper low	None			
	Toner low	Yes			
	Cover open	Yes			
	Fuser temperature	Yes			
	Paper size	None			
	Stacker full	None			
Font	Bitmap type face	LinePrinter USPS			
	Scalable 1 type face	Mono Type			
	Scalable 2 type face	Mono Type			
	Scalable 3 type face	Mono Type			
	Rasterizer	Mono Type			
	Barcode	12 types computational			
OCR.	OCR-A, B				

Scanner section specifications

Item		Description
Scanner type		Flat bed scanner with automatic document feeder device (RADF)
Image processor/Controller		MFA
Image sensor		Color CIS
Light source		LED
Optical resolution		300 x 300dpi, 300 x 600dpi, 600 x 600dpi
Output resolution		300 x 300dpi, 300 x 600dpi, 600 x 600dpi
Input level (A/D conversion)		48 bits (R,G, B, each 16 bits)
Output level		24 bits (R,G,B, each 8 bits) color, 8 bits grayscale, 4 bits CMYK, 1 bit monochrome
Document size	Flat bed	4.13 x 5.8~8.5 x 11.69in (105 x 148~215.9 x 296.6mm)
	RADF	Simplex : A6 - Legal14 Duplex : A5 - Legle14
Document thickness	Flat bed	20mm
	RADF	Simplex /Duplex : 60g/m ² – 105g/m ²
Reversing Auto document feeder (sheets)	RADF	50 sheets (80 g/m ²)
Maximum scanning range	Flat bed	Maximum 215.9 x 296.9mm
	RADF	4.13 x 5.8~8.5x 14in (105 x 148~215.9x355.6mm)
Scanning speed		Color : Approx. 6 sec/page (A4, 300 x 300dpi, Flatbed/ADF simplex) Mono : Approx. 1.6 sec/page (A4, 300 x 300dpi, Flatbed/ADF simplex) (note) Data transferring time is not included
Warm-up time		Less than 1 sec.
Life	MTBF	5,000H
	MTTR	Less than 20 min.
	Flat bed	5 years or 50,000 times of scan
	RADF	5 years or 240,000 sheets (single-sided scan)
Attachment file format		PDF (JPEG Compressed), M-TIFF (RAW/ G3/ G4 Compressed), JPEG (JFIF), XPS
Supported driver		MB461/ES4161: TWAIN Scanner driver (USB, Network) MB471/MB471w/MB491/ES4191: TWAIN Scanner driver (USB, Network), Fax Modem driver (Windows only)

Network specifications

Item	Description
Connection	Ethernet 10BaseT/100BaseTX automatic negotiation
Communication protocol	TCP/IP V4, TCP/IP V6, LPR, Port9100, IPP, FTP, SMTP, POP3, HTTP, HTTPS, Telnet, NetBIOS over TCP, SNMP Trap, SNMPv1, SNMPv3, DHCP/BOOTP, DNS,DDNS, WINS, SLP, UPnP, Bonjour, SNTP, ODNSP, SMB, CIFS, Q-Server over IP, Q-Server over IPX, R-Printer, N-Printer, NCP, PAP, NBP, LDAP, Kerberos, LLTD, WSD
Supported browser	Microsoft Internet Explorer Ver. 6.0 or higher Safari 2 or higher Firefox 3 or higher
Required setup information, configuration and others	IP address, sub net mask, gate way, SMTP/POP3 server, FTP server, Web server
Output/Input switch	Automatic

Wireless specifications

Item	Description
IEEE Standard	IEEE802.11b/11g/11n
Mode	Infrastructure mode
Security	WEP(40/104bit) WPA(Enterprise/Personal) WPA2(Enterprise/Personal)

Copy function

Categories		Description
Copy Resolution		Scan: 300x300dpi, 300x600dpi, 600x600dpi Print: 600x600dpi
Document Size	Flatbed	A4, A5, A6, B5, Executive, Letter
	RADF	A4, A5, A6, B5, Executive, Letter, Legal13, Legal13.5, Legal14 *A6 Duplex Scan not supported
Number of Copies		1 ~ 99
Collate(Sort)		ON/OFF
Zoom (Auto is supported)	Custom	25 ~ 400%, to scale by 1%.
	Preset	70% (A4→A5) 78% (Leg14→Let) 81% (Leg13.5→Let) 84% (Leg13→Let) 86% (A4→B5) 94% (A4→Let) 97% (Let→A4) 98% (Fit to page) 100% Auto (Document Size and Tray are specified) 115% (B5→A4) 141% (A5→A4)
Edge Erase	Set	ON, OFF
	Erase Width	2~50mm (increments of 1mm) 0.1~2.0 inch (increments of 0.1 inch)
Margin shift		Front Left/Top: 0 ~ ±25 mm 0.0~±1.0 inch (1mm/Step) Back Left/Top: 0 ~ ±25 mm 0.0~±1.0 inch (1mm/Step)
N-up	Document pages	OFF, 2-in-1, 4-in-1 Vertical, 4-in-1 Horizontal
ID Card Copy [ID Card Copy]		OFF, ON
Repeat Copy		OFF, 2 times, 4 times
Poster Copy		N/A
Document Direction		Portrait, Landscape

Categories		Description
Duplex Copy	Method	OFF, 1 sided→2 sided Long Edge 1 sided→2 sided Short Edge 2 sided→2 sided 2 sided Long Edge→1 sided 2 sided Short Edge→1 sided
	Binding Position	Long Edge, Short Edge * This can be set when the N-up or Repeat setting.
Mixed Size		OFF, ON The only available size combinations are Letter + Legal 13.5 and Letter + Legal14.
Job build scanning		OFF, ON
Banner Copy		N/A
Copy image quality adjustment		Background Removal, Density, Contrast

Copy Image Adjustments

Item	Setting	Description
Document type	Text/Photo , Text, Photo, Photo (Glossy)	Allows the user to select the type of images on the document and optimizes the image quality for the image to be scanned according to the selected type. With "Background Removal/Show-through Cancellation" selected, their levels can be adjusted.
Resolution	Nomal, High Quality, High Speed	
Background Remove	OFF, 1 ~ <u>3</u> ~ 6	Blocks out the color background of the image (assuming document has a color background) so that the background color is not printed.
Density	-3 (Light) ~ <u>0</u> ~ +3 (Dark)	Adjusts the darkness of images.
Contrast	-3 (Low) ~ <u>0</u> ~ +3 (High)	Adjusts the difference between the light and dark areas of an image.

ScanTo Common Specification

Items		Setting	Description
Document Type		Text, Text/Photo, Photo, Photo (Glossy)	Allows the user to select the type of images on the document and optimizes the image quality for the image to be scanned according to the selected type.
Background Removal		OFF, 1, 2, 3, 4, 5, 6	Blocks out the color background of the image (assuming document has a color background) so that the background color would not be printed.
Density		-3, -2, -1, 0, +1, +2, +3	Adjusts the darkness of images.
Resolution	Color	75, 100, 150, 200, 300, 400, 600dpi (400/600 can be set only for FB)	The resolution in which a document is scanned is selected *1
	Mono (Grayscale)	75, 100, 150, 200, 300, 400, 600dpi	
	Mono (2 levels)	75, 100, 150, 200, 300, 400, 600dpi	
Scan size (Document Size)		A4, Letter, Legal14, Legal13, Legal13.5, Executive, A6*2, A5, B5	Default Size is browsed, and if it is A4, AB-based sizes are placed higher in the operator panel display and if it is Letter, Letter-based sizes are.
Duplex Scan		OFF, Long Edge Binding, Short Edge Binding	Scans the images on front and back sides by launching Scan once.
Job Build Scanning		ON, OFF	Allows constructing a single scan job from multiple individual images on the documents.
Edge Erase	Settings	ON, OFF	Allows blocking out the peripheral area of the document (erasing the areas where spurious shadows and borders may occur).
	Width	5 ~ 50mm (in 1mm) 0.2 ~ 2.0 inch (In 0.1 inch)	[Not supported if Scan jobs are from PC via TWAIN]

Items		Setting	Description
Contrast		-3, -2, -1, 0, +1, +2, +3	Adjusts the difference between the light and dark areas of an image.
Saturation Adjustment (In Color mode only)		-3, -2, -1, 0, +1, +2, +3	Adjusts the saturation of an image.
Hue Adjustment (In Color mode only)		-3, -2, -1, 0, +1, +2, +3	Adjusts the balance between Red and Green with Yellow in the middle.
RGB Adjustment (In Color mode only)		-3, -2, -1, 0, +1, +2, +3	Enables individual RGB adjustments
Grayscale		ON, OFF	
File format	Color	PDF, TIFF, JPEG, XPS	File format used to save the scanned images as a file
	Mono (Grayscale)	PDF, TIFF, JPEG, XPS	Encrypt PDF is a new function to support.
	Mono (2 levels)	PDF, TIFF, XPS	
		Encrypt, Not Encrypt	With Encrypted PDF set to ON, Setup Wizard launches enabling to set each menu item.
Encrypted PDF (PDF document security) [New function]	Encryption level	Low (Compatible with Acrobat4.0 and later) Medium (Compatible with Acrobat5.0 and later) High (Compatible with Acrobat7.0 and later)	Specifies the level of encryption. The higher the level, the higher the security. Encrypted by RC4 (40bit) for Low, RC4 (128bit) for Medium, and AES (128bit) for High. Default value is Medium.
	Password to open a document	Not set Set Default password set	Sets a password to open created PDF documents. Setting from Admin Setting: * Either "Password to open a document" or "Access password" must be set. ("Not set" may not be selected for both.)

Items		Setting	Description
	Set	Password / Re-enter Password Default value is NULL	Sets a password to open created PDF document. NULL by default. Characters that can be entered are 1 to 32 alphanumeric characters (Upper-/Lower-case letters) and no symbols can be used. This cannot be the same as Access password. * Users are prompted to enter twice for confirmation.
	Access Password	Not set Set Default password set	Sets a password to restrict operations such as editing and printing created PDF documents. * Either "Password to open a document" or "Access password" must be set. ("Not set" may not be selected for both.)
	Set	Password / Re-enter Password Default value is NULL	Sets a password to restrict operations such as editing and printing created PDF documents. NULL by default. Characters that can be entered are 1 to 32 alphanumeric characters (Upper-/Lower-case letters) and no symbols can be used. This cannot be the same as Access password. * Users are prompted to enter twice for confirmation.
Document Access	Print the Document	Not allowed Low resolution (150dpi) High resolution	Low Resolution (150dpi) is displayed only when Encryption Level is other than Low.
	Extract Text and Graphics	Not allowed Allowed	Security Options in formatting in PDF: Extracting texts and graphics

Items		Setting	Description
	Change the Document	Not allowed Commenting allowed Page layout allowed ^{*3} Page Inserting, deleting, or rotating allowed. ^{*4} All operations but Page Extraction allowed	^{*3} Applicable only when Encryption Level is Low. ^{*4} Applicable only when Encryption Level is Medium or High.
Compression Level	Color	High, Medium, Low	Compression rate widely differs depending on the document images and file format subject to compression.
	Mono (Grayscale)	High, Medium, Low	
	Mono (2 levels)	High, Medium, Raw	

*1 Due to memory size available in this MFP, the setting of Resolution, Paper Size, for example, is restricted.

*2 Duplex Scan is not supported for A6 document.

ScanToEmail Function

Items		Setting
Address confirmation		To, Cc, Bcc (Up to 256 entries)
Address Book		List of Email addresses added to the Address Book Up to 100
Address Book (Group)		Group number Up to 20
Mail Send History		Email addresses manually typed in Up to 50
LDAP [E-mail Address from LDAP Server]		Up to 100 entries can be displayed after search.
Send destination	Direct Input	An Email address to which Email is sent manually typed in.
	Address Book Search	List of Email addresses added to the Address Book Up to 100 can be registered.
	LDAP Search	Up to 100 entries can be displayed after search.
Mail Edit	Subject selection	Subject Up to 5 selections can be registered.
	Subject	Subject text Up to 80 characters can be entered.
	Body selection	Body Up to 5 selections can be registered.
	Body	Body text Up to 256 characters can be entered.

ScanToNetworkPC Function

Items	Description
Protocol	FTP, HTTP, CIFS server
Max. number of File server settings	50 units
Separation Limit	N/A
FTP Passive mode	Yes
Encryption	Yes (FTPS/HTTPS)

ScanToUSB Memory Function

Items	Description
Interface	USB2.0 Host I/F
Support File System	FAT12, FAT16, FAT32 FAT32: Up to 32GB
Supported devices	USB Memory (USB1.1/2.0)

Network Twain Function

Items	Setting	Description
Network TWAIN	ON/OFF	Enables/disables the Network Twain function.
Port Number	1 ~ 65535	Number of the port that receives the Network Twain command from PC
PC Scan Modes	Simple Scan Mode/Secure Scan Mode	
Timeout setting	1 ~ 30 minutes	It is commonly set for USB and Network.

Push Scan Function

Item		Description
Interface (PC - FX750)		USB2.0 (High Speed) Device I/F, Ethernet 10/100 Base-T
Push Scan Utility		ActKey Utility
Scanner Driver		TWAIN, WIA : FX750 TWAIN Driver
To Application	Scan Method	Flatbed, ADF, Auto
	Scan Mode	* In Options Direction (Left/Upper) and Duplex can be selected. * ¹ * If Auto is selected, document is first scanned from ADF and then if there is none in ADF, from FBS assuming there is in Flatbed. Color (24bit), Grayscale (8bit), B/W, Halftone * No halftone scanner output. Executed on Scanner Driver side.
	Resolution	75, 100, 150, 200, 300, 400, 600, 800, 1200, 2400, 4800dpi * Scanner's basic performance varies with the selection of Color mode among other settings, and if a resolution exceeding this basic performance is specified, the driver runs the resolution process.
	File format	BMP, JPG, TIF, PCX, GIF, TGA, PNG, WMF, EMF, PDF, Multi-Page PDF, Multi-page TIF
	Document size	A4, A5, B5, A6, legal13, Legal13.5, Legal14, Letter, Executive * * Only ADF can be used for Legal 13, Legal 13.5, and Legal 14. (Not Flatbed). A6 Duplex Scan not supported.
To Folder	Scan Method	Same as To Application.
	Scan Mode	Same as To Application.
	Resolution	Same as To Application.
	File format	Same as To Application.
	Document size	Same as To Application.
PC-Fax	Scan Method	Same as To Application.
	Scan Mode	B/W
	File format	-
	Document size	Same as To Application.
	Encoding method	MH, MR, MMR, JBIG

*1 Duplex (Default : OFF) and Binding (on the left/right, top) can be set only when ADF is selected.

PC Scan Function

Item		Description
Interface (PC <-> MFP)		USB2.0 (High Speed), Ethernet (10/100 Base-T)
Scan Mode	Scan method	Flatbed, ADF, Auto * In Options Direction (Left/Upper) and Duplex can be selected. *2 * In Auto, document is first scanned from ADF and then if there is none in ADF, from FBS assuming there is in Flatbed.
	Color Mode	Color (24bit), Grayscale (8bit), B/W, Halftone * Device output: Color, Grayscale, B/W, Halftone is processed by driver.
Resolution	Custom	50 ~ 600dpi (in increments of 1dpi)
	Preset	75, 100, 150, 200, 300, 400, 600, 800, 1200, 2400, 4800dpi, 19200dpi * Scanner's basic performance varies with the selection of Color mode among other settings, and if a resolution exceeding this basic performance is specified, the driver runs the resolution process.
Scan Size	Custom	ADF : Min: 105 x 148 mm / Max : 215.9 x 355.6 mm Flatbed : Min:105 x 148 mm / Max : 215.9 x 296.9 mm
	Preset	A4, A5, B5, A6, Legal13, Legal13.5, Legal14, Letter, Executive * A6 Duplex Scan not supported
Image Process	Output scale	1% ~ 999%
	Sharpness	None, Sharpen, More Sharpen
	Background Remove	Level0 ~ Level6
	Edge Erase	5 ~ 50mm
	Center Erase	N/A
	Font smoothing	Yes
	De-screen	Yes
Image Quality Adjustment *1	Brightness	Yes
	Contrast	Yes
	Gamma	Yes
	Histogram Level	Yes
	Curves	Yes
	Color Balance	Yes
	HSB	H: Hue, S: Saturation, B: Brightness

*1 Can be set only in Advanced.

*2 Duplex (Default : OFF) and Binding (on the left/right, top) can be set only when ADF is selected.

Fax specification

Function		Description	
Basic Fax function	FAX, TEL line	PSTN, PBX	
	Line Interface	RJ11 × 2 (LINE1, TEL1)	
	External phone	Support	
	Image Memory Size	4MB (Flash Memory)	
	Storage capacity	200 pages (ITU-T No1 chart A4)	
	Compatibility	ITU-T T30 G3	
	Tx, Rx Resolution	Normal : 8 dots × 3.85 lines/mm (203x98dpi) Fine : 8 dots × 7.7 lines/mm (203x196dpi) Ext-Fine : 8 dots × 15.4 lines/mm (203x391dpi) Photo : 8 dots × 7.7 lines/mm (203x196dpi)	
	Compression	MH/MR/MMR/JBIG	
	Maximum Tx, Rx width	Letter size	
	FAX Speed	Maximum 33,600 bps (V34, V17, V29, V27ter)	
	T.30 error correction mode (ECM)	Yes (default : ON)	
	Polling function	Support as a part of F code function	
	F code function	F code confidential box, F code bulletin board box (Max.20)	
	Tx function (Send)	Scan function	Document size
Scanning mode			Normal : 8 dots × 3.85 lines/mm (203x98dpi) Fine : 8 dots × 7.7 lines/mm (203x196dpi) Ext-Fine : 8 dots × 15.4 lines/mm (203x391dpi) Photo : 8 dots × 7.7 lines/mm (203x196dpi)
Density adjustment			-3, -2, -1, 0, +1, +2, +3
Duplex scanning			Support
Job Build			Support

Function		Description	
Tx function (Send)	Transmission	Real-time Tx	Support
		Memory Tx	Support
	Dial	Manual Tx	Support
		Direct dial	Max 40 degits
		Group dial	Up to 20 group (100/group)
		Speed dial	Up to 100
		One touch key	Support
		Redial	Automatic
	Manual		Select from Tx history
	Tx dial history		Up to 50 records
	Sender/ Destination name	Tx w/ Sender name	Max 3 name
		Display Destination on the panel	Dial No is displayed on the Panel.
	Broadcast		Up to 100 destination
	Tx reservation (Dual access)		Support
	Delayed Tx (Send at specified time)		Up to 31 days, Up to 20
	F code	F code confidential transmission	Support (specify Sub-Address)
		F code bulletin board polling reception	Support (specify selective polling address)
		F code relay transmission	N/A
	Security function	ID check transmission	Support
		Dial double pressing	Support

Function		Description	
Rx function (Receive)	Automatic receive	Support	
	Manual receive	Support	
	Standby mode	FAX	Support
		MANUAL	Support
		FAX/TEL	Support
		ANS/FAX(TAD)	Support
		DRD	Support
	Receive mode	Memory receive	Yes
		Real-time receive	N/A
	Sender information	Display Sender TSI	N/A
		Receipt Time stamp	Support (A received document is printed with sender's fax number, and date/hour/minute added.)
	Security function	Secure Receive	Support
		Junk Fax Protection	Support
	Polling transmission (Accumulation of polling documents)		N/A
	F code	F code confidential reception	Support (specify Sub-Address)
F code bulletin board polling transmission		Support (specify selective polling address)	

Function		Description	
Rx function (Receive)	Print function	Effective record size	Legal14, Legal13.5, Legal13, Letter, A4
		Print margin	same as printer
		Threshold level	The value that determines the position in which received images are clipped or reduced when they do not fit in valid recording paper sizes.
		Page split	If the portion exceeding the valid recording size is larger than the threshold, the page is split.
		Reduction	Auto or 100%
		Duplex print	Support (Printer's Duplex Print settings are followed.)
		Specifying cassette	Support
	Number display	N/A	
Fax Forwarding		Support (Only be able to specify an Phone number)	
Others	Line monitor (Acoustic Monitor)	OFF/Type1/Type2 (Type1: till DIS, Type2: till on-hook)	
	Buzzer	Support	
	PC-FAX	Support	
	Internet FAX	T.37 simple mode+DSN, MDN	
Reports	Transmission confirmation certificate (MCF Report)	Support	
	Check message	Support (except for Real-time Tx)	
	Tx/Rx report (Transmit, Receipt Journal Report)	up to 50 records	
	F code reception notice (F code Box Journal Report)	Support	
	Erase notice (Erased Report)	Support	
	T30Monitor	Support	

Internet Fax

Function/Item		Description	
IFAX file format	Send	TIFF-S	File format supported in Internet FAX Send.
		TIFF-F	File format supported in Internet FAX Send.
	Receive	TIFF-S	File format supported in Internet FAX Received.
		TIFF-F	File format supported in Internet FAX Received.
IFAX Send/Receive	MDN	Send request for MDN	Requests for MDN.
		Send MDN reply	Sends an MDN reply in response to a received request for MDN.
		Receive MDN reply	Receives an MDN reply and processes.
	DSN	Send request for DSN	Requests DSN.
		Receive DNS reply	Receives a DNS reply and processes.
IFAX Report	Send/Receive management report	Send Management Report	Reports Send records (a summary of information).
		Receive Management Report	Reports Receive records (a summary of information)
	At reception of MDN reply	Communication report	A report printed automatically at reception of MDN reply.
	At reception of DNS reply	Transmission confirmation report	A report printed automatically at reception of DSN reply.
Auto Deliver/Transmission Data Save	Auto Deliver	IFAX Receive	Auto delivery associated with IFAX Receive
	Communication Data Detention	IFAX Send	Saves communication data associated with IFAX Send.
		IFAX Receive	Saves communication data associated with IFAX Receive.

Function/Item			Description	
IFAX Images	Basic Features	Scan size (Document Size)	A4, Letter, Legal13, 13.5, Legal14	
		Density	-3, -2, -1, 0, +1, +2, +3	
		Document type	Photo, Ex. Fine, Fine, Standard Resolution : 200 x 100, 200 x 200, 200 x 400, 200 x 200dpi respective	
		Background Removal	OFF, 1, 2, 3, 4, 5, 6	
		Application features	Duplex Scan	OFF, Long Edge, Short Edge
			Job Build Scanning	ON, OFF
	Compression Level		High, Medium, Low	

Report Print

No	Report Name	Manual				Auto
		Op Panel	Configuration Tool	Web Page	Special Operations	
1	Configuration	Yes	No	No	No	No
2	File List	Yes	No	No	No	No
3	Error Log	Yes	No	No	No	No
4	Demo Page	Yes	No	No	No	No
5	MFP Usage Report	Yes	No	No	No	No
6	Network Information	Yes	No	No	No	No
7	PCL Font List	Yes	No	No	No	No
8	PSE Font List	Yes	No	No	No	No
9	PPR Font List	Yes	No	No	No	No
10	FX Font List	Yes	No	No	No	No
11	Engine Menu Print	Yes*	No	No	No	No
12	File System Check Report	No	No	No	No	Yes
13	Scan To Log Report	Yes	No	No	No	No
14	E-Mail Address List	Yes	No	No	No	No
15	Speed Dial List	Yes	No	No	No	No
16	Group List	Yes	No	No	No	No
17	Transmit Journal, Receipt Journal	Yes	No	No	No	Yes
18	Transmit Confirmation Report	No	No	No	No	Yes
19	Check Message	No	No	No	No	Yes
20	F-CODE Box Journal	No	No	No	No	Yes
21	Erased Report	No	No	No	No	Yes
22	F-Code Box List	Yes	No	No	No	No
23	Block Junk Fax List	Yes	No	No	No	No
24	T30 Monitor	Yes	No	No	Yes	No
25	E-mail/Internet FAX/ FAX Server Transmit and Receipt Journal	Yes	No	No	No	Yes

No	Report Name	Manual				Auto
		Op Panel	Configuration Tool	Web Page	Special Operations	
26	E-mail/Internet FAX Transmit Confirmation Report	No	No	No	No	Yes
27	E-mail/Internet FAX Check Message Report	No	No	No	No	Yes
28	Network Syslog Print	Yes	No	No	No	No
29	Print check Pattern	Yes	No	No	No	No

* Default settings is not to be displayed in a menu item.

Print from USB memory

Item	Description
Interface	USB2.0 (High Speed) Host IF
Storage Device	USB Memory (Recognized up to 32GB)
File System	FAT12, FAT (FAT16), FAT32
USB port	Below the operator panel on the device's front side
Printable file format	JPEG, PDF (v1.7), M-TIFF (v6 Baseline), PRN (PCL, PS) (Encrypted PDF is not supported)
File size limit	The range that can be spooled to installed memory (RAM)
Print file selection	A list of files is displayed on the panel for selection. (Selection of multiple files is not supported.) Files for view are filtered by their extension. Extensions: JPG, JPEG, PDF, TIF, TIFF, PRN (no casesensitive)
Specifying Sub Folder	Yes
Displaying a file name in 2-byte characters	Yes
Unit of print	One file at a time, selected from the panel
Print Range	The entire file (pages cannot be specified)
Print Mode	
Paper Size	By the current Menu settings (Size of paper presently loaded in the tray can be selected from the panel.)
Copies	By the current Menu settings (With PRN, by the value specified at a time of file creation)
Duplex Print	By the current Menu settings (With PRN, by the value specified at a time of file creation)
Fitting	By the current Menu settings (A new item in the menu) Can be turned ON/OFF on the panel. (Always OFF with PRN)
N-up	No
Printing restrictions	Yes

Item	Description
Color/Mono switch	Possible to print color images in mono mode and monochrome images in color mode.
Print logs	Job Log : Print JA Log : Counted under USB Memory to Print.
Behavior when printing is disabled	The Print Job specs are followed. Behavior in case of encrypted PDF files: Displays an error on the panel and end the job.

Display information

Information provided (displayed)	Comment
Path	Can be displayed in Japanese (Maximum Length 2-byte Code : 255 characters)
Name	Can be displayed in Japanese (Maximum Length 2-byte Code : 255 characters)
Type	File or Directory only
Size	File only
Last update date	YYYY/MM/DD

Email To Print Overview Spec.

Item	Description	
Mail format	Compliant to MIME1.0.	
Printing mail text	No	
Printing attached file	PDF	Yes (v1.7)
	JPEG	Yes
	TIFF	Yes (v6 Baseline)
Valid extension	pdf / jpg / jpeg / tif / tiff	
Printing sequence	Files are printed in the order in which they are attached.	
Maximum number of attached files	10	
File size limit	Maximum size is 8MB per file.	
Print Mode	Paper Size	By image's page size.
	Copies	By the current Menu settings
	Duplex	By the current Menu settings
	Fitting	Dependent on the file format.
	N-up	No
	Others	N/A
Print Range	Entire file (Cannot be specified by page)	
Password for PDF print	Encrypted PDF is not supported.	
Printing restrictions	By NetPrint settings.	
Print logs	By attached file	
Behavior when printing is disabled	Don't display any warning message on the panel.	
	Don't send error notification by mail to Email senders.	

Auto Deliver Function (MB491/ES4191 only)

Items	SD Card has to be installed
Auto Deliver settings input method	From Product Web Page *1
Delivery data input source	FAX Receive, Email Receive, Internet FAX Receive *2
Delivery Destination	Email, Network Folder (CIFS, FTP, HTTP)
Printing at delivery	ON/OFF
Max registrable number of Auto Deliver settings	100
Attached file format in FAX Receive (Delivered file format)	PDF only
Attached file format in Email receive (Delivered file format)	PDF or TIFF *3
Email text delivery in Email Receive	Not delivered
Maximum file size in Email Receive	8MB
Maximum file size in FAX Receive	4MB *4
Recovery Print with Delivery Error	Supported
Auto Delivery Logs	Supported

*1 Basically from the Web Page. This can be set by PjL command from an external utility such as MFP Setup Tool.

*2 Internet FAX Receive works in the same way as when the format of a file received attached to a mail received in Email Receive is TIFF.

*3 The Delivery file format is determined by the attached file's format in Email Receive. The format will be PDF if the attached file format is PDF/JPEG and TIFF if TIFF.

*4 Up to 16MB. This depends on the available space on FAX memory at reception time.

Transmission Data Save Function (MB491/ES4191 only)

Items	SD Card has to be installed
Transmission Data Save input method	From Product Web Page *1
Subject to Transmission Data Save	FAX sent, FAX received, Email sent, Email received, Internet FAX sent *2, Internet FAX received *2, FAX Server
Save destination	Network Folder (CIFS, FTP, HTTP)
Attached file format in FAX Send/Receive (saved file format)	PDF only
Attached file format in Email Send/Receive (saved file format)	PDF or TIFF *3
Maximum file size in Email Send/Receive	8MB
Maximum file size in Fax Send/Receive	4MB *4
Communication Data Saving Logs	Supported

*1 Basically from the Web Page. This, however, can be set by PjL command from an external utility such as MFP Setup Tool.

*2 Sent Internet FAX works in the same way as when the attached file format in Email Send is TIFF, and received Internet FAX as when the attached file format in Email Receive is TIFF.

*3 The saved file format in Email Send will be PDF. In Email Receive, it is determined by the attached file format. The format will be PDF if the attached file format is PDF/JPEG and TIFF if TIFF.

*4 Up to 16MB. This depends on the available space on FAX memory at reception time.

Access Control and Job Accounting Functions Overview Specs

Item		Description
Access Control		Yes
	Copy	Color enabled / Color disabled / Printing disabled
	Print	Color enabled / Color disabled / Printing disabled
		In addition, Printing disabled / Forced to print in Mono in case of Color disabled
	Scan to Email	Use enabled / Use disabled
	Scan to Network PC	Use enabled / Use disabled
	Scan to USB Memory	Use enabled / Use disabled
	Push Scan	N/A
	PC Scan	N/A
	Fax Send	Use enabled / Use disabled
	Fax Receive	N/A
	PC Fax Send	Use enabled / Use disabled
	E-mail to Print	N/A (Not support by user)
	Print from USB Memory	Use enabled / Use disabled
	PIN ID	
	Number of ID that can be registered	Max. 100
	Register/Edit	Configuration Tool, Web Page, JA Server
User/Password		1 ~ 32 characters
	Number of ID that can be registered	Max. 100
	Register/Edit	Configuration Tool
	User Authentication Method	Local/LDAP/Secure Protocol

Item		Description
Job Accounting		Yes
	Number of JA Logs that can be saved	Approx. 5000 (w/SD Card), Approx. 200 (w/o SD Card)
	Copy	Counted as printed sheets
	Print	Yes
	Scan to Email	N/A
	Scan to Network PC	N/A
	Scan to USB Memory	N/A
	Push Scan	N/A
	PC Scan	N/A
	Fax Send	Yes
	Fax Received	Sheets printed with the images received by Fax are counted as printed sheets.
	PC Fax Send	Yes
	E-mail to Print	Yes
	Print from USB Memory	Yes (Counted as USB Memory to Print.)

1.5 Interface specifications

1.5.1 USB Interface Specification

1.5.1.1 Outline of USB Interface

- (1) Basic Specification
USB
- (2) Transmission Mode
Hi speed (480Mbps±0.05% max.)
- (3) Power Control
Self power device

1.5.1.2 USB Interface Connector and Cable

- (1) Connector
 - Printer side: B receptacle
Upstream port
Equivalent of UBR24-4K5C00 (made by ACON)

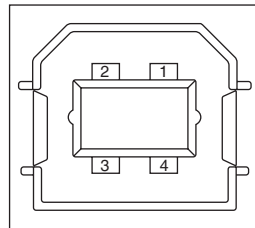

Connector pin arrangement

- Cable side: B plug (off)

- (2) Cable

Cable length : Specification Cable of USB2.0 spec. of less than 5m.(less than 2m is recommended)

1.5.1.3 USB Interface Signal

	Name of Single	Function
1	Vbus	Power Supply (+5V)(red)
2	D -	Data transmission (white)
3	D +	Data transmission (green)
4	GND	Single ground (black)
Shell	Shield	

1.5.2 Network Interface Specification

1.5.2.1 Outline of Network Interface

Table 1.5.2 Basic Specification of Network Interface

Protocol Family	Network Protocol	Application
TCP/IP	IPz4, TCP, ICMP, UDP	LPR, RAW SNMPv1 DHCP/BOOTP HTTP

1.5.2.2 Network Interface Connector and Cable

(1) Connector

100 BASE-TX/10 BASE-T (automatic switch, no simultaneous use)

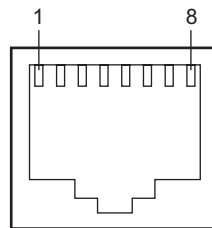

Connector pin arrangement

(2) Cable

Unshielded twist pair cable with RJ-45 connector (Category 5 is recommended.)

1.5.2.3 Network Interface Signal

Pin No.	Singles	Single Direction	Functions
1	TXD+	FROM PRINTER	Send Data +
2	TXD-	FROM PRINTER	Send Data -
3	RXD+	TO PRINTER	Received Data +
4	-	-	Unassigned
5	-	-	Unassigned
6	RXD-	TO PRINTER	Received Data -
7	-	-	Unassigned
8	-	-	Unassigned

1.5.3 Telephone Line Interface Specification (MB471/MB471w/MB491)

1.5.3.1 Outline of telephone Line Interface

The machine will reliably communicate with distant stations over voice-level telephone line.

1.5.3.2 Telephone Line Interface Connector and Cable

Connector Type : RJ-11

Cable Type : TEL Cable (With RJ-11 plug)

Connector contact arrangement

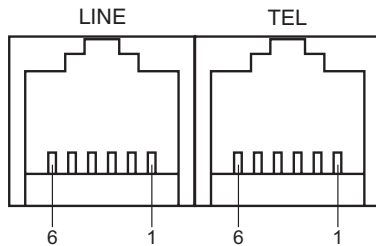

1.5.3.3 Telephone Line Interface signal

	Contact No.	Functions
TEL	1	Unspecified
	2	Unspecified
	3	TCP
	4	TCP
	5	Unspecified
	6	Unspecified
LINE	1	Unspecified
	2	Unspecified
	3	TCP
	4	TCP
	5	Unspecified
	6	Unspecified

TCP : Terminal Connection Point

1.5.4 USB Host Interface

1.5.4.1 Outline of USB Host Interface

- (1) Basic Specification
USB
- (2) Transmission Mode
Hi Speed (480Mbps±0.05% max.)
- (3) Supply Power
Max. 500mA
- (4) Connection devices
USB memory

1.5.4.2 USB Host Interface Connector

USB A plug connector

Equivalent of UBA-4R-D14-4DLF (JST Mfg. Co.,Ltd)

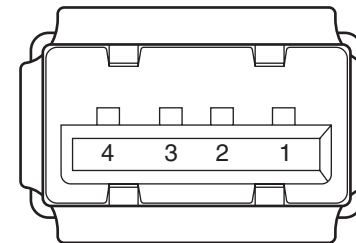

Connector pin arrangement

1.5.4.3 USB Host Interface Signal

	Name of Signal	Function
1	Vbus	Power Supply (+5V)(red)
2	D -	Data transmission (white)
3	D +	Data transmission (green)
4	GND	Single ground (black)
Shell	Shield	

1.5.5 Wireless LAN Interface(MB451w/MB471w)

1.5.5.1 Outline of Wireless LAN

- (1) Specification
IEEE 802.11b/g/n (2.4GHz)
- (2) Power connector
USB Micro B
- (3) Power supply voltage
5V
- (4) MFP side interfaces
IEEE 802.3u 10/100BASE (LAN port)

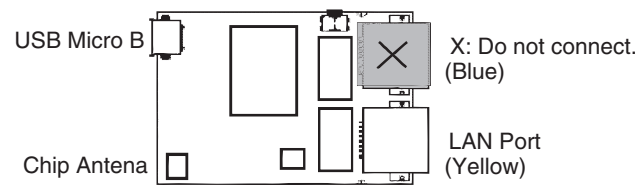

Note! This product cannot connect to a wired LAN and wireless LAN at the same time.

2. OPERATIONAL EXPLANATION

2.1 Electrophotographic process mechanism	2-2
2.2 Printing process.....	2-6
2.3 Toner entrance detection	2-9
2.4 Image Scanning process	2-10

2.1 Electrophotographic process mechanism

(1) Electrophotographic process

The following describes the overview of electrophotographic process.

1. Charging

Equally charge the surface of image drum by implying negative voltage to the charged roller due to negative charge.

2. Exposure

The light from LED Head is exposed on the negative-charged surface of image drum. The surface electrical potential of the exposed part of image drum surface becomes lower. Then forms electrostatic latent image.

3. Development

Negative-charged toner is attracted to the electrostatic latent image due to electrostatic while touching the image drum. Then forms viewable image.

4. Transfer

Overlap paper on the surface of OPC drum, from the backside of paper transfer toner image to the paper by applying electrical charge by transfer roller.

5. Fusing

The toner image that is transferred to paper is fused on paper by heat and pressure.

6. Drum cleaning

The cleaning blade scrapes off the toner that was not transferred and remains on the image drum.

7. Static elimination

Residual potential on the image drum is removed.

1. Charging

Charge the image drum surface by implying voltage to the charged roller that contacts the image drum surface.

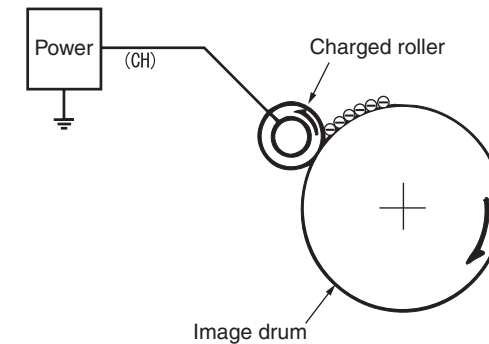

2. Exposure

The light emitting from the LED Head will be exposed to the negative charged image drum. When the surface electric potential of exposed part of the image drum goes to decrease, the electrostatic latent image complying with image signal is formed.

Image drum is coated by basic layer (UL), charge generating layer (CGL), charge transferring layer (CTL) on the basic material aluminum. The thickness of the organic light sensor (OPC) that is consisted by CTL and CGL is approximate 20 μ m.

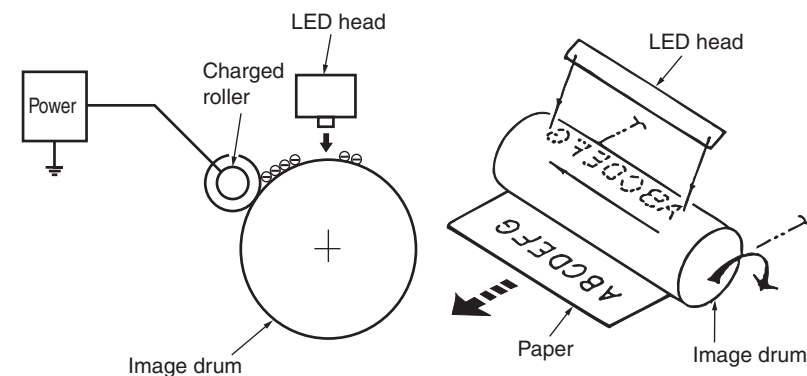

3. Image development

Toner is attracted to the electrostatic latent image on the image drum surface, then the electrostatic latent image changes to toner image.

1. As the roller on the supply spot of toner rotates while scrubbing the image-developing roller, friction electricity occurs between the image developing roller and toner; toner is attracted to the image-developing roller.

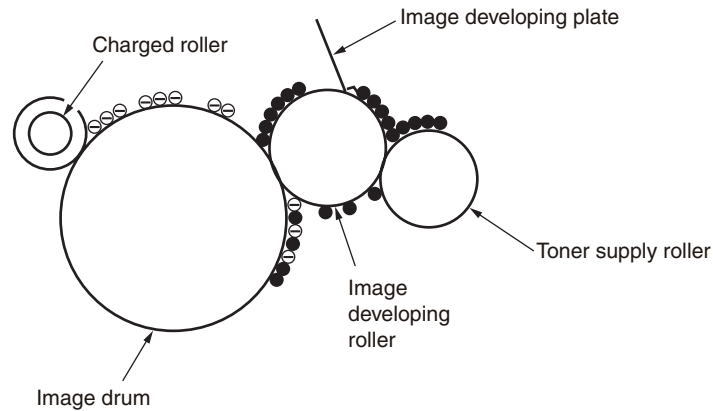

2. The toner that has been attracted to the image-developing roller is dropped down to the developing plate to make a thin toner film on the image developing roller side.
3. The toner is attracted by the exposed part (Low electrical potential part) of the image drum when the image drum contact the image developing roller, so as to see the electrostatic latent image.

Note! The necessary bypass voltage in image processing is impressed on the toner feeding roller and image developing roller as show below.

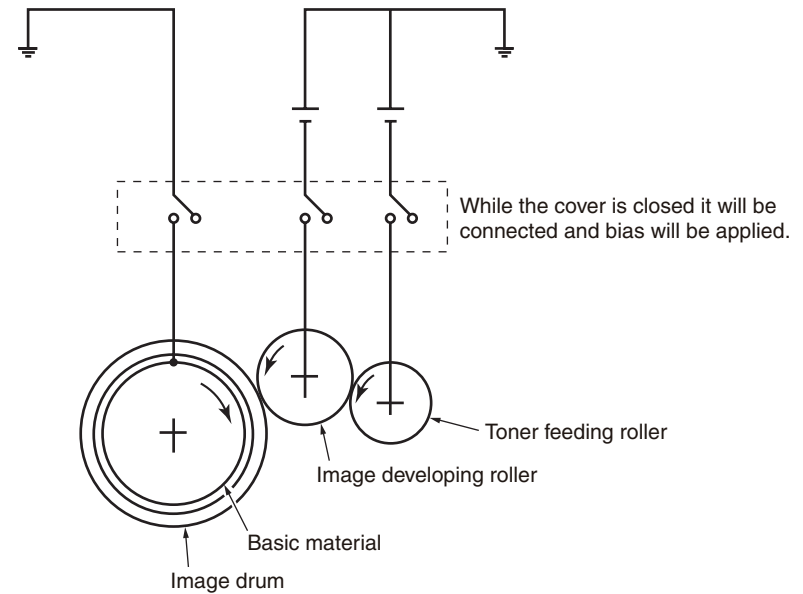

4. Transfer

The transfer roller, which is from conductive sponge material, is created to meet intimate attachment of image drum roller surface and feeding paper. The feeding paper is set up on the surface of image drum. Plus charge, which is the converse polarity with toner polarity, is applied from the backside of the paper.

As high plus voltage is applied to transfer roller from the power supply, the plus charge on the transfer roller surface is induced and transferred to the paper while the paper contact the transfer roller. The negative charged toner, which has been attracted to the image drum surface, is transferred to the surface of feeding paper by the plus charge of the backside of the paper.

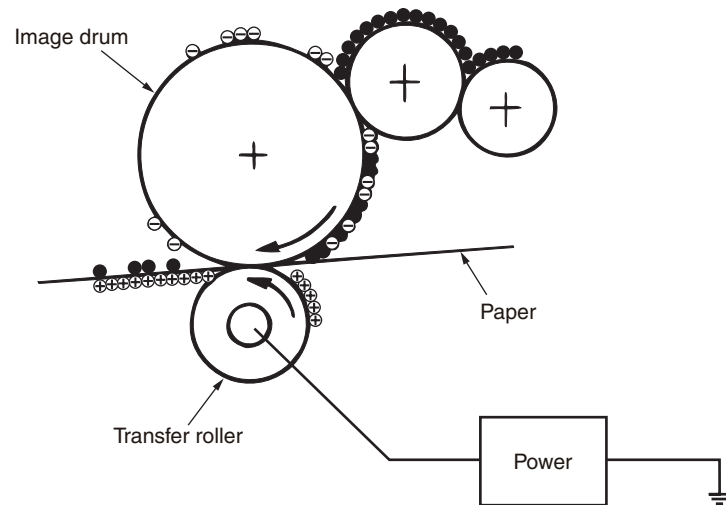

5. Fusing

After the termination of transfer the unsettled toner image is settled to paper by heat and pressure while passing between Heat roller and Back up roller. Heat roller is Teflon coated and is mounted by heater that can generate heat (Halogen lamp).

The thermistor that contacts the Heat roller adjusts the Heat roller temperature to the temperature specified by the menu complying with the paper width. For safety the thermostat shuts off the voltage supply to the Heater by opening the thermostat in the case of abnormally temperature increasing.

The back up roller is held by the pressure springs on each terminal due to the pressure applied.

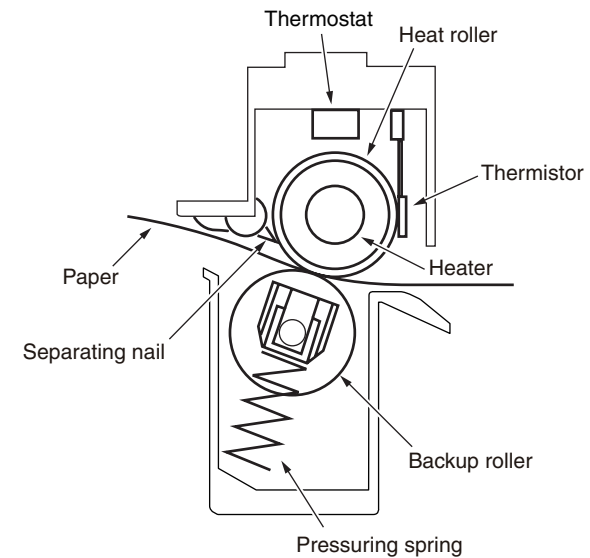

6. Drum cleaning

After completion of transfer, the toner remaining on the image drum is scraped off by the cleaning blade. As a result of this, the surface of the image drum is cleaned, and the remaining toner that has been scraped off is collected as waste toner in a waste toner area.

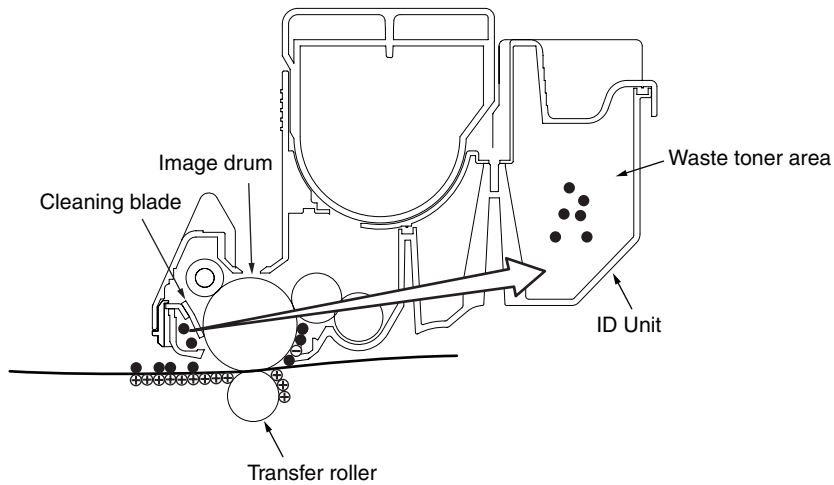

7. Static elimination

After completing transfer, the image drum is illuminated with its surface to decay static charge of its surface.

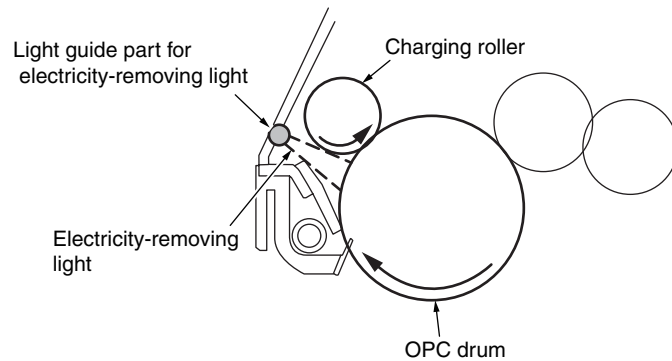

2.2 Printing process

The paper fed from Tray 1 and Tray 2 is conveyed by feeding roller, conveying roller, and resist roller. When feeding paper is from MPT, it is conveyed by MPT, feeding roller, and resist roller. After that the feeding paper that is conveyed by image drum and the nip part of transfer roller forms toner image on the paper through electrophotographic process. And then, the toner on the paper is fused by the heat and pressure as the fuser unit passing through. The paper that fused the toner image is ejected from the face down stacker of the ejecting roller. To eject printed pages on the face-up stacker, open the face-up stacker. (Duplex printing is not available during face-up ejection.)

The above is about the operations at simplex printing, yet the below explains the operations at duplex printing. While duplex printing, paper, which firstly passes the fuser unit after its backside is printed, is conveyed to the inside of the duplex unit, by the reverse rotation of the first and the second ejecting rollers in a certain period of time after the paper rear end passes the fuser unit. The paper is conveyed by the conveying roller of the duplex unit and then arrives the route for paper feeding from a tray. After that, the paper is handled in the same way as paper fed from a tray for simplex printing.

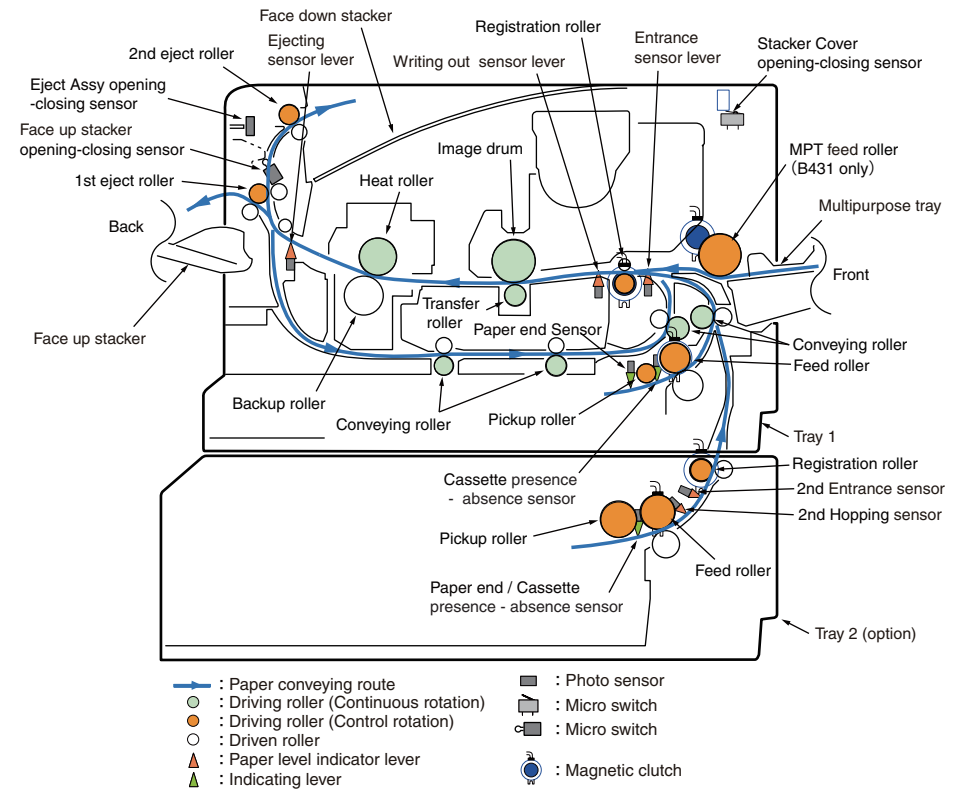

(1) Paper feeding from Tray 1

1. As DC motor rotating (Clockwise rotation), if set the paper feeding clutch as ON, as the paper feeding roller and pick up roller rotating, the paper that is inside the tray is conveyed.
2. The paper is conveyed by the conveying roller. After the entrance sensor level set to be ON, it bumps into the stopping resist roller, a certain more amount of paper is conveyed. (This corrects the paper skew.)
3. If set the resist clutch as ON, the paper is conveyed by resist roller.

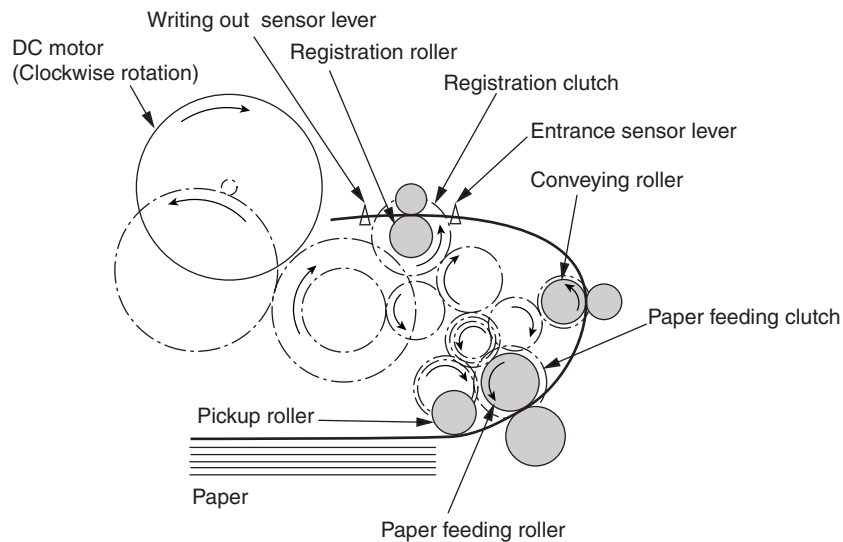

(2) Paper feeding from Multipurpose tray (MPT) (MB471/MB471w/MB491/ES4191)

1. As DC motor rotating (Clockwise rotation), if set paper feeding clutch as ON the MPT paper feeding roller starts to rotate, the paper in the tray is conveyed.
2. After setting the entrance sensor lever as ON, the paper bumps into the stopping resist roller, a certain more amount of paper is conveyed. (This corrects the skew of paper.)
3. If set the resist clutch as ON, the paper is conveyed by resist roller.

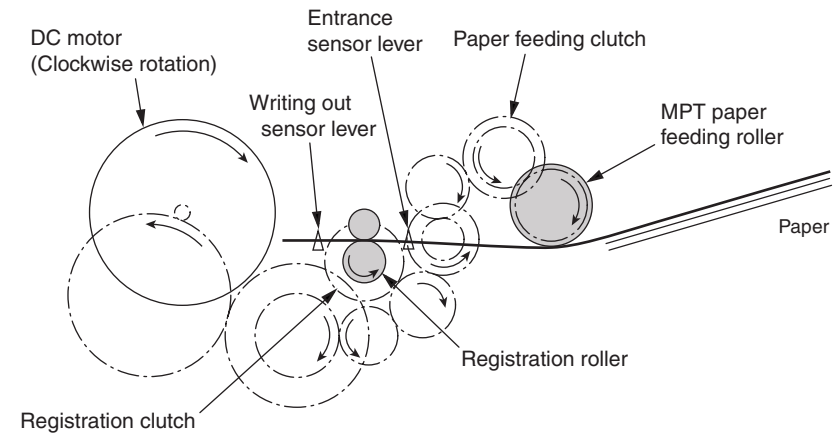

(3) Fuser unit and paper ejecting

1. The fuser unit is driven by the DC motor. After the DC motor starts running (clockwise), the heat roller starts rotating.
2. Simultaneously the eject motor starts running (counterclockwise), and then the eject roller starts rotating and ejects paper.

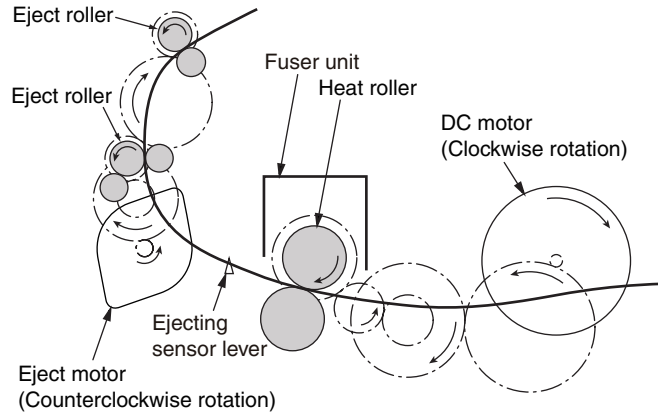

(4) Paper reversing and paper multi-feeding

1. In a certain period of time after the paper rear end passes the eject sensor lever, the eject motor runs backward (clockwise) and then the eject roller rotates in the reverse direction (clockwise).
2. By the inverse rotation of the eject roller the paper is inversely rotated and conveyed to Duplex.
3. Paper is conveyed by Duplex conveying roller.
4. After setting the entrance sensor lever as ON, paper bumps into the stopped resist roller, still a certain more amount of paper is conveyed. (This corrects the skew of paper.)
5. If set the Resist clutch as ON, paper is conveyed by Resist roller.

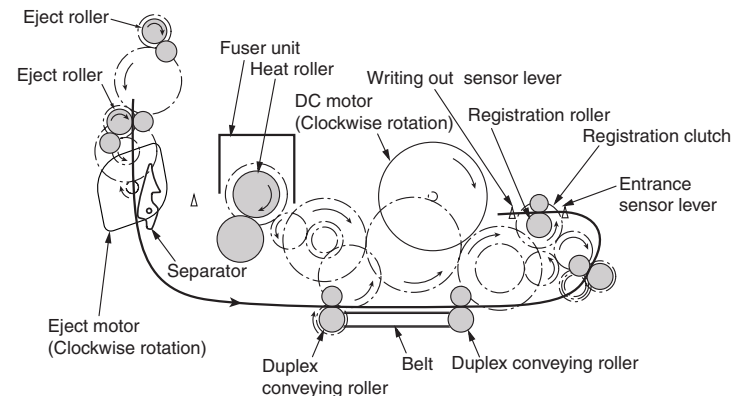
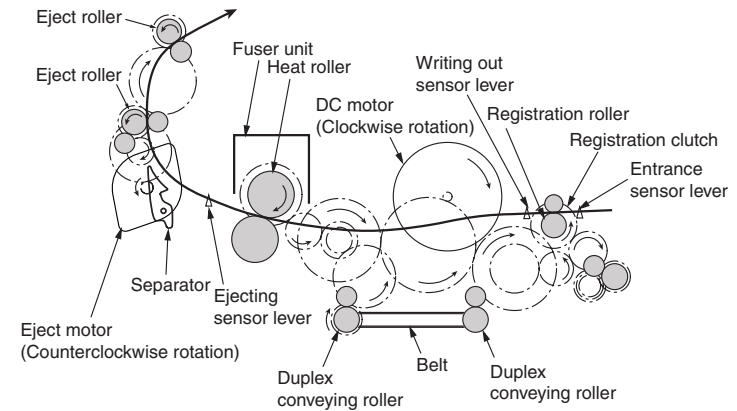

2.3 Toner entrance detection

2.3.1 Toner sensor detection principle

Toner low is detected by the toner sensor (reflect sensor) installed in the printer. The light shield plate is installed in the ID, and its rotation is synchronized with mixing of toner. If the light shield plate or toner sensor is dirty with toner or something, or the ID unit and the toner sensor are facing each other at an improper position due to improper setting of the ID unit or any reasons, toner low cannot be detected correctly, and a toner sensor error occurs.

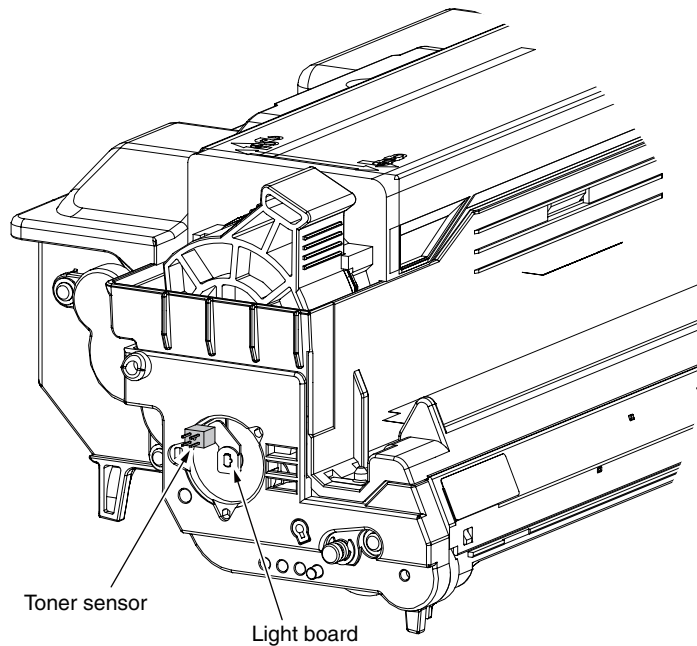

2.3.2 Toner count principle

After the image data is transformed into binary data which can be printed by the printer, the data is counted as print dot number by LSI. The amount of the used toner is calculated from this count value, and the residual amount is displayed on the menu.

Toner LOW detection (residual amount display on LCD) by the toner sensor is to detect a certain amount of the reduction of the toner left in ID.

2.4 Image Scanning process

2.4.1 Structure and process of RADF

2.4.1.1 Cross-section view

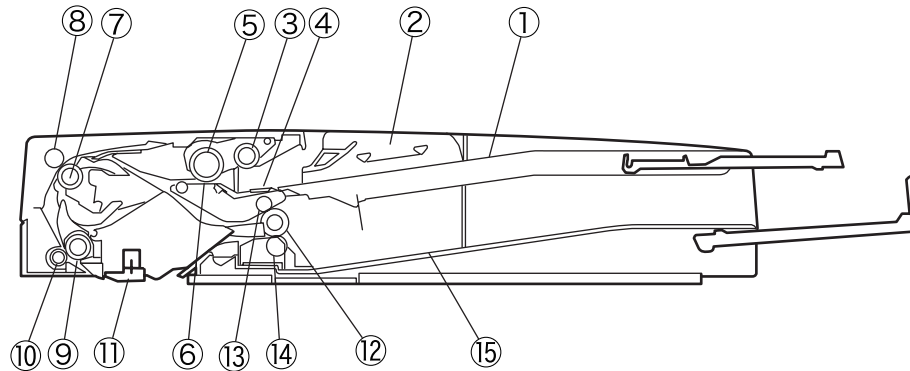

- | | |
|-------------------|----------------------|
| ① Paper tray | ⑨ Regist roller |
| ② Paper guide | ⑩ Pressure roller |
| ③ Pick-up roller | ⑪ Paper weight |
| ④ Friction pad | ⑫ Exit roller |
| ⑤ Feed roller | ⑬ Upper pinch roller |
| ⑥ Separation pad | ⑭ Lower pinch roller |
| ⑦ Transfer roller | ⑮ Paper stoker |
| ⑧ Pinch roller | |

2.4.1.2 Electrical configuration

Electrical circuit configuration

This Scanner is controlled by the SU board (MHE).

The ASIC mounted on the SU board (MHE) control the DC load devices such as motor, solenoid and clutch via the ADF board (MHD), in dependance of the sensor signals and control signals from the CU/PU board (98M) not to be shown in the below figure.

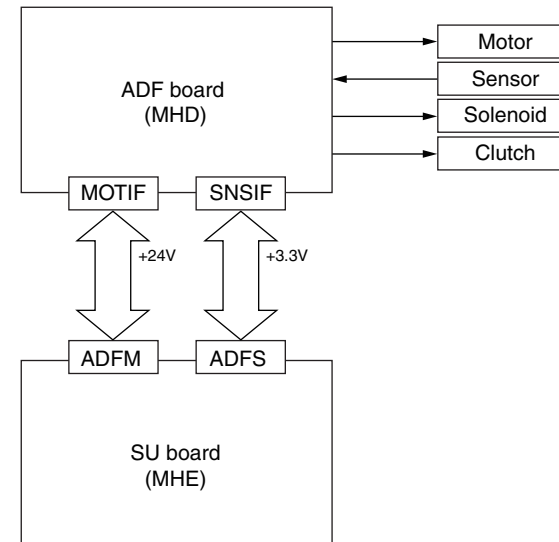

2.4.1.3 Fundamental operations

Drive force transmission diagram

The MFP is a document feed device of skim reading only.

Drive force diagram of the MFP is shown below.

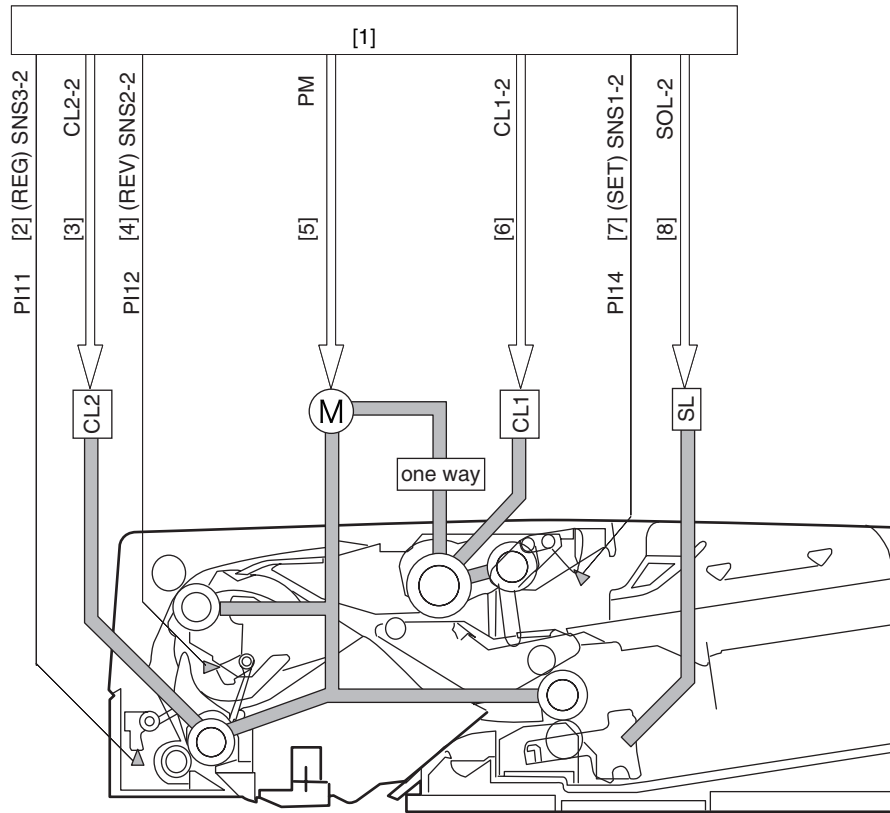

- [1] ADF board(MHD)
- [2] Document detection signal
- [3] Regist clutch signal
- [4] Document detection signal
- [5] Feed and transport motor drive signal
- [6] Feed clutch signal
- [7] Document set signal
- [8] Gear change solenoid signal

Overview of operation modes

There are four operation modes that are executed by the MFP. The respective operation modes are executed in accordance with the instructions given by the connected equipment to implement the print operation.

Name of the operation modes, the overview of the operation and the corresponding print modes are shown in the following table.

Name of the operation modes	Overview of the operation	Supporting print modes
[1] Normal direction feed paper/Unload paper	Document is fed and scanned. Upon completion of scan, document is unloaded as it is.	Single-sided document → Single-sided print Single-sided document → Both-sided print (This operation is performed in both cases when documents of same width and different width are used.)
[2] Normal direction feed paper/ Inverted unload paper	Document is fed and scanned. Upon completion of scan, document is inverted and unloaded.	Both-sided document → Both-sided print Both-sided document → single-sided print (This operation is performed in both cases when documents of same width and different width are used.)

Normal direction feed paper and unload paper (single-sided document → single sided print) operation

Outline of document flow is shown below.

Supplement : When a single-sided document is selected, this operation is performed regardless of the same size mixed documents or different sizes mixed documents.

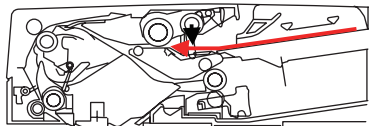

Feeding paper

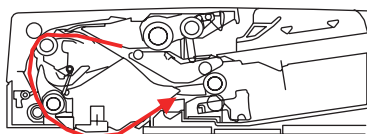

Scanning

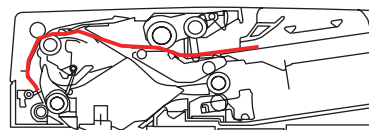

Loop creation

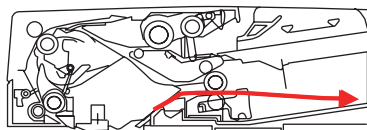

Discharging paper

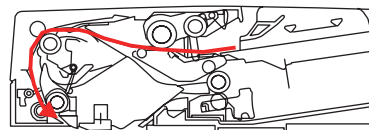

Scanning stand-by

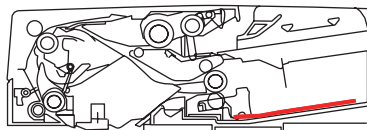

Job end

Normal direction feed paper/Inverted unloading of paper (both-sided document → both sided print) operation

Outline of document flow is shown below.

Supplement : When a both-sided document is selected, this operation is performed regardless of the same size mixed documents or different sizes mixed documents.

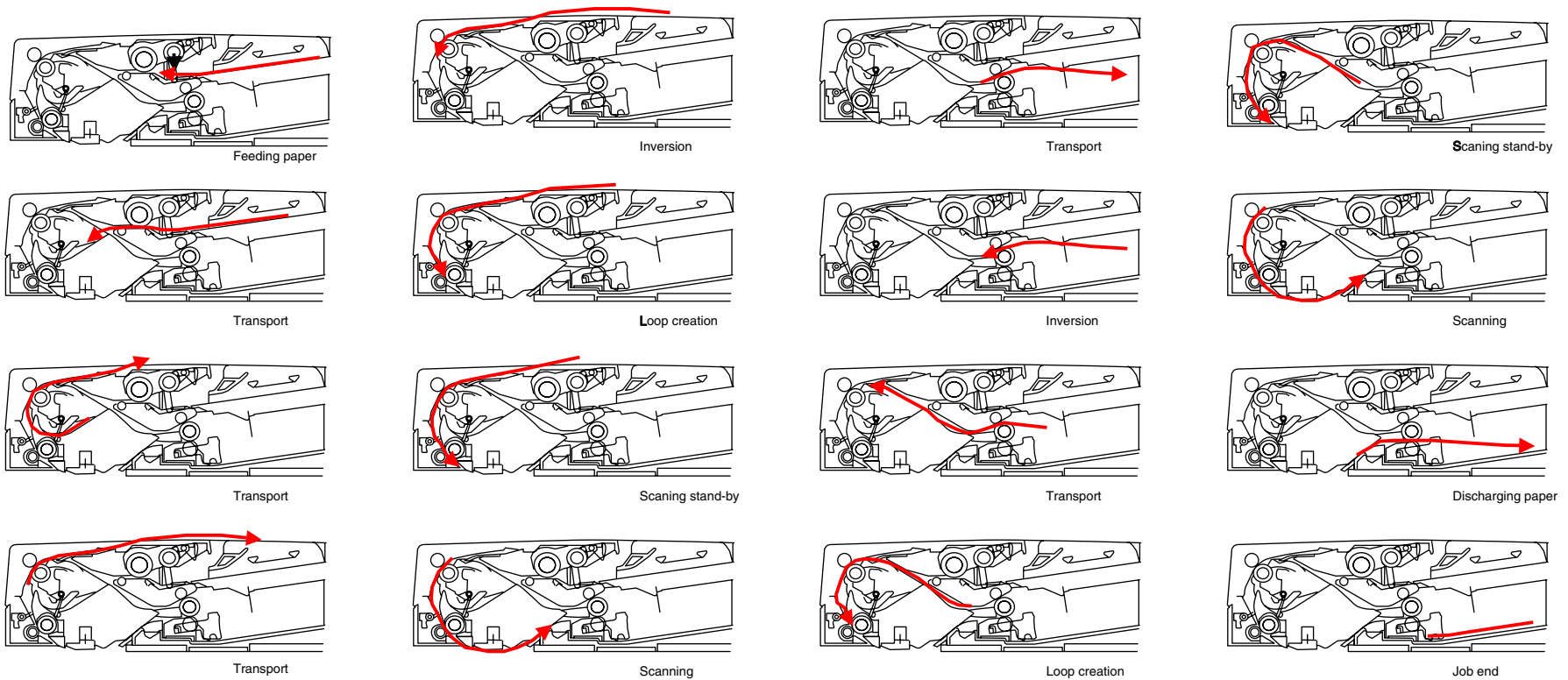

2.4.1.4 Document detection

Document present/absent detection

Document present/absent detection on the document tray is performed by document set sensor (PI14). When a document is placed on the document tray, the detection lever moves together with the light-shielding plate so that the photo interrupter that has been passing the light, shut down the light. Thus, the document set sensor (PI14) issues the document detection signal (SET) telling that a document is set, to the connected equipment via the ADF board (MHD).

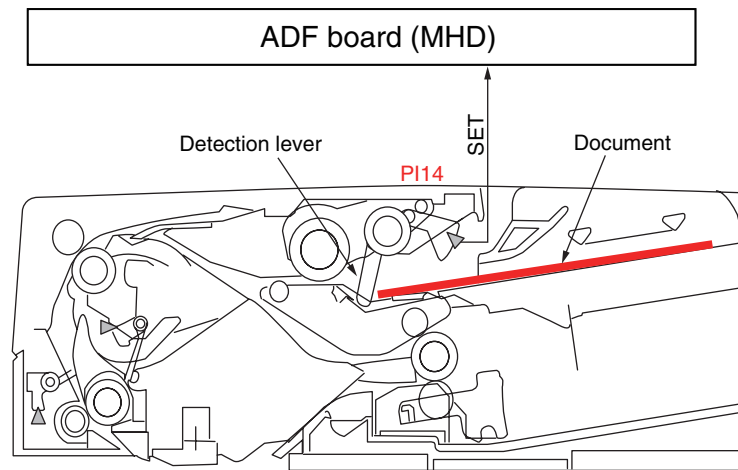

Detection of final document

The document set sensor (PI14) detects if the document that has started of the final document has passed the set sensor lever, the detection lever moves together with the light-shielding plate so that the photo interrupter that has been shutting down the light, passes the light. Thus, the document set sensor (PI14) issues the document set detection signal (SET). Telling that the document under feeding is the final document, to the connected equipment via the ADF board (MHD).

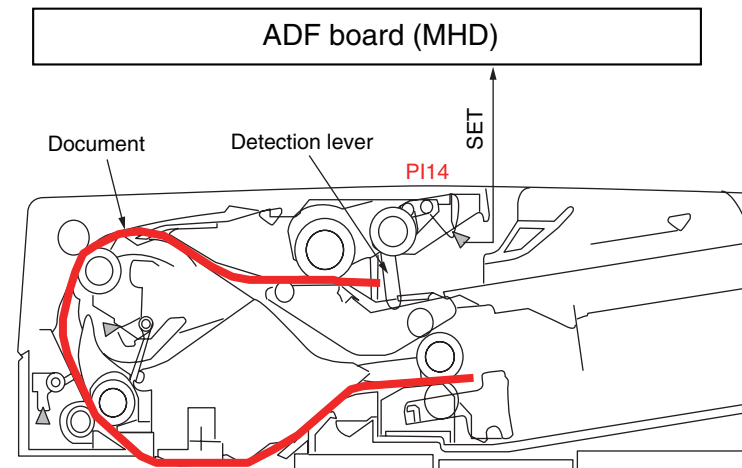

2.4.1.5 Jam detection

Document jam is detected by the sensors shown in the illustration. Check timing of the document jam detection has already been memorized in the ROM of the sensor main PCB beforehand so that jam occurrence can be judged from the information if a document exits or not, at the corresponding sensor block.

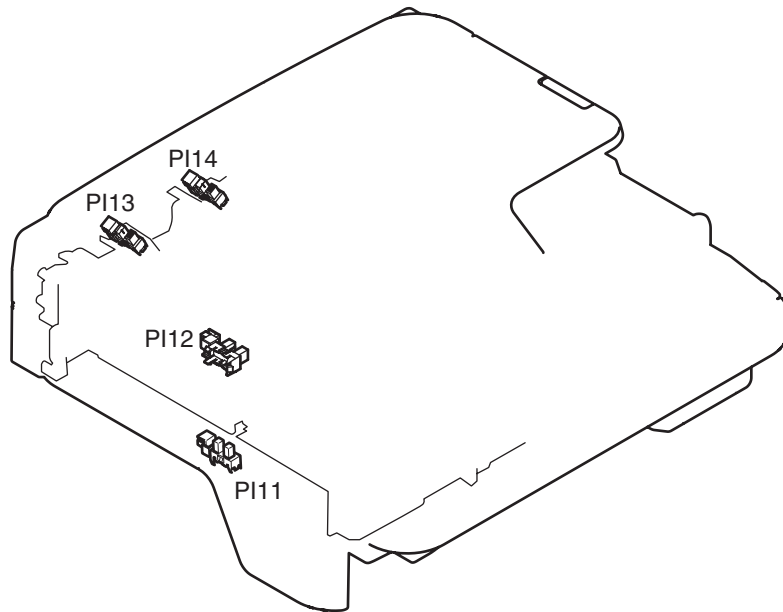

- PI11 : Regist paper sensor
- PI12 : Reverse paper sensor
- PI13 : Cover open/close sensor
- PI14 : Document set sensor

2.4.2 Document table structure

2.4.2.1 Overview

Flatbed unit consist of Cover-Top-Assy, Frame-Bottom-Assy, Carriage-Assy and Flatbed drive block.

The lamp (LED) is located on top of the Carriage-Assy. The light imadiated by the lamp (LED) rodrenze in this order and reaches the CMOS Sensor.

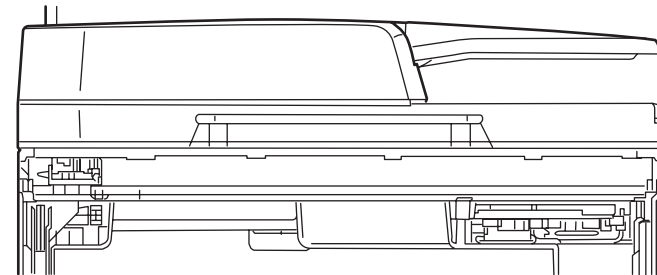

2.4.2.2 Exposure block

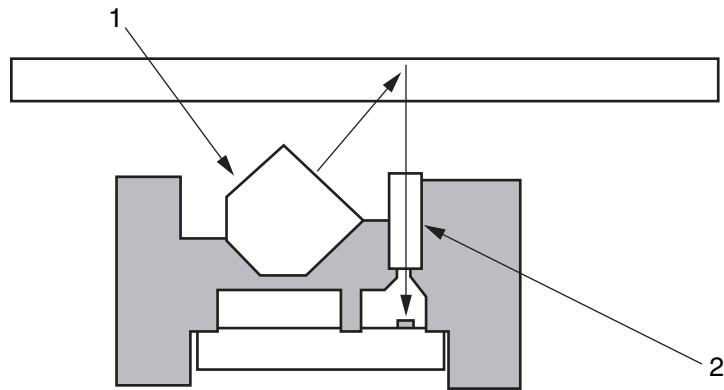

1. Light Source

LED (R, G, B) is used to irradiate light to document.

2. Rod lens

The reflected light from document is again reflected to the CMOS sensor.

2.4.2.3 Carriage-Assy drive mechanism

Carriage-Assy drive mechanism

Carriage-Assy performs the function of irradiating the lamp light uniformly over a document while moving its position.

The carriage-Assy is driven by a belt which is driven by the FB motor. Scanner moves at the scan speed corresponding to the respective magnification ratios that are set with reference to the standard scanning speed.

Home position of the carriage-Assy is the position where the home sensor is located. The home position is the reference position of the scanning operation.

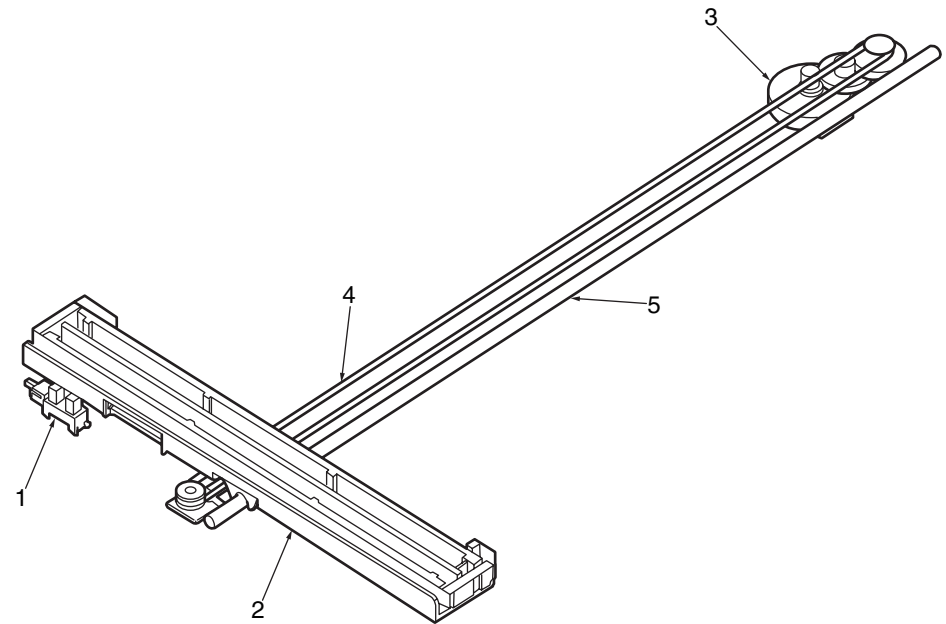

1	Home Sensor
2	Carriage Assy
3	FB Motor
4	Belt
5	Shaft

3. MFP INSTALLATION

3.1 Precautions and Prohibition.....	3-2
3.2 MFP Unpacking Procedure	3-3
3.3 MFP Installation Instructions	3-4
3.4 Packed Units and Attachments	3-5
3.5 Assembly Procedure	3-6
3.6 Configuration Page Print	3-22
3.7 Network Information Print.....	3-24
3.8 Connection Procedures.....	3-25
3.9 Checking of User Paper.....	3-29

3.1 Precautions and Prohibition

Warning

- Do not install the MFP in the vicinity of high temperature or fire.
- Do not install the MFP at the place where a chemical reaction may take place (laboratory, etc.).
- Do not install the MFP near flammable solution like alcohol, thinner, etc.
- Do not install the MFP at the place where a small child can reach.
- Do not install the MFP at an unstable place (unsteady frame, tilted place, etc.).
- Do not install the MFP at a highly humid or dusty place or under the direct sunshine.
- Do not install the MFP under the environment of sea breeze or caustic gas.
- Do not install the MFP at a highly vibrating place.
- When you drop the MFP or damage the cover, remove the power plug from the outlet and contact the Customers' Service Center.
Electric shock, fire or injury may occur.
- Do not connect the power cord, printer cable and earth wire as otherwise directed by the Manual. A fire may break out.
- Do not insert a thing in the vent hole.
Electric shock, fire or injury may occur.
- Do not place a cup with water on the MFP.
Electric shock or fire may occur.
- Do not touch the fuser unit when you open the printer cover.
Burn may occur.
- Do not throw the toner cartridge or image drum cartridge into fire.
Burn may occur by the dust explosion.
- Do not use a highly flammable spray near the MFP.
Fire may break out as there are high temperature parts inside the printer.
- When the cover becomes abnormally hot, a smoke arises or a strange odor comes out, remove the power plug from the outlet and contact the Customers' Service Center.
Fire may break out.
- When liquid like water drops inside the MFP, remove the power plug from the outlet and contact the Customers' Service Center.
Fire may break out.
- When a thing like a clip drops inside the MFP, remove the power plug from the outlet and take out that thing.
- Do not operate or disassemble the MFP as otherwise directed in the Manual.
Electric shock, fire or injury may occur.

Caution

- Do not install the MFP at the place where the vent hole is blocked.
- Do not install the MFP on the shaggy carpet.
- Do not install the MFP at the place with little draught or without ventilation like a room with no window.
- Install the MFP away from the monitor TV.
- When the MFP is to be moved, hold both ends of the printer.
- This MFP weighs about 20kg and should be lifted by 2 or more persons.
- When to switch the power on or while printing, do not come near the paper exit of the MFP.
Injury may occur.

As regards the items of caution, explain to the customer showing the items of caution of the User's Manual. Particularly, explain fully about the power supply cord and earth cable.

3.2 MFP Unpacking Procedure



Warning

Personal injury may occur.



This MFP weighs about 20kg. So lift it up with 2 or more persons.

- Open the upper lid.
- Take out the accessory box.
- Remove the upper buffer material.
- Take out the equipment

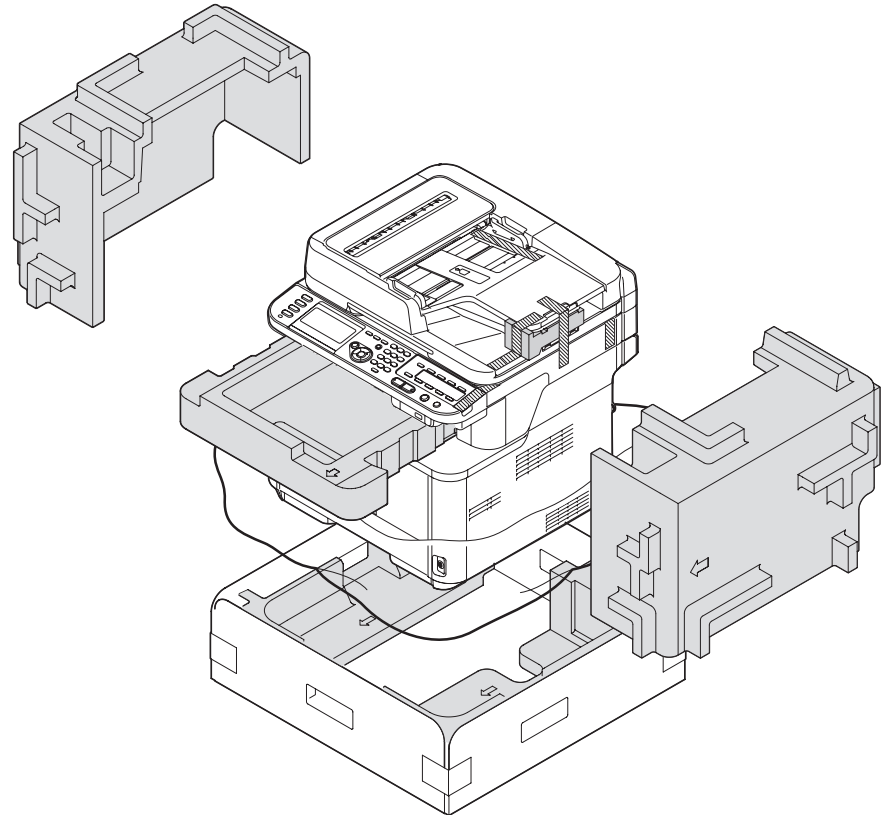

3.3 MFP Installation Instructions

- Install the MFP at a place under the following temperature and humidity:
 - Ambient Temperature : 10 to 32°C
 - Ambient Humidity : 20 to 80% relative humidity
 - Maximum Wet-Bulb Temperature : 25°C
- Be careful not to be bedewed.
- When the MFP is to be installed at a place where the humidity is less than 30%, use a humidifier or a static electricity prevention mat.

Installation Space

- Place the MFP on a flat desk with enough space for the legs of the MFP.
- Secure enough space around the MFP.

Top View

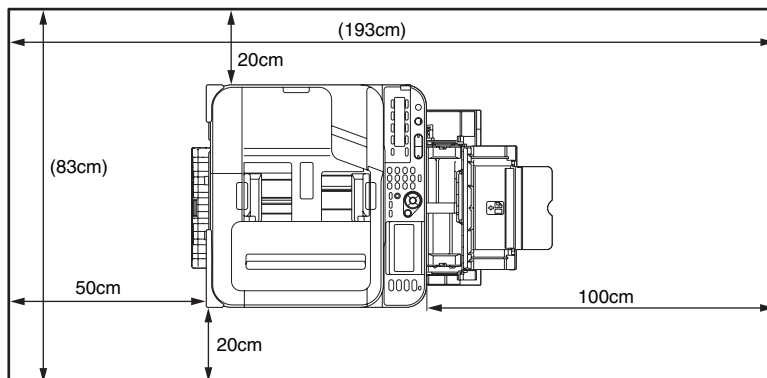

Side View

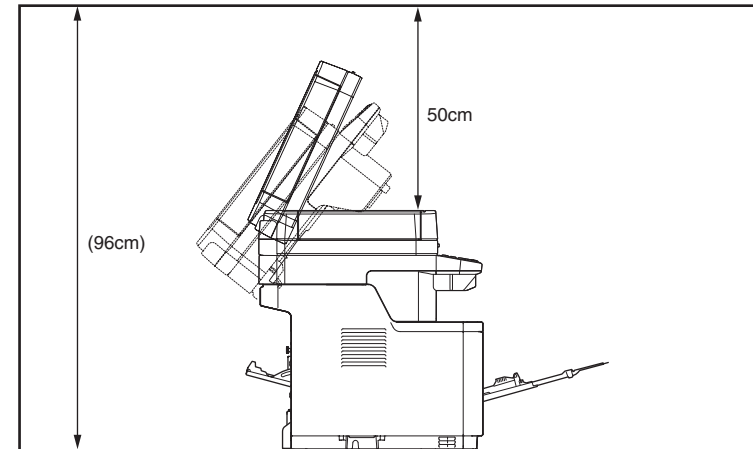

Side View (tray 2 installed)

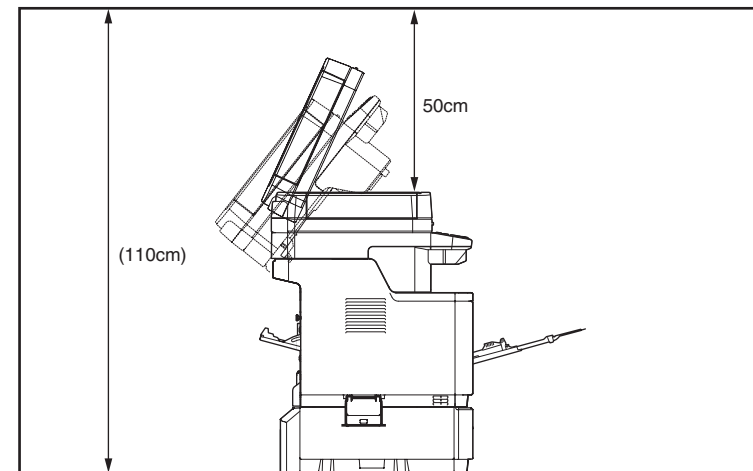

3.4 Packed Units and Attachments

- Confirm whether there are scratches, stains, etc. on the exterior of the MFP.
- Confirm whether there are lacking items, damages, etc. among the accessories.
- If anything unusual is found, contact the user's section in charge and follow its instruction



Warning

Personal injury may occur.



This MFP weighs about 20kg and should be lifted by 2 or more persons.

- MFP (main body)

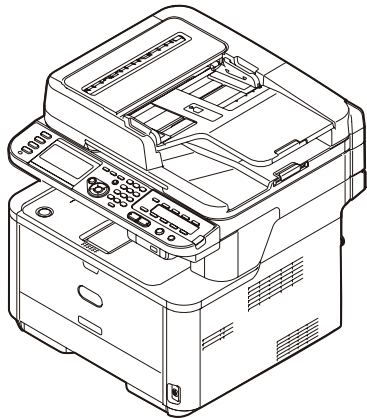

- Image Drum Cartridges with Starter Toner Cartridges (installed in the MFP)

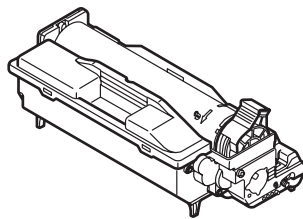

Explain to customers that the toner cartridge and the image drum cartridge are separable.

- MFP Software DVD
- Power Cord
- Warranty and Registration Card
- Set-up Guide
- Telephone cable

Note! The printer cable is not included in the accessories.

3.5 Assembly Procedure

3.5.1 MFP Main Body

Remove Protective Equipment

- (1) Lift the machine and place it where it is to be installed.

Note! Do not open the scanner unit till the procedure no.9 is completed.

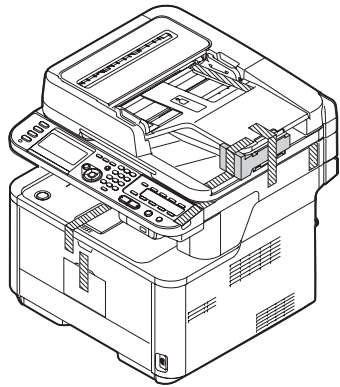

- (2) Remove the protection tapes at the top and sides of the machine to take out cushioning materials.

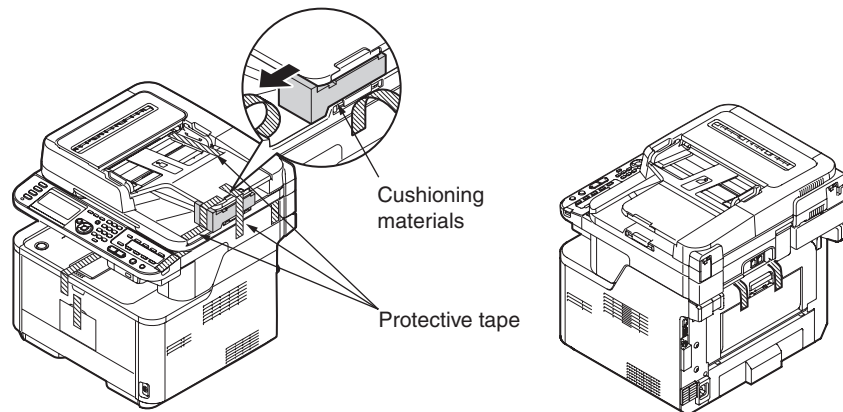

- (3) Remove the protection tapes to open the MP tray.

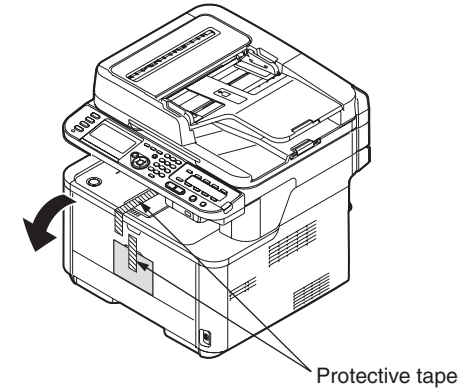

- (4) Remove the protection tape to pull the paper up.

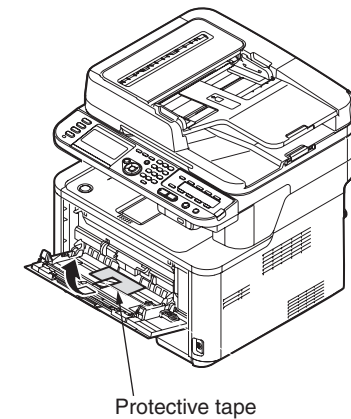

- (5) Close the MP tray.
- (6) Open the document glass cover.

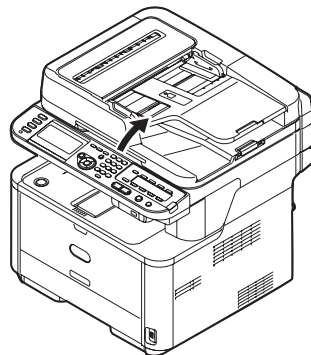

- (7) Remove the protection tapes.
Open the ADF and remove packaging tapes.

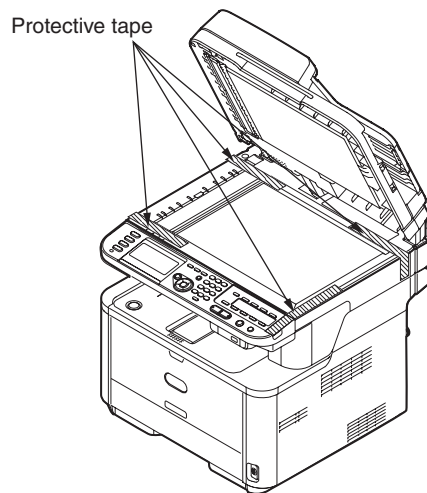

- (8) Close the document glass cover.
Now, you can open or close the scanner.
- (9) Open the scanner unit.

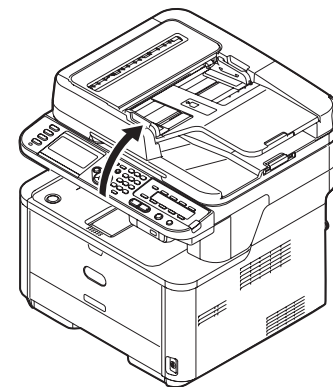

- (10) Remove the protection tapes, and remove desiccants and films.
- (11) Press the top cover open button and open the top cover.

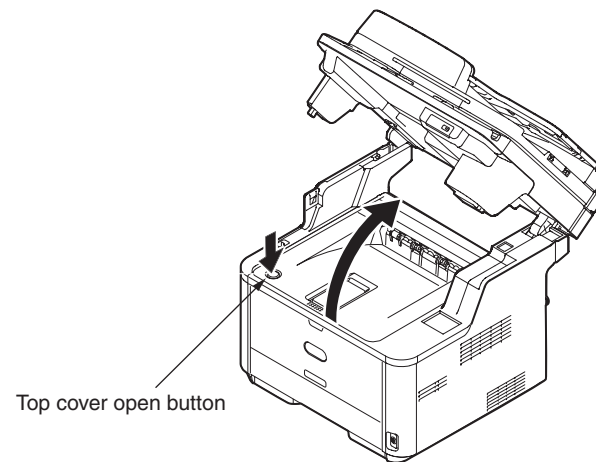

(12) Lift the image drum from printer.

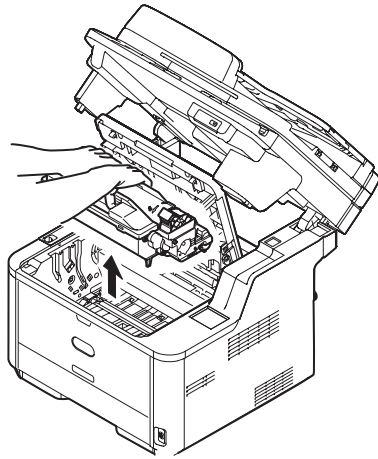

- Note!**
- Do not expose image drum to light for more than 5 minutes
 - Do not touch shiny green surface at bottom of image drum.

(13) Remove the silica gel pack before installation.

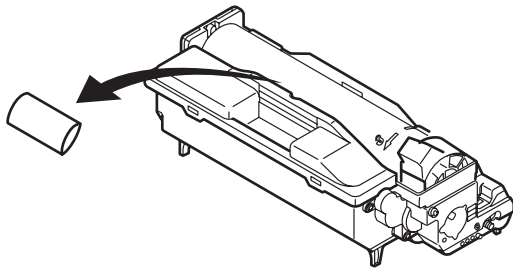

(14) Reinstall the image drum in the printer: lower it into place in the printer locating the pegs ① at each end into their slots in the sides of the printer cavity ②.

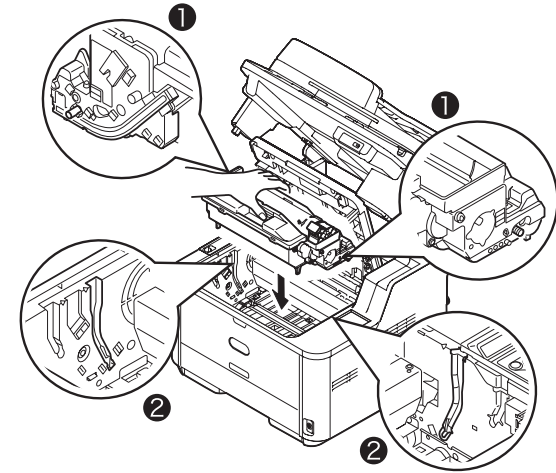

(15) Turn the lever in the direction shown.

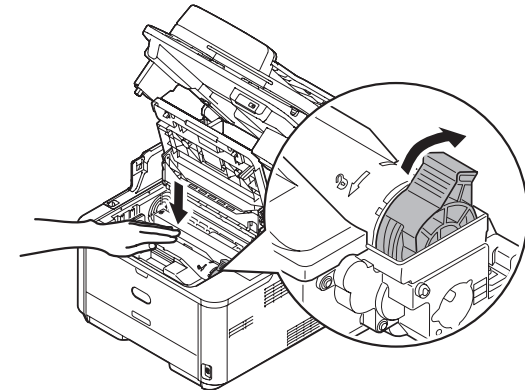

- The arrow on the lever should align with the arrow on the image drum.
- When the toner cartridge is not fully fixed, a decline in print quality may occur.

(16) Close the top cover.

(17) Close the scanner unit.

Reference! Please refer to "Loading Paper" P.32 for information on how to load paper into the machine

Loading Paper in Tray 1 and Tray 2

The following procedure explains how to load paper in tray 1 or tray 2 (optional).

Memo! The following procedure uses tray 1 as an example but the same is applied to tray 2.

- (1) Pull out the paper tray.

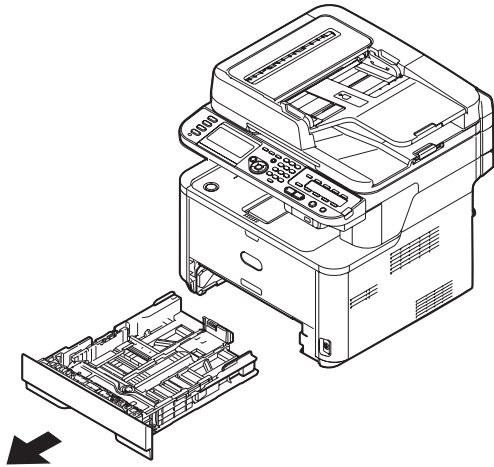

- (2) Slide the paper guide (1) to the width of paper to be loaded.

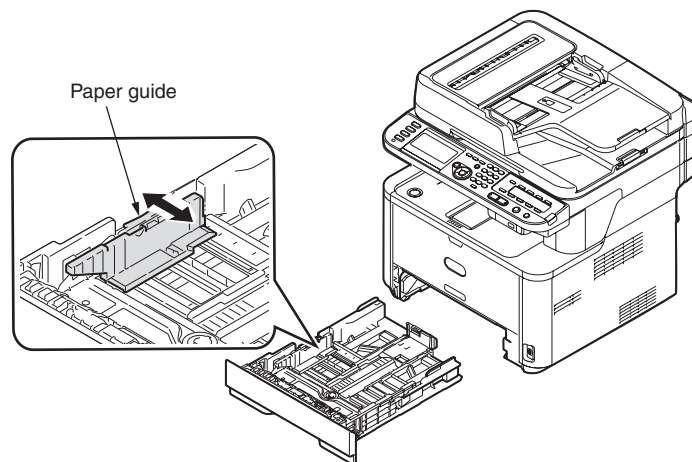

- (3) Slide the paper stopper (2) to the length of paper to be loaded.

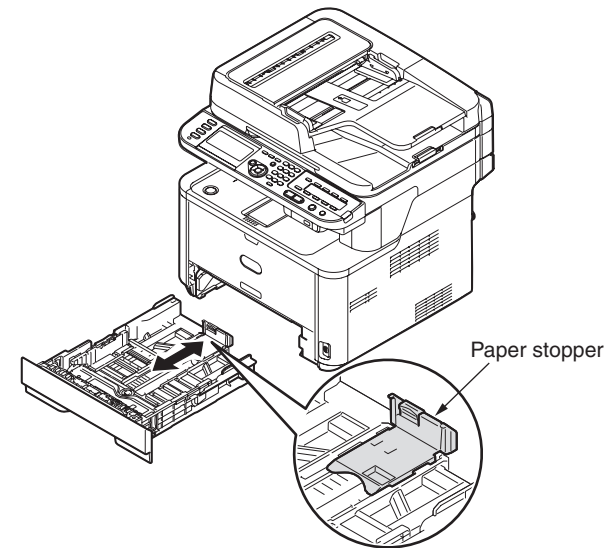

- (4) Flex paper back and forth, and then fan it. Straighten the edges of the paper stack on a level surface.

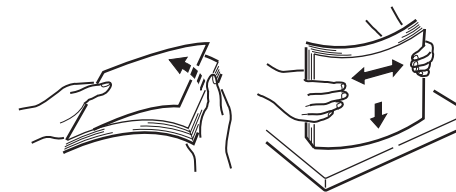

- (5) Load paper with the print side face down.
Note! Do not load paper above the fill line (3).

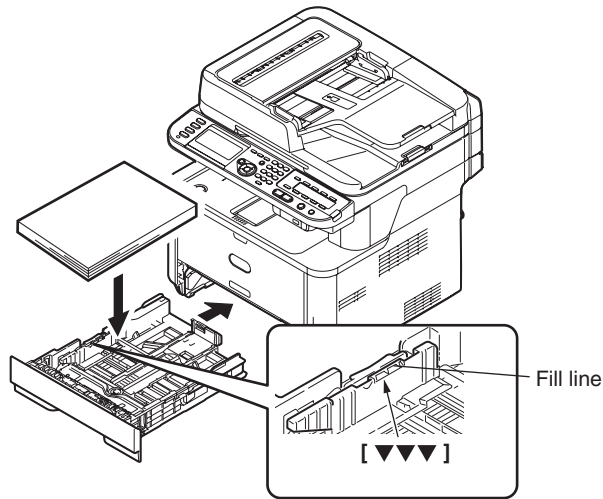

- (6) Push the paper tray until it stops.
 Register the loaded paper on the machine.
 Proceed to "Configuring the Tray Settings" P. 35.

Loading Paper on the MP Tray (MB471/MB471w/MB491/ES4191 MFP)

The following procedure explains how to load paper on the MP tray.

- (1) Open the MP tray.

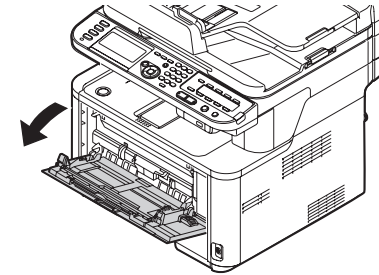

- (2) Pull out the paper support.

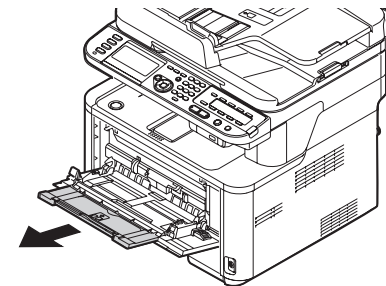

- (3) Pull out the sub support.

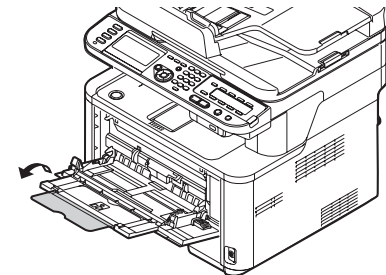

(4) Adjust the manual feeding paper guide to the width of paper to be loaded..

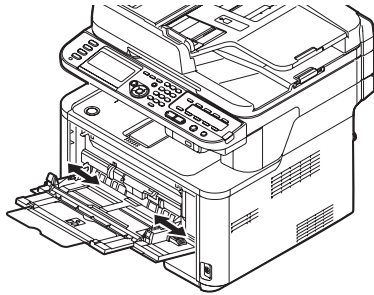

(5) Insert the paper with the print side face up until its edge touches the paper feed entrance.

Note! Do not load paper above the fill line.

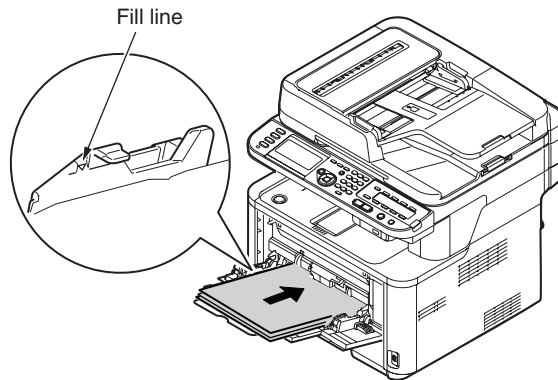

(6) Press the Set button.

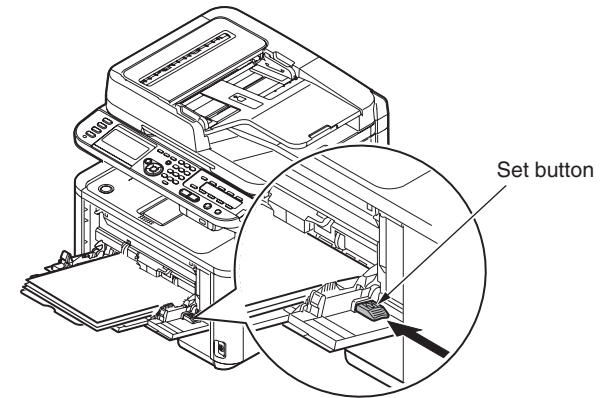

Register the loaded paper on the machine.

Proceed to "Configuring the Tray Settings".

- Note!**
- Do not load paper of different sizes, types or weights at the same time.
 - When adding paper, remove the paper on the MP tray and straighten the edges of both stacks of paper, and then load them again.
 - Do not put anything other than paper for printing.

Memo! When loading envelopes on the MP tray, load them face up with the orientation as stated below.

- You envelopes (Monarch, Com-9, Com-10, DL and C5) are loaded with the flap folded and the flap should come to the right side to the feeding direction.

Loading Paper on the Manual Feeder (MB461)

The following procedure explains how to load paper on the Manual Feeder.

- (1) Open the Manual Feeder.

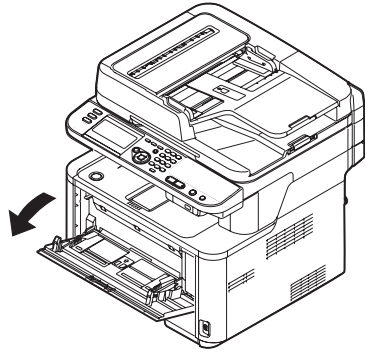

- (2) Adjust the manual feeding paper guide to the width of paper to be loaded.

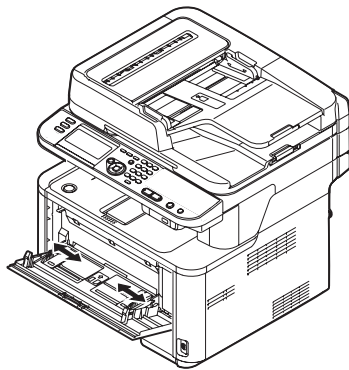

- (3) Load a paper.

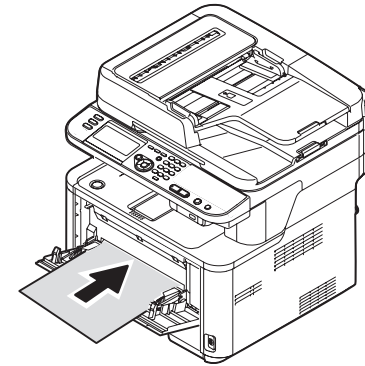

Note! Only one sheet can be set in the Manual Feeder each time.

Loading Documents on the ADF

- (1) Load your documents face up on the ADF.

If your documents are portrait, load them with the top edge of the documents in first.

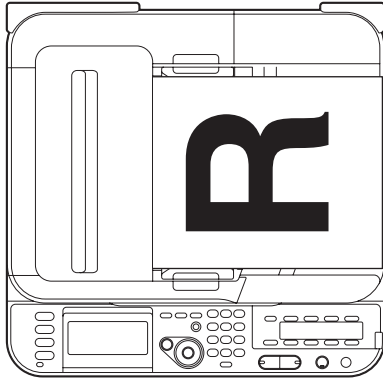

If your documents are landscape, load them with the left edge of the documents in first.

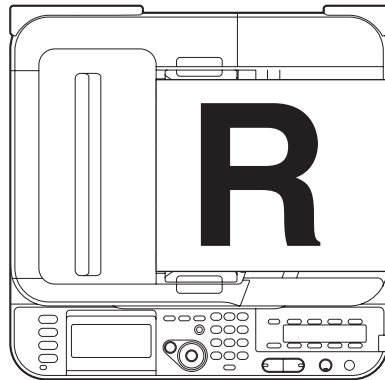

- (2) Adjust the document guides to the width of your documents.

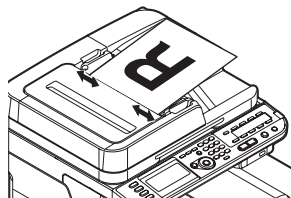

Loading Documents on the Document Glass

- (1) Lift and open the document glass cover.

- (2) Place a document face down on the document glass.

If your document is portrait, align its top edge to the upper-left corner of the glass.

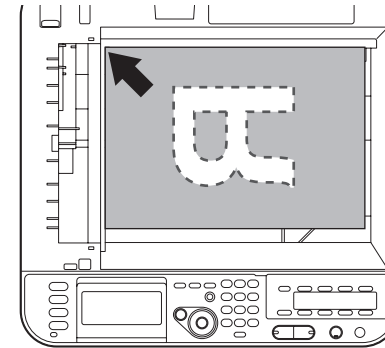

If your document is landscape, align its right edge to the upper-left corner of the glass.

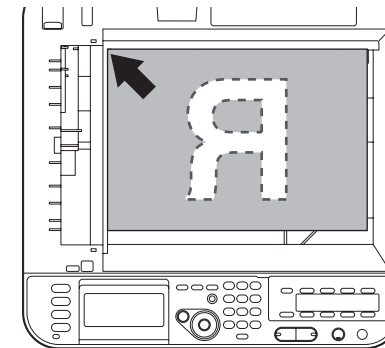

- (3) Close the document glass cover gently.

Reference If you want to use [N-in-1], [Sort] or [DuplexCopy] functions, change the [Document Direction] setting according to the direction of your document to get the output you want. The default setting is [Portrait].

3.5.2 Power Cable Connection

Conditions for Power Supplies

- Observe the following conditions:
 - Alternate Current (AC) : 110 ~127VAC(Range 99~140VAC)/220~240VAC(Range 198~264VAC)
 - Power Supply Frequency : 50Hz or 60Hz±2%
- Use a voltage regulator when the power supply is not stable.
- The maximum power consumption of this MFP is 950W. Confirm that the power supply has sufficient extra capacity.

Warning

It may expose you to electric shocks or cause a fire.



- Never fail to switch off the power supply at the time of connection or removal of the electric cord and earth cable.
- Always connect the earth cable to the earth terminal equipped only for that purpose. Never connect the earth cable with water pipe, gas pipe, telephone cable earth terminal, lightning rod, etc.
- Always grasp the power plug at the time of connection and removal of the electric cord.
- Always make sure that the electric plug is inserted fully into the outlet.
- Do not connect or disconnect the electric plug with the wet hand.
- Do not install the electric cord at the place liable to be stepped on and do not put things on the electric cord.
- Do not bundle up or tie up the electric cord
- Do not use the damaged electric cord.
- Do not put many loads on one electric outlet.
- Do not connect this MFP to the same outlet with other electric machines. Particularly, erroneous operation may occur by electric noise when the same outlet is shared by the air conditioner, duplicator, shredder, etc. at the same time. When the same outlet had to be used, use a noise filter or noise cut transformer on the market.
- Use the attached electric cord only.
- Do not use an extension cord. Use the cord of over rating 15A if you had to use one.
- When you use the extension cord, the MFP may not operate normally due to the drop of AC voltage.
- Do not shut down the power supply or remove the power plug while printing.
- Disconnect the power cord when the MFP would not be used for some long while due to consecutive holidays or journey.

As to the connection of the electric cord and earth cable, explain fully to the customer showing the User's Manual.

Turning On the Machine

- Plug the AC cord into the AC power socket of the machine.

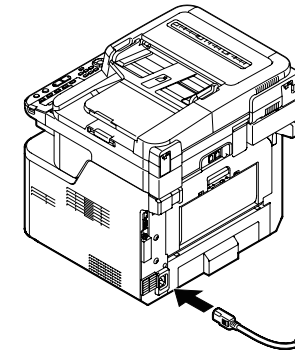

- Plug the AC cord into the electric socket.
- Check that no documents are on the document glass or ADF, and the ADF cover is closed.
- Hold down the power switch for about a second to turn on the power.

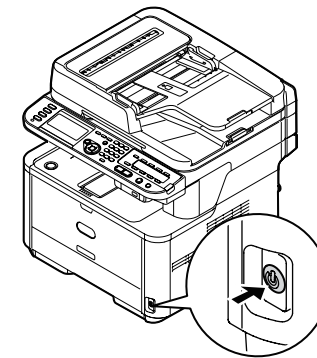

The copy standby screen is displayed after the machine became ready status.

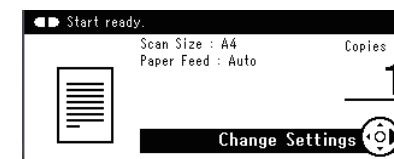

Note! Turn the power off, and when turning the power back on again, push the power switch after waiting for a few seconds.

Turning Off the Machine

- (1) Hold down the power switch for about a second.

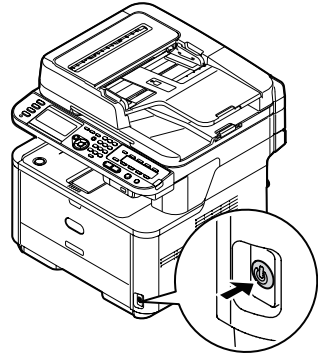

Note! Press the power switch for less than 5 seconds.

The message [Shutdown in progress. Please wait. The machine turns off automatically.] appears in the operator panel, and power switch indicator blinks every 1 second. Then the machine turns off automatically and power switch indicator goes out.

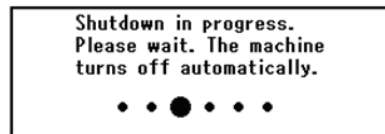

Note! Turn the power off, and when turning the power back on again, push the power switch after waiting for a few seconds.

Reference! The machine has the power save mode and sleep mode, and the auto power off function. For details on them, refer to the User's Manual (Basic) > "1. Setup" > "Installing The machine" > "Turning On and Off The machine" > "Power Save Mode and Sleep Mode" / "Auto Power Off".

3.5.3 Installation of Optional Components

This section explains how to install options. The following options are available:

- Second tray unit
- FDI Interface Kit (for MB491 only)

Important Be sure to turn off the machine and unplug the AC cable and Ethernet or USB cable before installing options. Installing options while the MFP is turned on may damage the MFP and options.

3.5.3.1 Second Tray Unit

Installing a Second Tray Unit

Install an optional second tray unit (tray 2) when you want to increase the paper capacity of the machine. After installation, you need to configure the printer driver settings.

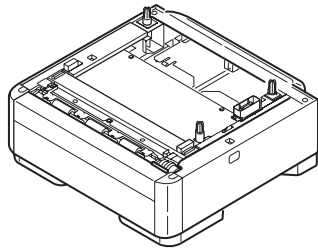

Model Number : N22204A

Reference! For the specification of the second tray unit (Tray2), refer to "Loading Paper" P. 32.

Installation



Warning

At least two people are needed to lift the MFP safely.

- (1) Hold down the power switch for about a second to turn off the power, and then unplug the AC cable and the Ethernet or USB cable.

Reference! "Turning Off The machine" P. 20

- (2) Lift the machine and align the three pins of the second tray unit with the holes at the bottom of the machine.

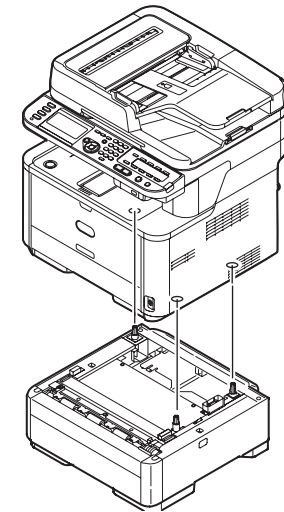

- (3) Place the machine on the second tray unit gently.

(4) Attach the lock parts.

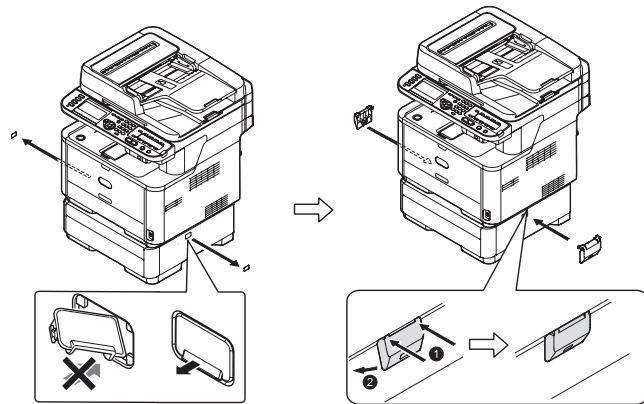

(5) Plug the AC cable and Ethernet or USB cable into the machine, and then push the power switch.

Printer Driver Configuration

The procedure differs according to which driver installed on the computer.

- Important**
- You must be logged in as an administrator to complete this procedure.
 - Windows PCL XPS printer driver is not available for Windows Server 2003 and Windows XP.

Reference The printer driver needs to be installed on the computer before doing this procedure.

For Windows PCL/PCL XPS Driver

- Note!**
- This procedure uses Windows 7 as an example. The display may differ depending on the operating system.
 - This procedure uses MB491 PCL driver as an example.

(1) Click [Start] > [Devices and Printers].

For Windows Server 2008 and Windows Vista, click [Start] → [Control Panel] → [Printer].

For Windows XP/Windows Server 2003, click [Start] → [Printers and Faxes].

(2) Right-click the OKI MB491 icon and select [Printer properties].

For Windows Server 2008, Windows Vista, Windows Server 2003 and Windows XP select [Properties].

For Windows 7, if you have installed multiple printer drivers, select [Printer properties] → [OKI MB491 (PCL)] or [OKI MB491 (PCL XPS)].

(3) Select the [Device Options] tab.

(4) For the network connection, select [Get Printer Settings].

For the USB connection, check [Lower Cassette].

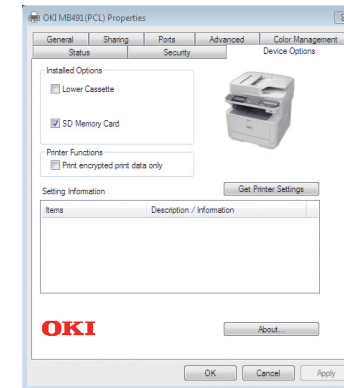

(5) Click [OK].

For Windows PS Driver

Note! This procedure uses Windows 7 as an example. The display may differ depending on the operating system.

(1) Click [Start] → [Devices and Printers].

For Windows Server 2008 and Windows Vista, click [Start] → [Control Panel] → [Printer].

For Windows XP/Windows Server 2003, click [Start] → [Printers and Faxes].

(2) Right-click the [OKI MB491 (PS)] icon and then select [Printer properties].

For Windows Server 2008, Windows Vista, Windows Server 2003 and Windows XP select [Properties].

For Windows 7, if you have installed multiple printer drivers, select [Printer properties] → [OKI MB491 (PS)].

(3) Select the [Device Settings] tab.

- For the network connection, select [Get installed options automatically] under [Installable Options], and then click [Setup].

For the USB connection, select [installed] for [Second Tray] under [Installable Options].

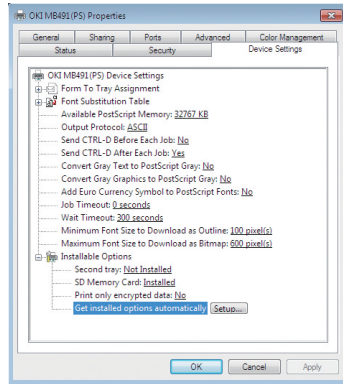

- Click [OK].

For Mac OS X PS/PCL Driver (Mac OS X 10.4)

Note! • This procedure uses Mac OS X 10.4 as an example.
 • This procedure uses MB471 driver as an example.

- From [Go], select [Utilities] and then double-click [Printer Setup Utility].
- Select the name of the machine and then click [Show Info].
- Select [Installable Options].

- Select the total number of trays installed on the machine for [Available Tray], and then click [Apply Changes].

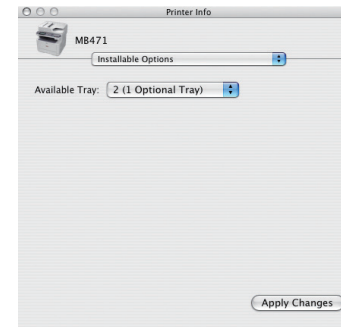

- Close [Printer Info].

For Mac OS X PS/PCL Driver (Mac OS X 10.5 to 10.7)

Note! • This procedure uses Mac OS X 10.7 as an example.
 • This procedure uses MB471 driver as an example.

- Select [System Preferences] from the Apple menu.
- Click [Print & Scan].
- Select the name of the machine and then click [Options & Supplies].
- Select the [Driver] tab.
- Select the total number of trays installed on the machine for [Available Tray], and then click [OK].

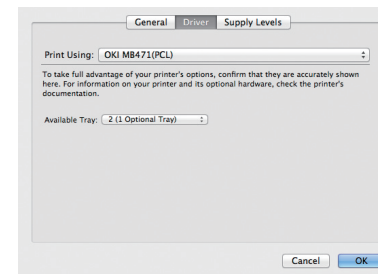

3.5.3.2 FDI Interface Kit (for MB491 only)

FDI Interface kit works with the specific accounting device only and can be installed on only the MB491.

Put the original metal cover on the correct position after FDI Interface kit is detached.

Pull the AC code off before FDI Interface Kit is installed.

- (1) Loosen the screw and remove the original metal cover on the back side.

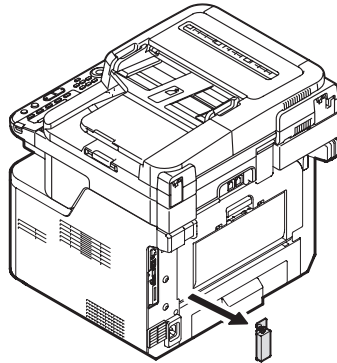

- (2) Connect the 12pin connector to the main board.

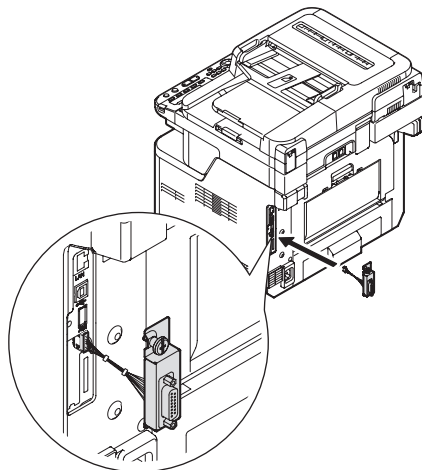

- (3) Push the rest of the cable towards the inside of the unit so that FDI Interface Kit and the unit backside do not pinch the cables.
Tighten the screw on the FDI Interface Kit.

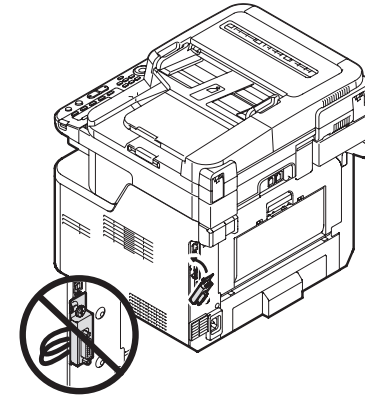



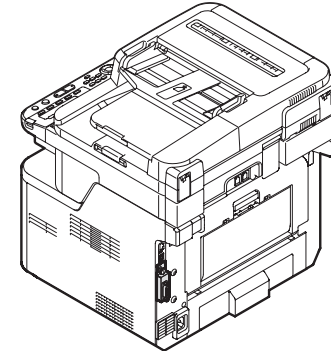







- (4) Completion





Note! Don't pull out an AC cable or FDI cable while in use.
Accounting device may count incorrectly.

Enabling Accounting

Following items must be operated by administrator.

- (1) Press the <SETTING> key on the operator panel.
- (2) Press the  to select [**Admin Setup**] and then press .
- (3) Enter the administrator password.
The default password is "aaaaaa".
- (4) Select  and then press .
- (5) Press the  to select [**Management**] and then press .
- (6) Press the  to select [**System Setup**] and then press .
- (7) Make sure that [**Access Control**] is selected and then press .
- (8) Press the  to select [**Accounting Device**] and then press .

[**Accounting Device**] will not be shown if FDI connection kit is not connected to the machine.

- (9) Press the  to select [**yes**] and then press .











Please note that after 9 panel will be locked and panel operation will not be possible unless user is authenticated through external device.

Memo! Setting is also possible by using WebPage or through Configuration Tool.

Disabling Accounting Device

Disable Accounting Device while FDI connection kit is connected to the machine.

Following items must be operated by administrator.

- (1) Unlock the operator panel by authenticating using the external device.
- (2) Press the <SETTING> key on the operator panel.
- (3) Press the  to select [**Admin Setup**] and then press .
- (4) Enter the administrator password.
The default password is "aaaaaa".
- (5) Select [Enter] and then press .
- (6) Press the  to select [**Management**] and then press .
- (7) Press the  to select [**System Setup**] and then press .
- (8) Make sure that [**Access Control**] is selected and then press .
- (9) Press the  to select [**Disable**] and then press .

Memo! When FDI connection kit is already disconnected from the machine, change the Access Control setting by using WebPage or Configuration Tool.

3.6 Configuration Page Print

Make sure that the MFP operates normally.

- (1) From the panel, press "Setting" button.
- (2) Select "Reports".
- (3) Select "Configuration".

(Press the down button to go to "Configuration" and then press the right button.)

(Sample) MB461

MB461

Configuration

Serial Number: BETA100109
 CU Version: 01.04 [01.18 U00.93 S5.11.1m B01.01 PPC 330MHz F64 J0]
 PU Version: 00.06.06 [P103.20 L000.00.01] ET:005106040405031B20290100010000F1 K-0
 PCL Program Version: 05.23 [04.32 X04-12 P00.52 F00.50]
 Scanner Version: 01.04
 Duplex Installed: Tray 1: Letter L
 Total Memory Size: 256 MB
 Flash Memory: 16 MB [F64] Language Format: 1.01 Language Panel Format: 1.00
 ODA MC: CP FX: E
 Network Version: 01.03 Web Remote: 01.02
 Panel Version: 02.05.02 SU Hardware Type: 000-N-03
 ENGINE: 29 K: 29 T: 0 I: 0 D: 55 W: 5088

<p>Reports</p> <ul style="list-style-type: none"> Configuration System <ul style="list-style-type: none"> File List Demo Page 01: DEMO1 Error Log MFP Usage Network Information E-mail <ul style="list-style-type: none"> Journal Report Address Book Print <ul style="list-style-type: none"> PCL Font List PPR Font List FX Font List Paper Setup <ul style="list-style-type: none"> Tray 1 <ul style="list-style-type: none"> Paper Size: Letter Media Type: Plain Media Weight: Medium Manual Feeder <ul style="list-style-type: none"> Paper Size: Letter Media Type: Plain Media Weight: Medium Select Tray <ul style="list-style-type: none"> Tray 1: ON (Prior) Duplex Last Page: Skip Blank Page Address Book <ul style="list-style-type: none"> E-mail Address E-mail Group Profile Network Scan Destination View Information <ul style="list-style-type: none"> System Information <ul style="list-style-type: none"> Serial No.: BETA100109 Asset No. Lot No. CU Version: 01.04 PU Version: 00.06.06 Scanner Version: 01.04 Panel Version: 02.05.02 Total Memory: 256 MB Flash Memory: 16 MB [F64] Network <ul style="list-style-type: none"> IPv4 Address: 192.168.100.100 Subnet Mask: 255.255.255.0 Gateway Address: 0.0.0.0 MAC Address: 006007BCC5C NIC Program Version: 01.03 Easy Setup <ul style="list-style-type: none"> Date/Time Setting Network Setting E-mail Setting 	<p>Admin Setup</p> <ul style="list-style-type: none"> Copy Setup <ul style="list-style-type: none"> Default Settings <ul style="list-style-type: none"> Scan Size: Letter Duplex Copy: OFF (Simplex) Zoom: 100% Sort ON Image Settings <ul style="list-style-type: none"> Density: 0 Document Type: Text&Photo Resolution: High Speed Background Removal: 3 Contrast: 0 Direction: Portrait ID Card Copy: OFF Continue Scan: OFF Margin: OFF Edge Erase: ON Width: 0.1 inch Scanner Setup <ul style="list-style-type: none"> Default Settings <ul style="list-style-type: none"> Scan Size: Letter Image Settings <ul style="list-style-type: none"> Density: 0 Document Type: Text&Photo Background Removal: 3 Resolution: 200dpi Contrast: 0 Hue: 0 Saturation: 0 RGB <ul style="list-style-type: none"> Red: 0 Green: 0 Blue: 0 Continue Scan: OFF Grayscale: OFF File Format <ul style="list-style-type: none"> Color: PDF Mono (Grayscale): PDF Mono (Binary): PDF Encrypted PDF: Setting Document Open Password Permissions Password Display Default Password: Disable Compression Rate <ul style="list-style-type: none"> Color: Low Mono (Grayscale): Low Mono (Binary): High Edge Erase: OFF E-mail Setup <ul style="list-style-type: none"> File Name Template Edit Subject <ul style="list-style-type: none"> Subject1 Subject2 Subject3 Subject4 Subject5 Edit Body Body1
--	---

(Sample) MB471

Configuration

MB471

Serial Number: BETA100032
 CU Version: 01.04 [01.18 U00.93 S5.11.1m B01.01 PPC330MHz F64 J0]
 PU Version: 00.06.06 [PI03.20 L000.00.01] ET: 001105040405031B1F230100010000F1 K-0
 PCL Program Version: 05.23 [04.32 X04.12 P00.52 F00.50] PS Program Version: 3017, PSE8. DPR: 1.5 68
 Scanner Version: 01.04 Country Code: U.S.A.
 Duplex: Installed Tray 1: Letter L
 Total Memory Size: 256 MB
 Flash Memory: 16 MB [F64] Language Format: 1.01 Language Panel Format: 1.00
 ODA MC: CP FX: E
 Network Version: 01.03 Web Remote: 01.02
 Panel Version: 02.05.02 SU Hardware Type: 000-A-03
 ENGINE: 12 K: 12 T: 0 I: 0 D: 32 W: 2194

<p>Reports</p> <ul style="list-style-type: none"> Configuration System File List Demo Page 01 : DEMO1 Error Log MFP Usage Network Information Fax Speed Dial List Group List Fax Tx/Rx Log Foodie Box List Block Junk Fax E-mail/Internet Fax Journal Report Address Book Print PCL Font List PSE Font List PPR Font List FX Font List Paper Setup Tray 1 Paper Size: Letter Media Type: Plain Media Weight: Medium MP Tray Paper Size: Letter Media Type: Plain Media Weight: Medium Select Tray Fax Tray 1: --- MP Tray: OFF Copy Tray 1: --- MP Tray: OFF Duplex Last Page: Skip Blank Page Address Book E-mail Address E-mail Group Phone Book Speed Dial Group No. Profile Network Scan Destination Store Document Settings View Information System Information Serial No.: BETA100032 Asset No. Lot No. 	<ul style="list-style-type: none"> CU Version: 01.04 PU Version: 00.06.06 Scanner Version: 01.04 Panel Version: 02.05.02 Total Memory: 256 MB Flash Memory: 16 MB [F64] Network IPv4 Address: 192.168.100.100 Subnet Mask: 255.255.255.0 Gateway Address: 0.0.0.0 MAC Address: 08087B243AF NIC Program Version: 01.03 Easy Setup Date/Time Setting Fax Setting Network Setting E-mail Setting Admin Setup Copy Setup Default Settings Scan Size: Letter Duplex Copy: OFF(Simplex) Zoom: 100% Sort: ON Image Settings Density: 0 Document Type: Text&Photo Resolution: High Speed Background Removal: 3 Contrast: 0 Direction: Portrait ID Card Copy: OFF Continue Scan: OFF Mixed Size: OFF Margin: OFF Edge Erase: ON Width: 0.1 inch Fax Setup Default Settings Resolution: Normal Density: 0 Scan Size: Letter Continue Scan: OFF TTI: ON Transmit Confirmation Report: ON Memory Tx: ON Foodie Box Security Function ID Check Tx: OFF Broadcast Destination: ON Confirm Dial: OFF Secure Receive Setting: OFF Password Other Settings Retrial Times: 1 time(s) Retrial Interval: 1 minute(s) Block Junk Fax Setting: OFF
---	---

(Sample) MB491

Configuration

MB491

Serial Number: BETA100054
 CU Version: 01.04 [01.18 U00.93 S5.11.1m B01.01 PPC330MHz F64 J0]
 PU Version: 00.06.06 [PI03.20 L000.00.01] ET: 000104040405031B1F230100010000F1 K-0
 PCL Program Version: 05.23 [04.32 X04.12 P00.52 F00.50] PS Program Version: 3017, PSE8. DPR: 1.5 68
 Scanner Version: 01.04 Country Code: U.S.A.
 Duplex: Installed Tray 1: Letter L
 Total Memory Size: 256 MB
 Flash Memory: 16 MB [F64] SD Memory Card: 4 GB [F64] Language Format: 1.01 Language Panel Format: 1.00
 ODA MC: CP FX: E
 Network Version: 01.03 Web Remote: 01.02
 Panel Version: 02.05.02 SU Hardware Type: 000-A-03
 ENGINE: 11 K: 11 T: 0 I: 0 D: 37 W: 1893

<p>Reports</p> <ul style="list-style-type: none"> Configuration System File List Demo Page 01 : DEMO1 Error Log MFP Usage Network Information Fax Speed Dial List Group List Fax Tx/Rx Log Foodie Box List Block Junk Fax E-mail/Internet Fax Journal Report Address Book Print PCL Font List PSE Font List PPR Font List FX Font List Paper Setup Tray 1 Paper Size: Letter Media Type: Plain Media Weight: Medium MP Tray Paper Size: Letter Media Type: Plain Media Weight: Medium Select Tray Fax Tray 1: --- MP Tray: OFF Copy Tray 1: --- MP Tray: OFF Duplex Last Page: Skip Blank Page Address Book E-mail Address E-mail Group Phone Book Speed Dial Group No. Profile Network Scan Destination Store Document Settings View Information System Information Serial No.: BETA100054 Asset No. Lot No. 	<ul style="list-style-type: none"> CU Version: 01.04 PU Version: 00.06.06 Scanner Version: 01.04 Panel Version: 02.05.02 Total Memory: 256 MB Flash Memory: 16 MB [F64] SD Memory Card: 4 GB [F64] Network IPv4 Address: 192.168.100.100 Subnet Mask: 255.255.255.0 Gateway Address: 0.0.0.0 MAC Address: 08087B2333C NIC Program Version: 01.03 Easy Setup Date/Time Setting Fax Setting Network Setting E-mail Setting Admin Setup Copy Setup Default Settings Scan Size: Letter Duplex Copy: OFF(Simplex) Zoom: 100% Sort: ON Image Settings Density: 0 Document Type: Text&Photo Resolution: High Speed Background Removal: 3 Contrast: 0 Direction: Portrait ID Card Copy: OFF Continue Scan: OFF Mixed Size: OFF Margin: OFF Edge Erase: ON Width: 0.1 inch Fax Setup Default Settings Resolution: Normal Density: 0 Scan Size: Letter Continue Scan: OFF TTI: ON Transmit Confirmation Report: ON Memory Tx: ON Foodie Box Security Function ID Check Tx: OFF Broadcast Destination: ON Confirm Dial: OFF Secure Receive Setting: OFF Password Other Settings Retrial Times: 1 time(s) Retrial Interval: 1 minute(s) Block Junk Fax
---	---

3.7 Network Information Print

Make sure that the MFP operates normally.

- (1) From the panel, press "Setting" button.
- (2) Select "Reports".
- (3) Select "System".
- (4) Select "Network Information".

(Press the down button to go to "Network Information" and then press the right button.)

(Sample) In case of MB491

<i>Network Information</i>			
System Information			
Serial Number	BETA100054	Asset Number	
General Information			
Device Name	OKI-MB491-B2233C	File Version (WEWJ/DF/LDLO)	01.02 / 01.02 / 01.00 / 01.00 / 01.00
Short Device Name	MB491-B2233C		
Firmware Version	01.03		
Web Remote	01.02		
MAC Address	00:80:87:B2:23:3C	TCP ACK	Type1
HUB Link Setting	Auto Negotiation		
HUB Link Status	LINK FAIL	Unsendable Packets	
Network Status	Unicast Packets Received	Bad Packets Received	
	Packets Transmitted		
	Total Packets Received		
IEEE802.1X Status	Disable		
Protocol ON/OFF			
TCP/IP	Enable	NetWare	Disable
NetBEUI	Disable	EtherTalk	Disable
NetBIOS over TCP	Enable		
TCP/IP Configuration			
IP Address Set	AUTO		
IP Address	192.168.100.100		
Subnet Mask	255.255.255.0		
Gateway Address	0.0.0.0		
WINS Server (Primary)	0.0.0.0		
WINS Server (Secondary)	0.0.0.0		
WINS Registration Status	Registration of a name is successful.		
DNS Server (Primary)	0.0.0.0		
DNS Server (Secondary)	0.0.0.0		
Dynamic DNS	Disable		
DDNS Host Name	MB491-B2233C		
DDNS Domain Name			
DDNS Registration Status			
Auto Discovery			
Windows		Disable	
Macintosh		Enable	
Printer Name(Printer is identified by this name.)		OKI-MB491-B2233C	
NetWare Configuration			
NetWare Mode	Queue Server Mode(Print Server + Bindery/NDS + IPX)		
Frame Type	Auto		
Network No.	00000000		
P-Server Mode			
Print Server Name	OKI-MB491-B2233C-PS		
Job Polling Rate	4 Sec		
Bindery Mode	Enable		
NDS Mode			
Tree Name			
Context Name			
R-Printer Mode			
Printer Name	OKI-MB491-B2233C-PR		
Job Timeout	10 Sec		
EtherTalk Configuration			
EtherTalk Printer Name	MB491		
Type Name	LaserWriter		
Zone Name			
Address			
Node			
NBT/NetBEUI Configuration			
Short Device Name	MB491-B2233C		
Workgroup Name	PrintServer		
Master Browser Setting	Enable		
Master Browser			

3.8 Connection Procedures

<USB Connection>

Prepare a USB Cable.

- Note!**
- The cable of the MFP is not attached. Users should buy separately.
 - Obtain the cable of USB specification by yourself.
 - Use the USB cable of Hi-Speed specification in case the connection is to be made using "HI-Speed" mode of USB2.0.

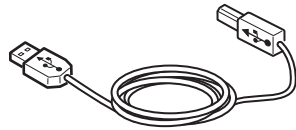

Switch off the power of the MFP and computer.

- Memo** Although the USB cable can be connected or removed with the switch of the computer and printer on, switch off the power of the MFP at this step in order to ensure installation of the MFP driver and USB driver later.

Connect the MFP with the computer.

- (1) Plug one end of the USB cable into the USB connection on the back of the MFP.

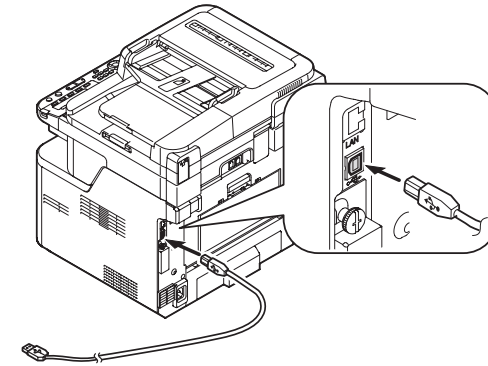

- (2) Plug the other end of the USB cable into the computer's USB interface connector.

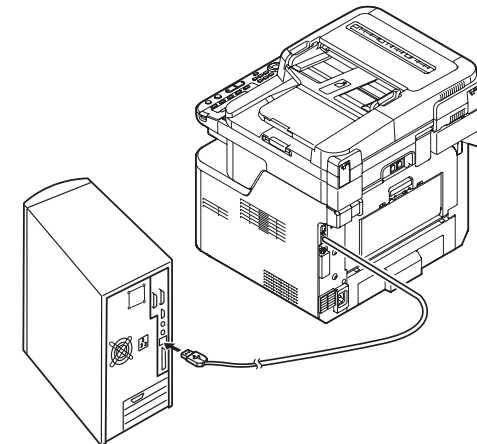

- Important**
- For Windows OSs, do not plug the other end of the USB cable into the computer until prompted while driver installation.
 - Do not plug the USB cable into the network connection. Doing so may cause a malfunction.

<LAN Cable Connection>

Prepare the LAN cable.

Switch off the power of the MFP and computer.

Connect the computer and MFP.

- (1) Plug one end of the Ethernet cable into the network connection on the back of the MFP.

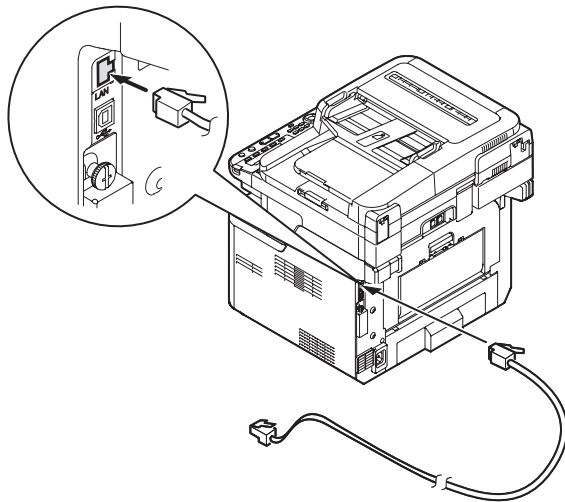

- (2) Plug the other end of the Ethernet cable into the hub.

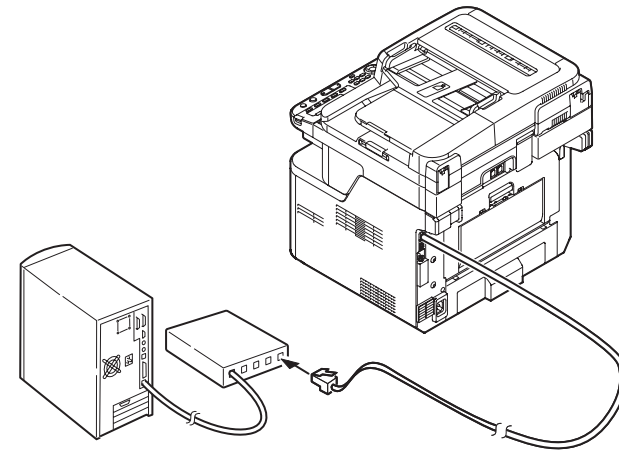

<TEL cable/ Line Cable Connection>

Prepare the TEL cable and Line cable.

Connecting for Fax only

- (1) Plug one end of the [Telephone cable] into the [LINE connection] of the machine and the other end into a [Public Line (Analog)].

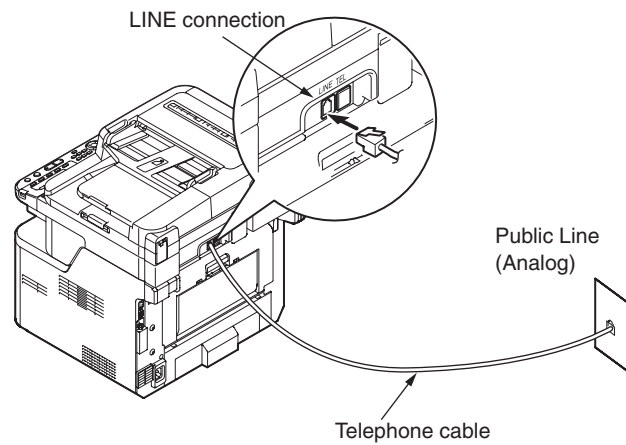

Note! Connect telephone cable to [LINE connection] without fail.
Never connect it to [TEL connection].

Connecting for Fax and Telephone

- (1) Plug one end of the [Telephone cable] into the [LINE connection] of the machine and the other end into a [Public Line (Analog)].

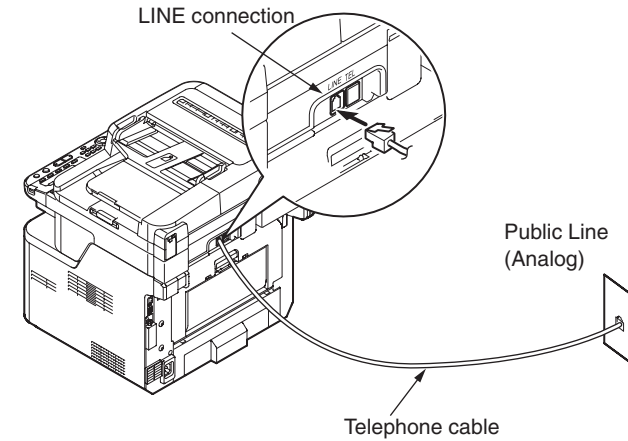

- (2) Remove the [Telephone connector cover].

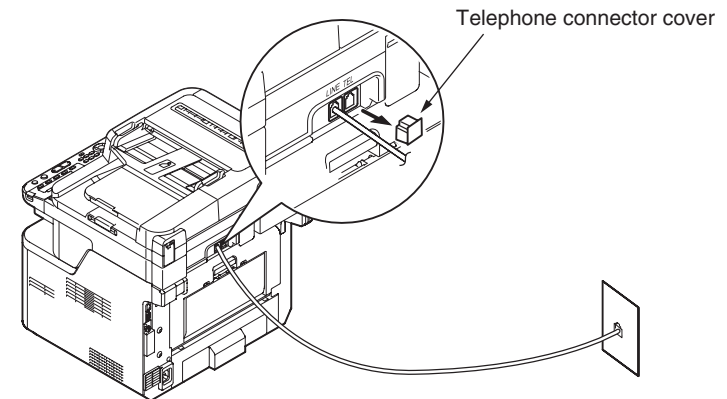

- (3) Plug the external telephone's cable into the [TEL connection] of the machine.

When you connect the telephone to the machine and use it, remove the [Telephone connector cover] into the [TEL connection] and then connect it.

The telephone that is connected to the machine is called external telephone.

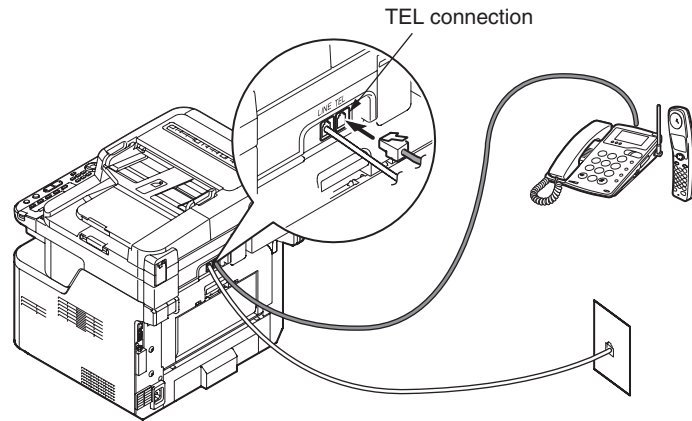

- Note!**
- The number of telephone that is able to be connected to the machine is only one.
 - Don't connect the telephone to the machine in parallel. If you connect the telephone to the machine in parallel, the following problem will occur and the machine will not work correctly.

- When you send fax or receive, the fax picture may be broken or communication error may occur by picking up the telephone.
- The fax transfer function is not able to work from the external telephone.

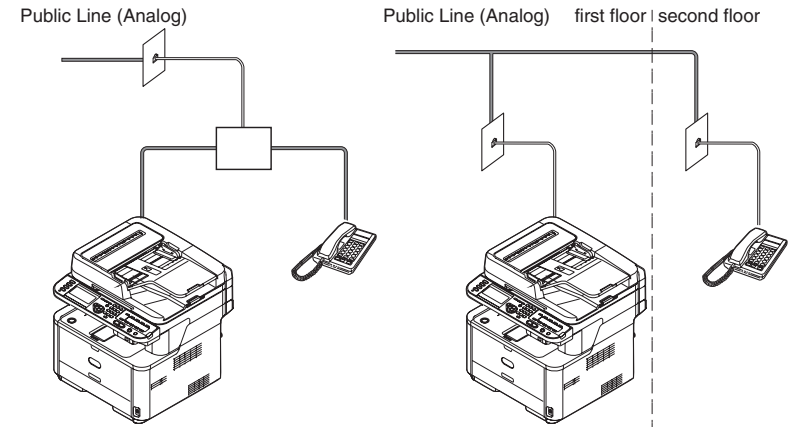

- Memo!** In the case of direct interconnection, the other construction is needed. Please contact the telephone company that you use.

3.9 Checking of User Paper

Load the media used by the user in the printer, make media weight/media type setting, print out MenuMap/Demo Page, and check printouts to make sure that no toner flakes off.

Type	Weight or thickness	Settings on the operator panel		Printer driver [Media weight] settings* ²
		Media weight (paper thickness)	Media weight (paper thickness) Media type (paper type)* ¹	
Plain paper* ³	52~54kg (60~63g/m ²)	LIGHT	PLAIN	Light
	55~64kg (64~74g/m ²)	MEDIUMLIGHT		Medium Light
	65~75kg (75~87g/m ²)	MEDIUM		Medium
	76~89kg (88~104g/m ²)	MEDIUM HEAVY		Medium Heavy
	90~105kg (105~122g/m ²)	HEAVY		Heavy
	106~140kg (123~163g/m ²)	ULTRA HEAVY		Ultra Heavy
Postcard* ⁴	—	—	—	—
Envelope* ⁴	—	—	—	—
Label	0.1 to under 0.15 mm	HEAVY	LABELS	Label 1

*1: The factory default for the media type is [PLAIN].

*2: Media weight and type can be set on the operator panel and in the printer driver. The settings in the printer driver take priority. Data is printed out in accordance with the settings on the operator panel when [Auto selection] is selected in [Feed tray] or when [Printer setting] is selected in [Media weight].

*3: The weight of paper supported for duplex print is 64 to 122g/m² (55 to 105 kg).

*4: It is not necessary to set media weight and type for postcards and envelopes.

Memo! Print speed decelerates when [MEDIUM] through [ULTRA HEAVY] of media weight or [LABELS] of media type is set.

4. REPLACEMENT OF PARTS

This chapter describes the procedures of the field replacement of parts, assemblies and units. The procedures are to detach them. Reverse the procedures to attach them.

The reference part numbers used in this manual (such as ① and ②) do not identical to the part numbers in the maintenance disassembly configuration diagram (44871001TL) and RSPL (44871001TR) for the manual.

4.1 Notes on replacement of parts	4-2
4.2 Part replacement procedure	4-4

4.1 Notes on replacement of parts

- (1) Prior to replacing a part, unplug the AC cord and the interface cable.
- (a) Be sure to use the following procedure to unplug the AC cord:
- ① Turn off the printer [Hold down the power switch for about a second.].
 - ② Pull out the AC plug of the AC cord from the AC power source.
 - ③ Unplug the AC cord and the interface cable.

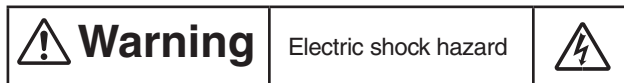

When replacing the low-voltage power supply, electric shock may occur. Wear insulated gloves, or be careful not to touch the conductors or terminals of the power supply directly. After the AC cord is unplugged, the capacitor may take about one minute to discharge completely or, due to PCB breakdown, could not discharge. Use caution about electric shock.

- (b) Always use the following procedure to reconnect the printer:
- ① Connect the AC cord and the interface cable to the printer.
 - ② Insert the AC plug into the AC power source.
 - ③ Turn on the printer [Hold down the power switch for about a second to turn on the power.].

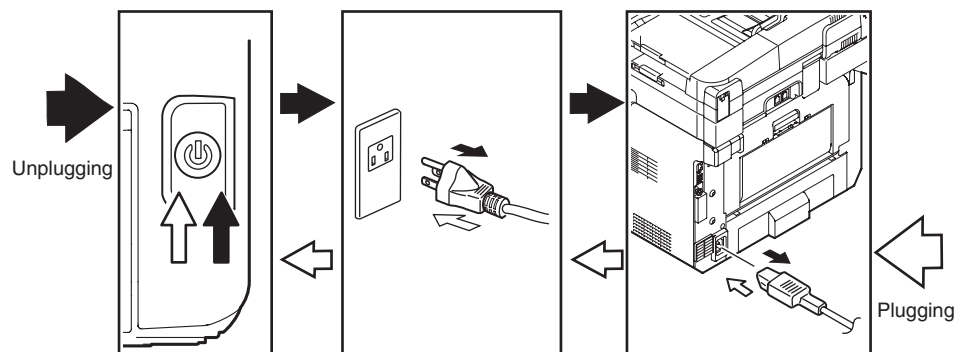





- (2) Do not disassemble the printer so long as it operates properly.
- (3) Minimize disassembly. Do not detach parts not shown in the part replacement procedure.
- (4) Use the replacement tools specified.
- (5) Conduct disassembly in the order instructed, or part damage may occur.
- (6) Removed small parts, such as screws or collars, should be tentatively installed in their original positions.
- (7) Do not use static-prone gloves when handling integrated circuits (ICs), including microprocessors, and ROM and RAM chips, or circuit boards.
- (8) Do not place printed-circuit boards (PCBs) directly on the printer or a floor.

Maintenance Tools:

Table 4-1-1 shows the tools necessary to replace printed-circuit boards and units:

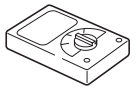
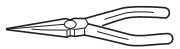

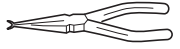
Table 4-1-1: Maintenance Tools

No.	Maintenance Tool	Quantity	Use	Remarks
1	 Phillips screwdriver with magnetic tip, No. 2-200	1	3- to 5-mm screws	
2	 Screwdriver No. 3-100	1		
3	 Screwdriver No. 5-200	1		
4	 Digital multimeter	1		
5	 Pliers	1		
6	 Handy vacuum cleaner (toner vacuum)	1		See note.
7	 E-ring pliers	1	E-shaped ring removal	

Note! Use a toner vacuum. Using a general-purpose vacuum may cause fire.

Table 4-1-2 shows the tools necessary to use Maintenance Utility software.

Table 4-1-2: Maintenance Tools

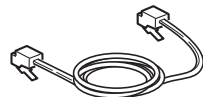
No.	Maintenance Tool	Quantity	Use	Remarks
1	 Notebook personal computer (with Maintenance Utility software installed)	1		See section 5.3 for Maintenance Utility.
2	 USB cable	1		
3	 Ethernet cable (crossover cable)	1		

4.2 Part replacement procedure

This section describes the procedure for replacing the parts and assemblies shown in the disassembly diagrams below.

4.2.1 Cover Side (L)

- (1) Remove the cassette assembly.
- (2) Open the Scanner, Cover-Assy-Stacker, Frame-Assy-MPT and Cover-Assy-Rear.
- (3) Unlatch the claws (10 portions) with to pull the front side of the mainbody to the arrow in figure to detach the Cover-Side (L) ①.

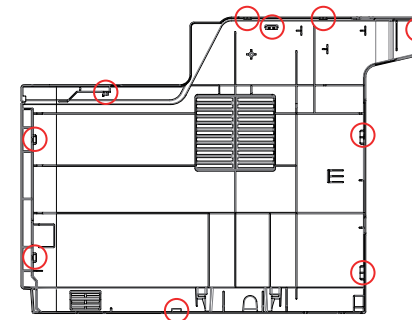
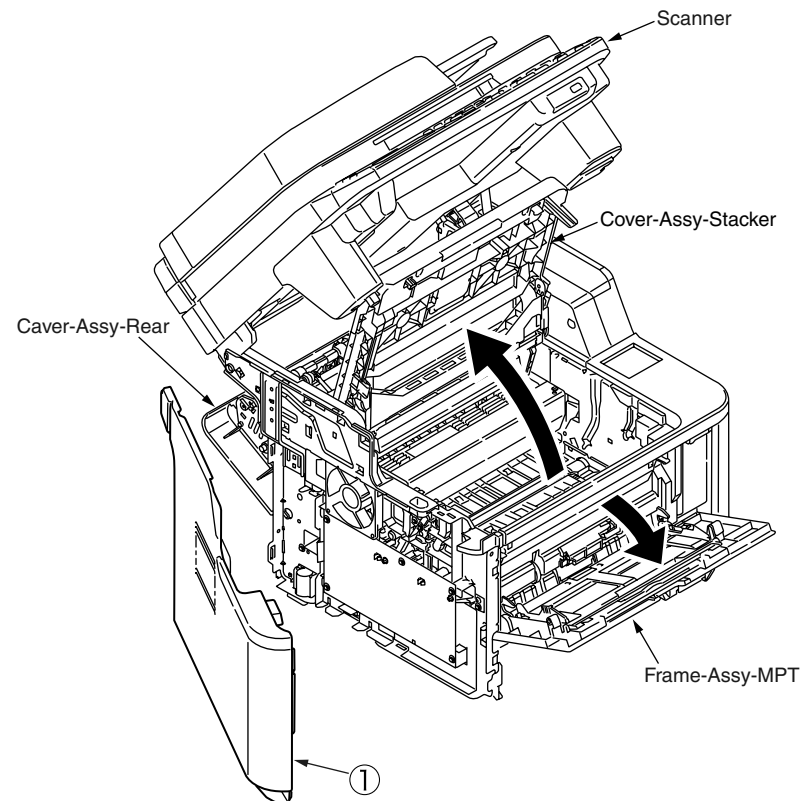

○ = Points of claws

4.2.2 Cover Side(R) / SD Card

- (1) Remove the Plate Shield (Access) ①. (Only MB491)
- (2) Remove the SD card ②.(Only MB491)
- (3) Remove the cassette assembly.
- (4) Open the Scanner, the Cover-Assy-Stacker, the Frame-Assy-MPT and the Cover-Assy-Rear.

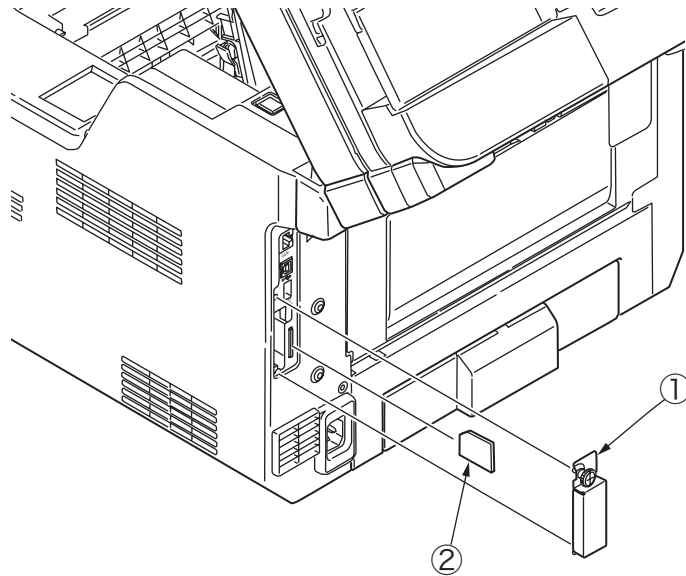

- (5) Remove the Screw (Black) ③ and the Screw (Silver) ④.
- (6) Unlatch the claws (7points) with to pull the front side of the mainbody to the arrow in figure to detach the Cover-Side (R) ⑤.

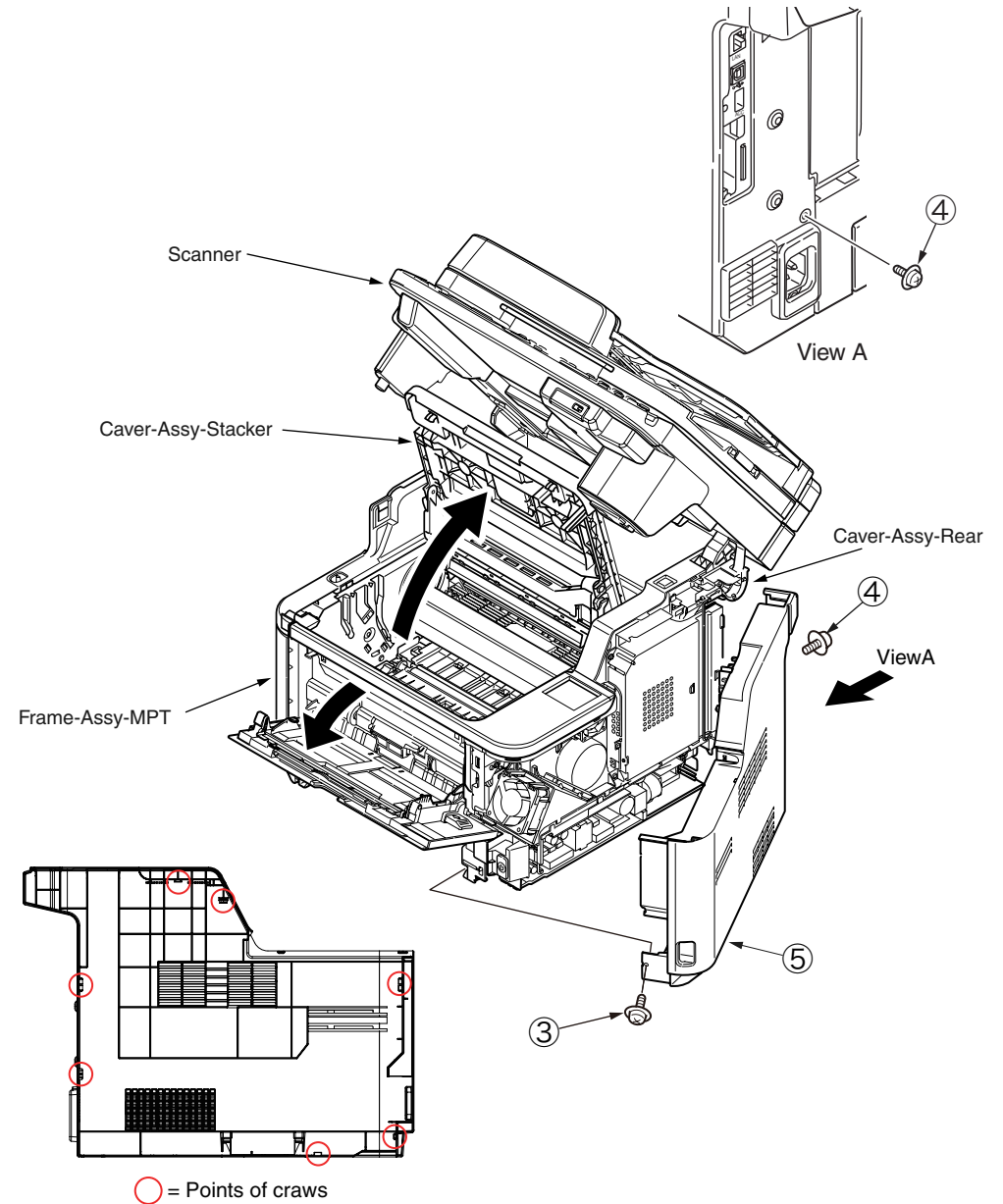

4.2.3 Board 98M

- (1) Remove the Cover Side (R). (Refer to 4.2.2)
- (2) Remove four Screws (Silver) ①, and remove the Plate Shield (CU) ②.

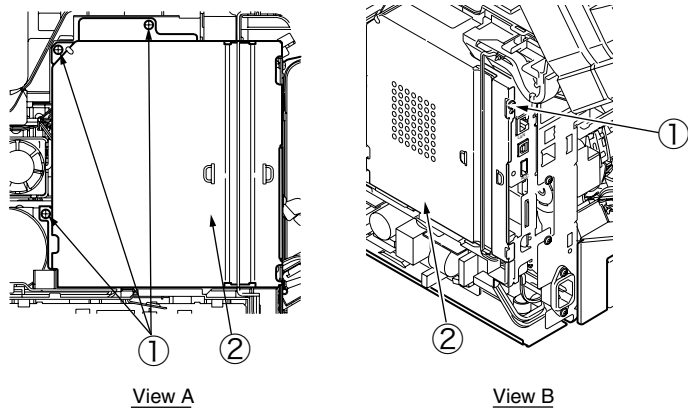
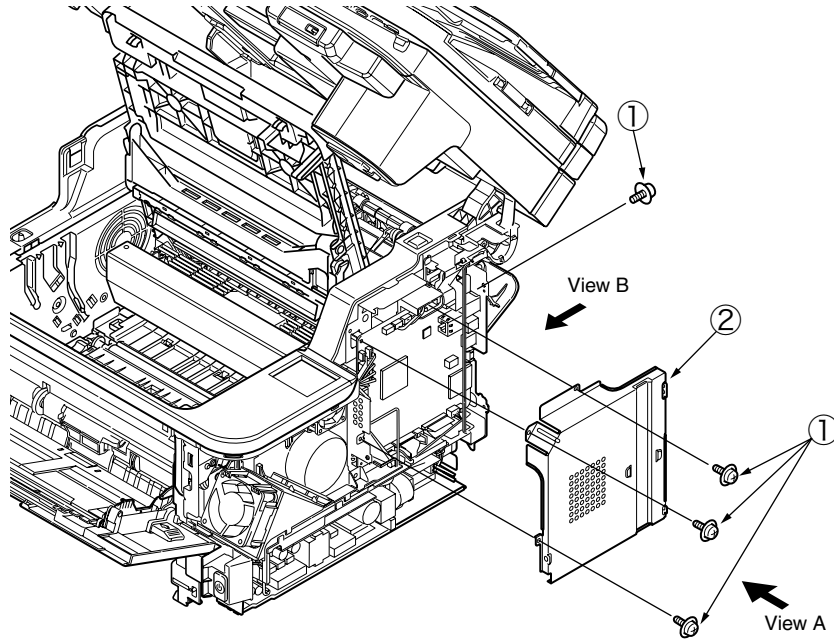

- (3) Remove four Screws (Silver) ④ to detach the Board 98M ③.

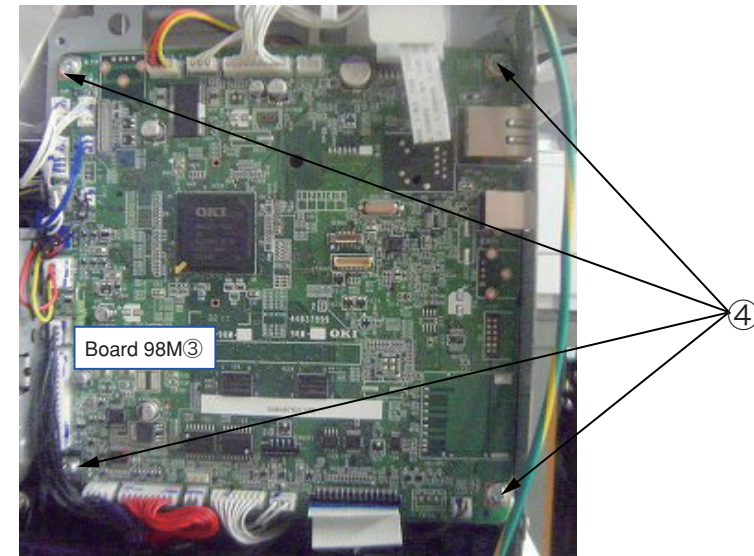

Note!

If replaced new board, update Firmware according to Chapter 9.3.

It is necessary to take the synchronization of the firmware version of SU board and CU board.

4.2.4 PWR unit

Warning

Electric shock hazard



When replacing the low-voltage power supply, electric shock may occur. Wear insulated gloves, or be careful not to touch the conductors or terminals of the power supply directly. After the AC cord is unplugged, the capacitor may take about one minute to discharge completely or, due to PCB breakdown, could not discharge. Use caution about electric shock.

- (1) Remove the Cover Side (R). (Refer to 4.2.2)
- (2) Disconnect cables from the PWR unit-ACDC Switch ①.
- (3) Remove two Screws (Silver) ②.
- (4) Unlatch the claws (3 points) to detach the PWR unit-ACDC Switch ①.

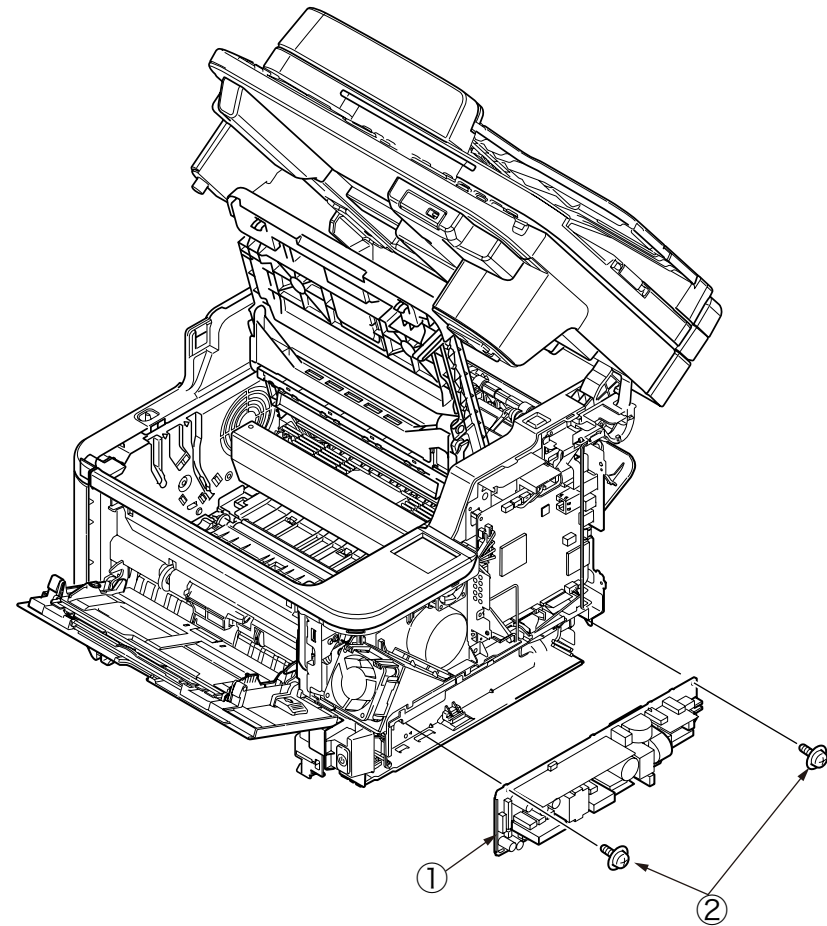
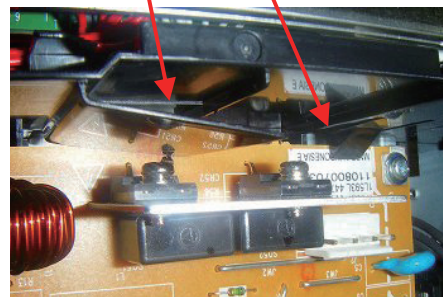
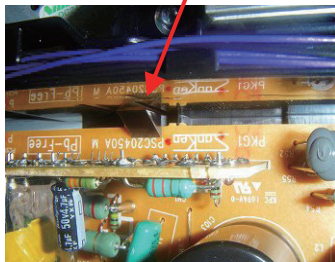
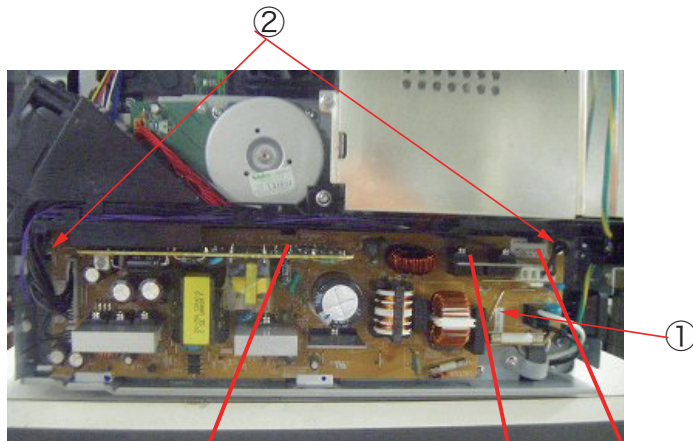

(Note on removing / installing)

1. Assemble the POWER to main body in accordance to the groove on guides (2 points).

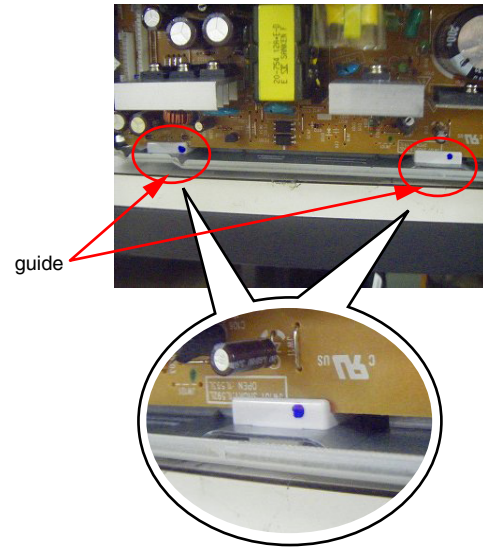

4.2.5 Cover Stay(R) / Cover Stay(L)

- (1) Remove the Cover-Side (L). (Refer to 4.2.1)
- (2) Remove the Cover Stay (L) ①.
- (3) Remove the Cover Side (R) . (Refer to 4.2.2)
- (4) Remove the Screw (Black) ② to detach the Cover-Stay(R) ③.

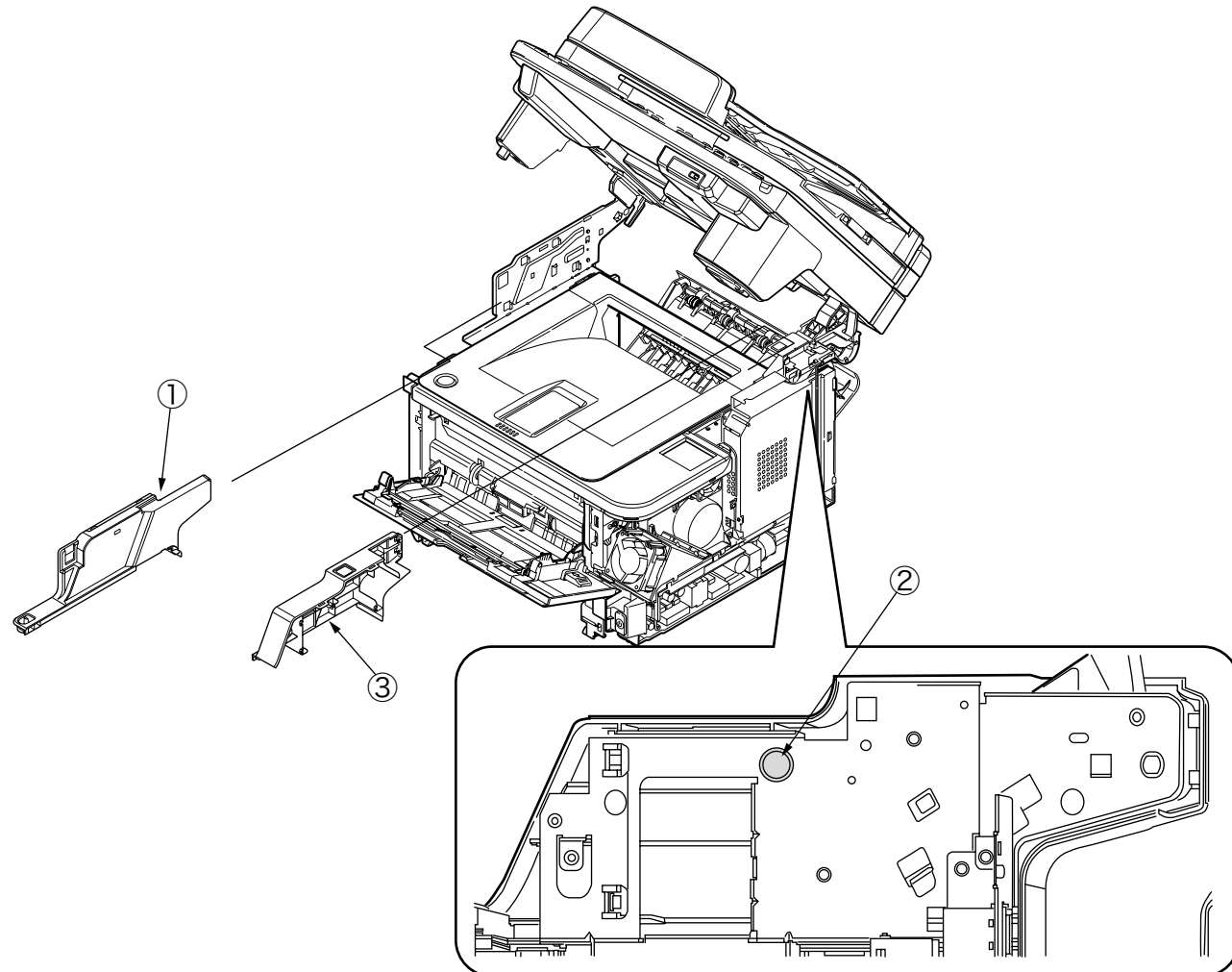

4.2.6 Cover Front (Top)

- (1) Remove the Cover Side (R) and Cover Side (L). (Refer to 4.2.1 and 4.2.2)
- (2) Remove two-Screws (Black) ① to detach the Cover Front (Top) ②.

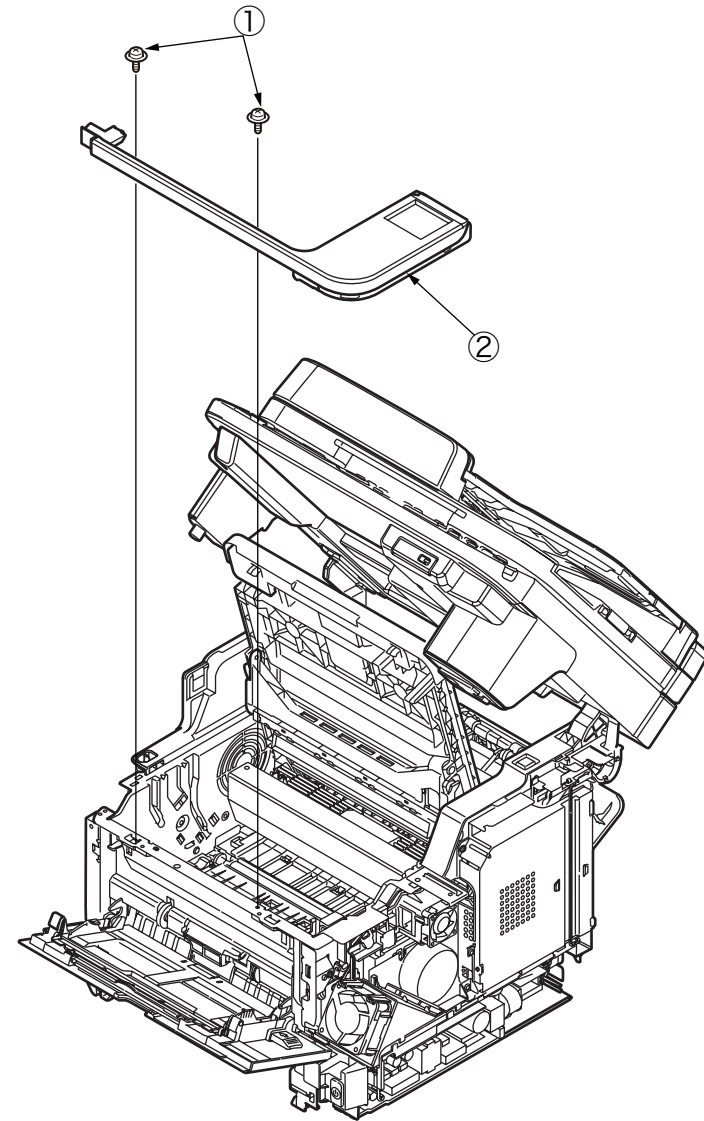
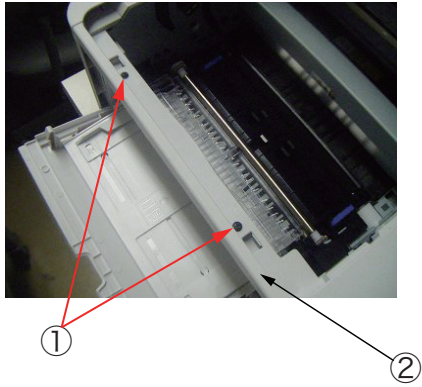

4.2.7 SW Assy

- (1) Remove the Cover Side (R). (Refer to 4.2.2)
- (2) Close the Frame-Assy-MPT.
- (3) Remove the Cable.
- (4) Remove the Screw (Silver) ① and to detach the SW Assy ②.

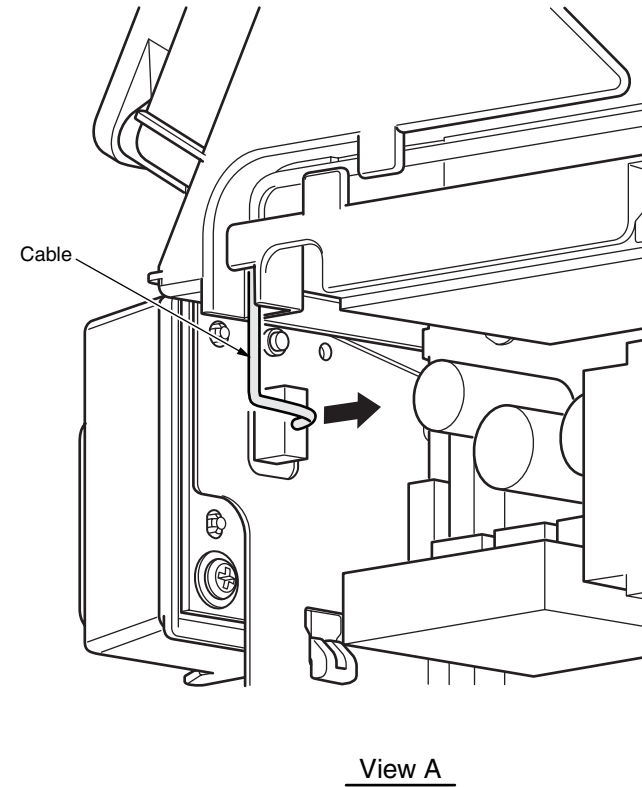
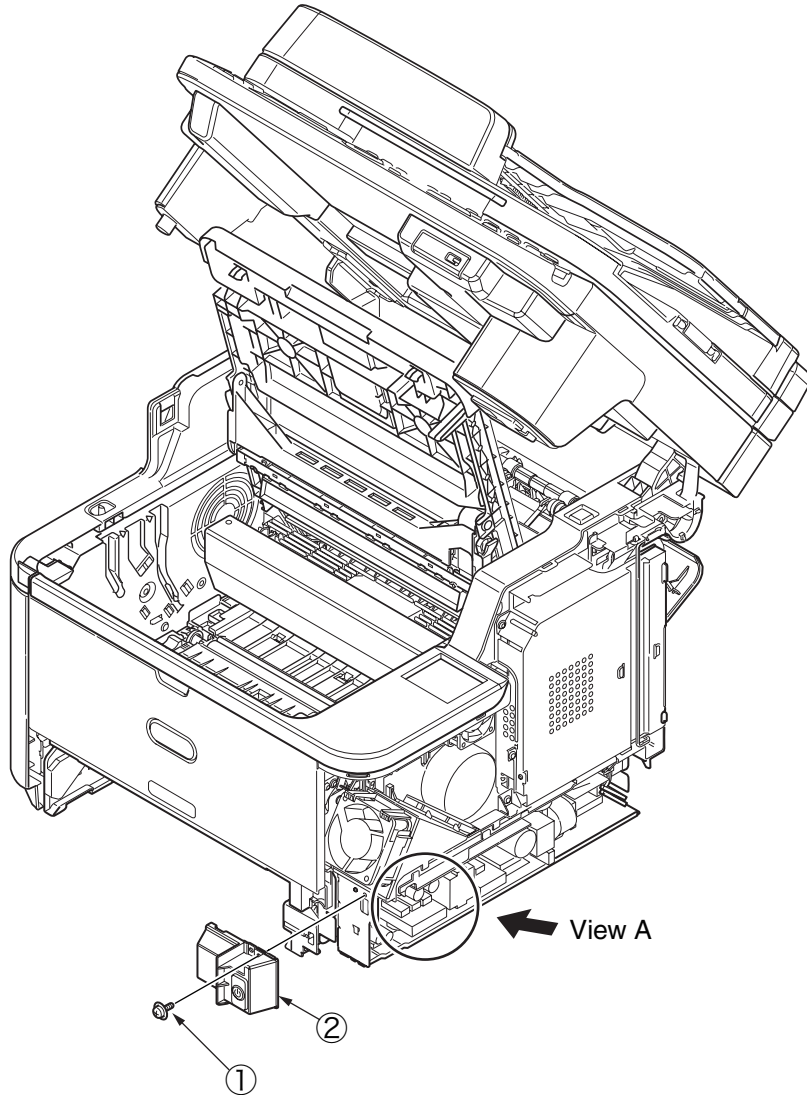

4.2.8 Scanner unit

- (1) Remove the Cover Side (L) and the Cover Side (R). (Refer to 4.2.1 and 4.2.2)
- (2) Remove the Cover Stay (R) and Cover Stay (L). (Refer to 4.2.5)
- (3) Remove the Screw (Silver) ①, and remove the FG-Cable ② from Guide Cable ③.

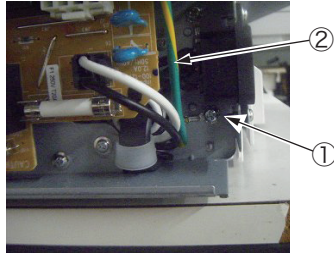

- (4) Remove the Screw (Silver) ④, and remove Plate Shield (CU) ⑤.

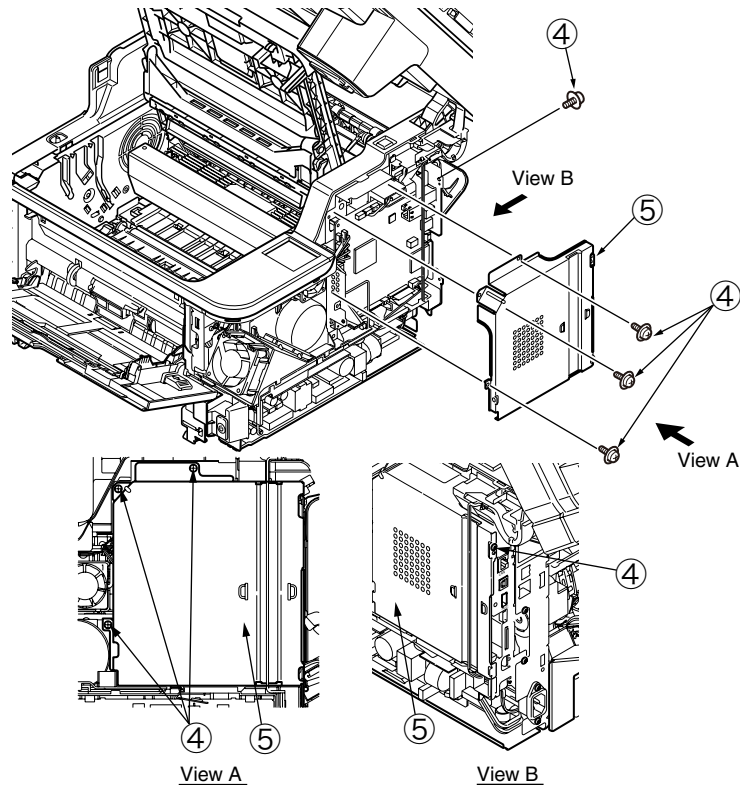

- (5) Disconnect the FFC ⑥ and the Cable ⑦ from the CU/PU Board ⑧.

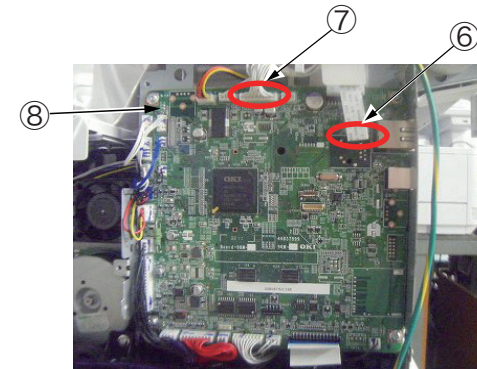

- (6) Remove the Screw (Silver) ⑨ and the Screw (Black) ⑩, and remove the FG Film (FFC) ⑪ and the Cable ⑫ from the Guide Cable ③.

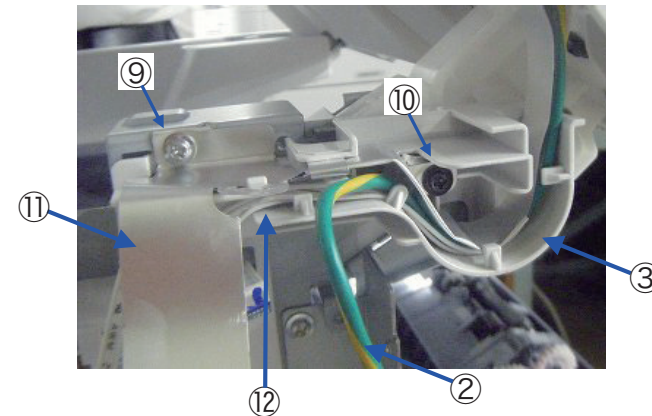

- (7) Open the scanner ⑭ and remove the E-shaped retainer ring (RE4-SK) ⑮ and screw ⑯.
- (8) Remove the E-shaped retainer ring (RE6-SK) ⑰.
- (9) Remove the shaft-stopper (hinge) ⑱ and remove the shaft-guide (hinge) ⑲.
- (10) Remove the scanner ⑭.

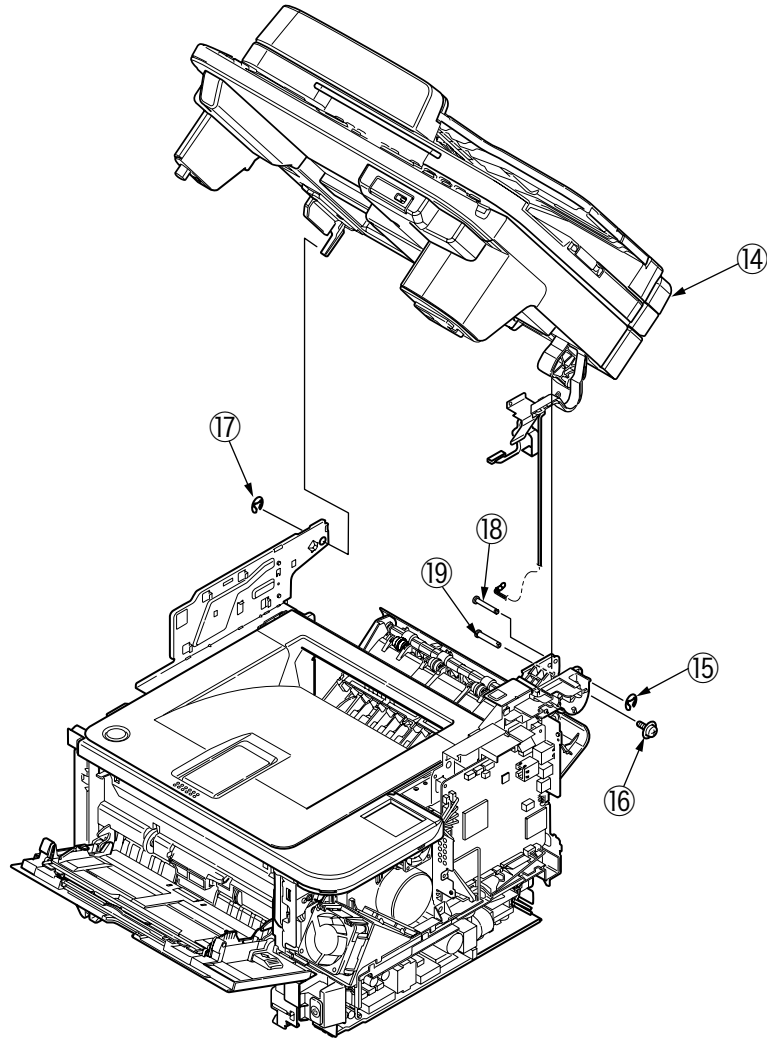
**Note! (to assemble)**

1. The case of to assemble for the scanner unit to the Mainbody, insert the the Shaft-Stopper (hinge) ⑱ to the hole with the marked 'N' on the Plate Assy Stay (R).

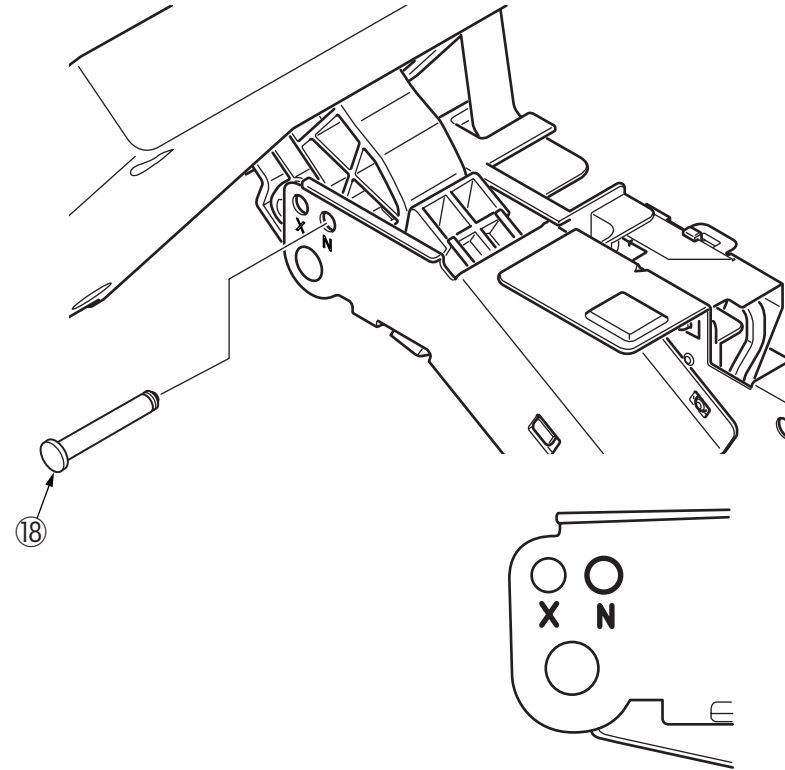

4.2.8.1 Tray-assy-document / Cover-ADF-R-assy

- (1) Open the cover-assy-top-ADF .
- (2) Remove the tray-assy-document ① by pull it in the direction of the arrow.

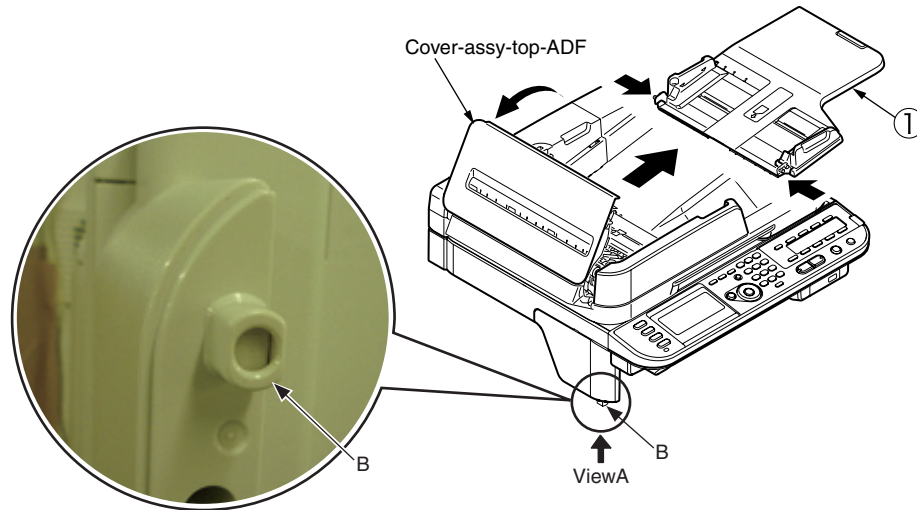

- (3) Open the ADF-unit while pushing the portion B, and push the claw of cover-ADF-R-assy ②.

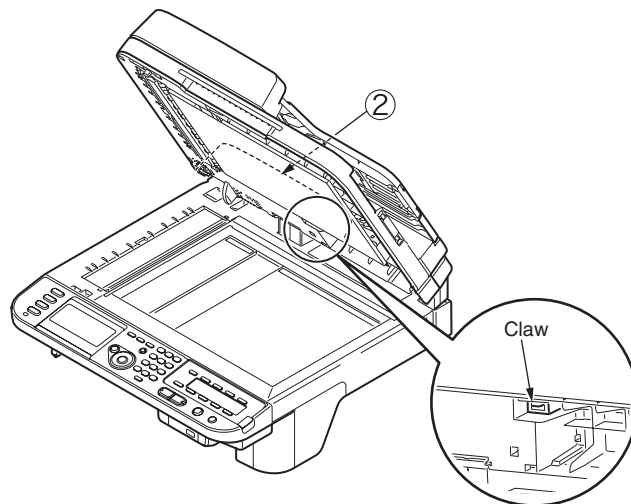

- (4) Push the portion A. (Concurrent to push the (3))

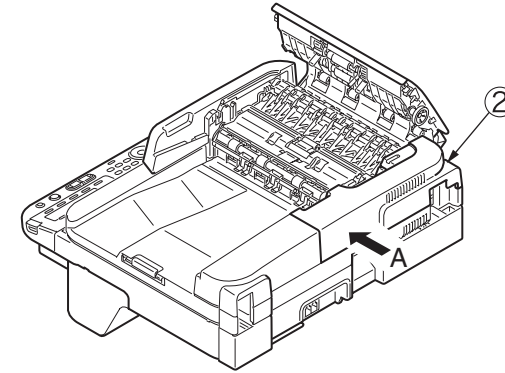

- (5) Remove the cover-ADF-R-assy ② in the direction of the arrow.

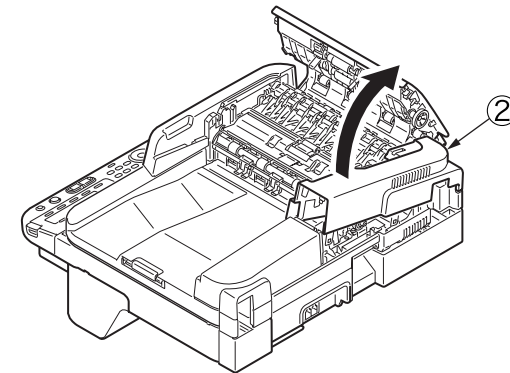

4.2.8.2 ADF-unit

- (1) Remove the cover-ADF-R-assy. (See 4.2.8.1)
- (2) Detach a connector ① and ② from the ADF board (MHD), and remove the screw ③ to remove the FG cable.

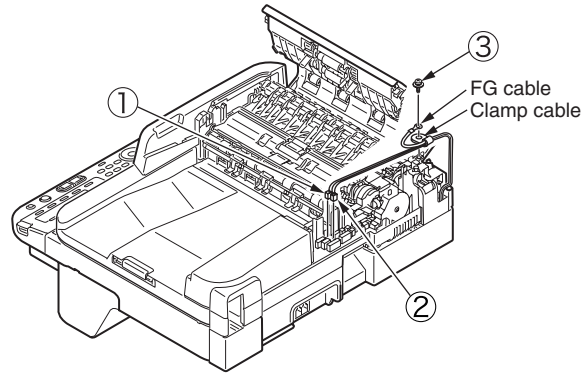

- (3) Remove the clamp cable and pull the cables out of the hinge, and Open the ADF-unit ④.

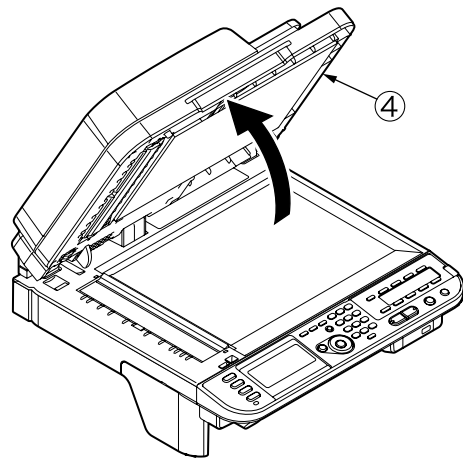

- (4) Remove the ADF-unit ④ by insert the screwdriver to gap between ADF-unit ④ and flatbed-unit.

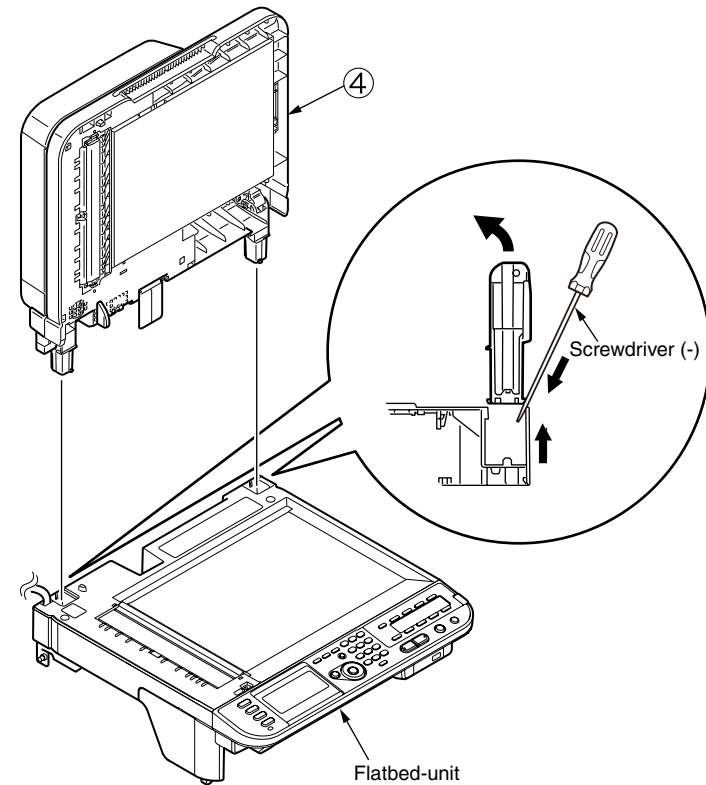

4.2.8.3 Sheet-document / Paper-weight-assy / Spring-PW-ADF

- (1) Open the ADF-unit.
- (2) Remove the sheet-document ①.
- (3) Remove two claws to remove the paper-weight-assy ② and two spring-PW-ADF ③.

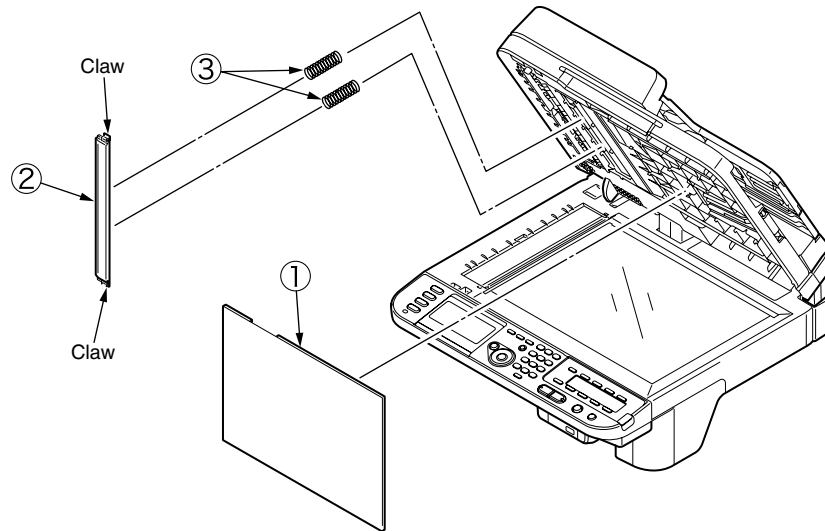

<Attention of affix the sheet-document>

- (1) Degrease the affix area of ADF-unit.
- (2) Remove the peeling-off sheet.
- (3) Set the sheet-document ① (see the figure below).
- (4) Close the ADF-unit.

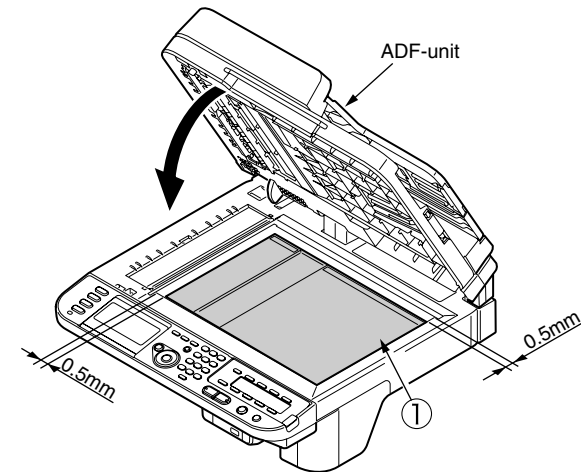

4.2.8.4 Hinge-assy-L / Hinge-assy-R

- (1) Remove two screws (L=10mm) ① and remove the hinge-Assy-R ②.

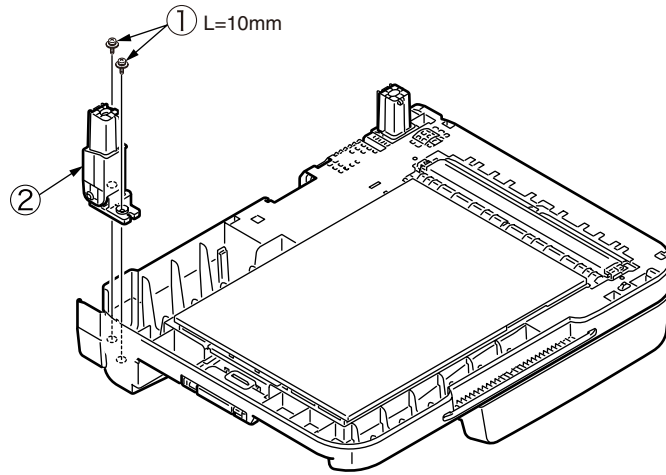

- (2) Remove two screws (L=10mm) ③ and remove the hinge-Assy-L ④.

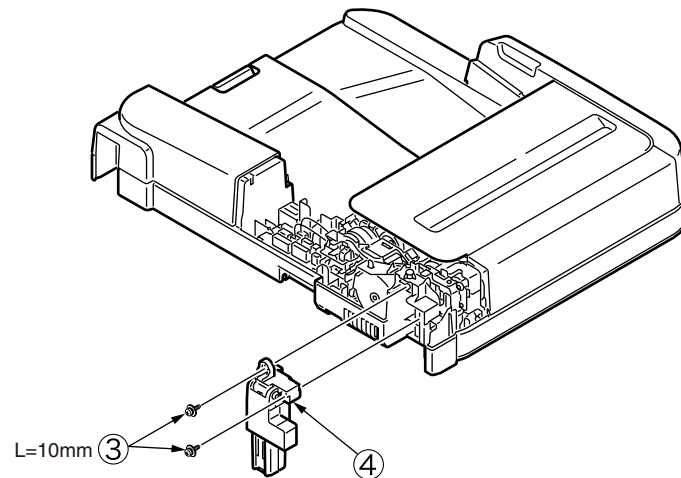

4.2.8.5 Cover-ADF-F / Guide-assy-exit-sub / ADF-assy / ADF board (MHD)

(1) Turn the ADF unit upside down and remove the support-sponge ①.

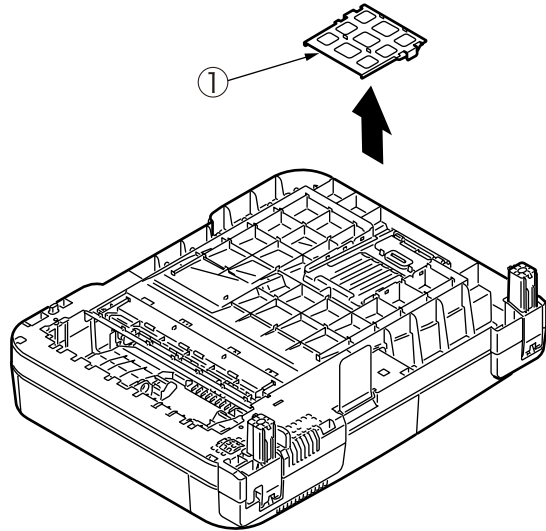

(2) Remove the guide-assy-exit-sub ② by pull it in the direction of the arrow.

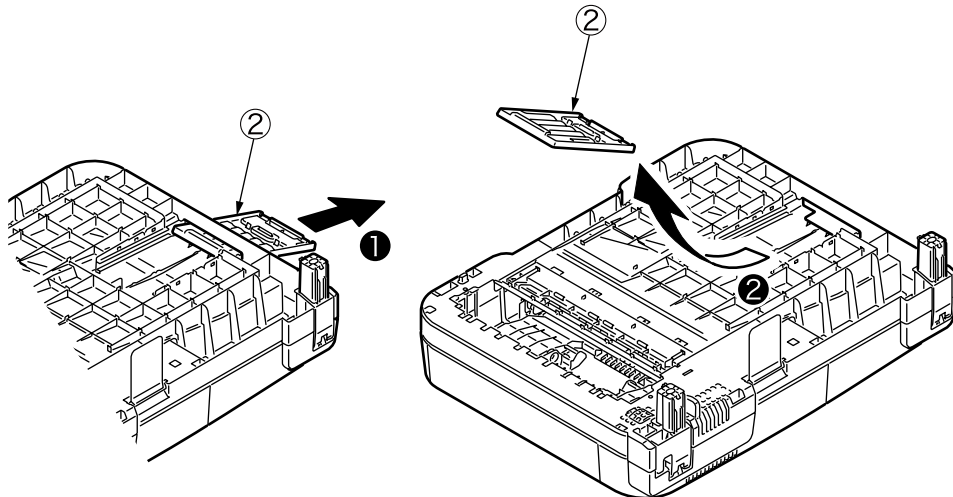

(3) Open the cover-top-ADF .

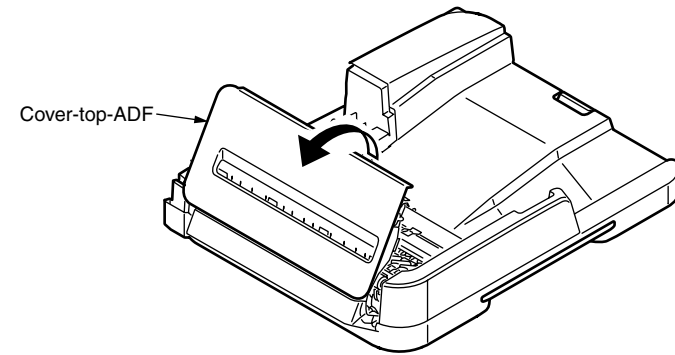

(4) Push the claw of cover-ADF-F ③.

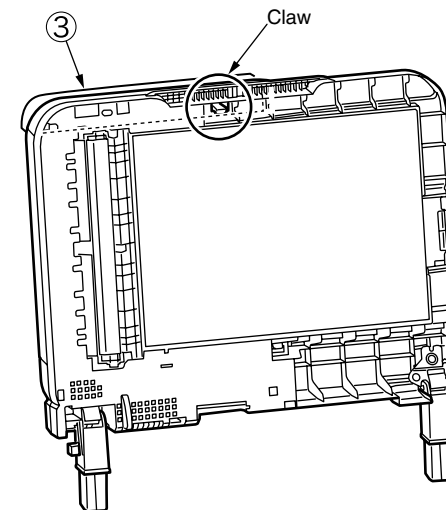

(5) Push the portion A (2 places). (Concurrent to push the (4))

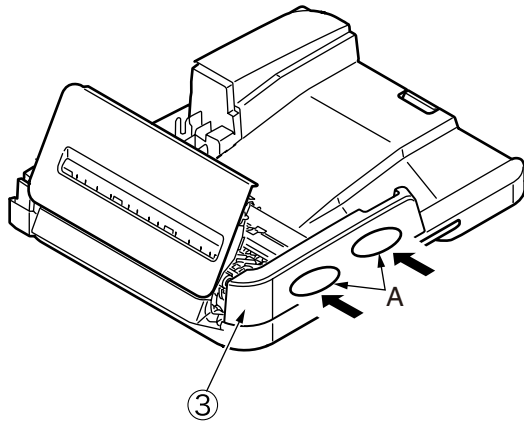

(6) Remove the cover-ADF-F (3) in the direction of the arrow.

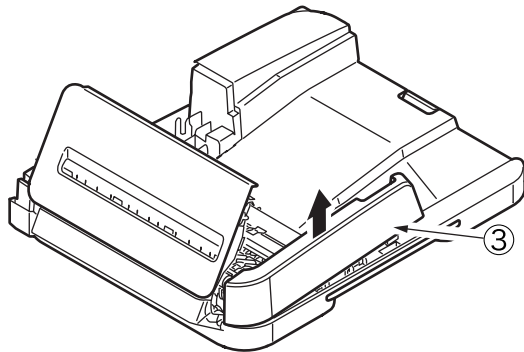

(7) Remove the screw (silver) (4) and remove the ADF board (MHD) (5).

(8) Remove two screws (black) (6) and remove the ADF-assy (7).

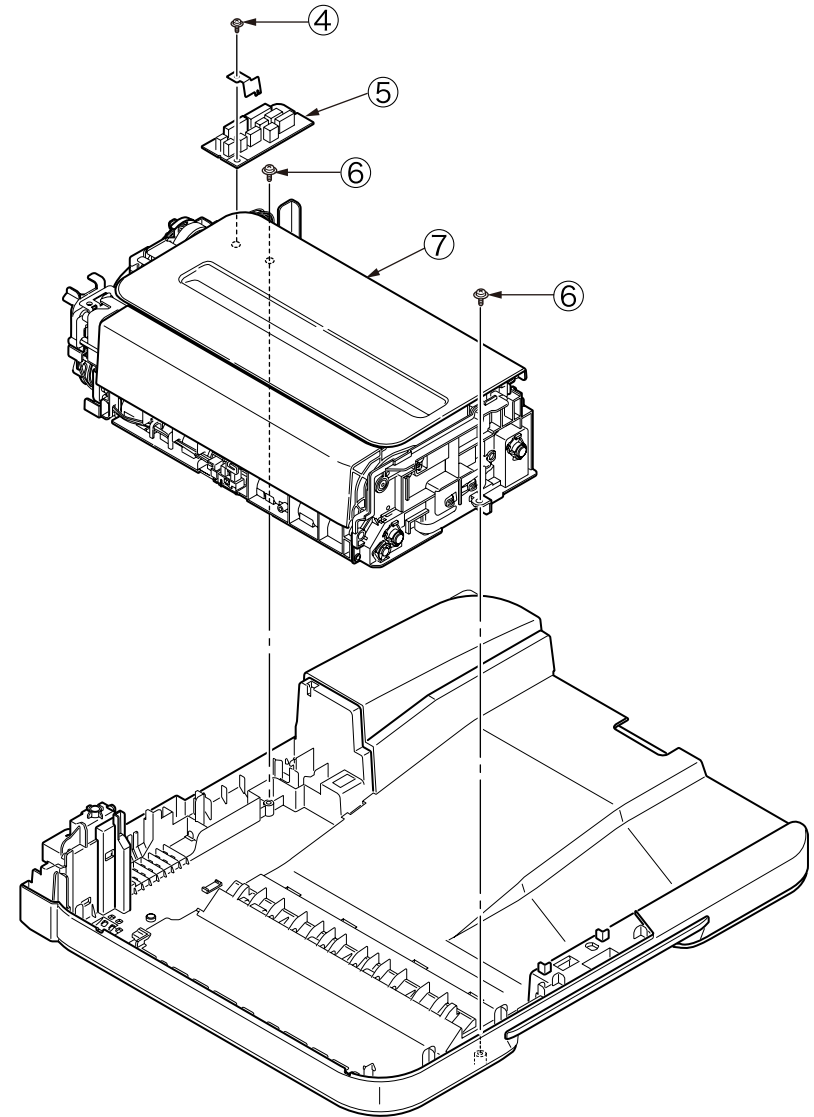

4.2.8.6 Cover-assy-top-ADF / Guide-assy / Roller / Motor / Clutch / Solenoid

- (1) Remove the cover-assy-top-ADF ①.
- (2) Remove the guide-assy-A ②.
- (3) Remove the guide-B ③.
- (4) Remove the guide-cable ④.
- (5) Remove the guide-assy-C ⑤.
- (6) Remove the guide-assy-D ⑥.
- (7) Remove two screws (silver) ⑦ and remove the Motor-KTL40M ⑧.
- (8) Remove the E-type retaining ring ⑨ and remove the clutch ⑩.
- (9) Remove the plate-FG-S ⑪.
- (10) Remove the E-type retaining ring ⑫ and remove the clutch ⑬.
- (11) Remove four screws (black) ⑭ and remove the plate-motor-ADF ⑮.
- (12) Remove the bearing-shaft ⑯ and remove the roller-assy-eject-ADF ⑰.
- (13) Remove the retainer-4 ⑱, spring ⑲ and washer-A ⑳.
- (14) Remove the solenoid ㉑.

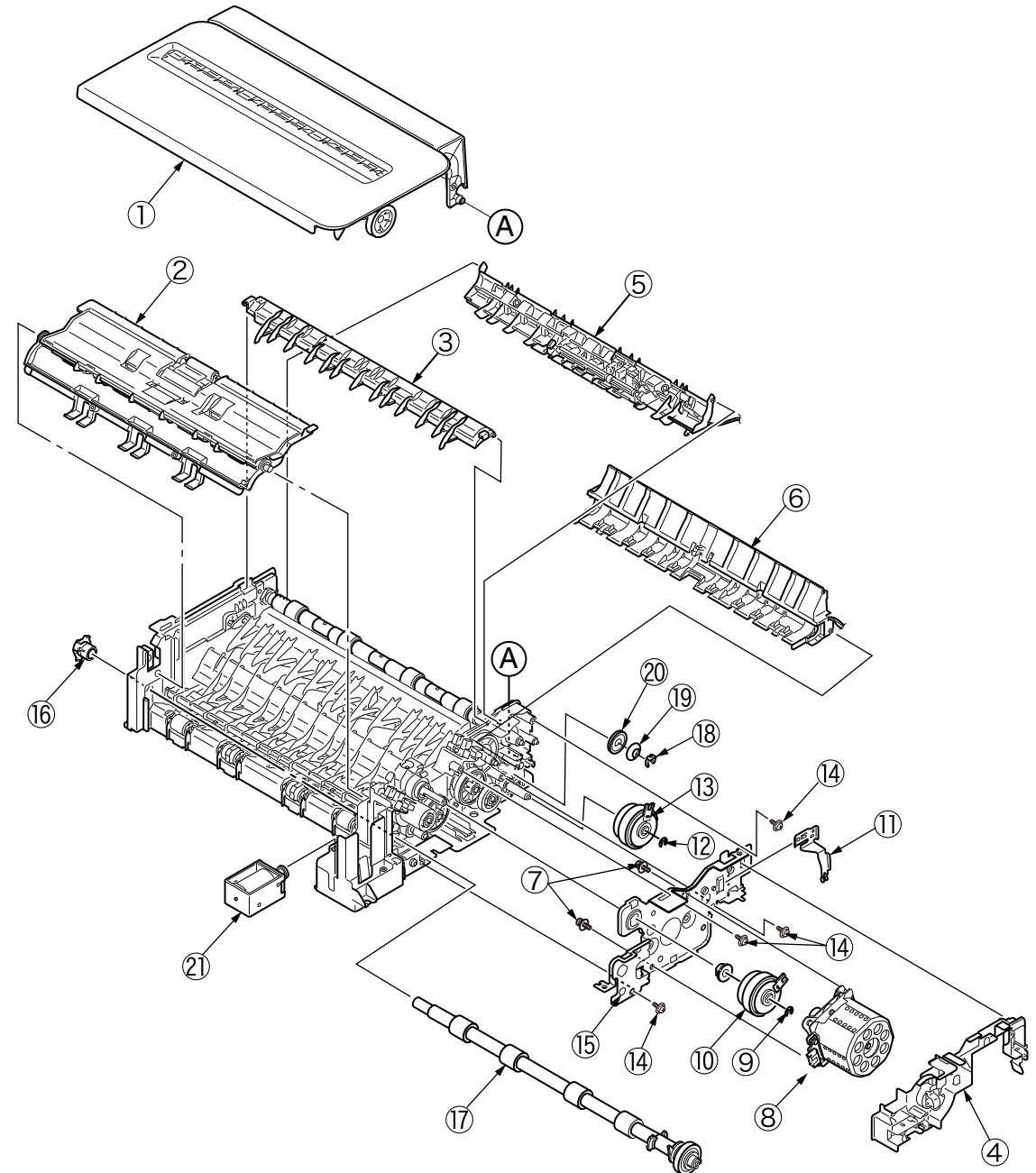

4.2.8.7 Guide-A-sub / Frame-assy-separator / Spring-separator / Rubber-friction

- (1) Remove the guide-A-sub ① with rubber-friction ②.
- (2) Remove the frame-assy separator ③ and spring-separator ④.

Note!

- If change the ②... Remove the ②, then degrease the ① and affix the ②.
- If change the ①... Remove the ① and ② together.

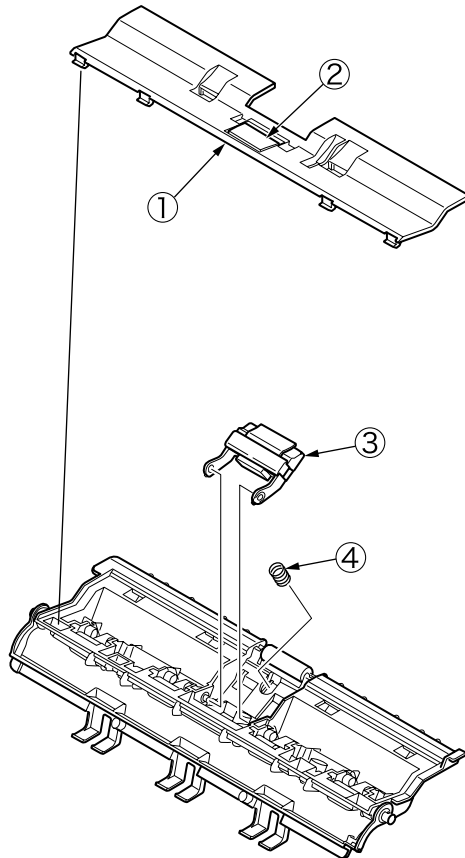

4.2.8.8 Cable (ADF-Rev SNS)

- (1) Remove the cable ①.

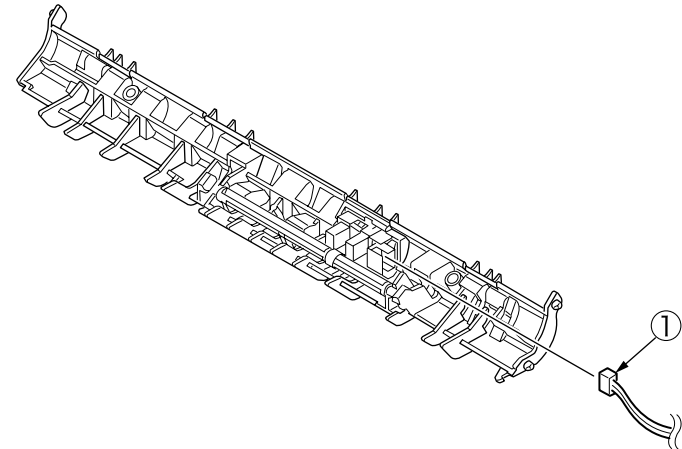

4.2.8.9 Cable (ADF-Reg SNS)

- (1) Remove the cable ①.

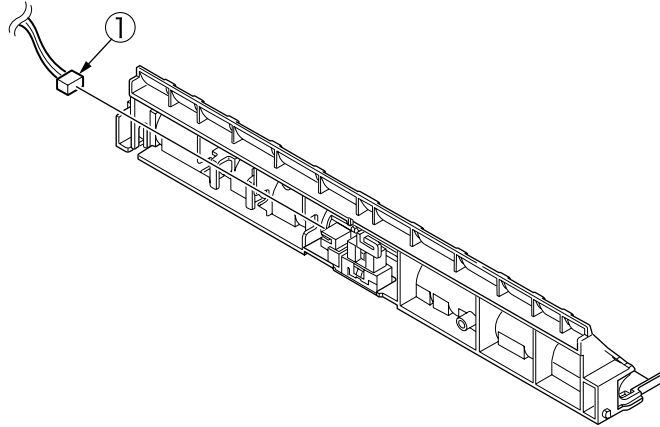

4.2.8.10 Frame-assy-OP

- (1) Remove eight claws to remove the frame-assy-OP ①.

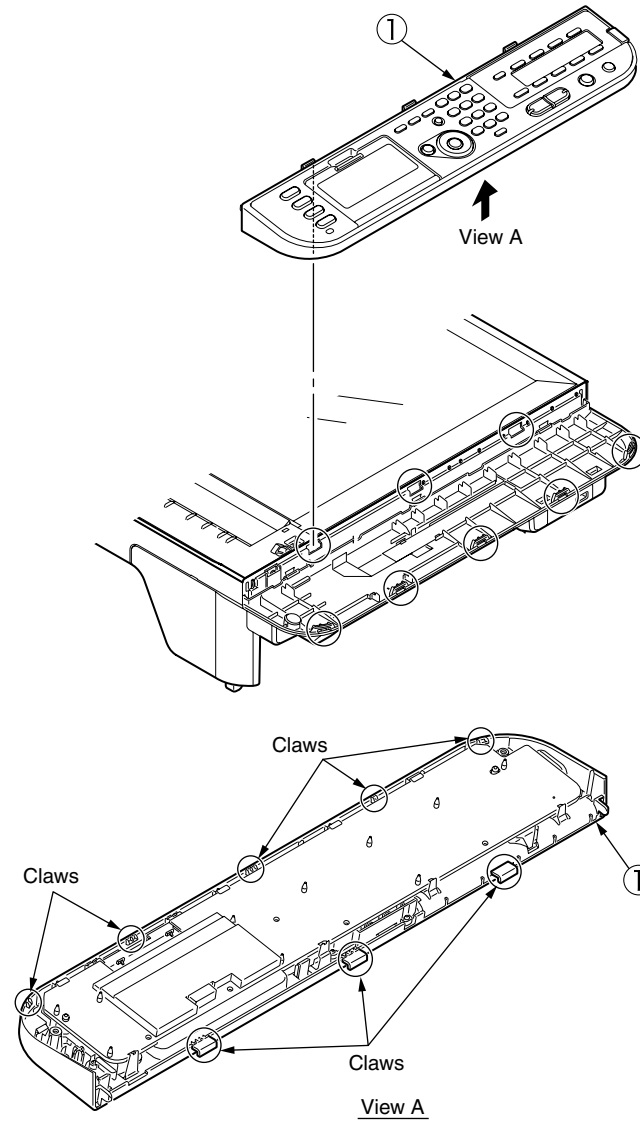

4.2.8.11 Frame-OP-panel / OPE board (Except MB461/ES4161)

- (1) Remove eight claws to remove the OPE board (OPM) ①.
- (2) Remove the LCD cable, while part A is raised in the direction of arrow.

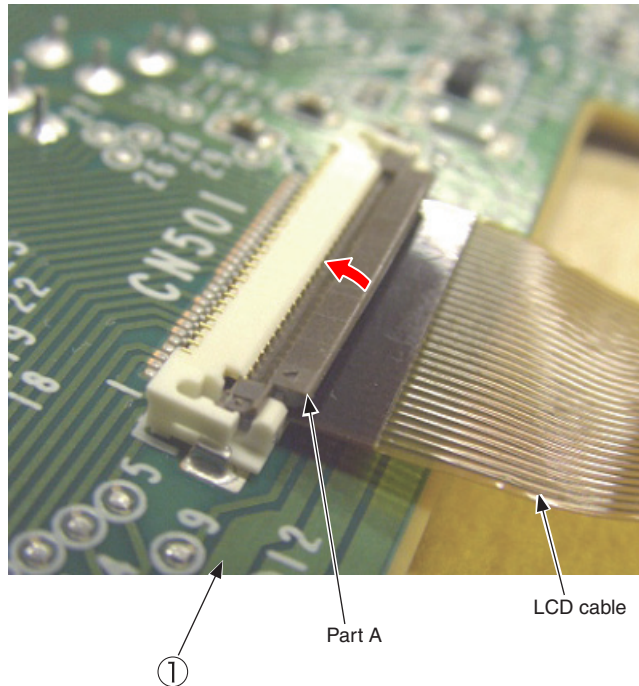

Method of removing LCD cable

- (3) Remove the rubber-pad (R) ② and rubber-pad (L) ③.
- (4) Remove the button and lens ④ to ⑮.
- (5) Remove the cover bottom ⑯ and cover-cable ⑰ and LCD-assy ⑱.
- (6) Remove eight latches to remove the cover-op-panel ⑲.
- (7) Remove the cover-KB-assy ⑳.
- (8) Remove the film-one-touch ㉑ and sheet-one-touch ㉒.

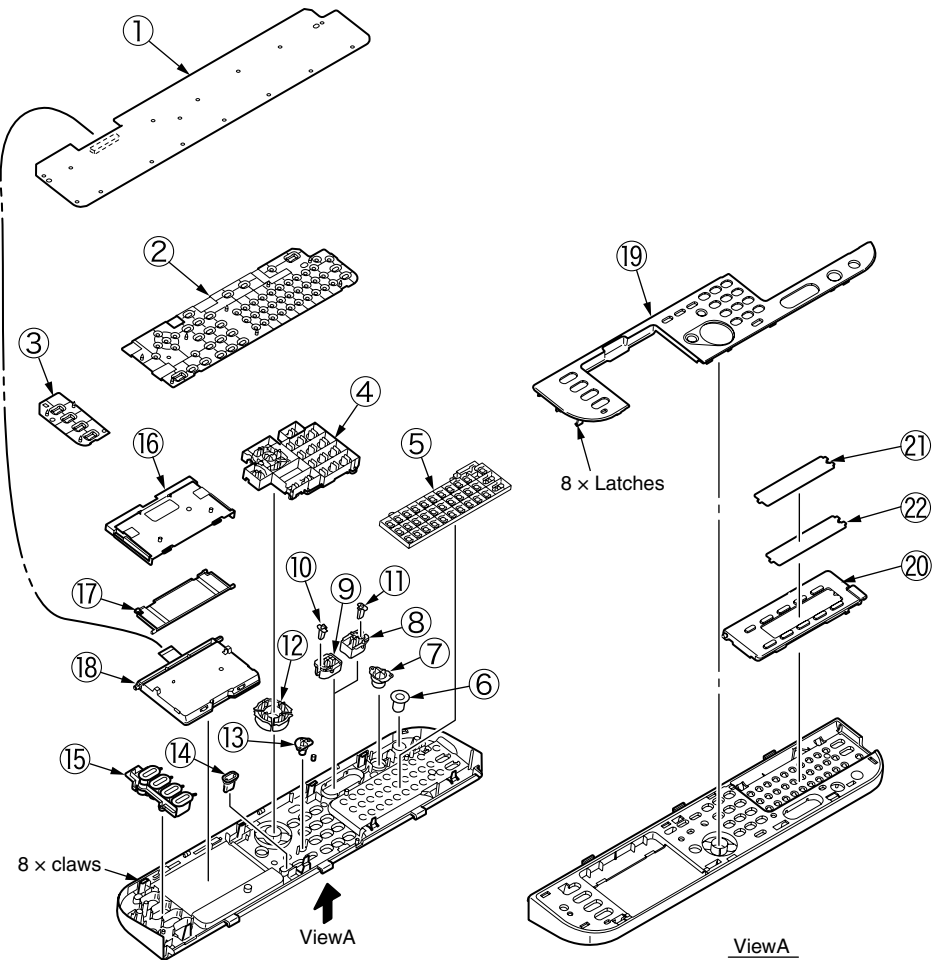

4.2.8.12 Frame-OP-panel / OPE board (MB461/ES4161)

- (1) Remove eight claws to remove the OPE board (OPM) ①.
- (2) Remove the LCD cable, while part A is raised in the direction of arrow.

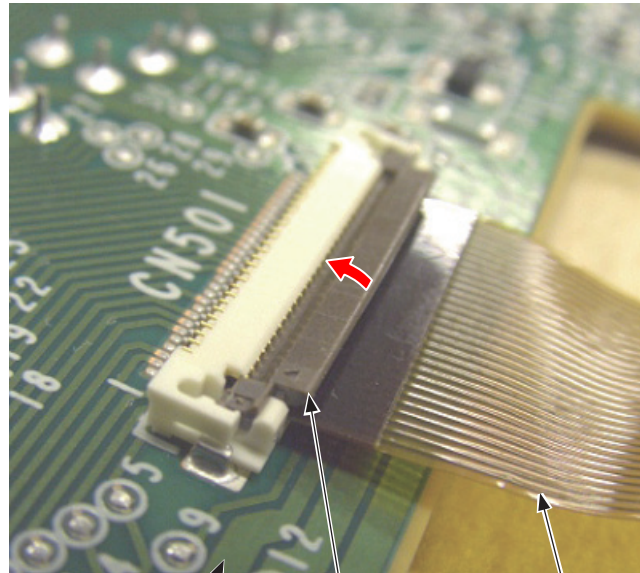

①
Part A
LCD cable

Method of removing LCD cable

- (3) Remove the rubber-pad (R) ② and rubber-pad (L) ③.
- (4) Remove the button and lens ④ to ⑭.
- (5) Remove the cover bottom ⑮ and cover-cable ⑯ and LCD-assy ⑰.
- (6) Remove eleven latches to remove the cover-op-panel ⑱.

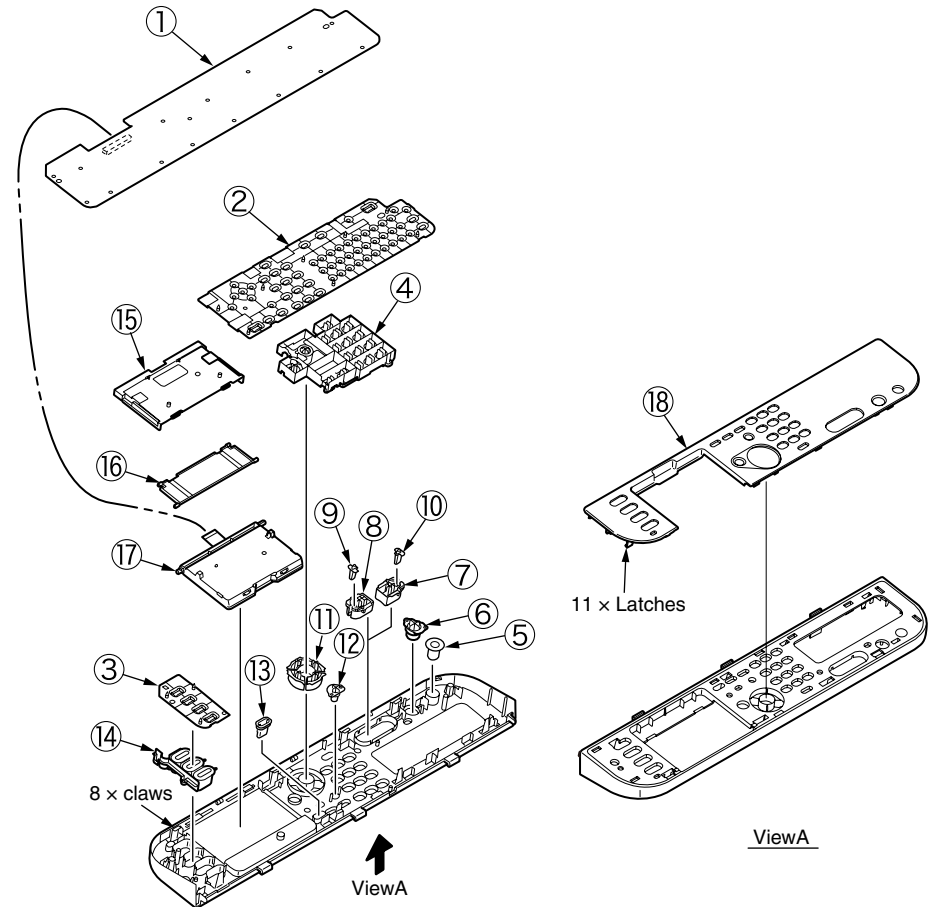

4.2.8.13 LCD-assy

- (1) Remove the LCD-assy ①.

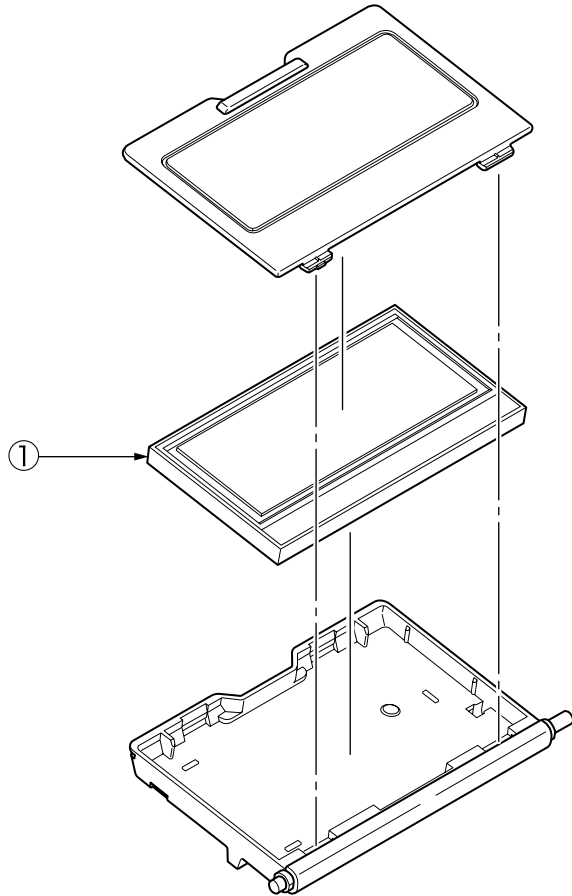

4.2.8.14 Frame-assy-FB

Note! • It exchanges it detaching the scanner unit from the MFP when the SU-board is exchanged.

- If replaced new board, update Firmware according to Chapter 9.3.
It is necessary to take the synchronization of the firmware version of SU board and CU board.

- (1) Remove the screw (silver-colored M4) ①. (Only MB471, MB471w and MB491)

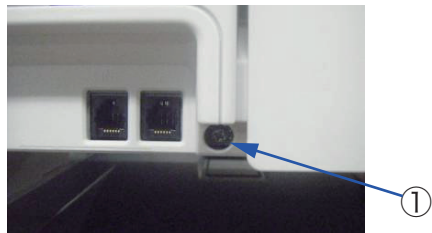

- (2) Remove four screws (black-colored, L=10mm) ② to remove the Cover Bottom ③.

- (3) Remove Plate-FG (FAX) ④ from Cover Bottom ③.

- (4) Remove five screws (silver-colored) ⑤ and five screws (black-colored, L=8mm) ⑥ to remove the Plate-Shield (SU) ⑦.

- (5) Remove the screw (silver-colored) ⑧ to remove the Clamp ⑨. And remove all SU-Board cables.

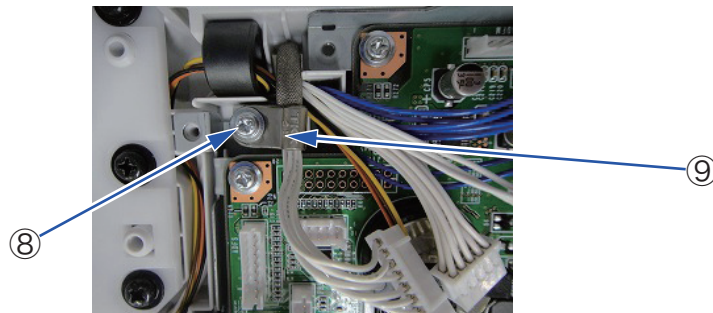

- (6) Remove the screw (silver-colored M4) ⑩ to remove the Plate-FG ⑪. (Only MB471, MB471w and MB491)

Remove four screws (silver-colored) ⑫ to remove the SU-Board ⑬.

- (7) Remove the screw (black-colored, L=8mm) ⑭ to remove the Plate-USB ⑮.

And remove two screws (silver-colored, L=12mm) ⑯ to remove the cord-USB ⑰.

And remove the core ⑱ from Cord-USB ⑰. (two claws)

- (8) Remove the screw (silver-colored M4) ⑲ to remove the cord-FG ⑳.

- (9) Remove three screws (black-colored, L=8mm) ㉑ to remove the Plate-Board (SU) ㉒.

- (10) Remove two screws (black-colored, L=10mm) ㉓ to remove the Cover-Assy-LF ㉔.

- (11) Remove four screws (black-colored, L=10mm) ㉕ to remove the Cover-Hinge-L ㉖ and the Plate-Hinge-L (Caulking) ㉗.

- (12) Remove seven screws (black-colored, L=10mm M4) ㉘ to remove the Cam-hinge ㉙.

Note! (to assemble)

1. Since a cable will be pushed by Plate-Shield (SU), please place downward.

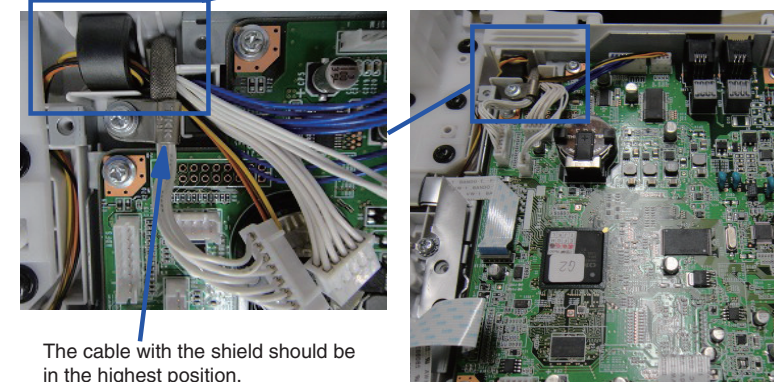
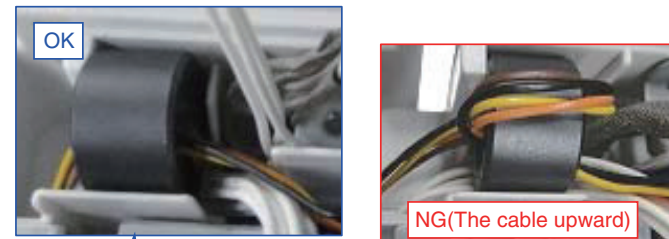

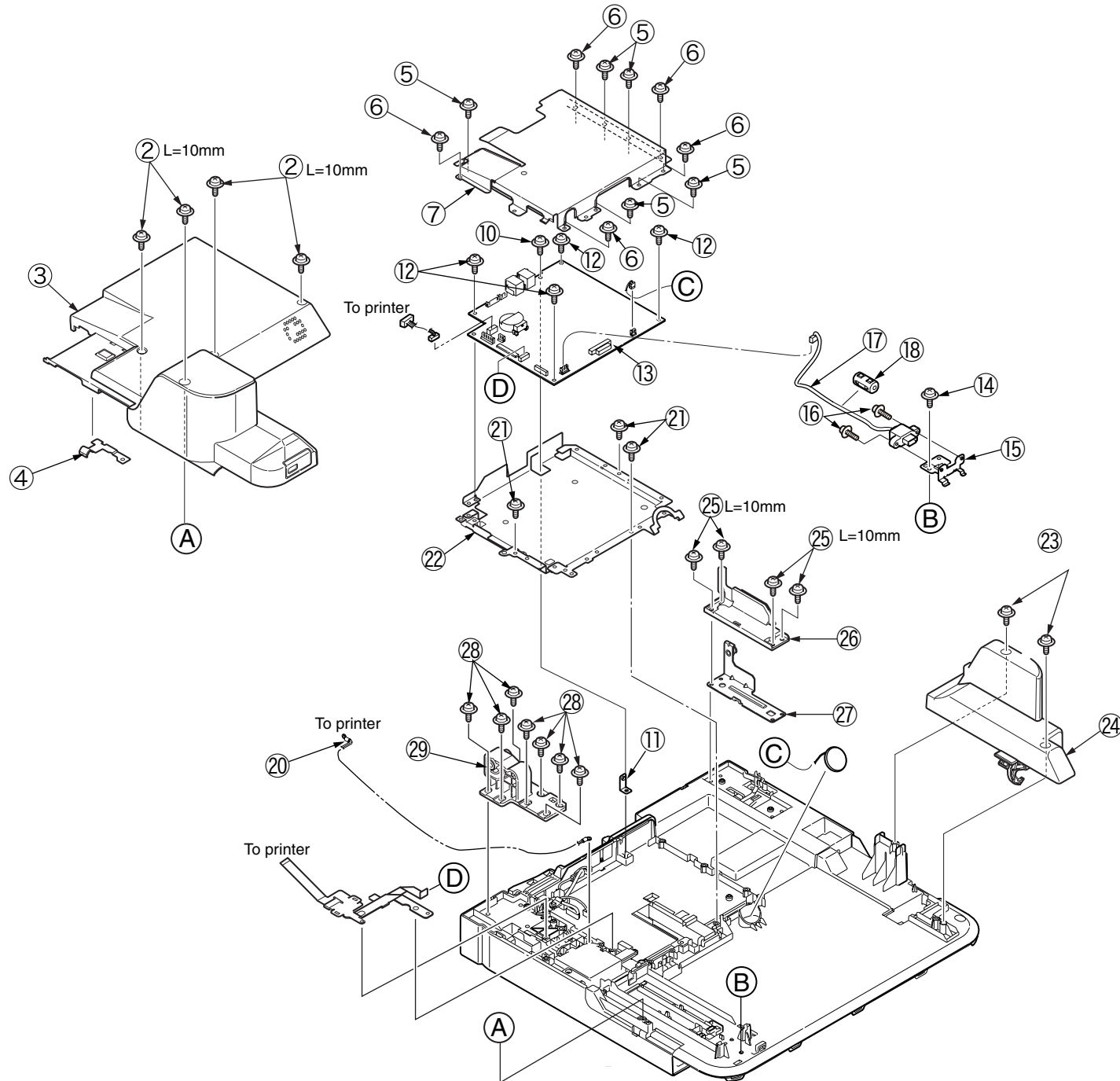

4.2.8.15 How to remove Battery (SU Board MHE)

(1) The position of the battery is shown in the below picture.

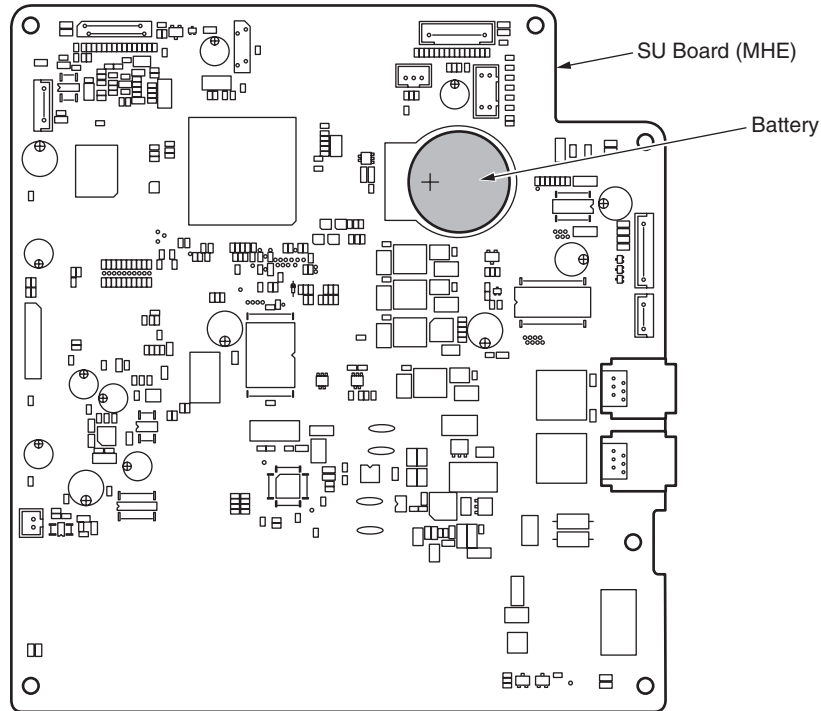

(2) How to remove the battery.

Insert finger, a needle or a rod in the gap between the battery and the its holder.

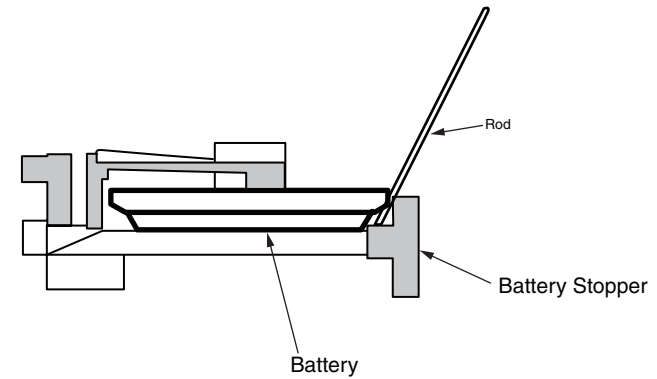

Raise the battery up so that it is put on the battery stopper, and remove it.

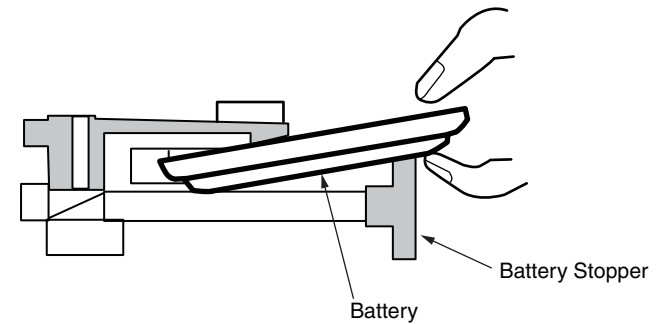

4.2.8.16 Frame-assy-hopping-ADF

(1) Slide the Gear-shaft-hopping while opening the stopper.

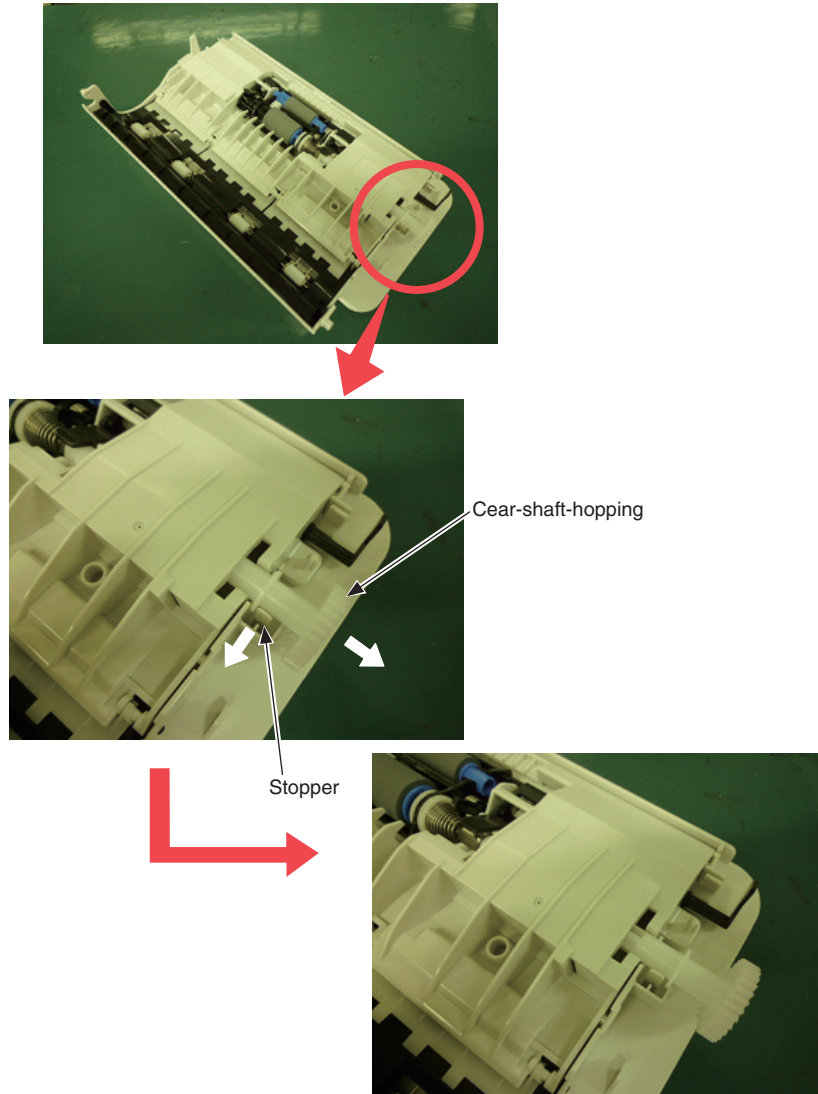

(2) Remove the Frame-assy-hopping-ADF ① and the Stopper-Assy-Gate ②.

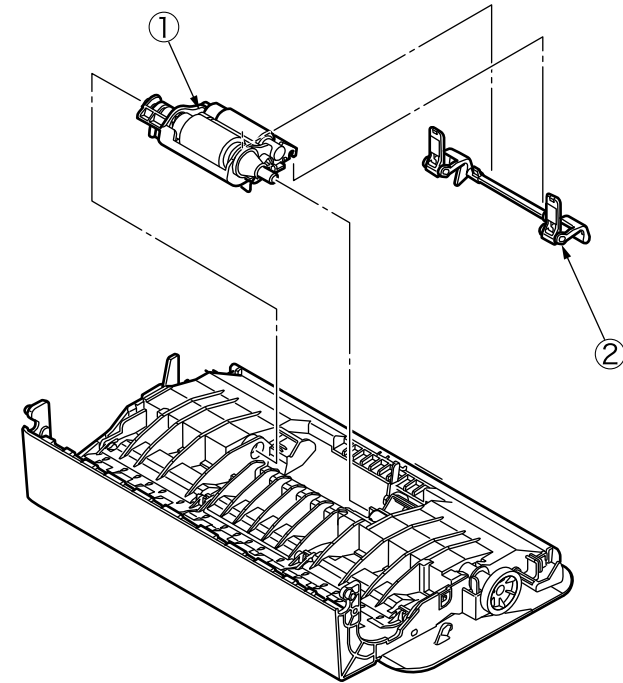

4.2.9 Plate Stay L / Plate Assy Stay R

- (1) Remove the Scanner unit. (Refer to 4.2.8)
- (2) Remove three screws ① and remove the plate support L ②. Remove two screws ③ and remove plate stay L ④.

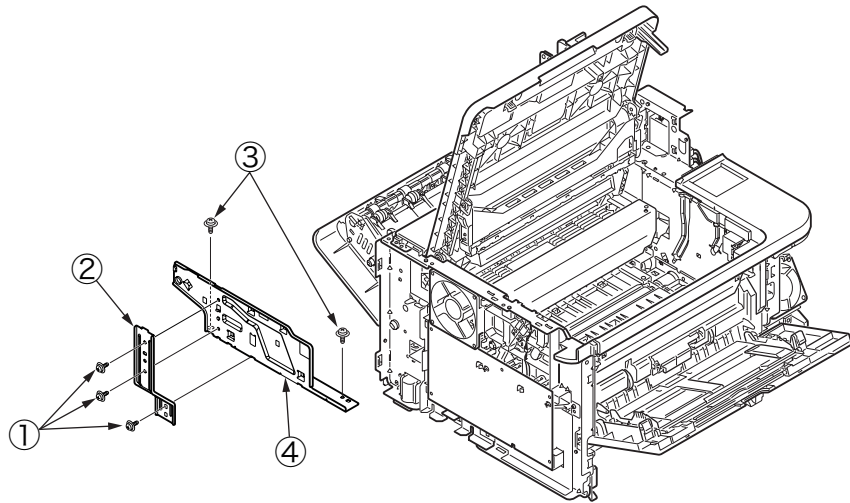

- (3) Remove the Guide Cable ⑤.

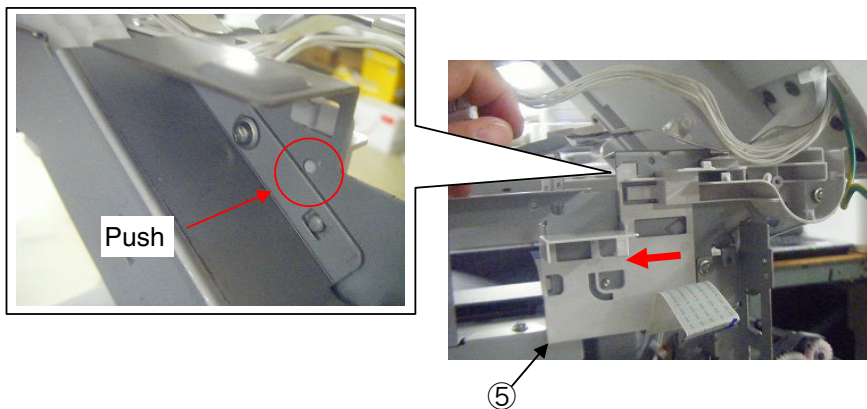

- (4) Remove four screws (Silver) ⑥ to detach the Plate Assy Stay (R) ⑦.

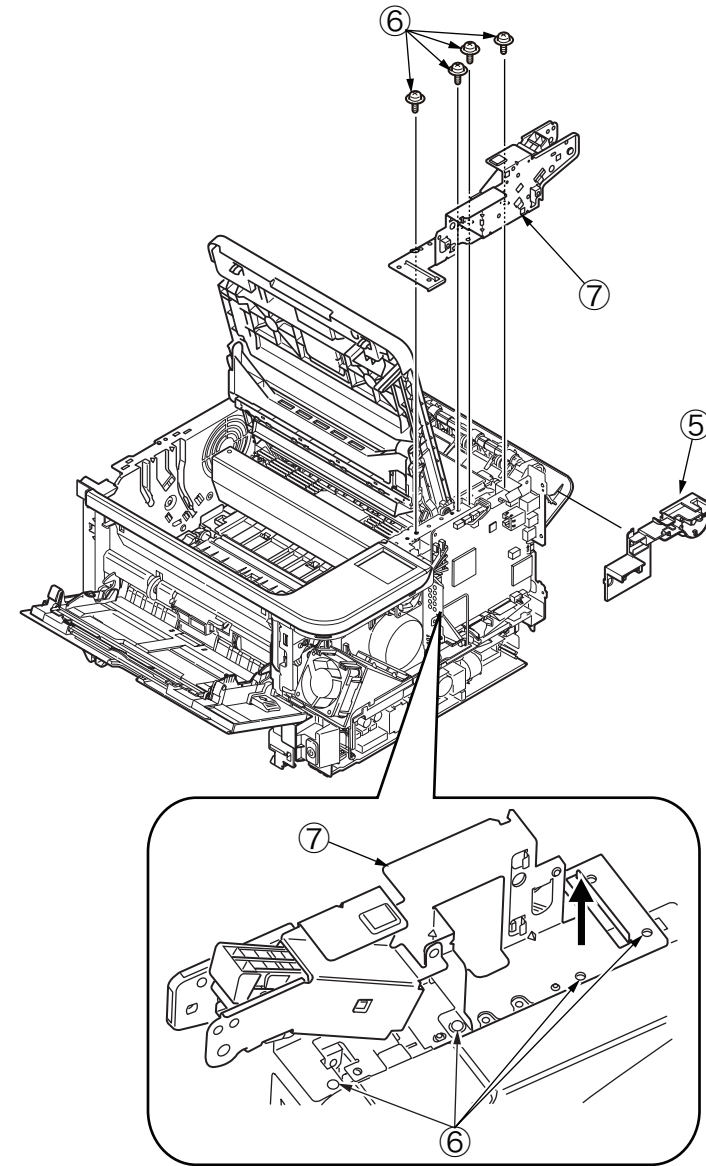

4.2.10 LED Head

- (1) Open the Stacker Cover.
- (2) Remove the ID UNIT.
- (3) Disengage the tab of the Holder-Head from the stacker cover by using a flat-head screwdriver or something.
- (4) Pull the Holder-Head toward you as illustrated below.
- (5) Open the Holder-Head by arrow direction and then remove the hook. remove the LED Head ①.
- (6) Remove the FFC cable from the connector of LED Head ①.
- (7) Installing is performed by the reverse procedure with removing.

Note! Beware of not to touch or press the SLA parts of LED Head directly.

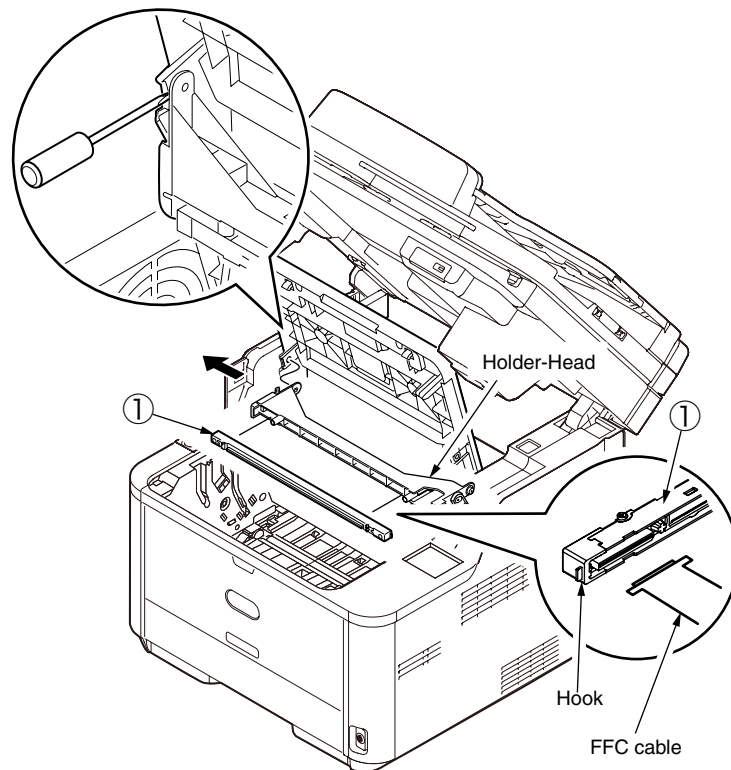

4.2.11 Frame-Assy-TR

- (1) Open the Stacker Cover.
- (2) Remove the ID UNIT.
- (3) Take the Frame-Assy-TR out of the printer.
- (4) Disengage the latches of Bearing-TR ① on both ends.
- (5) Hold the Bearing-TR ① on the both side, and then lift up the Roller-Transfer ②.
(At this moment, Gear-TR ③ is also removed.)
- (6) Installing is performed by the inverse procedure with removing.

Note! (to assemble)

1. While installing, pay attention to the up-and-down direction of Bearing-TR ①.
2. Operating carefully, not to touch Roller-Transfer ② surface.
3. Be careful not to fit each Bearing-TR ① to the Frame-Assy-TR with their springs inclined.

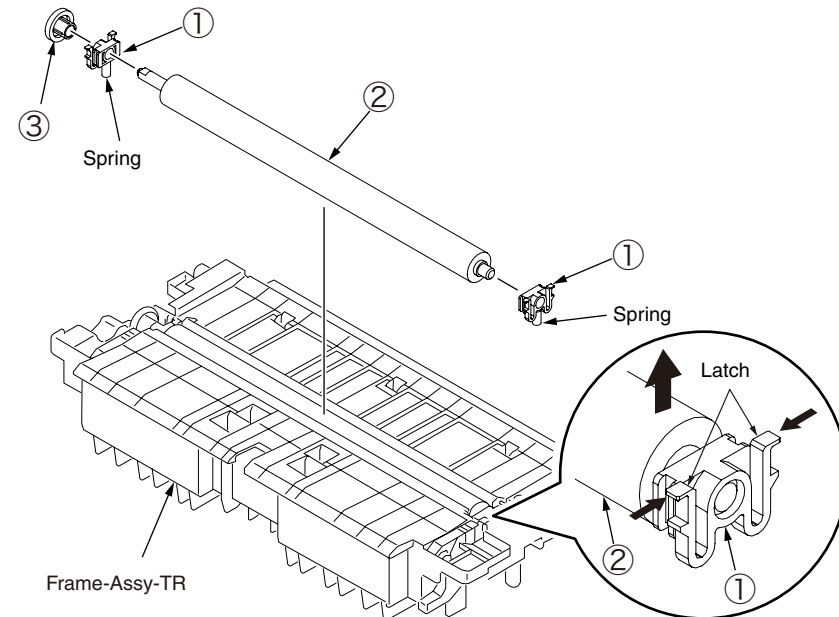

4.2.12 Duplex Belt Assy

- (1) Take out the Frame-Assy-TR. (Refer to 4.2.11)
- (2) Remove the cassette and set the printer unit on its right side.
- (3) Remove the E-ring (RE4-SK) ① and slide the Shaft-Dup-Clutch in the direction of the arrow.
- (4) Remove the screw (Silver) ② and Frame-Duplex-Assy ③.
- (5) Remove the four pieces of Bearing ④, Roller-Feed-Duplex ⑤ and Duplex-Belt ⑥.
- (6) Installing is performed by the inverse procedure with removing.

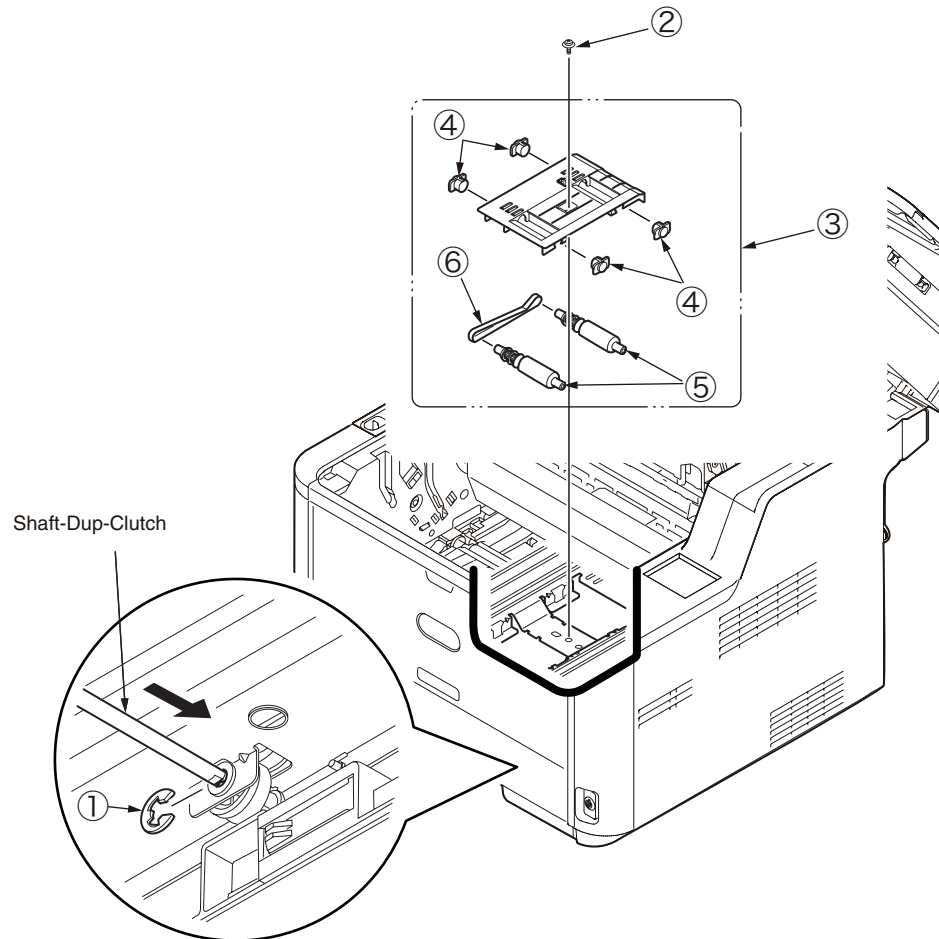

4.2.13 DC Motor

- (1) Remove the Cover Side (R). (Refer to 4.2.2)
- (2) Remove the screw (Silver) ①, and remove FG-Cable ②.

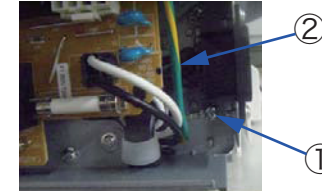

- (3) Remove four screws (Silver) ③, and remove PlateShield (CU) ④.

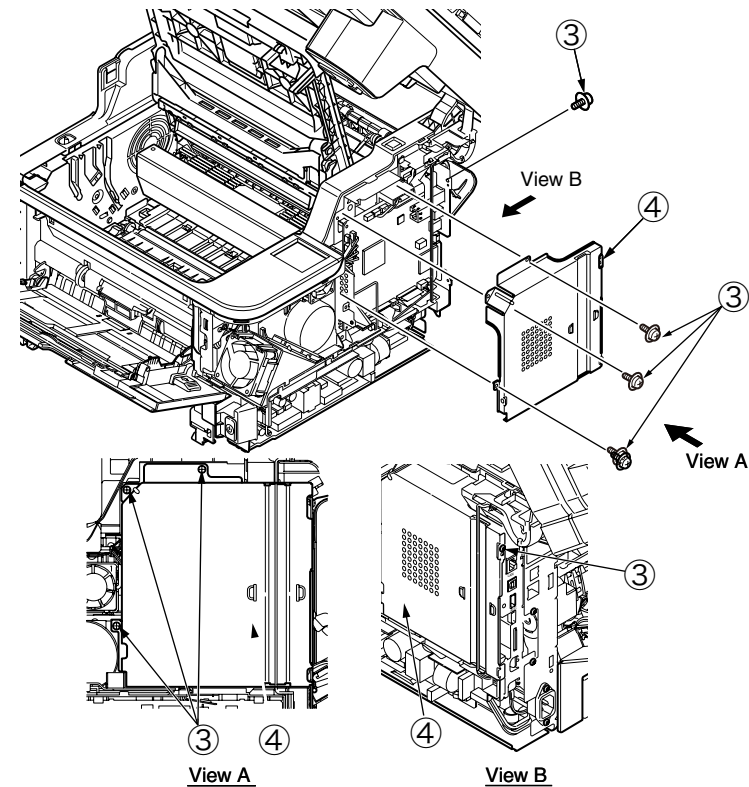

(4) Disconnect cables (4 point) ⑤ from the CU/PUBoard ⑥.

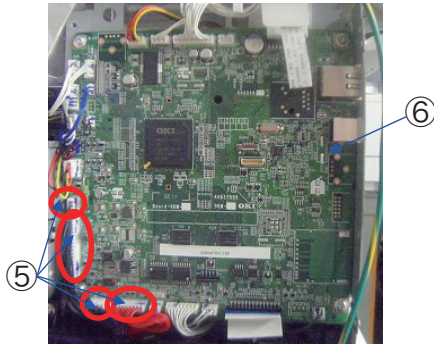

(5) Remove the PWR unit-ACDC Switch. (Refer to 4.2.4).

(6) Unlatch the claws (2points), and remove the Motor-FAN (60 x 25) ⑦ from the Duct Fan Power ⑧.

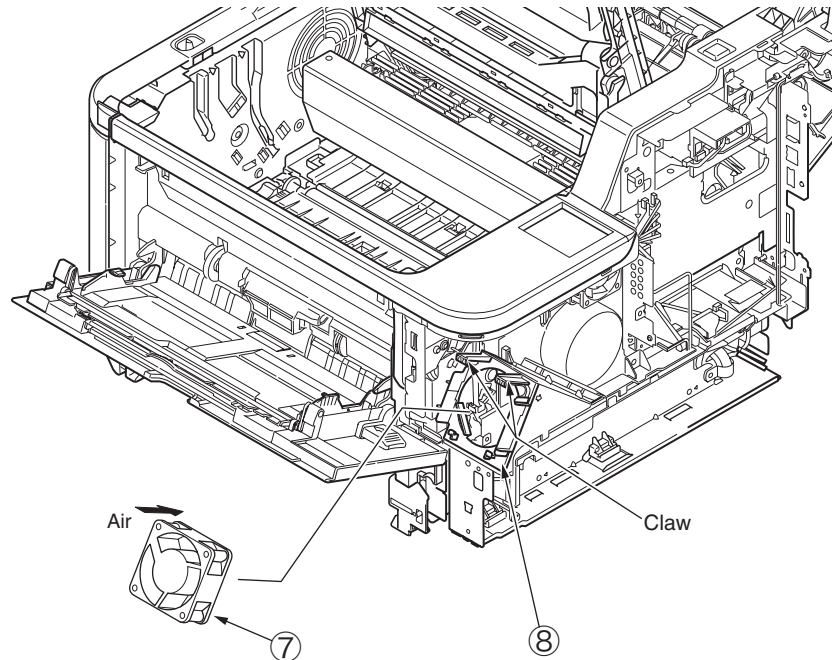

(7) Remove three screws (Silver) ⑨ to detach Duct Fan Power ⑧.

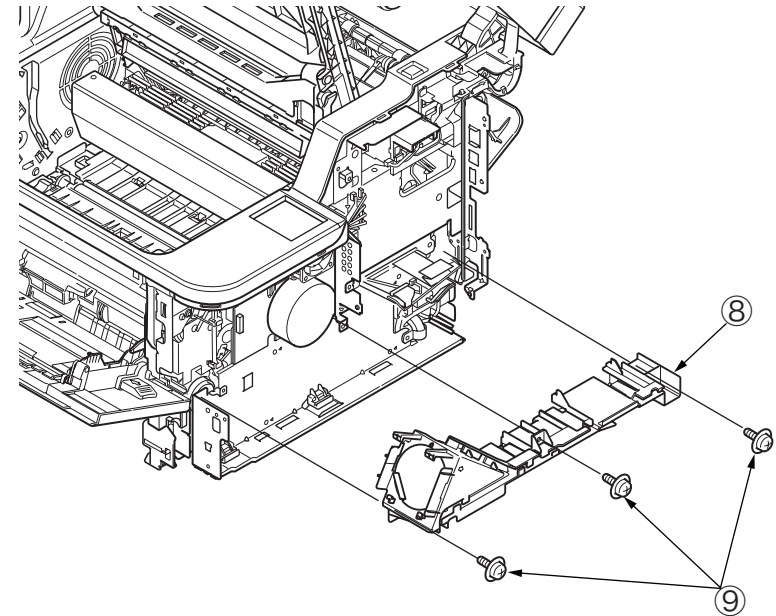

(8) Remove three screws(Silver) ⑩ to detach DC Motor ⑪.

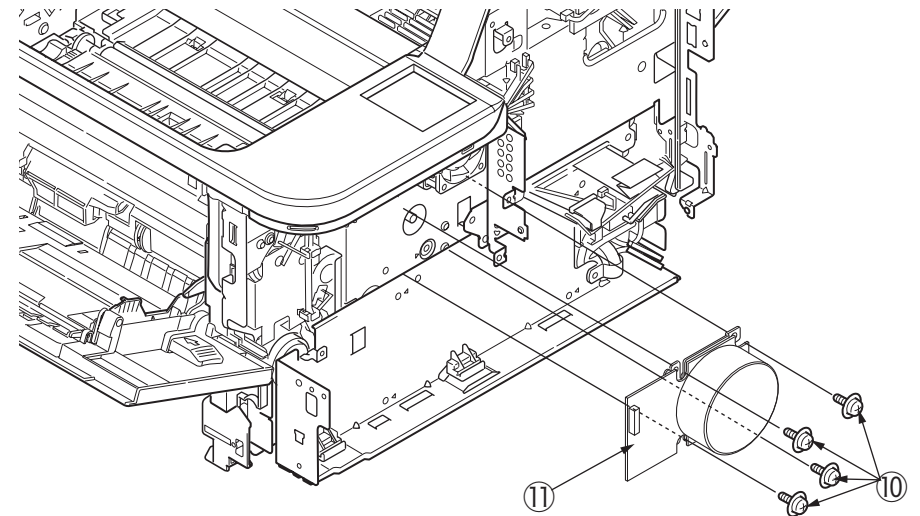

Note! (to assemble)

1. Note to assemble for the direction of the Motor-FAN's air flow.

4.2.14 Hopping Clutch / MPT Clutch / Regist Clutch

- (1) Remove the Board MHE. (Refer to 4.2.3).
- (2) Remove the screw (Silver) ①, and remove FG-Cable ② from the Guide Cable ③.
- (3) Remove the screw (Black) ④ and the screw (Silver) ⑤, and remove FG_Film (FFC) ⑥ and Cable ⑦ from Guide Cable ③.

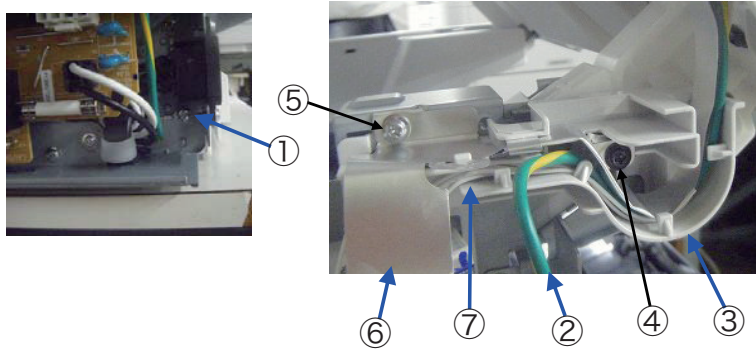

- (4) Remove the Guide Cable ③.

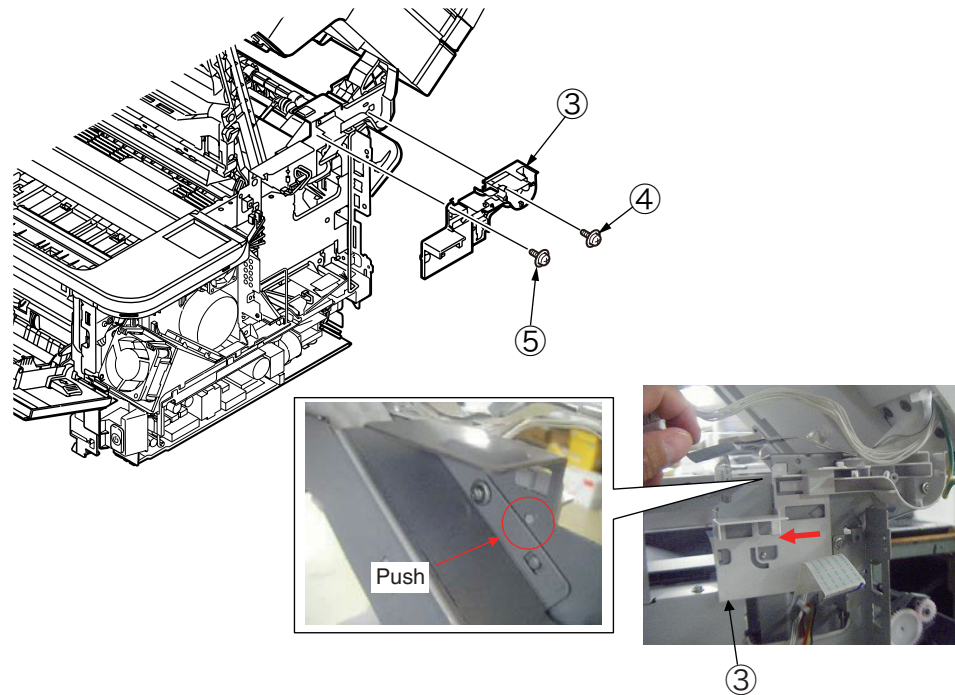

- (5) Remove the PWR unit-ACDC Switch. (Refer to 4.2.4)
- (6) Remove the DC Motor . (Rever to Refer to 4.2.13)
- (7) Remove eight screws (silver) ⑧ to detach the Plate Bracket (CU) ⑨.

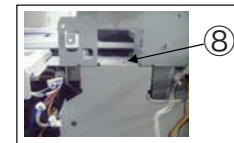
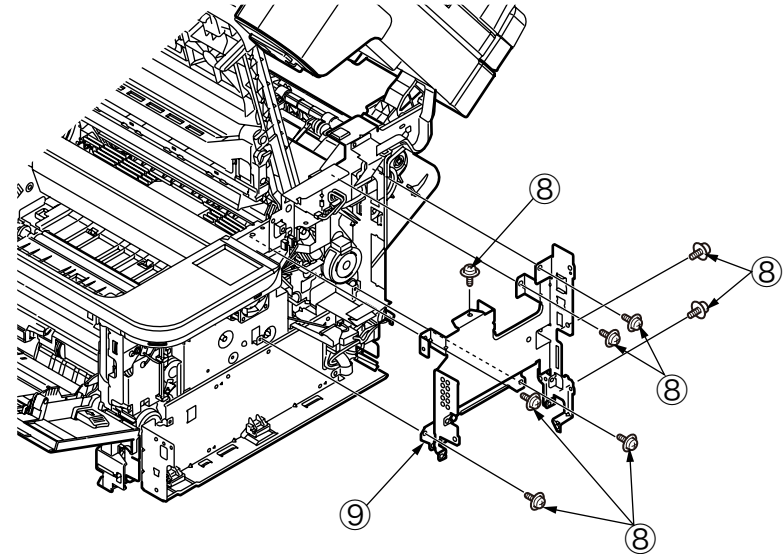

Note to assemble



Clamp together the screw and the FG-Film.

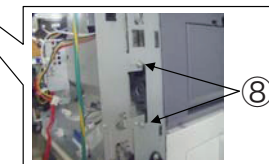
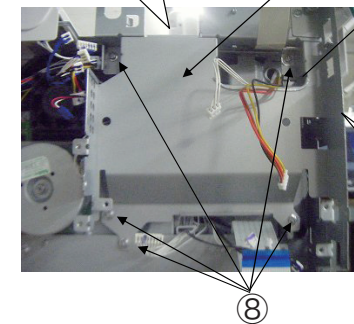

- (8) Remove the screw (silver, L=8mm) ⑩ to detach the Core ⑪.
- (9) Remove four screws (silver) ⑫, and remove the Plate Base (PWU) ⑬ with to slide along to the arrow in figure.

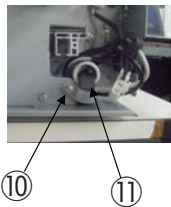
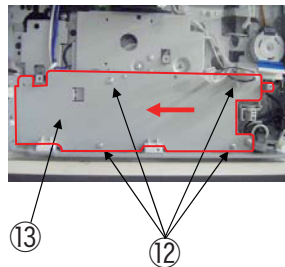
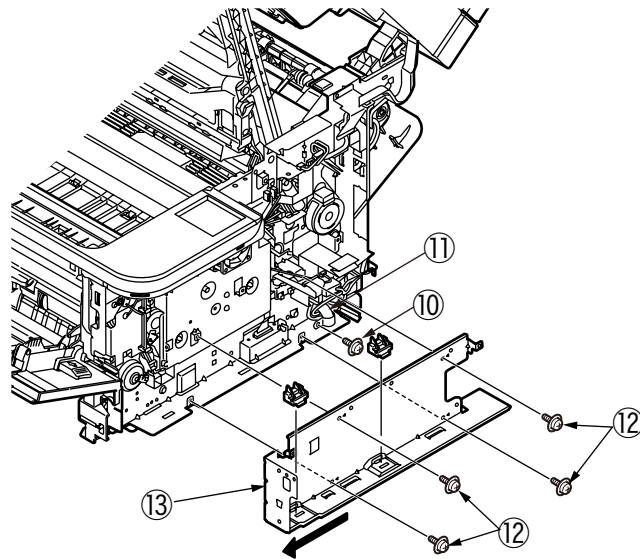

(Reference)

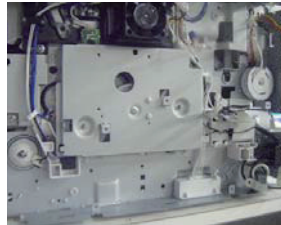

The situation of the Mainbody without the Plate Base (PWU).

- (10) Remove two screws (Black) ⑭ and the screw (Silver) ⑮, remove the Plate-Clutch-MPT ⑯.
- (11) Remove four screws (Silver) ⑰, remove the Plate-Gear ⑱.
- (12) Remove the Gear-Reduction ⑲.
- (13) Remove the E-ring(RE3-SK) ⑳, remove the Regist Clutch ㉑.
- (14) Remove the E-ring(RE3-SK) ㉒, remove the Hopping Clutch ㉓.

Remove the Spring ㉔ from the current Regist Clutch ㉑ or the current Hopping Clutch ㉓. This Spring ㉔ can be used to the new Regist Clutch ㉑ or the new Hopping Clutch ㉓.

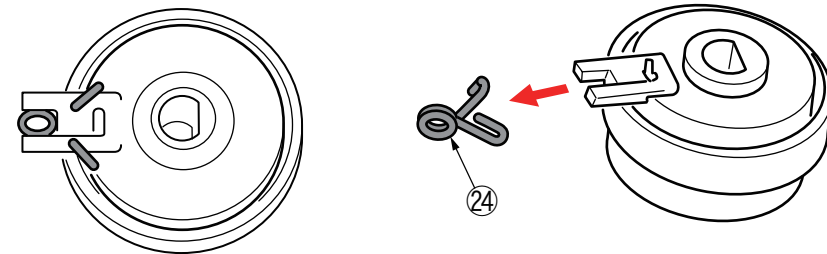

- (15) Remove the MPT Clutch ㉕ and the Gear-MPT ㉖. (MB471/MB471w/MB491)
- (16) Installing is performed by the inverse procedure with removing.

Note!

- 1. Beware of not to touch the DC motor inattentively (Do not rotate motor).

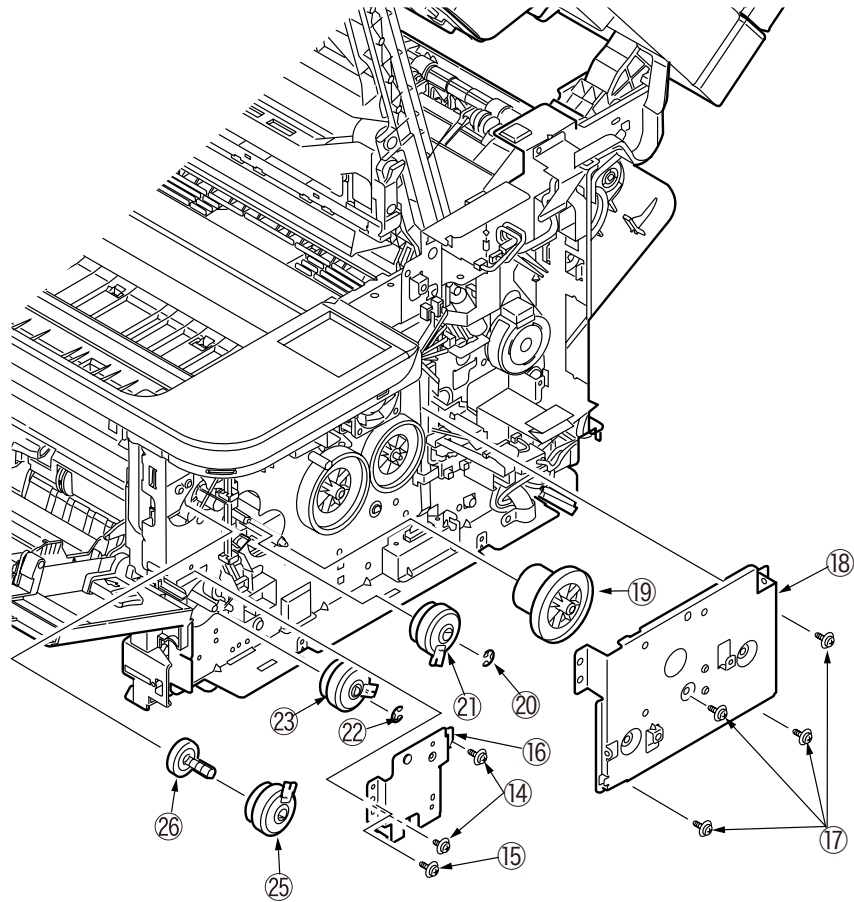

4.2.15 HV-Board / Motor-FAN

- (1) Remove the Cover Side (L). (Refer to 4.2.1)
- (2) Remove the screw (Black) ① and four screws (Silver) ②, disengage the two tabs (a and b), and remove HV-Board ③. Be careful not to lose Spring-Contact ④ that is removed with the board.
- (3) Disconnect all of the three cables from HV-Board ③.
- (4) Disengage the two tabs (c and d), and remove Motor-FAN (80×25) ⑤.
- (5) Installing is performed by the inverse procedure with removing.

Note!

1. Install Motor-FAN (80×25) ⑤ with the label side outward and with its notch fitted to the appropriate projection of the Plate-Side-L.
2. See 7.2 (2) for the HV-Board ③ connector layout.
3. While removing or installing FAN, do not press impeller of the FAN as shown by the following photo. In case of the impeller unfastened by mistake, do not reuse it and install a new FAN.

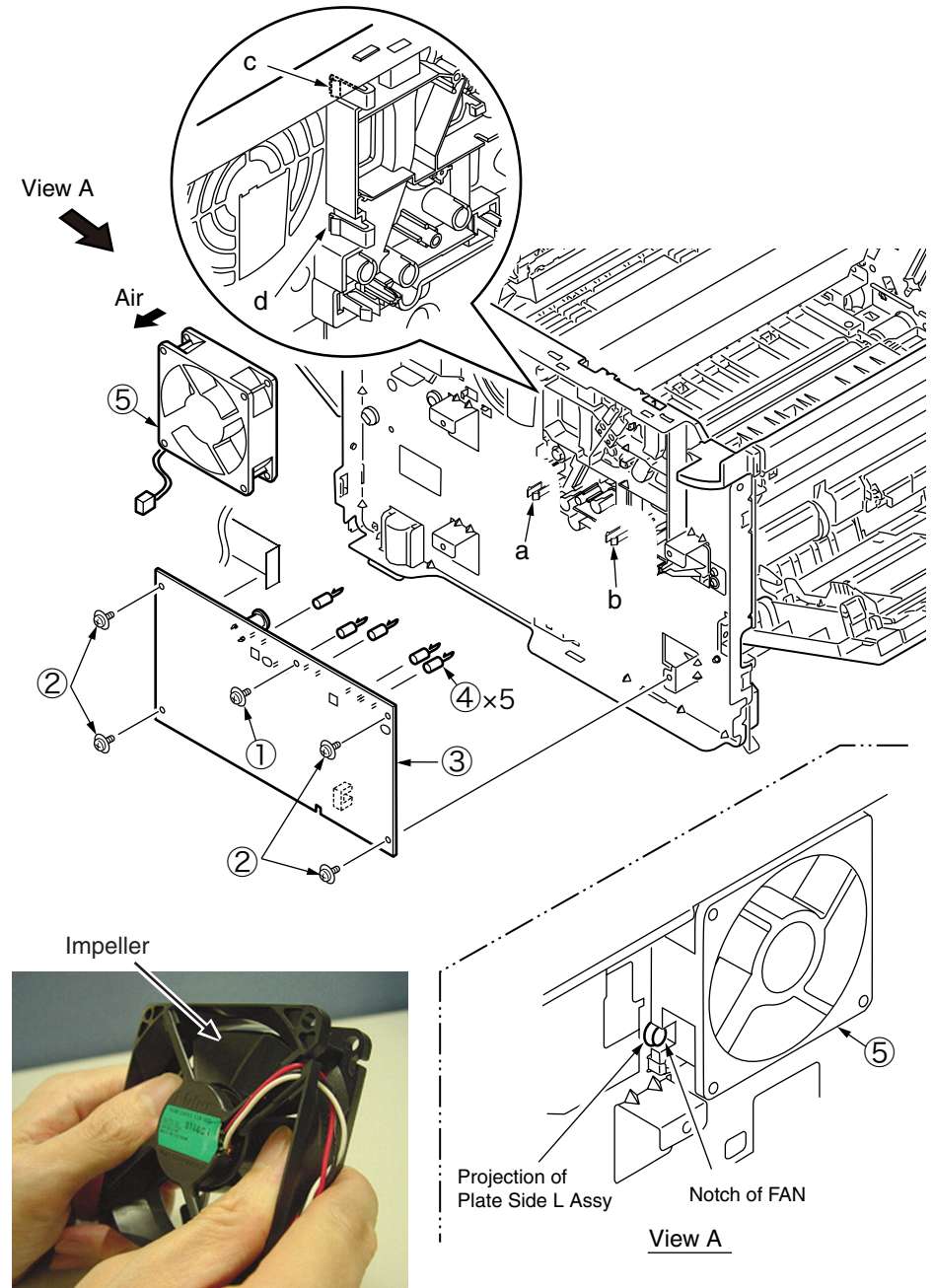

4.2.16 Cover Assy Stacker

- (1) Remove the Scanner unit. (Refer to 4.2.8)
- (2) Remove the CU/PU Board. (Refer to 4.2.3)
- (3) Remove the Guide Cable ①.

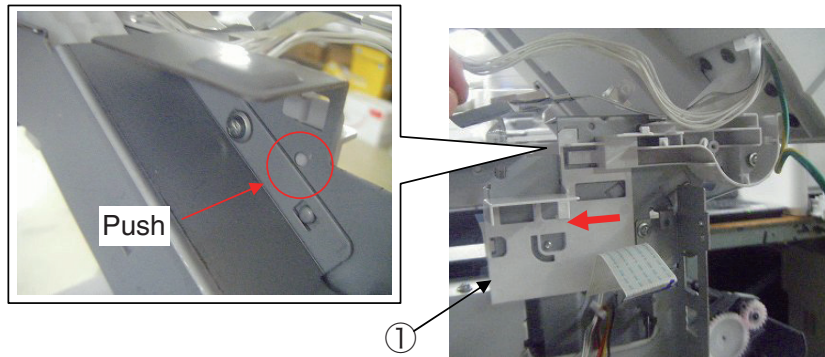
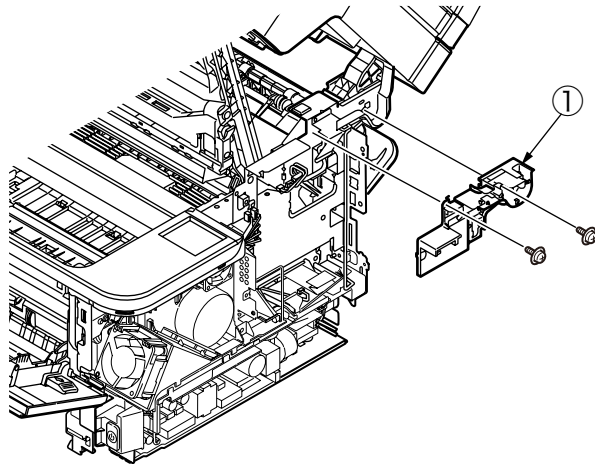

- (4) Remove the screw ②.

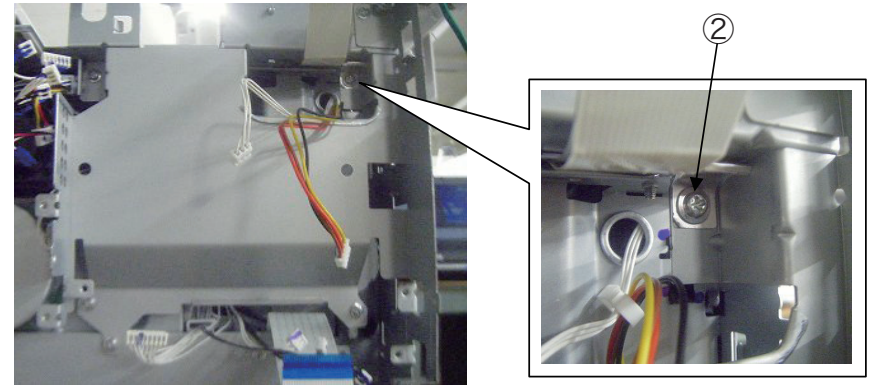

- (5) Remove two screws (Silver) ③ . Remove the Cover-Eject ④.
(At this moment, Plate-Rear ⑤ is also removed. Be careful not to damage FG film. FG film is inserted between ④ and ⑤.)
- (6) With the Cover Assy Stacker closed, detach Lever-Link-Fuser ⑥ (on both sides) from the Fuser Assy release lever by using a flat-head screwdriver or something.
- (7) With the Cover Assy Stacker opened, remove Spring-Stacker ⑧ (on both sides).

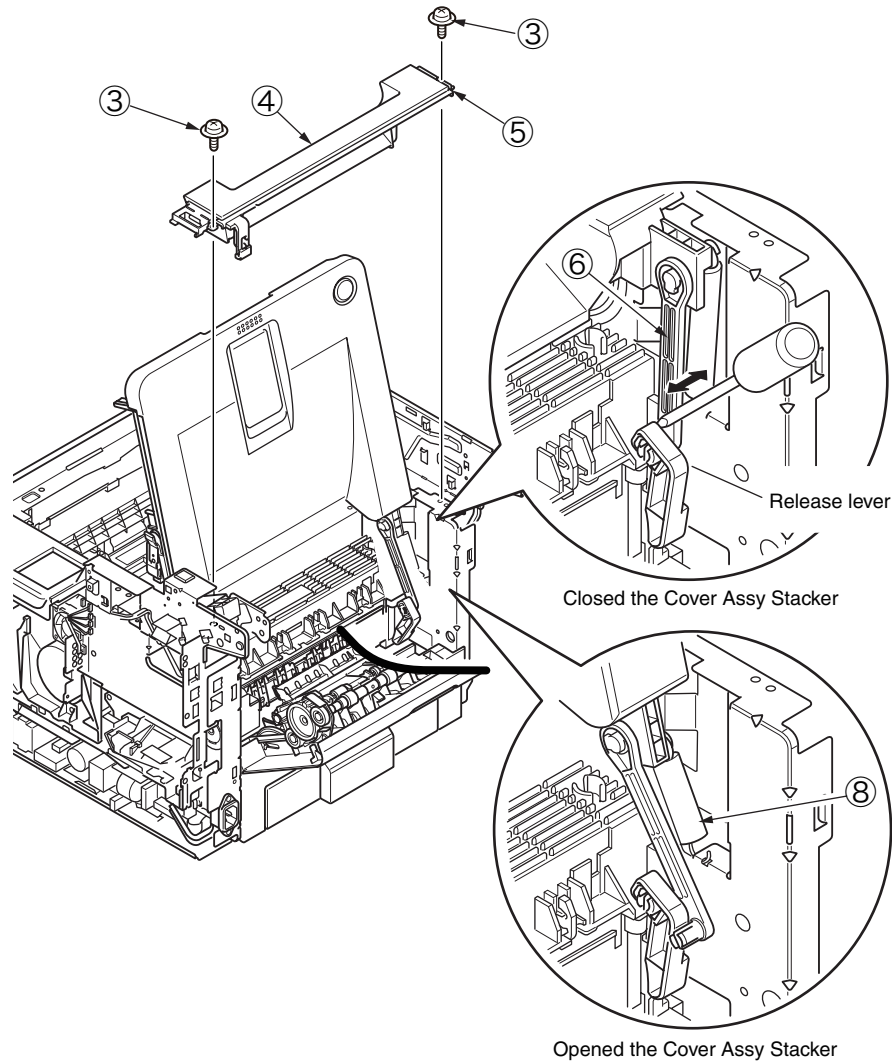

- (8) Remove the Cover Assy Stacker ⑨.
- (9) Installing is performed by the reverse procedure with removing.

Note!

1. Beware of not to touch the DC motor inattentively (Do not rotate moter).
2. Clamp together the screw and the FG-Film.

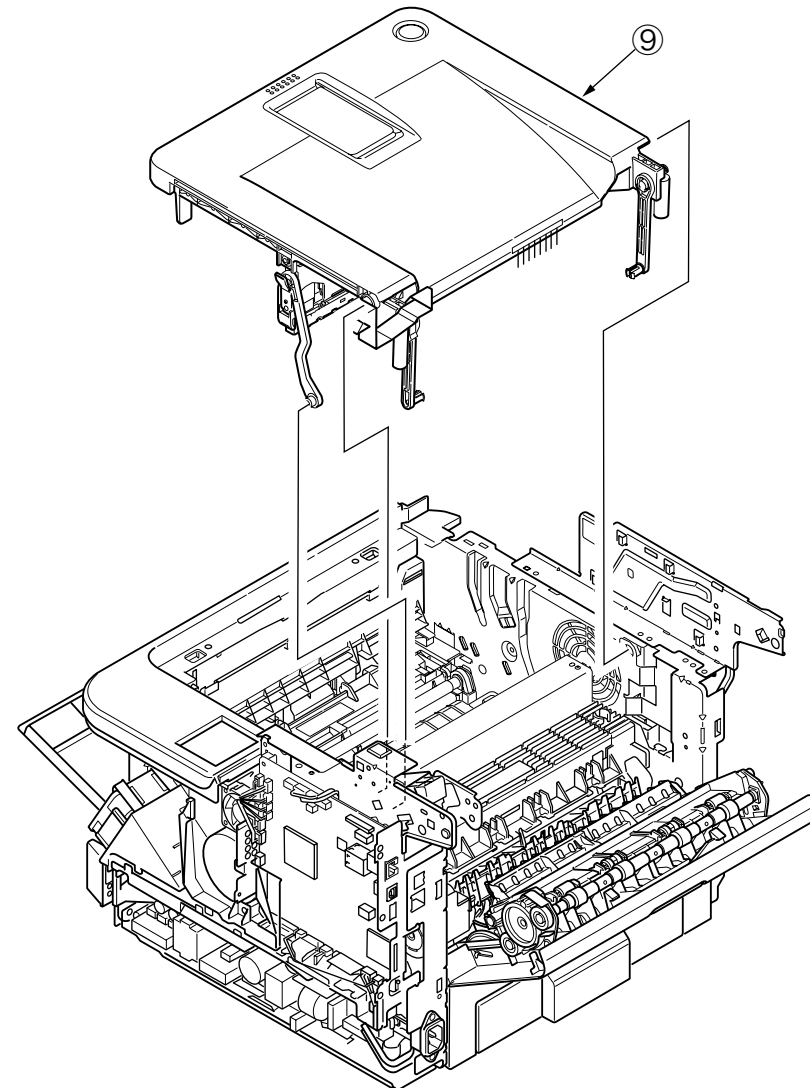

4.2.17 Stacker Cover

- (1) Remove the Cover Assy Stacker. (Refer to 4.2.16)
- (2) Remove the LED Head. (Refer to 4.2.10)
- (3) Remove the Lever-Link-Fuser ① (on both sides).
- (4) Remove four screws (Black) ②, remove the Cover-Lever ③.
- (5) Remove the Lever-Lock-Top ④, Lever-Lock-Button ⑤. Remove the Spring-Lever-Top ⑥.
- (6) Installing is performed by the reverse procedure with removing.

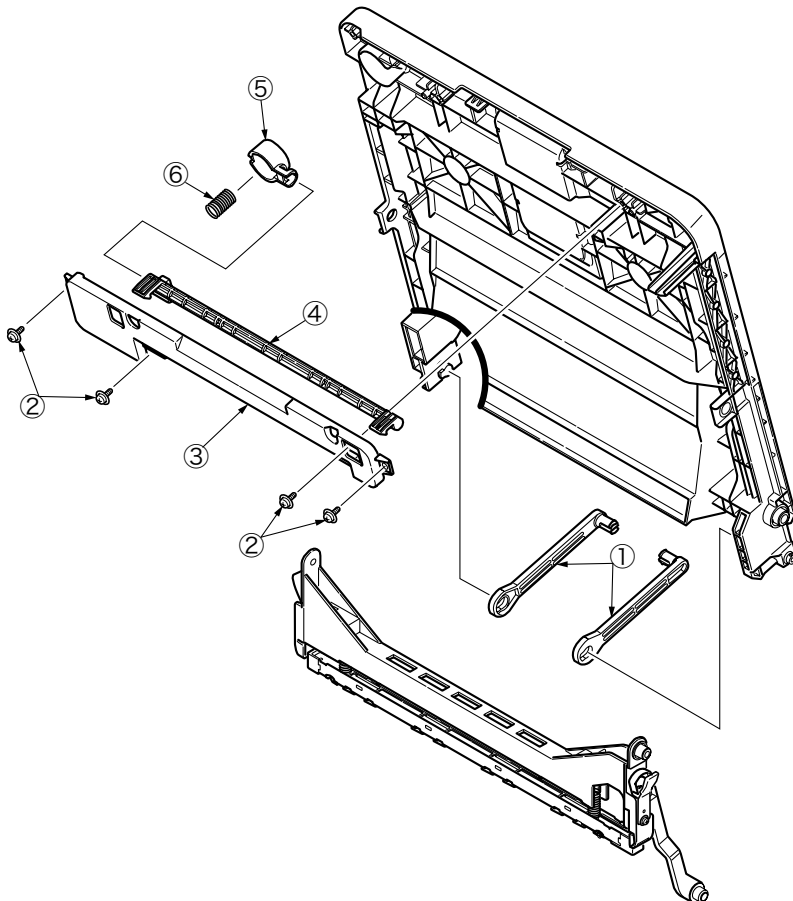

4.2.18 Fuser Assy

Note! Replace the Fuser-Assy by Assy unit.

It is forbidden for disassembling the Fuser-Assy, also, reusing the disassembled Fuser-Assy.

- (1) Remove the Frame Assy TR. (Refer to 4.2.11)
- (2) Remove the Scanner unit. (Refer to 4.2.8)
- (3) Remove the Cover Assy Stacker. (Refer to 4.2.16)
- (4) Remove the screw (Silver) ① and remove the FG-Cable ② from Guide Cable ③.
- (5) Remove the screw (Black) ④ and the screw (Silver) ⑤, and remove FG_Film (FFC) ⑥ from Guide Cable ③.

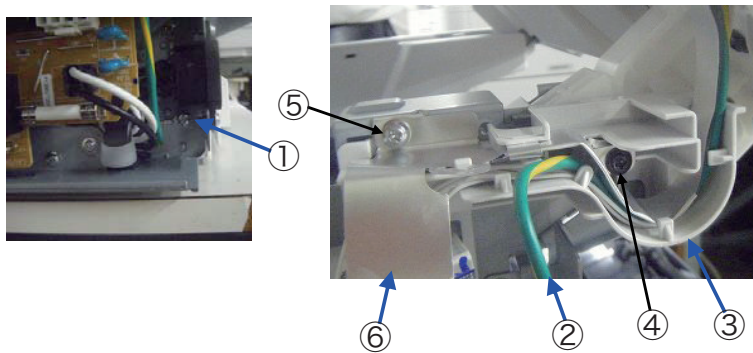

- (6) Remove the Guide Cable ③.

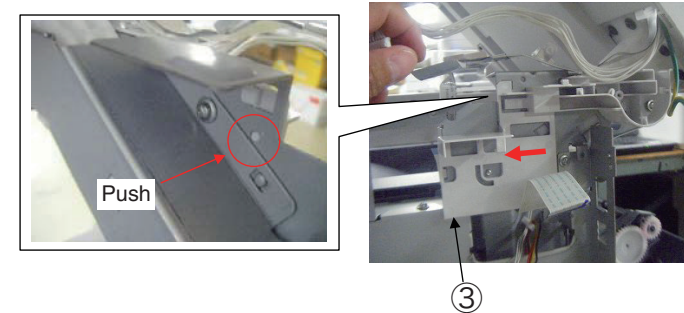
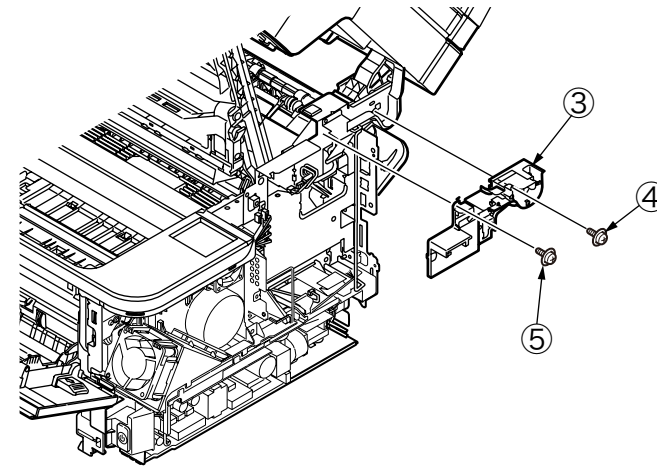

- (7) Remove the PWR unit-ACDC Switch. (Refer to 4.2.4)
- (8) Unlatch the claws (2 portions), and remove the Motor-FAN (60 x 25) from the Duct Fan Power ⑦.

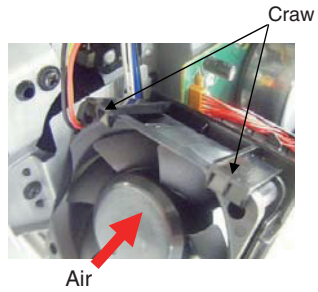

- (9) Remove three screws (Silver) ⑧ to detach the Duct Fan Power ⑦.

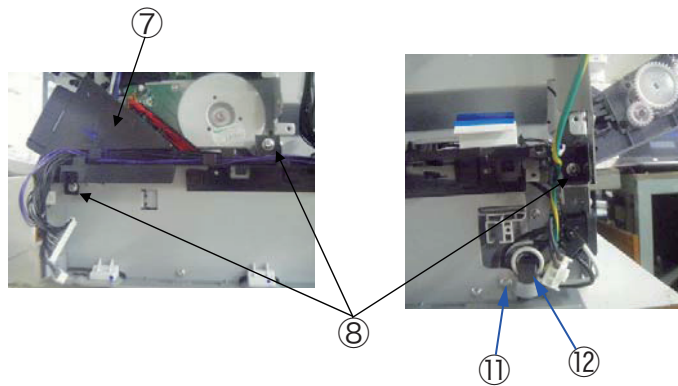

- (10) Remove eight screws (Silver) ⑨ to detach the Plate Bracket (CU) ⑩.
- (11) Remove the screw (Silver, L=8mm) ⑪, and remove core ⑫.
- (12) Remove four screws (Silver) ⑬, and remove the Plate Base (PWU) ⑭ with to slide along to the arrow in figure.

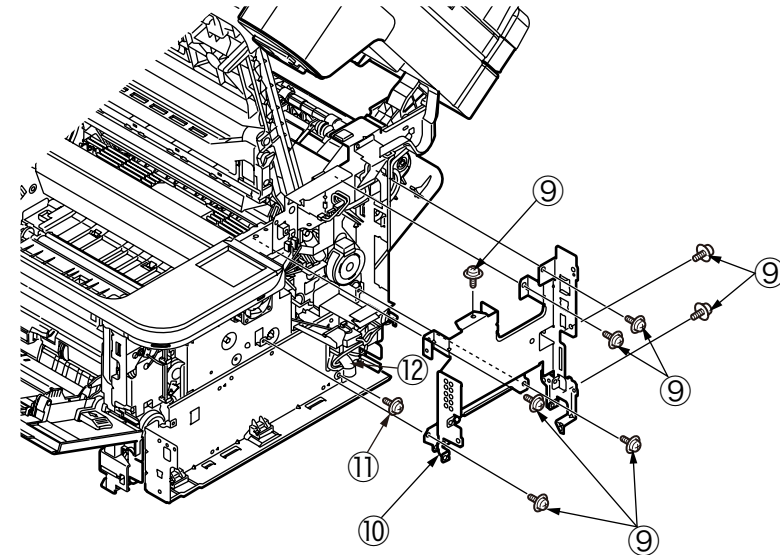

Note to assemble

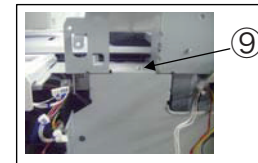

Clamp together the screw and the FG-Film.

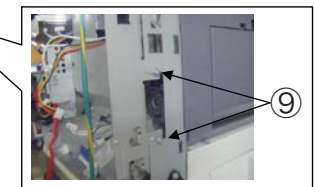
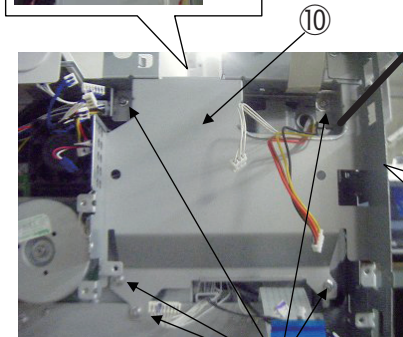

- (13) Remove two screws (Silver) ⑮. Remove the Plate-Duct-Assy ⑯.
- (14) Remove the screw (Silver) ⑰. Remove the Plate-Stacker-Lock ⑱.
- (15) Remove the screw (Silver) ⑲ and screw (Black) ⑳ and lift off Fuser-Assy ㉑ after disconnecting every cable from it.
- (16) Installing is performed by the inverse procedure with removing.

Note!

- 1. Fuser-Assy ㉑ may be really hot, beware of handling.
- 2. Beware of not to touch the DC motor inattentively (Do not rotate the motor).
- 3. Install the Fuser-Assy ㉑ carefully to avoid cables from being caught.

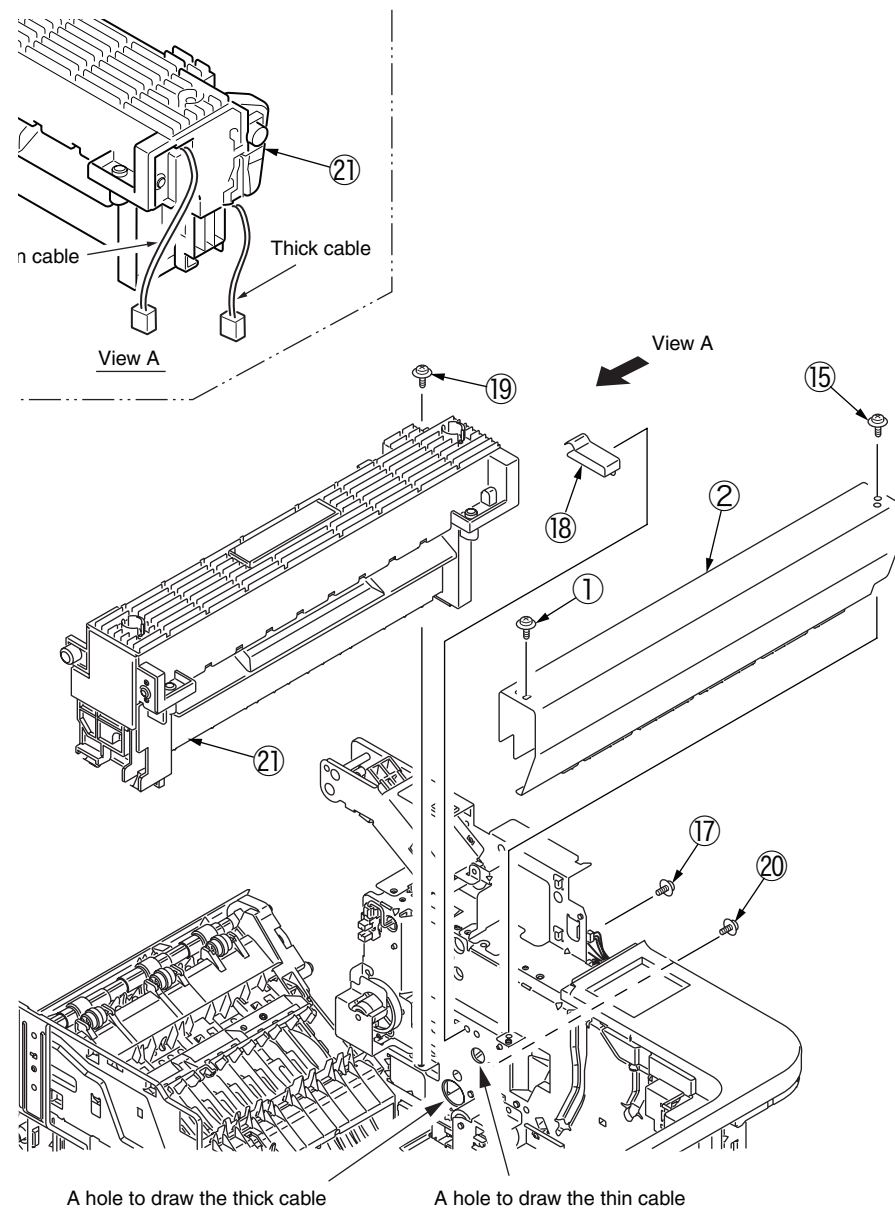

4.2.19 MPT Assy, Manual Assy

- (1) Remove the Cover Side (L) and Cover Side(R). (Refer to 4.2.1 / 4.2.2)
- (2) Remove the Cover Front (Top). (Refer to 4.2.6)
- (2) Remove the Cover-Assy-OPE. (Refer to 4.2.8.11 ~ 4.2.8.13)
- (3) Remove two screws (Silver) ①. Remove the Plate-Front ②.
- (4) Remove two screws (Silver) ③. Remove the screw (Black) ④.
- (5) Remove MPT Assy ⑤ (of MB471/471W/491) or Manual Assy ⑤ (of MB461).
- (6) Installing is performed by the inverse procedure with removing.

Note!

1. Beware of not to touch the DC motor inattentively (Do not rotate motor).

In case of MB461
Manual Assy

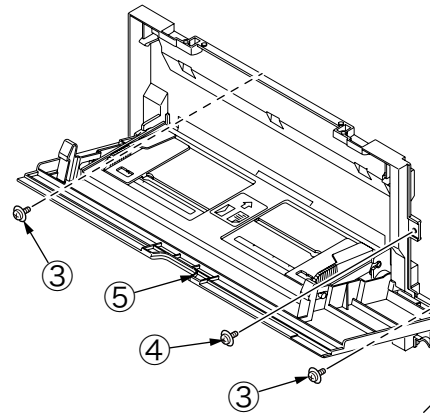

In case of MB471/MB471w/MB491
MPT Assy

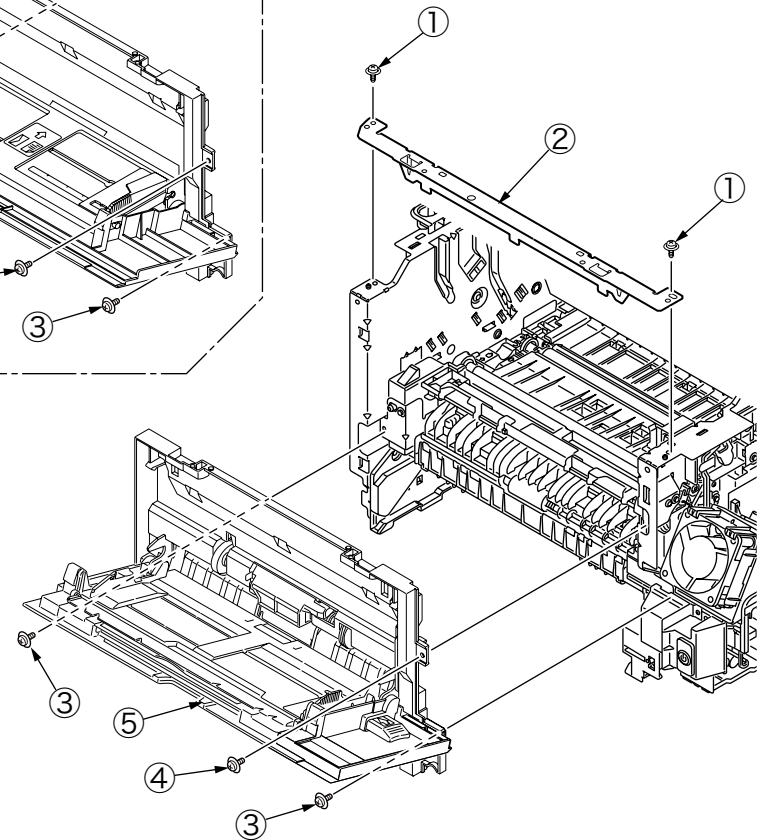

4.2.20 Cover Assy Rear

- (1) Remove the CU/PU Board. (Refer to 4.2.3)
- (2) Remove the screw (Silver) ① and remove the FG-Cable from Guide Cable ②.
- (3) Remove the screw (Black) ③ and the screw (Silver) ④, and remove FG_Film (FFC) ⑤ and Cable ⑥ from Guide Cable ②.

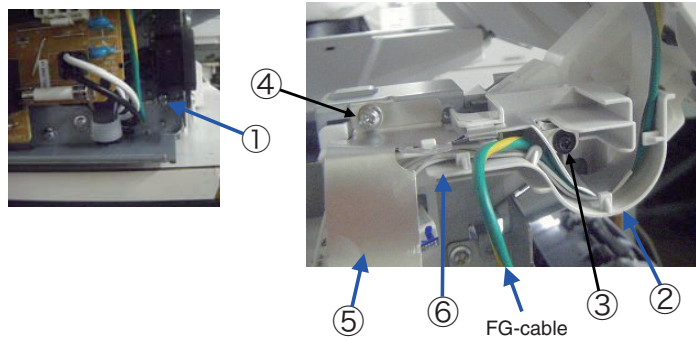

- (4) Remove the Guide Cable ②.
- (5) Remove the PWR unit-ACDC Switch. (Refer to 4.2.4)

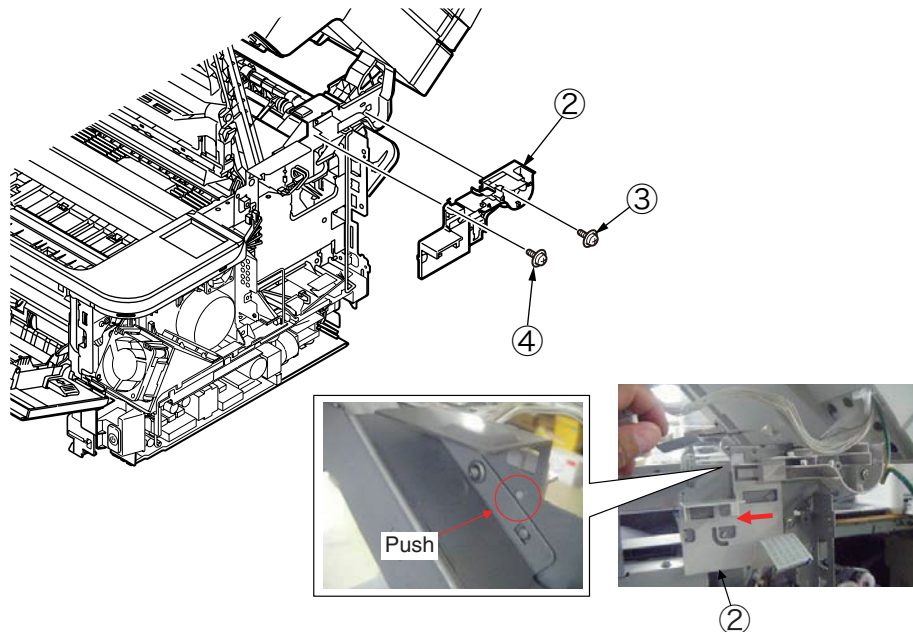

- (6) Unlatch the claws (2 portions), and remove the Motor-FAN (60 x 25) ⑦ from the Duct Fan Power ⑧.

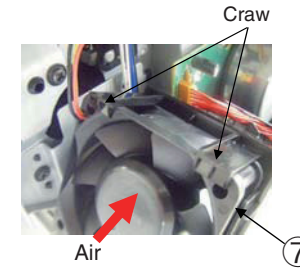

- (7) Remove three screws (Silver) ⑨ to detach the Duct Fan Power ⑧.

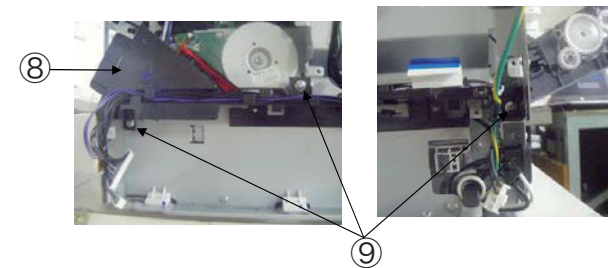

(8) Remove eight screws (Silver) ⑩ to detach the Plate Bracket (CU) ⑪.

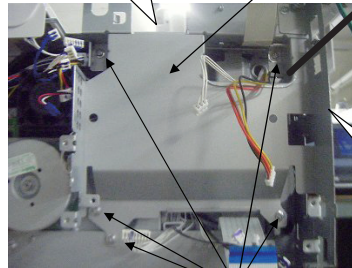
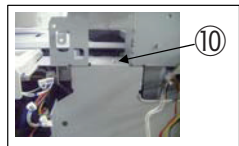
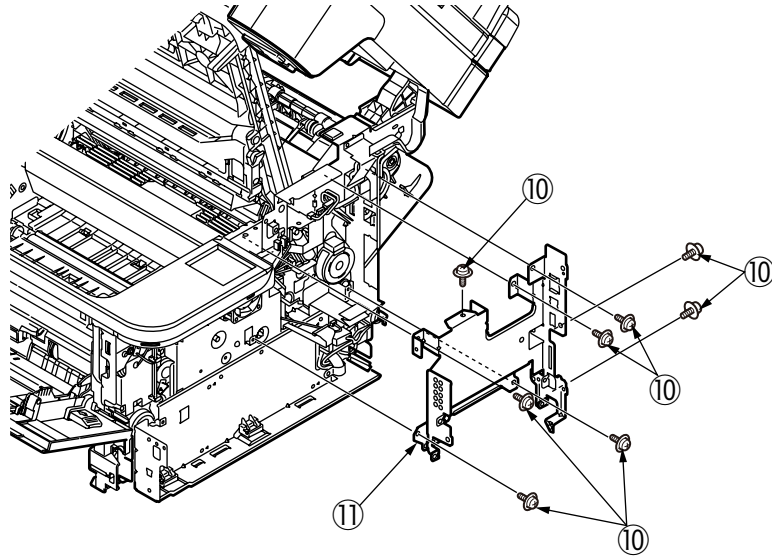

Note to assemble



Clamp together the screw and the FG-Film.

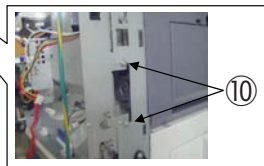

(9) Remove the screw (Silver, L=8mm) ⑫, and remove core ⑬.

(10) Remove four screws (Silver) ⑭, and remove the Plate Base (PWU) ⑮ with to slide along to the arrow in figure.

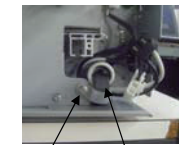
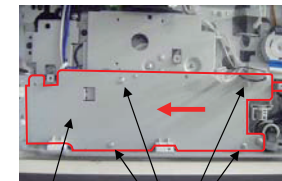
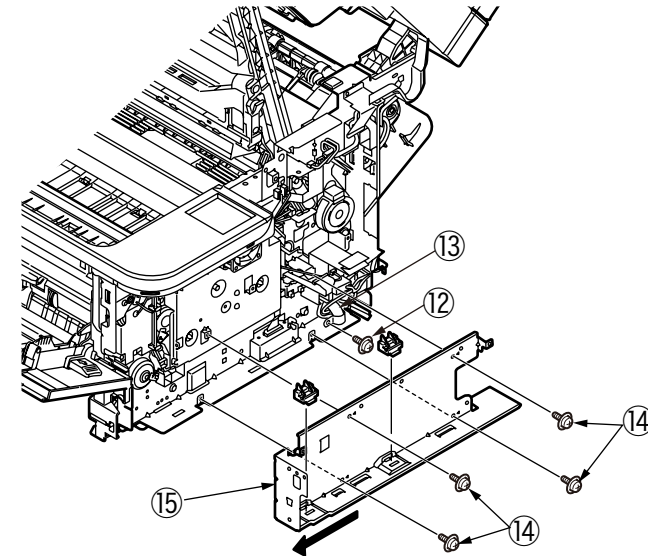

- (11) Remove the Spacer ⑰ .
- (12) Slide Cover Assy Rear ⑱ and pull it out of the hole on the right of the printer.
(Remove Cover Assy Rear ⑱ carefully to avoid Cable-Sensor-FU ⑲ from being caught.)

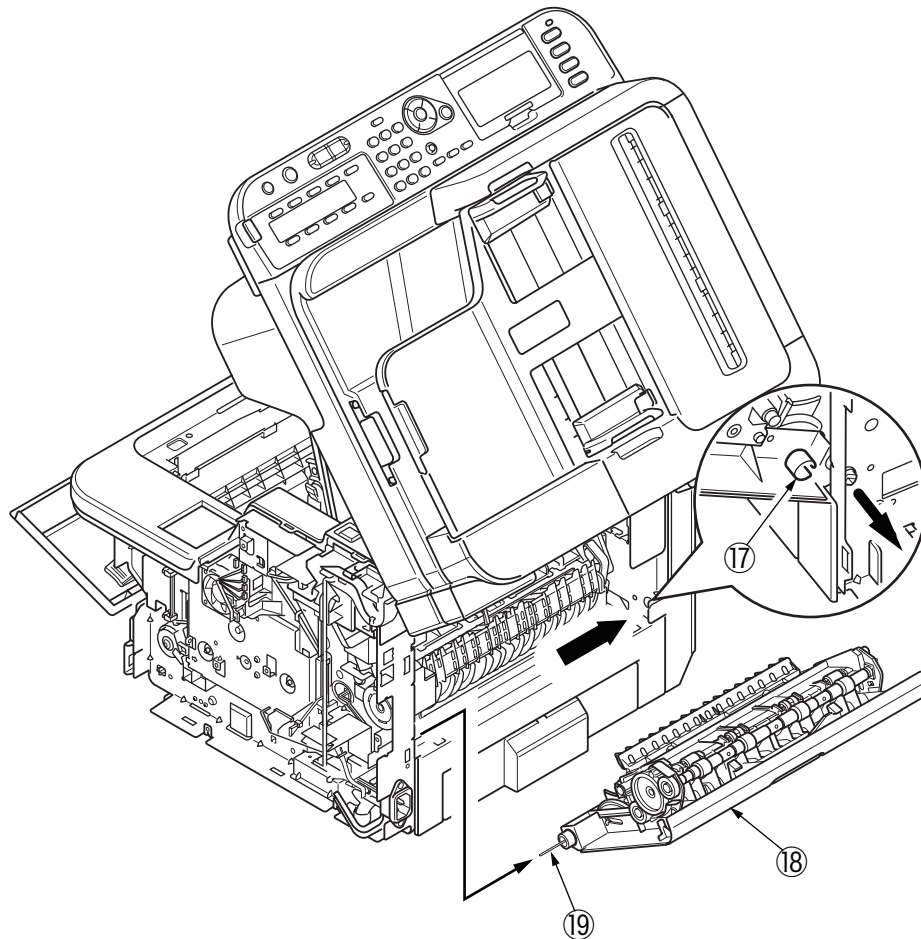

- (13) Remove two screws (Black) ⑳ and separate Cover-Rear ㉑ and Guide-Eject-Upper-Assy ㉒.
- (14) Remove the Gear-Idle ㉓.
- (15) Remove the Gear-Exit ㉔ (2 places), remove the Bearing-Eject_R ㉕ (2 places).
Remove the Bearing-Feeder ㉖ (2 places).
- (16) Remove the Shaft-Assy-Eject ㉗ (2 places).
- (17) Remove the Separator-FU ㉘ . Remove the Spring-Separator_FU ㉙.
- (18) Remove the Stacker-Sensor ㉚. Remove the Cable-Sensor-FU ㉛ .
- (19) Installing is performed by the inverse procedure with removing.

Note! (to assemble)

1. Beware of not to touch the DC motor inattentively (Do not rotate motor).

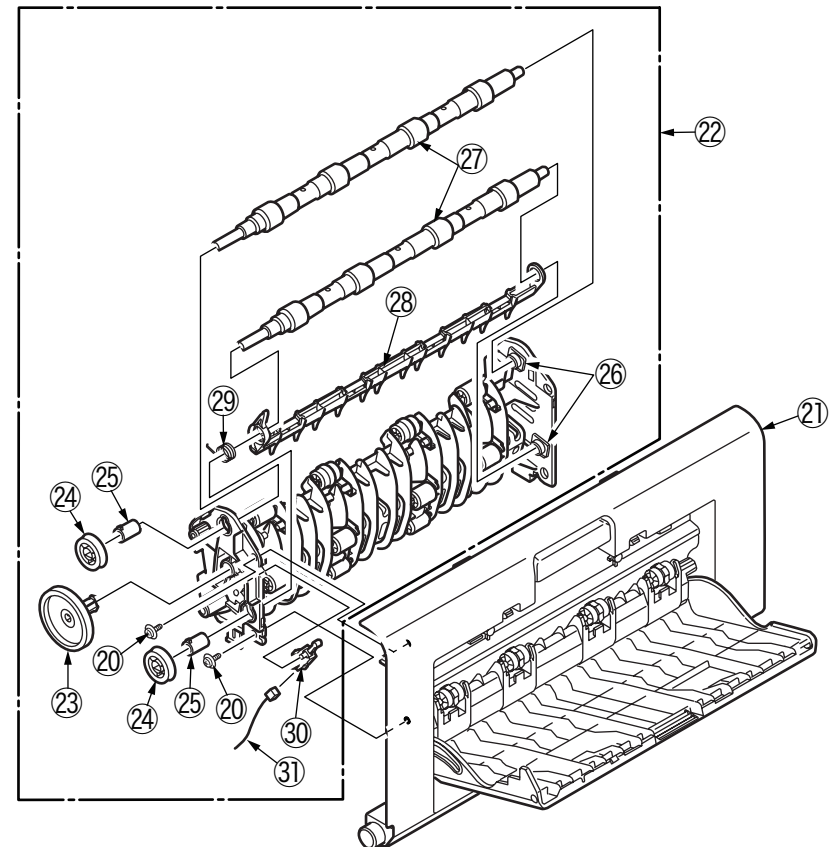

4.2.21 Guide Eject Lower Assy

- (1) Remove the Scanner unit. (Refer to 4.2.8)
- (2) Remove the Cover Assy Rear. (Refer to 4.2.20)
- (3) Remove two screws (Silver) ②. Remove the Cover-Eject ③.
(At this moment, Plate-Rear ④ is also removed.)
- (4) Remove two screws (Silver : 8mm) ⑤. Remove the Cover-Cassette-Rear Assy ⑥
and Guide-Eject-Lower-Assy ⑦.
- (5) Remove the post ⑧. Remove the Separator-SB-FD ⑨.
- (6) Remove the Lever-Exit-Sensor ⑩ and Spring-Sensor-Exit ⑪.
- (7) Installing is performed by the inverse procedure with removing.

Note!

1. Beware of not to touch the DC motor inattentively (Do not rotate motor).
2. Install Cover-Cassette-Rear Assy ⑥ carefully to avoid the FFC cable from being caught.

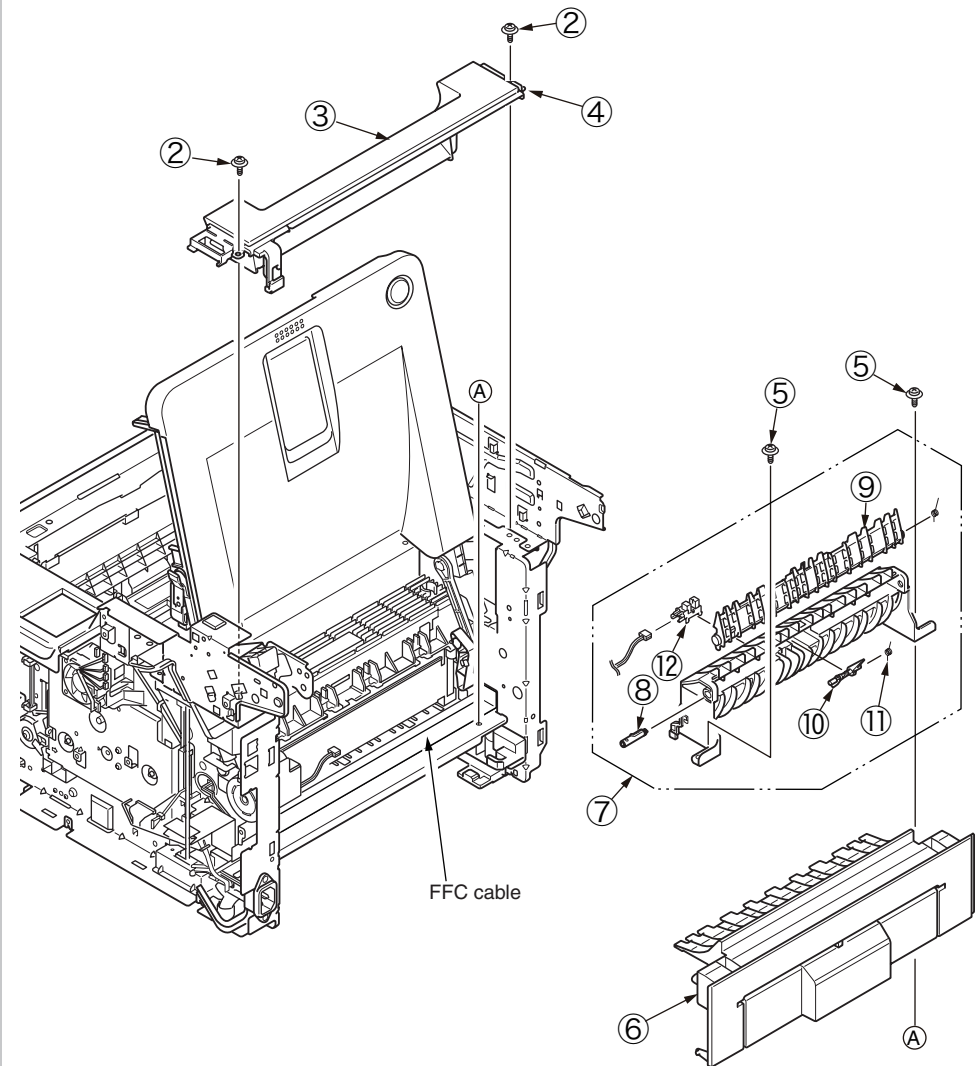

4.2.22 Eject Motor

- (1) Remove the Scanner unit. (Refer to 4.2.8)
- (2) Remove the Cover Assy Stacker. (Refer to 4.2.16)
- (3) Remove the Cover Assy Rear. (Refer to 4.2.20)
- (4) Remove the Guide-Eject-Lower-Assy. (Refer to 4.2.21)
- (5) Remove two screws (Silver) ①. Remove the Plate-Gear-Exit ② and Gear ③.
- (6) Remove two screws (Silver) ④. Remove the Eject-Motor ⑤.
- (7) Installing is performed by the inverse procedure with removing.

Note!

1. Beware of not to touch the DC motor inattentively (Do not rotate motor).

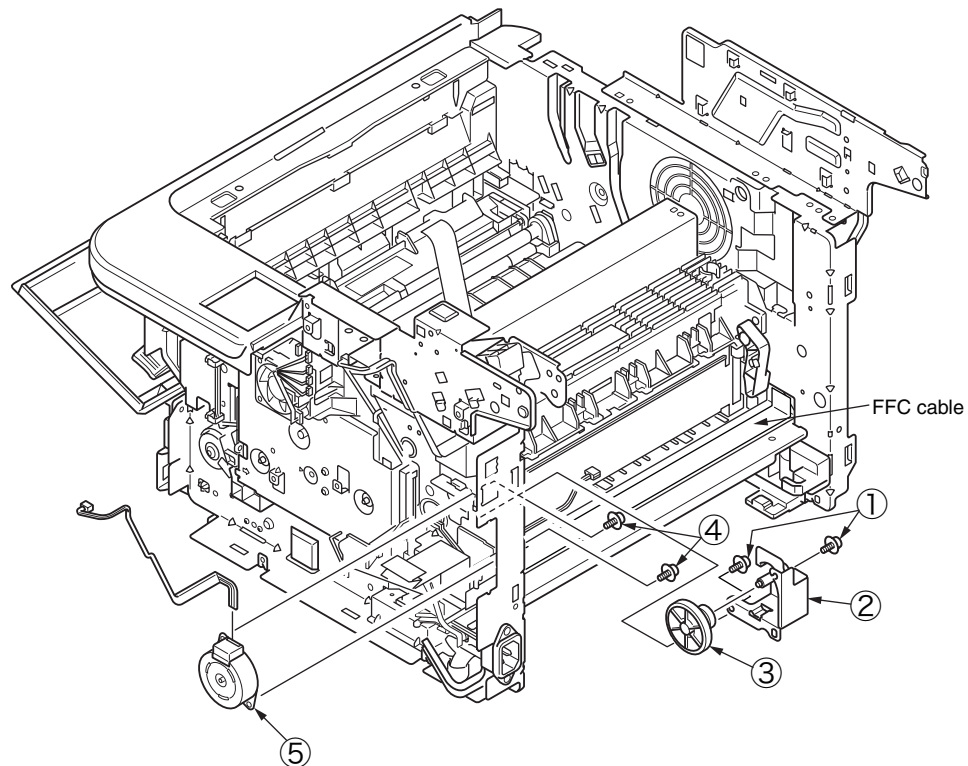

4.2.23 Plate Side R Assy / Plate Side L Assy / Front Assy

- (1) Remove the Scanner unit. (Refer to 4.2.8)
- (2) Remove the Plate Stay L and Plate Assy Stay R. (Refer to 4.2.9)
- (3) Remove the CU/PU Board. (Refer to 4.2.3)
- (4) Remove the Power Supply Unit. (Refer to 4.2.4)
- (5) Remove the DC Motor. (Refer to 4.2.13)
- (6) Remove the Hoppng / MPT / Regist Clutch. (Refer to 4.2.14)
- (7) Remove the HV-Board / Motor-FAN. (Refer to 4.2.15)
- (8) Remove the Cover Assy Stacker. (Refer to 4.2.16)
- (9) Remove the Fuser Assy. (Refer to 4.2.18)
- (10) Remove the MPT Assy, Manual Assy. (Refer to 4.2.19)
- (11) Remove the Cover Assy Rear. (Refer to 4.2.20)
- (12) Remove the Guide Eject Lower Assy. (Refer to 4.2.21)
- (13) Remove the screw (Black) ① and the two screws (Silver) ② and separate the Plate Side L Assy.
- (14) Remove the screw (Silver) ③, screw (Black) ④ and the two screws (Silver) ⑤ and separate the Plate Side R Assy.
- (15) Remove two screws (Silver) ⑥. Remove the Front Assy.
- (16) Installing is performed by the inverse procedure with removing.

Note!

1. Beware of not to touch the DC motor inattentively (Do not rotate motor).

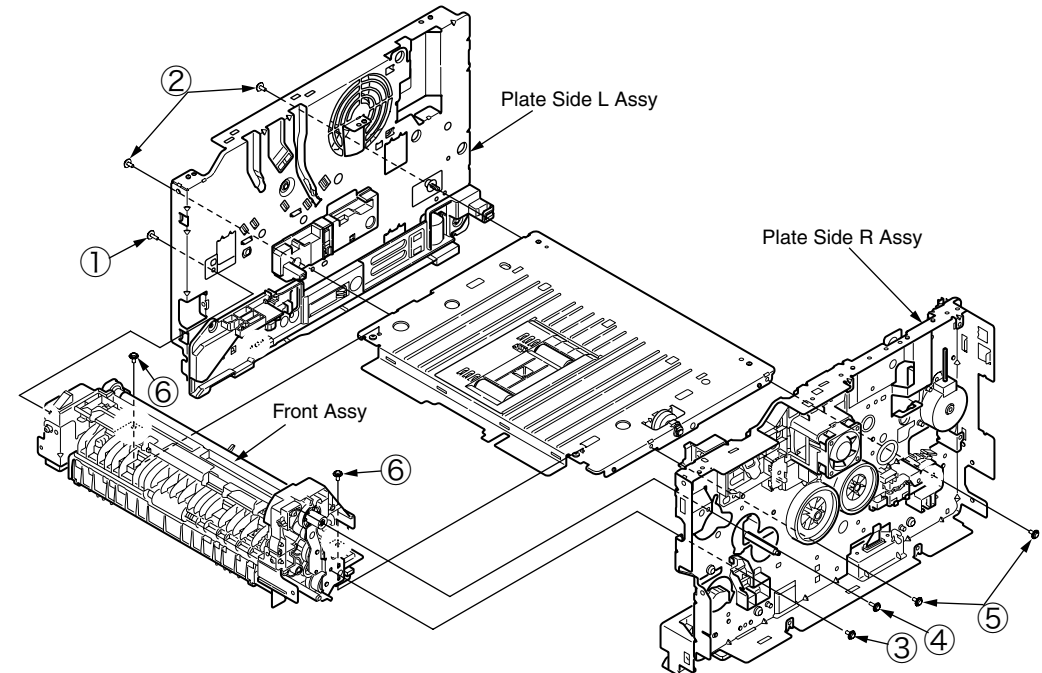

4.2.24 Plate Side L Assy

- (1) Separate the Plate Side L Assy. (Refer to 4.2.23)
- (2) Remove three screws (Silver) ①. Remove the Guide-Cassette-L ② and Spring-Lock-Cassette ③.
- (3) Remove Lever-Sensor Cassette ④ and Spring-Sensor ⑤ from the Guide-Cassette-L ②.
- (4) Remove two screws (Silver) ⑥. Remove the Frame-inner-L ⑦.
- (5) Remove the screw (Black) ⑧, disengage the two tabs (a and b), and remove Guide-ID-L ⑨.
- (6) Remove the Spring-ID-Lock-L ⑩.
- (7) Installing is performed by the inverse procedure with removing.

Note!

1. Beware of not to touch the DC motor inattentively (Do not rotate motor).

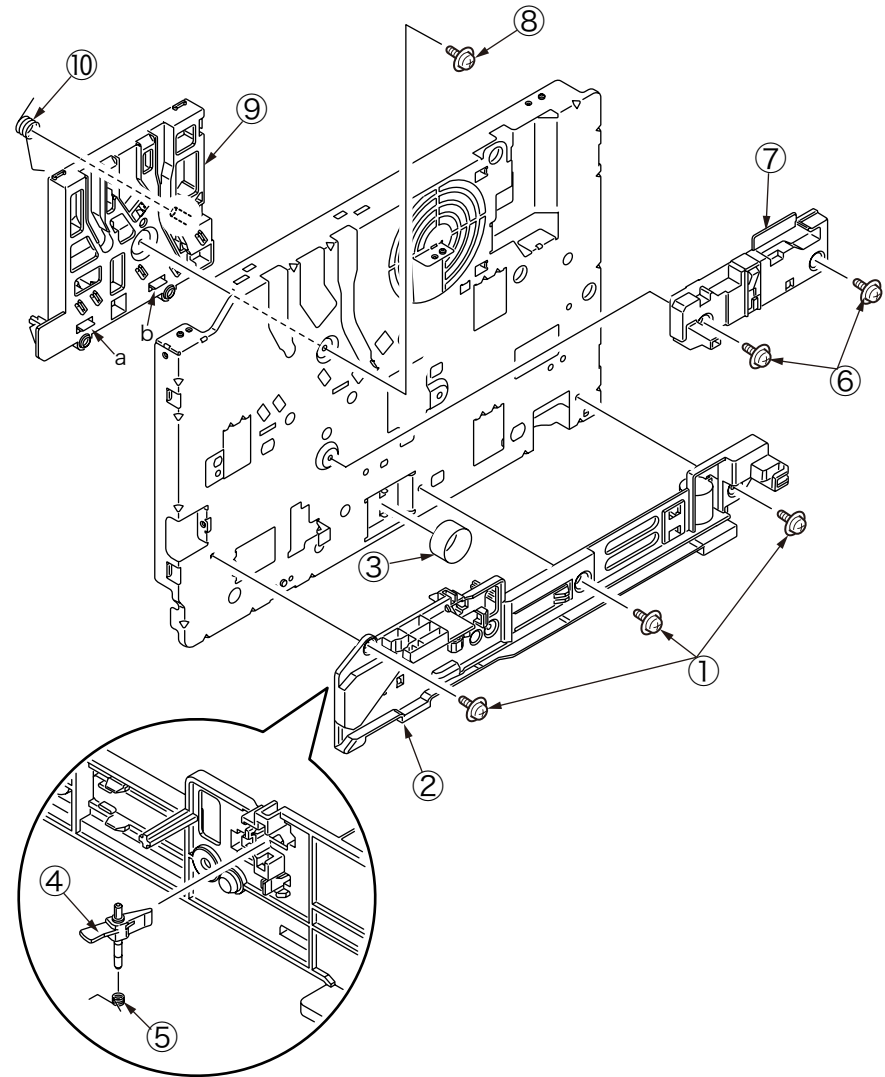

4.2.25 Plate Side R Assy

- (1) Separate the Plate Side R Assy. (Refer to 4.2.23)
- (2) Remove two (or three) screws (Silver) ①. Remove the Guide-Cassette-R ②.
- (3) Remove two screws (Black) ③. Remove the Connector ④.
- (4) Remove four screws (Silver) ⑤. Remove the Plate-ID-Gear ⑥, Gear-Idle-Z21 ⑦, Gear-Idle-Z30-33 ⑧.
- (5) Remove the screw (Silver) ⑨. Remove the Holder-Switch ⑩ and Micro switch ⑪.
- (6) Remove two screws (Silver) ⑫, the screw (Black) ⑬. Remove the Guide-ID-R ⑭ and Motor-Fan (40×15) ⑮, Board-974 ⑯, Spring-ID Lock R ⑰.
- (7) Remove the screw (Silver) ⑱. Remove the Guide-Cable ⑲.
- (8) Installing is performed by the inverse procedure with removing.

Note!

1. Beware of not to touch the DC motor inattentively (Do not rotate motor).
2. Install Motor-FAN (40×15) ⑮ with the label side inward and with its notch fitted to the appropriate projection of Guide-ID-R ⑭.
3. While removing or installing FAN, do not press impeller of the FAN as shown by the following photo. In case of the impeller unfastened by mistake, do not reuse it and install a new FAN.

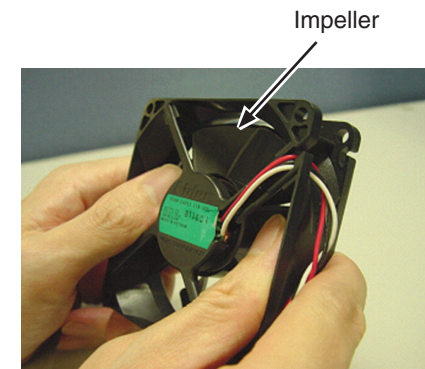
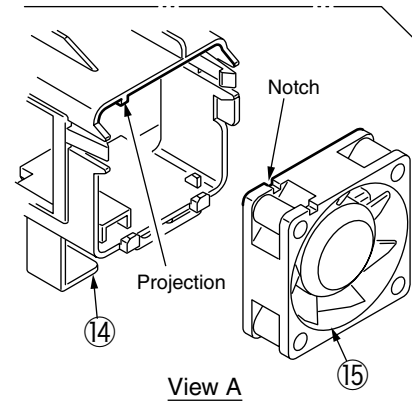
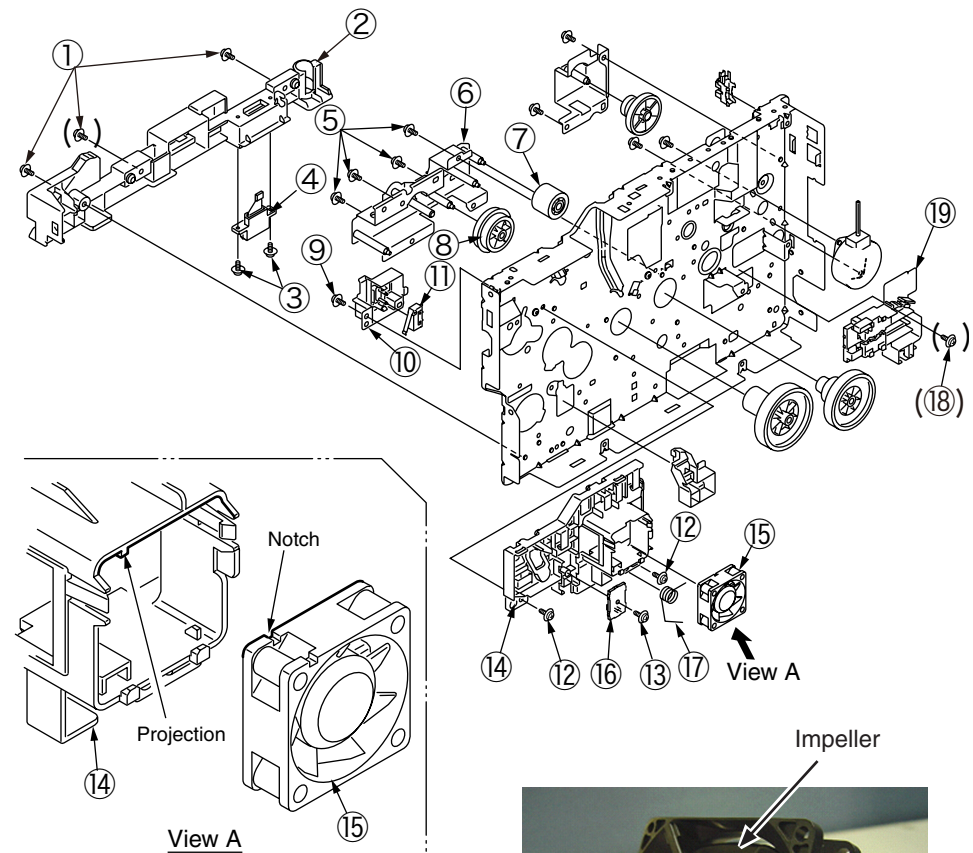

4.2.26 Front Assy

- (1) Separate the Front Assy. (Refer to 4.2.23)
- (2) Remove two screws (Black) ① and Plate-Feed-B ②.
(Be careful not to lose the gear that is removed with the plate.)
- (3) Remove the Gear-Idle-MPT ③. Remove the Gear-Reduction-MPT ④. (MB471/MB471w/MB491)
- (4) Remove the E-ring (RE5-SK) ⑤. Remove the Regist-Gear ⑥.
- (5) Remove the Gear-Pressure ⑦.
- (6) Remove the screw (Black) ⑧. Remove the Plate-Contact-REG ⑨.
- (7) Remove the two screws (Black) ⑩. Remove the Holder-Regist-L/R ⑪.
- (8) Remove the Roller-Pressure ⑫. Remove the Roller-Regist ⑬.
- (9) Installing is performed by the inverse procedure with removing.

Note! Beware of not to touch the DC motor inattentively (Do not rotate motor).

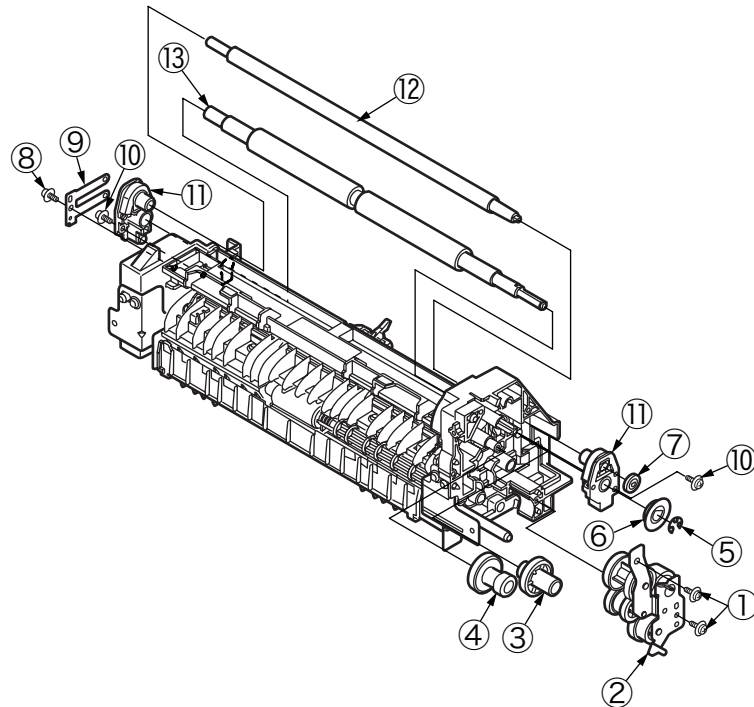

4.2.27 Roller Feed Assy

- (1) Separate the Front Assy. (Refer to 4.2.23)
- (2) Remove two screws (Black) ① and Plate-Feed-B ②.
(Be careful not to lose the gear that is removed with the plate.)
- (3) Remove two screws (Black) ③. Separate the Regist Assy.
- (4) Remove two screws (Silver) ④. Remove the Frame-Hopping-Upper ⑤.
- (5) Remove two Gear-Roller-Feed ⑥. Remove two Bush-Feed ⑦.
- (6) Remove two Roller-Feed-Assy ⑧.
- (7) Installing is performed by the inverse procedure with removing.

Note! Beware of not to touch the DC motor inattentively (Do not rotate motor).

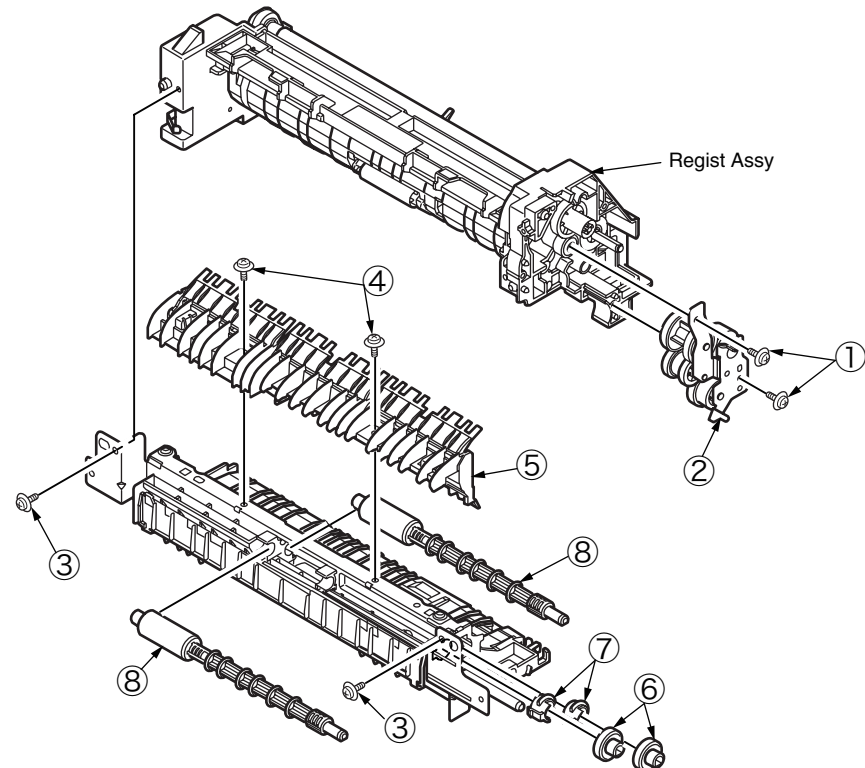

4.2.28 Lever In Sensor / Lever WR Sensor / Photo Interrupter

- (1) Separate the Front Assy. (Refer to 4.2.23)
- (2) Separate the Roller-Pressure and Roller Regist. (Refer to 4.2.26)
- (3) Remove two screws (Black) ①. Remove the Holder-Sensor ②.
- (4) Remove the Lever-In-Sensor ③. Remove the Spring-Sensor ④.
- (5) Remove the Lever-WR-Sensor ⑤. Remove the Spring-Sensor ⑥.
- (6) Remove two Photo Interrupter ⑦.
- (7) Installing is performed by the inverse procedure with removing.

Note!

1. Beware of not to touch the DC motor inattentively (Do not rotate motor).
2. Make sure that the latch B of Holder-Sensor ② has engaged the latch A of the Front.

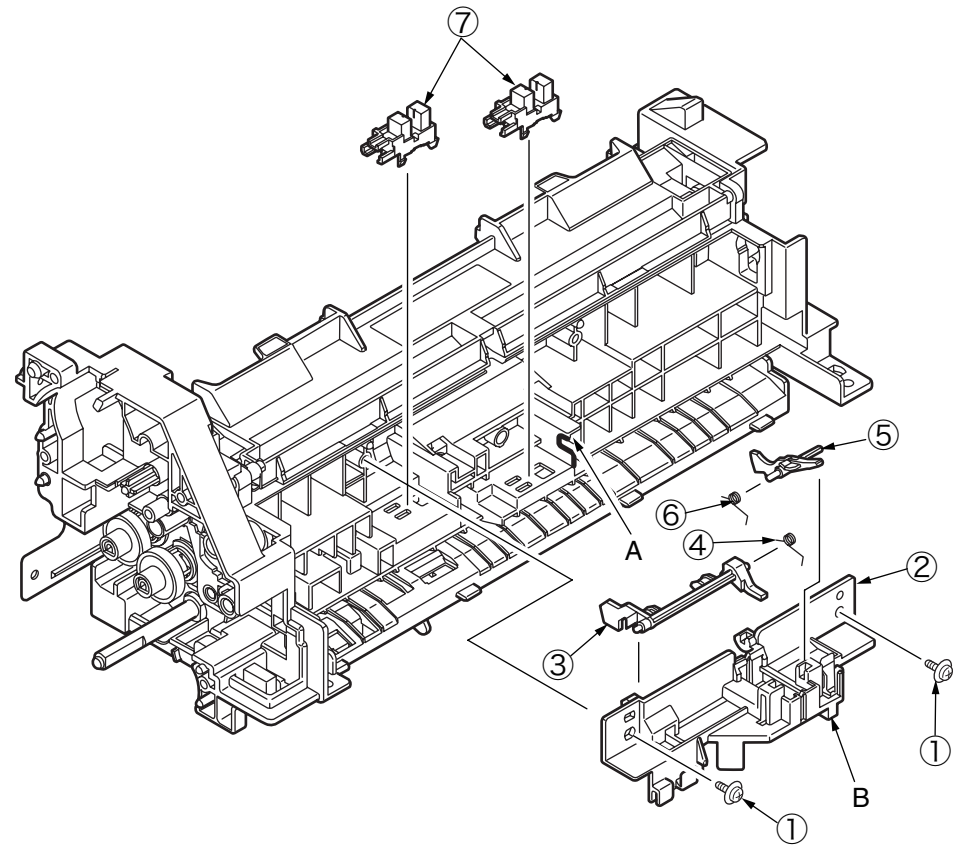

4.2.29 Paper feeding roller (Roller-Pick-Up, Roller-Feed-NOW, Roller-Assy-MPT)

- In the case of Tray 1

- Turn off the printer and pull out the paper cassette tray.
- Remove the feed roller ① as pushing its tab outward.

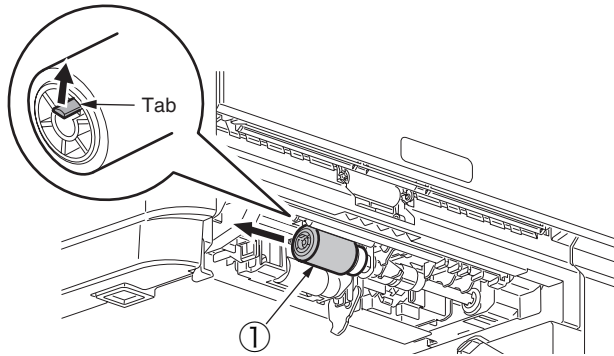

- As pushing the tab downward, open the cover (black) that is on the left of the feed roller ②.
- Pull out the feed roller ② downward.
- Installing is performed by the inverse procedure with removing.

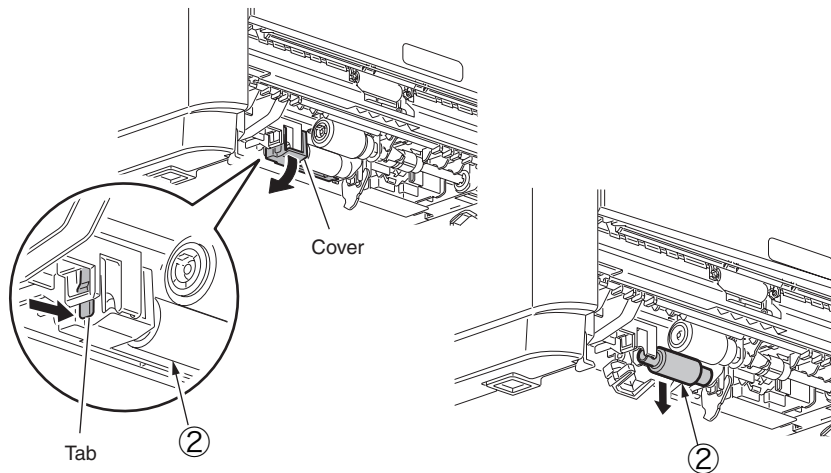

Note!

- To install the feed roller (with no gear: Roller-Feed-NOW) ①, keep pushing it until it clicks into place and is fixed to the shaft.
- To install the feed roller (with a gear: Roller-Pick-Up) ②, keep pushing the cover until the tab of the cover clicks into place.

- In the case of Multi-purpose Tray (MB471/471w/491)
 - (1) Turn off the printer.
 - (2) Open the multipurpose tray and the paper support.
 - (3) Open the feed roller cover by pushing its tab to the right.
 - (4) Remove the feed roller ① by rotating it toward you.
 - (5) Installing is performed by the inverse procedure with removing.

Note!

1. To install the feed roller (Roller-Assy-MPT) ①, keep pushing the cover until the tab of the cover clicks into place.

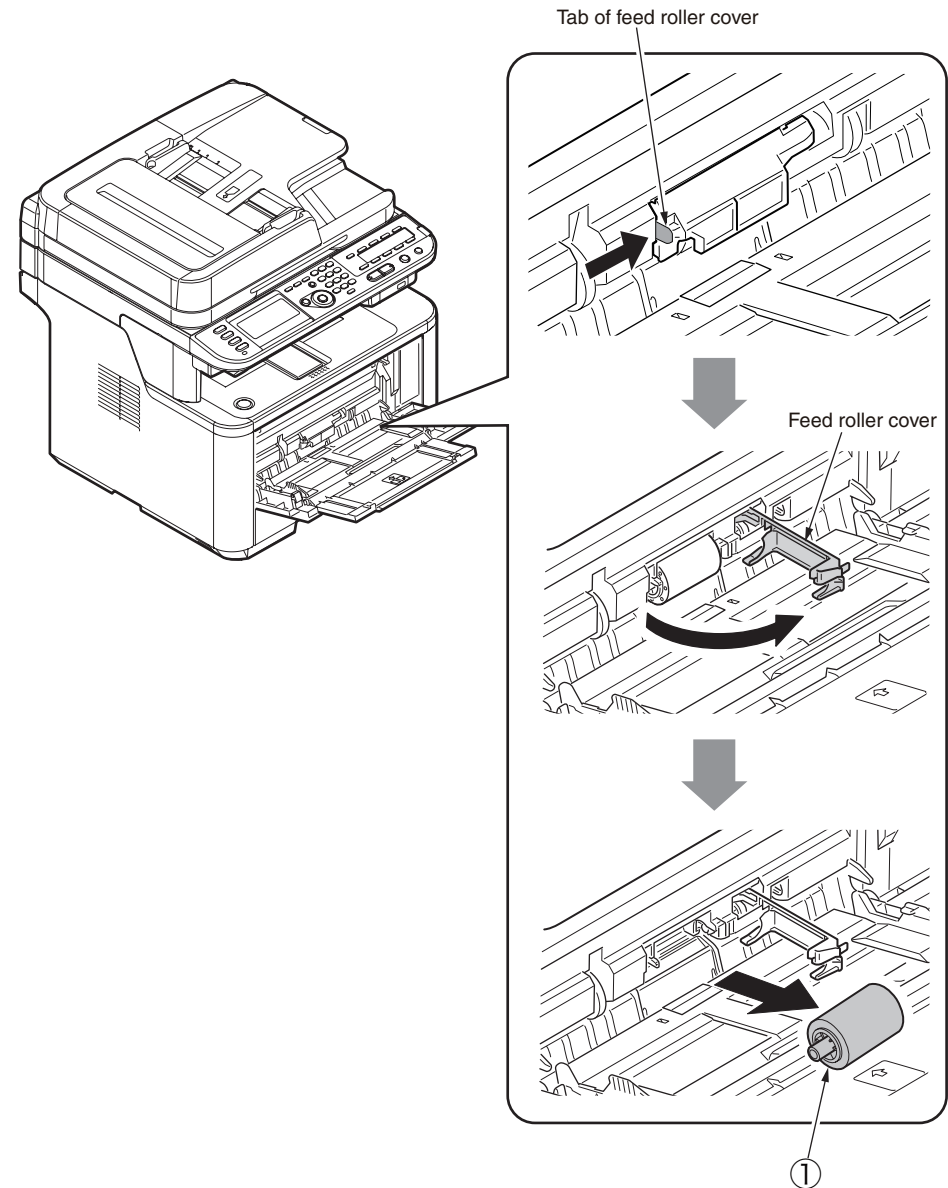

4.2.30 Frame-Assy-Retard, Spring-Retard

- (1) Remove the cassette.
- (2) Open the Retard-Cover by pushing two tabs in the directions of the arrows.
- (3) Remove Frame-Assy-Retard ① by pushing it in the direction of the arrow.
(Spring-Retard ② is removed together.)
- (4) Installing is performed by the inverse procedure with removing.

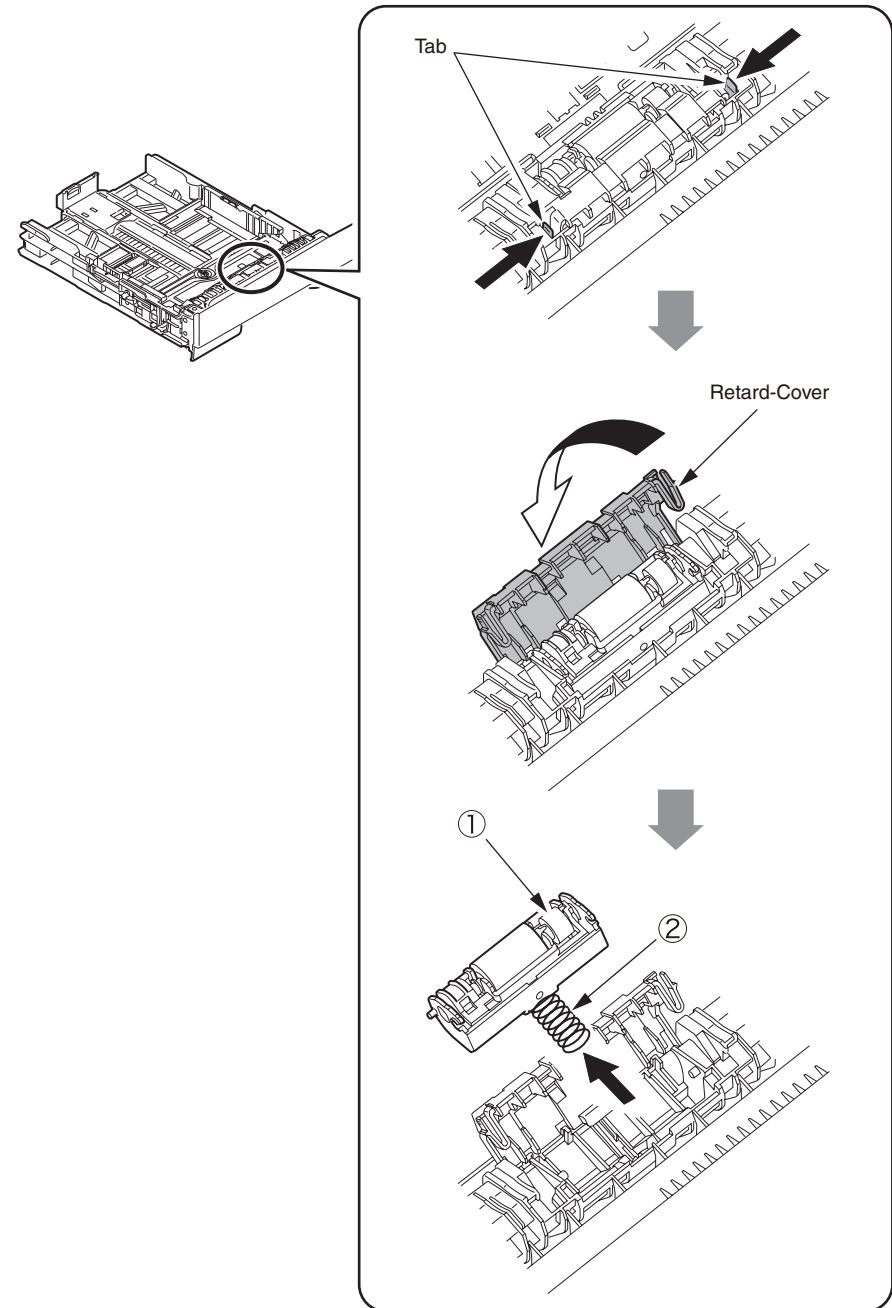

4.2.31 W-LAN Board (for MB471w only)

- (1) Remove the Cover Side(R) and the Cover Side(L). (Refer to 4.2.1/4.2.2)
- (2) Remove four Screws(Silver) ① to detach the plate Shield(CU) ② .

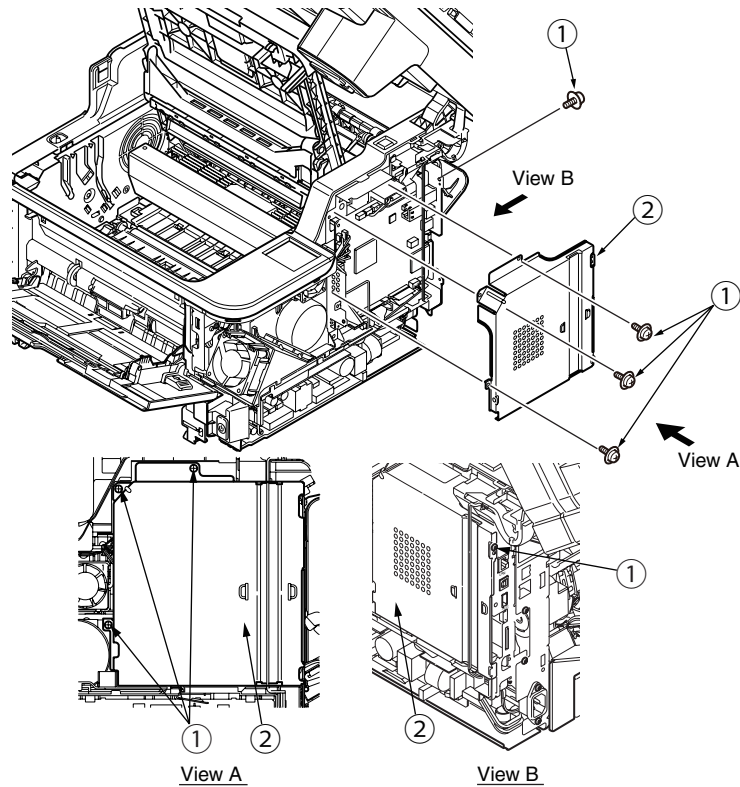

- (3) Remove the LAN-Cable ③ and the USB-Cable ④ form the Board 98M ⑤.

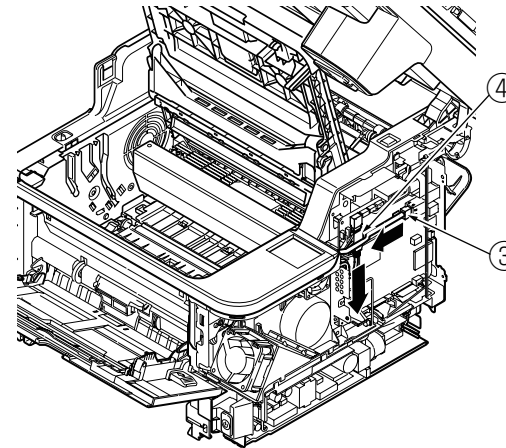

[Memo] Refer to remove the LAN-Cable ③

- 1. A wire should be put through to between the stopper of the LAN-Cable's Connector and the Board 98M.
(For example, the wire is the banding band, the aging (not useable) flat cabel or etc.)
- 2. Both ends of the wire should be pull to the right side of the Mainbody.
- 3. Check that the stopper released, and pull the LAN-Cable from the LAN Interface Connector on the Board 98M.

LAN Cable ③ Wire

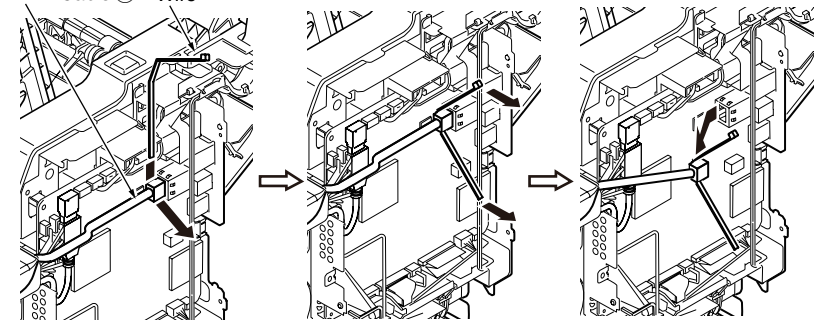

- (4) Remove two Screws(Black) ⑤ to detach the Cover Front(Top) ⑥ with W-LAN Board.

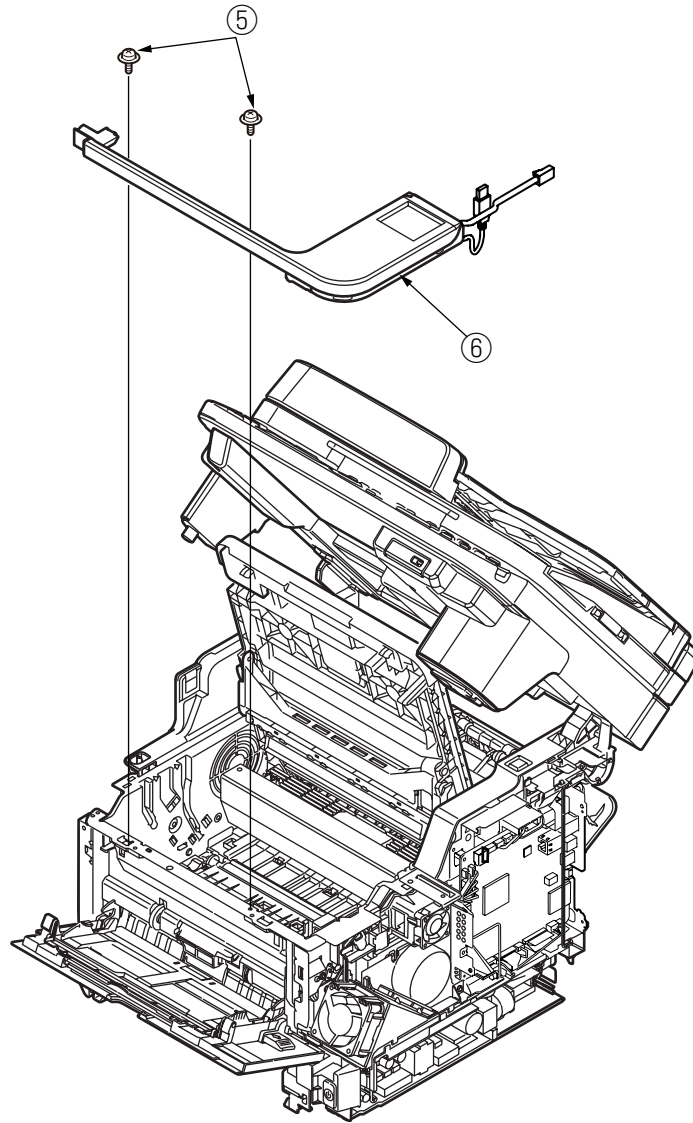

- (5) Remove a Screw ⑦ to detach the Film WLAN Core ⑧ from the inner side of the Cover Front(Top) ⑥.

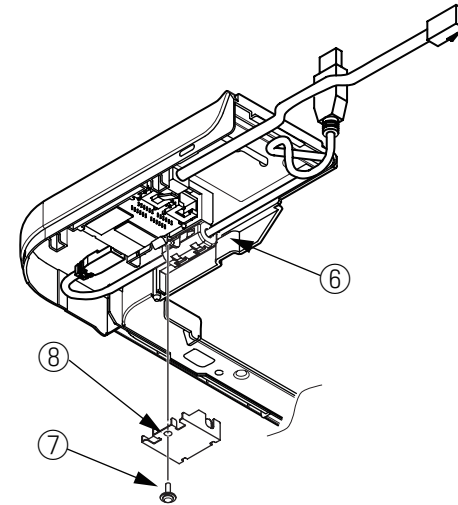

- (6) Remove the W-LAN Board ⑨ with to unfold a craw of the inner side of the Cover Front(Top) ⑥.

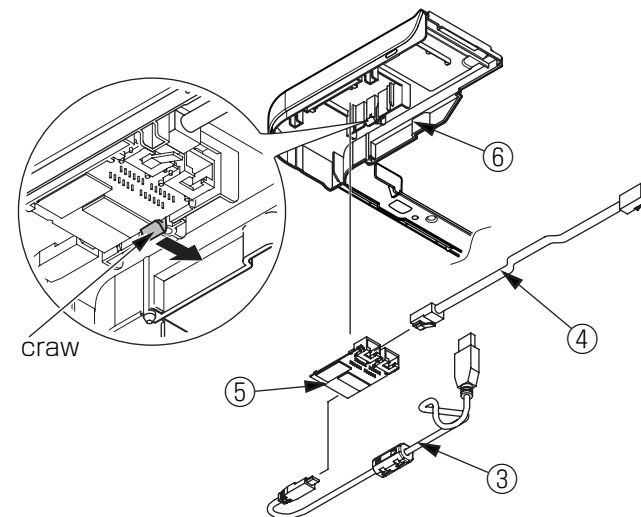

5. LUBRICATING POINT

5.1 Lubrication point5-2

5.1 Lubrication point

This subsection indicates the lubricating points of the printer. Conversely, it means that any other parts than the specified lubricating points must not be lubricated.

There is no need to lubricate in the midst of a disassembling job. However, if lubricating oil has been wiped off, supply the specified oil.

Lubricating work

(1) Symbols and names of oils

EM-D110 : MOLYKOTE EM-D110 (No : 44594501)

EM-30LP : MOLYKOTE EM-30LP (No : 44498501)

GE-334C : FLOIL GE-334C (No : 41823301)

SF-133 : HANARL SF-133

(2) Boundary samples of grease

Class	S	A	B	C	D	E	F
Amount of grease(cc)	0.0005	0.003	0.005	0.01	0.03	0.05	0.1
W(mm)	1.24	2.25	2.67	3.37	4.86	5.76	7.26
Sample	•	●	●	●	●	●	●



5.1.1 Printer

① 44563401PA Plate-Assy-Side-L

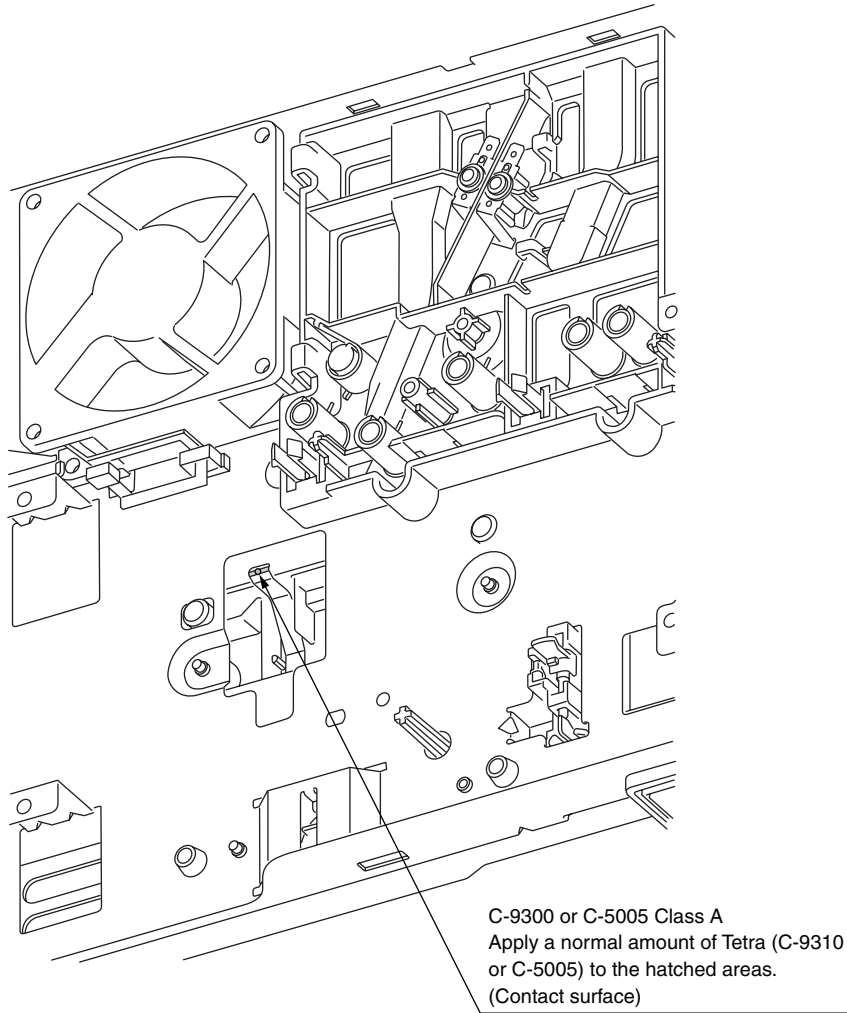

② -1 44563501PA Plate-Assy-Side-R

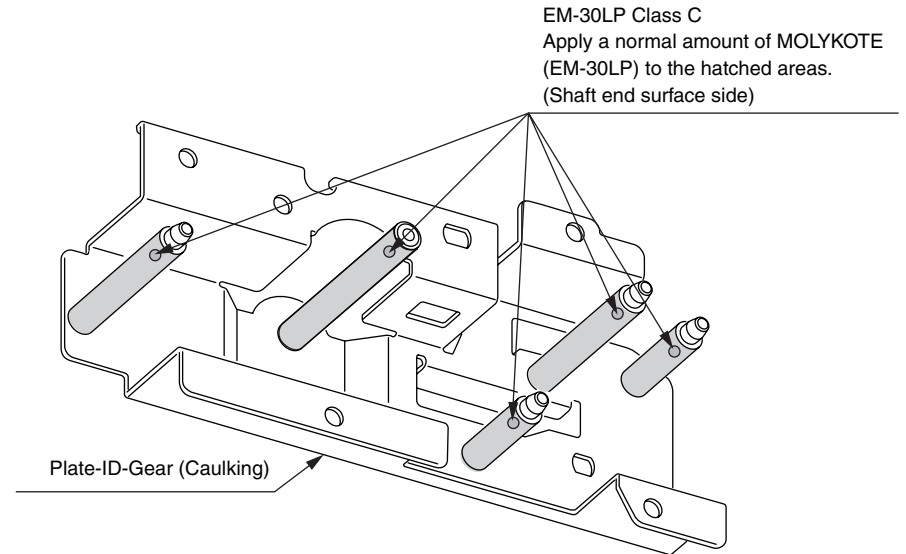

② -2 44563501PA Plate-Assy-Side-R

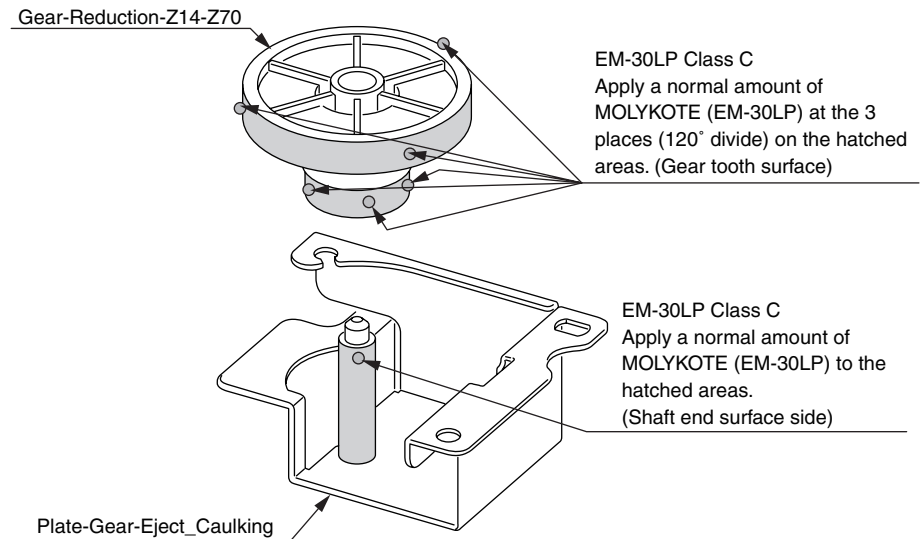

③ 44452801PA Frame-Assy. -Hopping

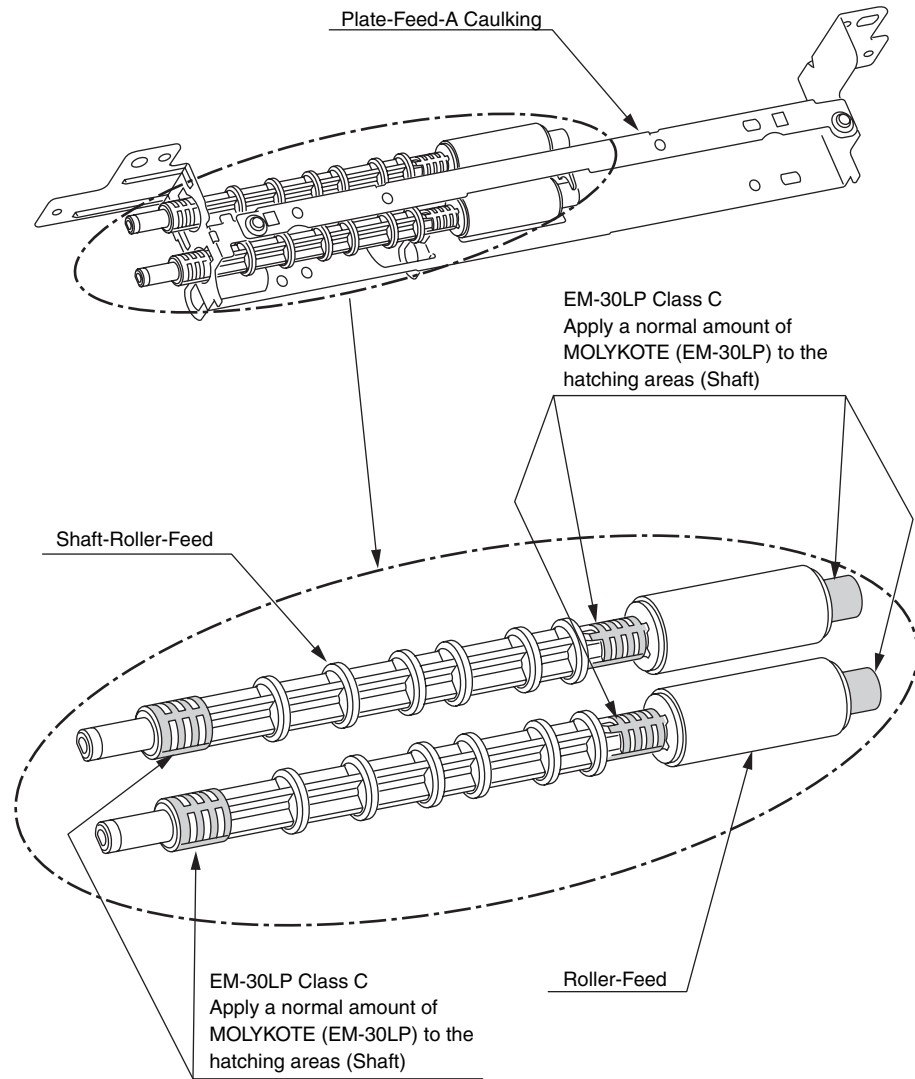

④ -1 44453301PA Frame-Assy. -Regist

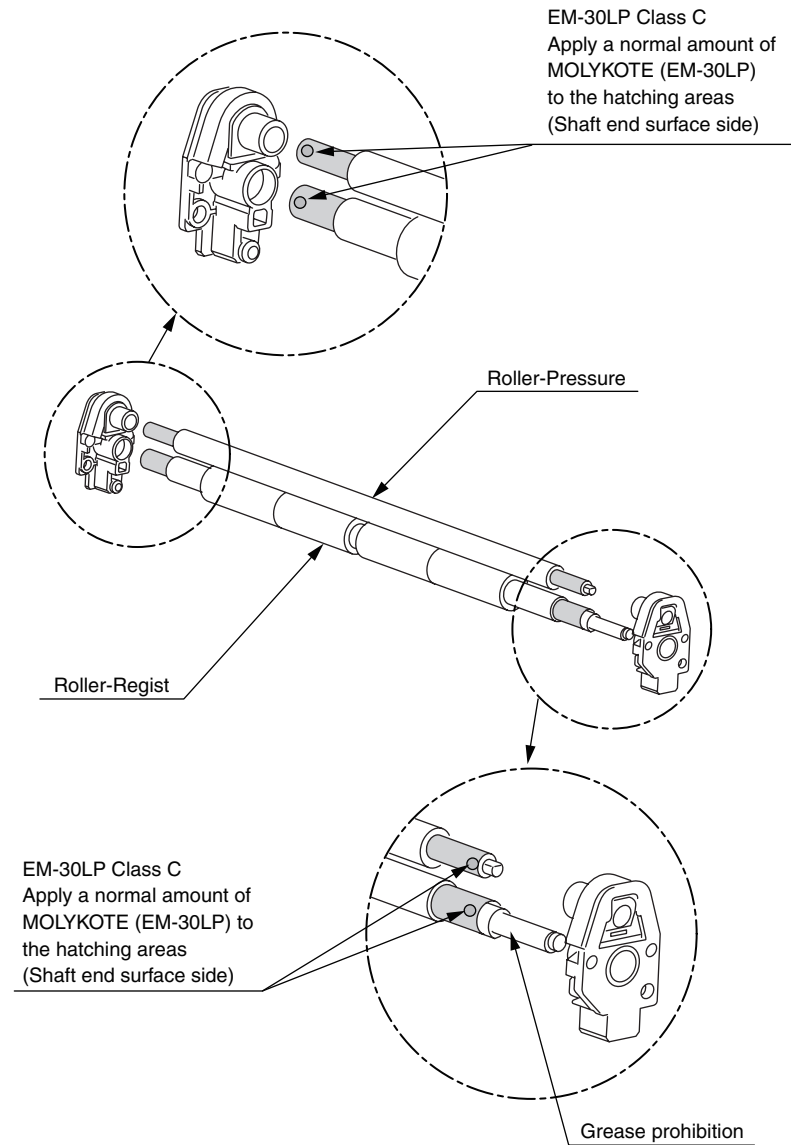

④ -2 44453301PA Frame-Assy. -Regist

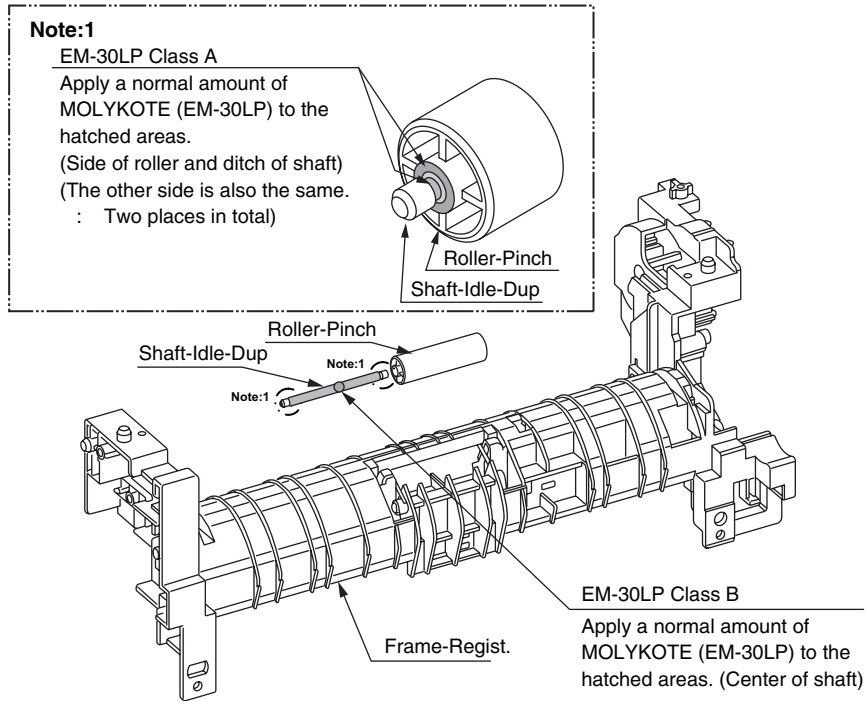

⑤ -1 44561501PA Front-Assy.

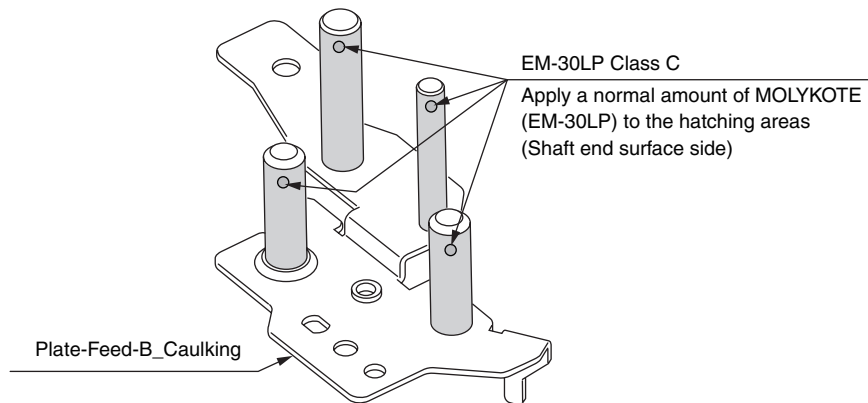

⑤ -2 44561501PA Front-Assy.

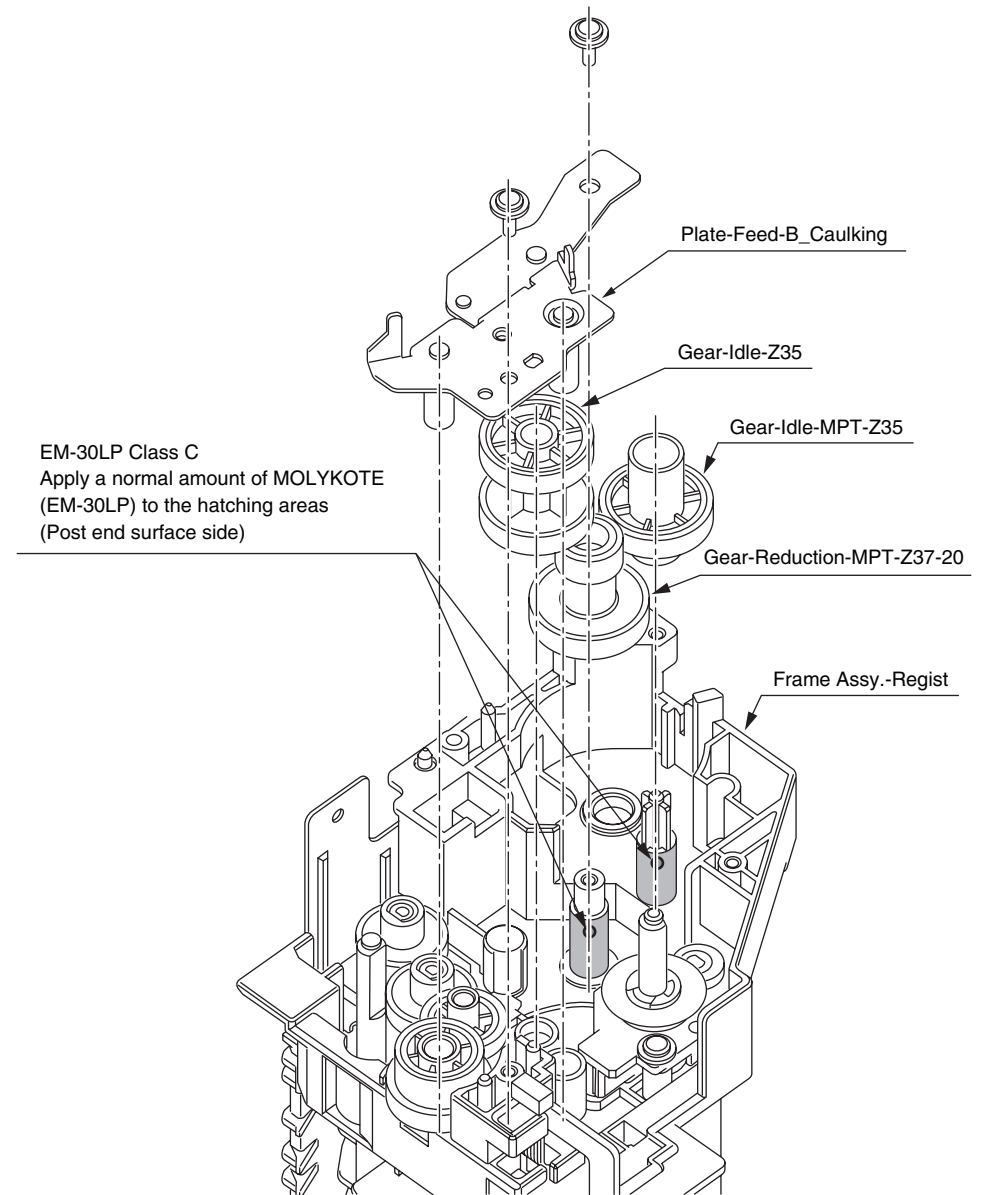

⑥ 44359201PA Frame-Assy. -MPT/
44564201PA Frame-Assy-Manual (MB461)

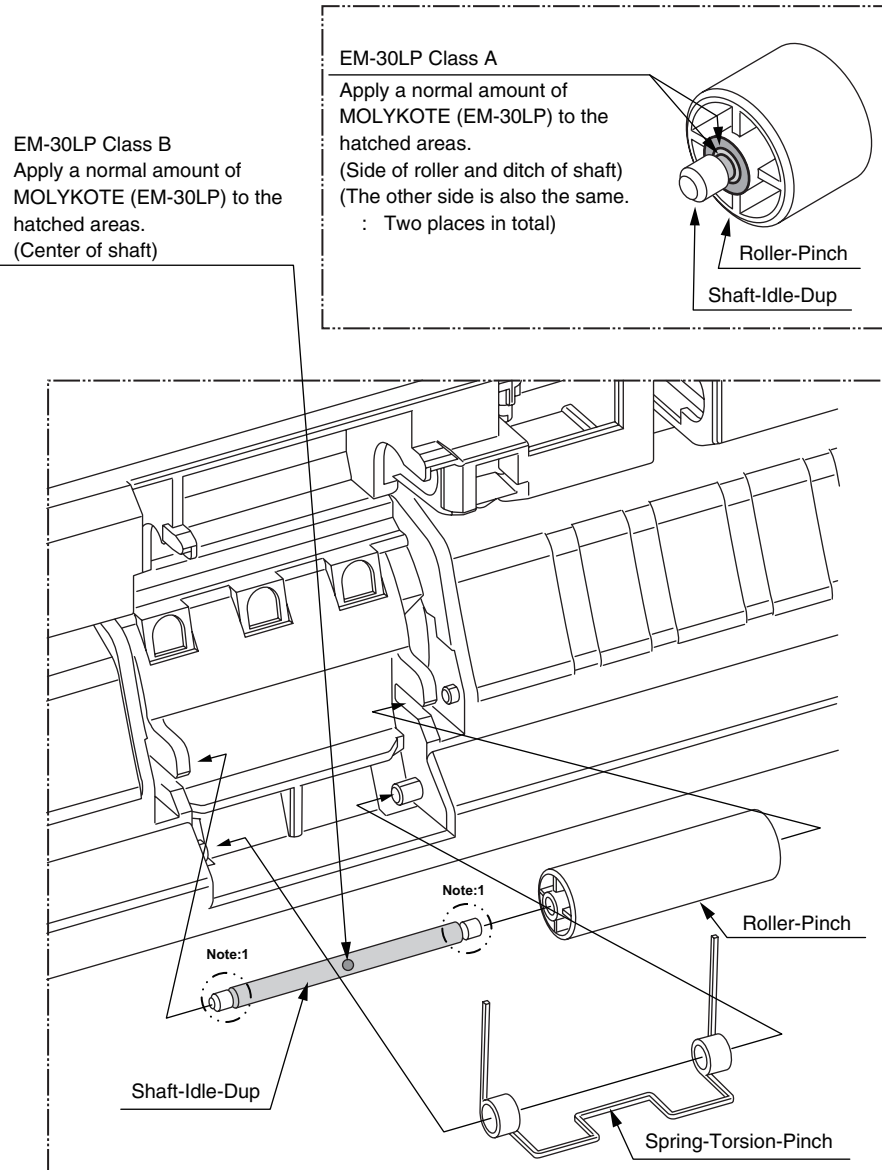

⑦ 44564001PA Guide-Assy-Eject-U

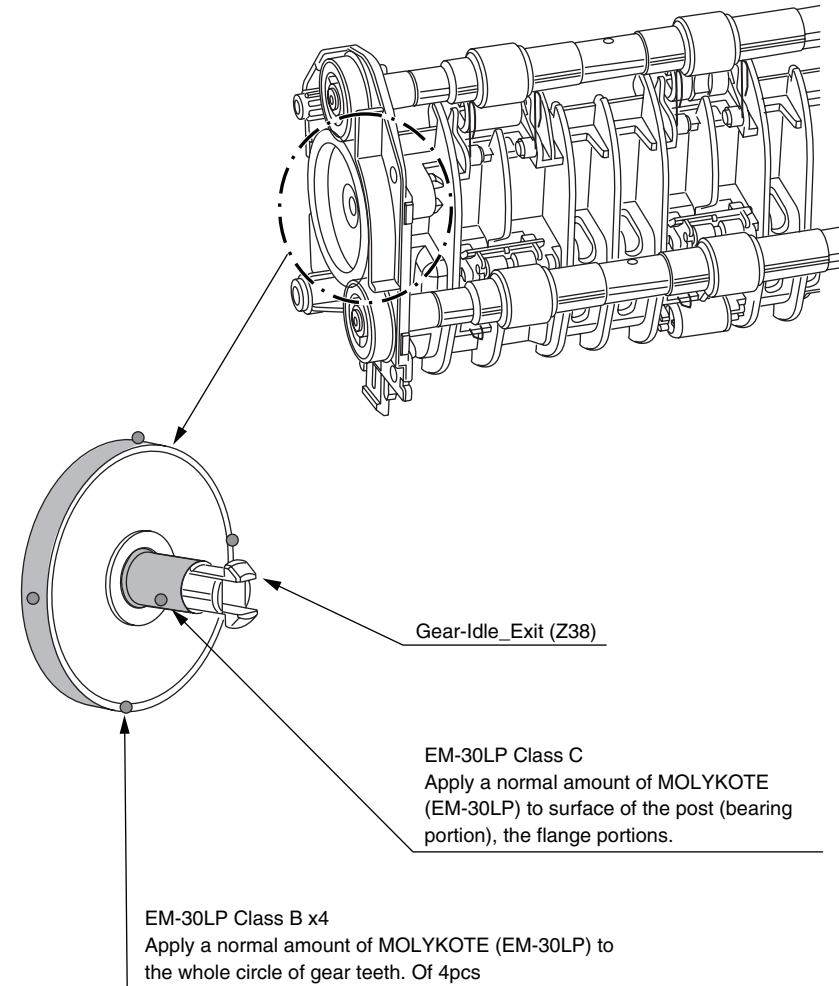

Detail

Note1) Please wipe the amount that grease began to see the sliding area off.

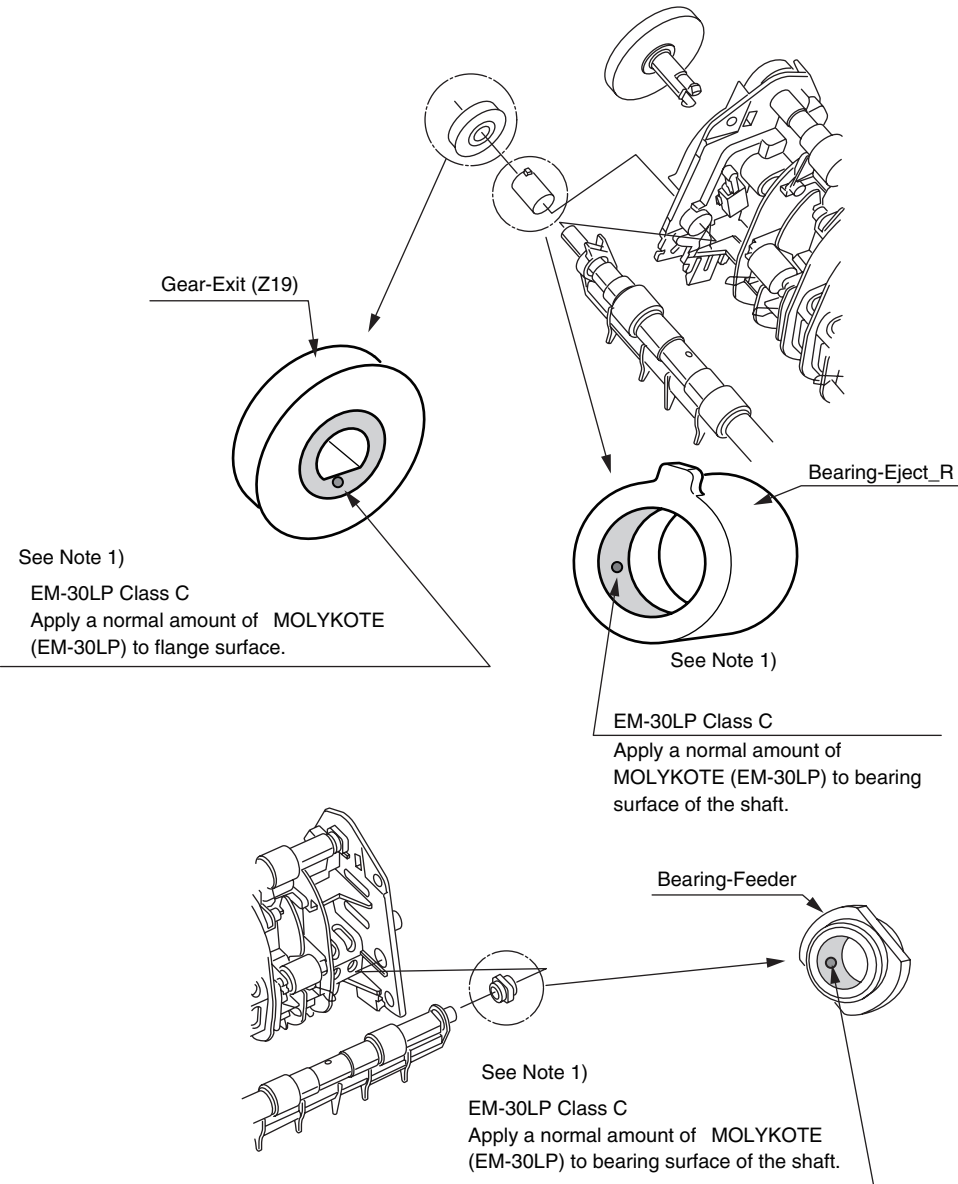

⑧ -1 44559301PA Frame-Assy-TR

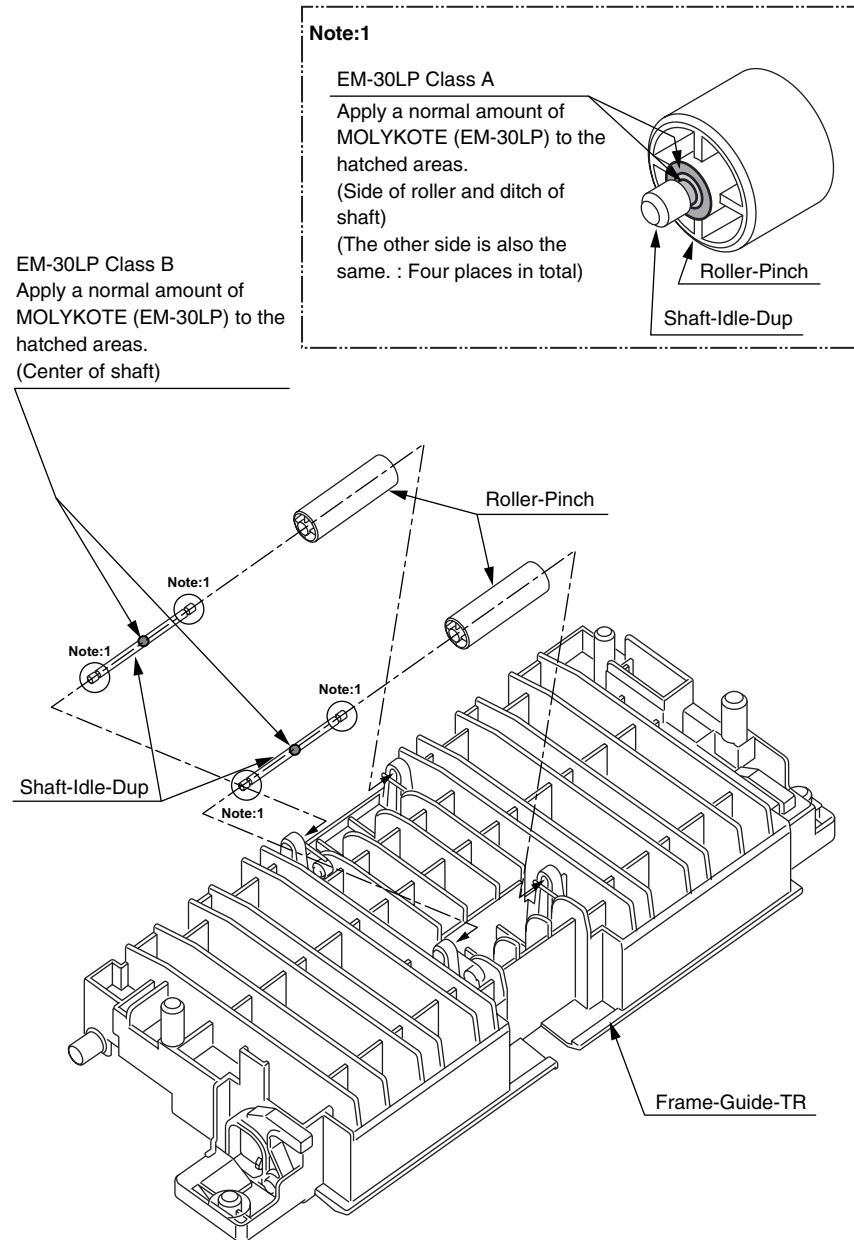

⑧ -2 44559301PA Frame-Assy-TR

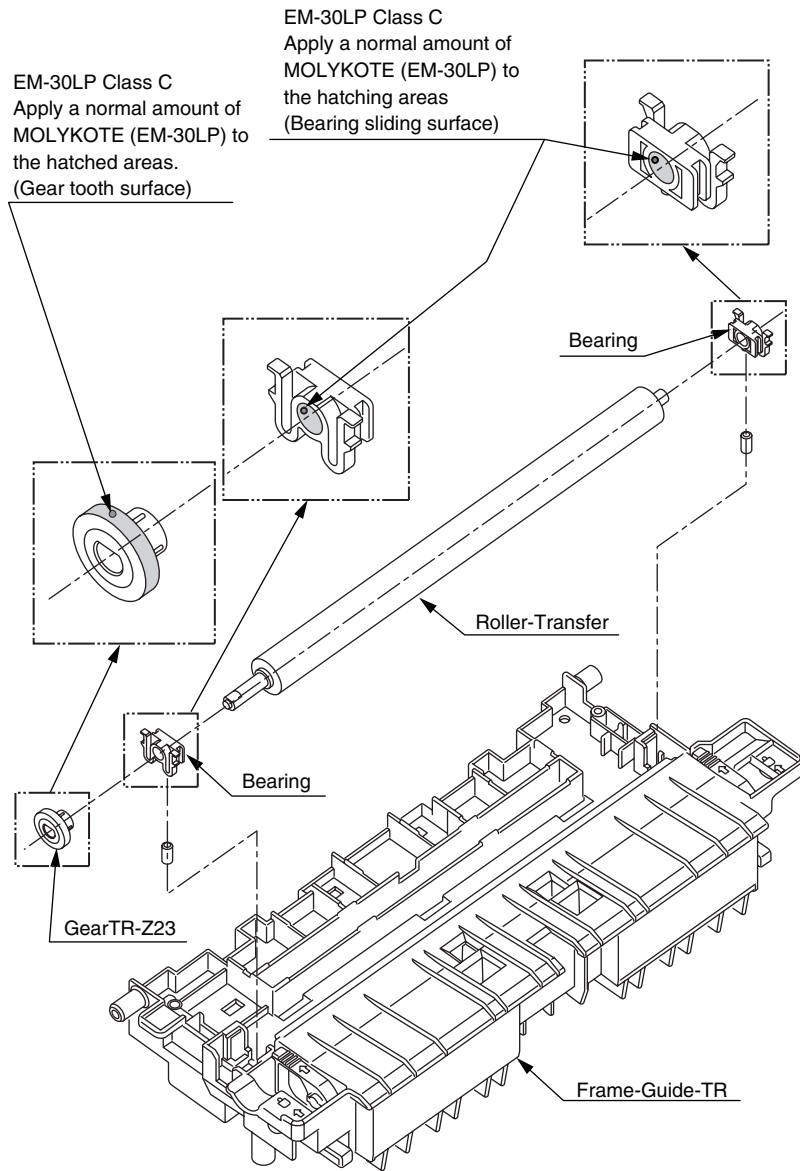

⑧ -3 44559301PA Frame-Assy-TR

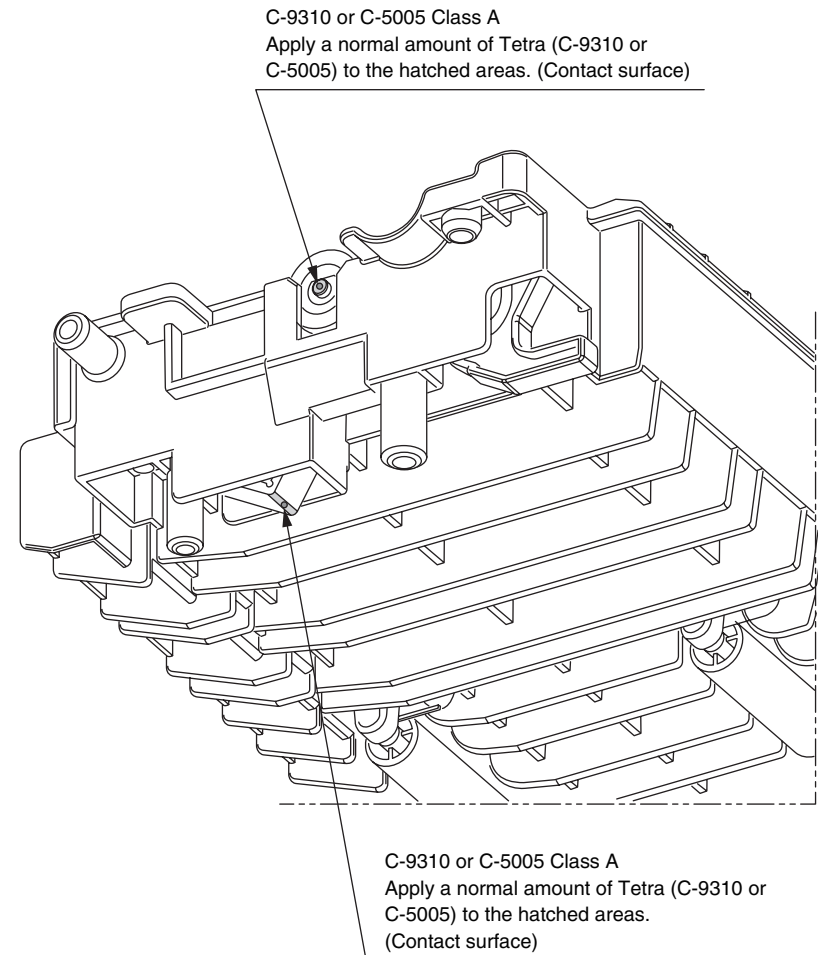

⑨ 44563701PA Duplex-Assy

EM-30LP Class B
Apply a normal amount of MOLYKOTE (EM-30LP) to the hatched areas.
(Shaft end surface side)

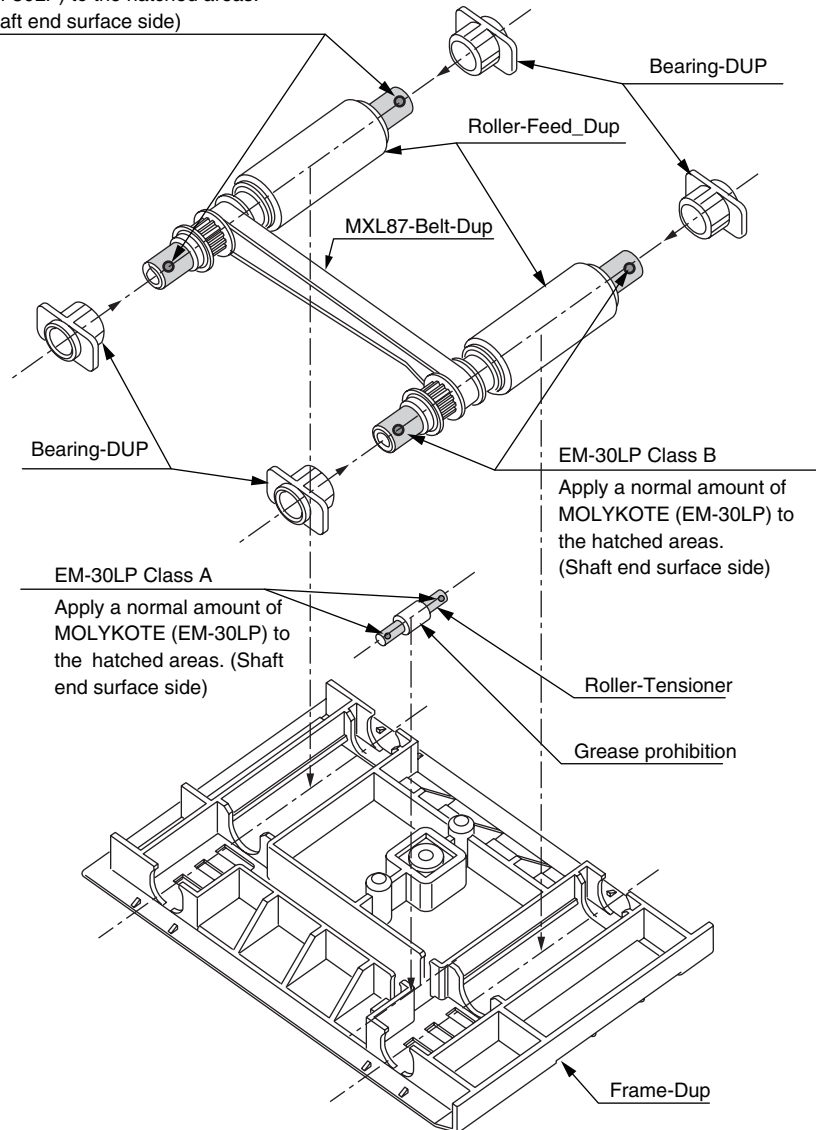

⑩ 44565801PA Fuser-Assy

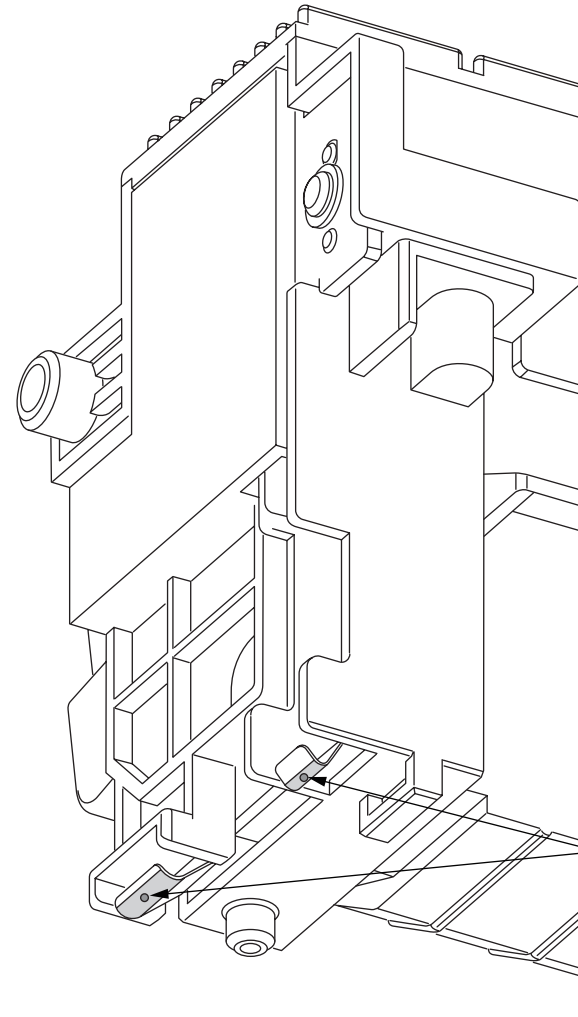

C-9310 or C-5005 Class A
Apply a normal amount of Tetra (C-9310 or C-5005) to the hatched areas.
(Contact surface)

⑪ -1 44914801PA Printer-Unit

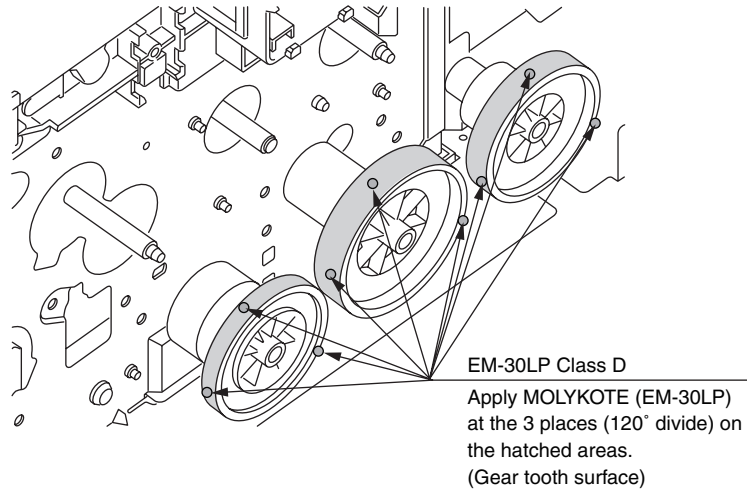

⑪ -2 44914801PA Printer-Unit

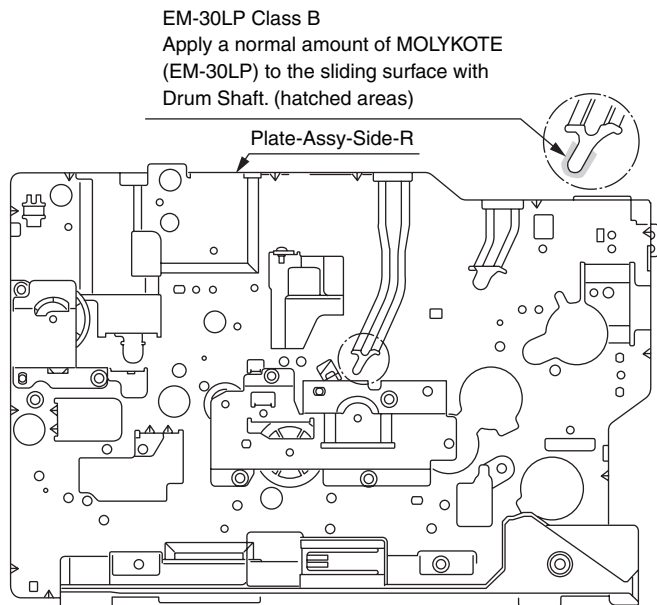

⑫ 44564901PA Cover-Assy-Stacker

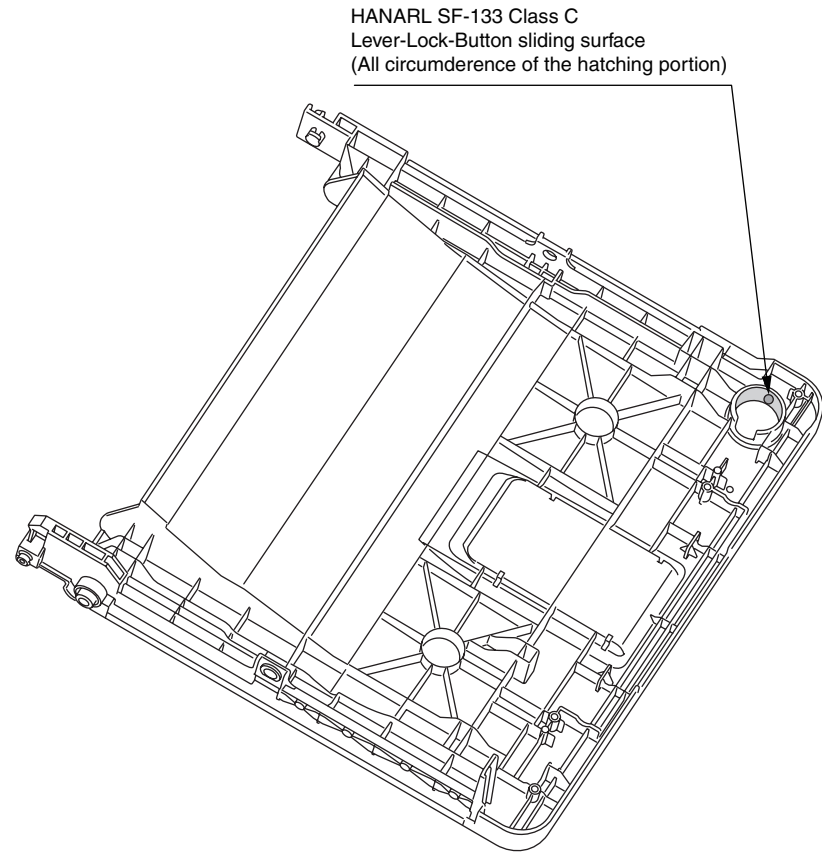

- ※ Leave it for about 30minutes (drying time) after painting HANARL SF-133, and then Assemble the Lever-Lock-Button.
- ※ HANARL SF-133 should not protrude outside from the exterior surface.

5.1.2 Scanner

① 44909201PA Plate Assy-Stay (R) : [FN296/7]

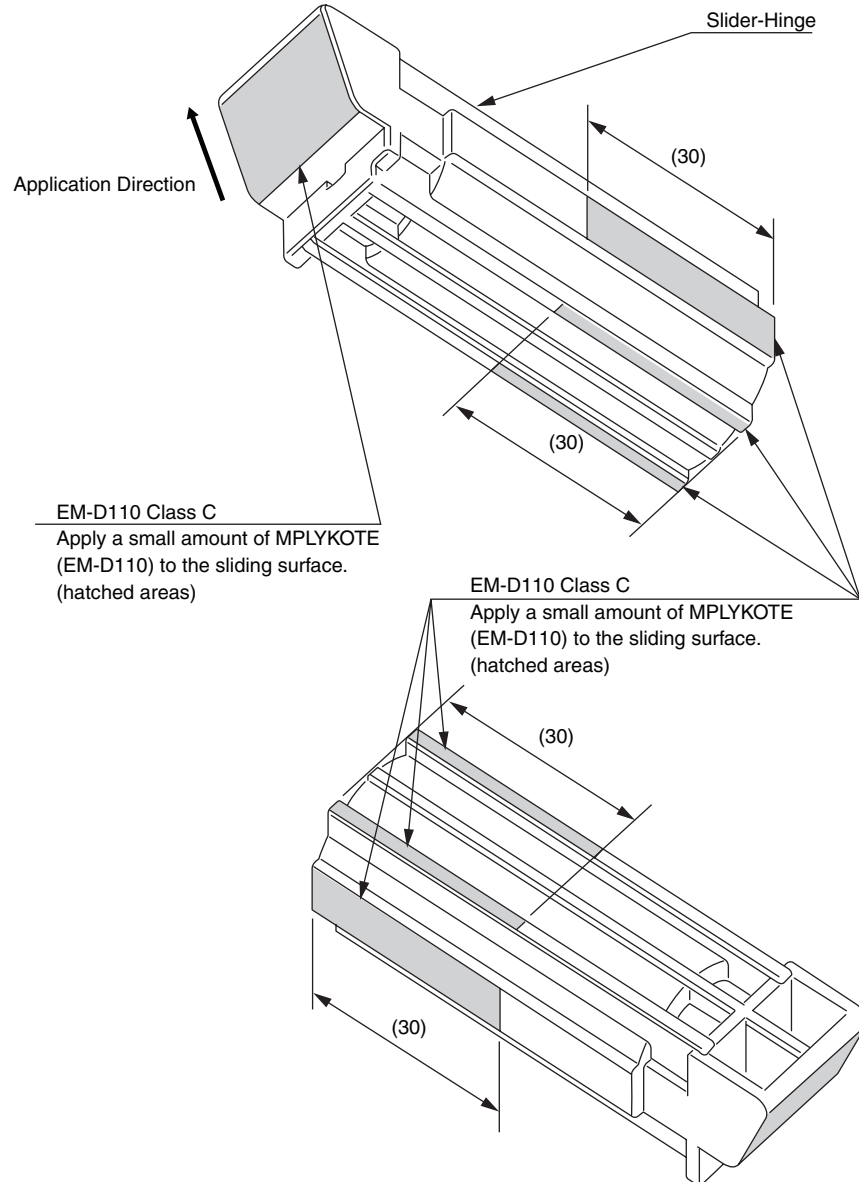

② 44659101PA Gear-Idle-Assy

SF-133 Class C
Apply a normal amount of HANARL (SF-133) to the hatched area. (all circumference of post)

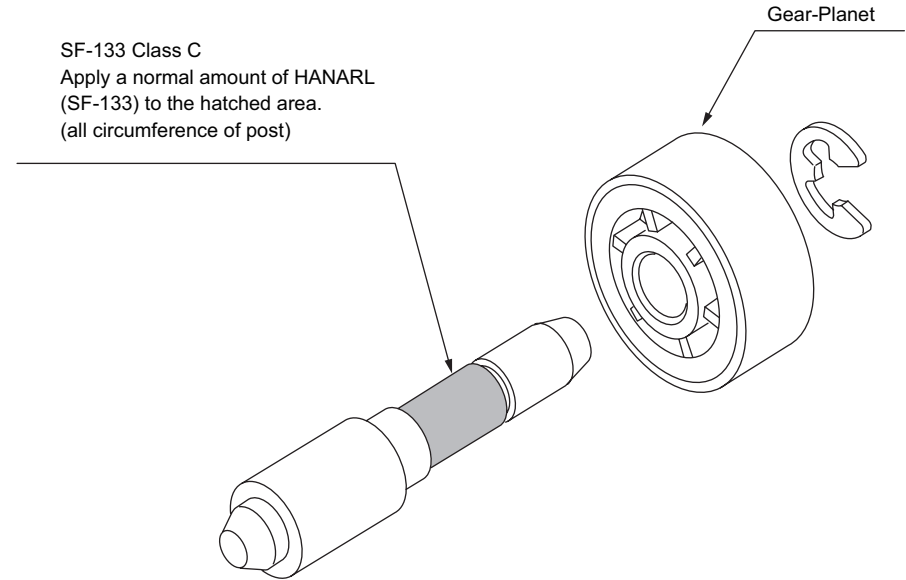

※ Leave it for about 3minutes (drying time) after painting HANARL SF-133, and then assemble the Gear-Idle-Assy.

③ 44875701PA ADF-Assy : [FN296/7]

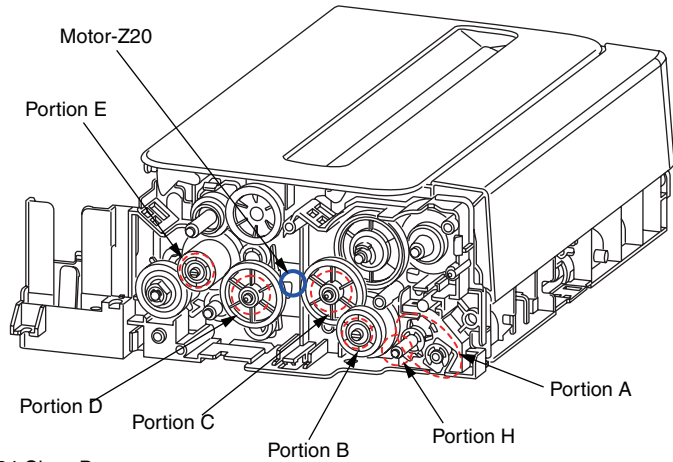

GE-334 Class B
Apply a normal amount of FLOIL
(GE-334C) to the shaft point of contact.
(FG sliding surface).

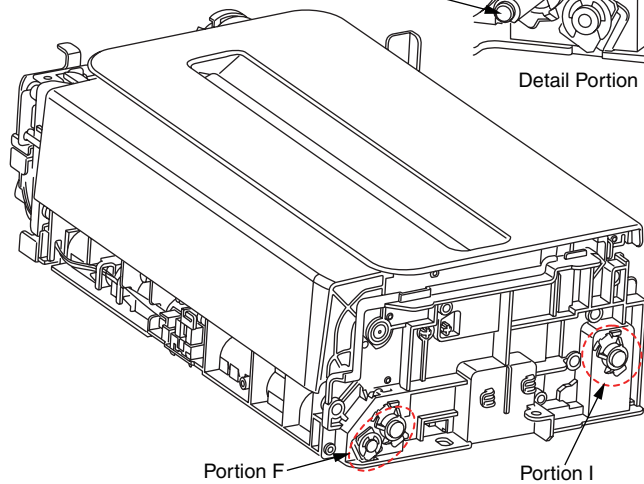
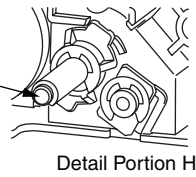

Portion A

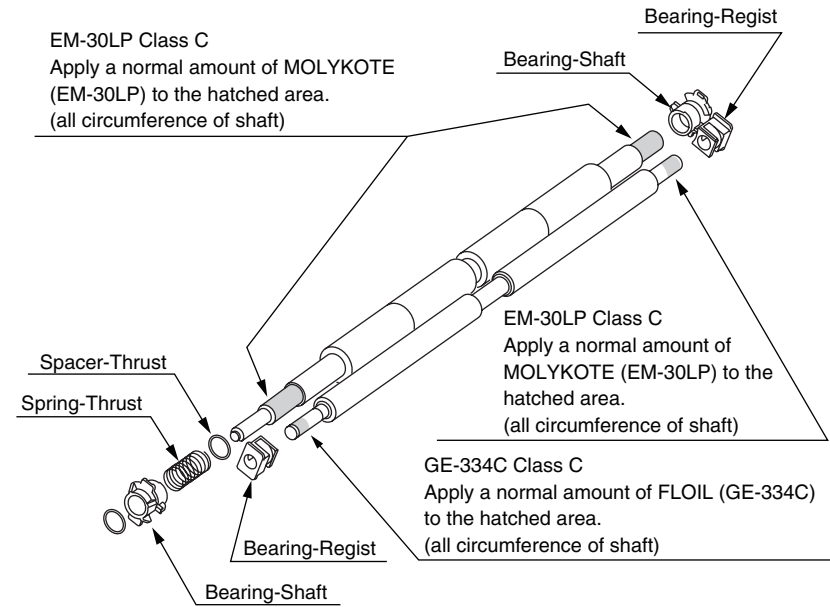

Portion I

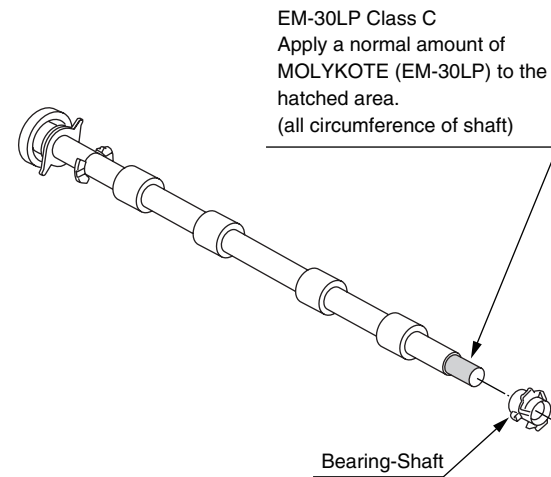

Portion B, C, D and E

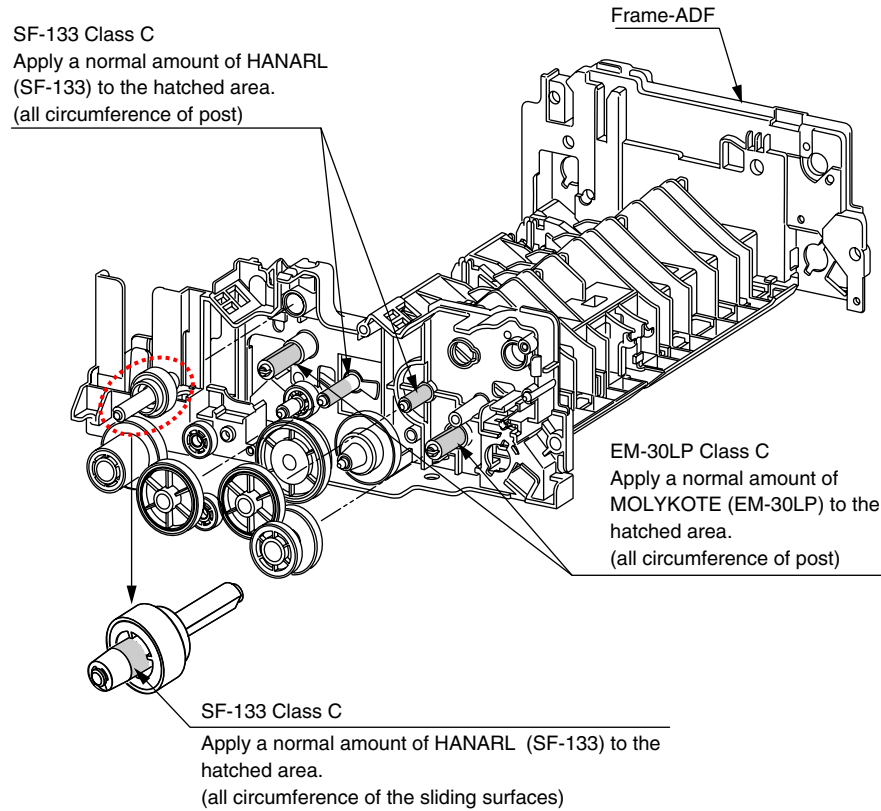

※ Leave it for about 3minutes (drying time) after painting HANARL SF-133, and then assemble the ADF-Assy.

For detail

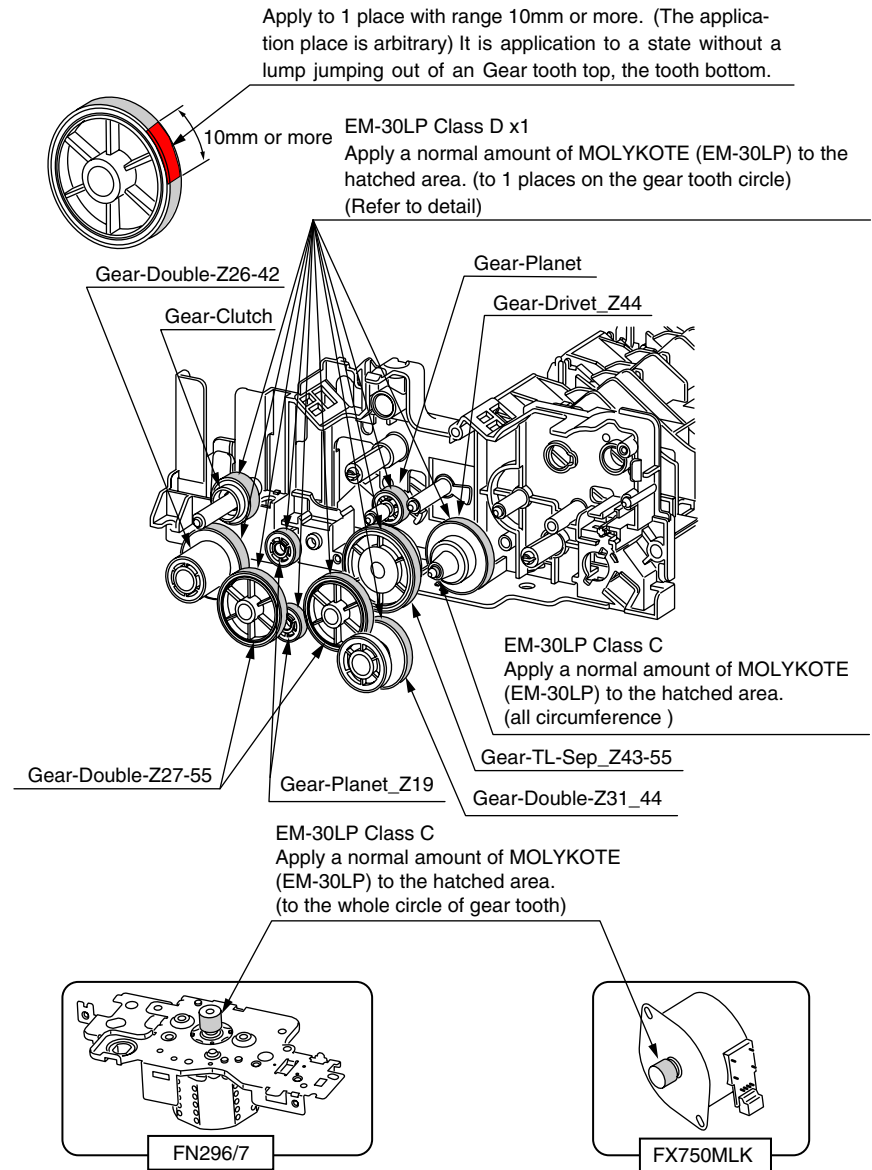

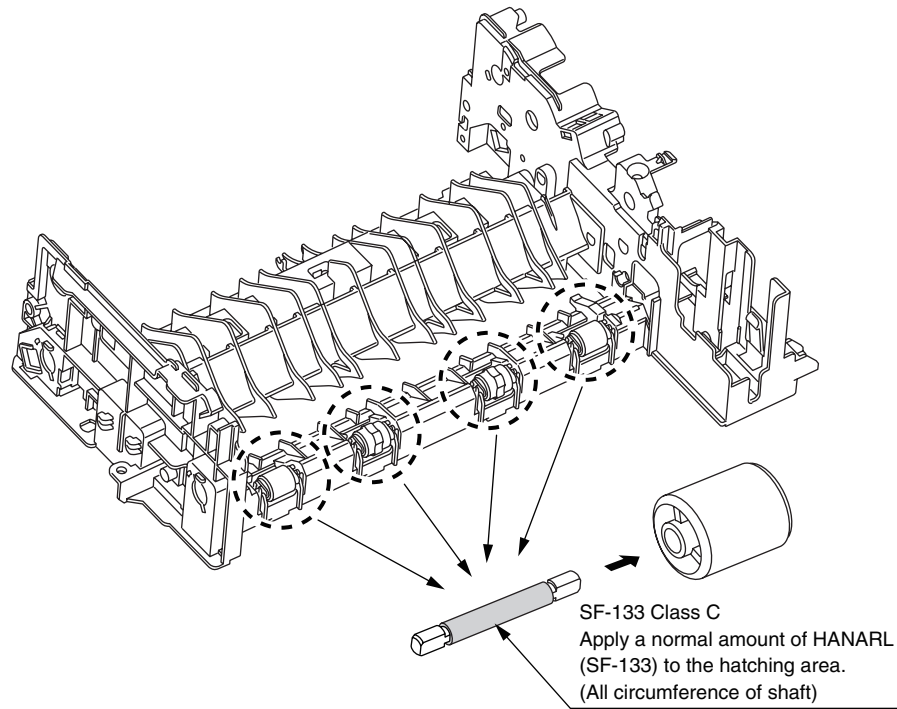

※ Leave it for about 3minutes (drying time) after painting HANARL SF-133, and then assemble the roller.

④ 44912501PA Frame-Assy-Hopping-ADF

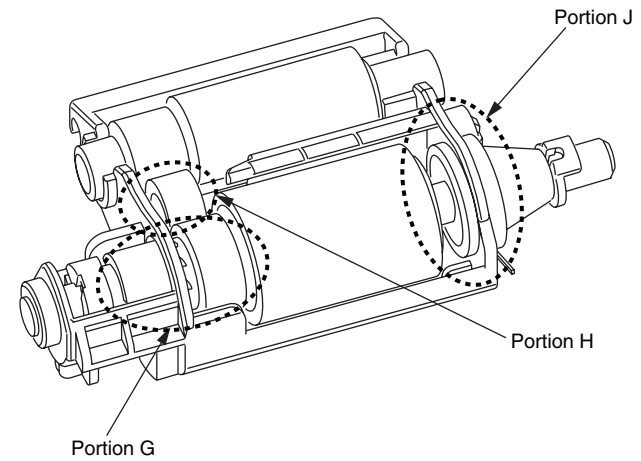

Portion G

EM-30LP Class B
Apply a normal amount of MOLYKOTE (EM-30LP) to the hatched area. (Boss-Coupling and Gear-Feed-Z21 sliding surfaces)

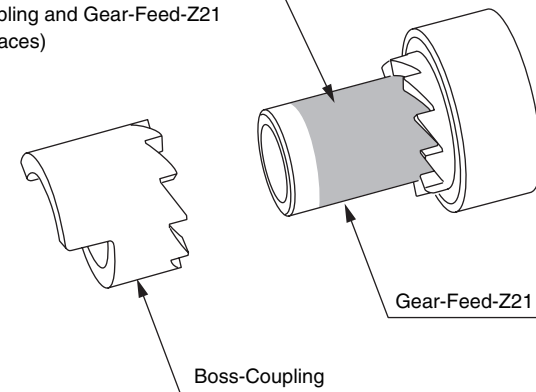

Portion H

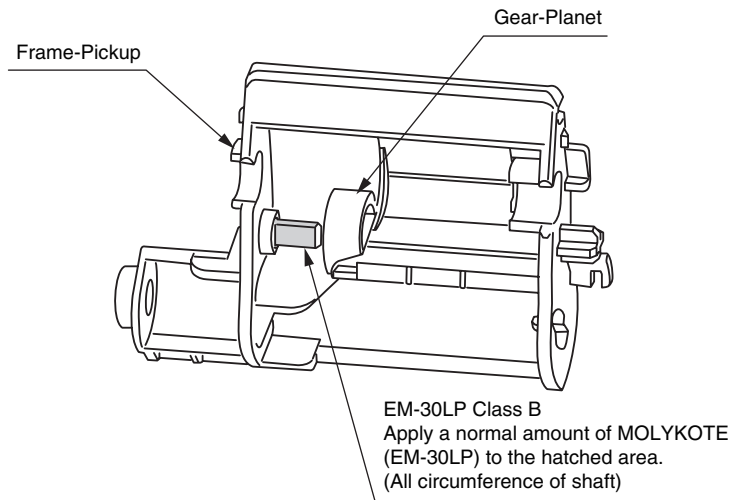

Portion J

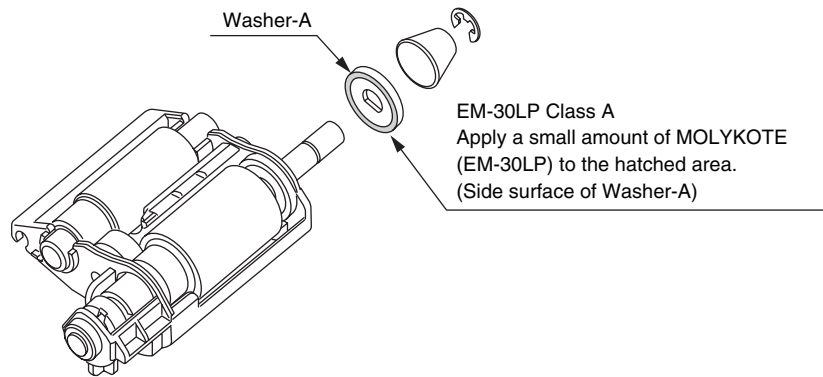

※ After assembly, please wipe off the grease that protrude.

⑤ 44452701PA Front Assy.-Reg/Hop

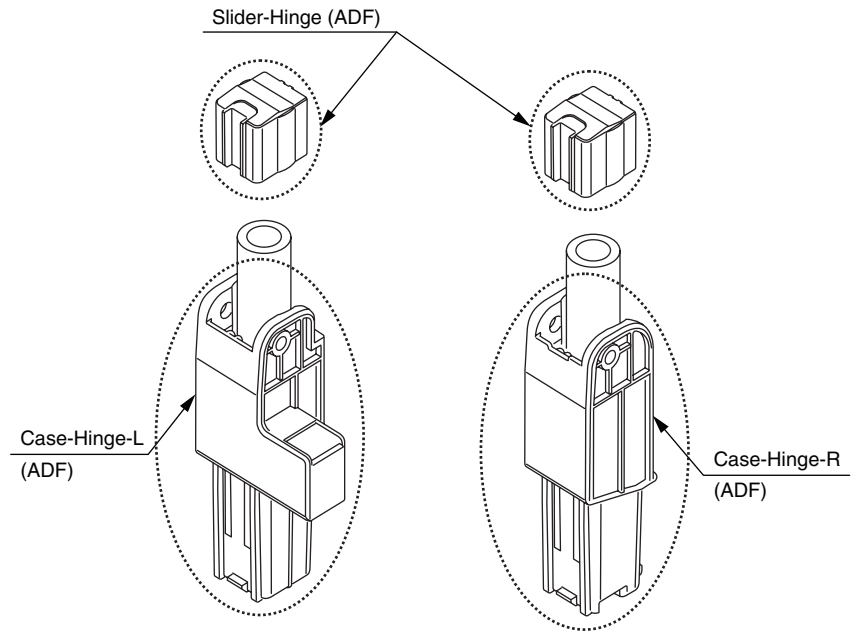

1) 44539601 Slider-Hinge (ADF)

EM-D110 Class C
Apply a normal amount of MOLYKOTE (EM-D110) to the hatched area.

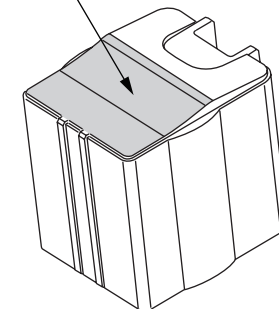

2) 44539401 Case-Hinge-L

EM-D110 Class C
Apply a normal amount of
MOLYKOTE (EM-D110) to the
hatched area. (4 surface)

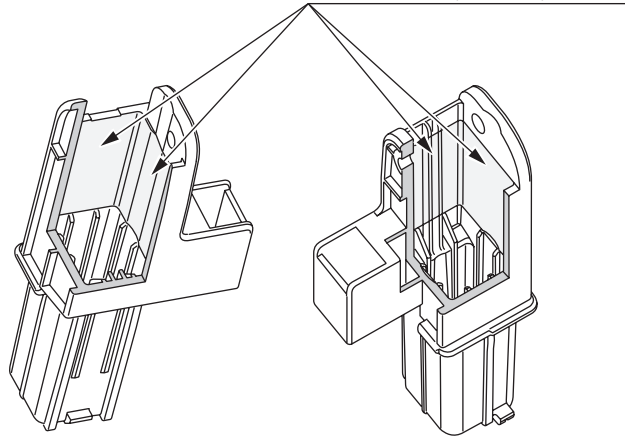

3) 44540001 Case-Hinge-R

EM-D110 Class C
Apply a normal amount of
MOLYKOTE (EM-D110) to the
hatched area. (4 surface)

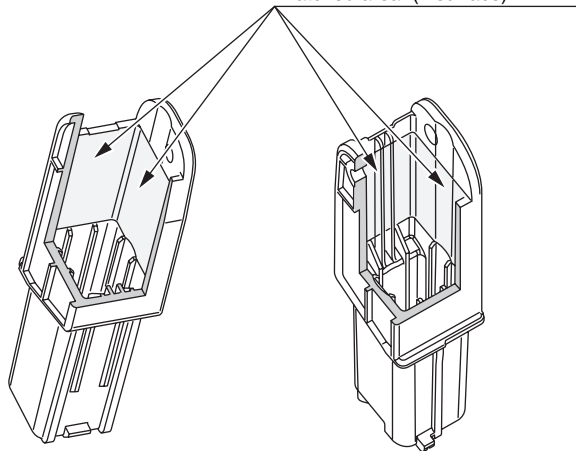

⑥ 44538701PA Tray-Assy-Document

44538801 Tray-Document

SF-133 Class C
Apply a normal amount of HANARL
(SF-133) to the hatched area.
(3 sliding surfaces)

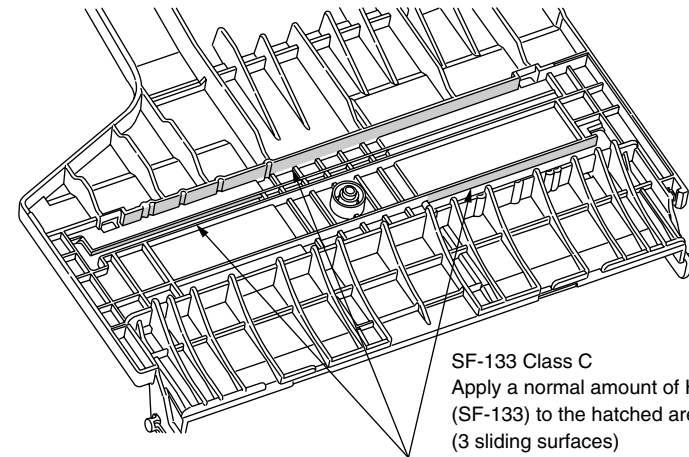
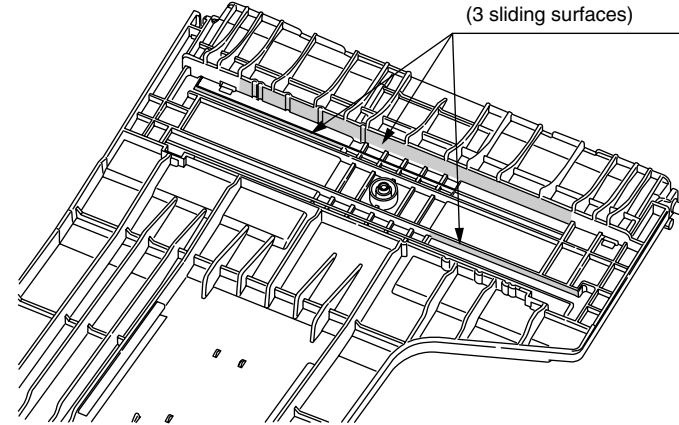

✦ Leave it for about 3minutes (drying time) after painting HANARL SF-133,
and then assemble the Tray-Assy-Document

⑦ 44534901PA Roller-Assy-Eject-ADF

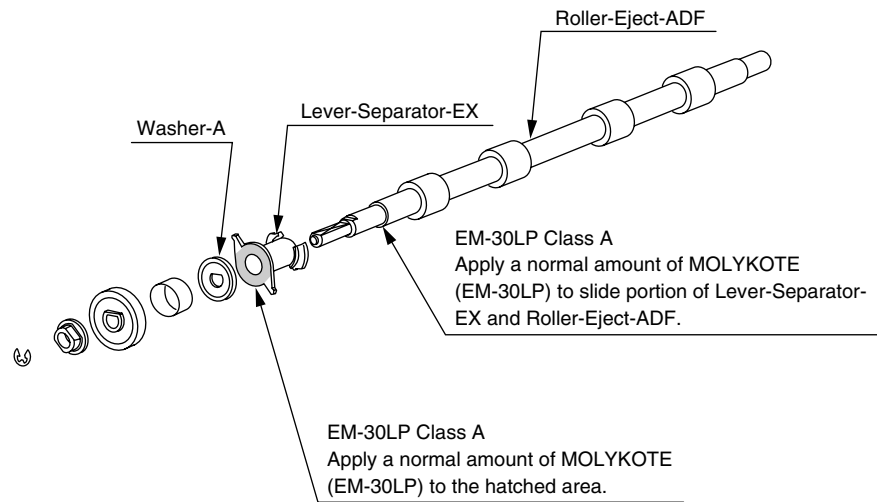

⑧ 44909401PA Frame-Assy-FB : [FN296/7]
44939601PA Frame-Assy-FB : [FX750MLK]

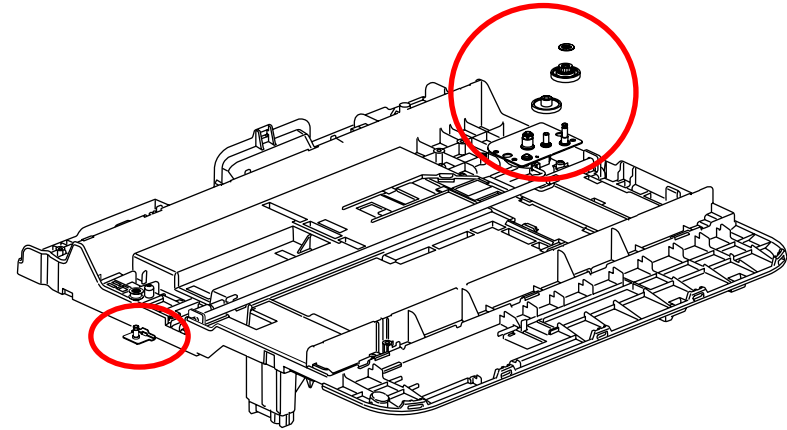

EM-30LP Class A It is application with harpoon coat regular in shaft upper part (●)
It is application at once to two places

1)-1 44596402 Motor-Assy

Without the internal perimeter surface grease adhesion

EM-30LP Class A It is application with harpoon coat regular in shaft upper part (●)
It is application with the first

※ The shaft upper part

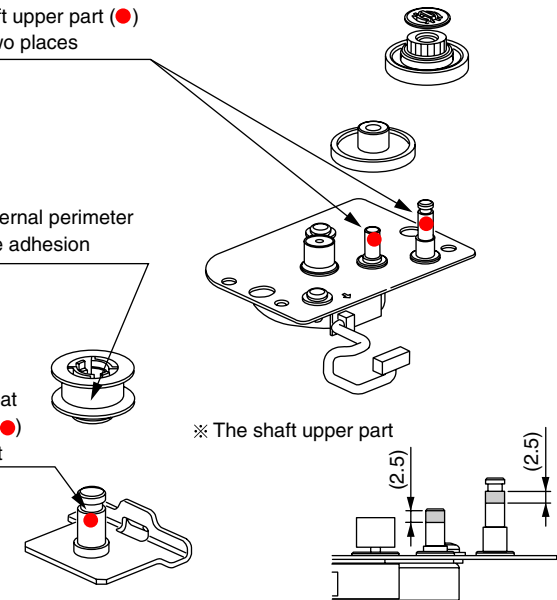

1)-2 4522401PP Plate-Pulley-Caulking

2) 44596402PA Motor-Assy
 44522701PP Gear-Idle
 44522801PP Gear-Pulley

Detail Fig-2

Apply to 1 place. (The application place is arbitrary)
 It is application to a state without a lump jumping out of an Gear tooth top, the tooth bottom.

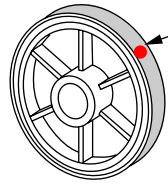

EM-30LP Class C x2
 It is application to each gear with MOLYKOTE (EM-30PL) regular on the gear tooth surface

44596402PA Motor-Assy
 Motor Gear

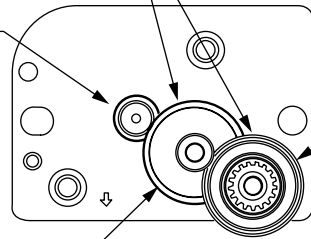

44522801PP Gear-Pulley)

44522701PP Gear-Idle

44522701PP Gear-Idle

MOLYKOTE (EM-30LP) to a side flange (凸) side in a gear tooth side.
 Apply all regular laps (All laps)

Flange convex grease application point Grease lump possibility (All laps)

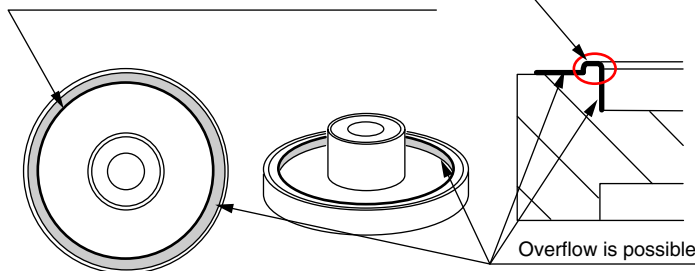

⑨ 44530702PA Guide-Assy-Top-B

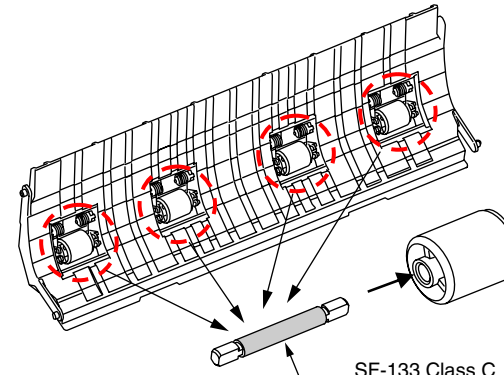

SF-133 Class C
 Apply a normal amount of HANARL (SF-133) to the hatching area. (All circumference of shaft)

※ Leave it for about 3minutes (drying time) after painting HANARL SF-133, and then assemble the roller.

⑩ 44532401PA Guide-Assy-A

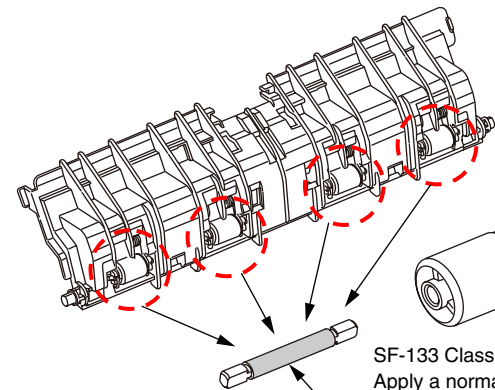

SF-133 Class C
 Apply a normal amount of HANARL (SF-133) to the hatching area. (All circumference of shaft)

※ Leave it for about 3minutes (drying time) after painting HANARL SF-133, and then assemble the roller.

6. MAINTENANCE MENUS

MB461/MB471/MB491 can be adjusted by using Maintenance Utility, or button operation on its operator panel.

The printer has maintenance menus in addition to general menus. The menus intended for adjustment purposes should be selected.

6.1 Maintenance Menu	6-2
6.2 Service Bit Menu	6-9
6.3 Maintenance Utility	6-10
6.4 Self-diagnostic mode	6-12
6.5 Switch pressing function when power supply is turned on	6-27
6.6 Settings after Parts Replacement.....	6-28

6.1 Maintenance Menu

Service Menu

When the equipment is in standby mode, access the password entry screen by pressing [Setting] → [#] → [0] → [1] → [0] → [3] → [*].

Note! The initial Password is set to "000000" (six zeros).

Item1	Item2	Item3	Item4	Item5	Value	Default value ODA	Default value OEL	Default value JP	Notes
Password					*****				Enter the password for accessing the maintenance menu. 6 to 12 characters (numerals and lower-case alphabetic characters) may be entered.
	System Maintenance	OKIUSER *MPS mode: MPS. Not shown during maintenance.			ODA OEL APS JP1 JPOEM1 OEMA OEML				Set the destination. JPOEM1 : OEM for Japan OEMA : OEM for overseas, with A4 as default size OEML : OEM for overseas, with Letter as default size Device reboots automatically after exiting the menu. Displayed under the following conditions: "However, operation when JP1/JPOEM/OEMA/OEML is chosen is not guaranteed. The display condition of the menu is following two. ① "System Maintenance" - "When "OKIUSER" is other than JPOEM1, OEMA or OEML ② "Manufacturer" is "OKI DATA CORP".
	Format SD Memory Card	*Shown only when an SD card is connected	Execute						Formats the SD card. A confirmation message is displayed when the Enter switch is pressed. When "No" has been selected, the system returns to the previous menu. When "Yes" has been selected, the menu is exited and formatting of the inserted SD card begins. Displayed under the following conditions: SD card inserted ("Boot Menu" - "Storage Setup" - "Enable SD Card" is Yes)
	Format Flash Memory		Execute						Formats flash ROM memory. When this command is executed, the menu is exited and formatting of the resident (onboard) flash device begins. Use of this command is strictly prohibited (contact design before use)
	Reset Admin Password		Execute						Returns the administrator password to the factory default value.
	All Reset	*MPS mode: MPS. Not shown during maintenance.	Execute						Returns the content of EEPROM, flash, and the HDD to their factory default values. When this command is executed, the following confirmation message is displayed: "This change will reboot the device automatically. Proceed?" When "No" has been selected, the system returns to the previous menu. When "Yes" has been selected, the menu is exited immediately and then, after rebooting, reset processing begins. See the "format scope" sheet for the scope of formatting.

Item1	Item2	Item3	Item4	Item5	Value	Default value ODA	Default value OEL	Default value JP	Notes
Password	System Maintenance	Test Print Menu			Enable Disable				Switches between displaying and not displaying the "ID Check" and "Engine Information" in the "Report" - "Print Report" category (default: DISABLE). If this item is set to "DISABLE," the "ID Check" and "Engine Information" will remain undisplayed at all times. The printer will reboot after changing the settings and exiting the menu.
		Change Password	New Password		*****				Set a new password for accessing the maintenance menu. 6 to 12 characters (numerals and lower-case alphabetic characters) may be entered.
			Verify Pass-word		*****				Have the user enter the new password for accessing the maintenance menu, set using "NEW PASSWORD," for confirmation purposes. 6 to 12 characters (numerals and lower-case alphabetic characters) may be entered.
		Check RTC						Displays a snapshot of the current time. (The time does not change during display.)	
		Save Syslog	Execute					Saves the network communication log (syslog) to nonvolatile memory.	
		Print Syslog	Execute					Prints the network communication log (syslog).	
	Panel Maintenance	Sound Test			Low Middle High			Select the volume of the forced buzzer. For the buzzer pattern, use the error sound (three buzzes)	
	Copy Maintenance	Print Check Pattern	Execute					Starts printing from the panel using a copy evaluation test chart inside the FW.	
	Scanner Maintenance	Scanner Calibration	Execute					Starts execution of scanner calibration. Instead of being conducted automatically after operating for a certain period of time, calibration is executed by the user as needed. During calibration, the fact that calibration is underway is displayed. Note: Also included under AdminSetting.	
		Adjust Scan Position	FBS	Side Reg.	+8 ~ -8 mm	0	0	0	Adjusting the position of the scanning start pixel by one Step=4/600 dpi (= 0.17mm) at the book scanning.
				Front Edge	+30 ~ -30 mm	0	0	0	During book scanning, add a value for the basic value (= 5 mm) when reading the shadow of the front edge of the document. Adjust in intervals of one step = 4/600 dpi (= 0.17 mm).

Item1	Item2	Item3	Item4	Item5	Value	Default value ODA	Default value OEL	Default value JP	Notes
Password	Scanner Maintenance	Adjust Scan Position	ADF (Front-side)	Side Reg.	+8 ~ -8 mm	0	0	0	Adjusting the position of the scanning start pixel by one Step=4/600 dpi (= 0.17mm) at the book scanning.
				Front Edge	+30 ~ -40 mm	0	0	0	When reading a document from the ADF, add a value for the basic value when reading the shadow of the front edge of the document. To skip the front edge of the document, add a negative value. Increase or decrease the number of motor pulses from detection by the sensor of the front edge of the media until actual reading starts. Adjust in intervals of one step = 4/600 dpi (= 0.17 mm).
				Back Edge	+30 ~ -40 mm	0	0	0	When reading a document from the ADF, add a value for the basic value when skipping the back edge of the document. To read the shadow of the back edge of the document, add a negative value. Increase or decrease the number of motor pulses from detection by the sensor of the back edge of the media until actual reading ends. Adjust in intervals of one step = 4/600 dpi (= 0.17 mm).
			ADF (Back-side)	Front Edge	+30 ~ -40 mm	0	0	0	When reading a document from the ADF, add a value for the basic value when reading the shadow of the front edge of the document. To skip the front edge of the document, add a negative value. Increase or decrease the number of motor pulses from detection by the sensor of the front edge of the media until actual reading starts. Adjust in intervals of one step = 4/600 dpi (= 0.17 mm).
				Back Edge	+30 ~ -40 mm	0	0	0	When reading a document from the ADF, add a value for the basic value when skipping the back edge of the document. To read the shadow of the back edge of the document, add a negative value. Increase or decrease the number of motor pulses from detection by the sensor of the back edge of the media until actual reading ends. Adjust in intervals of one step = 4/600 dpi (= 0.17 mm).
			Adjust ADF Scan Position		+30 ~ -30 mm	0	0	0	Set the CIS reading position of the ADF for the focusing standard. Adjust in intervals of one step = 4/600 dpi (= 0.17 mm). This is correlated to adjustment of the ADF front edge position.
			Adjust Mech.	Adjust FB Motor	FB Drive Current	10 ~ 1400 [mA]	300 [mA]	300 [mA]	
		FB Keep Current			10 ~ 1400 [mA]	50 [mA]	50 [mA]		
		Adjust ADF Motor		ADF Drive Current 1	10 ~ 1400 [mA]	800 [mA]	800 [mA]		
				ADF Drive Current 2	10 ~ 1400 [mA]	800 [mA]	800 [mA]		
				ADF Drive Current 3	10 ~ 1400 [mA]	800 [mA]	800 [mA]		
			ADF Drive Current 4	10 ~ 1400 [mA]	800 [mA]	800 [mA]			

Item1	Item2	Item3	Item4	Item5	Value	Default value ODA	Default value OEL	Default value JP	Notes
Password	Scanner Maintenance	Adjust Mech.	Adjust ADF Motor	ADF Keep Current	10 ~ 1400 [mA]	200 [mA]	200 [mA]		
		Adjust CIS	Adjust CIS		simple R continuous G continuous B continuous All continuous				Only for engineering test Sequentially light the designated RGB colors and check them during calibration configuration duties. Move the CIS to the standard position. In the position moved to, sequentially light R, followed by G and B in the same manner. Light each color for approximately 3 seconds. Display "Testing" during execution? → On the panel, display "CIS light testing" and "Cancel."
			Check CIS		300dpi 600dpi ---Results Displayed--- CCD_SIG9_WID_H 0x000000 CCD_SIG2_WID_H 0x000000				Only for engineering test Check CIS maintenance displays the exposure time at each resolution. When resolution is set, scanner calibration is conducted at that resolution and the following results are displayed: Red-1 Red-2 (No indication) Green-1 Green-2 (No indication) Blue-1 Blue-2 (No indication) Lsync Note : CIS exposure time varies with resolution.
			Set CIS Exposure time		0 ~ 4294967295				Only for engineering test Change LED exposure time settings, and then read the document using PC Scan. Reading implemented for the LED exposure time in the settings, without conducting calibration. A warning is displayed when a value greater than the Lsync cycle has been set. Settings are shown below. Red-1 Red-2 (No indication) Green-1 Green-2 (No indication) Blue-1 Blue-2 (No indication) Lsync

Item1	Item2	Item3	Item4	Item5	Value	Default value ODA	Default value OEL	Default value JP	Notes
Password	Scanner Maintenance	AEF Parameter			R3 (03h) R32 (20h) R33 (21h) R34 (22h) R35 (23h) R36 (24h) R37 (25h) R38 (26h) R39 (27h) R40 (28h) R41 (29h) R42 (2Ah) R43 (2Bh)				Only for engineering test Change AFE (IC) register settings (3 - 9 settings). Then, read the document using PC Scan. W : Display message showing that settings are complete. R : Display read value.
		Mechanical Test	ADF Test	Simplex/ Duplex	Simplex Duplex				Conduct mechanical testing (without reading an image). ADF : Test moving original document (stops when set document has been moved) May choose from single- or double-sided feeding. FBS : CIS moving test (stops after designated number of operations) Use fastest read speed (30 cpm). Display "Testing" during execution? → On the panel, indicate current number of executions using the message "Test no. xxx underway."
				Speed	Mono 300 x 300dpi Mono 300 x 600dpi Mono 600 x 600dpi Color 300 x 600dpi				
				Execute	--Results-- Test no. xxx underway				

Item1	Item2	Item3	Item4	Item5	Value	Default value ODA	Default value OEL	Default value JP	Notes
Password	Scanner Maintenance	Mechanical Test	FBS Test	Speed	Mono 300 x 600dpi Mono 600 x 600dpi Color 300 x 600dpi Color 600 x 600dpi				Conduct mechanical testing (without reading an image). ADF : Test moving original document (stops when set document has been moved) May choose from single- or double-sided feeding. FBS : CIS moving test (stops after designated number of operations) Use fastest read speed (40 cpm). Display "Testing" during execution? → On the panel, indicate current number of executions using the message "Test no. xxx underway."
				Times	0~65535				
				Execute	--results-- Test no. xxx underway				
			Sensor Test	Examples of this display are shown below: ① MEDIA H/L ② SCAN H/L ③ REVERSE H/L ④ ADF CVR H/L ⑤ FB H/L				Display sensor status (H/L) in real time. Change the content of the display as needed when the sensor status displayed changes. ① Set-document detection sensor (MEDIA) ② Scanning sensor (SCAN) ③ Reverse sensor (REVERSE) ④ ADF cover-open sensor (ADF CVR) ⑤ FB home-position sensor (FB HP)	
			ADF Motor Test	Forward Forward Continuous Reverse Reverse Continuous				Test the ADF motor ① After a short press of the button, rotate in the CW direction for 10 seconds and then stop. ② After a long press of the button, rotate in the CW direction continuously. Stop when the Stop button is pressed. ③ After a short press of the button, rotate in the CCW direction for 10 seconds and then stop. ④ After a long press of the button, rotate in the CCW direction continuously. Stop when the Stop button is pressed. Deemed successful at all times. No need to display results. Display "Testing" during execution? → Display a message on the panel showing that testing is underway.	
			Solenoid Test		Once Continuous				After a short press of the button, intake for 2 seconds and then stop. After a long press of the button, intake for 2 seconds and stop for 3 seconds repeat. Stop when the Stop button is pressed. Deemed successful at all times. No need to display results. Display "Testing" during execution? → Display a message on the panel showing that testing is underway.

Item1	Item2	Item3	Item4	Item5	Value	Default value ODA	Default value OEL	Default value JP	Notes
Password	Fax Maintenance *This menu not shown on models with no fax.	Line Test	Tone Send Test		2100Hz 1850Hz 1650Hz 1100Hz				Tone send test conducted.
			DP Send Test		0 ~ 9 Key				DP send test conducted.
			MF Send Test		0 ~ 9, #, * Key				MF send test conducted.
			Modem Signal Send Test		V.34 (33.6Kbps) V.34 (28.8Kbps) V.17 (14.4Kbps) V.17 (12.0Kbps) V.17 (9.6Kbps) V.17 (7.2Kbps) V.29 (9.6Kbps) V.29 (7.2Kbps) V.27 (4.8Kbps) V.27 (2.4Kbps) V.21 (0.3Kbps)				Modem-signal send test conducted. 11 types available, including V. 34 (33.6 Kbps).
	T.30 Monitor	Execute						The unit keeps the last transmission log (Tx/Rx commands) on volatile memory, and print when select "Execute". If turn off the unit, the records will be lost.	
Print Maintenance	Personality	IBM PPR III XL		Enable Disable	Enable	Enable	Disable		
		EPSON FX		Enable Disable	Enable	Enable	Disable		

6.2 Service Bit Menu

Additional Fax Setting menu

(When setup ServiceBit=ON, the following items will be displayed at Admin Setup→Fax Setup)

#	Item	Settings	Description	ODA	OEL
1	Tone For Echo (For Transmission)	Enable Disable	When an Item is Enable: First DIS is ignored. Echo Protection Tone is sent with V.29. Interval of DIS and DCS is 1000ms When an Item is Disable: First DIS is not ignored. Echo Protection Tone is not sent with V.29. Interval of DIS and DCS is 0ms	Disable	Disable
2	Tone For Echo (For Reception)	Enable Disable	When an Item is Enable : Interval of CED and DIS is 1000ms When an Item is Disable : Interval of CED and DIS is 075ms	Disable	Disable
3	Attenuator	0~15 dB	Enter Attenuator.	Depends on Country Code	
4	MF Attenuator	0~15 dB	Enter MF (Tone) Attenuator.	Depends on Country Code	
5	Pulse Make Ratio	33% 39% 40%	Sets the make rate of DP (10 pps) during call. It only shows, when ServiceBit = ON and Tone/Pulse setting = PULSE.	Depends on Country Code	
6	Pulse Dial Type	N 10-N N+1		Depends on Country Code	
7	MF (Tone) Duration	75, 85, 100 m seconds	Enter MF (Tone) Duration. It only shows, when ServiceBit = ON and Tone/Pulse setting = TONE.	Depends on Country Code	

#	Item	Settings	Description	ODA	OEL
8	Calling Timer	1~255 second (s)	Sets the call connection wait time (TO timer). When the setting value is "0", the MFP runs at the initial value of each country. When any value other than "0" is set, the call connection wait time (TO timer) can be selected in the range of 1 to 255 mm.	Depends on Country Code	

6.3 Maintenance Utility

6.3.1 Maintenance Utility

The adjustments described in table 5-1 should be made by using Maintenance Utility.

The following details the utility:

- (1) Maintenance Utility Operating Manuals:
42678801FU01 Ver. 1.36.0 or higher (Japanese)
42678801FU02 Rev. 1.36.0 or higher (English)

- (2) Maintenance Utility program:

Applicable operating system	File name	Part number
Win 2000/ XP/ Vista/ 7 (Japanese/ English)	MuWin.zip	42678801FW01 Rev. 1.36.0 or higher

Table 5-1: Adjustment options in Maintenance Utility

	Option	Adjustment	Section in Maintenance Utility Operating Manual	Operation from operator panel (section in this maintenance manual)
1	Board replacement	Copies information in the EEPROM in the PU block, and the settings in the EEPROM in the CU block. Purpose: To copy the above data onto a CU/PU board with which to replace the CU/PU board for a maintenance purpose.	2.4.1.1.9	Unavailable
2	Serial number setting	Rewrites the serial number recorded in the PU block and selects and rewrites the printer serial number recorded in the CU block and rewrites the output mode recorded in it. Purpose: To configure a maintenance replacement CU/PU board onto which the CU/PU board information cannot be copied with the board replacement function (e.g. due to an interface error).	2.4.1.1.10.3	Unavailable

	Option	Adjustment	Section in Maintenance Utility Operating Manual	Operation from operator panel (section in this maintenance manual)
3	Factory/ Shipping mode	Switches between the Factory and Shipping modes. Purpose: To configure a maintenance replacement CU/PU board onto which the CU/PU board information cannot be copied with the board replacement function (e.g. due to an interface error). The maintenance board is put to the Factory mode usually by default and, by using this function, must be set to the Shipping mode.	2.4.1.1.10.4	6.4.2.8
4	Scanner board replacement	Copies information in the EEPROM on the scanner board. Purpose: To copy the above data onto a scanner board with which to replace the scanner board for maintenance purpose.	2.4.1.1.8	Unavailable
5	Board option setup information	Checks serial number information and the Factory/Shipping mode.	2.4.1.1.7	Unavailable
6	NIC software update	Updates the NIC software.	2.4.2.2.17	Unavailable
7	MAC address setting	Sets the MAC address.	2.4.2.2.5	Unavailable
8	Consumable counter maintenance function	Copies the consumable counters: Image drum counter Toner counter Waste Toner Counter Purpose: To copy the counter value of each consumable in use in the printer to use in another printer.	2.4.1.2.1	Unavailable
9	Send to file	Send the specify file.	2.4.1.2.15	Unavailable
10	Destination/ PnP information setup	Sets and checks the printer's (CU) destination, device identification and USB identification.	2.4.1.2.9	5.4.3

	Option	Adjustment	Section in Maintenance Utility Operating Manual	Operation from operator panel (section in this maintenance manual)
11	Password initialization	Initializes a Password.	2.4.2.2.13	
12	Network log storage function	Stores a network log file.	2.4.2.2.14	Unavailable
13	PU log file storage function	Stores a PU log file	2.4.2.2.16	Unavailable
14	Saves a PU maintenance log file	Saves a PU maintenance log file.	2.4.1.2.17	Unavailable
15	Consumable counter display	Checks the current consumable counter values.	2.4.1.3.1	6.4.2.6
16	Menu setting check	Displays the menu settings set on the printer (CU).	2.4.1.3.2	Print a configuration report (Menu Map) (refer to user documentation).
17	Printer information check	Checks the MAC address and each firmware version.	2.4.1.3.3	Print a configuration report (Menu Map) (refer to user documentation).
18	CPU and Memory value check	Checks the information on the printer's installed (CU) CPU and memory.	2.4.1.3.4	Print a configuration report (Menu Map) (refer to user documentation).
19	Test print	Executes the local print function and sends a specified file. Purpose: To check the printer for operation it performs solely and send a download file.	2.4.1.4.1	Perform local printing (refer to System Specification).
20	Saves a local print data	Saves a local print data.	2.4.2.4.2	Unavailable
21	Switch scan test	Executes the switch scan test. Purpose: To check each sensor for operation.	2.4.1.5.1	6.4.2.3
22	Motor clutch test	Executes the motor clutch test. Purpose: To check each item, such as a motor or clutch, for operation.	2.4.1.5.2	6.4.2.4

	Option	Adjustment	Section in Maintenance Utility Operating Manual	Operation from operator panel (section in this maintenance manual)
23	Counter display	Checks the consumable, continuous consumable and waste toner counters.	2.4.1.5.6	6.4.2.6 6.4.2.7
24	Local parameter setting	Switches between the Factory and Shipping modes and checks the status of the fuse.	2.4.1.5.7	6.4.2.8
25	Engine parameter setting	Makes an engine parameter setting.	2.4.1.5.8	6.4.2.9
26	Media transfer parameter setting	Makes a print media transfer parameter setting.	2.4.1.5.9	6.4.2.9

Note! Do not operate or set options added with 'Never use this option,' or a malfunction is potentially caused.

Before starting the maintenance, please disable MPS mode setting when the unit activate MPS mode as Enable. The condition of MPS mode is displayed on the header of Configuration pages as "MPS : OFF/ON".

LEVEL0

(1) How to select the menu items

XXXX Menu items can be selected by long pressing of [4] or [✖], or by short pressing of [2] or [8].

XXXX Menu items can be entered by pressing of [6] or [4], and can be selected by pressing of [2] or [8].

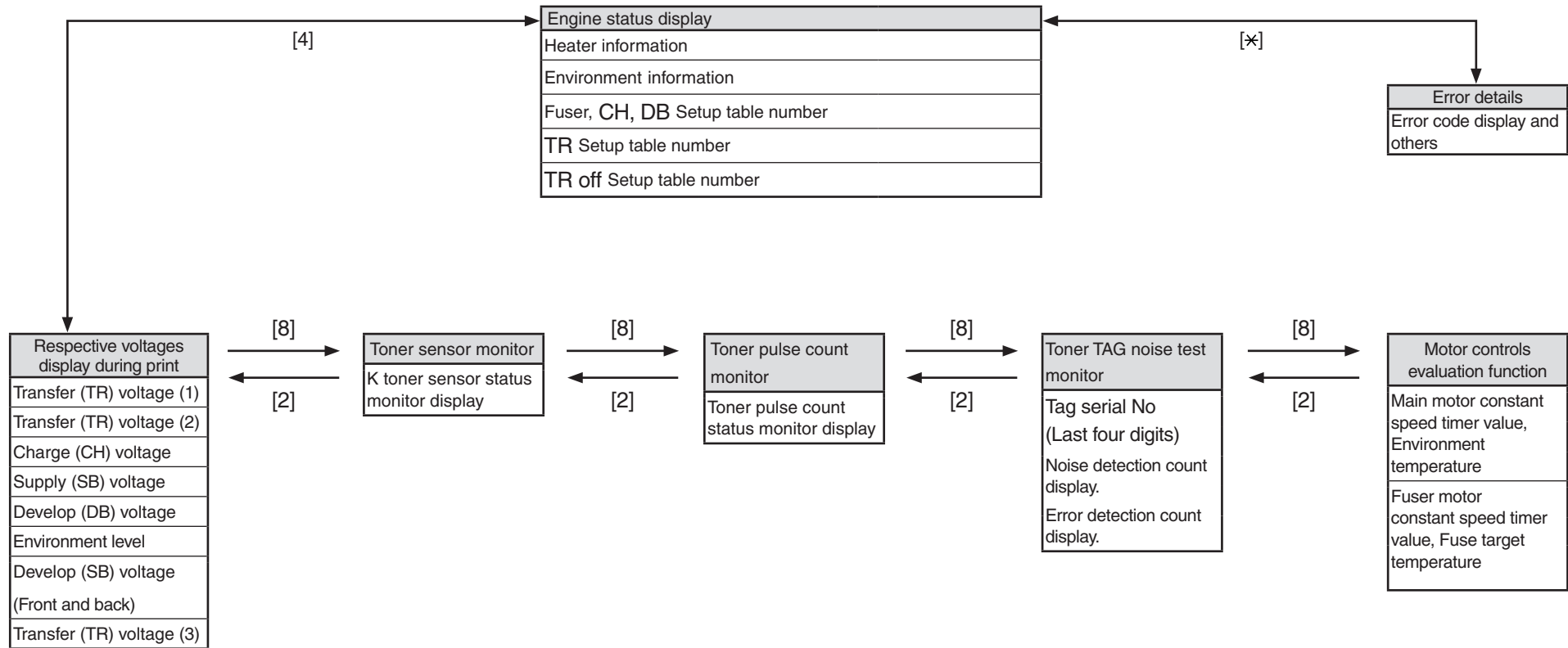

LEVEL1

(1) How to select the menu items

XXXXX Menu items can be selected by pressing either [2] or [8] key, and executed by pressing [6].

XXXXX Menu items can be entered by pressing of [6] or [4], and can be selected by pressing of [2] or [8].

The test can be executed by pressing [6], and can be exited by pressing [4].

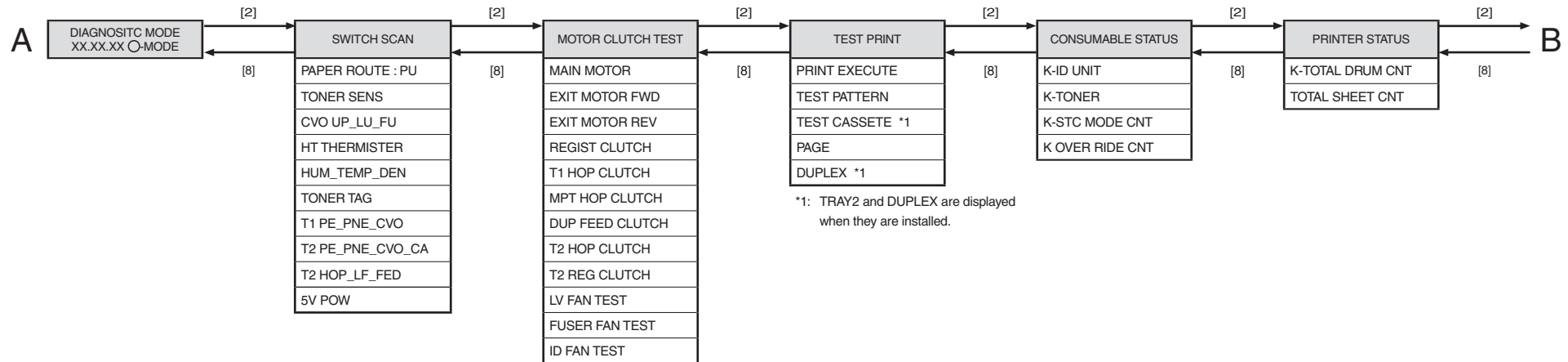

Note:
If [*] is pressed when selecting a motor, the motor keeps running.

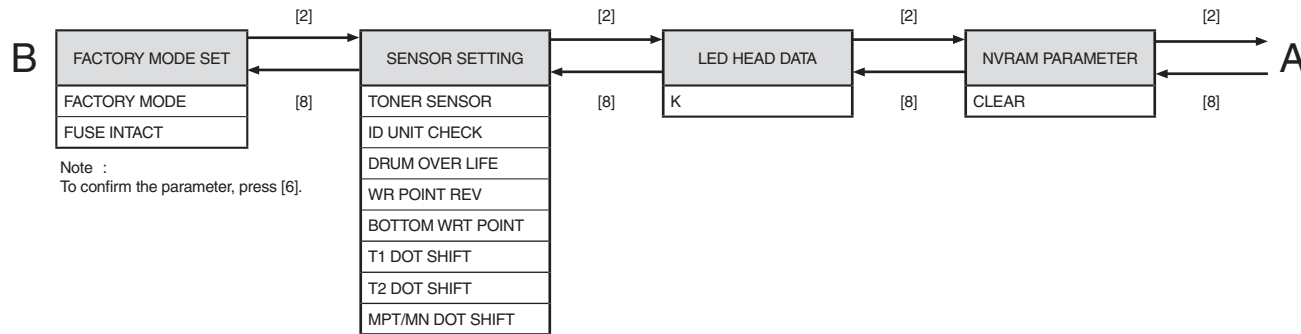

Note :
To confirm the parameter, press [6].

Note :
To confirm the parameter, press [6].

6.4.2 Ordinary self-diagnostic mode (level 1)

Menu items of the ordinary self-diagnostic mode are shown below.

	Item	Self-diagnostic menu	Adjustment contents	Maintenance utilities
1	Switch scan test	SWITCH SCAN	Entry sensor check and switch check	Refer to 5.3.1 No.21
2	Motor clutch test	MOTOR&CLTCH TEST	Motor and clutch operation test	Refer to 5.3.1 No.22
3	Test print execution	TEST PRINT	PU built-in test pattern print	It is not possible to operate it.
4	Consumable item counter display	CONSUMABLE STATUS	Consumable items consumption status display	Refer to 5.3.1 No.23
5	Consumable item accumulative counter display	PRINTER STATUS	Consumable items accumulative consumption status display	Refer to 5.3.1 No.23
6	Factory/Shipping mode selection	FACTORY MODE SET	Switching between the Factory mode and the Shipping mode	Refer to 5.3.1 No.3, No.24
7	FUSE status check		Respective FUSEs status display	Refer to 5.3.1 No.3, No.24
8	Engine parameter setting	SENSOR SETTING	Valid/Invalid setups of error detection by various sensors	Refer to 5.3.1 No.25
9	LED Head serial number display	LED HEAD DATA	LED Head serial number display	It is not possible to operate it.
10	NVRAM parameter setting	NVRAM PARAMETER	Do not use this item	It is not possible to operate it.

6.4.2.1 Entering self-diagnostic mode (level 1)

1. Make sure that the LCD is in standby state (no Error window is shown) and press the [Setting] to move to the setting window and then press the following button in the indicated sequence.
[#] → [0] → [1] → [0] → [3] → [✕]
2. Type in the password to enter Service Maintenance Menu. It is [000000] by default. (Enter 0 six times)
3. Select [Printer Maintenance] → [Engine Diag Mode] in the Service Maintenance Menu and press the [6].

6.4.2.2 Exiting self-diagnostic mode

1. When the [4] is pressed from Diag Mode (Window displaying/Factory state), the setting window will return.

6.4.2.3 Switch scan test

This self-diagnostic menu is used to check the entry sensor and the switch.

1. Enter the self-diagnostic mode (level 1), press the [2] or [8] key repeatedly, and press the [6] key when the "SWITCH SCAN" is displayed in the upper row of the display area. (Pressing the [2] key increments the test item and pressing the [8] key decrements the test item.)

SWITCH SCAN

2. Press either the [2] or [8] key until the desired menu item corresponding to the unit to be tested in Table 4-3 is displayed in the lower row of the display area. (Pressing the [2] key increments the test item and pressing the [8] key decrements the test item.)
3. Pressing the [6] key starts the test. Name and present status of the corresponding unit are displayed.

PAPER ROTE:PU
1=H 2=L 3=H 4=L

Activate the respective units. (Figure 4-1) Status of the respective units are displayed on the corresponding areas of the LCD display. (Display changes depending on each sensor. Refer to Table 4-3 for details.)

4. Press the [#] key to return to the status of step 2.
5. Repeat steps 2 to 4 as required.
6. Press the [4] key to exit the test. (Returns to the status of step 1.)

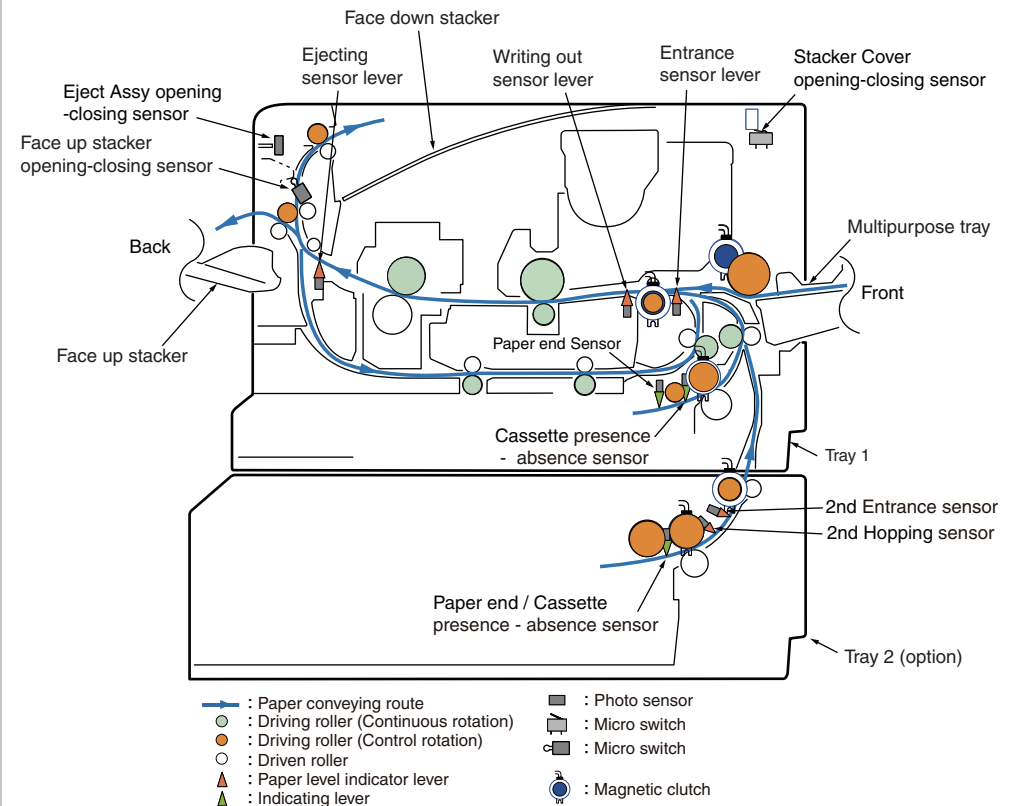

The sectional view of only printer

Table 4-3 SWITCH SCAN details

<Item having no function> Asterisk mark (*) is displayed in the lower row of display area.

* 1: "L" is displayed when the cover is opened.

NO	Display area, upper row	1		2		3		4	
		Details	Display area, lower row	Details	Display area, lower row	Details	Display area, lower row	Details	Display area, lower row
1	PAPER ROUTE : PU			In Sns	H : OFF L : ON	Write Sns	H : OFF L : ON	Exit Sns (OUT)	H : OFF L : ON
2	TONER SENS	Toner-K Sns	H : ON L : OFF						
3	CVO UP_LU_FU	Cover-Upper	H : Close L : Open	Cover Rear	H:Open L:Close	Cover-Face Up	H : Open L : Close		
4	HT THERMISTER					Upper-Side-Thermister	AD value: ***H		
5	HUM_TEMP_DEN	Hum Sns	AD value: ***H	Temperture-Sns	AD value: ***H				
6	TONER TAG	TAG-K presence or absence	UID: ***H						
7	T1 PE_PNE_CVO	1st-Paper-End Sns	Port level H, L					Cassette-Sns-1st	Port level H, L
8	T2 PE_PNE_CVO_CA	2nd-Paper-End Sns	Port level H, L						
9	T2 HOP_LF_FED	2nd-Hopping Sns	Port level H, L			2nd-Feed Sns (TBD)	Port level H, L		
10	5V POW	5V Power	AD value: ***H						

6.4.2.4 Motor clutch test

This self-diagnostic menu is used to test the motor and clutch.

1. Enter the self-diagnostic mode (level 1), press the [2] or [8] key repeatedly, and press the [6] key when the "MOTOR & CLUTCH TEST" is displayed in the upper row of the display area. (Pressing the [2] key increments the test item and pressing the [8] key decrements the test item.)
2. Press either the [2] or [8] key until the desired menu item corresponding to the unit to be tested in Table 4-4 is displayed in the lower row of the display area. (Pressing the [2] key increments the test item and pressing the [8] key decrements the test item.)

MOTOR & CLUTCH TEST
ID MOTOR

3. Pressing the [6] key starts the test. The unit name starts flashing and the corresponding unit is activated for 10 seconds. (Refer to Figure 4-2.)

Note! After the corresponding unit has activated for 10 seconds, it returns to the status of step2, and is re-activated when the corresponding switch is pressed.

- The clutch solenoid repeats turning on and off during the normal print drive. (If a clutch solenoid cannot be activated independently, the motor is driven at the same time.)
- If [✕] key is pressed when selecting a motor, the motor keeps running.

4. When the [#] key is pressed, the corresponding unit stops activating. (Display of the corresponding unit keeps displayed.)
5. Repeat steps 2 to 4 as required.
6. Pressing the [4] key terminates the test. (Returns to the status of step 1.)

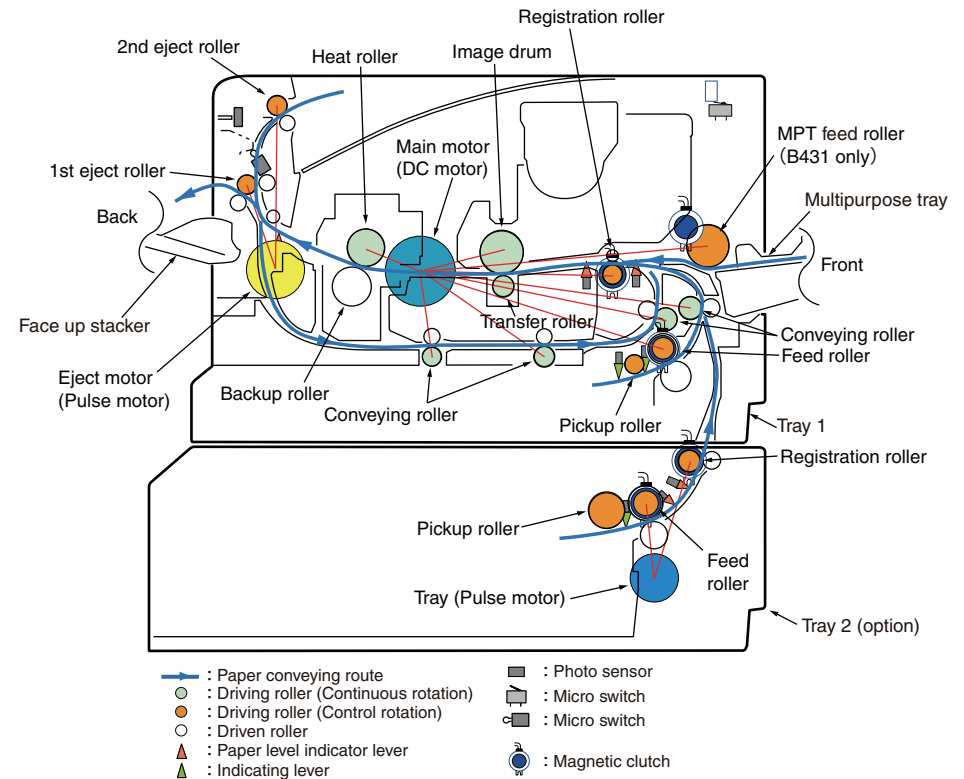

The sectional view of only printer

Table 4-4

Unit name display	Drive restriction condition	Remarks
MAIN MOTOR	-	-
EXIT MOTOR FWD	FaceUp Cover close	-
EXIT MOTOR REV	FaceUp Cover open	-
REGIST CLUTCH	MAIN MOTOR driving	-
T1 HOP CLUTCH	MAIN MOTOR driving	-
MPT HOP CLUTCH (*1)	MAIN MOTOR driving	-
DUP FEED CLUTCH (*2)	MAIN MOTOR driving	-
T2 HOP CLUTCH	TRAY2 MOTOR driving	OPTION
T2 REG CLUTCH	TRAY2 MOTOR driving	OPTION
LV FAN TEST	-	-
FUSER FAN TEST	-	-
ID FAN TEST	-	-

(*1) MB471/491 only.

(*2) No duplex feed clutch is installed.

Note! The rollers that rotate continuously (each of heat rollers, image drums, and conveying rollers) run in synchronization with the main motor.

6.4.2.5 Test print

This self-diagnostic menu is used to print the test pattern that is built inside PU. Other test patterns are stored in the controller.

This test print cannot be used to check the print quality.

Diagnosis for the abnormal print image should be performed in accordance with section 6.

1. Enter the self-diagnostic mode (level 1), press the [2] or [8] key repeatedly, and press the [OK] key when the "TEST PRINT" is displayed in the upper row of the display area. (Pressing the [2] key increments the test item and pressing the [8] key decrements the test item.)
2. The setting items that can be applied to the test print only is displayed in the lower row of display area. Keep pressing the [2], [8] key until the desired menu item is displayed. (Pressing the [2] key increments the test item and pressing the [8] key decrements the test item.) (If all setting items need no entry [Default setting], go to step 5.)
3. Keep pressing the [2], [8] key, and press the [6] key at the menu item set by step 2. Then, the setting item is displayed in the upper row of display area, and the setting value is displayed in the lower row of display area.

Pressing the [2] key increments the setting value. Pressing the [8] key decrements the setting value. (The setting value that is displayed at last is applied.) Pressing the [4] key determines the entry value, and returns to step 2. Repeat step 3 as required.

TEST PATTERN
1

Display	Setting value	Function
PRINT EXECUTE	–	Pressing the [6] key starts print/Pressing the [#] key terminates print. (In units of page)
TEST PATTERN	0	0: White paper print 1~7: Refer to next page. (Pattern print) 8~15: White paper print
TEST CASSETTE	TRAY1	Selecting source of paper supply.
	TRAY2	If the TRAY 2 is not installed, TRAY2 is not displayed.
	MPT	
PAGE	0000	Setting number of the test print copies
DUPLEX	OFF	Selecting OFF for duplex (2-sided) print. Duplex (1-sided) print is performed by the stack of one sheet of paper.
	1 PAGES STACK	

- is the initial default value. The menu item that is set here is valid in this menu item only.
(The setting item is not saved in EEPROM.)

Note! PAGE setting

Pressing the [2] key or the [8] key shifts the digit. Pressing the [×] key increments the setting value. Pressing the [#] key decrements the setting value. If print is executed while the number of print copies remains in "0000", printing will continue infinitely.

- While the message "PRINT EXECUTE" that is set by the operation specified in step 2 is being displayed, press the [6] key and the test print is executed with the setting value that has been set by steps 2 and 3.

Pressing the [#] key stops the test print.

If any alarm that is shown in the following details column is issued at startup of test print or while test print is in progress, the test print is interrupted. (For error details, refer to section 6.5.1 LCD Status Message/ Trouble Table. However, the comment to be displayed is different in the case of the PU test print.)

Panel display	Details
PAPER END SELECTED TRAY	No paper
SELECTED TRAY IS NOT INSTALLED	Selected tray is not installed.
INSTALL CASSETTE TRAY OPEN	Cassette removal

Print pattern (It cannot be used for checking PQ.)

0 to 15..... White paper print

- During printing, the following messages are displayed.

P=***

P : Number of test print copies (unit: copies)

- Displays are switched by pressing the [2] key.

T=*** U=***[###]
H=***%

U : *** = Upper heater temperature measurement value [unit:°C]

[***] = Print execution target temperature [unit:°C]

T : Environment temperature measurement value [unit:°C]

H : Environment humidity measurement value [unit: %]

- Displays are switched by pressing the [2] key.

KTR=* . **

KTR indicate the transfer voltage setting value. (unit: KV)

- Displays are switched by pressing the [2] key.

KR=*.**

KR : BLACK transfer roller resistance value [unit: uA]

- Displays are switched by pressing the [2] key.

ETMP=***UTMP=***

ETMP : Environment temperature [unit: DEC]

UTMP : Fuse target temperature [unit: DEC]

- Displays are switched by pressing the [2] key.

DB:k**

DB : Develop voltage setting table ID number [unit: HEX]

- Displays are switched by pressing the [2] key.

TR1:k**
TR2:k**

TR1 : Transfer voltage parameter VTR1 table ID number [unit: HEX]

TR2 : Transfer voltage parameter VTR2 table ID number [unit: HEX]

- Displays are switched by pressing the [2] key.

TROFF:**

TROFF : Transfer OFF voltage setting table ID number [unit: HEX]

- Repeat steps 2 to 4 as required.
- Pressing the [#] key terminates the test. (Returns to the status of step 1.)

6.4.2.6 Consumable item counter display

This self-diagnostic menu is used to display the consumption status of the consumable items.

1. Enter the self-diagnostic mode (level 1), press the [2] or [8] key repeatedly ,and press the [6] key when the "CONSUMABLE STATUS" is displayed in the upper row of the display area. (Pressing the [2] key increments the test item and pressing the [8] key decrements the test item.)
2. When the [2], [8] key is pressed, consumption statuses of the consumable items are displayed in order. (Pressing the [x] or [#] key is invalid.)
3. Pressing the [4] key terminates the test. (Returns to the status of step 1.)

Display area, upper row	Display area, lower row	Format	Unit	Details
K-ID UNIT	*****IMAGES	DEC	Images	It shows the number of rotations counted after installation of a new ID UNIT on a three A4 Pages/Job basis.
K-TONER	*****%	DEC	%	It shows the amount of toner consumption.
K-STC MODE CNT	***** * 8192	DEC	DOT	It shows the number of print dot counts of the toner. (It is a cumulative value counted after the first use of the printer.)
K OVER RIDE CNT	*****TIMES	DEC	Times	It shows the number of overrides of life warnings for the toner cartridge.

6.4.2.7 Number of print copies counter display

This self-diagnostic menu is used to display status of the number of copies of a printer.

1. Enter the self-diagnostic mode (level 1), press the [2] or [8] key repeatedly ,and press the [6] key when the "PRINTER STATUS" is displayed in the upper row of the display area. (Pressing the [2] key increments the test item and pressing the [8] key decrements the test item.)
2. When the [2], [8] key is pressed, statuses of the number of print copies are displayed in order. (Pressing the [x] or [#] key is invalid.)
3. Pressing the [4] key terminates the test. (Returns to the status of step 1.)

Display area, upper row	Display area, lower row	Format	Unit	Details
K-TOTAL DRUM CNT	*****IMAGES	DEC	Images	It shows the cumulative number of rotations.
TOTAL SHEET CNT	*****COUNTS	DEC	Prints	Total number of print copies are displayed.

6.4.2.8 Switching between the Factory mode and the Shipping mode

This self-diagnostic menu item is used to switch between the Factory mode and the Shipping mode.

1. Enter the self-diagnostic mode (level 1) and keep pressing the [2] or [8] key until the following message is displayed.

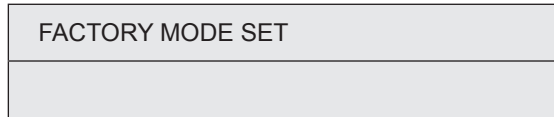

2. When the [6] key is pressed, the following message is displayed. Keep pressing the [2] or [8] key until the target item (refer to the following table) is displayed.

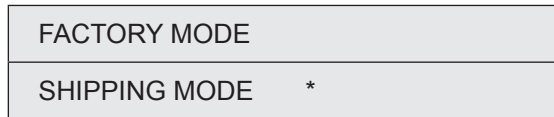

3. While the desired item to set is being displayed, press the [6] key that enables selection of the setting values.
4. While the desired setting value is being displayed, press the [6] key that registers the displayed value in EEPROM. (Returns to the status of step 2.)
5. Repeat steps 2 to 4 as required.
6. Pressing the [4] key terminates the test. (Returns to the status of step 1.)

Display	Setting value	Function
FACTORY MODE	FACTORY MODE	Sets the Factory working mode (fuse cut invalid mode).
	SHIPPING MODE	Releases the Factory working mode to make the fuse cut function valid.
FUSE INTACT Note: ***** indicates INTACT or BLOWN.	K-ID UNIT *****	Checks the fuse status of the K-ID unit.

6.4.2.9 Self-diagnostic function setting

This self-diagnostic menu is used to set valid/invalid of the error detection by the various sensors.

The error detection can be made invalid or valid for locating source of abnormality. However, this menu item requires expert knowledge to set among the engine operations. Handle this menu item with utmost care.

Be sure to return the setting to the default setting upon completion of usage of this item.

1. Enter the self-diagnostic mode (level 1) and keep pressing the [2] or [8] key until the following message is displayed.

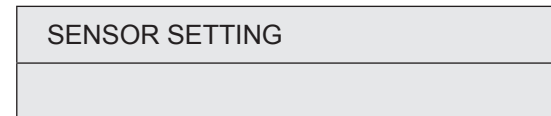

2. When the [6] key is pressed, the following message is displayed. Keep pressing the [2] or [8] key until the target item (refer to the table below) is displayed.



3. When the [6] key is pressed, the following message is displayed.
Pressing the [2] key increments the setting value.
Pressing the [8] key decrements the setting value.
4. While the desired setting value is being displayed, press the [6] key that registers the displayed value in EEPROM. (Returns to the status of step 2.)
5. Repeat steps 2 to 4 as required.
6. Pressing the [4] key terminates (except the status of step 4) the setting. (Returns to the status of step 1.)

Display	Setting value	Operation at the setting value	Function
TONER SENSOR	ENABLE	Detects	Valid/Invalid of toner sensor operation.
	DISABLE	Not to detect	
ID UNIT CHECK	ENABLE	Checks	Valid/Invalid of ID installation check operation.
	DISABLE	Not to check	
DRUM OVER LIFE	STOP	Not to continue	The restriction on extending the life of toner-related items five times is lifted.
	CONTINUANCE	To continue	
WR POINT REV TBL=**H±*.***mm	00H~FFH	Correction value	The correction value is added to the existing write-down position.
BOTTOM WRT POINT TBL=**H±*.***mm	00H~FFH	Cut value	Amount of cut at the rear end of a paper is set.
T1 DOT SHIFT **H mm	0H-FH	Correction value	The dot shift amount for TRAY1 is set.
T2 DOT SHIFT **H mm	0H-FH	Correction value	The dot shift amount for TRAY2 is set.
MPT / MN DOT SHIFT **H mm	0H-FH	Correction value	The dot shift amount for MPT/ MN is set.

Hatched portion: Default is shown

6.4.2.10 LED head serial number display

This self-diagnostic menu item is used to check whether the downloaded LED head data matches the serial number of the actual LED head.

1. Enter the self-diagnostic mode (level 1), press the [2] or [8] key repeatedly, and press the [6] key when the "LED HEAD DATA" is displayed in the upper row of the display area. (Pressing the [2] key increments the test item and pressing the [8] key decrements the test item.)
2. When the [2] key or the [8] key is pressed, serial numbers of the K LED head data are displayed in order.
3. Pressing the [4] key terminates the test. (Returns to the status of step 1.)

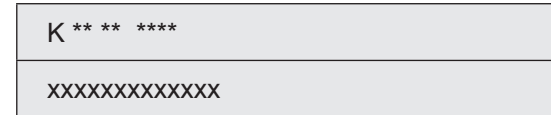

** * * **** : Rev number

XXXXXXXXXXXXXX : serial number

6.4.2.11 NVRAM parameter setting

Do not use this menu item.

6.4.3 Adjustment at part replacement

Adjustment is necessary while replacing the following part.

Replacing part	Adjustment
Main PCB board	EEPROM data upload / download

6.4.3.1 EEPROM data upload / download method

In the case of replacing the Print Board of Controller, copy the old EEPROM content to the new EEPROM of new board and then save the customer setting. To operate this, use Maintenance Utility.

About the operating method of Maintenance Utility, refer to Maintenance Utility Operating Specification.

Maintenance Utility is designed for working place engineer use only. It is not released to the end user.

Refer to 6.3.1 of Maintenance Utility Manual.

6.5 Switch pressing function when power supply is turned on

When power supply of printer is turned on, the functions of usable switches are as follows. And, the switches below are effective when pressed before LED is lighted in the special start confirming pattern.

- (1) [1] key and [▶] key

Despite of warning/error, always start by online mode (factory support function).

- (2) [▼] key and [STOP] key

Initialize NIC settings to Factory defaults.

When executing this initialize, all network settings will be returned to Factory defaults.

It's not use in normal condition.

6.6 Settings after Parts Replacement

The necessary adjustments after the parts exchange are explained as follows.

Replaced Part	Adjustment
LED Head	Not required.
Image Drum Cartridge	Not required.
Main (CU/PU board (98M))	Copy the EEPROM information; utility is required. Upgrade firmware by Firmware suite. See 9.3 Firmware Information.
SU board (MHE)	Copy the setting parameter of Scanner; utility is required.
Scanner Unit (Maintenance)	Setup of Country Code for Fax (mandatory). Upgrade firmware by Firmware suite. See 9.3 Firmware Information.

6.6.1 Notes on CU/PU board (98M) replacement

- When the EEPROM on a board to remove can be accessed (when SERVICE CALL 104 [Engine EEPROM Error] or 40 [EEPROM Error] is not displayed):
 - Remove information from the EEPROM in the PU block, and setting information from the EEPROM in the CU block, of the board, and temporarily store them onto an HDD of a computer, by using the board replacement function of Maintenance Utility (Maintenance Utility Operating Manual, section 2.4.1.1.9 about board replacement functionality).
 - By using the board replacement function, copy the information and setting information into the EEPROM of a board to replace with.
 - When only the information or setting information can be removed from the board to replace, copy it into the EEPROM of the replacement board by using the board replacement function. With the board replacement function, separately configure the other information, which cannot be removed. Perform PU-block serial-number setting (Maintenance Utility Operating Manual, section 2.4.1.1.9.5), and make a change to the Shipping mode (Maintenance Utility Operating Manual, section 2.4.1.1.9.6), in setting windows when the

information cannot be removed. Configure CU-block serial number information (Maintenance Utility Operating Manual, section 2.4.1.1.9.4) when the setting information cannot be removed.

Note! When removing or writing information from/into the EEPROM by using Maintenance Utility, use the procedure shown below to place the printer to the Forced ONLINE mode before accessing the EEPROM. Even in the forced ONLINE mode, the printer provides an error indication when having an error.

- The printer displays ONLINE when operating properly, and provides an error indication when having an error, where the printer is internally online, being ready to communicate.
- When the EEPROM on a board to remove cannot be accessed:

When the operator panel displays SERVICE CALL 104 (Engine EEPROM Error) for, or data cannot be read from the EEPROM of, a board to remove, follow the following procedure to perform operation by using Maintenance Utility after the board is replaced with a new one:

- [When facing OEL]
 - (1-1) Set the PU serial number
(Maintenance utility operation manual, Section 2.4.1.2, PU circuit board setting)
SAP serial number can be applied to the device. The SAP serial number is displayed in the highest rung of the serial number label. It is a 12-digit number including production place (2 digits), production year (2 digits), sequence number (6 digits) and revision number (2 digits).
 - PU serial number is a 10-digit number which is basically the same as SAP serial number except that it has no the 2-digit revision number.
 - Set on the menu of [Section 2.4.1.1.2.1, PU serial number setting] of [Section 2.4.1.1.2 PU circuit board setting function].

- If you want to specify the PU serial number, please add a "0" (a normal-width zero) then input the 11-digit number. (Please notice that when read out, the number will be 10 digits.)
As shown in the following image, on the menu of [PU serial number setting], eliminate the 2-digit revision number then add a normal-width zero to the 10-digit number and input it.

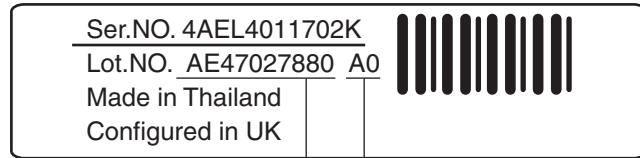

Add one-byte 0 to the top of 10-digit figure of Lot.NO.
Set "0AE47027880" in the setting screen.

Figure of Serial No. label image (labeled in UK Factory)

- PU serial number will be output to the Printer Serial Number column in the header of Status Page. For this reason, check of PU serial number is performed by printing Status Page.
- After the configuration in the UK factory, when facing OEL, the PU serial number is taken as Lot Number and shown in the Lot Number: column of the last line which is in the header of the Status Page.

(1-2) Set the CU serial number

SAP serial number can be applied to the device. The SAP serial number is displayed in the highest rung of the serial number label. It is a 12-digit number including production place (2 digits), production year (2 digits), sequence number (6 digits) and revision number (2 digits).

- CU serial number is given an original number which is within 12 digits in the UK factory.
- Please notice that if you set the CU serial number, the menu setting in CU will be reset (back to the default setting). (For reference, Maintenance utility operation manual)

- On the menu of [Section 2.4.1.1.4.3, Serial number information setting] of [Section 2.4.1.1.4 CU circuit board setting function], set the [Choose printer serial number] to [CU serial number] and [Output mode] to [Show both].
- If you want to specify the CU serial number, please input the 12-digit number. (When read out, it will be 12 digits, too.)

Input 12 digits for Ser. NO. Input "4AEL4011702K".



Figure of Serial No. label image (labeled in UK Factory)

- CU serial number is shown in the Printer Serial Number Column in the header of Status Page. Therefore, the confirmation of the CU serial number after the change can be done by printing the Status Page.
- The PU serial number is shown in the Lot Number: column of the last line which is in the header of the MenuMap.

(2) [When not facing OEL]

(2-1) Set the PU serial number

(Maintenance utility operation manual, Section 2.4.1.2, PU circuit board setting) SAP serial number can be applied to the device. The SAP serial number is displayed in the highest rung of the serial number label. It is a 12-digit number including production place (2 digits), production year (2 digits), sequence number (6 digits) and revision number (2 digits).

- PU serial number is a 10-digit number which is basically the same as SAP serial number except that it has no the 2-digit revision number.
- Set on the menu of [Section 2.4.1.1.2.1, PU serial number setting] of [Section 2.4.1.1.2 PU circuit board setting function].
- If you want to specify the PU serial number, please add a "0" (a normal-width zero) then input the 11-digit number. (Please notice that when read out, the number will be 10 digits.)

As shown in the following image, on the menu of [PU serial number setting], eliminate the 2-digit revision number then add a normal-width zero to the 10-digit number and input it.

Add one-byte 0 to the top of 10-digit figure of 12-digit SAP serial number to set. Set "0AE01234567" in the setting screen of PU serial number.

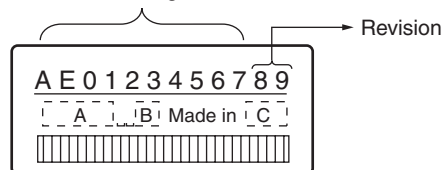

Figure of Serial No. label image

- PU serial number will be output to the Printer Serial Number column in the header of Status Page. For this reason, check of PU serial number is performed by printing Status Page.
- After the configuration in the UK factory, when facing OEL, the PU serial number is taken as Lot Number and shown in the Lot Number: column of the last line which is in the header of the Status Page.

(2-2) Set the CU serial number

CU serial numbe setting is unnecessary When not facing OEL.

(3) Change to Shipping mode (section 2.4.1.1.10.4 of Maintenance Utility Operating Manual)

The printer is placed in the Factory mode after the CU/PU board is replaced with a new one. Switch the printer to the Shipping mode.

- Use the window for the Factory/Shipping mode described section 2.4.1.1.10.4 in Maintenance Utility section 2.4.1.1.10 about board setting functionality

Note! Note that replacing the EEPROM (the engine control board) clears life information about units, including the toner and image drums, causing errors in managing the lives of the units until the units are replaced. Below is the counts cleared with such CU/PU board replacement. When the units are replaced with new ones, their respective counts except for Total Sheets Fed are cleared, the errors being corrected.

Item	Description	Count description
Image drum unit	Each the image drum unit life count for a color.	A value converted on an A4 page basis from the number of pages printed to date after installation of a new image drum unit.
Total number of sheets	A printer life count.	The total number of sheets fed.
Print black	Each the number of pages printed with an image drum.	The number of pages printed after installation of a new image drum unit.

6.6.2 Notes on SU board (MHE)/Scanner Unit replacement

1. Set the Scanner parameter when replacing the SU board (MHE)/Scanner Unit :
Before replacing the SU board (MHE)/Scanner Unit, try to get the scanner setting parameters from the board by using the SU board (MHE)/Scanner Unit replacement function of Maintenance Utility, if it is still able to be accessed by Maintenance Utility.

After replacing the SU board (MHE)/Scanner Unit to new one, restore the scanner setting parameters to new one by using Maintenance Utility. For further information, refer the instruction of the manual of Maintenance Utility.

7. REGULAR MAINTENANCE

7.1 Periodic Maintenance	7-2
7.2 Cleaning Rollers in the ADF	7-4
7.3 Cleaning the Document Glass.....	7-5

7.1 Periodic Maintenance

7.1.1 Periodic Replacement Parts

The following parts should be replaced at a specified cycle.

Name	Conditions	Cleaning	Remarks
Toner Cartridge	After printing approx. 4,000 pages	LED head	Consumables
Image Drum Cartridge	After printing approx. 44,000 pages See 1.4 (15).		Consumables

Note! After using a normal cartridge, the starter toner cartridge (attached at the printer purchase) can not be used. Use the starter toner cartridge first, and then, use the normal toner after [LOW TONER] is displayed.

7.1.2 Cleaning

Remove toner powder and dust in the printer inner section. Clean the inside of and the periphery of the printer with the cloth as needed. Clean the printer inner section with the handy cleaner (maintenance tool).

Note! Do not touch the image drum, LED lens array, and LED head terminal.

7.1.3 Cleaning of LED lens array

If the vertical white lines, and white belt (white spot, pale printing) occur in printing as shown below, the LED lens array should be cleaned or the toner cartridge should be replaced.

Note! As for the LED lens array, clean it with soft tissues or soft cloth after eliminating static electricity of a maintenance tool.

White lines or White belt
(White spot, pale printing)



Wipe the whole LED head softly with the soft tissues or cloth.

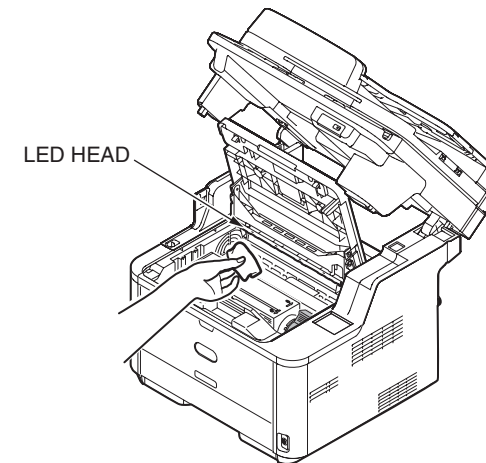

Note! Do not use solvents including methyl alcohol, and thinner.

7.1.4 Cleaning the Feed rollers and the Retard roller

- (1) Wipe the two feed rollers with a tightly wrung cloth soaked in water through the opening for installation of a paper cassette.

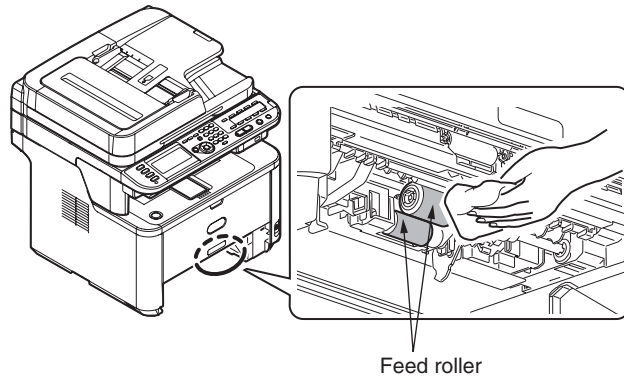

Note! Use water only.

- (2) Wipe the Retard roller of the paper cassette with a tightly wrung cloth soaked in water.

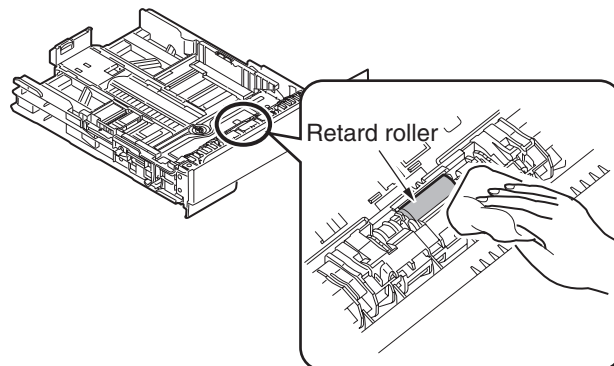

Note! Use water only.

7.2 Cleaning Rollers in the ADF

If the document feeding rollers in the ADF are contaminated with ink, toner particles or paper dust, documents and outputs get dirty and a paper jam may occur. To prevent this, it is recommended to clean the rollers once a month.

- (1) Turn off the power of MFP.
- (2) Open the ADF cover.

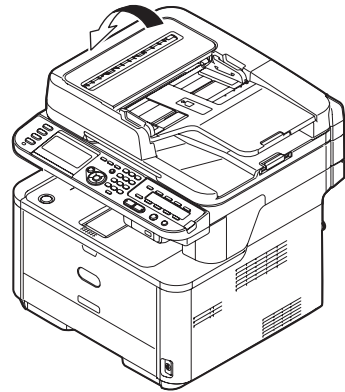

- (3) Wipe the document feeding rollers and surface of the Guide and the rubber pad and the rubber sheet with a soft cloth lightly moistened with water.
Wipe the whole surface of the roller and rubber pad while turning it with your hand.

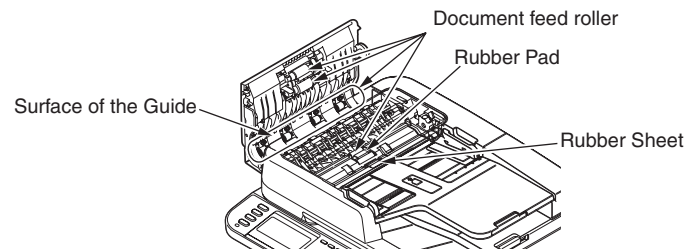

Note! If the rollers get too dirty, wipe them with a soft cloth lightly moistened with neutral detergent, and then wipe it again with a soft cloth lightly moistened with water..

- (4) Close the ADF Cover.

7.3 Cleaning the Document Glass

It is recommended to clean the document glass once a month to maintain image quality of the printouts.

- (1) Open the document glass cover.
- (2) Wipe the document holding pad, document glass and ADF document glass surface with a soft cloth lightly moistened with water.

Caution! Do not use benzine, thinners or alcohol as a cleaning agent. They may damage the plastic parts of the MFP.

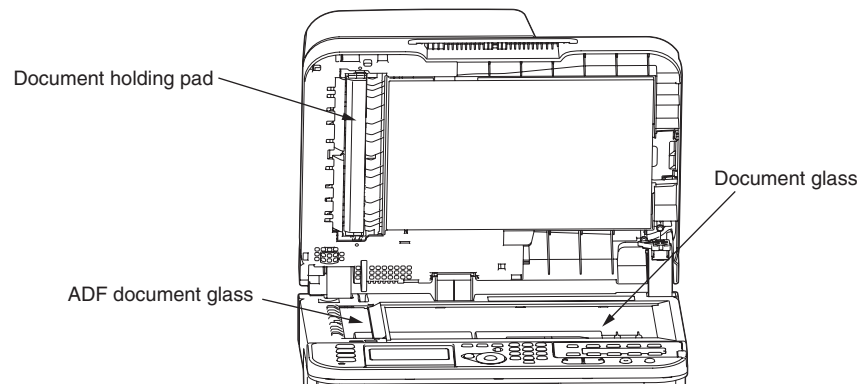

- (3) Close the document glass cover.

8. TROUBLESHOOTING PROCEDURES

8.1 Precautions prior to repair	8-2
8.2 Items to be checked prior to taking action on abnormal images ..	8-2
8.3 Precautions when taking action on abnormal images	8-2
8.4 Preparations for troubleshooting.....	8-2
8.5 Troubleshooting method	8-3
8.6 Fuse Checking.....	8-73

8.1 Precautions prior to repair

- (1) Confirm the basic check items indicated in the User's Manual.
- (2) Through hearing from the user, obtain information, as far in detail as possible, on the situation concerning the fault.
- (3) Inspect the printer in a condition close to the actual situation in which the fault occurred.

8.2 Items to be checked prior to taking action on abnormal images

- (1) Check to see if the printer is operated in an adequate environment.
- (2) Check to see if the consumables (toner, drum cartridges) are replaced properly.
- (3) Check to see if the right paper is used. See the paper specifications.
- (4) Check to see if the drum cartridges are installed properly.

8.3 Precautions when taking action on abnormal images

- (1) Do not bring your hand or any object in contact with the surface of the OPC drum.
- (2) Do not expose the OPC drum to direct sun.
- (3) Do not touch the fuser unit, which can be very hot.
- (4) Do not expose the image drums to light for over five minutes at the room temperature.

8.4 Preparations for troubleshooting

- (1) Display of LCD

The breakdown situation of this machine is display in LCD.

Do an appropriate trouble repair based on information displayed in LCD.

8.5 Troubleshooting method

If a trouble occurs in the printer, search for it by the following procedure:

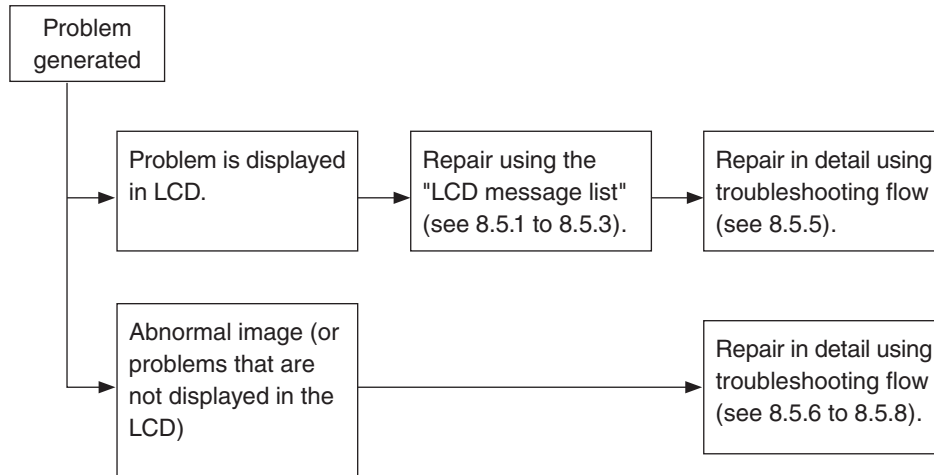

8.5.1 LCD messages list

Initializing & Shutdown

No.	Category	PJL Status Code	Error Warning	Description
1	Initializing	-	1 Menu Resetting 2 3 4 5	Indicates that EEPROM of the controller side is being reset. The condition that EEPROM is reset includes the followings. - Changes of destination channel - Compulsive initialization of EEPROM - Reset by a FactoryDefaults operator of PS - OEM set of PJL command
2	Initializing	-	1 Wait a moment. 2 Network initializing ... 3 4 5	The network is in initializing. If this status occurred during the unit initializing the message is displayed by English.
3	Initializing	-	1 Flash Memory Format 2 3 4 5	Displays that Flash memory is being formatted. It is displayed it when Resident/Option Flash memory not formatted are detected, or "Service Menu"- "System Maintenance"- "Format Flash Memory" of a system maintenance menu is performed. The function mentioned above is secret to users. Therefore, this status does not occur in a user environment.

No.	Category	PJL Status Code	Error Warning	Description
4	Initializing	-	1 Checking File System 2 3 4 5	Displays that SD Card file system is being checked. Process Check of File System is valid to start from "Management"->"Storage Maintenance Setup" of Admin Setup Menu, or "Check File System" of Boot Menu.
5	Initializing	-	1 Erasing Disk 2 %PERCENT% 3 4 5	Indicates that the SD Card is being erased. Erase process of the hard disk is valid to start from "Management"->"Storage Maintenance Setup"->"Erase SD Memory Card " of Admin Setup Menu. %PERCENT% : A ratio of the capacity that elimination was finished.

No.	Category	PJL Status Code	Error Warning	Description
6	Initializing	-	1 %STORAGE% Error: %ERRCODE% 2 To %STORAGE% 3 format, select [Format] 4 To shut down, select [Cancel] 5	%ERRCODE% : 0 Indicates that the unformatted storage is detected during the initializing. %ERRCODE% : 250 Indicates that machine detected broken file about secure print. Needs to format once again. [Format] pressed, Storage format is started and the unit is rebooted automatically. [Cancel] pressed, the unit is shut down. ----- The following is changed by a status parameter. %STORAGE% : HDD SD Card %ERRCODE% : Error Code
7	Shutdown	-	1 Shutdown in progress. 2 Please wait. The machine 3 turns off automatically. 4 5	It is shown that a unit is shutting down.

Normal

No.	Category	PJL Status Code	Error Warning	Description
1	Normal	40988	1 PU downloading ... 2 3 4 5	Downloading PU F/W (This is not user-level error) This function is secret to users. Therefore, this status does not occur in a user environment. It occurs during downloading firmware of option tray.
2	Normal	-	1 Updating ROM. 2 Please keep power ON. 3 4 5	Downloading scanner unit (Scanner, Fax, Panel) FW.
3	Normal	40825	1 Wait a moment. 2 Message Data processing ... 3 4 5	Indicates that message data to be updated is being processed.
4	Normal	40826	1 Wait a moment. 2 Message Data writing ... 3 4 5	Indicates that message data to be updated is being written.
5	Normal	40827	1 Power OFF/ON 2 Message Data written OK. 3 4 5	Indicates that message data to be updated has been written successfully.

No.	Category	PJL Status Code	Error Warning	Description
6	Normal	40828	1 Please check data. 2 Message Data Write Error %CODE% 3 4 5	Indicates that writing of message data to be uploaded has been failed. %CODE% is a decimal value (one digit) and represents the cause of failure in writing. = 1 ... FAIL: Other errors. = 2 ... DATA_ERROR: Hash check error in data reading/writing, or abnormal FLASH = 3 ... OVERFLOW: Downloading failure due to FLASH memory full at starting or during writing in a language file = 4 ... MEMORYFULL: Memory reservation failure = 5 ... UNSUPPORTED_DATA: Downloading data unsupported on the MFP
7	Normal	30993	1 Wait a moment. 2 Network initializing ... 3 4 5	This appears when the NIC initialization is occurred, as the setting was changed.
8	Normal	40967	1 Wait a moment. 2 Program Data receiving ... 3 4 5	Indicates that receiving the NIC download data.
9	Normal	40967	1 Wait a moment. 2 Program Data received OK. 3 4 5	Indicates that finished receiving the NIC download data.

No.	Category	PJL Status Code	Error Warning	Description
10	Normal	40967	1 Please check data. 2 Program Data Receive Error <%DLCODE%> 3 4 5	An error has happened while the printer is receive-processing the NIC download data. %DLCODE% 1: File size error 2: Check-sum error 3: Invalid printer model number 4: Invalid module I/F version 5: Invalid FAT version
11	Normal	40967	1 Wait a moment. 2 Program Data writing ... 3 4 5	The printer is writing the NIC download data.
12	Normal	40967	1 Power OFF/ON 2 Program Data written OK. 3 4 5	The printer finished writing the NIC download data.
13	Normal	40967	1 Please check data. 2 Program Data Write Error <%DLCODE%> 3 4 5	An error has happened while the printer is writing the NIC download data. %DLCODE% 1: Memory allocation error 2: Download file error 3: Device allocation error 4: No device space 5: File writing failure 6: CU-F/W mismatch
14	Normal	10798	1 SIP update in progress. 2 3 4 5	Indicates that downloading the SIP firmware data.

No.	Category	PJL Status Code	Error Warning	Description
15	Normal	-	1 Please check data. 2 Program Data Write Error <%DLCODE%> 3 4 5	Indicates that an error has happened while writing the SIP download data. %DLCODE% 1: Data transfer error 2: No device space 3: Check sum error 4: Chip detection error 5: Chip erase error 6: Chip writing error 7: Chip verify error 8: Data error (Product code is wrong e.t.c.) 9: Data size error
16	Normal	10795	1 %RDYMSG% 2 3 4 5	Indicates that the unit date is being updated by using PJL command.
17	Normal	10796	1 %RDYMSG% 2 3 4 5	Indicates that the requested process is finished. "Passed" is displayed, if the process is completed correctly. "Failed" is displayed, if the process is finished with an error. This indication disappear automatically after it displayed for three seconds.
18	Normal	10759	1 Wait a moment. 2 Executing maintenance. 3 4 5	Executing maintenance. While this status occurs, panel is locked.
19	Normal	40090	1 Error Postscript 2 3 4 5 Close	Interpreter detects an error due to the following reason. Receive data after this is ignored until the job completion. - The job has a grammatical error. - The page is complicated, and VM was used up.

No.	Category	PJL Status Code	Error Warning	Description
20	Normal	40994	1 Memory Overflow 2 3 4 Please see Help for details. 5 Close	Memory Overflow was occurred in the collate print.
21	Normal	30962	1 Expired Secure Job 2 3 4 Please see Help for details. 5 Close	Indicates that an applicable job has been automatically deleted as the retention period for authentication printing has expired.
22	Normal	30963	1 Received invalid data. 2 3 4 Please see Help for details. 5 Close	Indicates that a job has been deleted because corruption of data has been detected by the integrity verification in authentication printing.
23	Normal	10823	1 Access Limitation Error 2 Data was deleted due to the printing limitation. 3 4 Please see Help for details. 5 Close	Notifies users that jobs were cancelled because they are not permitted for printing. (Related to JobAccount Color Access Contorl.).
24	Normal	30938	1 Decode error occurred. 2 Please check image data. 3 4 5 Close	Indicates that an error has occurred during analysis of image data input to the MFP from an external source. This appears when an error has occurred during analysis of TIFF or JPEG data in A05: DirectPrint, A07: InternetFAX, E-mailPrint, or FaxToPrint (saving sent/received data) mode.

No.	Category	PJL Status Code	Error Warning	Description
25	Normal	-	1 Access denied to PC. 2 Please check PC. 3 4 5 Close	Indicates that PC rejects a PushScan request. (Select Close with the cursor and) press [OK] button, and the display will return to ScanTo standby screen. (At present, screens to return to after errors have been reset vary from function to function. It is desirable to return to the same screen.)
26	Normal	30929	1 Error PDF 2 3 4 5 Close	It appears when a PDF file contains a syntax error.
27	Normal	-	1 Invalid Password 2 3 4 5 Close	Notifies that the entered password does not match the password set to encrypted PDF. The file will not be printed unless the passwords match.
28	Normal	-	1 This document restricts printing to a valid owner password. 2 3 4 5 Close	PDF is print-restricted. The file will not be printed unless the owner password is entered.
29	Normal	-	1 USB Memory disconnected. 2 3 4 5 Close	Indicates that the USB memory is disconnected while PrintFromUSBMemory is running. Reading of the image file is cancelled.
30	Normal	-	1 Cannot open the file. 2 3 4 5 Close	Notifies that the specified file cannot be opened.

No.	Category	PJL Status Code	Error Warning	Description
31	Normal	-	1 Cannot read the file. 2 3 4 5 Close	Notifies that processing has failed, for instance, because of a fault in the equipment in which the data was to be stored.
32	Normal	-	1 E-mail receiving has been cancelled. 2 3 4 Please see Help for details. 5 Close	Indicates that Email receiving has been canceled. It has the following possibilities. - The format of email that has received is illegal or not supported. - The attached file is illegal or not supported. - The attached file that has received is too large, for example, file size exceeds 8MB. - Network connection has disconnected.
32	Normal	-	1 Status Mode 2 3 4 5	Displays that normal Online mode starts. Data (Job) from an external portion is processed even though an error takes place after Online (ready) state once this mode starts. Displays Error or Warning on a panel. This function is secret to users. Therefore, this status does not occur in a user environment.
33	Normal	10002	1 <Print Stand-by Screen> 2 Offline 3 4 ----- 5 <Status Key> Offline Mode	Shows Offline status.

No.	Category	PJL Status Code	Error Warning	Description
34	Normal	10993	1 File accessing ... 2 3 4 5	The status showing FILE SYSTEM (SD Card/HDD/FLASH) is being accessed.
35	Normal	10061	1 Data arrive. 2 3 4 5	Data receiving, process not started yet. Displayed mainly during PJL process without text print data or during job spooling.
36	Normal	10023	1 Processing ... 2 3 4 5	Data receiving or output processing
37	Normal	10096	1 Data present. 2 3 4 5	Un-printed data remains in Buffer. Waiting for data to follow.
38	Normal	10098	1 Print page %PAGES% No. of Copies %A%/ %B% 2 3 4 5	Printing the following print job and reports. - PC Printing - Engine Status - File System Error Report - T30 Monitor - MFP Usage Report "Print page" means the current number of printing page (%PAGES%). "No of Copies" is displayed as "%A%/ %B%". %A%: The number of copy in printing. %B%: the total number of printing.
39	Normal	10017	1 Demo Page printing ... 2 3 4 5	Printing Demo Pages. Indicates that the stored Demo Print data is printing, and the installed Demo Print data in Flash/ HDD is printing.

No.	Category	PJL Status Code	Error Warning	Description
40	Normal	10015	1 2 3 4 5	Font List printing ... Printing Font Lists. Indicates that printing sample data of the following fonts. - PCL Font List - PSE Font List - PPR Font List - FX Font List
41	Normal	10014	1 2 3 4 5	Configuration printing ... Printing Configuration. Indicates that printing of menu items and the current settings.
42	Normal	10056	1 2 3 4 5	File List printing ... Printing File Lists. Indicates that printing of the stored File (except hidden files) list in File system (FLASH/SD Card).
43	Normal	10057	1 2 3 4 5	Error Log printing ... Printing Error Logs
44	Normal	10942	1 2 3 4 5	Network Information printing ... It is shown that a network setup is printing. - Network Information - Network Syslog If chosen by menu "Reports"- "System"- "Network Information", printing of a network setup will be started.
45	Normal	10891	1 2 3 4 5	MFP Usage printing ... Printing MFP Usage Report.
46	Normal	10889	1 2 3 4 5	Scan To Log printing ... Printing Scan to Log.

No.	Category	PJL Status Code	Error Warning	Description
47	Normal	10099	1 2 3 4 5	Print page %PAGES% No. of Copies %A%/B% Collate printing. "Print page" means the current number of printing page (%PAGES%). "No of Copies" is displayed as "%A%/B%". %A%: The number of copy in printing. %B%: the total number of printing. The unit of "Print page" is "Impression". In simplex printing, "Print page" counter is increased by 1 when the paper exited from fuser. In duplex printing, "Print page" counter is increased by 2 when the paper exited from fuser (after the back side printed out).
48	Normal	10099	1 2 3 4 5	Print page %PAGES% No. of Copies %A%/B% Copy printing. "Print page" means the current number of printing page (%PAGES%). "No of Copies" is displayed as "%A%/B%". %A%: The number of pages in printing. %B%: The total number of printing. The unit of "Print page" is "Impression". In simplex printing, "Print page" counter is increased by 1 when the paper exited from fuser. In duplex printing, "Print page" counter is increased by 2 when the paper exited from fuser (after the back side printed out).

No.	Category	PJL Status Code	Error Warning	Description
49	Normal	10897	1 Verifying data. 2 3 4 5	Indicates that the integrity of print data for encrypted authentication is being verified (for corruption and tampering).
50	Normal	10007	1 Deleting data. 2 3 4 5	Indicates that job cancellation has been instructed and data is being ignored until the job completion.
51	Normal	10007	1 Deleting data. 2 3 4 5	Indicates if JAM occurs when Jam Recover is OFF, that job cancellation has been instructed and data is being ignored until the job completion.
52	Normal	10007	1 Deleting data. 2 3 4 5	Indicates a job being cancelled due to no print permit. (Related to JobAccount) 1. A job received from a user who is denied printing. 2. A color job received from a user who is denied color printing.
53	Normal	10003	1 Warming up 2 3 4 5	Warming up.
54	Normal	32002	1 File System is full. 2 3 4 5 Please see Help for details.	Disk-full is occurring. Because this is a temporary warning, it remains until the end of the job and disappears.
55	Normal	32026	1 File System is write protected. 2 3 4 5 Please see Help for details.	An attempt to write in a read-only file was done. Because this is a temporary warning, it remains until the end of the job and disappears.

No.	Category	PJL Status Code	Error Warning	Description
56	Normal	10898	1 File erasing ... 2 3 4 5	Indicates that a secret file is being erased.
57	Normal	30961	1 Deleting encrypted job. 2 3 4 5	It indicates the deletion of encrypted authentication print job and saving of deletion request of file.
58	Normal	30956	1 Wait a moment. 2 Network Configuration writing ... 3 4 5	This appears during the NIC configuration data is storing into the flash memory, as the setting was changed.
59	Normal	-	1 Cancelling ... 2 3 4 5	Indicates that copy job is cancelling.
60	Normal	10863	1 <Scan To Mail/ Network PC 2 Screen> 3 Scanning ... 4 5 P.%SCAN_PAGE% %LOCATION_INFO% %DOC_SIZE%	Indicates that it is scanning of documents. The unit of "Page" is "Impression". In duplex scanning, "Page" counter is increased by 1 when the front side of sheet scanning started, and the counter is increased by 1 when the back side scanning started.

No.	Category	PJL Status Code	Error Warning	Description
60	Normal	10863	<p><ScanToUSBMemory> Scanning ...</p> <p>P:%SCAN_PAGE% %DOC_SIZE%</p> <p><PushScan> Scanning ...</p> <p>%SCAN_PAGE%page %AP_INFO%</p> <p><PCScan> Scanning ...</p> <p><Status> Scanning ...</p> <p><Fax Sending Screen> Scanning ... %TXPAGE% Page(s) %DOC_SIZE%</p> <p><Fax Manual Sending Screen> Manual Fax sending: Sending ... %TXPAGE% Page(s) %DOC_SIZE%</p>	<p>%LOCATION_INFO%: Location Information (Scan To E-mail, Scan To Network PC only) %SCAN_PAGE% : the number of current scanning page. %DOC_SIZE% : Document size Scan Size setting is "Auto" : the detected document size. Scan Size setting isn't "Auto" : the selected scan size.</p> <p>-----</p> <p>Indicates that it is scanning of documents by ScanToUSBMemory.</p> <p>The unit of "Page" is "Impression". In duplex scanning, "Page" counter is increased by 1 when the front side of sheet scanning started, and the counter is increased by 1 when the back side scanning started.</p> <p>%SCAN_PAGE%: the number of current scanning page. %DOC_SIZE%: Document size Scan Size setting is "Auto" : the detected document size. Scan Size setting isn't "Auto" : the selected scan size.</p> <p>-----</p> <p>Indicates that it is scanning of documents by Push Scan / PC Scan. %AP_INFO% : Selected application setting.</p> <p>While a document is scanned by FAX memory transmission, status LED does not illuminate because this status is not raise.</p>

No.	Category	PJL Status Code	Error Warning	Description
61	Normal	-	<p>1 Scan Pages sss 2 Print Pages ppp 3 Copy aa/bb 4 5 ----- It cannot confirm this message from a status key.</p>	<p>Indicates that it is copying. sss: the number of current scanning page. ppp: the number of current printing page. aa: the number of current printing. bb: the total number of printing.</p> <p>The unit of "Scanned pages" is "Impression". For example, in duplex scanning, "Scanned pages" counter is increased +1 at the front side of sheet scanning started, and the counter is increased +1 at the back side scanning started.</p> <p>The unit of "Print pages" is "Impression". In simplex printing, "Print page" counter is increased by 1 when the paper exited from fuser. In duplex printing, "Print page" counter is increased by 2 when the paper exited from fuser (after the back side printed out).</p>
62	Normal	-	<p>1 <Copy Screen> 2 Please set next document. 3 4 ----- 5 <Scan To, Fax Sending Screen> Please set next document.</p>	<p>This screen is displayed at the time of the scanning completed in Job Build = ON.</p>
63	Normal	10861	<p>1 Cancelling ... 2 3 4 5</p>	<p>Indicates that the scanning for Scan To is cancelling by the pressing Stop key.</p>

No.	Category	PJL Status Code	Error Warning	Description
64	Normal	10859	1 Data writing to USB Memory. 2 3 4 5	Indicates that it is writing the image file to USB memory after the scanning completed. The cancel operation by STOP key pressing is unsupported during the writing to USB memory.
65	Normal	10797	1 Connecting to PC ... 2 3 4 5	Indicates that it is connecting to PC. This message will be displayed at Start key pressed after the original document set.
66	Normal	-	1 Telephone 2 3 4 5 Please see Help for details.	The screen that specified talking by telephone is displayed, when the handset hooked up.
67	Normal	-	1 Telephone 2 3 4 5	Indicates that the fax receiving started.
68	Normal	-	1 Fax receiving ... 2 3 Page: %RXPAGE% 4 5 ===== [F-code PollingRX] Fax receiving ... Page: %RXPAGE% %RXFAXNUMBER%	Indicates that it is receiving fax data. %RXPAGE% : number of the current receiving page %RXFAXNUMBER% : sender Fax no. (※ F -code PollingRX only) In the case that the F-code PollingRX is done by using speed dial, display field is the following... A dial number is displayed during dialing An entry name is displayed in fax no. field during fax receiving.

No.	Category	PJL Status Code	Error Warning	Description
69	Normal	-	1 Fax receiving ... 2 3 Page: %RXPAGE% 4 5 ===== [F-code PollingRX] Fax receiving ... Page: %RXPAGE% %RXFAXNUMBER%	Indicates that it is receiving fax data. %RXPAGE% : number of the current receiving page %RXFAXNUMBER% : sender Fax no. (※ F -code PollingRX only) In the case that the F-code PollingRX is done by using speed dial, display field is the following... A dial number is displayed during dialing An entry name is displayed in fax no. field during fax receiving.
70	Normal	-	1 Fax calling ... 2 3 4 %TXFAXNUMBER% 5	Indicates that it is calling. %TXFAXNUMBER% : fax number of the calling.
71	Normal	-	1 Fax calling ... 2 3 4 %TXFAXNUMBER% 5	Indicates that it is negotiating. %TXFAXNUMBER% : fax number of the calling.
72	Normal	-	1 Fax sending ... 2 3 Page: %TXPAGE% 4 %TXFAXNUMBER% 5 ===== [F-code PollingTX] Fax sending ... Page: %TXPAGE%	Indicates that it is sending fax data. %TXPAGE% : number of the current receiving page %TXFAXNUMBER% : recipient Fax no. (Not display on F-code PollingTX) In the case of manual fax sending, "Manual Fax sending: Sending ..." is displayed on LCD. Scan page count and document size are displayed in the left bottom. Page number, Fax no. are not displayed. In the case that the fax sending is done by using speed dial, fax no. is displayed during both dialing and sending.

No.	Category	PJL Status Code	Error Warning	Description
73	Normal	-	1 Fax sending ... 2 3 Page: %TXPAGE% 4 %TXFAXNUMBER% 5 ===== [F-code PollingTX] Fax sending ... Page: %TXPAGE%	Indicates that it is sending fax data. %TXPAGE% : number of the current receiving page %TXFAXNUMBER% : recipient Fax no.(Not display on F-code PollingTX) In the case of manual fax sending, "Manual Fax sending: Sending ..." is displayed on LCD. Scan page count and document size are displayed in the left bottom. Page number, Fax no. are not displayed. In the case that the fax sending is done by using speed dial, fax no. is displayed during both dialing and sending.
74	Normal	-	1 Cancelling ... 2 3 4 5	Indicates that the scanning for fax sending is cancelling by pressing Stop key.
75	Normal	10878 10868	1 Network communicating ... 2 %STATUS% 3 4 5	Indicates that the details of network communication. %STATUS% E-mail transmission in progress. Transmission in progress. E-mail transmission in progress: indicates that E-mail data is sending to Mail Server. Transmission in progress: indicates that data sending via network. The cancel operation by STOP key pressing is unsupported during E-mail and fail sending.

No.	Category	PJL Status Code	Error Warning	Description
76	Normal	10879	1 Connecting to server ... 2 3 4 5	Indicates that connecting to mail server. The cancel operation by STOP key pressing is unsupported during the connecting to mail server.
77	Normal	10875	1 Cancelling sending ... 2 3 4 5	Indicates that E-mail sending is cancelling. This message is displayed when an error is occurred during E-mail sending. When E-mail is being sent, user cannot cancel the sending by pressing "STOP" key. The key operation is disabled during this message displayed.
78	Normal	10869	1 Connecting to server ... 2 3 4 5	Indicates that connecting to file server. The cancel operation by STOP key pressing is unsupported during the connecting to file server.
79	Normal	10865	1 Cancelling sending ... 2 3 4 5	Indicates that file sending is cancelling. This message is displayed when an error is occurred during file sending. When file is being sent to server, user cannot cancel the sending by pressing "STOP" key. The key operation is disabled during this message displayed.
80	Normal	10799	1 Address Book printing ... 2 3 4 5	Indicates that printing of E-mail address list and Group address list that they are registered in Address Book.

No.	Category	PJL Status Code	Error Warning	Description
81	Normal	10800	1 Speed Dial List printing ... 2 3 4 5	Indicates that printing of fax location list that is registered in Speed dial.
82	Normal	10801	1 Group List printing ... 2 3 4 5	Indicates that printing of fax location list that is registered in Group dial.
83	Normal	10804	1 Transmit/Receipt Journal printing ... 2 3 4 5	Indicates that printing of fax communication (sending and receiving) result list.
84	Normal	10806	1 MCF Report printing ... 2 3 4 5	Indicates that printing of fax sending confirmation report.
85	Normal	10807	1 Check Message printing ... 2 3 4 5	Indicates that printing of fax communication error report.
86	Normal	10808	1 Fcode Box Journal printing ... 2 3 4 5	Indicates that printing of the message report that fax receiving data is stored in F code box by F code receiving.
87	Normal	10809	1 Erased Report printing ... 2 3 4 5	Indicates that printing of the message report that the stored fax data in memory was erased.
88	Normal	10810	1 Fcode Box List printing ... 2 3 4 5	Indicates that printing of the enabled F code box list.

No.	Category	PJL Status Code	Error Warning	Description
89	Normal	10811	1 Block Junk Fax List printing ... 2 3 4 5	Indicates that printing of the location list that is not permission to receive fax.
90	Normal	10793	1 Data transmission in progress. 2 3 4 5	Indicates that scanned image data sending to PC. Cannot see the message at broadband network environment.
91	Normal	10838	1 Cancelling ... 2 3 4 5	Indicates that the image data writing to USB memory is cancelling. This message is displayed when an error is occurred during the data writing to USB memory. The key operation is disabled during this message displayed.
92	Normal	-	1 Fax Rx Doc. printing ... 2 3 4 5	Printing fax Received Data.
93	Normal	-	1 Fax Store Doc. printing ... 2 3 4 5	Printing Stored fax sending data.
94	Normal	-	1 Do you wish to resume scanning? 2 3 4 5	Indicates to resume the ADF scanning for copy. The message is displayed when occurring some printer related errors and clearing the error conditions. If all sheets are scanned correctly and no remained before stopping the scanning, the message is not displayed.

No.	Category	PJL Status Code	Error Warning	Description
95	Normal	-	1 2 3 4 5	Cancelling ... Indicates that cancellation of PushScan (by panel operation) is accepted and being processed. The status falls when the processing is complete.
96	Normal	10007	1 2 3 4 5	Deleting data. It occurs when color data is received while a color toner is empty. Job cancellation is requested. The printer keeps discarding all the data it receives until the job is complete.
97	Normal	-	1 2 3 4 5	File loading from USB Memory. Indicates that a file is being read from a USB memory. Pressing Stop key will cancel the job.
98	Normal	-	1 2 3 4 5	Cancelling ... Indicates that reading from a USB memory is being cancelled.
99	Normal	-	1 2 3 4 5	An error occurred. Scanning is pending. Indicates that scanning has been suspended.
100	Normal	10764	1 2 3 4 5	MCF Report printing ... Indicates that printing of Internet fax sending confirmation report.
101	Normal	10765	1 2 3 4 5	Check Message printing ... Indicates that printing of Internet fax communication error report.
102	Normal	10766	1 2 3 4 5	Transmit/Receipt Journal printing ... Indicates that printing of Internet fax and E-mail communication (sending and receiving) and FAX server (sending) result list.

No.	Category	PJL Status Code	Error Warning	Description
103	Normal	-	1 2 3 4 5	Cancelling ... This appears when scanning is cancelled in ScanToFax mode.
104	Normal	10001	1 2 3 4 5	Online Mode Ready to print. Shows Online status.
105	Normal	10794	1 2 3 4 5	Please insert USB Memory. Indicates that Scan to USB memory / PrintFromUSBMemory is selected without USB memory connection.

Warning

No.	Category	PJL Status Code	Error Warning	Description
1	Warning	10081 (K)	1 %COLOR% Toner Low 2 3 4 5 Please see Help for details.	Toner amount is low. Moreover, when set as "Admin Setup"- "Management"- "System Setup"- "Near Life LED"=Disable, Alarm LED is switched off. %COLOR% K
3	Warning	10924 (K)	1 Please install new %COLOR% Toner Cartridge. 2 3 4 5 Please see Help for details.	It shows the toner cartridge of authorized 3rd party. (RFID Licensed to 3rd party) %COLOR% K
4	Warning	10954 (K)	1 %COLOR% Toner Cartridge Region Mismatch 2 3 4 5 Please see Help for details.	The Region ID of toner cartridge is not proper to the distribution channel. %COLOR% K
5	Warning	10950 (K)	1 Non Genuine %COLOR% Toner Cartridge 2 3 4 5 Please see Help for details.	The chip of RFID is not compatible. %COLOR% K
6	Warning	10076 (K)	1 Image Drum Unit Near Life 2 3 4 5 Please see Help for details.	The life of the drum (warning). Displayed in a combination of other message in the first line. The printer stops at the point when it reaches the drum life (Shifts to error, OFF-LINE.) Moreover, when set as "Admin Setup"- "Management"- "System Setup"- "Near Life LED"=Disable, Alarm LED is switched off.

No.	Category	PJL Status Code	Error Warning	Description
7	Warning	10965 (K)	1 %COLOR% Toner Empty 2 3 4 5 Please see Help for details.	Notifies the toner is empty. This is a warning only. This appears when the cover was opened and closed just after the toner empty error occurred. %COLOR% K
8	Warning	10938 (K)	1 %COLOR% Toner Cartridge not installed. 2 3 4 5 Please see Help for details.	Notifies the toner cartridge is not installed. This is a warning only. %COLOR% K
9	Warning	10969 (K)	1 Please install new Image Drum Unit. 2 3 4 5 Please see Help for details.	Notifies the life of the drum. This is a warning only. This appears when the cover was opened and closed just after the drum life error occurred.
10	Warning	10944 (K)	1 %COLOR% Head Data Error 2 3 4 5	The LED head calibration data is missing or invalid. Printing can be proceeded without calibrating light radiation. PU firmware does not notify this warning to CU firmware at the time of Shipping Mode. Therefore, this status does not occur in a user environment. %COLOR% K

No.	Category	PJL Status Code	Error Warning	Description
11	Warning	1601x x: Tray #	1 %TRAY% Empty 2 3 4 5 Please see Help for details.	%TRAY%: The tray is empty. Treated as Warning until printing to the empty tray is designated. %TRAY% Tray1 Tray2
12	Warning	1090x	1 %TRAY% missing. 2 3 4 5 Please see Help for details.	Indicates that paper trays are not installed. %TRAY% Tray1 Tray2
13	Warning	10814	1 Accounting Log Buffer is near full. 2 3 4 5 Please see Help for details.	It indicates the Job Accounting log buffer is near full.
14	Warning	10787	1 Accounting Log Buffer Full (Delete old logs) 2 3 4 5	The function isn't accepted because log buffer is full. (Related to JobAccount). This message is displayed, if the log buffer is full and "Operation at Log Full" in Job Accounting Server Software is set to "Delete old logs". The new jobs will be able to execute after the following operations. 1. The log in the unit must be got by Job Accounting Server Software. 2. The setting of "Operation at Log Full" must be changed to "Does not acquire logs".

No.	Category	PJL Status Code	Error Warning	Description
15	Warning	10071(K)	1 Please check %COLOR% Toner Cartridge. 2 3 4 Please see Help for details. 5	Something is wrong with the toner sensor during printing. %COLOR% K
16	Warning	10756	1 Wait Timeout is disabled. 2 If your printer is connected to USB port, it may become unable to print a job without via the USB port. 3 4 5	Indicates that Print Timeout is disabled.
17	Warning	30928	1 PDF Cache Write Error 2 3 4 5 Close	Notifies that writing a PDF file to the cache has failed. When an SD card is not used, add memory or an SD card. When an SD card is used, increase free space on the SD card.
18	Warning	10758	1 It was not possible to communicate with the SNTP server. 2 3 4 5	Notifies that the system has attempted to obtain the current time from the SNTP server and failed.
19	Warning	10962	1 Printer Life 2 3 4 5	
20	Warning	-	1 System received LOCK signal. 2 3 4 5 Close	Panel lock signal (Disable) is recognized during copy job movement, and a warning message is displayed.

No.	Category	PJL Status Code	Error Warning	Description
21	Warning	10750	1 Please change SD Memory Card. 2 Error Code : 085 3 4 5	Indicates that machine requests a user to exchange old SD memory card device for new one because the SD memory card device is life.
22	Warning	30928	1 PDF Cache Write Error 2 3 4 5 Close	It is notified that cash writing of a PDF file was failed in. When there is not a SD card, memory capacity is increased or a SD card is added. When there is a SD card, space capacity of a SD card is increased.
23	Warning	10830	1 Access Limitation Error 2 Deleted unauthorized user data. 3 4 Please see Help for details. 5 Close	Notifies users that jobs have been cancelled because they are not permitted for printing. (Related to JobAccount). Notifies users that jobs have been cancelled because they are not permitted for PC-Fax. (Related to JobAccount).
24	Warning	30114 10827	1 Received invalid data. 2 3 4 Please see Help for details. 5 Close	Invalid data was received. Press the OK key and eliminate the warning. Displayed when unsupported PDL command is received or a spool command is received without HDD.

No.	Category	PJL Status Code	Error Warning	Description
25	Warning	10815	1 Accounting Log Writing Error 2 3 4 Please see Help for details. 5 Close	The Job Accounting log is not registered correctly because of thr disc access error is occurred during accounting log writing into HDD (Related to Logging). This message is displayed until OK key pressed.
26	Warning	10818	1 Job Log Writing Error 2 3 4 Please see Help for details. 5 Close	The log is not registered correctly because of thr disc access error is occurred during system job log writing into HDD. This message is displayed until OK key pressed.

Error (Enable to restore)

No.	Category	PJL Status Code	Error Warning	Description
1	Error	10899	1 Erased Data Full 2 3 4 5 Please see Help for details.	Indicates that a secret file waiting to be erased is full.
2	Error	472yy 473yy	1 Please install paper on %TRAY%. 2 : %ERRCODE% Please set paper 3 (%MEDIA_SIZE%). 4 To cancel, select [Cancel] 5	Printing request is issued to an empty tray. Load paper that was set in %MEDIA_SIZE%. (It takes a while until the status disappears after you have closed the tray and the lever lifted.) %TRAY% Tray1 Tray2 The unit of paper size in Custom: The unit specified for MP Tray (menu setting) is used if no unit is specified by the driver. When the driver specifies a unit, the unit is used for display.
3	Error	4600x 46002 (Tray1)	1 Please close %TRAY%.: 430,440 2 3 To cancel, select [Cancel] 4 5	Indicates removal of the paper cassette of Tray 1 that is a paper path in attempting to print from Tray 2. %TRAY% Tray1

No.	Category	PJL Status Code	Error Warning	Description
4	Error	46012	1 Please close %TRAY%.: 430,440 2 3 To cancel, select [Cancel] 4 5	Indicates that paper feed is unavailable in attempting to print from Tray 1 due to removal of the paper cassette of Tray 1. %TRAY% Tray1 Note: If the paper cassette of the tray is removed during displaying paper request, system will display that tray is removed (this display)
5	Error	46013	1 Please close %TRAY%.: %ERRCODE% 2 3 To cancel, select [Cancel] 4 5	Indicates that paper feed is unavailable in attempting to print from Tray 2 due to removal of the paper cassette of Tray 2. %TRAY% Tray2 Note: If the paper cassette of the tray is removed during displaying paper request, system will display that tray is removed (this display)
6	Error	40028 (K)	1 %COLOR% Toner Empty: %ERRCODE% 2 3 4 5 Please see Help for details.	Toner ends. Error 413 : K Warning status takes effect at Cover Open/ Close.

No.	Category	PJL Status Code	Error Warning	Description
7	Error	40947 (K)	1 %COLOR% Toner Cartridge Region Mismatch: %ERRCODE% 2 3 4 5 Please see Help for details.	The signature ID of toner cartridge is not proper to the distribution channel, but the group of signature ID is proper (OKI regional mismatch). As probable missing to measure the amount of toner, the printer notifies error status and stop printing. Error 557 : K
8	Error	40910 (K)	1 %COLOR% Toner Cartridge Region Mismatch: %ERRCODE% 2 3 4 5 Please see Help for details.	The signature ID of toner cartridge is not proper to the distribution channel, and the group of signature ID is not proper (OEM channel mismatch). Error 617 : K
9	Error	40906 (K)	1 %COLOR% Toner Cartridge Region Mismatch: %ERRCODE% 2 3 4 5 Please see Help for details.	The signature ID of toner cartridge is not proper to the distribution channel, and the group of signature ID is protected (OEM mismatch). Error 623 : K

No.	Category	PJL Status Code	Error Warning	Description
10	Error	40943 (K)	1 %COLOR% Toner Cartridge Region Mismatch: %ERRCODE% 2 3 4 5 Please see Help for details.	The signature ID of toner cartridge can not be recognized (Unauthorized third party). As probable missing to measure the amount of toner, the printer notifies error status and stop printing. Error 553 : K Four following behavior is carried out by mode of operation. 1. Only warning display. (This error is not displayed). 2. Warning status takes effect at Cover Open/ Close. 3. With no automatic concentration compensation. 4. This error is displayed and it stops.
11	Error	40902 (K)	1 %COLOR% Toner Cartridge not installed.: %ERRCODE% 2 3 4 5 Please see Help for details.	The toner cartridge is not installed. Error 613 : K Four following behavior is carried out by mode of operation. 1. Only warning display. (This error is not displayed). 2. Warning status takes effect at Cover Open/ Close. 3. With no automatic concentration compensation. 4. This error is displayed and it stops.

No.	Category	PJL Status Code	Error Warning	Description
12	Error	40959 (K)	<ol style="list-style-type: none"> 1 Please check %COLOR% Toner Cartridge.: %ERRCODE% 2 3 4 5 Please see Help for details. 	<p>Something is wrong with the toner sensor. This status is indicated in Shipping Mode only. If the same error is detected in FACTORY Mode, it is indicated as service call of 163. Error 543 : K</p>
13	Error	30034	<ol style="list-style-type: none"> 1 Paper Size Error 2 Please open the scanner unit and the top cover and check paper size. 3 4 5 Please see Help for details. 	<p>Inappropriate size paper was fed from a tray. Check the paper in the tray or check for Multiple-feed. Open and close the cover to perform recovery printing, and continue.</p>
14	Error	40077	<ol style="list-style-type: none"> 1 Paper Jam: 390 2 Please open the scanner unit and the top cover. 3 4 5 Please see Help for details. 	<p>Paper Jam occurred during paper feeding from tray. Error 390 : MP Tray Error 390 : MANUAL</p>
15	Error	40077	<ol style="list-style-type: none"> 1 Paper Jam: %ERRCODE% 2 Please pull out the paper cassette of the indicated tray. 3 4 5 Please see Help for details. 	<p>Paper Jam occurred during paper feeding from tray. Error 391 : Tray1 Error 392 : Tray2</p>
16	Error	40078 40079	<ol style="list-style-type: none"> 1 Paper Jam: %ERRCODE% 2 Please open the scanner unit and the top cover. 3 4 5 Please see Help for details. 	<p>Jam has occurred in paper path. Error 381 : Transport Error 382 : Exit</p>

No.	Category	PJL Status Code	Error Warning	Description
17	Error	40819	<ol style="list-style-type: none"> 1 Paper Jam: 389 2 Please open the scanner unit and the top cover. 3 4 5 Please see Help for details. 	<p>Jam has occurred in paper path. Error 389 : Printing Page lost</p>
18	Error	40054	<ol style="list-style-type: none"> 1 Paper Jam: 372 2 Please open the scanner unit and the top cover. 3 4 5 Please see Help for details. 	<p>Jam has occurred nearby DUPLEX unit. Error 372 : Misfed from Duplex</p>
19	Error	40996 (K)	<ol style="list-style-type: none"> 1 Please install new Image Drum Unit. 2 3 4 5 Please see Help for details. 	<p>The life of the image drum (Alarm) Error 353 : K Warning status takes effect at Cover Open/ Close.</p>
20	Error	40936 (K)	<ol style="list-style-type: none"> 1 Please install new Image Drum Unit. 2 3 4 5 Please see Help for details. 	<p>The toner empty error is occurred after the image drum reached its life. Error 563 : K This is displayed until a user exchanges the image drum.</p>
21	Error	40914 (K)	<ol style="list-style-type: none"> 1 Please check %COLOR% Toner Cartridge.: %ERRCODE% 2 3 4 5 Please see Help for details. 	<p>Shows that the toner is not supplied (the toner cannot be detected). The lever of toner cartridge may not be locked, or toner cartridge may be set with protection tape. Shows that the toner cartridge lever has not been locked. %ERRCODE%: specifies 3 digits error code. Error 547 : K</p>

No.	Category	PJL Status Code	Error Warning	Description
22	Error	40021 40720	1 Please check the %COVER%.: %ERRRCODE% 2 3 Please close the %COVER%. 4 top cover 5 Please see Help for details.	The cover is open. Error 310 : Top Cover Error 587 : Rear Cover %COVER% top cover rear cover
23	Error	40788	1 ADF Cover Open 2 3 4 5 Please see Help for details.	Indicates that ADF cover of scanner unit is opened. Indicates that inter-lock cover of scanner unit is lifted up. Notes: If inter-lock cover is lifted up during scanning from document feeder, system will display document jam.
24	Error	40789	1 Document Jam 2 Please open the scanner unit and the ADF cover. 3 4 5 Please see Help for details.	Indicates that the document jam occurred during the scanning.
25	Error	40779	1 Lamp Error. Please call service. <%CODE%> 2 3 4 5 Please see Help for details.	Indicates that the lamp error is occurred. This message is displayed because of the light intensity of lamp is weaker. %CODE% : details =1 Calibration defective (device) =2 Calibration defective (LED) =3 Calibration defective (timewise deterioration)
26	Error	40780	1 Power OFF/ON 2 Carriage Error <1> 3 4 5 Please see Help for details.	Indicates that the caridge error is occurred. This message is displayed because of the calidge of scanner doesn't work normally. <1>: The calidge of scanner doesn't work normally.

No.	Category	PJL Status Code	Error Warning	Description
27	Error	40734	1 USB Memory Full 2 3 4 Please see Help for details. 5 Close	Indicates that the file saving is failed because of USB memory doesn't have enough free space. The file saving is aborted.
28	Error	40731	1 Writing Failed 2 3 4 Please see Help for details. 5 Close	Indicates that the file saving is failed for the reasons of being in a write-protected state.
29	Error	30941	1 USB Memory disconnected. 2 3 4 Please see Help for details. 5 Close	Indicates that the USB memory was extracted. When a USB memory is extracted all over ScanToMemory execution, the file saving of image file is stopped.
30	Error	40716	1 Connect to PC failed. 2 3 4 Please see Help for details. 5 Close	Indicates that it is failed to connect to PC. If the OK key is pressed, it shift to stand-by screen.
31	Error	-	1 Communication Error 2 3 4 5 Close	Indicates that the fax sending was failed. The details of the fax sending errors are not displayed. The message is shown after the job was finished by communication error and it is kept until pressing a OK key. It is reset at new transmission. (When Country Code is Germany, it is not applied by DTS.)

No.	Category	PJL Status Code	Error Warning	Description
32	Error	-	1 Communication Error 2 3 4 5 Close	Indicates that the fax receiving was failed. The details of the fax receiving errors are not displayed. The message is shown after the job was finished by communication error and it is kept until pressing a OK key. It is reset at new transmission. (When Country Code is Germany, it is not applied by DTS.)
33	Error	40593	1 File Transmission Error 2 3 4 Please see Help for details. 5 Close	Indicates that file sending was failed due to the file server problems, network cable disconnected or network trouble (Scan To Network PC). This message is cleared by the pressing OK key.
34	Error	40595	1 E-mail Transmission Error 2 3 4 Please see Help for details. 5 Close	Indicates that E-mail sending was failed due to the mail server problems, network cable disconnected or network trouble (Scan To E-mail). This message is cleared by the pressing OK key.
35	Error	40765	1 Please check SMTP settings. 2 3 4 Please see Help for details. 5 Close	Indicates that failed to connect with SMTP server.
36	Error	40764	1 Please check POP3 settings. 2 3 4 Please see Help for details. 5 Close	Indicates that failed to connect with POP3 server.
37	Error	40763	1 SMTP Login failed. 2 3 4 Please see Help for details. 5 Close	Indicates that failed to login in SMTP server.

No.	Category	PJL Status Code	Error Warning	Description
38	Error	40762	1 SMTP Auth. Unsupported 2 3 4 Please see Help for details. 5 Close	Indicates that authentication is unsupported by SMTP server.
39	Error	40761	1 POP3 Login failed. 2 3 4 Please see Help for details. 5 Close	Indicates that failed to login in POP3 server.
40	Error	40812	1 Getting target IP failed. 2 Please check DHCP settings. 3 4 5 Please see Help for details.	Indicates that DHCP server is not found out. Scan to E-mail, Scan to Network PC and Scan to Remote PC (WSD) are unusable during this status occurring. This message is displayed by the timing when "Mail", "Network PC" icons were pressed with a "Scan Menu" screen.
41	Error	40752	1 Please check DNS settings. 2 3 4 Please see Help for details. 5 Close	Indicates that failed to connect DNS Server. The same message is displayed, if name resolution is failed in DNS server.
42	Error	10821	1 Please remove the connected USB device. 2 3 Unsupported USB device 4 is connected. 5	Indicates that the unsupported USB device was connected. This message will be displayed until the unsupported USB device disconnected.
43	Error	10819	1 Please remove the USB Hub. 2 3 USB Hub is connected. 4 5	Indicates that the unsupported USB Hub was connected. This message will be displayed until the unsupported USB Hub disconnected.

No.	Category	PJL Status Code	Error Warning	Description
44	Error	40565	<ol style="list-style-type: none"> 1 Document Jam 2 Please open the scanner unit and the ADF cover. 3 4 5 Please see Help for details. 	At machine initial time (power-on, cover close and just after that a scan was completed), a manuscript was detected on a set sensor.
45	Error	40588	<ol style="list-style-type: none"> 1 Please close faceup stacker. 2 581:Cannot print with duplex. 3 4 5 	Indicates that the printer cannot carry out duplex printing because the faceup stacker is open. ※ This is handled as an error because in the case of FX750, if the faceup stacker is open, the printer does not reverse the exit motor and thus cannot draw the print medium onto the duplex path.
46	Error	40585	<ol style="list-style-type: none"> 1 Please open the top cover. 2 409:Faceup Stacker Error 3 4 5 	Indicates that an error has occurred as the faceup stacker was operated during printing and printing stopped.
47	Error	40587	<ol style="list-style-type: none"> 1 Please install new Image Drum Unit 2 3 4 5 Please see Help for details. 	The life of the image drum (Alarm)

No.	Category	PJL Status Code	Error Warning	Description
48	Error	411yy yy: paper size	<ol style="list-style-type: none"> 1 Please install paper on MP Tray. 2 Please set paper (%MEDIA_SIZE%). 3 To cancel, select [Cancel] 4 5 	Manual paper feed is required. Manually insert the paper shown by %MEDIA_SIZE%. The unit of paper size in Custom: The unit specified for MP Tray (menu setting) is used if no unit is specified by the driver. When the driver specifies a unit, the unit is used for display. Paper size displays in Custom mode: <width>x<length><unit>" ex.) 210 x 297mm 8.5 x 11.0inch
49	Error	470yy	<ol style="list-style-type: none"> 1 Please install paper on MP Tray. : 490 2 Please set paper (%MEDIA_SIZE%). 3 To cancel, select [Cancel] 4 5 	Printing request is issued to an empty MP Tray. Load paper that was set in %MEDIA_SIZE%. The unit of paper size in Custom: The unit specified for MP Tray (menu setting) is used if no unit is specified by the driver. When the driver specifies a unit, the unit is used for display. This error is occurred, when the MP Tray is in the home position and the sensor "PE SNS2" cannot detect papers.

No.	Category	PJL Status Code	Error Warning	Description
50	Error	411yy yy: paper siz	1 Please install paper on 2 Manual Feeder. Please set paper 3 (%MEDIA_SIZE%). 4 To cancel, select [Cancel] 5	Manual paper feed is required. Manually insert the paper shown by %MEDIA_SIZE%. The unit of paper size in Custom : The unit specified for Manual Feeder (menu setting) is used if no unit is specified by the driver. When the driver specifies a unit, the unit is used for display. Paper size displays in Custom mode: "<width> x <length> <unit>" ex.) 210 x 297 mm 8.5 x 11.0 inch
51	Error	-	1 Memory Overflow Rx 2 3 4 5	Indicates that the fax Memory Overflow was occurred during fax receiving.
52	Error	40778	1 Memory Overflow 2 3 4 Please see Help for details. 5 Close	Display that Memory Overflow is occurred during PC Fax Job receiving. Return to Mode Selection screen by the pressing OK key.

No.	Category	PJL Status Code	Error Warning	Description
53	Error	32000 ~ 32026	1 Disk Use Failed %FS_ERR% 2 3 4 Please see Help for details. 5 Close	A disk error is occurred, which is other than the file system fill or the disk write protected. Operation that does not involve a disk is available. This message is cleared by OK key pressed. %FS_ERR% = 0 GENERAL ERROR = 1 VOLUME NOT AVAILABLE = 3 FILE NOT FOUND = 4 NO FREE FILE DESCRIPTORS = 5 INVALID NUMBER OF BYTES = 6 FILE ALREADY EXISTS = 7 ILLEGAL NAME = 8 CANT DEL ROOT = 9 NOT FILE = 10 NOT DIRECTORY = 11 NOT SAME VOLUME = 12 READ ONLY = 13 ROOT DIR FULL = 14 DIR NOT EMPTY = 15 BAD DISK = 16 NO LABEL = 17 INVALID PARAMETER = 18 NO CONTIG SPACE = 19 CANT CHANGE ROOT = 20 FD OBSOLETE = 21 DELETED = 22 NO BLOCK DEVICE = 23 BAD SEEK = 24 INTERNAL ERROR = 25 WRITE ONLY

No.	Category	PJL Status Code	Error Warning	Description
54	Error	482yy 483yy	1 Tray Media Mismatch: %ERRCODE%	The media type in the tray and the print data do not match. Load paper that was set in %MEDIA_SIZE% and %MEDIA_TYPE% in tray. %TRAY% Tray1 Tray2 Paper size displays in Custom mode: <width>x<length><unit>" ex.) 210 x 297MM 8.5 x 11.0INCH The unit of paper size in Custom: The unit specified for MP Tray (menu setting) is used if no unit is specified by the driver. When the driver specifies a unit, the unit is used for display.
			2 Please install paper(%MEDIA_SIZE%	
			3 %MEDIA_TYPE%) on %TRAY%.	
			4	
			5	
55	Error	480yy	1 Tray Media Mismatch: %ERRCODE%	The media type in the tray and the print data do not match. Load paper that was set in %MEDIA_SIZE% and %MEDIA_TYPE% in tray. %TRAY% MP Tray Paper size displays in Custom mode:" <width>x<length><unit>" ex.) 210 x 297MM 8.5 x 11.0INCH The unit of paper size in Custom: The unit specified for MP Tray (menu setting) is used if no unit is specified by the driver. When the driver specifies a unit, the unit is used for display.
			2 Please install paper(%MEDIA_SIZE%	
			3 %MEDIA_TYPE%) on %TRAY%.	
			4	
			5	

No.	Category	PJL Status Code	Error Warning	Description
56	Error	482yy 483yy 485yy	1 Tray Media Mismatch: %ERRCODE%	The size of paper or media type in the tray does not match the print data. Load paper that was set in %MEDIA_SIZE% and %MEDIA_TYPE% in tray. (It takes a while until the status disappears after you have closed the tray and the lever lifted.) %TRAY% Tray1 Tray2 The paper size displaying form of the custom mode is the same as above.
			2 Please install paper(%MEDIA_SIZE%	
			3 %MEDIA_TYPE%) on %TRAY%.	
			4	
			5	
57	Error	480yy	1 Tray Media Mismatch: %ERRCODE%	The size of paper or media type in the tray does not match the print data. Load paper that was set in %MEDIA_SIZE% and %MEDIA_TYPE% in tray. %TRAY% MP Tray The paper size displaying form of the custom mode is the same as above.
			2 Please install paper(%MEDIA_SIZE%	
			3 %MEDIA_TYPE%) on %TRAY%.	
			4	
			5	
58	Error	30097	1 Memory Overflow: 420	Memory capacity overflows due to the following reason. Install expansion RAM or decrease the data amount. - Too much print data in a page. - Too much Macro data. - Too much DLL data. - After frame buffer compression, over flow occurred.
			2	
			3	
			4 Please see Help for details.	
			5 Close	

No.	Category	PJL Status Code	Error Warning	Description
59	Error	40735 40759 40748 40591 40710	1	Memory Overflow Please see Help for details. Close - Memory Overflow is occurred during the executing of copy. - Memory Overflow is occurred during the executing of Scan To mail. - Memory Overflow is occurred during the executing of Scan To Network PC. - Memory Overflow is occurred during the executing of Scan To USB memory. - Memory Overflow is occurred during the executing of Fax sending.
			2	
			3	
			4	
			5	
60	Error	40751	1	Please check Server setting. Please see Help for details. Close
			2	
			3	
			4	
			5	
61	Error	40750	1	Server Login failed. Please see Help for details. Close
			2	
			3	
			4	
			5	
62	Error	40718	1	Entering directory failed. Please see Help for details. Close
			2	
			3	
			4	
			5	
63	Error	40744	1	Changing data Transfer Type failed. Please see Help for details. Close Indicates that the data transfer type of FTP server is not supported by this unit. The file sending will be success by the changing of data transfer type in FTP serve.
			2	
			3	
			4	
			5	

No.	Category	PJL Status Code	Error Warning	Description
64	Error	40592	1	Not authorized to write file. Please see Help for details. Close
			2	
			3	
			4	
			5	
65	Error	40742	1	Storage Space Full Please see Help for details. Close
			2	
			3	
			4	
			5	
66	Error	40741	1	Please change File Name. Please see Help for details. Close
			2	
			3	
			4	
			5	
67	Error	40594	1	Device communication protocol not supported. Please see Help for details. Close
			2	
			3	
			4	
			5	
68	Error	40739	1	Please check Network Share Name. Please see Help for details. Close
			2	
			3	
			4	
			5	
69	Error	-	1	Memory Overflow has occurred during Fax Tx reservation. Close
			2	
			3	
			4	
			5	
70	Error	-	1	Memory Overflow Close
			2	
			3	
			4	
			5	

No.	Category	PJL Status Code	Error Warning	Description
71	Error	-	1 Wireless startup failed. 2 3 4 5 Please see Help for details.	Wireless startup failed. Restart the device.If the problem is not resolved, Check cableconnection between CU board and Wireless LAN board.
72	Error	-	1 Wireless settings are incomplete. 2 3 4 5 Please see Help for details.	Wireless settings are incomplete. Try making the manual settings or automatic settings once again.If the problem is not resolved, initialize the network settings, and then try making the manual settings or automatic settings once again.
73	Error	-	1 Not connected to wireless access point. 2 3 4 5 Please see Help for details.	Not connected to wireless access point. Check that the wireless access point power supply is ON. Check the wireless access point settings, and then try making the manual settings or automatic settings.

Error (Disable to restore)

No.	Category	PJL Status Code	Error Warning	Description
1	Error	40700 40701 40702 40703 40709	1 Inspection is required. 2 %ERRCODE%: SIP Error 3 4 5	Indicates that the processing of Scan Image Processing controller was failed. User must turn Off/ On the power supply, if this status occurred. %ERRCODE% =1 : RAM Check Error =2 : Illegal parameters =3 : Memory Overflow =4 : Scanner Receiving Time-out =5 : Others (Fatal Error)
2	Error	40724	1 Please call service. 2 Scanner unit failed to detect printer unit. 3 4 5	Indicates that scanner and printer is not connected. This message is displayed, if the communication between scanner and printer units could not be started. User must turn Off/ On the power supply, if this status occurred.
3	Error	40714	1 SIP Firmware Missing 2 3 4 5	Indicates that the firmware in board can not be detected.

No.	Category	PJL Status Code	Error Warning	Description
4	Error	-	1 Inspection is required. 2 PU Flash Error 3 4 5	It is shown that PU firmware has booted in Loader mode. If initialization is completed, it will change to the status of no.5. This status may occur also in a user environment. When it occurs, the maintenance by a maintenance member is required (equivalent to S/C). Communication error occurred between CU and PU. PU firmware may not be downloaded.
5	Error	-	1 Inspection is required. 2 PU Communication Error 3 4 5	Displays that communication to PU firmware failed. This status may occur also in a user environment. When it occurs, the maintenance by a maintenance member is required (equivalent to S/C). If this status occurred during the unit initializing the message is displayed by English.
6	Error	40978	1 %PUFLASH% Flash Error 2 3 4 5	PU flush error (Error occurs during the alteration of PU farm or it failed in the alteration in PU flush of such as LED Head information.) %PUFLASH% PU TRAY2

No.	Category	PJL Status Code	Error Warning	Description
7	Error	40057	1 Power OFF/ON 2 %ERRCODE%:Error 3 4 5	A fatal error occurred. For more information, see "Service Calls List." %ERRCODE%: specifies 3 digits (decimal) error code. The message of fatal error is specified by English only.
8	Error	40057	1 Inspection is required. 2 %ERRCODE%:Error 3 4 5	A fatal error occurred. For more information, see "Service Calls List." %ERRCODE%: specifies 3 digits (decimal) error code. The message of fatal error is specified by English only.
9	Error	40057	1 Inspection is required. 2 %ERRCODE%:Error %CODE% 3 4 5	A fatal error occurred. For more information, see "Service Calls List." %ERRCODE%: specifies 3 digits (decimal) error code. '%CODE%' specifies error code that is the detailed error cause. (2 digits, hexadecimal) The message of fatal error is specified by English only.
10	Error	40057	1 Power OFF/ON 2 %ERRCODE%:Error 3 4 5	A fatal error occurred. For more information, see "Service Calls List." %ERRCODE%: specifies 3 digits (decimal) error code. F0C, F0D, FFE, and FFF are hexadecimal code. The message of fatal error is specified by English only.

No.	Category	PJL Status Code	Error Warning	Description
11	Error	40057	1 Power OFF/ON 2 %ERRCODE%:Error 3 4 5	A fatal error occurred. For more information, see "Service Calls List." %ERRCODE%: specifies 3 digits (decimal) error code. The message of fatal error is specified by English only.
12	Error	40787	1 Power OFF/ON Carriage Error <%CODE%> 2 3 4 5	Indicates that it is carriage error. %CODE% : details =2 : Home position error (carriage connection error) =3 : Defective detecting black edge
13	Error	40057	1 Power OFF/ON 2 %ERRCODE%:Error %FATALSTRING1% 3 4 5	A fatal error occurred. For more information, see "Service Calls List." %ERRCODE%: specifies 3 digits (decimal) error code. '%FATALSTRING1%' specifies error code that is the detailed error cause. The message of fatal error is specified by English only.
14	Error	40057	1 %ERRCODE%:Error %FATALSTRING2% 2 3 4 5	A fatal error occurred. For more information, see "Service Calls List." %ERRCODE%: specifies 3 digits (decimal) error code. '%FATALSTRING2%' specifies error code that is the detailed error cause. The message of fatal error is specified by English only.

No.	Category	PJL Status Code	Error Warning	Description
15	Error	40057	1 Power OFF/ON 2 %ERRRCODE%:Error %CODE% 3 4 5	A fatal error occurred. For more information, see "Service Calls List." %ERRRCODE%: specifies 3 digits (decimal) error code. '%CODE%' specifies error code that is the detailed error cause. The message of fatal error is specified by English only.
16	Error	40057	1 Power OFF/ON 2 %ERRRCODE%:Download Error 3 4 5	Downloading Media Table to PU has failed. (Related to CustomMediaType.) %ERRRCODE%: specifies 3 digits (decimal) error code. The message of fatal error is specified by English only. "Download Error" is specified by Japanese and English only.
17	Error	30936	1 Unauthorized Scan 2 Error Code: X01 3 4 5 Close	Notifies that a particular pattern is detected (banknote detection) during scanning for photocopy. The message shall be written in English even when the MFP is bound for Japan. The exact words shall be displayed and they shall not be shortened. The message shall not be translated into any other languages.

No.	Category	PJL Status Code	Error Warning	Description
18	Error	-	1 This wireless firmware version does not operate on this device. 2 3 4 5 Please see Help for details.	This wireless firmware version does not operate on this device. Please confirm CU and Wireless LAN Firmware-Version. When needed, update each firmware.

8.5.2 Service Call List

Display	Cause	Error details		Measure
Power OFF/ON 002 : Error ~ 005 : Error	CPU Exception		Yes	Turn off and on the MFP. Replace the CU/ PU board.
Inspection is required. 024 : Error	Kanji Font Error			
Inspection is required. 030 : Error	CU RAM Check Error	Is the error display provided again?	Yes	Turn off and on the MFP. Replace the CU/ PU board.
Inspection is required. 040 : Error	CU EEPROM error	Is the error display provided again?	Yes	Turn off and on the MFP. Replace the CU/ PU board.
Inspection is required. 042 : Error 043 : Error. 045 : Error	Flash memory file system error	Accessing the flash ROM directly mounted on the CU/ PU board failed.		Turn off and on the MFP. Replace the CU/ PU board.
Inspection is required. 049 : Error	CU Engine Type Mismatch	Resolution of a LED head as opposed to a unit model is mismatch.		
Power OFF/ON 054 : Error	A communication error of the scanner unit	A communication error was detected between the Controller and scanner unit.		Record a value displayed far right at the bottom of LCD and turn on the power unit again.
Power OFF/ON 057 : Error	The timeout of command communication of the scanner	The timeout of command communication was detected between the Controller and scanner unit (A sub code indicates a cause). 01: There is no ACK for a command to start scanning. 02: There is no ACK for a command to cancel scanning. 03: There is no ACK for a command to cancel SU.		Record a value displayed far right at the bottom of LCD and turn off/on the power unit.

Display	Cause	Error details		Measure
Power OFF/ON 058 : Error	An error of the scanner controlling area	An internal error was detected in the scanner controlling area of the Controller.		Record a value displayed far right at the bottom of LCD and turn off/on the power unit.
Power OFF/ON 062 : Error	USB Driver Error			
Inspection is required. 064 : Error	SD Card Missing Error	Is a SD Card installed in the unit, properly?	No	Reinstall the SD card.
Inspection is required. 069 : Error	NIC Chip Error			
Power OFF/ON 070 : Error	PostScript error	Error is detected inside the postscript core		Take note of the address that is displayed on LCD. Turn off and on the MFP.
Power OFF/ON 072 : Error *	Engine interface error or PU-CU interface error	Is the CU/PU board installed properly?	No Yes	Reinstall the CU/ PU board properly. Replace the CU/ PU board.
Power OFF/ON 073 : Error **	Video error. An error was detected in expanding image data (an invalid data was received)	Is the CU/PU board installed properly? Does the error occur again?	No Yes	Reinstall it properly. Change the PC to a high-specification one or decrease the resolution, and perform printing again. Replace the CU/ PU board.
				Replace the interface cable. Reinstall the PC printer driver.
		Is the CU/PU board installed properly? Does the error occur again? Does the error depend on print data?	No Yes No Yes	Reinstall it properly. Perform printing again. Print other data. Replace the CU/PU board. Ask design people to analyze the data.

Display	Cause	Error details		Measure
Power OFF/ON 075 : Error **	Video error. An error was detected in expanding image data.	Is the CU/PU installed properly?	No Yes	Reinstall it properly. Replace it.
Power OFF/ON 080 : Error	Parameter I/O Error	An access error occurred in a storage point of a parameter by file damage.		
Inspection is required. 081 : Error	Parameter matching check error	Reading from or writing into EEPROM or flash memory cannot be made properly.		Turn off and on the MFP. Replace the CU/PU board when the symptom persists.
Inspection is required. 085 : Error	SD Card ECC Error	An ECC error was detected by read processing of a SD memory card.		
Inspection is required. 104 : Error	An engine EEPROM read/write error was detected.	Does the error occur again?	Yes	Turn off and on the MFP Replace the CU/PU board.
Inspection is required. 106 : Error	Engine control logic error	Does the error occur again?	Yes	Turn off and on the MFP Replace the CU/PU board.
Inspection is required. 112 : Error	The 2nd tray for a model different from the MFP was detected.	Is the 2nd tray for the MFP installed?	No	Install proper 2nd tray.
Inspection is required. 121 : Error	High-voltage power supply interface error	Is the cable between the CU/PU board and the high-voltage power unit connected properly? Is a contact faulty?	No Yes No	Reconnect it properly. Check the high-voltage line for no poor connection. Replace the high-voltage power supply.
Inspection is required. 122 : Error	Rear-fan error	Does the fan at the rear of the MFP operate? Is the connector of the fan connected properly?	No Yes No Yes	Be sure of the connection of the fan. Replace the CU/PU board. Connect the fan properly. Replace the CU/PU board.

Display	Cause	Error details		Measure
Inspection is required. 123 : Error	Ambient humidity error or non connection of humidity sensor	Is the cable from the CU/PU board to the toner sensor board connected properly?	No Yes	Re-connect it properly. Replace the toner sensor board.
Inspection is required. 124 : Error	Ambient temperature error	Is the cable from the CU/PU board to the toner sensor board connected properly?	No Yes	Re-connect it properly. Replace the toner sensor board.
Inspection is required. 127 : Error	An error of exhaust fan of the Fuser	Is the fan's connector properly connected? Does the error occur again?	No Yes No	Connect properly. Replace the fan's motor. Replace the PU board.
Inspection is required. 128 : Error 05	Image drum fan error	Is the connector of the fan connected properly? Does the error occur again?	No Yes No	Re-connect it properly. Replace the fan motor. Replace the CU/PU board.
Inspection is required. 134 : Error	LED head detection error (134=K)	Is the LED head installed properly? Is the LED head fuse broken? Does the error occur again?	No Yes Yes No Yes	Install the LED head unit. Check the LED head fuse. Check the fuse. Turn off and on the MFP. Replace the LED head unit.
Inspection is required. 153 : Error	Image drum unit fuse-cut error	Is the image drum unit installed properly? Does the error occur again?	No Yes Yes	Re-install it. Turn off and on the MFP. Be sure of the cable connection from the CU/PU board to the toner sensor board, and then replace the toner sensor board. Replace the CU/PU board.
		Is the MFP recovered by replacing the toner sensor board.	No	

Display	Cause	Error details		Measure
Inspection is required. 163 : Error	Toner sensor detection error (163=K). This error does not occur with the MFP in the factory shipped configuration.	Is the toner cartridge installed? Is the toner slide shutter set?	No No Yes	Install the toner cartridge. Turn it to the fixed position. Turn off and on the MFP. Replace the toner sensor assembly.
Inspection is required. 167 : Error	Thermistor slope error	Does an error message appear? Does the error occur again?	Yes	Turn off and on the MFP. Turn off and on the MFP after leaving it for 30 minutes.
Inspection is required. 170 : Error 171 : Error	A fuser thermistor short or open circuit was detected.	Does the error occur again?	Yes	Turn off and on the MFP. Replace the fuser unit.
Inspection is required. 172 : Error 173 : Error	A fuser thermistor temperature error (high or low temperature) was detected.	Does the error occur again? Does the error occur again?	Yes Yes	Turn off and on the MFP. Replace the fuser unit. Replace the low-voltage power supply, and then replace the CU/PU board when the error occurs again.
Inspection is required. 182 : Error	Option unit I/F error	Does the error occur again? Does the error occur again?	Yes Yes	Turn off and on the MFP. Be sure of connector connection. Replace the option unit.
Power OFF/ON 190 : Error	System memory overflow	Does the error occur again?	Yes	Turn off and on the MFP. Replace the CU/PU board.
Inspection is required. 200 : Error ~ 202 : Error	PU firmware download error	An error occurred in re-writing the PU firmware.		Turn off and on the MFP, and then re-download it (In general use of the MFP, this re-writing is not performed and this error does not occur).

Display	Cause	Error details		Measure
Power OFF/ON 203 : Error 204 : Error 207 : Error 208 : Error 213 : Error F0C : Error FFE : Error FFF : Error	CU program error (203 to 213 do not occur in general use of the MFP)	Invalid processing was performed with a CU program.		Replace the CU/PU board.
Power OFF/ON 209 : Download error	Custom Media Type table downloading failure	Custom Media Type table downloading failed.		Turn off and on the MFP, and then re-download it (In general use of the MFP, this downloading is not performed and this error does not occur).
Inspection is required. 231 : Error *	TAG interface error	IA TAG interface error was detected. 01 : A short-circuit error. 02 : TAG communication error.		Be sure the toner cartridges and the image drums are properly set. Replace the toner cartridges. When the error occurs again after the image drums are re-installed, be sure of the cable connection from the CU/PU board to the toner sensor board.
Power OFF/ON 250 : Error	SD card error			
Inspection is required. 251 : Error	SD card erasure error			
PRESS POWER SW FOR 5SEC Error : 802 Error : 803 Error : 805 Error : 807 Error : 808	SU Exception	Does the error occur again?	Yes	Turn off and on the MFP. Replace the SU board.

Display	Cause	Error details		Measure
PRESS POWER SW FOR 5SEC Error : 811 Error : 812 Error : 813	SU Com- munication Error	Communication error between the Controller and the Scanner Unit is detected.		Turn off and on the MFP.
PRESS POWER SW FOR 5SEC Error : 814	SU FW Removed	It is an error to notify that SU FW was erased by special key operation from a panel.		
PRESS POWER SW FOR 5SEC Error : 890	SU System Memory Overflow	Does the error occur again?	Yes	Turn off and on the MFP. Replace the SU board
Power OFF/ON Error : 899	CU Disconnect	In the situation that communication between CU and SU was able to establish, SU FW detected that CU FW had disappeared from a communications path (an USB line).		
Power OFF/ON 923 : Error	A lock error with black image drum	The image drum does not revolve properly. Does the error display is provided again by turning off and on the MFP?	Yes Yes	Be sure the image drum is properly installed properly. Replace the image drum unit. Replace the image drum motor.
Power OFF/ON 933 : Error	Tray-2 CPU clock frequency error			
Power OFF/ON 941 : Error 942 : Error 943 : Error	PU Error	A PU error was detected. 941 : Watch Doc Timer Error 942 : Detection of Unassigned Interruption 943 : CPU Error Detection		Turn off and on the MFP. When this error occurs again, replace the CU/ PU board.
Power OFF/ON Error : 946	AC Voltage Zero-crossing Error			
Inspection is required. 980 : Error	Media jamming error around fuser.	Media is jammed by entangling around the fuser.		Turn off the MFP. Replace the fuser.

Note! With the MFP's temperature not more than 0°C, Service call errors 168 Error, 171 Error, 175 Error, 903 Error and 904 Error may occur. After turn off the MFP, turn on the MFP after the MFP warms.

8.5.3 Fax Error List

Termination Code List

#	Value (Hex)	Description
1.	0	NORMAL (Ended normally)
2.	1	STOP (A user cancelled a job during sending.)
3.	2	An incoming call was received. The produdre ended unsuccessfully (T1 timeout).
4.	3	CANCEL for shutdown
5.	11	Document jam during real time sending
6.	14	Memory Full during RX / Memory Full (Insufficient avaialble memory at the time of receiving. Or exceeded a maximum number of received pages.)
7.	19	FAX ERROR_TX_JOB_DELETED (Cancellation of jobs waiting for sending: Redialing, calling again & resending, and prograded sending, including delayed transmission)
8.	21	CONNECTION FAIL (A line wasn't connected or a dial tone wasn't detected at the time of dial calling.)
9.	22	Failed sending during ringing (Conflict between sending and receiving) Timeout of T0 timer in Phase-A Timeout of T1 timer in Phase-B
10.	23	Redial All Failed (when all of redialing was NG)
11.	32	V8 negotiation Fail (Not compatible with a sender in V34 receiving)
12.	35	SUB discrepancy in confidential receiving
13.	36	Box full in confidential receiving
14.	37	SEP discrepancy in bulletin board polling sending
15.	38	The box was unavailabl in bulletin board polling sending.
16.	39	The box was unavailabl in confidential receiving.
17.	40	Retry Out (Sent DCS three times in fax sending and no resoponse.)
18.	41	Too Many FTT (Training failure)
19.	43	T2 Time Out (A machine on the other end didn't respond and T2 timeout.)
20.	45	Phase-B Command Rec Error (Failed to receive a control signal at the time of receiving) (Including SEP discrepancy in bulletin board polling receiving)
21.	46	Phase-B Response Rec Error (Failed to receive a control signal at the time of sending) (Including SUB discrepancy in confidential sending)

#	Value (Hex)	Description
22.	47	Phase-B Invalid Command/Response Rx (Received an invalid signal.)
23.	48	A machine on the other end was incapable of receiving.
24.	49	T1 timeout after EOM (T1 timeout after EOM receiving)
25.	4A	Invalid CSI error (Dialing numbers didn't match with ID of the machin on the other end in confirmation sending.)
26.	4B	Invalid TSI error (matches number denied acceptance registered as nuisance fax)
27.	4c	FIF:bit49 of a facing machine's DIS was 0 in confidential sending (A facing machine was incapable of confidential receiving).
28.	4d	FIF:bit47 of a facing machine's DIS was 0 in bulletin board polling receiving (A facing machine was incapable of bulletin board polling sending).
29.	51	Image Data not ready (Decoding or file system error in scanned or received images)
30.	52	Phase-C Time Out (EOL (not in ECM) or Frame (in ECM) timeout occurred during data receiving)
31.	60	Retry Out (A machine on the other end made no response in sending Phase-D. Retry error of post-command.)
32.	65	RNR time out (Time out error of flow control of RR/RNR in sending)
33.	66	RTN/PIN Received, EOR/ERR/DCN (Received RTN/PIN (N-ECM) ERR (ECM))
34.	67	Phase-D Invalid Command/Response Rx (Received an invalid signal.)
35.	69	Phase-D Response Rec Error (Failed to receive a control signal at the time of sending)
36.	6A	EOR error (Received EOR at the time of receiving)
37.	80	MODEM hung-up (Couldn't control a modem)
38.	82	V34 t1 timeout, control channel error (T1 timeout with V34 control channel)
39.	83	V34 t1 timeout, primary channel error (T1 timeout with V34 primary channel)
40.	84	Data not sent until guard timer expire (Timeout at PH-C guard timer)
41.	90	Exceeded the maximum number of digits of dial entry (A maximum of 80 digits after unfolding a dial symbol)

8.5.4 Email/Internet FAX/FAX Server Error List

ErrorCode	Description
1	Connection failed. Please check "SMTP Server" settings.
2	Connection failed. Please check "SMTP Server Port" settings.
3	Authentication failed. "SMTP Auth" Unsupported.
4	Authentication failed. "SMTP Auth" Login failed. Be sure of the login name and password for the mail server.
5	Authentication failed. Please check "POP Server" settings.
6	Authentication failed. Please check "POP Server Port" settings.
7	Authentication failed. "POP" Login failed. Be sure of the login name and password for the POP server.
8	SMTP Transmission Error. Check network configuration, cable connection and status, and the server status.
9	POP Transmission Error. Check network configuration, cable connection and status, and the server status.
11	SMTP Transmission Error. Sending Data is biggest. Please Check for Mailbox quota at SMTP Server.
12	SMTP Transmission Error. Please wait and retry.
13	SMTP Transmission Panic. Contact the network administrator.
15	Email receiving has been cancelled. Canceled from SMTP Client or POP Server.
16	Email receiving has been cancelled from user.
19	Email receiving has been cancelled. MIME Error. The format of email or the attached file may be not supported.
20	Email receiving has been cancelled. Unsupported MIME. The format of email or the attached file may be not supported.
22	Email receiving has been cancelled. An attached file may have exceed its size limit(8M Byte). Large files cannot be printed.
24	Email receiving has been cancelled. Contact the network administrator.

8.5.5 Preparing for troubleshooting

(1) LCD Display Trouble	8-39
(1-1) LCD displays nothing	8-39
(1-2) Display of OKI logo	8-40
(1-3) Error message display	8-40
(2) Abnormal MFP operation after powered on.....	8-40
(2-1) No operation	8-40
(2-2) Abnormal sound.....	8-42
(2-3) Abnormal odor	8-43
(2-4) Slow starting time.....	8-43
(3) Paper feed jam (Error code 391: 1st tray)	8-54
(3-1) Does a jam error occur when turning on the power?	8-54
(3-2) Jam occurs immediately after the paper feed is started. (1st tray)	8-54
(4) Feed jam (Error code 380, 381).....	8-55
(4-1) Jam occurs immediately after the power is turned on.	8-55
(4-2) Jam occurs immediately after the paper feed is started.....	8-55
(5) Paper feed jam (Error code 390: Multipurpose tray).....	8-56
(5-1) Does a jam error occur when turning on the power?	8-56
(5-2) Jam occurs immediately after paper feed is started. (Multipurpose tray)	8-57
(6) Paper running jam (Error code 381:).....	8-58
(6-1) Jam occurs immediately after the power is turned on.	8-58
(6-2) Jam occurs immediately after the paper feed is started.....	8-58
(7) Two-sided printing jam (Error code: 370, 371, 372, 373, 383)	8-58
(7-1) Two-sided printing jam.....	8-58
(8) Paper size error (Error code 400).....	8-59
(8-1) Jam occurs when paper end is located near the IN1 sensor.....	8-59
(9) Fuser unit error (Error 170 to 177)	8-59
(9-1) Error occurs immediately after the power is turned on.....	8-59
(9-2) Error occurs approx. 1 minute after the power is turned on.....	8-59
(10) Motor fan error (Error code 120, 127, 128).....	8-60
(10-1) The low voltage power supply fan does not rotate immediately after the power is turned on.	8-60
(10-2) All fans of the printer do not rotate.....	8-60
(11) Print speed is slow. (Performance is low.)	8-60
(11-1) Print speed decreases.....	8-60
(12) Option unit cannot be recognized.....	8-61
(12-1) Option try unit cannot be recognized.....	8-61
(13) LED head cannot be recognized. (Error code 131, 132, 133, 134).....	8-61
(13-1) Service call 131 to 134 (LED HEAD Missing).....	8-61
(14) Toner cartridge cannot be recognized. (Error code 540, 541, 542, 543)	8-62
(14-1) Error caused by the consumable items.....	8-62
(14-2) Error caused by the toner sensor	8-62
(14-3) Error caused by the defective mechanism.....	8-63
(15) Fuse cut error (Error codes 153 to 155)	8-63
(15-1) Fuse cut error	8-63
(16) Humidity sensor error (Error code 123).....	8-64
(16-1) Humidity sensor error	8-64

- Note!**
- When replacing the CU/PU board, please read the content on the EEPROM chip of the old board and copy it to the new board. (Refer to 5.6.1 when exchange the CU/PU board)
 - Connection diagram is see Fig1-1.

8.5.5.(1) LCD Display Trouble

(1-1) LCD displays nothing

Check item	Checking	Action in case of fail
(1-1-1) Checking fuse		
Fuse on SU board (MHE)	Check whether F1 or F5 has blown.	Replace F1 or F5 or SU board (MHE).
(1-1-2) Checking connections		
Connection between low-voltage power supply unit and SU board (MHE)	Make sure the low-voltage power supply unit is connected to the POWER connector on the SU board (MHE) properly. Check whether the cable connector is half-connected or tilted, or whether wires are broken. Check whether there is any fault in the cable assembly, e.g., missing wires.	Connect the cable properly.
Cable assembly connecting low-voltage power supply unit to SU board (MHE)		Replace the cable with a good cable.
Connection between SU board (MHE) and operation panel	Make sure the 16-pin FFC is connected to the OPE connector on the SU board (MHE) properly. Make sure the 16-pin FFC is connected to the CN1 connector on the OPE board (OPM) properly. Check whether the cable connector is half-connected or tilted.	Connect the cable properly.
FFC connecting SU board (MHE) to OPE board (OPM)	Check for broken wires using a tester. Check visually whether the sheath peels.	Replace the cable with a good cable.

Check item	Checking	Action in case of fail
(1-1-2) Checking connections		
Connection between SU board (MHE) and CU/PU board	Make sure the 10-pin FFC is connected to the GDIF connector on the SU board (MHE) properly. Make sure the 10-pin FFC is connected to the MFPIF connector on the CU/PU board (98M) properly. Check whether the cable connector is half-connected or tilted.	Connect the cable properly.
FFC connecting SU board (MHE) to CU/PU board (98M)	Check for broken wires using a tester. Check visually whether the sheath peels.	Replace the cable with a good cable
(1-1-3) Checking power supplies		
AC power supplied to the printer	Check the supplied voltage from the AC power source.	Supply AC power.
5V power supplied to SU board (MHE)	Check the 5V power at 3, 4pin of the POWER connector on the SU board (MHE).	Replace the low-voltage power supply.
3.3V power supplied to OPE board (OPM)	Check the 3.3V power at 14pin of the CN1 connector on the OPE board (OPM).	Replace the SU board (MHE).
(1-1-4) Checking for short circuit of power supply		
5V and 24V power supplied to SU board (MHE)	Check for a short circuit using the POWER connector on the SU board (MHE). 7, 8pin: 24V 3, 4pin: 5V 5, 6pin: 0V 9, 10pin: 0V If there is a short circuit, locate it. Disconnect the cables from the SU board (MHE) one by one to locate the short circuit.	Replace the short-circuited component.

Check item	Checking	Action in case of fail
(1-1-5) Checking LSI operation		
I/F signal from SU board (MHE) to OPE board (OPM)	Check whether signals are output to the OPE connector on the SU board (MHE). 9pin: Transmission data (sent from the SU board (MHE)) 11pin: Clock 13pin: Enabling 15pin: Reset Signals should be always output under normal conditions.	Replace the SU board (MHE).

(1-2) Display of OKI logo

Check item	Checking	Action in case of fail
(1-2-1) Operation panel display does not change.		
Operation panel display	OKI logo stays on.	Replace the SU board (MHE).

(1-3) Error message display

Check item	Checking	Action in case of fail
(1-3-1) Error message		
Error message display	Check the detail of the error on the error message list.	Follow the instructions.

8.5.5.(2) Abnormal MFP operation after powered on

(2-1) No operation

Check item	Checking	Action in case of fail
(2-1-1) Checking power supplies		
AC power supplied to the printer	Check the supplied voltage from the AC power source.	Supply AC power.
5V and 24V power supplied to CU/PU board (98M)	Check the power supply using the POWER connector on the CU/PU board (98M). 7, 8, 9pin: 24V 1, 2, 3pin: 5V 4, 5, 6pin: 0V 10, 11, 12pin: 0V	Replace the low-voltage power supply.
5V, and 24V power supplied to SU board (MHE)	Check the power supply using the POWER connector on the SU board (MHE). 3, 4pin: 5V 7, 8pin: 24V 5, 6pin: 0V 9, 10pin: 0V	Replace the low-voltage power supply.
3.3V power supplied to SU board (MHE)	Check the power supply using the GDIF connector on the SU board (MHE). 3pin: 3.3V 4, 6, 9pin: 0V	Replace the CU/PU board (98M).

Check item	Checking	Action in case of fail
(2-1-2) Confirmation of the power switch LED		
Power Switch LED	Confirm whether the LED is off. If the LED blinks rapidly, the number of blinking times in a cycleshows an error. The timing of blinking rapidly is shown in the below figure	Replace either of the power supply unit, the CU board (98M), SW-Assy (Front), the cables connected to the CU board and power supply unit or the cables connected to the CU board and SW-assy. In case of 2, 4, 8 or 10 times of LED blinking rapidly: Replace either of the power supply unit, the CU board (98M), the cables connected to the power supply unit and the CU board. In case of 3, 6 or 9 times of LED blinking rapidly: Replace the CU board (98M).
<div style="border: 1px solid black; padding: 5px; margin-bottom: 10px;">Rapid blinking of the LED</div>		

Check item	Checking	Action in case of fail
(2-1-3) Checking connections		
Connection between low-voltage power supply unit and CU/PU board (98M)	Make sure the low-voltage power supply unit is connected to the POWER connector on the CU/PU board (98M) properly. Check whether the cable connector is half-connected or tilted, or whether wires are broken. Check whether there is any fault in the cable assembly, e.g., missing wires.	Connect the cable properly.
Cable assembly connecting low-voltage power supply unit to CU/PU board (98M)		Replace the cable with a good cable.
Connection between low-voltage power supply unit and SU board (MHE)	Do the checking as described in (1-1-2).	Refer to (1-1-2).
Cable assembly connecting low-voltage power supply unit to SU board (MHE)		
Connection between CU/PU board (98M) unit and SU board (MHE)		
Cable assembly connecting CU/PU board (98M) to SU board (MHE)		

(2-2) Abnormal sound

Check item	Checking	Action in case of fail
(2-2-1) Checking for loss of synchronization of motor (driver failure)		
Operation of each motor	Check whether each motor operates properly using the self-diagnosis mode. Check by detection of a load. Noise that sounds like "pooh" is made when there is a fault.	Replace CU/PU board (98M) and SU board (MHE).
Condition of each motor cable	Check the wiring of each motor. Check for a short circuit by visual check and using a tester. Disconnect the motor cable from the PCB and check the resistance between the FG and each pin of the disconnected cable.	Replace the motor cable. Correct the wiring.
(2-2-2) Checking for loss of synchronization of motor (load by consumables)		
Operation of each motor	Check whether each motor operates properly using the self-diagnosis mode. Check by detection of a load. Noise that sounds like "pooh" is made when there is a fault.	Replace the consumable(s). When testing with a new consumable part, use the fuse keep mode on the system maintenance menu.
(2-2-3) Check for gear jumping (load by consumables)		
Operation of each motor	Check whether each motor operates properly using the self-diagnosis mode. Check by detection of a load. Noise that sounds like "batz batz" is made when there is a fault.	Replace the consumable(s). When testing with a new consumable part, use the fuse keep mode on the system maintenance menu.
Position of consumables	Check visually whether each consumable gear is in place and they engage with one another.	Replace or repair mechanical part(s).

Check item	Checking	Action in case of fail
(2-2-4) Checking cable wiring		
Cable wiring around cooling fans	Check whether a cable touches the blades of a fan as the cable is not properly laid. When it does, noise that sounds like "clack clack" is made.	Lay the cable properly.

(2-3) Abnormal odor

Confirmation Items	Confirmation Tasks	Action at NG
(2-3-1) Locate the position with abnormal odor occurred.		
Fuser unit	Take out the fuser and confirm the odor.	Perform (2-3-2).
Low-voltage power supply unit	Take out the low-voltage power supply unit and confirm the odor.	Exchange low-voltage power supply unit
(2-3-2) Check the condition of fuser.		
Life count of fuser	Confirm the life count of the fuser by the maintenance utility.	It may have abnormal smell around a new printer.
Foreign confirmation of fuser	Confirm whether the fuser is jammed with foreign body such as paper inside.	Remove the foreign body.

(2-4) Slow starting time

Confirmation Items	Confirmation Tasks	Action at NG
(2-4-1) Check a fuser unit		
Halogen lamp	Confirm the wattage of the halogen lamp mounted in the fuser.	Exchange for wattage parts of the rated voltage.
(2-4-2) Check optional parts		
Expansion memory	Reset the optional parts (expansion memory) and recheck the operation.	Exchange optional parts

● Paper Jams

This section explains how to clear paper jams.



- Reference!**
- For details on the location of each component of the machine, refer to "Cleaning the Machine" on P. 165.
 - For details on the location of each component of the machine, refer to "Names of Components" on P. 15.

Checking Error Messages

When a paper jam occurs, the [Paper jam] or [Document jam] message appears on the display screen and the <STATUS> key on the operator panel blinks. The error code and description differ according to where the paper jam occurs.



Clearing Paper Jams

 Caution	Possible to get burned.	
Since the fuser unit right is extremely hot, perform the operation with care.		

- Note!**
- The image drum (the green tube) is very delicate. Handle it carefully.
 - Do not expose the image drum to direct sunlight or very bright interior light (approximately more than 1500 lux). Even under the normal interior light, do not leave it for more than 5 minutes.

Error Code 370, 371, 372 (Duplex paper jam)

- (1) Remove any documents from the document tray if any.
- (2) Open the scanner unit.
- (3) Press the top cover open button ① and open the top cover.

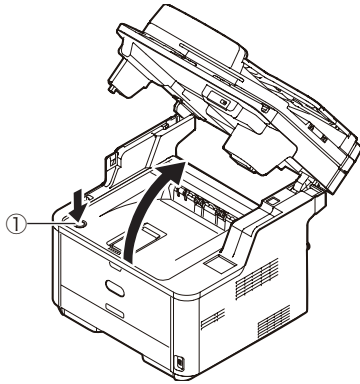

- (4) Carefully lift out the image drum, complete with the toner cartridge. Be careful not to touch or scratch the green drum surface.

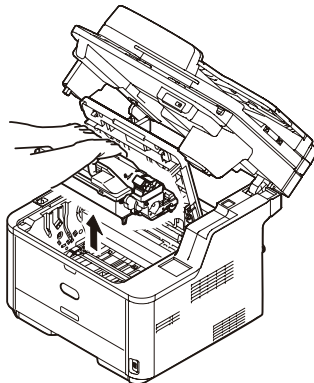

- (5) Remove the Image Drum as described in step 3, then, remove the Duplex unit (1) by raising the coloured handles (2) on each side, and then by holding the handles and gently lifting it out.

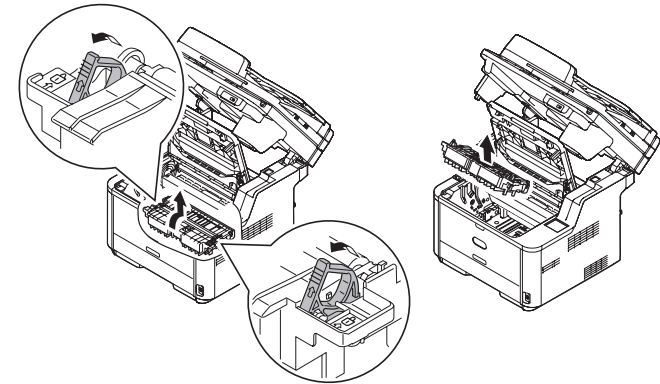

- (6) Remove any paper and replace the duplex unit.

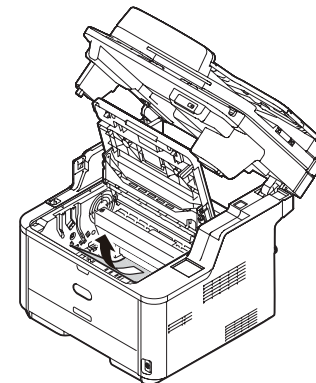

- (7) When you return the transcription unit into the printer, insert both projections (A) of the front end of transcription unit into holders of the printer.

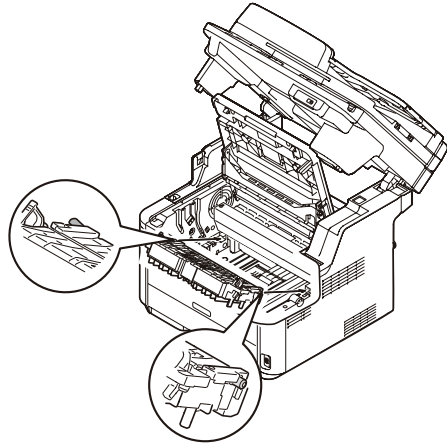

- (8) Insert rear projections, locating close to both handles of the transcription unit, into both mounting holes of the printer.

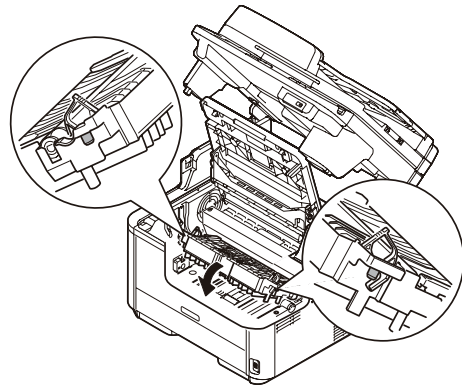

- (9) Secure the transcription unit to the printer by rotating both handles of the transcription unit in the arrow direction of .

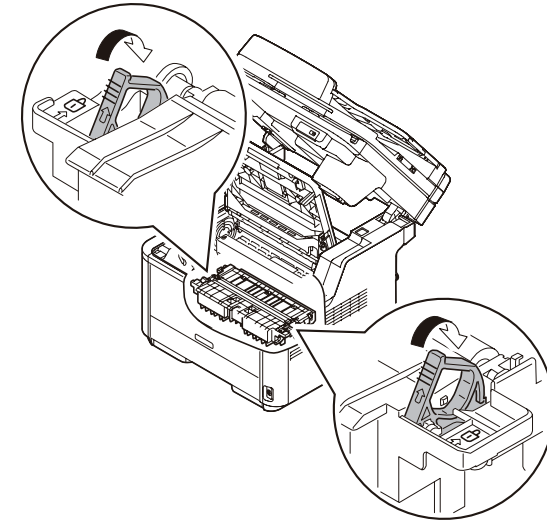

Note! Do not touch the sponge roller of the transcription unit by your hand.

- (10) Re-install the image drum complete with toner cartridge, ensuring that the pegs (1 & 2) correctly locate into the slots on each side of the printer (3).

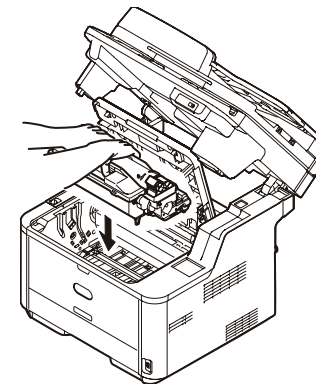

- (11) Close the top cover.

- (12) Close the scanner unit.

Error Code 380, 381, 382, 389 (Paper feed jam)

- (1) Remove any documents from the document tray if any.
- (2) Open the scanner unit.
- (3) Press the top cover open button ① and open the top cover.

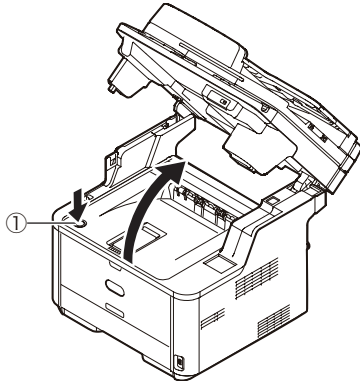

- (4) Carefully lift out the image drum, complete with the toner cartridge. Be careful not to touch or scratch the green drum surface.

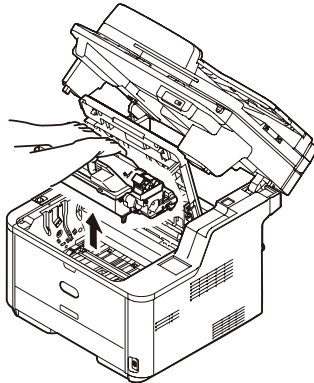

- (5) If the top end of paper is visible at the rear side of transparent resist guide, rotate the resist guide toward the fuser unit and hold the paper top end and carefully pull out the paper.

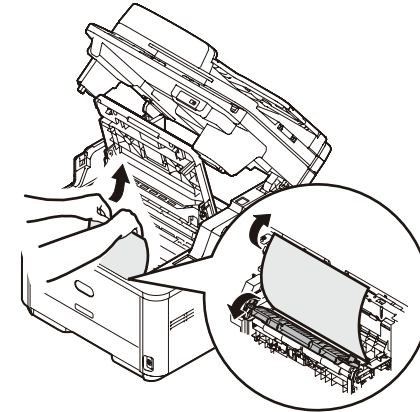

If neither the top or bottom end of paper is visible, move the jammed paper in the arrow direction as shown. Hold the top end of paper by your hands and carefully pull out the paper.

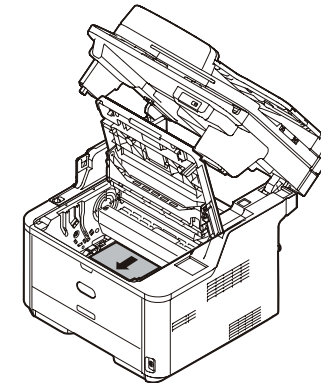

If the bottom end of paper is visible, hold the paper by your hands and carefully pull out the paper.

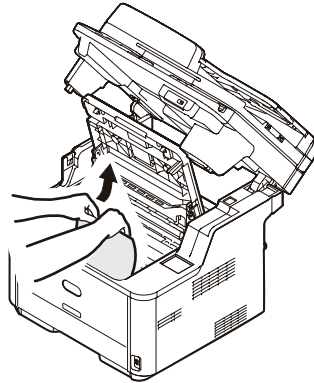

Paper discharge unit (Paper jammed)

• If the bottom end of paper is visible in the printer, hold and pull out the paper carefully.

Note! • If paper jams at the paper discharge unit and if the paper is visible inside of the top cover, pull out the paper toward the inside of the printer.

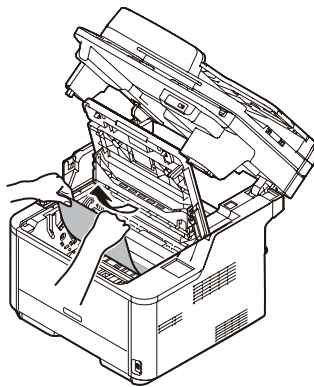

• If the bottom end of paper is not visible but its top end is visible at the paper discharge unit, hold the top end of paper and pull out the paper carefully. If you cannot remove the paper by following Steps (A)1 and (A)2, pull out the paper by following Steps (B).

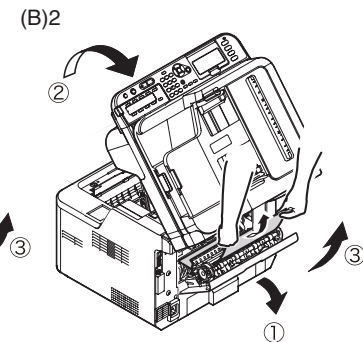
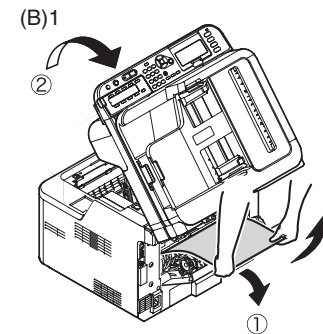
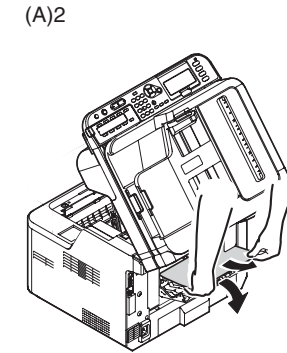
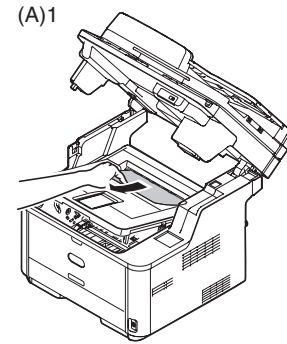

- If you have failed to remove jammed paper, do not force to pull out the paper but follow the steps below.

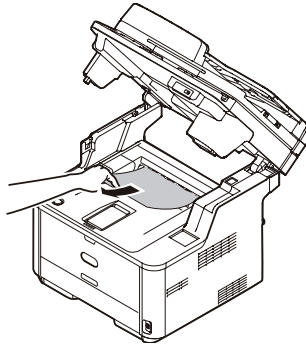

- ➊ Return the image drum cartridge into the printer, and close the top cover.
- ➋ Turn the printer Power switch OFF first, and then turn it ON again. When the motor starts to rotate, hold the top end of paper and pull out the paper.

Note! If paper jams when you load papers, check to see that no paper remains in each paper feed unit. Remember that you can release the alarm display only after you have opened the top cover first and then closed it again.

- (6) Re-install the image drum complete with toner cartridge, ensuring that the pegs (1 & 2) correctly locate into the slots on each side of the printer (3).

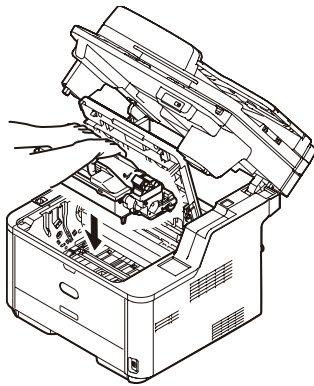

- (7) Close the top cover.
- (8) Close the scanner unit.

Error Code 390 (Paper feed jam (Multipurpose tray))

- (1) Remove any documents from the document tray if any.
- (2) Open the scanner unit.
- (3) Press the top cover open button (1) and open the top cover.
- (4) Carefully lift out the image drum, complete with the toner cartridge. Be careful not to touch or scratch the green drum surface.

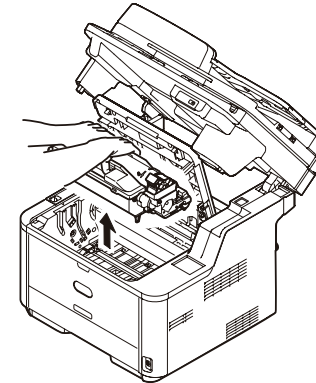

- (5) If the top end of paper is visible at the rear side of transparent resist guide, rotate the resist guide toward the fuser unit and hold the paper top end and carefully pull out the paper.

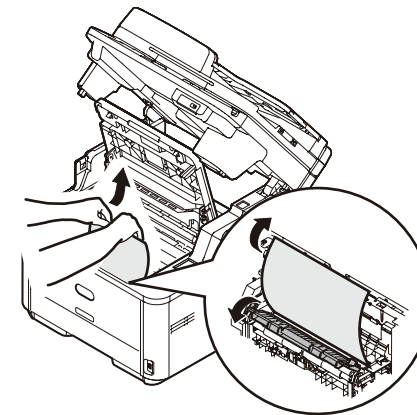

If neither the top or bottom end of paper is visible, move the jammed paper in the arrow direction as shown. Hold the top end of paper by your hands and carefully pull out the paper.

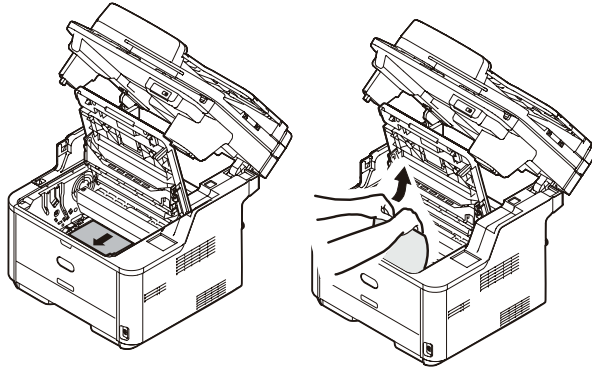

If the bottom end of paper is visible, hold the paper by your hands and carefully pull out the paper.

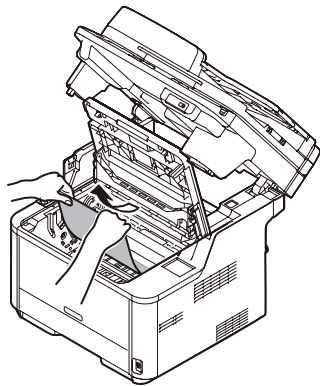

- (6) Re-install the image drum complete with toner cartridge, ensuring that the pegs (1 & 2) correctly locate into the slots on each side of the printer (3).

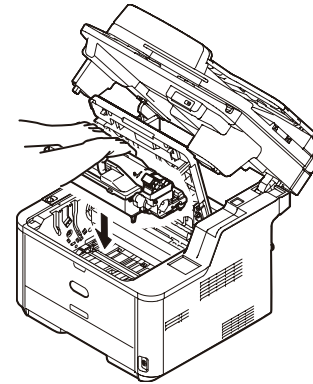

- (7) Close the top cover.
(8) Close the scanner unit.

Error Code 391, 392 (Paper feed jam)

Error Code 391 indicates an error in Tray1 and Error Code 392 indicates a paper jam in Tray2.

Memo! The following procedure uses tray 1 as an example.

- (1) Pull out and remove the paper cassette of the indicated tray.

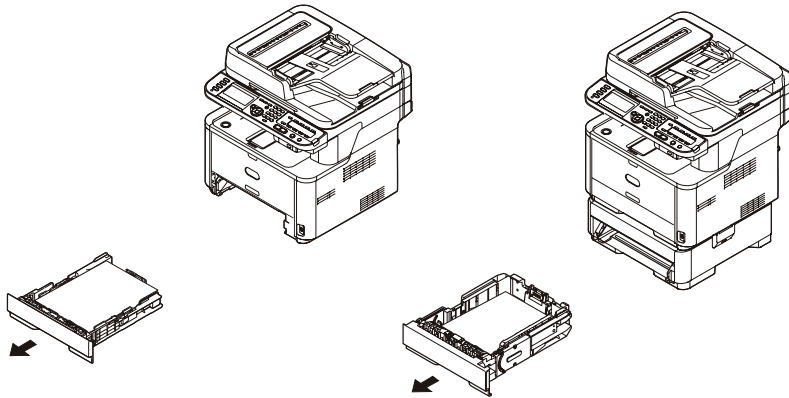

- (2) Remove jammed paper.

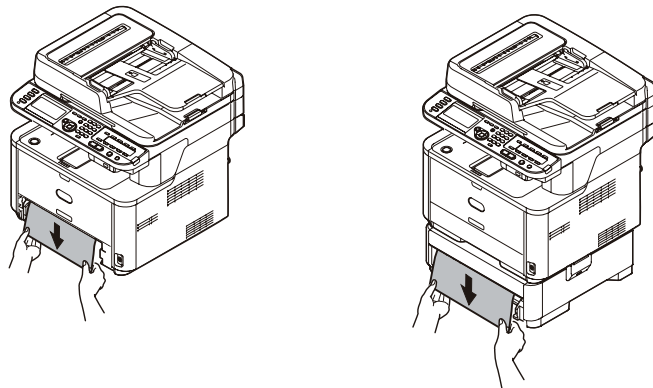

- (3) Return the tray into the machine.
- (4) Open the scanner unit.
- (5) Press the top cover open button ① and open the top cover.

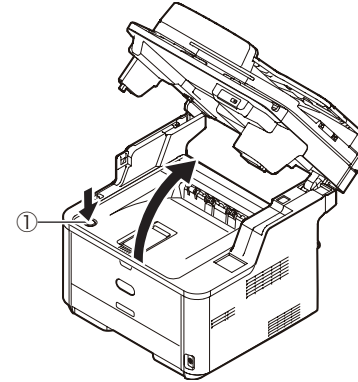

- (6) Close the top cover.
- (7) Close the scanner unit.

Document Jam Occurred

■ When you can see the document In the Duplex Paper Path

- (1) Open the ADF cover, and pull out the document upward.

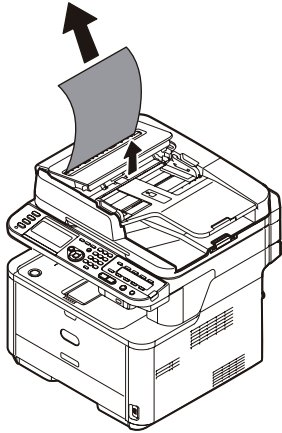

■ When you can see the document Inside the ADF

- (1) Remove any documents from the document tray if any.
- (2) Open the ADF cover.

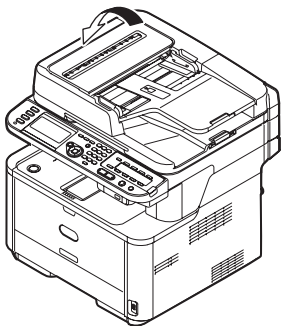

- (3) Hold jammed document by the top edge, and gently pull it out.

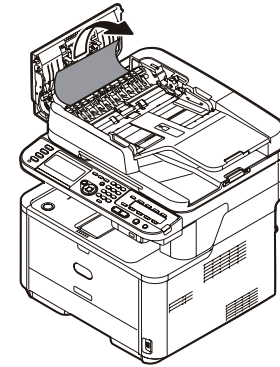

If the edge of the document can be seen under the paper guide ①, lift the paper guide and then pull out the document.

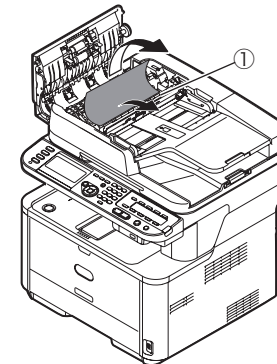

If the edge of the document cannot be seen in the ADF, lift the document tray ② and then pull out the document.

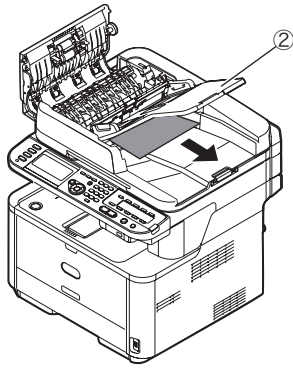

Pull down the document tray.

(4) Close the ADF cover.

8.5.5. (3) Paper feed jam (Error code 391: 1st tray)

(3-1) Does a jam error occur when turning on the power?

Check item	Check operation	Actions for NG results
(3-1-1) Check condition of paper running path		
Paper running path of the front unit	Open the front cover check if paper is not jammed in the paper running path.	Remove the paper
(3-1-2) Check condition of the mechanical parts		
Entrance sensor	Does the entrance sensor lever work normally? (It moves freely by touching.)	Replace the entrance sensor lever.
	Clean a sensor.	replace the main board.

(3-2) Jam occurs immediately after the paper feed is started. (1st tray)

Check item	Check operation	Actions for NG results
(3-2-1) Check condition of paper running path		
Paper running path of the front unit	Open the front cover check if paper is not jammed in the paper running path.	Remove the paper
(3-2-2) Check condition of the mechanical parts		
Entrance sensor	Is the paper sent to the entrance sensor lever?	Replace the paper feed roller, pick-up roller or paper cassette.
	Does the entrance sensor lever work normally? (It moves freely by touching.)	Replace the entrance sensor lever.
	Is the IN_WR connector of the main board connected properly?	Connect the IN_WR connector properly.

Check item	Check operation	Actions for NG results
(3-2-3) Check the paper feed roller rotate.		
Cassette	Does the paper feed roller rotate?	YES: Set the paper cassette appropriately. NO: Go next question.
Paper feed roller and shaft.	Does the paper feed clutch work normally?	YES: Replace the paper feed roller and shaft. NO: Go next question.
Connector	Is HCLT connector of the main board appropriately connected?	YES: Go next question. NO: Connect HCLT connector appropriately.
Clutch	Is the coil resistance of the paper feed clutch (Normal resistance: Pin1, Pin2, and approx. 192) normally?	YES: Replace the main board. NO: Replace the paper feed clutch.

8.5.5. (4) Feed jam (Error code 380, 381)

(4-1) Jam occurs immediately after the power is turned on.

Check item	Check operation	Actions for NG results
(4-1-1) Check condition of paper running path		
Paper running path of the front unit	Open the front cover check if paper is not jammed in the paper running path.	Remove the paper
(4-1-2) Check condition of the mechanical parts		
Write sensor	Does the write sensor lever work normally? (It moves freely by touching.)	Replace the paper sensor plate.
	Clean a sensor.	Replace the main board.

(4-2) Jam occurs immediately after the paper feed is started.

Check item	Check operation	Actions for NG results
(4-2-1) Check condition of paper running path		
Paper running path of the front unit	Open the front cover check if paper is not jammed in the paper running path.	Remove the paper
(4-2-2) Check condition of the mechanical parts		
Write sensor	Does the paper reach the write sensor lever?	YES: Go next question. NO: Go Check paper feed roller.
	Does the ejection sensor lever work normally? (It moves freely by touching.)	Replace the write sensor lever.
	Is the IN_WR connector of the main board connected properly?	Connect the IN_WR connector properly.
	Clean the write sensor	Replace the main board.
Paper feed roller	Does the paper feed roller rotate?	Replace Paper Feed Roller or Paper Feed Clutch.
	Is the image drum cartridge appropriately set?	Set the image drum cartridge appropriately.

Check item	Check operation	Actions for NG results
(4-2-2) Check condition of the mechanical parts		
Ejection sensor lever	Does the paper reach the ejection sensor lever?	YES: Go next question. NO: Go Check drum motor.
	Does the ejection sensor lever work normally? (It moves freely by touching.)	Replace the ejection sensor lever.
	Is the EXIT connector of the main board connected properly?	Connect the EXIT connector properly.
	Clean the ejection sensor	Replace the main board.
Drum motor	Does the main drum motor rotate?	YES: Go Check transfer roller. NO: Go next question.
	Is the DM connector of the main board connected appropriately?	Connect DM connector appropriately.
	Replace the main drum motor.	Replace the main board.
Transfer roller	Does the transfer roller rotate?	Check the gear. (Transfer roller gear, drum gear at the left of drum cartridge)
	Is the fuser unit Assy appropriately installed?	Install the fuser unit Assy.
Image drum cartridge	Is the image drum cartridge appropriately installed?	Set the image drum cartridge appropriately.

8.5.5. (5) Paper feed jam (Error code 390: Multipurpose tray)

(5-1) Does a jam error occur when turning on the power?

Check item	Check operation	Actions for NG results
(5-1-1) Check condition of paper running path		
Paper running path of the multipurpose tray	Open the front cover check if paper is not jammed in the paper running path.	Remove the paper
Sheet Receive of the multipurpose tray	Confirm that the Sheet Receive has moved up normally. Confirm that the support spindle and spring of the Sheet Receive have been installed in the specified positions normally.	Correct installation of the above parts so that the Sheet Receive moves up to the specified position normally.
(5-1-2) Check condition of the mechanical parts		
Entrance sensor	Does the entrance sensor lever work normally? (It moves freely by touching.)	Replace the entrance sensor lever.
Front cover	Confirm that the locks in the right and left of the front cover are locked normally.	Replace the front cover assembly
Check the feed roller and the pickup roller.	Check if any foreign materials such as paper dust on the surface of the feed roller or of the pickup roller or not.	Remove the foreign material.
	Clean a sensor.	Replace the main board.

(5-2) Jam occurs immediately after paper feed is started. (Multipurpose tray)

Check item	Check operation	Actions for NG results
(5-2-1) Check condition of paper running path		
Paper running path of the multipurpose tray	Open the front cover check if paper is not jammed in the paper running path.	Remove the paper
Sheet Receive of the multipurpose tray	Confirm that the Sheet Receive has moved up normally. Confirm that the support spindle and spring of the Sheet Receive have been installed in the specified positions normally.	Correct installation of the above parts so that the Sheet Receive moves up to the specified position normally.
(5-2-2) Check condition of the mechanical parts		
Entrance sensor	Is the paper sent to the entrance sensor lever?	Replace the paper feed roller, pick-up roller or paper cassette.
	Does the entrance sensor lever work normally? (It moves freely by touching.)	Replace the entrance sensor lever.
	Is the IN_WR connector of the main board connected properly?	Connect the IN_WR connector properly.

Check item	Check operation	Actions for NG results
(5-2-3) Check the paper feed roller rotate.		
Multipurpose tray	Does the paper feed roller rotate?	YES: Set the paper multipurpose tray appropriately. NO: Go next question.
Paper feed roller and shaft.	Does the paper feed clutch work normally?	YES: Replace the paper feed roller and shaft. NO: Go next question.
Connector	Is HCLT connector of the main board appropriately connected?	YES: Go next question. NO: Connect HCLT connector appropriately.
Clutch	Is the coil resistance of the paper feed clutch (Normal resistance: Pin1, Pin2, and approx. 192) normally?	YES: Replace the main board. NO: Replace the paper feed clutch.

8.5.5. (6) Paper running jam (Error code 381:)

(6-1) Jam occurs immediately after the power is turned on.

Check item	Check operation	Actions for NG results
(6-1-1) Check condition of paper running path		
Paper running path of the ejection unit	Open the rear cover and top cover check if paper is not jammed in the paper running path.	Remove the paper
(6-1-2) Check condition of the mechanical parts		
Ejecting sensor	Does the ejecting sensor lever work normally? (It moves freely by touching.)	Replace the ejecting sensor.
	Clean a sensor.	Replace the main board.

(6-2) Jam occurs immediately after the paper feed is started.

Check item	Check operation	Actions for NG results
(6-2-1) Check condition of paper running path		
Paper running path of the ejection unit	Open the rear cover and top cover check if paper is not jammed in the paper running path.	Remove the paper
(6-2-2) Check condition of the mechanical parts		
Paper ejection roller	Is the paper ejection roller appropriately installed?	Install the paper ejection roller appropriately.
Paper ejection spring	Is the paper ejection spring appropriately installed?	Install the paper ejection spring appropriately.
Cover-Assy Rear or fuser unit Assy.	Replace Cover-Assy Rear.	Replace fuser unit Assy.

8.5.5. (7) Two-sided printing jam (Error code: 370, 371, 372, 373, 383)

(7-1) Two-sided printing jam.

Check item	Check operation	Actions for NG results
(7-1-1) Check condition of the paper running path		
Paper running path of the Duplex unit	Check if paper is jammed or not in the paper running path. Open the front cover and check if any paper remains in the Duplex feeder or not. Open the rear cover and check if any paper remains in the paper reversing path or not. Remove the Duplex unit. Check if any paper exists in the Duplex insertion slot or not. Open the cover of the Duplex paper running path and check if any paper remains inside of the Duplex unit.	Remove the jammed paper.

8.5.5. (8) Paper size error (Error code 400)

(8-1) Jam occurs when paper end is located near the entrance sensor.

Check item	Check operation	Actions for NG results
(8-1-1) Check paper size and respective sensor.		
Paper size	Is the paper which is specified size used?	Use a specified-size paper.
Entrance sensor	Does the entrance sensor lever work normally? (It moves freely by touching.)	Replace the entrance sensor lever, or clean the entrance sensor.
Write sensor	Does the write sensor lever work appropriately? (It moves freely by touching.)	Replace the write sensor lever.
Main board	Clean the write sensor.	Replace the main board.

8.5.5. (9) Fuser unit error (Error 170 to 177)

(9-1) Error occurs immediately after the power is turned on.

Check item	Check operation	Actions for NG results
(9-1-1) Thermistor is defective (Note)		
Thermistor	Check the thermistors if they are shorted or opened internally. Check the resistance value at the connector pins in the bottom of the fuser unit. (Refer to section 9.1 Resistance check (fuser unit).)	Replace the fuser unit.

Note! Service calls 171 error and 171 error can occur when the printer temperature is below 0°C. Turn on the power again after the printer temperature has increased.

(9-2) Error occurs approx. 1 minute after the power is turned on.

Check item	Check operation	Actions for NG results
(9-2-1) Temperature increase of fuser unit		
Thermostat, halogen lamp	Heater of the fuser unit is controlled of its temperature. Check if the fuser unit gets hot or not by touching it with hands. If the fuser unit temperature does not increase and remains cold, check that the resistance between pin-1 and pin-2, and that in between pin-3 and pin-4 of the two connectors is in the range of several ohms to several ten ohms respectively. (Refer to section 9.1 Resistance value (fuser unit).)	Replace the fuser unit.
(9-2-2) AC power input to the halogen lamp		
AC power voltage from the low voltage power supply	Check if the AC voltage for heater is normally supplied or not. Power supply J2 connector, between pin-1 and pin-2.	Replace the low voltage power supply.
Heater ON signal that is output from CU/PU to the low voltage power supply	Check that the heater ON signal goes active at the warming up timing, or not. "L" active while ON. CU/PU board POWER connector 15 pin.	Replace the CU/PU board.

8.5.5. (10) Motor fan error (Error code 120, 127, 128)

(10-1) The low voltage power supply fan does not rotate immediately after the power is turned on.

Check item	Check operation	Actions for NG results
(10-1-1) Cable connection condition and wiring condition		
Cable connection condition and wiring condition of the low voltage power supply fan and those of the fuser fan	Check if the connectors are connected normally or not. Check if extra length of the cables does not touch the fan blade or not.	Correct the connection condition of the connectors. Correct the cable wiring route. Replace the fan.

(10-2) All fans of the printer do not rotate.

Check item	Check operation	Actions for NG results
(10-2-1) 24V power supply		
CU/PU board fuses, F1 and F2	Check if the fuses F1 and F2 are not open-circuit or not.	24V power supplied to the CU/PU board
24V power supplied to the CU/PU board	Check the power supply voltages at the POWER connector of the CU/PU board. Pins 7, 8 and 9: 24V Pins 4, 5 and 6: 0VL Pins 10, 11 and 12: 0VP	Replace the low voltage power supply.

8.5.5. (11) Print speed is slow. (Performance is low.)

(11-1) Print speed decreases.

Check item	Check operation	Actions for NG results
(11-1-1) Media Weight setting		
Media Weight that is specified for the print	Check if the wrong Media Weight has been specified or not.	Correct the Media Weight.

8.5.5. (12) Option unit cannot be recognized.

(12-1) Option try unit cannot be recognized.

Check item	Check operation	Actions for NG results
(12-1-1) Option try board		
Option tray unit	Check that it is Option Tray which can be used in MB4xx.	Replace it with an appropriate option tray unit.
(12-1-2) Check the system connection		
Connection between the CU/PU board and the option tray board (GOG PCB)	Check that the cord between the 2ND connector of the CU/PU board and the option tray board is properly connected.	Correct the connections.
Square connector connecting the option tray unit with the main unit	Check if any foreign material exists in the connecting portion of the square connector.	Remove the foreign material.
Square connector connecting the option tray unit with the main unit	Is the terminals of the square connector damaged?	Replace the connector.
(12-1-3) Check the control signals.		
Control signal that is output from the CU/PU board to the option tray board (GOG PCB)	Check the control signals that are output from the 2ND connector of the CU/PU board. Pin 6: TXD (PU -> 2nd) Pin 5: RXD (2nd -> PU)	Replace the CU/PU board.

8.5.5. (13) LED head cannot be recognized. (Error code 131, 132, 133, 134)

(13-1) Service call 131 to 134 (LED HEAD Missing)

Check item	Check operation	Actions for NG results
(13-1-1) Check the system connection		
Connecting condition of the CU/PU board connector and the head connector	Check the connecting condition of the FFC by the visual inspection.	Correct the connection to the normal connecting condition.
Head FFC	Remove the head FFC from the printer. Check if any open-circuit or peeling-off of sheath has occurred or not throughout the cable.	Replace the head FFC or CU/PU board.
Conduction of the fuse on the CU/PU board	Check that measurements taken at both ends of each capacitor CP12 show 5V. (See section 7.6.) Or, instead of the above, check if each fuse F502 is open or not.	Replace the CU/PU board.

8.5.5. (14) Toner cartridge cannot be recognized. (Error code 540, 541, 542, 543)

(14-1) Error caused by the consumable items.

Check item	Check operation	Actions for NG results
(14-1-1) Consumable items installation condition		
ID unit and toner cartridge	Check that the ID unit is installed in the normal position. Check that the lock lever of the toner cartridge is locked.	Correct the installation to the normal installation condition.

(14-2) Error caused by the toner sensor

Check item	Check operation	Actions for NG results
(14-2-1) Toner sensor condition		
Toner sensor	Is the receptor of the toner sensor stained?	Wipe off the stain from the toner sensor.
Toner sensor	Confirm that the toner sensor works normally by using the SWITCH SCAN function of the self-diagnostic mode. Place a white paper in front of the toner sensor, and check if the SCAN state changes or not.	Replace the toner sensor board, CU/PU board, or FFC that is located between the toner sensor board and the CU/PU board.

Note! Toner sensor operation check method using the SWITCH SCAN function of the self-diagnostic mode.

(1) How to check operation of the toner sensor at the printer side.

- Status change of the toner sensor can be checked from the Operator Panel using the self-diagnostic mode. First, switch the display to the Operator Panel display. For the method of switching the display to the Operator Panel display, refer to section 5.4.3 Switch Scan Test
- Remove the ID unit and the toner cartridge (TC) from a printer. There is a window inside a printer opposing the ID side when viewed from the front of a printer. The toner sensor is located inside the window.
- Place a white paper 3 mm away from the sensor window. The white paper should be placed in the manner of opposing the toner sensor.
- When light is reflected by a white paper so that incident light falls on the toner sensor, the Operator Panel display shows "L". When the paper is moved so that any light is not reflected by the paper so that the incident light does not reach the toner sensor, "H" is displayed on the Operator Panel.
- If the Operator Panel display toggles between "H" <-> "L" as a paper is flipped in front of the toner sensor, it indicates that the toner sensor and the related system of the printer are working normally.

Action to be taken at NG

- Clean surface of the toner sensor to remove the stains due to residual toner and paper dust.
- Check the connection state between the CU/PU board and the toner sensor board (97T) that are connected with the FFC cable.
- Check it once again, and if no change has found in the state, replace the CU/PU board or the toner sensor board (97T).

(2) How to check operation of the toner sensor at the toner cartridge (TC) side

- To the position where the toner sensor is confirmed to be operating normally in the printer itself by the above paragraph (1), install the TC and the ID unit to check operations by observing display on the Operator Panel.
- If the ID unit works normally, the display on the Operator Panel will toggle between "H" <-> "L" in synchronism with movement of the silver reflector plate that is located on the side of the ID.

Action to be taken at NG

- Check operation condition of the respective ID motors by using the Motor & Clutch Test of the self-diagnostic mode.
- Clean surface of the silver reflector plate on the side of ID to remove stains. (Stain due to toner or paper dust)
- Replace the TC of different color and the ID unit as a pair.
If a satisfactory operation is attained by using the a pair of TC of different color and the ID unit, replace the TC or replace the ID unit.

(14-3) Error caused by the defective mechanism

Check item	Check operation	Actions for NG results
(14-3-1) Mechanical load applied to the ID unit		
ID unit	<p>Check if a heavy mechanical load is being applied to the ID unit due to breakage of the waster toner belt, or not.</p> <p>Check if a heavy mechanical load is being applied to the ID unit by the waster toner box, or not.</p>	Replace the K toner.
(14-3-2) Motor operating condition		
ID motor	<p>Confirm that the respective ID motors work normally or not by using the Motor & Clutch Test of the self-diagnostic mode.</p> <p>Check if any extra load exists or not.</p>	Replace the CU/PU board or the ID motor.

8.5.5. (15) Fuse cut error (Error codes 153 to 155)

(15-1) Fuse cut error

Check item	Check operation	Actions for NG results
(15-1-1) Check the system connection		
FFC connecting the CU/PU board and the high voltage board (97T PCB)	Check if the HVIF connector of the CU/PU board or the HVIF connector of the high voltage board (97T PCB) is connected halfway or inserted in a slanted angle.	Connect the FFC normally. Alternately, replace the FFC.
(15-1-2) Fuse cut circuit		
CU/PU board	Upon completion of the system connection check, turn off the power once and back on. The, check if the error occurs or not.	Replace the CU/PU board.

8.5.5. (16) Humidity sensor error (Error code 123)

(16-1) Humidity sensor error

Check item	Check operation	Actions for NG results
(16-1-1) Check the system connection		
Connection to the CU/PU board and to the toner sensor board	Check if the 28-conductor FFC is connected to the HVIF connector of the CU/PU board normally.	Re-connect the cable normally.
FFC connecting the CU/PU board and the high voltage board	Check for open-circuit with HVIF. Check that peeling off of sheath does not occur in any cables by visual inspection.	Replace the FFC with the normal FFC.
(16-1-2) Environment condition		
Sharp change of environment condition	Is the environment condition changed sharply from a low temperature environment to a high environment condition within a short time? (Example is such a case that a printer is moved from storage condition of a cold area in winter to an office environment.)	Leave a printer for around one hour in the new environment to get used to the new environment. After that, turn on the power again. Before turn on the power, touch the metal panel of the controller panel and the metal plate inside a printer to feel temperature increase inside a printer with human hands. After confirmation that the printer temperature has increased close to the room temperature, turn on the power again.

8.5.6 Print Troubleshooting

The troubleshooting procedure of abnormal printing is described as follows. The typical abnormal printing is shown in the following Figure 7-1.

Trouble	Flowchart number
Pale printing or the whole printing is faded. (Fig.7-1 (A))	①
The white section is dirty. (Fig.7-1 (B))	②
White paper is outputted (Fig. 7-1 (C))	③
Vertical black belt/ Black line (Fig. 7-1 (D))	④
Periodic failure (Fig. 7-1 (E))	⑤
A part of printing is extracted	⑥
Inefficient fusing (when touching the printed sheet, printed characters or image is faded or come off.)	⑦
Vertical white belt/ White line (Fig. 7-1 (F))	⑧

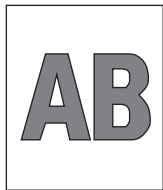

(A) Pale printing or the whole printing is faded



(B) The white section is dirty



(C) White paper

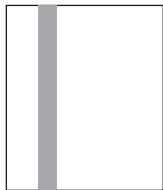

(D) Vertical black belt/ Black line

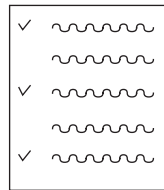

(E) Periodic failure



(F) Vertical white belt/ White line

Figure 7-1

① Pale printing or the whole printing is faded.

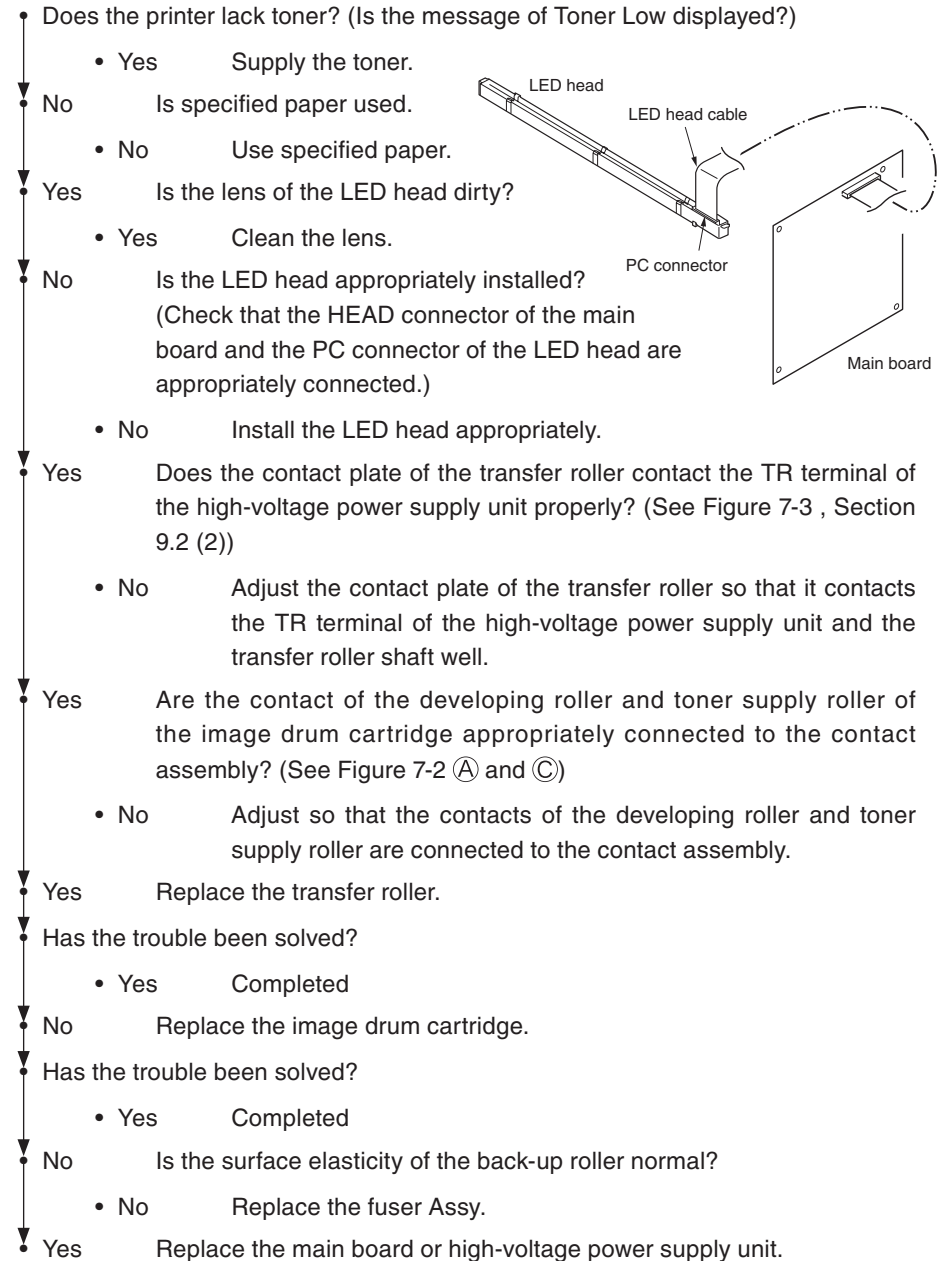

② The white section is dirty

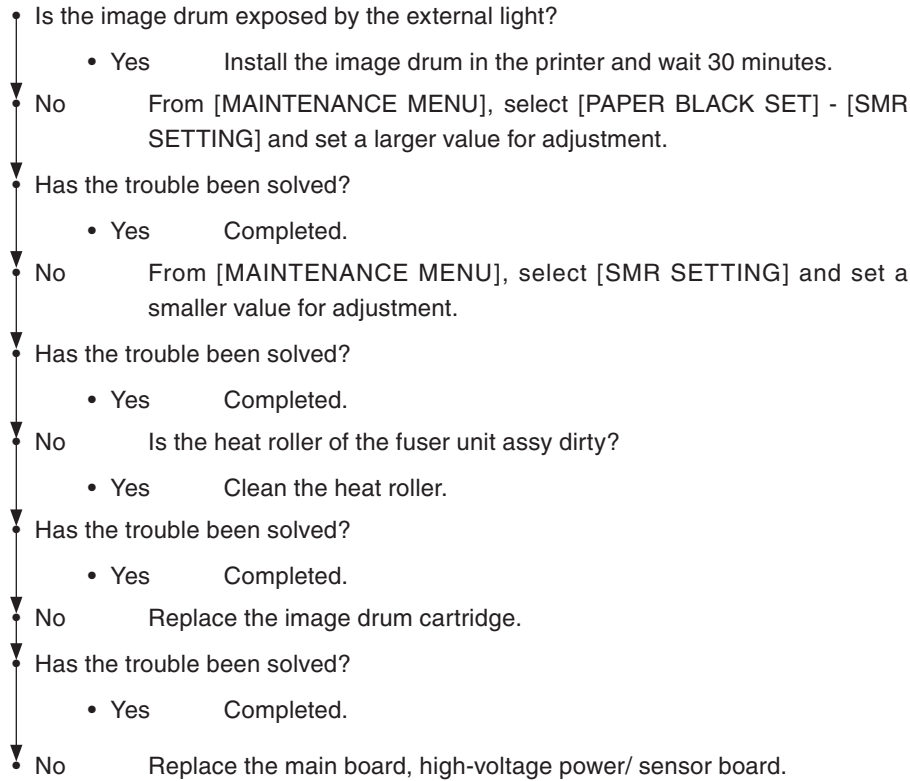

③ White paper is outputted

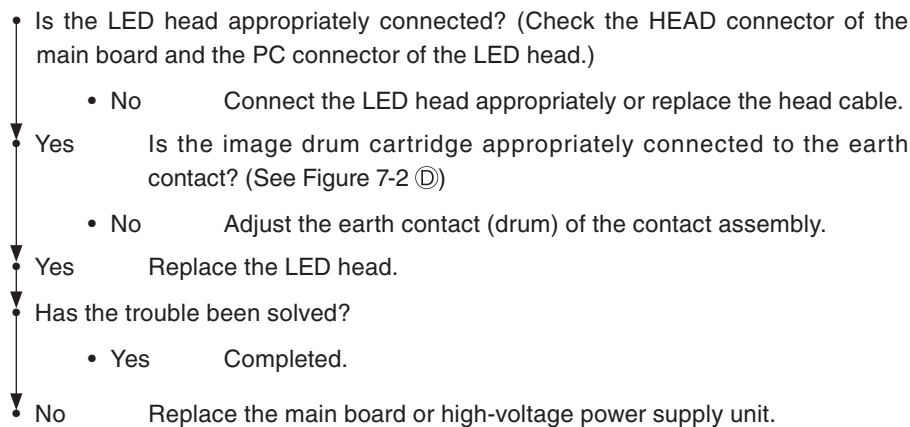

④ Vertical black belt/ Black line

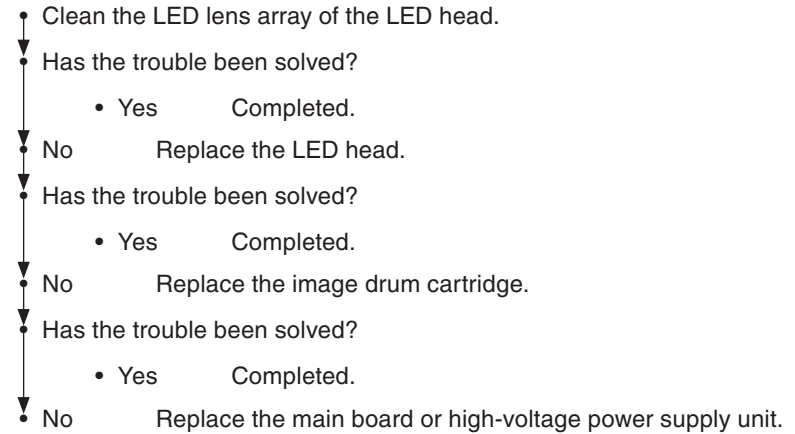

⑤ Periodic failure

	Cycle	Handling
Image Drum	94.25mm	Replace or clean the image drum cartridge.
Developing roller	39.68mm	Replace the image drum cartridge.
Toner supply roller	58.36mm	Replace the image drum cartridge.
Charging roller	37.70mm	Replace the image drum cartridge.
Transfer roller	51.52mm	Replace the transfer roller.
Heat roller	88.12mm	Replace the fuser unit Assy.
Back-up roller	89.54mm	Replace the back-up roller.

⑥ In case of error printing

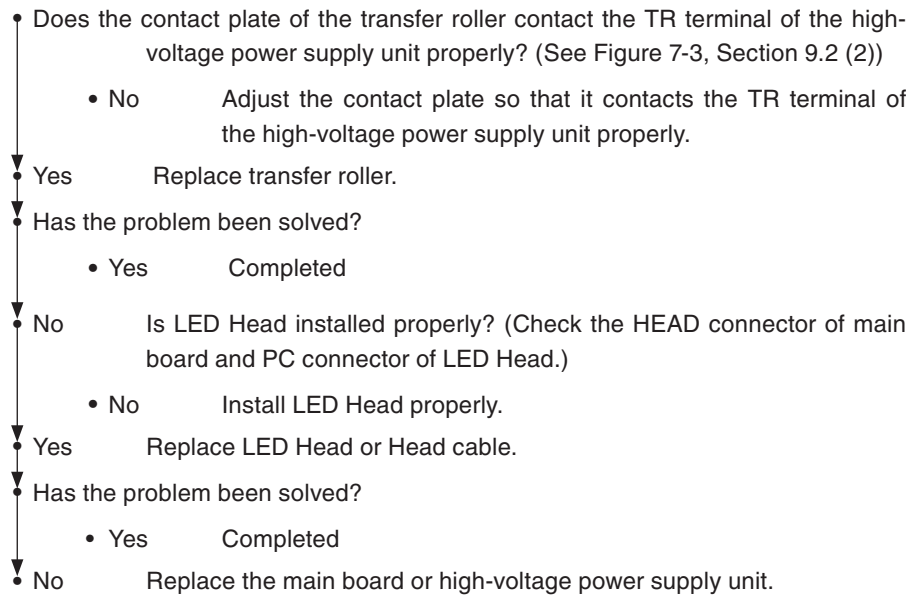

⑦ In case of inefficient fusing (If touch by hand the character or image that are printed on paper will be faded or unstuck.)

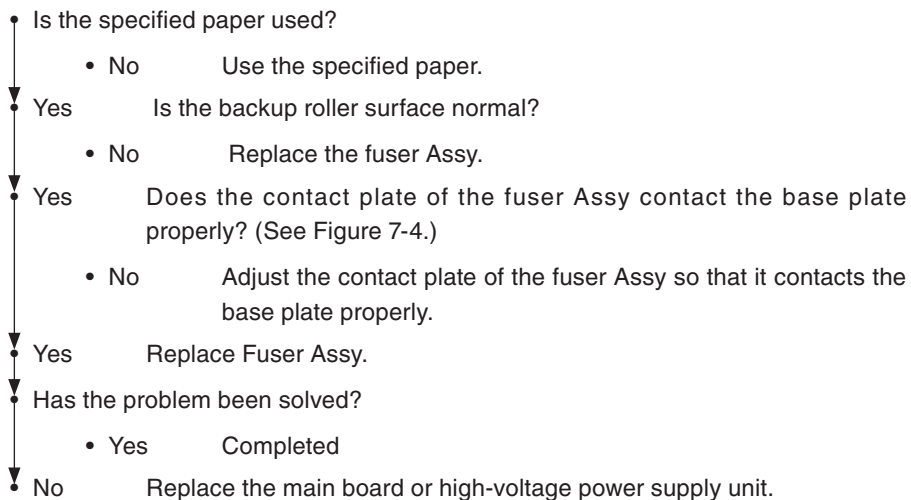

⑧ Vertical white belt/ White line

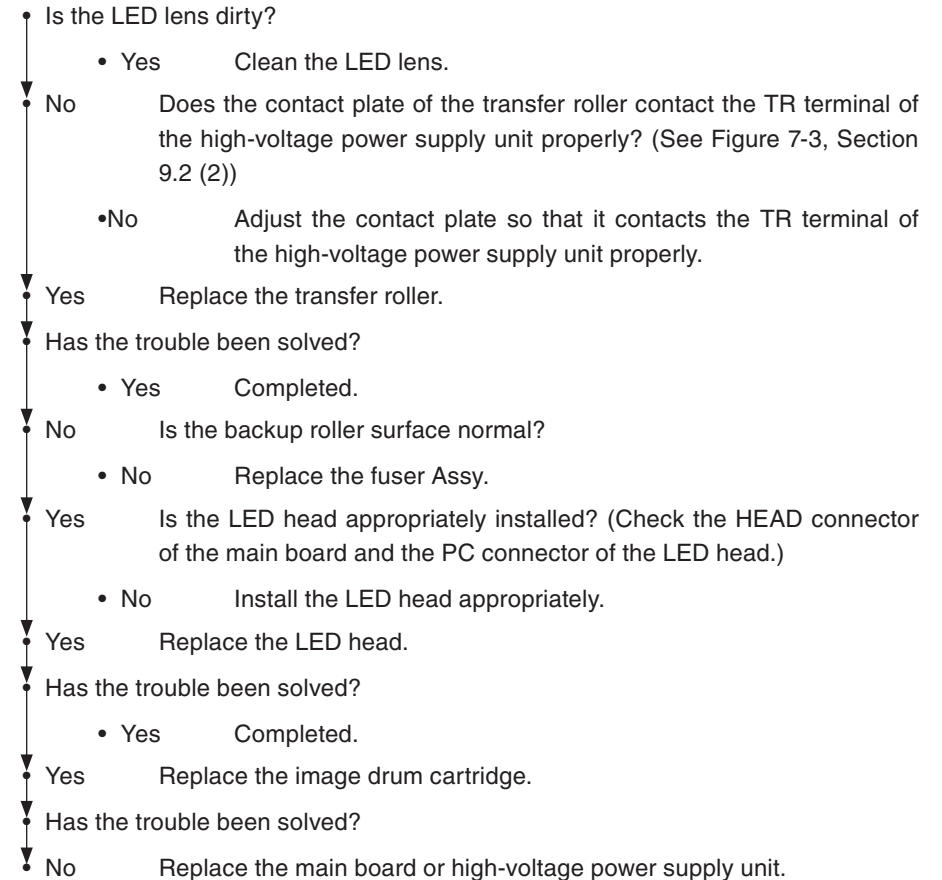

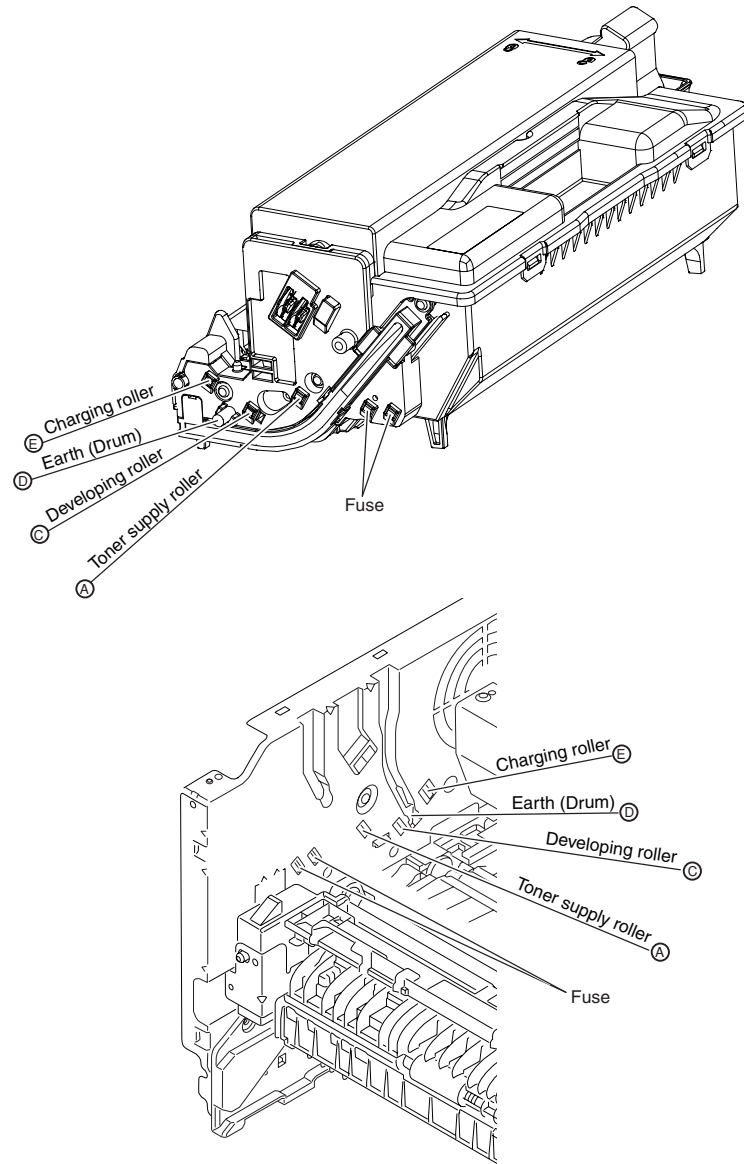

Figure 7-2

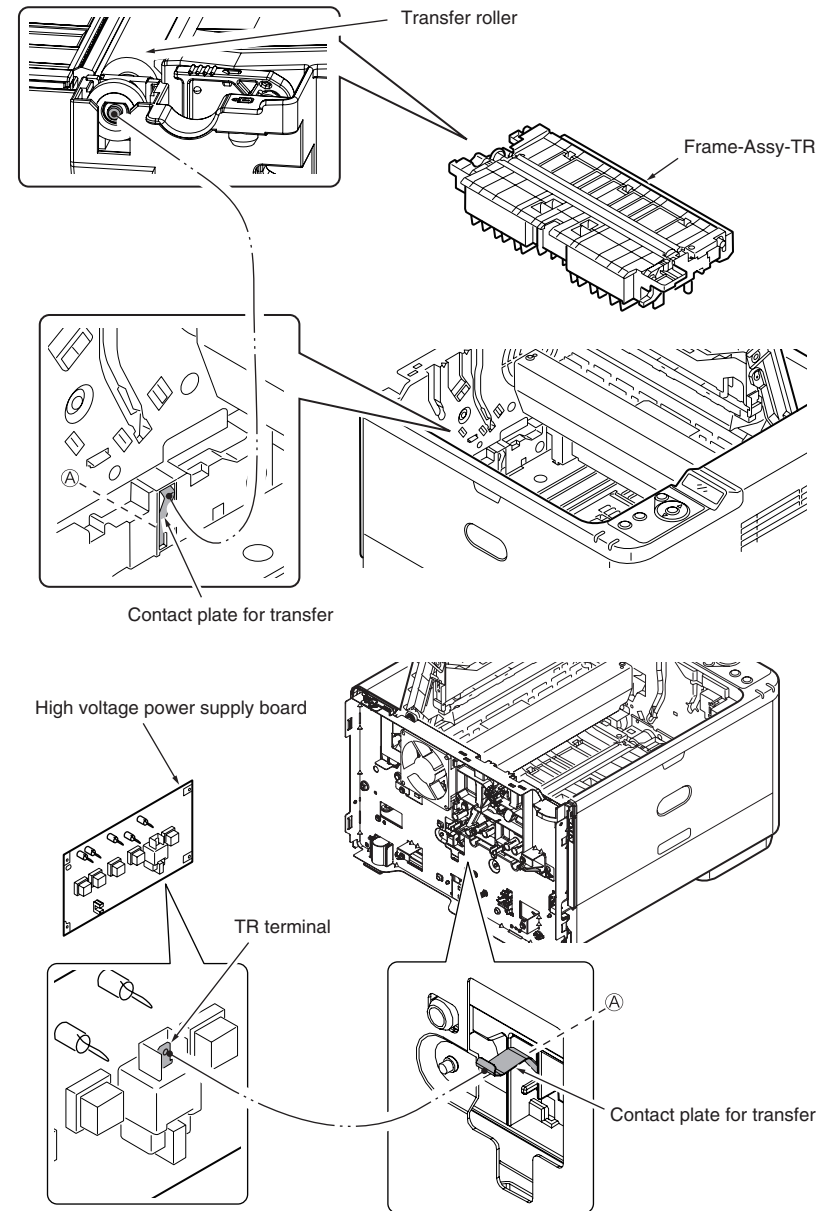

Figure 7-3

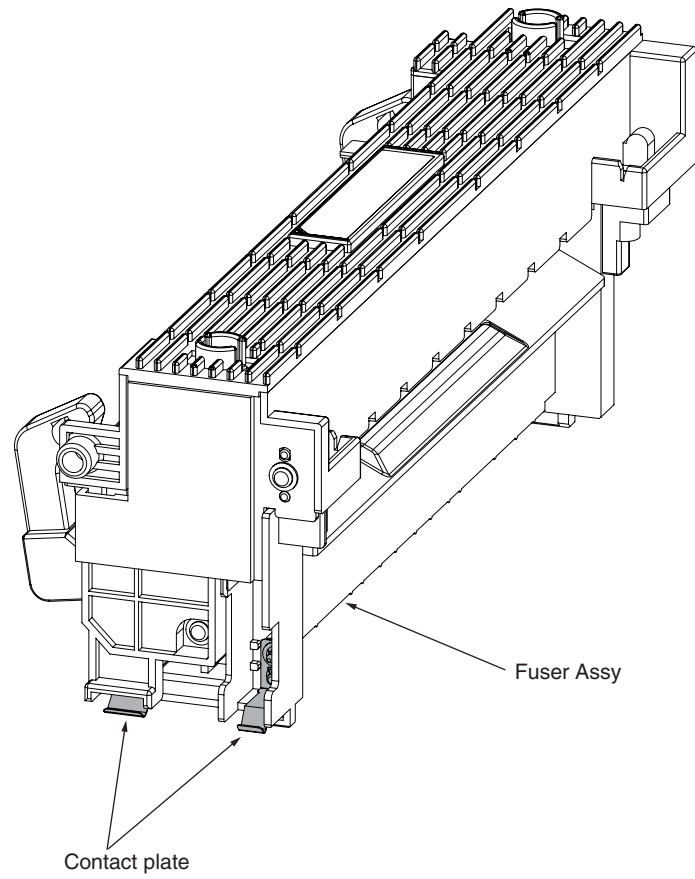

Figure 7-4

8.5.7 Response after Flash compulsive initialization

Explain the response after compulsive initialization is performed with trouble occurred in Flash.

(1) Flash compulsive initialization

If Flash compulsive initialization is performed, the following data would be deleted and the network and fax would not be available.

- NIC-Firmware
- WebPage data
- Log data
- Address data
- Message data
- Language file

It is necessary to write above Firmware and data into Flash by the maintenance utility.

Note! Do not carry it out usually.

8.5.8 Copy Image Abnormality Error Troubleshooting

- When the following symptom occurs in the copy image, implement the inspection and adjustment of the copy image.
 - ① Line appears on the copy image.
 - ② The copy image becomes slightly thin.
 - ③ The copy image becomes dark.
 - ④ The copy image becomes abnormal.
1. Identifying the problem.

Perform section 8.5.6 "-" to identify whether the problem is located in the printer or in the scanner.

If the cause of the problem is in the scanner, go to the next item.
 2. Cleaning

Perform sections 7.2 "Cleaning Rollers in the ADF", 7.3 "Cleaning the Document Glass" respectively.

8.5.9 Network Troubleshooting

(1) Cannot print from Utility.

Confirmation Items	Confirmation Tasks	Action at NG
(1) Check the LINK lamp.		
Check whether LINK lamp (green) is lighted.	Check whether HUB and printer are connected normally. (Check the network cable connection.)	Reconnect the network cable normally.
	Check whether straight cable is used.	Replace with straight cable.
	Try to insert the network cable into different HUB port.	Try to replace the HUB.
(2) Check the content of network information		
Check IP address, Subnet mask, Gateway address.	Print out the network information. Check IP address, Subnet mask, Gateway address.	Set the IP address, Subnet mask, Gateway address correctly.
(3) Check whether the communication on the network is normal.		
Send the Ping command from PC to printer to check	Send the Ping command from PC to printer, and check whether the response is correct.	Set the IP address, Subnet mask, Gateway address correctly.
(4) Check the utility		
Check the settings of OKI LPR utility.	Check the setting items of OKI LPR utility.	Set the setting items of OKI LPR utility correctly.
(5) Check the OS standard port.		
Check windows (XP, Vista, 7) standard LPR port.	Set windows (XP, Vista, 7) standard LPR port, and check whether print is normal.	Set windows (XP, Vista, 7) standard LPR port correctly.

8.5.10 Wireless Troubleshooting

(1) Cannot print through Wireless Network.

Confirmation Items	Confirmation Tasks	Action at NG
(1) Check Network Connection setting.		
Check Network Connection is Wireless not Wired.	Print out the network information. Check Network Connection setting is Wireless.	Set Wireless setting by Manual Setup or Auto Setup (WPS) to connect to wireless access point. Network Connection setting switches from Wired to Wireless.
(2) Check the connection to the wireless LAN access point.		
Check that the wireless LAN setting is right and the device is connecting to the wireless LAN access point.	Check the panel of the device, and Check whether the status ("Not connected to wireless access point.") has occurred.	*1
	Check the panel of the device, and Check whether the status ("Wireless settings are incomplete.") has occurred.	The settings of SSID, the security setting, the encryption key, and the certificate, etc. are insufficient. Please set all necessary settings.
(3) Check whether it is possible to communicate by way of wireless LAN.		
Check whether it is possible to communicate via wireless LAN.	Please refer to Network Troubleshooting for Checkation Tasks and Action at NG. Moreover, when wireless security is set to "WEP", the connection to wireless LAN access point might not be able to be communicated though does. Set it to the security setting of wireless LAN access point additionally again.	

*1 : Check once again whether the SSID, security setting, and an encrypting key of the wireless LAN access point are same as the settings of this device. When any one of settings is different, the device cannot be connected to the wireless LAN access point.

Check that a WEP key index of the wireless LAN access point is 1 when the security settings of the wireless LAN access point are WEP. When a WEP key index of the wireless LAN access point is not 1, it can not communicate with this device.

When a time-out error is displayed after automatic setting (WPS-PBC/PIN) execution, the connection setting with the wireless LAN access point is not completed in time.

Start WPS of the wireless LAN access point as soon as you start WPS of this device. (It is no problem that you start WPS of the wireless LAN access point first.)

When an overlap error is displayed after automatic setting (WPS-PBC) execution, there is a device carrying out WPS in others. Carry out WPS again after a while.

8.6 Fuse Checking

Table 7-6 MB441/MB451/MB451w/MB461/MB471/MB471w/MB491/ES4161/ES4191

Fuse Errors

Fuse Name	Error Description	Insert Point	Resistance	
CU/PU board (98M)	F1	Service Call 122	Fuser fan, power fan, ID unit, 2nd tray	1Ω or less
	F2	Stop with displaying the OKI LOGO	High voltage board, sensor, duct fan, LED head, USB hub, wireless LAN board, 2nd tray	
	F3	No Error, but unusable FDI	FDI	
	F4	No Error, but unavailable IC Card Reader	USB IC card	
	F5	No display on the operator panel	CU/PU. ROM, DRAM, SU board, LED head	
	F501	Power OFF/ON 923 Error	DC motor logic, regist clutch, hopping clutch, MPT clutch, EXIT motor	
	F502	No Error, but unusable printing (blank page)	LED head assy	
SU board (MHE)	F1	No display on the operator panel	MFA, DRAM, FAX board, OPE board	
	F2	unusable ADF copy and display "Document Jam", but usable FB copy	CIS, solenoid, clutch, FAX board	
	F3	Service Call "Power OFF/ON Carridge Error <02>"	ADF motor, FB motor	
	F4	Service Call "Lamp Error Please call service. <01>"	CIS 3.3VC_LDO	
	F5	No display on the operator panel	3.3V_DCDC, FAX board, OPE board	

9. CONNECTION DIAGRAMS

9.1 Check of resistance values	9-2
9.2 Layout of parts	9-4
9.3 Firmware Information	9-11

9.1 Check of resistance values

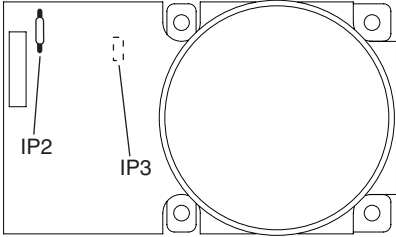
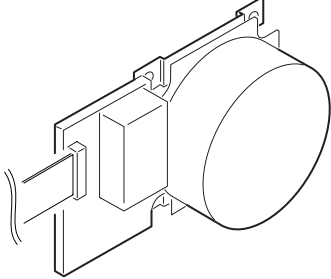
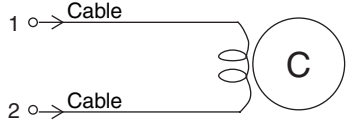
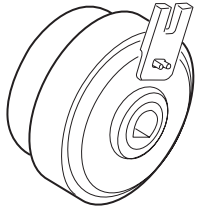
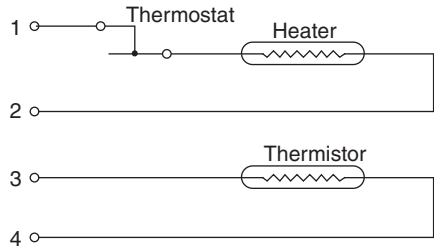
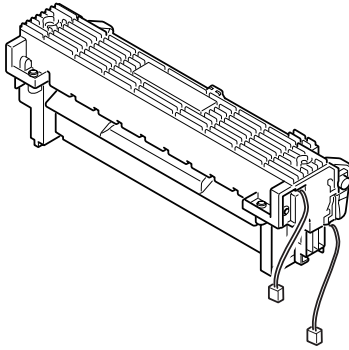
Unit	Circuit Diagram	Part Diagram	Resistance Value
DC Motor			Both ends of IP2 and IP3: 1 Ω or less
Clutch (Hopping) (Regist) (MP Tray)	 <p>※Cable Color : Black (Hopping) : Blue (Regist) : Yellow (MP Tray)</p>		Between Pin1 and Pin2 : 240 Ω
Fuser Assy			Between Pin1 and 2: Several to several tens of ohms Between pin3 and 4 :360K Ω At the ambient temperature (25°C)

Unit	Circuit Diagram	Part Diagram	Resistance Value
<p>FAN Motor (Fuser FAN, (80×25))</p>			
<p>FAN Motor (Duct FAN, (40×15))</p>			
<p>FAN Motor (Power FAN, (60×25))</p>			

9.2 Layout of parts

(1) CU/PU board (98M)

Component side

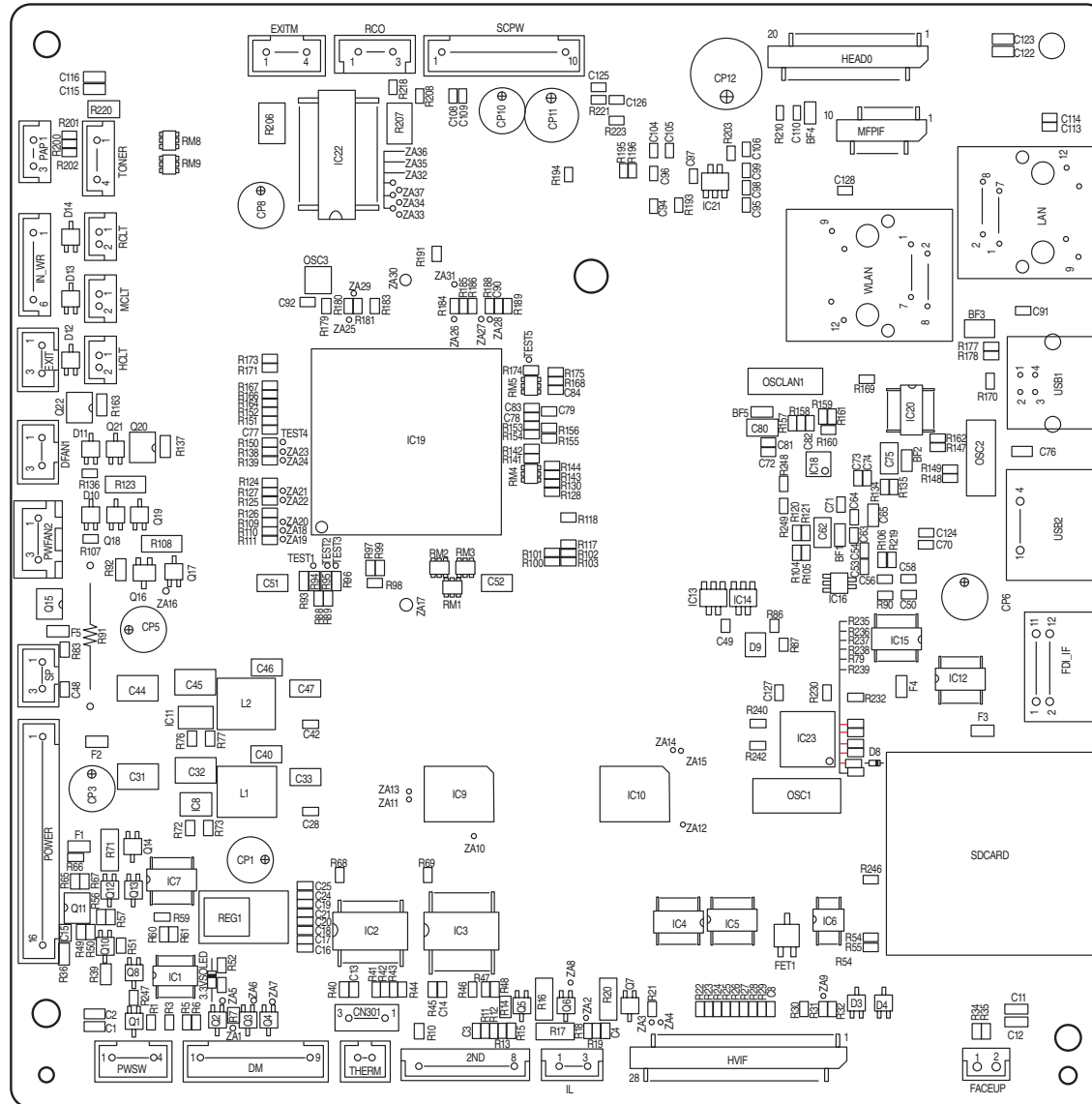

Soldering side

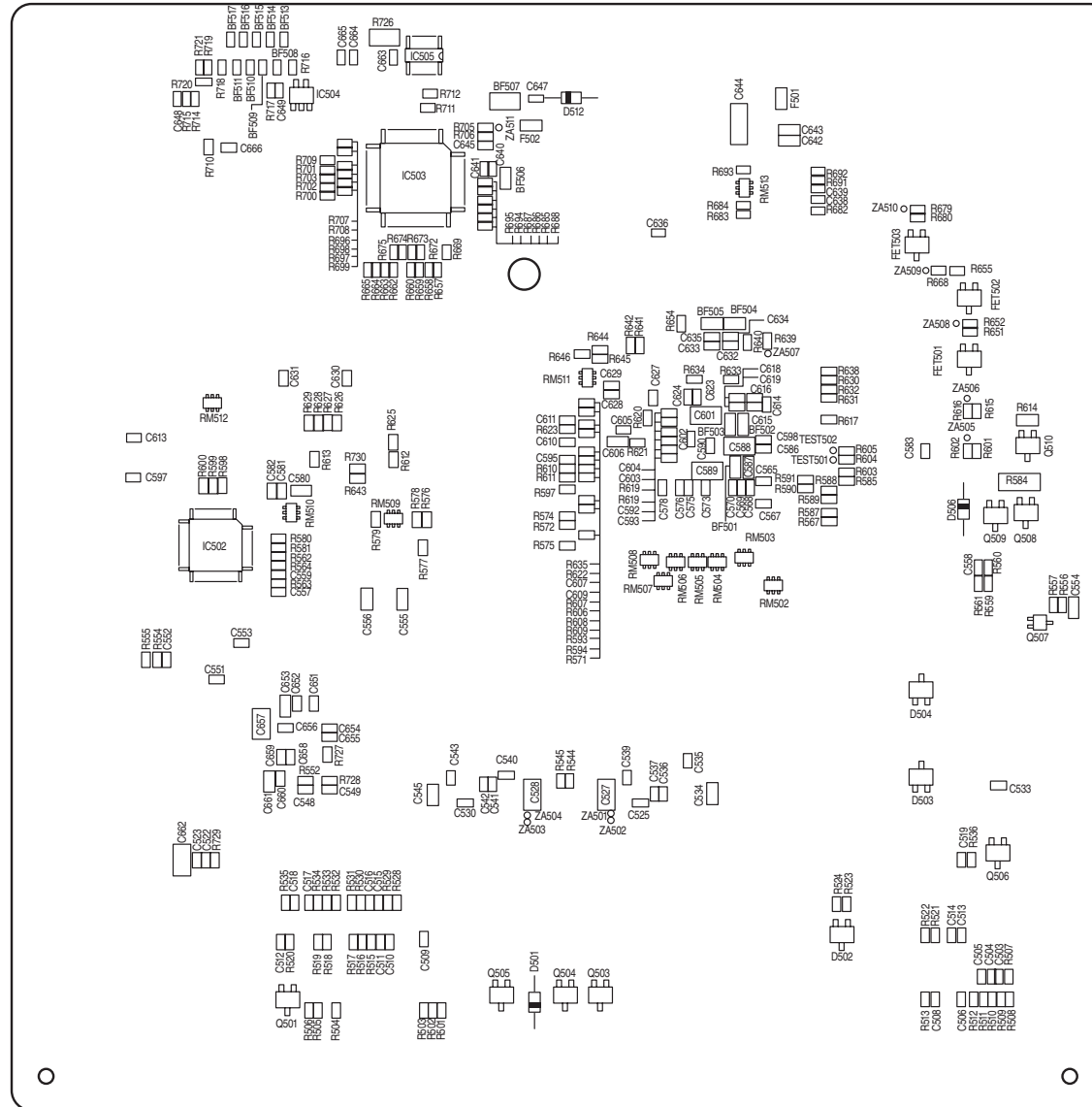

(2) High-Voltage Power/Sensor Board

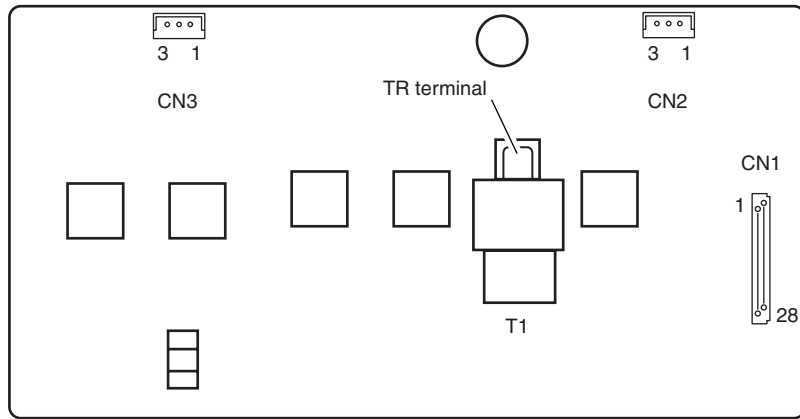

Component side

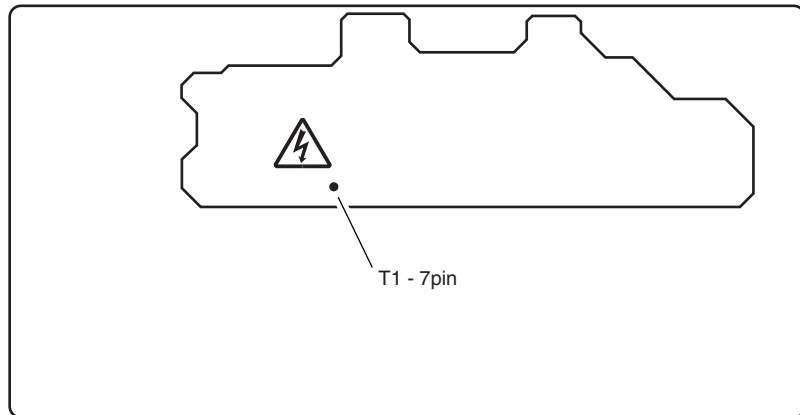

Soldering side

Checking contact between the transfer roller shaft and the TR terminal

Contact is normal if the resistance value measured between the transfer roller shaft and Pin 7 of T1 is 130 MΩ.

(3) Low-Voltage Power



A circuit (common to 100V and 200V) for applying a load between +5V and GND to check output by using a low-voltage supply unit alone.

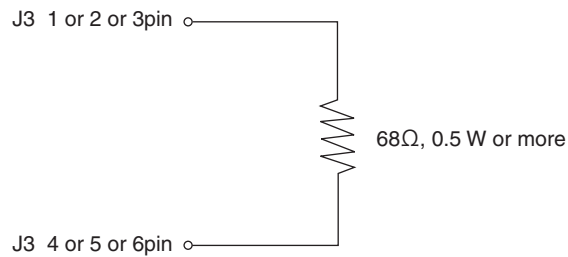

Use the above mentioned jigs to check output by using a low-voltage supply unit alone.

• Low-Voltage Power unit Pin Allocation

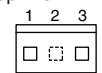
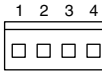
No	Item/ Display	Number of page	Pin No	Signal Name	Connector Name	Description
1	AC Input	3	1	NEUTRAL	BP-VH-BK Black (J.S.T. Mfg. Co., Ltd.)	Top View 
			(2)	-		
			3	LINE		
2	Heater	4	1	LINE1	B04P-NV (J.S.T. Mfg. Co., Ltd.)	Top View 
			2	NEUTRAL1		
			3	NEUTRAL2		
			4	LINE2		
3	DC output	16	1, 2, 3	+5V	B16B-PH-K-S (J.S.T. Mfg. Co., Ltd.)	
			4, 5, 6	EL (0V)		
			7, 8, 9	+24V		
			10, 11, 12	EP (0V)		
			13	ACZEROX-P		
			14	A CON1-N		
			15	A CON0-N		
			16	ACCOM-N		
4	DC output2	3	1	+3.3V	B3B-PH-K-S (J.S.T. Mfg. Co., Ltd.)	
			2	EL (0)		
			3	PowerSave-N		
5	DC output3	10	1	+3.3V	B10B-PH-K-S (J.S.T. Mfg. Co., Ltd.)	
			2	EL (0V)		
			3, 4	+5V		
			5, 6	EL (0V)		
			7, 8	+24V		
			9, 10	EP (0V)		

Soldering side

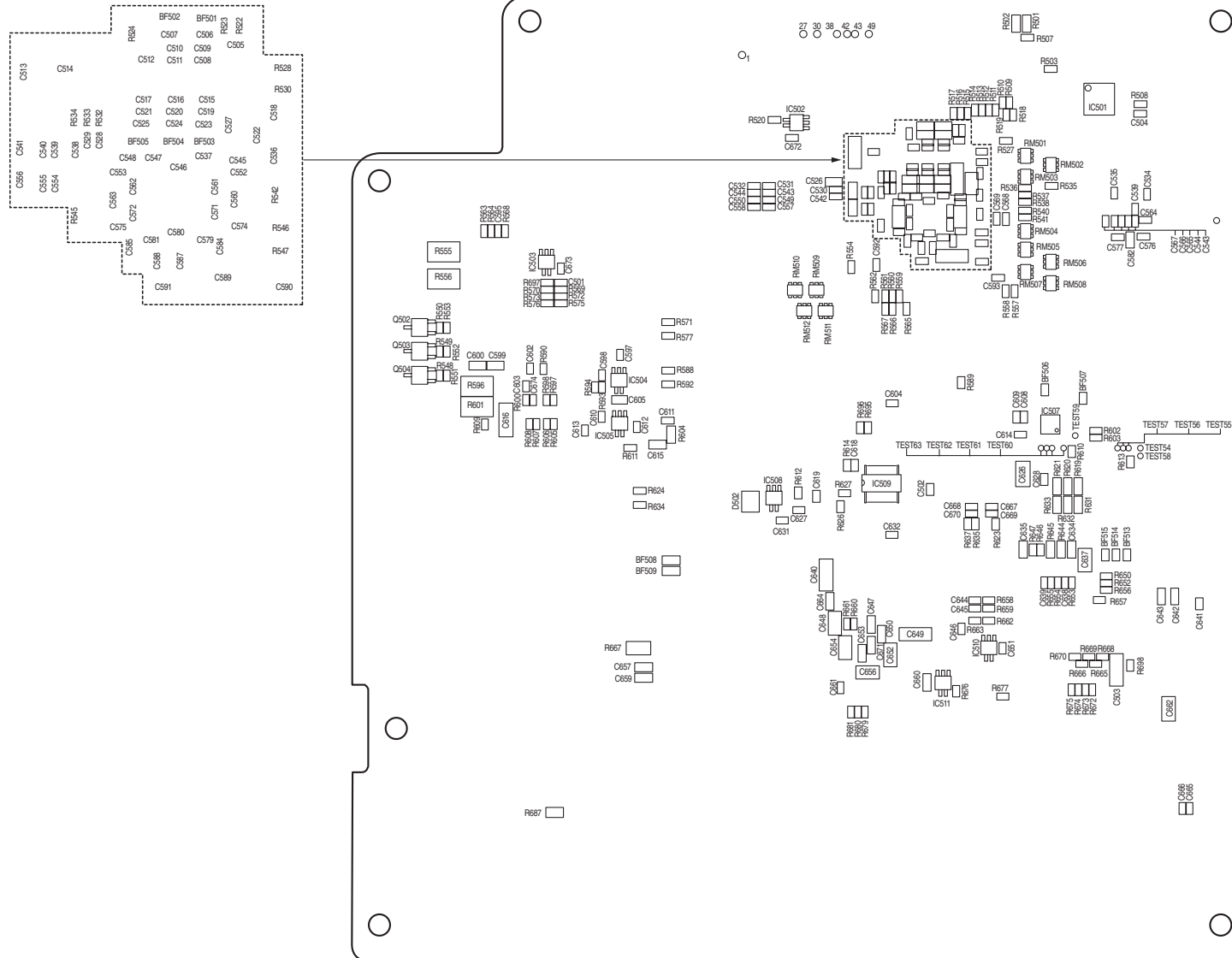

(5) Operation Panel (OPM)

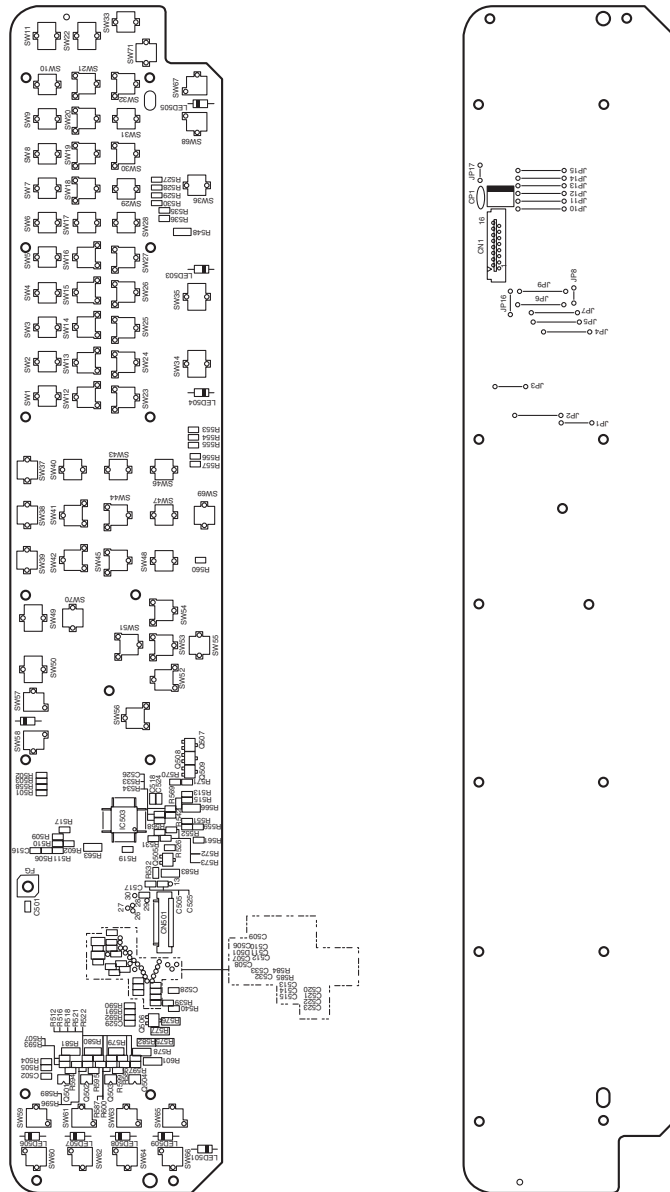

(6) ADF board (MHD)

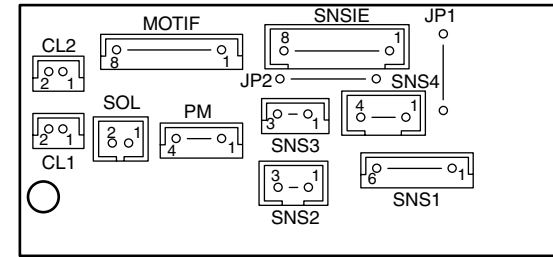

9.3 Firmware Information

9.3.1 ROM control numbers

(1) Firmware suite

This MFP can upgrade of a program using Firmware suite. Firmware suite is the file which combined and unified two or more firmware to one.

Firmware (PJL format)	Epsilon #	Notes
Firmware suite	44946001FY01	

Note! If SU board or CU board is replaced, Please upgrade firmware by Firmware suite.

It is necessary to take the synchronization of the firmware version of SU board and CU board.

9.3.2 Instruction of FW update

(1) FirmSuite includes all FWs listed below,

CU FW, NIC FW, PU FW, SU FW, Starting Logo.

The following is the updating order of FWs.

SU FW → Starting Logo → NIC FW → PU FW → CU FW

(2) Don't turn off the machine while it displays the message below,

"Wait a moment. Executing maintenance".

Please follow the steps below,

- i) Turn OFF/ON the machine.
- ii) Send Firm Suite
- iii) The machine displays "Wait a moment. Executing maintenance".
- iv) The machine displays "PASSED".
- v) Turn OFF/ON the machine
- vi) Check the firmware version

Note! This FW update should be removed the TEL cable from the Scanner unit of the mainbody.

9.3.3 Checking and indication of the revision number

- Print out MenuMap and check to make sure that the firmware revision number has been updated.

Configuration

Serial Number:ALPHA10029

CU Version:01.04 [I01.18 U00.93 S5.11.1m B01.01 PPC 330MHz F64]

PU Version:00.06.D6 [PI03.20 LO00.00.01] ET:000104040404031A23

PCL Program Version:05.23 [04.32 X04.12 P00.62 F00.50] PS Progr

Scanner Version:01.04 Country Code:International

Duplex:Installed Tray 1:A4 A

Total Memory Size:256 MB

Flash Memory:16 MB [F64] SD Memory Card:4 GB [F64]

OEL MC:CP FX:E

Network Version:01.03 Web Remote:01.02

Panel Version:01.04.01 SU Hardware Type:000-O-02

ENGINE:1717 K:1699 T:B I:0 D:1449 W:391232

9.3.4 Stamp of maintenance board indication

A designated article number is stamped in the area for maintenance board indication on the CU/PU board (98M) in accordance with the 44894901YA.

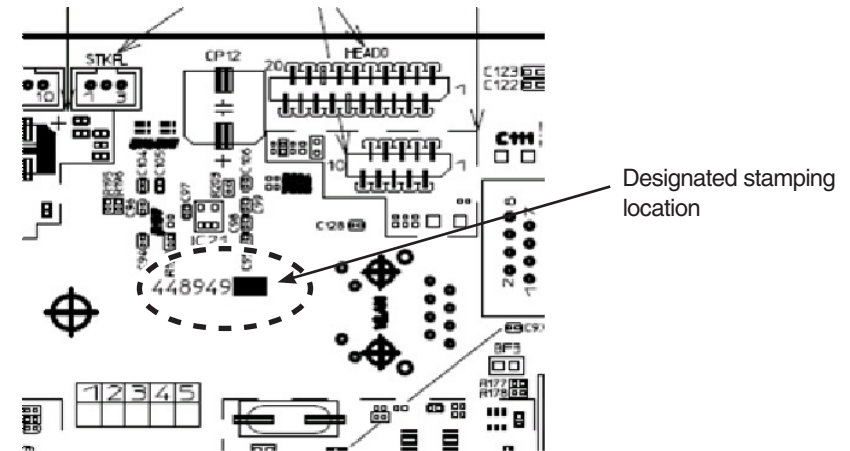

A designated article number is stamped in the area for maintenance board indication on the SU board (MHE) in accordance with the 44866301YA.

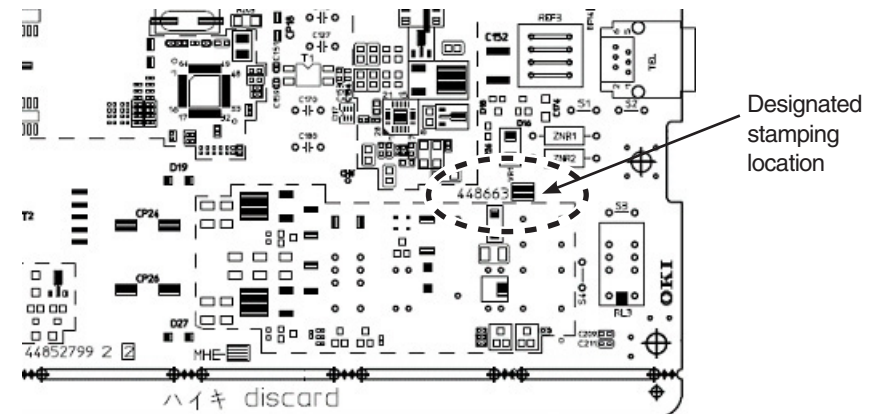

10. APPENDIX

10.1 List of Initialized range.....	10-2
10.2 Maintenance Manual for Second Tray unit.....	10-9

10.1 List of Initialized range

Setup Parameters		Administrator Setup											Service Technician Setup				Firmware Update		Remarks						
		Network factory defaults *1	SD Card initialization *2 (Format open to users)	SD Card format *3 (Common partitions)	SD Card format *3 (PCL partitions)	SD Card format *3 (PS partitions)	SD Card data erasing *4	FLASH initialization *5	Language initialization *6	Reset Settings *7	Erase Privacy Data *8	Main counter reset *9	Consumable replacement reset *10	Job log deletion *11	Format SD Card *12	Format Flash ROM *13	Reset Admin Password *14	ALL RESET *15		OKIUSER change *16 [Factory default]	Country code change *17 [Default setting by sales companies, etc.]	CU FW update	NIC FW update	Scanner FW update	
Registration data	E-mail address registration data														CL		CL								
	Access control information registration data														CL		CL								
	Speed dial registration data														CL		CL								
	F-code bulletin board document									CL	CL							CL	CL	CL					
	Profile list										CL					CL		CL							
	Networkconnected PCs list											CL				CL		CL							
	Job memory registration data									CL	CL							CL	CL	CL					
	Custom demo data (SD)		CL	CL			CL					CL				CL		CL							
	Custom demo data (FLASH)							CL				CL				CL		CL							
	Font (SD card PCL area)		CL		CL		CL					CL				CL		CL							
	Font (SD card PS area)		CL			CL	CL					CL				CL		CL							
	Font (FLASH PCL area)							CL				CL					CL		CL						
	Font (FLASH PS area)							CL				CL					CL		CL						
	Certificate											CL					CL		CL						
	Language file								CL								CL		CL						
	Auto delivery setup											CL					CL		CL						
Communication data save setup											CL						CL	CL							

Setup Parameters		Administrator Setup											Service Technician Setup					Firmware Update		Remarks				
		Network factory defaults *1	SD Card initialization *2 (Format open to users)	SD Card format *3 (Common partitions)	SD Card format *3 (PCL partitions)	SD Card format *3 (PS partitions)	SD Card data erasing *4	FLASH initialization *5	Language initialization *6	Reset Settings *7	Erase Privacy Data *8	Main counter reset *9	Consumable replacement reset *10	Job log deletion *11	Format SD Card *12	Format Flash ROM *13	Reset Admin Password *14	ALL RESET *15	OKUSER change *16 [Factory default]		Country code change *17 [Default setting by sales companies, etc.]	CU FW update	NIC FW update	Scanner FW update
Setup data	Administrator password								FR	FR						FR	FR	FR						
	Paper/Sorting setup								FR	FR								FR	FR					
	Copy function setup								FR	FR								FR	FR				Menu under "Admin Setup" - "Copy Setup"	
	Fax function setup								FR	FR					FR			FR	FR	FR	*18		Menu under "Admin Setup" - "Fax Setup"	
	F-code box								FR	FR								FR	FR	FR				
	Scanner function setup									FR	FR					FR	*19		FR	FR				Menu under "Admin Setup" - "Scanner Setup"
	Print function setup									FR	FR	*23	*23						FR	FR	*23			Menu under "Admin Setup" - "Print Setup"
	Network setup		FR							FR	FR						FR		FR	FR				Menu under "Admin Setup" - "Network Menu" - "Network Setup"
	Mail server setup		FR							FR	FR						FR		FR	FR				Menu under "Admin Setup" - "Network Menu" - "Mail Server Setup"
	LDAP server setup		FR							FR	FR						FR		FR	FR				Menu under "Admin Setup" - "Network Menu" - "LDAP Server Setting"

Setup Parameters		Administrator Setup											Service Technician Setup					Firmware Update		Remarks				
		Network factory defaults *1	SD Card initialization *2 (Format open to users)	SD Card format *3 (Common partitions)	SD Card format *3 (PCL partitions)	SD Card format *3 (PS partitions)	SD Card data erasing *4	FLASH initialization *5	Language initialization *6	Reset Settings *7	Erase Privacy Data *8	Main counter reset *9	Consumable replacement reset *10	Job log deletion *11	Format SD Card *12	Format Flash ROM *13	Reset Admin Password *14	ALL RESET *15	OKUSER change *16 [Factory default]		Country code change *17 [Default setting by sales companies, etc.]	CU FW update	NIC FW update	Scanner FW update
Setup data	Secure print server setup	FR							FR	FR					FR		FR	FR					Menu under "Admin Setup" - "Network Menu" - "Secure Protocol Server Setting"	
	Management setup							FR *25	FR								FR	FR					Menu under "Admin Setup" - "Management"	
	Time							FR	FR								FR						Value set through "Admin Setup" - "User Install" - "Time Setup", "Set Daylight Saving", "Time Zone"	
	User Install							FR	FR								FR	FR					Menu under "Admin Setting" - "User Install"	
	User Install (fax-related settings)							FR	FR						FR		FR	FR *18	FR *18				Menu under "Admin Setting" - "User Install"	
	Service technician password																	FR						
	System maintenance																	FR						
	Copy maintenance																	FR						Obsolete. Unsupported in FN296/7
Scanner maintenance																							Items other than "Service Maintenance" - "Scanner Maintenance" - "Adjust Scan Position" wouldn't be stored permanently.	

Setup Parameters		Administrator Setup											Service Technician Setup				Firmware Update		Remarks				
		Network factory defaults *1	SD Card initialization *2 (Format open to users)	SD Card format *3 (Common partitions)	SD Card format *3 (PCL partitions)	SD Card format *3 (PS partitions)	SD Card data erasing *4	FLASH initialization *5	Language initialization *6	Reset Settings *7	Erase Privacy Data *8	Main counter reset *9	Consumable replacement reset *10	Job log deletion *11	Format SD Card *12	Format Flash ROM *13	Reset Admin Password *14	ALL RESET *15		OKIUSER change *16 [Factory default]	Country code change *17 [Default setting by sales companies, etc.]	CU FW update	NIC FW update
Setup data	Fax maintenance																	FR	FR				Obsolete. Unsupported in FN296/7
	Printer maintenance																	FR *26					
	JA setting information								CL *27					CL		CL							
Job	Fax Tx data (pending)							CL	CL								CL	CL	CL				
	Fax Rx data (Print wait, Include Secure Receive image)							CL	CL								CL	CL	CL				
	Fax Rx data (confidential box)							CL	CL								CL	CL	CL				
	Secure print job		CL	CL		CL			CL					CL			CL						
	Encrypted secure print job		CL	CL		CL			CL					CL			CL						
Logs	JA log information (SD)					CL			CL *27					CL			CL						CAC Setting has been separated from AccessControl during the development of FX750. It behaves following the information same as JA log.
	JA log information (FLASH)								CL *27					CL		CL							Stored to SD card when SD is installed.
	Job log information							CL *28	CL			CL		CL		CL	CL *28						
	Debug log													CL		CL	CL						By default the setting is not stored.

Setup Parameters		Administrator Setup											Service Technician Setup					Firmware Update		Remarks								
		Network factory defaults *1	SD Card initialization *2 (Format open to users)	SD Card format *3 (Common partitions)	SD Card format *3 (PCL partitions)	SD Card format *3 (PS partitions)	SD Card data erasing *4	FLASH initialization *5	Language initialization *6	Reset Settings *7	Erase Privacy Data *8	Main counter reset *9	Consumable replacement reset *10	Job log deletion *11	Format SD Card *12	Format Flash ROM *13	Reset Admin Password *14	ALL RESET *15	OKUSER change *16 [Factory default]		Country code change *17 [Default setting by sales companies, etc.]	CU FW update	NIC FW update	Scanner FW update				
Logs	Email/Internet fax communication log														CL		CL	CL										
	Error log (SD card)						CL									CL			CL									Obsolete. Error log be stored on FLASH, even if SD card is installed.
	Error log (FLASH)							CL			CL					CL		CL										
	Dialing history																											Stored in RAM. Erased when poweroff. i.e, when reboot operation is executed, the contents disappear.
	Fax Tx/Rx history									CL	CL								CL	CL	CL							
	Mail address history									CL	CL								CL	CL	CL							
	IFAX send address history									CL	CL								CL	CL	CL							
	Fax communication result information									CL	CL								CL	CL	CL							Including T30 monitor.
Counters	Maintenance counters (life-related)																											The value is owned by PU.
	Maintenance counters (JA-related) *24																											
	Main counters (dealer statisticsrelated)										CL					CL		CL										
	Consumable replacement (related to the main counter)											CL				*22												
	Print statistic password *21																	FR	FR									

Setup Parameters		Administrator Setup												Service Technician Setup					Firmware Update		Remarks		
		Network factory defaults *1	SD Card initialization *2 (Format open to users)	SD Card format *3 (Common partitions)	SD Card format *3 (PCL partitions)	SD Card format *3 (PS partitions)	SD Card data erasing *4	FLASH initialization *5	Language initialization *6	Reset Settings *7	Erase Privacy Data *8	Main counter reset *9	Consumable replacement reset *10	Job log deletion *11	Format SD Card *12	Format Flash ROM *13	Reset Admin Password *14	ALL RESET *15	OKIUSER change *16 [Factory default]	Country code change *17 [Default setting by sales companies, etc.]		CU FW update	NIC FW update
FW	Scanner unit F/W (FAX included)																						
	NIC-F/W (web page included)														CL								
	IC Card Authentication Program		CL	CL			CL			CL				CL			CL	*20					
Other	Factory adjustment (gamma correction data)																						

- *1 : Network factory defaults: "Admin Setup" - "Network Menu" - "Network Setup" - "Factory Defaults"
: It is executed to reset only network settings to the factory defaults make settings again due to unsuccessful network access.
- *2 : SD Card initialization: "Admin Setup" - "Management" - "SD Memory Card Setup" - "Initialize"
- *3 : SD Card format: "Admin Setup" - "Management" - "SD Memory Card Setup" - "Format Partition"
- *4 : SD Card data erasing: "Admin Setup" - "Management" - "Storage Maintenance Setup" - "Erase SD Memory Card"
: Not displayed when Job Accounting is operating.
: Users must execute this menu with "Erase Privacy Data" before disposing of the device to prevent personal information from leaking.
Instead of the said timing, users must execute this menu when disposing of SD cards after replacement.
- *5 : FLASH initialization: "Admin Setup" - "Management" - "Flash Memory Setup" - "Initialize"
- *6 : Language initialization: "Admin Setup" - "Management" - "Language Maint Setup" - "Initialize"
: This menu is executed when users want to delete downloaded language data and reset the display language back to English temporarily.
- *7 : Reset Settings: "Admin Setup" - "Management" - "Reset Settings"
: This menu is executed to reset the device settings (including network settings) back to the defaults temporarily and make settings again when device operation is unstable, etc.
- *8 : Erase Privacy Data: "Admin Setup" - "User Install" - "Erase Privacy Data"
: Not displayed when Job Accounting is operating.
: Users must execute this menu with "Erase SD Memory Card" before disposing of the device to prevent personal information from leaking.
- *9 : Main counter reset: "Admin Setup" - "Management" - "Print Statistics" - "Reset Main Counter"
: Not displayed in MPS mode.
- *10 : Consumable replacement reset: "Admin Setup" - "Management" - "Print Statistics" - "Reset Supplies Counter"
: Not displayed in MPS mode.
- *11 : Job log deletion: "Admin Setup" - "Management" - "Job Log Setup" - "Clear Job Log"
: This menu is executed when users want to delete only the usage history of the device.
- *12 : Format SD Card: "Service Maintenance" - "System Maintenance" - "Format SD Memory Card"
- *13 : Format Flash ROM: "Service Maintenance" - "System Maintenance" - "Format Flash Memory"
- *14 : Reset Admin Password: "Service Maintenance" - "System Maintenance" - "Reset Admin Password"
: This menu is used to initialize only the administrator password by support when users forget the administrator password.
- *15 : ALL RESET: "Service Maintenance" - "System Maintenance" - "All Reset"
: Not displayed in MPS mode.
: This menu must be executed to delete customer information before dealers etc. lend devices to the next customers.
- *16 : OKIUSER change: "Service Maintenance" - "System Maintenance" - "OKIUSER"
: Not displayed in MPS mode.
- *17 : Country code change: "Admin Setup" - "Fax Setup" - "Fax Setting" - "Country Code"
- *18 : Settings are initialized when their defaults are changed due to changes in destinations or country codes.
- *19 : Only "File Name", "Template" under "Admin Setup" - "Scanner Setup" - "E-mail Setup" is initialized.
- *20 : IC Card Authentication Program stored on SD card is NOT deleted. Except for JP1, the version of IC Card Authentication Program wouldn't be printed in Configuration Report.
- *21 : No means is provided to change the setting of the print statistic password.
- *22 : Executing Format Flash ROM displays the total number of replacement retained in the CU FW of the device.
Consumable replacement information (toner/drum/belt/fuser) in a print statistic report shows a calculation result of the formula "actual PU replacement - CU display difference = replacement information."
Format Flash ROM clears the value of "CU display difference."
- *23 : "PS Setup" - "L1 Tray" cannot be initialized by "Reset Settings"/"ErasePrivacy Data"/"All Reset."
- *24 : In this item, the following Counters that belongs to Job Accounting's maintenance category is showed.
① Total Color A4/Letter Impressions
② Total Mono A4/Letter Impressions
③ Total ADF Pages Scanned [A4/Letter Conversion]
④ Total Pages Scanned [A4/Letter Conversion]
- *25 : "Admin Setup" - "Management" - "System Setup" - "Access Control" is NOT included. The resetting condition is same as Access control information registration data .
- *26 : "Service Maintenance" - "Print Maintenance" - "Dot Shift" is NOT resetted.
- *27 : "Erase Privacy Data" would NOT be showed in panel menu if Job Accounting is enabled.
- *28 : JobLog be deleted during reboot, for the item of JobLog's [store/no store] be resetted to [no store].

10.2 Maintenance Manual for Second Tray unit

10.2.1 Overview

10.2.1.1 Function

The extended paper feed unit is installed under the printer. the device performs the auto paper feed by the operation of the pulse motor (hopping) to control a signal from the printer.

The main function is as follows:

- Available paper:

[Paper Type]

- Standard paper : (Ream weight 55 to 105 kg) A4, A5, B5, Custom, LETTER, Executive, LEGAL 13, LEGAL 13.5, LEGAL14, 16K
*The custom is 148 to 215.9mm for width and 210 to 355.6 mm for length.

[Weight/ Thickness]

- Standard paper (Ream weight 55 to 105kg)

10.2.1.2 Exterior and Parts Name

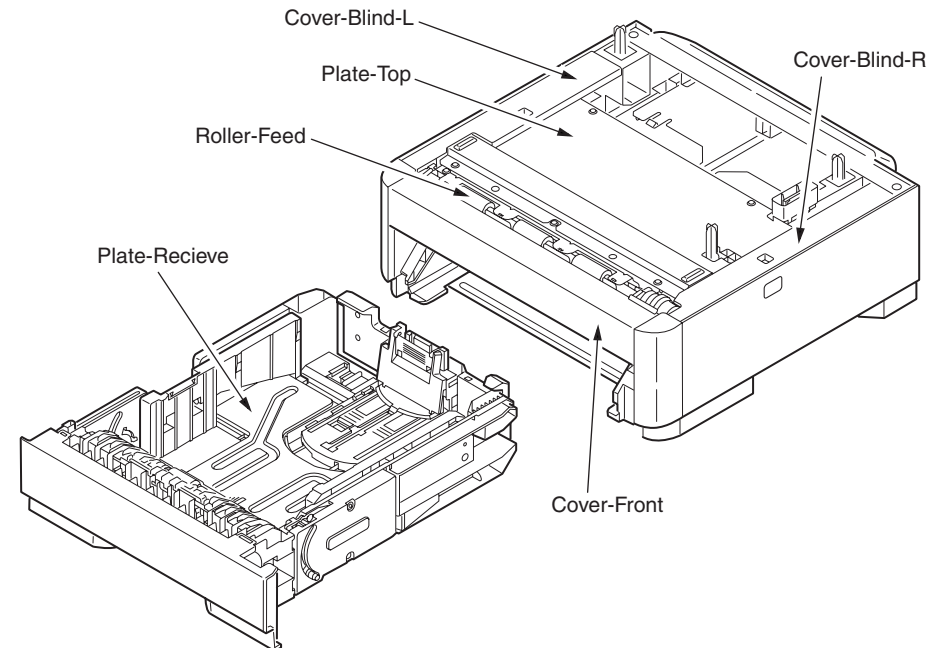

10.2.2 Description for Operation of Second Tray unit

Second Tray unit receives a signal from the printer main body and feeds paper to the printer main body.

Paper Feed from the Second Tray unit (Tray2)

1. When a signal is received from the printer main body, the pulse motor is rotated (Counterclockwise rotation), and by setting the paper feed clutch to ON, the paper feed roller and pick-up roller are rotated. Therefore, paper in a tray is fed.
2. After hitting the entrance sensor lever and switching the sensor to ON, the paper runs into the conveying roller (Tray 2) that is at rest, and then it is conveyed further by a certain amount. (This action corrects the paper skew.)
3. By setting the regist clutch to ON, the paper is carried by the regist roller.

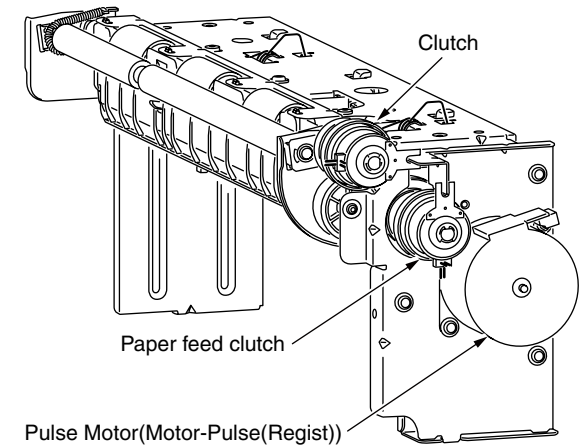
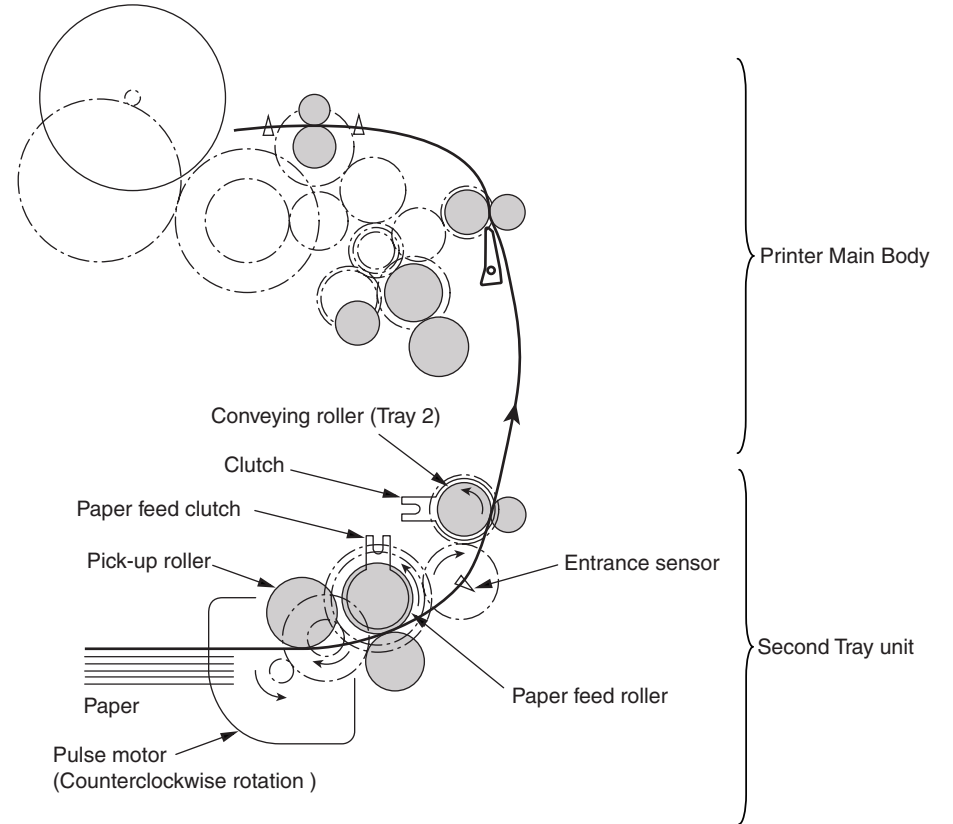

10.2.3 Part Replacement

This section describes how to disassemble/ assemble/ install in the field. This section describes how to disassemble, however, as for the assembly, take the opposite sequence to the disassembling procedure.





10.2.3.1 Precautions on replacing parts

- (1) Make sure to turn off the printer switch and remove the printer from the device before the part replacement.
- (2) Do not disassemble the printer while it operates normally.
- (3) Do not disassemble beyond the range. (Do not remove parts other than parts shown in the part replacement procedure.)
- (4) Use specified maintenance tools.
- (5) Disassemble the parts in the specified order. Parts may be damaged if they are not disassembled in proper order.
- (6) Set small items such as screws and collars in their original position temporarily since they can be lost easily.
- (7) Do not use gloves that build up static electricity when treating a print circuit board
- (8) Do not place the print circuit board on the device or floor directly.

[Maintenance Tool]

The following table shows the tools for the print board/ Assy/ Unit replacement in the field.

Table 3-1 Maintenance Tools

No.	Maintenance Tool	Amount	Purpose	Remarks
1	 No.2-220 + Magnetic driver	1	3~5 mm screw	
2	 No.3-200 driver	1		
3	 Digital multi-meter	1		
4	 Pliers	1		
5	 E-ring plier	1	For E ring removing	

10.2.3.2 Arrangement of Parts

The arrangement of main parts is as shown in the following figure.

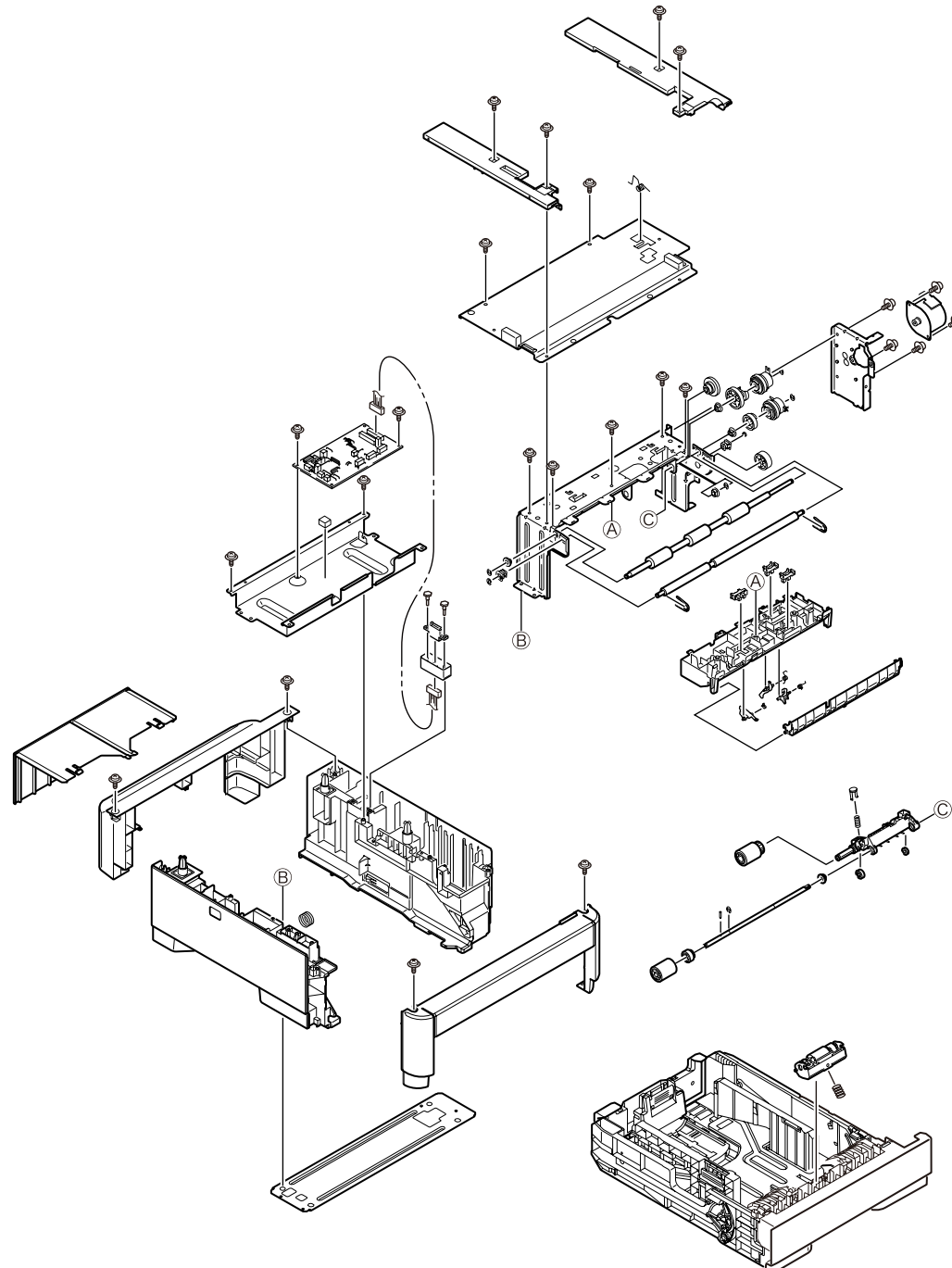

10.2.3.3 How to Replace Parts

This section describes how to replace parts shown in the following disassembling procedure.

In the part replacement procedure, parts on which a part number is displayed in white figure in the black circle are RSPL.

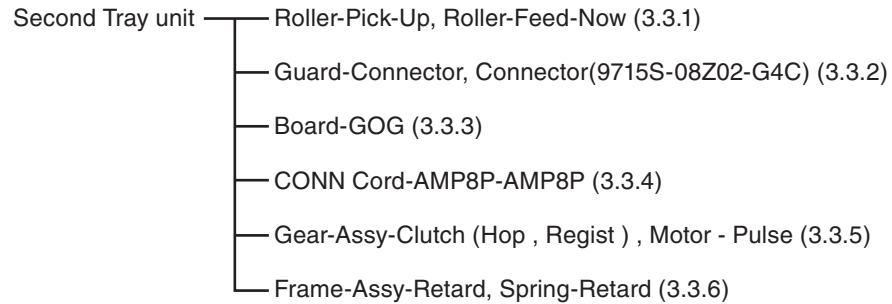

10.2.3.3.1 Roller-Pick-Up, Roller-Feed-Now

- (1) Remove Cassette-Assy.
- (2) Push the tab in the direction of the arrow to remove Roller-Pick-Up ①.
- (3) Push the tab in the direction of the arrow to remove Roller-Feed-NOW ②.
- (4) As for reinstalling, take the opposite sequence to removal sequence.

(Precautions on reinstalling)

1. When reinstalling Roller-Pick-Up ①, push it until it clicks.
2. When installing Roller-Feed-Now ②, push it until it clicks.

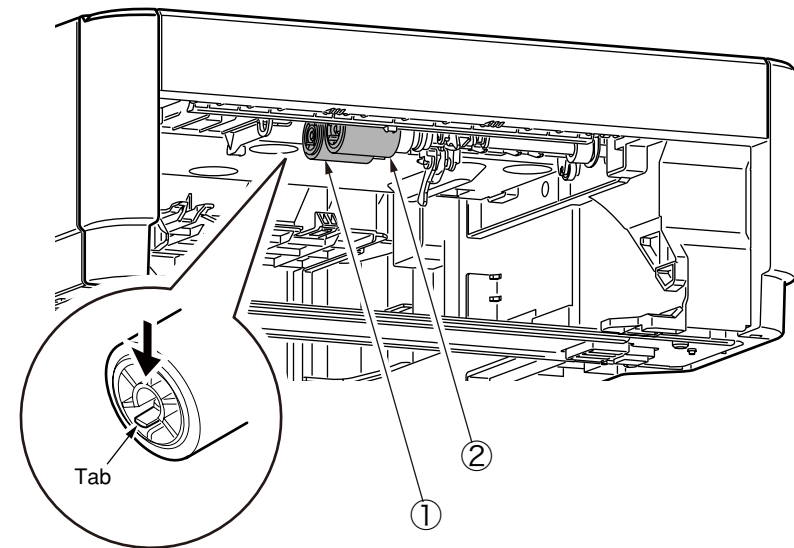

10.2.3.3.2 Guard-Connector, Connector (9715S-08Z02-G4C)

- (1) Remove the two screws ①. Remove the two nuts ②.
- (2) Disconnect the cable, and remove Guard-Connector ③ and Connector (9715S-08Z02-G4C) ④.
- (3) Installing is performed by the inverse procedure with removing.

(Note on removing / installing)

1. Be careful not to lose the nuts ②.

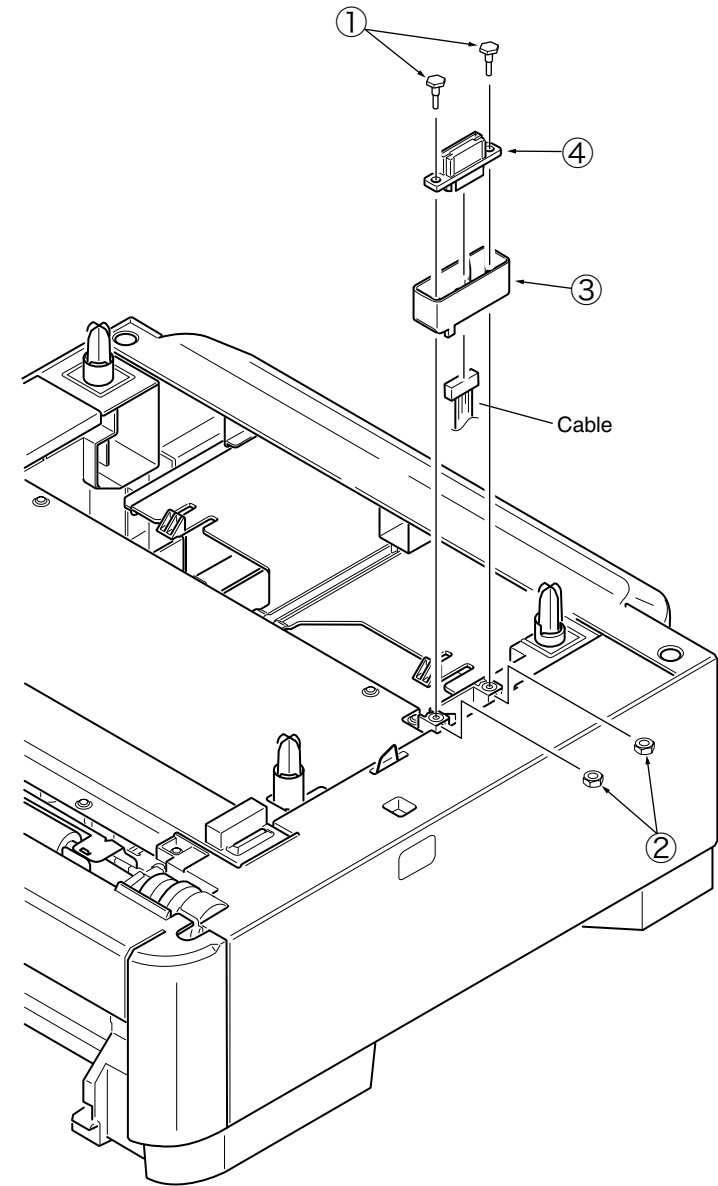

10.2.3.3.3 Board-GOG

- (1) Remove the two screws (Black) ①. Remove the Cover-Rear ②.
- (2) Remove the two screws (silver) ③. Remove the Cover-Blind-R ④.
- (3) Remove the two screws (silver) ⑤. Remove the Cover-Blind-L ⑥.
- (4) Remove the two screws (silver) ⑦. Remove the Plate-Top ⑧.
- (5) Disconnect the six connectors, and remove the two screws (silver) ⑨ and Board-GOG ⑩.
- (6) Installing is performed by the inverse procedure with removing.

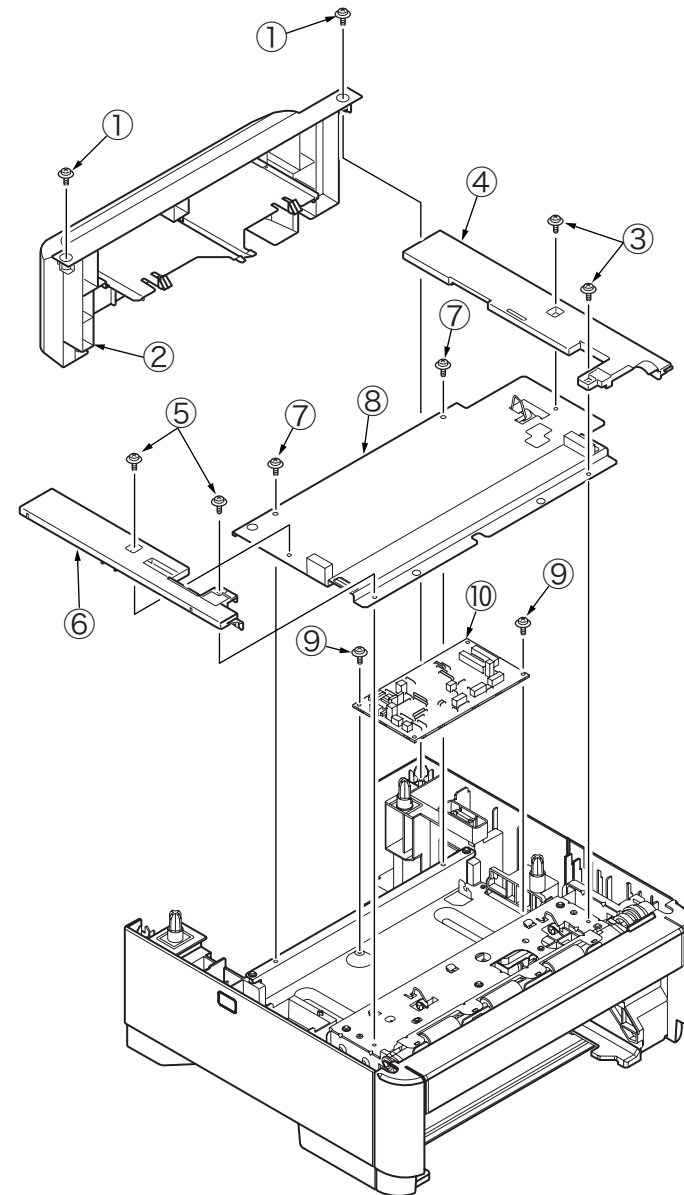

10.2.3.3.4 CONN Cord-AMP8P-AMP8P

- (1) Remove the Guard-Connector ①. (Refer to 3.3.2)
- (2) Remove the Cover-Rear, Cover-Blind-R/L, Plate-Top. (Refer to 3.3.3)
- (3) Remove CONN-Cord-AMP8P-AMP8P ② from Board-GOG.
- (4) Installing is performed by the inverse procedure with removing.

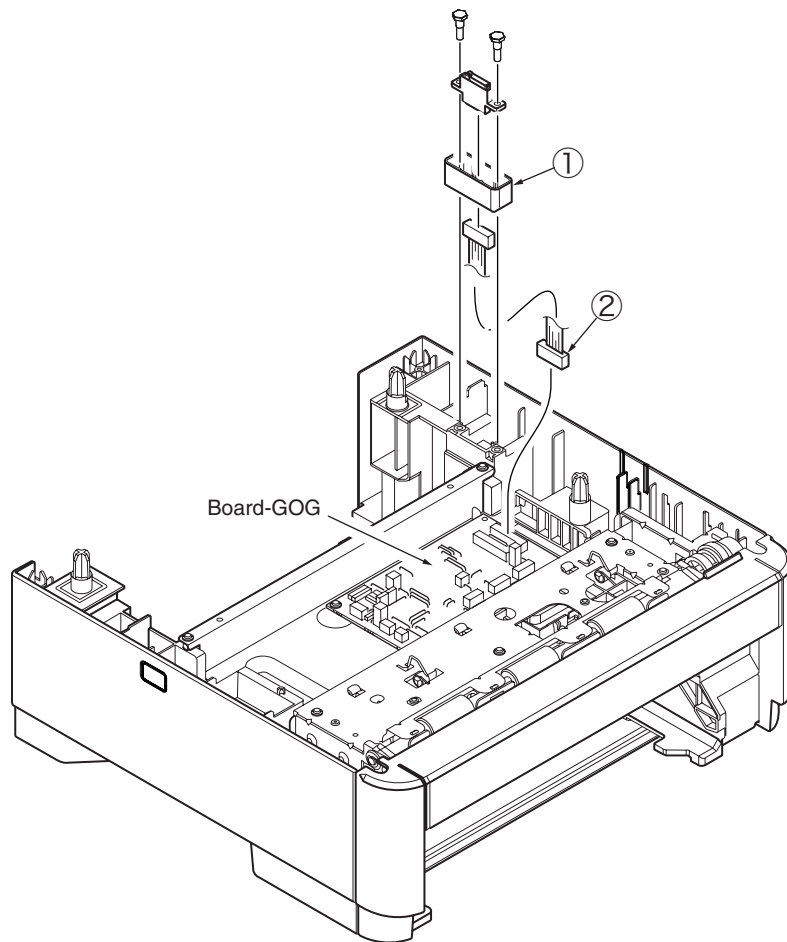

10.2.3.3.5 Gear-Assy-Clatch (Hop, Regist), Motor-Pulse

- (1) Remove the Cover-Rear, Cover-Blind-R/L, Plate-Top. (Refer to 3.3.3)
- (2) Remove the two screws (Black) ①, disengage the two tabs, and remove Cover-Front ②.

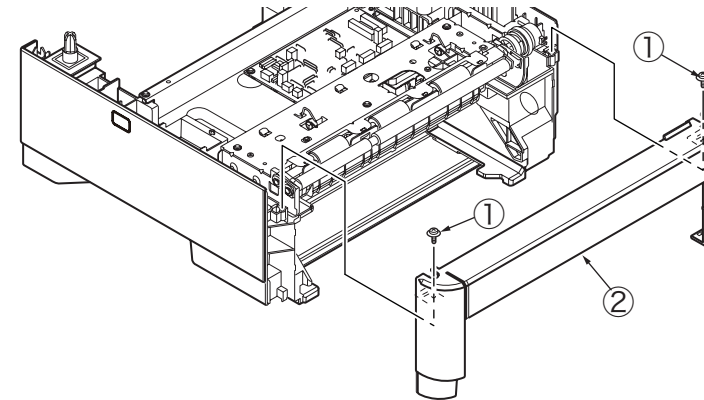

- (3) Remove the four screws (Black) ③. Remove the two screws (Silver) ④.
- (4) Disconnect the five connectors from Board-GOG, and remove Frame-Assy-Hop ⑤.

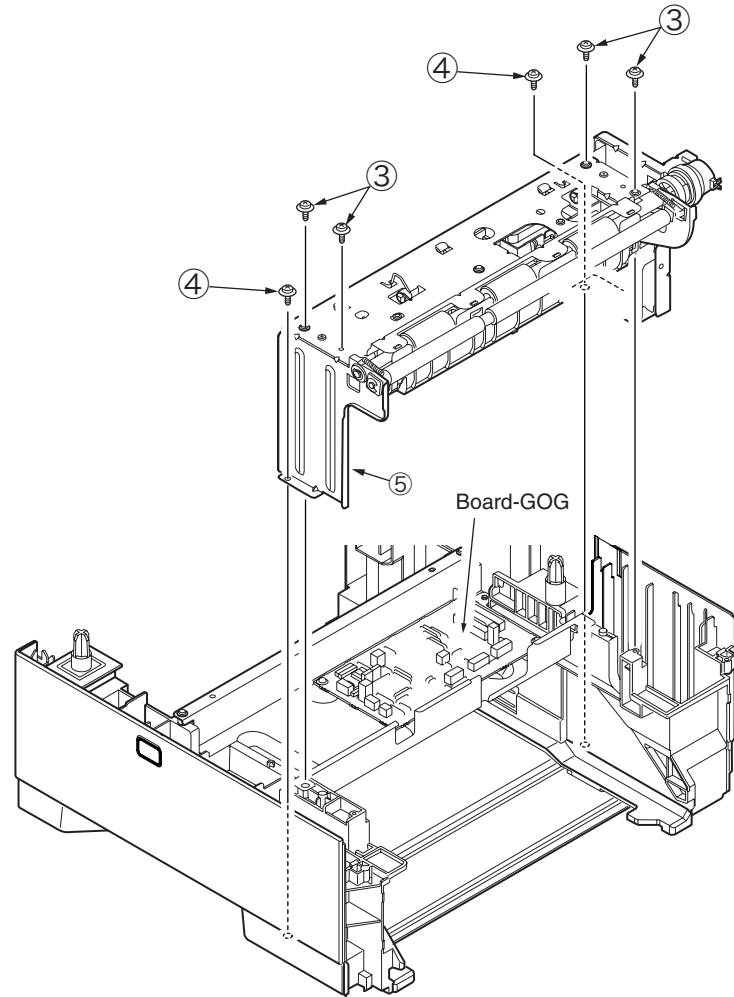

- (5) Remove the E-ring ⑥, Gear-Assy-Clutch (Hop) ⑦ and Gear-Assy-Clutch (Regist) ⑧.
- (6) Remove the two screws (Silver) ⑨. Remove the Motor-Pulse ⑩.
- (7) Installing is performed by the inverse procedure with removing.

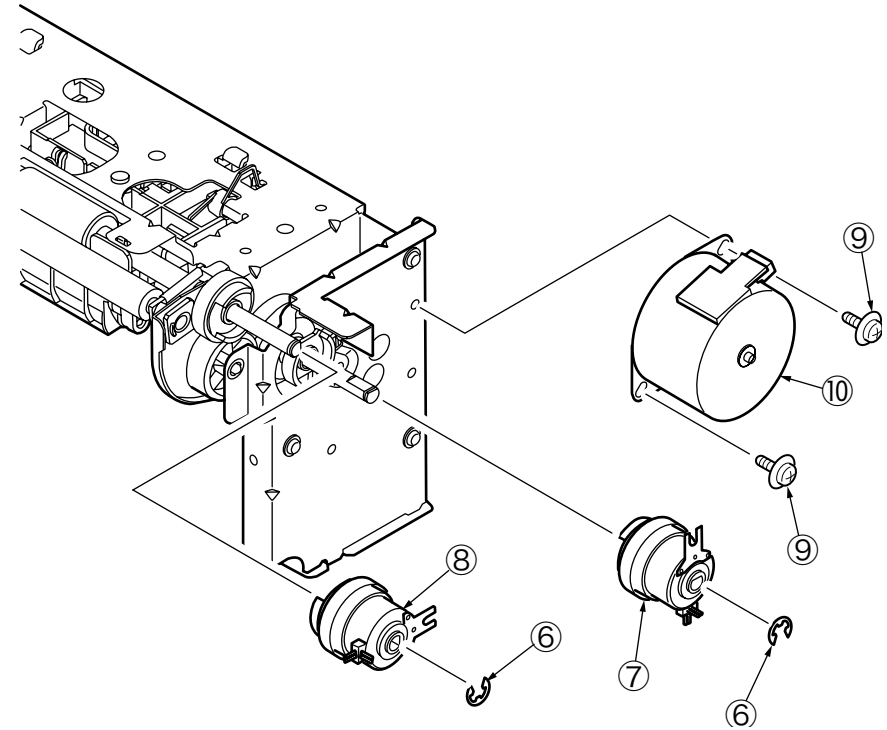

10.2.3.3.6 Frame-Assy-Retard, Spring-Retard

- (1) Detach Cassette-Assy.
- (2) Push two tabs in the direction of the arrow to remove Retard-Cover.
- (3) Push Frame-Assy Retard ① in the direction of the arrow. (Spring-Retard ② is also removed together.)
- (4) Installing is performed by the inverse procedure with removing.

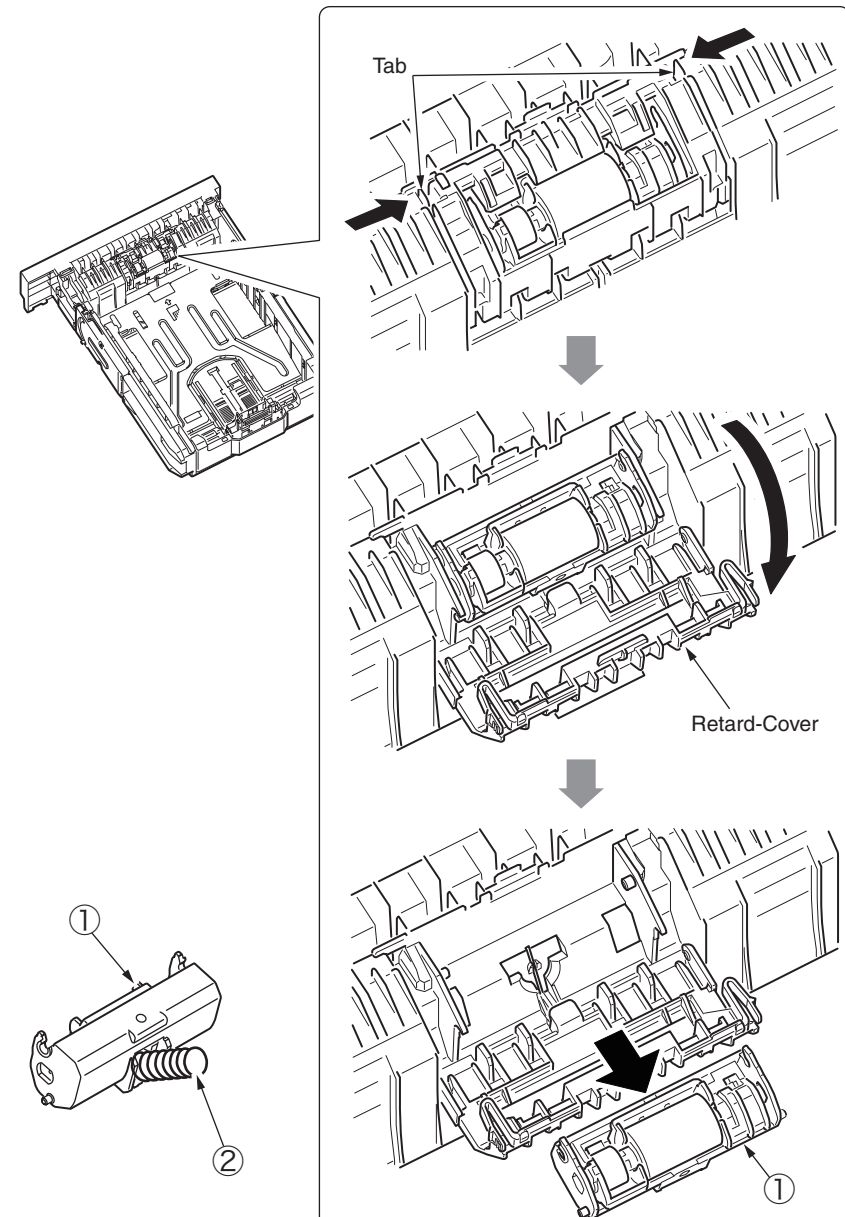

10.2.4 Cleaning of Paper Feed Roller and Separation Roller

Clean the rollers when [392: Paper Jam] often occurs.

- (1) Pull the paper cassette.
- (2) Wipe the two feed rollers with a tightly wrung cloth soaked in water through the opening for installation of a paper cassette.

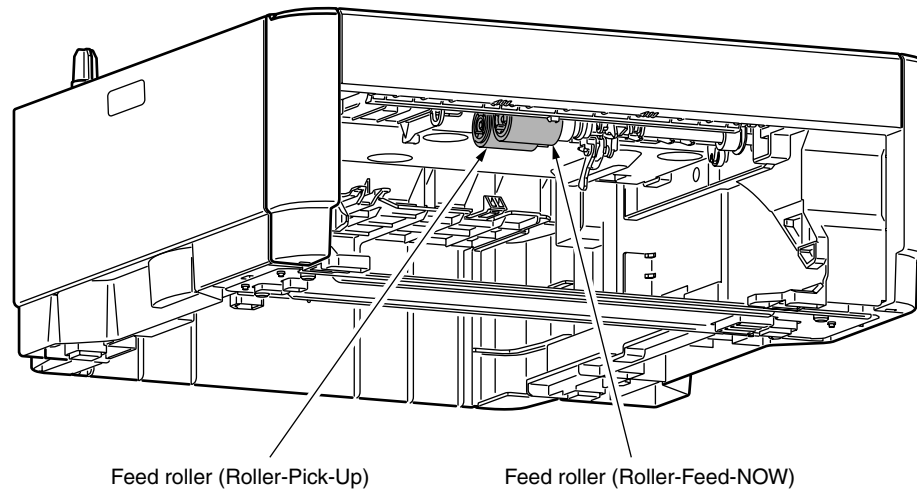

- (3) Open Retard-Cover of the paper cassette and wipe the retard roller with a tightly wrung cloth soaked in water. (Refer to 3.3.6 for how to open Retard-Cover.)

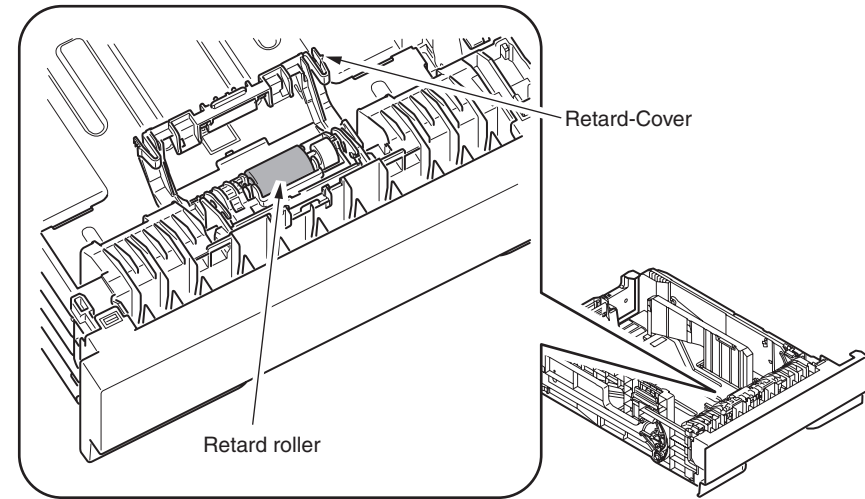

10.2.5 Procedure for Troubleshooting

10.2.5.1 Precautions for Troubleshooting

- (1) Check the basic items to be checked in the user's manual.
- (2) Obtain detail information at the failure from customers as much as possible.
- (3) Inspect the status which is close to the status at the failure.

10.2.5.2 Preparation before Troubleshooting

- (1) Display of Operator Panel

The failure status is displayed on the LCD (Liquid crystal display) of the operator panel. Follow the message displayed on LCD and make appropriate repairs.



- (Jam Error)

Paper Feed Jam

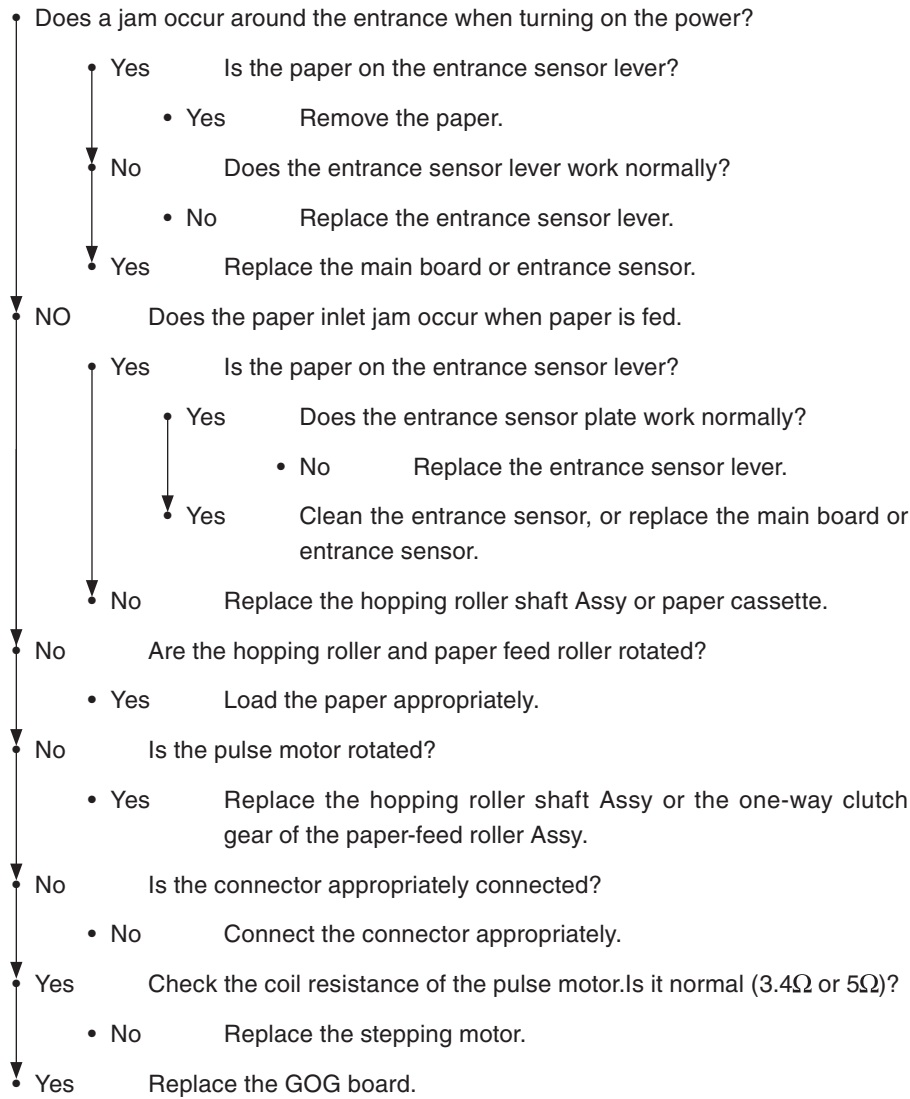

10.2.6 Connection Diagram

10.2.6.1 Connection diagram

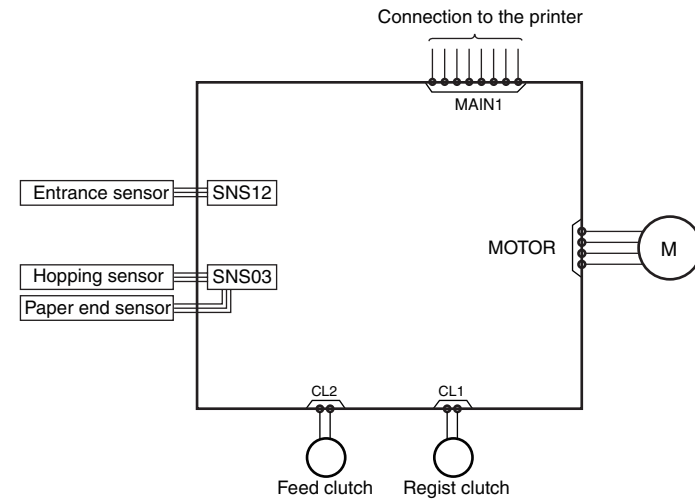

10.2.6.2 Board Arrangement

GOG board

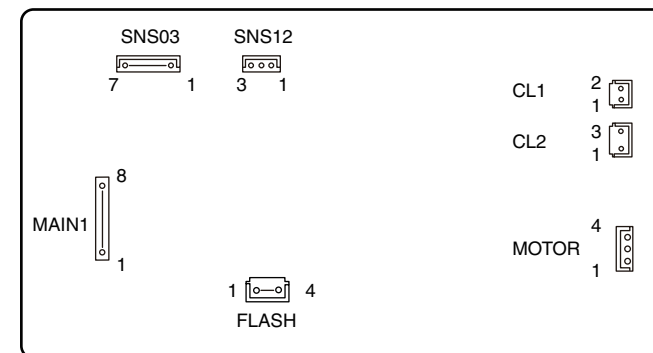

• MAIN1 Connector Pin Allocation

(Connection to the Main control board)

	PIN No.	I/O	Signal	Function
1	1	C	0VP	Analog Ground
2	2	O	24V	Motor/ Clutch Drive Power
3	3	C	0VL	Logic Ground
4	4	I	+5V	Logic Circuit Power supply
5	5	O	OPTSCK-N	OPT data output
6	6	I	OPTSD-P	OPT data input
7	7	O	OPTSDR-N	OPT status change
8	8	I	OPTPSIN-N	OPT transfer permission

• SNS03 Connector Pin Allocation

(Connection to the Hopping / Paper end sensor)

	PIN No.	I/O	Signal	Function
1	1	O	+5V	Logic Circuit Power supply
2	2	I	SNS3-N	Hopping sensor
3	3	C	0VL	Logic Ground
4	4	O	+5V	Logic Circuit Power supply
5	5	I	SNS0-N	Paper end sensor
6	6	C	0VL	Logic Ground

• SNS12 Connector Pin Allocation

(Connection to the Entrance sensor)

	PIN No.	I/O	Signal	Function
1	1	O	+5V	Logic Circuit Power supply
2	2	I	SNS1-N	Entrance sensor
3	3	C	0VL	Logic Ground

• CL1 Connector Pin Allocation

(Connection to the Regist clutch)

	PIN No.	I/O	Signal	Function
1	1	O	24V	Motor/ Clutch Drive Power
2	2	C	CLUTCH1	Analog Ground

• CL2 Connector Pin Allocation

(Connection to the Feed clutch)

	PIN No.	I/O	Signal	Function
1	1	O	POW	Motor/ Clutch Drive Power
2	2	C	CLUTCH2	Analog Ground
3	3	-	NC	Not used

• MOTOR Connector Pin Allocation

(Connection to the Pulse motor)

	PIN No.	I/O	Signal	Function
1	1	O	HOP4	Motor Drive Power
2	2	O	HOP3	Motor Drive Power
3	3	O	HOP2	Motor Drive Power
4	4	O	HOP1	Motor Drive Power

• FLASH Connector Pin Allocation

	PIN No.	I/O	Signal	Function
1	1	I/O	MODE	Serial Data
2	2	I	RESET	Reset
3	3	C	0VL	Logic Ground
4	4	O	VCC_CPU	Logic Circuit Power supply(+3.3)