

MB260MFP

Maintenance Manual

170809A

TABLE OF CONTENTS

1. DETAILED SECTION DESCRIPTIONS	1-1
1.1 COMPONENT LAYOUT	1-1
1.1.1 MECHANICAL COMPONENTS	1-1
1.2 PRINTING	1-2
1.2.1 PRINTING PROCESSES AROUND THE DRUM	1-2
1.2.2 CHARGE	1-3
1.2.3 LASER EXPOSURE	1-4
Overview	1-4
Block Diagram	1-5
Error Conditions	1-5
1.2.4 DEVELOPMENT	1-6
Overview	1-6
Toner End Detection	1-8
1.2.5 TRANSFER AND SEPARATION	1-9
Overview	1-9
Cleaning Mode	1-9
1.2.6 DRUM CLEANING	1-10
1.2.7 PAPER FEED AND REGISTRATION	1-11
Overview	1-11
Paper Feed Drive Mechanism	1-12
Paper Feed Operation	1-13
Registration	1-14
Paper End Detection	1-15
Jam Detection	1-16
1.2.8 FUSING	1-17
Overview	1-17
Power Save Control	1-18
1.2.9 COVER SWITCH	1-19
1.2.10 PAPER FEED DRIVE RELEASE AND FUSING DRIVE RELEASE	1-20
2. REPLACEMENT AND ADJUSTMENT	2-1
2.1 PAPER CASSETTE	2-2
2.1.1 PAPER CASSETTE	2-2
Side Fence	2-2
Bottom Plate	2-3
Friction Pad	2-3
2.2 LASER UNIT	2-4
2.3 FUSING AREA	2-6
2.3.1 FUSING UNIT	2-6
2.3.2 PAPER EXIT ASSEMBLY	2-7
2.3.3 FUSING LAMP AND HOT ROLLER	2-8
Fusing Lamp	2-8
Hot Roller	2-9
2.3.4 PRESSURE ROLLER	2-10

2.3.5 THERMISTOR.....	2-11
2.3.6 HOT ROLLER STRIPPERS.....	2-11
2.3.7 THERMOSTAT.....	2-12
2.4 PAPER FEED.....	2-13
2.4.1 PAPER FEED ROLLER REMOVAL.....	2-13
2.4.2 REGISTRATION ROLLER.....	2-15
(ALSO KNOWN AS 'ROLLER DRIVEN' IN THE PARTS CATALOG)	2-15
2.5 OTHERS	2-16
2.5.1 TRANSFER ROLLER	2-16
2.5.2 FAN MOTOR.....	2-17
2.5.3 MAIN MOTOR REMOVAL.....	2-18
2.5.4 DISCHARGE LAMP ASSY	2-19
2.6 PSU (KNOWN AS 'POWER SUPPLY UNIT' IN THE PARTS CATALOG).....	2-20
2.6.1 PSU REMOVAL	2-20

1. DETAILED SECTION DESCRIPTIONS

1.1 COMPONENT LAYOUT

1.1.1 MECHANICAL COMPONENTS

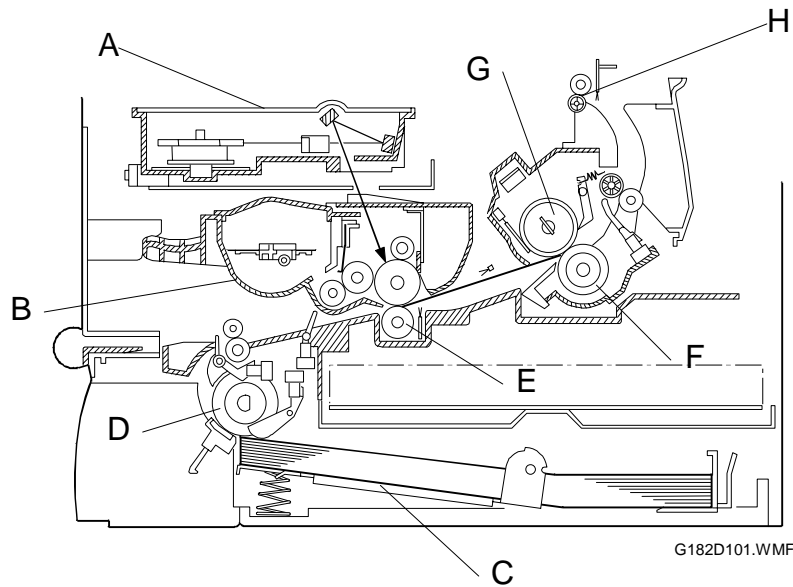

No.	Name	Description
A	Laser Unit	Consists of the laser diode unit, cylindrical lens, f-theta lens, polygon mirror motor, and other laser optical components.
B	Toner Cassette	Consists of the OPC drum, toner, toner application roller, development roller, charge brush roller, cleaning blade, and other development components.
C	Upper Tray Bottom Plate	Presses paper stacked in the upper paper tray against the paper feed roller.
D	Paper Feed Roller	Picks up the top sheet of paper from the stack in the upper paper tray and feeds it into the transfer area.
E	Transfer Roller	Applies a charge to the paper to pull the toner off the drum and onto the copy paper.
F	Pressure Roller	Applies pressure to the paper during fusing.
G	Hot Roller	Fuses the toner to the copy paper.
H	Paper Exit Roller	Feeds the paper out of the printer.

1.2 PRINTING

1.2.1 PRINTING PROCESSES AROUND THE DRUM

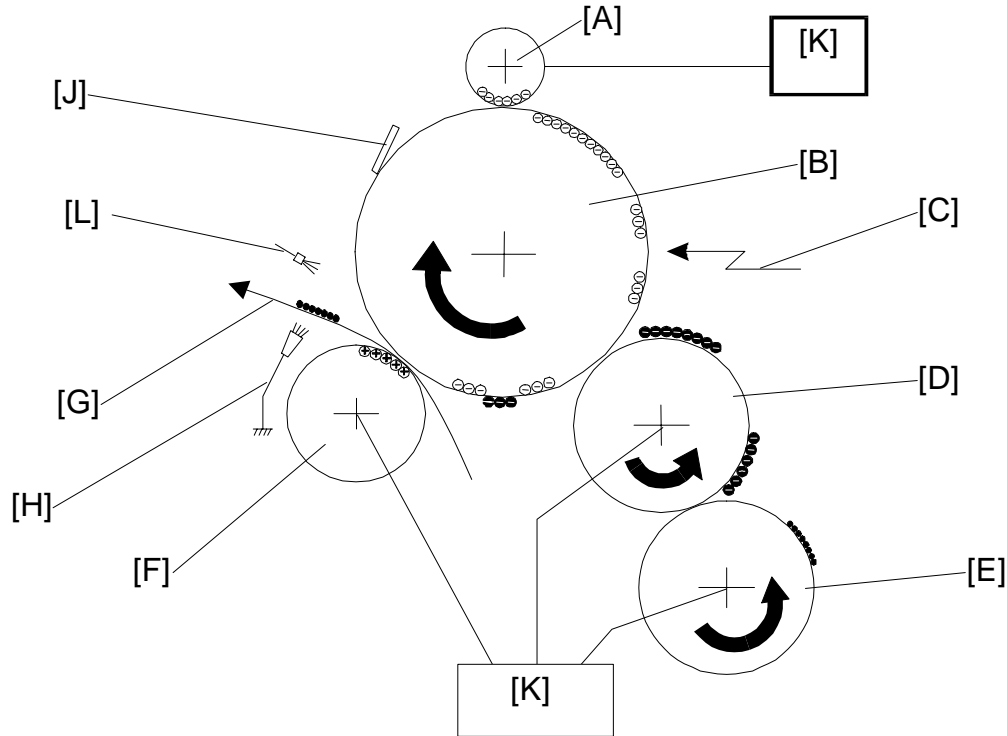

G182D010.WMF

This machine uses a “write to black” system, using negative toner.

Charge: The charge brush roller [A] gives the OPC drum [B] surface a negative charge.

Exposure: A laser [C] writes a latent image on the drum. The charge in the area exposed by the laser beam drops.

Development: The development roller [D] carries toner to the drum and develops the latent image on the drum. The following charges are applied.

Development bias (during printing):

Toner application roller [E]

Development roller [D]

Switching bias (At the start and the end of any print process):

Toner application roller [E]

Development roller [D]

Image Transfer: The transfer roller [F] pulls the toner from the drum onto the paper [G].

Paper Separation: The antistatic brush [H] removes the charge on the underside of the paper to help the paper separate from the drum.

Drum Cleaning: The Discharge Lamp [L] discharge the OPC drum [B] surface, The cleaning blade [J] removes any toner remaining on the drum after the image is transferred to paper.

The high voltages [K] are supplied from the Power Supply Unit board.

1.2.2 CHARGE

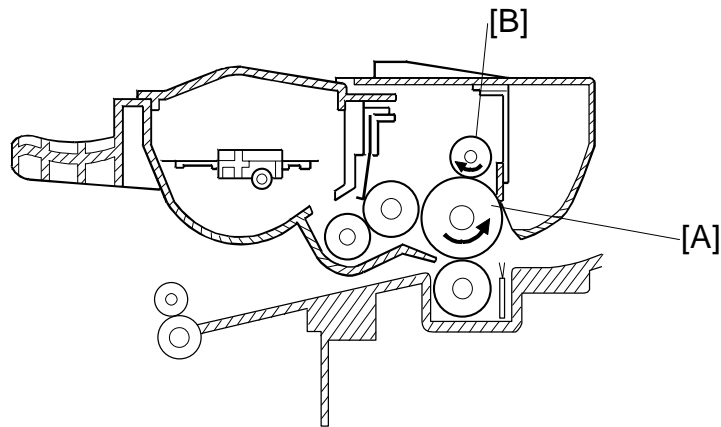

G182D102.WMF

The OPC (Organic Photoconductor) drum [A] used in this machine is small in diameter. This allows a very compact design.

A charge roller [B] charges the photoconductor. The charge roller has the advantage of not generating ozone. A large negative voltage is applied from the Power Supply Unit board to the charge roller. This charge roller gives the OPC drum surface a negative charge.

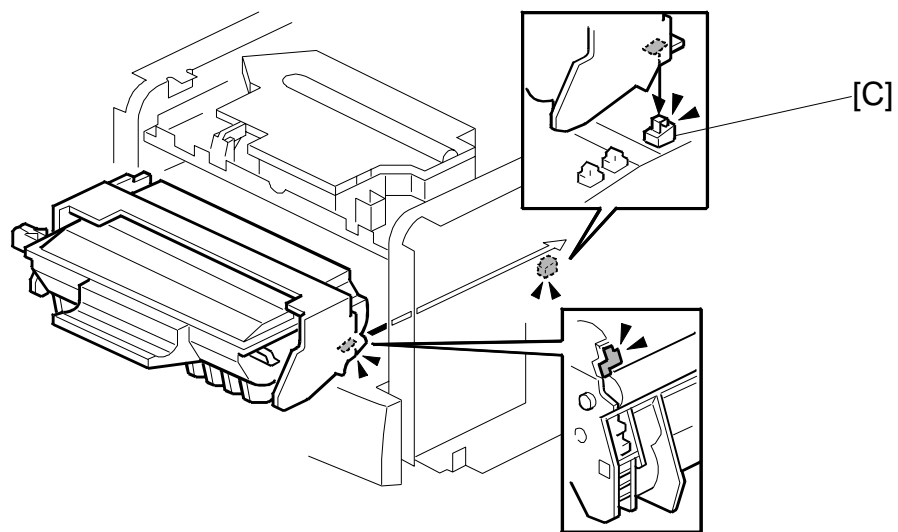

G182D003.WMF

The voltage to the charge roller is supplied through the terminal [C] from the Power Supply Unit board.

1.2.3 LASER EXPOSURE

Overview

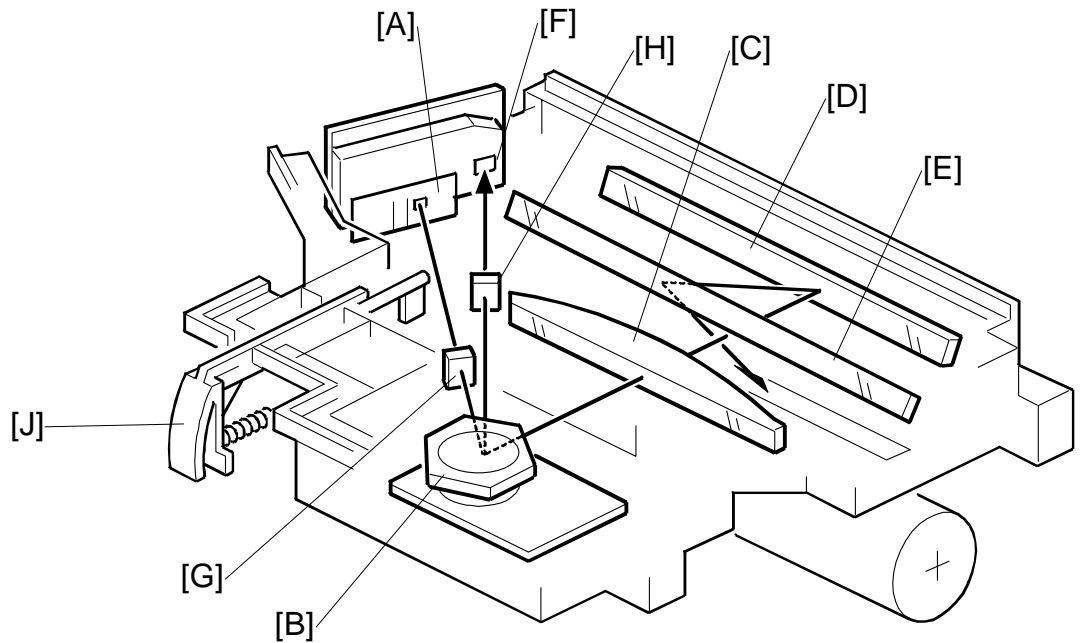

G182D004.WMF

Laser Unit Layout

A : Laser Diode Unit	F : Laser Synchronization Detector
B : Polygon Mirror Motor	G : Cylindrical Lens
C : F-theta Lens	H : Synchronization Detector Lens
D : First Mirror	J : Shutter
E : Second Mirror	

This machine uses a laser diode to produce an electrostatic latent image on the OPC drum. The laser diode unit converts image data into laser pulses, and the optical components direct these pulses to the OPC drum.

As a mechanical safety feature, the shutter [J] closes to block the laser beam path whenever the front door is opened.

Block Diagram

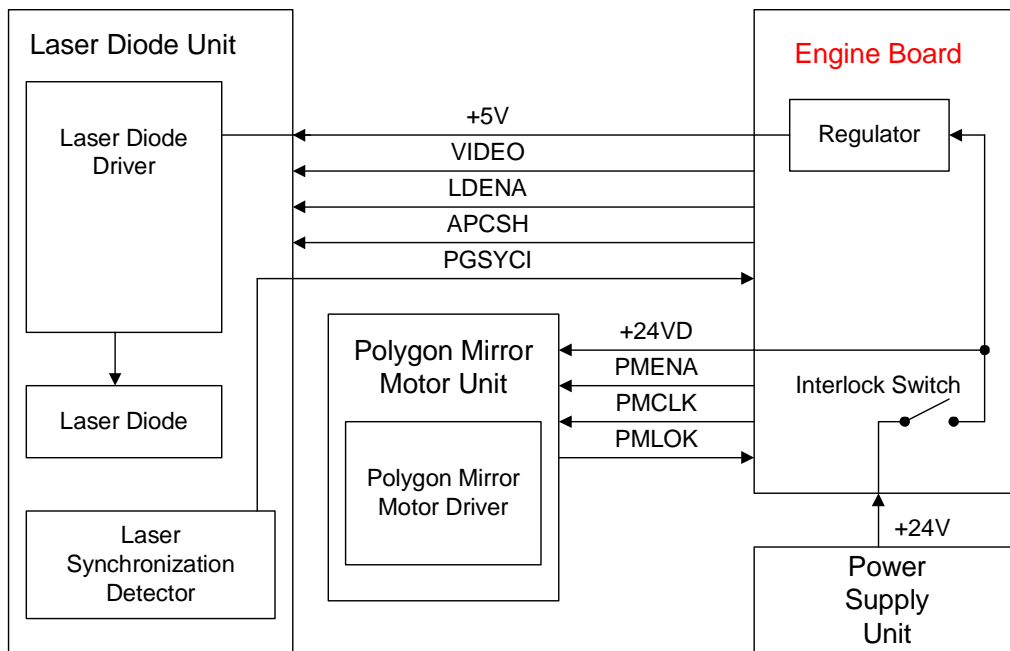

G182D012.WMF

Detailed
Descriptions

The Engine Board controls the laser diode power (APCSH) and transfers data for printing to the laser diode (VIDEO). As an electrical safety feature, there is an interlock switch on the Engine Board. This switch cuts +24 volts whenever the front door is opened.

Error Conditions

Laser Error

The machine detects laser synchronization signal pulses (PGSYCI) 70 milliseconds after the (LDENA) signal is sent. It detects a laser error if the pulse count does not reach the specified number within 400 milliseconds.

When this occurs, the machine warns the customer on the LCD panel (Error 56).

Polygon Mirror Motor Error

The machine detects a polygon mirror motor error when the (PMLOK) signal does not go low within 3.5 seconds of the (PMENA) signal. When this occurs, the machine warns the customer on the LCD panel (Error 57).

1.2.4 DEVELOPMENT

Overview

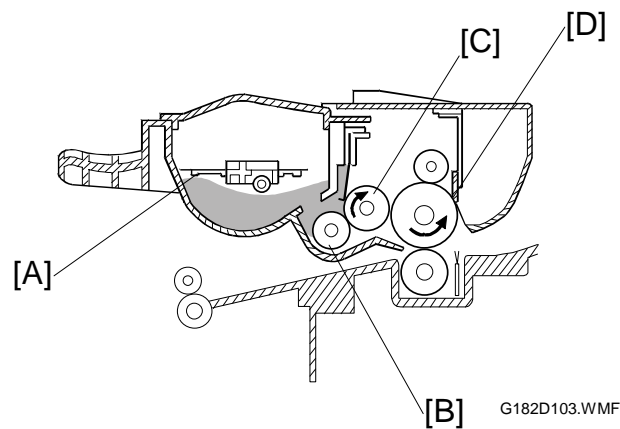

This machine uses mono-component toner, which is composed of resin and ferrite. The toner mixing bar [A] stirs and carries toner to the toner application roller [B]. The toner application roller supplies toner to the development roller [C]. As the development roller turns past the toner metering blade [D], only a thin coating of negatively charged toner particles stays adhered to the development roller.

During printing, a bias voltage is applied to the toner application roller and another bias voltage is applied to the development roller. The toner is transferred from the toner application roller to the development roller by the potential difference between these two rollers.

The development roller applies toner to the exposed areas of the latent image as they turn past the drum.

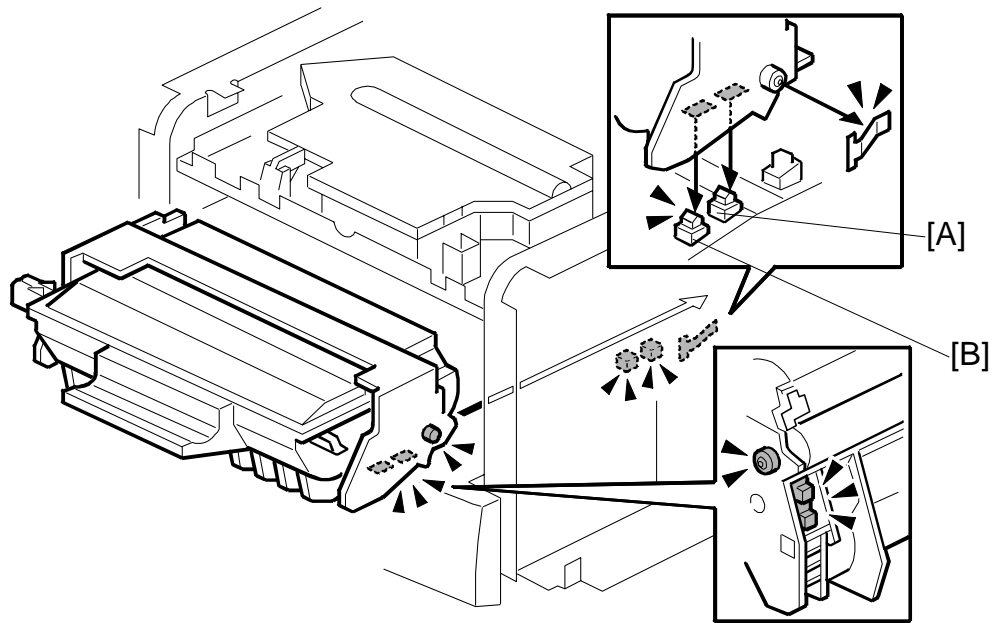

G182D005.WMF

The voltage to the development roller and the toner application roller is supplied through the terminals ([A] for the development roller and [B] for the toner application roller) from the Power Supply Unit board.

Toner End Detection

This machine does not have toner end detection.

1.2.5 TRANSFER AND SEPARATION

Overview

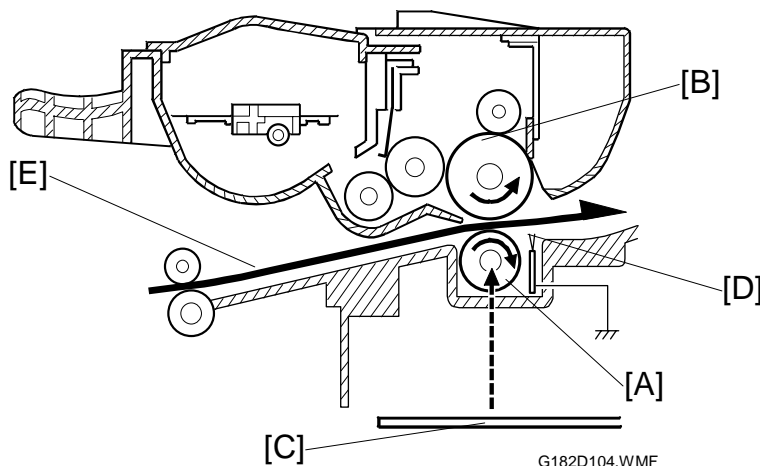

This machine uses a transfer roller [A], which touches the OPC drum [B] surface. A constant current is applied to the transfer roller from the power supply unit board [C]. The positively-biased transfer roller pulls negatively-charged toner off the drum. The curvature of the drum, and the antistatic brush [D], help the paper [E] to drop away from the drum.

Cleaning Mode

If a paper jam occurs during printing, toner may be transferred to the transfer roller surface. To prevent this toner from transferring to the underside of the paper, the transfer roller must be cleaned before the next printing run.

While the machine is in the cleaning mode, the Power Supply Unit board applies a negative voltage to the transfer roller.

The negatively charged toner on the transfer roller is then transferred back to the drum.

The machine goes through the cleaning mode at the following times.

- At power-up: The process starts when the fusing temperature reaches the standby temperature.
- When the cover is opened and then closed during the printing process.
- After a printer jam has been cleared.

1.2.6 DRUM CLEANING

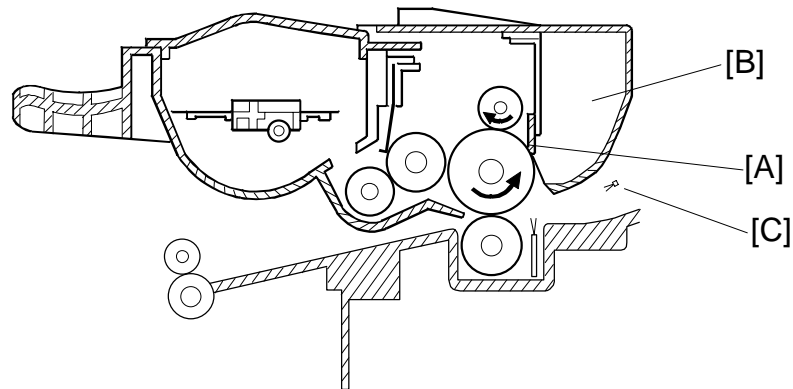

G182D102.WMF

The cleaning blade and the used toner tank are contained in the toner cartridge.

The Discharge Lamp and A counter blade system is used for drum cleaning. The Discharge Lamp [C] discharge the drum surface. The cleaning blade [A] removes any toner remaining on the drum after the image is transferred to the paper. This removed toner is stored in the used toner tank [B].

There is no used toner overflow detection mechanism, because the used toner tank is large enough for the lifetime of the toner cassette.

1.2.7 PAPER FEED AND REGISTRATION

Overview

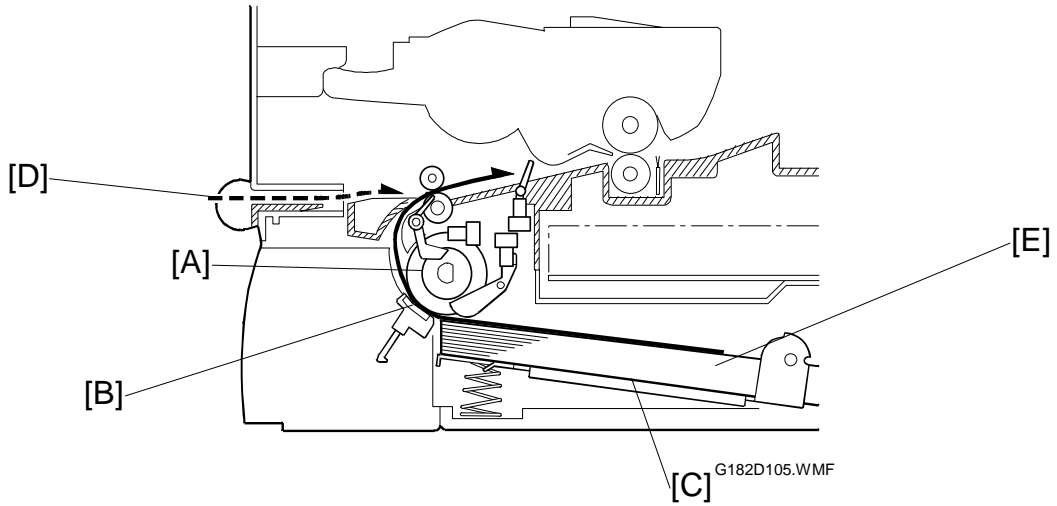

Detailed
Descriptions

Paper Feed System:	Feed roller [A] and Friction pad [B]
Paper Lift Mechanism:	Bottom plate with spring [C]
Sheet feeder	1 sheet feeder [D]
Tray Capacity:	250 sheets [E]
Paper End Detection:	Paper end sensor
Paper Size Detection:	None

Paper Feed Drive Mechanism

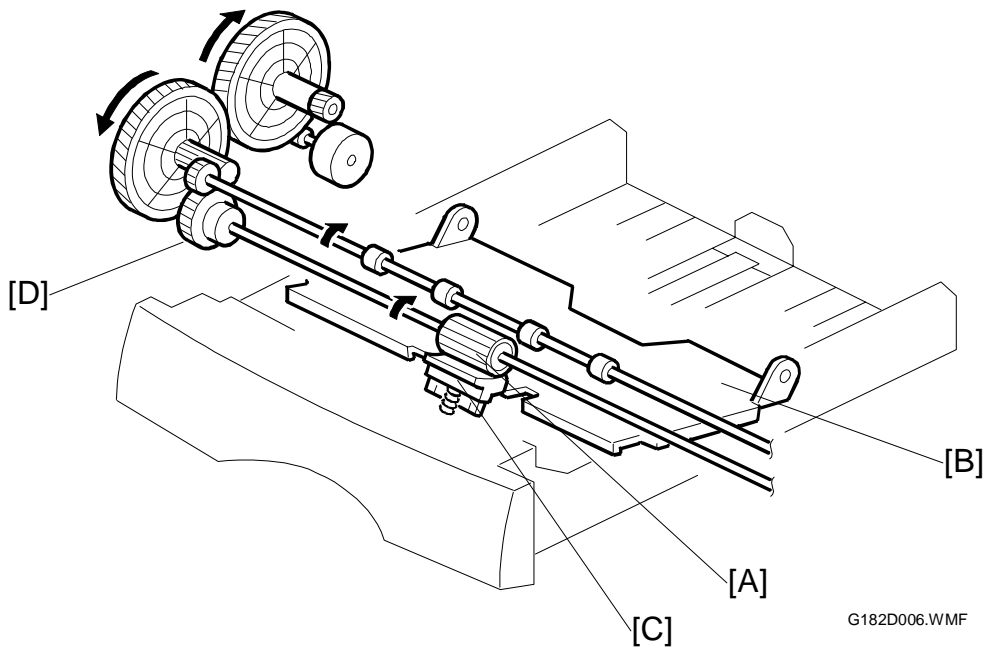

The feed roller [A] is located above the upper tray bottom plate [B], and the friction pad [C]. It allows only one sheet to feed from the paper tray. They are controlled by the paper feed clutch [D]. The registration sensor detects the leading edge of the paper and synchronizes paper feed with the activation of the laser diode to write the image on the OPC drum.

Paper Feed Operation

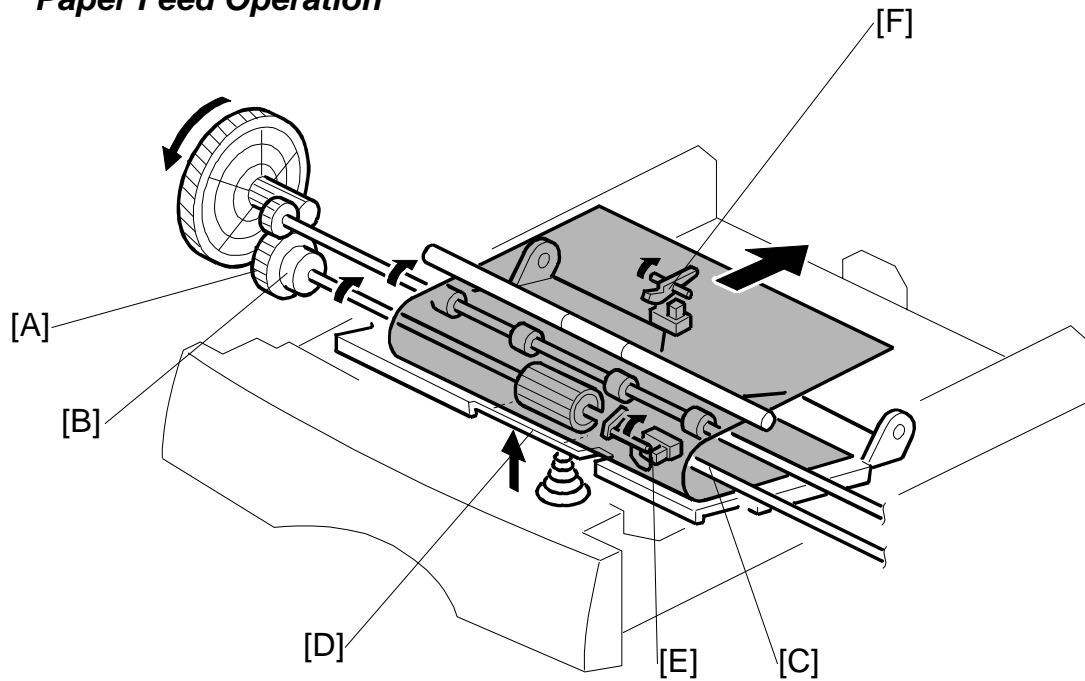

G182D007.WMF

- | | |
|---------------------------|-------------------------|
| A : Paper feed drive gear | D : Friction pad |
| B : Paper feed clutch | E : Paper feed sensor |
| C : Paper feed roller | F : Registration sensor |

The paper feed drive gear [A] always rotates while the main motor rotates, since the paper feed clutch (magnet clutch) [B] is energized to turn the paper feed roller [C].

When the paper feed clutch [B] is energized to turn the feed roller, the paper feed roller feeds one sheet of paper from the tray. The paper is fed into the machine by the registration roller.

Registration

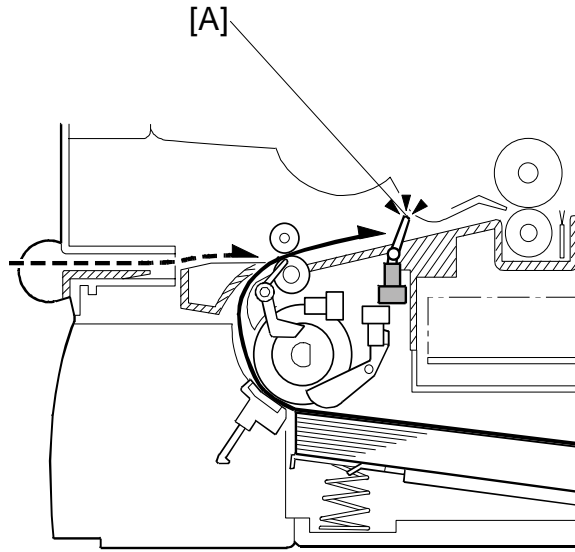

G182D107.WMF

The registration sensor [A] detects the leading edge of the paper and synchronizes paper feed with the writing of the image on the drum, so that the image and paper match up properly. This sensor also detects paper feed jams.

Paper End Detection

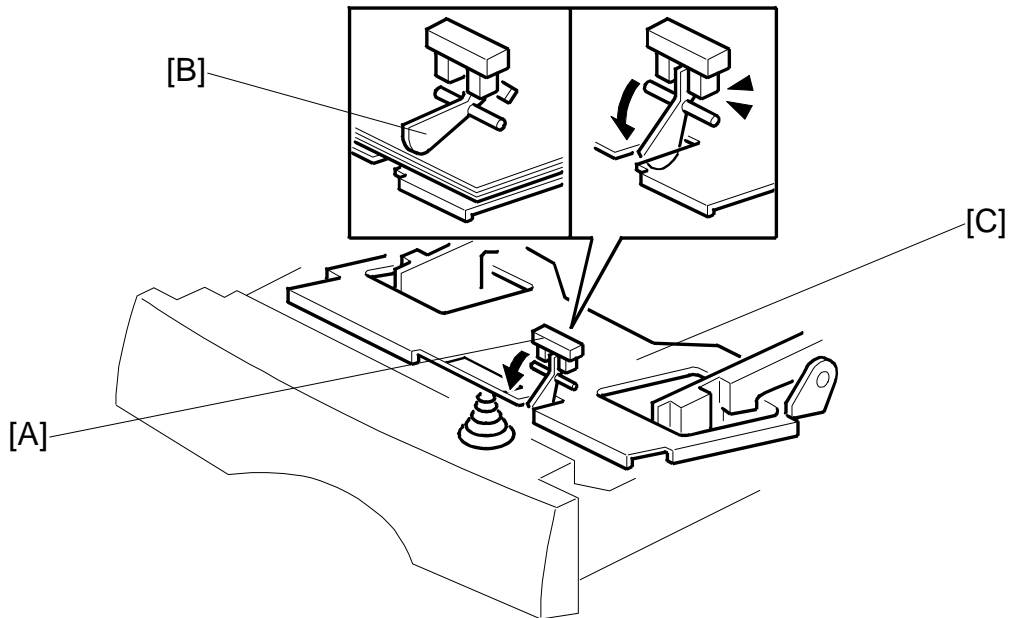

G182D008.WMF

The laser unit [A] has the paper end sensor [B] built into it. The paper end sensor detects the presence or absence of paper. The sensor has an actuator that extends through a slot in the paper tray bottom plate [C], so that the sensor is actuated when paper is placed in the upper tray.

When the upper tray runs out of paper, the actuator of the paper end sensor moves into the slot in the upper tray bottom plate. This informs the CPU that paper has run out.

Detailed
Descriptions

Jam Detection

Jam 1. Paper jam at the paper cassette

When the registration sensor does not turn on within 2.52 seconds after the paper pick-up clutch for the paper cassette turns on.

Jam 2. Paper did not pass the registration sensor

When the registration sensor does not turn off within the specified time for passing each paper size (see below) + 3 seconds after the registration sensor turns on.

Paper Size	A4SEF	A5SEF	A5LEF	A6SEF	B5SEF	B6SEF	Letter SEF	Legal SEF	Envelope (91x191mm)
Specified Time (msec)	2555	1807	1273	1273	2211	1566	2400	3059	1643

Jam 3. Paper did not reach the fusing unit

When the paper exit sensor does not turn on within 1.94 seconds after the registration sensor turns on.

Jam 4. Paper jam in the fusing exit area

When the paper exit sensor does not turn off within 2.99 seconds after the registration sensor turns off.

Jam 5. Paper no feed jam in the bypass tray

When the registration sensor does not turn on within 1.72 seconds after the main motor starts.

1.2.8 FUSING

Overview

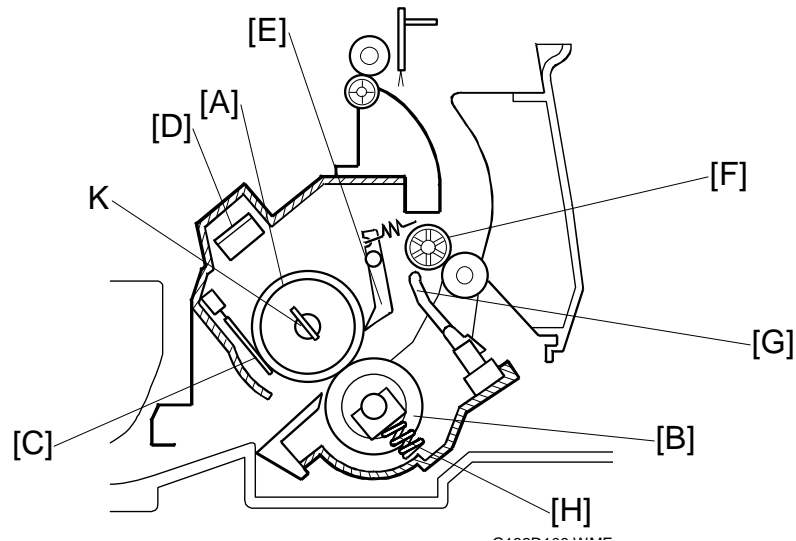

After the image is transferred, the copy paper enters the fusing unit. The image is fused to the copy paper by applying heat and pressure through the use of a hot roller [A] and pressure roller [B].

The CPU monitors the hot roller temperature through a thermistor [C] that is in contact with the hot roller surface. A thermostat [D] protects the fusing unit from overheating.

The hot roller strippers [E] separate the copy paper from the hot roller and direct it to the exit rollers [F]. The paper feed/exit sensor [G], which is under the fusing unit, monitors the progress of the copy paper through the fusing unit and detects misfeeds. The exit rollers [F] drive the copy paper to the paper output tray.

Springs [H] at the front and rear apply the proper fusing pressure between the hot roller and pressure roller.

The fusing lamp [K] is located in the hot roller.

Power Save Control

When the main switch is turned on, the machine turns on the fusing lamp. For printing, the machine raises the fusing temperature to 175°C. The fusing temperature is kept at 175°C during printing.

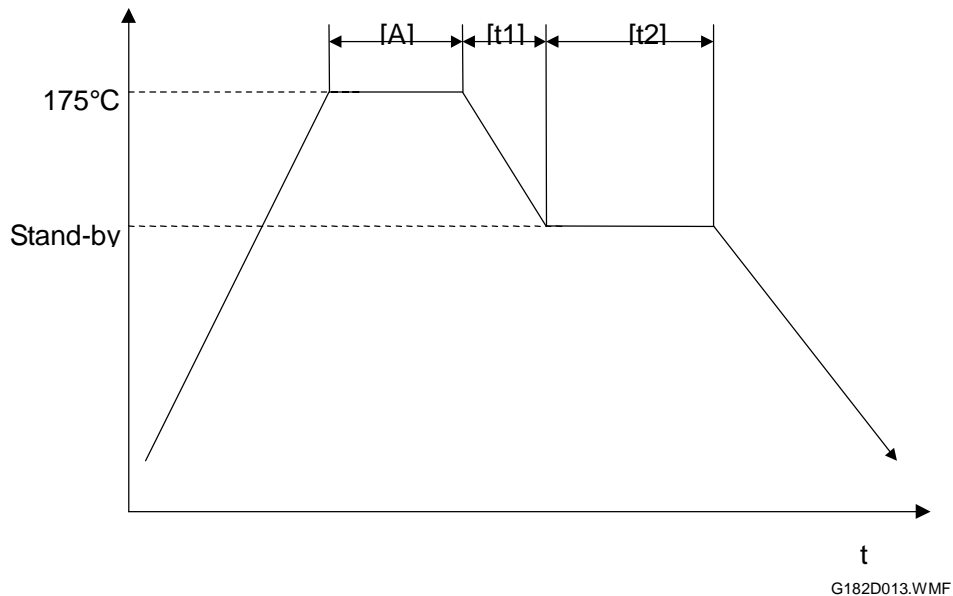

When the power saver timer expires, the machine automatically goes into energy saver mode.

Power saver timer

$t_1 = ?$ minutes.

- After time interval t_1 passes following printing, copying, scanning, or key-in [A], the LCD and all LED's go off.

$t_1 + t_2 = ?$ minutes or ? minutes (selectable)

- The default value is ? minutes. (Economy Mode)
- Pressing the Clear Modes key for more than one second will change this condition.
- When the Economy Mode LED is lit, $t_1 + t_2 = ?$ minutes.
- When the Economy Mode LED is not lit, $t_1 + t_2 = ?$ minutes.

1.2.9 COVER SWITCH

When the front door is opened, the interlock switch will be opened and power supply to the following parts will be cut.



G182D014.JPG

- Power pack
- Laser diode driver
- Fan motor
- Main motor
- Polygon mirror motor
- Fusing lamp

1.2.10 PAPER FEED DRIVE RELEASE AND FUSING DRIVE RELEASE

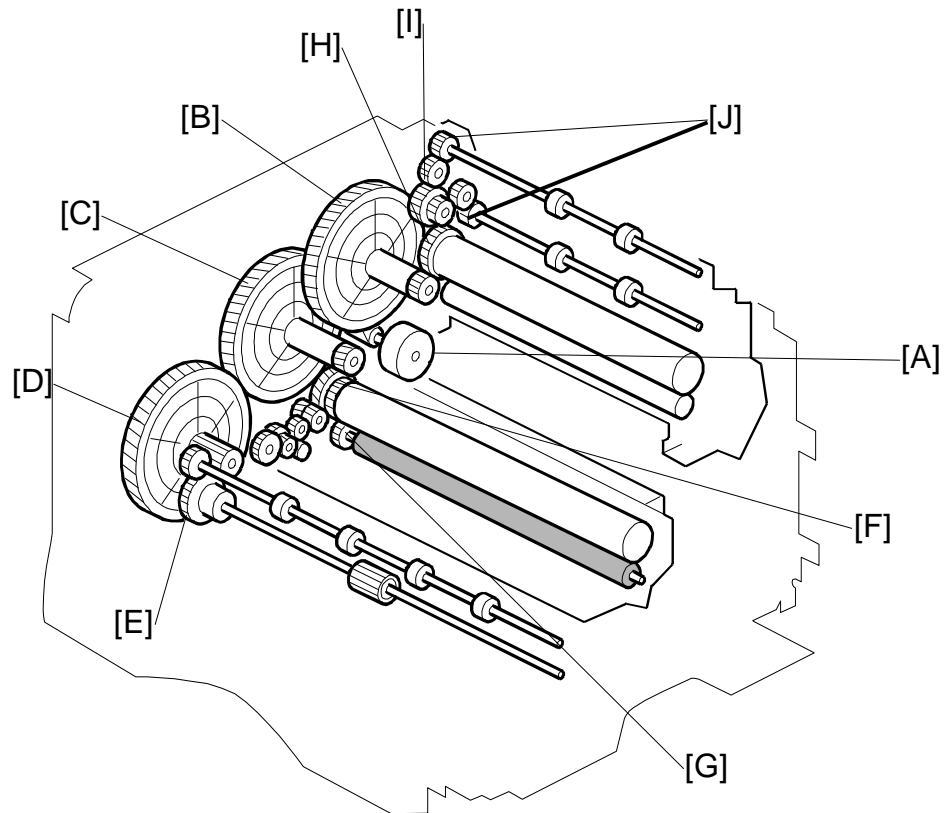

G182D009.WMF

The main motor drives the paper feed unit, the transfer roller, the toner cassette, and fusing unit through a series of gears as follows.

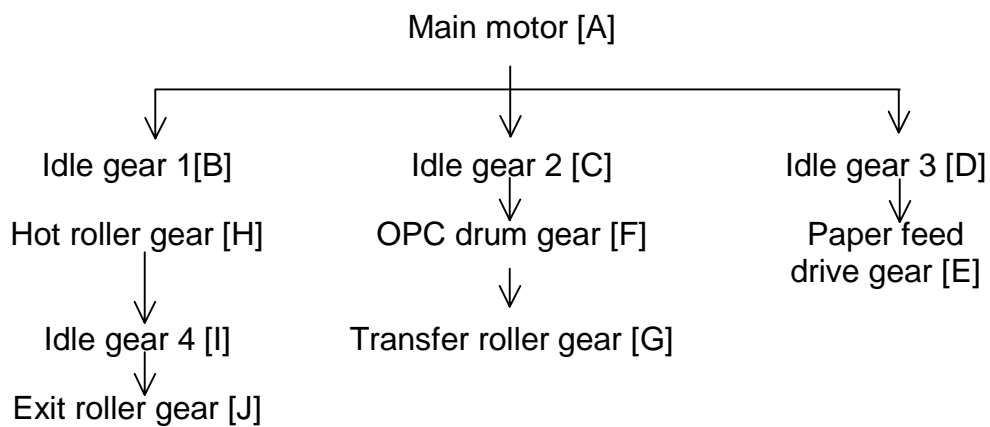

2. REPLACEMENT AND ADJUSTMENT

The following table shows the part replacement rank, which explains the difficulty of each replacement procedure.

Definition:

A: Replacement in the field cannot be recommended.

(It takes time and needs space.)

B: Replacement in the field is recommended. (It should take less than 10 minutes.)

C: Replacement in the field is recommended. (It should take less than 5 minutes.)

Part unit	Part Name	Rank
Paper cassette	Side fence	C
	Side fence gear	C
	Bottom plate	C
	Friction pad	C
Laser	Laser unit	C
Fusing	Fusing unit	C
	Paper exit area	C
	Hot roller	B
	Pressure roller	B
	Fusing lamp	B
	Thermistor	B
	Thermostat	B
Paper feed	Paper feed roller	B
Registration	Registration roller	A
Transfer	Transfer roller	C
Motors	Main motor	A
	Fan motor	C
PSU	PSU	A
Discharge Lamp	Discharge Lamp Assys	A

2.1 PAPER CASSETTE

2.1.1 PAPER CASSETTE

[A]: Paper cassette

[A]



G182R001.JPG

Side Fence

[B]: Side fence gear (pull it out)

[B]



G182R002.JPG

[C]

[C]: Side fence – Left
Unhook at the rear.

[D]: Side fence – Right
Unhook at the rear.

NOTE: Lift the bottom plate before
removing the side fences.



G182R003.JPG

[D]

Bottom Plate

[E]: Bottom plate

Unhook at both sides of the cassette [F].

Detach from the pin [G] at both sides.



Friction Pad

[H]: Friction pad (two hooks)

NOTE: Be careful not to lose the spring [I].

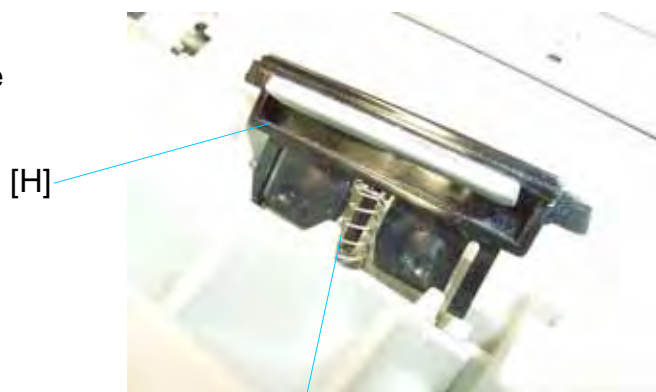

Replacement
Adjustment

2.2 LASER UNIT

WARNING FOR THE LASER UNIT

This machine contains a laser beam generator. Laser beams can cause permanent eye damage. Do not open the laser unit or look along the laser beam path while the main power is on.

This device complies with IEC60825-1:1993+A1:1997+A2:2001 standard, is classified as laser class 1 product and contains one class 3B laser diode, 10.72 mW max, 770-795 nm and other class 1 LEDs (280 μ W at 639 nm).

The maximum breakdown output power of radiation of laser diode is 50 mW at 770-795 nm.

Preparation:

- 1) Remove the upper unit. (See Upper Unit Removal.)

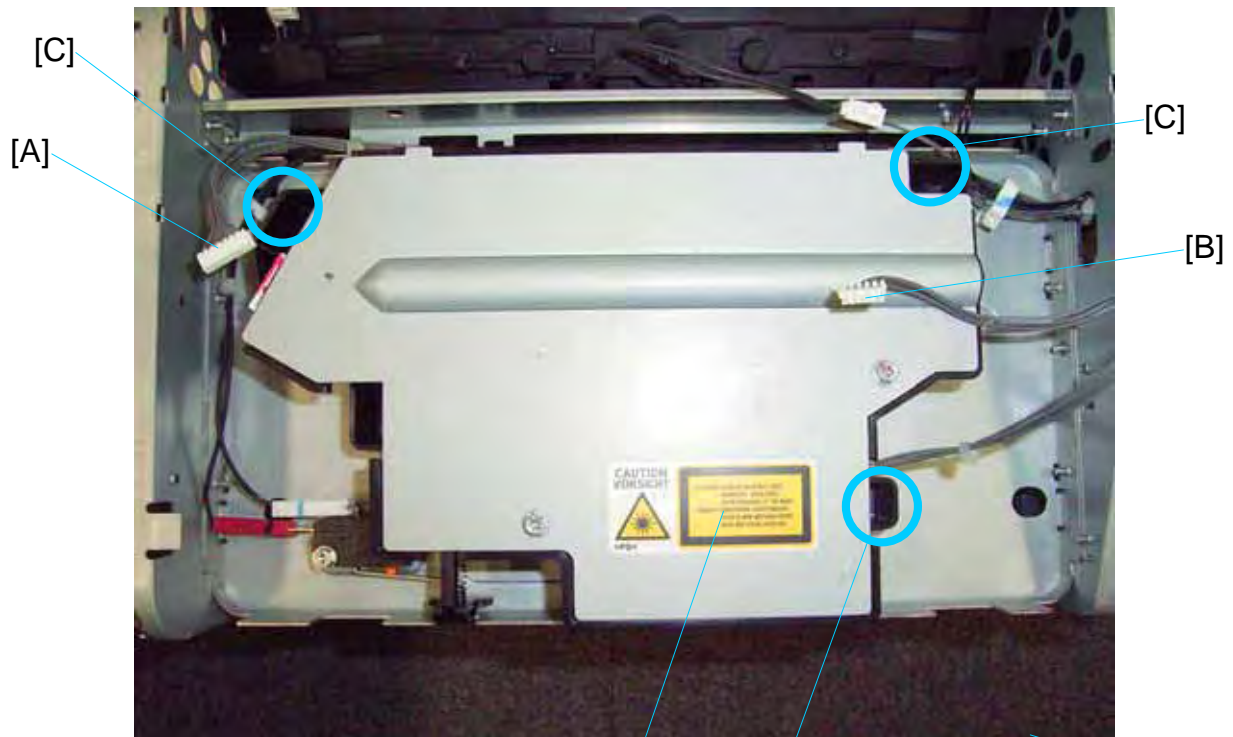

- [A]: Laser diode unit harness
- [B]: Polygon mirror motor harness
- [C]: Laser unit (3 screws [circled in blue above])

NOTE: When re-assembling, make sure to set the positioning pin [D] in the hole [E].

[F]: Warning label (see the following page)



[E]

G182R008.JPG

Warning Label [F]



3BLASERCAUTION.WMF

Replacement
Adjustment

2.3 FUSING AREA

2.3.1 FUSING UNIT

Preparation:

- 1) Remove the upper unit. (See Upper Unit Removal.)

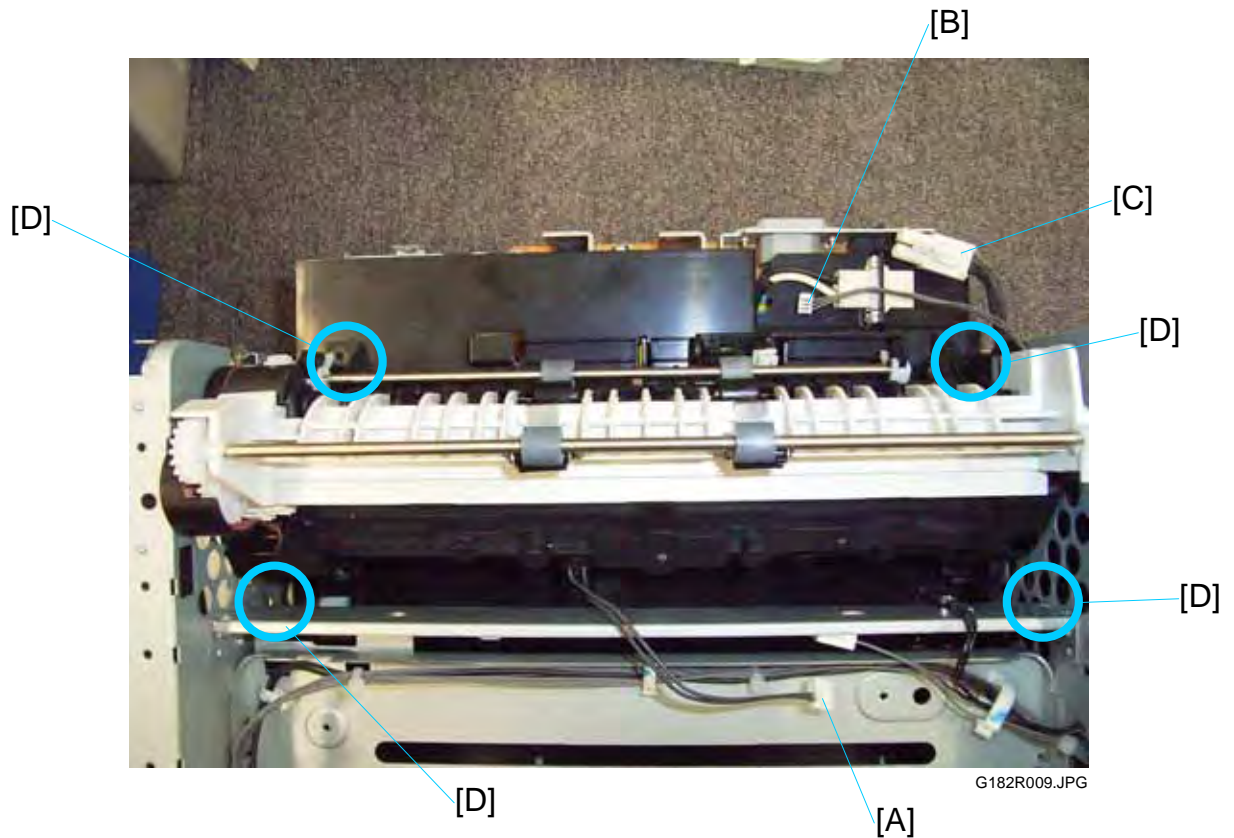

- [A]: Thermistor harness
- [B]: Paper exit sensor harness
- [C]: Fusing lamp harness
- [D]: Fusing unit (4 screws [circled in blue above])

2.3.2 PAPER EXIT ASSEMBLY

[A]: Fusing cover (1 screw)



G182R010.JPG

[B]: Paper exit assembly (2 screws [circled in blue in the lower diagram])



[B]

G182R012.JPG

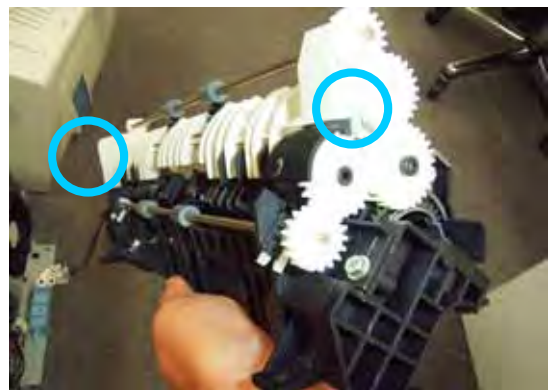

G182R011.JPG

Replacement
Adjustment

2.3.3 FUSING LAMP AND HOT ROLLER

Preparation:

- Remove the paper exit assembly (* 2.3.2).

Fusing Lamp

[A]: Fusing lamp (2 screws)

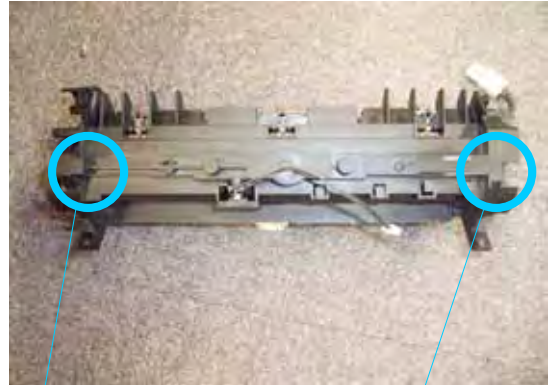

G182R013.JPG



G182R014.JPG



G182R015.JPG

NOTE: Do not touch the surface of the fusing lamp with bare hands.

[A]

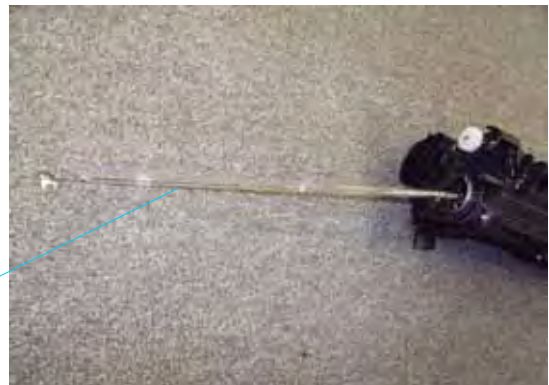

G182R018.JPG

Reassembly

When reassembling, be careful to set the fusing lamp on the frame first, then set the terminals [B] and [C].

[B]

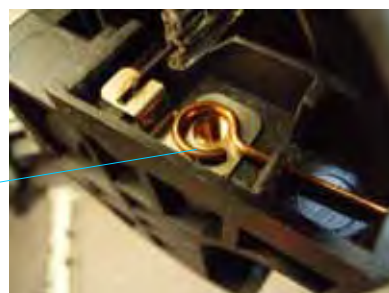

G182R017.JPG

[C]



G182R016.JPG

Hot Roller

[A]: Electrode (1 screw)



G182R019.JPG

[B]: Hot roller (pull it out)

NOTE: Do not touch the surface of the hot roller with bare hands.



G182R020.JPG

NOTE: When re-assembling, be careful not to damage the hot roller strippers [C].

Replacement
Adjustment

2.3.4 PRESSURE ROLLER

Preparation:

- Remove the paper exit assembly (* 2.3.2).
- Remove the fusing lamp and hot roller (* 2.3.3).

[A]: Pressure roller (1 bushing [B] and 1 spring [C] at each side)

[A]



G182R046.JPG

[B]

[C]



G182R048.JPG

[B]

[C]

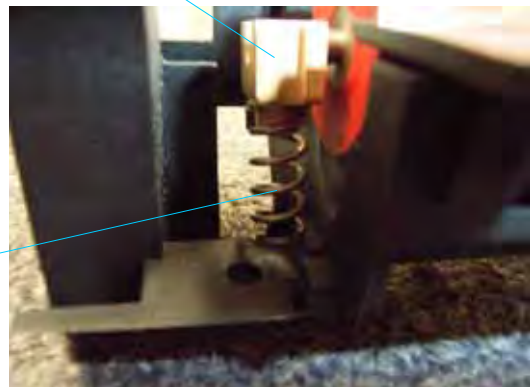

G182R047.JPG

NOTE: When re-assembling, be careful to set the bushing [B] and spring [C] in the correct position.

2.3.5 THERMISTOR

Preparation:

- Remove the paper exit assembly (* 2.3.2).

[A]: Thermistor (1 screw)

NOTE: When reassembling, do not damage the thermistor, and check that the element touches the hot roller.

[A]

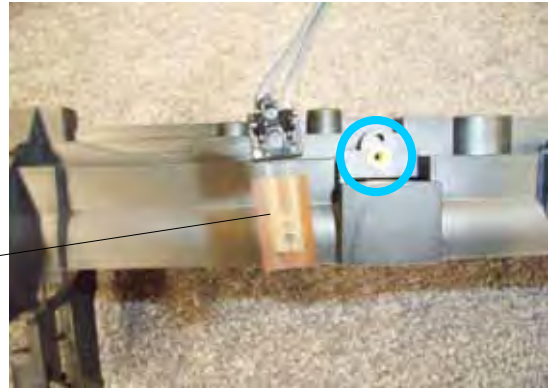

G182R023.JPG

2.3.6 HOT ROLLER STRIPPERS

Preparation:

- Remove the paper exit assembly (* 2.3.2).
- Remove the fusing lamp and hot roller (* 2.3.3).

There are 3 hot roller strippers [A] in the fusing unit.

[B]: Hot roller stripper (1 spring [B] each)

NOTE: When reassembling, be careful not to lose the spring [B].

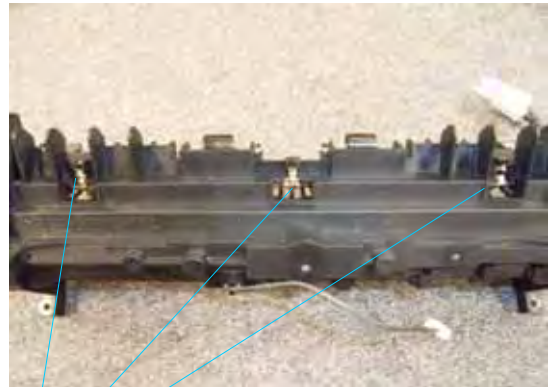

G182R022.JPG

[A]

[B]

[A]



G182R021.JPG

Replacement
Adjustment

2.3.7 THERMOSTAT

Preparation:

- Remove the paper exit assembly (* 2.3.2).
- Remove the fusing lamp and hot roller (* 2.3.3).

[A]: Thermostat (2 screws)



G182R024.JPG

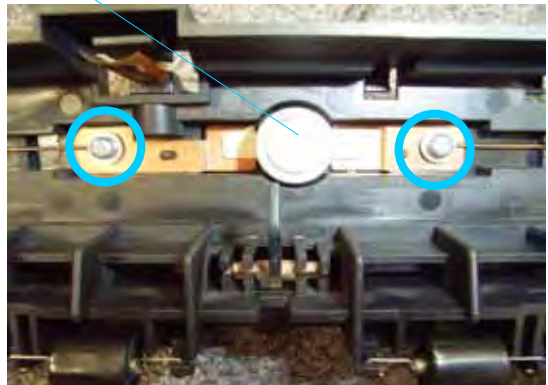

G182R025.JPG

2.4 PAPER FEED

2.4.1 PAPER FEED ROLLER REMOVAL

Preparation:

- 1) Remove the upper unit. (See Upper Unit Removal.)

[A]: Drive assembly (4 screws)

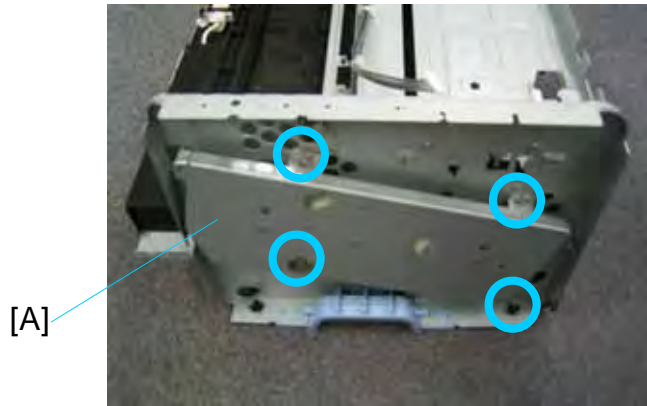

G182R026.JPG

[B]: Electromagnetic clutch assembly (1 clip)



G182R027.JPG



G182R028.JPG

[C]: Paper feed roller (2 clips, one at the left side [D], and one at the right side)



G182R030.JPG



G182R030.JPG

Replacement
Adjustment

Remove the paper feed roller [C] from the shaft.



G182R031.JPG

2.4.2 REGISTRATION ROLLER

(ALSO KNOWN AS 'ROLLER DRIVEN' IN THE PARTS CATALOG)

Preparation:

- 1) Remove the upper unit. (See Upper Unit Removal)
- 2) Remove the paper tray
- 3) Remove the toner cartridge

[A]: Paper tray guides (2 screws)

[B]: Left shield (13 screws & 2 screws at the bottom)

[C]: Right shield (9 screws)

[D]: Laser shield (4 screws)

[E]: Guide shield (4 screws)



G182R035.JPG

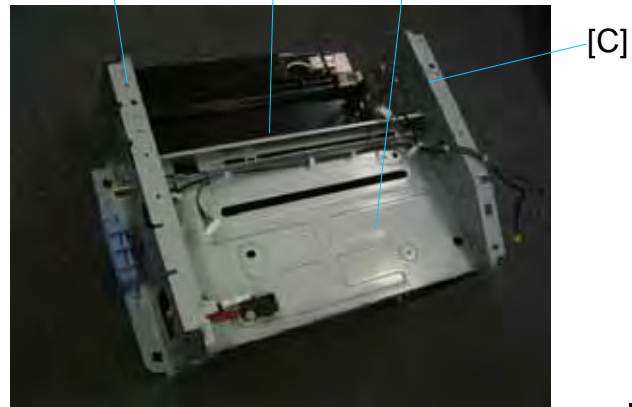

G182R040.JPG

[A]

[B]

[E]

[D]

[C]

[F]: Plate (2 screws)

[G]: White bushings

[H]: Registration roller (lift it out)

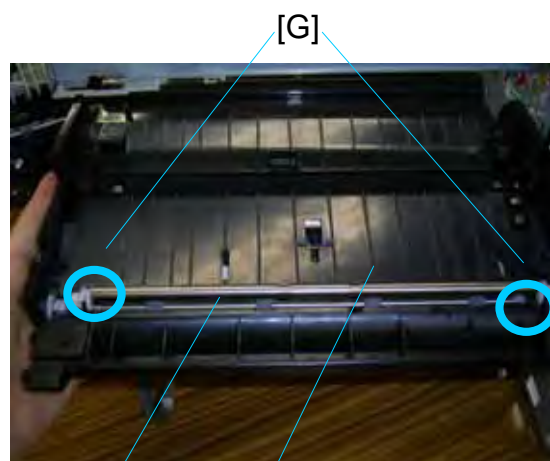

G182R034.JPG

[F]

[G]

[H]

Replacement
Adjustment

2.5 OTHERS

2.5.1 TRANSFER ROLLER

Preparation:

- 1) Remove the upper unit. (See Upper Unit Removal.)
- 2) Remove the toner cartridge.

[A]: Transfer roller
[B]: Black bushing

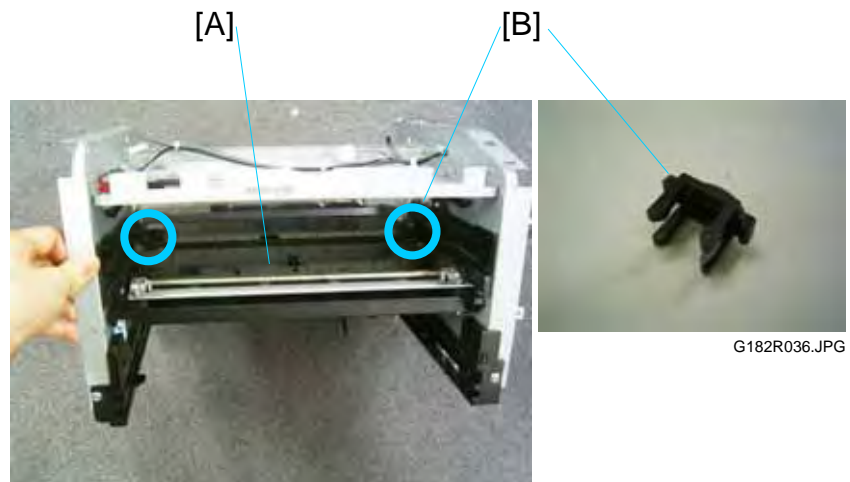

G182R035.JPG

G182R036.JPG

Remove the transfer roller with a flat-head (-) screwdriver.



G182R037.JPG

2.5.2 FAN MOTOR

Preparation:

- 1) Remove the upper unit. (See Upper Unit Removal.)

[A]: Fan motor (1 screw & 1 harness)

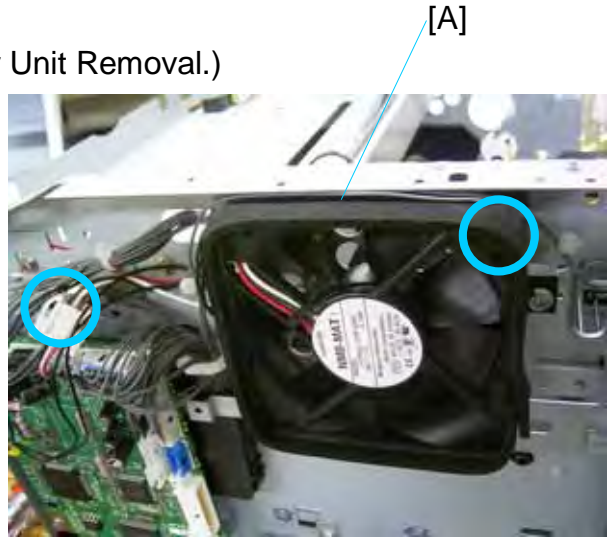

G182R038.JPG

Replacement
Adjustment

2.5.3 MAIN MOTOR REMOVAL

Preparation:

- 1) Remove the upper unit. (See Upper Unit Removal.)
- 2) Remove the paper tray.
- 3) Remove the toner cartridge.
- 4) Remove the laser unit (* 2.2).

[A]: Paper tray guides (2 screws)

[B]: Left shield (13 screws & 2 screws at the bottom)

[C]: Right shield (9 screws)

[D]: Laser shield (4 screws)

[E]: Guide shield (4 screws)

[F]: Main motor (3 screws and 1 harness)



G182R035.JPG

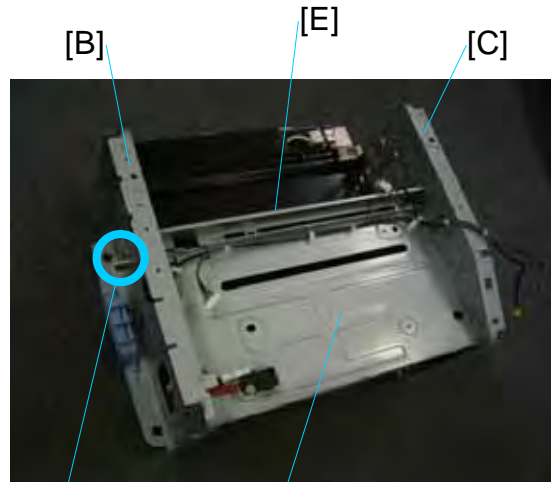

G182R040.JPG

[F]



G182R041.JPG

2.5.4 DISCHARGE LAMP-ASS'Y REMOVAL

Preparation:

- 1) Remove Fusing unit. (See Upper Unit Removal).

[A]: Ground Wire-Bracket-Discharge Lamp (1 screws)

[B]: Harness-Discharge Lamp

[C]: Discharge Lamp Assy (2 screws)

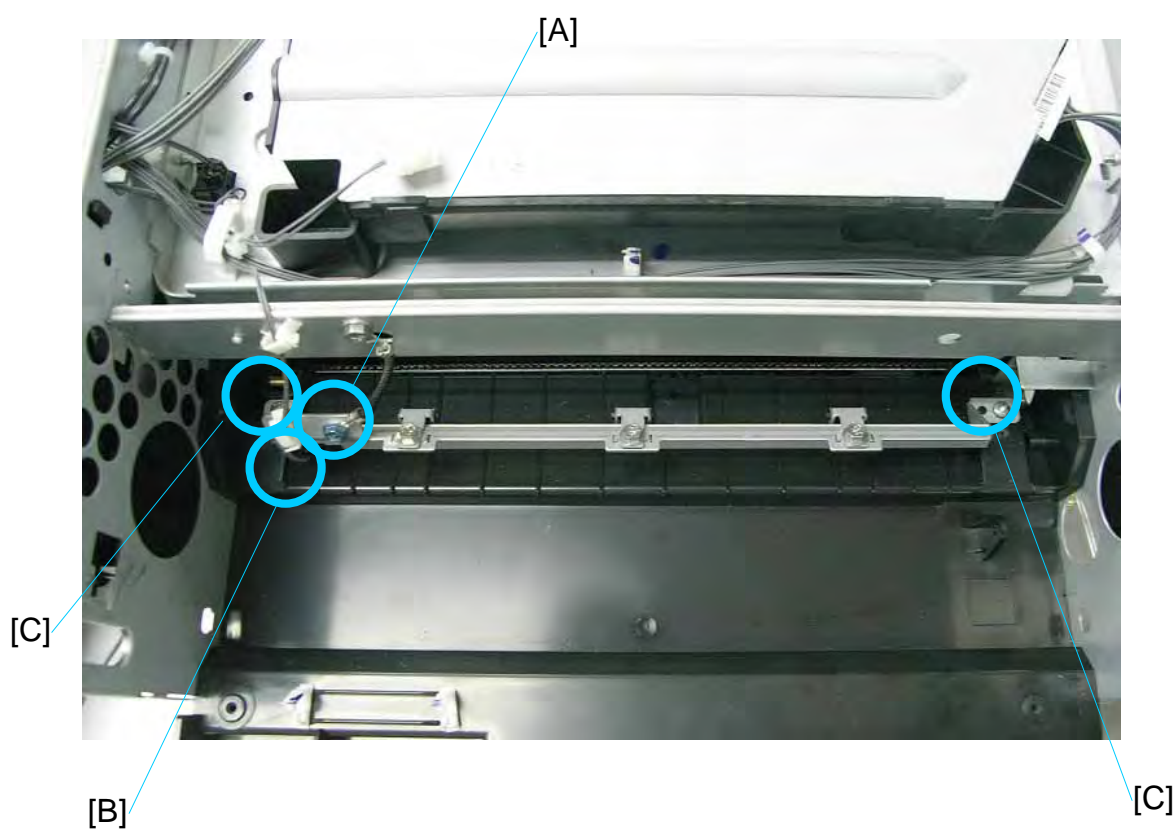

Replacement
Adjustment

2.6 PSU (KNOWN AS 'POWER SUPPLY UNIT' IN THE PARTS CATALOG)

2.6.1 PSU REMOVAL

Preparation

- 1) Remove the upper unit. (See Upper Unit Removal.)
- 2) Remove the paper tray.
- 3) Remove the toner cartridge.
- 4) Remove the right & left shield (* 2.5.3).

[A]: PSU (9 screws & 4 connectors)



G182R042.JPG