

CX3641MFP

Maintenance Manual

080402C

Copyright Information

Copyright © 2007 by Oki Data. All Rights Reserved

Disclaimer

Every effort has been made to ensure that the information in this document is complete, accurate, and up-to-date. The manufacturer assumes no responsibility for the results of errors beyond its control. The manufacturer also cannot guarantee that changes in software and equipment made by other manufacturers and referred to in this guide will not affect the applicability of the information in it. Mention of software products manufactured by other companies does not necessarily constitute endorsement by the manufacturer.

While all reasonable efforts have been made to make this document as accurate and helpful as possible, we make no warranty of any kind, expressed or implied, as to the accuracy or completeness of the information contained herein.

The most up-to-date drivers and manuals are available from the web site:
<http://www.okiprintingsolutions.com>

Preface

This manual describes the procedures of the maintenance of the CX3641MFP.

The document is produced for maintenance personnel use.

- Note!**
- The descriptions in this manual are subject to change without prior notice.
 - In preparing the document, efforts have been made to ensure that the information in it is accurate.
 - The parts used for the printers are sensitive and, if handled improperly, may be damaged. It is strongly recommended that the products are maintained by maintenance men registered with Oki Data.
 - Errors may be crept into the document. Oki Data assumes no responsibility for any damage resulting from, or claimed to be the results of, those repairs, adjustments or modifications to the printers which are made by users using the manual.
 - Be sure to eliminate static electricity before starting work.





In order to use the product with safety

In order to use the product with safety, make sure to read the user's manual (this manual) before using the product.

General Caution

 Warning	
	Do not touch the safety switch of the internal parts of the printer. Electric shock may occur due to the occurrence of high pressure. The rotation of the gear may also cause injury.
	Do not use an extremely flammable spray around the printer. Fire may occur because of parts with high temperature.
	Please let our staff in Customer Center know after unplugging mains connector when the cover gets extremely hot, is smoking, emits questionable odor, or is making strange noise. Fire may occur.
	Please let our staffs in Customer Center know after unplugging mains connector when liquid such as water goes into the printer. Fire may occur.
	Please take a foreign object away after unplugging when you drop foreign objects such as clips into the printer. That situation may case electric shock, fire, and/or injury.
	Do not conduct an operation or an analysis other than specified in user's manual. That situation may case electric shock, fire, and/or injury.
	Please let our staffs in Customer Center know after unplugging mains connector when the printer has fallen down or damaged. That situation may case electric shock, fire, and injury.
	Do not connect the power cord, the printer cable, or the ground wire other than instructed in user's manual. Fire can be induced if misused.
	Do not insert objects at the vent hole. Do not operate the printer with the rear cover opened. Electric shock, fire, and/or injuries may occur.
	Do not place a cup with liquid on the printer. Electric shock, fire, and/or injuries may occur.

Warning

	<p>Risk of explosion if battery is replaced by an incorrect type. Battery of the printer need not to be replaced. Do not touch the battery. Replace the whole board to replace the CU main board. In the case of replacing batteries at board repairs, replace with the specified type ones. Installation of another type batteries may result in explosion. Caution for used batteries are as follows; do not recharge, force open, heat or dispose of in fire.</p>
	<p>When open the printer cover, do not touch the fuser unit. You may get burned.</p>
	<p>Do not throw toner cartridges, or image drum cartridges into fire. You may get burned by dust explosion.</p>
	<p>We do not guarantee operations when UPS (Uninterruptible Power Supply) is used. Do not use UPS. It may cause fire.</p>

Caution

	<p>Do not go near an ejection area while the power is on and in printing. You may get injured.</p>
---	--

Contents

1.	Configuration	9
1.1	System Configuration.....	9
1.2	Printer Composition.....	10
1.3	Optional Composition.....	11
1.4	Specifications	13
1.5	Interface Specifications	15
1.5.1	USB Interface Specifications	15
1.5.2	Network Interface Specifications	16
1.5.3	Parallel Interface Specifications	17
2.	Descriptions of Operations	20
2.1	Main Control PCB.....	21
2.2	Engine Control PCB (S2V PWB).....	25
2.3	Power Unit.....	26
2.4	Mechanical process	27
2.4.1	Electrophotographic Processing Mechanism	28
2.4.2	Paper Processing Mechanism.....	32
2.5	Sensor	41
2.5.1	Paper-Related Sensor	41
2.5.2	Other Sensors.....	42
2.6	Color Drift Correction	43
2.7	Image Transfer Control According to Environmental Change (Room Temperature and Relative Humidity)	43
2.8	Paper Jam Detector.....	44
2.9	Cover Open.....	45
2.10	Toner Low Detection.....	46
2.11	Paper Size Detection.....	49
2.12	Power ON Process	50
2.12.1	Self-Diagnostic Test.....	50
2.13	Color Drift Detection	51
2.14	Reading Version of Routine Replacement Units.....	52
2.15	Life Counter of Replaceable Units.....	52
2.16	Toner Usage Level Detection.....	52
3.	Printer Installation	53
3.1	Precautions and Prohibition.....	53
3.2	Printer Unpacking Procedure	55
3.3	Printer Installation Instructions	56
3.4	Packed Units and Attachments.....	57
3.5	Assembly Procedure.....	58
3.5.1	Printer Main Body	58
3.5.2	Power Cable Connection.....	65
3.5.3	Installation of Optional Components	69
3.5.4	Checking of Optional-Component Recognition.....	83
3.6	MenuMap Printing	85
3.7	How to Connect	87
3.8	Checking of User Paper	90

4.	Parts Replacement	91
4.1	Precautions When Replacing Parts	91
4.2	Parts Layout	93
4.3	Parts Replacement Method	109
4.3.1	Cover-Rear, Cover-Side (R), and Cover-Side (R) Rear.....	110
4.3.2	Cover-Side (L) and Cover Assy-Front.....	111
4.3.3	Stacker Assy-FU.....	112
4.3.4	Cover Assy-OP Panel, Cover-Guard (R), Cover-Guard (Front) and Cover-Guard (L).....	113
4.3.5	OP PCB	114
4.3.6	Cover Assy-Top.....	115
4.3.7	FAN-PCB-Assy, CU-Board-Assy and S2V-PU-Board	116
4.3.8	Job-Offset-Assy 723 and Basket-Assy	117
4.3.9	Plate Top Assy	119
4.3.10	Eject-Assy	120
4.3.11	Motor-Pulse-Belt and Sensor-Resist-Assy	121
4.3.12	FDR Unit-MPT	122
4.3.13	FDR Unit-Resist.....	123
4.3.14	Duct Assy.....	124
4.3.15	HV-Assy	125
4.3.16	Power Unit	126
4.3.17	Low Voltage Power Source Assy and Motor-FAN	127
4.3.18	Belt-Assy.....	128
4.3.19	Fuser Unit-LBT.....	129
4.3.20	Unit-Duplex	130
4.3.21	Paper Feed Roller.....	131
4.3.22	MPT Feed Roller.....	132
5.	Adjustment	133
5.0	System Maintenance Menu	133
5.0.1	ID Check Pattern Print (“TEST PRINT MENU” Item)	135
5.0.2	Maintenance Utility	135
5.1	Maintenance Menu and Its Function	138
5.1.1	Maintenance Menu	138
5.1.2	Engine Maintenance Mode	138
5.1.3	Various Printing Methods with a Stand-Alone Printer Coming with a Controller	158
5.2	Adjustment After Replacing Parts	159
5.2.1	Precautions when Replacing the Engine Control PCB.....	159
5.2.2	Precautions Upon EEPROM Replacement	159
5.2.3	CU PCB of 1200 dpi Printer and Replacement of Mounted Components	161
5.2.4	Precautions in Key Chip Replacement (1200 dpi printer)	162
5.2.5	Precautions in EEPROM Replacement (1200 dpi printer)	163
5.2.6	Precautions in HDD Replacement (1200 dpi printer).....	164
5.2.7	Product Code of Maintenance HDD (1200 dpi printer)	165
5.2.8	Setup of EEPROM after replacement of TBX PCB	166
5.2.9	Setup of destination.....	167
5.3	Density Correction	168
5.4	Paper Thickness Detection/Sensitivity Correction	169

6.	Routine Replacement.....	171
6.1	Routine Replacement of Consumable Parts	171
6.2	Cleaning	171
6.3	LED Lens Array Cleaning	171
6.4	Pickup Roller Cleaning	172
6.5	Cleaning Feed Roller.....	173
7.	Malfunction Repair Procedure.....	179
7.1	Precautions Before Repairs.....	179
7.2	Items to Check Before Remedying Abnormal Image	179
7.3	Precautions Before Remedying Abnormal Image	179
7.4	Troubleshooting Preparations	179
7.5	Troubleshooting	179
7.5.1	LCD Message List	180
7.5.2	Preparing for Troubleshooting	190
7.5.3	Troubleshooting With Abnormal Image	204
7.6	Check Fuse	219
7.7	PU Error	220
8.	Connection Diagram	221
8.1	Check Resistance Value.....	221
8.2	Diagram of Part Layout of Various PCB	228
9.	Error message list.....	235
9.1	Message Chart of CX3641	235
9.2	Illustration appears on the operating panel.....	243

1. CONFIGURATION

1.1 System Configuration

Figure 1-1 illustrates the System Configuration of this printer.

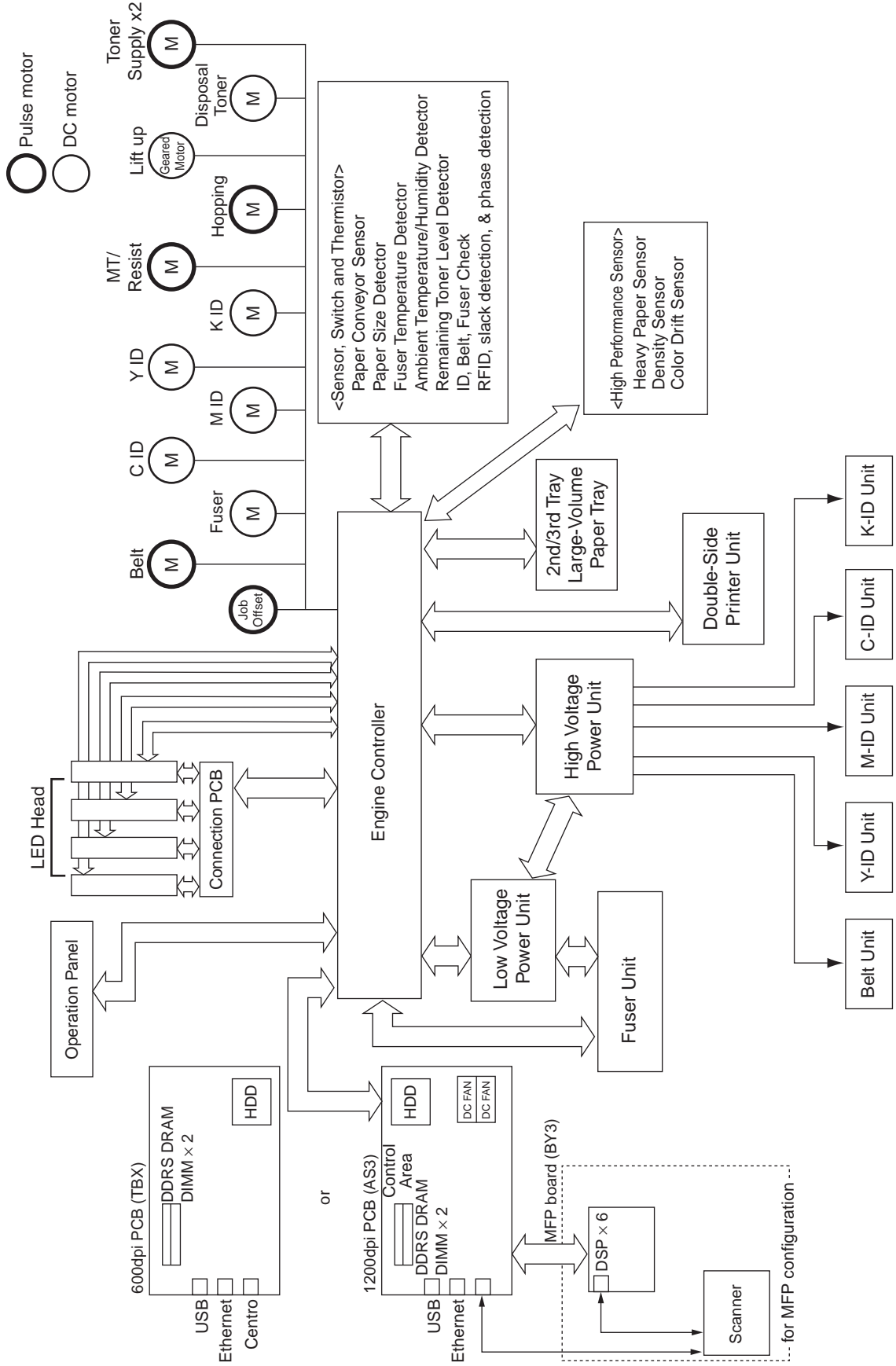

Figure 1-1

1.2 Printer Composition

The internal part of the printer consists of the following parts.

- Digital Photo Processor
- Paper Travel Path
- Control Unit (CU and PU)
- Operation Panel
- Power Source (High Voltage Area/Low Voltage Area)

Figure 1-2 illustrates the printer composition.

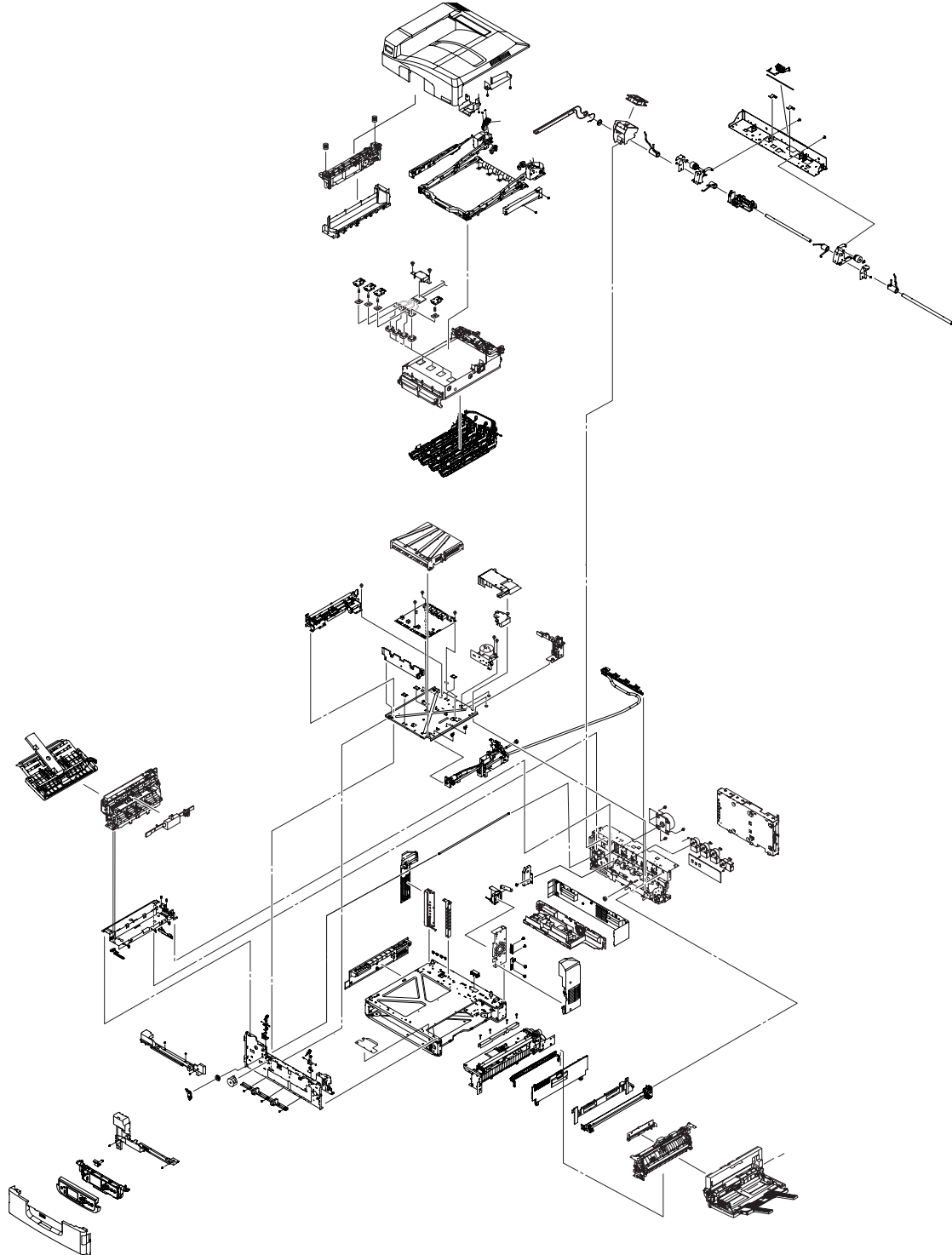
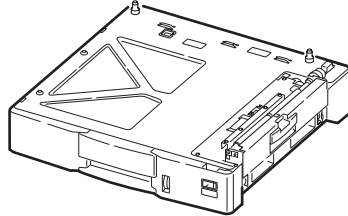

Figure 1-2

1.3 Optional Composition

This printer comes with the following options.

- (1) 2ndTray/3rdTray



- (2) Double-Side Printer Unit

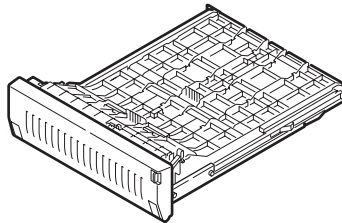

- (3) Large-Volume Paper Tray

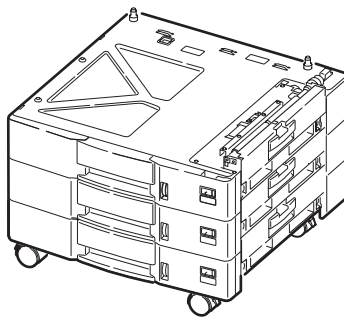

- (4) Additional Memory: 256, 512MB

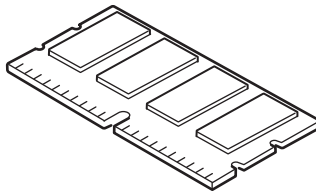

- (5) Internal Harddisk

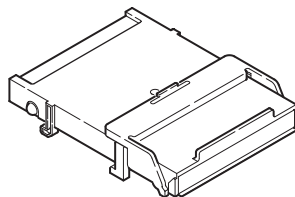

(7) Finisher Unit

- 5 Tray

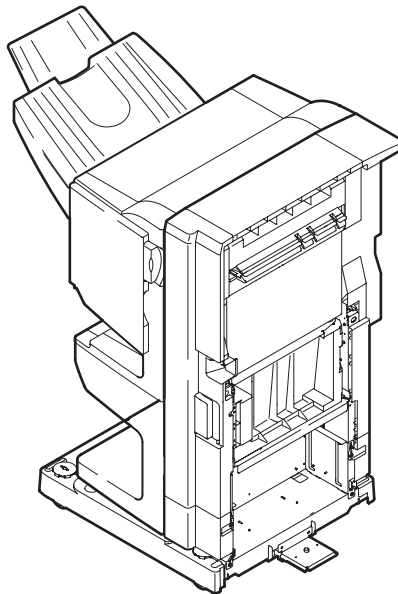

- 4 Tray

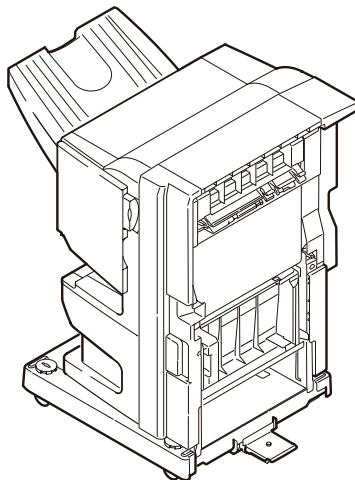

(8) Scanner Unit

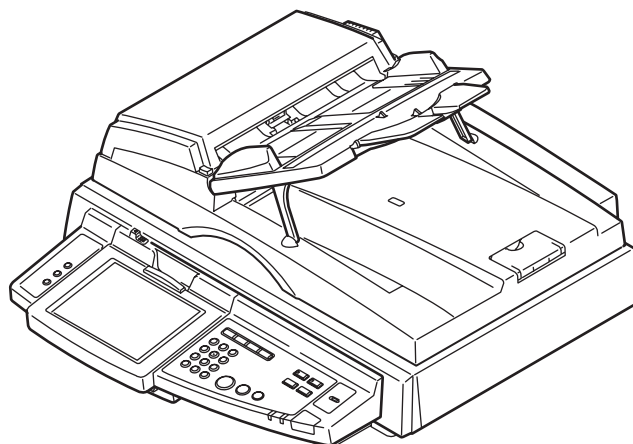

1.4 Specifications

- (1) Dimensions (H × W × D): 471 mm × 654 mm × 633 mm
- (2) Weight: 76.1 kg
- (3) Paper
 Paper Type: Regular paper and transparency
 Paper Size: Post Card, Legal 13" or 14", Executive, A4, A5, B5, A6, A3, A3 Nobi, B4, Letter, Tabloid
 (However, Post Card: 1st Tray and Multi-purpose-Tray only)
 Continuous Paper Feed: 1st Tray : 64 to 216 g/m²
 Multi-purpose-Tray : 64 to 307 g/m²
- (4) Print Speed
 Color: 36 ppm (OHP: 10 ppm)
 Monochrome: 40 ppm (OHP: 15 ppm)
 Post Card, Label, Heavy Paper: 15 ppm
- (5) Resolution: 1200 × 600/16 bit gray scale
 600 × 600/32 bit gray scale
- (6) Input Power: 110~127VAC ±10% 220~240VAC ±10%
- (7) Power Consumption
 Peak : 1500W
 Normal : 780W average (Reference value)
 Idle : 200W (Reference value)
 Power Save Mode : 34W
- (8) Frequency: 50/60Hz ± 1Hz
- (9) Noise
 During Operations: 54 dB (without optional unit)
 Standby Time: 42 dB
 Power Save: 28 dB
- (10) Life of Consumables
 Toner Cartridge: 5,000 page (A4 5% Duty) (Y, M, C, K each)
 Large-Volume Toner Cartridge: 15,000 page (A4 5% Duty) (Y, M, C, K each)
 Imaging Drum: 26,000 page (A4 5% Duty, Continuous Printing)
 (for 3P/J) (Y, M, C, K each)
- (11) Routine Replacement of Consumable Parts
 Fuser Unit Assy: Every 100,000 pages
 Transfer Belt Unit Assy: 100,000 page equivalent (for 3P/J)
 Feed Roller Set: Around 120,000 pages
 MPT Feed Roller Set: Around 120,000 pages
 Waste Toner Box: 30,000 pages or equivalent (3P/J)

(12) Temperature and Relative Humidity

Temperature

Temperature Conditions

	Temperature (°F)	Temperature (°C)	Remarks
Operating	50 to 89.6	10 to 32	17 to 27°C (Temperature guaranteeing full-color print quality)
Not Operating	32 to 109.4	0 to 43	Power OFF
Storage (1 Year Max)	-14 to 109.4	-10 to 43	Drum and Toner: Yes
Transport (1 month Max)	-20 to 122	-29 to 50	Drum: Yes/Toner: No
Transport (1 month Max)	-20 to 122	-29 to 50	Drum and Toner: Yes

Relative Humidity

Relative Humidity Conditions

	Relative Humidity (%)	Maximum Web Bulb Temperature (°C)	Remarks
Operating	20 to 80	25	50-70% (Temperature guaranteeing full-color print quality)
Not Operating	10 to 90	26.8	Power OFF
Storage	10 to 90	35	
Transport	10 to 90	40	

(13) Printer Life: every 1,000,000 page (for A4 paper) or 5 years

1.5 Interface Specifications

1.5.1 USB Interface Specifications

1.5.1.1 USB Interface Overview

- (1) Basic Specifications
 - USB 2.0 Compliant
- (2) Transfer Mode
 - Full Speed (max. 12Mbps+0.25%)
 - High Speed (max. 480Mbps+0.05%)
- (3) Power Control
 - Self-Power Device

1.5.1.2 USB Interface Connector and Cable

(1) Connector

Printer-Side B Receptacle (Female)
 UP Stream Port
 UBB-4R-D14T-1 (JST Mfg. Co., Ltd.) equivalent product

Connector Pin Layout

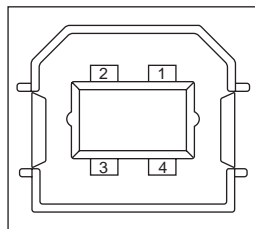

Cable: B Plug (Male)

(2) Cable

Cable Length: <2m USB 2.0 cable recommended.
 (Use a cable with shielded wire)

1.5.1.3 USB Interface Signal

	R1	Function
1	Vbus	Power Source (+5V) (Red)
2	D-	Data Transfer (White)
3	D+	Data Transfer (Green)
4	GND	Signal GND (Black)
Shell	Shield	

1.5.2 Network Interface Specifications

1.5.2.1 Network Interface

Network protocols: TCP/IP, NetWare, Ether Talk, & NetBEUI

1.5.2.2 Network Interface Connector and Cable

(1) Connector

1000 Base-T/100 Base-TX/10 Base-T

(automatically switched and not available simultaneously)

Connector pin layout

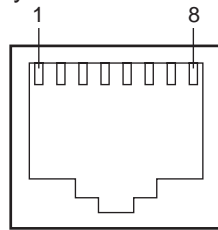

(2) Cable

Unshielded twisted pair cable with RJ-45 connector (Category 5 is recommended.)

1.5.2.3 Network Interface Signals

Pin #	Signal Name	Functions
1	BI-DA+	Bi-directional pair +A
2	BI-DA-	Bi-directional pair -A
3	BI-DB+	Bi-directional pair +B
4	BI-DC+	Bi-directional pair +C
5	BI-DC-	Bi-directional pair -C
6	BI-DB-	Bi-directional pair -B
7	BI-DD+	Bi-directional pair +D
8	BI-DD-	Bi-directional pair -D

1.5.3 Parallel Interface Specifications

1.5.3.1 Parallel Interface Overview

Item	Details
Corresponding mode	Comatible mode, nibble mode, ECP mode
Data bit length	Compatible: 8, Nibble: 4, ECP: 9 bit

1.5.3.2 Parallel Interface Connector and Cable

(1) Connector

Printer: 36pConnector (Female)
 57LE-40360-12 (D56) (DDK Ltd.) equivalent product

Cable: 36pConnector (Male)
 57FE-30360-20N (D8) (DDK Ltd.) equivalent product

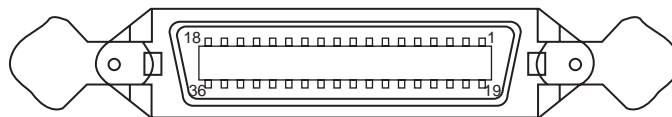

Pin arrangement from interface cable side

(2) Cable

Use a cable shorter than 1.8m.

(Use a cable with a shielded twisted-pair wire for to prevent noise interference.)

1.5.3.3 Parallel Interface Level

Low Level : 0.0V to +0.8V

High Level : +2.4V to +5.0V

1.5.3.4 Timing Chart

■ Compatible Mode

a) Data Reception Timing

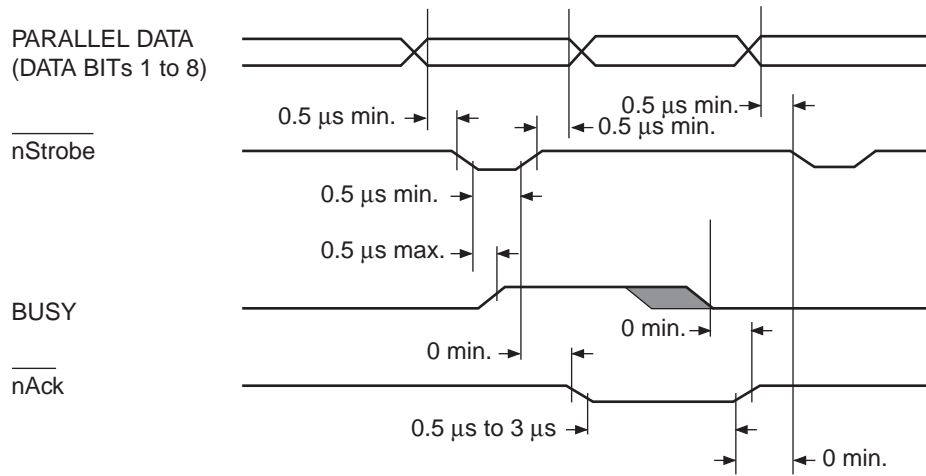

b) Online/Online SW for Offline Switching Timing

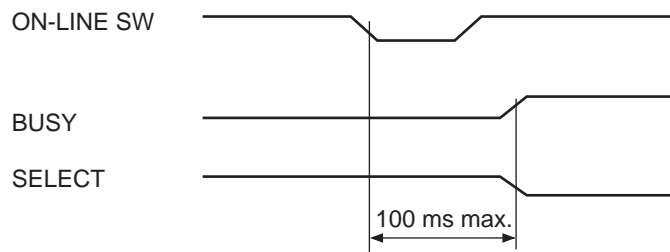

c) Offline/Online SW for Online Switching Timing

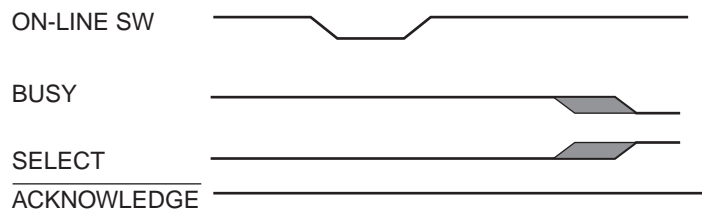

d) nInIt Timing (Default Invalid)

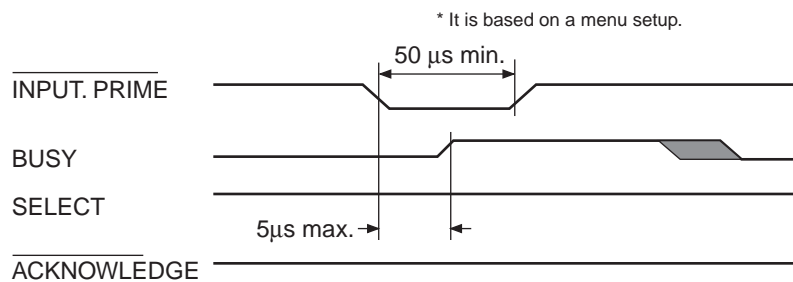

1.5.3.5 Parallel Interface Signal

The name of the interface signal and pin number is indicated in Table 9-1.

Table 1-1 Signals

Pin No.	Signal Name	Direction	Function
1	nStrobe (HostClk)	TO PRINTER	Pulse to read data. Data is read with the latter wire.
2	DATA 1	TO PRINTER	8bit parallel data. High Level: "1" "Low Level: "0"
3	DATA 2		
4	DATA 3		
5	DATA 4		
6	DATA 5		
7	DATA 6		
8	DATA 7		
9	DATA 8		
10	nAck (PtrClk)	FROM PRINTER	Signal indicating completion of incoming data.
11	Busy (PtrBusy)	FROM PRINTER	Indicates whether the printer state can accept data or not.Data cannot be accepted during High Level.
12	PError (AckDataReq)	FROM PRINTER	Paper error takes place during High Level.
13	Select (Xflag)	FROM PRINTER	Always High Level when the parallel interface is active.
14	nAutoFd (HostBusy)	TO PRINTER	Used for two-way communications.
15	Unused	-	Unconnected
16	GND	-	Ground for signal.
17	FG	-	Ground for chassis.
18	+5V	FROM PRINTER	Provides +5V. Cannot supply power to an external device.
19 to 30	GND	-	Ground for signal.
31	nInit (nInit)	TO PRINTER	Printer is initialized during Low Level.
32	nFault (nDataAvail)	FROM PRINTER	When printer is alarming the printer goes to Low Level state.
33	GND	-	The ground for signals
34	Unused	-	Un-connecting.
35	HILEVEL	FROM PRINTER	3.3kW inside printer is pulled up by +5V.
36	nSelectIn (IEEE1284 active)	TO PRINTER	Used for two-way communications. Always in Low Level in the compatible mode.

Note! Nibble mode signal names are indicated in the ().

Only indicates the Compatible Mode functions.

This printer supports the IEEE 1284-1994 Nibble Mode standardized by the Institute of Electric and Electronic Engineers (IEEE). Note that use of PCs and cables that do not comply with this standard may result in unforeseeable operations.

2. DESCRIPTIONS OF OPERATIONS

The CX3641 is an electrophotographic tandem color page printer. It features an LED array, OPC, dry one-component non-magnetic phenomenon, roller transfer, thermo-compression fuser and other technologies. The printer converts single-color (black) computer text into optical pulses to write them on the surface of its optical drums.

2.1 Main Control PCB

Main Control PCB (AS3-PWB) 1200dpi-RoHS

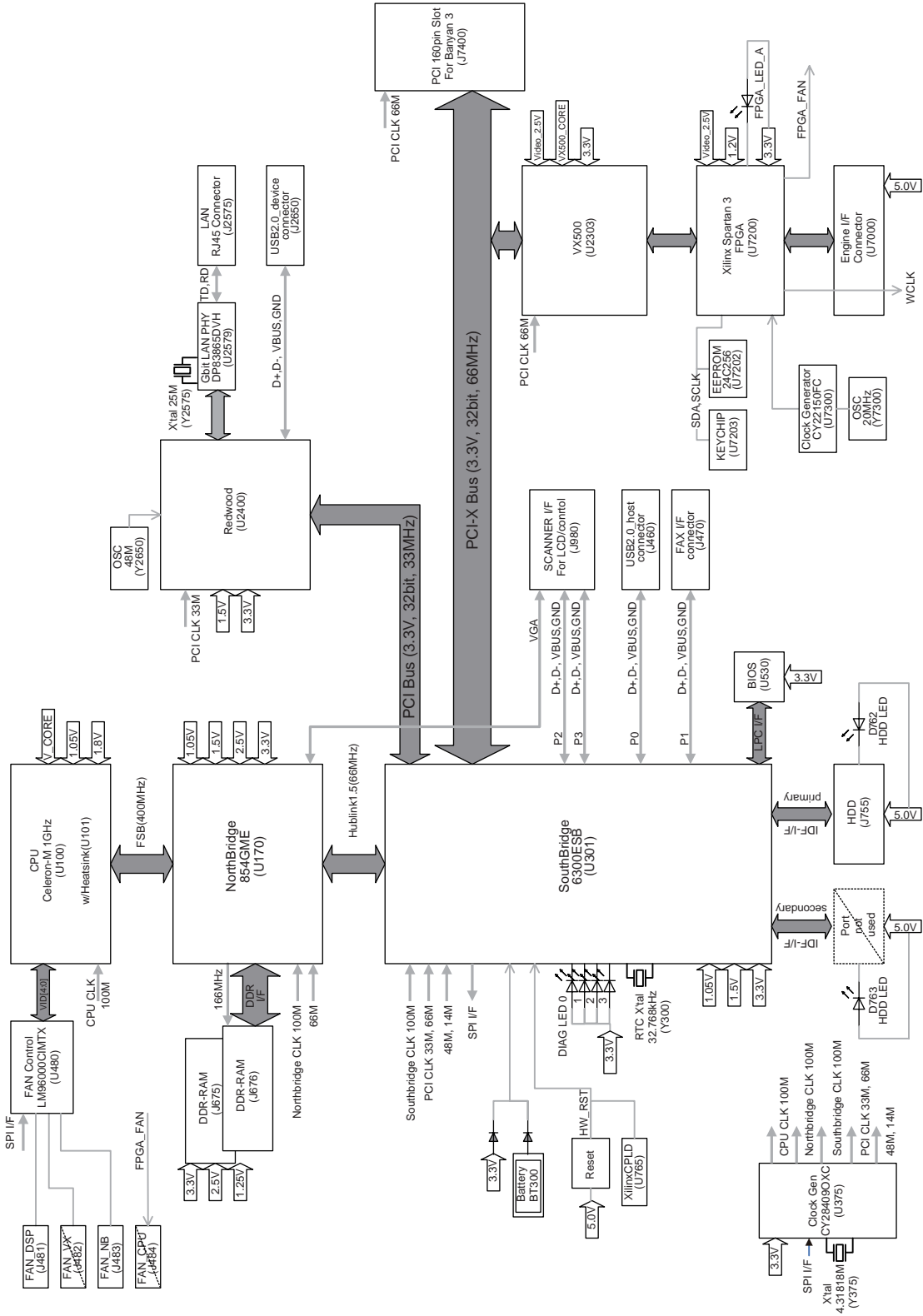

Figure 2-1-1

The main control PCB of the 1200dpi-Printer consists of a CPU, RAM, HDD, LSI, EEPROM, KeyChip, PCI Bus Option and Advanced Interface.

(1) CPU

CPU is Intel CeleronM-1G

(2) RAM

RAM is DDR_DIMM. RAM capacity is 256MB or 512MB. Max capacity is 1GB. DDR_DIMM used at AS3 are the same with the DIMM used at PX735/736.

(3) HDD

HDD function(store program and font) is same with ASP/AS2 but there's no compatibility.

(4) Chipset (North/South Bridge LSI)

NorthBridge :Intel_854GME. This chip has I/F with CPU and Memory.

SouthBridge :Intel 6300ESB. This chip controls all external I/F.

(5) Image Processing LSI(VX500)

AS3 uses VX500 as an Image Processing LSI.

(6) EEPROM

EEPROM stores Printer default settings and etc.

(7) KeyChip

KeyChip is royalty device.

(8) PCI option

MFP board(BY3) is PCI connection option.

(9) Advanced Interface

Standard : USB(USB2.0) I/F

Ethernet(10/100/1000 base. LAN is directly mounted on AS3 board)

Additional : MFP I/F

TBX Board block diagram

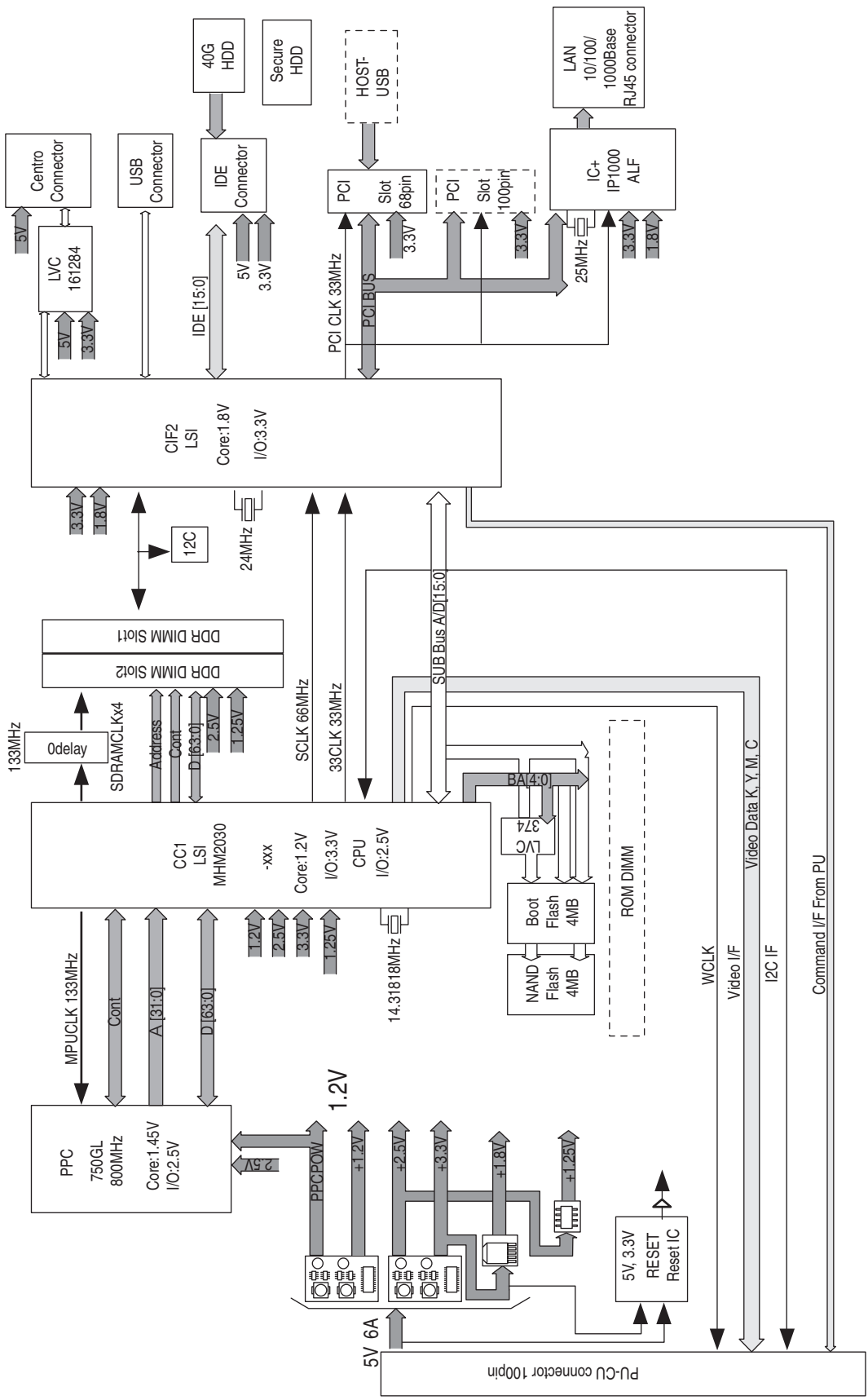

Figure 2-1-2

The main control PCB(TBX) of the 600dpi-Printer consists of a CPU, secondary cache SRAM, ROM, RAM, EEPROM, Flash ROM, memory control LSI (CB1), interface control LSI (CiF1), IDE HDD, PCI Bus Option and advanced interface.

(1) CPU

The CPU features a 64bit bus RISC PowerPC750GL processor. This operates at 800MHz, 6 times the speed of a 133MHz (bus clock) clock.

(2) Secondary Cache SRAM

The PowerPC750GL cache is inside the CPU, only.

Speed : Same as CPU Core CLK

Capacity : Primary Cache: D cache = 32KB, I cache = 32KB
Secondary Cache: 1MB

(3) RAM

RAM is DDR_DIMM. RAM_DIMM capacity is 256MB or 512MB. Max capacity is 1GB. DDR_DIMM used at TBX are the same with the DIMM used at AS3 and PX735/736/745/741.

(4) EEPROM

This is a 3.3V/32kbit EEPROM with an 8-pin DIP package mounted on the IC socket. It stores various settings that the control unit manages.

(5) ROM

A 64MB flash ROM is directly on the TBX PCB. It can store program, fonts, macro, etc.

(6) Memory Control LSI (CC1)

This ASIC mainly controls the CPU I/F, memory, video data compression/extraction, and video I/F with the PU.

(7) Interface Control LSI (CIF2)

This ASIC controls PU command I/F, the operation panel I/F, IDE I/F, Centro I/F, USB I/F, PCI I/F, EEPROM, and SPD (SDRAM DIMM) I/F.

(8) IDE HDD

The IDE connector is directly set on the PCB. The IDE HDD exclusively molded into an Assy is connected here. This is used to store font data, temporarily store video data that has already been edited and upon registering form data.

(9) PCI Bus

In addition, two PCI I/F slots are provided for optional circuit boards.

100-pin: This slot is not available (connector removed).

68-pin: A Host USB board is provided as optional equipment.

(10) Advanced Interface

Standard : Centronic Two-Way Parallel I/F (IEEE-1284)

USB (USB2.0) Interface

10/100 Base-TX, 1000Base-T Interface

Additional PCB : Host USB Board (68pin-PCI Bus Connection)

Security HDD (IDE bus)

2.2 Engine Control PCB (S2V PWB)

Figure 2-2 illustrates the block diagram of the Engine Control PCB (S2V PWB).

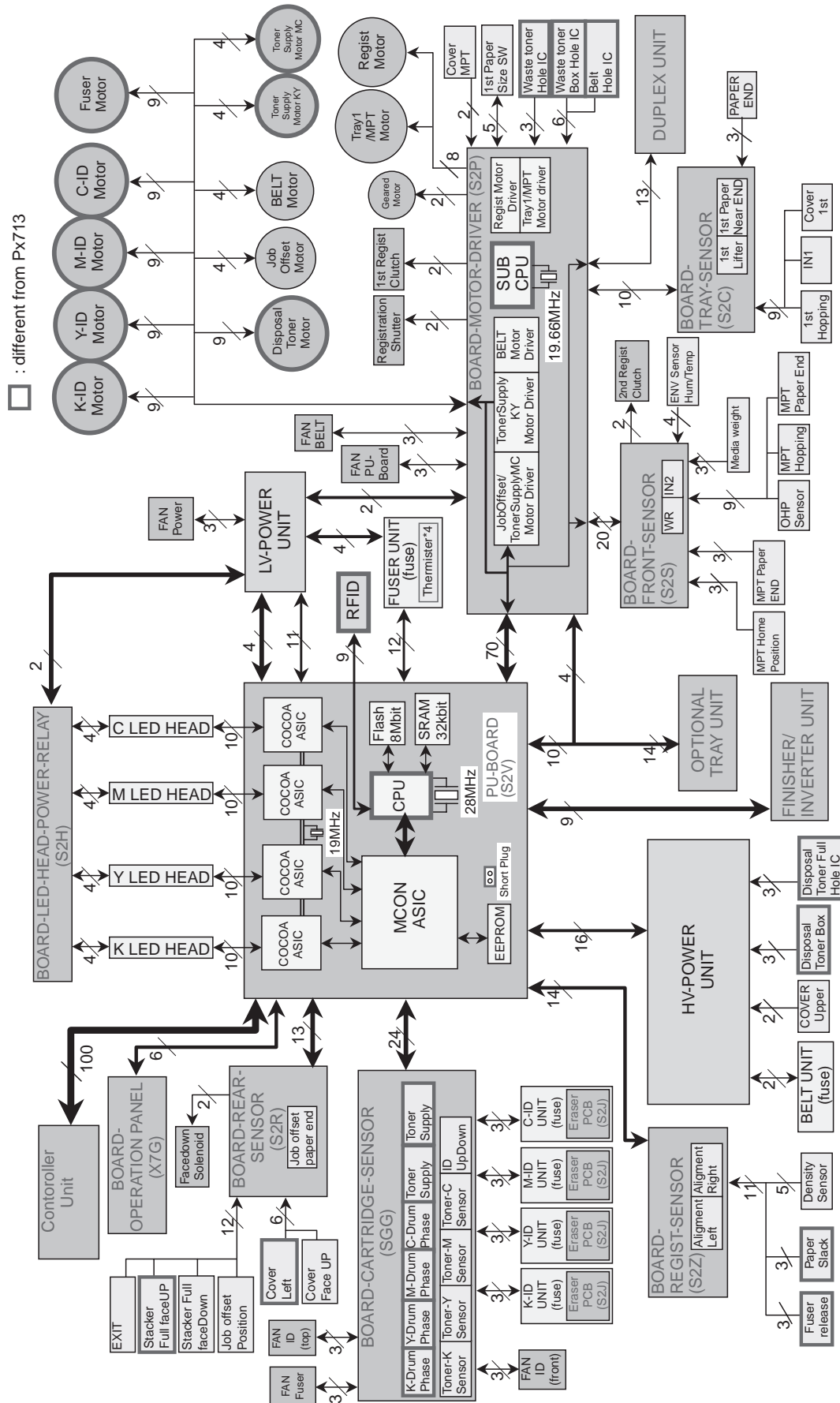

Figure 2-2

2.3 Power Unit

This is a high voltage power unit consisting of high voltage power source circuit and a low voltage power unit composed of a power unit consists of an AC filter circuit, low voltage power source circuit and heater drive circuit.

(1) Low Voltage Power Unit

This circuit generates the following voltage.

Output Voltage	Purpose
+5V (1)	PU, Logic Circuit Power Source
+5V (2)	LED Head
+5V (3)	CU
+24V	For Monitor Drive

(2) High Voltage Power Unit

This circuit generates the following voltage that is more powerful than +24V necessary for the electrophotographic process, according to the control sequence from the control PCB.

Output	Voltage	Purpose	Remarks
CH	-0.8 to -1.4kV	Power to Electrification Roller	
DB	-100 to -450V/250V	Power to Development Roller	
SB	-300 to -700V	Power to Toner Supply Roller	
BB	Drop from SB Output with Zener	Power to Development Roller	
TR	0 to 7kV	Power to Trasfer Roller	

2.4 Mechanical process

Figure 2-3 illustrates the mechanical process of the CX3641.

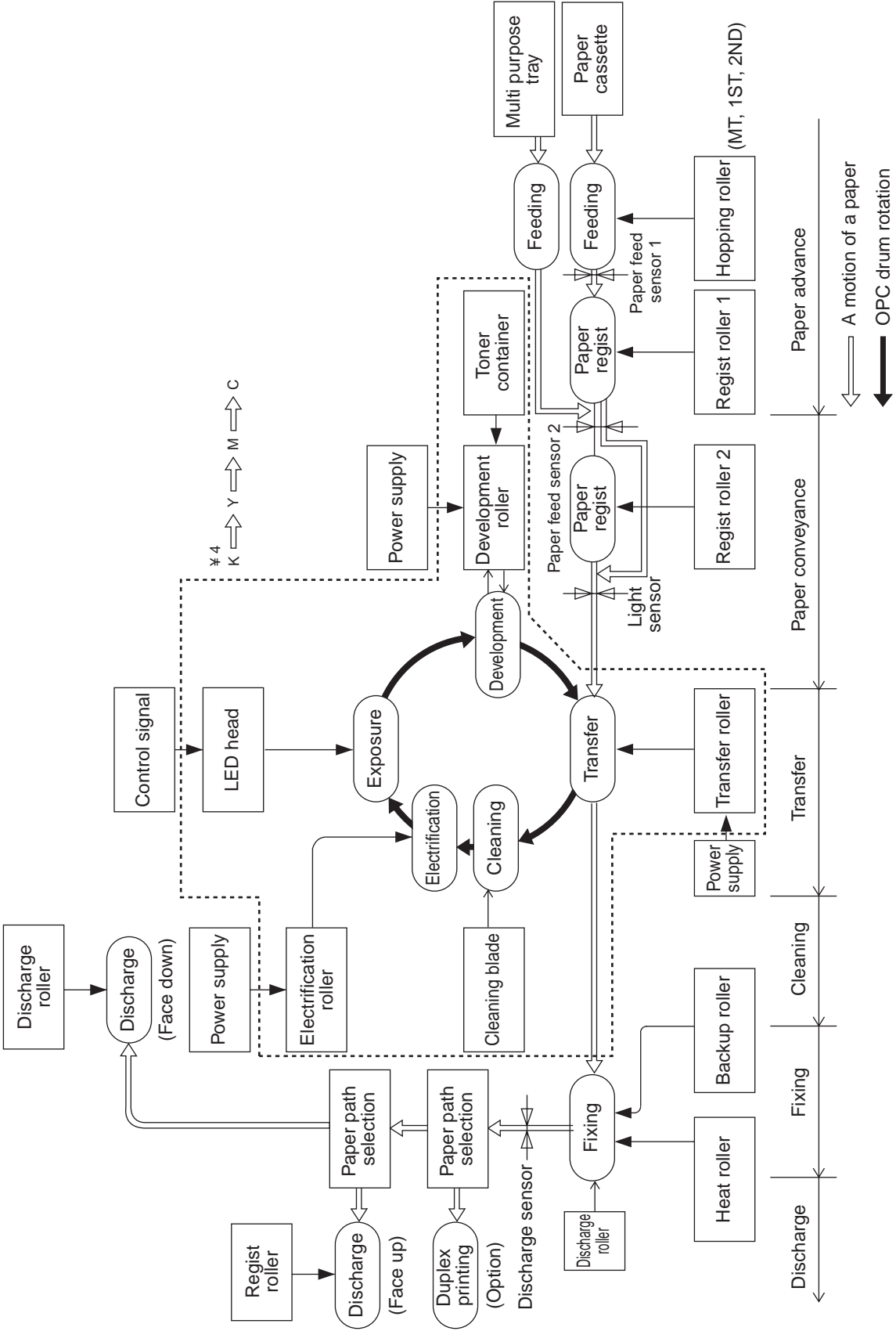

Figure 2-3

2.4.1 Electrophotographic Processing Mechanism

(1) Electrophotographic process

The overview of the electrophotographic process is described below.

① Electrification

DC power is applied to the CH roller to evenly negatively electrify the surface of the OPC drum.

② Exposure

The LED head irradiates light on the surface of the OPC drum that is charged with a negative electrical load. The negative electrical load attenuates according to the intensity of light, for the irradiation area of the OPC drum surface. Further, the electrostatic latent image is created on the OPC drum surface according to the electrical potential.

③ Development

The negatively charged toner comes in contact with the OPC drum to fuse the electrostatic latent image by electrostatic force, to create a significant image on the surface of the OPC drum.

④ Transfer

Paper is pressed against the surface of the OPC drum, then conveyed by the transfer roller from behind. The toner and positive electrical load of a reverse electrode is applied, then the toner image is transferred to the paper.

⑤ Cleaning

The cleaning blade removes residual toner on the OPC drum after the toner is transferred to the paper.

⑥ Fuser

Heat and pressure is applied to the toner image on the paper to fuse the image on the paper.

(2) Electrification

A negative DC power is applied to the electrification roller to evenly negatively electrify the surface of the OPC drum.

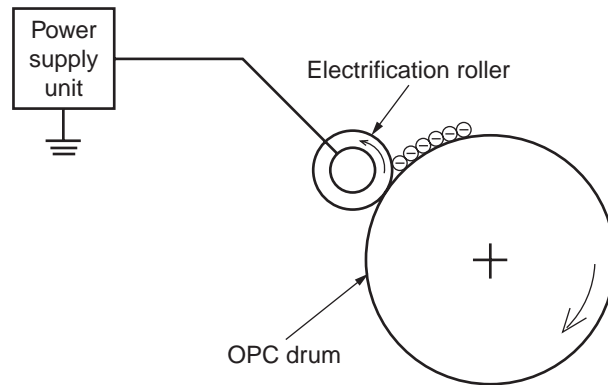

(3) Exposure

The LED head irradiates light on the surface of the OPC drum that is charged with a negative electrical load. The negative electrical load attenuates according to the intensity of light, for the irradiation area of the OPC drum surface. Further, the electrostatic latent image is created on the OPC drum surface according to the electrical potential.

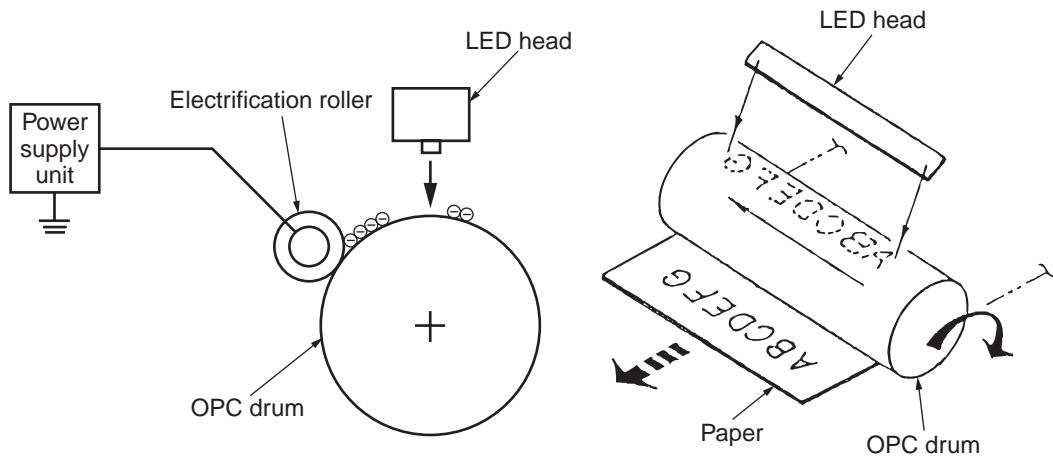

(4) Development

The negatively charged toner comes in contact with the OPC drum to fuse the electrostatic latent image by electrostatic force, to create a significant image on the surface of the OPC drum.

- ① The sponge roller precipitates toner on the development roller. The toner is then negatively electrified.

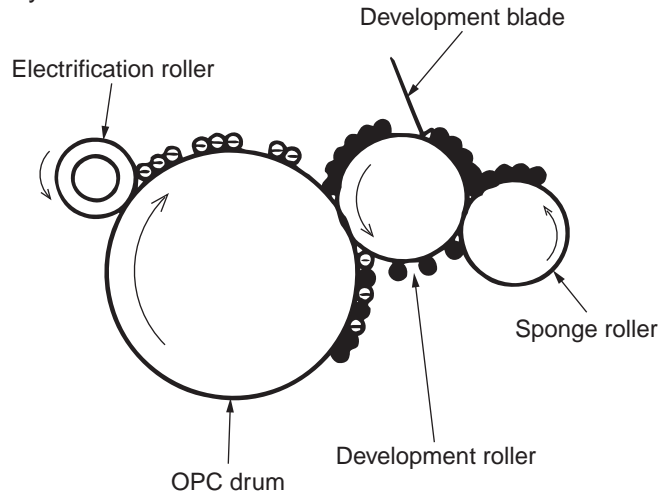

- ② The development blade removes excess toner from the development roller, then a thin toner layer is created on the development roller.
- ③ The toner is sucked into the electrostatic latent image where the OPC drum and development roller comes in contact.

(5) Transfer

The transfer roller is made of a conductive sponge. Paper is pressed against the OPC drum surface, then the paper and OPC drum surface is adhered.

Paper is pressed against the surface of the OPC drum, then conveyed by the transfer roller from behind. The toner and positive electrical load (that is reverse with the toner) is applied, then the toner image is transferred to the paper.

When the power source applies powerful positive power on the transfer roller, the positive electrical load induced by the transfer roller is transferred to the paper surface at the contact point between the transfer roller and paper. The negative electrical load toner is then sucked from the OPC drum surface on to the paper surface.

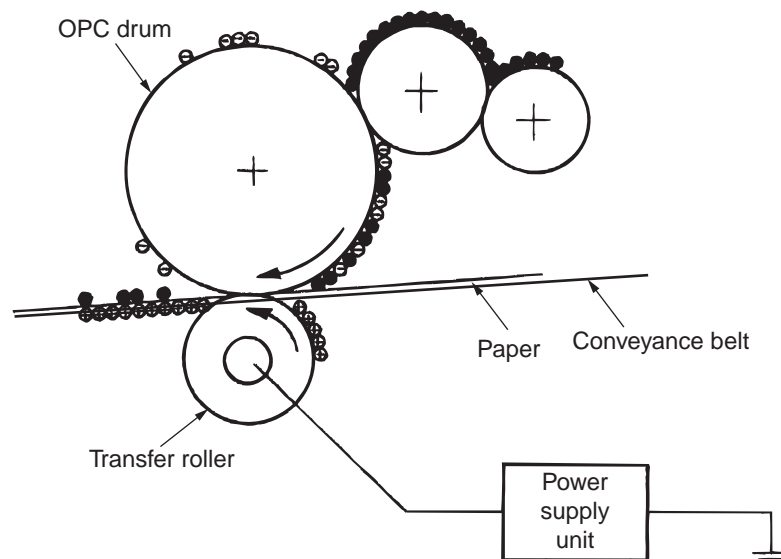

(6) Fuser

The toner image transferred on the paper is fused on the paper by heat and pressure when the paper passes through the heat roller and backup roller.

The Teflon coated heat roller is heated by a 800W or 350W internal halogen lamp, and backup roller is heated by a 50W internal halogen lamp. The fuser temperature is controlled according to the sum of the temperature that is not contacted with the thermistor ground against the heat roller surface and the temperature that is detected with the thermistor ground on the backup roller surface. There is also a thermostat for safety purposes. When the heat roller temperature rises above a certain temperature, the thermostat opens and shuts down the power supplied to the heater. The backup roller unit is pressed against the heater with a press spring on both sides.

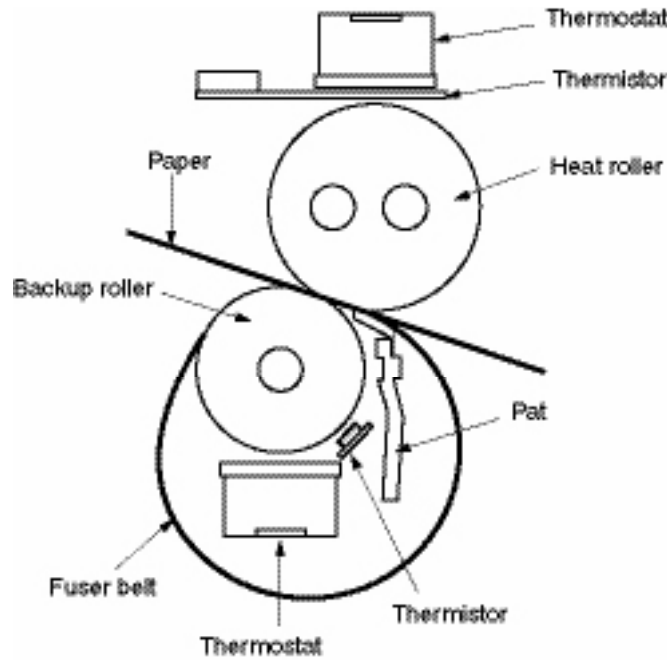

(7) Cleaning

The cleaning blade scrapes off residual toner on the OPC drum after the toner is transferred to the paper, then the disposal toner of the disposal toner box is collected at the rear.

(8) Cleaning

Toner residue on the Transfer Belt is scraped off with the cleaning blade and collected into the Belt Waste Toner Box at the front of the printer.

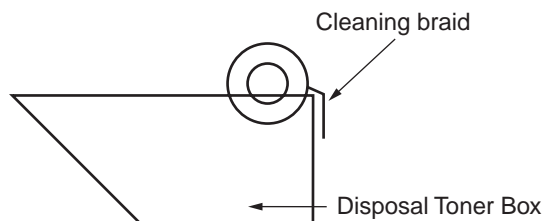

2.4.2 Paper Processing Mechanism

Figure 2-4 illustrates how the paper transfers through the CX3641.

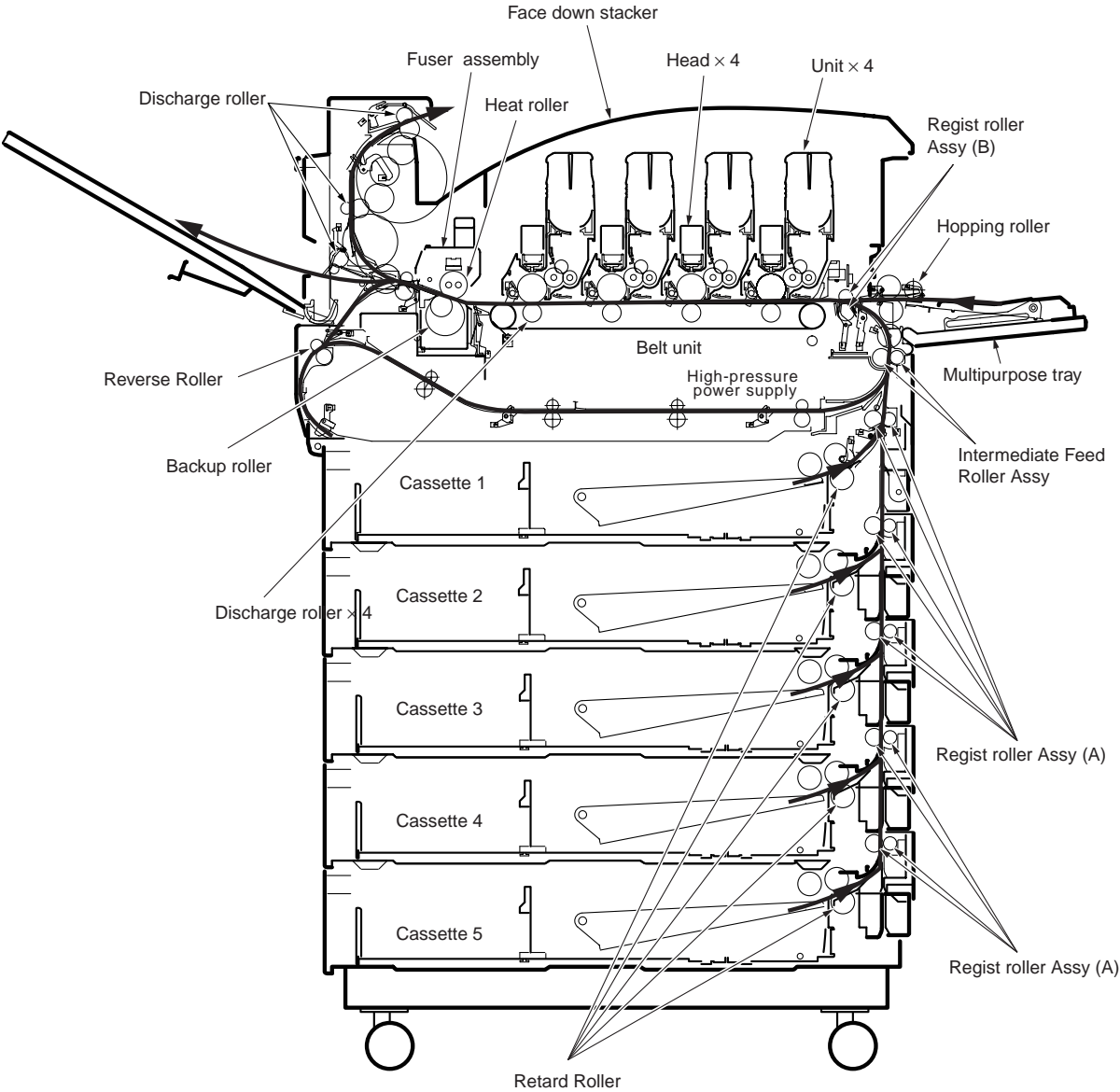

Figure 2-4 Paper Path

(1) Paper Supplied from the 1st Tray

1. Paper proceeds when the paper supply motor turns (CCW) and the paper supply clutch is connected, until the IN1 sensor turns ON.
2. When the IN1 sensor is turned ON, a certain volume of paper is further transported until it is against the 1st resist roller. (this corrects paper skew)
3. After paper has hit the roller while the Resist Motor is running (CW), the electromagnetic clutch that transmits drive power to the Resist Rollers 1 is connected and paper is sent 2 to the Feed Belt via Intermediate Feed Rollers and Resist Rollers.

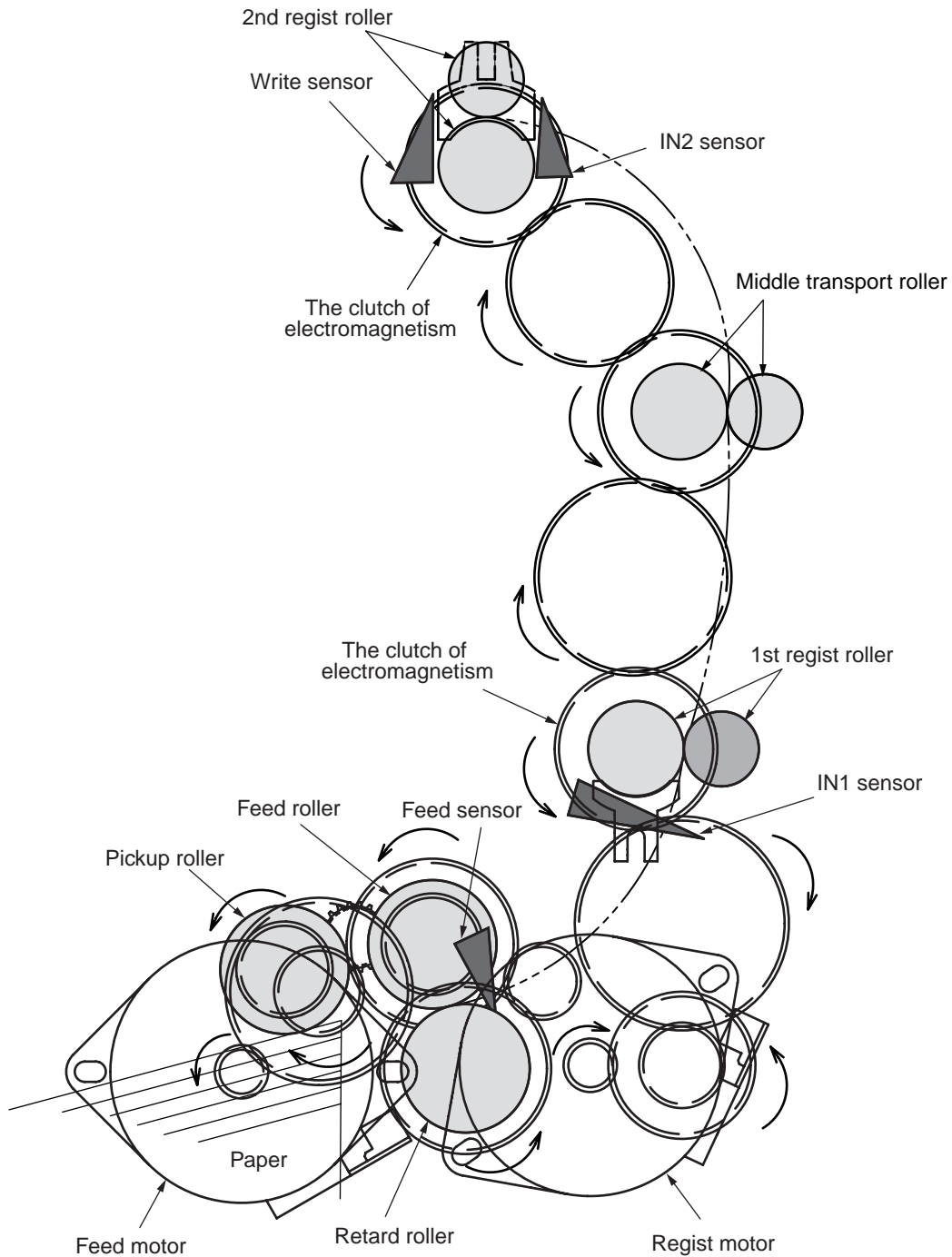

Figure 2-5

(2) Paper Supplied from the Option Tray

1. Paper proceeds when the paper supply motor turns (CCW) and the paper supply clutch is connected, until the IN sensor of the top tray to supply the paper, turns ON.
2. When the IN sensor is turned ON, a certain volume of paper is further transported against the regist roller. (this corrects paper skew)
3. The paper is conveyed to the CX3641 when the electromagnetic clutch which delivers power that the register strike motor is turning (CW) and the thrust reliance of a paper is completed to the 1st register strike roller is connected.

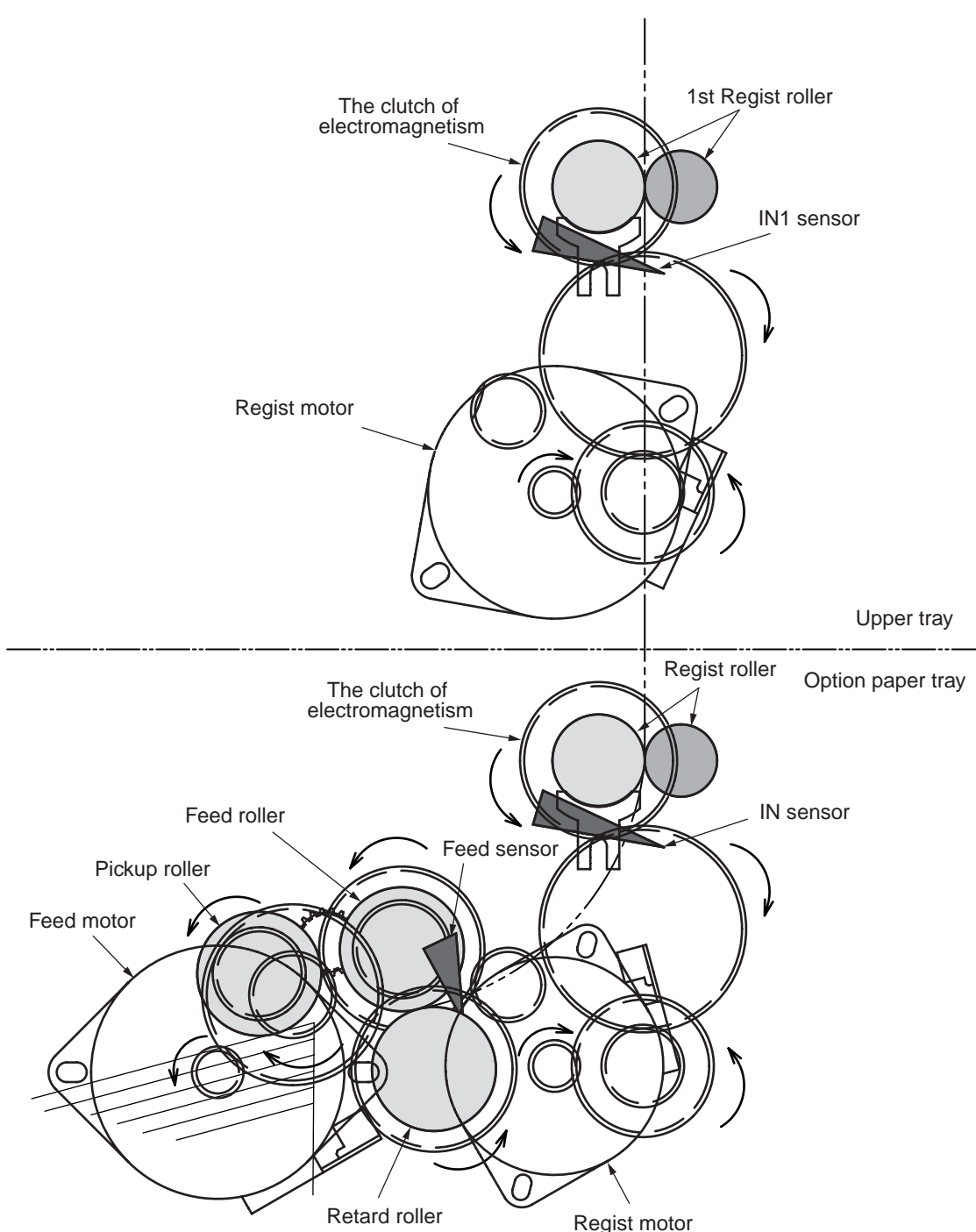

Figure 2-6

(3) Paper Supplied from MPT

1. In the usual case, sheet receiving is depressed by the arm for rise and fall at a home position.
2. When a regist motor rotates in the direction of (b), the arm for rise and fall drives and sheet receiving is rotated. The paper on sheet receiving goes up to the position where a lift rise sensor is turned on, and feeding is attained because the arm for rise and fall goes up.
3. The hopping motor is shared with the tray and MPT feeding uses the inversion of tray feeding.

If a hopping motor reverse-rotates, a pickup roller and a feed roller will drive and a paper will be sent out.
4. After an entrance sensor (2) is turned on by the paper tip, a paper is sent by specification length. A paper will stop, if the tip reaches the 2nd register strike roller Assy.
5. A regist motor rotates in the direction of (a) simultaneously, and a paper is conveyed with the 2nd regist roller Assy. A hopping motor is rotated until a paper arrives at the position of the image drum cartridge (black).
6. A hopping motor is rebooted, in order to make paper feed to the following paper, when an after the end escapes from the hopping sensor.
7. When operation of 4 to 6 is repeated and a lift rise sensor turns off, a regist motor is rotated in the direction of (b), and the arm for rise and fall is driven, and it goes up until a lift rise sensor turns on the paper on sheet receipt.
8. After the completion of paper sending operation, when a lift rise sensor detects off, a regist motor is rotated in the direction of (b), and sheet receiving is returned to a home position by dropping the arm for rise and fall.

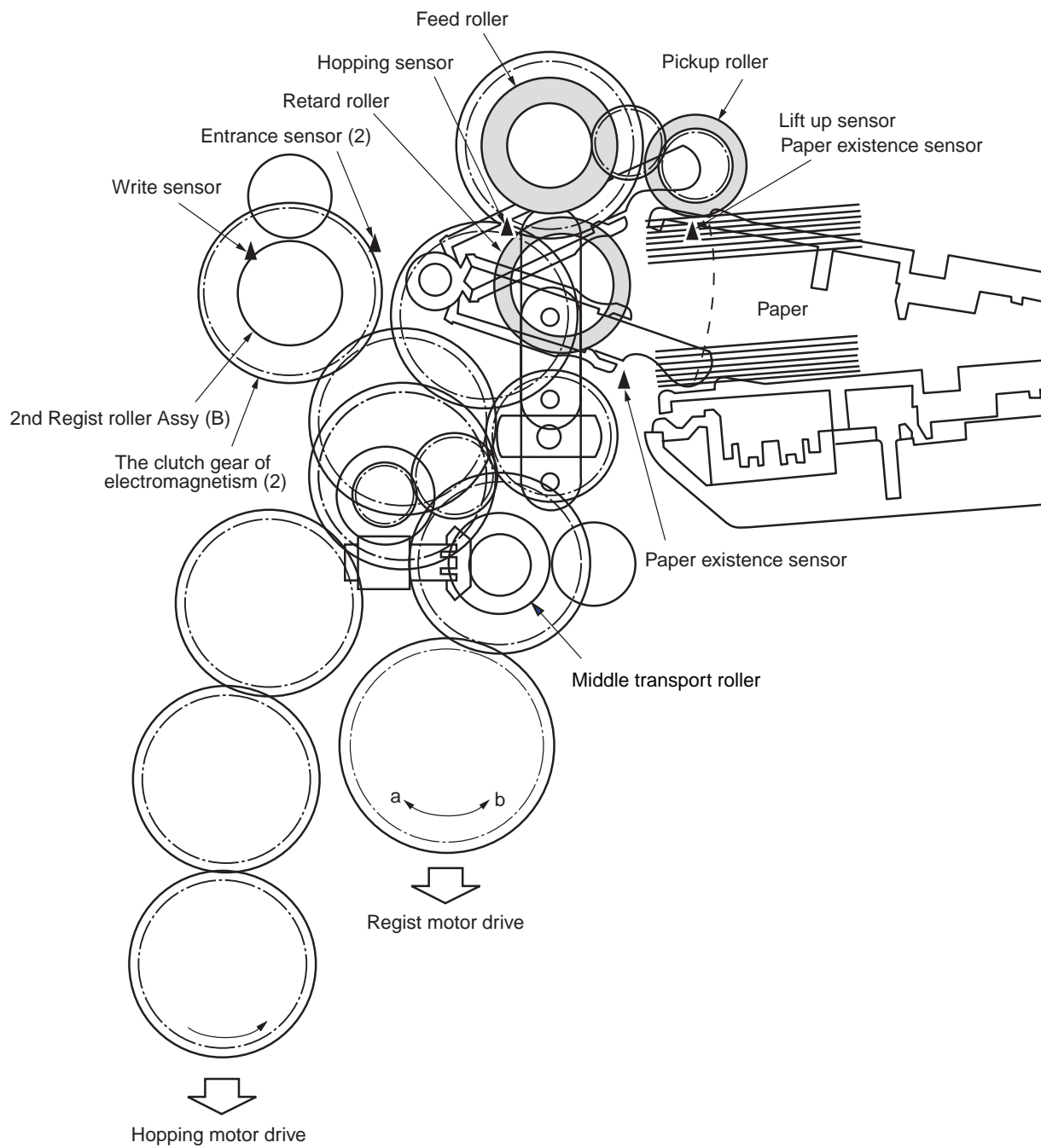

Figure 2-7

(4) Conveyor Belt

1. The conveyor belt motor drives the conveyor belt when turning in the direction of the arrow. The belt unit consists of one transfer roller that is directly under the drum for each color, with the conveyor belt in between the drum.

When a specified voltage is applied, the conveyor belt and transfer roller transfers the toner image on the drum for each color, then feeds the paper on the conveyor belt to the fuser unit.

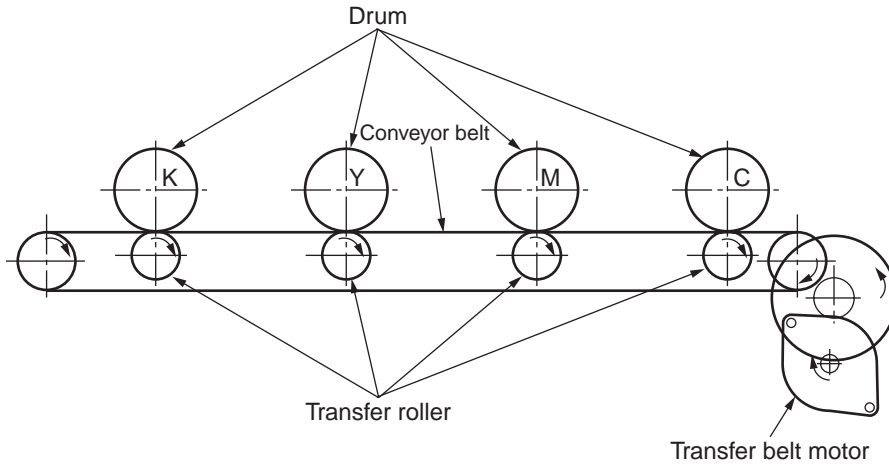

Figure 2-8

(5) ID Unit Up/Down Operations

1. The C-ID motor drives the ID unit up and down.
2. Figure 2-9-a indicates ID unit operations during color printing. When the C-ID motor rotates (CCW), the lift uplink slides to the left, and as indicated in Figure 2-9-a, each ID unit moves DOWN. The printer is now ready for color printing.
3. Figure 2-9-b indicates the ID unit operations during monochrome printing. When the C-ID motor rotates (CW), the lift uplink slides to the right, and as indicated in Figure 2-9-b, all units other than the K-ID moves UP. The printer is now ready for black-and-white printing.

ID Unit Operations During Color Printing

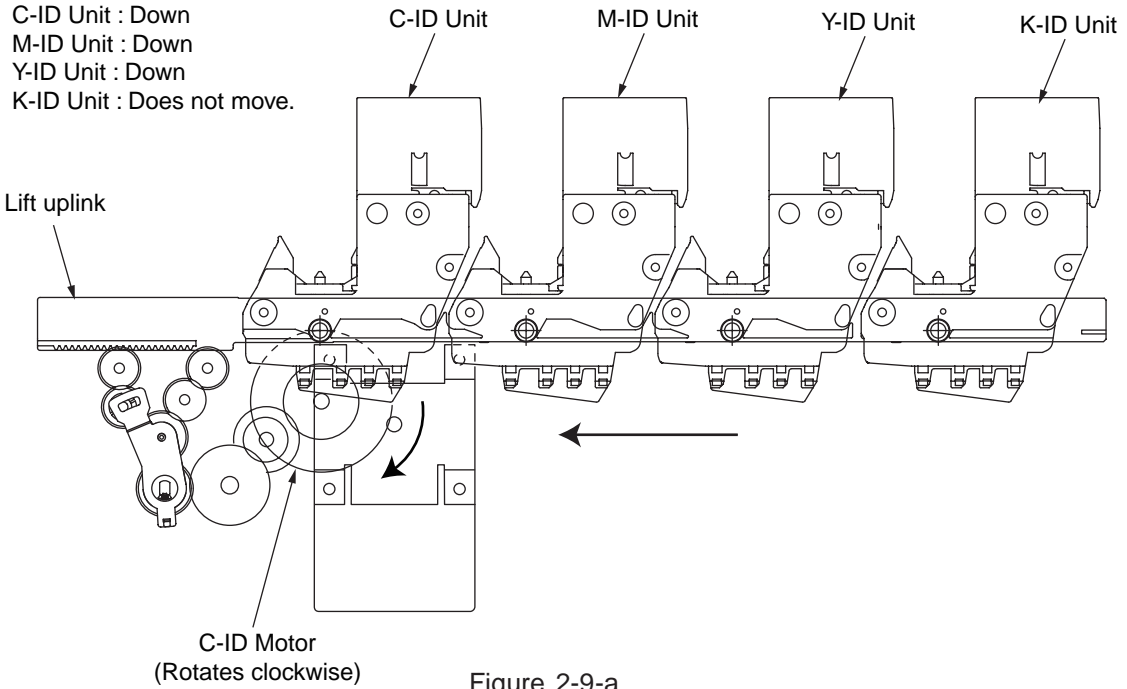

Figure 2-9-a

ID Unit Operations During Monochrome Printing

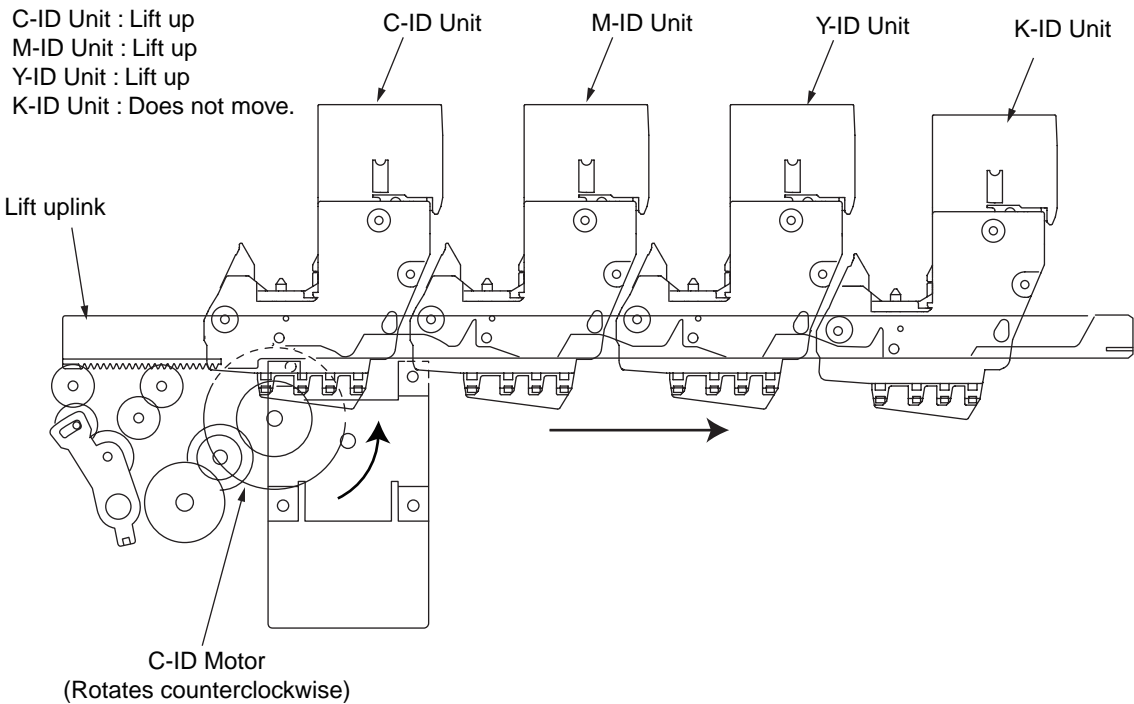

Figure 2-9-b

(6) Fuser Unit and Paper Output

1. The fuser unit and discharge roller is driven by a single DC motor. The heater roller turns when the fuser motor turns in the direction of the arrow (a). This roller fuses the toner image on the paper with heat and pressure.
2. At the same time, the four discharge rollers are activated to discharge paper.
3. The discharge path to the face-up or face-down stacker is automatically switched by the paper separator solenoid.

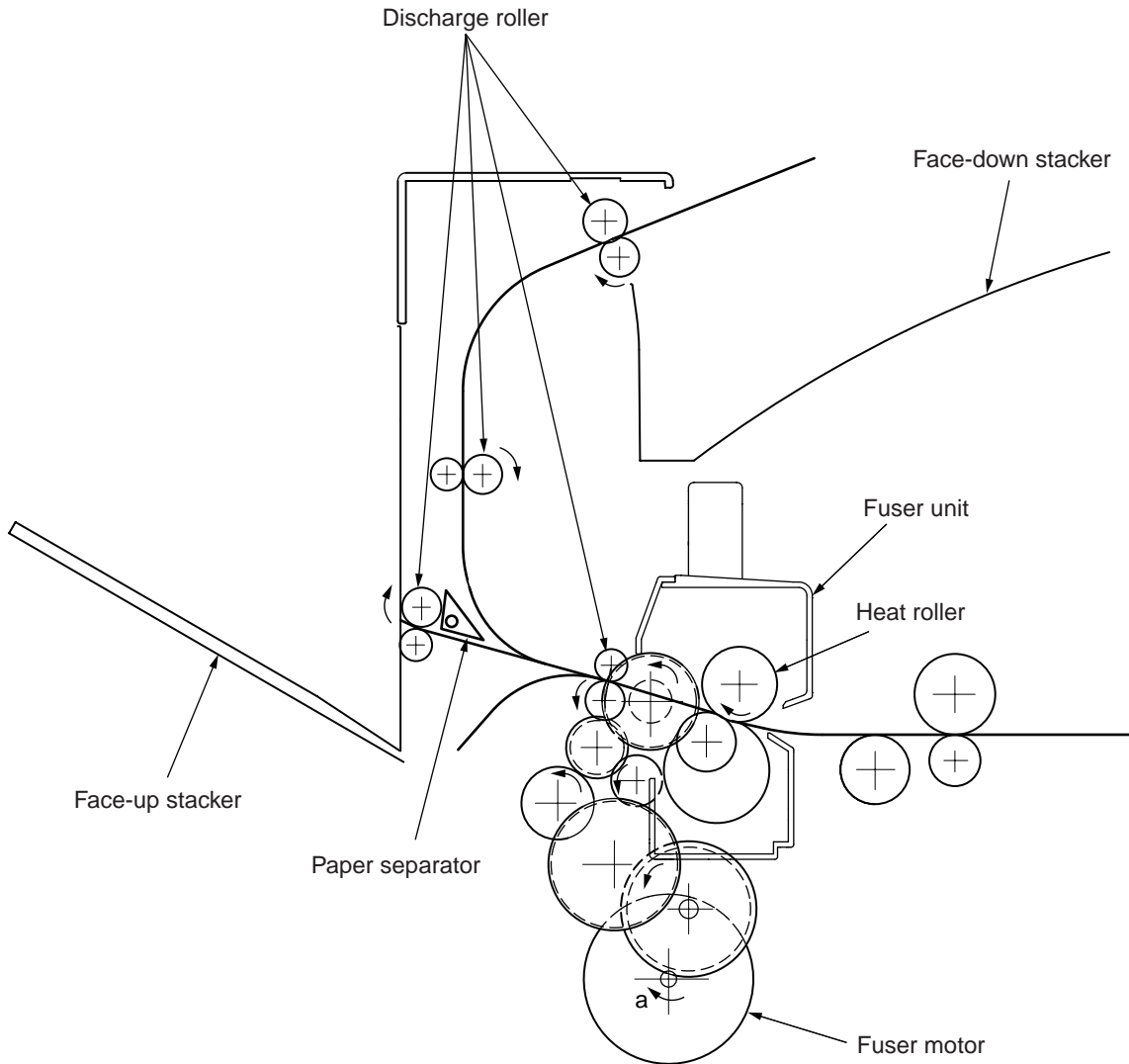

Figure 2-10

(7) Double-Side Printer Unit

1. When the double-side Printer Unit receives double-side print instructions, the separator is opened by the solenoid after one side of the paper fed from the tray is completely printed, then the path is switched to the double-side printer unit.

At this time, roller (1) turns in the direction of arrow (a), therefore, the paper is retracted to the undersurface of a double-side printer unit.

2. Further, when the tip of the paper passes through the double-side printer entrance sensor after a certain period of time, the roller starts a reverse rotation. Roller (1) turns in the direction of arrow (b), then sends the paper inside the double-side printer unit. After that, it passes through roller (2), (3), (4) and (5), prints the other side of the paper, then discharges the paper, and re-feeds it back to the unit.

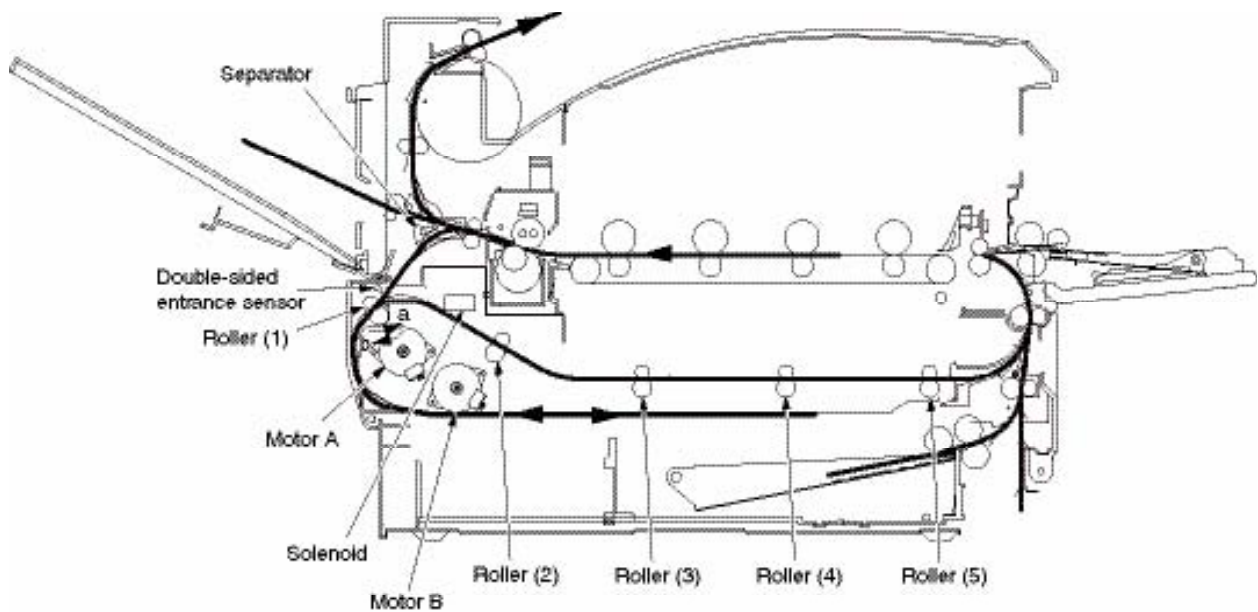
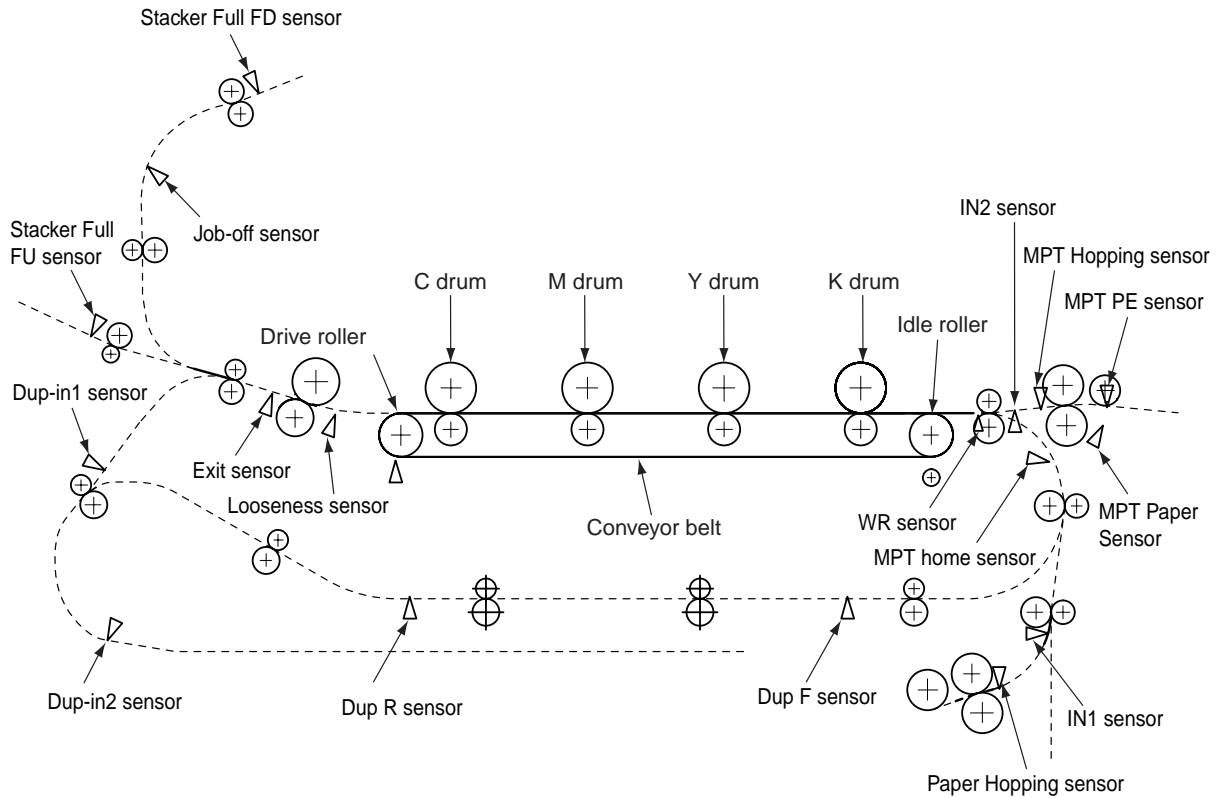

Figure 2-11

2.5 Sensor

2.5.1 Paper-Related Sensor



Sensor	Function	State of Sensor
MPT Hopping Sensor Paper Hopping Sensor	This detects the top of the paper entering and then determines the timing to switch from the hopping to the conveyor.	L :Paper Available H :Paper Unavailable
IN2 Sensor	Detects the leading edge of transferred paper. Determines the paper length from the time when the trailing edge turns off the sensor.	L :Paper Available H :Paper Unavailable
Paper Discharge Sensor (Exit sensor)	This detects the tip and end of the paper, then determines paper discharge.	L :Paper Available H :Paper Unavailable
Double-Side Print Entrance Sensor (Dup-in1 sensor)	This determines the tip of the paper entering the double-side printer unit, then determines the times it takes for the inverse roller to inverse from CCW to CW.	H :Paper Available L :Paper Unavailable
Double-Side Print Rear Sensor (Dup R sensor)	This detects the tip of the paper after inversion by the double-side printer unit.	H :Paper Available L :Paper Unavailable
Double-Side Print Front Sensor (Dup F sensor)	Detects the leading edge of paper reversed by the Duplex Unit. Determines whether to feed paper again.	H :Paper Available L :Paper Unavailable
Stack Full FD Sensor Stack Full FU Sensor	Detects Stacker full.	H :Stack Full L :Stack Empty
Job off Sensor	This detects paper conveyance to the paper discharge roller, then determines the timing to offset job operations.	H :Paper Available L :Paper Unavailable

2.5.2 Other Sensors

- ① Paper Empty Sensor
This sensor checks whether the paper cassette is empty or not.
- ② Paper Near-End Sensor
This sensor checks whether the paper cassette will be empty soon or not.
- ③ MPT Paper Empty Sensor
This sensor checks whether there is paper in the front feeder.
- ④ MBF Hopping Switch
This micro-switch checks whether the front feeder table is in the UP position or DOWN position.
- ⑤ Paper Size Switch
This sensor detects the size of the paper in the paper cassette.
- ⑥ ID UP/DOWN Sensor (one sensor each for Y, M, C, K)
This sensor checks whether the I/D unit is in the UP position or DOWN position.
- ⑦ Toner K, Y, M and C Sensor
This sensor checks the toner residual quantity in an image drum, when a sensor lever measures a time interval to open periodically.
- ⑧ RFID Sensor
The radio communications of this sensor are carried out to IC tip built in the toner cartridge, and it checks the existence of a toner cartridge, and the toner residual quantity in a toner cartridge.
- ⑨ Thermal Sensor
Refer to 2.7 “Image Transfer Control Due to Environmental Change”.
- ⑩ Humidity Sensor
Refer to 2.7 “Image Transfer Control Due to Environmental Change”.
- ⑪ Color Registration Sensor
This sensor reads the color registration pattern printed at the left and right edges of the Transfer Belt. (See 2.13.)
- ⑫ Density Sensor
This sensor measures the pattern density to measure the density printed on the conveyor belt.
- ⑬ Media Thickness Sensor
This sensor detects the thickness of the media.
- ⑭ Disposal Toner Sensor
This sensor checks whether the disposal toner in the disposal toner box is full or not.
- ⑮ Slack sensor
This sensor detects a slack in paper during feeding to control the Fuser speed.
- ⑯ Belt rotation sensor
- ⑰ Detection of spiral rotation of Waste Toner Dut
- ⑱ Waste Toner Box Spiral Sensor

2.6 Color Drift Correction

The CX3641 comes with several ID units and LED heads, therefore, causes color drift. This mechanical color drift can automatically be corrected with the following procedures.

(1) Automatically Corrected Color Drift

- ① X Axis Color Drift (position off-alignment due to LED head)
- ② Skew Color Drift (position off-alignment due to LED head)
- ③ Y Axis Color Drift (I/D unit and position off-alignment due to LED head)

(2) Correction Method

The color drift detection pattern set is printed on the belt. This is then read by the reflection sensor to detect the color drift value of each color and therefore, determine the correction level. The modification takes place by comparing the each colors' (Cyan, Magenta and Yellow) write timing with black, according to the correction value.

2.7 Image Transfer Control According to Environmental Change (Room Temperature and Relative Humidity)

The CX3641 measures the room temperature with the room temperature sensor and measures the relative humidity with the humidity sensor. It further computes the optimal transfer voltage under the environmental conditions (temperature and RH) measured. Then printing is controlled in real-time at this optimal voltage.

2.8 Paper Jam Detector

The CX3641 detects paper jam during printing after turning on the power source. If there is any paper jam detected, the printing process is immediately canceled. In this case, open the cover, remove the paper that is jammed, and close the cover to resume printing.

Error Code Displayed on LCD	Error	State
400,401	Paper Size Error	After the Entrance Cassette Sensor turns ON, it won't turn OFF for a certain period of time. It detects several different types of paper sizes.
372	Mis-feeding in Double-Side Print Conveyance Assy	Failure to feed paper from the Double-Side Print Conveyance Assy.
390	MT mis-feed.	Paper feed from the MT failed. (If, after Hopping, the Entrance MT Sensor does not turn ON within a certain period of time)
391 392 393 394 395	Cassette 1, 2, 3, 4 or 5 mid-feed.	Paper supply failed from Cassette 1, 2, 3, 4 and 5. (If, after Hopping, the Entrance Cassette Sensor does not turn ON within a certain period of time)
370	Paper jam when printing on the other side with Double-Side Print.	The double-side printer rear sensor does not turn ON when printing the other side with the double-side printer unit.
383	Paper jam at the entrance of the Double-Side Printer Unit.	The double-side printer IN sensor does not turn ON when supplying paper to the double-side printer unit.
371	Paper jam at the input of the Double-Side Printer Unit.	The double-side printer front sensor does not turn ON while the double-side printer unit is operating.
382	Paper discharge jam.	The paper discharge sensor senses the tip of the paper but does not sense the end of the paper after that within a certain period of time. The paper discharge sensor turns ON, but does not turn OFF after that.
381	Paper conveyance jam	The paper is conveyed on the belt, however, the paper discharge sensor does not turn ON.
380	Paper output jam.	After hopping is completed, the paper does not reach the entrance belt sensor or the MT sensor.
490	MT out of paper.	If printing is started when the MT is out of paper.
491 492 493 494 495	Cassette 1, 2, 3, 4 or 5 out of paper	Cassette 1, 2, 3, 4 or 5 out of paper

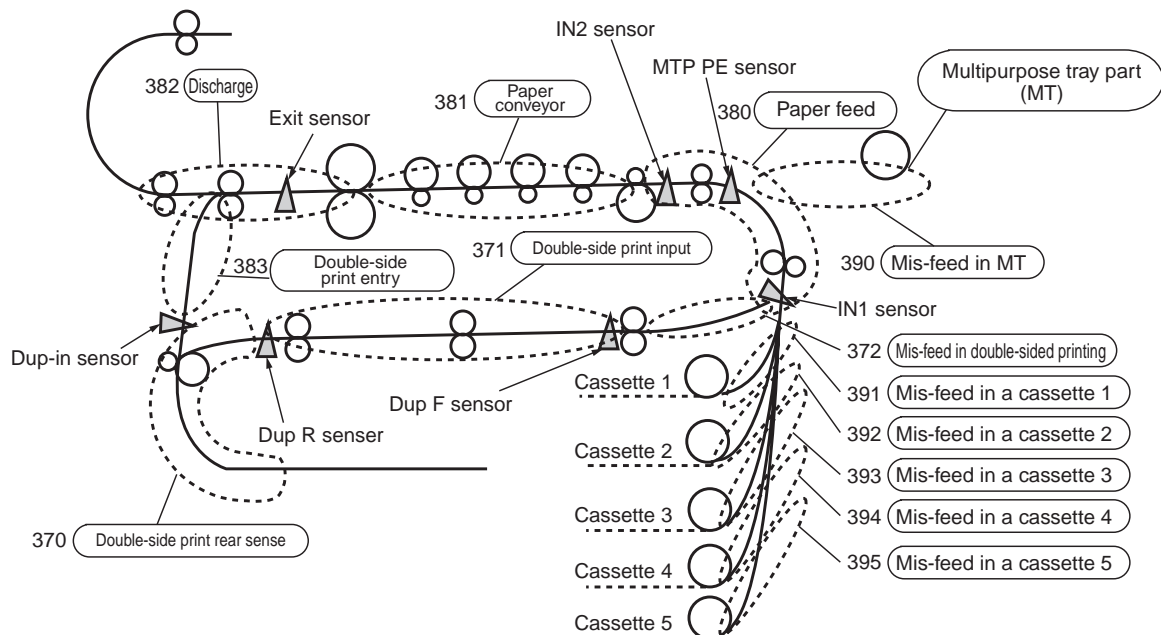

2.9 Cover Open

If the top cover of the CX3641 is open, the cover open micro switch turns OFF. Then the 24V to high voltage power source, and high voltage output is shutdown. At the same time, the CPU receives a COVOPN signal indicating the micro-switch state, to proceed with cover open processing.

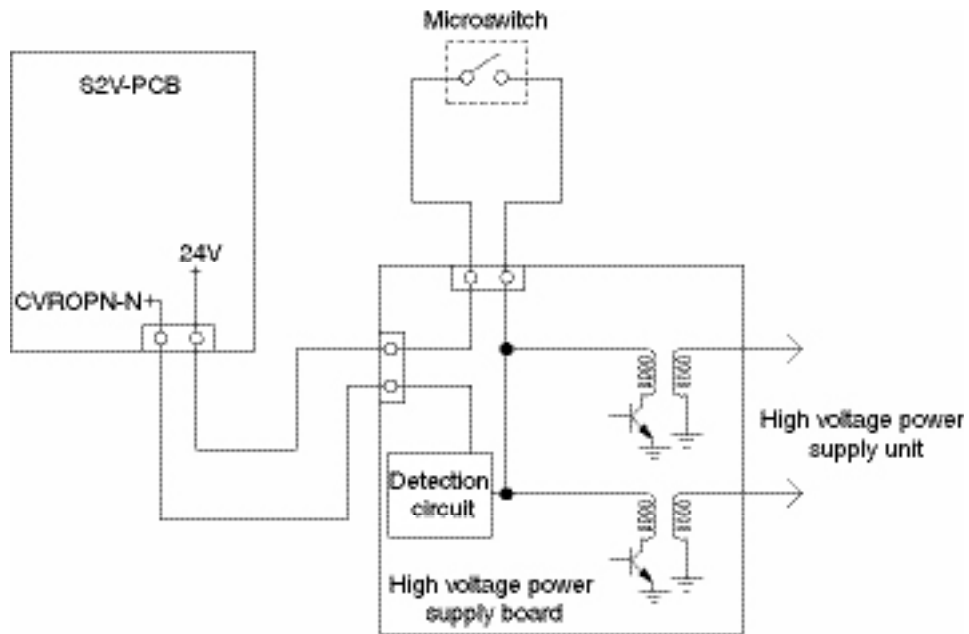

2.10 Toner Low Detection

- Structure

This device consists of a constant speed rotating agitation gear and agitation bar.

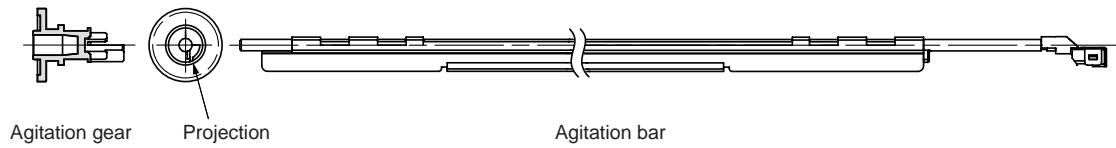

- Detection

The minimum height length of stay (OFF time) of a target board which attached the toner low level state in the end of a churning bar is measured and detected by the sensor.

OFF time (minimum height)

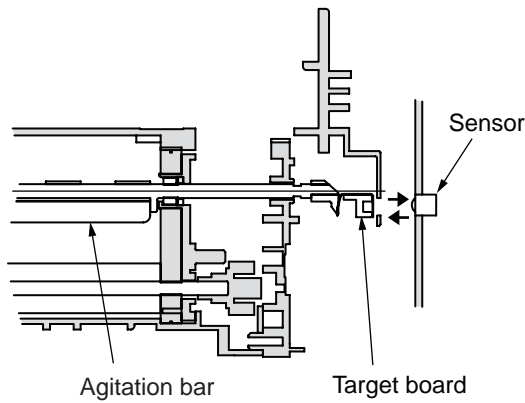

The light which emitted light by the sensor reflects with a target board, and received light by the sensor. Therefore, the minimum height length of stay is detectable.

ON time (maximum height)

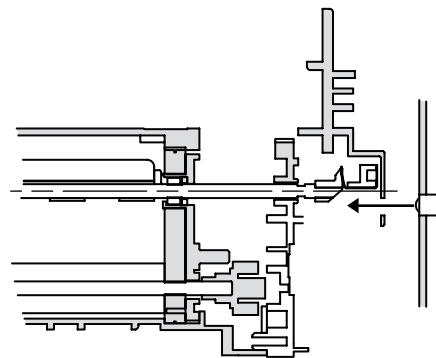

The light which emitted light by the sensor does not reflect with a target board, and does not received light by the sensor.

Toner High level State

- The agitation bar interlocks and turns with the agitation gear.
- Since there is a toner even if a agitation bar reaches the maximum height, the other side of the bar is still inside the toner. Therefore, the agitation bar turns by the force of the agitation gear.

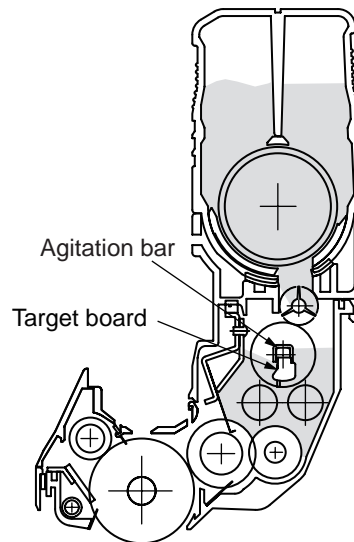

Toner Low Level State

- When the agitation bar reaches the maximum height, the agitation bar falls in the minimum height by prudence since there is no resistance by the toner. At this time, the minimum height length of stay of a target board becomes long. This time is measured and a toner low level state is detected.

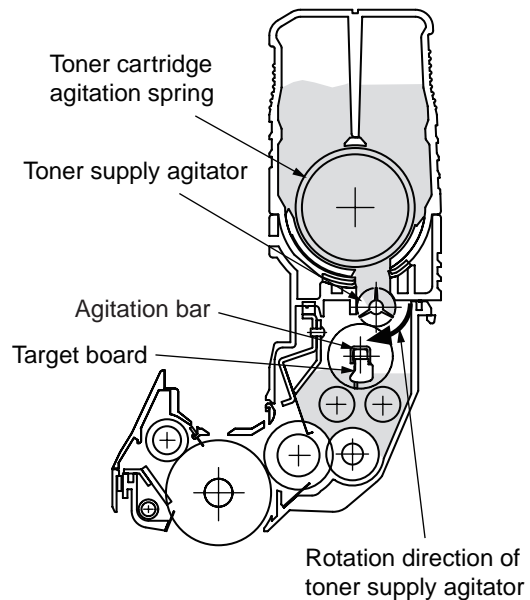

Toner Supply Operation

- When continuation 3 cycle detection of the toner low level state is carried out, a toner supply agitator and a toner cartridge agitation spring will rotate, and the toner of a toner cartridge will be supplied to the inside of an image drum cartridge. Then, when one cycle of toner high level is detected, toner supply agitator and a toner cartridge agitation spring will stop, and toner supply will stop.

Toner High Level State (at 37ppm*1)

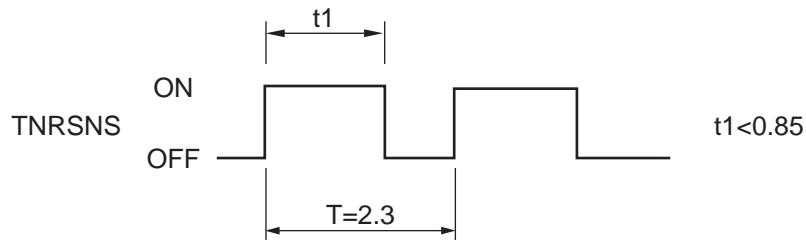

Toner Low Level State (at 37ppm*1)

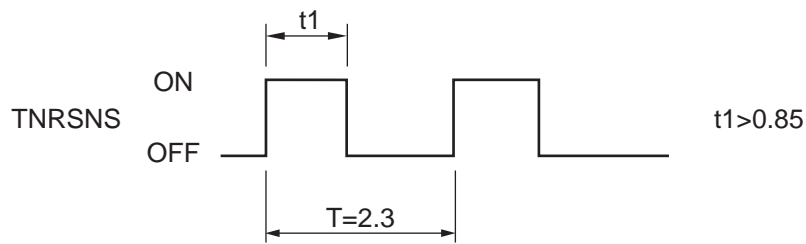

- After a toner supply start, when a toner low state is detected 20 consecutive times, it is recognized as the toner being low.

(After recognizing toner low, then toner low is displayed after printing an equivalent of 5% of 200 A4 sheets.)

The toner in a toner cartridge is lost.

- If a toner full state is detected 10 consecutive times, the toner low state is canceled.
- If the toner sensor does not change over 3 cycles (2.3 sec. X 3), then the toner sensor alarm is activated.
- The toner sensor does not detect anything when the drum motor is stopped.

*1 A 37ppm printout is at the warming up stage. T and $t1$ fluctuates in proportion to the printing speed.

2.11 Paper Size Detection

A cam is interlocked with the paper guide of the paper cassette, then four tab-pieces via this cam drives the system according to the paper guide setting position.

When the paper cassette is attached to the printer, the micro-switch detects the state of the tab-piece and then recognizes the size of the paper.

	PSZSW1	PSZSW2	PSZSW3	PSZSW4
Cassette NONE	0	0	0	0
A3 Nobi	0	0	1	1
Tabloid	1	0	1	1
A3	1	0	0	1
B4	0	0	0	1
Legal 14"	0	1	0	1
Legal 13"	0	1	0	0
A4 Portrait	1	1	1	0
Letter Portrait	1	1	1	1
Executive	1	1	0	1
B5 Portrait	1	1	0	0
Letter Landscape	1	0	1	0
A4 Landscape	0	0	1	0
A5	0	1	1	0
B5 Landscape	1	0	0	0
A6	0	1	1	1

2.12 Power ON Process

2.12.1 Self-Diagnostic Test

(1) Initial Test

When the power is turned On, the following check automatically takes place.

- (a) ROM Check
- (b) RAM Check
- (c) EEPROM Check
- (d) Mechanical Check
- (e) Option Unit Check

(2) ROM Check

The ROM is checked by calculating the HASH value.

(3) RAM Check

- (a) The type of RAM is checked for its specifications. Any RAM that falls out of the specifications will result in an Error.
- (b) The RAM in each slot is checked by read-after-write.

(4) EEPROM Check

The specific data stored in the fixed address of the EEPROM is checked.

(5) Option Unit Check

Before entering the run mode, the unit is checked for the presence of an optional units (HDD, NIC, Option Tray, Double-Side Printer Unit, Finisher, etc.).

2.13 Color Drift Detection

The Z71-PCB reflective optical sensor detects color drift. There is one each on the left and right side in front of the cleaning blade behind the belt unit. A color drift detection pattern is printed on both ends of the left and right side of the belt. Then the reflective optical sensor reads this detection pattern to measure the drift level based on black as a standard. The correction value is then determined based on this measurement. Then the main scanning, sub-scanning, and skewed color drift correction automatically takes place.

This detection takes place when the power is turned ON, cover is closed, the printer is left unused for 2 hours or longer, and every time after printing 400 sheets.

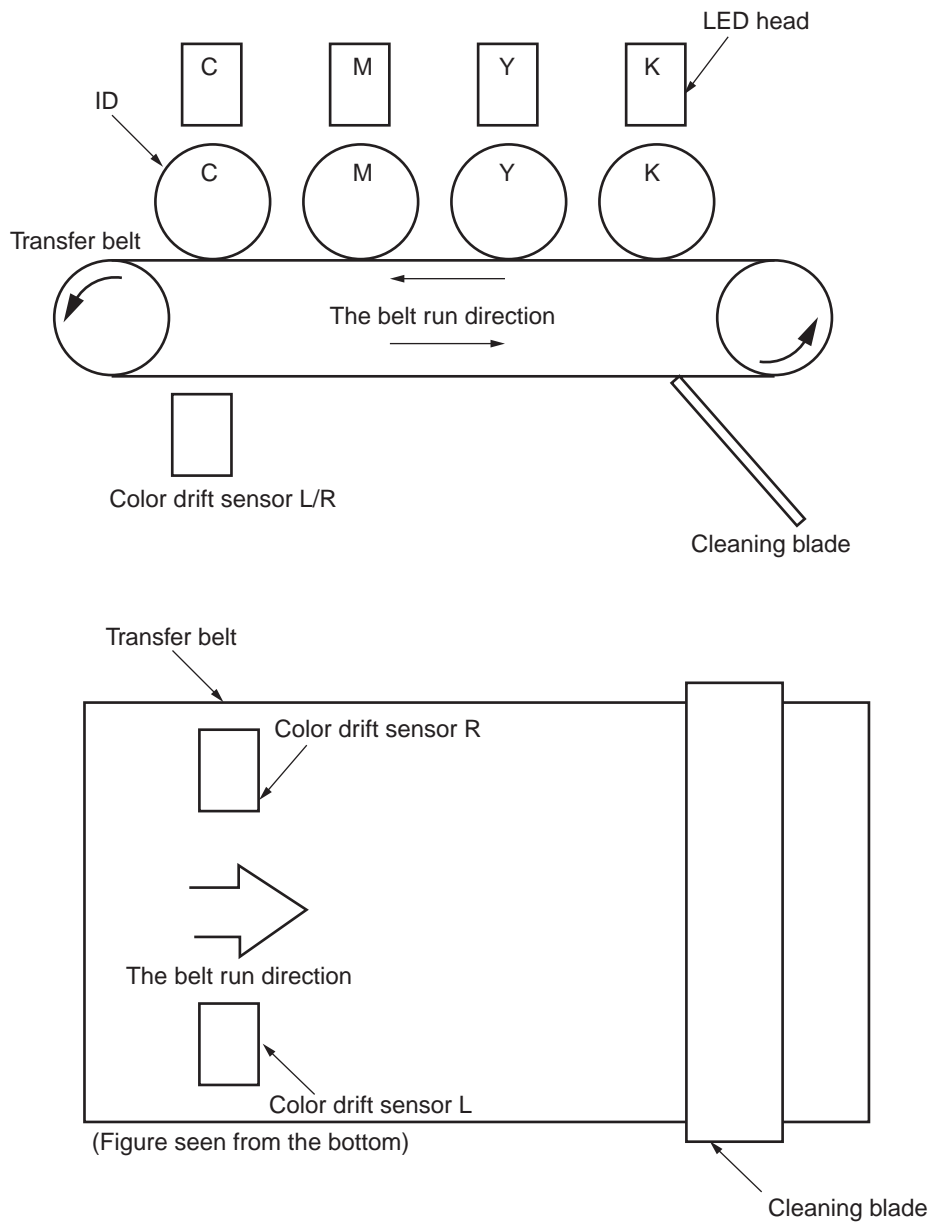

2.14 Reading Version of Routine Replacement Units

This determines whether the parts are new or old according to the I/D of the consumable parts that are routinely replaced, the fuser unit, and the state of the fuse in the belt unit (good/dead). If the fuse is in a conductive state, then it is considered a new unit. A NEW or OLD decision takes place when the power is turned ON and when the cover is closed. When the part is NEW, the life counter of the unit is reset, and the NEW/OLD decision-making fuse in each unit is cut.

2.15 Life Counter of Replaceable Units

The following Table lists the life counter of the I/D, fuser unit, and belt unit that are routinely replaced consumable parts.

Unit	State	Life processing
ID	Count the drum rotation in a unit of [Letter Paper Length + Paper Interval during continuous print]. Life :When printing a distance equivalent to 30K sheets (3P/J).	Stop Printing However, 1500 sheets can be printed by opening and closing the cover.
Toner Cartridge	Count the number of print dots. Determine the usage level according to the counter value. (Refer to 2.16)	Stop Printing However, 50 sheets can be printed by re-turning the power back ON or opening/closing the cover. (A4 5%)
Belt Unit	Convert the drum rotation into [Letter Paper Length + Distance Between Paper Upon Continuous Printing]. One sheet of paper passing through is counted as one on the counter. Life:When the counter value reached 100K.	Stop Printing However, 20 sheets can be printed by re-turning the power back ON or opening/ closing the cover.
Fuser Unit	Disposal Toner Near-Full state. If paper is longer than 13 inches, the number of the paper sheets will be an integer multiplied by 13 inches plus one. Life: When counter value is 100K.	Stop Printing However, power is turned off and on again or opening/ closing the cover, the printer will be able to print 500 more sheets or, after 150K, 50 more sheets.
Waste Toner Box	Converts the weight of discharged toner to the number of A4 sheets and counts the number. Life: When the counter has reached 30K.	Stop Printing When power is turned off and on again or opening/closing the cover, the printer will be able to print up to 50 counts.

2.16 Toner Usage Level Detection

The toner usage level is detected by counting the number of dots printed. The counted number of dots is written in in IC tip in a toner cartridge.

Once toner low is detected, the toner shall be considered empty after dot counting 1,050 A4 sheets at 5%.

However, when the power is turned back ON, and the cover is opened and closed, the printer can still print 50 more sheets.

3. PRINTER INSTALLATION

3.1 Precautions and Prohibition

Warning



- Keep away from high temperatures and open flames.
- Please do not install in a place from which a chemical reaction is started (laboratory etc.).
- Do not install near inflammable solutions such as alcohol or thinner.
- Keep out of reach of children.
- Do not install on an unstable surface (the shaky stand, leaning place, etc.).
- Keep away from dust, humidity and direct sunlight.
- Keep away from the sea breeze and corrosive gases.
- Keep away from sources of vibration.
- Pull the power plug out of the socket and contact with a customer's service centre when the printer is dropped or the cover is damaged.
There is a risk of getting an electric shock and/or causing fire leading to personal injury.
- Do not use a power code, a printer cable, or a ground wire other than those that are indicated in User's Manual.
Doing so may cause fire.
- Do not insert materials in a vent hole.
Doing so may cause an electric shock and/or fire leading to personal injury.
- Do not put a cup with liquids such as water on the printer.
Doing so may cause an electric shock and/or fire leading to personal injury.
- Do not touch the fuser and other parts when opened the cover.
Doing so may result in getting burns.
- Do not throw toner cartridges and image drum cartridges into fire. Doing so may cause dust explosion leading to get burns.
- Do not use an inflammable spray near the printer. Failure to follow may cause fire since there is an area heating up within the printer.
- Pull the power plug out of the socket and contact with a customer's service centre when the cover is unusually hot, smoking, giving off questionable odour, or making a strange noise.
There is a risk of fire.
- Pull the power plug out of the socket and contact with a customer's service centre when a liquid such as water enters in the internal parts of the printer.
There is a risk of fire.
- Pull the power plug out of the socket and remove foreign materials such as clips when they fall inside the printer.
There is a risk of getting an electric shock and/or causing fire leading to personal injury.
- Do not operate and/or disassemble the printer other than that which is directed in User's Manual.
Doing so may cause an electric shock and/or fire leading to personal injury.

⚠ Caution

- Do not block the vents on the printer.
- Do not place printer directly onto a carpet.
- Ensure printer has adequate ventilation.
- Keep printer way from sources of noise and magnetic fields.
- Do not install near a monitor or television.
- Please lift both sides when moving the printer.
- Since this printer has about 77kg of weight, please raise by three or more persons.
- Do not come closer to the paper's exit area when the power is turned on, and while in printing. Doing so may result in personal injury.

Explain instructions for use and settings to customers, showing instructions of the user's manual. Especially, explain the power cord and earth cable carefully.

3.2 Printer Unpacking Procedure

 Warning	Personal injuries may occur.	
--	------------------------------	---

Each printer weighs about 77 kg. Lift them by three persons or more.

- Punch four handle holes out each on the side and lift the carton box.

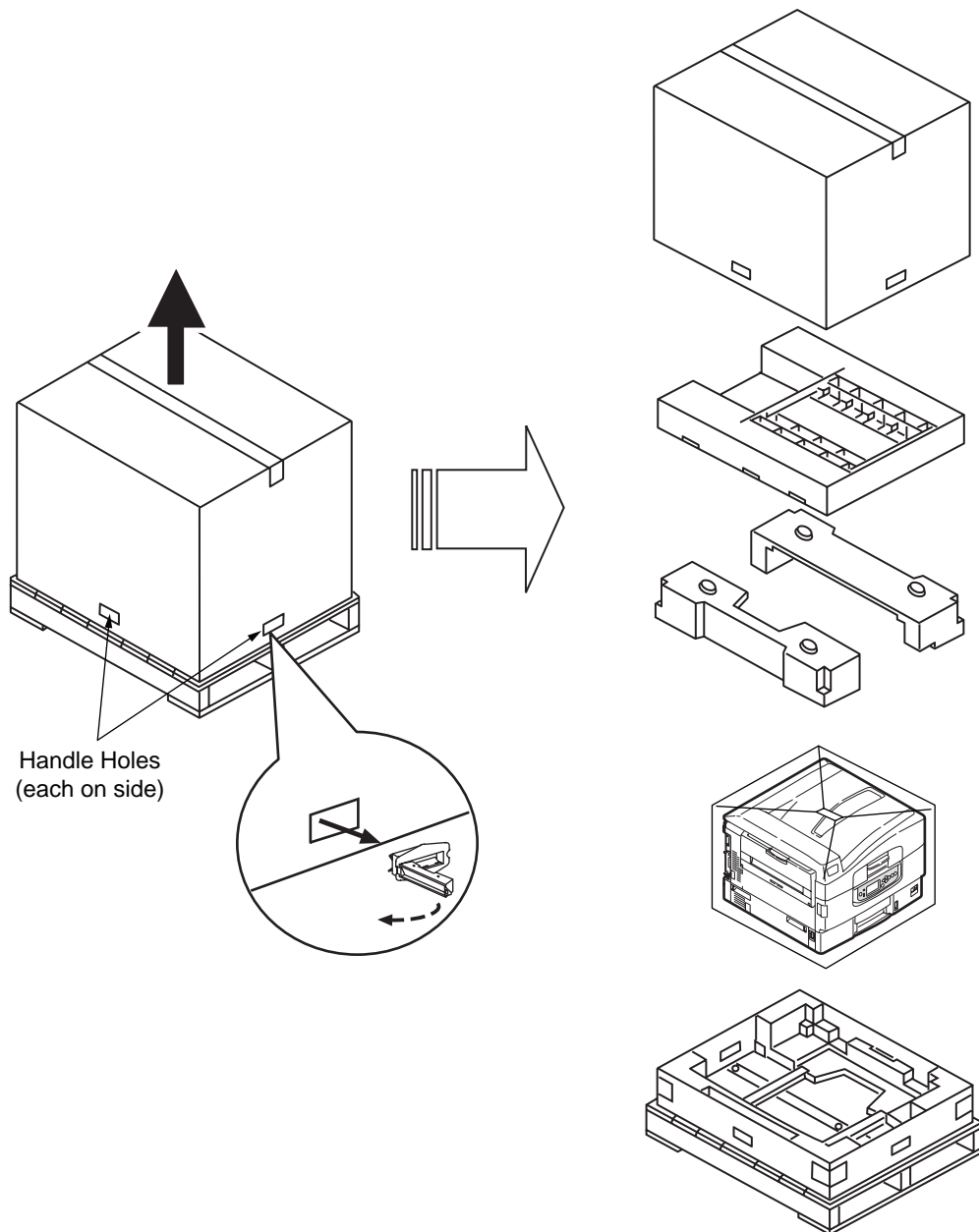

Handle Holes
(each on side)

3.3 Printer Installation Instructions

- Install a printer under the desired temperature and humidity condition:
 - Ambient Temperature : 10 to 32°C
 - Ambient Humidity : 20 to 80% relative humidity
 - Maximum Wet-Bulb Temperature : 25°C
- Take care not to allow dew condensation on printers.
- When installing printers in an area of which ambient humidity is 30% or less, use a humidifier or antistatic mat.

Installation Space

- Place a printer on a flat table, which has an adequate space for printer legs.
- Have an adequate room around printer.

Top View

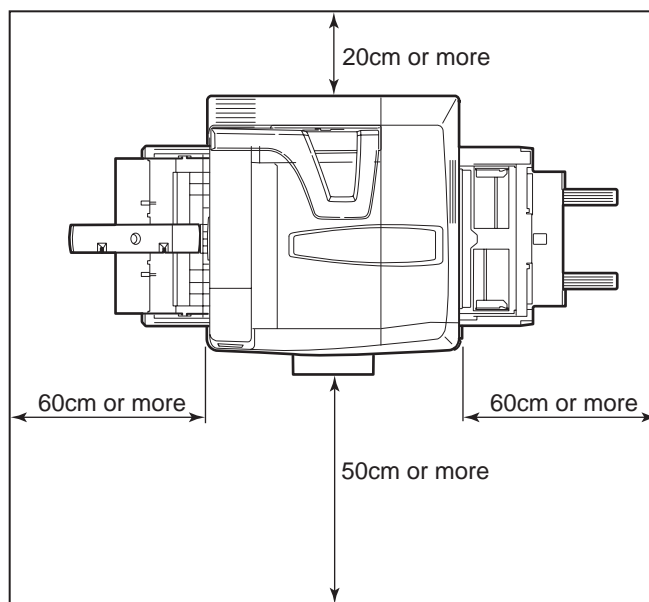

Side View

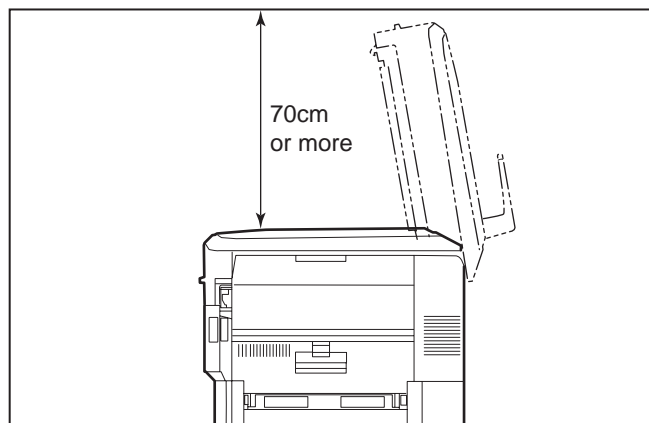

3.4 Packed Units and Attachments

- Check if the packed units are free of flaws and dirt.
- Check if there are no missed or damaged attachments.
- Should any defective or unusual conditions are found, contact the section in charge.

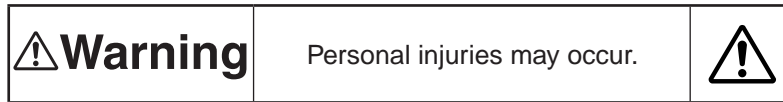

Each printer weighs about 77 kg. Lift them by three or more persons.

- Printer (main body) Image drum is mounted in the printer
- Toner cartridge (four sets)

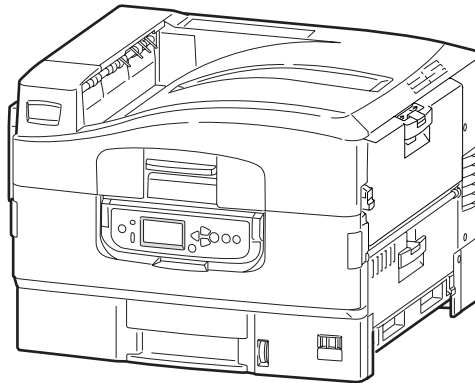

- Paper holder

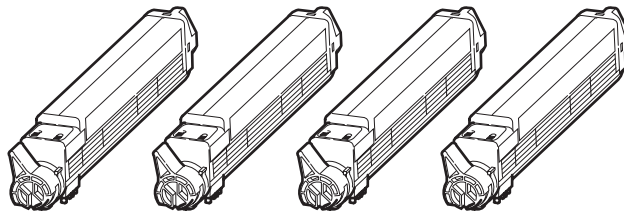

- Power cord
- Core
- Power Plug
- Warranty and Registration card
- Printer Software CD-ROM
- Utility CD-ROM
- Users Manual
 - Set up- For Windows users
 - Set up for Macintosh,UNIX,Linux users
 - Printer functions
 - Application
 - Guidance for Set up and control
 - Guidance for PS print
 - Guidance for Color
 - Guidance for Job control
- Guidance for Set up
- Quick Guidance
- Quick Guidance Bag

Note! No printer cables are included in printer packages.

3.5 Assembly Procedure

3.5.1 Printer Main Body

Remove Protective Equipment

- (1) Remove protection tapes on the side of printer (6 places), a sheet of paper, desiccant and Pad-Guard-Stacker on the top.

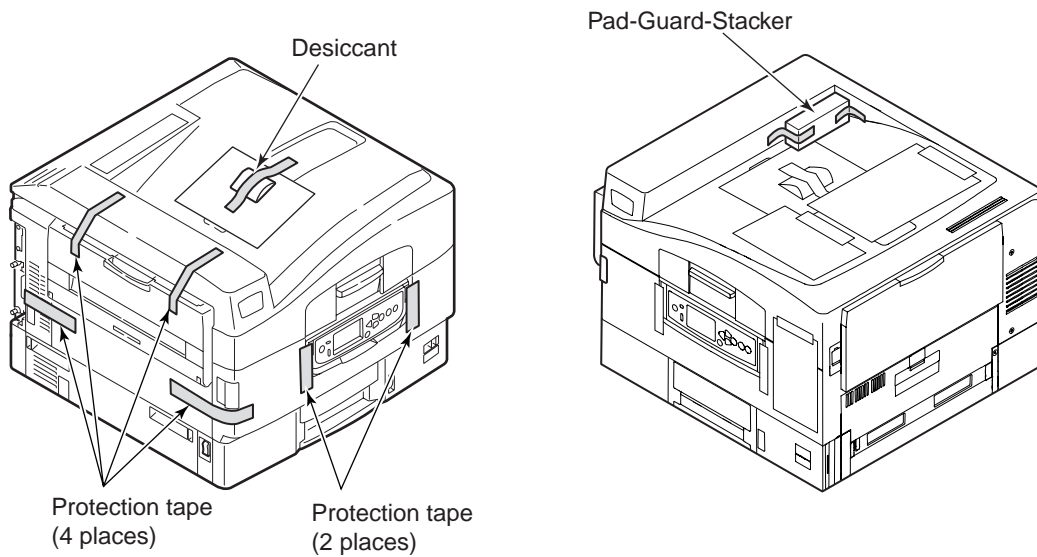

- (2) Press down the open button to open the top cover.
- (3) Pull out the protective equipment (8 places) and remove protection tapes.
- (4) Remove the paper cassette.
- (5) Remove the protective equipment inside the paper cassette.

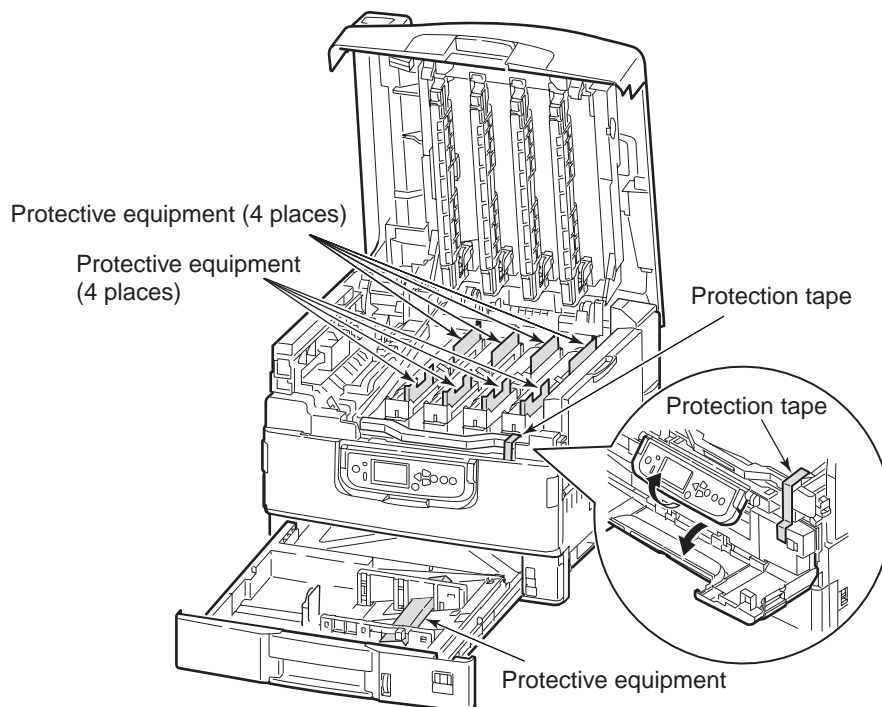

Install a toner cartridge in the printer

- (1) Open the top cover of printer and remove protection tapes; stoppers and toner cover which are installed in the printer

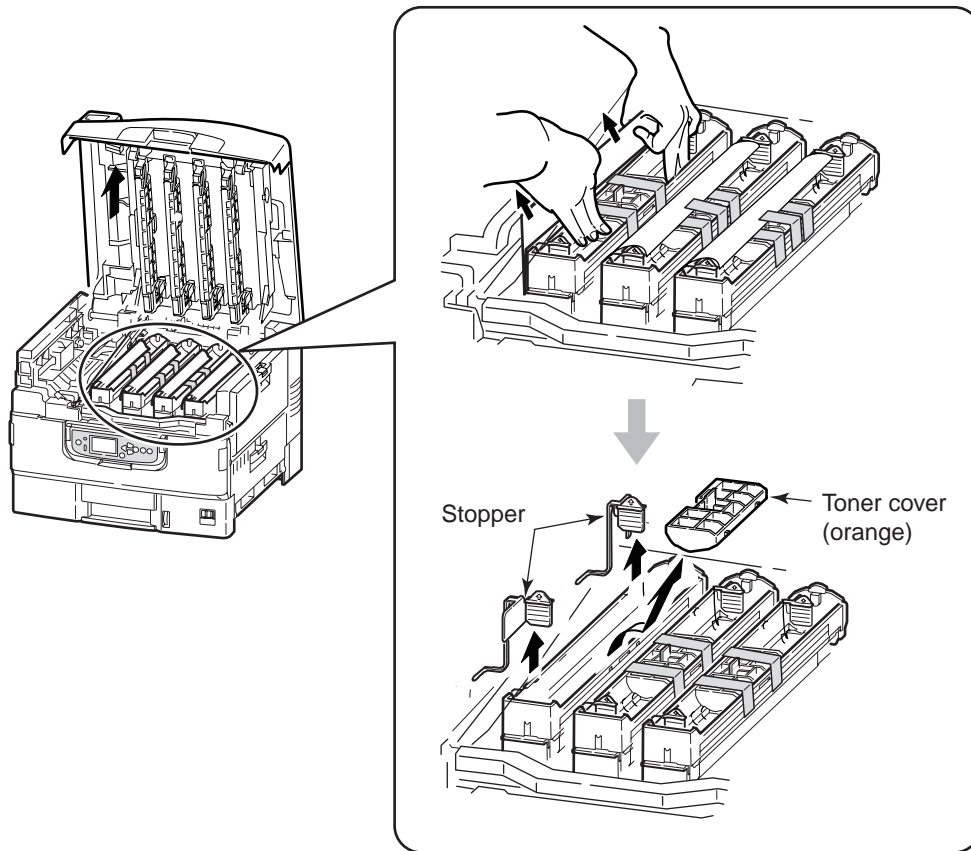

- (2) Shake the toner cartridge well and tear off the tape.

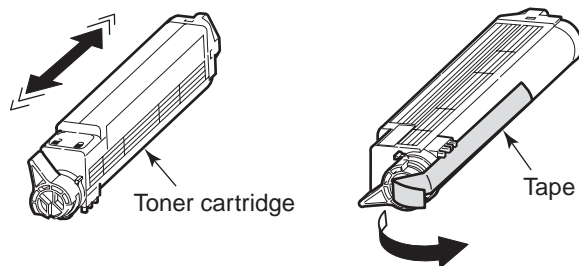

- (3) Place the toner cartridge on the image drum cartridge, fitting a post into the hole.

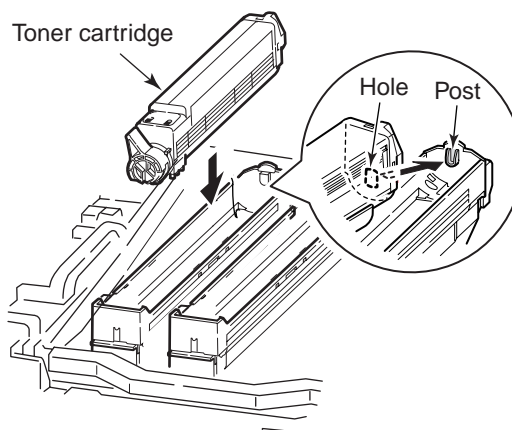

(4) Turn tightly the lever (blue) of toner cartridge toward the arrow direction.

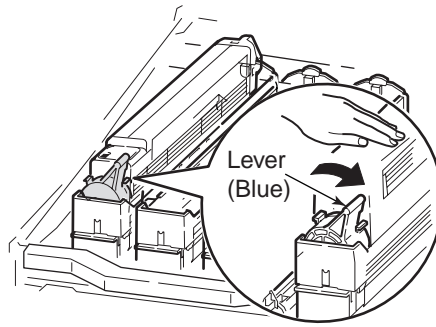

(5) Close the top cover.

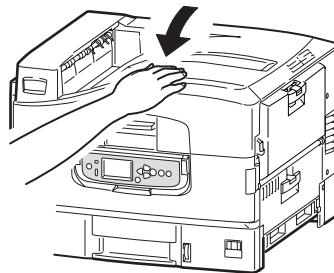

Place a paper holder on the printer

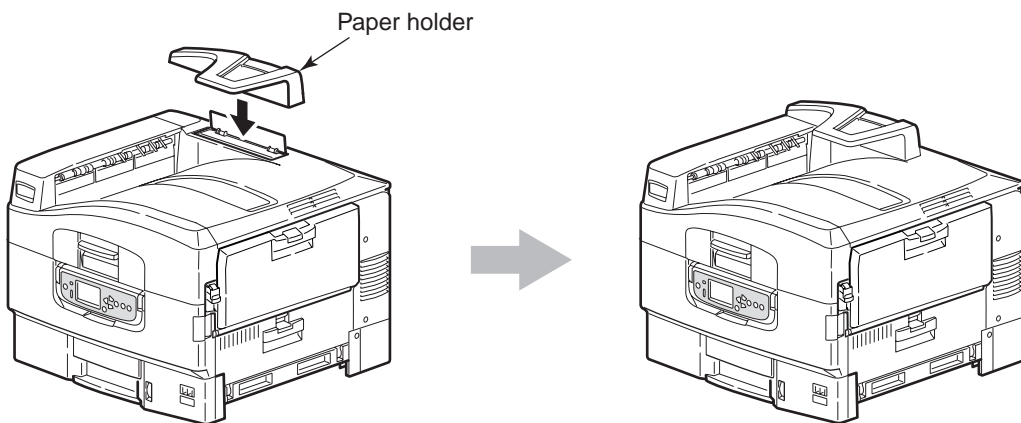

Attach the quick guide bag

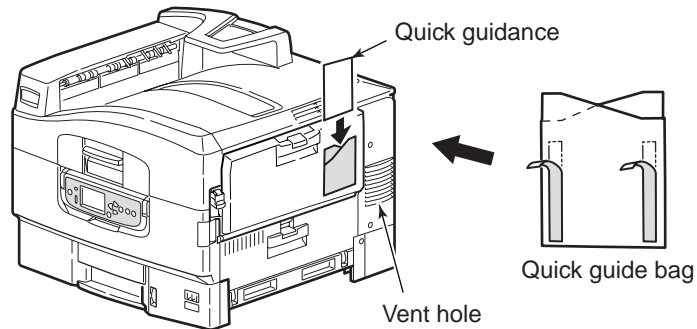

Note! Make sure to attach the bag to the place it does not cover vent hole.

Loading a Paper

For tray 1

(1) Slide out the tray 1

(2) Adjust to the desired paper size by an adjustment knob.

Reference: Same procedure for the tray 2, 3, 4 and 5 as of tray 1.

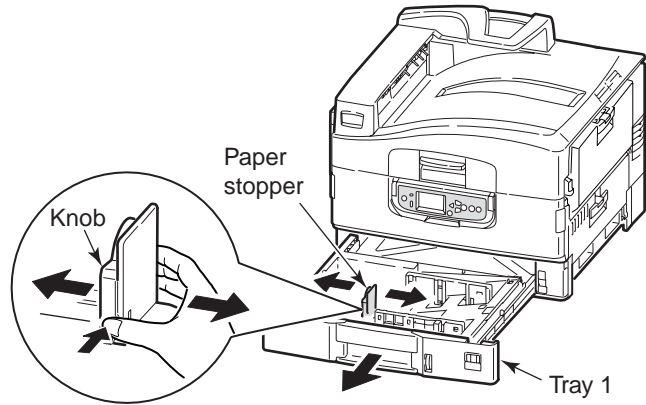

(3) Loosen the paper sufficiently and make sure their edge lined up.

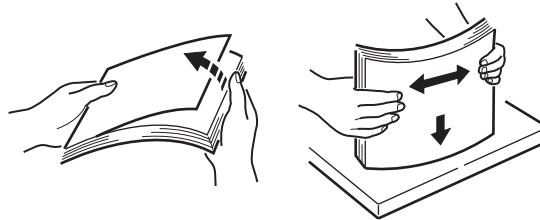

(4) Place the paper facing down on the right side of tray 1.

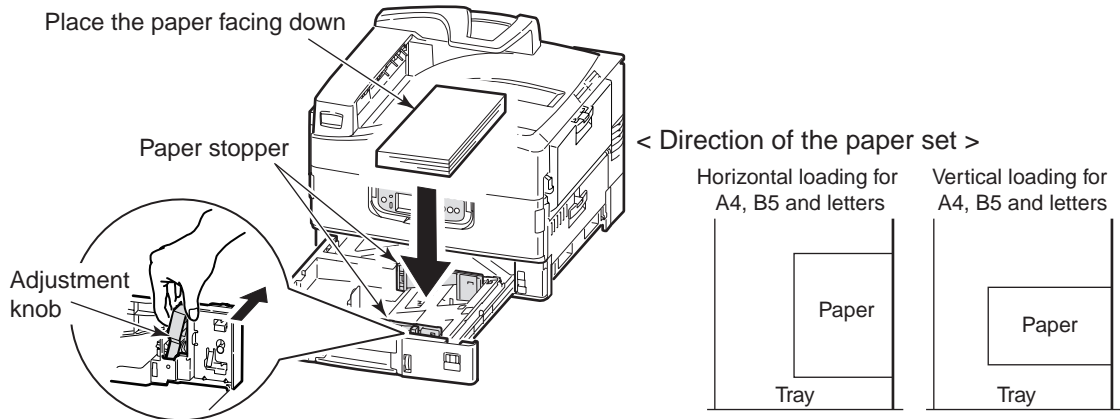

Note! Both vertical and horizontal loading are possible for A4, B5 sized papers and letters, but vertical loading only for the other sized of papers.

(5) Use an adjustment knob to adjust the size of papers.

(6) Place the tray 1 back to the printer.

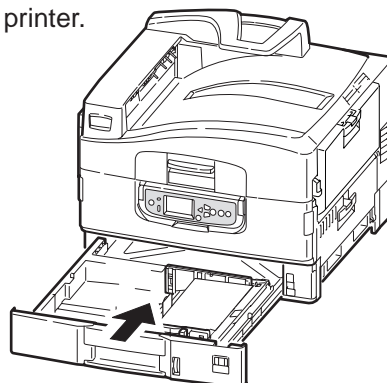

For Multipurpose Tray

After placing the sheet of papers on the multi-purpose tray, set up the size of paper on the operating panel. "Horizontal loading for A4" has set up for factory-configured.

- (1) Press down the lever on the right side of printer to open the multi-purpose tray.

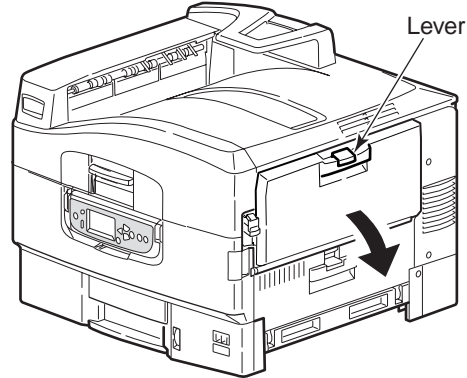

- (2) Open the paper supporter.

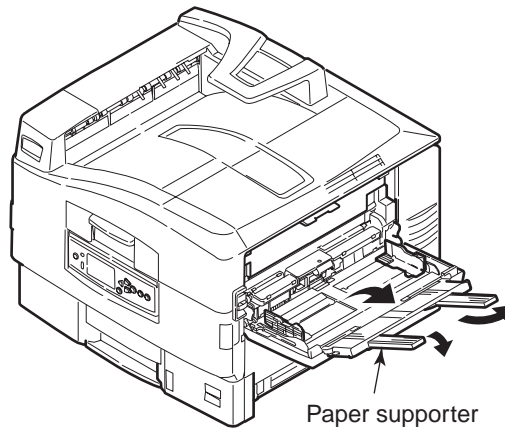

- (3) Adjust the paper guide to the paper width.

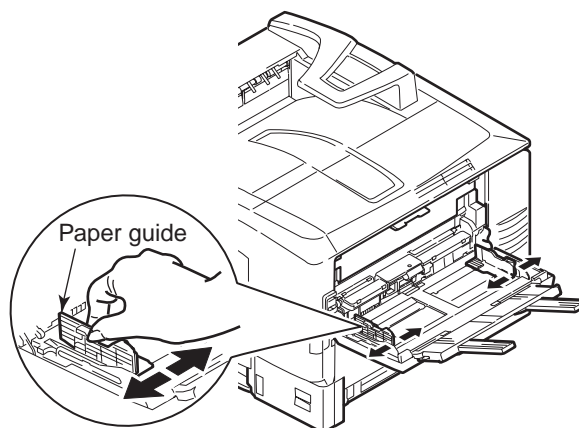

- (4) Loosen the papers sufficiently and make sure their edges lined up.

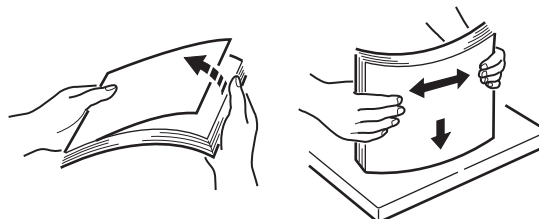

(5) Place the paper facing up-ward on the tray.

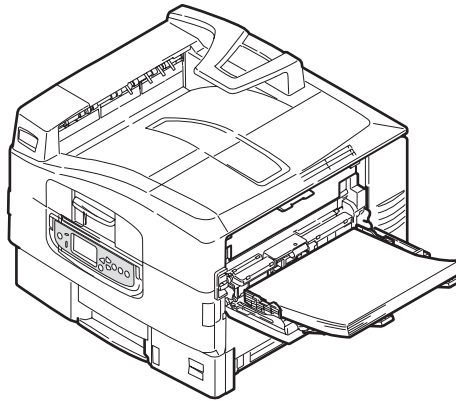

< Direction of the paper set >

Horizontal loading for A4, B5 and letters

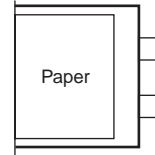

Multi-purpose tray

Vertical loading for A4, B5 and letters

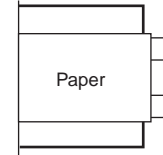

Multi-purpose tray

(6) Set up the size of multi-purpose tray on the operating panel.

① Check if "READY TO PRINT" appears on the screen.

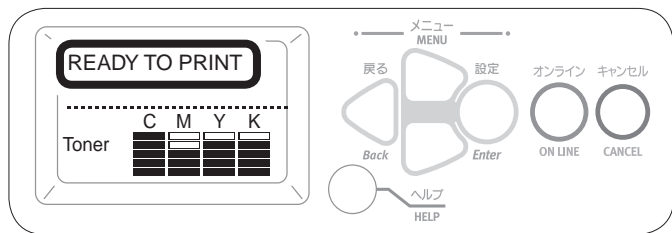

② Select "MENU" by Pressing the button several times and press the ENTER button.

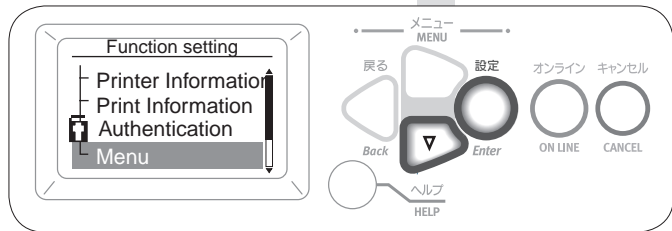

③ Select "TRAY STRUCTURE" by pressing the button several times and press the ENTER button.

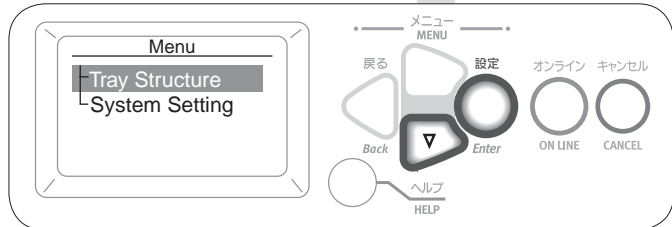

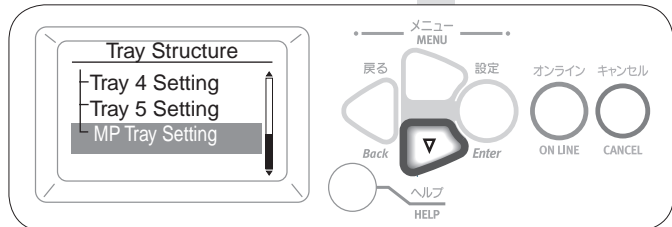

④ Select "MULTI-PURPOSE TRAY SETTING" by pressing the button several times.



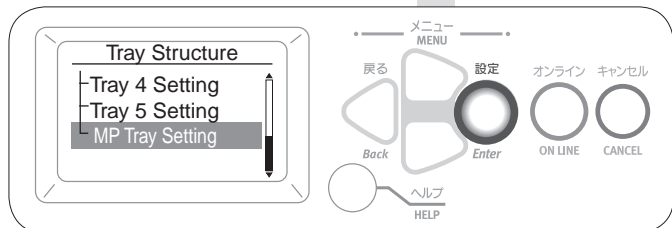

⑤ Press ENTER button.

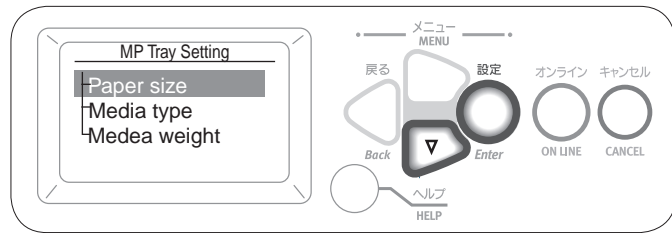

- ⑥ Select "PAPER SIZE" by pressing the button  several times and press ENTER button .



- ⑦ Select "PAPER SIZE" by pressing the button  several times and press ENTER button . The illustration is an example of selecting horizontal loading for letters

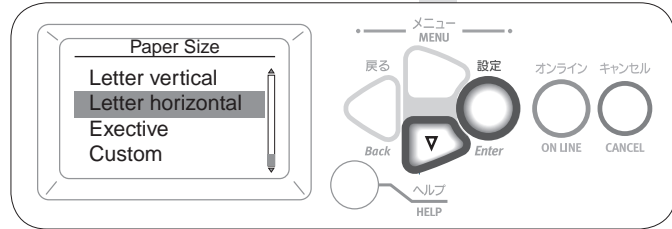

- ⑧ Check if a "*" mark appears at the left side of "HORIZONTAL FEEDING FOR LETTERS"

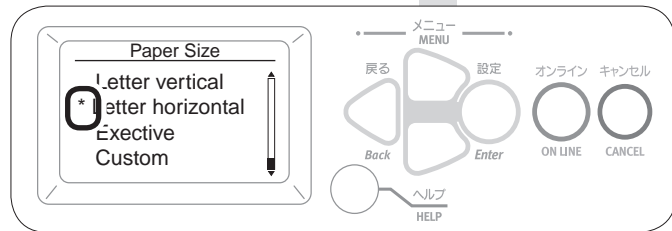

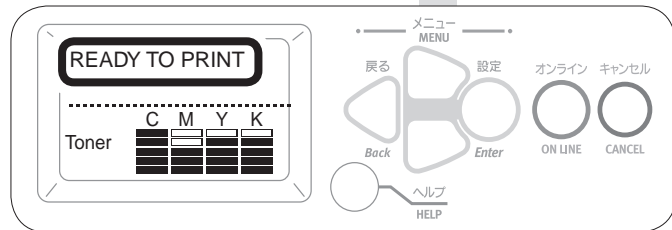

- ⑨ "READY TO PRINT" appears by pressing the ON LINE button .



3.5.2 Power Cable Connection

Conditions for Power Supplies

- The following conditions apply to the power supplies of printers:
 Alternate Current (AC) : 100 V ±10%
 Power Supply Frequency : 50, or 60 ±2 Hz
- For unstable power supplies, use voltage regulators etc.
- The maximum power consumptions of printers are 1,500 W. Be sure power supplies have power supply capacities adequate for the printers.

 Warning	It may expose you to electric shocks or cause a fire.	 
<ul style="list-style-type: none"> • Make sure to turn off printers before attaching and detaching power supply cords and grounding wires to the printers. Keeping the power supply ON causes a fire or an electric shock. • Grounding wires must be connected to dedicated grounding terminals. No grounding wires causes a fire or an electric shock. Consult with a dealer if grounding wires is impossible. • Never connect the ground wires to water or gas pipes, or telephone grounds, lightning conductors or other lines. They cause a fire, an electric shock or a gas explosion. • Always hold a plug while inserting or removing the power supply cord. Damaged cord is a result of pulling it, which causes a fire or an electric shock. • Do not insert or pull out power supply plugs with wet hands. Make sure the power supply cord is well inserted. Otherwise causes a fire or electric shock. • Do not insert or pull out the power supply plugs with wet hands. It causes an electric shock. • Do not step on the power supply cord or put the things on them. Otherwise damages the cord and causes a fire and an electric shock. • Do not tie the power supply cords in a bundle in use of the printer. It heats up and damages the cord, which is a result of a fire and an electric shock. • Do not use the damaged power supply cords. It causes a fire or an electric shock. • Do not use star-burst connections for printers. • Do not connect a printer to the same receptacle outlet being used for electrical equipment other than the printer. Connecting a printer such a receptacle outlet, particularly being used for air conditioning, copying or shredding equipment, may cause a malfunction in the printer due to electrical noises. If a printer is connected to such a receptacle outlet by necessity, use a commercially available noise filter or noise-cut transformer. • Do not use the extension cords. Normal printer operation may not be attained if using an extension cord due to the decreased AC voltage. If necessary, select the cord, which is rating 100 V, 15 A and more. Other types of cords cause a fire or an electric shock. • Do not turn off the printer or pull out the power supply plugs while the printer are in use. It causes of a broken down of printer or an electric shock. • Please disconnect printers from the mains supply if they will not be used for an extended period of time for safety. • Use only those attached cord. Using other types of cords cause a fire or an electric shock. • Do not use an attached cord to other appliances due to a fire or an electric shock. 		

Well explanation and showing the customers a user's manual avoids any troubles.

Connect Power Supply Cord

Note! Be certain the power switch is placed in the OFF (O) position.

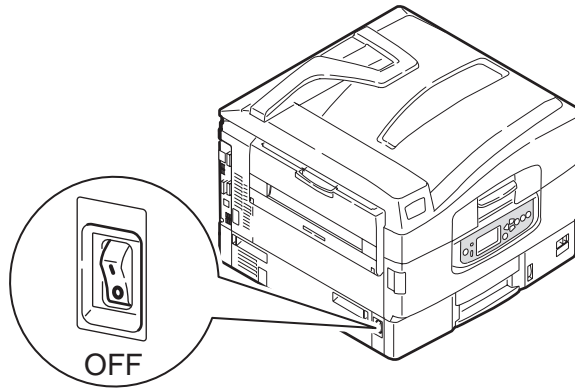

- (1) Plug the power supply cord in the printer.

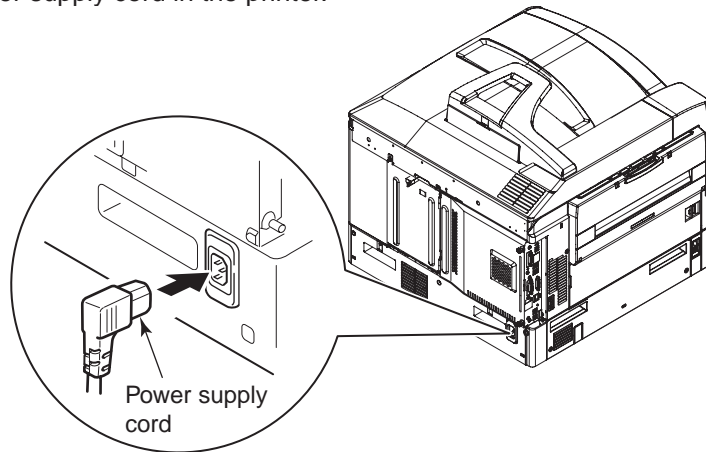

- (2) Insert the power supply cord into the receptacle socket.

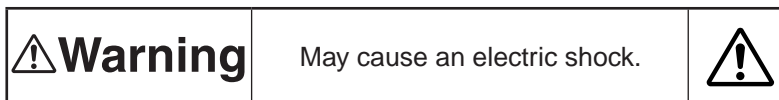

The connection of grounding wire is absolute.

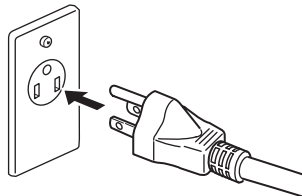

Press ON (I) of Power Switch

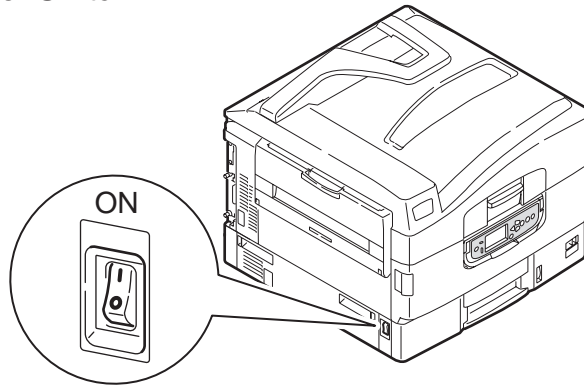

"READY TO PRINT" appears on the panel when ready.

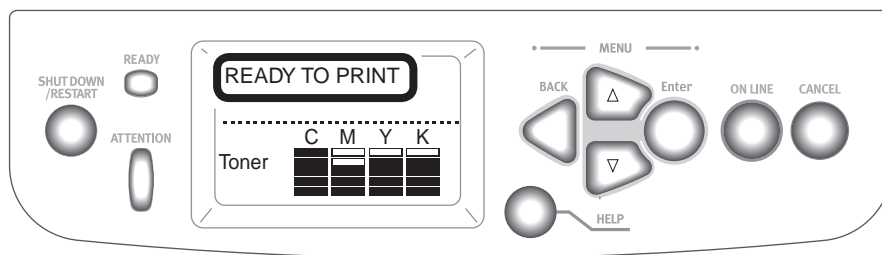

Turning off the Printer

Note! The internal hard disk may be damaged and unusable if the printer is switched off immediately.

- (1) Keep pressing the SHUT DOWN and RE-START button for more than 4 seconds.

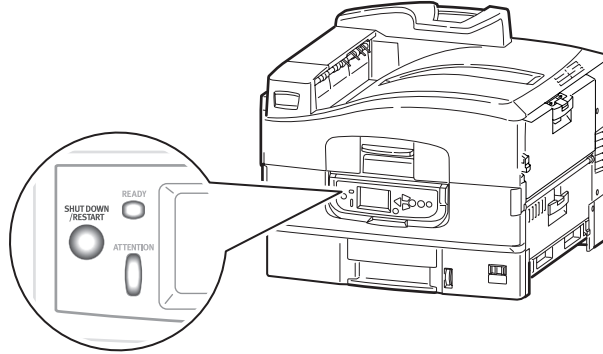

- (2) Press the OFF button where “COMPLETION OF SHUTDOWN/EITHER TURNING OFF THE SWITCH OR RE-START” appears on the screen.

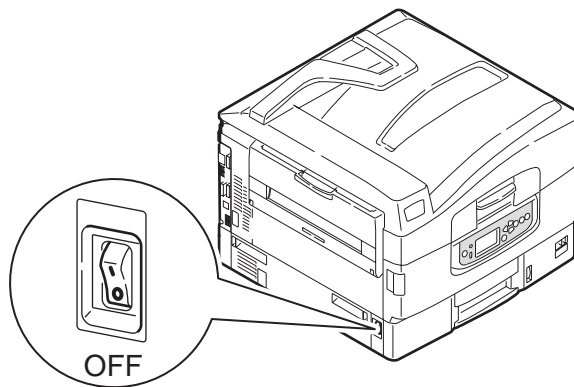
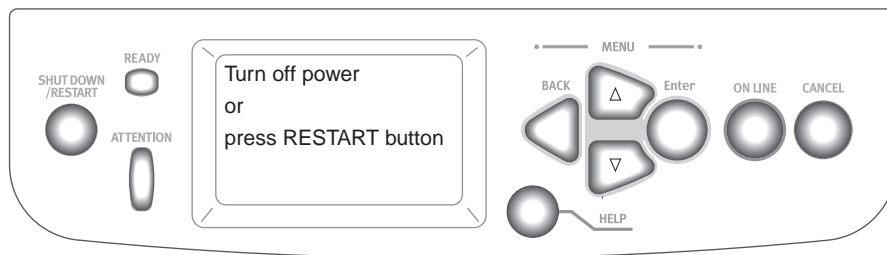

Memo: Press the SHUT DOWN/RE-START button as the procedure (2) to re-start the printer.

3.5.3 Installation of Optional Components

(1) Extension Memory Installation

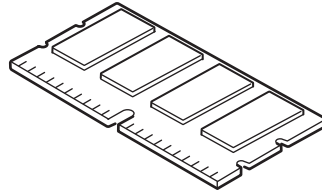

Install the extension memory to increase the memory space. Kinds of extension memory are 256 and 512MB.

- Note!**
- Reduce the degree of errors with adding extension memory when “memory overflow” or “collate error” appears on.
 - The limitcheck and VM errors when using a PS printer driver are thought to be the lack of memory space. Adding the extension memory may reduce the frequency of errors.
 - Normal operation is not guaranteed if using extension memory other than OKI Data genuine.
 - Printing speed does not change after adding the extension memory.

1. Power off printer and remove power supply cord and printer cable.

Note! Installing options to printers while the printers are powered on may cause a problem with the printers.

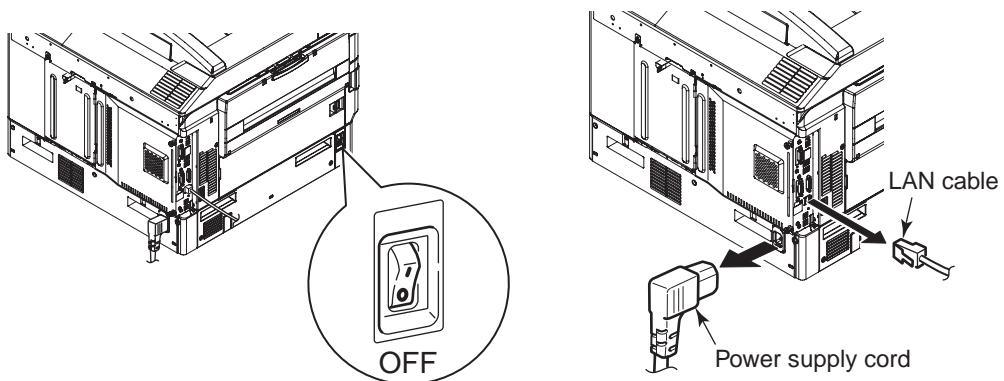

2. Loose 2 screws on the upper and lower area and open the gate side of printer.

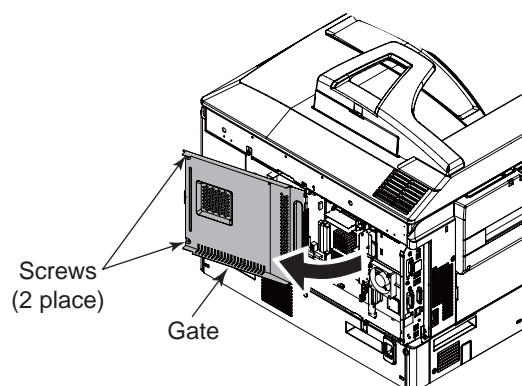

3. Before taking a memory out of bag, remove the electric static by bringing the bag into contact with the metal part of printer.

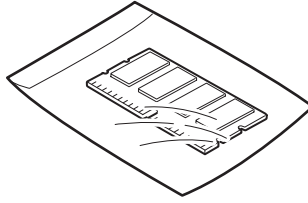

4. Insert a memory into the slot until hearing the sound of “click”.

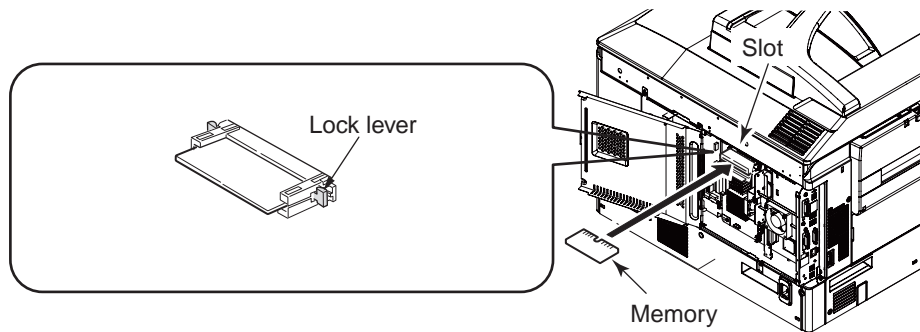

5. Check if a memory is held at the right and left of lock lever (blue color, 2 places).

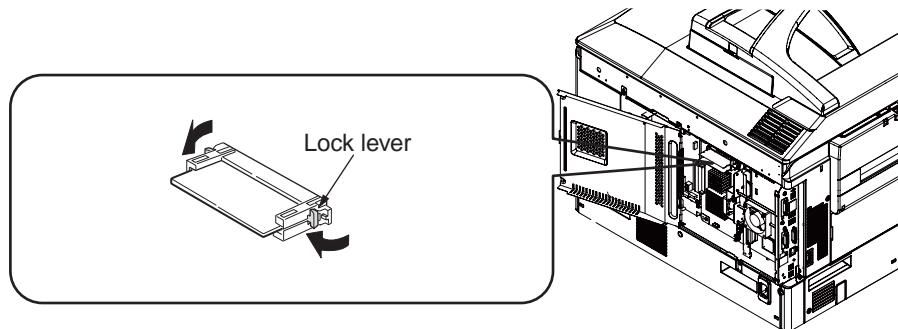

6. Close the gate and tighten the screws (2 screws, upper and lower)

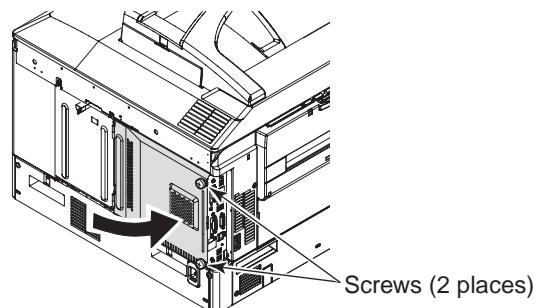

7. Plug in a power supply cord and a printer cable then press the power supply button.

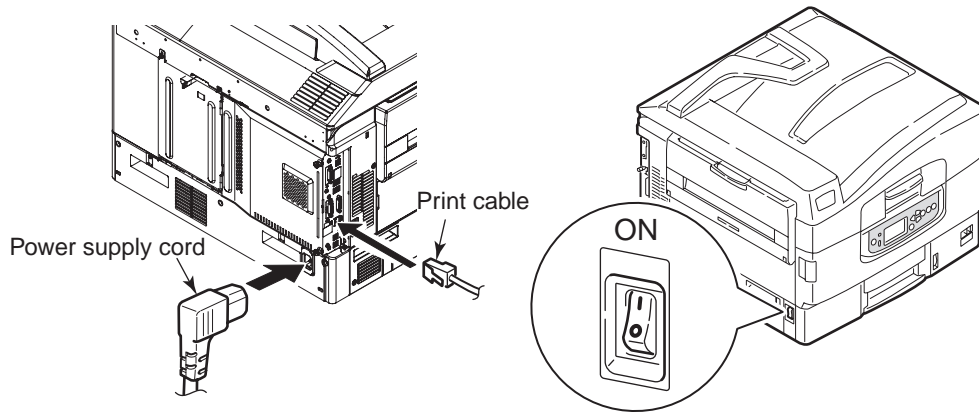

8. Print the Menu Map to see if installed correctly.
Re-install if an error appears on the Menu Map.

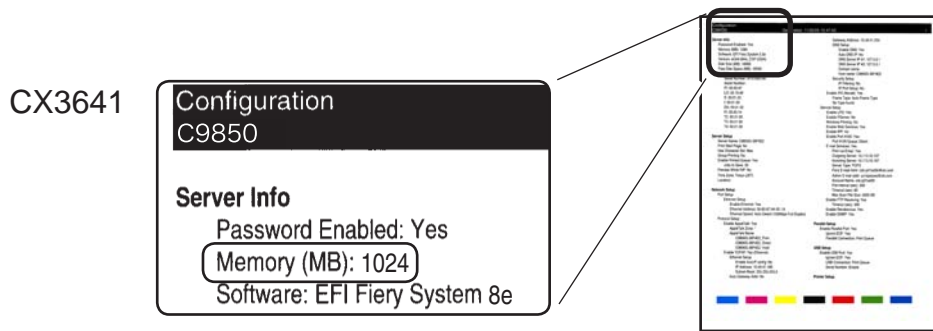

9. Set up for the extension memory is done by a printer driver.
Do the reverse procedure from installation for removal.

(2) Installation of Option Tray (Can hold large amount of papers)

Install the option tray where the number and kinds of papers need to be increased. Not only option tray has one layer but three layers tray, which combine into one tray. It is possible for option tray to install maximum of four layers, but five if the standard tray is included.

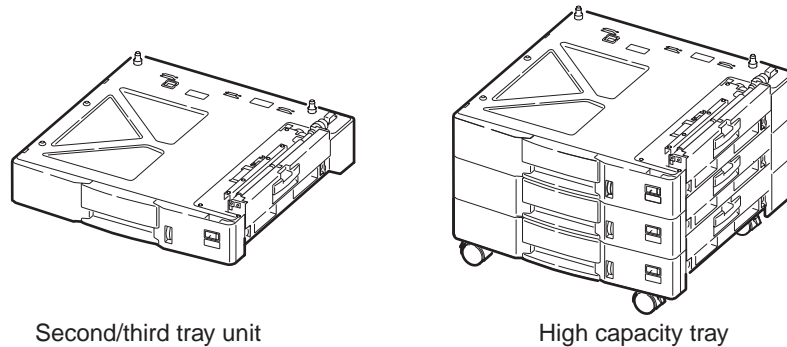

Installed option trays are called tray 2,3,4 and 5 from top to bottom order.

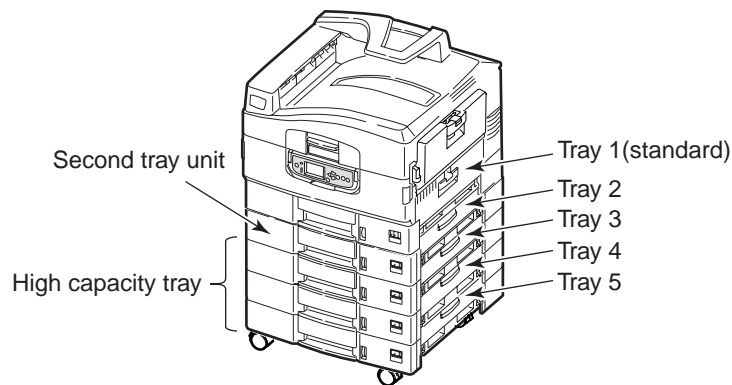

1. Power off printer and remove power supply cord and printer cable.

Note! Installing options to printers while the printers are powered on may cause a problem with the printers.

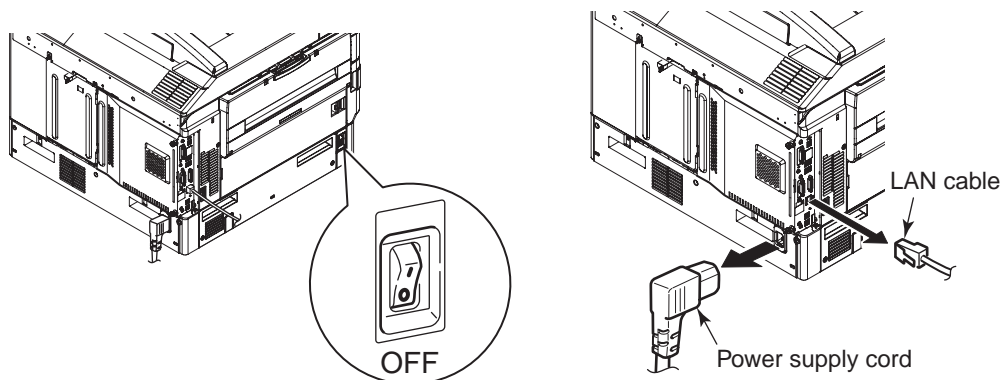

- Put the bottom surface of printer on the tray 2 aligning the protrusion with the cut on the bottom.

Note! The printer weighs about 77 kg. Lift it by three or more persons.

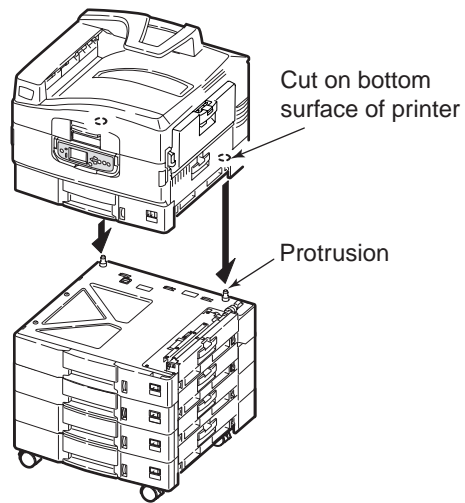

- Plug the power supply cord and the printer cable in and switch on the power supply.

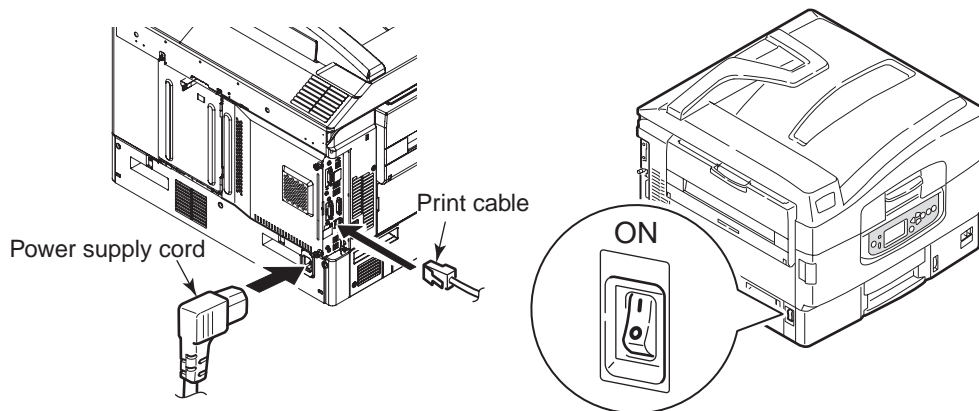

4. Print a menu map to see if installed correctly.

Re-install if an error appears on the menu map.

CX3641

Paper Size in Tray
Tray1: A4 Long Edge
MPTray: Letter Long Edge
Tray2: A3
Tray3: Letter Long Edge
Tray4: A4 Short Edge



5. Set up for the option tray by a printer driver.

Do the reverse procedure from installation for removal.

(3) Installation of Duplex-Unit

A duplex unit is used for printing both sides of papers.

Note! More memory is required for duplex-printing. Where the print speed become slow, the memory space lacks, either set up the print-quality “clear” or “normal” or installation of the extension memory are recommended.

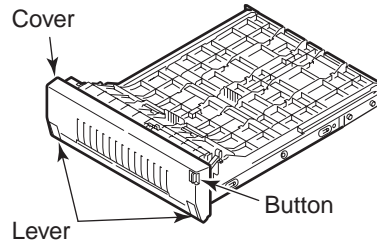

1. Power off printer and remove power supply cord and printer cable.

Note! Installing options to printers while the printers are powered on may cause a problem with the printers.

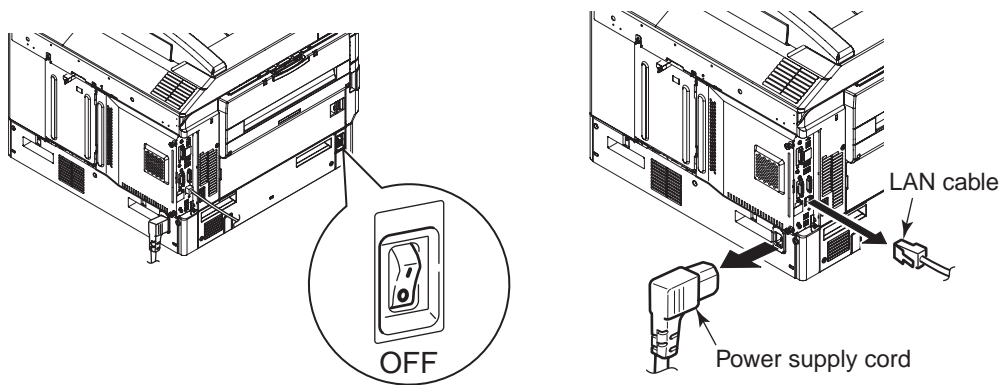

2. Hold a knob on the left side of printer.

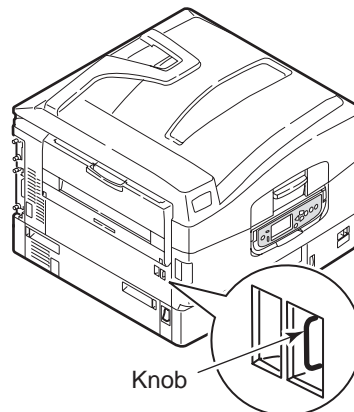

- Open and remove the cover toward the direction seen in figure.

Memo: Keep it until the duplex-print unit is removed.

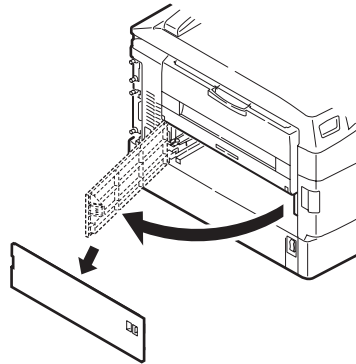

- Make sure that the rail posts on both sides of duplex-print unit are locked.

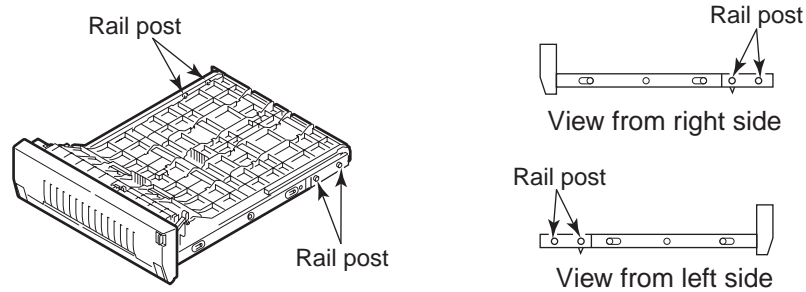

- Insert the duplex-print unit into the printer from the left side of printer.

Insert it up to the interior firmly.

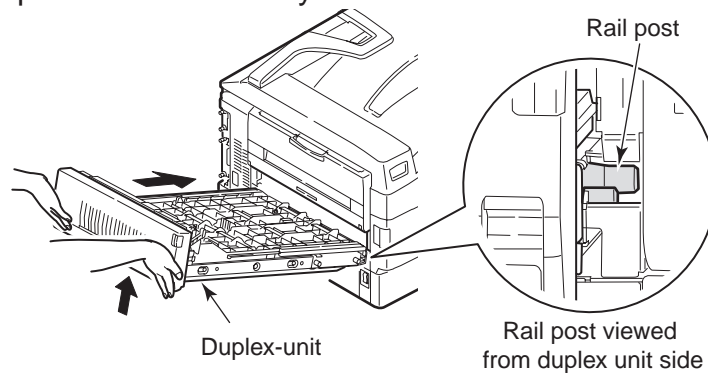

- Plug the power supply cord and the printer cable in and switch on the power supply.

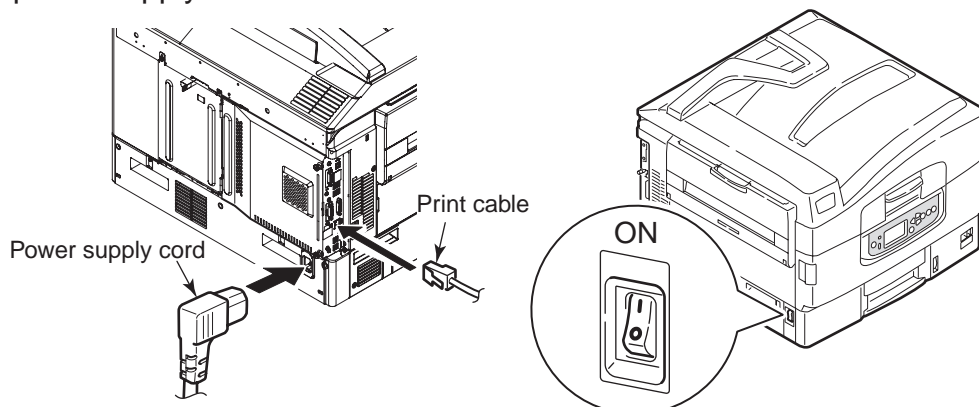

7. Print a menu map to see if installed correctly.

Re-install if an error appears on the menu map.

CX3641

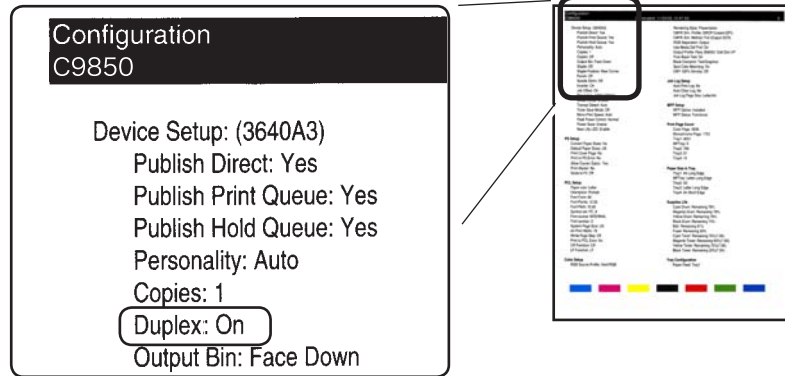

8. Set up for duplex-print unit on the icon.

Removal of Duplex- Print Unit

1. Turn off the power .

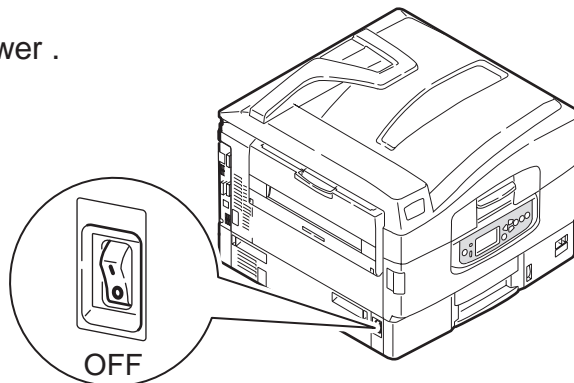

2. Press down the lever on the right side of unit.

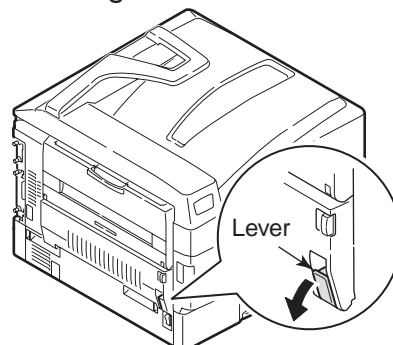

3. Hold the lever (both sides) and pull the unit until it stops. Remove it with holding unit up-wards.

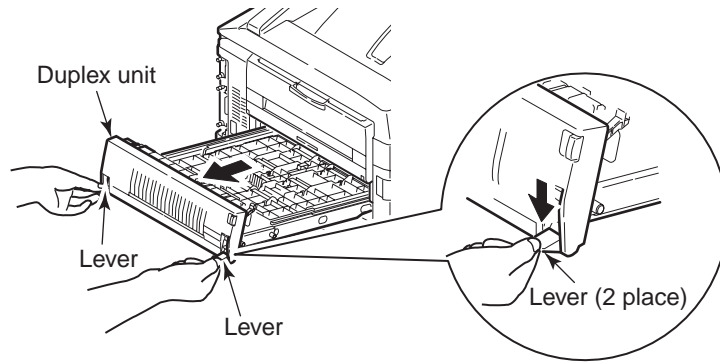

Memo: Install the cover, which is held in custody after the removal of duplex-print unit.

(4) Installation of internal hard disk

Note! Contact with a maker for download application and compatibility prior to download a font.

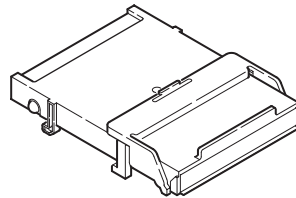

1. Power off printer and remove power supply cord and printer cable.

Note! Installing options to printers while the printers are powered on may cause a problem with the printers.

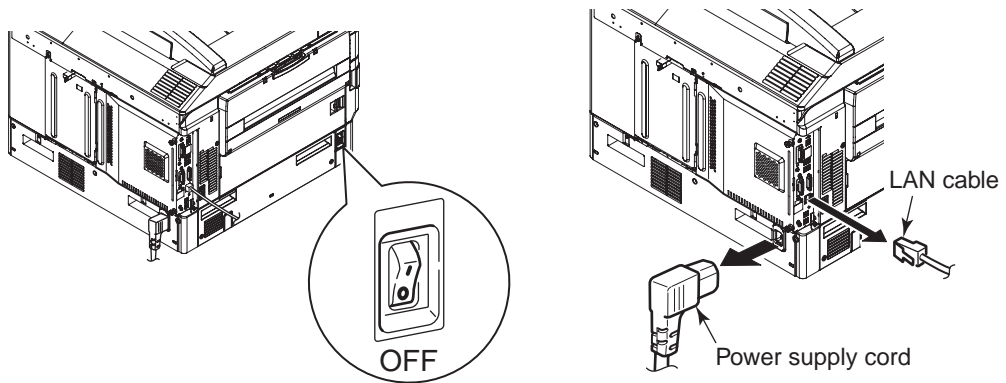

2. Loose 2 screws on the upper and lower area and open the gate side of printer.

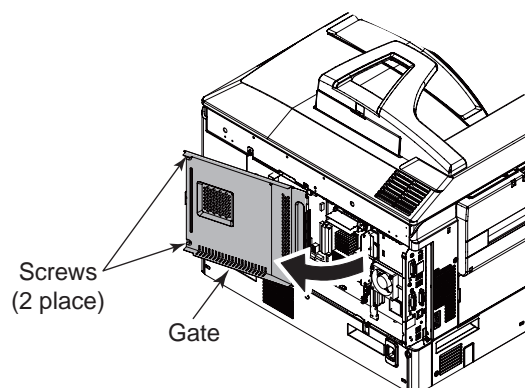

3. Hold a lock lever of internal hard disk.

* See "For Printer Model" if a printer is Printer Model.
See "For MFP Model" if a printer is MFP Model.

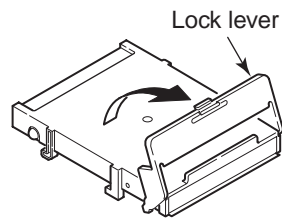

4. Set an internal hard disk fitting to "HDD" line.

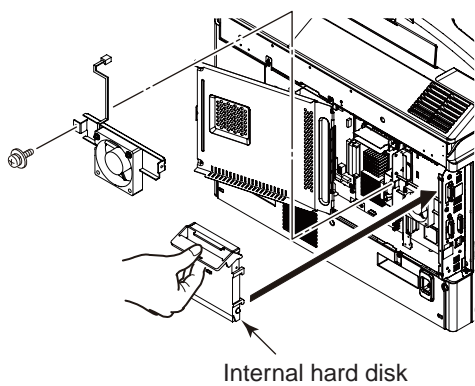

5. Fold the lock lever until hearing a sound of "click".

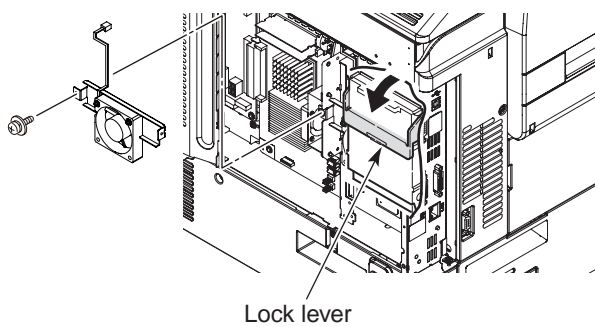

6. Close the gate and tighten the screws (2 places).

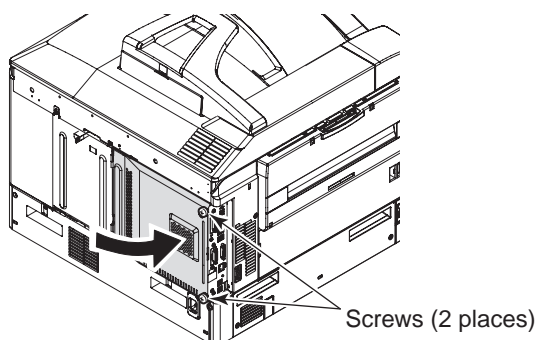

For MFP Model

- 4-1. Remove the two screws ①, and detach the FAN-Assy ②.
- 4-2. If a FAX-Board ③, which is an optional accessory, is attached, remove the three screws ④ and detach it .
- 4-3. Remove the four screws ⑤, and detach the Board-BANYAN ⑥.
- 4-4. Set an internal hard disk fitting to "HDD" line.

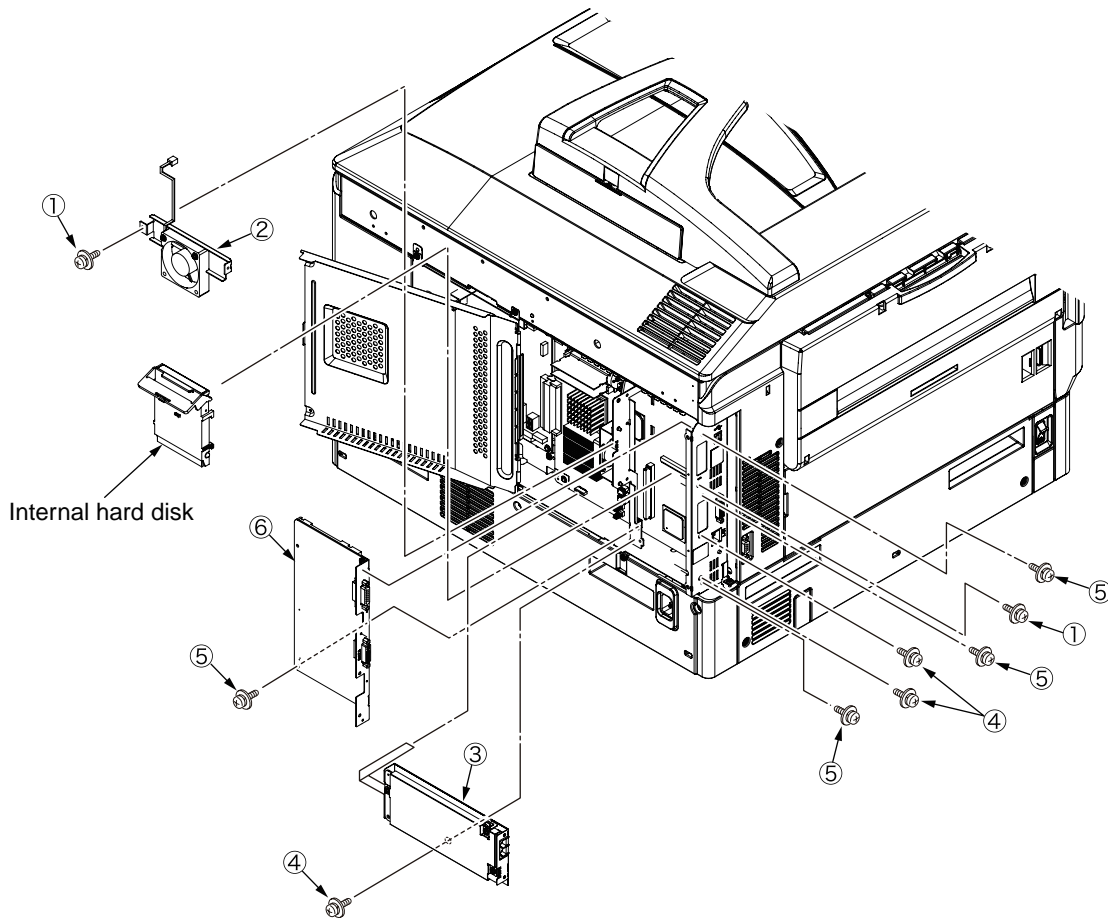

5-1. Fold the lock lever until hearing a sound of "click".

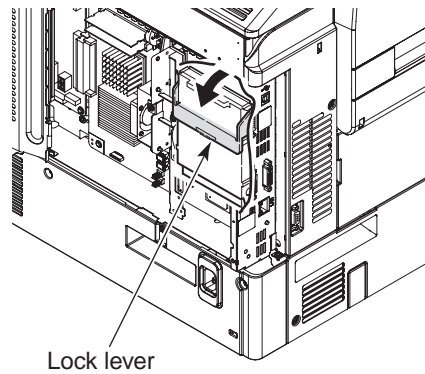

5-2. Replace the Board-BANYAN ⑥ , FAX-Board ③ and FAN-Assy ② .

6. Close the gate and tighten the screws(2 places).

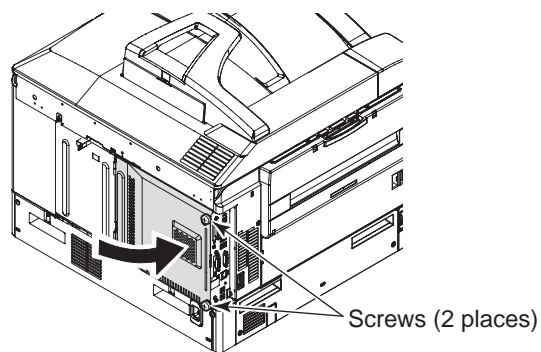

7. Plug the power supply cord and the printer cable in and switch on the power supply.

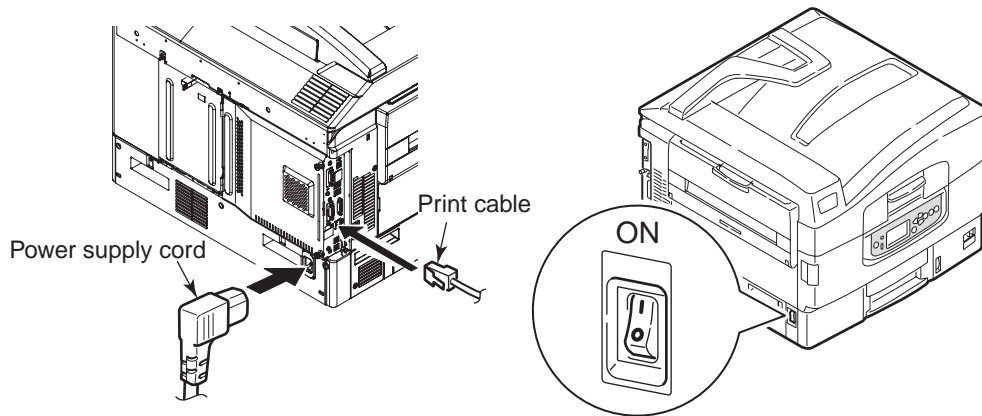

8. Print a menu map to see if installed correctly.

Re-install if an error appears on the menu map.

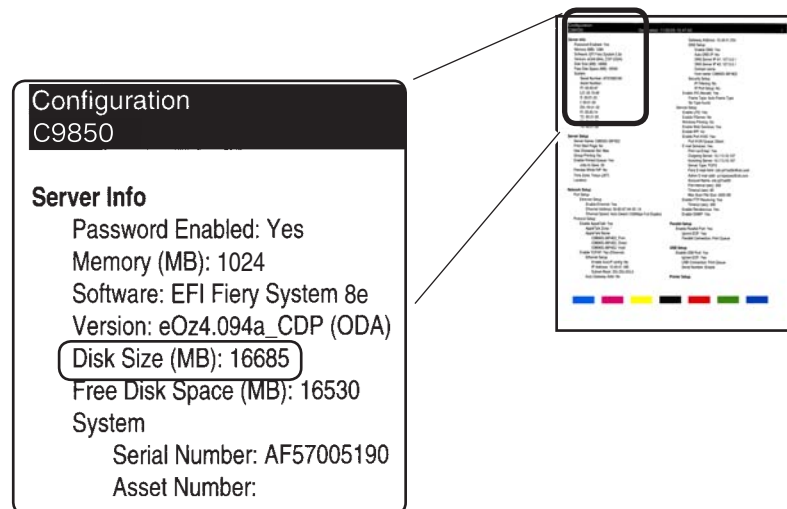

9. Set up the internal hard disk by a printer driver.

Do the reverse procedure from installation for removal.

3.5.4 Checking of Optional-Component Recognition

Please refer to “3.6 Menu Map Printing” to print MenuMap to confirm that options are correctly installed.

(1) Checking for Proper Extension Memory Recognition

Check Information Contained in MenuMap

Check the total memory size appearing at Total Memory Size on system information.

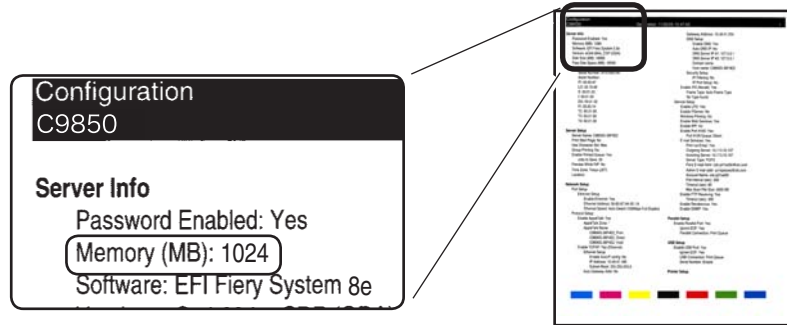

(2) Checking for Proper Second Tray Recognition

<Checking for Proper Second Tray Recognition>

Check Information Contained in MenuMap

Check Tray 2 is in the header part.

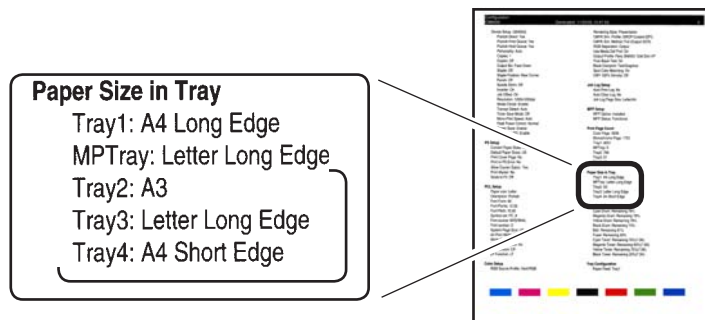

(3) Checking for Proper Duplex Unit Recognition

<Checking for Proper Duplex Unit Recognition>



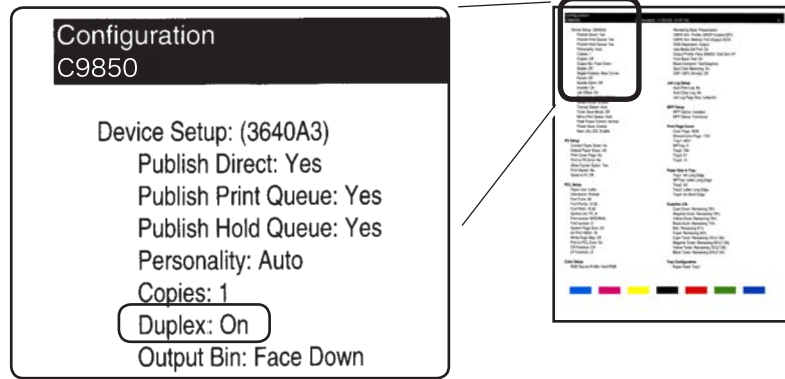

Check Information Contained in MenuMap

Check [Duplex printing : installed] is in the header of MenuMap.



3.6 MenuMap Printing

Make sure that the printer operates normally.

- (1) Place A4 sized papers on the tray.
- (2) Check if [READY TO PRINT] appears on the map.
- (3) Press the button  several times and select [PRINT PAGE] for CX3641, then press ENTER .
- (4) Press the button  and select [Network Info] for CX3641 and press ENTER .
- (5) Press the "ENTER"  switch.

(Sample) In case of CX3641



3.7 How to Connect

(1) Procedure for LAN cable

1. Prepare the LAN cable.

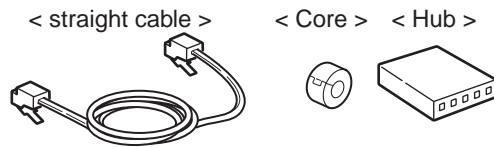

2. Turn off the printer and personal computer .

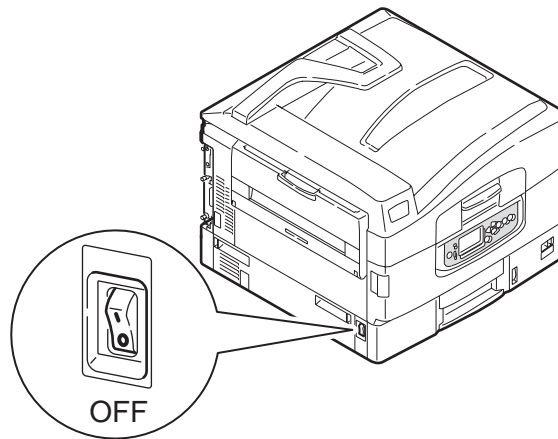

3. As seen in figure below, make a circle with a straight cable, which is about 3cm from the connector of printer.

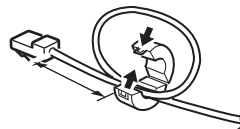

4. Connect a straight cable into the network interface connector of the printer.
5. Connect a straight cable into the hub.

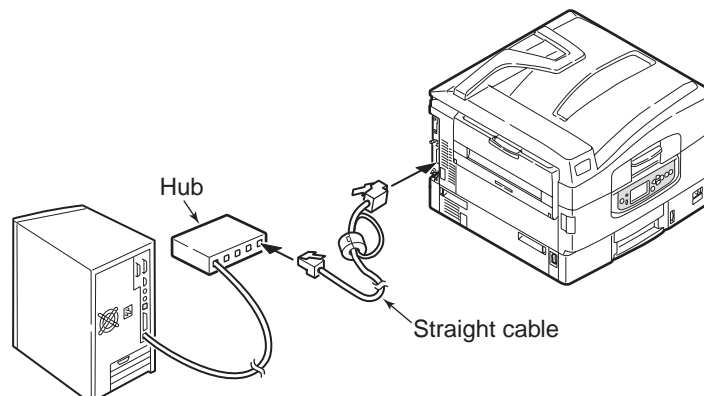

(2) USB Connection

1. Prepare a USB cable.

- Note!**
- No cables are included with the product. Prepare a cable.
 - A cable to be prepared must be a USB cable.
 - For connecting the printer in USB 2.0 Hi-Speed mode, use a Hi-Speed USB cable.



2. Power off printer and personal computer

Memo: The USB cable can be plugged in and off with the printer powered on. For the purpose of printer driver and USB driver installation to be performed later, power off the printer.

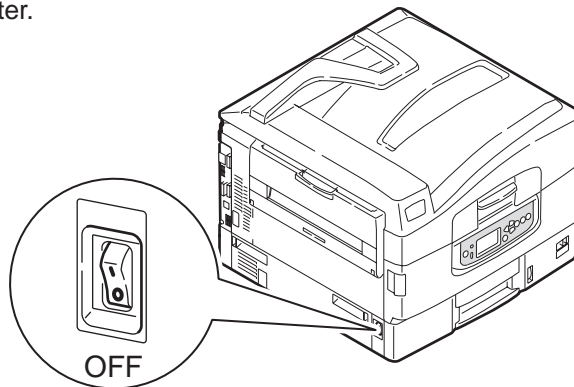

3. Connect personal computer and printer

- (1) Plug a prepared USB cable in the USB interface connector of the printer.
- (2) Plug the cable in the USB interface connector of the personal computer.

Note! Be careful not to plug the USB cable in the network interface connectors; a problem with the printer may result.

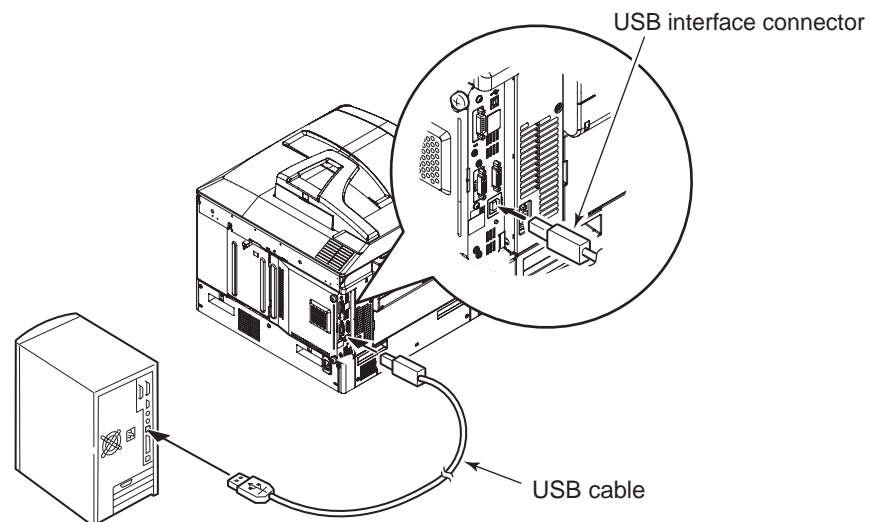

(3) Parallel Connection

1. Prepare a parallel cable.

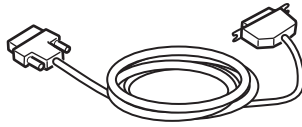

2. Power off Printer and Personal Computer

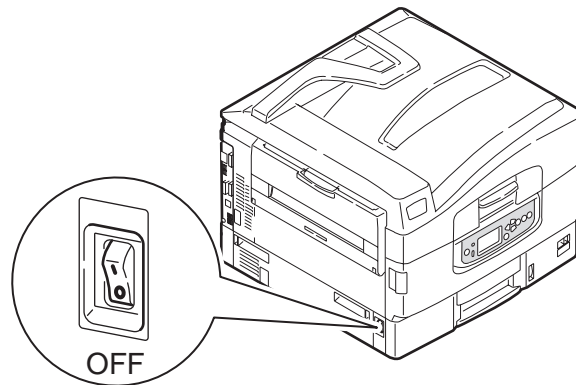

3. Connect Personal Computer and Printer

- (1) Connect a parallel cable into a parallel interface connector of printer and use metal fittings to secure the cable.
- (2) Connect a parallel cable into a parallel interface connector of PC and use screw to secure the cable.

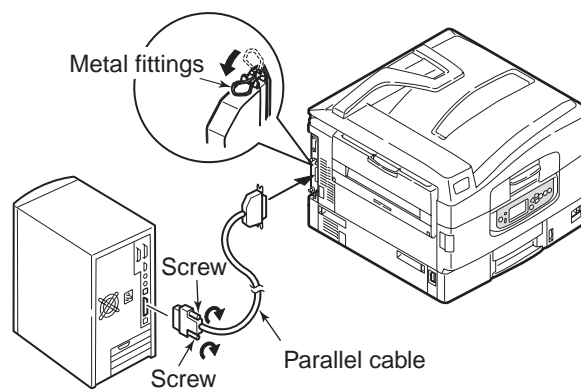

3.8 Checking of User Paper

Load the paper in printers used by users, select the settings at MEDIA TYPE and MEDIA WEIGHT and print MenuMap and Demo Page to check no occurrence of peeled off toner.

Types	Weight	Setting values of the operation panel		Setting *2 for [Media weight] of the printer driver
		Media weight	Media type *1	
Plain paper*3	17 ≤ W < 18 lb (64 ≤ W < 68g/m ²)	Light	Plain	Light
	18 ≤ W < 20 lb (68 ≤ W < 75g/m ²)	Medium Light		Medium
	20 ≤ W ≤ 28 lb (75 ≤ W ≤ 105g/m ²)	Medium		Heavy
	28 < W ≤ 32 lb (105 < W ≤ 120g/m ²)	Medium Heavy		Ultra heavy
	32 < W ≤ 34 lb (120 < W ≤ 128g/m ²)	Heavy		
	34 < W ≤ 50 lb (128 < W ≤ 188g/m ²)	Ultra Heavy		
	50 < W ≤ 57 lb (188 < W ≤ 216g/m ²)	Special Heavy1		
	57 < W ≤ 71 lb (216 < W ≤ 268g/m ²)	Special Heavy 2		
	71 < W ≤ 83 lb (268 < W ≤ 307g/m ²)	Special Heavy 3		-
Postcard*4	-	-	-	-
Envelope*4	-	-	-	-
	Less than 0.1-0.17mm	Light ~ Heavy	Label paper	Label paper 1
	0.17-0.2mm	Ultra Heavy ~		Label paper 2
Transparency*5 film	-	-	Transparency film	Transparencyfilm

*1 : [Light] is set as factory-default of media type.

*2 : Media weight and type can be set by the operation panel and the printer driver. The printer driver takes priority if it is set in the printer driver. Images are printed out by the setting of the operation panel when [Auto selection] is set in [Feed tray] or [Printer setting] is set in [Media weight].

*3 : The ream weight of the paper for duplex print is 17-32lb (64-120g/m²).

*4 : It is unnecessary for postcards and envelopes to set media weight and type.

*5 : Only media type is set for Transparency film. It is not required to set media weight.

Memo: Print speed decelerates when [Ultra heavy] of media weight or [Label paper], [Transparency film] of media type is set.

4. PARTS REPLACEMENT

This section describes the parts in the field, assembly and the procedures to replace the parts, assembly and unit. Note that only the disassembling procedures are described to replace parts. To assemble parts, just follow the steps in reverse order of disassembling.

4.1 Precautions When Replacing Parts

- (1) ALWAYS unplugging the AC cable and interface cables before replacing parts.
 - (a) ALWAYS perform the following procedures when unplugging the AC cable.
 - ① Press the shutdown button on the operator panel. When the printer is ready to be powered off, turn off the power switch of the printer.
 - ② Unplug the AC inlet plug of the AC cable from the AC receptacle.
 - ③ Unplug the AC cable and disconnect the interface cables from the printer.
 - (b) ALWAYS perform the following procedures to reconnect the printer.
 - ① Connect the AC cable and interface cables to the printer.
 - ② Connect the AC inlet plug into the AC receptacle.
 - ③ Turn ON "I" the power of the printer.

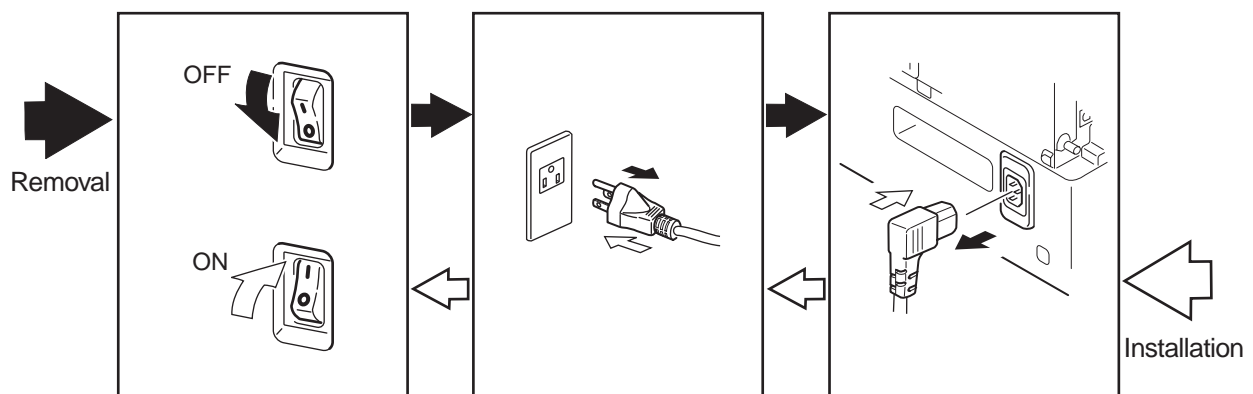









- (2) NEVER disassemble the printer when it is operating normally.
- (3) When disassembling the Assy, disassemble only the minimum necessary. NEVER remove any parts other than those indicated in the Parts Replacement Procedures.
- (4) Only use designated Maintenance Tools.
- (5) Disassemble the parts according to the order instructed. Failure to do so may result in damaging the parts.
- (6) Temporarily screw back on the screw, collar and other small parts on it's original location, to prevent losing these parts.
- (7) NEVER wear gloves when handling the micro processor, ROM, RAM and other IC parts or the circuit PCB, since gloves may generate static electricity.
- (8) NEVER place the printer PCB directly on the unit or floor.

[Maintenance Tools]

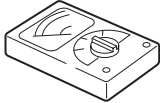
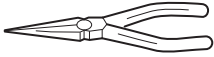
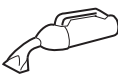
The tools necessary to replace the printed circuit board (PCB) and unit are indicated in Table 4-1.

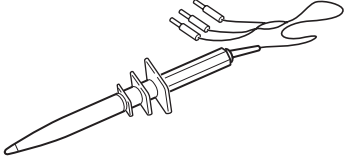
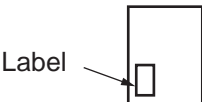
Table 4-1 Maintenance Tools

No.	Maintenance Tools	Quantity	Purpose	Remarks
1	 No. 1-100 + Screw Driver	1	2-2.5 mm screw	
2	 No. 2-200 + Magnetic Screw Driver	1	3-5 mm screw	
3	 No. 3-100 Screw Driver	1		
4	 No. 5-200 Screw Driver	1		
5	 Digital Multimeter	1		
6	 Pliers	1		
7	 Portable Vacuum Cleaner	1		
8	 LED Head Cleaner P/N 4PB4083-2248P001	1	LED Head Cleaner	
9	 High Voltage Probe	1		
10	 Cut-Sheet Film (Maintenance) 42404301	1	Paper Thickness Sensor for Adjustment Transparency Sheet	
11	 - Micro-Driver 2.0mm	1	Paper Thickness for Adjustment	

4.2 Parts Layout

MAIN

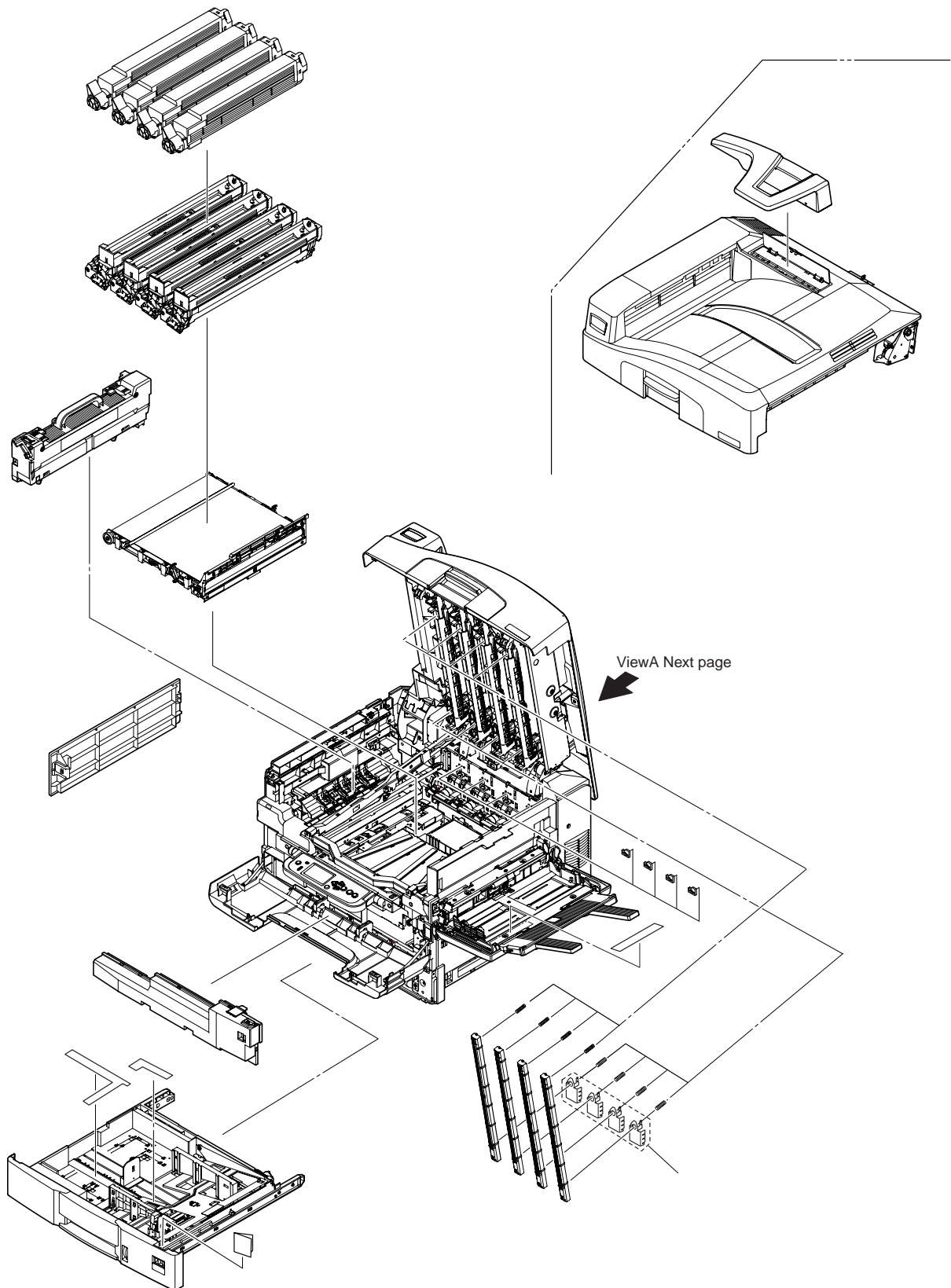

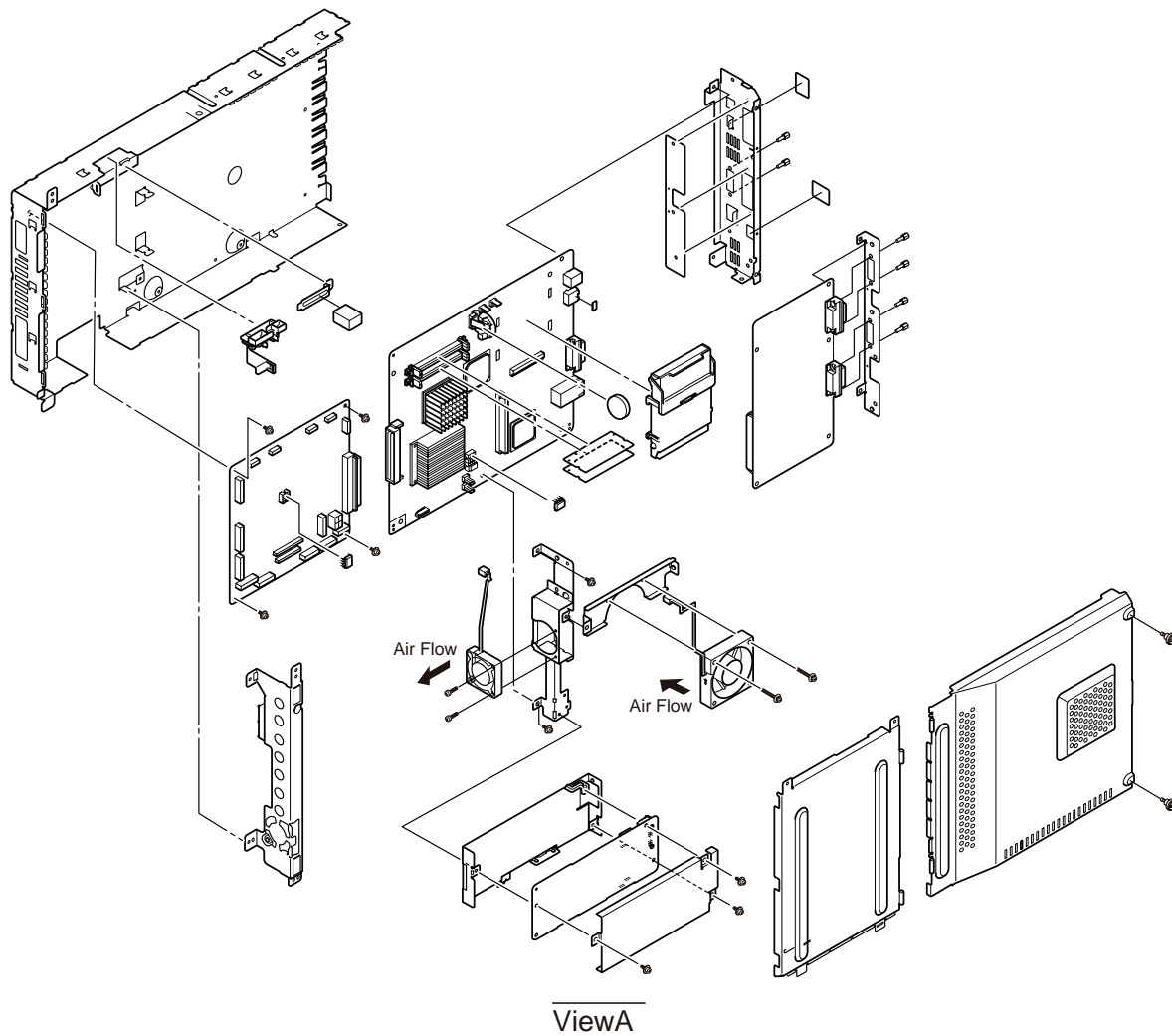

Printer Unit - (120V) (1/2)

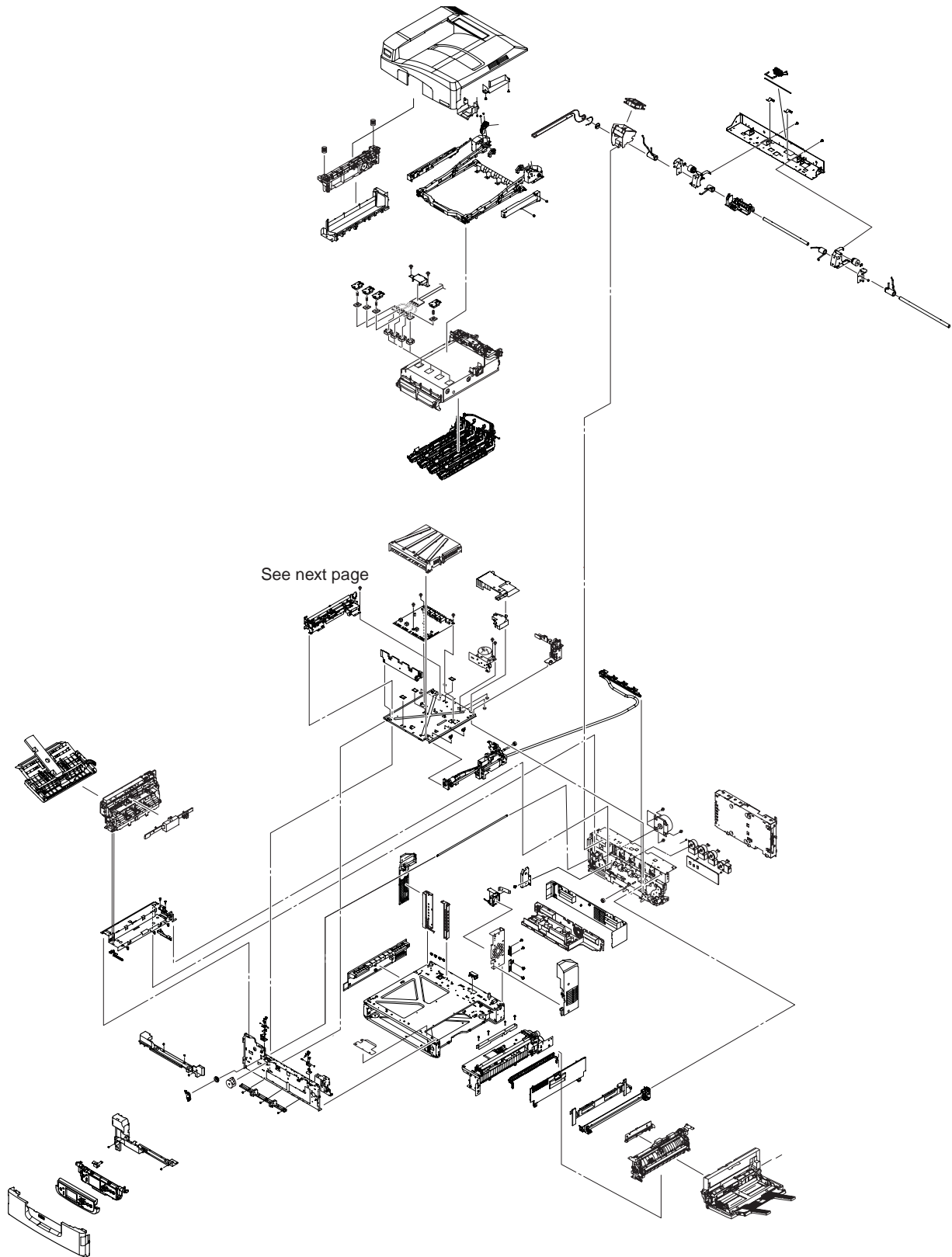

Printer Unit - (120V) (2/2)

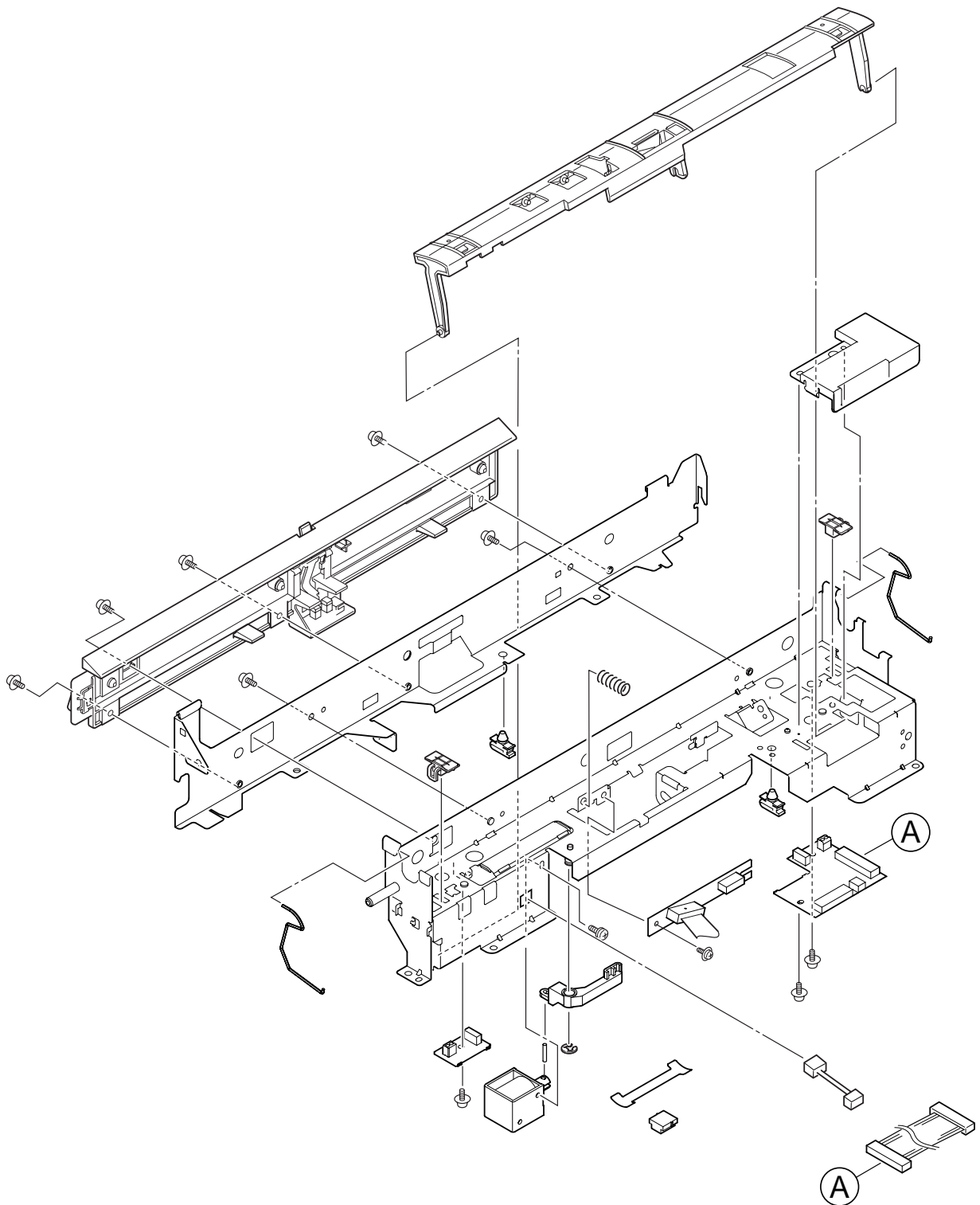
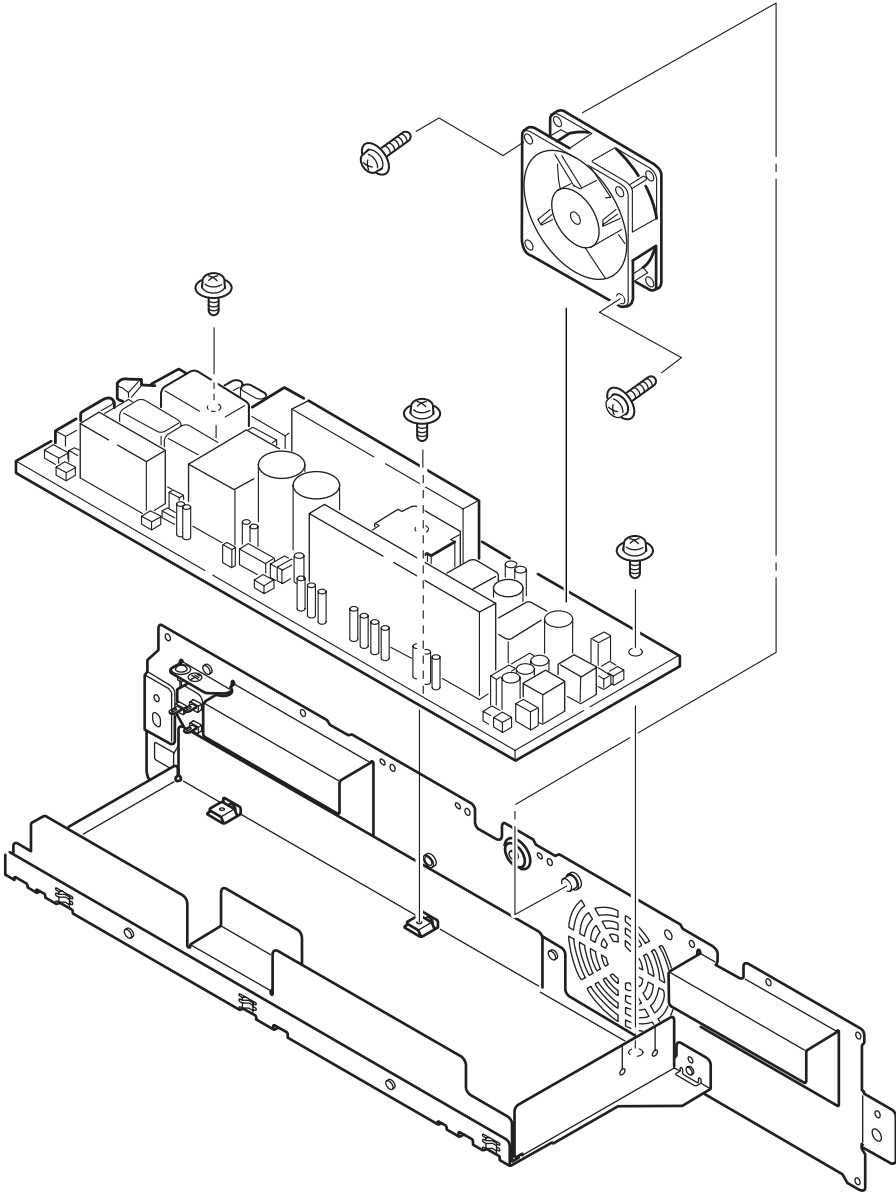
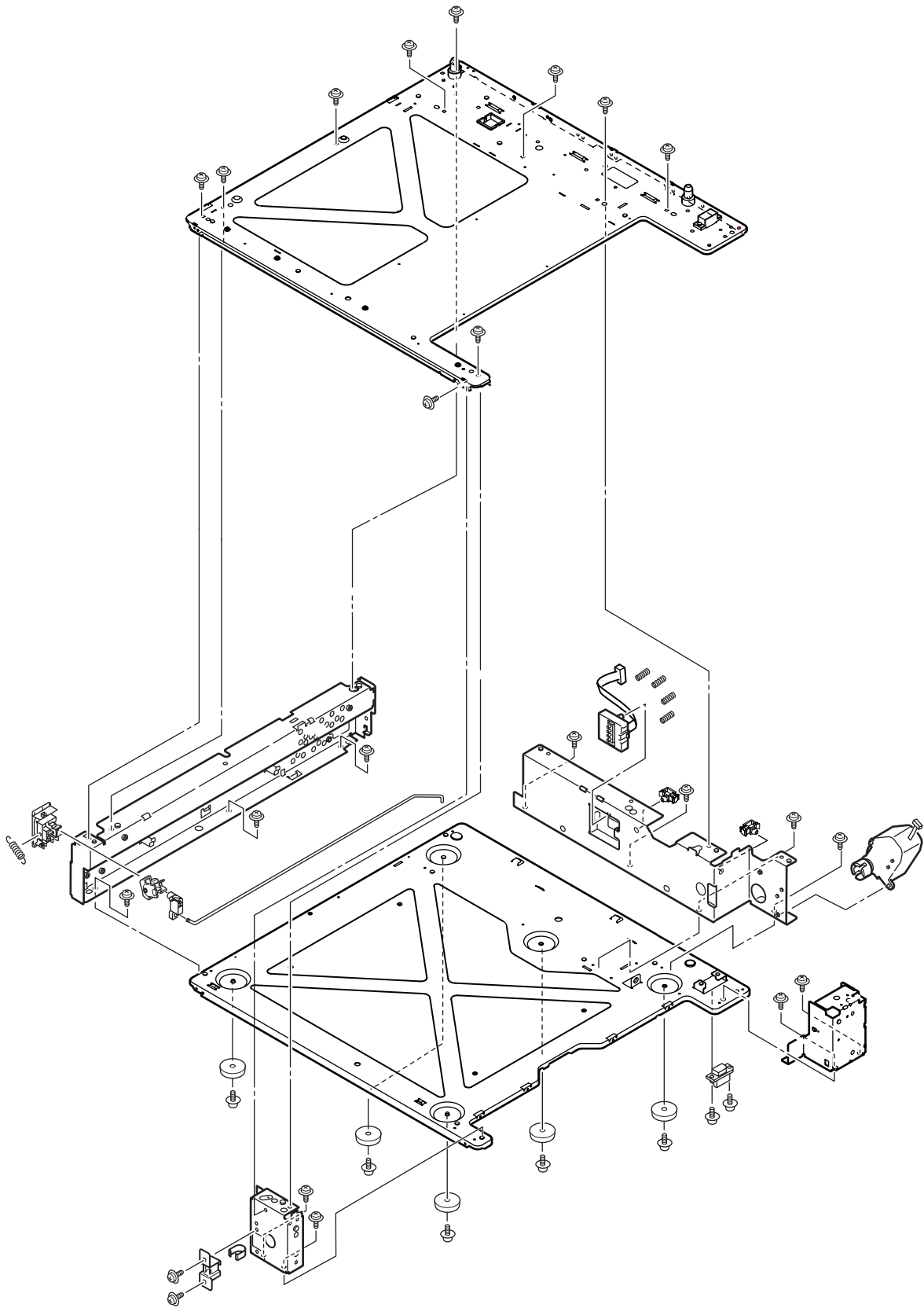

Plate-Assy-Power_100V/120V

Plate-Assy-Power_230V



Base-Assy (1/2)



Base-Assy (2/2)

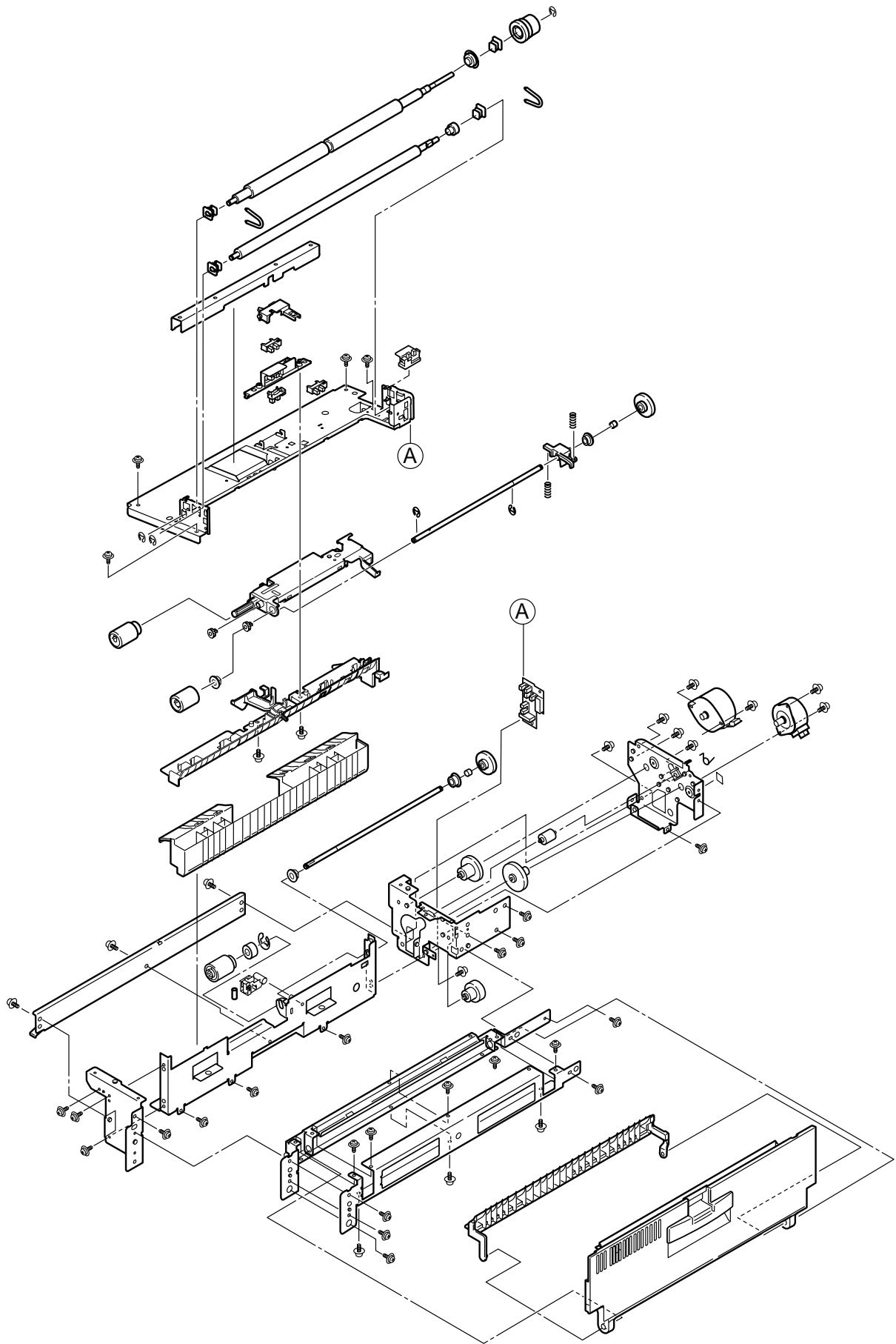

Side-R-Assy

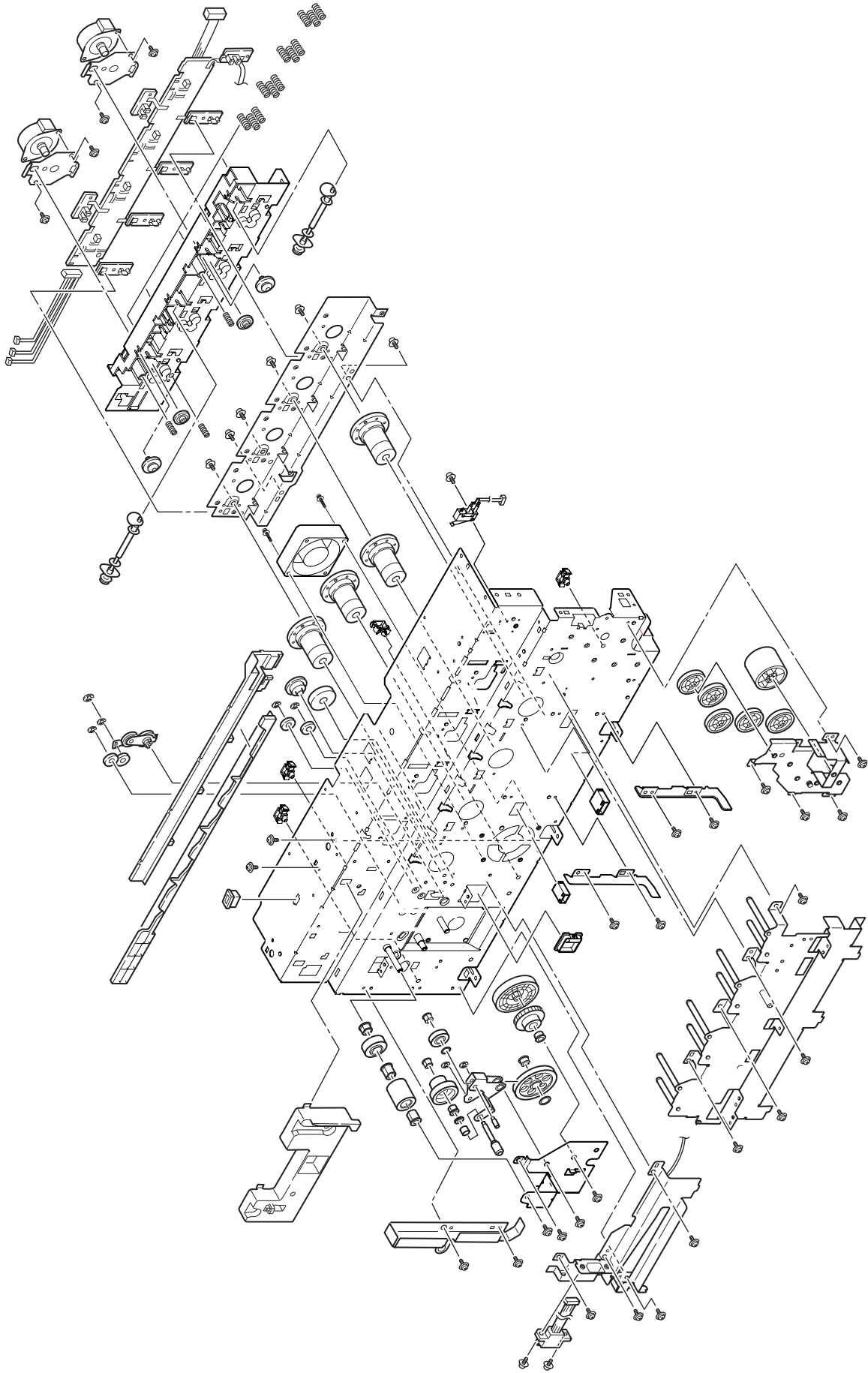

Side-F-Assy

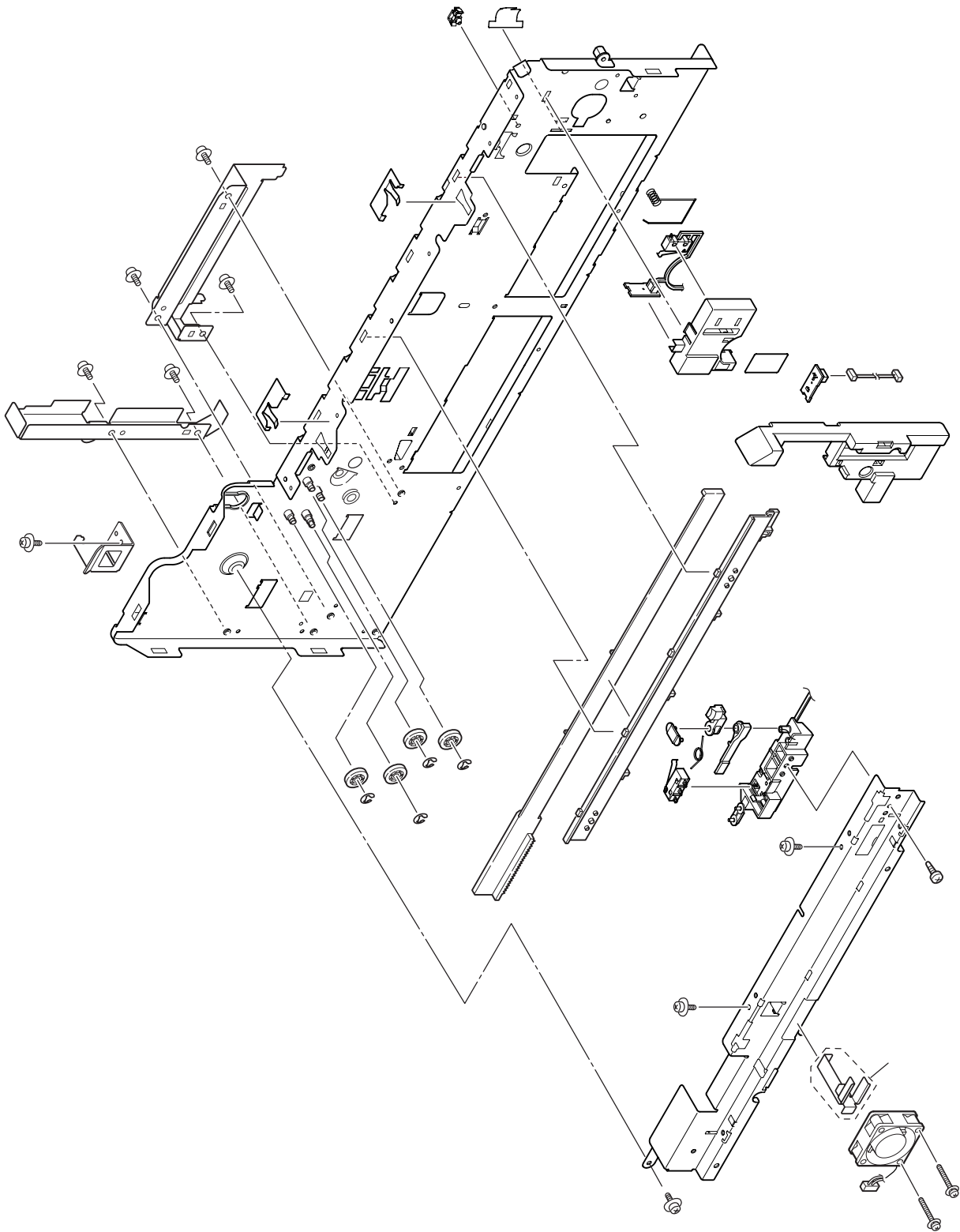

Duct-Drive-Assy

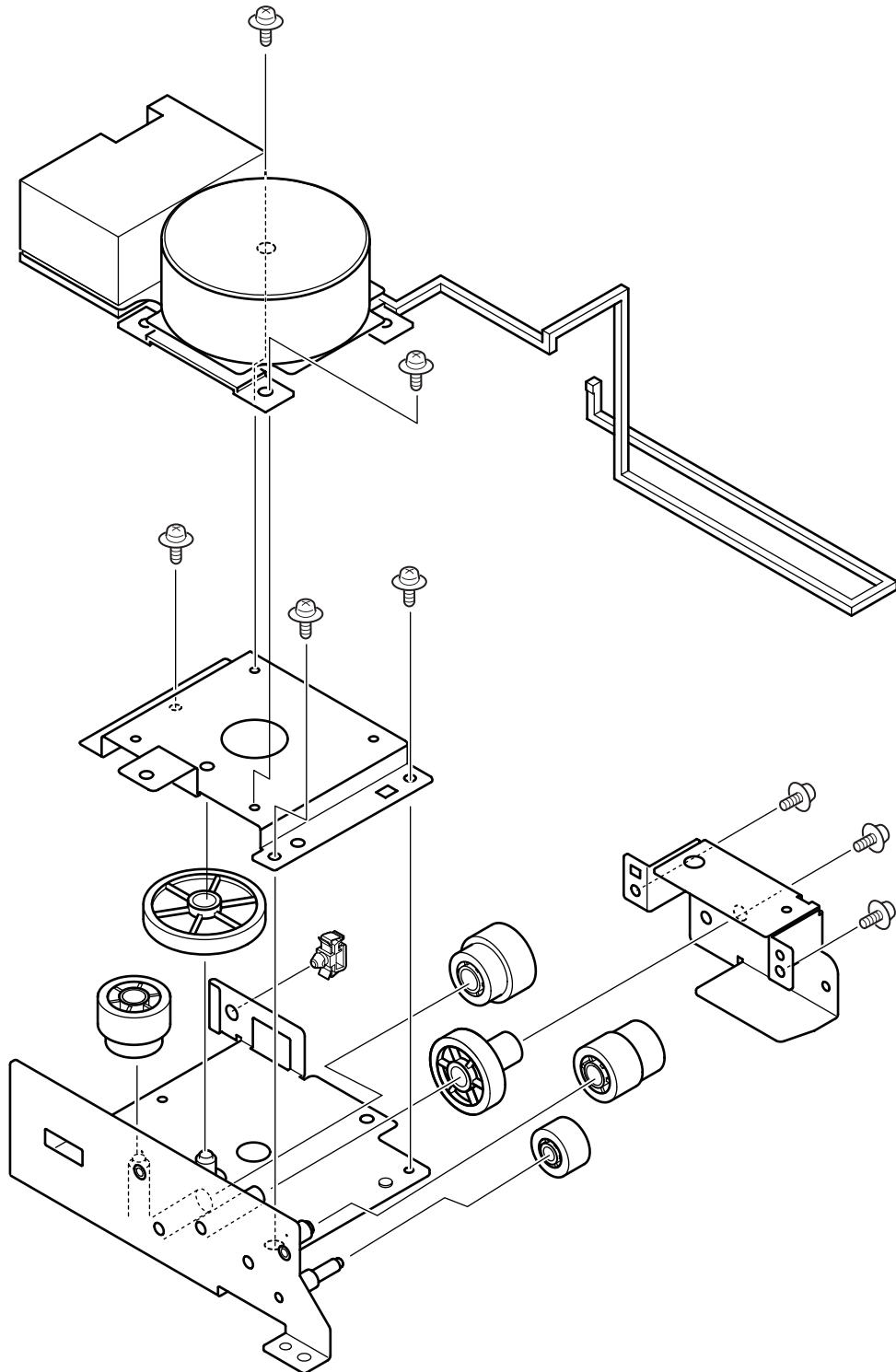

FDR-Unit-Regist

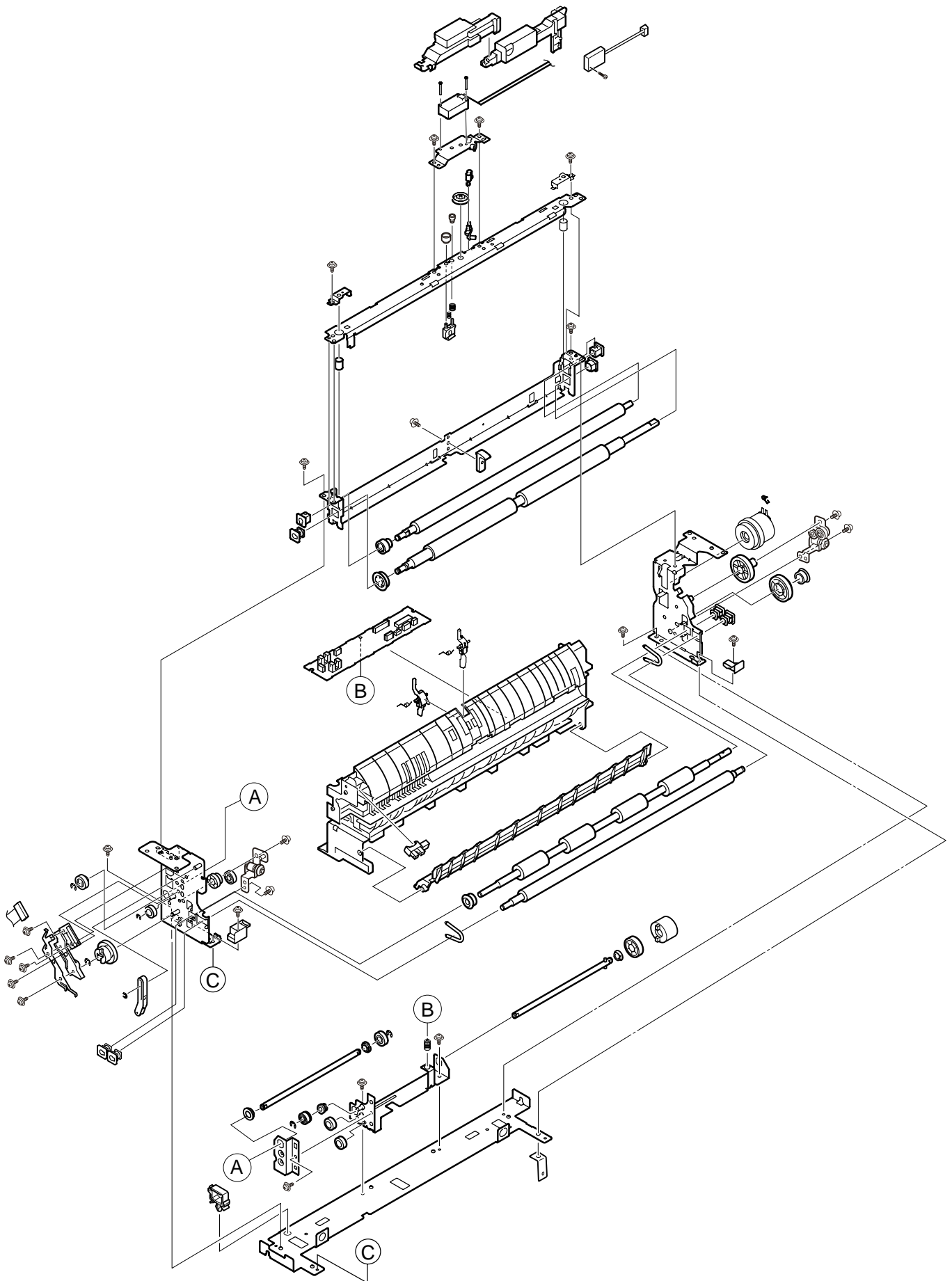

FDR-Unit-MPT

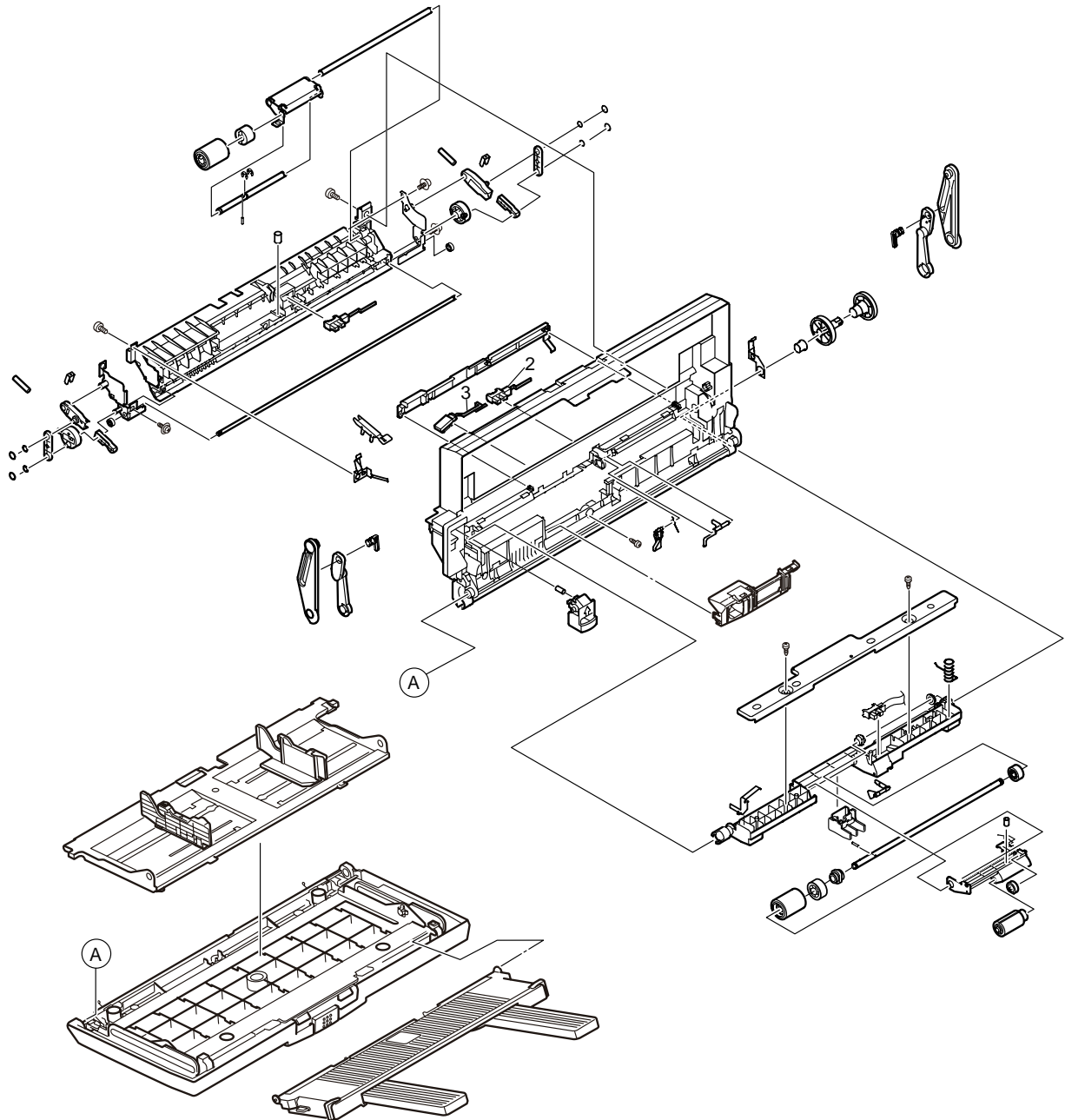

Eject-Assy

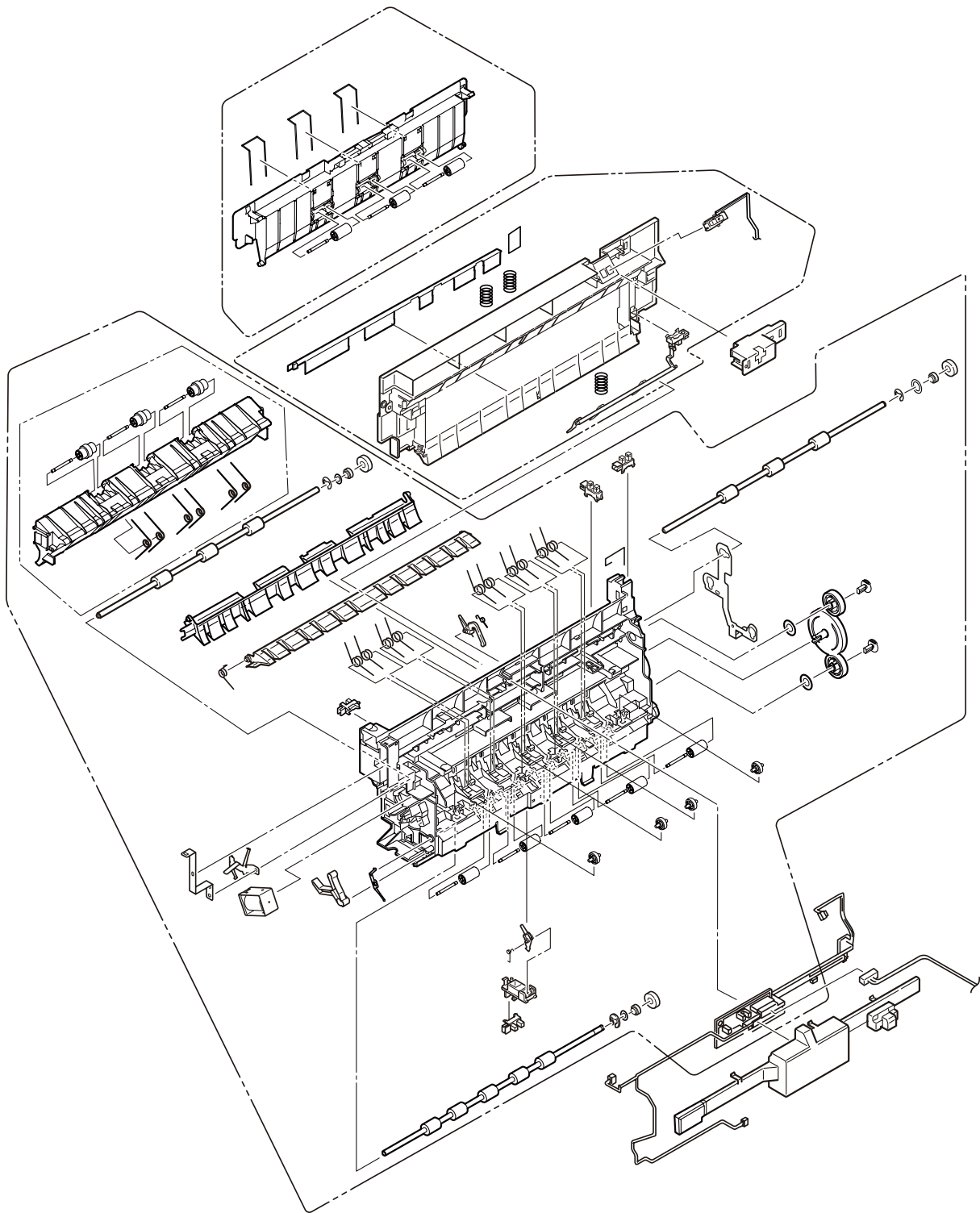
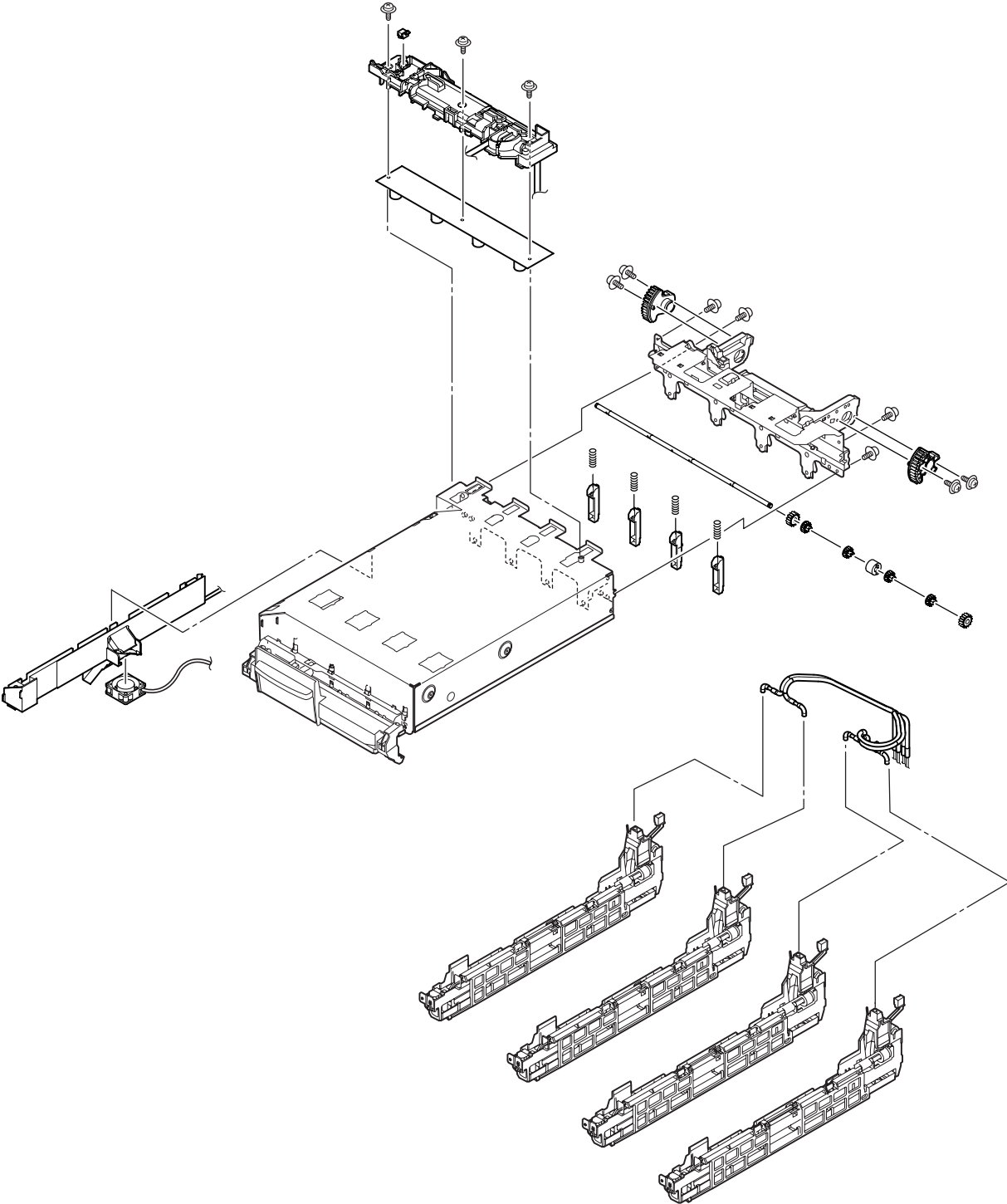
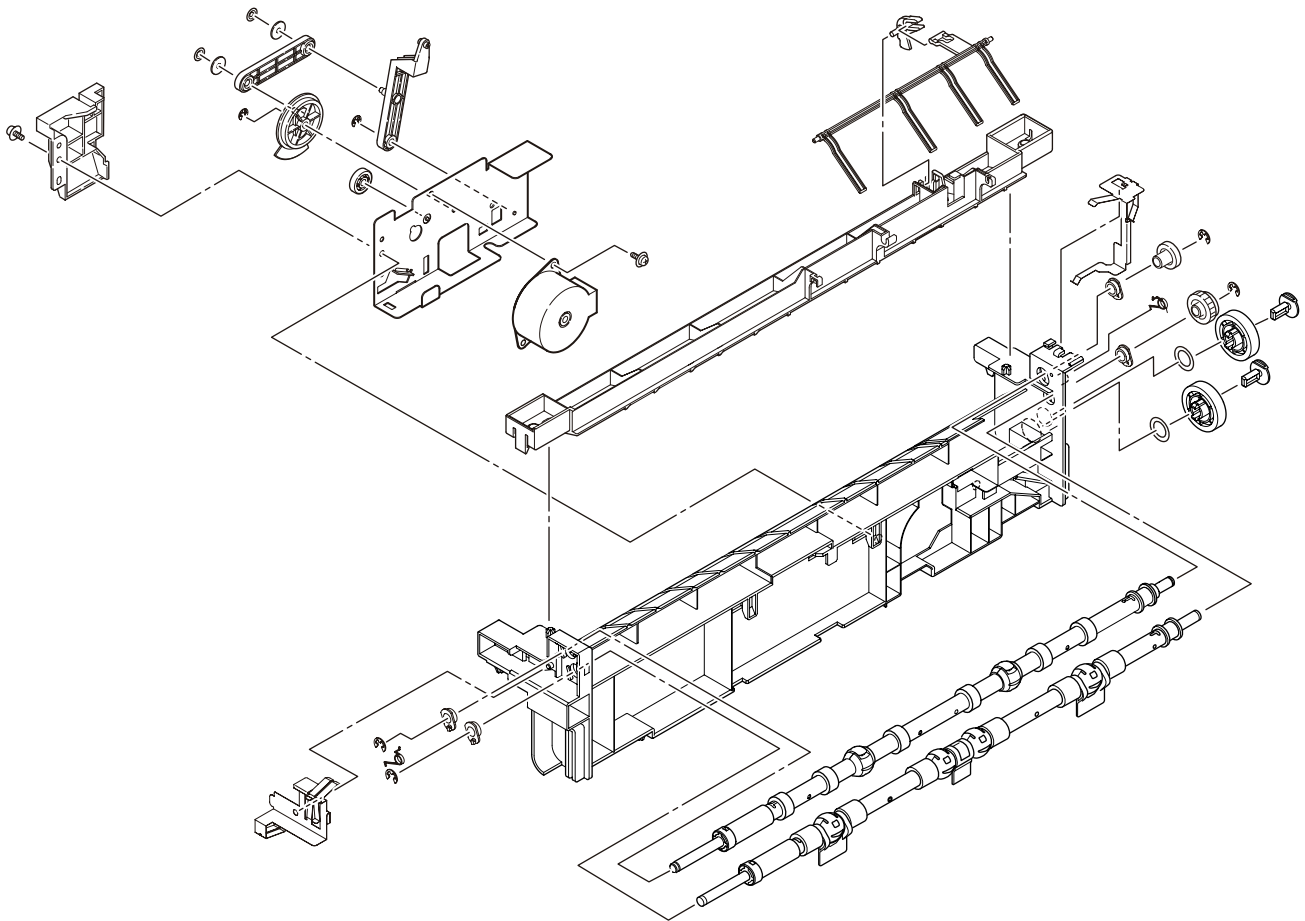

Plate-Top-Assy



Job-Offset-Assy



Basket-Assy

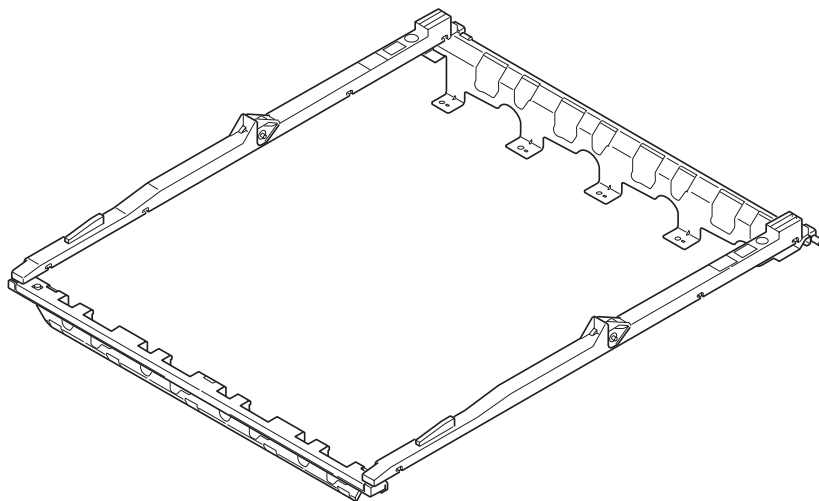
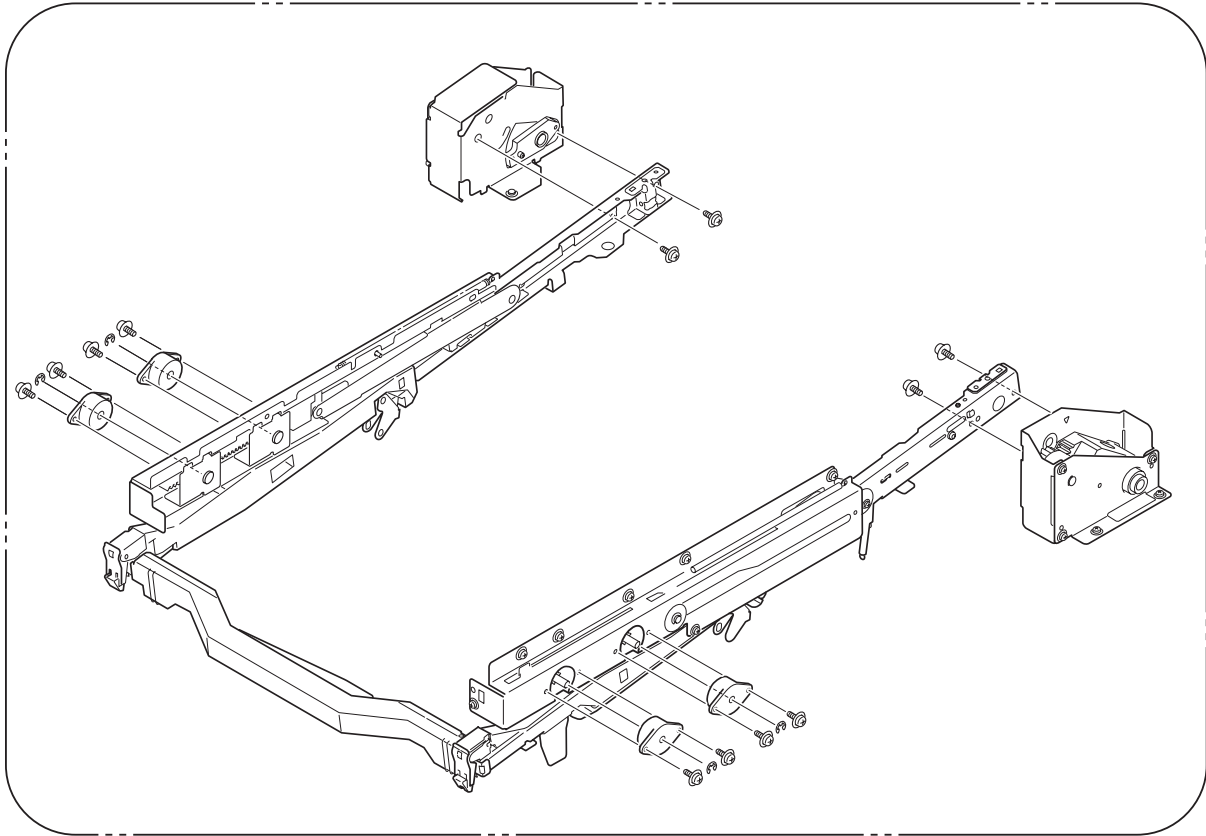

4.3 Parts Replacement Method

This section describes the procedures to replace the parts and assembly indicated in the disassembly diagram.

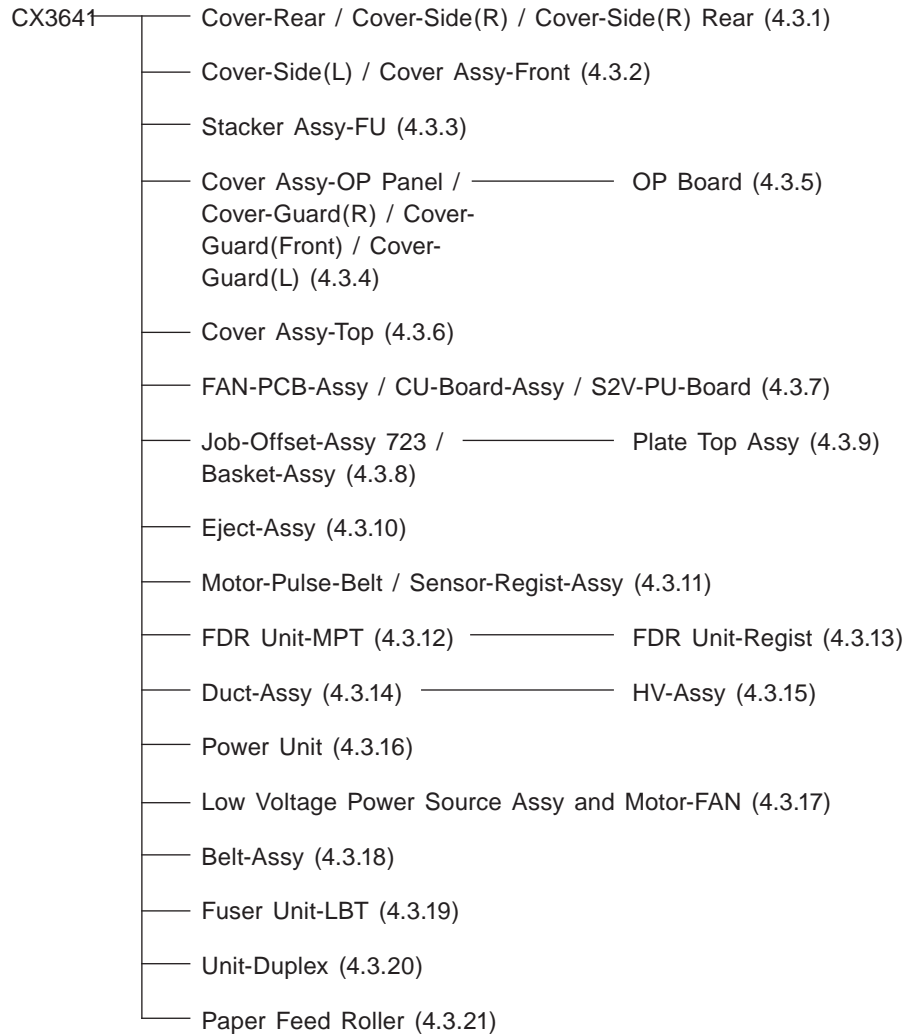

4.3.1 Cover-Rear, Cover-Side (R), and Cover-Side (R) Rear

- (1) Open Cover Assy-Top ①.
- (2) Unscrew the 5 screws ②, then remove Cover-Rear ③.
- (3) Unscrew the 2 screws ④, then remove Cover-Side (R) ⑤ with it warped.
- (4) Unscrew the screws ⑥, then remove Cover-Side (R) Rear ⑦.

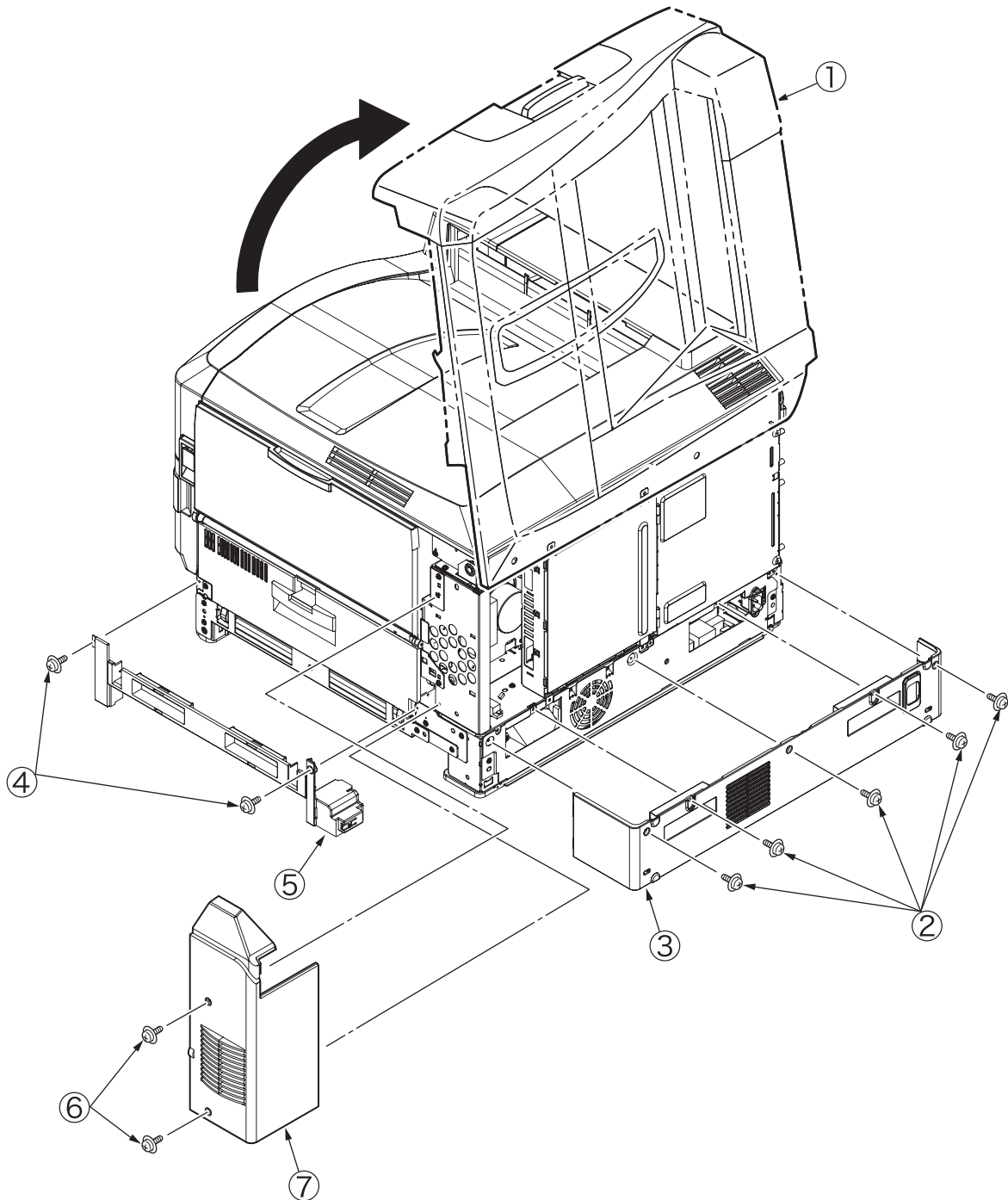

4.3.2 Cover-Side (L) and Cover Assy-Front

- (1) Open Cover Assy-Top ①.
- (2) Unscrew the 4 screws ②, then remove the Cover-Side (L) ③.
- (3) Open the Cover Assy-Front ④ by 90°, unscrew the 2 screws ⑤, then slide the Assy to the side and remove.

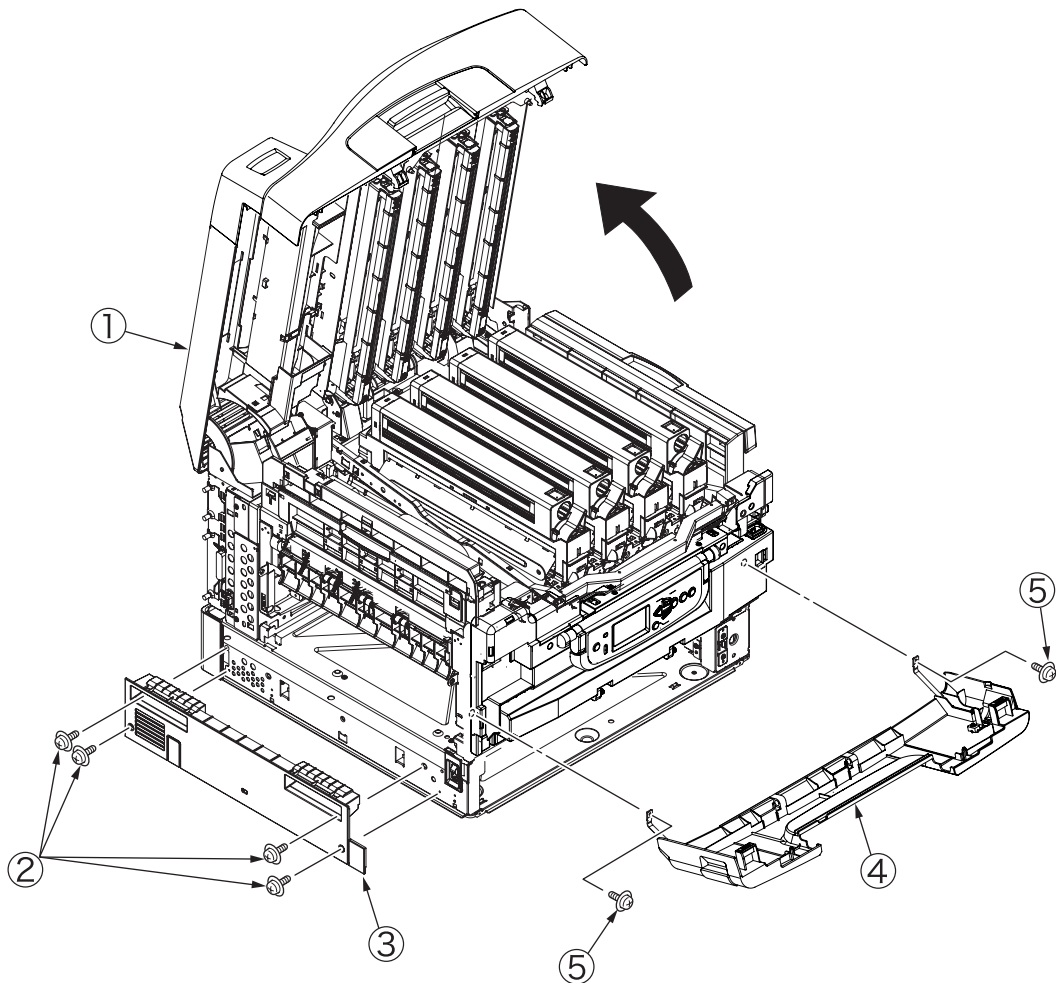

4.3.3 Stacker Assy-FU

- (1) Open Cover Assy-Top ①.
- (2) Open Stacker Assy-FU ②, then remove the 2 stoppers ③. Push these to one side, remove the post, then remove the Stacker Assy-FU ②.
- (3) Open the Stacker Assy-FU ③. Move the two stoppers ④ sideways and take them off. Remove the Stacker Assy-FU ③.

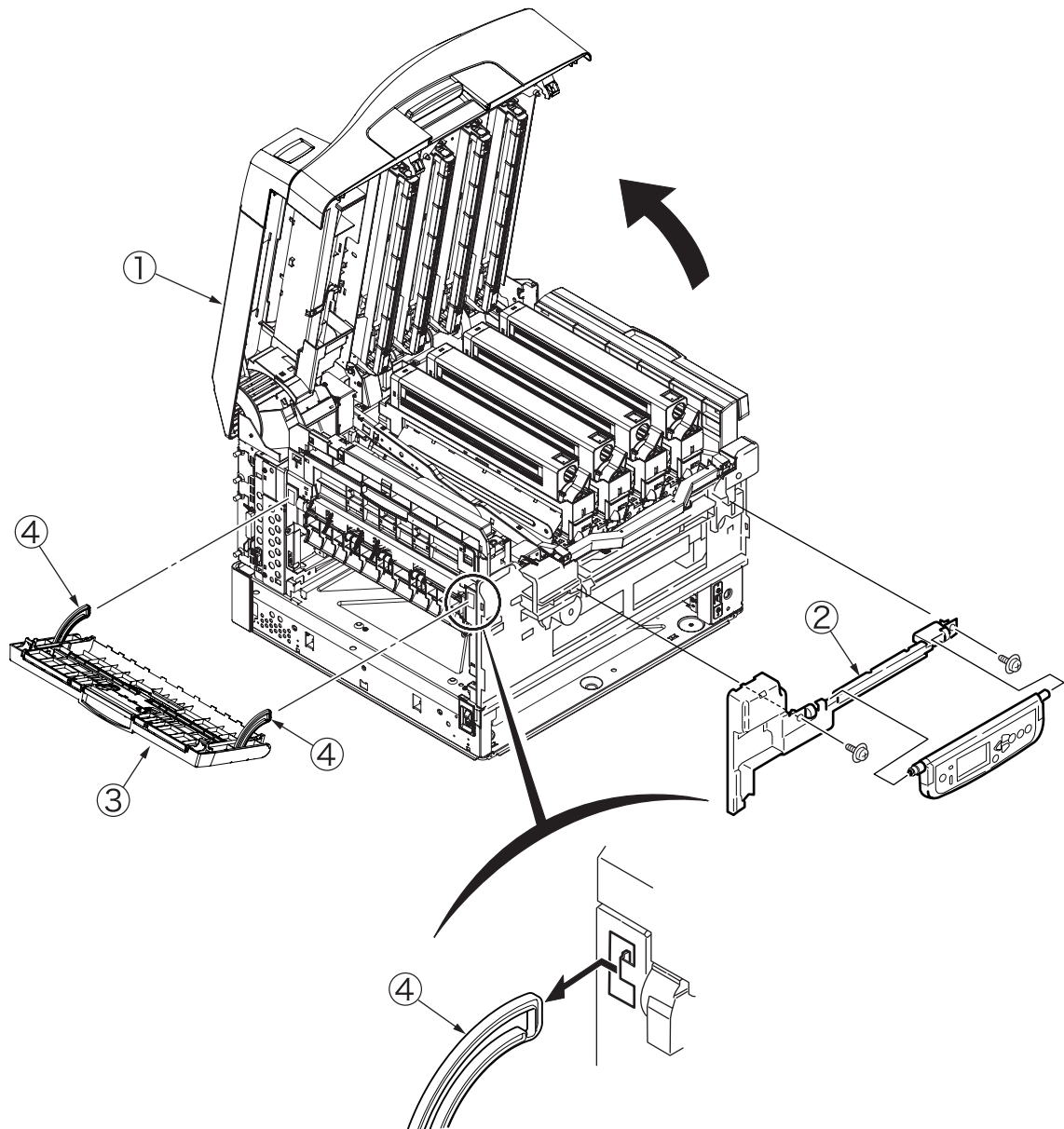

4.3.4 Cover Assy-OP Panel, Cover-Guard (R), Cover-Guard (Front) and Cover-Guard (L)

- (1) Open Cover Assy-Top ①, then lift Basket-Assy ②.
- (2) Remove Cover Assy-OP Panel ③ from its supporting point.
- (3) Unscrew screw ④, remove the hinges, and then remove Cover-Guard (R) ⑤.
- (4) Unscrew 2 screws ⑥, then remove Cover-Guard (Front) ⑦.
- (5) Unscrew 2 screw ⑧, then remove the 2 hinges and remove the Cover-Guard (L) ⑨.

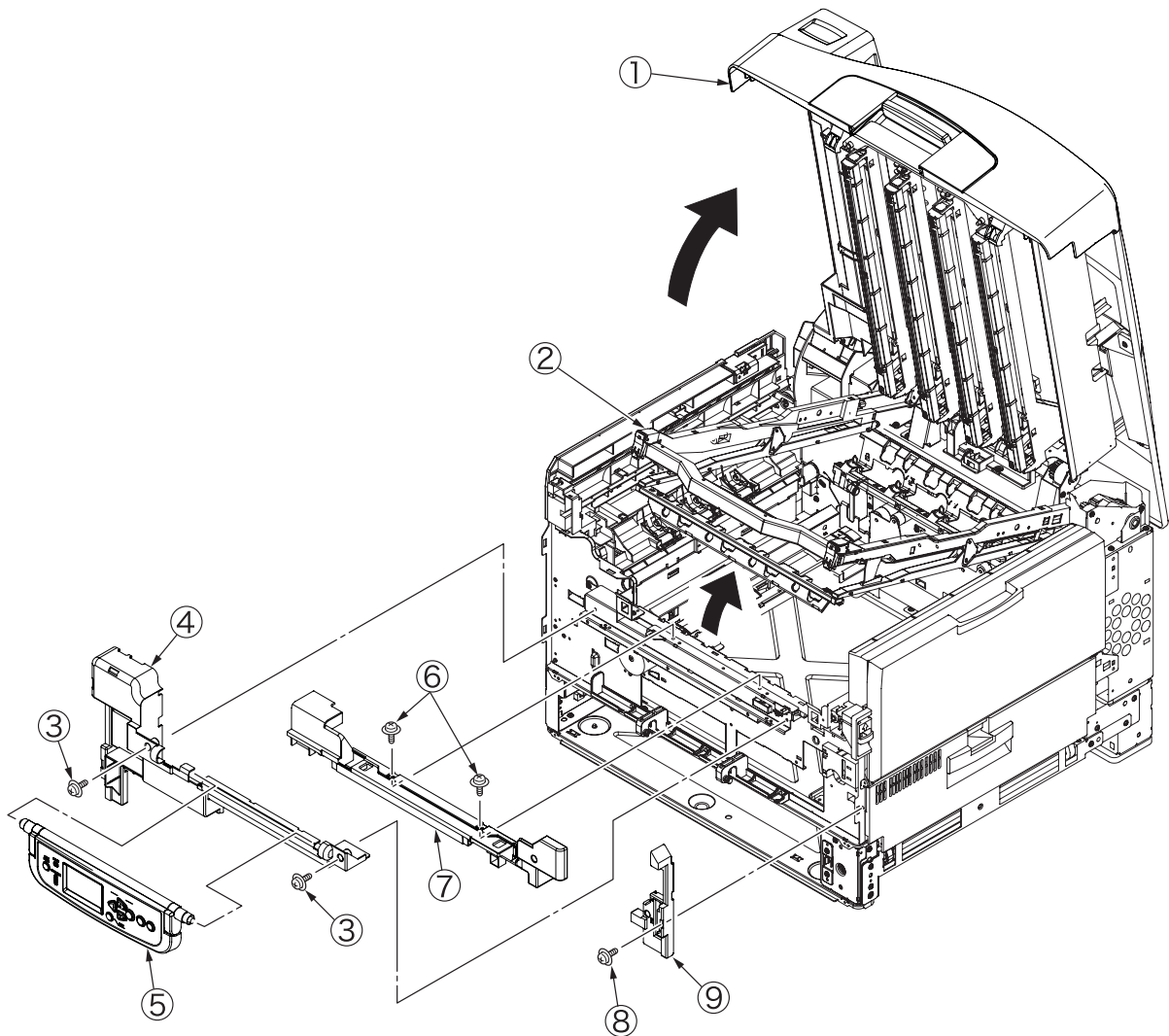

4.3.5 OP PCB

- (1) Remove the Cover Assy-OP Panel. (Refer to Section 4.3.4)
- (2) Remove Cover-OP Panel ② from Frame-OP-Panel ①.
- (3) Unscrew the 2 screws ③, then remove hinge (R) ④ and Cover Hinge (R) ⑤.
- (4) Unscrew 2 screws ⑥, then remove the Hinge (L) ⑦, Cover-Hinge (L) ⑧ and Plate-Shield (OP) ⑨.
- (5) Remove Cover-LCD ⑩, Button-key ⑪, and Lens-LED ⑫, then remove the OP PCB ⑬.

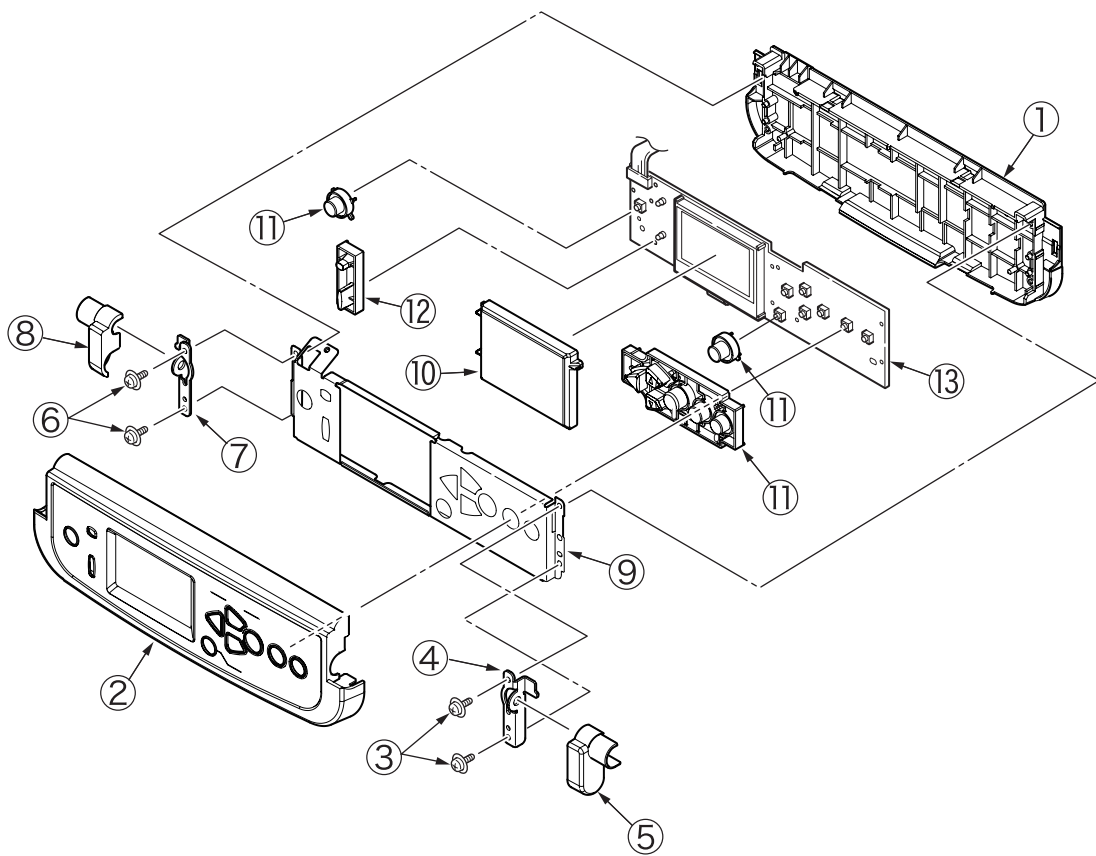

4.3.6 Cover Assy-Top

- (1) Open Cover Assy-Top ①.
- (2) Unscrew screw ②, then remove the Cover-Duct (L) ③.
- (3) Unscrew 8 screws ④, then remove the 3 hinges and the Cover Assy-Top ①.

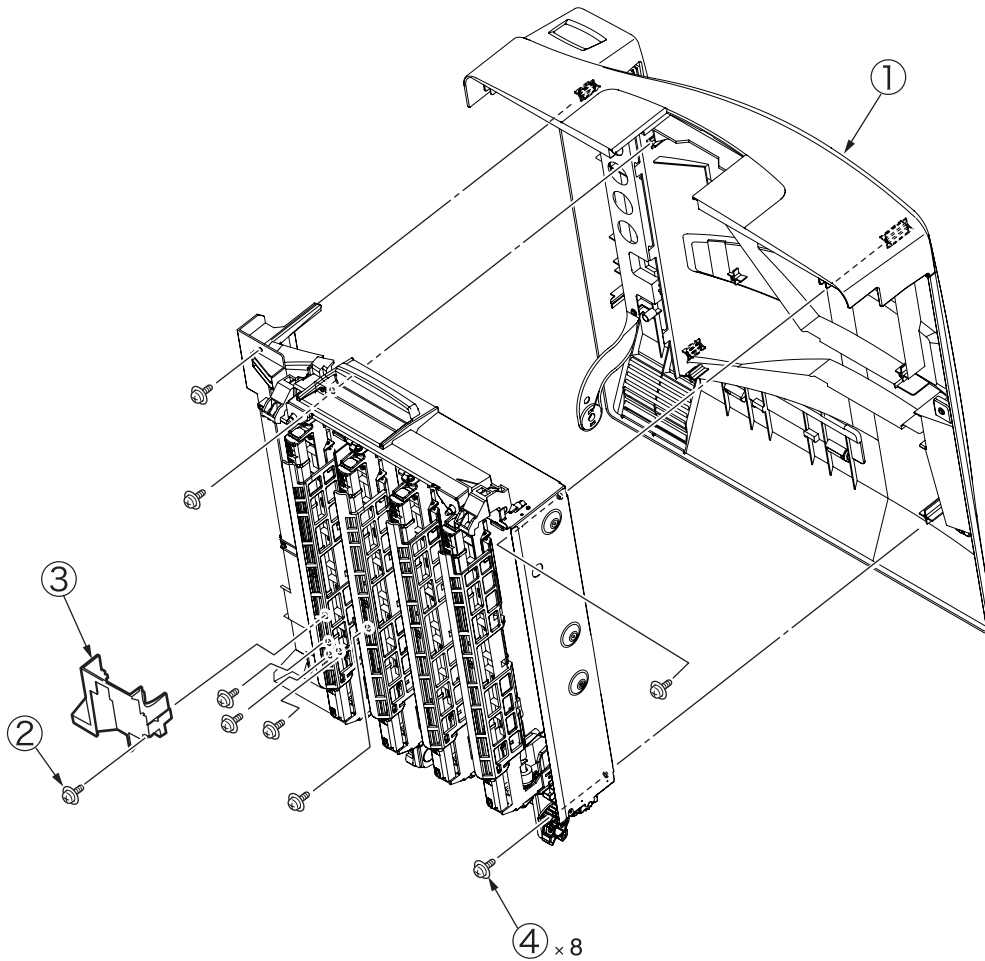

4.3.7 FAN-PCB-Assy, CU-Board-Assy and S2V-PU-Board

- (1) Open the Cover Assy-Top.
- (2) Remove the covers concerned. (Refer to Section 4.3.2)
- (3) Remove the connector, then Remove FAN-PCB-Assy ①.
- (4) Unscrew the ② screws, remove the Plate-Shield-Assy ③, then remove the connector.
- (5) Unscrew 8 screws ④, then remove CU-Board-Assy ⑤.
- (6) Disconnect all 17 Connectors, then unscrew 4 screws ⑥, and remove S2V-PU-Board ⑦.
- (7) Unscrew 9 screws ⑧, remove the Plate-Shield-Box-Assy ⑨, then remove all the connectors.

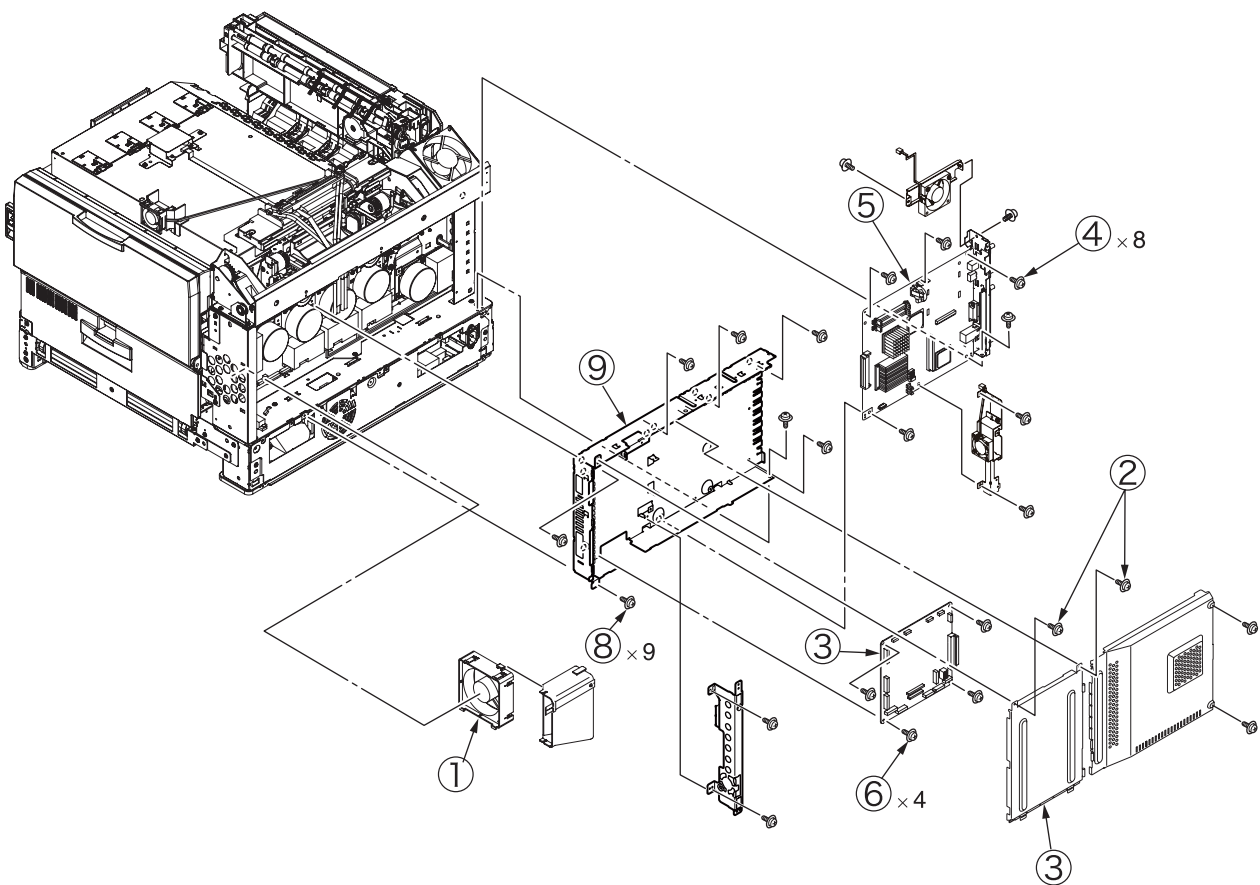

4.3.8 Job-Offset-Assy 723 and Basket-Assy

- (1) Open the Cover Assy-Top.
- (2) Unscrew screw ①, remove Frame-Duct ②, then remove the connector (remove the connector through the shaft)
- (3) Remove the 2 hinges, then remove the Job-Offset-Assy ③, and disconnect the connector.
- (4) Unscrew 2 screws ④, then remove the 2 hinges, and remove the Cover Assy-Top (Sub) ⑤.
- (5) Remove the six screws ⑥ of the Guide-Link-R and the three screws ⑦ of the Guide-Link-L. Remove the Plate-Top and the Basket Assy ⑧ with their interlock.
- (6) Remove the 2 hinges, then remove the Cover Assy-Top (Sub) ⑨.
- (7) Remove the Side Cover (L) Rear ⑩.
- (8) Remove the E-ring ⑪, unscrew 2 screws ⑫, then remove the Plate-Support (Top) ⑬, Collar ⑭, Shaft-Top (A) ⑮, Spring-Torsion-Top (L) ⑯, Spring-Torsion-Top (B) ⑰.
- (9) Unscrew 3 screws ⑱, then remove the Gear-Assy-L ⑲.
- (10) Unscrew 3 screws ⑳, then remove Gear-Assy-R ㉑.
- (11) Remove the high toner Assy tube ㉒, then remove Basket-Assy ㉓.

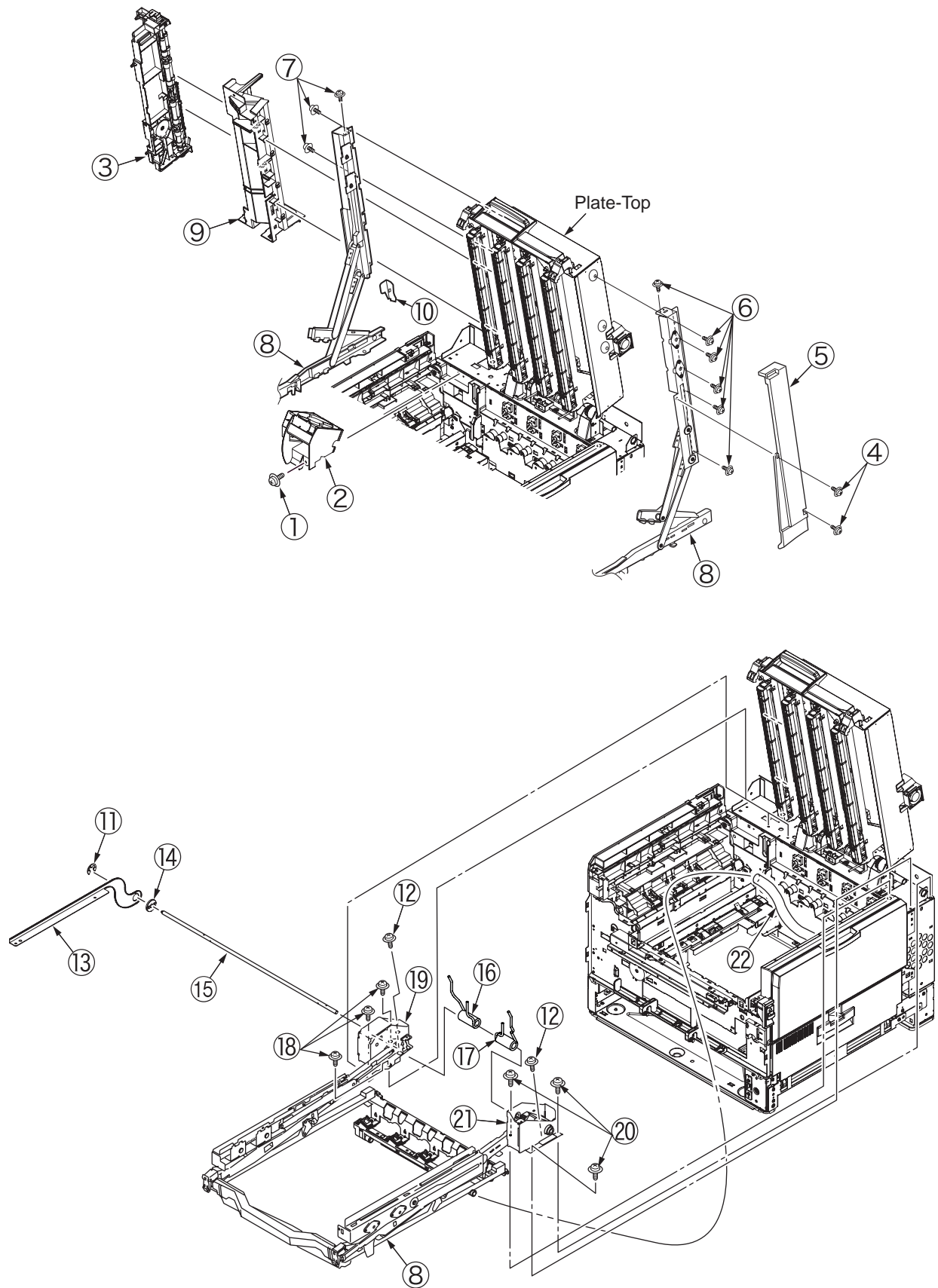

4.3.9 Plate Top Assy

- (1) Remove Job-Offset-Assy 723/Basket-Assy. (Refer to Section 4.3.6)
- (2) Lift back Plate-Top Assy ①.
- (3) Lift forward Plate-Top Assy ①, then unscrew 3 screws ② and remove Plate-Dumper-Assy (R) ③.
- (4) Unscrew 3 screws ④, then remove Plate-Dumper-Assy (L) ⑤.
- (5) Remove Shaft-Top ⑥, Spring-Torsion-BAS (L) ⑦, and Spring-Torsion-Top-R ⑧, then remove Plate-Top Assy ①.

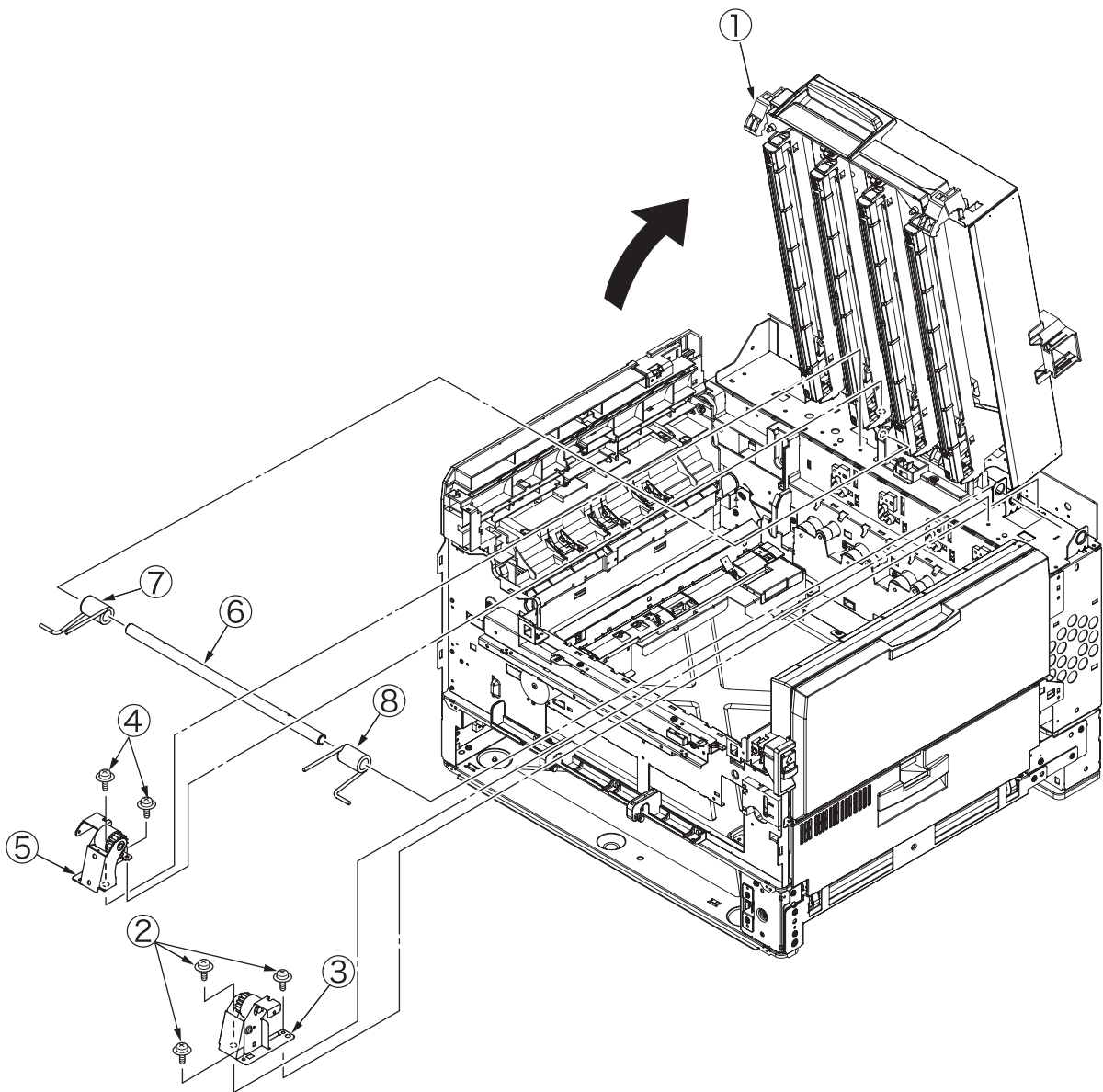

4.3.10 Eject-Assy

- (1) Remove the 7 hinges then remove Cover-Board ①.
- (2) Remove the 13 connectors, and unscrew the 2 screws ②. Then remove the 3 hinges and remove the Eject-Assy ③.

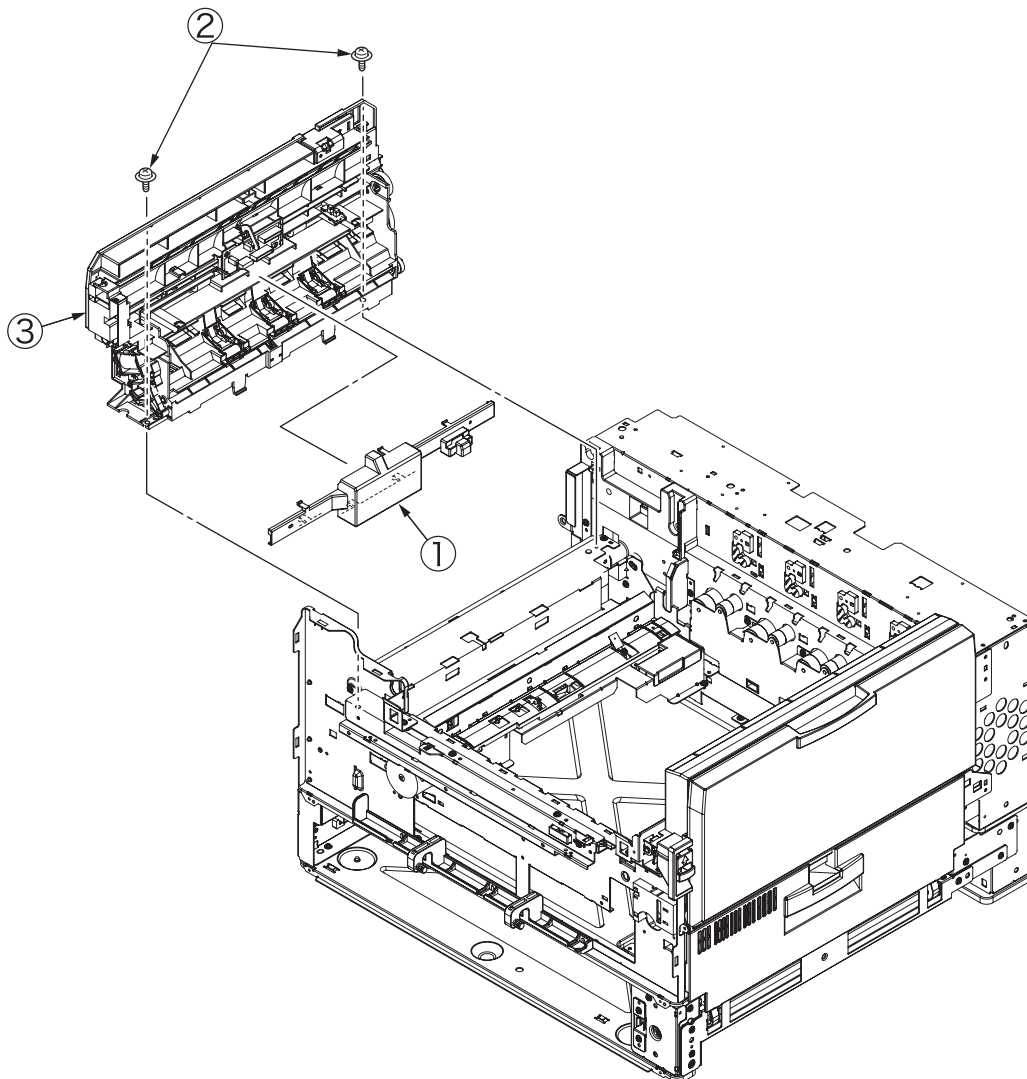

4.3.11 Motor-Pulse-Belt and Sensor-Resist-Assy

- (1) Unscrew the 2 screws ①, then remove the 4-pin connector and remove the Motor-Pulse-Belt ②.
- (2) Unscrew 7 screws ③, then remove the 3 connectors (2-pin, 14-pin, 3-pin), and remove the Sensor-Resist-Assy ④.

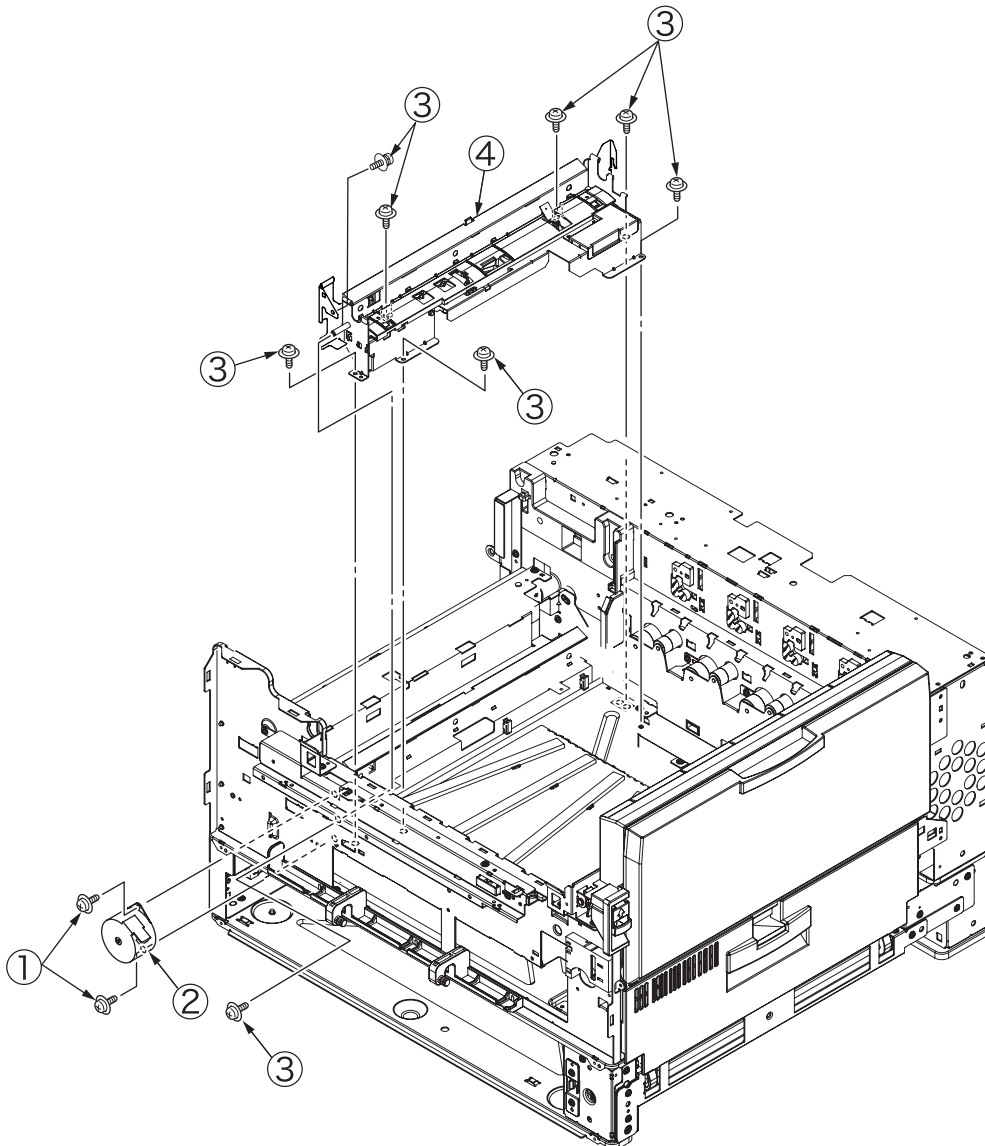

4.3.12 FDR Unit-MPT

- (1) Open the Cover Assy-Top.
- (2) Remove the Cover ① and remove the two connectors (Pin ● and Pin 2).
- (3) Open the FDR Unit-MPT ③ and remove the two screws ② fastening the stays on both sides.
- (4) Further open the FDR Unit-MPT ③ and remove the FDR Unit-MPT ③ from the support in two places.

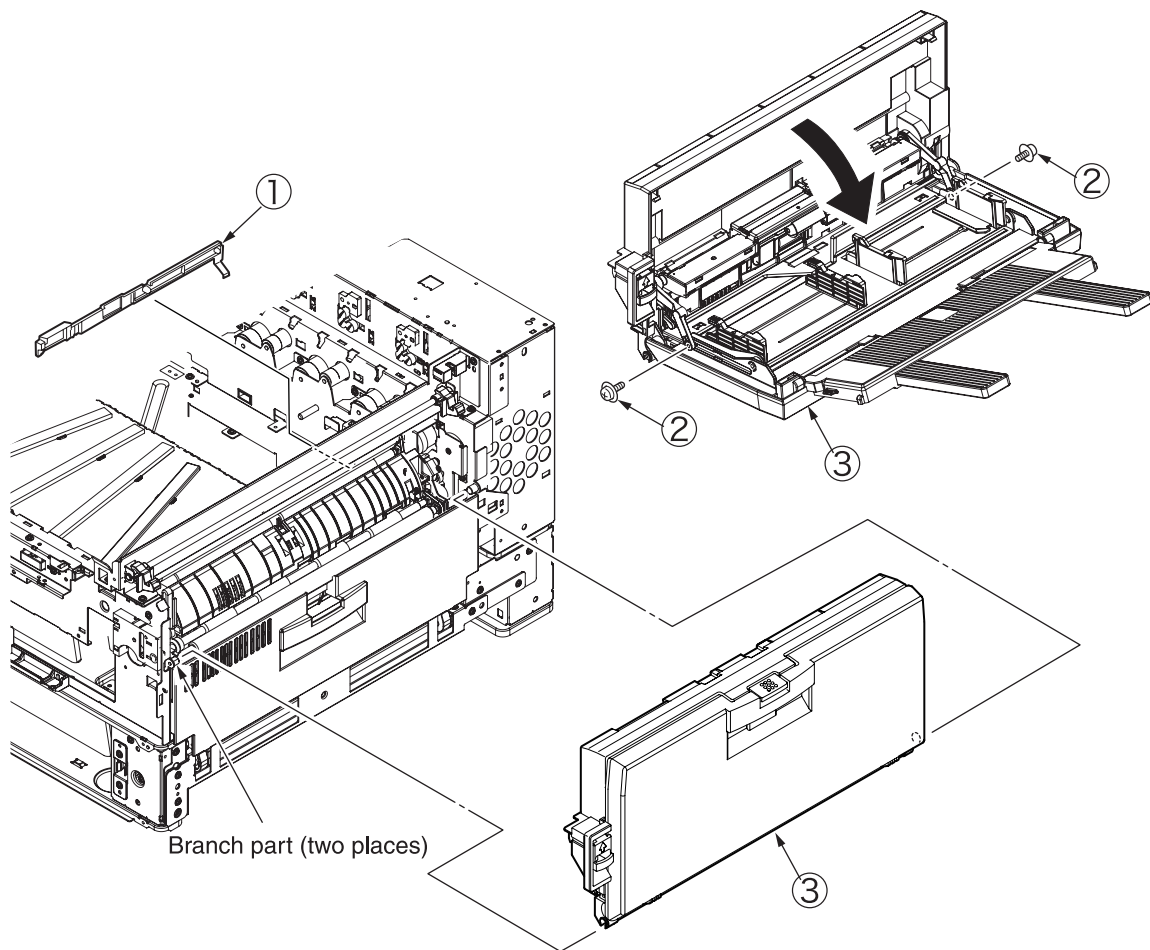

4.3.13 FDR Unit-Resist

- (1) Remove the FDR Unit-MPT. (Refer to Section 4.3.12)
- (2) Unscrew the 4 screws ① and disconnect connector ②, then remove Plate Assy-MPT Lock ③.
- (3) Open the Cover-Guide-1st-Assy ④ in the arrow direction.
- (4) Unscrew 2 screws ⑤, then remove FDR Unit-Resist ⑥.

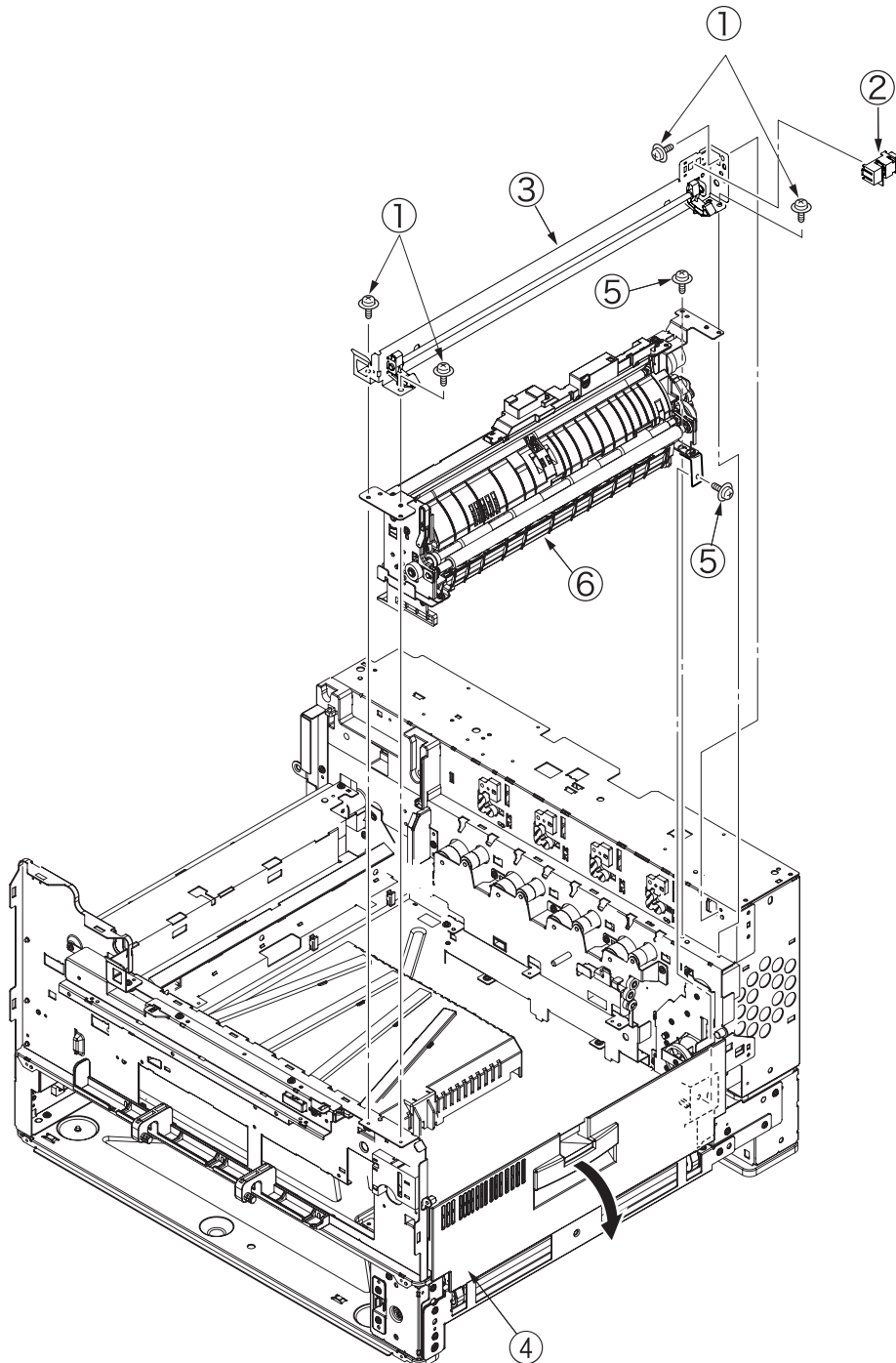

4.3.14 Duct Assy

- (1) Remove the hinge, then remove Cover-Middle ①.
- (2) Remove the hinge, then remove Guide Tube (L) ②.
- (3) Unscrew 2 screws ③, then remove Duct-Assy-Toner ④.
- (4) Unscrew screw ⑤, then remove Gear-Duct-B-Assy ⑥.
- (5) Unscrew screw ⑦, then remove Gear-Duct-ID Assy ⑧.
- (6) Unscrew 6 screws ⑨, then remove Duct-Drive-Assy ⑩.

[Precautions in Removal]

When removing the Duct-Drive-Assy ⑩, be sure to read 4.3.11 "Cover-Screw."

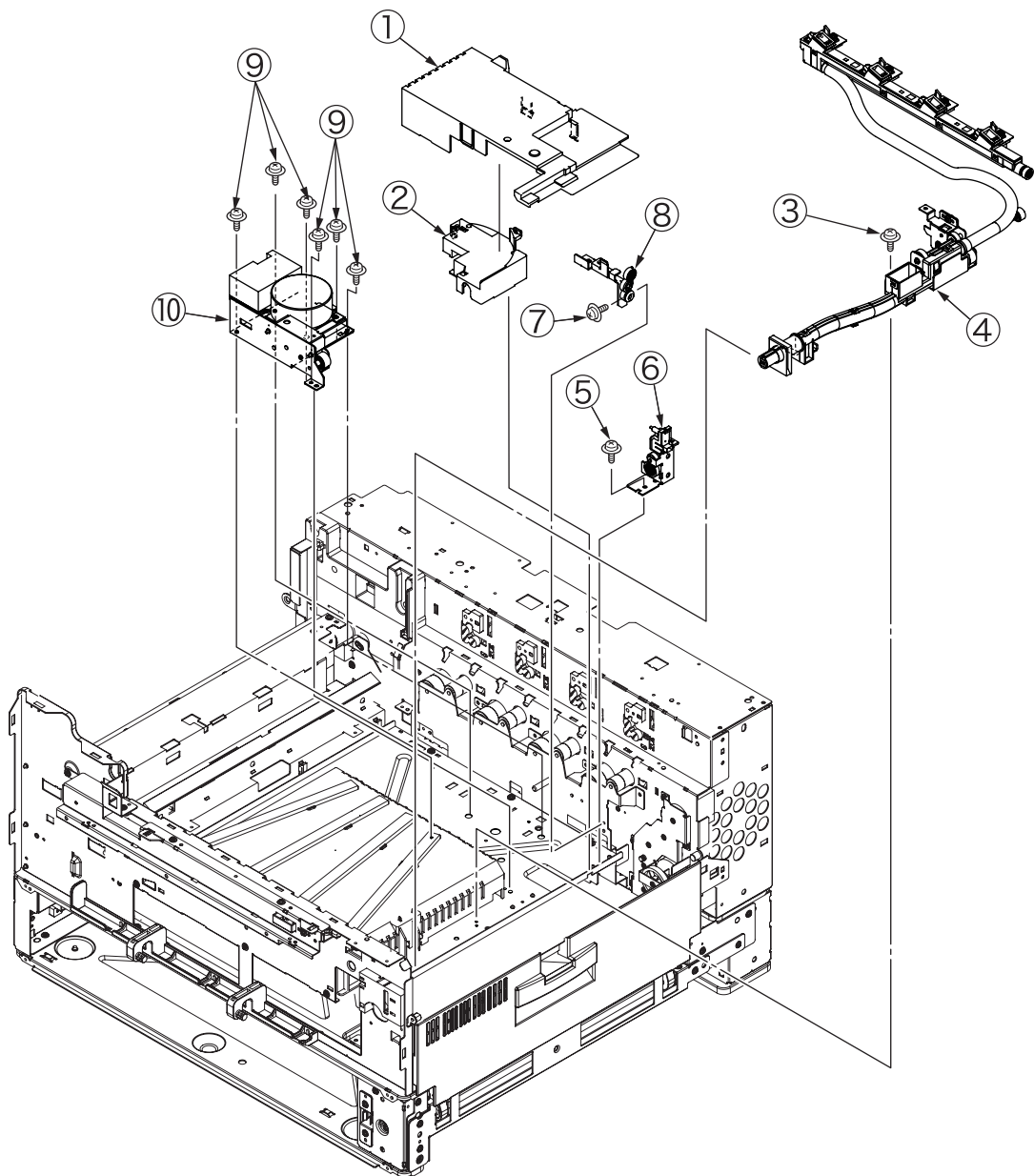

4.3.15 HV-Assy

- (1) Open the Cover Assy-Top, then remove the Belt-Assy.
- (2) Remove the Cover-Middle. (Refer to Section 4.3.14)
- (2) Unscrew screw ①, then remove Cover-HV-Assy ②.
- (3) Remove the 2 connectors and unscrew the 2 screws ③, then remove HV-Assy ④.
- (4) Remove the 2 hinges, then remove Bracket-HV-Assy ⑤.

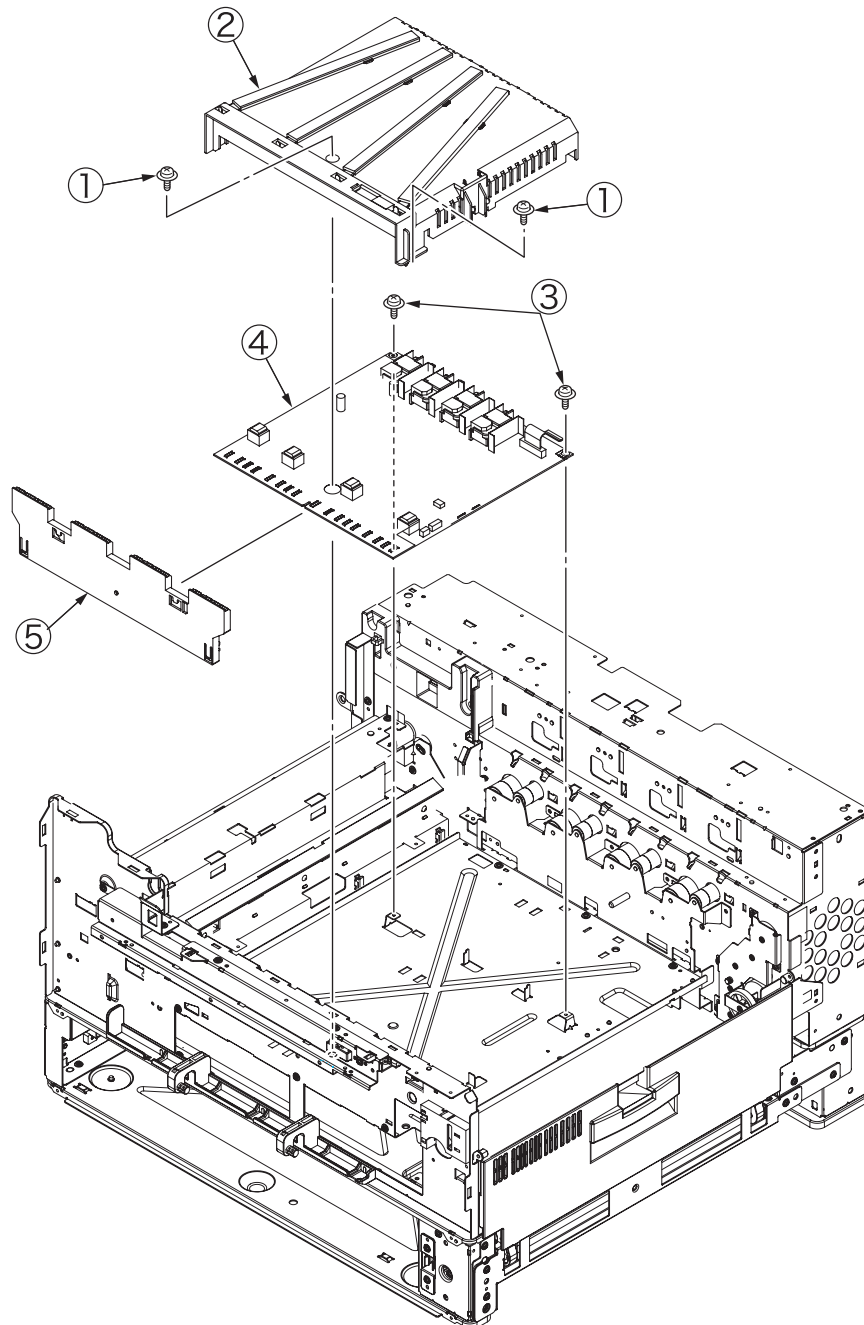

4.3.16 Power Unit

- (1) Remove the Cover-Rear. (Refer to Section 4.3.1)
- (2) Unscrew the 12 screws ①, disconnect all connectors, pull out the lever then remove the Power Unit ②.

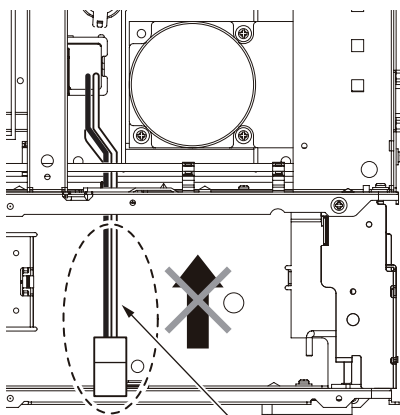
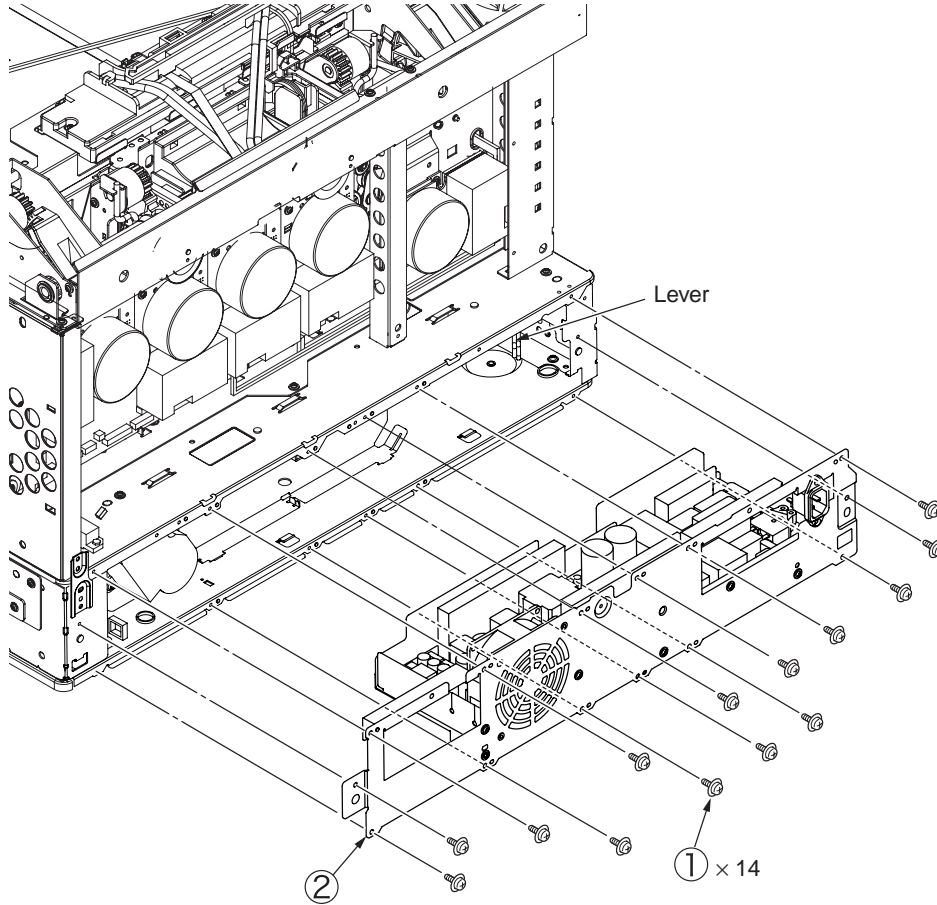

Do not push the cable upward, or allow slack in it above the partition.

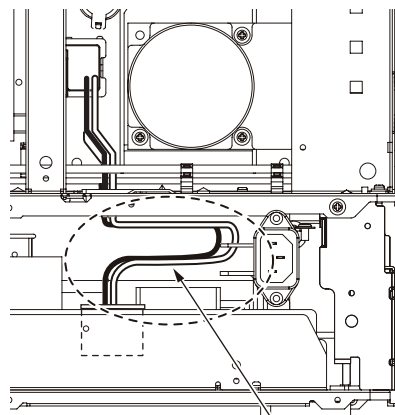

When installing a power supply unit, lay the cable at the top of the power unit in the shape as shown.

4.3.17 Low Voltage Power Source Assy and Motor-FAN

- (1) Remove the Power Unit. (Refer to Section 4.3.16)
- (2) Unscrew the 3 screws ①, then remove the low Voltage Power Source Assy ②, and Film-Insulation ③.
- (3) Unscrew the 2 screws ④, then remove the connector and Motor-FAN ⑤.

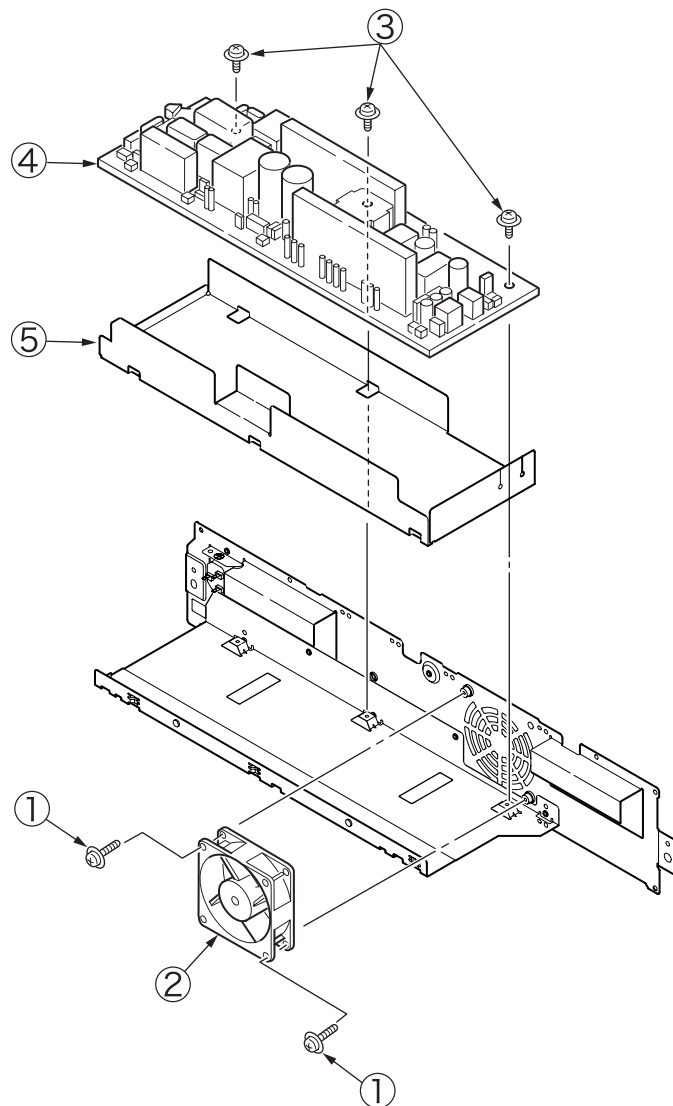

4.3.18 Belt-Assy

- (1) Open the Cover Assy-Top ①.
- (2) Remove ID Unit ②.
- (3) Lift up the 2 lock levers toward the arrow, then remove the Belt-Assy ③.
Remove Belt-Assy ③ by lifting handle ④, then remove along with handle ⑤.

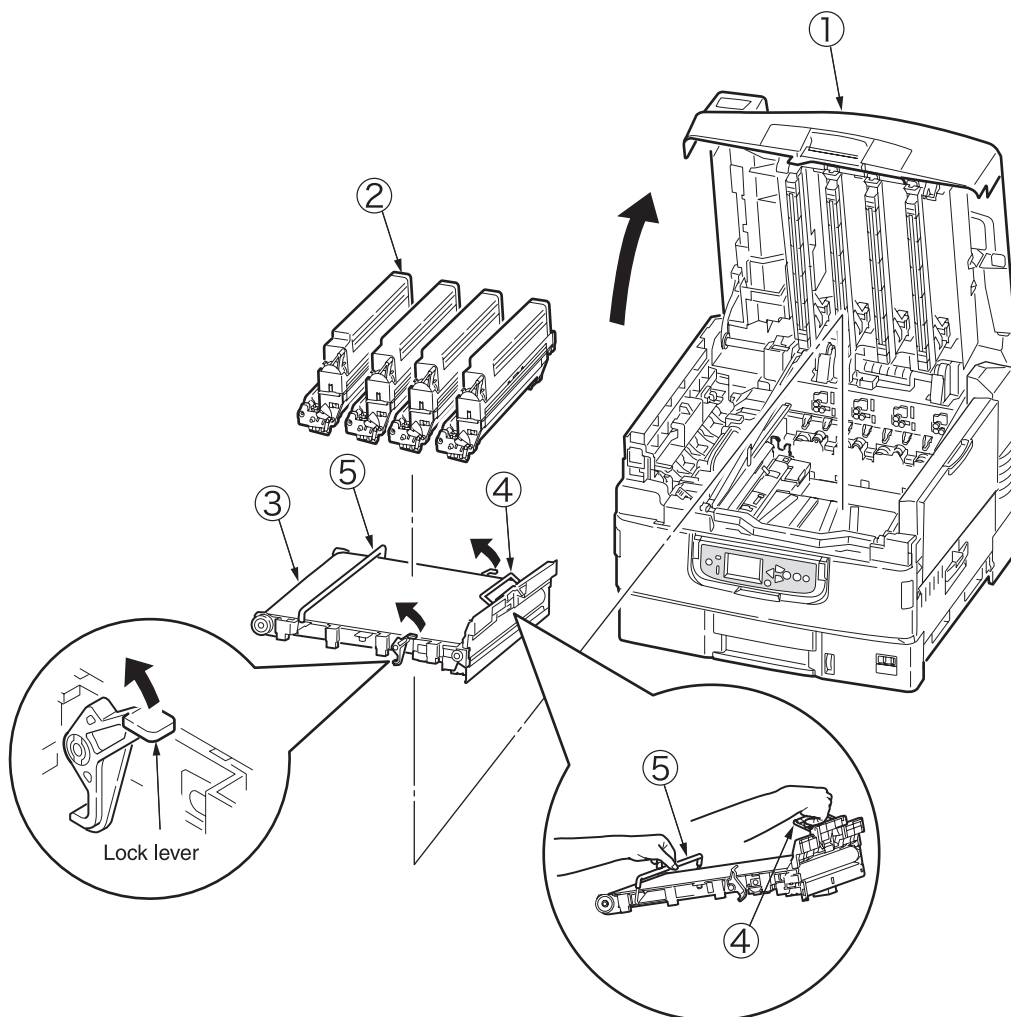

4.3.19 Fuser Unit-LBT

- (1) Open Cover Assy-Top ①.
- (2) Lift the lock lever toward the arrow, then remove the Fuser Unit-LBT ②.

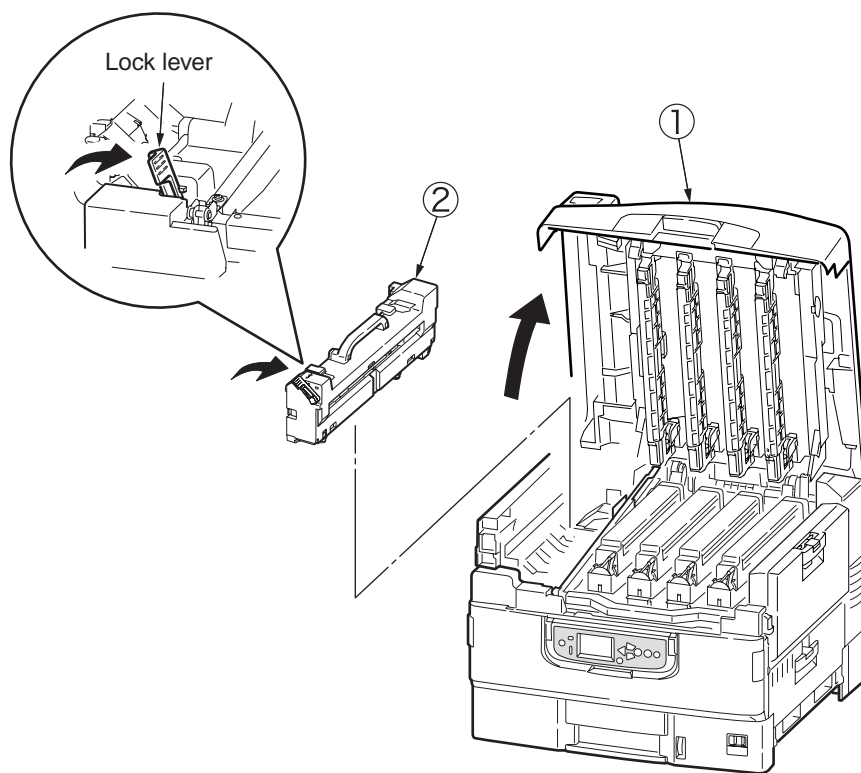

4.3.20 Unit-Duplex

- (1) While opening the lever, draw out the Unit-Duplex ①.

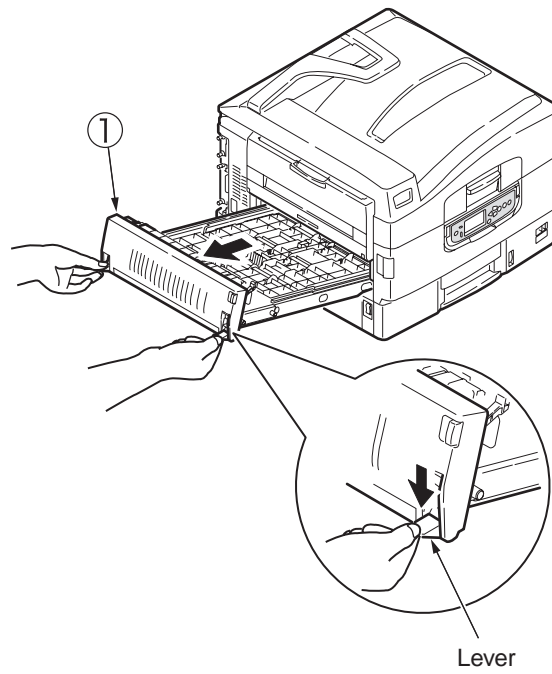

4.3.21 Paper Feed Roller

- (1) Open the tray 1 side cover ① and the paper guide ②.
- (2) Pull out Tray ③.
- (3) Pull outward the latches of the 3 paper feed rollers ④, and remove from the shaft.

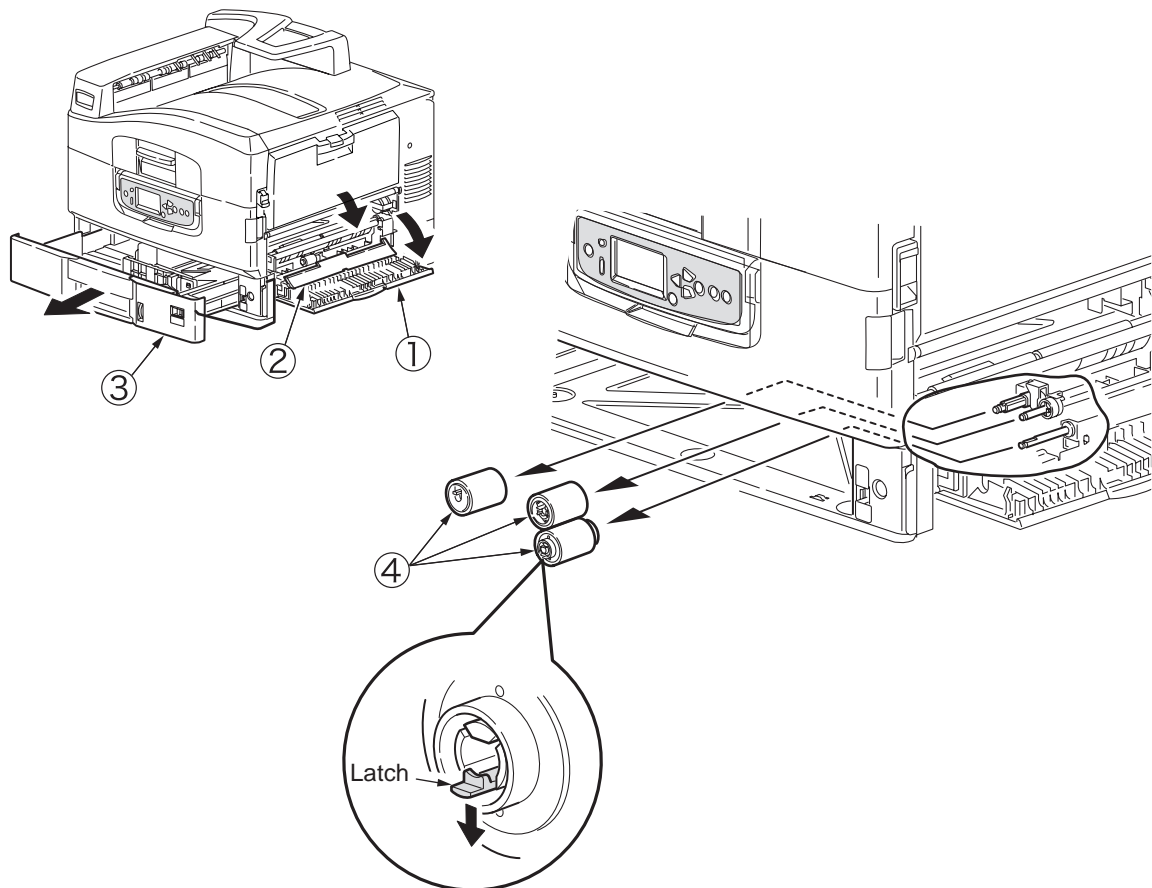

4.3.22 MPT Feed Roller

- (1) Open the Multipurpose Tray ①, push the lever in the arrow direction and remove the Multipurpose Tray ①.
- (2) Remove the cover ②.
- (3) While opening the claw of the Feed Roller ③ outward, slide the roller to the left and remove it.
- (4) Open the cover ④.
- (5) While opening the claw of the Feed Roller ⑤ outward, slide the roller to the left and remove it.

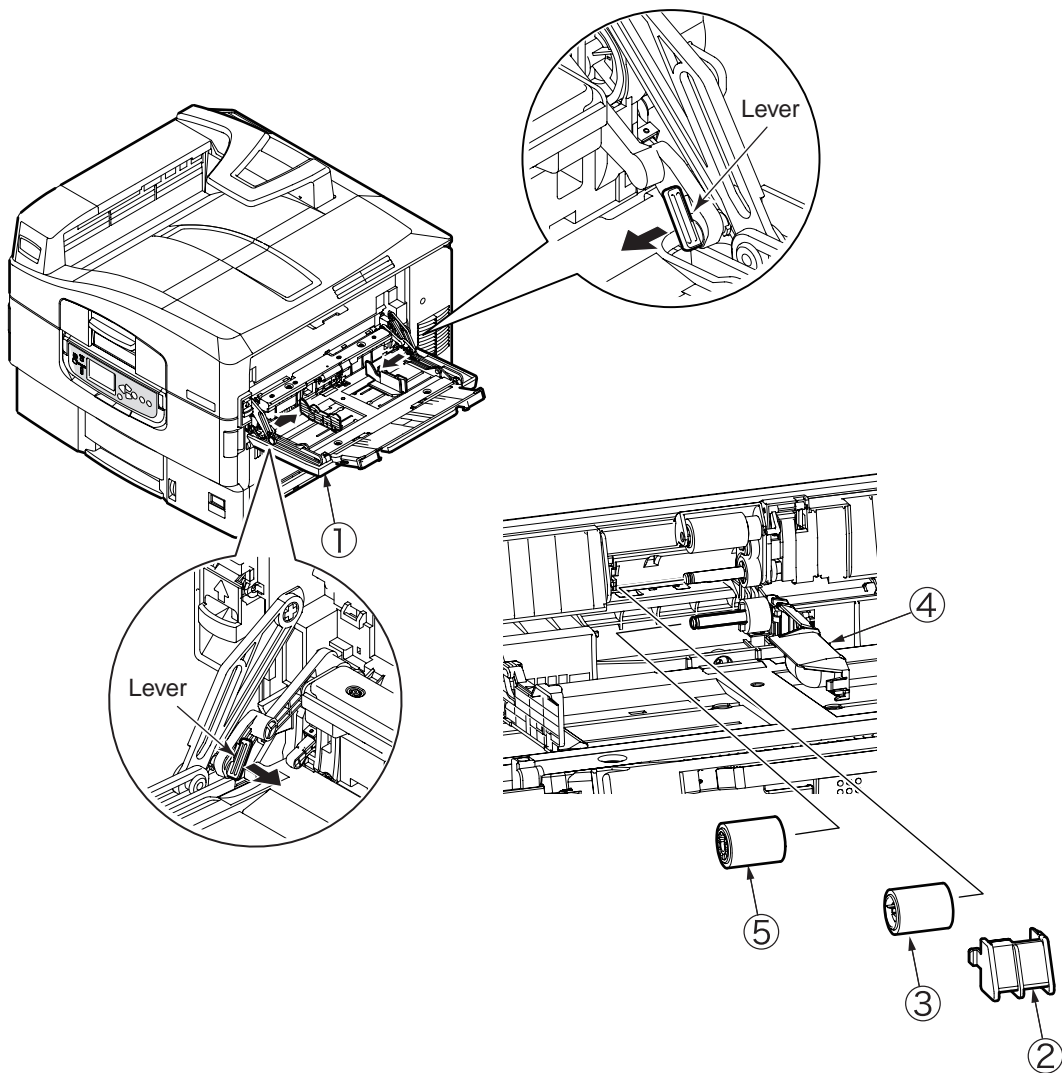

5. ADJUSTMENT

The printer is adjusted by key operation on the Maintenance Utility and the Operator Panel.

The CX3641 comes with a Maintenance Menu in the usual menu. Select the menu according to the items to adjust and the purpose of adjustment.

5.0 System Maintenance Menu

This menu is launched by turning on the power source while keeping the [Menu+]+[Menu-]+[Help] switches pressed.

The menu display is only available in English regardless of destination.

Note! •This menu can be modified according to the destination, etc. Therefore, it is not open (closed) to the end user.

Table 5-0. Maintenance Menu Display Table (1/2)

Category	Item	Value	DF	Old Menu	Function	Valid	Save
System Maintenance	OKI USER	ODA OEL APS JP1 JPOEM1 OEMA OEML	*	"SYSTEM MAINTENANCE MENU" - "OKIUSER" - "OKIUSER"	Set the destination. JPOEM1: Japan OEM OEMA : A4 Default Overseas OEM OEML : Letter Default Overseas OEM Automatically reboot after escaping from the menu. The default value for non-PS models is JP1.	RB	-
	Maintenance Menu	NEXT			This displays the menu to initialize the harddisk and Flash ROM.		
	Maintenance Print Menu	Enable Disable	*		This switches whether to Show/Hide the "Print Information" – "ID Check Pattern" and "Engine Status" of the Function Menu. If this item is disabled, the "Print Information" – "ID Check Pattern" and "Engine Status" of the Function Menu is never displayed. The printer is restarted after the settings are modified and escaping from the menu.	ET	-
	Print Page Count	Enable Disable	*	"SYSTEM MAINTENANCE MENU" - "PAGE CNT PRINT" - "PAGE CNT PRINT"	This sets whether to Show/Hide the display of the "Functions" - "Configuration" - "Print Page Count" - "Total Page".	ET	-
	Personality	NEXT			This displays the menu to edit the default PDL language supported according to destination.		
	Diagnostic Mode			"SYSTEM MAINTENANCE MENU"- "DIAGNOSTIC MODE XX.XX"	This goes to the engine's self-diagnosis mode.	ET	-
	Change Password						

Table 5-0. Maintenance Menu Display Table (2/2)

Category	Item	Value	DF	Old Menu	Function	Vailid	Save
Maintenance Menu	Format HDD	Execute	-	"SYSTEM MAINENANCE MENU" – "MAINTENANCE MENU" – "HDD INITIALIZE"	Initialize the HDD. When executed it will escape from the menu and start initializing the HDD.[Display Condition] • Mount HDD ("Boot Menu"- "Storage Setup"- "Enable Initialization "Enable, "Boot Menu"- "Storage Setup"- "Enable HDD" Yes)	ET	-
	FormatFlash ROM	NEXT	-	"SYSTEM MAINENANCE MENU"- "MAINTENANCE MENU" – "FLASH INITIALIZE"	This displays the menu to initialize the Flash ROM. * Do not use this Menu.	RB	-
	Reset EEPROM	Execute	-	"SYSTEM MAINENANCE MENU"- "MAINTENANCE MENU" – "MENU RESET"	This resets the EEPROM details to the factory preset (factory default) value. It automatically reboots after the settings are made and applied. * Some special items are not initialized.	RB	-
Personality	IBM PPRIII XL	Enable Disable	*E *J	"SYSTEM MAINENANCE MENU"- "PERONALITY" – "IBM PPR III XL"	Changes the default PDL language supported according to the destination.The PDL language disabled from this menu will no longer be displayed on the "Print Setup" – "Personality" of the Function menu. When receiving print data in the disabled PDL language, display "INVALID DATA" and dispose the incoming data. (HP-GL/2 is currently under development and there are no plans scheduled for application for the product). PDF requires Adobe Postscript, therefore, it is not possible to turn PDF ON/OFF by itself (if Adobe Postscript is DISABLED, the PDF Function will also be DISABLED). It is not possible to DISABLE Adobe Postscript and PDF with PX711/713. (It shall be usually used in the ENABLE state. Though DISABLE is set the incoming data will still be processed. It has been incorporated for future extension purposes.)		-
	EPSONFX	Enable Disable	*E *J	"SYSTEM MAINENANCE MENU"- "PERONALITY"– "EPSON fx"		ET	-
	HP-GL/2	Enable Disable	*JE	"SYSTEM MAINENANCE MENU"- "PERSONALITY" – "hp-gl/2"		ET	-
	IBM5577						

During the Engine Self-Diagnosis Mode, switch operations and the LCD display is instructed by the engine firmware, therefore, it will vary from the specifications of the controller firmware operations. Note that the Engine Self-Diagnosis Mode can also be executed in the state with the controller PCD removed.

For details, accordingly refer to the Engine Specifications Manual.

5.0.1 ID Check Pattern Print (“TEST PRINT MENU” Item)

This pattern can be used to investigate the cause (plain identification of problem or check cycle of problem) resulting from the ID or LED head. CMYK are each composed of a 20% duty pattern. (printing 2 sheets)

Test pattern printing procedure

1. Choose the "Maintenance Print Menu" in the System Maintenance Menu and then choose "Enable." Reboot the printer.
2. Press "Menu ▼" button once to display "Function Menu" and choose "Print Information" and then "ID Check Pattern."

- Vertical Black/White Lines (Vertical Black/White Lines)
- Vertical Black/White Band (Vertical Black/White Band)
- Horizontal Black/White Lines (Horizontal Black/White Lines)
- Horizontal Black/White Band (Horizontal Black/White Band)

Print pattern (Print Pattern):

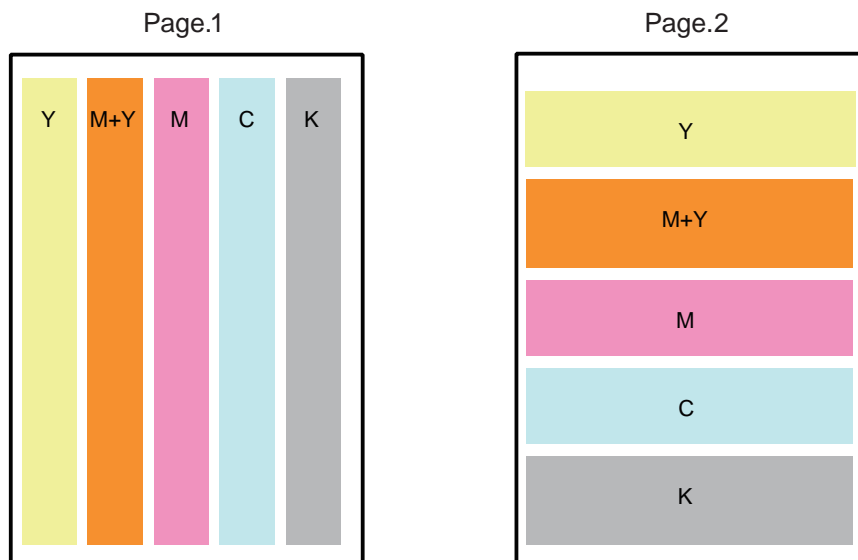

5.0.2 Maintenance Utility

Using the Maintenance Utility, the adjustments shown in Table 5-0-2 are made.

For details on the Maintenance Utility, see below.

- (1) Maintenance Utility Operations Manual: 42678801FU01 Rev. 5 or later (Japanese)
42678801FU02 Rev. 5 or later (English)

- (2) The Maintenance Utility programs are available as below.

* The programs are downloaded from the FTP server for manuals.
(The server is accessible to people in charge of Windows and manuals.)

Applicable OS	Filename	Product code
Win98/Me (Japanese/English)	MuWin_WinNT.zip	42678801FW01 Rev. 5 or later
Win2000/XP (Japanese/English)	MuWin_WinNT.zip	42678801FW02 Rev. 5 or later

Table 5-0-2 Maintenance Utility Adjustment Items (1/2)

	Item	Adjustment	Section No. in Operations Manual	Operation of Operator Panel (corresponding to section No. in service manual)
1	PU (S2V) PCB replacement	Copies EEPROM of the PU PCB. Copies the LED head correction data.*1 Purpose: Copy the data above to another PU PCB, when the current PCB has to be replaced for maintenance.	2.4.1.1.1 2.4.2.1.1 when copying LED head correction cata	NA
2	PU serial No. setting	Rewrites the printer serial No. stored in the PU.Purpose: Set the number on a maintenance PCB when the EEPROM of the PU PCB cannot be copied (e.g., I/F error). After the serial number of a printer is rewritten with new one, Factorydefault should be executed to reflect the new one on the HDD of the printer's CU. See section 5.2.7 for executing FactoryDefault.	2.4.2.1.2.2	NA
3	Factory/Shipping mode	Switches between the Factory mode and the Shipping mode.Purpose: Set the mode on a maintenance PCB when the EEPROM of the PU PCB cannot be copied (e.g., I/F error). The maintenance PCB is set in the Factory mode by default and it has to be set into the Shipping mode using this function.	2.4.1.1.2.3 2.4.1.2.2	Factory mode setting of the self diagnosis level 1
4	Setting of sensitivity correction of color density sensor[Prohibited]	Sets the correction value for the sensitivity of the density sensor for color printing.	Prohibited.	Prohibited.
5	LED head correction data download *1	Writes in the LED head correction data. Purpose: Download correction data prepared externally to the printer when the head (diagram No.42631901) doesn't have EEPROM for correction.	2.4.2.1.2.2	NA
6	Serial No. information setting	Rewrites the printer serial No. selection, output mode, and printer serial No. stored in the CU.	2.4.1.1.4.3	NA
7	Asset No. setting	Rewrites the asset No. stored in the CU. Purpose: Set the number on a maintenance PCB when the EEPROM of the CU PCB cannot be copied (e.g., I/F error).	2.4.1.1.4.4	NA
8	PCB setting information	Displays the serial No. information and Factory/Shipping mode.	2.4.1.1.7	NA
9	USB software update	Updates the USB software.	2.4.2.2.1	NA
10	NIC software update	Updates the NIC software.	2.4.2.2.2	NA
11	NIC Web Page update	Updates the NIC Web Page.	2.4.2.2.3	NA
12	MAC address setting	Sets the MAC address.	2.4.2.2.4	NA
13	Supplies counter maintenance function	Copies the supplies counters. Drum counter (Y, M, C & K) Fuser counter Belt counter Toner counter (Y, M, C & K)	2.4.1.2.1	NA
14	Correction of paper thickness detection sensitivity	Performs correction of the sensitivity of paper thickness detection.	2.4.1.2.5	Paper thickness detection sensitivity correction of the self diagnosis level 1

Table 5-0-2 Maintenance Utility Adjustment Items (2/2)

	Item	Adjustment	Section No. in Operations Manual	Operation of Operator Panel (corresponding to section No. in service manual)
15	LED head correction data swap *1	Swaps the retained LED head correction data within the printer. Purpose: Swap data, when LED heads need to be interchanged within a printer.	2.4.2.2.5.1	NA
16	LED head correction data download *1	Writes in the LED head correction data. Purpose: Download correction data prepared externally to the printer when the head (diagram No.42631901) doesn't have EEPROM for correction.	2.4.2.2.5.2	NA
17	LED head serial No. display *1	Displays the LED head serial No.	2.4.2.2.5.3	LED head information display of the self diagnosis level 1
18	Destination/PnP information setting	Sets/displays the destination of the printer (CU), device ID and USB ID.	2.4.1.2.11	5.2.4
19	Password initialization	Initializes passwords for administrator and printing count.	2.4.2.2.4, 2.4.2.2.8	NA
20	Supplies counter display	Displays the current supplies counter reading.	2.4.1.3.1	NA
21	Menu setting confirmation	Displays the settings of the menu of the printer (CU).	2.4.1.3.2	Menu map printing (See the user's manual.)
22	Printer information confirmation	Displays the MAC address of the printer and F/W versions.	2.4.1.3.3	Menu map printing (See the user's manual.)
23	On-board CPU/memory value confirmation	Displays the information on the CPU installed in the printer and on the on-board memory.	2.4.1.3.4	Menu map printing (See the user's manual.)
24	Test printing	Executes a local printing function and transmits the specified file. Purpose: Check the performance of the printer alone and transmit a downloaded file.	2.4.1.4.1	Local printing (See the system specification.)
25	Engine parameter setting	Sets the engine parameters	2.4.1.5.9	Engine parameter setting of the self diagnosis level 4

*1 There are restrictions on the functions.

Note! The operation or setting marked with [Prohibited] shall not be performed to avoid malfunction.

5.1 Maintenance Menu and Its Function

5.1.1 Maintenance Menu

5.1.2 Engine Maintenance Mode

Engine maintenance mode is a media conveyor mode that assists confirmation of the basic operations of the check and print system.

5.1.2.1 Operation Panel

Instructions on self-diagnosis operations is based on the following Operation Panel layout, as a prerequisite.

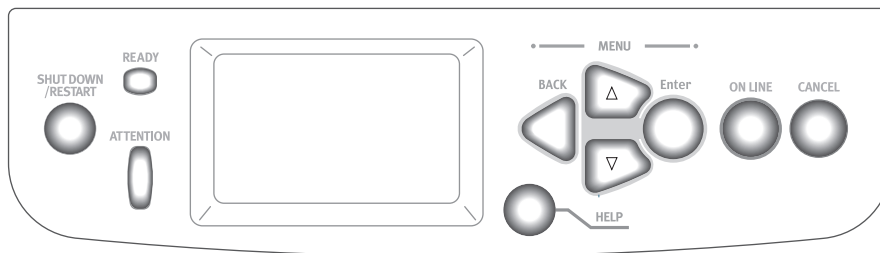

5.1.2.2 Regular Self-Diagnosis Mode (Level 1)

The Regular Self-Diagnosis Mode menu is as follows.

- SWITCH SCAN
- MOTOR & CLUTCH TEST
- TEST PRINT
- REG ADJ TEST
- DENSITY ADJ TEST
- DENSITY CALIBRATION
- MEDIA WEIGHT ADJ PA
- FACTORY MODE SET
- SENSOR SETTING
- NV-RAM INITIAL
- CONSUMABLE STATUS
- PRINTER STATUS
- LED HEAD DATA
- GRAPHIC PANEL ADJUST

5.1.2.2.1 How to Enter Self-Diagnosis Mode (Level 1)

1. Press the [MENU+], [MENU-] and [HELP] keys at the same time when turning ON the power to go to the System Maintenance Mode.
2. Press the [MENU+] and [MENU-] key until the “Diagnostic Mode” is displayed.

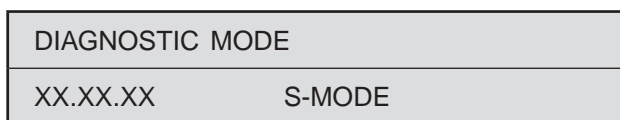

3. “Diagnostic Mode XX.XX.XX” appears on the LCD panel. The XX.XX.XX stands for the version of the ROM. At the bottom right the setting of the “Factory Working Mode” is displayed. This is usually “S-MODE”.
4. Press the [MENU+] or [MENU-] key to go to each self-diagnostic step. (The menu item rotates by pressing the [MENU+] or [MENU-] keys)

5.1.2.2.2 Escape from Self-Diagnosis Mode

1. Turn OFF the power then re-turn it ON after 10 seconds.

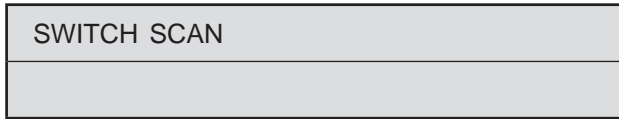

5.1.2.3 Switch Scan Test

This self-diagnosis is used to check the input sensor and switch.

1. Keep the [MENU+] and [MENU-] keys pressed until [SWITCH SCAN] appears at the top of the display and operations goes into the regular diagnosis mode. (The [MENU+] key = Increment Test Item / the [MENU-] key = Decrement Test Item.)
2. The following message appears by pressing [ENTER]

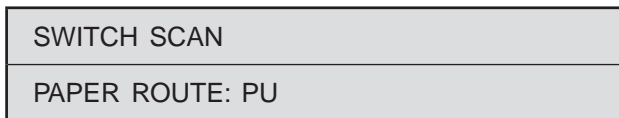

3. Keep the [MENU+] and [MENU-] keys pressed until the item that applies to the unit to test from Table 5-1-1 appears, at the top of the display.

Press the [MENU+] and [MENU-] keys. The [MENU+] key = Increment Test Item / the [MENU-] key = Decrement Test Item.

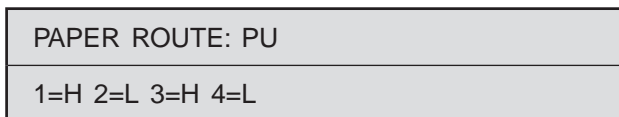

4. The test is started by pressing the [ENTER] key. The top of the display starts blinking and the applicable unit number (1-4) and the current state appears.

Operate each unit (Figure 5-1). Display the operations on each respective applicable LCD area. (The display varies according to each sensor. For details refer to Table 5-1-1.)

5. Press the [CANCEL] or [BACK] key to return to state 2.
6. Accordingly repeat Steps 2 to 4.
7. To end the test press the [BACK] key. (Return to state 1)

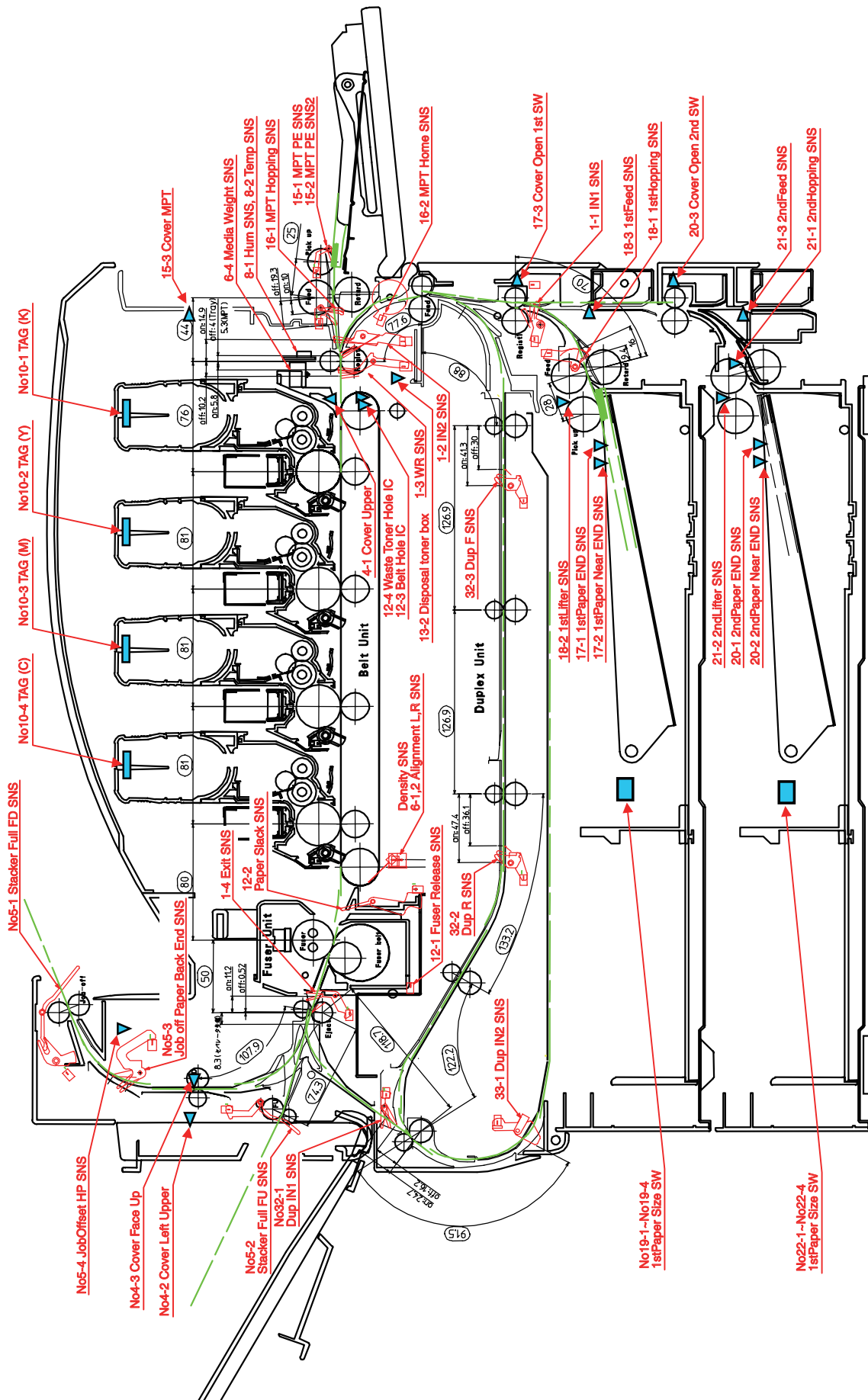

Figure 5-1 Location of Switching Sensor

Table 5-1-1 Switch Scan Details

No.	Top of the Display	1		2		3		4	
		Detail	Display	Detail	Display	Detail	Display	Detail	Display
1	PAPER ROUTE : PU	IN1 Sns	H:OFF L:ON	IN2 Sns	H:OFF L:ON	WR Sns	H:OFF L:ON	Exit Sns	H:OFF L:ON
2	PAPER ROUTE : SUB	IN1 Sns	H:OFF L:ON	IN2 Sns	H:OFF L:ON	WR Sns	H:OFF L:ON		
3	TONER SENS	Toner-K Sns	H:ON L:OFF	Toner-Y Sns	H:ON L:OFF	Toner-M Sns	H:ON L:OFF	Toner-C Sns	H:ON L:OFF
4	COVER UP_LU_FU	Cover-Upper	H:Open L:Close	Cover-Left Upper	H:Open L:Close	Cover-Face Up	H:Open L:Close		
5	STKF_FD_FU JOB OFFHOME	Stacker Full Sns (Face down)	H:Full L:Empty	Stacker Full Sns (Face up)	H:Full L:Empty	Job Offset Paper-End Sns	H:ON L:OFF	JobOffset Home Position Sns	H:ON L:OFF
6	REG L/R_DENS_WEIGHT	Alignment-Left-Sns	AD Value:***H	Alignment-Right-Sns	AD Value:***H			Media Weight-Sns	Frequency
7	HEATER THERMISTER	Upper-Center-Thermister	AD Value:***H	Lower-Center-Thermister	AD Value:***H	Upper-Side-Thermister	AD Value:***H	Detect-ambient temperature-Thermister	AD Value:***H
8	HUM_TEMP_OHP	Hum Sns	AD Value:***H	Temperture-Sns	AD Value:***H	OHP Sns	AD Value:***H		
9	ID UP/DOWN							ID UpDown Sns	H:Up L:Down
10	RFID COLOR	TAG-K presence	UID:***H	TAG-Y presence	UID:***H	TAG-M presence	UID:***H	TAG-C presence	UID:***H
11	DRUM PHASE SNS KYMC	K-Drum Phase Sns	Port Level H, L	Y-Drum Phase Sns	Port Level H, L	M-Drum Phase Sns	Port Level H, L	C-Drum Phase Sns	Port Level H, L
12	F-RLS SLK BLT DT-DCT	Fuser Release Sns	H:ON L:OFF	Paper Slack Sns	H:ON L:OFF	Belt Hole IC	H:ON L:OFF	Waste Toner Hole IC	H:ON L:OFF
13	DISTNR FULL_BOX_BOXSP	Disposal toner full	H:ON L:OFF	Disposal toner box	H:Not installed L:Installed				
14	TNR SPLY SNS KY_MC	K-Toner Supply Sns	Port Level H, L	Y-Toner Supply Sns	Port Level H, L	M-Toner Supply Sns	Port Level H, L	C-Toner Supply Sns	Port Level H, L
15	MPT PE_PE2_CV0	MPT-Paper-End Sns	Port Level H, L	MPT-Paper-End Sns 2	H:ON L:OFF	Cover-MPT	H:Open L:Close		
16	MPT HOP_HOME	MPT-Hopping Sns	H:ON L:OFF	MPT Home Position Sns	H:Open L:Close				
17	TRAY1 PE_PNE_CVO	1st-Paper-End Sns	Port Level H, L	1st-Paper-Near-End Sns	Port Level H, L	Cover-1st	H:Open L:Close		
18	TRAY1 HOP_LIFT	1st-Hopping Sns	Port Level H, L	1st-Lifter Sns	Port Level H, L	1st-Feed Sns	Port Level H, L		
19	TRAY1 CASSETTE SIZE	1st-Paper Size-1 Sw	Port Level H, L	1st-Paper Size-2 Sw	Port Level H, L	1st-Paper Size-3 Sw	Port Level H, L	1st-Paper Size-4 Sw	Port Level H, L
20	TRAY2 PE_PNE_CVO	2nd-Paper-End Sns	Port Level H, L	2nd-Paper-Near-End Sns	Port Level H, L	Cover-Open-2nd Sw	Port Level H, L		
21	TRAY2 HOP_LIFT_FEED	2nd-Hopping Sns	Port Level H, L	2nd-Lifter Sns	Port Level H, L	2nd-Feed Sns	Port Level H, L		
22	TRAY2 CASSETTE SIZE	2nd-Paper Size-1 Sw	Port Level H, L	2nd-Paper Size-2 Sw	Port Level H, L	2nd-Paper Size-3 Sw	Port Level H, L	2nd-Paper Size-4 Sw	Port Level H, L
23	TRAY3 PE_PNE_CVO	3rd-Paper-End Sns	Port Level H, L	3rd-Paper-Near-End Sns	Port Level H, L	Cover-Open-3rd Sw	Port Level H, L		
24	TRAY3 HOP_LIFT_FEED	3rd-Hopping Sns	Port Level H, L	3rd-Lifter Sns	Port Level H, L	3rd-Feed Sns	Port Level H, L		
25	TRAY3 CASSETTE SIZE	3rd-Paper Size-1 Sw	Port Level H, L	3rd-Paper Size-2 Sw	Port Level H, L	3rd-Paper Size-3 Sw	Port Level H, L	3rd-Paper Size-4 Sw	Port Level H, L
26	TRAY4 PE_PNE_CVO	4th-Paper-End Sns	Port Level H, L	4th-Paper-Near-End Sns	Port Level H, L	Cover-Open-4th Sw	Port Level H, L		
27	TRAY4 HOP_LIFT_FEED	4th-Hopping Sns	Port Level H, L	4th-Lifter Sns	Port Level H, L	4th-Feed Sns	Port Level H, L		
28	TRAY4 CASSETTE SIZE	4th-Paper Size-1 Sw	Port Level H, L	4th-Paper Size-2 Sw	Port Level H, L	4th-Paper Size-3 Sw	Port Level H, L	4th-Paper Size-4 Sw	Port Level H, L
29	TRAY5 PE_PNE_CVO	5th-Paper-End Sns	Port Level H, L	5th-Paper-Near-End Sns	Port Level H, L	Cover-Open-5th Sw	Port Level H, L		
30	TRAY5 HOP_LIFT_FEED	5th-Hopping Sns	Port Level H, L	5th-Lifter Sns	Port Level H, L	5th-Feed Sns	Port Level H, L		
31	TRAY5 CASSETTE SIZE	5th-Paper Size-1 Sw	Port Level H, L	5th-Paper Size-2 Sw	Port Level H, L	5th-Paper Size-3 Sw	Port Level H, L	5th-Paper Size-4 Sw	Port Level H, L
32	DUP INS_REAR_FRONT	Dup-In Sns	Port Level H, L	Dup-Rear Sns	Port Level H, L	Dup-Front Sns	Port Level H, L		
33	DUP STACK_COVER	Dup-Stack Sns	Port Level H, L	Dup-Cover Open Sns	Port Level H, L				

No.	Top of the Display	1		2		3		4	
		Detail	Display	Detail	Display	Detail	Display	Detail	Display
34	FIN S01_S02_ S03_S04	Uper Cover Sns [PI23]	H:OPEN L:CLOSE	Front door Sns [PI22]	H:OPEN L:CLOSE	Front door SW [MS2]	H:OPEN L:CLOSE	Joint SW [MS1]	H:OPEN L:CLOSE
35	FIN S05_S06_ S07_S08	Bookbinding position Sns[PI10]	H:Paper present L:Paper absent	Processing tray Sns [PI6]	H:Paper present L:Paper absent	Entrance Sns [PI1]	H:Paper present L:Paper absent	Punch timing Sns	H:Paper present L:Paper absent
36	FIN S09_S10_ S11_S12	Bookbinding tray paper Sns [PI13]	H:Paper present L:Paper absent	Bookbinding home position Sns [PI11]	H:Home position L:Except in the home position	Bookbinding roller home position Sns [PI12]	H:Home position L:Except in the home position	Front matching home position Sns [PI4]	H:Home position L:Except in the home position
37	FIN S13_S14_ S15_S16	Rear matching home position Sns [PI5]	H:Home position L:Except in the home position	Belt home position outlet Sns [PI7]	H:Home position L:Except in the home position	Feed roller home position Sns[PI3]	H:Home position L:Except in the home position	Paddle home position [PI2]	H:Home position L:Except in the home position
38	FIN S17_S18_ S19_S20	Staple / fold motor clock [PI14]	H/L:Clock	Self prime Sns [PI21]	H:Start staple detection L:Staple absent	Staple Sns [PI20]	H:Staple absent L:Staple present	Stapler safty SW [MS3]	H:Not to drive L:Drive
39	FIN S21_S22_ S23_S24	Staple home position Sns[PI19]	H:Home position L:Except in the home position	Stapler slide home position Sns [PI18]	H:Home position L:Except in the home position	Stapler connect signal	Hconnected Lunconnected	Stack tray lift motor clock[PI17]	H/L:Clock
40	FIN S25_S26_ S27_S28	Lower stack tray Sns [PI16]	H:Lower position L:Except in the lower position	Upper stack tray Sns [PI15]	H:Upper position L:Except in the upper position	Interlevel stack tray Sns [PI24]	H:Interlevel detection L:Interlevel undetection	Paper stack tray Sns [PI9]	H:Paper detect position L:Except in the paper detect position
41	FIN S29_S30_ S31_S32	Stack tray paper Sns [PI8]	H:Paper present L:Paper absent	Punch connect signal	Hconnected Lunconnected				
42	INV IN_OUT_ EXIT_COV	Entrance Sns [FP1]	H:ON L:OFF	Outlet Sns [FP2]	H:ON L:OFF	PU@Inverter Exit Sns Signal	H:ON L:OFF	Cover open SW [FMS1]	H:Open L:Close
43	INV REMAIN_ JOINT	Lower Sns[FP3]	H:ON L:OFF	Inverter connected Sns [FP4]	H:ON L:OFF	PU@Inverter CNT2 Signal	H:ON L:OFF		
44	HALL BELT_DT- BOX_DCT	Belt Hole IC	H:ON L:OFF	Waste Toner Box Hole IC	H:ON L:OFF	Waste Toner Hole IC	H:ON L:OFF		

Table 5-1-2 Paper Size Detection, Various Paper Types and Bits

No.	Paper	1	2	3	4
0	No cassette	H	H	H	H
1	B5-L	L	H	H	H
2	Legal 13-S	H	L	H	H
3	B5-S	L	L	H	H
4	A4-L	H	H	L	H
5	Letter-L	L	H	L	H
6	A5-S	H	L	L	H
7	A4-S	L	L	L	H
8	B4-S	H	H	H	L
9	A3-S	L	H	H	L
A	Legal 14-S	H	L	H	L
B	Executive-S	L	L	H	L
C	A3nobi-S	H	H	L	L
D	Ledger-S	L	H	L	L
E	A6-S	H	L	L	L
F	Letter-S	L	L	L	L

5.1.2.4 Motor/Clutch Test

This self-diagnosis routine is used to test the motor and clutch.

1. Continue to press the [MENU+] and [MENU-] keys until "Motor & Clutch Test" appears at the top of the display and the operation enters the self-diagnosis (Level 1) mode.

The [MENU+] key = Increment Test Item / the [MENU-] key = Decrement Test Item.

2. The following message appears when the [ENTER] is pressed. The suitable location of the unit to be tested as shown in Table 5-2 will appear at the bottom of the display.

Press the [MENU+] and [MENU-] keys.

The [MENU+] key = Increment Test Item / the [MENU-] key = Decrement Test Item.

MOTOR & CLUTCH TEST
PK – ID MOTOR

3. Press the [ENTER] key to start the test. The name of the unit will start blinking. Then the applicable unit will drive for 10 seconds.
Note! After driving for 10 seconds, it will return to State 2. The drive will start again by re-pressing the applicable switch.
 - To drive the applicable unit, there is a need to clear the drive limitational conditions indicated in Table 5-2. Launching a state drive that doesn't clear the limitation conditions is invalid. When this happens the clear information is displayed at the bottom of the display.
 - The clutch solenoid generally repeats ON/OFF with regular printer driver. (models that do not drive independently due to its mechanical structure will come be driven by a motor.)
4. Press the [CANCEL] key to stop the applicable unit drive. (maintain the display of the applicable unit, at this time)
5. Accordingly repeat Steps 2 to 4.
6. Press the [BACK] key to end the test. (Returns to state 1)

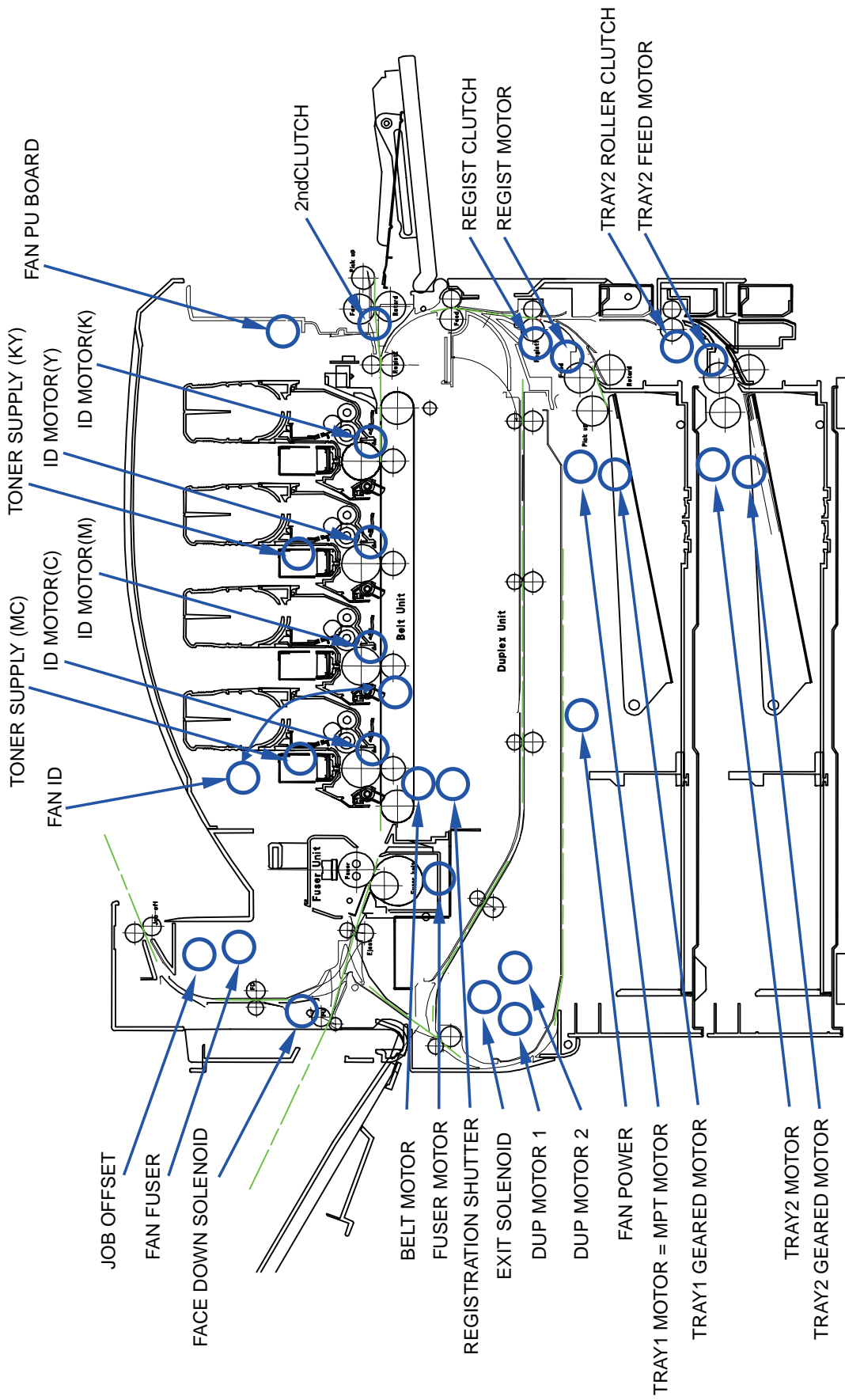

Figure 5-2 Location of Motor and Clutch

Table 5-2 Motor and Clutch Test

Unit Name Display	Drive Limitation	Error display	Remarks
K-ID MOTOR	-	-	-
Y-ID MOTOR	-	-	-
M-ID MOTOR	-	-	-
C-ID MOTOR	-	-	-
BELT MOTOR	-	-	-
FUSER MOTOR	-	-	-
FUSER MOTOR REVERSE	-	-	-
FUSER RLS	-	-	-
REGIST MOTOR	-	-	-
REGIST CLUTCH	-	-	-
MPT MOTOR	-	-	-
MPT LIFT UP	-	-	-
EXIT SOLENOID	-	-	-
FACEDOWN SOLENOID	-	-	-
REGISTRATION SHUTTER	-	-	-
JOB OFFSET	-	-	-
TRAY1 MOTOR	-	-	-
TRAY2 MOTOR	TRAY 2 is installed.	-	OPTION
TRAY3 MOTOR	TRAY 3 is installed.	-	OPTION
TRAY4 MOTOR	TRAY 4 is installed.	-	OPTION
TRAY5 MOTOR	TRAY 5 is installed.	-	OPTION
TRAY2 FEED MOTOR	TRAY 2 is installed and the cassette is not installed.	-	OPTION
TRAY3 FEED MOTOR	TRAY 2 is installed and the cassette is not installed.	-	OPTION
TRAY4 FEED MOTOR	TRAY 2 is installed and the cassette is not installed.	-	OPTION
TRAY5 FEED MOTOR	TRAY 2 is installed and the cassette is not installed.	-	OPTION
TRAY2 ROLLER CLUTCH	TRAY 2 is installed.	-	OPTION
TRAY3 ROLLER CLUTCH	TRAY 3 is installed.	-	OPTION
TRAY4 ROLLER CLUTCH	TRAY 4 is installed.	-	OPTION
TRAY5 ROLLER CLUTCH	TRAY 5 is installed.	-	OPTION
TRAY1 GEARED MOTOR	-	-	-
TRAY2 GEARED MOTOR	TRAY 2 is installed.	-	OPTION
TRAY3 GEARED MOTOR	TRAY 3 is installed.	-	OPTION
TRAY4 GEARED MOTOR	TRAY 4 is installed.	-	OPTION
TRAY5 GEARED MOTOR	TRAY 5 is installed.	-	OPTION
DUP MOTOR	Duplex unit is installed.	-	OPTION
DUP FAN	Duplex unit is installed.	-	OPTION

Unit Name Display	Drive Limitation	Error display	Remarks
FIN TRANSFER MOTOR	Finisher is installed.	-	OPTION
FIN SADDLE ROLLER	Finisher is installed.	-	OPTION
FIN BUNDLE MOTOR_FWD	Finisher is installed.	-	OPTION
FIN BUNDLE MOTOR_REW	Finisher is installed.	-	OPTION
FIN PADDLE	Finisher is installed.	-	OPTION
FIN BUNDLE ROLLER	Finisher is installed.	-	OPTION
FIN SLIDE MOTOR	Finisher is installed.	-	OPTION
FIN ORDER	Finisher is installed.	-	OPTION
FIN SHIFT MOTOR	Finisher is installed.	-	OPTION
FIN STAPLE EXEC	Finisher is installed.	-	OPTION
FIN SADDLE EXEC	Finisher is installed.	-	OPTION
FIN SADDLE TRANSFER	Finisher is installed.	-	OPTION
FIN SADDLE CLUTCH	Finisher is installed.	-	OPTION
FIN PUNCH HOLE	Finisher is installed.	-	OPTION
FIN PUNCH REG	Finisher is installed.	-	OPTION
INV MOTOR A	Inverter is installed.	-	OPTION
INV MOTOR B	Inverter is installed.	-	OPTION
INV SEPARATER	Inverter is installed.	-	OPTION
INV PRESSURE SOLENOID	Inverter is installed.	-	OPTION
INV REGIST CLUTCH	Inverter is installed.	-	OPTION
FAN POWER	-	-	-
FAN PU-BOARD	-	-	-
FAN FUSER	-	-	-
FAN BELT	-	-	-
FAN ID	-	-	-
TONER SUPPLY K	-	-	-
TONER SUPPLY Y	-	-	-
TONER SUPPLY KY	-	-	-
TONER SUPPLY M	-	-	-
TONER SUPPLY C	-	-	-
TONER SUPPLY MC	-	-	-
DISPOSAL TONER TUBE	-	-	-
ID UP/DOWN	-	-	-

5.1.2.5 Test Print

This self-diagnostic routine is used to print the test pattern in the PU. Other test patterns are stored in the controller.

1. Continue to press the [MENU+] and [MENU-] keys until "TEST PRINT" appears at the top row of the display, and the system is in the self-diagnosis (Lever 1) mode. The [MENU+] key = Increment Test Item / the [MENU-] key = Decrement Test Item.
2. Press the [ENTER] key only for the setting item applied for test printing appears at the bottom of the display. Press the [MENU+] and [MENU-] keys until the applicable item appears. The [MENU+] key = Increment Item / the [MENU-] key = Decrement Item. (Go to Item 5 to [Default Setting] if setting of each item is unnecessary.)
3. Press the [ENTER] key for the setting item to appear on the top row of the display and the setting value to appear at the bottom row of the display. Press the [MENU+] key for the setting value to increment. Press the [MENU-] key for the setting value to decrement (the final display setting value is applied). Accordingly repeat item 3.

TEST PATTERN
1

The settings shaded in are default settings.

Display	Setting value	Function
PRINT EXECUTE	-	Press [Enter] to start printing or [CANCEL] to stop printing (each page).
TEST PATTERN	0	0: Blank page1 to 7: See the "Test Print Pattern" table (pattern printing).8 to 15: Blank page
CASSETTE	TRAY1	Choose a paper feeder.
	TRAY2 *1	
	TRAY3 *1	
	TRAY4 *1	
	TRAY5 *1	
	MPT	
PAGE	0	Set the number of test print pages. Press [ONLINE] to move the cursor to the digit to be edited. Press[MENU_] to increase the set value, and [MENU_] to decrease the set value.
COLOR	ON	Choose Color or Monochrome.
	OFF	
DUPLEX *1	3 PAGES STACK	Prints on both sides of a stack of 3 sheets.
	OFF	Turns off duplex printing.Prints on both sides of one sheet.Turns the
	1 PAGES STACK	job offset function on and off.
JOB OFFSET	OFF	Turn the job offset function on and off.
	ON	
FINISHER *2	OUTPUT BIN	Choose an output bin.
	PUNCH	Turns the punch mode on and off.
	OFFSET	Turns the offset mode on and off.
	STAPLE	Choose the staple location.
	STAPLE PAGE	Set the number of sheets to be stapled (0 to 50).
	INVERT	Turns the invert mode on and off.

*1 TRAY 2 to TRAY 5 and DUPLEX will be displayed only when their respective units are installed.

*2 If the finisher is not installed, "OUTPUT BIN" is displayed and only the output bin is selectable.

• Presets: FACE DOWN/FACE UP Default: FACE DOWN

* These settings are valid in the test mode only (they will not be written to the EEPROM).

Note * COLOR Setting

When COLOR is on, if [ONLINE] is pressed, the settings below will appear and the print color-setting mode will be entered.

COLOR			
Y:ON	M:ON	C:ON	K:ON

Press [ONLINE] to move the cursor to the color to be turned on or off.

Press [MENU+] or [MENU-] to turn the setting of each color on or off, respectively[OK to add?].

Press [ENTER] to exit the print color-setting mode.

* FINISHER Setting

- (1) When "FINISHER" is shown at the bottom of the display panel, press [ENTER].
- (2) Press [MENU+] or [MENU-] until the setting item to be edited appears.
- (3) Press [ENTER]; the set value will appear at the bottom of the panel.
Press [MENU+] or [MENU-] until the desired value appears. ([MENU+] increases the value and [MENU-] decreases the value.)
- (4) Press [BACK] to return to step (2) above. Press [BACK] again to return to step (1).
- (5) Repeat steps (2) to (4) as necessary.

The settings shaded in are default settings.

Display	Setting value	Function
OUTPUT BIN	FACE DOWN	Printer face down
	FINISHER UPPER BIN	Finisher upper bin
	FINISHER LOWER BIN	Finisher lower bin
PUNCH	OFF	Punch on/off
	ON	
OFFSET	OFF	Offset on/off
	ON	
STAPLE MODE	OFF	Staple mode off
	Rear	Rear corner
	Center	Center corner
	Front	Front corner
	Saddle	Saddle stitch
STAPLE NUMBER	0	Set the number of sheets to be stapled (0 to 50). * When the staple mode is on, "STAPLE NUMBER" is selectable between 2 and 50.
INVERT	OFF	Invert on/off
	ON	

4. Operations in section 2 will execute test printing at the set value that is set in Steps 2 to 3, by pressing the [ENTER] key when the state displays "PRINT EXECUTE" at the bottom row of the display.

Press the [ENTER] key to stop test printing.

Print Test Pattern

Pattern No.	Print pattern
0	None (blank page)
1	2 by 2
2	4 by 4
3	Horizontal line
4	Slanted line
5	Vertical line
6	Vertical band
7	Full

- The following message appears when printing.

P=*** T=*** U=*** [###]
H=***% L=***[###]

P: Test Print Sheets (Unit: number of sheets)

U: Upper-side Heater temperature Measurement Value[Setting] (Unit: °C)

L: Lower-Side Heater temperature Measurement Value[Setting] (Unit: °C)

T: Environmental Temperature Measurement Value (Unit: %)

H: Environmental Humidity Measurement Value (Unit: %)

- Press [MENU+] key to switch the display.

KTR=*. **KV YTR=*. **KV
MTR=*. **KV CTR=*. **KV

YTR, MTR, CTR and KTR are image transfer voltage settings of each color. (Unit: KV)

- Press [MENU+] key to switch the display.

KR=*. **uA YR=*. **uA
MR=*. **uA CR=*. **uA

YR, MR, CR, and KR represent the electric current (uA) of the transfer roller for each color, respectively.

- Press [MENU+] key to switch the display.

THICK= *** TEMP=***
REGIST=**** EXIT=****

THICK: Detected medium thickness (µm)

TEMP: Fusing temperature (°C)

REGIST: Constant speed of resist motor (hexadecimal)

EXIT: Constant speed of fuser motor (hexadecimal)

- Accordingly repeat Steps 2 to 4.
- Press the [BACK] key to end the test. (Returns to state 1)

5.1.2.6 Initialize NVM

This self-diagnosis is used to initialize the nonvolatile memory.

1. Continue to press the [MENU+] and [MENU-] keys until "NV-RAM INITIAL" appears at the top row of the display, and the system is in the self-diagnosis (Level 1) mode. The [MENU+] key = Increment Test Item / the [MENU-] key = Decrement Test Item.
2. When the [ENTER] key is pressed, the Table No. to be initialized appears at the bottom row of the display. There are 3 tables initialized. Press the [MENU+] and [MENU-] keys until the applicable Table No. appears. The [MENU+] key = Increment Table No. / the [MENU-] key= Decrement Table No.

NV-RAM INITIAL
INITIAL 1

Note! Do not use INITIAL 2.

3. When the [ENTER] key is pressed, the "NV-RAM INITIAL" display blinks at the top row of the display. Press it for 10 consecutive seconds to initialize all items indicated in Table 5-3.
4. Press the [BACK] key to end the test. (Returns to state 1)

Table 5-3 NV-RAM Initial

Item to Initialize	Unit	Initial Setting	Detail
K-DRUM UNIT	IMAGES	0	Total number of revolutions since the ID unit for each color has been installed.
Y-DRUM UNIT	IMAGES	0	
M-DRUM UNIT	IMAGES	0	
C-DRUM UNIT	IMAGES	0	
FUSER UNIT	PRINTS	0	Total number of revolutions since the fuser unit has been installed.
TR BELT UNIT	IMAGES	0	Total number of revolutions since the belt unit has been installed.
K-DISTNR	-	0	Quantity of each color of toner to be discarded
Y-DISTNR	-	0	
M-DISTNR	-	0	
C-DISTNR	-	0	
DISTNR CNT	-	0	Quantity of toner discarded in toner disposal
DISTNR BOX TNR CNT	-	0	Quantity of toner discarded in toner disposal or for correction (e.g., color cast, color misregistration, and density)

5.1.2.7 Consumable Parts Counter Display

This self-diagnosis is used to display the consumption status of the consumable parts of the printer.

1. It will go into normal self-diagnosis. Continue to press the [MENU+] and [MENU-] keys until "CONSUMABLE STATUS" appears at the top row of the display. (The [MENU+] key to Increment the Test Item / the [MENU-] key to decrement the Test Item.)
2. After the [ENTER] key is pressed, press the [MENU+] and [MENU-] keys to sequentially display the consumption status according to consumable part.
3. Press the [BACK] key to end the test. (Returns to state 1)

Top of the Display	Bottom of the Display	Format	Detail
K-DRUM UNIT	***** IMAGES	DEC	Indicates the total number of revolutions since the ID unit for each color has been installed.
Y-DRUM UNIT			
M-DRUM UNIT			
C-DRUM UNIT			
FUSER UNIT	***** PRINTS	DEC	Indicates how many pages have been printed since the fuser unit has been installed.
TR BELT UNIT	***** IMAGES	DEC	Indicates how many pages have been printed since the belt unit has been installed.
K-TONER	***%	DEC	Indicates what quantity of each color of toner has been consumed. * Indicates 90% when the toner level is low.
Y-TONER			
M-TONER			
C-TONER			
STAPLE UNIT	***** JOBS	DEC	Indicates how many times stapling has been performed.
PUNCH UNIT	***** PRINTS	DEC	Indicates how many times punching has been performed.
PATTING ROLLER	***** PRINTS	DEC	Indicates how many sheets have passed by the patting roller.
STAPLE CONSUMPTION	***** PIECES	DEC	Indicates how many staples have been used. * The count is reset when staples are refilled.
STAPLE UNIT REPLACE	***** TIMES	DEC	Indicates how many times the staple unit has been replaced.
PUNCH UNIT REPLACE	***** TIMES	DEC	Indicates how many times the punch unit has been replaced.

5.1.2.8 Consumable Continual Counter Display

This self-diagnosis is used to display the consumption status of the consumable parts of the printer.

The life consumption status of consumable parts means that the counter value is not initialized though the consumable parts are replaced. It is a way to continually count the consumption level of the consumable parts of the printer.

1. It will go into normal self-diagnosis. Continue to press the [MENU+] and [MENU-] keys until "PRINTER STATUS" appears at the top row of the display. (The [MENU+] key to Increment the Test Item / the [MENU-] key to decrement the Test Item.)
2. After the [ENTER] key is pressed, press the [MENU+] and [MENU-] keys to sequentially display the life consumption status according to consumable part.
3. Press the [BACK] key to end the test. (Returns to state 1)

Top of the Display	Bottom of the Display	Format	Detail
K-IMPRESSIONS	***** PRINTS	DEC	Indicates how many pages have been printed using each color.
Y-IMPRESSIONS			
M-IMPRESSIONS			
C-IMPRESSIONS			
TOTAL SHEETS FEED	***** PRINTS	DEC	Indicates the total number of sheets fed.
FINISHER TOTAL PAGE	***** PRINTS	DEC	Indicates the total number of sheets having passed by the finisher.

5.1.2.9 Panel Display Details

Panel Display

Panel Display	Details
BLANCE ERROR	Balance Error
BELT LIFE OVER	Belt Life Over
BELT REFLECTION ERROR	Belt Reflection Error
BELT UNIT FUSE CUT ERROR	Belt Unit Fuse Cut Error
BLACK DENSITY CALIB ERROR	BLACK Density Calibration Error
BLACK DENSITY SENSOR ERROR	BLACK Density Sensor Error
BLACK DRUM LIFE OVER	BLACK Drum Life
BLACK DRUM NEAR LIFE	BLACK Drum Near Life Warning
BLACK DRUM UNIT FUSE CUT ERROR	BLACK Drum Unit Fuse Cut Error
BLACK DRUM UP/DOWN ERROR	BLACK Drum UP/DOWN Error
BLACK IRREGULAR ERROR	BLACK Outside Detection Range Error
BLACK LED HEAD ERROR	BLACK LED Head Error
BLACK REGISTRATION ERROR(PX711)	BLACK Color Drift Error
BLACK REGISTRATION OUT HORIZONTAL	BLACK Detected of Irregular Color Drift Correction Value in the Main Scanning Correction
BLACK REGISTRATION OUT LEFT	BLACK Outside Range of Correction Error (LEFT)
BLACK REGISTRATION OUT RIGHT	BLACK Outside Range of Correction Error (RIGHT)
BLACK SENSOR ERROR LEFT	BLACK LEFT Sensor Error
BLACK SENSOR ERROR RIGHT	BLACK RIGHT Sensor Error
BLACK TONER EMPTY	BLACK Toner EMPTY
BLACK TONER LOW	BLACK Toner LOW
BLACK TONER SENSOR ERROR	BLACK Toner Sensor Error
BLACK ID DENSITY ERROR 1	BLACK Density Correction ID Error 1
BLACK ID DENSITY ERROR 2	BLACK Density Correction ID Error 2
CALIBRATION CHIP ERROR	Color Calibration Chip Correction Value Error
CALIBRATION ERROR	Calibration Error
COLOR DENSITY CALIB ERROR	Color Density Calibration Error
COLOR DENSITY SENSOR ERROR	Color Density Sensor Error
COOLING DOWN	Cooling Down
CUSTOM DIAGNOSTICS MODE	Custom Diagnostic Mode
CYAN DRUM LIFE OVER	CYAN Drum Life
CYAN DRUM NEAR LIFE	CYAN Drum Near Life Warning
CYAN DRUM UNIT FUSE CUT ERROR	CYAN Drum Unit Fuse Cut Error
CYAN DRUM UP/DOWN ERROR	CYAN Drum UP/DOWN Error
CYAN IRREGULAR ERROR	CYAN Detection Value Error
CYAN LED HEAD ERROR	CYAN LED Head Error
CYAN REGISTRATION ERROR	CYAN Color Drift Error
CYAN REGISTRATION OUT HORIZONTAL	CYAN Detected of Irregular Color Drift Correction Value in the Main Scanning Correction
CYAN REGISTRATION OUT LEFT	CYAN Outside Range of Correction Error (LEFT)
CYAN REGISTRATION OUT RIGHT	CYAN Outside Range of Correction Error (RIGHT)
CYAN SENSOR ERROR LEFT	CYAN LEFT Sensor Error
CYAN SENSOR ERROR RIGHT	CYAN RIGHT Sensor Error
CYAN TONER EMPTY	CYAN Toner EMPTY
CYAN TONER LOW	CYAN Toner LOW
CYAN TONER SENSOR ERROR	CYAN Toner Sensor Error
CYAN ID DENSITY ERROR 1	CYAN Density Correction ID Error 1
CYAN ID DENSITY ERROR 2	CYAN Density Correction ID Error 2

Panel Display	Details
DIAGNOSTICS MODE	Engine Diagnostic Mode
DISPOSAL TONER FULL	Disposal Toner Full
DISPOSAL TONER NEAR FULL	Disposal Toner Near-Full
DRIVE MOTOR OVER HEAT	DRIVE Motor Overheat Error
DUPLEX I/F ERROR	DUPLEX I/F Error
DUPLEX TYPE MISMATCH	DUPLEX Type Error
DUPLEX UNIT OPEN(PX713)	DUPLEX Unit Open
ENGINE BOARD FAN MOTOR ERROR	PU PCB Fan Motor Error
ENGINE CONTROL ERROR	ENGINE Control Error
ENGINE EEPROM ERROR	EEPROM Error
ENGINE EEPROM MISSING	EEPROM Unmounted
ENGINE LIFE OVER	ENGINE Life Over
ENGINE RAM ERROR	RAM Error
ENGINE ROM ERROR	ROM Error
ENGINE SRAM ERROR	SRAM Error
ENV TEMP SENSOR ERROR	Environmental Temperature Sensor Error
FACE-UP STACKER OPEN	Face-Up Stacker Open
FLASH HARDWARE ERROR	FLASH Hardware Error
FLASH SOFTWARE ERROR	FLASH Software Error
FRONT COVER OPEN(PX711)	Front Cover Open
FUSER LIFE OVER	FUSER Life Over
FUSER UNIT FAN MOTOR ERROR	FUSER Fan Motor Error
FUSER UNIT FUSE CUT ERROR	Fuser Unit Fuse Cut Error
FUSER UNIT NISMATCH	Fuser Unit Mismatch
HOPPING ERROR DUPLEX	DUPLEX Hoping Error
HOPPING ERROR MULTI PURPOSE FEEDER	MP-FEEDER Hoping Error
HOPPING ERROR TRAY1	TRAY1 Hoping Error
HOPPING ERROR TRAY2	TRAY2 Hoping Error
HOPPING ERROR TRAY3	TRAY3 Hoping Error
HOPPING ERROR TRAY4	TRAY4 Hoping Error
HOPPING ERROR TRAY5	TRAY5 Hoping Error
HUMIDITY SENSOR DEW ERROR	Temperature Sensor Dew Error
HUMIDITY SENSOR ERROR	Relative Humidity Sensor Error
INFEED:DUPLEX	DUPLEX Hoping Error
INFEED:MP-FEEDER	MP-FEEDER Hoping Error
INFEED:TRAY1	TRAY1 Hoping Error
INFEED:TRAY2	TRAY2 Hoping Error
INFEED:TRAY3	TRAY3 Hoping Error
INFEED:TRAY4	TRAY4 Hoping Error
INFEED:TRAY5	TRAY5 Hoping Error
INITIALIZING	Initializing When Turning Power ON
INITIALIZING	Initializing When OPENCLOSE Cover
INITIALIZING DENSITY ADJUST	Automatic Density Correction Being Controlled
INITIALIZING REGISTRATION ADJUST	Automatic Color Drift Correction Control
INPATH:DUPLEX ENTRY	DUPLEX Internal Area Jam
INPATH:DUPLEX INPUT	DUPLEX Input Area Jam
INPATH:DUPLEX REVERSAL	DUPLEX Reversal Area Jam
INPATH:EXIT	Discharge Jam

Panel Display	Details
INPATH:FEED	Feed Jam
INPATH:TRANSPORT	Conveyance Jam
JAM DUPLEX ENTRY	DUPLEX Internal Area Jam
JAM DUPLEX INPUT	DUPLEX Input Area Jam
JAM DUPLEX REVERSAL	DUPLEX Reversal Area Jam
JAM EXIT	Discharge Jam
JAM FEED	Feed Jam
JAM TRANSPORT	Conveyance Jam
JOB OFFSET HOME ERROR(PX713)	Job Offset Home Error
LED HEAD OVER HEAT	LED head Overheat Error
LIFT ERROR TRAY1(PX713)	TRAY1 Liftup Error
LIFT ERROR TRAY2(PX713)	TRAY2 Liftup Error
LIFT ERROR TRAY3(PX713)	TRAY3 Liftup Error
LIFT ERROR TRAY4(PX713)	TRAY4 Liftup Error
LIFT ERROR TRAY5(PX713)	TRAY5 Liftup Error
LIFT UP TRAY1(PX713)	TRAY1 Lifting UP
LIFT UP TRAY2(PX713)	TRAY2 Lifting UP
LIFT UP TRAY3(PX713)	TRAY3 Lifting UP
LIFT UP TRAY4(PX713)	TRAY4 Lifting UP
LIFT UP TRAY5(PX713)	TRAY5 Lifting UP
LOWER HEATER HIGH TEMPER	LOWER Heater High Temperature (HOT) Error
LOWER HEATER LOW TEMPER	LOWER Heater Low Temperature (COLD) Error
LOWER HEATER OPEN ERROR	LOWER Heater Thermistor Open Error
LOWER HEATER SHORT ERROR	LOWER Heater Thermistor Short-Circuit Error
MAGENTA DRUM LIFE OVER	MAGENTA Drum Life
MAGENTA DRUM NEAR LIFE	MAGENTA Drum Near Life Warning
MAGENTA DRUM UNIT FUSE CUT ERROR	MAGENTA Drum Unit Fuse Cut Error
MAGENTA DRUM UP/DOWN ERROR	MAGENTA Drum UP/DOWN Error
MAGENTA IRREGULAR ERROR	MAGENTA Detection Value Error
MAGENTA LED HEAD ERROR	MAGENTA LED head Error
MAGENTA REGISTRATION ERROR	MAGENTA Color Drift Error
MAGENTA REGISTRATION OUT HORIZONTAL	MAGENTA Detected of Irregular Color Drift Correction Value in the Main Scanning Correction
MAGENTA REGISTRATION OUT LEFT	MAGENTA Outside Range of Correction Error (LEFT)
MAGENTA REGISTRATION OUT RIGHT	MAGENTA Outside Range of Correction Error (RIGHT)
MAGENTA SENSOR ERROR LEFT	MAGENTA LEFT Sensor Error
MAGENTA SENSOR ERROR RIGHT	MAGENTA RIGHT Sensor Error
MAGENTA TONER EMPTY	MAGENTA Toner EMPTY
MAGENTA TONER LOW	MAGENTA Toner LOW
MAGENTA TONER SENSOR ERROR	MAGENTA Toner Sensor Error
MAGENTA ID DENSITY ERROR 1	MAGENTA Density Correction ID Error 1
MAGENTA ID DENSITY ERROR 2	MAGENTA Density Correction ID Error 2
MAILBOX I/F ERROR(PX711)	MAILBOX I/F Error
MISSING BELT UNIT	BELT Unit Unmounted
MISSING BLACK DRUM	BLACK Drum Unmounted
MISSING CYAN DRUM	CYAN Drum Unmounted
MISSING FUSER UNIT	FUSER Unit Unmounted
MISSING MAGENTA DRUM	MAGENTA Drum Unmounted
MISSING YELLOW DRUM	YELLOW Drum Unmounted

Panel Display	Details
MULTI PURPOSE FEEDER STAGE POSITION	Multipurpose Stage Position Error
PAPER END MULTI PURPOSE FEEDER	MP-FEEDER Out-of-Paper
PAPER END TRAY1	TRAY1 Out-of-Paper
PAPER END TRAY2	TRAY2 Out-of-Paper
PAPER END TRAY3	TRAY3 Out-of-Paper
PAPER END TRAY4	TRAY4 Out-of-Paper
PAPER END TRAY5	TRAY5 Out-of-Paper
PAPER NEAR END MULTI PURPOSE FEEDER	MP-FEEDER Out-of-Paper Warning
PAPER NEAR END TRAY1	TRAY1 Out-of-Paper Warning
PAPER NEAR END TRAY2	TRAY2 Out-of-Paper Warning
PAPER NEAR END TRAY3	TRAY3 Out-of-Paper Warning
PAPER NEAR END TRAY4	TRAY4 Out-of-Paper Warning
PAPER NEAR END TRAY5	TRAY5 Out-of-Paper Warning
PAPER PILE OUT OF TRAY	Paper Conveyance Error
PAPER SIZE ERROR	Paper Size Error
POWER SUPPLY FAN MOTOR ERROR	PU Fan Motor Error
POWER SUPPLY LSI ERROR	Power Supply LSI Error
PROCESS CONTROL OFF	Process Control OFF
PROCESS WAIT MODE	Color Drift Density Correction Taking Place (when launched from CU)
PUNCH BOX NOT EXISTING(PX713)	Punch Dust Box Unmounted
PUNCH DUST OVERFLOW(PX713)	Punch Dust Overflow
REGISTRATION SENSOR CALIBRATION ERROR	Color Drift Sensor Calibration Error
R-SIDE COVER OPEN(PX713)	Right-Side Cover Open
SHUTTER ERROR1	Density Correction Shutter Error 1
SHUTTER ERROR2	Density Correction Shutter Error 2
STACKER FULL BOTTOM BIN(PX713)	Bottom Bin Stacker Full
STACKER FULL FACE DOWN	Face-Down Stacker Full
STACKER FULL MAIL BOX1(PX711)	MAIL BOX1 Stacker Full
STACKER FULL MAIL BOX2(PX711)	MAIL BOX2 Stacker Full
STACKER FULL TOP BIN(PX713)	Top Bin Stacker Full
THICKNESS ADJUSTING	Detecting Media Thickness
THICKNESS NON-PAPER AD ERROR	AD Value Outside Standard Error (Media Safe)
THICKNESS PAPER THICKNESS ERROR	Media Thickness Outside Detection Range Error
THICKNESS SNS AD ERROR	Sensor Output Difference Outside Standard Range Error (Media Safe)
THICKNESS THICK_PAPER ERROR	Sensitivity Correction Error
TOP COVER OPEN	Top Cover Open
TRAY1 TYPE MISMATCH	TRAY1 Type Error
TRAY2 COVER OPEN(PX713)	TRAY2 Cover Open
TRAY2 I/F ERROR	TRAY2 I/F Error
TRAY2 TYPE MISMATCH	TRAY2 Type Error
TRAY3 COVER OPEN(PX713)	TRAY3 Cover Open
TRAY3 I/F ERROR	TRAY3 I/F Error
TRAY3 TYPE MISMATCH	TRAY3 Type Error
TRAY4 COVER OPEN(PX713)	TRAY4 Cover Open
TRAY4 I/F ERROR	TRAY4 I/F Error
TRAY4 TYPE MISMATCH	TRAY4 Type Error
TRAY5 COVER OPEN(PX713)	TRAY5 Cover Open
TRAY5 I/F ERROR	TRAY5 I/F Error

Panel Display	Details
TRAY5 TYPE MISMATCH	TRAY5 Type Error
UPPER HEATER HIGH TEMPER	UPPER Heater High Temperature (HOT) Error
UPPER HEATER LOW TEMPER	UPPER Heater Low Temperature (COLD) Error
UPPER HEATER OPEN ERROR	UPPER Heater Thermistor Open Error
UPPER HEATER SHORT ERROR	UPPER Heater Thermistor Short-Circuit Error
WARMING UP	Warming Up
YELLOW DRUM LIFE OVER	YELLOW Drum Life
YELLOW DRUM NEAR LIFE	YELLOW Drum Near Life Warning
YELLOW DRUM UNIT FUSE CUT ERROR	YELLOW Drum Unit Fuse Cut Error
YELLOW DRUM UP/DOWN ERROR	YELLOW Drum UP/DOWN Error
YELLOW IRREGULAR ERROR	YELLOW Detection Value Error
YELLOW LED HEAD ERROR	YELLOW LED head Error
YELLOW REGISTRATION ERROR	YELLOW Color Drift Error
YELLOW REGISTRATION OUT HORIZONTAL	YELLOW Detected of Irregular Color Drift Correction Value in the Main Scanning Correction
YELLOW REGISTRATION OUT LEFT	YELLOW Outside Range of Correction Error (LEFT)
YELLOW REGISTRATION OUT RIGHT	YELLOW Outside Range of Correction Error (RIGHT)
YELLOW SENSOR ERROR LEFT	YELLOW LEFT Sensor Error
YELLOW SENSOR ERROR RIGHT	YELLOW RIGHT Sensor Error
YELLOW TONER EMPTY	YELLOW Toner EMPTY
YELLOW TONER LOW	YELLOW Toner LOW
YELLOW TONER SENSOR ERROR	YELLOW Toner Sensor Error
YELLOW ID DENSITY ERROR 1	YELLOW Density Correction ID Error 1
YELLOW ID DENSITY ERROR 2	YELLOW Density Correction ID Error 2

Jam Error Display Details

Panel Display	Details
INFEED:TRAY1	TRAY1 Hoping Error
INFEED:TRAY2	TRAY2 Hoping Error
INFEED:TRAY3	TRAY3 Hoping Error
INFEED:TRAY4	TRAY4 Hoping Error
INFEED:TRAY5	TRAY5 Hoping Error
INFEED:MP-FEEDER	MP-FEEDER Hoping Error
INFEED:DUPLEX	DUPLEX Hoping Error
INPATH:DUPLEX INPUT	DUPLEX Input Jam
INPATH:DUPLEX ENTRY	DUPLEX Internal Jam
INPATH:REVERSAL	DUPLEX Reversal Jam
INPATH:FEED	Feed Jam
INPATH:TRANSPORT	Conveyance Jam
INPATH:EXIT	Discharge Jam

INFEED ...Information on the paper remaining in the paper feed entry.

INPATH.....Information on the paper remaining in the travel path.

5.1.3 Various Printing Methods with a Stand-Alone Printer Coming with a Controller

Configuration Print

Print the Program Version, control unit composition, other printer compositions and settings.

Operations : Panel Switch press

600 Model : Enter→▽ (Print Information Selection)→Enter→Enter (Configuration Selection)→Enter (Execute)→Enter

1200 Model : Enter→▽ (Print Page Selection)→Enter→▽ (Configuration Selection)→Enter

File List Print

Print list of files stored on the HDD and Flash ROM.

Operations : Panel Switch press

600 Model : Enter→▽ (Print Information Selection)→Enter→▽→▽→▽ (File List Selection)→Enter (Execute)→Enter

1200 Model : No menu.

Font List Print (PS)

Print list of PS fonts.

Operations : Panel Switch press

600 Model : Enter→▽ (Print Information Selection)→Enter→▽→▽→▽→▽ (PS Font Selection)→Enter (Execute)→Enter

1200 Model : Enter→▽ (Print Page Selection)→Enter→▽→▽→▽→▽ (PS Font Selection)→Enter

Font List Print (PCL)

Print list of PCL fonts.

Operations : Panel Switch press

600 Model : Enter →▽ (Print Information Selection)→Enter →▽→▽→▽→▽→▽ (PCL Font Selection)→Enter (Execute)→Enter

1200 Model : Enter→▽ (Print Page Selection)→Enter→▽→▽→▽→▽→▽ (PCL Font Selection)→Enter

Demo Print

Print the demo pattern for each destination on the ROM and HDD.

Operations : Panel Switch press

600 Model : Enter→▽ (Print Information Selection)→Enter→▽→▽ (Demo Page Selection)→Enter (DEMO1)→Enter (Execute)→Enter

1200 Model : Enter→▽ (Print Page Selection)→Enter→▽→▽→▽→▽→▽ (Demo Page Selection)→Enter

Ethernet Board Self-Diagnosis

If an Ethernet board is mounted, then print the self-diagnostic results of the Ethernet board.

Operations : Press Panel Switch or Ethernet Board Switch (600 Model only)

600 Model : Enter→▽ (Print Information Selection)→Enter→▽→Enter (Network Selection)→Enter (Execute)

1200 Model : None (Configuration Print)

5.2 Adjustment After Replacing Parts

The following describes the adjustments necessary when replacing parts.

Color drift adjustment and correction is constantly necessary.

Replacement Parts	Adjustment Details
LED head	Unnecessary
Drum Cartridge (Y, M, C, K)	Unnecessary
Fuser Unit	Unnecessary
Belt Cassette Assy	Unnecessary
PU (S2V PCB)	Assemble EEPROM used with the PCB before it was replaced. *Note 1
CU (1200dpi: AS3 PCB)	Assemble EEPROM, HDD, Keychip (used with the PCB before it was replaced.) *Note 2
CU (600dpi: TBX PCB)	Assemble EEPROM used with the PCB before it was replaced *Note 3
Paper Thickness Sensor Assy	Paper Thickness Detection Sensitivity Correction and Media Thickness Detection Value Test

*Note 1 : When using a new EEPROM for the PU (S2V PCB), the paper thickness detection sensitivity shall be corrected.

*Note 2 : When replacing the CU board, HDD, or EEPROM of the 1200-dpi system, follow the instructions given in the annexed table.

*Note 3 : When a new EEPROM is used for the CU board of 600 dpi system, adjust it to customers setting. If the customer has registered files in the Flash, restore them (Form overlay and the like).

5.2.1 Precautions when Replacing the Engine Control PCB

When replacing the Engine Control PCB (SV2 PWB) remove the EEPROM from the old PCB. Then mount it on the new PCB. (For Error other than Engine EEPROM Error)

If on the Operation Panel, a "SERVICE CALL XXX (Engine EEPROM Error)" is displayed, replace with new EEPROM. In this case execute the procedures described in Section 5.2.2.

For ODA version

Be careful to change the engine-control substrate (S2V PWB) of 600 dpi device due to different substrate to change based on a destination (due to different version of PU-FW).

Standard device: S2V-11

Specified destination (for AB): S2V 18

5.2.2 Precautions Upon EEPROM Replacement

When replacing the Engine Control PCB (SV2 PWB), if the EEPROM was removed but not mounted on the new PCB, or if the EEPROM is replaced with a new EEPROM, then the Version Read Function (Fuse Cut) has become invalid. For this reason, there is a need to use the PjL command to switch the Factory Mode to the Shipping Mode to activate the new EEPROM.

[Details]

1. To set the Shipping Mode, send the applicable PjL File to the printer.
2. To apply the setting, restart the printer or send a reboot command (PjL File) to the printer.

[Procedure]

Execute the following procedures from the MS-DOS prompt.

1. Copy/b Pjl_ship.bin prn
2. Copy/b Pjl_reboot.bin prn
or Turn OFF/ON power source.

[Necessary PjLFile]

1. Pjl_ship.bin
2. Pjl_reboot.bin

Note! When replacing the EEPROM, the belt, toner, ID and other life information will be cleared. This will result in an error in life management until the next unit replacement time. Be careful of this difference. The count that is cleared with EEPROM replacement is as follows. Since everything other than "Total Sheets Feed" will be cleared when each unit is replaced with a new one, the error is resolved at this point.

Item	Details	Count Details
Fuser	Fuser Life Count	The number of printouts are converted into number of Letter Sheets, from when the new fuser unit is assembled.
Transfer Belt	Transfer Belt Life Count	The number of printouts are converted into number of Letter Sheets, from when the new belt unit is assembled.
Black Imaging DrumCyan Imaging DrumMagenta Imaging DrumYellow Imaging Drum	Imaging Drum Life Count of Each Color	The number of turn around is converted into number of Letter Sheets, from when the new ID unit is assembled.
Total Sheets Feed	Unit Life Count	Total number of printouts.
Black ImpressionsCyan ImpressionsMagenta ImpressionsYellow Impressions	Total Number of Printout Sheets	The number of printouts from when the new ID unit is assembled.

5.2.3 CU PCB of 1200 dpi Printer and Replacement of Mounted Components

Nonvolatile memory and a combination (at field)

Component	Adjustment	Recovery	Unrecoverable item
AS3 PCB	Mount the EEOROM, Keychip, HDD used for the old AS3 PCB(EEPROM and Keychip are not mounted on a maintenance AS3 PCB)	As the MAC address is changed, the password to login in the web page has to be changed	None
HDD	After a new HDD is mounted on the AS3 PCB, perform the Factory Default (the EEOROM setting data are copied to the HDD).	<ul style="list-style-type: none"> The user settings stored in the HDD will be lost. Set necessary parameters again. If static IP is selected for the network setting, it shall be set again. The clock shall be set again. User-installed fonts will be lost. These can be restored using the backup utility. 	If the fonts are not backed up, they cannot be restored.
EEPROM	<ul style="list-style-type: none"> Choose a maintenance EEPROM for the model. After a maintenance EEPROM is mounted on the AS3 PCB, perform the Factory Default (the EEPROM data are copied to the HDD). 	<ul style="list-style-type: none"> The user settings stored in the HDD will be lost. Set necessary parameters again. If static IP is selected for the network setting, it shall be set again. The clock shall be set again. 	<ul style="list-style-type: none"> The page count in the EEPROM of the CU will be lost and Color/Monochrome Page will be returned to zero. When the number of printed sheets and other information are necessary, print out the engine maintenance menu. The user-installed fonts will be lost.
KeyChip	After a new Key Chip is mounted on the AS3 PCB, perform the Factory Default.	The user settings stored in the HDD will be lost. Set necessary parameters again.	

* Factory Default Procedure

Operator panel operation: Hold down [MENU +] or [MENU -] key and choose "Administrator menu." → "Do you want to continue setting?" appears. Choose "Yes." → "Offline ... Starting setting ... Please wait" appears. → Press [MENU -] key and choose "Factory default." → Choose "Yes." → Reboot.

5.2.4 Precautions in Key Chip Replacement (1200 dpi printer)

EFI's controller PCB for a 1200 dpi printer has an EEPROM called Key Chip. The Key Chip contains EFI's management information. If the Key Chip is not mounted, the AS3 PCB won't work.

If the error message "This is not an authorized program 001" as shown in "7.5.1 LCD Message List" appears, replace the Key Chip with a new Key Chip. The removed Key Chip shall be returned to the ODC. The Key Chip is very expensive, as the royalty fee is included. Take great care in handling it.

5.2.4.1 KeyChip type

There is only one type of keychip and same keychip is used for all Roman and Japanese-Heisei/Morisawa model.

5.2.5 Precautions in EEPROM Replacement (1200 dpi printer)

When a 1200-dpi printer displays a message Unauthorized Software 004/SoftwareNotAuthorised 004 on its operation panel, does not properly print its model name in printing its configuration, or causes a toner mismatch error, its EEPROM may be faulty, or may be rewritten with new data. When such an error is not remedied by executing FactoryDefault, the EEPROM should be replaced with maintenance EEPROM (FactoryDefault should be executed after the EEPROM is replaced).

The maintenance EEPROM for a 1200 dpi printer is prepared separately for each model with the model No. and other data written in advance at Fukushima factory. This is to eliminate the necessity to download the file from a PC during replacement on site.

5.2.6 Precautions in HDD Replacement (1200 dpi printer)

HDD storage values are used for various set ups, such as network and model serial No. etc. in 1200dpi printer (EFI model.) If HDD is changed due to a trouble shooting or error message, it is necessary to re-setup the user set information, which has not saved in the EEPROM after coping the information stored in the EEPROM PCB into HDD.

See below for the procedure.

- ① Configuration print should take place before a change or addition of HDD.
(It is used for reference for later resetting.)
- ② Change HDD (keep the power off to execute.)
- ③ Execute the factory default (see 5.2.7 for details)
(Information stored in the EEPROM PCB such as the model name and P&P will be copied into HDD.)
- ④ Execute configuration print. Re-setup if not corresponded to the result of ①.

The removed HDD shall be returned to the ODC (JPN/AOS), ODA (North America), OEL (EMEA). The HDD label is very expensive, as the royalty fee is included. Take great care in handling it. The royalty fee varies from program to program (GA is more expensive than Std). Make sure the program is correct

5.2.7 Product Code of Maintenance HDD

The maintenance HDD's have different product codes according to program type and version. When ordering a maintenance HDD, be sure to choose the HDD with the same program type and version as those for the currently used HDD.

The program versions of maintenance HDDs of 1200-dpi printers should not be updated by replacing the HDDs; the EEPROM data of the printers may be lost.

Maintenance HDD

Maintenance HDD AS3 part No.

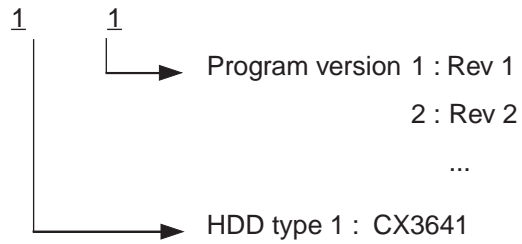

5.2.8 Setup of EEPROM after replacement of TBX PCB

When the TBX PCB is replaced, it is necessary for the new replacement PCB to take over the user-settings that the user has been using to that point, as well as the font install information. For this, copy the EEPROM by the Maintenance Utility, and set up the CU Serial No. However, if SERVICE CALL 40 is issued and the old EEPROM cannot be used, use the new PCB, and set the CU Serial No.(See Subsection 5.4.2.2) and check the setup of destination (See Subsection 5.4.3).

Meanwhile, in the case of the PCB, the EEPROM can be swapped directly between a new PCB and an old one. In this case, the CU Serial No. setup and destination setup are not required.

Replacement of EEPROM after replacement of PCB

The EEPROM of the PCB is installed in the IC socket. Replace the EEPROM in the following manner:

1. Remove the EEPROM and MAC address sticker label attached to the new PCB.
2. Insert a flat-tipped screwdriver in between the EEPROM of the old PCB and the IC socket, and take out the EEPROM, seeing to it that the leads of the EEPROM are not bent.
3. Install the EEPROM in the new PCB. In this operation, make sure that the silk print of the EEPROM and that of the PCB match in the same direction.
4. Remove the MAC address sticker label of the old PCB, and paste it to the new PCB.

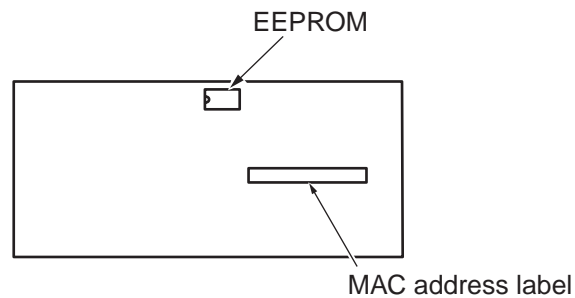

5.2.9 Setup of destination

[Checking method: Menu Map Print]

Always set the destination prior to shipping out a printer or maintenance PCB, since the default setting is OEL.

Note! This setting is stored on the EEPROM of the TBX PCB.

1. Setup on the operation panel: Start the printer in the maintenance mode, and set the destination.
 - Turn on the power with the MENU+ and MENU- key held down.
 - "Maintenance Menu" will be displayed briefly, which will change to "OKIUSER".
 - Press the MENU+ key to select the destination setting "OKIUSER" and press the ENTER key.
 - "OEL" will appear in the lower line of the LCD.
 - Press the ENTER key, select the destination by operating the MENU+ or MENU- key, and press the ENTER key.
 - Press the BACK key to define the setting. "JP1"
 - Press the BACK key twice, or the ONLINE key once. This will cause the printer to restart with the destination modified.

2. Explanation

PX734/735 are ROMs used in common for domestic and overseas markets.

This setting is stored on the EEPROM of the TBX PCB.

When the version number of the program ROM is changed, the setting will be reset to the default value.

Make this setup when there is no destination set up or the version number of the program has been changed.

5.3 Density Correction

When the printer is shipped, the Automatic Density Correction Mode is set to "Automatic". If it is set to "Manual" there may be drifting during use. Set this if there is any problem with the density.

Note! Set this when the printer is not running (Stop State). Do not set this while the printer is warming up.

- (1) Press the [ENTER] key several times. The [Color menu] will appear.
- (2) Press the [MENU+] or [MENU-] key to display the [Density Correction/Execute].
- (3) Press the [ENTER] key.

Automatic Density Correction starts.

5.4 Paper Thickness Detection/Sensitivity Correction

A maintenance utility is supported as an object for field maintenance. (Refer to the maintenance utility for the usage)

Overview

The sensitivity of the micro-displacement sensor used as the media thickness detector are not uniform in detection sensitivity. To learn the sensitivity of that unit's sensor beforehand, there is a need to pass a media source with a priorly known thickness through the detector. The sensitivity shall then be detected based on the output value of the sensor.

Adjustments are necessary when replacing the Paper Thickness Sensor, Resist Roller and PU PCB.

Prepare four media sources with a thickness already measured with a micrometer (MDQ-30M, MDQ-30). Then pass those sheets through the MP Tray. The media thickness sensitivity correction value is automatically set with the 3 sheets. Then the media thickness detection value is tested with the 4th sheet.

Media Used : Transparency Sheet (42404301)

Paper Thickness Detection Error: ±10µm or less

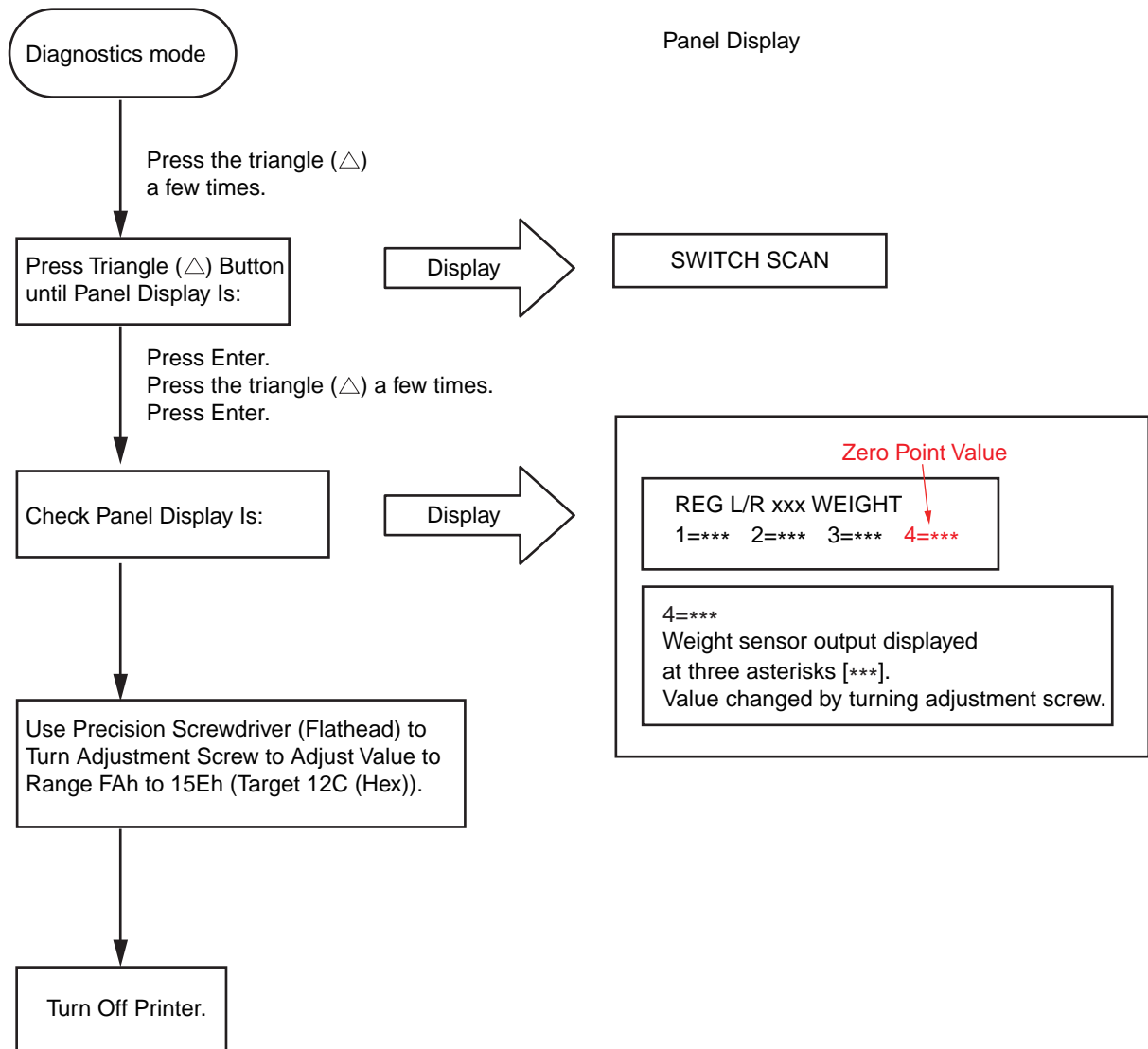

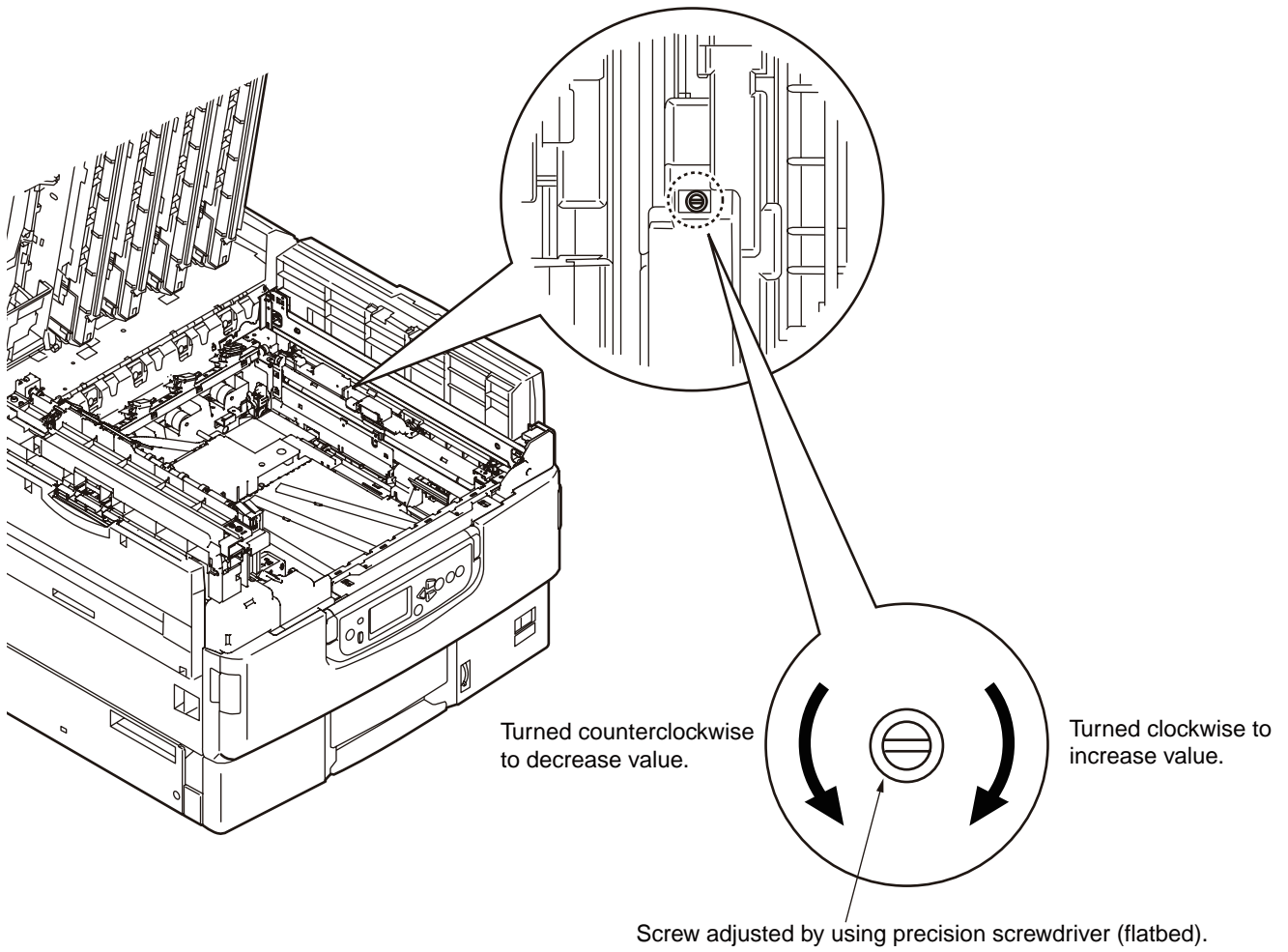

6. ROUTINE REPLACEMENT

6.1 Routine Replacement of Consumable Parts

We recommend that the user periodically replaces the following parts according to the guideline indicated. (Note that failure to replace these parts may result in malfunction and will not guaranty quality printout.)

Part	Replacement Period	Replacement Condition	Post-Replacement Adjustment
Heavy Duty Toner Cartridge	When the following display appears. "Insert toner."	When printing 15,000 sheets.	
Toner Cartridge		When printing 5,000 sheets.	
Image Drum Cartridge	When the following display appears. "Replace drum."	When printing 30,000 sheets. (3P/J)	
Fuser Unit	When the following display appears. "Replace fuser."	When printing 100,000 sheets.	
Belt Unit	When the following display appears. "Replace belt."	When printing 100,000 sheets. (3P/J)	
Paper Supply Roller	When mis-feed frequently occurs. (The number of sheets in the cassette must be appropriate)	When printing 120,000 sheets. (Guideline)	
Waste Toner Box	Replace when "Replace the waste toner box" appears.		

- Note!** 1. Supplies (image drum, toner cartridge, fuser and belt unit) are not included.
 2. The circuit boards, such as Power Supply PCB, PU PCB and CU PCB, are not included.

The user shall be held responsible in periodically replacing these consumable parts.

6.2 Cleaning

Accordingly clean the inside and outside of the CX3641 using a cloth and compact vacuum cleaner (hand-cleaner).

- Note!** NEVER touch the imaging drum terminal, LED lens array or LED head connector.

6.3 LED Lens Array Cleaning

Clean the LED lens array if a white band, white stripe (white-out, light printing) occurs in the vertical direction of the printout.

- Note!** ALWAYS use a LED head cleaner or soft tissue paper to clean the LED lens array. NEVER use methyl alcohol (isopropyl alcohol; rubbing alcohol), thinner or other solvents to clean the lens since this may damage the surface of the lens. (A LED head cleaner comes with the toner cartridge package)

White Band, White Stripe
(White-out, Light Printout)

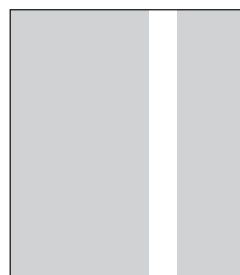

Cleaning LED Head

Do the cleaning in case of light print, white line, or blurred print.

- (1) Grasp the Top Cover Handle and open the Top Cover.



Do not touch it. The Fuser Unit is very hot. Do not touch it.

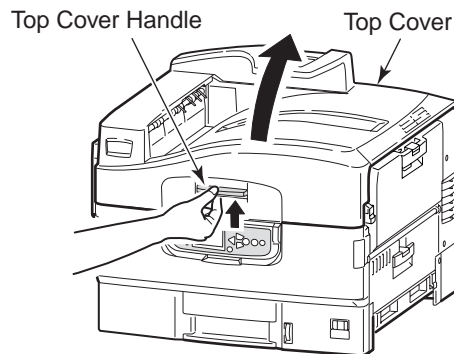

- (2) Gently wipe the lens surface of the LED Head (4 places) using the LED lens cleaner or soft tissue.

Note! Do not use solvents such as methyl alcohol or thinner as they will damage the lens surface.

Memo An LED lens cleaner is enclosed in an optional replacement toner cartridge.

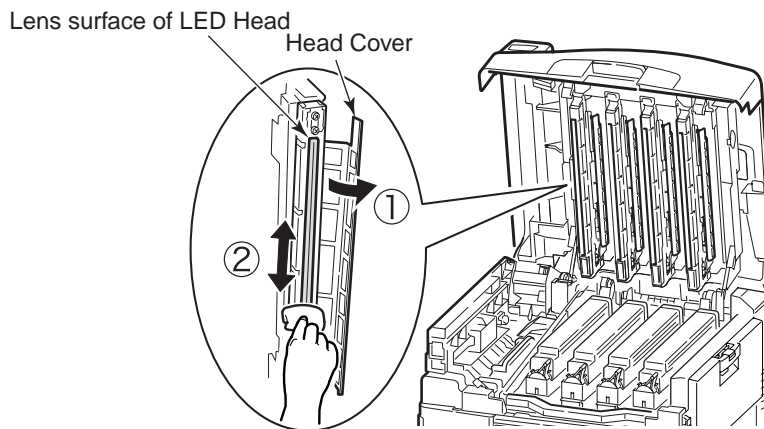

- (3) Close the Top Cover.

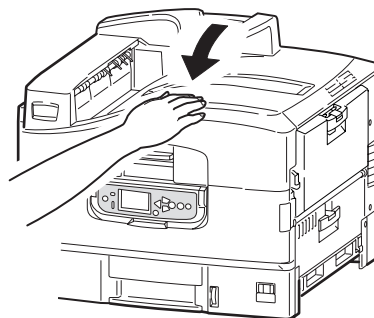

6.4 Pickup Roller Cleaning

Clean the pickup roller if there is any problem with paper feeding.

Note! Use a soft cloth, etc. with alcohol to clean the roller surface, with care not to scratch or damage the surface during the process.

6.5 Cleaning Feed Roller

Clean the Feed Rollers when paper jams occur frequently. Three Feed Rollers are provided for each tray. Cleaning method for the Trays 1 to 5 (Trays 2 to 5 are optional) is different from that for the Multipurpose Tray.

Tool: Soft wet cloth

Trays 1 to 5

The cleaning procedure below takes the Tray 1 as an example. The Trays 2 to 5 (optional) are cleaned in the same procedure.

- (1) Take off your wristwatch, bracelets and any other similar accessories.
- (2) Turn off power of the printer.

See page 19 for how to turn off power.

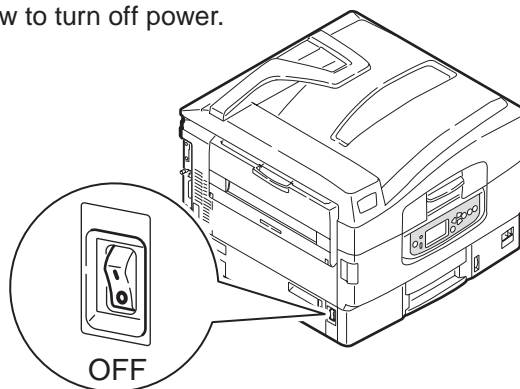

- (3) Open the Tray 1 Side Cover.

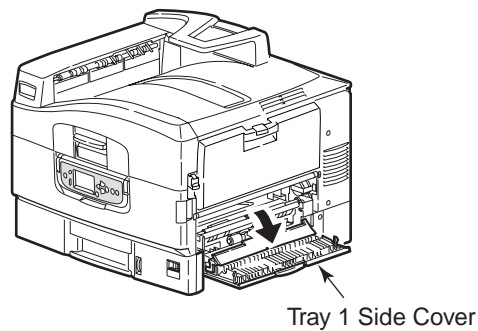

- (4) Draw out the Tray 1 fully.

Draw the Tray until it stops. While lifting it, draw out the Tray fully.

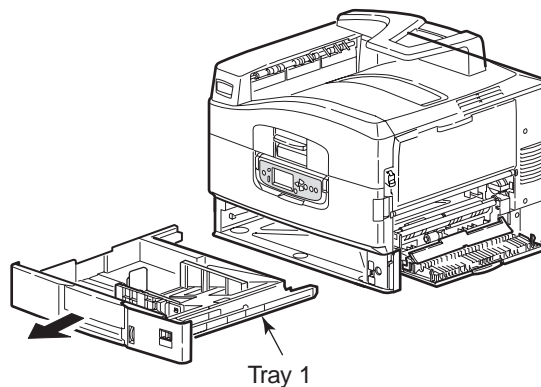

- (5) Put your hand into the opening where the Tray has been placed. Clean the three Feed Rollers using a soft wet cloth.

If it is hard to wipe the roller, put your hand from the Tray 1 Side Cover.

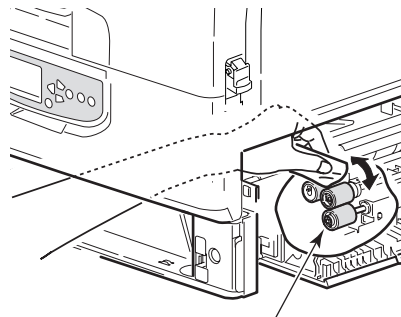

Feed Roller (3 rollers)

- (6) Insert the Tray 1 back into place.

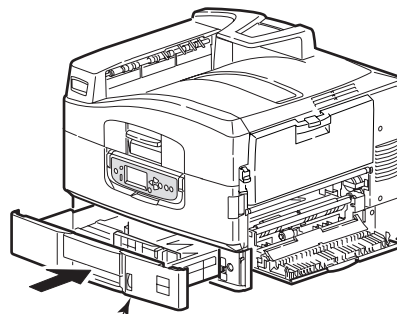

Tray 1

- (7) Close the Tray 1 Side Cover.

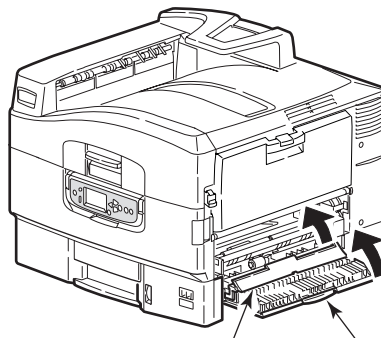

Paper Guide Tray 1 Side Cover

Cleaning of the Feed Rollers is completed.

Multipurpose Tray

- (1) Press the button on the right of the printer to open the Multipurpose Tray.

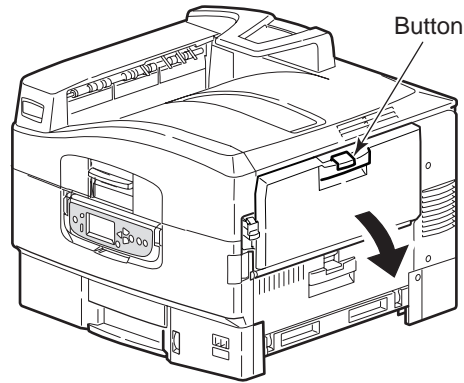

- (2) Open the Paper Support and move the Paper Guide slightly to the center.

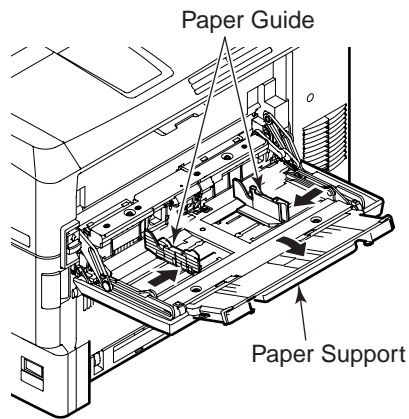

- (3) Move the lever on the right of the Multipurpose Tray at the joint of the tray and the printer into the position as shown below.

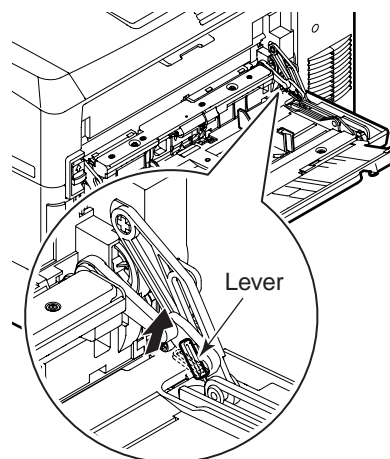

- (4) While lifting the Multipurpose Tray slightly with your right hand, push the lever inward with your left hand and loosen it.

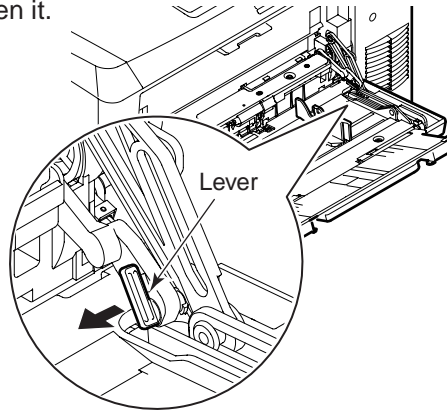

- (5) Just as in (3) above, move the lever on the left of the Multipurpose Tray at the joint of the tray and the printer into the position as shown below.

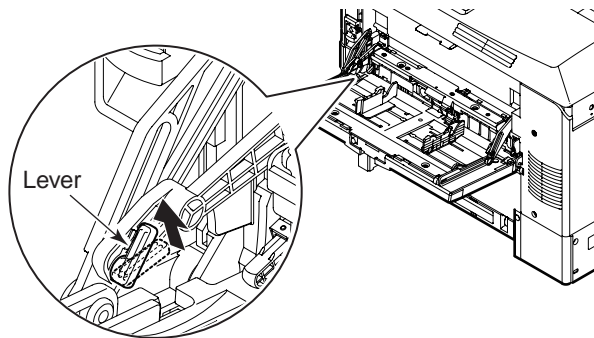

- (6) While lifting the Multipurpose Tray slightly with your left hand, push the lever inward with your right hand and loosen it.

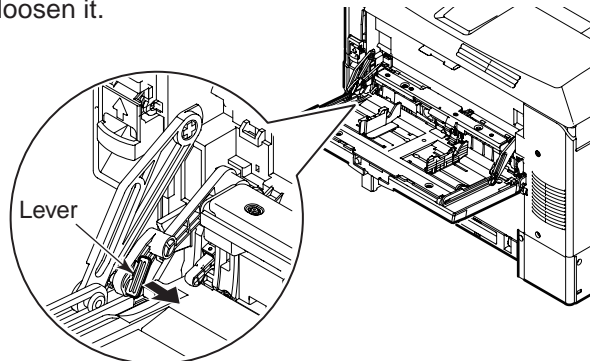

- (7) Move the loosened portions towards the printer. The cover will rise and the Feed Rollers will be revealed.

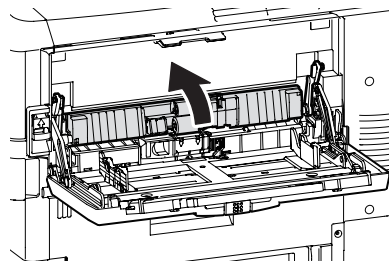

- (8) Put your finger into the hole under the rollers and open the cover in the arrow direction.

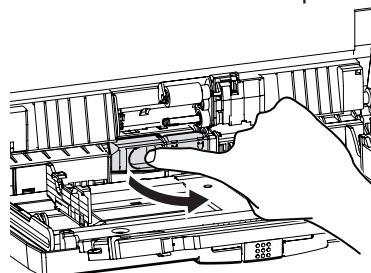

(9) Clean the three Feed Rollers using a soft wet cloth.

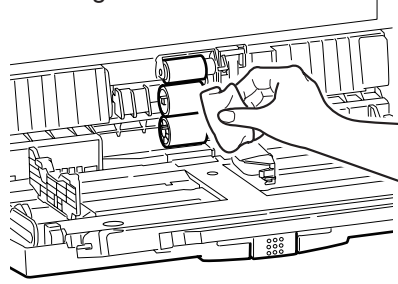

(10) Close the cover.

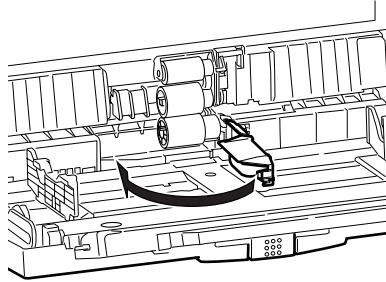

(11) Hold the joints of the printer and the Multipurpose Tray with both hands and lower the cover.

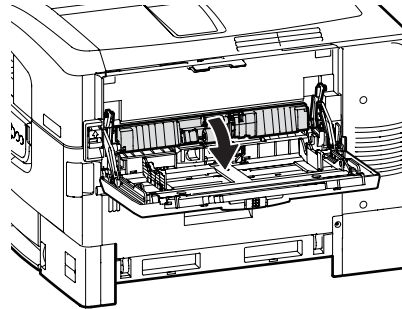

(12) While lifting the right edge of the Multipurpose Tray slightly, insert the protrusion of the lever as shown below.

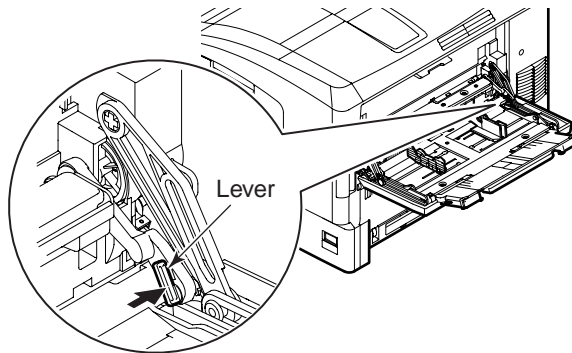

(13) Move the lever into the position below.

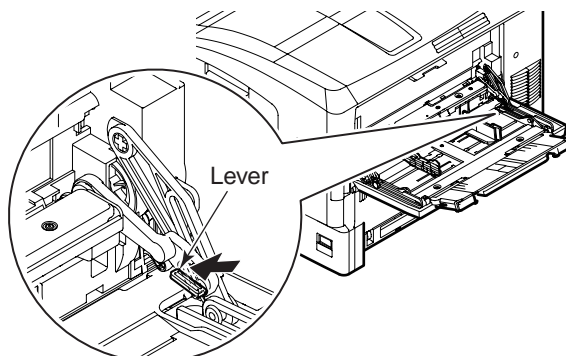

(14) While lifting the left edge of the Multipurpose Tray slightly, insert the protrusion of the lever as shown below.

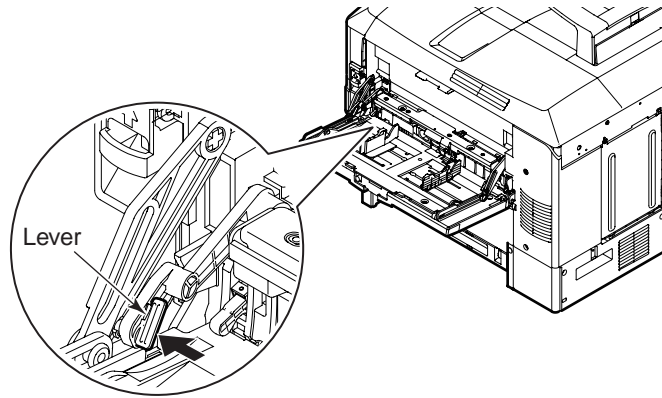

(15) Move the lever into the position below.

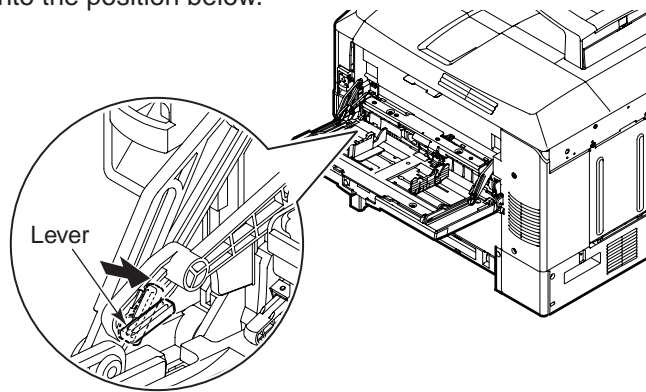

(16) Widen the Paper Guide and fold the Paper Support.

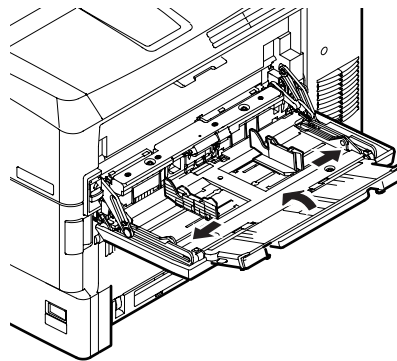

(17) Close the Multipurpose Tray.

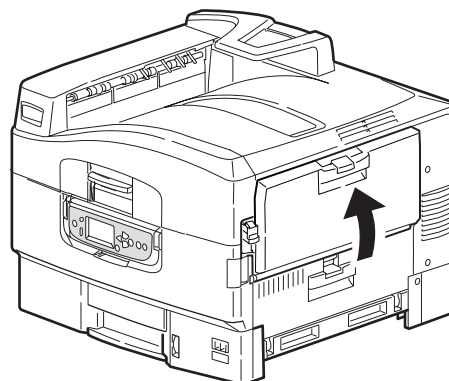

Cleaning of the Feed Rollers is completed.

7. MALFUNCTION REPAIR PROCEDURE

7.1 Precautions Before Repairs

- (1) Check the basic inspection items indicated in the User's Manual.
- (2) Learn from the customer the details on when malfunction occurs.
- (3) Inspect the state that closely resembles the state of a malfunction.

7.2 Items to Check Before Remediating Abnormal Image

- (1) Is the environmental conditions of this equipment appropriate?
- (2) Have the consumable parts (toner, drum cartridge) been properly replaced?
- (3) Is there anything wrong with the paper? Refer to the paper specification for more details on this.
- (4) Is the drum cartridge properly set?

7.3 Precautions Before Remediating Abnormal Image

- (1) Do not touch OPC drum surface with hand or foreign substance.
- (2) Do not expose the OPC drum to direct sunlight.
- (3) The fuser unit is hot. Therefore, do not touch with hands.
- (4) Do not expose the image drum to more than 5 minutes of light. This includes room lighting, as well.

7.4 Troubleshooting Preparations

- (1) Operation Panel Display

The troubleshooting state of this machine will be displayed on the LCD (Liquid Crystal Display) of the operator panel.

Take appropriate repair/maintenance measures according to the message displayed on the LCD.

7.5 Troubleshooting

When this printer troubleshoots, find the cause of trouble using the following procedure.

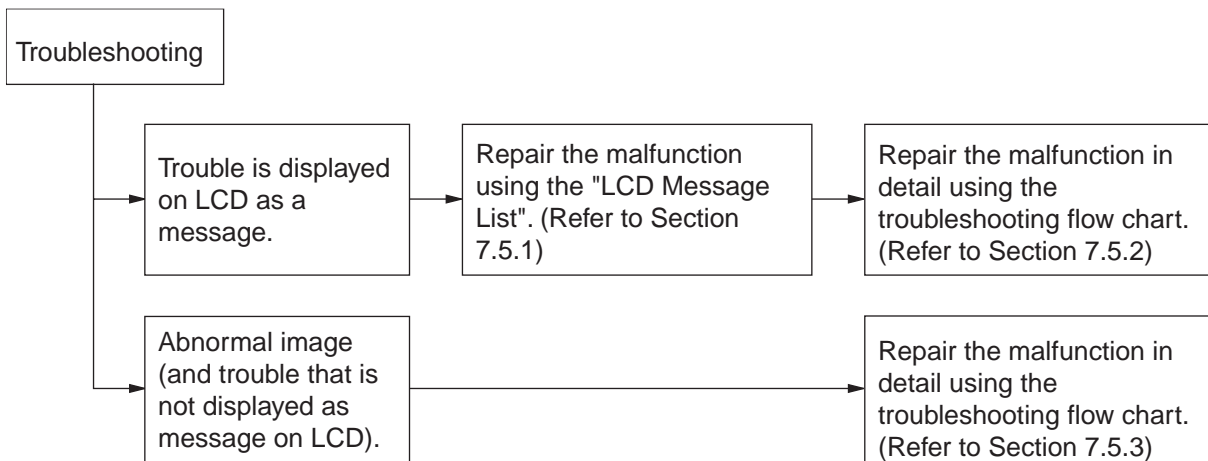

7.5.1 LCD Message List

When the printer detects errors that can be restored, it displays a service call error on the LCD, as shown below.

Service Call
nnn: Error

Note! nnn is an Error code.

When a service call is displayed, the error code and accompanying error information is displayed on the bottom row of the LCD. The meaning of the error code and the overview of the remedies are indicated in Table 7-1-1.

Table 7-1-1 Operator Alarm (1/10)

Display	Cause	Error Description and Analysis	Judgement	Remedy	600	1200
Service Call 001: Error	A heavy trouble of the CU substrate (defective substrate or power supply capacity shortage) was detected.	Is the error display reproducible? Is the error display reproducible?	Yes Yes	Power OFF/ON Replace CU PCB. (Must replace EEPROM)	✓	-
Service Call Power off/on nnn: Fatal Error PC: nnnnnnnn LR: nnnnnnnn FR: nnnnnnnn 002: Error to 007: Error	This stems from a variety of causes. For analyzing causes, record three numbers (called program counting value) indicated below LCD column and a printer firmware version. [Cause] ① Unmatched print data and printer FW ② Damaged EEPROM data ③ Defect ROM DIMM or RAM DIMM ④ Defect components etc. of CPU and ASIC ⑤ Others Keep on analyzing causes if an error still remains. Above mentioned ① to ④ are likelihood of causes.	Record three digital numbers below LCD column. Restart with OFF/ON? Does an error occur in a particular print data? Is the error display reproducible? Is the error display reproducible? Is the error display reproducible?	Yes No Yes No Yes No Yes	Notify three digital numbers below LCD column and F/W version. Check if it occurs depending on a print data. Request for print data investigation. Change RAM DIMM or ROM DIMM. Replace CU PCB. (Must replace EEPROM) Initialize EEPROM. Re-execute Network setup, such as user setup etc. for use. Change the printer.	✓	-
Service Call 020: Error or 024: Error	CU ROM Hash Check Error 1	Is the Slot A ROM DIMM mounted properly? Is operations restored by replacing the Slot A ROM DIMM?	No Yes No	Remount Slot A ROM DIMM Replace Slot A ROM DIMM. Replace CU PCB. (Must replace EEPROM)	✓	-
Service Call 025: Error	CU Font ROM Hash Error1	Detected a Font ROM_DIMM hash check error. (Japan Model only)		Is the Slot B ROM DIMM1 mounted normally? Is the problem corrected by replacing the Slot B ROM DIMM1?	✓	-
Service Call 030: Error	CU Resident RAM Check Error	Is the error display reproducible?	Yes	Replace CU PCB. (Must replace EEPROM)	✓	-
Service Call 031: Error	CU Slot1 DIMM RAM Check Error	Is the applicable RAM DIMM mounted properly? Is operation restored by replacing the applicable RAM DIMM?	No Yes No	Re-mount applicable RAM DIMM. Replace RAM DIMM. Replace CU PCB. (Must replace EEPROM)	✓	-

Table 7-1-1 Operator Alarm (2/10)

Display	Cause	Error Description and Analysis	Judgement	Remedy	600	1200
Service Call 032: Error	CU Slot2 DIMM RAM Check Error	Is the applicable RAM DIMM mounted properly? Is operation restored by replacing the applicable RAM DIMM?	No Yes No	Re-mount applicable RAM DIMM. Replace RAM DIMM. Replace CU PCB. (Must replace EEPROM)	✓	-
Service Call 036: Error	Slot1 RAM Spec error Specification of DIMM in CU RAM slot is unsupported.	Is this a standard RAM DIMM? Is the applicable RAM DIMM difference mounted normal? Is operation restored by replacing the applicable RAM DIMM?	No No Yes No	Use a standard RAM DIMM. Re-mount applicable RAM DIMM. Replace RAM DIMM Replace CU PCB. (Must replace EEPROM)	✓	-
Service Call 037: Error	Slot2 RAM Spec error Specification of DIMM in CU RAM slot2 is unsupported.	Is this a standard RAM DIMM? Is the applicable RAM DIMM difference mounted normal? Is operation restored by replacing the applicable RAM DIMM?	No No Yes No	Use a standard RAM DIMM. Re-mount applicable RAM DIMM. Replace RAM DIMM. Replace CU PCB. (Must replace EEPROM)	✓	-
Service Call 040: Error	CU EEPROM ERROR	Is the problem corrected by replacing the CU PCB EEPROM?	Yes No	REPLACE EEPROM. (User must correct environmental conditions) Replace CU PCB. (Must replace EEPROM)	✓	-
Service Call 041: Error	CU FLASH ERROR CU PCB flash ROM error	Is the error display reproducible?	Yes	Replace CU PCB. (Must replace EEPROM)	✓	-
Service Call 042: Error to 045: Error	CU PCB flash ROM error Flash File System Error	Failed to access flash memory that is surface-mounted on CU PCB.		Replace CU PCB (Must replace EEPROM) *1	✓	-
Service Call 048: Error	PS+PCL Model CU ROM is mounted on a PCL model unit.	Is a standard model program ROM mounted?	Yes No	Replace Program ROM DIMM. Replace with standard program ROM DIMM officially for the model.	✓	-
Service Call 049: Error	CU Type Mismatch CU ROM model mismatches unit.	Is a standard model program ROM mounted?	Yes No	Replace Program ROM DIMM. Replace with standard program ROM DIMM officially for the model.	✓	-
Service Call 050: Error	Operator Panel Error	Is the error display reproducible?	Yes	Refer to the flowchart on "Failure to appear on LCD".	✓	-
Service Call 051: Error	CU FAN ERROR CPU cooling fan of CU PCB is abnormal.	Is the connection of the CU PCB normal? Replace and restore fan?	No Yes No	Normally connect. Replace fan. Replace CU PCB. (Must replace EEPROM)	✓	-
Power Off/on 052: Error	Image Processor Driver Error	Is the error display reproducible?		Power OFF/ON Replace CU PCB. (Replace EEPROM)	✓	-
Power Off/on 060: Error	Parallel Interface Driver Error	Is the error display reproducible?		Power OFF/ON Replace CU PCB.(Replace EEPROM)	✓	-
Power Off/on 062: Error	USB Drive Error	Is the error display reproducible? Is the Network PCB properly mounted?		Power OFF/ON Replace CU PCB.(Replace EEPROM)	✓	-
Power Off/on 063: Error	Network comm. Error H/W I/F abnormality between CU-NIC.	Does replacement of the network PCB correct the problem?	No Yes No	Properly mount Replace Network Replace CU PCB. (Must replace EEPROM)	✓	-
Power Off/on 070: Error	CANT_HAPPEN PS Firmware Abnormality Detection	Check if problem is corrected by turning OFF/ON Power/	No	Replace CU PCB. (Must replace EEPROM)	✓	✓
Power Off/on 072: Error	Engine communication error I/F Error between PU- CU.	Is the CU Assy properly mounted? Does replacement of the CU PCB correct the problem?	No Yes No	Properly mount Replace CU PCB. (Must replace EEPROM) Replace PU PCB	✓	✓

Table 7-1-1 Operator Alarm (3/10)

Display	Cause	Error Description and Analysis	Judgement	Remedy	600	1200
Power Off/on 073: Error to 075: Error	Video overrun detect	Is the CU Assy properly mounted? Does replacement of the CU PCB correct the problem?	No Yes	Properly mount Replace CU PCB. (Must replace EEPROM)	✓	-
Service Call 081: Error	Parameter Match Check Error	Normal Read/Write not possible with EEPROM or Flash.		If the condition does not change replace CU PCB.	✓	-
Service Call 096: Error	Finisher Unrestorable Error	Is the error display reproducible?		If turning OFF and ON the power again does not correct the problem, maintenance by a servicing personnel is necessary.	✓	✓
Service Call 097: Error	Inverter power supply Error	Is the error display reproducible?		If turning OFF and ON the power again does not correct the problem, maintenance by a servicing personnel is necessary.	✓	✓
Service Call 104: Error	When turning ON the power, detected error in engine EEPROM test total.	Does the Error take place again?		Replace engine control PCB (S2V).	✓	✓
Service Call 105: Error	When turning ON the power, failed to detect the EEPROM (presence).	Is there an EEPROM? Does the Error take place again?	Yes No Yes	Check to see if there is an EEPROM. If not, mount an EEPROM. Mount the EEPROM. Replace engine control PCB (S2V).	✓	✓
Service Call 106: Error	Error detected in engine control logic.	Does the Error take place again?	Yes	Replace engine control PCB (S2V).	✓	✓
Service Call 111: Error to 117: Error	An optional unit for another model was detected. 111: Duplex unit 112: 2nd Tray 113: 3rd Tray 114: 4thTray 115: 5th Tray 116: Finisher 117: Inverter	Is the proper optional unit for that model mounted?	No No	Mount the proper optional unit. Check the connection. Then turn ON the power again. Replace the unit if operations is not restored.	✓	✓
Service Call 121: Error	Low Voltage Power FAN Error	1) Is the PU PCB high voltage power cable properly connected? 2) Does the Error take place again?	No Yes Yes	Connect properly Check to see if there is any contact-defects in the high voltage system. Replace High Voltage Power Unit	✓	✓
Service Call 123: Error	Sensor detects an inappropriate relative humidity for the operating environment.	1) Is an Error message displayed? 2) Does the Error take place again?	Yes Yes	Turn ON power again. Replace the environmental sensor.	✓	✓
Service Call 124: Error	Sensor detects an inappropriate room temperature for the operating environment.	1) Is an Error message displayed? 2) Does the Error take place again?	Yes Yes	Turn ON power again. Replace the environmental sensor.	✓	✓
Service Call 125: Error	Error detected in MPT home position.	1) Is an Error message displayed? 2) Does the Error take place again?	Yes Yes	Turn ON power again. Replace MPT	✓	✓
Turn OFF the power and wait for awhile. 126: Dew Error	Sensor Dew Error	Sensor Dew Error Detected		Wait a while then turn ON power again.	✓	✓

Table 7-1-1 Operator Alarm (4/10)

Display	Cause	Error Description and Analysis	Judgement	Remedy	600	1200
Service Call 128: Error	Engine FAN Motor Error	Error was detected in each fan. 01: Fuser FAN Error 02: Power FAN Error 03: PU Motor FAN Error 04: Belt FAN Error 05: IDFAN Error 06: Top Cover FAN Error		Is the applicable location of the fan connection normal? If the condition does not change Replace fan.	✓	✓
Service Call 131: Y Head 132: M Head 133: C Head 134: K Head	After turning ON the power or when cover is closed, the sensor detects that the unit is missing.	1) Is an Error message displayed? 2) Is the LED head properly mounted? 3) Does the Error take place again?	Yes No Yes	ICheck the OED head unit. Turn ON power again. Replace the LED head Assy.	✓	✓
Service Call 140: Y 141: M 142: Error	Color ID up/down error is detected.	1) Is an Error message displayed? 2) Does the Error take place again?	Yes Yes	Turn ON power again. Confirm that the Y, M, and C ID units are in position, and reboot.	✓	✓
Service Call 144: Y ID 145: M ID 146: C ID 147: K ID	This is indicated when the toner feed switch error or the toner lock-lever-open error occurs repeatedly when new toner is used.	1) Is the toner lock-lever-open error indicated? 2) Does the problem persist even if the ID units are replaced?	Yes Yes No	Confirm that the lever is in position. Replace the toner feed unit. Replace the ID units.	✓	✓
Service Call 150: Y 151: M 152: C 153: K	When ID unit fuse cannot be cut.	Check if the ID Unit is normally mounted.	Yes	Check cable connection, then replace engine PCB.	✓	✓
Service Call 154: Error	When belt unit fuse cannot be cut.	Is the belt unit mounted normally?	Yes	Check cable connection, then replace engine PCB.	✓	✓
Service Call 155: Error	When fuser unit fuse cannot be cut.	Is the fuser unit mounted normally?	Yes	Check cable connection, then replace engine PCB.	✓	✓
Service Call 160: Y Toner 161: M Toner 162: C Toner 163: K Toner	Toner sensor detected error.	1) Is an Error message displayed? 2) Does the Error take place again?	Yes Yes	Replace toner sensor or Assy (SGG-PWB). Replace toner sensor or Assy (SGG-PWB).	✓	✓
Service Call 167: Error	Thermistor Slope Error	1) Is an Error message displayed? 2) Does the Error take place again?	Yes Yes	Turn ON power again. Leave in that state for 30 minutes then turn ON power again.	✓	✓
Service Call 168: Error	Compensation Thermistor Error	1) Is an Error message displayed? 2) Does the Error take place again?	Yes Yes	Turn ON power again. Leave in that state for 30 minutes then turn ON power again.	✓	✓
Service Call 169: Error	Upper Side Thermistor Error	1) Is an Error message displayed? 2) Does the Error take place again?	Yes Yes	Turn ON power again. Leave in that state for 30 minutes then turn ON power again.	✓	✓
Service Call 170: Error 171: Error 174: Error 175: Error	Fuser Thermistor short-circuit or Open is detected (High Temperature (HOT) or Low Temperature (COLD))	1) Is an Error message displayed? 2) Does the Error take place again?	Yes Yes	Turn ON power again. Leave in that state for 30 minutes then turn ON power again.	✓	✓

Table 7-1-1 Operator Alarm (5/10)

Display	Cause	Error Description and Analysis	Judgement	Remedy	600	1200
Service Call 172: Error 176: Error	Thermistor indicates High Temperature (HOT) Error.	1) Is an Error message displayed? 2) Does the Error take place again?	Yes Yes	Turn ON power again. Leave in that state for 30 minutes then turn ON power again.	✓	✓
Service Call 173: Error 177: Error	Thermistor indicates Low Temperature (COLD) Error.	1) Is an Error message displayed? 2) Does the Error take place again?	Yes Yes	Turn ON power again. Leave in that state for 30 minutes then turn ON power again.	✓	✓
Service Call 179: Error	Wrong Fuser Standard	1) Is the model and power voltage of the fuser mounted proper? 2) Fuser is properly mounted, but Error results again.	No Yes	Assemble the proper fuser. Check to see that the fuser is properly assemble. Replace fuser.	✓	✓
Service Call 180: Error to 186: Error	The engine detects communication is not possible with the optional unit. 180:Envelope Feeder (Unused) 181:Duplex unit 182:Tray2 unit 183:Tray3 unit 184:Tray4 unit 185:Tray5 unit 186:Finisher unit	1) Is an Error message displayed? 2) Does the Error take place again?	Yes Yes	Turn ON power again. Replace optional unit.	✓	✓
Service Call 187: Error	Communication with control panel failed.	Is the control panel and cable connected properly?	No Yes	Connect properly Replace the control panel and cable.	✓	✓
Service Call 188: Error	Sub-CPU I/F Error	Sub-CPU Communication Error		Check the connection of the S2M board. Replace the S2M board.	✓	✓
Service Call 189: Error	Inverter Unit I/F Error	1) Inverter communications error 2) Does the Error take place again?	Yes Yes	Check the connection of the I/F cable. Replace the V72-3 board.	✓	✓
Service Call 190: Error	System Memory Overflow	System Memory Overflow		Power OFF/ON Replace CU PCB. (Replace EEPROM)	✓	✓
Service Call 200: Error to 202: Error	PU Firm Download Error	Error occurred when downloading PU firmware.		After turning ON the power again, try downloading again. (This process isn't executed for regular operations, therefore, will not occur)	✓	✓
Power On/off209: DOWNLOAD ERROR	Custom Media Table Download Error	Failed to download custom media table.		After turning ON the power again, try downloading again. (This process isn't executed for regular operations, therefore, will not occur)	✓	✓
Service Call 203: Error 204: Error 207: Error to 214: Error Power Off/on nnn: p 0xFOC: Error 0xFOD: Error 0xFFE: Error 0xFFFF: Error	CU Program Dysfunction	Detected illegal process with CU program.	Yes	Write down the 24 digit number displayed on the LCD panel and report it. Turn OFF the power. Then check the insertion of the CU board. Now turn ON the power again.	✓	-

Table 7-1-1 Operator Alarm (6/10)

Display	Cause	Error Description and Analysis	Judgement	Remedy	600	1200
Service Call 220: Error	Print Saticistic mismatch	HDD was removed or replaced after print statistic is set to ON.		Get the original HDD back.	✓	✓
Service Call 230: Error	RFID Reader not Installed	1) RFID read device error 2) Does the Error take place again?	Yes Yes	Check the connection of the RFID R/W board. Replace the RFID R/W board. Replace the S2V board.	✓	✓
Service Call 231: Error	RFID Reader I/F Error	An interface error was detected with the RFID reader device. 01: communication error between the RFID reader and the engine PCB. 02: the transceiver circuit error of the RFID reader. 03: communication error between the RFID reader and the Tag chip. 04: the RFID Tag detection error (more than 4 chips).		01: Same action as for error 230 02: Replace the RFID R/W board. 03: Check the connection of the antenna cable. 04: Check to confirm that the number of RFID tags is correct.	✓	✓
Service Call 240: Error to 245: Error 247: Error 248: Error	Engine Program Memory Error	240:Flash-memory hardware error 241 :Duplex flash-memory error 242:Optional tray-2 flash-memory error 243:Optional tray-3 flash-memory error 244:Optional tray-4 flash-memory error 245:Optional tray-5 flash-memory error 247:Sub-CPU flash-memory error 248:Inverter flash-memory error		If the error still occurs after rebooting, replace the circuit board of the relevant unit.	✓	✓
Close the Cover Top Cover Open Please see HELP for details	The printer engine cover is open.	1) Check to see if the top cover is open. 2) Check to see if the cover switch is normal.	Yes No	Close top cover Replace the cover switch.	✓	✓
Reset fuser Fuser Error Please see HELP for details	After turning ON the power or when cover is closed, the sensor detects that the unit is missing.	1) Is an Error message displayed? 2) Is the fuser unit mounted properly? 3) Does the Error take place again?	Yes No Yes	Check how the fuser is mounted. Re-mount the fuser, then turn ON the power again. Replace the Fuser Unit Assy	✓	✓
Check paper Paper thickness error TRAY Please see HELP for details	When media is missing, the sensor output value is outside the standard value. (Only for Factory Mode)	1) Has any abnormal substance get mixed in with the sensor? 2) Can the paper thickness detection be reset and restored by opening/closing the tray? 3) Is operation restored by turning OFF/ON the power?	Yes No	Remove obstruction/impurity. Normal	✓	✓
Check paper Paper thickness Error TRAY Please see HELP for details	Sensor Output Difference Value Outside Standard (Only for Factory Mode)	1) Has any abnormal substance get mixed in with the sensor? 2) Can the paper thickness detection be reset and restored by opening/closing the tray? 3) Is operation restored by turning OFF/ON the power?	Yes No	Remove obstruction/impurity. Normal	✓	✓
Check paper Paper thickness error TRAYP Please see HELP for details	Media Detection Value Outside Standard	1) Is there any abnormal media mixed in? 2) Has the media been fed as overlapped sheets?	Yes	Remove the abnormal media.	✓	✓

Table 7-1-1 Operator Alarm (7/10)

Display	Cause	Error Description and Analysis	Judgement	Remedy	600	1200
Check paper Paper thickness Error TRAY Please see HELP for details	U-Heavy Mode Media Detection Value Outside Standard	Is there any abnormal media mixed in?	Yes	Remove the abnormal media.	✓	✓
Reset the belt Please see HELP for details	After turning ON the power or when cover is closed, the sensor detects that the unit is missing.	1) Is an Error message displayed? 2) Is the belt unit properly mounted? 3) Does the Error take place again?	Yes No Yes	Check how the belt unit is mounted. Remount the belt unit, then turn ON the power again. Replace Belt Unit Assy	✓	✓
Reset the image drum Please see HELP for details	After turning ON the power or when cover is closed, the sensor detects that the unit is missing.	1) Is an Error message displayed? 2) Is the image drum properly mounted? 3) Does the Error take place again?	Yes No	Check how the ID is mounted. Turn ON power again. Replace ID Unit Assy	✓	✓
Replace with a new drum Drum Life Near- End COLOR Please see HELP for details	ID Unit Life	Is this immediately after replacing the ID unit?	Yes No	Check ID Unit Life Replace ID Unit	✓	✓
Replace with a new fuser Fuser Life Near-End Please see HELP for details	Fuser Life (This takes place when the fuser life is continually OFF)	Is this immediately after replacing the fuser?	Yes No	Check Fuser Life Replace fuser.	✓	✓
Replace with new belt Belt Life Near-End Please see HELP for details	Notify Belt Life (Alarm) Print N-count worth by opening/closing cover.	Is this immediately after replacing the belt?	Yes No	Check Belt Life Replace belt.	✓	✓
Replace with new double- side printer unit Please see HELP for details	If the Double Side Printer Unit is disassembled from this machine.	Are operations restored by re- inserting the Double-Side Printer Unit?	Yes No	Normal Replace double-side printer unit or replace engine PCB.	✓	✓
Check Duplex Please see HELP for details	Paper jam detected in double-side printer unit when turning over paper.	Check paper jam in double-side printer.	Yes No	Remove the paper jam. Check/replace double-side printer unit.	✓	✓
Check Duplex Please see HELP for details	Paper jam detected in double-side printer unit.	Check paper jam in double-side printer.	Yes No	Remove the paper jam. Check/replace double-side printer unit.	✓	✓
Check Duplex Please see HELP for details	Paper jam in paper supply from the double- side printer unit.	Check misfeed in double-side printer unit.	Yes No	Remove the misfed paper, then close cover. Check/replace double-side printer unit.	✓	✓
Open cover Paper Jam COVER Please see HELP for details	Paper jam in paper supply from Cassette 1, 2, 3, 4 or 5.	Check misfeed in the specified cassette.	Yes No	Remove the misfed paper, insert the cassette. Check/replace Cassette 1, 2, 3, 4 or 5.	✓	✓

Table 7-1-1 Operator Alarm (8/10)

Display	Cause	Error Description and Analysis	Judgement	Remedy	600	1200
Open cover Paper JamTop cover Please see HELP for details	Paper jam detected between Black ID and fuser.	1) Check paper jam between Yellow ID and fuser. 2) Check the load on the fuser unit.	Yes No	Remove the paper jam. Replace fuser unit.	✓	✓
Open cover Paper JamTop cover Please see HELP for details	Paper jam detected in fuser or between fuser and paper output area.	1) Check for paper jam inside the fuser and between the Yellow ID and fuser. 2) Check if the paper output switch is normal.	Yes No	Remove the paper jam. Replace paper output switch.	✓	✓
Open cover Paper Jam Top cover Please see HELP for details	Paper jam detected when paper started to enter double-side printer unit.	Check the entrance or inside the double-side printer for paper jam.	Yes No	Remove the paper jam. Check/replace double-side printer unit.	✓	✓
Open cover Paper Jam Side cover Please see HELP for details	Some sort of jam occurred in paper feed route.	JAM CHECK	Yes	Remove the paper jam.	✓	✓
Open cover Paper Jam COVER Please see HELP for details	Paper jam detected between cassette and black ID.	1) Check for paper jam around the cassette and between the Yellow ID. 2) Check to see if the paper entry switch is normal.	Yes No	Remove the paper jam. Replace the entry switch.	✓	✓
Check paper Paper size error TRAY Please see HELP for details	Printer engine detects paper that is abnormal (45mm or more) according to setting.	1) Is the paper a custom size? 2) Is the paper a standard size?	Yes Yes No	Remedy Unnecessary Adjust the cassette paper size guide. Paper Size Switch Replace.	✓	✓
Change Toner COLOR Please see HELP for details	One of the toners are almost empty.	1) The specified toner cartridge is almost empty. 2) Check to see if the specified toner sensor is normal.	Yes No	Replace with a new toner kit. Replace the specified toner sensor.	✓	✓
Remove paper Stacker Please see HELP for details	Paper Output Stacker is Full	1) Check if the stacker is full. 2) Check if the Stacker Full Sensor activator is normal.	Yes No	Remove paper from stacker. Replace the Stacker Full Sensor.	✓	✓
Insert paper MP Tray MEDIA SIZE Please see HELP for details	Specified Cassette is Out-Of-Paper or removed. Or the cassette used in the printing process is out- of-paper.	1) Check if MT is Out-Of-Paper. 2) Check and see if the out- of-paper sensor activator is normal.	Yes No	Put paper in MT. Replace Out-Of-Paper Sensor.	✓	✓
Insert paper TRAY MEDIA SIZE Please see HELP for details	Cassette 1, 2, 3, 4or 5 has been detected to be Out-Of-Paper	1) Check and see if the specified cassette is out-of-paper. 2) Check and see if the out- of-paper sensor activator is normal.	Yes No	Put paper in specified cassette. Replace the corresponding out- of-paper sensor.	✓	✓
Replace Fuser	Fuser Counter Exceed Life	1) Is an Error message displayed? 2) Is this immediately after the fuser unit was replaced?	Yes No	Check the Fuser Unit Life Replace the fuser immediately or at the next maintenance.	✓	✓
Tray*Paper Almost Finished	Paper Near-End Detection	Is the tray paper level low? (less than about 30 sheets)	Yes No	Refill with paper. Check Paper Near-End Sensor	✓	✓

Table 7-1-1 Operator Alarm (9/10)

Display	Cause	Error Description and Analysis	Judgement	Remedy	600	1200
File system access error <n>	Cannot write to HDD.	Is there any error in the operational procedures?	No Yes	Check the manual usage procedures. HDD malfunction. Replace HDD.	✓	✓
Power Off/on 910: Error to 914: Error	GDDC Error	910:Tray1 GDDC Error 911 :Tray2 GDDC Error 912:Tray3 GDDC Error 913:Tray4 GDDC Error 914:Tray3 GDDC Error		Check to confirm that the tray is mounted correctly. Replace the geared motor of the tray.	✓	✓
Power Off/on 917: Error	Belt Slit Sensor Error	The belt is not running properly. Does the error message still appear after rebooting?	Yes	Check to confirm that the belt is mounted correctly. Replace the belt.	✓	✓
Power Off/on 918: Error	Duplex FAN0 Alarm Detection	Error of the fan in the duplex unit Does the error still occur after rebooting?	Yes Yes	Check to confirm that the duplex unit is mounted correctly. Check the connection of the fan. Replace the fan.	✓	✓
Power Off/on 919: Error	Duplex 24V Abnormal Current Detection	24 V of power is not supplied to the duplex unit properly. Does the error still occur after rebooting?	Yes Yes	Check to confirm that the duplex unit is mounted correctly. Check the connection of the fan. Replace the fan.	✓	✓
Power Off/on 920: Error	Yellow Image Drum Lock Error	The Y ID unit is not operating properly. Does the error message still appear after rebooting?	Yes Yes	Check to confirm that the Y ID unit is in position. Replace the Y ID unit. Replace the Y ID motor.	✓	✓
Power Off/on 921: Error	Magenta Image Drum Lock Error	The M ID unit is not operating properly. Does the error message still appear after rebooting?	Yes Yes	Check to confirm that the M ID unit is in position. Replace the M ID unit. Replace the M ID motor.	✓	✓
Power Off/on 922: Error	Cyan Image Drum Lock Error	The C ID unit is not operating properly. Does the error message still appear after rebooting?	Yes Yes	Check to confirm that the C ID unit is in position. Replace the C ID unit. Replace the C ID motor.	✓	✓
Power Off/on 923: Error	Black Image Drum Lock Error	The K ID unit is not operating properly. Does the error message still appear after rebooting?	Yes Yes	Check to confirm that the K ID unit is in position. Replace the K ID unit. Replace the K ID motor.	✓	✓
Power Off/on 924: Error	Tray2 24V Abnormal Voltage Detection	24 V of power is not supplied to tray 2 properly.		Check to confirm that tray 2 is mounted correctly.	✓	✓
Power Off/on 925: Error	Tray3 24V Abnormal Voltage Detection	24 V of power is not supplied to tray 3 properly.		Check to confirm that tray 3 is mounted correctly.	✓	✓
Power Off/on 926: Error	Tray4 24V Abnormal Voltage Detection	24 V power is not supplied to tray 4 properly.		Check to confirm that tray 4 is mounted correctly.	✓	✓
Power Off/on 927: Error	Tray5 24V Abnormal Voltage Detection	24 V of power is not supplied to tray 5 properly.		Check to confirm that tray 5 is mounted correctly.	✓	✓
Power Off/on 928: Error	Fuser Motor Lock Error	The fuser is not operating properly. Does the error still occur?	Yes Yes	Check to confirm that the fuser is in position. Replace the fuser. Replace the fuser motor.	✓	✓
Power Off/on 929: Error	Waste Toner Transfer Motor Lock Error	The waste toner transfer motor is not operating properly. Does the error still occur?	Yes	Check to confirm that the waste toner transfer system is operating properly. Replace the waste toner motor.	✓	✓
Power Off/on 930: Error	Sub-CPU Clock Frequency Error	The Sub-CPU clock frequency is not correct. Does the error still occur?	Yes	Check the connection of the S2P board. Replace the S2P board.	✓	✓
Power Off/on 931: Error	Duplex CPU Clock Frequency Error	The duplex CPU clock frequency is not correct.Does the error still occur?	Yes	Check the connection of the V72-2 board. Replace the V72-2 board.	✓	✓

Table 7-1-1 Operator Alarm (10/10)

Display	Cause	Error Description and Analysis	Judgement	Remedy	600	1200
Power Off/on 932: Error	Inverter CPU Clock Frequency Error	The inverter CPU clock frequency is not correct. Does the error still occur?	Yes	Check the connection of the V72-3 board. Replace the V72-3 board.	✓	✓
Power Off/on 933: Error	Trya2 CPU Clock Frequency Error	The tray-2 CPU clock frequency is not correct. Does the error still occur?	Yes	Check the connection of the V72-1 board of tray 2. Replace the V72-1 board.	✓	✓
Power Off/on 934: Error	Trya3 CPU Clock Frequency Error	The tray-3 CPU clock frequency is not correct. Does the error still occur?	Yes	Check the connection of the V72-1 board of tray 3. Replace the V72-1 board.	✓	✓
Power Off/on 935: Error	Trya4 CPU Clock Frequency Error	The tray-4 CPU clock frequency is not correct. Does the error still occur?	Yes	Check the connection of the V72-1 board of tray 4. Replace the V72-1 board.	✓	✓
Power Off/on 936: Error	Trya5 CPU Clock Frequency Error	The tray-5 CPU clock frequency is not correct. Does the error still occur?	Yes	Check the connection of the V72-1 board of tray 5. Replace the V72-1 board.	✓	✓
Power Off/on 940: Error	Waste Toner Transfer Error	The transfer mechanism of the toner duct for ID is not operating properly. Does the error still occur?	Yes Yes Yes	Check to confirm that the basket assembly is in position (if it is engaged with the gear of the printer). Check to confirm that the holder magnet D contains a magnet, and check the magnetic polarity. Replace the HAL IC circuit board. Replace the duct assembly toner.	✓	✓
Software not authorized 001	Keychip check failed	AS3 PCB KeyChip unmounted or KeyChip Error is detected.		Power OFF/ON Replace KeyChip	-	✓
Software not authorized 002	Unauthorized hard disk copy	The AS3 PCB HDD is not a standard (official) product.		Power OFF/ON Replace HDD	-	✓
Software not authorized 003	Unauthorized software configuration	The AS3 PCB HDD program does not match the destination.		Power OFF/ON Replace HDD	-	✓
Software not authorized 004	EEPROM missing	The AS3 PCB EEPROM unmounted or EEPROM Error is detected.		Power OFF/ON Replace EEPROM	-	✓

7.5.2 Preparing for Troubleshooting

(1) Operation Panel Display

The state of malfunction is displayed on the LCD (Liquid Crystal Display) of the operator panel of this machine.

Execute proper repairs according to the message indicated on the LCD.

Order	Malfunction Details	Flowchart No.
1	The machine does not operate properly after turning ON the power.	①
2	Jam Error Paper Supply Jam (1st Tray) Paper Supply Jam (Multipurpose Tray) Fee Jam Paper Output Jam Double-Side Print Jam	② -1 ② -2 ② -3 ② -4 ② -5
3	Paper Size Error	③
4	I/D UP/DOWN Error	④
5	Fuser Unit Error	⑤
6	Fan Motor Error	⑥

Note! When replacing the engine PCB (S2V PWB), remove the EEPROM chip from the old PCB and then put the EEPROM that was removed on the new PCB replacement.

(2) CU Assy Troubleshooting (1200dpi Model)

a) Nothing is displayed on the LCD

- CU PCB Malfunction

Has the power short-circuited on the CU PCB? (C7099: +5v)/ Does the LED lightup normally? (PWR_GOOD Green: Light ON, IAG_LED3-0 Red: Light OFF, FPGA_LED Green: Light ON) → If NO GOOD, check to see if the RAM DIMM is normally inserted.

- Others

Power, Operation Panel, Fuse, etc.

b) "Communication Error" is displayed

- CU PCB Malfunction

Does the LED lightup normally? (PWR_GOOD Green: Light ON, DIAG_LED3-0 Red: Light OFF, FPGA_LED Green: Light ON) → If NO GOOD, remove in the sequential order of BY3 PCB (optional), RAM_DIMM, and HDD. Does the Light On state vary?

If the LED Light On state is Normal, replace the applicable part.

If light ON is not normal, then replace PCB.

c) "Initializing" remains displayed.

- CU PCB Malfunction

Does the LED lightup normally? (PWR_GOOD Green: Light ON, DIAG_LED 3-0 Red: Light OFF, FPGA_LED Green: Light ON) → If NO GOOD, remove in the sequential order of BY3 PCB (optional), RAM_DIMM, and HDD. Does the Light On state vary?

If the LED Light On state is Normal, replace the applicable part.

If light ON is not normal, then replace PCB.

d) Error Message Display

Following the processing procedures of the Error Message in the table attachment.

When "Communications Error" appears on the display panel, this message is displayed with the PU. This indicates a problem has occurred in the AS3 board during its initialization. In such a case, open the sheet metal of the CU board and check the lit LED on the AS3 board to locate the problem.

The LED mounted on the AS3 PCB come in the following types. The description of the cases when they do not light up normally are described below.

PWR_GOOD (Green): This indicates the power status of the AS3 PCB. It lights up when the various power output sources (CPU core voltage, 2.5V, 3.3V, 5V0 of the AS3 PCB are normal. If it does not light up, disassemble the BY3 PCB (optional), RAM_DIMM and HDD. Check to see if it will lightup in this state.

DIAG_LED[3: 0] (Red):This indicates the initialization processing state of the AS3 PCB. It will all lightup immediately after the power is turned ON. It will all dim down when the initialization process is successfully completed. If all lights do not dim, then there is a CU PCB malfunction. If all lights do not dim, then disassemble the BY3 PCB (optional), RAM_DIMM and HDD. Check to see if it will lightup again in this state.

* When the HDD is not correctly recognized or when the download switch is in the down position, DIAG_LEDs 2 and 0 are on and DIAG_LED 1 is out.

HDD_LED (Red): This lights up when accessing the HDD. If it does not start flashing even after the power is turned ON, replace the HDD and check to see if the problem is corrected. Check to see that the download switch is facing upward.

FPGA_LED (Green): This lights up when communication is enabled between the engine and panel interface. If it does not lightup, then disassemble the BY3 PCB (optional), RAM_DIMM and HDD. Check to see if it will lightup again in this state.

① Power is turned on and the printer doesn't work properly.

- Turn off power and on again.

- Does the backlight light up (for approx. one second)?

- NO Is the AC cable connected properly?

- NO Connect the AC cable properly.

- YES Is the power supply indicator LED of the Main PCB on?

- NO Does power go off when power is turned on again 2 minutes after power is turned off?

- YES Is the fuse F503 of the Engine PCB blown?

- YES Replace the Engine PCB.

- NO Are the Engine PCB FFC (inserting DRV0 and DRV1 connectors) and the power connector cable properly connected to the Motor Driver PCB and the power supply?

- NO Connect them properly or replace the FFC or the cable.

- YES Replace the power supply.

- YES Is the DIMM of the Main PCB set properly?

- NO Set the DIMM properly. If that does not solve the problem, replace the DIMM.

- YES Is the operator panel cable connected properly?

- NO Connect the cable properly.

- YES Is +5V output to the panel connector (OPEPANE) of the Engine PCB (S2V PWB)?
Pin 5: +5V, Pin 2: 0V

- NO Is +5V output to the DENGEN connector of the Engine PCB (S2V PWB)?
Pins 1 & 3: +5V, Pins 2 & 4: 0V

- NO After checking the DENGEN connector, replace the Low-Tension Power Supply Unit.

- YES Replace the Engine PCB.

- YES Is the problem solved after the Control Panel PCB (X7G PWB) is replaced?

- YES End

- NO Replace the Engine PCB.

(a)

(a)

▼ YES

Is the DIMM of the Main PCB set properly?

NO Set the DIMM properly. If that does not solve the problem, replace the DIMM.

▼ YES

Are the voltages below output to the PU IF connector of the Main PCB?

Pins 9, 10, 17, 18, 25, 26, 33, 34, 41, 42, 61, 69, 77, 85, 93: +5V±5%

Pins 1, 2, 5, 6, 13, 14, 21, 22, 29, 30, 37, 38, 45, 46, 47, 48, 49, 53, 57, 65, 73, 74, 81, 82, 89, 97, 99: 0V

YES Replace the Main PCB.

▼ NO

Is +5V output the DENGEN connector of the Engine PCB?

Pins 1 & 3: +5V, Pins 2 & 4: 0V

YES Replace the Engine PCB.

▼ NO

Replace the Low-Tension Power Supply Unit.

② -1 Paper Supply Jam (1st Tray)

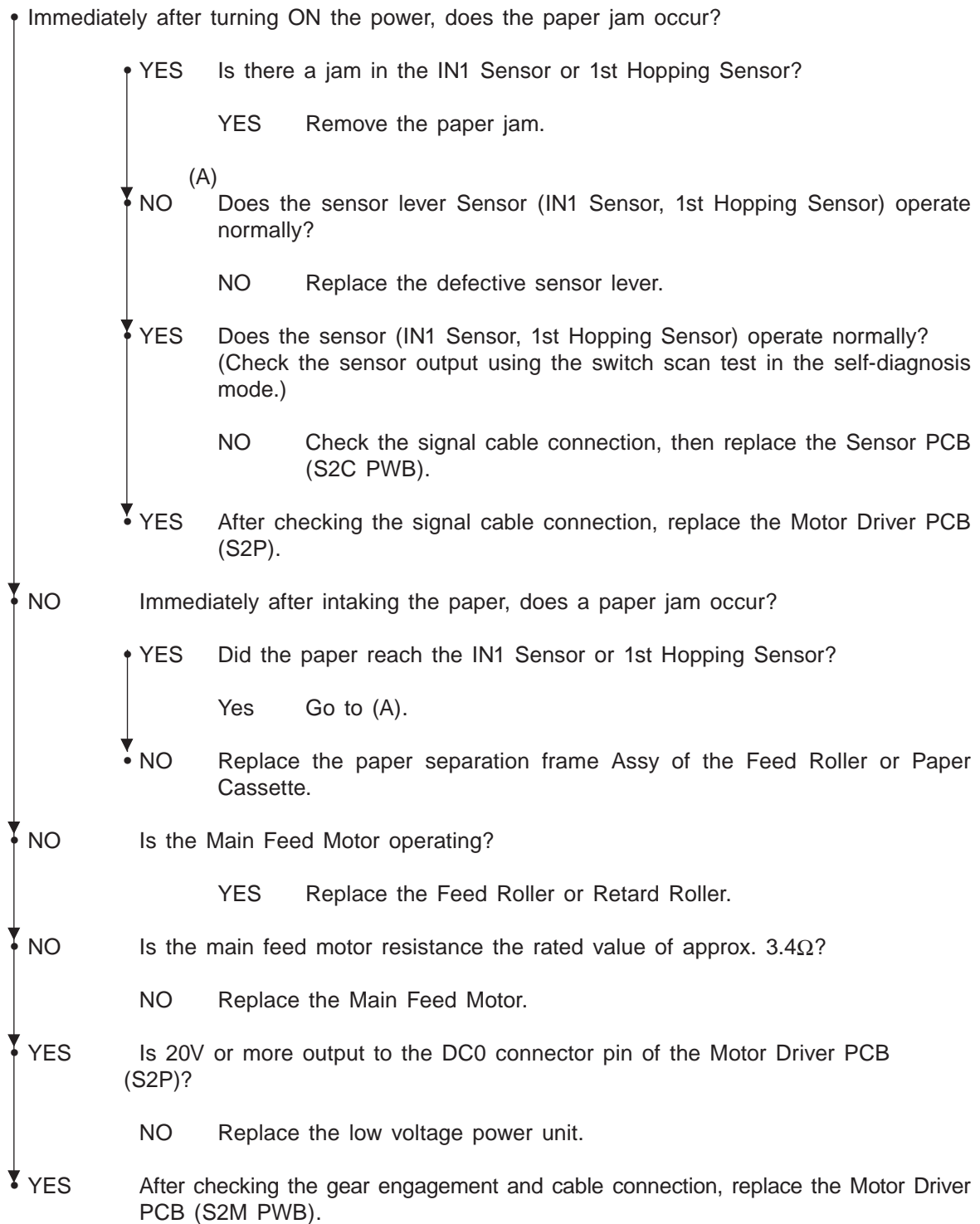

② -2 Paper Supply Jam (Multipurpose Tray)

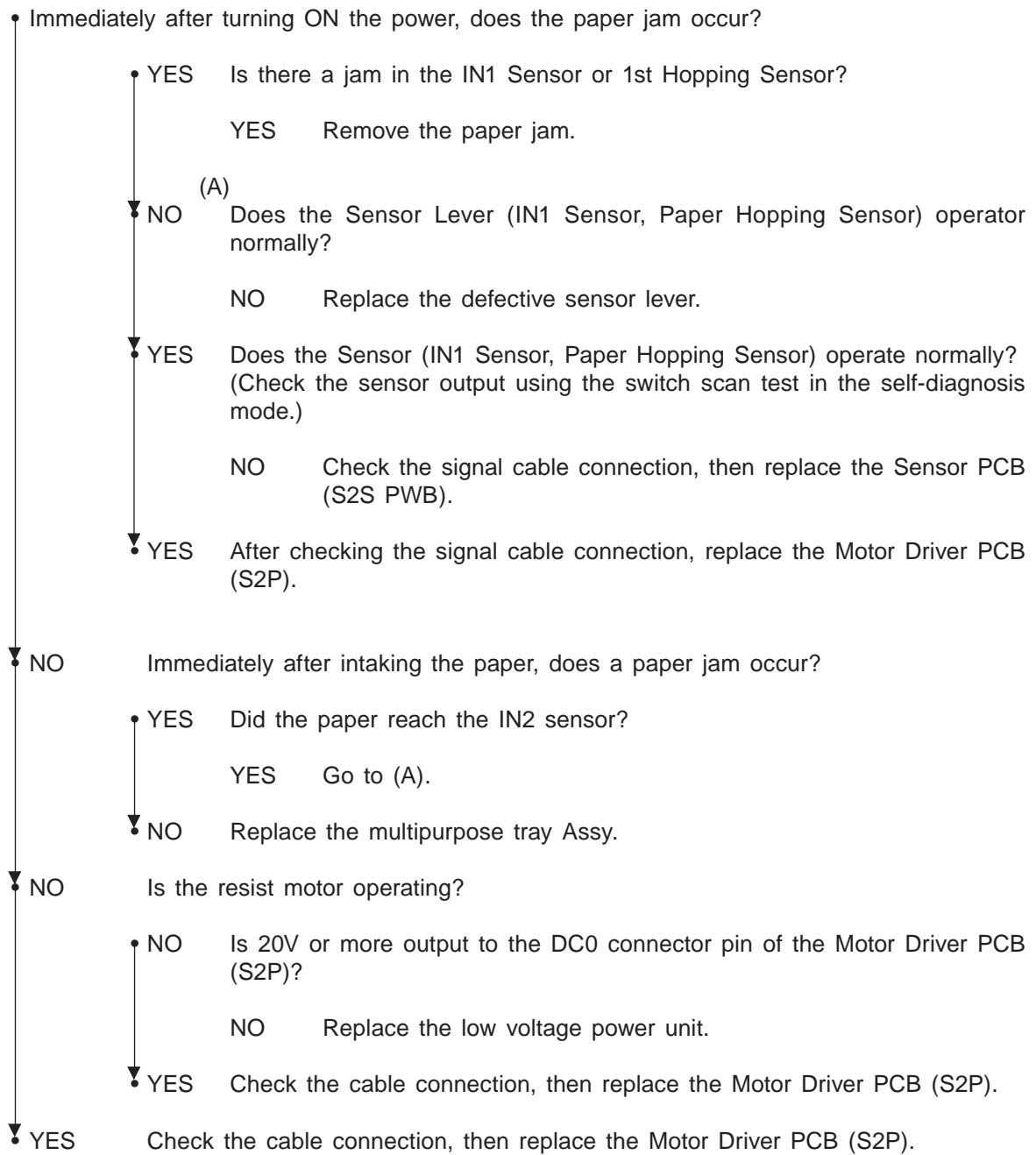

②-3 Paper feed Jam

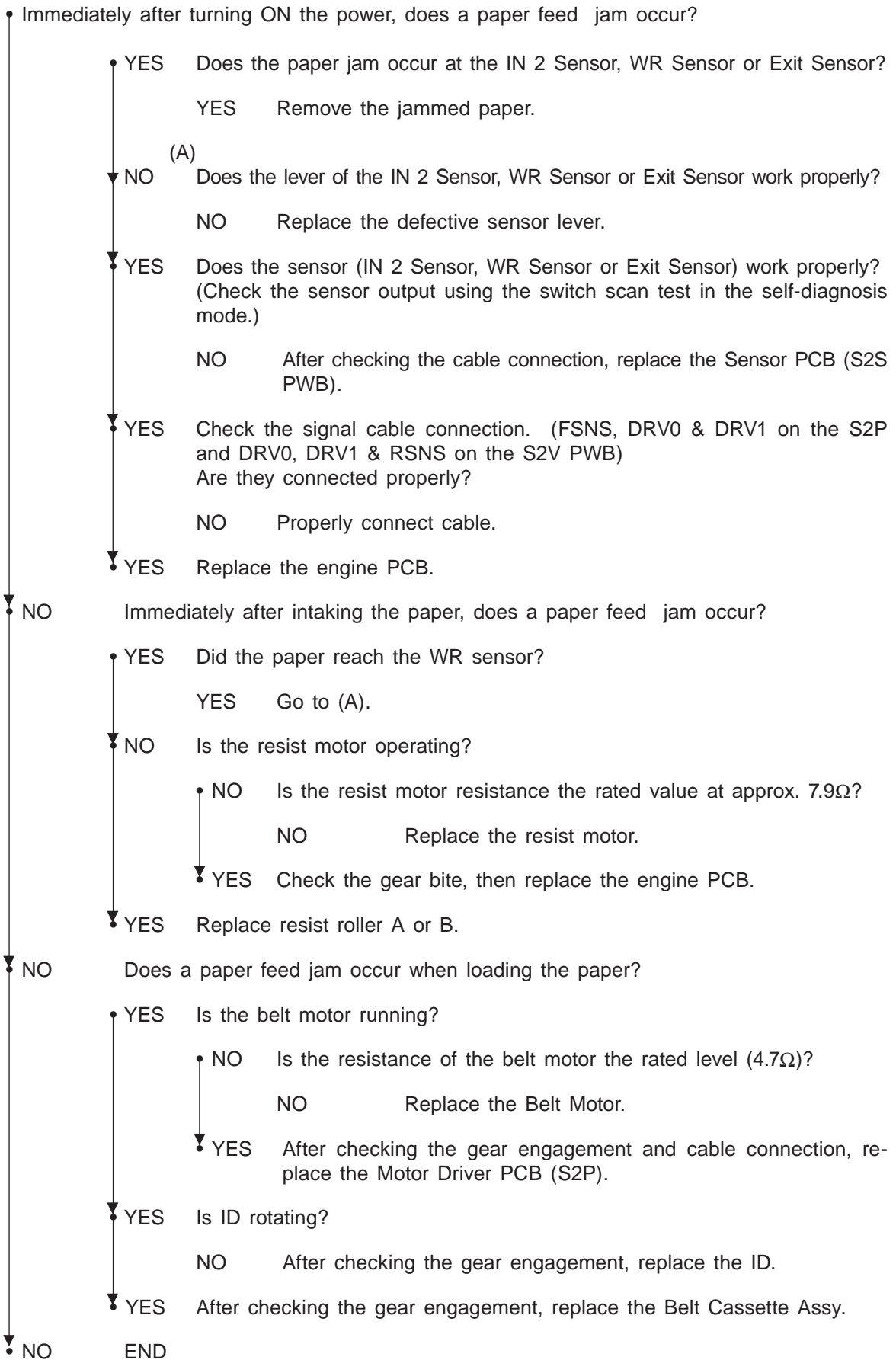

②-4 Paper Output Jam

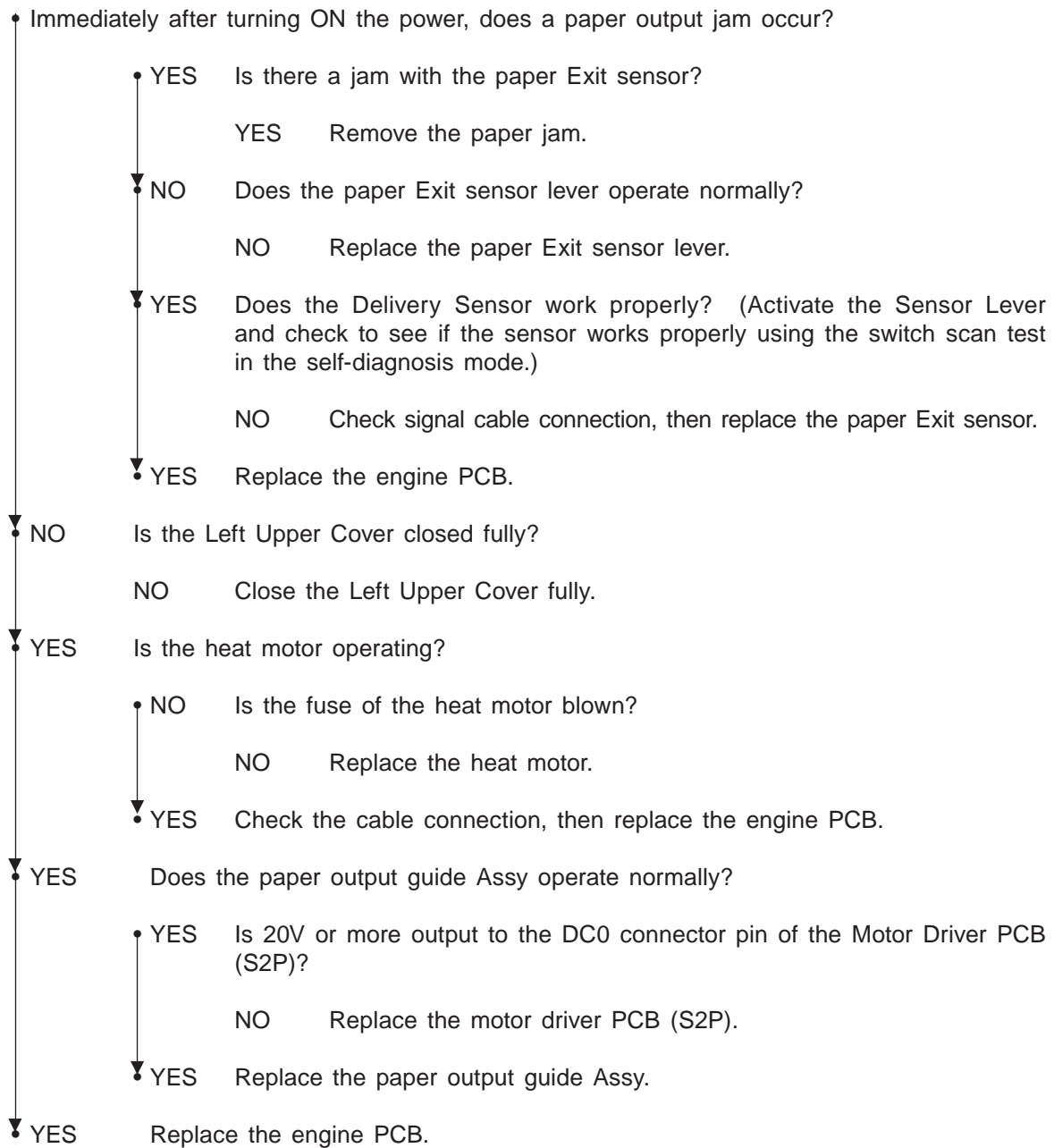

② -5 Double-Side Print Jam

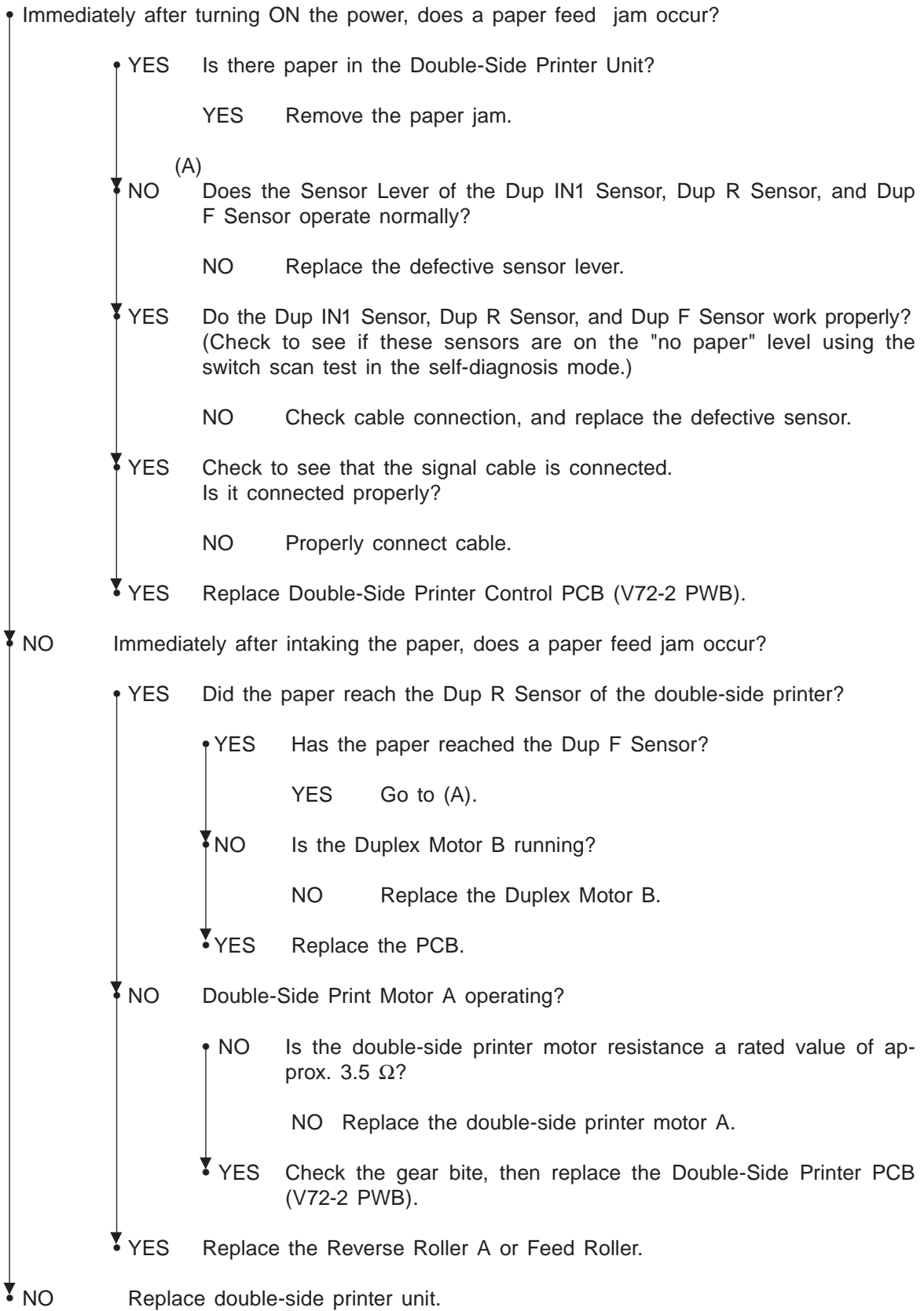

③ Paper Size Error

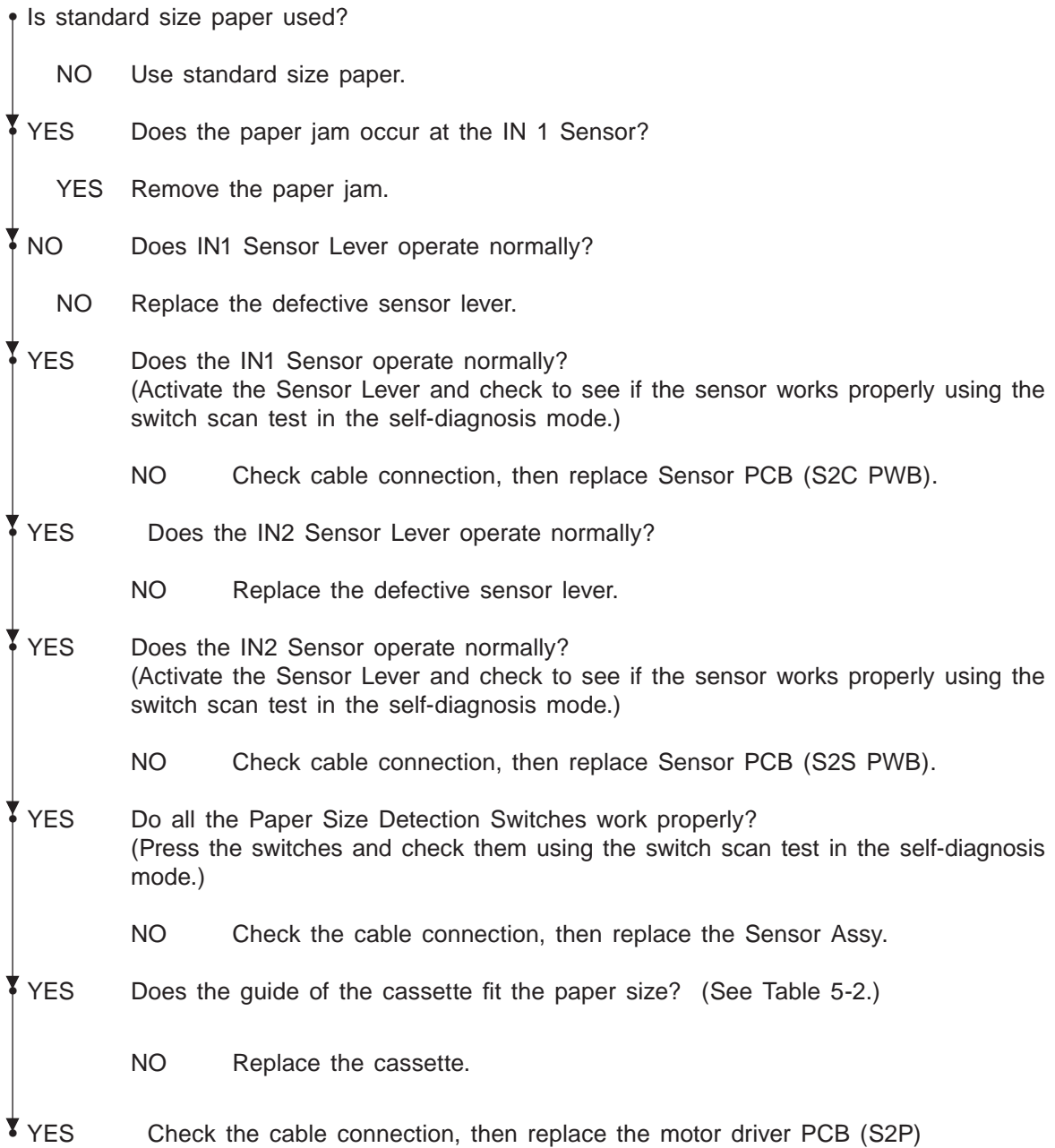

④ Image Drum Unit up/down movement error

- Check the ID up/down movement using the motor & clutch test in the self-diagnosis mode.

• Does the ID moves up and down?

• YES Check using the switch scan test in the self-diagnosis mode. Does the Up/Down Sensor work properly?

YES Replace the defective IDU Motor.

• NO Is the Engine PCB (S2V PWB) connected properly to the ID Sensor PCB (SGG PWB)?

NO Connect them properly.

• YES Make sure that the Up/Down Sensor is fastened securely and then replace the ID Sensor PCB. Is the error reset?

YES End

• NO Replace the Engine PCB.

• YES Is the C-ID Motor running properly?

• NO Does the motor rotate in one direction only?

• YES Is the problem solved by reconnecting the FFC to the Engine PCB and the Motor Driver PCB and the CID connectors?

YES End

• NO Is the problem solved by replacing the C-ID Motor?

YES End

• NO Replace the Engine PCB.

• NO After checking the gear engagement and ensuring that any connector is not tilted, replace the C-ID Motor.

• YES Check the engagement of the planet gear and replace the Planet Gear Unit (Planet-Assy-F and Plane-Assy-R).

⑤ Fuser Unit Error

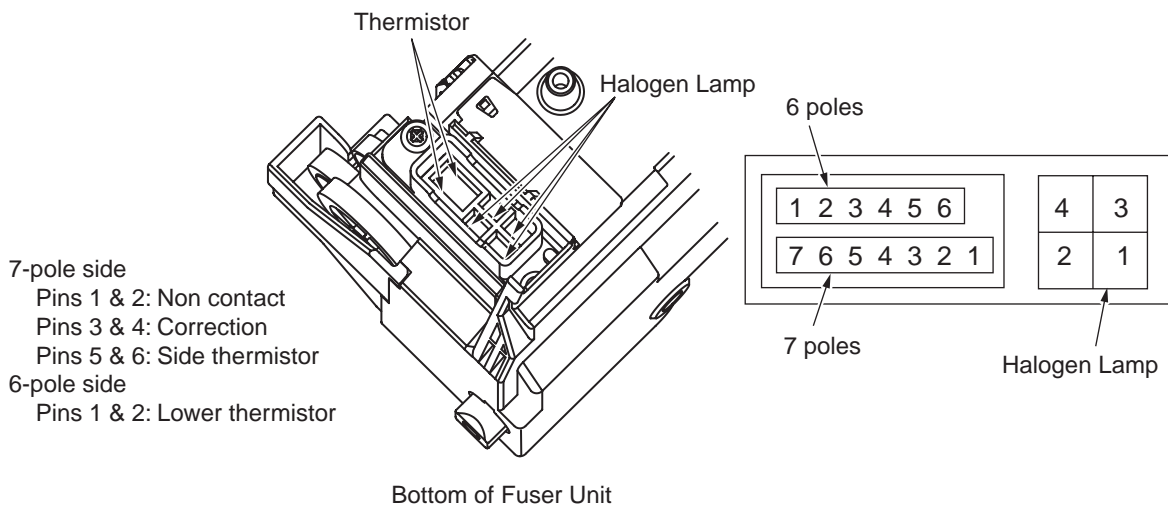
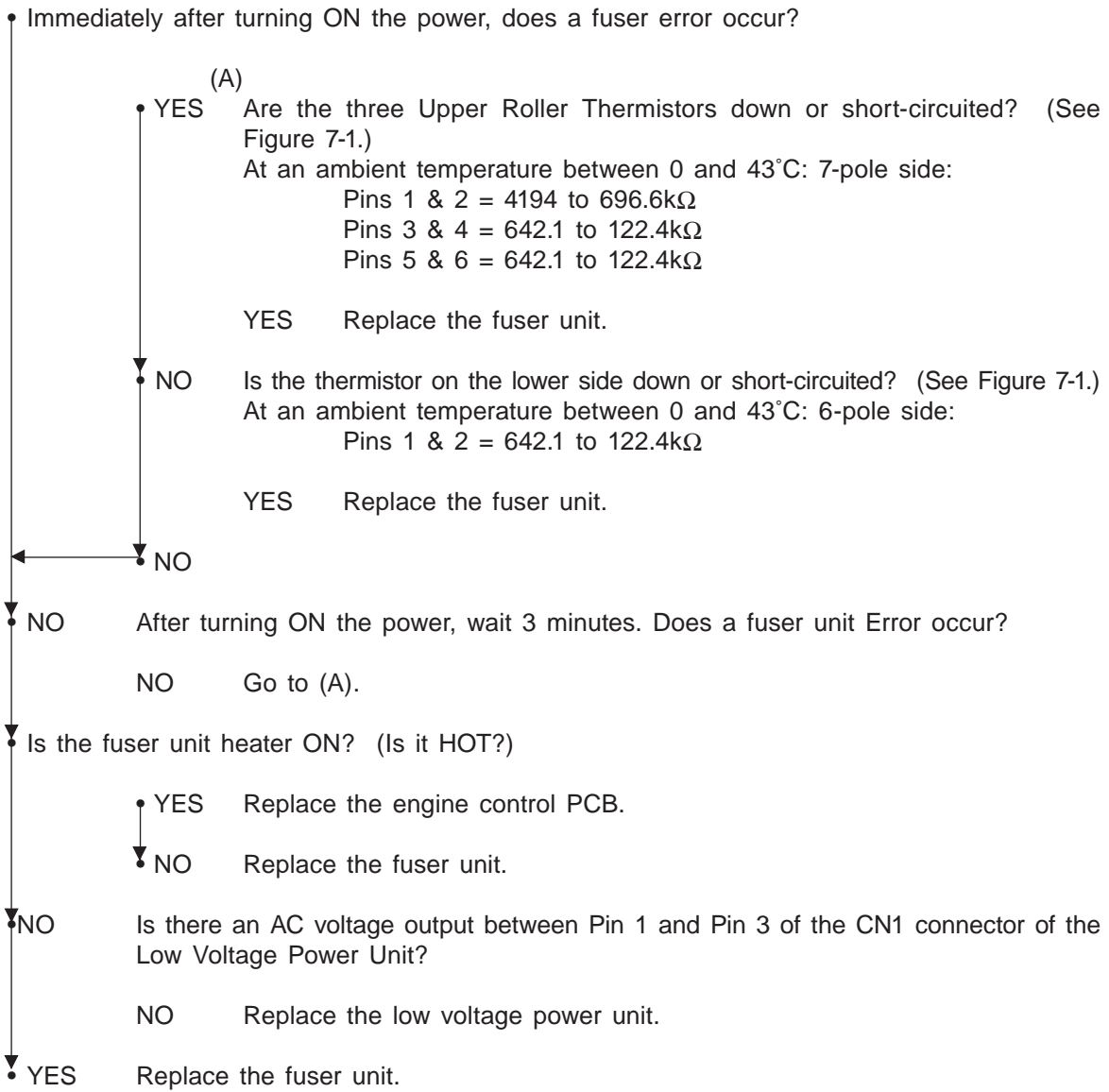

⑥ Motor Fan error

- Check the fan in question using the motor & clutch test in the self-diagnosis mode.

• Does the fan rotate?

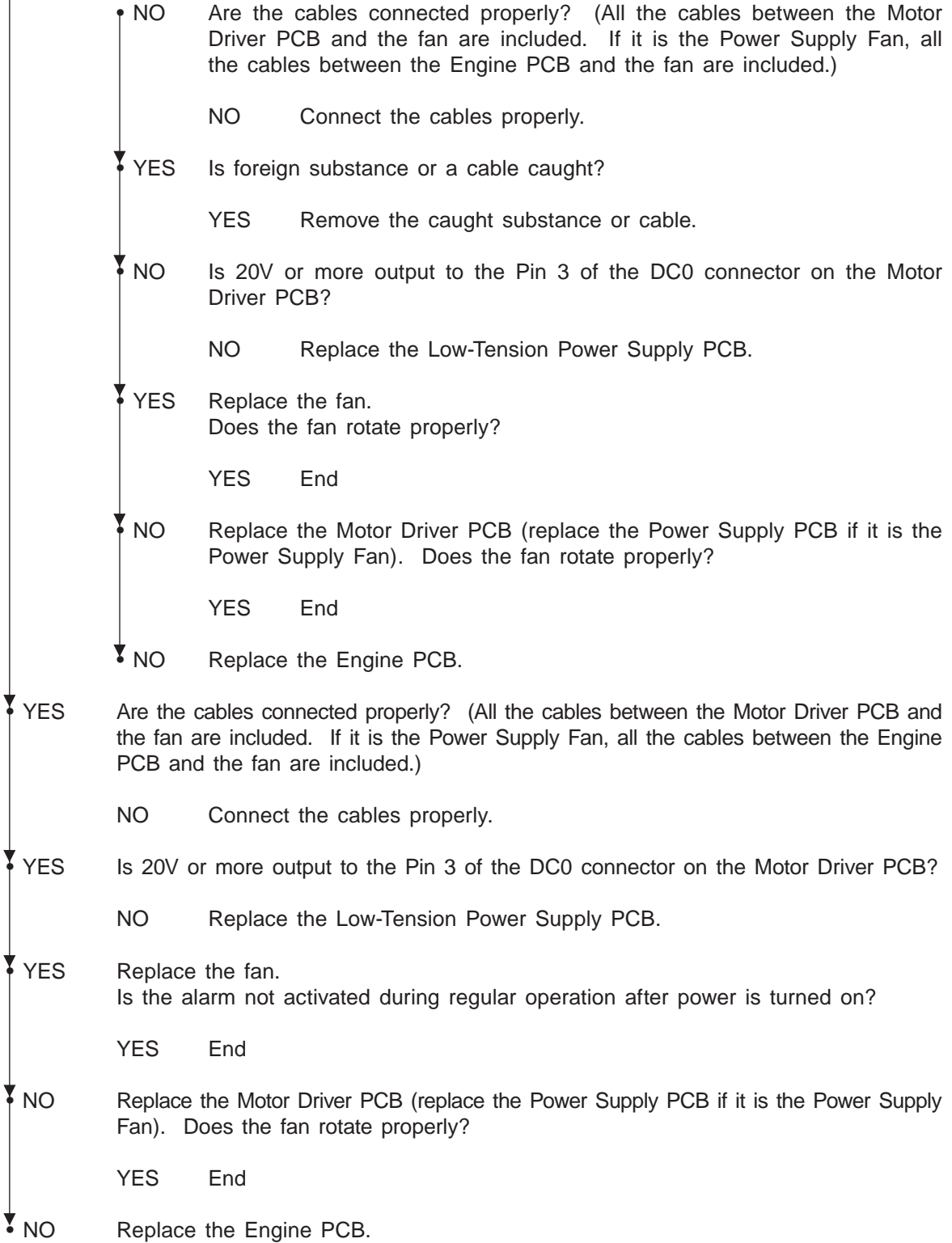

7.5.3 Troubleshooting With Abnormal Image

Troubleshooting with printout results that are irregular as shown in the diagrams below, are indicated.

Abnormal Image	Flow Chart No.
The overall image is too light or uneven, or the color tone is off centered, on the overall, while printing the image. (Figure 7-2 (A))	①
The white area gets dirty. (Figure 7-2 (B))	②
Blank sheet is output. (Figure 7-2 (C))	③
A band or stripe print appears in the vertical direction of the printout. (Black Band, Color Band, Black Stripe, Color Stripe). (Figure 7-2 (D))	④
A white band, white stripe, uneven color band or uneven color stripe occurs in the vertical direction.(Figure 7-2 (F))	⑤
Defective Fusion (the image smears or peels off when touched).	⑥
Periodicity Abnormality (Figure 7-2 (E))	⑦
Printout Falloff	⑧
Color Offset	⑨
Stripe in Horizontal Print Direction (Figure 7-2 (G))	⑩

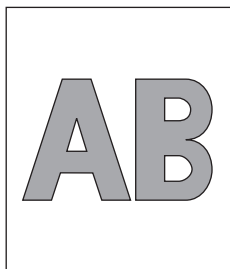

(A) On the overall too light or uneven print

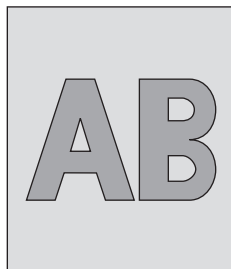

(B) White Area Gets Dirty

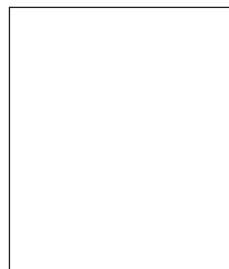

(C) Blank

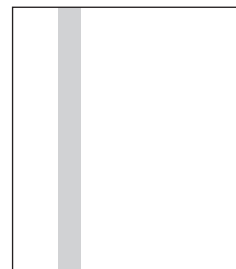

(D) Black Band/ Black Stripe in Vertical Direction

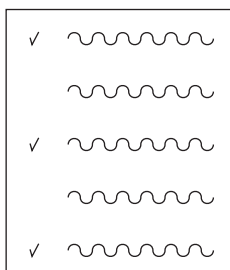

(E) Abnormal Periodicity

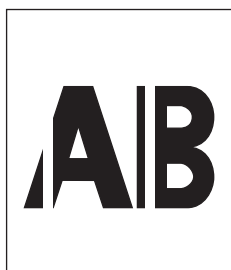

(F) White Band/White Strip in Vertical Direction

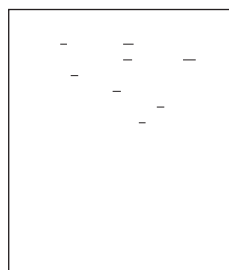

(G) Stripe in Horizontal

Figure 7-2

① The screen in light on the overall. Or there is overall color drift in the printed image.
(Figure 7-2 (A))

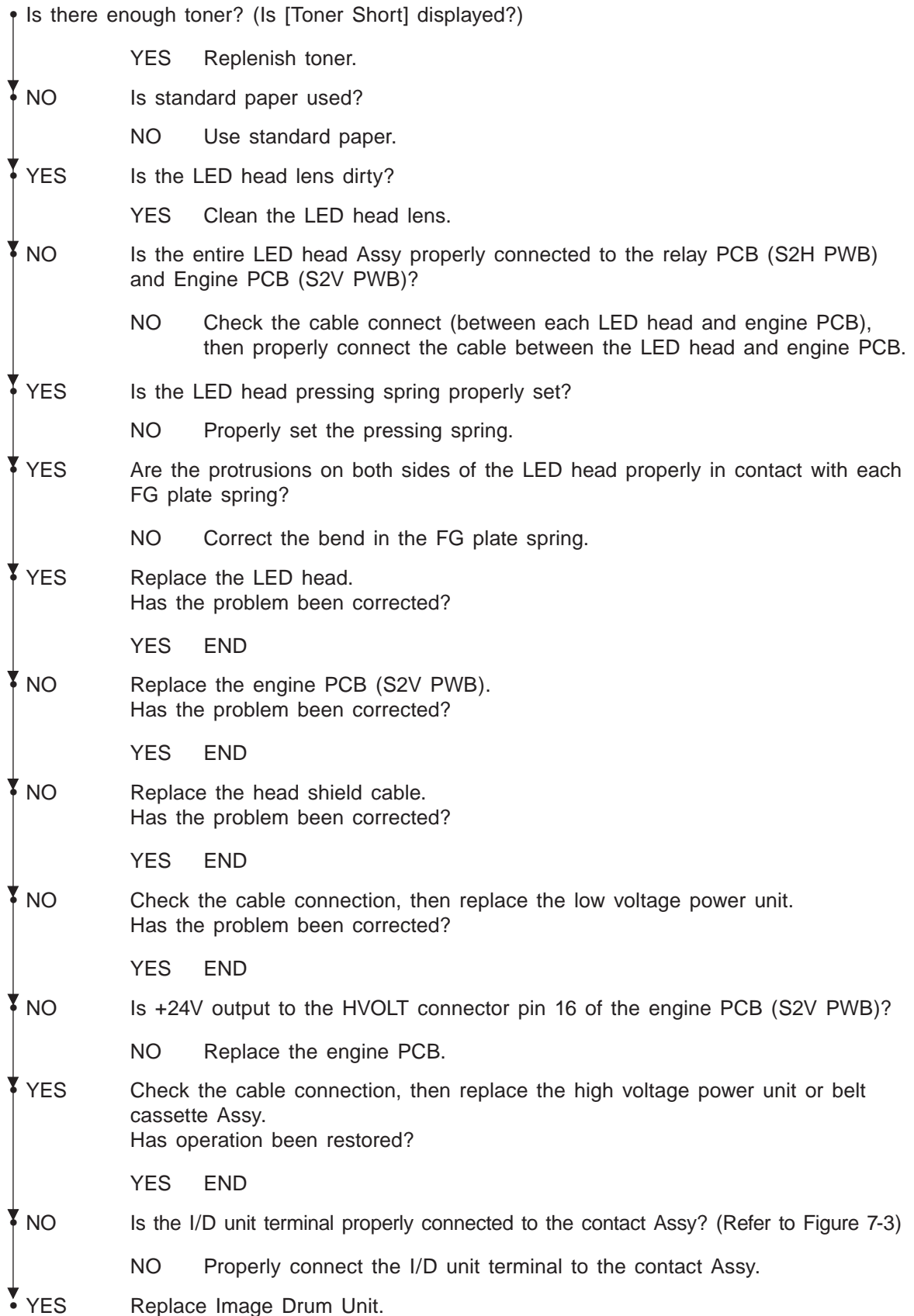

Note! 1. When replacing the Engine PCB (S2V PWB), remove the EEPROM from the old PCB, then mount that EEPROM on the new PCB.
2. If the EEPROM is not going to be replaced, refer to Section 5.2.2.

② The white area gets dirty. (Figure 7-2 ㉞)

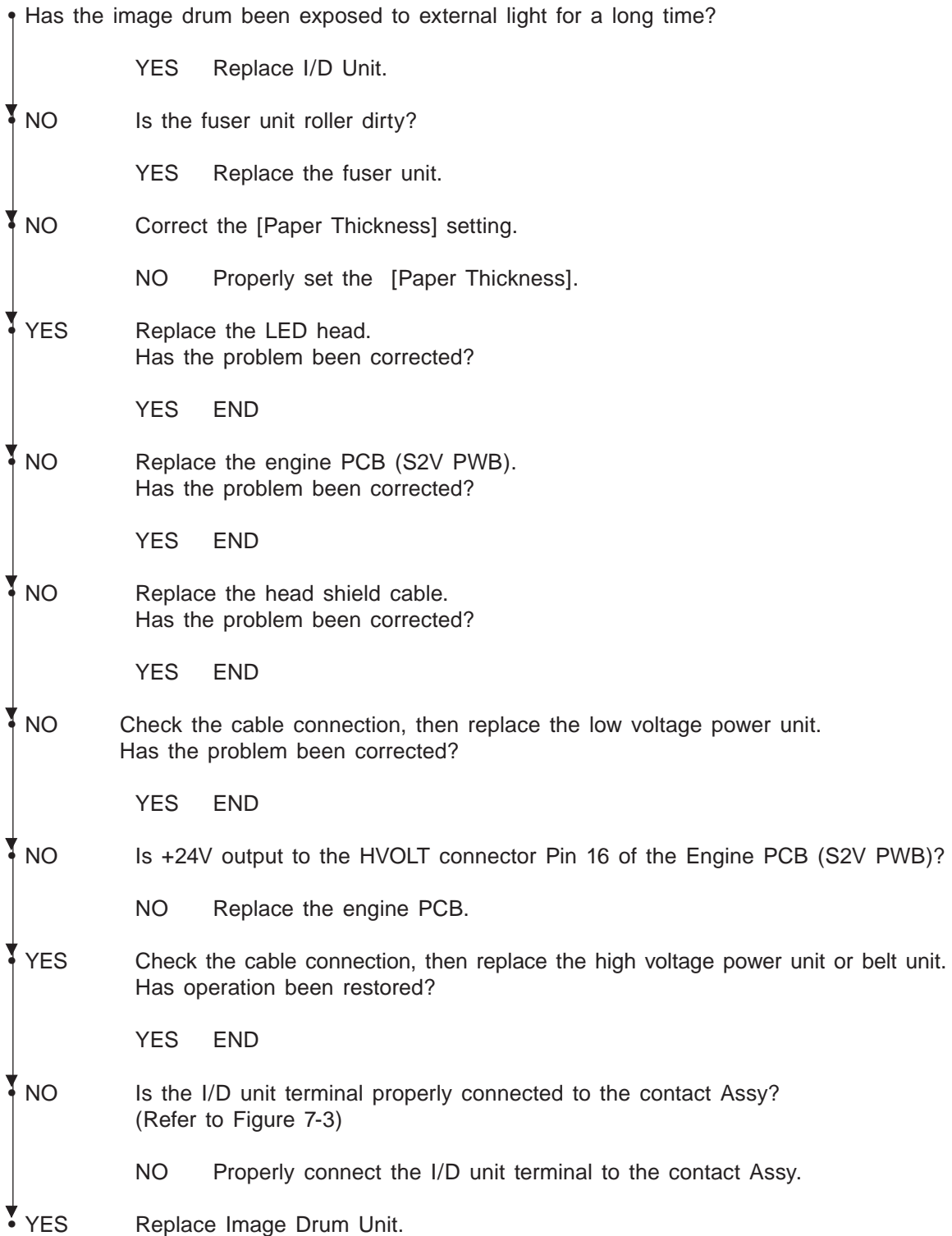

- Note!**
1. When replacing the Engine PCB (S2V PWB), remove the EEPROM from the old PCB, then mount that EEPROM on the new PCB.
 2. If the EEPROM is not going to be replaced, refer to Section 5.2.2.

③ Blank Sheet (Figure 7-2 ©)

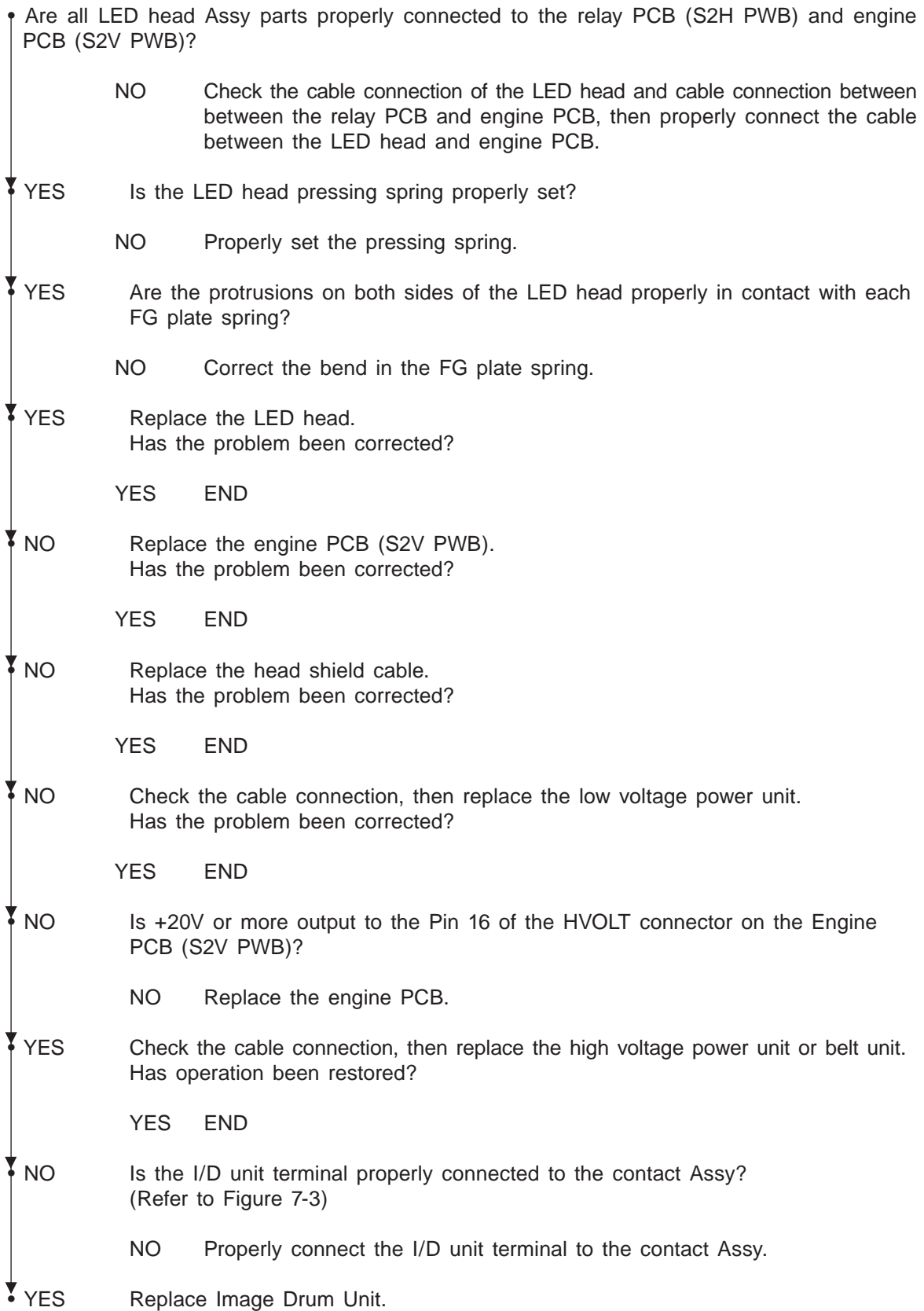

- Note!**
1. When replacing the Engine PCB (S2V PWB), remove the EEPROM from the old PCB, then mount that EEPROM on the new PCB.
 2. If the EEPROM is not going to be replaced, refer to Section 5.2.2.

④ Band or stripe appears in vertical direction of the printed area. (Black Band, Color Band, Black Stripe, Color Stripe) (Figure 7-2 ㉔)

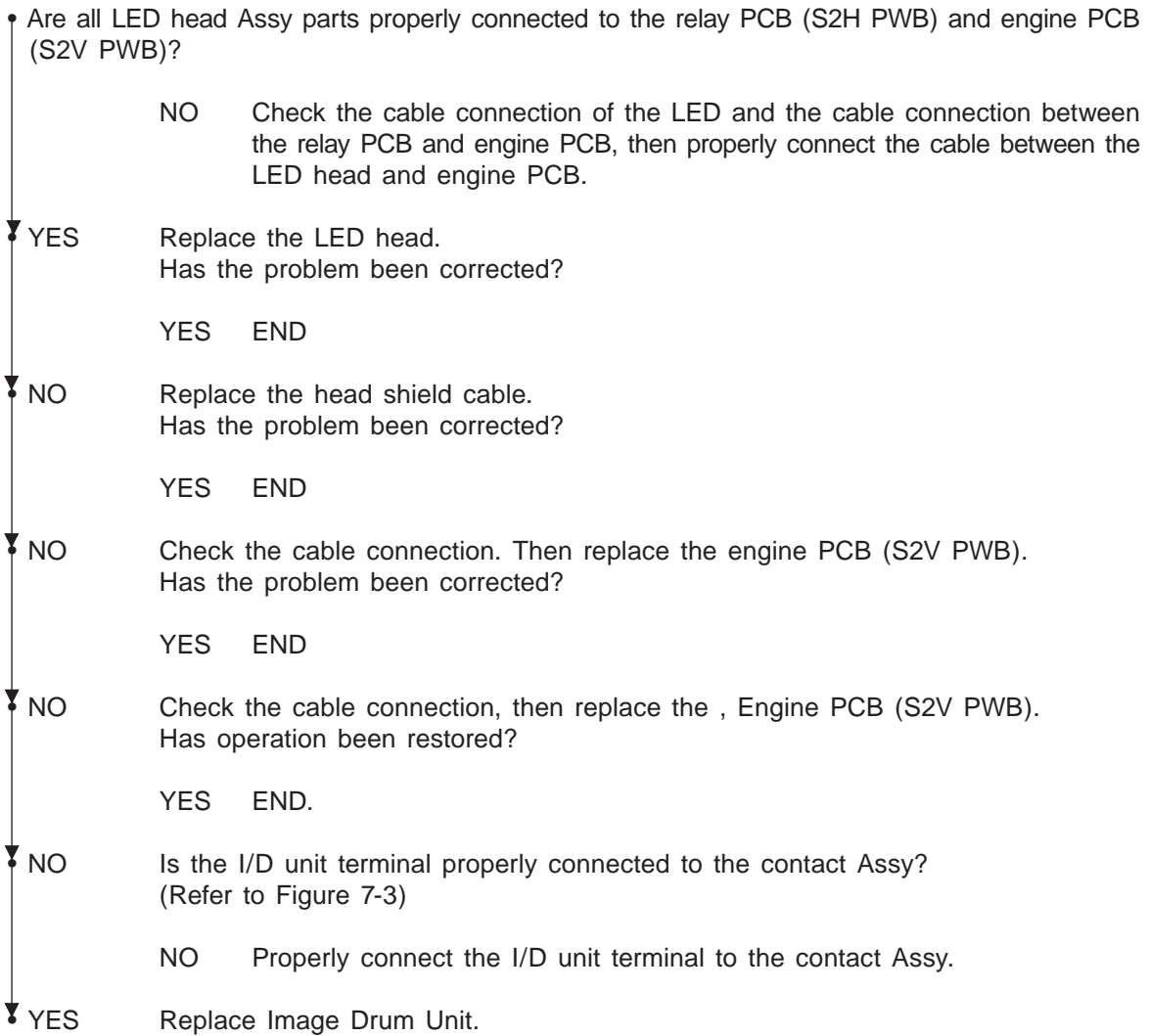

- Note!**
1. When replacing the Engine PCB (S2V PWB), remove the EEPROM from the old PCB, then mount that EEPROM on the new PCB.
 2. If the EEPROM is not going to be replaced, refer to Section 5.2.2.

⑤ White Band, White Stripe, Uneven Color Band, Uneven Color Stripe Occurring in Vertical Direction (Figure 7-2 ㉔)

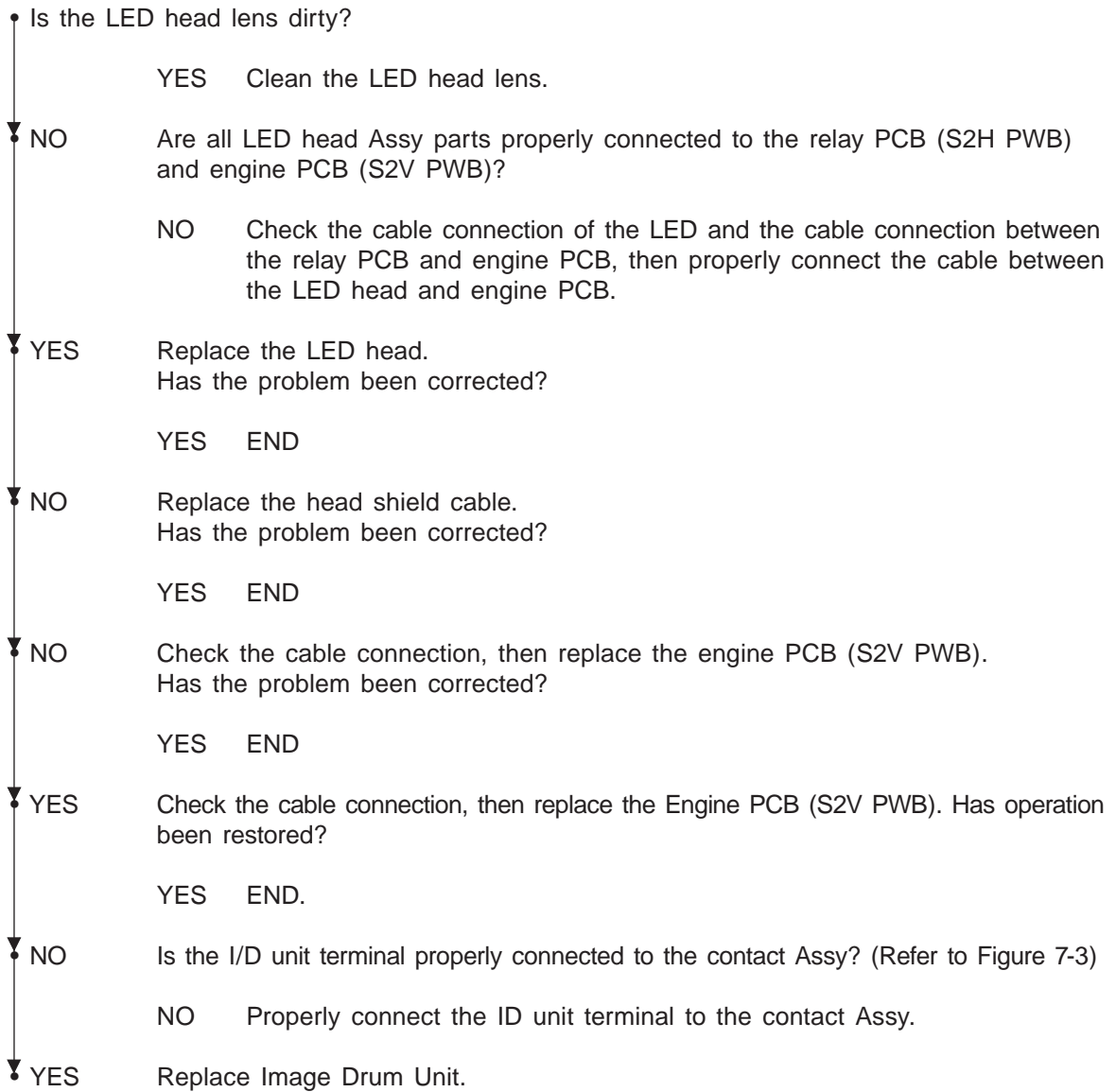

- Note!**
1. When replacing the Engine PCB (S2V PWB), remove the EEPROM from the old PCB, then mount that EEPROM on the new PCB.
 2. If the EEPROM is not going to be replaced, refer to Section 5.2.2.

⑥ Poor Fusion (lightly touching the toner causes the toner to wipe off or fall off)

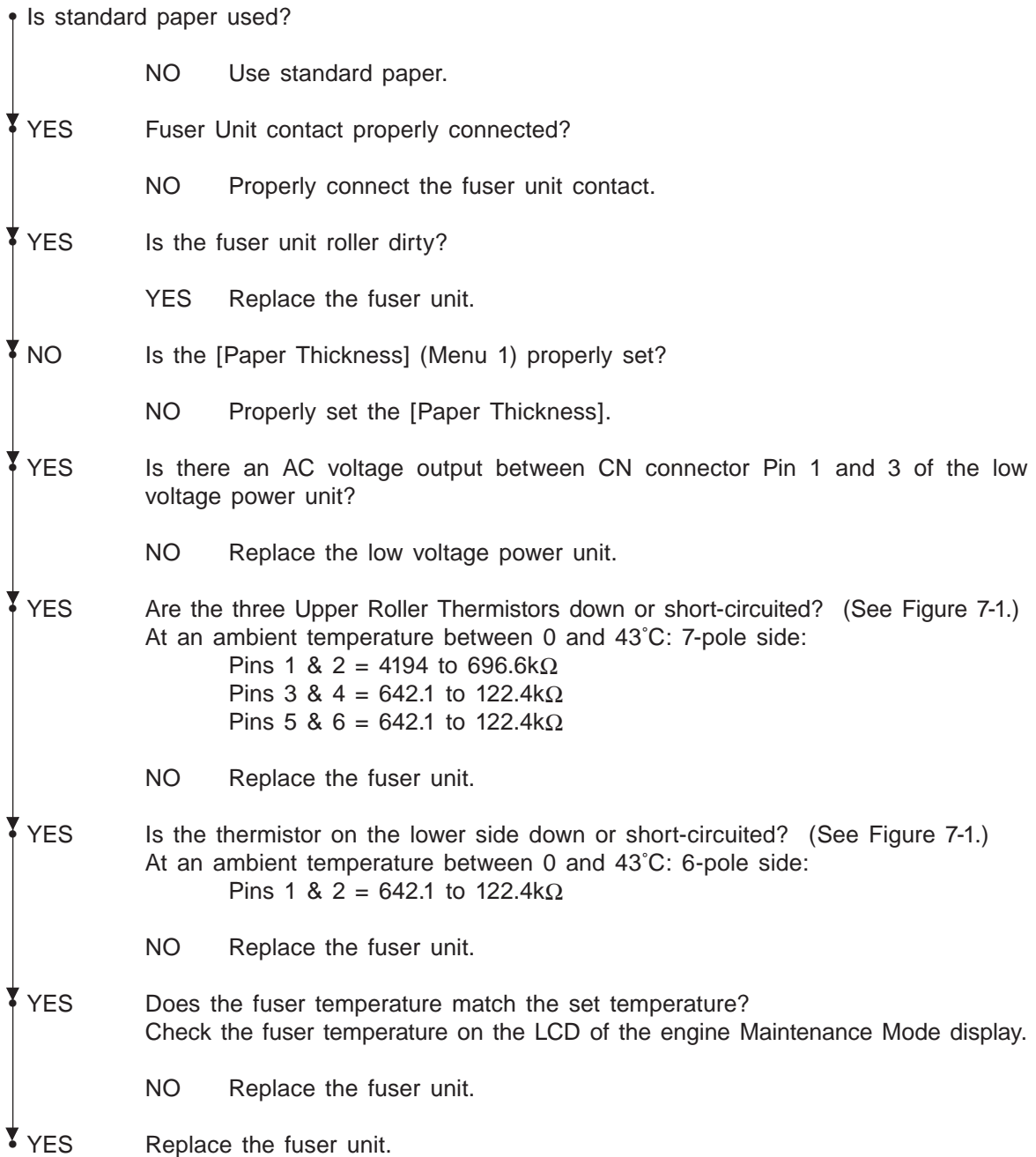

- Note!**
1. When replacing the Engine PCB (S2V PWB), remove the EEPROM from the old PCB, then mount that EEPROM on the new PCB.
 2. If the EEPROM is not going to be replaced, refer to Section 5.2.2.

⑦ Periodicity Abnormal (Refer to Figure 7-2 ⑤)

Periodicity	Malfunction Details	Restoration Method
94 mm	Image Drum	Replace the image drum cartridge.
49.6 mm	Development Roller	Replace the image drum cartridge.
54.8 mm	Sponge Roller	Replace the image drum cartridge.
37.7 mm	Charge Roller	Replace the image drum cartridge.
89 mm	Upper Roller	Replace the image drum cartridge.
125 mm	Lower Rolle	Replace the fuser unit.

Note! After replacing the Image Drum Cartridge, Fuser Unit or Belt Unit, reset the counter from the User Maintenance Mode.

⑧ Printing Thinned Out

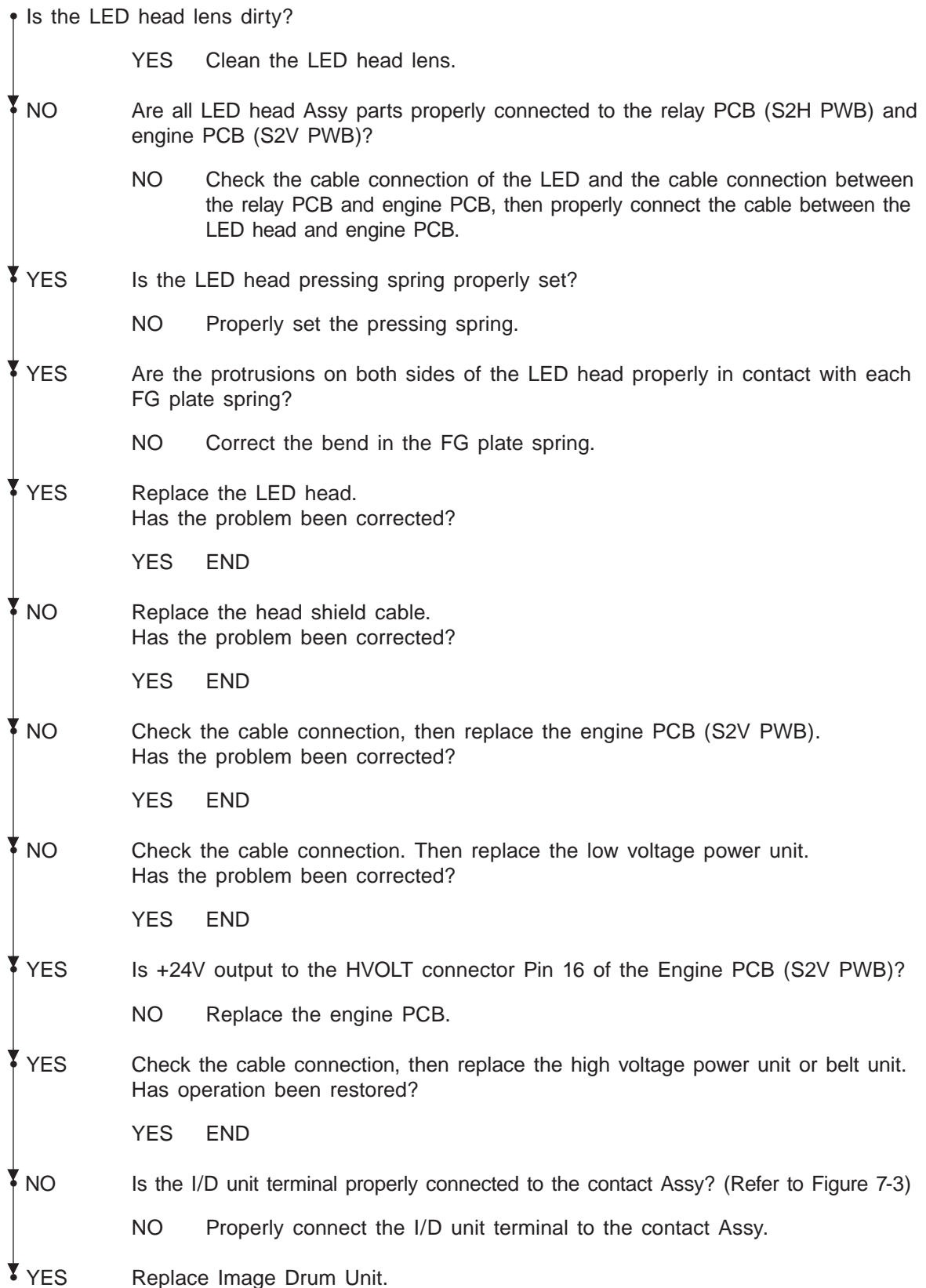

- Note!**
1. When replacing the Engine PCB (S2V PWB), remove the EEPROM from the old PCB, then mount that EEPROM on the new PCB.
 2. If the EEPROM is not going to be replaced, refer to Section 5.2.2.

⑨ Color Drift

• “Toner Low” is displayed.

YES Replenish toner. Has operation been restored?

YES END

• NO

Conduct a color drift test in the engine Maintenance Mode.

Method: Enter the Engine Maintenance Mode, and self-diagnostic mode (Level 1).

DIAGNOSTIC MODE
XX.XX.XX

Press [MENU+] key 4 times to display the [REG ADJUST TEST].

REG ADJUST TEST

Press [ENTER] key once to display the [REG ADJUST EXECUTE].

REG ADJUST EXECUTE

Press [ENTER] key to execute automatic correction of color drift (motor starts operating, and color drift correction is executed).

• Color drive correction operation does not take effect (motor does not operation), and immediately displays “OK”.

YES Error other than color drift occurred. Correct error. Has color drift been corrected and restored for proper color?

YES END

(A)

(A)

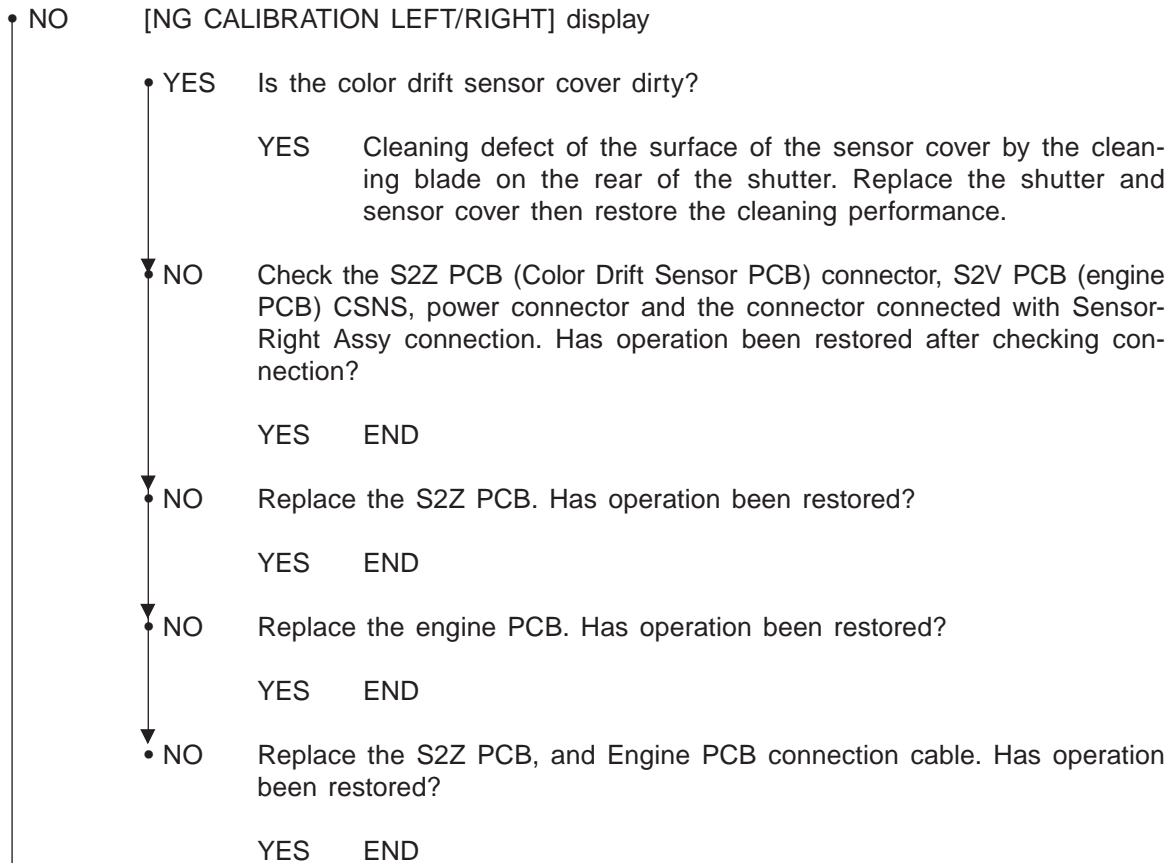

NO

[DYNAMICRANGE LEFT/RIGHT] display

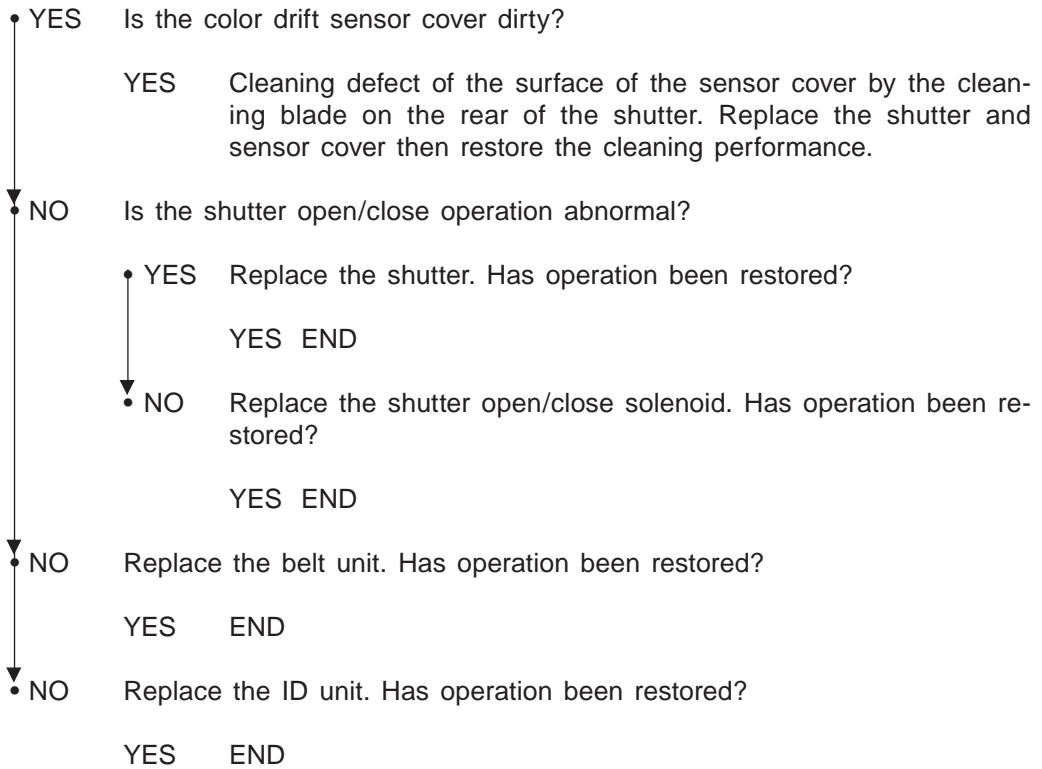

(B)

(B)

- [Yellow, Magenta, Cyan Left/Right/Horizontal] display

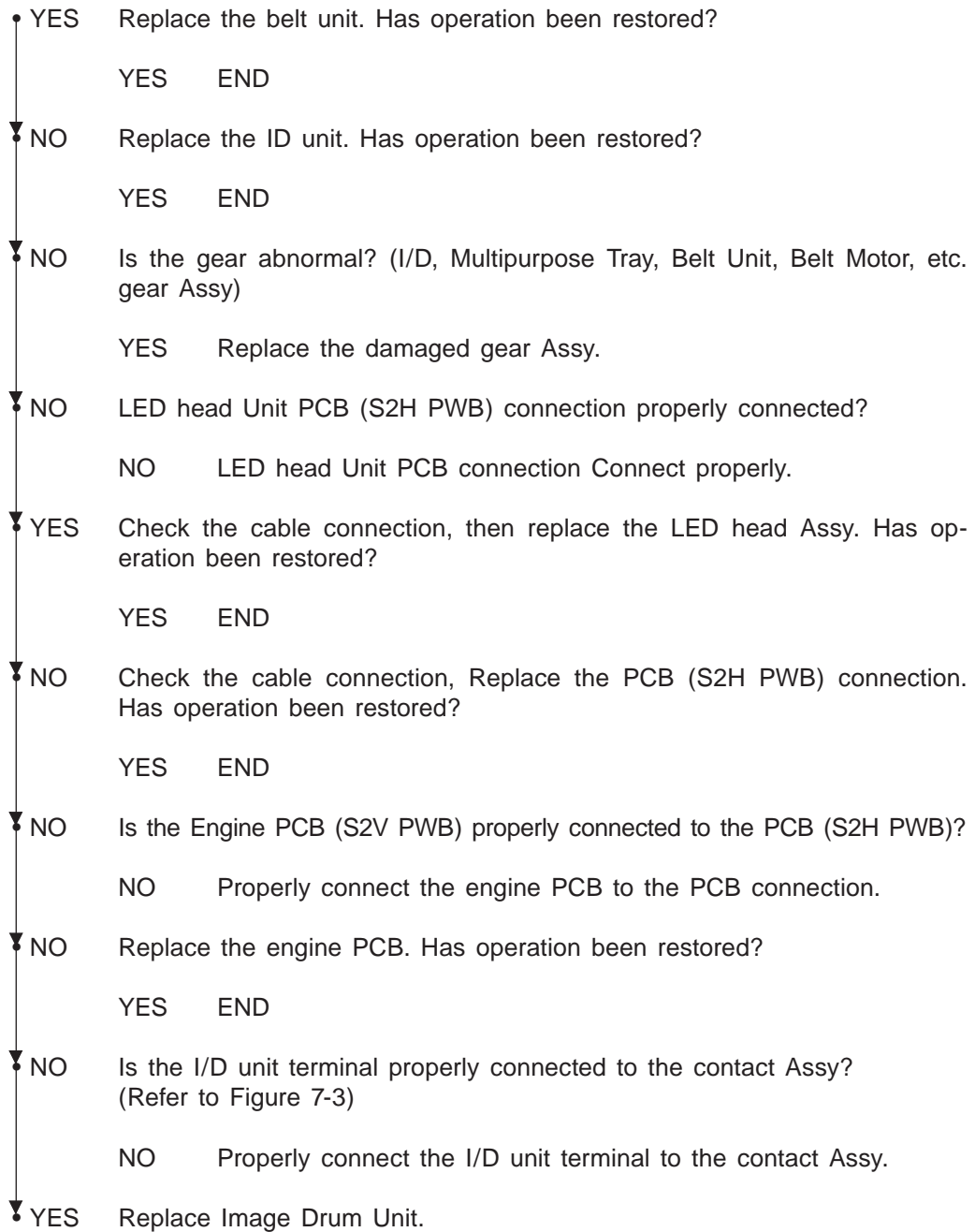

- Note!**
1. When replacing the Engine PCB (S2V PWB), remove the EEPROM from the old PCB, then mount that EEPROM on the new PCB.
 2. If the EEPROM is not going to be replaced, refer to Section 5.2.2.

⑩ Stripe in Horizontal Print Direction (Figure 7-2 ©)

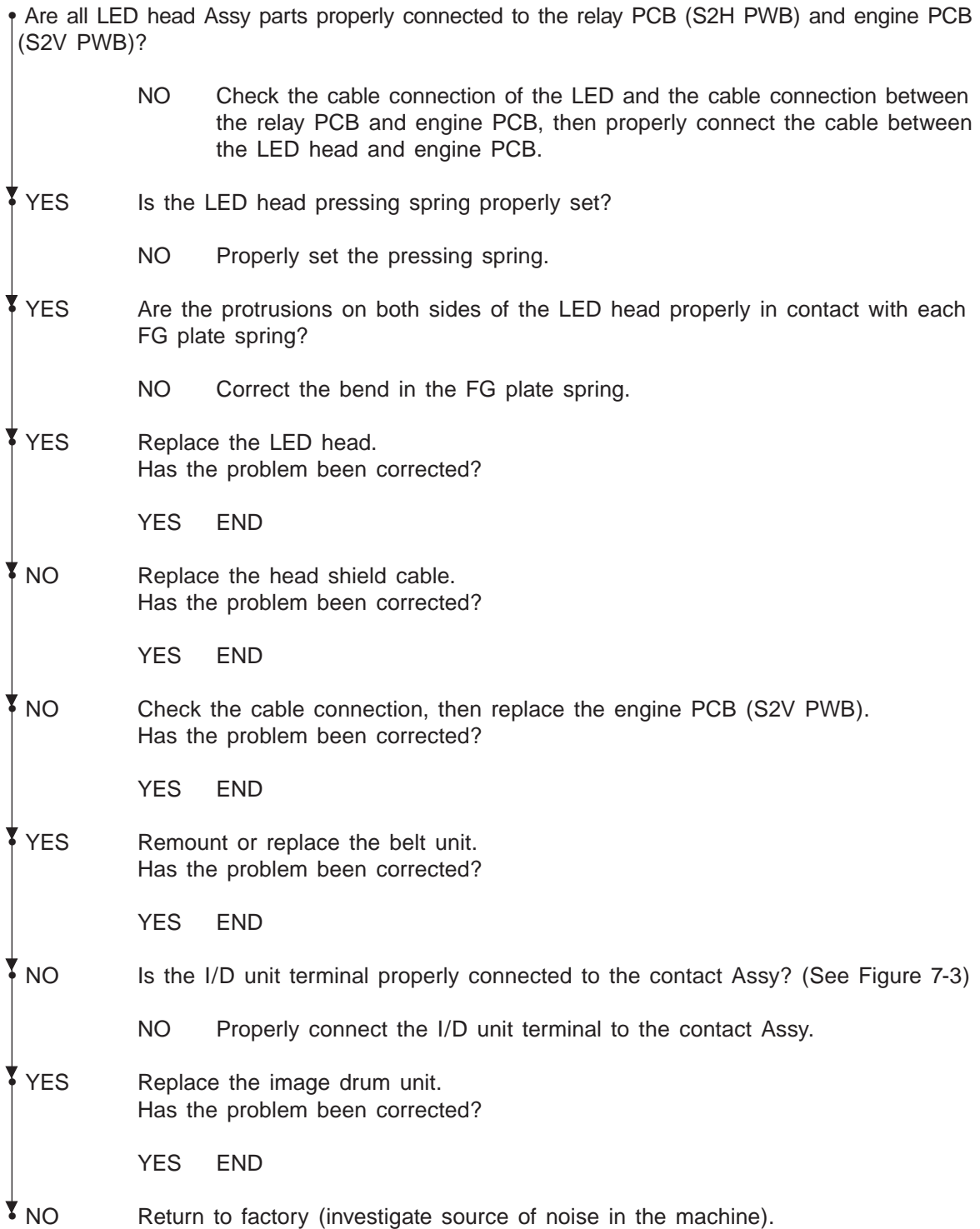

⑪ Paper Thickness Error (Err Code 323, 324)

- Is the Paper Thickness Sensor Connector disconnected?
- Is the PATHICK connector on the Sensor Relay PCB (S2S PWB) connected securely?

NO Connect the connector properly.

- YES Is any sensor cable down?

YES Replace the cable.

- YES Is 5V output to the Sensor Relay PCB (S2S PWB)?
 5V: PATHICK Pin 3 0V: PATHICK Pin 1
 FSNS Pin 1 FSNS Pin 9

Output of 5V		Judgement	Action
PATHICK	FSNS		
OK	OK	Normal	YEA
NG	NG	Abnormal	NO-(1)
NG	OK	Abnormal	NO-(2)

NO-(1): Replace the Motor Driver PCB (S2P).
 NO-(2) : Replace the Sensor Relay PCB (S2S PWB).

- YES Is a pulse wave between 250 and 350 kHz output to the Pin 2 of the PATHICK connector on the Sensor Relay PCB (S2S PWB)? (When the Belt Motor is not running.) (As an oscilloscope is used, this cannot be checked on site.)

NO Replace the Paper Thickness Sensor.

- YES Is the error reset after power is turned on and medium detection is performed?

NO Replace the Paper Thickness Sensor.

- YES End

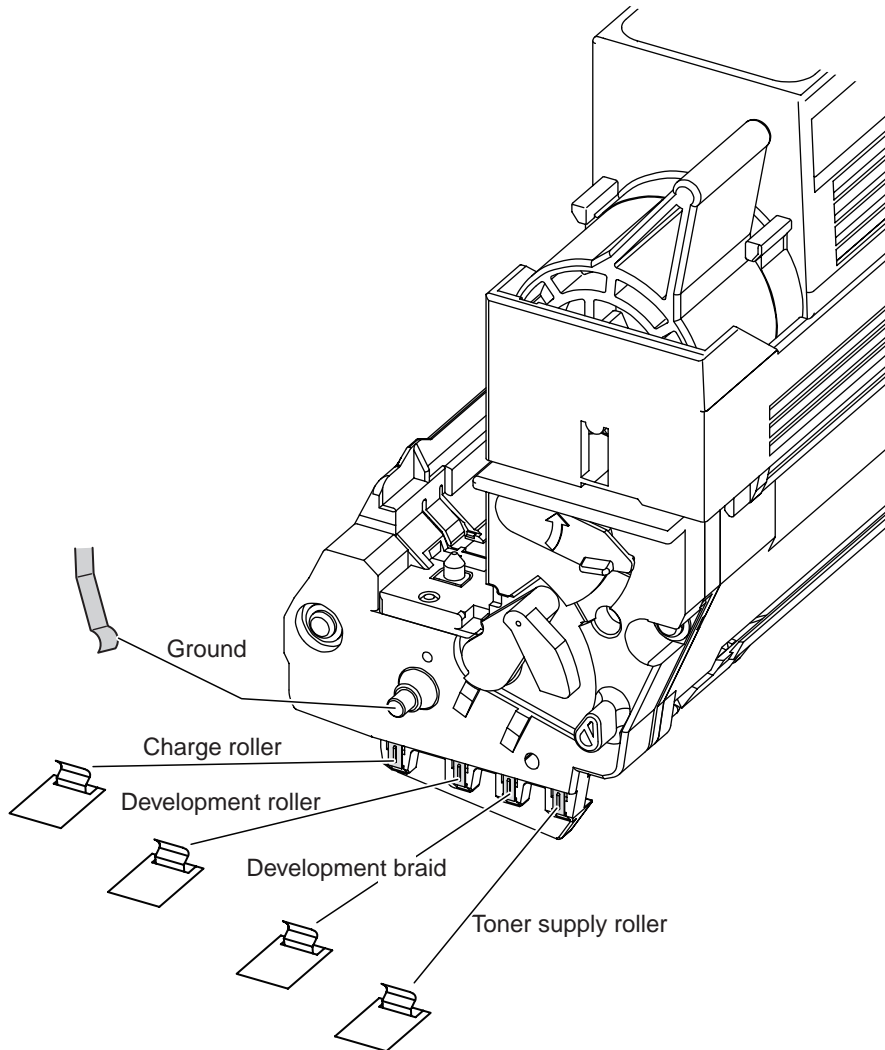
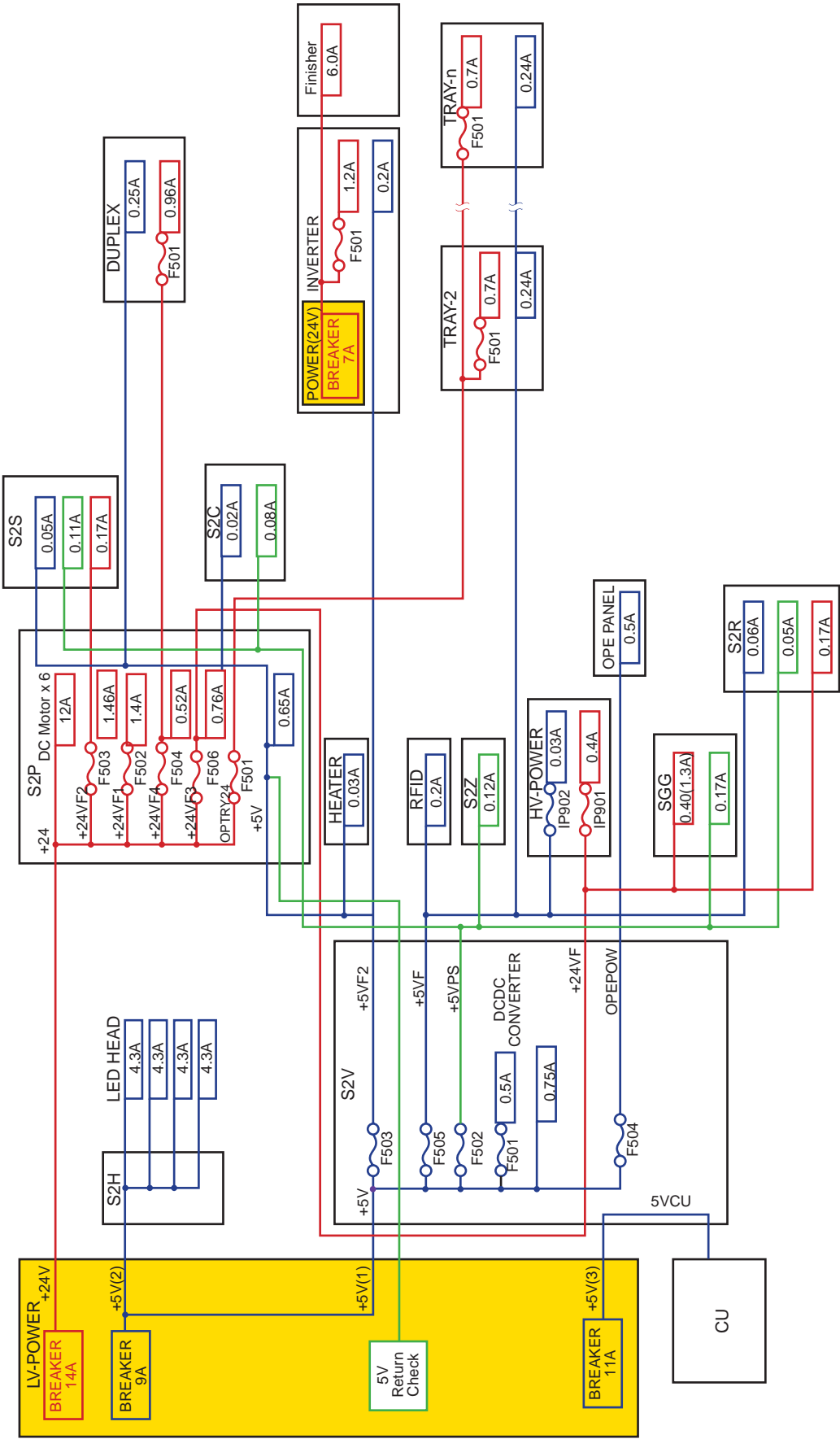

Figure 7-3

7.6 Check Fuse

The fuse system of the engine control part is composed as shown in the figure below.



7.7 PU Error

Display	Cause	Remedy
WDT ERROR	Time out error with WDT function of CPU	Reload PU-FW to Flash Memory Replace PU-PCB
BRK INST EXECUTE	BRK command execution error of CPU	Reload PU-FW to Flash Memory Replace PU-PCB
OPECODE TRAP ERROR	Invalid command execution error of CPU	Reload PU-FW to Flash Memory Replace PU-PCB
PU K ASIC ERROR	Initial check error of LSI for K-Head control on PU-PCB	Power OFF/ON Replace PU-PCB
PU Y ASIC ERROR	Initial check error of LSI for Y-Head control on PU-PCB	Power OFF/ON Replace PU-PCB
PU M ASIC ERROR	Initial check error of LSI for M-Head control on PU-PCB	Power OFF/ON Replace PU-PCB
PU C ASIC ERROR	Initial check error of LSI for C-Head control on PU-PCB	Power OFF/ON Replace PU-PCB
PU VIDEO ASIC ERROR	Initial check error of LSI for Head control on PU-PCB	Power OFF/ON Replace PU-PCB
PU LSI I/F BUSY	Time out error of Serial Bus (I2C) setting	Power OFF/ON Replace PU-PCB
SRAM ERROR	SRAM check error on PU-PCB	Power OFF/ON Replace PU-PCB
SDRAM ERROR	SDRAM check error on PU-PCB	Power OFF/ON Replace PU-PCB
Communication Error	Communication Error between PU-PCB and CU-PCB	Check the connection between PU-PCB and CU-PCB Replace PU-PCB or CU-PCB

8. CONNECTION DIAGRAM

8.1 Check Resistance Value

Unit	Circuit Diagram and Configuration	Parts Diagram	Resistance Value
<p>Conveyance Belt Motor</p>			<p>Between Pin 1 and Pin 2: 4.7Ω Between Pin 3 and Pin 4: 4.7Ω</p>
<p>Main Motor (Y)</p>			<p>Both ends of IP2: 1Ω or less</p>
<p>Main Motor (M)</p>			<p>Both ends of IP2: 1Ω or less</p>

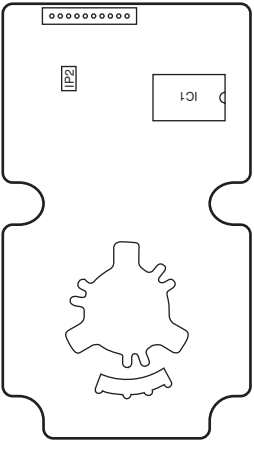
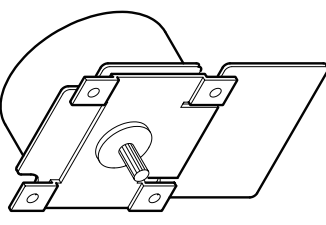
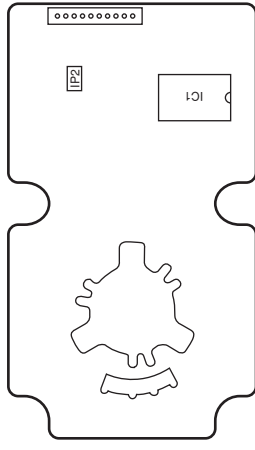
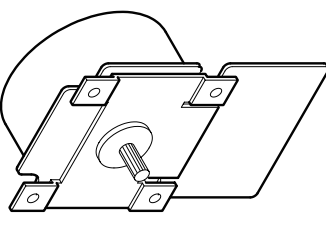
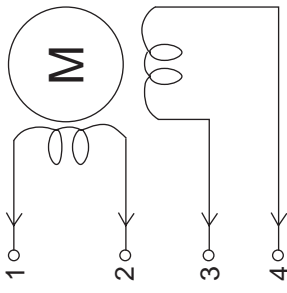
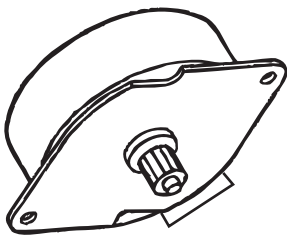
Unit	Circuit Diagram and Configuration	Parts Diagram	Resistance Value
Main Motor (C)			Both ends of IP2: 1Ω or less
Main Motor (K)			Both ends of IP2: 1Ω or less
MT Resist Motor			Between Pin 1 and Pin 2: 4.7Ω Between Pin 3 and Pin 4: 4.7Ω

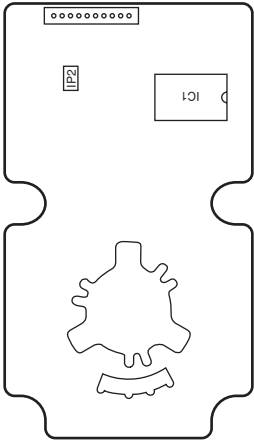
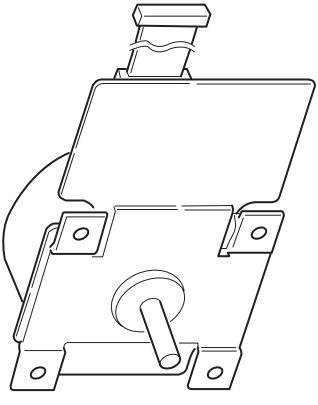
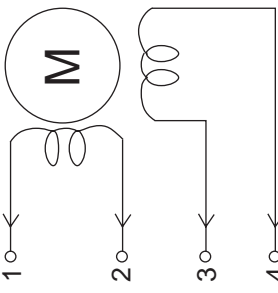
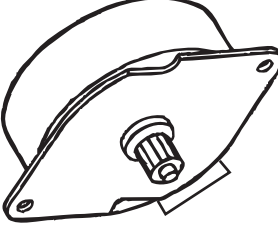
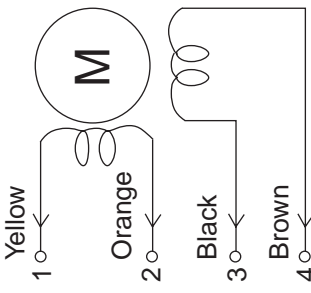
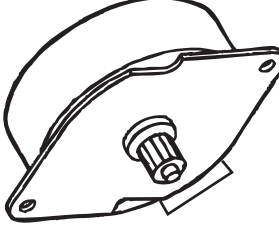
Unit	Circuit Diagram and Configuration	Parts Diagram	Resistance Value
Fuser Motor			Both ends of IP2: 1Ω or less
Paper Supply Motor			Between Pin 1 and Pin 2: 3.4Ω Between Pin 3 and Pin 4: 3.4Ω
Offset Motor			Between Pin 1 and Pin 2: 3.5Ω Between Pin 3 and Pin 4: 3.5Ω

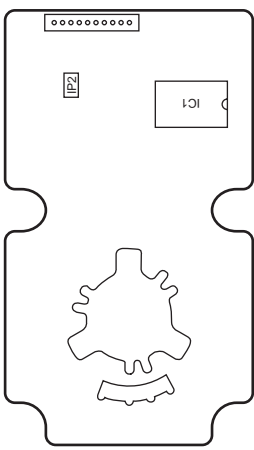
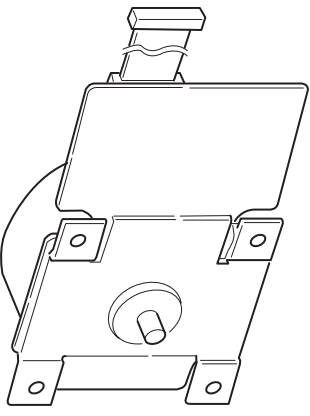
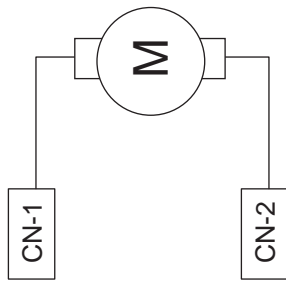
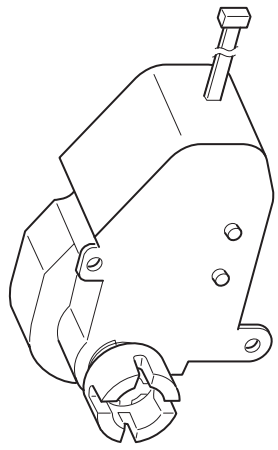
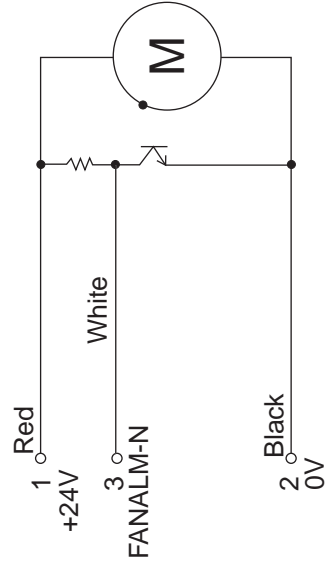
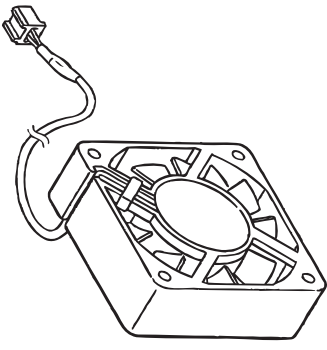
Unit	Circuit Diagram and Configuration	Parts Diagram	Resistance Value
<p>Waste Toner Transfer Motor</p>			<p>Both ends of IP2: 1Ω or less</p>
<p>Geared Motor</p>			
<p>Main Cooling Fan (PULL) and Cooling Fan for Controller</p>			

Unit	Circuit Diagram	Parts Diagram	Resistance Value
Power Supply Cooling Fan	<p>1 Red +24 V</p> <p>3 White FANALM-N</p> <p>2 Black 0V</p>		
Belt Cooling Fan	<p>1 Red +24 V</p> <p>3 White FANALM-N</p> <p>2 Black 0V</p>		
Fuser Exhaust Fan	<p>1 Red +24V</p> <p>3 White FANALM-N</p> <p>2 Black 0V</p>		

Unit	Circuit Diagram	Parts Diagram	Resistance Value
CU PCB Fan 2 (1200)	<p> 2 Red +5V 3 Yellow FANALM-N (Speed signal) 1 Black 0V </p>	<p>White label</p>	
ID Cooling Fan 1 and ID Cooling Fan 2	<p> 1 Red +24V 3 FANALM-N 2 Black 0V </p>		
CU PCB Fan 1 (600)	<p> 1 Red +5V 3 Yellow FANALM (Lock signal) 2 Black 0V </p>	<p>Blue label</p>	

Unit	Circuit Diagram	Parts Diagram	Resistance Value
			<p>7-pole side Pins 1 & 2: Non contact: 4194 to 696.6 kΩ Pins 3 & 4: Correction: 642 to 122.4 kΩ Pins 5 & 6: Side thermistor 642.1 to 122.4 kΩ</p> <p>6-pole side Pins 1 & 2: Lower thermistor 642.1 to 122.4 kΩ</p> <p>Both on the 7-pole side and the 6-pole side, the resistances shall be measured at an ambient temperature between 0 and 43°C.</p>

8.2 Diagram of Part Layout of Various PCB

(1)-1 Engine Control PWB (S2X-2 PWB: 600dpi)

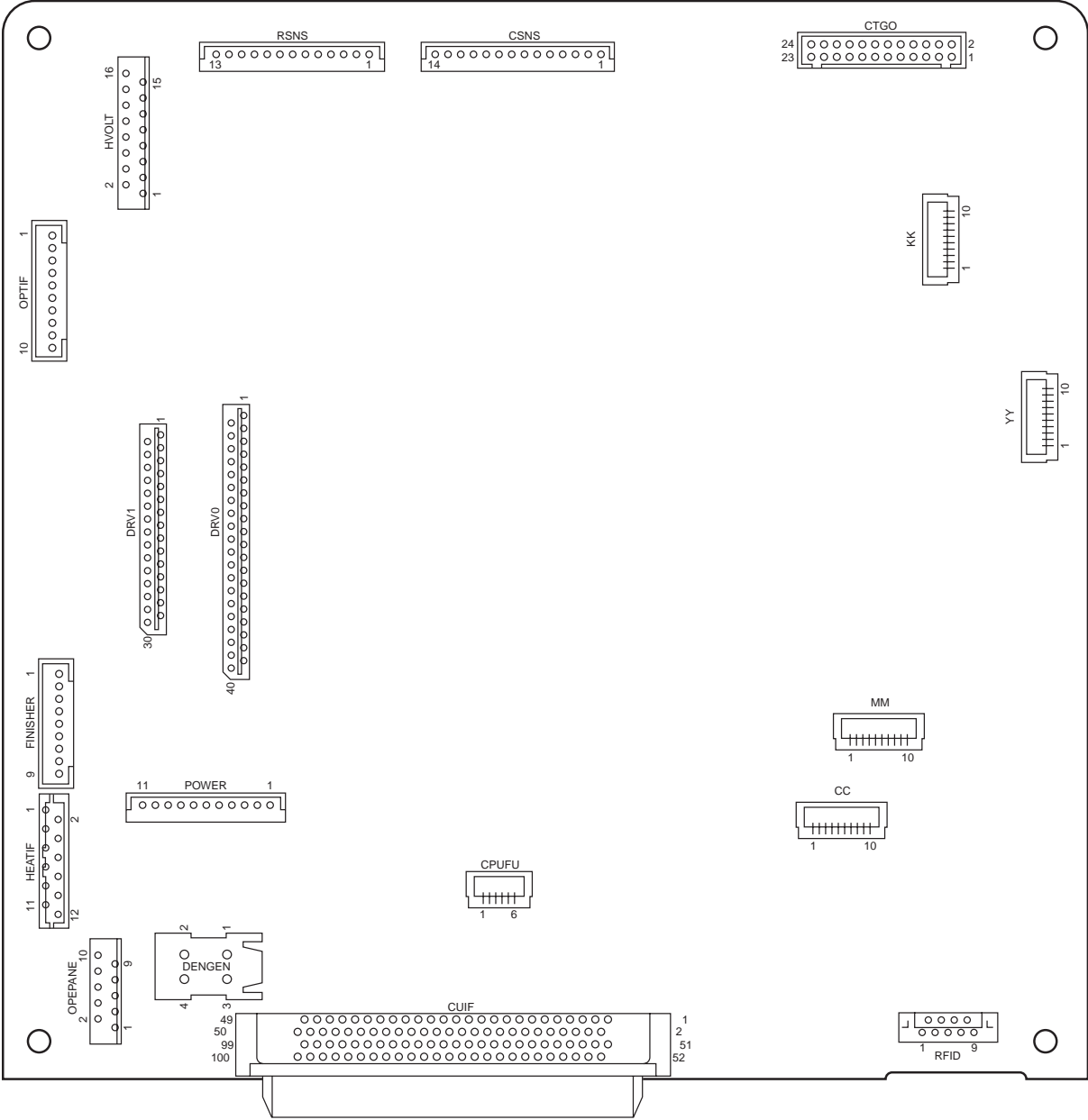

(1)-2 Engine Control PWB (S2V-21 PWB: 1200dpi)

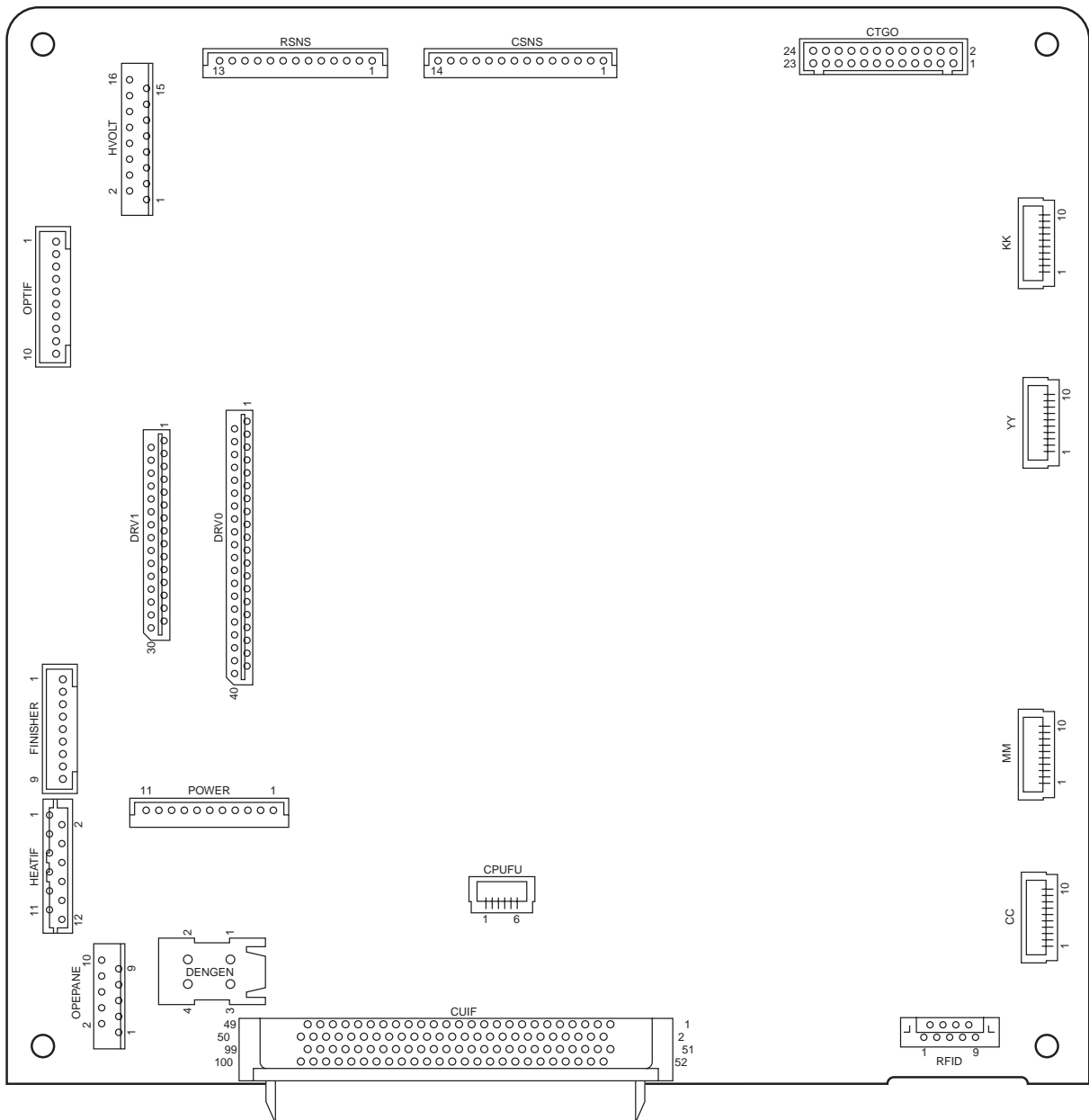

(2) Motor Driver PWB (S2P)

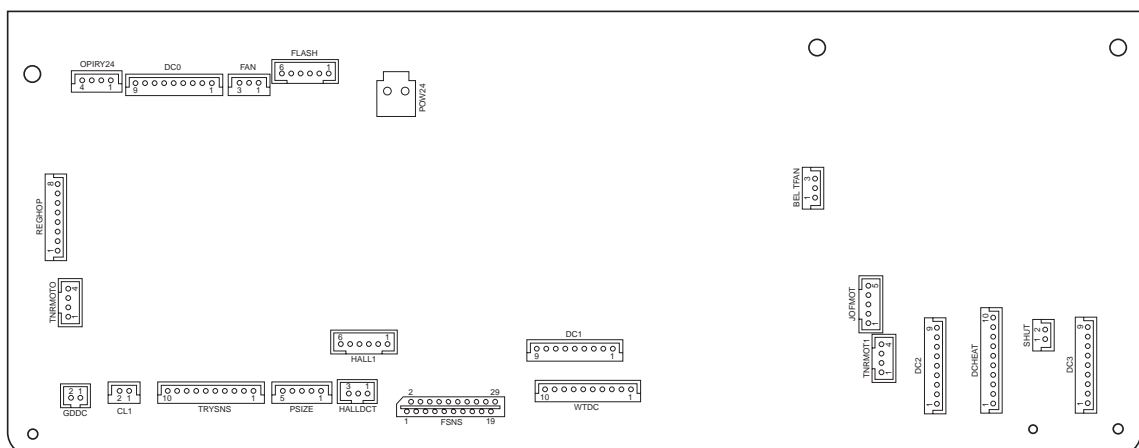

(3)-1 Main Controller PWB : AS3

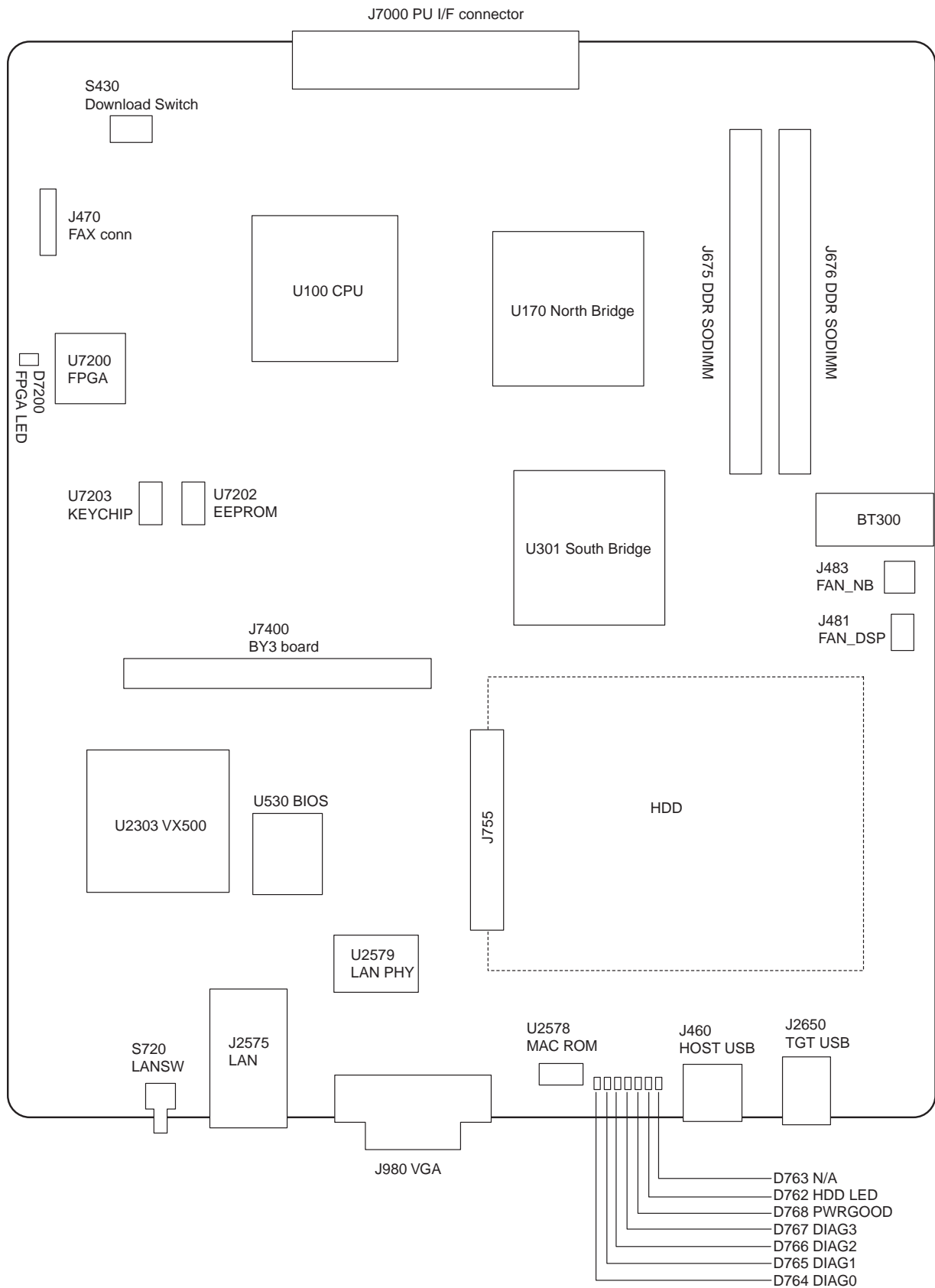

(3)-2 Main Controller PWB : TBX

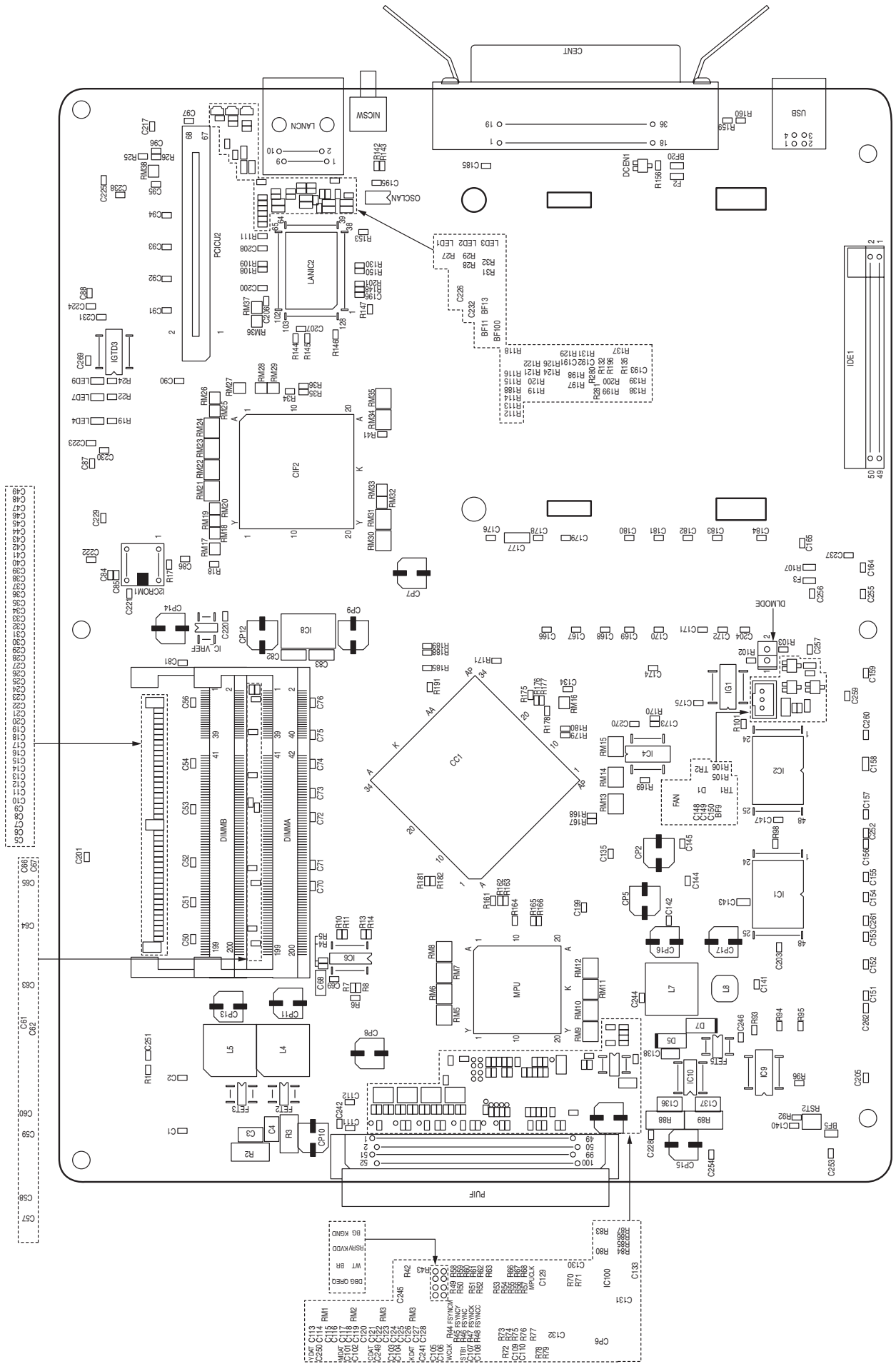

(4) LED Control PWB

a) (S2H PWB)

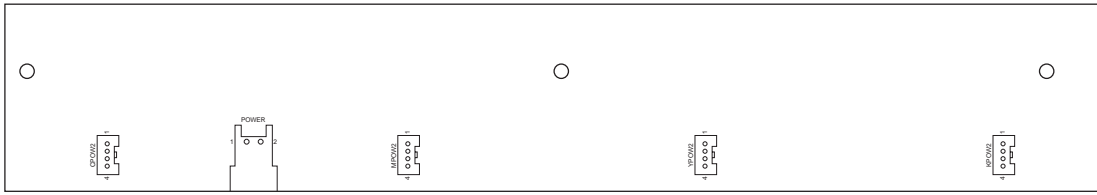

(5) Control Panel PWB (X7G- PWB)

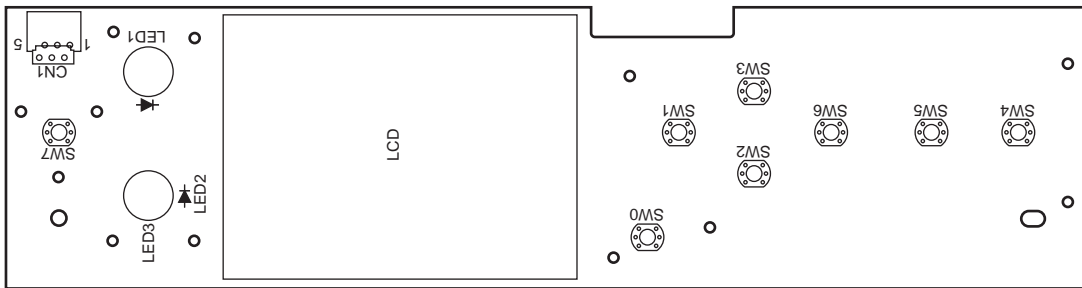

(6) ID System Sensor PWB(SGG-PWB)

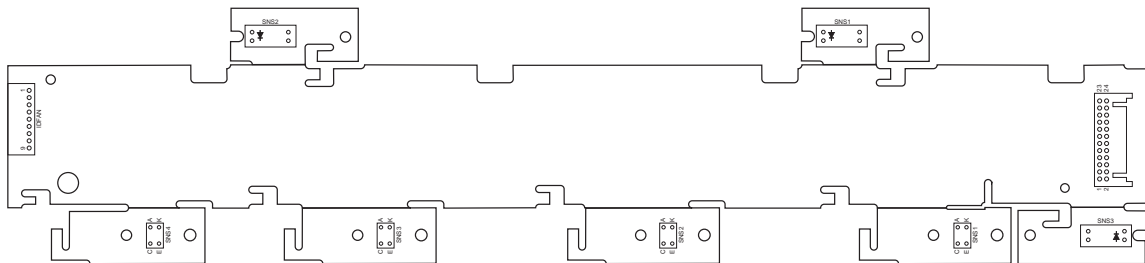

(7) Entrance Sensor PWB (S2C-PWB)

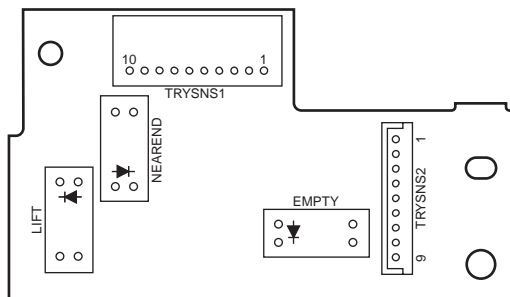

(8) Paper Size Detection PWB (S2S- PWB)

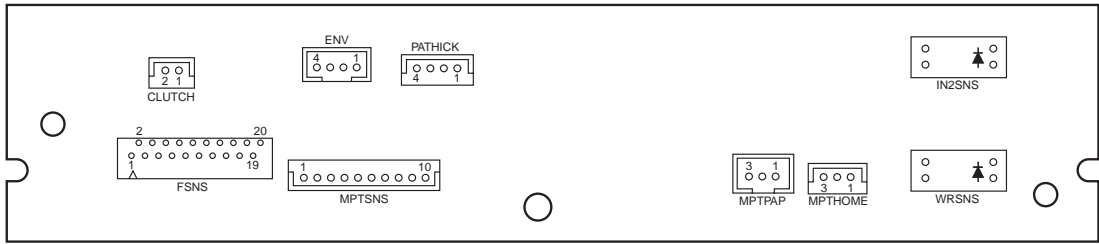

(9) Rear Sensor PWB (S2R- PWB)

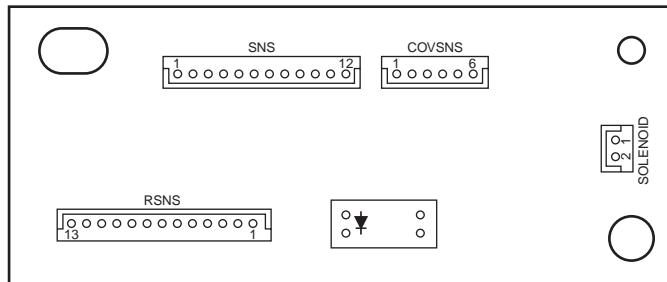

(10) Color Drift Sensor PWB (S2Z- PWB)

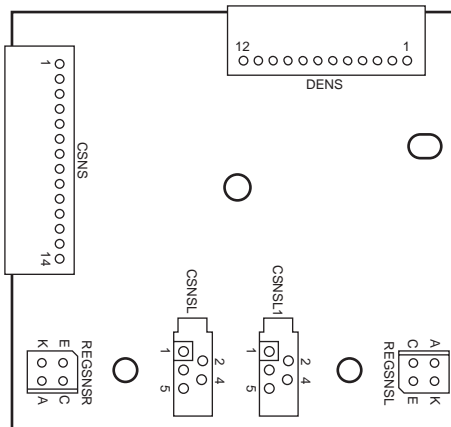

(11) Tray Control PWB (V72-1- PWB)

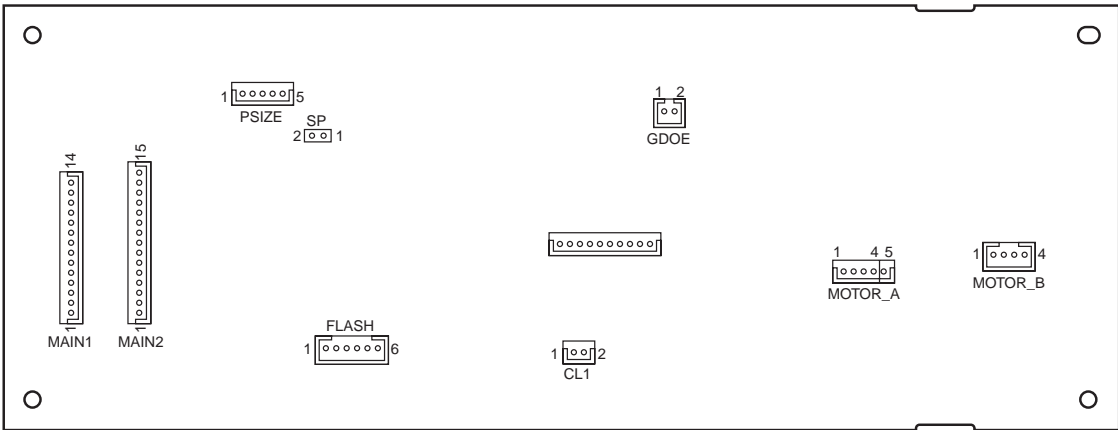

(12) Duplex Control PWB (V72-2- PWB)

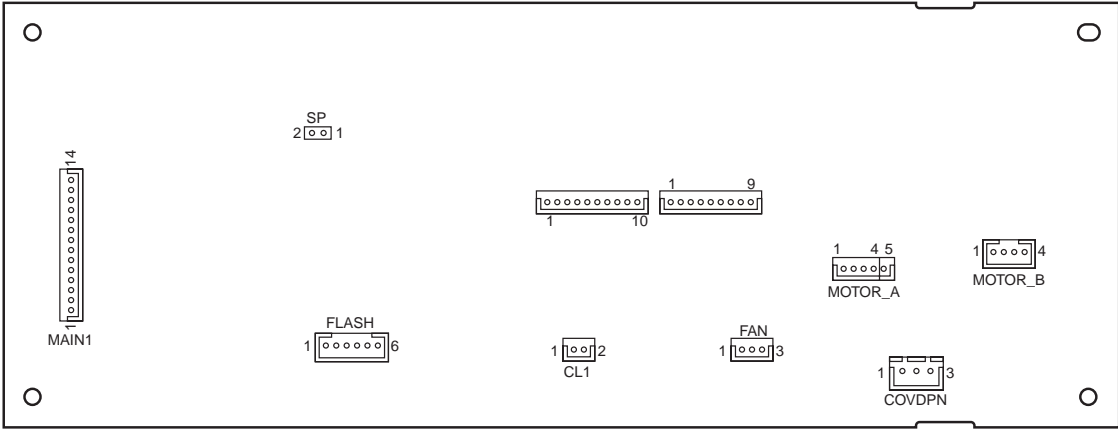

(13) Inverter PWB (V72-3- PWB)

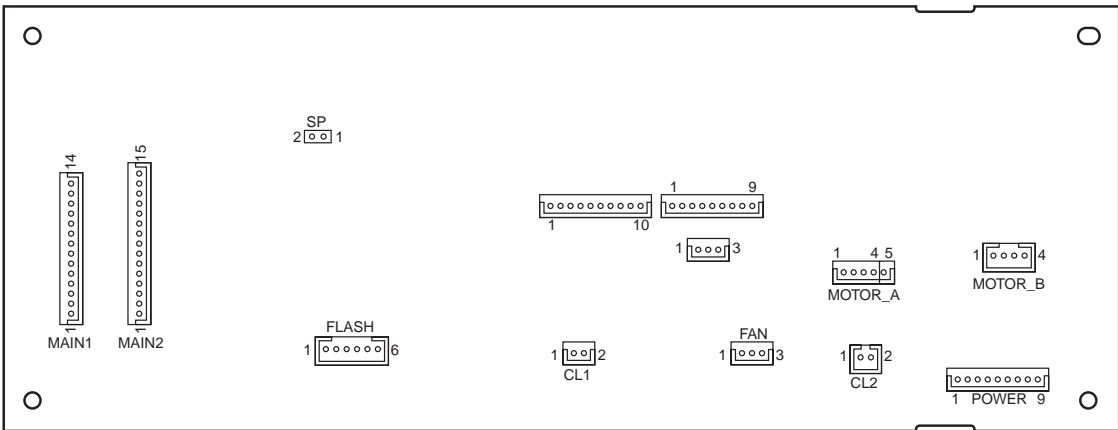

(14) Disposal Toner, Gear, Belt Rotation, Disposal Toner Sensor PWB (HAL-PWB)

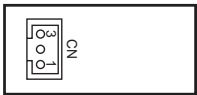

9. ERROR MESSAGE LIST

9.1 Message Chart of CX3641

Take appropriate actions for messages provided on the control panel of your printer. In the table, "CCCC" shows the toner color (cyan, magenta, yellow or black).

Display on Operating Panel	Meaning	Measures
126:Condensing Error	Condensation occurs in a printer.	Turn off the power and wait for a while.
Download Error	Download error.	Re-start a printer.
Communication Error	A communication error occurs.	Contact with a customer center.
EEPROM Reset	EEPROM is in resetting.	Wait for a while.
Initializing	The printer is in initializing.	Wait for a while.
NON OEM %COLOR% TONER DETECTED	A genuine CCCC toner cartridge is not installed.	Possible to operate even if a toner cartridge other than genuine CCCC is used.
PS Memory Overflow	Lack of a memory space while printing with a PS driver.	Either increase memory space or make a print data simple.
PU Flash Error	A communication error occurs.	Contact with a customer center
RAM Check nnn%	RAM checking is in process.	Wait for a while
Restarting	The printer is in restarting.	Wait for a while
USB I/F Error	USB Interface error.	Press the ON Line button to clear out an error.
Check Image Drum CCCC	A displayed image drum cartridge is not installed correctly.	Re-install a displayed image drum cartridge.
Yellow Toner Not Installed	A yellow toner cartridge is not installed in a printer or an unrecognized yellow toner cartridge is installed.	Install a genuine yellow toner cartridge.
Non Genuine Yellow Toner	An unrecognized yellow toner cartridge is installed.	Install a genuine yellow toner cartridge.
Yellow Toner Empty	A yellow toner cartridge runs out or a genuine yellow toner cartridge is not installed.	Install a new genuine yellow toner cartridge.
Yellow Toner Low	The printer runs out of a yellow toner soon.	Prepare a new yellow toner cartridge but unnecessary to change.
Yellow Toner Sensor Error	A sensor error of the yellow toner occurs.	Remove a yellow toner cartridge and re-install it.
Yellow Image Drum Near Life	A life of the image drum is about to end.	Prepare a new yellow image drum cartridge but unnecessary to change.
Yellow Image Drum Life	It is time to change a yellow image drum.	Change to a new yellow image drum cartridge.
Initializing	The printer is in initializing.	Wait for a while.
Install New Image Drum Image Drum Life CCCC	It is time to change a displayed drum cartridge.	Change to a new image drum cartridge.
Image Drum Life CCCC	It is time to change a displayed drum cartridge.	Change to a new image drum cartridge.
Ready To Print	The printer is ready to operate.	
Inverter is Removed	An unconnected inverter part of a finisher unit and a printer.	Connect an inverter part of a finisher unit and a printer.

Display on Operating Panel	Meaning	Measures
Install Inverter	An unconnected inverter part of a finisher and a printer.	Connect an inverter part of a finisher and a printer.
Check Inverter Paper Jam	A paper jam occurs around an inverter.	Take an inverter away from a printer and remove a paper jam.
Check Inverter Paper Remain	Paper is remains around an inverter of a finisher.	Take an inverter away from a printer and remove the remaining paper.
Print Error Log	A "LOG IN ERROR" is in printing.	Wait for a while.
Offline	The printer is off-line. Data reception is not available.	Press the ON-LINE button for data reception to show "READY TO PRINT" on the panel.
Open Cover Paper Jam COVER	A paper remains around a displayed cover.	Open a cover and remove the remaining paper.
Open Cover Paper Remain COVER	A paper jam occurs around a displayed cover.	Open a cover and remove a paper jam.
Open Cover Paper Jam Top Cover	A paper jam occurs in a printer.	Open a top cover and remove a paper jam.
Close Cover COVER	A displayed cover is open. Close a displayed cover.	Close a displayed cover.
Paper Jam	A paper jam occurs.	Press the HELP button and follow the instructions to remove a paper jam.
Color Adjusting	A color adjustment is in process.	Wait for a while.
Invalid ID. Job Rejected	A data of unauthorized users is deleted.	An user registration on a Job Accounting is necessary for printing.
Copy kkk/lll	"k" copies of "l" copies are being printed.	Wait for a while.
Rebooting <n>	The printer is in restarting.	Wait for a while.
Service Call nnn:Fatal Error PC:nnnnnnnn LR:nnnnnnnn FR:nnnnnnnn	An error occurs . Contact with a customer center.	Contact with a customer center and let them know the error number (nnn).
Cyan Toner Not Installed	A cyan toner cartridge is not installed in a printer or an unrecognized cyan toner cartridge is installed.	Install a genuine cyan toner cartridge.
Non Genuine Cyan Toner	An unrecognized cyan toner cartridge is installed.	Install a genuine cyan toner cartridge.
Cyan Toner Empty	A cyan toner cartridge runs out or a genuine cyan toner cartridge is not installed.	Install a new genuine cyan toner cartridge.
Cyan Toner Low	The printer runs out of a cyan toner soon.	Prepare a new cyan toner cartridge but unnecessary to change.
Cyan Toner Sensor Error	An sensor error of the cyan toner occurs.	Remove a cyan toner cartridge and re-install it.
Cyan Image Drum Near Life	A life of the image drum is about to end.	Prepare a new cyan image drum cartridge but unnecessary to change.
Cyan Image Drum Life	It is time to change a cyan image drum.	Change to a new cyan image drum cartridge.
Wait a Moment	Wait for a while.	Wait for a while.
Turn off power or press RESTART button	Restart a printer by either turning off the power or pressing the SHUTDOWN /RESTART button.	Restart a printer by either turning off the power or pressing the SHUTDOWN /RESTART button.

Display on Operating Panel	Meaning	Measures
Shutting down	The printer is in the shutdown process.	Wait for a while.
Statistics Log Buffer is Full	A memory space of an internal hard disk for saving the number of logs is not available.	Increase a memory space of a hard disk by deleting unnecessary parts. Press the ON-LINE switch to delete a displayed error.
Statistics Log Buffer is Not Available	A memory space of an internal hard disk for saving the number of logs is not available.	Install an internal hard disk (option).
Paper Multi Feed TRAY	Overlapped paper are fed.	Press the HELP button and follow the instructions.
Job Offset Home Error	An offset printing is not available due to an occurrence of the JOB OFFSET function error.	The offset function is unavailable but printing is available. Contact with a customer center if an error still remains.
Power Save	The printer is in the ENERGY SAVING MODE.	The ENERGY SAVING MODE will be canceled if printing starts.
Processing	The printer is in data processing.	Wait for a while.
Open Stacker Face Up Stacker	Paper can not be fed due to a closed face-up stacker.	Open a face-up stacker.
Checking Sectors	A sector of a hard disk is in checking.	Wait for a while.
Download Error	Download error. Restart a printer.	Re-start a printer.
Incompatible Toner CCCC	Either a toner cartridge from other companies is installed or a correct toner cartridge has not been installed.	Install a correct CCCC toner cartridge.
Collate Copy iii/jjj	A collated printing is in process. "i" copies of "j" copies are being printed.	—
Collate Fail:Too Many Pages	Printing is not available because a lack of memory space occurs during a collated printing.	Either install an extension memory or reduce the number of specified pages.
Adjusting Temp	A fusing temperature is in adjusting.	Wait for a while.
Fuser Unit Near Life	A life of fuser unit is about to end.	Prepare a new fuser unit but unnecessary to change.
Check Fuser Unit	A fuser unit is installed uncollectly. Reinstall it.	Reinstall it correctly.
Change Fuser Unit	It is time to change a fuser unit due to a life end of it.	Change to a new fuser unit.
Fuser Unit Life	It is time to change a fuser unit due to a life end of a fuser unit.	Change to a new fuser unit.
Data Present	There is an unprinted data.	Check out a data.
Check Data	An error occurs during a reception of a program data.	Check out a data.
Check Data Program Data Write Error	An error of writing data occurs.	Check out a data.
Check Data Program Data Receive Error <nnn>	An error occurs during a reception of data.	Check out a data.
Cancelling Job	A data is in deleting..	Wait for a while.
Data Arrive	A data is in receiving.	Wait for a while.
Print Demo Page	A DEMO page is in printing.	Wait for a while.

Display on Operating Panel	Meaning	Measures
Power Off and Wait for a while 126:Condensing Error	Condensation of a printeer occurs. Turn off the power and wait for a while.	Turn off the power and wait for a while.
Toner Not Installed CCCC	A CCCC toner cartridge is not installed or an unrecognized CCCC toner cartridge is installed.	Install a genuine CCCC toner cartridge.
Non Genuine Toner CCCC	An unrecognized CCCC toner cartridge is installed.	Install a genuine CCCC toner cartridge.
Check Toner Cartridge Improper Lock Lever Position CCCC	A toner cartridge is unlocked.	Check out a lever of a toner cartridge.
Install Toner CCCC	Either a displayed toner cartridge runs out or a genuine displayed toner cartridge is not installed.	Install a displayed genuine toner cartridge.
Reset Drum Basket	An error occurs during transferring of a disposal toner.	Open a top cover and reinstall a drum basket.
Reset Drum Basket Waste Toner Transfer Error	An error occurs during transferring of a disposal toner.	Open a top cover and reinstall a drum basket.
TRAY n Overfilled	Too much paper are set in a tray n.	Reduce the number of paper.
Change Paper in TRAY n MEDIA_SIZE MEDIA_TYPE Please see HELP for details	Paper loaded into a tray is different from the specified one.	Press the ONLINE button after loading a correct paper into a specified tray.
TRAY n Lift Up Error	Paper can not be fed from a tray n.	Place paper into a tray n correctly.
Printing(TRAY n)	A paper printing on a tray n is in process.	–
TRAY n Empty	No paper in a tray n.	Place paper into a tray n.
TRAY n Overfilled	Too much paper in a tray n.	Reduce the number of paper.
TRAY n Near End	The number of a paper in a tray n is about to end.	Prepare the specified paper on a tray n.
Reset Tray TRAY	Feeding paper from a displayed tray is not available. Reinstall a tray.	Reinstall a tray.
Install Tray TRAY	A displayed tray is installed uncorrectly. Reinstall it.	Reinstall a tray.
Network Error	A network error occurs.	Restart a printer.
Print Network Config	Printing a network setup is in process.	Wait for a while.
Network Initializing	A network setup is in initializing.	Wait for a while.
Network Configuration Writing	A network setup is in saving.	Wait for a while.
Density Adjusting	Correction of density is in process.	Wait for a while.
Waste Toner Transfer Error	An error occurs during transferring of a disposal toner.	Open a top cover and reinstall a drum basket.
Waste Toner Near Full	A life of a disposal toner box is about to end.	Prepare a new disposal toner box but unnecessary to change.
Check Waste Toner Box	A disposal toner box is installed uncollectly. Reinstall it.	Reinstall a disposal toner box.
Waste Toner Full	A disposal toner box is full. Change to a new one.	Change to a new disposal toner box.
Centro I/F Error	A parallel I/F error occurs.	Press the ONLINE button.

Display on Operating Panel	Meaning	Measures
Staple Jam	A staple is jammed in a stapler unit of a finisher.	Remove a staple.
Check Punch Chip Box	Either a punch dust box is full or not installed.	Either clear out a box or reinstall it.
File Accessing	The printer is in access to a file of an internal hard disk.	Wait for a while.
File System Operation failed <nnn>	An error occurs while a printer is in access to a file of an internal hard disk.	Normal printing is available. Contact with a customer center if an error still remains.
File System is Full	A space of a hard disk (option) or flash memory runs out.	Normal printing is available.
File System is Write Protected	An invalid writing on a hard disk (option) or a flash memory.	Normal printing is available.
Checking File System	Checking a file system is in process.	Wait for a while.
Print File List	Printing a file list is in process.	Wait for a while.
Install Finisher	A finisher is away from an inverter. Connect a finisher into a inverter.	Connect a finisher into a inverter.
Check Finisher Staple Jam	A staple is jammed in a stapler unit of a finisher. Remove it.	Remove a jammed staple.
Check Finisher Paper Jam	A paper jam occurs around a finisher.	Keep a finisher away from a inverter and remove the remaining papers.
Check Finisher Paper Remain	A sheet of paper remains around a finisher.	Wait for a while.
Print Font	Printing a font list is in process.	Wait for a while.
Press ONLINE Button for Restoration	Press the ONLINE button for recovery.	Press the ONLINE button.
Black Toner Not Installed	A black toner cartridge is not installed in a printer or an unrecognized black toner cartridge is installed.	Install a genuine black toner cartridge.
Non Genuine Black Toner	An unrecognized black toner cartridge is installed.	Install a genuine black toner cartridge.
Black Toner Empty	A black toner runs out or a genuine black toner cartridge is not installed.	Install a new genuine black toner cartridge.
Black Toner Low	The printer runs out of a black toner soon.	Prepare a new black toner cartridge but unnecessary to change.
Black Toner Sensor Error	A sensor error of the black toner occurs.	Remove a black toner cartridge and re-install it.
Black Image Drum Near Life	A life of the image drum is about to end.	Prepare a new black image drum cartridge but unnecessary to change.
Black Image Drum Life	It is time to change a black image drum.	Change to a new black image drum cartridge.
Condensing Error	Condensation occurs in a printer.	Turn off the power and wait for a while.
Power Off/On	Restart a printer.	Turn off the power again.
Power Off/On nnn:Error	Restart a printer due to an occurrence of an error.	Turn off the power again.
Program Update Mode	The printer is in the program update mode. (Printing is not available).	–
Program Data Received OK	A completion of program data reception.	Wait for a while.



















Display on Operating Panel	Meaning	Measures
Program Data Written OK	A completion of program data writing.	Restart a printer.
Program Data Receive Error <nnn>	An error occurs while a reception of program data.	Check out a data.
Program Data Receiving	The printer is receiving the program data.	Wait for a while.
Program Data Write Error <nnn>	An error occurs during a reception of program data.	Check out a data.
Program Data Writing	Writing a program data is in process.	Wait for a while.
Belt Unit Near Life	A life of a belt unit is about to end.	Prepare a new belt unit but unnecessary to change.
Check Belt Unit	A belt unit is installed incorrectly. Reinstall it.	Re-install a belt unit.
Change Belt Unit	It is time to change a belt unit due to a life end of it.	Change to a new belt unit.
Install New Belt Unit	It is time to change a belt unit due to a life end of it.	Change to a new belt unit.
Belt Unit Life	It is time to change a belt unit due to a life end of it.	Change to a new belt unit.
Belt Unit Life	It is time to change a belt unit due to a life end of it.	Change to a new belt unit.
Error Postscript	An error occurs while printing is in process using a PS driver.	Check out a printing data.
No Staple	A finisher unit is out of staples.	Reinstall a staple in a finisher unit.
Could Not Staple. No Staple	It is unable to staple because of no staple.	Set staples. Press the ONLINE button to clear out a displayed error.
Magenta Toner Not Installed	A magenta toner cartridge is not installed in a printer or an unrecognized magenta toner cartridge is installed.	Install a genuine magenta toner cartridge.
Non Genuine Magenta Toner	An unrecognized magenta toner cartridge is installed.	Install a genuine magenta toner cartridge.
Magenta Toner Empty	A magenta toner runs out or a genuine magenta toner cartridge is not installed.	Install a new genuine magenta toner cartridge.
Magenta Toner Low	The printer runs out of a magenta toner soon.	Prepare a new magenta toner cartridge but unnecessary to change.
Magenta Toner Sensor Error	A sensor error of the magenta toner occurs.	Remove a magenta toner cartridge and re-install it.
Magenta Image Drum Near Life	A life of the image drum is about to end.	Prepare a new magenta image drum cartridge but unnecessary to change.
Magenta Image Drum Life	It is time to change a magenta image drum due to a life end of it.	Change to a new magenta image drum cartridge.
MPTray Lift Up Error	Paper can not be fed from a multi-purpose tray.	Place paper into a multi-purpose tray correctly.
Printing(MPTray)	Paper is fed from a multi-purpose tray and being printed.	–
MPTray Empty	No paper on a multi-purpose tray.	Place a sheet of paper onto a multi-purpose tray.
MPTray Overfilled	Too much paper on a multi-purpose tray.	Reduce the number of paper.
MPTray Near End	Paper on a multi-purpose tray is about to run out.	Prepare the specified paper on a multi-purpose tray.













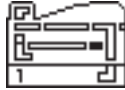



Display on Operating Panel	Meaning	Measures
Change Paper in MPTray MEDIA_SIZE MEDIA_TYPE Press ONLINE Button Please see HELP for details	Paper loaded onto a multi-purpose tray is different from the specified one.	Press the HELP button and follow the instructions.
Memory Overflow	Lack of memory space occurs.	Press the ONLINE button. Either increase a memory space or make a printing data simple.
Print Configuration	The printer is in printing a set-up value.	Wait for a while.
Please see HELP for details	Pressing the HELP button leads to a solution for clearing out an error.	Press the HELP button and follow the instructions.
Invalid Data	An invalid data is received.	Press the ONLINE button.
Remove Excess Paper TRAY	Reduce the number of paper loaded onto a displayed tray.	Reduce the number of paper loaded onto a displayed tray.
Remove Excess Paper MPTray	Reduce the number of paper loaded onto a multi-purpose tray.	Reduce the number of paper loaded onto a multi-purpose tray.
Could Not Staple/Punch. Paper Too Thick	Unable to staple due to thick-paper.	Press the ONLINE button to clear out an error.
Could Not Duplex. Paper Too Thick	The printer is unable to duplex-print due to thick-paper.	Press the ONLINE button to clear out an error.
Could Not Staple. Too Much Paper	Unable to staple due to too much paper.	Press the ONLINE button to clear out an error.
Paper Remain TRAY	A paper remains around a displayed cover.	Open a displayed cover and remove the remaining paper.
Paper Size Error TRAY	Different size of paper are fed from a displayed tray. Open and close a top cover to clear out an error.	Press the HELP button and follow the instructions.
Reset Paper MPTray	A sheet of paper is not fed from a multi-purpose tray. Reload a sheet of paper.	Reload a sheet of paper.
Check Paper	A different paper is Loaded.	Press the HELP button and follow the instructions.
Remove Paper STACKER	Remove a printed paper left on a displayed stacker.	Remove a printed paper left on a displayed stacker.
Remove Paper STACKER	Remove a printed paper left on a displayed finisher.	Remove a printed paper left on a displayed stacker of finisher.
Install Paper TRAY MEDIA_SIZE	Paper on a displayed tray runs out.	Load paper on a displayed tray.
Install Paper MPTray MEDIA_SIZE	No paper on a multi-purpose tray. Load a sheet of paper on a displayed tray.	Load a sheet of paper on a multi-purpose tray.
Install Paper MPTray MEDIA_SIZE Press ONLINE Button	Manual feed printing of the multi-purpose tray is in process.	Load a sheet of paper on a multi-purpose tray and press the ONLINE button to start printing.
Paper Thick Error TRAY	Different thickness of paper is detected on a displayed tray.	Press the HELP button and follow the instructions.
Non Paper Sense Error	A sensor error of the paper-thickness occurs.	If an error still remains after printing a couple of pages, set a MEDIA WEIGHT of a MENU to other than "AUTOMATIC" or contact with a customer center.









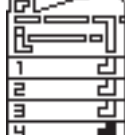
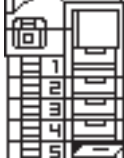
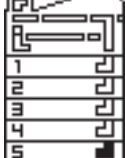

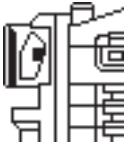
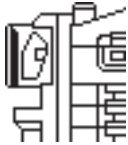

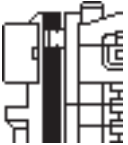





Display on Operating Panel	Meaning	Measures
Paper Sense Error	Paper other than a specified thickness is detected.	If an error still remains after printing some, set up MEDIA WEIGHT of MENU other than AUTOMATIC" or contact with a customer center.
Media Weight Detecting	The printer is checking for thickness.	Wait for a while.
Press RESTART button	The printer will restart after pressing the RESTART button.	Press the RESTART button to start a printer.
Improper Lock Lever Position CCCC	A displayed lock lever of a toner cartridge is located incorrectly.	Locate a lock lever of toner cartridge correctly.
Improper Lock Lever Position	A toner cartridge is unlocked.	Check out a lever of toner cartridge.
CheckDuplex Unit Paper Jam	A paper jam occurs around a duplex-printer unit.	Open a cover of duplex-printer unit and remove a paper jam.
Check Duplex Unit Paper Remain	Paper still remains around a duplex-printer unit.	Open a cover of duplex-printer unit and remove a paper jam.
Install Duplex Unit	A duplex-printer unit is not installed.	Install a duplex-printer unit correctly.

9.2 Illustration appears on the operating panel

When troubles occur, an illustration and message may appear on the operating panel. See the following table for detail instruction.

			
Front view of printer	Opening the top cover	Side view (left) of printer	Side view (right) of printer
			
Indicates a cyan toner cartridge	Indicates a magenta toner cartridge	Indicates a yellow toner cartridge	Indicates a black toner cartridge
			
Indicates a cyan image drum	Indicates a magenta image drum	Indicates a yellow image drum	Indicates a black image drum
			
Indicates a fixation unit	Indicates a fixation unit	Indicates a belt unit	Indicates a paper route inside printer
			
Indicates a disposal toner unit	Indicates a disposal toner unit		

			
<p>Indicates double-sided print units.</p>	<p>Being full of or left some papers around double-sided print units.</p>	<p>Being full of or left some papers around double-sided print units.</p>	<p>Being full of papers around double-sided print units.</p>
			
<p>Opening the side cover</p>	<p>Being full of or left some papers around side cover.</p>	<p>Being full of or left some papers around top cover.</p>	<p>Being full of or left some papers around top cover.</p>
			
<p>Being full of papers around top cover.</p>	<p>Opening the side cover of ejection part</p>	<p>Being full of papers around the side cover of ejection part.</p>	
			
<p>Opening the tray 1 of side cover</p>	<p>Being full of or left some papers around tray 1 of side cover.</p>	<p>Opening the tray 2 of side cover</p>	<p>Being full of or left some papers around tray 2 of side cover.</p>
			
<p>Opening the tray 3 of side cover</p>	<p>Being full of or left some papers around tray 3 of side cover.</p>	<p>Opening the tray 4 of side cover</p>	<p>Being full of or left some papers around tray 4 of side cover.</p>
			
<p>Opening the tray 5 of side cover</p>	<p>Being full of or left some papers around tray 5 of side cover.</p>		

			
It indicates the staple cartridge.	It indicates the staple cartridge.	It indicates the punch unit..	It indicates the punch unit..
			
It indicates the finisher unit.	It indicates the inverter.	It indicates the finisher.	It indicates the magnified image of the finisher.
			
A paper jam has occured or paper has remained in the inverter area.	A paper jam has occured or paper has remained in the inverter area.	A paper jam has occured in the inverter area.	A paper jam has occured in the inverter area.
			
A paper jam has occured in the finisher area.	A paper jam has occured in the finisher area.	A paper jam has occured or paper has remained in the finisher area.	A paper jam has occured or paper has remained in the finisher area.
			
A paper jam has occured or paper has remained in the finisher area.	A paper jam has occured or paper has remained in the finisher area.	A paper jam has occured or paper has remained in the finisher area.	Paper has remained in the booklet stacker area.