

CX1145

MJ-1101 Finisher

Maintenance Manual

11111A

Trademarks

- Molykote is a registered trademark of Dow Corning Corporation.
- FLOIL is a registered trademark of Kanto Kasei Ltd. CORPORATION.
- Other company names and product names in this manual are the trademarks of their respective companies.

General Precautions for Installation/Service/Maintenance for MJ-1101

The installation and service should be done by a qualified service technician.

- 1) When installing the MJ-1101, be sure to follow the instructions described in the “Unpacking/Set-Up Procedure for the MJ-1101”.
- 2) The MJ-1101 should be installed by an authorized/qualified person.
- 3) The MJ-1101 is quite heavy and weighs approximately 34 kg (74.96 lb), therefore pay full attention when handling it.
- 4) Before starting installation, servicing or maintenance work, be sure to turn OFF and unplug the equipment first.
- 5) Be sure to fix and plug in the power cable securely after the installation so that no one trips over it.
- 6) When selecting the installation site, avoid placing the finisher / hole punch unit and equipment on different levels or inclined floors.
- 7) When servicing or maintaining the MJ-1101, be careful about the rotating or operation sections such as gears, pulleys, sprockets, cams, belts, etc.
- 8) When parts are disassembled, reassembly is basically the reverse of disassembly unless otherwise noted in this manual or other related materials.
Be careful not to reassemble small parts such as screws, washers, pins, E-rings, toothed washers, harnesses to the wrong places.
- 9) Basically, the machine should not be operated with any parts removed or disassembled.
- 10) When servicing the equipment with the power turned ON, be sure not to touch live sections and rotating/operating sections.
- 11) Delicate parts for preventing safety hazard problems (such as switches, sensors, etc. if any) should be handled/installed/adjusted correctly.
- 12) Tools and instruments
 - Use designated jigs and tools.
 - Use recommended measuring instruments or equivalents.
- 13) During servicing or maintenance work, be sure to check the serial No. plate and other cautionary labels (if any) to see if they are clean and firmly fixed.
If not, take appropriate actions.
- 14) The PC board must be stored in antistatic envelope and handled carefully using a wristband, because the ICs on it may be damaged due to static electricity.
Before using the wrist band, pull out the power cable plug of the equipment and make sure that there is no uninsulated charged objects in the vicinity.
- 15) For the recovery and disposal of used MJ-1101, consumable parts and packing materials, follow the relevant local regulations/rules.

16)After completing installation, servicing and maintenance of the MJ-1101, return the MJ-1101 to its original state, and check operation.

17)When you move the finisher, do not move it in the direction of the arrow as shown in the figure below otherwise it might topple over.



18)Unplug the power cable and clean the area around the prongs of the plug and socket outlet once a year or more. A fire may occur when dust lies on this area.

CONTENTS

1. SPECIFICATIONS, ACCESSORY AND CONSUMABLES	1-1
1.1 Specifications.....	1-1
1.2 Accessory	1-4
1.3 Consumables.....	1-5
2. GENERAL DESCRIPTION.....	2-1
2.1 Main Components.....	2-1
2.2 Sectional View	2-2
2.3 Electric Parts Layout.....	2-4
2.4 Symbols and Functions of Various Components.....	2-5
2.5 Diagram of Signal Blocks.....	2-8
2.6 Description of Interface Signals.....	2-9
3. DESCRIPTION OF OPERATIONS	3-1
3.1 Basic Operations	3-1
3.2 Transport Operation.....	3-2
3.2.1 Paper feeding section.....	3-3
3.2.2 Paper transport section	3-4
3.2.3 Active drop mechanism section.....	3-5
3.2.4 Paper exit section.....	3-8
3.3 Bundle Job Offset Operation	3-11
3.4 Stapling Operation	3-12
3.5 Operation of Movable Tray	3-13
3.6 Flow Chart	3-15
3.7 Description Of Circuit.....	3-16
3.7.1 Buffer roller drive circuit.....	3-16
3.7.2 Buffer tray guide motor drive circuit.....	3-17
3.7.3 Front/rear alignment motor drive circuit.....	3-18
3.7.4 Stack transport motor drive circuit.....	3-19
3.7.5 Entrance motor	3-20
3.7.6 Stapler unit shift motor drive circuit	3-21
3.7.7 Transport motor drive circuit.....	3-22
3.7.8 Paddle motor drive circuit.....	3-23
3.7.9 Movable tray shift motor drive circuit.....	3-24
3.7.10 Stapler motor drive circuit.....	3-25
3.7.11 Reset circuit.....	3-25
4. DISASSEMBLY AND INSTALLATION.....	4-1
4.1 Covers	4-1
4.2 Units	4-12
4.3 Rollers.....	4-26
4.4 Motor / Motor Drive Sections	4-48
4.5 Solenoid.....	4-56
4.6 Sensors / Switches	4-63
4.7 PC Boards / Discharge Brush.....	4-85
4.8 Procedure for lowering the movable tray.....	4-88
5. ADJUSTMENTS	5-1
5.1 Adjusting the Alignment Position	5-1
5.2 Adjusting the Stapling Position	5-3
5.3 B4-size recycled paper mode settings.....	5-5
6. TROUBLESHOOTING	6-1
6.1 Paper Transport Jam.....	6-1

6.1.1	Paper jam in entrance section.....	6-1
6.1.2	Paper jam in buffer unit-1	6-2
6.1.3	Paper jam in buffer unit-2	6-3
6.1.4	Paper jam in finishing tray section.....	6-4
6.1.5	Paper jam in movable tray section	6-7
6.1.6	Paper jam due to cover open	6-8
6.2	Other Errors.....	6-8
6.2.1	Stapler related error	6-8
6.2.2	Communication Related Error	6-10
6.2.3	Memory error	6-10
6.3	Self-Diagnostic Modes.....	6-11
6.3.1	General description	6-11
6.3.2	Operation procedure	6-11
6.3.3	Checking operational status	6-12
6.3.4	Test list	6-13
6.3.5	Error indications	6-19
7.	PREVENTIVE MAINTENANCE (PM) / FIRMWARE UPDATE	7-1
7.1	Maintenance and Inspection Points.....	7-1
7.2	Firmware Update	7-6
7.2.1	Updating Finisher ROM.....	7-6
7.2.2	Updating Converter ROM.....	7-8
8.	ELECTRIC CIRCUIT	8-1
8.1	Harness Diagram.....	8-1
8.2	Circuit Diagram	8-2
8.3	PC board	8-14

1. SPECIFICATIONS, ACCESSORY AND CONSUMABLES

1.1 Specifications

- Product Type Console Type Finisher with 2 trays
- Paper Stacking Device Stationary Tray or Movable Tray
- Stacking Type Facedown
- Paper Size A3, A4, A4-R, A5, A5-R, A6-R, B4, B5, B5-R, FOLIO, A3 wide, LD, LG, LT, LT-R, ST, ST-R, COMPUTER, 13"LG, 8.5"SQ, 8K, 16K, 16K-R
- Paper Basis Weight 64 - 280g/m²
- Stacking Mode Simple, Job Offset, Staple and composite
- Stacking Height with

Stationary Tray

Paper Size	Stacking Height	The number of sheet	
		80g/m ² Paper	90g/m ² Paper
A4, B5, LT, A5-R, ST-R, 8.5"SQ, 16K, Postcard	36.75mm	250	225
A3, A4-R, B4, FOLIO, LD, LG, LT-R, COMPUTER, B5-R, 13"LG, 8K, 16K-R, A3 wide	18.4mm	125	112

Movable Tray

Paper Size	Stacking Height	The number of sheet		The number of set
		80g/m ² Paper	90g/m ² Paper	
A4, B5, LT, 8.5"SQ, 16K	250mm	2,000	1,800	30
A3, A4-R, B4, FOLIO, LD, LG, LT-R, COMPUTER, 13"LG, 8K	140mm	1,000	900	30

- * In the job offset and stapling stack modes, the paper-full status is detected when any of the stack height, the number of sheets and the number of copies has reached its limit first.

- Stapling Position
Front single position

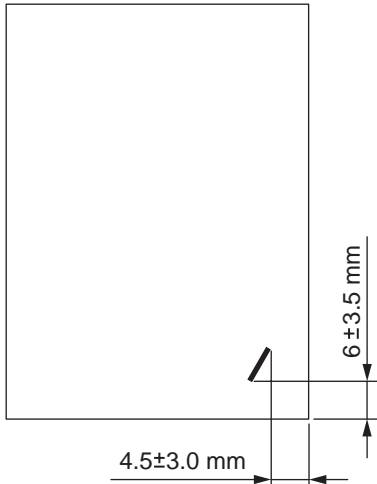

Fig. 1-1

- Stapling Position
Rear single position

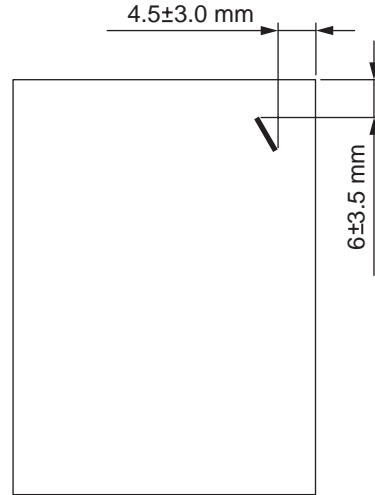

Fig. 1-2

- Stapling Position
Two Positions Stapling

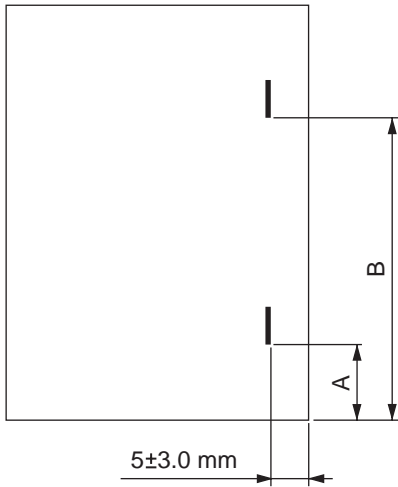

Fig. 1-3

(Unit: mm)

Paper Size	A	B
A3, A4	81±3.5	205±3.5
A4-R, FOLIO	37.5±3.5	161.5±3.5
B4, B5, COMPUTER	61±3.5	185±3.5
LD, LT	72±3.5	196±3.5
LT-R, LG	40.5±3.5	164.5±3.5

- Paper Size for stapling

Stapling Position	Paper Size
Near Side Single	A3, A4, A4-R, B4, B5, FOLIO, LD, LG, LT, LT-R, COMPUTER, 13"LG, 8.5"SQ, 8K, 16K
Opposite Side Single	A3, A4, A4-R, B4, B5, FOLIO, LD, LG, LT, LT-R, COMPUTER, 13"LG, 8.5"SQ, 8K, 16K
Two Positions	A3, A4, A4-R, B4, B5, FOLIO, LD, LG, LT, LT-R, COMPUTER

- The number of Stapleable Sheet

Paper Size	64 - 80g/m ² Paper	81 - 90g/m ² Paper	91 - 105g/m ² Paper
A4, B5, LT, 8.5"SQ, 16K	50	30	30
A3, A4-R, B4, FOLIO, LD, LG, LT-R, COMPUTER, 13"LG, 8K	30	15	15

- Paper Basis Weight for stapling 64 - 105g/m²
- Staple Loading exclusive cartridge (5,000 staples)
- Manual Stapling available
- Dimensions with Sub-tray put in: W 535 x D 598 x H 1092 (mm)
with Sub-tray drawn out: W 650 x D 598 x H 1092 (mm)
- Gross Weight Approximately 34kg (74.8 lb)
- Power Supply DC24V±10% and DC5V±5% supplied from the main equipment.
- Power Consumption DC77W or less

1.2 Accessory

- Unpacking Instruction (1set)
- Tray (1pc)
- Fixing bracket-F (1pc)
- Fixing bracket-R (1pc)
- Caster (1pc)
- Bridge unit fixing bracket (1pc)
- Converter board (1pc)
- Connector cover (1pc)
- Shoulder screw (4pcs)
- Screw: TBID M4x10 (2pcs)
- Screw: TBID M3x8 (3pcs)
- Screw: TBID M3x6 (2pcs)
- Lock support (1pc)
- Harness clamp (1pc)

1.3 Consumables

- Staples exclusive cartridge (STAPLE-2400: 5,000staples X 3 cartridges /box)

2. GENERAL DESCRIPTION

2.1 Main Components

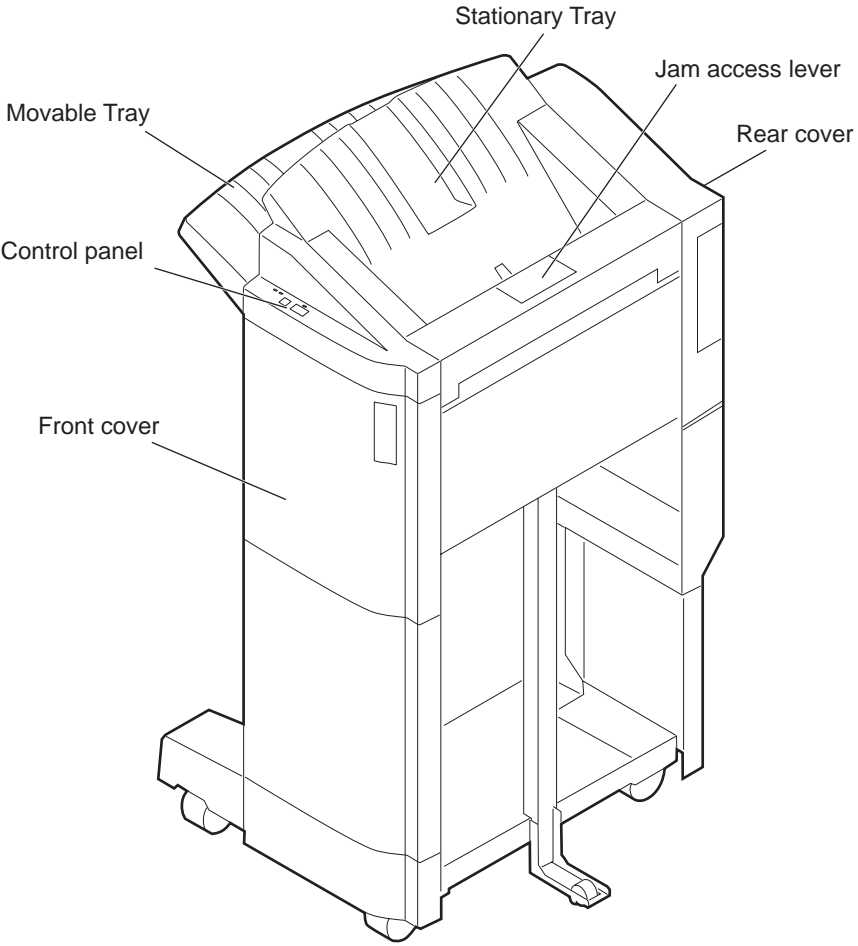

Fig. 2-1

2.2 Sectional View

[A] Front side view

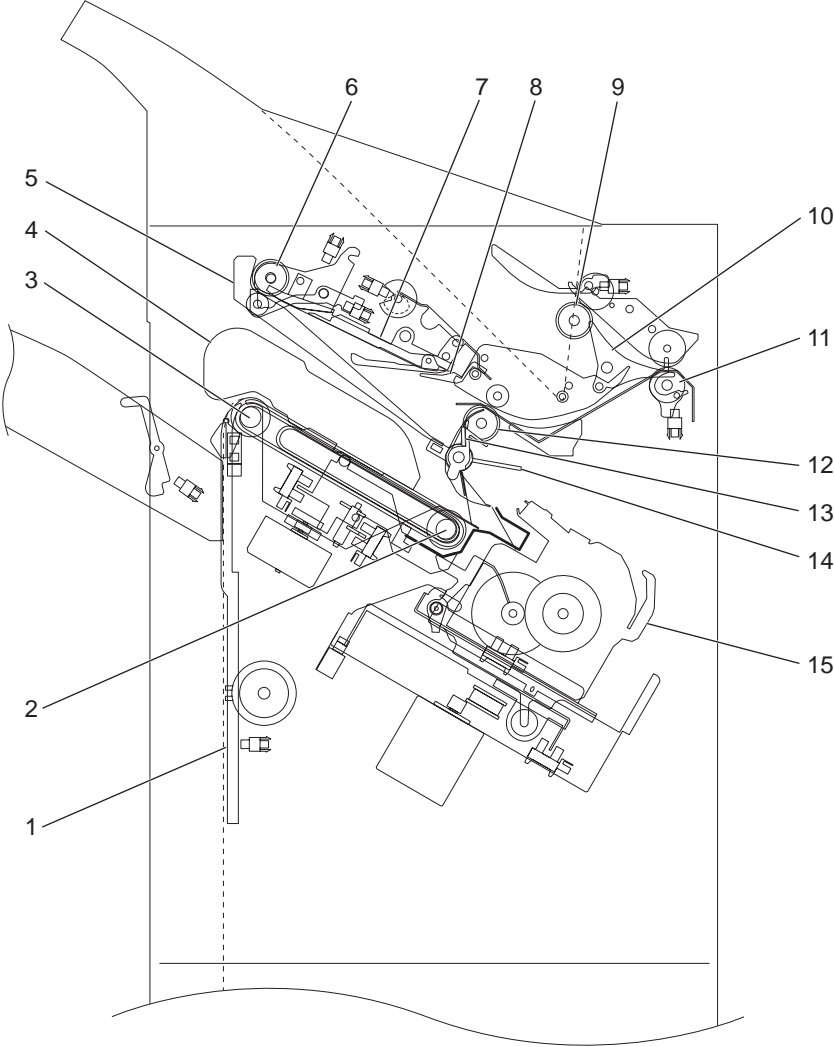

Fig. 2-2

1	Shutter
2	Stack transport roller-1
3	Stack transport roller-2
4	Finishing tray
5	Buffer tray
6	Buffer roller
7	Patting arm
8	Paper holder plate
9	Exit roller
10	Gate flap
11	Entrance roller
12	Transport roller
13	Catching pad
14	Paddle
15	Stapler unit

[B] Rear side view

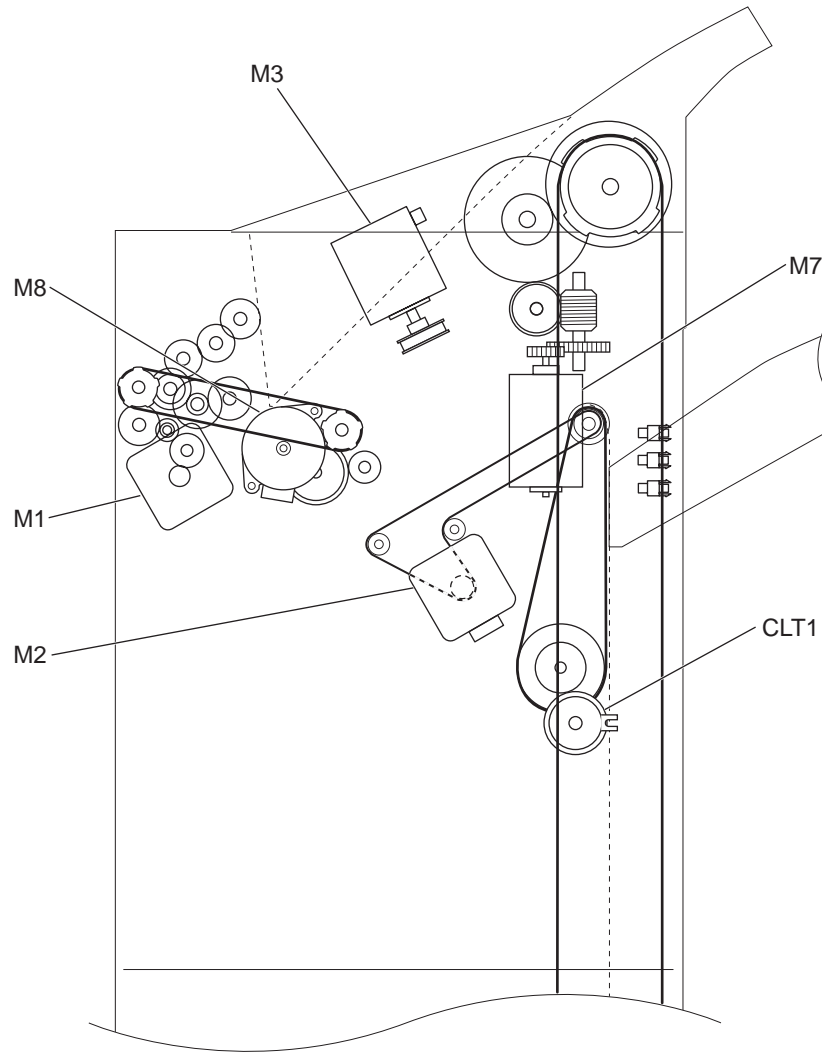

Fig. 2-3

M1	Entrance motor
M2	Transport motor
M3	Buffer tray guide motor
M7	Movable tray shift motor
M8	Paddle motor
CLT1	Shutter clutch

2.3 Electric Parts Layout

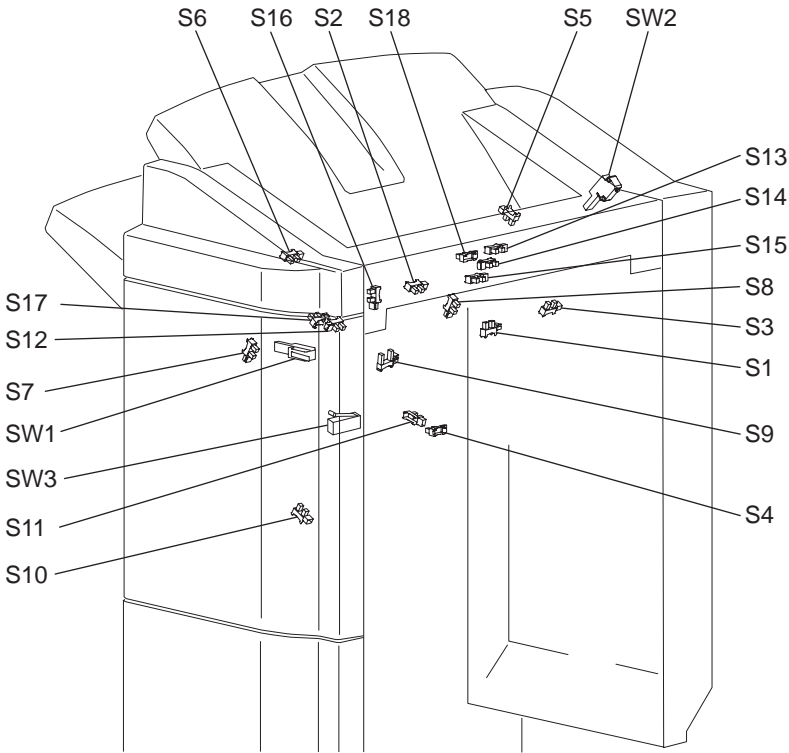

Fig. 2-4

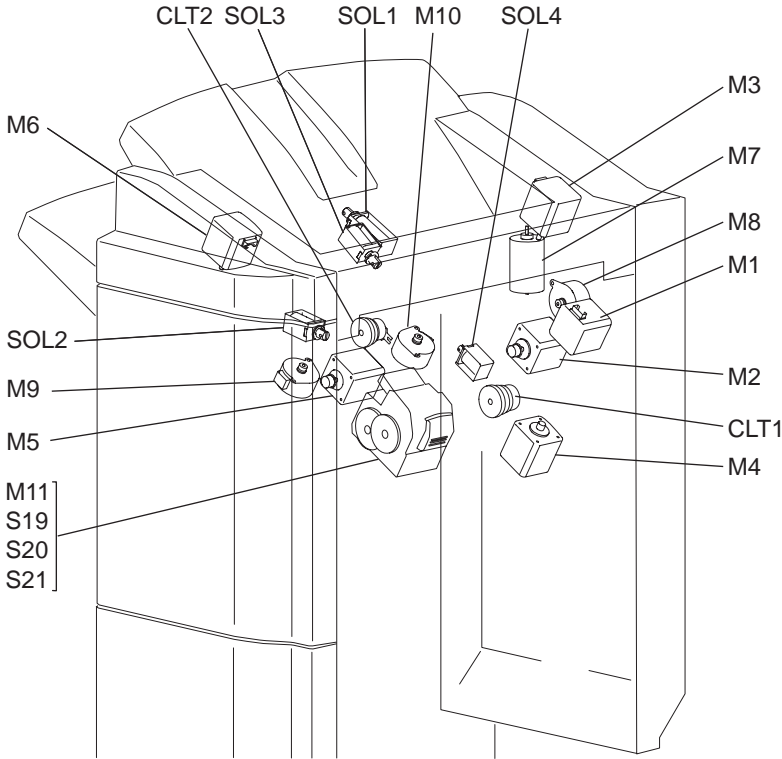

Fig. 2-5

2.4 Symbols and Functions of Various Components

The column <P-I> shows the page and item number in the parts list.

1) Motors

Symbol	Name	Function	P-I	Remarks
M1	Entrance motor	Transports paper from the main equipment to the buffer or stationary tray.	4-43	
M2	Transport motor	Drives the roller of the finishing tray and drives the shutter	2-25	
M3	Buffer tray guide motor	Adjusts the width of the buffer tray guide.	9-9	
M4	Stapler unit shift motor	Shifts the stapler unit right and left.	6-9	
M5	Stack transport motor	Drives the belt which outputs paper stack to the movable tray.	7-31	
M6	Buffer roller drive motor	Drives the buffer roller.	9-8	
M7	Movable tray shift motor	Lifts up/down the movable tray.	11-3	
M8	Paddle motor	Drives the paddle.	5-44	
M9	Front alignment motor	Drives the front alignment plate.	7-32	
M10	Rear alignment motor	Drives the rear alignment plate.	7-32	
M11	Stapler motor	Operates the stapler.	-	

2) Sensors and switches

Symbol	Name	Function	P-I	Remarks
S1	Entrance sensor	Detects the paper transported from the main equipment.	1-101	
S2	Transport sensor	Detects the paper transported to the entrance of the buffer tray.	8-101	
S3	Paddle home position sensor	Detects the home position of the paddle.	5-36	
S4	Shutter opening/closing sensor	Detects the home position of the shutter.	2-101	
S5	Buffer tray home position sensor	Detects that the buffer tray is at the outermost position.	9-102	
S6	Paper holder home position sensor	Detects the home position of the paper holder cam.	9-102	
S7	Front alignment plate home position sensor	Detects the home position of the front alignment plate.	7-102	
S8	Rear alignment plate home position sensor	Detects the home position of the rear alignment plate.	7-102	
S9	Stack exit belt home position sensor	Detects the home position of the stack exit belt.	7-102	
S10	Stapler unit home position sensor	Detects if the stapler unit is at the front side (home position).	6-104	
S11	Stapler interference sensor	Detects when the stapler unit interferes with other mechanical section.	6-104	
S12	Finishing tray paper detection sensor	Detects the presence/absence of the paper on the finishing tray.	7-102	
S13	Movable tray position A sensor	Detects the movable tray position.	3-101	
S14	Movable tray position B sensor	Detects the movable tray position.	3-101	
S15	Movable tray position C sensor	Detects the movable tray position.	3-101	
S16	Movable tray paper-full sensor	Detects the upper surface of paper set on the movable tray.	3-101	
S17	Movable tray paper exist sensor	Detects the presence/absence of the paper on the movable tray.	3-101	
S18	Stationary tray paper-full sensor	Detects the paper-full state of the stationary tray.	11-103	
S19	Stapler home position sensor	Detects the home position in the stapler for the stapling operation.	-	
S20	Staple top position sensor	Detects the staple top position in the stapler.	-	
S21	Staple empty sensor	Detects the empty status of staples in the stapler cartridge.	-	
SW1	Front cover switch	Cuts off the drive current (+24V) when the opening status of the front cover is detected.	5-2	
SW2	Stationary tray opening/closing switch	Detects the opening (lifting) of the stationary tray.	9-58	
SW3	Stapler interference switch	Automatically cut off the power supply to the stapler on detecting the no-operation area for the stapler unit.	6-25	

3) Electromagnetic spring clutches

Symbol	Name	Function	P-I	Remarks
CLT1	Shutter clutch	Transmits the drive of the transport motor to the shutter opening/closing section.	2-23	
CLT2	Paper exit guide clutch	Transmits the stack transport motor drive to the paper exit guide.	7-17	

4) Solenoids

Symbol	Name	Function	P-I	Remarks
SOL1	Buffer roller lift solenoid	Moves up/down the buffer roller. (Turned ON to lift up the roller)	9-46	
SOL2	Gate solenoid	Switches paper transport destination (stationary tray / movable tray).	8-25	
SOL3	Patting solenoid	Drops paper on the buffer tray to the finisher tray.	9-11	
SOL4	Catching solenoid	Catches paper on the buffer tray.	4-53	

5) PC board

Symbol	Name	Function	P-I	Remarks
FIN	Finisher control PC board	Controls the Finisher	2-17	

2.5 Diagram of Signal Blocks

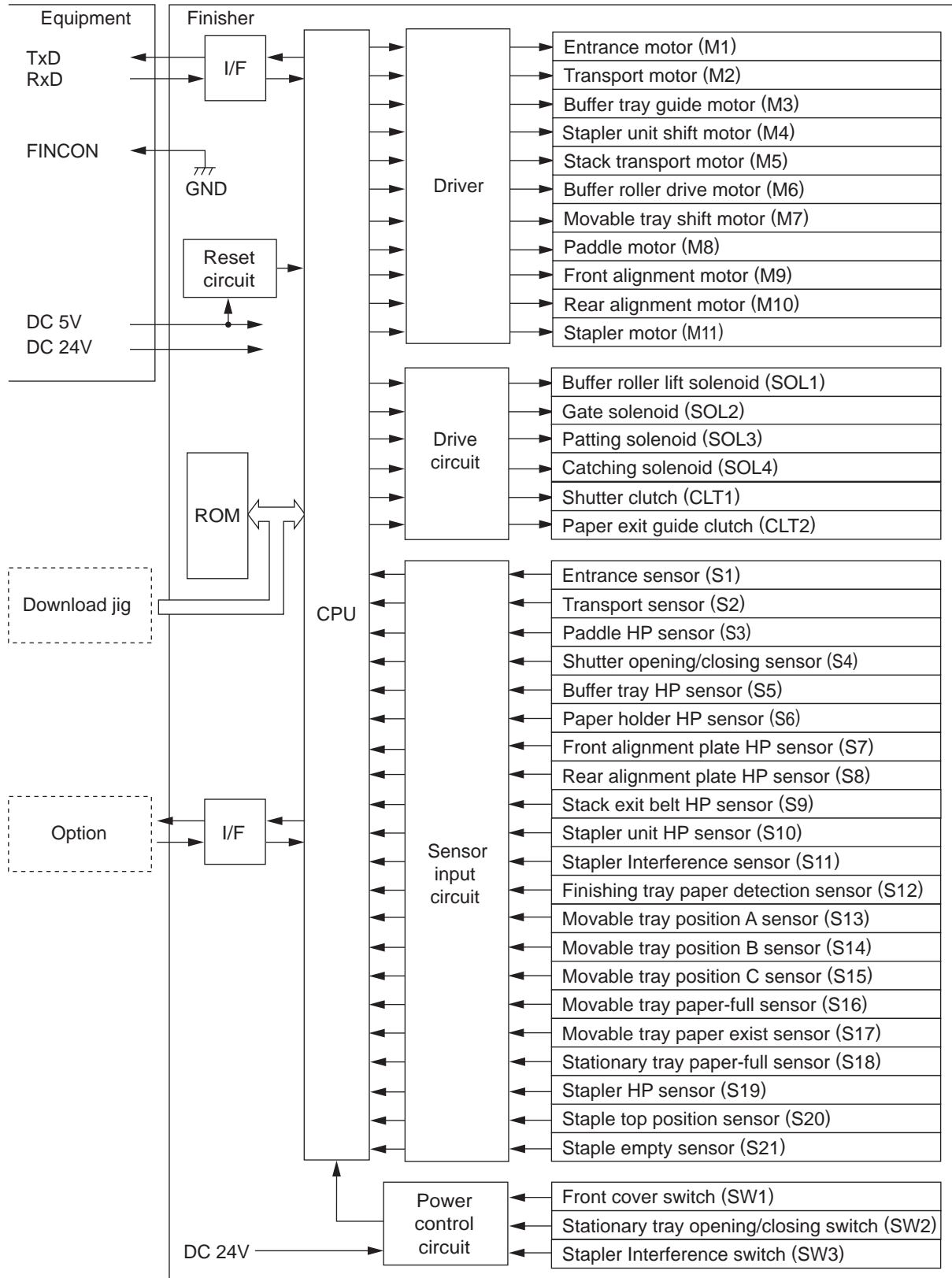

Fig. 2-6

2.6 Description of Interface Signals

The 2 lines; TxD and RxD are used to transmit/receive signals between the equipment and the Finisher. Also, the equipment detects the connection of the Finisher by the FINCON signal sent from the Finisher when it is connected to the equipment.

- TxD: Sent data (transmitted from the Equipment to the Finisher)
- RxD: Received data (transmitted from the Finisher to the Equipment)
- FINCON: Finisher connection signal (Low level: Connected)

Data communication (RxD and TxD) between the equipment and the Finisher has adopted the serial communication system which does not allow checking whether the signals are transmitted/ received properly using testing devices in the field.

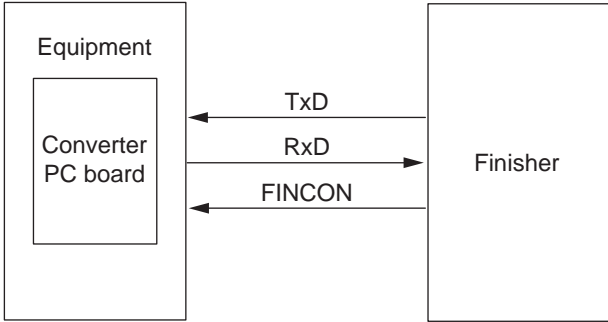

Fig. 2-7

3. DESCRIPTION OF OPERATIONS

3.1 Basic Operations

This machine exits paper transported from the main unit to the stationary tray or the movable tray. Its paper exit procedures are classified to these three types;: (1) simple stack which exits paper directly to the stationary tray or the movable tray, (2) bundle job offset which exits sorted bundles of paper one bundle by one, placing each bundle alternately a little forward and backward, and (3) stapling stack which staples and exits each bundle of paper.

The bundle job offset and the stapling stack exit bundles of paper onto the movable tray.

3.2 Transport Operation

- Simple stack

When the non-sort mode is set, paper exits in the procedure shown below.

- Ⓐ Paper is output to the stationary tray.
- Ⓑ Paper is output to the movable tray via the buffer tray.

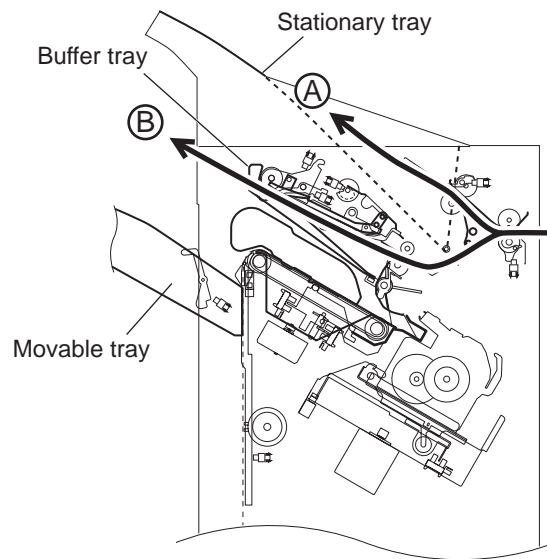

Fig. 3-1

- Bundle job offset / stapling stack

When the sort copying and the stapling function are set, paper exits in the procedure shown below.

- ① Paper is transported to the buffer tray.
- ② Paper is dropped from the buffer tray onto the finishing tray.
- ③ Paper stacked on the finishing tray is aligned and stapled, and then the bundled paper is output to the movable tray.

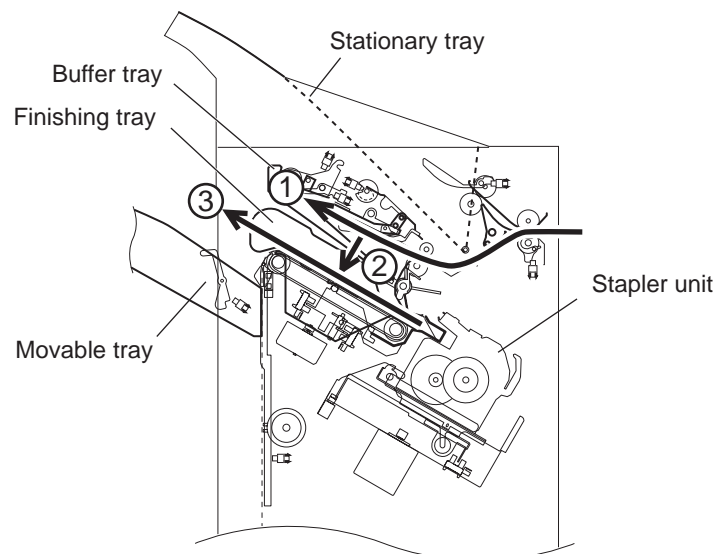

Fig. 3-2

3.2.1 Paper feeding section

The paper transported from the main unit is pulled in by the entrance roller driven by the entrance motor (M1).

At this stage, if the gate solenoid (SOL2) is turned ON and the gate flap goes down, the paper is fed to the stationary tray.

If the gate solenoid (SOL2) is turned OFF, the paper is fed to the buffer tray.

The paper transport is detected by the entrance sensor (S1).

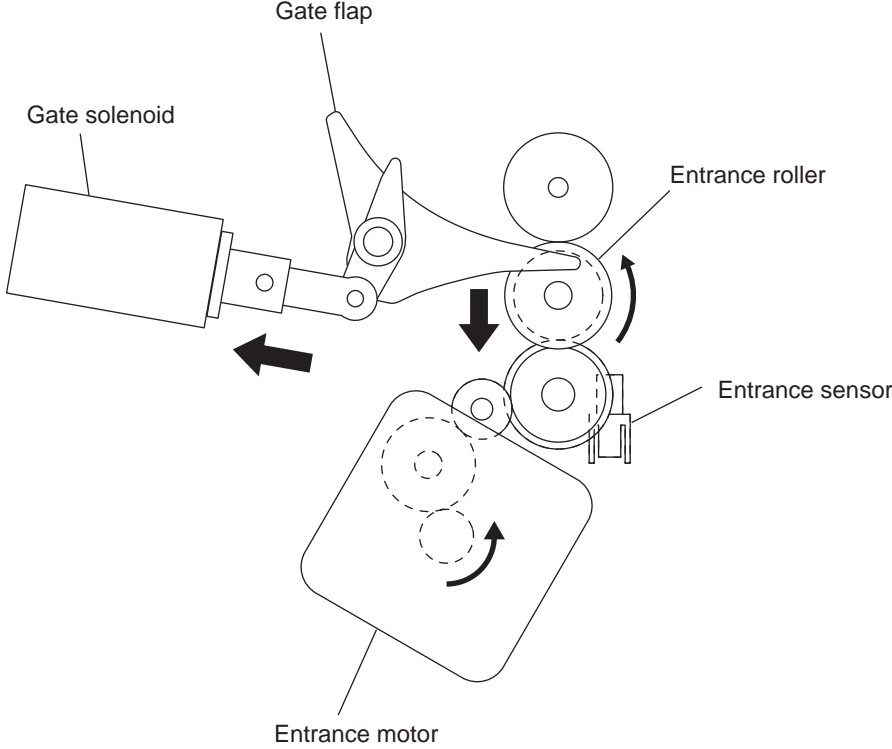

Fig. 3-3

3.2.2 Paper transport section

The paper transported from the paper feeding section is then transported to the buffer tray by the transport roller driven by the entrance motor (M1). At this stage, the buffer roller lift solenoid (SOL1) is turned ON to raise the buffer rollers and the buffer tray is moved by the buffer tray guide motor (M3) to the position where it matches with the paper width. The home position of the buffer tray is detected by the buffer tray home position sensor (S5). Paper transport is detected by the transport sensor (S2).

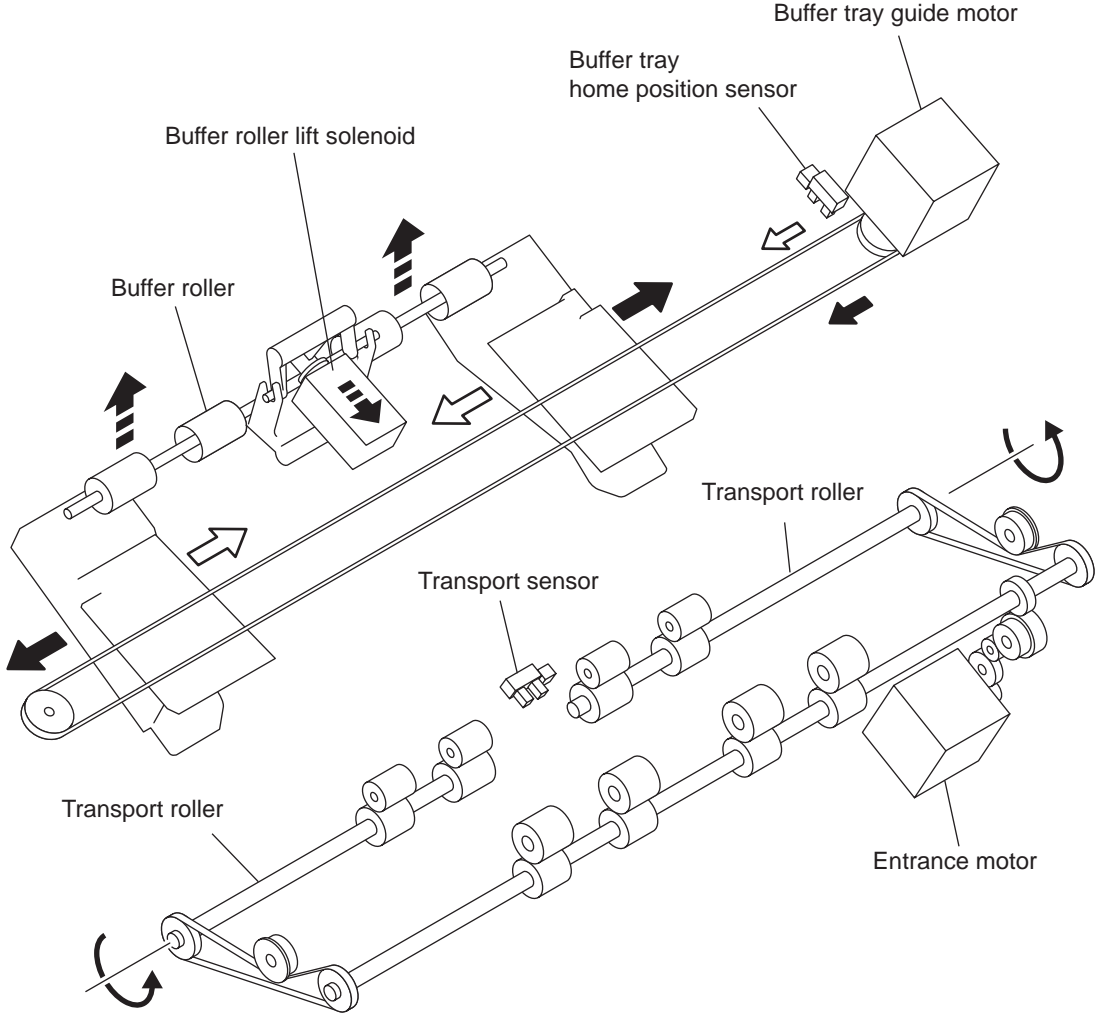

Fig. 3-4

3.2.3 Active drop mechanism section

The paper transported to the buffer tray is then moved to the finishing tray by the active drop mechanism to be aligned or stapled.

- (1) The paper on the buffer tray is pulled into the finishing tray side by the reverse rotation of the buffer roller drive motor (M6).
At this stage, this motor drives to rotate the paper holder cam through the one-way clutch, and the paper pushing plate is thus held down.
Then the catching solenoid (SOL4) is turned ON to rotate the catching pad, and the catching pad thus catches the paper with the paddle guides.

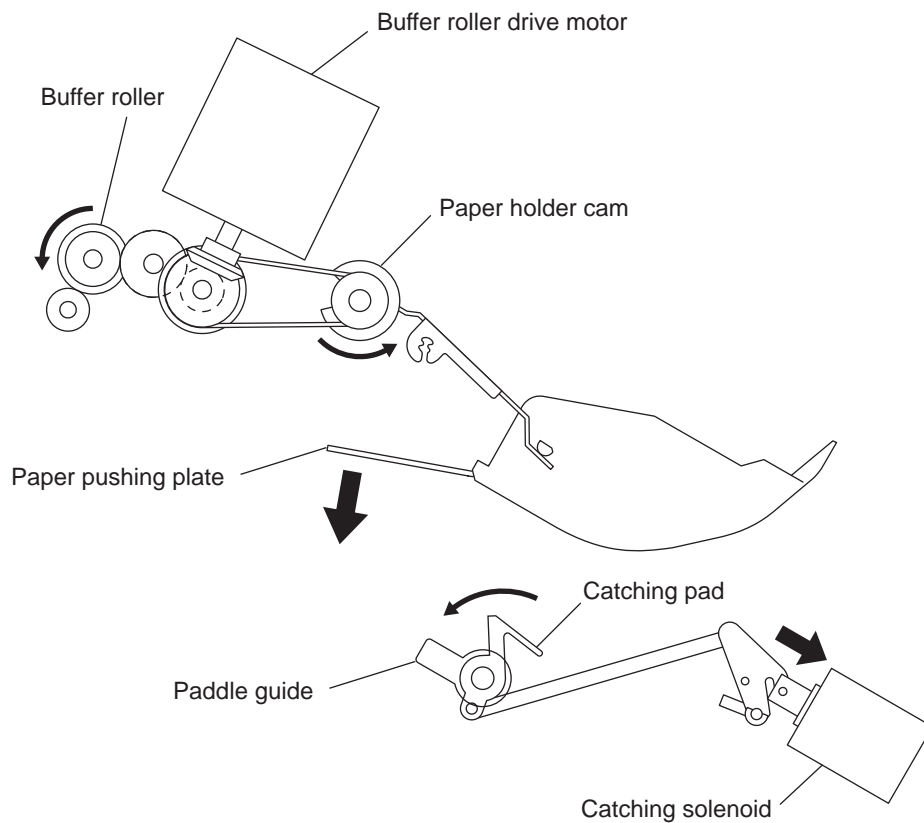

Fig. 3-5

- (2) When the buffer roller lift solenoid (SOL1) is turned ON, the buffer rollers are lifted up, and then the buffer tray guide motor (M3) opens the buffer tray. The paper on the buffer tray is thus dropped onto the finishing tray. At this stage, the patting solenoid (SOL3) is turned ON to drop the paper tapping arm so that the paper will certainly be dropped onto the finishing tray.

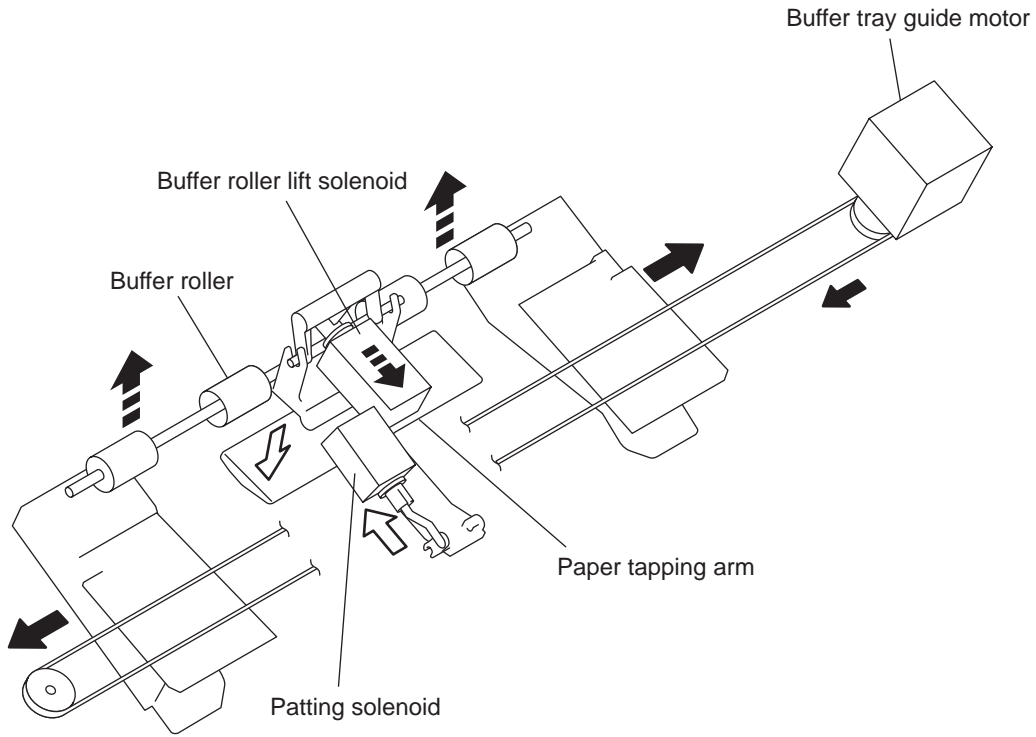

Fig. 3-6

- (3) The paper dropped onto the finishing tray is then pulled into the finishing position by the paddles driven by the paddle motor (M8) and the stack transport rollers-1 and -2 driven by the transport motor (M2).
The finishing tray paper detection sensor (S12) detects whether paper is on the finishing tray or not.
The home position of the paddles is detected by the paddle home position sensor (S3).

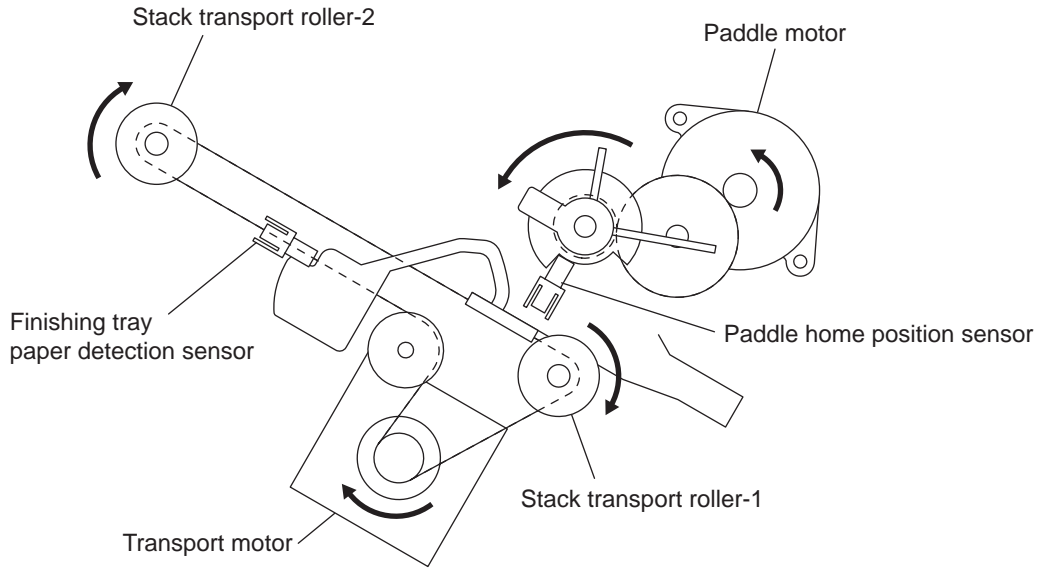

Fig. 3-7

3.2.4 Paper exit section

- Simple stack (using the stationary tray)
The paper transported from the paper feeding section is then exited to the stationary tray by the transport roller driven by the entrance motor (M1).
The entrance sensor (S1) detects the paper transport to the stationary tray.
The stationary tray paper-full sensor (S18) detects the overload of paper on the stationary tray.

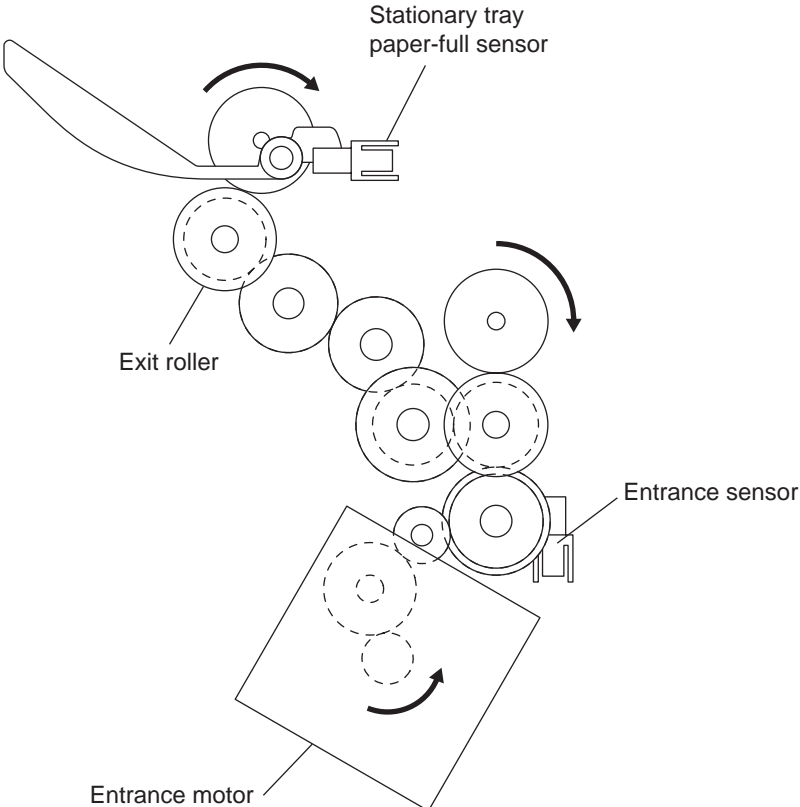

Fig. 3-8

- Simple stack (using the movable tray)
The paper transported to the buffer tray it then exited to the movable tray by the buffer rollers driven by the buffer roller drive motor (M6).
At this stage, the shutter clutch (CLT1) is turned ON and the shutter is pulled up by the drive of the transport motor (M2) to prevent the paper from being transported to the finishing tray.
The opening and closing statuses of the shutter is detected by the shutter opening/closing sensor (S4).

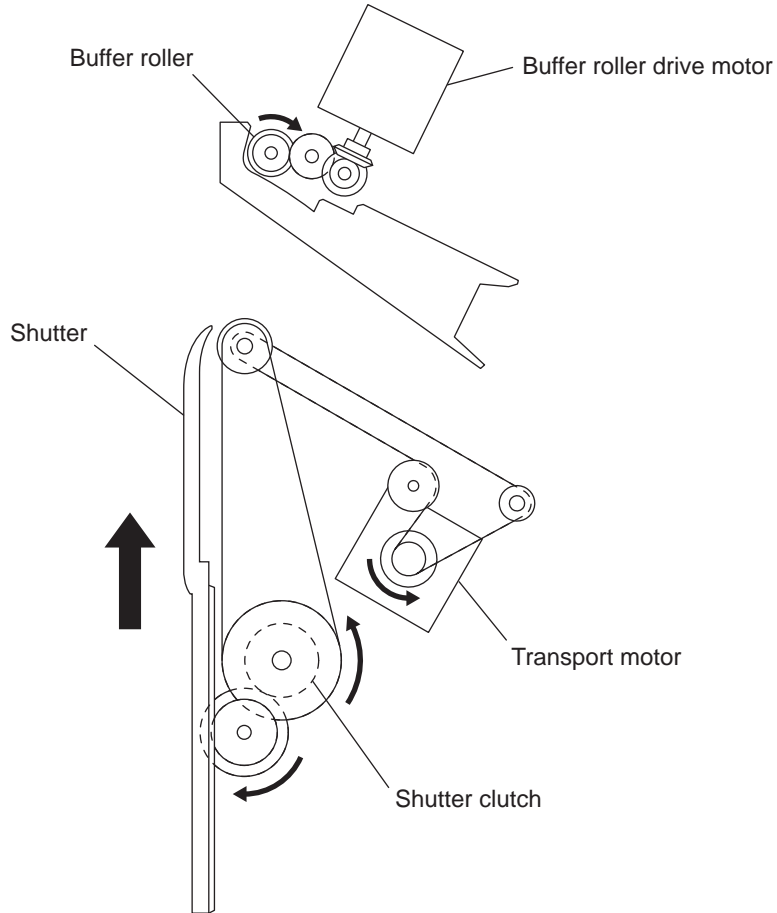

Fig. 3-9

- Bundle job offset / stapling stack
 Bundles of the paper aligned or stapled on the finishing tray are then pulled up by the paper exit guide driven by the stack transport motor (M5) with the turning ON of the paper exit guide clutch (CLT2).
 Then the paper is exited by the paper exit belt driven by the stack transport motor (M5) and the stack transport rollers-1 and -2 driven by the transport motor (M2) onto the movable tray.
 The home position of the paper exit belt is detected by the stack exit belt home position sensor (S9).

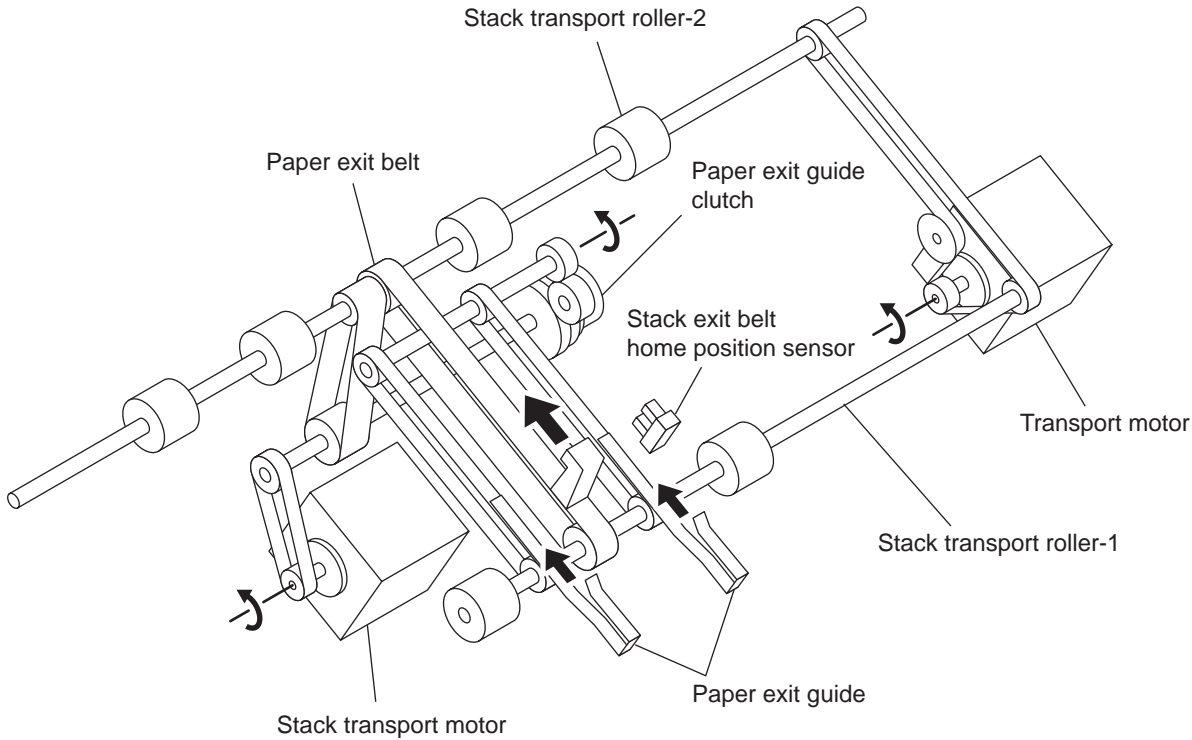

Fig. 3-10

3.3 Bundle Job Offset Operation

The bundle job offset operation is to sort bundles of paper by placing the first bundle a little forward and placing the next bundle a little backward, and repeating this set of movement. The paper transported to the finishing tray is bundled and each bundle is placed by the alignment plates driven by the front alignment motor (M9) and the rear alignment motor (M10). The home position of each alignment plate is detected by the front alignment plate home position sensor (S7) and the rear alignment plate home position sensor (S8).

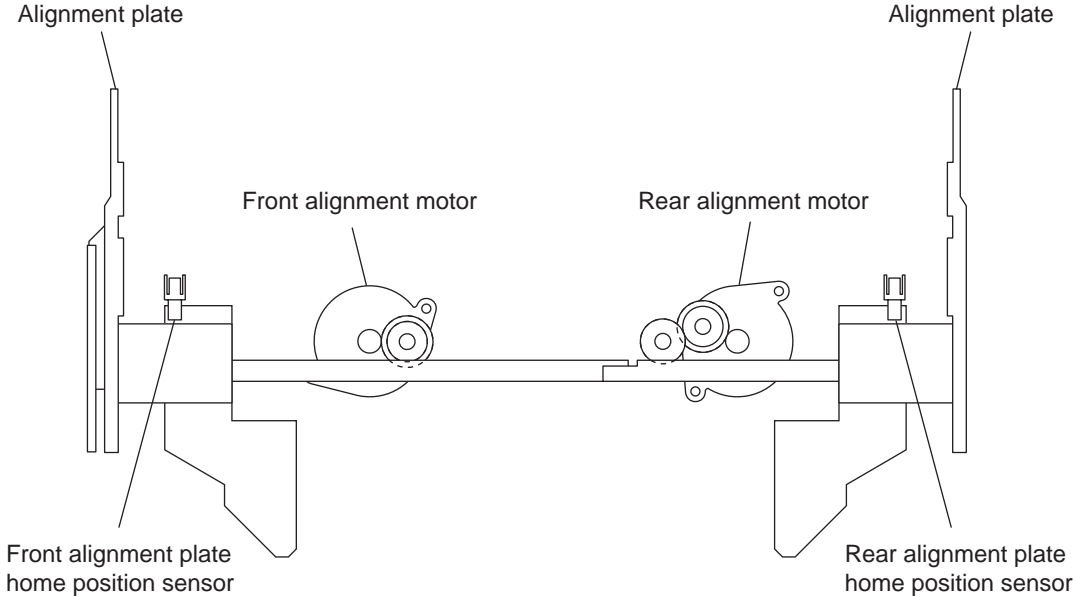

Fig. 3-11

3.4 Stapling Operation

The stapling operation is to staple a specified number of paper with the stapler unit. The stapler unit is moved to the stapling position (the position differs depending on the paper size) by the stapler unit shift motor (M4). The home position of the stapler unit is detected by the stapler unit home position sensor (S10). The stapler interference switch (SW3) detects the no-operation area for the stapling operation and cuts off the power supply to the stapler while it is switched ON. The stapling operation is also stopped in the area where while the stapler interference sensor (S11) is turned ON to prevent the stapler from interfering with other mechanical sections in the equipment.

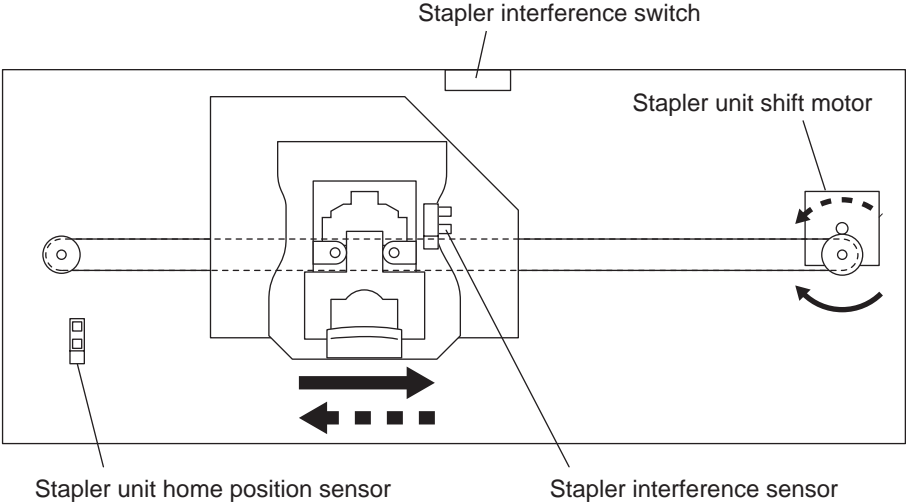

Fig. 3-12

3.5 Operation of Movable Tray

The movable tray is shifted up and down by the drive from the movable tray shift motor (M7) according to the paper exit from the buffer tray or finishing tray, and the amount of the paper stack. Whether paper is set on the movable tray or not is detected by the Movable tray paper exit sensor (S17).

Detecting the position of the movable tray is performed as follows.

- 1) Home position of the movable tray when the paper is output from the buffer tray
The movable tray is shifted up during initializing until the movable tray paper-full sensor (S16) is turned ON. After that, the tray is moved down for a specified period of time and it is stopped where the movable tray position A sensor (S13) is turned ON. This will be the home position.
- 2) Home position of the movable tray when the paper is output from the finishing tray
The movable tray is shifted down from the home position when the paper is output from the buffer tray, and the tray is stopped where the movable tray position C sensor (S15) is turned ON. This will be the home position.
- 3) Position of the movable tray when the paper loading capacity is 1,000 to 2,000 sheets
If the movable tray paper-full sensor (S16) is turned ON when the movable tray is in either the home position when the paper is output from the buffer tray or the home position when the paper is output from the finishing tray, it goes down to the position where the movable tray position B sensor (S14) is turned ON. This is the position of the movable tray when the paper loading capacity is 1,000 to 2,000 sheets.
- 4) Position of the movable tray when the paper loading capacity is 2,000 sheets or more
When the movable tray is in the position of the paper loading capacity of 1,000 to 2,000 sheets, and the movable tray paper-full sensor (S16) is turned ON, the tray is shifted to the position where the movable tray position A sensor (S13) is turned OFF. This is the position of the movable tray when the paper loading capacity is 2,000 or more.

Movable tray position	Movable tray position A sensor	Movable tray position B sensor	Movable tray position C sensor
(1)	ON	OFF	OFF
(2)	ON	OFF	ON
(3)	ON	ON	ON
(4)	OFF	ON	ON

ON: The sensor signal is interrupted by the rib of the sensor rail.

OFF: The sensor signal is not interrupted by the rib of the sensor rail.

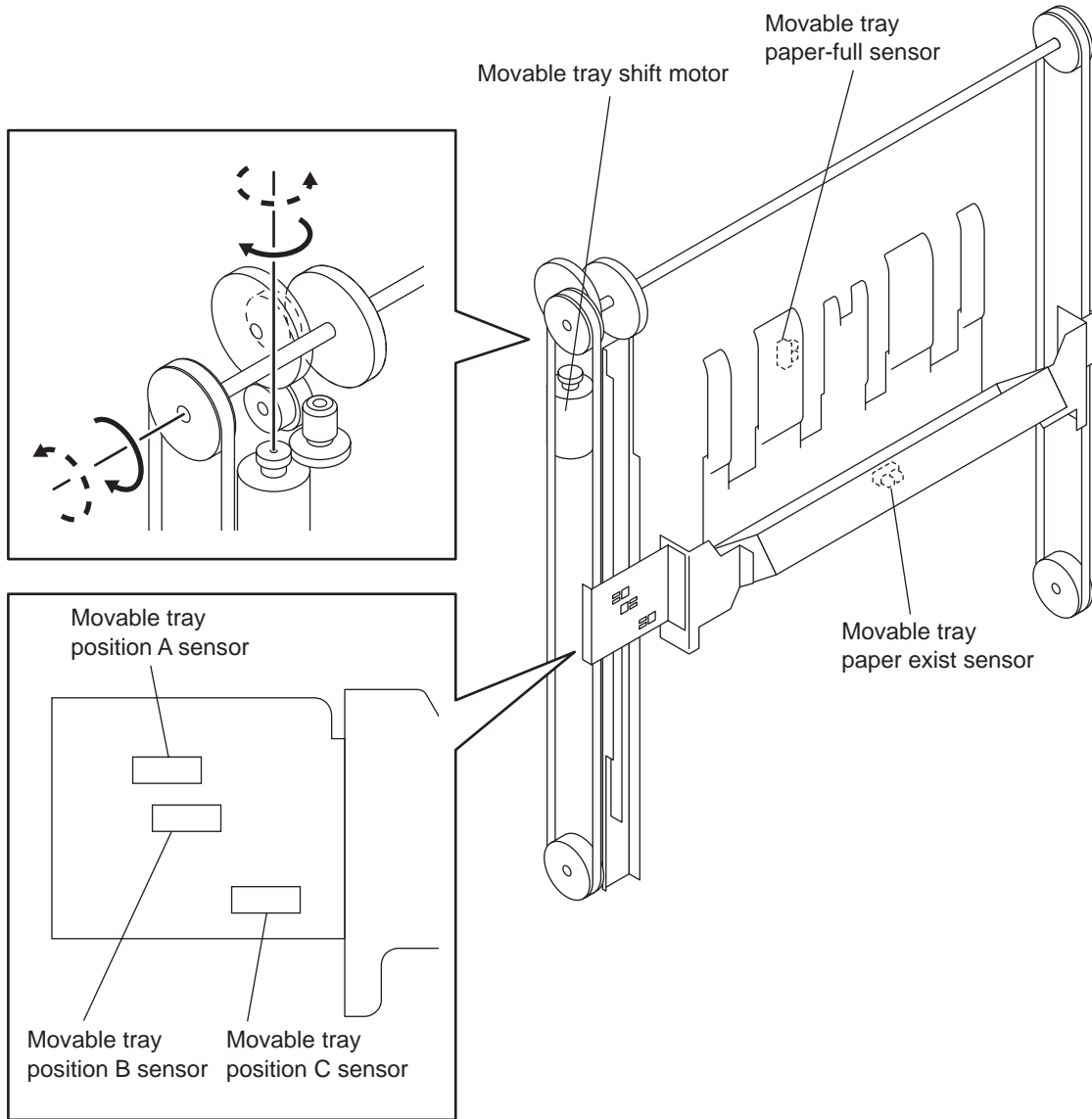

Fig. 3-13

3.6 Flow Chart

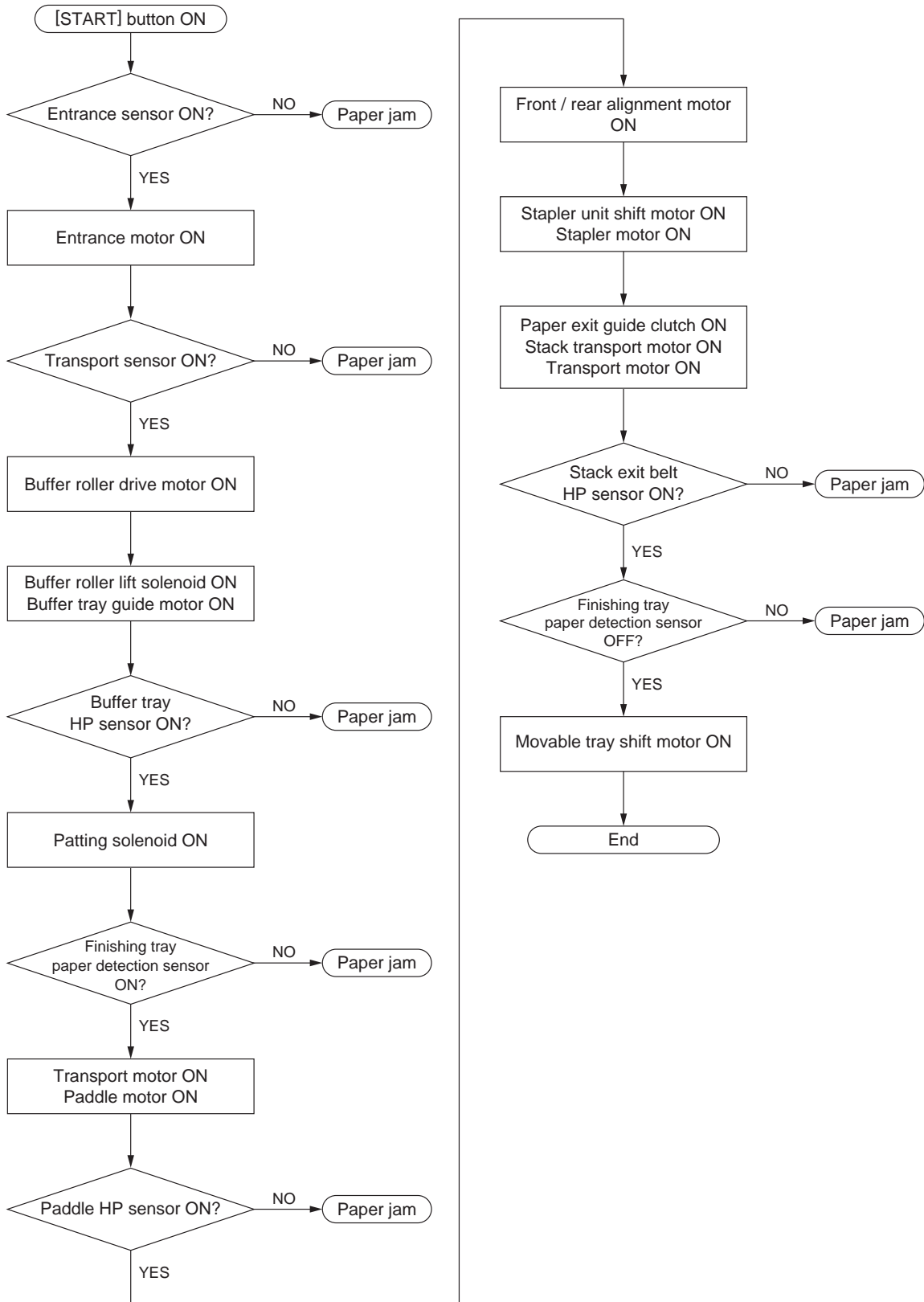

Fig. 3-14

3.7 Description Of Circuit

3.7.1 Buffer roller drive circuit

The buffer roller drive circuit controls the rotation and stoppage, rotational direction and motor current of the buffer roller drive motor.

The buffer roller drive motor is driven by pulse signals (MT4-OUT1A, MT4-OUT1B, MT4-OUT2A and MT4-OUT2B) output from the motor driver (IC37) under the command of a clock signal (TIOCA4), a rotational direction signal (MOT4-DIR) and a current setting signal (MOT4-CUR0) from the CPU of the finisher control PC board, and thus this motor rotates the buffer roller.

TIOCA4	MOT4-DIR	MOT4-CUR0	Motor rotation	Remarks
Clock signal	H	L	Normal	Paper is transported to the movable tray.
Clock signal	L	L	Reverse	Paper is pulled into the finishing position and is pushed down on to the paddle with the paper pushing plate.
-	-	H	Stop	

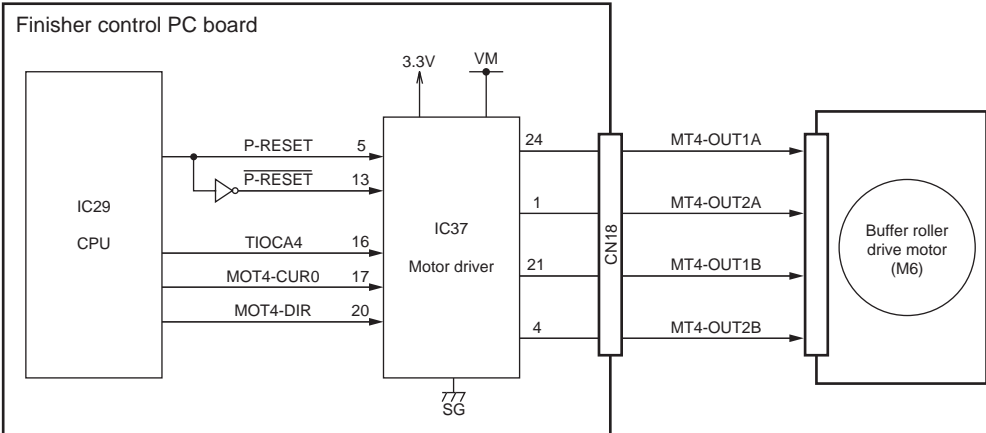

Fig. 3-15

3.7.2 Buffer tray guide motor drive circuit

The buffer tray guide motor drive circuit controls the rotation and stoppage, rotational direction and motor current of the buffer tray guide motor.

The buffer tray guide motor is driven by pulse signals (MT2-OUT1A, MT2-OUT1B, MT2-OUT2A and MT2-OUT2B) output from the motor driver (IC38) under the command of a clock signal (TIOCA1), a rotational direction signal (MOT2-DIR) and a current setting signal (MOT2-CUR0) from the CPU of the finisher control PC board, and thus this motor opens or closes the buffer tray guide.

TIOCA1	MOT2-DIR	MOT2-CUR0	Motor rotation	Remarks
Clock signal	H	L	Normal	The guide is closed.
Clock signal	L	L	Reverse	The guide is opened.
-	-	H	Stop	

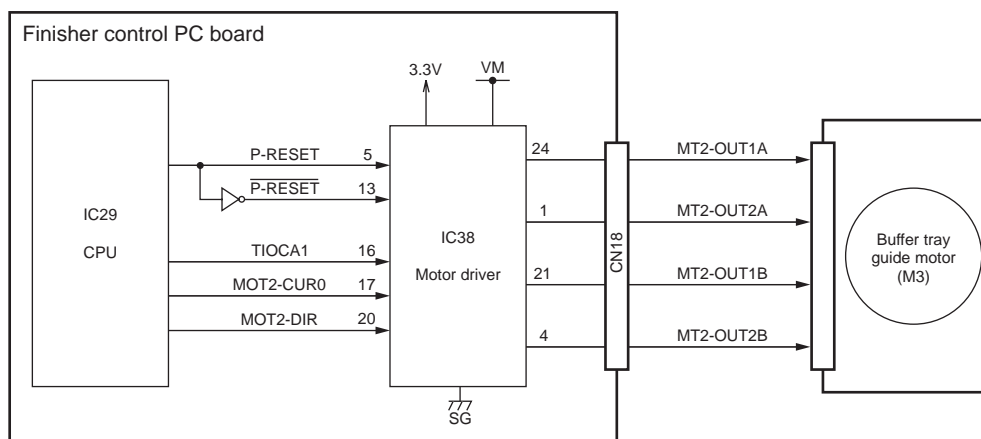

Fig. 3-16

3.7.3 Front/rear alignment motor drive circuit

The front / rear alignment motor drive circuit controls the rotation and stoppage, rotational direction and motor current of the front alignment motor.

The front alignment motor is driven by pulse signals (MT5-OUT1A, MT5-OUT1B, MT5-OUT2A and MT5-OUT2B) output from the motor driver (IC13) under the command of a clock signal (TMO1), a rotational direction signal (MOT5-DIR) and a current setting signal (MOT5-CUR0) from the CPU of the finisher control PC board, and thus this motor opens or closes the front alignment plate of the finishing tray.

The rear alignment motor is driven by pulse signals (MT6-OUT1A, MT6-OUT1B, MT6-OUT2A and MT6-OUT2B) output from the motor driver (IC19) under the command of a clock signal (TMO3), a rotational direction signal (MOT6-DIR) and a current setting signal (MOT6-CUR0) from the CPU of the finisher control PC board, and thus this motor opens or closes the rear alignment plate of the finishing tray.

TMO1	MOT5-DIR	MOT5-CUR0	Motor rotation	Remarks
Clock signal	H	L	Normal	The front alignment plate is closed.
Clock signal	L	L	Reverse	The front alignment plate is opened.
-	-	H	Stop	

TMO3	MOT6-DIR	MOT6-CUR0	Motor rotation	Remarks
Clock signal	H	L	Normal	The rear alignment plate is closed.
Clock signal	L	L	Reverse	The rear alignment plate is opened.
-	-	H	Stop	

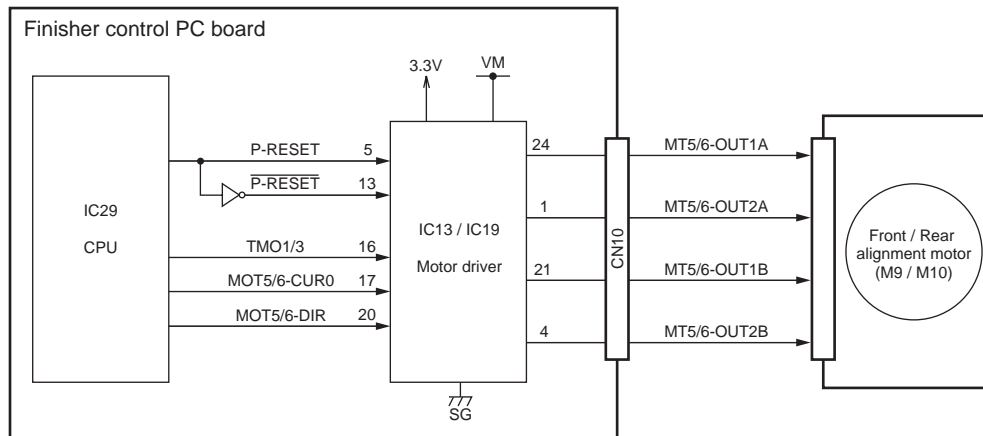

Fig. 3-17

3.7.4 Stack transport motor drive circuit

The stack transport motor drive circuit controls the rotation and stoppage, rotational direction and motor current of the stack transport motor.

The stack transport motor is driven by pulse signals (MT8-OUT1A, MT8-OUT1B, MT8-OUT2A and MT8-OUT2B) output from the motor driver (IC25) under the command of a clock signal (STEP8), a rotational direction signal (MOT8-DIR) and current setting signals (MOT8-CUR0 and MOT8-CUR1) from the CPU of the finisher control PC board, and thus this motor rotates the stack transport belt.

STEP8	MOT8-DIR	MOT8-CUR0	MOT8-CUR1	Motor rotation	Remarks
Clock signal	H	L	L	Normal	Jam recovery operation (Only when paper jam occurs.)
Clock signal	L	L	L	Reverse	Paper is transported to the movable tray.
-	-	-	H	Stop	

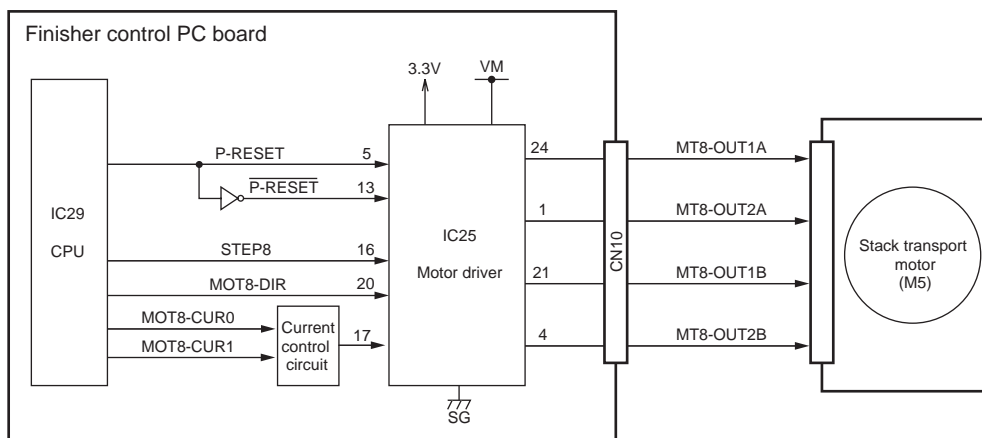

Fig. 3-18

3.7.5 Entrance motor

The entrance motor drive circuit controls the rotation and stoppage, rotational direction and motor current of the entrance motor.

The entrance motor is driven by pulse signals (MT1-OUT1A, MT1-OUT1B, MT1-OUT2A and MT1-OUT2B) output from the motor driver (IC11) under the command of a clock signal (TIOCA0), a rotational direction signal (MOT1-DIR) and current setting signals (MOT1-CUR1 and MOT1-CUR0) from the CPU of the finisher control PC board, and thus this motor rotates the entrance roller, paper exit roller and transport roller.

TIOCA0	MOT1-DIR	MOT1-CUR0	MOT1-CUR1	Motor rotation	Remarks
Clock signal	H	H	L	Normal (Low speed)	Paper is pulled in. (At the transport speed of 45 to 200mm/s)
Clock signal	H	L	L	Normal (High speed)	Paper is pulled in. (At the transport speed of 45 to 200mm/s)
Clock signal	L	H	L	Reverse (Low speed)	Paper is pulled in. (At the transport speed of 180 to 800mm/s)
Clock signal	L	L	L	Reverse (High speed)	Paper is pulled in. (At the transport speed of 180 to 800mm/s)
-	-	-	H	Stop	

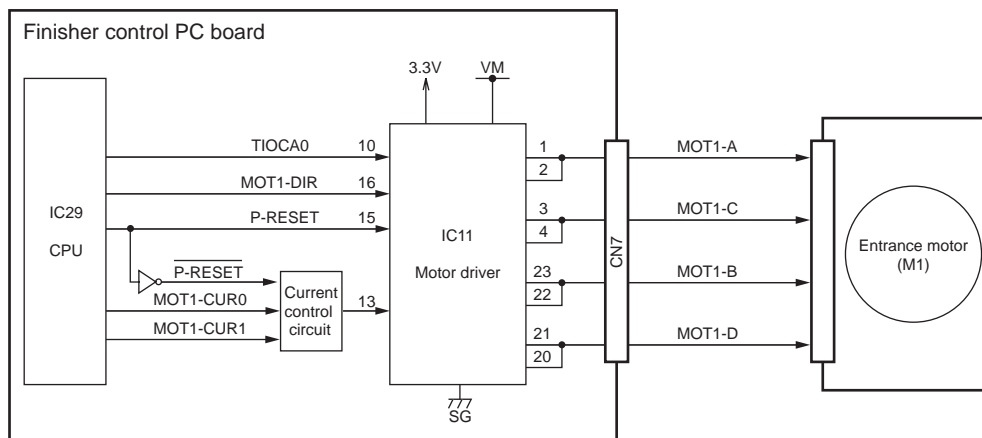

Fig. 3-19

3.7.6 Stapler unit shift motor drive circuit

The stapler unit shift motor drive circuit controls the rotation and stoppage, rotational direction and motor current of the stapler unit shift motor.

The stapler unit shift motor is driven by pulse signals (MT9-OUT1A, MT9-OUT1B, MT9-OUT2A and MT9-OUT2B) output from the motor driver (IC4) under the command of a clock signal (STEP9), a rotational direction signal (MOT9-DIR) and a current setting signal (MOT9-CUR0) from the CPU of the finisher control PC board, and thus this motor shifts the stapler unit back and forth.

STEP9	MOT9-DIR	MOT9-CUR0	Motor rotation	Remarks
Clock signal	H	L	Normal	The stapler unit is shifted to the front side.
Clock signal	L	L	Reverse	The stapler unit is shifted to the rear side.
-	-	H	Stop	

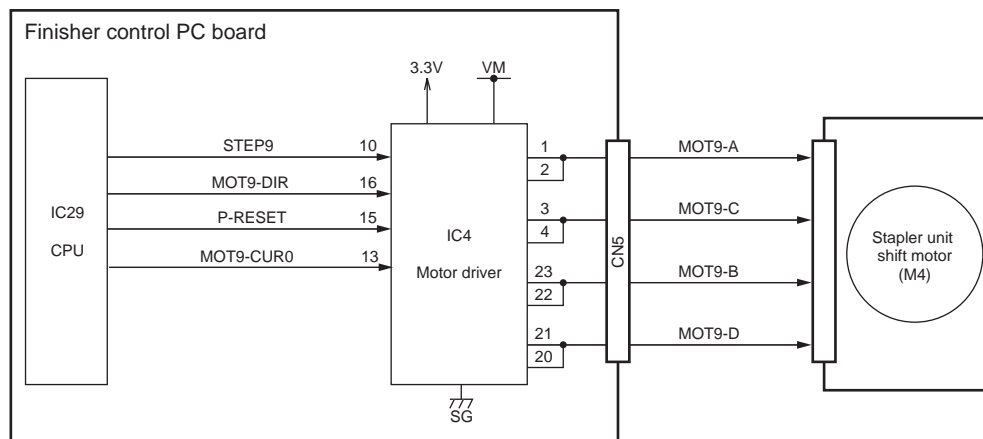

Fig. 3-20

3.7.7 Transport motor drive circuit

The transport motor drive circuit controls the rotation and stoppage, rotational direction and motor current of the transport motor.

The transport motor is driven by pulse signals (MT7-OUT1A, MT7-OUT1B, MT7-OUT2A and MT7-OUT2B) output from the motor driver (IC10) under the command of a clock signal (TIOCA2), a rotational direction signal (MOT7-DIR) and current setting signals (MOT7-CUR0 and MOT7-CUR1) from the CPU of the finisher control PC board, and thus this motor rotates the stack transport roller-1 and -2.

TIOCA2	MOT7-DIR	MOT7-CUR0	MOT7-CUR1	Motor rotation	Remarks
Clock signal	H	L	L	Normal	Paper is transported to the finishing position.
Clock signal	L	L	L	Reverse	Paper is transported to the movable tray.
-	-	-	H	Stop	

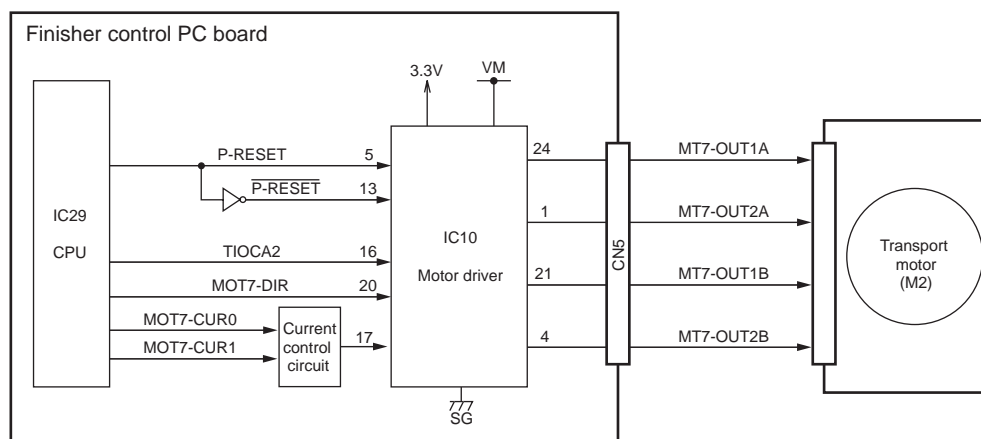

Fig. 3-21

3.7.8 Paddle motor drive circuit

The paddle motor drive circuit controls the rotation and stoppage, rotational direction and motor current of the paddle motor.

The paddle motor is driven by pulse signals (MT3-OUT1A, MT3-OUT1B, MT3-OUT2A and MT3-OUT2B) output from the motor driver (IC5) under the command of a clock signal (TMO2), a rotational direction signal (MOT3-DIR) and a current setting signal (MOT3-CUR0) from the CPU of the finisher control PC board, and thus this motor rotates the paddle.

TMO2	MOT3-DIR	MOT3-CUR0	Motor rotation	Remarks
Clock signal	H	L	Normal	Paper is transported to the finishing position.
Clock signal	L	L	Reverse	Eliminates backlash.
-		H	Stop	

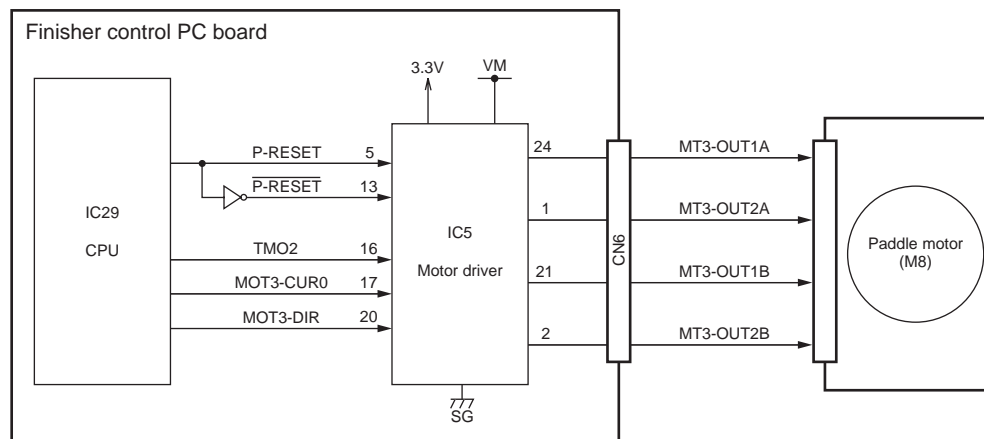

Fig. 3-22

3.7.9 Movable tray shift motor drive circuit

The movable tray shift motor drive circuit controls the rotation and stoppage, rotational direction and motor current of the movable tray shift motor.

The movable tray shift motor is a DC motor which is driven by rotation control signals (DM1-CNT0 and DM1-CNT1) from the CPU of the finisher control PC board, and thus this motor shifts the movable tray in a hoisting movement. For the case when an overcurrent status is detected, a protection circuit is mounted to turn the movable tray shift motor off.

DM1-CNT0	DM1-CNT1	Motor rotation	Remarks
H	L	Normal	The movable tray unit is shifted to the lower side.
L	H	Reverse	The movable tray unit is shifted to the upper side.
H	H	Stop	

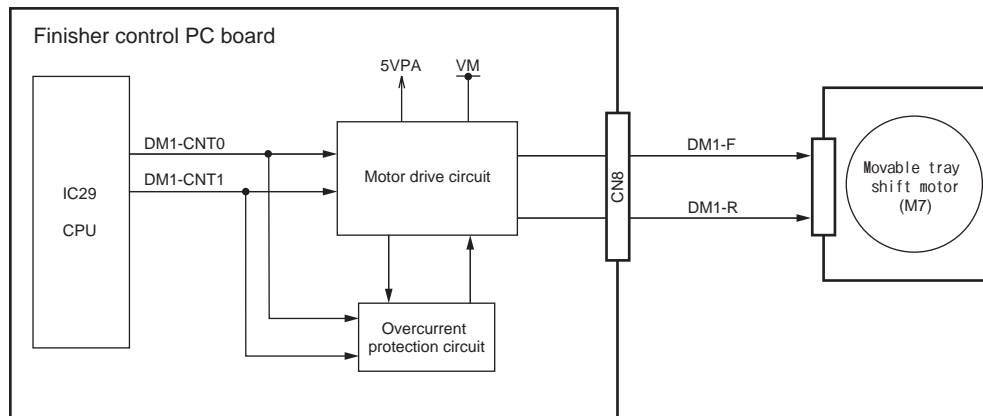

Fig. 3-23

3.7.10 Stapler motor drive circuit

The stapler motor drive circuit controls the rotation and stoppage, rotational direction and motor current of the stapler motor.

The stapler motor is a DC motor which is driven by rotation control signals (DM3-CNT0 and DM3-CNT1) from the CPU of the finisher control PC board, and thus this motor performs a stapling operation. For the case when an overcurrent status is detected, a protection circuit is mounted to turn the stapler motor off.

DM3-CNT0	DM3-CNT1	Motor rotation	Remarks
H	L	Normal	Operates the stapler.
L	H	Reverse	Initial operation (Only when the stapler operates abnormally.)
H	H	Stop	

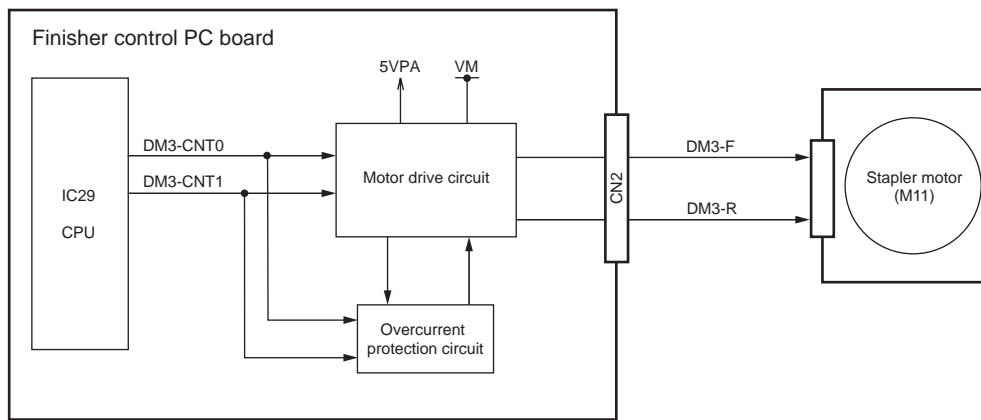

Fig. 3-24

3.7.11 Reset circuit

The reset circuit generates a reset signal when the power is turned ON and when the power supply voltage is lowered. When 5VPA voltage is 4.25V or lower, the reset IC (IC35) resets the CPU (IC28) and Flash ROM (IC21) by determining that the output of pin 1 is at a low level.

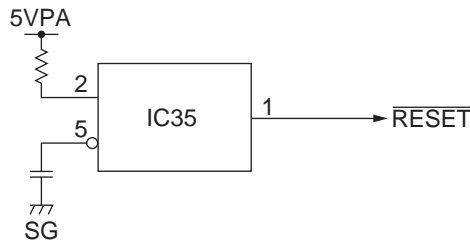

Fig. 3-25

4. DISASSEMBLY AND INSTALLATION

4.1 Covers

[A] Rear upper cover / Rear lower cover

- (1) Remove 2 screws, and then take off the rear lower cover.

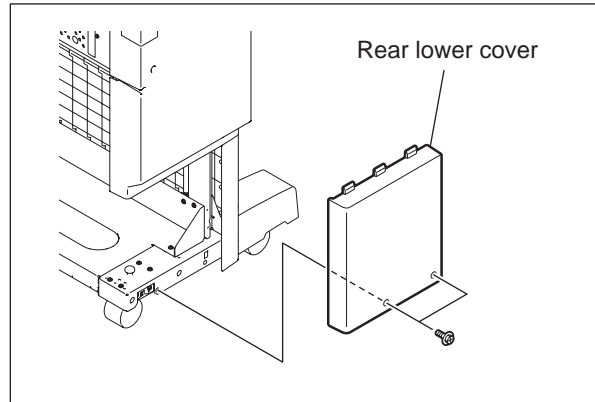

Fig. 4-1

- (2) Remove the finisher cable out of the groove of the rear upper cover.
- (3) Remove 3 screws, and then take off the rear upper cover by sliding it upward.

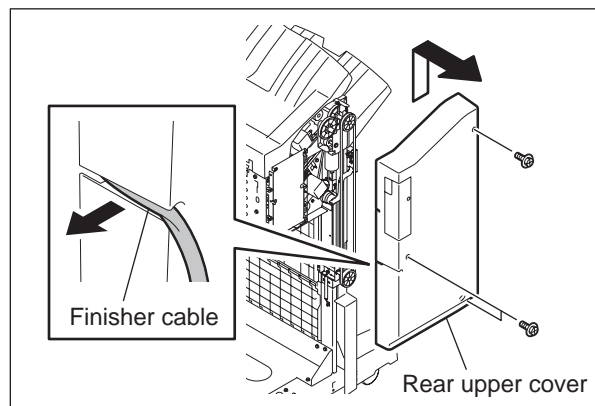

Fig. 4-2

[B] Left upper cover

- (1) Take off the rear upper cover and the rear lower cover.
📖 P. 4-1 "[A] Rear upper cover / Rear lower cover"
- (2) Open the stationary tray.
- (3) Remove 2 screws, and then take off the left upper cover.

Note:

When installing the left upper cover, hang the hook of the cover on the hole of the frame.

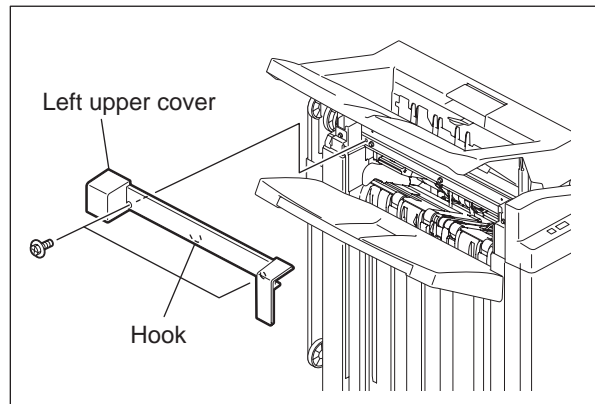

Fig. 4-3

[C] Control panel unit

- (1) Take off the rear upper cover and the rear lower cover.
📖 P. 4-1 "[A] Rear upper cover / Rear lower cover"
- (2) Take off the left upper cover.
📖 P. 4-2 "[B] Left upper cover"
- (3) Open the front cover assembly.
- (4) Remove 3 screws, release the harness from the harness clamp, and then disconnect the connector to take off the control panel unit.

Note:

When installing the control panel unit, install the harness as shown in the figure.

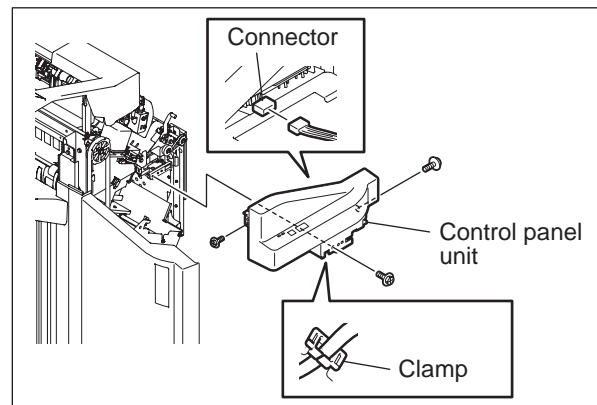

Fig. 4-4

[D] Front upper cover / Front lower cover

- (1) Take off the rear upper cover and the rear lower cover.
📖 P. 4-1 "[A] Rear upper cover / Rear lower cover"
- (2) Take off the left upper cover.
📖 P. 4-2 "[B] Left upper cover"
- (3) Take off the control panel unit.
📖 P. 4-2 "[C] Control panel unit"
- (4) Remove 1 screw, and then remove the lower stay of the front cover assembly by sliding it upward.
- (5) Take off the front cover assembly by sliding it upward.

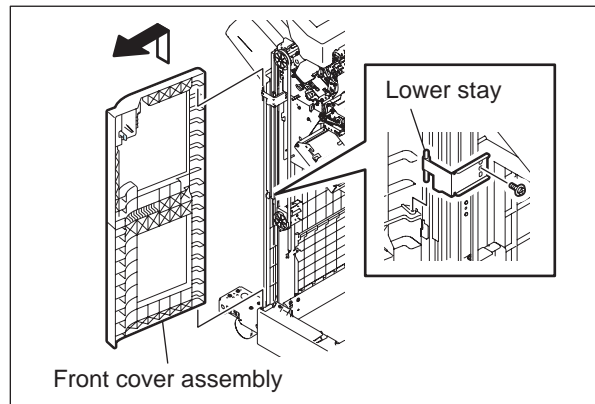

Fig. 4-5

- (6) Remove 1 screw, and then separate the front upper cover and the front lower cover of the front cover assembly.

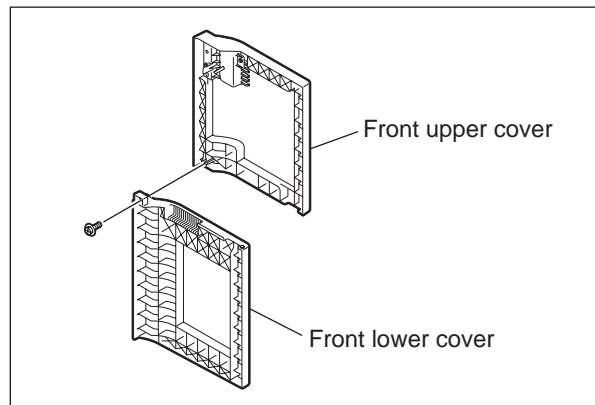

Fig. 4-6

[E] Front foot cover

- (1) Remove 1 screw, and then take off the front foot cover by sliding it in the direction of the arrow.

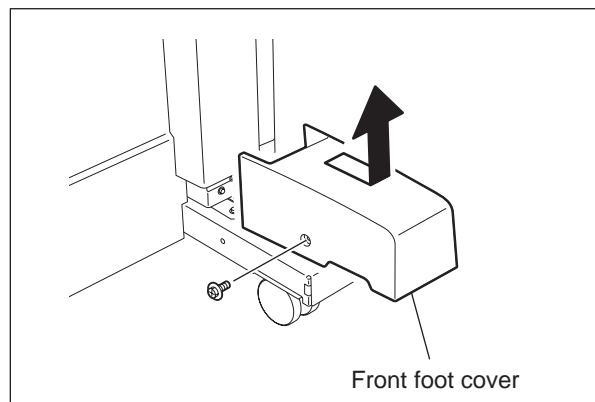

Fig. 4-7

[F] Rear foot cover

- (1) Remove 1 screw, and then take off the rear foot cover by sliding it in the direction of the arrow.

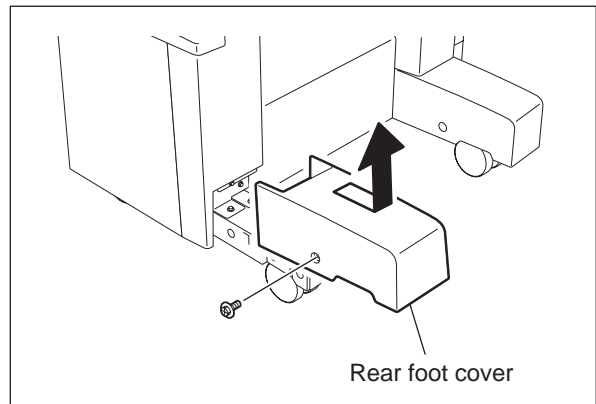

Fig. 4-8

[G] Movable tray cover

- (1) Remove 2 screws and slide the movable tray cover obliquely upward to take it off.

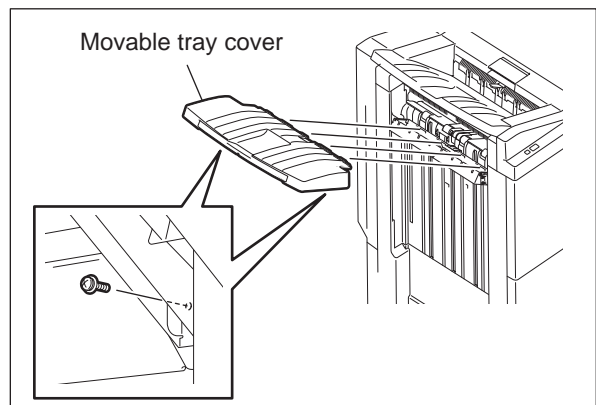

Fig. 4-9

[H] Front rail cover

- (1) Take off the rear upper cover and the rear lower cover.
📖 P. 4-1 "[A] Rear upper cover / Rear lower cover"
- (2) Take off the left upper cover.
📖 P. 4-2 "[B] Left upper cover"
- (3) Take off the control panel unit.
📖 P. 4-2 "[C] Control panel unit"
- (4) Take off the front cover assembly.
📖 P. 4-3 "[D] Front upper cover / Front lower cover"
- (5) Take off the front foot cover.
📖 P. 4-3 "[E] Front foot cover"
- (6) Take off the movable tray cover.
📖 P. 4-4 "[G] Movable tray cover"
- (7) Loosen 1 lower side screw, remove 1 upper side screw, and then take off the front rail cover while sliding it upward.

Note:

When installing the front rail cover, hang the 3 hooks of the cover on the holes of the frame.

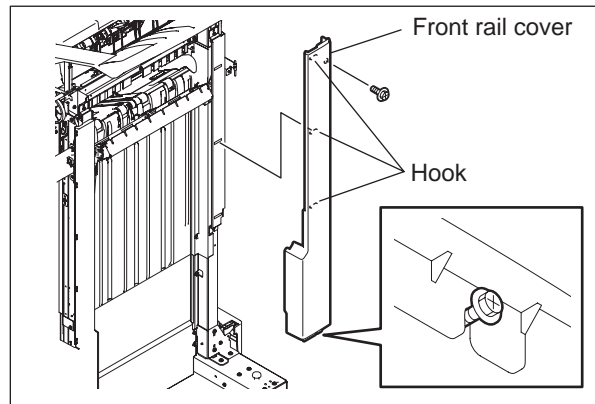

Fig. 4-10

[I] Rear rail cover

- (1) Take off the rear upper cover and the rear lower cover.
📖 P. 4-1 "[A] Rear upper cover / Rear lower cover"
- (2) Take off the left upper cover.
📖 P. 4-2 "[B] Left upper cover"
- (3) Take off the rear foot cover.
📖 P. 4-4 "[F] Rear foot cover"
- (4) Take off the movable tray cover.
📖 P. 4-4 "[G] Movable tray cover"
- (5) Loosen 1 lower side screw, remove 1 upper side screw, and then take off the rear rail cover while sliding it upward.

Note:

When installing the rear rail cover, hang the 3 hooks of the cover on the holes of the frame.

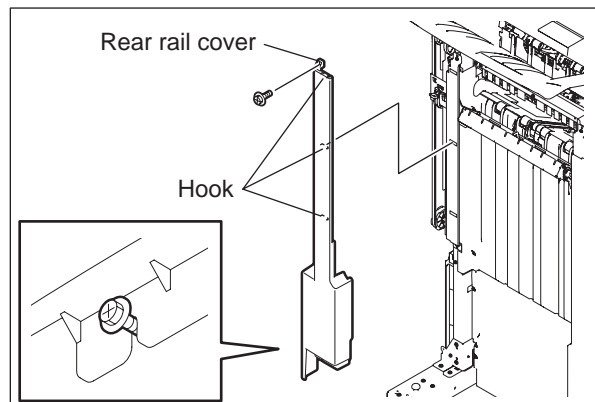

Fig. 4-11

[J] Blind cover

- (1) Remove 1 screw, and then take off the blind cover.

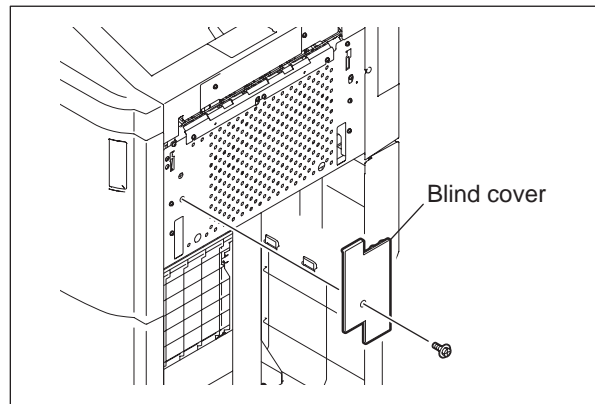

Fig. 4-12

[K] Shield metal plate

- (1) Take off the rear upper cover and the rear lower cover.
P. 4-1 "[A] Rear upper cover / Rear lower cover"
- (2) Take off the blind cover.
P. 4-6 "[J] Blind cover"
- (3) Open the stationary tray.
- (4) Remove 9 screws to take off the paper feed discharge brush, and then take off the shield metal plate by sliding it upward.

Note:

When installing the Shield metal plate, hang the 2 hooks of the cover on the holes of the frame.

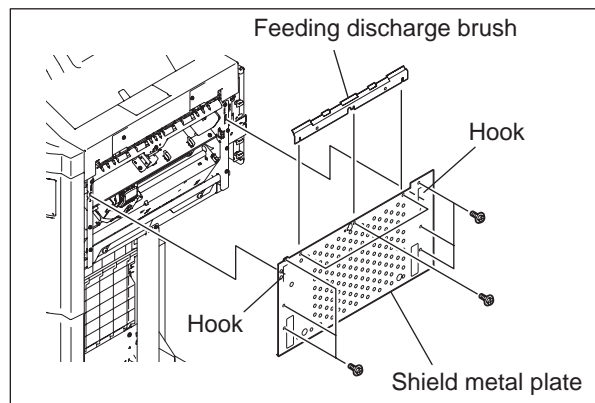

Fig. 4-13

[L] Grate-shaped guide

- (1) Take off the rear upper cover and the rear lower cover.
📖 P. 4-1 "[A] Rear upper cover / Rear lower cover"
- (2) Take off the left upper cover.
📖 P. 4-2 "[B] Left upper cover"
- (3) Take off the control panel unit.
📖 P. 4-2 "[C] Control panel unit"
- (4) Take off the front cover assembly.
📖 P. 4-3 "[D] Front upper cover / Front lower cover"
- (5) Take off the front foot cover.
📖 P. 4-3 "[E] Front foot cover"
- (6) Take off the rear foot cover.
📖 P. 4-4 "[F] Rear foot cover"
- (7) Take off the movable tray cover.
📖 P. 4-4 "[G] Movable tray cover"
- (8) Take off the front rail cover.
📖 P. 4-5 "[H] Front rail cover"
- (9) Take off the rear rail cover.
📖 P. 4-5 "[I] Rear rail cover"
- (10) Take off the movable tray drive unit.
📖 P. 4-4 "[G] Movable tray cover"
- (11) Remove 2 screws, and take off the stopper.
- (12) Release the harness out of 1 clamp, and then disconnect the connector of the CN3 and CN13 on the FIN board.
Disconnect the relay connector of the shutter opening/closing sensor.

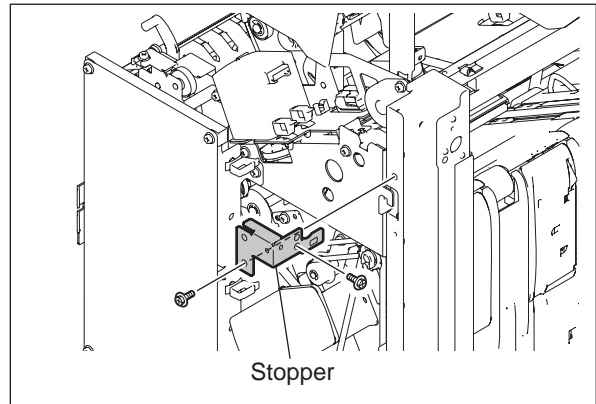

Fig. 4-14

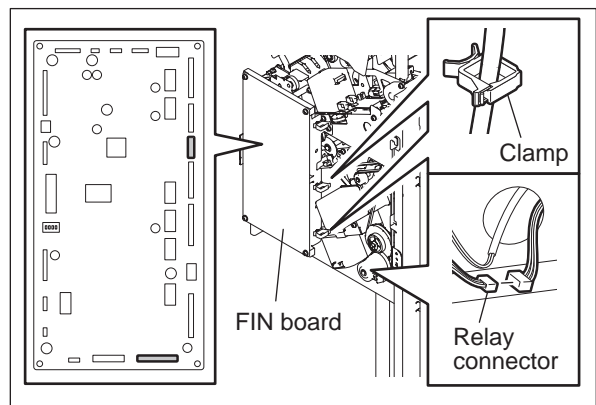

Fig. 4-15

- (13) Take off the movable tray shift frame by moving it upward.

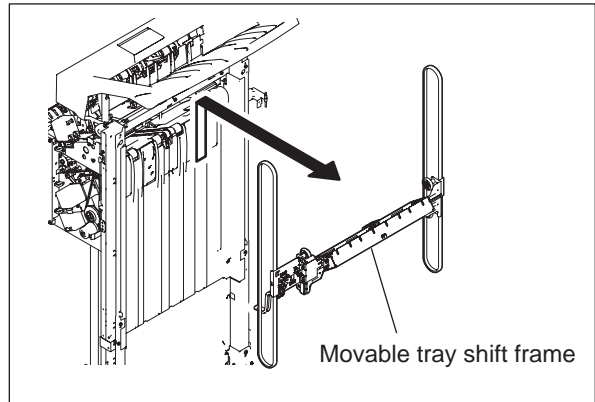

Fig. 4-16

- (14) Move the front alignment plate and the rear alignment plate to the center, and then take them off by pulling them out upward.

Note:

If the shutter is raised, move the frame downward.

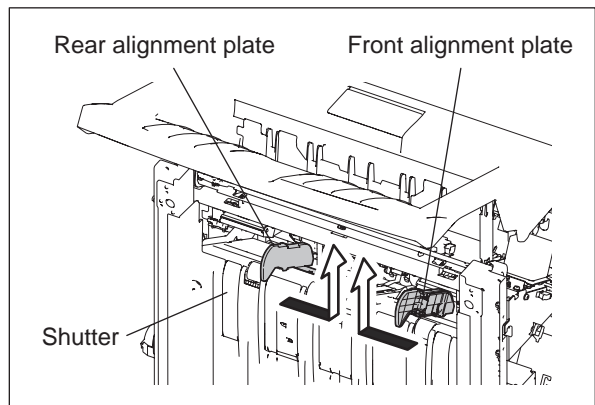

Fig. 4-17

- (15) Remove 4 screws, and then take off the grate-shaped guide by sliding it upward.

Note:

When installing the grate-shaped guide, hang the 2 hooks of the cover on the hooks of the frame.

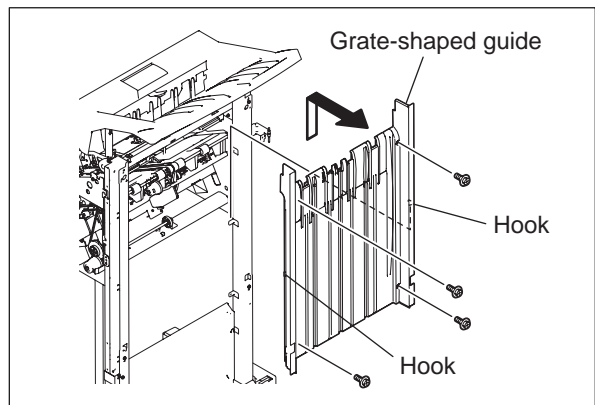

Fig. 4-18

Note:

When installing the grate-shaped guide, install the harness as shown in the figure.

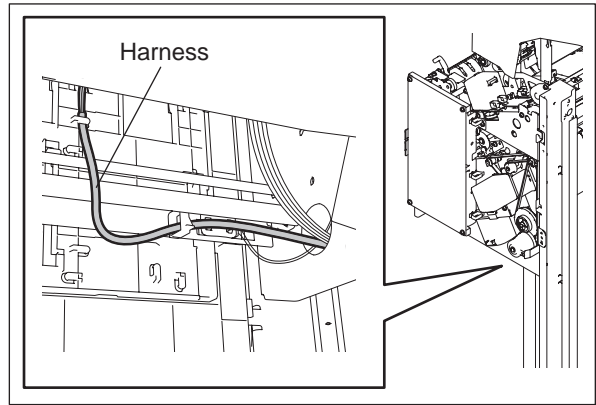

Fig. 4-19

[M] Left lower cover

- (1) Take off the rear upper cover and the rear lower cover.
📖 P. 4-1 "[A] Rear upper cover / Rear lower cover"
- (2) Take off the left upper cover.
📖 P. 4-2 "[B] Left upper cover"
- (3) Take off the control panel unit.
📖 P. 4-2 "[C] Control panel unit"
- (4) Take off the front cover assembly.
📖 P. 4-3 "[D] Front upper cover / Front lower cover"
- (5) Take off the front foot cover.
📖 P. 4-3 "[E] Front foot cover"
- (6) Take off the rear foot cover.
📖 P. 4-4 "[F] Rear foot cover"
- (7) Take off the movable tray cover.
📖 P. 4-4 "[G] Movable tray cover"
- (8) Take off the front rail cover.
📖 P. 4-5 "[H] Front rail cover"
- (9) Take off the rear rail cover.
📖 P. 4-5 "[I] Rear rail cover"
- (10) Remove 4 screws, and take off the left lower cover.

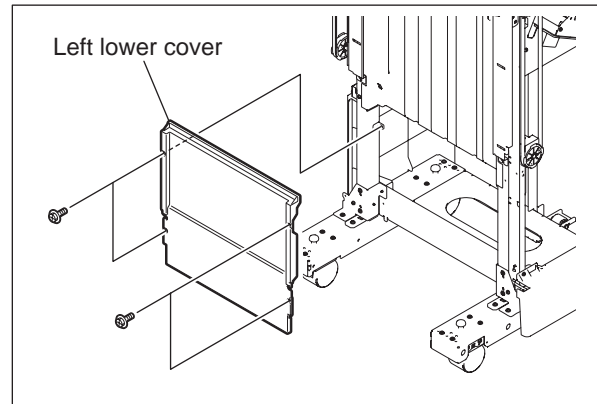

Fig. 4-20

[N] Stationary tray cover

- (1) Open the stationary tray.
- (2) Loosen 2 screws each from the front and back side cover, and remove 2 right side screws.
- (3) Lift the stationary cover upward to take off while pulling the jam access lever.

Notes:

- Be sure to install or remove the stationary tray cover with the stationary tray being opened, otherwise the upper exit roller guide may be damaged.
- Be sure not to damage the actuator of the stationary tray paper-full sensor.

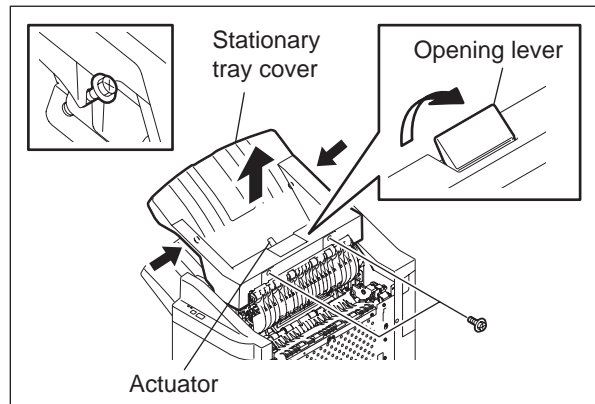

Fig. 4-21

Notes:

- Be sure not to lose 4 pins of the buffer unit-1.
- Before installing the stationary tray cover, adjust the installing positions of the 4 pins of the buffer unit-1 to the center position.

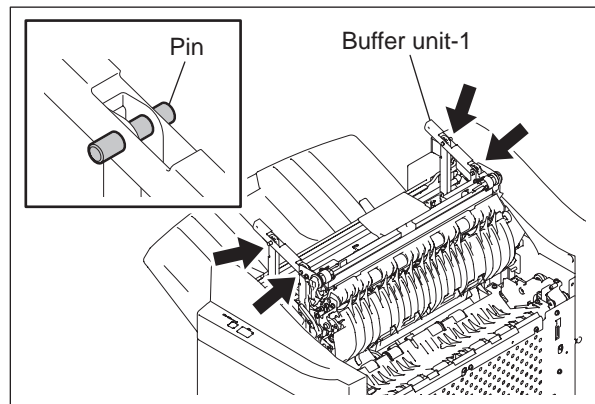

Fig. 4-22

[O] Front lowermost cover

- (1) Open the front cover assembly.
- (2) Remove 2 screws, and then take off the front lowermost cover.

Note:

When installing the front lowermost cover, hang the 2 hooks of the cover on the holes of the frame.

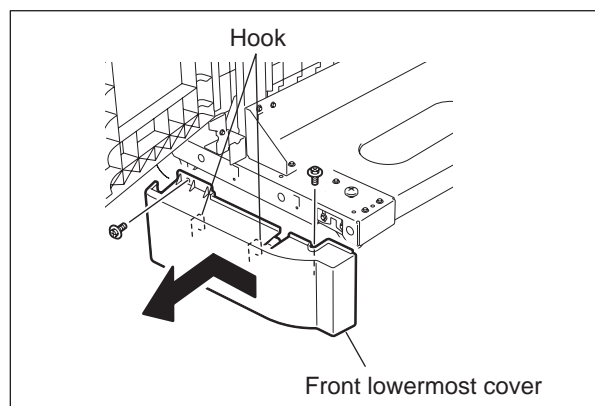

Fig. 4-23

[P] Handle cover

- (1) Open the front cover assembly.
- (2) Remove 2 screws, and then take off the handle cover.

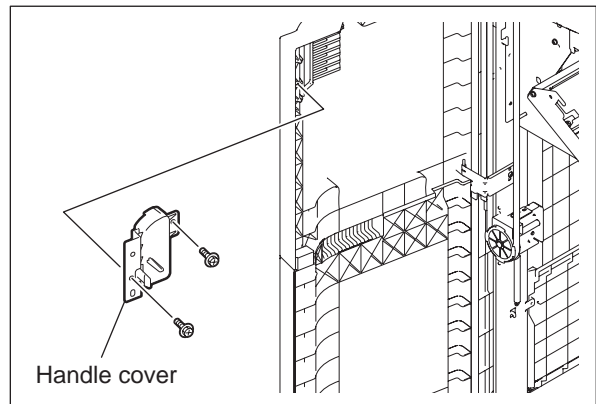

Fig. 4-24

4.2 Units

[A] Buffer unit

- (1) Take off the rear upper cover and the rear lower cover.
📖 P. 4-1 "[A] Rear upper cover / Rear lower cover"
- (2) Take off the left upper cover.
📖 P. 4-2 "[B] Left upper cover"
- (3) Take off the control panel unit.
📖 P. 4-2 "[C] Control panel unit"
- (4) Take off the front cover assembly.
📖 P. 4-3 "[D] Front upper cover / Front lower cover"
- (5) Take off the front foot cover.
📖 P. 4-3 "[E] Front foot cover"
- (6) Take off the rear foot cover.
📖 P. 4-4 "[F] Rear foot cover"
- (7) Take off the movable tray cover.
📖 P. 4-4 "[G] Movable tray cover"
- (8) Take off the front rail cover.
📖 P. 4-5 "[H] Front rail cover"
- (9) Take off the rear rail cover.
📖 P. 4-5 "[I] Rear rail cover"
- (10) Take off the movable tray drive unit.
📖 P. 4-20 "[E] Movable tray drive unit / Movable tray shift motor unit"
- (11) Take off the stationary tray cover.
📖 P. 4-10 "[N] Stationary tray cover"
- (12) Release the harness out of 1 clamp, and then disconnect each connector of CN16, CN17, CN18, CN19, CN20, CN21 and CN22 on the FIN board.
- (13) Disconnect the connector of the front cover switch.

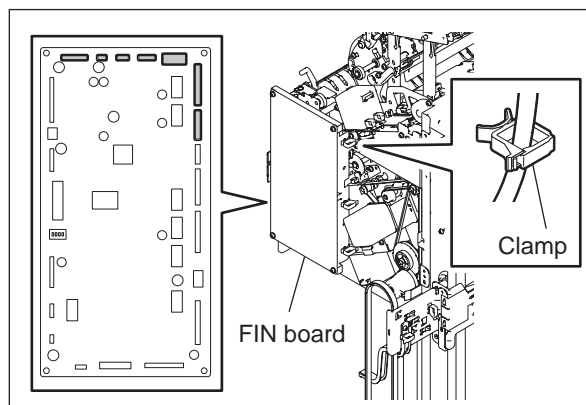

Fig. 4-25

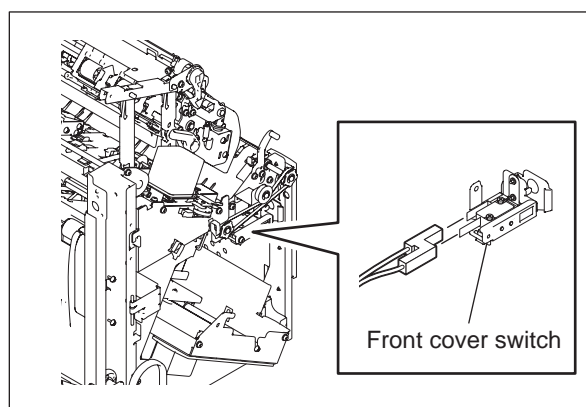

Fig. 4-26

- (14) Remove 5 screws, and then take off the buffer unit.

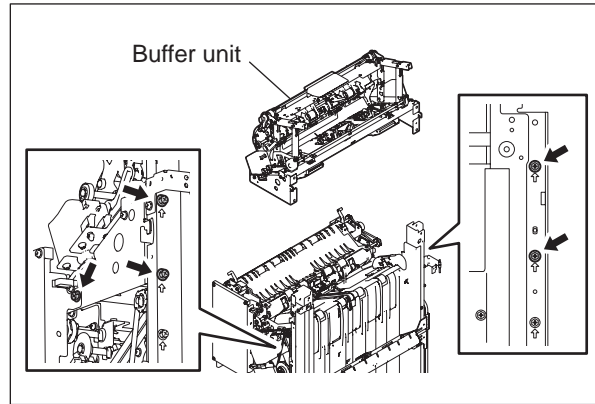

Fig. 4-27

Note:

When the buffer unit has been taken off, place the unit as shown in the figure in order not to damage the buffer guide or the paper holder plate.

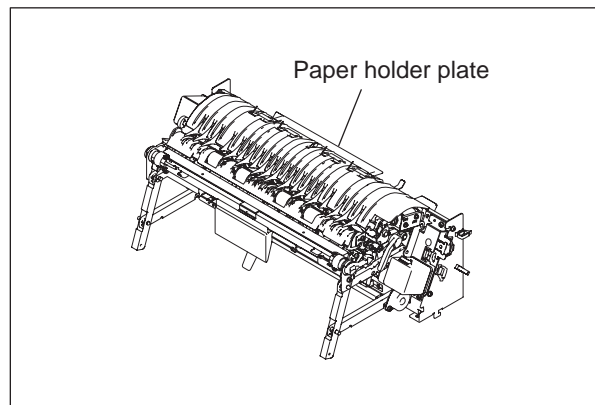

Fig. 4-28

[B] Buffer unit-1

- (1) Take off the rear upper cover and the rear lower cover.
 P. 4-1 "[A] Rear upper cover / Rear lower cover"
- (2) Take off the left upper cover.
 P. 4-2 "[B] Left upper cover"
- (3) Take off the control panel unit.
 P. 4-2 "[C] Control panel unit"
- (4) Take off the stationary tray cover.
 P. 4-10 "[N] Stationary tray cover"
- (5) Release the harness out of 3 clamps, and then disconnect each connector of CN16, CN17, CN18, CN19, CN20, CN21 and CN22 on the FIN board.

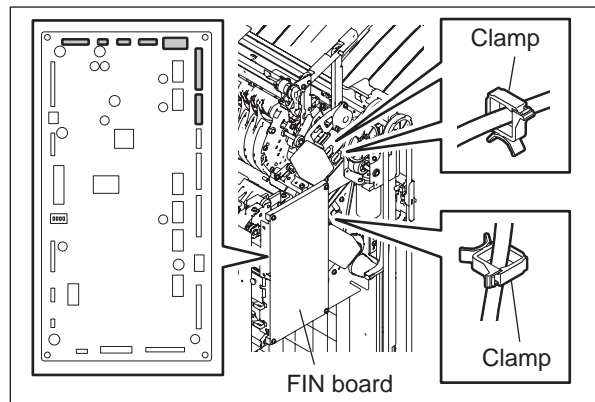

Fig. 4-29

- (6) Disconnect the connector of the buffer roller drive motor and release the harness out of the clamp.

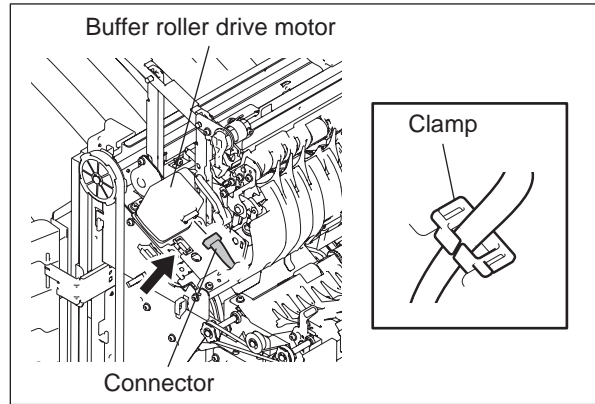

Fig. 4-30

- (7) Remove 1 screw and release the harness out of 2 clamps.

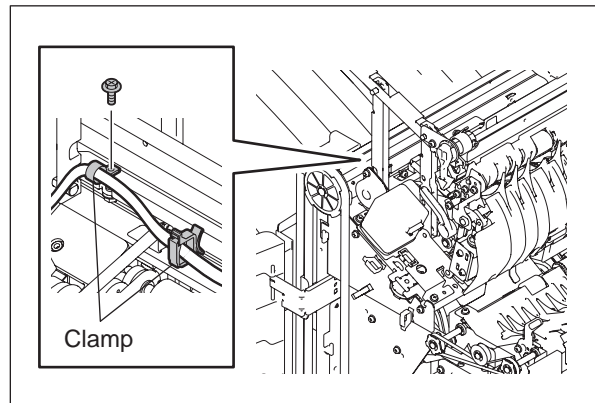

Fig. 4-31

- (8) Disconnect the connector of the buffer tray guide motor.

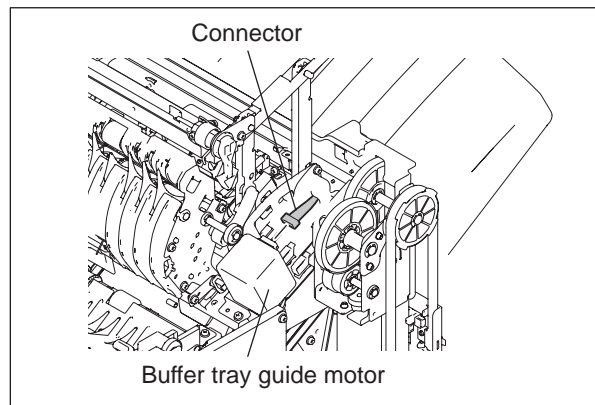

Fig. 4-32

- (9) Loosen 1 screw, and then tighten the screw by pushing the plate in the direction of the arrow. (Loosen the belt tension.)

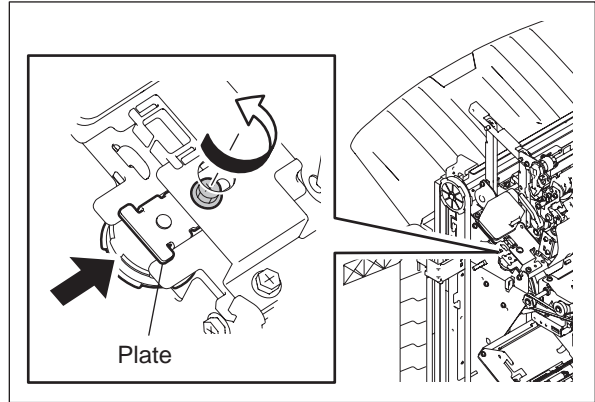

Fig. 4-33

- (10) Remove 4 screws, and then release the harness out of the hole of the frame to take off the buffer unit-1.

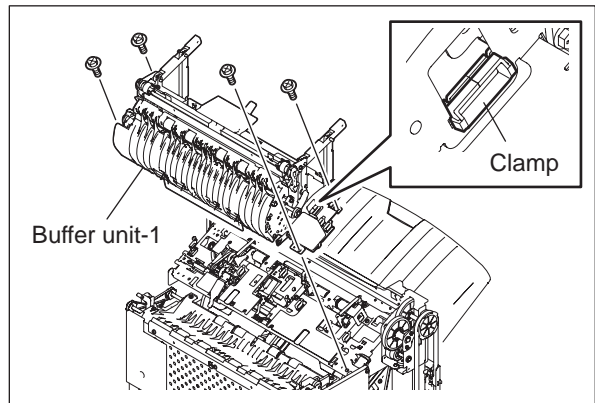

Fig. 4-34

[C] Finishing tray unit

- (1) Take off the rear upper cover and the rear lower cover.
📖 P. 4-1 "[A] Rear upper cover / Rear lower cover"
- (2) Take off the left upper cover.
📖 P. 4-2 "[B] Left upper cover"
- (3) Take off the control panel unit.
📖 P. 4-2 "[C] Control panel unit"
- (4) Take off the front cover assembly.
📖 P. 4-3 "[D] Front upper cover / Front lower cover"
- (5) Take off the front foot cover.
📖 P. 4-3 "[E] Front foot cover"
- (6) Take off the rear foot cover.
📖 P. 4-4 "[F] Rear foot cover"
- (7) Take off the movable tray cover.
📖 P. 4-4 "[G] Movable tray cover"
- (8) Take off the front rail cover.
📖 P. 4-5 "[H] Front rail cover"
- (9) Take off the rear rail cover.
📖 P. 4-5 "[I] Rear rail cover"
- (10) Take off the movable tray drive unit.
📖 P. 4-20 "[E] Movable tray drive unit / Movable tray shift motor unit"
- (11) Take off the grate-shaped guide.
📖 P. 4-7 "[L] Grate-shaped guide"
- (12) Take off the stationary tray cover.
📖 P. 4-10 "[N] Stationary tray cover"
- (13) Take off the buffer unit.
📖 P. 4-12 "[A] Buffer unit"
- (14) Release the harness out of 2 clamps, and then disconnect each connector of CN10 and CN11 on the FIN board unit.
- (15) Remove 1 clip on the front side of the stack transport roller-2. Then remove the bushing.

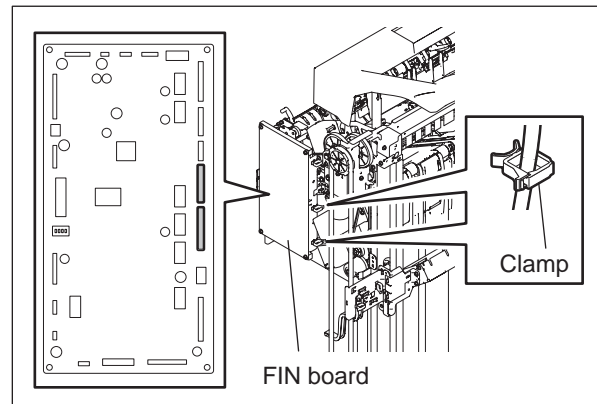

Fig. 4-35

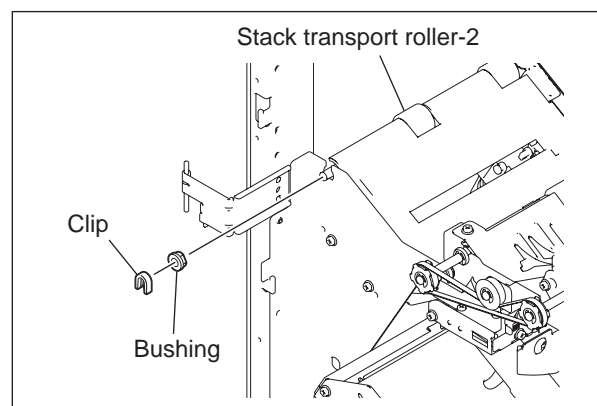

Fig. 4-36

- (16) Remove the spring, and then loosen 2 screws to free the belt tension.

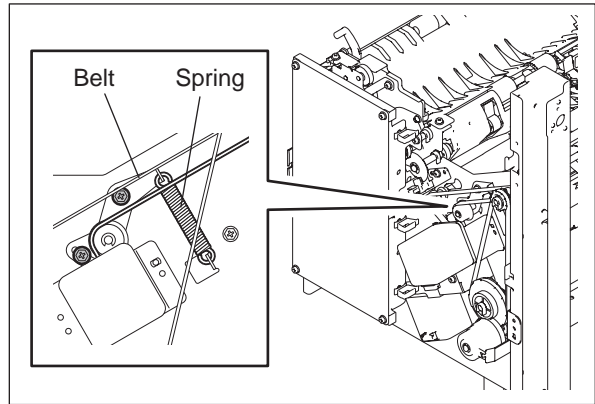

Fig. 4-37

- (17) Remove 3 clips on the rear side of the stack transport roller-2. Then remove the transport roller pulley-1, transport roller pulley -2, 2 pins, bushing and belt.

Notes:

- Be sure not to lose the fixing pins for the pulleys.
- Be sure not to lose the belt.

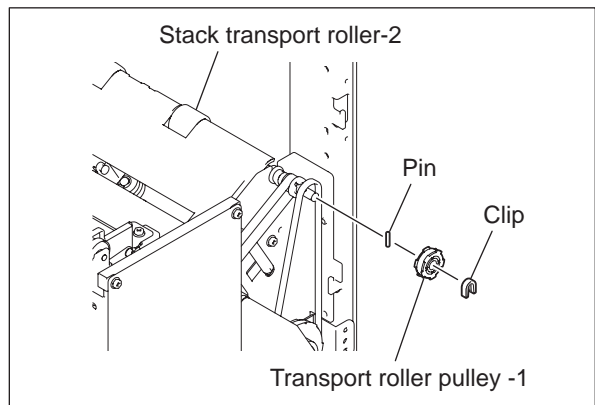

Fig. 4-38

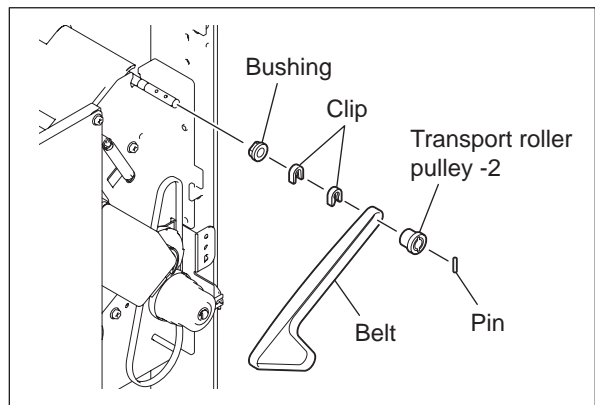

Fig. 4-39

- (18) Remove 2 clips on the rear side of the stack transport roller-1. Then remove the transport roller pulley -3, pin and bushing.

Note:

Be sure not to lose the fixing pins for the pulleys.

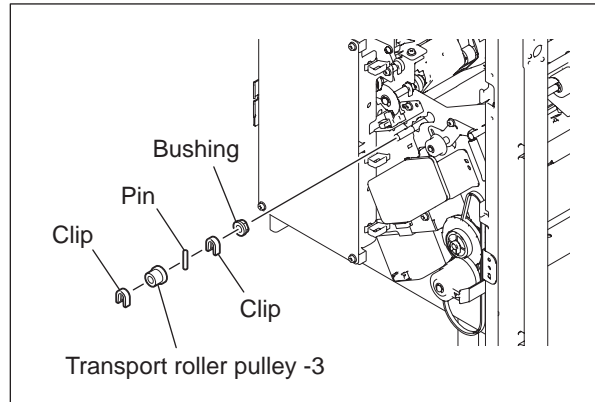

Fig. 4-40

- (19) Move the stapler to the staple replacing position (the first position from the front).
- (20) Remove 4 screws and take off the stack transport roller-2 in the finishing tray unit from the frame. Move the stack transport roller-1 as shown in the figure, and then lift the front side of the finishing tray unit to take it off.

Note:

Be sure not to deform the finishing tray guide.

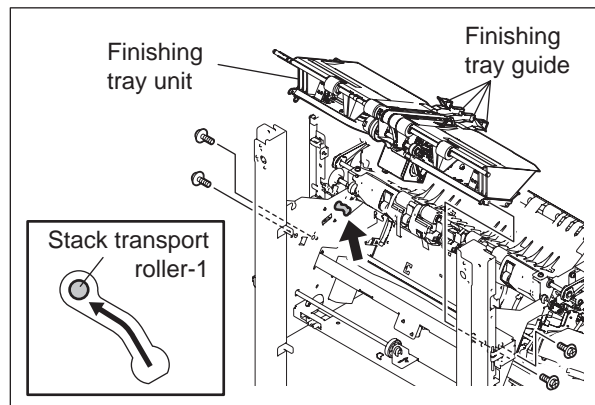

Fig. 4-41

[D] Stapler

- (1) Open the front cover assembly.
- (2) Move the stapler to the staple replacing position (the first position from the front).
- (3) Release the clamp to disconnect the flexible cable out of the connector.

Note:

When installing the stapler, place the flexible cable on the protrusion of the stapler and fix it with the clamp.

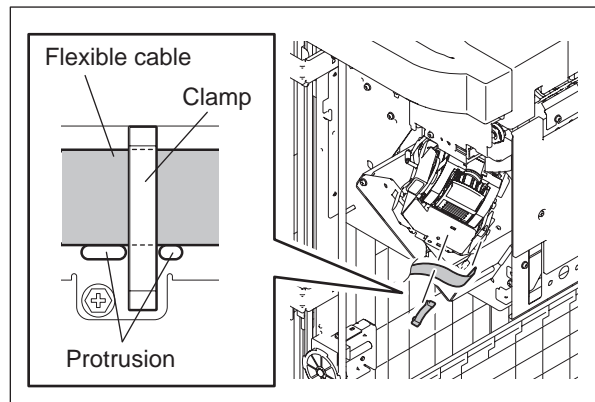

Fig. 4-42

- (4) Remove 1 screw, and then take off the stapler carrier.

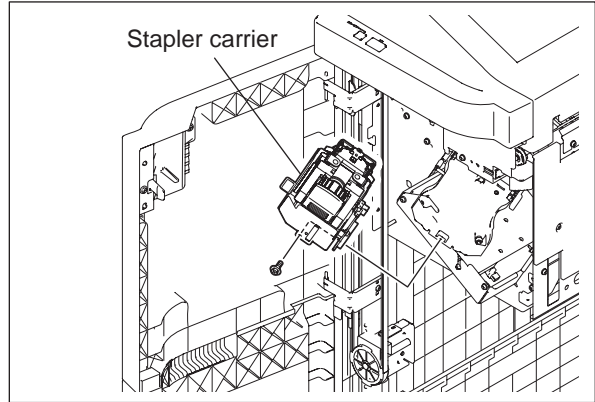

Fig. 4-43

- (5) Remove 2 screws, and then disconnect 2 connectors of the stapler to take off the stapler.

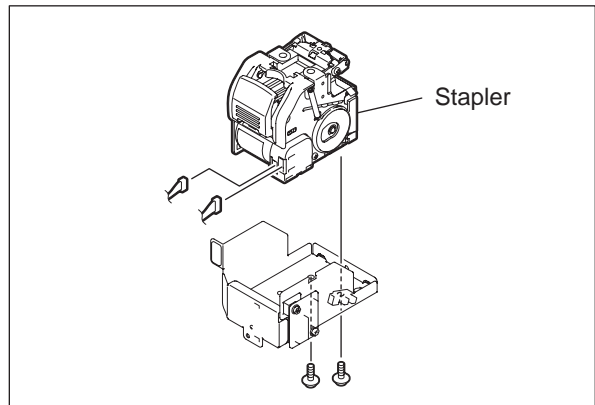

Fig. 4-44

[E] Movable tray drive unit / Movable tray shift motor unit

- (1) Take off the rear upper cover and the rear lower cover.
📖 P. 4-1 "[A] Rear upper cover / Rear lower cover"
- (2) Take off the left upper cover.
📖 P. 4-2 "[B] Left upper cover"
- (3) Take off the control panel unit.
📖 P. 4-2 "[C] Control panel unit"
- (4) Take off the front cover assembly.
📖 P. 4-3 "[D] Front upper cover / Front lower cover"
- (5) Take off the front foot cover.
📖 P. 4-3 "[E] Front foot cover"
- (6) Take off the rear foot cover.
📖 P. 4-4 "[F] Rear foot cover"
- (7) Take off the movable tray cover.
📖 P. 4-4 "[G] Movable tray cover"
- (8) Take off the front rail cover.
📖 P. 4-5 "[H] Front rail cover"
- (9) Take off the rear rail cover.
📖 P. 4-5 "[I] Rear rail cover"
- (10) Move the movable tray shift frame to the middle position. If the movable tray shift frame needs to be lowered, push the gear of the movable tray shift motor unit in the direction of the arrow to unlock the frame. (Be sure to hold the movable tray gear frame with your hands because it may fall when the gear is pushed.)
- (11) Remove 2 screws, and then take off the sensor rail by sliding it downward.

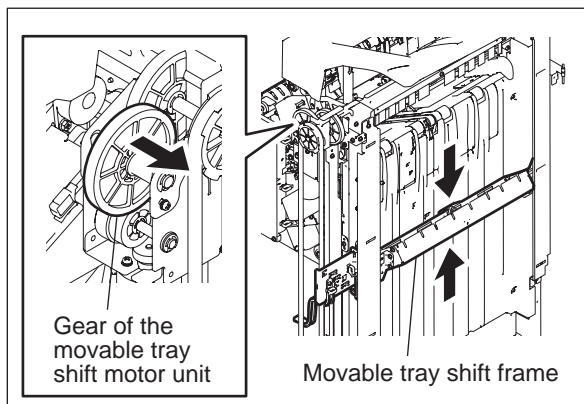

Fig. 4-45

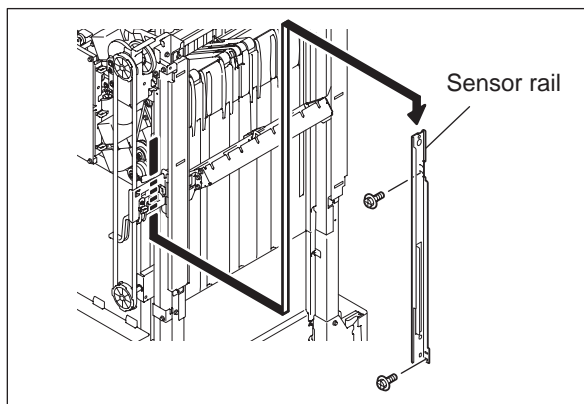

Fig. 4-46

Note:

When installing the movable tray drive unit, fix it at the position where the gap between the center mark of the scale on the sensor rail and the edge of the movable tray position-A sensor is from 0 to 1 mm. Be sure to adjust the installation position by shifting the movable tray shift frame and measure the positions at the upper and lower measuring points on the sensor rail as shown in the figure.

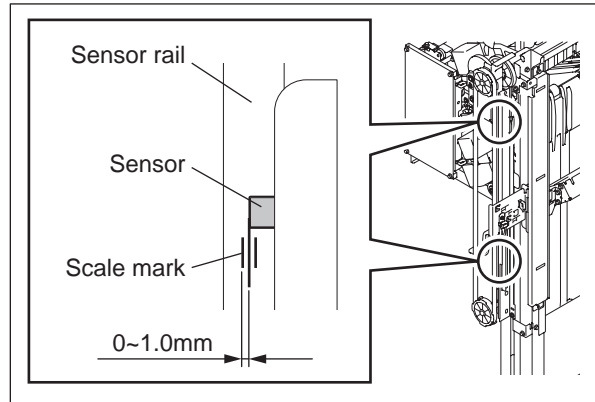

Fig. 4-47

- (12) Remove 1 screw, and then take off the front rail guide.
- (13) Remove 2 screws, and then take off the rear rail guide.

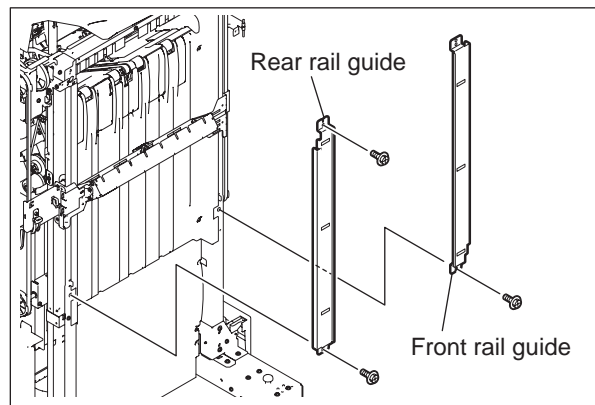

Fig. 4-48

- (14) Move the movable tray shift frame to the lowest position.
- (15) Remove the spring, and then remove 2 screws to take off the front bracket of the movable tray shift pulley.

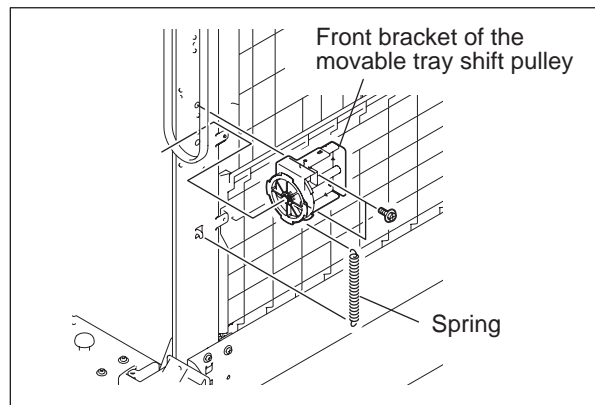

Fig. 4-49

- (16) Remove the spring, and then remove 2 screws to take off the rear bracket of the movable tray shift pulley.

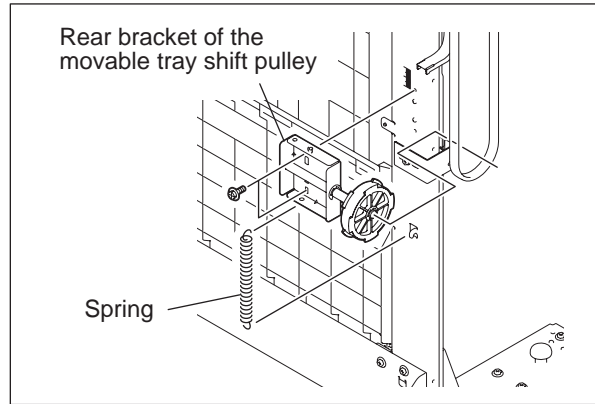

Fig. 4-50

Note:

When installing the front and rear brackets of the movable tray shift pulley, lower the movable tray shift frame to the lowest position by pushing the gear of the movable tray shift motor unit in the direction of the arrow. Then check if the bottom of the movable tray shift frame is contacting with 2 protrusions. (Be sure to hold the movable tray shift frame with your hands because it may fall when the gear is pushed.)

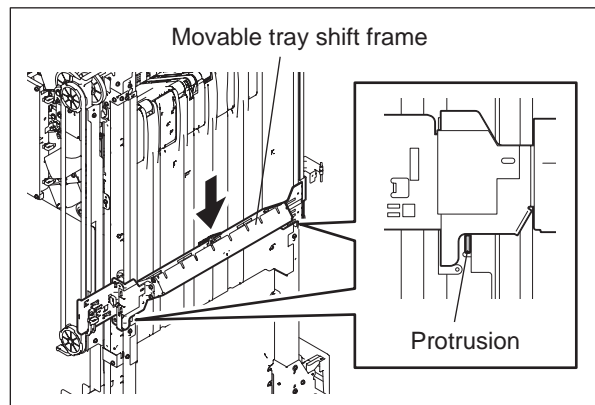

Fig. 4-51

Note:

If the bottom of the movable tray frame does not contact with either of these protrusions, remove 1 screw of the rear belt fixing stay to take this stay off, and fix the stay at the position where 2 brackets contact with the protrusions.

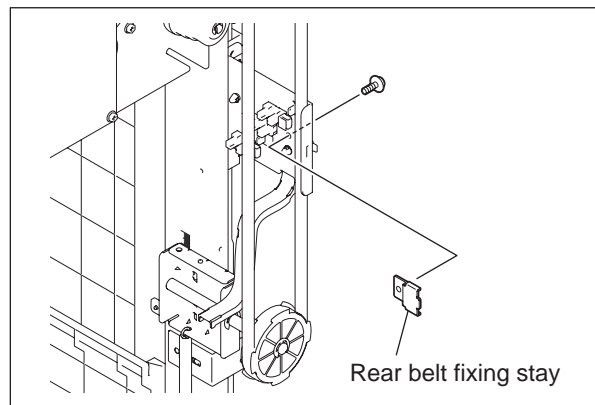

Fig. 4-52

- (17) Release the harness out of 2 clamps, and then disconnect the connector of CN8 on the FIN board.

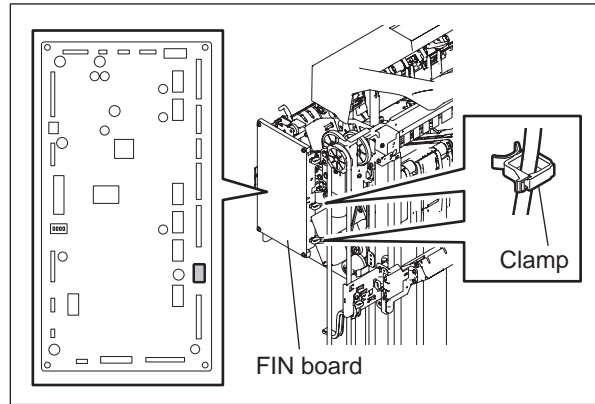

Fig. 4-53

- (18) Remove each belt from the 2 pulleys of the movable tray drive unit.
(19) Close the stationary tray cover halfway and leave it, and then remove 4 screws to take off the movable tray drive unit.

Note:

When installing the movable tray drive unit, slide the unit to the front side of the equipment and fix it at that position.

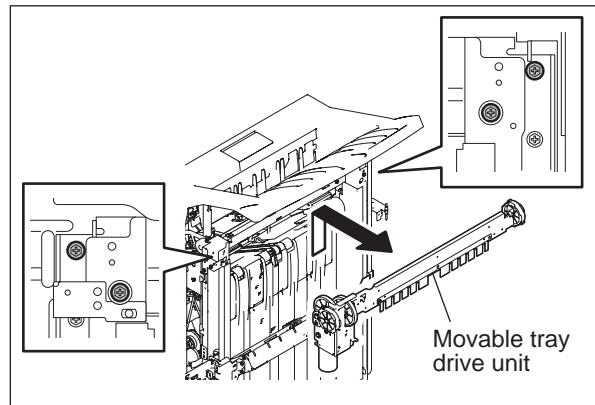

Fig. 4-54

- (20) Remove 1 E-ring, 1 pulley and 1 pin.

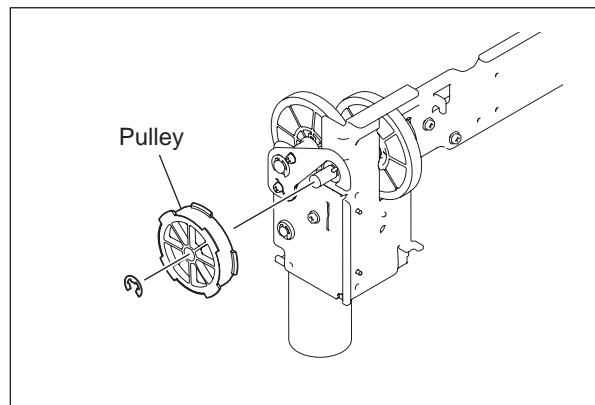

Fig. 4-55

(21) Remove 4 screws.

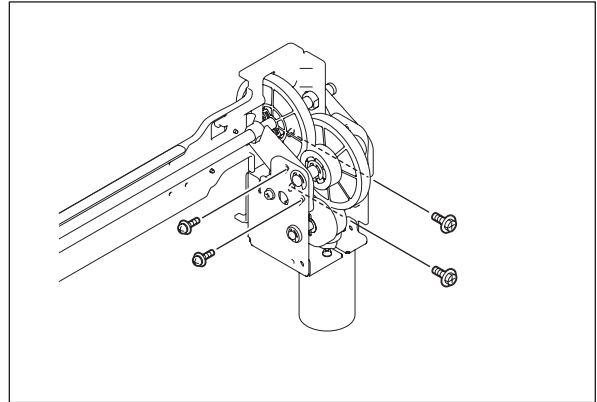

Fig. 4-56

(22) Move the front stay in the direction of the arrow to release from the bushing, and take off the movable tray shift motor unit.

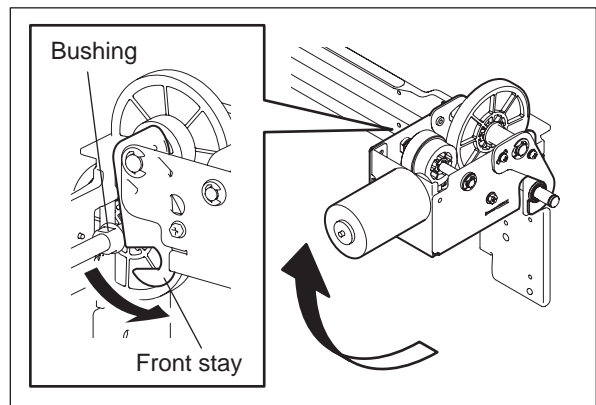

Fig. 4-57

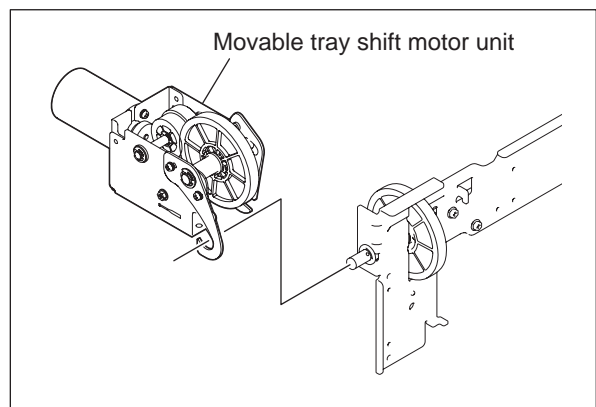

Fig. 4-58

- (23) Remove 2 screws and 4 E-rings, and then take off the shaft, rear stay, 2 spacers, spring, 2 gears and the front stay from the movable tray shift motor unit.

Note:

Since the movable tray shift motor unit is assembled using a jig, do not try to disassemble it.

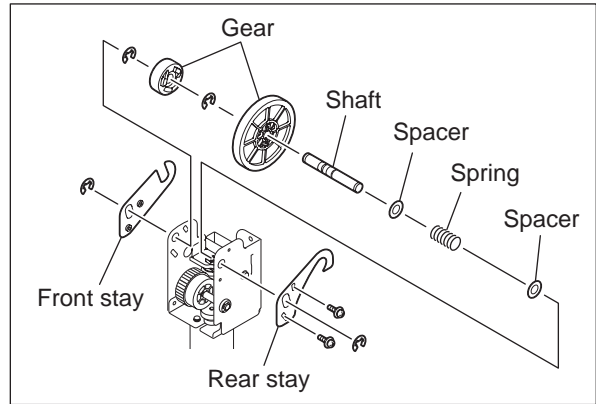

Fig. 4-59

4.3 Rollers

[A] Paddle-1 / Paddle-2 / Paddle-3 / Catching pad / Paddle-4 / Paddle-5 / Paddle-6

- (1) Take off the rear upper cover and the rear lower cover.
📖 P. 4-1 "[A] Rear upper cover / Rear lower cover"
- (2) Take off the blind cover.
📖 P. 4-6 "[J] Blind cover"
- (3) Take off the shield metal plate.
📖 P. 4-6 "[K] Shield metal plate"
- (4) Take off the stationary tray cover.
📖 P. 4-10 "[N] Stationary tray cover"
- (5) Remove 1 screw, and then take off the sensor bracket of the entrance sensor.

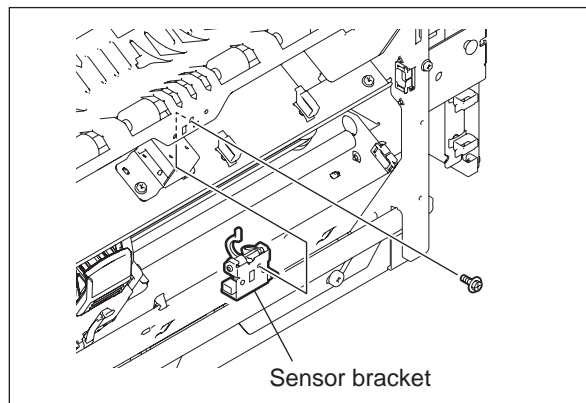

Fig. 4-60

- (6) Close the buffer unit-1 halfway and leave it. Then remove 1 screw.

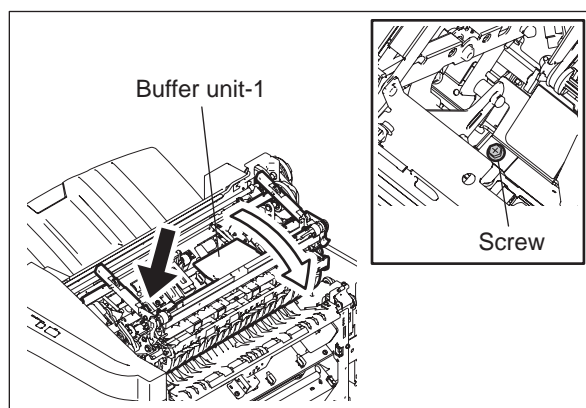

Fig. 4-61

- (7) Remove 3 screws, and then take off the transport guide.

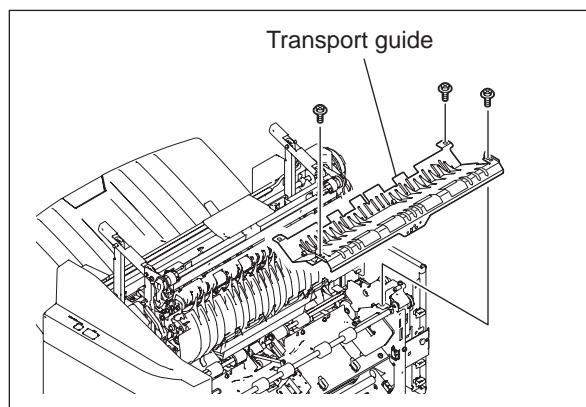

Fig. 4-62

- (8) Take off the arm by pulling it out upward.

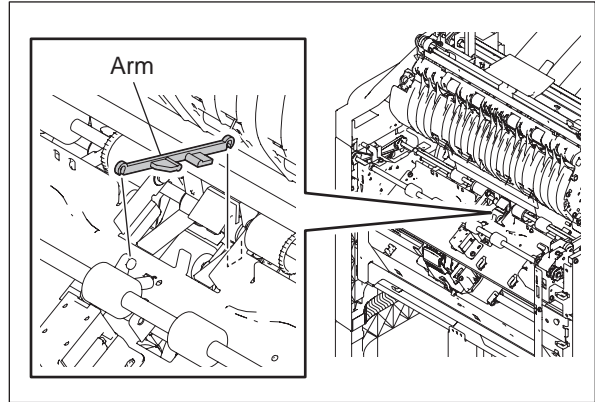

Fig. 4-63

Note:

When installing, be sure that the ring of the arm comes downside.

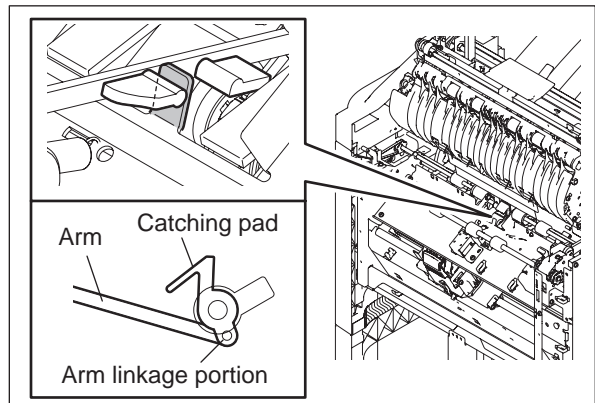

Fig. 4-64

- (9) Move each of the buffer guides to each side.

Note:

If the shutter is raised, move the frame downward.

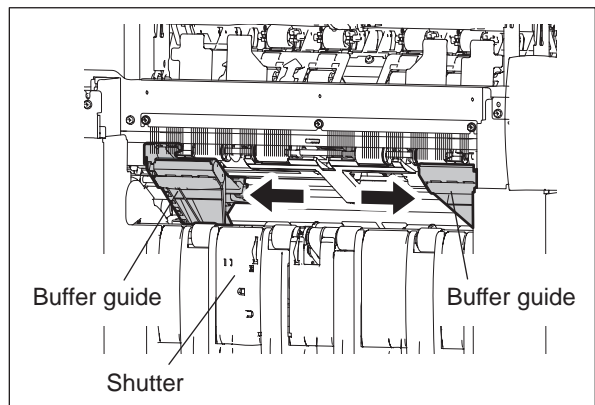

Fig. 4-65

- (10) Move the front and rear alignment plates to the center, and then pull them out upward to take them off.

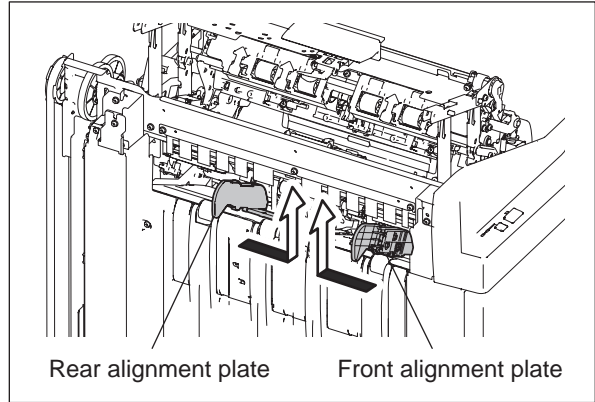

Fig. 4-66

- (11) Remove 4 screws of the front and rear pull-in guides.

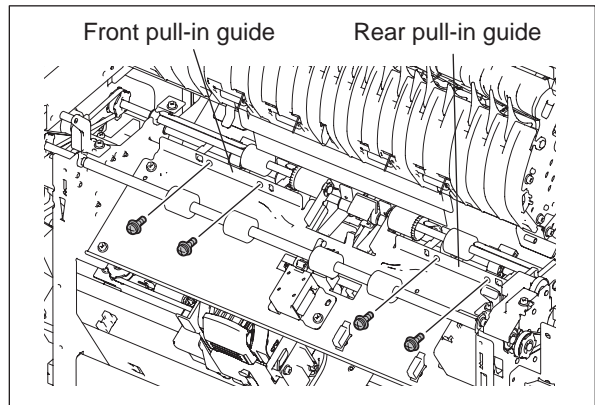

Fig. 4-67

Notes:

When replacing the front and rear pull-in guides, adjust the position with a jig. Install them based on adjustment area B of the jig so that the gap between the front and rear finishing tray covers is more than adjustment area A and less than C.

6LB10056000 JIG-GID-PDL-2

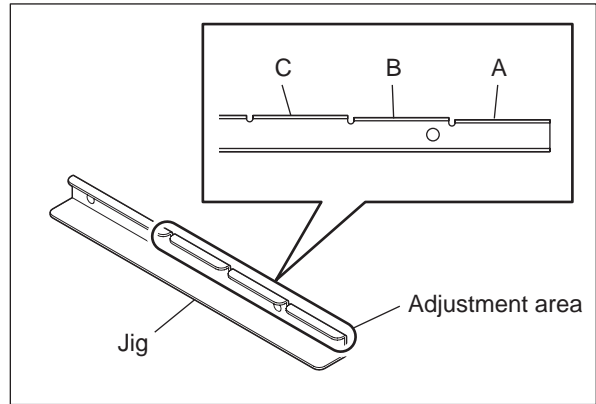

Fig. 4-68

1. Close the buffer unit 1.
2. Place the jig on the rear finishing tray cover and fix the one with the rear pull-in guide by 2 screws at the position of adjustment area B. Measure the height at the 2 measuring points where there are no protrusions of the rear pull-in guide as shown in the figure.
3. After fixing the screws, check that the dimension of the gap is more than adjustment area A and less than C.
4. Adjust the front pull-in guide in the same manner.

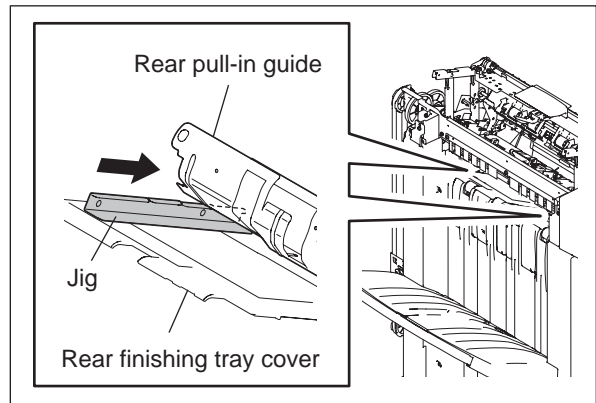

Fig. 4-69

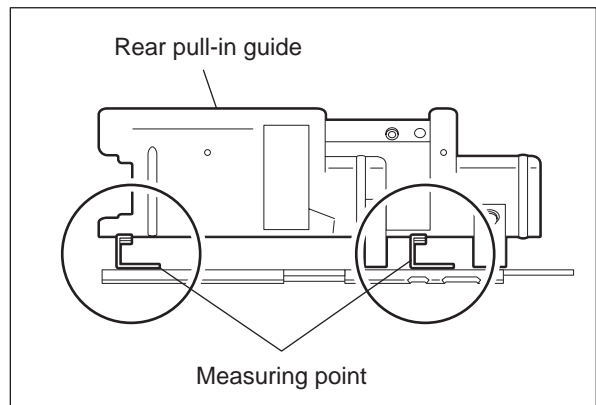

Fig. 4-70

- (12) Open the front cover assembly.
- (13) Remove 1 clip on the rear side of the paddle shaft, and then slide the bushing.

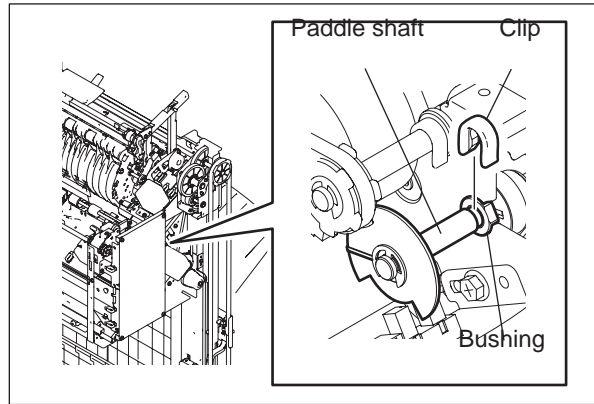

Fig. 4-71

- (14) Take off the paddle shaft, and the front and rear pull-in guides.

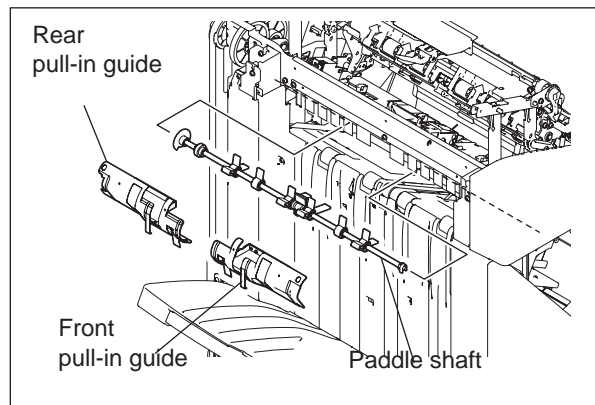

Fig. 4-72

- (15) Remove 1 clip and 10 E-rings. Then remove 6 paddles, 8 pins, 2 bushings. Then take off the catching pad, catching pad collar, spring, gear and actuator.

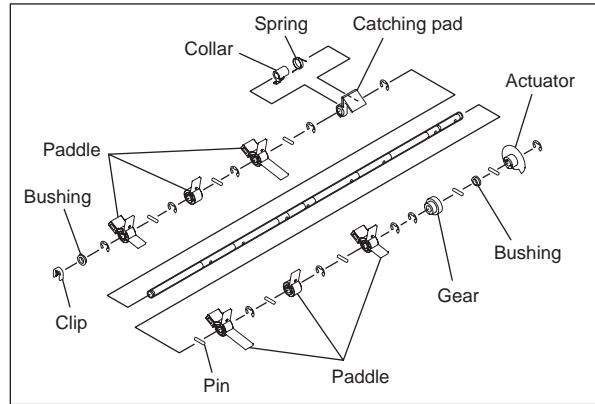

Fig. 4-73

Notes:

- Install the catching pad, catching pad collar and spring in the directions shown in the figure.
- When installing the paddle-1, paddle-2, paddle-3, paddle-4, paddle-5 and paddle-6, be sure that each star mark of the paddles is seen as shown in the figure.

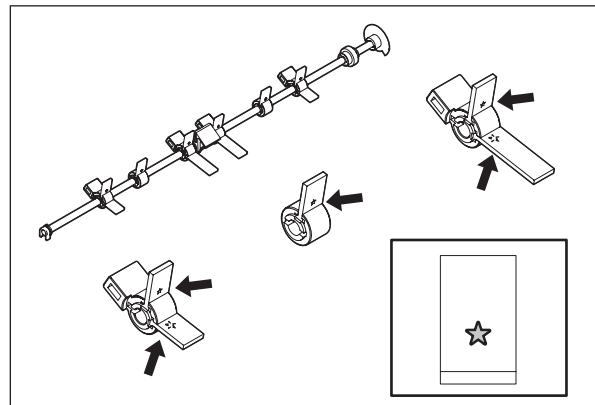

Fig. 4-74

[B] Front transport roller / Rear transport roller

- (1) Take off the rear upper cover and the rear lower cover.
 P. 4-1 "[A] Rear upper cover / Rear lower cover"
- (2) Take off the left upper cover.
 P. 4-2 "[B] Left upper cover"
- (3) Take off the control panel unit.
 P. 4-2 "[C] Control panel unit"
- (4) Take off the blind cover.
 P. 4-6 "[J] Blind cover"
- (5) Take off the shield metal plate.
 P. 4-6 "[K] Shield metal plate"
- (6) Take off the stationary tray cover.
 P. 4-10 "[N] Stationary tray cover"
- (7) Remove 1 screw, and then take off the sensor bracket of the entrance sensor.

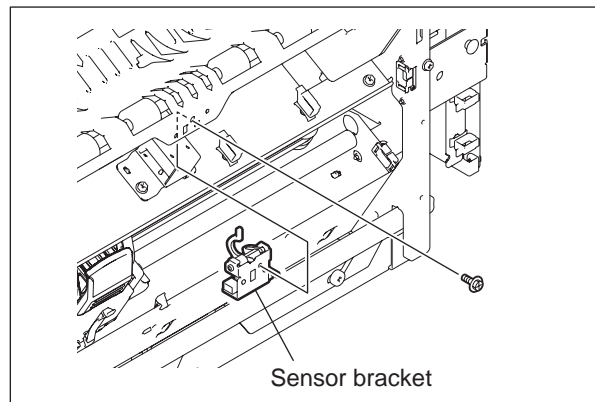

Fig. 4-75

- (8) Close the buffer unit-1 halfway and leave it. Then remove 1 screw.

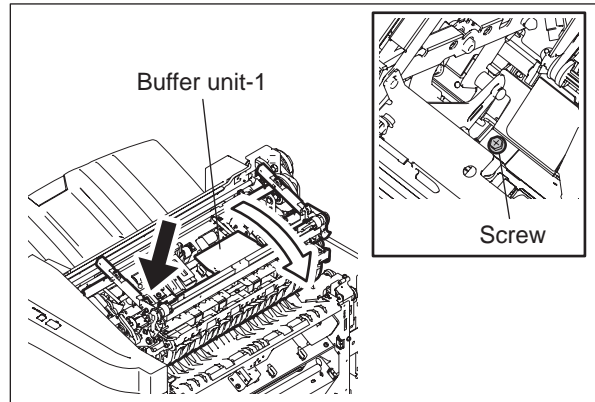

Fig. 4-76

- (9) Remove 3 screws, and then take off the transport guide.

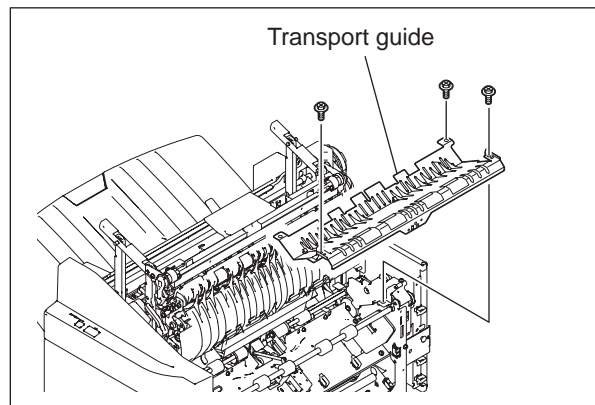

Fig. 4-77

- (10) Remove 1 E-ring, and then take off the front transport roller by sliding the bushing.

Note:

Be sure not to lose the belt.

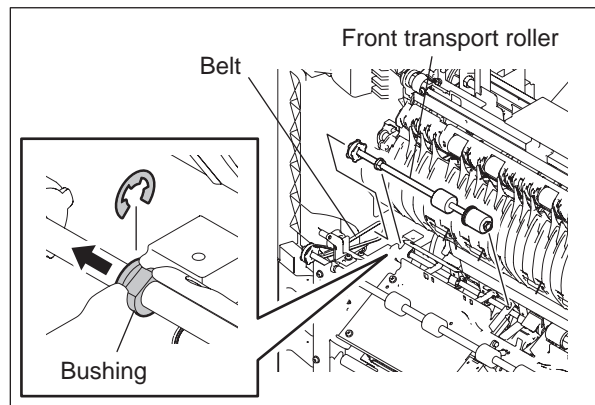

Fig. 4-78

- (11) Remove 1 clip, and then take off the rear transport roller by sliding the bushing.

Note:

Be sure not to lose the belt.

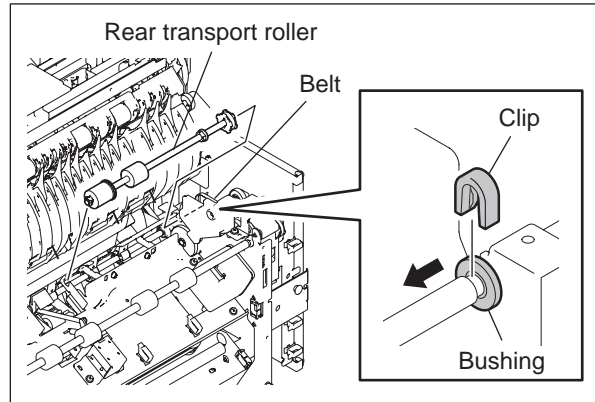

Fig. 4-79

- (12) Remove each 2 E-rings from the front and rear transport rollers. Then remove 2 bushings, the pulley and the pin.

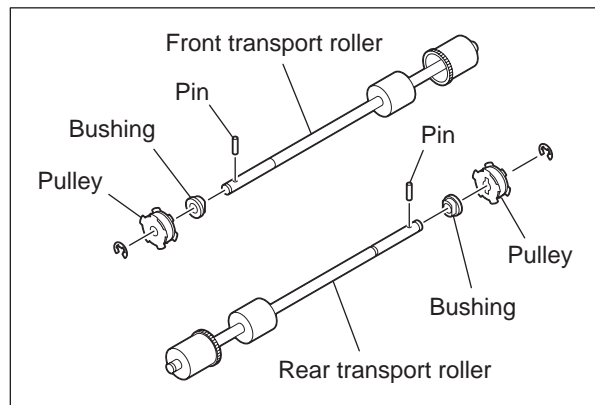

Fig. 4-80

[C] Entrance roller

- (1) Take off the rear upper cover and the rear lower cover.
 P. 4-1 "[A] Rear upper cover / Rear lower cover"
- (2) Take off the blind cover.
 P. 4-6 "[J] Blind cover"
- (3) Take off the shield metal plate.
 P. 4-6 "[K] Shield metal plate"
- (4) Take off the stationary tray cover.
 P. 4-10 "[N] Stationary tray cover"
- (5) Open the front cover assembly.
- (6) Remove 1 screw, and then take off the sensor bracket of the entrance sensor.

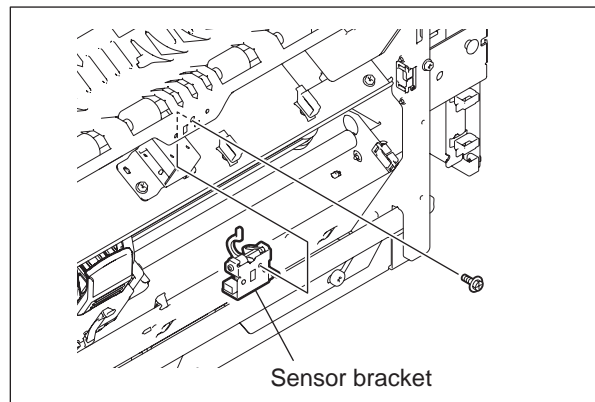

Fig. 4-81

- (7) Close the buffer unit-1 halfway and leave it. Then remove 1 screw.

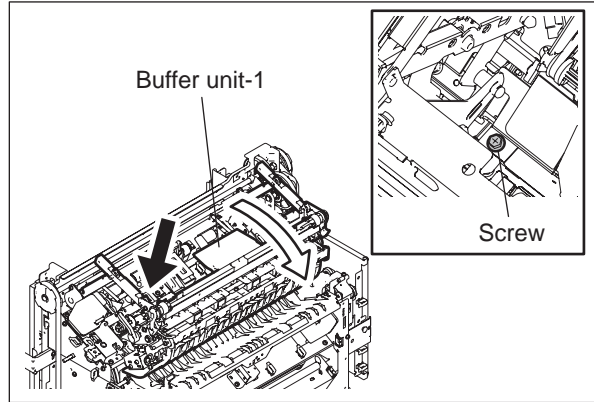

Fig. 4-82

- (8) Remove 3 screws, and then take off the transport guide.

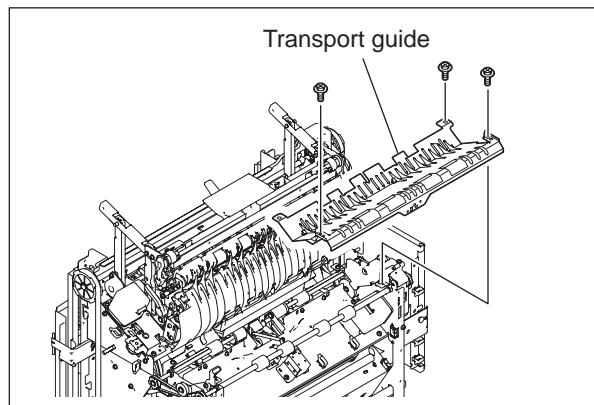

Fig. 4-83

- (9) Release the harnesses from 6 harness clamps.

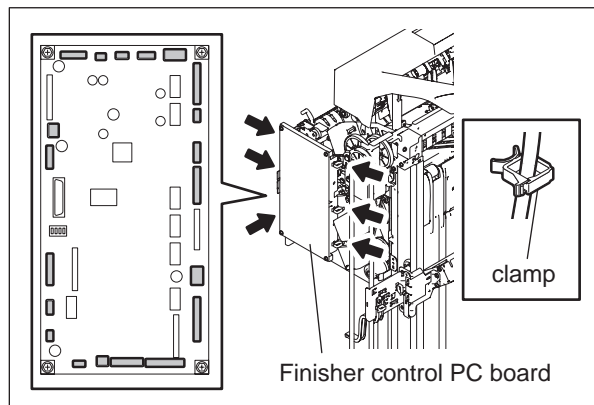

Fig. 4-84

- (10) Remove 4 screws, then take off the FIN board assembly.

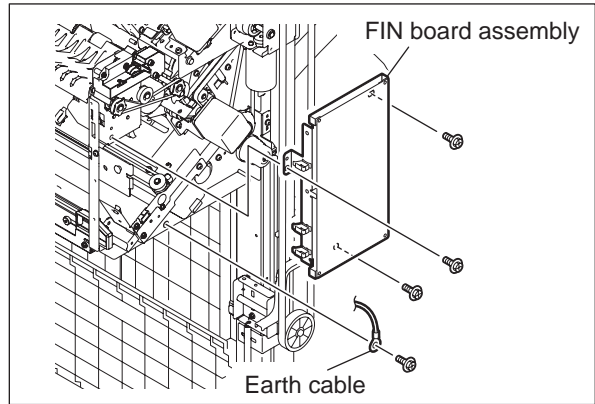

Fig. 4-85

- (11) Remove 1 screw to take off the switch cover.

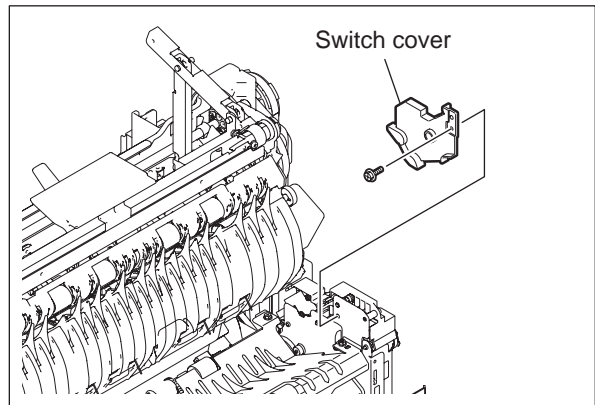

Fig. 4-86

- (12) Remove 3 screws, then take off the tray switch unit.

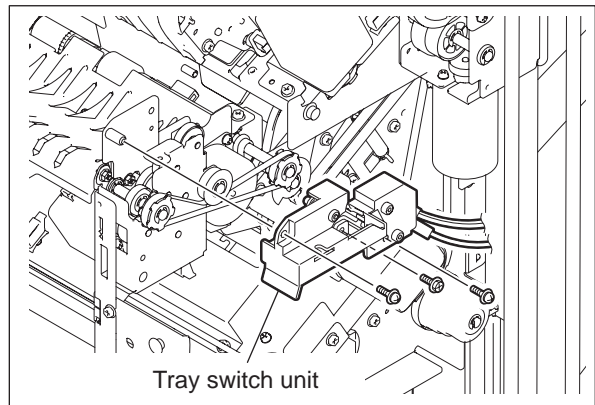

Fig. 4-87

- (13) Remove 2 E-rings, and then slide 2 bushings. Then remove 2 belts to take off the entrance roller.

Note:

Be sure not to lose the 2 belts.

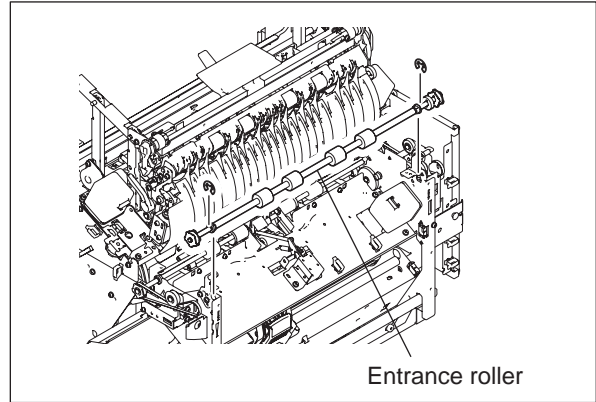

Fig. 4-88

- (14) Remove 3 E-rings. Then remove 2 pulleys, 2 bushings, 1 gear and 3 pins from the entrance roller.

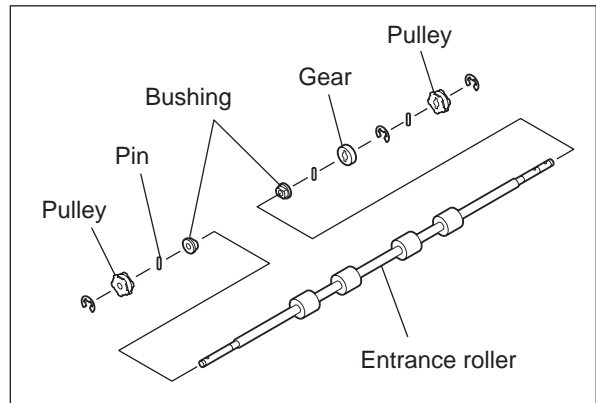

Fig. 4-89

[D] Stack transport roller-1

- (1) Take off the rear upper cover and the rear lower cover.
📖 P. 4-1 "[A] Rear upper cover / Rear lower cover"
- (2) Take off the left upper cover.
📖 P. 4-2 "[B] Left upper cover"
- (3) Take off the control panel unit.
📖 P. 4-2 "[C] Control panel unit"
- (4) Take off the front cover assembly.
📖 P. 4-3 "[D] Front upper cover / Front lower cover"
- (5) Take off the front foot cover.
📖 P. 4-3 "[E] Front foot cover"
- (6) Take off the rear foot cover.
📖 P. 4-4 "[F] Rear foot cover"
- (7) Take off the movable tray cover.
📖 P. 4-4 "[G] Movable tray cover"
- (8) Take off the front rail cover.
📖 P. 4-5 "[H] Front rail cover"
- (9) Take off the rear rail cover.
📖 P. 4-5 "[I] Rear rail cover"
- (10) Take off the movable tray drive unit.
📖 P. 4-20 "[E] Movable tray drive unit / Movable tray shift motor unit"
- (11) Take off the grate-shaped guide.
📖 P. 4-7 "[L] Grate-shaped guide"
- (12) Take off the stationary tray cover.
📖 P. 4-10 "[N] Stationary tray cover"
- (13) Take off the buffer unit.
📖 P. 4-12 "[A] Buffer unit"
- (14) Take off the finishing tray unit.
📖 P. 4-16 "[C] Finishing tray unit"
- (15) Remove 2 screws, and then take off the front finishing tray cover.
- (16) Remove 2 screws, and then take off the rear finishing tray cover.

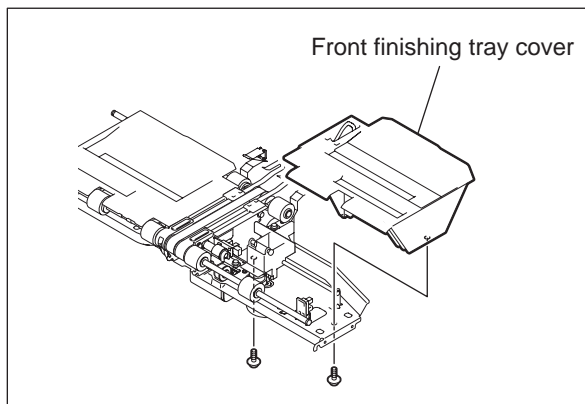

Fig. 4-90

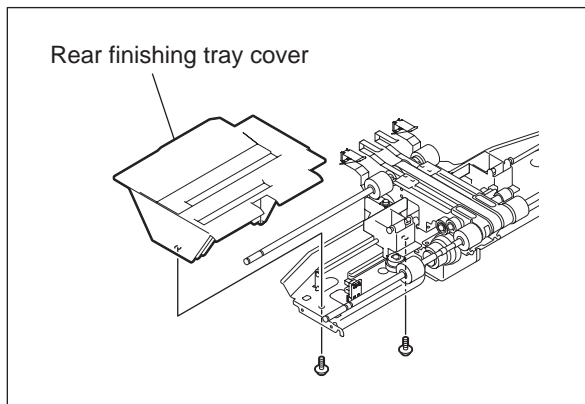

Fig. 4-91

- (17) Remove 2 E-rings, and then take off the pin and the stack transport roller-1.

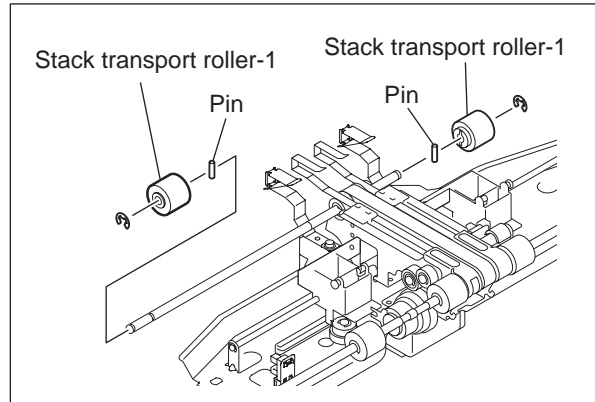

Fig. 4-92

[E] Stack transport roller-2

- (1) Take off the rear upper cover and the rear lower cover.
 ☞ P. 4-1 "[A] Rear upper cover / Rear lower cover"
- (2) Take off the left upper cover.
 ☞ P. 4-2 "[B] Left upper cover"
- (3) Take off the control panel unit.
 ☞ P. 4-2 "[C] Control panel unit"
- (4) Take off the front cover assembly.
 ☞ P. 4-3 "[D] Front upper cover / Front lower cover"
- (5) Take off the front foot cover.
 ☞ P. 4-3 "[E] Front foot cover"
- (6) Take off the rear foot cover.
 ☞ P. 4-4 "[F] Rear foot cover"
- (7) Take off the movable tray cover.
 ☞ P. 4-4 "[G] Movable tray cover"
- (8) Take off the front rail cover.
 ☞ P. 4-5 "[H] Front rail cover"
- (9) Take off the rear rail cover.
 ☞ P. 4-5 "[I] Rear rail cover"
- (10) Take off the movable tray drive unit.
 ☞ P. 4-20 "[E] Movable tray drive unit / Movable tray shift motor unit"
- (11) Take off the grate-shaped guide.
 ☞ P. 4-7 "[L] Grate-shaped guide"
- (12) Take off the stationary tray cover.
 ☞ P. 4-10 "[N] Stationary tray cover"
- (13) Take off the buffer tray unit.
 ☞ P. 4-12 "[A] Buffer unit"
- (14) Take off the finishing tray unit.
 ☞ P. 4-16 "[C] Finishing tray unit"
- (15) Remove 2 screws, and then take off the front finishing tray cover.

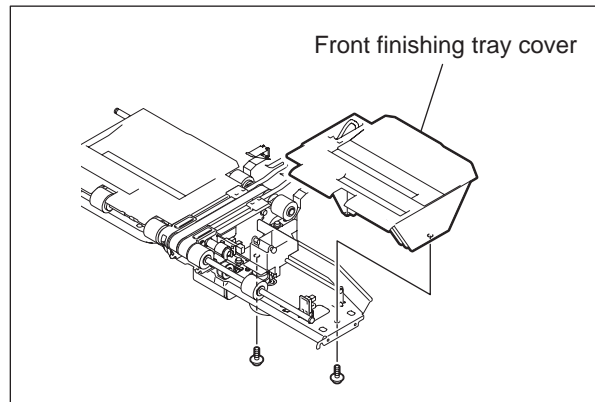

Fig. 4-93

- (16) Remove 2 screws, and then take off the rear finishing tray cover.

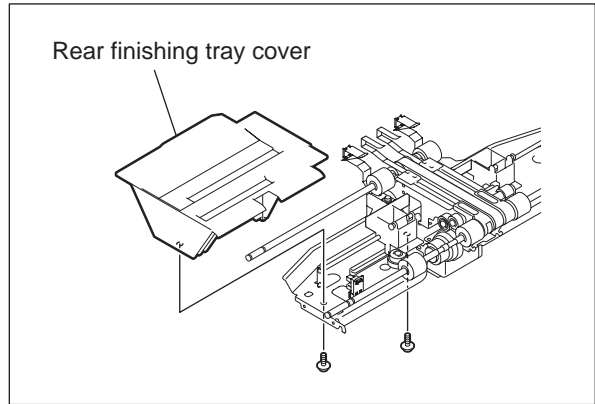

Fig. 4-94

- (17) Remove 4 E-rings and 4 pins, and then take off 4 stack transport rollers-2.

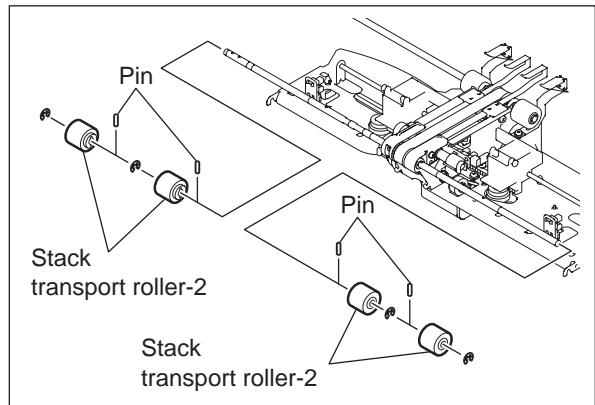

Fig. 4-95

[F] Buffer roller

- (1) Take off the rear upper cover and the rear lower cover.
📖 P. 4-1 "[A] Rear upper cover / Rear lower cover"
- (2) Take off the left upper cover.
📖 P. 4-2 "[B] Left upper cover"
- (3) Take off the control panel unit.
📖 P. 4-2 "[C] Control panel unit"
- (4) Take off the front cover assembly.
📖 P. 4-3 "[D] Front upper cover / Front lower cover"
- (5) Take off the front foot cover.
📖 P. 4-3 "[E] Front foot cover"
- (6) Take off the rear foot cover.
📖 P. 4-4 "[F] Rear foot cover"
- (7) Take off the movable tray cover.
📖 P. 4-4 "[G] Movable tray cover"
- (8) Take off the front rail cover.
📖 P. 4-5 "[H] Front rail cover"
- (9) Take off the rear rail cover.
📖 P. 4-5 "[I] Rear rail cover"
- (10) Take off the movable tray drive unit.
📖 P. 4-20 "[E] Movable tray drive unit / Movable tray shift motor unit"
- (11) Take off the stationary tray cover.
📖 P. 4-10 "[N] Stationary tray cover"
- (12) Take off the buffer tray unit.
📖 P. 4-12 "[A] Buffer unit"
- (13) Loosen 1 screw, and then tighten the screw by pushing the plate in the direction of the arrow. (Loosen the belt tension.)
- (14) Remove 1 screw, and then release the harness out of 4 clamps.

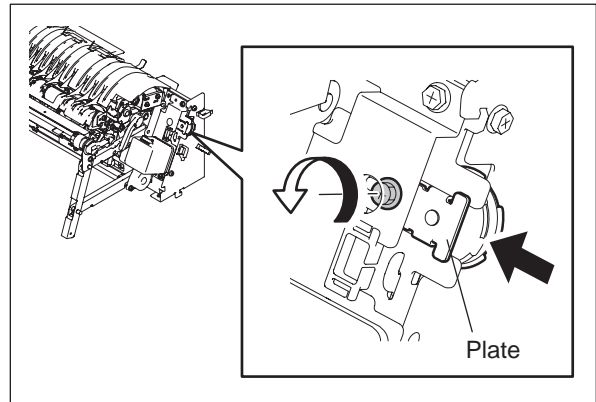

Fig. 4-96

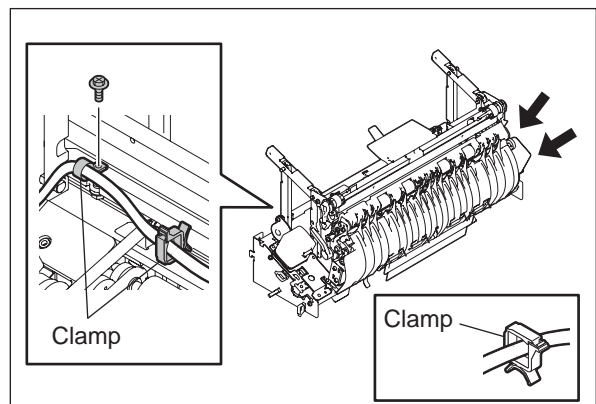

Fig. 4-97

- (15) Remove 4 screws, and then release the harness out of the clamp and the hole of the frame to take off the buffer unit-1.

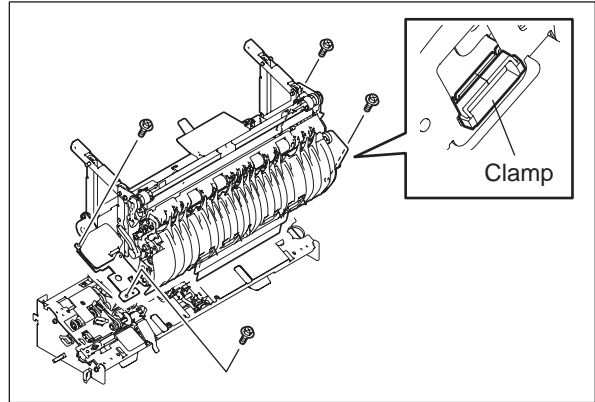

Fig. 4-98

- (16) Loosen 1 screw, and then tighten the screw by applying tension on the belt.

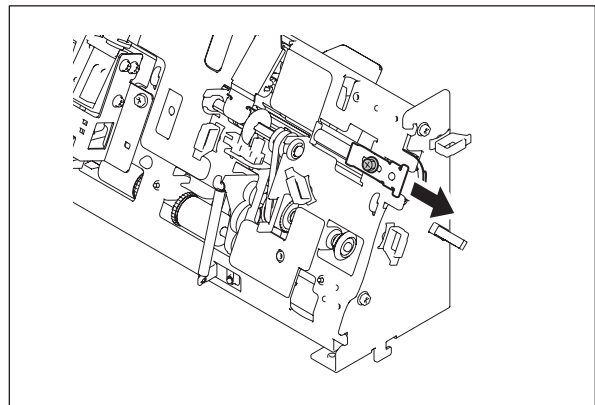

Fig. 4-99

- (17) Release the harness out of 3, and then remove 2 screws to take off the front side frame.
- (18) Remove 2 screws, and then take off the rear side frame.

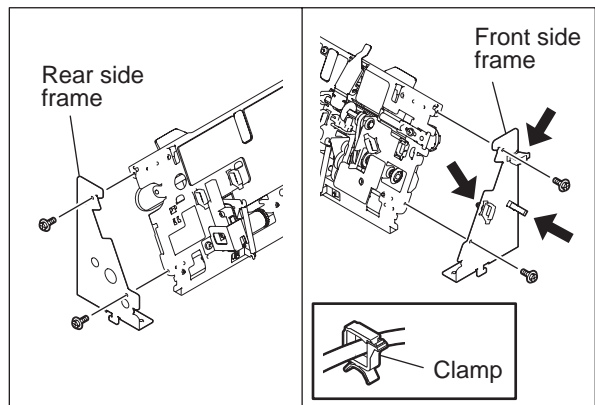

Fig. 4-100

- (19) Remove 1 E-ring, and then take off the shaft from the buffer guide.

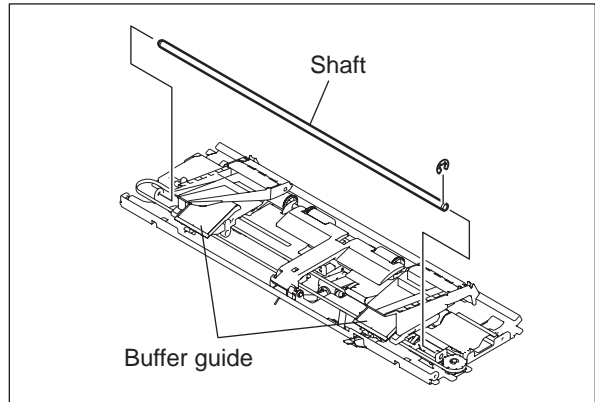

Fig. 4-101

- (20) Move the buffer guide to both ends by pushing the buffer roller.

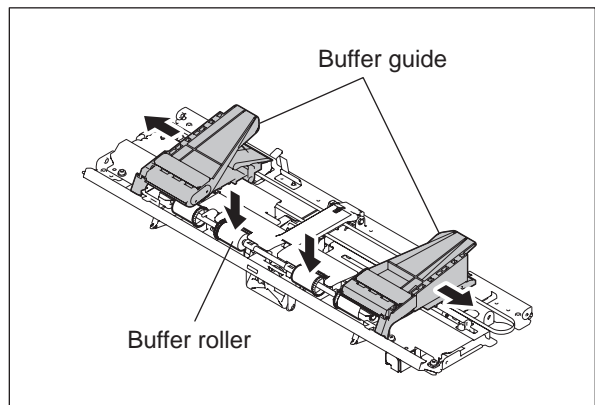

Fig. 4-102

- (21) Lift the tapping arm up, and then take off the buffer guide and the belt by pulling the belt out.

Note:
Do not take off the belt from the buffer guide.

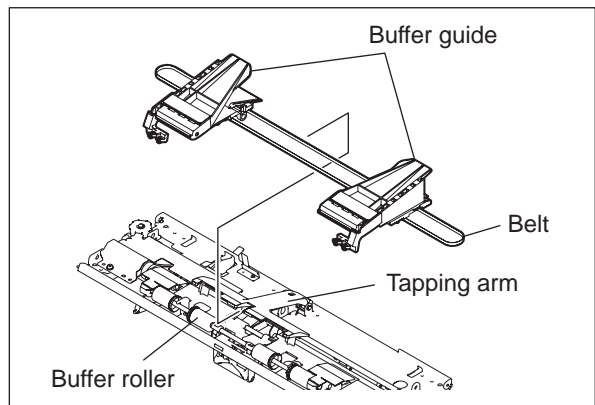

Fig. 4-103

- (22) Remove 1 E-ring. Then remove the shaft and the spring to take off the tapping arm.

Note:

Install the tapping arm as shown in the figure.

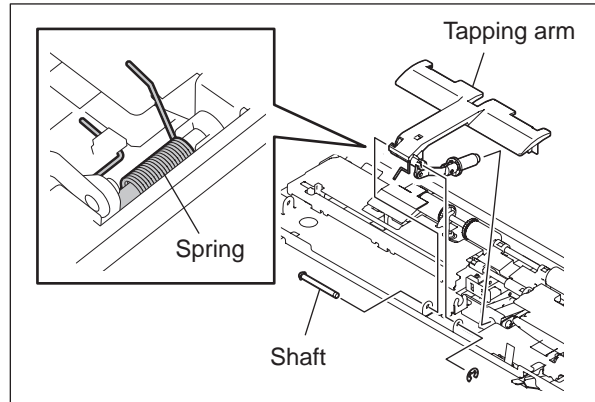

Fig. 4-104

- (23) Remove 6 screws, and then take off the front safety cover and the rear safety cover.

Note:

When installing the front safety cover and the rear safety cover, hang the hook of the cover on the hole of the frame.

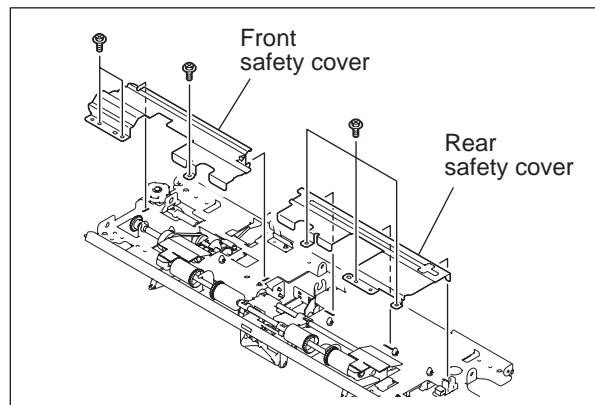

Fig. 4-105

- (24) Remove 2 E-rings, and then remove 2 bushings to take off the actuator of the paper holder home position sensor.

Note:

Be sure not to lose 1 pulley.

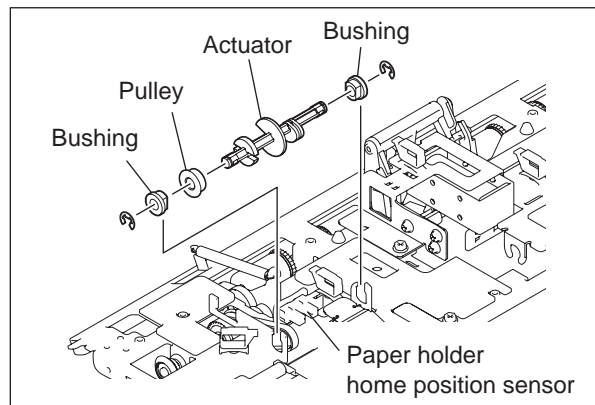

Fig. 4-106

- (25) Remove 1 E-ring. Then remove the bushing and the spring, and then remove the pulley and the gear shaft.

Note:

Be sure not to lose 1 gear and 1 belt of the rear buffer roller guide.

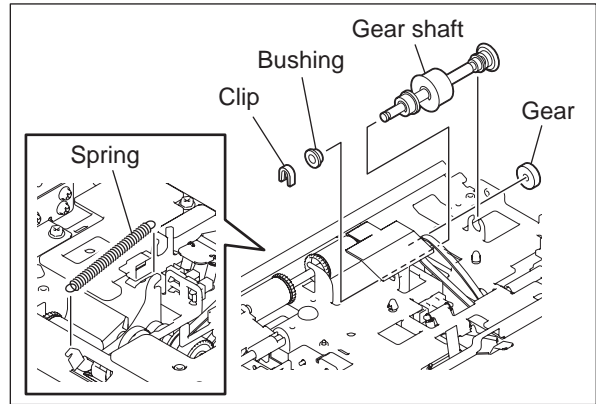

Fig. 4-107

- (26) Remove the spring and 2 E-rings. Then take off the front buffer roller guide.

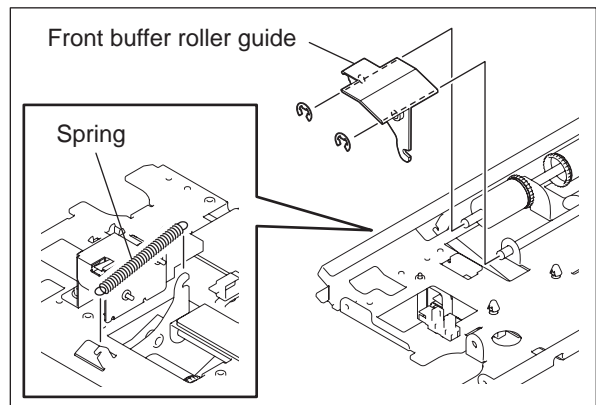

Fig. 4-108

- (27) Remove the E-ring, and then take off the shaft from the lift guide to take off the buffer roller.

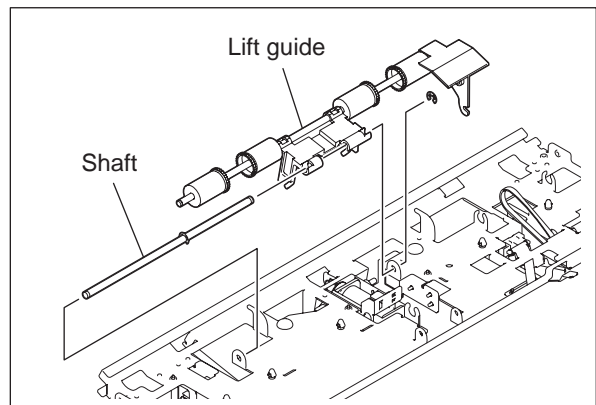

Fig. 4-109

(28) Take off the lift guide from the buffer roller.

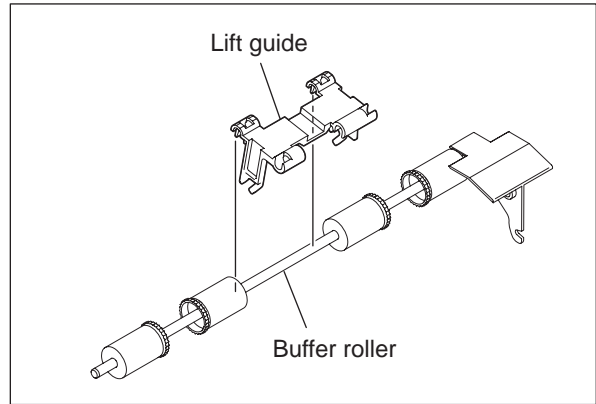

Fig. 4-110

(29) Remove 2 E-rings, the gear and the pin. Then take off the rear buffer roller guide.

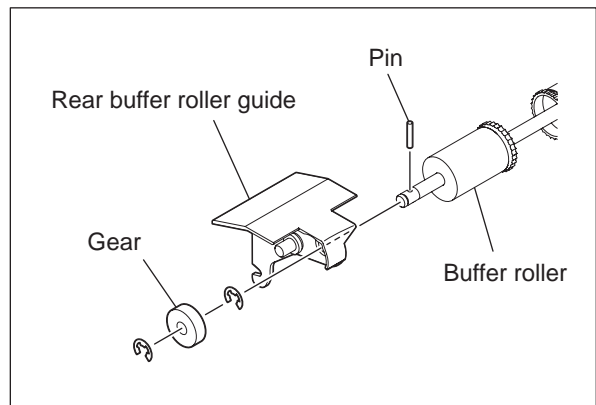

Fig. 4-111

[G] Upper exit roller / Upper exit roller guide

- (1) Take off the rear upper cover and rear lower cover.
📖 P. 4-1 "[A] Rear upper cover / Rear lower cover"
- (2) Take off the left upper cover.
📖 P. 4-2 "[B] Left upper cover"
- (3) Take off the control panel unit.
📖 P. 4-2 "[C] Control panel unit"
- (4) Remove 2 screws, and then take off the front and rear stays and 2 spacers.

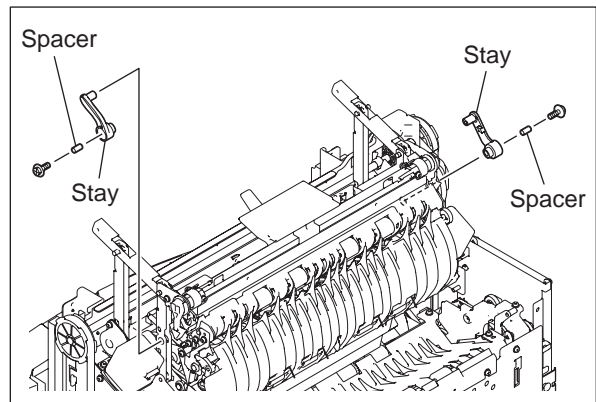

Fig. 4-112

- (5) Loosen 2 screws each for the front and rear stationary tray discharge brushes.
- (6) Remove 4 screws and take off the front and rear stationary tray transport guides.

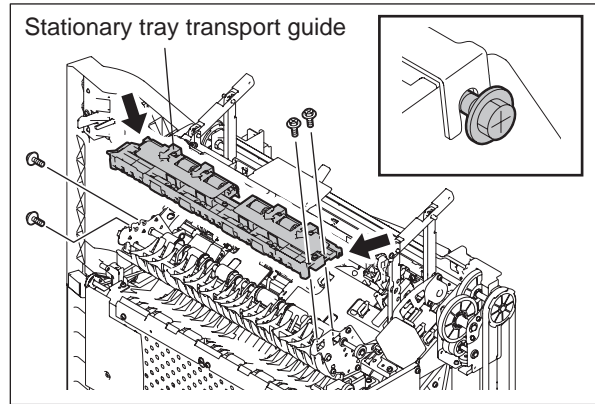

Fig. 4-113

Note:

When installing the front and rear stationary tray transport guides, fix them at the positions where the gap between the trailing edges of the guides and the frame is 1 mm. Check if the flap and the upper exit roller move smoothly after screws are tightened.

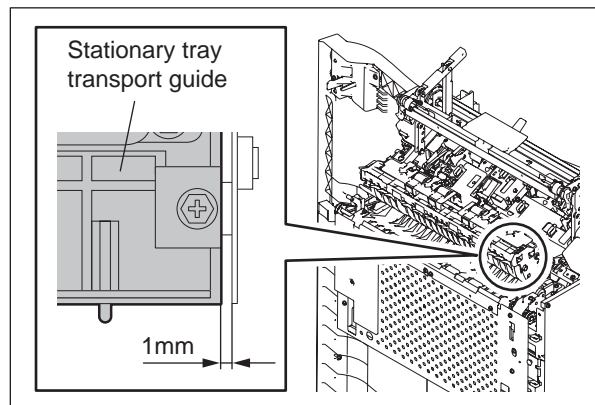

Fig. 4-114

- (7) Remove 4 screws of the upper exit roller guide.

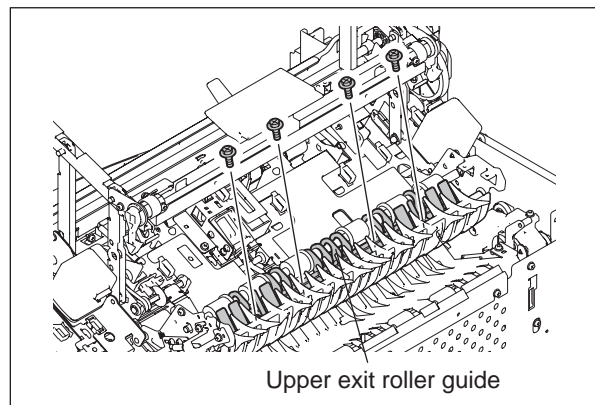

Fig. 4-115

- (8) Remove 3 E-rings, 1 gear, 1 pin and 2 bushings.

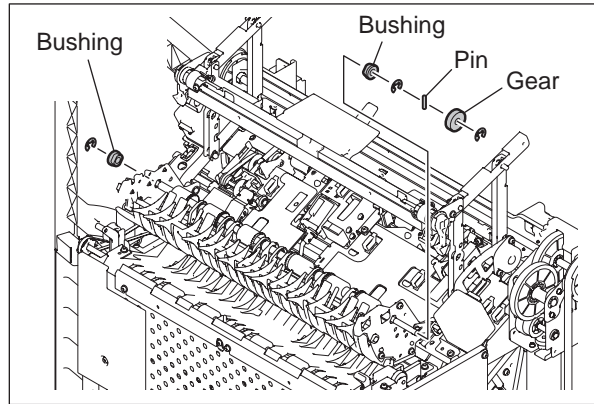

Fig. 4-116

- (9) Take off the upper exit roller and the upper exit roller guide.

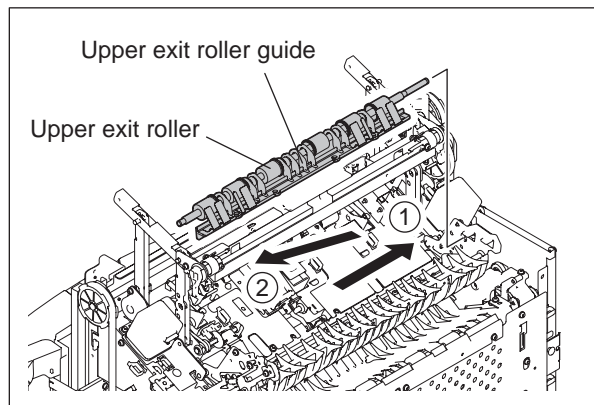

Fig. 4-117

Note:

Install the upper exit roller so that the 5 skids of it come at the positions of the upper exit roller guide as shown in the figure below.

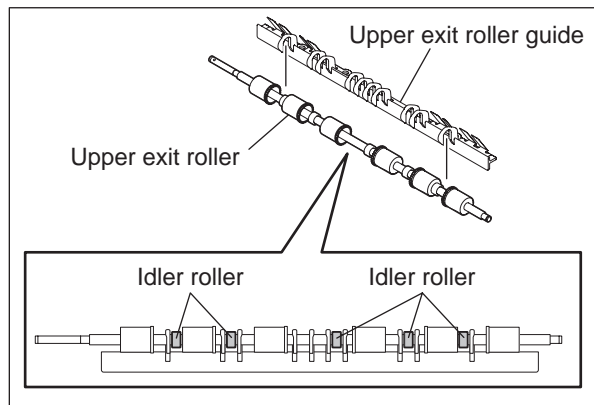

Fig. 4-118

4.4 Motor / Motor Drive Sections

[A] Buffer roller drive motor

- (1) Take off the rear upper cover and the rear lower cover.
📖 P. 4-1 "[A] Rear upper cover / Rear lower cover"
- (2) Take off the left upper cover.
📖 P. 4-2 "[B] Left upper cover"
- (3) Take off the control panel unit.
📖 P. 4-2 "[C] Control panel unit"
- (4) Take off the stationary tray cover.
📖 P. 4-10 "[N] Stationary tray cover"
- (5) Take off the buffer unit-1.
📖 P. 4-13 "[B] Buffer unit-1"
- (6) Remove 3 screws, 3 spacers, 3 screw dampers, the grounding plate and the motor damper, and then take off the buffer roller drive motor.

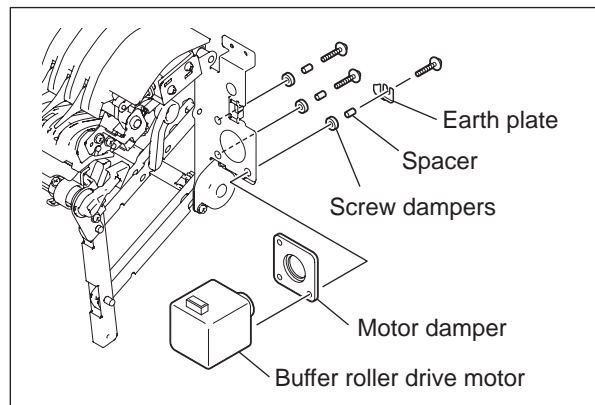

Fig. 4-119

[B] Buffer tray guide motor

- (1) Take off the rear upper cover and the rear lower cover.
📖 P. 4-1 "[A] Rear upper cover / Rear lower cover"
- (2) Take off the left upper cover.
📖 P. 4-2 "[B] Left upper cover"
- (3) Take off the control panel unit.
📖 P. 4-2 "[C] Control panel unit"
- (4) Take off the stationary tray cover.
📖 P. 4-10 "[N] Stationary tray cover"
- (5) Take off the buffer unit-1.
📖 P. 4-13 "[B] Buffer unit-1"
- (6) Remove 3 screws, and then take off the buffer tray guide motor.

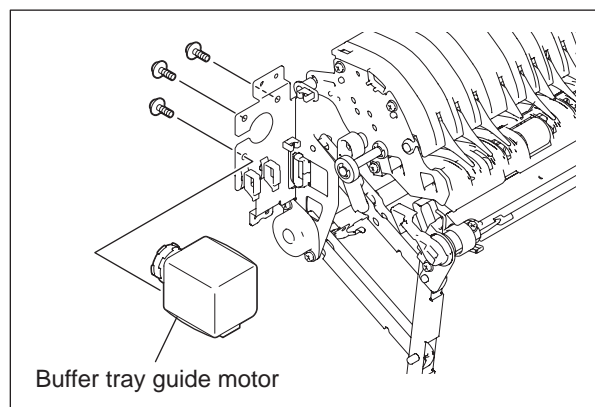

Fig. 4-120

[C] Front alignment motor

- (1) Take off the rear upper cover and the rear lower cover.
📖 P. 4-1 "[A] Rear upper cover / Rear lower cover"
- (2) Take off the left upper cover.
📖 P. 4-2 "[B] Left upper cover"
- (3) Take off the control panel unit.
📖 P. 4-2 "[C] Control panel unit"
- (4) Take off the front cover assembly.
📖 P. 4-3 "[D] Front upper cover / Front lower cover"
- (5) Take off the front foot cover.
📖 P. 4-3 "[E] Front foot cover"
- (6) Take off the rear foot cover.
📖 P. 4-4 "[F] Rear foot cover"
- (7) Take off the movable tray cover.
📖 P. 4-4 "[G] Movable tray cover"
- (8) Take off the front rail cover.
📖 P. 4-5 "[H] Front rail cover"
- (9) Take off the rear rail cover.
📖 P. 4-5 "[I] Rear rail cover"
- (10) Take off the grate-shaped guide.
📖 P. 4-7 "[L] Grate-shaped guide"
- (11) Release the harness out of the clamp, and then disconnect the relay connector.
- (12) Remove 2 screws, and then take off the front alignment motor.

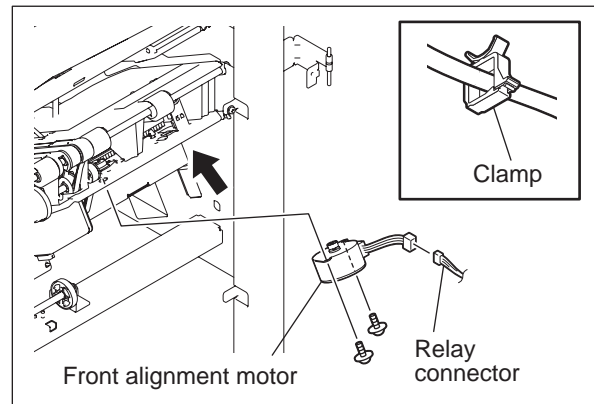

Fig. 4-121

[D] Rear alignment motor

- (1) Take off the rear upper cover and the rear lower cover.
📖 P. 4-1 "[A] Rear upper cover / Rear lower cover"
- (2) Take off the left upper cover.
📖 P. 4-2 "[B] Left upper cover"
- (3) Take off the control panel unit.
📖 P. 4-2 "[C] Control panel unit"
- (4) Take off the front cover assembly.
📖 P. 4-3 "[D] Front upper cover / Front lower cover"
- (5) Take off the front foot cover.
📖 P. 4-3 "[E] Front foot cover"
- (6) Take off the rear foot cover.
📖 P. 4-4 "[F] Rear foot cover"
- (7) Take off the movable tray cover.
📖 P. 4-4 "[G] Movable tray cover"
- (8) Take off the front rail cover.
📖 P. 4-5 "[H] Front rail cover"
- (9) Take off the rear rail cover.
📖 P. 4-5 "[I] Rear rail cover"
- (10) Take off the grate-shaped guide.
📖 P. 4-7 "[L] Grate-shaped guide"
- (11) Remove 2 screws, and then disconnect the relay connector to take off the rear alignment motor.

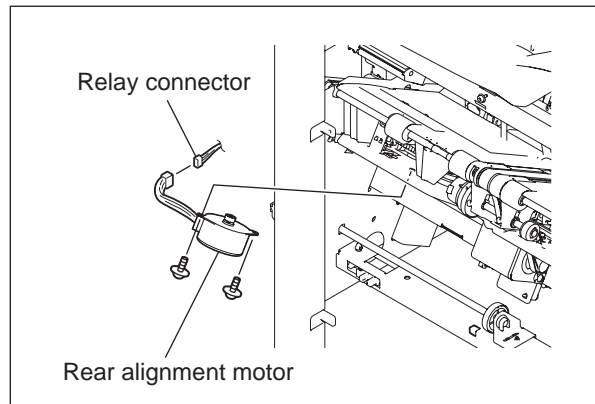

Fig. 4-122

[E] Stack transport motor

- (1) Take off the rear upper cover and the rear lower cover.
📖 P. 4-1 "[A] Rear upper cover / Rear lower cover"
- (2) Take off the left upper cover.
📖 P. 4-2 "[B] Left upper cover"
- (3) Take off the control panel unit.
📖 P. 4-2 "[C] Control panel unit"
- (4) Take off the front cover assembly.
📖 P. 4-3 "[D] Front upper cover / Front lower cover"
- (5) Take off the front foot cover.
📖 P. 4-3 "[E] Front foot cover"
- (6) Take off the rear foot cover.
📖 P. 4-4 "[F] Rear foot cover"
- (7) Take off the movable tray cover.
📖 P. 4-4 "[G] Movable tray cover"
- (8) Take off the front rail cover.
📖 P. 4-5 "[H] Front rail cover"
- (9) Take off the rear rail cover.
📖 P. 4-5 "[I] Rear rail cover"
- (10) Take off the grate-shaped guide.
📖 P. 4-7 "[L] Grate-shaped guide"
- (11) Disconnect the connector and remove the belt. Then remove 2 screws to take off the stack transport motor.

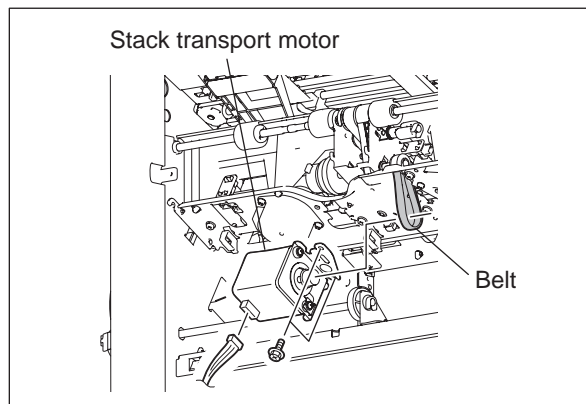

Fig. 4-123

[F] Stapler unit shift motor

- (1) Take off the rear upper cover and the rear lower cover.
📖 P. 4-1 "[A] Rear upper cover / Rear lower cover"
- (2) Take off the FIN board assembly.
📖 P. 4-85 "[A] Finisher control PC board (FIN board) / FIN board assembly"
- (3) Remove 2 screws, and then disconnect the connector to take off the stapler unit shift motor.

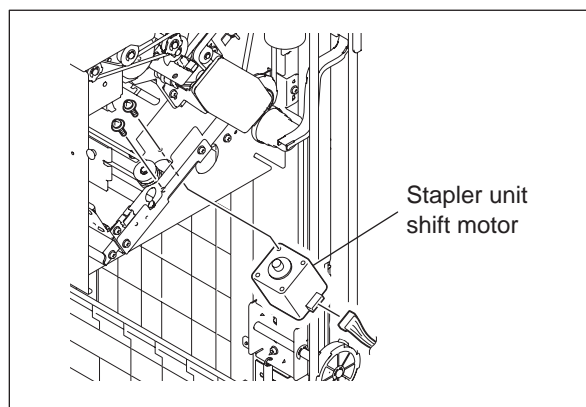

Fig. 4-124

[G] Transport motor

- (1) Take off the rear upper cover and the rear lower cover.
📖 P. 4-1 "[A] Rear upper cover / Rear lower cover"
- (2) Remove the spring, and then loosen 2 screws to free the belt tension.

Note:

When installing the transport motor, loosen the 2 screws of the tension plate after the spring is hooked.

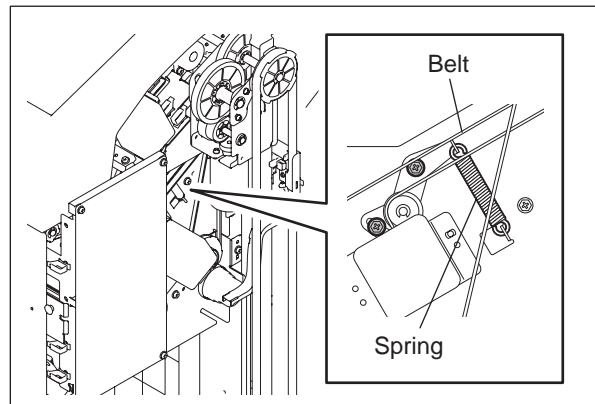

Fig. 4-125

- (3) Remove 2 screws, and then disconnect the connector and remove the belt to take off the transport motor.

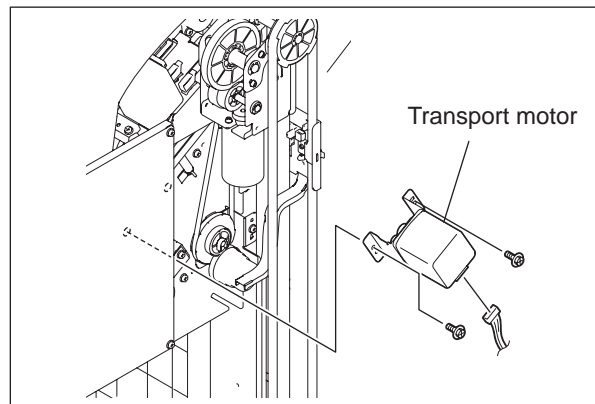

Fig. 4-126

[H] Paddle motor

- (1) Take off the rear upper cover and the rear lower cover.
📖 P. 4-1 "[A] Rear upper cover / Rear lower cover"
- (2) Take off the FIN board assembly.
📖 P. 4-85 "[A] Finisher control PC board (FIN board) / FIN board assembly"
- (3) Remove 1 screw, then take off the switch cover.

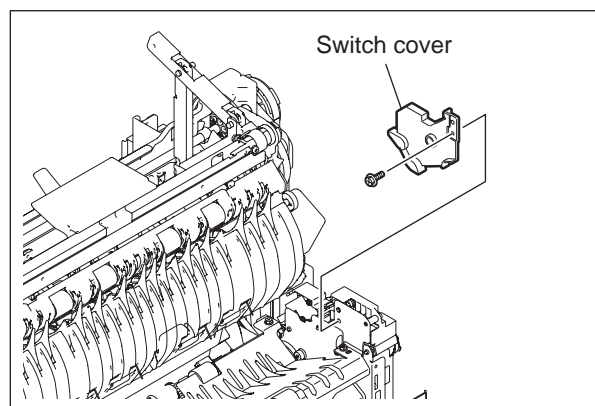

Fig. 4-127

- (4) Remove 3 screws, and then take off the tray switch unit.

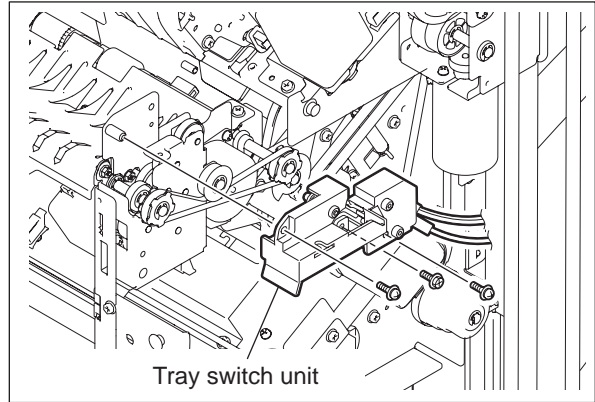

Fig. 4-128

- (5) Release the harness of the paddle motor out of the clamp.
- (6) Remove 2 screws, and then take off the paddle motor.

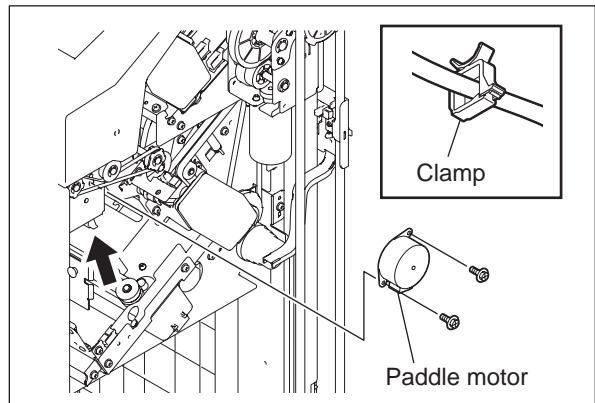

Fig. 4-129

[I] Entrance motor / Entrance motor gear block

- (1) Take off the rear upper cover and the rear lower cover.
📖 P. 4-1 "[A] Rear upper cover / Rear lower cover"
- (2) Take off the blind cover.
📖 P. 4-6 "[J] Blind cover"
- (3) Take off the shield metal plate.
📖 P. 4-6 "[K] Shield metal plate"
- (4) Take off the FIN board assembly.
📖 P. 4-85 "[A] Finisher control PC board (FIN board) / FIN board assembly"
- (5) Remove 1 screw to take off the gear cover.

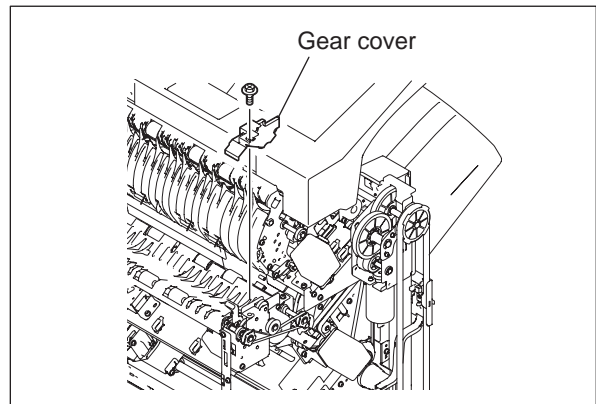

Fig. 4-130

- (6) Remove 1 E-ring, and then remove the entrance motor pulley-1, belt and pin.

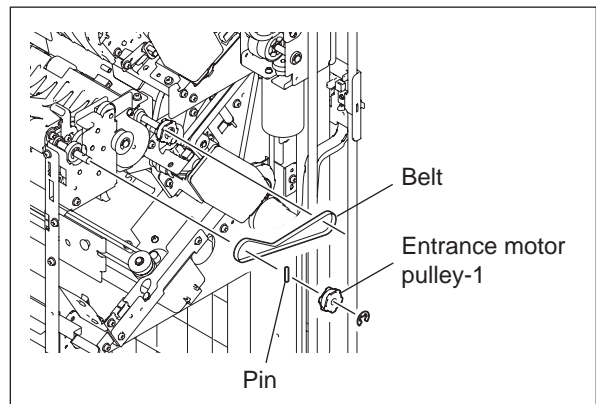

Fig. 4-131

- (7) Remove 1 E-ring, and then remove the entrance motor gear and the pin.

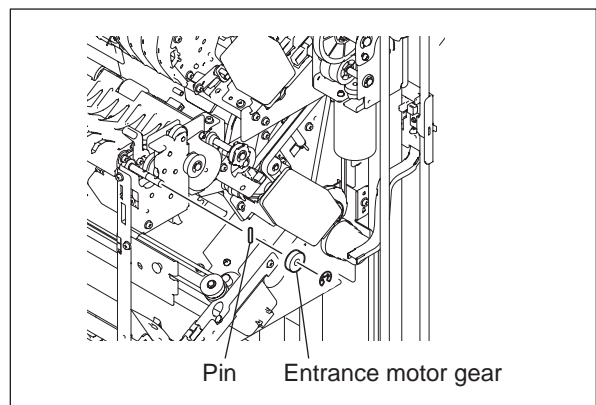

Fig. 4-132

- (8) Release the harness out of the clamp of the entrance motor gear block.
- (9) Remove 3 screws, and then take off the entrance motor gear block.

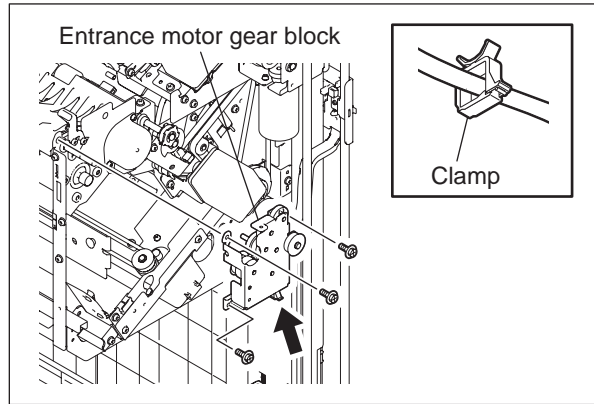

Fig. 4-133

- (10) Remove 3 screws. Then disconnect the connector and remove 3 spacers, 3 screw dampers, the grounding plate and the motor damper to take off the entrance motor.

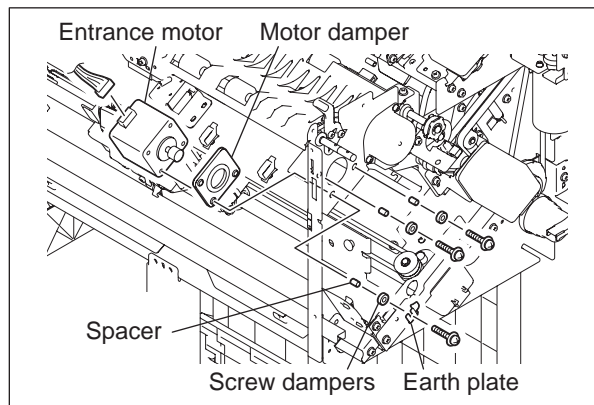

Fig. 4-134

4.5 Solenoid

[A] Gate solenoid

- (1) Take off the rear upper cover and the rear lower cover.
📖 P. 4-1 "[A] Rear upper cover / Rear lower cover"
- (2) Take off the left upper cover.
📖 P. 4-2 "[B] Left upper cover"
- (3) Take off the control panel unit.
📖 P. 4-2 "[C] Control panel unit"
- (4) Take off the blind cover.
📖 P. 4-6 "[J] Blind cover"
- (5) Take off the shield metal plate.
📖 P. 4-6 "[K] Shield metal plate"
- (6) Take off the stationary tray cover.
📖 P. 4-10 "[N] Stationary tray cover"
- (7) Remove 1 screw, and then take off the sensor bracket of the entrance sensor.
- (8) Close the buffer unit-1 halfway and leave it. Then remove 1 screw.

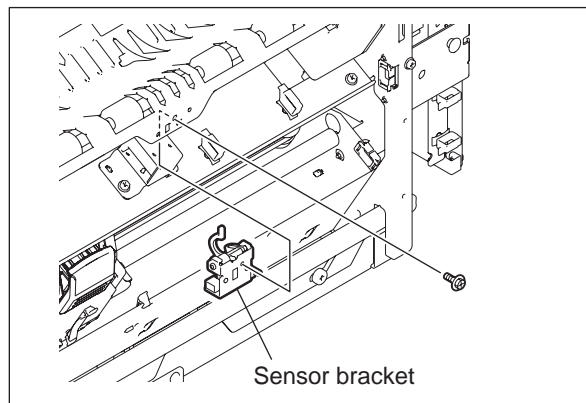

Fig. 4-135

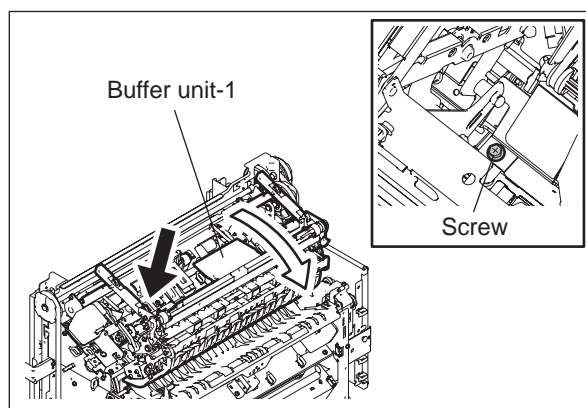

Fig. 4-136

- (9) Remove 3 screws, and then take off the transport guide.

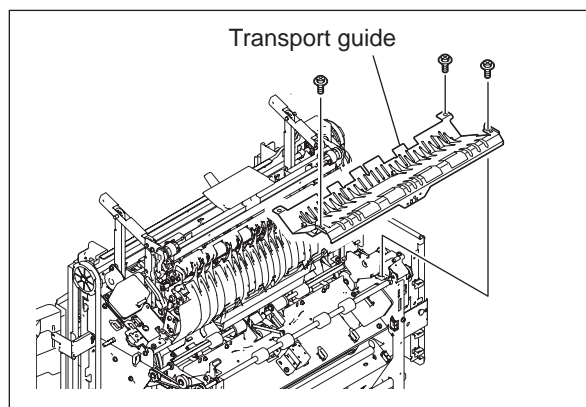

Fig. 4-137

(10) Remove the spring.

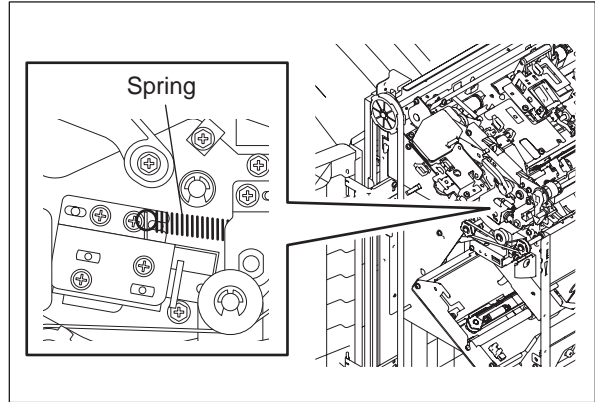

Fig. 4-138

(11) Remove 2 screws, and then disconnect the relay connector and remove the arm to take off the bracket.

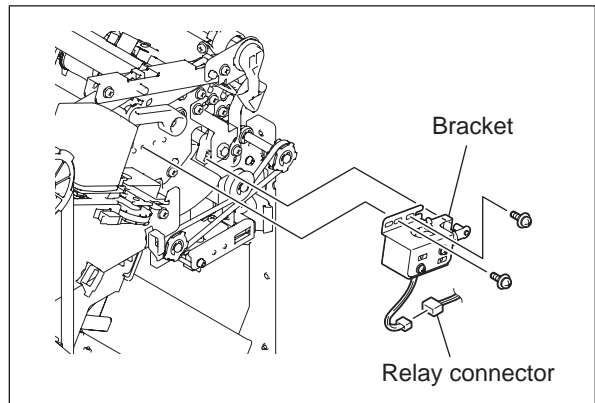

Fig. 4-139

Note:

When installing the gate solenoid, adjust the edge of the bracket to come at the mark on the scale one step left from the center as shown in the figure and fix it with 2 screws.

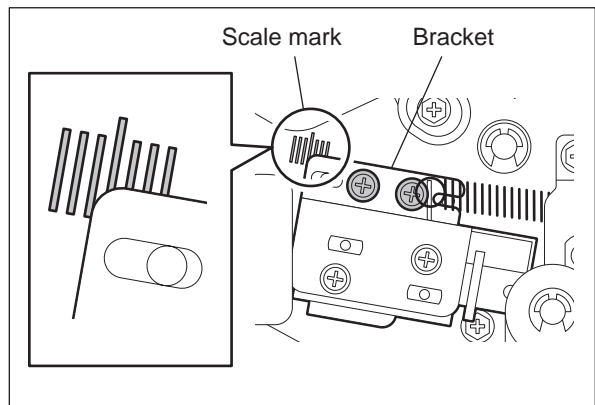

Fig. 4-140

- (12) Remove 2 screws, and then take off the gate solenoid.

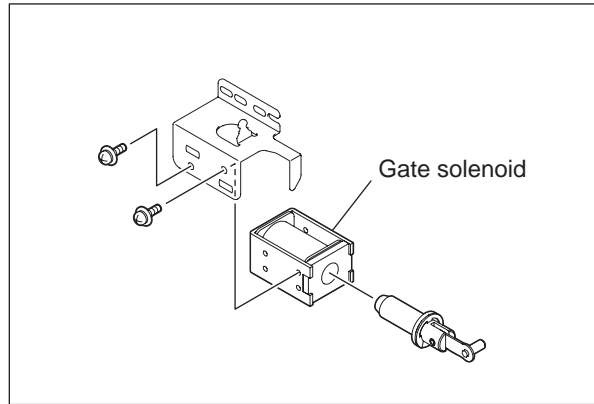

Fig. 4-141

Note:

When installing the gate solenoid, install the bracket with 2 screws as shown in the figure, and then fix it at the position where the gap between the gate flap and the shaft of the entrance roller falls within 0.4 to 0.8 mm.

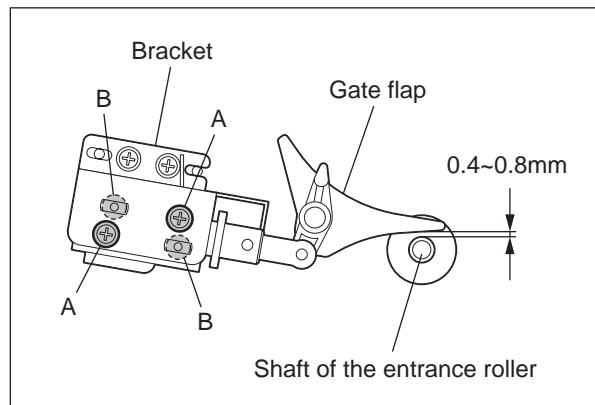

Fig. 4-142

[B] Buffer roller lift solenoid / Patting solenoid

- (1) Take off the stationary tray cover.
📖 P. 4-10 "[N] Stationary tray cover"
- (2) Close the buffer unit-1.
- (3) Release the harness of the buffer roller lift solenoid and the patting solenoid out of 2 clamps, and then disconnect 2 relay connectors.

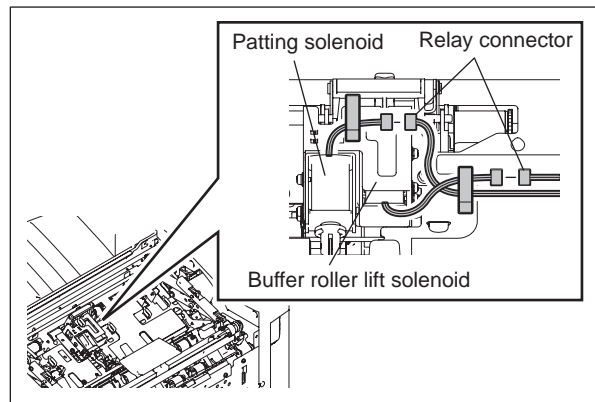

Fig. 4-143

- (4) Remove 2 screws, and then disconnect the plunger to take off the solenoid sensor unit.

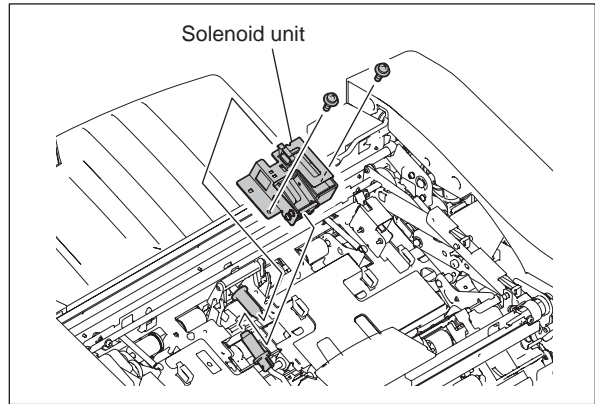

Fig. 4-144

- Buffer roller lift solenoid
 - Remove 3 screws, and then take off the buffer roller lift solenoid.

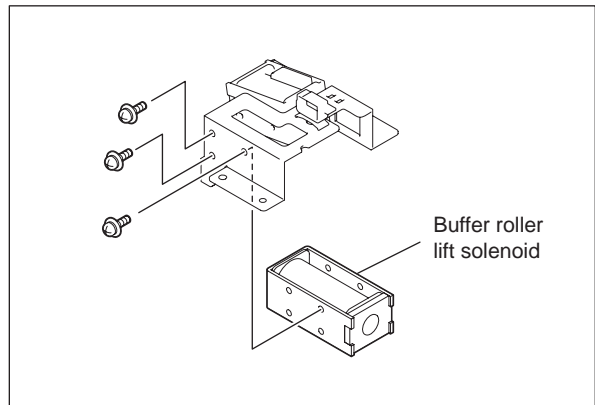

Fig. 4-145

- Patting solenoid
 - Remove 3 screws, and then take off the patting solenoid.

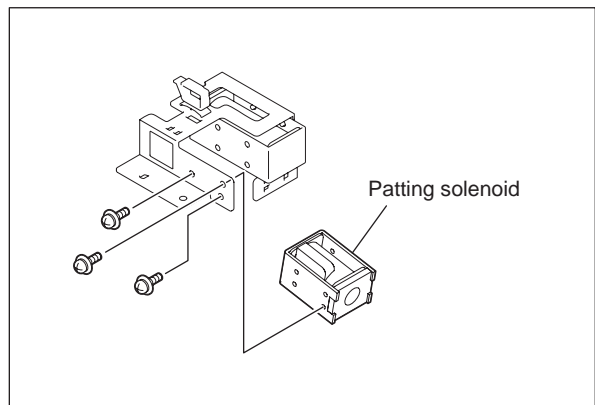

Fig. 4-146

[C] Paper exit guide clutch

- (1) Take off the rear upper cover and the rear lower cover.
📖 P. 4-1 "[A] Rear upper cover / Rear lower cover"
- (2) Take off the left upper cover.
📖 P. 4-2 "[B] Left upper cover"
- (3) Take off the control panel unit.
📖 P. 4-2 "[C] Control panel unit"
- (4) Take off the front cover assembly.
📖 P. 4-3 "[D] Front upper cover / Front lower cover"
- (5) Take off the front foot cover.
📖 P. 4-3 "[E] Front foot cover"
- (6) Take off the rear foot cover.
📖 P. 4-4 "[F] Rear foot cover"
- (7) Take off the movable tray cover.
📖 P. 4-4 "[G] Movable tray cover"
- (8) Take off the front rail cover.
📖 P. 4-5 "[H] Front rail cover"
- (9) Take off the rear rail cover.
📖 P. 4-5 "[I] Rear rail cover"
- (10) Take off the grate-shaped guide.
📖 P. 4-7 "[L] Grate-shaped guide"
- (11) Remove 4 E-rings, and then slide the bushing.
- (12) Take off the belt of the stack transport motor.

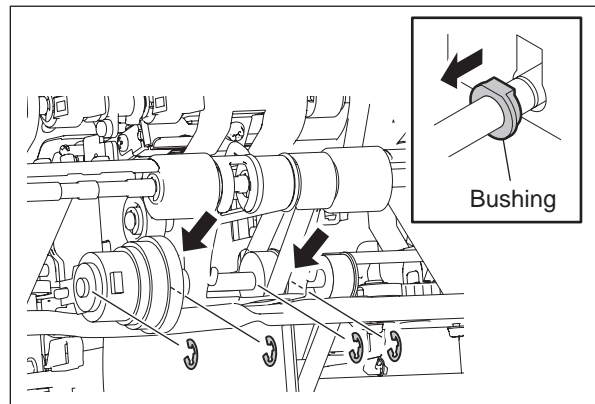

Fig. 4-147

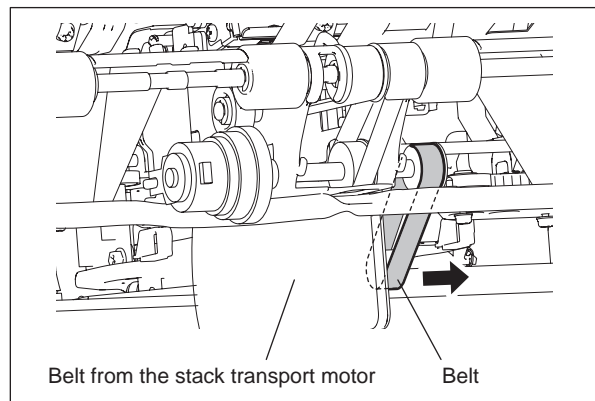

Fig. 4-148

- (13) Slide the shaft in the direction of the arrow to remove the pin.

Notes:

- Be sure not to lose the belt.
- When installing the paper exit guide clutch, attach a rotation protection.

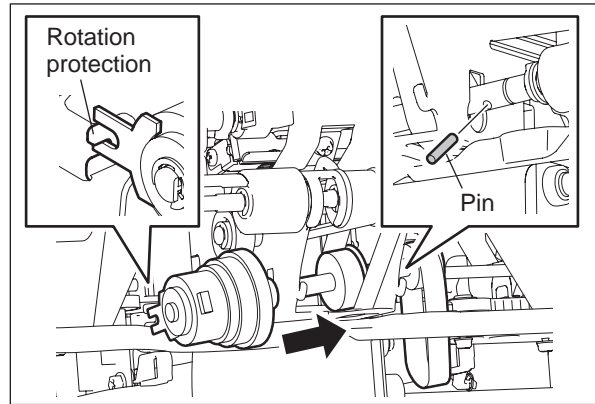

Fig. 4-149

- (14) Then take off the paper exit guide clutch by sliding the shaft. Disconnect the relay connector, and then take off the paper exit guide clutch.

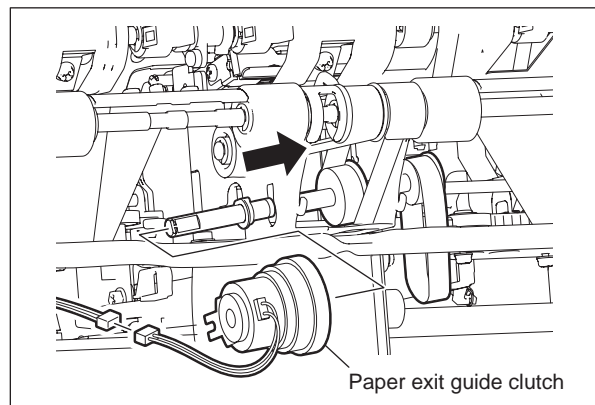

Fig. 4-150

[D] Catching solenoid

- (1) Take off the rear upper cover and the rear lower cover.
 📖 P. 4-1 "[A] Rear upper cover / Rear lower cover"
- (2) Take off the blind cover.
 📖 P. 4-6 "[J] Blind cover"
- (3) Take off the shield metal plate.
 📖 P. 4-6 "[K] Shield metal plate"
- (4) Disconnect the connector (CN4) on the FIN board, and then release the harness out of 5 clamps.

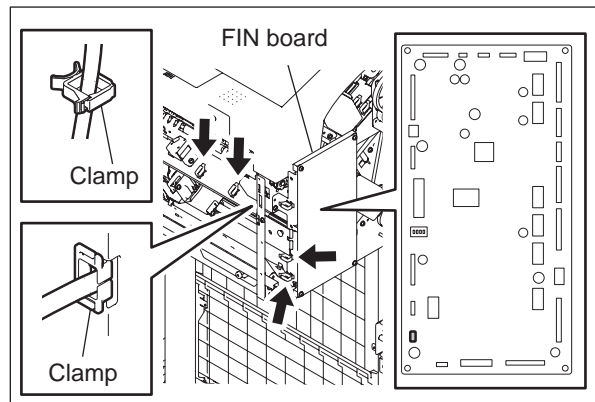

Fig. 4-151

- (5) Remove 2 screws, and then take off the catching solenoid.

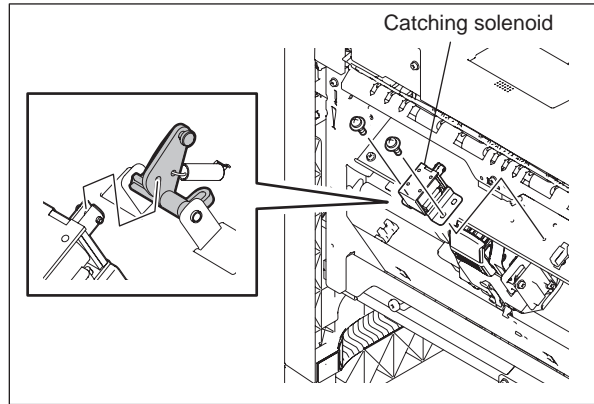

Fig. 4-152

[E] Shutter clutch

- (1) Take off the rear upper cover and the rear lower cover.
P. 4-1 "[A] Rear upper cover / Rear lower cover"
- (2) Remove 1 E-ring, and then disconnect the relay connector to take off the shutter clutch.

Note:
When installing the shutter clutch, attach a rotation protection.

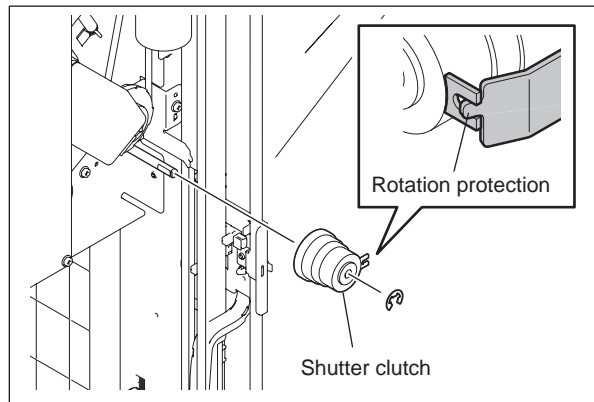

Fig. 4-153

4.6 Sensors / Switches

[A] Transport sensor

- (1) Take off the stationary tray cover.
P. 4-10 "[N] Stationary tray cover"
- (2) Close the buffer unit-1.
- (3) Release the latch while lifting up the actuator, and then disconnect the connector to take off the transport sensor.

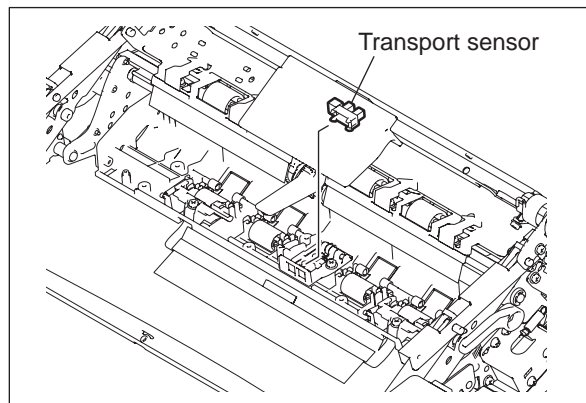

Fig. 4-154

[B] Paper holder home position sensor

- (1) Take off the stationary tray cover.
P. 4-10 "[N] Stationary tray cover"
- (2) Close the buffer unit-1.
- (3) Remove 2 E-rings, and then take off the bushing to remove the paper holder cam while pressing the paper holder plate.

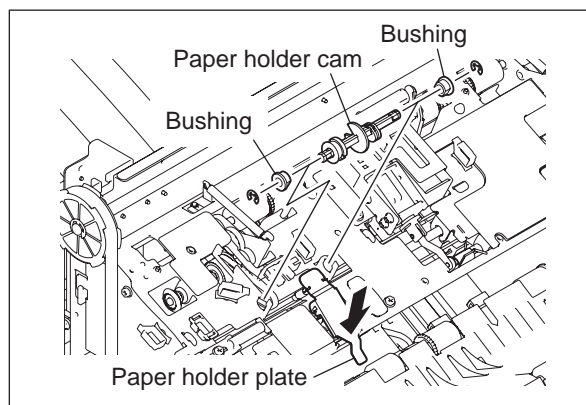

Fig. 4-155

- (4) Release the latch, and then disconnect the connector to take off the paper holder home position sensor while pressing the paper holder plate.

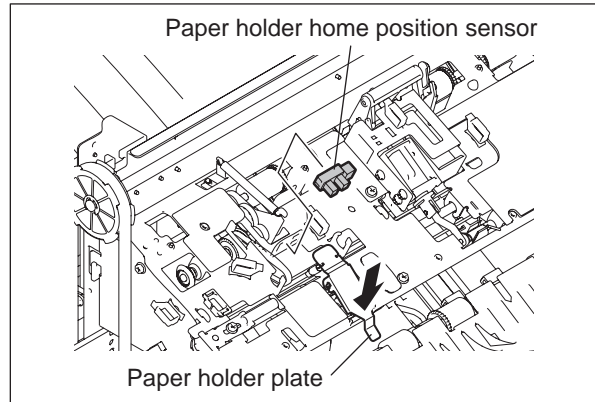

Fig. 4-156

[C] Stationary tray paper-full sensor

- (1) Take off the stationary tray cover.
P. 4-10 "[N] Stationary tray cover"
- (2) Hold up the jam access lever. Then remove 1 screw and disconnect the connector to take off the bracket.

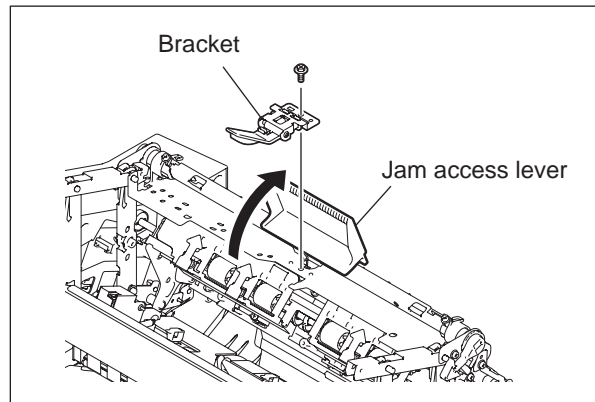

Fig. 4-157

- (3) Remove 1 screw, and then take off the actuator and the spacer.

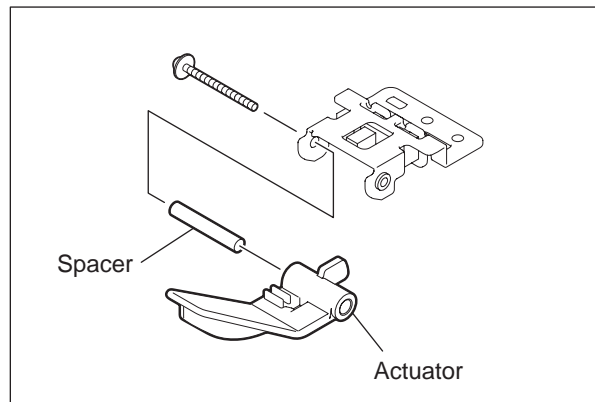

Fig. 4-158

- (4) Release the latch, and then take off the stationary tray paper-full sensor.

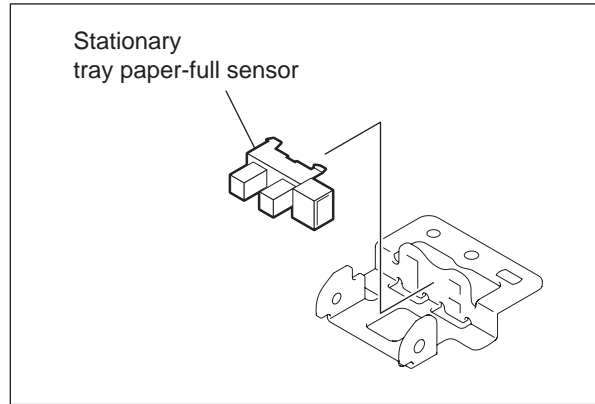

Fig. 4-159

[D] Stationary tray opening/closing switch

- (1) Take off the rear cover and the rear lower cover.
 📖 P. 4-1 "[A] Rear upper cover / Rear lower cover"
- (2) Take off the left upper cover.
 📖 P. 4-2 "[B] Left upper cover"
- (3) Take off the control panel unit.
 📖 P. 4-2 "[C] Control panel unit"
- (4) Take off the stationary tray cover.
 📖 P. 4-10 "[N] Stationary tray cover"
- (5) Disconnect the connector (CN16) of the FIN board, and then release the harness out of 3 clamps.

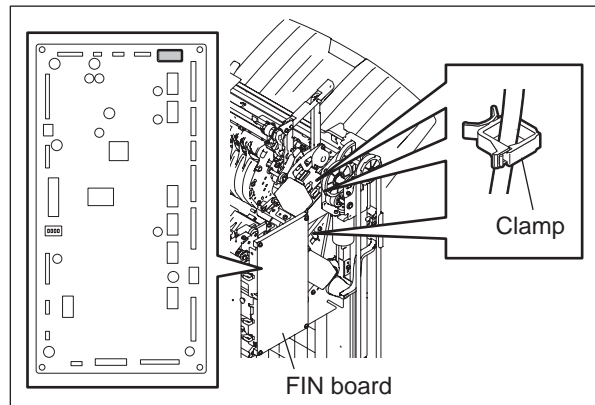

Fig. 4-160

- (6) Release the harness out of 5 clamps.

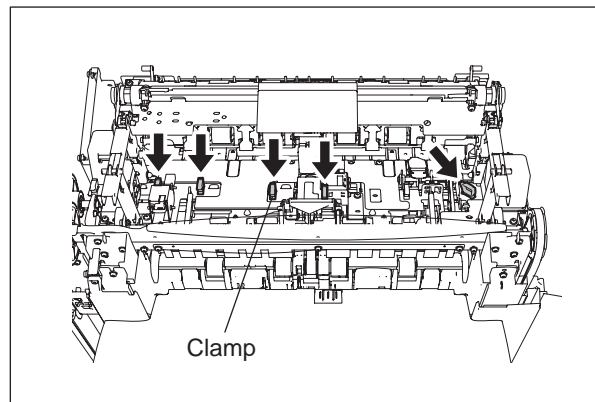

Fig. 4-161

- (7) Remove 1 screw, and then release the harness out of 2 clamps.

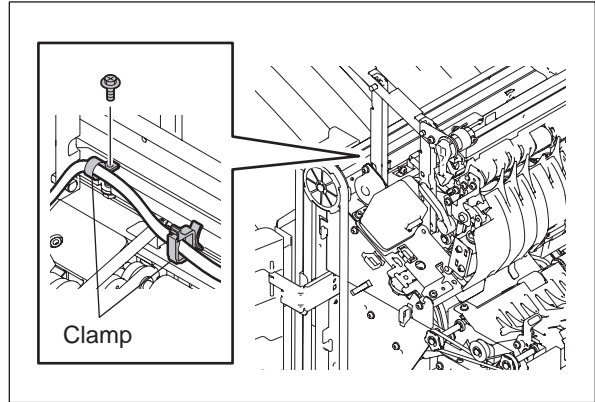

Fig. 4-162

- (8) Disconnect the connector of the front cover switch, and then release the harness out of 3 clamps.

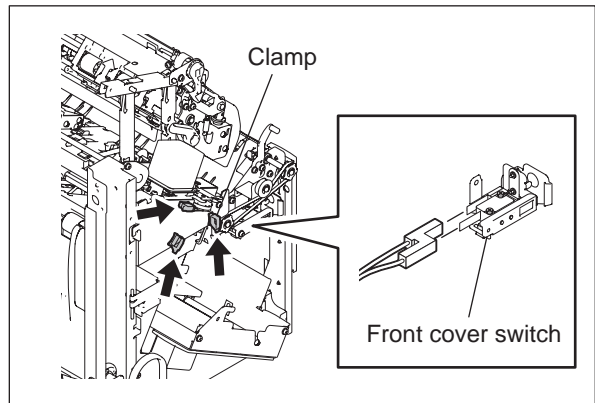

Fig. 4-163

- (9) Loosen 1 screw, and then tighten the screw while pressing the plate in the direction of the arrow. (Loosen the belt tension.)

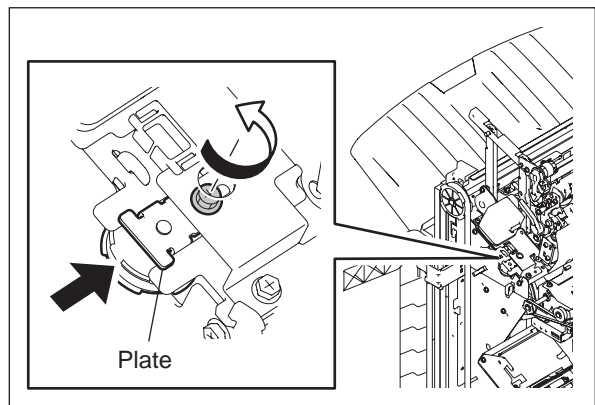

Fig. 4-164

(10) Remove 4 screws of the buffer unit-1.

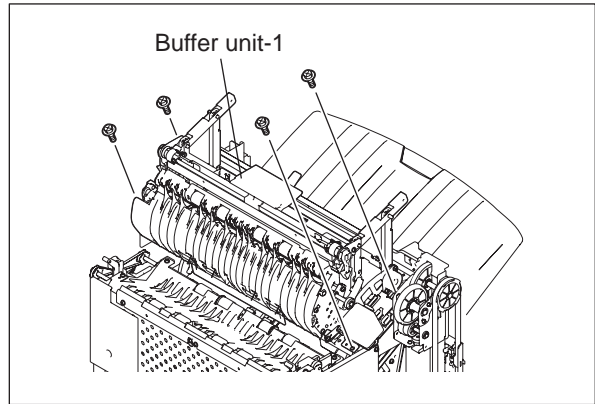

Fig. 4-165

(11) Release the harnesses from 6 harness clamps.

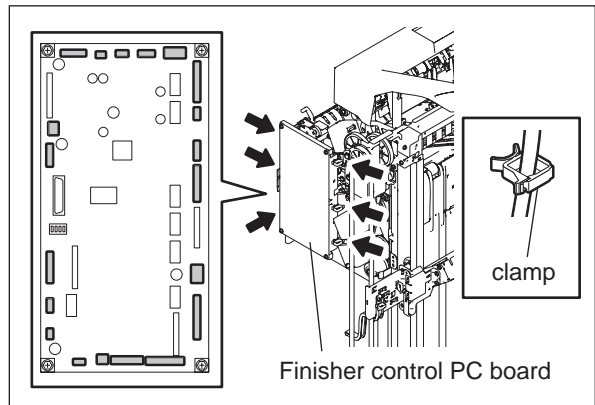

Fig. 4-166

(12) Remove 4 screws, then take off the FIN board assembly.

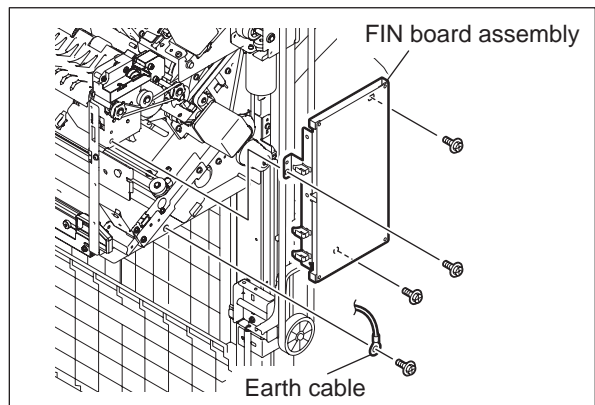

Fig. 4-167

- (13) Remove 1 screw, then take off the switch cover.

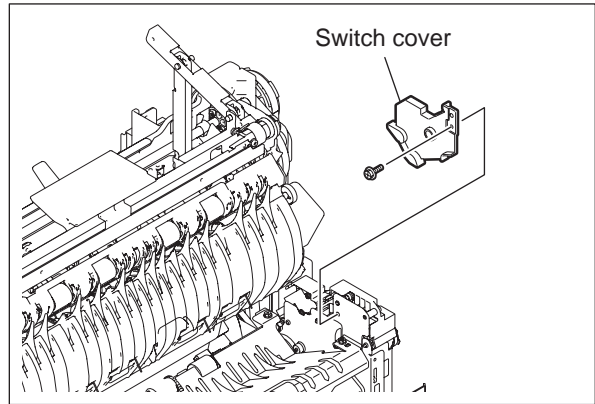

Fig. 4-168

- (14) Remove 3 screws, then take off the tray switch unit.

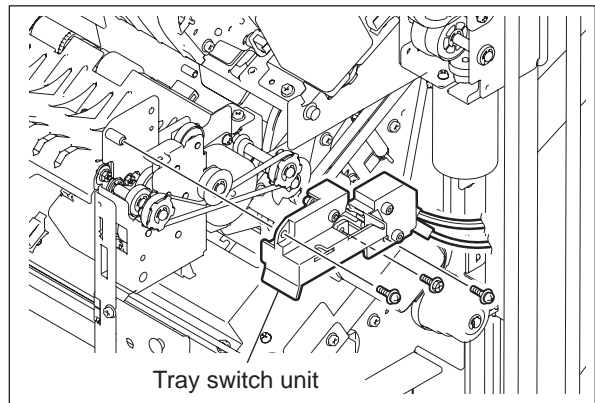

Fig. 4-169

- (15) Take off the stationary tray opening/closing switch.

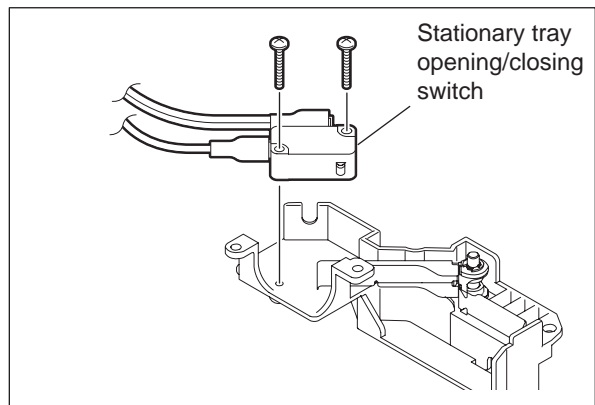

Fig. 4-170

[E] Buffer tray home position sensor

- (1) Take off the rear upper cover and the rear lower cover.
📖 P. 4-1 "[A] Rear upper cover / Rear lower cover"
- (2) Take off the left upper cover.
📖 P. 4-2 "[B] Left upper cover"
- (3) Take off the control panel unit.
📖 P. 4-2 "[C] Control panel unit"
- (4) Take off the front cover assembly.
📖 P. 4-3 "[D] Front upper cover / Front lower cover"
- (5) Take off the front foot cover.
📖 P. 4-3 "[E] Front foot cover"
- (6) Take off the rear foot cover.
📖 P. 4-4 "[F] Rear foot cover"
- (7) Take off the movable tray cover.
📖 P. 4-4 "[G] Movable tray cover"
- (8) Take off the front rail cover.
📖 P. 4-5 "[H] Front rail cover"
- (9) Take off the rear rail cover.
📖 P. 4-5 "[I] Rear rail cover"
- (10) Take off the movable tray drive unit.
📖 P. 4-20 "[E] Movable tray drive unit / Movable tray shift motor unit"
- (11) Take off the stationary tray cover.
📖 P. 4-10 "[N] Stationary tray cover"
- (12) Take off the buffer unit.
📖 P. 4-12 "[A] Buffer unit"
- (13) Loosen 1 screw, and then tighten the screw while pressing the plate in the direction of the arrow. (Loosen the belt tension.)
- (14) Remove 1 screw, and then release the harness out of 2 clamps.

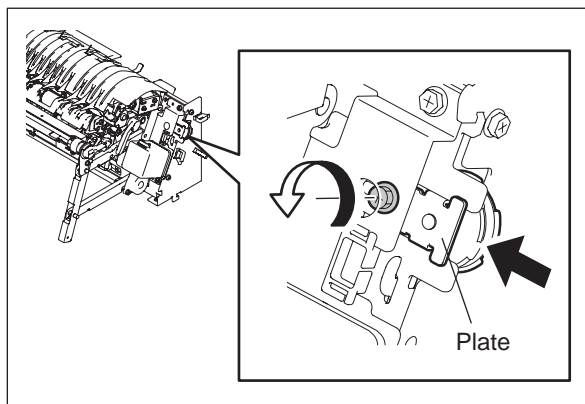

Fig. 4-171

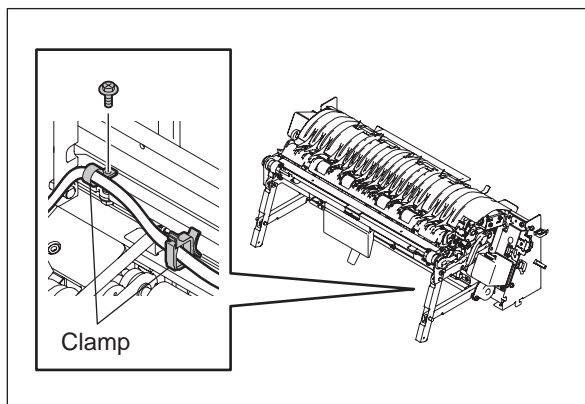

Fig. 4-172

- (15) Remove 4 screws, and then release the harness out of the hole of the frame to take off the buffer unit-1.

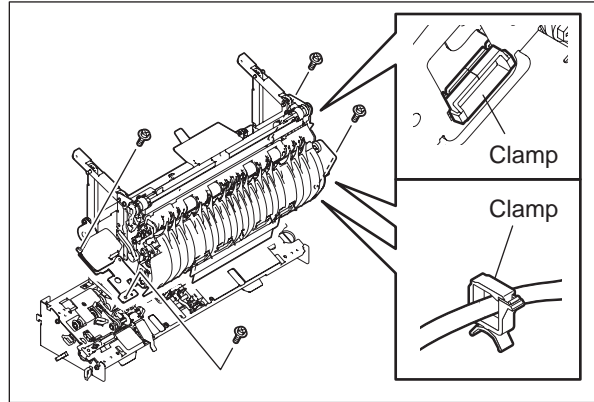

Fig. 4-173

- (16) Loosen 1 screw, and then tighten the screw while applying tension to the belt.

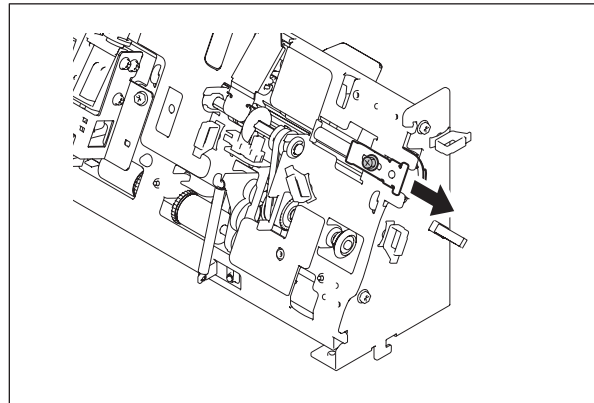

Fig. 4-174

- (17) Release the harness out of the clamp, and then remove 2 screws to take off the front side frame.
- (18) Remove 2 screws to take off the rear side frame.

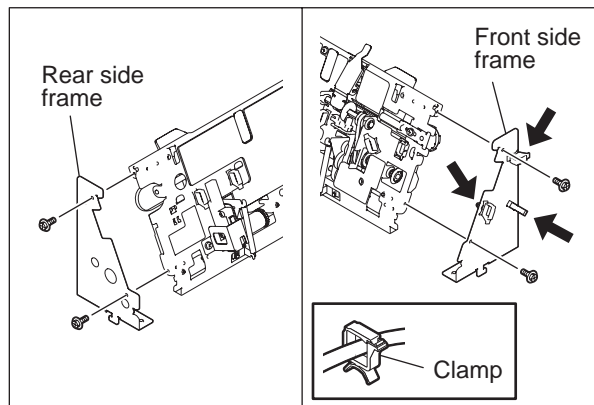

Fig. 4-175

- (19) Remove 1 E-ring, and then remove the shaft from each buffer guide.

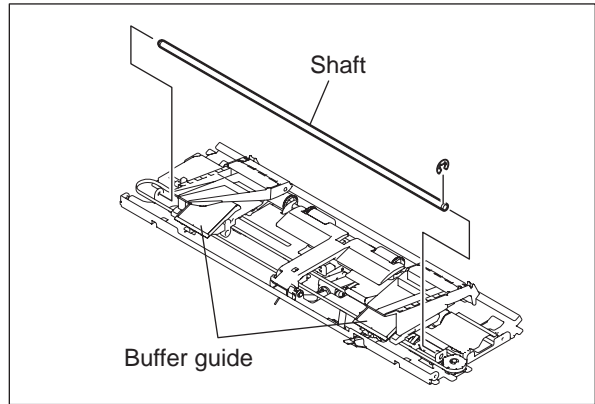

Fig. 4-176

- (20) Move each buffer guide to each end while pressing the buffer roller.

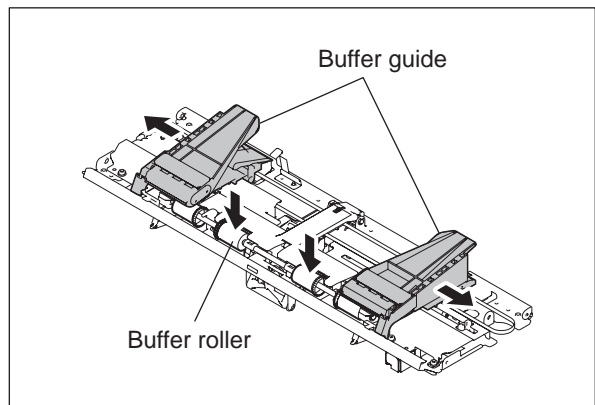

Fig. 4-177

- (21) Lift up the patting arm, and then pull out the belt to take off the buffer guides and the belt.

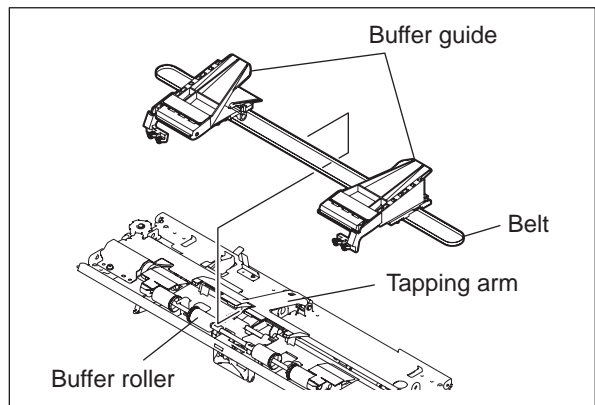

Fig. 4-178

- (22) Remove 1 E-ring, and then remove the shaft and the spring to take off the patting arm.

Note:

When installing the patting arm, install it as shown in the figure.

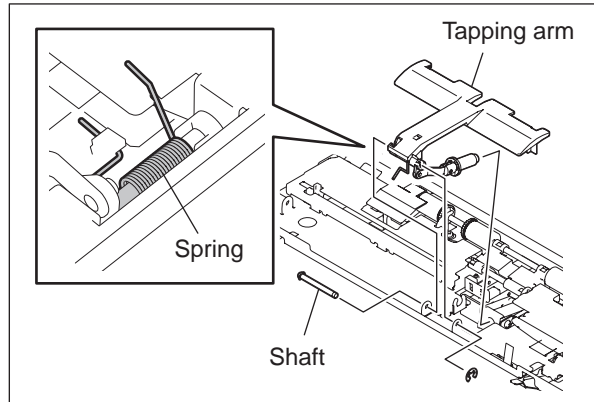

Fig. 4-179

- (23) Remove 3 screws to take off the rear safety cover.

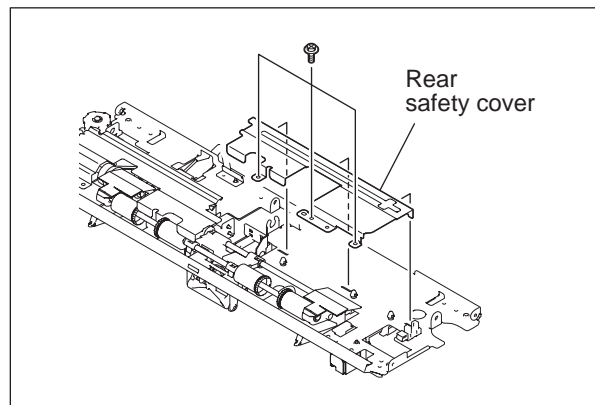

Fig. 4-180

- (24) Release the latch, and then disconnect the connector to take off the buffer tray home position sensor while holding up the rear safety cover.

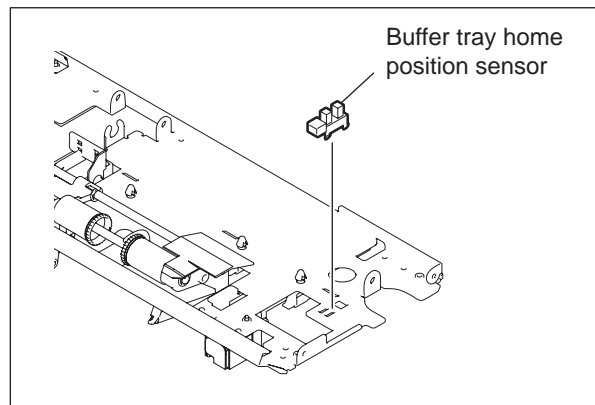

Fig. 4-181

[F] Finishing tray paper detection sensor

- (1) Take off the rear upper cover and the rear lower cover.
📖 P. 4-1 "[A] Rear upper cover / Rear lower cover"
- (2) Take off the left upper cover.
📖 P. 4-2 "[B] Left upper cover"
- (3) Take off the control panel unit.
📖 P. 4-2 "[C] Control panel unit"
- (4) Take off the front cover assembly.
📖 P. 4-3 "[D] Front upper cover / Front lower cover"
- (5) Take off the front foot cover.
📖 P. 4-3 "[E] Front foot cover"
- (6) Take off the rear foot cover.
📖 P. 4-4 "[F] Rear foot cover"
- (7) Take off the movable tray cover.
📖 P. 4-4 "[G] Movable tray cover"
- (8) Take off the front rail cover.
📖 P. 4-5 "[H] Front rail cover"
- (9) Take off the rear rail cover.
📖 P. 4-5 "[I] Rear rail cover"
- (10) Take off the movable tray drive unit.
📖 P. 4-20 "[E] Movable tray drive unit / Movable tray shift motor unit"
- (11) Take off the grate-shaped guide.
📖 P. 4-7 "[L] Grate-shaped guide"
- (12) Take off the stationary tray cover.
📖 P. 4-10 "[N] Stationary tray cover"
- (13) Take off the buffer unit.
📖 P. 4-12 "[A] Buffer unit"
- (14) Remove 2 screws, and then take off the front finishing tray cover.
- (15) Move the front alignment plate guide in the direction of the arrow.
- (16) Release the latch, and then disconnect the connector to take off the finishing tray paper detection sensor.

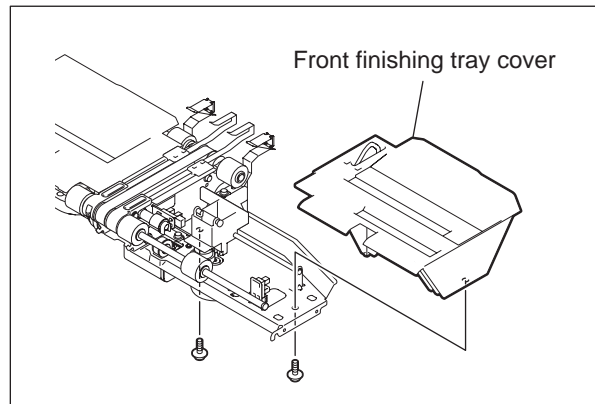

Fig. 4-182

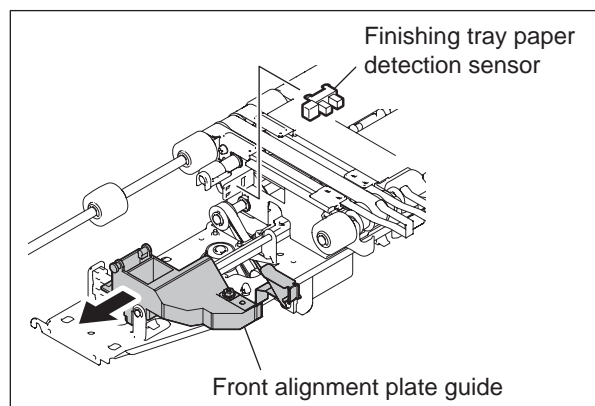

Fig. 4-183

[G] Stack exit belt home position sensor

- (1) Take off the rear upper cover and the rear lower cover.
📖 P. 4-1 "[A] Rear upper cover / Rear lower cover"
- (2) Take off the left upper cover.
📖 P. 4-2 "[B] Left upper cover"
- (3) Take off the control panel unit.
📖 P. 4-2 "[C] Control panel unit"
- (4) Take off the front cover assembly.
📖 P. 4-3 "[D] Front upper cover / Front lower cover"
- (5) Take off the front foot cover.
📖 P. 4-3 "[E] Front foot cover"
- (6) Take off the rear foot cover.
📖 P. 4-4 "[F] Rear foot cover"
- (7) Take off the movable tray cover.
📖 P. 4-4 "[G] Movable tray cover"
- (8) Take off the front rail cover.
📖 P. 4-5 "[H] Front rail cover"
- (9) Take off the rear rail cover.
📖 P. 4-5 "[I] Rear rail cover"
- (10) Take off the movable tray drive unit.
📖 P. 4-20 "[E] Movable tray drive unit / Movable tray shift motor unit"
- (11) Take off the grate-shaped guide.
📖 P. 4-7 "[L] Grate-shaped guide"
- (12) Take off the stationary tray cover.
📖 P. 4-10 "[N] Stationary tray cover"
- (13) Take off the buffer unit.
📖 P. 4-12 "[A] Buffer unit"
- (14) Take off the finishing tray unit.
📖 P. 4-16 "[C] Finishing tray unit"
- (15) Remove 2 screws, and then take off the front finishing tray cover.
- (16) Remove 2 screws, and then take off the rear finishing tray cover.

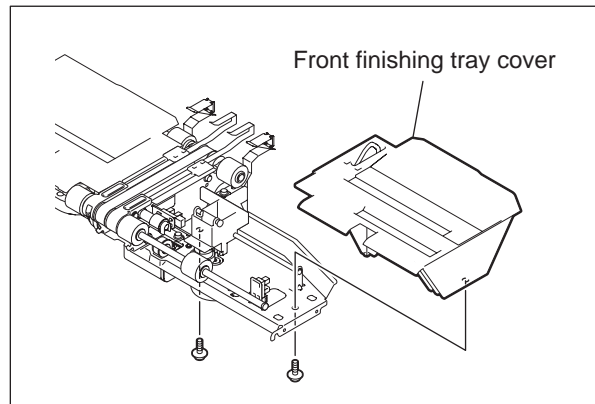

Fig. 4-184

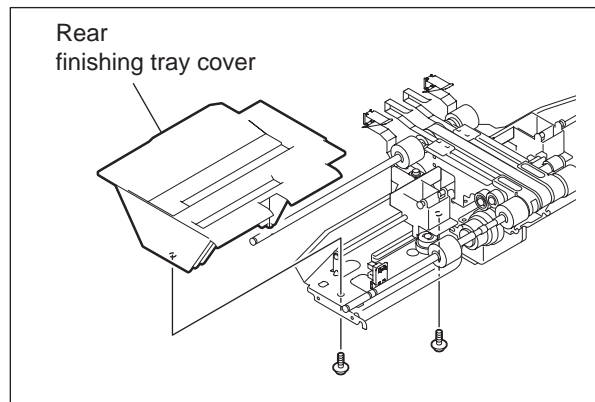

Fig. 4-185

- (17) Take off the belt from the stack transport motor.

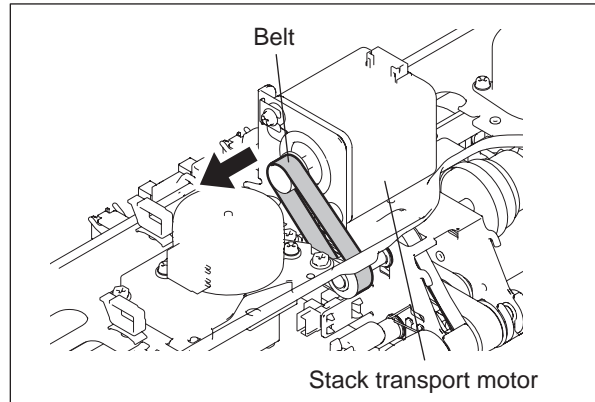

Fig. 4-186

- (18) Remove 3 screws, and then disconnect each connector of the finishing tray paper detection sensor and the stack exit belt home position sensor and the relay connector of the paper exit guide clutch. Then take off the stack exit belt unit.

Notes:

- Be sure not to lose the belt.
- When installing the stack transport belt unit, attach the rotation protection of the paper exit guide clutch.

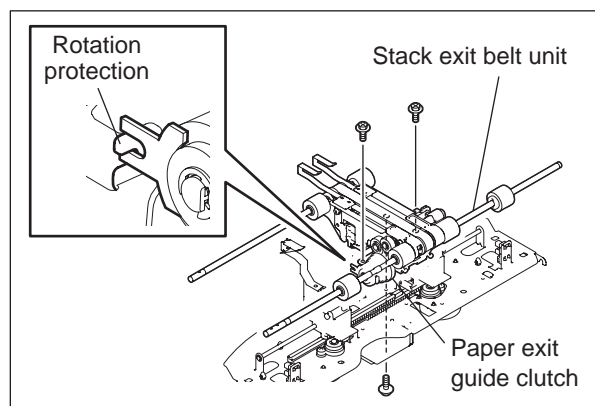

Fig. 4-187

- (19) Remove 1 screw, and then take off the sensor bracket.

Note:

When taking off the sensor bracket, the actuator and the spring are also taken off. Be sure not to lose the actuator and the spring.

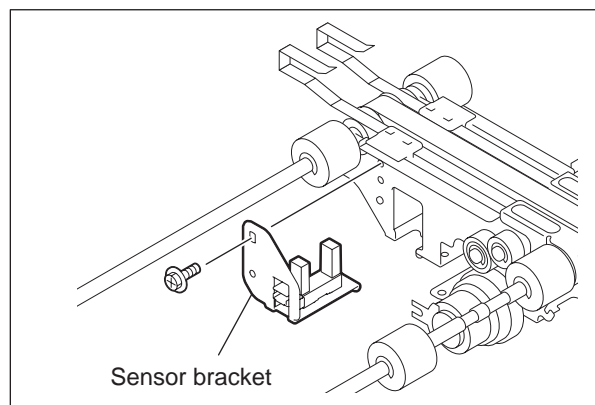

Fig. 4-188

- (20) Release the latch, and then take off the stack exit belt home position sensor.

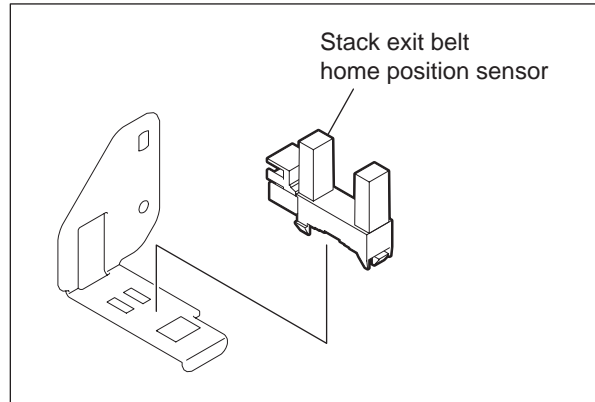

Fig. 4-189

[H] Front alignment plate home position sensor

- (1) Take off the rear upper cover and the rear lower cover.
📖 P. 4-1 "[A] Rear upper cover / Rear lower cover"
- (2) Take off the left upper cover.
📖 P. 4-2 "[B] Left upper cover"
- (3) Take off the control panel unit.
📖 P. 4-2 "[C] Control panel unit"
- (4) Take off the front cover assembly.
📖 P. 4-3 "[D] Front upper cover / Front lower cover"
- (5) Take off the front foot cover.
📖 P. 4-3 "[E] Front foot cover"
- (6) Take off the rear foot cover.
📖 P. 4-4 "[F] Rear foot cover"
- (7) Take off the movable tray cover.
📖 P. 4-4 "[G] Movable tray cover"
- (8) Take off the front rail cover.
📖 P. 4-5 "[H] Front rail cover"
- (9) Take off the rear rail cover.
📖 P. 4-5 "[I] Rear rail cover"
- (10) Take off the movable tray drive unit.
📖 P. 4-20 "[E] Movable tray drive unit / Movable tray shift motor unit"
- (11) Take off the grate-shaped guide.
📖 P. 4-7 "[L] Grate-shaped guide"
- (12) Release the latch, and then disconnect the connector to take off the front alignment plate home position sensor.

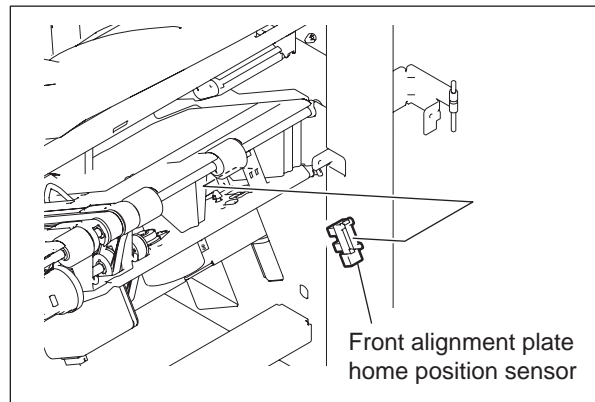

Fig. 4-190

[I] Rear alignment plate home position sensor

- (1) Take off the rear upper cover and the rear lower cover.
📖 P. 4-1 "[A] Rear upper cover / Rear lower cover"
- (2) Take off the left upper cover.
📖 P. 4-2 "[B] Left upper cover"
- (3) Take off the control panel unit.
📖 P. 4-2 "[C] Control panel unit"
- (4) Take off the front cover assembly.
📖 P. 4-3 "[D] Front upper cover / Front lower cover"
- (5) Take off the front foot cover.
📖 P. 4-3 "[E] Front foot cover"
- (6) Take off the rear foot cover.
📖 P. 4-4 "[F] Rear foot cover"
- (7) Take off the movable tray cover.
📖 P. 4-4 "[G] Movable tray cover"
- (8) Take off the front rail cover.
📖 P. 4-5 "[H] Front rail cover"
- (9) Take off the rear rail cover.
📖 P. 4-5 "[I] Rear rail cover"
- (10) Take off the movable tray drive unit.
📖 P. 4-20 "[E] Movable tray drive unit / Movable tray shift motor unit"
- (11) Take off the grate-shaped guide.
📖 P. 4-7 "[L] Grate-shaped guide"
- (12) Release the latch, and then disconnect the connector to take off the rear alignment plate home position sensor.

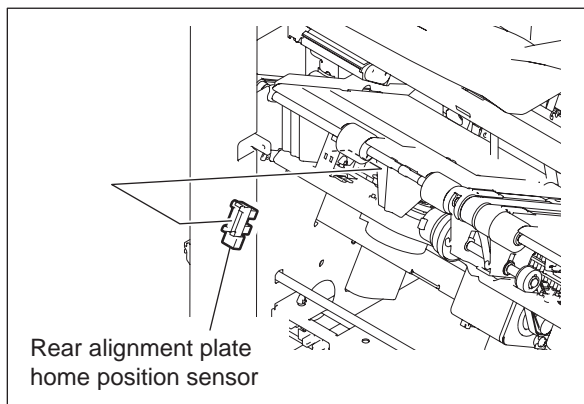

Fig. 4-191

[J] Stapler unit home position sensor

- (1) Open the front cover assembly.
- (2) Move the stapler to the position where the stapler unit home position sensor is seen.
- (3) Release the latch, and then disconnect the connector to take off the stapler unit home position sensor.

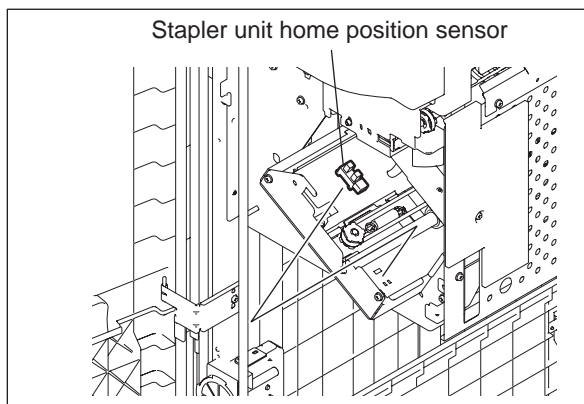

Fig. 4-192

[K] Stapler interference sensor / Actuator

- (1) Open the front cover assembly.
- (2) Take off the stapler.
P. 4-18 "[D] Stapler"
- (3) Release the latch, and then disconnect the connector to take off the stapler interference sensor.

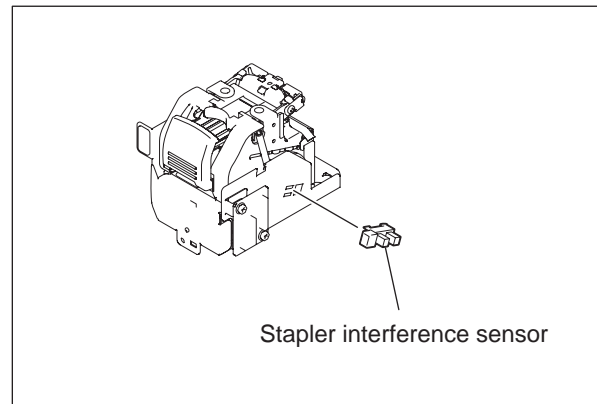

Fig. 4-193

- (4) Remove the clip, and then take off the stapler base frame.

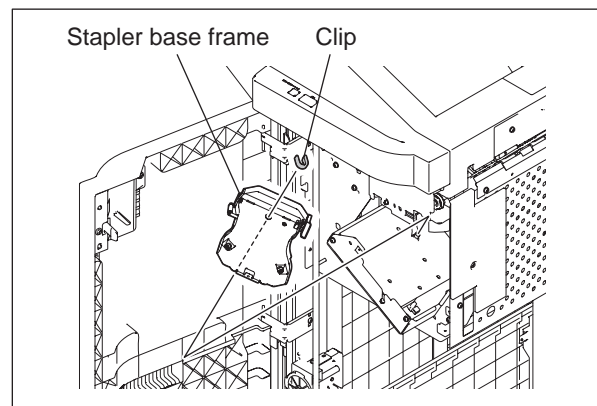

Fig. 4-194

- (5) Remove the spring, and then remove the clip to take off the actuator.

Note:

When installing the actuator, be sure to insert the clip from the side of the actuator.

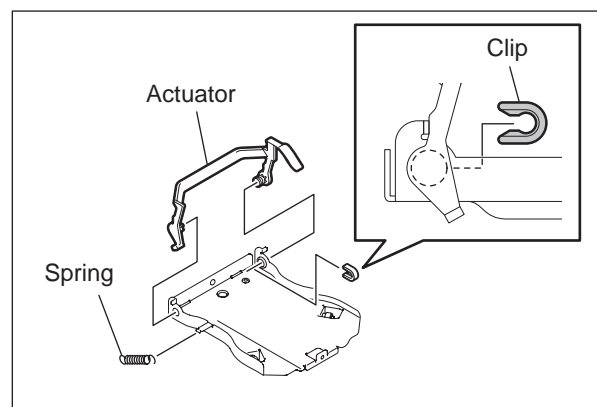

Fig. 4-195

[L] Stapler interference switch

- (1) Take off the rear upper cover and the rear lower cover.
P. 4-1 "[A] Rear upper cover / Rear lower cover"
- (2) Release the harness out of 2 clamps, and then disconnect the connector of CN23 on the FIN board.

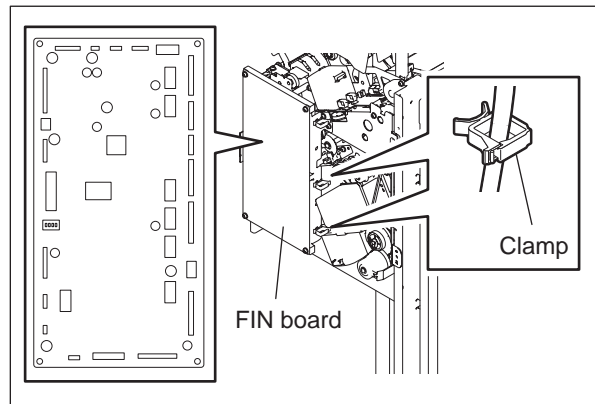

Fig. 4-196

- (3) Remove 2 screws, and then take off the stapler interference switch.

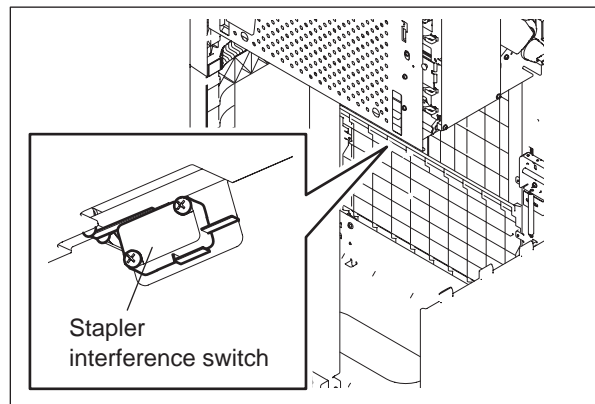

Fig. 4-197

[M] Movable tray paper exist sensor

- (1) Take off the movable tray cover.
P. 4-4 "[G] Movable tray cover"
- (2) Disconnect the connector of the movable tray paper exist sensor.
- (3) Release the latch, and then take off the movable tray paper exist sensor.

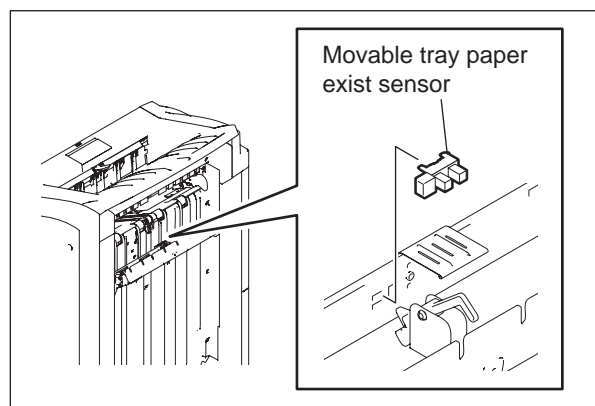

Fig. 4-198

[N] Paddle home position sensor

- (1) Take off the rear upper cover and the rear lower cover.
📖 P. 4-1 "[A] Rear upper cover / Rear lower cover"
- (2) Take off the FIN board assembly.
📖 P. 4-85 "[A] Finisher control PC board (FIN board) / FIN board assembly"
- (3) Remove 1 screw, and then disconnect the connector to take off the sensor bracket.

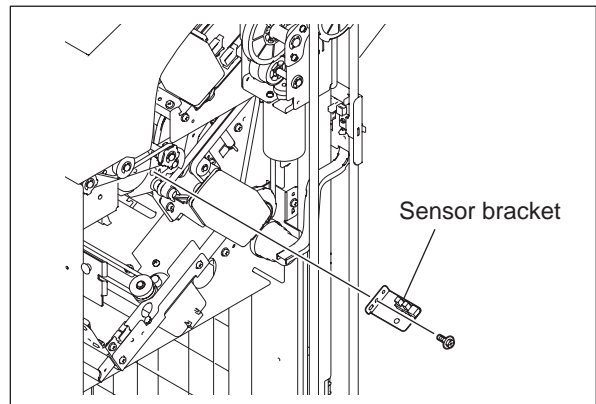

Fig. 4-199

- (4) Release the latch, and then take off the paddle home position sensor.

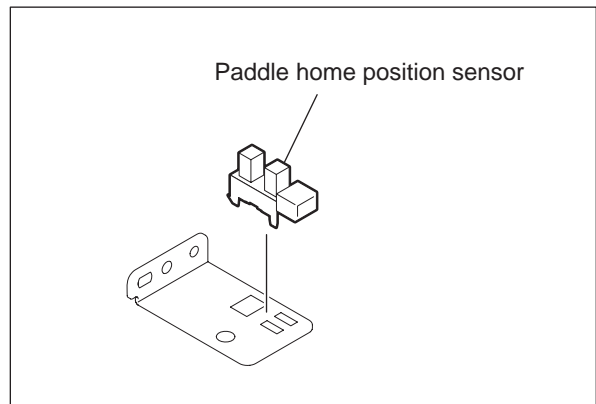

Fig. 4-200

[O] Front cover switch

- (1) Take off the rear upper cover and the rear lower cover.
📖 P. 4-1 "[A] Rear upper cover / Rear lower cover"
- (2) Take off the left upper cover.
📖 P. 4-2 "[B] Left upper cover"
- (3) Take off the control panel unit.
📖 P. 4-2 "[C] Control panel unit"
- (4) Remove 2 screws, and then take off the switch bracket.

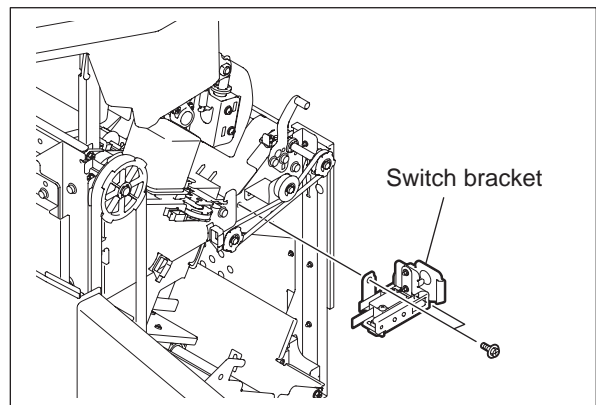

Fig. 4-201

- (5) Remove 2 screws, and then take off the front cover switch.

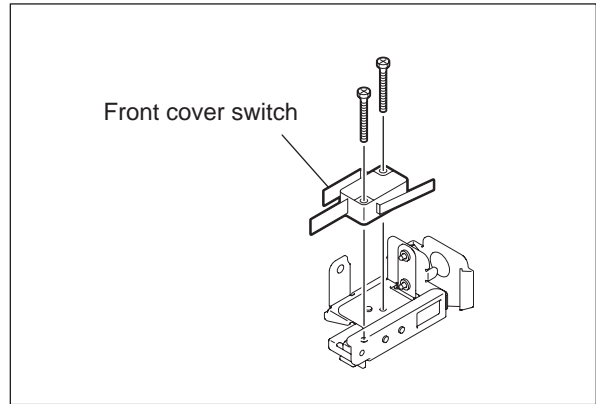

Fig. 4-202

[P] Entrance sensor

- (1) Take off the rear upper cover and the rear lower cover.
📖 P. 4-1 "[A] Rear upper cover / Rear lower cover"
- (2) Take off the blind cover.
📖 P. 4-6 "[J] Blind cover"
- (3) Take off the shield metal plate.
📖 P. 4-6 "[K] Shield metal plate"
- (4) Remove 1 screw, and then disconnect the connector to take off the sensor bracket.

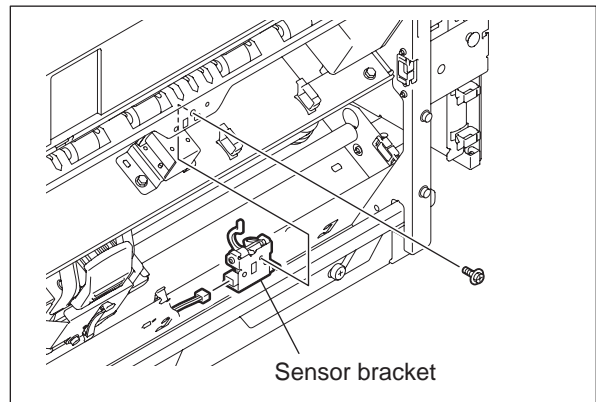

Fig. 4-203

- (5) Release the latch, and then take off the entrance sensor.

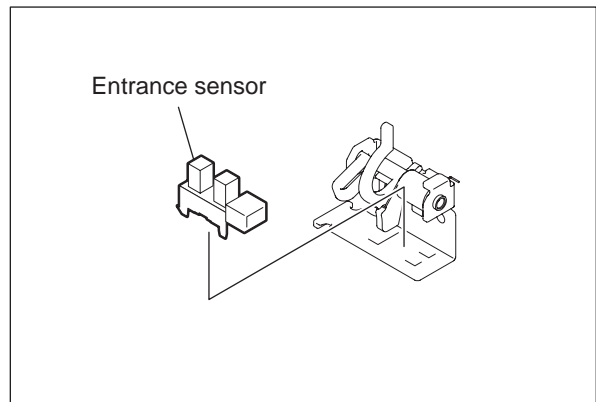

Fig. 4-204

[Q] Movable tray position sensor / Movable tray upper position sensor / Movable tray lower position sensor

- (1) Take off the rear upper cover.
P. 4-1 "[A] Rear upper cover / Rear lower cover"
- (2) Remove 2 screws, and then take off the sensor rail by moving each movable tray to the highest position.

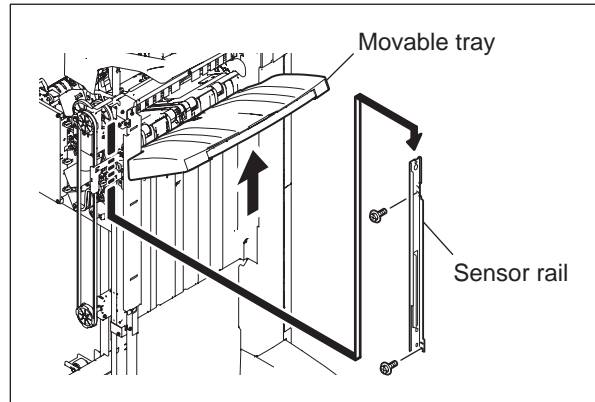

Fig. 4-205

Note:

When installing the movable tray drive unit, fix it at the position where the gap between the center mark of the scale on the sensor rail and the edge of the movable tray position-A sensor is from 0 to 1 mm. Be sure to adjust the installation position by shifting the movable tray shift frame and measure the positions at the upper and lower measuring points on the sensor rail as shown in the figure

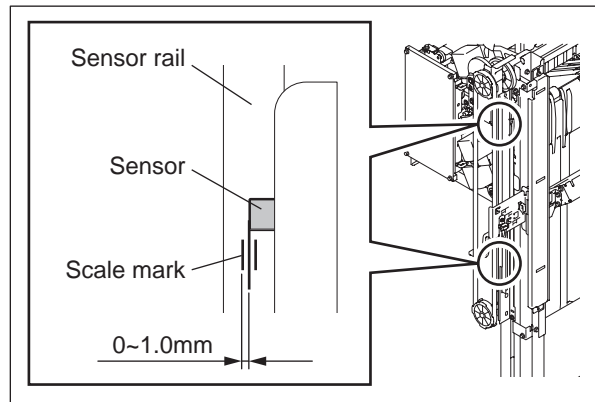

Fig. 4-206

- (3) Move back each movable tray to the middle position. When lowering each tray, press the gear of the movable shift motor unit in the direction of the arrow, and then release the lock to lower each tray. (Be sure to hold the movable trays by hands because they fall when the gear is pressed.)

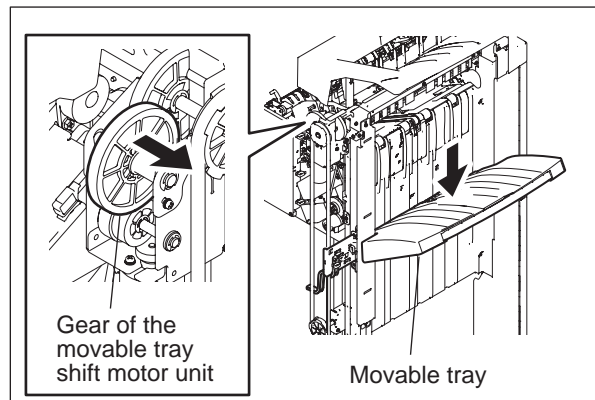

Fig. 4-207

- (4) Release the latch, and then disconnect the connectors to take off the movable tray position-A sensor, movable tray position-B sensor and movable tray position-C sensor.

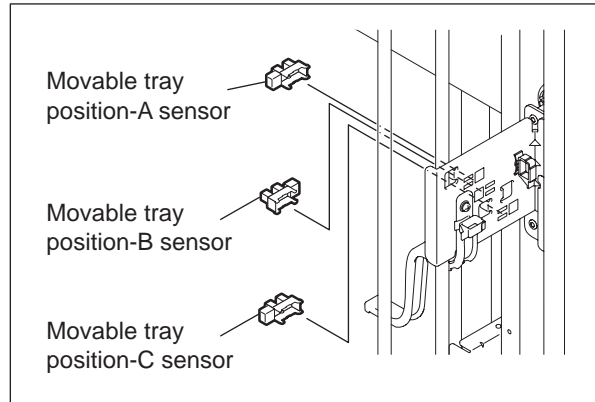

Fig. 4-208

[R] Movable tray paper-full sensor

- (1) Take off the rear upper cover and the rear lower cover.
 ☞ P. 4-1 "[A] Rear upper cover / Rear lower cover"
- (2) Take off the left upper cover.
 ☞ P. 4-2 "[B] Left upper cover"
- (3) Take off the control panel unit.
 ☞ P. 4-2 "[C] Control panel unit"
- (4) Take off the front cover assembly.
 ☞ P. 4-3 "[D] Front upper cover / Front lower cover"
- (5) Take off the front foot cover.
 ☞ P. 4-3 "[E] Front foot cover"
- (6) Take off the rear foot cover.
 ☞ P. 4-4 "[F] Rear foot cover"
- (7) Take off the movable tray cover.
 ☞ P. 4-4 "[G] Movable tray cover"
- (8) Take off the front rail cover.
 ☞ P. 4-5 "[H] Front rail cover"
- (9) Take off the rear rail cover.
 ☞ P. 4-5 "[I] Rear rail cover"
- (10) Take off the grate-shaped guide.
 ☞ P. 4-7 "[L] Grate-shaped guide"
- (11) Release the latch, and then disconnect the connector to take off the sensor bracket.
- (12) Release the latch, and then take off the movable tray paper-full sensor.

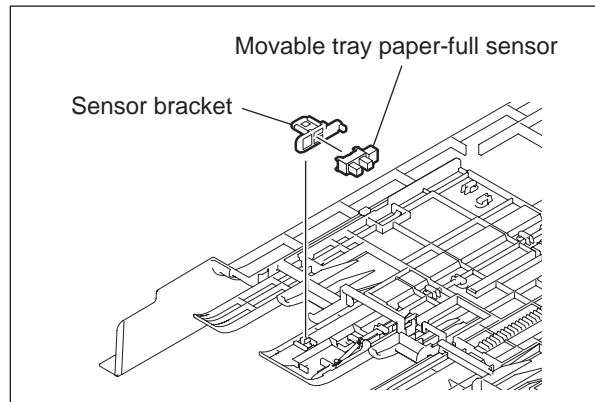

Fig. 4-209

[S] Shutter opening / closing sensor

- (1) Take off the rear upper cover and the rear lower cover.
📖 P. 4-1 "[A] Rear upper cover / Rear lower cover"
- (2) Take off the left upper cover.
📖 P. 4-2 "[B] Left upper cover"
- (3) Take off the control panel unit.
📖 P. 4-2 "[C] Control panel unit"
- (4) Take off the front cover assembly.
📖 P. 4-3 "[D] Front upper cover / Front lower cover"
- (5) Take off the front foot cover.
📖 P. 4-3 "[E] Front foot cover"
- (6) Take off the rear foot cover.
📖 P. 4-4 "[F] Rear foot cover"
- (7) Take off the movable tray cover.
📖 P. 4-4 "[G] Movable tray cover"
- (8) Take off the front rail cover.
📖 P. 4-5 "[H] Front rail cover"
- (9) Take off the rear rail cover.
📖 P. 4-5 "[I] Rear rail cover"
- (10) Take off the grate-shaped guide.
📖 P. 4-7 "[L] Grate-shaped guide"
- (11) Release the latch, and then disconnect the connector to take off the shutter opening / closing sensor.

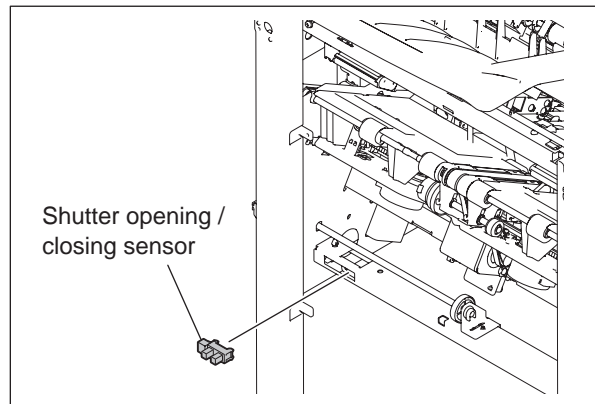

Fig. 4-210

4.7 PC Boards / Discharge Brush

[A] Finisher control PC board (FIN board) / FIN board assembly

Note:

After the Finisher control PC board (FIN board) has been replaced, check that the firmware is the latest version. If not, upgrade it.

- (1) Take off the rear upper cover and the rear lower cover.
P. 4-1 "[A] Rear upper cover / Rear lower cover"
- (2) Disconnect all connectors connecting to the FIN board.

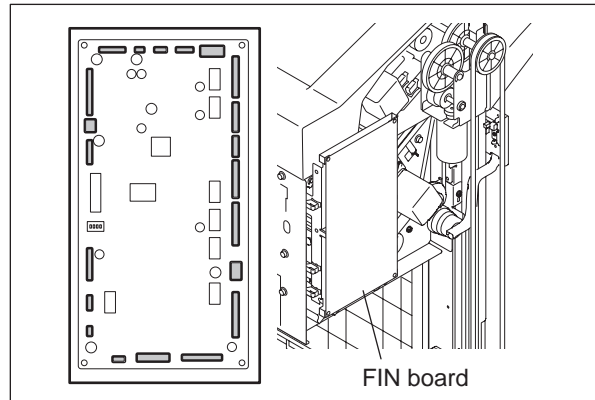

Fig. 4-211

- Finisher control PC board (FIN board)
 - Remove 4 screws, and then take off the FIN board.

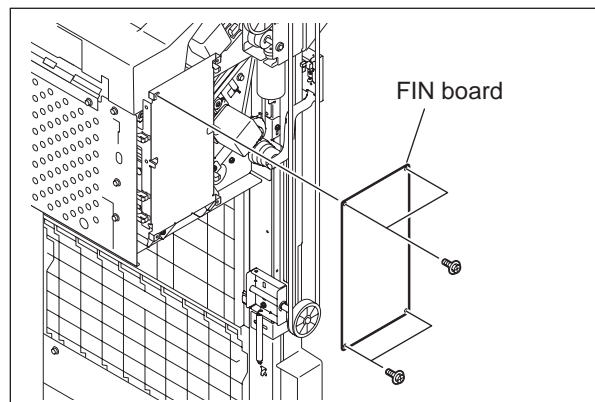

Fig. 4-212

- FIN board assembly
 - Cut off a band binding the finisher cable and the flexible cable.
 - Remove 3 screws, and then disconnect all connectors out of the clamps to take off the FIN board assembly.

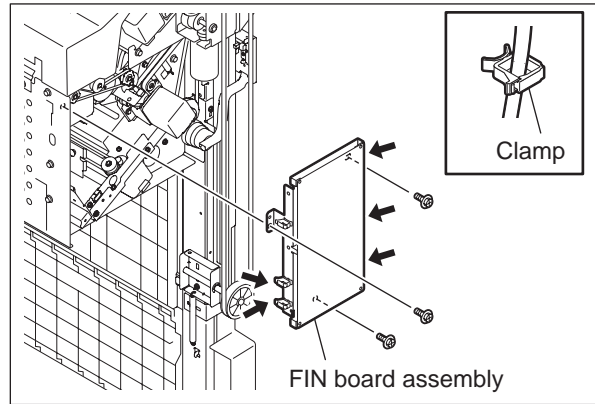

Fig. 4-213

[B] Front stationary tray discharge brush / Rear stationary tray discharge brush

- (1) Take off the stationary tray cover.
 P. 4-10 "[N] Stationary tray cover"
- (2) Loosen 1 rear side screw. Peel off the Mylar form around the screws, remove 2 screws, and then take off the front stationary tray discharge brush.

Note:
When installing the brush, fix the Mylar form securely.

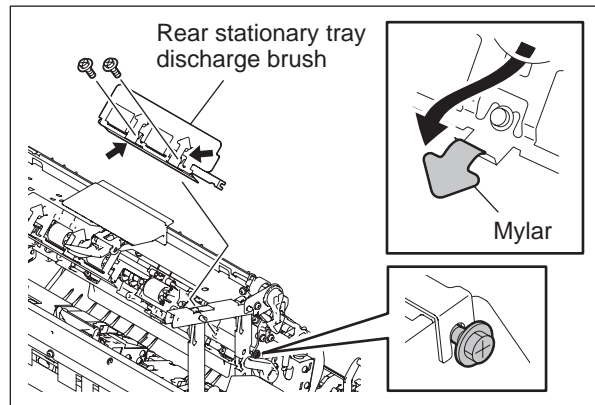

Fig. 4-214

- (3) Loosen 1 front side screw. Peel off the Mylar form around the screws, remove 2 screws, and then take off the rear stationary tray discharge brush.

Note:
When installing the brush, fix the Mylar form securely.

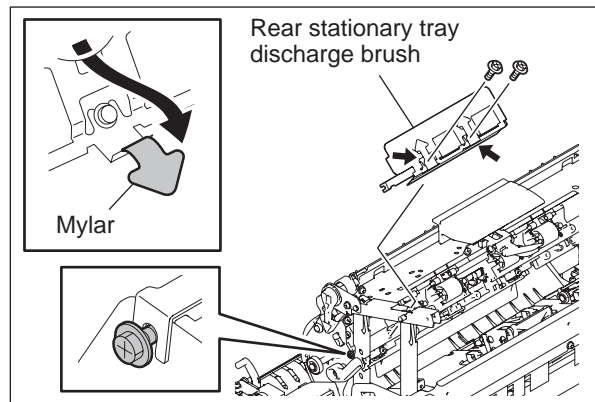

Fig. 4-215

[C] Feeding discharge brush.

- (1) Open the stationary tray cover.
- (2) Loosen 3 screws, and then take off the feeding discharge brush.

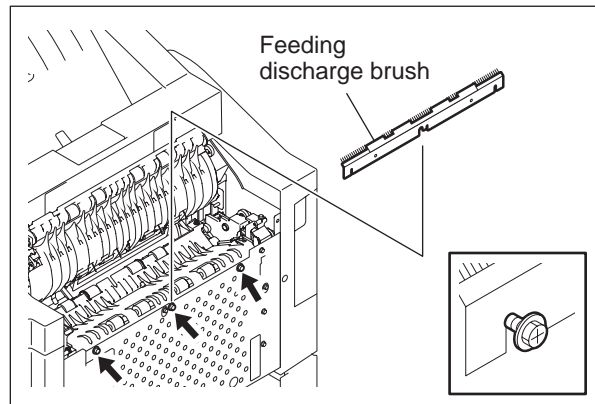

Fig. 4-216

[D] Paper exit discharge brush

- (1) Take off the rear upper cover and the rear lower cover.
P. 4-1 "[A] Rear upper cover / Rear lower cover"
- (2) Take off the left upper cover.
P. 4-2 "[B] Left upper cover"
- (3) Loosen 3 screws, and then take off the paper exit discharge brush.

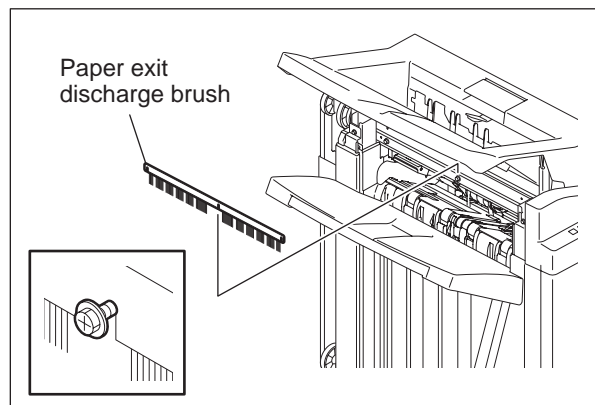

Fig. 4-217

4.8 Procedure for lowering the movable tray

The movable tray can be lowered by releasing its driving gear without disassembling the finisher.

- (1) Open the stationary tray.

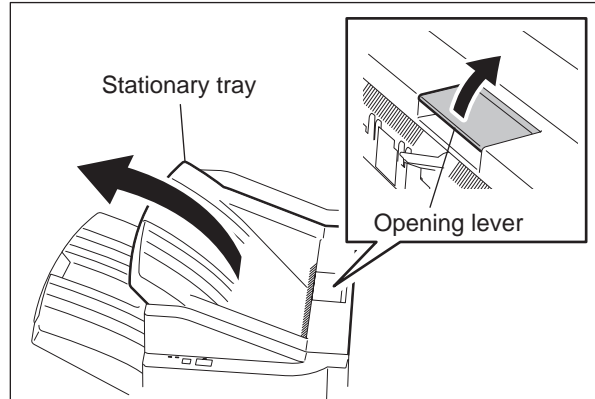

Fig. 4-218

- (2) When the driving gear of the movable tray is released, hold the tray with your hand because it will drop suddenly.

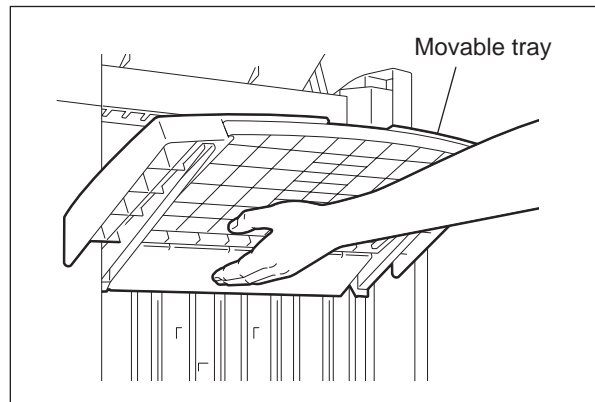

Fig. 4-219

- (3) While the movable tray is held with your hand, insert the screwdriver in the hole on the rear upper cover.

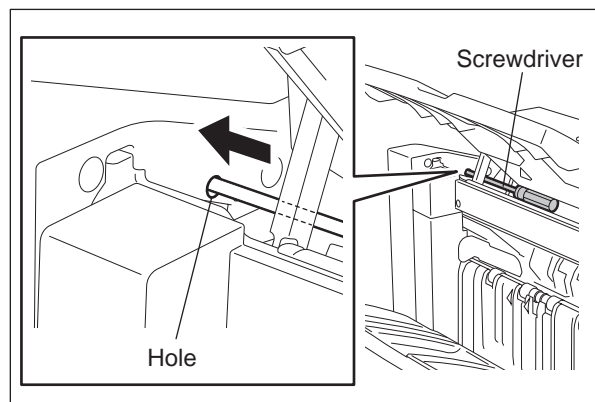

Fig. 4-220

- (4) Since the insertion of the screwdriver has released the driving gear of the movable tray, it can now be lowered. If the screwdriver is taken out, the movable tray will stop in that particular position.

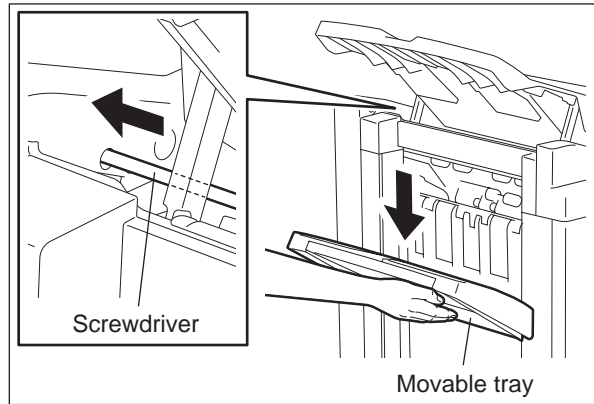

Fig. 4-221

- (5) The movable tray can be moved upward without being released by the screwdriver.

Note:

Be sure that the movable tray does not stay above its paper-full sensor. If printing is performed with the sensor turned ON, "Movable tray paper-full detection error" (CB31) will occur. The movable tray must be moved lower than the sensor.

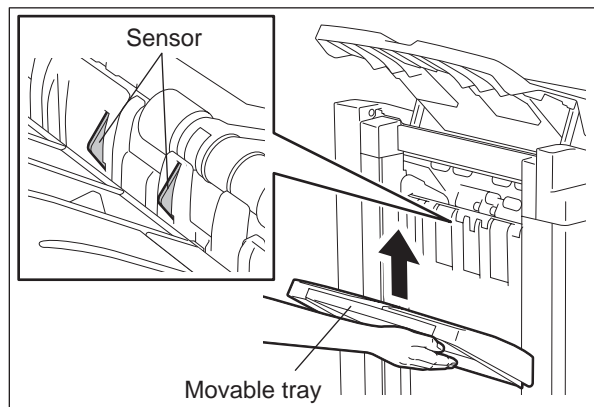

Fig. 4-222

5. ADJUSTMENTS

Note:

Before performing each adjustment, make sure that all covers (incl. those of the finisher and host machine) are closed. Otherwise, the power is not supplied to the finisher and the adjustment may not be performed properly.

5.1 Adjusting the Alignment Position

Perform this adjustment after replacing the Finisher control board or when the alignment position must be changed for some reason.

- (1) Turn OFF the power of the equipment.
- (2) Remove 1 screw and take off the board access cover.
- (3) Set the SW1 on the Finisher control board as shown in the figures below.

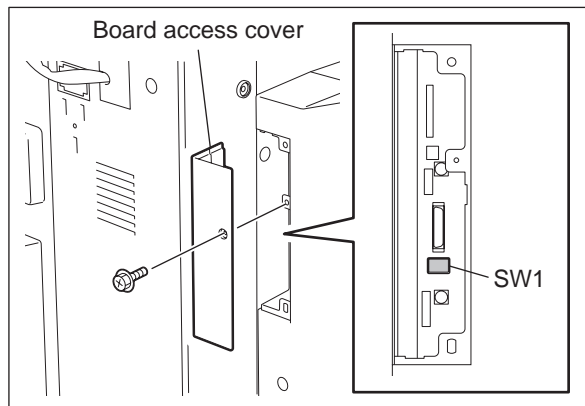

Fig. 5-1

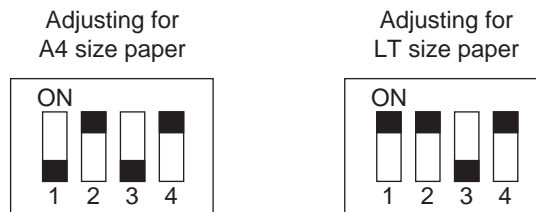

Fig. 5-2

- (4) Turn ON the power of the equipment while [0] button and [8] button are pressed simultaneously. The alignment plate moves to the A4 or LT size position and stops. (It stops at the position of -5 steps from the center value of the adjustment range.)

- (5) Press the [Button1] to adjust the alignment position.
 Every time the [Button1] is pressed, the alignment plate shifts 1 step (0.419 mm/step) toward the “+” direction. (The gap between the alignment plates becomes narrower.)
 Adjustment range is from -5 to +5 steps.
 If the [Button1] is pressed when the alignment position is at the “+5 step”, the plate will return to the home position and then moves to the position of “-5 step”.

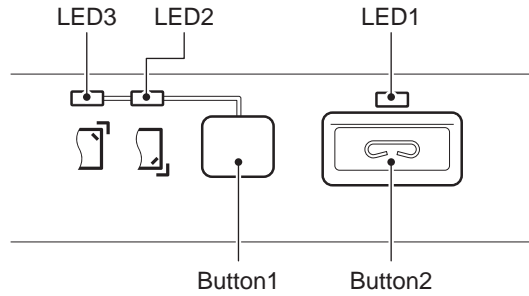

Fig. 5-3

- (6) When the adjustment is completed, press the [Button2] on the finisher control panel to store the adjustment value in memory.
 When the value is stored normally, the [LED1] on the control panel will blink for a number of times that corresponds to the adjustment value set for the equipment.
 See the following table for the number of times the [LED1] blinks and its corresponding adjustment value.

Number of Blinking	Adjustment Value
1	-5
2	-4
3	-3
4	-2
5	-1
6	0
7	+1
8	+2
9	+3
10	+4
11	+5

- (7) Turn OFF the power of the equipment.
 (8) Turn OFF all bits of the SW1 on the Finisher control board.
 (9) Install the board access cover.

5.2 Adjusting the Stapling Position

Perform this adjustment after replacing the Finisher control board or when the stapling position must be changed for some reason.

- (1) Turn OFF the power of the equipment.
- (2) Remove 1 screw and take off the board access cover.
- (3) Set the SW1 on the Finisher control board as shown in the figures below.

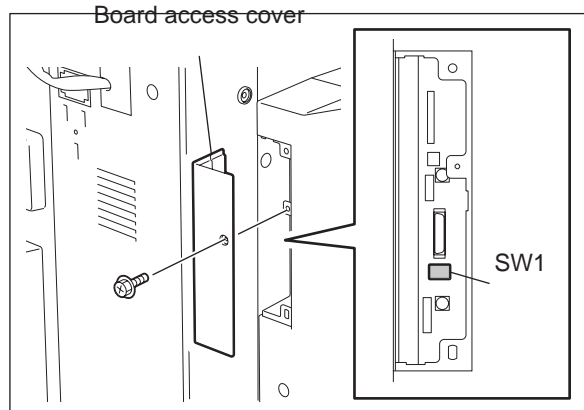
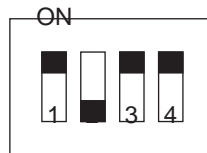
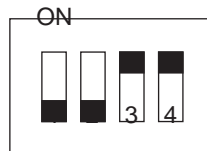

Fig. 5-4

When adjusting the rear side for A4 size paper



When adjusting the front side for A4 size paper



When adjusting the rear side for LT size paper



When adjusting the front side for LT size paper

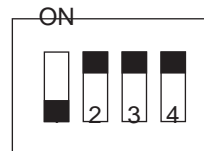

Fig. 5-5

- (4) Turn ON the power of the equipment while [0] button and [8] button are pressed simultaneously. The alignment plate moves to the rear or front side stapling position and stops. (It stops at the position of -20 steps from the center value of the adjustment range.)

- (5) Press [Button 1] to adjust the stapling position.
 Every time [Button 1] is pressed, the alignment plate shifts 4 steps (0.45 mm) toward the "+" direction. (It moves toward the rear side.)
 Adjustment range is from -20 to +20 steps. If [Button 1] is pressed when the alignment position is at the "+20 steps", the plate will return to the home position and then moves to the position of "-20 steps".

Note:

Stapling for checking the position can be done by pressing [Button 2] with sheets placed on the finishing tray. (stapled on the rear side)

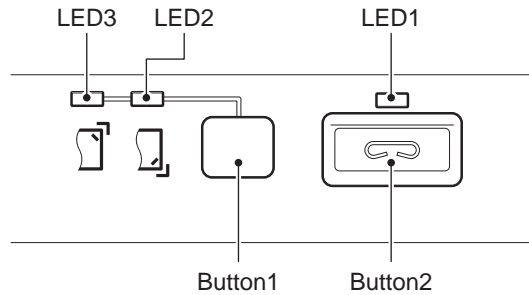

Fig. 5-6

- (6) When the adjustment is completed, press [Button 2] on the finisher control panel to store the adjustment value in memory without sheets on the finishing tray.
 When the value is stored normally, [LED 1] on the control panel will blink for a number of times that corresponds to the adjustment value set for the equipment.
 See the following table for the number of times [LED 1] blinks and its corresponding adjustment value.

Number of blinking	Adjustment value
1	-20
2	-16
3	-12
4	-8
5	-4
6	0
7	+4
8	+8
9	+12
10	+16
11	+20

- (7) Turn OFF the power of the equipment.
 (8) Turn OFF all bits of the SW1 on the Finisher control board.
 (9) Install the board access cover.

5.3 B4-size recycled paper mode settings

Set this mode if the trailing edge of the paper gets caught by the exit section of the finisher while B4-size recycled paper is used. This mode increases the paper exiting speed when the paper exits to the movable tray in the sort mode, or to the stationary tray in the non-sort mode.

- (1) Turn OFF the power of the equipment.
- (2) Remove 1 screw and take off the board access cover.
- (3) Set the SW1 on the Finisher control board as shown in the figures below.

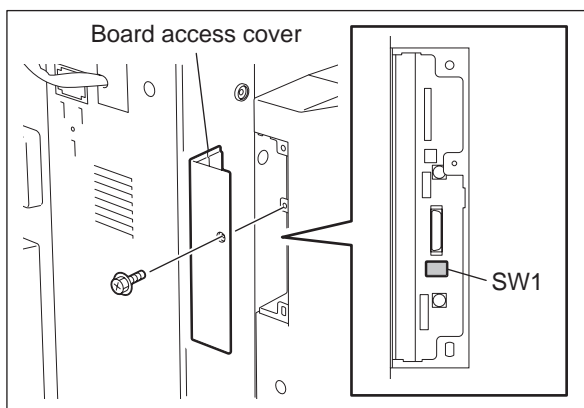

Fig. 5-7

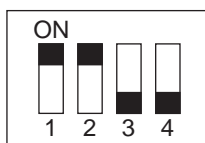

Fig. 5-8

- (4) Turn ON the power of the equipment while [0] button and [8] button are pressed simultaneously.

- (5) Press [Button1] and [Button2] as described in the following table to set the B4-size recycled paper mode. Press [Button1] and [Button2] on the control panel as below to set the B4-size recycled paper mode.

Note:

Be sure to press [Button1] and [Button2] the correct number of times.
Press [Button1] and [Button2] simultaneously to cancel the operation.

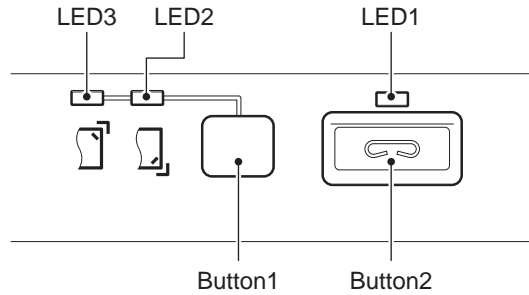

Fig. 5-9

B4-size recycled paper mode

Step	Buttons	Number of pressing	Remarks
1	Button1	1	
2	Button2	1	Confirms the input value
3	Button1	8	
4	Button2	1	Confirms the input value

Note:

To change settings from the B4-size recycled paper mode to the normal mode, perform steps (1) through (4), and then press [Button1] and [Button2] on the control panel as shown below to set the normal mode.

Normal mode

Step	Buttons	Number of pressing	Remarks
1	Button1	1	
2	Button2	1	Confirms the input value
3	Button1	6	
4	Button2	1	Confirms the input value

- (6) When the settings are stored normally, [LED1] on the control panel is lit. [LED1] blinks, if an error occurs. In this case, turn the power OFF and make the settings again from step (4).
- (7) Turn OFF the power of the equipment.
- (8) Turn OFF all bits of the SW1 on the Finisher control board.
- (9) Install the board access cover.

6. TROUBLESHOOTING

6.1 Paper Transport Jam

6.1.1 Paper jam in entrance section

[EA10] Paper transport delay jam

- 1) Check if there is any paper in the finisher or on the transport path of the equipment and remove it if there is.
- 2) Is there a disconnection of the connector, incorrect installation or breakage of the entrance sensor (S1)?
- 3) Is the gap between the flapper and entrance roller shaft other than 0.60?0.20mm when the gate solenoid (SOL2) is pulled?.
- 4) Is the harness between the entrance motor (M1) and the finisher control PC board (CN7) disconnected or open circuited?
- 5) Is the harness between the gate solenoid (SOL2) and the finisher control PC board (CN22) disconnected or open circuited?
- 6) Replace the finisher controller PC board.

[EA60] Early arrival jam

- 1) Check if there is any paper in the finisher or on the transport path of the equipment or on the finishing tray. Remove it if there is.
- 2) Check if there is any disconnection, incorrect installation or breakage on the entrance sensor (S1). Correct if any.
- 3) Check if the connector CN7 on the finisher controller PC board is disconnected from the entrance sensor (S1) and the harnesses are disconnected or open circuited. Correct if any.
- 4) Replace the entrance sensor.
- 5) Replace the finisher controller PC board.

[CB10] Entrance motor abnormality

Is there any mechanical problem when the entrance roller is rotated?

↓ →YES Fix the mechanism.

NO

Is the harness between the entrance motor (M1) and the finisher control PC board (CN7) disconnected or open circuited?

↓ →YES

- Reconnect the connector securely.
- Replace the harness.

NO

- 1) Replace the entrance motor (M1).
- 2) Replace the finisher control PC board.

6.1.2 Paper jam in buffer unit-1

[EA20] Paper transport stop jam

- 1) Check if there is any paper in the finisher or on the transport path of the equipment and remove it if there is.
- 2) Check if the connector CN22 on the finisher controller PC board are disconnected from the transport sensor (S2), or the harnesses are open circuited. Correct if any.
- 3) Replace the sensor.
- 4) Replace the finisher controller PC board.

[EA21] Paper size error jam (outlet sensor)

- 1) Check if there is any paper in the finisher or on the transport path of the equipment and remove it if there is.
- 2) Is the paper size used shorter than the size specified in the specifications?
- 3) Check if the connectors CN7 and CN22 on the finisher controller PC board are disconnected from the entrance sensor (S1) and the transport sensor (S2), or the harnesses are open circuited. Correct if any.
- 4) Reinstall the sensor correctly.
- 5) Replace the sensor.
- 6) Replace the finisher controller PC board.

[EA23] Paper transport stop jam (transport sensor)

[EA24] Paper transport stop jam (between entrance & transport sensor)

[EA25] Paper transport stop jam (after paper stack exit)

[EA26] Paper transport stop jam (stop command request)

[EA27] Paper transport stop jam (paper not inserted)

[EA28] Paper transport stop jam (paper holder plate operation delay)

[EA29] Paper transport stop jam (stack transport delay)

- 1) Check if there is any paper in the finisher or on the transport path of the equipment and remove it if there is.
- 2) Check if the connectors CN7 and CN22 on the finisher controller PC board are disconnected from the entrance sensor (S1) and the transport sensor (S2), or the harnesses are open circuited. Correct if any.
- 3) Replace the sensor.
- 4) Replace the finisher controller PC board.

[EA31] Transport path paper remaining jam

- 1) Check if there is any paper in the finisher or on the transport path of the equipment and remove it if there is.
- 2) Check if the connector CN22 on the finisher controller PC board is disconnected from the transport sensor (S2) or the harnesses are open circuited. Correct if any.
- 3) Reinstall the sensor correctly.
- 4) Replace the sensor.
- 5) Replace the finisher controller PC board.

6.1.3 Paper jam in buffer unit-2

[ED16] Buffer tray home position error

- 1) Open and close the buffer tray guide. If there is any mechanical problem, fix its mechanism.
- 2) Check if the connectors on the finisher controller PC board are disconnected from the buffer tray home position sensor (S5) and the buffer tray guide motor (M3), or the harnesses are open circuited. Correct if any.
- 3) Replace the buffer tray guide motor (M3).
- 4) Replace the buffer tray home position sensor (S5).
- 5) Replace the finisher controller PC board.

[CB11] Buffer tray guide motor abnormality

Is there any mechanical problem when the buffer tray guide is opened/closed while the buffer roller is lifted up?

↓ →YES Fix the mechanism.

NO

Is the harness between the buffer tray guide motor (M3) and the finisher control PC board (CN18) disconnected or open circuited?

↓ →YES

- Reconnect the connector securely.
- Replace the harness.

NO

- 1) Replace the buffer tray guide motor (M3).
- 2) Replace the finisher control PC board.

[CB12] Buffer roller drive motor abnormality

Is there any mechanical problem when the buffer roller is rotated?

↓ →YES Fix the drive mechanism.

NO

Is the harness between the buffer roller drive motor (M6) and the finisher control PC board (CN18) disconnected or open circuited?

↓ →YES

- Reconnect the connector securely.
- Replace the harness.

NO

- 1) Replace the buffer roller drive motor (M6).
- 2) Replace the finisher control PC board.

6.1.4 Paper jam in finishing tray section

[ED13] Front alignment plate home position error

- 1) Move the front alignment plate. If there is any mechanical problem, fix its mechanism.
- 2) Check if the connectors on the finisher controller PC board are disconnected from the front alignment plate home position sensor (S7) and the front alignment motor (M9), or the harnesses are open circuited. Correct if any.
- 3) Replace the front alignment motor (M9).
- 4) Replace the front alignment plate home position sensor (S7).
- 5) Replace the finisher controller PC board.

[ED14] Rear alignment plate home position error

- 1) Move the rear alignment plate. If there is any mechanical problem, fix its mechanism.
- 2) Check if the connectors on the finisher controller PC board are disconnected from the rear alignment plate home position sensor (S8) and the rear alignment motor (M10), or the harnesses are open circuited. Correct if any.
- 3) Replace the rear alignment motor (M10).
- 4) Replace the rear alignment plate home position sensor (S8).
- 5) Replace the finisher controller PC board.

[CB40] Front alignment motor abnormality

Is there any mechanical problem when the front alignment plate is moved?

↓ →YES Fix the mechanism.

NO

Is the harness between the front alignment motor (M9) and the finisher control PC board (CN10) disconnected or open circuited?

↓ →YES • Reconnect the connector securely.
↓ • Replace the harness.

NO

- 1) Replace the front alignment motor (M9).
- 2) Replace the finisher control PC board.

[CC80] Rear alignment motor abnormality

Is there any mechanical problem when the rear alignment plate is moved?

↓ →YES Fix the mechanism.

NO

Is the harness between the rear alignment motor (M10) and the finisher control PC board (CN10) disconnected or open circuited?

↓ →YES • Reconnect the connector securely.
↓ • Replace the harness.

NO

- 1) Replace the rear alignment motor (M10).
- 2) Replace the finisher control PC board.

[ED15] Paddle home position error

- 1) Rotate the paddle. If there is any mechanical problem, fix its mechanism.

- 2) Check if the connectors on the finisher controller PC board are disconnected from the paddle home position sensor (S3) and the paddle motor (M8), or the harnesses are open circuited. Correct if any.
- 3) Replace the paddle motor (M8).
- 4) Replace the paddle home position sensor (S3).
- 5) Replace the finisher controller PC board.

[CDE0] Paddle motor abnormality

Is there any mechanical problem with the paddle is rotated?

↓ →YES Fix the mechanism.

NO

Is the harness between the paddle motor (M8) and the finisher control PC board (CN6) disconnected or open circuited?

↓ →YES

- Reconnect the connector securely.
- Replace the harness.

NO

- 1) Replace the paddle motor (M8).
- 2) Replace the finisher control PC board.

[EA70] Stack exit belt home position error

- 1) Check if the connector CN11 on the finisher controller PC board is disconnected from the stack belt exit home position sensor (S9) and the harnesses are open circuited. Correct if any.
- 2) Is the harness between the stack transport motor (M5) and the finisher control PC board (CN10) disconnected or open circuited?
- 3) Replace the sensor.
- 4) Replace the finisher controller PC board.

[CC30] Stack transport motor abnormality

Is there any mechanical problem when the stack transport belt is moved?

↓ →YES Fix the mechanism.

NO

Is the harness between the stack transport motor (M5) and the finisher control PC board (CN10) disconnected or open circuited?

↓ →YES

- Reconnect the connector securely.
- Replace the harness.

NO

- 1) Replace the stack transport motor (M5).
- 2) Replace the finisher control PC board.

[CC31] Transport motor abnormality

Is there any mechanical problem when the stack transport roller -1 and -2 are rotated?

↓ →YES Fix the mechanism.

NO

Is the harness between the transport motor (M2) and the finisher control PC board (CN5) disconnected or open circuited?



- I →YES • Reconnect the connector securely.
↓ • Replace the harness.

NO

- 1) Replace the transport motor (M2).
- 2) Replace the finisher control PC board.

[CC41] Paper holder cam home position abnormality

Is there any mechanical problem when the paper holder cam is rotated?

- ↓ →YES Fix the mechanism.

NO

Is the harness between the paper holder home position sensor (S6) and the finisher control PC board (CN17) disconnected or open circuited?

- I →YES • Reconnect the connector securely.
↓ • Replace the harness.

NO

- 1) Replace the paper holder home position sensor (S6).
- 2) Replace the finisher control PC board.

[EA32] Exit paper remaining jam

- 1) Check if there is any paper in the finisher or on the transport path of the equipment and remove it if there is.
- 2) Check and correct the mechanism.
- 3) Check if the connector CN11 on the finisher controller PC board is disconnected from the finishing tray paper detection sensor (S12) or the harnesses are open circuited. Correct if any.
- 4) Reinstall the sensor correctly.
- 5) Replace the sensor.
- 6) Replace the finisher controller PC board.

6.1.5 Paper jam in movable tray section

[CB30] Movable tray shift motor abnormality

Is there any mechanical problem when the movable tray is moved?

↓ →YES Fix the mechanism.

NO

Is the harness between the movable tray shift motor (M7) and the finisher control PC board (CN8) disconnected or open circuited?

↓ →YES

- Reconnect the connector securely.
- Replace the harness.

NO

Is there a disconnection of the connector, incorrect installation or breakage of the movable tray position A, B, and C sensors (S13, S14, and S15)?

↓ →YES

- Replace the harness.
- Reinstall the sensor correctly.
- Replace the sensor.

NO

- 1) Replace the movable tray shift motor (M7).
- 2) Replace the finisher control PC board.

[CB31] Movable tray paper-full detection error

Is there any mechanical problem when the actuator of the movable tray paper-full detection sensor (S16) is moved?

↓ →YES Fix the mechanism.

NO

Is there a disconnection of the connector, incorrect installation or breakage of the movable tray paper-full detection sensor (S16)?

↓ →YES

- Connect the connector securely.
- Reinstall the sensor correctly.
- Replace the sensor.

NO

Is the harness between the movable tray paper-full detection sensor (S16) and the finisher control PC board (CN13) disconnected or open circuited?

↓ →YES

- Reconnect the connector securely.
- Replace the harness.

NO

Replace the finisher control PC board.

[ED12] Shutter home position error

- 1) Open and close the shutter. If there is any mechanical problem, fix its mechanism.

- 2) Check if the connectors on the finisher controller PC board are disconnected from the shutter opening/closing sensor (S4) and the shutter clutch (CLT1), or the harnesses are open circuited. Correct if any.
- 3) Replace the shutter clutch (CLT1).
- 4) Replace the shutter opening/closing sensor (S4).
- 5) Replace the finisher controller PC board.

6.1.6 Paper jam due to cover open

[EA40] Door open jam

- 1) Close the front cover or the stationary tray cover if they are opened.
- 2) Replace the handle cover installed inside of the front cover if it is broken.
- 3) Reinstall the stationary tray opening/closing switch if it is incorrectly installed.
- 4) Check if the connector CN16 on the finisher controller PC board is disconnected from the front cover switch (SW1) and the stationary tray opening/closing switch (SW2) or the harnesses are open circuited. Correct if any.
- 5) Replace the sensors.
- 6) Replace the finisher controller PC board.

6.2 Other Errors

6.2.1 Stapler related error

[EA50] Stapling jam

- 1) Check if there is any paper in the finisher or on the transport path of the equipment or on the finishing tray. Remove it if there is.
- 2) Is the jam cleared by taking off the staple cartridge from the finisher and removing the staple sheet slid from the staple case?
- 3) Check if the actuator of the stapler interference sensor (S11) moves smoothly.
- 4) Check if the connector CN2 on the finisher controller PC board is disconnected from the stapler or the harnesses are open circuited. Correct if any.
- 5) Check the harnesses in the stapler are disconnected or open circuited. Correct if any.
- 6) Replace the finisher controller PC board.

[CB50] Stapler home position error

Is the harness between the stapler and the finisher control PC board (CN2) disconnected or open circuited?

- | | | |
|---|------|-------------------------------------|
| | →YES | • Reconnect the connector securely. |
| ↓ | | • Replace the harness. |

NO

Are the harnesses in the stapler disconnected or open circuited?

- | | | |
|---|------|-------------------------------------|
| | →YES | • Reconnect the connector securely. |
| ↓ | | • Replace the harness. |

NO

Replace the finisher control PC board.

[CB51] Stapler shift home position error

Is there any mechanical problem when the stapler is moved?

↓ →YES Fix the mechanism.

NO

Is there a disconnection of the connector, incorrect installation or breakage of the stapler unit home position sensor (S10)?

↓ →YES

- Connect the connector securely.
- Reinstall the sensor correctly.
- Replace the sensor.

NO

Is the harness between the stapler unit home position sensor (S10) and the finisher control PC board (CN1) disconnected or open circuited?

↓ →YES

- Reconnect the connector securely.
- Replace the harness.

NO

Is the harness between the stapler unit shift motor (M4) and the finisher control PC board (CN5) disconnected or open circuited?

↓ →YES

- Reconnect the connector securely.
- Replace the harness.

NO

Replace the finisher control PC board.

[CB60] Stapler unit shift motor abnormality

Is there any mechanical problem when the stapler is moved?

↓ →YES Fix the mechanism.

NO

Is the harness between the stapler unit shift motor (M4) and the finisher control PC board (CN5) disconnected or open circuited?

↓ →YES

- Reconnect the connector securely.
- Replace the harness.

NO

- 1) Replace the stapler unit shift motor (M4).
- 2) Replace the finisher control PC board.

6.2.2 Communication Related Error

[CB00] Finisher not connected

[CB01] Finisher communication error

(when MJ-6101 is not connected)

- 1) Is the error recovered when the power of the equipment is turned OFF and then back ON?
- 2) Check if the MJ-1101 is set as the specified finisher on the equipment.
- 3) Check if the harness connecting the converter PC board and the finisher controller PC board is disconnected or open circuited.
- 4) Check if the conductor pattern on the converter PC board is open circuited or short circuited.
- 5) Check if the conductor pattern on the finisher controller PC board is open circuited or short circuited.
- 6) Try to update the finisher firmware again.
- 7) Replace the converter PC board.
- 8) Replace the finisher control PC board.

(when MJ-6101 is connected)

- 1) Is the error recovered when the power of the equipment is turned OFF and then back ON?
- 2) Check if the MJ-1101 is set as the specified finisher on the equipment.
- 3) Check if the harness connecting the converter PC board and the finisher controller PC board is disconnected or open circuited.
- 4) Check if the harness connecting the hole punch control PC board and the finisher control PC board is disconnected or open circuited.
- 5) Check if the conductor pattern on the converter PC board is open circuited or short circuited.
- 6) Check if the conductor pattern on the finisher controller PC board is open circuited or short circuited.
- 7) Check if the conductor pattern on the hole punch control PC board is open circuited or short circuited.
- 8) Try to update the finisher firmware again.
- 9) Replace the converter PC board.
- 10) Replace the finisher control PC board.
- 11) Replace the hole punch control PC board.

6.2.3 Memory error

[CB80] RAM abnormality

Is the error recovered when the power of the equipment is turned OFF and then back ON?

↓ →YES End.

NO

Replace the finisher control PC board.

[CB81] Flash ROM abnormality

Is the error recovered when the power of the equipment is turned OFF and then back ON?

↓ →YES End.

NO

- 1) Check if the conductor pattern on the finisher controller PC board is open circuited or short circuited.
- 2) Replace the finisher control PC board.

6.3 Self-Diagnostic Modes

6.3.1 General description

Check the operations of the motors, clutches, solenoids and sensors in the Finisher.

6.3.2 Operation procedure

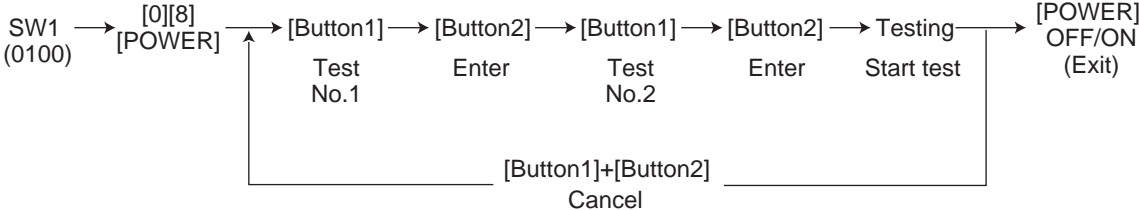

Fig. 6-1

- (1) Remove 1 screw and take off the board access cover.
- (2) Set SW1 on the Finisher control board as shown in the figures below.

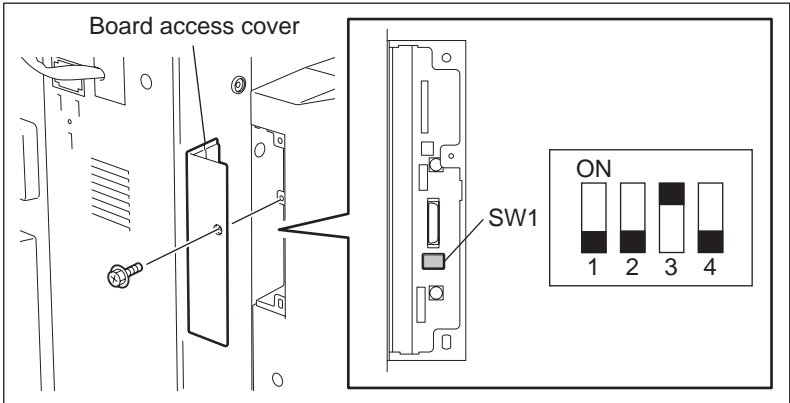

Fig. 6-2

- (3) Turn ON the power of the equipment while the [0] button and the [8] button are pressed simultaneously.

- (4) Check the test list and press [Button1] as many times as noted for Test No. 1 whose operation you want to check.

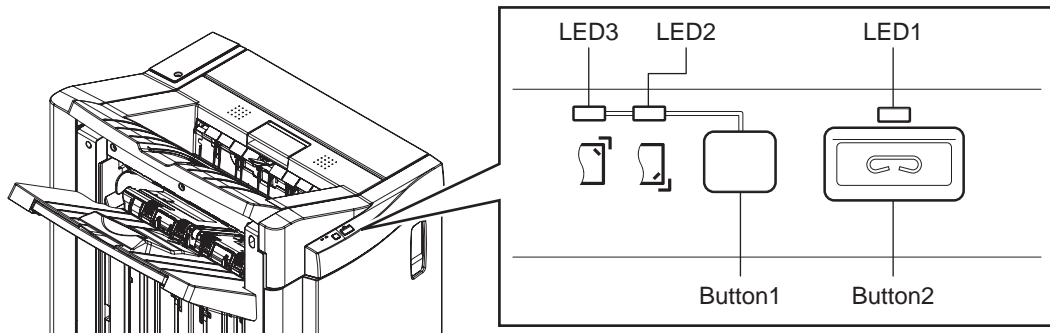

Fig. 6-3

- (5) Press [Button2] once. (To enter the number of Test No. 1)
 (6) Check the test list and press [Button1] as many times as noted for Test No. 2 whose operation you want to check.
 (7) Press [Button2] once. (To enter the number of Test No. 2)
 (8) The test is started.
 * To cancel the test, press [Button1] and [Button2] simultaneously.
 (9) Turn OFF the power of the equipment.

* Example of operation

In case of an operation check for the paddle motor, the number of Test No. 1 is "2" and the one for Test No. 2 is "8".

Therefore press [Button1] 2 times and then press [Button2] once. Then press [Button1] 8 times and then press [Button2] once. This starts the operation check for the paddle motor.

Note:

In case of an error, open and close the front cover or the stationary tray of the Finisher to clear the error, and then start the next test.

6.3.3 Checking operational status

The operational status can be checked with LEDs on the control panel.

LED1(ON)	"1" is detected in a sensor check or the operation is finished normally
LED1(OFF)	"0" is detected in a sensor check or the operation is in progress
LED1(Blinks in a single pattern)	Turning power ON / during initialization / waiting for paper insertion
LED1(Blinks in a multiple pattern)	The operation is finished abnormally P. 6-19 "6.3.5 Error indications"
LED2: ON, LED3: OFF	Waiting for Test No. 1 number to be entered
LED2: OFF, LED3: ON	Waiting for Test No. 2 number to be entered
LED2: ON, LED3: ON	Test in progress
LED2: OFF, LED3: OFF	Test finished

6.3.4 Test list

1) Aging

Test No. 1 number	Test No. 2 number	Description	Symbol	Contents of operation
1	1	Aging 1	-	Performs dummy 2-position stapling on A4 paper. Continues the operation until it is canceled. (If a staple cartridge is installed, stapling is not performed. If it is removed, dummy stapling is performed.)
1	2	Aging 2	-	Performs dummy sorting on A4-R paper. Continues the operation until it is canceled.
1	3	Aging 3	-	Performs dummy exiting to the stationary tray in the non-sort mode. Continues the operation until it is canceled.
1	4	Aging 4	-	Performs dummy exiting to the movable tray in the non-sort mode. Continues the operation until it is canceled.
1	5	Punch-aging (Aging 5)	-	Drives the entrance motor of the Finisher. Outputs a mechanical initial command to the Hole Punch unit in every 4 seconds. Continues the operation until it is canceled.

2) Operation check for motors

Test No. 1 number	Test No. 2 number	Description	Symbol	Contents of operation
2	1	Entrance motor	M1	Opens the shutter. Drives the motor for 10 seconds and then stops it. Closes the shutter.
2	2	Transport motor	M2	Opens the shutter. Drives the motor for 3 seconds and then stops it. Closes the shutter.
2	3	Buffer tray guide motor	M3	Opens the shutter. Performs initialization (stopping at the standby position after detecting the home position). Closes the shutter.
2	4	Stapler unit shift motor	M4	Opens the shutter. Performs initialization (stopping at the standby position after detecting the home position). Closes the shutter.
2	5	Stack transport motor	M5	Opens the shutter. Moves the latch to the exiting position and then stops it for 10 seconds. Returns it to the home position. Closes the shutter.
2	6	Buffer roller drive motor	M6	Opens the shutter. Drives the motor for 10 seconds and then stops it. Closes the shutter.
2	7	Movable tray shift motor	M7	Opens the shutter. Lowers the movable tray to its lower limit. Closes and opens the shutter. Raises the movable tray to its upper limit with the shutter open. Closes the shutter.
2	8	Paddle motor	M8	Opens the shutter. Performs initialization (stopping at the standby position after detecting the home position). Closes the shutter.

Test No. 1 number	Test No. 2 number	Description	Symbol	Contents of operation
2	9	Front alignment motor	M9	Opens the shutter. Performs initialization (stopping at the standby position after detecting the home position). Closes the shutter.
2	10	Rear alignment motor	M10	Opens the shutter. Performs initialization (stopping at the standby position after detecting the home position). Closes the shutter.
2	11	Stapler motor	M11	Opens the shutter. Performs stapling. Closes the shutter. (If the staple cartridge is installed, stapling is not performed. If it is removed, dummy stapling is performed.)

3) Operation check for solenoids and clutches

Test No. 1 number	Test No. 2 number	Description	Symbol	Contents of operation
3	1	Catching solenoid	SOL1	Opens the shutter. Turns the solenoid ON for 3 seconds and then turns it OFF. Closes the shutter.
3	2	Buffer roller lift solenoid	SOL2	Opens the shutter. Turns the solenoid ON for 3 seconds and then turns it OFF. Closes the shutter.
3	3	Patting solenoid	SOL3	Opens the shutter. Turns the solenoid ON for 3 seconds and then turns it OFF. Closes the shutter.
3	4	Gate solenoid	SOL4	Opens the shutter. Turns the solenoid ON for 3 seconds and then turns it OFF. Closes the shutter.
3	5	Shutter clutch	CLT1	Opens the shutter. Waits for 4 seconds. Turns the clutch ON for 3 seconds and then turns it OFF. Closes the shutter.
3	6	Paper exit guide clutch	CLT2	Opens the shutter. Waits for 4 seconds. Turns the clutch ON for 3 seconds and then turns it OFF. Closes the shutter.

4) Real time operation check for sensors and switches

Test No. 1 number	Test No. 2 number	Description	Symbol	Contents of operation
4	1	Front cover switch	SW1	The status of the switch is indicated with the LED1 in real time as follows: LED1 ON: Open LED1 OFF: Close Continues the operation until it is canceled.
4	2	Stationary tray opening/closing switch	SW2	The status of the switch is indicated with the LED1 in real time as follows: LED1 ON: Open LED1 OFF: Close Continues the operation until it is canceled.

Test No. 1 number	Test No. 2 number	Description	Sym- bol	Contents of operation
4	3	Entrance sensor	S1	The status of the sensor is indicated with the LED1 in real time as follows: LED1 ON: 1 LED1 OFF: 0 Continues the operation until it is canceled.
4	4	Transport sensor	S2	The status of the sensor is indicated with the LED1 in real time as follows: LED1 ON: 1 LED1 OFF: 0 Continues the operation until it is canceled.
4	5	Paddle home position sensor	S3	The status of the sensor is indicated with the LED1 in real time as follows: LED1 ON: 1 LED1 OFF: 0 Continues the operation until it is canceled.
4	6	Shutter opening/closing sensor	S4	The status of the sensor is indicated with the LED1 in real time as follows: LED1 ON: 1 LED1 OFF: 0 Continues the operation until it is canceled.
4	7	Buffer tray home position sensor	S5	The status of the sensor is indicated with the LED1 in real time as follows: LED1 ON: 1 LED1 OFF: 0 Continues the operation until it is canceled.
4	8	Paper holder home position sensor	S6	The status of the sensor is indicated with the LED1 in real time as follows: LED1 ON: 1 LED1 OFF: 0 Continues the operation until it is canceled.
4	9	Front alignment plate home position sensor	S7	The status of the sensor is indicated with the LED1 in real time as follows: LED1 ON: 1 LED1 OFF: 0 Continues the operation until it is canceled.
4	10	Rear alignment plate home position sensor	S8	The status of the sensor is indicated with the LED1 in real time as follows: LED1 ON: 1 LED1 OFF: 0 Continues the operation until it is canceled.
4	11	Stack exit belt home position sensor	S9	The status of the sensor is indicated with the LED1 in real time as follows: LED1 ON: 1 LED1 OFF: 0 Continues the operation until it is canceled.
4	12	Stapler unit home position sensor	S10	The status of the sensor is indicated with the LED1 in real time as follows: LED1 ON: 1 LED1 OFF: 0 Continues the operation until it is canceled.

Test No. 1 number	Test No. 2 number	Description	Symbol	Contents of operation
4	13	Stapler interference sensor	S11	The status of the sensor is indicated with the LED1 in real time as follows: LED1 ON: 1 LED1 OFF: 0 Continues the operation until it is canceled.
4	14	Finishing tray paper detection sensor	S12	The status of the sensor is indicated with the LED1 in real time as follows: LED1 ON: 1 LED1 OFF: 0 Continues the operation until it is canceled.

5) Real time operation check for sensors and switches

Test No. 1 number	Test No. 2 number	Description	Symbol	Contents of operation
5	1	Movable tray position-A sensor	S13	The status of the sensor is indicated with the LED1 in real time as follows: LED1 ON: 1 LED1 OFF: 0 Continues the operation until it is canceled.
5	2	Movable tray position-B sensor	S14	The status of the sensor is indicated with the LED1 in real time as follows: LED1 ON: 1 LED1 OFF: 0 Continues the operation until it is canceled.
5	3	Movable tray position-C sensor	S15	The status of the sensor is indicated with the LED1 in real time as follows: LED1 ON: 1 LED1 OFF: 0 Continues the operation until it is canceled.
5	4	Movable tray paper-full sensor	S16	The status of the sensor is indicated with the LED1 in real time as follows: LED1 ON: 1 LED1 OFF: 0 Continues the operation until it is canceled.
5	5	Movable tray paper exist sensor	S17	The status of the sensor is indicated with the LED1 in real time as follows: LED1 ON: 1 LED1 OFF: 0 Continues the operation until it is canceled.
5	6	Stationary tray paper-full sensor	S18	The status of the sensor is indicated with the LED1 in real time as follows: LED1 ON: 1 LED1 OFF: 0 Continues the operation until it is canceled.
5	7	Stapler home position sensor	S19	The status of the sensor is indicated with the LED1 in real time as follows: LED1 ON: 1 LED1 OFF: 0 Continues the operation until it is canceled.

Test No. 1 number	Test No. 2 number	Description	Symbol	Contents of operation
5	8	Staple top position sensor	S20	The status of the sensor is indicated with the LED1 in real time as follows: LED1 ON: 1 LED1 OFF: 0 Continues the operation until it is canceled.
5	9	Staple empty sensor	S21	The status of the sensor is indicated with the LED1 in real time as follows: LED1 ON: 1 LED1 OFF: 0 Continues the operation until it is canceled.

6) Real time operation check for sensors and switches (Punch)

Test No. 1 number	Test No. 2 number	Description	Symbol	Contents of operation
6	1	Front cover sensor	S1	The status of the sensor is indicated with the LED1 in real time as follows: LED1 ON: 1 LED1 OFF: 0 Continues the operation until it is canceled.
6	2	Paper position sensor	S6	The status of the sensor is indicated with the LED1 in real time as follows: LED1 ON: 1 LED1 OFF: 0 Continues the operation until it is canceled.
6	3	Paper position sensor-1	S6	The status of the sensor is indicated with the LED1 in real time as follows: LED1 ON: 1 LED1 OFF: 0 Continues the operation until it is canceled.
6	4	Paper position sensor-2	S6	The status of the sensor is indicated with the LED1 in real time as follows: LED1 ON: 1 LED1 OFF: 0 Continues the operation until it is canceled.
6	5	Paper position sensor-3	S6	The status of the sensor is indicated with the LED1 in real time as follows: LED1 ON: 1 LED1 OFF: 0 Continues the operation until it is canceled.
6	6	Paper position sensor-4	S6	The status of the sensor is indicated with the LED1 in real time as follows: LED1 ON: 1 LED1 OFF: 0 Continues the operation until it is canceled.
6	7	Skew sensor-1	S7	The status of the sensor is indicated with the LED1 in real time as follows: LED1 ON: 1 LED1 OFF: 0 Continues the operation until it is canceled.

Test No. 1 number	Test No. 2 number	Description	Symbol	Contents of operation
6	8	Skew sensor-2	S7	The status of the sensor is indicated with the LED1 in real time as follows: LED1 ON: 1 LED1 OFF: 0 Continues the operation until it is canceled.
6	9	Punched scrap full sensor	S8	The status of the sensor is indicated with the LED1 in real time as follows: LED1 ON: 1 LED1 OFF: 0 Continues the operation until it is canceled.

6.3.5 Error indications

When an error occurs during a test, LED1 blinks in a multiple pattern to indicate the cause of the error. In case of an error, the LED1 is turned ON for 2 seconds and then turned OFF for 2 seconds (standard indication) as shown in the figure. Then it indicates the type of the error in combination of blinking patterns (0.5-second intervals) for Error code 1 and Error code 2.

In the case shown in the figure, it is a combination of 3-time blinking and 2-time blinking. This indicates the error is “paddle home position error (ED15)”.

An error can be cleared by opening and closing the front cover or the stationary tray of the Finisher.

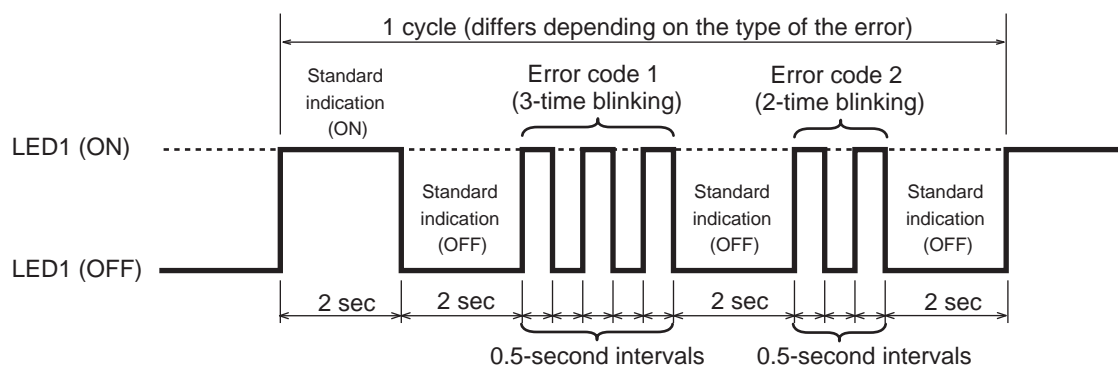

Fig. 6-4

1) LED1 blinking pattern error code: Jams

Error code 1	Error code 2	Description	Error code (when connected to the equipment)
1	1	Transport path paper remaining jam in Finisher	EA31
1	2	Exit paper remaining jam	EA32
1	3	Transport delay jam (paper not inserted)	EA10
1	4	Short length paper jam in Finisher (transport sensor)	EA21
1	6	Paper transport jam in Finisher (entrance sensor)	EA20
1	7	Cover open error	EA40
1	8	Stapling jam	EA50
2	8	Stack exit belt home position error	EA70
2	9	Early arrival jam	EA60
3	1	Buffer tray home position error	ED16
3	2	Paddle home position error	ED15
3	3	Rear alignment plate home position error	ED14
3	4	Front alignment plate home position error	ED13
3	5	Shutter home position error	ED12
3	6	Skew adjustment motor (M1) home position detection abnormality	ED11
3	7	Sideways adjustment motor (M2) home position detection error	ED10
3	8	Punching jam	E9F0

Error code 1	Error code 2	Description	Error code (when connected to the equipment)
11	7	Short length paper jam in Finisher (paper position sensors S6-1/2)	EA22
11	8	Paper transport jam in Finisher (transport sensor)	EA23
11	9	Paper transport jam in Finisher (entrance sensor - transport sensor)	EA24
12	1	Paper transport jam in Finisher (after paper stack was exited)	EA25
12	2	Paper transport jam in Finisher (Stop signal received from equipment)	EA26
12	3	Paper transport jam in Finisher (Paper not inserted but paper detected)	EA27
12	4	Paper transport jam in Finisher (paper holding delay)	EA28
12	5	Paper transport jam in Finisher (paper stack transport delay)	EA29

2) LED1 blinking pattern error code: Hardware errors[

Error code 1	Error code 2	Description	Error code (when connected to the equipment)
4	1	Entrance motor (M1) abnormality	CB10
4	2	Buffer tray guide motor (M2) abnormality	CB11
4	3	Paddle motor (M3) abnormality	CDE0
4	4	Buffer roller drive motor (M4) abnormality	CB12
4	5	Rear alignment motor (M6) abnormality	CC80
4	6	Front alignment motor (M5) abnormality	CB40
4	7	Transport motor (M7) abnormality	CC31
4	8	Stack transport motor (M8) abnormality	CC30
4	9	Stapler unit shift motor (M9) abnormality	CB60
5	1	Movable tray shift motor (M12) abnormality	CB30
5	2	Flash ROM abnormality	CB81
5	3	RAM abnormality	CB80
5	4	Finisher not connected	CB00
5	5	Finisher communication error	CB01
5	8	Stapler shift home position error	CB51
5	9	Stapler home position error	CB50
6	1	Movable tray paper-full detection error	CB31
6	3	Paper pusher cam home position abnormality	CC41
7	1	Punch motor (M3) home position detection error	CC61
7	4	Sideways adjustment motor (M2) abnormality	CC51
7	6	Skew adjustment motor (M1) abnormality	CC52

Error code 1	Error code 2	Description	Error code (when connected to the equipment)
7	7	Punch ROM checksum error	CC71
7	8	Punch RAM read/write error	CC72
7	9	Punch communication error	CE00
9	2	Finisher main program error	CB82
9	4	Punch unit main program error	CB84

3) LED1 blinking pattern error code: Alerts

Error code 1	Error code 2	Description	Error code (when connected to the equipment)
10	1	The stationary tray is full.	-
10	2	The movable tray is full.	-
10	4	The punched scrap box is full.	-
10	6	The staple cartridge for the finisher section is empty.	-

7. PREVENTIVE MAINTENANCE (PM) / FIRMWARE UPDATE

7.1 Maintenance and Inspection Points

Perform preventive maintenance according to the check list.

* Perform preventive maintenance for the Finisher at the same interval as for the main equipment to which the Finisher is connected.

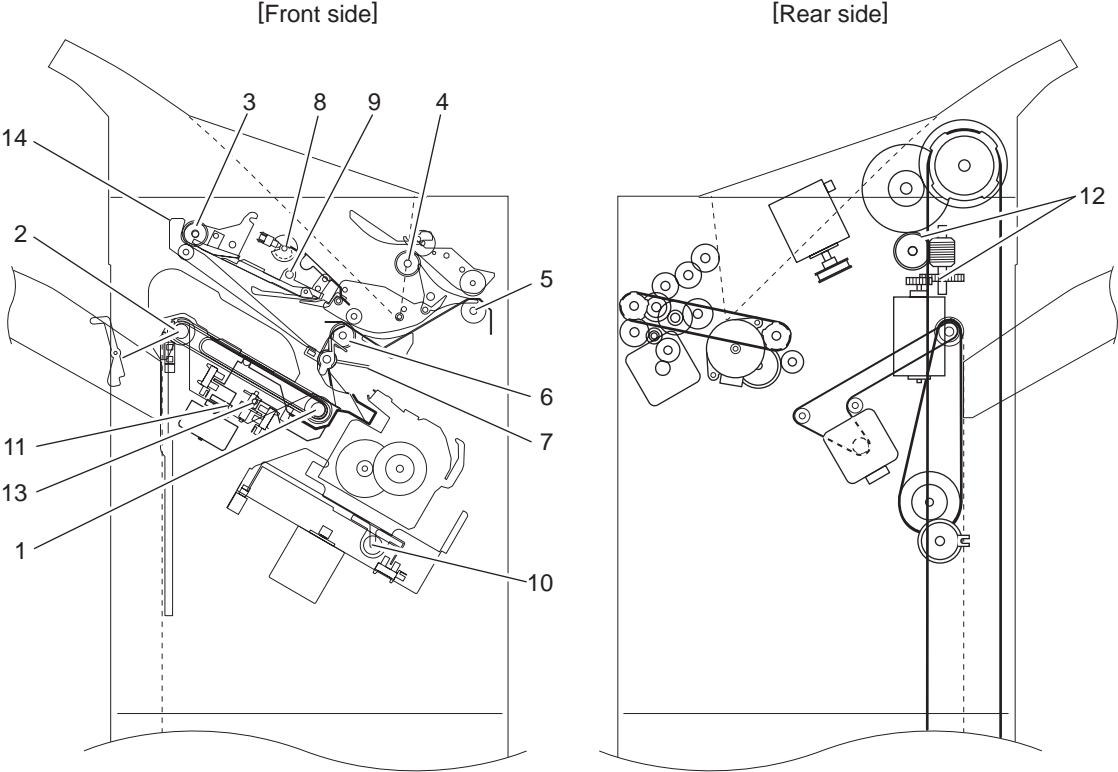

Fig. 7-1

Symbols used in the checklist

Cleaning	Lubrication/Coating	Replacement	Operation check
A: Clean with alcohol B: Clean with soft pad, cloth or vacuum cleaner	L: Launa 40 SI: Silicon oil W1: White grease (Molykote X5-6020) W2: White grease (Molykote HP-300) W3: White grease (Molykote EM-30L) AV: Alvania No.2 FL: Floil (GE-334C)	Value: Replacement cycle (output pages or develop counts) R: Replace if deformed or damaged	O: After cleaning or replacement, confirm there is no problem.

Preventive Maintenance Checklist

Items to check		Cleaning	Lubrication	Replacement (x1,000)	Operation check	Parts list (P-I)	Remarks
1	Stack transport roller-1	A					
2	Stack transport roller-2	A					
3	Buffer roller	A					
4	Exit roller	A					
5	Entrance roller	A					
6	Transport roller	A					
7	Paddle			1,000			
8	Paper holder cam		W3				*a
9	Buffer tray shaft		W3				*b
10	Stapler carrier shaft		W3				*c
11	Rack & pinion gear (Aligning plate)		W3				*d
12	Movable tray drive gear		W3				*e
13	Buffer tray guide		W3				*f
14	Finishing tray shaft		W3				*g

***a. Paper holder cam**

Apply an adequate amount of white grease (Molykote EM-30L) all around the paper holder cam.

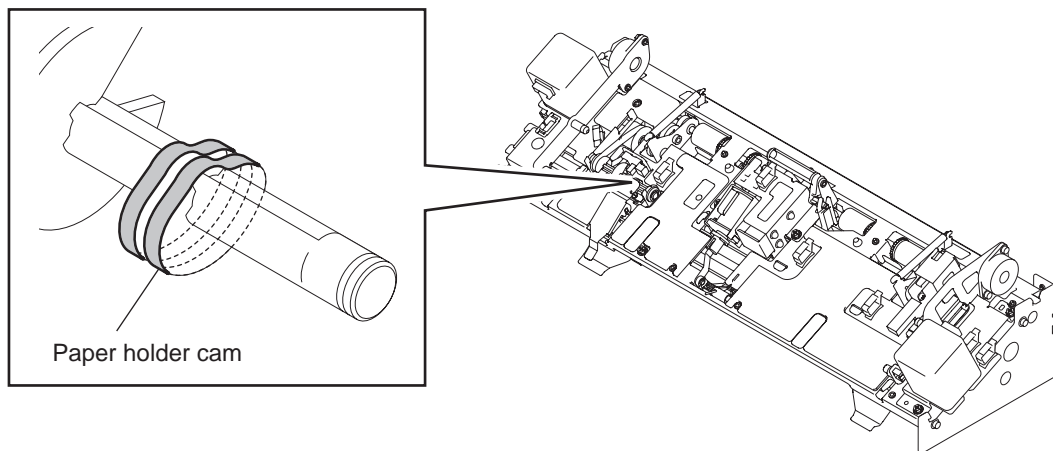

Fig. 7-2

***b. Buffer tray shaft**

Apply an adequate amount of white grease (Molykote EM-30L) to the entire buffer tray shaft.

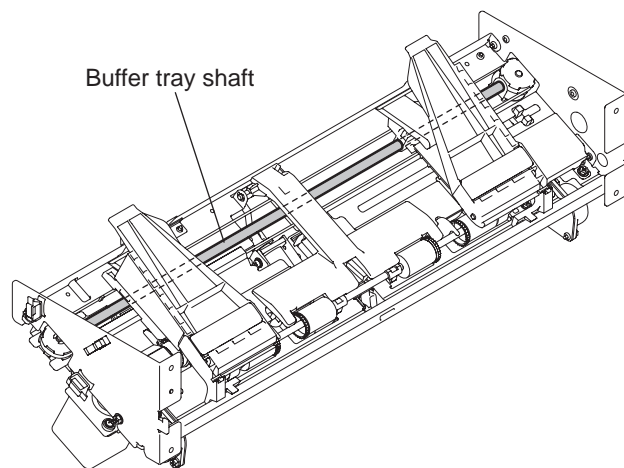

Fig. 7-3

*c. Stapler carrier shaft

Apply an adequate amount of white grease (Molykote EM-30L) to the entire stapler carrier shaft.

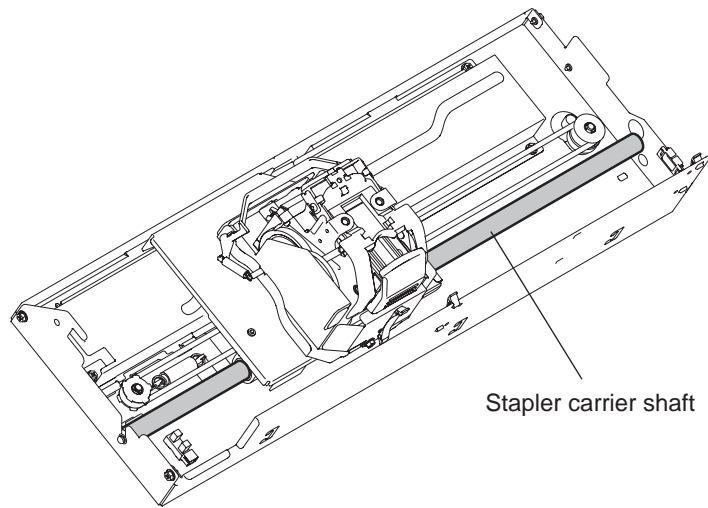

Fig. 7-4

*d. Rack gear, pinion gear (Aligning plate)

*g. Finishing tray shaft

1) Take off the metal shield plate. (P. 4-6 "[K] Shield metal plate")

* If the hole punch unit is installed, take it off beforehand.

2) Apply oil as follows through the opening which shows up when the metal shield plate has been removed.

Apply an adequate amount of white grease (Molykote EM-30L) to the gear teeth of the rack and pinion gears which drive the aligning plate, and the entire finishing tray shaft.

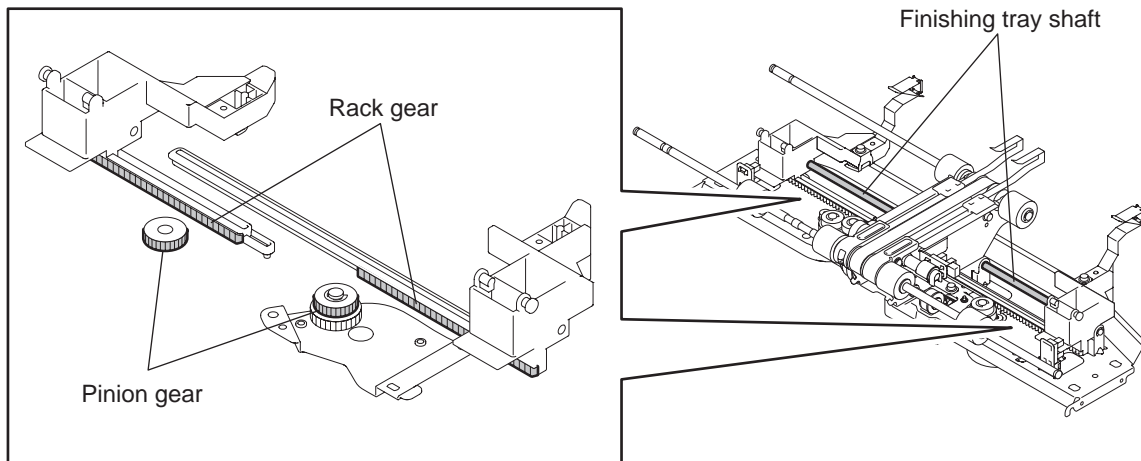

Fig. 7-5

*e. Movable tray drive gear

Apply an adequate amount of white grease (Molykote EM-30L) to the gear teeth of the gear-A and gear-B.

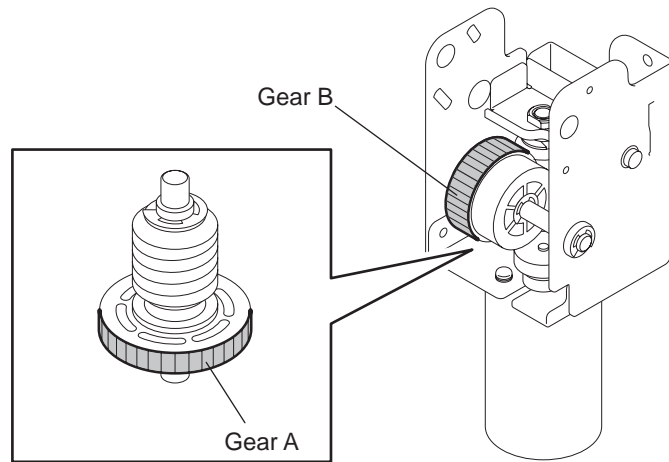

Fig. 7-6

*f. Buffer tray guide

Apply an adequate amount of white grease (Molykote EM-30L) to the entire buffer tray guide (inside of the folded section of the plate).

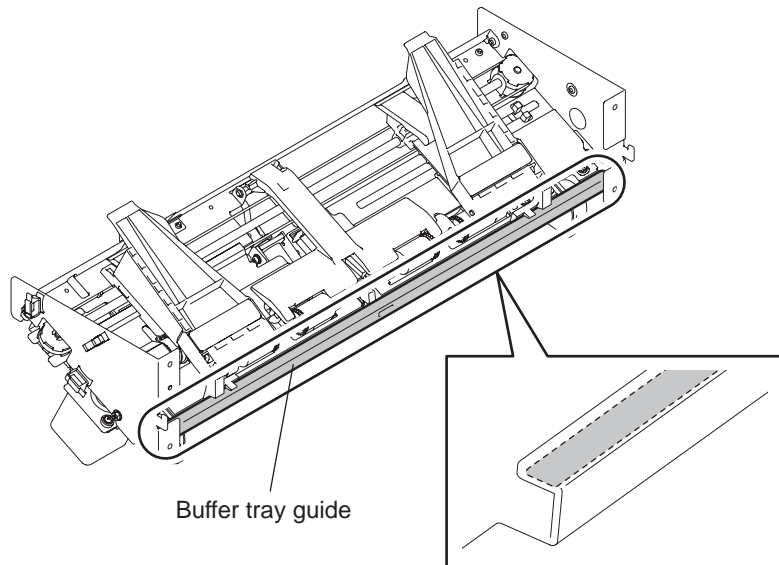

Fig. 7-7

7.2 Firmware Update

Connect the download jig to the control board and turn ON the power of the equipment to start the firmware update automatically.

Use the K-PWA-DLM-320 as a download jig.

7.2.1 Updating Finisher ROM

- (1) Attach the ROM to the download jig.
Make sure that the ROM and its direction are correct.

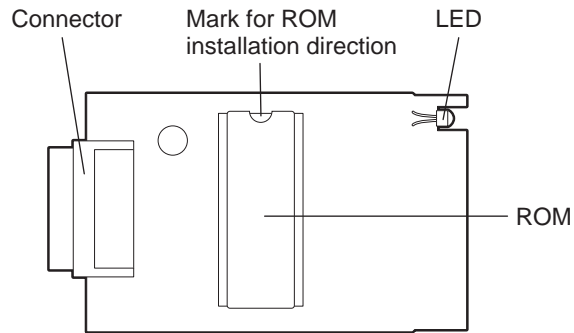

Fig. 7-8

- (2) Turn OFF the power of the equipment.
- (3) Remove 1 screw and take off the board access cover.

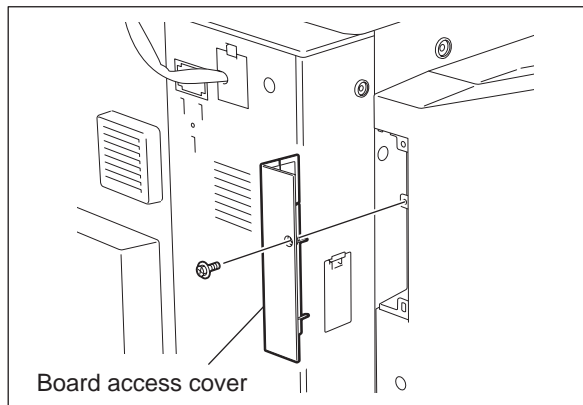

Fig. 7-9

- (4) Connect the download jig with the jig connector (CN9) on the Finisher control board.

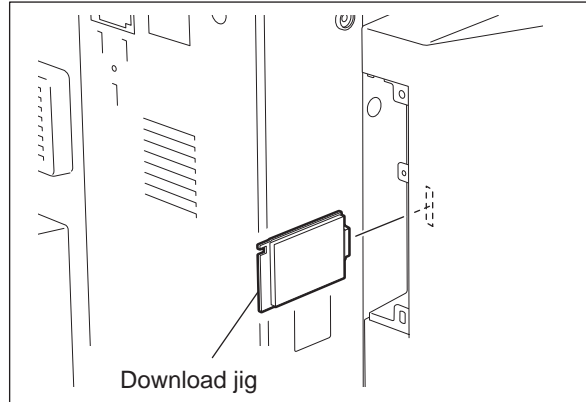

Fig. 7-10

- (5) Turn ON the power while pressing [0] and [8] simultaneously.
Updating starts and the LED on the download jig lights
- (6) When the update completes normally, the LED on the download jig starts blinking.

The LED on the download jig starts blinking in approx. 12 seconds after the update started.
It is assumed that the update is failed if the LED does not start blinking even after 20 seconds have elapsed.

In this case, turn the power OFF and check the following items.
Then, clear the problem and restart updating from the beginning.

- Is the downloading jig connected properly?
- Is the ROM attached to the downloading jig properly?
- Has the update data been written correctly to the ROM on the jig?
- Is the download jig or the equipment damaged?

- (7) Turn the power OFF and remove the download jig.
- (8) Install the board access cover.

7.2.2 Updating Converter ROM

Important:

- The harness jig for board connection (HRNS-CNV-DL-JIG) is required for updating the firmware of the converter PC board of the finisher (MJ-1101) as well as the download jig (K-PWA-DLM-320).
- Be sure to connect the equipment and finisher (MJ-1101) before updating the converter firmware.
- Be sure to shut down the equipment before installing and removing the download jig.
- Do not shut down the equipment during the update. The data could be damaged and not be operated properly.

- (1) Install the ROM to the download jig.
Make sure the direction is correct.

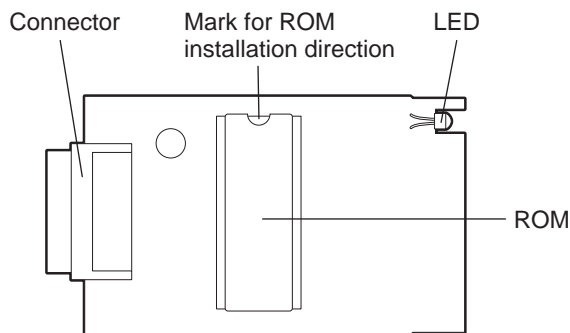

Fig. 7-11

- (2) Shut down the equipment.
- (3) Take off the finisher board access cover.

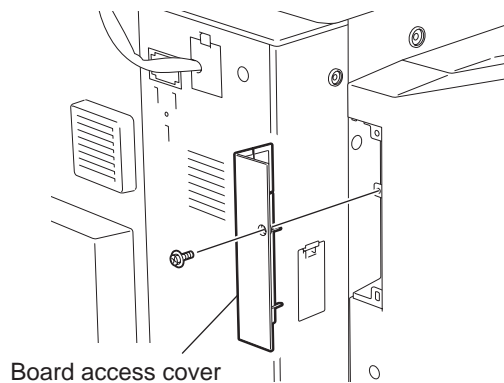

Fig. 7-12

- (4) Remove the converter PC board from the equipment.

- (5) Connect the 10-pin side of the harness jig for board connection (HRNS-CNV-DL-JIG) to the connector (CN2) of the converter PC board.

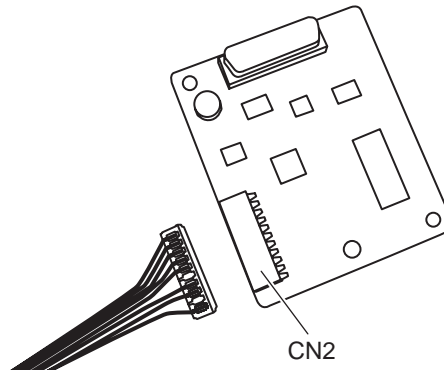

Fig. 7-13

- (6) Connect the 15-pin side of the harness jig for board connection to the connector (CN15) of the finisher control PC board.

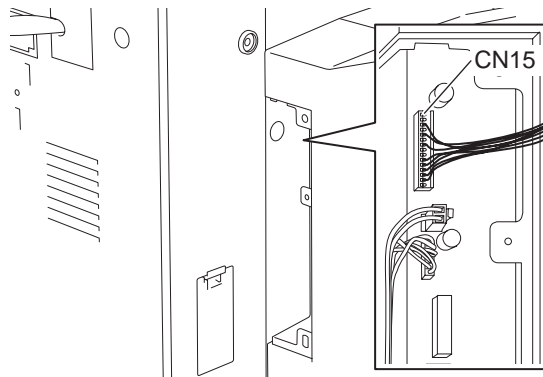

Fig. 7-14

Notes:

- Be sure to release the connection cable from the connector (CN15) of the finisher control PC board when the hole punch unit (MJ-6101) has been installed.
- Be careful not to short-circuit any part of the converter PC board.

- (7) Connect the download jig with the jig connector (CN9) on the Finisher control board.

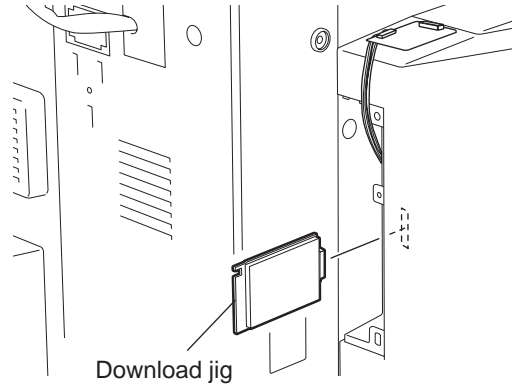

Fig. 7-15

- (8) Turn ON the power while [0] button and [8] button are pressed simultaneously. Updating starts and the LED on the download jig lights.
- (9) When the update completes normally, the LED on the download jig starts blinking.

The LED on the download jig starts blinking approx. 20 seconds after the update started. It is assumed that the update has failed if the LED does not start blinking even after 30 seconds have elapsed. In this case, shut down the equipment and check the following items. Then clear the problems and restart updating from the beginning.

- Is the downloading jig connected properly?
- Is the ROM attached to the downloading jig properly?
- Have the update data been written correctly to the ROM on the jig?
- Is the download jig or the equipment damaged?
- Is the harness jig for board connection connected to connector (CN2) of the converter PC board and the connector (CN15) of the finisher control PC board correctly?

- (10) Shut down the equipment.
- (11) Remove the download jig and the harness jig for board connection from the finisher control PC board.

Note:

Be sure to secure the connection cable in the connector (CN15) of the finisher control PC board when the hole punch unit (MJ-6101) has been installed.

- (12) Install the board access cover.
- (13) Remove the harness jig for board connection from the converter PC board.
- (14) Install the converter PC board in the equipment.

8. ELECTRIC CIRCUIT

8.1 Harness Diagram

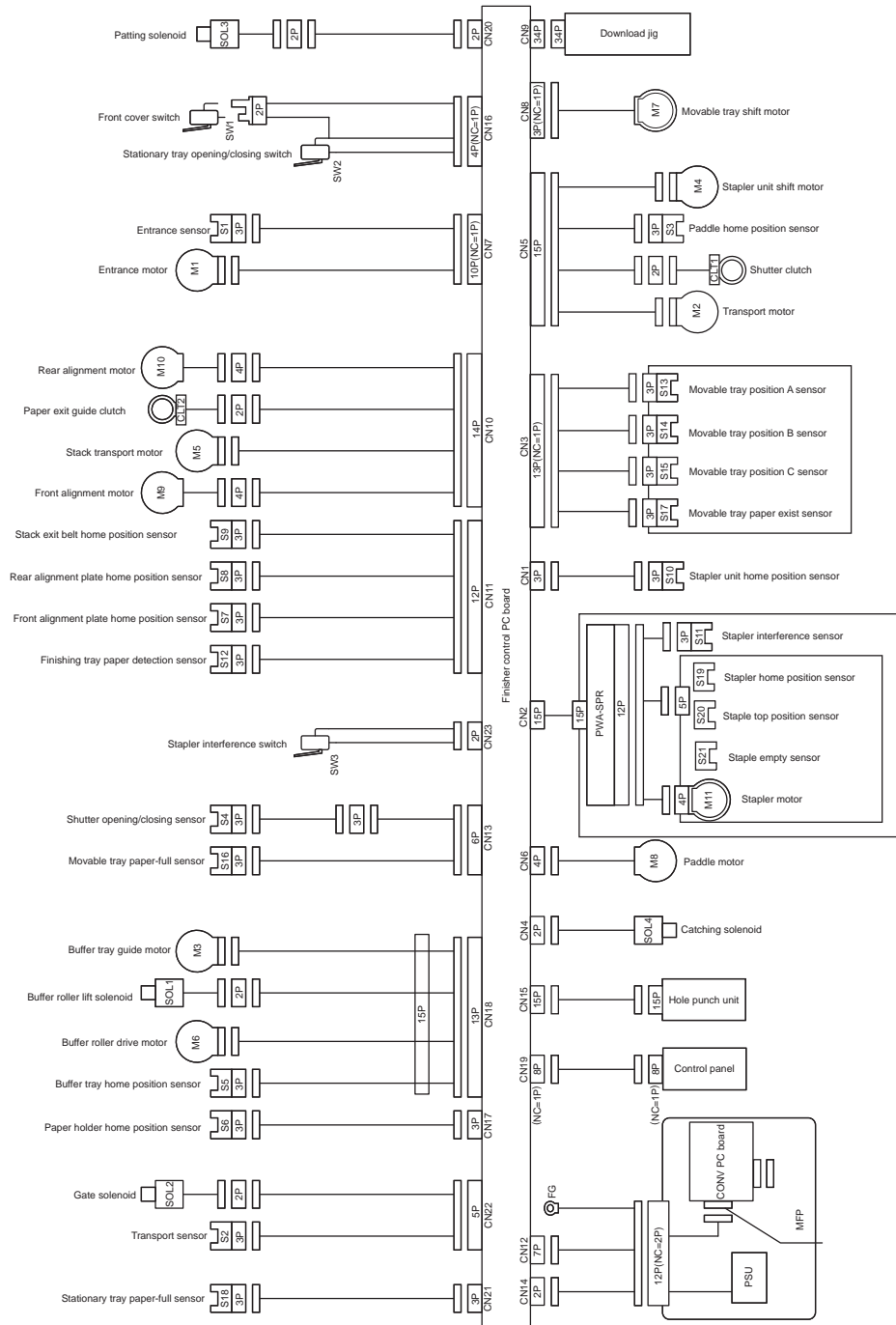

Fig. 8-1

8.2 Circuit Diagram

1) Circuit Diagram (1)

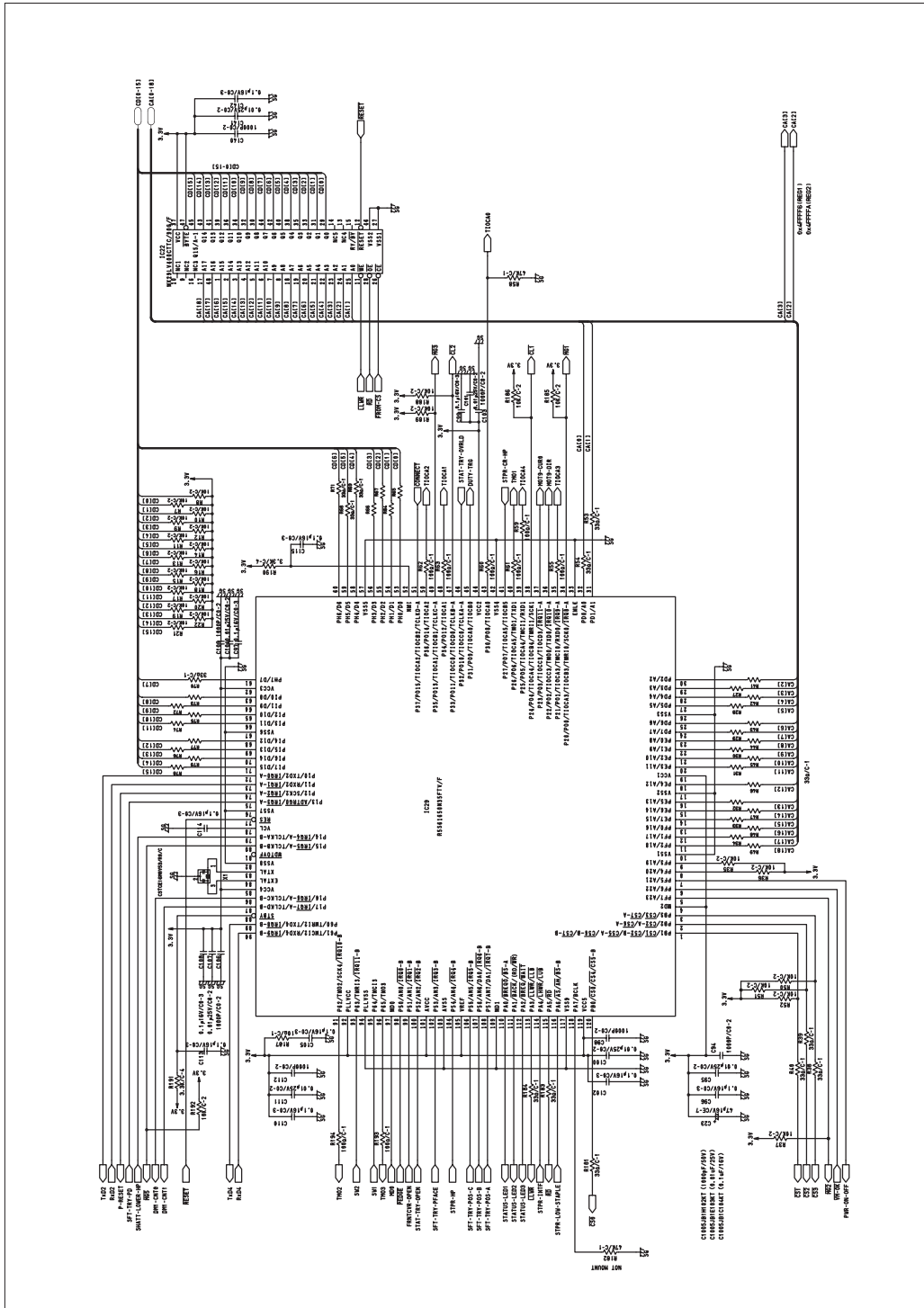

Fig. 8-2

3) Circuit Diagram (3)

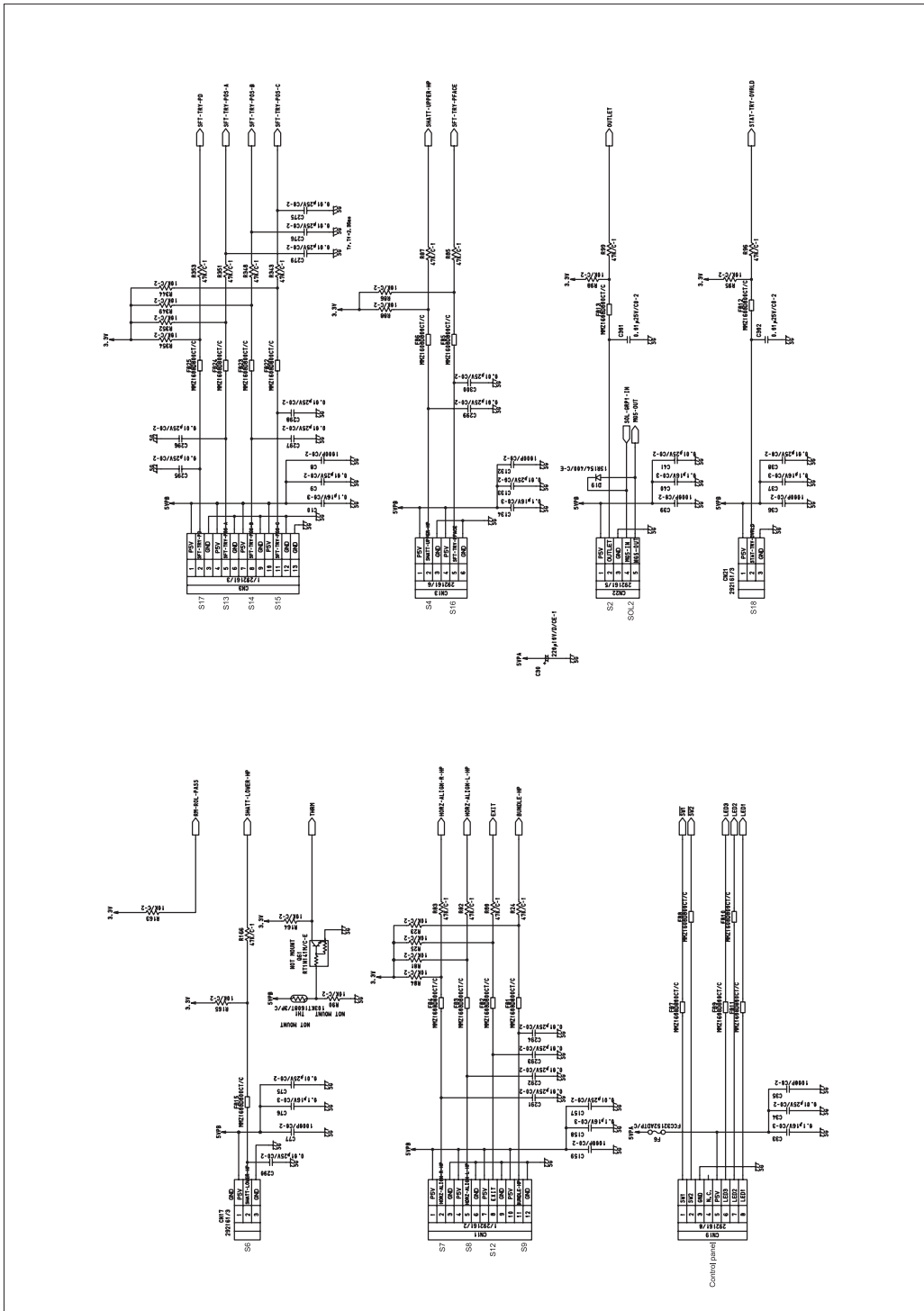

Fig. 8-4

4) Circuit Diagram (4)

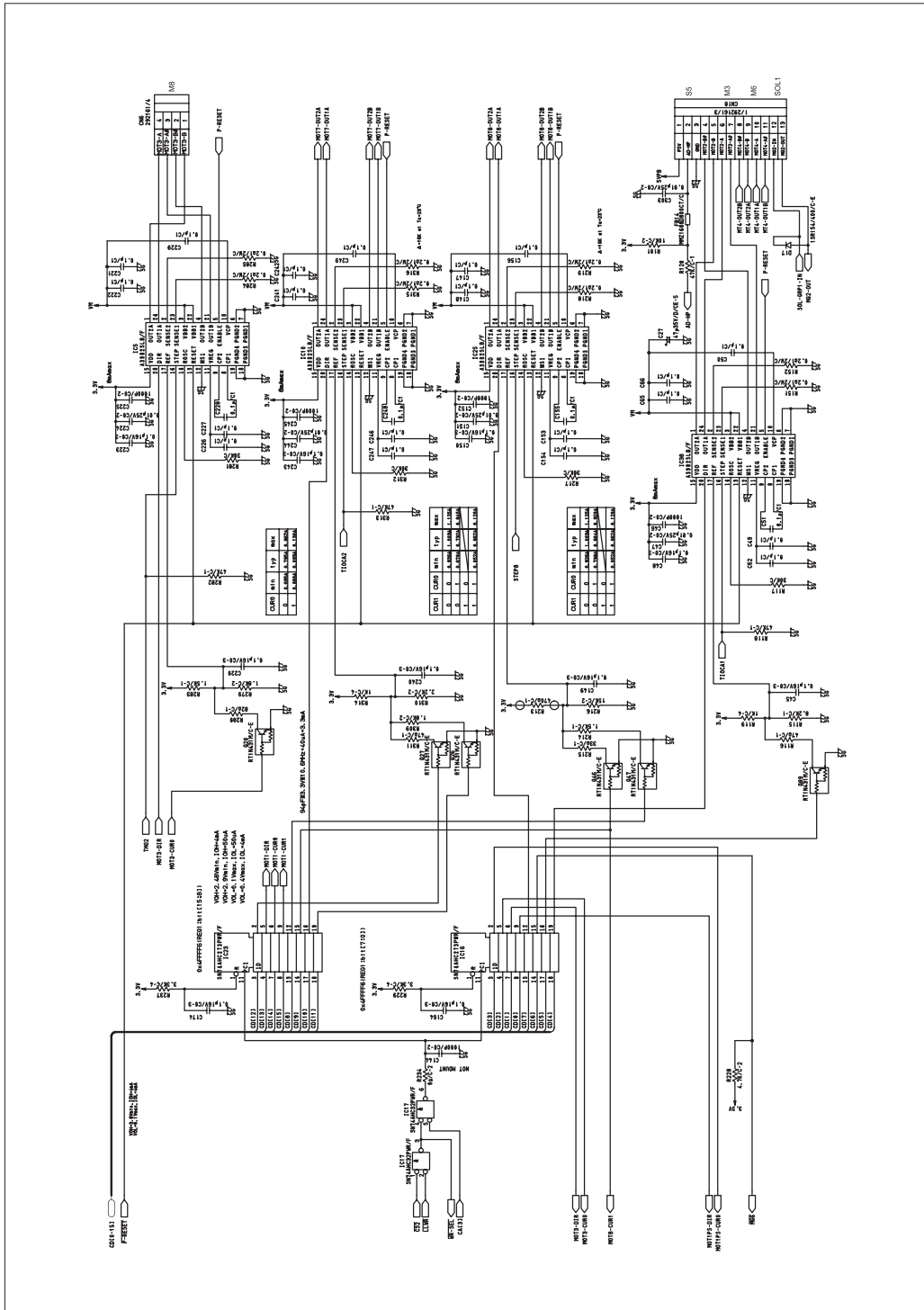

Fig. 8-5

5) Circuit Diagram (5)

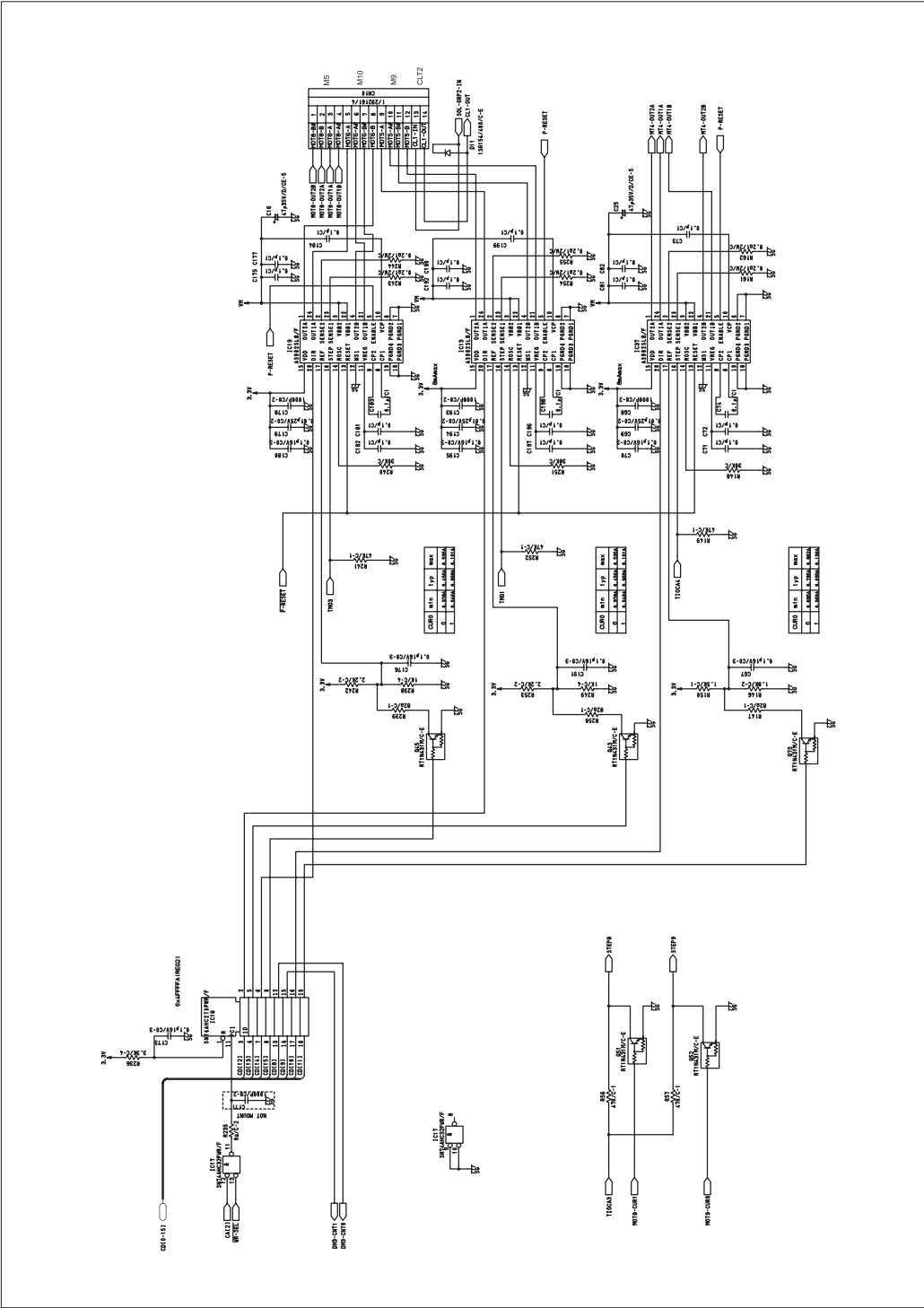

Fig. 8-6

6) Circuit Diagram (6)

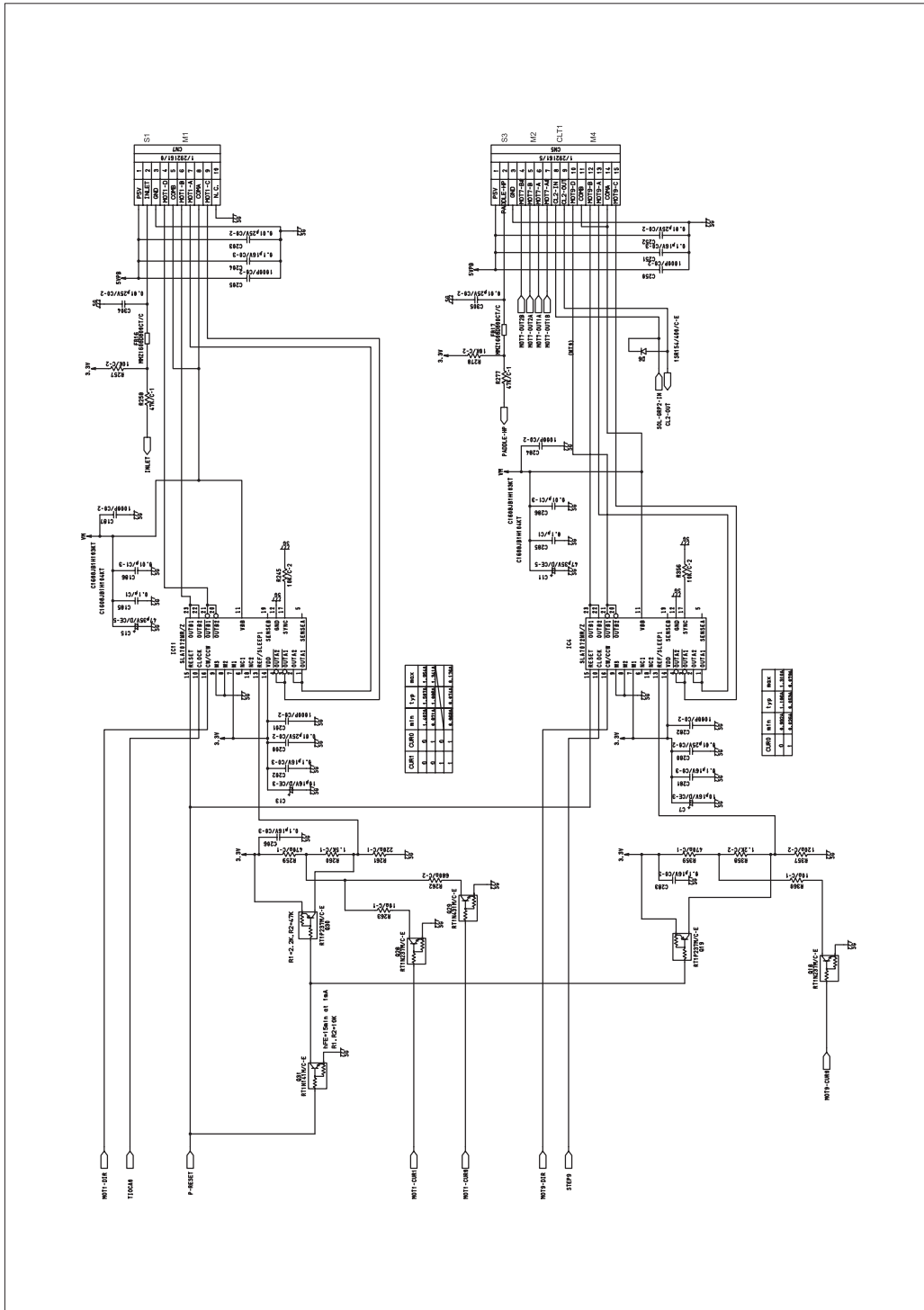

Fig. 8-7

7) Circuit Diagram (7)

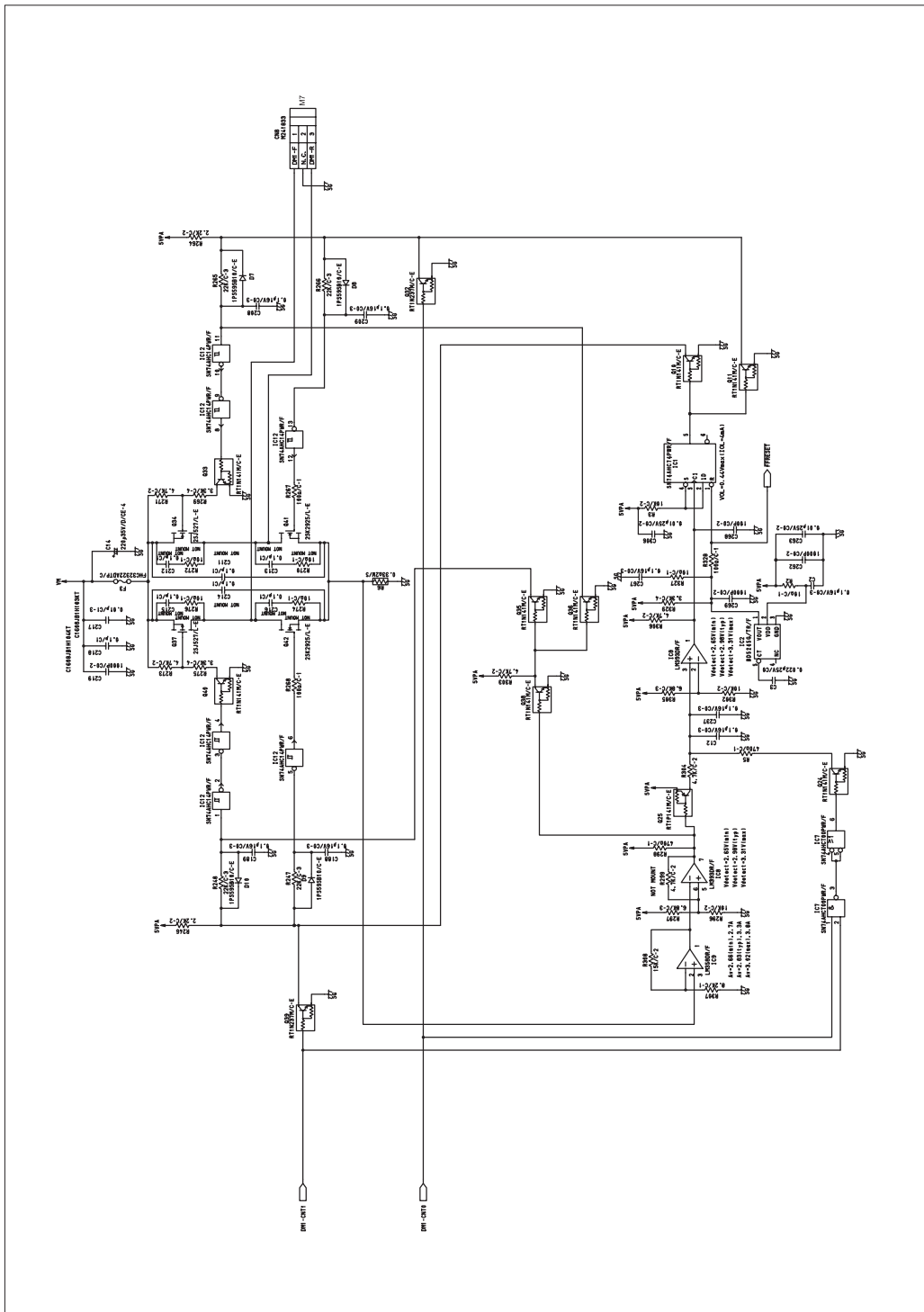

Fig. 8-8

9) Circuit Diagram (9)

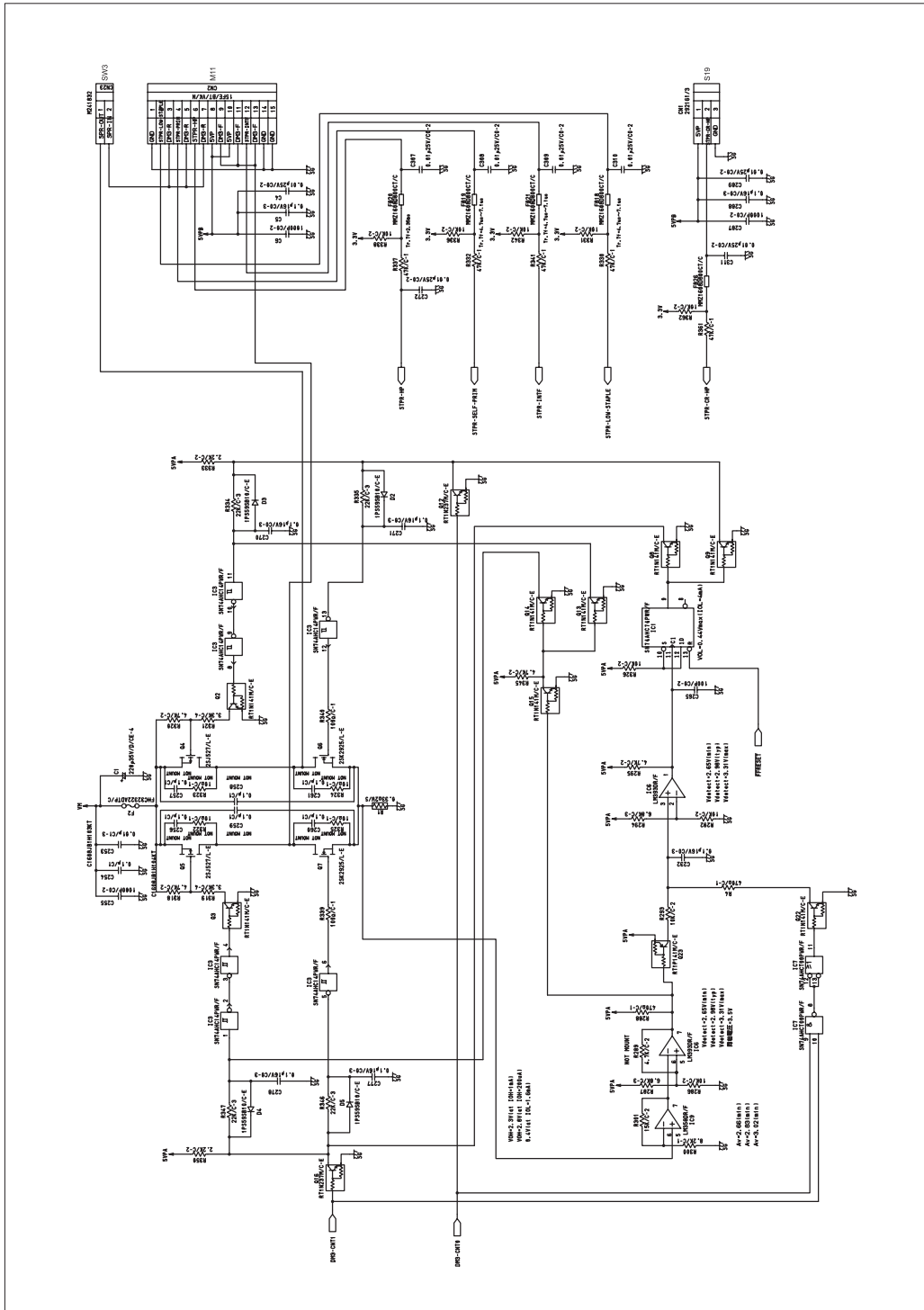

Fig. 8-10

10)Circuit Diagram (10)

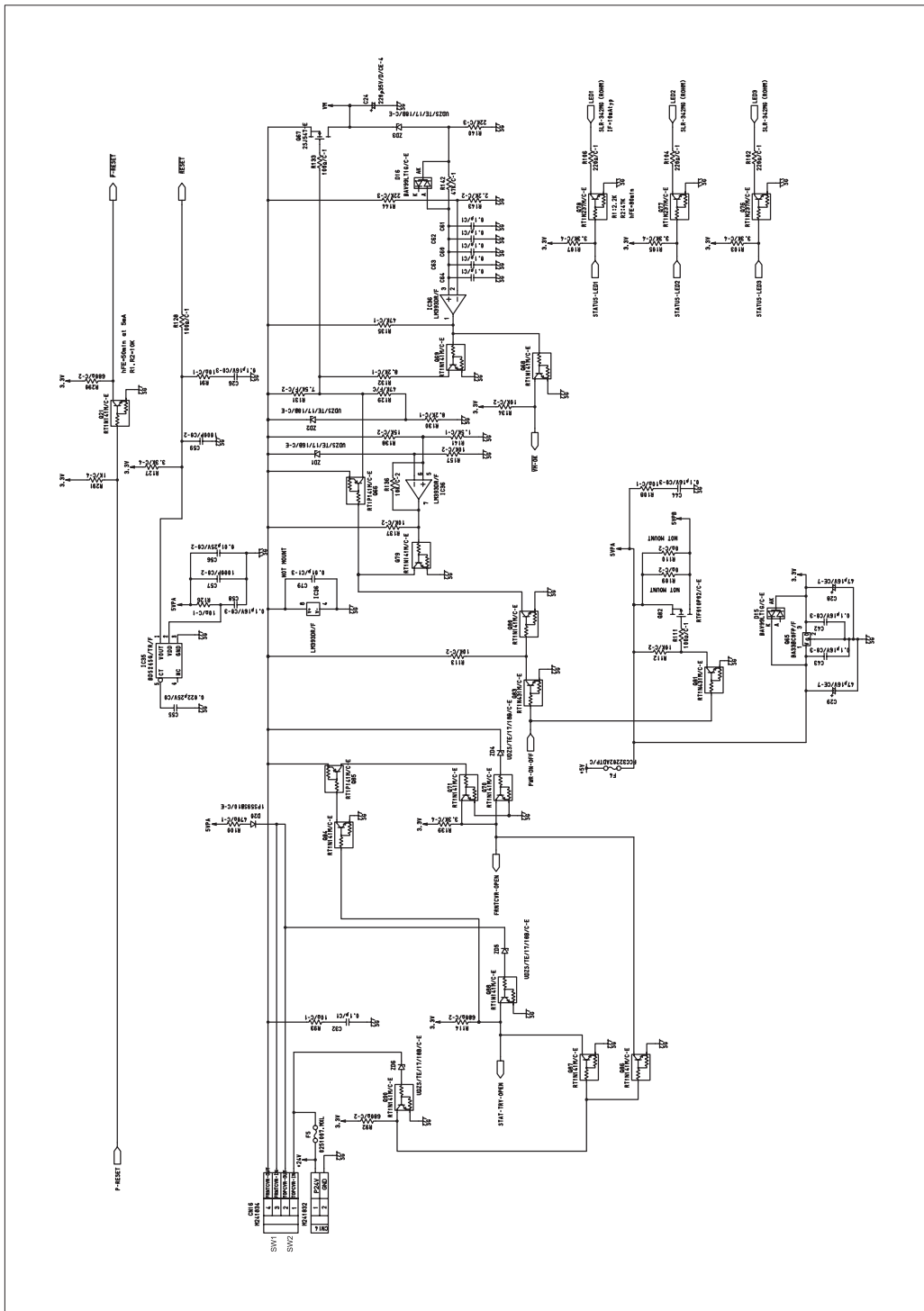

Fig. 8-11

11) Circuit Diagram (11)

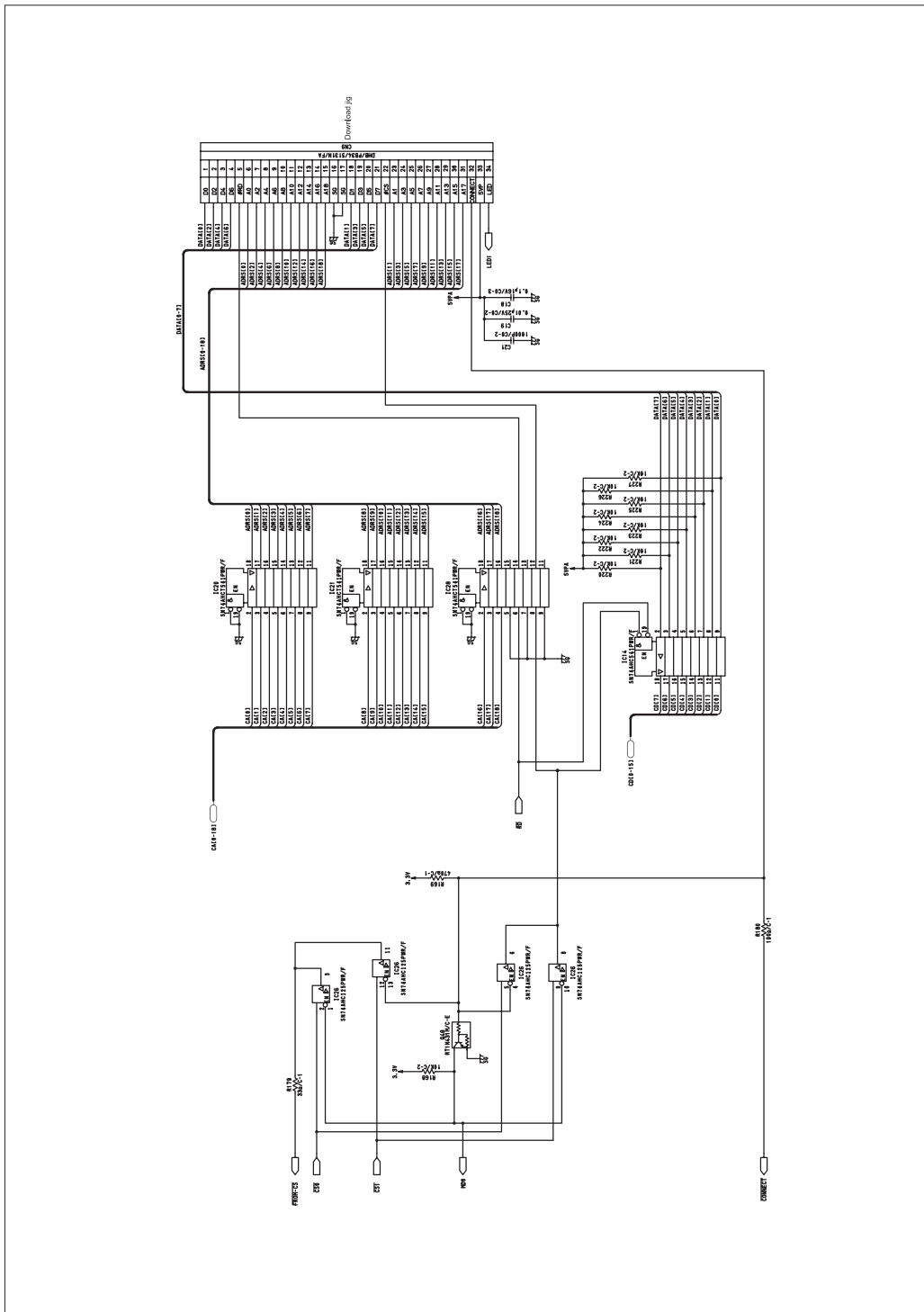

Fig. 8-12

12)Circuit Diagram (12)

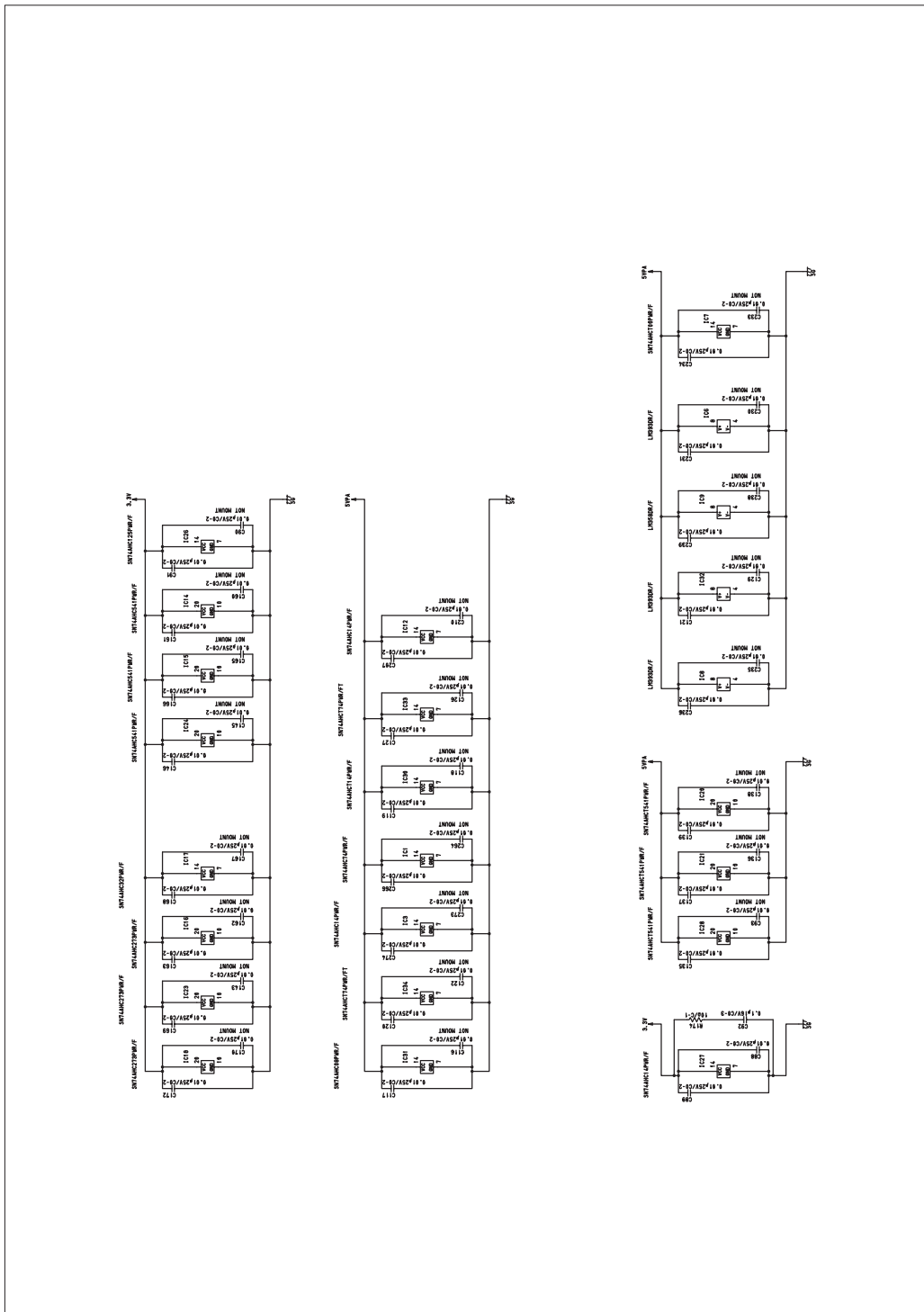

Fig. 8-13

8.3 PC board

1) Finisher controller PC board

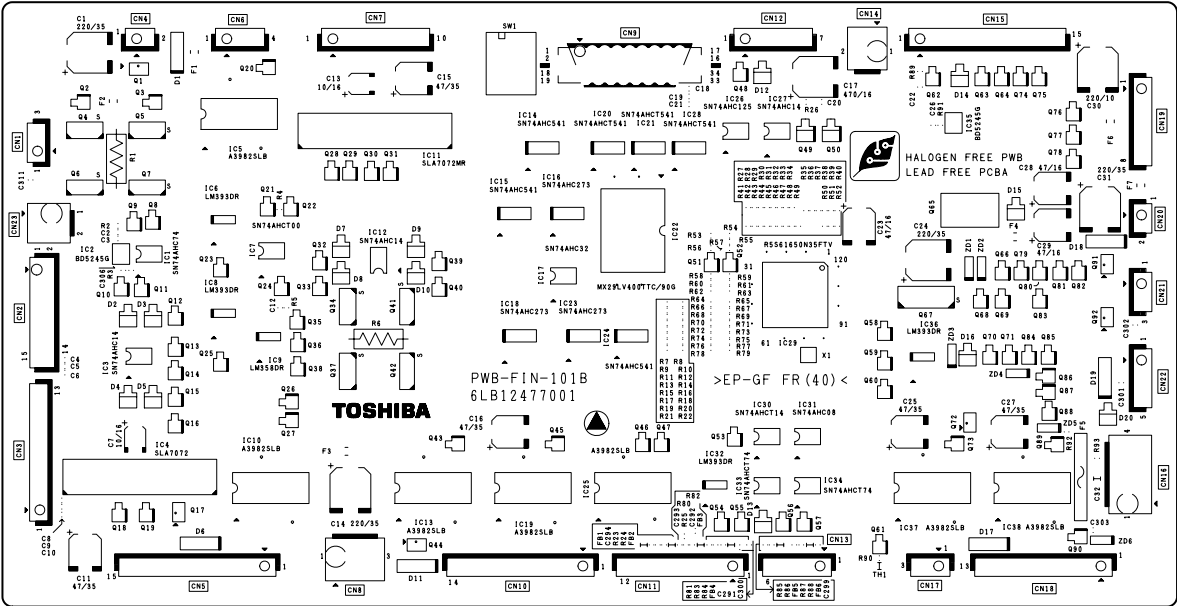

Fig. 8-14

2) Converter PC board

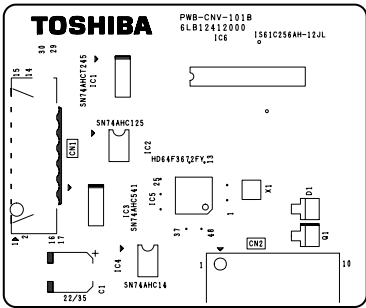

Fig. 8-15

