

CX1145MFP

Spare Parts

Illustration Manual

051414C

EXPLANATION OF SERVICE-PARTS LIST

1. HOW TO READ THE PARTS LIST

- (1) Number of pieces
The number of pieces in the list denotes total pieces used per unit. But the numbers in the list for PACKING MATERIAL and ACCESSORY denote total pieces used per machine.
- (2) One pack of screws in the list includes 50 pieces.
- (3) ABBREVIATED CODES

QTY/PAC {

- QTY.....one piece
- PAC.....one pack
- 1/P.....one piece packed in polyethylene bag
- 1/S.....one piece packed in special pack
- 1/C.....one piece packed in carton box
- 1/PP.....one piece packed in paper and polyethylene bag
- 1/KP.....one piece packed in polyethylene bag with cardboard
- 1/D.....one piece packed in polyethylene-cushion bag
- 1/SB.....one piece packed in shielding bag
- N/A.....not available

P {

- P.....PURPOSE
- A.....ADD
- B.....DELETE
- C.....CHANGE
- D.....QTY, CHANGE
- E.....MISENTRY
- F.....OMISSION

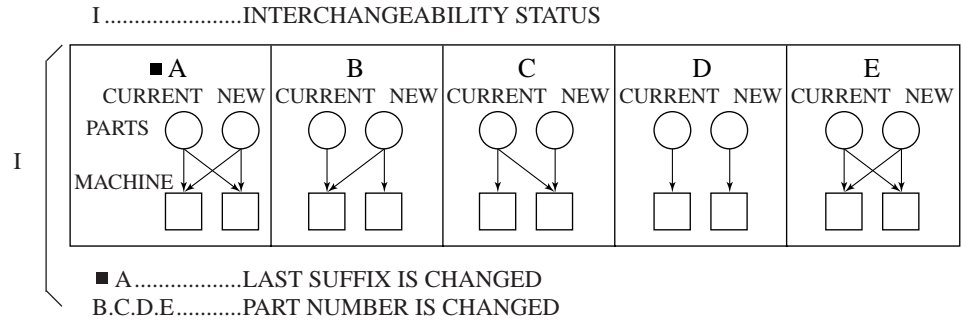

CONTENTS

COVER-1-ASM	1	FUSER-2-ASM.....	40
COVER-2-ASM	2	FUSER-3-ASM.....	41
CONTROL-PANEL-ASM.....	3	FUSER-4-ASM.....	42
BASE-FRAME-ASM.....	4	ADU-ASM.....	43
FRONT-FRAME-ASM	5	DRAWER-ASM	44
REAR-FRAME-ASM	6	JIGS & GREASE.....	101
POWER-SUPPLY-ASM.....	7	DOWNLOAD JIGS	102
CASE-SYS-ASM.....	8	SUPPLIES.....	103
CASE-LGC-ASM.....	9	REPLACE UNIT	104
LASER-OPTICAL-UNIT-ASM	10	PM-KIT	105
OPTICAL-FRAME-ASM	11		
TR2-UNIT-1-ASM.....	12		
TR2-UNIT-2-ASM.....	13		
DRUM-DRIVE-ASM	14		
DEV-DRIVE-ASM.....	15		
FEED-DRIVE-ASM	16		
OPTICAL-DRIVE-ASM.....	17		
FEEDER-1-ASM	18		
FEEDER-2-ASM	19		
BYPASS-ASM	20		
BYPASS-FEEDER-1-ASM	21		
BYPASS-FEEDER-2-ASM	22		
ALIGNING-1-ASM.....	23		
ALIGNING-2-ASM.....	24		
PLATEN-ASM.....	25		
CRG-1-ASM.....	26		
CRG-2-ASM.....	27		
MAIN-CHARGER-ASM	28		
TRANSPORT-BELT-UNIT-1-ASM	29		
TRANSPORT-BELT-UNIT-2-ASM	30		
BELT-CLEAN-UNIT-ASM	31		
CLEANER-ASM	32		
DEVELOPER-YMC-ASM	33		
DEVELOPER-BLACK-ASM	34		
REVOLVER-UNIT-1-ASM	35		
REVOLVER-UNIT-2-ASM	36		
TONER-1-ASM.....	37		
TONER-2-ASM.....	38		
FUSER-1-ASM.....	39		

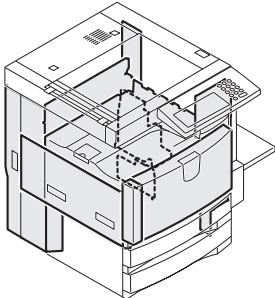
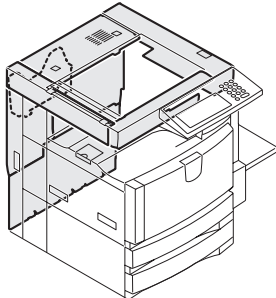
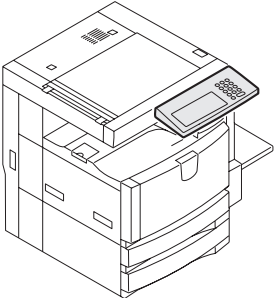
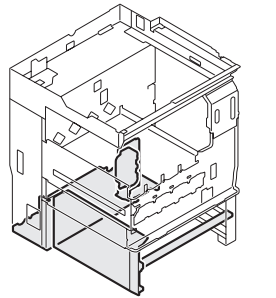
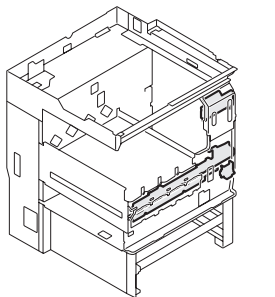
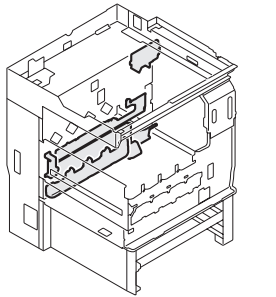
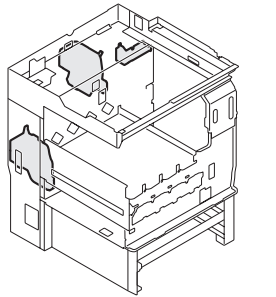
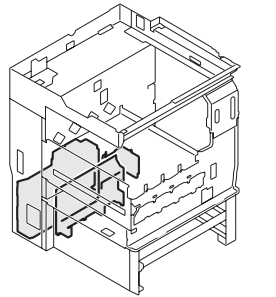
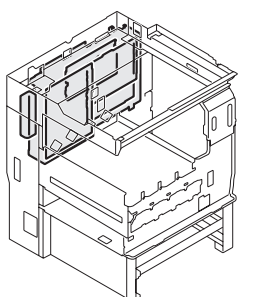
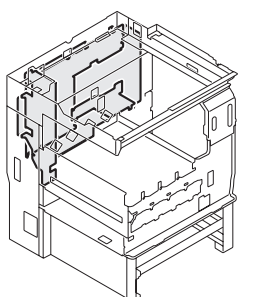
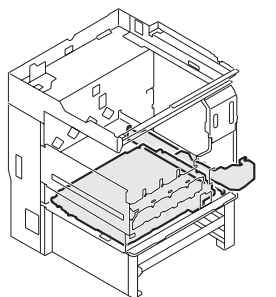
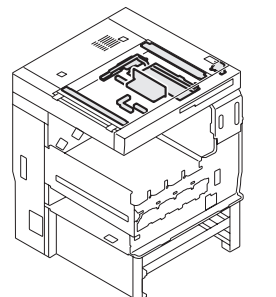
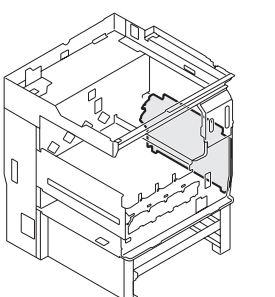
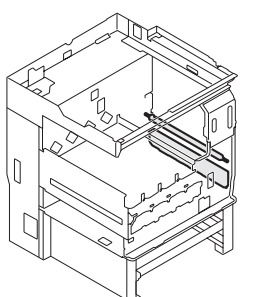
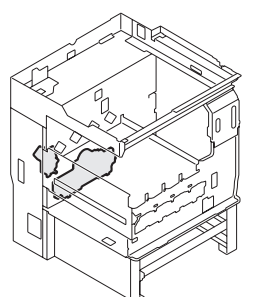
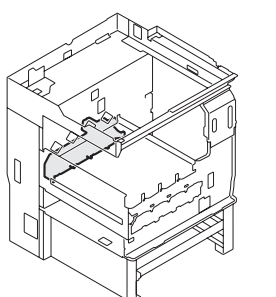
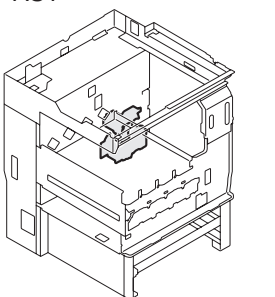
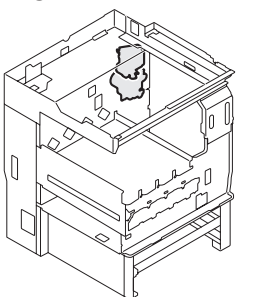
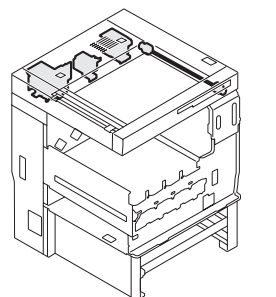
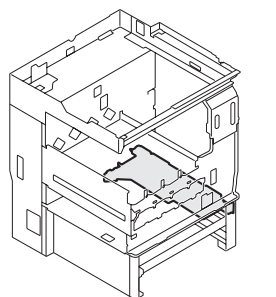
<p>1. COVER-1-ASY</p> 	<p>2. COVER-2-ASY</p> 	<p>3. CONTROL-PANEL-ASY</p> 	<p>4. BASE-FRAME-ASY</p> 
<p>5. FRONT-FRAME-ASY</p> 	<p>6. REAR-FRAME-ASY-1</p> 	<p>7. REAR-FRAME-ASY-2</p> 	<p>8. POWER-SUPPLY-ASY</p> 
<p>9. CASE-PCB-ASY</p> 	<p>10. COV_SATAY-PCB-ASY</p> 	<p>11. LASER-OPTICAL-UNIT</p> 	<p>12. OPTICAL-FRAME-ASY</p> 
<p>13. TRU-UNIT-1</p> 	<p>14. TRU-UNIT-2</p> 	<p>15. DEV_TBU-DRIVE-ASY</p> 	<p>16. DRUM-DRIVE-ASY</p> 
<p>17. REGIST&TR1-DRIVE-ASY</p> 	<p>18. FUSER&EXIT-DRIVE-ASY</p> 	<p>19. OPTICAL-DRIVE-ASY</p> 	<p>20. FEEDER-1-ASY</p> 

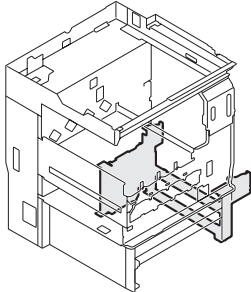
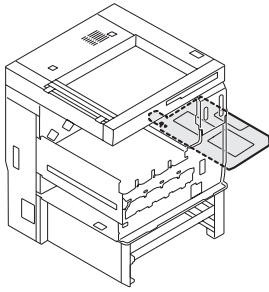
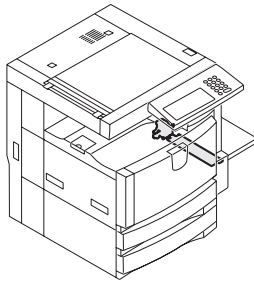
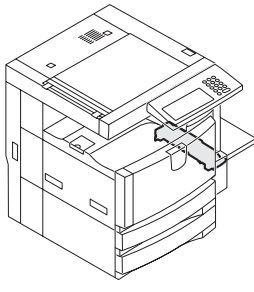
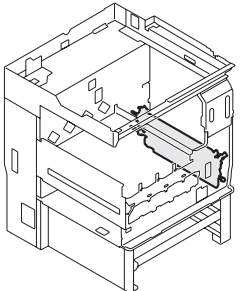
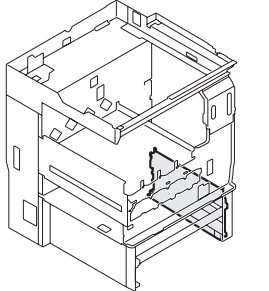
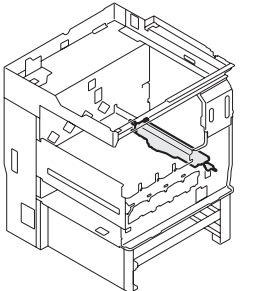
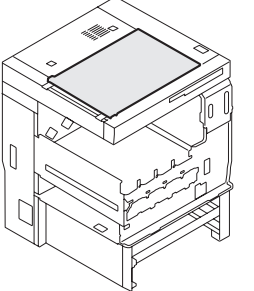
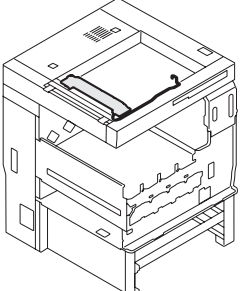
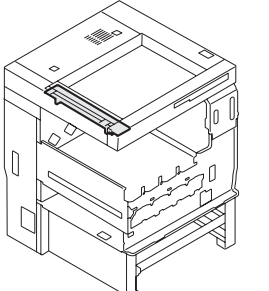
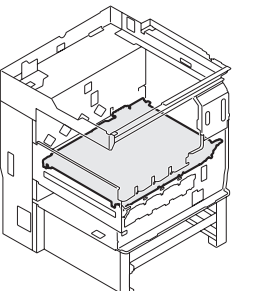
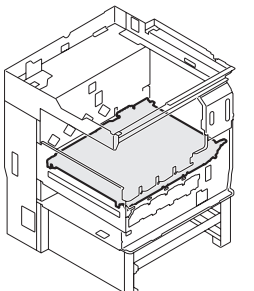
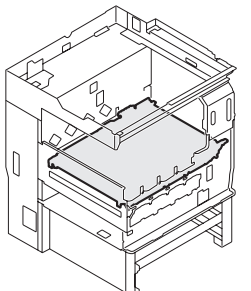
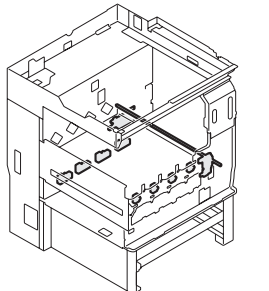
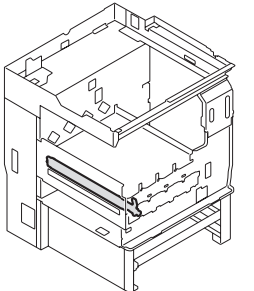
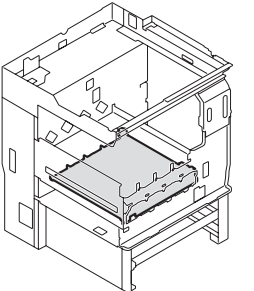
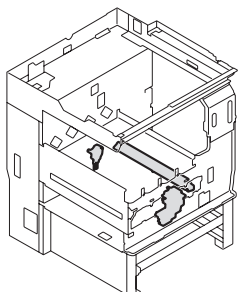
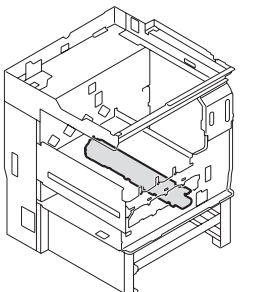
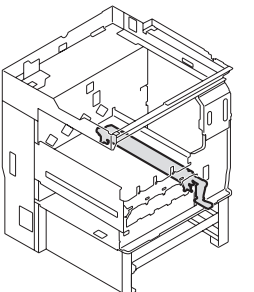
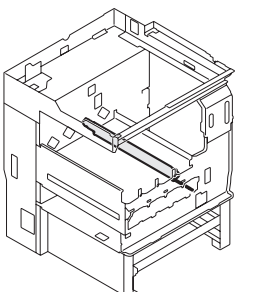
<p>21. FEEDER-2-ASY</p> 	<p>22. BYPASS-ASY</p> 	<p>23. BYPASS-FEEDER-1-ASY</p> 	<p>24. BYPASS-FEEDER-2-ASY</p> 
<p>25. ALIGNING-ASY</p> 	<p>26. COV&GUIDE-FEED-ASY</p> 	<p>27. LIFT-TRU&SNR-POS-ASY</p> 	<p>28. PLATEN-ASY</p> 
<p>29. CRG-1-ASY</p> 	<p>30. CRG-2-ASY</p> 	<p>31. TRANSPORT-BELT-UNIT-1</p> 	<p>32. TRANSPORT-BELT-UNIT-2</p> 
<p>33. TRANSPORT-BELT-UNIT-3</p> 	<p>34. TRANSPORT-BELT-UNIT-4</p> 	<p>35. BELT-CLEAN-UNIT-ASY</p> 	<p>36. SHUTTER-ASY</p> 
<p>37. EPU-SUB-ASY</p> 	<p>38. DEVELOPER-ASY</p> 	<p>39. CLN-DRUM-ASY</p> 	<p>40. MAIN-CHARGER-ASY</p> 

41. TONER-1-ASY

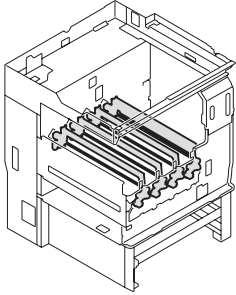

42. TONER-2-ASY

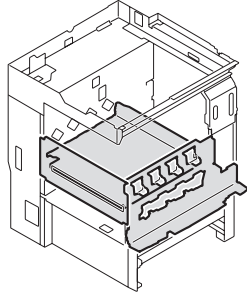

43. FUSER-1-ASY

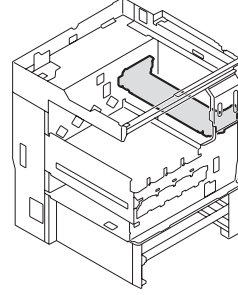

44. FUSER-2-ASY

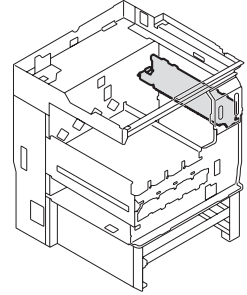

45. FUSER-3-ASY

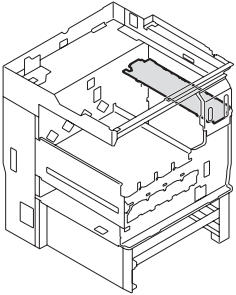

46. FUSER SATY&GUIDE
EXIT-ASY

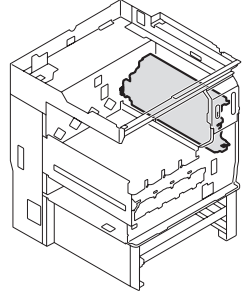

47. INNER-COVER-ASY

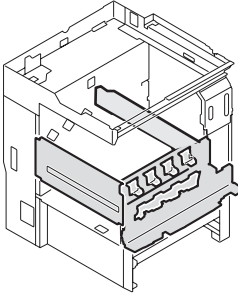

48. ADU-ASY-1

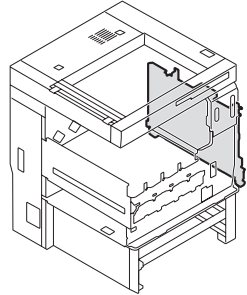

49. ADU-ASY-2

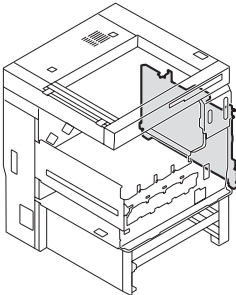

50. DRAWER-ASY

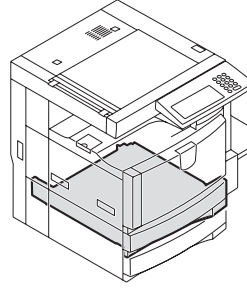

COVER-1-ASM

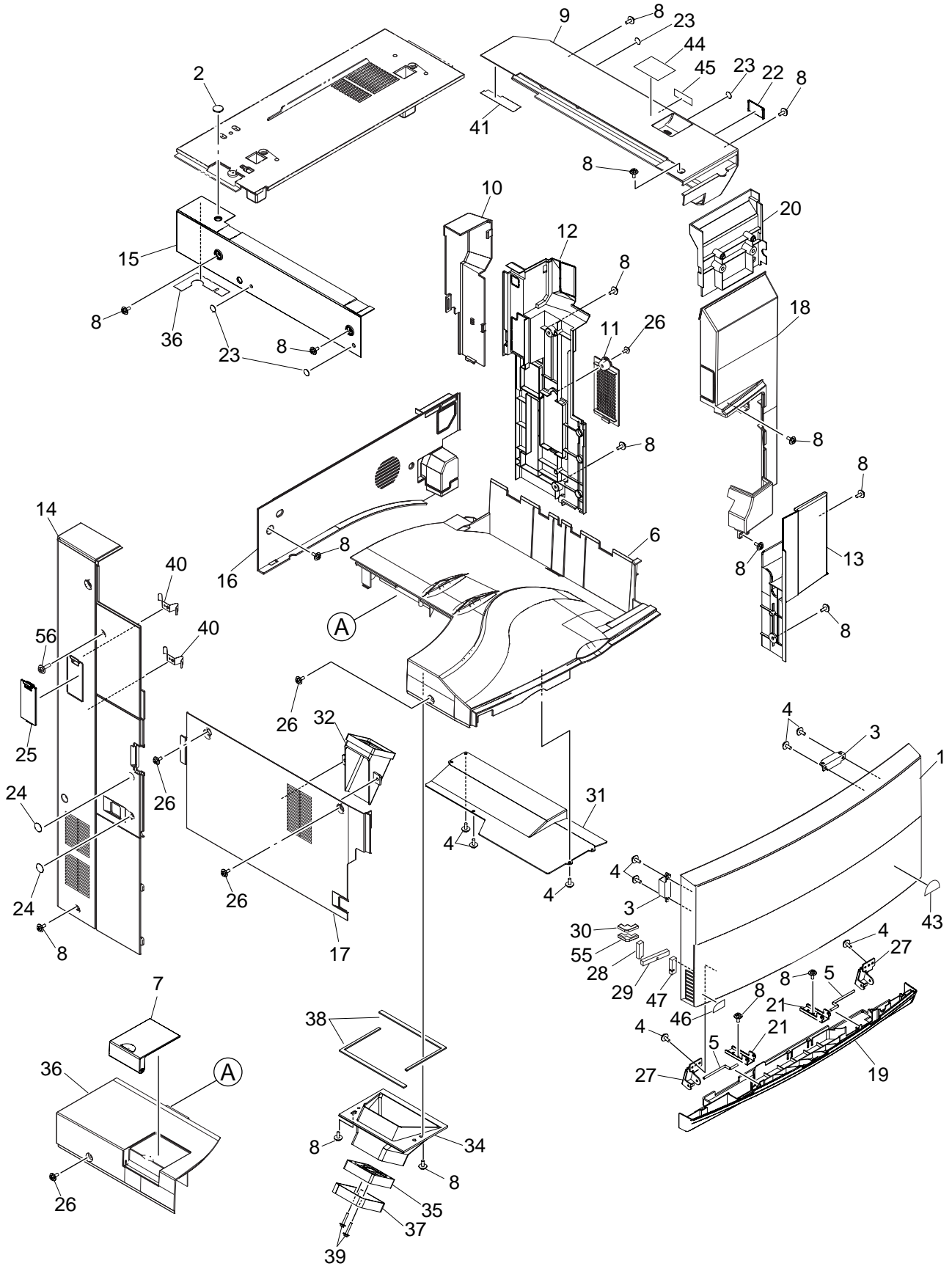

COVER-2-ASM

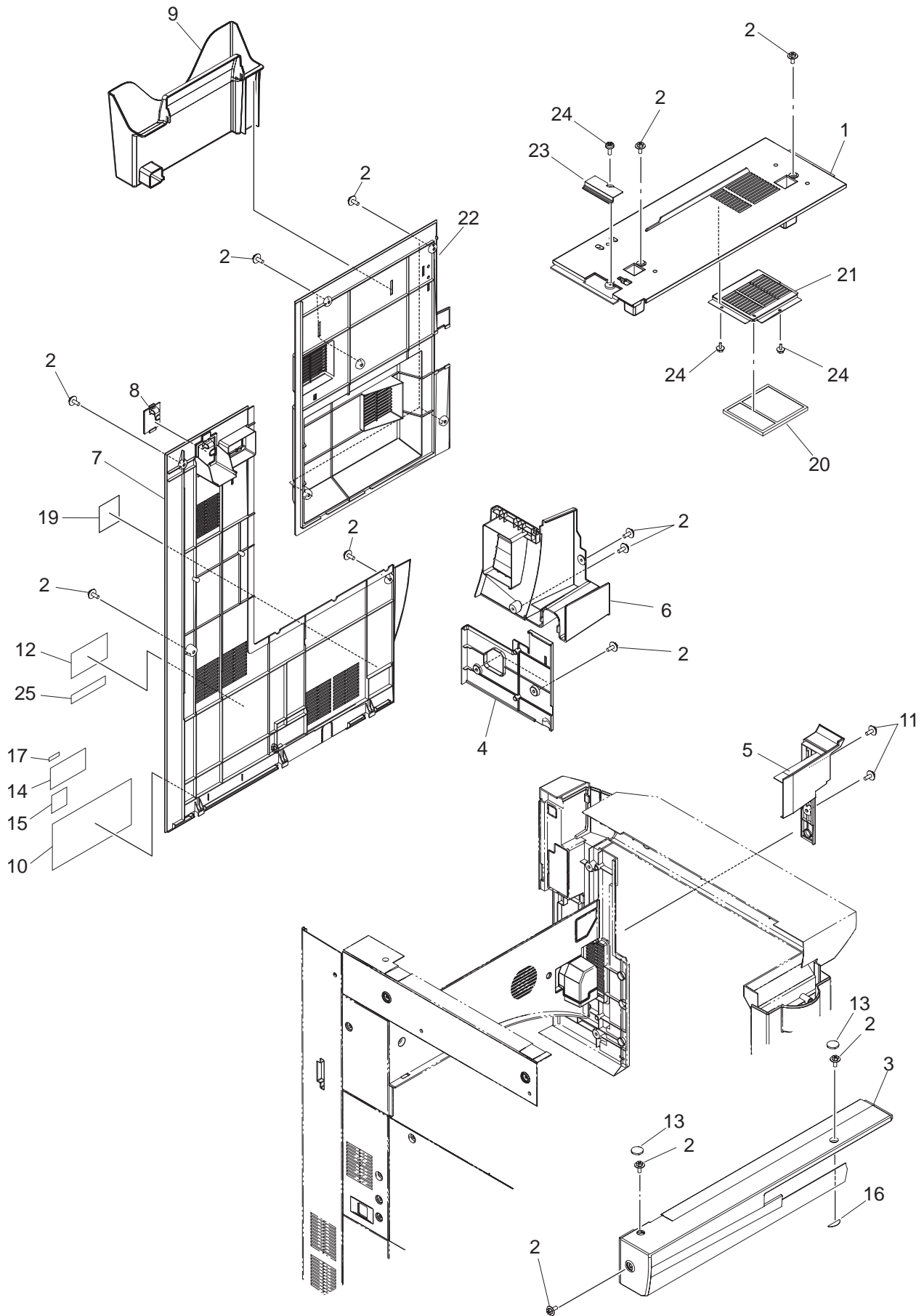

CONTROL-PANEL-ASM

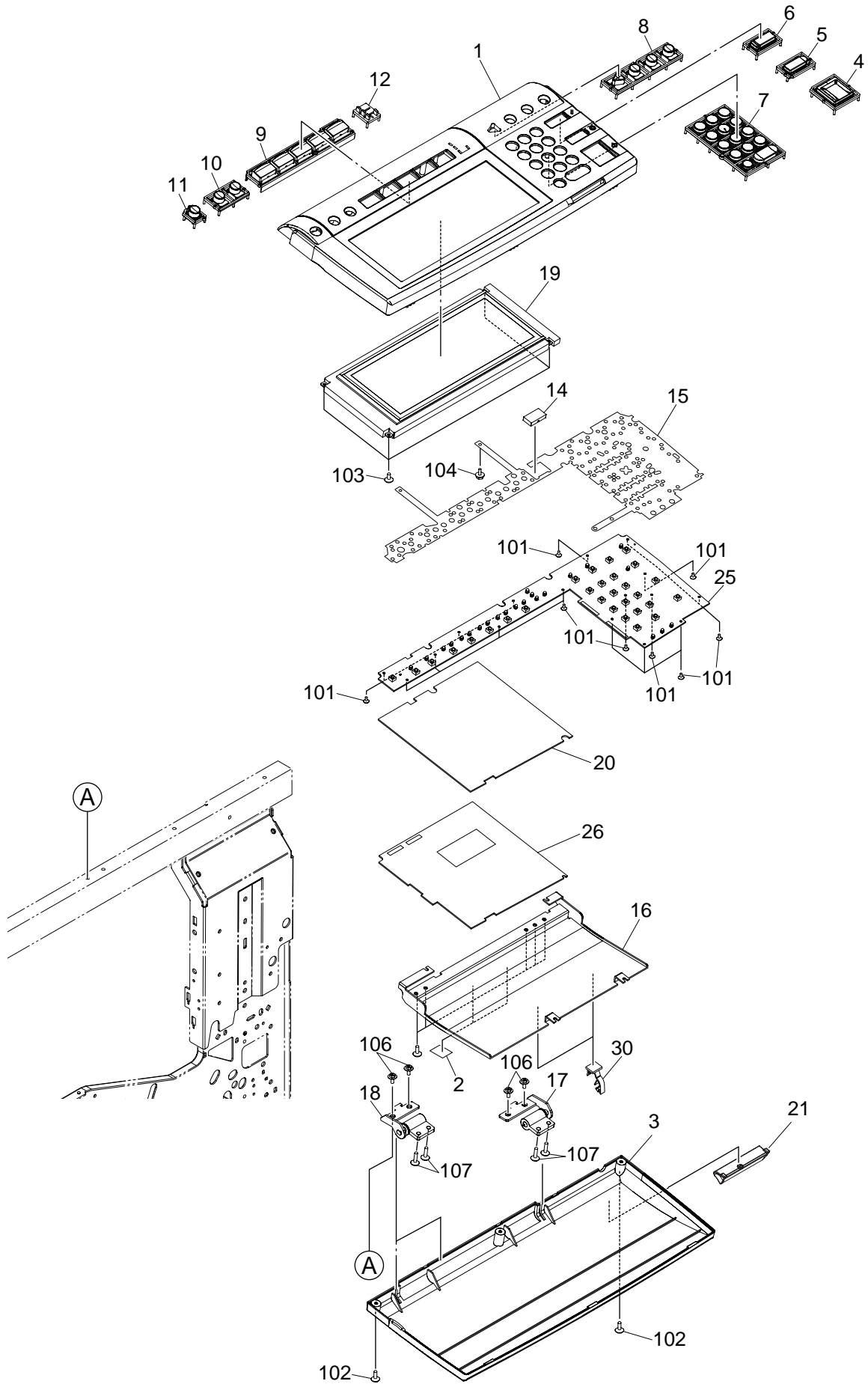

FRONT-FRAME-ASM

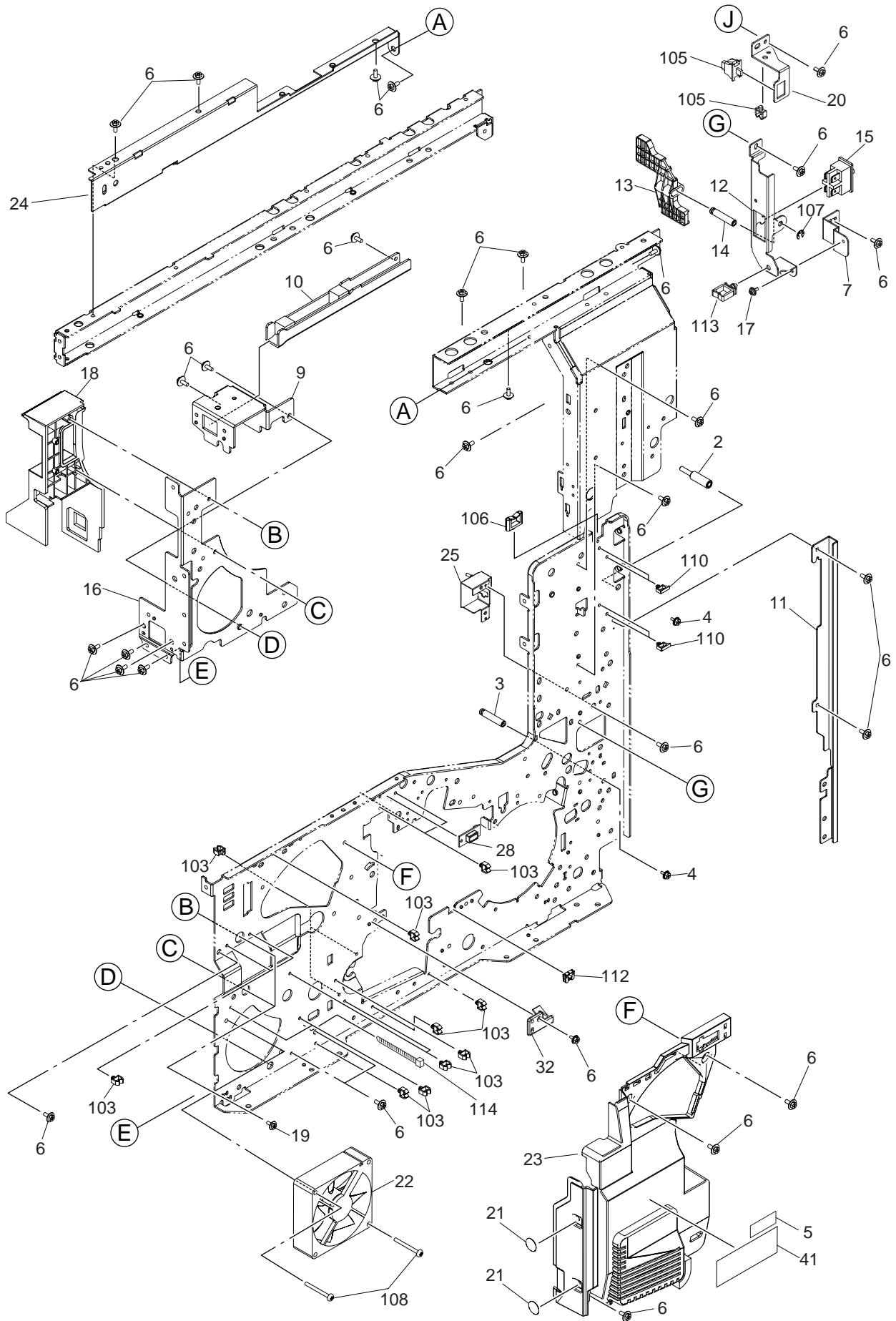

POWER-SUPPLY-ASM

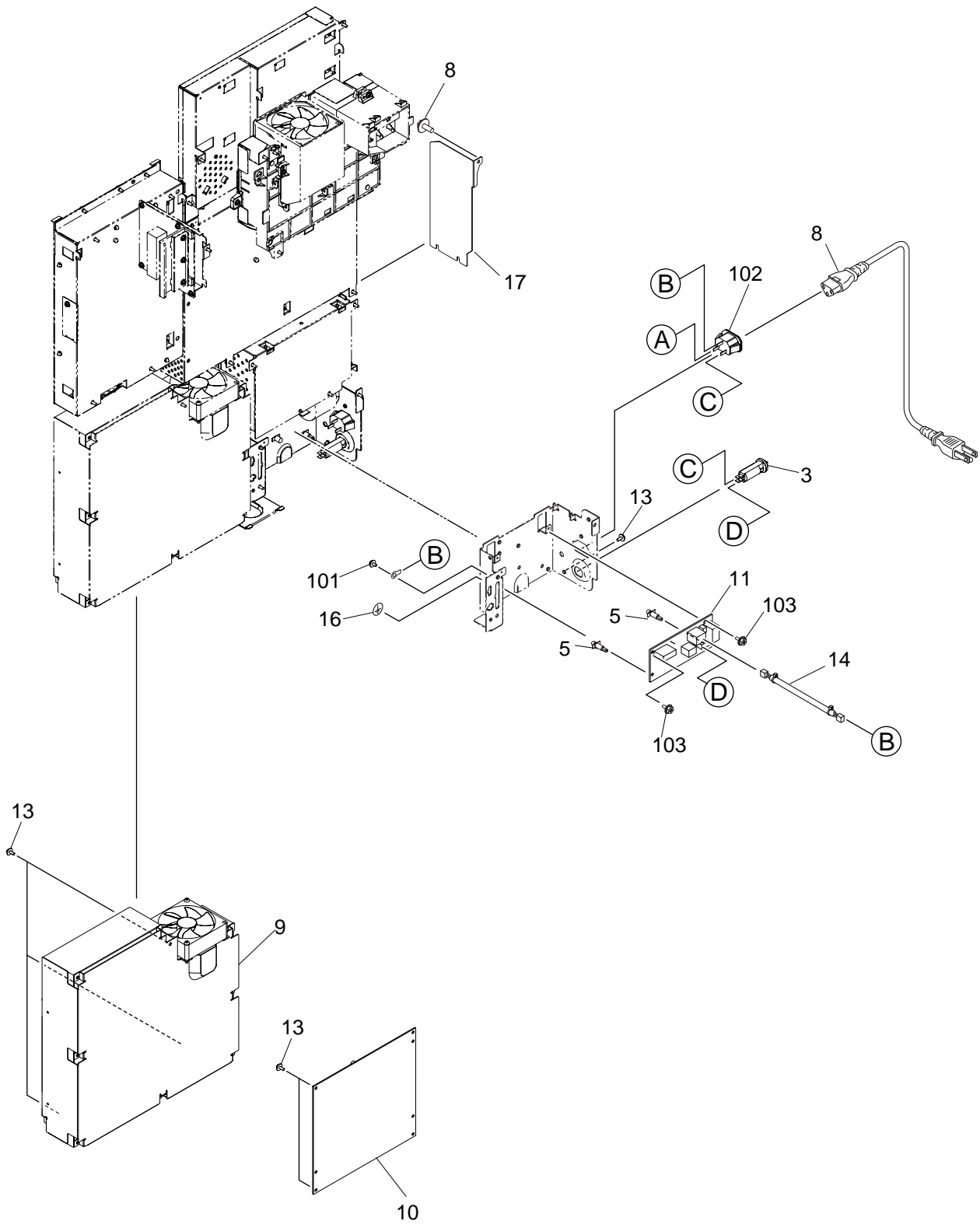

CASE-SYS-ASM

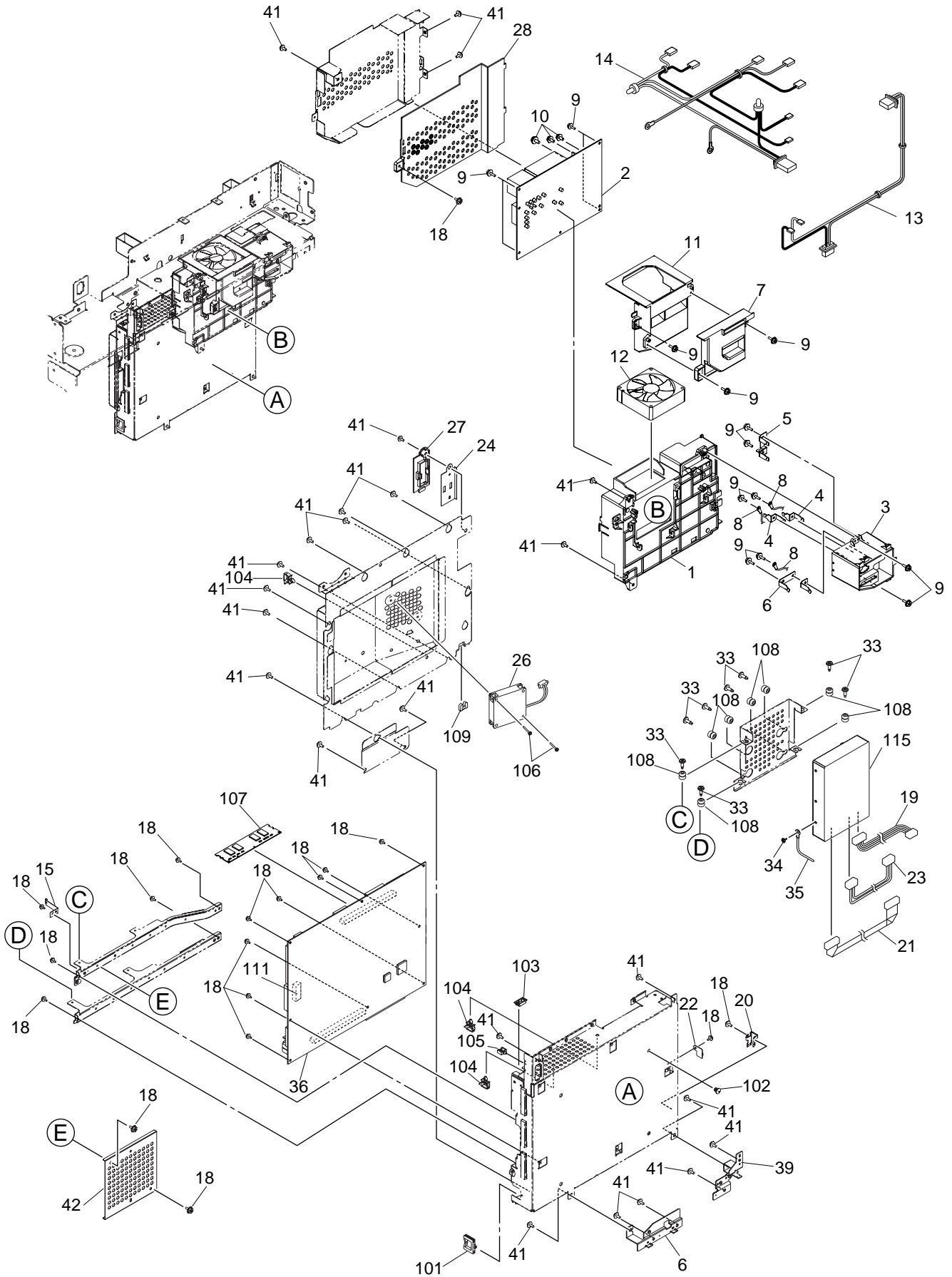

CASE-LGC-ASM

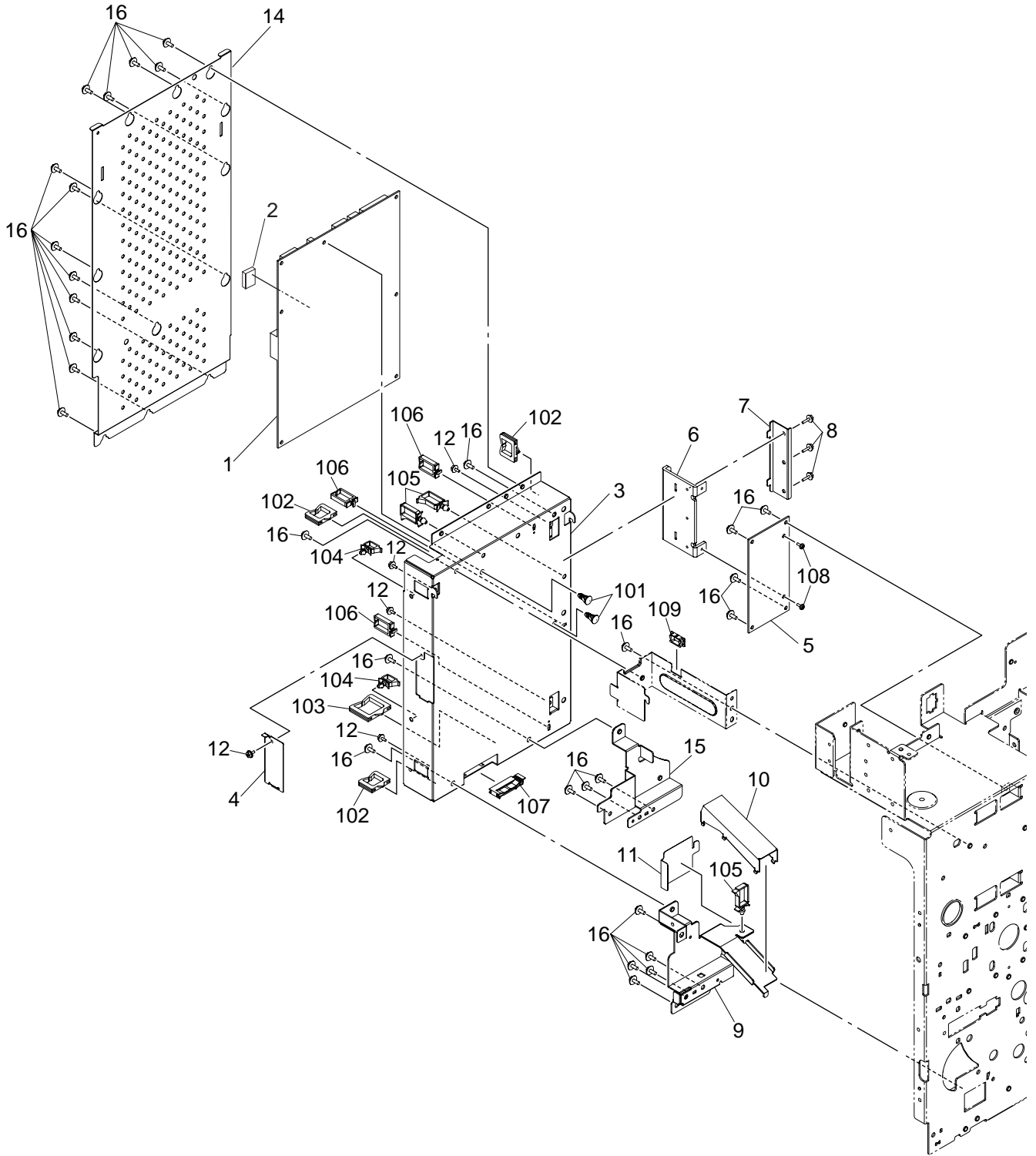

LASER-OPTICAL-UNIT-ASM

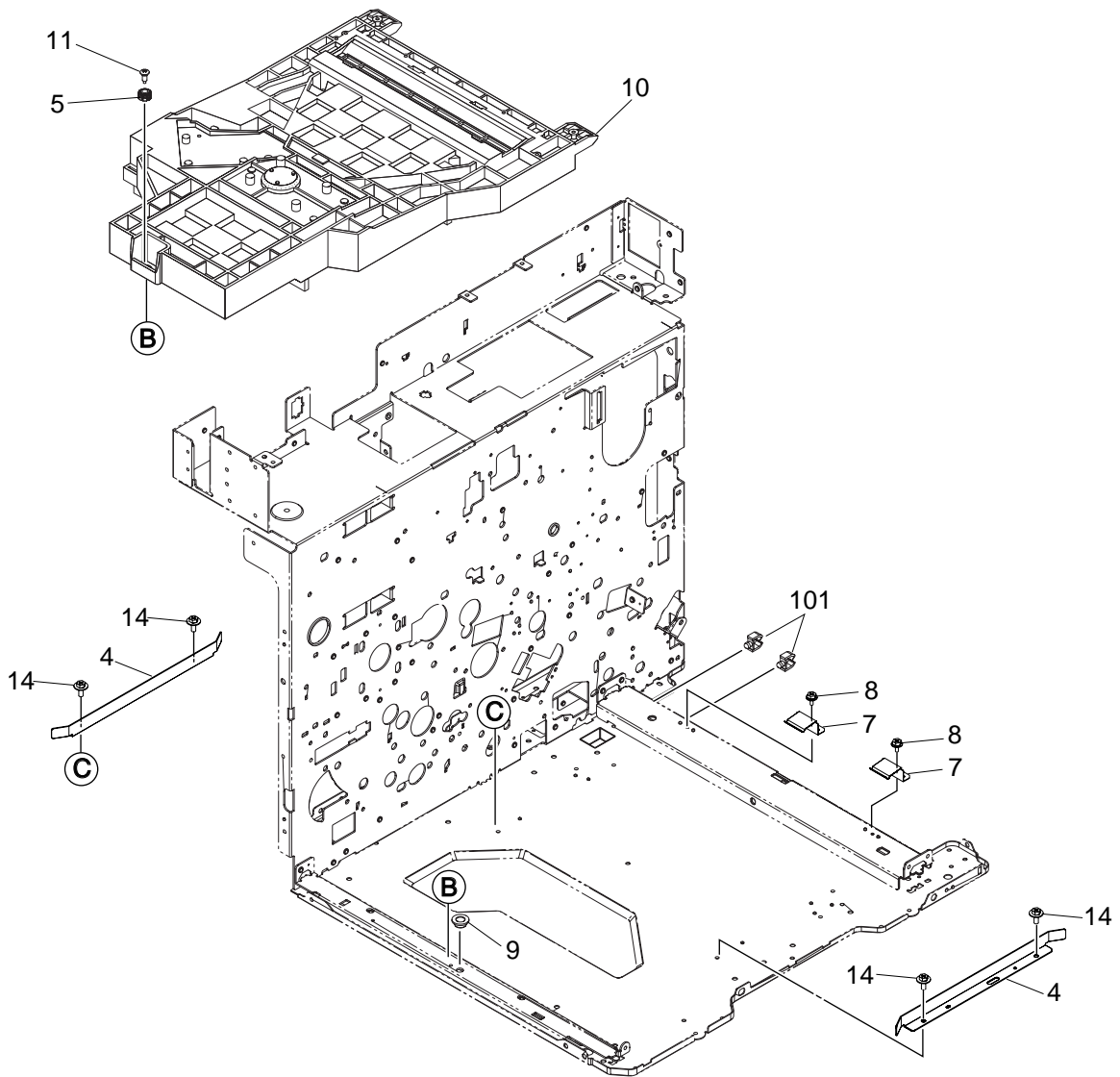
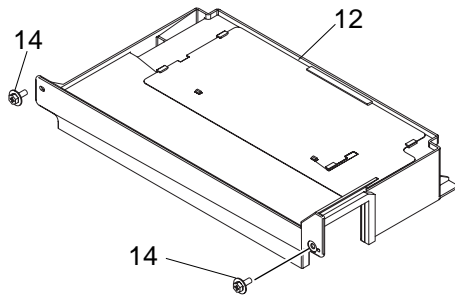

OPTICAL-FRAME-ASM

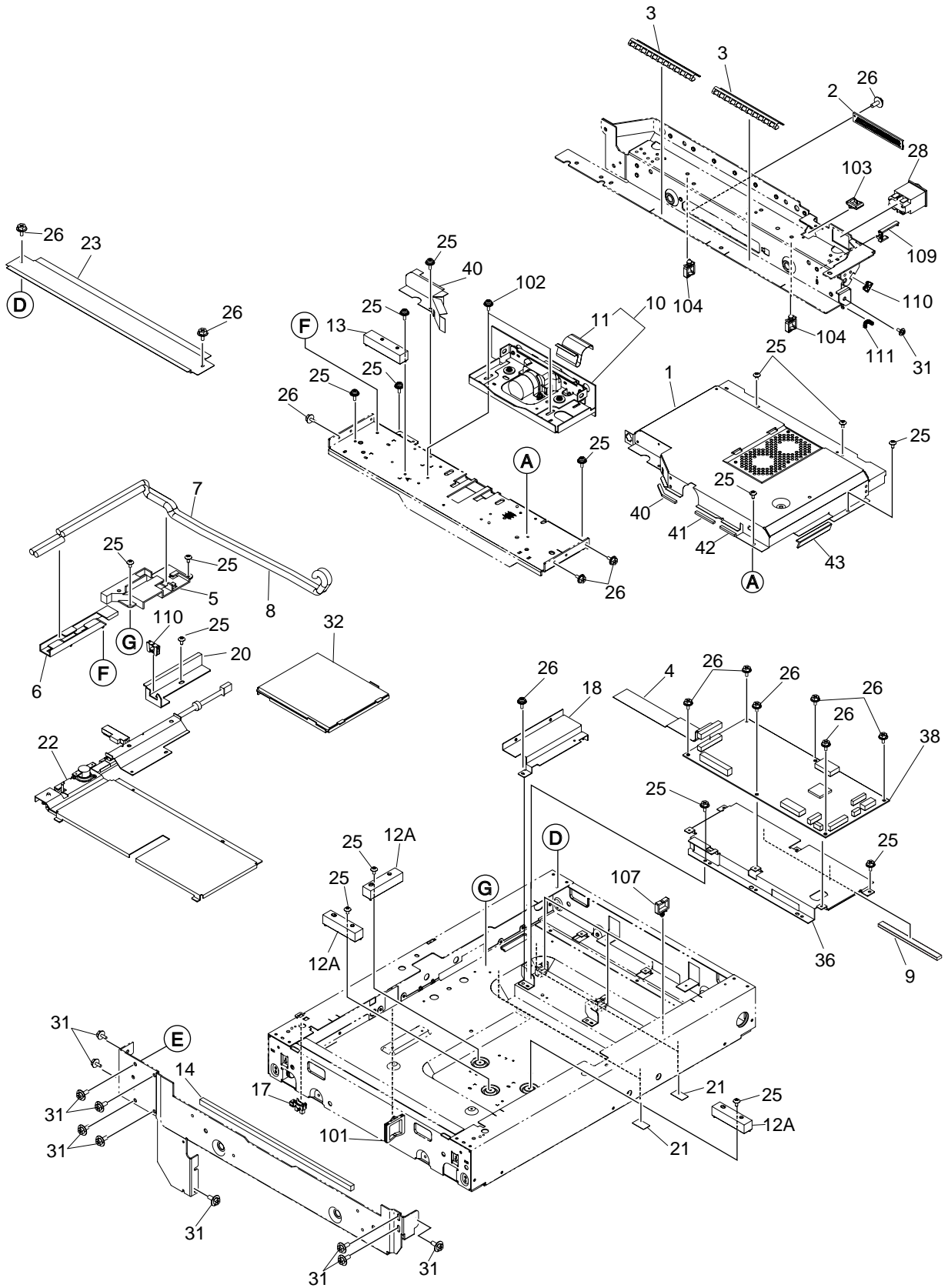

TR2-UNIT-1-ASM

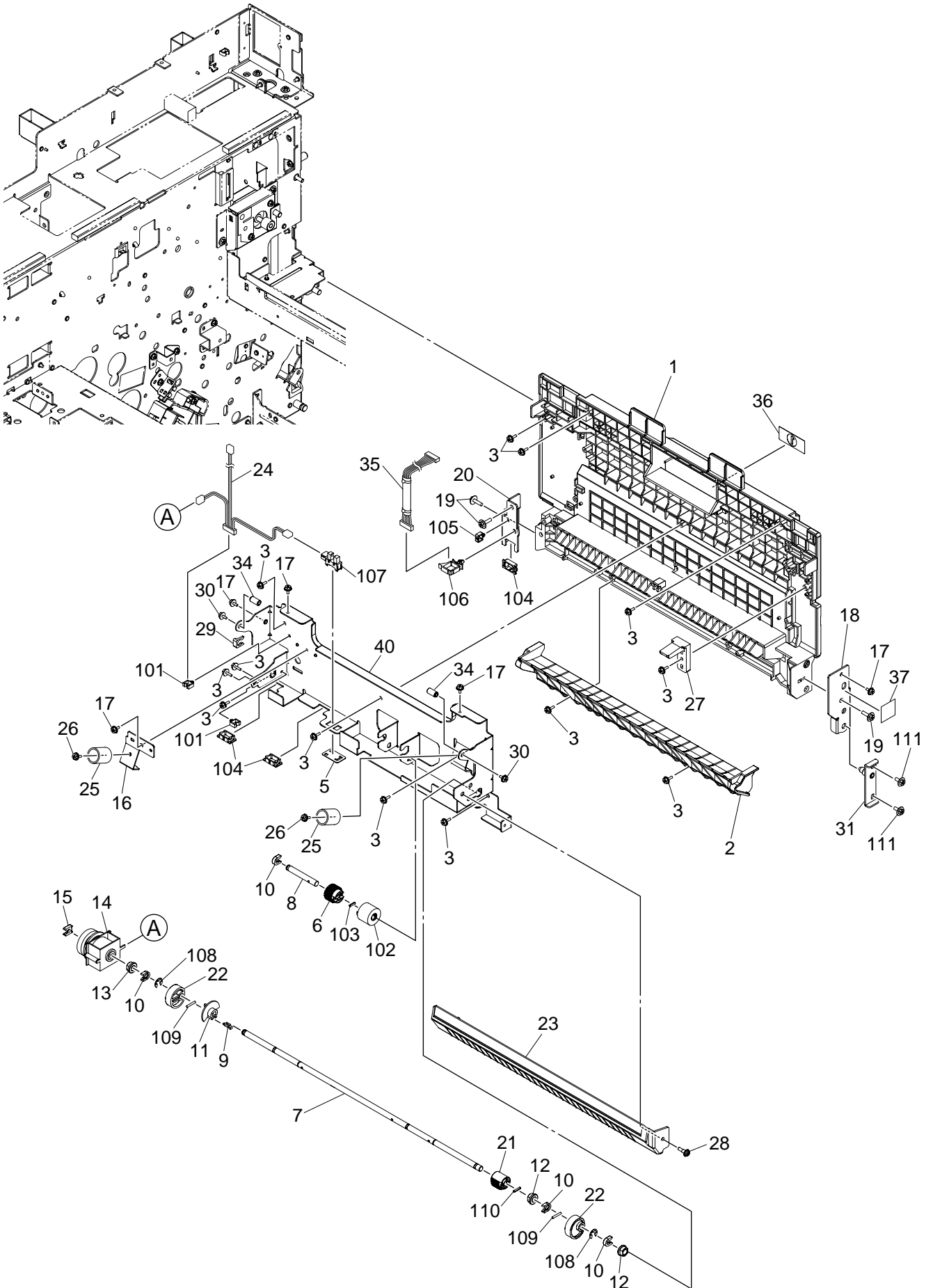

TR2-UNIT-2-ASM

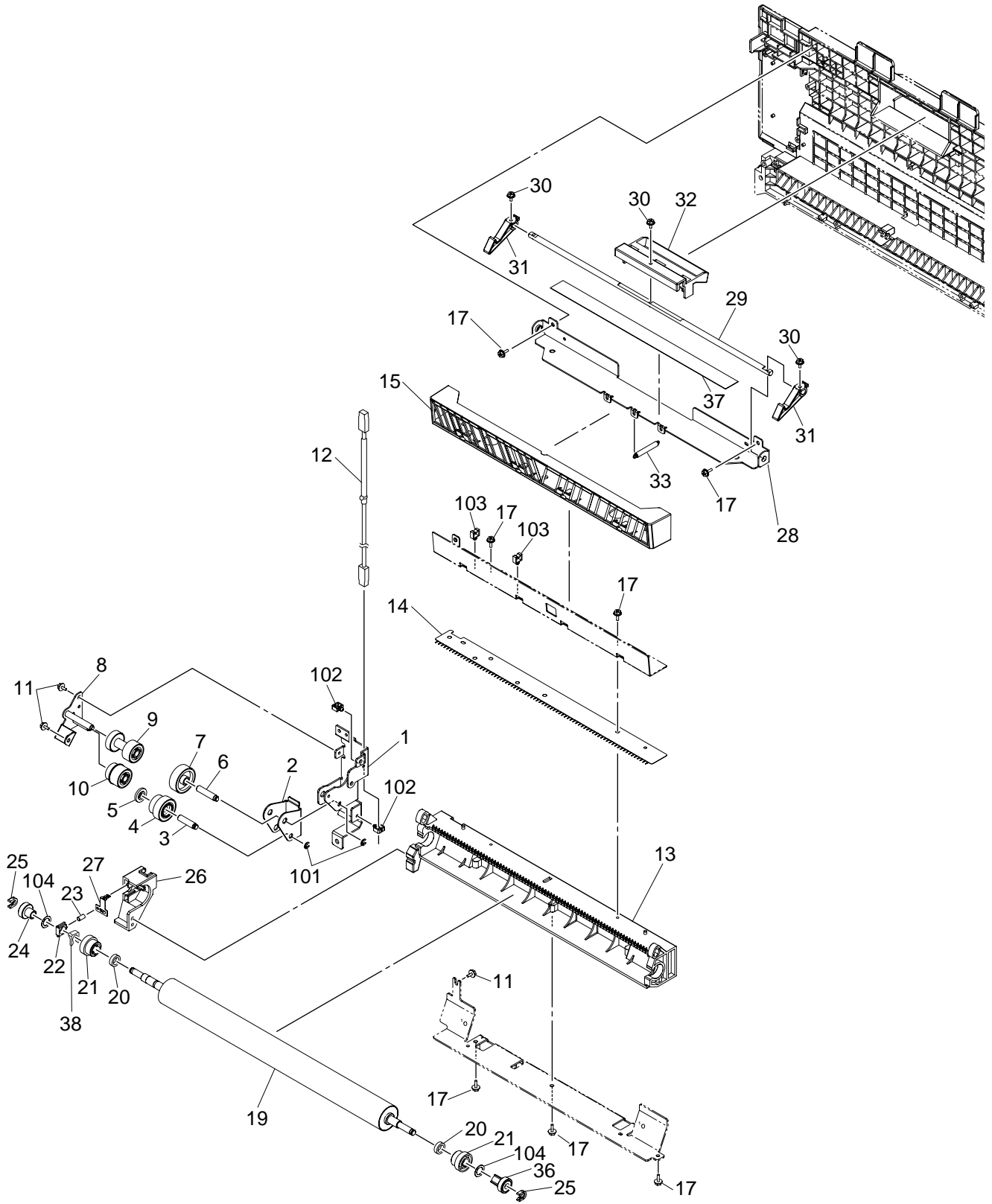

DRUM-DRIVE-ASM

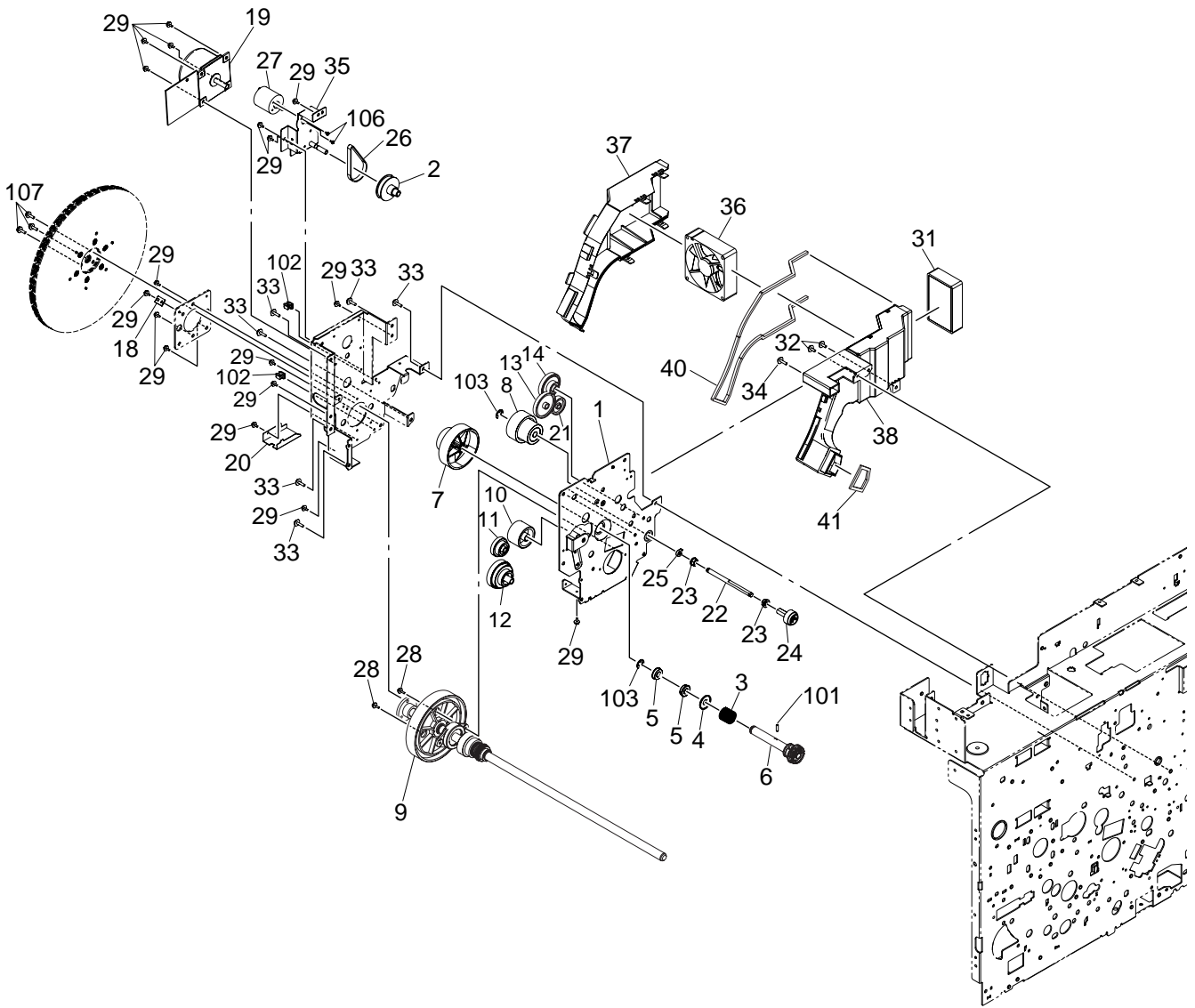

DEV-DRIVE-ASM

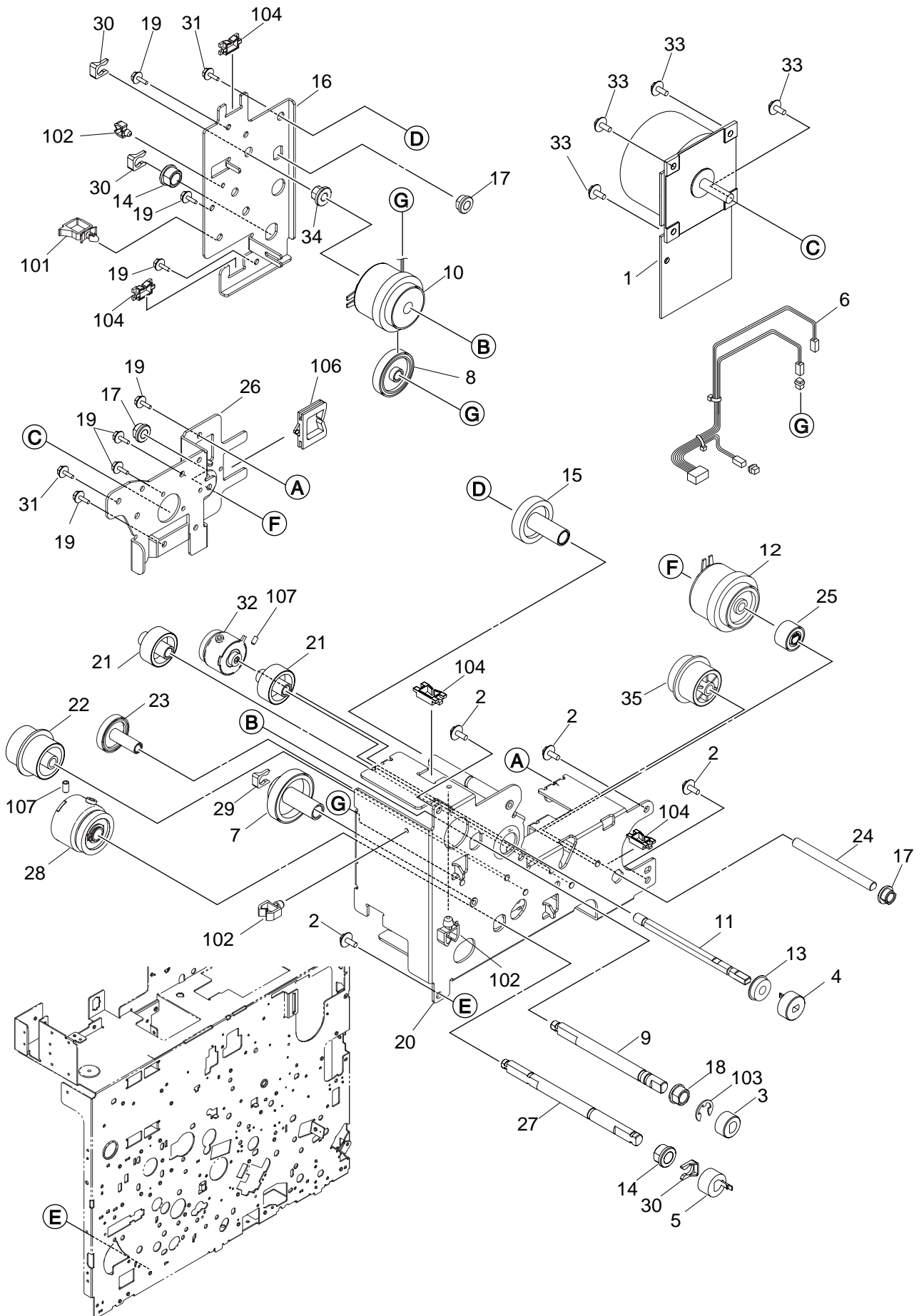

FEED-DRIVE-ASM

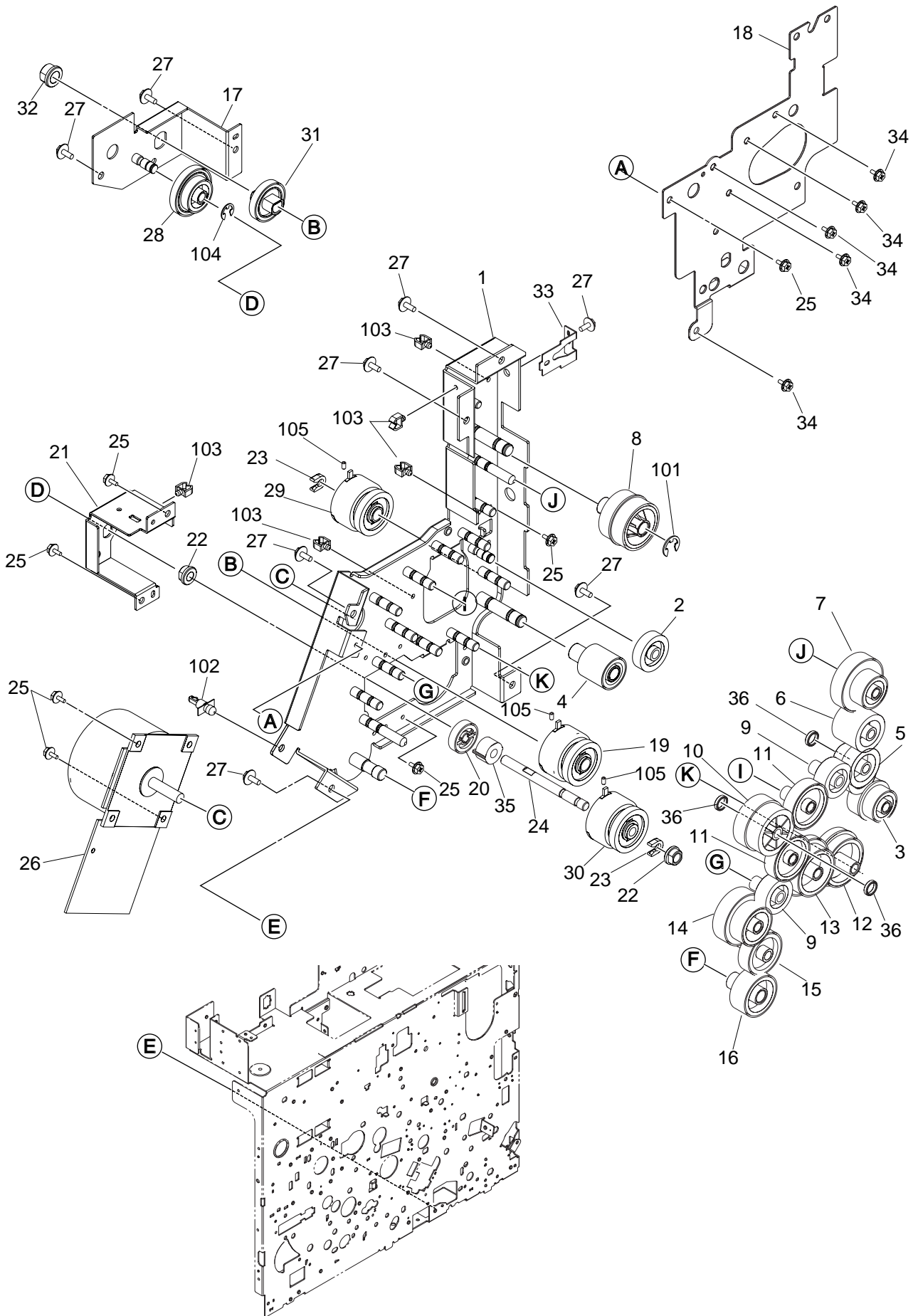

OPTICAL-DRIVE-ASM

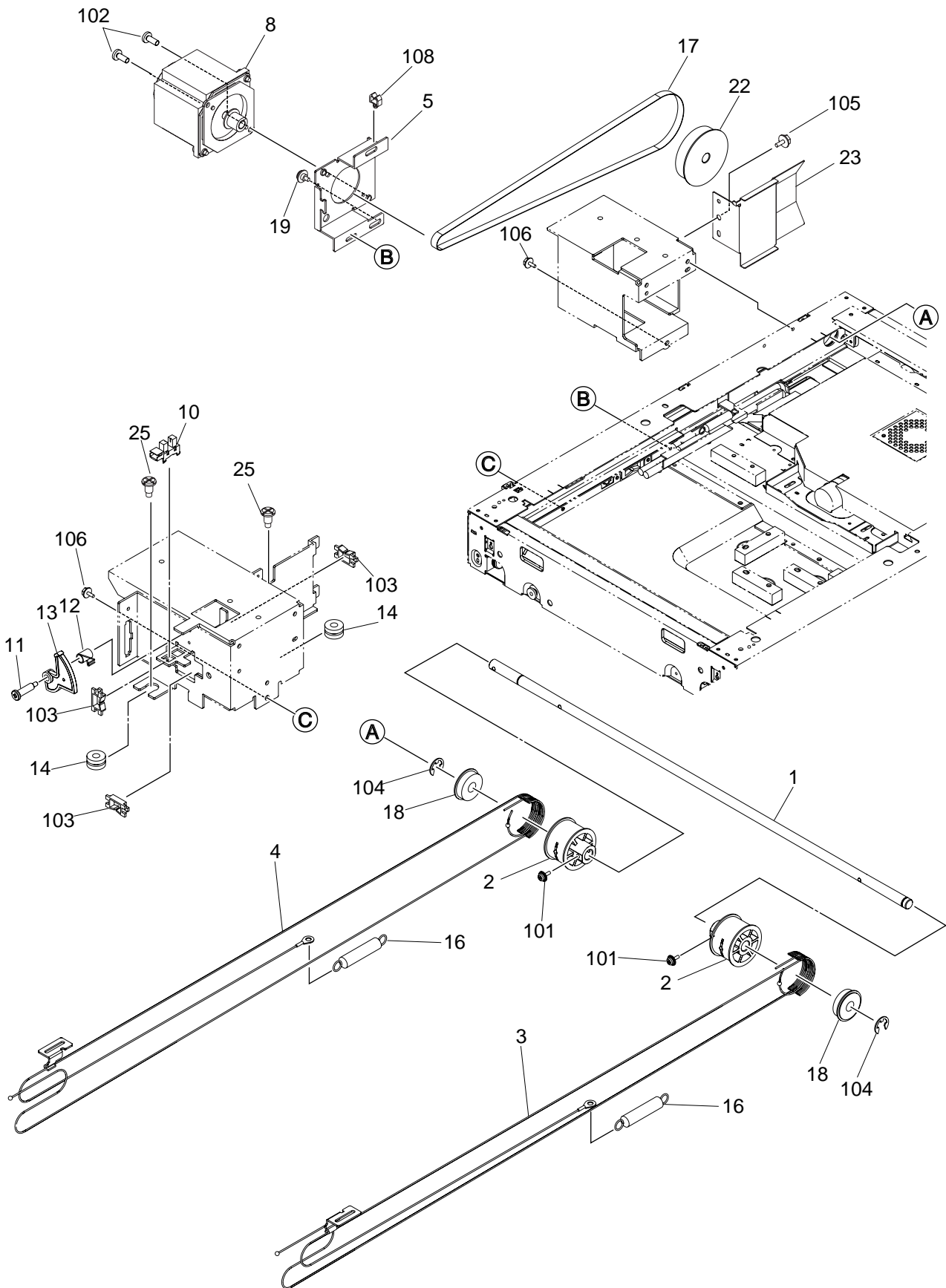

FEEDER-1-ASM

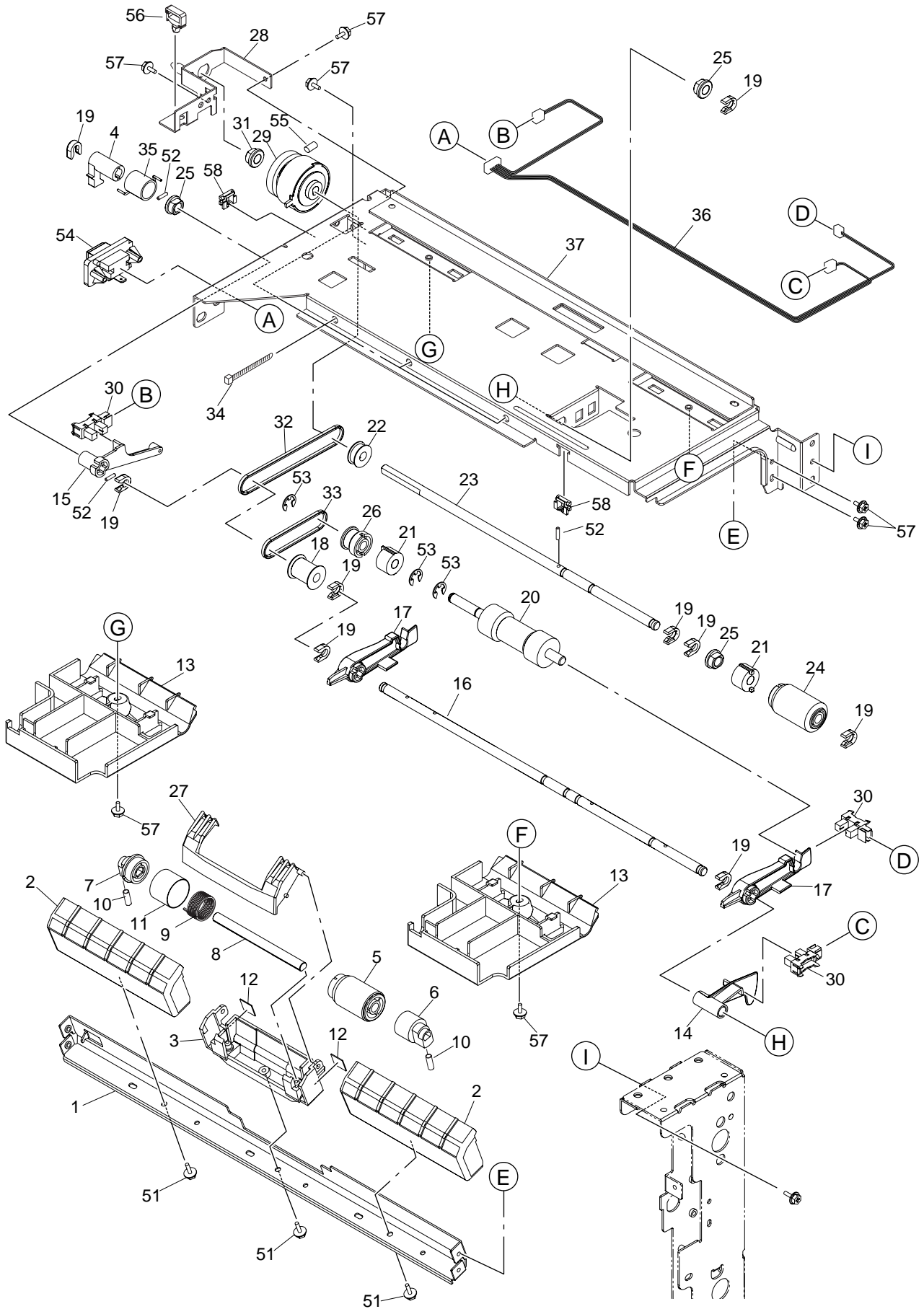

FEEDER-2-ASM

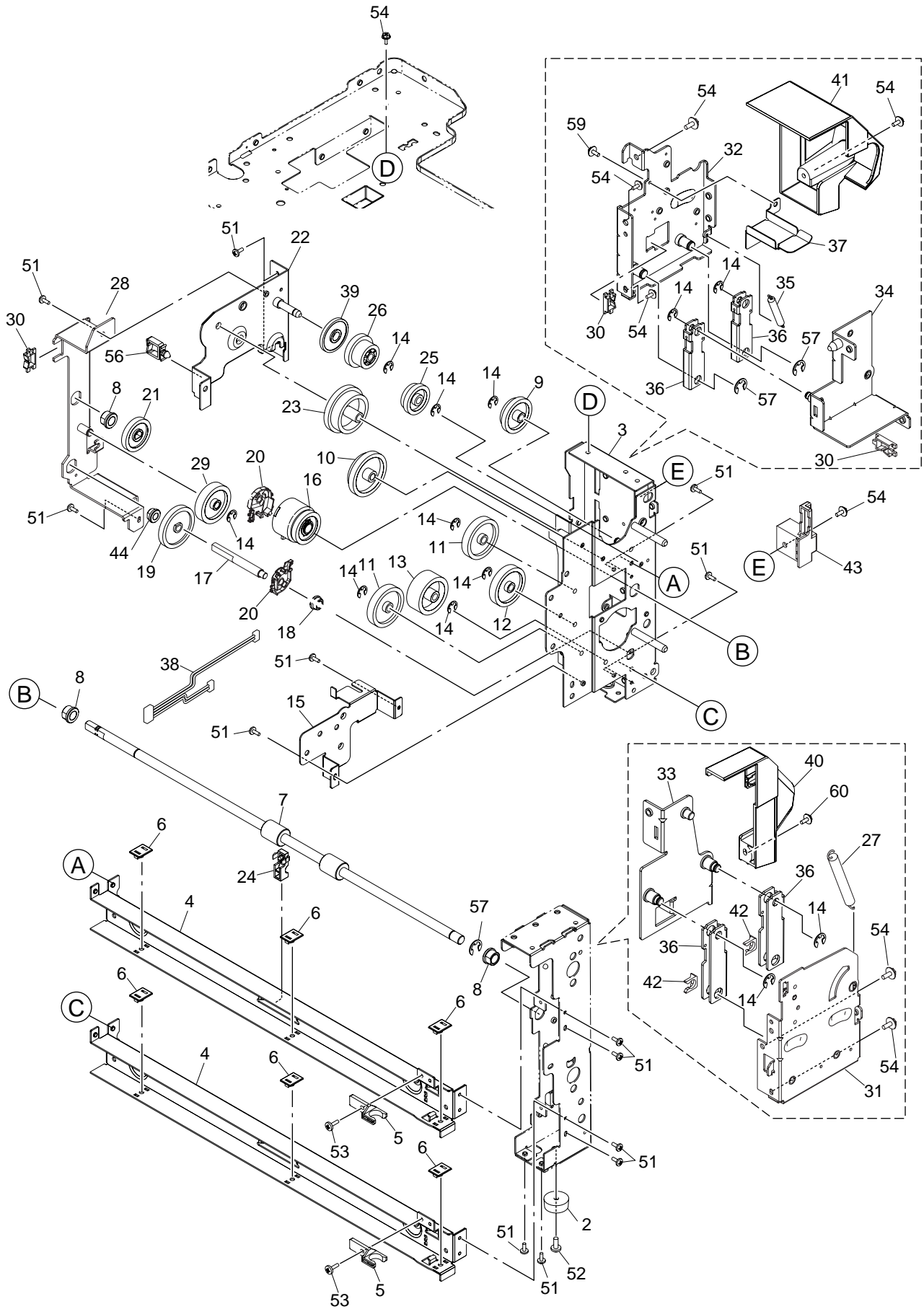

BYPASS-ASM

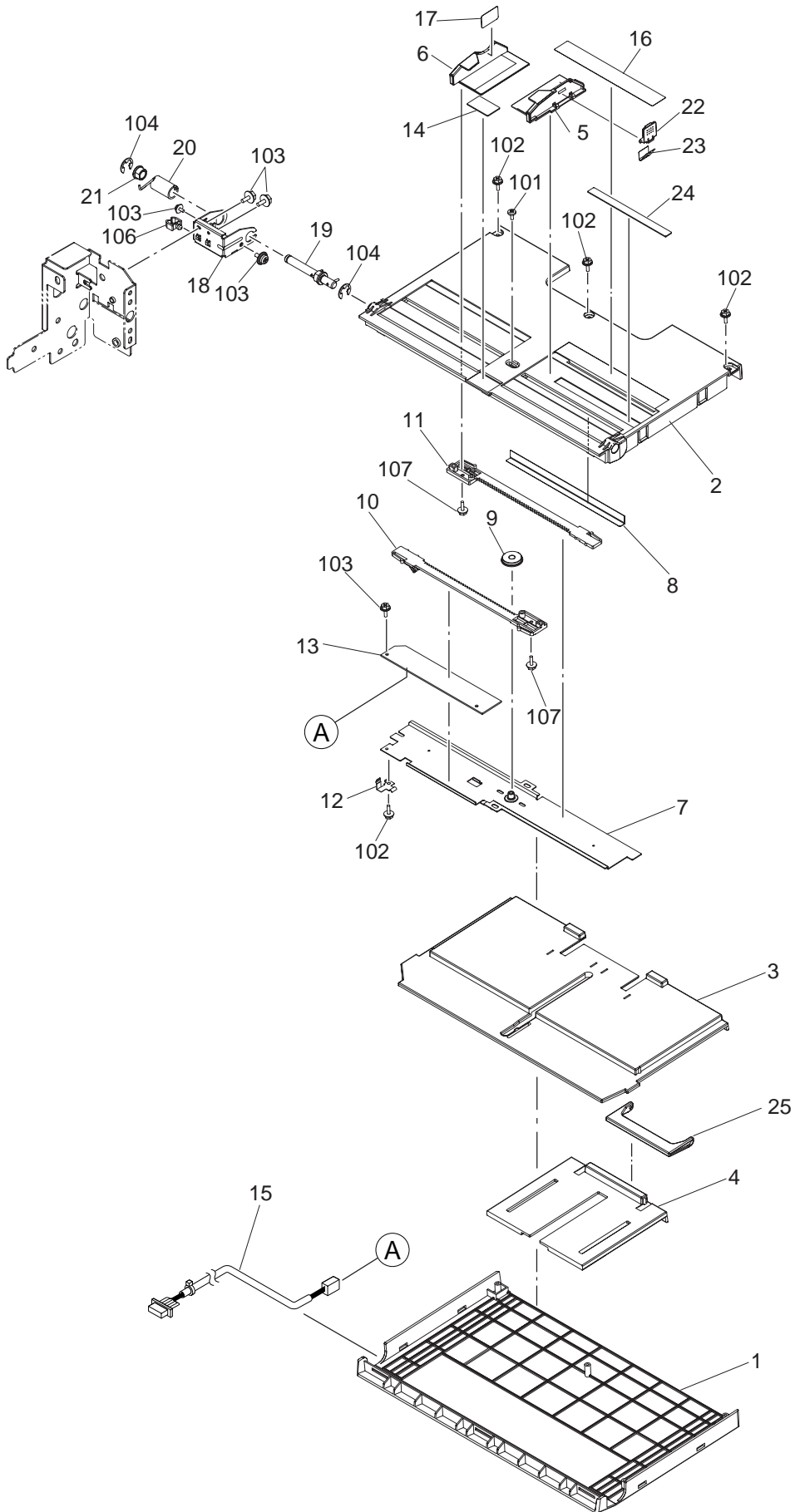

BYPASS-FEEDER-1-ASM

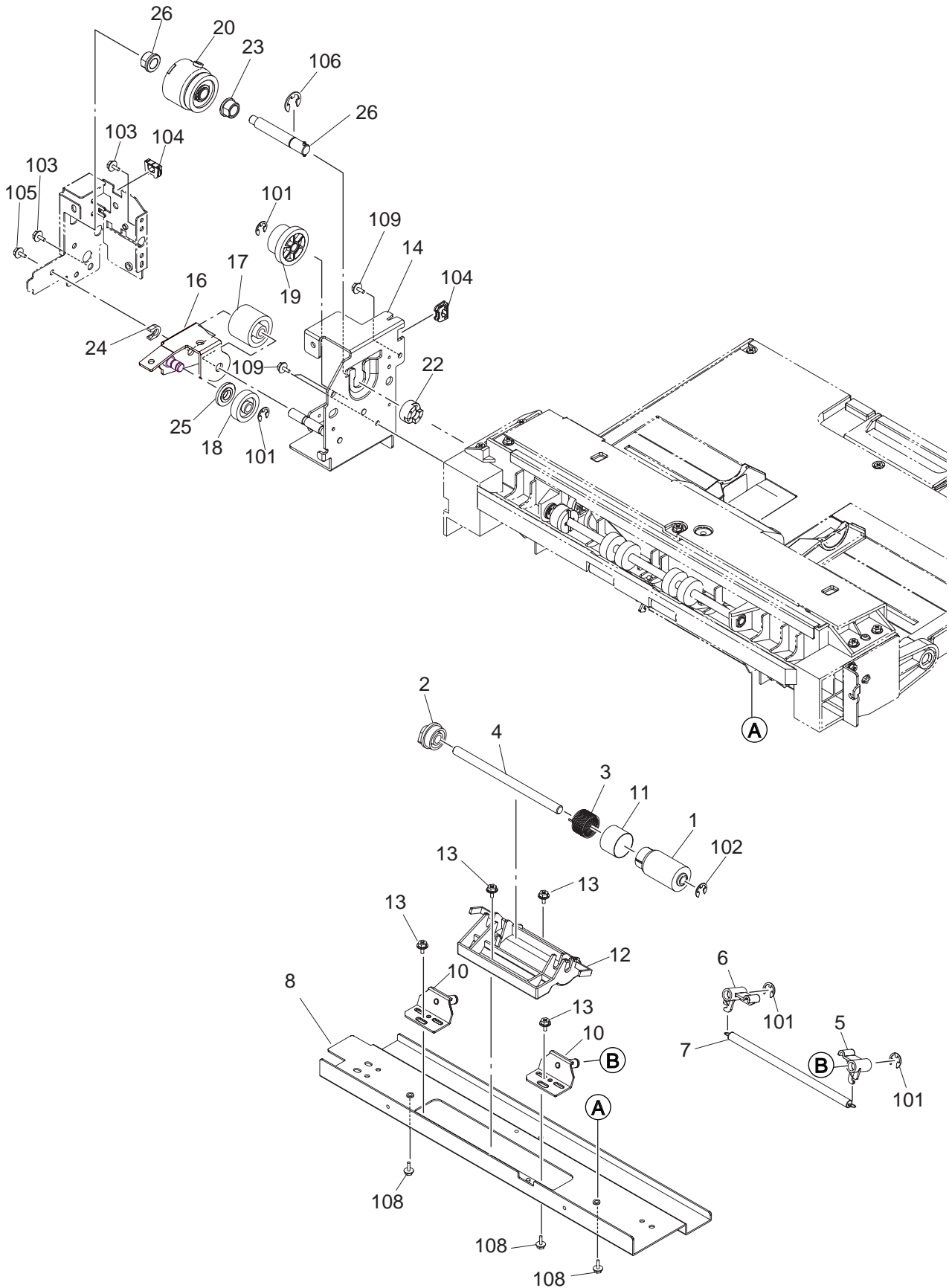

BYPASS-FEEDER-2-ASM

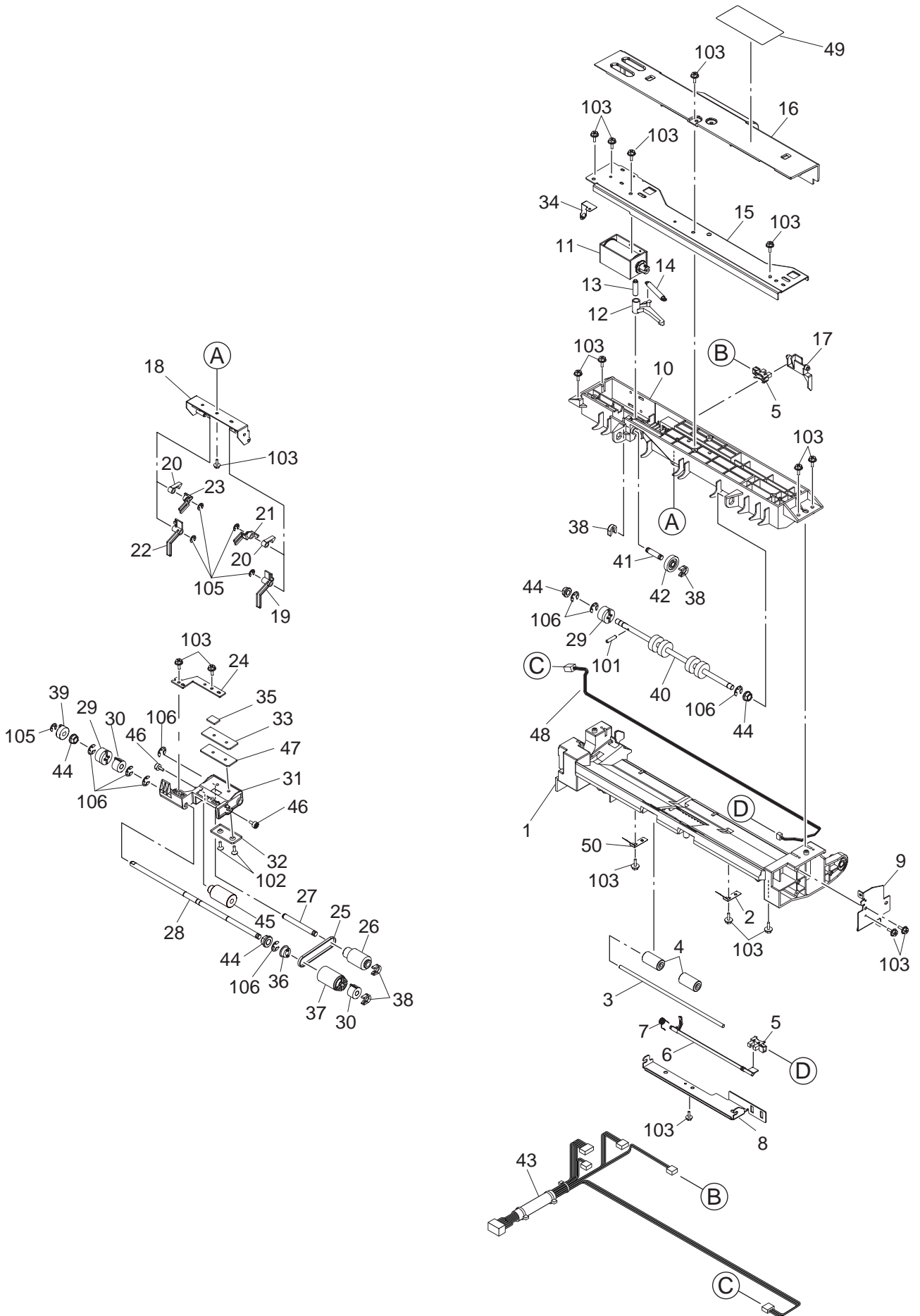

ALIGNING-1-ASM

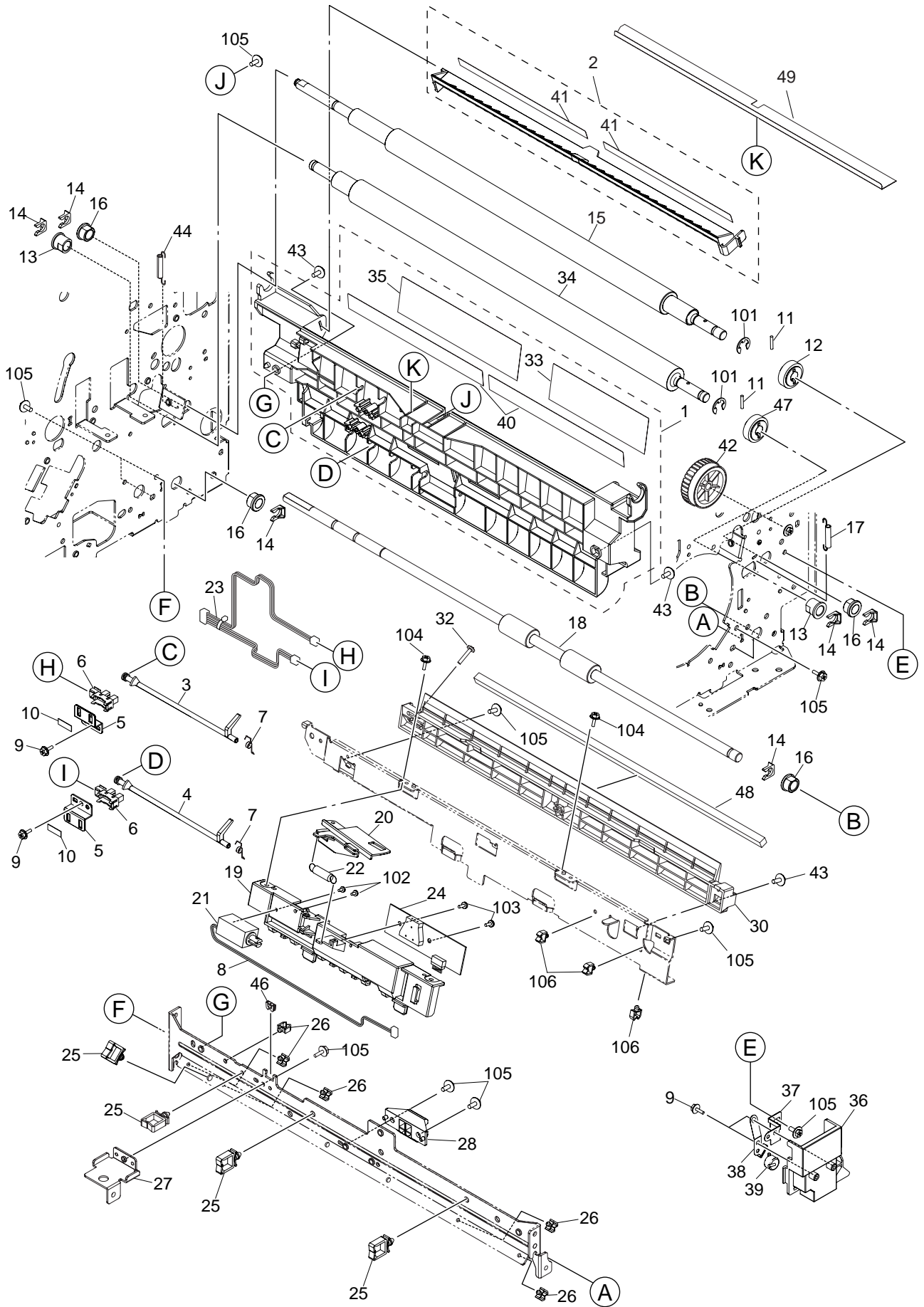

ALIGNING-2-ASM

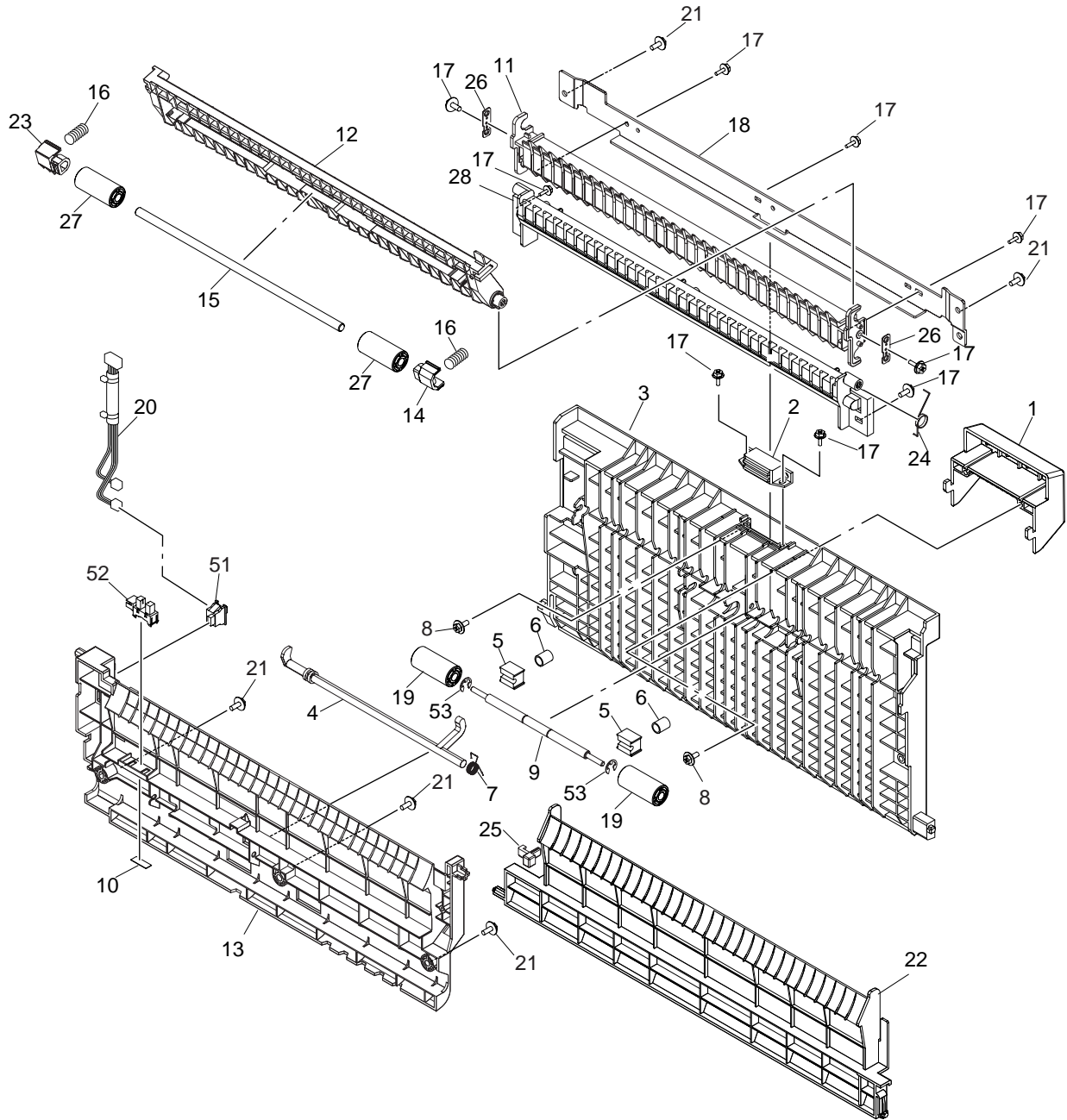

PLATEN-ASM

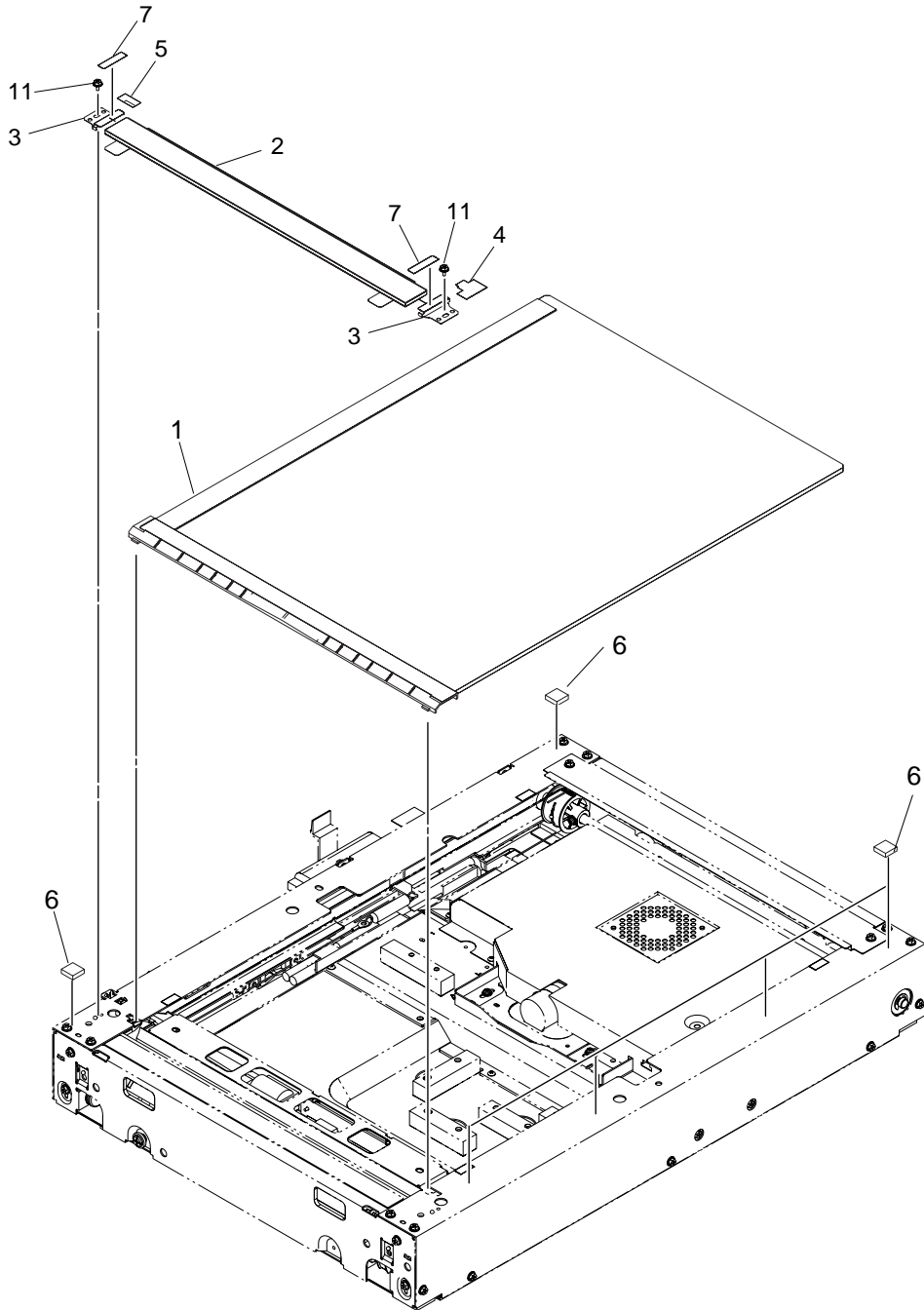

CRG-1-ASM

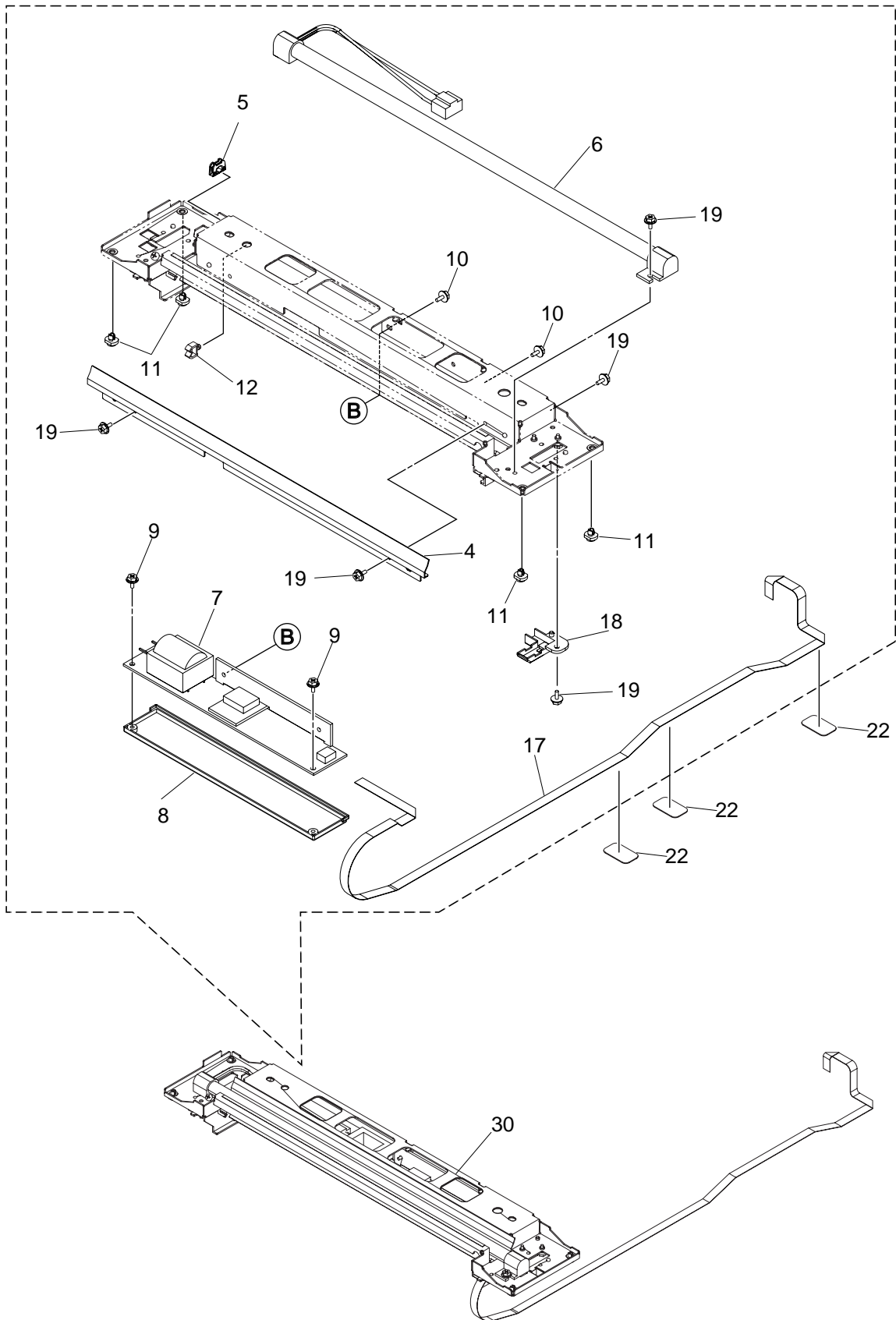

CRG-2-ASM

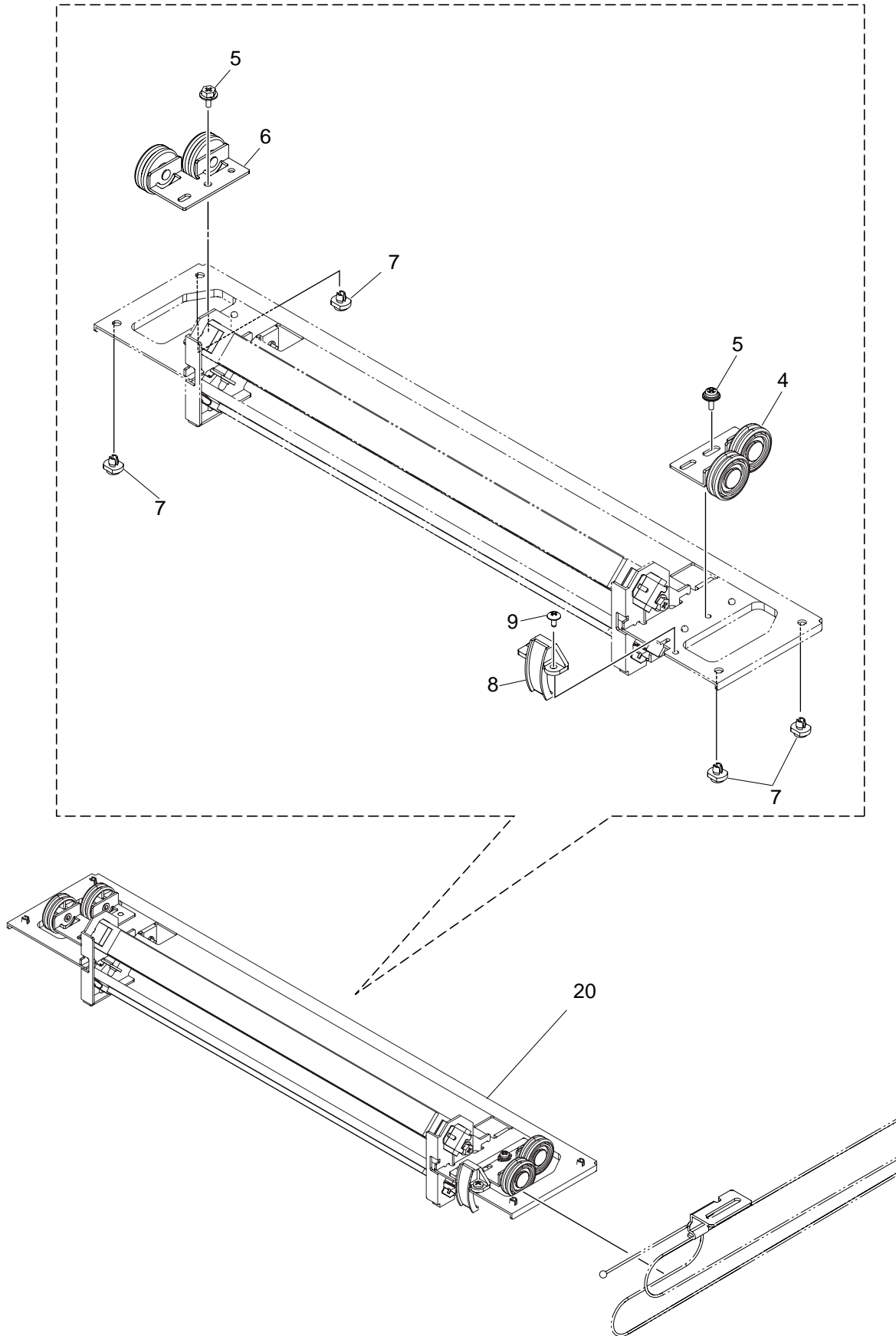

MAIN-CHARGER-ASM

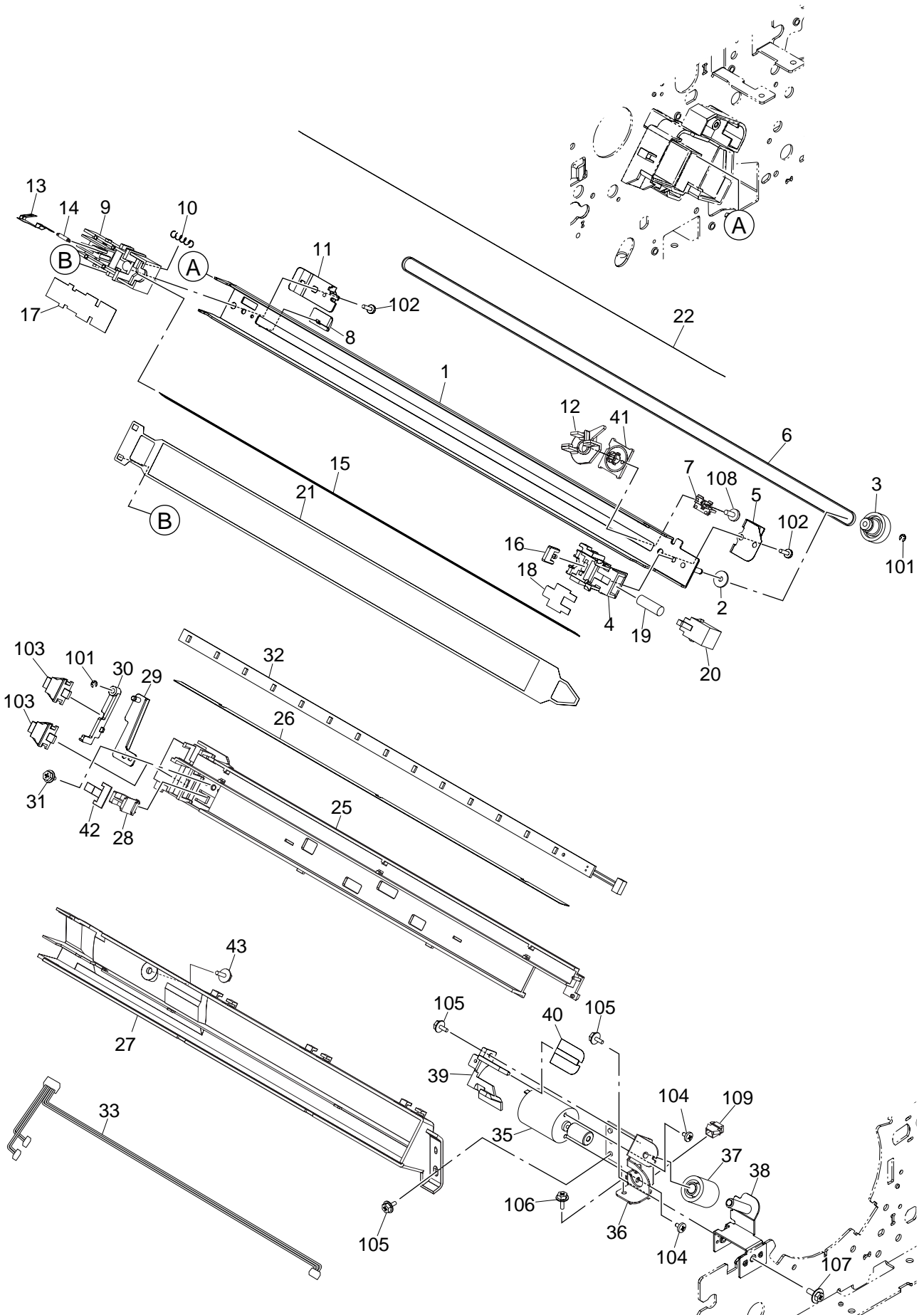

TRANSPORT-BELT-UNIT-1-ASM

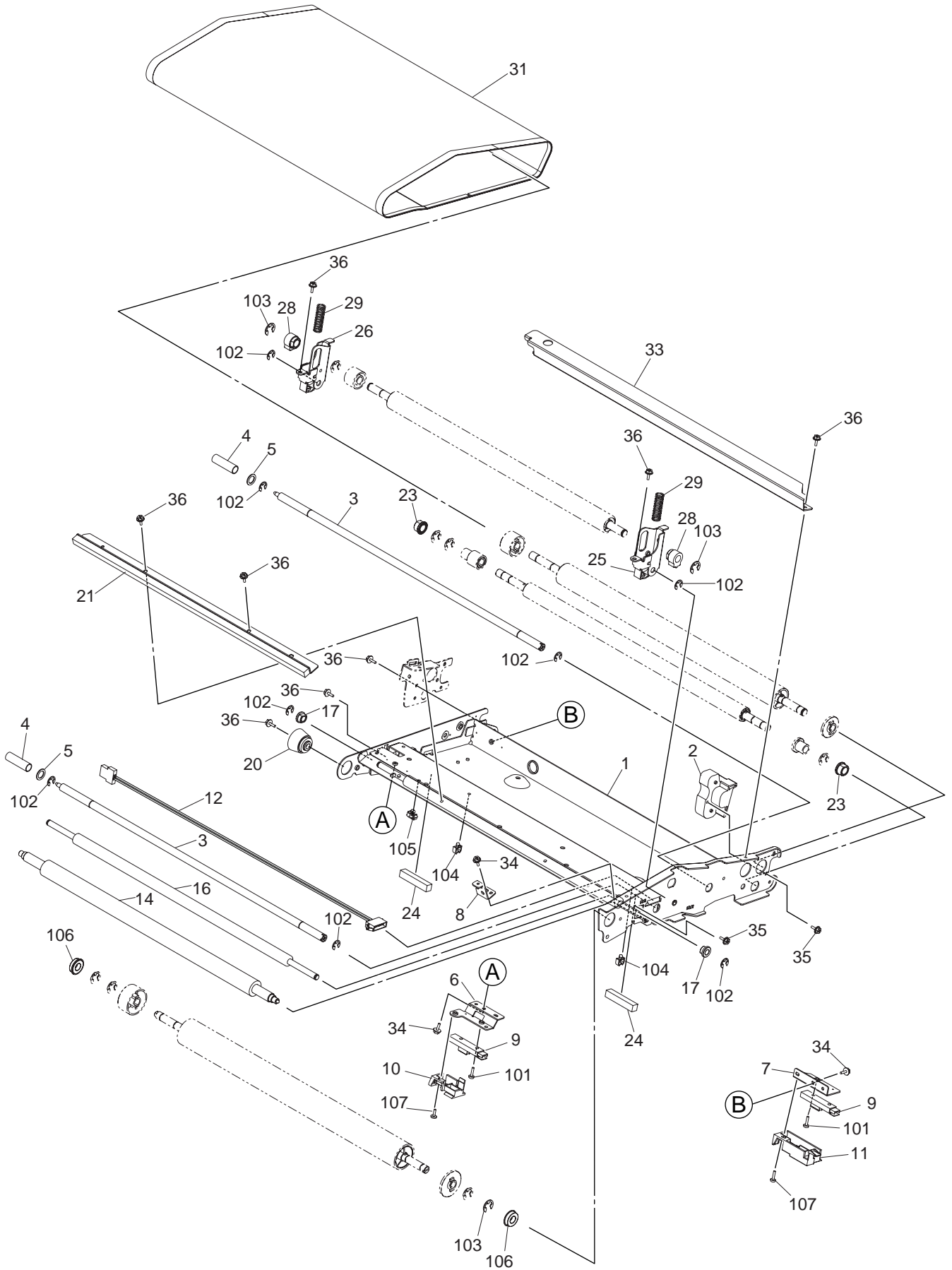

BELT-CLEAN-UNIT-ASM

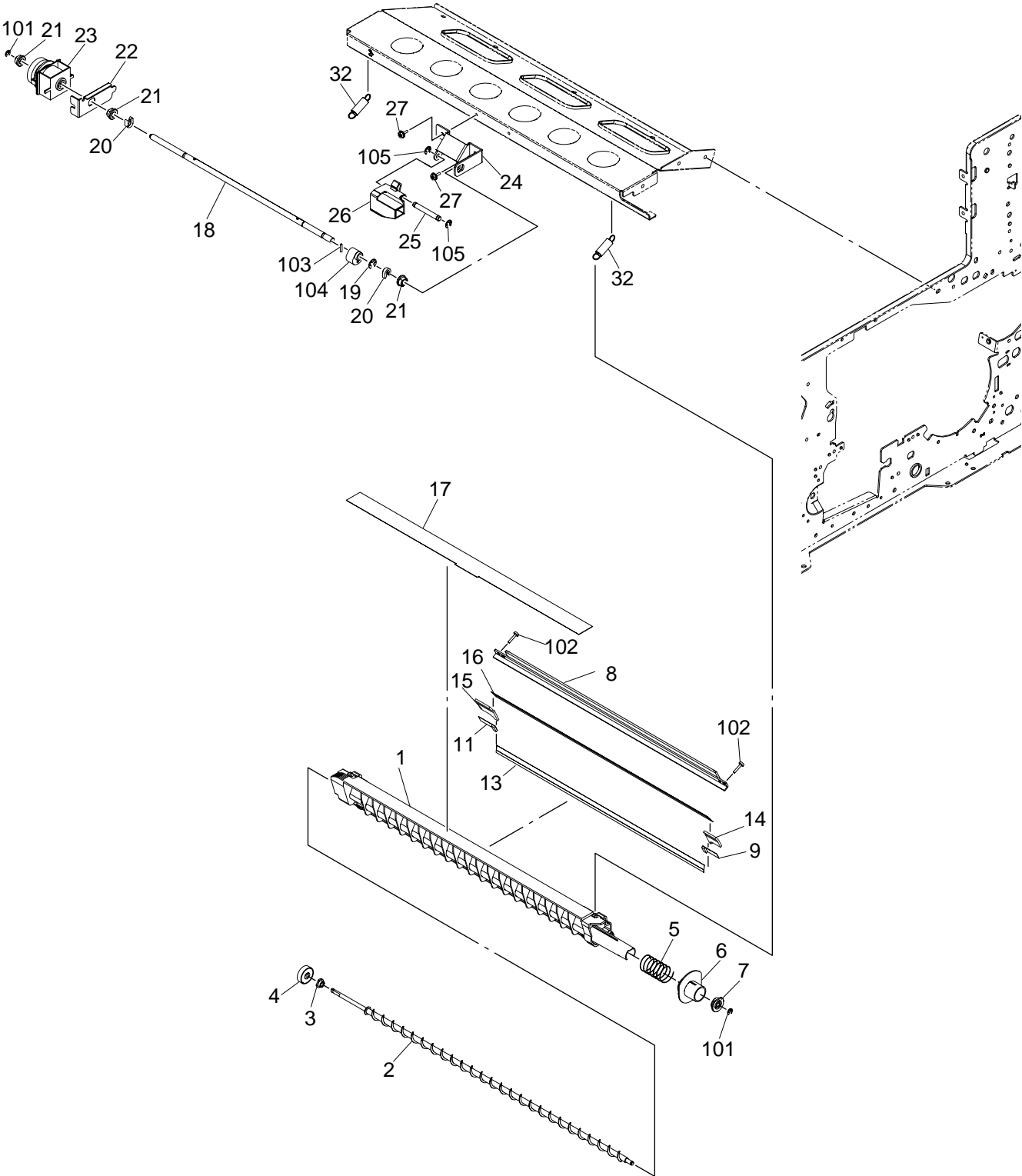

CLEANER-ASM

ITEM No.	PART No.	PART NAME	Q'TY / PAGE	Q'TY / PACK	P	I	R	BSI No.	TO	FROM	REMARKS
1	51033801	SHAFT-BRUSH-CLNR-RER	1	1/P							
2		ASYS-RTNR-DRUM-FRT	1	1/P							
3		ASYS-AUGER-DRUM-LWR	1	1/PP							
4		ASYS-AUGER-DRUM-UPR	1	1/PP							
5		BL-3511D	1	1/S							
6	51034101	ASYS-FRAME-DRUM-FRT	1	1/P							
7		ASYS-NOZZLE-CLNR-DRUM	1	1/C							
8		ASYS-STAY-CLN-DRUM-L	1	1/KP							
9		AUGER-CLNR-DRUM-350	1	1/KP							
10		B-281C	1	1/S							
11		GEAR-10S24-4-AUGER	1	1/P							
12		HLDR-BLASE-DRUM-350	1	1/P							
13		HLDR-THMS-DRUM-350	1	1/P							
14		PLATE-GAP-BLK-F	1	1/P							
15		BUSH-0612-D6F-M	1	5/P							
16	50320807	BUSH-0410-05F-M	2	5/P							
17		HANDL-DRUM-U-TNR	1	1/P							
18		S/TPP/FHEXM-3X8-NI	9	10/P							
19		S/TPS/FHEXM-3X8-ZU3	12	10/P							
20		SHAFT-BRUSH-CLNR-FRT	1	1/P							
21		PLATE-FLICKER-410	1	1/P							
22		SHEET-AUGER-FRT-350	1	5/KP							
23		SHEET-AUGER-LWR	1	5/KP							
24		SHEET-AUGER-RER-350	1	5/KP							
25		SHEET-BRUSH-CLNR	2	5/P							
26	58391701	SHEET-RECOVERY-DRUM	1	1/KP							
27		SHLD-BLADE-CNR-FRT	1	1/P							
28		SHLD-BLADE-CNR-RER	1	1/P							
29		SPG-C-5R9XR4X8L	1	5/P							
30		SPG-E-6XR55X17R4-BLADE	1	1/P							
31		THMS-DRM-410	1	1/C							
33		GEAR-10S16-15	1	1/P							
34		GEAR-10S16-5-AG	1	1/P							
35		PLATE-GAP-BLK-RER	1	1/P							
36		GUIDE-DRUM-LFT-LWR	1	1/P							
37		SHEET-RECOVERY-RER	1	5/P							
38		SHLD-BLADE-SIDE-RER	1	5/P							
39		SPG-E-4R4-10-GAP	1	1/P							
40		TERM-BLADE-DRUM-350	1	1/D							
41		ASYS-PLATE-RTNR-DRUM-R	1	1/P							
42		SPL-BRUSH-CLN-DRUM	1	1/P							
43		ASYB-HLDR-BRG-SFT-DRUM	1	1/P							
47		ASYS-BRKT-MOT-AUG-CLT	1	1/P							
48		GEAR-IDLE-AUG-CLT	1	1/P							
49		ASYS-MOT-CLT	1	1/D							
50		COVER-IN-F-R	1	1/PP							
51		LEVER-BOX-U-TNR	1	1/P							
52		SCREW-TBU-LOCK-41X-LFT	1	5/P							
54		HLDR-PLATE-GAP-F	1	1/P							
55		WSHR-CLNR-AUGER	2	5/P							
56	50320711 50320803	S/HEX/M4X8-ZC3	4	10/P							
57		S/FHEXM-M3X8-NI	3	10/P							
58		S/TPS/FHEXM-4X8-ZU3	1	10/P							
59		SCREW-ACTR-TRU	1	10/P							
60		GUIDE-DRUM-SUB	1	1/P							
61		ASYS-HLDR-CLN-BELT-F41X	1	1/PP							
62		SHLD-BLADE-RER	1	5/P							
63		BRKT-ADJ-SCREW-F41X	1	1/P							
64		BRKT-GUIDE-TBU-FRT-F41X	1	1/P							
65		SCREW-ADJ-TBU-F41X	1	5/P							
66	50321001	S/PAN/SWWP-M3X8-ZC3	2	10/P							
101		S/BID-M3X4-NI	3	10/P							
102		S/BID-M3X8-NI	1	10/P							
103		S/TPP/BID-3X8-SS	6	10/P							
105		RR/E-4-SS	1	10/P							

DEVELOPER-YMC-ASM

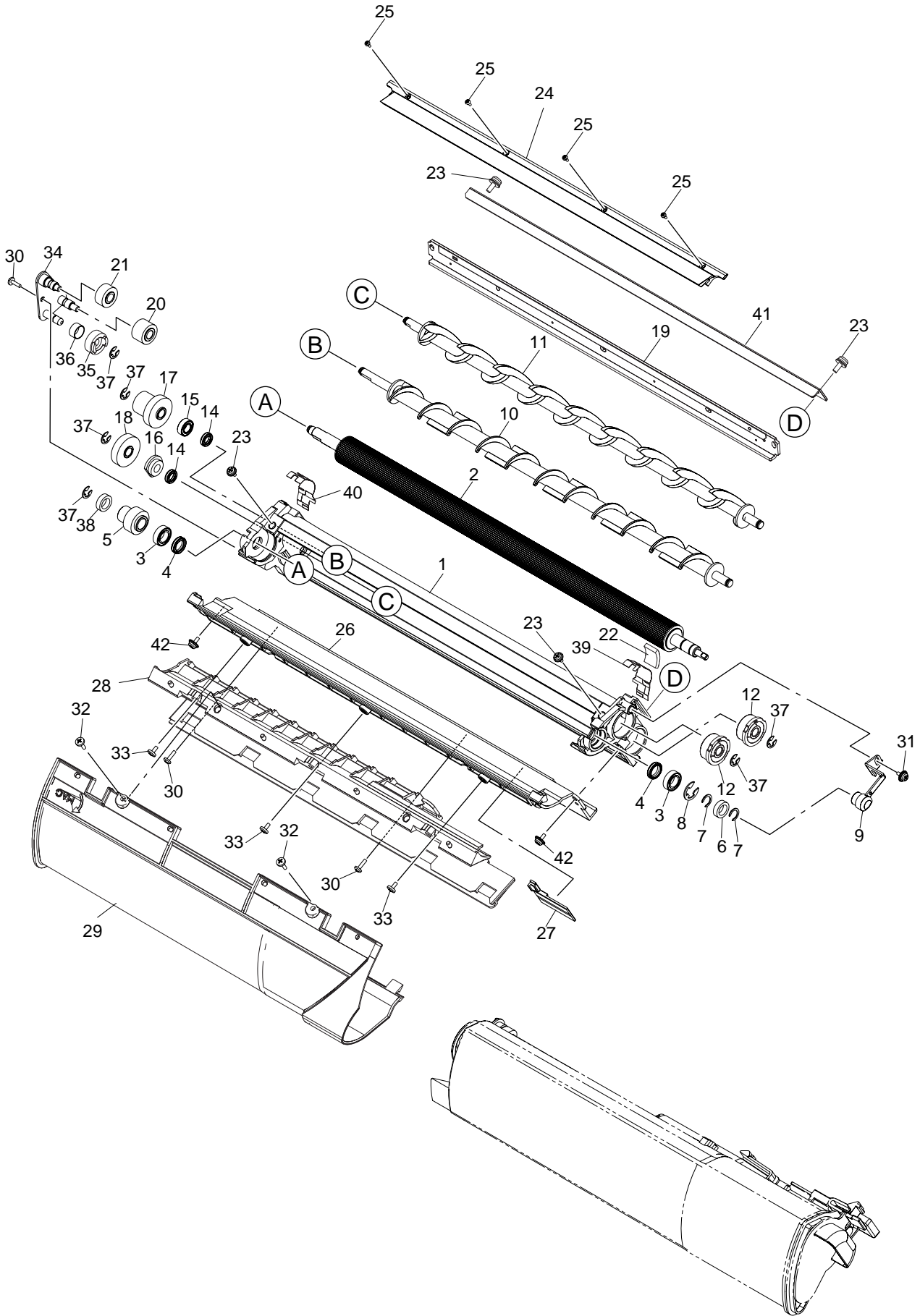

DEVELOPER-BLACK-ASM

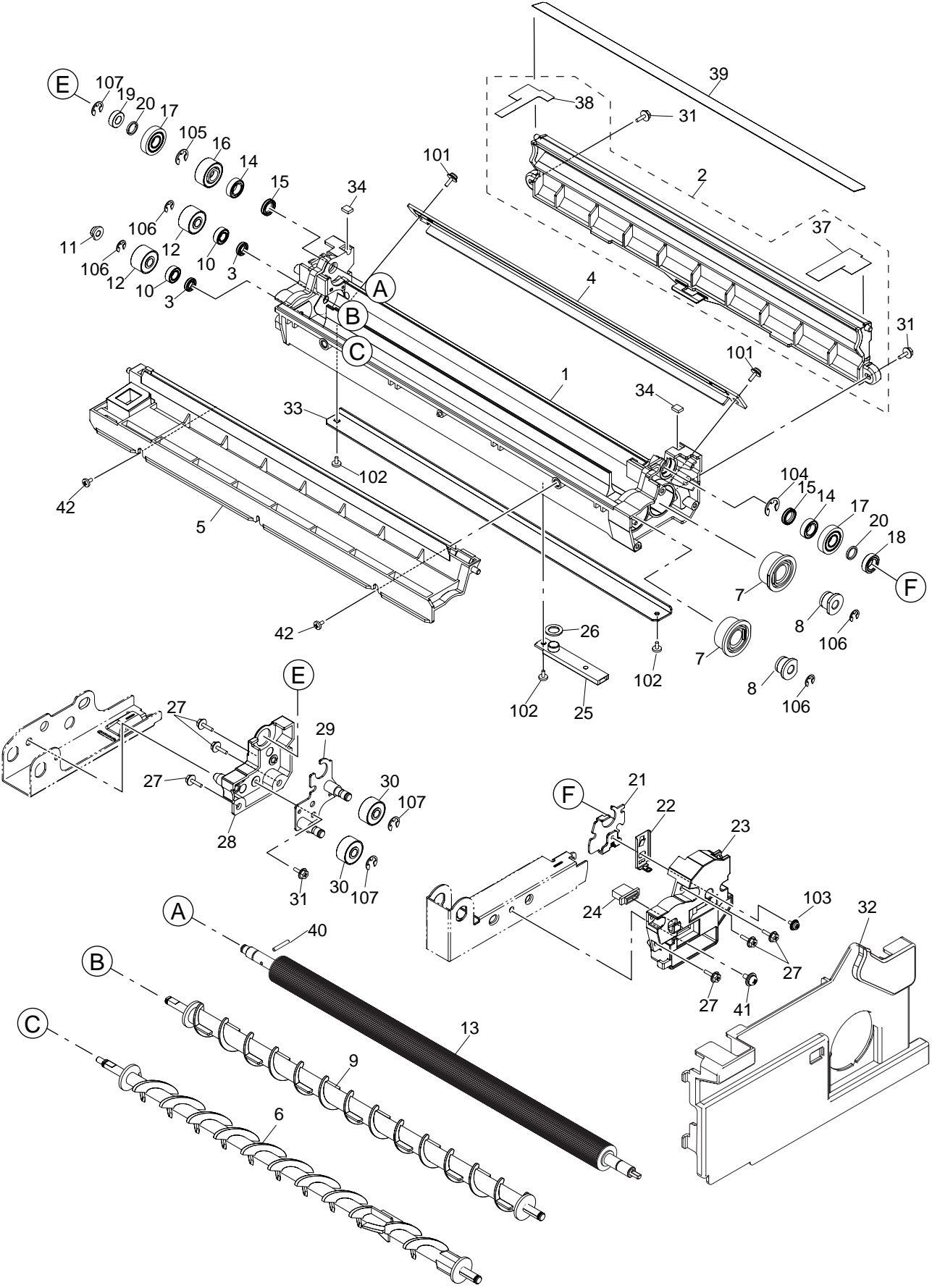

REVOLVER-UNIT-1-ASM

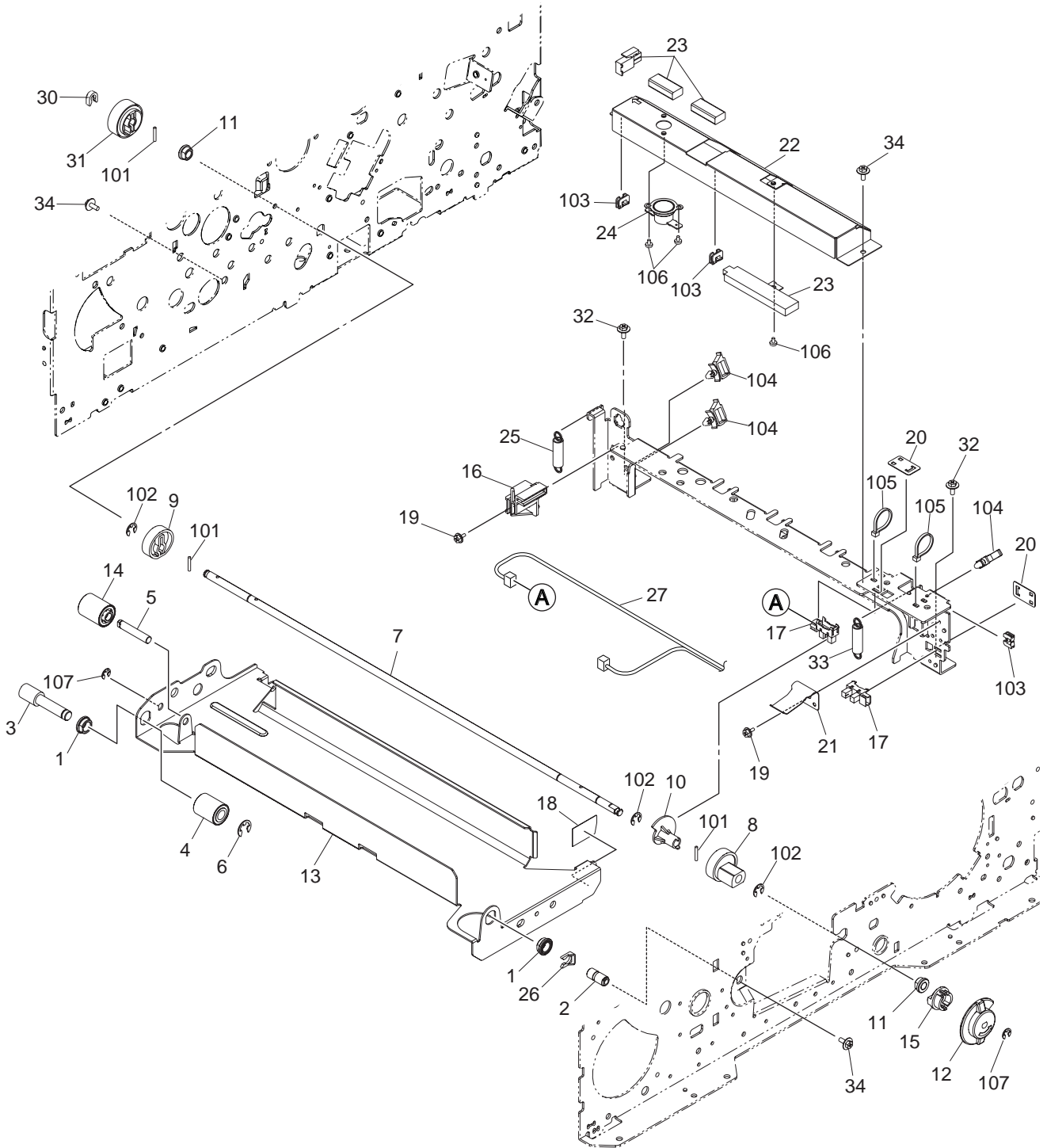

REVOLVER-UNIT-2-ASM

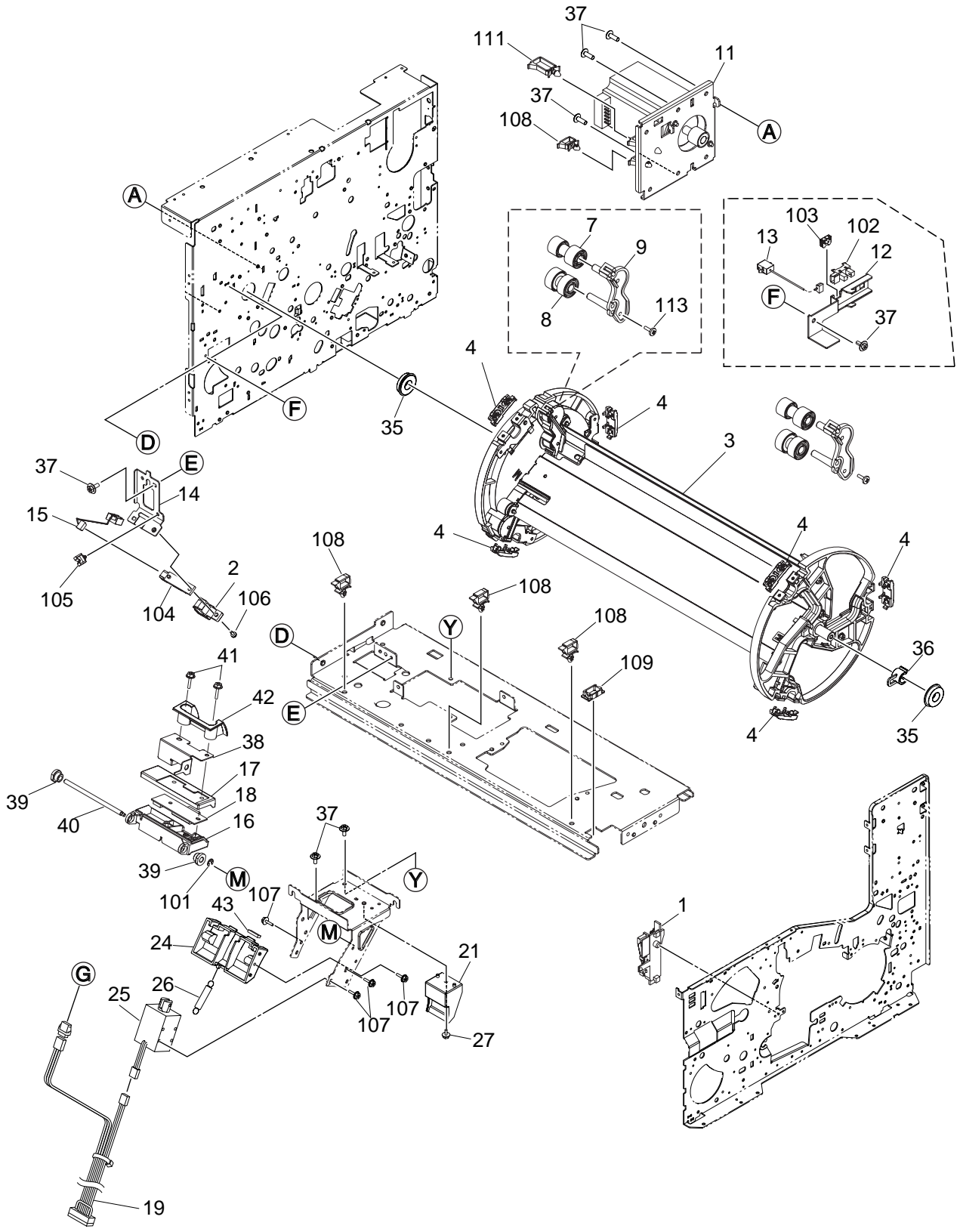

TONER-1-ASM

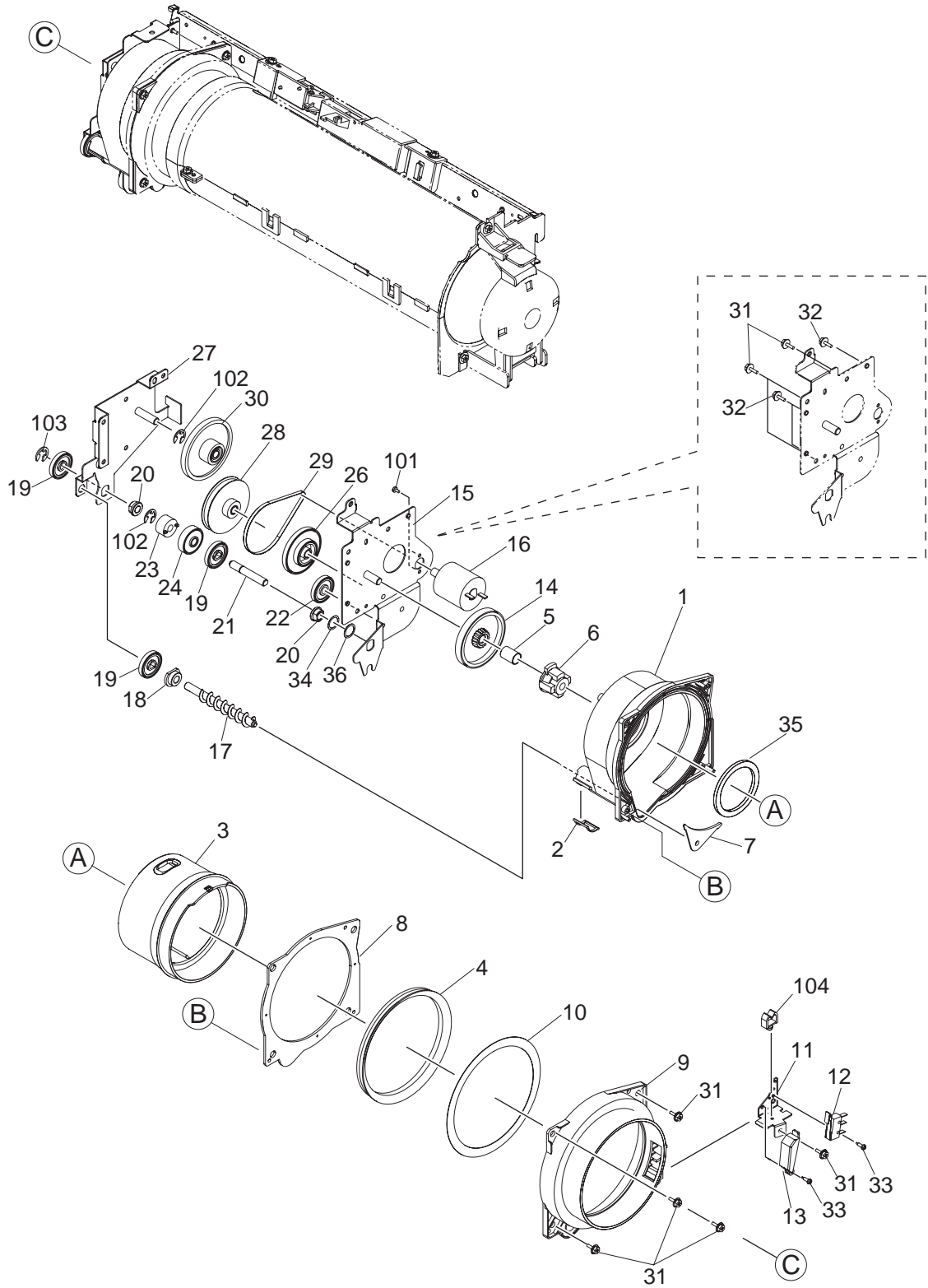

TONER-2-ASM

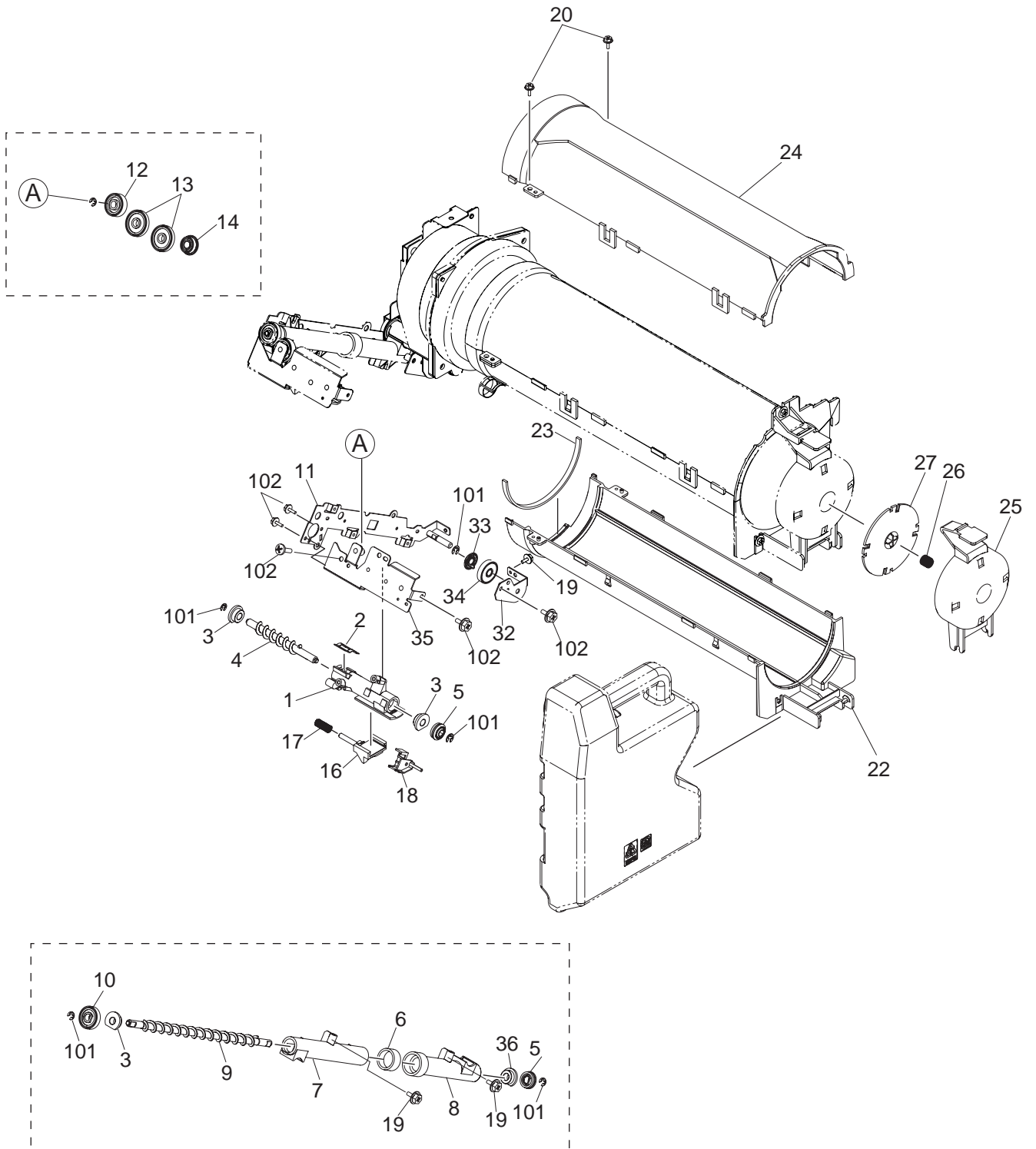

FUSER-1-ASM

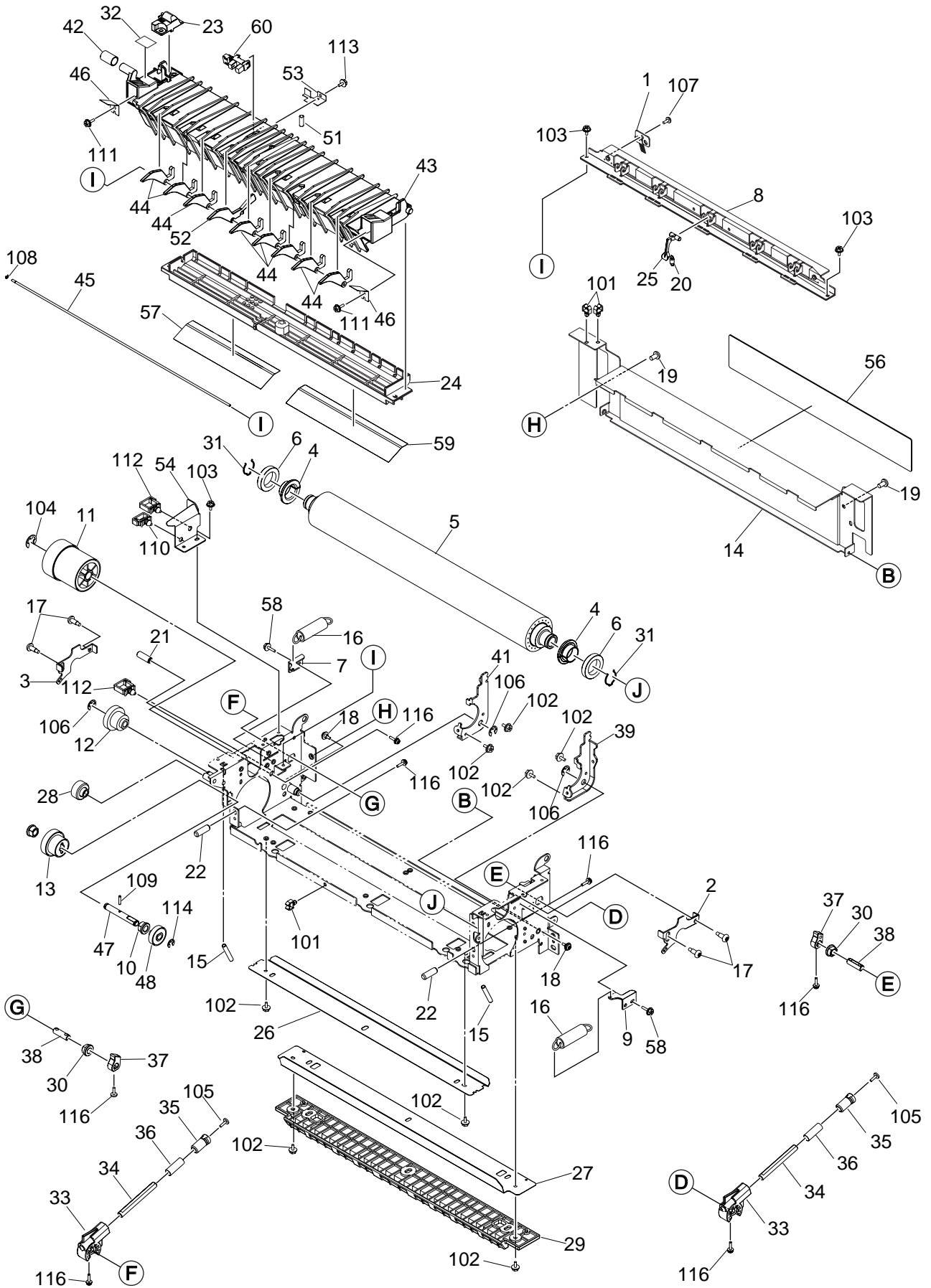

FUSER-1-ASM

ITEM No.	PART No.	PART NAME	Q'TY / PAGE	Q'TY / PACK	P	I	R	BSI No.	TO	FROM	REMARKS
1	51311801	BRUSH-FUS-PR	1	1/KP							
2		BRKT-ARM-F	1	1/P							
3		BRKT-ARM-R	1	1/P							
4		COLLAR-BRG-PS	2	1/P							
5	53363001	HR-281C- L	1	1/S							
6		6803ZZS1C4KZ	2	1/P							
7		BRKT-SPL-R	1	1/P							
8		BRKT-SCR-PR	1	1/P							
9		BRKT-SPL	1	1/P							
10	51613601	BUSH-6 (Plastic Bush)	1	5/P							
11		GEAR-10S37-10S34-8	1	1/P							
12	51259201	GEAR-IDLE-15-23	1	1/P							
13		GEAR-10S18-10S25-6	1	1/P							
14		ASYS-COV-FUS-PR	1	1/PP							
15		SPG-E-FUS-BELT	2	1/P							
16		SPG-ARM-FUSER	2	1/P							
17		SCREW-M3-FUS	4	5/P							
18		SCREW-BKT-DEV	3	10/P							
19		SCREW-FUSER-M4B-N	2	5/P							
20	50939701	SPG-E-SCRAPER	1	5/P							
21		STUD-IH-R	1	1/P							
22		STUD-FUS-STAY	2	1/P							
23		COV-GER-R	1	1/P							
24		COV-GUIDE-RTN-L	1	1/PP							
25	51118701	SCRAPR-FUS-350	1	5/P							
26		PLATE-ENT-HR	1	1/P							
27		PLATE-ENT-PR	1	1/P							
28		GEAR-SEP-IDLE-1	1	1/P							
29		GUIDE-ENT-PR	1	1/PP							
30		BUSH-6-GCB	2	5/P							
31		SPG-BRG-RL-PS	2	5/P							
32		LBL-FUS-4	1	5/KP							
33		LEVER-ARM-FUSER	2	1/P							
34		SHAFT-ARM-FUSER	2	1/P							
35	50815201	LEVER-FUS-ARM-H	2	1/P							
36	50940201	SPG-C-7R4XR4X20R	2	1/P							
37		CAM-ARM-FUSER	2	1/P							
38		SHAFT-LEVER-ARM	2	1/P							
39		ARM-FUSER-F-S	1	1/P							
41		ARM-FUSER-R-S	1	1/P							
42		SHEET-FUS-HND	1	5/P							
43		GUIDE-EXIT-RTN	1	1/PP							
44	51119001	GATE-FUSER	8	1/P							
45		SHAFT-GATE-L	1	1/KP							
46		SPL-GUIDE-R-350	2	1/P							
47		SHAFT-IDLE-CL	1	1/P							
48		GEAR-10S18-6	1	1/P							
51		SPG-C-4R46XR15X17R3	1	5/P							
52		GATE-FUSER-SEN	1	1/P							
53		SHEET-SNSR-EXIT	1	1/P							
54		BRKT-COV-HNS-R-410	1	1/P							
56 A		SHEET-FUS-HOT	1	1/KP							NAD,MJD,SAD,ASD,AUD,CND,ASU,KRD
58		S/TPS/BID-3X10-ZU3	2	10/P							
60	50426801	SNSR-HOME-141	1	1/P							
101	50712101	UAMS-05L-0-46	3	10/P							
102	50320701	S/FHEXM-M3X6-NI	9	10/P							
103		S/TPS/FHEXM-3X6-ZU3	3	10/P							
104	50711881	RR/E-7-SS	1	10/P							
105	50321001	S/BID-M3X8-NI	2	10/P							
106	50711861	RR/E-5-SS	3	10/P							
107		S/TPS/BID-3X6-ZU3	1	10/P							
108		RR/E-1.5-SS	1	10/P							
109		P/SPW/AW-2X10-SS	1	10/P							
110	50712001	PLWS-1-46B	1	5/P							
111	50320807	S/TPP/FHEXM-3X8-NI	2	10/P							

FUSER-2-ASM

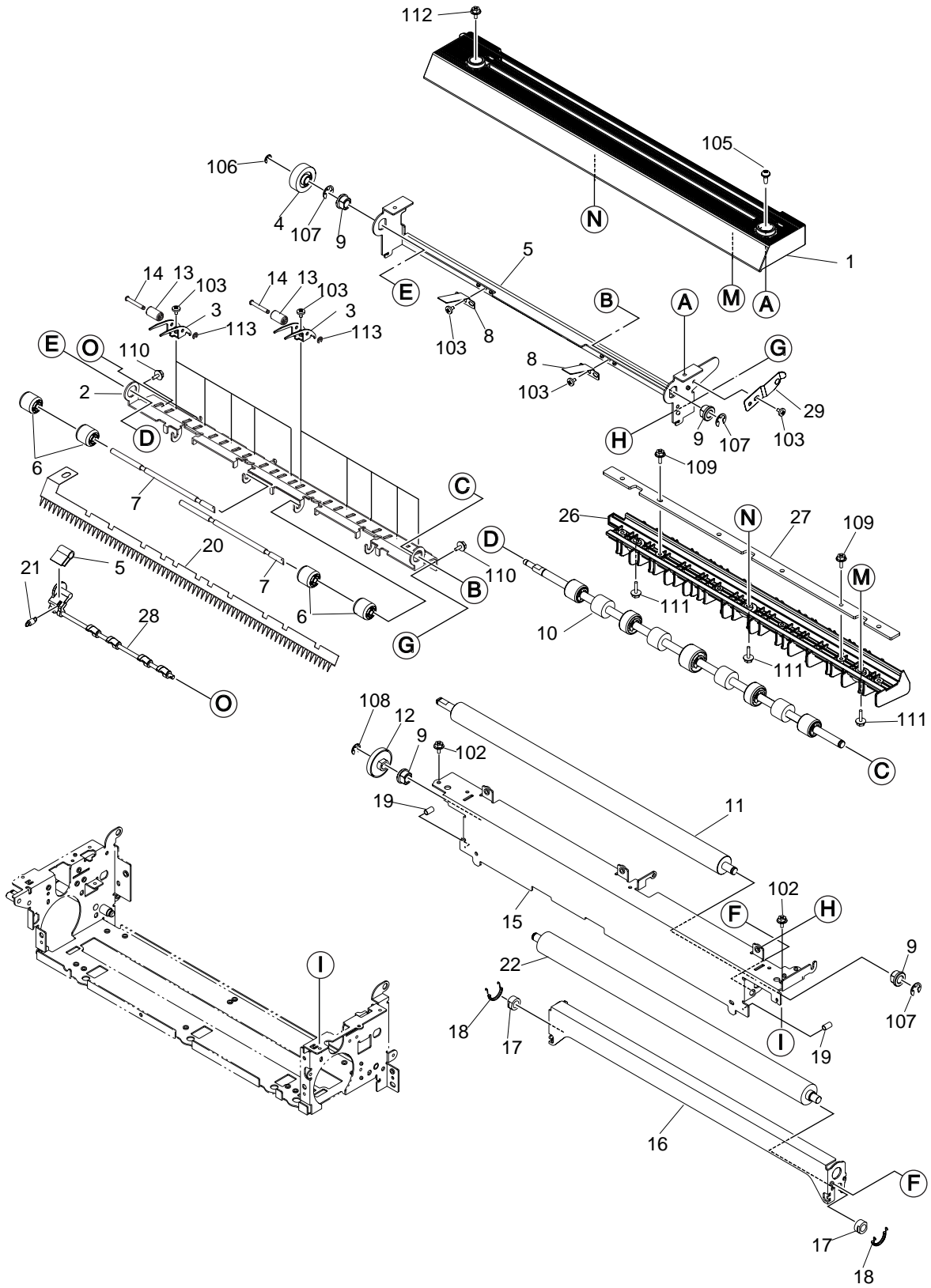

FUSER-3-ASM

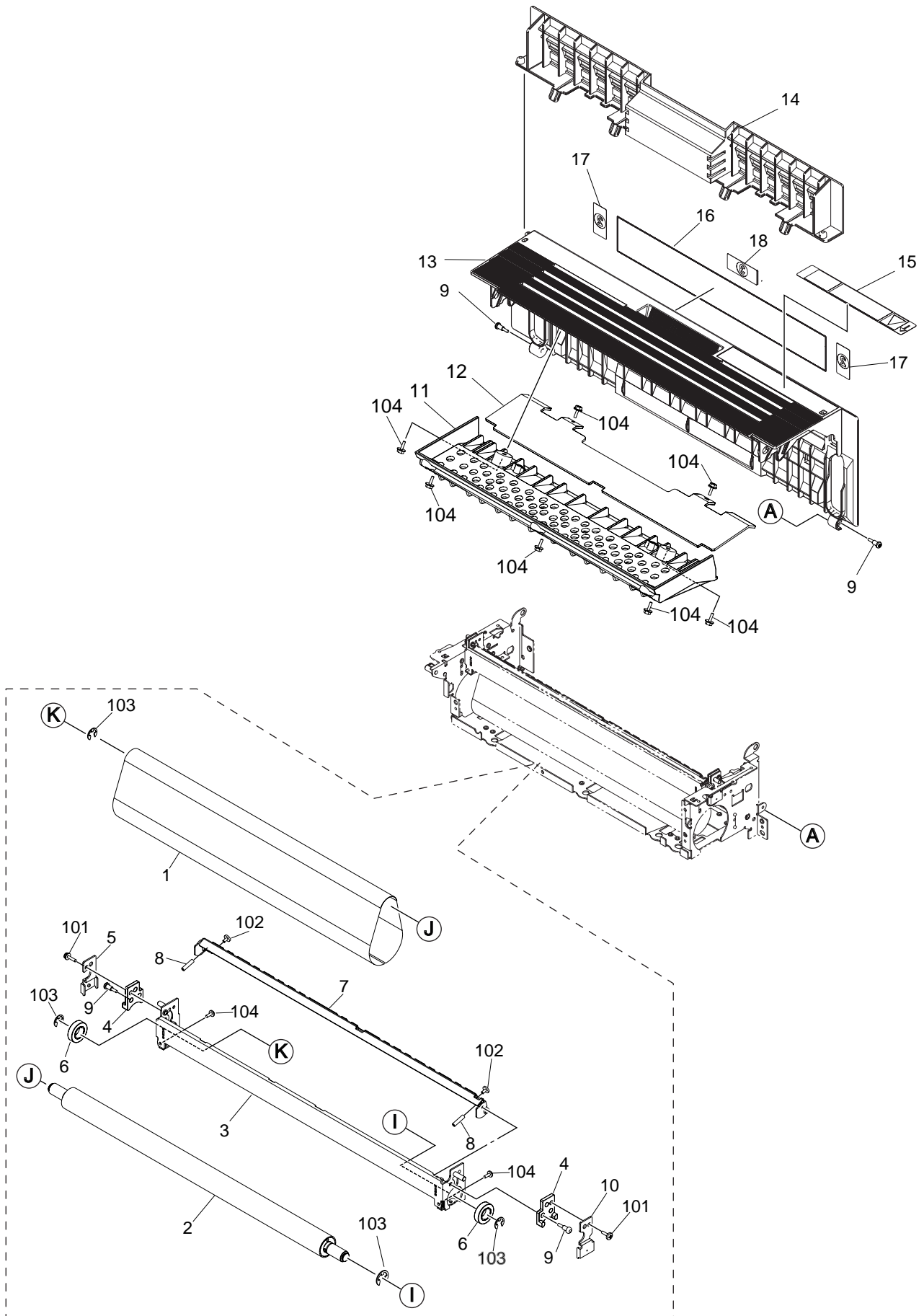

FUSER-4-ASM

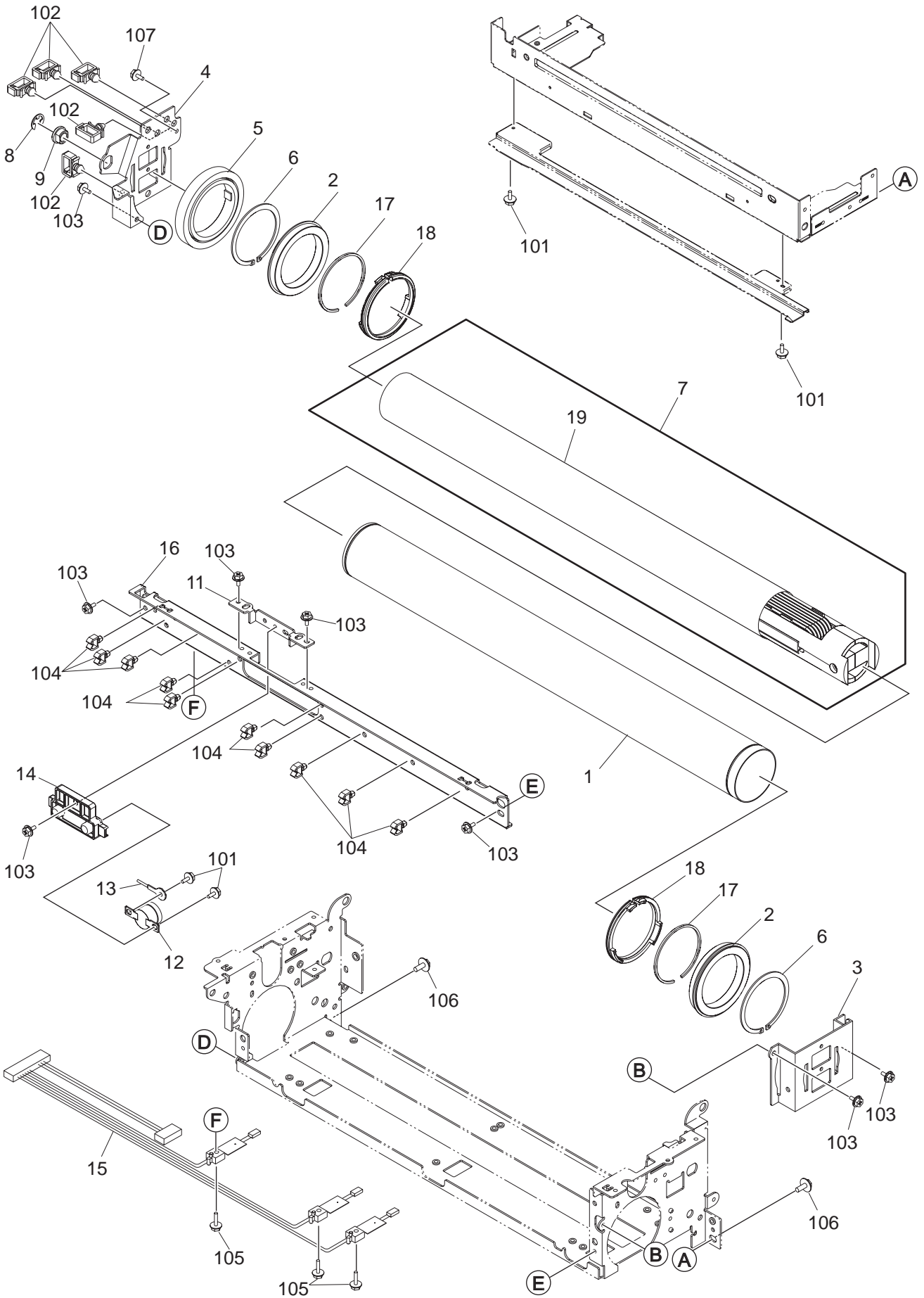

ADU-ASM

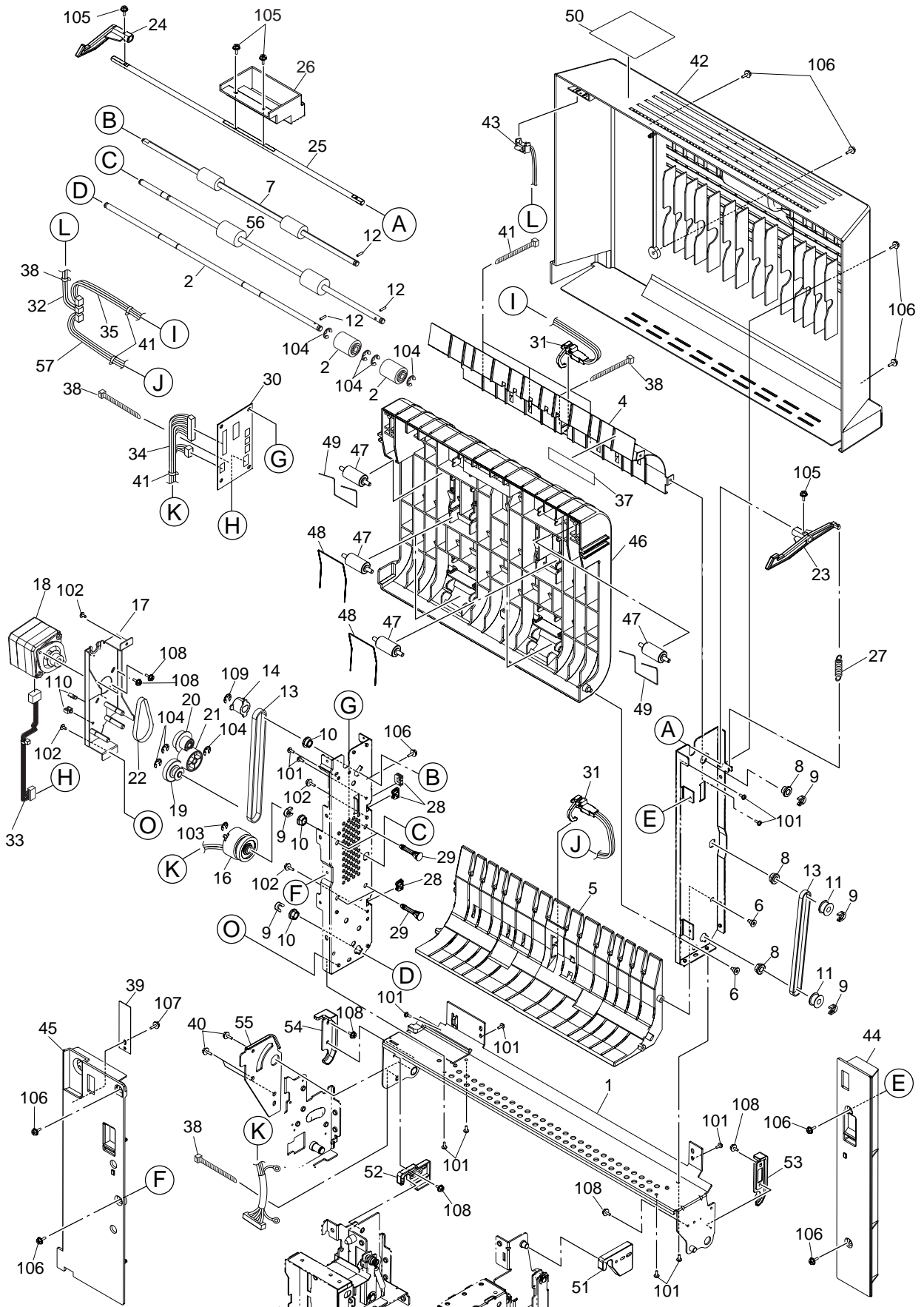

ADU-ASM

ITEM No.	PART No.	PART NAME	Q'TY / PAGE	Q'TY / PACK	P	I	R	BSI No.	TO	FROM	REMARKS
1		ASYS-FRAME-BTM-ADU	1	1/P							
2		SFT-TR-L-20	1	1/P							
3		ROL-TR-CLT-ADU-DK	2	1/P							
4		GUIDE-P-U-380	1	1/PP							
5		GUIDE-PAPER-L32D	1	1/P							
6		SCREW-CASET	2	5/P							
7		ROLL-TR-U-16	1	1/KP							
8		BUSH-6-GCB	3	5/P							
9	50711701	STOP-RING-6-5	6	5/P							
10		BUSH-6-POM	3	5/P							
11		PLY/T-2GT020-6F	2	1/P							
12	50610901	P/PRL/AH7-2X8-SS	3	10/P							
13		BLT/T-286-2GT-5	1	1/P							
14		PLY/T-2GT016-6F	1	1/P							
15		BLT/T-258-2GT-5	1	1/P							
16		CLUTCH-G28-06D-35E	1	1/D							
17		ASYS-BKT-MOT-ADU-380	1	1/P							
18		AYSY-MOTR-S-ADU-371	1	1/C							
19		GEAR-10S28-P2GT20-6	1	1/P							
20		GEAR-10S15-PS2M39-6	1	1/P							
21		GEAR-10S28-06	1	1/P							
22		BLT-SY-S2M-120-4	1	1/P							
23		LEVER-LATCH-F	1	1/P							
24		LEVER-LATCH-R32	1	1/P							
25		SHAFT-OPEN-350	1	1/P							
26		LEVER-OPEN-ADU	1	1/P							
27		SPE-068-070-241	1	1/P							
28		ES-0505	3	5/P							
29		KGLS-24RTV0	4	5/P							
30	55103601	PWA-F-ADU-410	1	1/C							
31	50426501	SNSR-FED-390	2	1/P							
32		HRNS-ADU-CVSW-371	1	1/P							
33		HRNS-ADU-MOT-371	1	1/P							
34		HRNS-ADU-410	1	1/P							
35		HRNS-ADU-FED-U-410	1	1/P							
37		LBL-W-HOT-STAY-390	1	5/P							
38		T18R	3	5/P							
39		SPL-ADU-320	1	1/P							
40	50320803	S/TPS/FHEXM-4X8-ZU3	3	10/P							
41		SG-130	3	5/P							
42		CASE-ADU-380	1	1/PP							
43		SP-CS3A-B2BA	1	1/D							
44		COVER-IN-F-380	1	1/P							
45		COVER-IN-R-320	1	1/P							
46		GUIDE-P-IN-DK-B1	1	1/PP							
47		ROLL-TRANS-IDLE-371	6	1/P							
48		SPR-IDLE	4	1/C							
49		SPR-IDLE-U	2	1/D							
50 A		LBL-O-PLACE-COV	1	1/KP							NAD,MJD,SAD,ASD,AUD,CND,ASU,KRD
51		HLDR-BYPASS-FRT	1	1/P							
52		HLDR-BYPASS-RER	1	1/P							
53		COVER-HINGE-SUB-FRT	1	1/P							
54		COVER-HINGE-SUB-RER	1	1/P							
55		PLATE-POS-ADU	1	1/P							
56		ROLL-TRANS-C-371	1	1/KP							
57		HRNS-ADU-FED-L-360	1	1/P							
101		S/TPS/FHEXM-3X6-ZU3	13	10/P							
102		SCR-M3X6BISR-NI	7	10/P							
103		RR/E-4-SS	1	10/P							
104	50711861	RR/E-5-SS	8	10/P							
105	50320711	S/FHEXM-M3X8-NI	4	10/P							
106		S/TPS/FHEXM-3X8-ZU3	8	10/P							
107	50320807	S/TPP/FHEXM-3X8-NI	4	10/P							
108	50320701	S/FHEXM-M3X6-NI	4	10/P							
109	50711841	RR/E-3-SS	1	10/P							

DRAWER-ASM

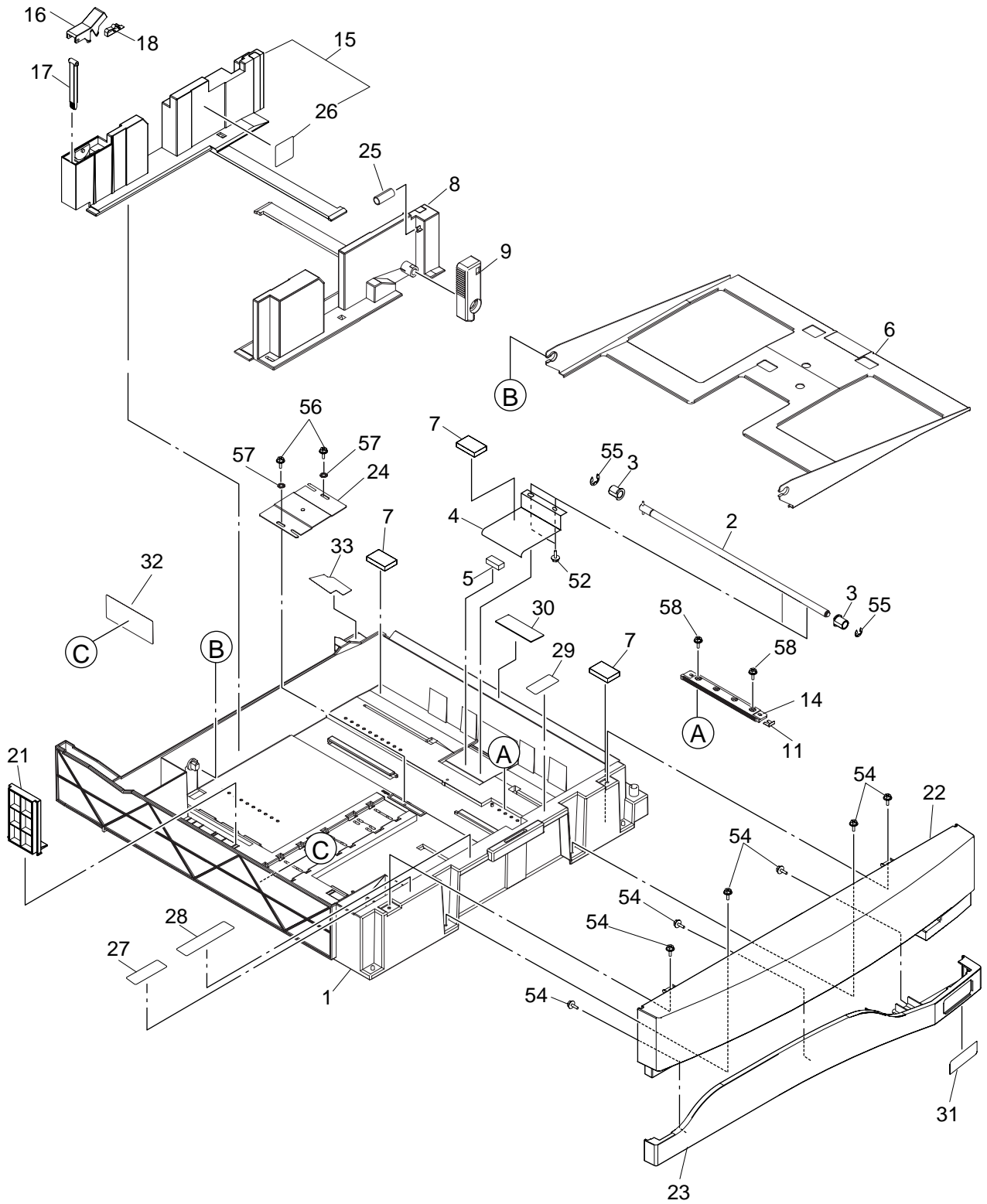

JIGS & GREASE

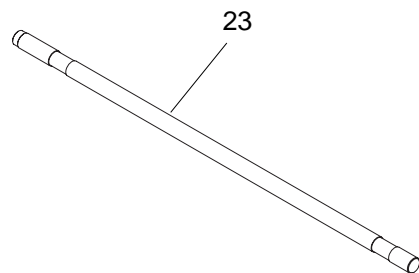
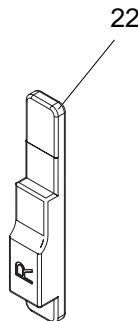
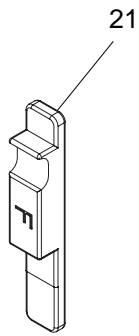
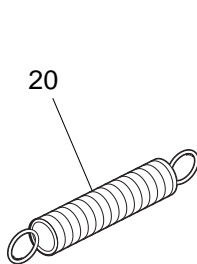
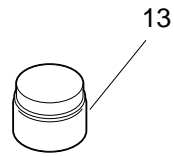
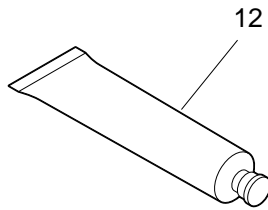
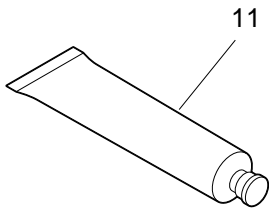
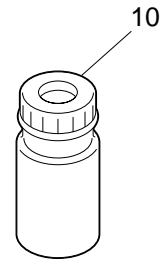
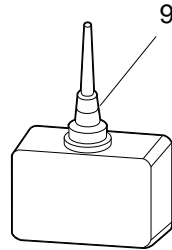
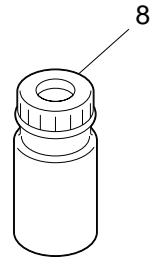
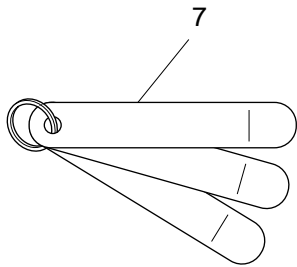
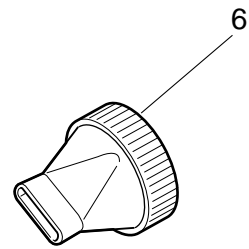
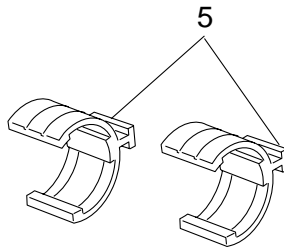
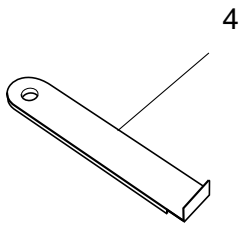
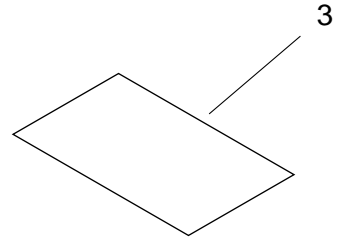
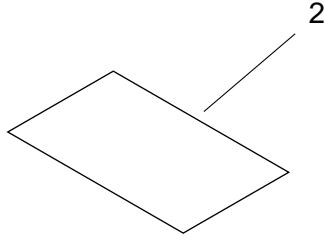
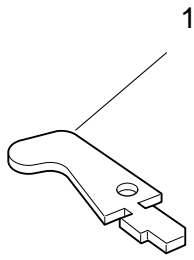

DOWNLOAD JIGS

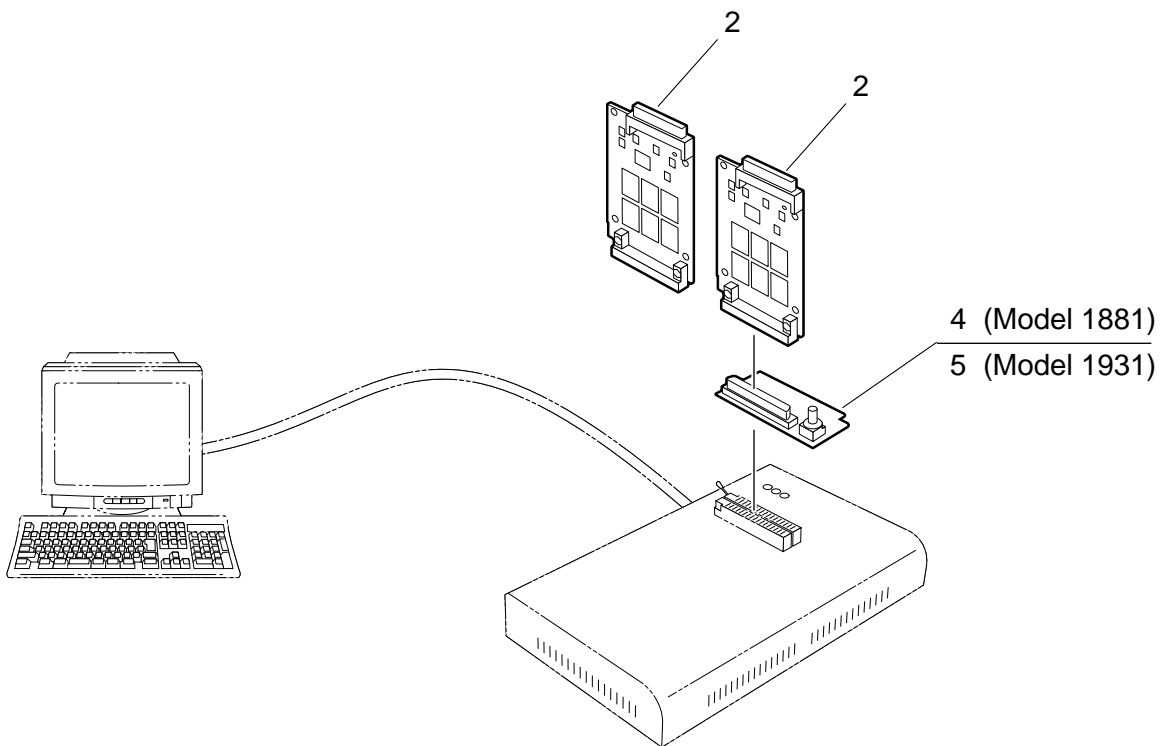
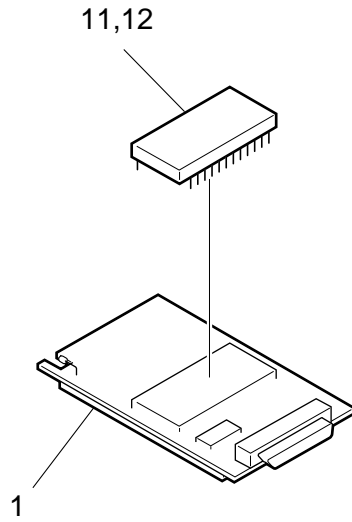

SUPPLIES

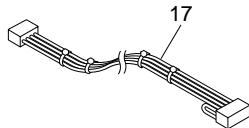
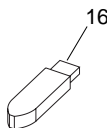
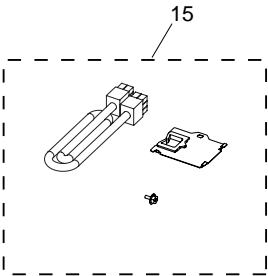
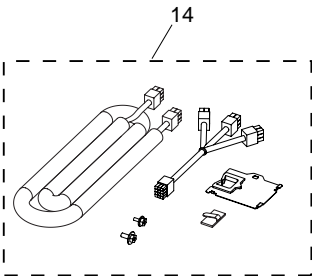
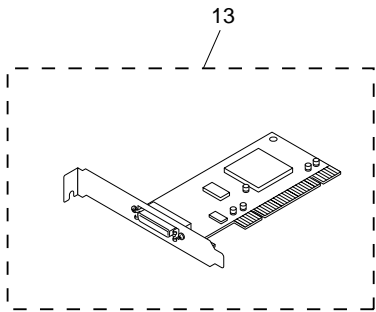
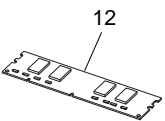
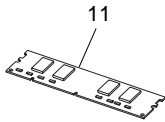
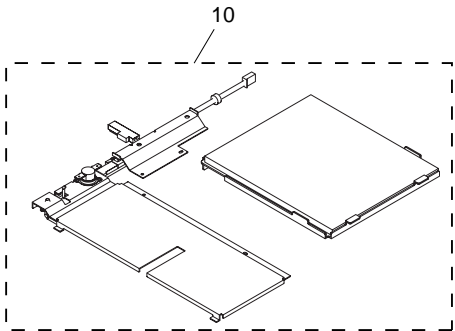
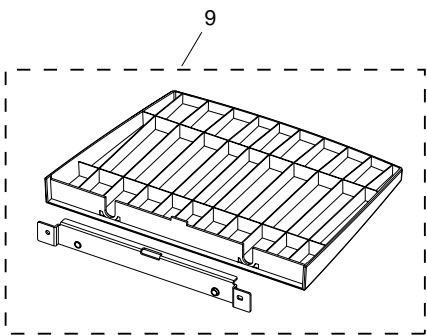
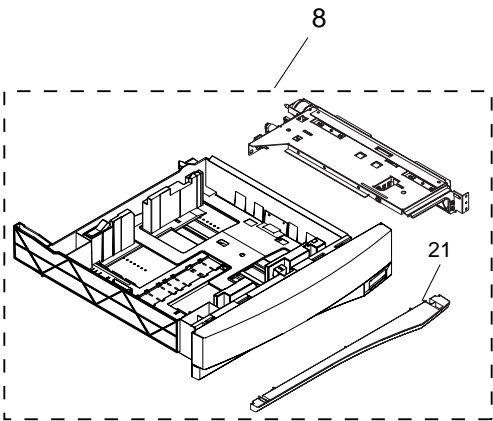
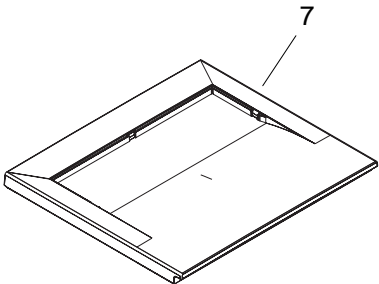
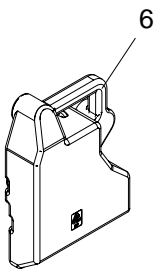
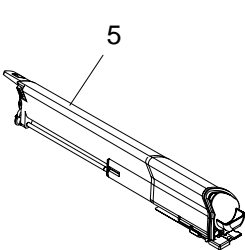
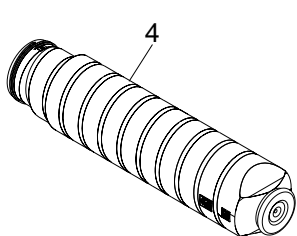
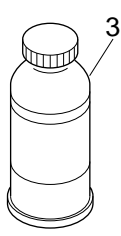
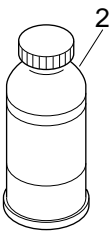
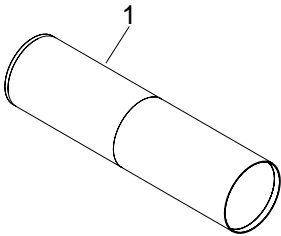

REPLACE UNIT

1

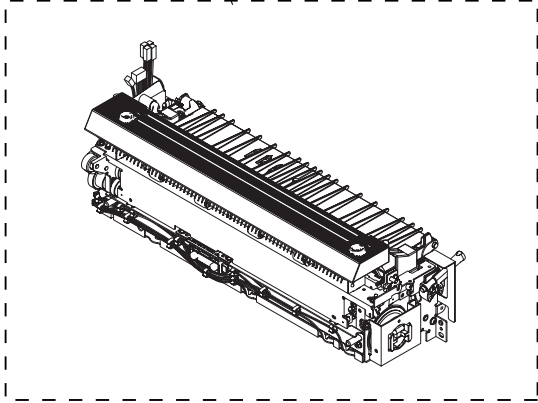

2

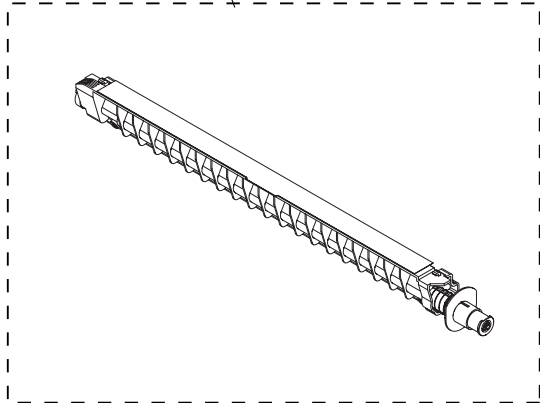

3

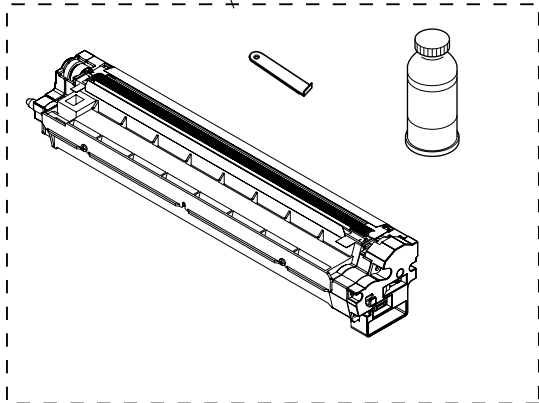

4

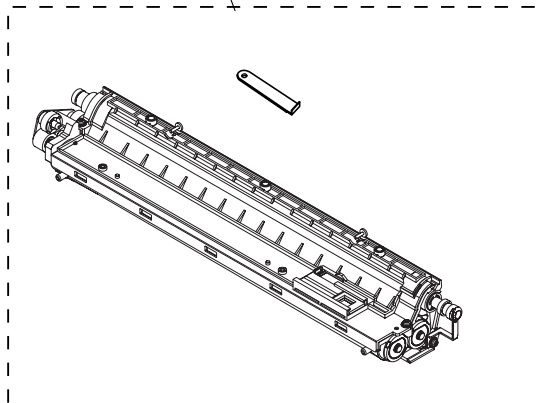

5

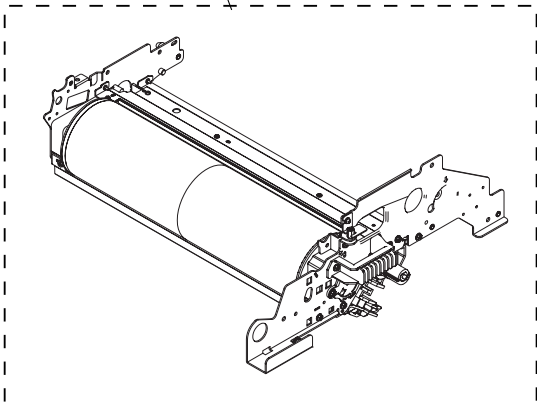

6



PM-KIT

