

C7550/C7350,C7500/C7300  
Color LED Page Printer  
Maintenance Manual

[041124A]

# **OKI**

---

## **C7300/C7350/C7500/C7550 Maintenance Manual**

061116B

**Document Revision History**

Rev.No.	Date	Corrected items			Person in change
		No.	Page	Description of change	
1	2002-10-23				
2	2002-11-29				NP11 Haruyama
3	2003-06-06	7	158	Part No. of the Control Panel Bezel	ME4 Ueda
4	2003-07-14			Add CU(VE Version)	CN11 Yamanaka
5	2003-12-19			Add PU(VE Version)	NP32 Ishizuka
6	2004-01-26		21,159	Partial change	CN11 Yamanaka
7	2004-03-05			Partial change	NP32 Ishizuka
8	2004-09-08			Add to C7550/C7350	NP51 Oshima

# PREFACE

This manual describes the procedures of the maintenance of the C7550/C7350, C7500/C7300 of printers.

The document is produced for maintenance personnel use. For details on the procedures for handling the C7550/C7350, C7500/C7300 of printers, see its user documentation.

- Note!**
- The descriptions in this manual are subject to change without prior notice.
  - In preparing the document, efforts have been made to ensure that the information in it is accurate. However, errors may be crept into the document. Oki Data assumes no responsibility for any damage resulting from, or claimed to be the results of, those repairs, adjustments or modifications to the printers which are made by users using the manual.
  - The parts used for the printers are sensitive and, if handled improperly, may be damaged. It is strongly recommended that the products are maintained by maintenance men registered with Oki Data.
  - Oki Data strongly recommends that you do NOT connect our LED page printers to an uninterruptible Power Supply (UPS). For further information, please contact Oki Data directly at 800-OKIDATA or [www.okidata.com](http://www.okidata.com).

# CONTENTS

<b>1. CONFIGURATIONS .....</b>	<b>7</b>
1.1 System Configuration .....	7
1.2 Printer Configuration .....	8
1.3 Option Configuration .....	9
1.4 Specifications .....	10
<b>2. PARTS REPLACEMENT .....</b>	<b>12</b>
2.1 Precautions in Replacing Parts .....	12
2.2 Parts layout .....	14
2.3 Replacing Parts .....	20
2.3.1 Top Cover .....	22
2.3.2 LED Head / LED Spring / Post-Guide .....	23
2.3.3 Top Cover Unit .....	24
2.3.4 Control Panel Assy/ Control Panel Bezel/ LED Control PWB/ Toner Sensors/ Stacker Full Sensor/ Control Panel/ Control Panel Tape Harness/ Eject Rollers ..	25
2.3.5 Top Cover Handle/ Top Cover Latch/ Top Cover Latch Spring .....	26
2.3.6 Eject Guide Assy .....	27
2.3.7 Cassette Assy/ Front Cover Assy/ Front Cover Inner Baffle .....	28
2.3.8 Retard Pad Assy/ Retard Pad Assy Spring .....	29
2.3.9 Feed Roller and Nudger Roller .....	30
2.3.10 Rear Cover .....	31
2.3.11 Face-Up Tray .....	32
2.3.12 Left Side Cover .....	33
2.3.13 Right Side Cover .....	34
2.3.14 Multipurpose Tray Assy/ Multipurpose Tray Cover Assy/ Links/ Multipurpose Tray Top Cover/ Multipurpose Tray Drive Gear .....	35
2.3.15 Drum Contact Assys .....	36
2.3.16 Media Thickness Sensor Assy .....	37
2.3.17 Registration Roller Assy (A)/ Registration Drive Gear (A) .....	38
2.3.18 Registration Roller Assy (B) .....	39
2.3.19 Registration Clutch and Registration Motor Assy .....	40
2.3.20 Main Cooling Fan .....	41
2.3.21 Color Registration Sensor Assy .....	42
2.3.22 Duplex Guide Assy .....	43
2.3.23 Electrical Chassis Cooling Fan .....	44
2.3.24 Printer Engine Controller PWB .....	45
2.3.25 Printer Unit Chassis .....	46
2.3.26 Entrance Cassette Sensor Actuator .....	47
2.3.27 Entrance Sensor PWB .....	48
2.3.28 Entrance MT Sensor Actuator / Entrance Belt Sensor Actuator / Entrance Waste Chassis Sensor Actuator .....	49
2.3.29 Fuser Exit Roller .....	50
2.3.30 Exit Sensor Assy .....	51
2.3.31 Fuser Latching Handle (L) .....	52
2.3.32 Belt Motor Assy .....	53
2.3.33 Fuser Latching Handle (R) .....	54
2.3.34 Main Motor Assy .....	55
2.3.35 Main Feeder Drive Motor .....	56
2.3.36 Contact Assy/ Left Plate Assy .....	57
2.3.37 Low Voltage Power Supply .....	58
2.3.38 High voltage power supply .....	59
2.3.39 Main Feed Assy .....	60
2.3.40 Cassette/ Left Guide Assy .....	61
2.3.41 Cassette/ Right Guide Assy .....	62
2.3.42 Fuser Unit .....	63
2.3.43 Belt Unit .....	64

2.3.44	Duplex Unit .....	65
2.3.45	Guide Rails (L) and (R).....	66
2.3.46	Duplex Transport Assembly .....	67
2.3.47	CU Assy .....	69
2.3.47	CU Assy .....	69
<b>3.</b>	<b>Adjustment .....</b>	<b>72</b>
3.0	System Maintenance MENU .....	72
3.0.1	ID Check Pattern Printing ( " TEST PRINT MENU " item ).....	73
	.....	73
3.1	Maintenance Mode and Functions .....	73
3.1.1	Maintenance menu .....	73
3.1.2	Engine maintenance mode .....	75
3.1.2.1	Operator panel .....	75
3.1.2.2	Normal self-diagnostic mode (Level 1).....	75
	3.1.2.2.1 Entering self-diagnostic mode (Level 1) .....	76
	3.1.2.2.2 Exiting the self-diagnostic mode .....	76
3.1.2.3	Switch scan test .....	76
3.1.2.4	Motor clutch test .....	80
3.1.2.5	Test print .....	82
3.1.2.6	Initializing NVM .....	86
3.1.2.7	Displaying the consumables counter .....	87
3.1.2.8	Displaying the consumables continuation counter .....	87
3.1.2.9	Panel display details .....	88
3.1.3	Various print jobs with single printer unit attached with a controller .....	93
3.2	Adjustment After Replacing Parts .....	94
3.2.1	Precautions in replacing the engine control board .....	94
3.2.2	Precautions in replacing EEPROM.....	94
3.2.3	Replacing EEPROM after replacing the CU board .....	95
3.2.4	Destination Setting (Checking Method: Printing Demo Page).....	95
3.2.5	Recovery Flash ROM data on CU board .....	96
3.2.6	Notes on replacing Oki LAN8100e or CU boards equipped with Oki LAN8100e.....	96
3.3	Adjusting the Density .....	96
3.4	Paper Thickness Detection Sensitivity Adjustment and Media Thickness Detection Value Check.....	97
3.4.1	Applicable Operating Systems and Interfaces, and File Required .....	97
3.4.2	Setting .....	98
	3.4.2.1 Menu Setting .....	98
	3.4.2.2 Media Setting .....	100
	3.4.2.3 Sensitivity Adjustment .....	101
	3.4.2.4 Actions for NG Sensitivity Adjustment .....	102
3.4.3	Inputting the density of the calibration chip for density detection .....	103
	3.4.3.1 Density Adjustment Menu Setting .....	103
3.4.4	Electronic Serial Number Input .....	105
<b>4.</b>	<b>regular maintenance .....</b>	<b>106</b>
4.1	Parts Replaced Regularly .....	106
4.2	Cleaning .....	106
4.3	Cleaning the LED Lens Array .....	106
4.4	Cleaning the Pick-up Roller .....	106
<b>5.</b>	<b>Troubleshooting Procedures .....</b>	<b>107</b>
5.1	Precautions before troubleshooting .....	107
5.2	Precautions before handling an abnormal image .....	107
5.3	Precautions upon handling an abnormal image .....	107
5.4	Preparing for Troubleshooting .....	108

5.5	Troubleshooting Procedure .....	108
5.5.1	LCD message list .....	109
5.5.2	Preparing for troubleshooting .....	115
5.5.3	Troubleshooting for abnormal images .....	126
5.6	Fuse check .....	141
5.7	Life Counter Tool .....	141
<b>6.</b>	<b>CONNECTION DIAGRAM .....</b>	<b>142</b>
6.1	Resistance Checks .....	142
6.2	Program/Font ROM Layouts .....	146
	<b>APPENDIX A INTERFACE SPECIFICATIONS .....</b>	<b>154</b>
1.	Parallel Interface Specifications .....	154
1.1	Parallel Interface .....	154
1.2	Parallel Interface Connector and Cable .....	154
1.3	Parallel Interface Level .....	154
1.4	Timing Charts .....	155
1.5	Parallel I/F Signals .....	156
2.	Universal Serial Bus (USB) Interface Specifications .....	157
2.1	USB Interface .....	157
2.2	USB Interface Connector and Cable .....	157
2.3	USB Interface Signals .....	157
	<b>APPENDIX B 2ND/3RD TRAY MAINTENANCE .....</b>	<b>158</b>
1.	Parts Replacement .....	158
1.1	Cover Idle Roller Assy .....	158
1.2	PCB .....	159
1.3	Feeder Drive Assy .....	160
	<b>APPENDIX C C7100/7300/7350/9300/9500 SERIES ERROR MESSAGES ....</b>	<b>161</b>
1.	C7100/7300/7350/9300/9500 Series (Error messages) .....	161
2.	C7100/7300/7350/9300/9500 Series (Error messages : Related to Color, Media Detect) ...	168
3.	C7100/7300/7350/9300/9500 Series (Warning messages : Related to usage, media) .....	171
4.	C7100/7300/7350/9300/9500 Series (Warning messages : Job Account) .....	172
5.	C7100/7300/7350/9300/9500 Series (Other Warning) .....	173

# 1. CONFIGURATIONS

## 1.1 System Configuration

Figure 1-1 shows the system configuration of the C7550/C7350, C7500/C7300 of printers.

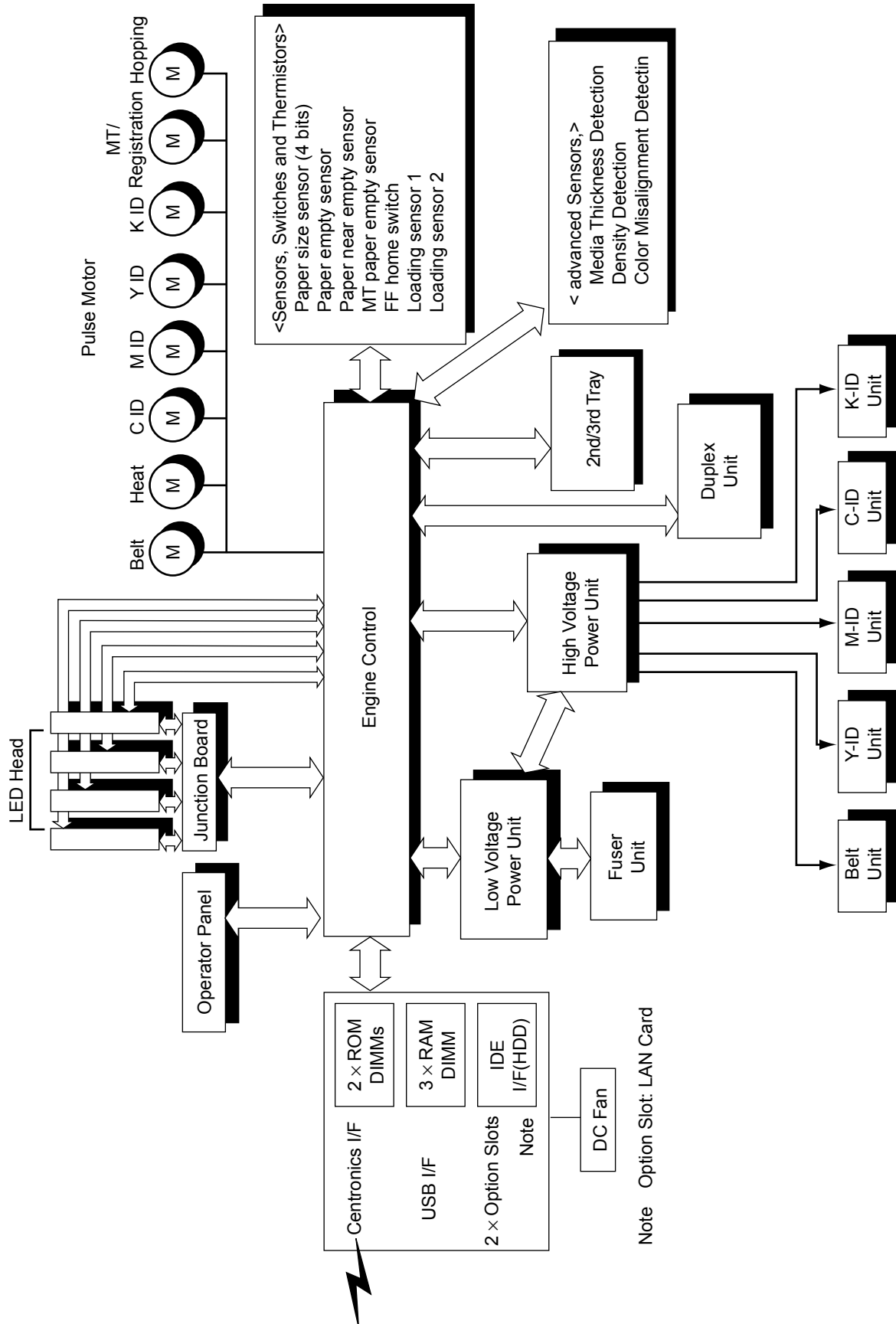

Figure 1-1



## 1.2 Printer Configuration

The inside of the printers is composed of the followings:

- Electrophotographic Processor
- Paper Paths
- Controller Block (CU and PU)
- Operator Panel
- Power Units (High Voltage Unit and Low Voltage Unit)

Figure 1-2 shows the printer configuration.

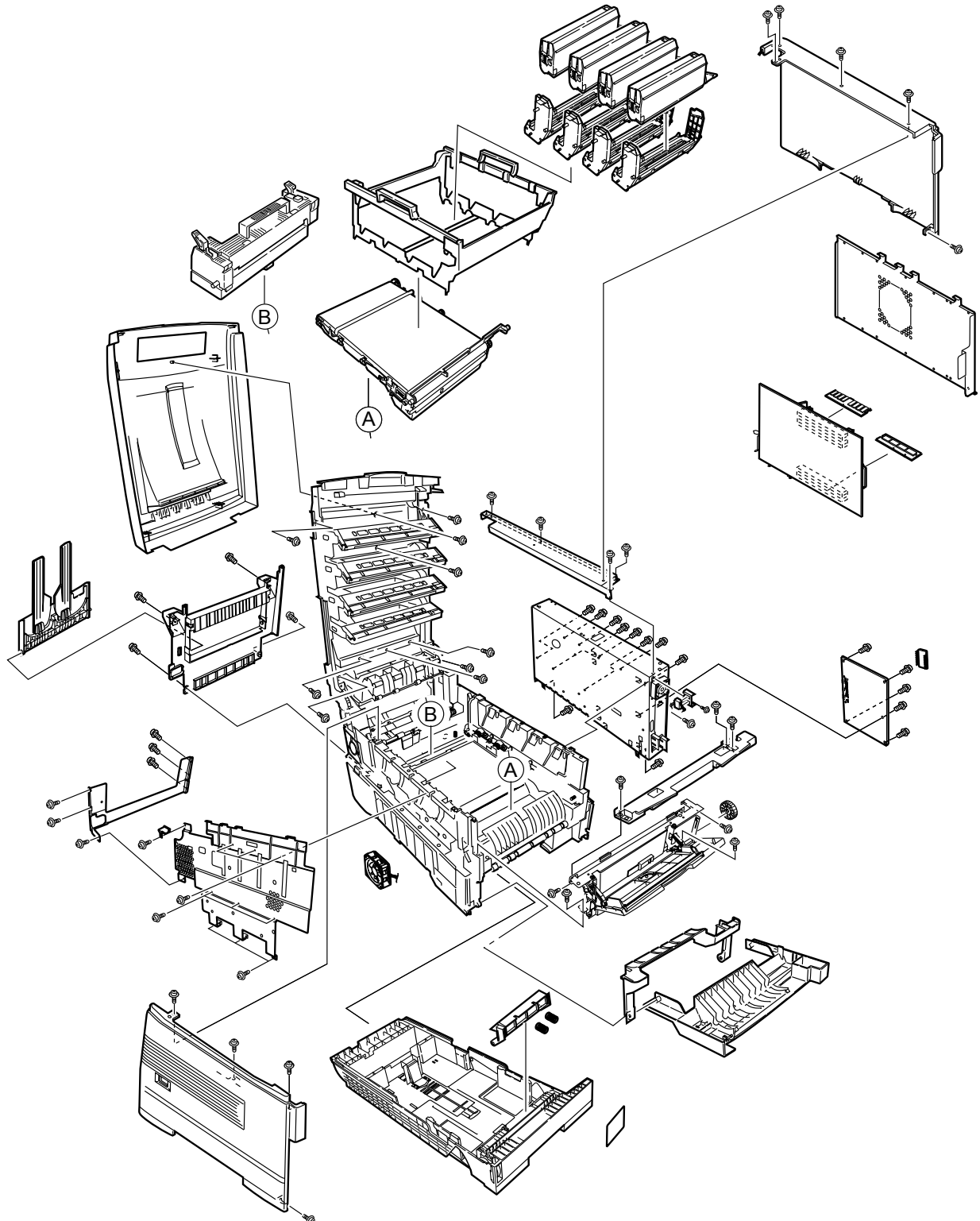
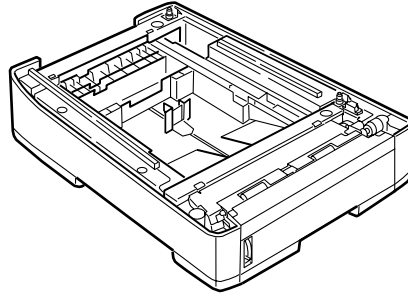

Figure 1-2

### 1.3 Option Configuration

The followings are available as options on the C7550/C7350, C7500/C7300 of printers.

(1) 2nd Tray/ 3rd Tray



Note: Don't use one for  
C9200/C9400

(2) Duplex Unit

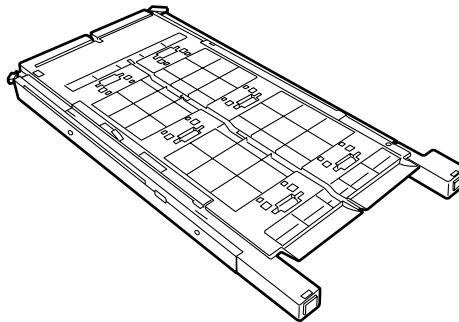

Note: Don't use one for  
C9200/C9400

(3) Expansion Memory 64/128/256/512 MB

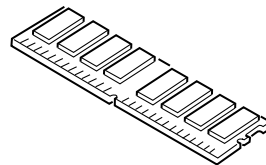

Note: Don't use one for  
C9200/C9400

(4) Internal Hard Disk

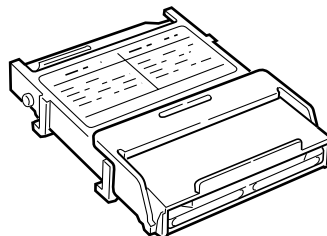

Note: Don't use one for  
C9200/C9400

(5) Ethernet Board

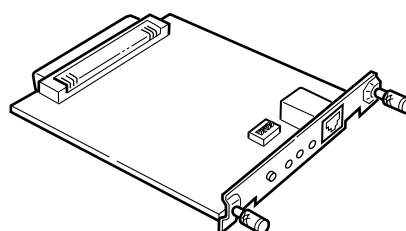

Note: Don't use one for  
C9200/C9400

## 1.4 Specifications

- |                                  |  |
|----------------------------------|--|
| (1) External Dimensions          | Height: 430mm Width: 430mm Length: 620mm   |
| (2) Weight                       | 42 kg  |
| (3) Papers                       | Type: Ordinary paper, Transparencies (Recommended: MLOHP01)<br>Size: Postal card, Legal 13" or 14", Executive, A4, A5, B5, A6 (Only the 1st tray and the front feeder support A6 and postal-card sizes.)<br>Weight: 1st tray 55 kg to 151 kg (64 to 176g/m <sup>2</sup> )<br>Front feeder 55 kg to 172 kg (64 to 203g/ m <sup>2</sup> )  |
| (4) Print Speed                  | C7500/C7300<br>Color:20 pages per minute (Transparency: 8 pages per minute)<br>Monochrome: 24 pages per minute (Transparency: 12 pages per minute)<br>Postal Card, Label, Thick Paper: 12 pages per minute<br>C7550/C7350<br>Color:24 pages per minute (Transparency: 8 pages per minute)<br>Monochrome: 26 pages per minute (Transparency: 12 pages per minute)<br>Postal Card, Label, Thick Paper: 12 pages per minute |
| (5) Resolution                   | 600 × 600 dots per inch (C7550/C7350)<br>1200 × 1200 dots per inch (C7550/C7350)   |
| (6) Power Input                  | 115 - 127 V , 220 - 240 V  |
| (7) Power Consumption            | Peak: 1500W Normal Operation: 500W (5% duty)<br>Idle: 150W Power Saving Mode: 45W or less  |
| (8) Frequency                    | 50Hz or 60Hz ±2Hz  |
| (9) Noise                        | Operation: 56 dB (Without second tray)<br>Standby: 45 dB<br>Power Saving: 43 dB  |
| (10) Consumable Life             | Toner Cartridge: 5,000 pages (5% duty) (each of Y, M, C and K)<br>Large-Capacity Toner Cartridge: 10,000 pages (5% duty)<br>(each of Y, M, C and K)<br>Image Drum: 30,000 pages (5% duty, Continuous printing)<br>(each of Y, M, C and K)  |
| (11) Parts Replaced Periodically | Fuser Unit Assy: Every 60,000 pages<br>Belt Cassette Assy: Equivalent of 60,000 pages (3 pages/job)  |

## (12) Temperatures and Relative Humidities

## Temperature

## Temperature Condition

	Temperature( F)	Temperature( C)	Remark
Operation	50 to 89.6	10 to 32	17 to 27 C (Temperatures to assure full color print quality)
Non-Operation	32 to 109.4	0 to 43	Power-off
Storage (Max. One Year)	-14 to 109.4	-10 to 43	With drum and toner
Transport (Max. One Month)	-20 to 122	-29 to 50	With drum and without toner
Transport (Max. One Month)	-20 to 122	-29 to 50	With drum and toner

## Humidity

## Humidity Condition

	Relative Humidity (%)	Max. Wet-Bulb Temperature( C)	Remark
Operation	20 to 80	25	50 to 70% (Humidities to assure full color print quality)
Non-Operation	10 to 90	26.8	Power-off
Storage	10 to 90	35	
Transport	10 to 90	40	

(13) Printer Life 600,000 pages (on a A4-size basis) or five years

## 2. PARTS REPLACEMENT

This section describes the procedure for replacing the parts, assemblies and units in the field. The replacing procedure is given for detachment. To attach, use the reverse procedure.

### 2.1 Precautions in Replacing Parts

(1) Before replacing the parts, be sure to remove the AC cable and the interface cable.

(a) To remove the AC cable, always use the following procedure.

- i) Flip the power switch of the printer off (to "O").
- ii) Pull the AC inlet plug of the AC cable out of the AC receptacle.
- iii) Remove the AC cable and the interface cable from the printer.

(b) To connect the printer again, always use the following procedure.

- i) Connect the AC cable and the interface cable to the printer.
- ii) Insert the AC inlet plug into the AC receptacle.
- iii) Flip the power switch of the printer on (to "I").

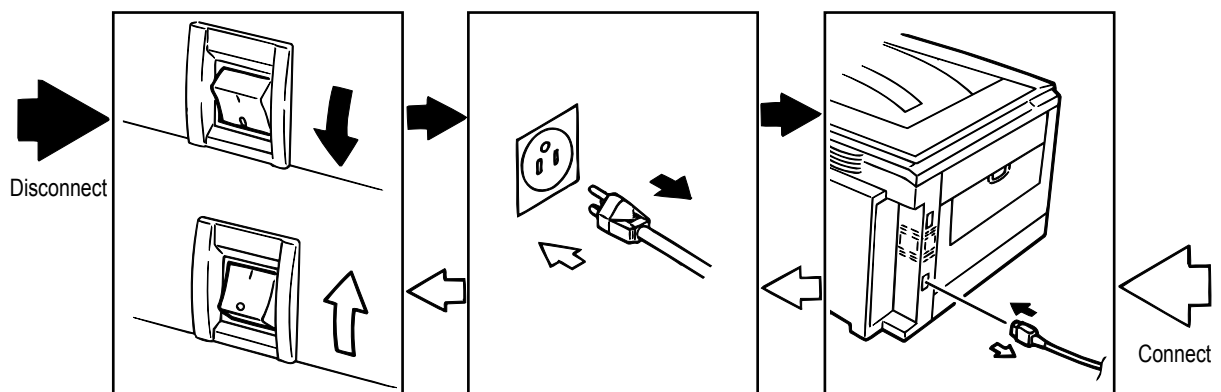

(2) Do not disassemble the printer so long as it operates properly.

(3) Minimize the disassembly. Do not detach parts other than those shown in the replacing procedure.

(4) For maintenance, use designated tools.

(5) Follow the order instructed to disassemble the printer. Incorrect order may damage the parts.

(6) Small parts such as screws and collars tend to get lost, so temporarily place and fix them in their original positions.







(7) When handling ICs and circuit boards such as microprocessors, ROMs and RAMs, do not use gloves that likely to have static.

(8) Do not place the printed circuit boards directly on the printer or the floor.

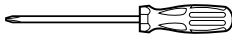
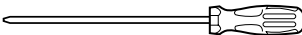
## [Maintenance Tools]

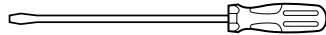
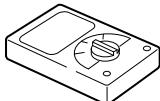
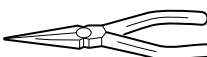
Table 2-1 lists tools necessary to replace the printed circuit boards and the units.

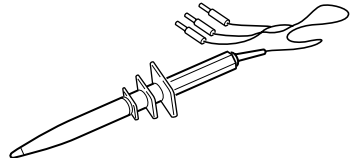
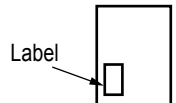
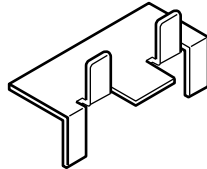
Table 2-1 Maintenance Tools

No.	Service Tools	Q' ty	Place of use	Remarks
1	 No. 1-100 Philips screwdriver	1	2~2.5 mm screws	
2	 No. 2-200 Philips screwdriver, Magnetized	1	3~5 mm screws	
3	 No. 3-100 screwdriver	1		
4	 No. 5-200 screwdriver	1		
5	 Digital multimeter	1		
6	 Pliers	1		
7	 Handy cleaner	1		
8	 LED Head cleaner P/N 4PB4083-2248P001	1	Cleans LED head	
9	 High voltage probe	1		
10	 Transparency sheet ( thickness premeasured) 42404301	1	Adjustment for Media Thickness sensor	
11	 Stage height adjustment jig 42423701	1	Adjustment for Media Thickness sensor	
12	 ⊖ Microdriver 2.0mm	1	Adjustment for Lever adjust (Media Thickness)	

## 2.2 Parts layout

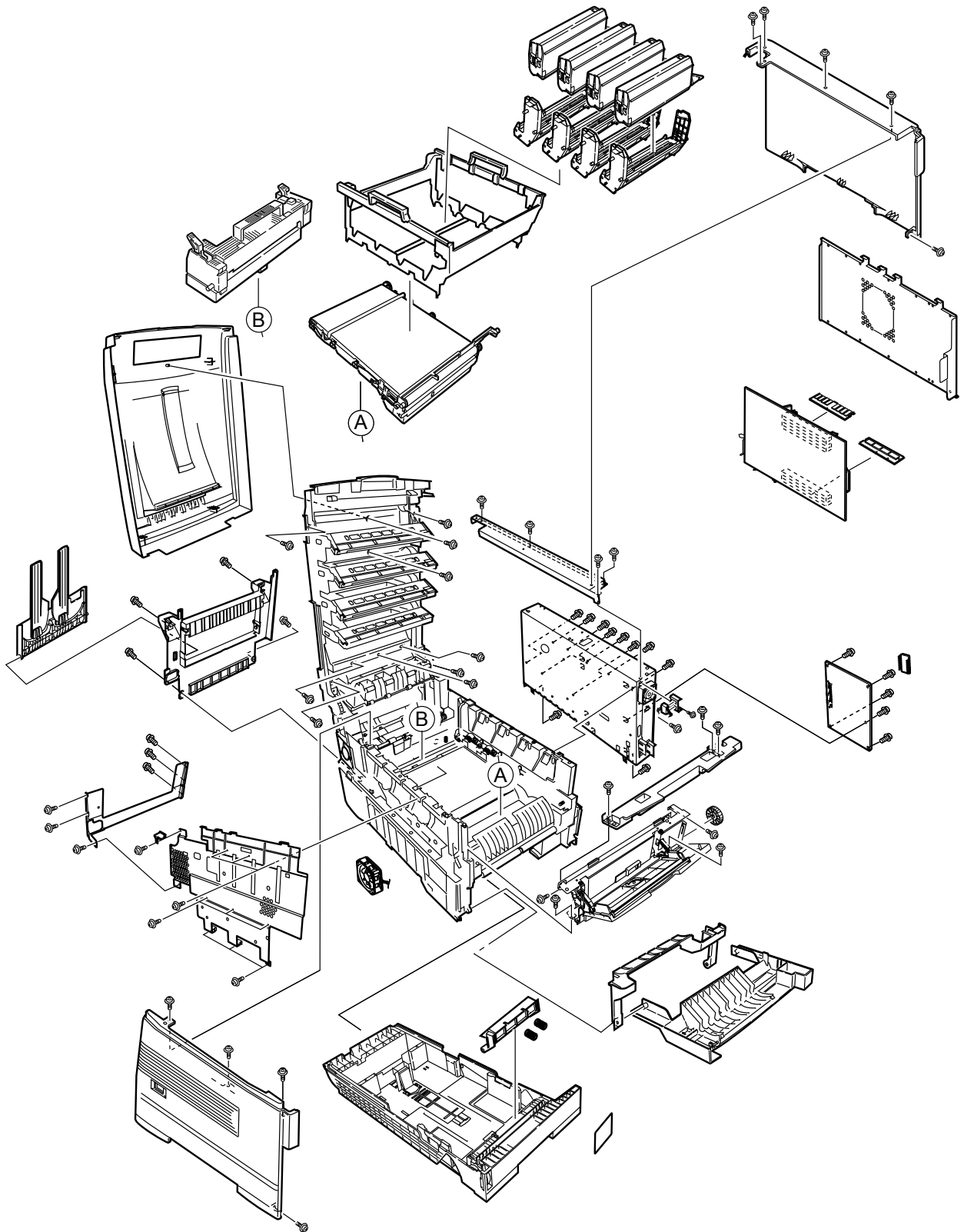

Figure 2-1

[Top Cover Assy]

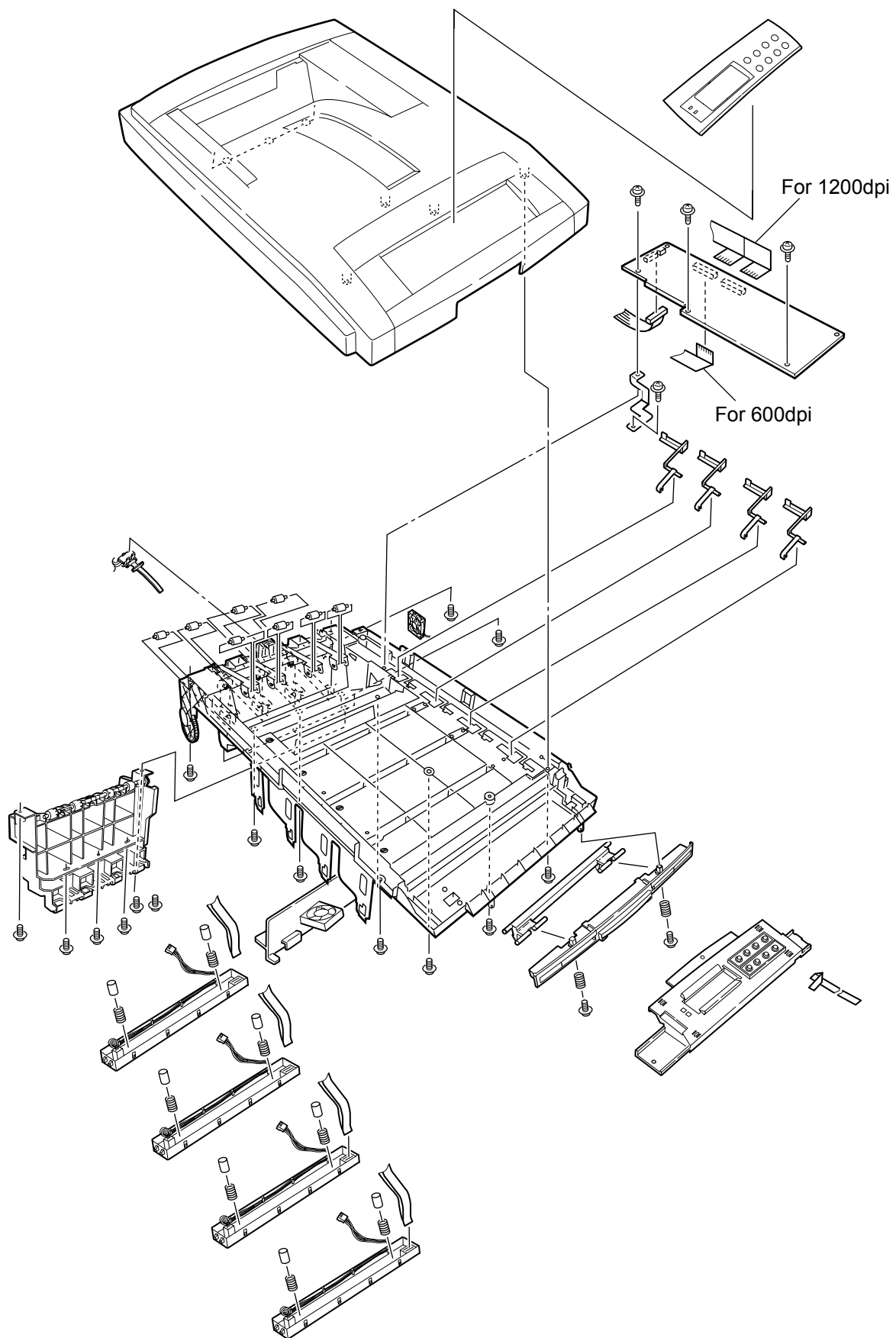

Figure 2-2



[Printer Unit-1/2]

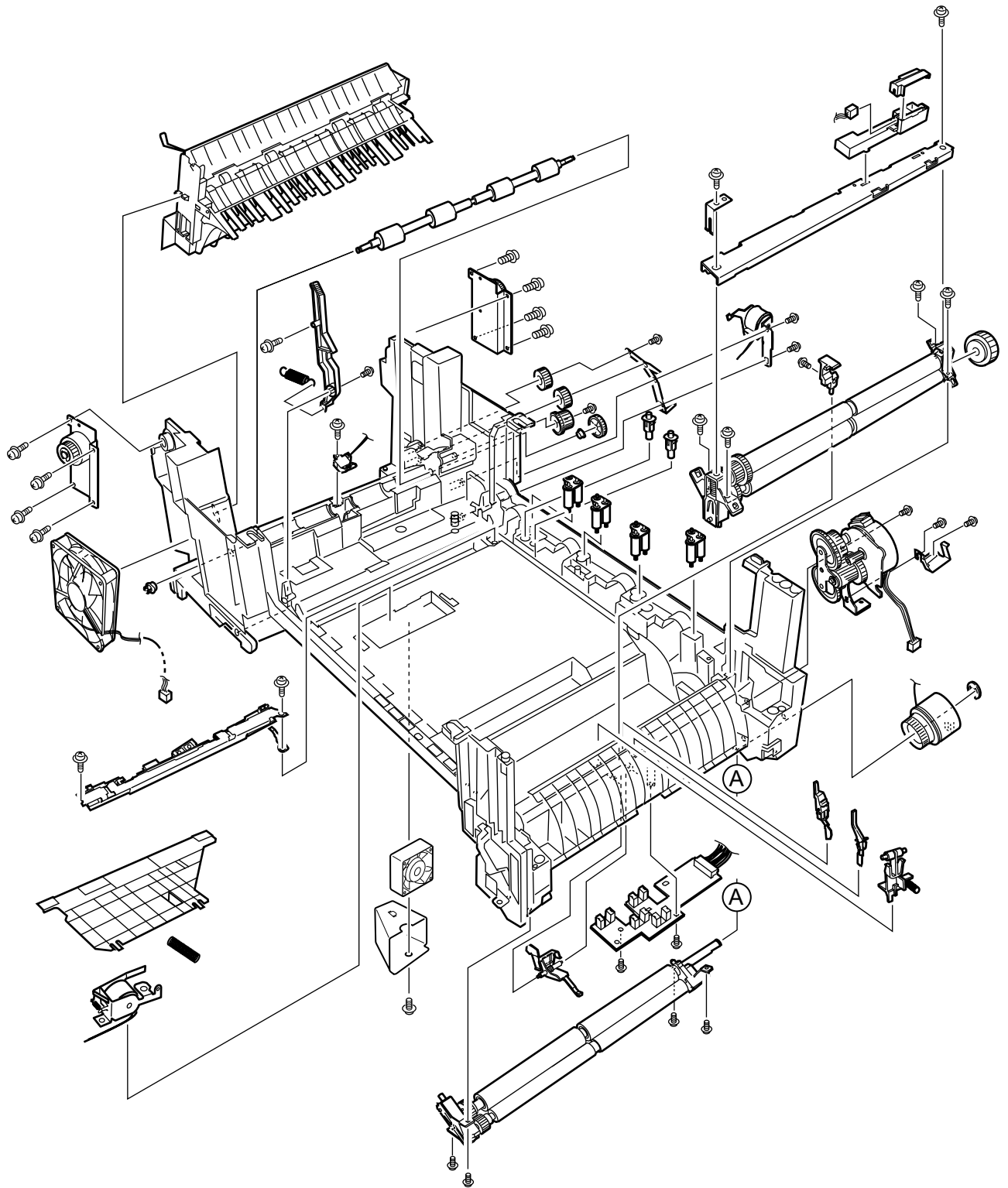

Figure 2-3

[Printer Unit-2/2]

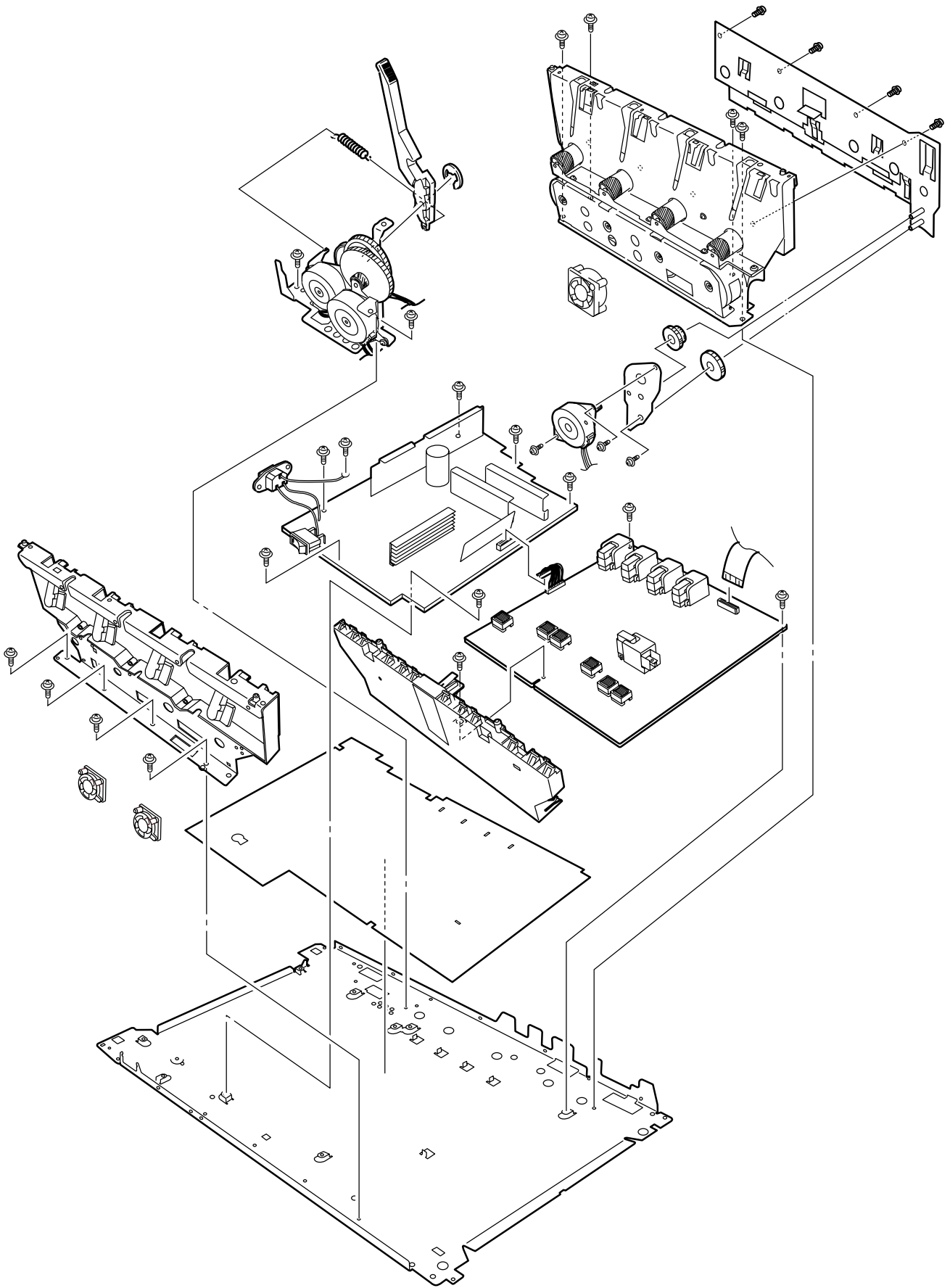

Figure 2-4

[Cassette Guide Assy (L),(R)]

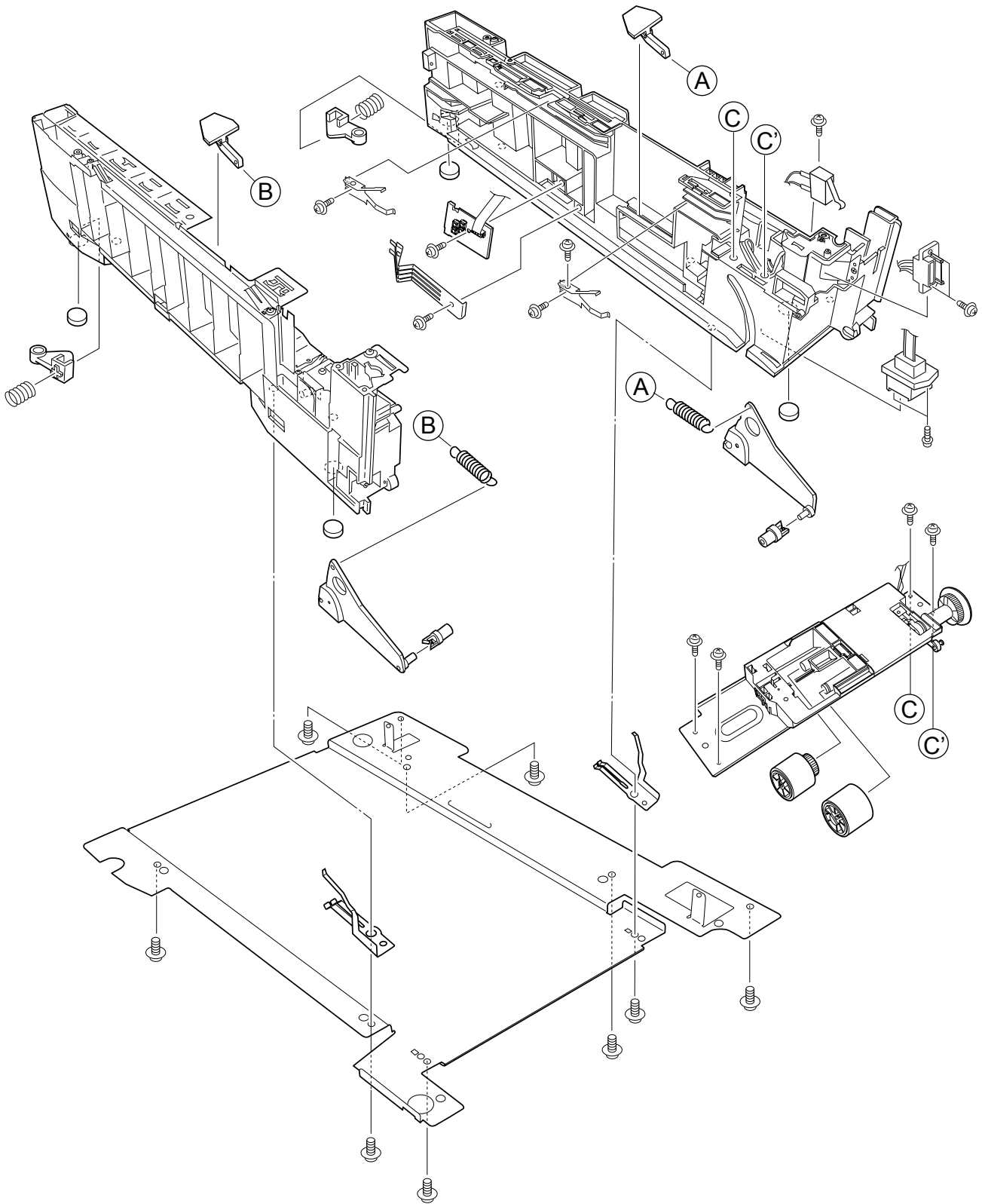

Figure 2-5

[Duplex Unit]

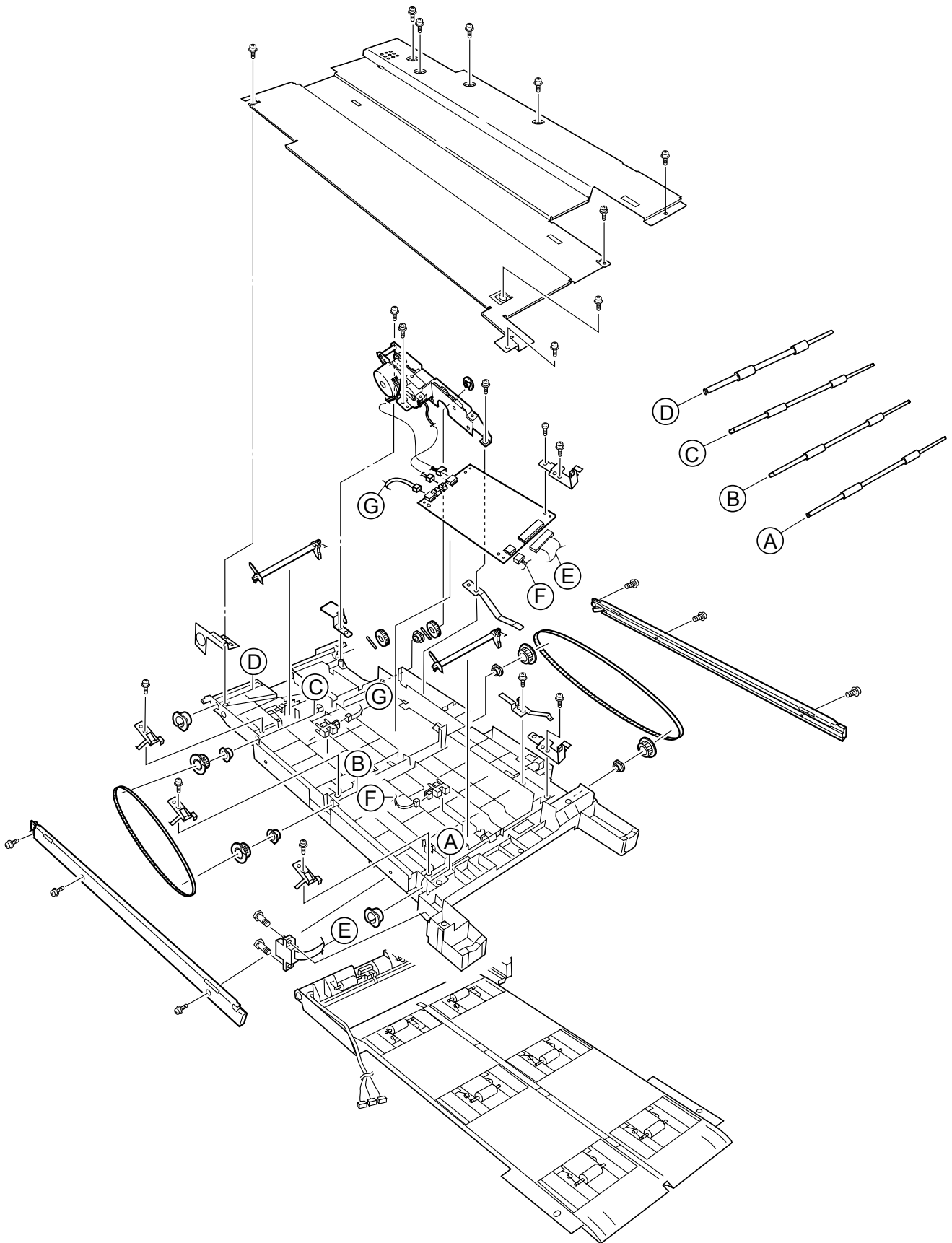
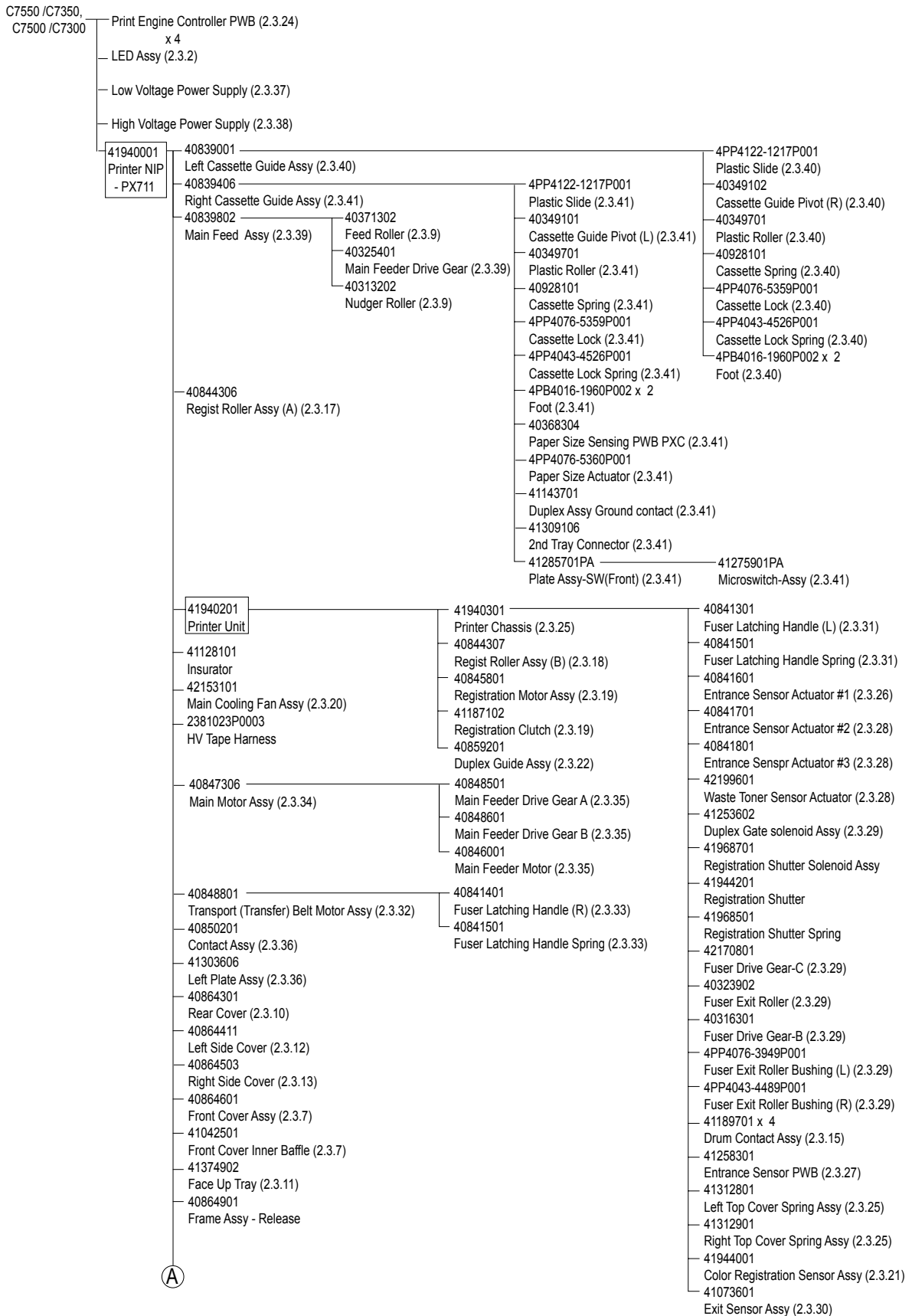
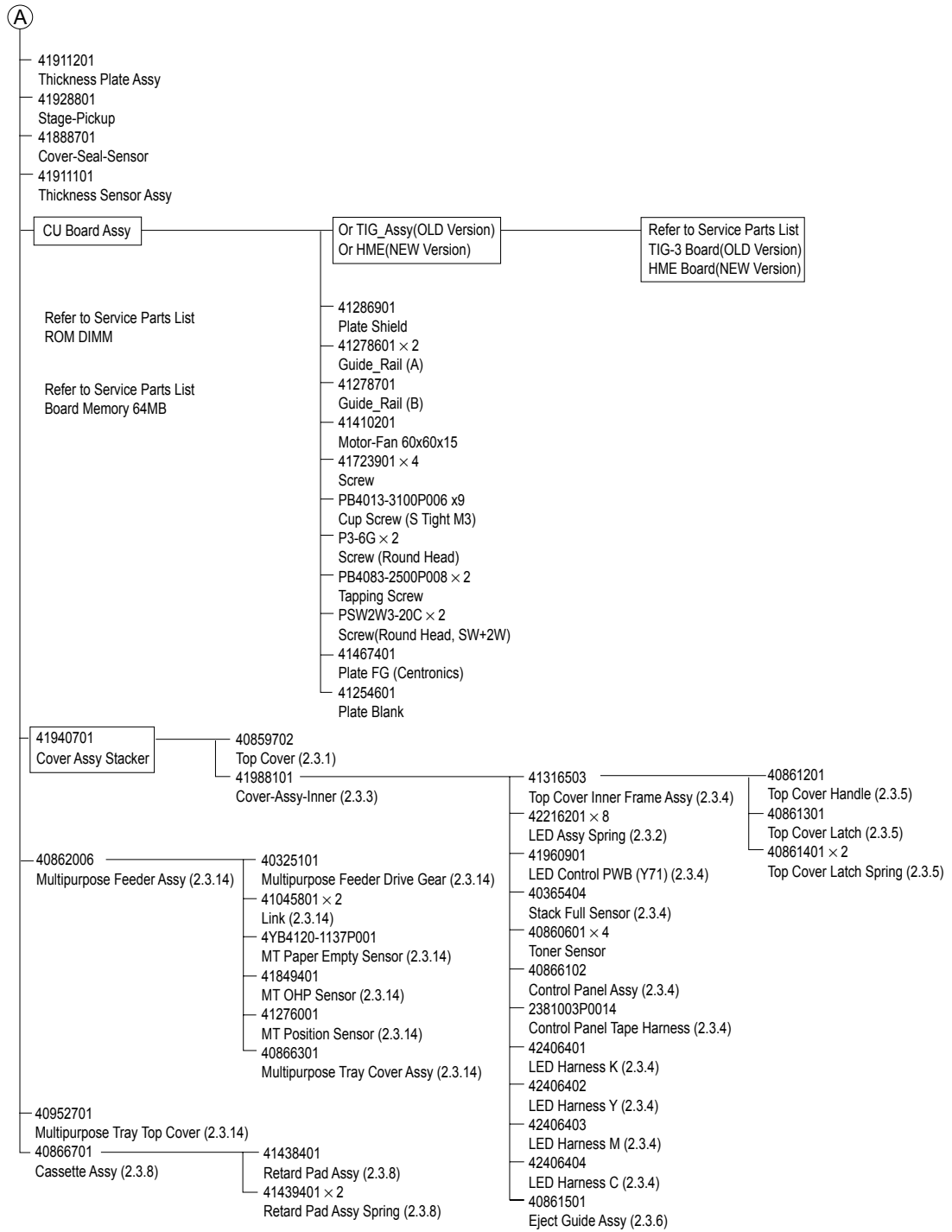

Figure 2-6

## 2.3 Replacing Parts

This section describes how to replace the parts and assemblies shown in the following disassembling system diagram.





### 2.3.1 Top Cover

- (1) Open the Top Cover assy.
- (2) Remove the nine screws ① to detach the top cover ②.

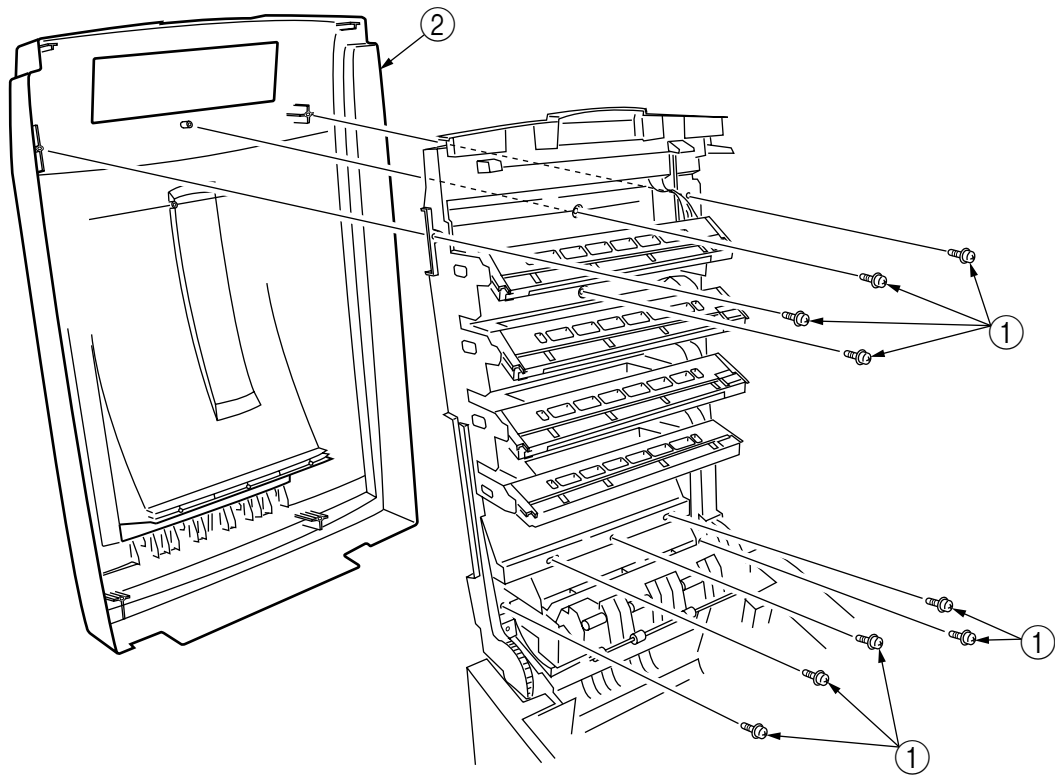

Figure 2-3-1 Top Cover

### 2.3.2 LED Head / LED Spring / Post-Guide

- (1) Open the top cover ①.
- (2) Remove the three cables, and unhook the LED Head ② at two places to demount it (the two springs ③, Post-Guide ④ become detached together with the LED Head ②).

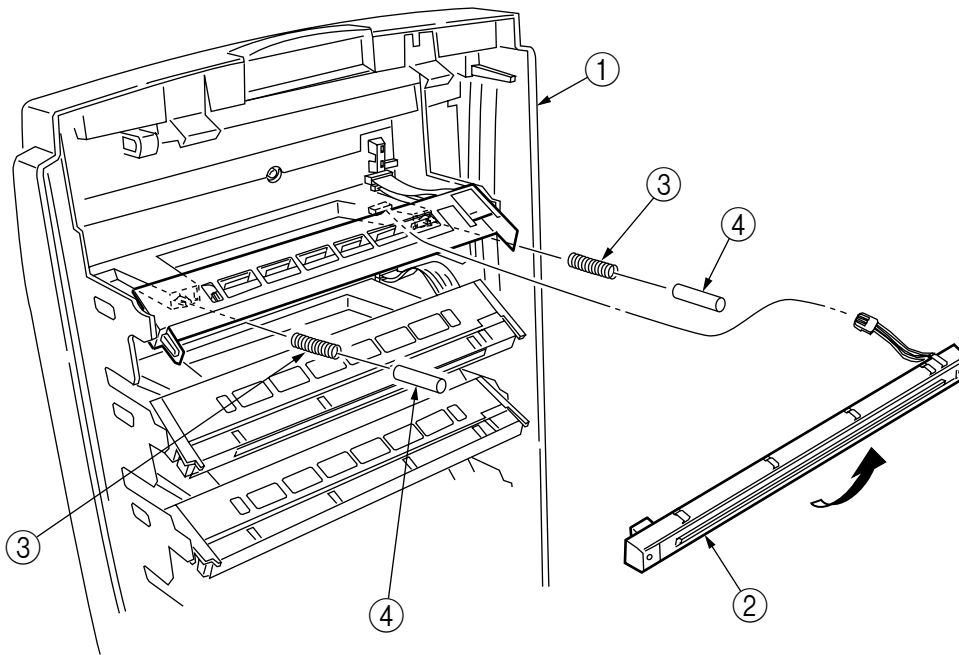

Figure 2-3-2 LED Head / LED Spring / Post-Guide



### 2.3.3 Top Cover Unit

- (1) Remove the top cover (see section 2.3.1).
- (2) Remove the rear cover (see section 2.3.10).
- (3) Remove the left side cover (see section 2.3.12).
- (4) Remove the right side cover (see section 2.3.13).
- (5) Remove the shield plates A and B (see section 2.3.23), and unplug the connector to separate the top cover.
- (6) Disengage the top cover unit ① at two places to detach it.

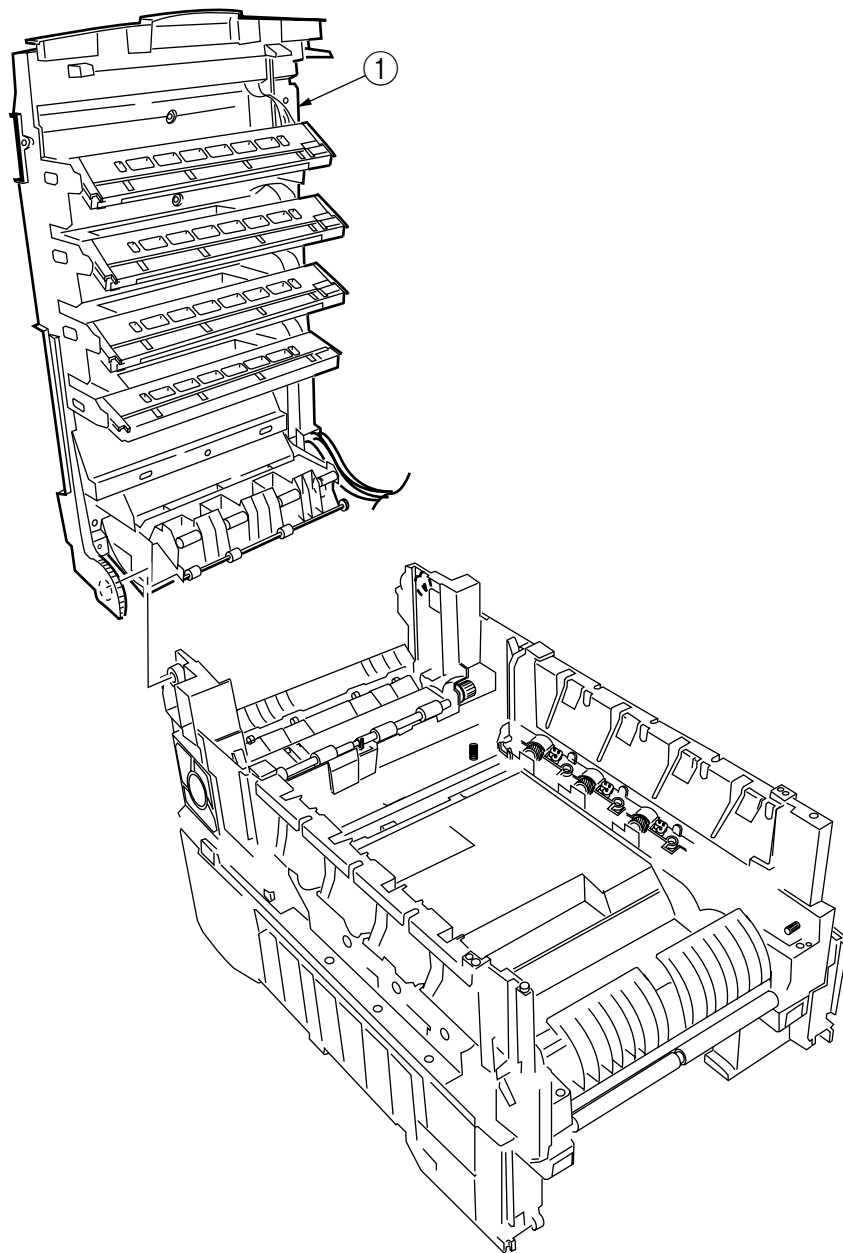

Figure 2-3-3 Top Cover Unit

### 2.3.4 Control Panel Assy/ Control Panel Bezel/ LED Control PWB/ Toner Sensors/ Stacker Full Sensor/ Control Panel/ Control Panel Tape Harness/ Eject Rollers

- (1) Remove the control panel Assy ①.
- (2) Detach the control panel tape harness ②.
- (3) Remove the top cover unit (see section 2.3.3).
- (4) Unscrew the six screws ③ to remove the earth plate ④.
- (5) Remove the two screws ⑤, unhook all the connectors ⑥ and demount the LED control PWB ⑦.
- (6) Disengage the four claws to demount the toner sensor ⑧.
- (7) Demount the stacker full sensor ⑨.
- (8) Demount the exit rollers ⑪.
- (9) Detach the LED harnesses, K, Y, M and C ⑫.
- (10) Detach the top cover inner frame Assy ⑬.

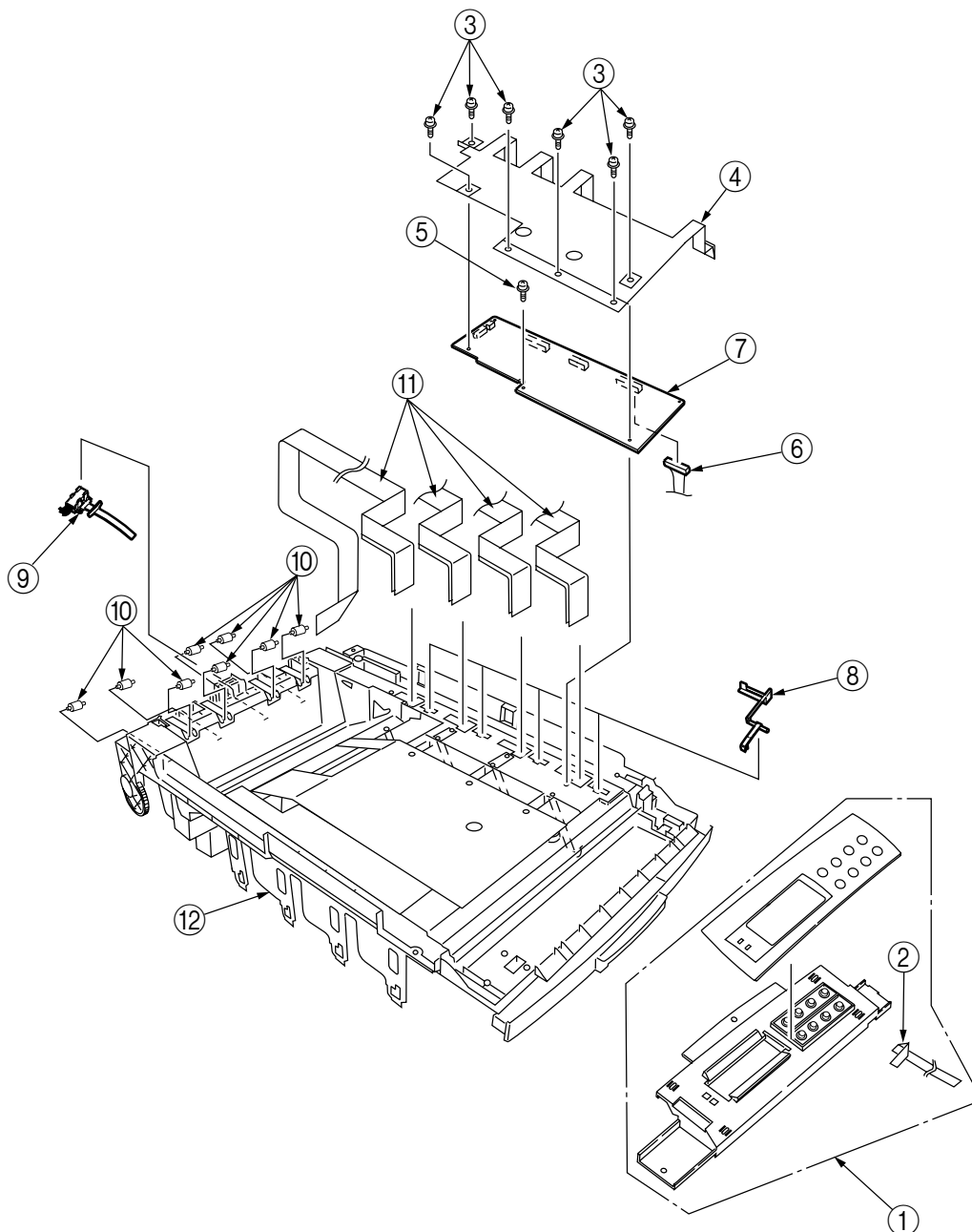

Figure 2-3-4 Control Panel Assy/ Control Panel Bezel/ LED Control PWB/ Toner Sensors/ Stacker Full Sensor/ Control Panel/ Control Panel Tape Harness/ Eject Rollers

### 2.3.5 Top Cover Handle/ Top Cover Latch/ Top Cover Latch Spring

- (1) Remove the two screws ① to detach the top cover handle ② and disengage the top cover latch ③ (at the same time, the two top cover latch springs ④ become detached).

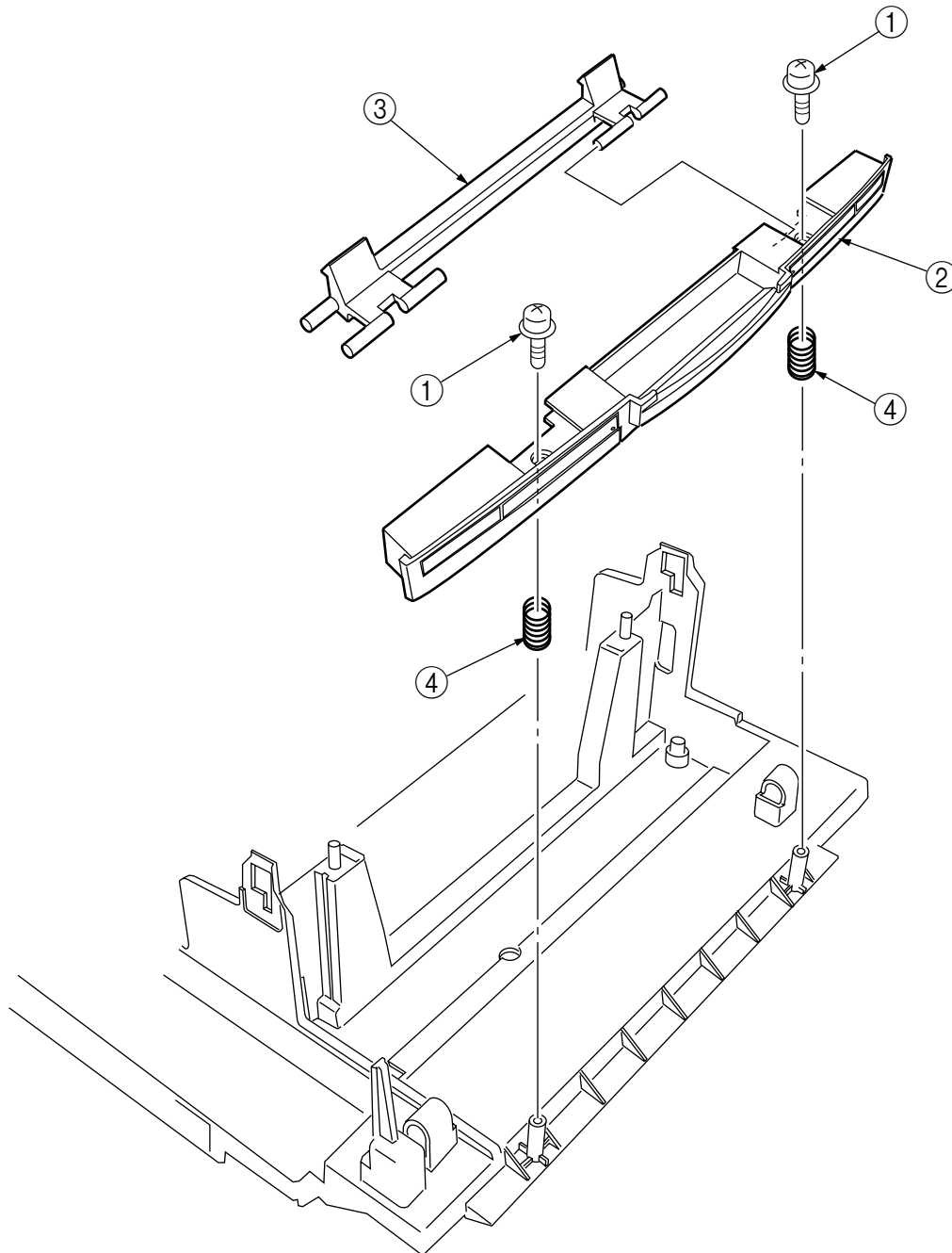

Figure 2-3-5 Top Cover Handle/ Top Cover Latch/ Top Cover Latch Spring

### 2.3.6 Eject Guide Assy

- (1) Remove the five screws ① to detach the eject guide Assy ②.

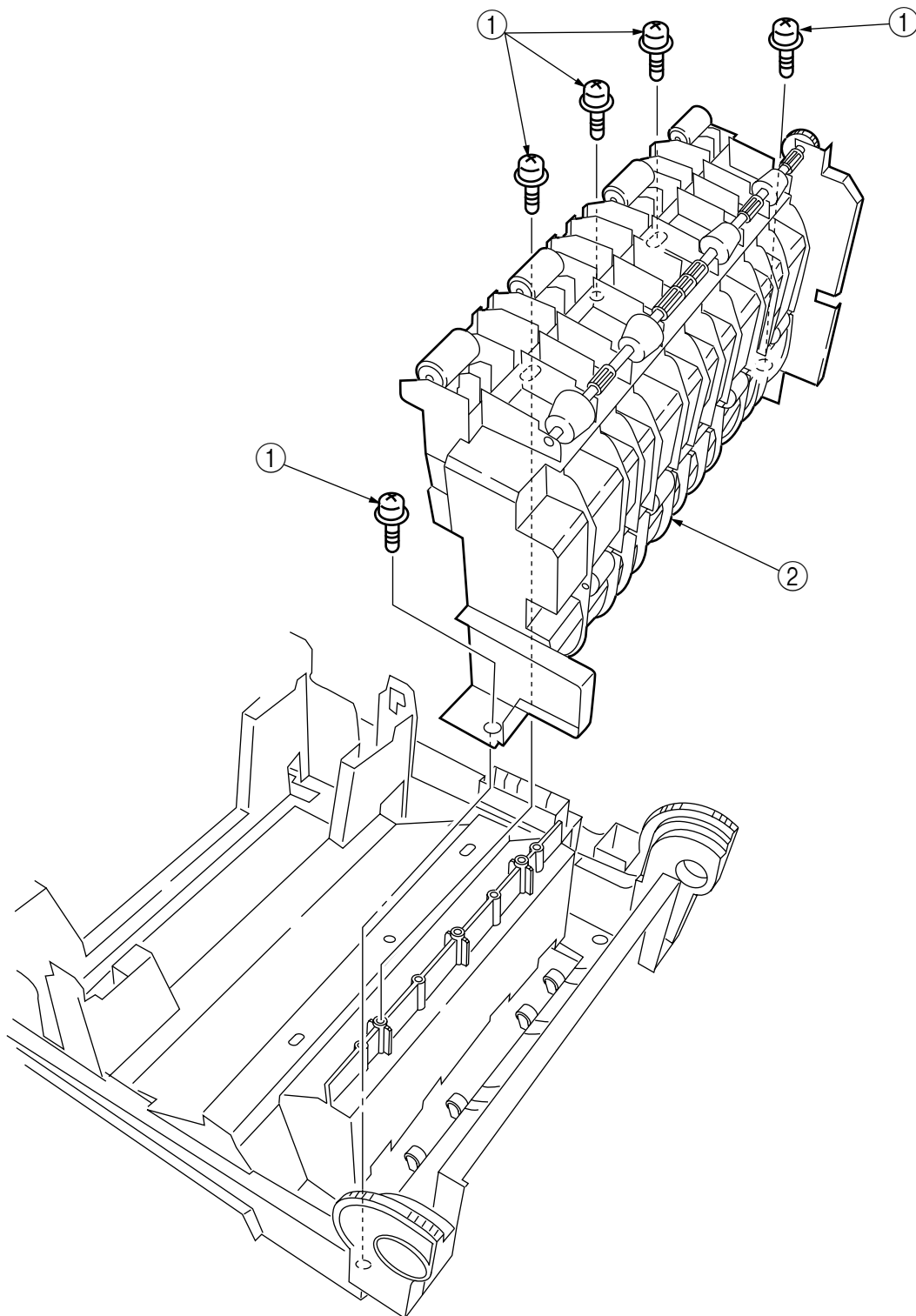

Figure 2-3-6 Eject Guide Assy

### 2.3.7 Cassette Assy/ Front Cover Assy/ Front Cover Inner Baffle

- (1) Detach the cassette Assy ①.
- (2) Open the front cover ②, and disengage it at two places to detach it.
- (3) Detach the front cover inner baffle ③.

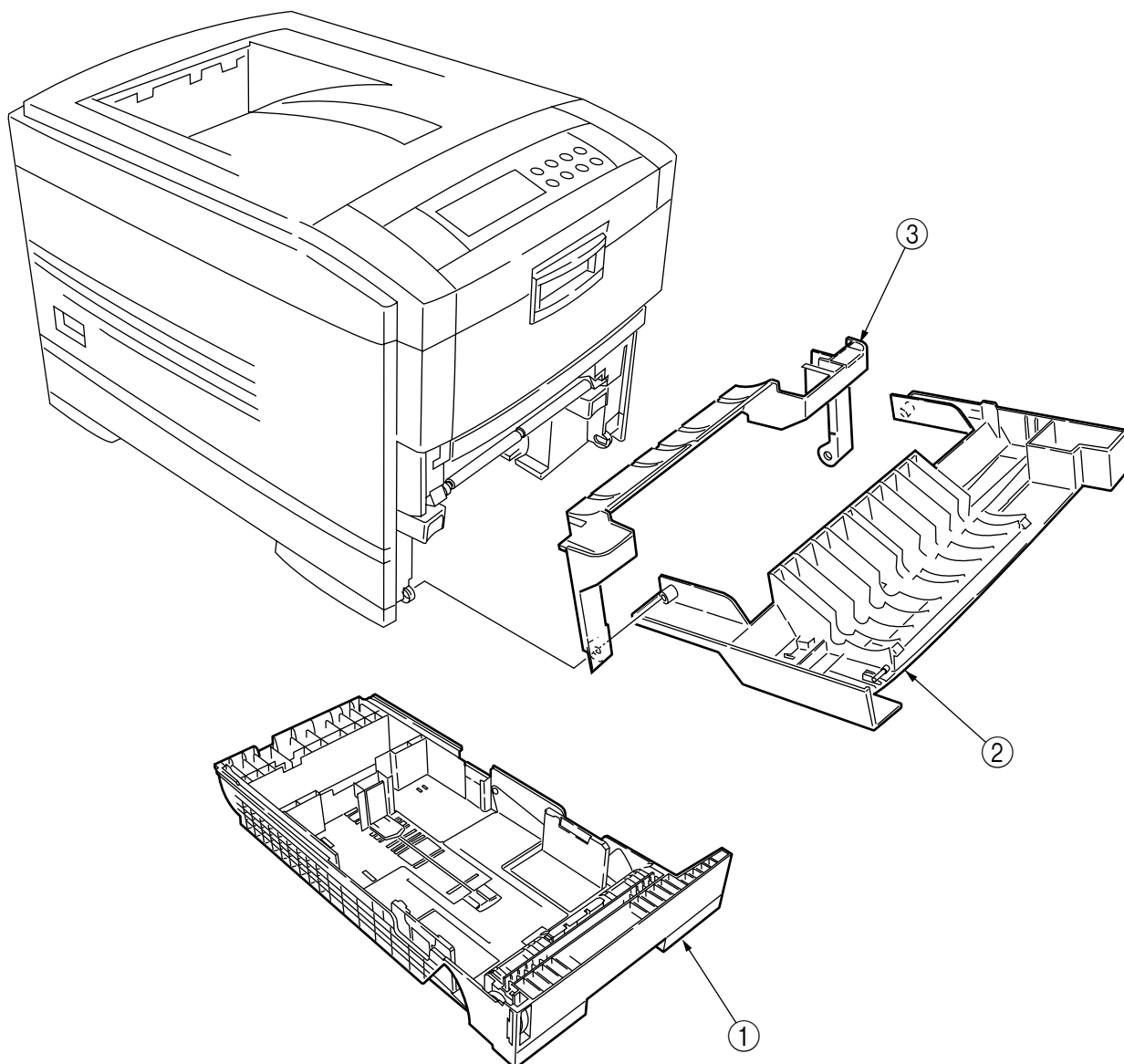

Figure 2-3-7 Cassette Assy/ Front Cover Assy/ Front Cover Inner Baffle

### 2.3.8 Retard Pad Assy/ Retard Pad Assy Spring

- (1) Remove the cassette ①.
- (2) Detach the retard pad Assy ② (at the same time, the spring ③ becomes detached).

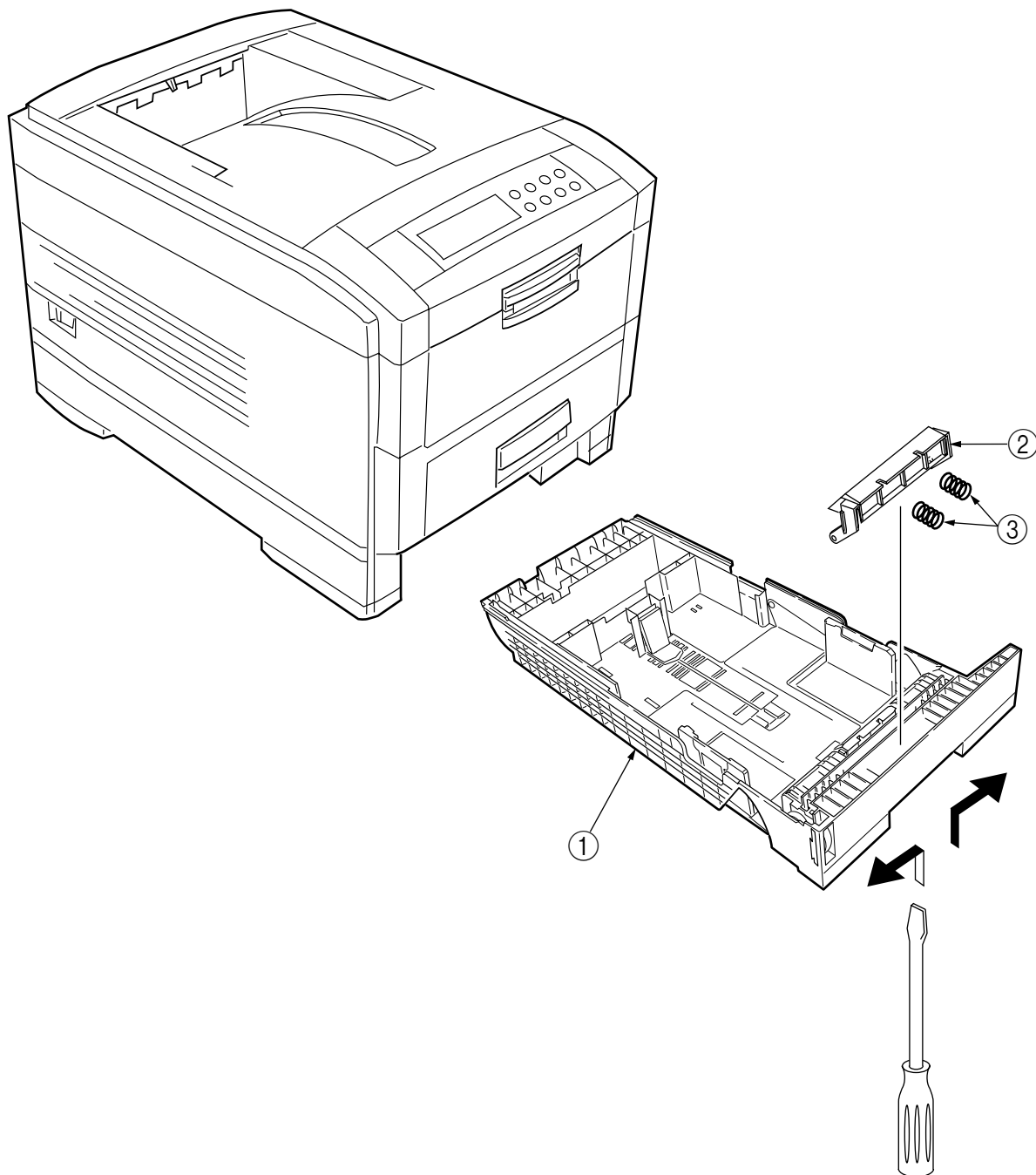

Figure 2-3-8 Retard Pad Assy/ Retard Pad Assy Spring

### 2.3.9 Feed Roller and Nudger Roller

- (1) Remove the cassette.
- (2) Unlatch and demount the feed roller ①.
- (3) Unlatch and demount the nudger roller ②.

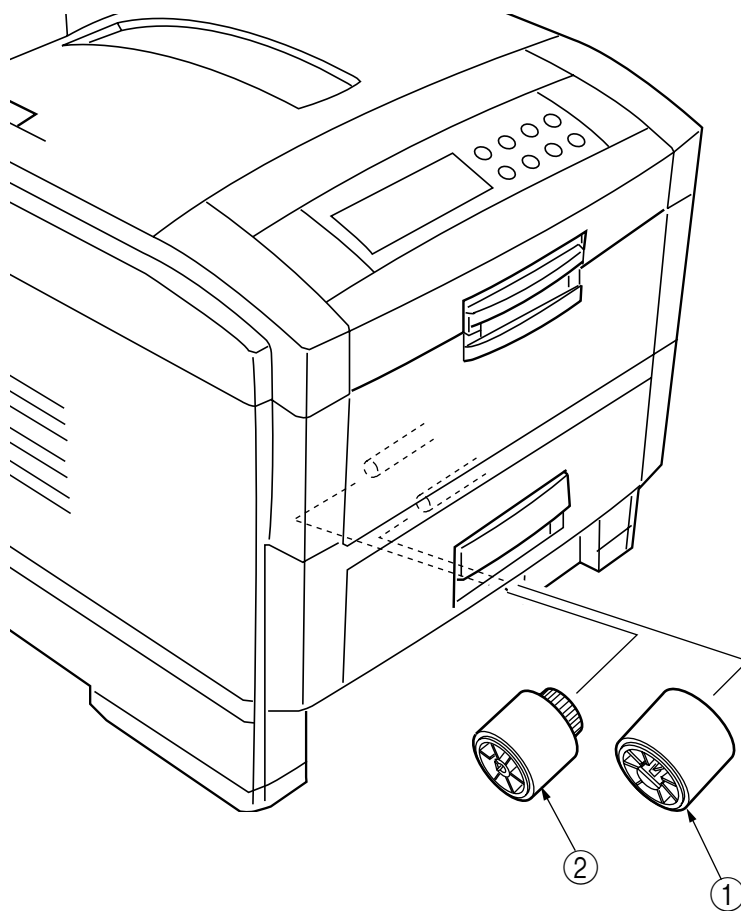

Figure 2-3-9 Feed Roller and Nudger Roller

### 2.3.10 Rear Cover

- (1) Remove the left side cover (see section 2.3.12).
- (2) Remove the four screws ① to detach the rear cover ②.

**Note!** When attaching the rear cover, take care not to allow the spring ③ to get caught in parts.

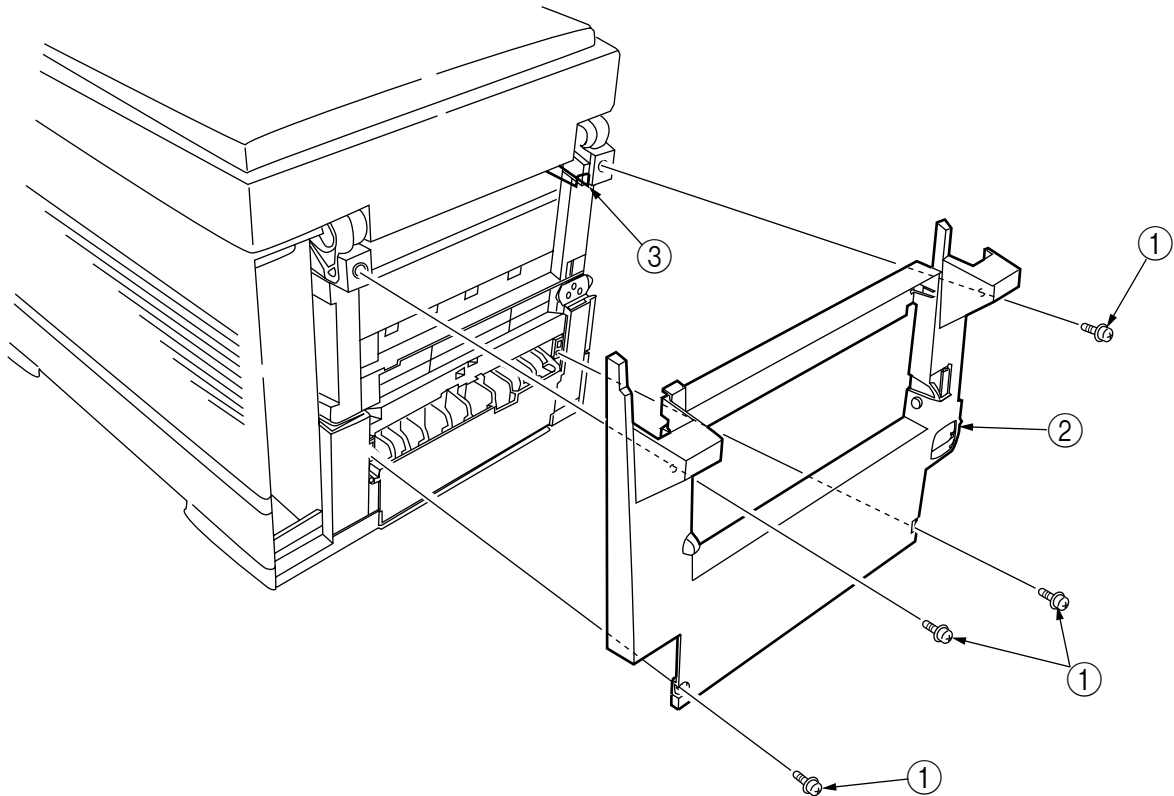

Figure 2-3-10 Rear Cover



### 2.3.11 Face-Up Tray

- (1) Open the face-up tray ① in the arrow direction, and disengage it at two places to detach it.

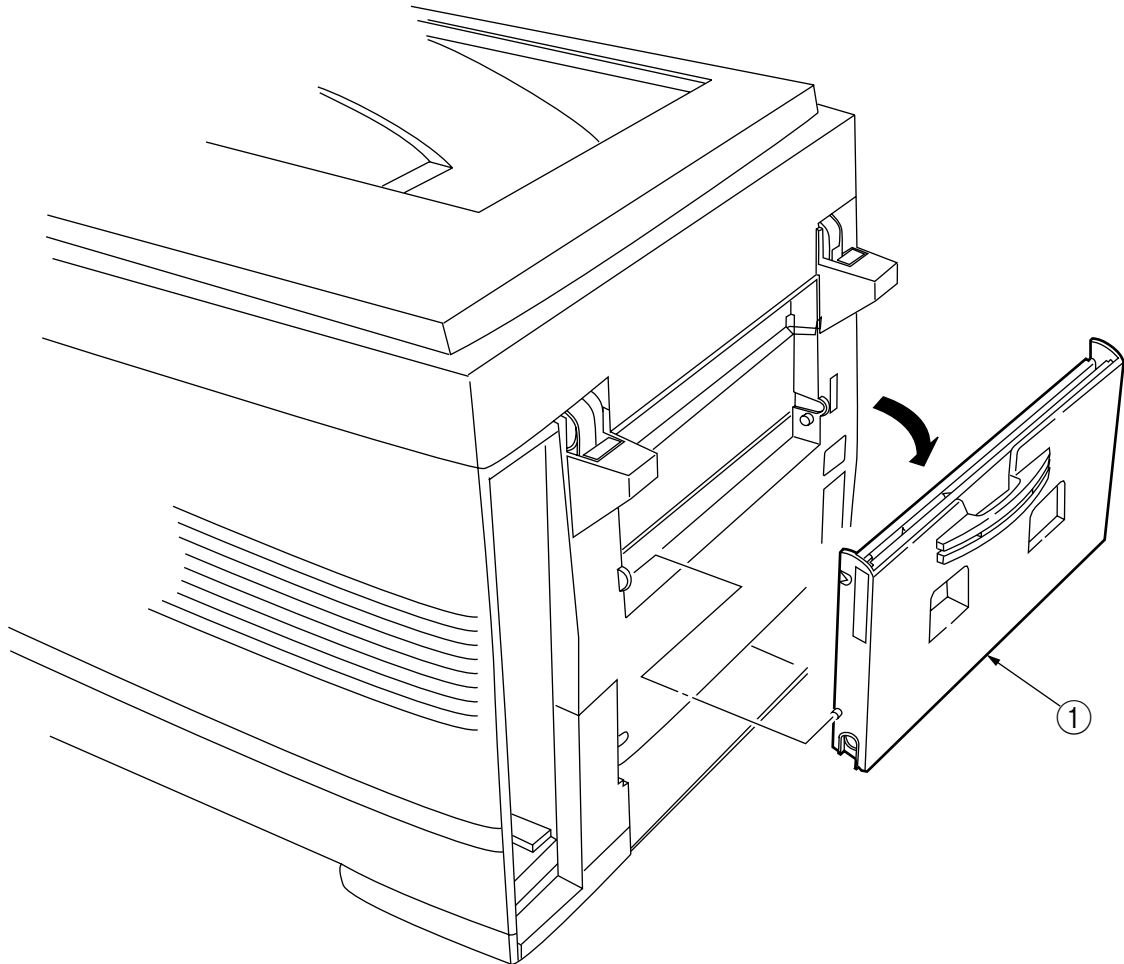

Figure 2-3-11 Face-Up Tray

### 2.3.12 Left Side Cover

- (1) Open the top cover ①.
- (2) Open the front cover ② and undo the screw ③.
- (3) Remove the three screws ④ to detach the left side cover ⑤.

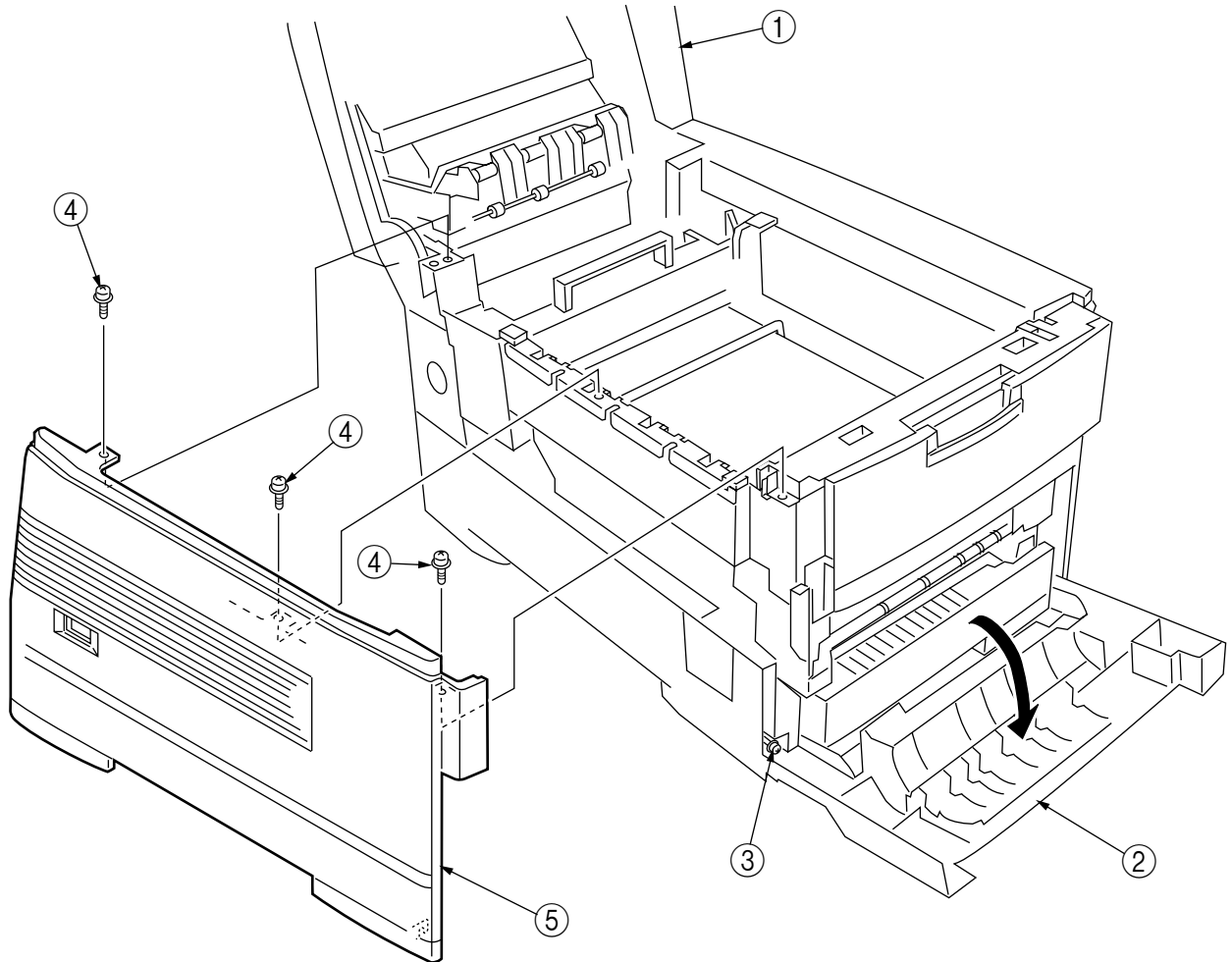

Figure 2-3-12 Left Side Cover

### 2.3.13 Right Side Cover

- (1) Open the top cover ①.
- (2) Open the front cover ② and undo the screw ③.
- (2) Remove the four screws ④ to detach the right side cover ⑤.

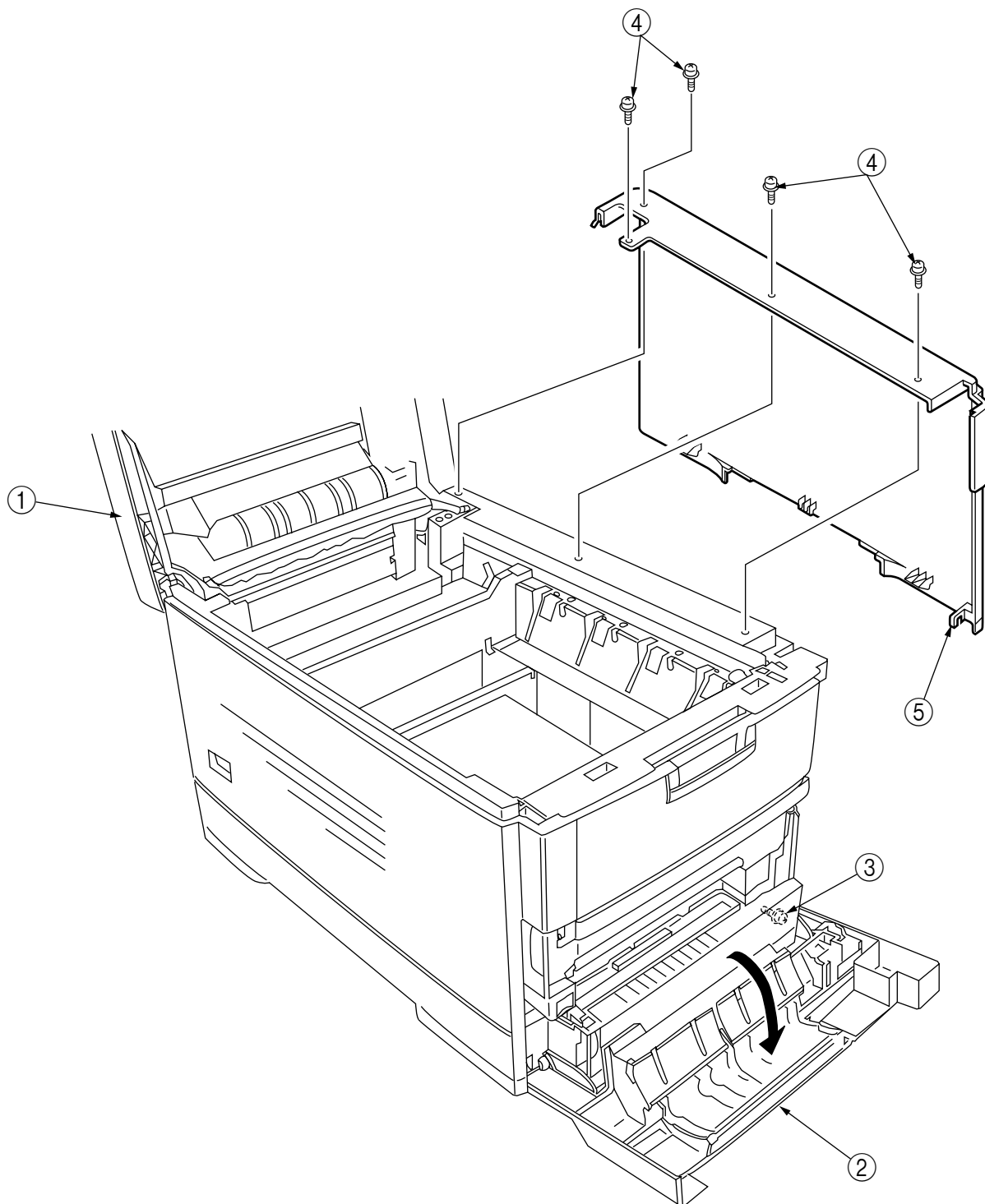

Figure 2-3-13 Right Side Cover

### 2.3.14 Multipurpose Tray Assy/ Multipurpose Tray Cover Assy/ Links/ Multipurpose Tray Top Cover/ Multipurpose Tray Drive Gear

- (1) Remove the left side cover (see section 2.3.12).
- (2) Remove the right side cover (see section 2.3.13).
- (3) Detach the Cover Seal Sensor and the Thickness Sensor Connector (see section 2.3.16).
- (4) Remove the three screws ① to detach the multipurpose tray top cover ②.
- (5) Remove the three screws ③ (two of them are black) and the connector to detach the multipurpose tray ④.
- (6) Disengage ① and ② at both sides of the assembly to detach the multipurpose tray cover Assy ⑤ (at the same time, the links ⑥ become detached).
- (7) Unhook and detach the multipurpose tray drive gear ⑦.

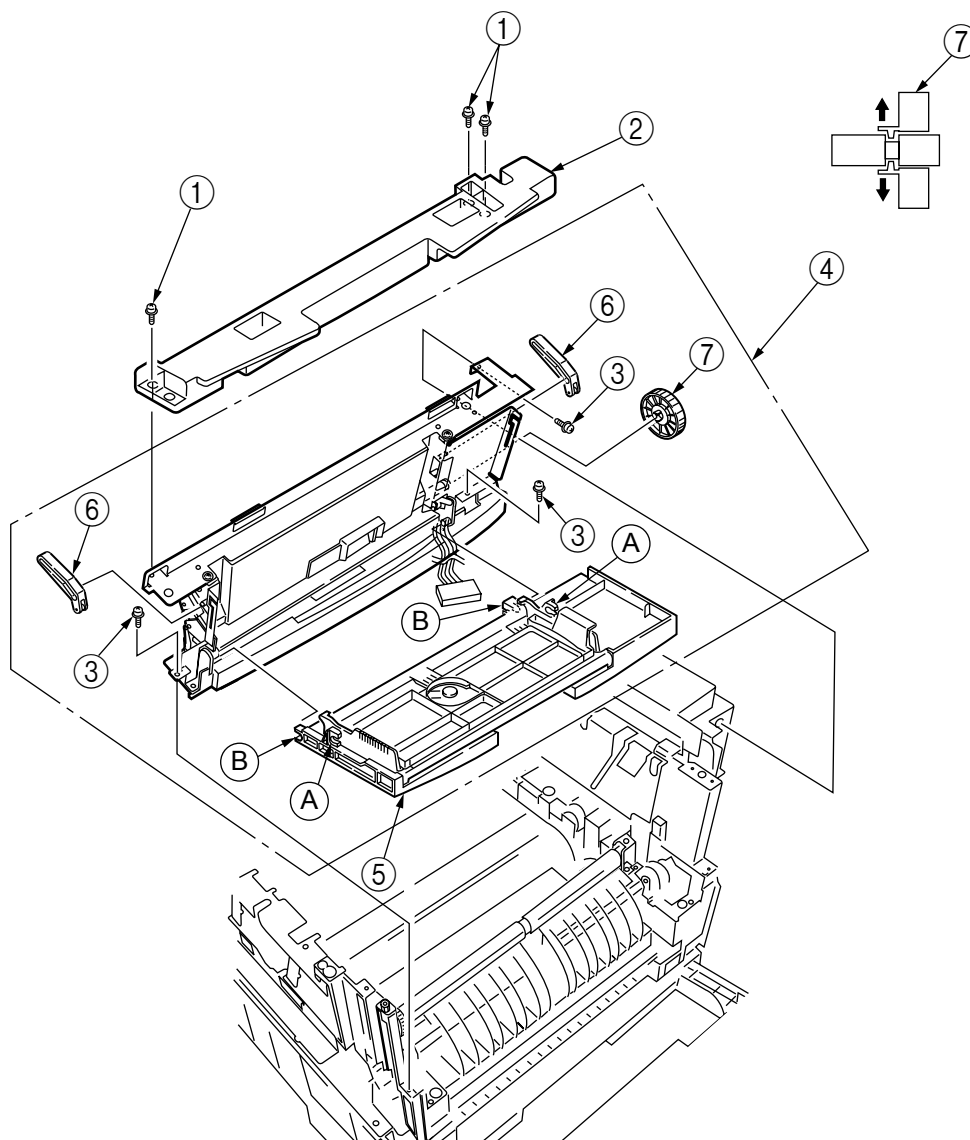

Figure 2-3-14 Multipurpose Tray Assy/ Multipurpose Tray Cover Assy/ Links/ Multipurpose Tray Top Cover/ Multipurpose Tray Drive Gear

### 2.3.15 Drum Contact Assys

- (1) Insert a flatblade screwdriver between the printer case and the drum contact Assy ① to demount the drum contact Assy ①.

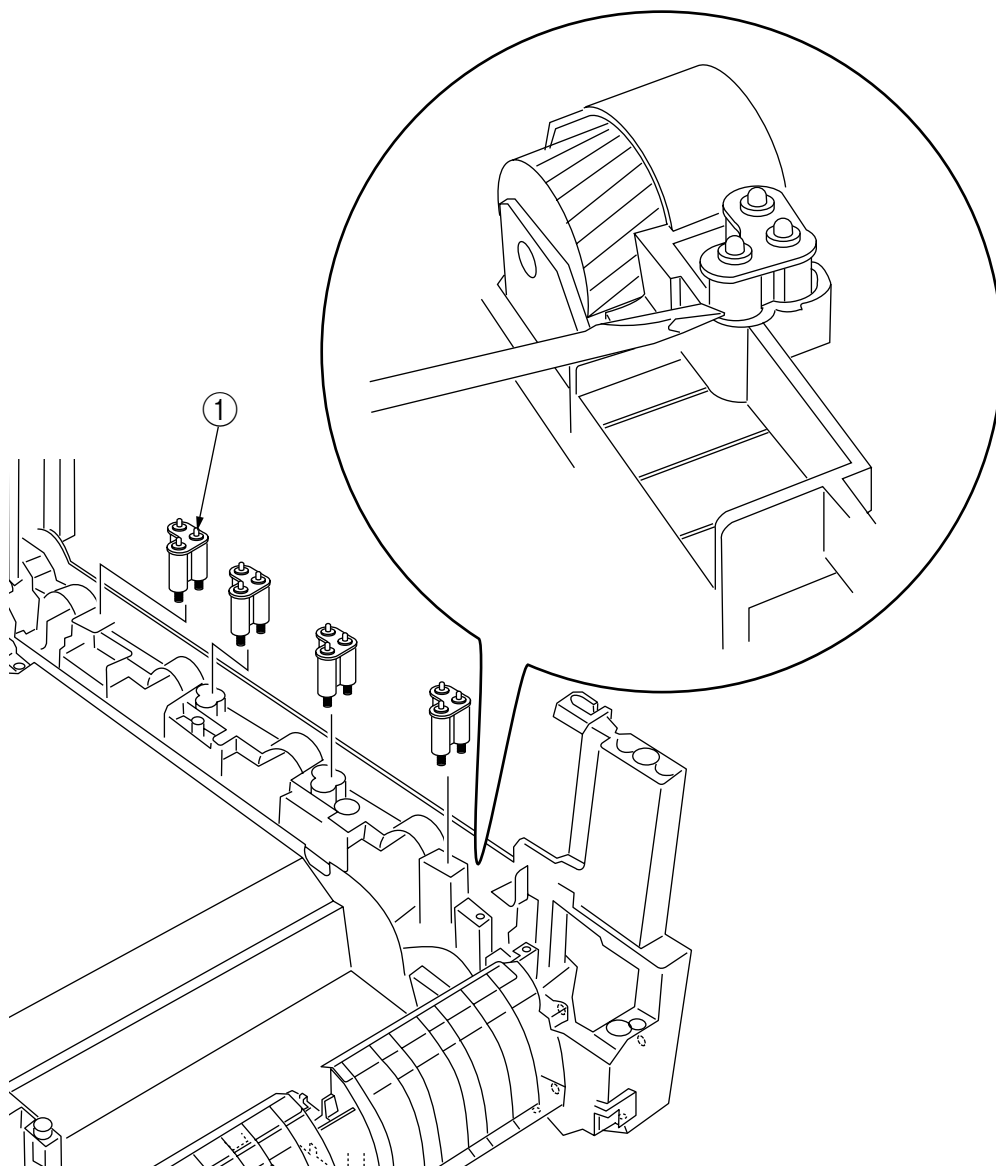

Figure 2-3-15 Drum Contact Assys

## 2.3.16 Media Thickness Sensor Assy

- (1) Detach the Cover Seal Sensor ① and the Thickness Sensor Connector ②.
- (2) Remove the two screws ③ to demount the Media Thickness Assy.
- (3) Insert a microdriver(-) between the Thickness Plate Assy ④ and Thickness Sensor Assy ⑤ to demount the Thickness Sensor Assy ⑤

**Note!** When attaching the Media Thickness Assy, adjust [Spin lever adjust by microdriver(-)] the position of lever (White).

The upper surface of the lever be in agreement with a datum level. (Adjustment range 0/-0.5mm)

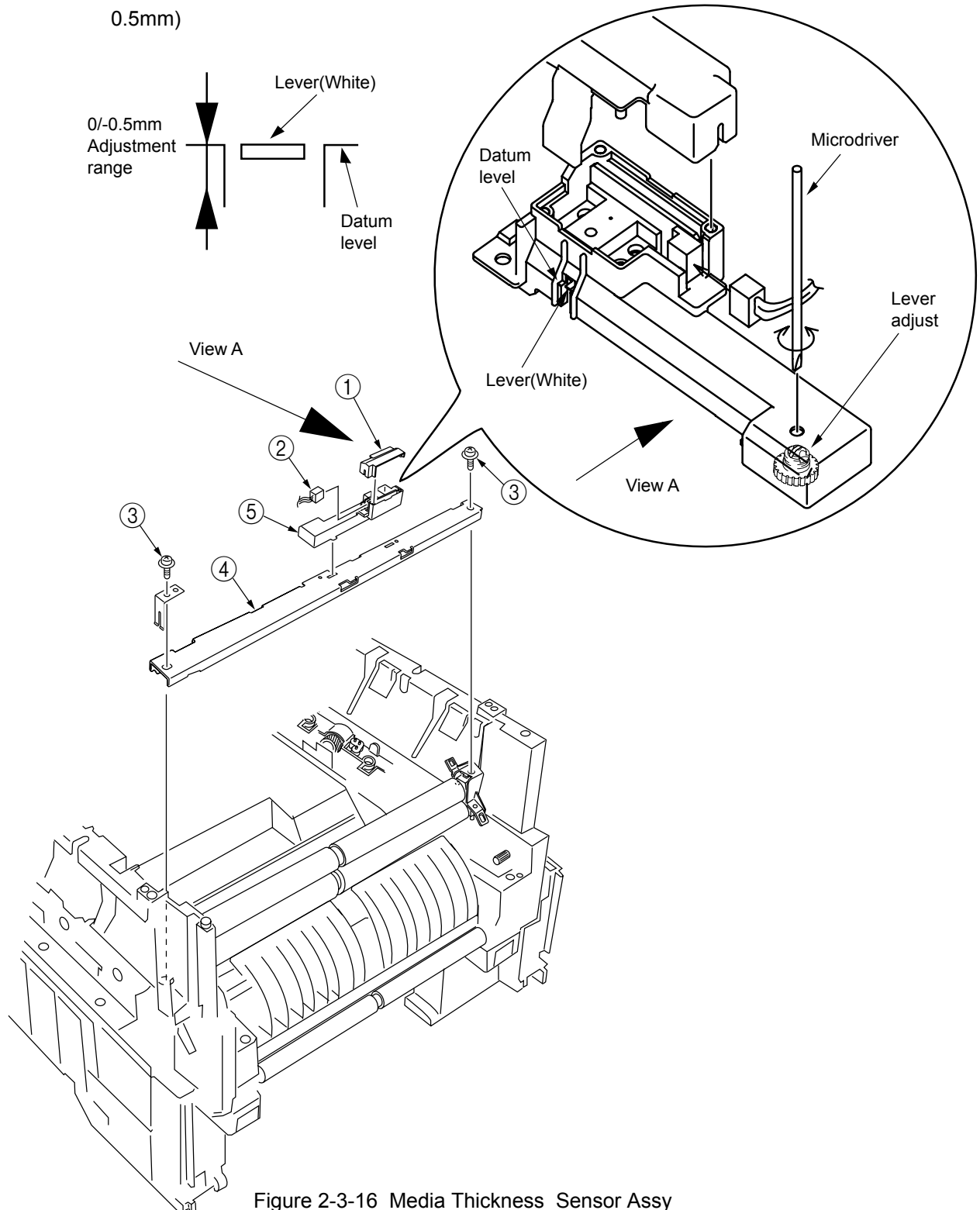

Figure 2-3-16 Media Thickness Sensor Assy

## 2.3.17 Registration Roller Assy (A)/ Registration Drive Gear (A)

- (1) Remove the left side cover (see section 2.3.12).
- (2) Remove the right side cover (see section 2.3.13).
- (3) Remove the multipurpose tray (see section 2.3.14).
- (4) Remove the Media Thickness Sensor Assy. (see section 2.3.16).
- (5) Remove the screw ① of the Pickup Stage ②.
- (6) Remove the four screws ③ to demount the registration roller Assy (A) ④ and the Pickup Stage ②.
- (7) Remove the E ring ⑤ to detach the registration gear (A) ⑥.

**Note!** When attaching the pickup stage ②, place the stage height adjustment jig between the pressure roller and the registration roller and, until the top surface of the pickup stage reaches the jig, move the pickup stage toward the jig. (See Table 2-1 Maintenance Tools)

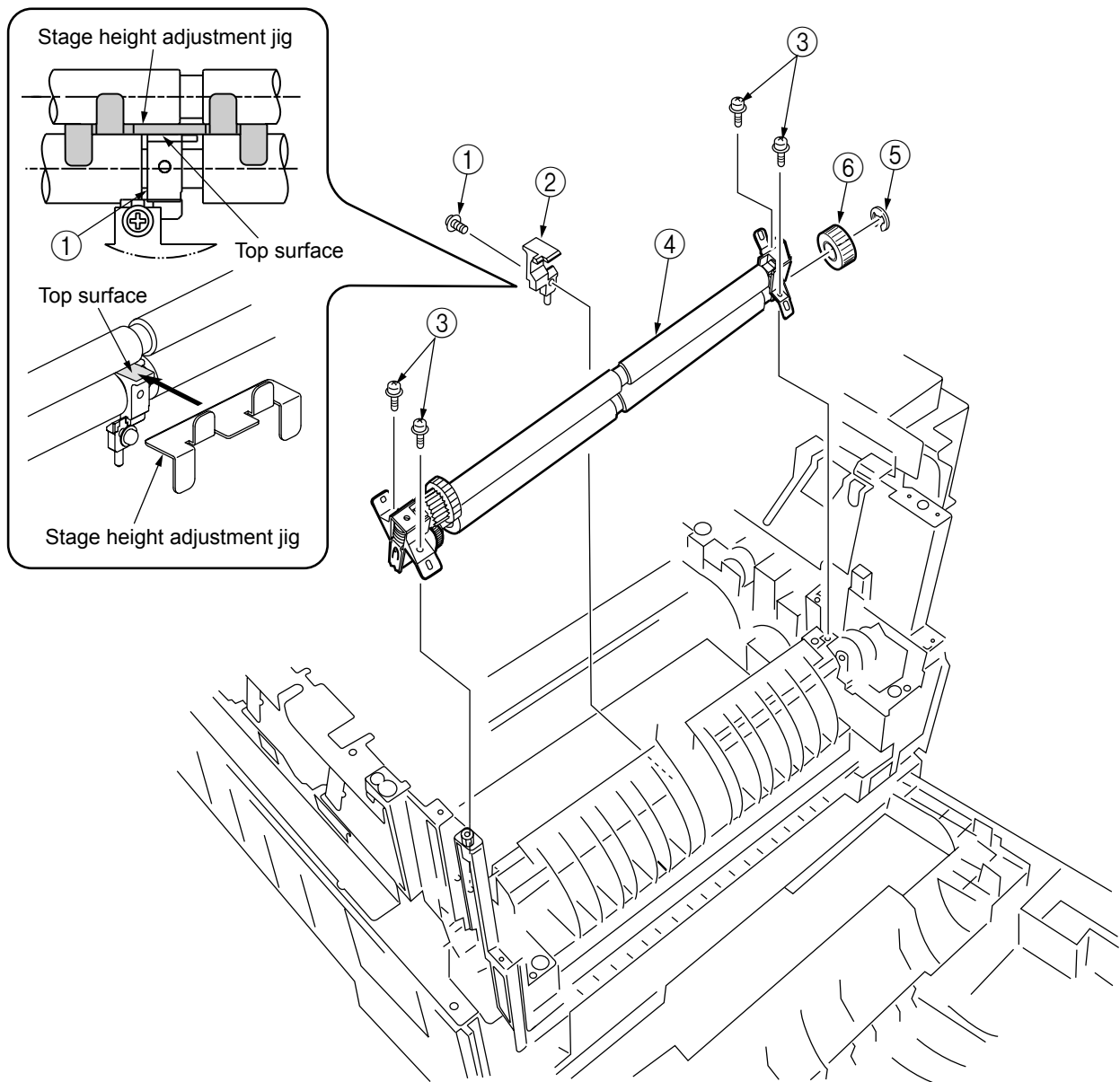

Figure 2-3-17 Registration Roller Assy (A)/ Registration Driver Gear (A)

### 2.3.18 Registration Roller Assy (B)

- (1) Remove the cassette Assy.
- (2) Open the front cover.
- (3) Remove the right side cover (see section 2.3.13).
- (4) Remove the left plate Assy (see section 2.3.23).
- (5) Remove the registration clutch (see section 2.3.19).
- (7) Unscrew the four screws ①, and pull out the registration Assy (B) ① in the arrow direction.

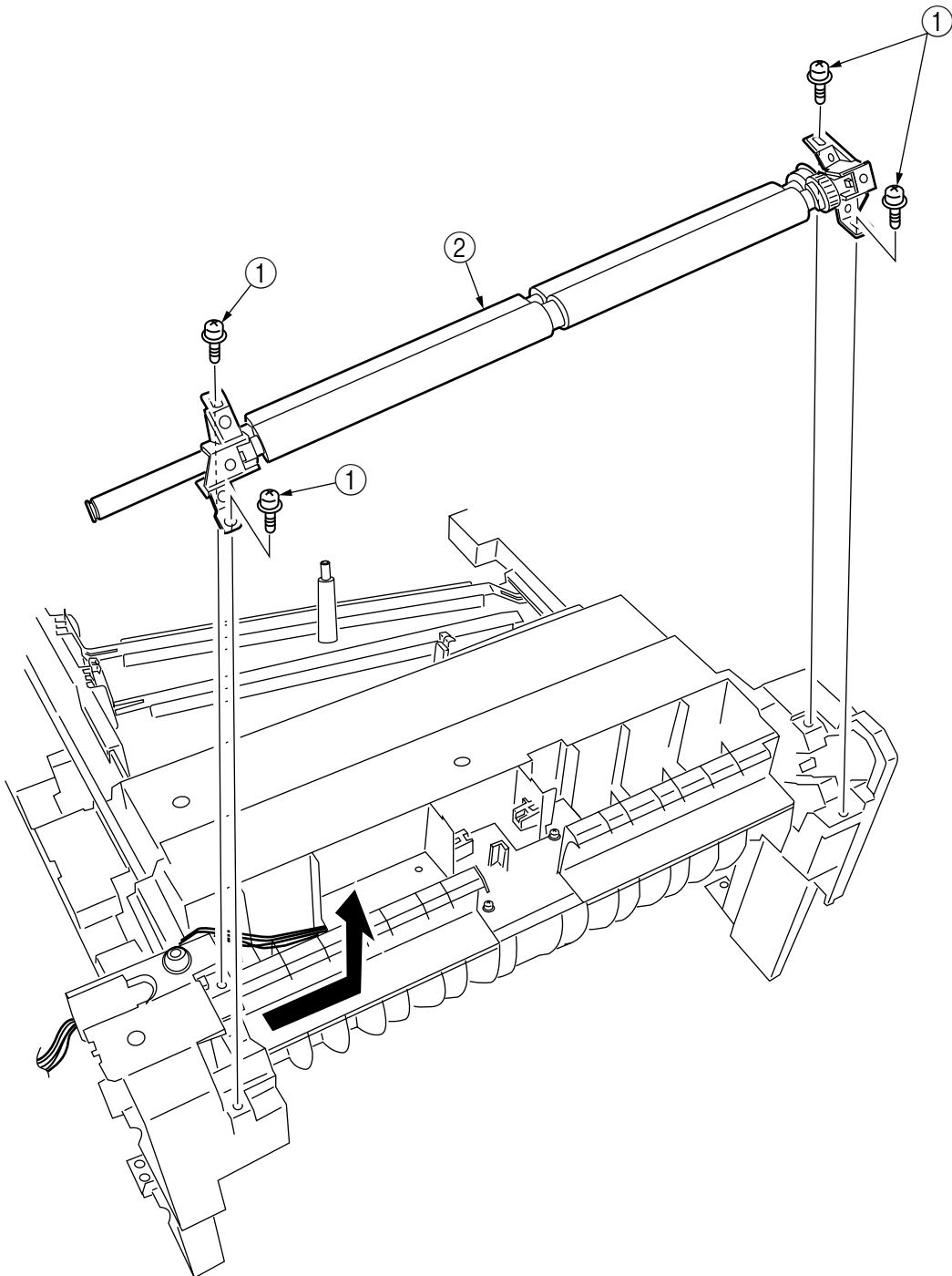

Figure 2-3-18 Registration Roller Assy (B)



### 2.3.19 Registration Clutch and Registration Motor Assy

- (1) Remove the left side cover (see section 2.3.12).
- (2) Remove the left plate Assy (see section 2.3.23).
- (3) Remove the connector and the E ring ①, then remove the two screws ②, the earth ③ and the registration clutch ④.
- (4) Remove the connector to remove the two screws ⑤ and the registration motor Assy ⑥.

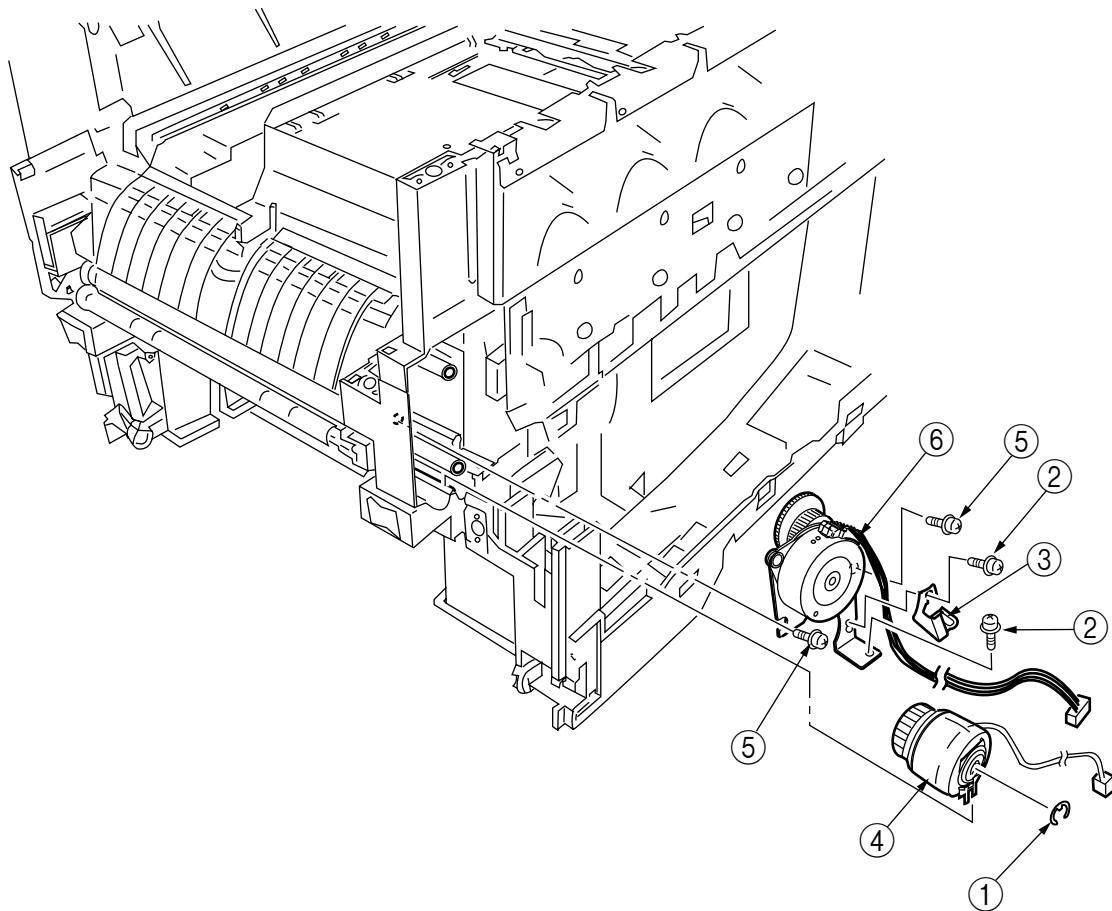

Figure 2-3-19 Registration Clutch and Registration Motor Assy

### 2.3.20 Main Cooling Fan

- (1) Unhook the connector ①, and remove the screw ② and the cooling fan ③.

**Note!** When attaching the cooling fan, observe its correct orientation.

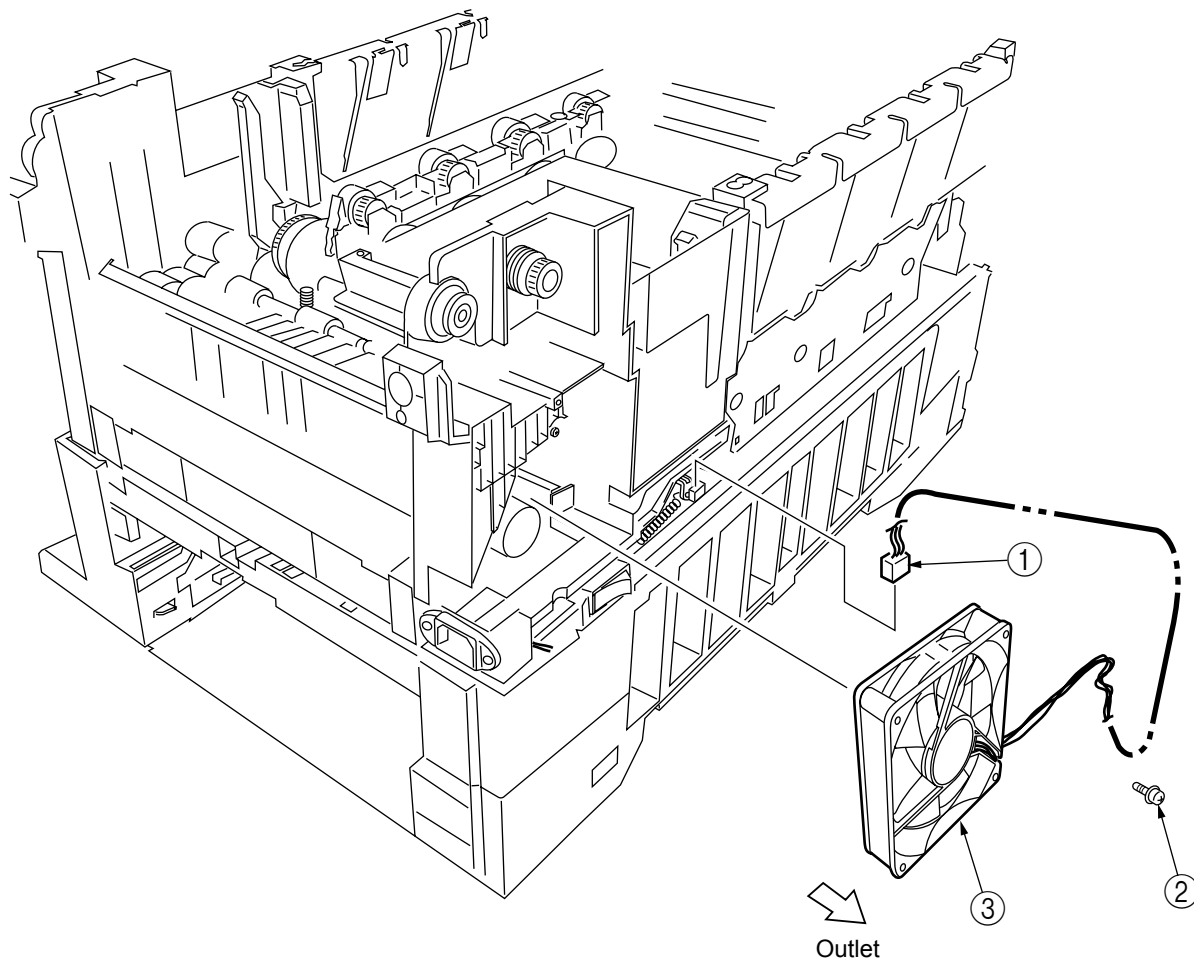

Figure 2-3-20 Main Cooling Fan

### 2.3.21 Color Registration Sensor Assy

- (1) Remove the two screws ① and the two connectors to demount the color registration sensor Assy ②.
- (2) Remove the earth plate B ③.

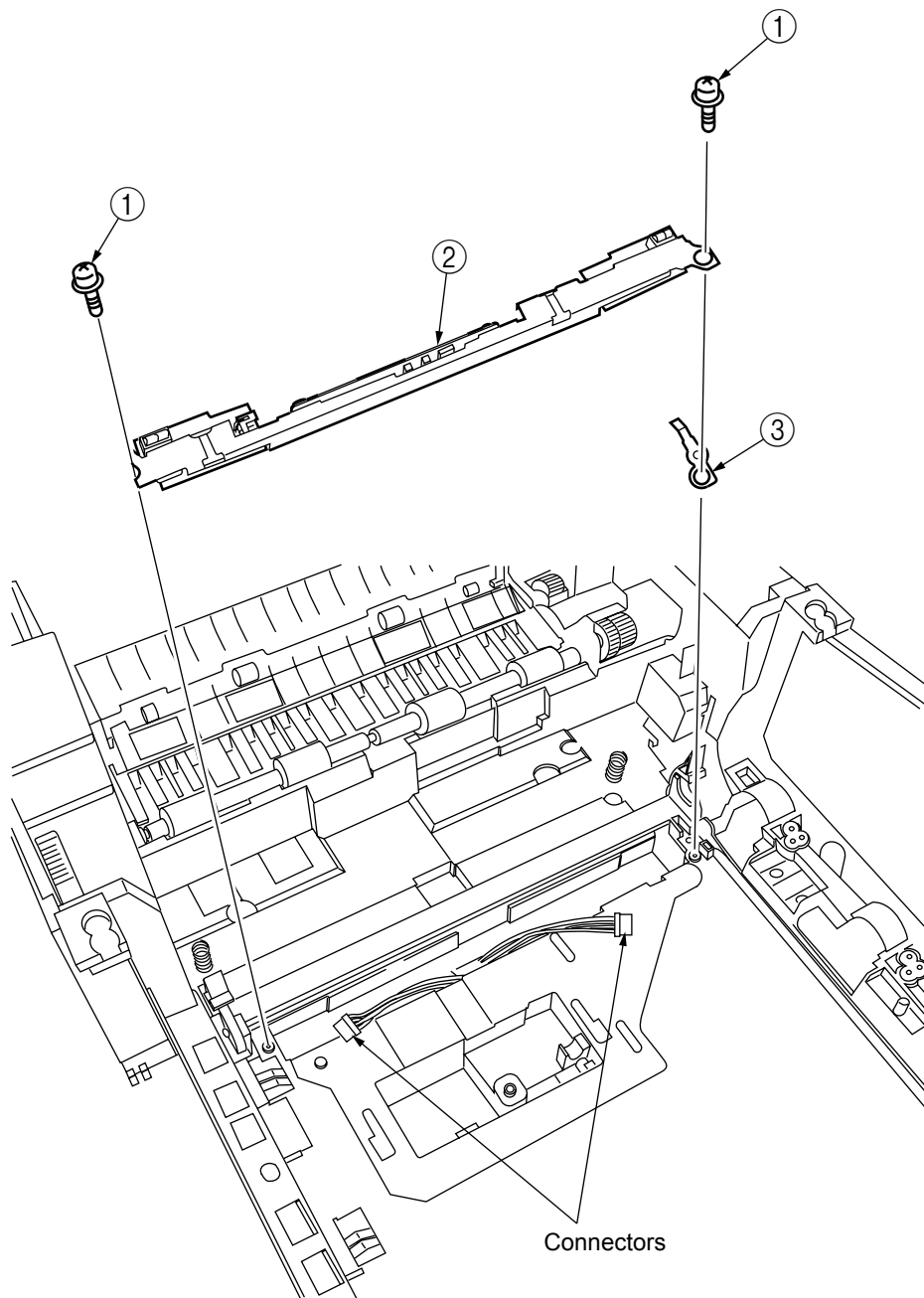

Figure 2-3-21 Color Registration Sensor Assy

### 2.3.22 Duplex Guide Assy

- (1) Unlatch and demount the duplex guide ①.

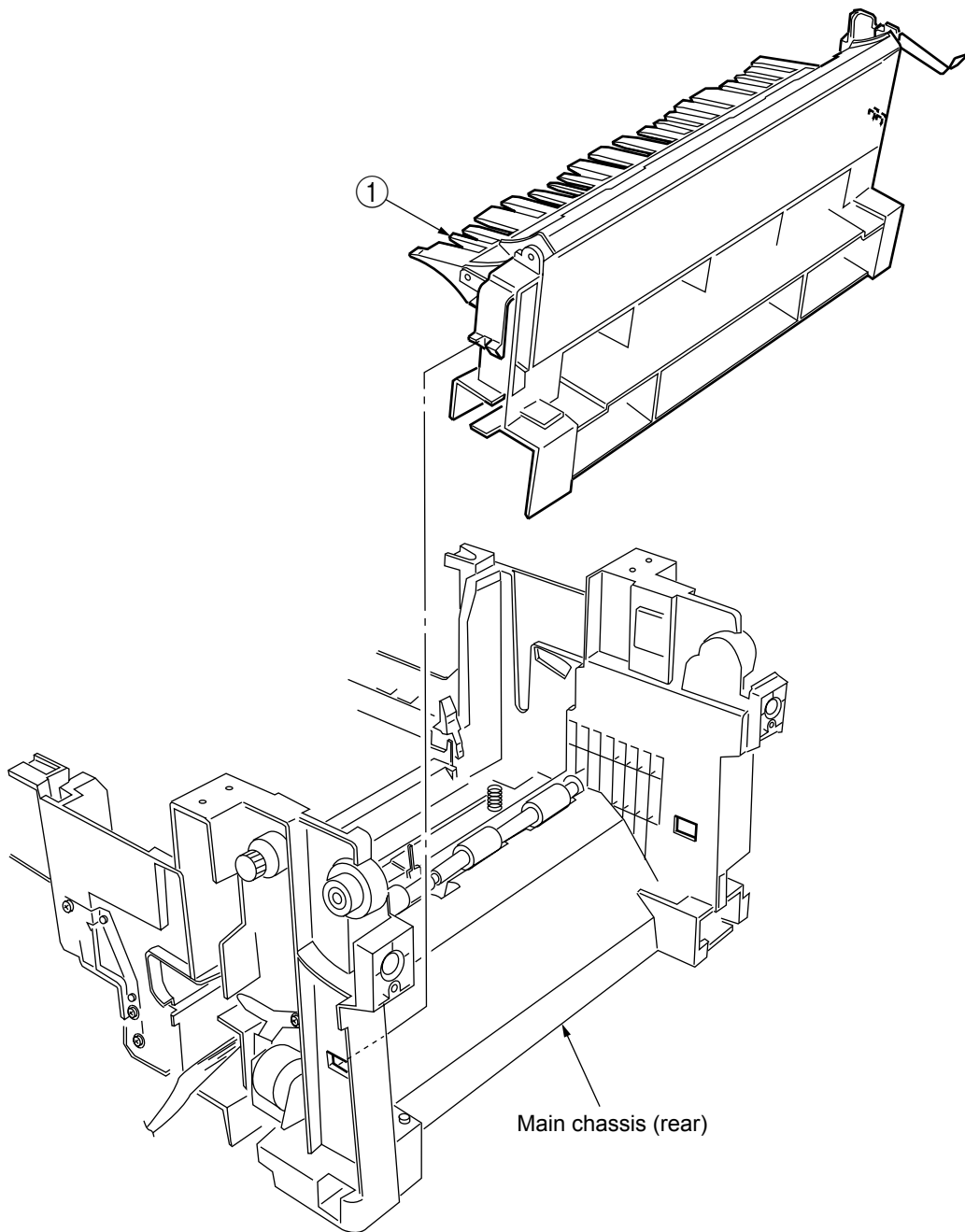

Figure 2-3-22 Duplex Guide Assy

### 2.3.23 Electrical Chassis Cooling Fan

- (1) Unscrew the four screws ① to remove the plate A ②.
- (2) Unscrew the thirty-four screws ③ to remove the shield plate B ④.
- (3) Remove the printer engine controller PWB (see section 2.3.24).
- (4) Unscrew the eleven screws ⑤ to remove the shield plate ⑥.
- (5) Unscrew the two screws ⑦ to demount the electrical chassis cooling fan ⑧.

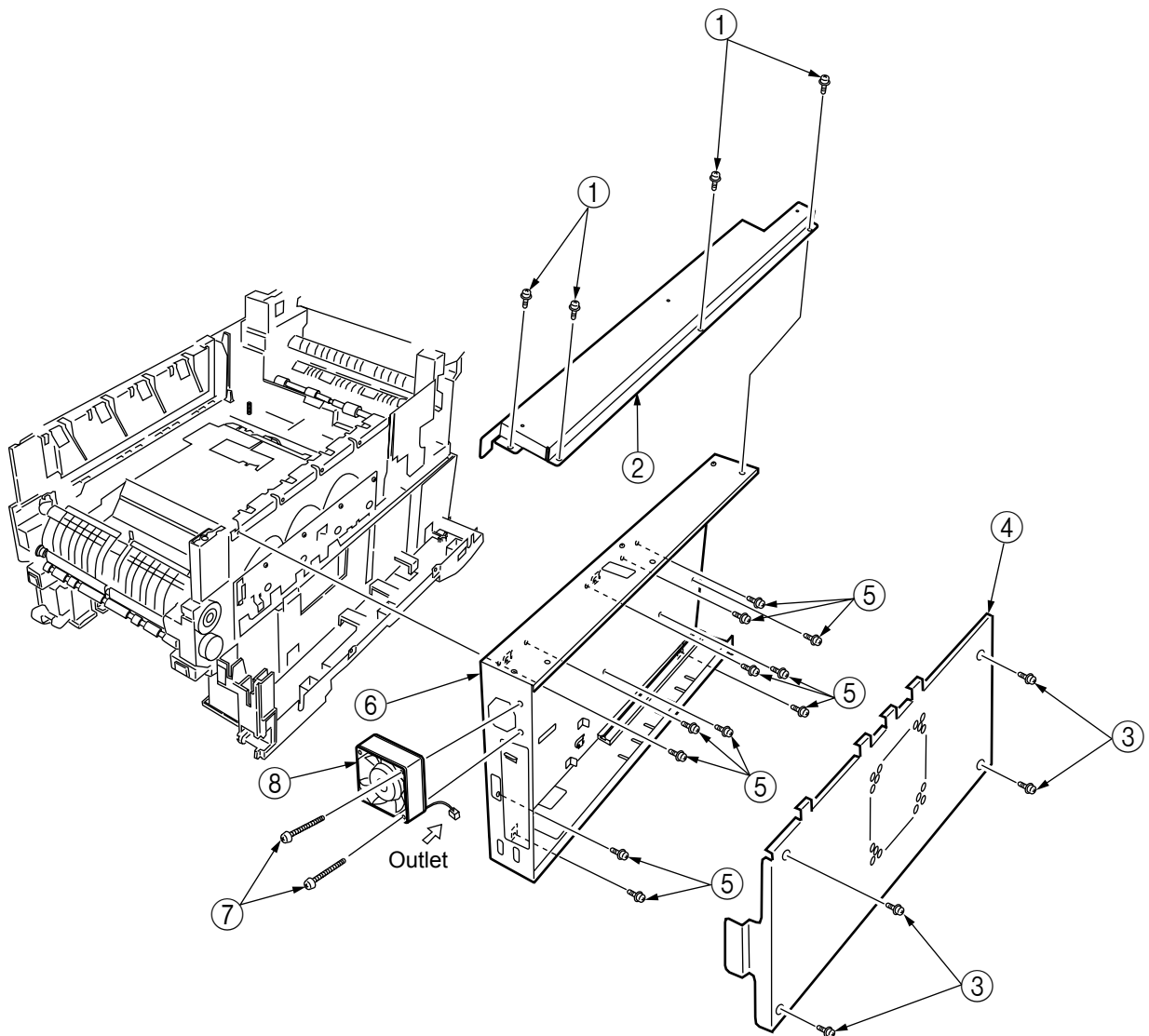

Figure 2-3-23 Electrical Chassis Cooling Fan

### 2.3.24 Printer Engine Controller PWB

- (1) Remove the right side cover (see section 2.3.13).
- (2) Remove the left plate Assy (see section 2.3.23).
- (3) Remove the five screws ① and all the connectors to demount the printer engine controller PWB ②.

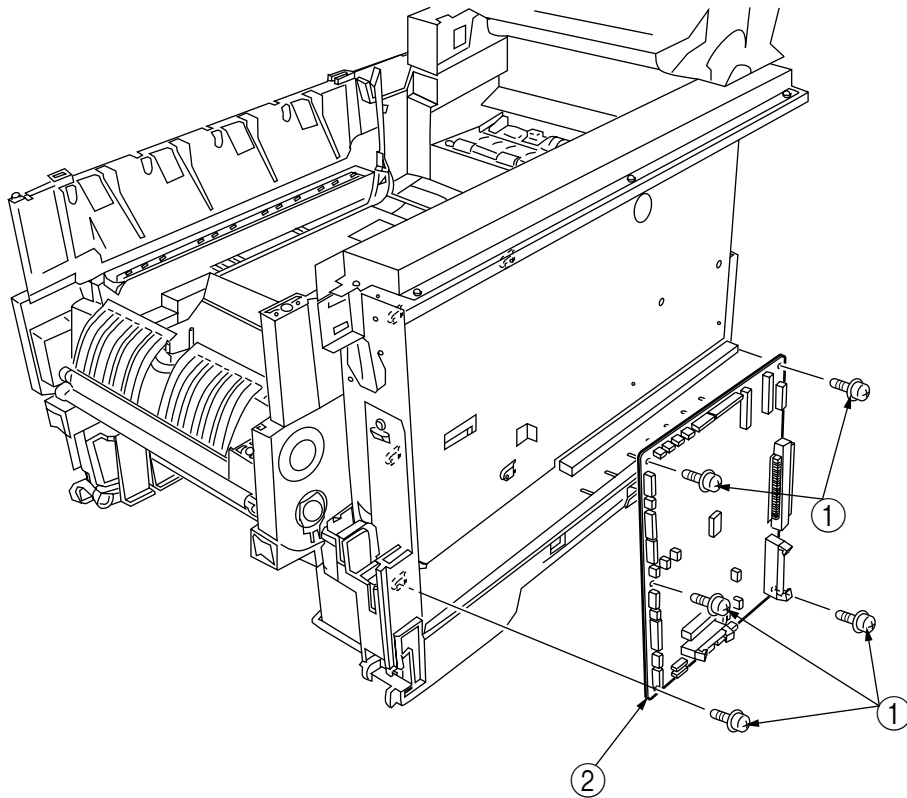

Figure 2-3-24 Printer Engine Controller PWB

## 2.3.25 Printer Unit Chassis

- (1) Unscrew the two screws ① and remove the AC inlet ②.
- (2) Unscrew the four black screws ③ and six screws ④ to detach the printer unit chassis ⑤.
- (3) Unscrew the four black screws ⑥ and remove the left top cover spring Assy ⑦.
- (4) Unscrew the four black screws ⑧ and remove the right top cover spring Assy ⑨.

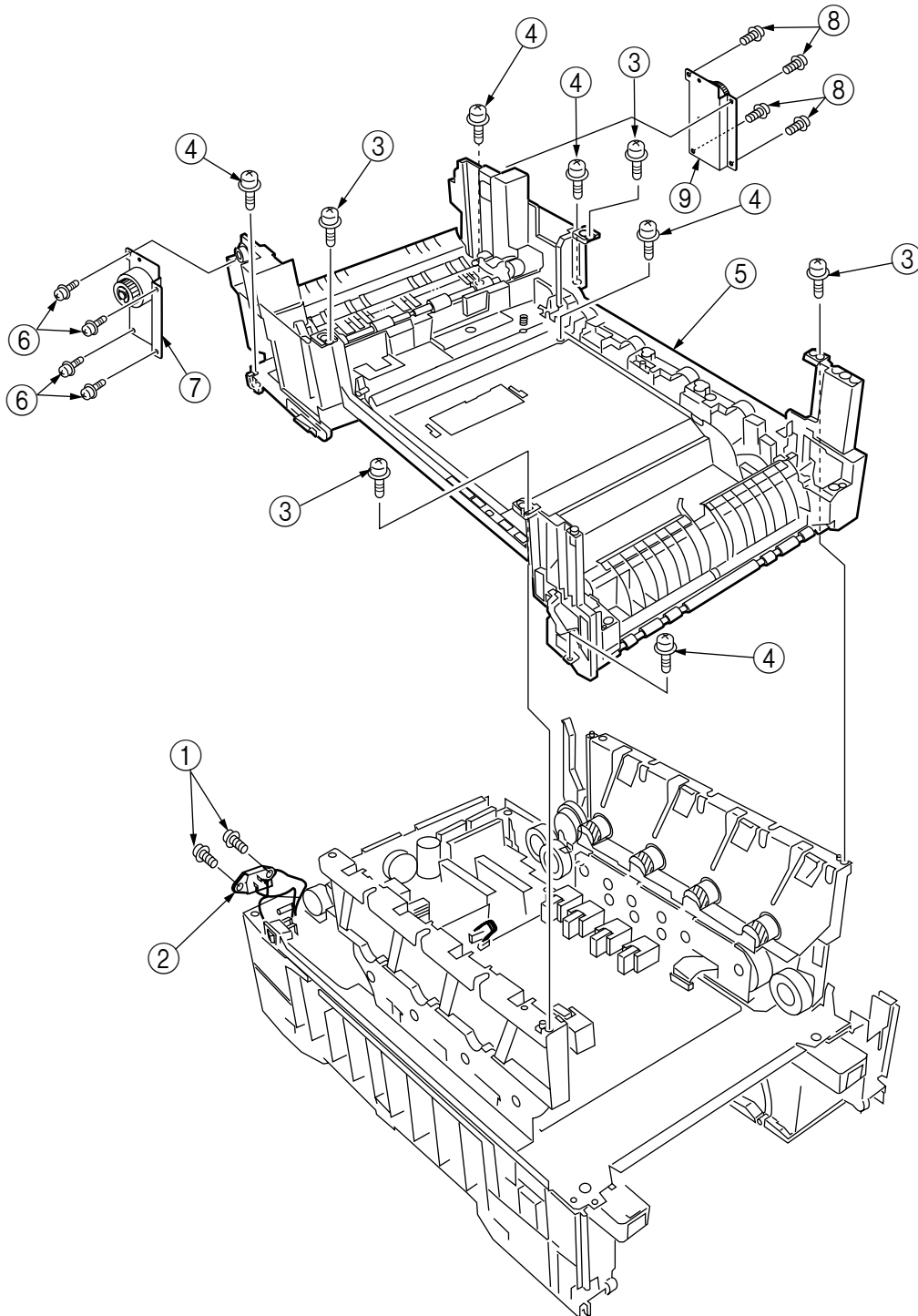

Figure 2-3-25 Printer Unit Chassis

### 2.3.26 Entrance Cassette Sensor Actuator

- (1) Remove the printer unit chassis (see section 2.3.25).
- (2) Turn over the main chassis.
- (3) Remove the two clamps with tweezers to demount the entrance cassette sensor actuator ①.

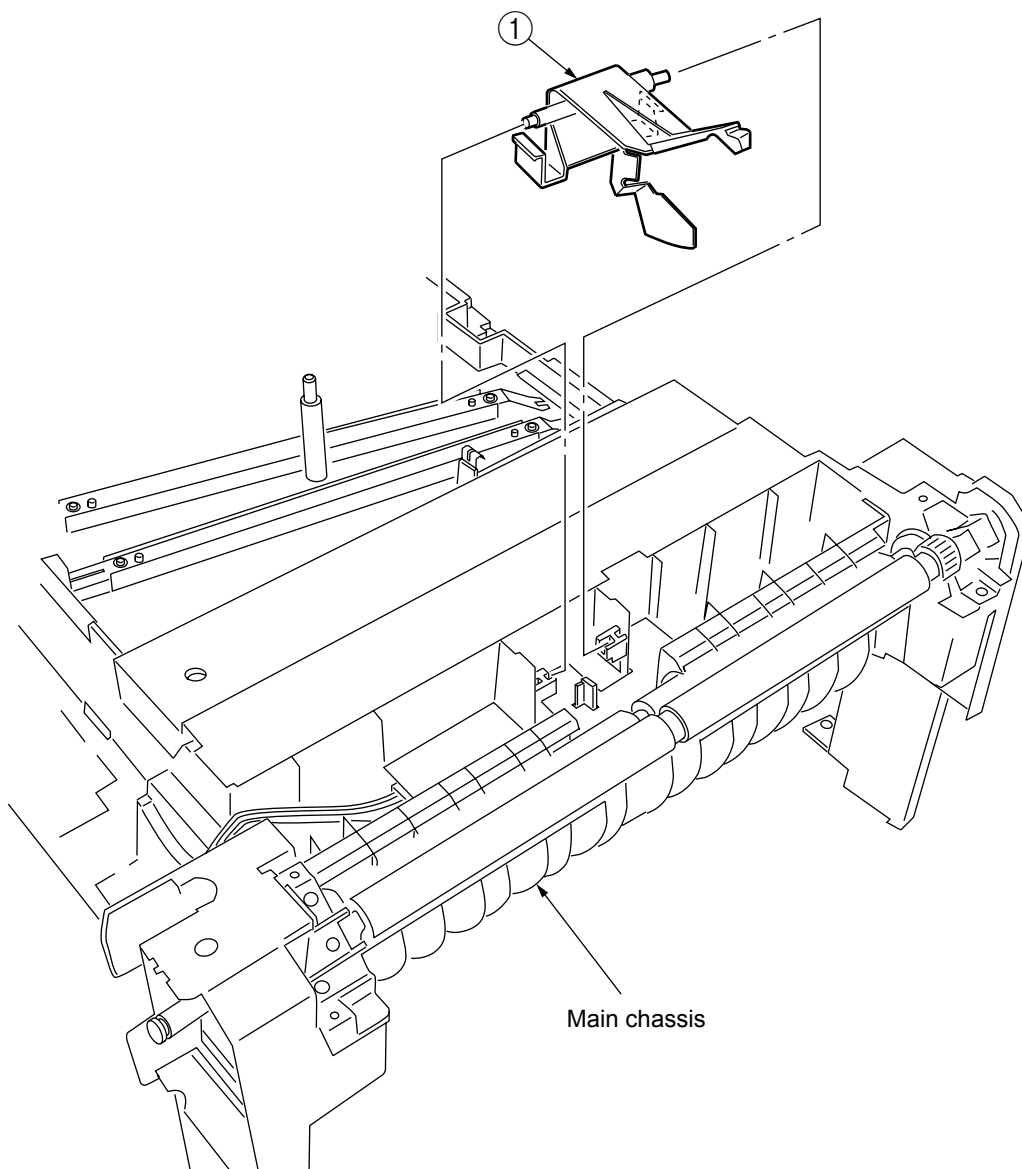

Figure 2-3-26 Entrance Cassette Sensor Actuator



### 2.3.27 Entrance Sensor PWB

- (1) Remove the registration roller Assy (B) (see section 2.3.18).
- (2) Remove the two screws ① to demount the entrance sensor PWB ②.

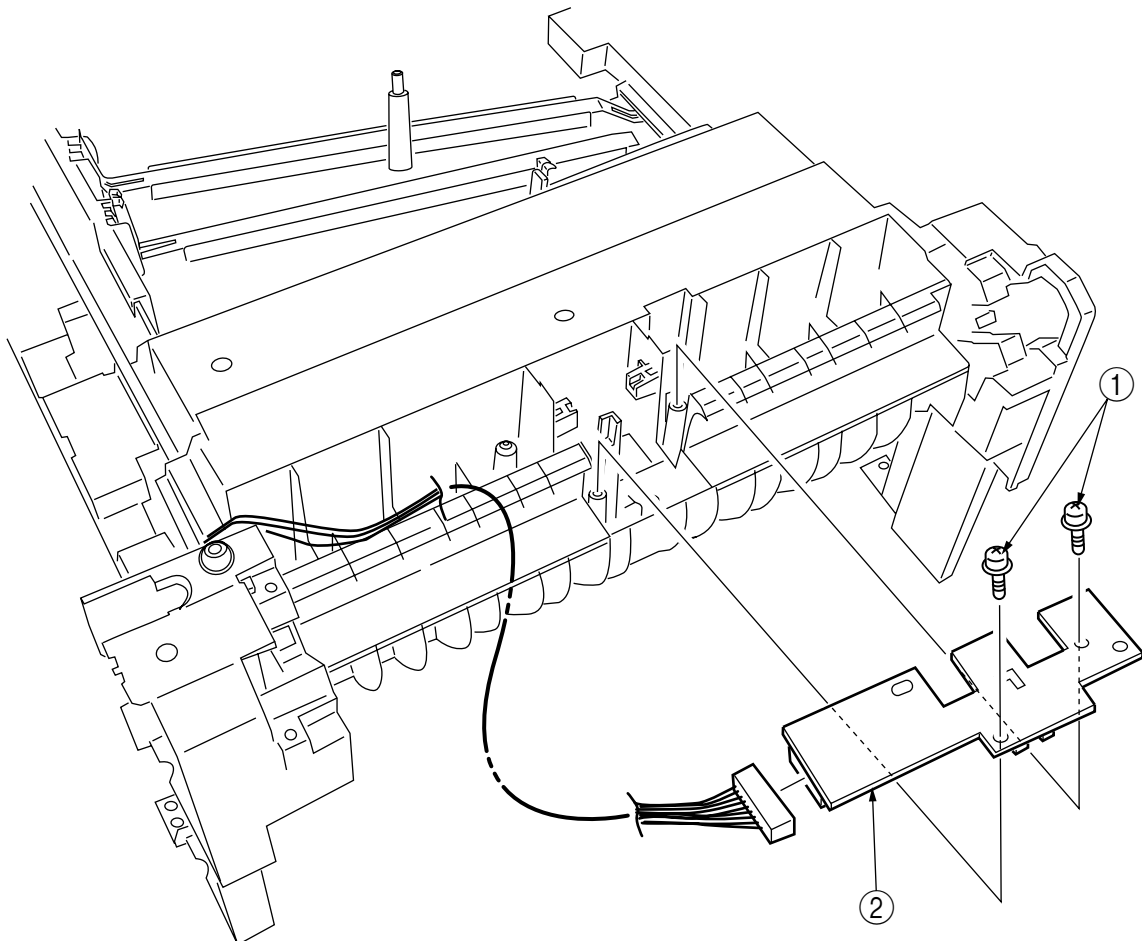

Figure 2-3-27 Entrance Sensor PWB

### 2.3.28 Entrance MT Sensor Actuator / Entrance Belt Sensor Actuator / Entrance Waste Chassis Sensor Actuator

- (1) Remove the entrance sensor PWB (R71) (see section 2.3.27).
- (2) Unlatch and detach the entrance MT sensor actuator ①.
- (3) Unlatch and detach the entrance belt actuator ②.
- (4) Release the latch and remove the Entrance Waste Chassis Sensor Actuator ③.

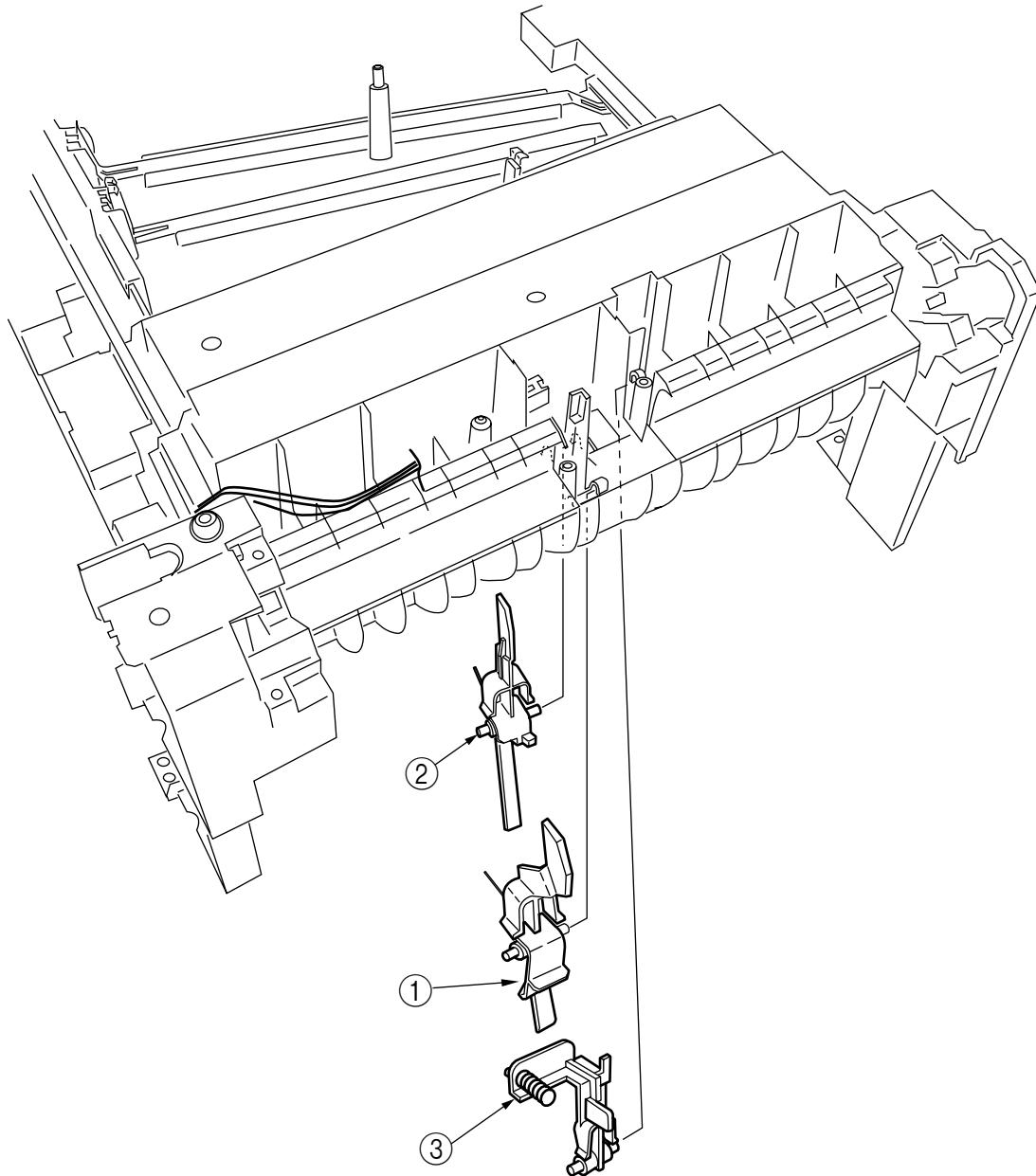

Figure 2-3-28 Entrance MT Sensor Actuator / Entrance Belt Sensor Actuator / Entrance Waste Chassis Sensor Actuator

## 2.3.29 Fuser Exit Roller

- (1) Unscrew the two screws ① to remove the duplex gate solenoid Assy ②.
- (2) Unscrew the screw ③ to remove the fuser exit roller contact ④.
- (3) Remove the fuser drive gear -A ⑤ and fuser drive gear -A ⑥.
- (4) Unscrew the screw ⑦ to remove the fuser drive gear -C ⑧.
- (5) Unlatch and detach the fuser drive gear -B ⑨ and fuser exit roller bush (R) ⑩.
- (6) Unlatch and detach the fuser exit roller bush (L) ⑪ and fuser exit roller ⑫.

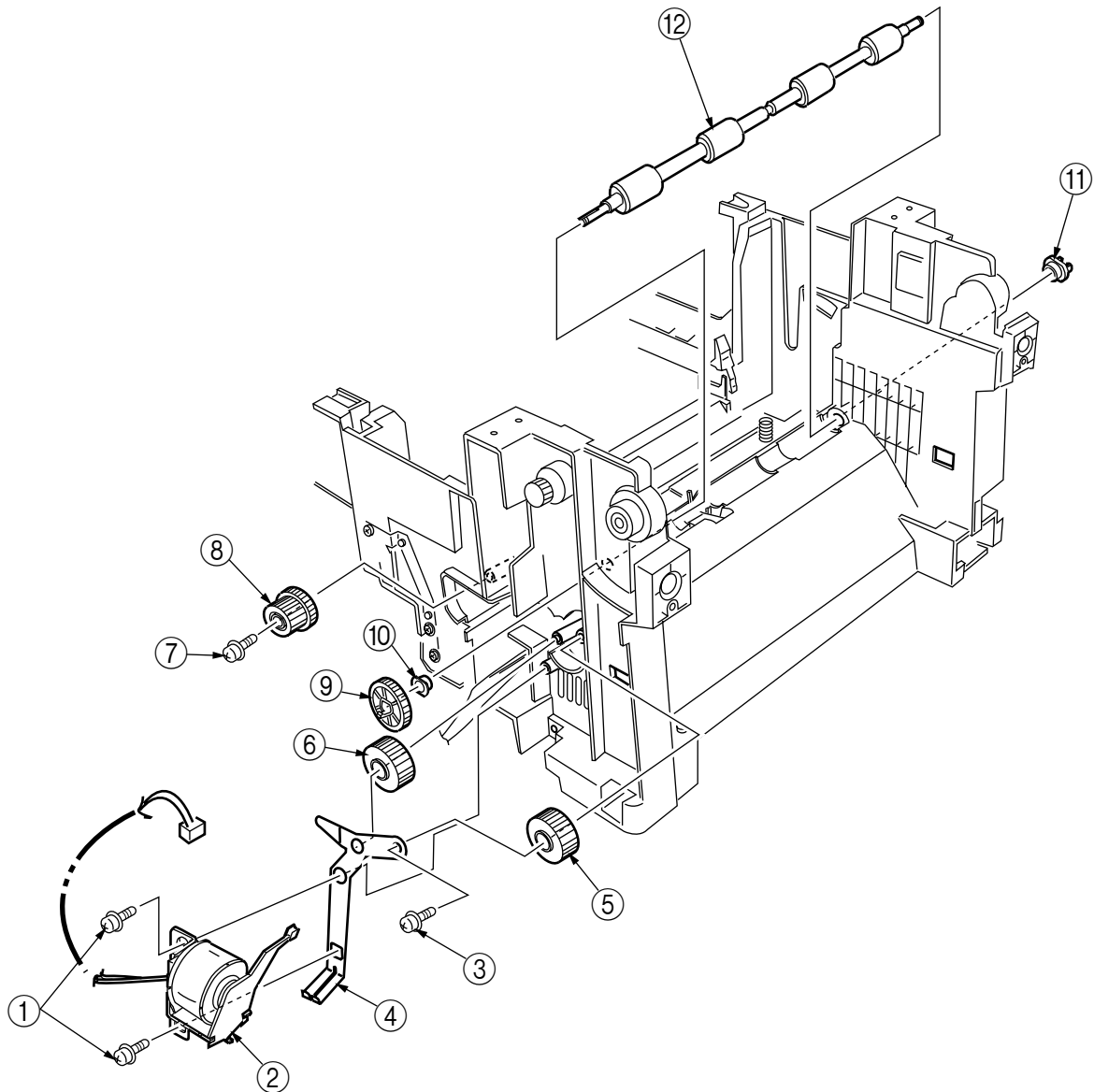

Figure 2-3-29 Fuser Exit Roller

### 2.3.30 Exit Sensor Assy

- (1) Remove the fuser exit roller (see section 2.3.29).
- (2) Remove the screw ① and connector to demount the (red and blue) exit sensor Assy ②.

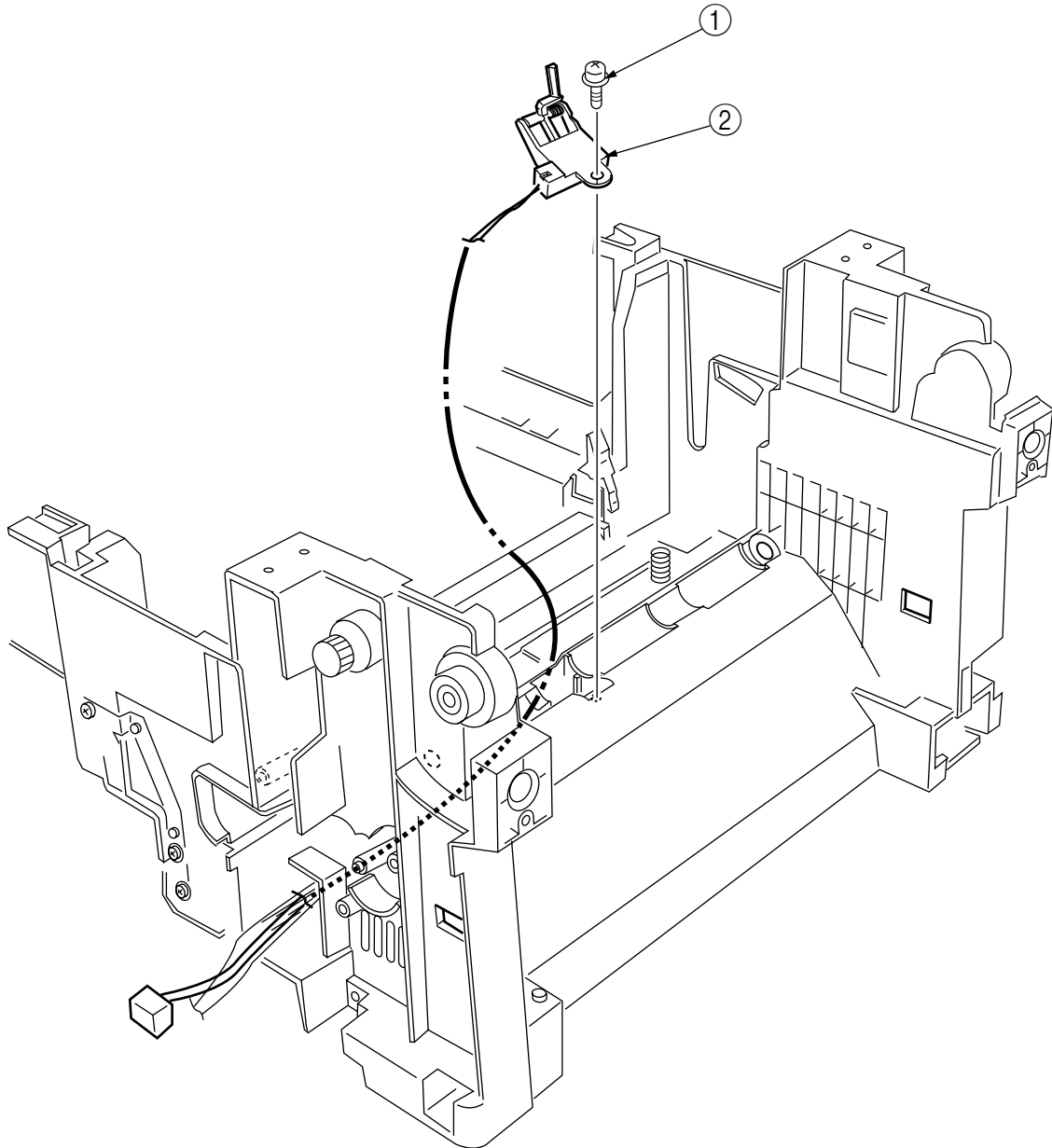

Figure 2-3-30 Exit Sensor Assy

### 2.3.31 Fuser Latching Handle (L)

- (1) Remove the latching handle spring ①.
- (2) Unscrew the screw ② to detach the fuser latching handle (L) ③.

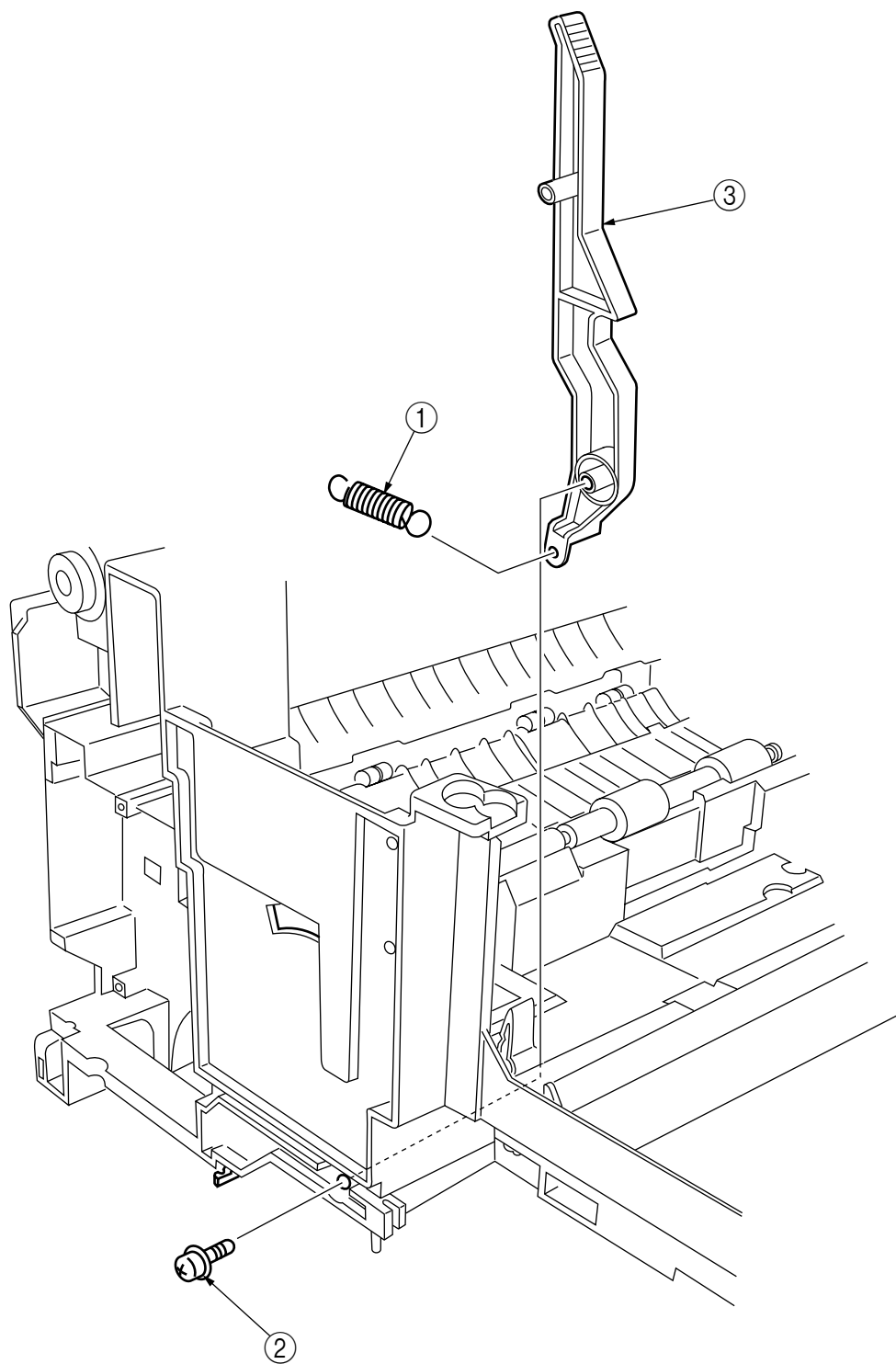

Figure 2-3-31 Fuser Latching Handle (L)

### 2.3.32 Belt Motor Assy

- (1) Remove the fuser latching handle (R) (see section 2.3.33).
- (2) Remove the two screws ① to detach the two connectors ②.
- (3) Demount the belt motor Assy ③.

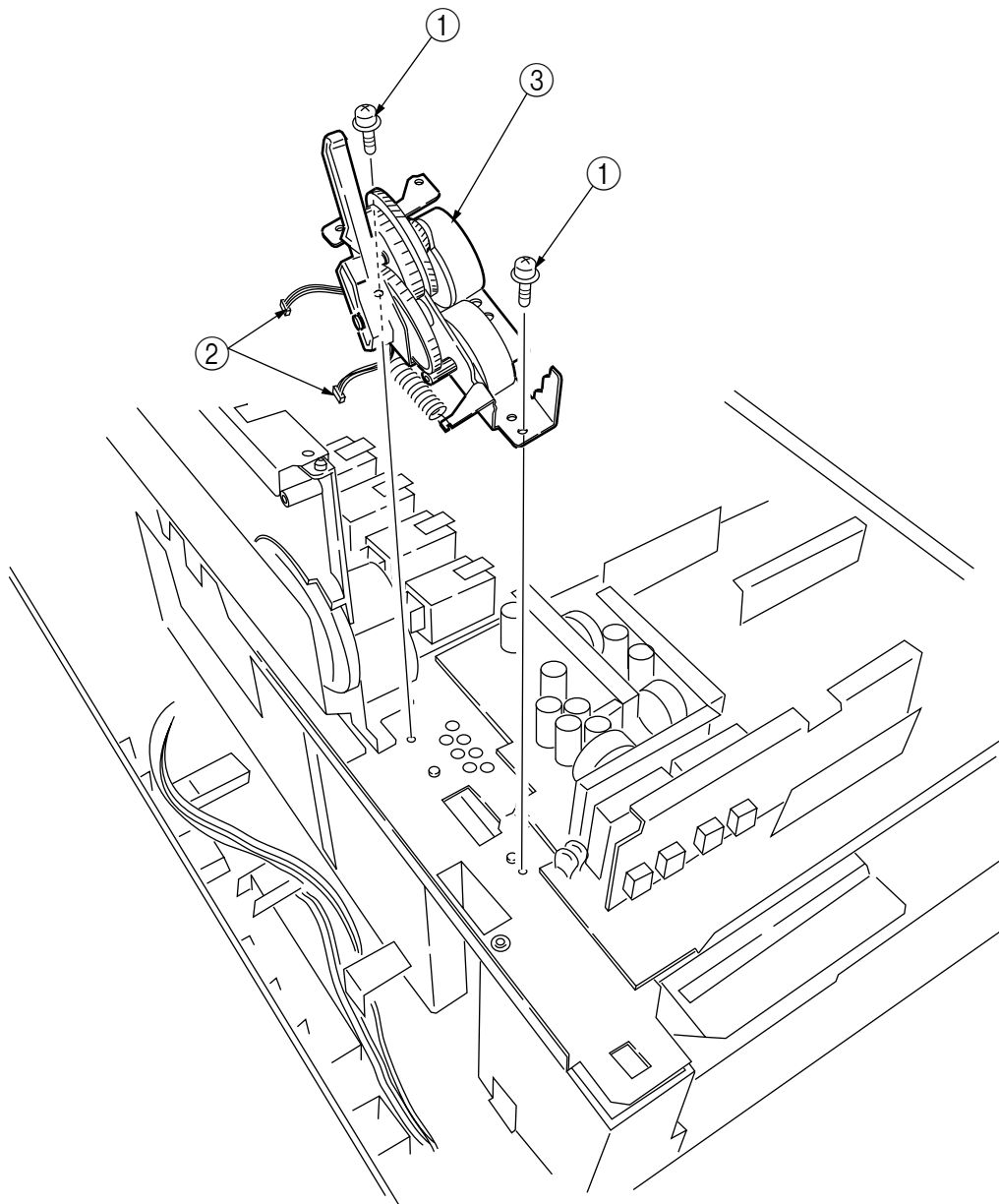

Figure 2-3-32 Belt Motor Assy

### 2.3.33 Fuser Latching Handle (R)

- (1) Remove the printer unit chassis (see section 2.3.25).
- (2) Remove the E ring ①.
- (3) Remove the fuser latching handle spring ② to detach the fuser latching handle (R) ③.

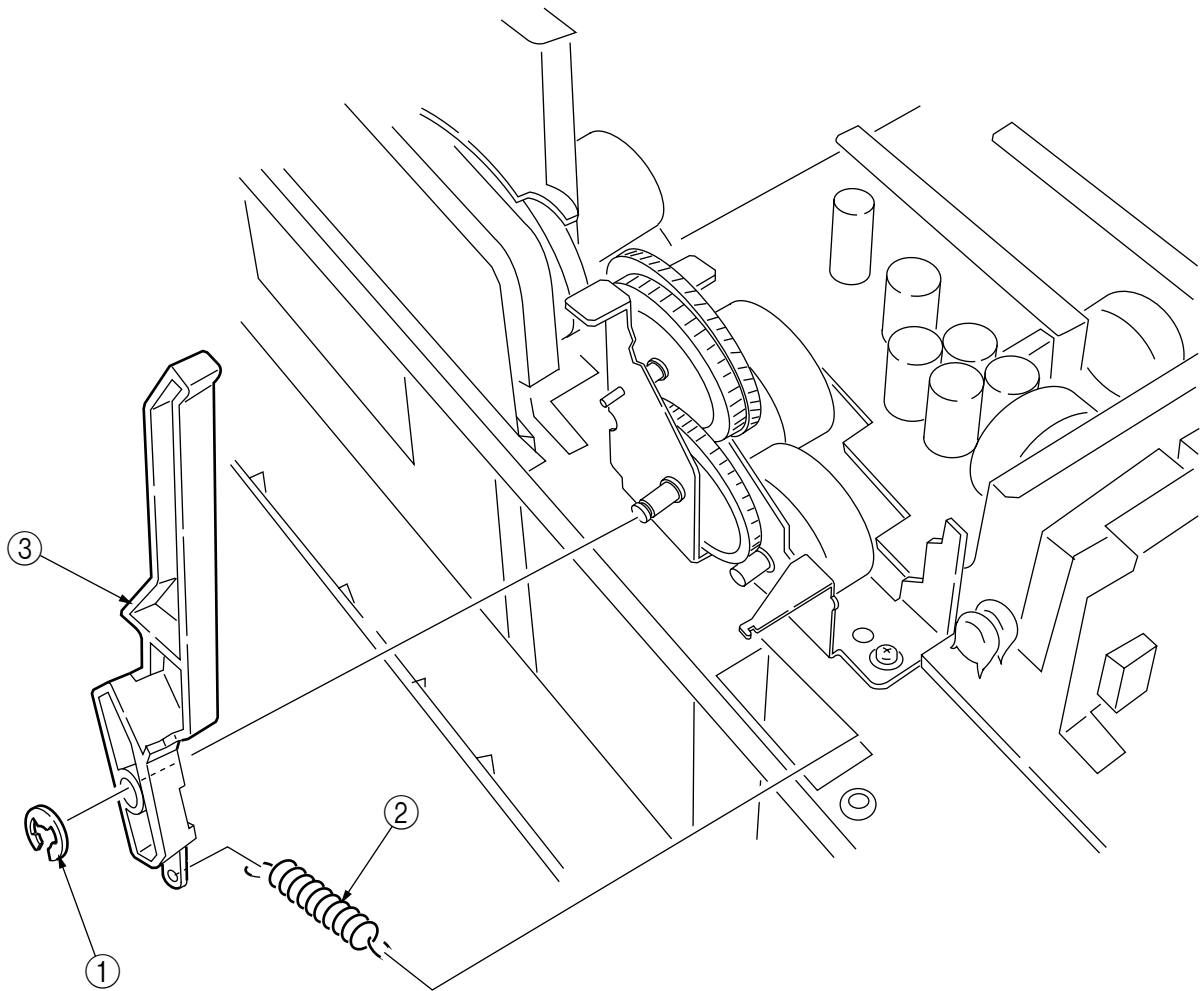

Figure 2-3-33 Fuser Latching Handle (R)

### 2.3.34 Main Motor Assy

- (1) Remove the belt motor Assy (see section 2.3.32).
- (2) Remove all the connectors.
- (3) Remove the four screws ① to demount the main motor Assy ②.

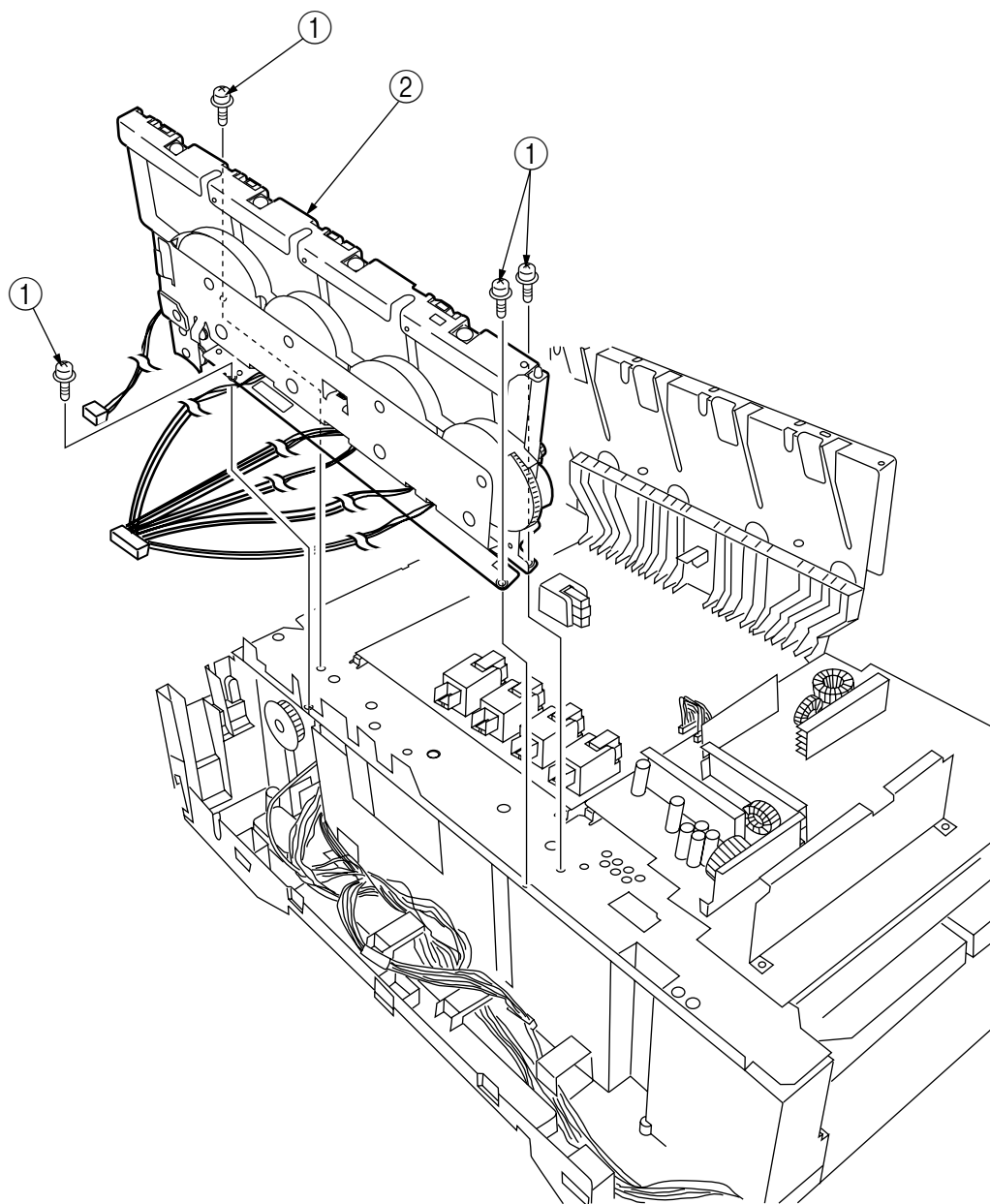

Figure 2-3-34 Main Motor Assy



### 2.3.35 Main Feeder Drive Motor

- (1) Remove the two screws ① to detach the main feeder drive motor ②.
- (2) Unscrew the screw ③ to remove the main feeder drive motor bracket ④.
- (3) Remove the main feeder drive motor gears A ⑤ and B ⑥.

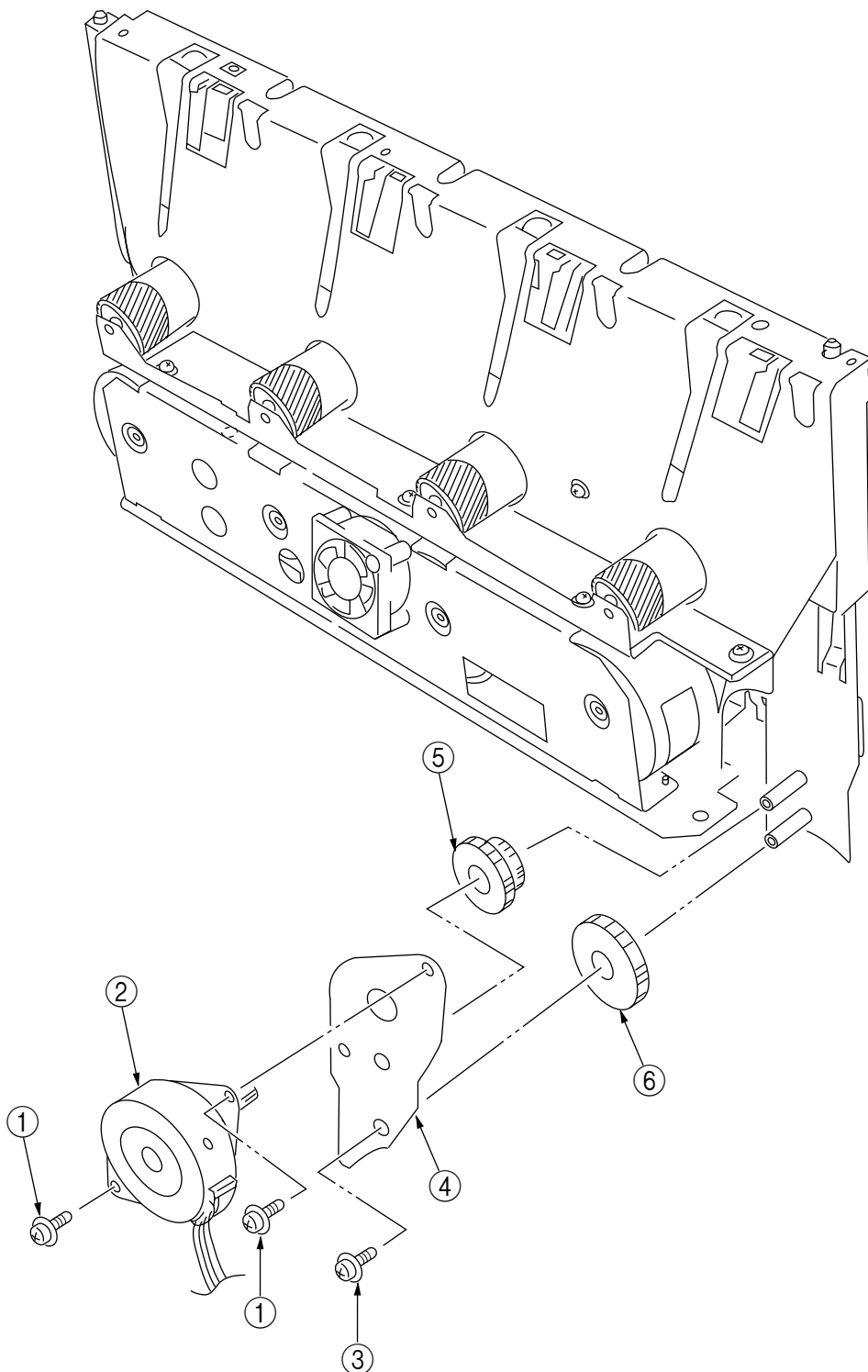

Figure 2-3-35 Main Feeder Drive Motor

### 2.3.36 Contact Assy/ Left Plate Assy

- (1) Remove the printer unit chassis (see section 2.3.25).
- (2) Remove the four screws ① to detach the left plate Assy ②.
- (3) Remove the screw ③ to detach the contact Assy ④.

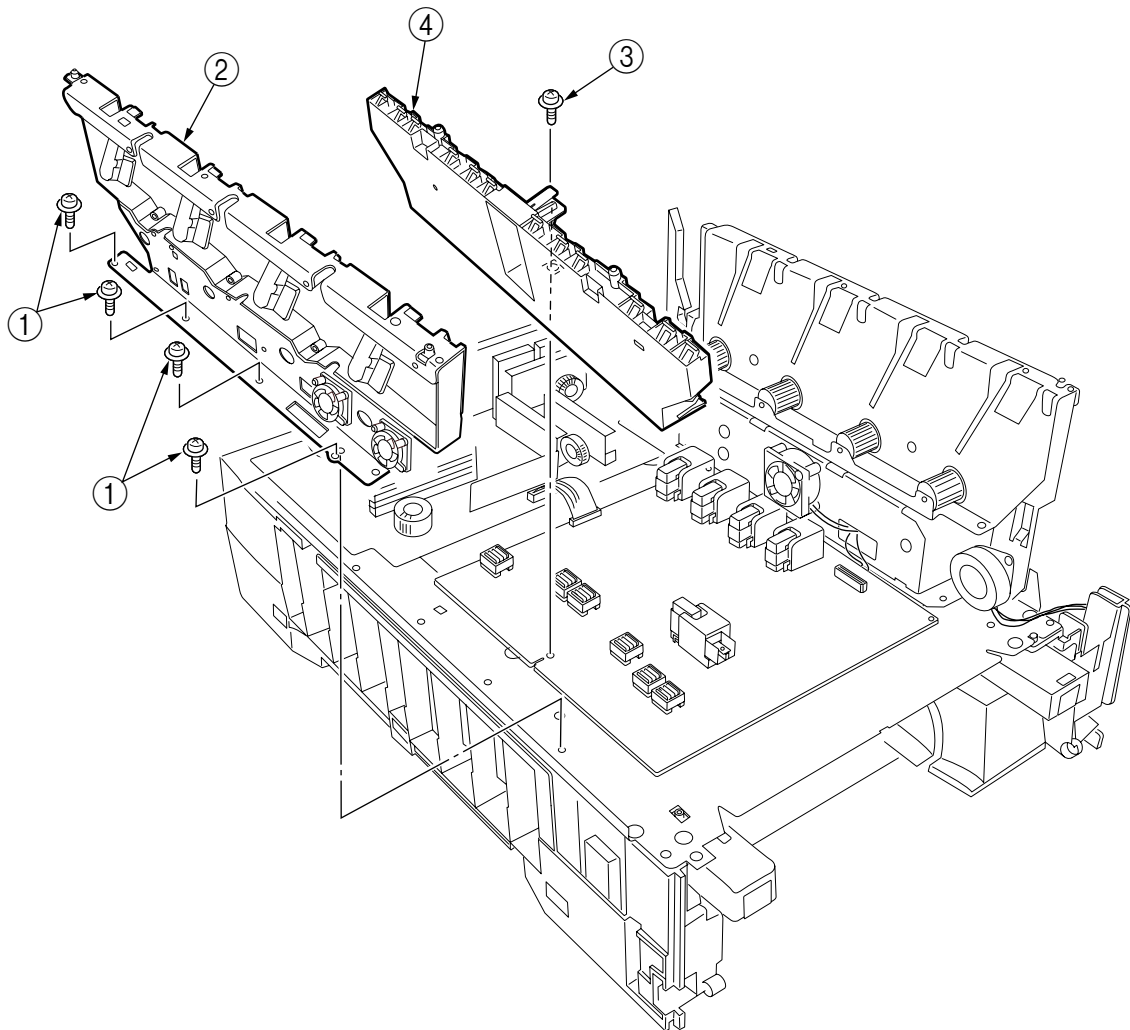

Figure 2-3-36 Contact Assy/ Left Plate Assy

### 2.3.37 Low Voltage Power Supply

- (1) Remove the printer unit chassis (see section 2.3.25).
- (2) Unhook the connector ①.
- (3) Unscrew the screw ② to remove the earth cable ③.
- (4) Unscrew the six screws ④ to demount the low voltage power supply ⑤.

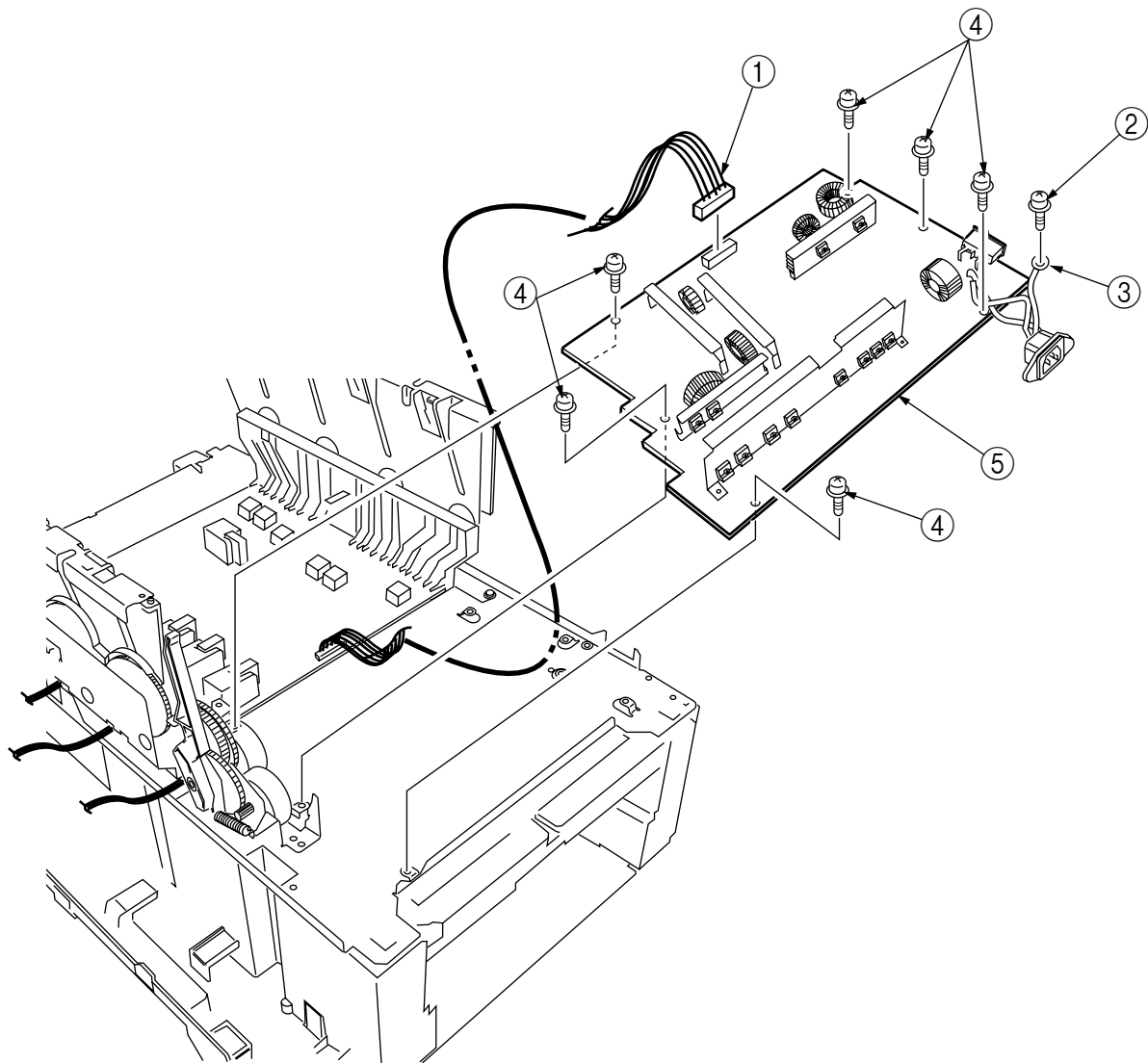

Figure 2-3-37 Low Voltage Power Supply

### 2.3.38 High voltage power supply

- (1) Remove the contact Assy (see section 2.3.36).
- (2) Unhook the connector of the high voltage power supply ①.
- (3) Remove the two screws ② to detach the high voltage power supply ① and the tape harness ③.

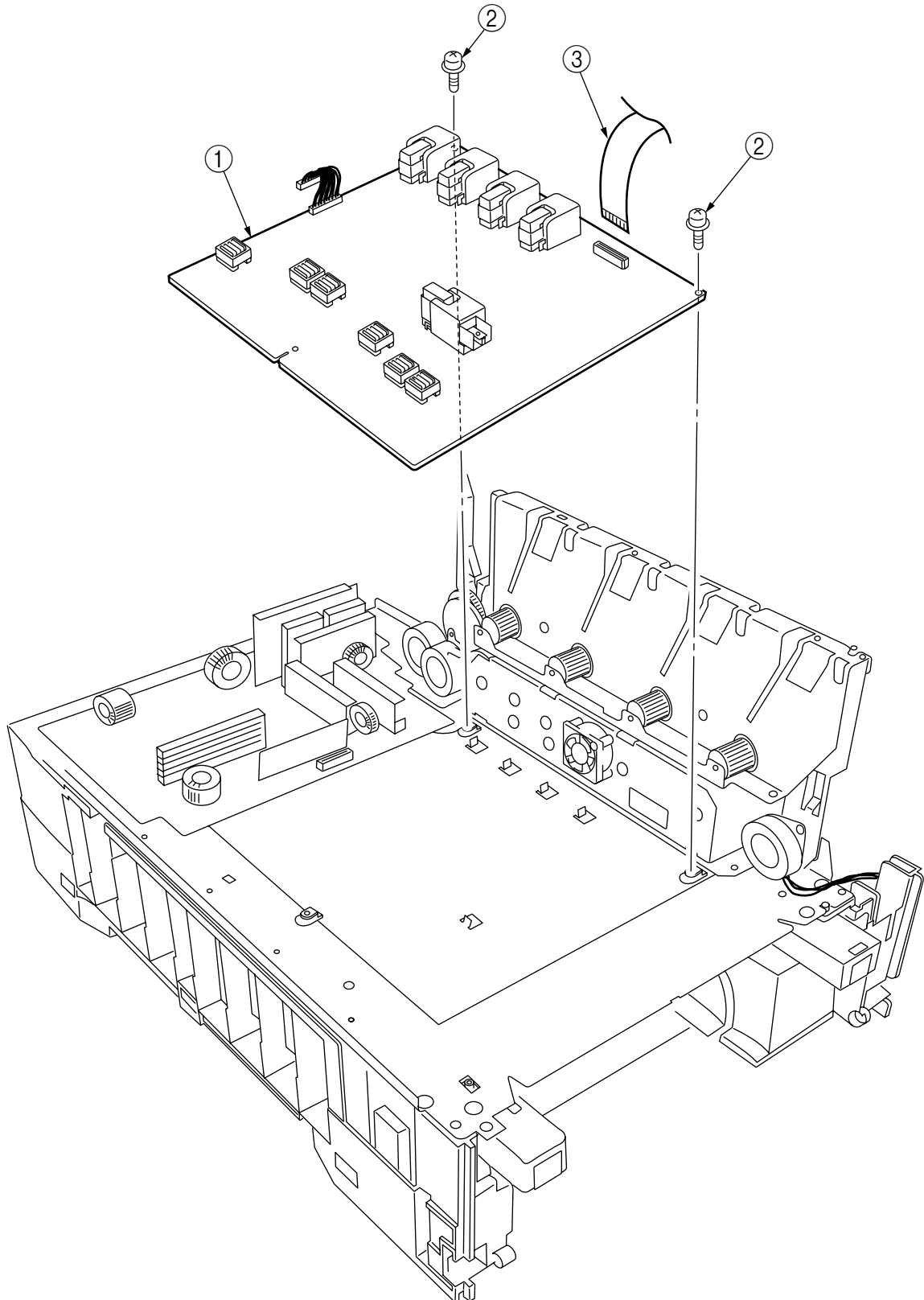

Figure 2-3-38 High Voltage Power Supply

### 2.3.39 Main Feed Assy

- (1) Remove the printer unit chassis (see section 2.3.25).
- (2) Remove the low voltage power supply and high voltage power supply (see sections 2.3.37 and 2.3.38).
- (3) Unscrew the five screws ① to remove the lower plate ②.
- (4) Unscrew the four screws ③ to demount the main feed Assy ④.
- (5) Unhook and remove the main feed drive gear ⑤.

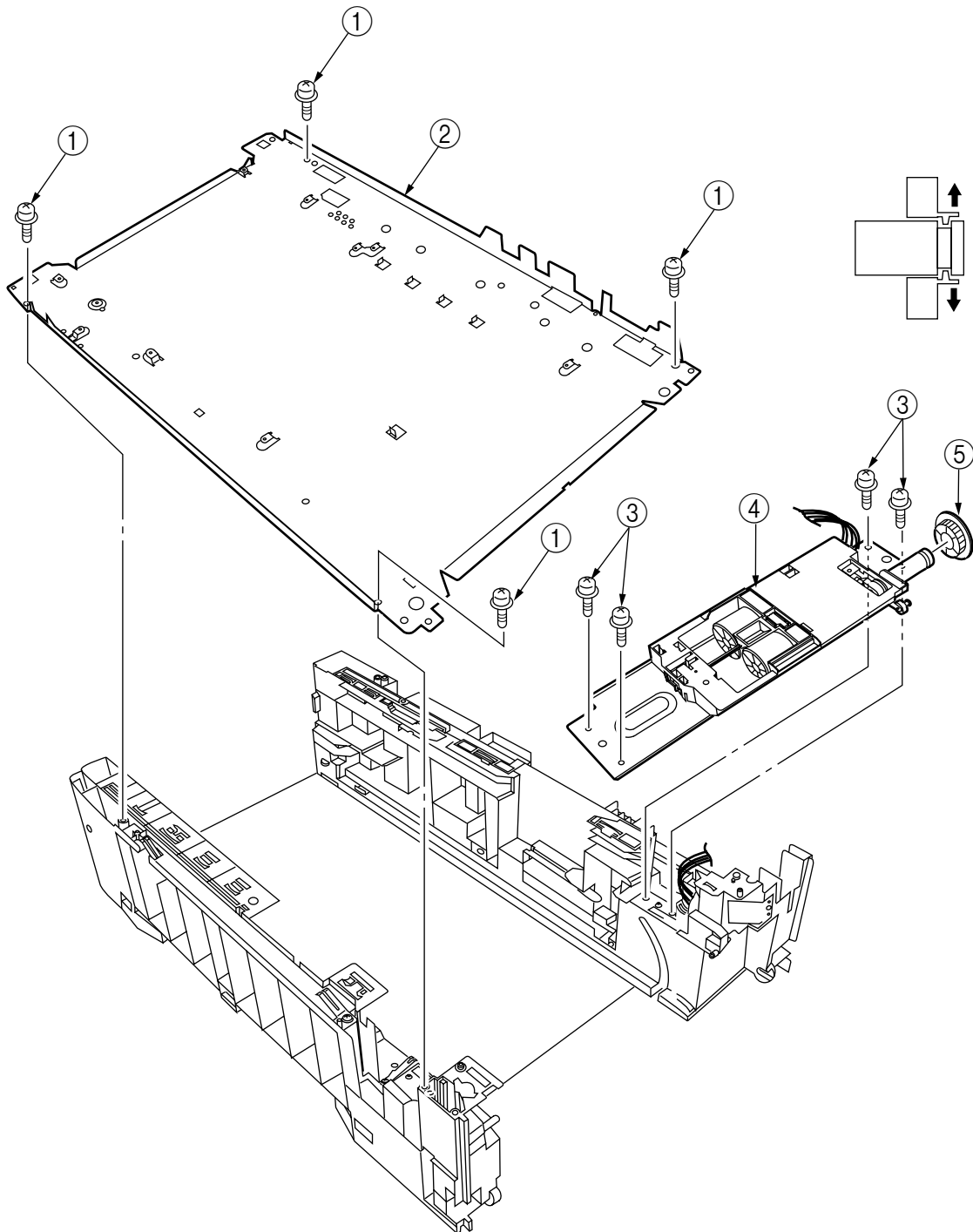

Figure 2-3-39 Main Feed Assy

### 2.3.40 Cassette/ Left Guide Assy

- (1) Remove the printer unit chassis (see section 2.3.25).
- (2) Remove the main feed Assy (see section 2.3.39).
- (3) Remove the three screws ① to detach the left cassette guide Assy ②. At the same time, the earth plate ③ becomes detached.
- (4) Remove the cassette lift spring ④, then remove the plastic slide ⑤, the cassette lift arm (L) ⑥ and the plastic roller ⑦.
- (5) Remove the two feet ⑧.
- (6) Remove the cassette lock spring ⑨, then remove the cassette lock ⑩.

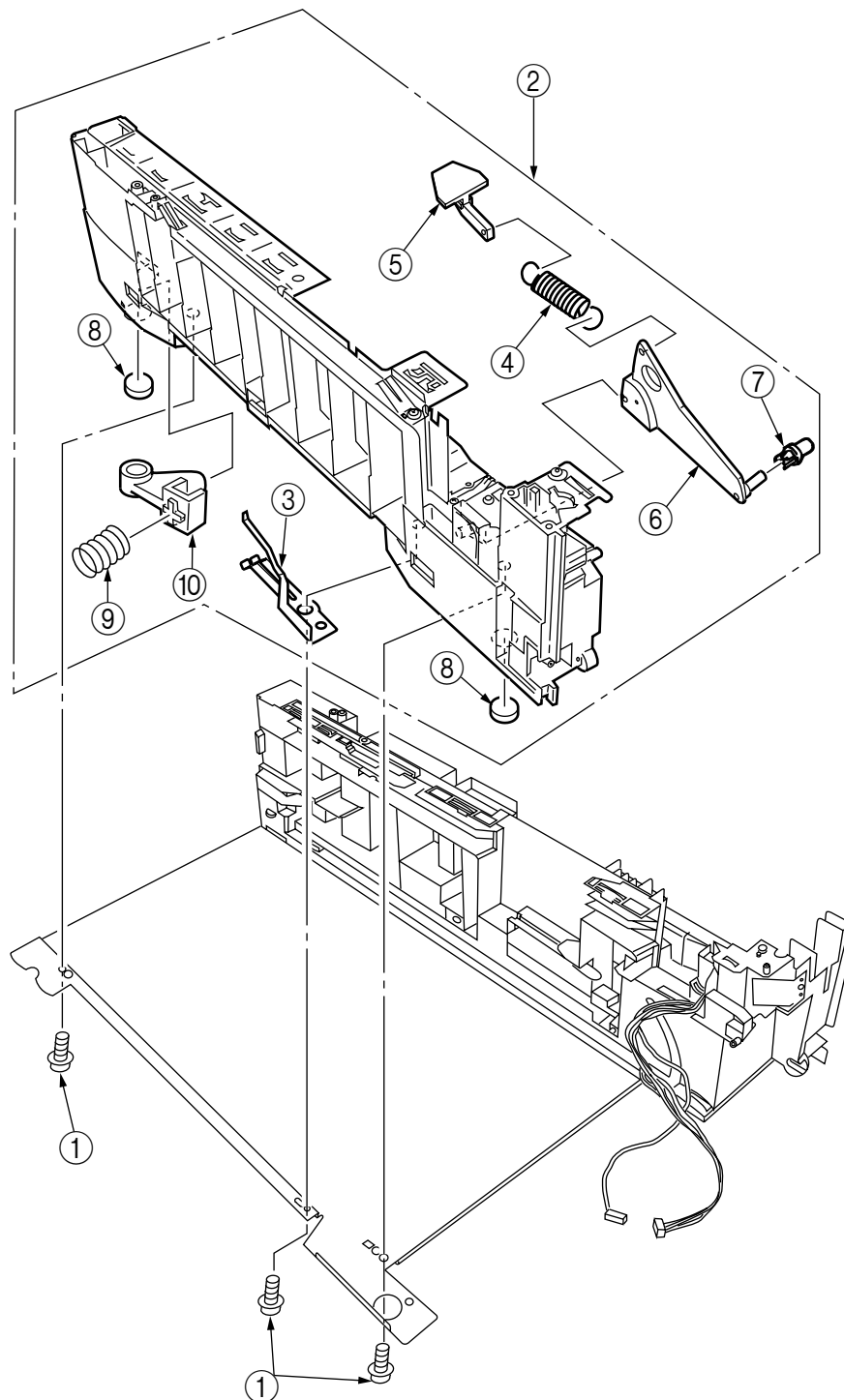

Figure 2-3-40 Cassette/ Left Guide Assy

## 2.3.41 Cassette/ Right Guide Assy

- (1) Remove the printer unit chassis (see section 2.3.25).
- (2) Remove the main feed Assy (see section 2.3.39).
- (3) Remove the five screws ① to detach the right cassette guide Assy ②. At the same time, the earth plate ③ becomes detached.
- (4) Remove the cassette lift spring ④, then detach the plastic slide ⑤, the cassette lift arm (L) ⑥ and the plastic roller ⑦.
- (5) Unscrew the screw ⑧ to remove the paper size actuator ⑨.
- (6) Unscrew the screw ⑩ to remove the paper size sensing PWB ⑪ in the downward direction.
- (7) Remove the two feet ⑫.
- (8) Remove the cassette lock spring ⑬, then remove the cassette lock ⑭.
- (9) Unscrew the two screws ⑮ to remove the 2nd tray connector ⑯.
- (10) Unscrew the screw ⑰, then remove the duplex Assy ground contact ⑱.

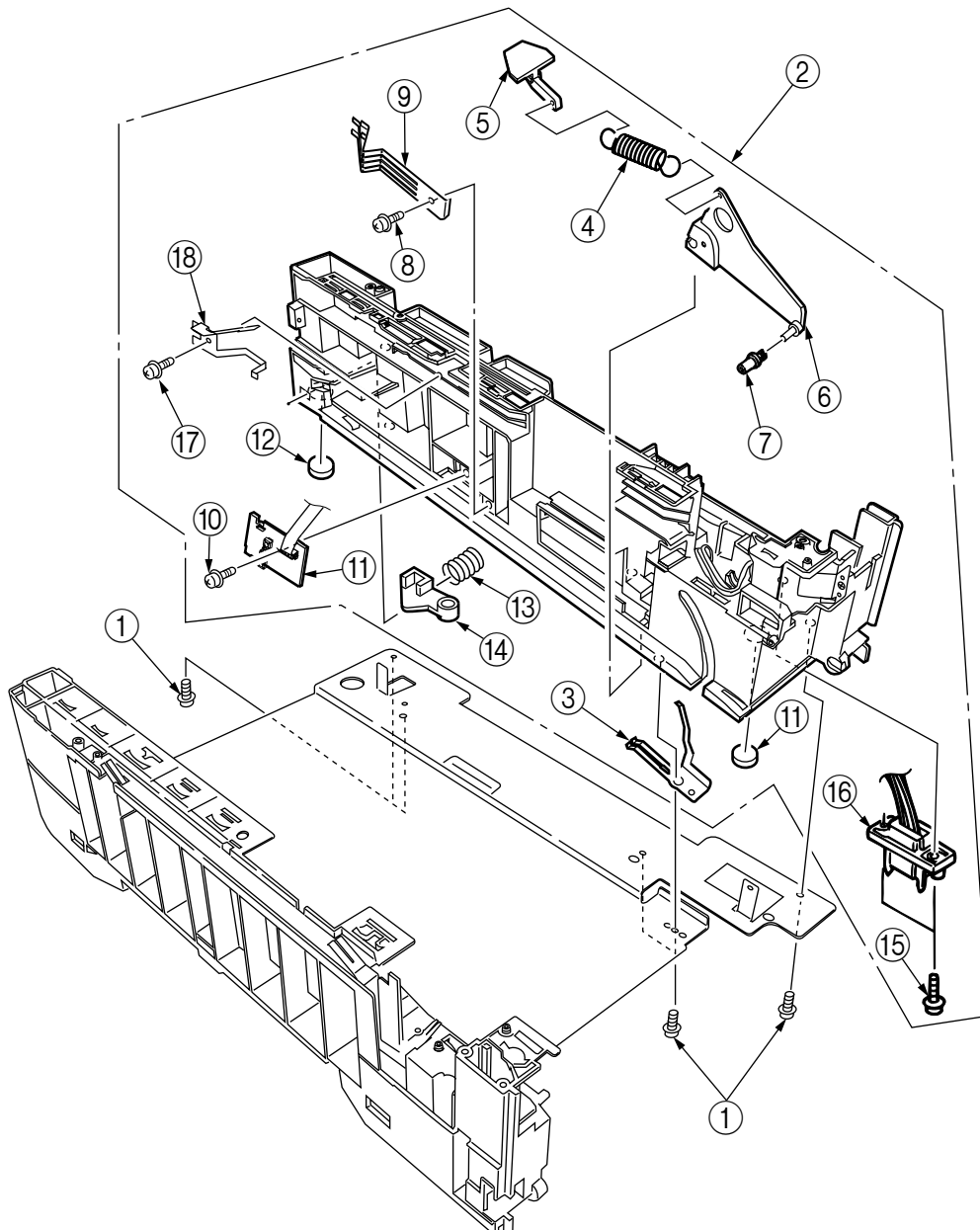

Figure 2-3-41 Printer Tray/ Right Guide Assy

### 2.3.42 Fuser Unit

- (1) Open the top cover ①.
- (2) Push the right and left fuser levers (blue) ② in the arrow direction to detach the fuser unit ③.

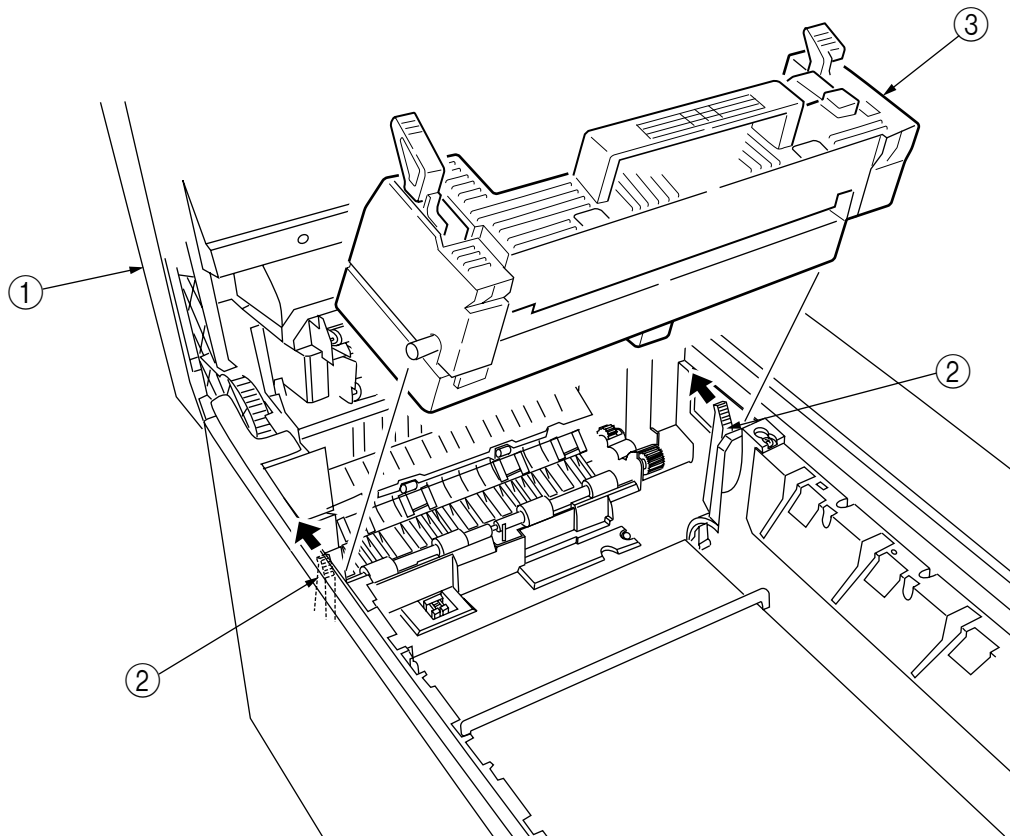

Figure 2-3-42 Fuser Unit



### 2.3.43 Belt Unit

- (1) Open the top cover ①.
- (2) Remove the I/D unit.
- (3) Push the lever (blue) ② in the arrow direction, raise the handle (blue) ③ and detach the belt unit ④.

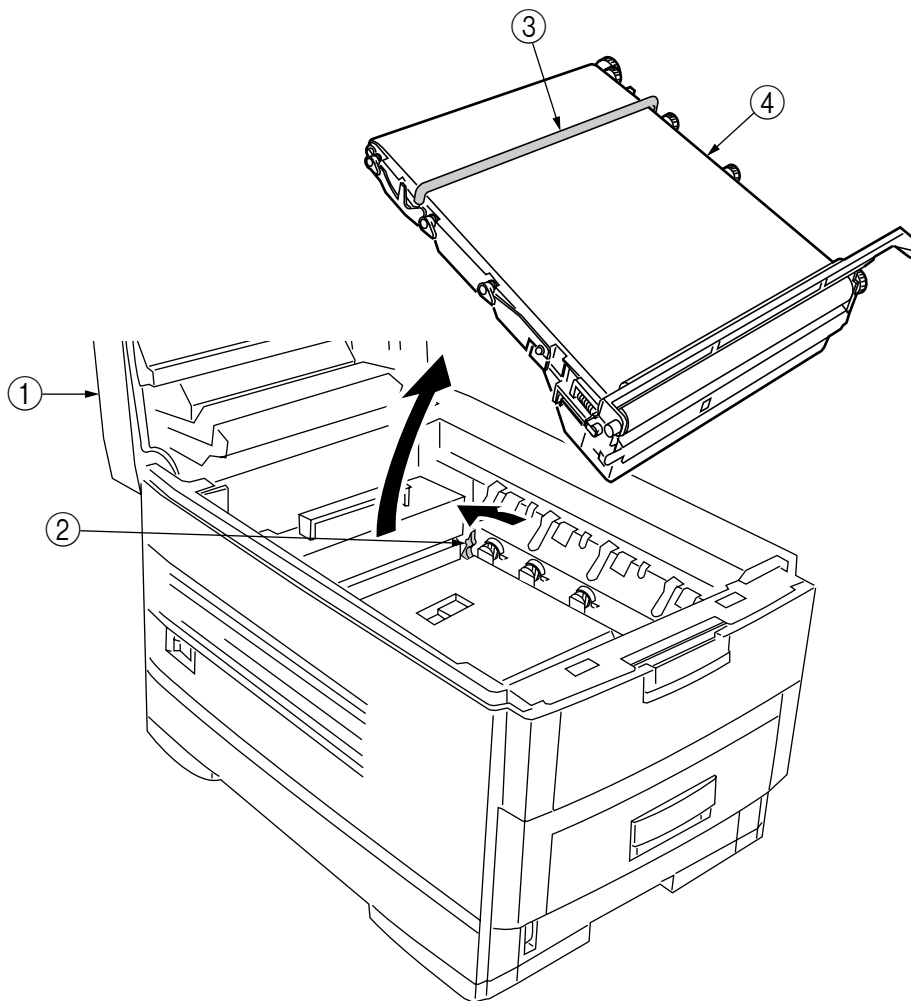

Figure 2-3-43 Belt Unit

### 2.3.44 Duplex Unit

- (1) Remove the cassette Assy, the front cover Assy and the front cover inner baffle.
- (2) Unlatch the rear at the right and left, and pull the duplex unit ① toward the front.

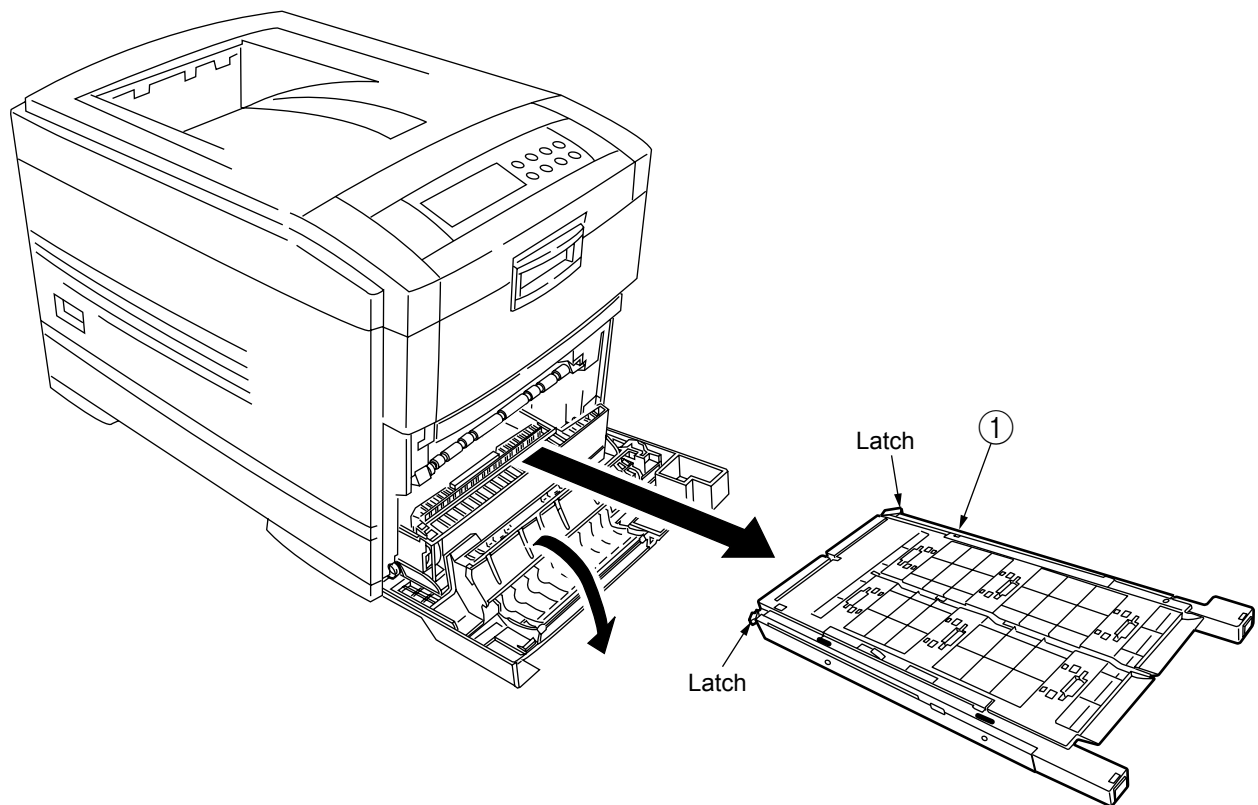

Figure 2-3-44 Duplex Unit

### 2.3.45 Guide Rails (L) and (R)

- (1) Remove the duplex unit (see section 2.3.44).
- (2) Remove the six screws ① to detach the guide rails (L) ② and (R) ③.

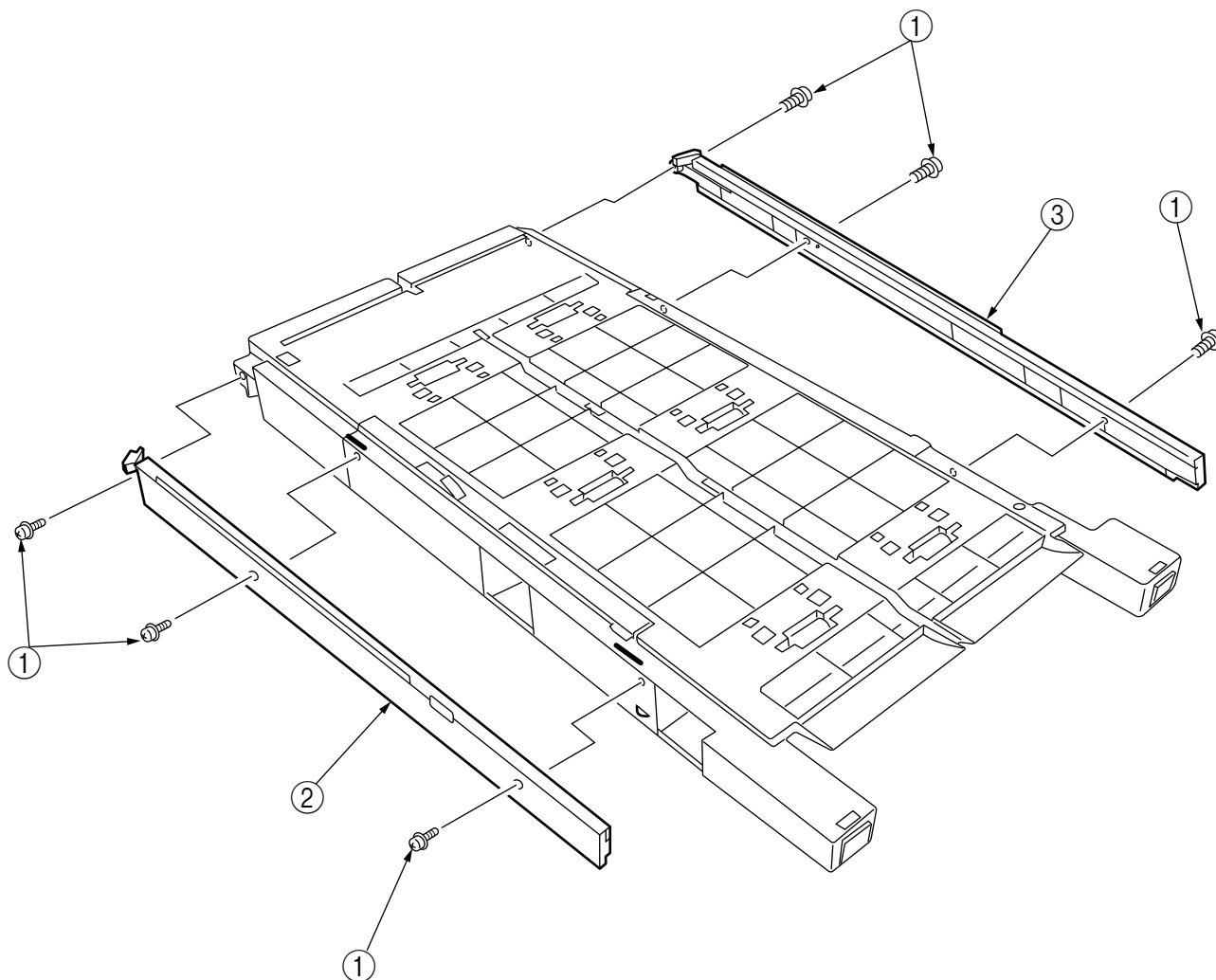

Figure 2-3-45 Guide Rail (L), (R)

### 2.3.46 Duplex Transport Assembly

- (1) Turn over the duplex transport Assy.
- (2) Unscrew the three screws ① and five screws ② to detach the plate ③.
- (3) Unplug the connector and detach the mold Assy ④.
- (4) Detach the two actuators ⑤.
- (5) Unscrew the screws ⑥ and ⑦ to remove the earth ⑧.
- (6) Unhook the connector and disengage the two claws to detach PCB-MOP ⑨.
- (7) Unplug the cable and, warping the claw, detach the transport sensor.
- (8) Unscrew the two screws to detach the cord duplex connector Assy.
- (9) Unscrew the screw ⑩ to remove the earth ⑪.
- (10) Unscrew the screw ⑫ to remove the earth ⑬.
- (11) Unscrew the screw ⑭ to remove the earth ⑮.
- (12) Detach the bush ⑯, gear ⑰ and bush ⑱, then detach the roller ⑲.
- (13) Unscrew the screw ⑳ to remove the earth ㉑.
- (14) Detach the gear ㉒ and bush ㉓. At the same time, the mini pitch belt ㉔ becomes detached.
- (15) Detach the gear ㉕ and bush ㉖, then detach the roller ㉗. At the same time, the mini pitch belt ㉘ becomes detached.
- (16) Unscrew the screw ㉙ to remove the earth ㉚.
- (17) Remove the E ring ㉛ and three screws ㉜ to detach the motor Assy ㉝. At the same time, the earth ㉞ becomes detached.
- (18) Detach the gear ㉟ and bush ㊱.
- (19) Detach the gear ㊲, knock-pin ㊳ and bush ㊴, then detach the roller ㊵.
- (20) Detach the bush ㊶, gear ㊷, knock-pin ㊸ and bush ㊹, then detach the roller ㊺. At the same time, the earths ㊻ and ㊼ become detached.
- (21) Detach the idle roller shaft and the idle roller, then detach the idle roller springs (eight springs).
- (22) Remove the cable of the duplex transport sensor Assy from the claw of the cover-upper. Disengage the claw, then detach the sensor.

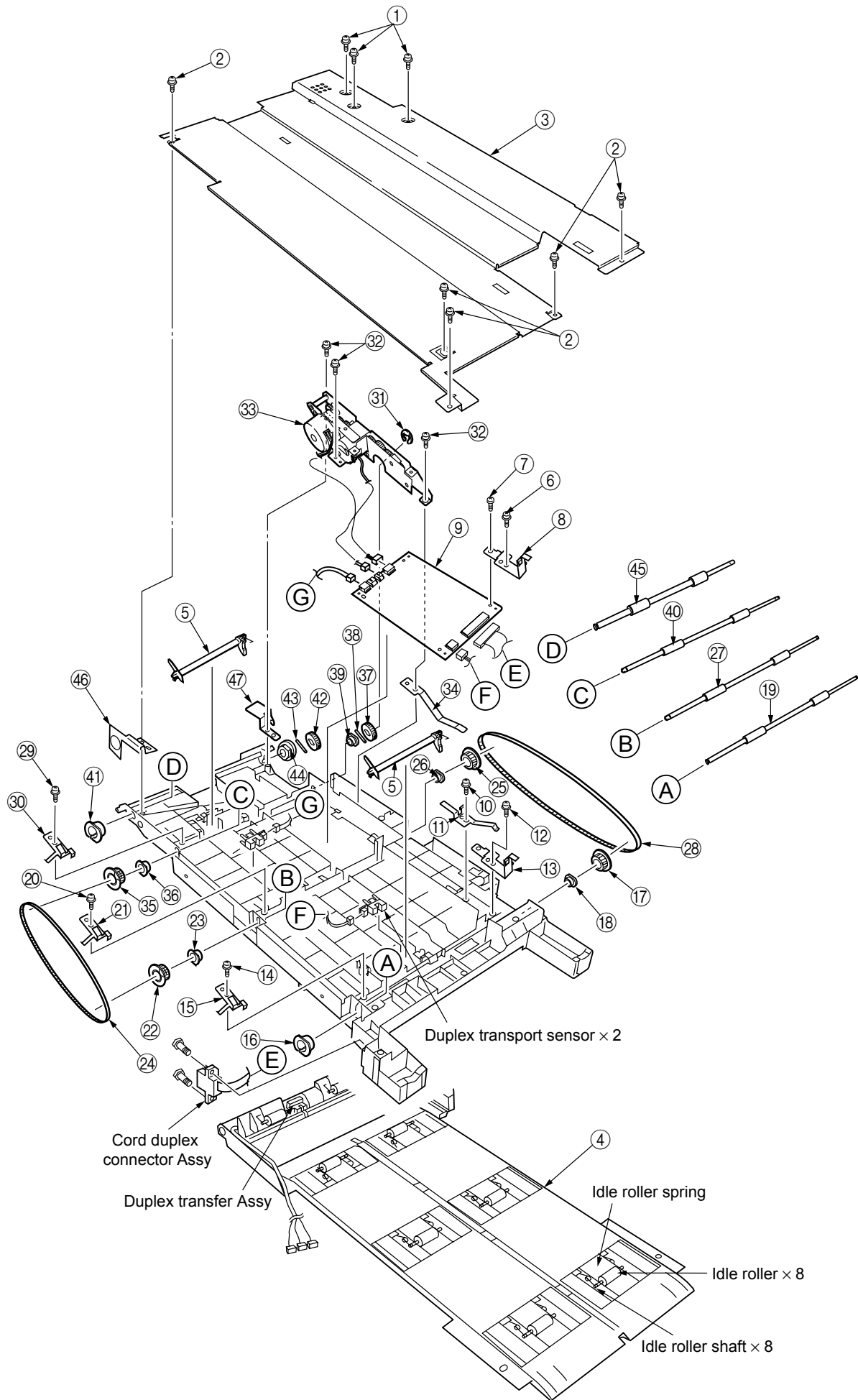

Figure 2-3-46 Duplex Transport Assembly

2.3.47 CU Assy

CU Assy confirmation subject.

[CU main board]

There are two kinds of CU main boards of C7550/C7350,C7500/C7300.

OLD Version : TIG-3  
 NEW Version : HME  
 ROM DIMM and EEPROM of each board cannot be used with the board of another side.

Combination	OK/NG	Main Board	Program DIMM	EEPROM
OLD Version	OK	TIG-3	Ver.x1.xx or x2.xx	93C86
NEW Version	OK	HME	Ver.x3.xx or x4.xx	24C32
NG Combination	NG Blank LCD	TIG-3	Ver.x1.xx or x2.xx	24C32(NG)
		TIG-3	Ver.x3.xx or x4.xx(NG)	93C86
		HME	Ver.x1.xx or x2.xx(NG)	24C32
		HME	Ver.x3.xx or x4.xx	93C86(NG)

How to recognize

1:Serial No.

OLD Version    xxxA xxxxxxxx  
 NEW Version    xxxB xxxxxxxx or  
 SAP system serial No.

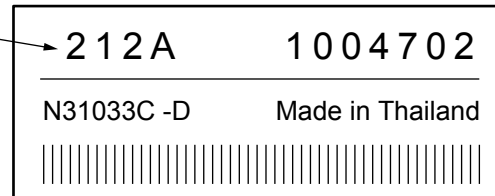

2:Main Map printing(CU F/W Ver.)

OLD Version : x1.xx or x2.xx  
 NEW Version : x3.xx or x4.xx

3:Board appearance

OLD Version :  
 NEW Version : There is printing of "NBC-2" on the board.  
 The position of HDD and Centoro.(See page 150)

[Program ROM DIMM]

There are two kinds of program ROM DIMM.

CRF : Flash ROM DIMM  
 TNY : P2ROM DIMM. Parts(No. are also changed whenever the versions change.)

Flash ROM is rewritable.

P2ROM is not rewritable.(Parts number are also changed whenever the versions change.)

[NIC Card]

There are three kinds of NIC Cards.

Okidata LAN 6200e+ ODA  
 Okidata LAN 7300e ODA/OEL/APS  
 Okidata LAN 8100e ODA/OEL/APS

**Note:** To use Okidata LAN 8100e, software for the NIC must be downloaded to a CU main board. Software for the NIC is downloaded to a CU main board (HME) before shipment of a printer or a service board. As software is deleted when forced initialization is performed to a Flash ROM, re-downloading of the software is required. Software is not downloaded to a TIG-3 also a program ROM DIMM doesn't support the software. Accordingly, the Soft NIC (Okidata LAN 8100e) is not usable even if software for the NIC is downloaded to a TIG-3 board.

## CU Assy disassembly procedures

- (1) Pulling out Controller Board
  1. Undo the two screws ①.
  2. Pull the controller board ② out.
  3. Place the controller board ② on a flat table.
- (2) Detaching Fan
  1. Remove the connector ③.
  2. Remove the two screws ④.
  3. Detach the fan ⑤.

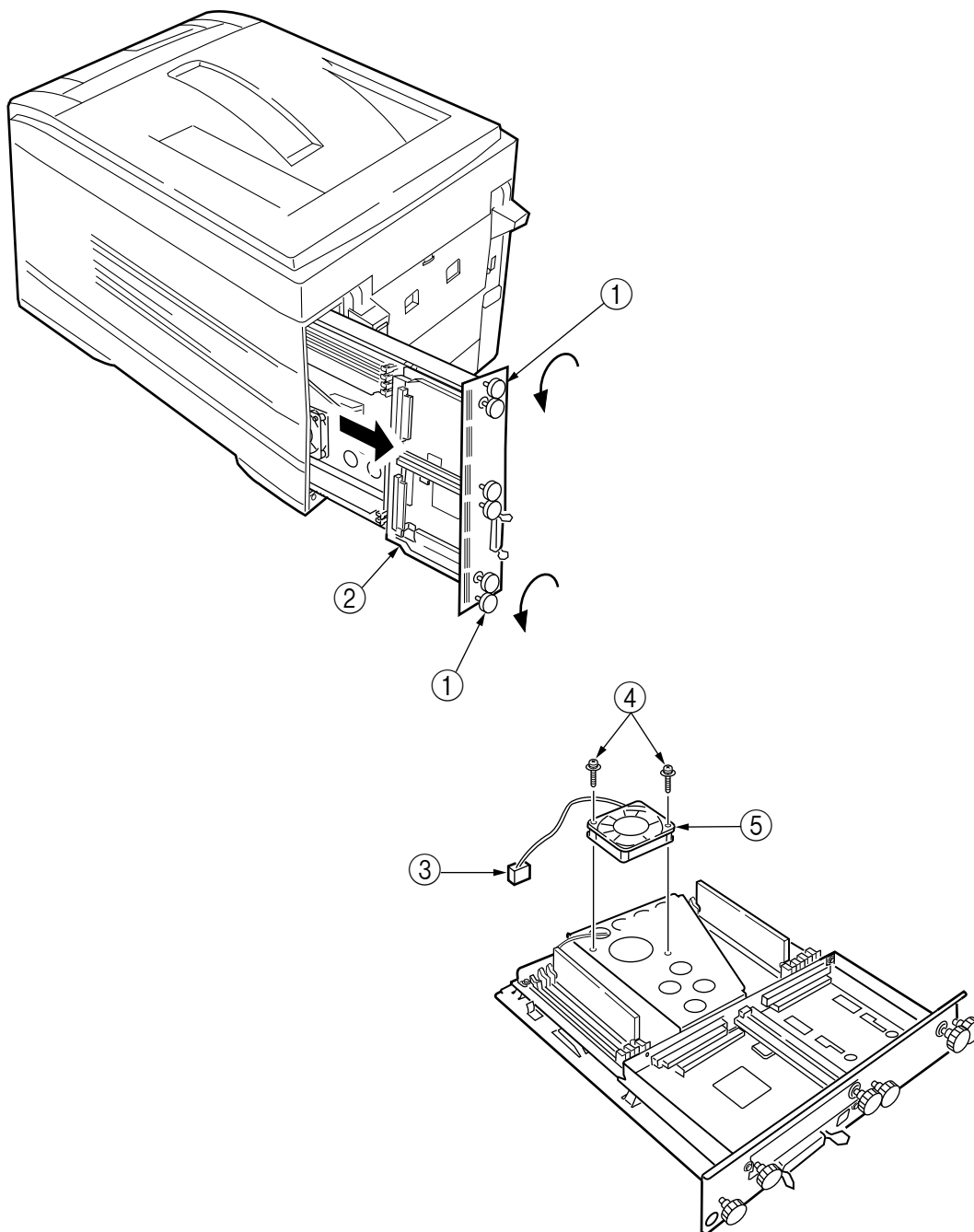

Figure 2-3-47 CU Assy (1/2)

(3) Demounting CU Board

1. Remove the three screws ⑥ and screw ⑦ to detach the fan bracket ⑧.
2. Remove the screw ⑨ and four screws ⑩ to detach the plate support ⑪ and the guide rail A⑫.
3. Remove the two screws ⑬ to detach the guide rail B⑭.
4. Remove the two screws ⑮ and two screws ⑯ and the plate-FG(Centro)⑰, then demount the CU board ⑱.

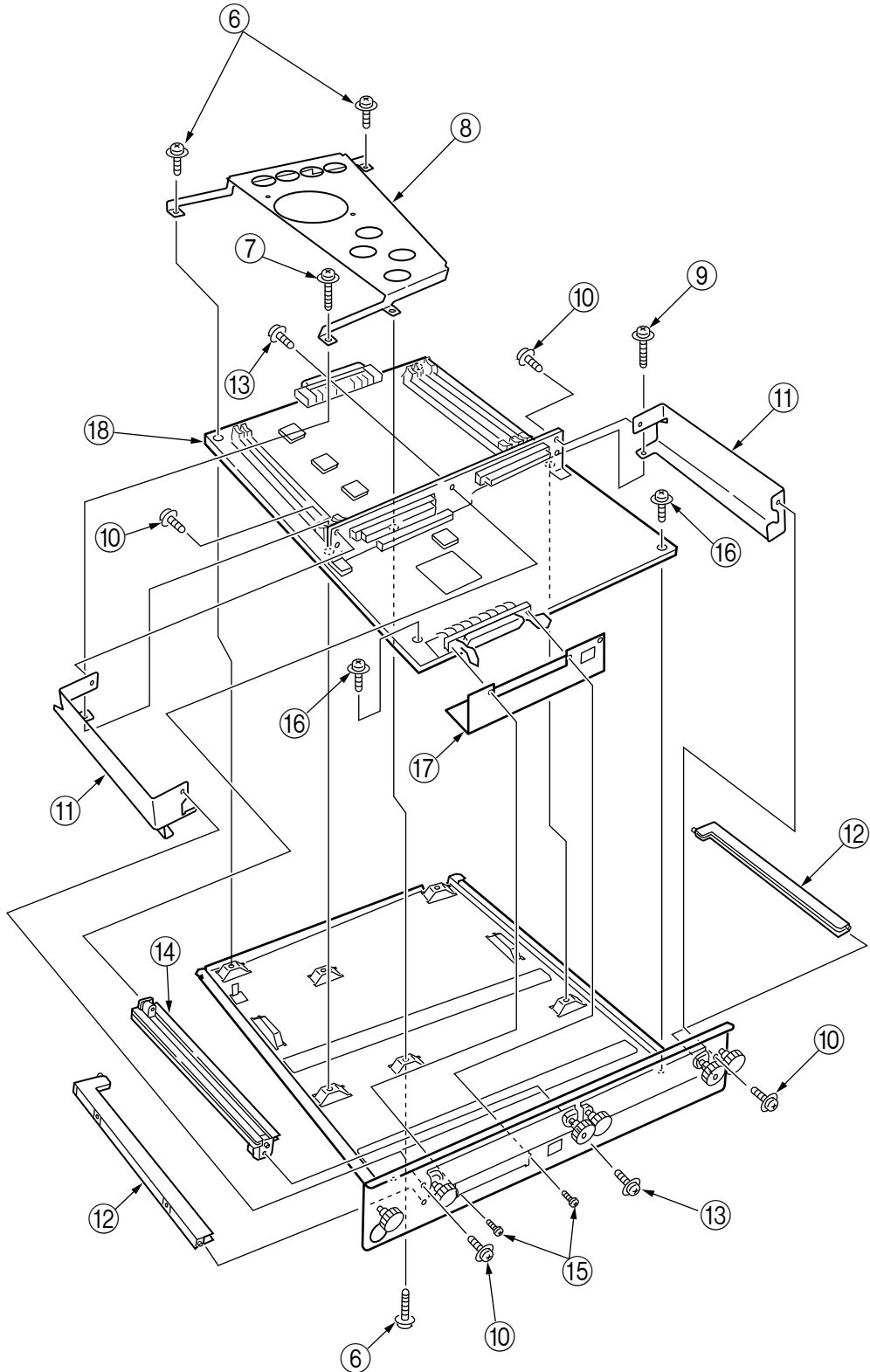

Figure 2-3-47 CU Assy (2/2)



### 3. ADJUSTMENT

This device is adjusted by key input from the operator panel.

Other than the general menu, this device supports a maintenance menu. Select the menu that matches your objective.

#### 3.0 System Maintenance MENU

The printer enters this mode when you turn on the power supply switch while holding down the [Menu]+[Item]+[Value]+[Cancel] (0+1+6+7)switches.

**Note:** This menu is not disclosed to end-users because changes can be made to brand/destination, etc.

Table 3-0 (1/2) Maintenance Menu display Table

Category	Item(1st Line)	Value(2nd Line)	DF	Functions
OKIUSER	OKIUSER	ODA OEL APS JP1 JPOEM1 OEMA OEML	*	Sets Brand JPOEM1: Japan OEM OEMA: Overseas OEM for A4 default OEML: Overseas OEM for Letter default Boots up automatically when the Menu is existed.
CONFIGURATION MENU	ENGINE SPEED	HIGH LOW	*	For swithing the engine speed between the overseas 16/24PPM model and the 20/24PPM, 24/26PPM model. (Valid only for PX711 600dpi Head) HIGH: 20/24PPM model (C7300), 24/26PPM model (C7350). LOW : 16/24PPM model (C7100) Reboots automatically as the menu is exited. note: This function for PX713 is ignored.
	HIGH RESOLUTION	ENABLE DISABLE	*	Not used. note: Don't change the setting value.
ENG STATUS PRINT	ENG STATUS PRINT	EXECUTE		Selecting by the Select switch, then pressing the On-line switch will prompt initialization and printing Engine information.
TEST PRINT MENU	TEST PRINT MENU	ENABLE DISABLE	*	Switches ENABLE and DISABLE to display the TEST PRINT MENU category in the User Menu. ( See "ID Check Pattern" section. )
PAGE CNT PRINT	PAGE CNT PRINT	ENABLE DISABLE	*	Sets printing or not printing the total page count in PRINT MENU MAP.
PERSONALITY	PCL	ENABLE DISABLE	*	Cange the default PDL for each brand.  PDLs that are disabled in this Menu will not be displayed on User Menu or Adomin Menu's PERSONALITY.  When print data in the PDL language set to DISABLE is received, the printer will display INVALID DATA and discard received data. (HP-GL/2 is under development, and there is no plan to implement as yet in the product. ) The PDF function requires Adobe Postscript; thus, switching ON/OFF of PDF alone is disabled. (Setting Adobe Postscript on DISABLE will set the PDF function to DISABLE as well. ) On the PX711/713, neither Adobe Postscript nor PDF can be set to DISABLE. (They are to be always set to ENABLE for use. Even if they are set to DISABLE, the printer processes the data it receives. This item is incorporated only in the menu ahead of time for future extension. )
	IBM PPR III XL	ENABLE DISABLE	*	
	EPSON FX	ENABLE DISABLE	*	
	Adobe Postscript	ENABLE DISABLE	*	
	HP-GL/2	ENABLE DISABLE	*	
	PCL XL	ENABLE DISABLE	*	
	PDF	ENABLE DISABLE	*	

Table 3-0 (2/2) Maintenance Menu display Table

Category	Item(1st Line)	Value(2nd Line)	DF	Functions
NETWORK				The details depend on Network. ( Not used )
DIAGNOSTIC MODE XX.XX.XX				Enters engine self-diagnostic mode. The display in place of xx.xx varies among the PU version. (The display within this category depends on the Engine Maintenance specs.)

Switch operations and LCD displays in Engine Self-diagnostic Mode depend on the instructions from the Engine F/W; hence, they are different from the operation spec in the Controller F/W.  
Engine Self-diagnostic Mode is executable even if the Controller board is removed.

For details, see the Engine Unit spec as needed.

### 3.0.1 ID Check Pattern Printing ( " TEST PRINT MENU " item )

This pattern can be used for the cause investigation (specifying of color(C,M,Y,K) of the problem item, the confirmation of the periodicity) of the following problem that it originated in ID, the LED head. It is composed of CMYK color 20% duty each of the patterns (print 2 pages).

Operation: (Press switch)

Without HDD: "0" - "0" - "3" - "3"

With HDD : "0" - "0" - "0" - "3" - "3"

- Vertical Black/White Lines
- Vertical Black/White Bands
- Horizontal Black/White Lines
- Horizontal Black/White Bands

Print pattern:

Page.1

Page.2

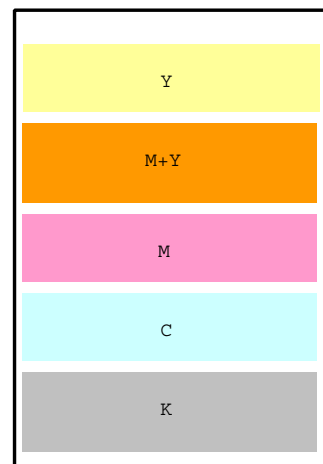
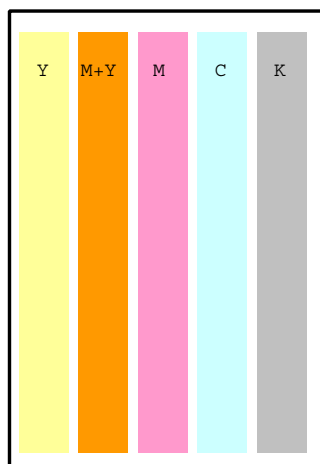

## 3.1 Maintenance Mode and Functions

### 3.1.1 Maintenance menu

A maintenance menu category is located in the general menu category.  
The following items are those that can be set with this menu.

## Maintenance Menu

Category	Item(1st Line)	Value(2nd Line)	DF	Functions
MAINTENANCE MENU	EEPROM reset	EXECUTE	*	Resets EEPROM for CU.
	SAVE MENU Save menu setting	EXECUTE	*	Saves current menu setting. A message asking Are you sure? and a choice of YES/NO will appear.
	RESTORE MENU Return to saved menu setting	EXECUTE	*	Changes setting to the stored menu setting. (Displayed only when a menu setting is stored.) <i>NOTE:</i> Stored in CU Flash (directly attached). In HDD if HDD exists.
	POWER SAVE Power save function	Enabled Disabled	*	Enables or disables the power save mode. The time to switch to Power Save Enable can be changed with the Power Save Delay Time Item in the System Configuration Menu.
	Normal paper black setting	0 +1 +2 -2 -1	*	Normal Paper/Black Print Used for fine adjustment when scratches or dots are notable on print results. Decrement if the highly-dense print portion seems dispersed or scattered with white dust. Increment if the print result seems faint.
	Normal paper color setting	0 +1 +2 -2 -1	*	Normal Paper/Color Print Used for fine adjustment when scratches or dots are notable on print results. Decrement if the highly-dense print portion seems dispersed or scattered with white dust. Increment if the print result seems faint.
	OHP paper black setting	0 +1 +2 -2 -1	*	OHP/Black Print Used for fine adjustment when scratches or dots are notable on print results. Decrement if the highly-dense print portion seems dispersed or scattered with white dust. Increment if the print result seems faint.
	OHP paper color setting	0 +1 +2 -2 -1	*	OHP/Color Print Used for fine adjustment when scratches or dots are notable on print results. Decrement if the highly-dense print portion seems dispersed or scattered with white dust. Increment if the print result seems faint.

### 3.1.2 Engine maintenance mode

Three modes from Level 1 to Level 3 are in the engine maintenance mode. Level 1 is a mode that checks the media transport and basic movement of the print system. Level 2 checks the counter for consumables and tests the correcting function of color displacement, and is a mode that does not require special knowledge. Level 3, on the other hand, requires special knowledge for handling the process parameter setting and is contained in the independent experimental element of PU. Basically, levels other than Level 1 should not be used.

#### 3.1.2.1 Operator panel

The description for operations related to self-diagnosis is made presuming the arrangement of the operator panel shown below.



#### 3.1.2.2 Normal self-diagnostic mode (Level 1)

Items in the normal self-diagnostic mode menu are listed below.

- Switch scan test
- Motor & clutch test
- Executing test pattern
- NVM initialization
- Consumables counter display
- Consumables continuation counter display

### 3.1.2.2.1 Entering self-diagnostic mode (Level 1)

1. The system maintenance menu mode is entered by turning the power ON while pressing the **0**, **1**, **6**, and **7** keys simultaneously.
2. Press the **0** key several times until [DIAGNOSTIC MODE] is displayed.

DIAGNOSTIC MODE	
XX.XX.XX	FACTORY/SHIPPING

3. The [XX.XX.XX] in [DISGNOSTIC MODE XX.XX.XX] that is displayed in the LCD display is the ROM version. The set value for FACTORY WORKING MODE is displayed in the right side of the bottom line. [SHIPPING] is normally set.
4. Proceed to each self-diagnosis step by pressing the **1** or **5** key.  
(The menu item rotates by pressing the **1**, **5** key.)

### 3.1.2.2.2 Exiting the self-diagnostic mode

1. Turn the power OFF, then turn it on after ten seconds.

### 3.1.2.3 Switch scan test

This self-diagnosis is used for checking the input sensor and switch.

1. Press the **1** and **5** keys until the normal diagnostic mode is entered and [SWITCH SCAN] is displayed on the top line.  
(Key **1** increments the test item and Key **5** decrements the test item.)

SWITCH SCAN

2. Press the **2** and **6** keys until the SCAN number that corresponds to the unit subject to the following test listed in Table 3-1. (Key **2** increments the item and Key **6** decrements the item.)

SWITCH SCAN 00
1=H 2=L 3=H 4=L

3. The test starts by pressing the **3** key. The SWITCH SCAN number begins to blink and the number of the corresponding unit (1-4) is displayed along with the current status. Manipulate each unit (Fig 3-1). The items are displayed in the LCD that corresponds to each item. (The display differs for each sensor. See Table 3-1 for details.)
4. The SWITCH SCAN number reappears in the display status (blinking ceased) by pressing the **7** key.
5. Repeat Steps 2 to 4 as required.
6. Press the **4** key to end the test. (Status returns to that described in 1.)

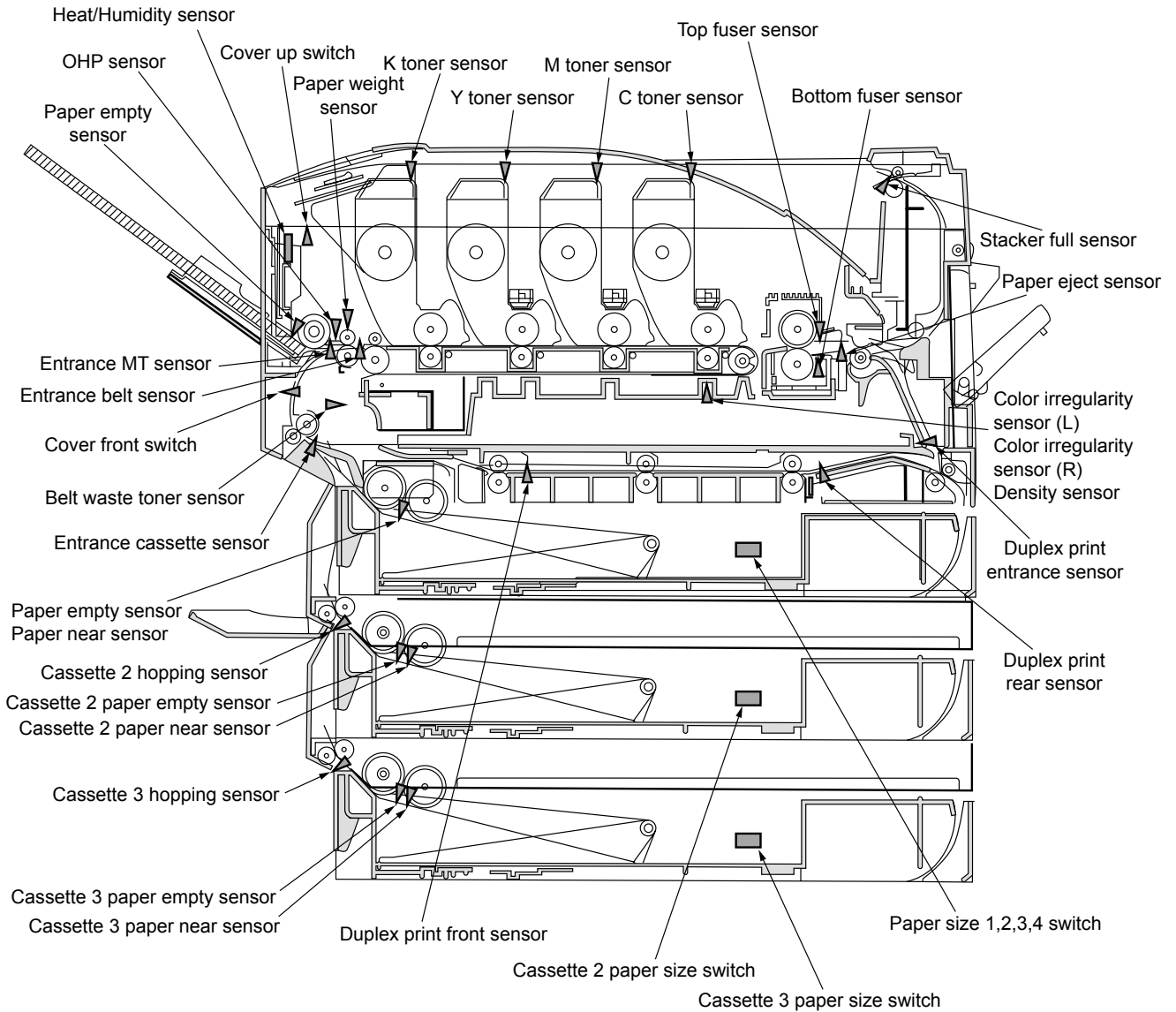

Figure 3-1 Switch Sensor Position

Table 3-1 SWITCH SCAN Details

SCAN ROW	NUMBER				
	1	2	3	4	Display
SWITCH SCAN 00	Cassette 1 paper end sensor	Cassette 1 paper near end sensor	Entrance cassette sensor	Entrance MT sensor	Port level H,L,L
SWITCH SCAN 01	Entrance belt sensor	Eject sensor	Stacker full sensor	Belt waste toner	Port level H,L,L
SWITCH SCAN 02	K toner sensor	C toner sensor	M toner sensor	Y toner sensor	Port level H,L,L
SWITCH SCAN 03	Upper cover SW	Front cover SW	-	-	-
SWITCH SCAN 04	-	-	-	-	-
SWITCH SCAN 05	-	-	-	-	-
SWITCH SCAN 06	MT hop switch	MT paper empty SW	-	OHP sensor	Port level H,L,L
SWITCH SCAN 07 (See Table 4-2)	Cassette 1 paper size SW	Cassette 1 paper size 2 SW	Cassette 1 paper size 3 SW	Cassette 1 paper size 4 SW	Port level H,L,L
SWITCH SCAN 08	Color irregularity sensor	Color displacement sensor (R)	Density sensor	Paper weight sensor	AD value ***H
SWITCH SCAN 09	Center sensor above fuser	-	Center sensor below fuser	-	AD value ***H
SWITCH SCAN 10	Humidity sensor	Temperature sensor	-	-	-
SWITCH SCAN 11 (Option)	Duplex print entrance sensor	Duplex print rear sensor	-	Duplex print front sensor	Port level H,L,L
SWITCH SCAN 12 (Option)	Cassette 2 paper size 1 SW	Cassette 2 paper size 2 SW	Cassette 2 paper size 3 SW	Cassette 2 paper size 4 SW	Port level H,L,L
SWITCH SCAN 13 (Option)	Cassette 2 paper empty sensor	Cassette paper near end sensor	-	-	-
SWITCH SCAN 14 (Option)	-	-	Cassette 2 hopping sensor (paper feed)	-	Port level H,L,L
SWITCH SCAN 15 (Option)	Cassette 3 paper size 1 SW	Cassette 3 paper size 2 SW	Cassette 3 paper size 3 SW	Cassette 3 paper size 4 SW	Port level H,L,L
SWITCH SCAN 16 (Option)	Cassette 3 paper empty sensor	Cassette 3 paper near end sensor	-	-	-
SWITCH SCAN 17 (Option)	-	-	Cassette 3 hopping sensor (paper feed)	-	Port level H,L,L
SWITCH SCAN 24	Black head temperature	Yellow head temperature	Magenta head temperature	Cyan head temperature	AD value ***H
SWITCH SCAN 25	Black ID up/down sensor	Yellow ID up/down sensor	Magenta ID up/down sensor	Cyan ID up/down sensor	AD value ***H

Table 3-2 Paper Size Detection - Paper /Bit Correspondence Table

No.	Paper	1	2	3	4
[0]	No cassette	H	H	H	H
[1]	Letter-S	L	L	L	L
[2]	Legal13-S	H	L	H	H
[3]	A4-S	L	L	L	H
[4]	B5-S	L	L	H	H
[5]	Executive-S	L	L	H	L
[6]	A6-S	H	L	L	L
[7]	Not supported	—	—	—	—
[8]	Legal14-S	H	L	H	L
[9]	Not supported	—	—	—	—
[A]	Not supported	—	—	—	—
[B]	Not supported	—	—	—	—
[C]	A5-S	H	L	L	H
[D]	Not supported	—	—	—	—
[E]	Not supported	—	—	—	—
[F]	Not supported	—	—	—	—



### 3.1.2.4 Motor clutch test

This self-diagnostic routine is used to test the motor and clutch.

1. Press the ① and ⑤ keys until the self-diagnostic (Level 1) mode is entered and [MOTOR & CLUTCH TEST] is displayed in the top line. (Key ① increments the test item and Key ⑤ decrements the test item.)
2. Press the ② and ⑥ keys until the section that corresponds to the unit subject to the next test in Table 3-2 is displayed in the top line of the display. (Key ② increments the item and Key ⑥ decrements the item.)

MOTOR & CLUTCH TEST
BLACK - ID MOTOR

3. The test starts by pressing the ③ key. The name of the unit begins to blink and the corresponding unit drives for 10 seconds. (See Fig 3-3.)

**Note:** The status returns to that described in 2 after driving 10 seconds, and the unit will start driving again by pressing the corresponding switch.

- The drive control conditions listed in Table 3-2 must be fulfilled in order to drive the corresponding unit. A unit cannot be driven without fulfilling the conditions, and if attempted, instructions will appear in the bottom display line.
  - For clutch solenoid, ON and OFF is repeated for normal print drive. (For those that cannot be driven independently due to their mechanism, drive with the motor.)
4. A driving unit is stopped by pressing the ⑦ key. (The display of the corresponding unit is maintained.)
  5. Repeat Steps 2 to 4 as required.
  6. Press the ④ key to end the test. (Status returns to that described in 1.)

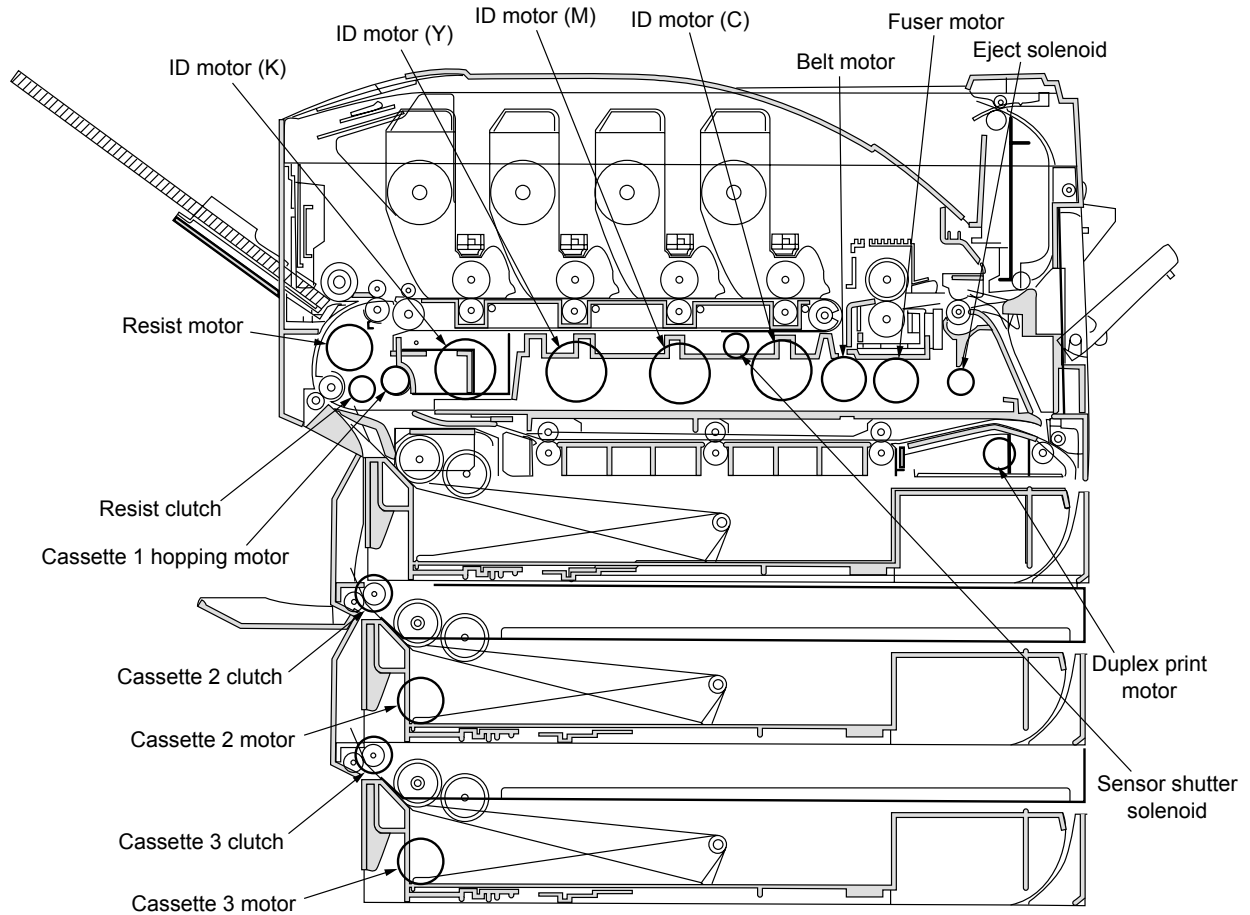

Figure 3-3

Table 3-2

Displayed Unit	Drive Restrictions	Restriction Display
ID motor (black)	Drive by removing all ID (yellow/black/magenta/cyan).	Remove ID
ID motor (yellow)		
ID motor (magenta)		
ID motor (cyan)		
Belt motor	-	-
Fuser motor	-	-
Resist motor	-	-
Cassette 1 hopping motor	Drive by removing Cassette 1.	Remove Cassette 1
Resister clutch	-	-
Sensor shutter solenoid	-	-
Eject solenoid	-	-
Duplex print motor (option)	-	-
Duplex print clutch (option)	-	-
Cassette 2 motor (option)	Drive by removing Cassette 2.	Remove Cassette 2
Cassette 2 roller clutch (option)	-	-
Cassette 3 feeder motor (option)	Drive by removing Cassette 3.	Remove Cassette 3
Cassette 3 roller clutch (option)	-	-
ID UP/DOWN	-	-
FAN1 TEST (Power Source Fan)	-	-
FAN2 TEST (Control Unit Fan)	-	-

## 3.1.2.5 Test print

This self-diagnostic routine is used to print the test patterns in the PU. The other test patterns are stored in the controller.

1. Press the ① and ⑤ keys until the self-diagnostic (Level 1) mode is entered and [TEST PRINT] is displayed in the top line. (Key ① increments the test item and Key ⑤ decrements the test item.)
2. The bottom line displays the setup items applied only for test print. Press the ② and ⑥ keys until the corresponding item is displayed. (Key ② increments the item and Key ⑥ decrements the item.)
3. When the ③ and ⑦ keys are pressed, the setup items appear in the top line and set values appear in the bottom line. The set value increments by pressing the ③ key and decrements by pressing the ⑦ key. (The value that is set at the end will be applied.) Repeat Step 3 as required.

TEST PATTERN
1

Display	Set Value	Function
PRINT EXECUTE	—	Press Key ③ to start print. / Press Key ⑦ to end print. (In page unit.)
TEST PATTERN	0	0: empty page 1-7: Refer to the following page (pattern print). 8-15: empty page
CASSET	TRAY1	Set paper feed source.
	TRAY2	
	TRAY3	
	FF	
PAGE	0000	Set number of pages to test print.
COLOR	ON	Select color or monochrome.
	OFF	
DUPLEX	2 PAGES STACK	Perform duplex print with 2-page stack.
	OFF	Set duplex print to OFF.
	1PAGES STACK	Perform duplex print with 1-page stack.

- is the default. The set items are valid only in this test mode. (They will not be written in EEPROM.)

**Note:** Page setting: Key ① or ⑤ shifts the digits.

Color setting: The following indications appear in the panel when Key ① or ⑤ is pressed when set to [ON].

Print setting for each color:

Shifts by pressing Key ① or ⑤.

Switch between [ON] and [OFF] is set by pressing Key ③ or ⑦.

Panel indication returns by pressing Key ② or ⑥.

COLOR
Y:ON M:ON C:ON K:ON

4. Test print will be executed under the values set in Steps 2 and 3 by pressing the ③ key when [PRINT EXECUTE] is displayed in the bottom row of the display.

Press the ⑦ key to stop the test print.

When an alarm indicated under Details in the table is detected at the start of test print or during test print, a message will appear in the panel display and the print operation will be interrupted. (Refer to “3.1.2.9 Panel display details” for details on errors.)

Print pattern

0, 8-15: Empty print

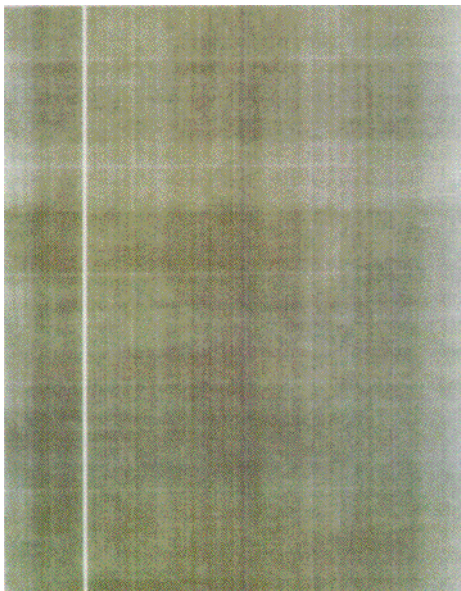

Pattern 1

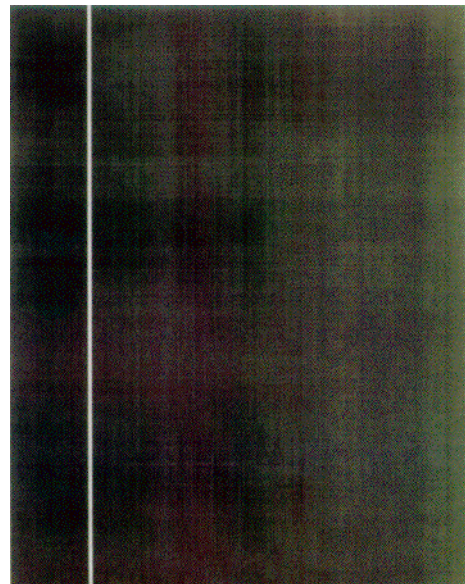

Pattern 2

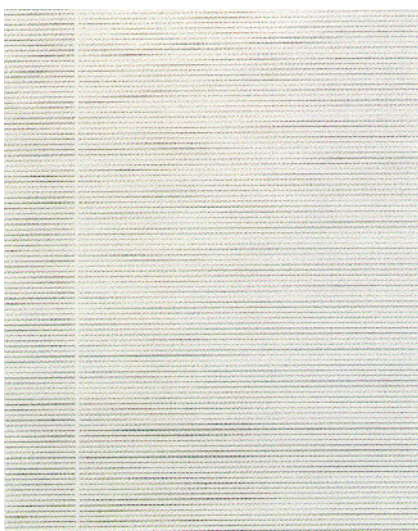

Pattern 3

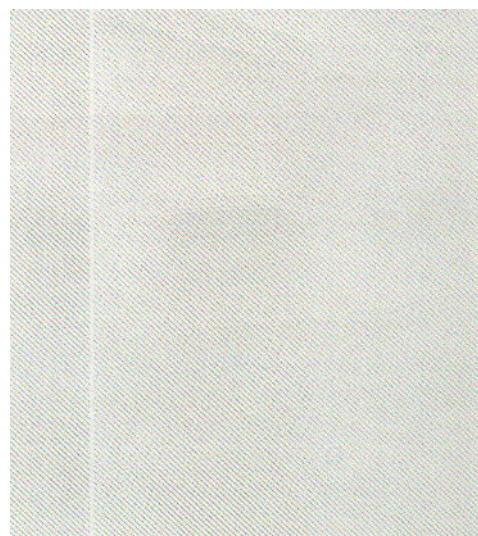

Pattern 4



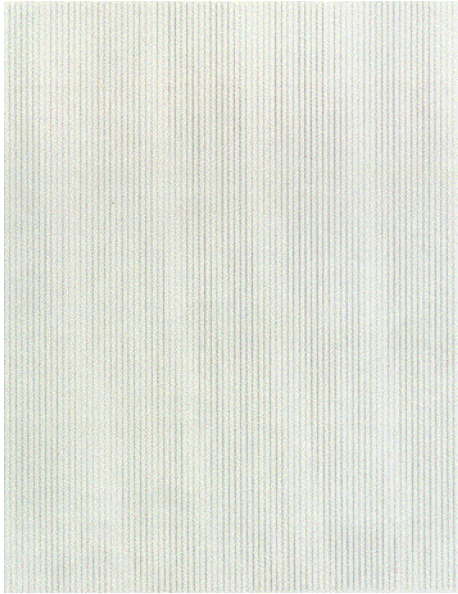

Pattern 5

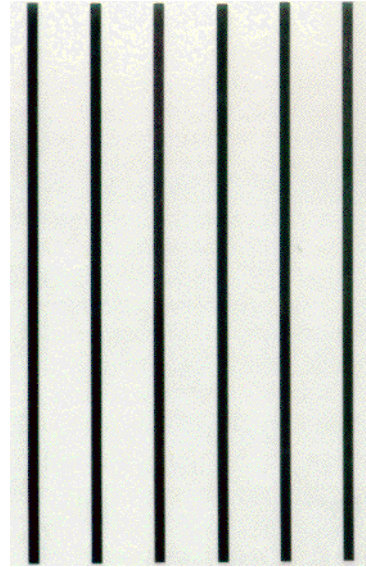

Pattern 6

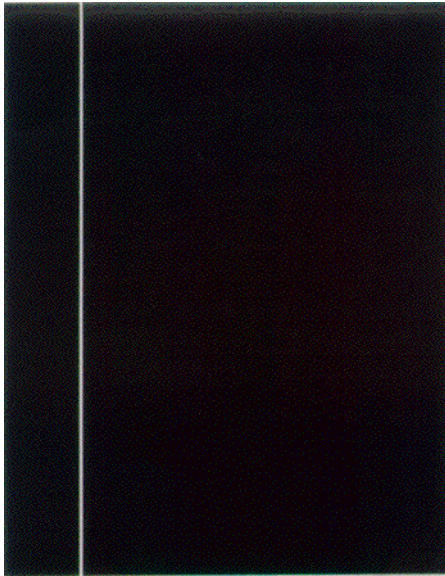

Pattern 7

- The following messages appear during print operation.

P=*** T=*** U=*** [###]
H=***% L=*** [###]

P: No. of test print pages (unit: page)  
 U: Temperature of top heater [Set value] (unit: Celsius)  
 L: Temperature of bottom heater [Set value] (unit: Celsius)  
 T: Environment temperature (unit: Celsius)  
 H: Environment humidity (unit: percent)

- The display changes by pressing the **③** key.

KTR=* . **KV YTR=* . **KV
MTR=* . **KV CTR=* . **KV

YTR, MTR, CTR, KTR are values of the set transfer voltage. (unit: KV)

- The display changes by pressing the **③** key.

KR=* . **KV YR=* . **KV
MR=* . **KV CR=* . **KV

YR, MR, CR, KR are transfer rollers of each color values of the set transfer voltage. (unit: KV)

- Repeat Steps 2 to 4 as required.
- Press the **④** key to end the test. (Status returns to that described in 1.)

## 3.1.2.6 Initializing NVM

This self-diagnosis is used for initializing non-volatile memory.

1. Press the ① and ⑤ keys until the self-diagnostic (Level 1) mode is entered and [NV-RAM INITIAL] is displayed in the top line. (Key ① increments the item and Key ⑤ decrements the item.)
2. The bottom line displays the table number subject to initialization. There are three tables to initialize. Press the ② and ⑥ keys until the corresponding table number is displayed. (Key ② increments the table number and Key ⑥ decrements the table number.)

**Note:** Do not use Table 2.

NV-RAM INITIAL
TABLE 1

3. The [NV-RAM INITIAL] display blinks when the ③ key is pressed and all items in Table 3-3 will be initialized by pressing the key for 10 seconds continuously.
4. Press the ④ key to end the test. (Status returns to that described in 1.)

Table 3-3 (1/2) Items to Initialize in Table 2

Item to Initialize		Details	Initial Value	Unit
Drum counter	Black Yellow Magenta Cyan	Initialize internal counter since exchanging the drum.	0	-
Belt unit counter		Initialize internal counter since exchanging the belt unit.	0	-
Fuser unit counter		Initialize internal counter since exchanging the fuser unit.	0	-
Toner counter	Black Yellow Magenta Cyan	Initialize internal counter since recovering the toner error.	0	-

Table 3-3 (2/2) Items to Initialize in Table 2

Item to Initialize		Details	Initial Value	Unit
Color irregularity adjust point X axis	Yellow Magenta Cyan	Initialize X axis correction value for the LED head (yellow, magenta, cyan).	0	1/1200 inch
Color irregularity adjust point Y axis (L)	Yellow Magenta Cyan	Initialize Y axis (L) correction value for the LED head (yellow, magenta, cyan).	0	1/1200 inch
Color irregularity adjust point Y axis (R)	Yellow Magenta Cyan	Initialize Y axis (R) correction value for the LED head (yellow, magenta, cyan).	0	1/1200 inch
Engine parameter		Initialize all items set in Level 2 and 3 in the engine maintenance mode.		

### 3.1.2.7 Displaying the consumables counter

This self-diagnosis is used for displaying the consumed status of consumables.

1. Press the **①** and **⑤** keys until the normal self-diagnostic mode is entered and [CONSUMABLE STATUS] is displayed in the top line. (Key **①** increments the item and Key **⑤** decrements the item.)
2. The consumed status of consumables is displayed by pressing the **②** and **⑥** keys. (Keys **③** and **⑦** are invalid.)
3. Press the **④** key to end the test. (Status returns to that described in 1.)

Item	Top Display	Bottom Display	Format	Unit	Details
Fuser unit	FUSER UNIT	***** PRINTS	Decimal system	Printed sheets	Displays number of pages since installing a new fuser.
Belt unit	TR BELT UNIT	***** PRINTS	Decimal system	Printed sheets	Displays number of pages since installing a new drum unit.
ID unit - black	BLACK ID UNIT	***** IMAGES	Decimal system	Printed sheets	Displays number of rotations by converting to A4 3Page/Job since installing a new ID unit.
ID unit - yellow	YELLOW ID UNIT	***** IMAGES	Decimal system	Printed sheets	
ID unit - magenta	MAGENTA ID UNIT	***** IMAGES	Decimal system	Printed sheets	
ID unit - cyan	CYAN ID UNIT	***** IMAGES	Decimal system	Printed sheets	
Toner - black	BLACK TONER	***%	Decimal system	%	Displays amount of color toner used.
Toner - yellow	YELLOW TONER	***%	Decimal system	%	
Toner - magenta	MAGENTA TONER	***%	Decimal system	%	
Toner - cyan	CYAN TONER	***%	Decimal system	%	

### 3.1.2.8 Displaying the consumables continuation counter

This self-diagnosis is used for displaying the continuous status of a consumable.

Continuous status of a consumable is the total count of a consumable that is not initialized even upon being replaced. The consumed amount is counted continuously.

1. Press the **①** and **⑤** keys until the normal self-diagnostic mode is entered and the continuous status of a consumable is displayed in the top line. (Key **①** increments the item and Key **⑤** decrements the item.)
2. The total consumed amount of a consumable is displayed by pressing the **②** and **⑥** keys. (Keys **③** and **⑦** are invalid.)
3. Press the **④** key to end the test. (Status returns to that described in 1.)

Item	Top Display	Bottom Display	Format	Unit	Details
Total sheets fed	TOTAL SHEETS FEED	***** PRINTS	Decimal system	Printed sheets	Total number of fed sheets including passed paper.
Print - black	BLACK IMPRESSIONS	***** IMAGES	Decimal system	Printed sheets	Displays number of printed sheets for each color ID.
Print - yellow	YELLOW IMPRESSIONS	***** IMAGES	Decimal system	Printed sheets	
Print - magenta	MAGENTA IMPRESSIONS	***** IMAGES	Decimal system	Printed sheets	
Print - cyan	CYAN IMPRESSIONS	***** IMAGES	Decimal system	Printed sheets	



## 3.1.2.9 Panel display details

## Panel display

Panel Display	Details
BLANCE ERROR	Balance error
BELT LIFE OVER	Belt life over
BELT REFLECTION ERROR	Belt reflection error
BELT UNIT FUSE CUT ERROR	Belt unit fuse cut error
BLACK DENSITY CALIB ERROR	Black density calibration error
BLACK DENSITY SENSOR ERROR	Black density sensor error
BLACK DRUM LIFE OVER	Black drum life over
BLACK DRUM NEAR LIFE	Black drum life warning
BLACK DRUM UNIT FUSE CUT ERROR	Black drum unit fuse cut error
BLACK DRUM UP/DOWN ERROR	Black drum up/down error
BLACK IRREGULAR ERROR	Black detect range out error
BLACK LED HEAD ERROR	Black LED head error
BLACK REGISTRATION ERROR(PX711)	Black irregularity error
BLACK REGISTRATION OUT HORIZONTAL	Abnormal color irregularity registration value detected in black sub-scan registration
BLACK REGISTRATION OUT LEFT	Black registration range out error (left)
BLACK REGISTRATION OUT RIGHT	Black registration range out error (right)
BLACK SENSOR ERROR LEFT	Black left sensor error
BLACK SENSOR ERROR RIGHT	Black right sensor error
BLACK TONER EMPTY	Black toner empty
BLACK TONER LOW	Black toner low
BLACK TONER SENSOR ERROR	Black toner sensor error
BLACK ID DENSITY ERROR 1	Black ID density error 1
BLACK ID DENSITY ERROR 2	Black ID density error 2
CALIBRATION CHIP ERROR	CALIBRATION CHIP ERROR
CALIBRATION ERROR	CALIBRATION ERROR
COLOR DENSITY CALIB ERROR	COLOR DENSITY CALIB ERROR
COLOR DENSITY SENSOR ERROR	COLOR DENSITY SENSOR ERROR
COOLING DOWN	COOLING DOWN
CUSTOM DIAGNOSTICS MODE	CUSTOM DIAGNOSTICS MODE
CYAN DRUM LIFE OVER	CYAN DRUM LIFE OVER
CYAN DRUM NEAR LIFE	CYAN DRUM NEAR LIFE
CYAN DRUM UNIT FUSE CUT ERROR	CYAN DRUM UNIT FUSE CUT ERROR
CYAN DRUM UP/DOWN ERROR	CYAN DRUM UP/DOWN ERROR
CYAN IRREGULAR ERROR	CYAN DETECT VALUE ERROR
CYAN LED HEAD ERROR	CYAN LED HEAD ERROR
CYAN REGISTRATION ERROR	CYAN COLOR IRREGULARITY ERROR
CYAN REGISTRATION OUT HORIZONTAL	Abnormal color irregularity registration value detected in cyan sub-scan registration
CYAN REGISTRATION OUT LEFT	CYAN REGISTRATION OUT LEFT
CYAN REGISTRATION OUT RIGHT	CYAN REGISTRATION OUT RIGHT
CYAN SENSOR ERROR LEFT	CYAN SENSOR ERROR LEFT
CYAN SENSOR ERROR RIGHT	CYAN SENSOR ERROR RIGHT
CYAN TONER EMPTY	CYAN TONER EMPTY
CYAN TONER LOW	CYAN TONER LOW
CYAN TONER SENSOR ERROR	CYAN TONER SENSOR ERROR
CYAN ID DENSITY ERROR 1	CYAN ID DENSITY ERROR 1
CYAN ID DENSITY ERROR 2	CYAN ID DENSITY ERROR 2
DIAGNOSTICS MODE	DIAGNOSTICS MODE
DISPOSAL TONER FULL	DISPOSAL TONER FULL
DISPOSAL TONER NEAR FULL	DISPOSAL TONER NEAR FULL

Panel Display	Details
DRIVE MOTOR OVER HEAT	DRIVE MOTOR OVER HEAT
DUPLEX I/F ERROR	DUPLEX I/F ERROR
DUPLEX TYPE MISMATCH	DUPLEX TYPE MISMATCH
DUPLEX UNIT OPEN(PX713)	DUPLEX UNIT OPEN(PX713)
ENGINE BOARD FAN MOTOR ERROR	ENGINE BOARD FAN MOTOR ERROR
ENGINE CONTROL ERROR	ENGINE CONTROL ERROR
ENGINE EEPROM ERROR	ENGINE EEPROM ERROR
ENGINE EEPROM MISSING	ENGINE EEPROM MISSING
ENGINE LIFE OVER	ENGINE LIFE OVER
ENGINE RAM ERROR	ENGINE RAM ERROR
ENGINE ROM ERROR	ENGINE ROM ERROR
ENGINE SRAM ERROR	ENGINE SRAM ERROR
ENV TEMP SENSOR ERROR	ENV TEMP SENSOR ERROR
FACE-UP STACKER OPEN	FACE-UP STACKER OPEN
FLASH HARDWARE ERROR	FLASH HARDWARE ERROR
FLASH SOFTWARE ERROR	FLASH SOFTWARE ERROR
FRONT COVER OPEN(PX711)	FRONT COVER OPEN(PX711)
FUSER LIFE OVER	FUSER LIFE OVER
FUSER UNIT FAN MOTOR ERROR	FUSER UNIT FAN MOTOR ERROR
FUSER UNIT FUSE CUT ERROR	FUSER UNIT FUSE CUT ERROR
FUSER UNIT MISMATCH	FUSER UNIT MISMATCH
HOPPING ERROR DUPLEX	HOPPING ERROR DUPLEX
HOPPING ERROR MULTI PURPOSE FEEDER	HOPPING ERROR MULTI PURPOSE FEEDER
HOPPING ERROR TRAY1	HOPPING ERROR TRAY1
HOPPING ERROR TRAY2	HOPPING ERROR TRAY2
HOPPING ERROR TRAY3	HOPPING ERROR TRAY3
HOPPING ERROR TRAY4	HOPPING ERROR TRAY4
HOPPING ERROR TRAY5	HOPPING ERROR TRAY5
HUMIDITY SENSOR DEW ERROR	HUMIDITY SENSOR DEW ERROR
HUMIDITY SENSOR ERROR	HUMIDITY SENSOR ERROR
INFEED:DUPLEX	Duplex hopping error
INFEED:MP-FEEDER	MP feeder hopping error
INFEED:TRAY1	Tray 1 hopping error
INFEED:TRAY2	Tray 2 hopping error
INFEED:TRAY3	Tray 3 hopping error
INFEED:TRAY4	Tray 4 hopping error
INFEED:TRAY5	Tray 5 hopping error
INITIALIZING	Controlling initialization upon power ON
INITIALIZING	Controlling initialization upon cover open/close
INITIALIZING DENSITY ADJUST	Controlling adjustment of auto density
INITIALIZING REGISTRATION ADJUST	Controlling adjustment of auto color irregularity
INPATH:DUPLEX ENTRY	Duplex internal jam
INPATH:DUPLEX INPUT	Duplex transport jam
INPATH:DUPLEX REVERSAL	Duplex reversal unit jam
INPATH:EXIT	Ejection jam
INPATH:FEED	Feed jam
INPATH:TRANSPORT	Transport jam
JAM DUPLEX ENTRY	Duplex internal jam
JAM DUPLEX INPUT	Duplex transport jam
JAM DUPLEX REVERSAL	Duplex reversal unit jam
JAM EXIT	Ejection jam
JAM FEED	Feed jam

Panel Display	Details
JAM TRANSPORT	Transport jam
JOB OFFSET HOME ERROR(PX713)	JOB OFFSET HOME ERROR(PX713)
LED HEAD OVER HEAT	LED HEAD OVER HEAT
LIFT ERROR TRAY1(PX713)	LIFT ERROR TRAY1(PX713)
LIFT ERROR TRAY2(PX713)	LIFT ERROR TRAY2(PX713)
LIFT ERROR TRAY3(PX713)	LIFT ERROR TRAY3(PX713)
LIFT ERROR TRAY4(PX713)	LIFT ERROR TRAY4(PX713)
LIFT ERROR TRAY5(PX713)	LIFT ERROR TRAY5(PX713)
LIFT UP TRAY1(PX713)	LIFT UP TRAY1(PX713)
LIFT UP TRAY2(PX713)	LIFT UP TRAY2(PX713)
LIFT UP TRAY3(PX713)	LIFT UP TRAY3(PX713)
LIFT UP TRAY4(PX713)	LIFT UP TRAY4(PX713)
LIFT UP TRAY5(PX713)	LIFT UP TRAY5(PX713)
LOWER HEATER HIGH TEMPER	LOWER HEATER HIGH TEMPER
LOWER HEATER LOW TEMPER	LOWER HEATER LOW TEMPER
LOWER HEATER OPEN ERROR	LOWER HEATER OPEN ERROR
LOWER HEATER SHORT ERROR	LOWER HEATER SHORT ERROR
MAGENTA DRUM LIFE OVER	MAGENTA DRUM LIFE OVER
MAGENTA DRUM NEAR LIFE	MAGENTA DRUM NEAR LIFE
MAGENTA DRUM UNIT FUSE CUT ERROR	MAGENTA DRUM UNIT FUSE CUT ERROR
MAGENTA DRUM UP/DOWN ERROR	MAGENTA DRUM UP/DOWN ERROR
MAGENTA IRREGULAR ERROR	MAGENTA IRREGULAR ERROR
MAGENTA LED HEAD ERROR	MAGENTA LED HEAD ERROR
MAGENTA REGISTRATION ERROR	MAGENTA REGISTRATION ERROR
MAGENTA REGISTRATION OUT HORIZONTAL	Abnormal color irregularity registration value detected in magenta sub-scan registration
MAGENTA REGISTRATION OUT LEFT	MAGENTA REGISTRATION OUT LEFT
MAGENTA REGISTRATION OUT RIGHT	MAGENTA REGISTRATION OUT RIGHT
MAGENTA SENSOR ERROR LEFT	MAGENTA SENSOR ERROR LEFT
MAGENTA SENSOR ERROR RIGHT	MAGENTA SENSOR ERROR RIGHT
MAGENTA TONER EMPTY	MAGENTA TONER EMPTY
MAGENTA TONER LOW	MAGENTA TONER LOW
MAGENTA TONER SENSOR ERROR	MAGENTA TONER SENSOR ERROR
MAGENTA ID DENSITY ERROR 1	MAGENTA ID DENSITY ERROR 1
MAGENTA ID DENSITY ERROR 2	MAGENTA ID DENSITY ERROR 2
MAILBOX I/F ERROR(PX711)	MAILBOX I/F ERROR(PX711)
MISSING BELT UNIT	MISSING BELT UNIT
MISSING BLACK DRUM	MISSING BLACK DRUM
MISSING CYAN DRUM	MISSING CYAN DRUM
MISSING FUSER UNIT	MISSING FUSER UNIT
MISSING MAGENTA DRUM	MISSING MAGENTA DRUM
MISSING YELLOW DRUM	MISSING YELLOW DRUM
MULTI PURPOSE FEEDER STAGE POSITION	MULTI PURPOSE FEEDER STAGE POSITION
PAPER END MULTI PURPOSE FEEDER	PAPER END MULTI PURPOSE FEEDER
PAPER END TRAY1	PAPER END TRAY1
PAPER END TRAY2	PAPER END TRAY2
PAPER END TRAY3	PAPER END TRAY3
PAPER END TRAY4	PAPER END TRAY4
PAPER END TRAY5	PAPER END TRAY5
PAPER NEAR END MULTI PURPOSE FEEDER	PAPER NEAR END MULTI PURPOSE FEEDER
PAPER NEAR END TRAY1	PAPER NEAR END TRAY1
PAPER NEAR END TRAY2	PAPER NEAR END TRAY2
PAPER NEAR END TRAY3	PAPER NEAR END TRAY3

Panel Display	Details
PAPER NEAR END TRAY4	PAPER NEAR END TRAY4
PAPER NEAR END TRAY5	PAPER NEAR END TRAY5
PAPER PILE OUT OF TRAY	Paper transport error
PAPER SIZE ERROR	PAPER SIZE ERROR
POWER SUPPLY FAN MOTOR ERROR	PU fan motor error
POWER SUPPLY LSI ERROR	POWER SUPPLY LSI ERROR
PROCESS CONTROL OFF	PROCESS CONTROL OFF
PROCESS WAIT MODE	Adjusting color irregularity / density (upon starting from CU)
PUNCH BOX NOT EXISTING(PX713)	PUNCH BOX NOT EXISTING(PX713)
PUNCH DUST OVERFLOW(PX713)	PUNCH DUST OVERFLOW(PX713)
REGISTRATION SENSOR CALIBRATION ERROR	REGISTRATION SENSOR CALIBRATION ERROR
R-SIDE COVER OPEN(PX713)	R-SIDE COVER OPEN(PX713)
SHUTTER ERROR1	Density adjustment shutter error 1
SHUTTER ERROR2	Density adjustment shutter error 2
STACKER FULL BOTTOM BIN(PX713)	STACKER FULL BOTTOM BIN(PX713)
STACKER FULL FACE DOWN	STACKER FULL FACE DOWN
STACKER FULL MAIL BOX1(PX711)	STACKER FULL MAIL BOX1(PX711)
STACKER FULL MAIL BOX2(PX711)	STACKER FULL MAIL BOX2(PX711)
STACKER FULL TOP BIN(PX713)	STACKER FULL TOP BIN(PX713)
THICKNESS ADJUSTING	THICKNESS ADJUSTING
THICKNESS NON-PAPER AD ERROR	AD out of regulated value error (upon no media)
THICKNESS PAPER THICKNESS ERROR	Media thickness out of range error
THICKNESS SNS AD ERROR	Sensor output difference out of range error (upon no media)
THICKNESS THICK_PAPER ERROR	Speed adjustment error
TOP COVER OPEN	TOP COVER OPEN
TRAY1 TYPE MISMATCH	TRAY1 TYPE MISMATCH
TRAY2 COVER OPEN(PX713)	TRAY2 COVER OPEN(PX713)
TRAY2 I/F ERROR	TRAY2 I/F ERROR
TRAY2 TYPE MISMATCH	TRAY2 TYPE MISMATCH
TRAY3 COVER OPEN(PX713)	TRAY3 COVER OPEN(PX713)
TRAY3 I/F ERROR	TRAY3 I/F ERROR
TRAY3 TYPE MISMATCH	TRAY3 TYPE MISMATCH
TRAY4 COVER OPEN(PX713)	TRAY4 COVER OPEN(PX713)
TRAY4 I/F ERROR	TRAY4 I/F ERROR
TRAY4 TYPE MISMATCH	TRAY4 TYPE MISMATCH
TRAY5 COVER OPEN(PX713)	TRAY5 COVER OPEN(PX713)
TRAY5 I/F ERROR	TRAY5 I/F ERROR
TRAY5 TYPE MISMATCH	TRAY5 TYPE MISMATCH
UPPER HEATER HIGH TEMPER	UPPER HEATER HIGH TEMPER
UPPER HEATER LOW TEMPER	UPPER HEATER LOW TEMPER
UPPER HEATER OPEN ERROR	UPPER HEATER OPEN ERROR
UPPER HEATER SHORT ERROR	UPPER HEATER SHORT ERROR
WARMING UP	WARMING UP
YELLOW DRUM LIFE OVER	YELLOW DRUM LIFE OVER
YELLOW DRUM NEAR LIFE	YELLOW DRUM NEAR LIFE
YELLOW DRUM UNIT FUSE CUT ERROR	YELLOW DRUM UNIT FUSE CUT ERROR
YELLOW DRUM UP/DOWN ERROR	YELLOW DRUM UP/DOWN ERROR
YELLOW IRREGULAR ERROR	YELLOW IRREGULAR ERROR
YELLOW LED HEAD ERROR	YELLOW LED HEAD ERROR
YELLOW REGISTRATION ERROR	YELLOW REGISTRATION ERROR
YELLOW REGISTRATION OUT HORIZONTAL	Abnormal color irregularity registration value detected in magenta sub-scan registration
YELLOW REGISTRATION OUT LEFT	YELLOW REGISTRATION OUT LEFT

Panel Display	Details
CYAN REGISTRATION OUT RIGHT	CYAN REGISTRATION OUT RIGHT
CYAN SENSOR ERROR LEFT	CYAN SENSOR ERROR LEFT
CYAN SENSOR ERROR RIGHT	CYAN SENSOR ERROR RIGHT
CYAN TONER EMPTY	CYAN TONER EMPTY
CYAN TONER LOW	CYAN TONER LOW
CYAN TONER SENSOR ERROR	CYAN TONER SENSOR ERROR
CYAN ID DENSITY ERROR 1	CYAN ID DENSITY ERROR 1
CYAN ID DENSITY ERROR 2	CYAN ID DENSITY ERROR 2

#### Details of jam error display

Panel Display	Details
INFEED:TRAY1	Tray 1 hopping error
INFEED:TRAY2	Tray 2 hopping error
INFEED:TRAY3	Tray 3 hopping error
INFEED:TRAY4	Tray 4 hopping error
INFEED:TRAY5	Tray 5 hopping error
INFEED:MP-FEEDER	MP feeder hopping error
INFEED:DUPLEX	Duplex hopping error
INPATH:DUPLEX INPUT	Duplex transport jam
INPATH:DUPLEX ENTRY	Duplex internal jam
INPATH:REVERSAL	Duplex reversal unit jam
INPATH:FEED	Feed jam
INPATH:TRANSPORT	Transport jam
INPATH:EXIT	Ejection jam

INFEED: Data on paper remaining at paper feed slot.

INPATH: Data on paper remaining in paper path.

### 3.1.3 Various print jobs with single printer unit attached with a controller

#### Menu map print

Prints program version, configuration of the control unit, and other printer configuration and setting.

Operation: (Press switch)

Without HDD : "0" → "3" → "3"

With HDD : "0" → "0" → "3" → "3"

#### File list print

Prints a file list stored in the HDD or Flash ROM.

Operation: (Press switch)

Without HDD : "0" → "3" → "1" → "3"

With HDD : "0" → "0" → "3" → "1" → "3"

#### Font list print (PCL)

Prints a font list for PCL.

Operation: (Press switch)

Without HDD : "0" → "3" → "1" → "1" → "3"

With HDD : "0" → "0" → "3" → "1" → "1" → "3"

#### Font list print (PS)

Prints a font list for PS.

Operation: (Press switch)

Without HDD : "0" → "3" → "1" → "1" → "1" → "3"

With HDD : "0" → "0" → "3" → "1" → "1" → "1" → "3"

#### Demo print

Prints a demo pattern for each subject installed in the ROM.

Operation: (Press switch)

Without HDD : "0" → "3" → "1" → "1" → "1" → "1" → "3"

With HDD : "0" → "0" → "3" → "1" → "1" → "1" → "1" → "3"

#### Ethernet self-diagnostic print

If an Ethernet board is installed, perform self-diagnosis by pressing the Ethernet board SW for two seconds or longer and print the result.

### 3.2 Adjustment After Replacing Parts

The following describes the adjustments that are required after each part replacement. Adjustment and correction of color registration are always required for each part replacement.

Replaced Part	Adjustment
LED Head	Not required
Drum Cartridge (Y, M, C, K)	Not required.
Fuser Unit	Not required.
Belt Cassette Assy	Not required.
PU (K7N Board)	Re-mounting the EEPROM used on the board before the replacement. *Note 1
PU (K7V Board)	Reading EEPROM data before replacement, and writing the read data after the replacement, using a life counter tool.
CU (TIG board)	Re-mounting the EEPROM used on the board before the replacement. *Note 2
CU (HME board)	Re-mounting the EEPROM used on the board before the replacement. *Note 2 Network information initialization described in section 3.2.6, in replacing CUs containing Oki LAN8100e.
Oki LAN8100e (HMN Board)	Network information initialization described in section 3.2.6.
Shutter	Setting the correction value of the calibration chip for detecting density.
Media Thickness Sensor Assy	Adjusting paper thickness detection sensitivity and checking media thickness detection value setting.

\* Note:1. When the EEPROM of PU (K7N board) is replaced to a new one, color balance must be adjusted.

\* Note: 2. When the EEPROM of CU board is replaced to a new one, the Destination Setting must be adjusted.

#### 3.2.1 Precautions in replacing the engine control board

When replacing the engine control board (K7N PWB), remove the EEPROM from the old board and mount it on a new board (for errors other than those of engine EEPROM).

When SERVICE CALL xxx (Engine EEPROM Error) is displayed on the operator panel, the EEPROM must be replaced with a new one. In this case, perform the operation described in section 3.2.2.

For replacement with K7V PWBs, the EEPROM data on old engine control boards must be uploaded and, after the replacement, the uploaded data must be downloaded to the K7V PWBs, using a life counter tool.

#### 3.2.2 Precautions in replacing EEPROM

When the EEPROM is not removed from the board and placed on the new board at the time of engine control board (K7N PWB) replacement, the Version Read function (fuse cut) is disabled. The printer must be switched from the factory mode to the shipping mode by the PjL command.

##### [Description]

1. Sending of an appropriate PjL file to the printer to place it in Shipping mode
2. Sending of a repower-on or reboot command (PjL file) to complete the setting

##### [Procedure]

At the MS-DOS prompt, perform the following steps:

1. Enter Copy /b Pjl\_ship.bin prn and hit <Enter>.
2. Enter Copy /b Pjl\_reboot.bin prn and hit <Enter>, or power the printer off and on.

##### [PjL Files Required]

1. Pjl-ship.bin
2. Pjl-reboot.bin

**Note:** Life data for consumables such as belt, toner, and ID is cleared when replacing EEPROM, therefore, be cautious as there will be a tolerance in life management upon replacing the unit in the future. The following count will be cleared when replacing EEPROM. Other than Total Sheets Feed is cleared when each unit is replaced, therefore, the tolerance will be cleared at that point.

Item	Contents	Count
Fuser	Life count of the fuser	Value in which the number of printed pages is converted to the number of Letter paper after installing a new fuser unit.
Transfer Belt	Life count of the transfer belt	Value in which the number of printed pages is converted to the number of Letter paper after installing a new fuser unit.
Black Imaging Drum Cyan Imaging Drum Magenta Imaging Drum Yellow Imaging Drum	Life count of the imaging drums for each color	Value in which the number of rotations is converted to the number of Letter paper after installing a new ID unit.
Black Toner Cyan Toner Magenta Toner Yellow Toner	Count of the used toner amount for each color	Count of the number of printed dots.
Total Sheets Feed	Life count of the printer	Total number of printed pages.
Black Impressions Cyan Impressions Magenta Impressions Yellow Impressions	Total number of printed pages	Number of printed pages after installing a new ID unit.

### 3.2.3 Replacing EEPROM after replacing the CU board

When replacing the CU board, remove EEPROM from the board used by the user and set it to the replaced board. (This is to pass on the user set contents and font install data to the new board.) Furthermore, if the user's EEPROM cannot be used due to damages, use the EEPROM on the new board. In this case, the new board and EEPROM should be set with destinations.

### 3.2.4 Destination Setting (Checking Method: Printing Demo Page)

The destination setting of each main control board, which takes on ODA by default, must be set, at the time of printer shipment, to correspond to the destination of the printer equipped with the board.

Japan indirect sales, ODA, OEL and APS maintenance boards are to be shipped with the destination setting left at its default.

Setting on Operation Panel:

Powering up each printer in maintenance mode and then setting its destination are made.

While holding SWs ①, ②, ⑥, and ⑦ down, turn on printer.

After MAINTENANCE MENU is displayed on LCD, the display changes to OKIUSER.

Press SW ① to select OKIUSER for destination setting.

ODA \* appears on the lower display. Press SW ② to select a destination.

Confirm the setting by pressing SW ③.

Printer restarts, and comes up with the destination changed.

Description:

Each of Japan domestic and over seas C9500/C9300 uses a common ROM.

Destination setting must be made for the common ROM to be used in the printers to various destinations (the setting in the ROM default to ODA).

Settings are stored in CU board's EEPROM.

Maintenance boards are to be shipped with the destination setting at its default and, when Settings are stored in CU board's EEPROM.



### 3.2.5 Recovery Flash ROM data on CU board

A 4MB Flash ROM that enables a user to register an arbitrary file is installed on the CU board. When a CU board has to be replaced, print a file list of the information menu and check the registered files before replacing the board.

Re-register necessary files when the CU board is replaced.

### 3.2.6 Notes on replacing Oki LAN8100e or CU boards equipped with Oki LAN8100e

With the replacement of Oki LAN8100e (software NIC HMN board) or a CU (HME board) containing Oki LAN8100e, or the concurrent replacement of a CU (HME board) and Oki LAN8100e, network information stored in their Flash ROM must be initialized.

- Network information initialization is required at:

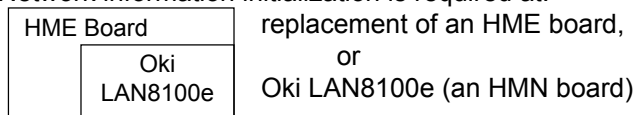

- Network information initialization is not required at:

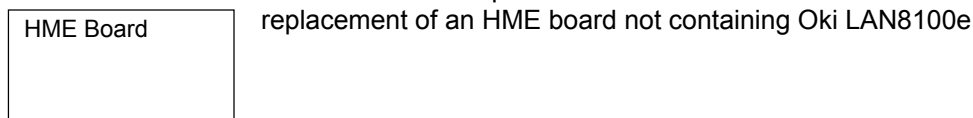

[Network Information Initialization Procedure]

- (1) Turn the printer off.
- (2) When a network cable is connected to the printer, plug off the cable from the connector on the printer side.
- (3) While holding the black push switch ([Test] button) of Oki LAN8100e down, turn the printer on. The black push switch should be held down until "NETWORK INITIALIZING" (the network is being initialized) appears on the upper display and "WAIT A MOMENT" (to wait a moment) appears on the lower display. Release the black push switch when they are displayed.
- (4) When "ONLINE" is displayed on the operator panel, initialization is complete.

[Network Information Initialization Checking Procedure]

- (1) Execute "PRINT MENU MAP" in "INFORMATION MENU".
- (2) Check the following two points in the Network Information of the first sheet from the result of Oki LAN8100e menu printing.

```

General Information
MAC Address
TCP/IP Configuration   □□□□□○○○○○
Auto Discovery
Printer Name           △△○○○○○
  
```

The Mac Address and Printer Name values at the portions indicated by ○ (three bytes) are the same, network information has been initialized successfully.

## 3.3 Adjusting the Density

The auto density adjust mode is set to [Auto] when the printer is delivered, however, problems may occur upon using the printer if the mode is set to [Manual]. Perform the procedure when the density is improper.

**Note:** Perform the task when the printer is not in operation. Do not perform during warm-up.

- (1) Press ① several times and display [Color Menu].
- (2) Press ① or ⑤ and display [Density Adjust/Start].
- (3) Press ③.

The auto density adjustment will begin.

### 3.4 Paper Thickness Detection Sensitivity Adjustment and Media Thickness Detection Value Check

#### Outline:

The sensitivity of a micro displacement sensor used for detecting media thickness varies from one to another. Therefore, to ascertain the sensitivity in advance, check the output value of the sensor by passing media of known thickness through the printer equipped with the sensor. The sensitivity is fixed based on the output value.

Adjustments must be made when the paper thickness sensor, the registration roller and the PU board are replaced.

By passing, from the multipurpose tray, four sheets of paper whose thickness has been measured with a micrometer (MDQ-30M, MDQ-30), the correction value for media thickness sensitivity is automatically set with the first three sheets. Check the media thickness detection value with the fourth sheet.

Media: Transparency (42404301)

Paper thickness difference: Within  $\pm 10\mu\text{m}$

#### 3.4.1 Applicable Operating Systems and Interfaces, and File Required

Software: AdjustmentMM.exe (Ver. 1.12) File Required: Opusbase.dll

OS	I/F	File Type	File Name	Remarks
Win9x Series (95/98/Me)	Centronics	No file required	No file required	The interface port must be checked for its bidirectional setting.
	USB	USB driver	Oki USB Driver for Win98.exe	With the insertion of a USB, installation screen display is provided.
Win2000/XP	Centronics			Inapplicable
	USB	No file required	No file required	

**Note:** For use of a Centronics interface, the interface port must be checked for its bidirectional setting.

Checking: Check the parallel port is set to bidirectional in the BIOS setup (Parallel Mode parameter: Bi directional. No ECP/EEP).

**Note:** BIOS setup and program words vary with personal computers. Be sure to refer to the user documentation for the PC used.

(Example for NEC PCs)

- (1) Power on the PC.
- (2) POST (Power On Self-Test) details are displayed on the PC screen and then, at the lower left of the screen, Press <F2> to enter SETUP is shown.
- (3) At the press of <F2>, SETUP is activated and the Main menu appears.
- (4) Select Peripheral Configuration from the Advanced menu.
- (5) Select Parallel Mode and check the parallel port is set to Bi directional.
- (6) Press Esc to end the checking.

### 3.4.2 Setting

#### 3.4.2.1 Menu Setting

- (1) Power on the PC.
- (2) Create an arbitrary folder, and copy the two files AdjustMM.exe and Opusbacc.dll into it (refer to the screen that is an example when the folder C:\MediaThickness has been created).

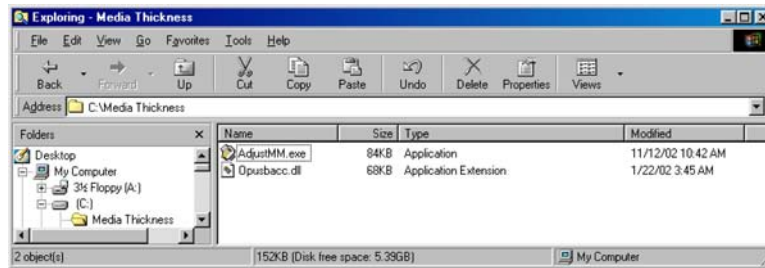

- (3) On the PC, activate the adjustment software AdjustMM (press OK on the screen that is provided only when the software is activated first time).



Perform steps (2) to (4) only in first-time menu setting.

- (4) Connect the printer AC cable and Centronics interface cable.

- Note:**
- When a Centronics is used, operation is not performed unless the Centronics is set to bidirectional. Refer to 3.4.1 Applicable Operating Systems and Interfaces, and File Required.
  - When a USB is used with a Win9x series (Win95/98/Me), the USB driver "Oki USB Driver for Win98.exe" must be installed.

- (5) Power on the printer. Wait until the printer is placed on-line.
- (6) Mark the Config(C) checkbox and then press Setup Data.

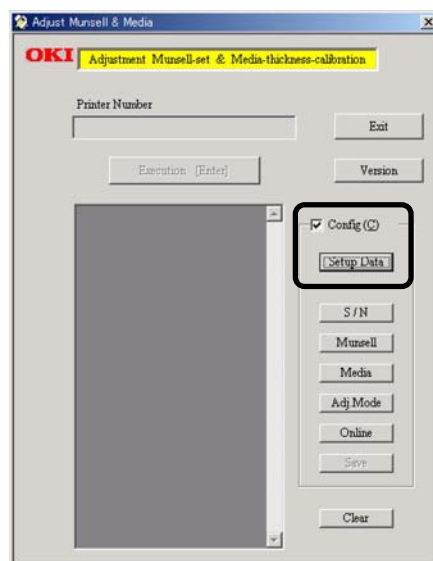

(7) Setting screen appears. Select (mark) LPT1 or USB on the Printer Port menu. Press OK.

**Note:** Do not change settings other than those instructed here.

The 'Setting' dialog box contains the following fields and controls:

- Input setting data:** A text input field.
- Media Set Sequence:** Radio buttons for 'Forward' and 'Reverse' (selected).
- Spec. AD Limit of medialess:** Input fields for 'Max' (814) and 'Min' (317).
- Spec. Media-thickness [Input-data]:** Input fields for 'Max' (150) and 'Min' (80), with a unit label '[um]'.
- Spec. Munsell-correction [Input-data]:** Input fields for 'Max' (6) and 'Min' (-4).
- Printer Port:** Radio buttons for 'LPT1:' (selected) and 'USB'.
- Machine:** Text input field containing 'ODC000'.
- Save data path:** Text input field containing 'c:\MediaThickness'.
- Buttons:** 'OK' and 'Cancel' buttons are located on the right side.

(8) The screen returns to the Adjust Munsell & Media screen. Press Media.

The 'Adjust Munsell & Media' dialog box contains the following fields and controls:

- Printer Number:** Text input field.
- Exit:** Button.
- Emulation [Enter]:** Button.
- Version:** Button.
- Config (C):** Checked checkbox.
- Buttons in Config (C):** 'Setup Data', 'S/N', 'Munsell', 'Media' (highlighted), 'Adj.Mode', 'Online', 'Save', and 'Clear'.

3.4.2.2 Media Setting

- (1) The media thickness input screen is displayed.  
 Prepare four sensitivity adjustment transparency sheets (42404301) and enter the thicknesses with which the transparency sheets are labeled.

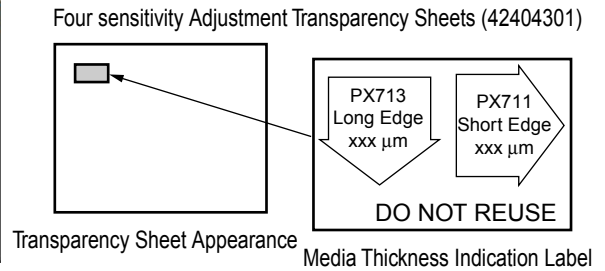
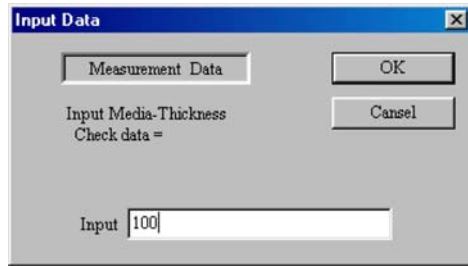

- Note:**
- Make thickness entries in  $\mu\text{m}$  (simply type in the value that is indicated on each transparency sheet). Enter the value of the short edge.
  - Load the sheets in the multipurpose tray, in the order of their thickness entry (the media of the first entered thickness is to be lowermost in the multipurpose tray).

Thickness Entry Order	Screen Display	Tray Loading Order	Feed Order	Remarks
4	sample 1=	4 MP try top	1	Sensitivity adjustment 1st sheet
3	sample 2=	3	2	Sensitivity adjustment 2nd sheet
2	sample 3=	2	3	Sensitivity adjustment 3rd sheet
1	Check data=	1 MP try bottom	4	Check sheet

- (2) After the completion of the thickness entry of the fourth sheet, the ADJUSTMM screen is shown.

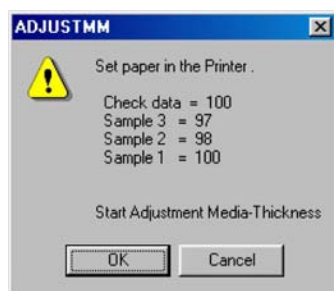

Paper Orientation: Portrait

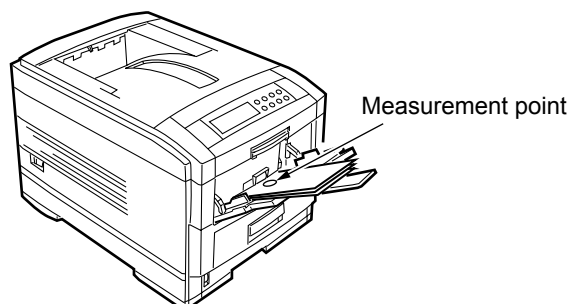

- \* Load four sheets of media so as that their measurement points are located at the front feeder - plate hopper.

### 3.4.2.3 Sensitivity Adjustment

- (1) With the press of OK on the ADJUSTMM screen, sensitivity adjustment is performed. The printer boots up, and four sheets of media are passed through it.

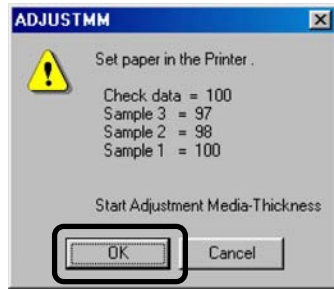

- (2) When the sensitivity adjustment is completed properly, the ADJUSTMM screen and the Adjust Munsell & Media screen are displayed.

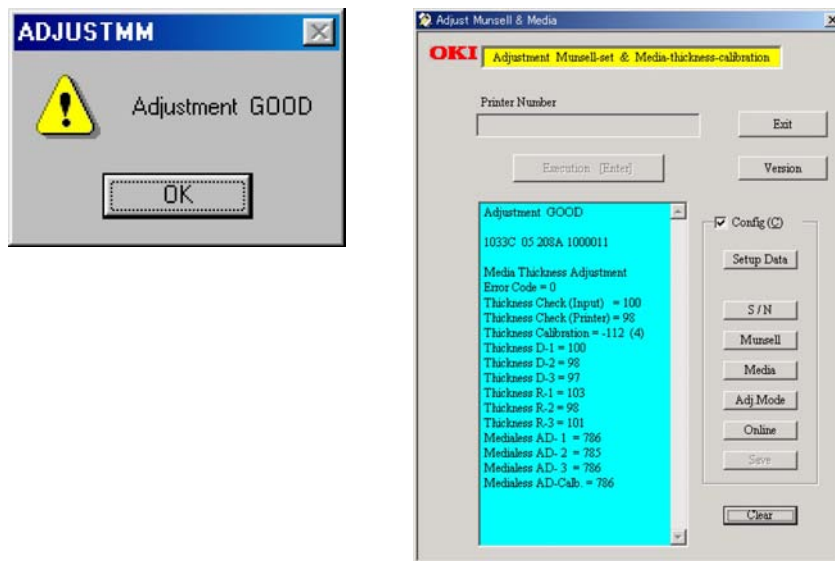

- (3) When the sensitivity adjustment is not properly completed, the screen appears. In such cases, see Actions for NG Sensitivity Adjustment.

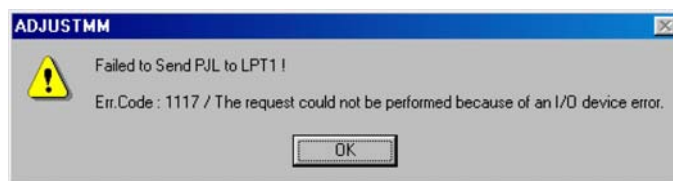

- (4) The folder C:\MediaThickness is automatically created, storing the result of the sensitivity adjustment in the CSV format. Determine cause(s) of NG results from the stored file. After the cause(s) are corrected, conduct sensitivity adjustment again.

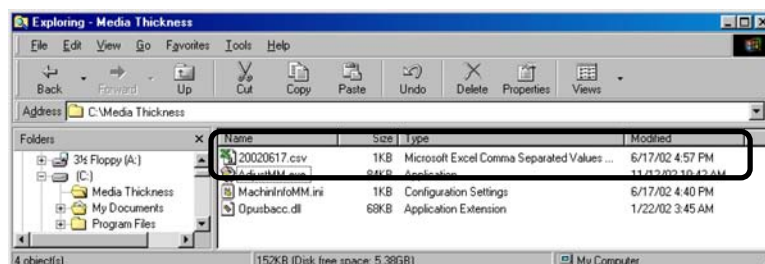

- (5) Power off the printer and disconnect the interface cable.

### 3.4.2.4 Actions for NG Sensitivity Adjustment

When a CSV format file stored automatically in sensitivity adjustment is opened, the opened file contains the following. The yellow-shaded area shows errors. For error code-to-description correspondence, see the flow chart shown below.

#### Data stored in CSV format (Example)

Calibration of Media-thickness adjustment & Munsell correction writing #####

Lot: 0121 M059970 Machin ODC-000

IR Number	Err.Code	Check Input	Check Meas	Calb	Data-D1	Data-D2	Data-D3	Data-R1	Data-R2	Data-R3	AD-1	AD-2	AD-3	AD-Che	Munsell	Judg	Date	Time
17	0	101	107	141	101	103	102	99	105	104	754	760	762	763	FE	GOOD	#####	8:55:06
18	0	99	103	146	100	102	103	97	108	112	627	634	634	633	FE	GOOD	#####	10:14:21
37	0	96	100	145	103	101	101	101	109	107	640	653	654	654	0	GOOD	#####	10:18:42
1	0	101	105	139	98	99	103	98	98	102	772	779	781	781	3	GOOD	#####	10:38:15
13	0	101	105	136	98	103	104	91	100	104	687	697	698	697	2	GOOD	#####	10:45:58
5	0	102	98	140	101	104	101	97	106	102	752	760	759	758	2	GOOD	#####	10:58:27

#### Action procedure for NG sensitivity adjustment on media thickness detection part

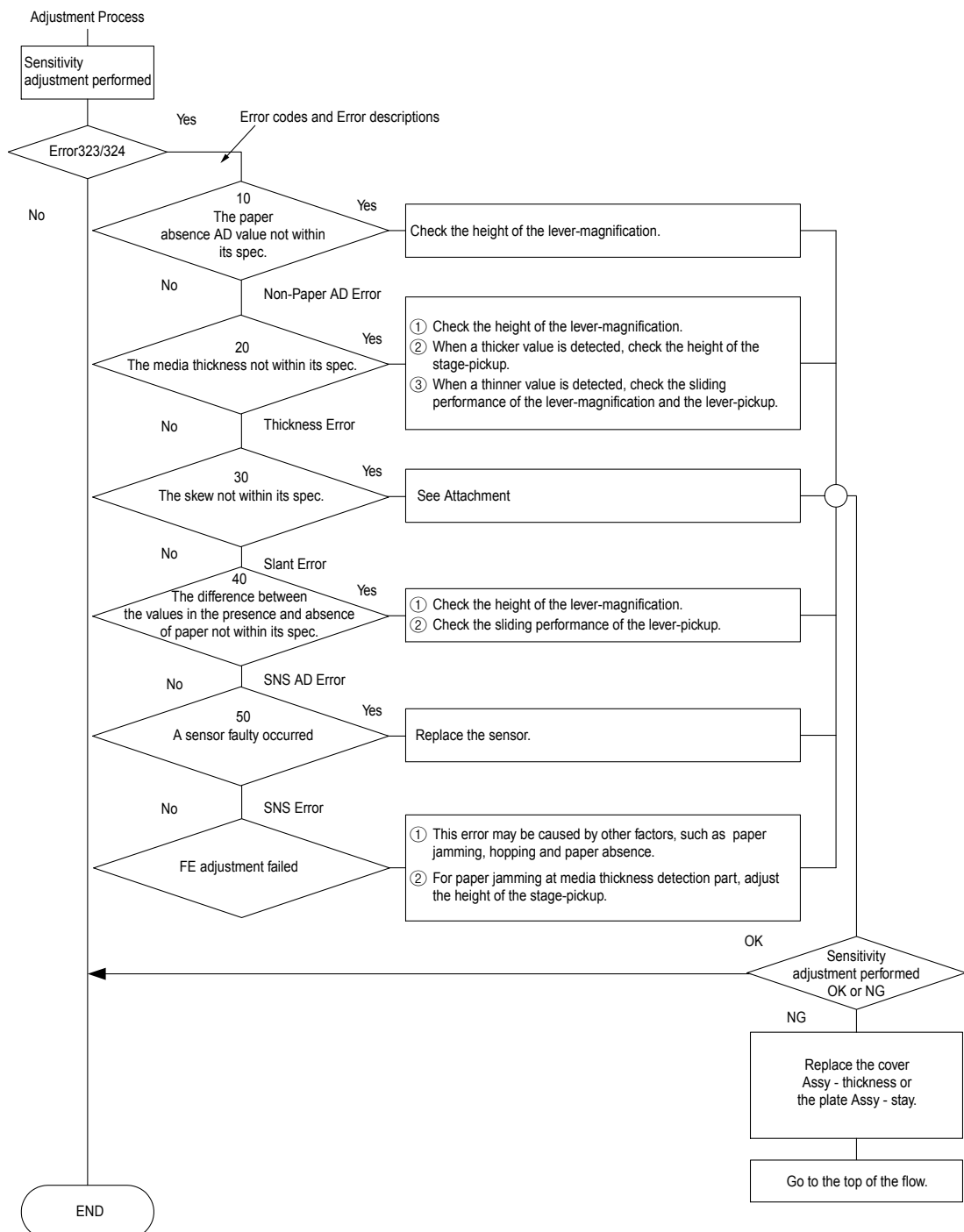

### 3.4.3 Inputting the density of the calibration chip for density detection

Write the calibration target adjustment value (last 2 digits in the barcode, refer to the figure below) indicated on the shutter label.

The adjustment value of the shutter must be reset when Sheet Color, density sensor, or PU sensor is replaced.

#### 3.4.3.1 Density Adjustment Menu Setting

For the steps (1) to (8) of menu setting, see Media Thickness Detection Adjustment Calibration 3.4.2.1, steps (1) to (8).

(9) The screen returns to the Adjust Munsell & Media screen. Press Munsell.

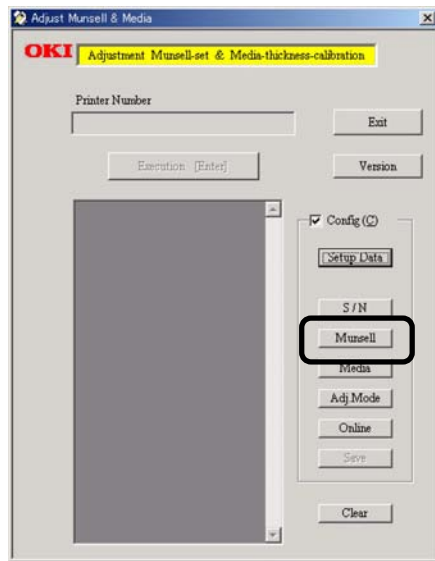

(10) Press Yes.



(11) The Munsell sheet correction value input screen appears.

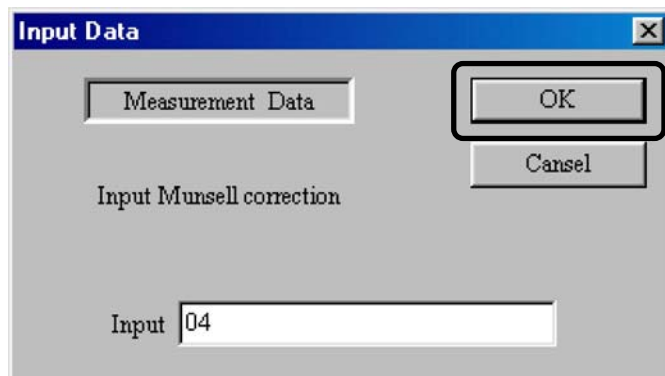



- (12) Enter the correction value marked on the barcode label on the shutter into the Input field and press OK (the Munsell sheet correction value is sent from the PC to the printer and set).
- (13) When the density adjustment is completed properly, the ADJUSTMM screen and the Adjust Munsell & Media screen are brought up.

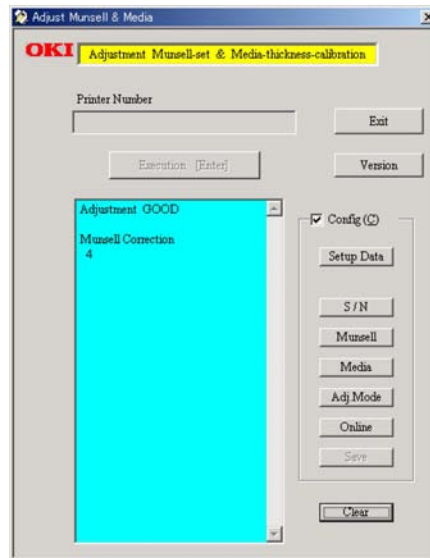

Barcode specification:

- ① Applied code : code39
- ② Barcode digit : 12 digits
- ③ Written content :

From the left: \*1 digit

Date 4 digits

(ID barcode) method

Year 1 digit - 1 digit (x) in (200x)

Month 1 digit (10th, 11th, 12th month are indicated as X, Y, Z.)

Day 2 digits

Empty 4 digits

Set zeros "0000".

2 adjustment digits

(Same as the data format input manually for the printer.)

00~04 for 0 to 4, FF~FC for -1 to -4.

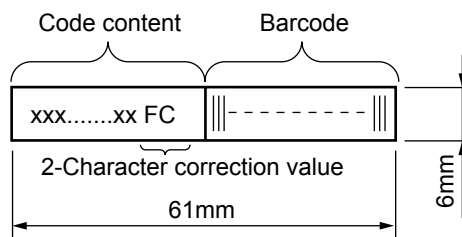

- ④ Barcode length  
YC4116-1006P001 label sheet 1/4"

### 3.4.4 Electronic Serial Number Input

**[Outline]**

The 22-character electronic serial number (E-S/N) that has been marked on each printer's nameplate is to be entered.

**[Case that Requires Electronic Serial Number Input]**

The EEPROM mounted on the PU board of a printer is replaced with a new one.

**[Setting Method]**

For the steps (1) to (8) of menu setting, see Media Thickness Detection Adjustment Calibration 3.4.2.1, steps (1) to (8).

(9) The screen returns to the Adjust Munsell & Media screen. Press S/N.

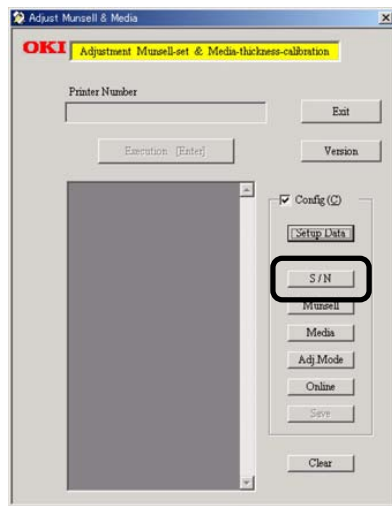

(10) The Input Data screen is displayed. Type 22-character electronic serial number in the Input field and press OK.

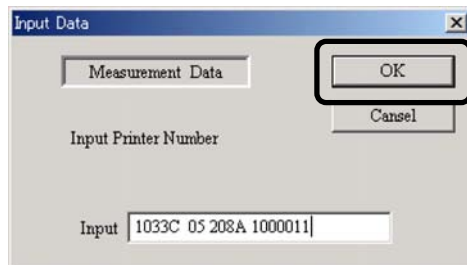

(11) When the electronic serial number input is completed properly, the Adjust Munsell & Media screen appears.

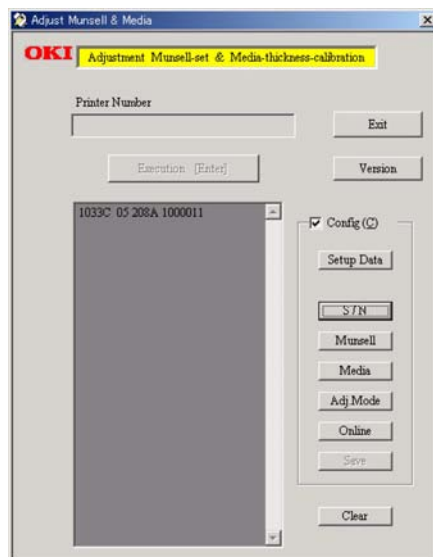

## 4. REGULAR MAINTENANCE

### 4.1 Parts Replaced Regularly

Users are recommended to replace parts periodically according to the table below. (Print quality cannot be assured and damages may occur, when the parts are not replaced.)

Part Name	Time of Replacement	Condition for Replacement	Adjustment (after replacement)
Large toner cartridge	When [Fill Toner] is displayed.	10,000 pages are printed.	
Toner cartridge	When [Fill Toner] is displayed.	5,000 pages are printed.	
ID	When [Drum Life] is displayed.	20,000 pages are printed. (3P/J)	
Fuser unit	When [Fuser Life] is displayed.	60,000 pages are printed.	
Belt unit	When [Belt Life] is displayed.	60,000 pages are printed.	
Feed Roller Components	When non-feeding of paper is frequent (a proper paper amount is loaded).	120,000 pages are printed (this is given as a guide).	

Parts are replaced periodically by users.

### 4.2 Cleaning

Clean the internal and external sections of the printer with waste and a small vacuum cleaner as required.

**Note:** Do not touch the image drum terminals, the LED lens array, and the LED head connector.

### 4.3 Cleaning the LED Lens Array

Clean the LED head array while white bands or lines (white-out, faint print) appear in the vertical direction on a printed page.

**Note:** Be sure to clean the LED lens array with the LED lens array cleaner. (the LED head cleaner is packed together with the toner cartridge.)

White band, white stripe  
(Void or light printing)

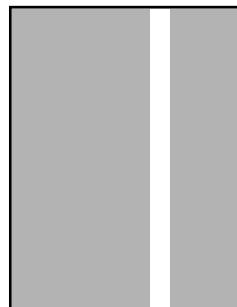

### 4.4 Cleaning the Pick-up Roller

Clean the pick-up roller if lines appear in the vertical direction on the printed page.

**Note:** Use a soft cloth in order to avoid scratching the roller surface.

## 5. TROUBLESHOOTING PROCEDURES

### 5.1 Precautions before troubleshooting

- (1) Confirm the basic inspection items described in the user manual.
- (2) Obtain as much information regarding the problem from the user as possible.
- (3) Check the printer in a condition close to that upon generating the problem.

### 5.2 Precautions before handling an abnormal image

- (1) Confirm that the environment for using this printer is appropriate.
- (2) Confirm that consumables (toner, drum cartridge) are replaced appropriately.
- (3) Confirm that paper is accurate. Refer to paper specifications.
- (4) Confirm that the drum cartridge is set appropriately.

### 5.3 Precautions upon handling an abnormal image

- (1) Do not touch or allow foreign objects to contact the OPC drum surface.
- (2) Do not expose the OPC drum to direct sunlight.
- (3) Do not touch the fuser unit as it is heated significantly.
- (4) Do not expose the image drum to light for longer than five minutes in room temperature.

## 5.4 Preparing for Troubleshooting

### (1) Operator panel display

Problems that occur with the printer are indicated in the LCD.

Apply proper remedies according to the message indicated in the LCD.

## 5.5 Troubleshooting Procedure

Confirm the problem in the following method when the printer generates a problem.

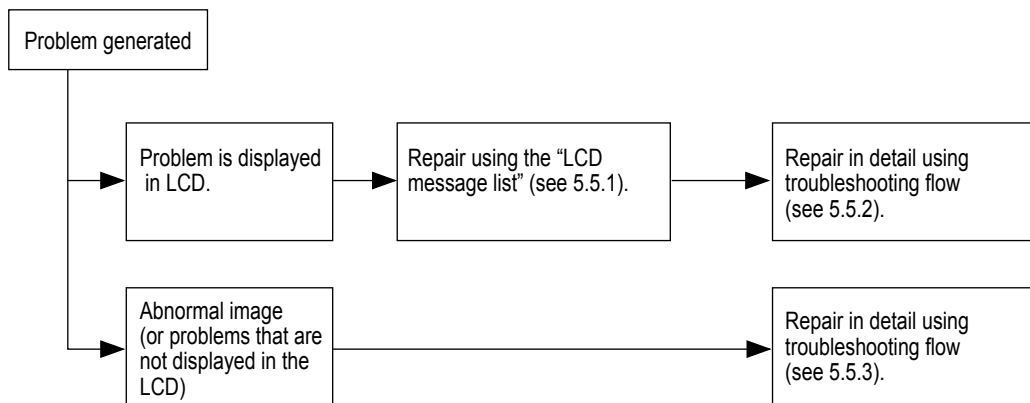

5.5.1 LCD message list

When the printer detects a non-recoverable error, the following service call error is displayed in the LCD.

Service call  
nnn: error

**Note:** nnn is an error code.

When [Service call] is displayed, error information that corresponds to the error code appears in the bottom line in the LCD. Error codes, their definitions and remedies are described in Table 5-1-1.

Table 5-1-1 Operator Alarm (1/6)

Message	Cause	Error Description		Solutions
Service Call 001: Error ~ 011: Error	CPU Exception	Does error display reappear? Does error display reappear?	Yes Yes	Turn power OFF and ON. Replace CU board. (Replace EEPROM)
Service Call 020: Error	CU ROM Hash Check Error 1	Is program ROM DIMM set properly? Is error recovered by replacing program ROM DIMM?	No Yes No	Reset program ROM DIMM. Replace program ROM DIMM. Replace CU board. (Replace EEPROM)
Service Call 030: Error	CU Slot1 DIMM RAM Check Error	Is subject RAM DIMM set properly? Is error recovered by replacing subject ROM DIMM?	No Yes No	Reset subject RAM DIMM. Replace RAM DIMM. Replace CU board. (Replace EEPROM)
Service Call 031: Error	CU Slot2 DIMM RAM Check Error	Is subject RAM DIMM set properly? Is error recovered by replacing subject ROM DIMM?	No Yes No	Reset subject RAM DIMM. Replace RAM DIMM. Replace CU board. (Replace EEPROM)
Service Call 032: Error	CU Slot3 DIMM RAM Check Error	Is subject RAM DIMM set properly? Is error recovered by replacing subject ROM DIMM?	No Yes No	Reset subject RAM DIMM. Replace RAM DIMM. Replace CU board. (Replace EEPROM)
Service Call 035: Error	Slot1 RAM Spec Error. The CU RAM Slot1 DIMM specification is not supported.	Is RAM DIMM genuine? Is subject RAM DIMM gap setting proper? Is error recovered by replacing subject ROM DIMM?	No No Yes No	Use genuine RAM DIMM. Reset subject RAM DIMM. Replace RAM DIMM. Replace CU board. (Replace EEPROM)
Service Call 036: Error	Slot2 RAM Spec Error. The CU RAM Slot2 DIMM specification is not supported.	Is RAM DIMM genuine? Is subject RAM DIMM gap setting proper? Is error recovered by replacing subject ROM DIMM?	No No Yes No	Use genuine RAM DIMM. Reset subject RAM DIMM. Replace RAM DIMM. Replace CU board. (Replace EEPROM)
Service Call 037: Error	Slot3 RAM Spec Error. The CU RAM Slot3 DIMM specification is not supported.	Is RAM DIMM genuine? Is subject RAM DIMM gap setting proper? Is error recovered by replacing subject ROM DIMM?	No No Yes No	Use genuine RAM DIMM. Reset subject RAM DIMM. Replace RAM DIMM. Replace CU board. (Replace EEPROM)
Service Call 040: Error	CU EEPROM Error	Is error recovered by replacing EEPROM on CU board?	Yes No	Replace EEPROM. (Recover user environment.) Replace CU board. (Replace EEPROM)
Service Call 041: Error	CU Flash Error Flash ROM error on CU board.	Does error display reappear?	Yes	Replace CU board. (Replace EEPROM.)

Table 5-1-1 Operator Alarm (2/6)

Message	Cause	Error Description		Solutions
Service Call 042: Error ~ 044: Error	Flash File SYSTEM Error	Failed access to Flash set directly on CU board.		Press ①, ③, ⑤, ⑥ to turn power ON, release buttons when [FLASH FORMAT] appears, wait until [ON-LINE] (2sec) and replace CU board if symptom does not change.
Service Call 048: Error	CU ROM for PS+PCL was set in Non-PS device.	Is proper program ROM set?	Yes No	Replace program ROM DIMM. Replace with proper program ROM DIMM.
Service Call 049: Error	CU type mismatch CU ROM does not match with the device.	Is proper program ROM set?	Yes No	Replace program ROM DIMM. Replace with proper program ROM DIMM.
Service Call 050: Error	Operater Panel Error	Does error display reappear?	Yes	Refer to no LCD display flow chart.
Service Call 051: Error	CU Fan Error Abnormal CPU cooling fan on CU board.	Is connector set properly on CU board?  Is error recovered by replacing fan?	No Yes No	Connect properly. Replace fan. Replace CU board. (Replace EEPROM.)
Service Call 063: Error	Network comm. Error Abnormal H/W I/F between CU-NIC.	Is network board set properly?  Is error recovered by replacing network board?	No Yes No	Set properly. Replace Network. Replace CU board. (Replace EEPROM.)
Service Call 065: Error	NIC Combination Error	Is proper Network board for the model set?	Yes No	Replace NIC card. Replace with proper Network board.
Service Call 070: Error	CANT_HAPPEN PS firmware fault detected.	Confirm that error is recovered by turning power OFF/ON.	No	Replace CU board. (Replace EEPROM.)
Service Call 072: Error	Engine communication error I/F error between PU-CU.	Is CU assembly set properly?  Is error recovered by replacing CU board?	No Yes No	Set properly. Replace CU board. (Replace EEPROM.) Replace PU board.
Service Call 073: Error ~ 075: Error	Video overrun detect	Is CU assembly set properly? Is error recovered by replacing CU board?	No Yes	Set properly. Replace CU board. (Replace EEPROM.)
Service Call 102: Error	Error in engine RAM read/write detected at power ON.	Does error reoccur?	Yes	Replace engine control board.
Service Call 103: Error	Error in engine SRAM read/write detected at power ON.	Does error reoccur?	Yes	Replace engine control board.
Service Call 104: Error	Error in engine EEPROM check total detected at power ON.	Does error reoccur?	Yes	Replace engine control board.
Service Call 105: Error	EEPROM not detected at power ON.	Does EEPROM exist? Does error reoccur?	Yes Yes	Check for EEPROM and set if not found. Replace engine control board.
Service Call 106: Error	Error in engine control logic detected at power ON.	Does error reoccur?	Yes	Replace engine control board.
Service Call 107: Error	Engine ROM check sum error.	Does error reoccur? Is error recovered by reloading PU F/W?	Yes No	Reload PU I/F. Replace engine control board.

Table 5-1-1 Operator Alarm (3/6)

Message	Cause	Error Description		Solutions
Service Call 110: Error ~ 116: Error 110: Envelope Feeder 111: Duplex unit 112: 2nd Tray 113: 3rd Tray 114: 4th Tray 115: 5th Tray 116: Finisher	Option unit for different model detected.	Is a proper option unit for the printer set?	Yes No	Set proper option unit. Check connections and turn power ON. If error is not recovered, replace the unit.
Service Call 120: Error	PU unit fan motor error.	1) Is fan in PU unit operating? 2) Error reoccurs after replacing fan motor.	No Yes Yes	Replace fan motor. Replace engine control board. Replace engine control board.
Service Call 121: Error	High-voltage power supply I/F error.	Is cable between PU board and high-voltage power LSI connected properly?	No Yes	Connect properly. Replace high-voltage power supply. Check improper connections for high-voltage.
Service Call 122: Error	Low-voltage power supply fan error. Low-voltage power supply temperature error.	1) Is fan in low-voltage power supply unit operating? 2) Error reoccurs after replacing fan motor.	No Yes Yes	Replace fan motor. Replace low-voltage power supply. Replace low-voltage power supply.
Service Call 123: Error	Improper environment humidity detected by sensor.	1) Is error message displayed? 2) Does error reoccur?	Yes Yes	Turn ON power again. Replace humidity sensor.
Service Call 124: Error	Improper environment temperature detected by sensor.	1) Is error message displayed? 2) Does error reoccur?	Yes Yes	Turn ON power again. Replace humidity sensor.
Service Call 125: Error	Error detected at MT home position.	1) Is error message displayed? 2) Does error reoccur?	Yes Yes	Turn ON power again. Replace MT.
Turn power OFF and wait 126: Dew error	Sensor dew error.	Sensor dew error detected.		Turn ON power after a while.
Service Call 130: Error	Temperature rise detected at LED head.	1) Is error message displayed? 2) Does error reoccur?	Yes Yes Yes	Leave alone for 30 min. Turn power OFF. Leave for 30 min., then turn power ON. Replace LED head.
Service Call 131: Y Head 132: M Head 133: C Head 134: K Head	Same unit not detected upon power ON or opening cover.	1) Is error message displayed? 2) Is LED head properly set? 3) Does error reoccur?	Yes No Yes	Confirm that LED head is set properly. Turn power ON again. Replace LED head assembly.
Service Call 140: Y ID 141: M ID 142: C ID 143: K ID	Error detected at proper ID position.	1) Is error message displayed? 2) Does error reoccur?	Yes Yes	Turn power ON again. Replace drum assembly.
Service Call 150: Y 151: M 152: C 153: K	When a fuse could not be disconnected in the ID unit.	Is ID unit set properly?	Yes	Check cable connections and replace engine board.
Service Call 154: Error	When belt unit fuse cannot be disconnected.	Is belt unit set properly?	Yes	Check cable connections and replace engine board.
Service Call 155: Error	When fuser unit fuse cannot be disconnected.	Is fuser unit set properly?	Yes	Check cable connections and replace engine board.



Table 5-1-1 Operator Alarm (4/6)

Message	Cause	Error Description		Solutions
Service Call 160: Y Toner 161: M Toner 162: C Toner 163: K Toner	Error detected by toner sensor.	1) Is error message displayed? 2) Does error reoccur?	Yes Yes	Replace toner sensor or assembly (Y71-PWB). Same as above.
Service Call 170: Error 171: Error 174: Error 175: Error	Short circuit in fuser thermistor or open detected (high temp. or low temp.)	1) Is error message displayed? 2) Does error reoccur?	Yes Yes	Turn ON power again. Replace thermistor and turn power OFF. Leave aside for 30 min.
Service Call 172: Error 176: Error	Thermistor indicates high-temperature error.	1) Is error message displayed? 2) Does error reoccur?	Yes Yes	Turn ON power again. Replace thermistor and turn power OFF. Leave aside for 30 min.
Service Call 173: Error 177: Error	Thermistor indicates low-temperature error.	1) Is error message displayed? 2) Does error reoccur?	Yes Yes	Turn ON power again. Replace thermistor and turn power OFF. Leave aside for 30 min.
Service Call 179: Error	Wrong fuser standard.	1) Does fuser match with model and power voltage? 2) Error reoccurs after setting fuser properly.	No Yes Yes	Set proper fuser. Check if fuser is set properly. Replace fuser.
Service Call 180: Error ~ 186: Error	Communication disability with option unit detected by engine.	1) Is error message displayed? 2) Does error reoccur?	Yes Yes	Turn ON power again. Replace option unit.
Service Call 187: Error	Communication with control panel disabled.	Is cable properly connected to control panel?	No Yes	Connect properly. Replace control panel and cable.
Close cover 310: Top cover open	Printer engine cover open.	1) Check if top cover is open. 2) Check if cover switch is proper.	Yes Yes No	Close top cover. Close side cover. Replace cover switch.
Reset fuser 320: Fuser error	Same unit not detected upon power ON or opening cover.	1) Is error message displayed? 2) Is fuser unit set properly? 3) Does error reoccur?	Yes No Yes	Check if fuser is set properly. Reset fuser and turn ON power again. Replace fuser unit assembly.
Turn power OFF and wait 321: MOTOR OVERHEAT	Printer cannot be used temporarily due to motor overheat.			Turn ON power after a while.
Open/close cover 323: Paper thickness error	Sensor output out of range with no media. (Only for Factory Mode)	1) Are foreign objects mixed in sensor? 2) Does printer recover when detecting paper thickness by opening/closing tray? 3) Does printer recover by power OFF/ON.	Yes No	Remove foreign objects. Normal.
Open/close cover 324: Paper thickness error	Sensor output gap out of range with no media. (Only for Factory Mode)	1) Are foreign objects mixed in sensor? 2) Does printer recover when detecting paper thickness by opening/closing tray? 3) Does printer recover by power OFF/ON.	Yes No	Remove foreign objects. Normal.
Open/close cover 325: Paper thickness error	Media detect value out of range.	1) Is different media type mixed in? 2) Is media being double fed?	Yes	Remove foreign objects.
Open/close cover 326: Paper thickness error	U-Heavy mode media detect value out of range.	Is different media type mixed in?	Yes	Remove foreign objects.

Table 5-1-1 Operator Alarm (5/6)

Message	Cause	Error Description		Solutions
Reset belt 330: Belt error	Same unit not detected upon power ON or closing cover.	1) Is error message displayed? 2) Is belt unit set properly? 3) Does error reoccur?	Yes No Yes	Check set condition of belt unit. Reset belt unit and turn power ON again. Replace belt unit assembly.
Reset drum 330~343: Drum error	Same as above.	1) Is error message displayed? 2) Is image drum set properly? 3) Does error reoccur?	Yes No Yes	Check set condition of ID. Turn power ON again. Replace ID unit assembly.
Set new drum 350: Yellow drum life 351: Magenta drum life 352: Cyan drum life 353: Black drum life	ID unit life.	Right after replacing ID unit?	Yes No	Check ID unit life. Replace ID unit.
Set new fuser 354: Fuser life	Fuser life (occurs when fuser life continuation is OFF).	Right after replacing fuser?	Yes No	Check fuser life. Replace fuser.
Set new belt 355: Belt life	Belt life notified (alarm). Print N-count by opening and closing cover.	Right after replacing belt?	Yes No	Check belt life. Replace belt.
Set new belt 356: Belt life	Waste toner belt life notified (alarm). Print N-count by opening and closing cover. N=20	Right after replacing belt?	Yes No	Check belt life. Replace belt.
Set duplex unit 360: Duplex unit is open.	When duplex unit is removed from printer.	Does error recover by resetting duplex unit?	Yes No	Normal. Replace duplex unit or engine board.
Check DUPLEX 370: Paper jam	Paper jam detected after paper rotated in duplex unit.	Check paper jam in duplex unit.	Yes No	Remove jammed paper. Check/replace duplex unit.
Check DUPLEX 371: Paper jam	Paper jam during paper feed from duplex unit.	Check paper jam in duplex unit.	Yes No	Remove jammed paper. Check/replace duplex unit.
Check DUPLEX 372: Paper jam		Check miss-feed in duplex unit.	Yes No	Remove miss-fed paper and close cover. Check/replace duplex unit.
Open front cover 380: Paper jam	Paper jam during paper feed from cassette 1, 2, 3, 4 or 5.	Check miss-feed in duplex unit.	Yes No	Remove miss-fed paper and set cassette. Check/replace cassette 1, 2, 3, 4, or 5.
Open top cover 381: Paper jam	Paper jam detected between black ID and fuser	1) Check paper jam between yellow ID and fuser. 2) Check fuser unit load.	Yes No	Remove jammed paper. Replace fuser unit.
Open top cover 382: Paper jam	Paper jam detected in fuser or during paper ejection from fuser.	1) Check paper jam in fuser and between yellow ID and fuser. 2) Check if paper ejection switch is proper.	Yes No	Remove jammed paper. Replace paper ejection switch.
Open top cover 383: Paper jam	Paper jam detected when paper started to enter duplex print unit.	Check paper jam in duplex unit or at entrance.	Yes No	Remove jammed paper. Check/replace duplex unit.

Table 5-1-1 Operator Alarm (6/6)

Message	Cause	Error Description		Solutions
Open top cover 389: Paper jam	Jam generated in paper path.	Open front cover and check jammed paper.	Yes	Remove jammed paper.
Check MP tray 390: Paper jam	Paper jam during paper feed from MT.	Check for miss-fed paper around MT cassette.	Yes No	Remove miss-fed paper and close cover. Check/replace MT.
Check tray * 391~395: Paper jam	Paper jam detected between cassette and black ID.	1) Check jammed paper between cassette and yellow ID. 2) Check if paper entry switch is normal.	Yes No	Remove jammed paper. Replace entry switch.
Open top cover 400: Paper size error	Non-set paper (45mm or above) detected by printer engine.	1) Is paper custom size? 2) Is paper standard size?	Yes Yes No	No treatment required. Adjust paper size guide in cassette. Replace paper size board (PXC PWB).
Refill toner 410: Yellow 411: Magenta 412: Cyan 413: Black	Certain toner is almost empty.	1) Selected toner cartridge is almost empty. 2) Check if selected toner cartridge is normal.	Yes No	Replace with new toner kit. Replace selected toner sensor.
Remove paper 480: Stacker full	Paper ejection stacker is full.	1) Check if stacker is full. 2) Check if stacker full sensor is operating properly.	Yes No	Remove paper from stacker. Replace stacker full sensor.
Set *** 490: No paper in MP tray (* stands for A4 B4, etc.)	No paper in selected cassette. cassette is not set, or paper ran out in cassette being used.	1) Check if paper is empty in MT. 2) Check if paper-end sensor is operating properly.	Yes No	Set paper in MT. Replace paper-end sensor.
Set *** 491~495: No paper in * tray (* stands for A4 B4, etc.)	Paper empty in cassette 1, 2, 3, 4, or 5.	1) Check if paper is empty in selected cassette. 2) Check if paper-end sensor is operating properly.	Yes No	Set paper in selected cassette. Replace the corresponding paper-end sensor.
Replace fuser	Fuser counter exceeded life.	1) Is error message displayed? 2) Was fuser unit just replaced?	Yes No	Check fuser unit life. Replace fuser immediately or at next maintenance.
Paper in * tray nearly empty	Paper near end detected.	Are only few papers remaining in tray? (approx. 30 sheets or less)	Yes No	Refill paper. Check paper near end sensor.
Disk operation error	Cannot write in HDD.	Is faulty operation being applied?	No Yes	Check manual operation. HDD abnormality. Replace HDD.

5.5.2 Preparing for troubleshooting

(1) Operator panel display

Problems that are generated in this device are indicated in the LCD.  
Apply proper measures according to the message displayed in the LCD.

No.	Problem	Flow Chart No.
1	The printer does not function properly after power ON.	①
2	Jam error Feed jam (1st tray) Feed jam (multipurpose tray) Path jam Exit jam Duplex jam	②-1 ②-2 ②-3 ②-4 ②-5
3	Paper size error	③
4	I/D up/down error	④
5	Fuser unit error	⑤
6	Fan motor error	⑥

**Note:** When changing the engine board (K7N/K7V PWB), remove the EEPROM chip from the old board and install it on the newly replaced board

(2) CU assembly troubleshooting

No operation

Is an error message displayed?

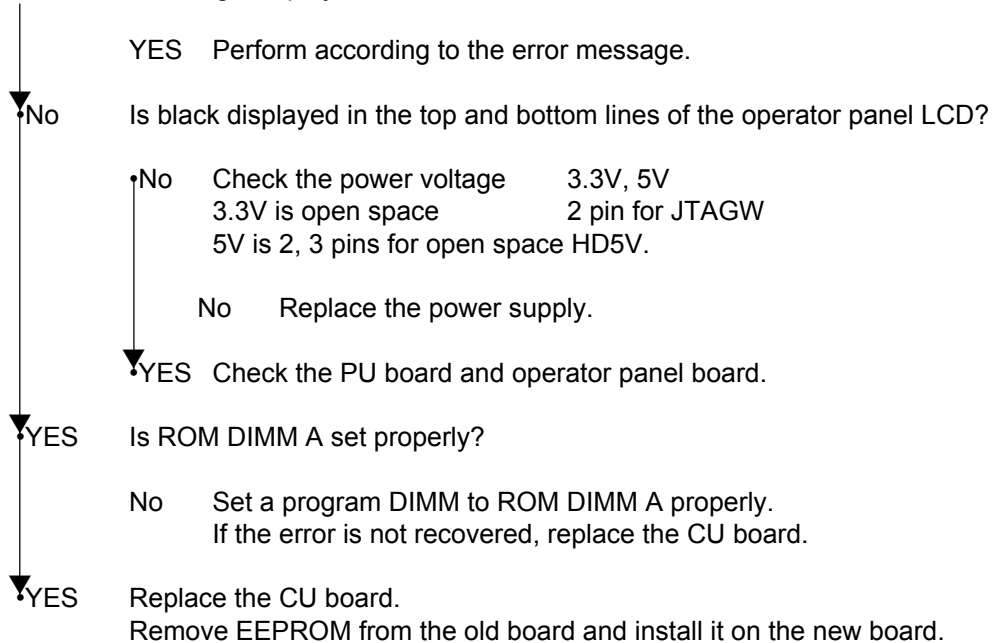

## ① The printer does not function properly after power ON.

- Turn the power OFF then ON.
- Is  displayed? (Approx. 1 sec.)
  - No Is the AC cable connected properly?
    - No Connect the AC cable properly.
  - ▼ Yes Is +5V output to the panel connector (OPTN connector) on the engine board (K7N/K7V PWB)?
    - Pin 10, 11, 18: +5V      Pin 5, 7, 15,20: 0V
    - Yes Is +5V output to the panel connector on the relay board (Y73 PWB)?
      - Pin 5: +5V      Pin 2: 0V
      - No Replace the relay board.
    - Yes Is the operator panel cable connected properly?
      - No Connect the cable properly.
      - Yes Replace the operator panel cable. Is operation recovered?
        - No Replace the cover assembly of the operator panel.
        - Yes End.
  - ▼ No Is +5V output to the power connector on the engine board (K7N/K7V PWB)?
    - Pin 5, 6, 7, 8: +5V      Pin 1, 2, 3, 4, 9, 10, 11: 0V
    - No Check the power connection connector, then replace the low-voltage power supply unit.
  - Yes Replace the engine board.
  - ▼ Yes Are the following voltages output to the PU IF connector on the main board?
    - Pin 137-147, 187-197 : +5V      Pin 125-136, 175-186 : +3.3V
    - Pin 148, 198 : +12V      Pin 101-124, 149-174, 199, 200 : 0V
    - Yes Replace the main board.
  - ▼ No Is the following voltage output to the power connector on the engine board?
    - Pin 5, 6, 7, 8 : +5V
    - Pin 15 : +12V
    - Pin 12, 13, 14 : +34V      Pin 1, 2, 3, 4, 9, 10, 11 : 0V
    - Yes Replace the engine board.
  - ▼ No Replace the low-voltage power supply unit.

## ②-1 Feed jam (1st tray)

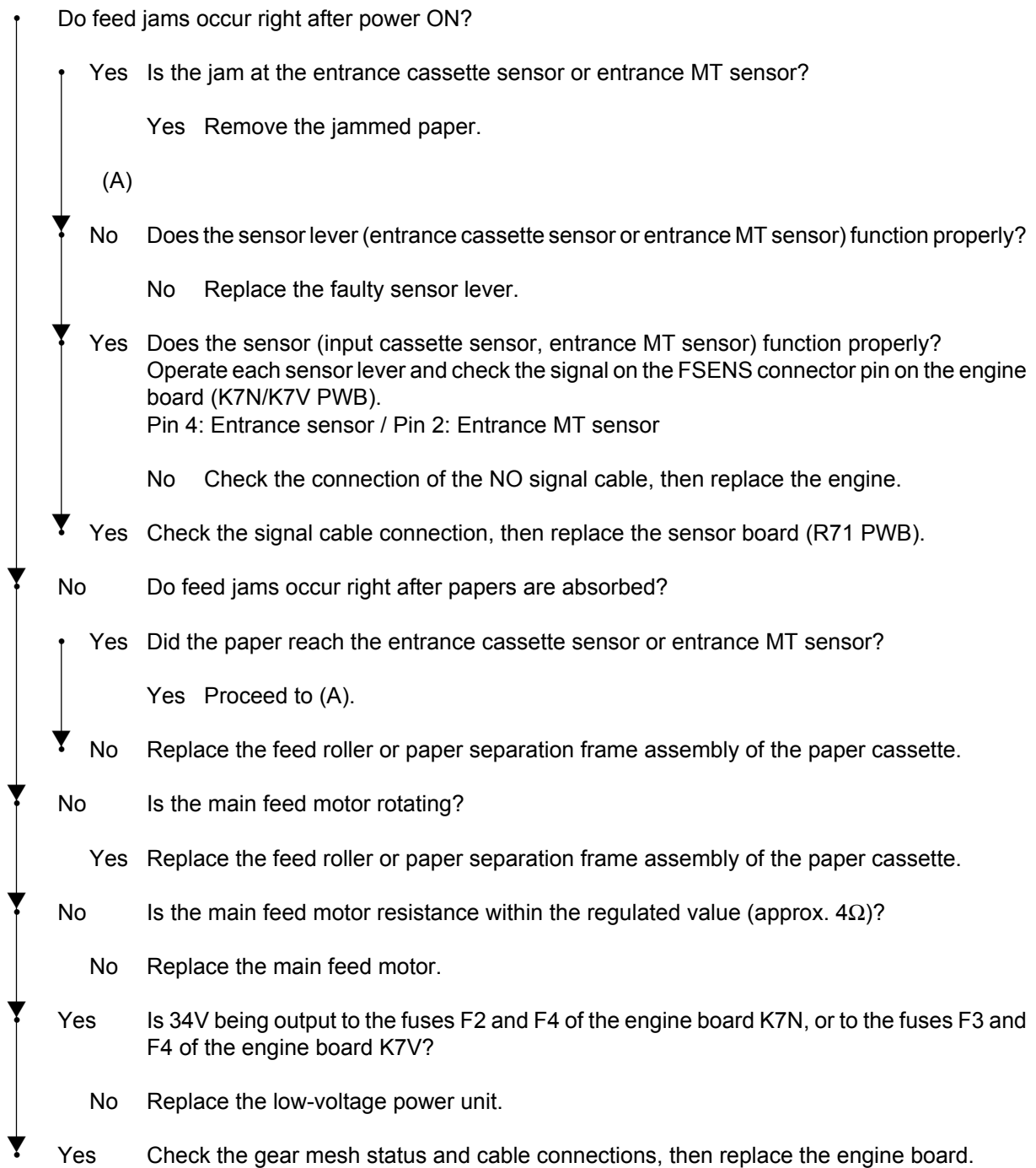

## ②-2 Feed jam (multipurpose tray)

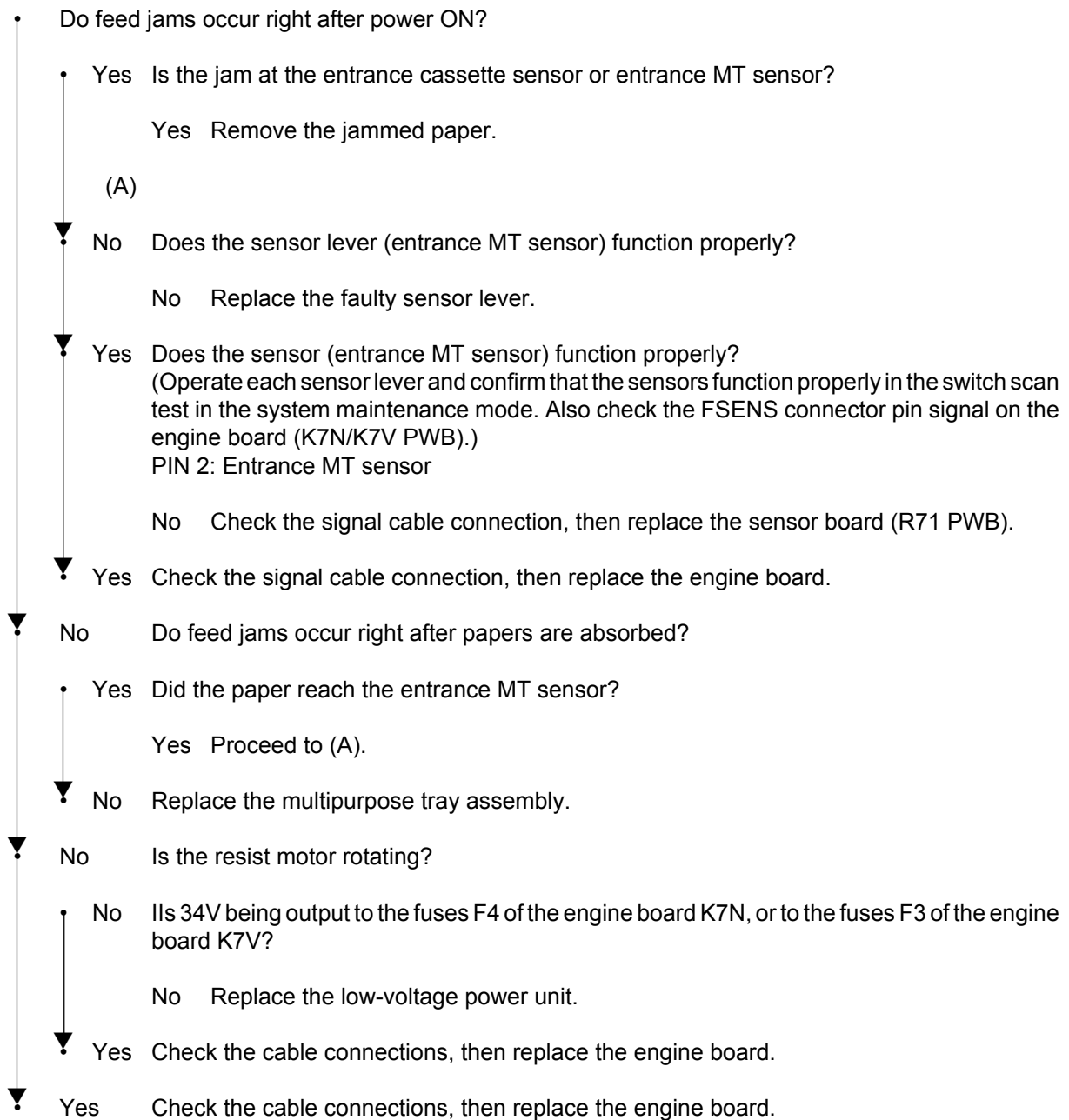

②-3 Path jam

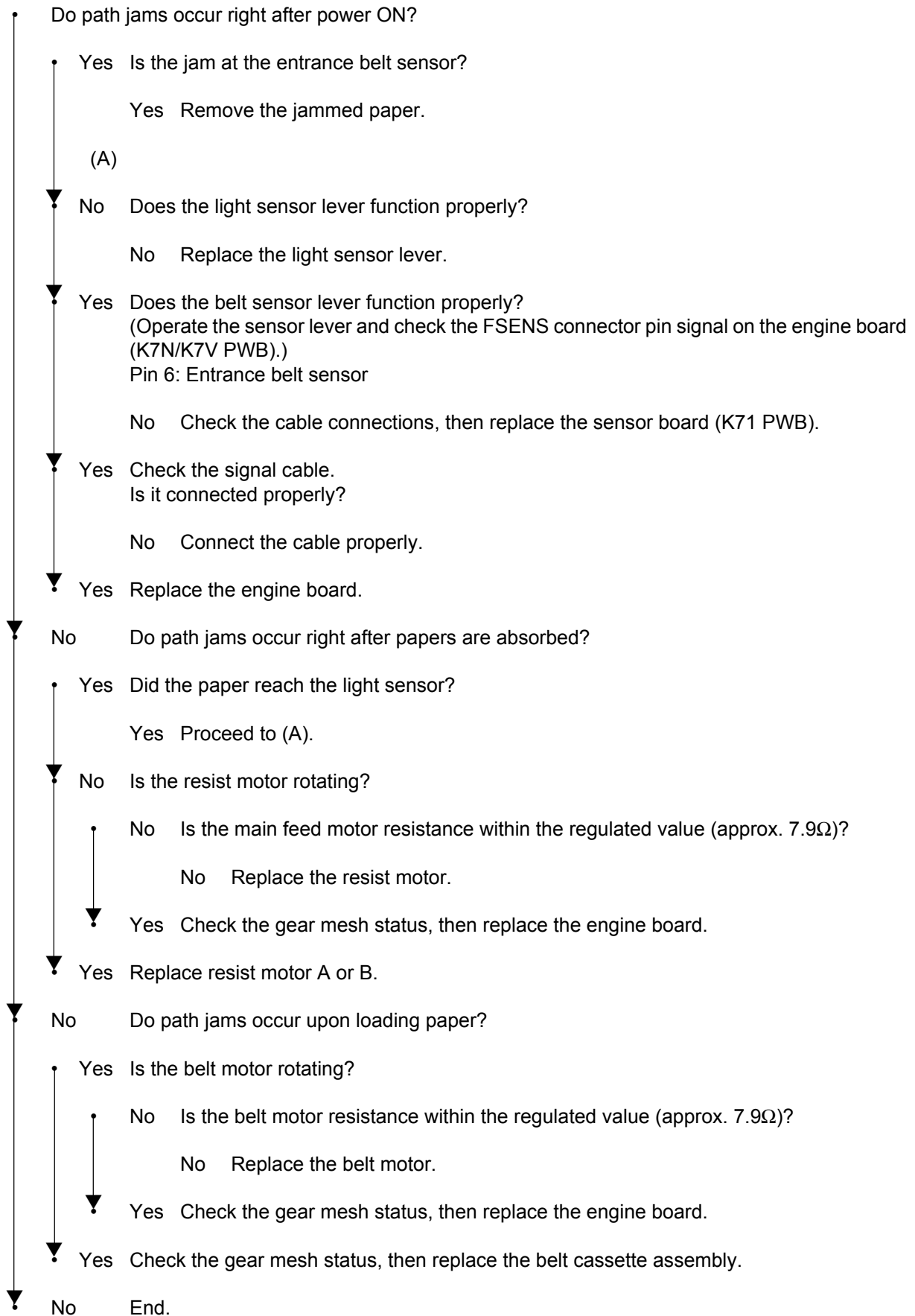



## ②-4 Exit jam

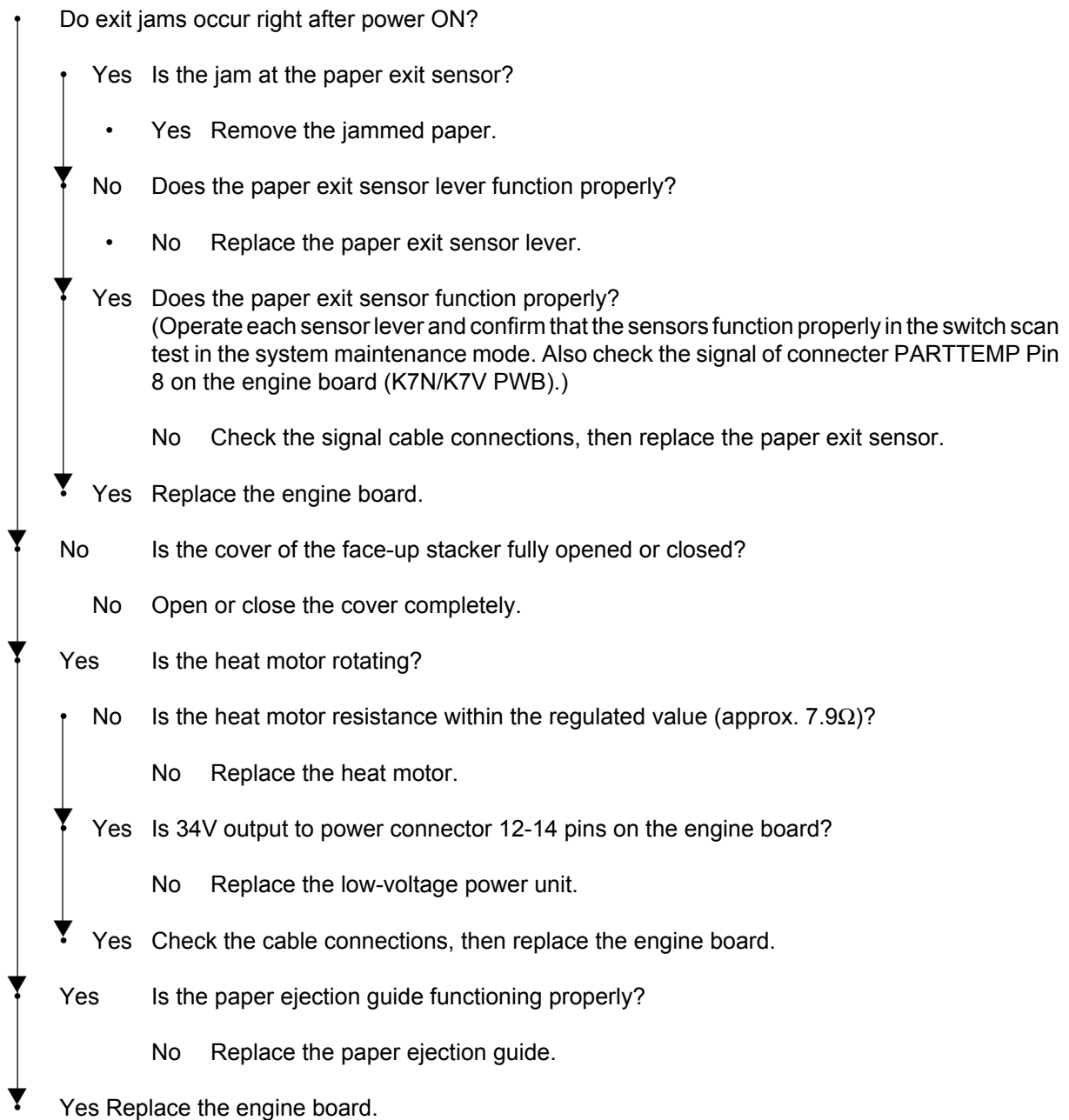

## ②-5 Duplex jam

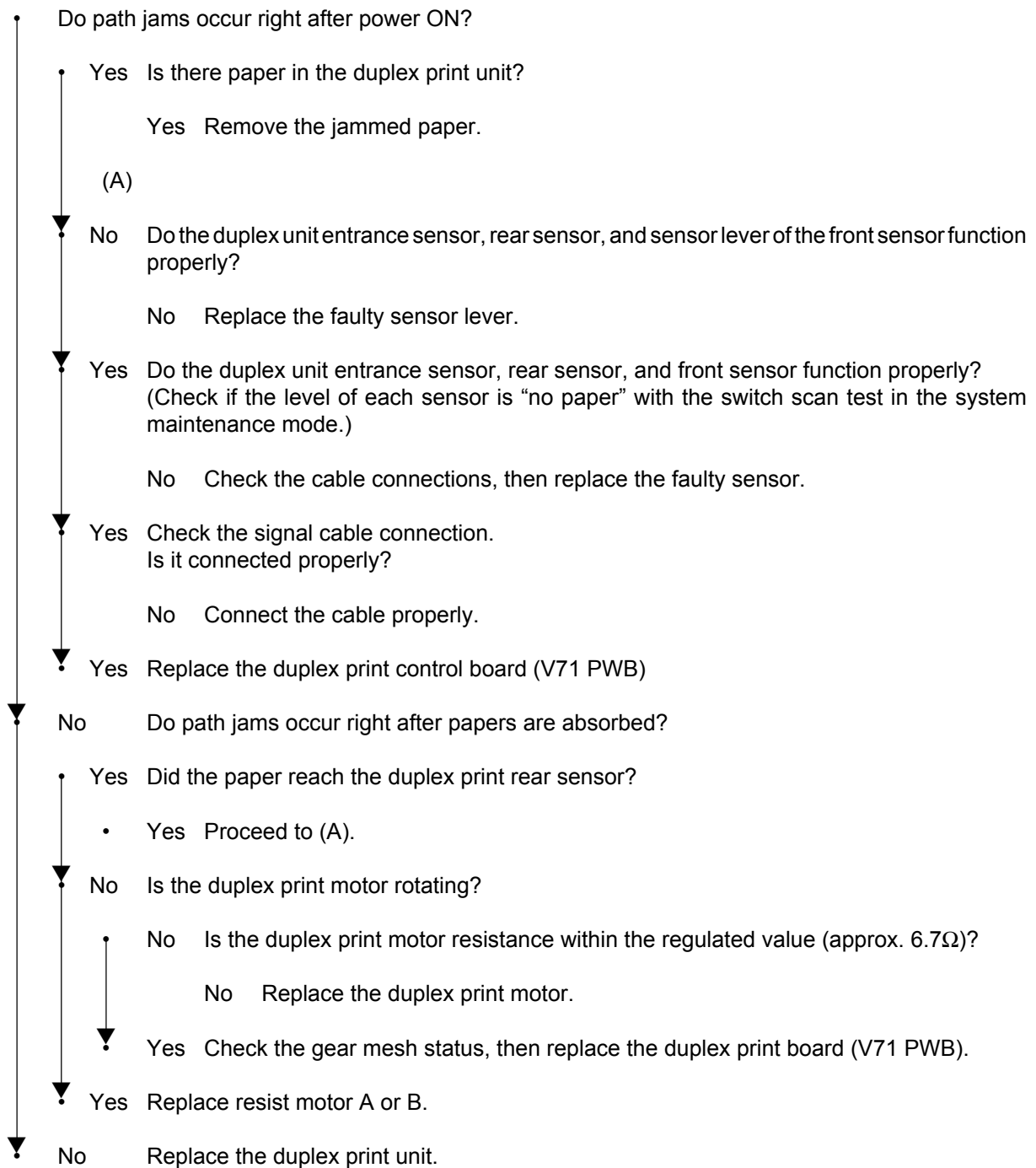

## ③ Paper size error

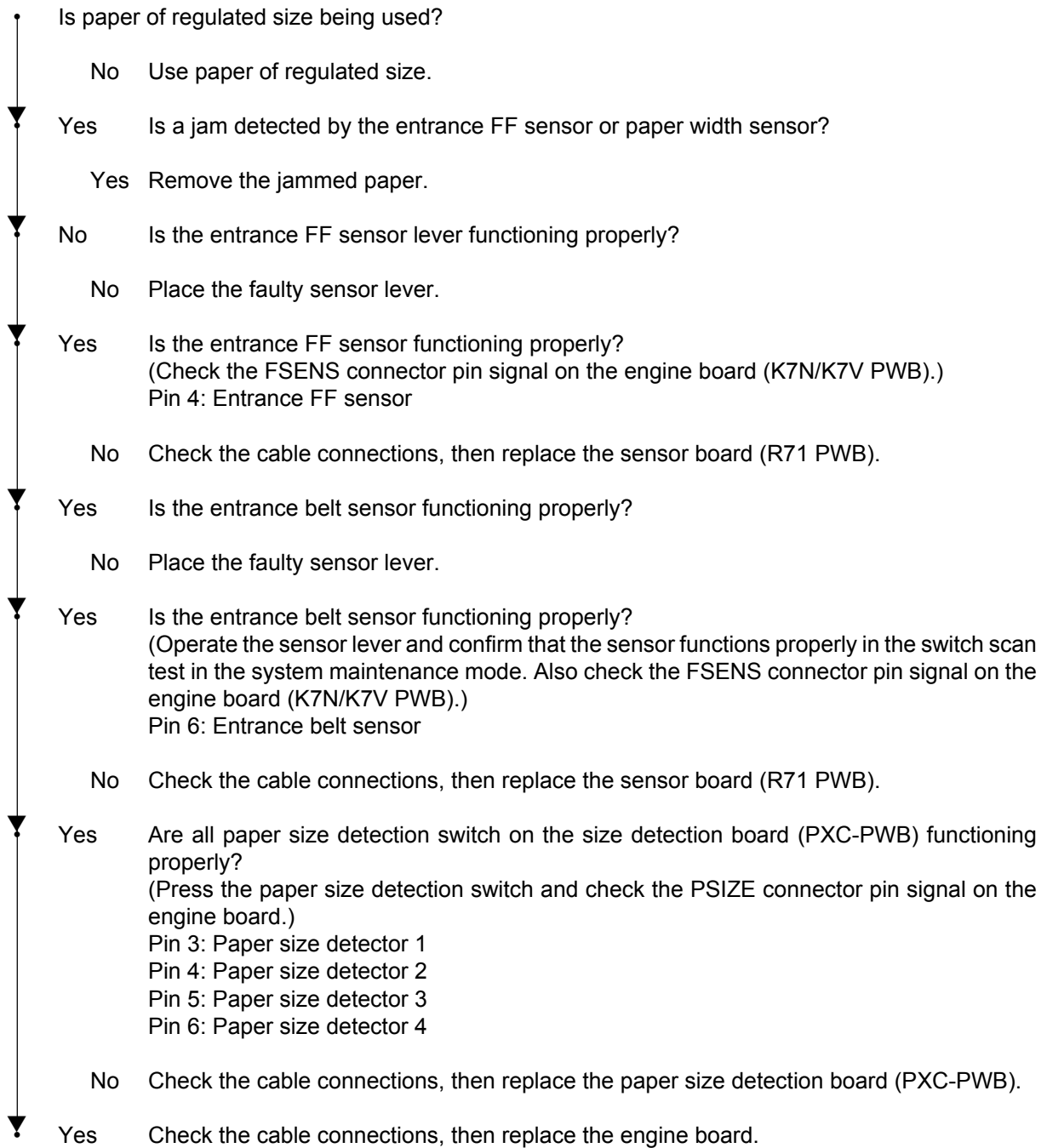

## ④ Up/Down movement error of the image drum unit (ID)

- Turn the printer OFF, then turn it ON after a few seconds.

• Are all ID drums rotating properly during print operation?

• No Is the ID motor resistance within the regulated value (approx.  $8.6\Omega$ )?

No Replace the faulty IDU motor.

▼ Yes Is 34V output to F3 and F5 on the engine board?

No Replace the low-voltage power unit.

▼ Yes Check the cable connections, then replace the engine board.

▼ Yes Is the IDU sensor terminal functioning properly?

No Check the gear mesh status and sensor terminal function, then replace the gear or sensor terminal.

▼ Yes Is the ID sensor terminal functioning properly?

(Check the JODEN connector pin signal on the driver board (K7N/K7V PWB).)

Pin 12 : IDU sensor - yellow

Pin 2 : IDU sensor - magenta

Pin 4 : IDU sensor - cyan

Pin 14 : IDU sensor - black

Are all at 5V level or 0V level?

No Replace the connection board (N71 PWB).

▼ Yes Check the cable connection between the connection board (N71 PWB) and engine board (K7N PWB), then replace the engine board.

⑤ Fuser unit error

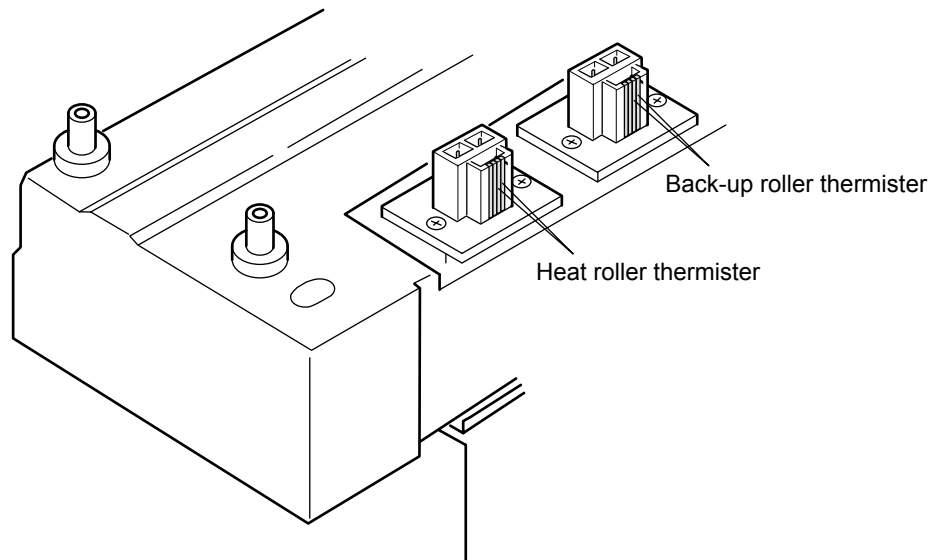
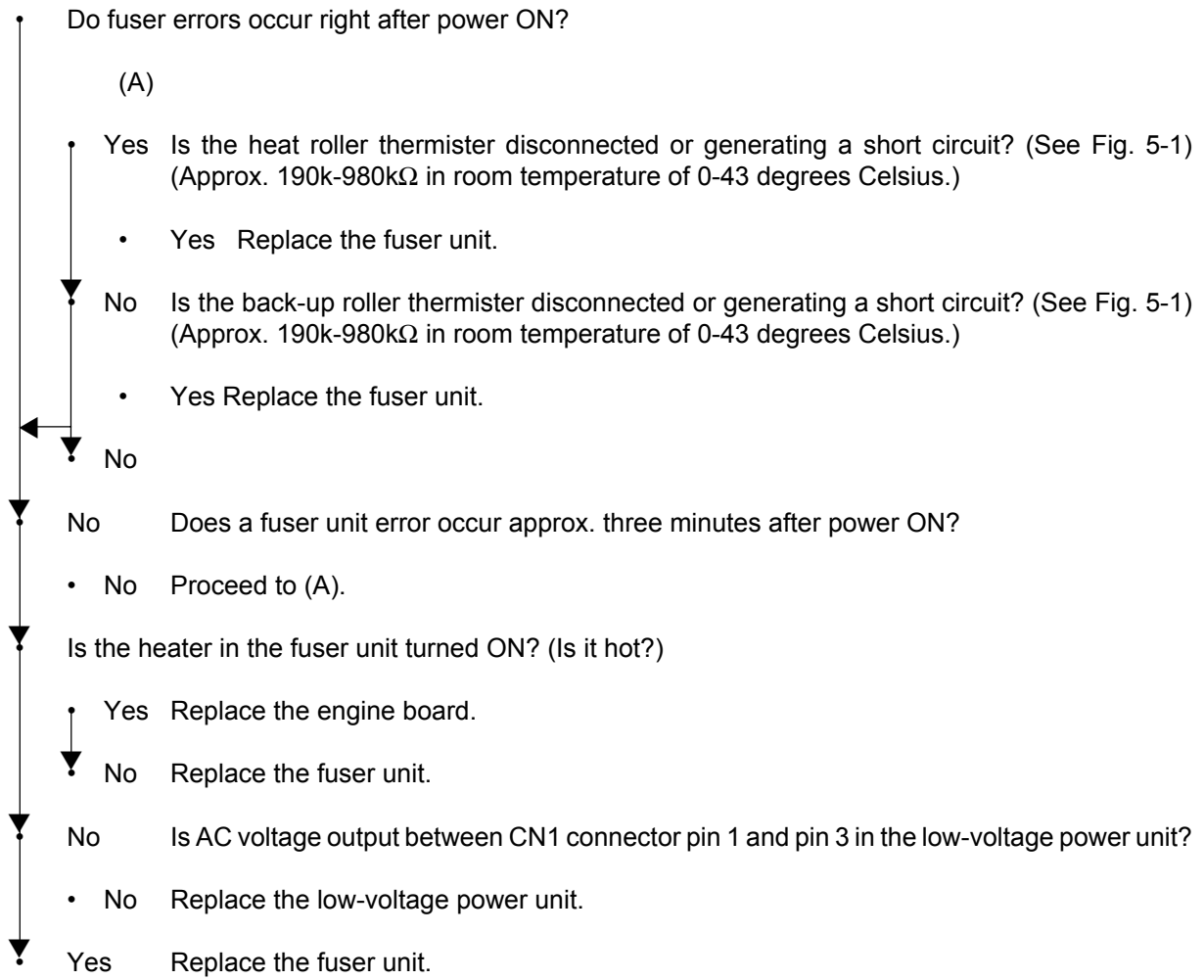
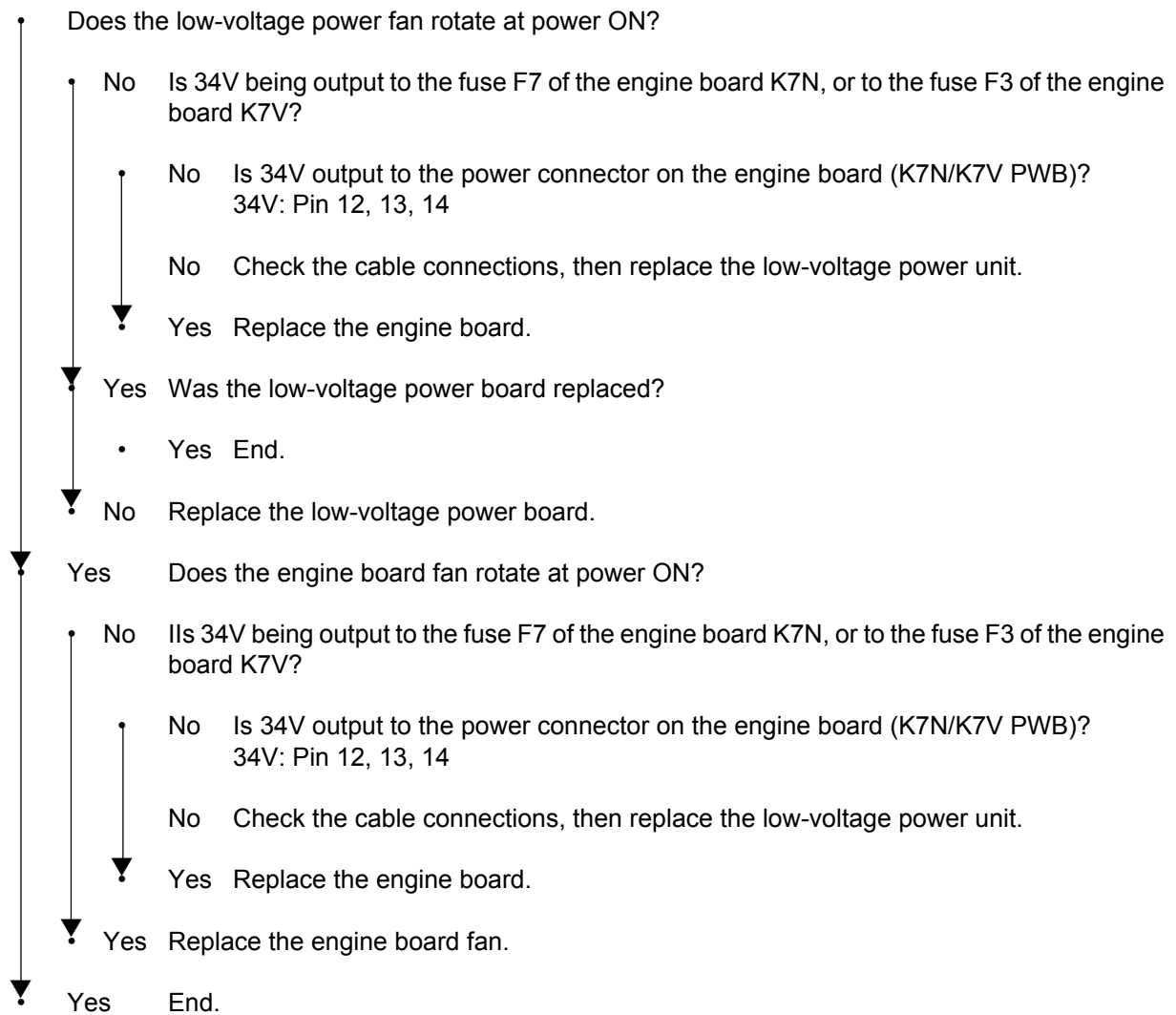

Figure 5.1

## ⑥ Motor fan error



5.5.3 Troubleshooting for abnormal images

Apply remedies according to the following table when printed images are abnormal as shown below.

Abnormal Image	Flowchart No.
The entire image is faint or the color is irregular. (Figure 5.2- <b>A</b> )	①
The white portion is dirty. (Figure 5.2- <b>B</b> )	②
A white page is output. (Figure 5.2- <b>C</b> )	③
Streaks or solid lines appear in the vertical direction. (Black line, color line / black streak, color streak) (Figure 5.2- <b>D</b> )	④
White solid lines / streaks or blurred color lines / streaks appear in the vertical direction. (Figure 5.2- <b>E</b> )	⑤
Faulty fusing (image blurs or scatters when touched)	⑥
Consistent abnormality (Figure 5.2- <b>E</b> )	⑦
Color detachment	⑧
Color irregularity	⑨
Different color compared with the original.	⑩

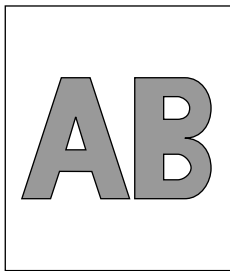

Ⓐ Faint or blurred

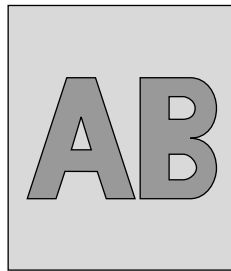

Ⓑ Dirty white portion



Ⓒ All white

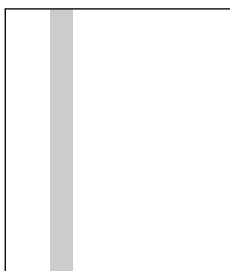

Ⓓ Vertical lines/streaks

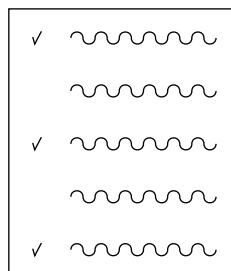

Ⓔ Consistent abnormality

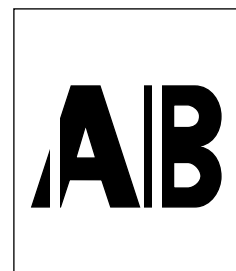

Ⓕ Vertical white lines/streaks

Figure 5.2

## ① An image is generally faint or the color is irregular. (Fig 5-2 (A))

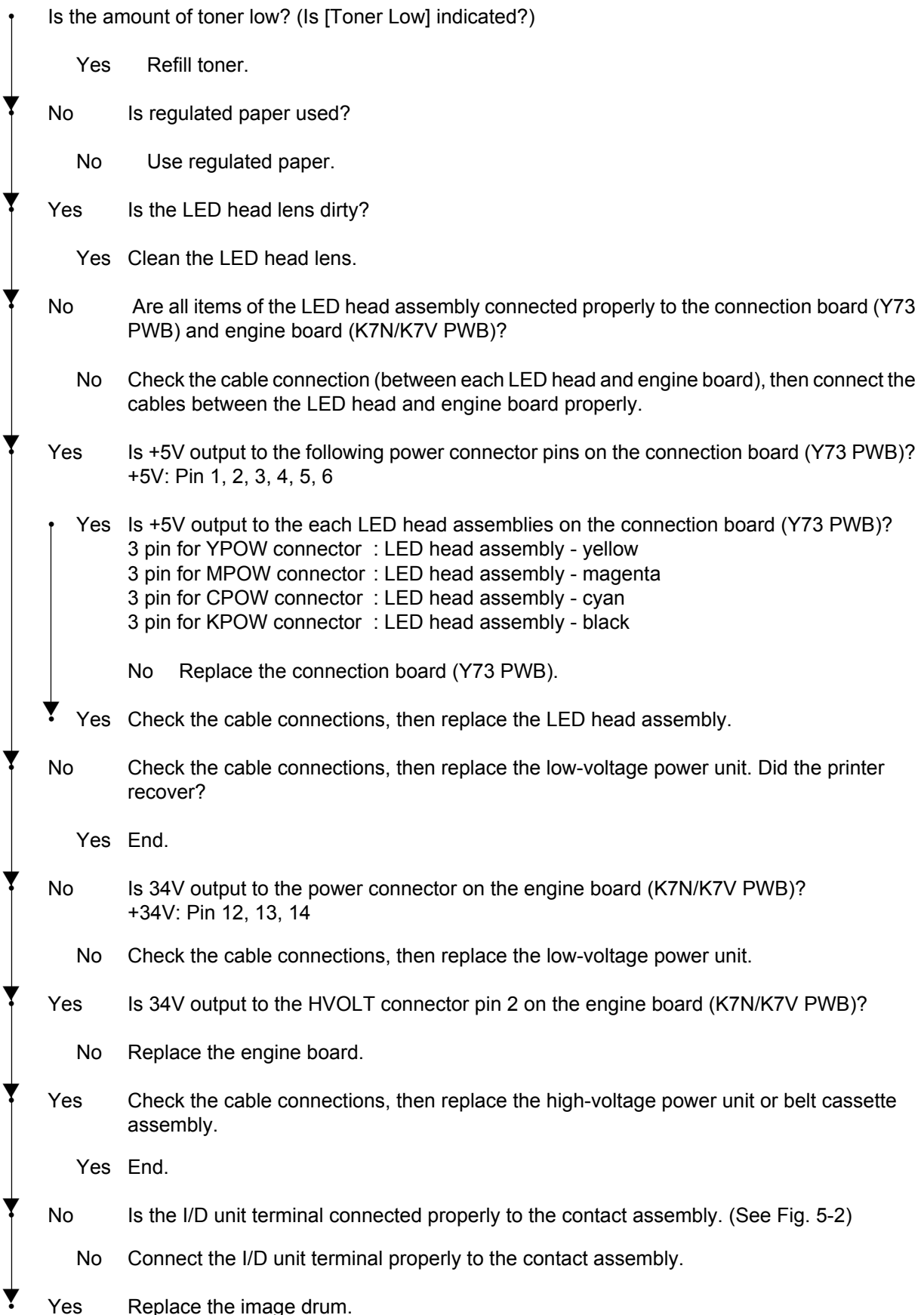

**Note:** 1. Remove EEPROM from the old board and set it on the new board upon replacing the engine board (K7N PWB).  
2. If EEPROM is not replaced, refer to section 3.2.2.  
3. When replacing the engine board (K7V PWB), upload EEPROM data from the board and then download it to a new board, using a life counter tool.



## ② Dirty Background. (Fig. 5-2 ㉔)

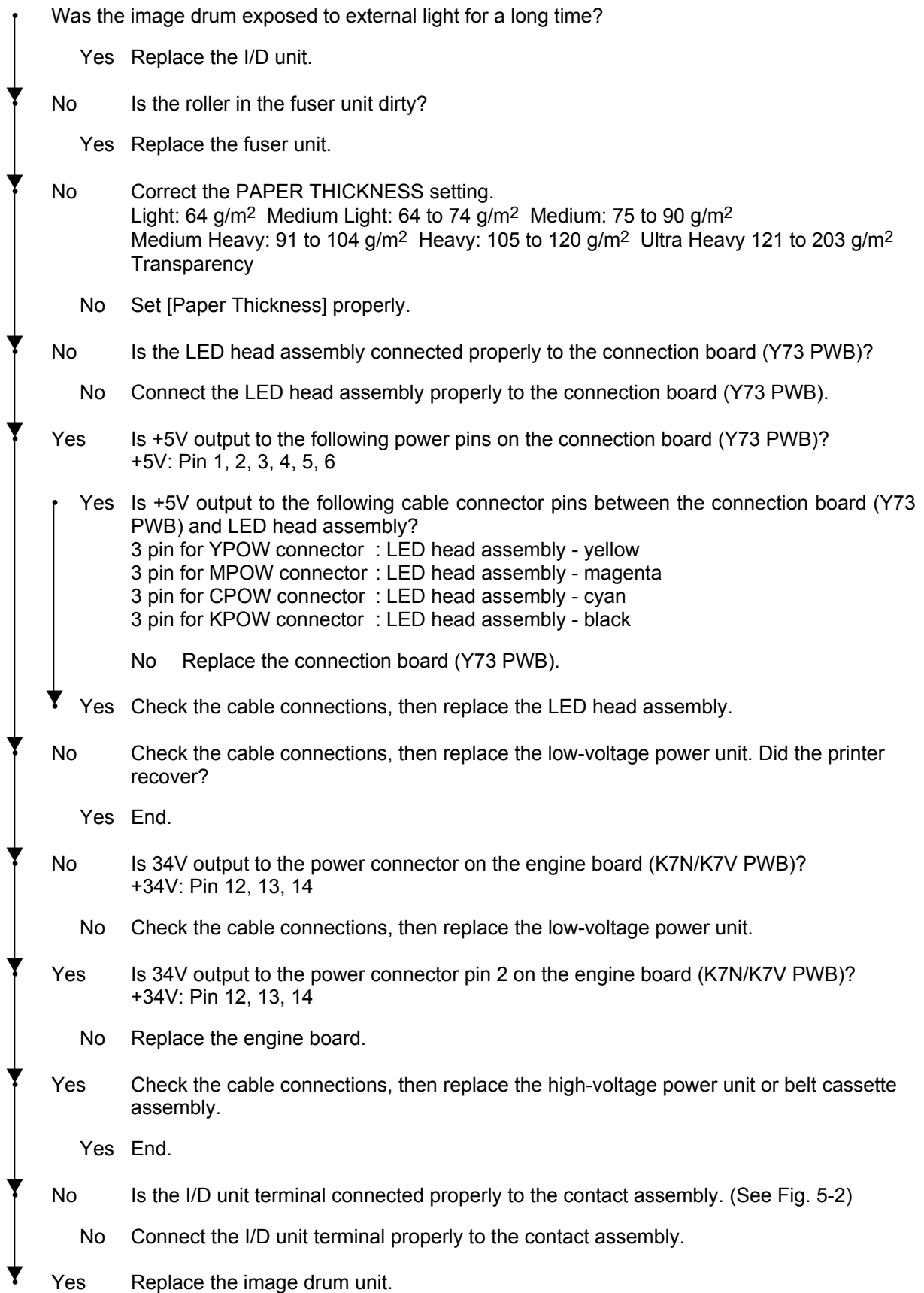

**Note:** 1. Remove EEPROM from the old board and set it on the new board upon replacing the engine board (K7N PWB).  
2. If EEPROM is not replaced, refer to section 3.2.2.  
3. When replacing the engine board (K7V PWB), upload EEPROM data from the board and then download it to a new board, using a life counter tool.

## ③ White page (Fig 5-2 ©)

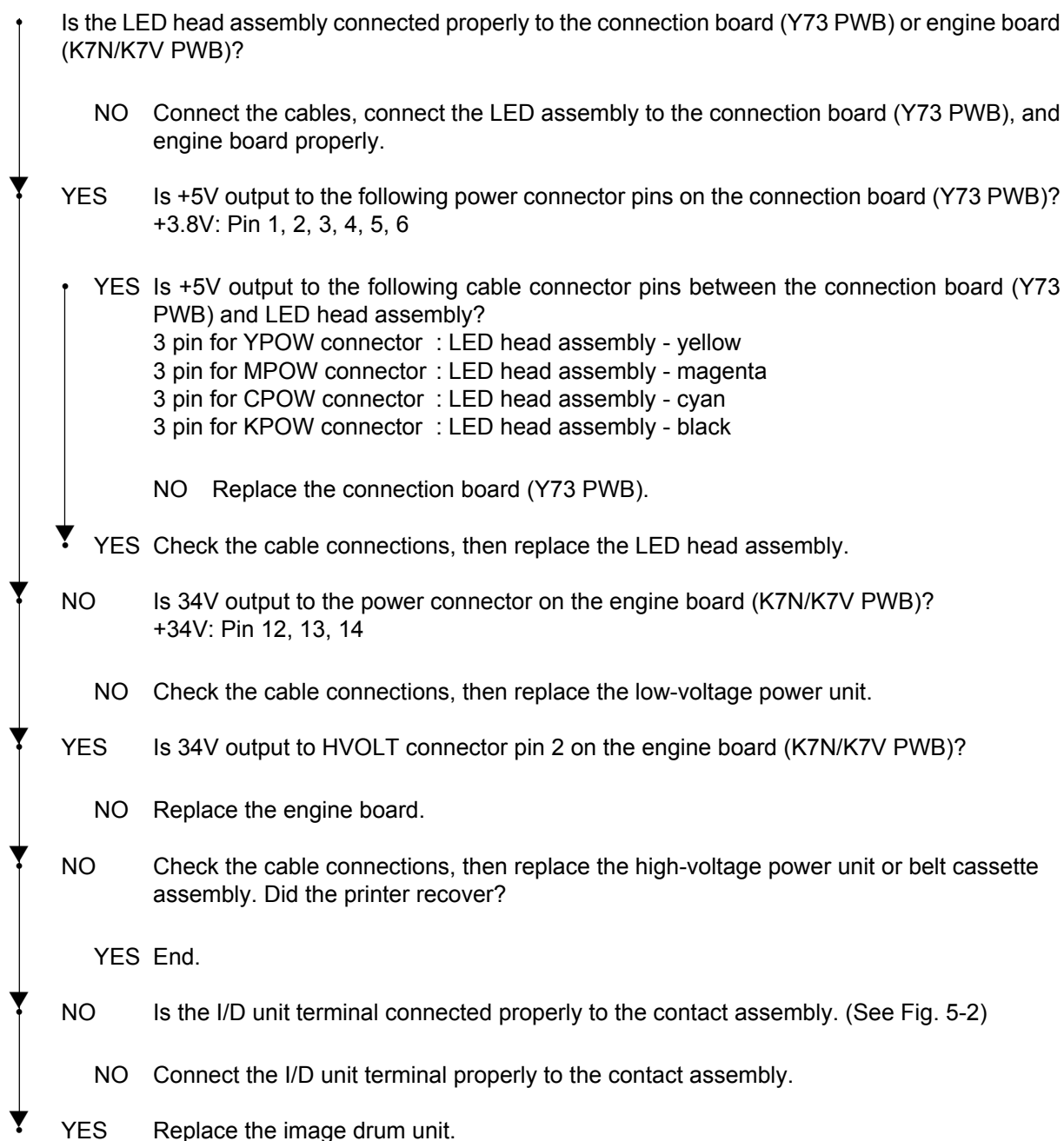

- Note:**
1. Remove EEPROM from the old board and set it on the new board upon replacing the engine board (K7N PWB).
  2. If EEPROM is not replaced, refer to section 3.2.2.
  3. When replacing the engine board (K7V PWB), upload EEPROM data from the board and then download it to a new board, using a life counter tool.

- ④ Solid lines or streaks appear in the vertical direction. (Black lines, color lines / black streaks, color streaks) (Fig. 5-2 ㊦)

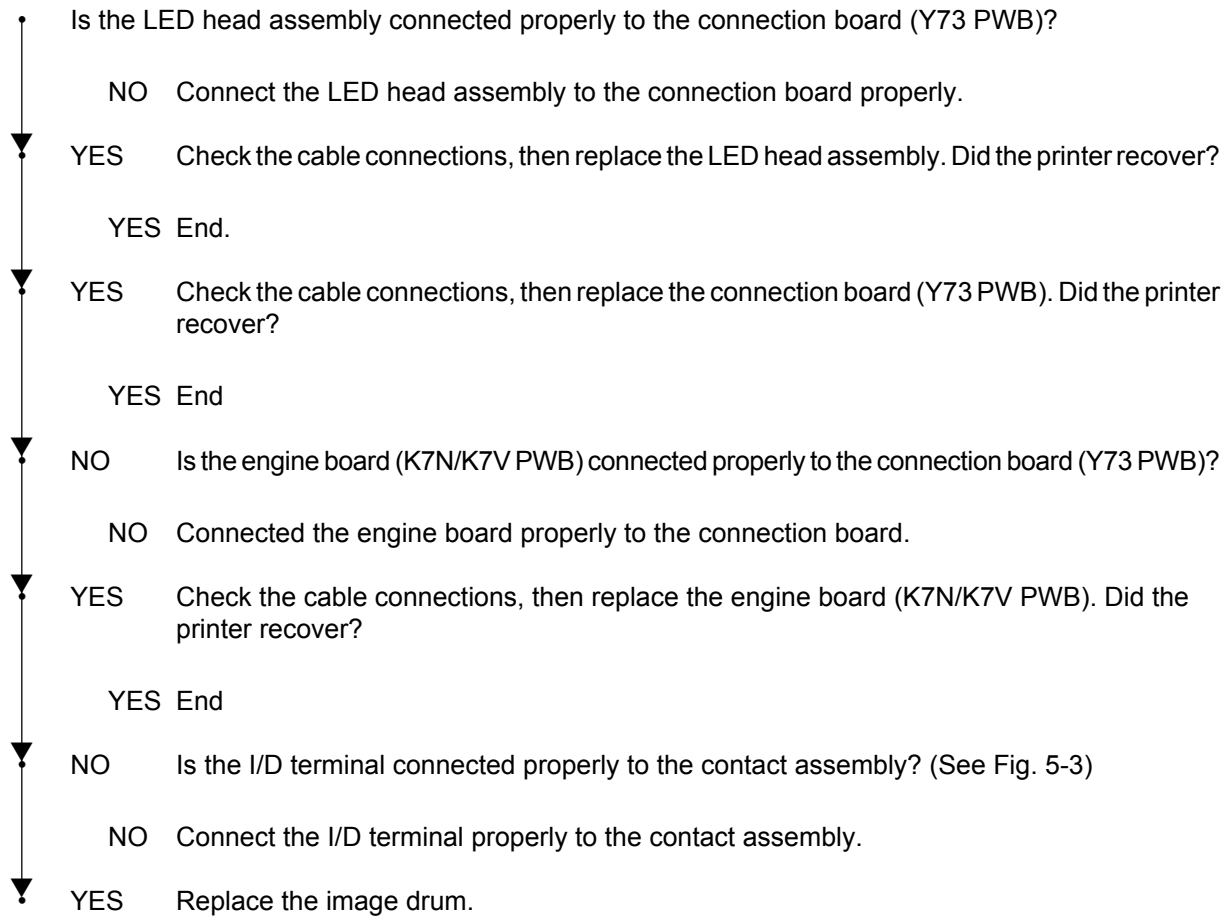

- Note:**
1. Remove EEPROM from the old board and set it on the new board upon replacing the engine board (K7N PWB).
  2. If EEPROM is not replaced, refer to section 3.2.2.
  3. When replacing the engine board (K7V PWB), upload EEPROM data from the board and then download it to a new board, using a life counter tool.

- ⑤ Thick white lines / streaks or blurred color lines / streaks appear in the vertical direction (Fig. 5-2 ㉔)

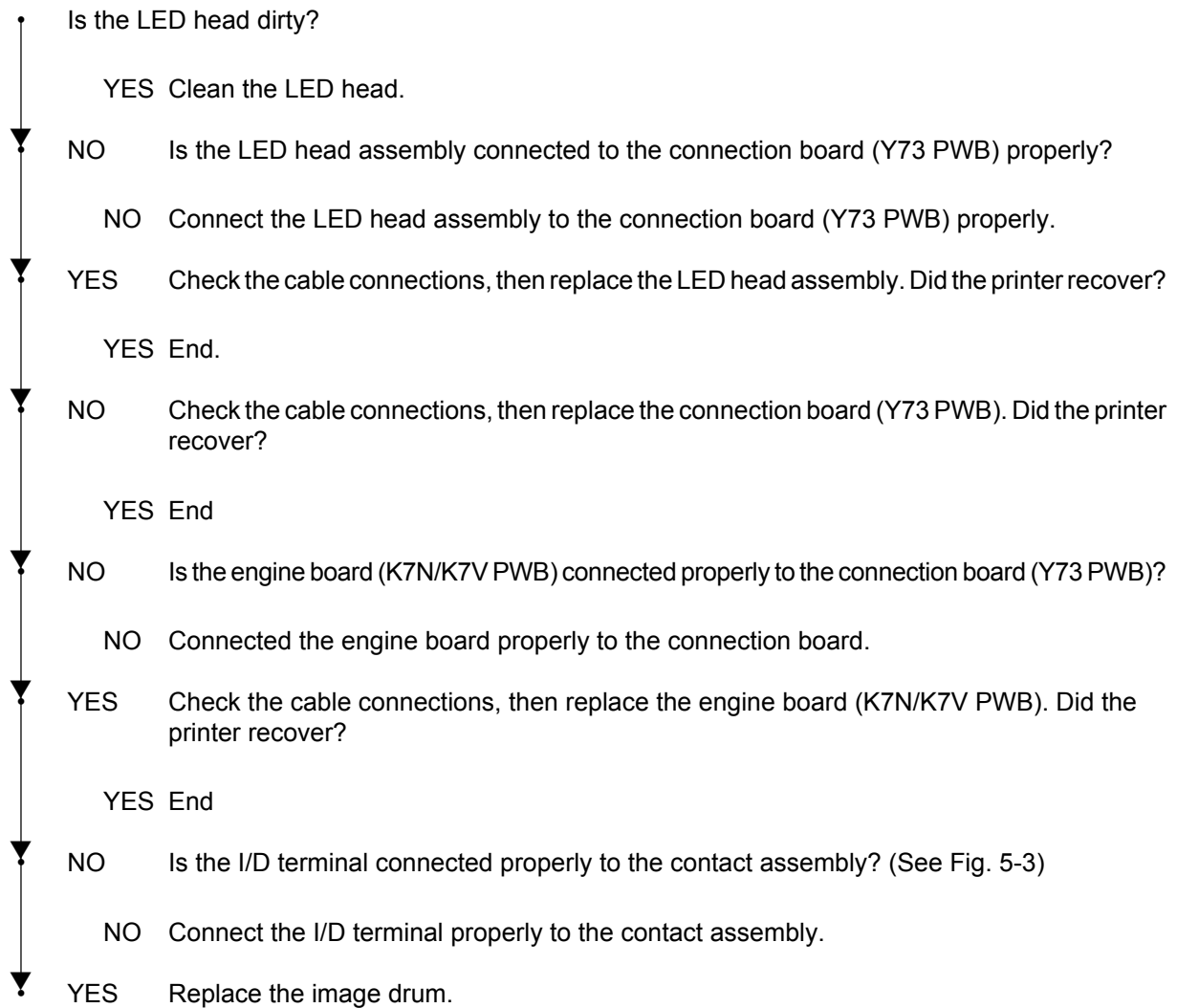

- Note:**
1. Remove EEPROM from the old board and set it on the new board upon replacing the engine board (K7N PWB).
  2. If EEPROM is not replaced, refer to section 3.2.2.
  3. When replacing the engine board (K7V PWB), upload EEPROM data from the board and then download it to a new board, using a life counter tool.

## ⑥ Poor Fusing (Ink spreads or peels when touched with fingers)

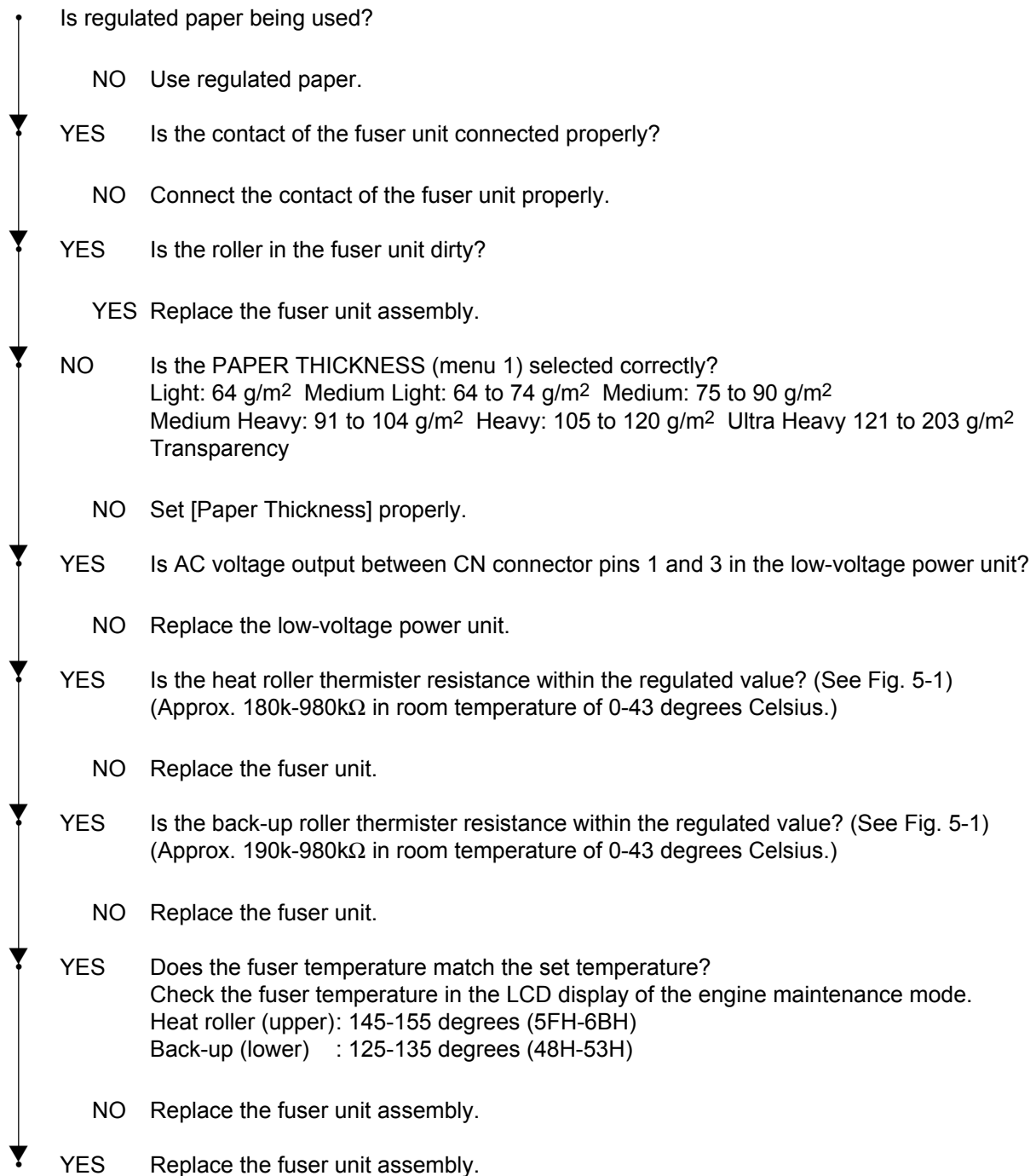

- Note:**
1. Remove EEPROM from the old board and set it on the new board upon replacing the engine board (K7N PWB).
  2. If EEPROM is not replaced, refer to section 3.2.2.
  3. When replacing the engine board (K7V PWB), upload EEPROM data from the board and then download it to a new board, using a life counter tool.

## ⑦ Consistent abnormality (Figure 5.2-⑤)

Consistency	Problem	Remedy
94.2 mm	Image Drum	Replace the ID unit.
63.6 mm	Developing Roller	Replace the ID unit.
57.8 mm	Toner Supply Roller	Replace the ID unit.
44.0 mm	Charge Roller	Replace the ID unit.
113.1 mm	Fuser Roller (Upper)	Replace the fuser unit.
	Fuser Roller (Lower)	Replace the fuser unit.
57.8 mm	Transfer Roller	Replace the belt cassette assembly.

**Note:** The life counter for the I/D unit, fuser unit, and belt cassette unit is reset automatically when the unit is replaced.

## ⑧ Color detaches.

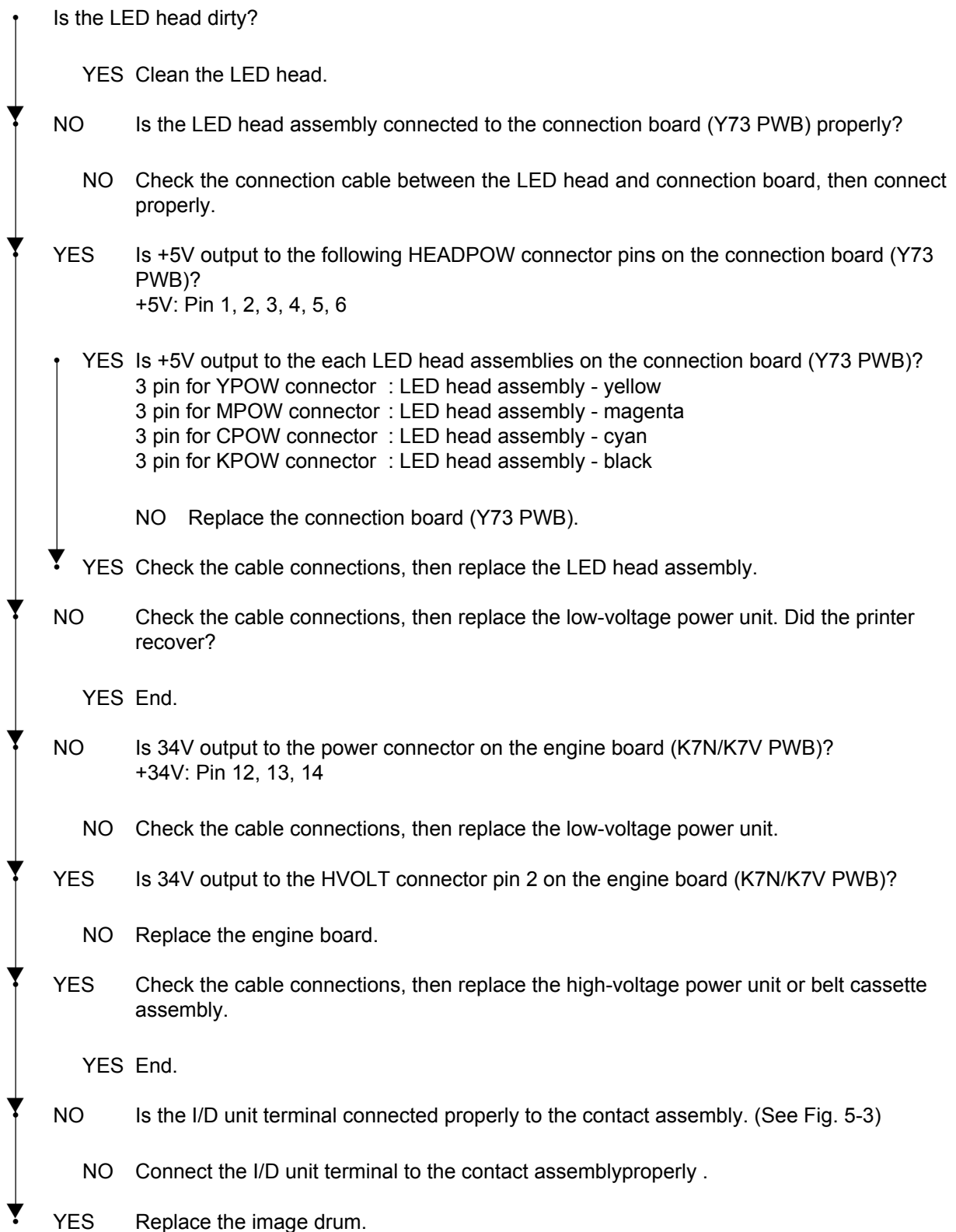

- Note:**
1. Remove EEPROM from the old board and set it on the new board upon replacing the engine board (K7N PWB).
  2. If EEPROM is not replaced, refer to section 3.2.2.
  3. When replacing the engine board (K7V PWB), upload EEPROM data from the board and then download it to a new board, using a life counter tool.

## ⑨ Color irregularity

[Toner Low] is displayed.

YES Refill toner. Did the printer recover?

YES End.

NO Perform the color irregularity test in the engine maintenance mode.  
Method: Enter the self-diagnostic mode (Level 1) in the engine maintenance mode.

DIAGNOSTIC MODE
XX.XX.XX

Press the ① and ④ keys and enter the self-diagnostic mode (Level 2).

ENGINE DIAG LEVEL2

Press the ① key three times and display [REG ADJUST TEST].

REG ADJUST TEST

Press the ② key once and display [REG ADJUST EXECUTE].

REG ADJUST EXECUTE

Press the ③ key and execute auto adjustment for color irregularity. (The motor will start to rotate and adjustment for color irregularity will begin.)

[OK] is displayed immediately with executing color irregularity adjustment. (Motor does not rotate.)

YES Error other than color irregularity has generated. Did color irregularity recover after the error was released?

YES End.

(A)



(A)

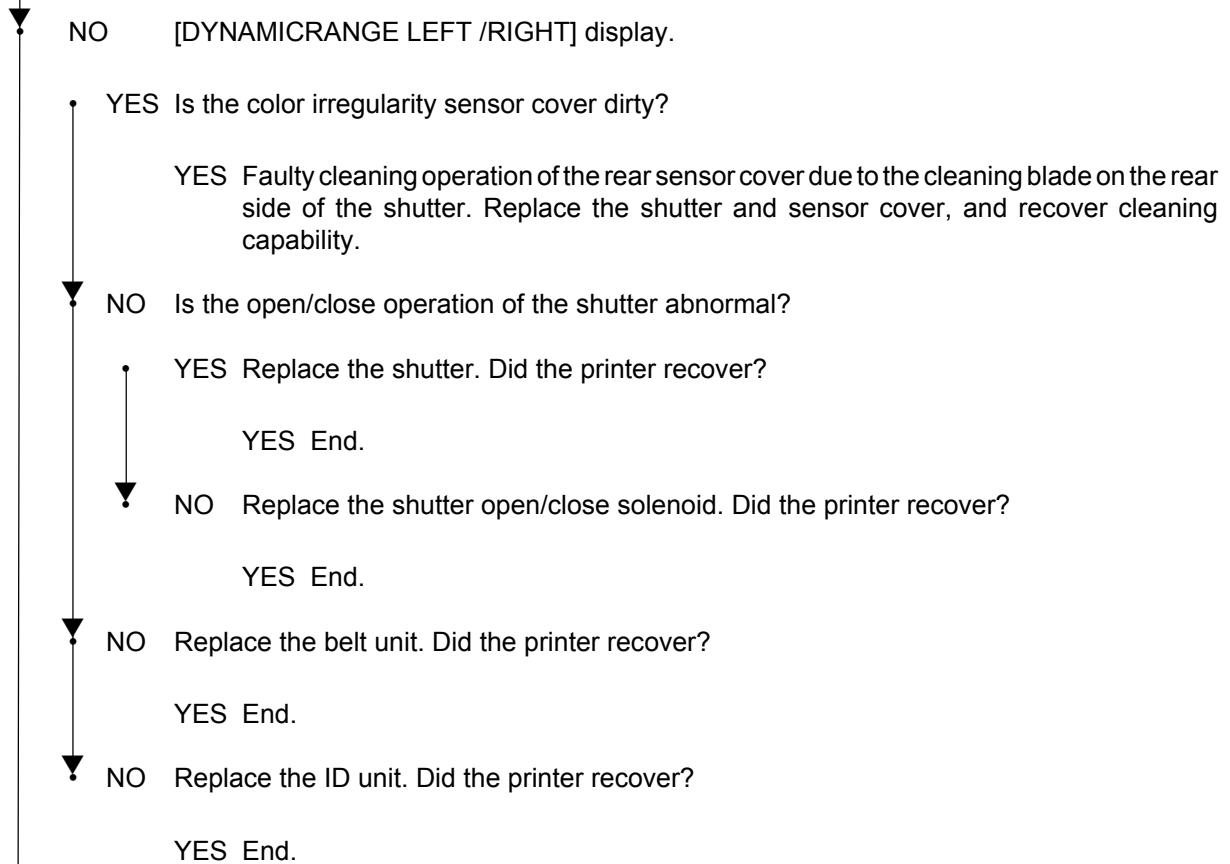
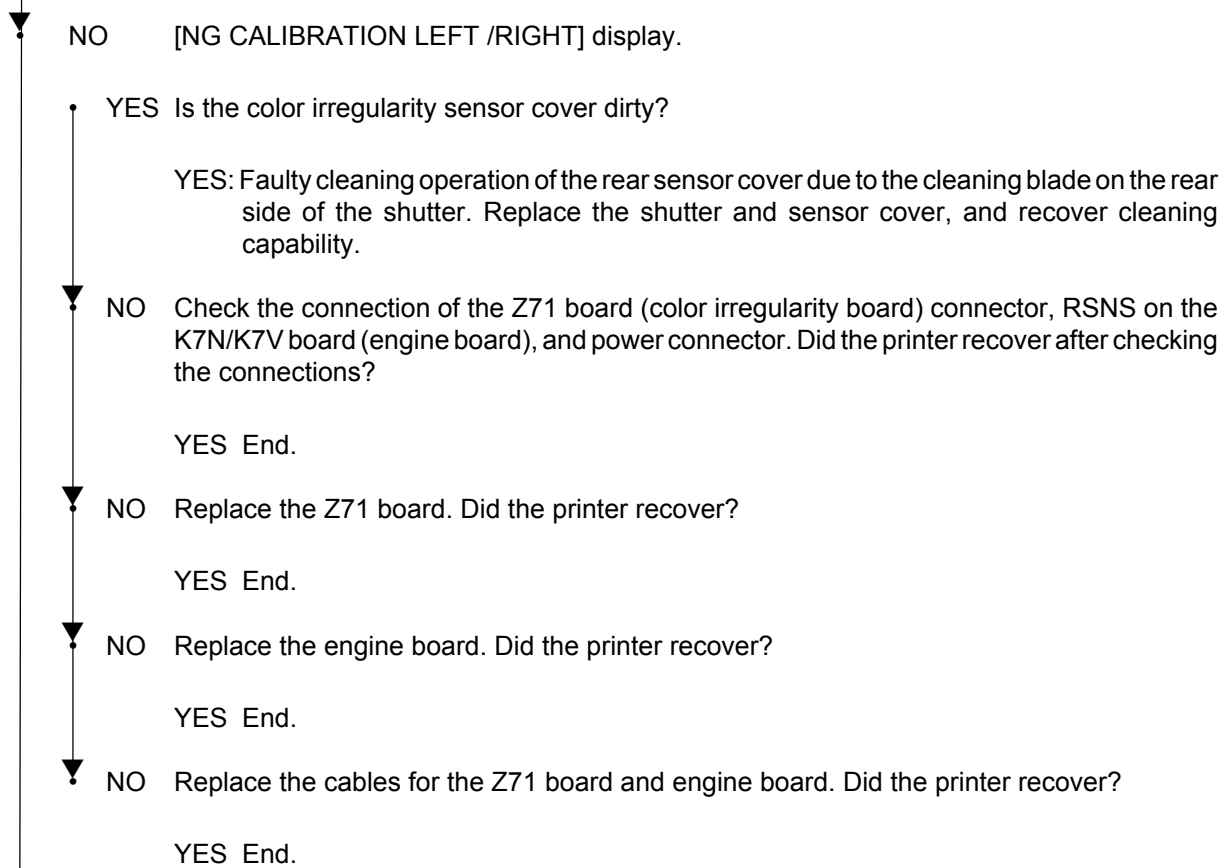

(B)

(B)

- [Yellow/Magenta/Cyan Left/Right/Horizontal] display
  - ▼ YES Replace the belt unit. Did the printer recover?
    - YES End.
  - ▼ NO Replace the ID unit. Did the printer recover?
    - YES End.
  - ▼ NO Is the gear abnormal? (Gear assembly such as I/D, multipurpose tray, belt unit, belt motor.)
    - YES Replace the damaged gear assembly.
  - ▼ NO Is the LED head unit connected to the connection board (Y73 PWB) properly?
    - NO Connect the LED head unit to the connection board properly.
  - ▼ YES Check the cable connections, then replace the LED head assembly. Did the printer recover?
    - YES End.
  - ▼ NO Check the cable connections, then replace the connection board (Y73 PWB). Did the printer recover?
    - YES End.
  - ▼ NO Is the engine board (K7N/K7V PWB) connected to the connection board (Y73 PWB) properly?
    - NO Connect the engine to the connection board properly.
  - ▼ NO Replace the engine board. Did the printer recover?
    - YES End.
  - ▼ NO Is the I/D terminal connected to the contact assembly properly? (See Fig. 5-3)
    - NO Connect the I/D terminal to the contact assembly properly.
  - ▼ YES Replace the image drum.

- Note:**
1. Remove EEPROM from the old board and set it on the new board upon replacing the engine board (K7N PWB).
  2. If EEPROM is not replaced, refer to section 3.2.2.
  3. When replacing the engine board (K7V PWB), upload EEPROM data from the board and then download it to a new board, using a maintenance utility.

## ⑩ Color irregularity compared with the original

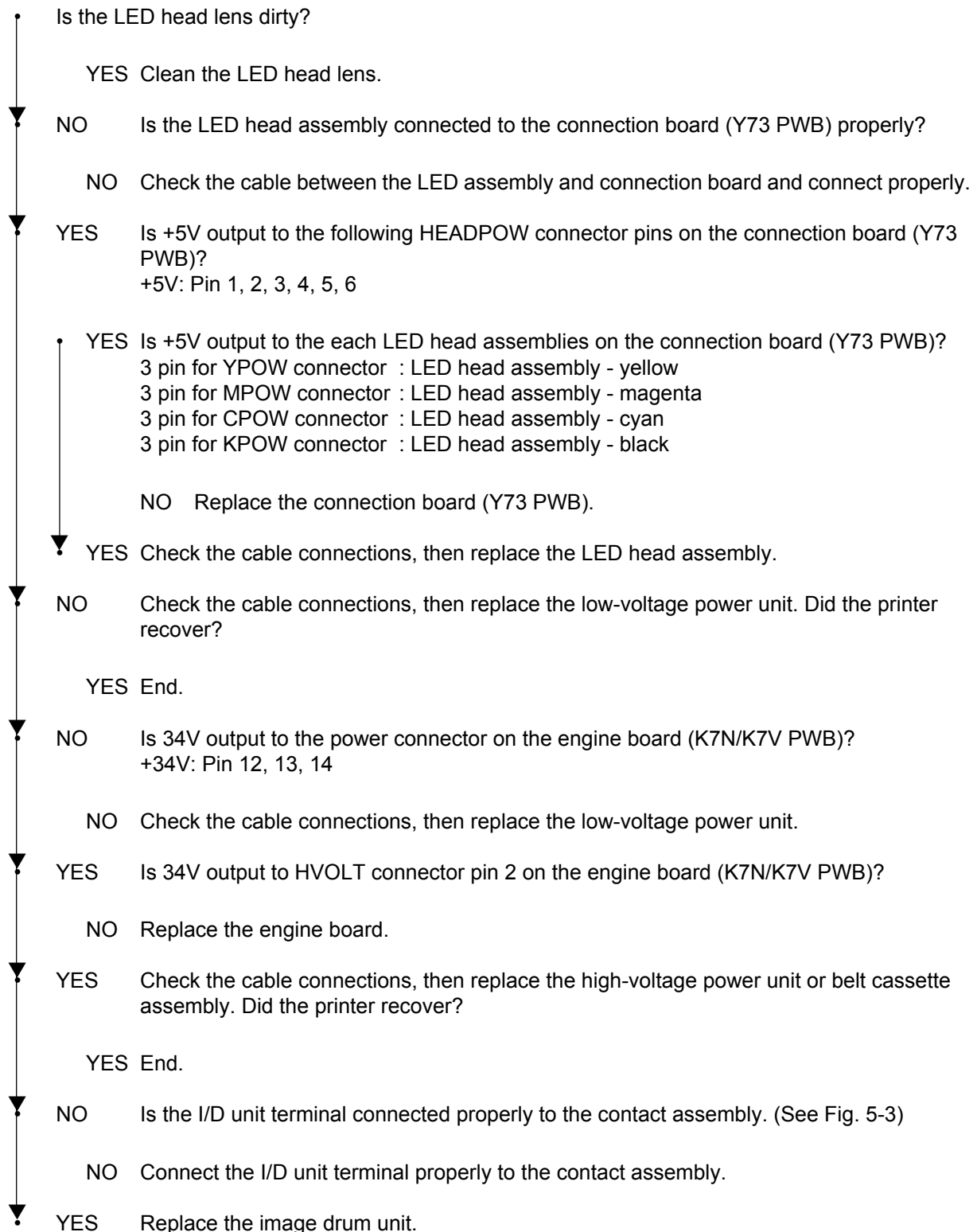

- Note:**
1. Remove EEPROM from the old board and set it on the new board upon replacing the engine board (K7N PWB).
  2. If EEPROM is not replaced, refer to section 3.2.2.
  3. When replacing the engine board (K7V PWB), upload EEPROM data from the board and then download it to a new board, using a life counter tool.

## ⑪ Paper thickness error (Err Code 323, 324)

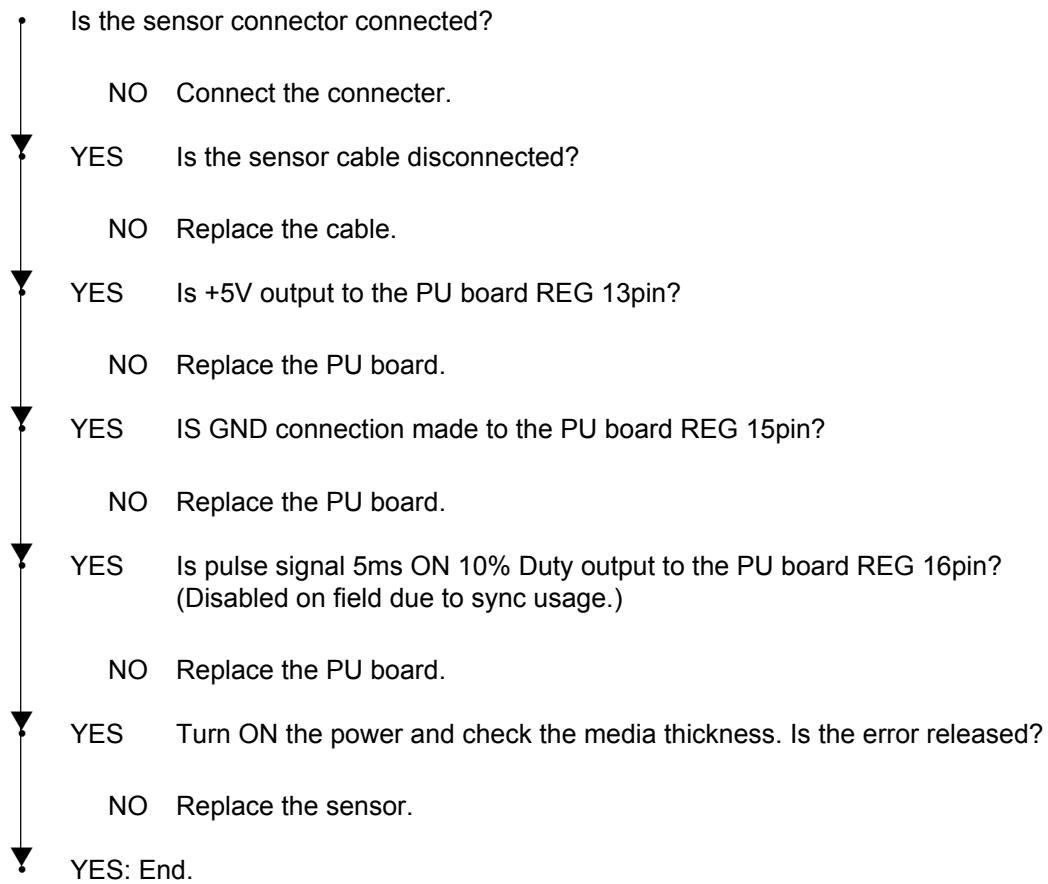

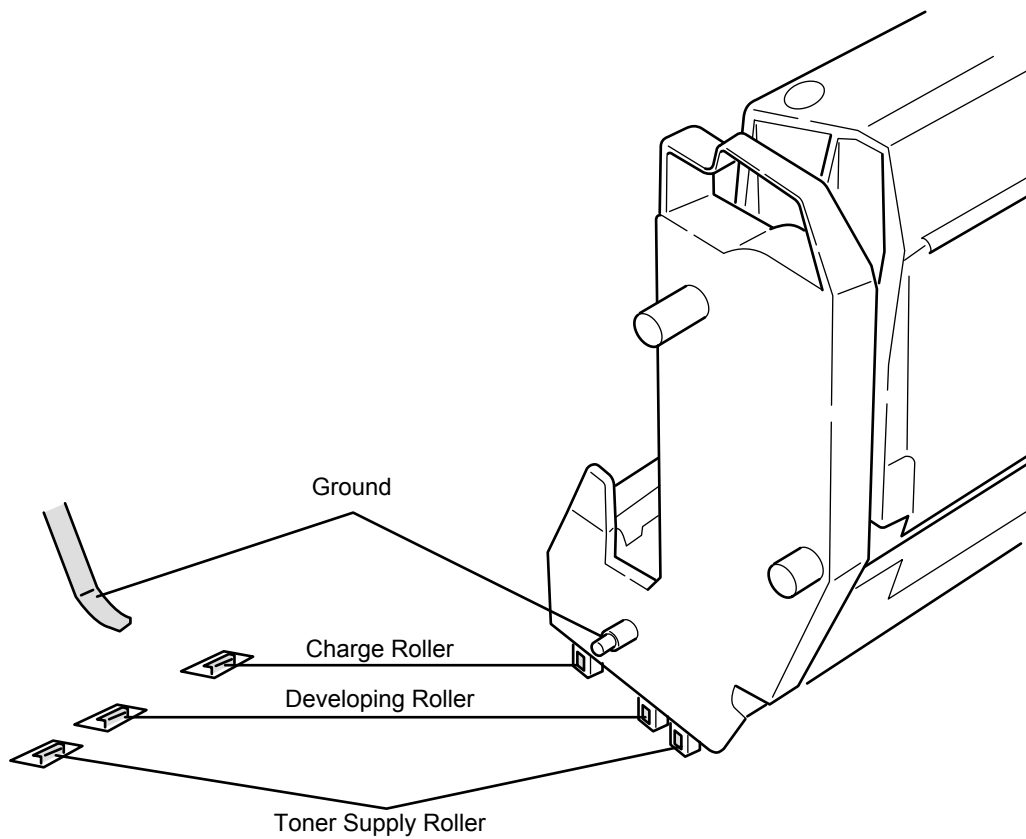

Figure 5.3

## 5.6 Fuse check

When it is occurred bellow errors, check these fuses on Print Engine Controller PWB.

Table 5-6 Fuse Error (K7N PWB)

Fuse Name	Error Description	Insert Point
F1	2nd or 3rd TRY Hopping Error	Option TRY 34V
F2	MID UP/DOWN Error	MID,Hopping Motor Driver
F3	Fuse Cut Error	YID,Fuser Motor Driver JODEN-board
F4	JAM	KID,Registraiton Motor Driver
F5	CID UP/DOWN Error	CID,Belt Motor Driver
F6	POEWR OFF	5V Sensor
F7	PU FAN Error FAN Clutch	JobOff Motor Driver
F8	Cover Open	Cover Open Switch

Table 5-7 Fuse Error (K7V PWB)

Fuse Name	Error Description	Insert Point
F1	POEWR OFF	5V Sensor
F2	Cover Open	Cover Open Switch
F3	JAM, PU FAN Error	Registraiton, Belt, JODEN-board
F4	YID UP/DOWN Error	YID, KID, Hopping Motor Driver
F5	CID UP/DOWN Error	CID, MID, Fuser Motor Driver
F6	2nd or 3rd TRY Hopping Error	Option TRY 340

## 5.7 Life Counter Tool

The following tool can be used for printer maintenance.

Name	Part Number	Use for
Life Counter Tool (CD)	41955701FV01	Windows95/98/Me/NT4.0/2000/XP

For using the life counter tool, see an appropriate operation guide on CD-ROM.

## 6. CONNECTION DIAGRAM

### 6.1 Resistance Checks

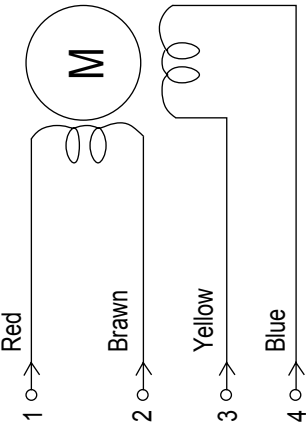
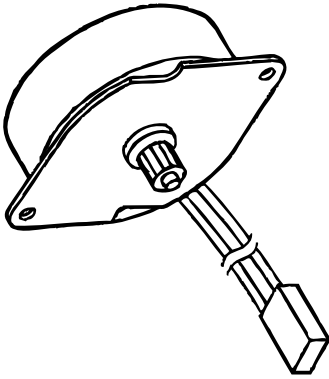
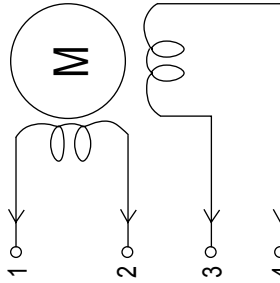
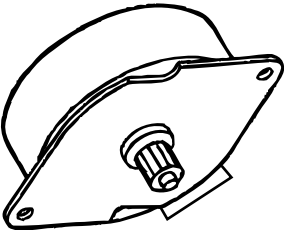
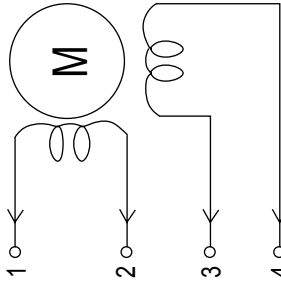
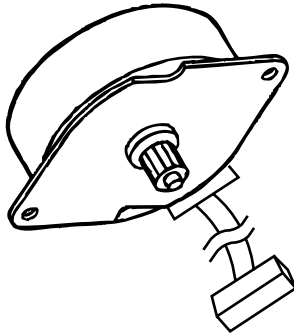
Unit	Circuit Diagram	Illustration	Resistance
Transport Belt Motor			<p>Between pins 1 and 2: 7.9Ω                      Between pins 3 and 4: 7.9Ω</p>
Main Motor (Y)			<p>Between pins 1 and 2: 8.6Ω                      Between pins 3 and 4: 8.6Ω</p>
Main Motor (M)			<p>Between pins 1 and 2: 8.6Ω                      Between pins 3 and 4: 8.6Ω</p>

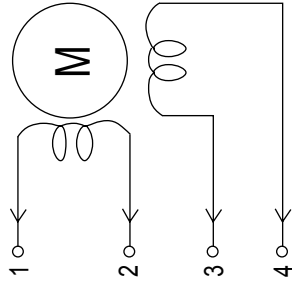
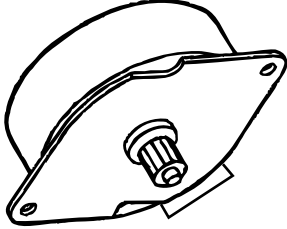
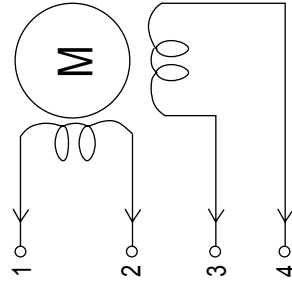
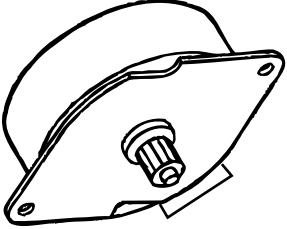
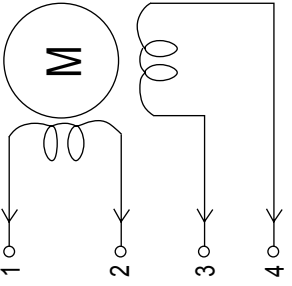
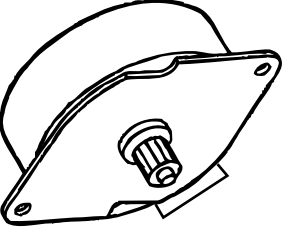
Unit	Circuit Diagram	Illustration	Resistance
Main Motor (C)			Between pins 1 and 2: 8.6Ω Between pins 3 and 4: 8.6Ω
Main Motor (K)			Between pins 1 and 2: 8.6Ω Between pins 3 and 4: 8.6Ω
Registration Motor			Between pins 1 and 2: 7.9Ω Between pins 3 and 4: 7.9Ω

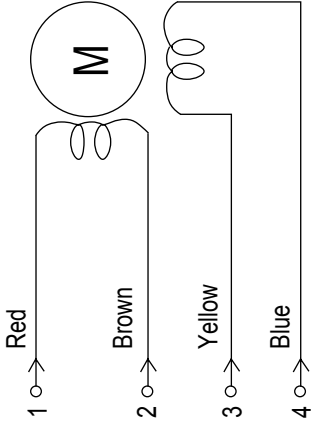
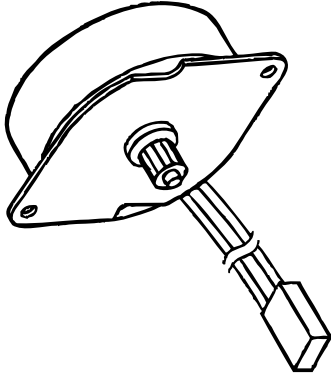
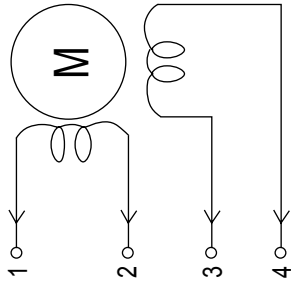
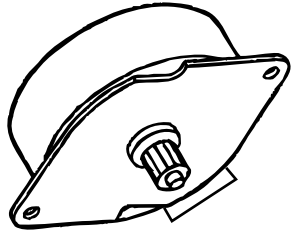
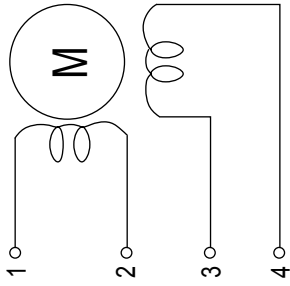
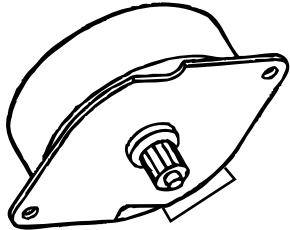

Unit	Circuit Diagram	Illustration	Resistance
Fuser Motor			<p>Between pins 1 and 2: 7.9Ω                      Between pins 3 and 4: 7.9Ω</p>
Feeder Motor			<p>Between pins 1 and 2: 7.9Ω                      Between pins 3 and 4: 7.9Ω</p>
Duplex Motor			<p>Between pins 1 and 2: 6.7Ω                      Between pins 3 and 4: 6.7Ω</p>

Unit	Circuit Diagram	Illustration	Resistance
Fuser Unit	<p>The circuit diagram shows two parallel paths. Path 1 (Upper roller) includes a Heater and a Thermostat in series, connected to terminals a and b. Path 2 (Backup roller) includes a Heater and a Thermostat in series, connected to terminals c and d. A Fuse is connected between terminals e and f.</p>	<p>The illustration shows the physical layout of the fuser unit. The upper roller side is shown with pins labeled a, b, c, d, e, and f. The backup roller side is also shown with a similar pin configuration.</p>	<p>1. Upper Roller Side            Between pins "a" and "b":            Between pins "c" and "d": 363k (at 25 C)            Between pins "e" and "f": Open</p> <p>2. Backup Roller Side            Between pins "a" and "b":            Between pins "c" and "d": 363k (at 25 C)            Between pins "e" and "f": 0 or open</p>

## 6.2 Program/Font ROM Layouts

- (1) Print Engine Controller PWB
  - a) (K7N PWB : 600dpi)

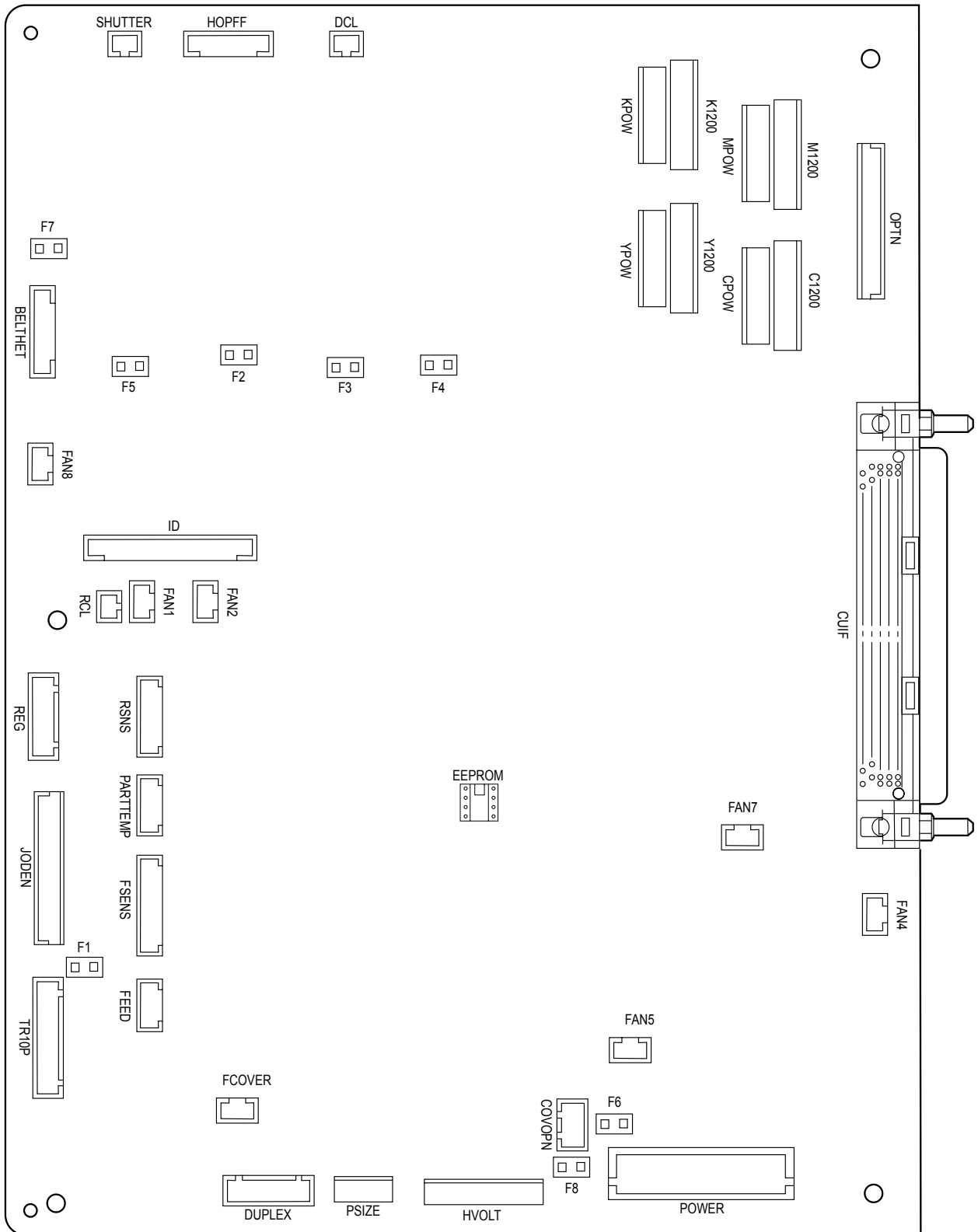

b) (K7N PWB : 1200dpi)

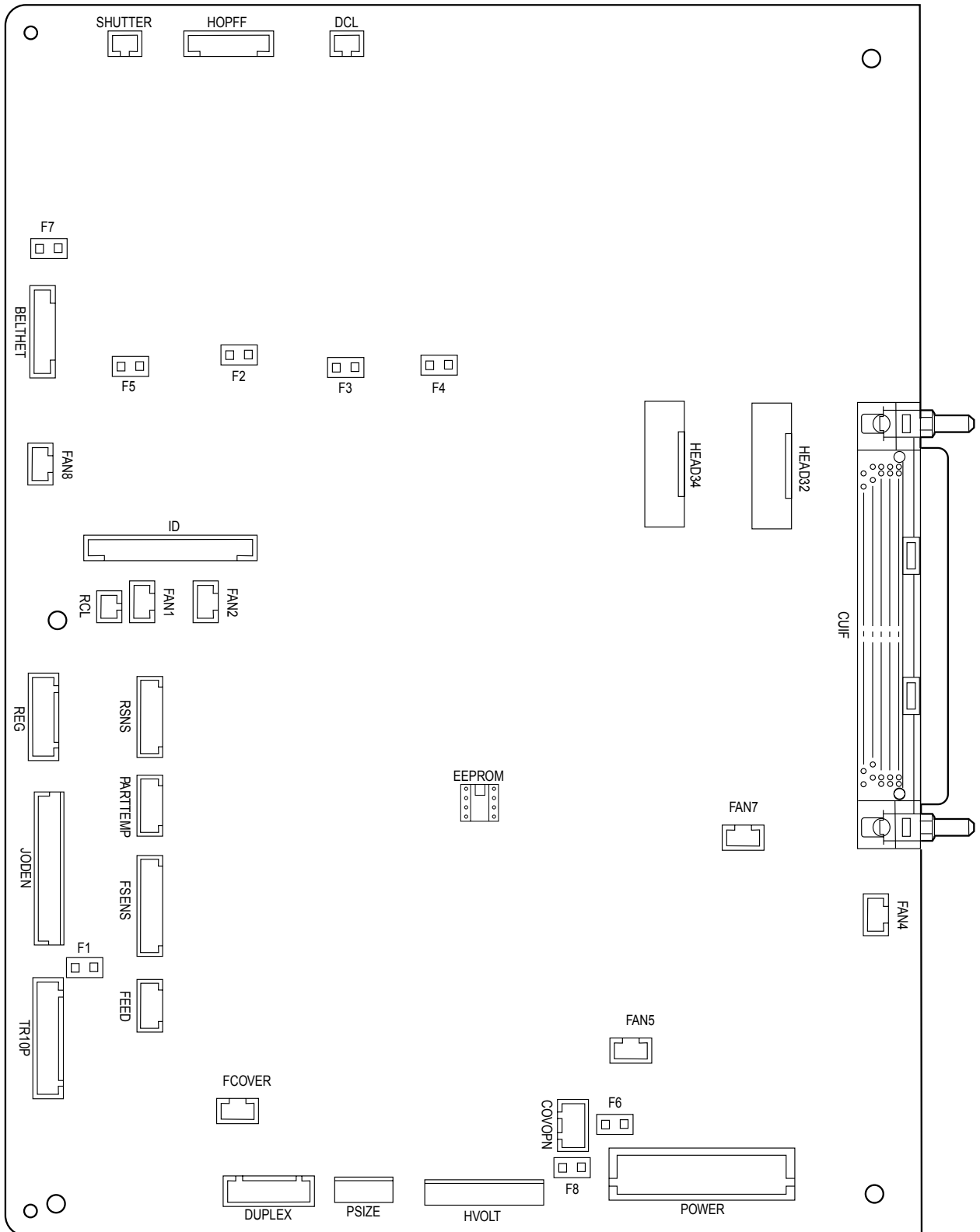

c) (K7V PWB : 600dpi)

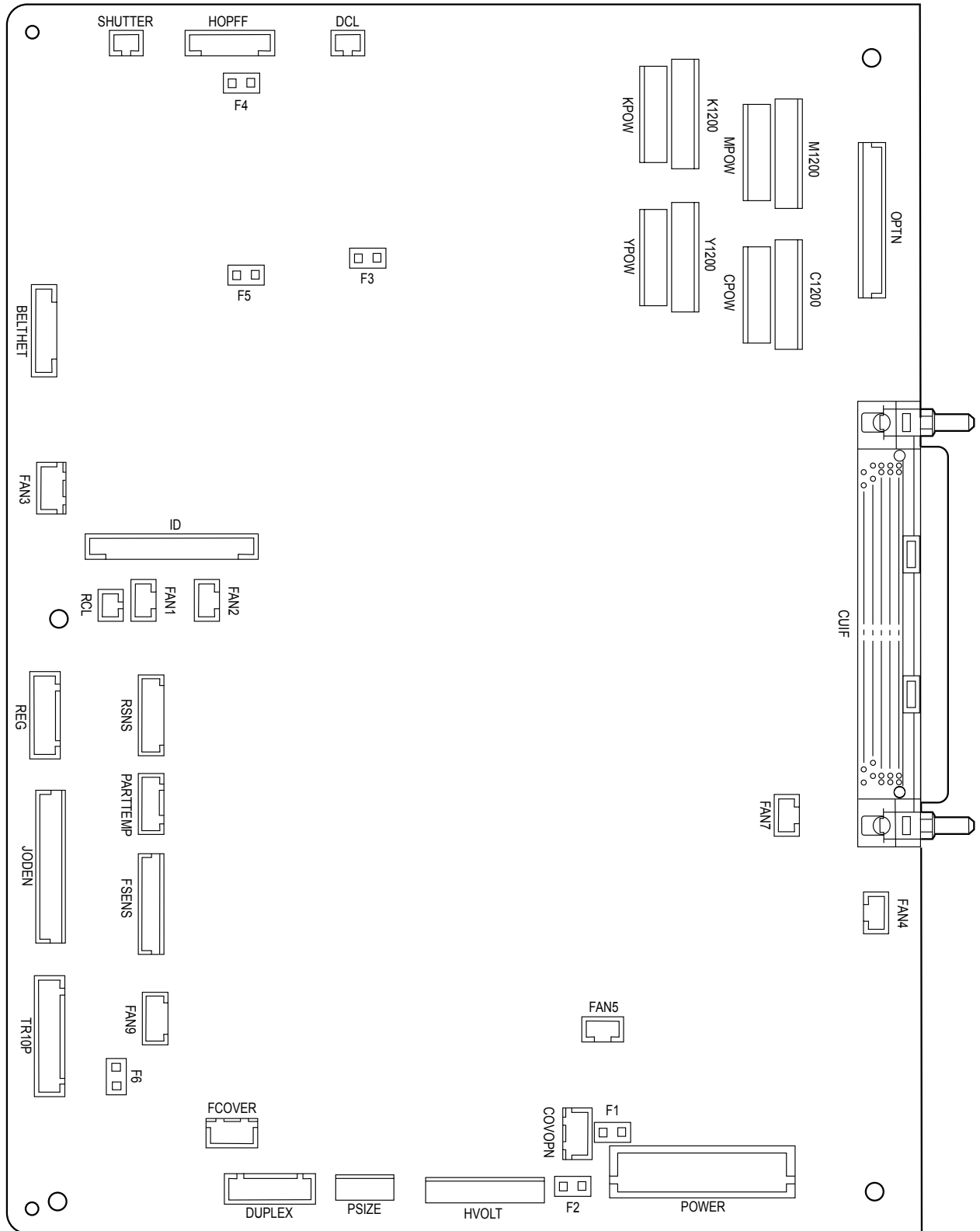

(2) Main Controller PWB  
 a) (TIG-3)

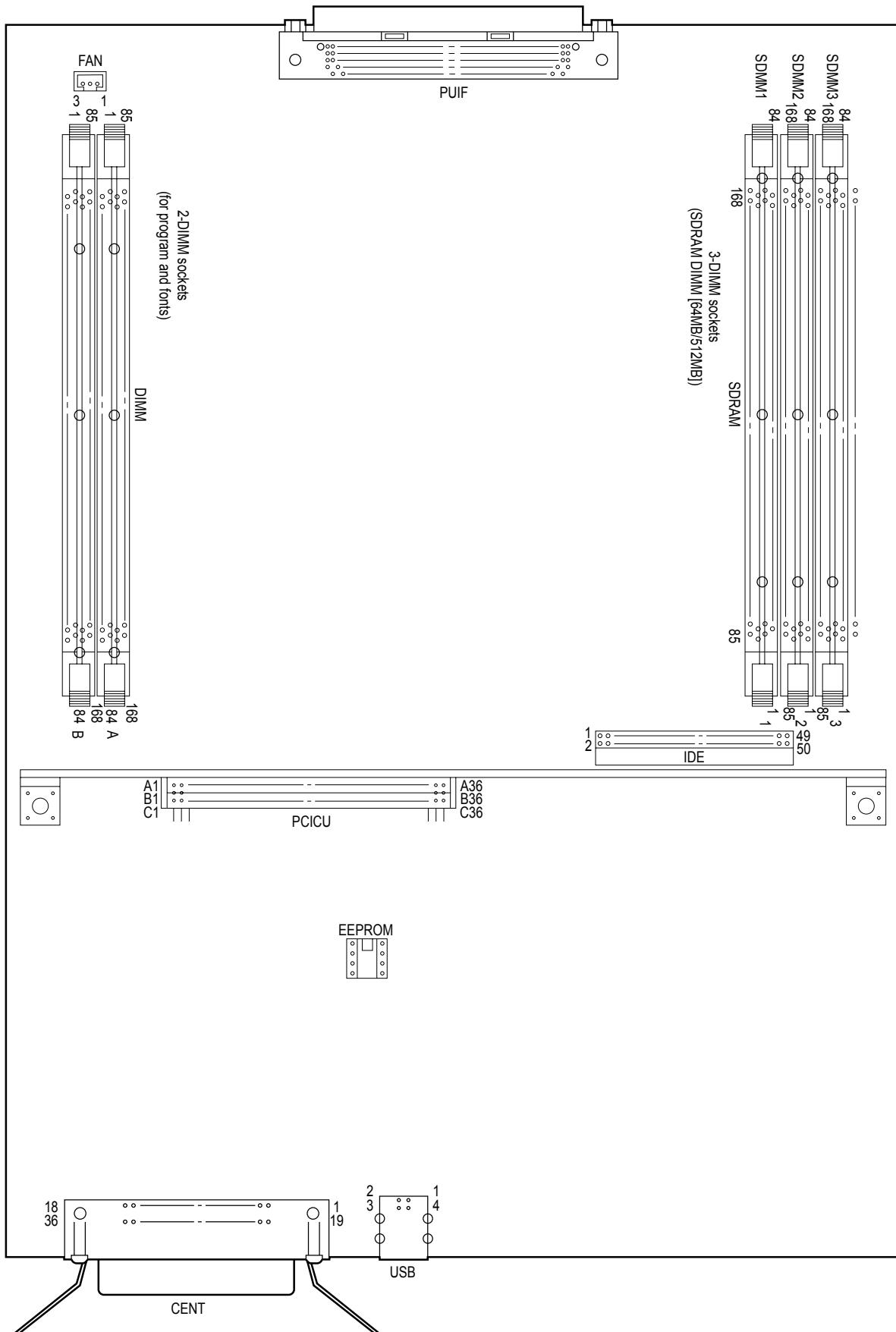

b) (HME)

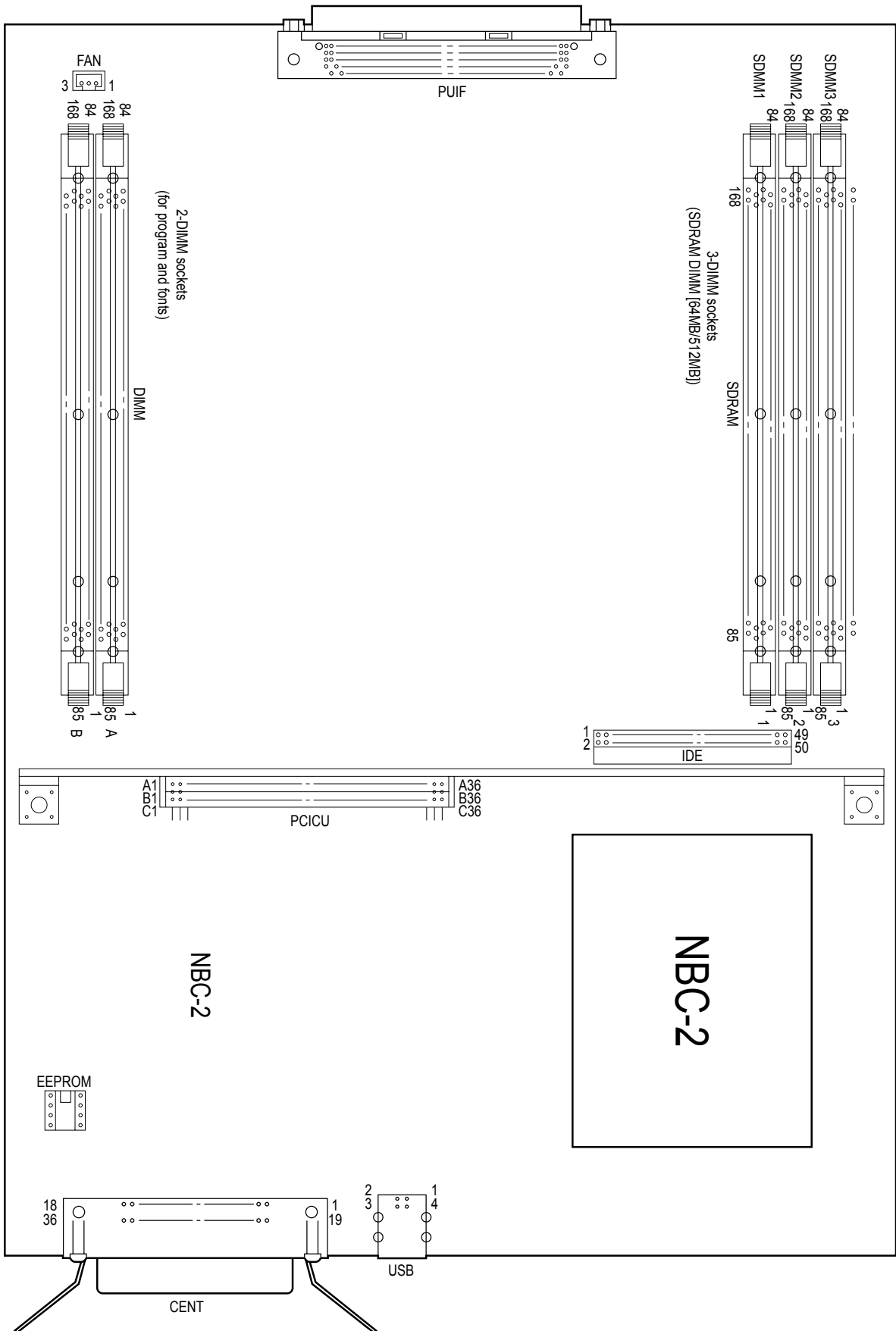

(3) LED Control PWB  
 a) (Y73-1 PWB:600dpi)

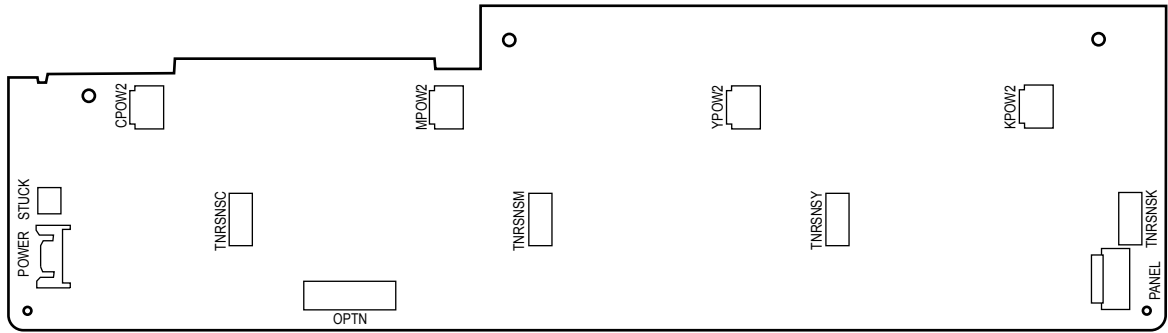

b) (Y7X-1 PWB:1200dpi)

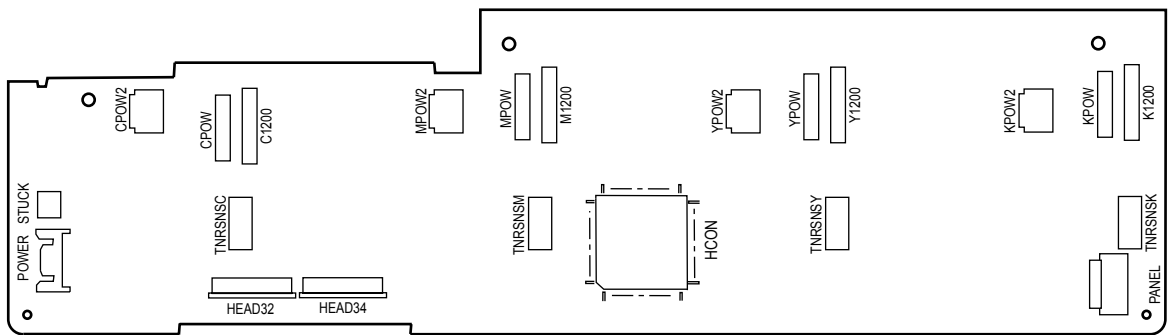

(4) Duplex Control PWB (V71--N PWB)



(5) Control Panel PWB (X7N PWB)

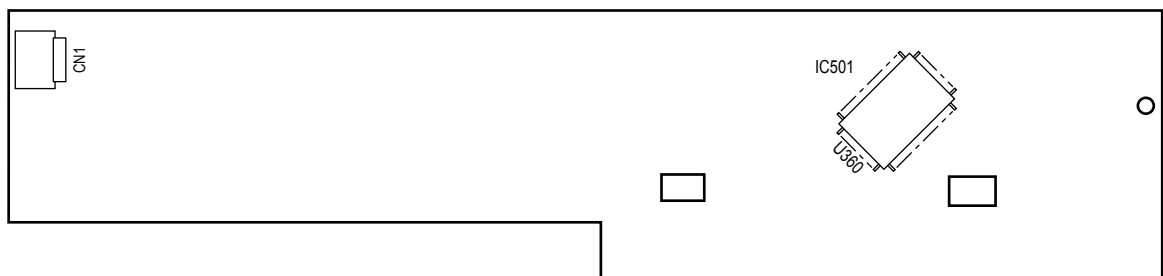



(6) N71 PWB

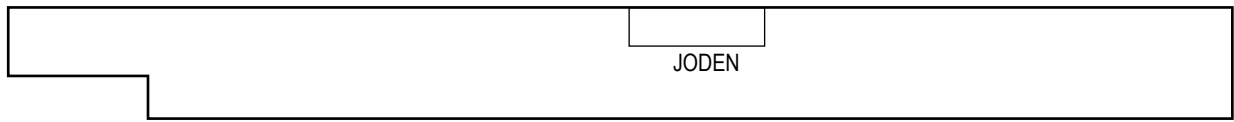

(7) Entrance Sensor PWB (R71 PWB)

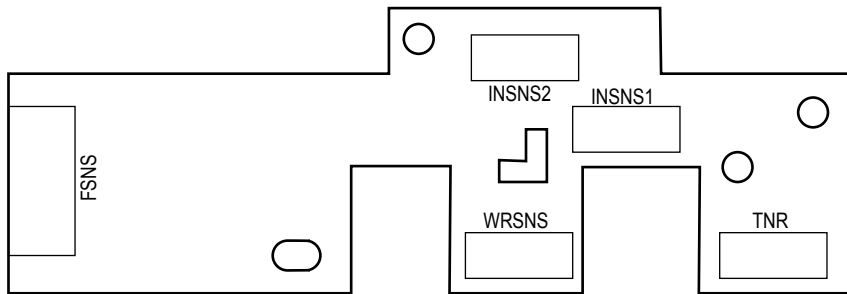

(8) Paper Size Sensing PWB (PXC PWB)

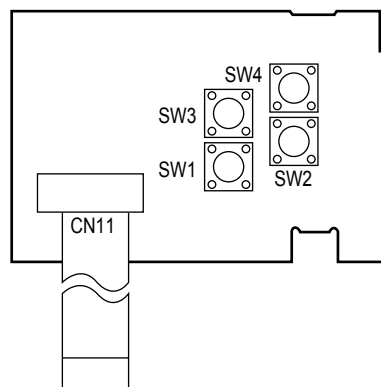

(9) High voltage power supply PWB

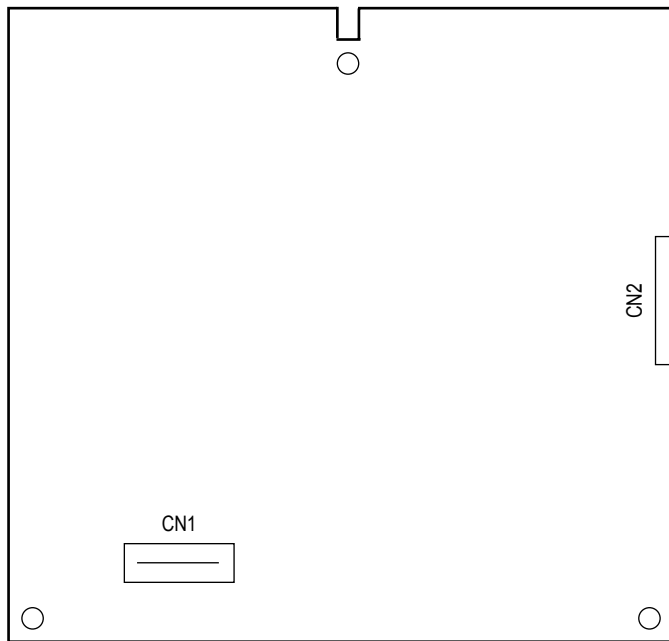

(10) Low voltage power supply PWB

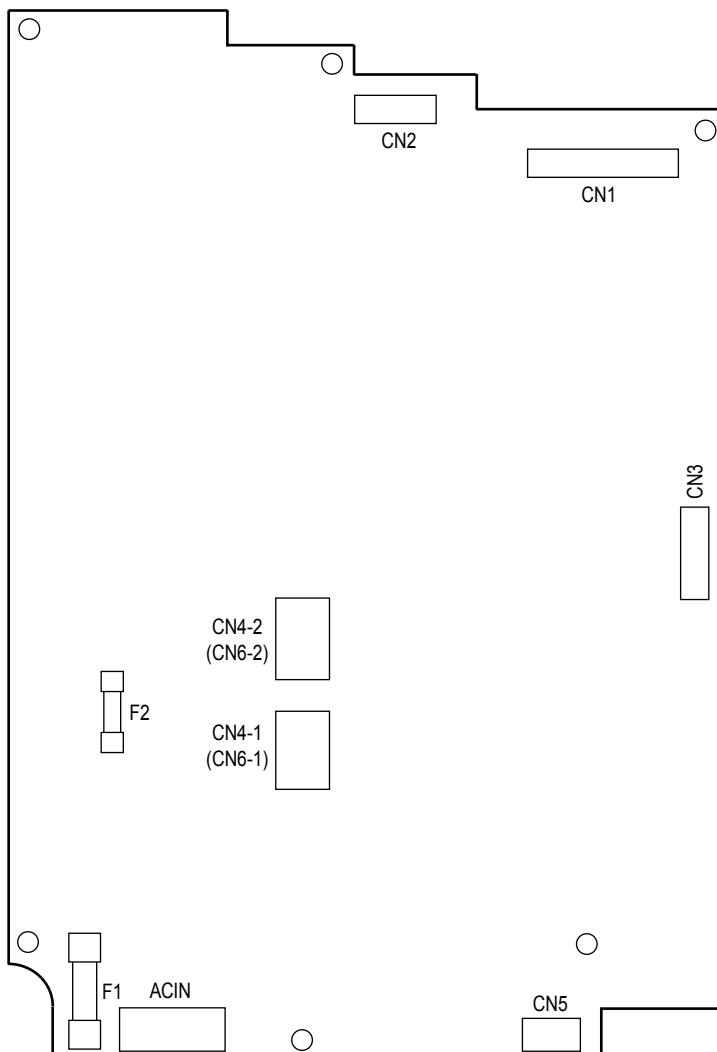

## APPENDIX A INTERFACE SPECIFICATIONS

### 1. Parallel Interface Specifications

#### 1.1 Parallel Interface

Item	Description
Mode	Compatibility mode, Nibble mode, ECP mode
Data bit length	8 bits: Compatibility mode, 4bits: Nibble mode,9 bits: ECP mode

#### 1.2 Parallel Interface Connector and Cable

##### 1) Connector

Printer side: 36-pin receptacle  
Type 57LE-40360-12 (D56) (made by Daiichi Denshi) or equivalent

Cable side: 36-pin plug  
Type 57FE-30360-20N (D8) (made by Daiichi Denshi) or equivalent

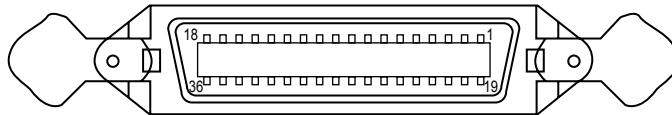

Connector Pin Arrangement Viewed from Cable Side

##### 2) Cable

Cable length: 1.8 m max.

(A shielded cable composed of twisted pair wires is recommended for noise prevention.)

#### 1.3 Parallel Interface Level

LOW: 0 V to +0.8 V

HIGH: +2.4 V to 5.0 V

1.4 Timing Charts

Compatible mode

a) Data receiving timing

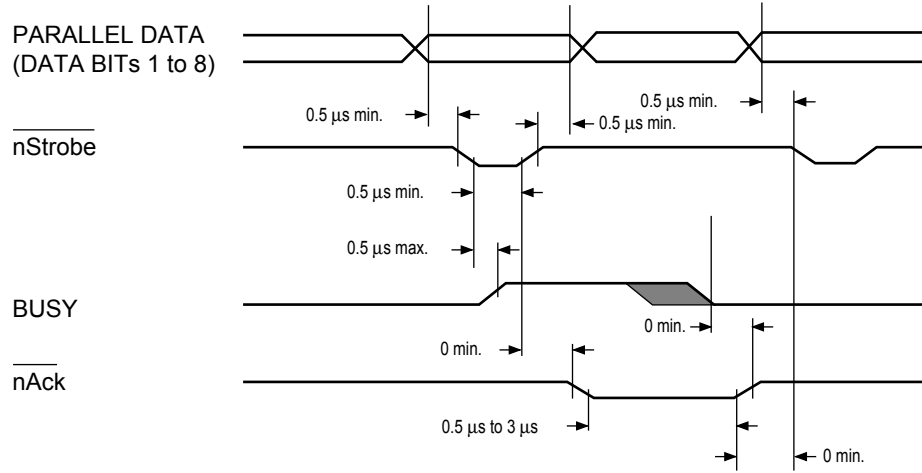

b) On-line (off-line switching timing by ON-LINE SW)

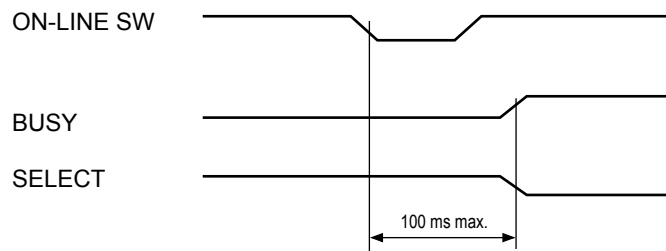

c) Off-line (on-line switching timing by ON-LINE SW)

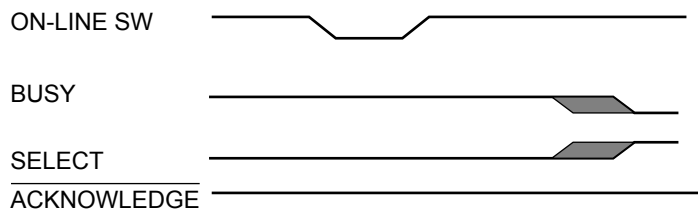

d) nlnit timing (invalid by default)

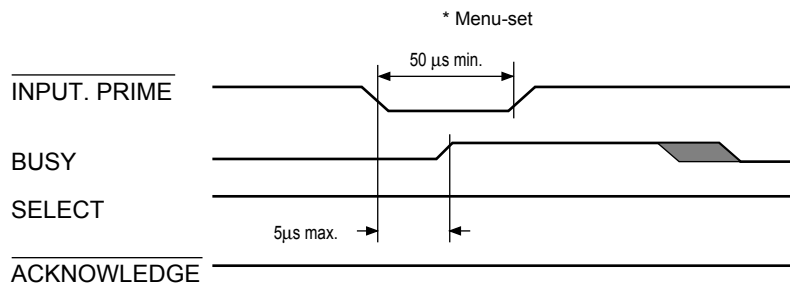

## 1.5 Parallel I/F Signals

Table 8-1 shows interface signal names and pin numbers.

Table 8-1 Signals

Pin No.	Signal Name	Signal Direction	Functions
1	Nstrobe (HostClk)	→PR	Pulse for reading data in at trailing edge.
2	DATA 1		
3	DATA 2		
4	DATA 3		8-bit parallel data.
5	DATA 4	→PR	Each signal is HIGH when data is logical 1 and LOW when it is logical 0.
6	DATA 5		
7	DATA 6		
8	DATA 7		
9	DATA 8		
10	nAck (PtrClk)	←PR	Indicates the completion of data reception.
11	Busy (PtrBusy)	←PR	Indicates whether the printer is ready for receiving data. Data cannot be received while the signal is HIGH.
12	PError (AckDataReq)	←PR	Indicates paper error when held HIGH.
13	Select (Xflag)	←PR	HIGH without exception when the parallel interface is enabled.
14	NAutoFd (HostBusy)	→PR	Used in bidirectional communication.
15	-		Unassigned.
16	GND		Signal ground.
17	FG		Chassis ground.
18	+5V	←PR	Used for supplying +5V. Power cannot be supplied to the outside of the printer.
19			
~	GND		Signal ground.
30			
31	Ninit (nInit)	→PR	Initializes the printer when held LOW.
32	NFault (nDataAvail)	←PR	LOW during alarm.
33	GND		Signal ground.
34	-		Unassigned.
35	HILEVEL	←PR	Pulled up to +5V at 3.3KΩ inside the printer.
36	Nselectin (IEEE 1284 active)	→PR	Used in bidirectional communication. Low without exception in compatible mode.

**Note:** Parenthesized signal names are used in nibble mode.

Only functions in compatible mode are listed.

The C9300/C9500 series of printers supports the IEEE std 1284-1994 nibble mode. Note that, when used with personal computers or cables that do not comply with the standards, the printers may exhibit unpredictable behavior.

## 2. Universal Serial Bus (USB) Interface Specifications

### 2.1 USB Interface

- (1) Basic specifications  
Conforms to USB specification, revision 1.1.
- (2) Transmission mode  
Full speed (max. 12 Mbps + 0.25%)
- (3) Power Control  
Self-power device

### 2.2 USB Interface Connector and Cable

- (1) Connector  
Printer side: Type B receptacle  
Upstream port  
UBB-4R-D14T-1 (made by JST) or equivalent

Connector pin layout

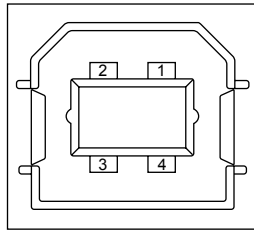

Cable side: Type B plug

- (2) Cable  
Cable length: 5 m max. (cable compliant with USB specification, revision 1.1)  
(A shielded cable must be used.)

### 2.3 USB Interface Signals

	R1	Function
1	Vbus	Power Supply (+5V) (red)
2	D -	Data transmission (white)
3	D +	Data transmission (green)
4	GND	Signal ground (black)
Shell	Shield	

## APPENDIX B 2ND/3RD TRAY MAINTENANCE

### 1. Parts Replacement

#### 1.1 Cover Idle Roller Assy

- (1) Unscrew the four screws ① to remove the cover side ② and the plate cover PCB ③.
- (2) Unscrew the two screws ④ to demount the cover idle roller Assy ⑤.

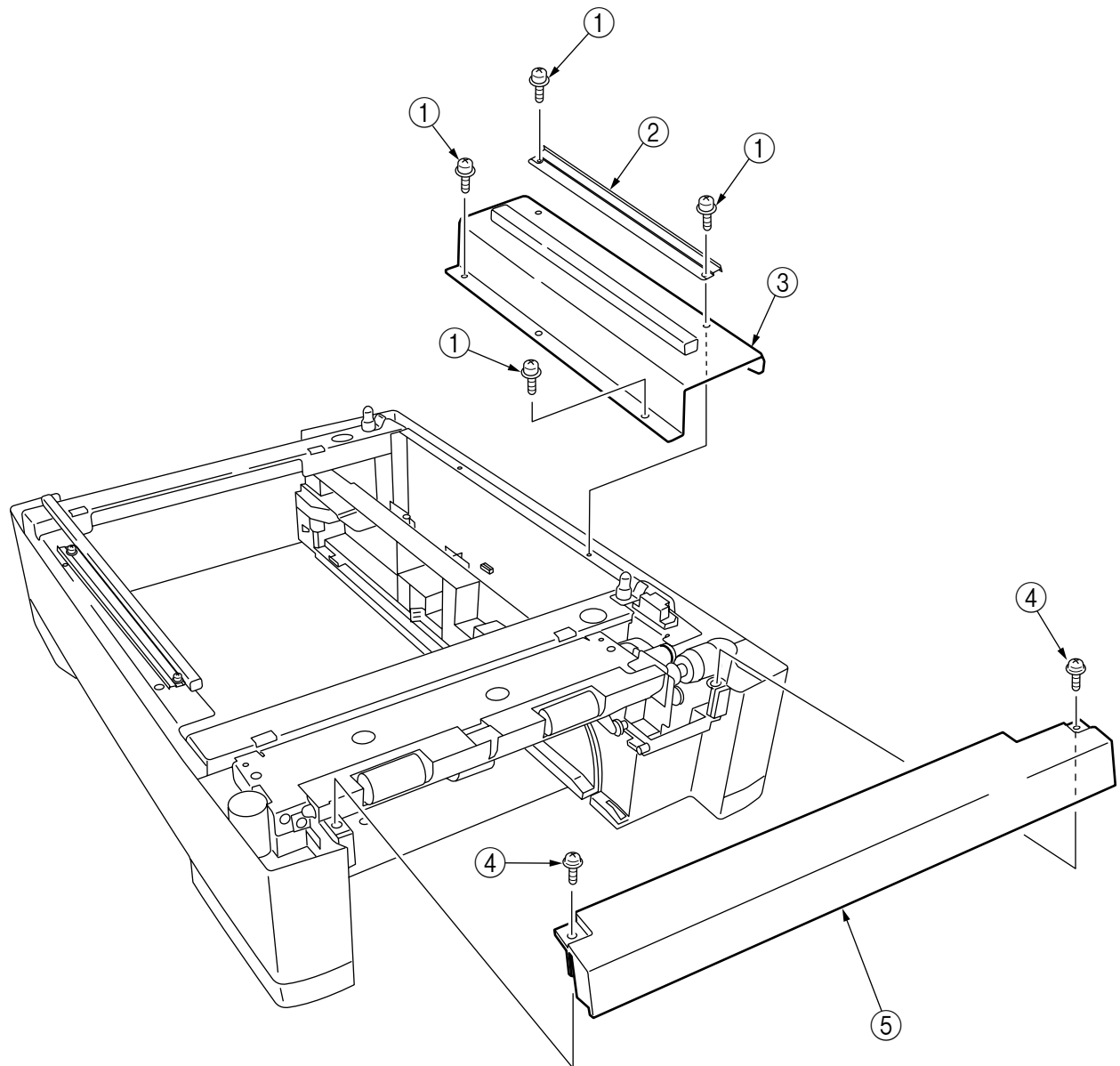

## 1.2 PCB

- (1) Unscrew the four screws ① to remove the plate cover PCB ②.
- (2) Remove the connectors (at seven places) and the two screws ③, then demount the board ④.

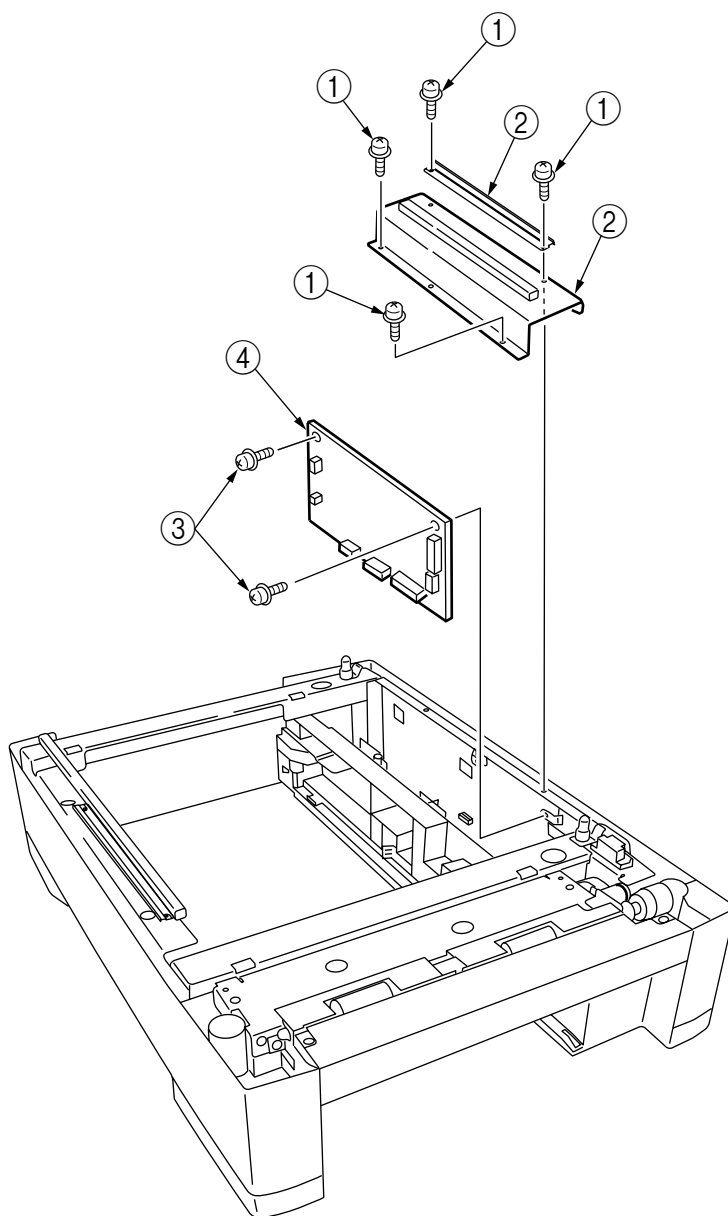



### 1.3 Feeder Drive Assy

- (1) Remove the four screws ①, six screws ② and the eight screws ③.
- (2) Remove the cover sides ④ and ⑤, the plate cover PCB ⑥ and the frame hopping Assy ⑦.
- (3) Remove the E ring ⑧, the clutch ⑨ and the two screws ⑩.
- (4) Unscrew the two screws ⑪ to remove the core ⑫ and the connector ⑬.
- (5) Unscrew the two screws ⑭, then detach the motor ⑮.
- (6) Unscrew the two screws ⑯ to remove the connector ⑰.

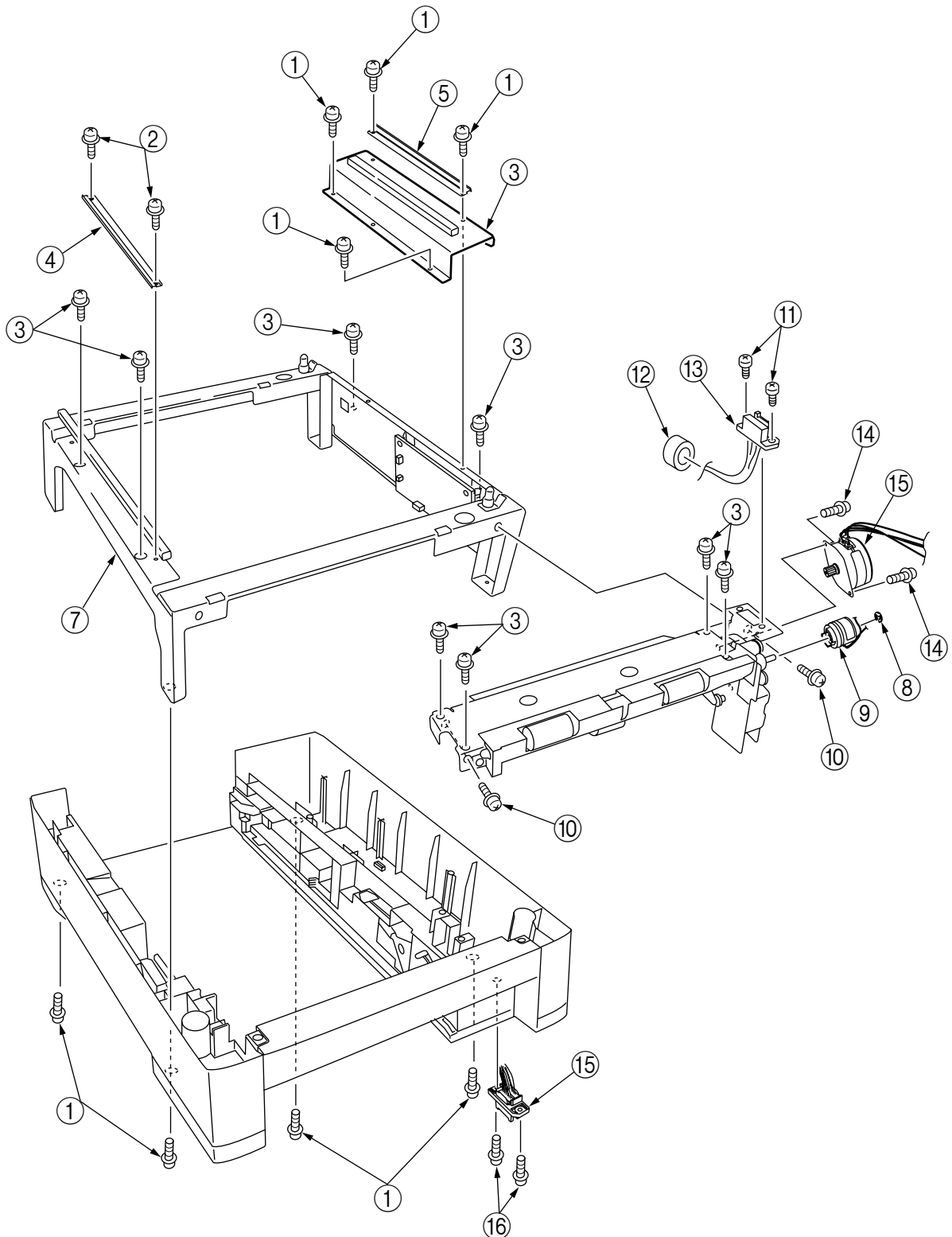

## APPENDIX C C7100/7300/7350/9300/9500 SERIES ERROR MESSAGES

### 1. C7100/7300/7350/9300/9500 Series (Error messages)

(Caution) \* : Raise in the factory mode only.

\*\* : Not raise in the standard config machines.

Err Code	LCD Messages	LED Ready	LED Atten	Description	Comments
300	POWER OFF/ON 300:NETWORK ERROR	OFF	Blink	A network error is occurring.	
310	CLOSE COVER 310:UPPER COVER OPEN	OFF	Blink	The cover is open.	
311	CLOSE COVER 311:SIDE COVER OPEN	OFF	Blink	The cover is open.(PX711)	
311	CLOSE COVER 311:SIDE COVER OPEN	OFF	Blink	The cover is open.(PX713)	
312	CLOSE COVER 312:TRAY2 COVER OPEN	OFF	Blink	The cover is open.	
313	CLOSE COVER 313:TRAY3 COVER OPEN	OFF	Blink	The cover is open.	
314	CLOSE COVER 314:TRAY4 COVER OPEN	OFF	Blink	The cover is open.	
315	CLOSE COVER 315:TRAY5 COVER OPEN	OFF	Blink	The cover is open.	
320	CHECK FUSER UNIT 320:FUSER UNIT MISSING	OFF	Blink	The fuser unit is not correctly installed	
321	POWER OFF AND WAIT FOR A WHILE 321:MOTOR OVERHEAT	OFF	Blink	Motor (Driver LSD) overheat error	
323	OPEN AND CLOSE COVER 323:PAPER THICK ERROR	OFF	Blink	A Sensor output at Medea Empty is outside the spec.(factory mode only raise)	Anomalies with Media Weight Detection sensor.
324	OPEN AND CLOSE COVER 324:PAPER THICK ERROR	OFF	Blink	The difference among Sensor outputs is outside the spec.(factory mode only raise)	
325	OPEN AND CLOSE COVER 325:PAPER THICK ERROR	OFF	Blink	Media detected values are outside the spec.	
326	OPEN AND CLOSE COVER 326:PAPER THICK ERROR	OFF	Blink	Media detected values in U-Heavy Mode are outside the spec.	
327 *	DOWNLOAD CHIP DATA 327:DENSITY CALIBRATION CHIP ERROR	OFF	Blink	Density Adjustment's calibration chip correction errorOmission of factory default setting. To prevent setting mistake.Error that does not occur at user level.Displayed only in Factory Mode.	

Err Code	LCD Messages	LED Ready	LED Atten	Description	Comments
330	CHECK BELT UNIT 330:BELT UNIT MISSING	OFF	Blink	The belt unit is not correctly installed.	
340	CHECK IMAGE DRUM 340:YELLOW DRUM MISSING	OFF	Blink	The drum is not correctly installed.	
341	CHECK IMAGE DRUM 340:MAGENTA DRUM MISSING	OFF	Blink		
342	CHECK IMAGE DRUM 340:CYAN DRUM MISSING	OFF	Blink		
343	CHECK IMAGE DRUM 340:BLACK DRUM MISSING	OFF	Blink		
350	INSTALL NEW IMAGE DRUM 350:YELLOW DRUM LIFE	OFF	Blink	The life of the drum (Alarm) Warning status takes effect at Cover Open/Close, while allowing 500 pages printing at maximum	
351	INSTALL NEW IMAGE DRUM 351:MAGENTA DRUM LIFE	OFF	Blink		
352	INSTALL NEW IMAGE DRUM 352:CYAN DRUM LIFE	OFF	Blink		
353	INSTALL NEW IMAGE DRUM 353:BLACK DRUM LIFE	OFF	Blink		
355	INSTALL NEW BELT UNIT 355:BELT UNIT LIFE	OFF	Blink	Notifies the transfer belt has reached its life.This is the error displayed based on the counter to indicate that the belt has reached its life, and printing will stop.	
356	INSTALL NEW BELT UNIT 356:BELT UNIT LIFE	OFF	Blink	Notifies the transfer belt has reached its life.This is the error to indicate that the belt has reached its life because the waste toner has filled up the container, and printing will stop.	
360	INSTALL DUPLEX UNIT 360:DUPLEX UNIT OPEN	OFF	Blink	Duplex unit is open (removed). When this error is detected, printing stops.(PX713 only)	
361	REMOVE FINISHER 361:PAPER JAM	OFF	Blink	Jam has occurred nearby FINISHER unit.(Only install the FINISHER unit) 361:Before Input 362:Input Area 363:Regist Roller 364:Invert Path 365:Invert Stack 366:Output Bin1 Exit 367:Output Bin2 Exit	
362	REMOVE FINISHER 362:PAPER JAM	OFF	Blink		
363	REMOVE FINISHER 363:PAPER JAM	OFF	Blink		
364	REMOVE FINISHER 364:PAPER JAM	OFF	Blink		
365	REMOVE FINISHER 365:PAPER JAM	OFF	Blink		
366	REMOVE FINISHER 366:PAPER JAM	OFF	Blink		
367	REMOVE FINISHER 367:PAPER JAM	OFF	Blink		

Err Code	LCD Messages	LED Ready	LED Atten	Description	Comments
370	CHECK DUPLEX 370:PAPER JAM	OFF	Blink	Jam has occurred nearby DUPLEX unit.(Duplex Reversal)	
371	CHECK DUPLEX 371:PAPER JAM	OFF	Blink	Jam has occurred nearby DUPLEX unit.(Duplex Input)	
372	CHECK DUPLEX 372:PAPER JAM	OFF	Blink	Jam has occurred nearby DUPLEX unit.(Duplex Missfeed)	
380	OPEN FRONT COVER 380:PAPER JAM	OFF	Blink	Jam has occurred in paper path.(PX711)	
380	OPEN FRONT COVER 380:PAPER JAM	OFF	Blink	Jam has occurred in paper path.(PX713)	
381	OPEN UPPER COVER 381:PAPER JAM	OFF	Blink	Jam has occurred in paper path.(Transport)	
382	OPEN UPPER COVER 382:PAPER JAM	OFF	Blink	Jam has occurred in paper path.(Exit)	
383	OPEN UPPER COVER 383:PAPER JAM	OFF	Blink	Jam has occurred in paper path.(Duplex Entry)	
389	OPEN UPPER COVER 389:PAPER JAM	OFF	Blink	Jam has occurred in paper path.(Others)	
390	CHECK MPTRAY 390:PAPER JAM	OFF	Blink	Paper jam occurred during paper feeding from each tray.	
391	CHECK TRAY1 391:PAPER JAM	OFF	Blink		
392	CHECK TRAY2 392:PAPER JAM	OFF	Blink		
393	CHECK TRAY3 393:PAPER JAM	OFF	Blink		
394	CHECK TRAY4 394:PAPER JAM	OFF	Blink		
395	CHECK TRAY5 395:PAPER JAM	OFF	Blink		
400	OPEN UPPER COVER 400:PAPER SIZE ERROR	OFF	Blink	Inappropriate size paper was fed from a tray. Check the paper in the tray or check for Multiple-feed. Open and close the cover to perform recovery printing, and continue.	
401	OPEN UPPER COVER 401:PAPER MULTI FEED	OFF	Blink	Warns that inappropriate long paper has been fed from the tray. Check whether Multi-feed has happened. Recovery Print takes place at Cover Open/Close, allowing the operation to continue.	

Err Code	LCD Messages	LED Ready	LED Atten	Description	Comments
410	INSTALL NEW TONER 410:YELLOW TONER EMPTY	OFF	Blink	Toner of (Yellow/Magenta/Cyan/Black) ends. Warning status takes effect at Cover Open/Close, while allowing printing at least 20 pages	
411	INSTALL NEW TONER 411:MAGENTA TONER EMPTY	OFF	Blink		
412	INSTALL NEW TONER 412:CYAN TONER EMPTY	OFF	Blink		
413	INSTALL NEW TONER 413:BLACK TONER EMPTY	OFF	Blink		
420	INSTALL ADDITIONAL MEMORY 420: MEMORY OVERFLOW	OFF	Blink	Memory capacity overflows due to the following reason. Press ON-LINE switch so that it continues. Install expansion RAM or decrease the data amount. - Too much print data in a page. - Too much Macro data. - Too much DLL data. - After frame buffer compress	
430	INSTALL PAPER CASSETTE 430:TRAY1 MISSING	OFF	Blink	The tray cassette of paper to which printing is intended is removed, and paper cannot be fed.	
431	INSTALL PAPER CASSETTE 431:TRAY2 MISSING	OFF	Blink		
432	INSTALL PAPER CASSETTE 432:TRAY3 MISSING	OFF	Blink		
433	INSTALL PAPER CASSETTE 433:TRAY4 MISSING	OFF	Blink		
434	INSTALL PAPER CASSETTE 434:TRAY5 MISSING	OFF	Blink		
440	INSTALL PAPER CASSETTE 440:TRAY1 OPEN	OFF	Blink	The tray cassette that is a paper path for the paper to be printed to is removed.(PX711 only)	
441	INSTALL PAPER CASSETTE 441:TRAY2 OPEN	OFF	Blink		
442	INSTALL PAPER CASSETTE 442:TRAY3 OPEN	OFF	Blink		
443	INSTALL PAPER CASSETTE 443:TRAY4 OPEN	OFF	Blink		
440	INSTALL PAPER CASSETTE 440:TRAY1 OPEN	OFF	Blink	The tray cassette that is a paper path for the paper to be printed to is removed.(PX711 only)	
441	INSTALL PAPER CASSETTE 441:TRAY2 OPEN	OFF	Blink		
442	INSTALL PAPER CASSETTE 442:TRAY3 OPEN	OFF	Blink		
443	INSTALL PAPER CASSETTE 443:TRAY4 OPEN	OFF	Blink		Not raise (TRAY4:not configuration)

Err Code	LCD Messages	LED Ready	LED Atten	Description	Comments
450	REMOVE THE PAPER 450:TRAY1 UNSUITABLE SIZE	OFF	Blink	Paper that cannot be used in the tray is set. (It takes a while until the status appears after you have closed the tray and the lever lifted.)	
451	REMOVE THE PAPER 451:TRAY2 UNSUITABLE SIZE	OFF	Blink		
452	REMOVE THE PAPER 452:TRAY3 UNSUITABLE SIZE	OFF	Blink		
453	REMOVE THE PAPER 453:TRAY4 UNSUITABLE SIZE	OFF	Blink		
454	REMOVE THE PAPER 454:TRAY5 UNSUITABLE SIZE	OFF	Blink		
460	CHANGE PAPER TO mmmmmmmmm/ppppppp 460:MPTRAY MEDIA MISMATCH	OFF	Blink	The size of paper or media type in the tray does not match the print data. Load mmmmm/ppppp paper in the tray (It takes a while until the status disappears after you have closed the tray and the lever lifted.)  mmmmm : Paper Size (A4 , . ,B5 ,A6) pppp	
	CHANGE PAPER TO mmmmmmmmm/ppppppp 460:MPTRAY SIZE MISMATCH	OFF	Blink		
461	CHANGE PAPER TO mmmmmmmmm/ppppppp 461:TRAY1 MEDIA MISMATCH	OFF	Blink		
	CHANGE PAPER TO mmmmmmmmm/ppppppp 461:TRAY1 SIZE MISMATCH	OFF	Blink		
462	CHANGE PAPER TO mmmmmmmmm/ppppppp 462:TRAY2 MEDIA MISMATCH	OFF	Blink		
	CHANGE PAPER TO mmmmmmmmm/ppppppp 462:TRAY2 SIZE MISMATCH	OFF	Blink		
463	CHANGE PAPER TO mmmmmmmmm/ppppppp 463:TRAY3 MEDIA MISMATCH	OFF	Blink		
	CHANGE PAPER TO mmmmmmmmm/ppppppp 463:TRAY3 SIZE MISMATCH	OFF	Blink		
464	CHANGE PAPER TO mmmmmmmmm/ppppppp 464:TRAY4 MEDIA MISMATCH	OFF	Blink		
	CHANGE PAPER TO mmmmmmmmm/ppppppp 464:TRAY4 SIZE MISMATCH	OFF	Blink		

Err Code	LCD Messages	LED Ready	LED Atten	Description	Comments
465	CHANGE PAPER TO mmmmmmmmm/ppppppp 465:TRAY5 MEDIA MISMATCH	OFF	Blink	The size of paper or media type in the tray does not match the print data. Load mmmmm/pppppp paper in the tray (It takes a while until the status disappears after you have closed the tray and the lever lifted.)	
	CHANGE PAPER TO mmmmmmmmm/ppppppp 465:TRAY5 SIZE MISMATCH	OFF	Blink		
469 **	(Reserved : for FRONT FEEDER)	OFF	Blink	mmmmm : Paper Size (A4 , . ,B5 ,A6) pppp	
	(Reserved : for FRONT FEEDER)	OFF	Blink		
471	CHECK STAPLER CARTRIDGE 471:STAPLER CARTRIDGE MISSING	OFF	Blink	The stapler cartridge of Finisher unit is removed	
472	CHECK PUNCH CHIP BOX 472:PUNCH CHIP BOX MISSING	OFF	Blink	The punch chip box of Finisher unit is removed	
473	INSTALL FINISHER 473:FINISHER IS REMOVED	OFF	Blink	The finisher unit is removed	
480	REMOVE THE PAPER 480:STACKER FULL	OFF	Blink	Stacker-full is occurring in the upper part of the printer.	
481	REMOVE THE PAPER 481:FINISHER STACKER FULL	OFF	Blink	Stacker-full in the finisher is occurring.	
482	REMOVE THE PAPER 482:FINISHER STACKER FULL	OFF	Blink	Stacker-full in the finisher is occurring.	
490	LOAD mmmmmmmmm 490:MPTRAY EMPTY	OFF	Blink	Printing request is issued to the empty tray. Load mmmmmmmmm paper. (It takes a while until the status disappears after you have closed the tray and the lever lifted.)  mmmmmmmmmm : Paper Size (A4 ,,B5, A6 )	
491	LOAD mmmmmmmmm 491:TRAY1 EMPTY	OFF	Blink		
492	LOAD mmmmmmmmm 492:TRAY2 EMPTY	OFF	Blink		
493	LOAD mmmmmmmmm 493:TRAY3 EMPTY	OFF	Blink		
494	LOAD mmmmmmmmm 494:TRAY4 EMPTY	OFF	Blink		
495	LOAD mmmmmmmmm 495:TRAY5 EMPTY	OFF	Blink		
499 **	(Reserved : for FRONT FEEDER)	OFF	Blink		
500	SET mmmmmm ON MPTRAY AND PUSH ON-LINE SWITCH	Light	OFF	Manual paper feed is required. Manually insert the paper shown by mmmmm. mmmmmmmmm :Paper Size (A4 ,,B5, A6 )	

Err Code	LCD Messages	LED Ready	LED Atten	Description	Comments
520	CHECK PAPER CASSETTE 520:TRAY1 LIFT UP ERROR	OFF	Blink	Print request was made to Tray1~5, to which Tray Lift Up Error has occurred. Lift Up Retry will take place when the tray is removed and put back in. (PX713 only)	
521	CHECK PAPER CASSETTE 521:TRAY2 LIFT UP ERROR	OFF	Blink		
522	CHECK PAPER CASSETTE 522:TRAY3 LIFT UP ERROR	OFF	Blink		
523	CHECK PAPER CASSETTE 523:TRAY4 LIFT UP ERROR	OFF	Blink		
524	CHECK PAPER CASSETTE 524:TRAY5 LIFT UP ERROR	OFF	Blink		
530	REMOVE EXCESS PAPER 530:TRAY1 OVERFILLED	OFF	Blink	Print request was made to Tray 1~5, which has been detected to have too much paper. This status will be cleared when excess paper is removed from that tray and the tray is put back in. (PX713 only)	
531	REMOVE EXCESS PAPER 531:TRAY2 OVERFILLED	OFF	Blink		
532	REMOVE EXCESS PAPER 532:TRAY3 OVERFILLED	OFF	Blink		
533	REMOVE EXCESS PAPER 533:TRAY4 OVERFILLED	OFF	Blink		
534	REMOVE EXCESS PAPER 534:TRAY5 OVERFILLED	OFF	Blink		



2. C7100/7300/7350/9300/9500 Series (Error messages : Related to Color, Media Detect)  
(Caution) \* : Raise in the factory mode only.

Err Code	LCD Messages	LED Ready	LED Atten	Description	Comments
	— COLOR ADJUSTING	Varies	Varies	Executing Auto Color Adjusting	
	— DENSITY ADJUSTING	Varies	Varies	Executing Auto Density Adjustment	
	— MEDIA WEIGHT DETECTING	Varies	Varies	Detecting media weight.	
	— YELLOW TONER SENSOR ERROR	Varies	Light	Something is wrong with the toner sensor. When the Engine setting is Shipping mode, displayed in a combination of other message in the first line. If the engine setting is Factory mode, error display appears as mentioned later	
	— MAGENTA TONER SENSOR ERROR	Varies	Light		
	— CYAN TONER SENSOR ERROR	Varies	Light		
	— BLACK TONER SENSOR ERROR	Varies	Light		
	— NON PAPER SENSE ERROR	Varies	Light	A Sensor output at Paper Empty is outside the spec. Prints according to the Media Weight MEDIUM when this error occurs	
	— PAPER SENSE ERROR	Varies	Light	The difference in Sensor outputs is outside the spec. (The weight is beyond the recognizable limits.) At Error, Prints according to the Media Weight MEDIUM	
*	BELT REFLEX ERROR	Varies	Light	Belt Reflex Check Error.Error that does not occur at user level.Displayed only in FactoryMode.	
*	DENSITY SHUTTER ERROR2	Varies	Light	Density Adjustment Shutter Error 2.Error that does not occur at user level.Displayed only in FactoryMode.	
*	DENSITY SHUTTER ERROR1	Varies	Light	Density Adjustment Shutter Error 1.Error that does not occur at user level.Displayed only in FactoryMode.	
*	DENSITY COLOR CALIBRATION ERROR	Varies	Light	Density Adjustment Color Calibration Error.Error that does not occur at user level.Displayed only in FactoryMode.	

Err Code	LCD Messages	LED Ready	LED Atten	Description	Comments
*	DENSITY COLOR SENSOR ERROR	Varies	Light	Density Adjustment Color Sensor Error.Error that does not occur at user level.Displayed only in FactoryMode.	
*	DENSITY BLACK CALIBRATION ERROR	Varies	Light	Density Adjustment Black Calibration Error.Error that does not occur at user level.Displayed only in FactoryMode.	
*	DENSITY BLACK SENSOR ERROR	Varies	Light	Density Adjustment Black Sensor Error.Error that does not occur at user level.Displayed only in FactoryMode.	
*	—YELLOW IMAGE DRUM SMEAR ERROR	Varies	Light	Density Adjustment C/M/Y/K ID ERROR 2. Smear due to the ID failure.	
*	—MAGENTA IMAGE DRUM SMEAR ERROR	Varies	Light		
*	—CYAN IMAGE DRUM SMEAR ERROR	Varies	Light		
*	—BLACK IMAGE DRUM SMEAR ERROR	Varies	Light		
*	—YELLOW LOW DENSITY ERROR	Varies	Light	Density Adjustment C/M/Y/K ID ERROR. LED out of focus is assumed.	
*	—MAGENTA LOW DENSITY ERROR	Varies	Light		
*	—CYAN LOW DENSITY ERROR	Varies	Light		
*	—BLACK LOW DENSITY ERROR	Varies	Light		
*	REGISTRATION ERROR1	Varies	Light	Registration Error.This is not user-level error.	
*	SENSOR CALIBRATION ERROR	Varies	Light	Sensor Calibration Error.This is not user-level error.	
*	REGISTRATION ERROR2	Varies	Light	Gamma error(Yellow) This is not user-level error.	
*	REGISTRATION ERROR3	Varies	Light	Gamma error(Magenta) This is not user-level error.	
*	REGISTRATION ERROR4	Varies	Light	Gamma error(Cyan) This is not user-level error.	
*	REGISTRATION ERROR5	Varies	Light	Gamma error(Black) This is not user-level error.	
*	REGISTRATION SENSOR ERROR2	Varies	Light	Registration Sensor Error(Yellow) This is not user-level error.	

Err Code	LCD Messages	LED Ready	LED Atten	Description	Comments
*	REGISTRATION SENSOR ERROR3	Varies	Light	Registration Sensor Error(Magenta) This is not user-level error.	
*	REGISTRATION SENSOR ERROR4	Varies	Light	Registration Sensor Error(Cyan) This is not user-level error.	
*	REGISTRATION SENSOR ERROR5	Varies	Light	Registration Sensor Error(Black) This is not user-level error.	
	PRESS ONLINE SW COULD NOT STAPLE/PUNCH.TOO THICK PAPER	Varies	Varies	Staple/Punch could not be executed because the media was too thick. This appears when the media too thick to be stapled/punched has been detected. Detection of Transparency falls under this category. Pressing the ONLINE key will clear the message. (R	
	PRESS ONLINE SW COULD NOT DUPLEX. TOO THICK PAPER	Varies	Varies	Could not perform Duplex printing because the paper is too thick. Displays when paper is detected to be too thick for Duplex printing. The message will disappear when the ONLINE key is pressed.	

## 3. C7100/7300/7350/9300/9500 Series (Warning messages : Related to usage, media)

Err Code	LCD Messages	LED Ready	LED Atten	Description	Comments
	— tttt NEAR END	Varies	Varies	The paper in the selected tray is near end.	
	— YELLOW TONER LOW	Varies	Light	Toner amount is low. Displayed in a combination of other message in the first line. In case of MENU hLOW TONER=STOP, h ATTENTION LED blinks and the printer shifts to OFF Line. When ON-LINE switch is pressed, printing can continue until TONER EMPTY.	
	— MAGENTA TONER LOW	Varies	Light		
	— CYAN TONER LOW	Varies	Light		
	— BLACK TONER LOW	Varies	Light		
	— YELLOW DRUM NEAR LIFE	Varies	Light	The life of the drum (warning). Displayed in a combination of other message in the first line. The printer stops at the point when it reaches the drum life (Shifts to error, OFF-LINE.)	
	— MAGENTA DRUM NEAR LIFE	Varies	Light		
	— CYAN DRUM NEAR LIFE	Varies	Light		
	— BLACK DRUM NEAR LIFE	Varies	Light		
	— FUSER UNIT NEAR LIFE	Varies	Light	Notifies the fuser unit is near its life.	
	— BELT UNIT NEAR LIFE	Varies	Light	Notifies the belt unit is near its life. This is a warning; thus, printing will not stop.	
	— CHANGE FUSER UNIT	Varies	Light	Notifies the life of the fuser unit (warning). Displayed in a combination of other message in the first line. Warning only (No Life error)	
	— tttt EMPTY	Varies	Varies	tttt: The tray is empty. Treated as Warning until printing to the empty tray is designated.	tttt:TRAY1~5,MPTRAY
	— tttt LIFT UP ERROR	Varies	Varies	Lift Up Error has occurred to ttttt Tray. That tray is treated "Paper Empty" as a result, and printing from that tray becomes disabled. (This sometimes occurs only to PX713.)	tttt:TRAY1~5
	— tttt OVERFILLED	Varies	Varies	Displays that there is too much paper in Tray ttttt. This is a warning; thus, printing will not stop.(This sometimes occurs only to PX713.)	tttt:TRAY1~5

## 4. C7100/7300/7350/9300/9500 Series (Warning messages : Job Account)

Err Code	LCD Messages	LED Ready	LED Atten	Description	Comments
	FILE ACCESSING	Varies	Varies	Accessing the File System (HDD/FLASH) on the CU board.	
	CANCELLING(USER DENIED)	Blink	Varies	Job cancellation due to no print permit. (Related to JobAccount)1. A job received from a user who is denied printing.2. A color job received from a user who is denied color printing.	
	CANCELLING(BUFFER FULL)	Blink	Light	Indicates that a job has been cancelled because the printer area where the logs are stored has been used up and also "Cancel job" is specified as an operation at the time of Log Full. (Related to JobAccount)	
	_INVALID ID.JOB REJECTED	Varies	Light	Notifies users that jobs have been cancelled because they are not permitted for printing. (Related to JobAccount). Stays displayed until the ON LINE key is pressed.	
	_LOG BUFFER FULL.JOB REJECTED	Varies	Light	Notifies users that jobs have been cancelled because the buffer is full. (Related to JobAccount.)Stays displayed until the ON LINE key is pressed.	

5. C7100/7300/7350/9300/9500 Series (Other Warning)  
(Caution) \* : Raise in the factory mode only.

Err Code	LCD Messages	LED Ready	LED Atten	Description	Comments
	DISK FILE SYSTEM IS FULL	Varies	Light	Disk-full is occurring. Because this is a temporary warning, it remains until the end of the job and disappears	
	DISK IS WRITE PROTECTED	Varies	Light	An attempt to write in a read-only file was done. Because this is a temporary warning, it remains until the end of the job and disappears.	
	DISK FILE OPERATION FAILED nnn	Varies	Light	Operation that does not involve a disk is available. nnn: An identifier to Error type (For details, see the Error table provided in the subsequent chapter.)	See right table
	JOB OFFSET HOME ERROR	Varies	Light	Job Offset Home Position Sensor ErrorThe Job Offset function becomes disabled, however, printing can continue.	
*	PU FLASH ERROR	Varies	Light	Error occurred while writing over the PU firmware(This does not occur at user level.)	
	COLLATE FAIL:TOO MANY PAGES	Varies	OFF	The data of MOPY is memory-full.	

In case of occurrence of Disk Operation Error, error numbers will be displayed according to individual errors as follows:

Errors	LCD Display	PJL Status Code
GENERAL ERROR	DISK FILE OPERATION FAILED 0	32000
VOLUME NOT AVAILABLE	DISK FILE OPERATION FAILED 1	32001
DISK FULL	DISK FILESYSTEM IS FULL	32002
FILE NOT FOUND	DISK FILE OPERATION FAILED 3	32003
NO FREE FILE DESCRIPTORS	DISK FILE OPERATION FAILED 4	32004
INVALID NUMBER OF BYTES	DISK FILE OPERATION FAILED 5	32005
FILE ALREADY EXISTS	DISK FILE OPERATION FAILED 6	32006
ILLEGAL NAME	DISK FILE OPERATION FAILED 7	32007
CANT DEL ROOT	DISK FILE OPERATION FAILED 8	32008
NOT FILE	DISK FILE OPERATION FAILED 9	32009
NOT DIRECTORY	DISK FILE OPERATION FAILED 10	32010
NOT SAME VOLUME	DISK FILE OPERATION FAILED 11	32011
READ ONLY	DISK FILE OPERATION FAILED 12	32012
ROOT DIR FULL	DISK FILE OPERATION FAILED 13	32013
DIR NOT EMPTY	DISK FILE OPERATION FAILED 14	32014
BAD DISK	DISK FILE OPERATION FAILED 15	32015
NO LABEL	DISK FILE OPERATION FAILED 16	32016
INVALID PARAMETER	DISK FILE OPERATION FAILED 17	32017
NO CONTIG SPACE	DISK FILE OPERATION FAILED 18	32018
CANT CHANGE ROOT	DISK FILE OPERATION FAILED 19	32019
FD OBSOLETE	DISK FILE OPERATION FAILED 20	32020
DELETED	DISK FILE OPERATION FAILED 21	32021
NO BLOCK DEVICE	DISK FILE OPERATION FAILED 22	32022
BAD SEEK	DISK FILE OPERATION FAILED 23	32023
INTERNAL ERROR	DISK FILE OPERATION FAILED 24	32024
WRITE ONLY	DISK FILE OPERATION FAILED 25	32025
WRITE PROTECTED	DISK IS WRITE PROTECTED	32026