

C711 / MPS711c

Maintenance Manual

020712B

Copyright Information

Copyright © 2007 by Oki Data. All Rights Reserved

Disclaimer

Every effort has been made to ensure that the information in this document is complete, accurate, and up-to-date. The manufacturer assumes no responsibility for the results of errors beyond its control. The manufacturer also cannot guarantee that changes in software and equipment made by other manufacturers and referred to in this guide will not affect the applicability of the information in it. Mention of software products manufactured by other companies does not necessarily constitute endorsement by the manufacturer.

While all reasonable efforts have been made to make this document as accurate and helpful as possible, we make no warranty of any kind, expressed or implied, as to the accuracy or completeness of the information contained herein.

The most up-to-date drivers and manuals are available from the web site:
<http://www.okiprintingsolutions.com>

PREFACE

This manual provides an overview of method for maintaining the C711n.

This manual is intended for maintenance staff. For more information about how to operate the C711n, please refer to User 's manual.

- Note!**
- Manual may be revised and updated at any time without notice.
 - Unexpected mistakes may exist in the manual.
OKI will not assume any responsibility whatsoever for damage to the equipment repaired/adjusted/changed by the user etc with this manual.
 - The parts used for this printer may be damaged when handling inappropriately. We strongly recommend maintaining this machine by our registration maintenance staff.
 - Please operate the machine after removing static electricity.

Index

1. Configuration	6		
1.1 System configuration	7		
1.2 The Configuration of printer.....	8		
1.3 Optional parts	9		
1.4 Specifications	10		
1.5 Specification of interface	13		
1.5.1 Specification of USB interface	13		
1.5.1.1 General of USB interface	13		
1.5.1.2 Connector and cable of USB interface.....	13		
1.5.1.3 USB interface signal	13		
1.5.2 Specification of network interface	14		
1.5.2.1 General of network interface.....	14		
1.5.2.2 Connector and cable of network interface	14		
1.5.2.3 Signal of network interface	14		
1.5.3 Specification of ACC interface	15		
1.5.4 Specification of parallel interface	16		
1.5.4.1 General of parallel interface.....	16		
1.5.4.2 Connector and cable of parallel interface	16		
1.5.4.3 Parallel interface level	16		
1.5.4.4 Signal of interface	16		
2. Operating instructions	17		
2.1 Electrophotographic processing mechanism.....	18		
2.2 Printing process.....	22		
3. Set up	33		
3.1 Notes and precautions.....	34		
3.2 Unpack method	35		
3.3 Setting method	36		
3.4 List of equipments and accessories	37		
3.5 Assembling method	38		
3.5.1 Assemble the main body of the printer	38		
3.5.2 Cable connect	44		
3.5.3 Optional part installation and confirmation.....	46		
3.6 Setting content print (Configuration).....	57		
3.7 Connecting method	58		
3.8 User used Paper confirmation	60		
4. Component replacement	61		
4.1 Precautions on component replacement.....	62		
4.2 Method of component replacement.....	64		
4.2.1 Belt unit.....	64		
4.2.2 Fuser unit	65		
4.2.3 Left side cover.....	65		
4.2.4 Right side cover	66		
4.2.5 Faceup tray	66		
4.2.6 Rear cover.....	67		
4.2.7 LED Assy/ LED Assy spring.....	67		
4.2.8 Control PCB.....	68		
4.2.9 Top cover Assy.....	69		
4.2.10 Top cover	70		
4.2.11 Control panel Assy	70		
4.2.12 Board PRG/ LCD	71		
4.2.13 Frame panel Assy.....	72		
4.2.14 Low voltage power supply/Low voltage FAN/ Hopping motor/ Fuse motor .	73		
4.2.15 Guide eject Assy/ Color regist Assy/ Board-PRY	74		
4.2.16 FAN(Fuser) / Belt motor/ High-voltage board/ Cover open switch	75		
4.2.17 MPT Assy	75		
4.2.18 Cover Assy front/ Board-RSF/MPT hopping roller/ Frame Assy separator/ Feeder Assy regist.....	76		
4.2.19 Board-PRZ/ Liftup motor/ Hopping motor//Paper end sensor/ Hopping sensor.....	77		
4.2.20 Feed roller.....	78		
4.2.21 Shaft eject Assy (FU)/ Shaft eject Assy(FD/ Eject sensor	79		
4.3 Oiling spots.....	80		
5. Maintenance Menu	91		
5.1 System maintenance menu (for maintenance engineer)	92		

5.2	Maintenance Utilities	94	7.5.3	Troubleshooting the abnormal images	182
5.3	Maintenance menu functions.....	96	7.5.4	Network troubleshooting	189
5.3.1	Self-diagnostic mode	96	7.5.4.1	Connection error occurs with the Web browser	189
5.3.1.1	Operation panel	96	7.5.4.2	Print operation is not possible.....	195
5.3.1.2	Ordinary self-diagnostic mode (level 1)	98	7.5.4.3	Cannot create Certificate	196
5.3.1.3	Switch scan test.....	99	7.5.4.4	Installation of Certificate is not possible.....	196
5.3.1.4	Motor clutch test	101	7.5.4.5	Other questionnaires	198
5.3.1.5	Test print	103	7.5.4.7	Network function restrictions on Sleep mode	201
5.3.1.6	Color registration correction test.....	107	7.6	Fuse check	202
5.3.1.7	Density correction test	108	7.7	Paper cassette switches versus Paper size correspondence table	203
5.3.1.8	Consumable item counter display.....	110	8. Connection diagrams.....	204	
5.3.1.9	Number of print copies counter display	111	8.1	Resistance value check.....	205
5.3.1.10	Switching between the Factory mode and the Shipping mode.....	111	8.2	Parts location.....	209
5.3.1.11	Self-diagnostic function setting.....	112	8.3	F/W version number	218
5.3.1.12	LED head serial number display	113	8.3.1	ROM control number	218
5.3.1.13	NVRAM parameter setting	113	8.3.2	ROM version check and display	219
5.3.2	Various prints with the printer as a standalone unit	113	8.3.3	PCB Maintenance Indication Stamp.....	219
5.3.3	Functions of keys at power on	114			
5.4	Setups upon completion of part replacement.....	115			
5.4.1	Precautions when replacing the CU/PU board	115			
5.5	Density control manual setting	117			
5.6	Printer boot menu list.....	118			
6. Periodic Maintenance	120				
6.1	Cleaning	121			
6.2	How to clean the LED lens array	122			
6.3	How to clean the pickup roller	124			
6.4	How to clean inside of printer	125			
7. Troubleshooting and repair procedure	127				
7.1	Before starting the repair work	128			
7.2	Confirmation items before taking corrective action against abnormalities	128			
7.3	Precautions when taking corrective action against abnormality	128			
7.4	Preparation for troubleshooting	128			
7.5	Troubleshooting method	129			
7.5.1	LCD message list.....	129			
7.5.2	Preparation for troubleshooting.....	150			

1. Configuration

1.1 System configuration	7
1.2 The Configuration of printer.....	8
1.3 Optional parts	9
1.4 Specifications	10
1.5 Specification of interface.....	13

1.1 System configuration

Figure 1-1 represents the system configuration of the printer.

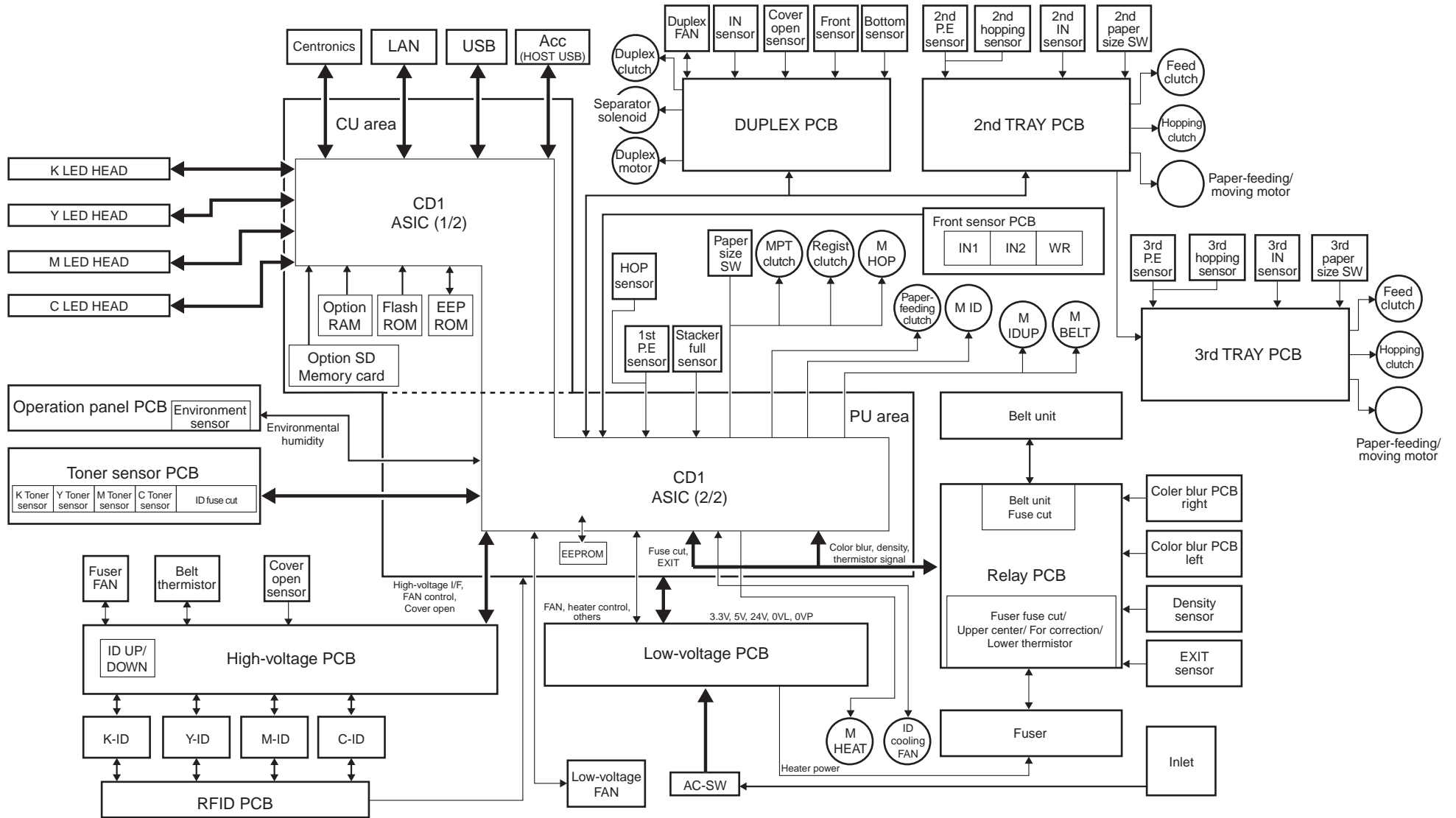

Fig1-1

1.2 The Configuration of printer

The parts in the C711n are shown as below.

- Electrophotography process mechanism
- Paper feed path
- Control part (CU part/ PU part)
- Operator panel
- Power part (High-voltage part/low-voltage part)

The Configuration of the printer is shown in Fig 1-2.

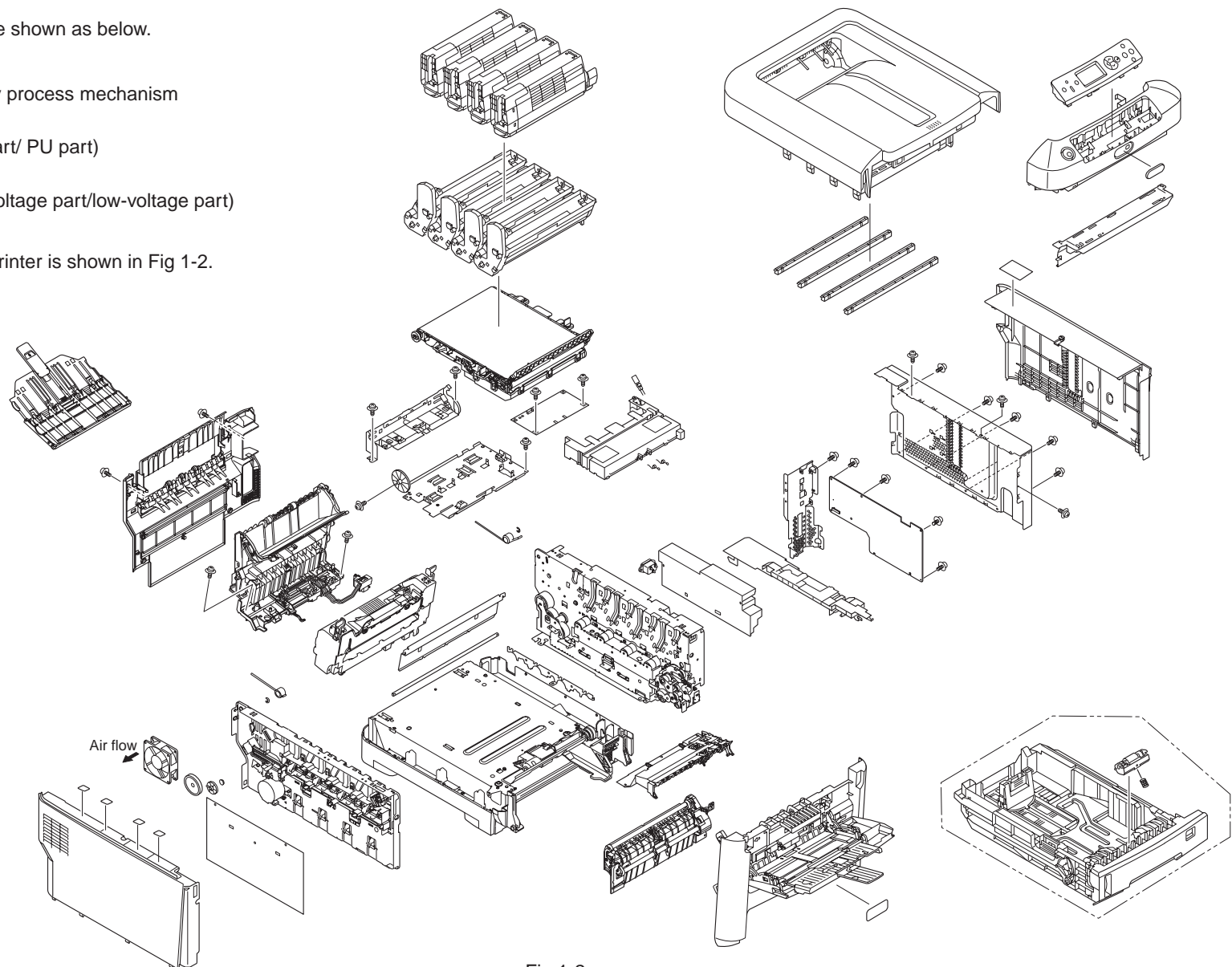
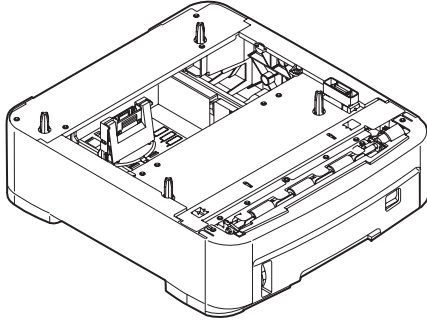

Fig 1-2

1.3 Optional parts

The optional parts for this printer are shown as below.

(1) Optional tray(second tray/ third tray)



(2) Duplex Unit

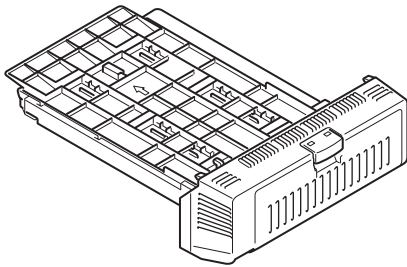

(3) Optional memory

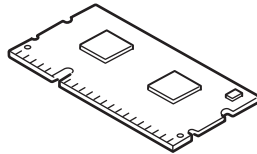

(4) SD memory card

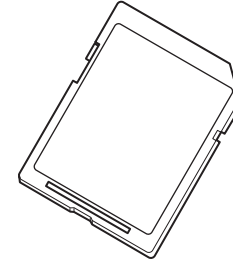

1.4 Specifications

Division	Item	
Dimension	Width	435mm
	Depth	536mm
	Height	389mm
	Weight	About 28kg
Width of print	Width of print	Letter size, vertical
Print speed	Engine speed (A4)	34PPM(Color) 36PPM(Mono)
Print start	First print time	8sec(mono), 9sec(color) (A4)
	Warmup time	60sec
	Low noise mode	Not applicable
Resolution	LED head	600dpi
	Maximum input resolution	600×1200dpi
	Output resolution	True 600×1200dpi True 600×600dpi
	Step	4 step 600×600dpi
	Econo mode	Save toner by recreasing brightness
CPU	Core	PowerPC464
	I-cash, / D-cash	L1-I=32KB L1-D=32KB
	Clock	532MHz
	Bus width	32bit
RAM	Resident	256MB
ROM	Program+font	64MB

Division	Item	
Power consumption	Input power supply	(120V)110~127VAC±10%, (230V)220~240VAC±10%
	Power save mode	Less than 15W
	Sleep mode	About 0.9W (less than 1W) at AC120V About 1W (less than 1.2W) at AC230V
	Idle	100W (Average)
	Usual operation	600W (It differs from operating environment)
	Peak	1300W
Operating environment (Temperature)	During operating	10°C~32°C, 17°C~27°C (Temperature requirement for full-color print)
	During non-operating	0°C~43°C, power off
	During keeping (for a year at most)	-10°C~43°C, with drum and toner
	During transferring (for a month at most)	-29°C~50°C, with drum, without toner
	During transferring (for a month at most)	-29°C~50°C, with drum, without toner
Operating environment (Humidity)	During operating	20%~80%, 50%~70% (Humidity requirement for full-color print) The highest wet bulb temperature is 25°C
	During non-operating	10%~90%, The highest wet bulb temperature is 26.8°C, power off
	During keeping	10%~90%, The highest wet bulb temperature is 35°C
	During transferring	10%~90%, The highest wet bulb temperature is 40°C

Division	Item	
Operation life	Printer operation life	600,000 pieces A4 transvers direction, 5years
	Print duty (M=L/12, A=L/12/5)	Max 60,000 pages / month Average 6,000 pages/ month
	MTBF (2.3% duty)	Not applicable
	MPBF	50,000 pages
	MTTR	Within 20 minutes
	Toner operation life (ISO/IEC19798)	Mounting toner: 4,000 pages(black), 4,000 pages(color)
		Standard: 11,000 pages(black), 11,500 pages(color) For the first new drum: about 10,200 pages(black), 10,700 pages(color)
	Image drum operation life	20,000 pages (when 3 pages /job) 12,000 pages (when 1 page/job) 27,000 pages (when continuously print) Drum count all reset
Transcribing belt operation life	60,000 pages (A4 transverse size, when 3 pages /job) count auto reset	
Fuser operation life	60,000 pages (A4 size) count auto reset	
Operation sound	During operation	54dBA (ISO 7779 front) (without option unit)
	During standby	37dB(ISO 7779 front)
	Power save mode	Background level

Division	Item	
Paper handling	Paper stack capacity (1st tray)	Legal /Universal cassette 530 pieces (70kg)
	Paper stack capacity (optional tray)	Legal /Universal cassette 530 pieces (70kg)
	Paper stack capacity (Manual/auto)	Standard multipurpose tray or 100 pieces (70kg), or 10 pieces of envelop
	Paper rejection	350 pieces (70kg), facedown/ 100 pieces (70kg), faceup tray
	Duplex	Standard/ Option
	Paper size	A4, A5, B5, A6*, letter, legal(13/13.5/14), Executive, post card**, return post card**, custom***, envelope , Index card 3x5in, Photo size 4x6 5x7in * : The paper of A6 cannot be used in tray 1, 2, 3 **: The post card, return post card and envelope can be used in MPT only ***: As for custom, the available size can be adjusted by using different tray. The length is up to 1321mm.
Minimum paper size	Tray 1	A5
	Tray 2(option)	A5
	Tray 3(option)	A5
	MPT	Postcard
Thickness of paper	Tray 1	64g/m ² ~220g/m ²
	Tray 2(option)	64g/m ² ~220g/m ²
	Tray 3(option)	64g/m ² ~220g/m ²
	MPT	64g/m ² ~250g/m ²
Control panel	LCD	Resolution 128x64 dot graphic panel Paper size is not displayed
	LED (color)	2 (Greenx1, dark umbarx1)
	Switch	8

Division	Item	
Status switch/ sensor	Paper out	Have
	Paper low	None
	Toner low	Have (Y, M, C, K)
	Cover open	Have
	Temperature of fuser	Have
	Paper size	Have (Manual setting)
	Stacker full	Have
Communication interface	Standard (On the PCB)	<ul style="list-style-type: none"> • Hi-Speed USB • Ethernet • Centronics
	Input and output switch	Auto
Emulation	Standard	PCL(PCL5c, HP-GL) / PCL XL3.0
		PostScript3 (Clone)
		XPS
	Emulation switch	Auto
Font	Bitmap Typeface	Have
	Scalable font	Have
	Rasterizer	Have
	Barcode	Have
	OCR	Have
	Japanese PCL font	Have
	Japanese PS font	Have

Division	Item	
Option (can be removed)	RAM	256/512MB DIMM
	SD memory card It is possible to be installed by user	16GB or 32GB SD memory card
	Tray mechanism	2nd tray mechanism, 3rd tray mechanism
	Cassette	Universal (530 pieces)
	Double print unit	Standard/ Option
	Others	Not available
	Others	USB-IF logo
Windows logo		Have
UPS operation		The operation with UPS(Uninterruptible Power Supplies) is not guaranteed. Please do not use the UPS.

1.5 Specification of interface

1.5.1 Specification of USB interface

1.5.1.1 General of USB interface

- (1) Spec.
USB (Support Hi speed USB)
- (2) Transmission mode
Full speed (Maximum 12Mbps 0.25%)
High speed(Maximum 480Mbps 0.05%)
- (3) Power control
Self power device

1.5.1.2 Connector and cable of USB interface

- (1) Connector
 - Printer side: B Receptacle (female)
Up-stream port
(UBR24-4K5C00 (made by ACON)) Equivalent goods

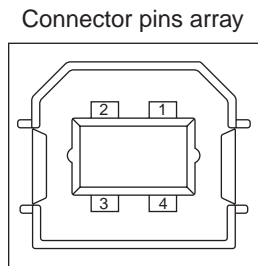

- Cable side: B plug(male)

(2) Cable

The length of the cable: the cable of less than 5m with USB 2.0 spec.
(Less than 2m is recommended)
(Please use the shielded wire for the cable.)

1.5.1.3 USB interface signal

	Signal name	Function
1	Vbus	Power (+5V)
2	D-	For data transmission
3	D+	For data transmission
4	GND	Signal Ground
Shell	Shield	

1.5.2 Specification of network interface

1.5.2.1 General of network interface

Spec.

Network Protocol

TCP/IP sepc. Network layer
ARP, IP, ICMP, IPv6, IPSec

Transfer layer

TCP, UDP

Application layer

LPR, Port9100, FTP, HTTP, HTTPS, IPP, SNMPv1/v3, TELENET, DHCP/BOOTP, DNS, DDNS, WINS, UPmP, Bonjour, SNTP, SMTP, POP, Windows Rally (WSD Print, LLTD).

NBT/NetBEUI: SMB, NetBIOS, NetBIOS over TCP

Netware: Remote printer mode(Maximum 8 print sever)

Print sever mode (Maximum 8 files sever: 32 queue)

For encrypted password (when it is print sever mode)

NetWare6J/5J/4.1J (NDS, bindery)

SNMP

EtherTalk: ELAP, AARP, DDP, AEP, NBP, ZIP, RTMP, ATP, PAP

IEEE802.1X: EAP-TLS, PEAP

1.5.2.2 Connector and cable of network interface

(1) Connector

100BASE-TX/10 BASE-T (Auto switch, cannot be used simultaneously)

Connector pins array

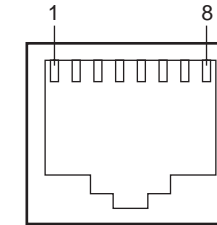

(2) Cable

Non-shield twisted-pair cable with RJ-45 connector

(Category 5 is recommended)

1.5.2.3 Signal of network interface

Pin No.	Signal name	Direction	Function
1	TXD+	FROM PRINTER	Transmission data +
2	TXD-	FROM PRINTER	Transmission data -
3	RXD+	TO PRINTER	Receive data +
4	-	-	Not use
5	-	-	Not use
6	RXD-	TO PRINTER	Receive data -
7	-	-	Not use
8	-	-	Not use

1.5.3 Specification of ACC interface

- 1) Connector
 Printer side: USB A receptacle (female)
 Downstream port
 DUSB-ARA42-T11A (DDK product) or equivalent
 Cable side: USB A plug (male)
- 2) Cable
 Hi-Speed USB2.0
 Cable length: 2.0 m max.
 (Use a shielded cable.)
Note! A cable doesn't come with the printer.

3) Interface signals

Contact No.	Signal Name	Function
1	VBUS	Power supply(+5V)
2	D-	For data transfer
3	D+	For data transfer
4	GND	Signal ground Shell
Shell	Shield	Shield

4) Conector pin arrangement

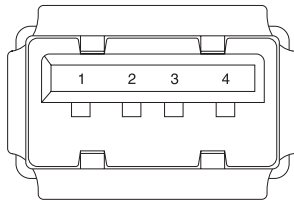

- 5) Connecting device
 ODC-authorized card reader/writer
 Maximum current supplied to the printer: 100 mA

1.5.4 Specification of parallel interface

1.5.4.1 General of parallel interface

Spec.

IEEE1284-1994 conforming parallel interface

Item	Content
Related mode	Compatible mode, nibble mode, and ECP mode
Data bit length	Compatible: 8, nibble: 4, ECP: 9bit

1.5.4.2 Connector and cable of parallel interface

(1) Connector

Printer side : 36-Pole connector (Female)

57LE-40360-12(D56) (made by DDK) equivalent goods

Cable side : 36-Pole connector (male)

57FE-30360-20N(D8) (made by DDK) equivalent goods

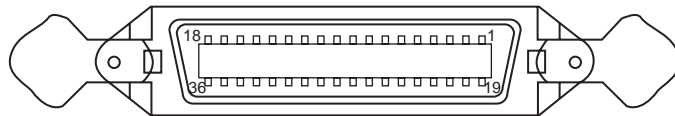

Pin layout seen from interface cable side

(2) Cable

IEEE1284-1994 cable of less than 1.8m is used.

(For avoiding noise interference, please use shielded cable with the twisted-pair wire.)

1.5.4.3 Parallel interface level

Low level 0.0V~+0.8V

High level +2.4V~+5.0V

1.5.4.4 Signal of interface

Pin NO.	Name of signal	Direction	Function
1	nStrobe (HostClk)	TO PRINTER	It is a pulse to read data. Data is read by posterior end.
2~9	DATA 1~DATA 8	Bi-direction	It is parallel data of 8 bits. The high level is "1", and the Low level is "0".
10	nAck(PtrClk)	FROM PRINTER	It is a signal that shows the data reception completion.
11	Busy(PtrBusy)	FROM PRINTER	It is a signal that shows if the printer is receiving the data. Data cannot be received when it is at the high level.
12	PError (AckDataReq)	FROM PRINTER	The paper error is shown when it is at the high level.
13	Select(Xflag)	FROM PRINTER	When parallel interface is effective, it is always in high-level state.
14	nAutoFd(HostBusy)	TO PRINTER	It is used by the bidirectional communication.
15	-	-	Not use
16	GND	-	Signal ground
17	FG	-	Chassis ground
18	+5V	FROM PRINTER	It cannot supply power outside.
19~30	GND	-	Signal ground
31	nInit(nInIt)	TO PRINTER	The printer is initialized with the low level.
32	nFault(nDataAvail)	FROM PRINTER	When the printer is in alarm state, it becomes low level.
33	GND	-	Signal ground
34	-	-	Not use
35	HILEVEL	FROM PRINTER	It is pulled up to +5V at 3.3KΩ in the printer.
36	nSelectIn (IEEE1284 active)	TO PRINTER	It is used by bidirectional communication. It must be low level when it is in compatible mode.

- Notes!**
- The signal name showed in the bracket is a signal name in nibble mode.
 - It only describes the function in compatible mode.
 - The nibble mode of IEEEstd1284-1994 regulated by Institute of Electrical and Electronics Engineers is supported. Using the computer and the cable unsupported this standard may lead to unexpected operation.

2. Operating instructions

2.1 Electrophotographic processing mechanism.....	18
2.2 Printing process.....	22

2.1 Electrophotographic processing mechanism

(1) Electrophotographic processing

The general of Electrophotography process is described as below.

1. Charging

The voltage is impressed to CH roller, and the surface of OPC drum is electrified.

2. Exposure

LED head irradiates light to the image signal on the surface of the electrified OPC drum. The electricity of the irradiated part on the surface of the OPC drum is attenuated by changing in light intensity, the electrostatic latent image is formed on the surface of the OPC drum.

3. Development

The electrified toner adheres to the electrostatic latent image of the OPC drum by electrostatic force, and the image is developed on the surface of the OPC drum.

4. Transfer

The paper is overlapped on the surface of the OPC drum, and the electricity is generated on the back of the paper by transfer roller, the toner image is transcribed to the paper.

5. Fusing

Heat and pressure are applied to the toner image on the paper in order to make it fusing.

6. Drum cleaning

The drum cleaning blade removes the toner left on the OPC drum after transfer.

7. Electricity removal

The electric potential left on the drum is removed.

8. Belt cleaning

The belt cleaning blade removes the toner left on the belt.

(2) Charging

The voltage is impressed to the charging roller in contact with the surface of OPC drum, and the surface of OPC drum is charged.

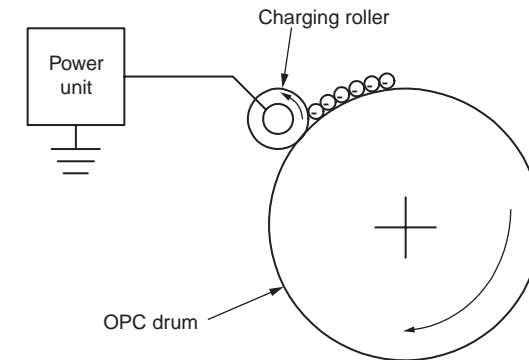

(3) Exposure

The light generated from LED head is irradiated onto the surface of the electrified OPC drum. The electricity of the irradiated part on the surface of the OPC drum is attenuated by changing in light intensity, the electrostatic latent image is formed on the surface of the OPC drum.

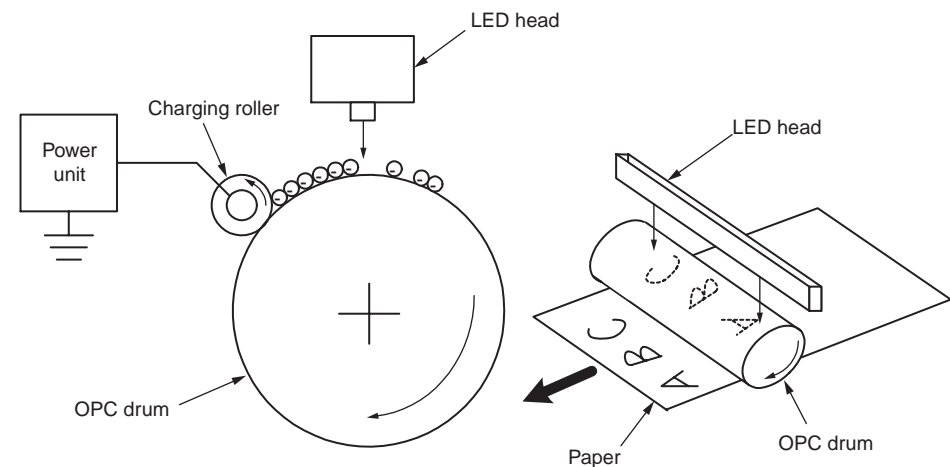

(4) Development

The toner adheres to the electrostatic latent image on the surface of the drum, and the electrostatic latent image is changed into the toner image.

1. The sponge roller makes the toner adhere to the developing roller.

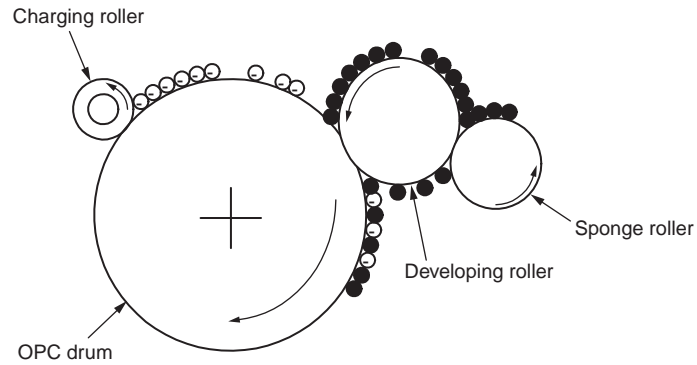

2. The electrostatic latent image on the surface of the OPC drum surface is visualized by toner.

(5) Transfer

The paper is overlapped on the surface of the OPC drum, and the electricity is generated on the back of the paper by transfer roller.

When high voltage is impressed from the power supply to the transfer roller, the electricity induced in the transfer roller is moved to the surface of the paper via contact surface, and the toner is drawn from the surface of the OPC drum to the surface of the paper.

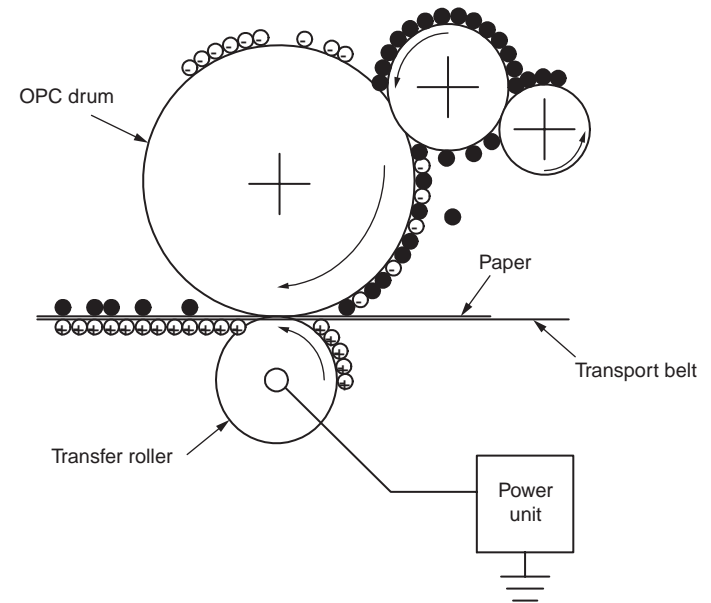

(6) Fusing

When the paper passes through the heat roller and backup roller unit, heat and pressure are applied to the toner image on the paper and the toner is fused onto the paper.

The halogen lamps of 800W and 400W are built in heat roller. The backup roller without built-in halogen lamp is heated by the heat transmission from the heat roller. The fusing temperature is controlled by the temperature detected by the thermistor that is not in contacting with the surface of the heat roller. On the other hand, the temperature detected by the thermistor rubbing the surface of backup roller is used for controlling the fusing temperature under specified conditions. Furthermore, a thermostat is used to limit the temperature rise, if the temperature rise of heat roller exceeds a set point, the thermostat would be open and the voltage supply to the heater would be cut off. The backup roller unit is pressed on the heat roller by the spring on both sides.

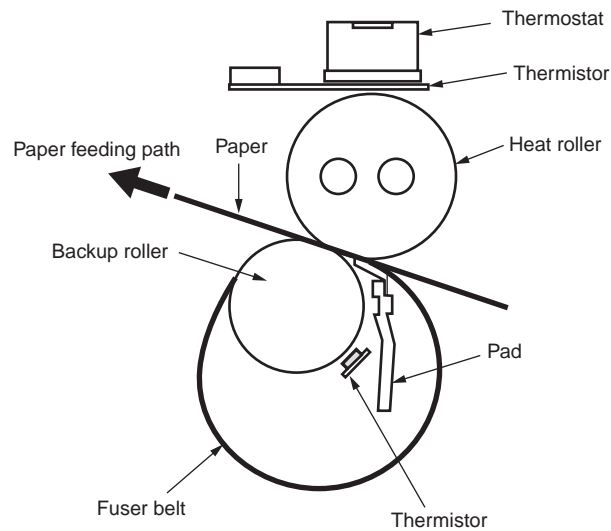

(7) Drum cleaning

The Unfused toner left on the OPC drum is cleaned up by the drum cleaning blade, and all residual toner is collected in the waste toner area of the toner cartridge.

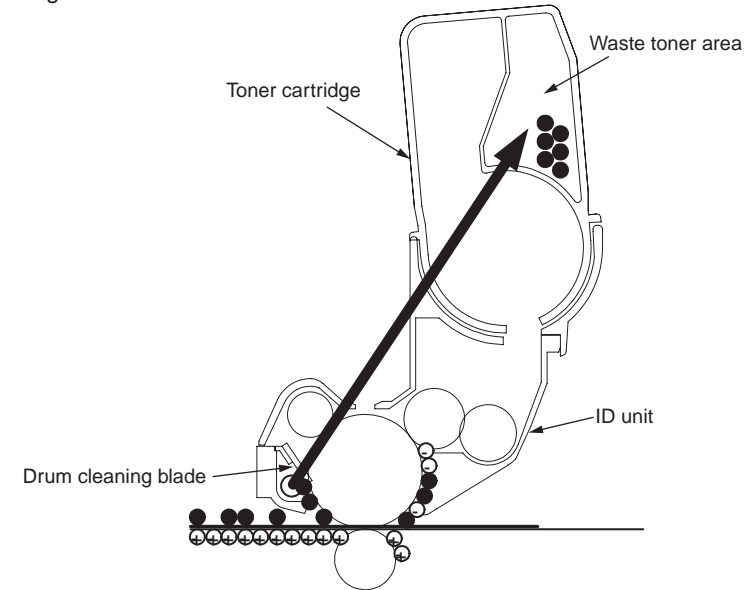

(8) Electricity removal

The electricity on the surface of the OPC drum is attenuated by irradiating the light to the surface of the OPC drum after transfer.

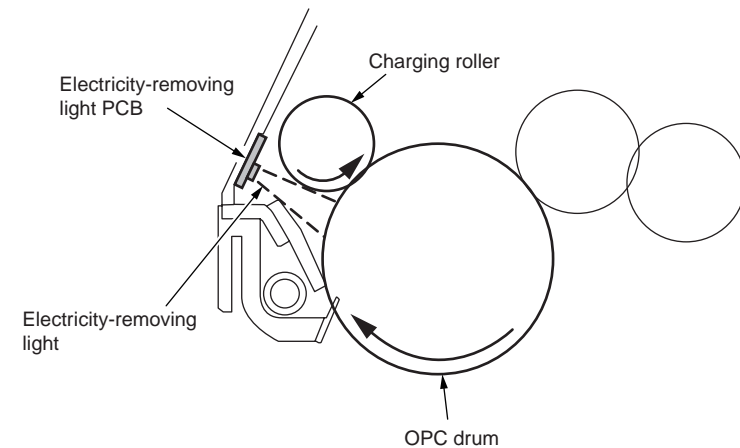

(9) Belt cleaning

The toner left on the transport belt is cleaned up by the belt cleaning blade, and all residual toner is collected in the waste toner box of the transport belt unit.

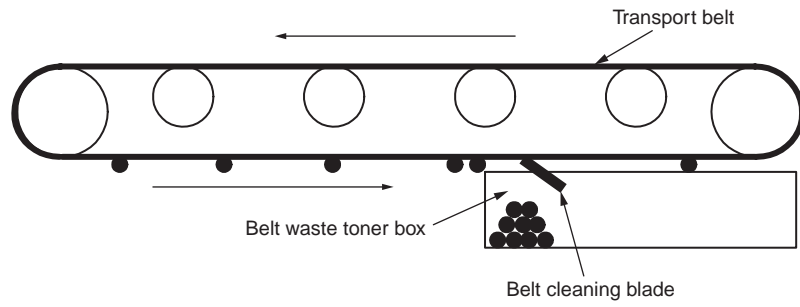

2.2 Printing process

The paper fed from tray 1 or tray 2, tray.3 is transferred by feeder roller, resister roller L, and transfer roller. It is transferred by MPT paper feed roller and resister roller U when the paper is fed from MPT. After that, the paper on the belt passes through the electrophotography process of KYMC, and sequentially the unfused toner image is generated on the paper. And then, the toner is fused by heat and pressure when it is passed through the fuse unit. After fusing, the paper is delivered to the faceup or facedown stacker by utilization of different delivery methods by opening or closing the faceup stacker.

The operation of single-sided printing is described as above. The operation of duplex printing is described as below.

As for the duplex print, the paper passed the fuse unit after initially back printing is drawn into the Duplex unit by separator DUP. The paper entered into the paper reversing path is transferred from the paper reversing path to the inside of Duplex by reverse operation of reversal roller. The paper passed over the inside of Duplex is fed from paper feed path of Duplex by the transfer roller set in the transfer path of Duplex inside, which is shared with the same paper feed path from the tray. The following operation is same as single-sided printing with paper feeding from the tray.

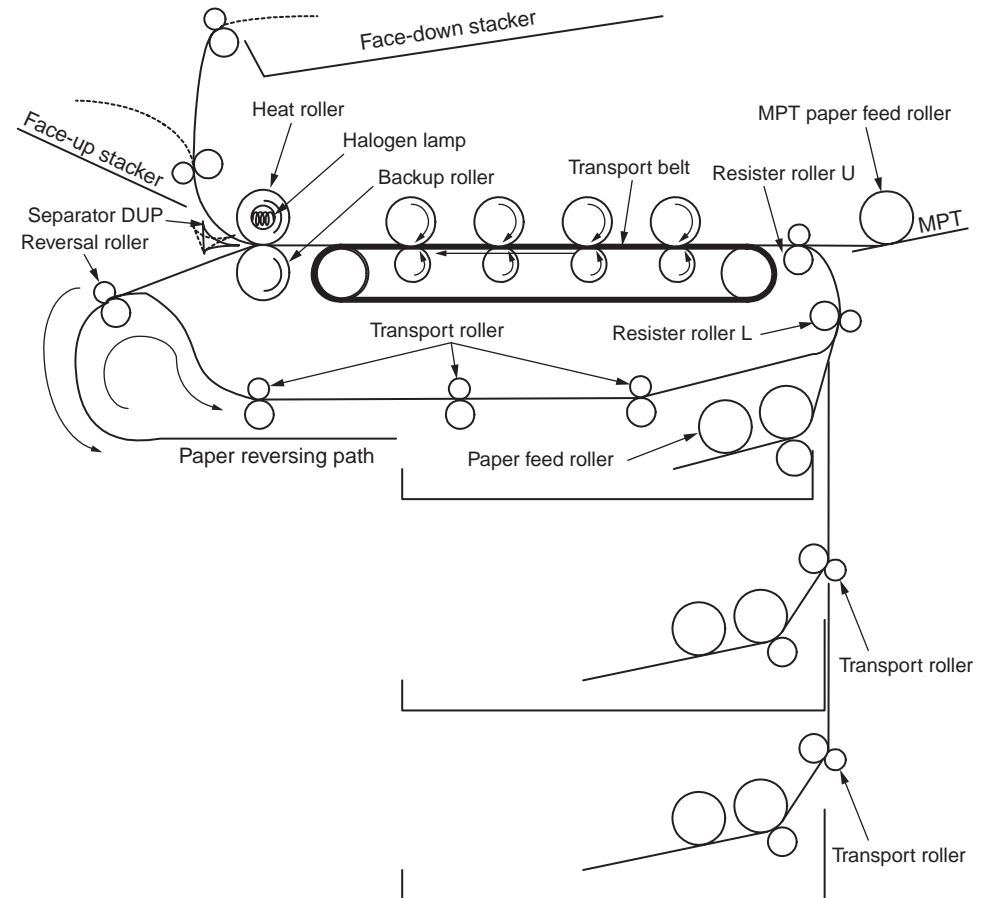

(1) Paper feeding from 1st tray

1. As figure 2-1 shows, a feed motor runs clockwise, a feed clutch engages and paper is fed (a feed roller rotates when the feed clutch engages).
2. After turning on an IN1 sensor, the paper is fed further a determined length until it touches a registration sensor L (this corrects skews of the paper).
3. As figure 2-2 shows, a registration clutch engages and the registration roller L feeds paper (the registration roller L rotates when the registration clutch engages).

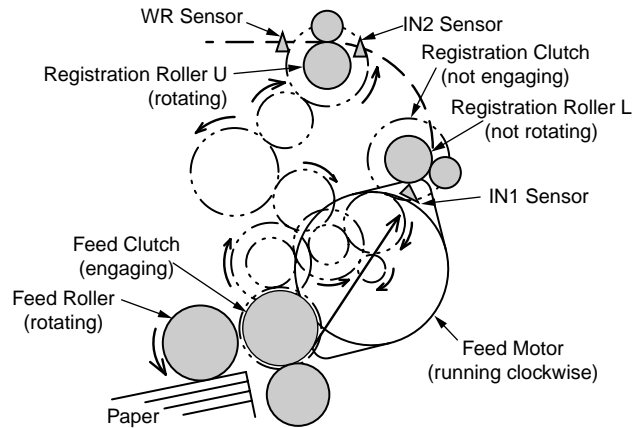

Figure 2-1

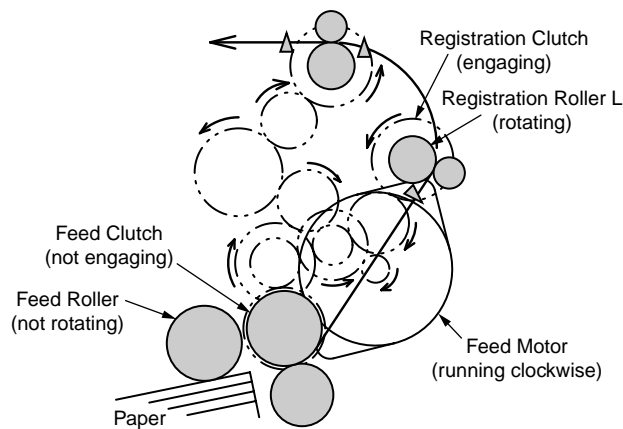

Figure 2-2

(2) Paper feeding from MPT

1. As figure 2-3 shows, a feed motor runs counterclockwise, an MPT clutch engages and paper is fed (an MPT feed roller rotates when the MPT clutch engages).
2. After turning on an IN2 sensor, the paper is fed further a determined length until it touches a registration roller U (this corrects skews of the paper).
3. As figure 2-4 shows, the feed motor runs clockwise and the registration roller U feeds the paper (the registration roller U rotates when the feed motor runs clockwise).

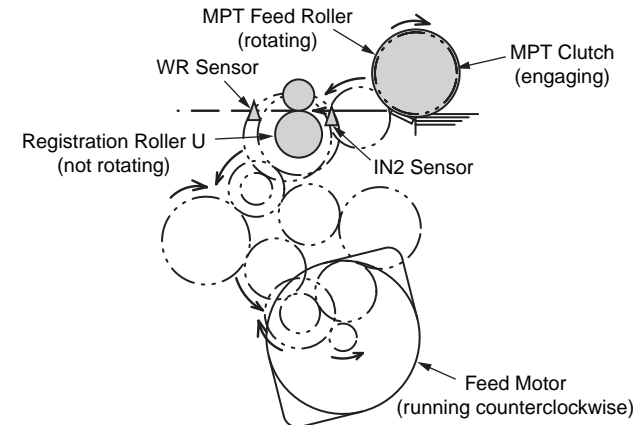

Figure 2-3

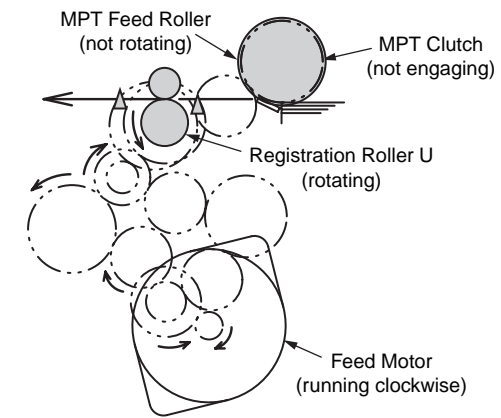

Figure 2-4

(3) Transport belt

1. When the transport belt motor is rotated in the direction of the arrow, the transport belt is driven. As for the belt unit, a transfer roller is set over under each color drum. The belt is caught and installed between the transfer roller and drum.

As for the transport belt and transfer roller, if the specified voltage is impressed, the paper on the transport belt would be delivered to the fuser unit while transcribing the toner image on each color drum.

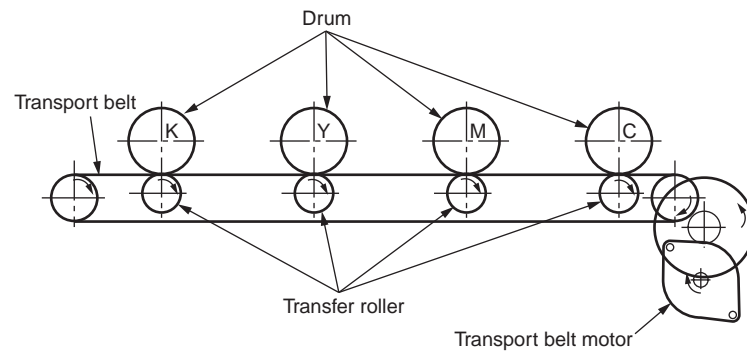

Figure 2-5

(4) Updown operation of ID unit

1. The up and down operation of the ID unit is done by driving the liftup motor.
2. Fig. 2-6 shows the operation of each ID unit when color printing. When the liftup motor is rotated (counter clockwise), the liftup link slides to left, and each ID unit is in DOWN condition as shown in Fig. 2-6. Under this condition, the color printing is available.
3. Fig. 2-7 shows the operation of each ID unit when mono printing. When the liftup motor is rotated (clockwise), the liftup link slides to right, and each ID unit (except K-ID unit) is in UP condition as shown in Fig. 2-7. Under this condition, the mono printing is available.

The operation of each ID unit when color printing

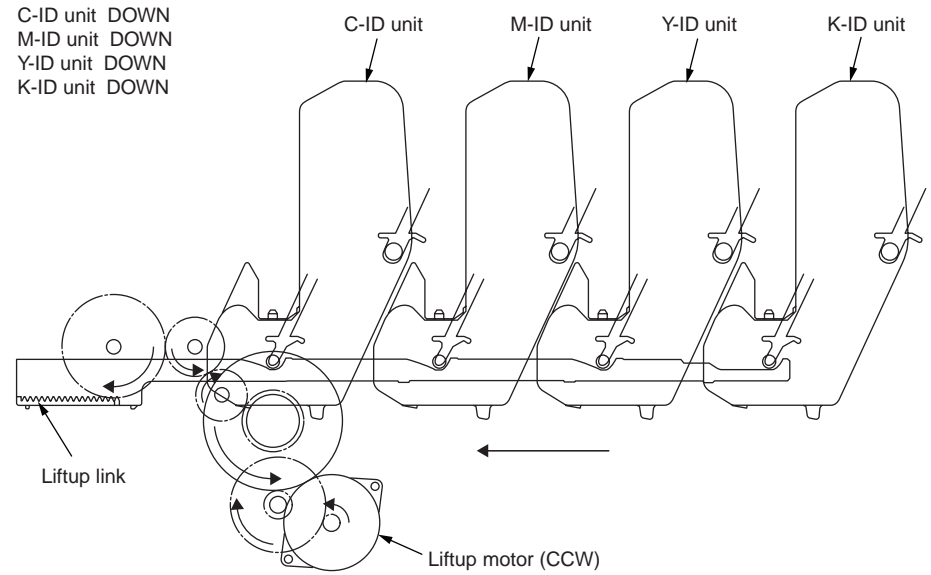

Figure 2-6

The operation of each ID unit when mono printing

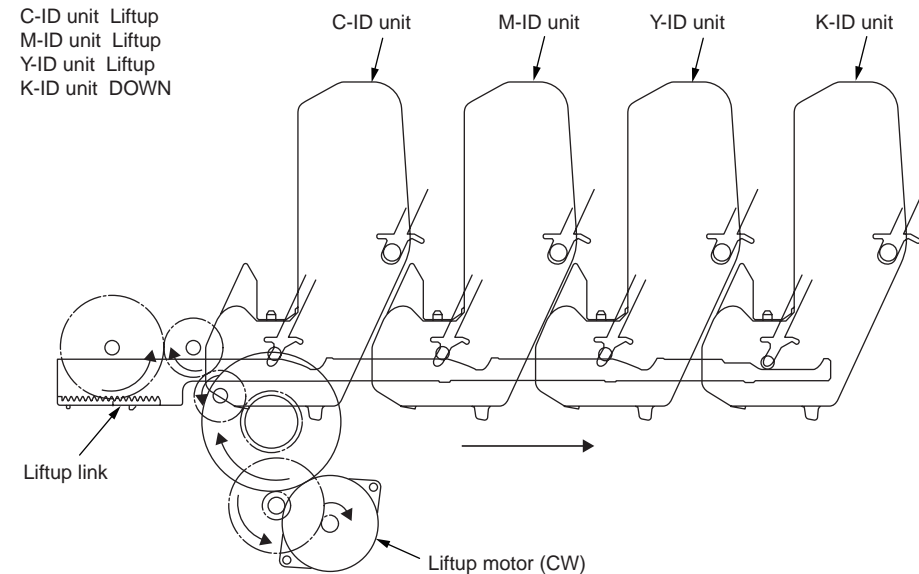

Figure 2-7

(5) Fuse unit and paper delivery

1. The fuse unit and the delivery roller are driven by the DC motor as shown in Fig. 2-8. When the fuse motor is rotated (counter clockwise), the heat roller will begin to rotate. The heat roller makes the toner image fused to the paper by heat and pressure.
2. The paper exits while the delivery roller rotates.

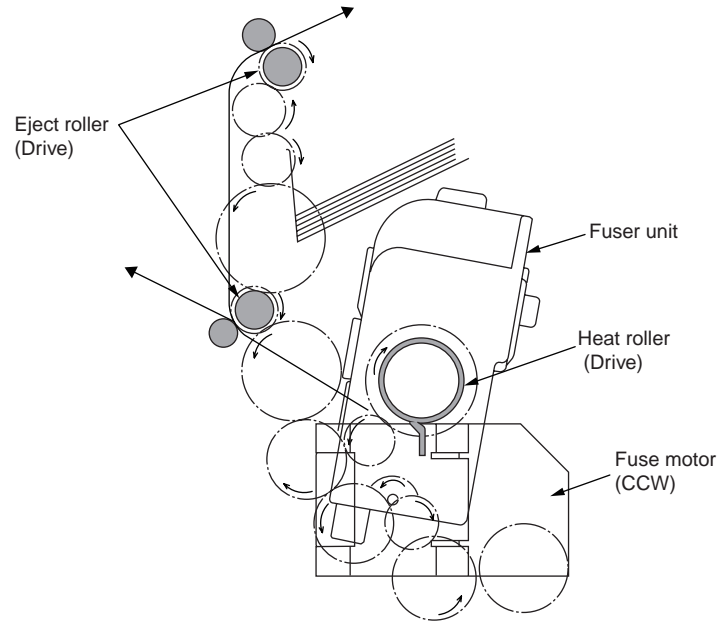

Figure 2-8

(6) Cover open operation of color blur sensor and density sensor

1. As shown in Fig. 2-9, when the fuse motor is rotated (clockwise), the cover open gear is operated and the cover of color blur sensor and density sensor is open.
2. When the fuse motor is rotated (counter clockwise) in the opposite direction, the cover open gear is moved out of engagement and the cover of color blur sensor and the density sensor is close.

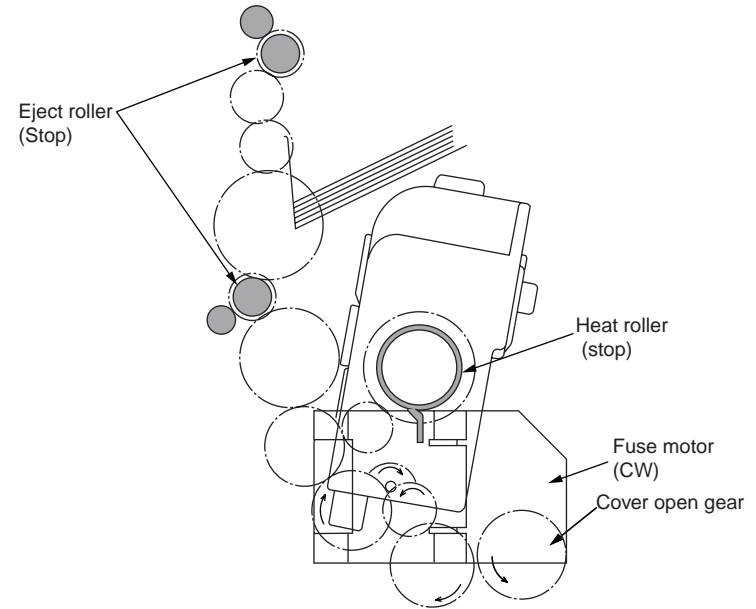

Figure 2-9

General of color blur correction

The color blur correction is operated by reading the pattern for correction printed on the belt with a sensor set in the sensor shutter under the belt unit.

The pattern is detected by this sensor, and the correction is operated.

Color blur correction auto-start timing

- When the power is on
- When the cover is closed after the cover is opened once
- When more than 400 copies are printed or when more than 6 hours have elapsed since the last print
- The Sleep mode has no color blur correction auto-start timings.

The amount of toner of the pattern, the toner left on the sensor and the open-close trouble of the shutter etc. may lead to correction error. However, as the error message may not display even if the error is occurred, it is necessary to perform the color blur correction (see 5.3.2.6) by the utilization of the self-diagnostic mode and confirm the error display.

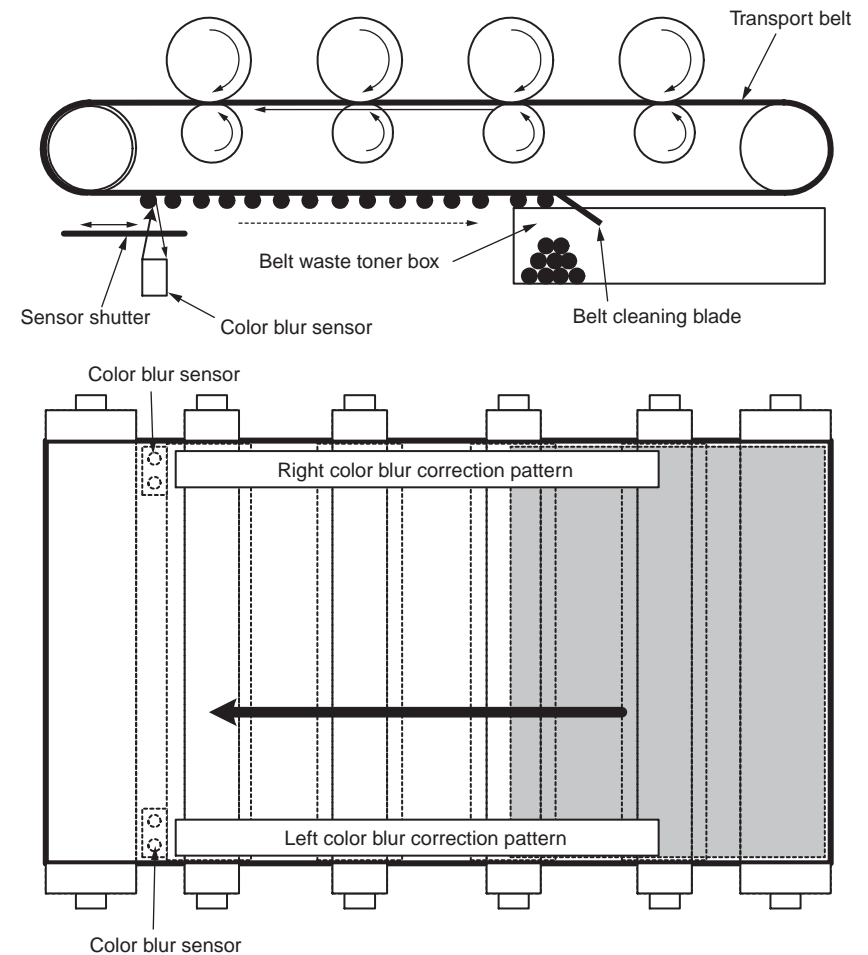

Error-confirming method and Error-solving method

Use the color blur correction test function in self-diagnostic mode to confirm the error. (See 5.3.1.6)

Error solving method

- CALIBRATION(L or R), DYNAMICRANGE(L or R)

Check 1: When the above display appears, please check the connection of sensor cable (FFC).

When the connection is abnormal, please set it properly.

Check 2: Please check if the surface of the sensor is dirty with the toner and paper melts etc.

Check 3: Please confirm if the open and close operation of sensor shutter is normal by utilization of MOTOR&CLUTCH TEST in self-diagnostic mode. Exchange the shutter unit when the open and close operation is in trouble.

If there are no problems in check 1, 2, and 3, please check the circuit.

Please exchange the color adjust sensor PCB, relay PCB, PU PCB, and the cable one by one, and then check if the error is displayed.

- BELT REFLX ERR

Check 4: When this display appears, please check the cleaning of the toner left on the surface of the belt after finishing the above-mentioned check 1, 2, and 3. Remove the belt unit, and rotate the left inboard drive gear. Please confirm that the surface of the belt is cleaned completely.

When the residual toner left on the surface of the belt could not be cleaned completely even if the drive gear is rotated, please exchange the belt unit.

- (Y or M or C) LEFT, (Y or M or C) RIGHT, (Y or M or C) HORIZONTAL

Check 5: When the above display appears, please confirm if the toner of NG color is empty.

Please exchange the toner cartridge as required.

General of the density correction

The density correction is operated by reading the pattern for correction printed on the belt with a sensor set in the sensor shutter under the belt unit.

Density correction auto-start timing

- The environment is remarkably different from last time when the power is on.
- When one or more ID count among the four ID count show the status of new part, at the power on
- The ID count value exceeds 500-count from last operation.
- When one or more UD is replaced with the new ID.
- When the belt is replaced with the new belt
- When toner cartridge is replace due to Toner Low, or Toner Empty so that Toner Low or Toner Empty has disappeared

The amount of toner of the pattern, the toner dirt and the open-close trouble of the shutter etc. may lead to correction error.

However, as the error message may not display even if the error is occurred, it is necessary to perform the density correction (see 5.3.1.7) by the utilization of the self-diagnostic mode and confirm the error display.

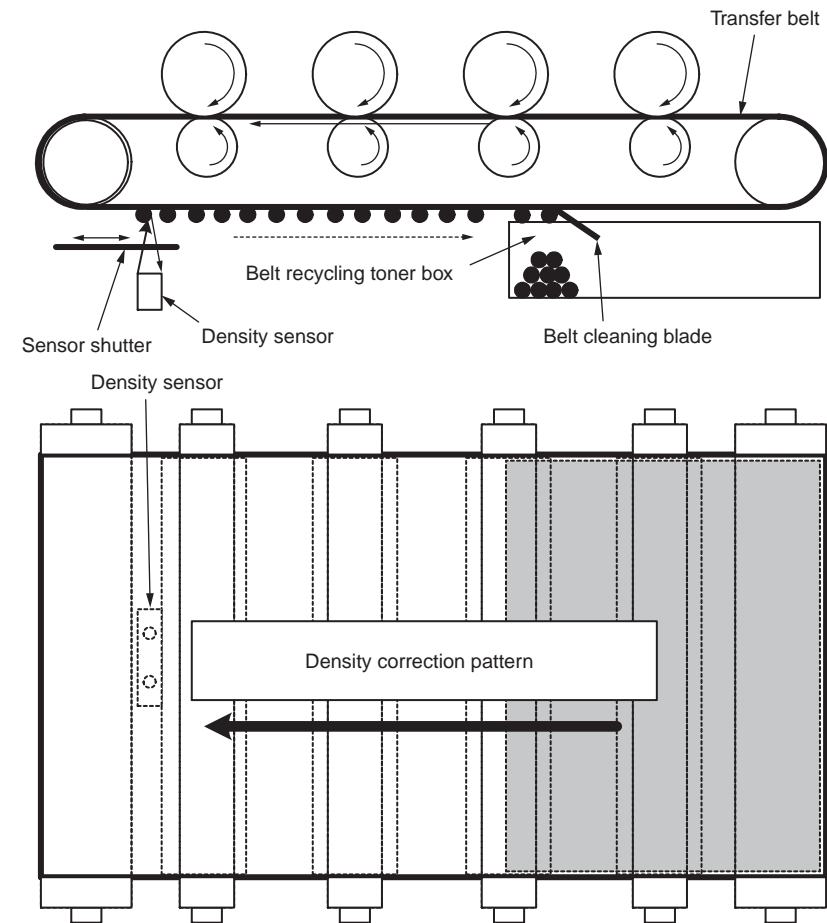

Error-confirming method and Error-solving method

Use the density correction test function in self-diagnostic mode to confirm the error.

(See 5.3.1.7)

Error solving method

- CALIBRATION ERR, DENS SENSOR ERR

Check 1: When the above display appears, please check the connection of sensor cable.

When the connection is abnormal, please set it properly.

Check 2: Please check if the surface of the sensor is dirty with the toner and paper melts etc.

Please wipe the dirt off if the sensor is dirty.

If there are no problems in check 1, 2, and 3, please check the circuit.

Please exchange the density sensor, relay PCB, PU PCB, and the cable one by one, and then check if the error is displayed.

- DENS SHUTTER ERR

Check 3: Please confirm if the open and close operation of sensor shutter is normal by utilization of MOTOR&CLUTCH TEST in self-diagnostic mode.

Exchange the shutter unit when the open and close operation is in trouble.

- DENS ID ERR

Check 4: Remove the ID unit, and confirm if the toner abnormally leaves on the surface of the drum.

Exchange LED head (Focus control). Or exchange the ID unit.

When a new ID unit is tried to use, please set the fuse keep mode of the maintenance menu.

Toner sensor detection principle

Toner low is detected by the toner sensor (reflect sensor) installed in the equipment. The light board is installed in ID, and its rotation is synchronized with the mixing of toner. Moreover, the shutter is installed in ID. Toner cartridge set properly by the lever of toner cartridge and synchronized toner sensor can be detected.

The following problems may lead to abnormal detection and the toner sensor error is occurred.

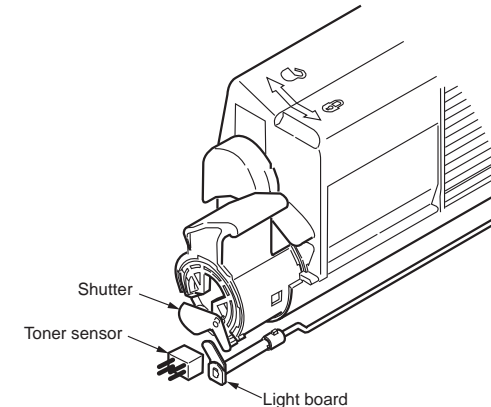

Toner count principle

After the image data is transformed into binary data which can be printed by the printer, the data is counted as print dot number by LSI. The amount of the used toner is calculated from this count value, and the residual amount is displayed on the menu.

Toner LOW detection (residual amount display on LCD) by the toner sensor is to detect a certain amount of the reduction of the toner left in ID.

The principle of ID counter, belt counter, fuse counter

ID counter : when 3 pieces of A4 paper are continuously printed, one third of the rotation of the drum is set as one count.

Belt counter : when 3 pieces of A4 paper are continuously printed, one third of the rotation of the drum is assumed as one count.

Fuse counter : The length of paper of legal 13 inch is set as nominal value.

If the length of paper is less than this nominal value, it is assumed as one count. If the length of paper is more than this nominal value, the counted number is determined by the times of legal 13 inch.

(The number after decimal point is rounded up.)

Counter spec

	Total printed page number	MPT printed page number	Tray 1 printed page number	Tray 2 printed page number	Tray 3 printed page number	Color-printed page number	Mono-printed page number
Description	Total printed page number	Hopping page number from MPT	Hopping page number from Tray1	Hopping page number from Tray2	Hopping page number from Tray3	Printed page number by color-printing	Printed page number by mono-printing
Count method A4 conversion or size independence	Count up after passing the writing sensor	Count up if MPF(MPT) hopping is finished	Count up if Tray1 hopping is finished	Count up if Tray2 hopping is finished	Count up if Tray3 hopping is finished	The page number is counted up by detecting the paper passing the fuser in color-printing mode after the job is finished. (1*) The value is A4/Letter value. Please refer to A4/ Letter conversion table (P31).	The page number is counted up by detecting the paper passing the fuser in mono-printing mode after the job is finished. (1*) The value is A4/Letter value. Please refer to A4/ Letter conversion table (P31).
Operation when paper jammed	Cannot count when paper feeding (hopping) jam and feed jam are occurred. It can count except the above-mentioned jam. As total printed page number is counted up when the front end of the page passes the writing sensor, according to the jam type, the feeding jam (380) is also included in the limits for counted.					Cannot count if the jam is occurred before the paper passes the fuser. It can count if the jam is occurred after the paper passes the fuser.	
Operation for Duplex	Front/Back count(+2)	Only front count (+1)				Double count If the color page and mono page exist together, the color printing page number would be plus 1 and the mono printing page number would be plus 1.	
Reset condition	None	None				1) When "Format Flash ROM" of system maintenance menu is performed. 2) When CU PCB is replaced. 3) When MENU RESET of system maintenance menu is performed. 4) When CU PCB is replaced.	
Value storage destination	PU	PU	PU	PU	PU	CU	CU
Menu/MenuMap output	○ (*2)	○	○	○	○	○	○
EngineMenuMap output	○	○ (*3)	○ (*3)	○ (*3)	○ (*3)	-	-

*1. Count cannot be updated if the power is turned off when the jam is occurred.

*2. In the initial state MenuMap output is not available. It is possible to switch in the system maintenance menu.

*3. EngineMenuMap output divides into Engine Menu Print (the first page) and Engine EEPROM Dump Print (the last page), however, the number of paper fed from each tray is output only to the latter one (DUMP display only).

A4/Letter conversion table

The paper is counted up as this sheet.

Paper size	Simplex	Duplex
LETTER	1	2
EXECUTIVE	1	2
LEGAL14	1	2
LEGAL13.5	1	2
LEGAL13	1	2
A4	1	2
A5	1	2
A6	1	-
B5	1	2
COM-9	1	-
COM-10	1	-
MONARCH	1	-
DL	1	-
C5	1	-
CUSTOM LENGTH ≤ 210mm	1	2
CUSTOM 210mm < LENGTH ≤ 899mm	2	4
CUSTOM 900mm ≤ LENGTH	4	-

3. Set up

3.1	Notes and precautions.....	34
3.2	Unpack method	35
3.3	Setting method	36
3.4	List of equipments and accessories	37
3.5	Assembling method	38
3.6	Setting content print (Configuration).....	57
3.7	Connecting method	58
3.8	User used Paper confirmation	60

3.1 Notes and precautions

Warning

- Do not set it in any high-temperature locations or near any heat sources.
- Do not set it in a place where the chemical reaction may occur (laboratory etc.).
- Do not set it near any liquid that may ignite such as alcohol and thinner.
- Do not keep it out of reach of children.
- Do not place it on an unstable or uneven surface (unstable table and slanting place, etc.).
- Do not put it in direct sunshine. And do not put it in a moist or dusty place.
- Do not set it in wet or corrosive environment.
- Do not set it in a place where may cause vibration.
- If the printer is dropped down or the cover is damaged, please pull out the power plug from the outlet and contact the customer center.
This may cause an electric shock, fire, injury.
- Please read this manual carefully before connecting the power supply cable, printer cable, ground cable.
This may cause fire.
- Do not insert any foreign objects into the vent hole.
This may cause an electric shock, fire, injury.
- Do not put a vessel(s) filled with water on the printer.
This may cause an electric shock, fire.
- Do not touch the fuser unit when you open the cover of the printer.
It is hot and could cause burns.
- Do not throw the toner cartridge, the image drum cartridge into the fire.
It may cause burns due to dust explosion.
- Do not use inflammable sprays near the printer.
It may cause fire because some parts in the printer may become very hot.
- If the cover becomes abnormally hot, smoke rises, it smells strange or it sounds abnormal, please pull out the power plug from the outlet and contact the customer center.
It may cause fire.

Warning

- If the liquid such as water enters the printer, please pull out the power plug from the outlet and contact the customer center. It may cause fire.
- If you drop the foreign objects such as clip in the printer, please pull out the power plug from the outlet and take the foreign objects out.
This may cause an electric shock, fire, injury.
- Do not disassemble the printer unless following the correct procedure written in the manual. This may cause an electric shock, fire, injury.

Caution

- Do not set it in a place where the vent hole of the printer is blocked.
- Do not set it directly on heavy wool or shag carpet.
- Do not place it in locations of poor ventilation such as enclosed areas.
- Give particular attention to adequate ventilation care when using it continuously in a narrow room for a long time.
- Do not place it close to strong magnetic fields and noise source.
- Do not place it next to the monitor and television.
- Hold tightly the both sides of the printer when you move the printer.
- Because the weight of the printer is approximately 33kg (in a state of packing), it needs more than two adults to lift it up.
- Do not come close to the paper exit part while printing.
This may cause injury.

Please explain the safety precautions about installation and handling with showing the all precautions in user's manual to customer. Especially, the details about power supply cable and the ground cable must be explained completely.

3.2 Unpack method

Warning

Personal injuries may occur.



Because the weight of the printer (without Duplex unit) is approximately 33kg (in a state of packing), it needs more than two adults to lift it up.

- Take out the gripe on each side as shown in the following figure, and lift the cardboard box up.

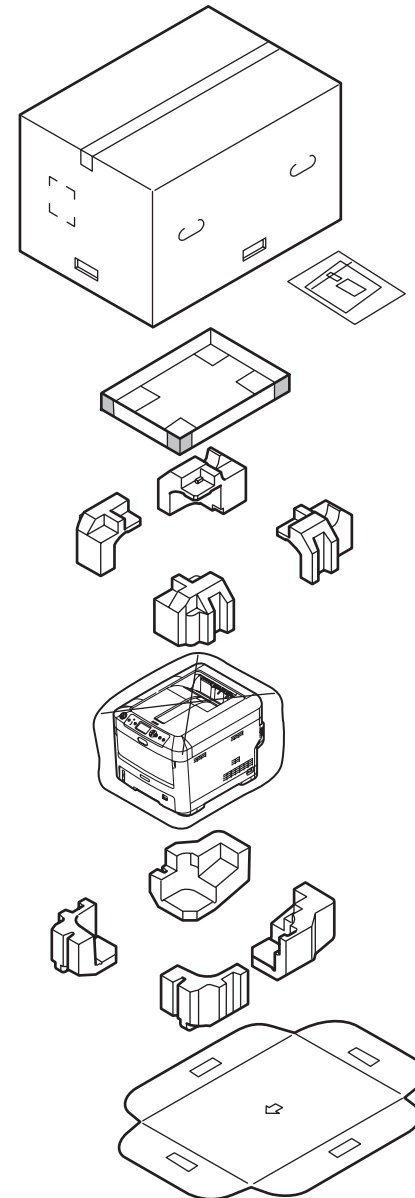
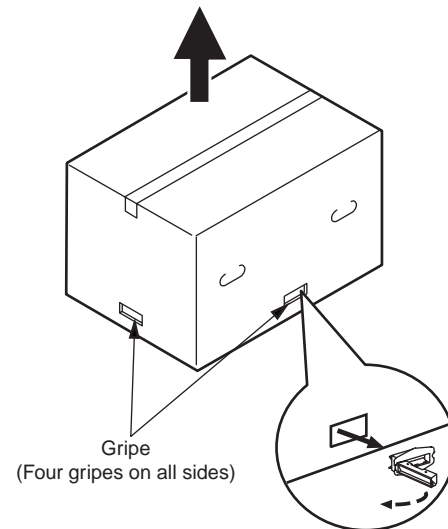

3.3 Setting method

- Set the printer under these conditions.
 - Surrounding environment: 10~32°C
 - Surrounding humidity: 20~80%RH (Relative humidity)
 - Highest wet bulb temperature: 25°C
- Protect the printer from dew formation.
- Use the humidifier or the static electricity prevention mats etc. when setting the printer in the environment where the humidity is 30% or less.

Set space

- The flat desk should be wide enough to put the printer on.
- Ensure that there is enough room around the printer for proper ventilation.

Plan view

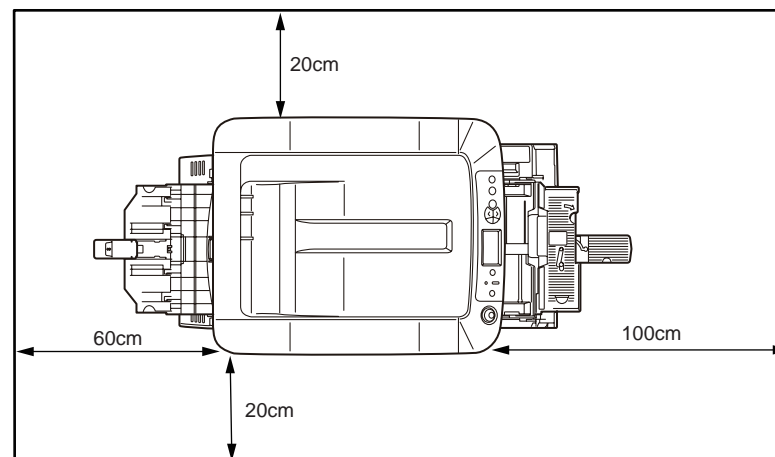

Side view

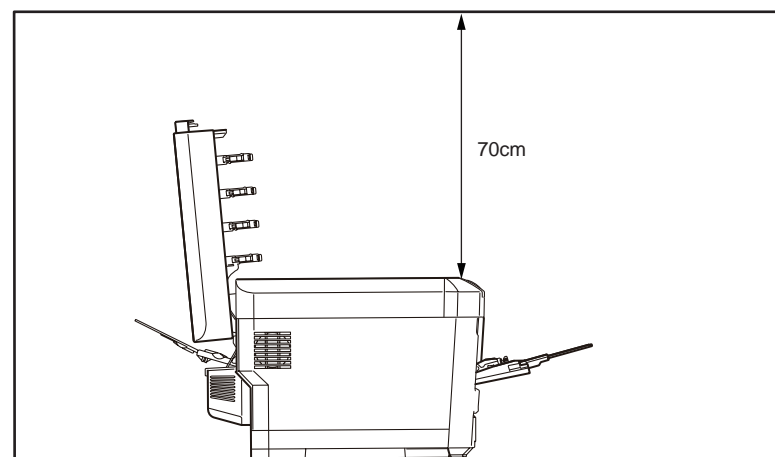

3.4 List of equipments and accessories

- Make sure that the appearance of the equipment is not damaged or dirty etc.
- Make sure that the following accessories are supplied with your printer.
- If you are missing any of these accessories, contact your customer service department immediately.

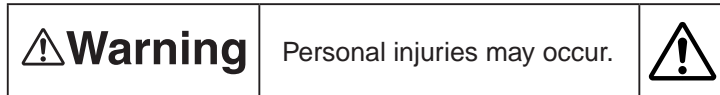

Because the weight of the printer body is approximately 28kg (33kg in a state of packing), it needs more than two adults to lift it up.

- Printer (Body)

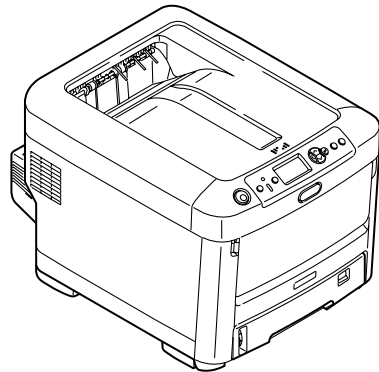

- Image drum cartridge (1 Cyan, 1 the magenta, 1 yellow, and 1 black) (mounted in the printer)

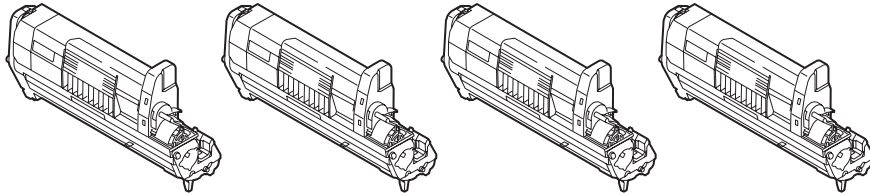

Explain to the customer that the toner cartridge and the image drum cartridge can be separated.

- Printer software CD-ROM
- Power supply cord
- Guarantee card and user registration card
- User's manual (Setup)
- User's manual (CD-ROM)

Notes! The printer cable is not included.

3.5 Assembling method

3.5.1 Assemble the main body of the printer

Remove the protective materials.

- (1) Peel off the desiccant and the protection tape (four places) on the printer.

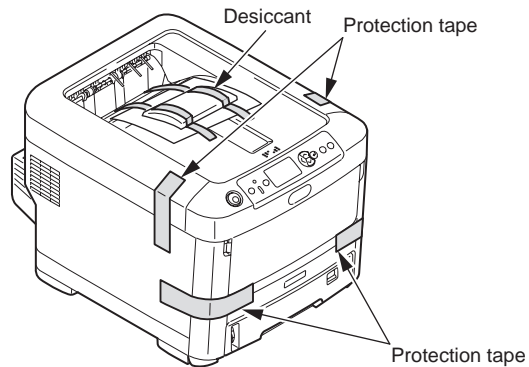

- (2) Peel off the paper on the front of printer.

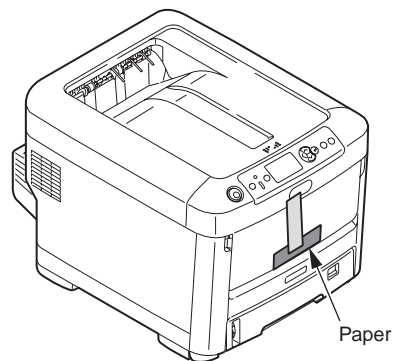

- (3) Peel off the protection tape (4 places) on the back of the printer.

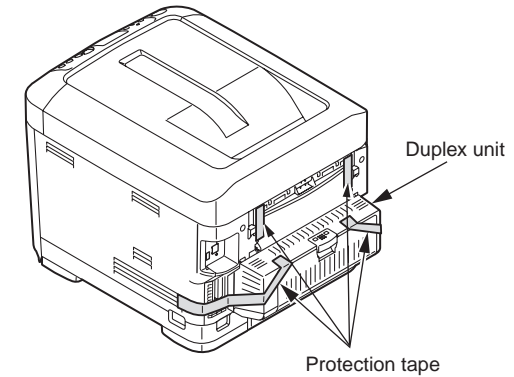

- (4) Confirm that the Duplex unit is fixed tightly.

- (5) Pull the paper cassette out.

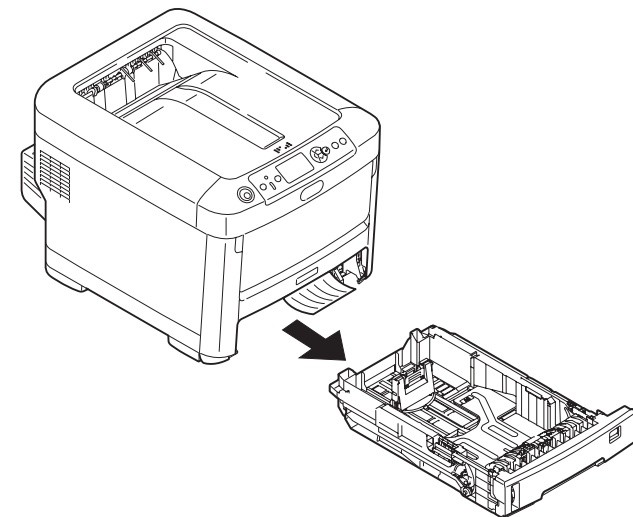

- (6) Pull the retainer out in the direction of the arrow (1). Return the paper cassette to the main body of the printer.

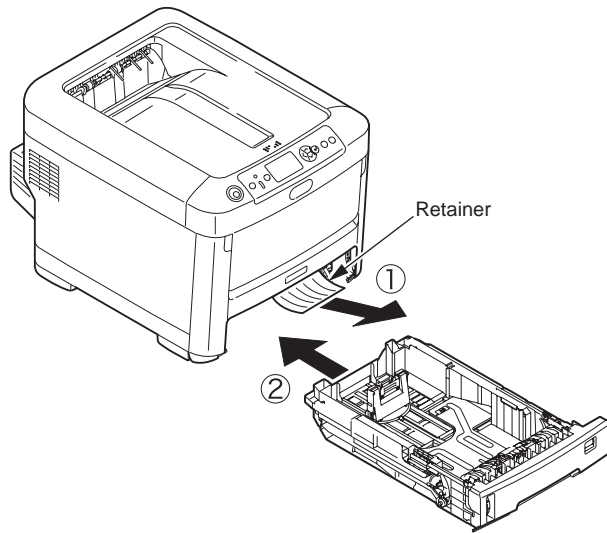

- (7) Press down the OPEN button, and open the top cover.

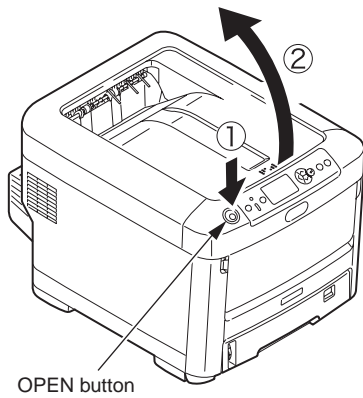

- (8) Remove the stopper (orange) when pressing down the lever of the fuser unit (blue) in the direction of arrow ①.

Note! If you do not use the printer for a long time or transport it, please use the stopper. Please keep it carefully.

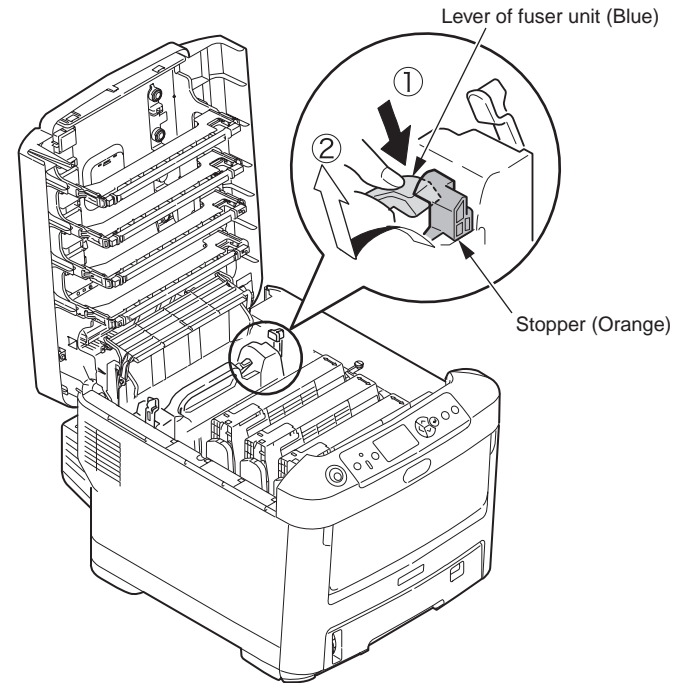

Set the image drum cartridge.

- (1) Take the image drum cartridge (four) out slowly.

- Note!**
- The image drum (green cylinder) is very fragile. Please pay special attention to handling it.
 - Do not expose the image drum cartridge to direct sunshine and strong light (about 1500 lux). And do not expose it to room light for more than 5 minutes.

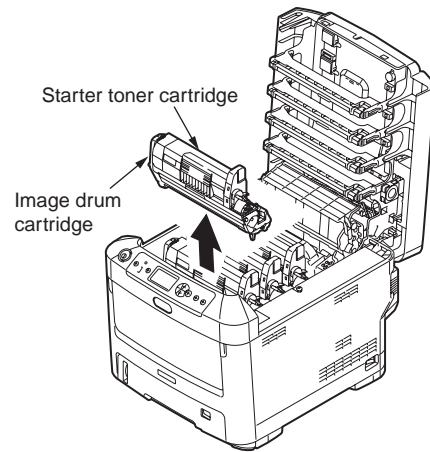

- (2) Put the image drum cartridge on the newspaper etc, peel off the tape of protection sheet 1 and pull it out in the direction of the arrow.

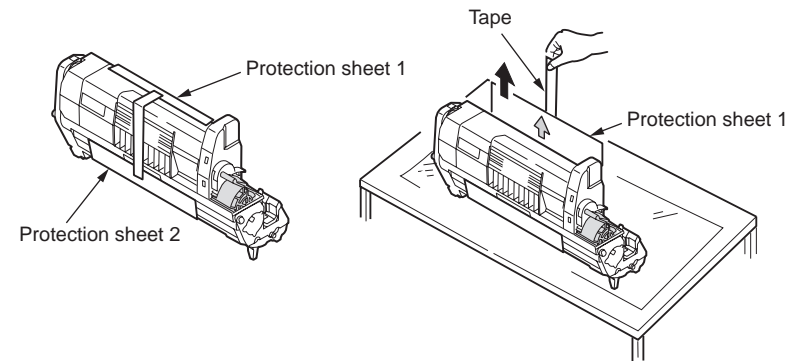

- (3) Pull the protection sheet 2 out from image drum cartridge in the direction of arrow.

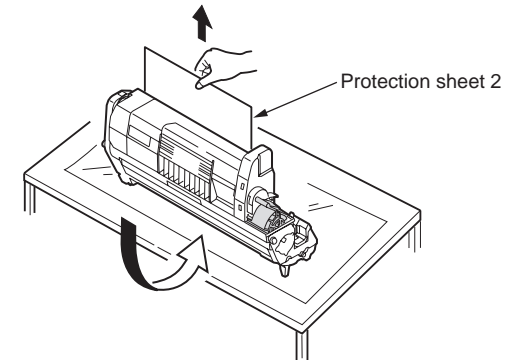

- (4) Remove all protection sheets from the image drum cartridge.

(5) Return the image drum cartridge back to the printer.

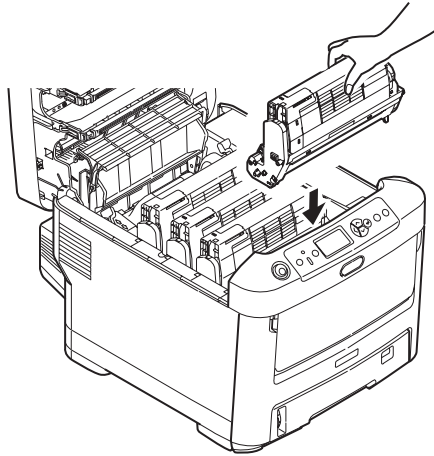

(6) Turn the lever of each starter toner cartridge in the direction of the arrow.
(Four levers)

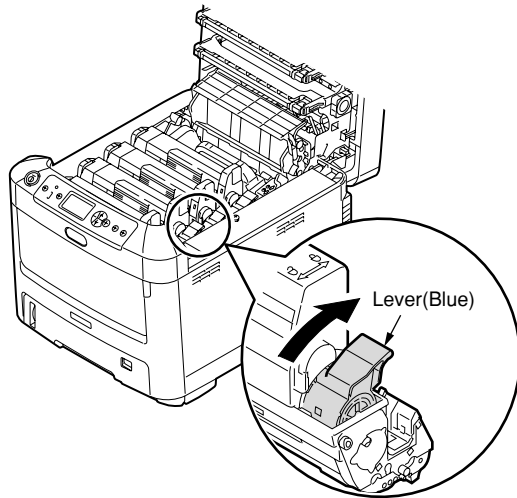

(7) Close the top cover.

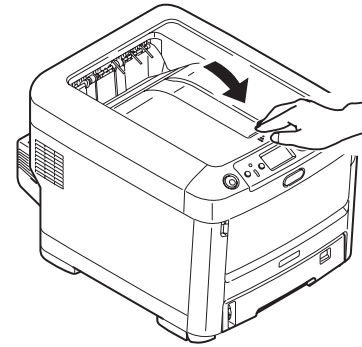

Note! If the message of [%COLOR% Waste Toner Full.Replace Toner.] on the control panel doesn't disappear indefinitely, please make sure that the lever of the toner cartridge is fully moved in the direction of the arrow.

Set the paper into the paper cassette.

- (1) Pull out the paper cassette.
Do not peel off the rubber attached to the plate.
- (2) Adjust the paper stopper and the paper guide to match the size of the paper, and then fix them tightly.

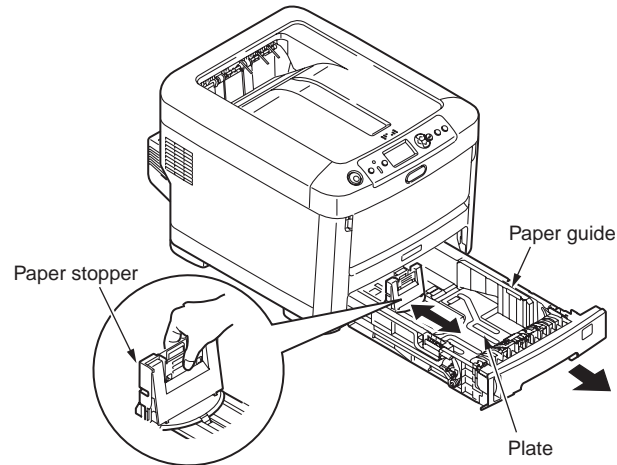

- (3) Flex the paper back and forth. Do not fold or crease the paper. Straighten the edges on a level surface.

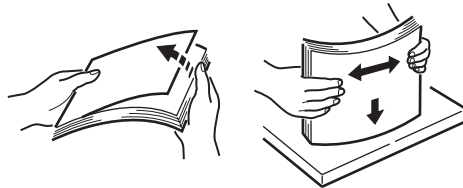

- (4) Place the paper in the cassette with the side to be printed facing down.

- Note!**
- Place the paper with the top of the page nearest the paper cassette tab.
 - Do not place the paper higher than the "▽" mark on the paper guide. (530 pieces for 70kg paper)

- (5) Place the paper in position by paper guide.
- (6) Rotate the paper size dial to match the paper.
- (7) Return the paper cassette back to the printer.

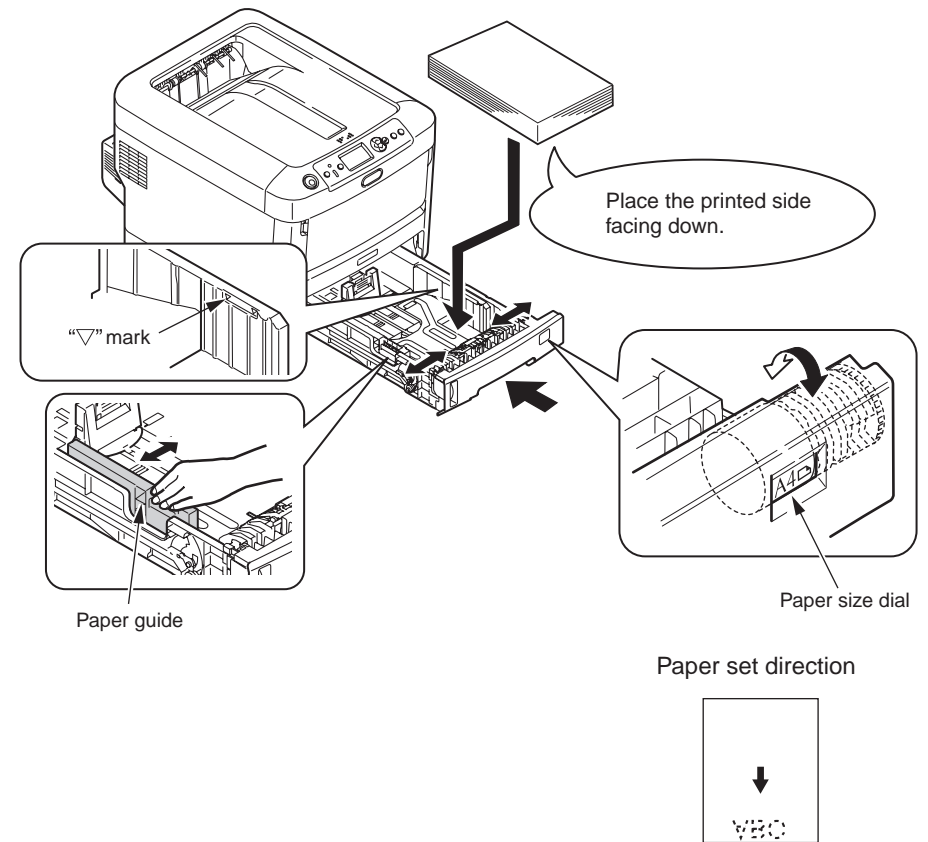

Set the paper in multi-paper tray.

- (1) Open the multi-paper tray, and open the paper supporter.

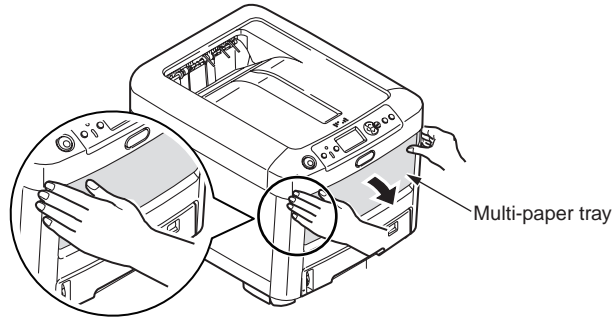

- (2) Match the manual insertion guide to the size of the paper.
 (3) Flex the paper back and forth. Straighten the edges on a level surface.

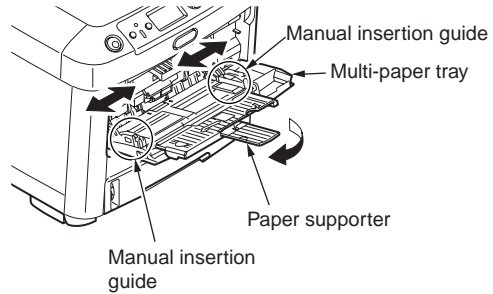

- (4) Place the printed side facing up, and insert the paper along the manual insertion guide straightly until bumping up.

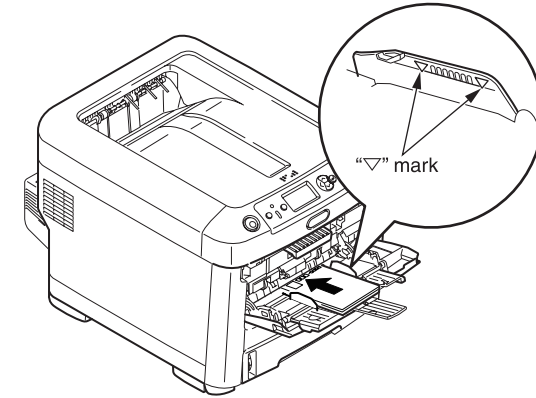

Note! Set papers so that paper should not exceed the "▽" mark. (100 sheets of paper with ream weight of 70 kg or 10 envelopes)

- (5) Press down the set button.

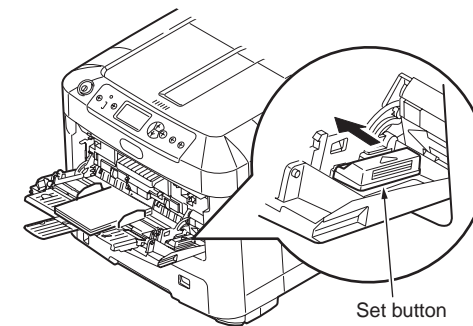

3.5.2 Cable connect

Power condition

- Keep the following items.
 - AC voltage : 110~127V \pm 10%/ 220~240V \pm 10%
 - Frequency of the power supply : 50Hz or 60Hz \pm 2%
- Use the voltage adjusting transformer etc. when the power supply is unstable.
- The maximum power consumption of this printer is 1,300W. Confirm the power supply can provide enough power.
- The operation with UPS (uninterruptible power supplies) is not guaranteed.
Explain to the customers that do not use UPS (uninterruptible power supplies).

⚠ Warning	It may cause an electric shock, fire.	
<ul style="list-style-type: none"> • Installation and removal of the power supply cord and the ground cable must be performed after pressing down the power switch to OFF. • Please connect the ground cable with a specified ground terminal. Please contact the dealer if you cannot get it. • Be careful not to connect it with the lightning rod, the water pipe, the gas pipe, and the earth of the telephone wire. • Connection of the ground terminal must be performed before inserting the power plug into the power outlet. And, removal of the ground terminal must be performed after pulling the power plug out of the power outlet. • Please hold the power plug to disconnect or plug in the power supply cord. • Please insert the power plug firmly into the outlet. • Do not pull out or plug in the power plug with wet hands. • Do not locate the printer in a place where the cord may be abused by persons walking on, and do not place the heavy objects on the power cord. • Do not use the power supply cord that is bundled or connect the power supply with an extension cord. • Do not use a damaged power supply cord. • Do not use a multiple outlet extension cord. • Please connect this printer into an outlet different from that to which other electric products is connected. Especially, the operation of the printer might be affected by the electrical noise when the printer is connected simultaneously with the air-conditioner, the copier and shredder etc. Please use the noise filter or the noise cut-off transformer sold at the market if you have to connect the printer into a same outlet. • Please use the attached power cord and insert it into the outlet directly. Do not use an unspecified power cord. • Do not use an extension cable. Please use a cable that is more than 15A current rating if you have to use an extension cable. • If the extension cord is used, the printer might operate abnormally by the decrease of AC voltage. • Do not unplug the power cord or switch off the power during printing. • Please unplug the power cord if you do not use the printer for a long time (long vacation or travel etc). • Do not use the attached power cord of this printer to the other electric products. 		

Explain completely the connection of the power supply cable and the ground cable with showing the user's manual to customer.

Connect the power cord.

Note! Confirm that the power switch is turned to OFF "O".

- (1) Insert the power cord into the printer.

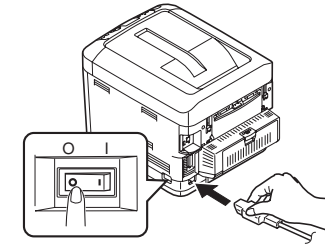

- (2) Connect the ground cable with the ground terminal of the outlet.

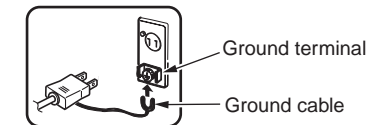

⚠ Warning It may cause an electric shock. 

The ground cable must be connected.

- (3) Insert the power plug into the outlet.

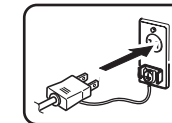

Press down the power switch to ON (|).

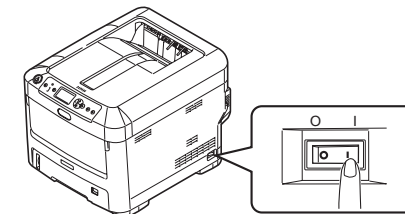

If the printer is completely started up, the message "Ready To Print" would be displayed on the control panel shown as follows.

Note! When the printer is getting cold, it may lead to error if the power is turned on. (Error number 126,171,175,177,320). At this time, please turn off the power and wait for a while, and then turn on the power again.

Turn the power off.

Note! If you turn off the power without properly shutting down, it may cause damage to the printer. Please follow the following procedure to turn the power off.

- (1) A message [Shut down Yes/No] appears. Be sure Yes is selected and press the

Set  [Back] button.

A message [Shutting down] appears, the printer being shutting down.

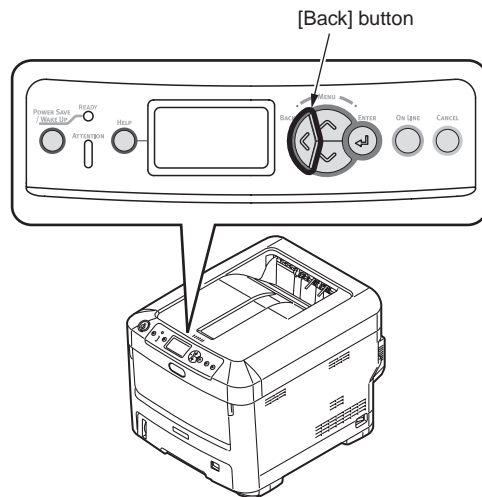

- (2) If the message [Turn off power/Shutdown completed] is displayed, press down the power switch to OFF "O".

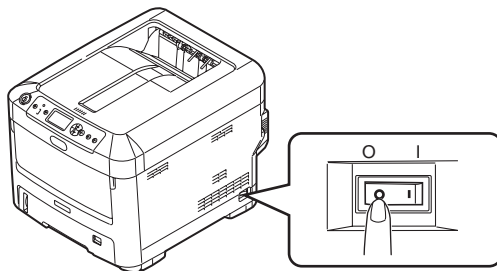

When you do not use the printer for long time

Please explain to the customer about the following items.

Unplug the power cord if you do not use the printer for a long time (long vacation or travel etc).
Install the stopper to the fuser.

Note! Please remove the ground terminal after pulling the power plug out of the power outlet.

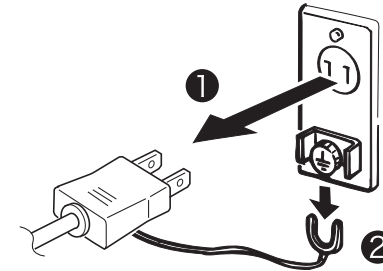

Note! Even if the power plug of this printer is pulled out for a long time (four weeks or more), the functional problems will not be caused easily. However, please explain to the customer that the deterioration of consumable such as toners and the image drums is not guaranteed.

3.5.3 Optional part installation and confirmation

(1) Installation of the optional tray unit (second/ third tray)

It is a traditional paper tray for adding paper into printer.

530 pieces of 70kg paper can be set. Using it with a standard paper cassette and a multi-purpose tray can print 1690 pieces of pages continuously.

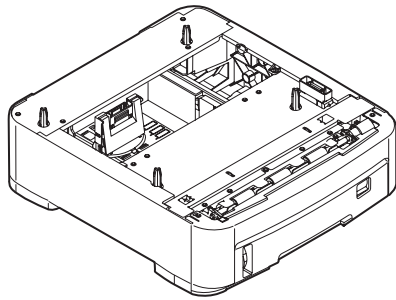

(1)-1. Turn the printer power to OFF and pull out the power cord from the outlet.

Turn the power off with following the procedure in chapter 3.5.2 [Turn the power off.].

- Notes!**
- If you turn off the power without properly shutting down, it may cause damage to the printer. Please operate the [Shutdown Menu].
 - It may cause damage to the printer, if you install the optional tray with power ON.

(1)-2. Install the optional tray unit to the printer.

Note! Because the weight of the printer body is approximately 28kg, it needs more than two adults to lift it up.

- 1 Match the tab into the hole in the bottom of the printer.
- 2 Put the printer on the optional tray unit slowly. Please remove it following the steps 1-2 in reverse order.

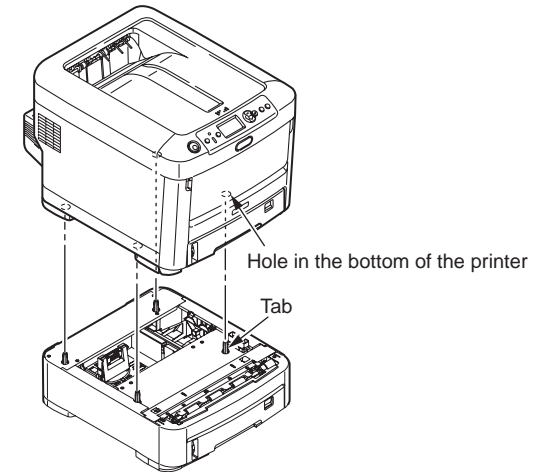

Note! When you install two optional trays to the printer, set the optional tray directly on top of the other optional tray, and then put them on the printer.

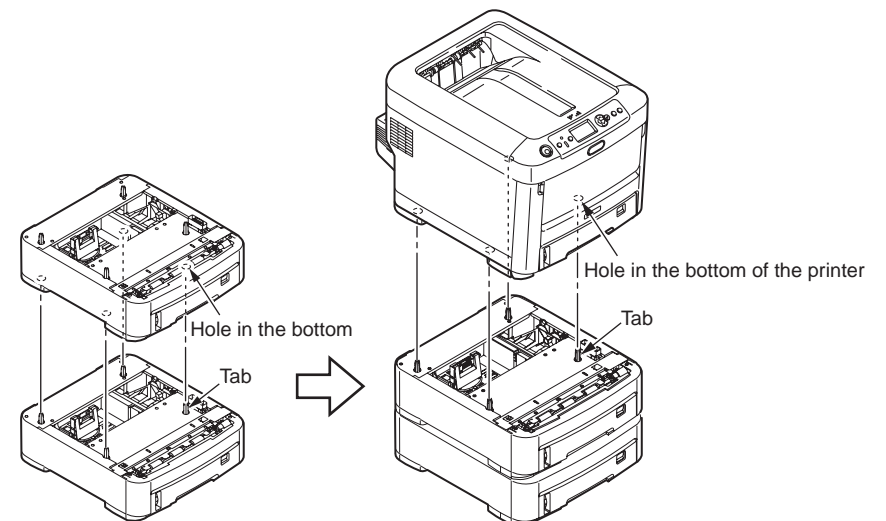

(1)-3. Connect the power cord and printer cable to the printer and turn the power on.

Note! If the message [Service Call/182: Fatal Error] or [Service Call/183: Fatal Error] is displayed, reinstall the optional tray unit.

(1)-4. Print the setting content and confirm if the option tray unit is installed properly.

- ① Print the setting content with following the procedure in chapter 3.6.
- ② Confirm the content of [tray 2] or [tray 3] is display in header part.

Unit of Measurement : millimeter
 Tray1 Config
 Paper Size : Cassette Size
 Media Type : Plain
 Media Weight : Medium Light
 Tray2 Config
 Paper Size : Cassette Size
 Media Type : Plain
 Media Weight : Medium Light

Note! If the content of [tray 2] or [tray 3] is not displayed, reinstall the second tray unit.

(1)-5. Set the number of tray by the printer driver.

The printer driver setup for recognizing the option tray unit is required.

If the printer driver is not set up, please set up the printer driver completely referring to the user's manual (Setup) firstly, and then finish the following setting procedure.

Note! The authority of the computer administrator is required.

For windows PS printer driver

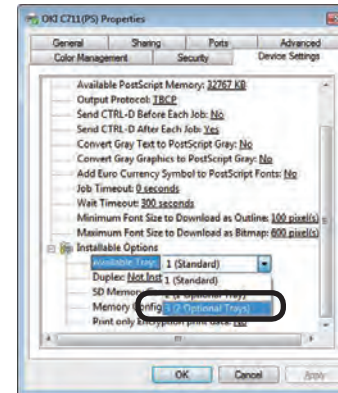

(For Windows XP)

- ① For Windows Vista, click on [start] => [control panel] => [printer].
 For Windows XP, click on [start] => [control panel] => [printer and other hardware] => [printers and Faxes].
 For WindowsServer 2003, click on [start] => [printers and faxes].
 For Windows 2000, click on [start] => [Settings] => [printers].
- ② Click the [C711(PS)] icon with right-click button on your mouse and choose the [Properties].
- ③ Choose [get information from printer] from [installable options] in [Device options] tab, and click [setup] or [get information from printer]. For USB connection, set [Optional paper source] manually.
- ④ Click [OK].

For Windows PCL printer driver



(For Windows XP)

- 1 For Windows Vista, click on [start] => [control panel] => [printer].
For Windows XP, click on [start] => [control panel] => [printer and other hardware] => [printers and Faxes].
For WindowsServer 2003, click on [start] => [printers and faxes].
For Windows 2000, click on [start] => [Settings] => [printers].
- 2 Click [C711(**)] (** is PCL or PCL XPS (printer driver type)) icon with right-click button on your mouse and choose [Properties].
- 3 Choose [get information from printer] in [Device options] tab. For USB connection, input the optional tray number in [Optional devices] manually.
- 4 Click [OK].

For Mac OS X

When the optional device has been added into in Mac OS X before installing the printer driver, the device information is gotten automatically. However, if the printer is connected by [IP print] and [Bonjour (Rendezvous)], the device information could not be gotten automatically.

If the printer is connected by [AppleTalk], the device information could also not be gotten automatically when the optional device has been added into in Mac OS X before installing the printer driver.

Please finish the following setting procedure for above.

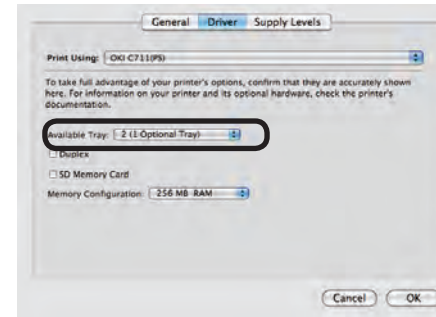

- 1 Double-click [Applications] for hard disk => [utility] => [print setting utility] ([Applications] => [Utility] => [print center] in Mac OS X)
- 2 Select [C711], click [Show info] and open [printer info].
- 3 Choose [installable options].
- 4 Select the [Optional paper source], and click [Apply].
- 5 Close [printer info].

(2) Installation of Duplex unit

This unit is used for printing on two sides of paper.

Note! For two-sides printing, it is recommended to add expansion memory. For details, see "Expansion memories."

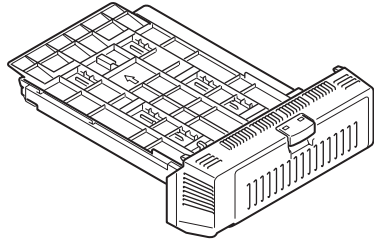

(2)-1. Turning OFF the printer power and disconnecting the power cord

Note! If an expansion memory is installed with the power switched ON, the printer may be broken.

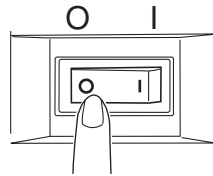

(2)-2. Peeling the protective tapes off the Duplex unit

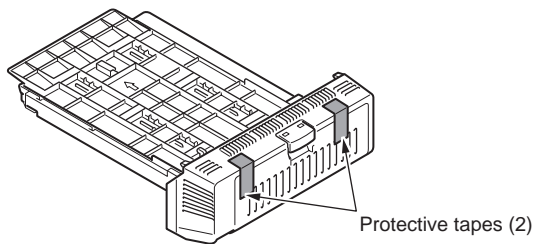

(2)-3. Install Duplex Unit

- ❶ Insert the Duplex unit into the lower part on the back of the printer as far as it will go.
- ❷ Ensure that the claw on either side of the Duplex unit is securely accommodated in the hole of the printer.

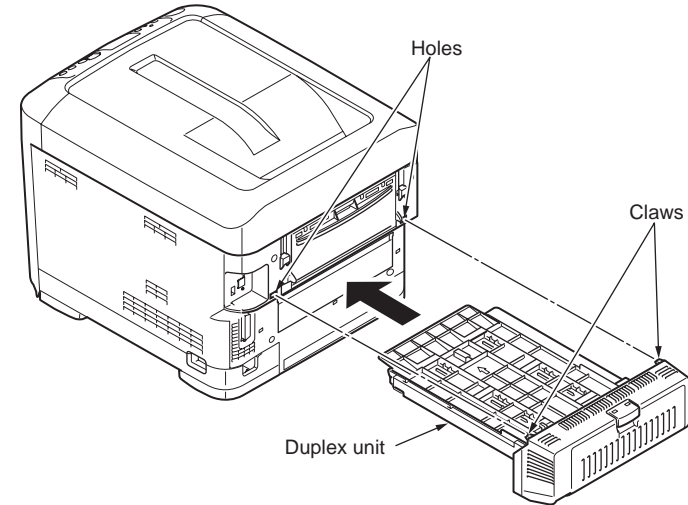

(3) Add the optional memory.

It is used to increase the memory capacity of the printer.

Please add the optional memory as following problems occur:

“Out of memory” error [Memory Overflow] occurs when printing complex data.

Combination print error occurs when printing the whole file at once.

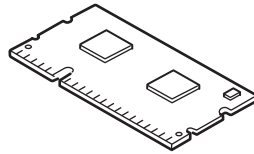

Optional memory

Type name	Memory capacity (Total memory capacity)
None (Standard)	256MB (256MB)
MEM256G	+256MB (512MB)
MEM512D	+512MB (768MB)

- Notes!**
- The operation cannot be guaranteed when using an unspecified product. Please use OKI product.
 - It is recommended to add 256MB optional memory when long size printing.
 - The slot for memory is one slot.

(3)-1. Turn the power of printer off, and pull out the power cord.

Turn off the power with following the procedure in chapter 3.5.2 [Turn off power].

- Notes!**
- If you turn off the power without properly shutting down, it may cause damage to the optional memory. Operate the [Shutdown Menu].
 - It may cause damage to the printer, if you install the optional memory with power ON.

(3)-2. Open the top cover and front cover.

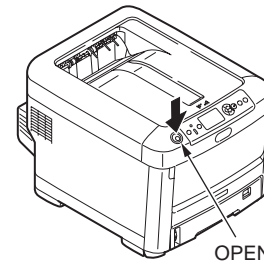

OPEN button

- ① Press down the OPEN button, and open the top cover.

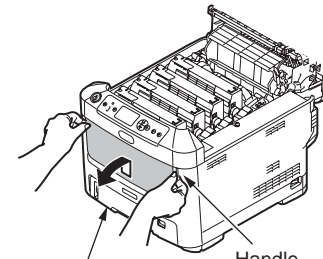

Multi-purpose tray

Handle

- ② Open the multi-purpose tray.

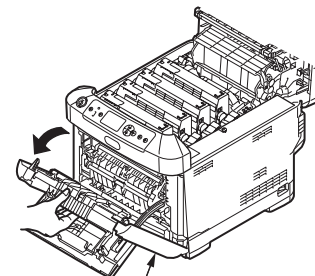

Front cover

- ③ Pull up on the handle (blue) at the center of the front cover, and open the front cover forward.

(3)-3. Remove the side cover.

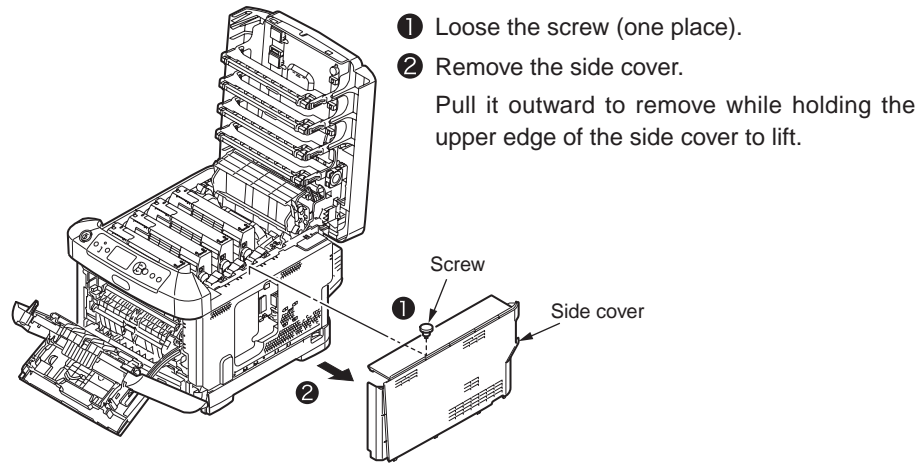

(3)-4. Install the memory.

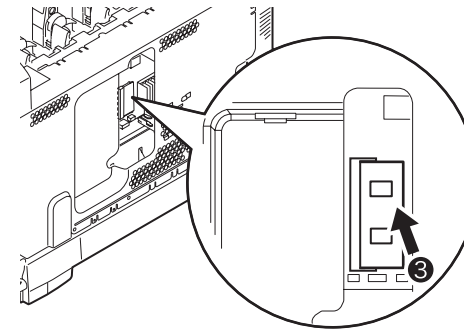
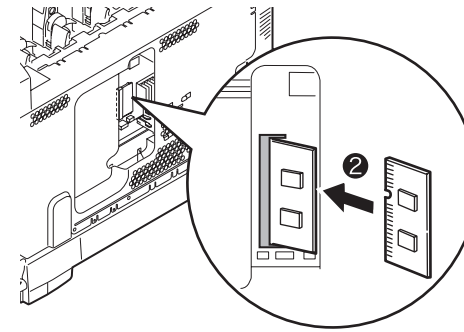

- Notes!**
- Do not touch any electrical parts and terminals of connectors.
 - Be careful to install the memory in the proper direction. A notch on the terminal of the memory is matched to the connector of the slot.

(3)-5. Install the side cover.

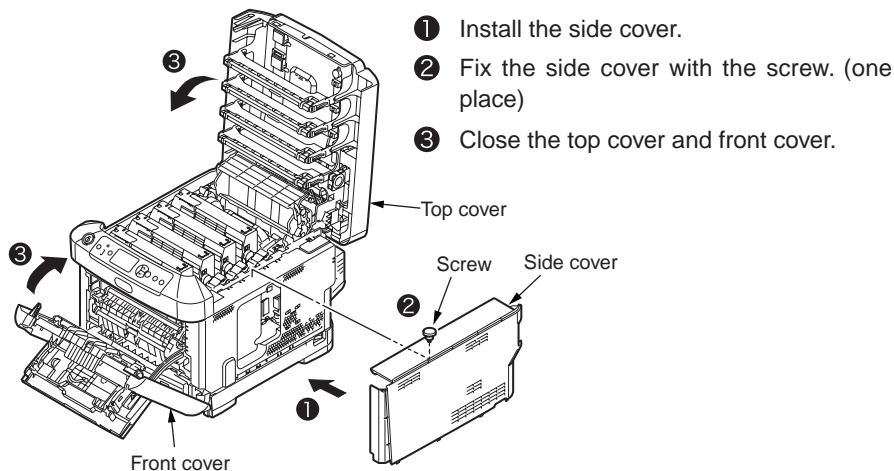

(3)-6. Connect the power cord and printer cable to the printer, and turn the power on.

Note! If the message [Service Call/031:Fatal Error] is displayed, please reinstall the memory.

(3)-7. Print the setting content and confirm if the optional memory is installed properly.

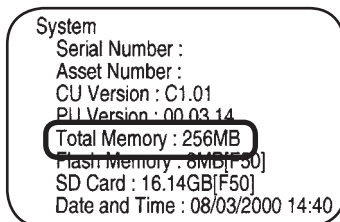

- ① Print the setting content with following the procedure in chapter 3.6.
- ② Confirm the total memory capacity displayed in [Total Memory] of [System] part.

Note! If total memory capacity displayed in [Total Memory] is incorrect, please reinstall the memory.

(4) Install the SD memory card.

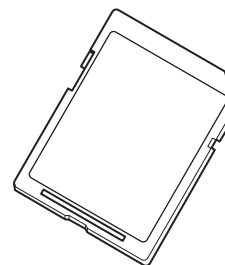

Note! Be careful that the font cannot be downloaded.

(4)-1. Turn the power of printer off, and pull out the power cord.

Please turn off the power with following the procedure in chapter 3.5.2 [Turn off power].

- Notes!**
- If you turn off the power without properly shutting down, it may cause damage to the printer. Please operate the [Shutdown Menu].
 - It may cause damage to the printer, if you install the optional memory with power ON.

(4)-2. Open the top cover and front cover.

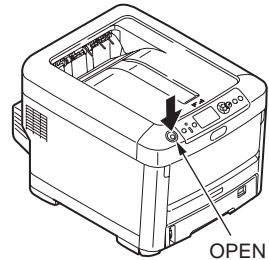

OPEN button

- 1 Press down the OPEN button, and open the top cover.

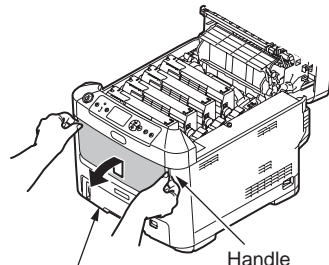

Multi-purpose tray

Handle

- 2 Open the multi-purpose tray.

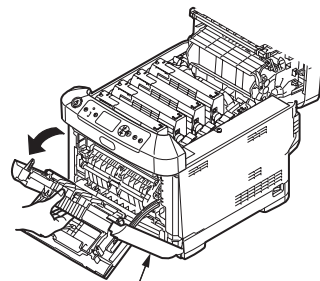

Front cover

- 3 Pull up on the handle (blue) at the center of the front cover, and open the front cover forward.

(4)-3. Remove the side cover.

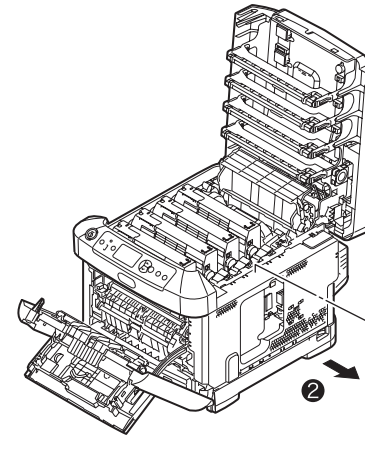

- 1 Loosen the screw (one place).

- 2 Remove the side cover.

Pull it outward to remove while holding the upper edge of the side cover to lift.

Screw

Side cover

(4)-4. Install the built-in SD Memory Card.

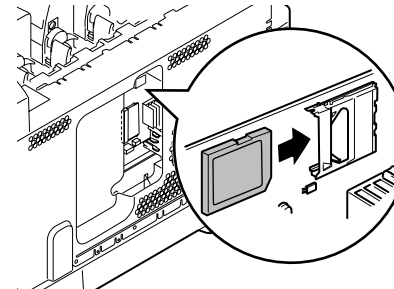

- 1 Observing the orientation of the SD memory card, insert it into the slot on the printer side.

Note! The card cannot be used with its write-protect switch (to guard against accidental erasure on the card) in the unlocked position. To use the card, be sure to place the switch in the locked position.

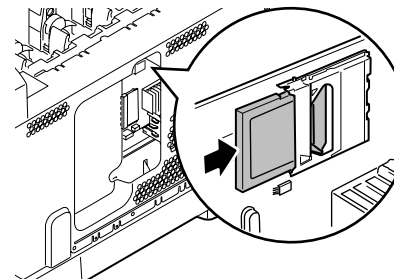

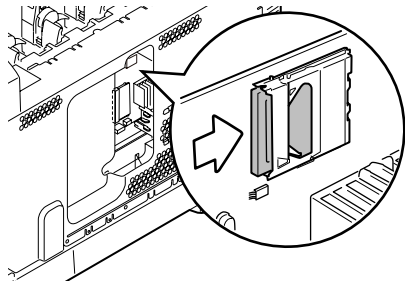

② Press the SD memory card until it clicks.

(4)-7. Print the setting content and confirm if the SD memory card is installed properly.

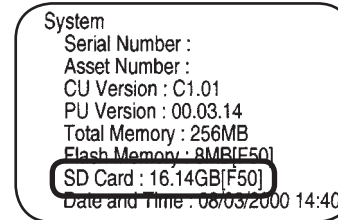

(4)-5. Install the side cover.

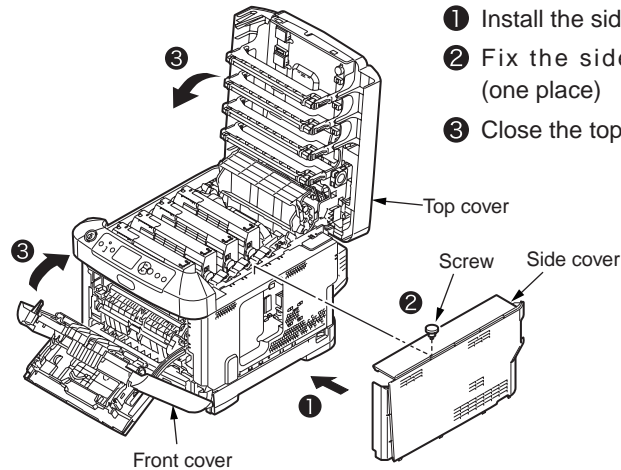

- ① Install the side cover.
- ② Fix the side cover with the screw.
(one place)
- ③ Close the top cover and front cover.

- ① Print the setting content with following the procedure in chapter 3.6.
- ② Confirm the SD Memory Card capacity displayed in [SD Card].

Memo The capacity of SD memory card might be different from the example of the above figure.

Note! Please reinstall the SD memory card when the capacity of SD Card is not displayed.

(4)-6. Connect the power cord and printer cable to the printer, and turn the power on.

And, the printer driver setup for recognizing the SD memory card disk is required. If the printer driver is not set up, please set up the printer driver completely referring to the user's manual (Setup) firstly, and then finish the following setting procedure.

(4)-8. Set [SD memory card] by printer driver

Note! The authority of the computer administrator is required.

For windows PS printer driver

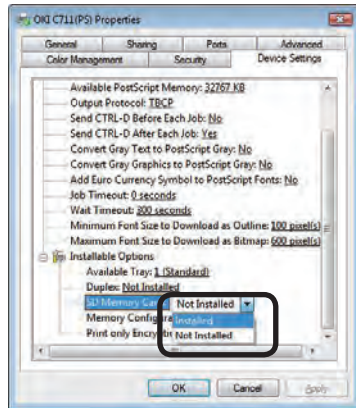

(For Windows XP)

- ① For Windows Vista, click on [start] => [control panel] => [printer].
For Windows XP, click on [start] => [control panel] => [printer and other hardware] => [printers and Faxes].
For Windows Server 2003, click on [start] => [printers and faxes].
For Windows 2000, click on [start] => [Settings] => [printers].
- ② Click the [C711(PS)] icon with right-click button on your mouse and choose the [Properties].
- ③ Choose [get information from printer] from [installable options] in [Device options] tab, and click [setup] or [get information from printer]. For USB connection, set [SD Memory card] as [Install] manually.
- ④ Click [OK].

For Windows PCL printer driver



(For Windows XP)

- ① For Windows Vista, click on [start] => [control panel] => [printer].
For Windows XP, click on [start] => [control panel] => [printer and other hardware] => [printers and Faxes].
For WindowsServer 2003, click on [start] => [printers and faxes].
For Windows 2000, click on [start] => [Settings] => [printers].
- ② Click [C711(PCL)]icon with right-click button on your mouse and choose [Properties].
- ③ Choose [get information from printer] in [Device options] tab. For USB connection, select the option [SD Memory card] manually.
- ④ Click [OK].

For Mac OS X

When the optional device has been added into in Mac OS X before installing the printer driver, the device information is gotten automatically. However, if the printer is connected by [IP print] and [Bonjour (Rendezvous)], the device information could not be gotten automatically.

If the printer is connected by [AppleTalk], the device information could also not be gotten automatically when the optional device has been added into in Mac OS X before installing the printer driver.



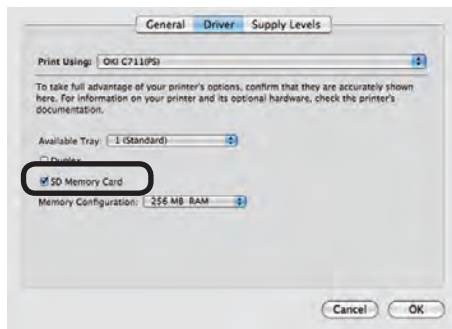

Please finish the following setting procedure for above.





- 1 Double-click [Applications] for hard disk => [utility] => [print setting utility] ([Applications] => [Utility] => [print center] in Mac OS X)
- 2 Select [C711], click [Show info] and open [printer info].
- 3 Choose [installable options].
- 4 Select the [SD Memory Card] option, and click [Apply].
- 5 Close [printer info].
- 6 Confirm the added printer is shown in [Printer list], and close [print center].

3.6 Setting content print (Configuration)

To confirm the printer operates normally, please print the [Configuration].

- (1) Set A4 paper in tray.
- (2) Press the  button for several times so that [Print Information] is displayed, and press down the  button.
- (3) Press the  button and select [Configuration], press down the setting button.
- (4) Press down the  button.

The setting content print is started.

Memo When printing the network setting information (2 pieces Network Information), press the  button after (2), and press down the  button after [Network] is displayed.

A Demo page or a file list can be printed in the same way as Network does.

(C711n sample)

08/03/2000 14:18
C711

Configuration

CUI version: C1.01 | 01.23 UJ.03.13 S3.5.2g B01.08 L01.03 532MHz 14241C00 000C0091 F50_J0
 PU version: 03.14 | P903.10 L000.00.08 DL0.00.02.01 | ET 0050000000004031 C291D1000000000F
 PCL Program version: 05.06 | 04.30 X04.02 P00.48 F00.48 | IM version: 01.02
 PS Program version: 3017, PSE13
 Duplex installed: Tray1 A4
 OEL: P900 DPLR1.52 MIC/CP
 C.O.M: Y.O.K.O KYMC-0000
 Network version: 01.00 Web Remote: 01.02
 ENGINE: 57 K:1 C:50 T:0:0:1, R:0:0:0, B:0, F:0
 Language format: 1.00
 Language version: 1.00
 Language: JAPANESE

<p>Configuration</p> <p>Tray Count Tray1 : 59 MPTray : 0</p> <p>Supplies Life</p> <p>Cyan Drum : Remaining 99 % Magenta Drum : Remaining 99 % Yellow Drum : Remaining 99 % Black Drum : Remaining 99 % Belt : Remaining 99 % Fuser : Remaining 99 % Cyan Toner (4.0K) : Remaining 100 % Magenta Toner (4.0K) : Remaining 100 % Yellow Toner (4.0K) : Remaining 100 % Black Toner (4.0K) : Remaining 100 %</p> <p>Network</p> <p>Printer Name : OKI-C711-849C9B Short Printer Name : C711-849C9B IPv4 Address : 192.254.112.104 Subnet Mask : 255.255.0.0 Gateway Address : 0.0.0.0 MAC Address : 009007949C9B Network FW Version : 01.00 Web Remote Version : 01.02</p> <p>System</p> <p>Serial Number : Asset Number : CUI Version : C1.01 PU Version : 00.03.14 Total Memory : 256MB P-RAM Memory : 9MB(F50) SD Card : uninstalled Date and Time : 08/03/2000 14:18</p> <p>Print Information</p> <p>Configuration Network Demo Page DEMO1 File List PS Font List PCL Font List IBM PPS Font List EPSON FX Font List Usage Report Error Log Color Profile List</p> <p>Shutdown</p> <p>Shutdown Start</p> <p>Menus</p> <p>Tray Configuration Paper Feed : Tray1 Auto Tray Switch : On Tray Sequence : Down Unit of Measurement : millimeter</p> <p>Tray Config Paper Size : A4 Media Type : Plain Media Weight : Medium</p> <p>MPTray Config Paper Size : A4 Media Type : Plain Media Weight : Medium Tray Usage : Do Not Use</p>	<p>System Adjust</p> <p>Power Save Time : 30 minutes Sleep Time : 10 minutes Cassette Warning : ONLINE Auto Continue : Off Manual Timeout : 60 seconds Wait Timeout : 40 seconds Low Toner : Continue Jam Recovery : On Error Report : Off Print Position Adjust X Adjust : 0.00 millimeter Y Adjust : 0.00 millimeter Duplex X Adjust : 0.00 millimeter Duplex Y Adjust : 0.00 millimeter Paper Black Setting : 0 Paper Color Setting : 0 Films Black Setting : 0 Films Color Setting : 0 SMR Setting : 0 BQ Setting : 0 Drum Cleaning : Off Hex Dump</p> <p>Admin Setup</p> <p>Network Setup TCP/IP : Enable IP Version : IP v4 NetBEUI : Disable NetBIOS over TCP : Enable NetWare : Disable EtherTalk : Disable IP Address Set : Auto IPv4 Address : 192.254.112.104 Subnet Mask : 255.255.0.0 Gateway Address : 0.0.0.0 Web : Enable Telnet : Disable FTP : Disable IRISec : Disable SNMP : Enable Network Scale : Normal Hub Link Setting : Auto Negotiate Factory Defaults?</p> <p>Print Setup</p> <p>Personality : Auto Copies : 1 Duplex : Off Media Check : Enable Resolution : 600x1200dpi Toner Save Mode : Off Mono-Print Speed : Auto Default Orientation : Portrait Form Length : 64 lines Edit Size : Cassette Size X Dimension : 210 millimeter Y Dimension : 297 millimeter</p> <p>PS Setup</p> <p>Network Protocol : RAW USB Protocol : RAW</p> <p>PCL Setup</p> <p>Font Source : Resident Font Number : 10 Font Pitch : 10.00 CPI Symbol Set : PC-8 A4 Print Width : 78 column</p>
---	--



3.7 Connecting method

<USB connection>

Note! Please refer to user's manual for operation environment.

Prepare for USB cable

- Notes!**
- The printer cable is not included. Provide the USB2.0 cable for special user.
 - When connecting the cable in [Hi-Speed] mode of USB 2.0, please use the USB cable with Hi-Speed spec.
 - Select the USB cable of less than 5m. It is recommended to use the USB cable of less than 2m.



Turn the printer and computer OFF.

Memo Although USB cable can plug-and-play with computer and printer power on, after this the setup of printer driver and USB driver may be required. Here the printer is turned off to plug-and-play the USB cable.

Connect the computer to the printer.

- (1) Insert the USB cable into the USB interface connector of printer.
- (2) Insert the USB cable into the USB interface connector of computer.

Note! Do not insert the USB cable into the network interface connector. It may cause trouble.

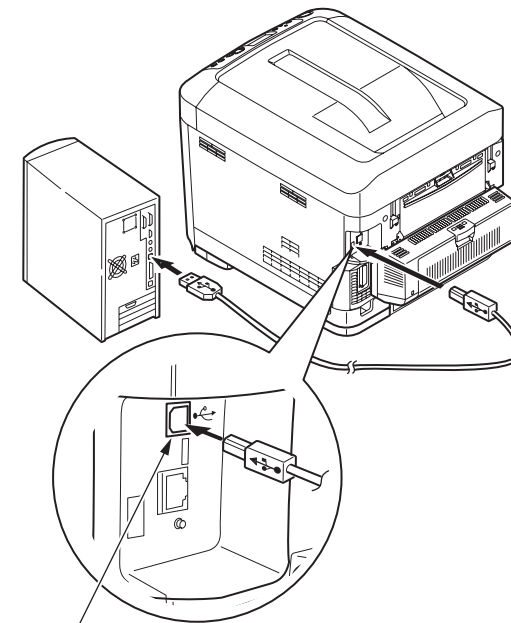

USB Interface connector

Memo Please refer to user's manual for setup of printer driver.

< Ethernet cable connection >

Note! Refer to user's manual for operation environment.

Prepare for Ethernet cable

Note! The Ethernet cable and Hub is not included in printer. Provide the Ethernet cable and Hub for special user.

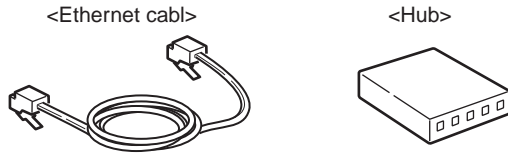

Turn the printer and computer OFF.

Connect the computer to the printer.

- (1) Insert the Ethernet cable into the network interface connector of printer.
- (2) Insert the Ethernet cable into Hub.

Memo Refer to user's manual for setup of printer driver.

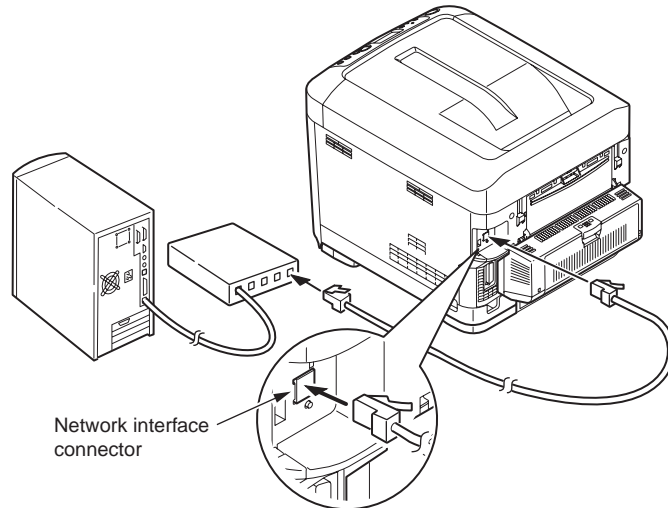

< Parallel connection >

Prepare for Parallel cable

Note! The parallel cable is not included in printer. Provide it for special user.

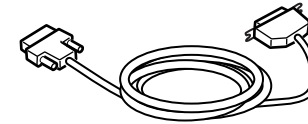

Turn the printer and computer OFF.

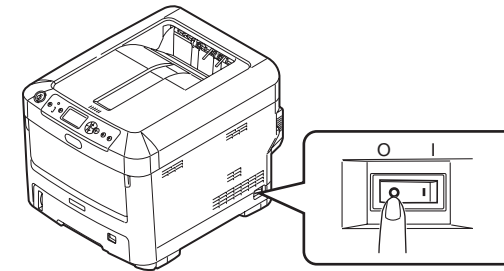

Connect the computer to the printer.

- (1) Insert the parallel cable into the parallel interface connector of printer, and Lock it firmly by metal fittings.
- (2) Insert the parallel cable into the parallel interface connector of computer, and fix it firmly with screws.

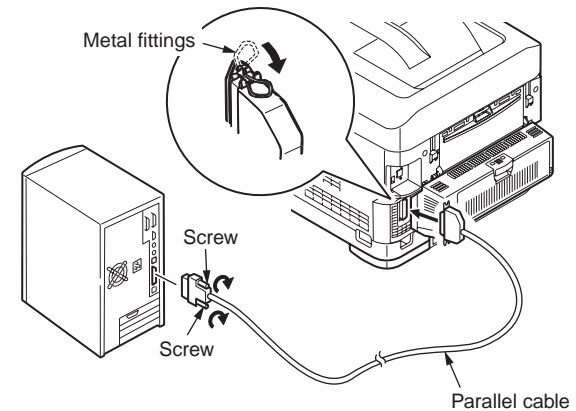

3.8 User used Paper confirmation

Load the paper used by user, set the media type/weight, print the setting content/demo, and confirm if the toner is chipped off.

Type	Thickness	settings of control panel		[Thickness of paper] settings of printer driver*2
		Media weight (Thickness of paper)	Media type (Type of paper)*1	
Plain paper*3	55~64kg (64~74g/m ²)	Light	Plain paper	Light
	65~70kg (75~82g/m ²)	Medium Light		Medium Light
	71~89kg (83~104g/m ²)	Medium		Medium
	90~103kg (105~120g/m ²)	Heavy		Heavy
	104~162kg (121~188g/m ²)	Ultra heavy1		Ultra heavy1
	163~189kg (189~220g/m ²)	Ultra heavy2		Ultra heavy2
	190~215kg (221~250g/m ²)	Ultra heavy3		Ultra heavy3
Post card*4	—	—	—	—
Envelope*4	—	—	—	—
Label paper	Less than 0.1~0.17mm	Heavy	Label paper	Label paper1
	0.17~0.2mm	Ultra heavy1		Label paper2

*1 : The factory default setting of media type of the printer is set as [plain paper].

*2 : The thickness and type of paper could be set by control panel and printer driver. The settings set by printed driver have priority. When [Paper feed method] is selected as [Auto select] or [Paper thickness] is set as [print setting] in the printer driver, the print operation is set by control panel.

*3 : The thickness of the paper for duplex printing is 55~189kg (64~220g/m²).

*4 : The setting of media weight and media type for postcard and envelope is not required.

Memo If the media weight is set as [Heavy] or [Ultra Heavy1, 2, 3], or the media type is set as [label paper], the print speed would be reduced.

4. Component replacement

In this chapter, the procedures for replacement of part and assembly and unit are described.

The replacement procedure is described by removal of the parts. Please install the new parts with following the replacement procedure in reverse order.

The parts (such as ①, ②) shown in this manual are different from the parts used in the Disassembly for Maintenance figure (44205401TL) and RSPL (44205401TR).

4.1	Precautions on component replacement	62
4.2	Method of component replacement	64
4.3	Oiling spots	80

4.1 Precautions on component replacement

(1) Remove the AC cord and the interface cable before replacing the parts.

(a) Remove the AC cord according to the following procedure.

- ① Switch the power switch of printer off "O".
- ② Disconnect the AC insertion plug of the AC power cord from the AC power source.
- ③ Disconnect the earth wire from the earth terminal of the AC power source outlet.
- ④ Disconnect the AC cord and the interface cable with the printer.



There is a risk of electric shock during replacement of the low voltage power supply. Use insulating gloves or avoid direct contact with any conducting part of the power supply, and caution should be exercised during replacement.

The capacitor may take one minute to complete discharge after the AC cord is unplugged. Also, there is a possibility that the capacitor doesn't discharge because of a breakage of the PCB, etc., so remember the possibility of electric shock to avoid electric shock.

(b) Reconnect the printer according to the following procedure.

- ① Connect the AC cord and the interface cable with the printer.
- ② Connect the earth wire to the earth terminal of the AC power source outlet.
- ③ Connect the AC power cord insertion plug to the AC power source outlet.
- ④ Switch the power switch of printer on "I".

(2) Do not disassemble it if the printer works normally.

(3) Disassemble it as required. Do not remove the part that is not shown in the replacement procedure.

(4) Please use the specified maintenance tool.

(5) Disassemble it according to the proper procedure. It may cause damage to the parts if disassemble it without following the proper procedure.

(6) As the small parts such as the screws are lost easily, please fix them to the original position temporarily.

(7) Do not use gloves that may cause static electricity easily when handling IC and the circuit board such as microprocessor, ROM, and RAM.

(8) Do not put the PCB on the device and the floor directly.



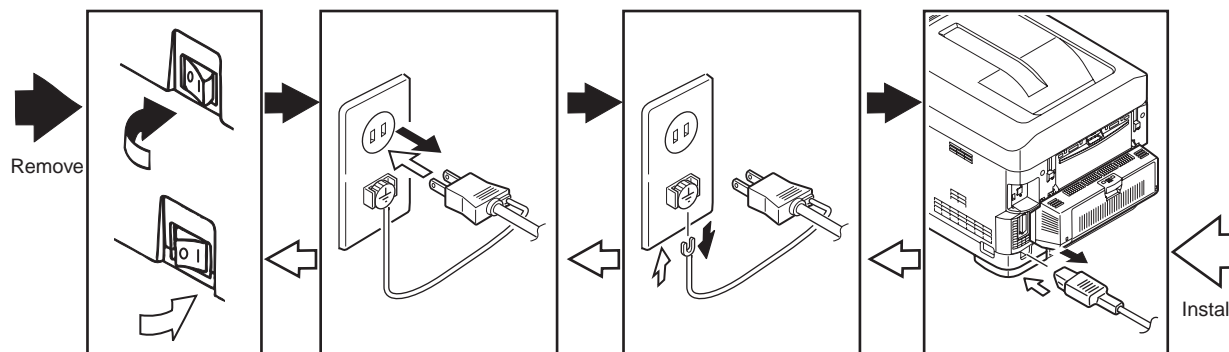

(9) Do not work for a long time with the printer with the top cover open, and an image drum unit installed in it.



[Maintenance tool]

The required tools for replacing the PCB and the unit are shown in Table 4-1-1.

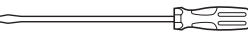

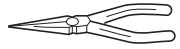
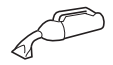
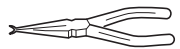
Table 4-1-1 Maintenance tools

No.	Maintenance tools	Amount	Purpose	Note
1	 No. 2-200 ⊕ Magnetic driver	1	3 - 5mm Screw	
2	 No. 3-100 Driver	1		
3	 No. 5-200 Driver	1		
4	 Digital multimeter	1		
5	 Combination pliers	1		
6	 Handy cleaner (the type corresponds to the toner)	1		Refer to the following note.
7	 E Ring pliers	1	For E ring detaching	

Note! Use the specified cleaner corresponding to the toner. It may cause a fire when using a general-purpose cleaner.

The required tools for using the maintenance utility are shown in Table 4-1-2.

Table 4-1-2 required tools

No.	Maintenance tools	Amount	Purpose	Note
1	 Notebook Please install the maintenance utility.	1		Refer to the chapter 5.2 for the maintenance utility.
2	 USB cable	1		
3	 Ethernet cable (Cross cable)	1		

4.2 Method of component replacement

In this chapter, the replacement of parts and assemblies is described by the disassemble figures.

4.2.1 Belt unit

- (1) Open the top cover.
- (2) Remove the ID unit ①.

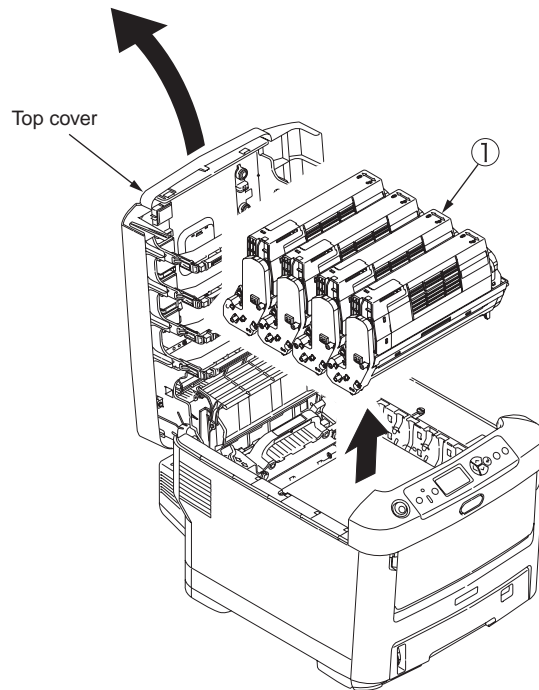

Note! Cover the removed image drum cartridge with black paper.

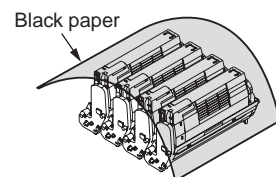

- (3) Rotate the lock lever (blue, 2 places) of the belt unit ② in the direction of arrow , and hold the lever (blue) to remove the belt unit.

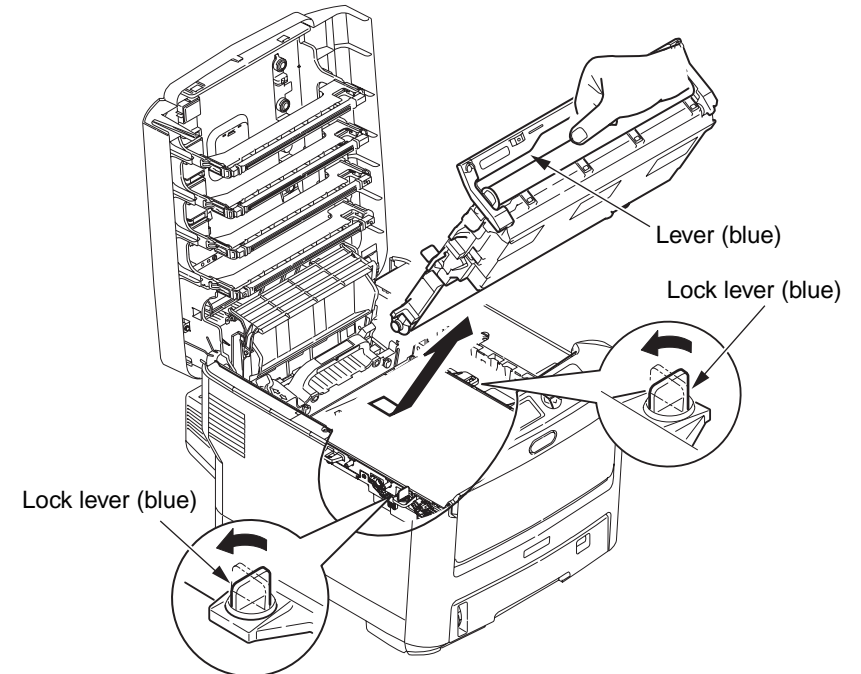

4.2.2 Fuser unit

- (1) Open the top cover.
- (2) Push up the fix lever of fuser unit in the direction of arrow, and remove the fuser unit ①.

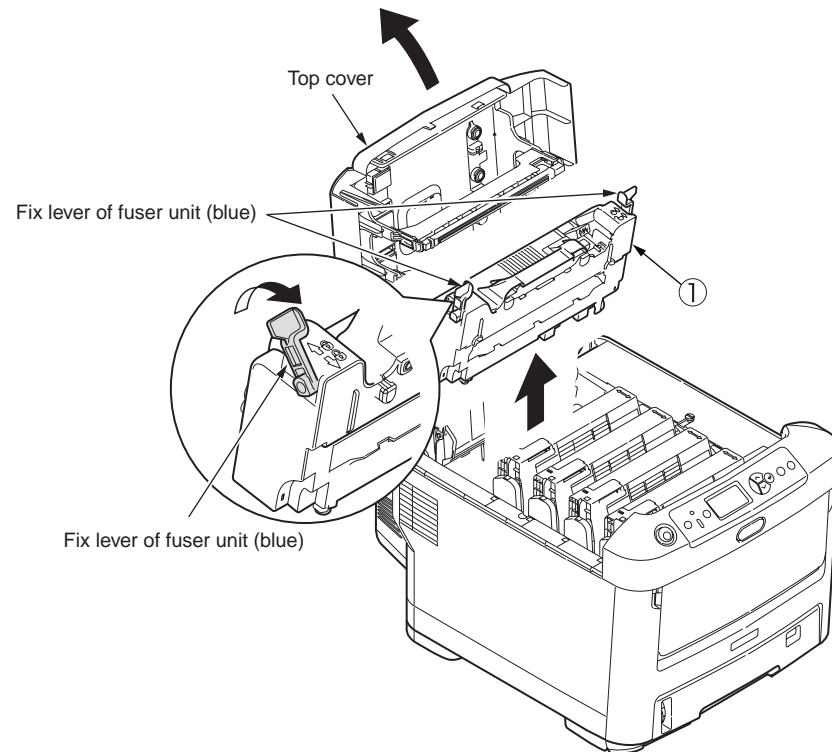

4.2.3 Left side cover

- (1) Open the top cover.
- (2) Open the feeder unit.
- (3) Remove the screw ① (silver), and remove the left side cover ②.

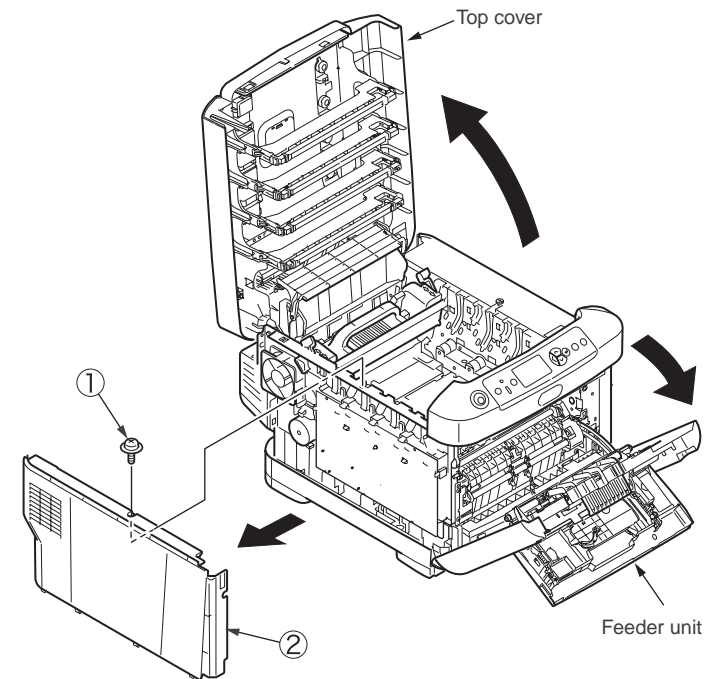

4.2.4 Right side cover

- (1) Open the top cover.
- (2) Open the feeder unit.
- (3) Loosen the screw (silver, No:41723901) ① and remove the right side cover ②.

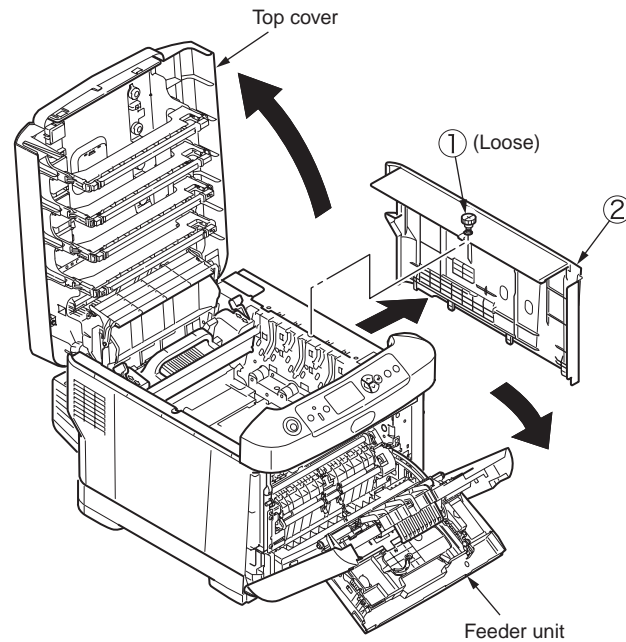

4.2.5 Faceup tray

- (1) Draw out the Duplex unit ①.
- (2) Open the faceup tray ② in the direction of arrow, and unlock the left and right pins while bending. Remove the faceup tray ②.

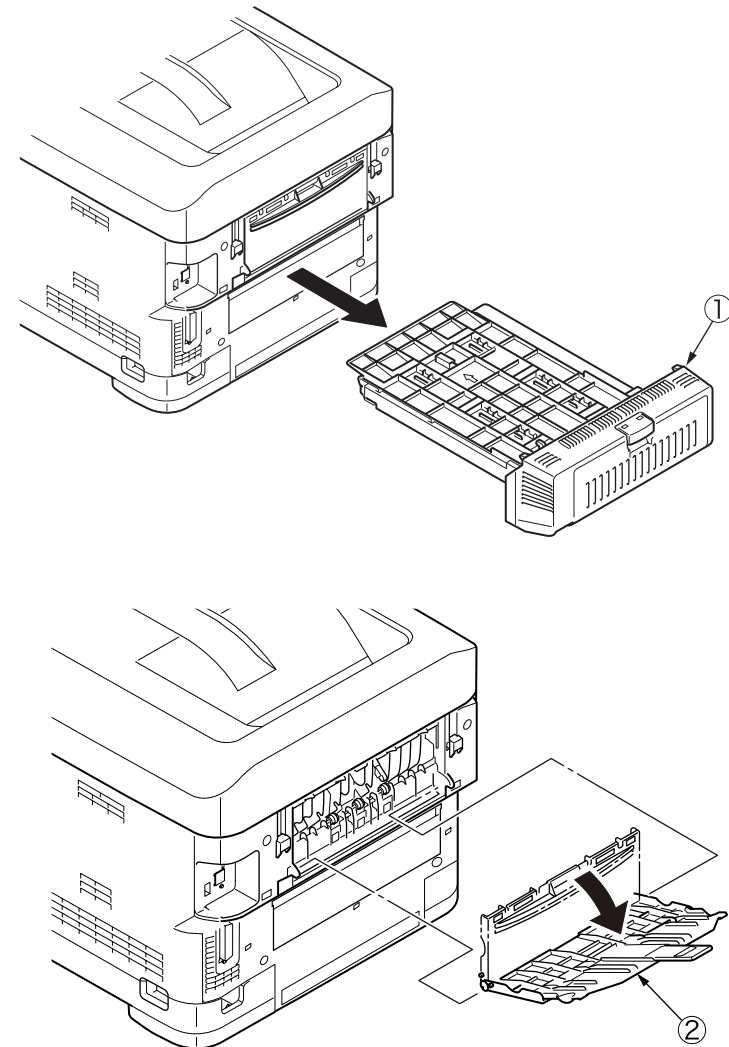

4.2.6 Rear cover

- (1) Open the faceup tray.
- (2) Remove the two screws ① (silver, No:42920406).
- (3) As shown in fig 2, insert the minus driver into the hole A to disengage the claw A (2 place).
- (4) Disengage the claw B (2 places) and pull the upper side of the rear cover ② in the direction of A.
- (5) As shown in fig 3, push the lower side of the rear cover ② in the direction of B, and disengage the claw C (3 places) to remove the rear cover ②.

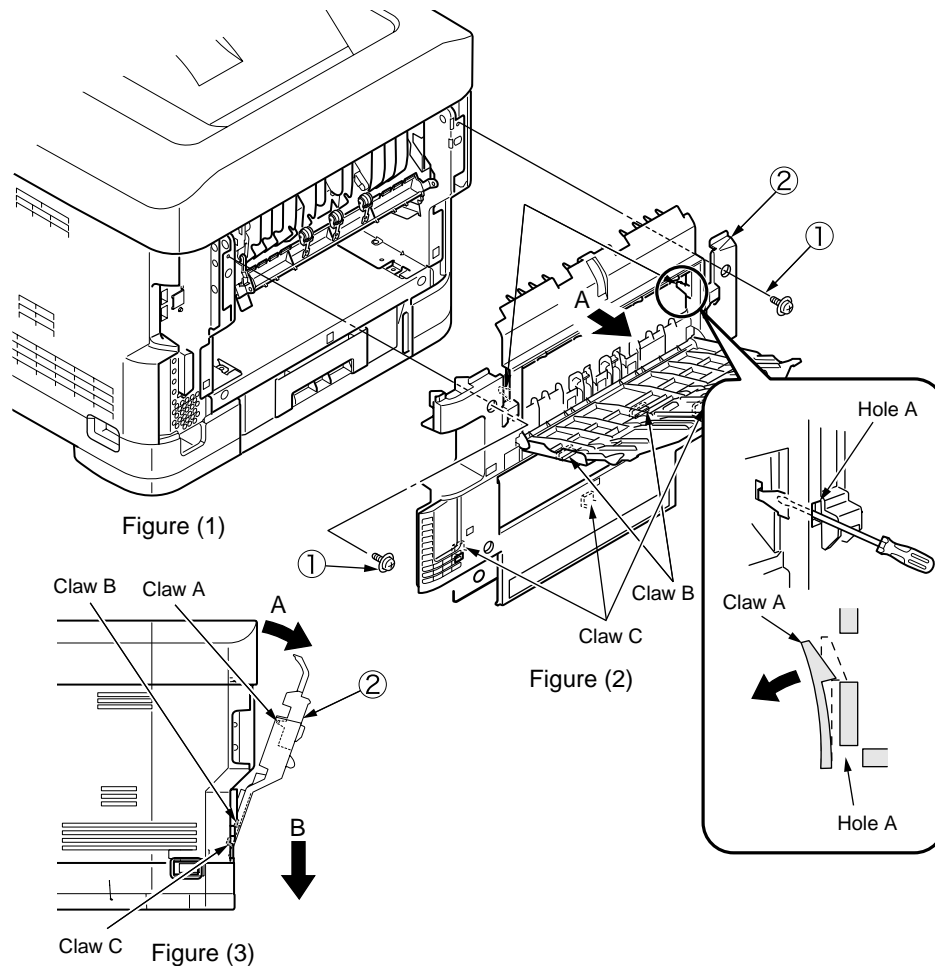

4.2.7 LED Assy/ LED Assy spring

- (1) Open the top cover
 - (2) After removing the cable, as shown in fig 2, push the LED assy ① tightly in the direction of arrow. Take the hook A out firstly, and then take the hook B out, at last remove the LED assy.
- (At this time, the two springs ② is removed with LED Assy ①.)

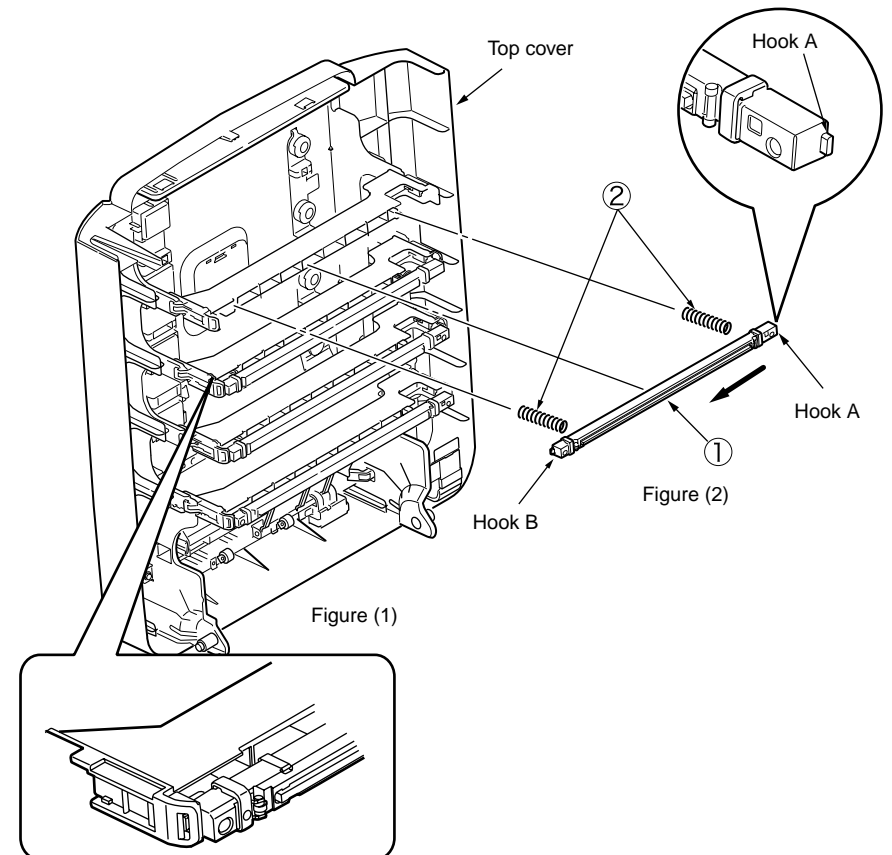

4.2.8 Control PCB

- (1) Open the top cover.
- (2) Remove the right side cover. (See section 4.2.4)
- (3) Remove the Rear cover. (See section 4.2.6)
- (4) Remove the eight screws ① (silver, No:42920406), remove the connector and disengage the claw A to take the plate-shield ② out.
- (5) Remove the screw ③ (silver, No:42920406) and disconnect the head cable ④.
- (6) Remove the six screws ⑤ (silver, No:42920406) and all cables, and take the control PCB ⑥ out.

Note! To attach the head cable, insert the end of the film-FG inside the plate-side-R, preventing from touching the edge of the plate-side-R.

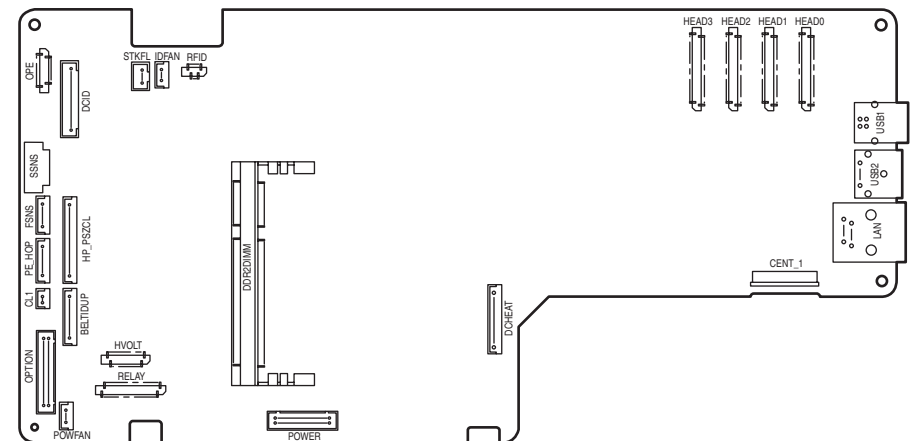
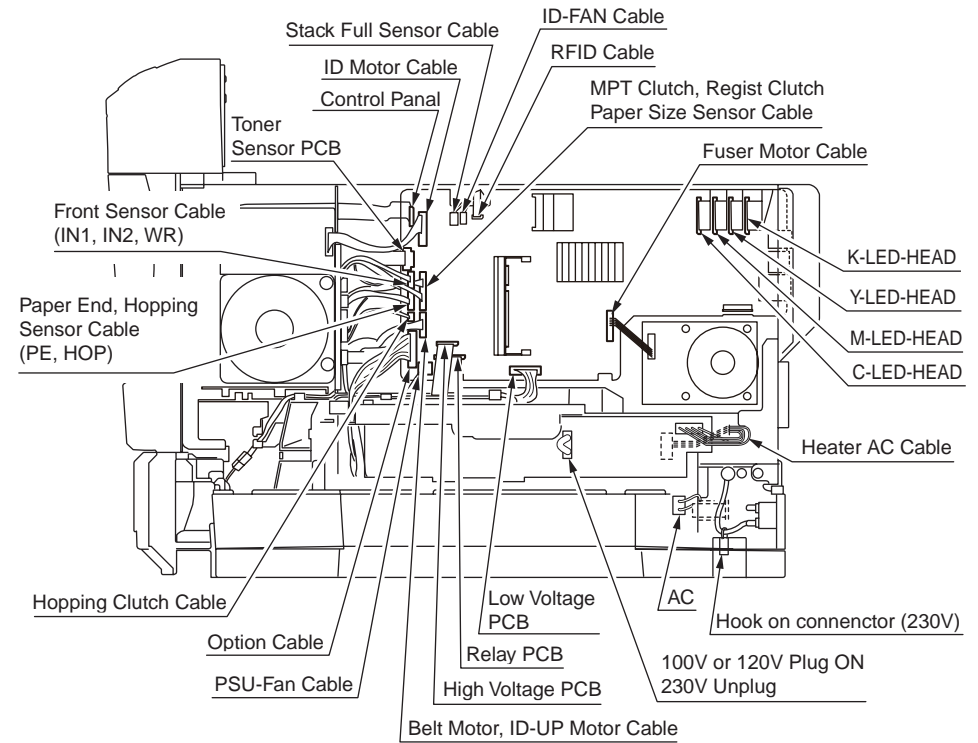
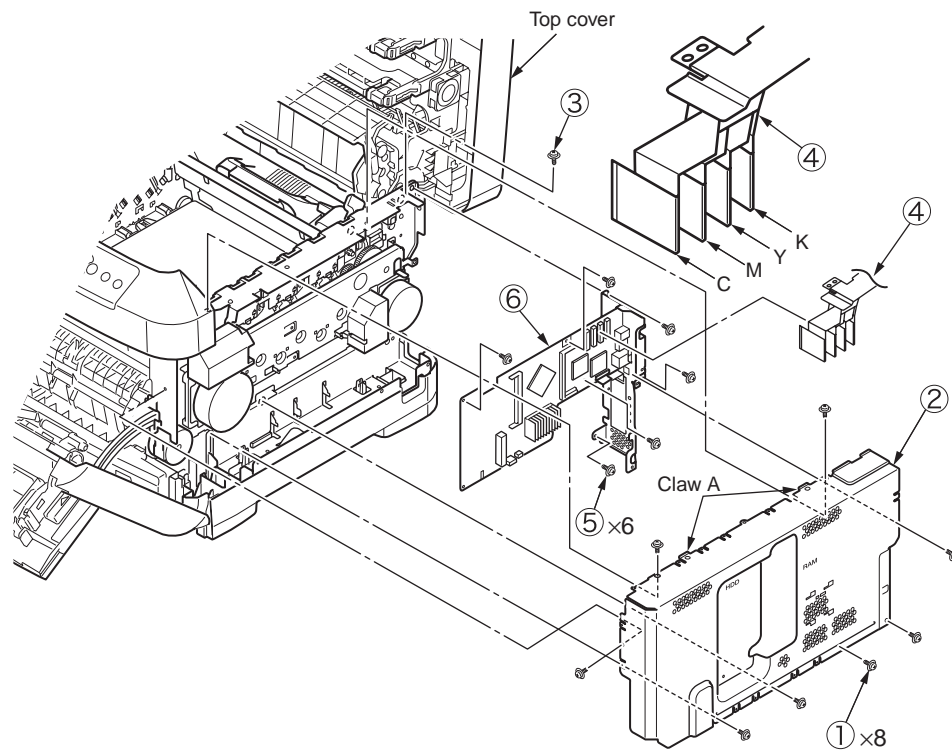

4.2.9 Top cover Assy

- (1) Remove the left side cover. (See section 4.2.3)
- (2) Remove the right side cover. (See section 4.2.4)
- (3) Remove the rear cover. (See section 4.2.6)
- (4) Remove the plate shield and take the control PCB out. (See section 4.2.8)
- (5) Remove the connectors of the stack full sensor cable and ID-FAN cable, remove the connector and the hanging RFID cable ①.
- (6) Remove two E type stop rings ② and two torsion springs ③, and remove the top cover Assy ④.

- Notes!**
- Perform the following RFID circuit behavior check after replacement of the top cover assy:
 - By executing RFID COLOR for the switch scan test described in 5.3.1.3, check that the printer can display UID **H for each of cyan, magenta, yellow and black with nonempty consumable cyan, magenta, yellow and black toner cartridges installed in it. The printer cannot detect the UID usage for a color with a starter toner cartridge installed for the color. Note the printer's starter cartridge for a color cannot be reinstalled in it once replaced with an empty consumable toner cartridge for the color.

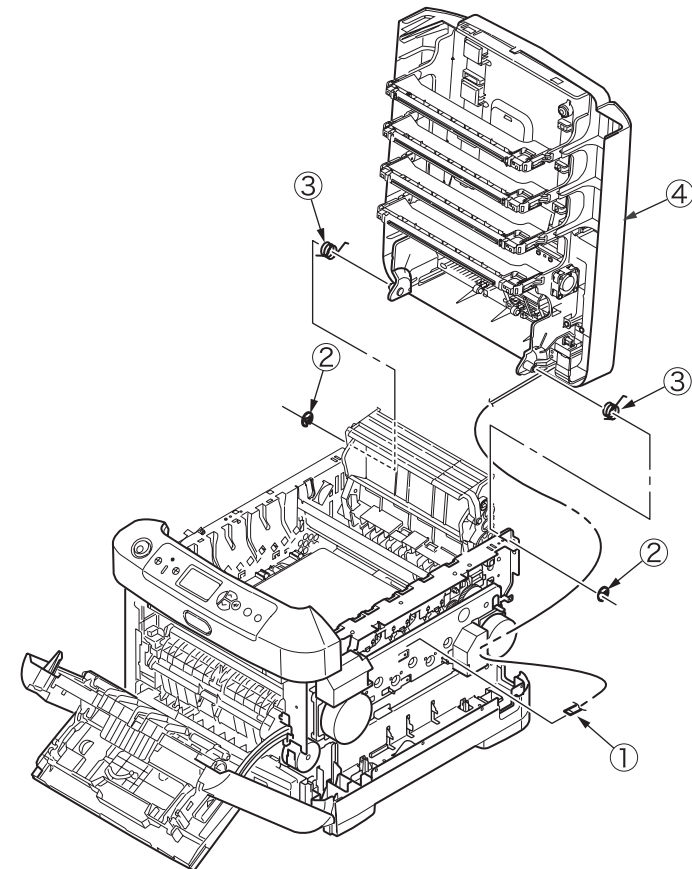

4.2.10 Top cover

- (1) Remove the top cover Assy. (See section 4.2.9)
- (2) Remove ten screws ① (Black, No:42932708), and remove the top cover ②.

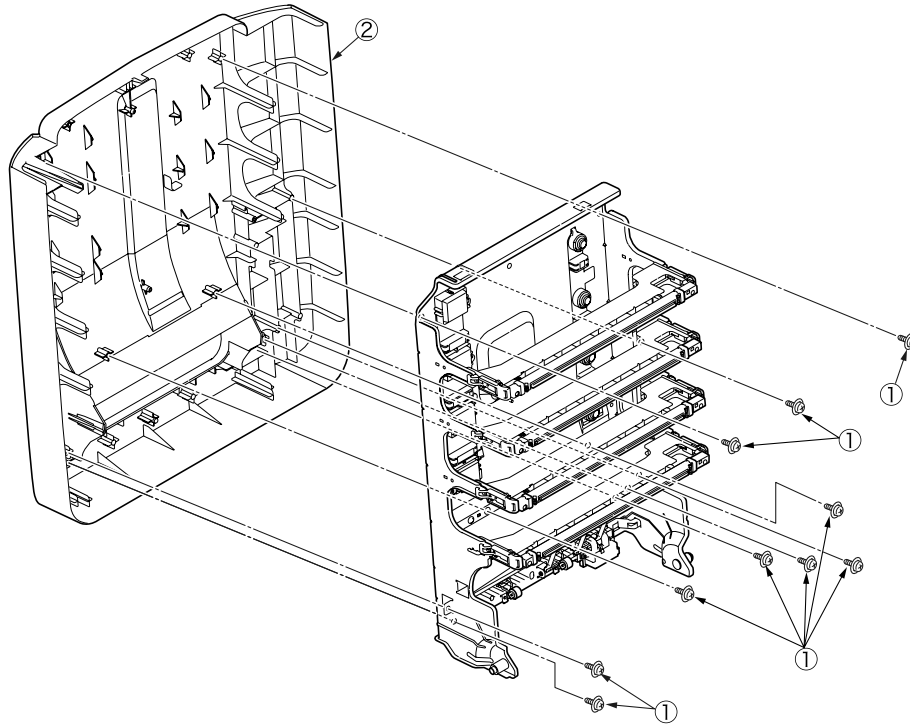

4.2.11 Control panel Assy

- (1) Open the top cover.
- (2) Insert the minus driver into the upper side of the slit (3 places) to disengage the claws on the control panel Assy ①, remove the connector and take the control panel Assy ① out.

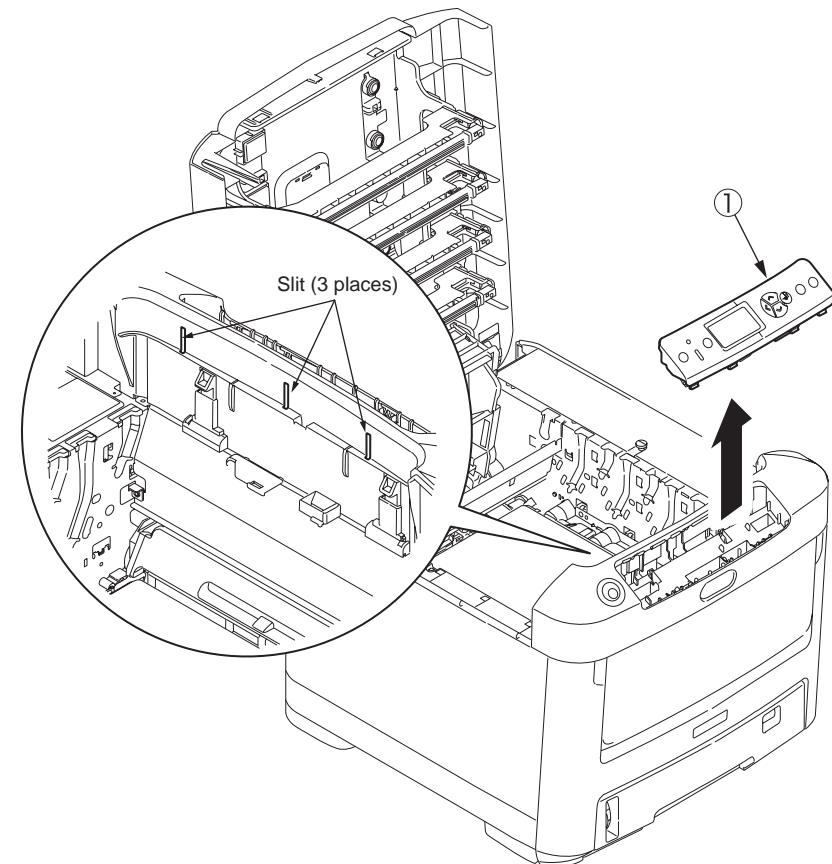

4.2.12 Board IBG/ LCD

- (1) Remove the control panel Assy. (See section 4.2.11)
- (2) Remove the screws (black, No:42932708) ① (2 places), remove the connector and cable of LCD ④ and remove the Board IBG ②.
- (3) Remove the screws (black, No:42932708) ③ (2 places), and remove the LCD ④.

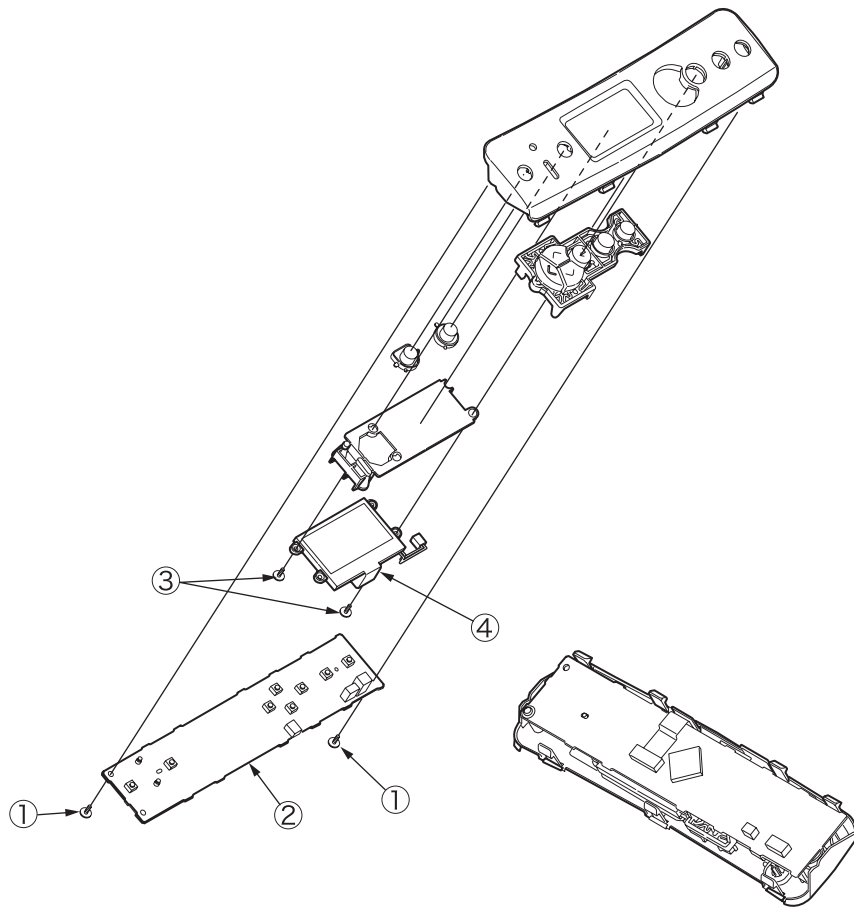

4.2.13 Frame panel Assy

- (1) Open the top cover.
- (2) Open the feeder unit.
- (3) Remove the right side cover. (See section 4.2.4)
- (4) Remove the plate shield. (See section 4.2.8 (4))
- (5) Remove the connector of frame panel and remove the hanging cable.
- (6) Remove the control panel Assy. (See section 4.2.11)
- (7) Remove the two screws ① (silver, No:42920406), disengage the claws (3 places) on frame panel Assy, and remove the frame panel Assy ②.

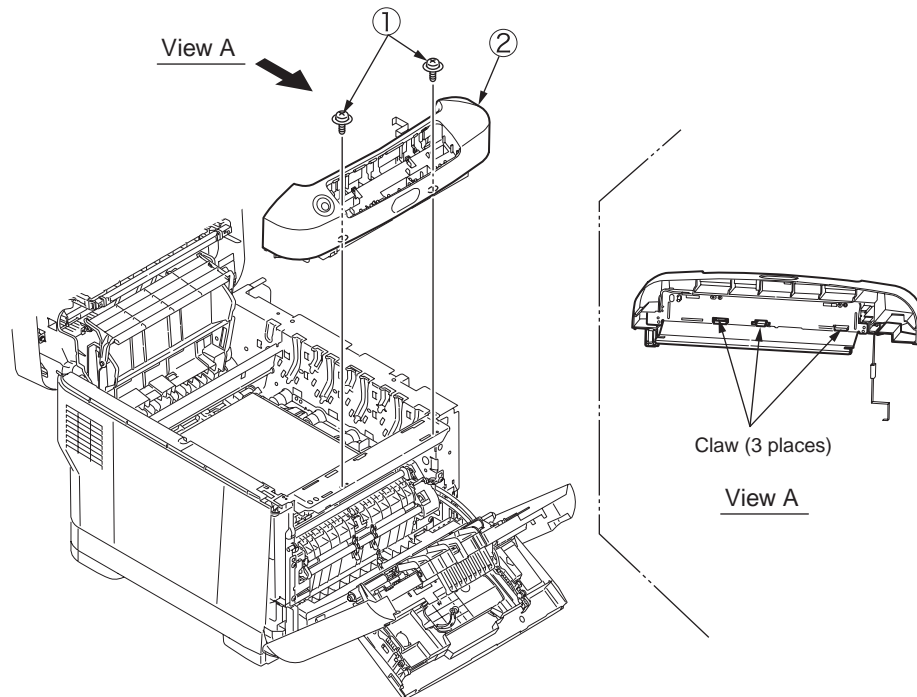

- (8) Remove the lever lock ③, compression spring ④, torsion spring ⑤, button switch ⑥, cable Assy ⑦ from the frame panel ⑧.

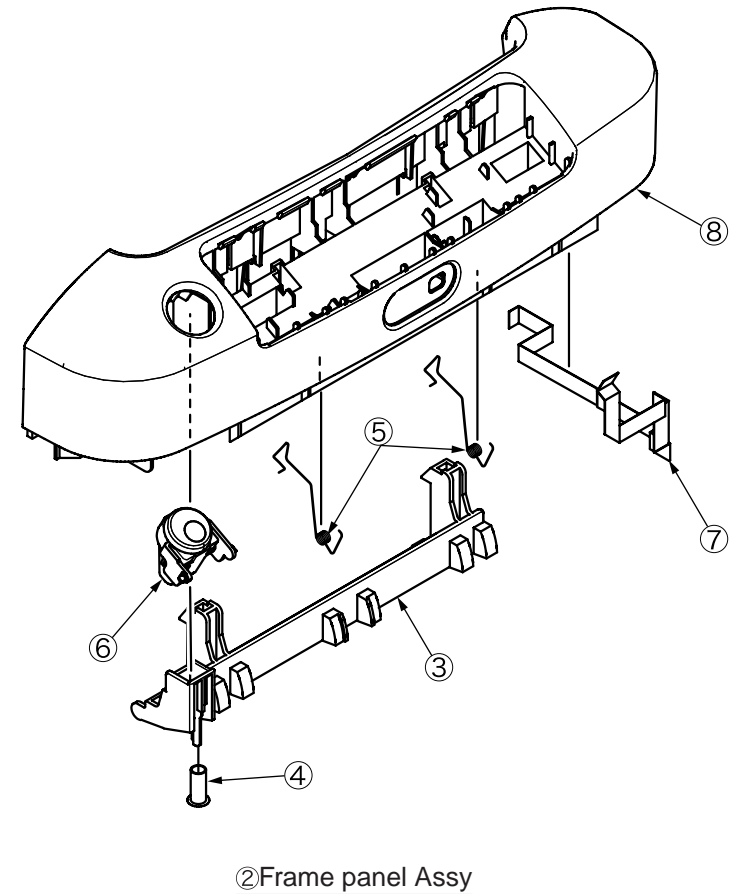

4.2.14 Low voltage power supply/Low voltage FAN/ Hopping motor/ Fuse motor



There is a risk of electric shock during replacement of the low voltage power supply.

Use insulating gloves or avoid direct contact with any conducting part of the power supply, and caution should be exercised during replacement.

The capacitor may take one minute to complete discharge after the AC cord is unplugged. Also, there is a possibility that the capacitor doesn't discharge because of a breakage of the PCB, etc., so remember the possibility of electric shock to avoid electric shock.

- (1) Take the cassette Assy out.
- (2) Remove the control PCB. (See section 4.2.8)
- (3) Remove all cables from Guide cable PowerLow.
- (4) Remove the fuse I/F connector from low voltage power supply, disengage the claws (2 places), and remove the Guide cable PowerLow ①.
- (5) Remove the two screws ② (silver, No:42920406) and four connectors (CN1, CN2, CN3), and remove the low voltage power supply ③.
At the same time, remove the screw ④ (black, No:42932708) and remove the AC inlet Assy ⑤.
- (6) Disengage the claw C and remove the low voltage FAN ⑥.
- (7) Disengage the claw D (2 places) and claw E, and remove the motor cover ⑦.
- (8) Remove the four screws ⑩ (silver, No:42920406) and connector, and take the fuse motor ⑪ out.
- (9) Remove the three screws ⑫ (silver, No:42920406) and connector, and take the ID motor ⑬ out.

- Notes!**
- Be careful to install the low voltage FAN ⑥ in the proper direction.
 - Please confirm the setting of AC input voltage when installing the low voltage power supply ③.
 - 100V: the short plug is mounted to the connector CN6
 - 230V: the short plug is not mounted to the connector CN6
 - Low-voltage power supply ③ and AC Inlet Assy ⑤ should be replaced together. (The pair of low-voltage power supply and AC Inlet Assy meets the safety standards.)

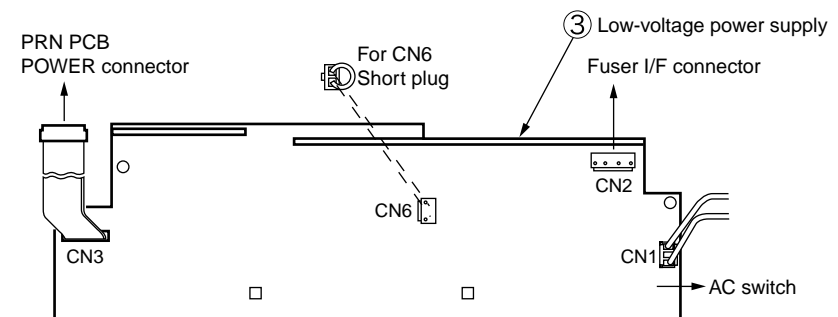
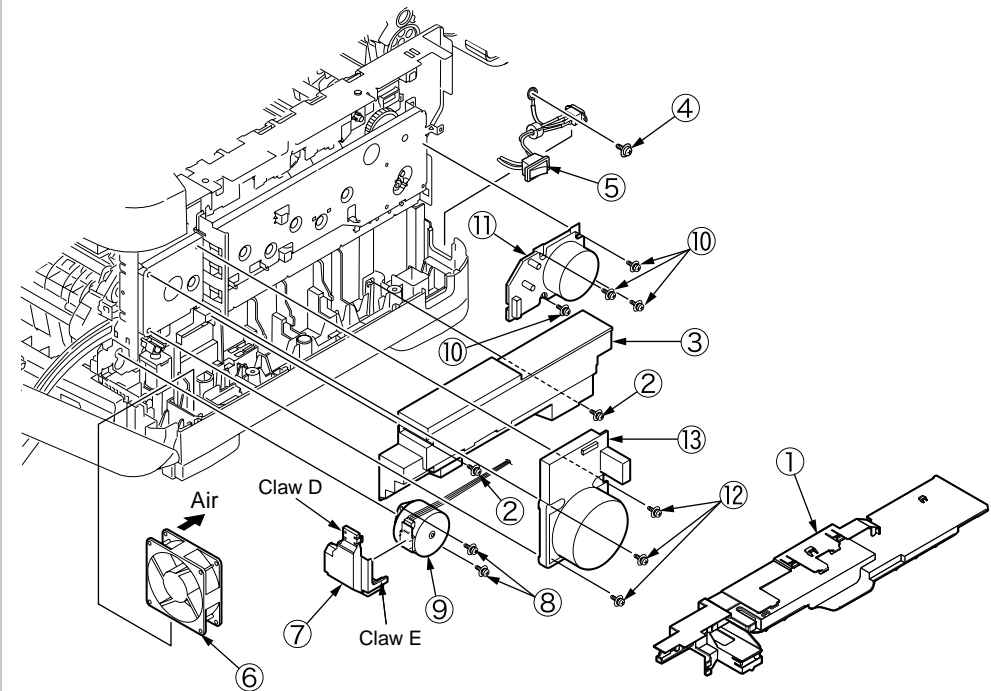

Note! CN6: A connector used to switch the AC input voltage setting
100V short plug is mounted/ 230V short plug is not mounted.

4.2.15 Guide eject Assy/ Color regist Assy/ Board-PRY

- (1) Remove the left side cover, right side cover, rear cover, top cover Assy. (See section 4.2.3, 4.2.4, 4.2.6, 4.2.9)
- (2) Remove the control PCB and low-voltage power supply. (See section 4.2.8, 4.2.14(3))
- (3) Remove the connector of belt thermistor, remove the two torsion springs ①, and disengage four claws (4 places) by minus driver, remove the cover driver ②.
- (4) Remove the screws ③ (silver, No:42920406) and connectors (6 places), remove the Board PRY ④.
- (5) Remove the two screws ⑤ (silver, No:42920406) and remove the color regist Assy ⑥.
- (6) Remove the two screws ⑦ (silver, No:42920406), remove the cable ⑧ of fuse I/F connector from clamp, and slide the claw of cable guide ⑨ to disengage, remove the guide eject Assy ⑩.

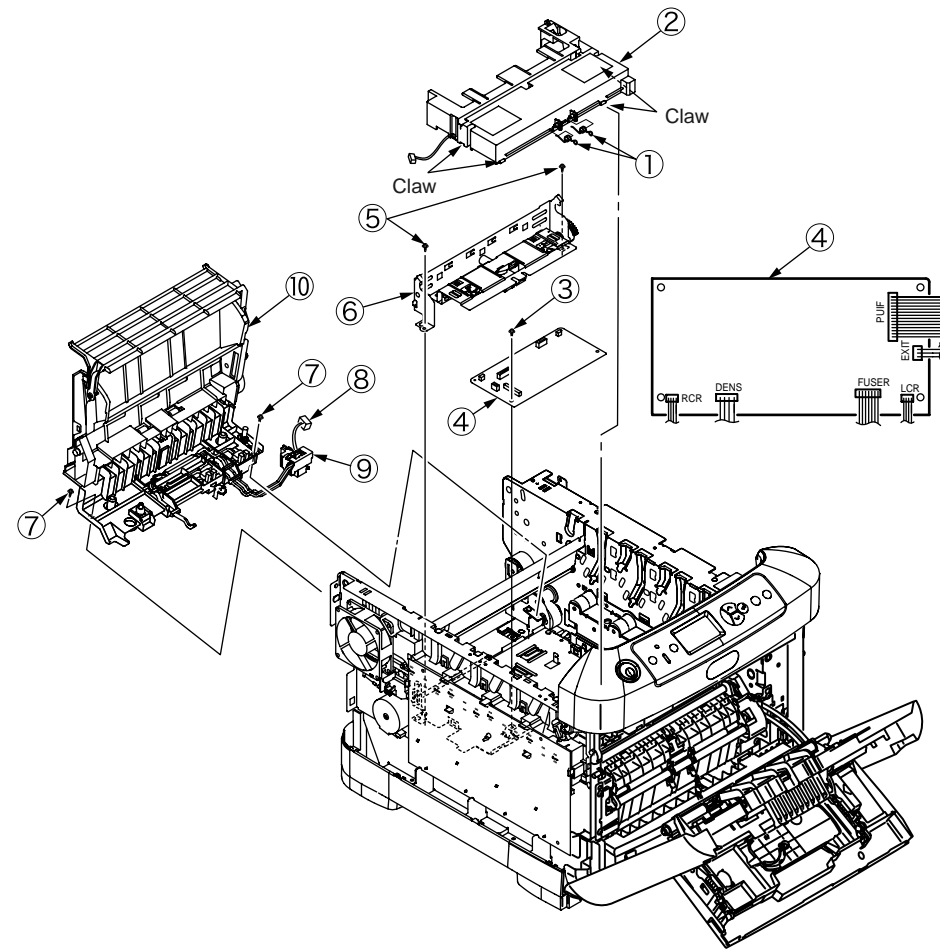

4.2.16 FAN(Fuser) / Belt motor/ High-voltage board/ Cover open switch

- (1) Remove the left side cover. (See section 4.2.3)
- (2) Remove the screw ① (silver, No:42920406) and connector, and remove the belt motor ②.
- (3) Remove the connector, and rotate the FAN (Fuser) ③ clockwise to remove.
- (4) Remove the connector and disengage the claw A (2 places), and remove the cover open switch ④.
- (5) Remove the 2 screws ⑤ (silver, No:42920406 and black, No:42932708) and connectors (2 places), and disengage the claw B (7 places). Remove the high-voltage power supply ⑥.

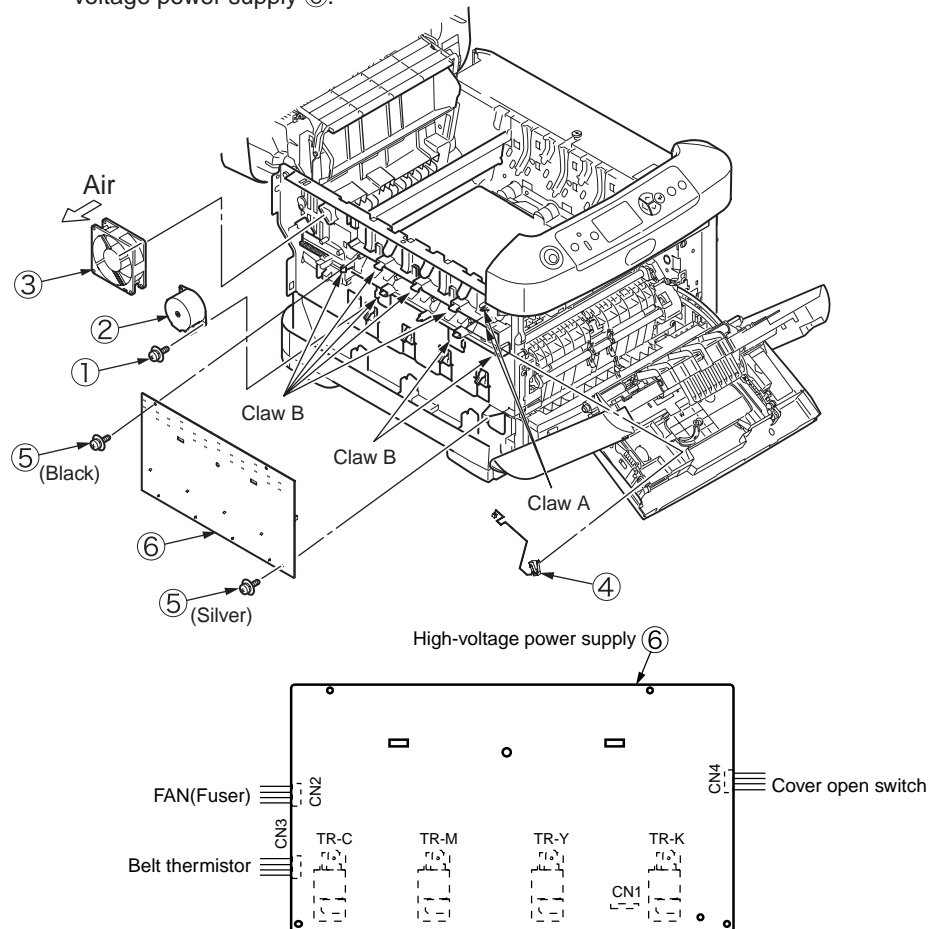

4.2.17 MPT Assy

- (1) Open the MPT Assy ①.
- (2) Remove the stoppers (2 places) while pushing the arms (2 places) on MPT Assy ① outside, pull the supporters (2 places) in the direction of the arrow and remove them, and remove the MPT Assy ①.

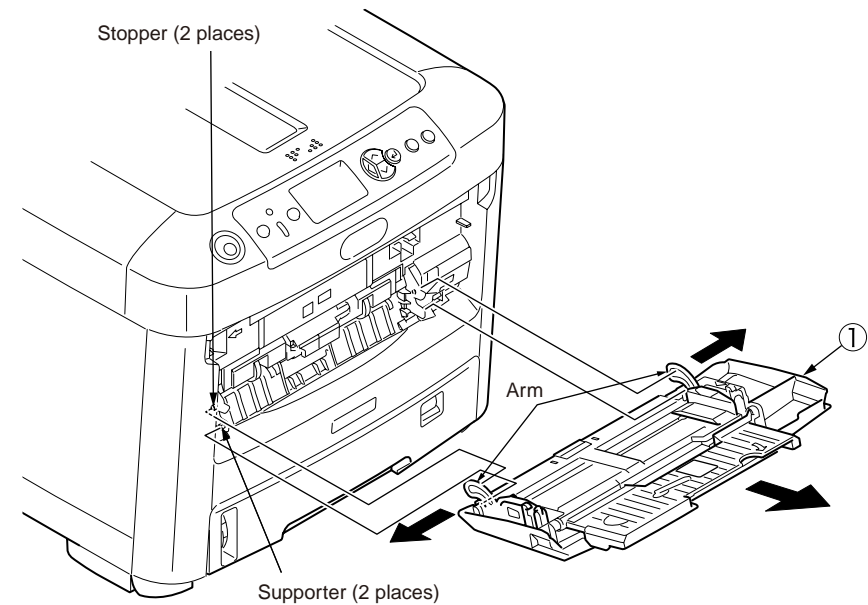

4.2.18 Cover Assy front/ Board-RSF/MPT hopping roller/ Frame Assy separator/ Feeder Assy regist

- (1) Open the top cover.
- (2) Remove the plate shield and remove the connector. (See section 4.2.8)
- (3) Disengage the claws of stay L ①.
- (4) Remove the motor cover. (See section 4.2.14)
- (5) Remove the four screws ⑥ (silver, No:42920406) and remove the feeder unit ⑫.
- (6) Disengage the claw, and remove the cover sensor ⑬.
- (7) Remove the connector and remove the Board-RSF ⑭.
- (8) Remove the MPT Assy. (See section 4.2.17)
- (9) Rotate until the claw of lever ③ is disengaged, and remove it.
- (10) Remove the two screws ⑥ (black, No:42932708), and remove the guide Assy top ⑦.
- (11) Remove the two lock shafts ④ and two springs ⑤.
- (12) Remove the hopping roller shaft ⑧.
- (13) Remove the supporters (2 places), and remove the frame Assy separator ⑨ and spring ⑩.

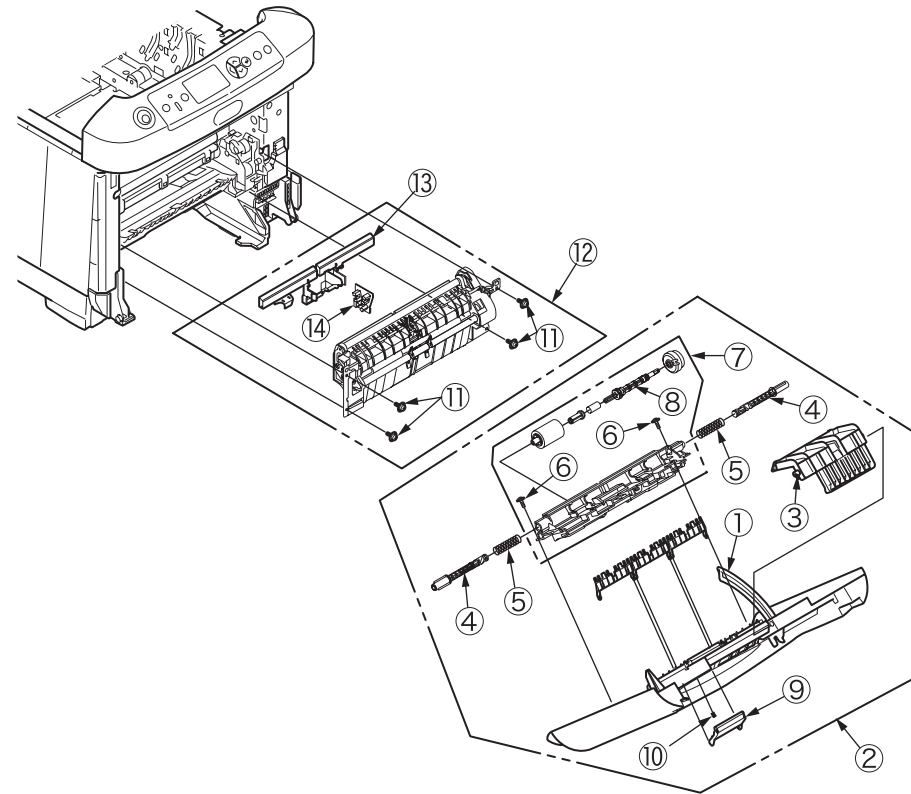

4.2.19 Board-PRZ/ Lifting motor/ Hopping motor/ Paper end sensor/ Hopping sensor

- (1) Remove the left side cover, right side cover, rear cover, top cover unit, feeder Assy regist. (See section 4.2.3, 4.2.4, 4.2.6, 4.2.9, 4.2.18)
- (2) Remove the control PCB. (See section 4.2.8)
- (3) Remove the guide cable Power Low, low-voltage power supply, low-voltage FAN. (See section 2.2.14)
- (4) Remove the cover driver, Board-PRY, color regist Assy, eject Assy. (See section 4.2.15)
- (5) Remove the two screws ① (silver, No:42920406), and remove the plate driver ②.
- (6) Remove the connector of 2ND tray and remove the hopping cover ③.
- (7) Remove the FAN(Fuser). (See section 4.2.16)
- (8) Remove the latches (2 places) and remove the gear ④, remove the E Ring (RE3-SK), remove the latch and remove the gear ⑤.
- (9) Remove the ten screws ⑩ (silver, No:42920406), plate outer ⑪, E Ring (RE3-SK), remove the latch of gear ⑥ and remove the shaft ⑦.
- (10) Remove the two screws ⑧ (silver, No:42920406) and remove the side plate R Assy ⑨.
- (11) Remove the two gear idle IDs ⑫, two gear idle IDs ⑬, two gears ⑭, gear ⑮, two colors ⑯, one washer ⑰, gear ⑱, ⑲, ⑲, ⑲, and ⑲.
- (12) Remove the latches (2 places), and remove the guide Assy side R ⑳ while slide it up.
- (13) Remove the latch (6 places), and remove the board-PRZ ㉓.
- (14) Remove the screw ㉔ (silver, No:42920406), and remove the plate lockout ID ㉕ and four screws ㉖ (silver, No:42920406), remove the inner plate ㉗.
- (15) Remove the two screws ㉘ (silver, No:42920406) and connector, and remove the lifting motor ㉙.
- (16) Remove the screw ㉚ (silver, No:42920406) and remove the hopping motor ㉛.
- (17) Remove the paper end sensor lever ㉜, remove the paper end sensor ㉝ and remove the connector.
- (18) Remove the hopping sensor lever ㉞, the hopping sensor lever spring ㉟, remove the hopping sensor ㊱ and remove the connector.

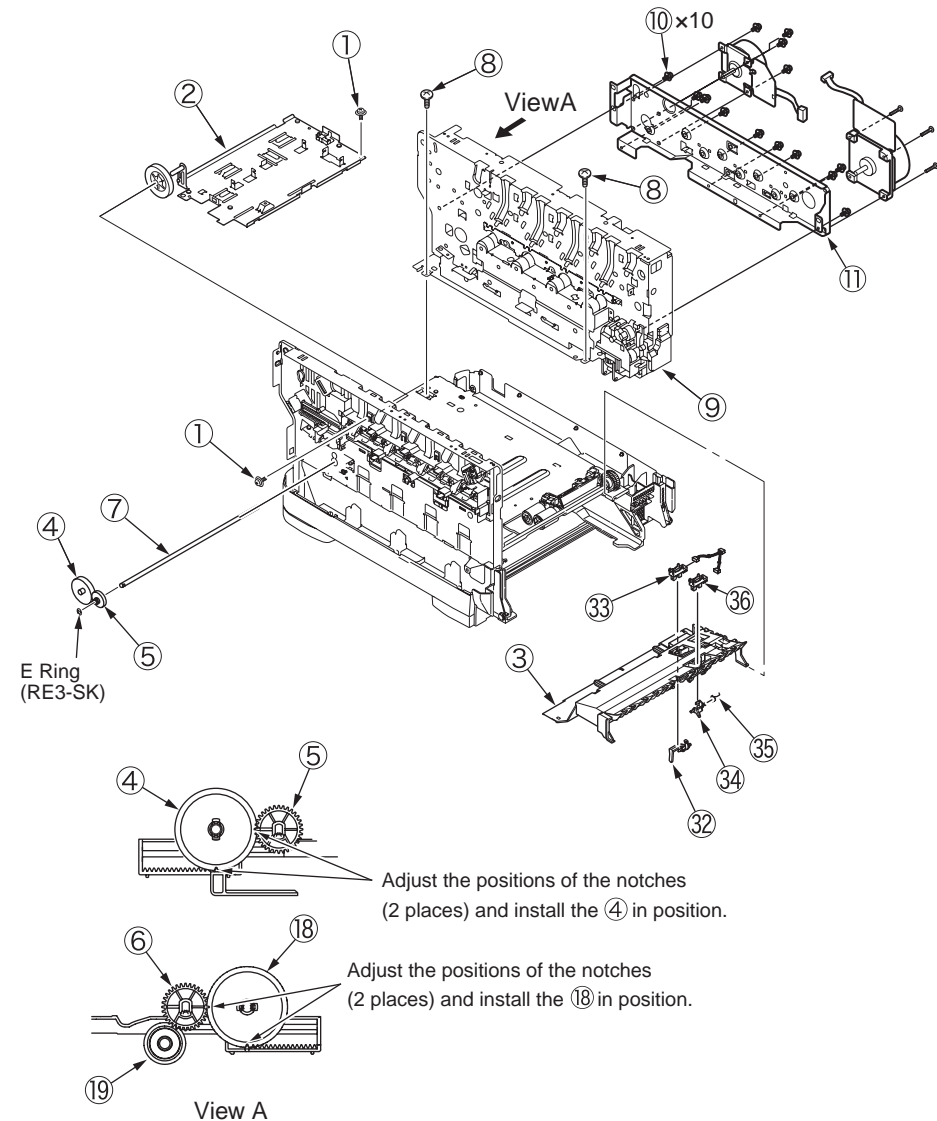

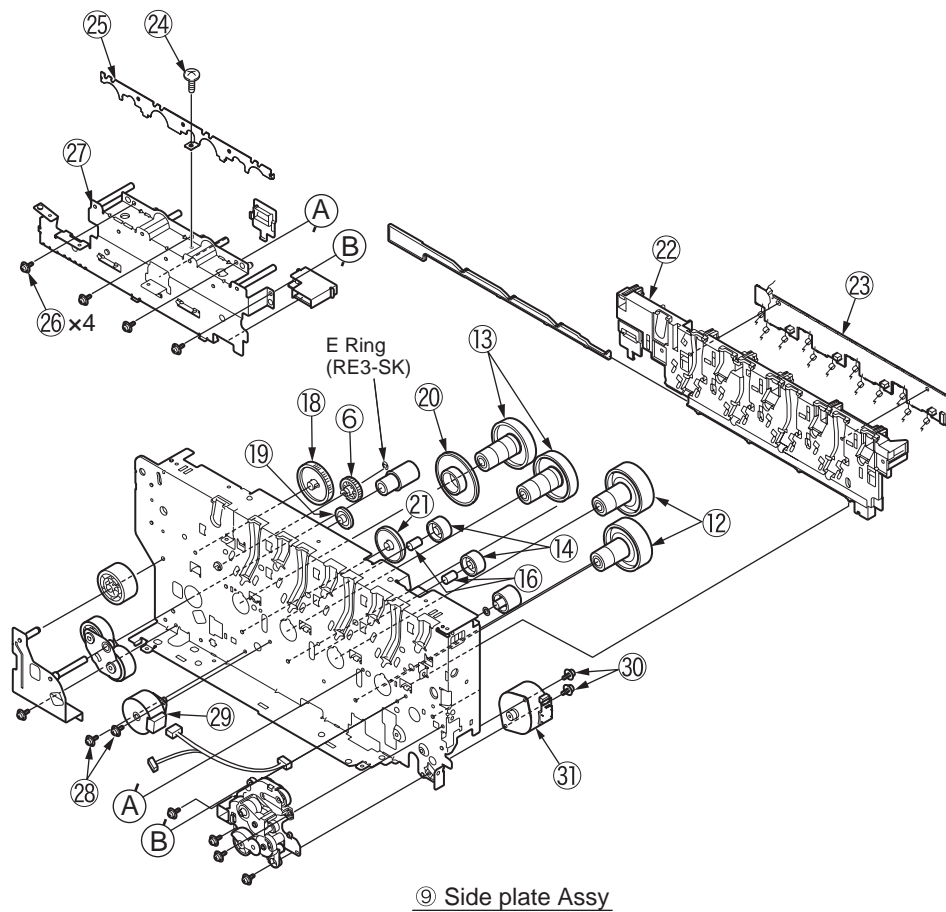

4.2.20 Feed roller

- (1) Remove the cassette.
- (2) Remove the latch and remove the feed roller (2 pieces)①.

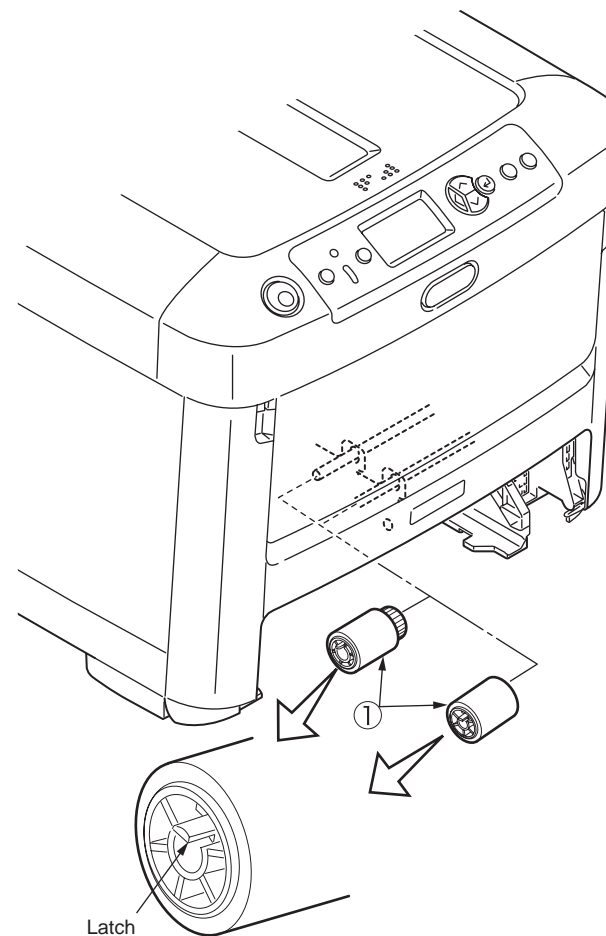

4.2.21 Shaft eject Assy (FU)/ Shaft eject Assy(FD/ Eject sensor

- (1) Remove the eject Assy. (See section 4.2.15)
- (2) Disengage the claws (2 places), and disassemble the Assy into guide eject lower ① and guide eject upper ②.
- (3) Remove the gear idle eject ③, ④, ⑤, ⑥ and remove the shaft Assy eject (FU) ⑦ and shaft Assy eject (FD) ⑧.
- (4) Remove the lever eject sensor ⑨ and eject sensor ⑩.

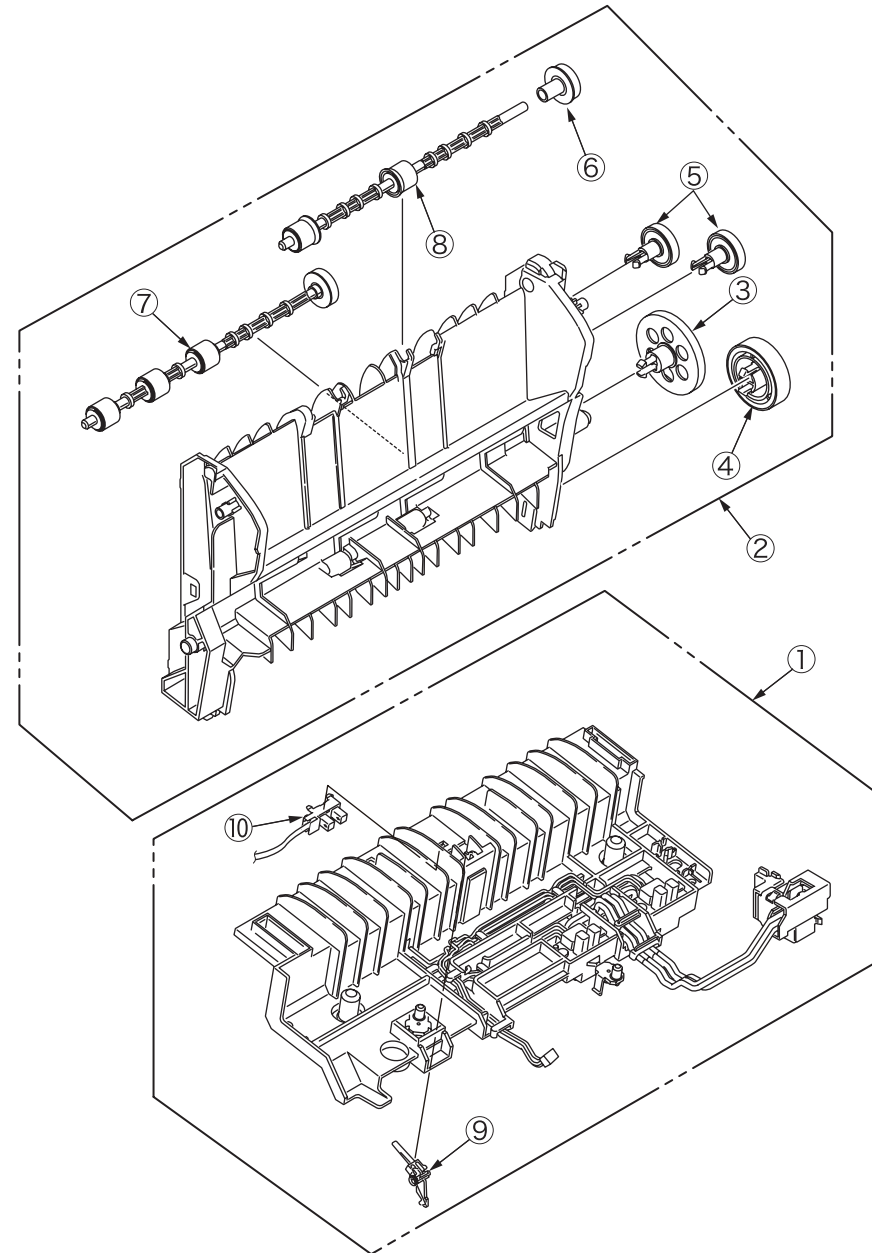

4.3 Oiling spots

This chapter shows the oiling spots. Do not oil the other spots that are not shown here.

It is not necessary to inject the machine-oil during disassembling. However, please add the specified oil when you wipe the oil off.

Oiling operation

(1) Oil type and name

EM-30L: MOLYKOTE

HP-300: MOLYKOTE

PM: Pan motor oil 10W-40 or ZOA 10W-30

(2) Grease limit sample

Class	S	A	B	C	D	E	F
Amount of grease (cc)	0.0005	0.003	0.005	0.01	0.03	0.05	0.1
W(mm)	1.24	2.25	2.67	3.37	4.86	5.76	7.26
Sample	•	●	●	●	●	●	●

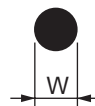

① 44259301PA Gear Assy.-HP

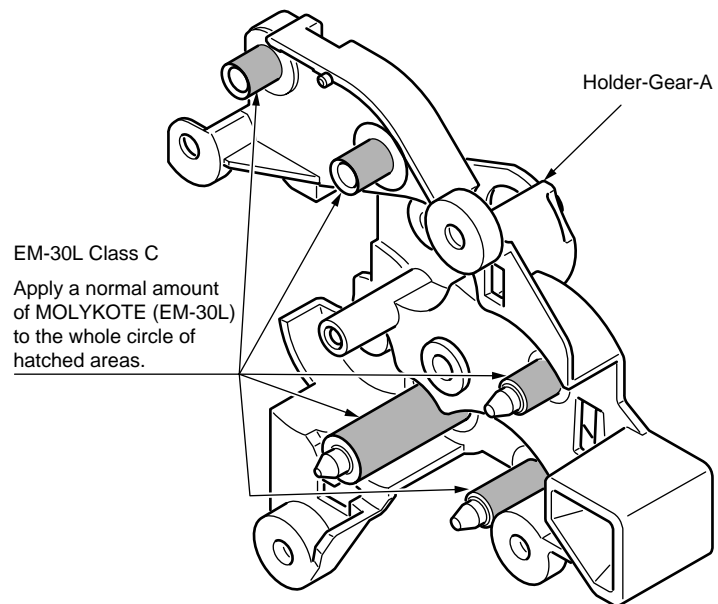

② -1 44259101PA Plate-Assy.-Side R

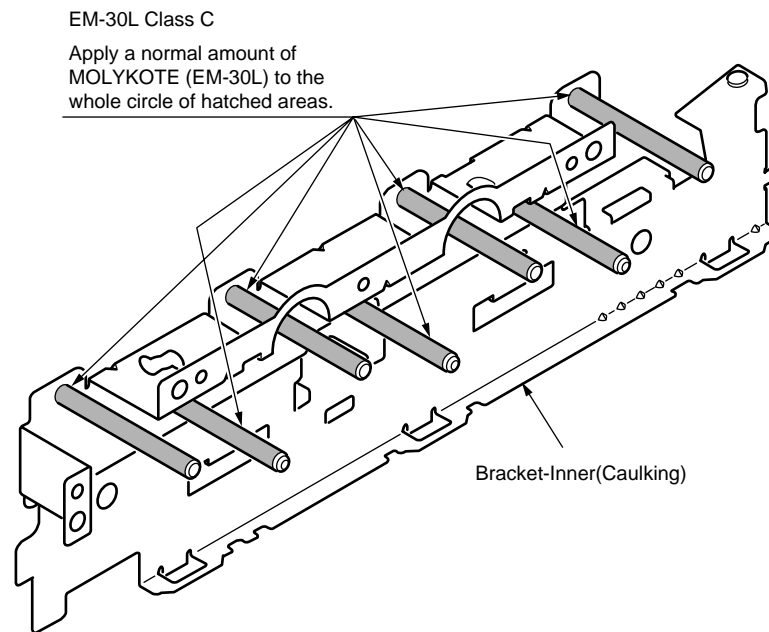

② -2 44259101PA Plate-Assy.-Side R

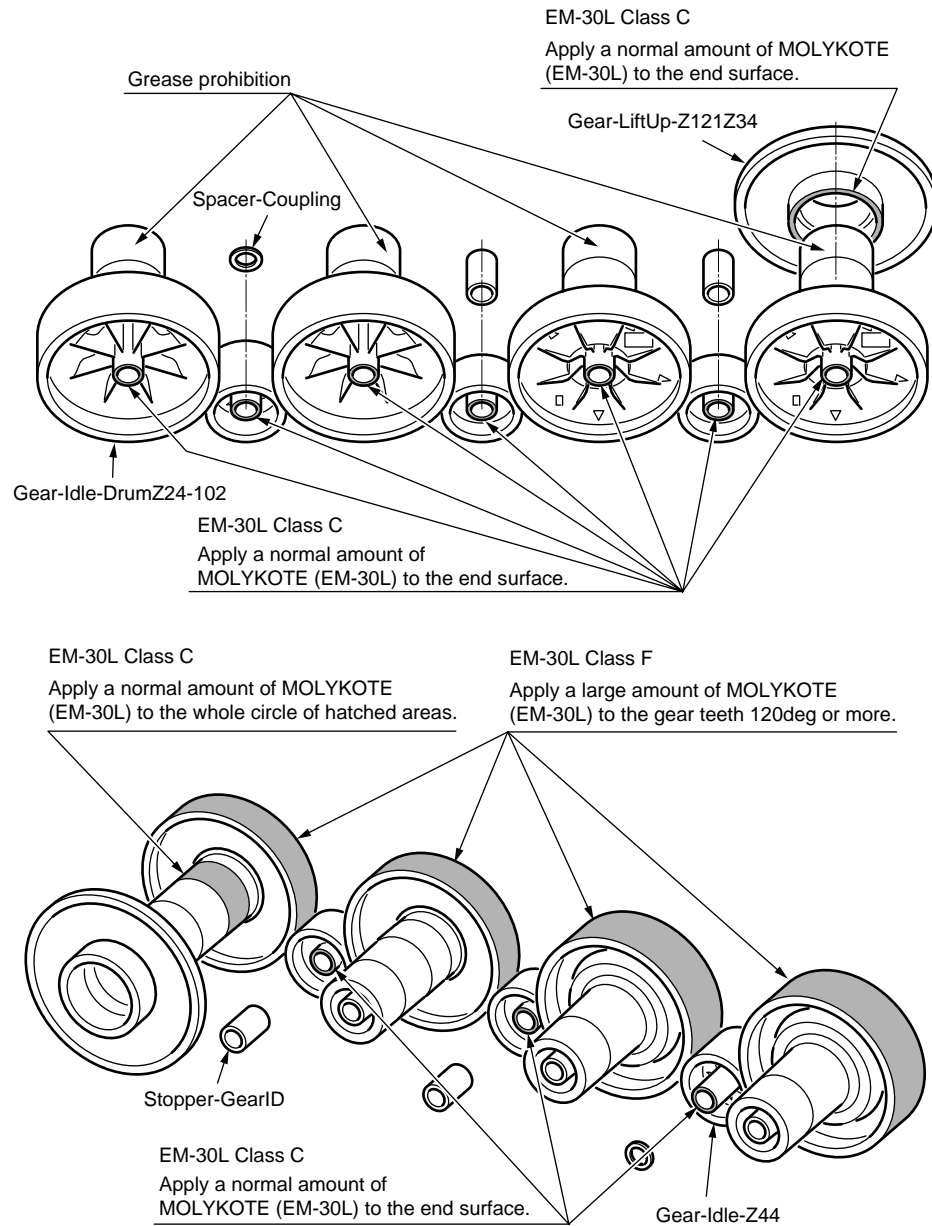

② -3 44259101PA Plate-Assy.-Side R

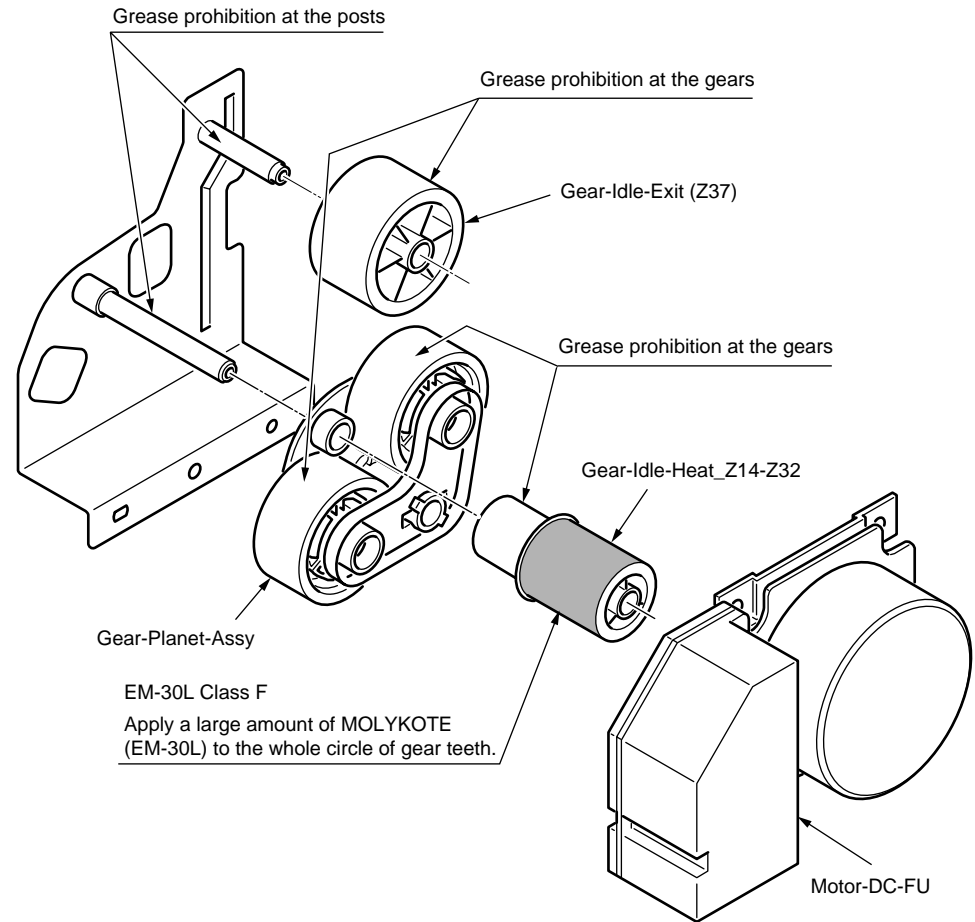

② -4 44259101PA Plate-Assy.-Side R

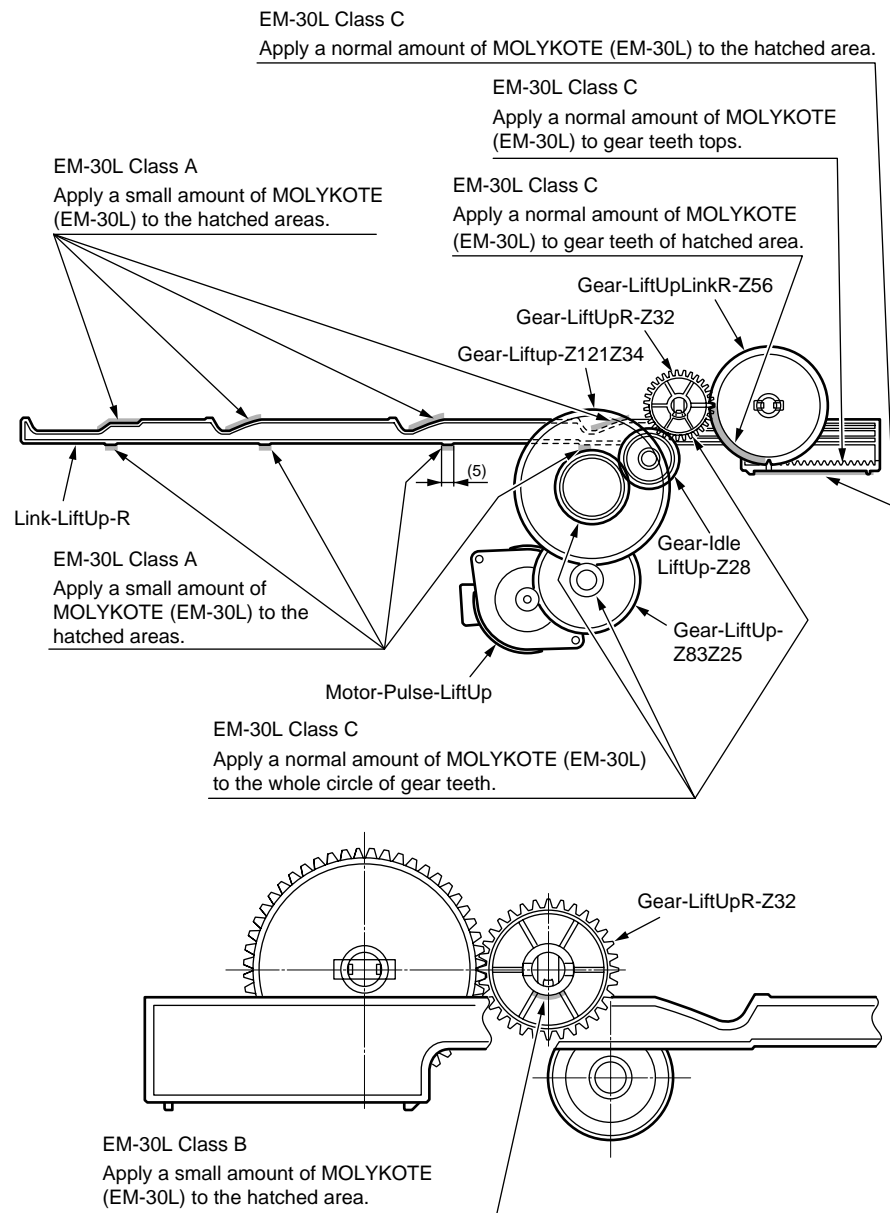

② -5 44259101PA Plate-Assy.-Side R

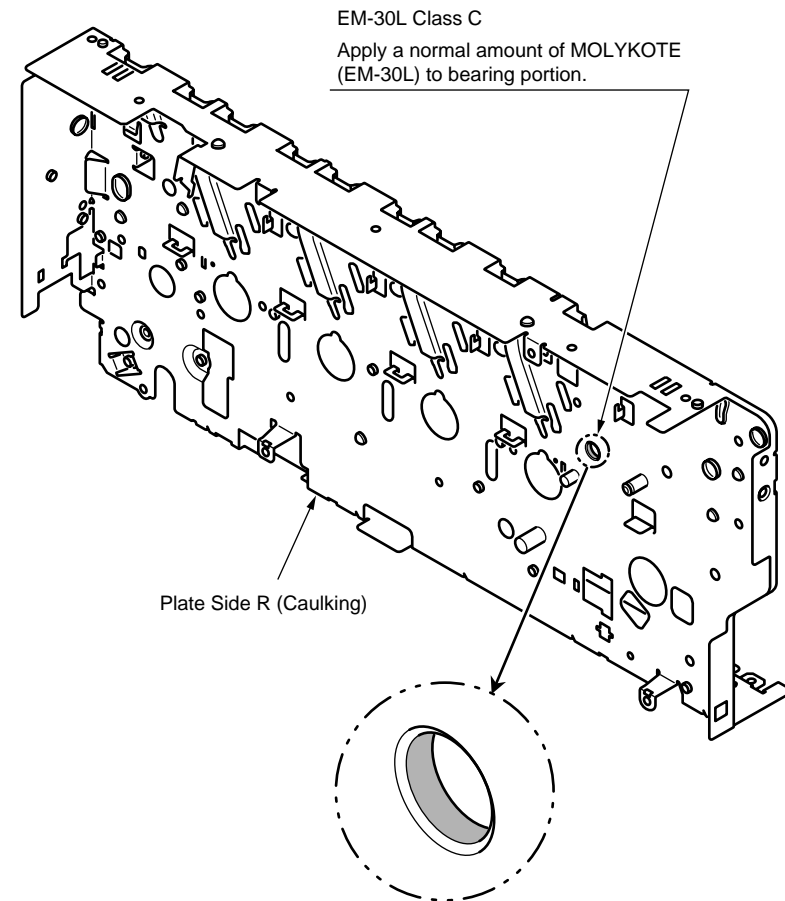

③ 43074904PA Plate-Assy.-Side-L

EM-30L Class C

Apply a normal amount of MOLYKOTE (EM-30L) to the gear tooth tops.

EM-30L Class A

Apply a small amount of MOLYKOTE (EM-30L) to the hatched areas.

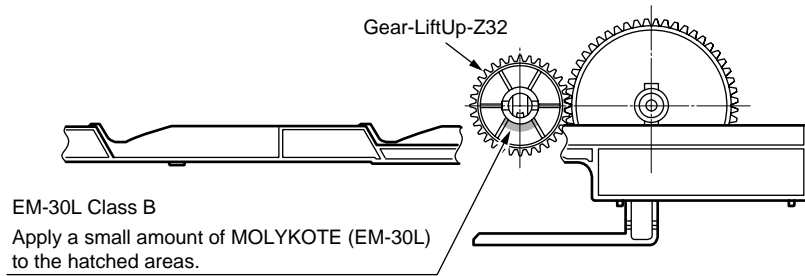
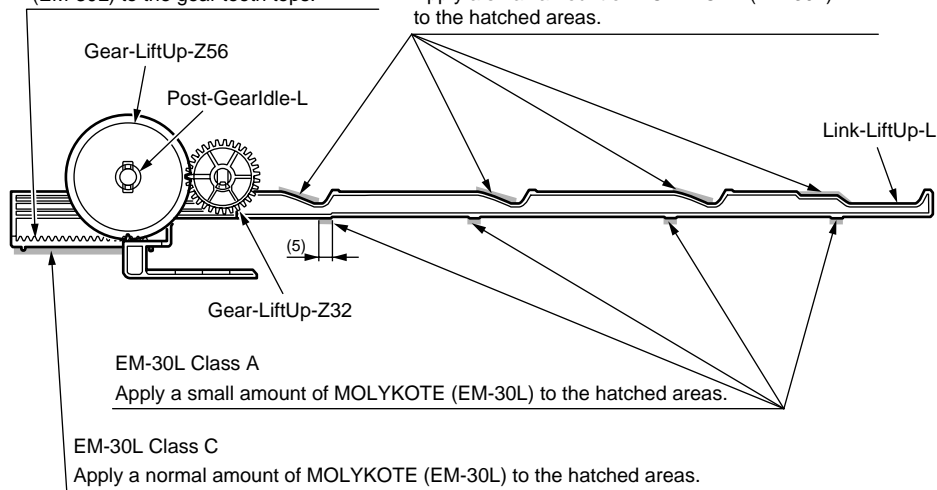

④ 42071401PA Holder Assy.-Regist-L

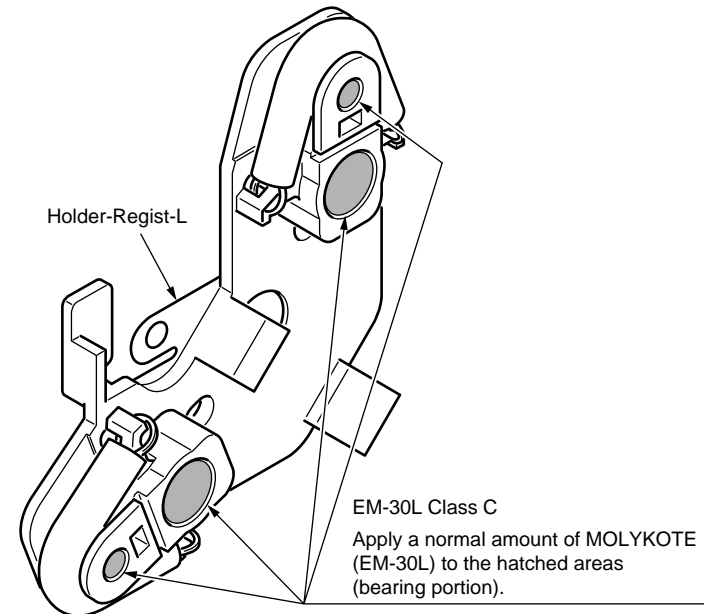

⑤ 44261901PA Feeder Assy.-Regist

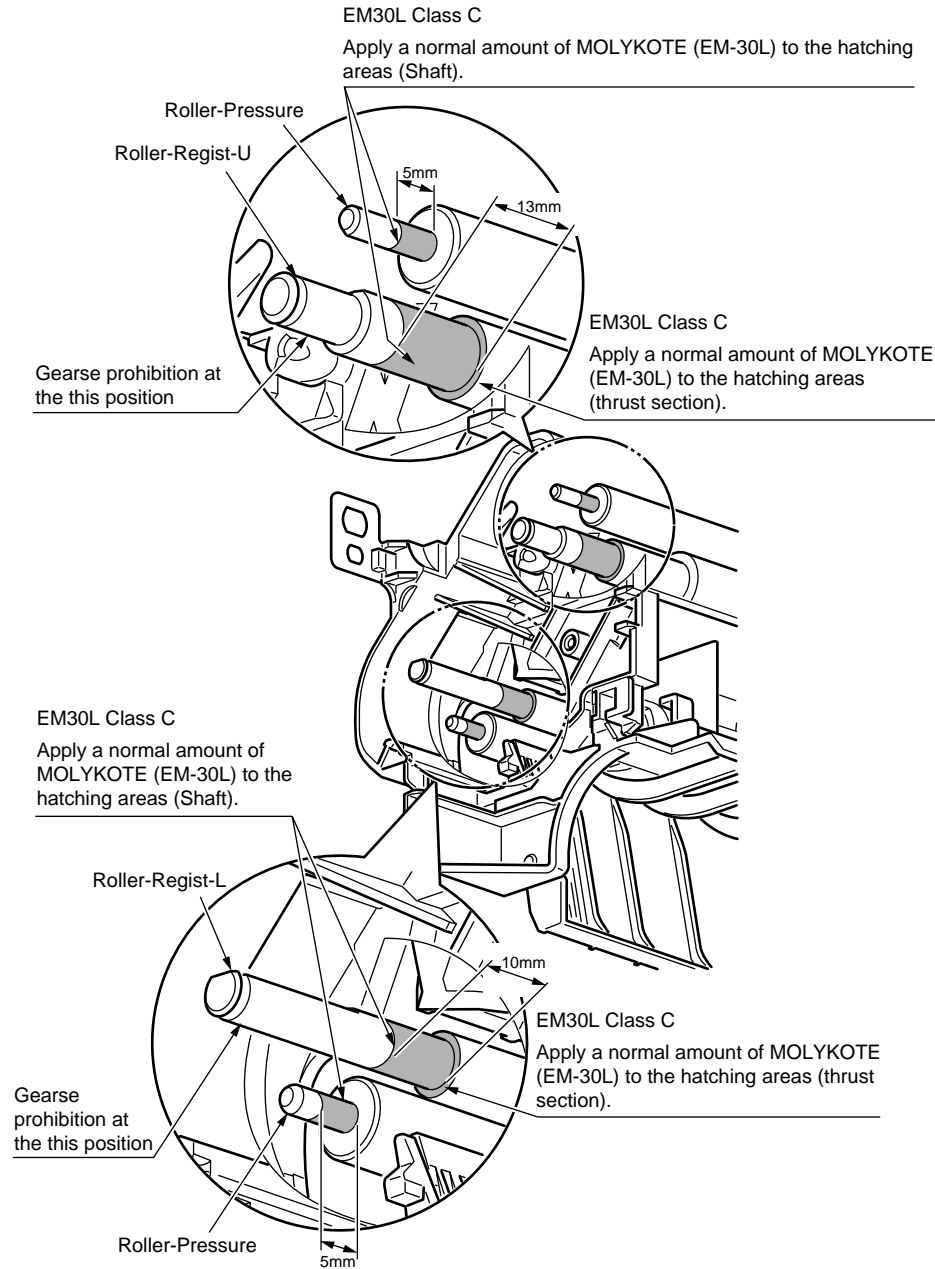

⑥ 44286901PA Fuser-Assy

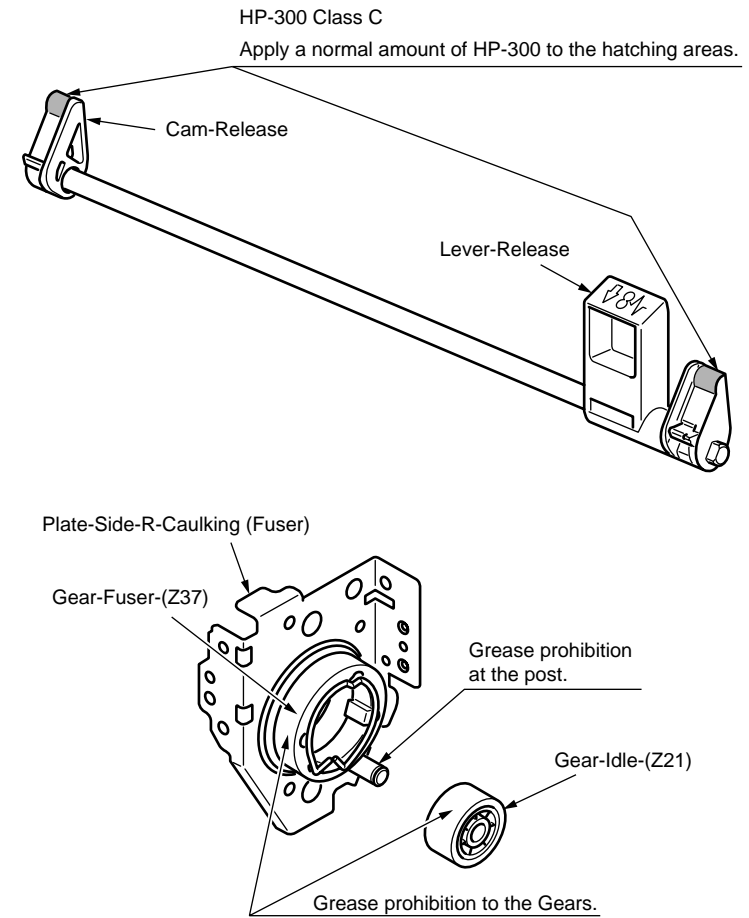

⑦ 44263501PA Guide-Assy.-Eject-U

EM-30L Class C

Apply a normal amount of MOLYKOTE (EM-30L) to surface of the post (bearing portion) and the flange portion.

EM-30L Class C

Apply a normal amount of MOLYKOTE (EM-30L) to surface of the shaft.
Grease prohibition at the paper running face.

EM-30L Class C

Apply a normal amount of MOLYKOTE (EM-30L) to the gear teeth.

EM-30L Class C

Apply a normal amount of MOLYKOTE (EM-30L) to surface of the shaft and flange portions.
Grease prohibition at the paper running face.

EM-30L Class C

Apply a normal amount of MOLYKOTE (EM-30L) to each of the gear teeth 3 place.

Gear-Idle-Exit-Z36

EM-30L Class C

Apply a normal amount of MOLYKOTE (EM-30L) to surface of the post (bearing portion)

EM-30L Class B

Apply a small amount of MOLYKOTE (EM-30L) to surface of the shaft.
Grease prohibition at the paper running face.

Grease prohibition at the paper running face.

Shaft-Assy.-Eject(FD)

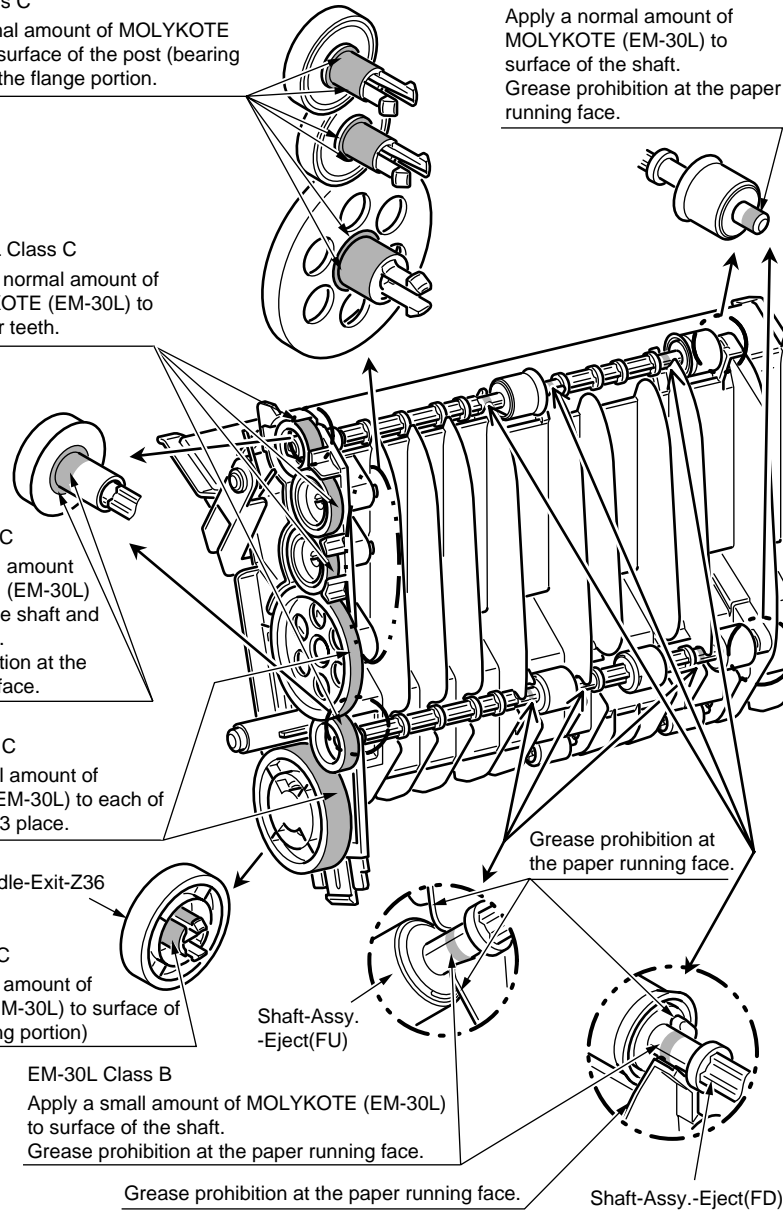

⑧-1 44257901PA Printer Unit-PX757

EM-30L Class C

Apply a normal amount of MOLYKOTE (EM-30L) to the tips of terminal.

Plate-Assy.-Side-L

Plate-Contact-TR

3

3

Application range of grease

EM-30L Class C

Apply a normal amount of MOLYKOTE (EM-30L) to the whole circle of gear teeth.

EM-30L Class C

Apply a normal amount of MOLYKOTE (EM-30L) to the post.

EM-30L Class C

Apply a normal amount of MOLYKOTE (EM-30L) to the end surface.

Plate-Driver-PU (Caulking)

Gear-Idle-Belt-Z20Z93

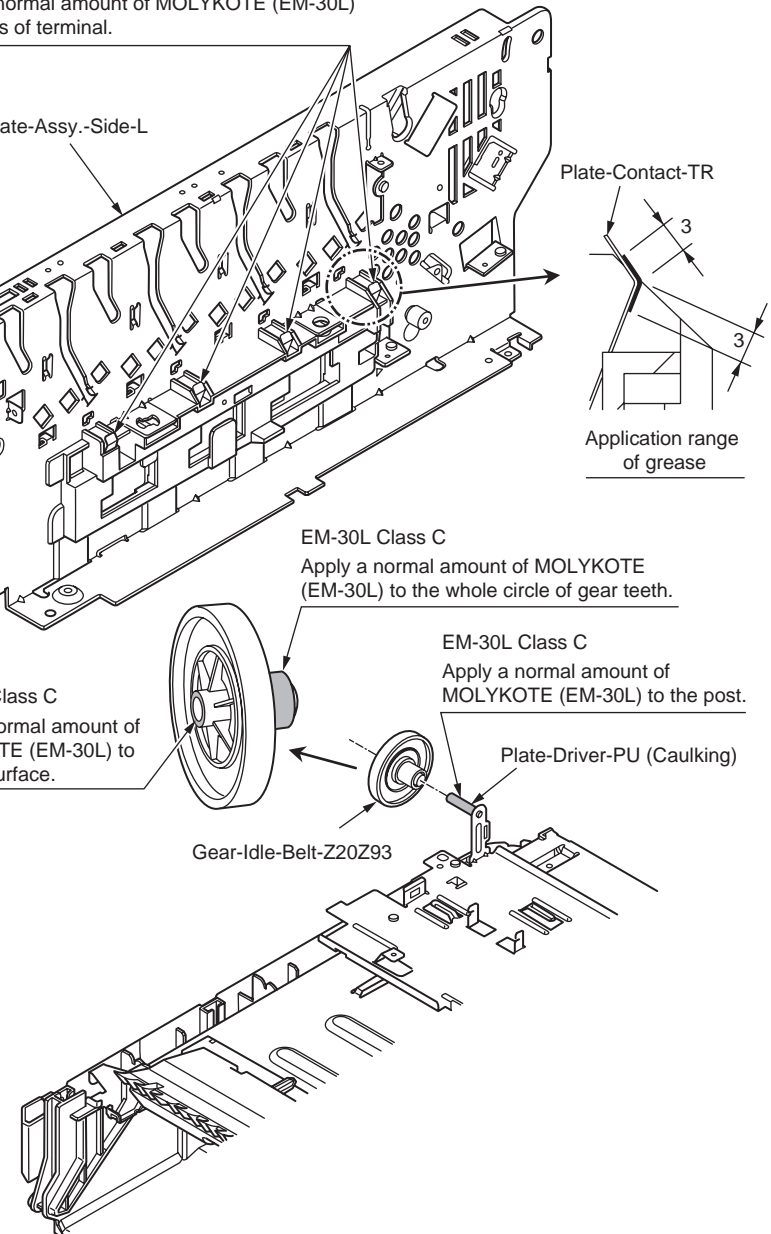

⑧-2 44257901PA Printer Unit-PX757

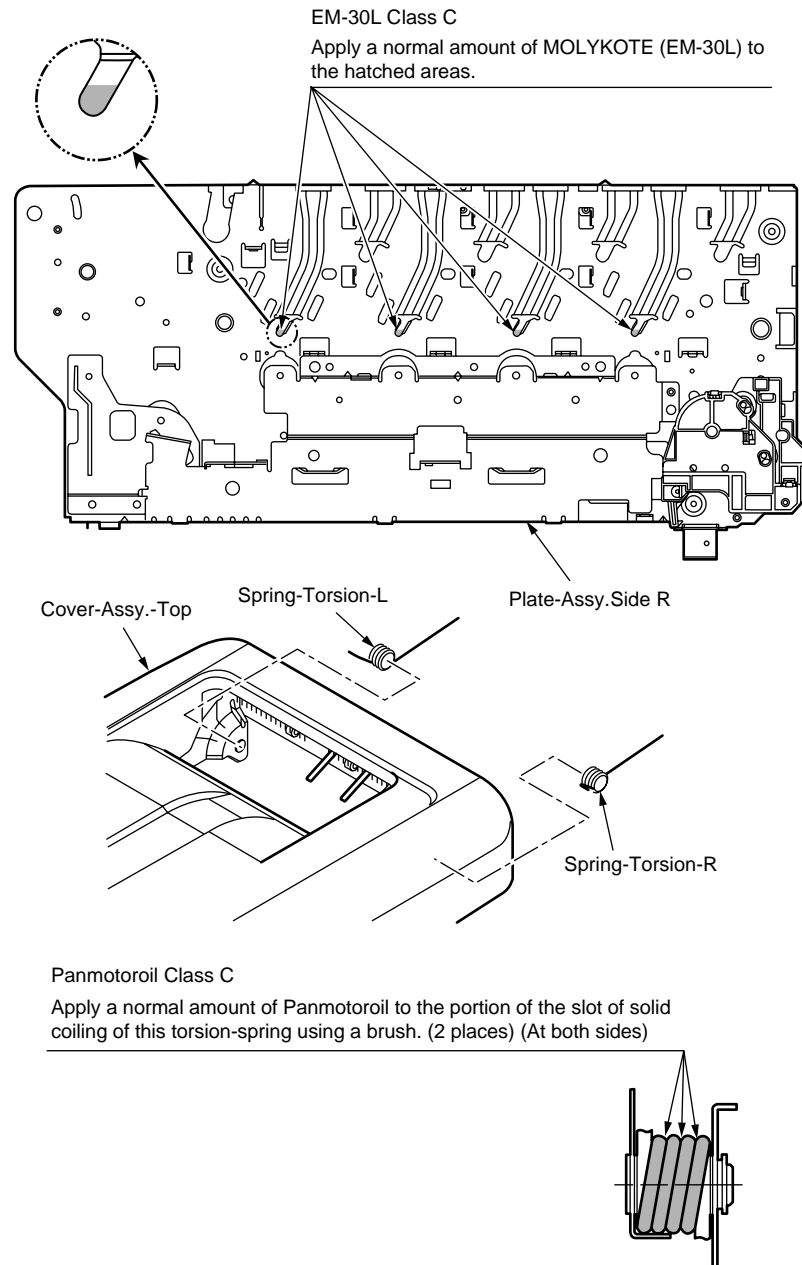

⑨ 44342001PA Belt-Assy

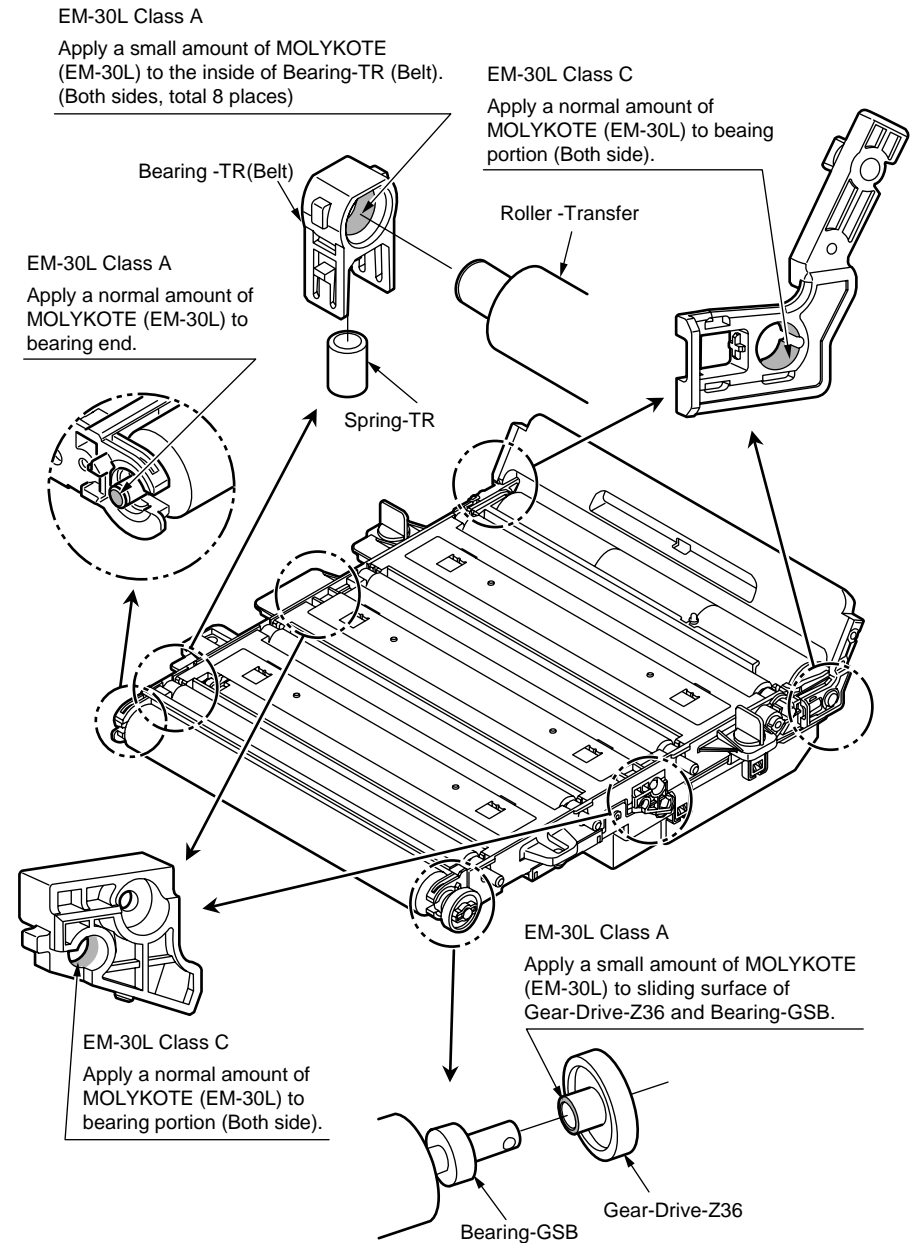

⑩ 43917501PA Sensor Assy. -Color Regist

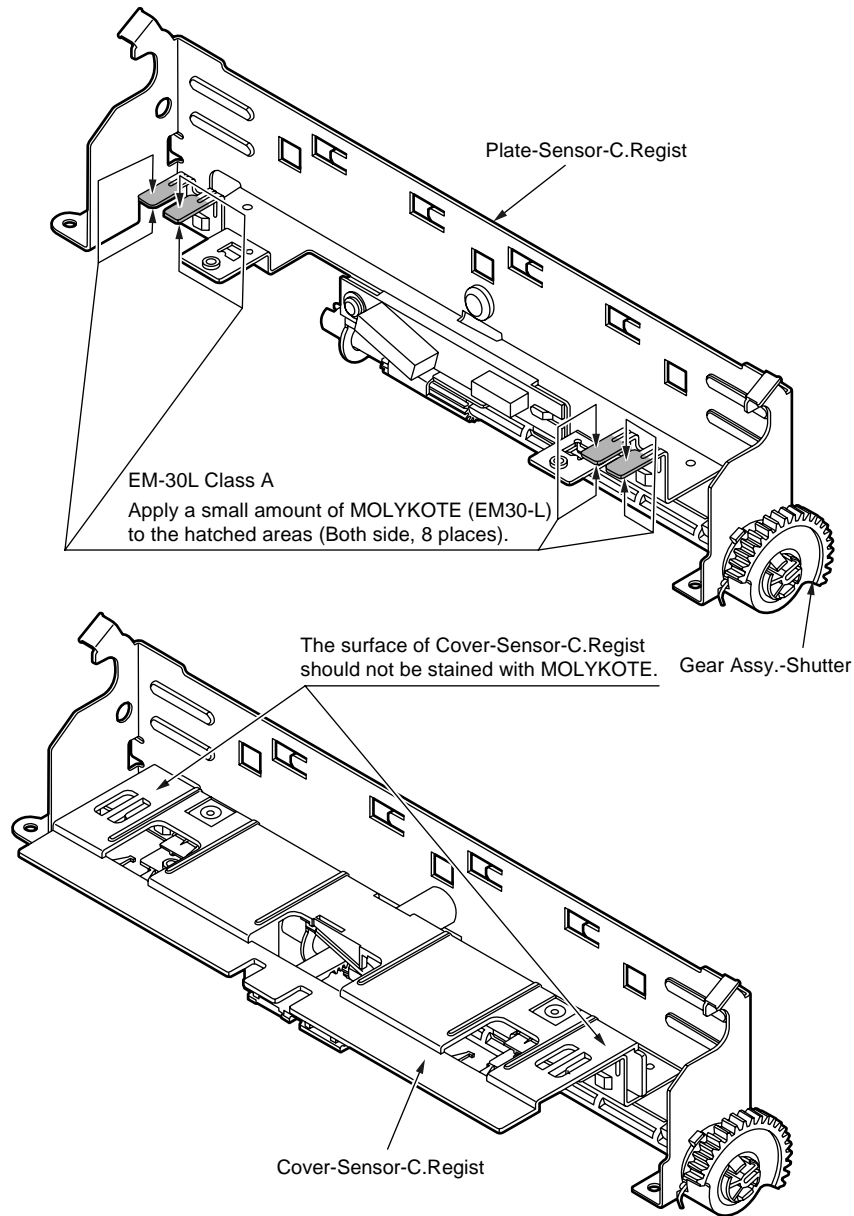

⑪ 43081301PA Roller-Assy. -Idle(FD)

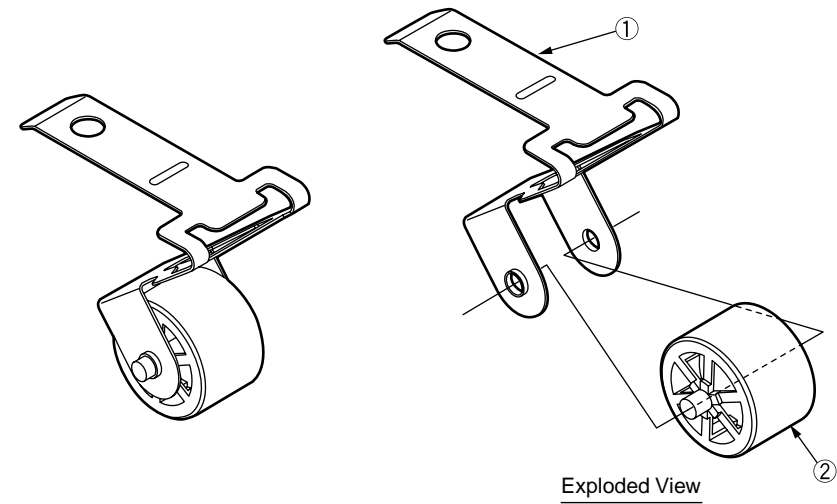

Method of amount grease

EM-30L Class S
Before ② assemble to ①, apply a minimum amount of MOLYKOTE (EM-30L) to the sliding portions of ① and ② (the hatched areas).

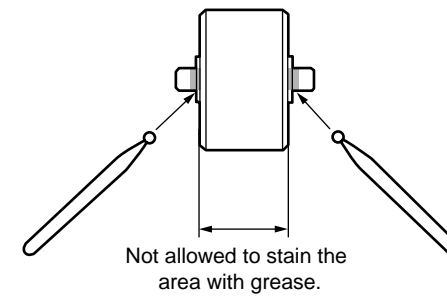

⑫ 43301601PA Roller-Assy. -BIAS(FU)C

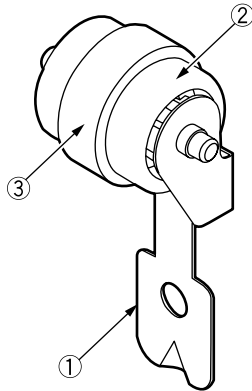

Method of amount grease

EM-30L Class S

After ③ assemble to ②, apply a minimum amount of MOLYKOTE (EM-30L) to the sliding portions of ① and ② (the hatched areas).

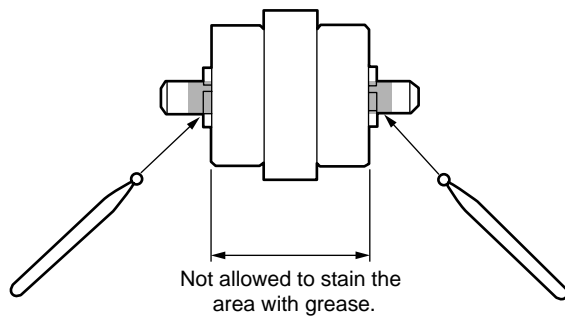

⑬-1 43894903PA Cassette-Assy-PX757

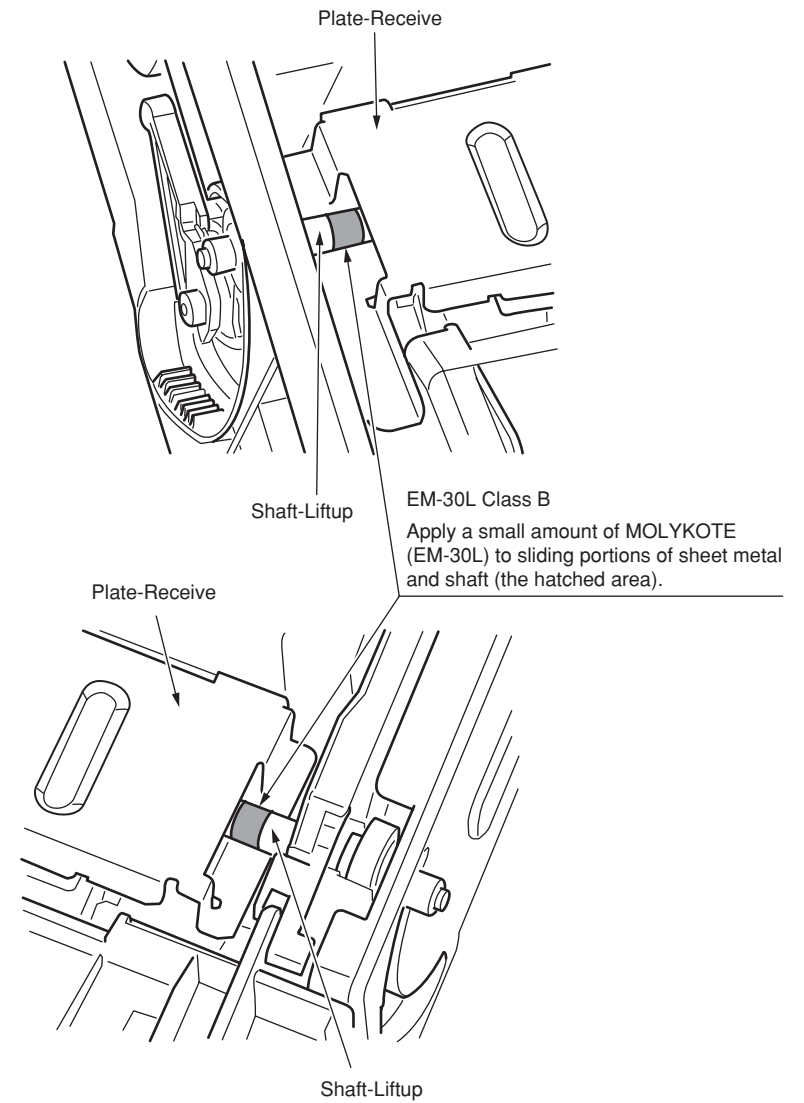

⑬-2 43894903PA Cassette-Assy-PX757

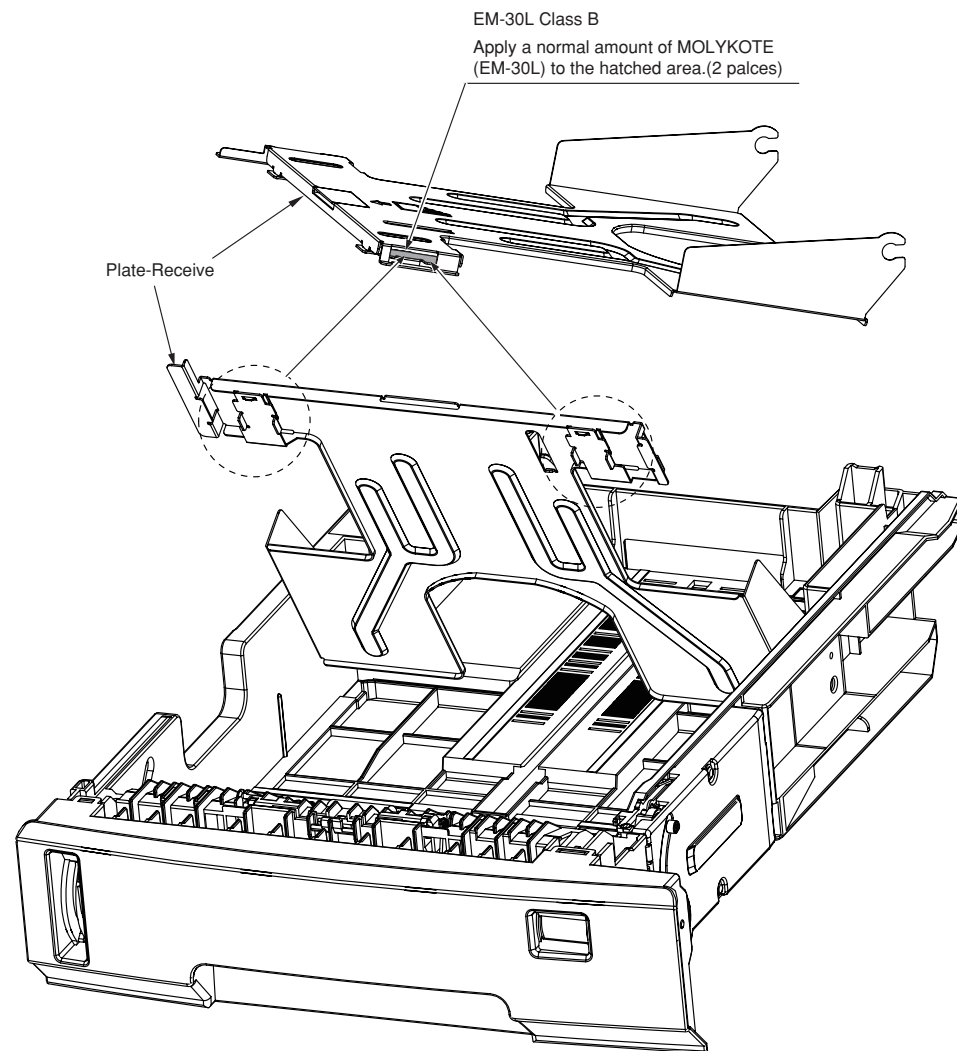

5. Maintenance Menu

Adjustment of this printer can be performed from the Maintenance Utilities by entering the corresponding menu from the keyboard of the operator panel.

This printer contains the maintenance menu in addition to the normal operation menus. Select an appropriate menu in accordance with the objective of adjustment.

5.1	System maintenance menu (for maintenance engineer)	92
5.2	Maintenance Utilities	94
5.3	Maintenance menu functions.....	96
5.4	Setups upon completion of part replacement.....	115
5.5	Density control manual setting	117
5.6	Printer boot menu list.....	118

5.1 System maintenance menu (for maintenance engineer)

While pressing the MENU+ and MENU- keys, turn on the power to enter the maintenance menu. The menu indications are shown in English only regardless of the destination of the printer.

Note! The system maintenance menu is internally use only, and should not be disclosed to end user because destination and other parameters can be modified using this menu.

Table 5-1 Maintenance menu function table

Category	Item (1st Line)	Value (2nd Line)	DF	Function
System Maintenance	Enter Password	***** *****	000 000	Enter the password to enter the system maintenance menu. Default value is "000000". A password can be entered in the range of 6- to 12-digit alphanumeric. For more details, refer to the "Password" sheet.
OKIUSER	OKIUSER	ODA OEL APS JP1 JPOEM1 OEMA OEML	*	Set the destination. JPOEM1: Japanese OEM OEMA: Overseas OEM outside Japan of A4 size default OEMA: Overseas OEM outside Japan of the Letter size default When the printer exits the menu, the printer reboots automatically.
Maintenance Menu				[Display condition] Encrypted SD Memory Card function is disabled.
	Format SD Card	Execute	-	Initializes an SD card. Pressing the Enter button for this option displays the confirmation message: Are You Sure? Yes No Selecting No restores the last menu view. Selecting Yes exits the menu, starting formatting an SD card installed in the printer. [Display condition] The printer has an SD Card (Boot Menu-Storage Setup-Enable SD Card is set to Yes). * With Boot Menu-Storage Setup-Enable Initialization set to Yes, the option can be displayed.

Category	Item (1st Line)	Value (2nd Line)	DF	Function
Maintenance Menu	Format Flash ROM	Execute	-	Initializes flash ROM. Pressing the Enter button for this option displays the confirmation message: Are You Sure? Yes No Selecting No restores the last menu view. Selecting Yes exits the menu, starting formatting an (on-board) flash device resident in the printer. * Never use the option.
	Reset EEPROM	Execute	-	Returns the EEPROM contents to the setup by the manufacturer when shipped from the factory (factory default profile) value. Upon completion of the setting change, the system reboots automatically. * Some specific items are not initialized.
Maintenance Print Menu	Maintenance Print Menu	Enable Disable	*	Selects whether or not to display "Print Information" - "ID Check Pattern" and "Engine Status". When this menu item is set to "Disable", the function menu "Print Information" - ID Check Pattern" and "Engine Status" are not displayed all the time. When exiting this menu upon completion of setting change, the printer reboots automatically.
Fuse Keep Mode	Fuse Keep Mode	Execute	-	When the ENTER key is pressed, the command is issued from CU to PU to set the system in ON LINE. Replace the consumable part with the new part while the power is turned on. (In this case, fuse of the new consumable part is not cut, and the operational counts are reset so that the count value of old consumable part is not added.) The check mode is terminated when the power is turned off. The check mode is disabled when the power is turned on next time.
Personality	XPS	Enable Disable	*	Changes the default of Support PDL per brand. PDL which is "Disable" in this menu is not displayed at "Print Setup" - "Personality" of Function menu. INVALID DATA shows up and received data is abandoned when print data of PDL which is "Disable" is received.
	IBM 5577	Enable Disable	*	
	IBM PPR III XL	Enable Disable	*	
	EPSON FX	Enable Disable	*	
	HP-GL/2	Enable Disable	*	

Category	Item (1st Line)	Value (2nd Line)	DF	Function
Change Password			-	Changes the password. When the ENTER switch is pressed after entering in this menu, the messages "NEW PASSWORD" and "VERIFY PASSWORD" are displayed enabling user to enter a new password.
	New Password	***** *****	-	Sets the new password to enter the maintenance menu. A password can be entered in the range of 6- to 12-digit alphanumeric.
	Verify Password	***** *****	-	Prompting user to verify the new password that has been set by "NEWPASSWORD", to enter the system maintenance menu. A password can be entered in the range of 6- to 12-digit alphanumeric.
Diagnostic Mode			-	Enters the self-diagnostic mode.

5.2 Maintenance Utilities

The maintenance utilities enables user to perform the adjustment shown in Table 5-2.

Details of the maintenance utilities are available in the following documents.

(1) Maintenance Utilities Operation Manual:

42678801FUOI Ver24.0 and higher (Japanese)

42678801FUO2 Ver24.0 and higher (English)

(2) The maintenance utilities programs shown below.

Applicable OS	Filename	Model number
Win9X/Me/NT/2000/XP (Japanese/English)	MuWin.zip	42678801FW01 Ver1.25.0 and higher

Table 5-2 Maintenance utilities adjustment items

	Item	Adjustment contents	Maintenance Utilities Operation Manual item number	Operation on the operator panel (Item number corresponds to that of the Maintenance Manual.)
1	Board replacement	Copies the PU part EEPROM data and CU part EEPROM setup value of the board. Adjustment objective: Copies the EEPROM data of existing board to the new board when the existing board needs to be replaced with the new board during maintenance.	Section 2.4.1.1.9	Operation from the operator panel cannot be made.
2	Serial number information setting	Re-writing the printer serial number saved in PU part. and re-writing the printer serial number selections, output mode and printer serial number that are saved in CU part. Adjustment objective: When copying the EEPROM data is not possible (due to I/F error or others), re-write the serial number information in the new replacement board.	Section 2.4.1.1.10.3	Operation from the operator panel cannot be made.
3	Factory/Shipping mode	Switching between the Factory mode and the Shipping mode. Adjustment objective: When copying the EEPROM data is not possible (due to I/F error or others), implement switching between the Factory mode and the Shipping mode. When the replacement board is supplied for maintenance, it has been set in the Factory mode as the default setting. Switching from the Factory mode to the Shipping mode needs to be performed using this function.	Section 2.4.1.1.10.4	Section 5.3.2.10

	Item	Adjustment contents	Maintenance Utilities Operation Manual item number	Operation on the operator panel (Item number corresponds to that of the Maintenance Manual.)
4	Setup information of board items	Verifying the serial number information and the Factory/Shipping mode.	Section 2.4.1.1.7	Operation from the operator panel cannot be made.
5	USB software upgrade	Upgrading the USB software	Section 2.4.2.2.1	Operation from the operator panel cannot be made.
6	NIC software upgrade	Upgrading the NIC software	Section 2.4.2.2.17	Operation from the operator panel cannot be made.
7	Mac address setting	Setting the Mac address	Section 2.4.2.2.5	Operation from the operator panel cannot be made.
8	Consumable items counter maintenance function	Copies the consumable items counter data Drum counter (Y, M, C, K) Fuser counter Belt counter Toner counter (Y, M, C, K) Adjustment objective: Copies the data of the respective consumable item counters in the case when an existing consumable item that is in the middle of its usage is removed and installed in another printer.	Section 2.4.1.2.1	Operation from the operator panel cannot be made.
9	Destination PnP information setting	Sets/verifies the printer (CU) destination, device ID and USB ID.	Section 2.4.1.2.9	Section 5.4.3
10	Password initialization	Initialization of administrator password	Section 2.4.2.2.13	Operation from the operator panel cannot be made.
11	Network log save function	Saving the network log	Section 2.4.2.2.14	Operation from the operator panel cannot be made.
12	PU Log Save function	Saving files of PU log.	Section 2.4.2.2.16	Operation from the operator panel cannot be made.
13	Consumable items counter display	Verifies present data of the consumable items counter.	Section 2.4.1.3.1	Section 5.1 ENG STATUS PRINT

	Item	Adjustment contents	Maintenance Utilities Operation Manual item number	Operation on the operator panel (Item number corresponds to that of the Maintenance Manual.)
14	Menu setup value confirmation	Displays the setup values that have been set in the printer (CU).	Section 2.4.1.3.2	Menu map print (Refer to the User's Manual.)
15	Printer information confirmation	Verifies the Mac address and various F/W versions of the printer.	Section 2.4.1.3.3	Menu map print (Refer to the User's Manual.)
16	Verifies the installed CPU/memory values.	Verifies the CPU information of if the installed CPU and information of the installed memory.	Section 2.4.1.3.4	Menu map print (Refer to the User's Manual.)
17	Test print	Executes the local print function, and sends the specified file. Adjustment objective: Checks operation of the printer as the standalone printer, and sends the downloaded file.	Section 2.4.1.4.1	Local print (Refer to the system specification.)
18	Switch scan test	Execution of switch scan test Adjustment objective: Operation check of the respective sensors	Section 2.4.1.5.1	
19	Motor clutch test	Execution of motor clutch test Adjustment objective: Operation check of the respective motors and clutches.	Section 2.4.1.5.2	
20	Color registration correction test	Color registration correction test Execution of color registration correction test.	Section 2.4.1.5.3	
21	Density correction test	Execution of density correction test	Section 2.4.1.5.4	
22	Automatic density correction control parameter setting [Use prohibition]	Setting the automatic density correction control parameter	Use prohibition	
23	Counter display	Checking reading of the consumable items counter, consumables continue counter and waste toner counter.	Section 2.4.1.5.6	
24	Local parameter setting	Switching of Factory mode and Shipping mode, confirmation of fuse status	Section 2.4.1.5.7	

	Item	Adjustment contents	Maintenance Utilities Operation Manual item number	Operation on the operator panel (Item number corresponds to that of the Maintenance Manual.)
25	Engine parameter setting	Setting values of the engine parameter items	Section 2.4.1.5.8	
26	Translate Parameter Setting	Setting set values of translate parameter items.	Section 2.4.1.5.9	

Note! Do not perform any operations/settings for the items that are specified as [Use of this menu item is prohibited.] If this caution is not observed, it may result in danger of abnormal operations of the printer.

5.3 Maintenance menu functions

5.3.1 Self-diagnostic mode

This section describes the self-diagnostic LEVEL 0 and LEVEL 1 respectively.

5.3.1.1 Operation panel

The following description on operating the self-diagnostic is premised on the operation panel layout as shown below.



(1) How to select the menu items

Self-diagnostic mode layout (overall)

- XXXXX Menu items can be selected directly.
- XXXXX Menu items can be selected by pressing either [MENU+] or [MENU-] key.

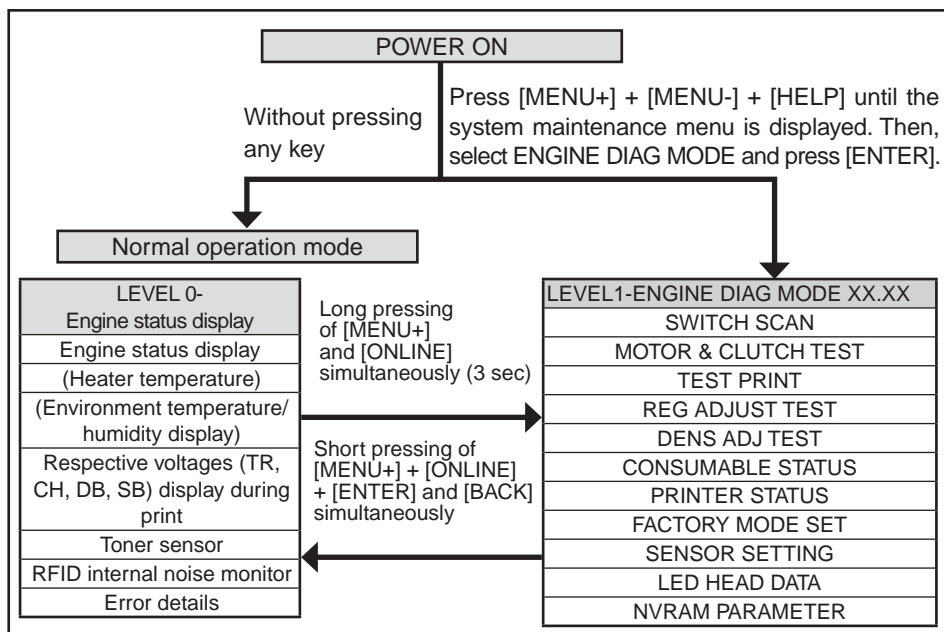

(1) How to select the menu items

LEVEL0

- XXXX Menu items can be selected by long pressing of [BACK] or [ONLINE], or by short pressing of [MENU+] or [ONLINE].
- XXXX Menu items can be selected by pressing either [MENU+] or [MENU-] key. Long pressing of [BACK] returns the screen to the menu item selection screen.

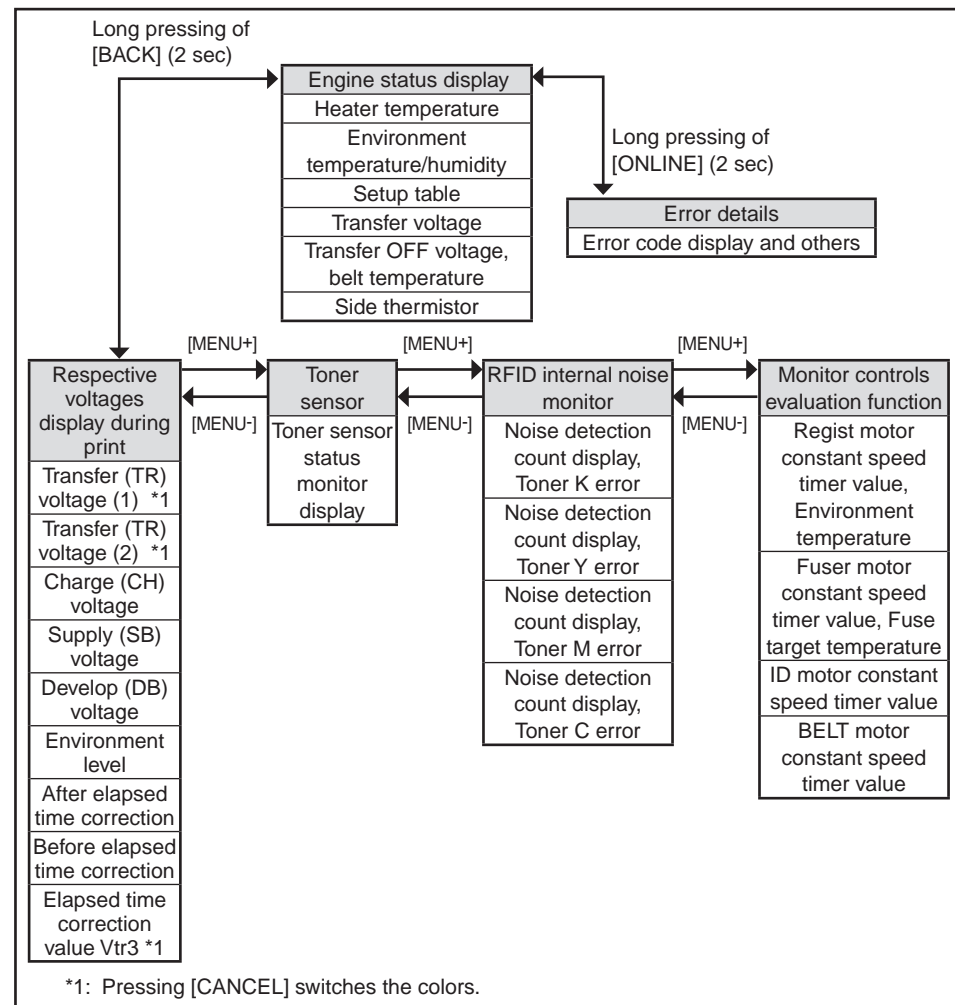

LEVEL1

(1) How to select the menu items

XXXXXX Menu items can be selected by pressing either [MENU+] or [MENU-] key, and executed by pressing [ENTER].

XXXXXX Menu items can be entered by pressing of [ENTER] or [BACK], and can be selected by pressing of [MENU+] or [MENU-].

The test can be executed by pressing [ENTER], and can be exited by pressing [BACK].

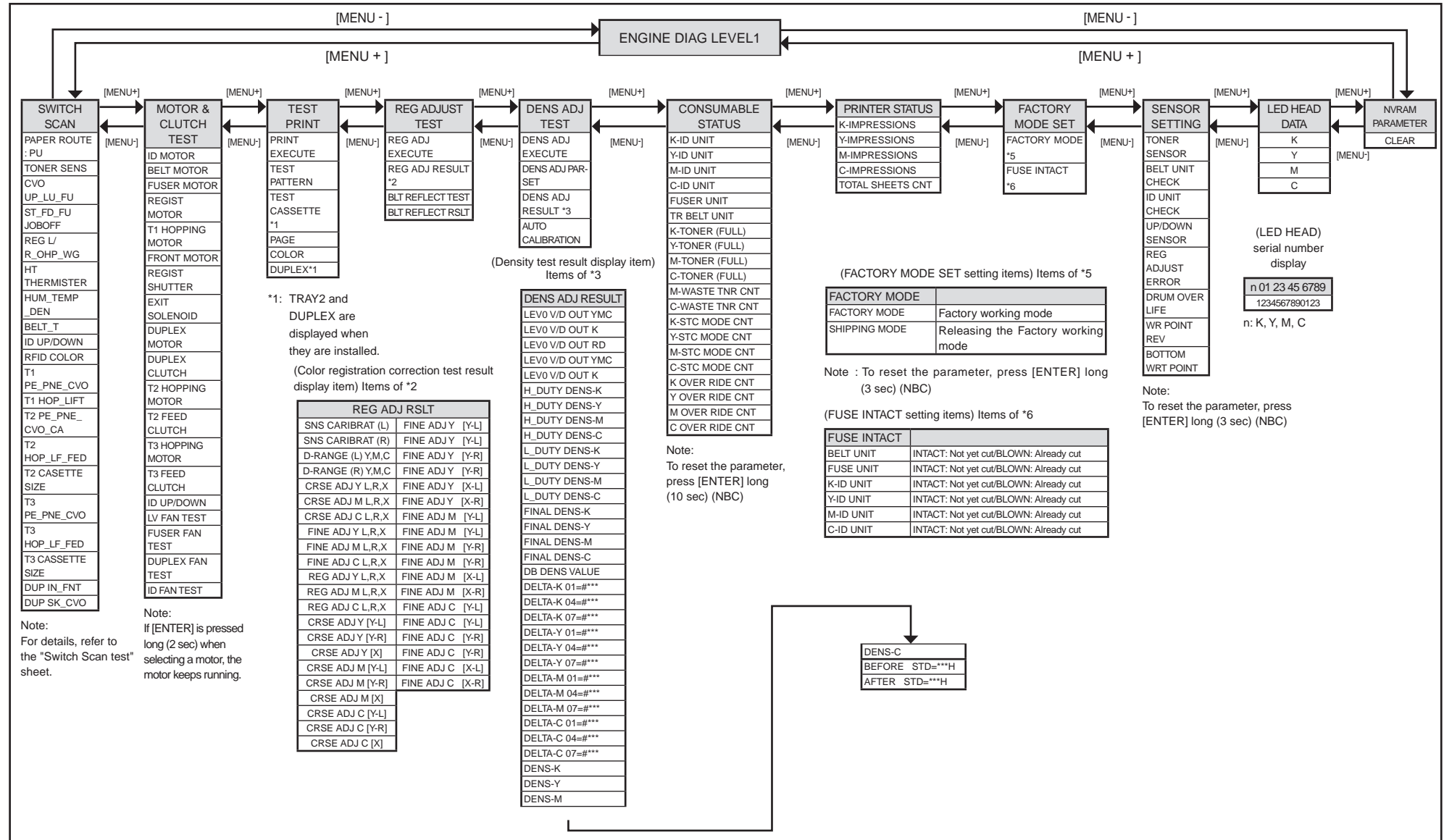

5.3.1.2 Ordinary self-diagnostic mode (level 1)

Menu items of the ordinary self-diagnostic mode are shown below.

	Item	Self-diagnostic menu	Adjustment contents	Maintenance utilities
1	Switch scan test	SWITCH SCAN	Entry sensor check and switch check	No.18
2	Motor clutch test	MOTOR&CLTCH TEST	Motor and clutch operation test	No.19
3	Test print execution	TEST PRINT	PU built-in test pattern print	Operation from the maintenance utilities cannot be made.
4	Color registration correction test	REG ADJUST TEST	Color registration mechanism check	No.20
5	Density correction test	DENS ADJ TEST	Density correction mechanism check	No.21
6	Consumable item counter display	CONSUMABLE STATUS	Consumable items consumption status display	No.23
7	Consumable item accumulative counter display	PRINTER STATUS	Consumable items accumulative consumption status display	No.23
8	Factory/Shipping mode selection	FACTORY MODE SET	Switching between the Factory mode and the Shipping mode	No.3, No.24
9	FUSE status check		Respective FUSES status display	No.24
10	Engine parameter setting	SENSOR SETTING	Valid/Invalid setups of error detection by various sensors	No.25
11	NVRAM parameter setting	NVRAM PARAMETER	Do not use this item	Use of this menu item is prohibited

5.3.1.2.1 How to enter the self-diagnostic mode (level 1)

Note! For C711, password is required to enter the system maintenance menu mode. Refer to Table 5-1 (C711)

1. While pressing the MENU+ and MENU- keys simultaneously, turn on the power to enter the system maintenance mode.
2. Press the MENU+ key or MENU- key several times until the message "ENGINE DIAG MODE" is displayed. Then, press the ENTER key to display "DIAGNOSTIC MODE".

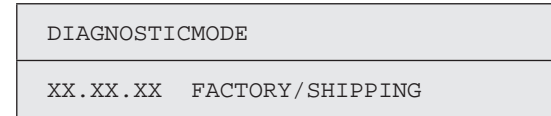

3. XXX.XX.XX of the message "DIAGNOSTIC MODE XX.XX.XX" that is displayed on the LCD display area indicates the PU firmware version number. The FACTORY WORKING MODE setup value is displayed in the right of the lower row. S-MODE of "SHIPPING" is displayed normally.
4. Press the MENU+ key or MENU- key to advance to the desired step of each self-diagnostic menu. (The menu items rotate when either the MENU+ key or MENU- key is pressed.)

5.3.1.2.2 How to exit the self-diagnostic mode

1. Turn off the power once and back on 10 seconds later.

5.3.1.3 Switch scan test

This self-diagnostic menu is used to check the entry sensor and the switch.

1. Enter the self-diagnostic mode (level 1) and press the MENU+, MENU- key until "SWITCH SCAN" is displayed in the upper row of the display area. (Pressing the MENU+ key increments the test item and pressing the MENU- key decrements the test item.)

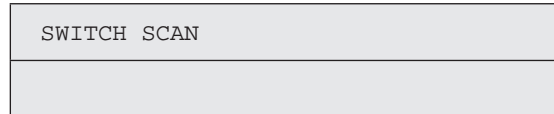

2. Press either the MENU+ or MENU- key until the desired menu item corresponding to the unit to be tested in Table 5-3 is displayed in the lower row of the display area. (Pressing the MENU+ key increments the test item and pressing the MENU- key decrements the test item.)
3. Pressing the ENTER key starts the test. Name and present status of the corresponding unit are displayed.

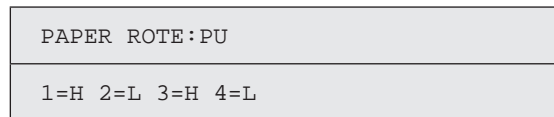

Activate the respective units. (Figure 5-1) Status of the respective units are displayed on the corresponding areas of the LCD display. (Display changes depending on each sensor. Refer to Table 5-3 for details.)

4. Press the CANCEL key to return to the status of step 2.
5. Repeat steps 2 to 4 as required.
6. Press the BACK key to exit the test. (Returns to the status of step 1.)

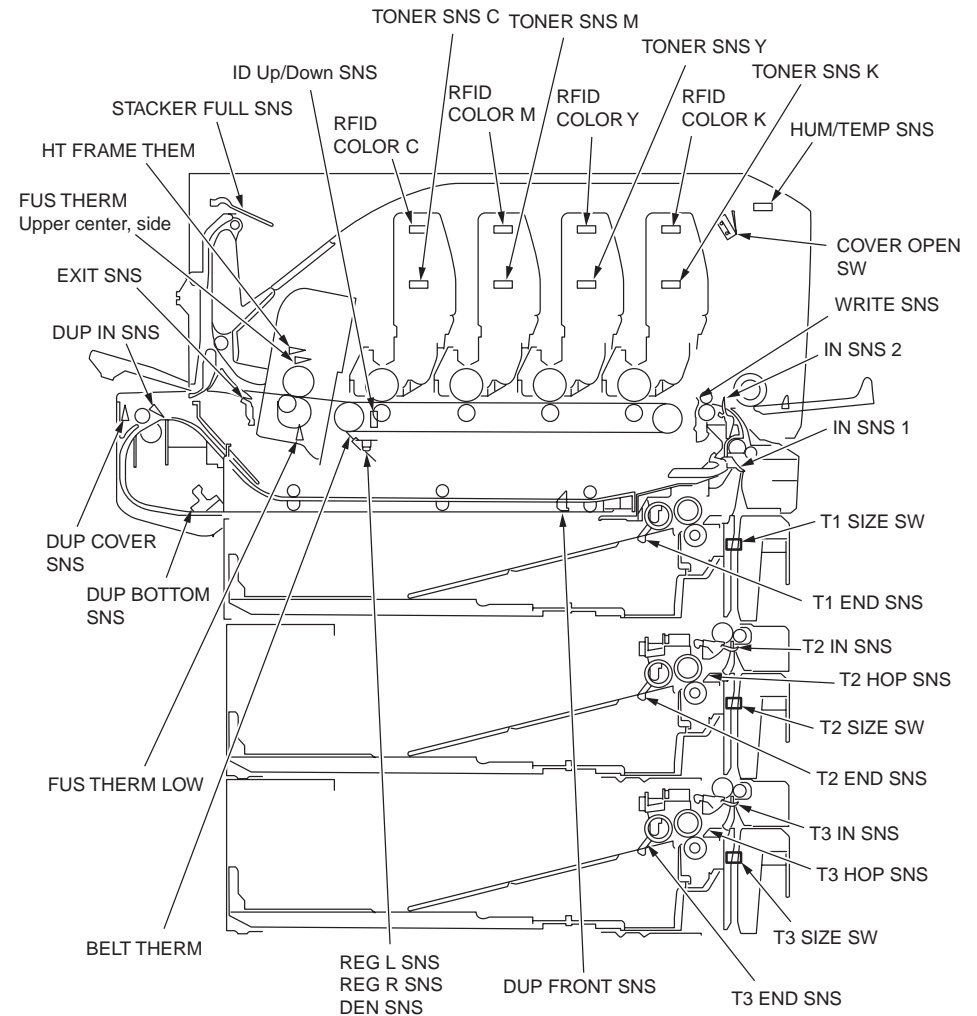

Figure 5-1 Switch and sensor location diagram

Table 5-3 SWITCH SCAN details

<Item having no function> Asterisk mark (*) is displayed in the lower row of display area.

* 1: "L" is displayed when the cover is opened.

Display area, upper row	1		2		3		4	
	Details	Display area, lower row	Details	Display area, lower row	Details	Display area, lower row	Details	Display area, lower row
PAPER ROUTE : PU	Entrance sensor 1	H: No paper L: Paper exists	Entrance sensor 2	H: No paper L: Paper exists	Write sensor	H: No paper L: Paper exists	Exit sensor	H: No paper L: Paper exists
TONER SENS	Toner sensor K	H: Light is interrupted L: Reflected	Toner sensor Y	H: Light is interrupted L: Reflected	Toner sensor M	H: Light is interrupted L: Reflected	Toner sensor C	H: Light is interrupted L: Reflected
CVO UP_LU_FU	Cover open switch	H: Close L: Open						
ST_FD_FU JOBOFF	Stacker down sensor	H: No paper L: Paper exists						
REG L/R_OHP_WG	Color registration sensor L	AD value: ***H	Color registration sensor R	AD value: ***H				
HT THERMISTER	Fuser thermistor, upper sensor	AD value: ***H	Fuser thermistor, lower sensor	AD value: ***H	Fuser thermistor, upper sensor, side	AD value: ***H	Heater frame thermistor	AD value: ***H
HUM_TEMP_DEN	Humidity sensor	AD value: ***H	Humidity sensor	AD value: ***H	Humidity sensor (k)	AD value: ***H	Humidity sensor (YMC)	AD value: ***H
BELT_T	Belt thermistor	AD value: ***H						
ID UP/DOWN	GREY	GREY					ID UpDown Sns	H: Down L: Up
RFID COLOR*1	RFID antenna K	UID: ***H	RFID antenna Y	UID: ***H	RFID antenna M	UID: ***H	RFID antenna C	UID: ***H
T1 PE_PNE_CVO	Tray 1 paper end sensor	H: No paper L: Paper exists						
T1 CASSETTE SIZE*1	Size setting switch 1	Port level H, L	Size setting switch 2	Port level H, L	Size setting switch 3	Port level H, L	Size setting switch 4	Port level H, L
T2 PE_PNE_CVO_CA	Tray 2 paper end sensor	H: No paper L: Paper exists						
T2 HOP_LF_FED	2nd-Hopping Sns	H: No paper L: Paper exists			Tray 2 entrance sensor	H: No paper L: Paper exists		
T2 CASSETTE SIZE*1	Size setting switch 1	Port level H, L	Size setting switch 2	Port level H, L	Size setting switch 3	Port level H, L	Size setting switch 4	Port level H, L
T3 PE_PNE_CVO	Tray 3 paper end sensor	H: No paper L: Paper exists						
T3 HOP_LF_FED	3rd-Hopping Sns	H: No paper L: Paper exists			Tray 3 entrance sensor	H: No paper L: Paper exists		
T3 CASSETTE SIZE	Size setting switch 1	Port level H, L	Size setting switch 2	Port level H, L	Size setting switch 3	Port level H, L	Size setting switch 4	Port level H, L
DUP IN_RA_FNT	Duplex (2-sided printing) entrance sensor	H: No paper L: Paper exists			Duplex (2-sided printing) front sensor	H: No paper L: Paper exists		
DUP SK_CVO	Duplex (2-sided printing) bottom sensor	H: No paper L: Paper exists	Duplex (2-sided printing) cover sensor	H: Close L: Open				

5.3.1.4 Motor clutch test

This self-diagnostic menu is used to test the motor and clutch.

1. Enter the self-diagnostic mode (level 1) and press the MENU+, MENU- key until "SWITCH SCAN" is displayed in the upper row of the display area.
(Pressing the MENU+ key increments the test item and pressing the MENU- key decrements the test item.)
2. Press either the MENU+ or MENU- key until the desired menu item corresponding to the unit to be tested in Table 5-4 is displayed in the lower row of the display area. (Pressing the MENU+ key increments the test item and pressing the MENU- key decrements the test item.)

MOTOR & CLUTCH TEST
ID MOTOR

3. Pressing the ENTER key starts the test. The unit name starts flashing and the corresponding unit is activated for 10 seconds. (Refer to Figure 5-2.)

Note! After the corresponding unit has activated for 10 seconds, it returns to the status of step2, and is re-activated when the corresponding switch is pressed.

- The clutch solenoid repeats turning on and off during the normal print drive. (If a clutch solenoid cannot be activated independently, the motor is driven at the same time.) * "ID UP/DOWN" keeps activated until the CANCEL key is pressed.
- If [ENTER] is pressed long (2 sec) when selecting a motor, the motor keeps running.

4. When the CANCEL key is pressed, the corresponding unit stops activating. (Display of the corresponding unit keeps displayed.)
5. Repeat steps 2 to 4 as required.
6. Pressing the BACK key terminates the test. (Returns to the status of step 1.)

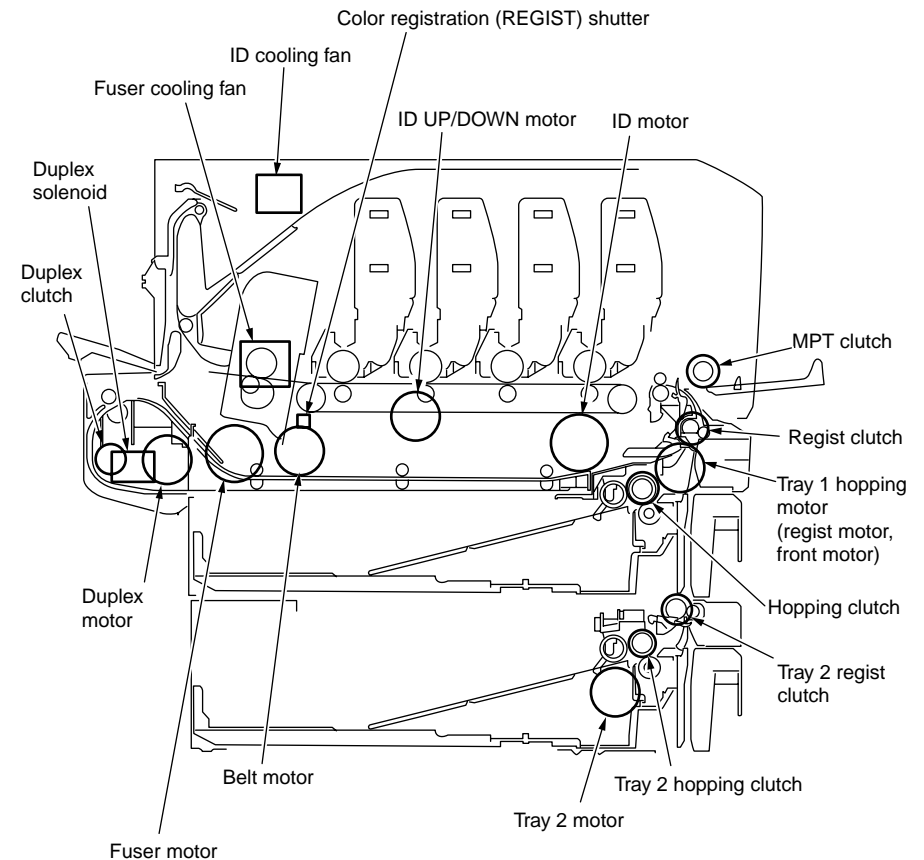

Figure 5-2

Table 5-4

Unit name display	Drive restriction condition	Remarks
ID MOTOR	To be driven when all of the ID (K/Y/M/C) are removed.	-
BELT MOTOR	To be driven when all of the ID (K/Y/M/C) are removed.	-
FUSER_RLS	-	-
REGIST MOTOR	-	-
T1 HOPPING MOTOR	-	-
FRONT MOTOR	-	-
REGIST SHUTTER	-	-
EXIT SOLENOID	-	-
DUPLEX MOTOR	-	-
DUPLEX CLUTCH	-	-
T2 HOPPING MOTOR	-	OPTION
T2 FEED CLUTCH	-	OPTION
T3 HOPPING MOTOR	-	OPTION
T3 FEED CLUTCH	-	OPTION
ID UP/DOWN	TOP/FRONT cover closed status	-
LV FAN TEST	-	-
FUSER FAN TEST	-	-
DUPLEX FAN TEST	-	OPTION
ID FAN TEST	-	-

Note! Display while ID Up/Down execution is in progress

MOTOR & CLUTCH TEST
ID UP/DOWN ***

*** Number of times of execution

Display when the REGIST SHUTTER [ENTER] key is pressed long

MOTOR & CLUTCH TEST
SHT ***

*** Number of times of execution

5.3.1.5 Test print

This self-diagnostic menu is used to print the test pattern that is built inside PU. Other test patterns are stored in the controller.

This test print cannot be used to check the print quality.

Diagnosis for the abnormal print image should be performed in accordance with section 7.

1. Enter the self-diagnostic mode (level 1) and keep pressing the MENU+, MENU- key until "TEST PRINT" is displayed in the upper row of the display area. Then, press the ENTER key. (Pressing the MENU+ key increments the test item and pressing the MENU- key decrements the test item.)
2. The setting items that can be applied to the test print only is displayed in the lower row of display area. Keep pressing the MENU+, MENU- key until the desired menu item is displayed. (Pressing the MENU+ key increments the test item and pressing the MENU- key decrements the test item.) (If all setting items need no entry [Default setting], go to step 5.)
3. Keep pressing the MENU+, MENU- key, and press the ENTER key at the menu item set by step 2. Then, the setting item is displayed in the upper row of display area, and the setting value is displayed in the lower row of display area.

Pressing the MENU+ key increments the setting value. Pressing the MENU- key decrements the setting value. (The setting value that is displayed at last is applied.) Pressing the BACK key determines the entry value, and returns to step 2. Repeat step 3 as required.

TEST PATTERN
1

Display	Setting value	Function
PRINT EXECUTE	–	Pressing the ENTER key starts print/Pressing the CANCEL key terminates print. (In units of page)
TEST PATTERN	0	0: White paper print 1–7: Refer to next page. (Pattern print) 8–15: White paper print
TEST CASSETTE	TRAY1	Selecting source of paper supply. If the TRAY 2 is not installed, TRAY2 is not displayed. If the TRAY 3 is not installed, TRAY3 is not displayed.
	TRAY2	
	TRAY3	
	MFP	
PAGE	0000	Setting number of the test print copies
COLOR	ON	Selecting either color/monochrome print * When ON is specified, ON/OFF setting for each color becomes available.
	OFF	
DUPLEX	2 PAGES STACK	Duplex (2-sided) print is performed by the stack of two sheets of paper. Selecting OFF for duplex (2-sided) print. Duplex (1-sided) print is performed by the stack of one sheet of paper.
	OFF	
	1PAGES STACK	

- is the initial default value. The menu item that is set here is valid in this menu item only.
(The setting item is not saved in EEPROM.)

Note! PAGE setting

Pressing the MENU+ key or the MENU- key shifts the digit. Pressing the ONLINE key increments the setting value. Pressing the MENU+ key increments the setting value. If print is executed while the number of print copies remains in "0000", printing will continue infinitely.

COLOR setting

When the ENTER key is pressed while ON is set, the following contents are displayed on the panel.

Print setting for each color

Pressing the MENU+ key or the MENU- key shifts the setting. Pressing the ONLINE key or the CANCEL, the ON/OFF switchover will be set. Pressing the BACK key returns the panel display.

COLOR	→	Y : ON M : ON
ON		C : ON K : ON

- While the message "PRINT EXECUTE" that is set by the operation specified in step 2 is being displayed, press the ENTER key and the test print is executed with the setting value that has been set by steps 2 and 3.

Pressing the CANCEL key stops the test print.

If any alarm that is shown in the following details column is issued at startup of test print or while test print is in progress, the test print is interrupted. (For error details, refer to section 5.3.2.14 Panel display details. However, the comment to be displayed is different in the case of the PU test print.)

Panel display	Details
STACKER FULL	Stacker full
PAPER END SELECTED TRAY	No paper
DUPLEX UNIT IS NOT INSTALLED	DUPLEX is not installed
SELECTED TRAY IS NOT INSTALLED	Selected tray is not installed.
REMOVE PAPER OUT OF DUPLEX	DUPLEX internal error
INSTALL CASSETTE TRAY OPEN	Cassette removal

Print pattern (It cannot be used for checking PQ.)

0, 8 to 15..... White paper print



Pattern 1

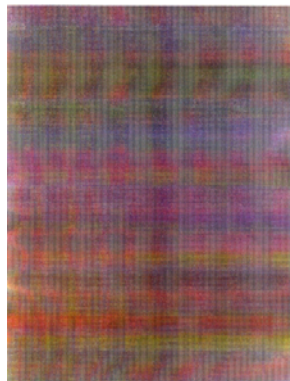

Pattern 2



Pattern 3



Pattern 4

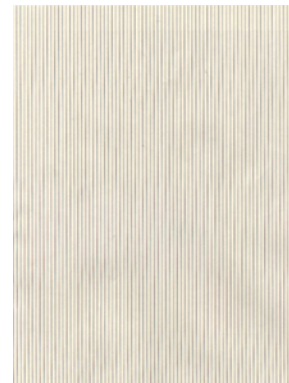

Pattern 5

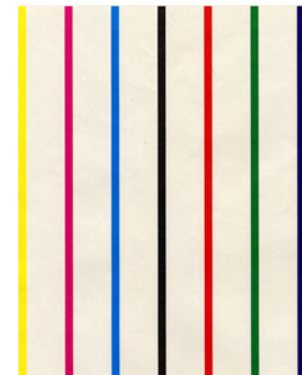

Pattern 6



Pattern 7

Note! If the solid print (pattern 7) among the local print function is selected and printed with the setting of 100% each color, offset occurs. To prevent print from this trouble, the print setting of each color should be made in accordance with the instruction specified in step 5.3.2.5-3 when performing the sold print, and number of print colors should be two colors or less.

- During printing, the following messages are displayed.

P=***
W=***

P : Number of test print copies (unit: copies)
 W : Print waiting time (unit: second)

- Displays are switched by pressing the MENU+ key.

T=*** U=*** [###]
H=***%L=*** [###]

U : *** = Upper heater temperature measurement value [unit:°C]
 [***] = Print execution target temperature [unit:°C]
 L : *** = Lower heater temperature measurement value [unit:°C]
 [###] = Lower thermistor read-out AD value [unit: HEX]
 T : Environment temperature measurement value [unit:°C]
 H : Environment humidity measurement value [unit: %]

- Displays are switched by pressing the MENU+ key.

KTR=* . ** YTR=* . **
MTR=* . ** CTR=* . **

YTR, MTR, CTR and KTR indicate the transfer voltage setting value for each color (unit: KV)

- Displays are switched by pressing the MENU+ key.

KR=* . ** YR=* . **
MR=* . ** CR=* . **

KR : BLACK transfer roller resistance value [unit: uA]
 YR : YELLOW transfer roller resistance value [unit: uA]
 MR : MAGENTA transfer roller resistance value [unit: uA]
 CR : CYAN transfer roller resistance value [unit: uA]

- Displays are switched by pressing the MENU+ key.

ETMP=***UTMP=***
REG=****EXT=***

ETMP : Hopping motor constant speed correction parameter
 (environment temperature) [unit: DEC]
 UTMP : Fuser motor constant speed correction parameter
 (fuse target temperature) [unit: DEC]
 REG : Hopping motor constant speed timer value (I/O setting value)
 [unit: HEX]
 EXT : Fuse motor constant speed timer value (I/O setting value) [unit: HEX]

- Displays are switched by pressing the MENU+ key.

ID=****

KID, YID, MID and CID are the constant speed timer value of the respective ID motors (I/O setting value) [unit: HEX]

- Displays are switched by pressing the MENU+ key.

BELT=****
FRM [***] (xxx)

BELT : Hopping motor constant speed timer value (I/O setting value) [unit: HEX]
 FRM : [***] = Frame thermistor read-out AD value [unit: HEX]
 (XXX) = Frame temperature [unit: °C]

- Displays are switched by pressing the MENU+ key.

DB:k**y**m**c**

DB : Develop voltage setting table ID number [unit: HEX]

- Displays are switched by pressing the MENU+ key.

TR1 : k**y**m**c**
TR2 : k**y**m**c**

TR1 : Transfer voltage parameter VTR1 table ID number [unit: HEX]

TR2 : Transfer voltage parameter VTR2 table ID number [unit: HEX]

- Displays are switched by pressing the MENU+ key.

TROFF : **
BELT xxx (***)

TROFF : Transfer OFF voltage setting table ID number [unit: HEX]

BELT : XXX = Belt thermistor read-out AD value [unit: HEX]

*** Belt temperature [unit: °C]

5. Repeat steps 2 to 4 as required.
6. Pressing the CANCEL key terminates the test. (Returns to the status of step 1.)

5.3.1.6 Color registration correction test

This self-diagnostic menu item is used for the color registration error adjustment and to investigate cause of the error of a printer.

If the color registration error is recognized by the color registration correction test, correct it by following section 2 "Color registration correction method overview".

1. Enter the self-diagnostic mode (level 1) and keep pressing the [MENU+] or [MENU-] key until the following message is displayed.

REG ADJUST TEST

2. When the [ENTER] key is pressed, the following message is displayed. Keep pressing the [MENU+] or [MENU-] key until the target item is displayed.

REG ADJUST TEST
REG ADJ EXECUTE

3. When the [ENTER] key is pressed, test of the item that is displayed on the panel is executed.

<<During execution of REG ADJ EXECUTE>>

- ① The color registration correction test is executed. (The [ONLINE] lamp flashes.)
- ② When the test is complete, the test result (OK or error name) is displayed in the upper row of the display area, and ****RESULT is displayed in the lower row of the display area

OK
REG ADJ RESULT

When the [MENU+] key is pressed, the test results are displayed by incrementing them.

When the [MENU-] key is pressed, the test results are displayed by decrementing them.

Pressing the [BACK] key returns the screen to the state of step 2.

Remarks The following message is displayed during initialization, when the cover is opened and during alarm.

NG
REG ADJ RESULT

- ③ When the [CANCEL] key is pressed while test is in progress (while the [ON LINE] lamp is lighting), the screen returns to the state of step 2.

<<During execution of REG ADJ RESULT>>

The same as the key operations of step 2. During execution of REG ADJ EXECUTE.

<<During execution of BLT REFLECT TEST>>

- ① The color registration correction test is executed. (The [ONLINE] lamp flashes.)
- ② When the test is complete, the test result (OK or error name) is displayed in the upper row of the display area, and ****RESULT is displayed in the lower row of the display area

OK
BLT REFLECT RSLT

When the [MENU+] key is pressed, the test results are displayed by incrementing them.

When the [MENU-] key is pressed, the test results are displayed by decrementing them.

Pressing the [BACK] key returns the screen to the state of step 2.

- ③ When the [CANCEL] key is pressed while test is in progress (while the [ON LINE] lamp is lighting), the screen returns to the state of step 2.

<<During execution of BLT REFLECT RSLT>>

The same as the key operations of step ②. During execution of BLT REFLECT TEST.

Remarks The following message is displayed during initialization, when the cover is opened and during alarm.

NG
REG REFLECT RSLT

4. Repeat steps 2 and 3 as required.
5. Pressing the [BACK] terminates the test. (Returns to the status of step 1.)

Color registration correction test items

Display	Details
REG ADJ EXECUTE	Executing the color registration correction
REG ADJ RESULT	Referring to result of the color registration correction
BLT REFLECT TEST	Executing judgment of GOOD/BAD of reflectance rate of color registration correction belt
BLT REFLECT RSLT	Referring to result of the judgment of GOOD/BAD of reflectance rate of color registration correction belt.

5.3.1.7 Density correction test

This self-diagnostic menu item is used to test the density correction function of a printer, and to refer to result of the test execution.

At the same time, GOOD/BAD of the density correction function is judged by executing this test.

If an error is issued, correct it by following section 2 "Density correction method overview".

1. Enter the self-diagnostic mode (level 1) and keep pressing the [MENU+] or [MENU-] key until the following message is displayed.

DENS ADJ TEST

2. When the [ENTER] key is pressed, the following message is displayed. Keep pressing the [MENU+] or [MENU-] key until the target item is displayed.

DENS ADJ TEST

DENS ADJ EXECUTE

3. When the [ENTER] key is pressed, test of the item that is displayed on the panel is executed.

<<During execution of REG ADJ EXECUTE>>

- ① The density correction test is executed. (The [ONLINE] lamp flashes.)
- ② When the test is complete, the test result (OK or error name) is displayed in the upper row of the display area, and ****RESULT is displayed in the lower row of the display area

OK

DENS ADJ RESULT

[When the [MENU+] key is pressed, the test results are displayed by incrementing them.

When the [MENU-] key is pressed, the test results are displayed by decrementing them.

Pressing the [BACK] key returns the screen to the state of step 2.

- ③ When the [CANCEL] key is pressed while test is in progress (while the [ON LINE] lamp is lighting), the screen returns to the state of step 2.

<<During execution of DENS ADJ RESULT>>

The same as the key operations of step 2. During execution of DENS ADJ EXECUTE.

<<During execution of DENS ADJ PAR - SET>>

Setup of the density correction parameter is displayed.

<<During execution of AUTO CALIBRATION>>

- ① The automatic setting of the density sensor sensitivity correction value is executed. (The [ON LINE] lamp flashes.)
- ② When the test is complete, the test result (OK or error name) is displayed in the upper row of the display area, and ****RESULT is displayed in the lower row of the display area

OK
DENS ADJ RESULT

When the [MENU+] key is pressed, the test results are displayed by incrementing them.

When the [MENU-] key is pressed, the test results are displayed by decrementing them.

Pressing the [BACK] key returns the screen to the state of step 2.

- ③ When the [CANCEL] key is pressed while test is in progress (while the [ON LINE] lamp is lighting), the screen returns to the state of step 2.

Remarks The following message is displayed during initialization, when the cover is opened and during alarm.

NG
DENS ADJ RESULT

- 4. Repeat step 3 as required.

- 5. Pressing the [BACK] key terminates the test. (Returns to the status of step 1.)

Density correction test items

Display	Details
DENS ADJ EXECUTE	Executing the density correction
DENS ADJ PAR-SET	Setting the control values with respect to the automatic density correction
DENS ADJ RESULT	Referring to result of the density correction
AUTO CALIBRATION	Automatic setting of the density sensor sensitivity correction value

5.3.1.8 Consumable item counter display

This self-diagnostic menu is used to display the consumption status of the consumable items.

1. Enter the ordinary self-diagnostic mode and press the MENU+, MENU- key until "CONSUMABLE STATUS" is displayed in the display area. (Pressing the MENU+ key increments the test item and pressing the MENU- key decrements the test item.)
2. When the MENU+, MENU- key is pressed, consumption statuses of the consumable items are displayed in order. (Pressing the ONLINE or CANCEL key is invalid.)
3. Pressing the BACK key terminates the test. (Returns to the status of step 1.)

Display area, upper row	Display area, lower row	Format	Unit	Details
K-ID UNIT	*****IMAGES	DEC	Images	Number of rotations from the time when the ID UNITS of respective colors are installed up to the present time is displayed after converting them to the units of A4 3Page/Job.
Y-ID UNIT	*****IMAGES	DEC	Images	
M-ID UNIT	*****IMAGES	DEC	Images	
C-ID UNIT	*****IMAGES	DEC	Images	
FUSER UNIT	*****PRINTS	DEC	Prints	Number of copies from the time of installation of a new fuser unit up to the present time is displayed.
TR BELT UNIT	*****IMAGES	DEC	Images	Number of copies from the time of installation of a new belt unit up to the present time is displayed.
K-TONER (FULL)	*****%	DEC	%	Amount of consumption of the respective toners is displayed.
Y-TONER (FULL)	*****%	DEC	%	
M-TONER (FULL)	*****%	DEC	%	
C-TONER (FULL)	*****%	DEC	%	
M-WASTE TNR CNT	*****TIMES	DEC	Times	Amount of waste toner is displayed. * When the times reaches 32 times or more, the waste toner full is issued.
C-WASTE TNR CNT	*****TIMES	DEC	Times	

Display area, upper row	Display area, lower row	Format	Unit	Details
K-STC MODE CNT	*****TIMES	DEC	Times	Number of print dot counts of the toner of the respective colors are displayed. (Accumulative value since start of the system operation.)
Y-STC MODE CNT	*****TIMES	DEC	Times	
M-STC MODE CNT	*****TIMES	DEC	Times	
C-STC MODE CNT	*****TIMES	DEC	Times	
K OVER RIDE CNT	*****TIMES	DEC	Times	Number of times of continues of the toner cartridge of the respective colors are displayed.
Y OVER RIDE CNT	*****TIMES	DEC	Times	
M OVER RIDE CNT	*****TIMES	DEC	Times	
C OVER RIDE CNT	*****TIMES	DEC	Times	

5.3.1.9 Number of print copies counter display

This self-diagnostic menu is used to display status of the number of copies of a printer.

1. Enter the ordinary self-diagnostic mode and press the MENU+, MENU- key until "PRINTER STATUS" is displayed in the display area. (Pressing the MENU+ key increments the test item and pressing the MENU- key decrements the test item.)
2. When the MENU+, MENU- key is pressed, statuses of the number of print copies are displayed in order.(Pressing the ONLINE or CANCEL key is invalid.)
3. Pressing the BACK key terminates the test. (Returns to the status of step 1.)

Display area, upper row	Display area, lower row	Format	Unit	Details
K-IMPRESSIONS	*****IMAGES	DEC	Images	Number of print copies of the respective colors are displayed.
Y-IMPRESSIONS	*****IMAGES	DEC	Images	
M-IMPRESSIONS	*****IMAGES	DEC	Images	
C-IMPRESSIONS	*****IMAGES	DEC	Images	
TOTAL SHEET CNT	*****COUNTS	DEC	Prints	Total number of print copies are displayed.

5.3.1.10 Switching between the Factory mode and the Shipping mode

This self-diagnostic menu item is used to switch between the Factory mode and the Shipping mode.

1. Enter the self-diagnostic mode (level 1) and keep pressing the [MENU+] or [MENU-] key until the following message is displayed.

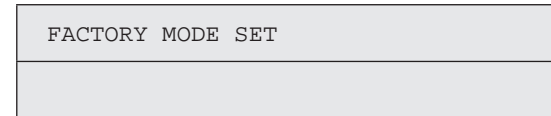

2. When the [ENTER] key is pressed, the following message is displayed. Keep pressing the [MENU+] or [MENU-] key until the target item (refer to the following table) is displayed.

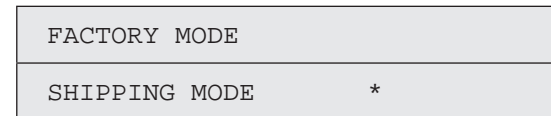

3. While the desired item to set is being displayed, press the [ENTER] key that enables selection of the setting values.
4. While the desired setting value is being displayed, press the [ENTER] key for long period (3 seconds) that registers the displayed value in EEPROM. (Returns to the status of step 2.)
5. Repeat steps 2 to 4 as required.
6. Pressing the [BACK] key terminates the test. (Returns to the status of step 1.)

Display	Setting value	Function
FACTORY MODE	FACTORY MODE	Sets the Factory working mode (fuse cut invalid mode).
	SHIPPING MODE	Releases the Factory working mode to make the fuse cut function valid.
FUSE INTACT Note: ***** indicates INTACT or BLOWN.	BELT UNIT *****	Checks the fuse status of the transport belt unit.
	FUSE UNIT *****	Checks the fuse status of the fuser unit.
	K-ID UNIT *****	Checks the fuse status of the K-1D unit.
	Y-ID UNIT *****	Checks the fuse status of the Y-1D unit.
	M-ID UNIT *****	Checks the fuse status of the Y-1D unit.
	C-ID UNIT *****	Checks the fuse status of the C-1D unit.

5.3.1.11 Self-diagnostic function setting

This self-diagnostic menu is used to set valid/invalid of the error detection by the various sensors.

The error detection can be made invalid or valid for locating source of abnormality. However, this menu item requires expert knowledge to set among the engine operations. Handle this menu item with utmost care.

Be sure to return the setting to the default setting upon completion of usage of this item.

1. Enter the self-diagnostic mode (level 1) and keep pressing the [MENU+] or [MENU-] key until the following message is displayed.

SENSOR SETTING

2. When the [ENTER] key is pressed, the following message is displayed. Keep pressing the [MENU+] or [MENU-] key until the target item (refer to the table below) is displayed.

TONER SENSOR
ENABLE *

3. When the [ENTER] key is pressed, the following message is displayed.
Pressing the [MENU+] key increments the setting value.
Pressing the [MENU-] key decrements the setting value.
4. While the desired setting value is being displayed, press the [ENTER] key for long period (3 seconds) that registers the displayed value in EEPROM. (Returns to the status of step 2.)
5. Repeat steps 2 to 4 as required.
6. Pressing the [BACK] key terminates (except the status of step 4) the setting. (Returns to the status of step 1.)

Display	Setting value	Operation at the setting value	Function
TONER SENSOR	ENABLE	Detects	Valid/Invalid of toner sensor operation
	DISABLE	Not to detect	
BELT UNIT CHECK	ENABLE	Checks	Valid/Invalid of belt installation check operation
	DISABLE	Not to check	

Display	Setting value	Operation at the setting value	Function
ID UNIT CHECK	ENABLE	Checks	Valid/Invalid of ID installation check operation
	DISABLE	Not to check	
UP/DOWN SENSOR	ENABLE	Detects	Valid/Invalid of ID UP/DOWN sensor operation
	DISABLE	Not to detect	
REG ADJUST ERROR	ENABLE	Stops	Valid/Invalid of error stop by the color registration detection value
	DISABLE	Not to stop	
DRUM OVER LIFE	STOP	Not to continue	Setting of valid/invalid of continuance when drum comes to end of its life
	CONTINUANCE	To continue	
WR POINT REV TBL=**H± * .***mm	00H~FFH	Correction value	The correction value is added to the existing write-down position.
BOTTOM WRT POINT TBL=**H± * .***mm	00H~FFH	Cut value	Amount of cut at the rear end of a paper is set.

Hatched portion: Default is shown

5.3.1.12 LED head serial number display

This self-diagnostic menu item is used to check whether the downloaded LED head data matches the serial number of the actual LED head.

1. Enter the self-diagnostic mode (level 1) and press the MENU+, MENU- key until "SWITCH SCAN" is displayed in the upper row of the display area. (Pressing the MENU+ key increments the test item and pressing the MENU- key decrements the test item.)
2. When the MENU+ key or the MENU- key is pressed, serial numbers of the K/Y/M/C LED head data are displayed in order.
3. Pressing the BACK key terminates the test. (Returns to the status of step 1.)

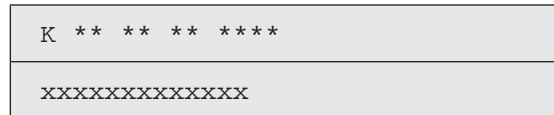

** * * * *: Rev number

XXXXXXXXXXXXXXXXX: serial number

5.3.1.13 NVRAM parameter setting

Do not use this menu item.

5.3.2 Various prints with the printer as a standalone unit

Menu map print

Information of the program version number and that of the control block configuration are printed out.

Operation:

- ① While the system is in the [Ready To Print] state, press the ENTER key once to display [Print Information].
- ② Press the ENTER key to display [Configuration/Execute].
- ③ Press the ENTER key.

Network information print

Operation:

- ① While the system is in the [Ready To Print] state, press the ENTER key once to display [Print Information].
- ② Press the ENTER key.
- ③ Press the MENU+ key several times to display [Network/Execute].
- ④ Press the ENTER key.

Demo print

Prints the demo patterns of the various destinations that are saved in the ROM.

Operation:

- ① While the system is in the [Ready To Print] state, press the ENTER key once to display [Print Information].
- ② Press the ENTER key.
- ③ Press the MENU+ key several times to display [Demo Page/Execute].
- ④ Press the ENTER key.

5.3.3 Functions of keys at power on

Functions of the respective keys when the printer power is turned on are displayed below. Each of the following keys becomes valid if the key is kept pressed until "RAM Check" is displayed in the upper row of LCD and the several asterisk (*) marks are displayed in the lower row.

(1) MENU+ key & MENU- key & ENTER key

The printer starts up in the CU program upgrade mode. If the printer starts up in this mode, the network does not function.

(2) BACK key & ONLINE key & CANCEL key

The object that is added by the download mode is not started but the CU program is started up.

(3) MENU+ key & MENU- key & HELP key

The system maintenance menu is started up.

(4) MENU+ key & MENU- key & ENTER key

The printer starts up in the mode that sets the printer in the on-line mode all the time by ignoring the warning/error. (Factory assistance function)

(5) ONLINE key

The printer starts up in the dedicated mode in which the objects such as network or USB is going to be downloaded.

(6) ENTER key

The Boot Menu is started up.

5.4 Setups upon completion of part replacement

The adjustments that are required upon completion of part replacement are described below.

Replacement parts	Adjustment contents
LED head See note.	Not required
Drum cartridges (Y, M, C, K)	Not required
Fuser unit	Not required
Belt unit	Not required
CU/PU board	Copying the EEPROM information and utilities are required.

5.4.1 Precautions when replacing the CU/PU board

1. When access to the EEPROM of the board to remove is possible. (When the SERVICE CALL 104 [Engine EEPROM Error] or 40 [EEPROM Error] is not displayed:)
 - (1) Obtain the EEPROM information from the board to remove, by using the board replacement function (Maintenance Utilities Operation Manual section 2.4.1.1.9 Board replacement function) of the Maintenance Utilities, and save in the hard disk of PC temporarily.
 - (2) Copy the EEPROM information that has been saved in the hard disk of PC by step (1), into the EEPROM of the new replacement board by using the Board replacement function (Maintenance Utilities Operation Manual section 2.4.1.1.9 Board replacement function) of the Maintenance Utilities.
 - (3) Alternatively, when only the PU-part EEPROM information or the CU-part EEPROM setting information could be taken and stored in step (2), copy it into the EEPROM of the replacement board by using the board replacement function of Maintenance Utility (Maintenance Utilities Operation Manual section 2.4.1.1.9 Board replacement function). With the function but separately from this operation, configure the EEPROM with the information that could not be taken from the board being replaced with: Configure the PU part serial number setting (Maintenance Utilities Operation Manual section 2.4.1.1.9.5) and switching to the Shipping mode (Maintenance Utilities Operation Manual section 2.4.1.1.9.6) on an appropriate setting window when the untaken information is PU-part EEPROM information, and the CU part serial number information setting (Maintenance Utilities Operation Manual section 2.4.1.1.9.4) when the untaken information is CU-part EEPROM setting information.

Note! When obtaining and copying the EEPROM information by using the Maintenance Utilities, set the printer into the "Forced ONLINE mode" by following the procedure described below. If the printer is in the error state, the error display is issued even during the forced ONLINE mode.

1. When turning on the printer power, keep pressing [BACK] + [MENU-] + [ENTER] until "Status Mode" is displayed on the operator panel.
2. If the printer is normal, "ON LINE" display is shown. If the printer has an error, the error display is shown. However, the printer has entered the ON LINE state in which communication is enabled.

2. When access to the EEPROM of the board to remove is impossible.

If the SERVICE CALL 104 [Engine EEPROM Error] or 40 [EEPROM Error] is displayed on the operator panel with the board to remove, or is EEPROM data cannot be read-out, perform the following procedure by using the Maintenance Utilities.

(1) Setting the serial number information (Maintenance Utilities Operation Manual section 2.4.1.1.10.3)

The SAP serial number is applied to printer. The SAP serial number is displayed in the top-most row of the serial number label. Its number indicates the production place with 2 digits, manufacture date with 2 digits, serial number (sequential number) with 6 digits and revision number with 2 digits totaling 12 digits number.

- Select PU Serial Number for the printer serial number, and Show Only Serial Number for the output mode. Do not enter the CU serial number.
- The PU serial number is the 10 digits number excluding the revision number of 2 digits among the 12 digits SAP serial number.
- Perform the above setting by using the Maintenance Utilities section “2.4.1.1.10 Board setting function” – section “2.4.1.1.10.3 Serial number information setting”.
- To specify the PU serial number, enter the 11 digits number after adding “0” (Zero in single-byte character) at the top. (Be careful that the read-out data shows the 10 digits number.)
Enter the 11 digit number by adding “0” (Zero in single-byte character) before the 10 digit number excluding the revision 2 digits that is shown in conceptual drawing of “Serial number information setting” screen as shown below.

Enter the 11 digit number after adding “0” (zero in single-byte character) before the 10 digit number. (Enter “OAE0123456789”.)

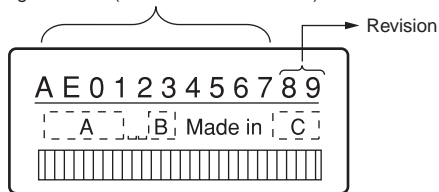

Serial number label conceptual drawing

- The PU serial number is output to the System/Serial Number column of the Configuration. Therefore, confirmation upon completion of rewriting the PU serial number can be performed by printing the Configuration.

(2) Switching to the Shipping mode (Maintenance Utilities Operation Manual section 2.4.1.1.10.4)

When the board is replaced with the new board, the new board has been set in the Factory working mode. Therefore, it should be switched to the Shipping mode.

- Switch the mode by using the Maintenance Utilities section “2.4.1.1.10 Board setting function” – section “2.4.1.1.10.4 Factory/Shipping mode” screen.





Note! Note that replacing the CU/PU board with a new one without copying information onto the new one from the board’s EEPROM clears information about the lives of units of the printer, including the belt, toner and image drums, causing errors in managing these lives on the printer until the units are replaced. The counts cleared with such CU/PU board replacement are as shown in the list below and chapter 2 Counter Specifications. When the units are replaced with new ones, their respective counts except for Total Sheets Fed are cleared, the errors being corrected.

Item	Contents	Count contents
Fuser unit	Fuser unit life count	Number of print copies after the new fuser unit is installed, after the data is converted to equivalent number of A4 size paper counts.
Belt unit	Belt unit life count	Number of print copies after the new belt unit is installed, after the data is converted to equivalent number of A4 size paper counts.
ID unit : Black ID unit : Yellow ID unit : Magenta ID unit : Cyan	Life count of respective ID units	Number of print copies after the new ID unit is installed, after the data is converted to equivalent number of A4 size paper counts.
Total number of papers fed	Printer life count	Total number of papers fed
Print : Black Print : Yellow Print : Magenta Print : Cyan	Number of print copies of each ID	Number of print copies after the new ID unit is installed.

5.5 Density control manual setting

When a printer is shipped from the factory, the automatic density correction mode has been set in "Automatic". If a printer is used after the density correction mode is set to "Manual", density may change during usage of a printer. Actions to be taken when density is not normal.

Note! Perform the followings while a printer is in the still state. Do not perform the followings during warm-up.

- (1) Press the MENU  or MENU  key several times until the [Calibration] is displayed. Then, press the ENTER key.
- (2) Press the MENU  or MENU  key to display [Adjust Density/Execute].
- (3) Press the ENTER  key.

The automatic density correction starts.

5.6 Printer boot menu list

While pressing the  SET button, turn on the power to display the Boot Menu.

Memo To display the Boot Menu, entry of password is required. Default value of password is "aaaaaa".

Category	Item	Setting value	Function
	Enter Password	*****	Enter password to enter Boot Menu. Enter the password of 6 to 12 digits of alphanumeric. The initial value is "aaaaaa".
Parallel Setup	Parallel	Enable	Setting Valid/Invalid of parallel interface.
		Disable	
	Bi-Direction	Enable	Setting Valid/Invalid of bi-direction of parallel interface.
		Disable	
	ECP	Enable	Setting Valid/Invalid of ECP mode.
		Disable	
	Ack Width	Narrow	Setting the ACK width when receiving the compatible data. NARROW = 0.5 μs MEDIUM = 1.0 μs WIDE = 3.0 μs
Medium			
Wide			
Ack/Busy Timing	Ack in Busy	Setting order of outputting the BUSY signal and the ACK signal when receiving the compatible data.	
	Ack while Busy		
I-Prime	3 microseconds 50 microseconds	Setting Valid time/Invalid of the I- PRIME signal	
	Disable		
Offline Receive	Enable	Setting Valid/Invalid of the function that enables to keep the signal reception possible without changing I/F signal even when an alarm is issued.	
	Disable		
USB Setup	USB	Enable	Setting Valid/Invalid of USB interface.
		Disable	
	Speed	480Mbps	Setting the maximum transfer speed of USB interface.
		Enable	
	Soft Reset	Enable	Setting Valid/Invalid of Soft Reset.
Disable			
Offline Receive	Enable Disable	Setting Valid/Invalid of the function that enables to keep the signal reception possible without changing I/F signal even when an alarm is issued.	
Serial Number	Enable	Setting Valid/Invalid of USB serial number.	
	Disable		

Category	Item	Setting value	Function
Security Setup	Job Limitation	Off	Limits the job to accept. The encrypted authentication print only is accepted. It is displayed when the optional internal SD Memory Card is installed.
		Encrypted Job	
	Make Secure SD Card	Execute	Enables encryption functionality for data to store on an SD card. This option enables encryption key generation and applies the information for such encryption (security mode) functionality, initializing the SD card. The option first displays the message: Are You Sure? Yes No Selecting No restores the last menu view. Selecting Yes makes the printer reboot automatically, enabling the encryption functionality. [Display condition] The printer has an SD card, its SD card encryption functionality is disabled and Storage Setup-Enable Initialization is set to Yes.
			Make Normal SD Card
Reset Cipher Key	Execute	Re-generates the encryption key that is used in the encrypted SD Memory Card. It is displayed when the optional internal SD Memory Card is installed, and the encrypted SD Memory Card function is made valid.	

Category	Item	Setting value	Function
Storage Setup	Check File System	Execute	Resolves the un-match between the actual (free) space and displayed free space of file system, and recovers the control data (FAT information.)
	Check All Sectors	Execute	Recovers the SD Memory Card sector information defect and un-match of the above file system.
	Enable SD Card	No	A printer can start up even if SD Memory Card cannot start as it is damaged when it is installed, by setting "No" regardless of the SD Memory Card installation as a printer recognizes that SD Memory Card is not installed.
		Yes	
	Erase SD Card	Execute	Deletes all data stored in a SD Memory Card so that the data cannot be recovered. It is displayed when the optional internal SD Memory Card is installed.
Enable Initialization	No	The internal SD Memory Card and flash memory are set so that they cannot be changed including initialization.	
	Yes		
Power Setup	Peak Power Control	Normal	Sets Yes/No of low peak power control.
		Low	
	Power Save	Enable	Setting Valid/Invalid of the save power mode.
		Disable	
Sleep	Enable	Sets Enable/Disable of Sleep Mode.	
	Disable		
USB Host Power	Off	Sets the power supply provided for a USB host in the Power Save mode. Off reduces the supply of power. On provides normal supply of power.	
	On		
Language Setup	Language Initialize	Execute	Deletes the message file in a flash memory.

6. Periodic Maintenance

6.1	Cleaning	121
6.2	How to clean the LED lens array	122
6.3	How to clean the pickup roller.....	124
6.4	How to clean inside of printer	125

6.1 Cleaning

Clean inside and outside of the printer with clean dry cleaning cloth and small vacuum cleaner (hand cleaner) as required.

Note! Be careful not to touch the image drum terminals, the LED lens array and the LED head connectors.

6.2 How to clean the LED lens array

If the white banding, white stripe (white drop-out, light printing) in the vertical direction occurs on the print surface, clean the LED lens array.

White banding, white stripe
(white drop-out, light printing)

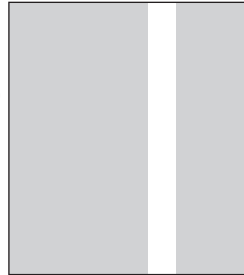

Perform cleaning of the LED head.

If any light print or white banding is recognized or if print character becomes blurred, clean the LED head as described below.

- (1) Turn off the power of the printer.

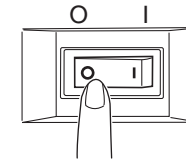

- (2) Press down the OPEN button to open the top cover.

Caution

Personal injuries may occur.



The fuser unit gets very hot. Do not touch the fuser unit.

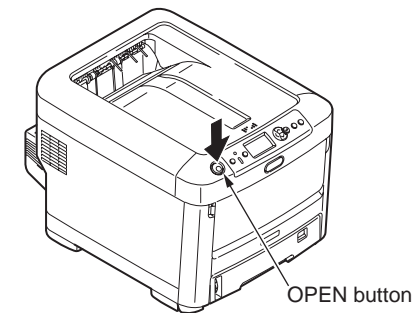

- (3) Wipe the lens surface (at the four positions) of the LED head with soft tissue paper gently and lightly.

Note! Do not use the solvents such as methyl alcohol or thinner for cleaning the LED head lens because they can damage the LED head.

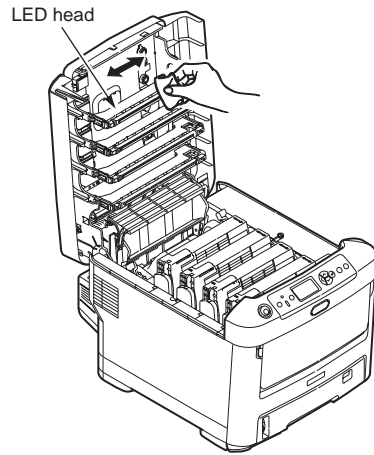

- (4) Close the top cover.

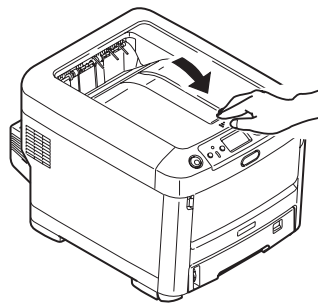

6.3 How to clean the pickup roller

If the vertical banding in the vertical direction occurs on the print surface, clean the pickup roller.

Note! Be sure to use a soft cloth or the like for cleaning the pickup roller. Otherwise, the roller surface can be damaged.

Perform cleaning of the feed roller and the separation roller.

Perform this cleaning when the error code [Open Cassette/Paper Jam/Tray1/Please see HELP for details] occurs frequently.

- (1) Draw out the paper tray.
- (2) Clean the 2 feed rollers with a clean cloth stringently wrung out of clean water.

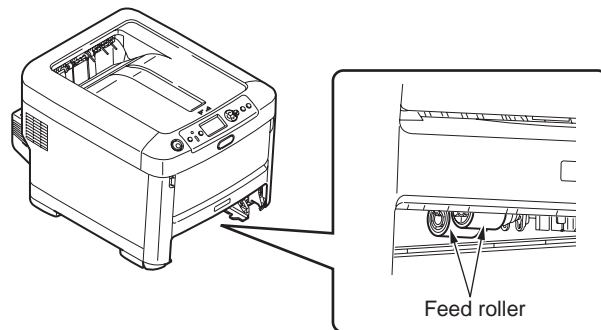

- (3) Clean the separation roller of the paper tray with a clean cloth wrung out stringently of clean water.

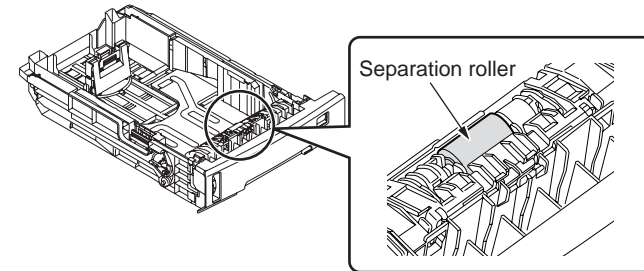

- Note!**
- Clean the second tray (option) in the same manner when the error code [Open Cassette/Paper Jam/Tray2/Please see HELP for details] occurs frequently.
 - Clean the feeder roller of the multi-purpose tray in the same manner when the error code [Open Cover/Paper Jam/Front Cover/Please see HELP for details] occurs frequently.

6.4 How to clean inside of printer

Clean inside of the printer.

Toner can adhere to the metal shaft located in between the fuser and the cyan image drum cartridge depending on the print patter. Perform cleaning of inside of the printer if toner has adhered to the metal shaft.

- (1) Turn off the power of the printer.

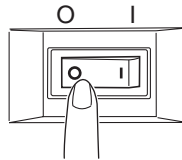

- (2) Press down the OPEN to open the top cover.

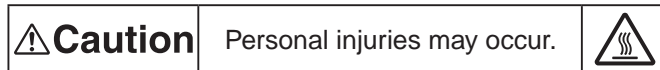

The fuser unit gets very hot. Do not touch the fuser unit.

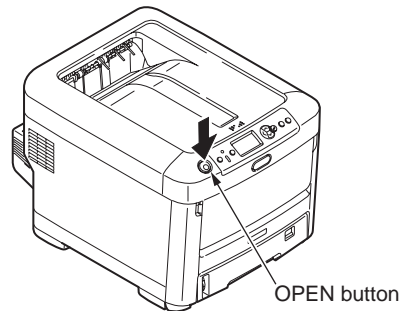

- (3) Remove the image drum cartridge.

1. Remove the four image drum cartridges and place them on a flat workbench.
2. Cover the removed image drum cartridge with a black paper.

- Note!**
- The image drum (green tubular portion) is highly inherently-brittle. Be very careful when handling it.
 - Be very careful not to expose the image drum to direct sun light or intense light (light of approx. 1500 lux or more). Do not leave it under the normal illumination even indoor for 5 minutes or longer.)

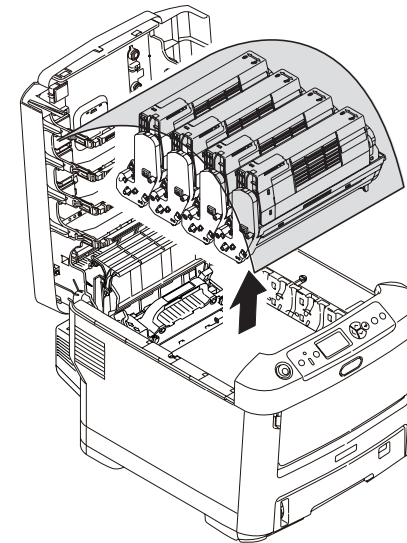

- (4) Remove the fuser unit.

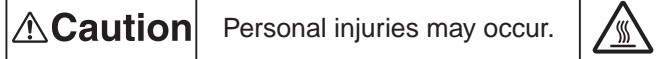

The fuser unit gets very hot. Be very careful not to touch the fuser unit with your hands.

If it got hot, stop the work and wait until it cools down. After it has cooled down, start the following steps.

1. Raise the fuser unit lock levers (two levers shown in blue) in the direction shown by the arrow.
2. Hold the handle of the fuser unit and remove it.

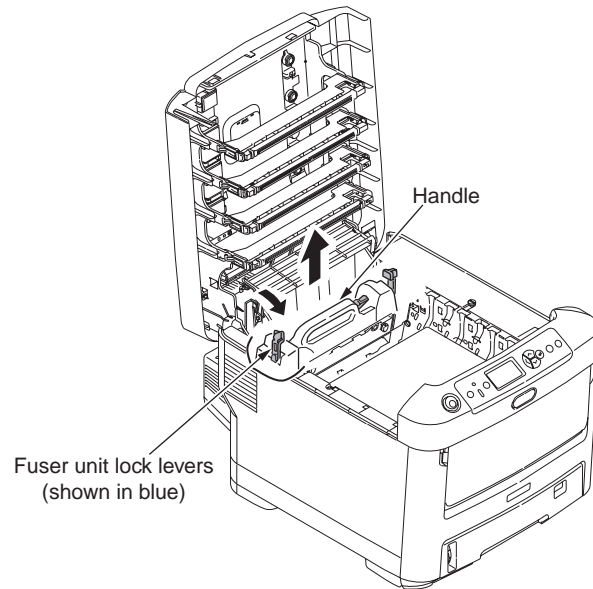

- (5) Clean the metal shaft with soft clean cloth or soft tissue paper.

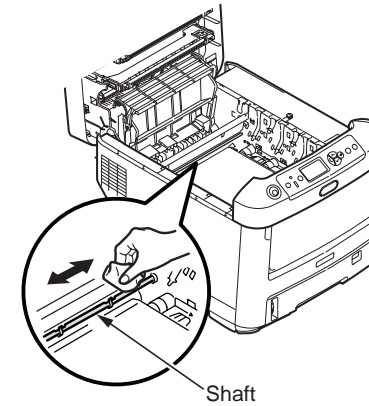

- (6) Install the fuser unit.

For the detailed procedure, refer to the User's Manual – Setup Guide "Replacing fuser unit".

- (7) Return the four image drum cartridges to the printer gently and carefully.
- (8) Close the top cover.

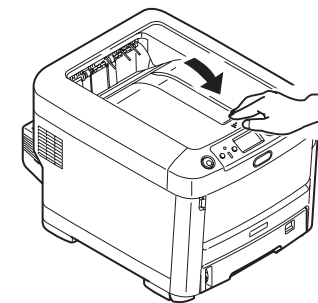

7. Troubleshooting and repair procedure

7.1	Before starting the repair work	128
7.2	Confirmation items before taking corrective action against abnormalities	128
7.3	Precautions when taking corrective action against abnormality	128
7.4	Preparation for troubleshooting	128
7.5	Troubleshooting method	129
7.6	Fuse check	202
7.7	Paper cassette switches versus Paper size correspondence table	203

7.1 Before starting the repair work

- (1) Confirm the basic check/inspection points described in User's Manual.
- (2) Get the information/status from client at the time when the trouble has occurred as much in details as possible
- (3) Create the status close to the user's status when the trouble has occurred, and inspect a printer in that status.

7.2 Confirmation items before taking corrective action against abnormalities

- (1) Is the usage environment of a printer normal?
- (2) Are the consumable items (toner, drum cartridge) replaced normally?
- (3) Is the print media (paper) normal? Refer to Specifications – Paper in User's Manual.
- (4) Is the drum cartridge installed normally?

7.3 Precautions when taking corrective action against abnormality

- (1) Do not touch the OPC drum surface with your hand or any foreign materials.
- (2) Do not expose the OPC drum to the direct sunlight.
- (3) The fuser unit will be hot. Do not touch.
- (4) Do not expose the image drum to any light for 5 minutes or longer under the normal room temperature.

7.4 Preparation for troubleshooting

- (1) Display on the Operator Panel
Error status of this printer is displayed on the LCD (Liquid crystal display) of the Operator Panel.
Take appropriate troubleshooting action in accordance with the message displayed on the LCD.

7.5 Troubleshooting method

When a trouble occurs in this printer, perform troubleshooting by following the steps described below.

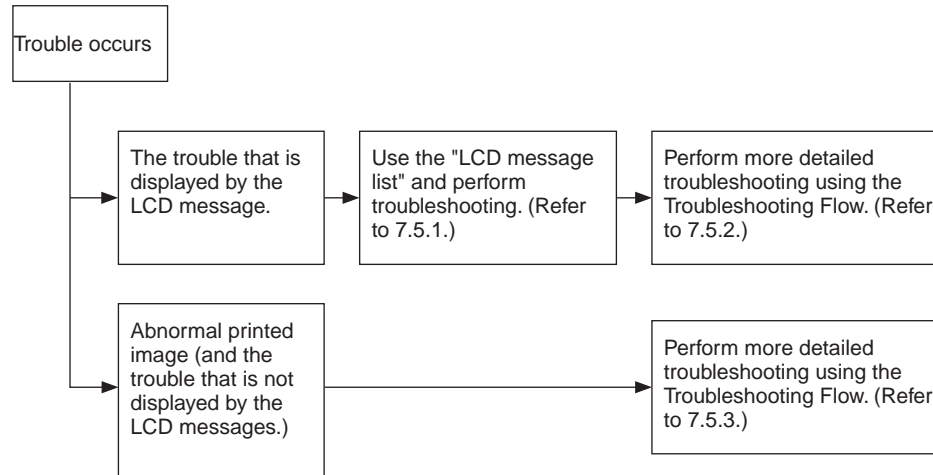

7.5.1 LCD message list

Initializing

Panel display (The <input type="checkbox"/> mark indicates no message in the upper row.)	ON LINE lamp	Inspection lamp	Details
PLEASE WAIT	Off	Off	It is displayed until the RAM expansion of the CU program is in progress.
Initializing	Off	Off	Indicates initialization of the controller side is in progress.
EEPROM Reset	Off	Off	Indicates the controller side EEPROM is reset. The conditions for resetting the EEPROM are shown below. <ul style="list-style-type: none"> • CU ROM is changed (Unmatch of the CU F/W version is detected.) • Destination is changed. • Forced initialization of EEPROM (System Maintenance Menu) • Setting OEM by the P.JL command.
RAM Check *****	Off	Off	Indicates that RAM check is in progress. Percentage of the checked capacity against the total capacity is shown in the second line.
Wait a Moment Network Initializing	Off	Off	Indicates the network initialization is in progress.
Flash Memory Format	Off	Off	Indicates that the flash memory formatting is in progress. If a resident/option flash memory that is not formatted yet is detected, it is displayed when the menu item [Format Flash ROM] is selected from [Maintenance Menu] of the System Maintenance Menu. Because the above menu item is internally use only and is not disclosed to user, this status does not occur in the user environment.
Checking File System	Off	Off	Displays that SD Card file system is being checked. Process Check of File System is valid to start from "Storage Setup"->"Check File System" of Boot Menu.
Erasing SD Card	Off	Off	Indicates that the SD Card is being erased. Erase process of the SD Card is valid to start from "Storage Setup"->"Erase SD Card" of Boot Menu.

Panel display (The <input type="checkbox"/> mark indicates no message in the upper row.)	ON LINE lamp	Inspection lamp	Details
Checking Sectors nnn%	Off	Off	Displays that a sector of SD Card is being checked. Check process of the sector is valid to start from "Storage Setup"- "Check All Sectors" of Boot Menu. nnn Percentage of checked capacity
Program Update Mode	Off	Off	Indicates that the printer has entered in the dedicated mode for upgrading the NIC program (controller firmware) version.
Wait a Moment Program Data Received	Off	Blink	Indicates that reception of the NIC program data for upgrading is in progress.
Wait a Moment Program Data Received OK	Off	Off	Indicates that reception of the NIC program data for upgrading is complete.
Check Data Program Data Receive Error <nnn>	Off	On	Indicates that an error has occurred during reception of the NIC program data for upgrading. %DLCODE% 1 : Size error 2 : Checksum error 3 : Printer model number error 4 : Module I/F version error 5 : FAT version error
Wait a Moment Program Data Writing	Off	Blink	Indicates that writing of the NIC program data for upgrading is in progress.
Power Off/On Program Data Writing OK	Off	Off	Indicates that writing of the NIC program data for upgrading is in complete.
Check Data Program Data Write Error <nnn>	Off	On	Indicates that an error has occurred during writing of the NIC program data for upgrading. %DLCODE% 1 : Memory allocation error 2 : Download file error 3 : Device free space acquisition error 4 : Device insufficient free space error 5 : File write error 6 : CU-F/W mismatch error

Panel display (The <input type="checkbox"/> mark indicates no message in the upper row.)	ON LINE lamp	Inspection lamp	Details
PU Flash Error	Off	Off	Indicates that the PU firmware has started up in the Loader mode. It is indicated when the PU firmware has returned "00.00.00" against the Leisus command "VERSIONR 01H" requesting (PU) firmware version information supplied from the CU firmware at power-on. When initialization is finished, it is switched to the Priority 251 status. This error can occur in the user environment. If this error occurs, maintenance by a maintenance engineer is required. (Same as S/C)
Communication Error	Off	Off	Indicates that communication with the PU firmware has failed. This error can occur in the user environment. If this error occurs, maintenance by a maintenance engineer is required. (Same as S/C)
Status Mode	Off	Off	Indicates that the printer has started in the ON LINE mode always. When a printer starts up in this mode, it processes the data (job) from outside (host) even when an error occurs if a printer has entered the ON LINE mode once. Error and warning are displayed on the panel. A printer can enter in this mode if the power of a printer is turned on while pressing the switches of <Enter> + <Back> + <Down> all simultaneously. Because this pattern of pressing the multiple switches at the same time at power-on is not disclosed to user, this status will not occur in the user environment.

Normal

Panel display (The <input type="checkbox"/> mark indicates no message in the upper row.)	ON LINE lamp	Inspection lamp	Details	Remedial measure
Ready To Print	On	Off	Indicates that a printer is in the Online status.	–
Offline	Off	Off	Indicates that a printer is in the Offline status. * The Ready LED is turned off all the time during Offline.	To start printing from a PC, press the ON LINE button to enter the ON LINE state.
File Accessing	Varies	Varies	Indicates that access to a file system (SD Memory Card/FLASH) is under way.	–
Data Arrive	Varies	Varies	Indicates that the data reception is in progress, and processing has not started yet. This error indicates during the period of PJJ processing without character print, or during job through mainly.	–
Processing	Blink	Varies	Indicates that data reception or output processing is progress.	–
Data Present	Varies	Varies	Indicates that the un-printed data remains in buffer. A printer is in the state of waiting for the data to receive	If a printer is stopped while indicating the state of "Remaining data exists", print the data forcibly by pressing the ON LINE button, or delete the remaining data by pressing the CANCEL button.

Panel display (The <input type="checkbox"/> mark indicates no message in the upper row.)	ON LINE lamp	Inspection lamp	Details	Remedial measure
Printing(%TRAY%)	Varies	Varies	Indicates that a printer is in the midst of printing job.	–
Printing Demo Page	Varies	Varies	Indicates that a printer is in the midst of printing demo page.	–
Print Font	Varies	Varies	Indicates that a printer is in the midst of printing menu map.	–
Print Network Config	Varies	Varies	Indicates that a printer is in the midst of printing the network setting. When the menu [Information Menu] – [Network] is selected, printing of the network setting starts.	–
Print Configuration	Varies	Varies	Printing Menu Maps.	
Print File List	Varies	Varies	Printing File Lists.	
Print Error Log	Varies	Varies	Printing Error Logs.	
<input type="checkbox"/> <input type="checkbox"/> Collate Copy iii/jjj	Varies	Varies	Indicates that a printer is in the midst of gather print. iii indicates number of copies in progress, and jjj indicates total number of printed copies. When total number of copies is 1, the normal indication of PRINTING is displayed.	–
<input type="checkbox"/> <input type="checkbox"/> Copy kkk/lll	Varies	Varies	Indicates that a printer is in the midst of Copy printing. kkk indicates number of copies in progress, and lll indicates total number of printed copies. When total number of copies is 1, the normal indication of PRINTING is displayed.	–
Verifying Job	Blink	Varies	Indicates that the integrity of print data for encrypted authentication is being verified (for corruption and tampering).	
Cancelling Job	Blink	Varies	Cancel of the job is indicated. A printer is discarding the data until end of the job.	–
Cancelling Job	Blink	Varies	This message is displayed when a jam occurs during jam recovery off. Cancel of the job is indicated. A printer is discarding the data until end of the job.	–

Panel display (The <input type="checkbox"/> mark indicates no message in the upper row.)	ON LINE lamp	Inspection lamp	Details	Remedial measure
Cancelling Job	Blink	Varies	Indicates that canceling of a printing without permission is in progress. (Job Account related) 1. When a job is received from a user that is not authorized to print. 2. When a color job is received from a user that is not authorized to make a color print.	–
Cancelling Job	Blink	Varies	Indicates that canceling a job is in progress because the log storage area inside a printer has run out of memory space, and the operation "Cancel the job" is specified at log full. (JobAccount)	–
<input type="checkbox"/> Calibrating	Varies	Varies	Indicates RFID RD/WR checking is in progress.	–
<input type="checkbox"/> Adjusting Temp.	Varies	Varies	Indicates that a printer is in the midst of cooling down. Note that (period) is added at the end of message "Adjusting the fuse temperature."	–
<input type="checkbox"/> Adjusting Temp	Varies	Varies	Indicates that a printer is in the midst of warming up. During this period, #0 of the Leisus I/F: STSENG bit is "0".	–
<input type="checkbox"/> Optimizing Temp	Varies	Varies	Indicates that printing is stopped temporarily due to high temperature of a drum. Alternately, this message indicates that a printer is in the standby state waiting for the thermal cooling down when switching paper size from narrow to wide.	–
<input type="checkbox"/> Power Save	Varies	Varies	Indicates that a printer is in the power save status. When a printer enters the power save mode, the LCD backlight turns off. When it exits the power save mode, the LCD backlight turns on. If the switch is pressed while the backlight is off (in the power save mode), the backlight turns on, and then turns off in 30 seconds. However, the power save mode is not canceled. The backlight turns on during shut-down (Priority 365).	–

Panel display (The <input type="checkbox"/> mark indicates no message in the upper row.)	ON LINE lamp	Inspection lamp	Details	Remedial measure
Invalid Operation	Varies	Varies	Pops up with the press of the Power Save button while the printer cannot switch to Power Save. Three seconds after that, the display reverts to the one before that. The message is also displayed by repeatedly pressing the button.	–
<input type="checkbox"/> Color Adjusting	Varies	Varies	Indicates that the automatic color registration correction is in progress.	–
<input type="checkbox"/> Density Adjusting	Varies	Varies	Indicates that the automatic density correction is in progress. The status code 10988 corresponds to the density read-out (Leisus – STSDEN #1) and 10994 corresponds to the density correction (Leisus – STSDEN #0).	–
Flash Download	Varies	Varies	Indicates that downloading of the PU firmware program data is in progress. Since downloading of the PU firmware is opened internally only and not disclosed to user, the status will not occur in the user environment.	–

Warning

Panel display (The □ mark indicates no message in the upper row.)	ON LINE lamp	Inspection lamp	Details	Remedial measure
□ %COLOR% Toner Low	Varies	On (Blink) (Off)	<p>Toner amount is low. Displayed in a combination of other message in the first line.</p> <p>In case of MENU "Menus"- "System Adjust"- "Low Toner"=Stop, ATTENTION LED blinks and the printer shifts to OFF Line.</p> <p>When an ONLINE switch is pushed, or when arbitrary errors occur and the error is canceled, an off-line state is canceled, and printing is continued until it is set to Toner Empty. Arbitrary errors are errors of Priority 301-361.</p> <p>"Toner Low" status occurs when the power is on, the LED of ATTENTION in a case of MENU "Menus"- "System Adjust"- "Low Toner"=Stop is blinked and go back to the off line after the initializing process.</p> <p>It is possible to operate until "Toner Empty" by pressing "ONLINE switch".</p> <p>Moreover, when set as Admin Setup "System Setup"- "Near Life LED"=Disable, Attention LED is switched off.</p> <p>%COLOR% Yellow Magenta Cyan Black</p>	-

Panel display (The □ mark indicates no message in the upper row.)	ON LINE lamp	Inspection lamp	Details	Remedial measure
□ %COLOR% Waste Toner Full. Replace Toner.	Varies	On	<p>This warning is displayed at Cover Open/Close or Power OFF/ON after a waste-toner full error (Priority: 321.8) occurs. (Not occur for Black/Yellow.) Displayed in a combination of other message in the first line. As long as this warning is being displayed, a waste toner full error occurs, the printer shifts to Offline and stops each time it has printed about 20 copies.</p> <p>%COLOR% Magenta Cyan</p>	Replace the toner cartridge of the indicated color.
□ Non OEM %COLOR% Toner Detected	Varies	On	<p>Indicates the toner cartridge is not for use in the printer.</p> <p>%COLOR% Yellow Magenta Cyan Black</p>	Prompt user to use the appropriate toner cartridge.
□ %COLOR% Toner Regional Mismatch	Varies	On	<p>Indicates the toner cartridge is not for use in the printer.</p> <p>%COLOR% Yellow Magenta Cyan Black</p>	Prompt user to use the appropriate toner cartridge.
□ Non Genuine %COLOR% Toner	Varies	On	<p>Indicates the toner cartridge is not for use in the printer.</p> <p>%COLOR% Yellow Magenta Cyan Black</p>	Tell user that the trouble caused by usage of the inappropriate toner cartridge is outside the range of free repair by warranty to prompt user to use the appropriate toner cartridge.

Panel display (The <input type="checkbox"/> mark indicates no message in the upper row.)	ON LINE lamp	Inspection lamp	Details	Remedial measure
<input type="checkbox"/> %COLOR% Toner Sensor Error	Varies	On	Toner sensor warning: Indicates the printer has a toner sensor problem. Be sure the image drum cartridges and toner cartridges are properly installed. Toner sensor error: Indicates a toner sensor failure occurred, toner cartridge lever turning was omitted or an image drum is not properly installed. Be sure the toner cartridges and image drums are properly installed. Contact an appropriate customer service center when this error persists.	
<input type="checkbox"/> Error Postscript	Blink	Varies	Interpreter detects an error due to the following reason. Receive data after this is ignored until the job completion. When the job is completely received, this is automatically cleared. - The job has a grammatical error. - The page is complicated, and VM was used up.	
<input type="checkbox"/> %COLOR% Image Drum Near Life	Varies	On (Off)	The life of the drum (warning). Displayed in a combination of other message in the first line. The printer stops at the point when it reaches the drum life (Shifts to error, OFF-LINE.) Moreover, when set as Admin Setup "System Setup"-"NearLifeLED" = "Disable", Attention LED is switched off. %COLOR% Yellow Magenta Cyan Black	-
<input type="checkbox"/> Fuser Unit Near Life	Varies	On (Off)	Notifies the fuser unit is near its life. Moreover, when set as Admin Setup "System Setup"-"NearLifeLED" = "Disable", Attention LED is switched off.	-

Panel display (The <input type="checkbox"/> mark indicates no message in the upper row.)	ON LINE lamp	Inspection lamp	Details	Remedial measure
<input type="checkbox"/> Belt Unit Near Life	Varies	On (Off)	Notifies the belt unit is near its life. This is a warning; thus, printing will not stop. Moreover, when set as Admin Setup "System Setup"-"NearLifeLED" = "Disable", Attention LED is switched off.	-
<input type="checkbox"/> Change Fuser Unit	Varies	On	Notifies the life of the fuser unit (warning). Displayed in a combination of other message in the first line. Warning only (No Life error). This appears when the cover was opened and closed just after the fuser life error occurred.	Replace the fuser with the new fuser.
<input type="checkbox"/> Change Belt Unit	Varies	On	Notifies the transfer belt is end of its life (Warning). This status message is displayed when opening/closing a cover or turning power on again after the transfer belt life error or belt waste toner full error occurs.	Replace the belt unit with the new belt unit.
<input type="checkbox"/> %COLOR% Toner Empty	Varies	On	Notifies toner is empty. This status message (warning) is displayed when opening/closing a cover or turning power on again after the toner empty error occurs. %COLOR% Yellow Magenta Cyan Black	Replace the toner cartridge with the new toner cartridge.
<input type="checkbox"/> %COLOR% Toner Not Installed	Varies	On	Indicates that the toner cartridge is not installed. This status is warning only. %COLOR% Yellow Magenta Cyan Black	Install the toner cartridge. Be careful that the toner cartridge supplied with the product cannot be used if the toner cartridge of other supply is used.

Panel display (The <input type="checkbox"/> mark indicates no message in the upper row.)	ON LINE lamp	Inspection lamp	Details	Remedial measure
<input type="checkbox"/> %COLOR% Image Drum Life	Varies	On	Indicates that the image drum has reached end of life. This status (warning) is issued when the cover is Opened/Closed once after the Image Drum Life end error is issued to recover the printer once. %COLOR% Yellow Magenta Cyan Black	Replace the image drum of the indicated color.
<input type="checkbox"/> Belt Reflex Error	Varies	On	Belt reflectance check error Because the PU firmware does not notice this status to the CU firmware in the Shipping Mode even when the PU firmware has detected this status, this error does not occur in the user environment.	-
<input type="checkbox"/> Density Shutter Error2	Varies	Varies	Density correction shutter error 2 Because the PU firmware does not notice this status to the CU firmware in the Shipping Mode even when the PU firmware has detected this status, this error does not occur in the user environment.	-
<input type="checkbox"/> Density Shutter Error1	Varies	Varies	Density correction shutter error 1 Because the PU firmware does not notice this status to the CU firmware in the Shipping Mode even when the PU firmware has detected this status, this error does not occur in the user environment.	-
<input type="checkbox"/> Density Color Calibration Error	Varies	Varies	Density correction color calibration error Because the PU firmware does not notice this status to the CU firmware in the Shipping Mode even when the PU firmware has detected this status, this error does not occur in the user environment.	-
<input type="checkbox"/> Density Color Sensor Error	Varies	Varies	Density correction color sensor error Because the PU firmware does not notice this status to the CU firmware in the Shipping Mode even when the PU firmware has detected this status, this error does not occur in the user environment.	-

Panel display (The <input type="checkbox"/> mark indicates no message in the upper row.)	ON LINE lamp	Inspection lamp	Details	Remedial measure
<input type="checkbox"/> Density Black Calibration Error	Varies	Varies	Density correction black calibration error. Because the PU firmware does not notice this status to the CU firmware in the Shipping Mode even when the PU firmware has detected this status, this error does not occur in the user environment.	-
<input type="checkbox"/> Density Black Sensor Error	Varies	Varies	Density correction black sensor error. Because the PU firmware does not notice this status to the CU firmware in the Shipping Mode even when the PU firmware has detected this status, this error does not occur in the user environment.	-
<input type="checkbox"/> %COLOR% Image Drum Smear Error	Varies	Varies	Density correction ID ERROR 2. This error occurs when abnormal density due to the LED head focus error is detected. (Extremely stained LED head) Because the PU firmware does not notice this status to the CU firmware in the Shipping Mode even when the PU firmware has detected this status, this error does not occur in the user environment. %COLOR% Yellow Magenta Cyan Black	-
<input type="checkbox"/> %COLOR% Low Density Error	Varies	On	Density correction ID ERROR. This error occurs when abnormal density is detected when stain has occurred in print due to ID error. (Extremely out of focus). Because the PU firmware does not notice this status to the CU firmware in the Shipping Mode even when the PU firmware has detected this status, this error does not occur in the user environment. %COLOR% Yellow Magenta Cyan Black	-

Panel display (The □ mark indicates no message in the upper row.)	ON LINE lamp	Inspection lamp	Details	Remedial measure
□ Sensor Calibration Error	Varies	On	Sensor adjustment error Because the PU firmware does not notice this status to the CU firmware in the Shipping Mode even when the PU firmware has detected this status, this error does not occur in the user environment	-
□ Registration Error <n>	Varies	On	Color registration correction error. Indicates that an error has occurred during the coarse adjustment or in the main scanning line correction. Because the PU firmware does not notice this status to the CU firmware in the Shipping Mode even when the PU firmware has detected this status, this error does not occur in the user environment. n 2 = Yellow 3 = Magenta 4 = Cyan	-
□ Registration Sensor Error <n>	Varies	On	Color registration correction sensor error Because the PU firmware does not notice this status to the CU firmware in the Shipping Mode even when the PU firmware has detected this status, this error does not occur in the user environment. n 2 = Yellow 3 = Magenta 4 = Cyan	-
□ %COLOR% Head Data Error	Varies	On	Cannot fine the correction data for the LED head. Alternately, the correction data for the LED head is illegal. Because the PU firmware does not notice this status to the CU firmware in the Shipping Mode even when the PU firmware has detected this status, this error does not occur in the user environment. %COLOR% Yellow Magenta Cyan Black	-

Panel display (The □ mark indicates no message in the upper row.)	ON LINE lamp	Inspection lamp	Details	Remedial measure
□ %TRAY% Empty	Varies	On	Indicates that the tray runs out of paper. Warning only is issued until the tray that runs out paper is specified for print. %TRAY% Tray 1 Tray 2 Tray 3 MP Tray	Feed paper to the indicated tray.
□ File System is Full	Varies	On	Indicates that the file system that has been constructed on the recording device (SD Memory Card/FLASH) runs out of free space. Because this is a temporary warning, this warning is indicated until the job is complete. It disappears at the completion of the job.	Explain user that no remedial measure is required.
□ File System is Write Protected	Varies	On	Indicates that an attempt is made to write data in the file system that has been constructed on the recording device (SD Memory Card/FLASH), and is prohibited of writing data. Because this is a temporary warning, this warning is indicated until the job is complete. It disappears at the completion of the job.	Explain user that no remedial measure is required.
□ File Erasing	Varies	On	Indicates that a secret file is being erased.	
□ Deleting Encrypted Job	Varies	On	It indicates the deletion of encrypted authentication print job and saving of deletion request of file.	
□ Erased Data Full	Varies	On	Indicates that a secret file waiting to be erased is full.	
□ ***Flash Error	Varies	Varies	PU flash error (Error has occurred during re-writing of the PU firmware.) %PUFLASH% is described below. PU Tray2 Tray3 Duplex	-

Panel display (The <input type="checkbox"/> mark indicates no message in the upper row.)	ON LINE lamp	Inspection lamp	Details	Remedial measure
<input type="checkbox"/> USB Hub Unsupported Please detach it	Varies	Varies	Indicates a USB hub not supported by the printer is connected to it. This message is showing while the printer has a connection to such a hub.	
<input type="checkbox"/> Unsupported USB Device Detected Please detach it	Varies	Varies	Indicates a USB device not supported by the printer is connected to it. This message is showing while the printer has such a USB device connected to it.	
<input type="checkbox"/> Collate Fail:Too Many Pages Press ONLINE Button	Varies	Varies	Indicates that the MOPY memory is data full. This error is kept displayed until the ON LINE key is pressed.	Reduce the number of pages that are going to be printed at once.
<input type="checkbox"/> Statistics Log Buffer is Full Press ONLINE Button	Varies	On	Indicates that the free space of the storage device is too small to execute PRINT STATISTICS SYSTEM.	
<input type="checkbox"/> Color Restricted. Mono Printed Press ONLINE Button	Varies	On	Notifies users that jobs have been printed in monochrome because they are not permitted for color printing. (Related to JobAccount). Stays displayed until the ONLINE button is pressed.	
<input type="checkbox"/> Color Restricted. Job Rejected Press ONLINE Button	Varies	On	Notifies users that jobs have been cancelled because they are not permitted for color printing. (Related to JobAccount). Stays displayed until the ONLINE button is pressed.	

Panel display (The <input type="checkbox"/> mark indicates no message in the upper row.)	ON LINE lamp	Inspection lamp	Details	Remedial measure
<input type="checkbox"/> Print Restricted. Job Rejected Press ONLINE Button	Varies	On	Notify user that the job is canceled because the print permission is not set. (Job Account related). This error is kept displayed until the ON LINE key is pressed.	<ul style="list-style-type: none"> • Set the user ID of the job account in the printer driver. • If the user ID has been set in the driver, confirm the user ID and its setting with the job account administrator.
<input type="checkbox"/> Log Buffer is Full. Job Rejected Press ONLINE Button	Varies	On	Notify user that the job is canceled because the log buffer is full. (Job Account related) This error is kept displayed until the ON LINE key is pressed.	Executeto [Acquire immediately] on the server PC of the print job accounting.
<input type="checkbox"/> Expired Secure Job Press ONLINE Button	Varies	On	Indicates that an applicable job has been automatically deleted as the retention period for authentication printing has expired.	

Panel display (The <input type="checkbox"/> mark indicates no message in the upper row.)	ON LINE lamp	Inspection lamp	Details	Remedial measure
<input type="checkbox"/> File System Operation failed <nnn> Press ONLINE Button	Varies	On	Indicates that a file system error other than the above-described file system related status error, has occurred. The processing that does not used the file system can be operated. %FS_ERR% =0 GENERAL ERROR =1 VOLUME NOT AVAILABLE =3 FILE NOT FOUND =4NO FREE FILE DESCRIPTORS =5 INVALID NUMBER OF BYTES =6 FILE ALREADY EXISTS =7 ILLEGAL NAME =8 CANT DEL ROOT- =9 NOT FILE =10 .. NOT DIRECTORY =11 .. NOT SAME VOLUME =12 .. READ ONLY =13 .. ROOT DIR FULL =14 .. DIR NOT EMPTY =15 .. BAD DISK =16 .. NO LABL =17 .. INVALID PARAMETER =18 .. NO CONTIG SPACE =19 .. CANTCHANGE ROOT =20 .. FD OBSOLETE =21 .. DELETED =22 .. NO BLOCK DEVICE =23 .. BAD SEEK =24 .. INTERNAL ERROR =25 .. WRITE ONLY	Replace the SD Memory Card. No remedial action is required when print such as authentication print is not used.
<input type="checkbox"/> Invalid Secure Data Press ONLINE Button	Varies	Varies	Indicates that a job has been deleted because corruption of data has been detected by the integrity verification in authentication printing.	

Panel display (The <input type="checkbox"/> mark indicates no message in the upper row.)	ON LINE lamp	Inspection lamp	Details	Remedial measure
<input type="checkbox"/> Invalid Data Press ONLINE Button	Varies	Varies	Invalid data was received. Press the On-line switch and eliminate the warning. Displayed when unsupported PDL command is received or a spool command is received without SD Card.	Press the ON LINE switch.
Install Paper MPTray %MEDIA_SIZE% Press ONLINE Button	On	Off	Indicates that the print request of manual paper feed is issued. Prompt user to feed manually the paper that is indicated by %MEDIA_SIZE%. Unit of paper size in the Custom mode follows the unit specified display unit (menu setting) of the MP tray unless otherwise specified by driver. If unit of paper size is specified by driver, it is displayed in units specified by driver. Paper size in the Custom mode is displayed as "<width> x <length> <unit>" ex: 210 x 297 mm 8.5 x 11.0 inch	Press the ON LINE switch. * The data will be deleted unless the ON LINE switch is pressed within the time set by [Manual Timeout].

If a printer detects an un-recoverable error, the following service call error is displayed on the LCD.

Service call

nnn: error

Note! nnn indicates an error code.

When a service call is displayed, the error code and the associated error information are displayed in the lower row of the LCD display at the same time.

Be sure to take note of this error information (numerals indicating address and others) and inform it to the related departments because the information is used for trouble analysis and solution. Meaning of error codes and remedial measures are shown in Tables 7-1-1 and 7-1-2.

Table 7-1-1 Operator alarm

Display on operator panel	ON LINE lamp	Inspection lamp	Contents	Code nnn
Change Paper in %TRAY% %MEDIA_SIZE% %MEDIA_TYPE% Press ONLINE Button Please see HELP for details	Off	Blink	Indicates unmatched media type in the tray and the print data occurs.	Error
			Prompt user to insert paper in the tray.	
			Error 661 : Tray1 Error 662 : Tray2 Error 663 : Tray3	661 662 663
			Unit of paper size in the Custom mode follows the unit specified display unit (menu setting) of the MP tray unless otherwise specified by driver. If unit of paper size is specified by driver, it is displayed in units specified by driver. Paper size in the Custom mode is indicated as follows: "<Width> x <Length> <unit>" ex : 210 x 297 mm 8.5 x 11.0 inch User is requested to change paper of the tray and press the ON LINE key.	

Display on operator panel	ON LINE lamp	Inspection lamp	Contents	Code nnn
Change Paper in MPTray %MEDIA_SIZE% %MEDIA_TYPE% Press ONLINE Button Please see HELP for details	Off	Blink	Indicates unmatched media type in the tray and the print data occurs. Prompt user to insert paper in the tray.	Error
			Error 660: MP Tray Unit of paper size in the Custom mode follows the unit specified display unit (menu setting) of the MP tray unless otherwise specified by driver. If unit of paper size is specified by driver, it is displayed in units specified by driver. ex: 210 x 297mm 8.5 x 11.0 inch User is requested to change paper of the tray and press the ON LINE key.	660
Change Paper in %TRAY% %MEDIA_SIZE% %MEDIA_TYPE% Press ONLINE Button Please see HELP for details	Off	Blink	Indicates that the paper size of the tray or the paper size, and the media type do not match the print data.	Error
			Prompt user to insert paper in the tray.	
			Error 461: Tray 1 Error 462: Tray 2 Error 462: Tray 3	461 462 463
			Unit of paper size in the Custom mode follows the unit specified display unit (menu setting) of the MP tray unless otherwise specified by driver. If unit of paper size is specified by driver, it is displayed in units specified by driver. ex: 210 x 297mm 8.5 x 11.0 inch User is requested to change paper of the tray and press the ON LINE key.	

Display on operator panel	ON LINE lamp	Inspection lamp	Contents	Code nnn
Change Paper in MPTray %MEDIA_SIZE% %MEDIA_TYPE% Press ONLINE Button Please see HELP for details	Off	Blink	Indicates that the paper size of the tray or the paper size, and the media type do not match the print data. Prompt user to insert paper in the tray. Error 460 : MPTray Unit of paper size in the Custom mode follows the unit specified display unit (menu setting) of the MP tray unless otherwise specified by driver. If unit of paper size is specified by driver, it is displayed in units specified by driver. ex: 210 x 297mm 8.5 x 11.0 inch User is requested to change paper of the tray and press the ON LINE key.	Error 460
Wait a Moment Message Data Processing	Varies	Varies	Indicates that processing of the message data for upgrade is in progress.	Error (ONLINE)
Wait a Moment Message Data Writing	Varies	Varies	Indicates that writing of the message data for upgrading is in progress.	Error (ONLINE)
Power Off/On Message Data Received OK	Varies	Varies	Indicates that writing of the message data for upgrading has completed with success.	Error (ONLINE)
Check Data Message Data Write Error<%CODE%>	Varies	Varies	Indicates that writing of the message data for upgrading has failed. %CODE% is a decimal value (single digit) indicating cause of the writing failure. =1 FAIL Cause of the failure is unknown. =2 DATA_ERROR Hash check error during data read/write. FLASH error =3 OVERFLOW Download failure because the FLASH capacity became full during writing or reading the language file. =4 MEMORY FULL Failed to secure memory space. =5 UNSUPPORTED_DATA Download of the data that is not supported by the printer.	Error (ONLINE)
Wait a Moment Network Configuration Writing	Varies	Varies	When the network related setting items are updated, contents of them are saved in the flash memory.	Error (ONLINE)

Display on operator panel	ON LINE lamp	Inspection lamp	Contents	Code nnn
Wait a Moment Network Initializing	Varies	Varies	Indicates the network initialization is in progress.	Error (ONLINE)
Install Paper %TRAY% %MEDIA_SIZE% Please see HELP for details	Off	Blink	Indicates that a print request is issued to the tray that has run out of paper. Prompting user to refill paper. Error 491 : Tray1 Error 492 : Tray2 Error 493 : Tray3 Unit of paper size in the Custom mode follows the unit specified by menu unless otherwise specified by driver. If unit of paper size is specified by driver, it is displayed in units specified by driver.	Error 491 492 493
Install Paper MPTray %MEDIA_SIZE% Press ONLINE Button Please see HELP for details	Off	Blink	Indicates that a print request is issued to the multipurpose tray that has run out of paper. Paper feed restarts when user pressed the ON LINE switch. Error 490 : MPTray Unit of paper size in the Custom mode follows the unit specified by menu unless otherwise specified by driver. If unit of paper size is specified by driver, it is displayed in units specified by driver. This error occurs when the tray is in the home position, and the sensor "PE SENS 2" cannot detect paper.	Error 490
Remove Paper Face Down Stacker Please see HELP for details	Off	Blink	The printed paper is overfilled on the paper stacker of the printer unit. Error 480 : Face Down Stacker	Error 480
Install Paper Cassette %TRAY% Please see HELP for details	Off	Blink	Indicates that cassette is removed from the tray 1 that is located in the path when a print from tray 2 is attempted. Error 440 : Tray1 Error 441 : Tray2	Error 440 441

Display on operator panel	ON LINE lamp	Inspection lamp	Contents	Code nnn
Install Paper Cassette %TRAY%	Off	Blink	Indicates that paper feeding is not possible because cassette has been removed from the corresponding tray when a print from the tray is attempted.	Error 430 431 432
Please see HELP for details			Error 430 : Tray1 Error 431 : Tray2 Error 432 : Tray3	
Press ONLINE Button for Restoration Memory Overflow	Off	Blink	Memory capacity overflows due to the following reason. Press ON-LINE switch so that it continues. Install expansion RAM or decrease the data amount. - Too much print data in a page. - Too much Macro data. - Too much DLL data - After frame buffer compression, overflow occurred.	Error 420
Replace Toner %COLOR% Waste Toner Full	Off	Blink	Indicates that the waste toner of %COLOR% is full requiring replacement of toner.	Error 415 416
Please see HELP for details			Error 415 : Magenta Error 416 : Cyan (This error does not occur in the Black /Yellow toner.)	
Install Toner %COLOR%	Off	Blink	Indicates that the printer runs out of toner. When the cover is opened/closed, it changes to the warning status.	Error 410 411 412 413
Please see HELP for details			Error 410 : Yellow Error 411 : Magenta Error 412 : Cyan Error 413 : Black	
Toner Regional Mismatch %COLOR%	Off	Blink	Indicates the toner cartridge is not for use in the printer. The printer recovers from the error after replacement of the toner cartridge with a toner cartridge for the printer.	Error 554 555 556 557
Please see HELP for details			Error 554 : Yellow Error 555 : Magenta Error 556 : Cyan Error 557 : Black	

Display on operator panel	ON LINE lamp	Inspection lamp	Contents	Code nnn
Incompatible Toner %COLOR%	Off	Blink	Indicates the toner cartridge is not for use in the printer. The printer recovers from the error after replacement of the toner cartridge with a toner cartridge for the printer.	Error 614 615 616 617
Please see HELP for details			Error 614 : Yellow Error 615 : Magenta Error 616 : Cyan Error 617 : Black	
Incompatible Toner %COLOR%	Off	Blink	Indicates the toner cartridge is not for use in the printer. The printer recovers from the error after replacement of the toner cartridge with a toner cartridge for the printer.	Error 620 621 622 623
Please see HELP for details			Error 620 : Yellow Error 621 : Magenta Error 622 : Cyan Error 623 : Black	
Non Genuine Toner %COLOR%	Off	Blink	Indicates the toner cartridge is not for use in the printer. The printer recovers from the error after replacement of the toner cartridge with a toner cartridge for the printer.	Error 550 551 552 553
Please see HELP for details			Error 550 : Yellow Error 551 : Magenta Error 552 : Cyan Error 553 : Black The engine is confirmed again by cover open/close. And, when the toner cartridges have not been exchanged, it shifts to Warning. And it is possible to print up to 20.	
Toner Not Installed %COLOR%	Off	Blink	Indicates that toner cartridge is not installed.	Error 610 611 612 613
Please see HELP for details			Error 610 : Yellow Error 611 : Magenta Error 612 : Cyan Error 613 : Black The engine is confirmed again by cover open/close. And, when the toner cartridges have not been exchanged, it shifts to Warning. And it is possible to print up to 20.	

Display on operator panel	ON LINE lamp	Inspection lamp	Contents	Code nnn
Open Cassette Paper Remain %TRAY%	Off	Blink	Additional paper is detected when a paper jam has occurred. Error 632 : Tray2 Cassette Error 633 : Tray3 Cassette	Error 632 633
Please see HELP for details				
Open Cover Paper Remain Front Cover	Off	Blink	Additional paper is detected when a paper jam has occurred. Error 637 : J0: Paper Feed Path	Error 637
Please see HELP for details				
Open Cover Paper Remain Top Cover	Off	Blink	Additional paper is detected when a paper jam has occurred. Error 638 : J1: Paper Transport Path	Error 638
Please see HELP for details				
Open Cover Paper Remain Top Cover	Off	Blink	Contents Additional paper is detected when a paper jam has occurred. Error 639 : J2: Paper Exit Path Error 640 : J4: Duplex Entry Path In case of Error code 639, paper may be left in around the side cover at the exit part.	Error 639 640
Please see HELP for details				
Check Duplex Unit Paper Remain	Off	Blink	Additional paper is detected when a paper jam has occurred. Error 641 : J5: Duplex Reversal Path Error 642 : J3: Duplex Transport Path	Error 641 642
Please see HELP for details				
Toner Sensor Error %COLOR%	Off	Blink	Indicates that the toner sensor has detected the error. Error 540 : Yellow Error 541 : Magenta Error 542 : Cyan Error 543 : Black	Error 540 541 542 543

Display on operator panel	ON LINE lamp	Inspection lamp	Contents	Code nnn
Check Paper Paper Size Error %TRAY%	Off	Blink	Informes that a paper of illegal size is fed from the tray. Check paper in the tray, or check if multiple sheets of paper are transported simultaneously by mistake or not. The recovery print is executed when the cover is Opened/Closed	Error 400
Please see HELP for details				
Open Cover Paper Jam Front Cover	Off	Blink	Indicates that jam has occurred during feeding paper from the MP tray. Error 390: MP Tray	Error 390
Please see HELP for details				
Open Cassette Paper Jam %TRAY%	Off	Blink	Indicates that jam has occurred during feeding paper from the this tray. Error 391 : Tray 1 Error 392 : Tray 2 Error 393 : Tray 3	Error 391 392 393
Please see HELP for details				
Open Cover Paper Jam Front Cover	Off	Blink	Indicates that jam has occurred in the paper path. Error 380 : Feed	Error 380
Please see HELP for details				
Open Cover Paper Jam Top Cover	Off	Blink	Indicates that jam has occurred in the paper path. Error 381 : Transport Error 382 : Exit Error 383 : Duplex Entry Error 385 : Fuser Unit Error 389 : Printing Page Lost	Error 381 382 383 385 389
Please see HELP for details				
Check Duplex Unit Paper Jam	Off	Blink	Indicates that jam has occurred in the vicinity of Duplex unit. Error 370 : Duplex Reversal Error 371 : Duplex Input	Error 370 371
Please see HELP for details				
Open Cover Paper Jam Front Cover	Off	Blink	Indicates that jam has occurred in the vicinity of Duplex unit. Error 372 : Misfeed from Duplex	Error 372
Please see HELP for details				

Display on operator panel	ON LINE lamp	Inspection lamp	Contents	Code nnn
Install Duplex Unit Please see HELP for details	Off	Blink	Indicates that the Duplex unit is removed. If this error is detected, printing is stopped.	Error 360
Install New Image Drum Image Drum Life %COLOR% Please see HELP for details	Off	Blink	Informs the image drum has reached end of line (alarm). When the cover is opened/closed, it changes to the warning status. Error 350 : Yellow Error 351 : Magenta Error 352 : Cyan Error 353 : Black	Error 350 351 352 353
Install New Image Drum Image Drum Life %COLOR% Please see HELP for details	Off	Blink	Informs the image drum has reached end of line (alarm). It is displayed until the image drum is replaced. Error 560 : Yellow Error 561 : Magenta Error 562 : Cyan Error 563 : Black	Error 560 561 562 563
Install New Fuser Unit Fuser Unit Life Please see HELP for details	Off	Blink	Informs the image drum has reached end of line. This error is issued when the counter detects that the fuser has reached end of life. Print is stopped. When the cover is opened/closed, it changes to the warning status.	Error 354
Install New Belt Unit Belt Unit Life Please see HELP for details	Off	Blink	Informs that the transfer has reached end of line. This error is issued when the counter detects that the belt has reached end of life. Print is stopped. When the cover is opened/closed, it changes to the warning status.	Error 355
Install New Belt Unit Belt Unit Life Please see HELP for details	Off	Blink	Indicates that the waster toner is full. It changes to the warning status after the cover is opened and closed only once. This error is issued again after 500 copies are printed.	Error 356

Display on operator panel	ON LINE lamp	Inspection lamp	Contents	Code nnn
Check Toner Cartridge Improper Lock Lever Position %COLOR% Please see HELP for details	Off	Blink	Indicates that toner is not being supplied (toner cannot be detected). The lever of the toner cartridge is left unlocked, or the cartridge was installed without removing the protective tape, therefore, the toner cannot be supplied, and it might cause this error. Error 544 : Yellow Error 545 : Magenta Error 546 : Cyan Error 547 : Black	Error 544 545 546 547
Check Image Drum %COLOR% Please see HELP for details	Off	Blink	Indicates that the image drum is not installed normally. Error 340 : Yellow Error 341 : Magenta Error 342 : Cyan Error 343 : Black	Error 340 341 342 343
Check Fuser Unit Please see HELP for details	Off	Blink	Indicates that the fuser is not installed normally.	Error 320
Check Belt Unit Please see HELP for details	Off	Blink	Indicates that the belt is not installed normally.	Error 330
Close Cover %COVER% Please see HELP for details	Off	Blink	Indicates that the cover is open. Error 310 : Top Cover Error 311 : Front Cover Error 316 : Duplex Unit	Error 310 311 316
Wait a Moment Program Data Receiving	Off	Blink	Indicates that reception of the NIC program data for upgrading is in progress.	Error
Wait a Moment Program Data Received OK	Off	Off	Indicates that reception of the NIC program data for upgrading is complete.	Error

Display on operator panel	ON LINE lamp	Inspection lamp	Contents	Code nnn
Check Data Program Data Receive Error <nnn>	Off	On	Indicates that an error has occurred during reception of the NIC program data for upgrading. %DLCODE% 1: Size error 2: Checksum error 3: Printer model number error 4: Module I/F version error 5: FAT version error	Error
Wait a Moment Program Data Writing	Off	Blink	Indicates that writing of the NIC program data for upgrading is in progress.	Error
Power Off/On Program Data Written OK	Off	Off	Indicates that writing of the NIC program data for upgrading is in complete.	Error
Check Data Program Data Write Error <nnn>	Off	On	Indicates that an error has occurred during writing of the NIC program data for upgrading. %DLCODE% 1: Memory allocation error 2: Download file error 3: Device free space acquisition error 4: Device insufficient free space error 5: File write error 6: CU-F/W mismatch error	Error
Wait a Moment Rebooting <n>	Off	On	Indicates the reboot of the controller unit is progress. %CODE% is a decimal value (single digit) indicating cause of the reboot. =0....Reboot that is resulted from a cause other than the below. =1....Reboot by the PJL command =2....Reboot caused by the menu change =4....Reboot caused by the network utilities (including web)	Error
Shutting down	Off	Off	Indicates that a printer is shutting down. The shut-down process is started by pressing the BACK button for more than 4 seconds upon completion of printer initialization process.	Error

Display on operator panel	ON LINE lamp	Inspection lamp	Contents	Code nnn
Turn off power Shutdown completed	Off	Off	Indicates that the shut-down process of a printer is complete. (The LCD backlight turns off.)	Error
Power Off and Wait for a while 126:Condensing Error	Off	Blink	Dew condensation error (This error is handled in the same way as the service call error though display only is different.) *The Fatal Errors are not supported by the various languages.	Fatal 126
Power Off/On nnn:Fatal Error	Off	Blink	Indicates that a fatal error has occurred. For detailed contents, refer to "Service Calls List". *The Fatal Errors are not supported by the various languages.	Fatal <nnn>
Service Call nnn:Fatal Error	Off	Blink	Indicates that a fatal error has occurred. For detailed contents, refer to "Service Calls List". *The Fatal Errors are not supported by the various languages.	Fatal <nnn>
Service Call nnn:Fatal Error *	Off	Blink	Indicates that a fatal error has occurred. For detailed contents, refer to "Service Calls List". The asterisk mark "*" indicates the detailed information. *The Fatal Errors are not supported by the various languages.	Fatal 096 231 128 168 169
Power Off/On nnn:Fatal Error PC:nnnnnnnn LR:nnnnnnnn FR:nnnnnnnn	Off	Blink	Indicates that a fatal error has occurred. For detailed contents, refer to "Service Calls List". "nnnnnnnn" indicates the detailed information. *The Fatal Errors are not supported by the various languages.	Fatal 002 011, F0C F0D FFE FFF
Power Off/On 209:Download Error	Off	Blink	Indicates failure of the Media table downloading to PU. (Custom Media Type related) *The Fatal Errors are not supported by the various languages.	Fatal 209

Table 7-1-2 Service Call Error List

Display	Cause	Error details		Remedial measure
Restart the printer. 002: Error~ 007: Error 009: Error~ 011: Error	CPU Exception	Does the error display recur?	Yes No	If the RAM DIMM is installed, remove it and turn off the power of the printer and back on. Replace the CU/PU board. Re-install the RAM DIMM. Replace the RAM DIMM.
Service call 020: Error	CU ROM Hash Check Error	Does the error display recur?	Yes	Turn off the power of the printer and back on. Replace the CU/PU board.
Service call 030: Error	CU RAM Check Error	Does the error display recur?	Yes	Turn off the power of the printer and back on. Replace the CU/PU board.
Service call 031: Error	CU Optional RAM Check Error	Is installation of the RAM DIMM normal? Does the printer recover from the error when the RAM DIMM is replaced?	No Yes No	Re-install the RAM DIMM. Replace the RAM DIMM. Replace the CU/PU board.
Service call 040: Error	CU EEPROM Error	Does the error display recur?	Yes	Turn off the power of the printer and back on. Replace the CU/PU board.
Service call 041: Error	CU Flash Error. Flash ROM Error on the CU board	Does the error display recur?	Yes	Turn off the power of the printer and back on. Replace the CU/PU board.
Service call 042: Error~ 043: Error 045: Error	Flash File System Error	Failed to access to the Flash ROM that is directly soldered to the CU/PU board.		Turn off the power of the printer and back on. Replace the CU/PU board.

Display	Cause	Error details		Remedial measure
Restart the printer. 072: Error. Xx	Engine I/F Error. I/F error between PU and CU	Is the CU/PU assembly installed normally? Does the printer recover from the error when the CU/PU board is replaced?	No Yes No	Re-install the CU/PU assembly normally. Replace the CU/PU board.
Restart the printer. 073: Error xxxxxxxx	Video Error Error is detected when expanding the video data. (Illegal data is received.)	Is the CU/PU assembly installed normally? Does this error recur?	No Yes Yes	Re-install the CU/PU assembly normally. Change the PC with another PC having high specifications, or alternately reduce resolution power and execute the print again. Replace the CU/PU board.
		Is the CU/PU assembly installed normally? Does this error recur? Does the error depend on print data?	No Yes No Yes	Replace the interface cable. Re-install the PC printer driver. Re-install the CU/PU assembly normally. Execute the print again. Print any other data. Replace the CU/PU board. Send the data to design division and request analysis of the data.
Restart the printer. 074: Error xxxxxxxx 075: Error xxxxxxxx	Video Error Error is detected when expanding the video data.	Is the CU/PU assembly installed normally?	No Yes	Re-install the CU/PU assembly normally. Replace the CU/PU board.

Display	Cause	Error details		Remedial measure
Service call 081: Error	Parameter integrity check	Either EEPROM or Flash ROM cannot read/write normally.		Turn the printer power off and then back on. If the error symptom remains unchanged, replace the CU/PU board.
Service call 104: Error	Read/write error of the engine EEPROM is detected.	Does this error recur?	Yes	Turn off the power of the printer and back on. Replace the CU/PU board.
Service call 106: Error	Engine control logic has an error.	Does this error recur?	Yes	Turn off the power of the printer and back on. Replace the CU/PU board.
Service call 111: Error	Duplex unit for other model is detected.	Is the Duplex unit for that specific model installed?	No	Install the correct duplex unit.
Service call 112: Error	2nd tray for other model is detected.	Is the 2nd tray for that specific model installed?	No	Install the correct 2nd tray.
Service call 113: Error	3rd tray for other model is detected.	Is the 3rd tray for that specific model installed?	No	Install the correct 3rd tray.
Service call 121: Error	High voltage power supply interface error.	Is the cable connecting the CU/PU board to the high voltage unit connected normally? Have you checked defective contact of contactor points? Note)	No Yes No	Re-connect them normally. Check for defective contact of the high voltage system. Replace the high voltage power supply.
Service call 122: Error	Low voltage power supply fan error	Is the fan (bottom right of the front) of the low voltage power supply block working? Is the fan connector connected normally?	No Yes No Yes	Check for sure connection of the fan connector. Replace the CU/PU board. Replace the fan motor.

Display	Cause	Error details		Remedial measure
Service call 123: Error	Environment humidity is abnormal./ Humidity sensor is not connected.	Does this error recur?	Yes	Turn off the power of the printer and back on. Replace the control panel board.
Service call 124: Error	Environment temperature is abnormal.	Does this error recur?	Yes	Turn off the power of the printer and back on. Replace the control panel board.
Service call 126: Error	Dew condensation of the printer is detected.	This error can easily occur when a printer is brought in to indoor from outdoor. Leave the printer for 2 hours or half day under room temperature, and turn on the power again. Does this error recur?	Yes	After leaving a printer under room temperature, turn on the power again. Replace the control panel board.
Service call 127: Error	Fuser exhaust fan error	Is the fan connector connected normally? Does this error recur?	No Yes No	Re-connect it normally. Replace the fan motor. Replace the CU/PU board.
Service call 128: Error	ID cooling fan error	Is the fan connector connected normally? Does this error recur?	No Yes No	Re-connect it normally. Replace the fan motor. Replace the CU/PU board.
Service call 131: Error~ 134: Error	LED head detection error (131=Y, 132=M, 133=C, 134=K)	Is the LED head connected normally? Is the LED HEAD fuse brown? Does this error recur?	No Yes Yes No Yes	Install the LED head unit normally. Check the LED HEAD fuse. After checking fuse Turn on the power again. For the method of checking the LED head unit fuse, refer to section 7.6.
Service call 142: Error	ID Up/Down position detection error	Is the ID unit caught by anything when it is removed and re-installed? Does this error recur?	Yes No Yes	Re-install the ID unit. Turn on the power again. Replace the ID UP/DOWN sensor.

Display	Cause	Error details		Remedial measure
Service call 150: Error~ 153: Error	The ID unit fuse has blown out. (150=Y, 151=M, 152=C, 153=K)	Is the ID unit installed normally? Does this error recur? Does the printer recover from the error when the PU/PRZ board is replaced?	No Yes Yes No	Re-install the ID unit. Turn on the power again. After checking for the sure connection of the cable between PRZ board and CU/PU board, replace the PRZ board. Replace the CU/PU board.
Service call 154: Error	The belt unit fuse has blown out.	Is the belt unit connected normally? Does this error recur?	No Yes Yes	Re-install the belt unit. Turn on the power again. After checking for the sure cable connection, replace the CU/PU board.
Service call 155: Error	The fuser unit fuse has blown out.	Is the fuser unit installed normally? Does this error recur?	No Yes Yes	After cleaning the connecting connector of the fuser unit, re-install the fuser unit. Turn on the power again. After checking for the sure cable connection, replace the CU/PU board.
Service call 160: Error~ 163: Error	Toner sensor detection error. (160=Y, 161=M, 162=C, 163=K) This error does not occur with the default settings.	Is the toner cartridge installed? Is the lock lever of the toner set? Does this error recur?	No No Yes	Install the toner cartridge. Rotate the lock lever of toner to the lock position. Turn on the power again. Replace the toner sensor assembly.

Display	Cause	Error details		Remedial measure
Service call 167: Error	Thermistor Slope Error	Is the error message displayed? Does this error recur?	Yes	Turn on the power again. After leaving a printer for 30 minutes, turn on the power again.
Service call 168: Error (Note)	Compensation Thermistor Error	Is the error message displayed? Does this error recur?	Yes	Turn on the power again. After leaving a printer for 30 minutes, turn on the power again.
Service call 170: Error 171: Error (Note)	Short-circuit or open-circuit of fuser thermistor is detected.	Does this error recur?	Yes	Turn on the power again. Replace the fuser unit.
Service call 172: Error 173: Error	The fuser thermistor has detected an abnormal temperature (high temperature or low temperature.)	Does this error recur? Does this error recur?	Yes Yes	Turn on the power again. Replace the fuser unit. Replace the low voltage power supply unit.
Service call 174: Error	The backup roller thermistor is detected of its short-circuit. (At high temperature)	Does this error recur?	Yes	Turn on the power again. Replace the fuser unit.
Service call 175: Error (Note)	The backup roller thermistor is detected of its open-circuit. (At low temperature)	Does this error recur?	Yes	Turn on the power again. Replace the fuser unit.

Display	Cause	Error details		Remedial measure
Service call 176: Error 177: Error	The backup roller thermistor has detected an abnormal temperature (high temperature or low temperature.)	Does this error recur? Does this error recur?	Yes Yes	Turn on the power again. Replace the fuser unit. Replace the low voltage power supply unit.
Service call 181: Error 182: Error 183: Error	Option unit I/F error (181=Duplex Unit, 182=2nd Tray, 183=3rd Tray)	Does this error recur? Does this error recur?	Yes Yes	Turn on the power again. Check for sure connection of the connectors. Replace the option unit.
Re-start the printer. 190: Error	System memory overflow	Does this error recur?	Yes	Turn on the power again. Increase the add-on RAM DIMM.
Service call 200: Error~ 202: Error	PU Firmware Download Error	Error has occurred during re-writing of the PU firmware.		After turning on the power again, perform downloading again. (This error does not occur during the normal operation because this processing is not carried out.)
Re-start the printer. 209: Download Error	Custom Media Type table downloading has failed.	Custom Media Type table downloading has failed.		After turning on the power again, perform downloading again. (This error does not occur during the normal operation because this processing is not carried out.)

Display	Cause	Error details		Remedial measure
Re-start the printer. 203: Error 204: Error 207: Error 208: Error 214: Error FOC: Error FFF: Error	CU program error (The error numbers 203 through 214 do not occur under the normal operation.)	Illegal processing is executed by the CU program.		After turning off the power, check for the normal connection CU/PU board. Then, turn on the power again.
Service call 230: Error	RFID Reader not Installed	RFID read device error Does this error recur?	Yes Yes	Check for normal connection of the RFID R/W board. Replace the RFID R/W. Replace the CU/PU board.
Service call 231: Error	RFID reader I/F error	Interface error with the RFID reader is detected. 01: Communication error between the RFID reader and the engine circuit boards. 02: Error in the wireless circuit of the RFID reader 03: Communication error between the RFID reader and the toner cartridge. 04: Error is detected in the RFID toner cartridge. (In more than 4)		01: Same as the error no. 230 02: Replace the RFID R/W board. 03: Check for normal connection of the antenna cable. 04: Check if quantity of the toner cartridge is correct or not.
Re-start the printer. 901: Error~ 904: Error Note)	Abnormal temperature of belt 901: Short-circuit 902: Open circuit 903: High temperature 904: Low temperature	Is the cable from belt thermistor to the high voltage board connected normally? Does this error recur?	No Yes No	Re-connect the cables normally. Turn on the power again. Replace the belt thermistor.

Display	Cause	Error details		Remedial measure
Re-start the printer. 918: Error	Duplex FAN Alarm Caution	Fan error inside the Duplex unit. Does the error recur when the power is turned off once and back on? Does the error recur when the power is turned off once and back on?	Yes Yes	Check if the Duplex unit is installed normally or not. Check if the fans are installed normally or not. Replace the fan.
Re-start the printer. 923: Error	Black image drum lock error	The K ID does not rotate normally. Does the error display recur when the power is turned off once and back on?	Yes Yes	Check if the K ID is installed normally or not. Replace the K ID unit. Replace the K ID motor.
Service call 928: Error	Fuser motor lock error	Fuser does not rotate normally. Does this error recur?	Yes Yes	Check if the fuser is installed normally or not. Replace the fuser. Replace the fuser motor.
Service call 980: Error	Media wrapped around the fuser error	Media has wrapped around the fuser.		Turn off the power. Replace the fuser.
Service call 982: Error	4th tray detection error	The 4th tray is installed.		Remove the 4th tray.
Service call 983: Error	Error due to detection of the toner cartridges of the same color	Two or more toner cartridges of the same color are detected.		Install the cartridge of the specified in the specified position.

Display	Cause	Error details		Remedial measure
Service call 984: Error~ 987: Error	Detection of an unsupported toner cartridge	An unsupported toner cartridge has been detected. 984:Black toner cartridge position 985:Yellow toner cartridge position 986:Magenta toner cartridge position 987:Cyan toner cartridge position		Replace it with an appropriate toner cartridge.
WDT ERROR R14=xxxxxxxx	PU firmware runaway	Does this error recur?	Yes	Turn on the power again. Replace the CU/ PU board.
COMMUNICATION ERROR	I/F error between PU and CU	Does this error recur?	Yes	Replace the CU/ PU board.
ASIC ERROR	DCON access error	Does this error recur?	Yes	Replace the CU/ PU board.

Note! Service calls 168 error, 171 error, 175 error, 903 error and 904 error; These errors can occur when the printer temperature is below 0 °C. Turn on the power again after the printer temperature has increased.

7.5.2 Preparation for troubleshooting

(1) LCD display error	149	(8-4) Two-sided printing jam occurs during transporting paper inside the Duplex unit.....	170
(1-1) LCD does not display anything.....	149	(8-5) Paper is not supplied from the Duplex unit to the regist roller.....	170
(1-2) PLEASE WAIT	150	(9) Paper size error (error code 400).....	170
(1-3) Error messages related to Operator Panel are displayed.....	150	(9-1) Jam occurs when paper end is located near the IN1 sensor.....	170
(1-4) "RAM check in progress" or "Initializing" display is kept appearing.....	150	(10) ID unit Up/Down error (Service call 140 to 143).....	171
(2) Abnormal operations of printer after the power is turned on.....	151	(10-1) Error occurs during the Up movement of the ID unit	171
(2-1) Any operation does not start at all.....	151	(10-2) Error occurs during the Down movement of the ID unit.....	171
(2-2) Abnormal sound is heard.....	151	(11) Fuser unit error (error 170 to 177).....	172
(2-3) Bad odors are generated.....	152	(11-1) Error occurs immediately after the power is turned on.....	172
(2-4) Rise-up time is slow.....	152	(11-2) Error occurs approx. 1 minute after the power is turned on.....	172
(3) Paper feed jam (error code 391: 1st tray).....	159	(12) Motor fan error (error code 122, 127, 128, 918, 051).....	173
(3-1) Jam occurs immediately after the power is turned on. (1st tray).....	159	(12-1) The low voltage power supply fan does not rotate immediately after the power is turned on.....	173
(3-2) Jam occurs immediately after the paper feed is started. (1st tray)	159	(12-2) Duplex fan does not rotate during the Duplex printing.....	173
(4) Feed jam (error code 380)	161	(12-3) All fans of the printer do not rotate.....	173
(4-1) Jam occurs immediately after the power is turned on.....	161	(13) Print speed is slow. (Performance is low.).....	174
(4-2) Jam occurs immediately after the paper feed is started.....	161	(13-1) Print speed decreases.....	174
(5) Paper feed jam (error code 390: Multipurpose tray).....	162	(14) Option unit cannot be recognized.....	174
(5-1) Jam occurs immediately after the power is turned on. (Multipurpose tray).....	162	(14-2) Option try unit cannot be recognized.....	174
(5-2) Jam occurs immediately after paper feed is started. (Multipurpose tray).....	163	(15) LED head cannot be recognized. (error code 131, 132, 133, 134)	175
(6) Paper running jam (error code 381:).....	164	(15-1) Service call 131 to 134 (LED HEAD Missing).....	175
(6-1) Jam occurs immediately after the power is turned on.....	164	(16) Toner cartridge cannot be recognized. (error code 540, 541, 542, 543)	176
(6-2) Jam occurs immediately after a paper is taken into printer.....	164	(16-1) Error caused by the consumable items.....	176
(6-3) Jam occurs in the middle of paper running path.....	165	(16-2) Error caused by the toner sensor	176
(6-4) Jam occurs immediately after paper has reached the fuser.	166	(16-3) Error caused by the defective mechanism.....	177
(7) Paper unloading jam (error code 382).....	166	(17) Fuse cut error (error codes 150 to 155)	177
(7-1) Paper unloading jam occurs immediately after the power is turned on.	166	(17-1) Fuse cut error	177
(7-2) Paper unloading jam occurs after a paper is taken into printer.....	167	(18) Humidity sensor error (error code 123).....	178
(7-3) Paper unloading jam occurs in the middle of paper running path.	168	(18-1) Humidity sensor error	178
(8) Two-sided printing jam (error code: 370, 371, 372, 373, 383).....	168	(19) Wiring diagram.....	179
(8-1) Two-sided printing jam occurs immediately after the power is turned on..	168		
(8-2) Two-sided printing jam occurs during taking in the paper into Duplex unit.....	169		
(8-3) Two-sided printing jam occurs in the process of reversing paper.....	169		

Note! When replacing the CU/PU board, read the EEPROM chip contents of the old board first, and copy them to the new board upon completion of the replacement. (Refer to section 5.4.1 Precautions when replacing the engine control board.)

7.5.2. (1) LCD display error

Memo For the numbers from ① through ⑳ after name of the respective connectors, refer to section 7.5.2 (19) "Wiring diagram".

(1-1) LCD does not display anything.

Check item	Check work	Action to be taken at NG
(1-1-1) Check the fuse.		
F3,F5 (fuse) of the CU/PU board	Check if F3,F5 has blown out or not.	Replace CU/PU board.
(1-1-2) Check the system connection		
Connection between the low voltage power supply unit and the CU/PU board.	Check if the cable from the low voltage power supply to the POWER connector ⑦ of the CU/PU board is normally connected or not. Check if the connector is connected only in the half-way or not, and check if the connector is inserted in slanted angle or not.	Re-connect the cable normally.
Cable assembly connecting the low voltage power supply unit and the CU/PU board.	Check if the cable is half-open circuit. Check if sheath of the cable has not peeled off or not. Check if the cable assembly is defective such as internal wires are disconnected or not.	Replace the cable with the normal cable. Note!
Connection between the CU/PU board and Operator Panel	Check if the 11-conductor FFC is connected to the OPE connector ⑭ of the CU/PU board normally or not. Check if the 11-conductor FFC is connected to the OPE connector ⑰ of the CU/PU board normally or not. Check if the connector is connected in the half-way only or not, and check if the connector is inserted in a slanted angle or not.	Re-connect the cable normally.
FFC connecting the CU/PU board and the Operator Panel board	Check if the cable has open circuit or not with VOM. Check if sheath of the cable has not peeled off or not by visual inspection.	Replace the FFC with the normal FFC.

Check item	Check work	Action to be taken at NG
(1-1-3) Check the peripherals of the power supplies		
Primary AC power source that is connected to the printer.	Check the supplied voltage of the AC power source.	Supply the AC power.
Voltage setting of the lower voltage power supply unit (100V system/230V system)	Measure the AC voltage supplied. Check the power voltage setting of the equipment in use. (Check the shorting plug that is used for selection of the voltage power supplies.) Shorting plug is Used/Not used = 100V system/230V system.	Set the low voltage power supply setting.
5V power that is supplied to the CU/PU board.	Check for the 5V power supply at pin-1, 2, 3 of the POWER connector ⑦ of the CU/PU board.	Replace the low voltage power supply.
3.3V power that is supplied to the Operator Panel.	Check for the 3.3V power supply at pin-11 of the CN connector ⑰ of the Operator Panel board.	Replace F2 or the CU/PU board.
(1-1-4) Check that power supply circuit has no short-circuit.		
5V power and 24V power that are supplied to the CU/PU board.	Check that power supply circuit has no short-circuit at the POWER connector no. 10 of the CU/PU board. The follow voltage must appear respectively. pins-7, 8 and 9: 24V pin-1, 2 and 3: 5V pin-4, 5 and 6: 0VL pins-10, 11 and 12: 0VP If any voltage does not appear and short-circuit is detected, locate the source of the short-circuit as follows: Disconnect the cables that are connected to the CU/PU board one cable after another until location of the short-circuit is found out.	Replace the part causing short-circuit.

Check item	Check work	Action to be taken at NG
(1-1-5) LSI operation check		
I/F signal supplied from the CU/PU board to the Operator Panel board.	Check if the signal is output to the OPE connector ⑭ of the CU/PU board or not. Pin-2: Send data (Sending data from the CU/PU board) Pin-5: CLR If it is normal, the signal is output always.	Replace the CU/PU board.
I/F signal supplied from the CU/PU board to the Operator Panel board.	Check if the signal is output to the OPE connector ⑭ of the CU/PU board or not. Pin-3: Send data (Sending data from the CU/PU board) If it is normal, the signal is output always.	Replace the Operator Panel board.

(1-2) PLEASE WAIT

(If the message is left attended, the error number changes to "COMMUNICATION ERROR".)

Check item	Check work	Action to be taken at NG
(1-2-3) Implement version upgrade of the PU firmware		
Version upgrade of the PU firmware	When the PU firmware version upgrade is completed, this display appears. Check the PU firmware version number by using the menu print or the maintenance function.	If the message reappears after the power is re-started again, implement the confirmations of sections (1-3-1).

(1-3) Error messages related to Operator Panel are displayed.

Check item	Check work	Action to be taken at NG
(1-3-1) Error message		
Error message	Check the error contents by referring to the Error Message List.	Follow the instruction.

(1-4) "RAM check in progress" or "Initializing" display is kept appearing.

Check item	Check work	Action to be taken at NG
(1-4-1) Operator Panel display freezes.		
Operator Panel display	"RAM check in progress" or "Initializing" display is kept appearing.	Replace the ROM DIMM of CU, or replace the CU/PU board. Remove the optional RAM and SD Memory card. Then perform the check. If the check result shows NG, replace the CU/PU board.

7.5.2. (2) Abnormal operations of printer after the power is turned on

(2-1) Any operation does not start at all.

Check item	Check work	Action to be taken at NG
(2-1-1) Check the peripherals of the power supplies		
Primary AC power source that is connected to the printer.	Check the supplied voltage of the AC power source.	Supply the AC power.
Voltage setting of the lower voltage power supply unit (100V system/230V system)	Measure the AC voltage supplied. Check the power voltage setting of the equipment in use. (Check the shorting plug that is used for selection of the voltage power supplies. [CN6]) Shorting plug is Used/Not used = 100V system/ 230V system.	Set the low voltage power supply setting.
5V power and 24V power that are supplied to the CU/ PU board.	Check the power supply voltages at the POWER connector ⑦ of the CU/PU board. The follow voltage must appear respectively. Pins-7, 8 and 9: 24V Pin-1, 2 and 3: 5V Pin-4, 5 and 6: 0V Pins-10, 11 and 12: 0VP	Replace the low voltage power supply.
(2-1-2) Check the system connection		
Connection condition of Operator Panel	Check contents of (1-1). Any operation of a printer will not start until the Operator Panel is detected and is started of its operation.	Follow the contents of (1-1).

(2-2) Abnormal sound is heard.

Check item	Check work	Action to be taken at NG
(2-2-1) Check loss of synchronization of motor (Driver error)		
Operating conditions of the respective motors	Check if operations of the respective motors are normal or not by using the self-diagnostic mode. Check if any load exists or not. "Buzzer" sound when an error occurs.	Replace the CU/PU board.
Condition of the motor cable	Check for normal wiring conditions of the respective motors. Perform the visual check and measure resistance at open circuit with VOM as follows. Remove the motor cable at the board end. Measure resistance between the respective pins of the removed cable and FG with VOM.	Replace the motor cable. Re-connect the cable for normal conditions.
(2-2-2) Check loss of synchronization of motor (Abnormal load of the consumable item)		
Operating conditions of the respective motors	Check if operations of the respective motors are normal or not by using the self-diagnostic mode. Check if any load exists or not. "Buzzer" sound when an error occurs.	Replace the corresponding consumable item. If any attempt of using new part as a trial is going to be made, be sure to use the System Maintenance Menu FUSE KEEP MODE.

Check item	Check work	Action to be taken at NG
(2-2-3) Check the jumping phenomena of gear tooth. (Abnormal load of the consumable item)		
Operating conditions of the respective motors	Check if operations of the respective motors are normal or not by using the self-diagnostic mode. Check if any load exists or not. "Buzz buzz" sound is generated when an error occurs.	Replace the corresponding consumable item. If any attempt of using new part as a trial is going to be made, be sure to use the System Maintenance Menu FUSE KEEP MODE.
Installation condition of each consumable item	Check by visual inspection if the respective consumable items are installed in their normal positions in which gears of the consumable items engage accurately or not.	Replace an appropriate mechanical part as required, or adjust or repair
(2-2-4) Check the wiring conditions of cables		
Wiring conditions of the cables in the vicinity of the respective cooling fans	Check if the cable contacts with the fan blade because wiring conditions of the cables near fan is poor or not. "Clap, clap" sound is generated when an error occurs.	Correct the wiring conditions of the cable.
(2-2-5) Check installation condition of mechanical parts		
Check the installation conditions of the partition plate under the CU/PU boards.	Remove the CU/PU board, and inspect the installation conditions of the partition plate by visual inspection.	If they are not hooked on the normal specified positions, correct them.

(2-3) Bad odors are generated.

Check item	Check work	Action to be taken at NG
(2-3-1) Locating the exact position of generating bad odor		
Fuser unit	Remove the fuser unit and check the odor.	Implement section (2-3-2).
Low voltage power supply unit	Remove the low voltage power supply unit and check the odor.	Replace the low voltage power supply unit
(2-3-2) Check conditions of the fuser unit		
Life count of fuser unit	Check the life count of the fuser unit by using the self-diagnostic mode.	The fuser close to the new fuser unit smells some odors.
Check that no foreign material exists in fuser unit.	Check that no foreign materials such as paper are stuck inside of the fuser unit.	Remove the foreign material.

(2-4) Rise-up time is slow.

Check item	Check work	Action to be taken at NG
(2-4-1) Check the fuser unit		
Halogen lamp	Check that 120V or 230V is shown on the label on the rear of the fuser unit. (120V:ODA,230V:ODA/OEL)	Replace the fuser unit.
(2-4-2) Check the optional parts Note:		
Add-on memory	Install the optional parts (add-on memory) again and re-check the operations.	Replace the optional part.
SD Memory card	Install the optional part (SD Memory card) again and re-check the operations.	Replace the optional part.

Note! If any troubles such as printer does not start up normally occurs, remove the CU options (RAM, SD Memory card) and check if the trouble symptom changes or not.

(3) Paper Jams

When paper jams occur or paper remains in the printer, "Paper Jam", or "Paper Remain" is displayed on the operation panel.

By pressing the Help button, a method to remove the paper is displayed, remove the paper in the printer according to [Handling].

In addition, A method to remove paper is also described in the reference page at the right table.

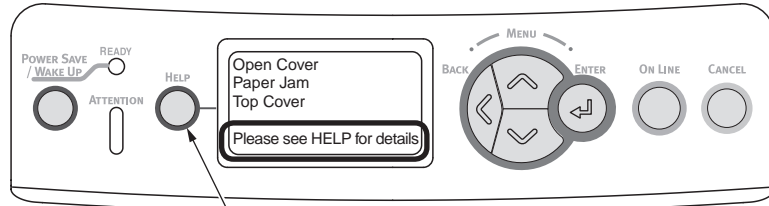

By pressing this button, a method to remove paper is displayed.

Message to be displayed	Reference page
Open Cassette Paper Jam [Tray Name]	Page 156
Open Cassette Paper Remain [Tray Name]	
Open Cover Paper Jam Front Cover	Page 157
Open Cover Paper Remain Front Cover	
Open Cover Paper Jam Top Cover	Page 158
Open Cover Paper Remain Top Cover	
Check Duplex Unit Paper Jam	Page 160
Check Duplex Unit Paper Remain	

JAM location of occurrence outline chart

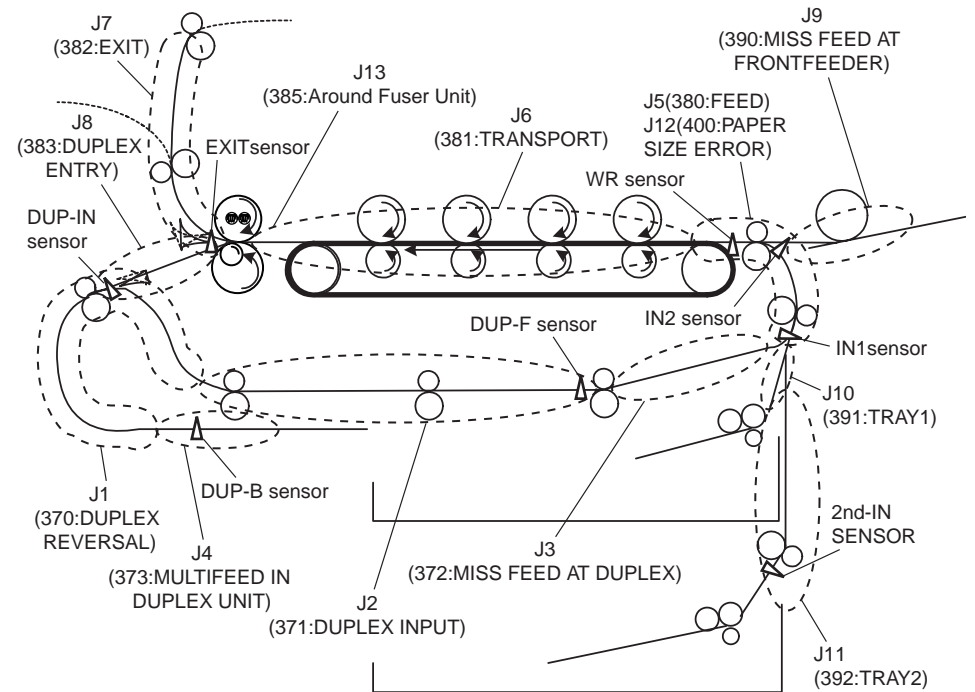

Open Cassette
Paper Remain
[Tray Name]

Open Cassette
Paper Jam
[Tray Name]

When the above messages are displayed.
Tray1 is applied here as an example.

(1) Pull the displayed tray.

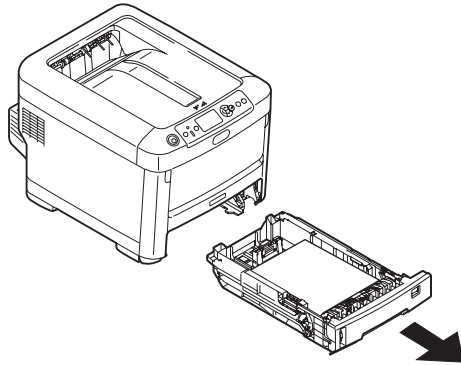

(2) Remove paper.

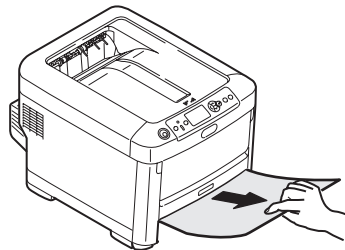

(3) Return the tray to the printer.

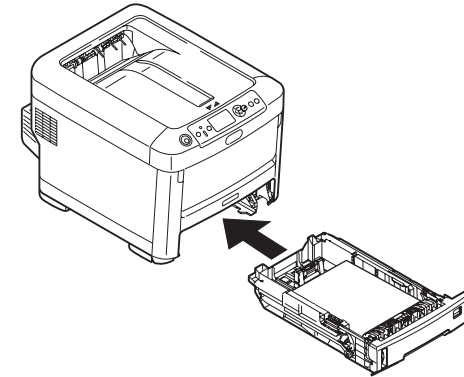

(4) Open and close the top cover.

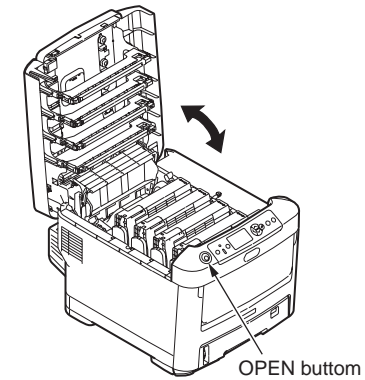

Open Cover
Paper Remain
Front Cover

Open Cover
Paper Jam
Front Cover

When the above messages are displayed.

- (1) Open the multipurpose tray.

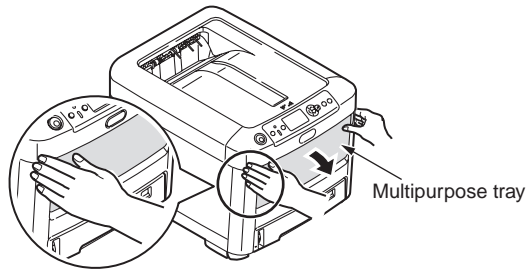

- (2) Push up the center handle (blue), to open the front cover.

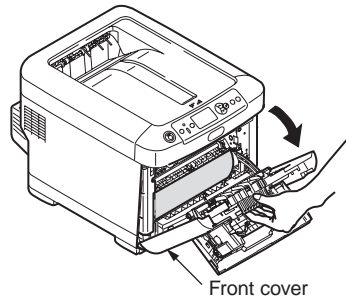

- (3) Slowly pull out the jammed paper.

- ① If you see the top edge of paper
- ② If you do not see the top edge of paper

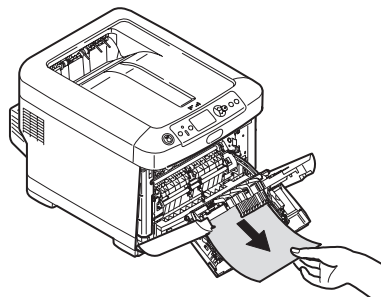
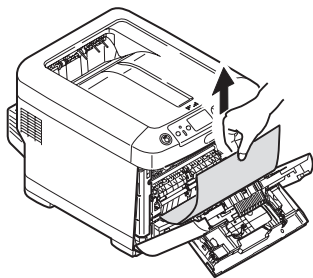

- (4) Close the front cover.

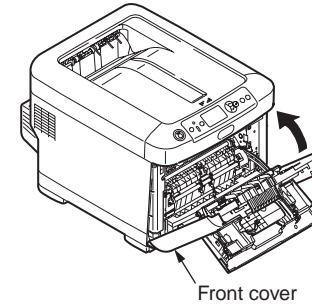

- (5) Close the multipurpose tray.

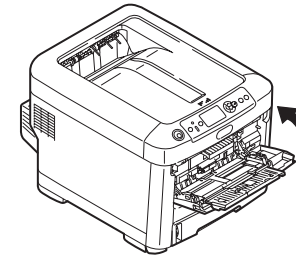

Open Cover
Paper Remain
Top Cover

Open Cover
Paper Jam
Top Cover

When the above messages are displayed.

- (1) Open the top cover.

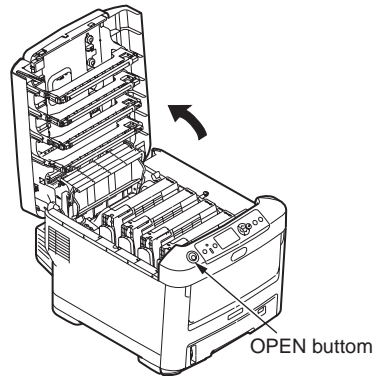

- (2) Touch the screw with a hand to discharge static.

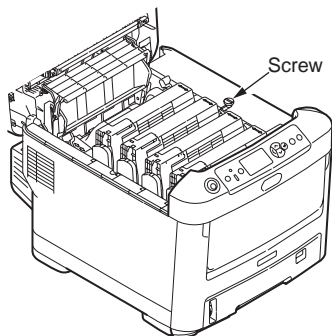

- (3) 2Uninstall the four image drum cartridges and put them on a flat table.

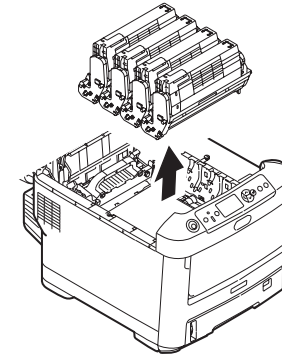

- (4) Cover the uninstalled image drum cartridges with black paper.

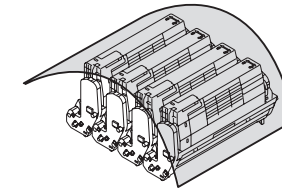

- (5) (a) If you see the top edge of paper
Pull up the jammed paper slowly.

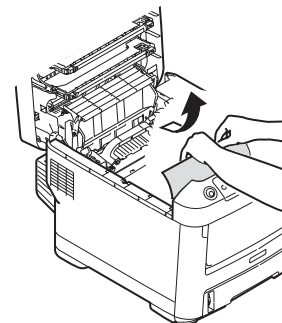

(b) If you do not see the top edge of paper

Pull up the jammed paper slowly while pushing the jam release lever of the fuser unit.

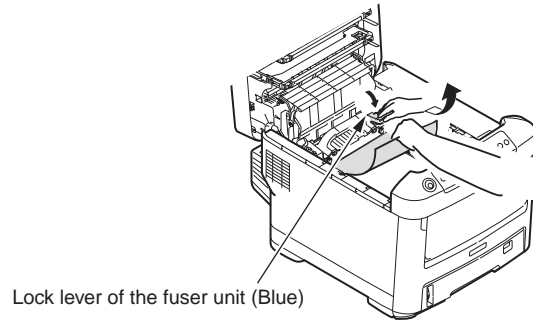

(c) If paper is jammed in the fuser unit

Pull the lock levers (2 levers) of the fuser unit to remove the fuser unit.

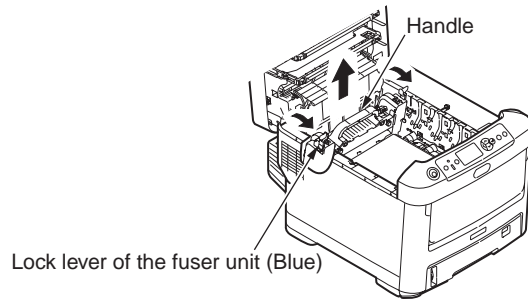

Pull the jammed paper to the front side while pressing the jam release lever.

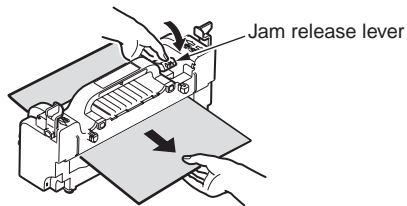

Set the fuser unit in the printer body and fold backward the lock lever (2 levers).

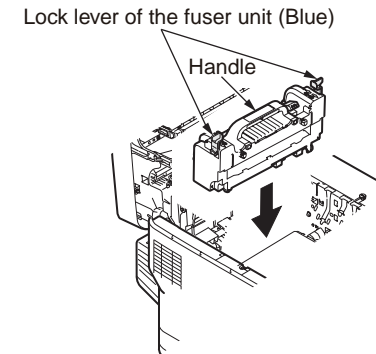

(6) Set four image drums in the printer.

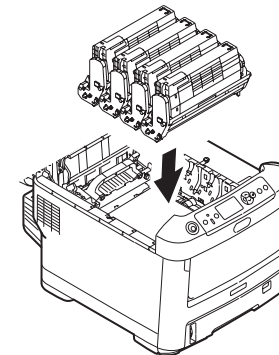

(7) Close the top cover.

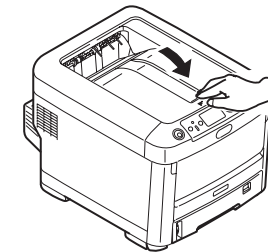

Check Duplex Unit
Paper Remain

Check Duplex Unit
Paper Jam

When the above messages are displayed.

- (1) Hold and press down the jam release lever of the Duplex unit to open the Duplex unit cover.

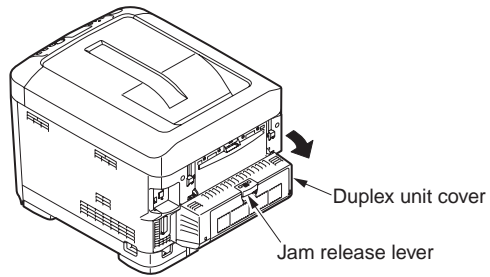

- (2) Release jammed paper.

If you do not see the paper, by closing the Duplex unit cover, the paper is automatically outputted.

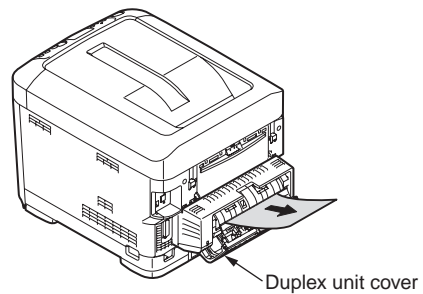

- (3) Close the Duplex unit cover.

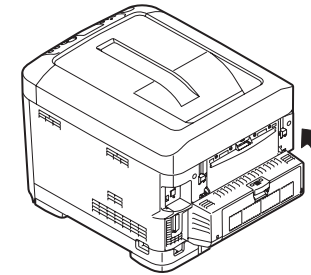

7.5.2. (3) Paper feed jam (error code 391: 1st tray)

(3-1) Jam occurs immediately after the power is turned on. (1st tray)

Check item	Check work	Action to be taken at NG
(3-1-1) Check condition of the paper running path		
Paper running path of the front unit	Open the front cover check if paper is not jammed in the paper running path.	Remove the jammed paper.
(3-1-2) Check condition of the mechanical parts		
Check the sensor levers of the paper entrance sensor 1 and the paper entrance sensor 2.	Check if shape and movement of the sensor levers have any abnormality or not.	Replace the sensor lever with the good sensor lever.
(3-1-3) Check condition of electrical parts		
Check the detection condition of the sensor signal.	Confirm that the sensor signals are normally detected by using the Maintenance Menu SWITCH SCAN function.	Replace either the CU/PU board or the front sensor board (RSF PCB) or connection cable.
Check output signal level of the paper entrance sensor 1 and that of the paper entrance sensor 2.	Check for the following signals at the FSNS connector ⑬ of the CU/PU board. Pin-4: Paper entrance sensor 1 Pin-3: Paper entrance sensor 2 Confirm that the above signal levels change when the sensor lever is operated.	Replace the front sensor board (RSF PCB)
Check the power voltages supplied to the front sensor board (RSF PCB)	Check the 5V power at the FSNS connector ⑬ of the front sensor board (RSF PCB). Pin-1: 5V power supply Pin-5: OVL	Replace the connection cable.

(3-2) Jam occurs immediately after the paper feed is started. (1st tray)

Check item	Check work	Action to be taken at NG
(3-2-1) Check condition of the paper running path		
Paper running path of the front unit	Check if paper is jammed or not in the paper running path.	Remove the jammed paper.
(3-2-2) Check condition of the mechanical parts		
Check the sensor levers of the paper entrance sensor 1 and the paper entrance sensor 2.	Check if shape and movement of the sensor levers have any abnormality or not.	Replace the sensor with the good sensor lever.
Check the separator assemblies of the feed roller, the pickup roller and the tray.	Check if any foreign materials such as paper dust on the surface of the feed roller or of the pickup roller or not.	Remove the foreign material.
	Check if the feed roller or the pickup roller has worn out or not.	Replace the separator assemblies of the feed roller, pickup roller and tray.
(3-2-3) Motor operation check		
Paper feed motor	Confirm that the paper feed motor works normally by using the Motor & Clutch Test of the self-diagnostic mode.	Replace the CU/PU board or the paper feed motor.
Paper feed motor driver	Remove the HP_PSZCL connector ⑨ of the CU/PU board and check the followings at the connector side. Several MΩ between pin-1 – FG. Several MΩ between pin-2 – FG. Several MΩ between pin-3 – FG. Several MΩ between pin-4 – FG.	Replace the CU/PU board.

Check item	Check work	Action to be taken at NG
(3-2-4) Check the system connection		
Paper feed motor drive cable	Check the connection condition of the cable. Check if the connector is connected in the half-way only or not, and check if the connector is inserted in a slanted angle or not. Check also that cables are assembled without any abnormality.	Replace the cable with the good cable that normalizes the connection condition.
Paper feed motor drive cable	Check that any cable is not pinched during assembling of the printer. Remove the HP_PSZCL connector ⑨ of the CU/PU board and check the followings at the cable side. Short circuit between pin-1 – FG Short circuit between pin-2 – FG Short circuit between pin-3 – FG Short circuit between pin-4 – FG	Replace the cable with the good cable that normalizes the connection condition.
Paper feed motor	Remove the HP_PSZCL connector ⑨ of the CU/PU board and check that approx. 3.4Ω can be measured between pin-1 -pin-2 at the cable end, and that approx. 5Ω can be measured between pin-3 -pin-4 respectively.	Replace the paper feed motor.
(3-2-5) Solenoid operation check		
Paper feed clutch	Confirm that the paper feed clutch or regist clutch works normally by using the Motor & Clutch Test of the self-diagnostic mode. Remove the metal plate from the right side of a printer so that the clutch becomes visible. Then, check operation of the clutch.	Replace the CU/PU board, or replace the paper feed clutch or regist clutch.

Check item	Check work	Action to be taken at NG
(3-2-6) Check the system connection		
Paper feed clutch cable	Check the connection condition of the cable. Check if the connector is connected in the half-way only or not, and check if the connector is inserted in a slanted angle or not. Check also that cables are assembled without any abnormality.	Replace the cable with the good cable that normalizes the connection condition.
Paper feed clutch cable	Check that any cable is not pinched during assembling of the printer. Remove the CL1 connector ⑩ of the CU/PU board and check the followings at the cable side. Short circuit between pin-1 – FG Remove the CL1 connector ⑩ of the CU/PU board and check that approx. 240Ω can be measured between pin-1 and pin-2.	Replace the solenoid and re-assemble the printer correctly.

7.5.2. (4) Feed jam (error code 380)

(4-1) Jam occurs immediately after the power is turned on.

Check item	Check work	Action to be taken at NG
(4-1-1) Check condition of the paper running path		
Paper running path of the front unit	Open the front cover check if paper is not jammed in the paper running path.	Remove the jammed paper.
(4-1-2) Check condition of the mechanical parts		
Check the sensor levers of the paper entrance sensor 1, that of the paper entrance sensor 2 and that of the WR sensor.	Check if shape and movement of the sensor levers have any abnormality or not.	Replace the sensor with the good sensor lever.
(4-1-3) Check condition of electrical parts		
Check the detection condition of the sensor signal.	Confirm that the sensor signals are normally detected by using the Maintenance Menu SWITCH SCAN function.	Replace either the CU/PU board or the front sensor board (RSF PCB) or connection cable.
Check the output signal levels of the paper entrance sensor 1, that of the paper entrance sensor 2 and that of the WR sensor.	Check for the following signals at the FSNS connector ⑬ of the CU/PU board. Pin-4: Paper entrance sensor 1 Pin-3: Paper entrance sensor 2 Pin-2: WR sensor Confirm that the above signal levels change when the sensor lever is operated.	Replace the front sensor board (RSF PCB)
Check the power voltages supplied to the front sensor board (RSF PCB)	Check the 5V power at the FSNS connector ⑬ of the front sensor board (RSF PCB). Pin-1: 5V power supply Pin-5: 0V	Replace the connection cable.

(4-2) Jam occurs immediately after the paper feed is started.

Check item	Check work	Action to be taken at NG
(4-2-1) Check condition of the paper running path		
Paper running path of the front unit	Check if paper is jammed or not in the paper running path.	Remove the jammed paper.
(4-2-2) Check condition of the mechanical parts		
Check the sensor levers of the paper entrance sensor 1, that of the paper entrance sensor 2 and that of the WR sensor.	Check if shape and movement of the sensor levers have any abnormality or not.	Replace the sensor with the good sensor lever.
(4-2-3) Motor operation check		
Paper feed motor	Confirm that the paper feed motor works normally by using the Motor & Clutch Test of the self-diagnostic mode.	Replace the CU/PU board, or replace the paper feed motor.
Paper feed motor driver	Remove the HP_PSZCL connector ⑨ of the CU/PU board and check the followings at the connector side. Several MΩ between pin-1 – FG Several MΩ between pin-2 – FG Several MΩ between pin-3 – FG Several MΩ between pin-4 – FG	Replace the CU/PU board.

Check item	Check work	Action to be taken at NG
(4-2-4) Check the system connection		
Paper feed motor drive cable	Check the connection condition of the cable. Check if the connector is connected in the half-way only or not, and check if the connector is inserted in a slanted angle or not. Check also that cables are assembled without any abnormality.	Replace the cable with the good cable that normalizes the connection condition.
Paper feed motor drive cable	Check that any cable is not pinched during assembling of the printer. Remove the HP_PSZCL connector ⑨ of the CU/PU board and check the followings at the cable side. Short circuit between pin-1 – FG Short circuit between pin-2 – FG Short circuit between pin-3 – FG Short circuit between pin-4 – FG	Replace the cable with the good cable that normalizes the connection condition.
Paper feed motor	Remove the HP_PSZCL connector ⑨ of the CU/PU board and check that approx. 3.4Ω can be measured between pin-1 -pin-2 at the cable end, and that approx. 5Ω can be measured between pin-3 -pin-4 respectively.	Replace the paper feed motor.

7.5.2. (5) Paper feed jam (error code 390: Multipurpose tray)

(5-1) Jam occurs immediately after the power is turned on. (Multipurpose tray)

Check item	Check work	Action to be taken at NG
(5-1-1) Check condition of the paper running path		
Paper running path of the multipurpose tray	Check if paper is jammed or not in the paper running path.	Remove the jammed paper.
(5-1-2) Check condition of the mechanical parts		
Check the sensor levers of the paper entrance sensor 2 and the WR sensor.	Check if shape and movement of the sensor levers have any abnormality or not.	Replace the sensor with the good sensor lever.
(5-1-3) Check condition of electrical parts		
Check the detection condition of the sensor signal.	Confirm that the sensor signals are normally detected by using the SWITCH SCAN function of the self-diagnostic mode.	Replace either the CU/PU board or the front sensor board (RSF PCB) or connection cable.
Check the sensor output signal level of the paper entrance sensor 2 and the WR sensor.	Check for the following signals at the FSNS connector ⑬ of the CU/PU board. Pin-2: WR sensor Pin-3: Paper entrance sensor 2 Confirm that the above signal levels change when the sensor lever is operated.	Replace the front sensor board (RSF PCB)
Check the power voltages supplied to the front sensor board (RSF PCB)	Check the 5V power at the CN connector ⑱ of the front sensor board (RSF PCB). Pin-1: 5V power supply Pin-5: OVL	Replace the connection cable.

(5-2) Jam occurs immediately after paper feed is started. (Multipurpose tray)

Check item	Check work	Action to be taken at NG
(5-2-1) Check condition of the paper running path		
Paper running path of the multipurpose tray	Check if paper is jammed or not in the paper running path.	Remove the jammed paper.
Sheet Receive of the multipurpose tray	Confirm that the Sheet Receive has moved up normally. Confirm that the support spindle and spring of the Sheet Receive have been installed in the specified positions normally.	Correct installation of the above parts so that the Sheet Receive moves up to the specified position normally.
(5-2-2) Check condition of the mechanical parts		
Check the sensor levers of the paper entrance sensor 2 and the WR sensor.	Check if shape and movement of the sensor levers have any abnormality or not.	Replace the sensor with the good sensor lever.
Planetary gear for paper feed control	Rotate the paper feed motor (FRONT MOTOR) using the Motor & Clutch Test of the self-diagnostic mode, and confirm that both of the two planetary gears rotate at the bottom position. (The planetary gear box can be located because it is the white molded block that is located on the right side when the front cover is opened.)	Replace the planetary gear box
Front cover	Confirm that the locks in the right and left of the front cover are locked normally.	Replace the front cover assembly
Check the feed roller and the pickup roller.	Check if any foreign materials such as paper dust on the surface of the feed roller or of the pickup roller or not.	Remove the foreign material.
	Check if the feed roller has worn out or not.	Replace the feed roller.

Check item	Check work	Action to be taken at NG
(5-2-3) Motor operation check		
Paper feed motor	Confirm that the paper feed motor works normally by using the Motor & Clutch Test of the self-diagnostic mode.	Replace the CU/PU board, or replace the paper feed motor.
Paper feed motor driver	Remove the HP_PSZCL connector ⑨ of the CU/PU board and check the followings at the connector side. Several MΩ between pin-1 – FG Several MΩ between pin-2 – FG Several MΩ between pin-3 – FG Several MΩ between pin-4 – FG	Replace the CU/PU board.
(5-2-4) Check the system connection		
Paper feed motor drive cable	Check the connection condition of the cable. Check if the connector is connected in the half-way only or not, and check if the connector is inserted in a slanted angle or not. Check also that cables are assembled without any abnormality.	Replace the cable with the good cable that normalizes the connection condition.
Paper feed motor drive cable	Check that any cable is not pinched during assembling of the printer. Remove the HP_PSZCL connector ⑨ of the CU/PU board and check the followings at the cable side. Short circuit between pin-1 – FG Short circuit between pin-2 – FG Short circuit between pin-3 – FG Short circuit between pin-4 – FG	Replace the cable with the good cable that normalizes the connection condition.
Paper feed motor	Remove the HP_PSZCL connector ⑨ of the CU/PU board and check that approx. 3.4Ω can be measured between pin-1 -pin-2, and that approx. 5Ω can be measured between pin-3 -pin-4 respectively.	Replace the paper feed motor.

7.5.2. (6) Paper running jam (error code 381:)

(6-1) Jam occurs immediately after the power is turned on.

Check item	Check work	Action to be taken at NG
(6-1-1) Check condition of the running path.		
Paper running path of the front unit	Check if paper is jammed or not in the paper running path.	Remove the jammed paper.
(6-1-2) Check condition of the mechanical parts		
Check the sensor lever of the WR sensor.	Check if shape and movement of the sensor levers have any abnormality or not.	Replace the sensor lever with the good sensor lever.
(6-1-3) Check condition of electrical parts		
Check the detection condition of the sensor signal.	Confirm that the sensor signals are normally detected by using the SWITCH SCAN function of the self-diagnostic mode.	Replace either the CU/PU board or the front sensor board (RSF PCB) or connection cable.
Check the sensor lever of the WR sensor.	Check for the following signals at the FSNS connector ⑬ of the CU/PU board. Pin-2: WR sensor Confirm that the above signal levels change when the sensor lever is operated.	Replace the front sensor board (RSF PCB)
Check the power voltages supplied to the front sensor board (RSF PCB)	Check the 5V power at the CN connector ⑱ of the front sensor board (RSF PCB). Pin-1: 5V power supply Pin-5: 0V	Replace the connection cable.

(6-2) Jam occurs immediately after a paper is taken into printer.

Check item	Check work	Action to be taken at NG
(6-2-1) Check condition of the paper running path		
Paper running path on the belt.	Remove the ID unit and check if paper is jammed or not in the paper running path.	Remove the jammed paper.
(6-2-2) Check condition of the mechanical parts		
Check the sensor lever of the WR sensor.	Check if shape and movement of the sensor levers have any abnormality or not.	Replace the sensor lever with the good sensor lever.
(6-2-3) Motor operation check		
Paper feed motor driver, belt motor driver and ID motor	Confirm that the paper feed motor, belt motor and ID motor work normally by using the Motor & Clutch Test of the self-diagnostic mode. Check if any load exists or not.	Replace the CU/PU board, or replace the defective motor among paper feed motor, belt motor and ID motor, or replace the ID unit or belt unit. If any attempt of using new ID unit or new belt unit as a trial is going to be made, be sure to use the System Maintenance Menu FUSE KEEP MODE.
Paper feed motor, belt motor	Remove the BELT ID UP connector ② of the CU/PU board and check the followings at the connector side. Several MΩ between pin-5 – FG Several MΩ between pin-6 – FG Several MΩ between pin-7 – FG Several MΩ between pin-8 – FG Remove the HP_PSZCL connector ⑨ of the CU/PU board and check the followings at the connector side. Several MΩ between pin-1 – FG Several MΩ between pin-2 – FG Several MΩ between pin-3 – FG Several MΩ between pin-4 – FG	Replace either paper feed motor, belt motor or CU/PU board.

Check item	Check work	Action to be taken at NG
(6-2-4) Check the system connection		
Paper feed motor drive cable, ID motor drive cable, belt motor drive cable, ID Up motor drive cable, fuser motor drive cable	Check the connection condition of the cables. CU/PU board HP_PSZCL connector ⑨, DC ID connector ①, DCHEAT connector ③, BELT ID UP connector ②, RELAY connector ⑥. Check if the connector is connected in the half-way only or not, and check if the connector is inserted in a slanted angle or not. Check also that cables are assembled without any abnormality.	Normalize the connection condition. Replace the cable with the normal cable.
Paper feed motor drive cable, ID motor drive cable, belt motor drive cable, ID Up motor drive cable	Check that any cable is not pinched during assembling of the printer. Remove the BELT ID UP connector ② of the CU/PU board and check the followings at the connector side. Short circuit between pin-1 – FG Short circuit between pin-2 – FG Short circuit between pin-3 – FG Short circuit between pin-4 – FG Short circuit between pin-5 – FG Short circuit between pin-6 – FG Short circuit between pin-7 – FG Short circuit between pin-8 – FG Remove the HP_PSZCL connector ⑨ of the CU/PU board and check the followings at the cable side. Short circuit between pin-1 – FG Short circuit between pin-2 – FG Short circuit between pin-3 – FG Short circuit between pin-4 – FG	Replace the cable with the good cable that normalizes the connection condition.
Paper feed motor, belt motor, ID Up motor	Remove the respective connectors from the board, and confirm that the following resistance exists between the corresponding pins, at the cable side. CU/PU board HP_PSZCL connector ⑨ Between pin-1 - pin-2 Approx. 3.4Ω or approx. 5Ω. Between pin-3 - pin-4 Approx. 3.4Ω or approx. 5Ω. CU/PU board BELT ID UP connector ② Between pin-1 - pin-2 Approx. 6.1Ω or approx. 8.5Ω. Between pin-3 - pin-4 Approx. 6.1Ω or approx. 8.5Ω. Between pin-5 - pin-6 Approx. 3.4Ω or approx. 5Ω. Between pin-7 - pin-8 Approx. 3.4Ω or approx. 5Ω.	Replace paper feed motor, belt motor, ID Up motor.

(6-3) Jam occurs in the middle of paper running path.

Check item	Check work	Action to be taken at NG
(6-3-1) Motor operation check		
Paper feed motor driver, belt motor driver and ID motor	Confirm that the paper feed motor, belt motor and ID motor work normally by using the Motor & Clutch Test of the self-diagnostic mode. Check if any load exists or not.	Replace the CU/PU board, or replace the defective motor among paper feed motor, belt motor and ID motor, or replace the ID unit or belt unit. If any attempt of using new ID unit or new belt unit as a trial is going to be made, be sure to use the System Maintenance Menu FUSE KEEP MODE.
Paper feed motor, belt motor	Remove the BELT ID UP connector ② of the CU/PU board and check the followings at the connector side. Several MΩ between pin-5 – FG Several MΩ between pin-6 – FG Several MΩ between pin-7 – FG Several MΩ between pin-8 – FG Remove the HP_PSZCL connector ⑨ of the CU/PU board and check the followings at the connector side. Several MΩ between pin-1 – FG Several MΩ between pin-2 – FG Several MΩ between pin-3 – FG Several MΩ between pin-4 – FG	Replace either paper feed motor, belt motor or CU/PU board.

(6-4) Jam occurs immediately after paper has reached the fuser.

Check item	Check work	Action to be taken at NG
(6-4-1) Motor operation check		
Fuser motor	Confirm that the fuser motor works normally by using the Motor & Clutch Test of the self-diagnostic mode. Check if any load exists or not.	Replace the CU/PU board. Replace the fuser motor. Replace the fuser unit. If any attempt of using new fuser unit as a trial is going to be made, be sure to use the System Maintenance Menu FUSE KEEP MODE.
(6-4-2) Temperature control of the roller rotation speed		
Heat roller detected temperature	Check the detected temperature of the heat roller using the self-diagnostic mode. Is abnormally high temperature or abnormally temperature detected?	Replace fuser unit, or relay board (PRY PCB) or the CU/PU board. If any attempt of using new fuser unit as a trial is going to be made, be sure to use the System Maintenance Menu FUSE KEEP MODE.
(6-4-3) Check the installation condition of fuser unit		
Fuser unit	Check that the fuser unit is installed normally. (Is it pushed in down to the bottom-most point?)	Install the fuser unit correctly in a printer.

7.5.2. (7) Paper unloading jam (error code 382)

(7-1) Paper unloading jam occurs immediately after the power is turned on.

Check item	Check work	Action to be taken at NG
(7-1-1) Check condition of the paper running path		
Paper running path of the paper unloading unit	Check if paper is jammed or not in the paper running path.	Remove the jammed paper.
(7-1-2) Check condition of the mechanical parts		
Check the sensor lever of the paper exit sensor.	Check if shape and movement of the sensor levers have any abnormality or not.	Replace the sensor lever with the good sensor lever.
(7-1-3) Check condition of electrical parts		
Check the detection condition of the sensor signal.	Confirm that the sensor signals are normally detected by using the SWITCH SCAN function of the self-diagnostic mode.	Replace the CU/PU board or EXIT sensor or its cable or its connection cable.
Check the output signal level of the EXIT sensor.	Check for the following signals at the RELAY connector ⑥ of the CU/PU board. Pin-9: EXIT sensor Confirm that the above signal levels change when the sensor lever is operated.	Replace the EXIT sensor.
Check the power voltages supplied to the relay board.	Check the 5V power voltage at the EXIT connector ② of the relay board. Pin-1: 5V power supply Pin-3: 0VL	Replace the connection cable.

Check item	Check work	Action to be taken at NG
(7-1-4) Check the system connection		
Signal cable for relay board, EXIT sensor cable	Check that FFC is normally inserted at the RELAY connector ⑥ of the CU/PU board and at the PU IF connector ⑳. Check that the relay board and the EXIT sensor are normally connected.	Normalize the connection condition.
Signal cable for relay board, EXIT sensor cable	Confirm that the cables are not pinched, sheathes are not peeled off, and they are assembled normally.	Replace the connecting cable and normalize the assembled condition.

(7-2) Paper unloading jam occurs after a paper is taken into printer.

Check item	Check work	Action to be taken at NG
(7-2-1) Check condition of the paper running path		
Face Up Stacker Cover	Confirm that it is either fully opened or fully closed	Eliminate any in-between condition of the cover between the fully open position and fully closed position.
Duplex pull-in gate	Confirm that the Duplex pull-in gate works normally by using the Motor & Clutch Test of the self-diagnostic mode. Is it set to the paper unloading side normally?	Replace the Duplex pull-in gate or the Duplex solenoid
Rear panel	Check that the installation condition of the rear panel hampers smooth movement of a paper in the paper running path, or not.	Remove the rear panel and re-install it.
Paper running path of unloading unit	Check that any mechanical load does not exist that hampers the smooth movement of paper in the paper running path of the paper unloading unit, by the visual inspection. Check if the paper unloading motor becomes difficult to rotate or not.	Correct the portion that becomes mechanical load.

Check item	Check work	Action to be taken at NG
(7-2-2) Check condition of the mechanical parts		
Sensor lever of the paper exit sensor	Check if shape and movement of the sensor levers have any abnormality or not.	Replace the sensor lever with the good sensor lever.
(7-2-3) Motor operation check		
Fuser motor	Confirm that the fuser motor works normally by using the Motor & Clutch Test of the self-diagnostic mode. Check if any load exists or not.	Replace the CU/PU board or fuser motor or fuser unit. If any attempt of using new fuser unit as a trial is going to be made, be sure to use the System Maintenance Menu FUSE KEEP MODE.
(7-2-4) Check the system connection		
Fuser motor drive cable	Check the connection condition of the cables. CU/PU board DCHEAT connector ③, Check if the connector is connected in the half-way only or not, and check if the connector is inserted in a slanted angle or not. Check also that cables are assembled without any abnormality.	Replace the cable with the good cable that normalizes the connection condition.
Fuser motor		Replace the fuser motor.

(7-3) Paper unloading jam occurs in the middle of paper running path.

Check item	Check work	Action to be taken at NG
(7-3-1) Motor operation check		
Fuser motor	Confirm that the fuser motor works normally by using the Motor & Clutch Test of the self-diagnostic mode. Check if any load exists or not.	Replace the CU/PU board or fuser motor or fuser unit. If any attempt of using new fuser unit as a trial is going to be made, be sure to use the System Maintenance Menu FUSE KEEP MODE.

7.5.2. (8) Two-sided printing jam (error code: 370, 371, 372, 373, 383)

(8-1) Two-sided printing jam occurs immediately after the power is turned on.

Check item	Check work	Action to be taken at NG
(8-1-1) Check condition of the paper running path		
Paper running path of the Duplex unit	Check if paper is jammed or not in the paper running path. Open the front cover and check if any paper remains in the Duplex feeder or not. Open the rear cover and check if any paper remains in the paper reversing path or not. Remove the Duplex unit. Check if any paper exists in the Duplex insertion slot or not. Open the cover of the Duplex paper running path and check if any paper remains inside of the Duplex unit.	Remove the jammed paper.
(8-1-2) Check condition of the mechanical parts		
Check the sensor levers of the respective sensors of the Duplex unit.	Check if shape and movement of the sensor levers have any abnormality or not.	Replace the sensor lever with the good sensor lever.
(8-1-3) Check condition of electrical parts		
Check the detection condition of the sensor signal.	Confirm that the sensor signals are normally detected by using the SWITCH SCAN function of the self-diagnostic mode. For all sensors except the Dup-IN sensor, check the detection condition of the respective sensor in the two status: One is the status in which paper remains inside the Duplex unit. The other is the status in which paper is removed from the Duplex unit.	Replace the Duplex board (V7Y PCB), or replace the defective sensor or connection cable.

(8-2) Two-sided printing jam occurs during taking in the paper into Duplex unit.

Check item	Check work	Action to be taken at NG
(8-2-1) Solenoid operation check		
Duplex solenoid	Confirm that the Duplex solenoid works normally by using the Motor & Clutch Test of the self-diagnostic mode.	Replace the V7Y board or solenoid.
Separator DUP (Paper unloading/ DUP paper taking-in switching gate located immediately after the fuser unit)	Check visually movement of the gate by using the Motor & Clutch Test of the self-diagnostic mode. (EXIT SOLENOID) Check if movement is unsmooth or not, if amount of open/close is abnormal or not.	Replace the separator DUP.
ON/OFF timing of the Duplex solenoid	While the cover is in the opened state, perform the test print and confirm if the timing to open the separator DUP is correct or not.	Replace the WR sensor lever or solenoid.
(8-2-2) Sensor lever operation check		
Dup-IN sensor lever	Open the rear cover. Touch the Dup-IN sensor lever to check if its movement is unsmooth or not.	Replace the Dup-IN sensor lever
DUP-IN sensor	Confirm that the sensor signals are normally detected by using the SWITCH SCAN function of the self-diagnostic mode.	Replace the Duplex board (V7Y PCB), or replace the defective sensor or connection cable.
(8-2-3) Check condition of the paper running path		
Paper inverting transport path	Check that any foreign materials such as paper chip or blue do not exist that hampers the smooth movement of paper in the paper inverting transport path.	Remove the foreign material.

Check item	Check work	Action to be taken at NG
(8-2-4) Motor operation check		
Duplex motor	Confirm that the Duplex solenoid works normally by using the Motor & Clutch Test of the self-diagnostic mode. Open the rear cover and check rotation of the roller.	Replace the V7Y board or motor.
Duplex pull-in/reversing roller and its pinch roller	Check if the pull-in/reversing roller of the Duplex unit contacts or not with the pinch roller of the cover side when the Duplex rear cover is closed. (Does the pinch roller rotate when the roller is rotating?)	Replace the rear cover.

(8-3) Two-sided printing jam occurs in the process of reversing paper.

Check item	Check work	Action to be taken at NG
(8-3-1) Sensor lever operation check		
Dup-IN sensor lever	Open the rear cover. Touch the Dup-IN sensor lever to check if its movement is unsmooth or not.	Replace the Dup-IN sensor lever
DUP-IN sensor	Confirm that the sensor signals are normally detected by using the SWITCH SCAN function of the self-diagnostic mode.	Replace the Duplex board (V7Y PCB), or replace the defective sensor or connection cable.
(8-3-2) Motor operation check		
Duplex motor	Check if the paper reversing operation is started or not by visual inspection when viewing through slit of the rear cover. If the paper reversing operation is not started, check if movement of the planetary gear inside the Duplex unit is unsmooth or not.	Replace the planetary gear.

(8-4) Two-sided printing jam occurs during transporting paper inside the Duplex unit.

Check item	Check work	Action to be taken at NG
(8-4-1) Sensor lever operation check		
Dup-R, Dup-F sensor lever	Remove the Duplex unit and check movement of the sensor lever.	Replace the sensor lever.
(8-4-2) Sensor check		
Check the detection condition of the sensor signal	Confirm that the sensor signals are normally detected by using the SWITCH SCAN function of the self-diagnostic mode. For all sensors except the Dup-IN sensor, check the detection condition of the respective sensor in the two status: One is the status in which paper remains inside the Duplex unit. The other is the status in which paper is removed from the Duplex unit.	Replace the Duplex board (V7Y PCB), or replace the defective sensor or connection cable.

(8-5) Paper is not supplied from the Duplex unit to the regist roller.

Check item	Check work	Action to be taken at NG
(8-5-1) Clutch operation check		
Duplex clutch	Confirm that the Duplex clutch works normally by using the Motor & Clutch Test of the self-diagnostic mode. Confirm it by listening to the sound.	Replace the V7Y board or clutch.

7.5.2. (9) Paper size error (error code 400)

(9-1) Jam occurs when paper end is located near the IN1 sensor.

Check item	Check work	Action to be taken at NG
(9-1-1) Check paper feed condition		
Multifeed of papers	Open the front cover and check if multifeed of papers occurs or not.	If the multifeed occurs again after the jammed paper is removed, replace the flap of the tray in use.
Paper size	Does the paper size specified for print match the paper size of paper stuck in the tray.	Change the specified paper size or size of paper inside the tray.
Paper entrance sensor 1	Check if shape and movement of the sensor levers have any abnormality or not.	Replace the sensor lever with the good sensor lever.

7.5.2. (10) ID unit Up/Down error (Service call 140 to 143)

(10-1) Error occurs during the Up movement of the ID unit

Check item	Check work	Action to be taken at NG
(10-1-1) Check the mechanical load during the Up movement		
Mechanical load during installation and removal of the ID unit	Check if abnormal heavy load is applied when removing the ID unit.	IRemove the ID unit, or replace the right/left side plate. If any attempt of using new ID unit as a trial is going to be made, be sure to use the System Maintenance Menu FUSE KEEP MODE.
Greasing to the right and left Up/Down link levers	Check if the slant surface of the link lever is coated by grease or not.	Apply grease.
Assembled condition of the right and left Up/Down link levers	Check if any part exists or not in the vicinity of link lever, that hampers movement of the link lever.	Assemble them correctly.
(10-1-2) Up/Down mechanism		
Assembled condition of the peripheral mechanism of the link lever	Is the mechanism assembled so that the link lever is connected to the planetary driving gear?	Assemble them correctly.
Right and left link levers	Check if the link lever is set in the correct position that enables the specified engagement of gears. (Check if the link lever is set in the wrong position that results in the wrong engagement of gears by several teeth.)	Assemble them correctly.

Check item	Check work	Action to be taken at NG
(10-1-3) Sensor check		
Up/Down sensor lever (unified structure with the left link lever)	Check if shape and movement of the sensor levers have any abnormality or not.	Replace the left link lever.
Up/Down sensor	Confirm that the sensor signals are normally detected by using the SWITCH SCAN function of the self-diagnostic mode. Check if the SCAN state changes or not when the incoming light is interrupted/passed by using a piece of paper or the like for the transparent type sensor.	Replace the high voltage board.

(10-2) Error occurs during the Down movement of the ID unit

Check item	Check work	Action to be taken at NG
(10-2-1) Check the mechanical load during the Down movement		
Mechanical load during installation and removal of the ID unit	Check if abnormal heavy load is applied when removing the ID unit.	Replace the ID unit, or replace the right/left side plate.
Greasing to the right and left Up/Down link levers	Check if the slant surface of the link lever is coated by grease or not.	Apply grease.
Assembled condition of the right and left Up/Down link levers	Check if any part exists or not in the vicinity of link lever, that hampers movement of the link lever.	Assemble them correctly.

7.5.2. (11) Fuser unit error (error 170 to 177)

(11-1) Error occurs immediately after the power is turned on.

Check item	Check work	Action to be taken at NG
(11-1-1) Thermistor is defective Note)		
Upper thermistor, lower thermistor, frame thermistor	Check the respective thermistors if they are shorted or opened internally. Check the resistance value at the connector pins in the bottom of the fuser unit. (Refer to section 8.1 Resistance check (fuser unit).)	Replace the fuser unit. If any attempt of using new fuser unit as a trial is going to be made, be sure to use the System Maintenance Menu FUSE KEEP MODE.
Installed condition of fuser unit.	Check if the fuser nit is pressed in until the connector in the bottom of the fuser unit is surely connected.	Re-set the fuser unit.

Note! Service calls 171 error and 171 error can occur when the printer temperature is below 0°C. Turn on the power again after the printer temperature has increased.

(11-2) Error occurs approx. 1 minute after the power is turned on.

Check item	Check work	Action to be taken at NG
(11-2-1) Temperature increase of fuser unit		
Thermostat, halogen lamp	Heater of the fuser unit is controlled of its temperature. Check if the fuser unit gets hot or not by touching it with hands. If the fuser unit temperature does not increase and remains cold, check that the resistance between pin-1 and pin-6 of connector A, and that in between pin-1 and pin-6 of connector B of the two connectors is in the range of several ohms to several ten ohms respectively. (Refer to section 8.1 Resistance value (fuser unit).)	Replace the fuser unit. If any attempt of using new fuser unit as a trial is going to be made, be sure to use the System Maintenance Menu FUSE KEEP MODE.

Check item	Check work	Action to be taken at NG
(11-2-2) Temperature increase of fuser unit		
Installation position of the upper thermistor	Check if the upper thermistor is installed in the far position from the specified position or not causing detection of the lower temperature than the actual temperature of fuser unit. Remove the heater cover, and check warpage of sensor by visual inspection.	Replace the fuser unit. If any attempt of using new fuser unit as a trial is going to be made, be sure to use the System Maintenance Menu FUSE KEEP MODE.
Installation position of the lower thermistor	The lower thermistor must be installed while contacting with the fuser unit. Check if the lower thermistor is installed in the far position from the specified position or not causing detection of the lower temperature than the actual temperature of fuser unit.	Replace the fuser unit. If any attempt of using new fuser unit as a trial is going to be made, be sure to use the System Maintenance Menu FUSE KEEP MODE.
(11-2-3) AC power input to the halogen lamp		
AC power voltage from the low voltage power supply	Check if the AC voltage for heater is normally supplied or not. Power supply CN2 connector ㉓, between pin-1 and pin-2, and between pin-3 and pin-4.	Replace the low voltage power supply.
Heater ON signal that is output from PU to the low voltage power supply	Check that the heater ON signal goes active at the warming up timing, or not. "L" active while ON. Power connector ㉗ of the CU/PU board, between pin-14 and pin-15.	Replace the CU/PU board.

7.5.2. (12) Motor fan error (error code 122, 127, 128, 918, 051)

(12-1) The low voltage power supply fan does not rotate immediately after the power is turned on.

Check item	Check work	Action to be taken at NG
(12-1-1) Cable connection condition and wiring condition		
Cable connection condition and wiring condition of the low voltage power supply fan and those of the fuser fan	Check if the connectors are connected normally or not. Check if extra length of the cables does not touch the fan blade or not.	Correct the connection condition of the connectors. Correct the cable wiring route. Replace the fan.

(12-2) Duplex fan does not rotate during the Duplex printing.

Check item	Check work	Action to be taken at NG
(12-1-2) Cable connection condition and wiring condition		
Cable connection condition and wiring condition of the Duplex fan	Check if the connectors are connected normally or not. Check if extra length of the cables does not touch the fan blade or not.	Correct the connection condition of the connectors. Correct the cable wiring route. Replace the fan. Replace the fan.
24V fuse F501 of the Duplex board (V7Y PCB)	Check if the fuse F501 has blown out or not.	Replace the Duplex board (V7Y PCB).
24V power supplied to the Duplex board (V7Y PCB).	Check if the fuse F4 of the CU/PU board has blown out or not.	Replace the CU/PU board.

(12-3) All fans of the printer do not rotate.

Check item	Check work	Action to be taken at NG
(12-3-1) 24V power supply		
CU/PU board fuses F1	Check if the fuse F1 is not open-circuit or not.	Replace the CU/PU board.
24V power that is supplied to the CU/PU board.	Check the power supply voltages at the POWER connector ⑦ of the CU/PU board. The follow voltage must appear respectively. Pins-7, 8 and 9: 24V Pins-10, 11 and 12: 0VP	Replace the low voltage power supply.

7.5.2. (13) Print speed is slow. (Performance is low.)

(13-1) Print speed decreases.

Check item	Check work	Action to be taken at NG
(13-1-2) Media Weight setting		
Media Weight that is specified for the print	Check if the wrong Media Weight has been specified or not.	Correct the Media Weight.

7.5.2. (14) Option unit cannot be recognized.

(14-1) Duplex unit cannot be recognized.

Check item	Check work	Action to be taken at NG
(14-1-1) Duplex board		
Duplex unit	Check if the Duplex unit of C711 specification is being used or not.	Replace the Duplex unit.
(14-1-2) Check the system connection		
Check the system connection from the CU/PU board to the Duplex board (V7Y PCB).	Check that the cable between the CU/PU board option connector ⑩ to the Duplex board is normally connected.	Correct the connections.
Square connector connecting the Duplex unit to the printer.	Check if any foreign material exists in the connecting portion of the square connector.	Remove the foreign material.
Square connector connecting the Duplex unit to the printer.	Is the terminals of the square connector damaged?	Replace the connector.
(14-1-3) Check the control signals.		
Check the control signal that is output from the CU/PU board to the Duplex board (V7Y PCB).	Check the control signal that is output from the CU/PU board option connector ⑩. Pin-6: TXD (PU → DUP) Pin-4: RXD (DUP → PU)	Replace the CU/PU board.

(14-2) Option try unit cannot be recognized.

Check item	Check work	Action to be taken at NG
(14-2-1) Option try board		
Option try unit	Check if the option try unit of C711 specification is being used or not.	Replace the option tray unit.

Check item	Check work	Action to be taken at NG
(14-2-2) Check the system connection		
Check the system connection from the CU/PU board to the option tray board (V7Y PCB).	Check that the cable between the CU/PU board option connector ⑩ to the option tray board is normally connected.	Correct the connections.
Square connector connecting the option tray unit to the printer.	Check if any foreign material exists in the connecting portion of the square connector.	Remove the foreign material.
Square connector connecting the option tray unit to the printer.	Is the terminals of the square connector damaged?	Replace the connector.
(14-2-3) Check the control signals.		
Check the control signal that is output from the CU/PU board to the option tray board (V7Y PCB).	Check the control signal that is output from the CU/PU board option connector ⑩. Pin-5: TXD (PU → 2nd) Pin-3: RXD (2nd → PU)	Replace the CU/PU board.

7.5.2. (15) LED head cannot be recognized. (error code 131, 132, 133, 134)

(15-1) Service call 131 to 134 (LED HEAD Missing)

Check item	Check work	Action to be taken at NG
(15-1-1) Check the system connection		
Connecting condition at the CU/PU board connector and at the head connector.	Check the connecting condition of the FFC by the visual inspection.	Correct the connection to the normal connecting condition.
Head FFC	Remove the head FFC from the printer. Check if any open-circuit or peeling-off of sheath has occurred or not throughout the cable.	Replace the head FFC or the CU/PU board.
Conduction of the fuse on the CU/PU board.	Check that 5V appears across the capacitor CP8. (Refer to section 7.6.) Check if the fuses F15 and F12 are not open-circuit or not.	Replace the CU/PU board.

7.5.2. (16) Toner cartridge cannot be recognized. (error code 540, 541, 542, 543)

(16-1) Error caused by the consumable items.

Check item	Check work	Action to be taken at NG
(16-1-1) Consumable items installation condition		
ID unit and toner cartridge	Check that the ID unit is installed in the normal position. Check that the lock lever of the toner cartridge is locked.	Correct the installation to the normal installation condition.

(16-2) Error caused by the toner sensor

Check item	Check work	Action to be taken at NG
(16-2-1) Toner sensor condition		
Toner sensor	Is the receptor of the toner sensor stained?	Wipe off the stain from the toner sensor.
Toner sensor	Confirm that the toner sensor works normally by using the SWITCH SCAN function of the self-diagnostic mode. Place a white paper in front of the toner sensor, and check if the SCAN state changes or not.	Replace the toner sensor board, or the CU/PU board, or the FFC between the toner sensor board and the CU/PU board.

Note! Toner sensor operation check method using the SWITCH SCAN function of the self-diagnostic mode.

(1) How to check operation of the toner sensor at the printer side.

- Status change of the toner sensor can be checked from the Operator Panel using the self-diagnostic mode. First, switch the display to the Operator Panel display. For the method of switching the display to the Operator Panel display, refer to section 5.3.2.3 Switch Scan Test
- Remove the ID unit and the toner cartridge (TC) from a printer. There is a window inside a printer opposing the ID side when viewed from the front of a printer. The toner sensor is located inside the window.
- Place a white paper 3 mm away from the sensor window. The white paper should be placed in the manner of opposing the toner sensor.
- When light is reflected by a white paper so that incident light falls on the toner sensor, the Operator Panel display shows "L". When the paper is moved so that any light is not reflected by the paper so that the incident light does not reach the toner sensor, "H" is displayed on the Operator Panel.
- If the Operator Panel display toggles between "H" <-> "L" as a paper is flipped in front of the toner sensor, it indicates that the toner sensor and the related system of the printer are working normally.

Action to be taken at NG

- Clean surface of the toner sensor to remove the stains due to residual toner and paper dust.
- Check the connection condition of the FFC cable at the PU main board (PU) and at the toner sensor board (PRZ).
- Perform the operation check again. If the situation is not improved and remains unchanged, replace the PU main board (PU) or the toner sensor board (PRZ).

(2) How to check operation of the toner sensor at the toner cartridge (TC) side

- To the position where the toner sensor is confirmed to be operating normally in the printer itself by the above paragraph (1), install the TC and the ID unit to check operations by observing display on the Operator Panel.
- If the ID unit works normally, the display on the Operator Panel will toggle between "H" <-> "L" in synchronism with movement of the silver reflector plate that is located on the side of the ID.

Action to be taken at NG

- Check operation condition of the respective ID motors by using the Motor & Clutch Test of the self-diagnostic mode.
- Clean surface of the silver reflector plate on the side of ID to remove stains. (Stain due to toner or paper dust)
- Replace the TC of different color and the ID unit as a pair.

If a satisfactory operation is attained by using the a pair of TC of different color and the ID unit, replace the TC or replace the ID unit.

(16-3) Error caused by the defective mechanism

Check item	Check work	Action to be taken at NG
(16-3-1) Mechanical load applied to the ID unit		
ID unit	Check if a heavy mechanical load is being applied to the ID unit due to breakage of the waster toner belt, or not.	Replace the ID unit. If any attempt of using new ID unit as a trial is going to be made, be sure to use the System Maintenance Menu FUSE KEEP MODE.
(16-3-2) Motor operating condition		
ID motor	Confirm that the respective ID motors work normally or not by using the Motor & Clutch Test of the self-diagnostic mode. Check if any extra load exists or not.	Replace the CU/PU board or the ID motor.

7.5.2. (17) Fuse cut error (error codes 150 to 155)

(17-1) Fuse cut error

Check item	Check work	Action to be taken at NG
(17-1-1) Check the system connection		
FFC connecting the CU/PU board and the toner sensor board (PRZ PCB)	Check if the connector is connected in the half-way only or not, and is inserted in a slanted angle or not at the SSNS connector ⑮ of the CU/PU board, and at the SSNS connector ⑯ of the toner sensor board (PRZ PCB). Check if FFC has open-circuit of sheath of the FFC has not peeled off or not.	Connect the FFC normally. Alternately, replace the FFC.
(17-1-2) Fuse cut circuit		
CU/PU board	Upon completion of the system connection check, turn off the power once and back on. The, check if the error occurs or not.	Replace the CU/PU board.

7.5.2. (18) Humidity sensor error (error code 123)

(18-1) Humidity sensor error

Check item	Check work	Action to be taken at NG
(18-1-1) Check the system connection		
Connection between the CU/PU board and Operator Panel	Check if the 11-conductor FFC is connected to the OPE connector ⑭ of the CU/PU board normally or not. Check if the 11-conductor FFC is connected to the CN1 connector ⑰ of the Operator Panel board normally or not. Check if the connector is connected in the half-way only or not, and check if the connector is inserted in a slanted angle or not.	Re-connect the cable normally.
FFC connecting the CU/PU board and the Operator Panel board	Check for open-circuit with VOM. Check that peeling off of sheath does not occur in any cables by visual inspection.	Replace the FFC with the normal FFC.

Check item	Check work	Action to be taken at NG
(18-1-2) Environment condition		
Sharp change of environment condition	Is the environment condition changed sharply from a low temperature environment to a high environment condition within a short time? (Example is such a case that a printer is moved from storage condition of a cold area in winter to an office environment.)	Leave a printer for around one hour in the new environment to get used to the new environment. After that, turn on the power again. Before turn on the power, touch the metal panel of the controller panel and the metal plate inside a printer to feel temperature increase inside a printer with human hands. After confirmation that the printer temperature has increased close to the room temperature, turn on the power again.

7.5.2. (19) Wiring diagram

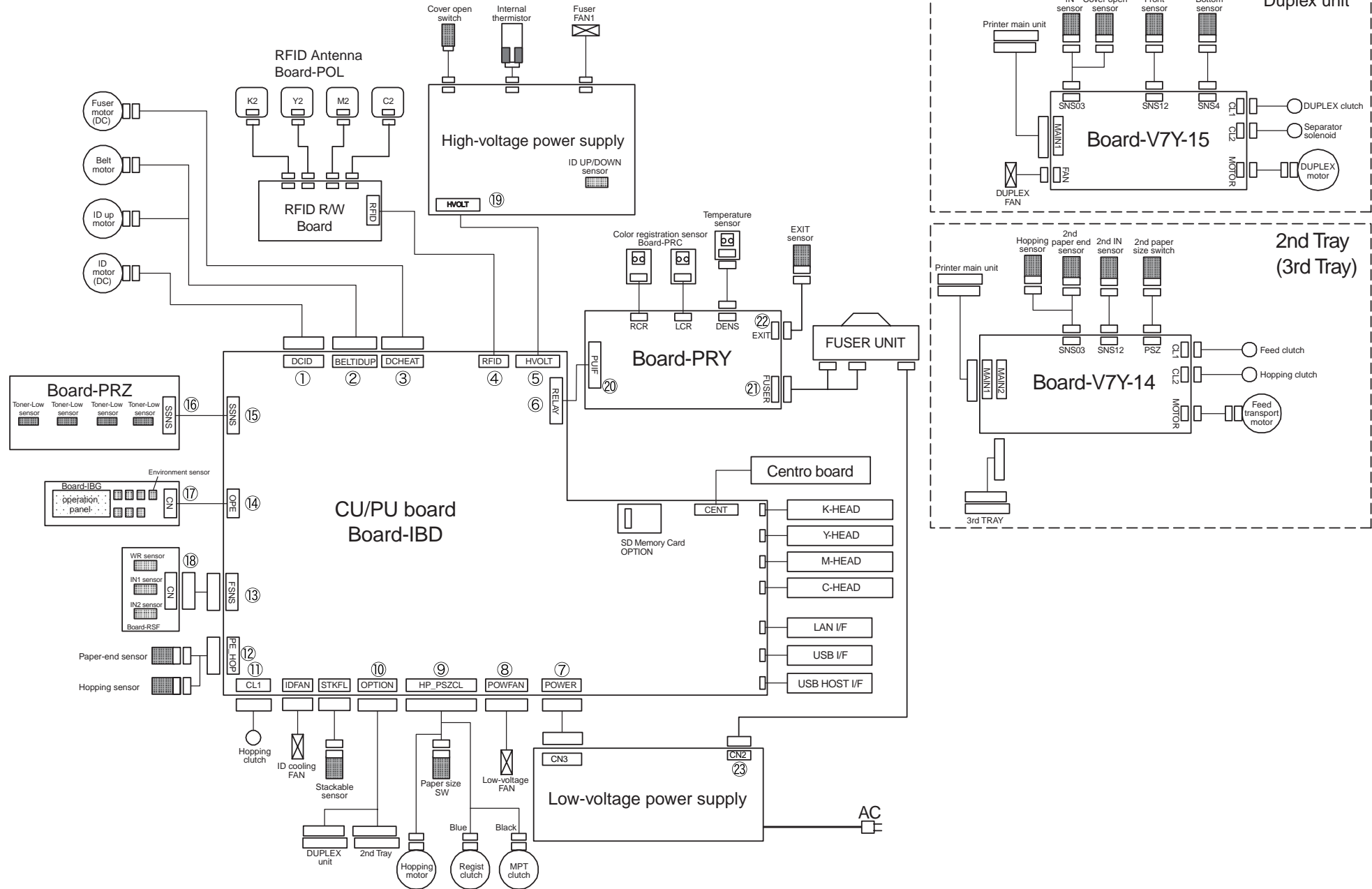

7.5.3 Troubleshooting the abnormal images

(1) Color has faded-out and blurred entirely. (Refer to Figure 7-2A.)	181
(1-1) Color are faded-out and blurred.	181
(2) Stain on white print (Refer to Figure 7-2B.)	182
(2-1) Stain on white print (Partial stain)	182
(2-2) Stain on white print (overall stain)	182
(3) White print (Refer to Figure 7-2C.)	183
(3-1) White print over entire page	183
(4) Black banding/black streaking in vertical direction	184
(4-1) Thin vertical line (with color) (Refer to Figure 7-2D.)	184
(4-2) Thin vertical line (without color) (Refer to Figure 7-2F.)	184
(5) Cyclic abnormality (Refer to Figure 7-2E.)	184
(5-1) Cyclic abnormality occurs in vertical direction	184
(6) Heavy color registration error	185
(6-1) Display of the message "Color adjustment is in progress" appears only short time.	185
(6-2) Though REG ADJUST TEST of engine maintenance function is ok, color blur occurs	185
(7) Entirely black print	185
(7-1) All black print over entire page	185

Note! When an attempt is going to be made to replace the PU board, read data contents of the EEPROM chip from the old PU board beforehand, and copy the data contents into the new board after the new PU board is installed.

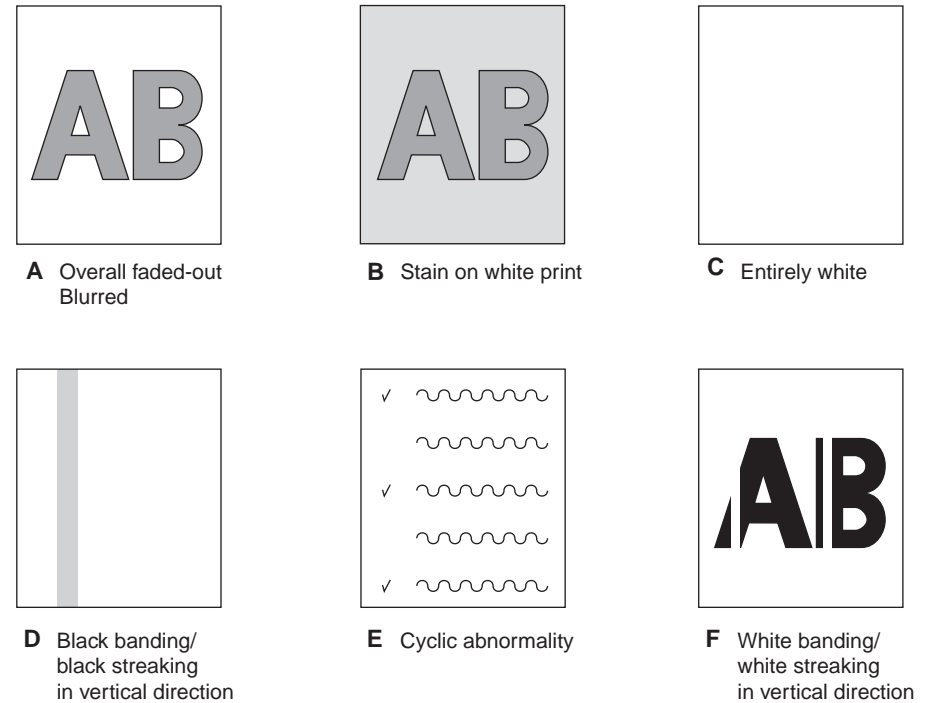

Figure 7-2

7.5.3.(1) Color has faded-out and blurred entirely. (Refer to Figure 7-2A.)

(1-1) Color are faded-out and blurred.

Check item	Check work	Action to be taken at NG
(1-1-1) Toner		
Remaining amount of toner	Check if the message "Prepare toner replacement." or "Replace the toner." appears or not.	Replace toner cartridge with new one.
Tape attached to the toner cartridge opening slot	Check to see that the tape attached to the toner cartridge opening slot has been peeled off.	Move the toner cartridge lever to CLOSE position and remove tape from opening slot.
(1-1-2) LED head		
Lens of the LED head	Check if surface of the lens of the LED head is stained or not by toner and paper dust.	Clean the lens with soft tissue paper.
Mounting condition of LED head	Check that the LED head is mounted on the LED head holder correctly. Check that the right and left tension springs are normally installed.	Correct for normal condition.
(1-1-3) Print media		
Media type	Check to see that the print media which is used for printing is not a specially thick media	Use the normal paper.
(1-1-4) High voltage terminal		
ID unit terminal	Check that the high voltage terminal of the ID unit is contacting with the Contact Assembly normally by visual inspection. (Refer to Figure 7-3.)	Replace the ID unit or correct the high voltage terminal. If any attempt of using new ID unit as a trial is going to be made, be sure to use the System Maintenance Menu FUSE KEEP MODE.

Check item	Check work	Action to be taken at NG
(1-1-5) ID unit installation condition		
ID unit DOWN position (Defective transfer)	Move the ID unit in and out with hand to confirm that any abnormal mechanical load does not exist, and the ID unit can be moved down to the DOWN position normally. If a piece of paper is inserted in between drum and belt, if top end of the paper can enter easily, it is NG (No Good).	Check the U-shaped groove of the side plate for any abnormality. If repair is found impossible, replace the equipment.

7.5.3.(2) Stain on white print (Refer to Figure 7-2B.)

(2-1) Stain on white print (Partial stain)

Check item	Check work	Action to be taken at NG
(2-1-1) ID unit		
Exposure of drum to light	Is the drum left in a circumstance in which drum surface is exposed to direct light for a long time?	Replace the ID unit. If any attempt of using new ID unit as a trial is going to be made, be sure to use the System Maintenance Menu FUSE KEEP MODE.
Leakage of toner	Does toner leak out from either ID unit or from toner cartridge?	Replace the ID unit or toner cartridge. If any attempt of using new ID unit as a trial is going to be made, be sure to use the System Maintenance Menu FUSE KEEP MODE.
(2-1-2) Fuser unit		
Offset toner of the fuser unit	Check if the offset toner of the previous printing is left adhered on the fuser unit or not, by visual inspection.	Repeat blind printing using unwanted media until offset toner is created on print media. Alternately replace the fuser unit. If any attempt of using new fuser unit as a trial is going to be made, be sure to use the System Maintenance Menu FUSE KEEP MODE.

(2-2) Stain on white print (overall stain)

Check item	Check work	Action to be taken at NG
(2-2-1) Print media		
Type of print media	Check to see that the print media which is used for printing is not a specially thin media.	Use the normal paper.
(2-2-2) High voltage terminal		
ID unit terminal	Check that the high voltage terminal of the ID unit is contacting with the Contact Assembly normally by visual inspection. (Refer to Figure 7-3.)	Replace the ID unit or correct the high voltage terminal. If any attempt of using new ID unit as a trial is going to be made, be sure to use the System Maintenance Menu FUSE KEEP MODE.

7.5.3.(3) White print (Refer to Figure 7-2C.)

(3-1) White print over entire page

Check item	Check work	Action to be taken at NG
(3-1-1) Toner condition		
Remaining amount of toner	Confirm that sufficient amount of toner remains inside the toner cartridge.	Replace the toner cartridge.
(3-1-2) Exposure condition to light		
LED head	Confirm that the LED head is positioned in the normal position where the LED head opposes again the drum when the cover is closed. Check that no obstacle exists in front of the LED head, that hampers light emission from the illuminating surface of the LED head.	Correct the installation condition of the LED head.
Connecting condition of the LED head	Check that the LED head is normally connected.	Replace the LED head.
Drum shaft	Check that the drum shaft keeps contacting with the right and left side plates normally.	Replace the ID unit. If any attempt of using new ID unit as a trial is going to be made, be sure to use the System Maintenance Menu FUSE KEEP MODE.
F506, fuse on the CU/PU board	Measure resistance of F506. 1 ohm or less: Normal Higher than 1 ohm: NG	Replace the CU/PU board

Check item	Check work	Action to be taken at NG
(3-1-3) High voltage terminal		
ID unit terminal	Check that the high voltage terminal of the ID unit is contacting with the Contact Assembly normally by visual inspection. (Refer to Figure 7-3.)	Replace the ID unit or correct the high voltage terminal. If any attempt of using new ID unit as a trial is going to be made, be sure to use the System Maintenance Menu FUSE KEEP MODE.

7.5.3.(4) Black banding/black streaking in vertical direction

(4-1) Thin vertical line (with color) (Refer to Figure 7-2D.)

Check item	Check work	Action to be taken at NG
(4-1-1) ID unit condition		
Filming of the ID unit	Is print attempted without toner?	Replace toner cartridge with new one. If replacement does not solve the problem, replace the ID unit. If any attempt of using new ID unit as a trial is going to be made, be sure to use the System Maintenance Menu FUSE KEEP MODE.

(4-2) Thin vertical line (without color) (Refer to Figure 7-2F.)

Check item	Check work	Action to be taken at NG
(4-2-1) LED head condition		
LED head	Is any foreign material attached on the light emitting surface of the cell fox lens of the LED head?	Remove the foreign material.
(4-2-2) Condition of paper running path		
Paper running path	Check that any burr that may scatter the unfused toner on the paper running path does not exist.	Remove the burr.

7.5.3.(5) Cyclic abnormality (Refer to Figure 7-2E.)

(5-1) Cyclic abnormality occurs in vertical direction

Check item	Check work	Action to be taken at NG
(5-1-1) Cycle		
Image drum	Check that the cycle is 94.3 mm.	Replace the ID unit
Developing roller	Check that the cycle is 39.7 mm.	Replace the ID unit
Toner feed roller	Check that the cycle is 58.4 mm.	Replace the ID unit
Charge roller	Check that the cycle is 37.7 mm.	Replace the ID unit
Roller on top of fuser	Check that the cycle is 90.5mm.	Replace the fuser unit.
Fuser belt	Check that the cycle is 96.3 mm.	Replace the fuser unit.
Transfer roller	Check that the cycle is 50.3 mm.	Replace the belt unit.
		If any attempt of using new consumable item as a trial is going to be made, be sure to use the System Maintenance Menu FUSE KEEP MODE.

7.5.3.(6) Heavy color registration error

(6-1) Display of the message "Color adjustment is in progress" appears only short time.

Check item	Check work	Action to be taken at NG
(6-1-1) Result of color registration error correction		
Color registration error correction time (If a printer is normal, it is approx. 40 seconds.)	Use the self-diagnostic mode and execute the REG ADJUST TEST. Check the result. Error is issued but is not displayed on the ON LINE display.	Replace the sensor that causes the error. Clean the sensor to remove stain. Replace the shutter. Replace the CU/PU board.
(6-1-2) Toner		
Remaining amount of toner	Check if the message "Prepare toner replacement." or "Replace the toner." appears or not.	Replace toner cartridge with new one.
(6-1-3) Color registration error detection sensor		
Sensor is dirty	Is toner or paper dust attached to the sensor?	Clean the sensor to remove stain
(6-1-4) Color registration error detection sensor shutter		
Shutter operation is faulty	Check the shutter operation by the self-diagnostic mode	Replace the shutter or tune the mechanism

(6-2) Though REG ADJUST TEST of engine maintenance function is ok, color blur occurs

Check item	Check work	Action to be taken at NG
(6-2-1) Paper feed system		
Paper feed system of the paper running path	Check if any obstacle exists in the paper feeding path, that hampers smooth paper run.	Remove the obstacle

7.5.3.(7) Entirely black print

(7-1) All black print over entire page

Check item	Check work	Action to be taken at NG
(7-1-1) High voltage contacting condition		
CH terminal	Check that the terminal coming from the printer body contacts with the high voltage terminal that is located on the left side of the ID unit when viewed from the top by visual inspection.	Replace the terminal of printer side.
CH terminal	Check that the high voltage terminal keeps the normal contacting condition on the high voltage board. Open the left cover and remove the high voltage board. Then, check that the terminal is not installed in the abnormal installation condition.	Correct the installation condition of the terminal to the normal condition.
ID unit terminal	Check that the high voltage terminal of the ID unit is contacting with the Contact Assembly normally by visual inspection. (Refer to Figure 7-3.)	Replace the ID unit or replace the high voltage board or correct the high voltage terminal. If any attempt of using new ID unit as a trial is going to be made, be sure to use the System Maintenance Menu FUSE KEEP MODE.
(7-1-2) High voltage output condition		
CH output	If high voltage probe is available as a maintenance tool, open the left cover, and check the CH output with the high voltage probe from the soldering side of the high voltage board. (The high voltage probe is not an ordinary maintenance tool.)	Replace the high voltage board.

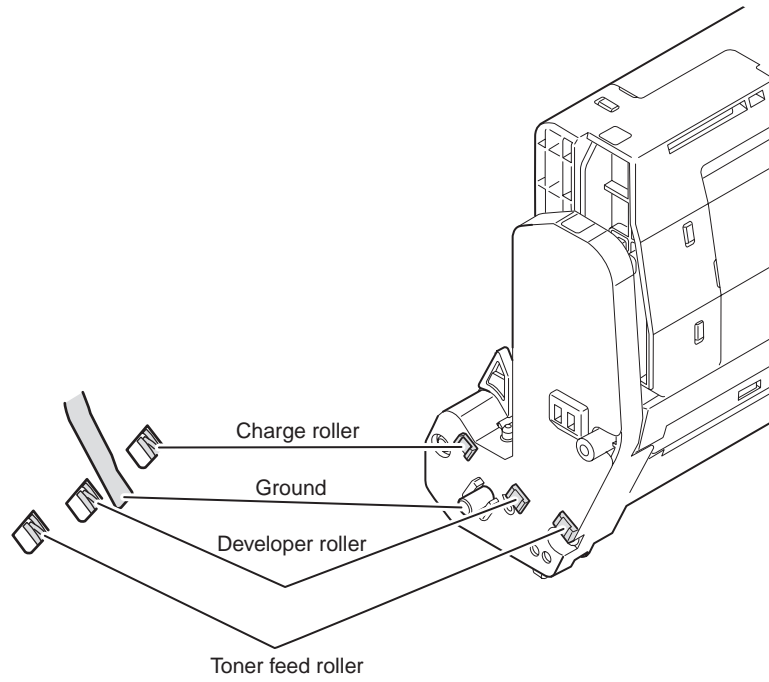

Figure 7-3

7.5.4 Network troubleshooting

(1) Print cannot be activated from Utilities.

Check item	Check work	Action to be taken at NG
(1) Check the LINK lamp		
Check if the LINK lamp (green) is illuminating or not.	Check if the HUB and a printer are connected normally. (Check that the network cable is connected normally.)	Re-connect the network cable normally.
	Confirm that the straight network cable is being used.	Replace the cable with the straight cable.
	Make an attempt to change connection of the network cable to other port of a HUB.	Try to change the HUB.
(2) Check the network information		
Check if the network information can be printed normally or not.	Print the [NetworkInformation] by select [Print Information]-[Network].	Re-write the NIC-F/W by using Utilities.
(3) Check contents of the network information.		
Confirm the IP address, SUB net mask and gateway address.	Confirm the IP address, SUB net mask and gateway address that are printed on the network information.	Set the IP address, SUB net mask and gateway address normally.
(4) Check if communication is possible or not through network		
Confirm if the Ping command can be sent or not from a PC to a printer.	Confirm if correct reply is returned from a printer to a PC when the PC sends the Ping to a printer.	Set the IP address, SUB net mask and gateway address normally.
(5) Check the Utilities.		
Check setting of the OKI LPR Utilities.	Check the setting items of the OKI LPR Utilities.	Set the OKI LPR Utilities setting items correctly.

Check item	Check work	Action to be taken at NG
(6) Check the following from an OS standard port		
Confirm the standard LPR port of the WINDOWS standard (NT, 2000, XP).	Set the standard LPR port of the WINDOWS standard (NT, 2000, XP), and confirm if printing can be performed or not.	Set the standard LPR port of the WINDOWS standard (NT, 2000, XP) correctly.

7.5.4.1 Connection error occurs with the Web browser

If the printer setting page cannot be displayed by the web browser "https://<printer IP address>", check the followings.

Establish connection by "https://<printer IP address>".

1) If the printer setting page is displayed, the followings are probable.

Take an appropriate measure by referring to the following items.

* Certificate is not created yet. (Or failed to create certificate.)

→ Refer to section "7.5.4.1.1 Is the certificate created?".

* Certificate has been created but the SSL/TLS setting is turned off.

→ Refer to section "7.5.4.1.2 Is the SSL/TLS setting set to [ON]?".

2) If the printer setting page is not displayed, the followings are probable.

* Version number of the browser is old.

→ Refer to section "7.5.4.1.3 Check version number of the Web browser".

* Encryption strength has been set to Strong.

→ Refer to section "7.5.4.1.3 Check encryption strength of a printer".

* The key exchange system of a printer is not supported by the browser. (Compatibility problem)

→ Refer to section "7.5.4.1.5 Check the key exchange type of the certificate".

7.5.4.1.1 Is the certificate created?

Log-on in as the administrator, and select "Security" → "Encryption (SSL/TLS)".

If the following screen is displayed, certificate of the printer is not created yet. (The same screen is displayed when failed to create certificate.)

Solution: Create certificate by referring to the User's Manual (Advanced edition).

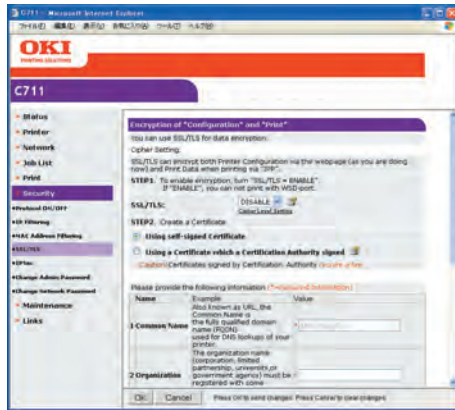

Before creating certificate (default state)

7.5.4.1.2 Is the SSL/TLS setting set to [ON]?

Log-on in as the administrator, and select "Security" → "Encryption (SSL/TLS)".

If the following screen is displayed, certificate has already been created, but the SSL/TLS setting is turned [OFF].

Solution: Set the SSL/TLS setting to [ON].



7.5.4.1.3 Check version number of the Web browser

Check version number of the Web browser in use.

How to check version number.

For Internet Explorer

Launch the browser and select "HELP" → "Version information".

Recommended version is Internet Explorer 5.5 and higher.

Solution : Install the newest web browser. Alternately, install the high encryption pack.

If any version that is older than the recommended version is used, communication can become possible sometimes when the encryption strength is set to "Weak". If the encryption strength is set to "Weak", security level lowers. To change the encryption strength, refer to section "7.5.4.1.4 Confirm encryption strength of a printer".



For Netscape

Launch the web browser and select "HELP" → "Netscape".

Recommended version is Netscape 6 and higher.

Solution : Install the newest web browser.

If any version that is older than the recommended version is used, communication can become possible sometimes when the encryption strength is set to "Weak". If the encryption strength is set to "Weak", security level lowers. To change the encryption strength, refer to section "7.5.4.1.4 Confirm encryption strength of a printer".

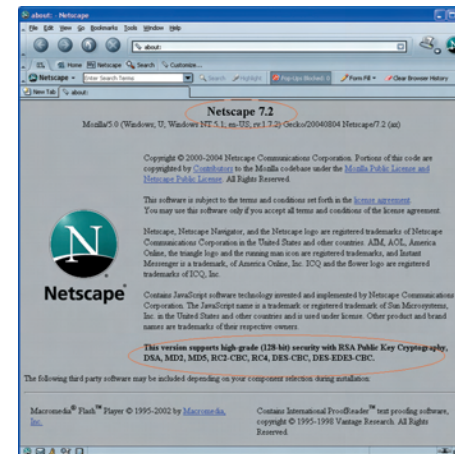

7.5.4.1.4 Confirm encryption strength of a printer

Version display of the browser that is confirmed by section "7.5.4.1.3 Check version number of the Web browser" has description on encryption strength of the browser. The browser in which the encryption strength is not set to 128 bits, the browser cannot establish communication with the printer in which the encryption strength is not set to "Standard".

Either, upgrade the browser until it supports 128 bits (high encryption) or set the printer encryption strength to "Weak".

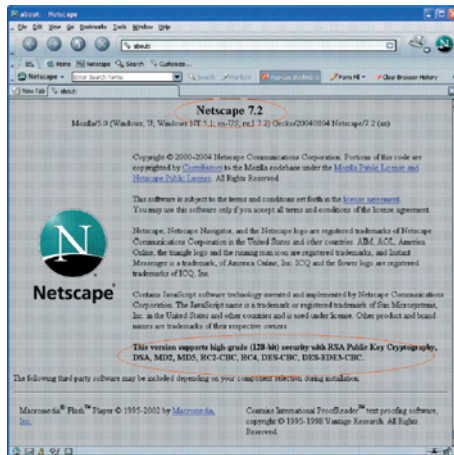

Change encryption strength with AdminManager

1. Launch AdminManager and select (by highlighting) a desired printer from the printer list.

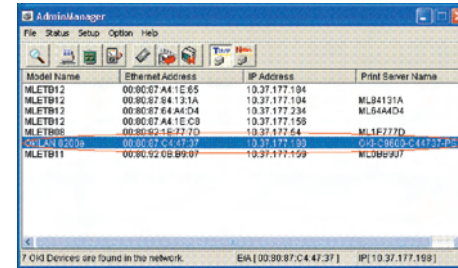

2. Press the "Oki Device Setup" button, or alternately select "Setup" → "Oki Device Setup", and open the setup screen.

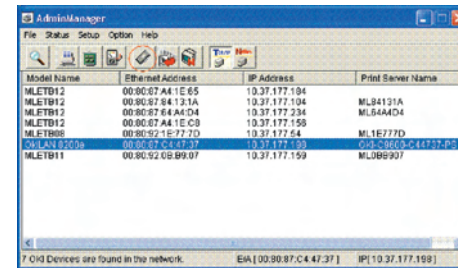

3. Input the administrator password and open the setup screen as an administrator.

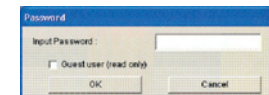

4. Select the "SSL/TLS" tab.

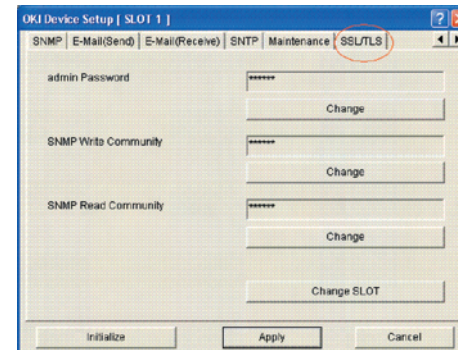

5. Check the "Encryption Strength".

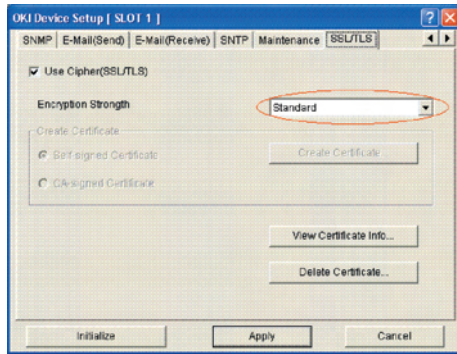

6. Set the "Encryption Strength" to "Weak" and press the "Apply" button.

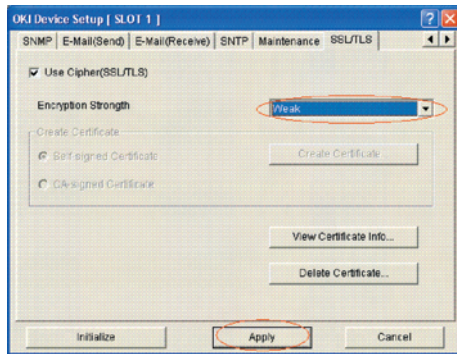

7. Check the setup contents, and press "OK".



8. A message prompting your confirmation will be displayed. Click "Yes".
(NIC reboots in order to reflect the setup value.)

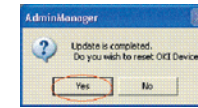

9. If the printer is displayed in the printer list, the setup is complete with success.

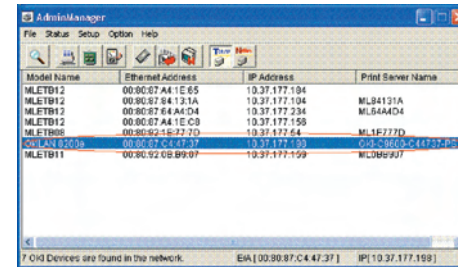

Solution: Set the encryption strength to "Weak".

How to change encryption strength with Telnet

Note! Telnet cannot be used if it remains in the default setting. To change the encryption strength, Telnet must be set to Enable.

Select the command prompt (DOS prompt) and enter "Telnet <printer IP address>", and press Return.

Establish connected using administrator user name and password

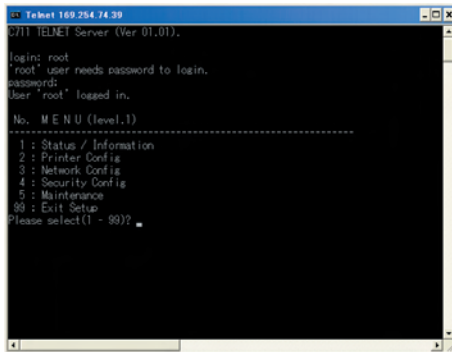

```
Telnet 169.254.74.39
C:\11 TELNET Server (Ver 01.01).
login: root
"root" user needs password to login.
password:
User "root" logged in.
No. M E N U (level.1)
-----
1 : Status / Information
2 : Printer Config
3 : Network Config
4 : Security Config
5 : Maintenance
99 : Exit Setup
Please select(1 - 99)?
```

Select the menus in this order: [4: Security Config] → [5: Cipher (SSL/TLS)] → [2: Cipher Strength]. Then, change the cipher strength as desired (1: Strong, 2: Standard, 3: Weak).

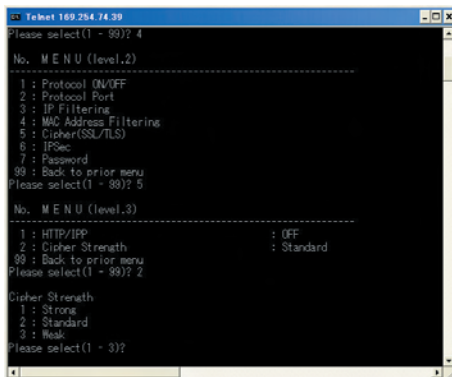

```
Telnet 169.254.74.39
Please select(1 - 99)? 4
No. M E N U (level.2)
-----
1 : Protocol ON/OFF
2 : Protocol Port
3 : IP Filtering
4 : MAC Address Filtering
5 : Cipher(SSL/TLS)
6 : IPsec
7 : Password
99 : Back to prior menu
Please select(1 - 99)? 5
No. M E N U (level.3)
-----
1 : HTTP/IPP : OFF
2 : Cipher Strength : Standard
99 : Back to prior menu
Please select(1 - 99)? 2
Cipher Strength
1 : Strong
2 : Standard
3 : Weak
Please select(1 - 3)?
```

7.5.4.2 Print operation is not possible

If print operation is not possible by using the encrypted IPP printer, check the followings.

Establish connection by "https://<printer IP address>".

- 1) If the printer setting page is displayed, the followings are probable.
Take an appropriate measure by referring to the following items.
 - * Certificate is not created yet. (Or failed to create certificate.)
→ Refer to section "7.5.4.1.1 Is the certificate created?".
 - * Certificate has been created but the SSL/TLS setting is turned off.
→ Refer to section "7.5.4.1.2 Is the SSL/TLS setting set to [ON]?".
- 2) If the printer setting page is not displayed, the followings are probable.
Take an appropriate measure by referring to the following items.
 - * Version number of the browser is old.
→ Refer to section "7.5.4.1.3 Check version number of the Web browser".
 - * Encryption strength has been set to Strong.
→ Refer to section "7.5.4.1.4 Check encryption strength of a printer".
 - * The key exchange system of a printer is not supported by the browser. (Compatibility problem)
 - * The OS does not support the IPP (encrypted) printing.
→ Refer to section "7.5.4.2.1 Check OS (Operating System)".
 - * IPP (encrypted) printer is not created yet.
→ Refer to section "7.5.4.2.2 Is the Printer created?".
 - * IPP setup of the Printer is not Enabled.
→ Refer to section "7.5.4.2.3 Is the IPP setting set to Enabled?".

7.5.4.2.1 Check OS (Operating System)

The IPP print (encryption) function is supported by Windows 2000, Windows XP, Windows 2003 Server and Windows Vista only.

It is not supported by other operating systems.

7.5.4.2.2 Is the Printer created?

Printer may not be created normally.

To use the IPP print (encryption) function, the Printer must have been created by setting port to URL" [HYPERLINK "https://<" https://< printer IP address>/ipp"](https://< printer IP address>/ipp) when creating the Printer.

For more details of Printer creation method, refer to the User's Manual (Advanced edition).

7.5.4.2.3 Is the IPP setup Enabled?

The IPP setup may not be set to Enable.

As the default setting of printer, IPP has been set to Disable.

To use the IPP print (encryption) function, the IPP setup must have been set to Enable.

For the method of changing the IPP setup, refer to the User's Manual (Advanced edition).

7.5.4.3 Cannot create Certificate

When Certificate cannot be created, the following causes are probable. Take an appropriate measure by referring to the following items.

- * Required input items are not fully entered
 - Refer to section "7.5.4.3.1 Required input items are not fully entered".
- * The printer is printing.
 - Refer to section "7.5.4.3.2 The printer is printing".

7.5.4.3.1 Required input items are not fully entered

Unless all of the required input items are fully entered, Certificate cannot be created.

When creating Certificate, entry into the items of Common Name, Organization, Locality, State/Province, Country/Region is the must item. (Entry into Organizational Unit can be omitted.)

Solution : Enter the appropriate value into all of the required input items, and execute creation of Certificate.

For more details of the input items, refer to the User's Manual (Advanced edition).

7.5.4.3.2 The printer is printing.

Certificate cannot be created while printing is in progress. (Print operation has priority.)

Solution : Create Certificate when all other operations are complete.

During creation of self-sign certification, during creation of CSR for Certificate of certifying authority, and during installation of Certificate, the printer must not perform any other operations (such as printing) until the operation is complete (creation of self-sign certification is complete, creation of CSR is complete, and installation of Certificate is complete).

7.5.4.4 Installation of Certificate is not possible

When installation of Certificate fails, the following causes are probable.

Take an appropriate measure by referring to the following items.

- * User has changed the IP address of a printer to other IP address than the "IP address during creation of CSR".
 - Refer to section "7.5.4.4.1 IP address of the printer has been changed".
- * "Network card is initialized" while user is applying issuance of certification to certifying authority (i.e., in the state of Waiting for Installation of Certificate).
 - Refer to section "7.5.4.4.2 "Network card is initialized".
- * "Deletion of CSR" was executed while user is applying issuance of certification to certifying authority (i.e., in the state of Waiting for Installation of Certificate).
 - Refer to section "7.5.4.4.3 "Deletion of CSR" is executed.
- * Intermediate Certificate is installed.
 - Refer to section "7.5.4.4.4 "Installation of intermediate Certificate" is desired.

7.5.4.4.1 User has changed the IP address of a printer

If IP address of a printer is changed to other IP address than the "IP address during creation of CSR", error is issued and installation of Certificate become impossible.

If the changed setup is only the "IP address of printer", error will not be issued if the IP address is returned to the original address.

Solution : Return the IP address of printer back to the "IP address during creation of CSR", and then install Certificate.

Note! Do not change any setup of printer while creation of Certificate of certifying authority is in progress (during the period starting from creation of CSR up until installation of Certificate). If changed, the already issued Certificates become invalid necessitating re-setup starting from the very beginning. If printer setup is changed after Certificate is obtained, the "Security warning" is displayed on the web browser.

If IP address of printer is changed, the Certificate becomes invalid. In the case of Certificate of certifying authority requiring some charge for issuance, another charge may be required for creating Certificate once again. For details, contact certifying authority.)

7.5.4.4.2 "Network card is initialized"

If network card is initialized (to default setup) while creation of Certificate of certifying authority is in progress (during the period starting from creation of CSR up until installation of Certificate), the setup information of the Certificate is deleted. If information is deleted once, the information cannot be recovered by any means. (Even when the same information as before is entered, the same Certificate cannot be created.)

Solution : Repeat all the steps from the very beginning. (Certificate under application is already invalid.)

7.5.4.4.3 "CSR is deleted"

If CSR is deleted (if Certificate is deleted) while creation of Certificate of certifying authority is in progress (during the period starting from creation of CSR up until installation of Certificate), the setup information of the Certificate is deleted. If information is deleted once, the information cannot be recovered by any means. (Even when the same information as before is entered, the same Certificate cannot be created.)

Solution : Repeat all the steps from the very beginning. (Certificate under application is already invalid.)

7.5.4.4.4 Installation of intermediate Certificate is desired

Some certification authorities use the procedure of installing the SSL server Certificate (printer Certificate) and the intermediate Certificate into printer as the same time.

However, printer of this model supports installation of only a single Certificate, intermediate Certificate cannot be installed in printer. Be sure to install the SSL server Certificate in printer.

When installation of intermediate Certificate is required, install the intermediate Certificate not in printer, but in client PC (browser).

For the method of installing the intermediate Certificate in client PC (browser), refer to the following.

Installing the intermediate Certificate (or CA certificate) in client PC (browser).

[Procedure]

1. Double-click the intermediate Certificate (or CA certificate) that is issued by certifying authority, on a client PC to display the intermediate Certificate (or CA certificate).
 - ex.) For an example, the intermediate Certificate of Comodo has the text (PEM) format: ComodoJapanCA.Crt, and the binary format: ComodoJapanCA.cer. Either one of these formats can be opened. (Same result can be obtained.)
 - Open either ComodoJapanCA.crt or ComodoJapanCA.cer.

2. Press the "General" tab of the displayed Certificate information, and press "Install Certificate" button.

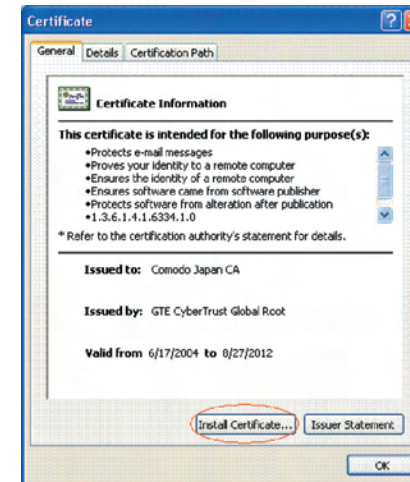

3. The "Certificate Import Wizard" is displayed. Install Certificate in accordance with the displayed procedure. Select "Automatically select the certificate store based on the types of certificate". Then, the Certificate will be installed automatically.

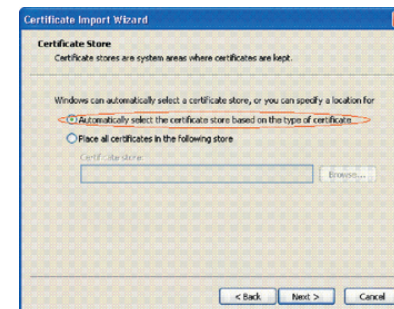
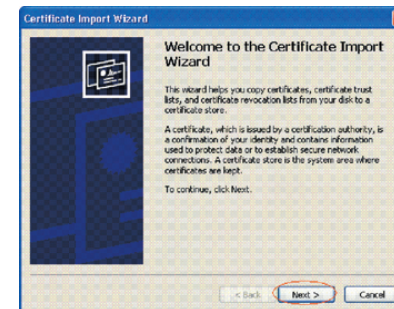

7.5.4.5 Other questionnaires

Other probable questionnaires are described below.

7.5.4.5.1 Time required for creation of Certificate

It takes several ten seconds for creation of Certificate.

7.5.4.5.2 Communication time when the encryption function is enabled

A time longer than the ordinary communication time is required for communication when the encryption function is used.

7.5.4.5.3 Can the encrypted printing be performed by any printer other than IPP?

Answer : Any printer other than IPP cannot encrypt printing.
Only the IPP printing can encrypt printing.

7.5.4.5.4 What will happen if SSL/TLS is turned OFF after Certificate has been created (or installed)?

Answer : Certificate will be kept saved as it is.
If SSL/TLS is turned ON again, the Certificate becomes usable.

7.5.4.5.5 Want to change the port number

Answer : The port number during the SSL/TLS communication is fixed to 443.
It cannot be changed.

7.5.4.5.6 The error message "The security certificate was issued by a company you have not chosen to trust. View the certificate to determine whether you want to trust the certifying authority" is displayed.

If this error is indicated, it means that the certificate which is installed in a printer is self-sign certificate.

In the case of self-sign certificate, error (security warning) will not be displayed if the self-sign certificate of printer is installed in the client PC.

In the case of certificate of certifying authority, error (security warning) will not be displayed if the CA certificate of certifying authority is installed in the client PC.

Solution : Install certificate in the client PC (browser).

[Procedure]

1. Click the "View Certificate" button on the error (security warning) screen.



- Press the "General" tab of the displayed Certificate information, and press "Install Certificate" button.

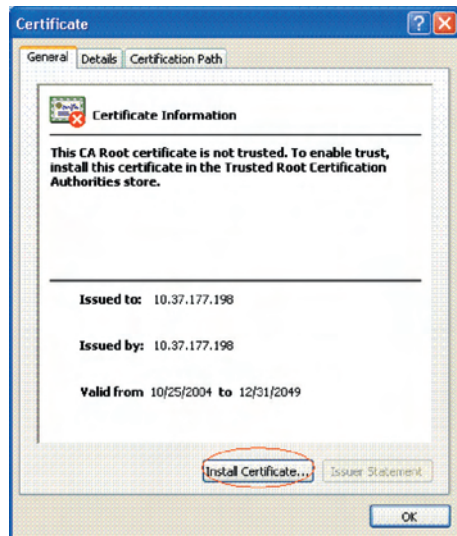

- The "Certificate Import Wizard" is displayed. Install Certificate in accordance with the displayed procedure. Select "Automatically select the certificate store based on the types of certificate". Then, the Certificate will be installed automatically.

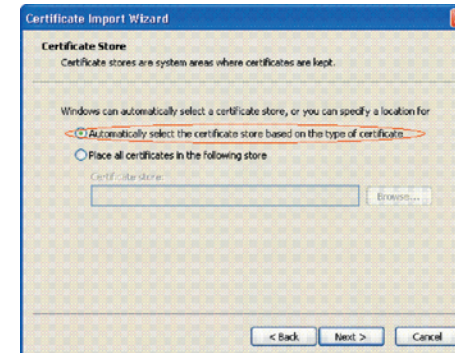
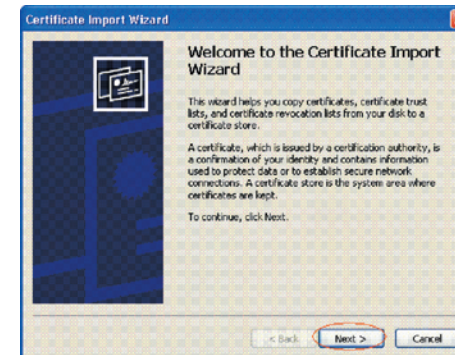

7.5.4.5.7 The error message "Name of security certificate is invalid or does not match the site name" is displayed.

It means that the IP address of printer is different from the IP address that is described on certificate, or from the IP address when the certificate is created.

Solution : Return the IP address of printer back to the address when self-sign certificate is created, or to the address when CSR is created.

7.5.4.6 Restrictions when using Internet Explore 7

Several restrictions are imposed when using Internet Explore 7. This is because security restriction became more severe in IE7.

7.5.4.6.1 Warning indication when SSL is made valid by self-sign certificate

When SSL is made valid by self-sign certificate, the following picture is obtained when web page is accessed, and page will not be displayed.

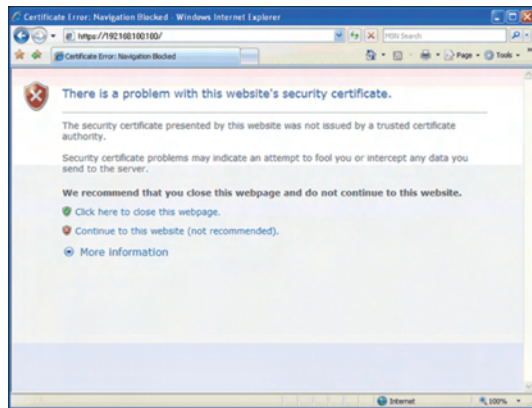

Web display when SSL is made valid by self-sign certificate

Solution : When "Continue browsing this site (not recommended)" is clicked on the warning screen, the web page will be displayed.

However, it has no effect on the web page function. It can be used for browsing or to change setting of printer setup.

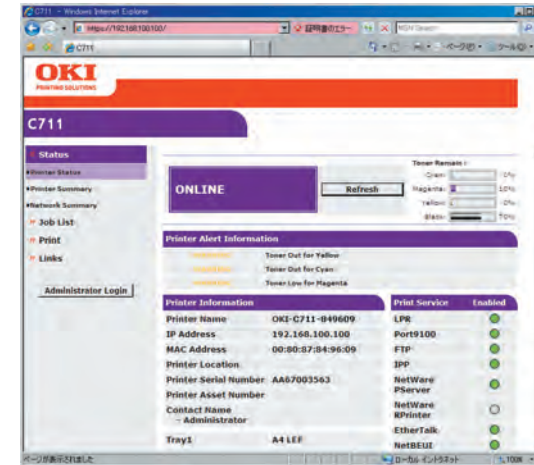

Web page display when "Continue browsing this site (not recommended)" is clicked.

7.5.4.7 Network function restrictions on Sleep mode

Network functions restrict the Sleep mode of each printer as follows.

7.5.4.7.1 Disabled Sleep mode

- 1) With IPSec enabled
- 2) With NetBEUI enabled
- 3) With NetWare enabled
- 4) With EtherTalk enabled
- 5) With a TCP connection established

Example: When a telnet or ftp connection to a printer is disconnected when the time period that can elapse with the printer left unattended in a power saving state before it enters the Sleep mode elapses, it enters the Sleep mode.

* To enable the Sleep mode of a printer, disable IPSec, NetBEUI, NetWare and EtherTalk for the printer.

7.5.4.7.2 Disabled printing

While in the Sleep mode, printers cannot perform printing that uses any of the following protocols:

- 1) NetBEUI
- 2) NBT
- 3) NetWare
- 4) EtherTalk *1
- 5) Bonjour *1

*1: Printers can perform printing in the Sleep mode when connected by using IP Print of Mac OS X.

7.5.4.7.3 Disabled discovery and setting options

By using any of the following functions or protocols, printers in the Sleep mode cannot be discovered, and no settings can be made for them:

- 1) PnP-X
- 2) UPnP
- 3) Bonjour
- 4) LLTD
- 5) FLDP
- 6) ODNBP
- 7) JCP
- 8) MIB *2

*2: Information for a printer in the Sleep mode can be viewed by using that part of a MIB which supported by the printer (a Get command).

7.5.4.7.4 Disabled protocols having client functionality

- 1) Email alerting *3
- 2) SNMP trapping
- 3) WINS *4
- 4) SNTP *5

*3: The periodical email alert time intervals for a printer include no time elapsed with the printer in the Sleep mode.

*4: The WINS refresh time intervals for a printer include no time elapsed with the printer in the Sleep mode. The WINS registration for printers in the Sleep mode is not periodically refreshed and a name registered with a WINS server may be deleted.

*5: The refresh time intervals for a NTP server for a printer include no time elapsed with the printer in the Sleep mode.

7.5.4.7.5 Protocols used with Sleep mode disabled

Disable the Sleep mode of a printer for which to use any of the following protocols:

- 1) IPv6
- 2) NetBEUI
- 3) NetWare
- 4) EtherTalk

7.6 Fuse check

If the following error is issued, check the corresponding fuse of the CU/PU control board and high voltage power supply board.

(Refer to Table 7-6.)

Table 7-6 Fuse error

Fuse Name	Error Description	Insert Point	Resistance
CU/PU board (PU area)	F4	Service call 918 (However, if the Duplex unit is not installed, it is the 2nd/3rd hopping error.)	Duplex, 2nd/3rd 24V
	F3, F5	Power supply shut-down (Not displayed on operator panel)	CU 3.3V, PU 5V
	F7	ID UP/DOWN error. Service call 142	Belt motor, ID UP/DOWN motor, Hopping clutch 24V
	F1	Cover open	High voltage power supply board, ID cooling fan, fuser fan 24V
	F10	Service call 122	Power supply fan, feed clutch, MPT clutch, Fuse cut, feed motor 24V
High voltage power supply board	IP901	Cover open	High voltage 24V
	IP902	Service call 121	High voltage 5V
CU/PU board (CU area)	F15	<ul style="list-style-type: none"> Service call 131 to 134 error All white page print 	LED HEAD 5V
	F12	Service call 131 to 134 error	LED HEAD 3.3V
	F8	CENTRONICS interface error	CENTRONICS interface 5V
	F9	CENTRONICS interface error	CENTRONICS interface 3.3V
	F11	Host USB error	Host USB 5V

Less than
1 ohm

7.7 Paper cassette switches versus Paper size correspondence table

Dial display size	Bit No.			
	1	2	3	4
TRAY1~3	1	2	3	4
Cassette: none	H	H	H	H
Legal 14"	H	L	H	L
Legal 13.5"	H	L	H	H
Legal 13"	L	L	L	H
Letter	L	L	L	L
Executive	L	L	H	L
Blank	L	L	L	L
Blank	H	H	L	L
A4	L	H	L	L
B5	L	H	H	L
A5	H	H	H	L
Not used	L	L	H	H
Not used	L	H	L	H
Not used	H	H	L	H
Not used	H	L	L	H
Not used	L	H	H	H
Not used	H	L	L	L

* When switch is pressed: Low

8. Connection diagrams

8.1 Resistance value check	205
8.2 Parts location	209
8.3 F/W version number	218

8.1 Resistance value check

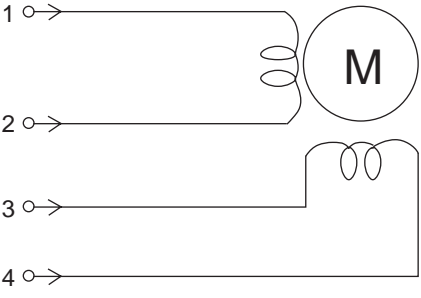
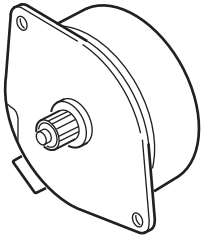
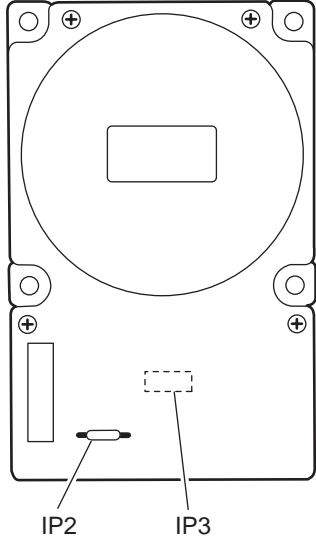
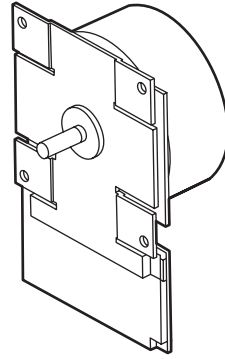
Unit	Electrical circuit diagram, connection	Part outside view	Resistance value
<p>Transport belt motor</p>			<p>Between pin-1 and pin-2: 3.4Ω Between pin-3 and pin-4: 3.4Ω</p>
<p>ID motor</p>			<p>Across both ends of IP2 and IP3: 1Ω or less</p>

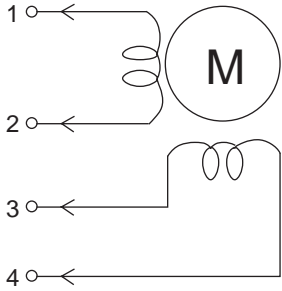
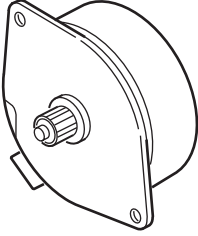
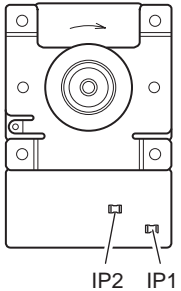
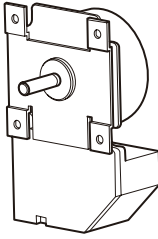
Unit	Electrical circuit diagram, connection	Part outside view	Resistance value
ID up/down motor			<p>Between pin-1 and pin-2: 6.1Ω Between pin-3 and pin-4: 6.1Ω</p>
Fuser unit motor			<p>Across both ends of IP1 and IP2: 1Ω or less</p>

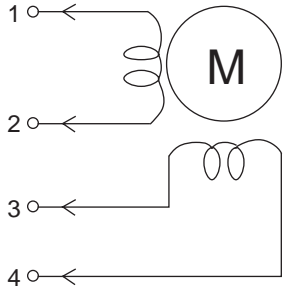
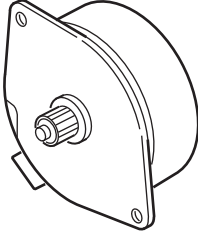
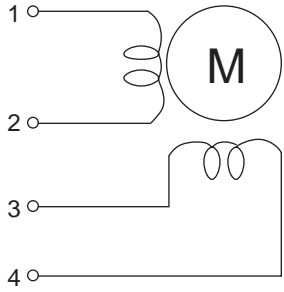
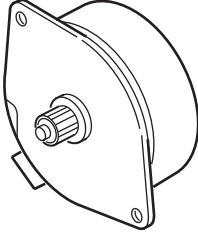
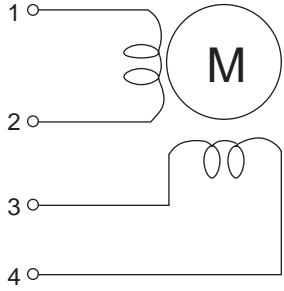
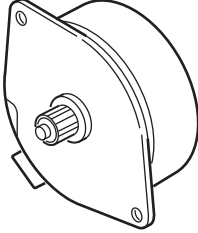
Unit	Electrical circuit diagram, connection	Part outside view	Resistance value
Feed motor	 <p>The diagram shows a motor symbol 'M' with two coils. The first coil is connected between pins 1 and 2. The second coil is connected between pins 3 and 4.</p>	 <p>A perspective drawing of a small, square-shaped motor with a central shaft and four mounting holes on the corners.</p>	<p>Between pin-1 and pin-2: 3.4Ω Between pin-3 and pin-4: 3.4Ω</p>
Both-sided print motor	 <p>The diagram shows a motor symbol 'M' with two coils. The first coil is connected between pins 1 and 2. The second coil is connected between pins 3 and 4.</p>	 <p>A perspective drawing of a small, square-shaped motor with a central shaft and four mounting holes on the corners.</p>	<p>Between pin-1 and pin-2: 3.2Ω Between pin-3 and pin-4: 3.2Ω</p>
2nd / 3rd tray feed motor	 <p>The diagram shows a motor symbol 'M' with two coils. The first coil is connected between pins 1 and 2. The second coil is connected between pins 3 and 4.</p>	 <p>A perspective drawing of a small, square-shaped motor with a central shaft and four mounting holes on the corners.</p>	<p>Between pin-1 and pin-2: 3.4Ω Between pin-3 and pin-4: 3.4Ω</p>

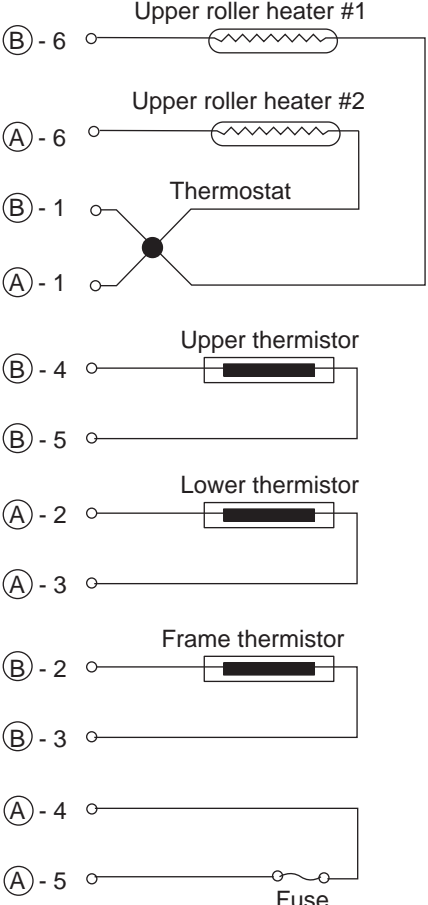
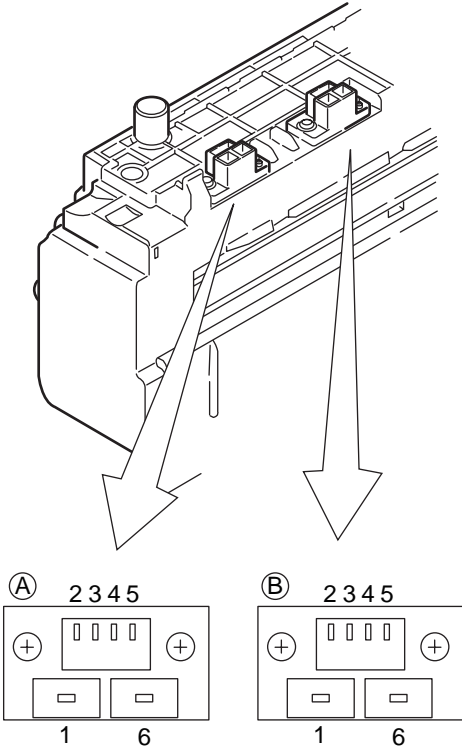
Unit	Electrical circuit diagram, connection	Part outside view	Resistance value
Fuser unit			<p>Between pins (A)-1 and (A)-6: Several ohms to several ten ohms Between pins (B)-1 and (B)-6: Several ohms to several ten ohms Between pins (B)-4 and (B)-5: Approx. 590kΩ to 5338kΩ (0 to 93°C) Between pins (A)-2 and (A)-3: Approx. 104.5kΩ to 806.5kΩ (0 to 43°C) Between pins (B)-2 and (B)-3: Approx. 104.5kΩ to 806.5kΩ (0 to 43°C) Between pins (A)-4 and (A)-5: Open</p>

8.2 Parts location

(1) CU/PU PCB

Component side

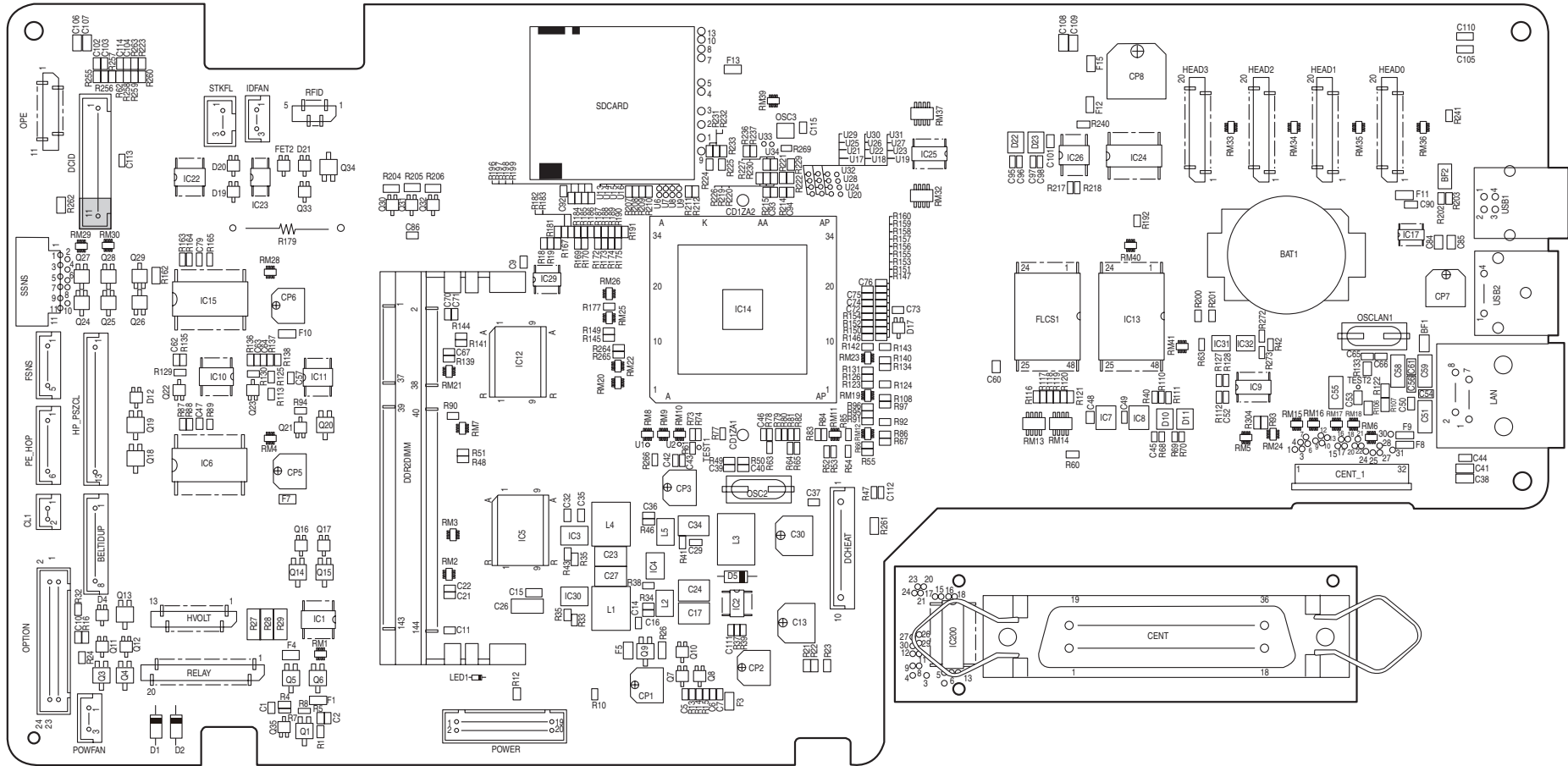

Soldering side

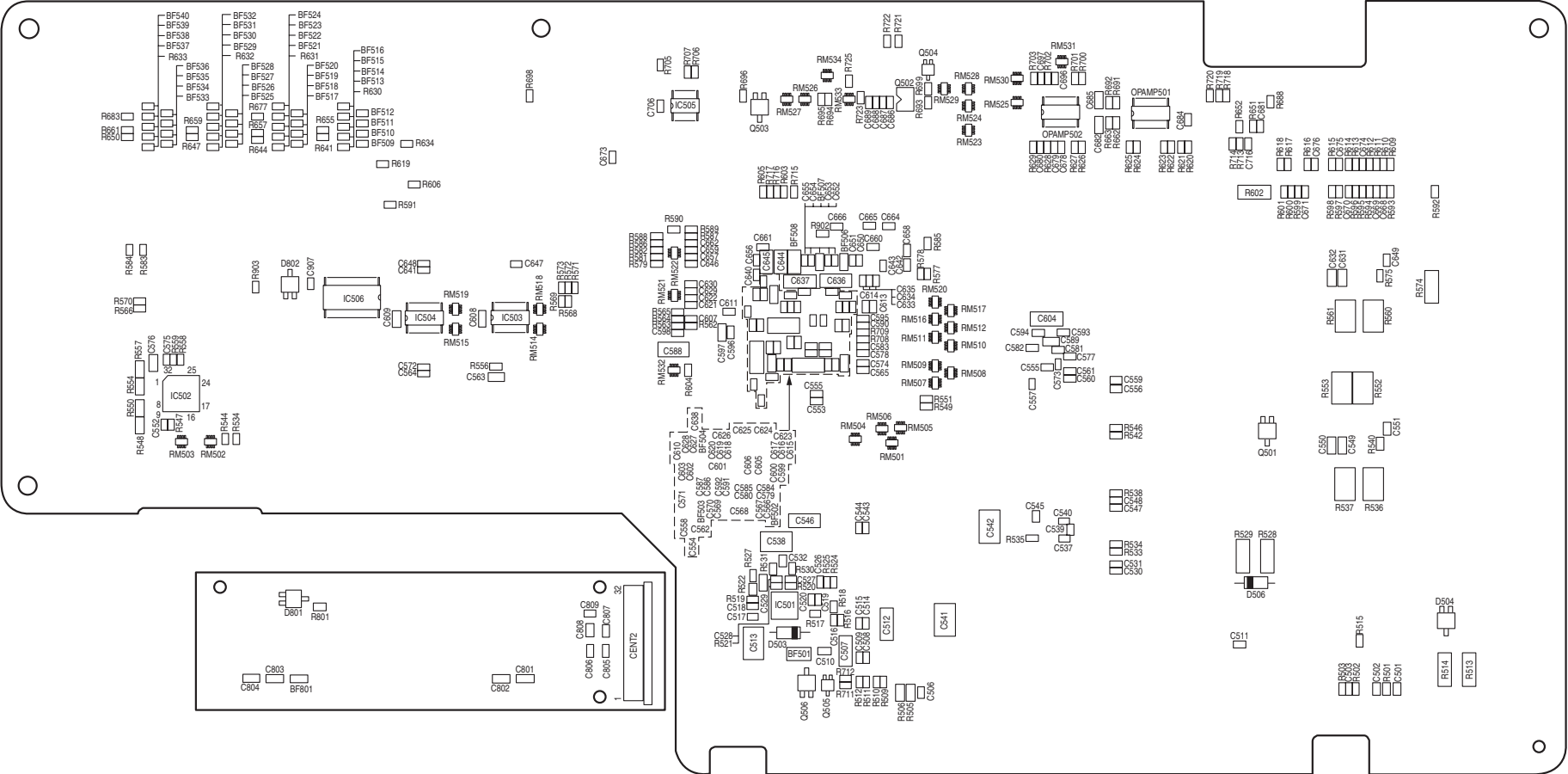

(2) Relay PCB

Component side

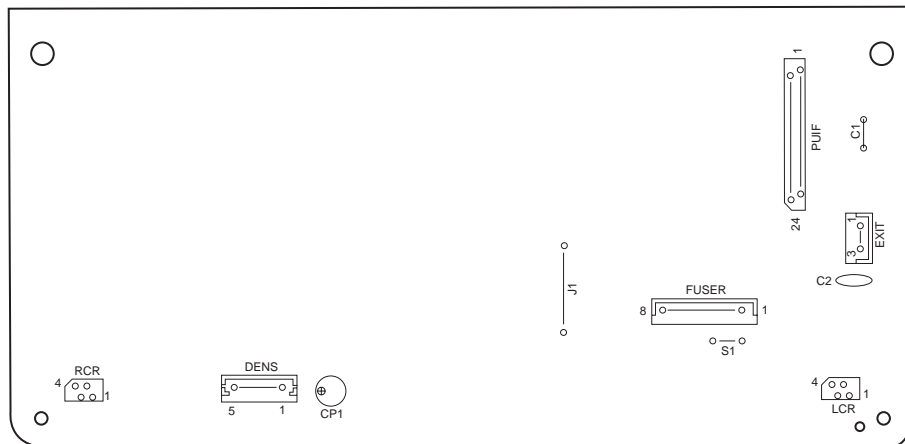

Soldering side

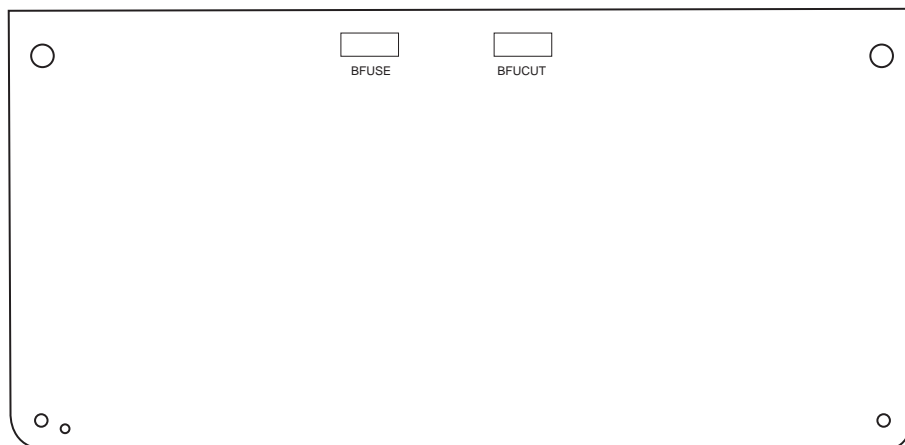

(3) Both-sided Printing Control PCB

Component side

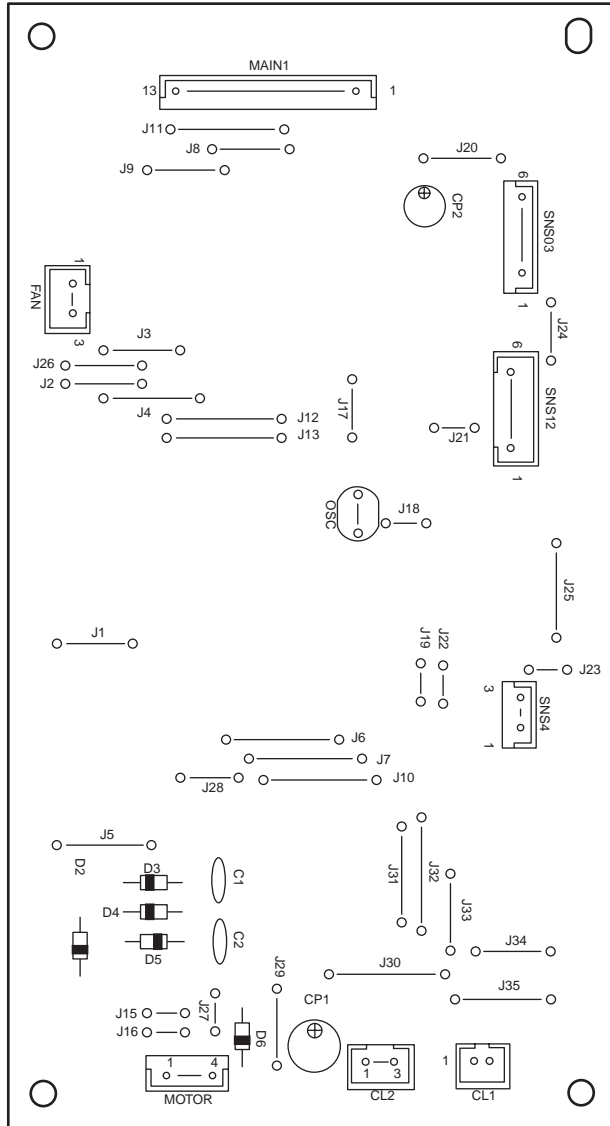

Soldering side

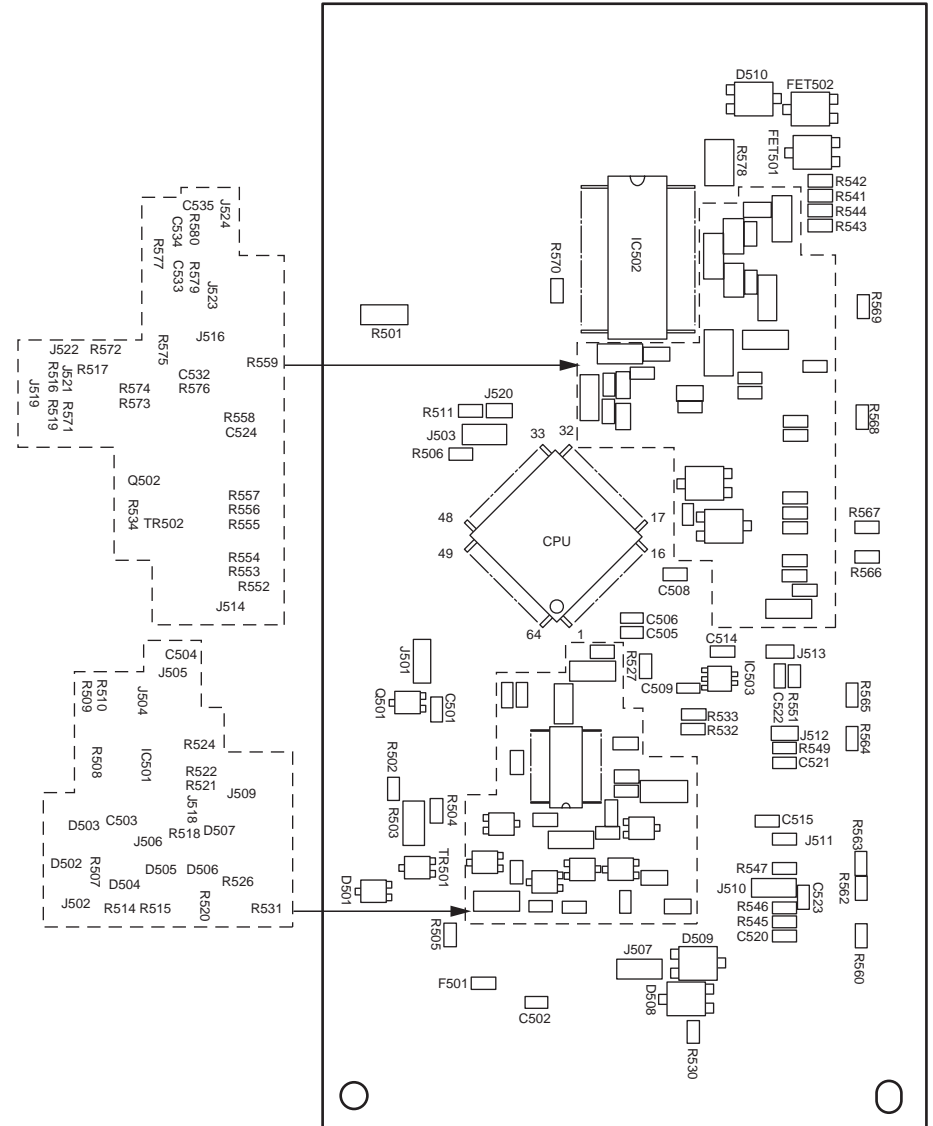

(4) Second Tray Control PCB

Component side

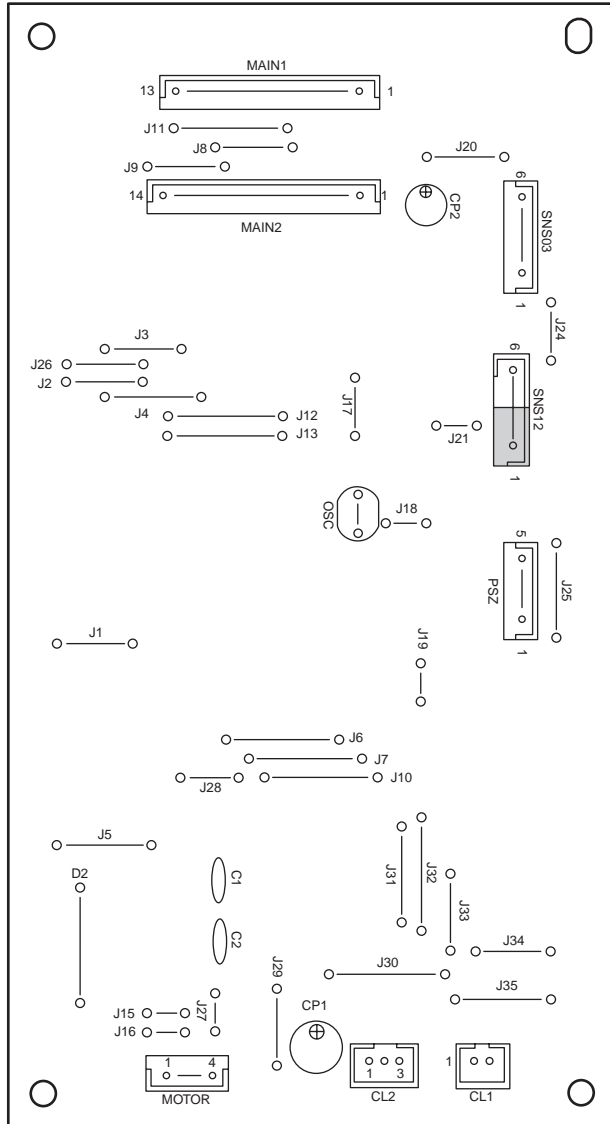

Soldering side

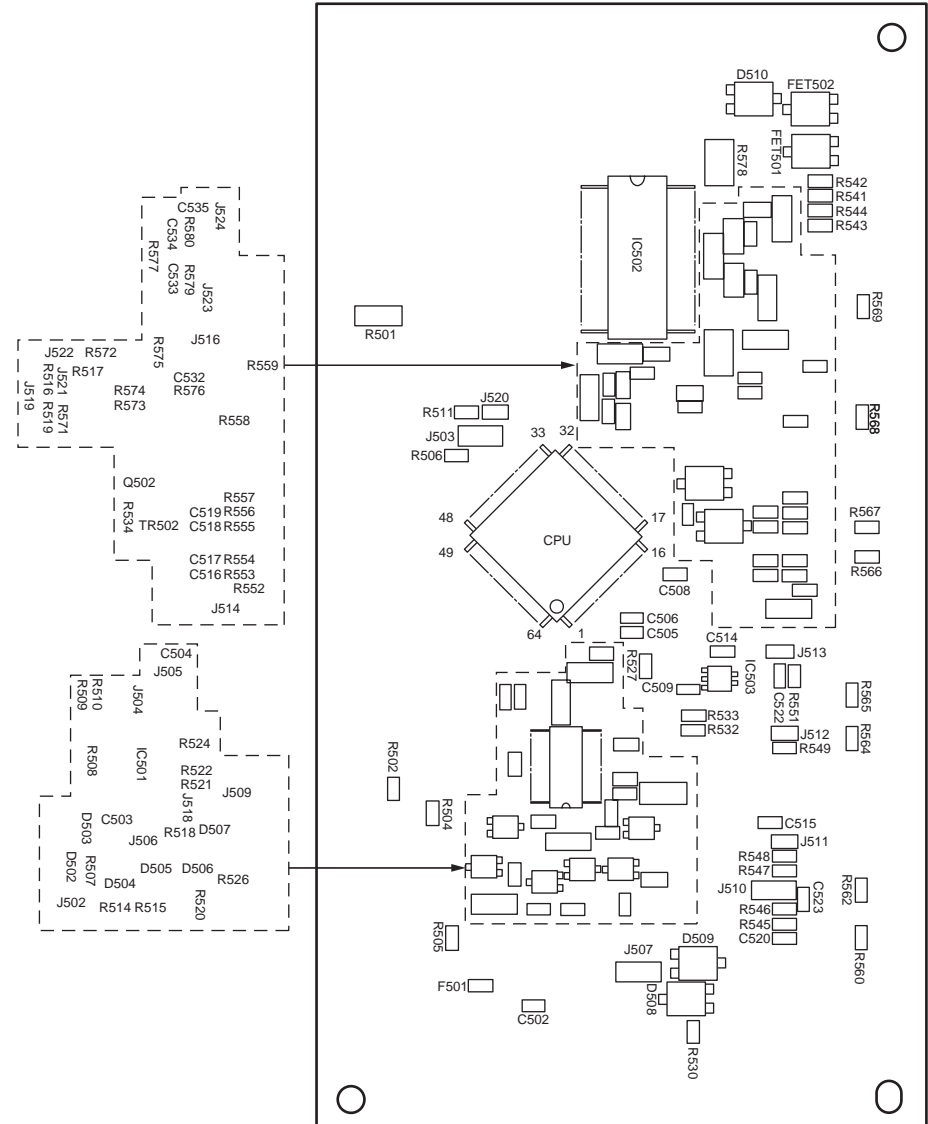

(5) Control Panel PCB

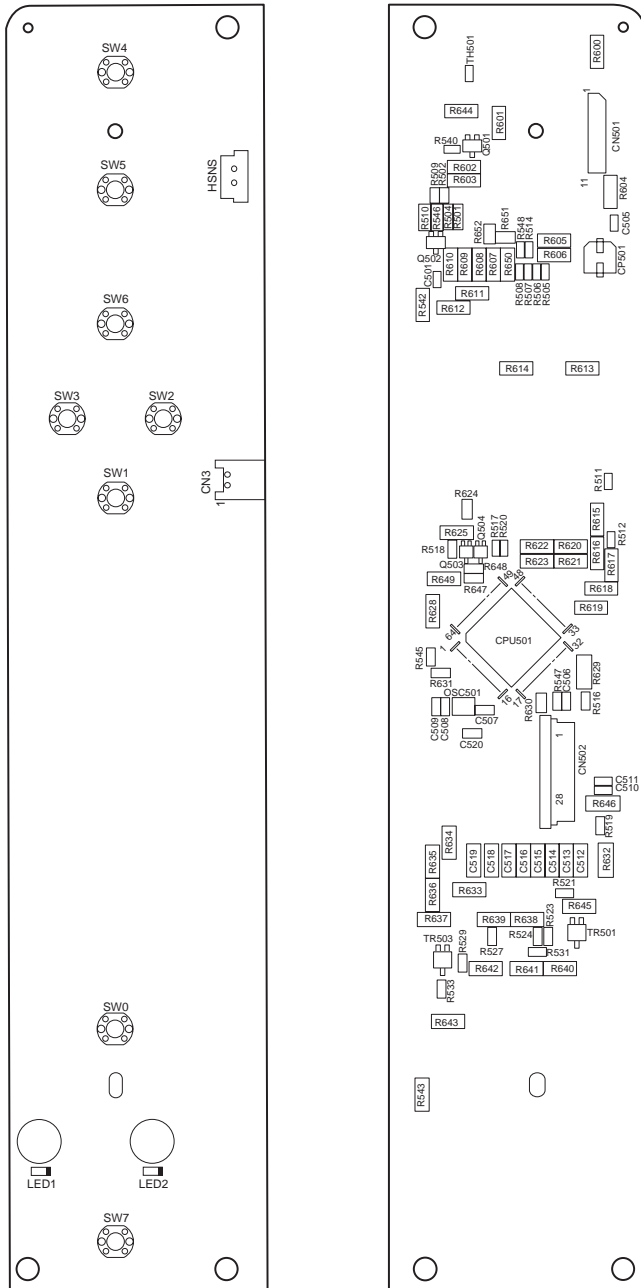

(6) Toner Low Sensor PCB

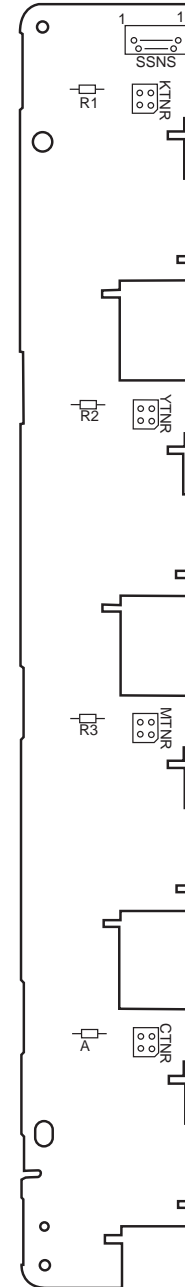

(7) Entrance Sensor PCB

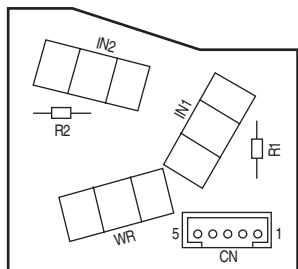

(8) Color Adjustment Sensor PCB

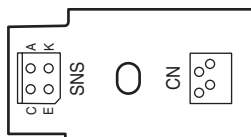

(9) High-Voltage Power Supply PCB

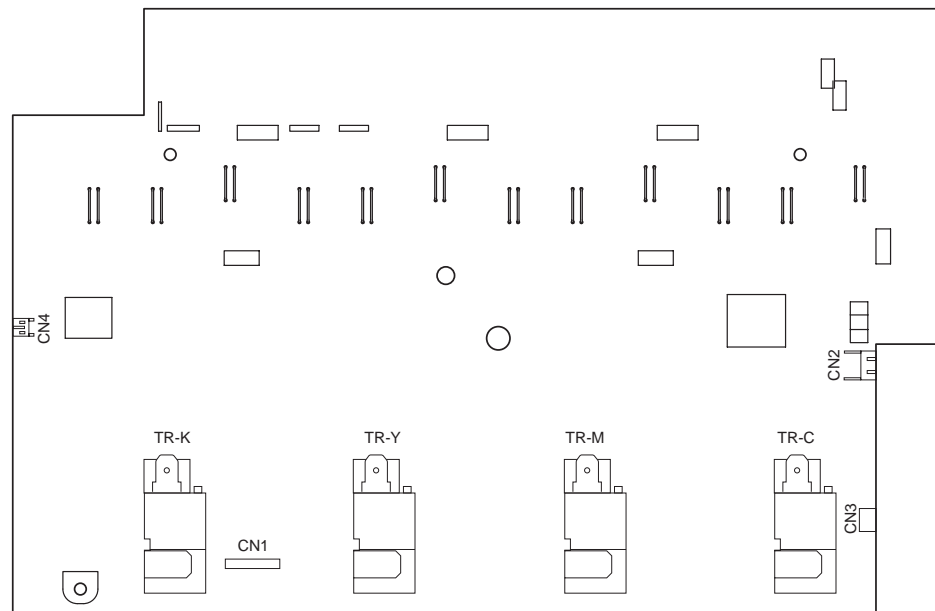

(10) Low-Voltage Power Supply PCB

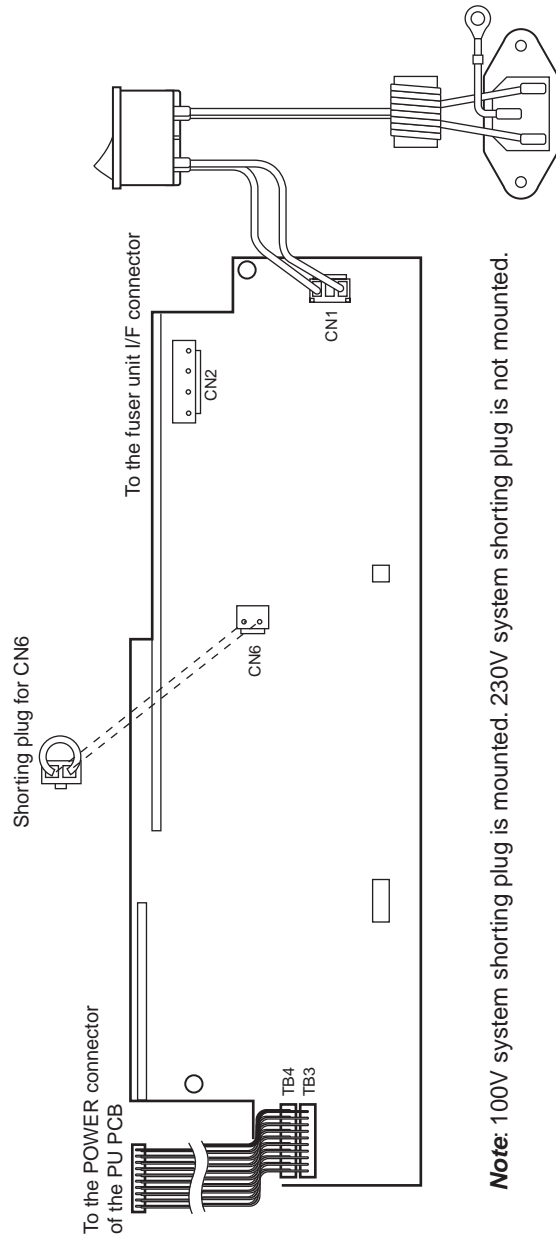

Note: 100V system shorting plug is mounted. 230V system shorting plug is not mounted.

(11) ID unit

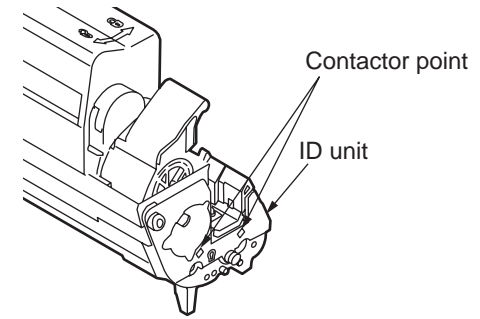
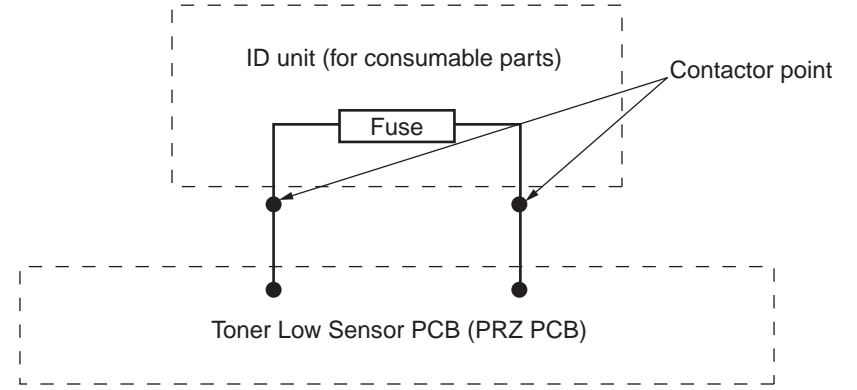

(12) Transfer belt unit

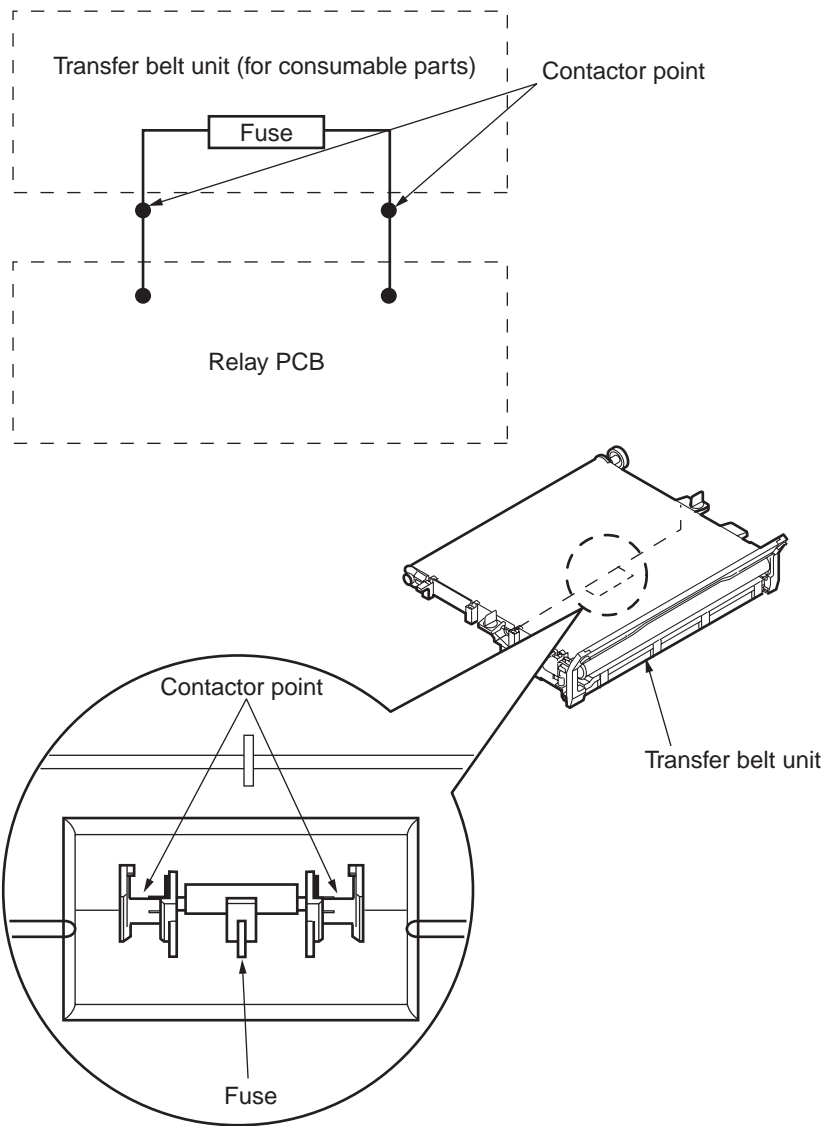

8.3 F/W version number

8.3.1 ROM control number

ROM nameplate version number fill-out version	Date	CU F/W 44267202FY02		NIC F/W 44267202FY03			PU F/W 44267202FY04		Remarks
		Rev.	File Rev.	NIC F/W	Web Page	File Rev.	Rev.	File Rev.	
5	2009.10.21	D1.01	2	01.00	01.02	2	00.00.15	3	PSU~

8.3.2 ROM version check and display

- (1) Perform the menu map printing and confirm that the F/W version number has been upgraded.
- (2) Fill out the ROM label that is attached to the location shown below in accordance with the downloaded F/W version number.

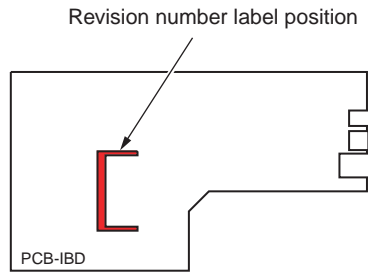

Revision number label details

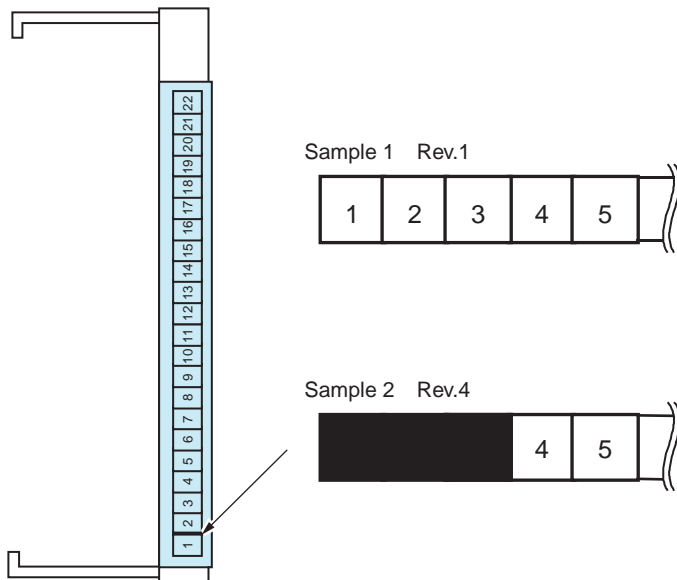

8.3.3 PCB Maintenance Indication Stamp

The specified article numbers are stamped in the PCB Maintenance Indication column on the CU/PU PCB in accordance with the table shown below.

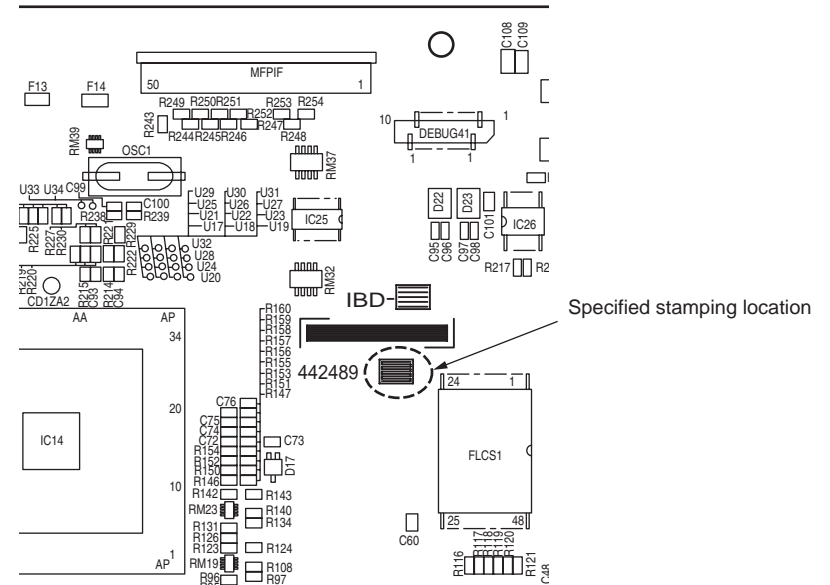

Article number	Seal	Board TB2(YU) Series No.	Use
44248909	09	44184502	ODA
44248911	11	44184502	OEL
44248912	12	44184502	AOS
44248915	15	44184502	ES7411