

# C710n

# Maintenance Manual

082805A

## Copyright Information

---

Copyright © 2007 by Oki Data. All Rights Reserved

## Disclaimer

---

Every effort has been made to ensure that the information in this document is complete, accurate, and up-to-date. The manufacturer assumes no responsibility for the results of errors beyond its control. The manufacturer also cannot guarantee that changes in software and equipment made by other manufacturers and referred to in this guide will not affect the applicability of the information in it. Mention of software products manufactured by other companies does not necessarily constitute endorsement by the manufacturer.

While all reasonable efforts have been made to make this document as accurate and helpful as possible, we make no warranty of any kind, expressed or implied, as to the accuracy or completeness of the information contained herein.

The most up-to-date drivers and manuals are available from the web site:  
<http://www.okiprintingsolutions.com>

# PREFACE

---

This manual provides an overview of method for maintaining the C710n.

This manual is intended for maintenance staff. For more information about how to operate the C710n, please refer to User 's manual.

- Note!**
- Manual may be revised and updated at any time without notice.
  - Unexpected mistakes may exist in the manual.  
OKI will not assume any responsibility whatsoever for damage to the equipment repaired/adjusted/changed by the user etc with this manual.
  - The parts used for this printer may be damaged when handling inappropriately. We strongly recommend maintaining this machine by our registration maintenance staff.
  - Please operate the machine after removing static electricity.

# Index

<b>1. Configuration</b> .....	<b>6</b>		
1.1 System configuration .....	7		
1.2 The Configuration of printer.....	8		
1.3 Optional parts .....	9		
1.4 Specifications .....	10		
1.5 Specification of interface .....	13		
1.5.1 Specification of USB interface .....	13		
1.5.1.1 General of USB interface .....	13		
1.5.1.2 Connector and cable of USB interface.....	13		
1.5.1.3 USB interface signal .....	13		
1.5.2 Specification of network interface .....	14		
1.5.2.1 General of network interface.....	14		
1.5.2.2 Connector and cable of network interface .....	14		
1.5.2.3 Signal of network interface .....	14		
1.5.3 Specification of parallel interface .....	15		
1.5.3.1 General of parallel interface.....	15		
1.5.3.2 Connector and cable of parallel interface .....	15		
1.5.3.3 Parallel interface level .....	15		
1.5.3.4 Signal of interface .....	15		
<b>2. Operating instructions</b> .....	<b>16</b>		
2.1 Electrophotographic processing mechanism.....	17		
2.2 Printing process.....	21		
<b>3. Set up</b> .....	<b>32</b>		
3.1 Notes and precautions.....	33		
3.2 Unpack method .....	34		
3.3 Setting method .....	35		
Set space.....	35		
3.4 List of equipments and accessories .....	36		
3.5 Assembling method .....	37		
3.5.1 Assemble the main body of the printer .....	37		
3.5.2 Cable connect .....	43		
3.5.3 Optional part installation and confirmation.....	45		
3.6 Setting content print (Configuration).....	56		
3.7 Connecting method .....	57		
3.8 User used Paper confirmation .....	59		
<b>4. Component replacement</b> .....	<b>60</b>		
4.1 Precautions on component replacement.....	61		
4.2 Method of component replacement.....	63		
4.2.1 Belt unit.....	63		
4.2.2 Fuser unit.....	64		
4.2.3 Left side cover.....	64		
4.2.4 Right side cover .....	65		
4.2.5 Faceup tray .....	65		
4.2.6 Rear cover.....	66		
4.2.7 LED Assy/ LED Assy spring.....	66		
4.2.8 Control PCB.....	67		
4.2.9 Print engine controller PCB.....	68		
4.2.10 Top cover Assy.....	69		
4.2.11 Top cover .....	70		
4.2.12 Control panel Assy .....	70		
4.2.13 Board PRG/ LCD .....	71		
4.2.14 Frame panel Assy .....	72		
4.2.15 Low voltage power supply/Low voltage FAN/ Hopping motor/ Fuse motor.....	73		
4.2.16 Guide eject Assy/ Color resist Assy/ Board-PRY .....	74		
4.2.17 FAN(Fuser) / Belt motor/ High-voltage board/ Cover open switch .....	75		
4.2.18 MPT Assy .....	75		
4.2.19 Feeder unit/ Board-RSF/MPT hopping roller/ Frame Assy separator/ Cover front .....	76		
4.2.20 Board-PRZ liftup motor/ Hopping motor/ Solenoid/Paper end sensor .....	77		
4.2.21 Feed roller.....	78		
4.2.22 Shaft eject Assy (FU)/ Shaft eject Assy(FD/ Eject sensor .....	79		
4.3 Oiling spots.....	80		

<b>5. Maintenance Menu .....</b>	<b>91</b>
5.1 System maintenance menu (for maintenance engineer) .....	92
5.2 TBD.....	93
5.3 Maintenance menu functions.....	95
5.3.1 Self-diagnostic mode .....	95
5.3.1.1 Operation panel .....	95
5.3.1.2 Ordinary self-diagnostic mode (level 1) .....	97
5.3.1.2.1 How to enter the self-diagnostic mode (level 1) .....	97
5.3.1.2.2 How to exit the self-diagnostic mode .....	97
5.3.1.3 Switch scan test.....	98
5.3.1.4 Motor clutch test.....	100
5.3.1.5 Test print.....	102
5.3.1.6 Color registration correction test.....	106
5.3.1.7 Density correction test .....	107
5.3.1.8 Consumable item counter display.....	109
5.3.1.9 Number of print copies counter display .....	110
5.3.1.10 Switching between the Factory mode and the Shipping mode .....	110
5.3.1.11 Self-diagnostic function setting.....	111
5.3.1.12 LED head serial number display .....	112
5.3.1.13 NVRAM parameter setting .....	112
5.3.2 Various prints with the printer as a standalone unit .....	112
5.3.3 Functions of keys at power on .....	113
5.4 Setups upon completion of part replacement.....	114
5.4.1 Precautions when replacing the engine control board.....	114
5.4.2 EEPROM setting upon completion of CU board .....	115
replacement.....	115
5.5 Density control manual setting .....	116
5.6 Printer boot menu list.....	117
<b>6. Periodic Maintenance .....</b>	<b>118</b>
6.1 Cleaning .....	119
6.2 How to clean the LED lens array .....	120
6.3 How to clean the pickup roller .....	122
6.4 How to clean inside of printer .....	123

<b>7. Troubleshooting and repair procedure .....</b>	<b>125</b>
7.1 Before starting the repair work .....	126
7.2 Confirmation items before taking corrective action against abnormalities .....	126
7.3 Precautions when taking corrective action against abnormality .....	126
7.4 Preparation for troubleshooting .....	126
7.5 Troubleshooting method .....	127
7.5.1 LCD message list.....	127
7.5.2 Preparation for troubleshooting.....	148
7.5.3 Troubleshooting the abnormal images .....	180
7.5.4 Network troubleshooting .....	187
7.5.4.1 Connection error occurs with the Web browser .....	187
7.5.4.2 Print operation is not possible.....	193
7.5.4.3 Cannot create Certificate .....	194
7.5.4.4 Installation of Certificate is not possible.....	194
7.5.4.5 Other questionnaires .....	196
7.5.4.6 Restrictions when using Internet Explore 7 .....	198
7.6 Fuse check .....	199
7.7 Paper cassette switches versus Paper size correspondence table .....	200
7.8 Data protection kit-A1 .....	201
7.8.1 Data protection kit-A1 (DPK-A1) overview .....	201
<b>8. Connection diagrams.....</b>	<b>205</b>
8.1 Resistance value check .....	206
8.2 Parts location.....	210
8.3 F/W version number .....	221
8.3.1 ROM control number .....	221
8.3.2 ROM version check and display .....	222
8.3.3 PCB Maintenance Indication Stamp.....	222

# 1. Configuration

---

1.1 System configuration .....	7
1.2 The Configuration of printer .....	8
1.3 Optional parts .....	9
1.4 Specifications .....	10
1.5 Specification of interface .....	13

# 1.1 System configuration

Figure 1-1-1 represents the system configuration of the printer.

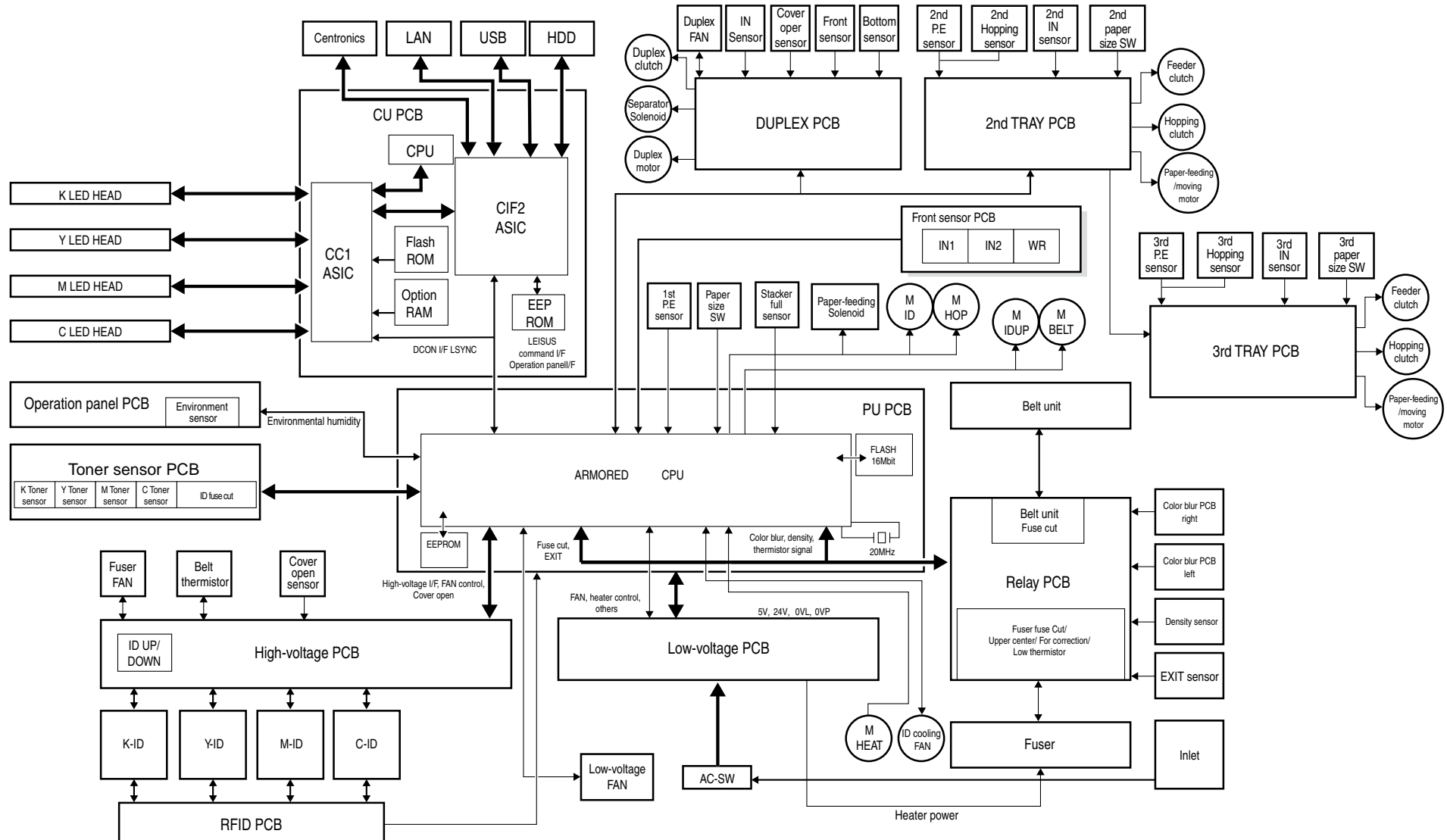

Fig1-1

## 1.2 The Configuration of printer

The parts in the C710n are shown as below.

- Electrophotography process mechanism
- Paper feed path
- Control part (CU part/ PU part)
- Operator panel
- Power part (High-voltage part/low-voltage part)

The Configuration of the printer is shown in Fig 1-2.

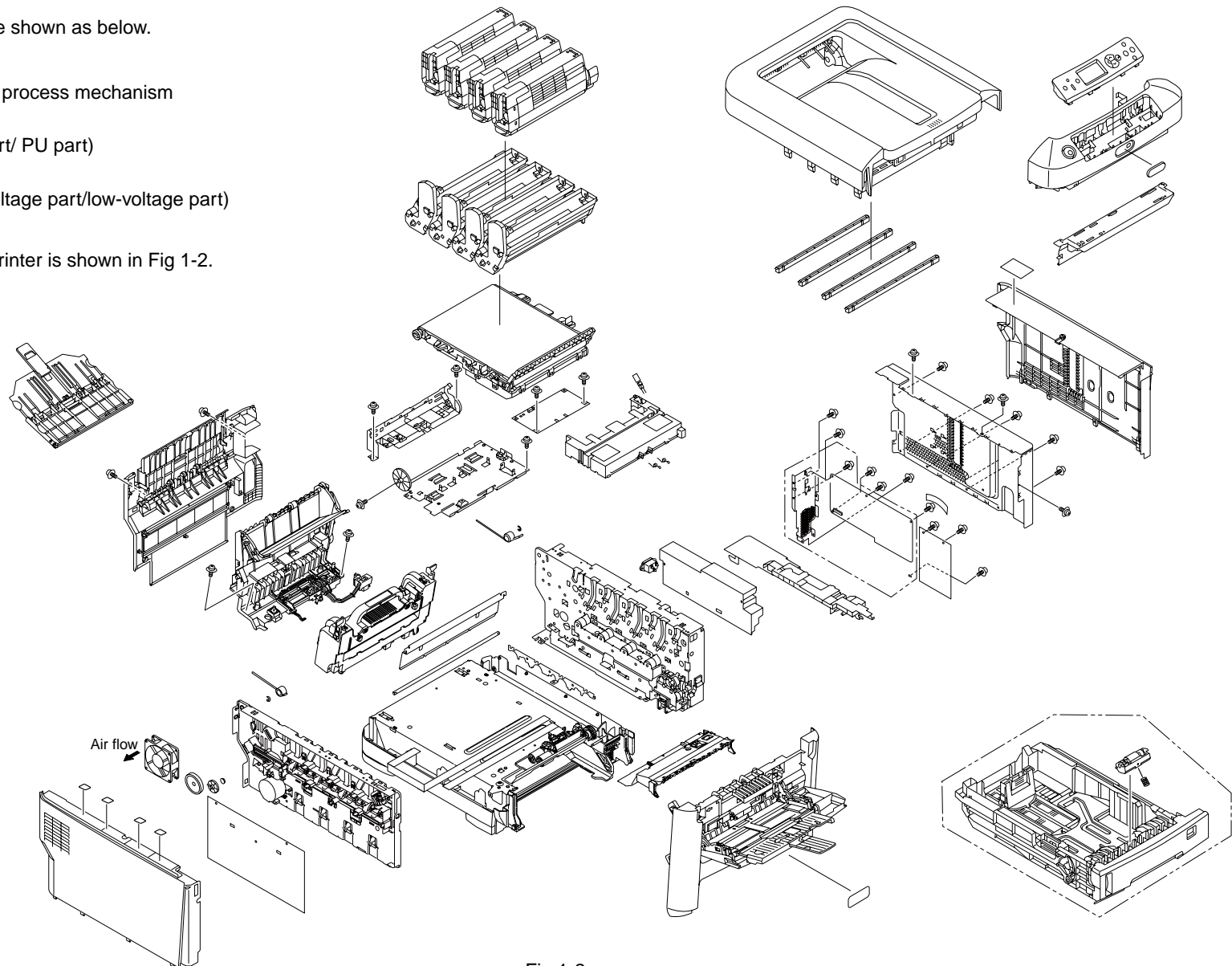

Fig 1-2



## 1.3 Optional parts

The optional parts for this printer are shown as below.

(1) Optional tray(second tray/ third tray)

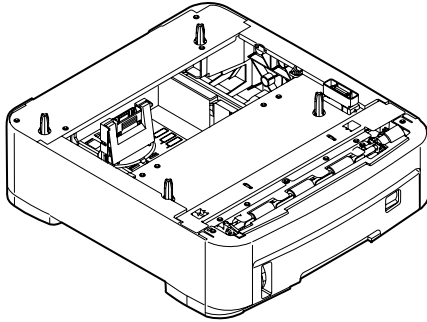

(2) Duplex Unit

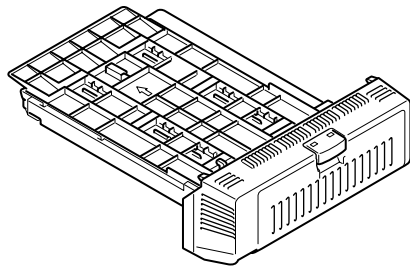

(3) Optional memory

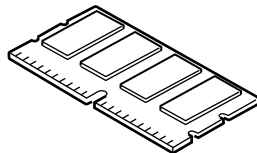

(4) Built-in hard disk

(Standard built-in hard disk, data protection kit A1)

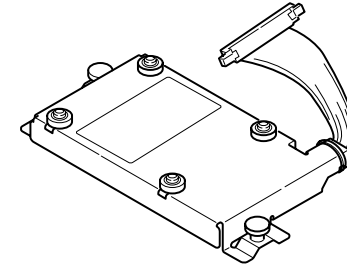

## 1.4 Specifications

Division	Item	
Dimension	Width	435mm
	Depth	536mm
	Height	389mm
	Weight	About 28kg
Width of print	Width of print	Letter size, vertical
Print speed	Engine speed (A4)	30PPM(Color)
		32PPM(Mono)
Print start	First print time	8sec(mono), 9sec(color) (A4)
	Warmup time	60sec
	Low noise mode	Unavailable
Resolution	LED head	600dpi
	Maximum input resolution	600×1200dpi
	Output resolution	True 600×1200dpi
		True 600×600dpi
	Step	4 step 600×600dpi
Econo mode	Save toner by decreasing brightness	
CPU	Core	PowerPC750
	I-cash, / D-cash	L2=256KB
	Clock	700MHz
	Bus width	64bit
RAM	Resident	256MB

Division	Item	
ROM	Program+font	64MB
Power consumption	Input power supply	(120V)110~127VAC±10%, (230V)220~240VAC±10%
	Power save mode	Less than 17W
	Idle	100W (Average)
	Usual operation	530W (It differs from operating environment)
	Peak	1200W
Operating environment (Temperature)	During operating	10°C~32°C, 17°C~27°C (Temperature requirement for full-color print)
	During non-operating	0°C~43°C, power off
	During keeping (for a year at most)	-10°C~43°C, with drum and toner
	During transferring (for a month at most)	-29°C~50°C, with drum, without toner
	During transferring (for a month at most)	-29°C~50°C, with drum, without toner
Operating environment (Humidity)	During operating	20%~80%, 50%~70% (Humidity requirement for full-color print) The highest wet bulb temperature is 25°C
	During non-operating	10%~90%, The highest wet bulb temperature is 26.8°C, power off
	During keeping	10%~90%, The highest wet bulb temperature is 35°C
	During transferring	10%~90%, The highest wet bulb temperature is 40°C

Division	Item	
Operation life	Printer operation life	600,000 pieces A4 transvers direction, 5years
	Print duty (M=L/12, A=L/12/5)	Max 100,000 pages / month Average 6,000 pages/ month
	MTBF (2.3% duty)	Unavailable
	MPBF	50,000 pages
	MTTR	Within 20 minutes
	Toner operation life (5% duty)	Mounting toner: 4,000 pages(black), 4,000 pages (color)
		Standard: 10,000 pages(black), 10,000 pages(color) S type: 5,000 pages(black), 5,000 pages(color) For the first new drum: about 9,200 pages(standard), 4,200 pages(S type)
	Image drum operation life	20,000 pages (when 3 pages /job) 12,000 pages (when 1 page/job) 27,000 pages (when continuously print) Drum count all reset
	Transcribing belt operation life	60,000 pages (A4 transverse size, when 3 pages /job) count auto reset
Fuser operation life	60,000 pages (A4 size) count auto reset	
Operation sound	During operation	55.6dBA (ISO 7779 front) (without option unit)
	During standby	37dB(ISO 7779 front)
	Power save mode	Background level

Division	Item	
Paper handling	Paper stack capacity (1st tray)	Legal /Universal cassette 530 pieces (70kg)
	Paper stack capacity (optional tray)	Legal /Universal cassette 530 pieces (70kg)
	Paper stack capacity (Manual/auto)	Standard multipurpose tray or 100 pieces (70kg), or 10 pieces of envelop
	Paper rejection	350 pieces (70kg), facedown/ 100 pieces (70kg), faceup tray
	Duplex	Standard/ Option
	Paper size	A4, A5, B5, A6*, letter, legal(13/13.5/14), Executive, post card**, return post card**, custom***, envelope , Index card 3x5in, Photo size 4x6 5x7in  * : The paper of A6 cannot be used in tray 1, 2, 3 **: The post card, return post card and envelope can be used in MPT only ***: As for custom, the available size can be adjusted by using different tray. The length is up to 1220mm.
Minimum paper size	Tray 1	A5
	Tray 2(option)	A5
	Tray 3(option)	A5
	MPT	Postcard
Thickness of paper	Tray 1	64g/m <sup>2</sup> ~188g/m <sup>2</sup>
	Tray 2(option)	64g/m <sup>2</sup> ~203g/m <sup>2</sup>
	Tray 3(option)	64g/m <sup>2</sup> ~203g/m <sup>2</sup>
	MPT	64g/m <sup>2</sup> ~220g/m <sup>2</sup>

Division	Item	
Control panel	LCD	Resolution 128x64 dot graphic panel Paper size is not displayed
	LED (color)	2 (Greenx1, dark umbarx1)
	Switch	8
Status switch/ sensor	Paper out	Have
	Paper low	None
	Toner low	Have (Y, M, C, K)
	Cover open	Have
	Temperature of fuser	Have
	Paper size	Have (Manual setting)
	Stacker full	Have
Communication interface	Standard (On the PCB)	<ul style="list-style-type: none"> <li>• Hi-Speed USB</li> <li>• Ethernet</li> <li>• Centronics</li> </ul>
	Input and output switch	Auto
Emulation	Standard	PCL(PCL5c, HP-GL) / PCL XL2.1
		PostScript3 (Clone)
	Emulation switch	Auto
Font	Bitmap Typeface	Have
	Scalable font	Have
	Rasterizer	Have
	Barcode	Have
	OCR	Have
	Japanese PCL font	Have
	Japanese PS font	Have

Division	Item	
Option (can be removed)	RAM	256/512MB DIMM
	2.5" IDE HDD It is possible to be installed by user	<ul style="list-style-type: none"> <li>• Standatd built-in HDD</li> <li>• Data protection kit A1</li> </ul>
	Tray mechanism	2nd tray mechanism, 3rd tray mechanism
	Cassette	Universal (530 pieces)
	Double print unit	Standard/ Option
	Others	Univailable
Others	USB-IF logo	Have
	Windows logo	Have
	UPS operation	The operation with UPS(Uninterruptible Power Supplies) is not guaranteed Please do not use the UPS

# 1.5 Specification of interface

## 1.5.1 Specification of USB interface

### 1.5.1.1 General of USB interface

- (1) Spec.  
USB (Support Hi speed USB )
- (2) Transmission mode  
Full speed (Maximum 12Mbps 0.25%)  
High speed(Maximum 480Mbps 0.05%)
- (3) Power control  
Self power device

### 1.5.1.2 Connector and cable of USB interface

- (1) Connector
  - Printer side: B Receptacle (female)  
Up-stream port  
(UBR24-4K5C00 (made by ACON)) Equivalent goods

Connector pins array

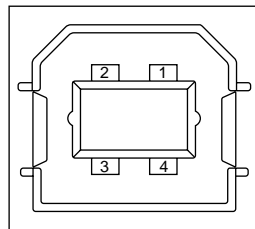

- Cable side: B plug(male)

- (2) Cable  
The length of the cable: the cable of less than 5m with USB 2.0 spec.  
(Less than 2m is recommended)  
(Please use the shielded wire for the cable.)

### 1.5.1.3 USB interface signal

	Signal name	Function
1	Vbus	Power (+5V)
2	D-	For data transmission
3	D+	For data transmission
4	GND	Signal Ground
Shell	Shield	

## 1.5.2 Specification of network interface

### 1.5.2.1 General of network interface

Spec.

Network Protocol

TCP/IP sepc. Network layer

ARP, IP, ICMP, IPv6

Transfer layer

TCP, UDP

Application layer

LPR, Port9100, FTP, HTTP, HTTPS, IPP, SNMPv1/v3, TELENET, DHCP/BOOTP, DNS, DDNS, WINS, UPnP, Bonjour, SNTP, SMTP, POP, Windows Rally (WSD Print, LLTD).

NetBEUI: SMB, NetBIOS

Netware: Remote printer mode(Maximum 8 print sever )

Print sever mode (Maximum 8 files sever: 32 queue)

For encrypted password (when it is print sever mode)

NetWare6J/5J/4.1J (NDS, bindery)

SNMP

EtherTalk: ELAP, AARP, DDP, AEP, NBP, ZIP, RTMP, ATP, PAP

IEEE802.1X: EAP-TLS, PEAP

### 1.5.2.2 Connector and cable of network interface

(1) Connector

100BASE-TX/10 BASE-T (Auto switch, cannot be used simultaneously)

Connector pins array

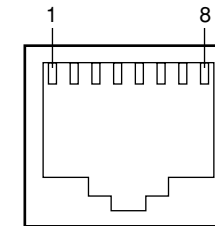

(2) Cable

Non-shield twisted-pair cable with RJ-45 connector

(Category 5 is recommended)

### 1.5.2.3 Signal of network interface

Pin No.	Signal name	Direction	Function
1	TXD+	FROM PRINTER	Transmission data +
2	TXD-	FROM PRINTER	Transmission data -
3	RXD+	TO PRINTER	Receive data +
4	-	-	Not use
5	-	-	Not use
6	RXD-	TO PRINTER	Receive data -
7	-	-	Not use
8	-	-	Not use

### 1.5.3 Specification of parallel interface

#### 1.5.3.1 General of parallel interface

##### Spec.

IEEE1284-1994 conforming parallel interface

Item	Content
Related mode	Compatible mode, nibble mode, and ECP mode
Data bit length	Compatible: 8, nibble: 4, ECP: 9bit

#### 1.5.3.2 Connector and cable of parallel interface

##### (1) Connector

Printer side : 36-Pole connector (Female)

57LE-40360-12(D56) (made by DDK) equivalent goods

Cable side : 36-Pole connector (male)

57FE-30360-20N(D8) (made by DDK) equivalent goods

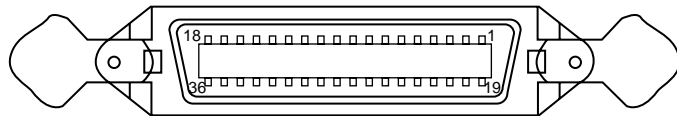

Pin layout seen from interface cable side

##### (2) Cable

IEEE1284-1994 cable of less than 1.8m is used.

(For avoiding noise interference, please use shielded cable with the twisted-pair wire.)

#### 1.5.3.3 Parallel interface level

Low level 0.0V~+0.8V

High level +2.4V~+5.0V

#### 1.5.3.4 Signal of interface

Pin NO.	Name of signal	Direction	Function
1	nStrobe (HostClk)	TO PRINTER	It is a pulse to read data. Data is read by posterior end.
2~9	DATA 1~DATA 8	Bi-direction	It is parallel data of 8 bits. The high level is "1", and the Low level is "0".
10	nAck(PtrClk)	FROM PRINTER	It is a signal that shows the data reception completion.
11	Busy(PtrBusy)	FROM PRINTER	It is a signal that shows if the printer is receiving the data. Data cannot be received when it is at the high level.
12	PError(AckDataReq)	FROM PRINTER	The paper error is shown when it is at the high level.
13	Select(Xflag)	FROM PRINTER	When parallel interface is effective, it is always in high-level state.
14	nAutoFd(HostBusy)	TO PRINTER	It is used by the bidirectional communication.
15	-	-	Not use
16	GND	-	Signal ground
17	FG	-	Chassis ground
18	+5V	FROM PRINTER	It cannot supply power outside.
19~30	GND	-	Signal ground
31	nInit(nInit)	TO PRINTER	The printer is initialized with the low level.
32	nFault(nDataAvail)	FROM PRINTER	When the printer is in alarm state, it becomes low level.
33	GND	-	Signal ground
34	-	-	Not use
35	HILEVEL	FROM PRINTER	It is pulled up to +5V at 3.3KΩ in the printer.
36	nSelectIn (IEEE1284 active)	TO PRINTER	It is used by bidirectional communication. It must be low level when it is in compatible mode.

- Notes!**
- The signal name showed in the bracket is a signal name in nibble mode.
  - It only describes the function in compatible mode.
  - The nibble mode of IEEEstd1284-1994 regulated by Institute of Electrical and Electronics Engineers is supported. Using the computer and the cable unsupported this standard may lead to unexpected operation.

# 2. Operating instructions

---

2.1 Electrophotographic processing mechanism.....	17
2.2 Printing process.....	21



## 2.1 Electrophotographic processing mechanism

### (1) Electrophotographic processing

The general of Electrophotography process is described as below.

#### 1. Charging

The voltage is impressed to CH roller, and the surface of OPC drum is electrified.

#### 2. Exposure

LED head irradiates light to the image signal on the surface of the electrified OPC drum. The electricity of the irradiated part on the surface of the OPC drum is attenuated by changing in light intensity, the electrostatic latent image is formed on the surface of the OPC drum.

#### 3. Development

The electrified toner adheres to the electrostatic latent image of the OPC drum by electrostatic force, and the image is developed on the surface of the OPC drum.

#### 4. Transfer

The paper is overlapped on the surface of the OPC drum, and the electricity is generated on the back of the paper by transfer roller, the toner image is transcribed to the paper.

#### 5. Fusing

Heat and pressure are applied to the toner image on the paper in order to make it fusing.

#### 6. Drum cleaning

The drum cleaning blade removes the toner left on the OPC drum after transfer.

#### 7. Electricity removal

The electric potential left on the drum is removed.

#### 8. Belt cleaning

The belt cleaning blade removes the toner left on the belt.

### (2) Charging

The voltage is impressed to the charging roller in contact with the surface of OPC drum, and the surface of OPC drum is charged.

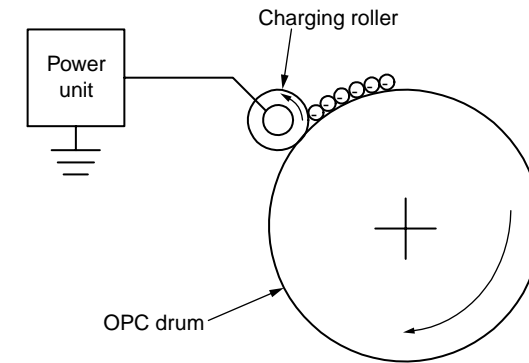

### (3) Exposure

The light generated from LED head is irradiated onto the surface of the electrified OPC drum. The electricity of the irradiated part on the surface of the OPC drum is attenuated by changing in light intensity, the electrostatic latent image is formed on the surface of the OPC drum.

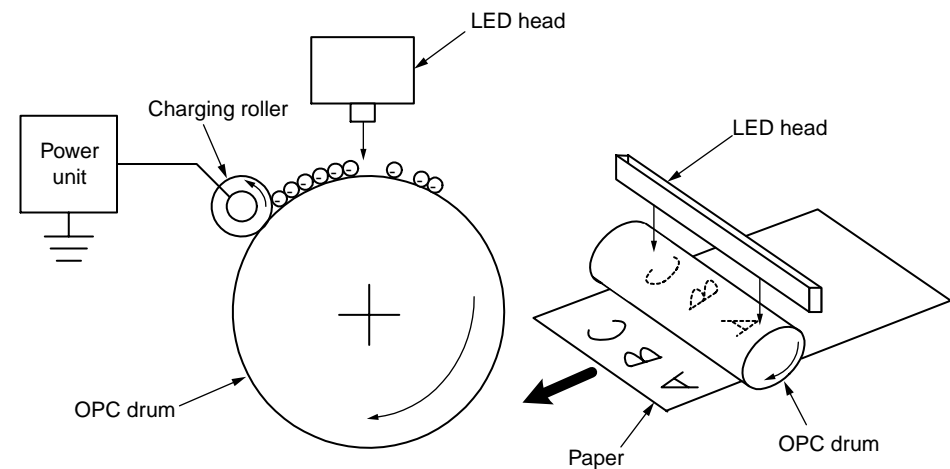

(4) Development

The toner adheres to the electrostatic latent image on the surface of the drum, and the electrostatic latent image is changed into the toner image.

1. The sponge roller makes the toner adhere to the developing roller.

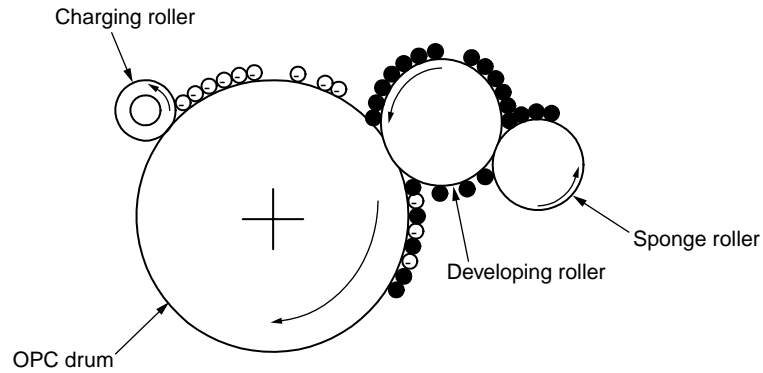

2. The electrostatic latent image on the surface of the OPC drum surface is visualized by toner.

(5) Transfer

The paper is overlapped on the surface of the OPC drum, and the electricity is generated on the back of the paper by transfer roller.

When high voltage is impressed from the power supply to the transfer roller, the electricity induced in the transfer roller is moved to the surface of the paper via contact surface, and the toner is drawn from the surface of the OPC drum to the surface of the paper.

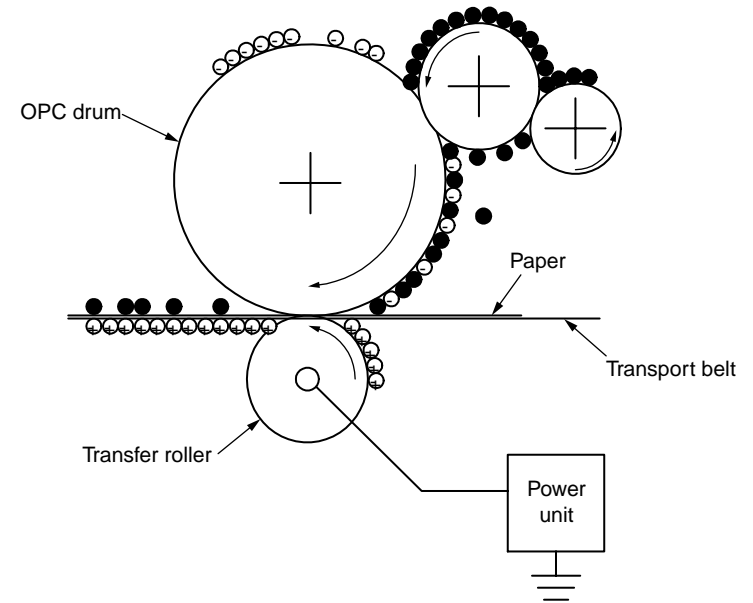

(6) Fusing

When the paper passes through the heat roller and backup roller unit, heat and pressure are applied to the toner image on the paper and the toner is fused onto the paper.

The halogen lamps of 800W and 300W are built in heat roller. The backup roller without built-in halogen lamp is heated by the heat transmission from the heat roller. The fusing temperature is controlled by the temperature detected by the thermistor that is not in contacting with the surface of the heat roller. On the other hand, the temperature detected by the thermistor rubbing the surface of backup roller is used for controlling the fusing temperature under specified conditions. Furthermore, a thermostat is used to limit the temperature rise, if the temperature rise of heat roller exceeds a set point, the thermostat would be open and the voltage supply to the heater would be cut off. The backup roller unit is pressed on the heat roller by the spring on both sides.

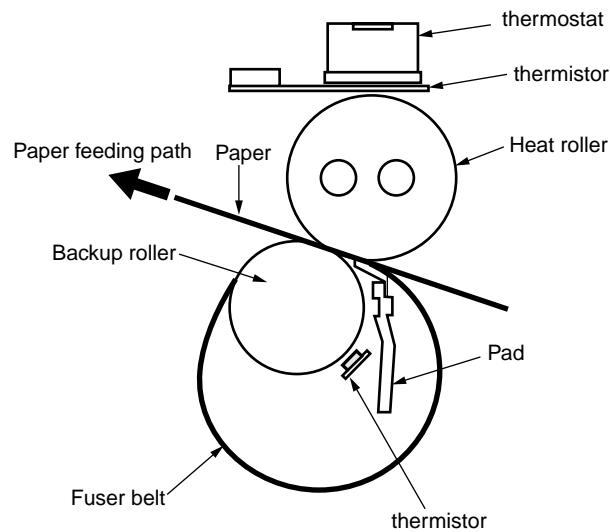

(7) Drum cleaning

The Unfused toner left on the OPC drum is cleaned up by the drum cleaning blade, and all residual toner is collected in the waste toner area of the toner cartridge.

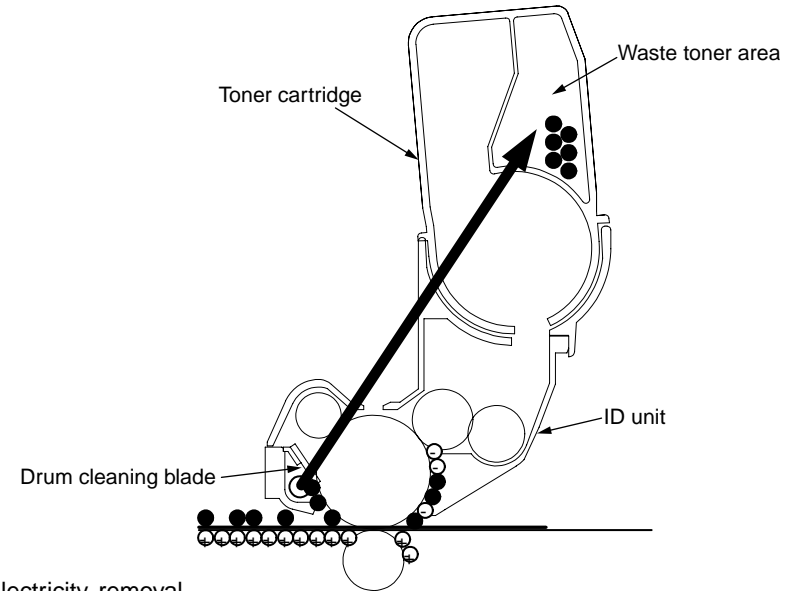

(8) Electricity removal

The electricity on the surface of the OPC drum is attenuated by irradiating the light to the surface of the OPC drum after transfer.

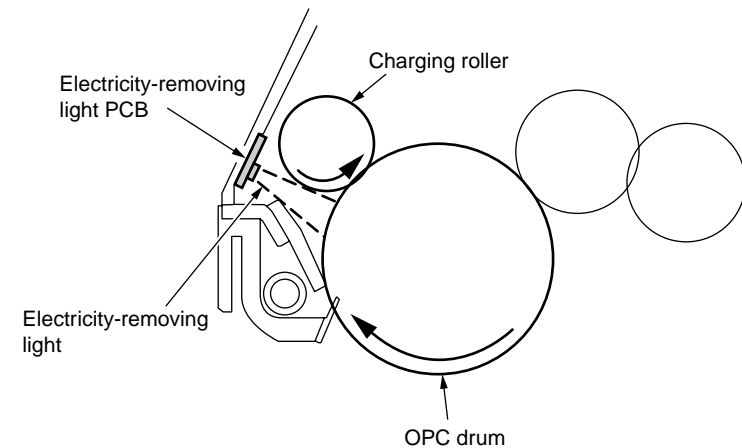

(9) Belt cleaning

The toner left on the transport belt is cleaned up by the belt cleaning blade, and all residual toner is collected in the waste toner box of the transport belt unit.

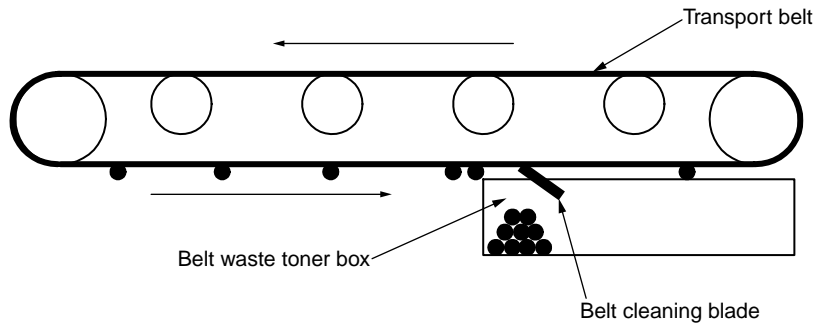

## 2.2 Printing process

The paper fed from tray 1 or tray 2, tray.3 is transferred by feeder roller, resister roller L, and transfer roller. It is transferred by MPT paper feed roller and resister roller U when the paper is fed from MPT. After that, the paper on the belt passes through the electrophotography process of KYMC, and sequentially the unfused toner image is generated on the paper. And then, the toner is fused by heat and pressure when it is passed through the fuse unit. After fusing, the paper is delivered to the faceup or facedown stacker by utilization of different delivery methods by opening or closing the faceup stacker.

The operation of single-sided printing is described as above. The operation of duplex printing is described as below.

As for the duplex print, the paper passed the fuse unit after initially back printing is drawn into the Duplex unit by separator DUP. The paper entered into the paper reversing path is transferred from the paper reversing path to the inside of Duplex by reverse operation of reversal roller. The paper passed over the inside of Duplex is fed from paper feed path of Duplex by the transfer roller set in the transfer path of Duplex inside, which is shared with the same paper feed path from the tray. The following operation is same as single-sided printing with paper feeding from the tray.

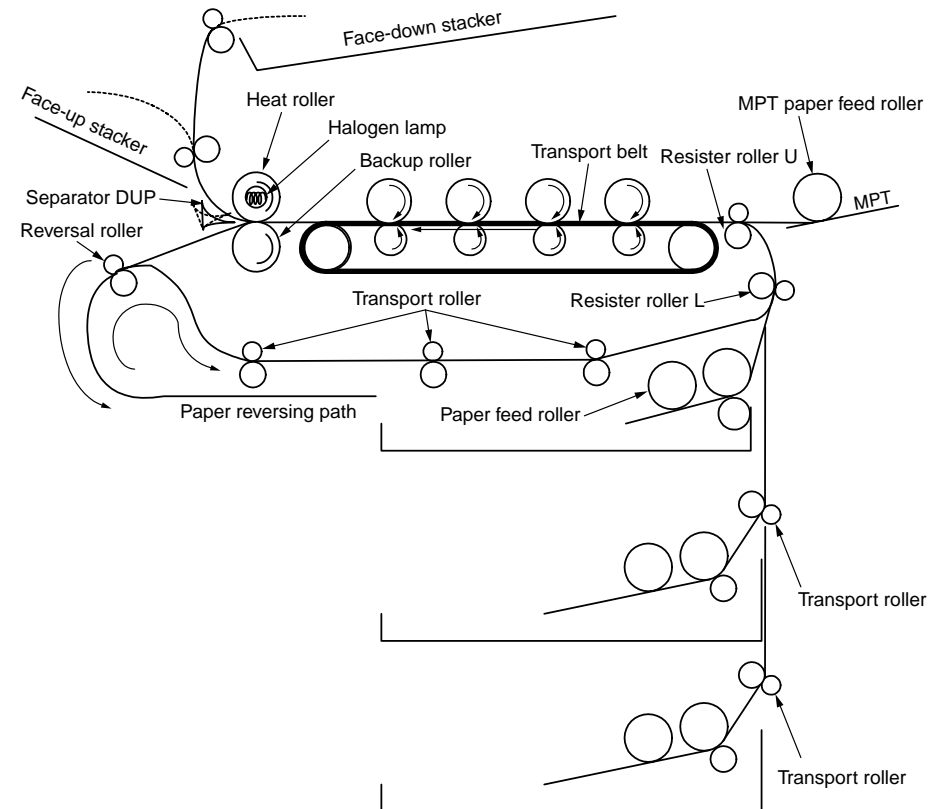

(1) Paper feed from 1st tray

1. As shown in Fig.2-1, while the solenoid is set as ON, the paper-feeding motor is rotated (counter clockwise) to transfer the paper until the IN1 sensor is turned ON. (When the solenoid is turned ON, the paper-feeding roller is driven.)
2. After the IN1 sensor is turned ON, a certain amount of paper is transferred and the resist roller L is bumped. (In this process, the skew of the paper is compensated.)
3. As shown in Fig.2-2, the solenoid is turned OFF, and the paper is transferred by resist roller L. (When the solenoid is turned OFF, the resist roller L is driven.)

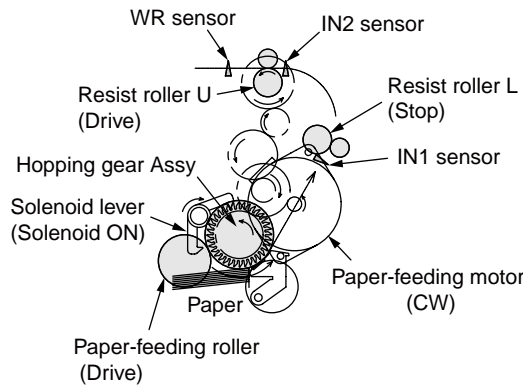

Figure 2-1

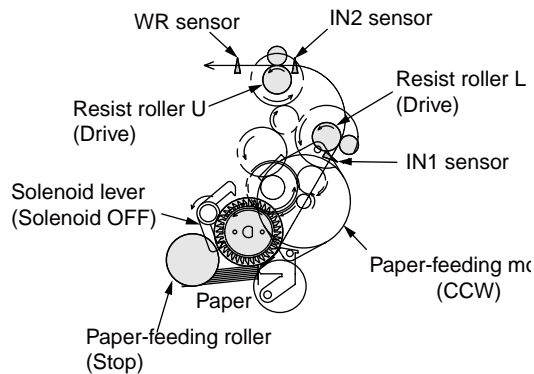

Figure 2-2

(2) Paper feed from MPT

1. As shown in Fig.2-3, while the solenoid is set as OFF, the paper-feeding motor is rotated (clockwise) to transfer the paper until the IN2 sensor is turned ON. (When the paper-feeding motor is rotated clockwise, the MPT paper-feeding roller is driven.)
2. After the IN2 sensor is turned ON, a certain amount of paper is transferred and the resist roller U is bumped. (In this process, the skew of the paper is compensated.)
3. As shown in Fig.2-4, the paper-feeding motor is rotated (counter clockwise), and the paper is transferred by resist roller U. (When the paper-feeding motor is rotated counter clockwise, the resist roller U is driven.)

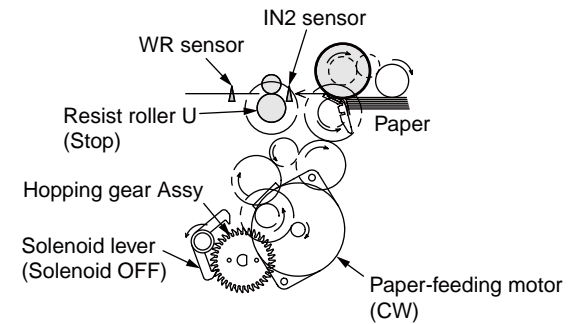

Figure 2-3

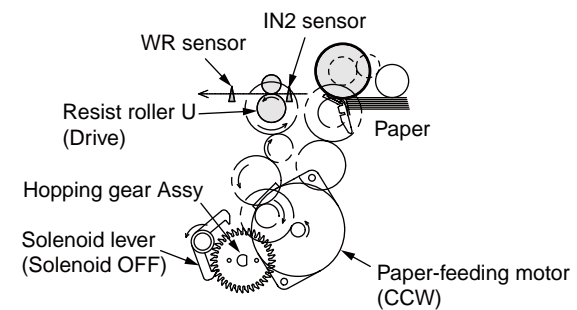

Figure 2-4

## (3) Transport belt

1. When the transport belt motor is rotated in the direction of the arrow, the transport belt is driven. As for the belt unit, a transfer roller is set over under each color drum. The belt is caught and installed between the transfer roller and drum.

As for the transport belt and transfer roller, if the specified voltage is impressed, the paper on the transport belt would be delivered to the fuser unit while transcribing the toner image on each color drum.

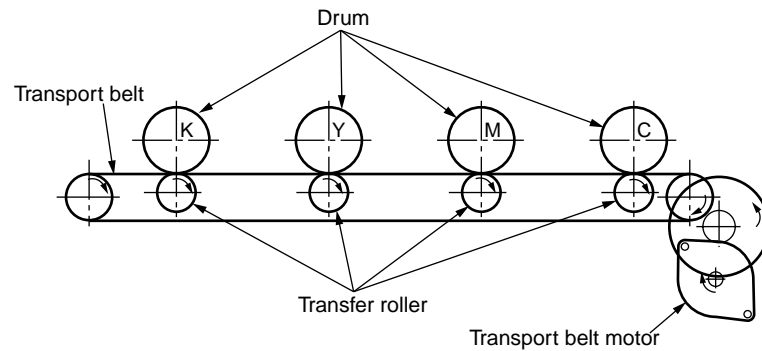

Figure 2-5

(4) Updown operation of ID unit

1. The up and down operation of the ID unit is done by driving the liftup motor.
2. Fig. 2-6 shows the operation of each ID unit when color printing. When the liftup motor is rotated (counter clockwise), the liftup link slides to left, and each ID unit is in DOWN condition as shown in Fig. 2-6. Under this condition, the color printing is available.
3. Fig. 2-7 shows the operation of each ID unit when mono printing. When the liftup motor is rotated (clockwise), the liftup link slides to right, and each ID unit (except K-ID unit) is in UP condition as shown in Fig. 2-7. Under this condition, the mono printing is available.

The operation of each ID unit when color printing

C-ID unit DOWN  
 M-ID unit DOWN  
 Y-ID unit DOWN  
 K-ID unit DOWN

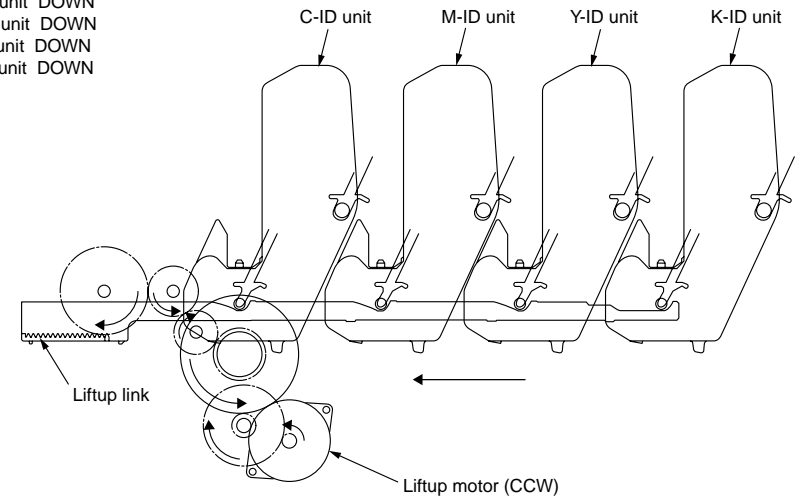

Figure 2-6

The operation of each ID unit when mono printing

C-ID unit Liftup  
 M-ID unit Liftup  
 Y-ID unit Liftup  
 K-ID unit DOWN

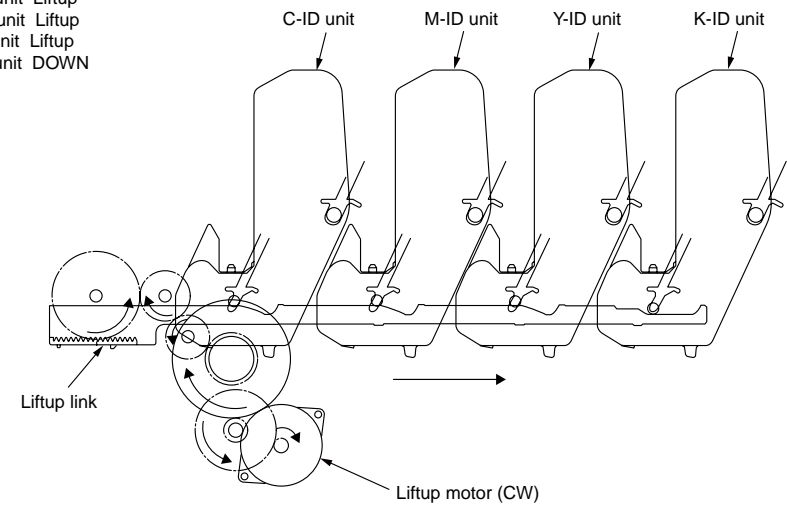

Figure 2-7



## (5) Fuse unit and paper delivery

1. The fuse unit and the delivery roller are driven by the DC motor as shown in Fig. 2-8. When the fuse motor is rotated (counter clockwise), the heat roller will begin to rotate. The heat roller makes the toner image fused to the paper by heat and pressure.
2. The paper exits while the delivery roller rotates.

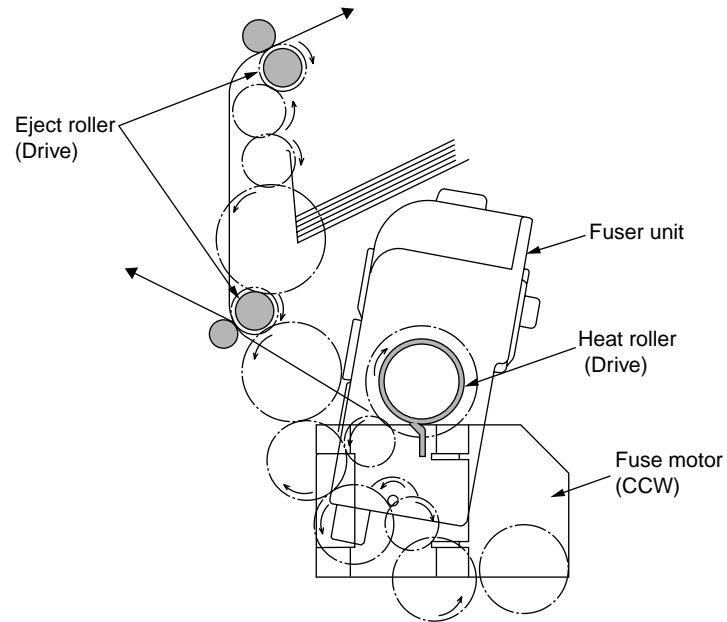

Figure 2-8

## (6) Cover open operation of color blur sensor and density sensor

1. As shown in Fig. 2-9, when the fuse motor is rotated (clockwise), the cover open gear is operated and the cover of color blur sensor and density sensor is open.
2. When the fuse motor is rotated (counter clockwise) in the opposite direction, the cover open gear is moved out of engagement and the cover of color blur sensor and the density sensor is close.

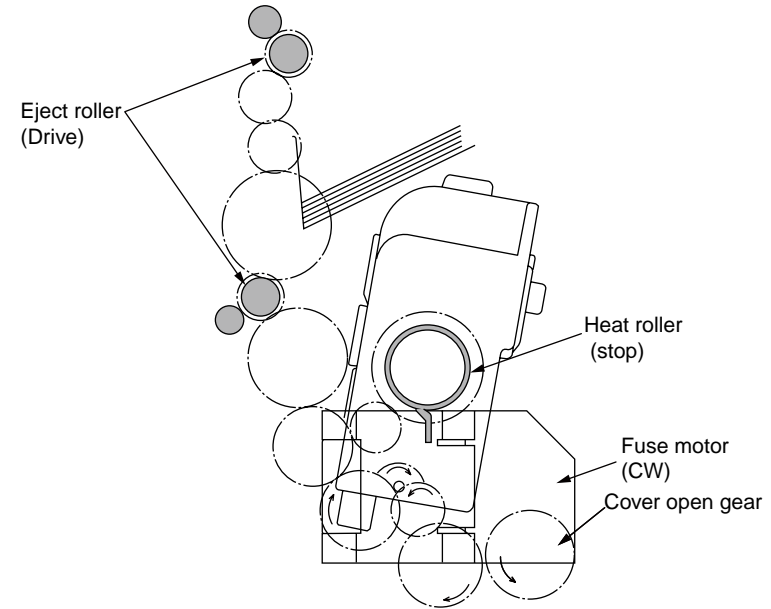

Figure 2-9

## General of color blur correction

The color blur correction is operated by reading the pattern for correction printed on the belt with a sensor set in the sensor shutter under the belt unit.

The pattern is detected by this sensor, and the correction is operated.

### Color blur correction auto-start timing

- When the power is on
- When the cover is closed after the cover is opened once
- When more than 400 copies are printed or when more than 6 hours have elapsed since the last print

The amount of toner of the pattern, the toner left on the sensor and the open-close trouble of the shutter etc. may lead to correction error. However, as the error message may not display even if the error is occurred, it is necessary to perform the color blur correction (see 5.3.2.6) by the utilization of the self-diagnostic mode and confirm the error display.

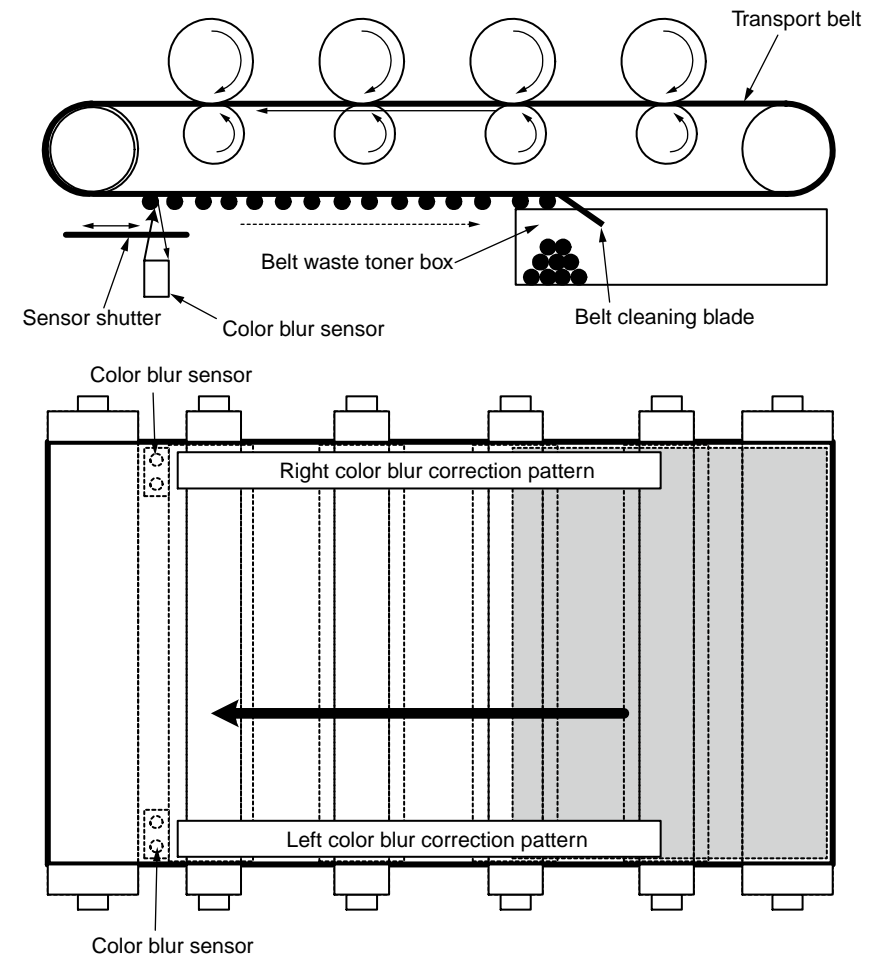

### Error-confirming method and Error-solving method

Use the color blur correction test function in self-diagnostic mode to confirm the error. (See 5.3.1.6)

### Error solving method

- CALIBRATION(L or R), DYNAMICRANGE(L or R)

Check 1: When the above display appears, please check the connection of sensor cable (FFC).

When the connection is abnormal, please set it properly.

Check 2: Please check if the surface of the sensor is dirty with the toner and paper melts etc.

Check 3: Please confirm if the open and close operation of sensor shutter is normal by utilization of MOTOR&CLUTCH TEST in self-diagnostic mode. Exchange the shutter unit when the open and close operation is in trouble.

If there are no problems in check 1, 2, and 3, please check the circuit.

Please exchange the color adjust sensor PCB, relay PCB, PU PCB, and the cable one by one, and then check if the error is displayed.

- BELT REFLX ERR

Check 4: When this display appears, please check the cleaning of the toner left on the surface of the belt after finishing the above-mentioned check 1, 2, and 3. Remove the belt unit, and rotate the left inboard drive gear. Please confirm that the surface of the belt is cleaned completely.

When the residual toner left on the surface of the belt could not be cleaned completely even if the drive gear is rotated, please exchange the belt unit.

- (Y or M or C) LEFT, (Y or M or C) RIGHT, (Y or M or C) HORIZONTAL

Check 5: When the above display appears, please confirm if the toner of NG color is empty.

Please exchange the toner cartridge as required.

## General of the density correction

The density correction is operated by reading the pattern for correction printed on the belt with a sensor set in the sensor shutter under the belt unit.

### Density correction auto-start timing

- The environment is remarkably different from last time when the power is on.
- When one or more ID count among the four ID count show the status of new part, at the power on
- The ID count value exceeds 500-count from last operation.
- When one or more UD is replaced with the new ID.
- When the belt is replaced with the new belt
- When toner cartridge is replace due to Toner Low, or Toner Empty so that Toner Low or Toner Empty has disappeared

The amount of toner of the pattern, the toner dirt and the open-close trouble of the shutter etc. may lead to correction error.

However, as the error message may not display even if the error is occurred, it is necessary to perform the density correction (see 5.3.1.7) by the utilization of the self-diagnostic mode and confirm the error display.

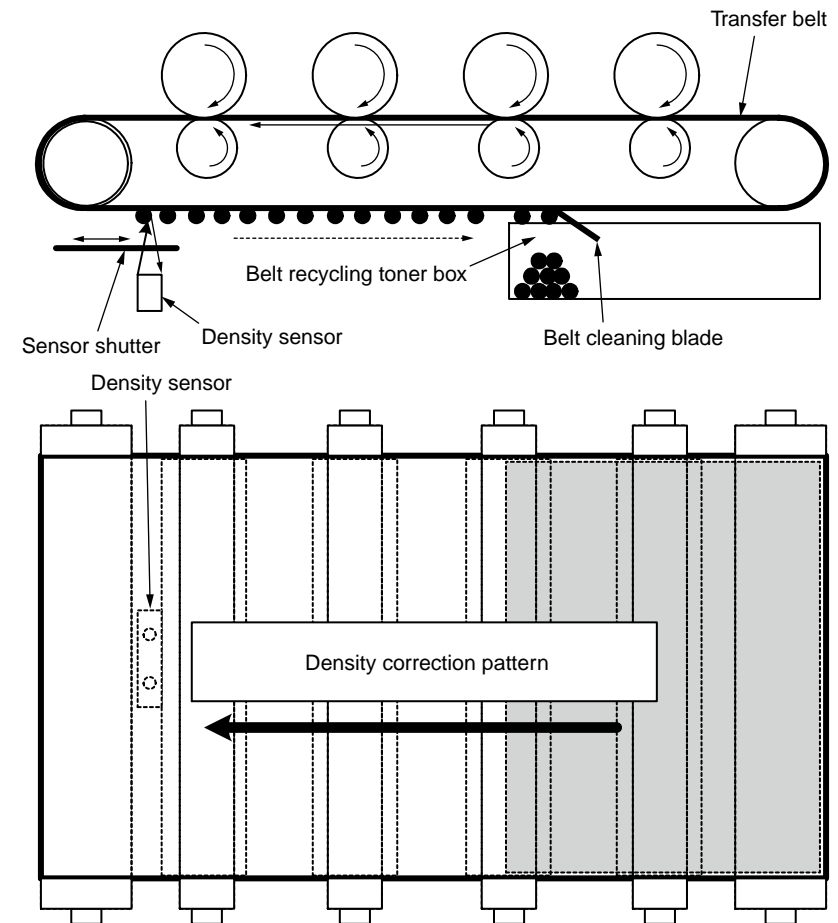

### Error-confirming method and Error-solving method

Use the density correction test function in self-diagnostic mode to confirm the error.

(See 5.3.1.7)

### Error solving method

- CALIBRATION ERR, DENS SENSOR ERR

Check 1: When the above display appears, please check the connection of sensor cable.

When the connection is abnormal, please set it properly.

Check 2: Please check if the surface of the sensor is dirty with the toner and paper melts etc.

Please wipe the dirt off if the sensor is dirty.

If there are no problems in check 1, 2, and 3, please check the circuit.

Please exchange the density sensor, relay PCB, PU PCB, and the cable one by one, and then check if the error is displayed.

- DENS SHUTTER ERR

Check 3: Please confirm if the open and close operation of sensor shutter is normal by utilization of MOTOR&CLUTCH TEST in self-diagnostic mode. Exchange the shutter unit when the open and close operation is in trouble.

- DENS ID ERR

Check 4: Remove the ID unit, and confirm if the toner abnormally leaves on the surface of the drum.

Exchange LED head (Focus control). Or exchange the ID unit.

When a new ID unit is tried to use, please set the fuse keep mode of the maintenance menu.

### Toner sensor detection principle

Toner low is detected by the toner sensor (reflect sensor) installed in the equipment. The light board is installed in ID, and its rotation is synchronized with the mixing of toner. Moreover, the shutter is installed in ID. Toner cartridge set properly by the lever of toner cartridge and synchronized toner sensor can be detected.

The following problems may lead to abnormal detection and the toner sensor error is occurred.

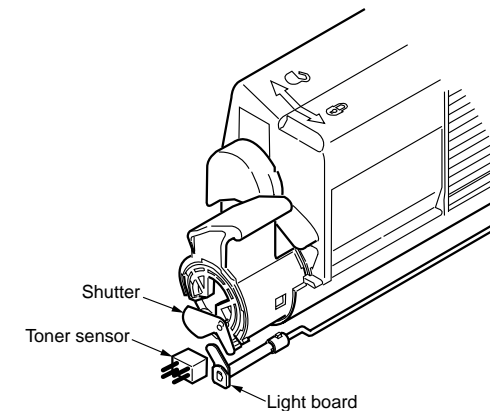

### Toner count principle

After the image data is transformed into binary data which can be printed by the printer, the data is counted as print dot number by LSI. The amount of the used toner is calculated from this count value, and the residual amount is displayed on the menu.

Toner LOW detection (residual amount display on LCD) by the toner sensor is to detect a certain amount of the reduction of the toner left in ID.

### The principle of ID counter, belt counter, fuse counter

- ID counter : when 3 pieces of A4 paper are continuously printed, one third of the rotation of the drum is set as one count.
- Belt counter : when 3 pieces of A4 paper are continuously printed, one third of the rotation of the drum is assumed as one count.
- Fuse counter : The length of paper of legal 13 inch is set as nominal value. If the length of paper is less than this nominal value, it is assumed as one count. If the length of paper is more than this nominal value, the counted number is determined by the times of legal 13 inch. (The number after decimal point is rounded up.)

## Counter spec

	Total printed page number	MPT printed page number	Tray 1 printed page number	Tray 2 printed page number	Tray 3 printed page number	Color-printed page number	Mono-printed page number
Description	Total printed page number	Hopping page number from MPT	Hopping page number from Tray1	Hopping page number from Tray2	Hopping page number from Tray3	Printed page number by color-printing	Printed page number by mono-printing
Count method A4 conversion or size independence	Count up after passing the writing sensor	Count up if MPF(MPT) hopping is finished	Count up if Tray1 hopping is finished	Count up if Tray2 hopping is finished	Count up if Tray3 hopping is finished	The page number is counted up by detecting the paper passing the fuser in color-printing mode after the job is finished. (1*) The value is A4/Letter value. Please refer to A4/ Letter conversion table (P31).	The page number is counted up by detecting the paper passing the fuser in mono-printing mode after the job is finished. (1*) The value is A4/Letter value. Please refer to A4/ Letter conversion table (P31).
Operation when paper jammed	Cannot count when paper feeding (hopping) jam and feed jam are occurred. It can count except the above-mentioned jam. As total printed page number is counted up when the front end of the page passes the writing sensor, according to the jam type, the feeding jam (380) is also included in the limits for counted.					Cannot count if the jam is occurred before the paper passes the fuser. It can count if the jam is occurred after the paper passes the fuser.	
Operation for Duplex	Front/Back count(+2)	Only front count (+1)				Double count If the color page and mono page exist together, the color printing page number would be plus 1 and the mono printing page number would be plus 1.	
Reset condition	None	None				1)When "Format Flash ROM" of system maintenance menu is performed. 2) When CU PCB is replaced. 3) When MENU RESET of system maintenance menu is performed. 4) When CU PCB is replaced.	
Value storage destination	PU	PU	PU	PU	PU	CU	CU
Menu/MenuMap output	○(*2)	○	○	○	○	○	○
EngineMenuMap output	○	○(*3)	○(*3)	○(*3)	○(*3)	-	-

\*1. Count cannot be updated if the power is turned off when the jam is occurred.

\*2. In the initial state MenuMap output is not available. It is possible to switch in the system maintenance menu.

\*3. EngineMenuMap output divides into Engine Menu Print (the first page) and Engine EEPROM Dump Print (the last page), however, the number of paper fed from each tray is output only to the latter one (DUMP display only).

A4/Letter conversion table

The paper is counted up as this sheet.

Paper size	Simplex	Duplex
LETTER	1	2
EXECUTIVE	1	2
LEGAL14	1	2
LEGAL13.5	1	2
LEGAL13	1	2
A4	1	2
A5	1	2
A6	1	-
B5	1	2
COM-9	1	-
COM-10	1	-
MONARCH	1	-
DL	1	-
C5	1	-
CUSTOM	1	2
CUSTOM LENGTH > 330mm	2	4
CUSTOM LENGTH > 900mm	4	-

# 3. Set up

---

3.1 Notes and precautions.....	33
3.2 Unpack method .....	34
3.3 Setting method .....	35
3.4 List of equipments and accessories .....	36
3.5 Assembling method .....	37
3.6 Setting content print (Configuration).....	56
3.7 Connecting method .....	57
3.8 User used Paper confirmation .....	59



## 3.1 Notes and precautions

### Warning

- Do not set it in any high-temperature locations or near any heat sources.
- Do not set it in a place where the chemical reaction may occur (laboratory etc.).
- Do not set it near any liquid that may ignite such as alcohol and thinner.
- Do not keep it out of reach of children.
- Do not place it on an unstable or uneven surface (unstable table and slanting place, etc.).
- Do not put it in direct sunshine. And do not put it in a moist or dusty place.
- Do not set it in wet or corrosive environment.
- Do not set it in a place where may cause vibration.
- If the printer is dropped down or the cover is damaged, please pull out the power plug from the outlet and contact the customer center.  
This may cause an electric shock, fire, injury.
- Please read this manual carefully before connecting the power supply cable, printer cable, ground cable.  
This may cause fire.
- Do not insert any foreign objects into the vent hole.  
This may cause an electric shock, fire, injury.
- Do not put a vessel(s) filled with water on the printer.  
This may cause an electric shock, fire.
- Do not touch the fuser unit when you open the cover of the printer.  
It is hot and could cause burns.
- Do not throw the toner cartridge, the image drum cartridge into the fire.  
It may cause burns due to dust explosion.
- Do not use inflammable sprays near the printer.  
It may cause fire because some parts in the printer may become very hot.
- If the cover becomes abnormally hot, smoke rises, it smells strange or it sounds abnormal, please pull out the power plug from the outlet and contact the customer center.  
It may cause fire.

### Warning

- If the liquid such as water enters the printer, please pull out the power plug from the outlet and contact the customer center. It may cause fire.
- If you drop the foreign objects such as clip in the printer, please pull out the power plug from the outlet and take the foreign objects out.  
This may cause an electric shock, fire, injury.
- Do not disassemble the printer unless following the correct procedure written in the manual. This may cause an electric shock, fire, injury.

### Caution

- Do not set it in a place where the vent hole of the printer is blocked.
- Do not set it directly on heavy wool or shag carpet.
- Do not place it in locations of poor ventilation such as enclosed areas.
- Give particular attention to adequate ventilation care when using it continuously in a narrow room for a long time.
- Do not place it close to strong magnetic fields and noise source.
- Do not place it next to the monitor and television.
- Hold tightly the both sides of the printer when you move the printer.
- Because the weight of the printer is approximately 33kg (in a state of packing), it needs more than two adults to lift it up.
- Do not come close to the paper exit part while printing.  
This may cause injury.

Please explain the safety precautions about installation and handling with showing the all precautions in user's manual to customer. Especially, the details about power supply cable and the ground cable must be explained completely.

## 3.2 Unpack method

### **Warning**

Personal injuries may occur.



Because the weight of the printer is approximately 33kg  
(in a state of packing), it needs more than two adults to lift it up.

- Take out the gripe on each side as shown in the following figure, and lift the cardboard box up.

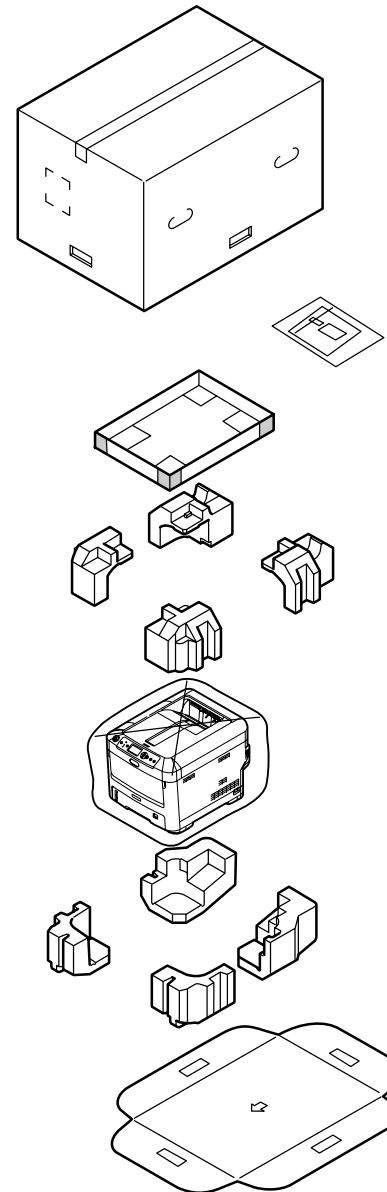
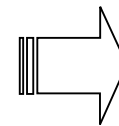
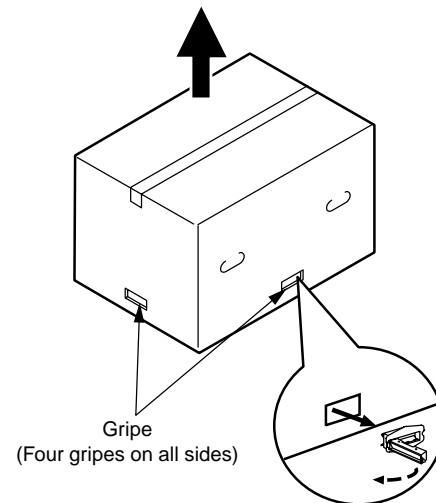

## 3.3 Setting method

- Set the printer under these conditions.
  - Surrounding environment: : 10~32°C
  - Surrounding humidity: : 20~80%RH (Relative humidity)
  - Highest wet bulb temperature: : 25°C
- Protect the printer from dew formation.
- Use the humidifier or the static electricity prevention mats etc. when setting the printer in the environment where the humidity is 30% or less.

### Set space

- The flat desk should be wide enough to put the printer on.
- Ensure that there is enough room around the printer for proper ventilation.

Plan view

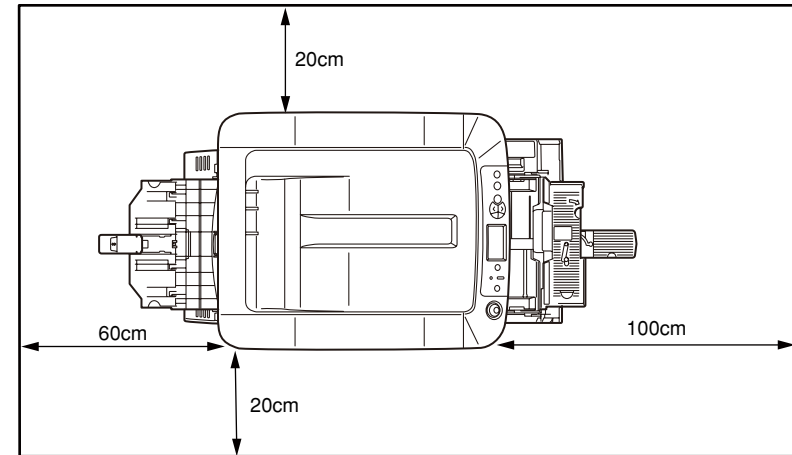

Side view

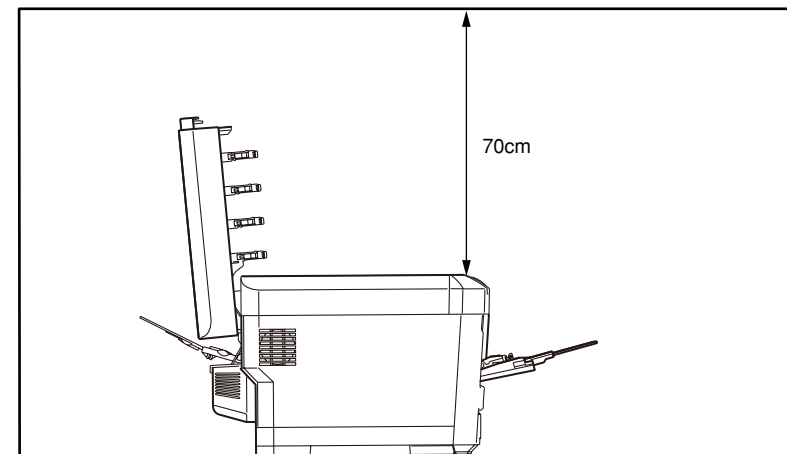

## 3.4 List of equipments and accessories

- Make sure that the appearance of the equipment is not damaged or dirty etc.
- Make sure that the following accessories are supplied with your printer.
- If you are missing any of these accessories, contact your customer service department immediately.

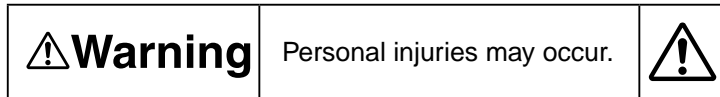

Because the weight of the printer body is approximately 28kg (33kg in a state of packing), it needs more than two adults to lift it up.

- Printer (Body)

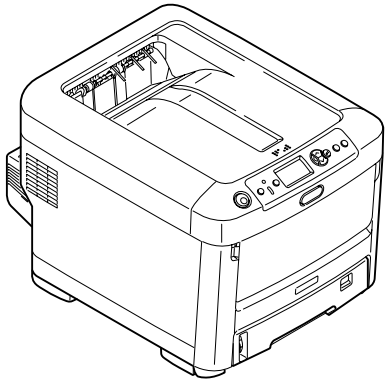

- Image drum cartridge (1 Cyan, 1 the magenta, 1 yellow, and 1 black)  
(mounted in the printer)

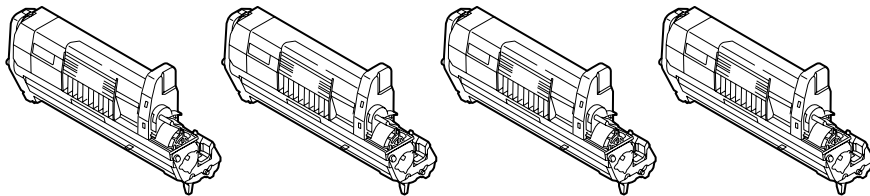

Explain to the customer that the toner cartridge and the image drum cartridge can be separated.

- Printer software CD-ROM
- Power supply cord
- Guarantee card and user registration card
- User's manual (Setup)
- User's manual (CD-ROM)

**Notes!** The printer cable is not included.

## 3.5 Assembling method

### 3.5.1 Assemble the main body of the printer

Remove the protective materials.

- (1) Peel off the desiccant and the protection tape (four places) on the printer.

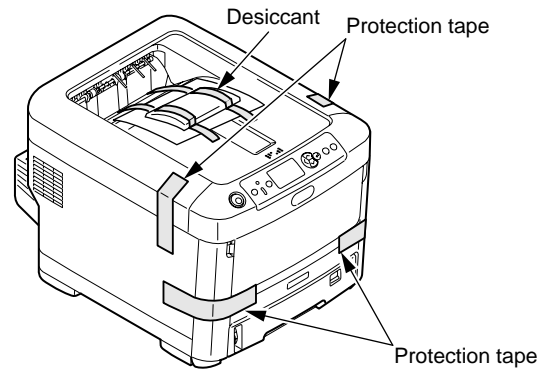

- (2) Peel off the paper on the front of printer.

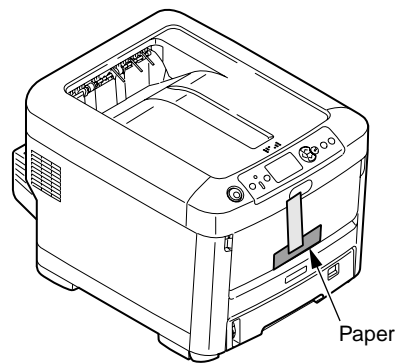

- (3) Peel off the protection tape (2 places) on the back of the printer.

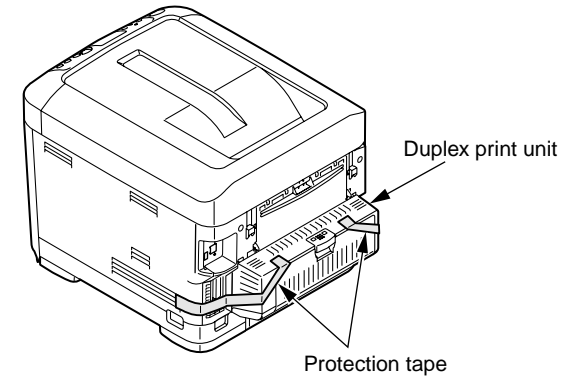

- (4) Confirm that the duplex print unit is fixed tightly.

- (5) Pull the paper cassette out.

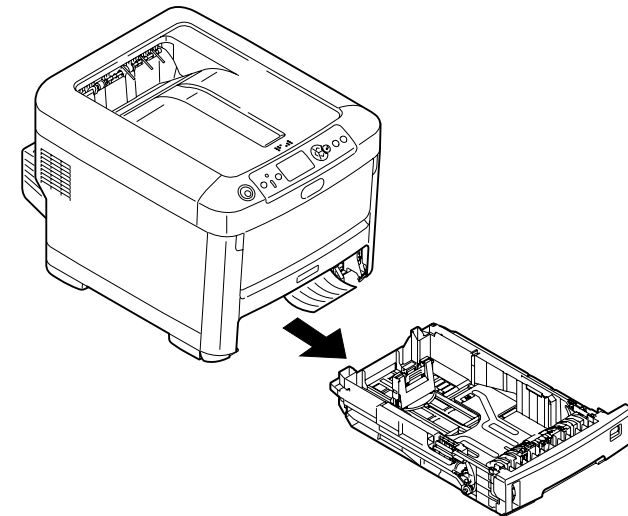

- (6) Pull the retainer out in the direction of the arrow (1). Return the paper cassette to the main body of the printer.

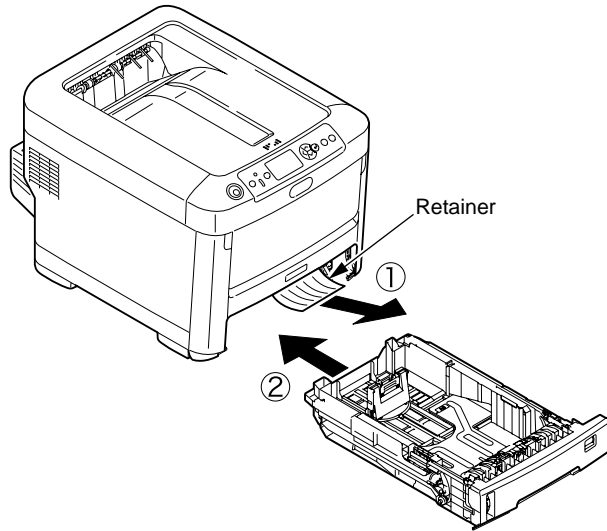

- (7) Press down the OPEN button, and open the top cover.

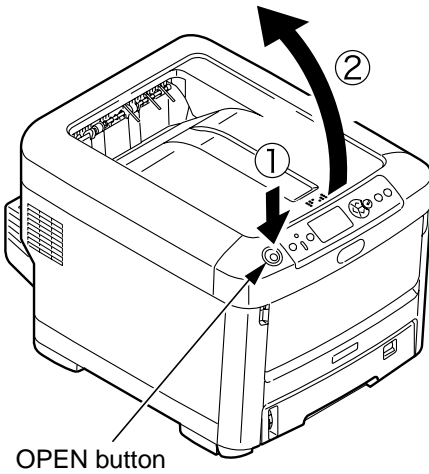

- (8) Remove the stopper (orange) when pressing down the lever of the fuser unit (blue) in the direction of arrow ①.

**Note!** If you do not use the printer for a long time or transport it, please use the stopper. Please keep it carefully.

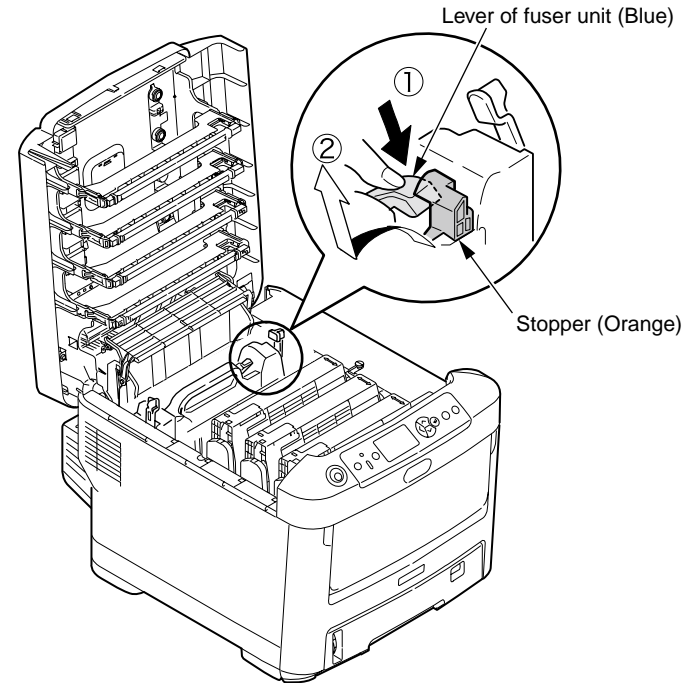

## Set the image drum cartridge.

- (1) Take the image drum cartridge (four) out slowly.

**Note!**

- The image drum (green cylinder) is very fragile. Please pay special attention to handling it.
- Do not expose the image drum cartridge to direct sunshine and strong light (about 1500 lux). And do not expose it to room light for more than 5 minutes.

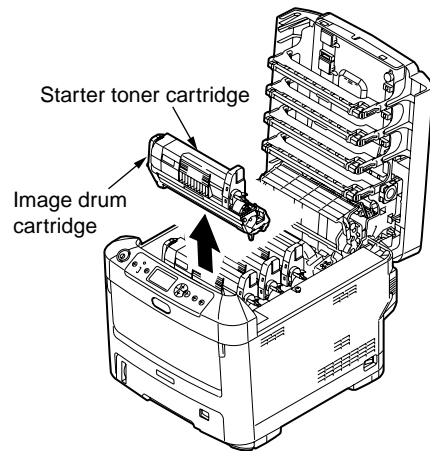

- (2) Put the image drum cartridge on the newspaper etc, peel off the tape of protection sheet 1 and pull it out in the direction of the arrow.

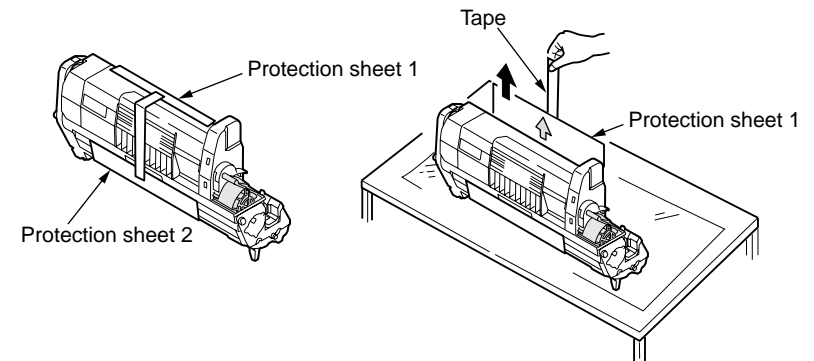

- (3) Pull the protection sheet 2 out from image drum cartridge in the direction of arrow.

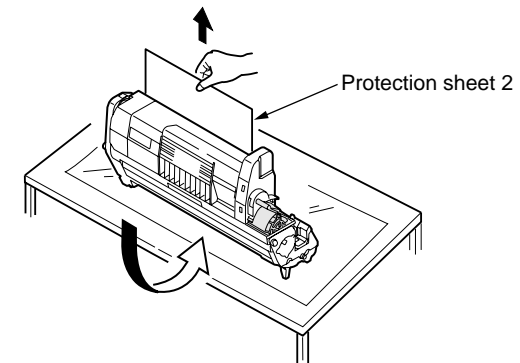

- (4) Remove all protection sheets from the image drum cartridge.

(5) Return the image drum cartridge back to the printer.

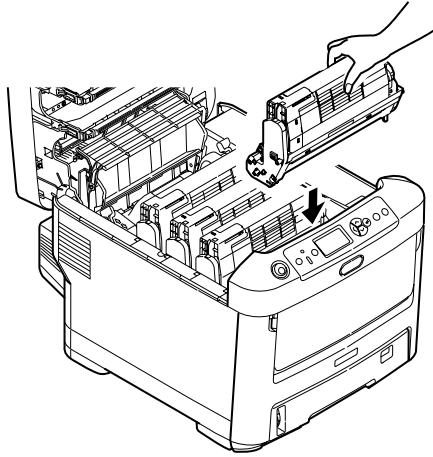

(6) Close the top cover.

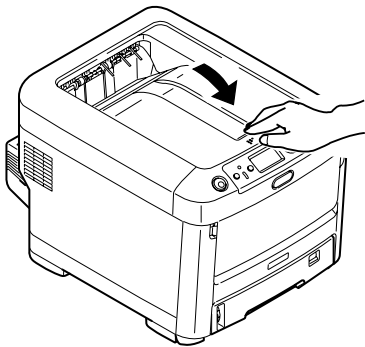

**Note!** If the message of [please exchange the toner] on the control panel doesn't disappear indefinitely, please make sure that the lever of the toner cartridge is fully moved in the direction of the arrow.



## Set the paper into the paper cassette.

- (1) Pull out the paper cassette.  
Do not peel off the rubber attached to the plate.
- (2) Adjust the paper stopper and the paper guide to match the size of the paper, and then fix them tightly.

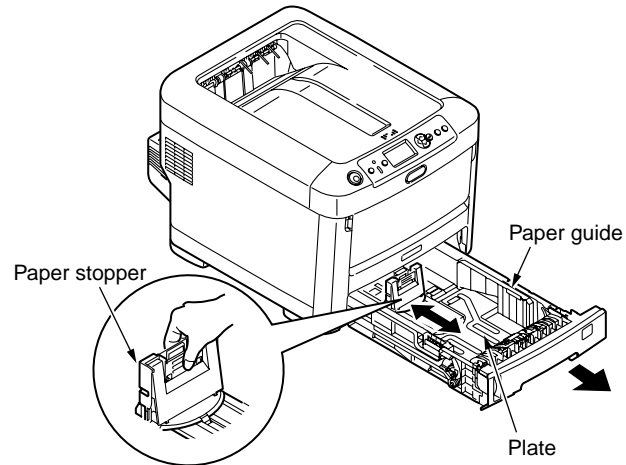

- (3) Flex the paper back and forth. Do not fold or crease the paper. Straighten the edges on a level surface.

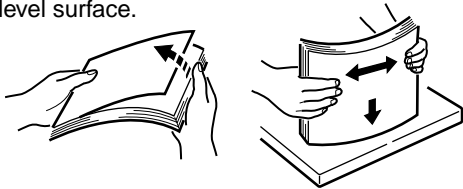

- (4) Place the paper in the cassette with the side to be printed facing down.

- Notes!**
- Place the paper with the top of the page nearest the paper cassette tab.
  - Do not place the paper higher than the "▽" mark on the paper guide. (530 pieces for 70kg paper)

- (5) Place the paper in position by paper guide.
- (6) Rotate the paper size dial to match the paper.
- (7) Return the paper cassette back to the printer.

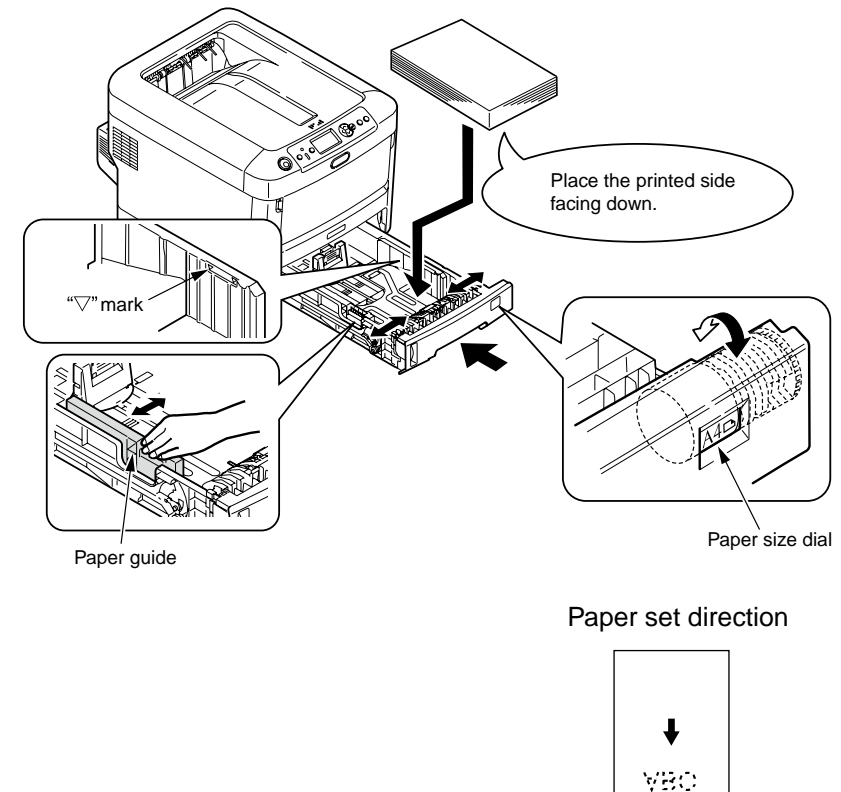

## Set the paper in multi-paper tray.

- (1) Open the multi-paper tray, and open the paper supporter.

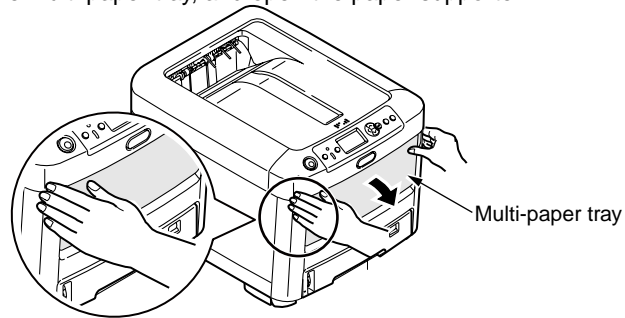

- (2) Match the manual insertion guide to the size of the paper.  
 (3) Flex the paper back and forth. Straighten the edges on a level surface.

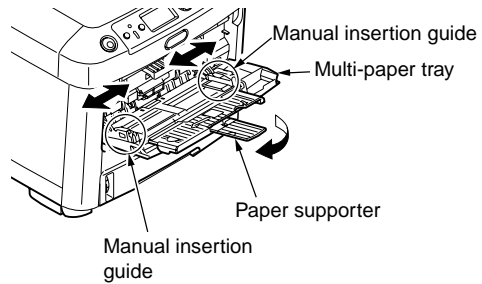

- (4) Place the printed side facing up, and insert the paper along the manual insertion guide straightly until bumping up.

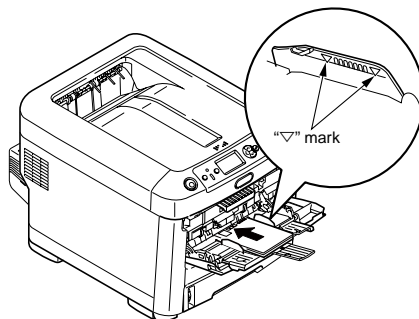

**Note!** Set papers so that paper should not exceed the "▽" mark. (100 sheets of paper with ream weight of 70 kg or 10 envelopes)

- (5) Press down the set button.

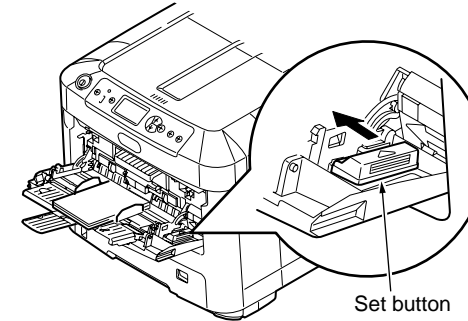

## 3.5.2 Cable connect

### Power condition

- Keep the following items.  
AC voltage : 110~127V ± 10%/ 220~240V ± 10%  
Frequency of the power supply : 50Hz or 60Hz ± 2Hz
- Use the voltage adjusting transformer etc. when the power supply is unstable.
- The maximum power consumption of this printer is 1,200W. Confirm the power supply can provide enough power.
- The operation with UPS (uninterruptible power supplies) is not guaranteed.  
Explain to the customers that do not use UPS (uninterruptible power supplies).

<b>Warning</b>	It may cause an electric shock, fire.	
<ul style="list-style-type: none"> <li>• Installation and removal of the power supply cord and the ground cable must be performed after pressing down the power switch to OFF.</li> <li>• Please connect the ground cable with a specified ground terminal. Please contact the dealer if you cannot get it.</li> <li>• Be careful not to connect it with the lightning rod, the water pipe, the gas pipe, and the earth of the telephone wire.</li> <li>• Connection of the ground terminal must be performed before inserting the power plug into the power outlet. And, removal of the ground terminal must be performed after pulling the power plug out of the power outlet.</li> <li>• Please hold the power plug to disconnect or plug in the power supply cord.</li> <li>• Please insert the power plug firmly into the outlet.</li> <li>• Do not pull out or plug in the power plug with wet hands.</li> <li>• Do not locate the printer in a place where the cord may be abused by persons walking on, and do not place the heavy objects on the power cord.</li> <li>• Do not use the power supply cord that is bundled or connect the power supply with an extension cord.</li> <li>• Do not use a damaged power supply cord.</li> <li>• Do not use a multiple outlet extension cord.</li> <li>• Please connect this printer into an outlet different from that to which other electric products is connected. Especially, the operation of the printer might be affected by the electrical noise when the printer is connected simultaneously with the air-conditioner, the copier and shredder etc. Please use the noise filter or the noise cut-off transformer sold at the market if you have to connect the printer into a same outlet.</li> <li>• Please use the attached power cord and insert it into the outlet directly. Do not use an unspecified power cord.</li> <li>• Do not use an extension cable. Please use a cable that is more than 15A current rating if you have to use an extension cable.</li> <li>• If the extension cord is used, the printer might operate abnormally by the decrease of AC voltage.</li> <li>• Do not unplug the power cord or switch off the power during printing.</li> <li>• Please unplug the power cord if you do not use the printer for a long time (long vacation or travel etc).</li> <li>• Do not use the attached power cord of this printer to the other electric products.</li> </ul>		

Explain completely the connection of the power supply cable and the ground cable with showing the user's manual to customer.

### Connect the power cord.

**Note!** Confirm that the power switch is turned to OFF "O".

- (1) Insert the power cord into the printer.

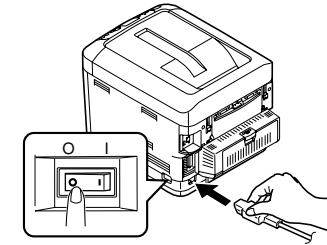

- (2) Connect the ground cable with the ground terminal of the outlet.

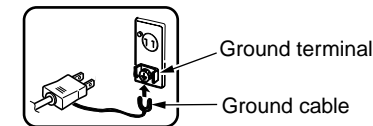

**Warning** It may cause an electric shock. 

The ground cable must be connected.

- (3) Insert the power plug into the outlet.

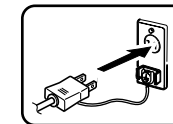

### Press down the power switch to ON (|).

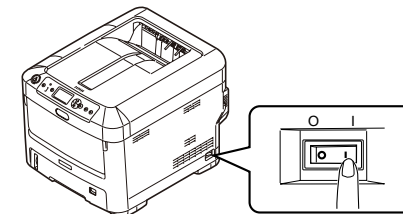

If the printer is completely started up, the message "Can print" would be displayed on the control panel shown as follows.

**Note!** When the printer is getting cold, it may lead to error if the power is turned on. (Error number 126,171,175,177,320). At this time, please turn off the power and wait for a while, and then turn on the power again.

## Turn the power off.

**Note!** If you turn off the power without properly shutting down, it may cause damage to the printer. Please follow the following procedure to turn the power off.

- (1) Press down the  [Return] switch for more than 4 seconds, the [shutdown menu] message would display.

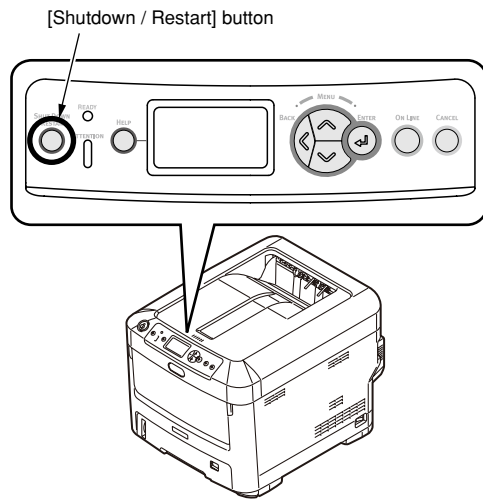

- (2) Press down the  [Set] switch.  
If the message [shutdown] is displayed, the shutdown operation would start.
- (3) If the message [Turn off the power/shutdown completely] is displayed, press down the power switch to OFF "O".

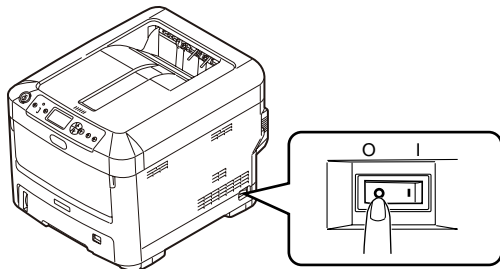

## When you do not use the printer for long time

Please explain to the customer about the following items.

Unplug the power cord if you do not use the printer for a long time (long vacation or travel etc).  
Install the stopper to the fuser.

**Note!** Please remove the ground terminal after pulling the power plug out of the power outlet.

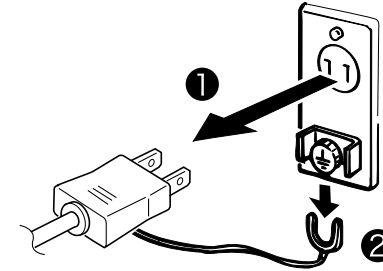

**Note!** Even if the power plug of this printer is pulled out for a long time (four weeks or more), the functional problems will not be caused easily. However, please explain to the customer that the deterioration of consumable such as toners and the image drums is not guaranteed.

### 3.5.3 Optional part installation and confirmation

#### (1) Installation of the optional tray unit (second/ third tray)

It is a traditional paper tray for adding paper into printer.

530 pieces of 70kg paper can be set. Using it with a standard paper cassette and a multi-purpose tray can print 1690 pieces of pages continuously.

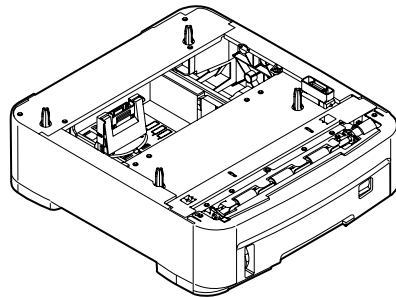

(1)-1. Turn the printer power to OFF and pull out the power cord from the outlet.

Turn the power off with following the procedure in chapter 3.5.2 [Turn the power off.].

- Notes!**
- If you turn off the power without properly shutting down, it may cause damage to the printer. Please operate the [shutdown menu].
  - It may cause damage to the printer, if you install the optional tray with power ON.

(1)-2. Install the optional tray unit to the printer.

**Note!** Because the weight of the printer body is approximately 31kg, it needs more than two adults to lift it up.

- ① Match the tab into the hole in the bottom of the printer.
- ② Put the printer on the optional tray unit slowly. Please remove it following the steps 1-2 in reverse order.

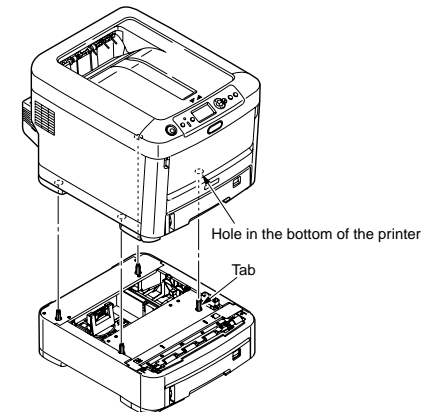

**Note!** When you install two optional trays to the printer, set the optional tray directly on top of the other optional tray, and then put them on the printer.

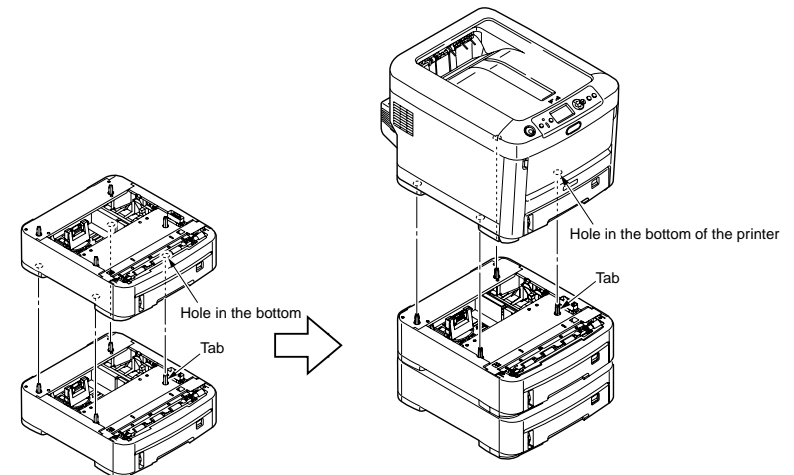

(1)-3. Connect the power cord and printer cable to the printer and turn the power on.

**Note!** If the message [SERVICE CALL182:FATAL ERROR] is displayed, reinstall the optional tray unit.

(1)-4. Print the setting content and confirm if the option tray unit is installed properly.

- ① Print the setting content with following the procedure in chapter 3.6.
- ② Confirm the content of [tray 2] is display in header part.

```

Tray Sequence : Down
Unit of Measurement : millimeter
Tray1 Config
Paper Size : Cassette Size
Media Type : Plain
Media Weight : Medium Light
Tray2 Config
Paper Size : Cassette Size
Media Type : Plain
Media Weight : Medium Light
  
```

**Note!** If the content of [tray 2] is not displayed, reinstall the second tray unit.

(1)-5. Set the number of tray by the printer driver.

The printer driver setup for recognizing the option tray unit is required.

If the printer driver is not set up, please set up the printer driver completely referring to the user's manual (Setup) firstly, and then finish the following setting procedure.

**Note!** The authority of the computer administrator is required.

For windows PS printer driver

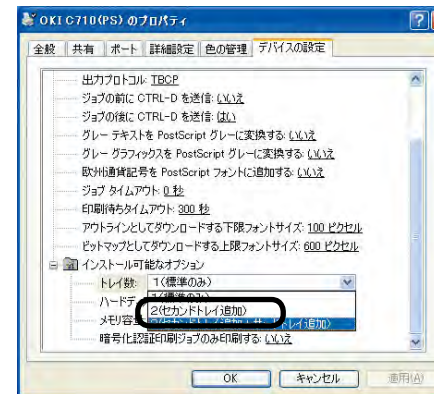

(For Windows XP)

- ① For Windows Vista, click on [start] => [control panel] => [printer].  
For Windows XP, click on [start] => [control panel] => [printer and other hardware] => [printers and faxes].  
For WindowsServer 2003, click on [start] => [printers and faxes].  
For Windows 2000, click on [start] => [Settings] => [printers].
- ② Click the [C710(PS)] icon with right-click button on your mouse and choose the [Properties].
- ③ Choose [get information from printer] from [installable options] in [Device options] tab, and click [setup] or [get information from printer]. For USB connection, set [Optional paper source] manually.
- ④ Click [OK].

For Windows PCL XPS printer driver



(For Windows XP)

- ① For Windows Vista, click on [start] => [control panel] => [printer].  
For Windows XP, click on [start] => [control panel] => [printer and other hardware] => [printers and Faxes].  
For WindowsServer 2003, click on [start] => [printers and faxes].  
For Windows 2000, click on [start] => [Settings] => [printers].
- ② Click [C710(\*\*)] (\*\* is PCL or PCL XPS (printer driver type)) icon with right-click button on your mouse and choose [Properties].
- ③ Choose [get information from printer] in [Device options] tab. For USB connection, input the optional tray number in [Optional devices] manually.
- ④ Click [OK].

For Macintosh

When the optional device has been added into in Macintosh before installing the printer driver, the device information is gotten automatically. Please finish the following procedure to set up the optional device, if you want to add an optional device after installing the printer driver.

For network connection

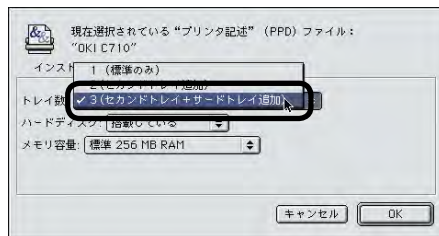

- ① Select the printer in [select], and click [reset].
- ② Click [Configurations].
- ③ Choose [Optional paper source], and click [OK].
- ④ Close [select].

For USB connection

- ① Drag the printer icon on the desktop to the Recycle Bin, and empty it.
- ② Use the desktop printer Utility to reset desktop printer. If desktop printer is reset, the setting should also be updated.

**Memo** Please refer to [desktop printer setup] of [Set up for USB connection in Macintosh] in user's manual (Setup) for the desktop printer setup method.

For Mac OS X

When the optional device has been added into in Mac OS X before installing the printer driver, the device information is gotten automatically. However, if the printer is connected by [IP print] and [Bonjour (Rendezvous)], the device information could not be gotten automatically.

If the printer is connected by [AppleTalk], the device information could also not be gotten automatically when the optional device has been added into in Mac OS X before installing the printer driver.

Please finish the following setting procedure for above.

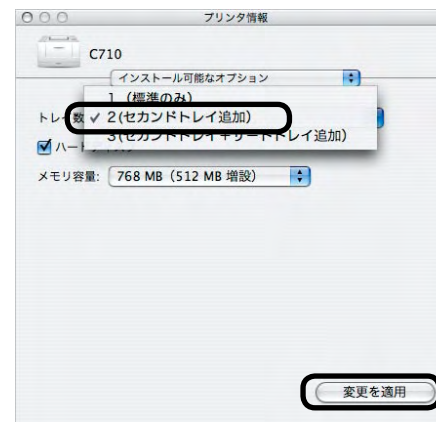

- ① Double-click [Applications] for hard disk => [utility] => [print setting utility] ([Applications] => [Utility] => [print center] in Mac OS X)
- ② Select [C710], click [Show info] and open [printer info].
- ③ Choose [installable options].
- ④ Select the [Optional paper source], and click [Apply].
- ⑤ Close [printer info].

## (2) Installation of duplex unit

This unit is used for printing on two sides of paper.

**Note!** For two-sides printing, it is recommended to add expansion memory. For details, see "Expansion memories."

Type: DXU-C4D

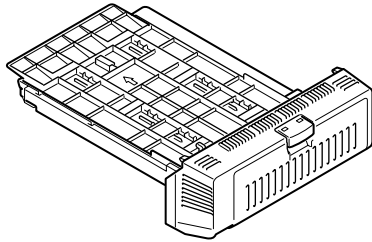

### (2)-1. Turning OFF the printer power and disconnecting the power cord

**Note!** If an expansion memory is installed with the power switched ON, the printer may be broken.

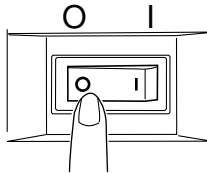

### (2)-2. Peeling the protective tapes off the duplex unit

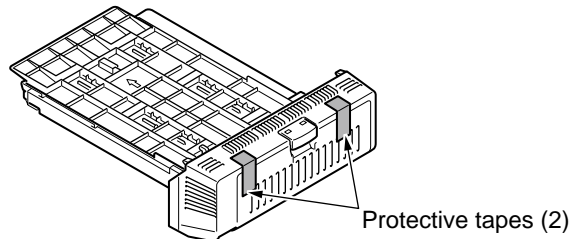

### (2)-3. Install Duplex Unit

- ❶ Insert the duplex unit into the lower part on the back of the printer as far as it will go.
- ❷ Ensure that the claw on either side of the duplex unit is securely accommodated in the hole of the printer.

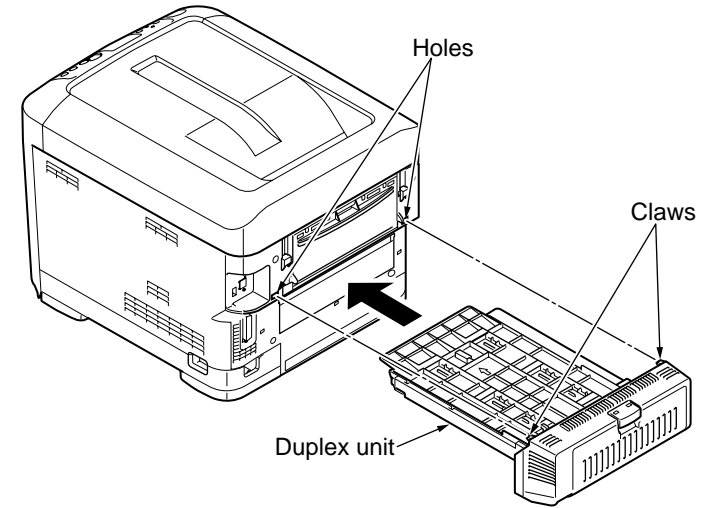



(3) Add the optional memory.

It is used to increase the memory capacity of the printer.

Please add the optional memory as following problems occur:

“Out of memory” error [memory overflow] occurs when printing complex data.

Combination print error occurs when printing the whole file at once.

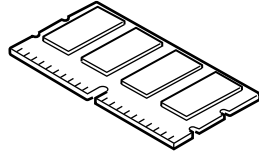

Optional memory

Type name	Memory capacity (Total memory capacity)
None (Standard)	256MB (256MB)
MEM256E	+256MB (512MB)
MEM512C	+512MB (768MB)

- Notes!**
- The operation cannot be guaranteed when using an unspecified product. Please use OKI product.
  - It is recommended to add 256MB optional memory when long size printing.
  - The slot for memory is one slot.

(3)-1. Turn the power of printer off, and pull out the power cord.

Turn off the power with following the procedure in chapter 3.5.2 [Turn the power off].

- Notes!**
- If you turn off the power without properly shutting down, it may cause damage to the optional memory. Operate the [shutdown menu].
  - It may cause damage to the printer, if you install the optional memory with power ON.

(3)-2. Open the top cover and front cover.

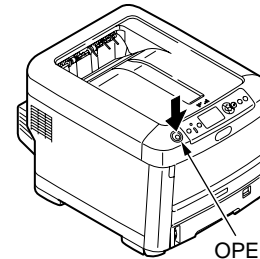

OPEN button

- ① Press down the OPEN button, and open the top cover.

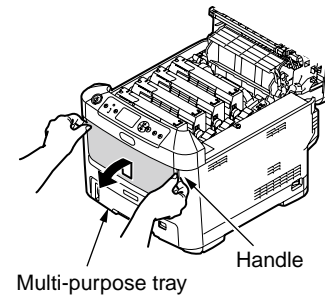

Multi-purpose tray

Handle

- ② Open the multi-purpose tray.

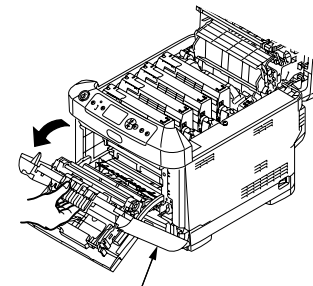

Front cover

- ③ Pull up on the handle (blue) at the center of the front cover, and open the front cover forward.

## (3)-3. Remove the side cover.

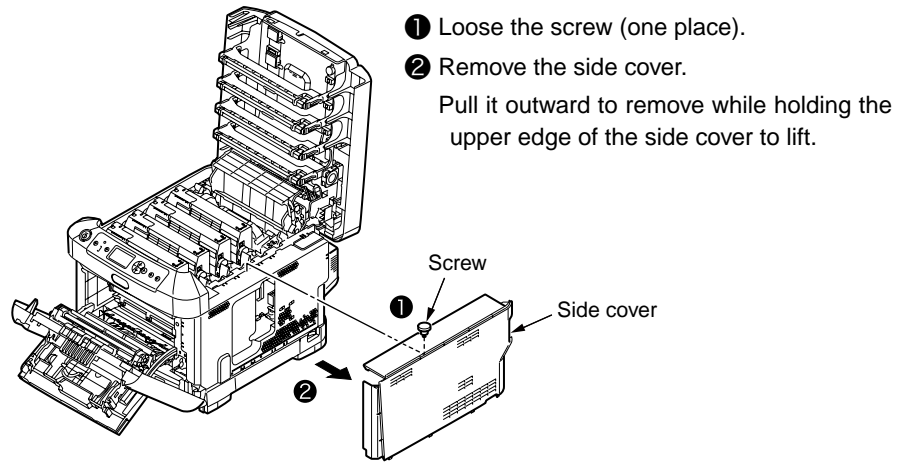

## (3)-4. Install the memory.

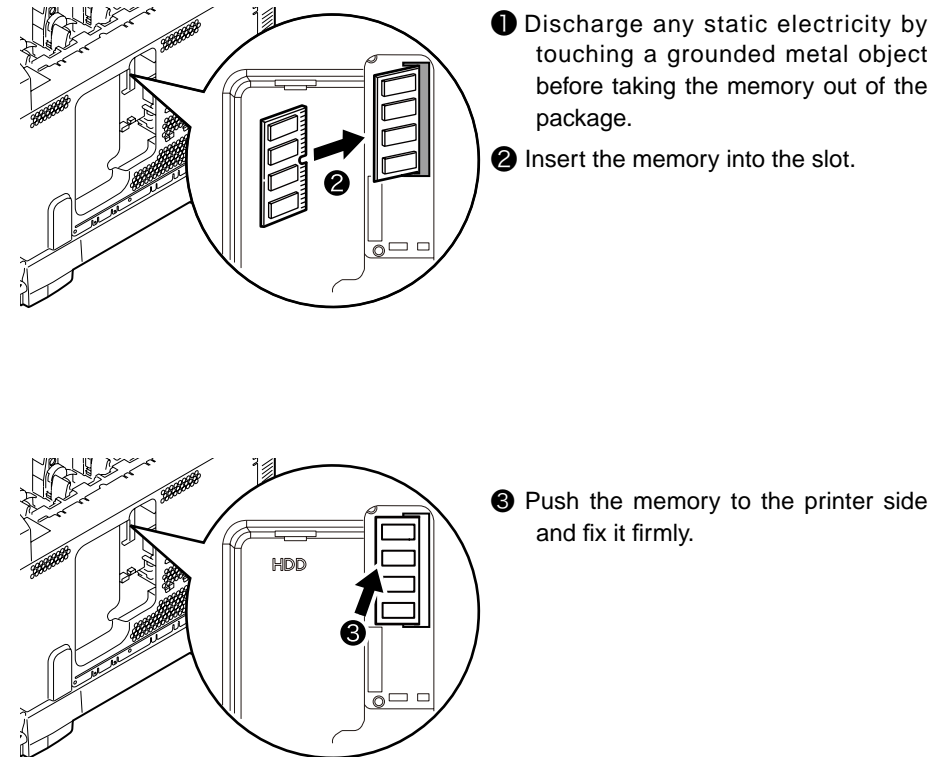

- Notes!**
- Do not touch any electrical parts and terminals of connectors.
  - Be careful to install the memory in the proper direction. A notch on the terminal of the memory is matched to the connector of the slot.

(3)-5. Install the side cover.

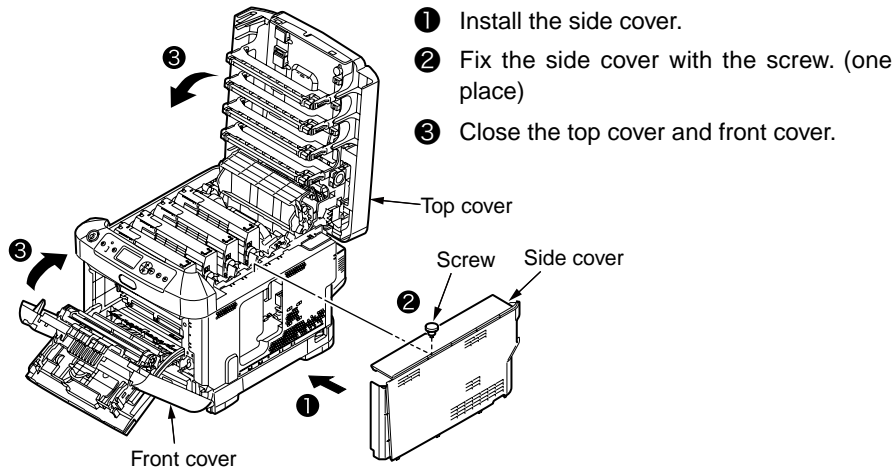

(3)-6. Connect the power cord and printer cable to the printer, and turn the power on.

**Note!** If the message [SERVICE CALL031:FATAL ERROR] is displayed, please reinstall the memory.

(3)-7. Print the setting content and confirm if the optional memory is installed properly.

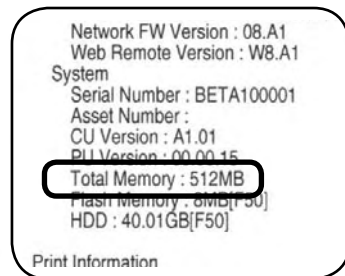

- ① Print the setting content with following the procedure in chapter 3.6.
- ② Confirm the total memory capacity displayed in [Total Memory] of [System] part.

**Note!** If total memory capacity displayed in [Total Memory] is incorrect, please reinstall the memory.

(4) Install the built-in hard disk.

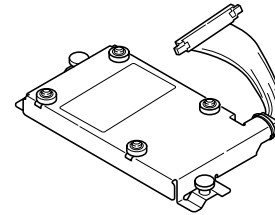

**Note!** Be careful that the font cannot be downloaded.

There are 2 types of built-in hard disk as C710n options.

- Standard built-in hard disk (Type name: HDD-C1B)  
 It is a built-in hard disk added to the printer.  
 It is used under following conditions:  
 Authentication print, print job save, buffer print operate  
 Combination print error occurs when printing the whole file at once.
- Data protection kit-A1 (Type name: DPK-A1)  
 Please refer to chapter 7.8.

One of the above hard disks could be installed.

(4)-1. Turn the power of printer off, and pull out the power cord.

Please turn off the power with following the procedure in chapter 3.5.2 [Turn the power off].

- Notes!**
- If you turn off the power without properly shutting down, it may cause damage to the printer. Please operate the [shutdown menu].
  - It may cause damage to the printer, if you install the optional memory with power ON.

(4)-2. Open the top cover and front cover.

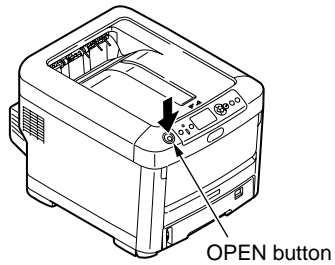

- 1 Press down the OPEN button, and open the top cover.

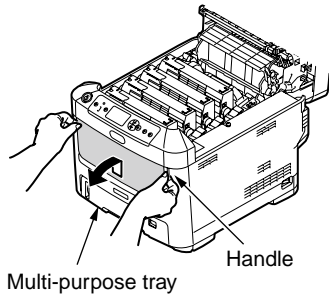

- 2 Open the multi-purpose tray.

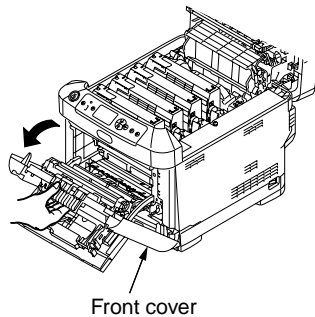

- 3 Pull up on the handle (blue) at the center of the front cover, and open the front cover forward.

(4)-3. Remove the side cover.

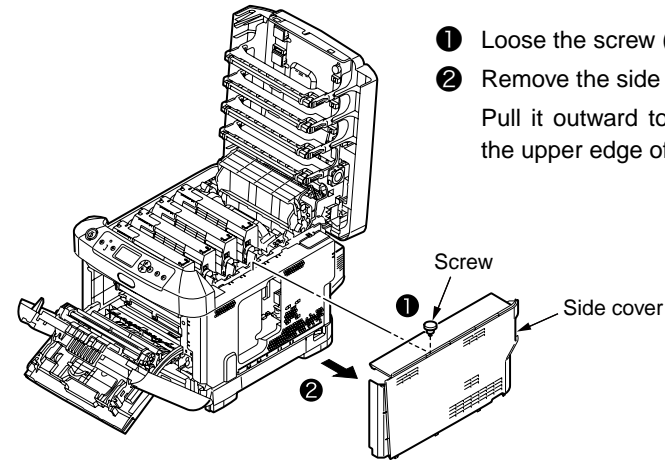

- 1 Loosen the screw (one place).
- 2 Remove the side cover.  
Pull it outward to remove while holding the upper edge of the side cover to lift.

## (4)-4. Install the built-in hard disk.

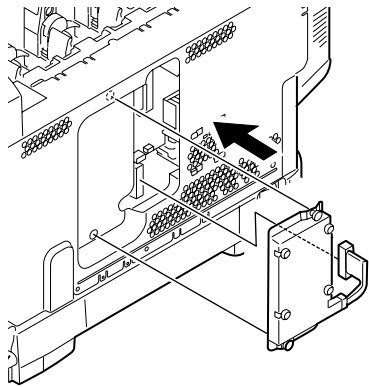

- ① Insert the tab of the built-in hard disk into the slot on the printer.
- ② Fix the disk with screws (2 places).
- ③ Push the connector into the slot until a slight click is heard.

## (4)-5. Install the side cover.

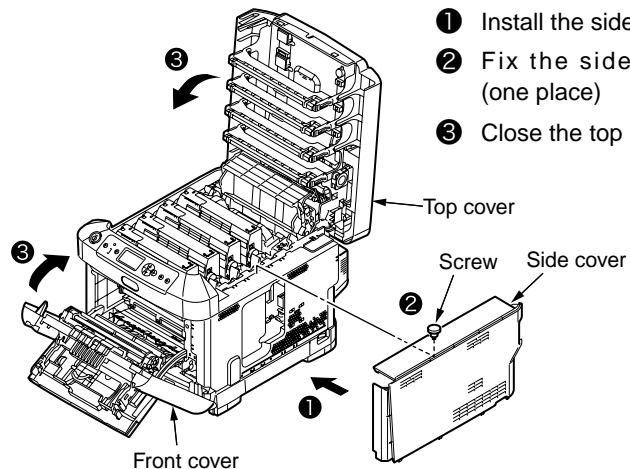

- ① Install the side cover.
- ② Fix the side cover with the screw. (one place)
- ③ Close the top cover and front cover.

## (4)-6. Connect the power cord and printer cable to the printer, and turn the power on.

## (4)-7. Print the setting content and confirm if the built-in hard disk is installed properly.

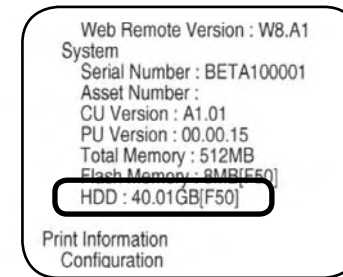

- ① Print the setting content with following the procedure in chapter 3.6.
- ② Confirm the built-in hard disk capacity displayed in [HDD].

**Memo** The capacity of built-in hard disk might be different from the example of the above figure.

**Note!** Please reinstall the built-in hard disk when the capacity of HDD is not displayed.

**Note!** Read the manual of the hard disk when you install the built-in hard disk for IC card authentication.

**Note!** Read the manual of the kit when you install data protection kit-A1.

And, the printer driver setup for recognizing the built-in hard disk is required.

If the printer driver is not set up, please set up the printer driver completely referring to the user's manual (Setup) firstly, and then finish the following setting procedure.

## (4)-8. Set [hard disk] by printer driver

**Note!** The authority of the computer administrator is required.

## For windows PS printer driver

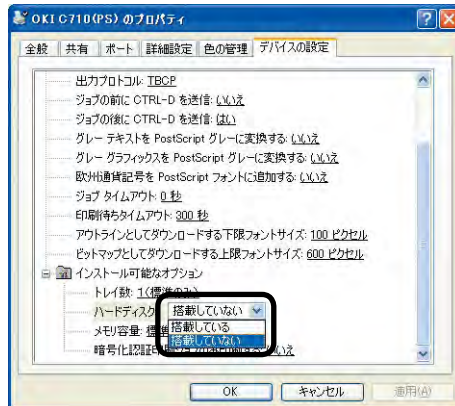

(For Windows XP)

- 1 For Windows Vista, click on [start] => [control panel] => [printer].

For Windows XP, click on [start] => [control panel] => [printer and other hardware] => [printers and Faxes].

For WindowsServer 2003, click on [start] => [printers and faxes].

For Windows 2000, click on [start] => [Settings] => [printers].

- 2 Click the [C710(PS)] icon with right-click button on your mouse and choose the [Properties].
- 3 Choose [get information from printer] from [installable options] in [Device options] tab, and click [setup] or [get information from printer]. For USB connection, set [Hard disk] as [Install] manually.
- 4 Click [OK].

## For Windows PCL XPS printer driver



(For Windows XP)

- 1 For Windows Vista, click on [start] => [control panel] => [printer].

For Windows XP, click on [start] => [control panel] => [printer and other hardware] => [printers and Faxes].

For WindowsServer 2003, click on [start] => [printers and faxes].

For Windows 2000, click on [start] => [Settings] => [printers].

- 2 Click [C710 (PCL)] icon with right-click button on your mouse and choose [Properties].
- 3 Choose [get information from printer] in [Device options] tab. For USB connection, select the option [Hard disk] manually.
- 4 Click [OK].

### For Macintosh

When the optional device has been added into in Macintosh before installing the printer driver, the device information is gotten automatically.

Please finish the following procedure to set up the optional device, if you want to add an optional device after installing the printer driver.

#### For network connection

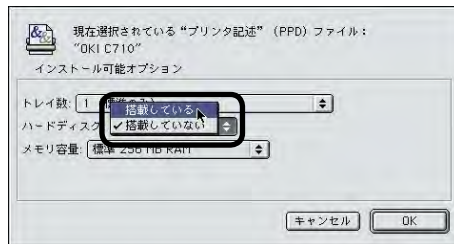

- ① Select the printer in [select], and click [reset].
- ② Click [Configurations].
- ③ Set [Hard disk] as [Install], and click [OK].
- ④ Close [select].

#### For USB connection

- ① Drag the printer icon on the desktop to the Recycle Bin, and empty it.
- ② Use the desktop printer Utility to reset desktop printer. If desktop printer is reset, the setting should also be updated.

**Memo** Please refer to [desktop printer setup] of [Set up for USB connection in Macintosh] in user's manual (Setup) for the desktop printer setup method.

### For Mac OS X

When the optional device has been added into in Mac OS X before installing the printer driver, the device information is gotten automatically. However, if the printer is connected by [IP print] and [Bonjour (Rendezvous)], the device information could not be gotten automatically.

If the printer is connected by [AppleTalk], the device information could also not be gotten automatically when the optional device has been added into in Mac OS X before installing the printer driver.

Please finish the following setting procedure for above.







- ① Double-click [Applications] for hard disk => [utility] => [print setting utility] ([Applications] => [Utility] => [print center] in Mac OS X)
- ② Select [C710], click [Show info] and open [printer info].
- ③ Choose [installable options].
- ④ Select the [Hard disk] option, and click [Apply].
- ⑤ Close [printer info].
- ⑥ Confirm the added printer is shown in [Printer list], and close [print center].



(For Mac OS X 10.2, choose the added printer, and select the option [Hard disk] of [Installable options] panel in [Show info] menu of [Printer], and click [Apply].)

## 3.6 Setting content print (Configuration)

To confirm the printer operates normally, please print the [Configuration].

- (1) Set A4 paper in tray.
- (2) Press the  button for several times so that [printer Information] is displayed, and press down the  button.
- (3) Press the  button and select [Configuration], press down the setting button.
- (4) Press down the  button.

The setting content print is started.

**Memo** When printing the network setting information (2 pieces Network Information), press the  button after (2), and press down the  button after [Network] is displayed.

(C710n sample)





## 3.7 Connecting method

### <USB connection>

**Note!** Please refer to user's manual for operation environment.

### Prepare for USB cable

- Notes!**
- The printer cable is not included.  
Provide the USB2.0 cable for special user.
  - When connecting the cable in [Hi-Speed] mode of USB 2.0, please use the USB cable with Hi-Speed spec.
  - Select the USB cable of less than 5m. It is recommended to use the USB cable of less than 2m.

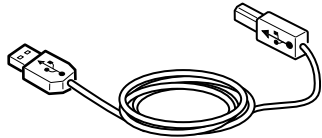

### Turn the printer and computer OFF.

**Memo** Although USB cable can plug-and-play with computer and printer power on, after this the setup of printer driver and USB driver may be required. Here the printer is turned off to plug-and-play the USB cable.

### Connect the computer to the printer.

- (1) Insert the USB cable into the USB interface connector of printer.
- (2) Insert the USB cable into the USB interface connector of computer.

**Note!** Do not insert the USB cable into the network interface connector. It may cause trouble.

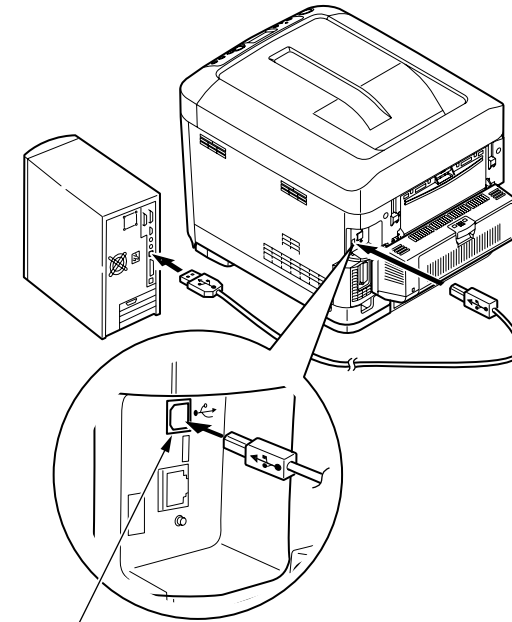

USB Interface connector

**Memo** Please refer to user's manual for setup of printer driver.

### < Ethernet cable connection >

**Note!** Refer to user's manual for operation environment.

#### Prepare for Ethernet cable

**Note!** The Ethernet cable and Hub is not included in printer.  
Provide the Ethernet cable and Hub for special user.

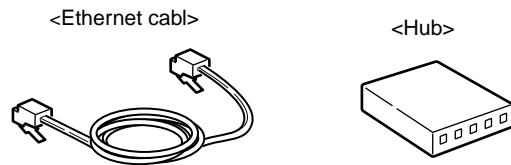

Turn the printer and computer OFF.

Connect the computer to the printer.

- (1) Insert the Ethernet cable into the network interface connector of printer.
- (2) Insert the Ethernet cable into Hub.

**Memo** Refer to user's manual for setup of printer driver.

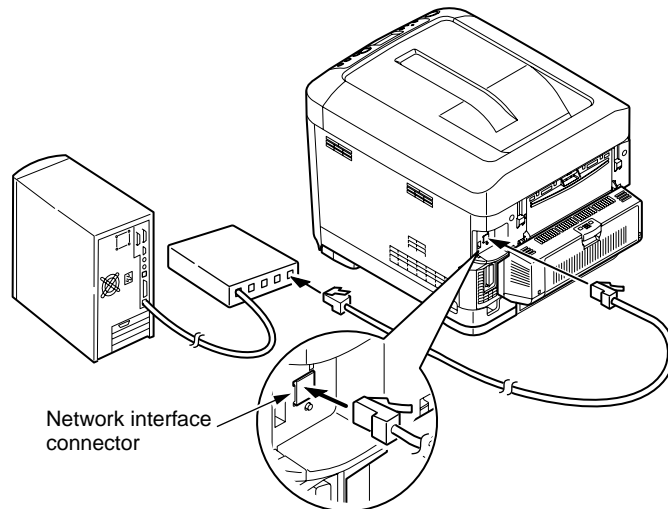

### < Parallel connection >

Prepare for Ethernet cable

**Note!** The parallel cable is not included in printer. Provide it for special user.



Turn the printer and computer OFF.

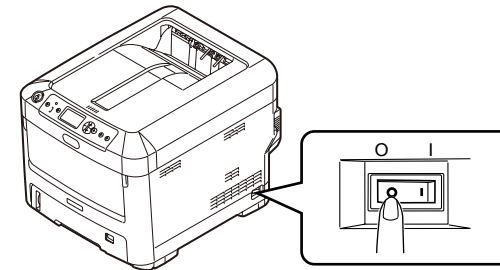

Connect the computer to the printer.

- (1) Insert the parallel cable into the parallel interface connector of printer, and Lock it firmly by metal fittings.
- (2) Insert the parallel cable into the parallel interface connector of computer, and fix it firmly with screws.

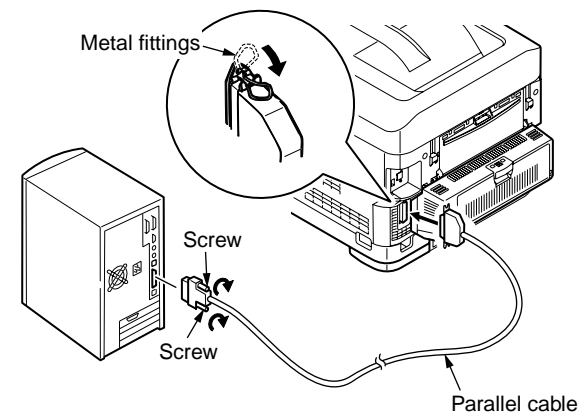

## 3.8 User used Paper confirmation

Load the paper used by user, set the media type/weight, print the setting content/demo, and confirm if the toner is chipped off.

Type	Thickness	settings of control panel		[Thickness of paper] settings of printer driver*2
		Media weight (Thickness of paper)	Media type (Type of paper)*1	
Plain paper*3	55~64kg (64~74g/m <sup>2</sup> )	Light	Plain paper	Light
	65~70kg (75~82g/m <sup>2</sup> )	Medium Light		Medium Light
	71~89kg (83~104g/m <sup>2</sup> )	Medium		Medium
	90~103kg (105~120g/m <sup>2</sup> )	Heavy		Heavy
	104~162kg (121~188g/m <sup>2</sup> )	Ultra heavy1		Ultra heavy1
	163~189kg (189~220g/m <sup>2</sup> )	Ultra heavy2		Ultra heavy2
Post card*4	—	—	—	—
Envelope*4	—	—	—	—
Label paper	Less than 0.1~0.17mm	Heavy	Label paper	Label paper1
	0.17~0.2mm	Ultra heavy1		Label paper2
Transparencies	—	—	Transparency film	Transparency film

\*1 : The factory default setting of media type of the printer is set as [plain paper].

\*2 : The thickness and type of paper could be set by control panel and printer driver. The settings set by printed driver have priority. When [Paper feed method] is selected as [Auto select] or [Paper thickness] is set as [print setting] in the printer driver, the print operation is set by control panel.

\*3 : The thickness of the paper for duplex printing is 55~103kg (64~120g/m<sup>2</sup>).

\*4 : The setting of media weight and media type for postcard and envelope is not required.

**Memo** If the media weight is set as [Heavy] or [Ultra Heavy1, 2], or the media type is set as [label paper], the print speed would be reduced.

# 4. Component replacement

---

In this chapter, the procedures for replacement of part and assembly and unit are described.

The replacement procedure is described by removal of the parts. Please install the new parts with following the replacement procedure in reverse order.

The parts (such as ①, ②) shown in this manual are different from the parts used in the Disassembly for Maintenance figure (43856301TL) and RSPL (43856301TR).

4.1 Precautions on component replacement .....	61
4.2 Method of component replacement .....	63
4.3 Oiling spots .....	80

## 4.1 Precautions on component replacement

(1) Remove the AC cord and the interface cable before replacing the parts.

(a) Remove the AC cord according to the following procedure.

- ① Switch the power switch of printer off "O".
- ② Unplug the AC plug of AC cord from the AC outlet.
- ③ Disconnect the AC cord and the interface cable with the printer.

(b) Reconnect the printer according to the following procedure.

- ① Connect the AC cord and the interface cable with the printer.
- ② Insert the AC plug into the AC outlet.
- ③ switch the power switch of printer on "I".

(2) Do not disassemble it if the printer works normally.

(3) Disassemble it as required. Do not remove the part that is not shown in the replacement procedure.

(4) Please use the specified maintenance tool.

(5) Disassemble it according to the proper procedure. It may cause damage to the parts if disassemble it without following the proper procedure.

(6) As the small parts such as the screws are lost easily, please fix them to the original position temporarily.

(7) Do not use gloves that may cause static electricity easily when handling IC and the circuit board such as microprocessor, ROM, and RAM.

(8) Do not put the PCB on the device and the floor directly.

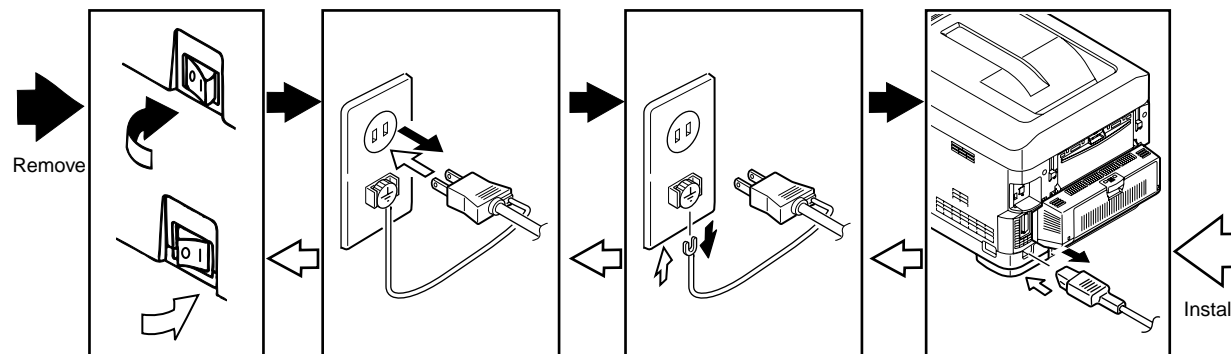

[Maintenance tool]

The required tools for replacing the PCB and the unit are shown in Table 4-1-1.

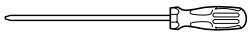
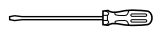
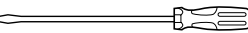
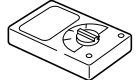
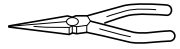
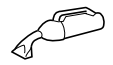
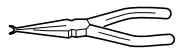

Table 4-1-1 Maintenance tools

No.	Maintenance tools	Amount	Purpose	Note
1	 No. 2-200 ⊕ Magnetic driver	1	3 - 5mm Screw	
2	 No. 3-100 Driver	1		
3	 No. 5-200 Driver	1		
4	 Digital multimeter	1		
5	 Combination pliers	1		
6	 Handy cleaner (the type corresponds to the toner)	1		Refer to the following note.
7	 E Ring pliers	1	For E ring detaching	

**Note!** Use the specified cleaner corresponding to the toner. It may cause a fire when using a general-purpose cleaner.

The required tools for using the maintenance utility are shown in Table 4-1-2.

Table 4-1-2 required tools

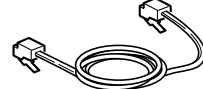
No.	Maintenance tools	Amount	Purpose	Note
1	 Notebook  Please install the maintenance utility.	1		Refer to the chapter 5.2 for the maintenance utility.
2	 USB cable	1		
3	 Ethernet cable (Cross cable)	1		

## 4.2 Method of component replacement

In this chapter, the replacement of parts and assemblies is described by the disassemble figures.

### 4.2.1 Belt unit

- (1) Open the top cover.
- (2) Remove the ID unit ①.

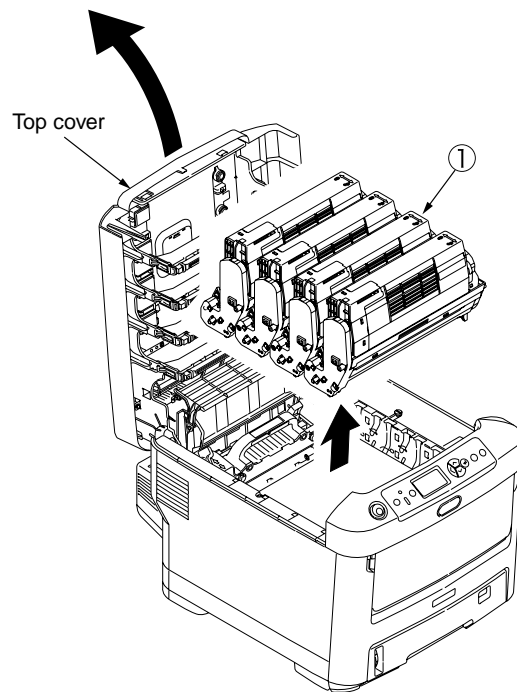

**Note!** Cover the removed image drum cartridge with black paper.

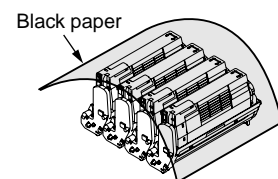

- (3) Rotate the lock lever (blue, 2 places) of the belt unit ② in the direction of arrow , and hold the lever (blue) to remove the belt unit.

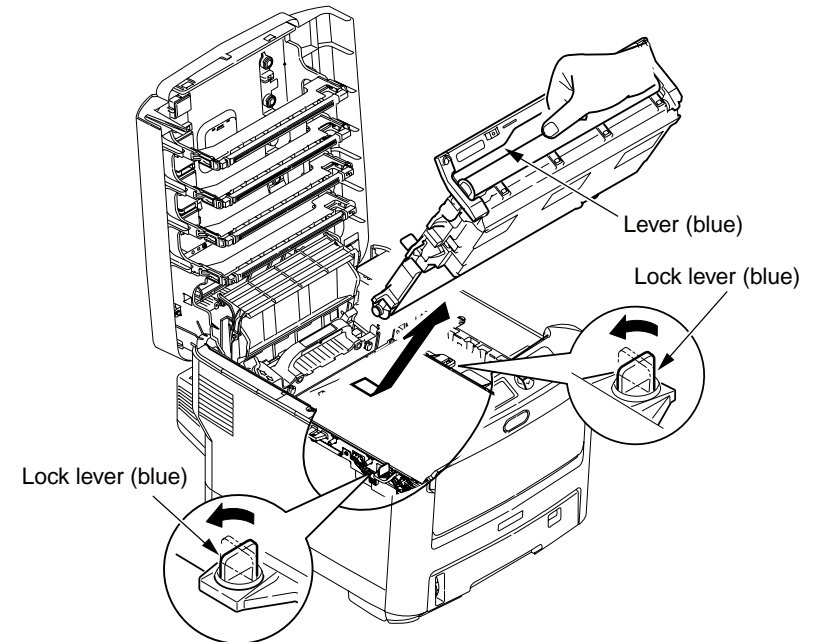

### 4.2.2 Fuser unit

- (1) Open the top cover.
- (2) Push up the fix lever of fuser unit in the direction of arrow, and remove the fuser unit ①.

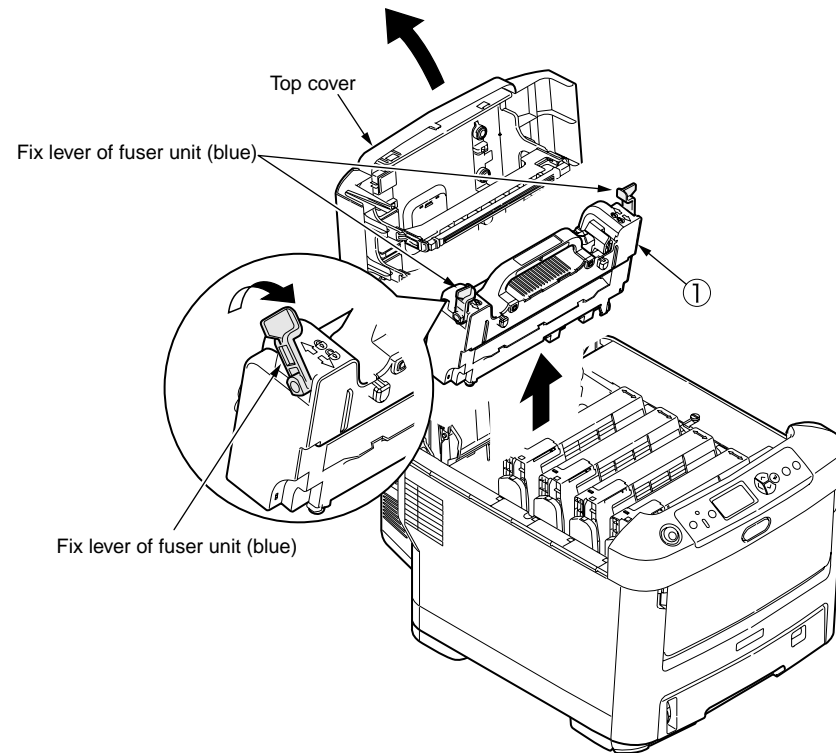

### 4.2.3 Left side cover

- (1) Open the top cover.
- (2) Open the feeder unit.
- (3) Remove the screw ① (silver), and remove the left side cover ②.

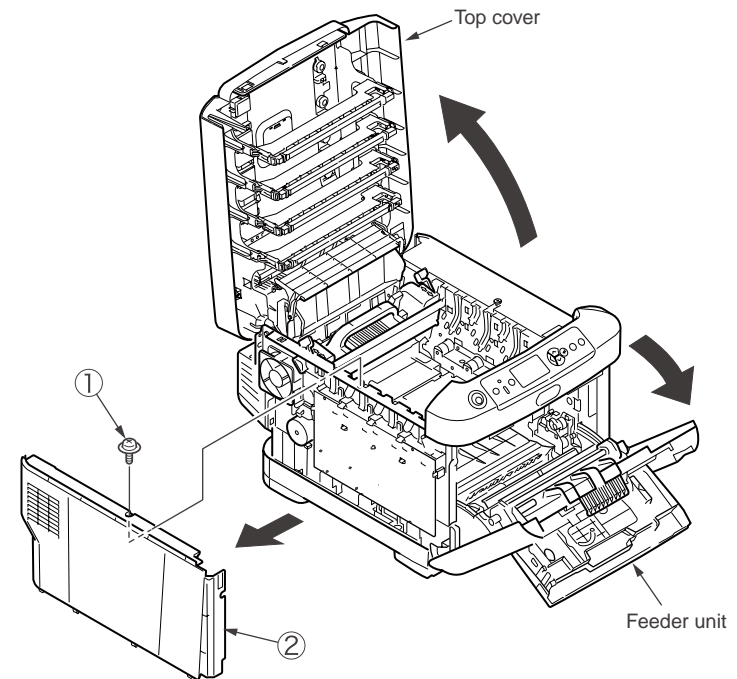



### 4.2.4 Right side cover

- (1) Open the top cover.
- (2) Open the feeder unit.
- (3) Loosen the screw ① and remove the right side cover ②.

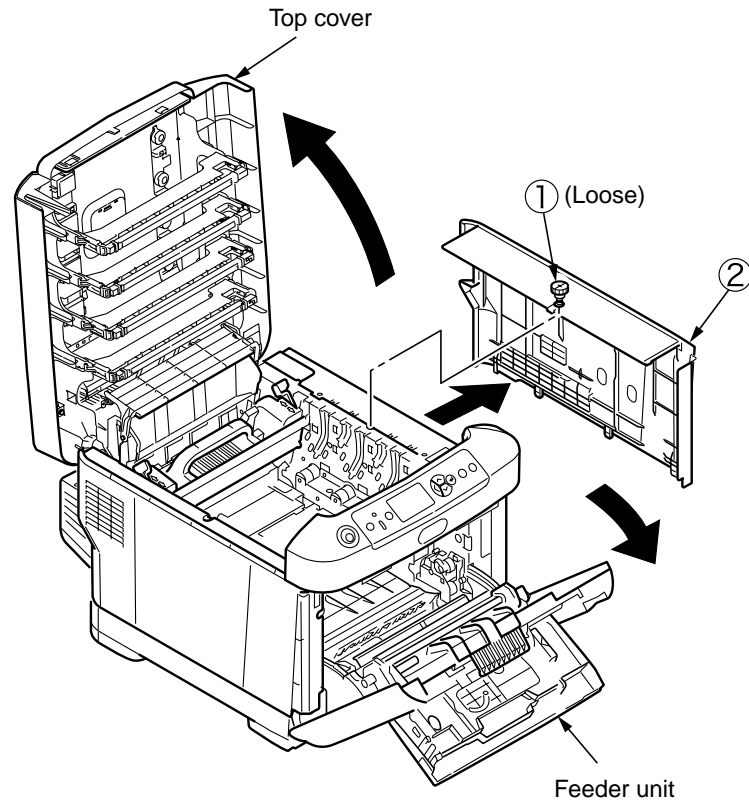

### 4.2.5 Faceup tray

- (1) Draw out the duplex unit ①.
- (2) Open the faceup tray ② in the direction of arrow, and unlock the left and right pins while bending. Remove the faceup tray ②.

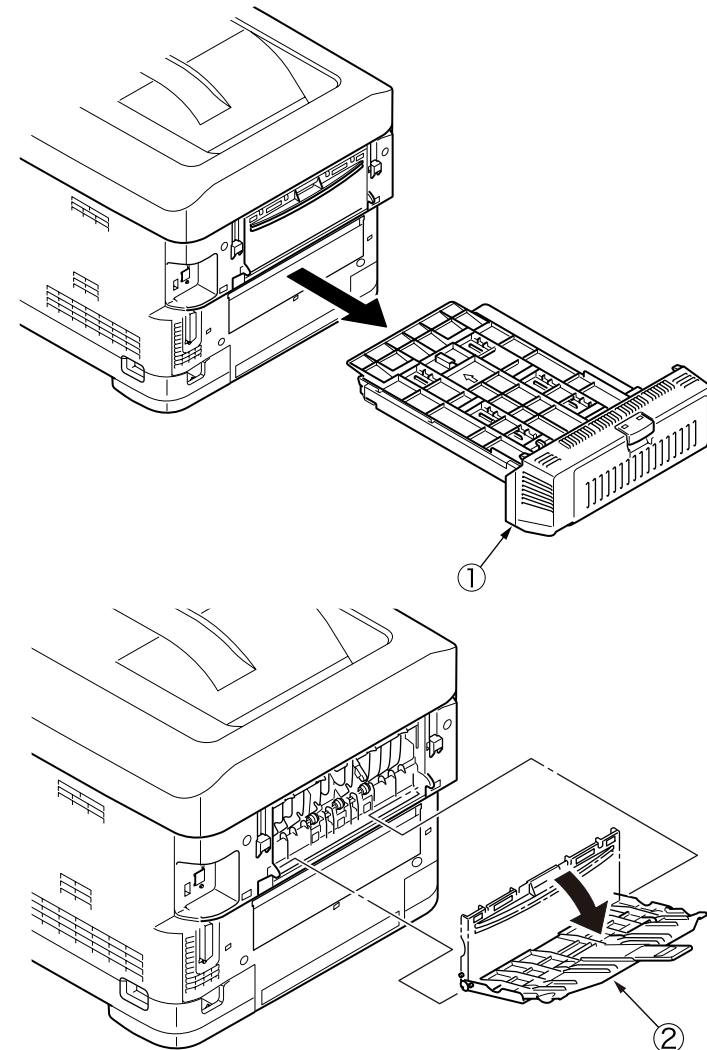

### 4.2.6 Rear cover

- (1) Open the faceup tray.
- (2) Remove the two screws ① (silver).
- (3) As shown in fig 2, insert the minus driver into the hole A to disengage the claw A (2 place).
- (4) Disengage the claw B (2 places) and pull the upper side of the rear cover ② in the direction of A.
- (5) As shown in fig 3, push the lower side of the rear cover ② in the direction of B, and disengage the claw C (3 places) to remove the rear cover ②.

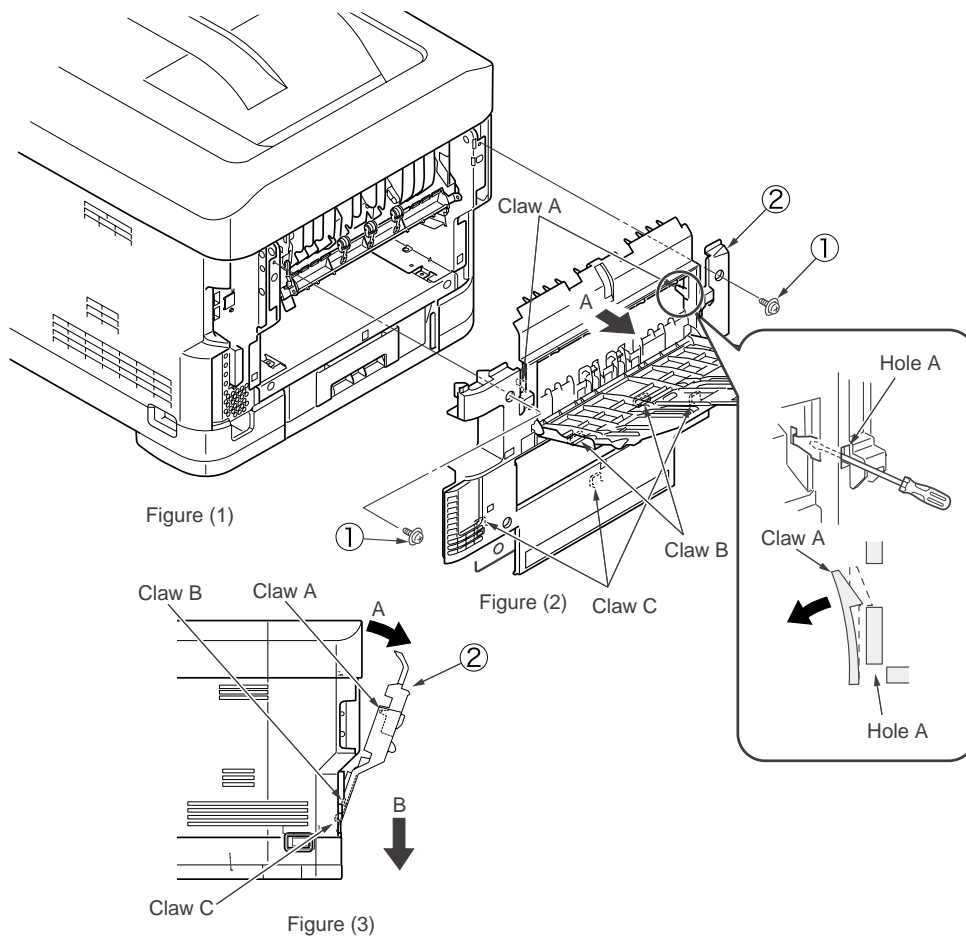

### 4.2.7 LED Assy/ LED Assy spring

- (1) Open the top cover
  - (2) After removing the cable, as shown in fig 2, push the LED assy ① tightly in the direction of arrow. Take the hook A out firstly, and then take the hook B out, at last remove the LED assy.
- (At this time, the two springs ② is removed with LED Assy ①.)

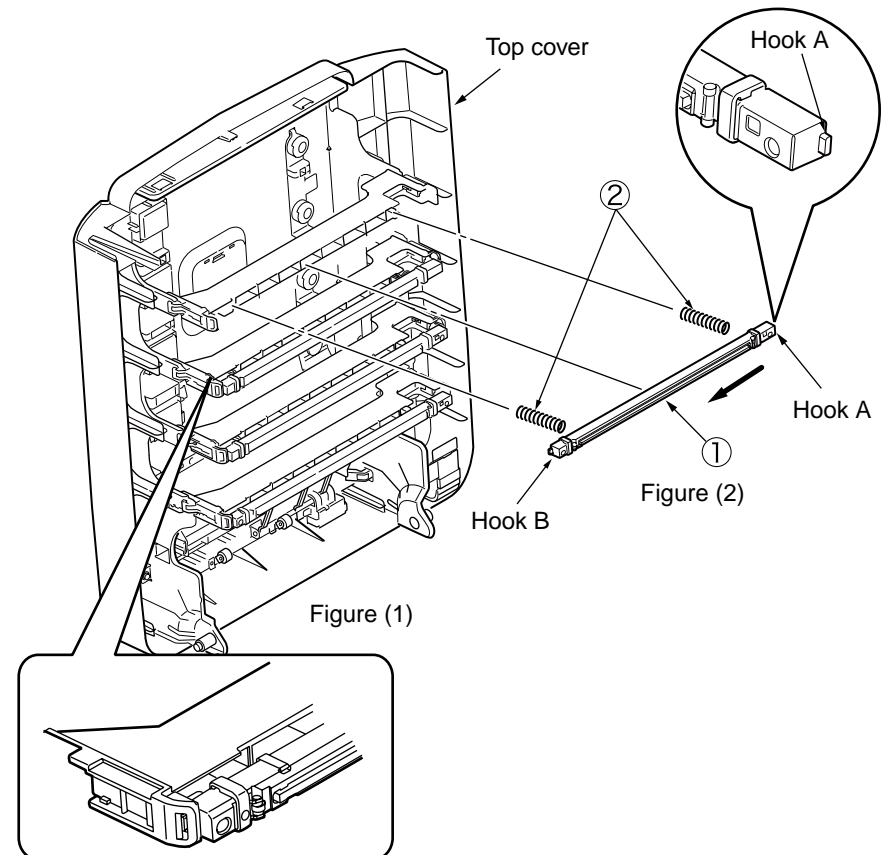

## 4.2.8 Control PCB

- (1) Open the top cover.
- (2) Remove the right side cover. (See section 4.2.4)
- (3) Remove the Rear cover. (See section 4.2.6)
- (4) Remove the eight screws ① (silver), remove the connector and disengage the claw A to take the plate-shield-Assy (PCL) ② out.
- (5) Remove the two screws (silver) ⑦, and remove the HOST USB PCB ⑨ by holding the tip of nylon stud ⑧ with a pair of pliers.
- (6) Remove the screw ③ and disconnect the head cable ④.
- (7) Remove the seven screws ⑤ (silver) and all cables, and take the control PCB ⑥ out.

**Note!** To attach the head cable, insert the end of the film-FG inside the plate-side-R, preventing from touching the edge of the plate-side-R.

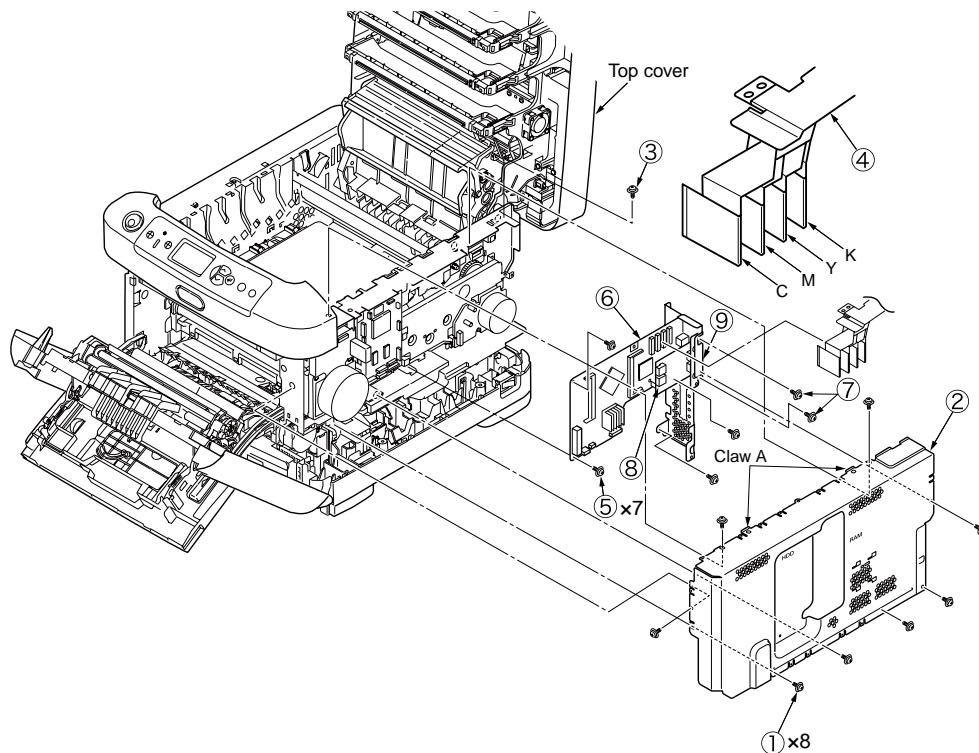

### 4.2.9 Print engine controller PCB

- (1) Remove the plate shield Assy (PCL). (See section 4.2.8(1)-(3))
- (2) Remove all connectors and two screws ① (silver) to take the print engine controller PCB ② out.

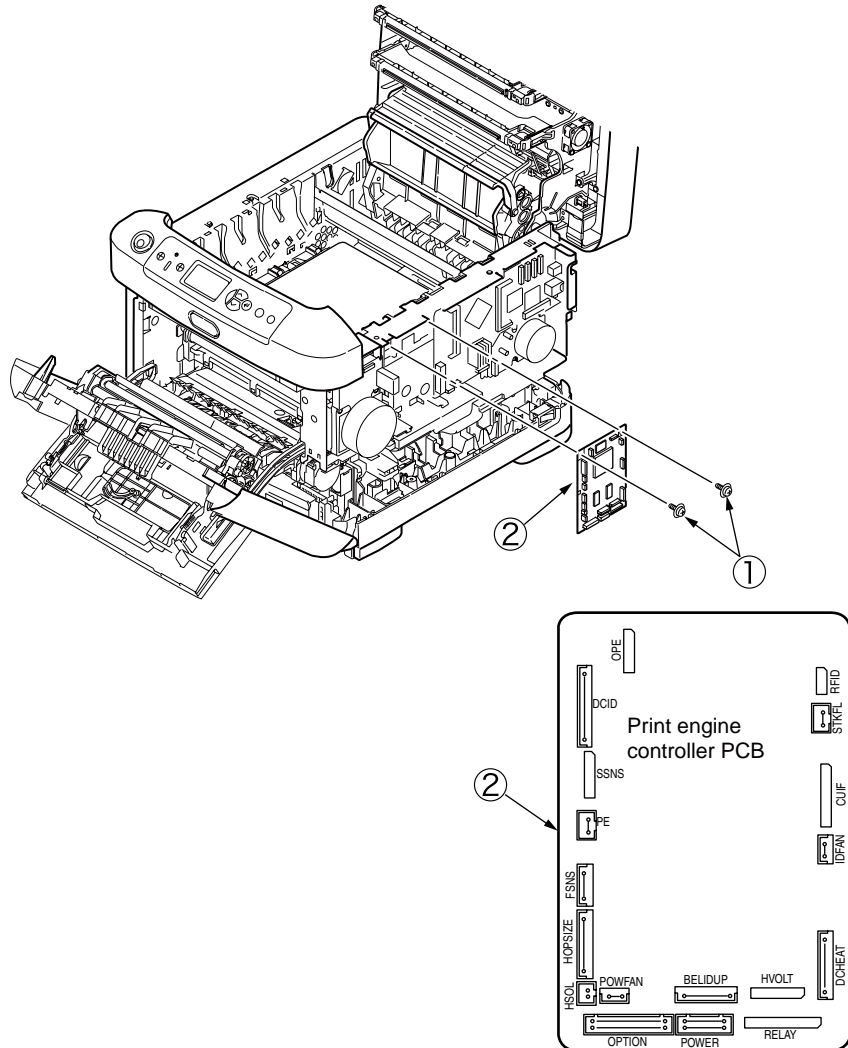

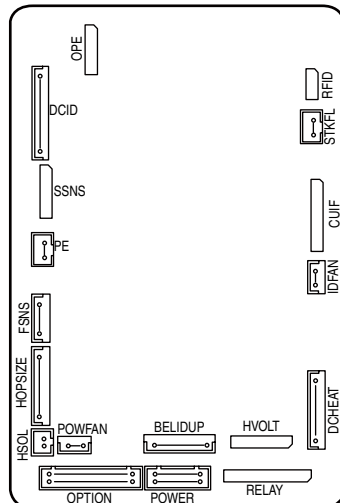
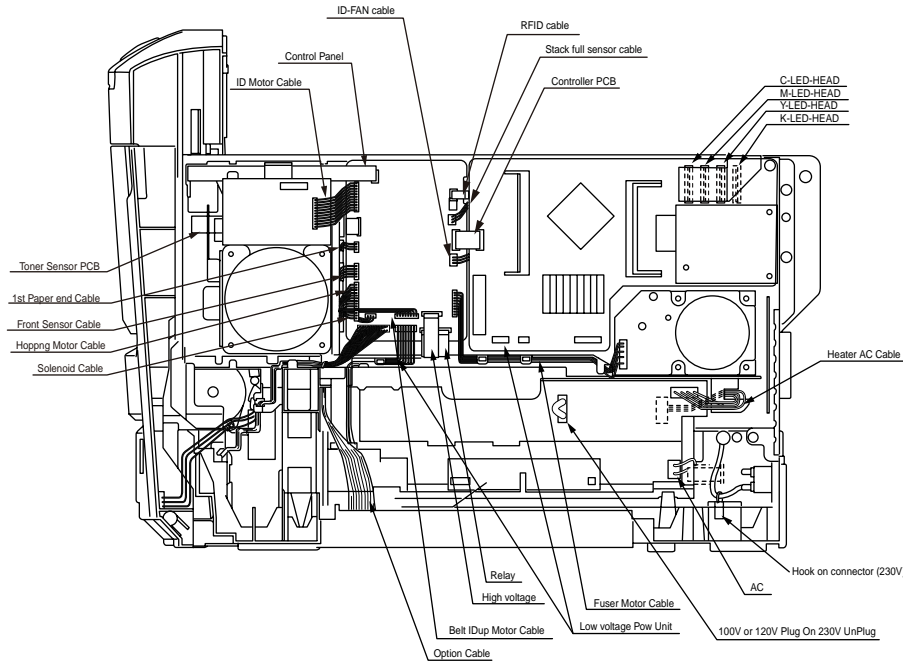

### 4.2.10 Top cover Assy

- (1) Remove the left side cover. (See section 4.2.3)
- (2) Remove the right side cover. (See section 4.2.4)
- (3) Remove the rear cover. (See section 4.2.6)
- (4) Remove the plate shield Assy (PLD/GDI) and take the control PCB out. (See section 4.2.8 (1)-(7))
- (5) Remove the connectors of the stack full sensor cable and ID-FAN cable, remove the connector and the hanging RFID cable ①.
- (6) Remove two E type stop rings ② and two torsion springs ③, and remove the top cover Assy ④.

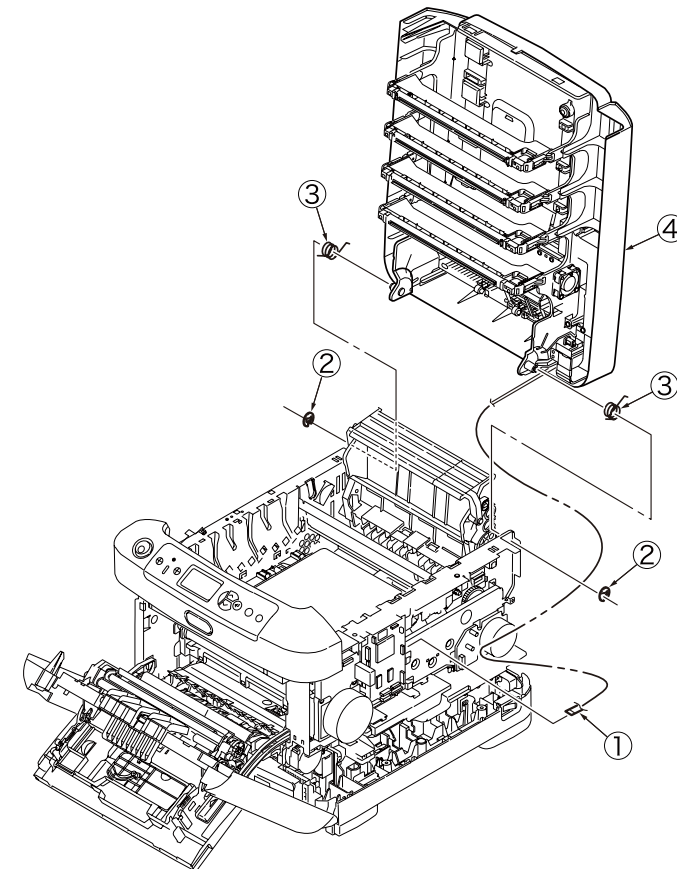

### 4.2.11 Top cover

- (1) Remove the top cover Assy. (See section 4.2.10)
- (2) Remove ten screws ① (Black), and remove the top cover ②.

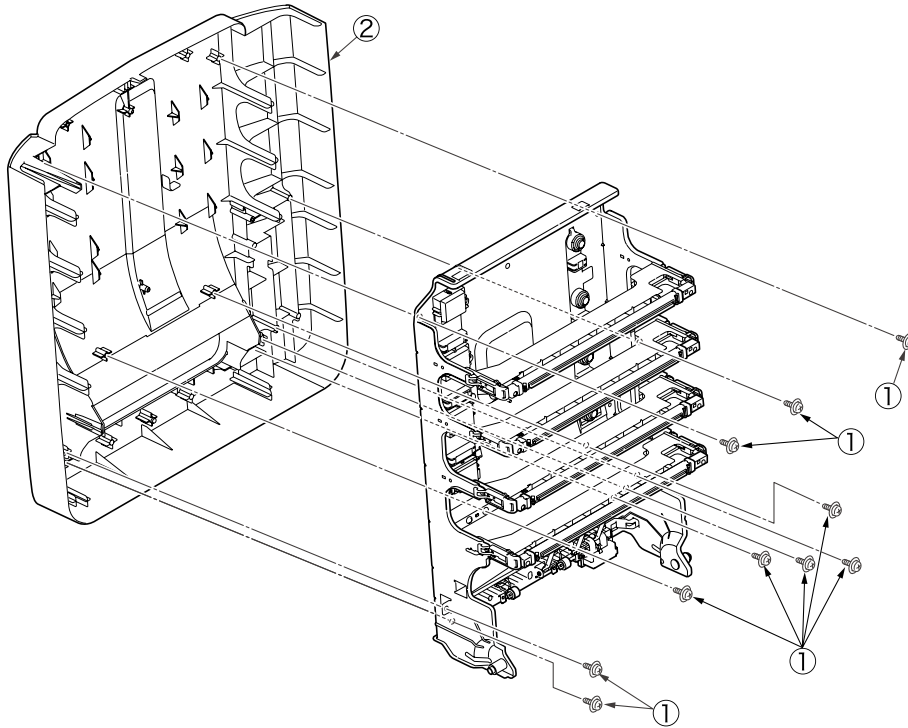

### 4.2.12 Control panel Assy

- (1) Open the top cover.
- (2) Insert the minus driver into the upper side of the slit (3 places) to disengage the claws on the control panel Assy ①, remove the connector and take the control panel Assy ① out.

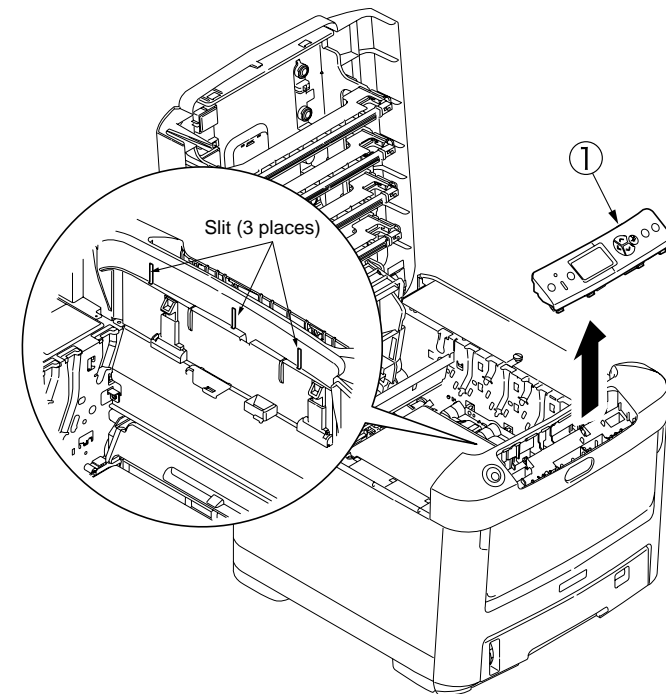

### 4.2.13 Board PRG/ LCD

- (1) Remove the control panel Assy. (See section 4.2.12)
- (2) Remove the screws ① (2 places), remove the connector and cable of LCD ③ and remove the Board PRG ②.
- (3) Remove the screws ④ (2 places), and remove the LCD ③.

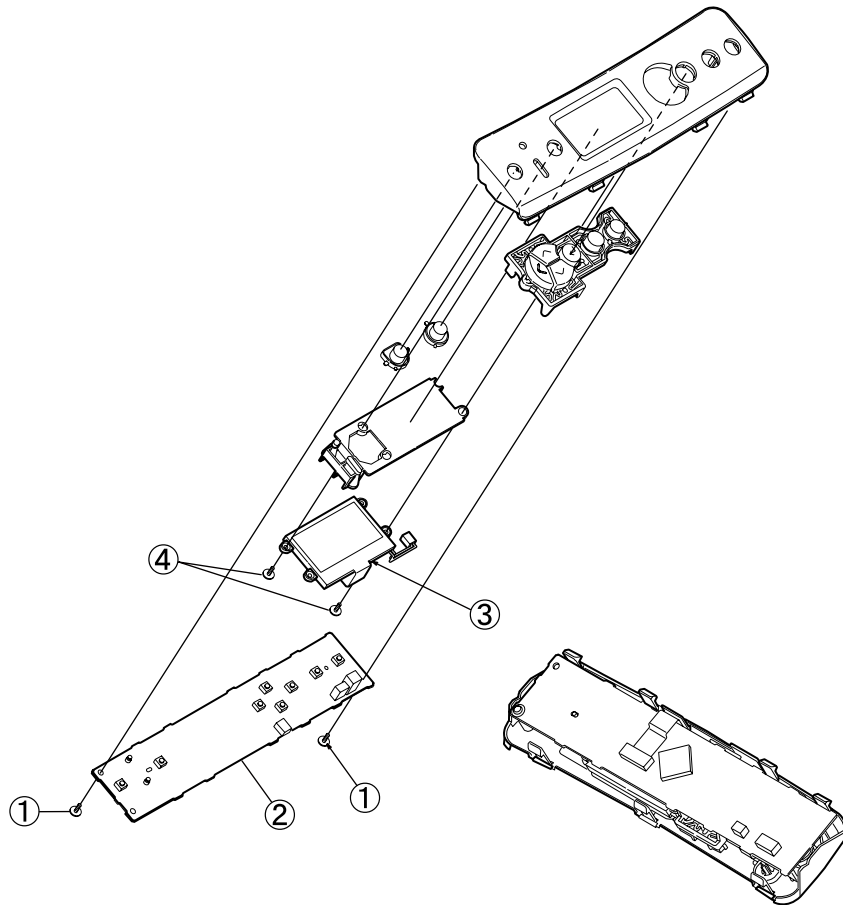

## 4.2.14 Frame panel Assy

- (1) Open the top cover.
- (2) Open the feeder unit.
- (3) Remove the right side cover. (See section 4.2.4)
- (4) Remove the plate shield Assy. (See section 4.2.8 (3))
- (5) Remove the connector of frame panel Assy and remove the hanging cable.
- (6) Remove the control panel Assy. (See section 4.2.12)
- (7) Remove the two screws ① (silver), disengage the claws (3 places) on frame panel Assy, and remove the frame panel Assy ②.

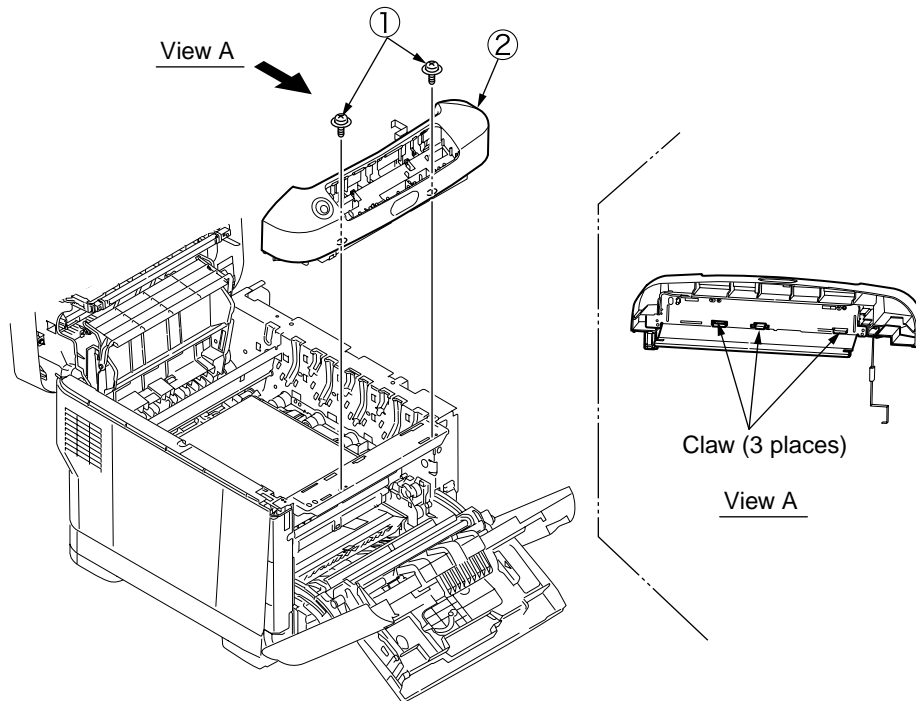

- (8) Remove the lever lock ③, compression spring ④, torsion spring ⑤, button switch ⑥, cable Assy ⑦ from the frame panel ⑧.

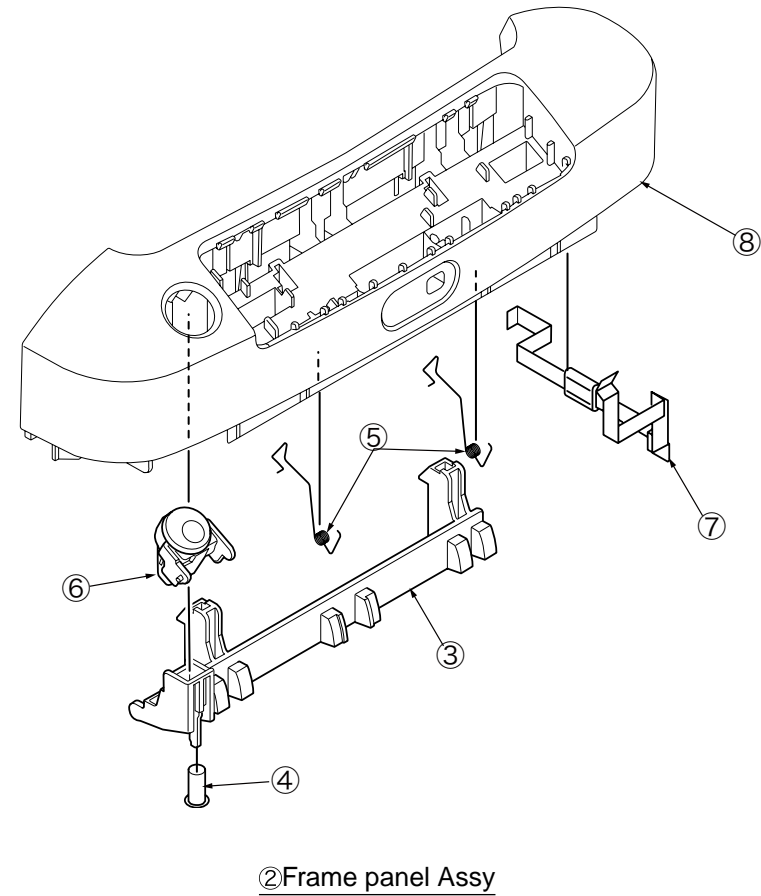



### 4.2.15 Low voltage power supply/Low voltage FAN/ Hopping motor/ Fuse motor

- (1) Take the cassette Assy out.
- (2) Remove the print engine controller PCB. (See section 4.2.9)
- (3) Remove the control PCB. (See section 4.2.8)
- (4) Remove all cables from Guide cable PowerLow.
- (5) Remove the fuse I/F connector from low voltage power supply, disengage the claws(2 places), and remove the Guide cable PowerLow ①.
- (6) Remove the two screws ② (silver) and four connectors (CN1, CN2, CN3), and remove the low voltage power supply ③.
- At the same time, remove the screw ④ and remove the AC inlet Assy ⑤.
- (7) Disengage the claw C and remove the low voltage FAN ⑥.
- (8) Disengage the claw D(2 places) and claw E, and remove the motor cover ⑦.
- (9) Remove the 3 or 4 screws ⑩ (silver) and connector, and take the fuse motor ⑪ out.
- (10) Remove the three screws ⑫ (silver) and connector, and take the ID motor ⑬ out.

- Notes!**
- Be careful to install the low voltage FAN ⑥ in the proper direction.
  - Please confirm the setting of AC input voltage when installing the low voltage power supply ③.
    - 100V: the short plug is mounted to the connector CN6
    - 230V: the short plug is not mounted to the connector CN6
  - Low-voltage power supply ③ and AC Inlet Assy ⑤ should be replaced together.(The pair of low-voltage power supply and AC Inlet Assy meets the safety standards.)
  - The number of screws varies between fuser motors.
    - Three screws: 43963301 (Sanyo)
    - Four screws: 43070601 (Nidec)

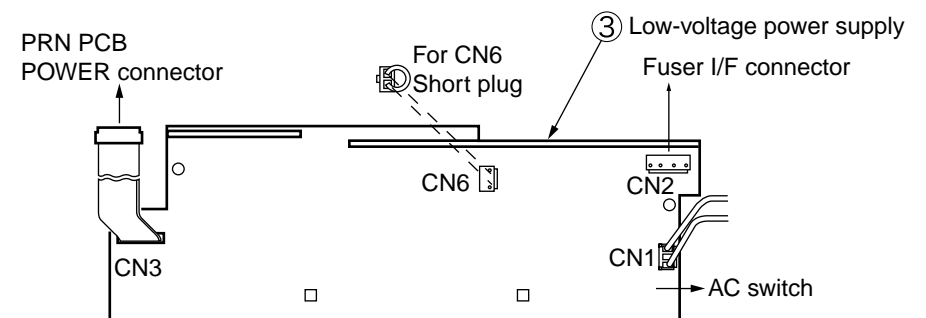
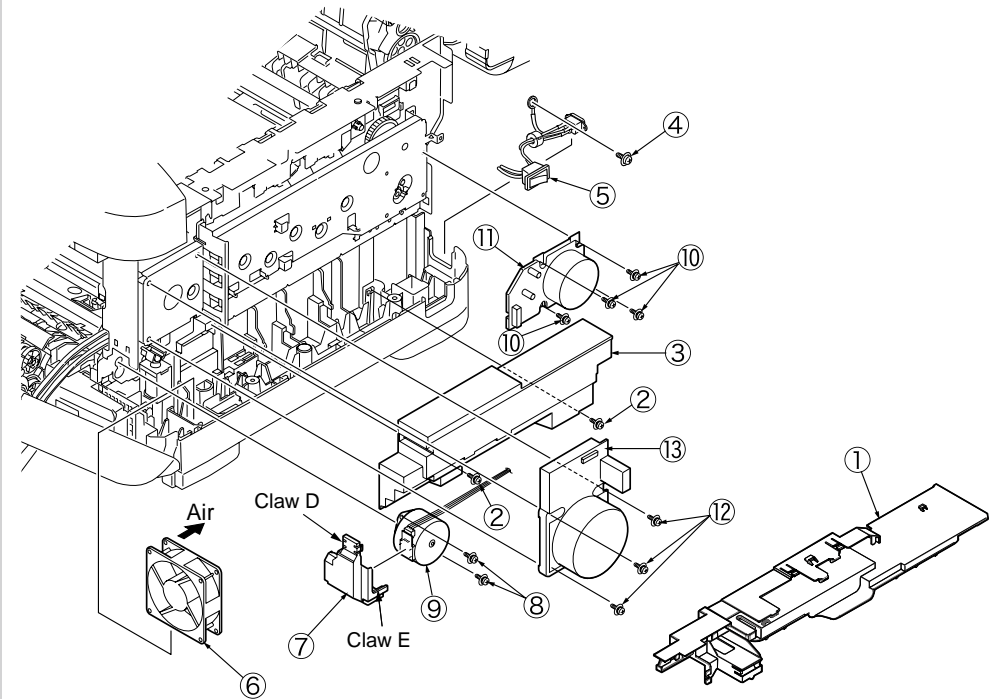

**Note!** CN6: A connector used to switch the AC input voltage setting  
100V short plug is mounted/ 230V short plug is not mounted.

### 4.2.16 Guide eject Assy/ Color resist Assy/ Board-PRY

- (1) Remove the left side cover, right side cover, rear cover, top cover Assy. (See section 4.2.3, 4.2.4, 4.2.6, 4.2.10 )
- (2) Remove the print engine controller PCB, control PCB and low-voltage power supply. (See section 4.2.8, 4.2.9, 4.2.15(3))
- (3) Remove the connector of belt thermistor, remove the two torsion springs ①, and disengage four claws (4 places) by minus driver, remove the cover driver ②.
- (4) Remove the screws ③ (silver) and connectors (6 places), remove the Board PRY ④.
- (5) Remove the two screws ⑤ (silver) and remove the color resist Assy ⑥.
- (6) Remove the two screws ⑦ (silver), remove the cable ⑧ of fuse I/F connector from clamp, and slide the claw of cable guide ⑨ to disengage, remove the guide eject Assy ⑩.

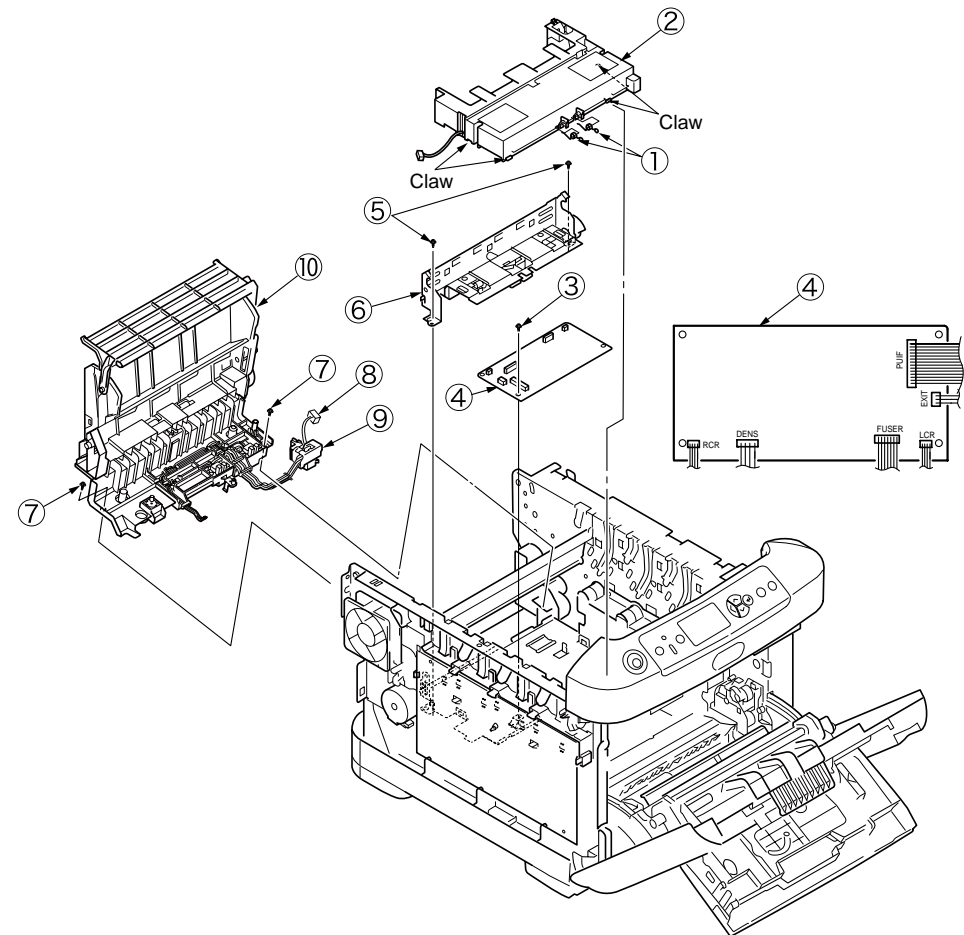

### 4.2.17 FAN(Fuser) / Belt motor/ High-voltage board/ Cover open switch

- (1) Remove the left side cover. (See section 4.2.3)
- (2) Remove the screw ① (silver) and connector, and remove the belt motor ②.
- (3) Remove the connector, and rotate the FAN (Fuser) ③ clockwise to remove.
- (4) Remove the connector and disengage the claw A (2 places), and remove the cover open switch ④.
- (5) Remove the 2 screws ⑤ and connectors (2 places), and disengage the claw B (7 places). Remove the high-voltage power supply ⑥.

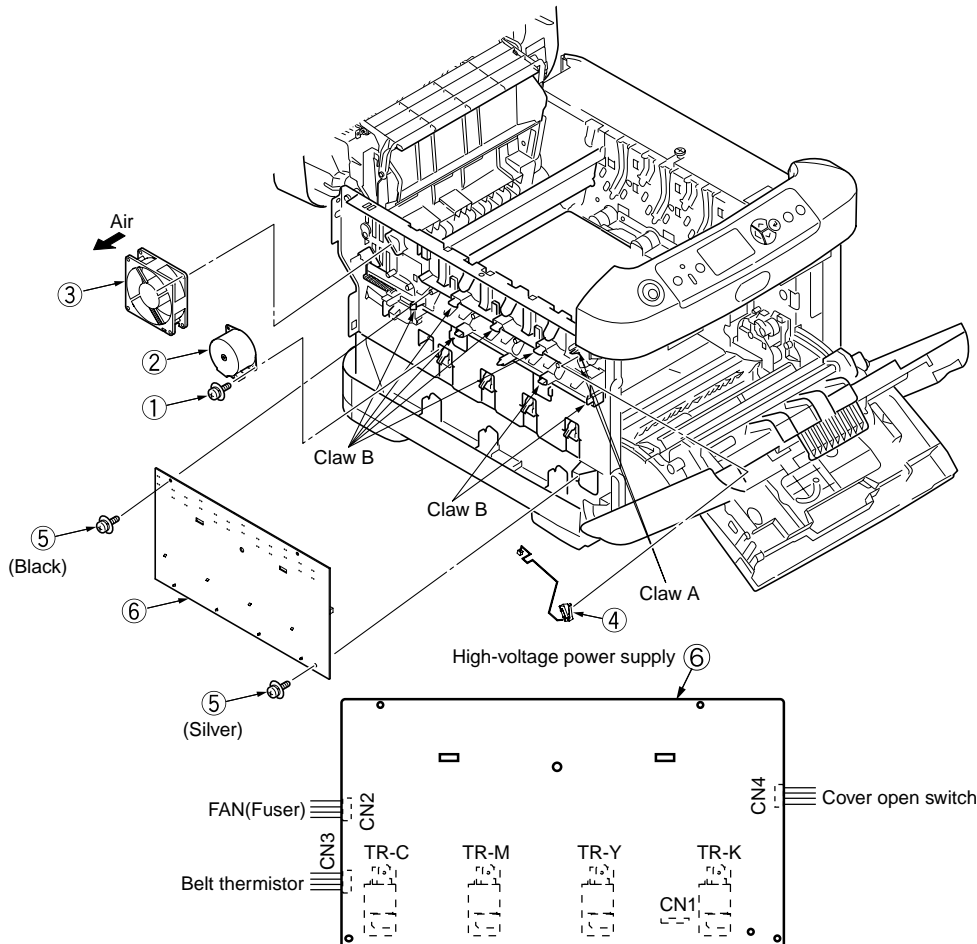

### 4.2.18 MPT Assy

- (1) Open the MPT Assy ①.
- (2) Remove the stoppers (2 places) while pushing the arms (2 places) on MPT Assy ① outside, pull the supporters (2 places) in the direction of the arrow and remove them, and remove the MPT Assy ①.

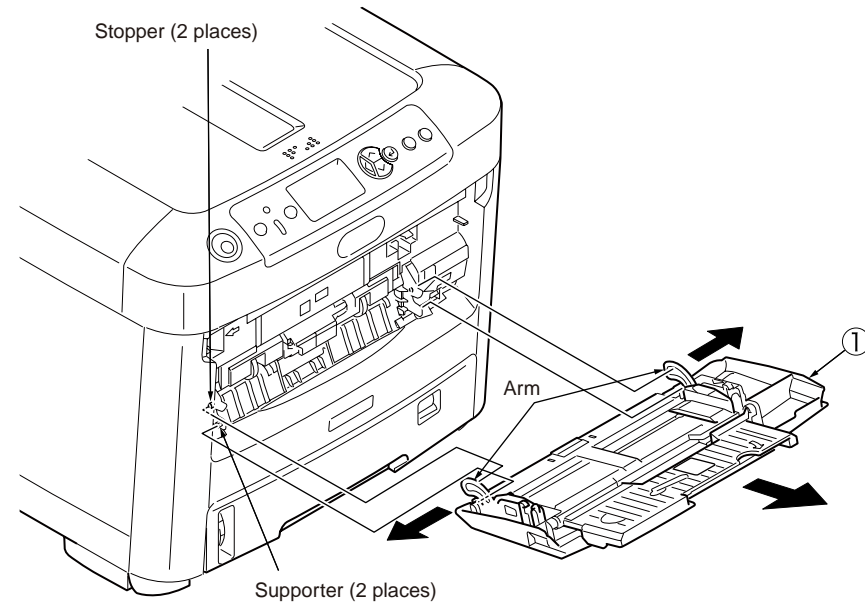

### 4.2.19 Feeder unit/ Board-RSF/MPT hopping roller/ Frame Assy separator/ Cover front

- (1) Open the top cover.
- (2) Remove the plate shield and remove the connector. (See section 4.2.8)
- (3) Disengage the claws of stay L ① and stay R ②, slide the feeder unit ③ to right and remove it.
- (4) Remove the motor cover. (See section 4.2.15)
- (5) Disengage the claw, and remove the cover sensor ④.
- (6) Remove the connector and remove the Board-RSF ⑤.
- (7) Remove the MPT Assy. (See section 4.2.18)
- (8) Rotate until the claw of lever ⑥ is disengaged, and remove it.
- (9) Remove the two screws (Black), and remove the stay L ①.
- (10) Remove the four screws ⑧ (Black), disengage the claw B (2 places), and remove the feeder Assy ⑨.
- (11) Remove the two lock shafts ⑩ and two springs ⑪, and disengage the claws (4 places) and remove the guide Assy ⑫.
- (12) Remove the hopping roller shaft ⑬.
- (13) Remove the supporters (2 places), and remove the frame Assy separator ⑭ and spring ⑮.

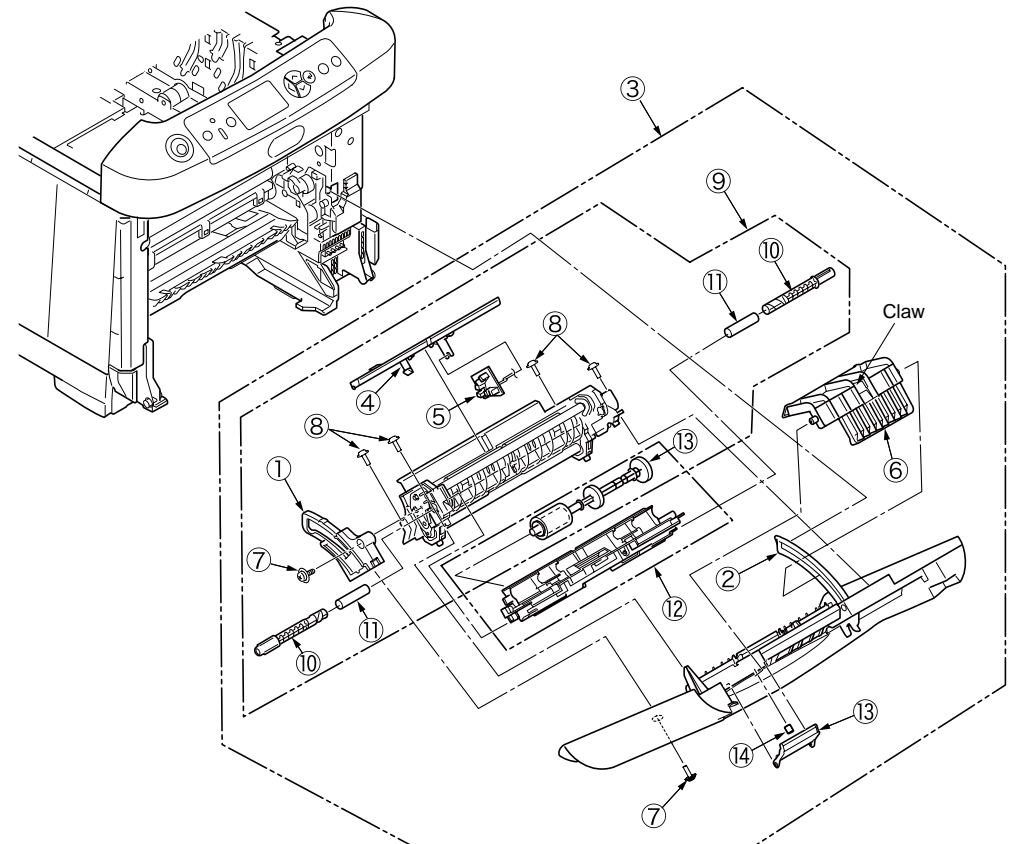

## 4.2.20 Board-PRZ liftup motor/ Hopping motor/ Solenoid/ Paper end sensor

- (1) Remove the left side cover, right side cover, rear cover, top cover unit, feeder unit. (See section 4.2.3, 4.2.4, 4.2.6, 4.2.10, 4.2.19)
- (2) Remove the print engine controller PCB, control PCB. (See section 4.2.8, 4.2.9)
- (3) Remove the guide cable Power Low, low-voltage power supply, low-voltage FAN. (See section 2.2.15)
- (4) Remove the cover driver, Board-PRY, color resist Assy, eject Assy. (See section 4.2.16)
- (5) Remove the two screws ① (silver), and remove the plate driver ②.
- (6) Remove the connector of 2ND tray and remove the hopping cover ③.
- (7) Remove the FAN(Fuser). (See section 4.2.17)
- (8) Remove the latches (2 places) and remove the gear ④, remove the latch and remove the gear ⑤, remove the gear ⑥ of latch and remove the shaft ⑦.
- (9) Remove the two screws ⑧ (silver) and remove the side plate R Assy ⑨.
- (10) Remove the ten screws ⑩ (silver), outer plate ⑪, two gear idle IDs ⑫, two gear idle IDs ⑬, two gears ⑭, gear ⑮, two colors ⑯, one washer ⑰, gear ⑱, ⑲, ⑲, ⑲, and spring ⑳ of solenoid.
- (11) Remove the latches (2 places), and remove the guide Assy side R ㉓ while slide it up.
- (12) Remove the screw ㉔ (silver), and remove the plate lockout ID ㉕ and four screws ㉖, remove the inner plate ㉗.
- (13) Remove the two screws ㉘ (silver) and connector, and remove the liftup motor ㉙.
- (14) Remove the screw ㉚ (silver) and remove the solenoid ㉛.
- (15) Remove the screw ㉜ (silver) and remove the hopping motor ㉝.
- (16) Remove the paper end sensor lever ㉞, the end sensor lever spring ㉟, remove the paper end sensor ㊱ and remove the connector.

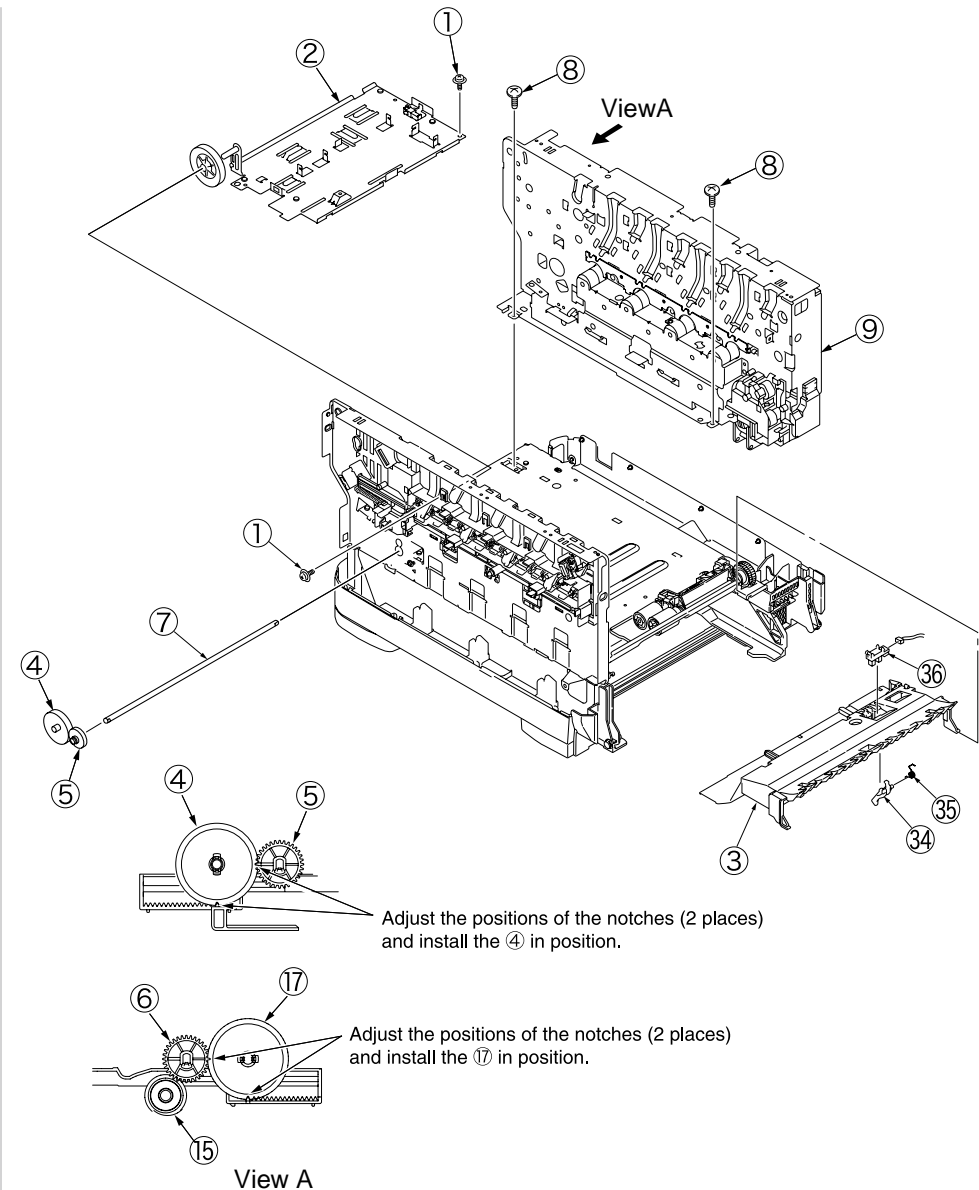

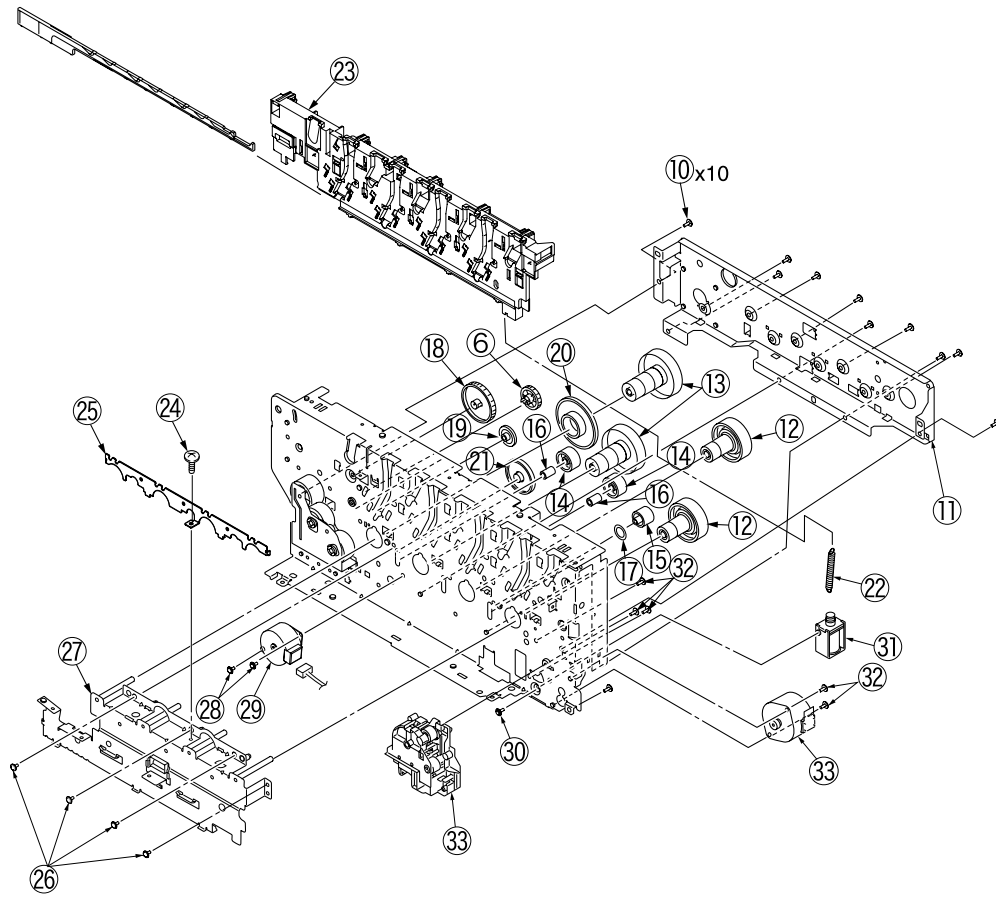

⑨ Side plate Assy

### 4.2.21 Feed roller

- (1) Remove the cassette.
- (2) Remove the latch and remove the feed roller (2 pieces)①.

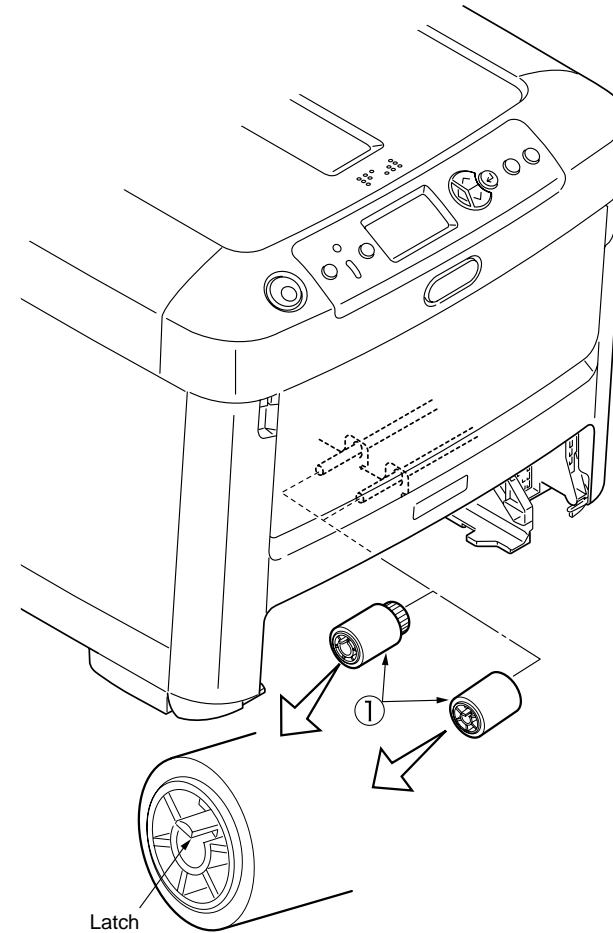

#### 4.2.22 Shaft eject Assy (FU)/ Shaft eject Assy(FD/ Eject sensor

- (1) Remove the eject Assy. (See section 4.2.16)
- (2) Disengage the claws (2 places), and disassemble the Assy into guide eject lower ① and guide eject upper ②.
- (3) Remove the gear idle eject ③, ④, ⑤, ⑥ and remove the shaft Assy eject (FU) ⑦ and shaft Assy eject (FD) ⑧.
- (4) Remove the lever eject sensor ⑨ and eject sensor ⑩.

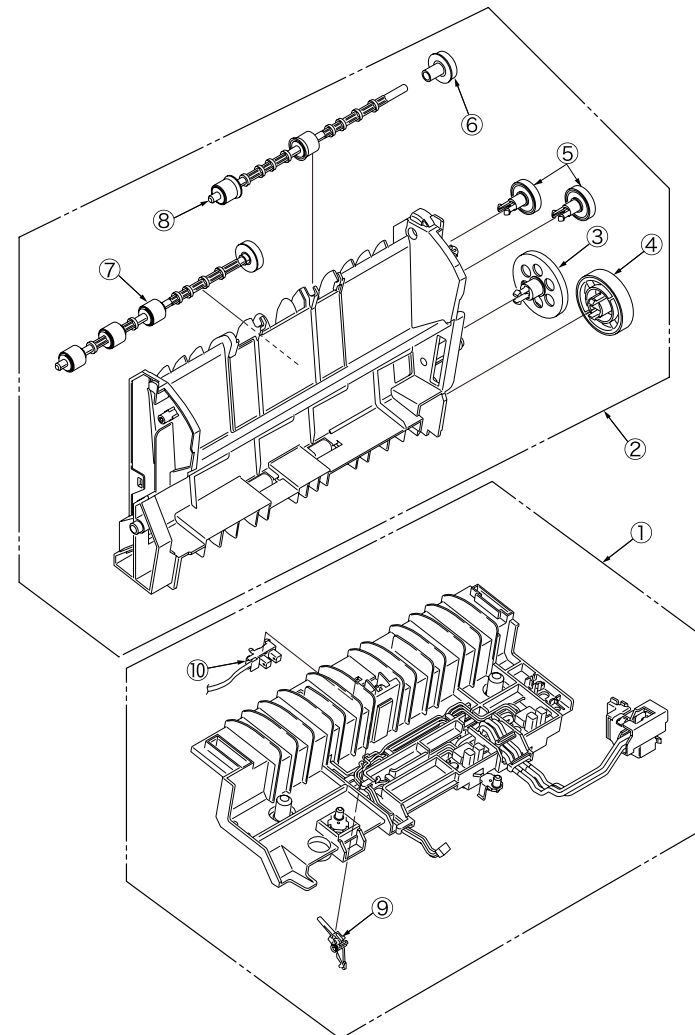

## 4.3 Oiling spots

This chapter shows the oiling spots. Do not oil the other spots that are not shown here.

It is not necessary to inject the machine-oil during disassembling. However, please add the specified oil when you wipe the oil off.

### Oiling operation

(1) Oil type and name

EM-30L: MOLYKOTE

HP-300: MOLYKOTE

PM: Pan motor oil 10W-40 or ZOA 10W-30

(2) Grease limit sample

Class	S	A	B	C	D	E	F
Spreading amount (cc)	0.0005	0.003	0.005	0.01	0.03	0.05	0.1
W(mm)	1.24	2.25	2.67	3.37	4.86	5.76	7.26
Sample	•	•	•	•	•	•	•

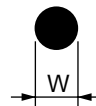



① Plate-Assy.-Base

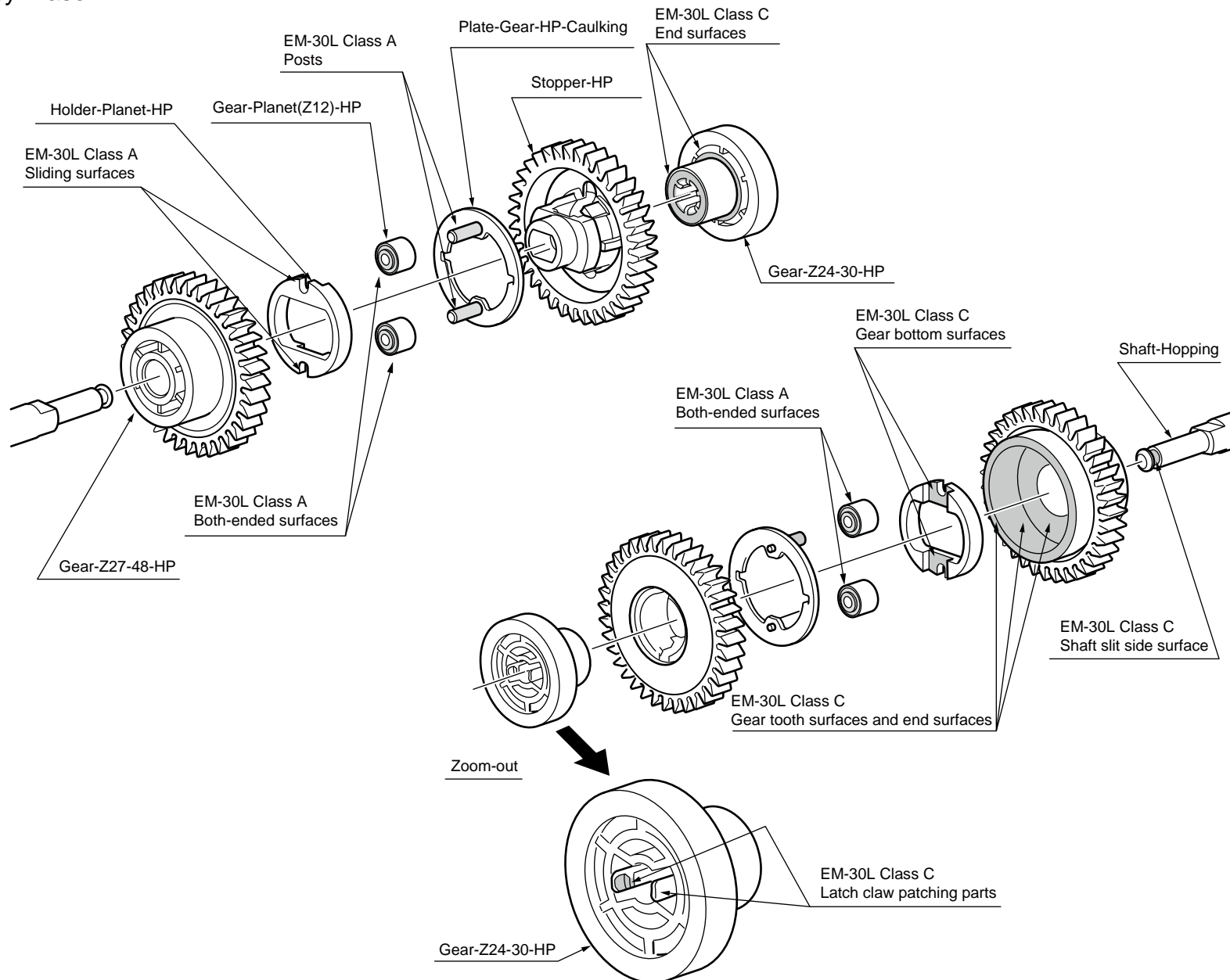

② Gear-Assy.-HP

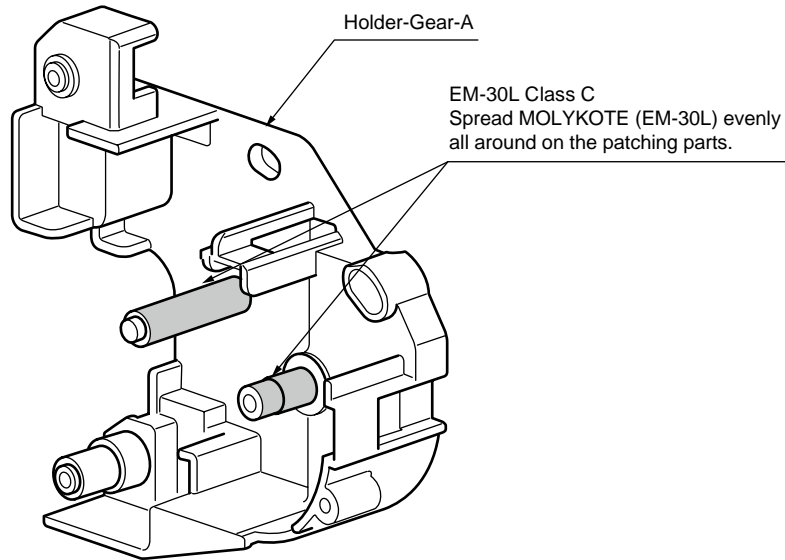

③ Gear-Planet-Assy.

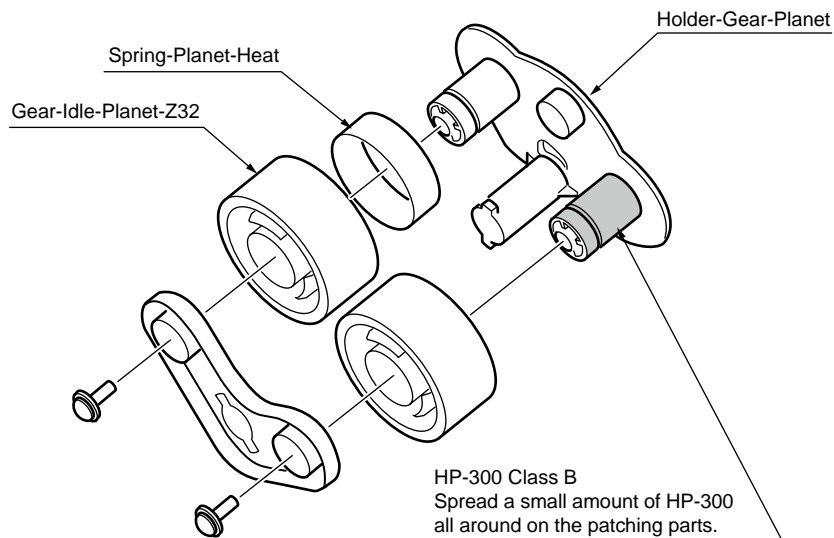

④-1 Plate-Assy. -Side R

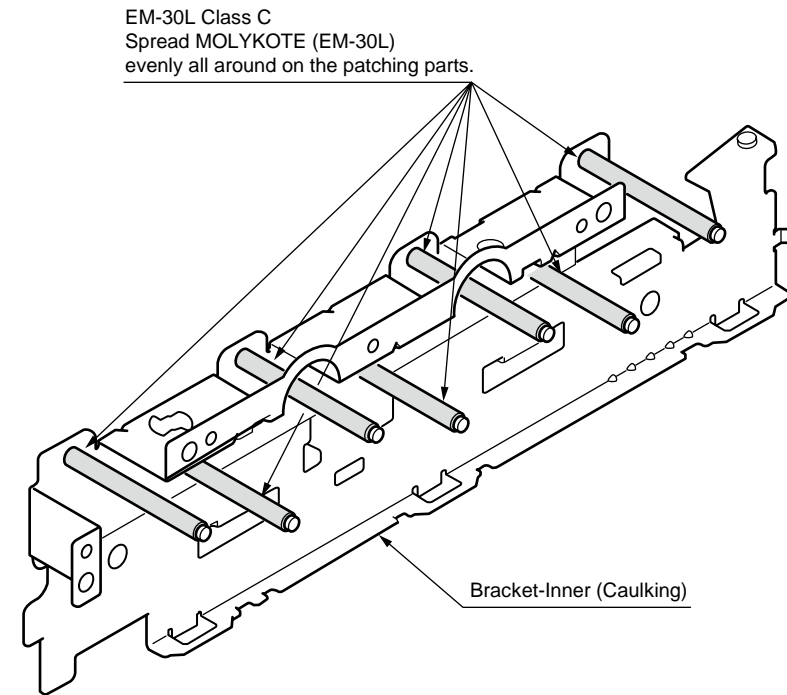

④-2 Plate-Assy.-Side R

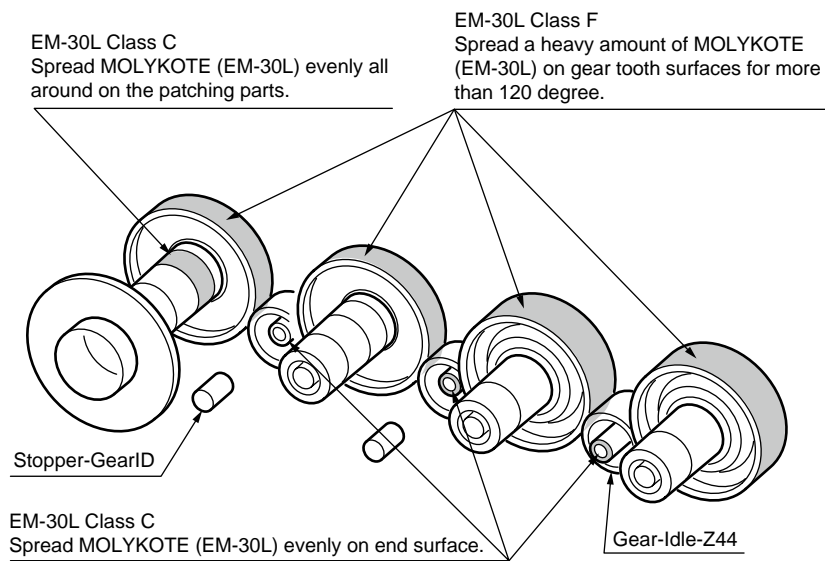
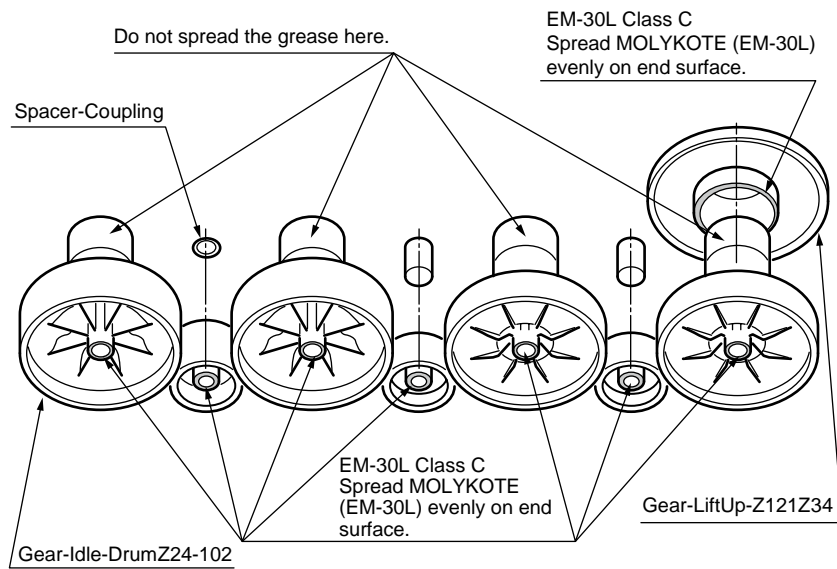

④-3 Plate-Assy.-Side R

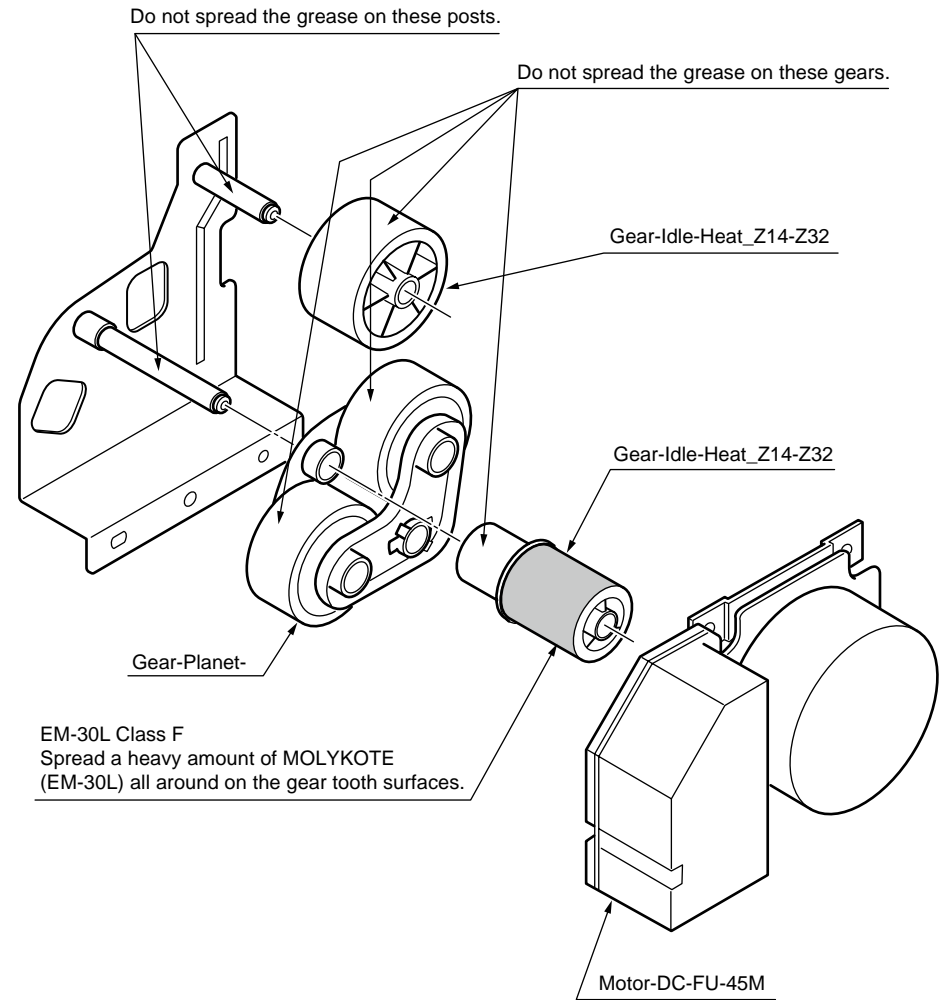

④-4 Plate-Assy.-Side R

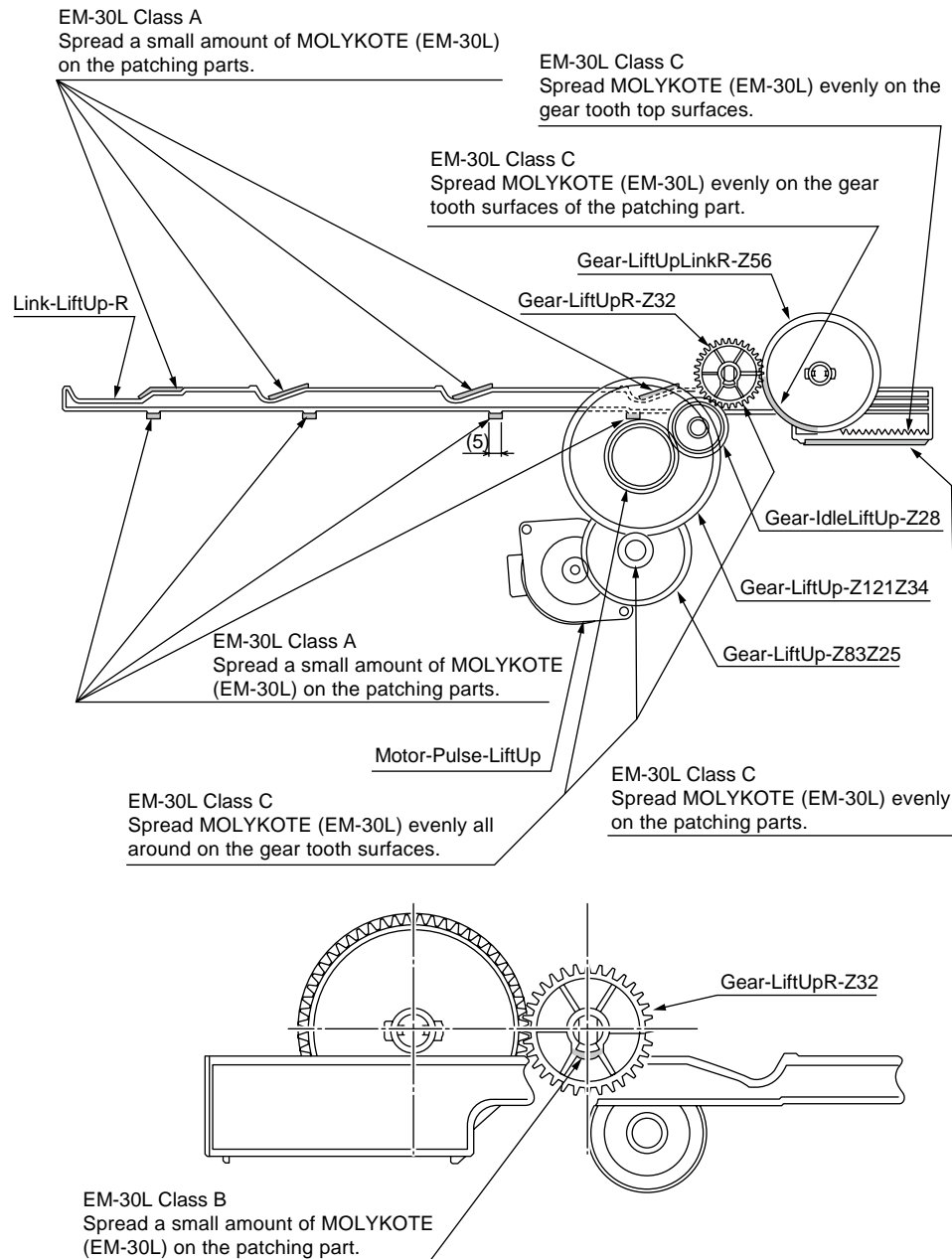

④-5 Plate-Assy.-Side R

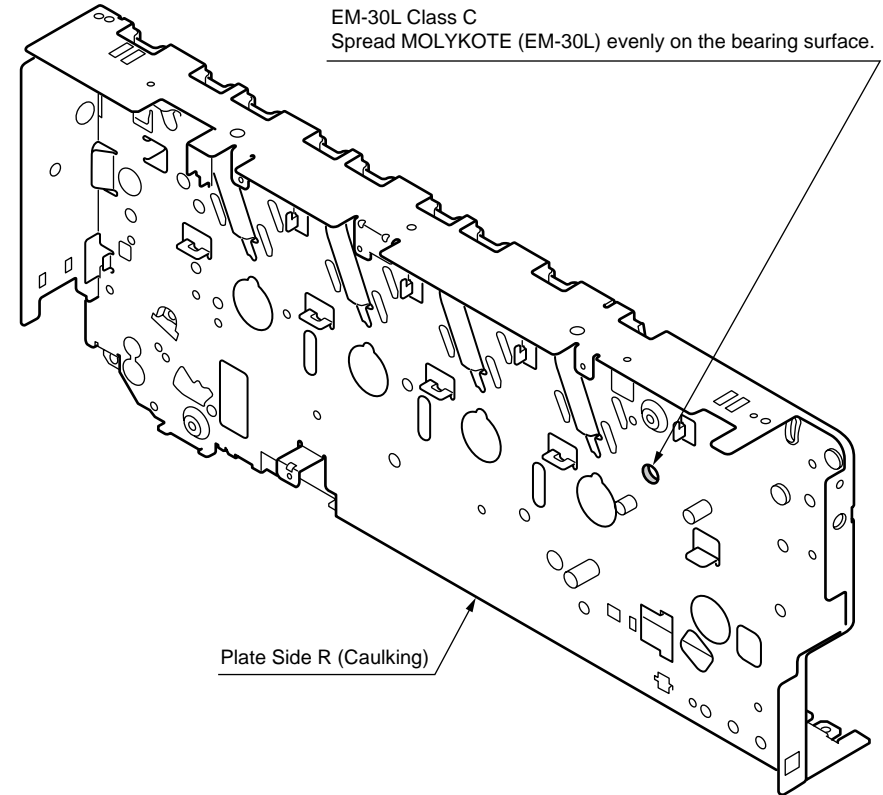

⑤ Plate-Assy.-Side L

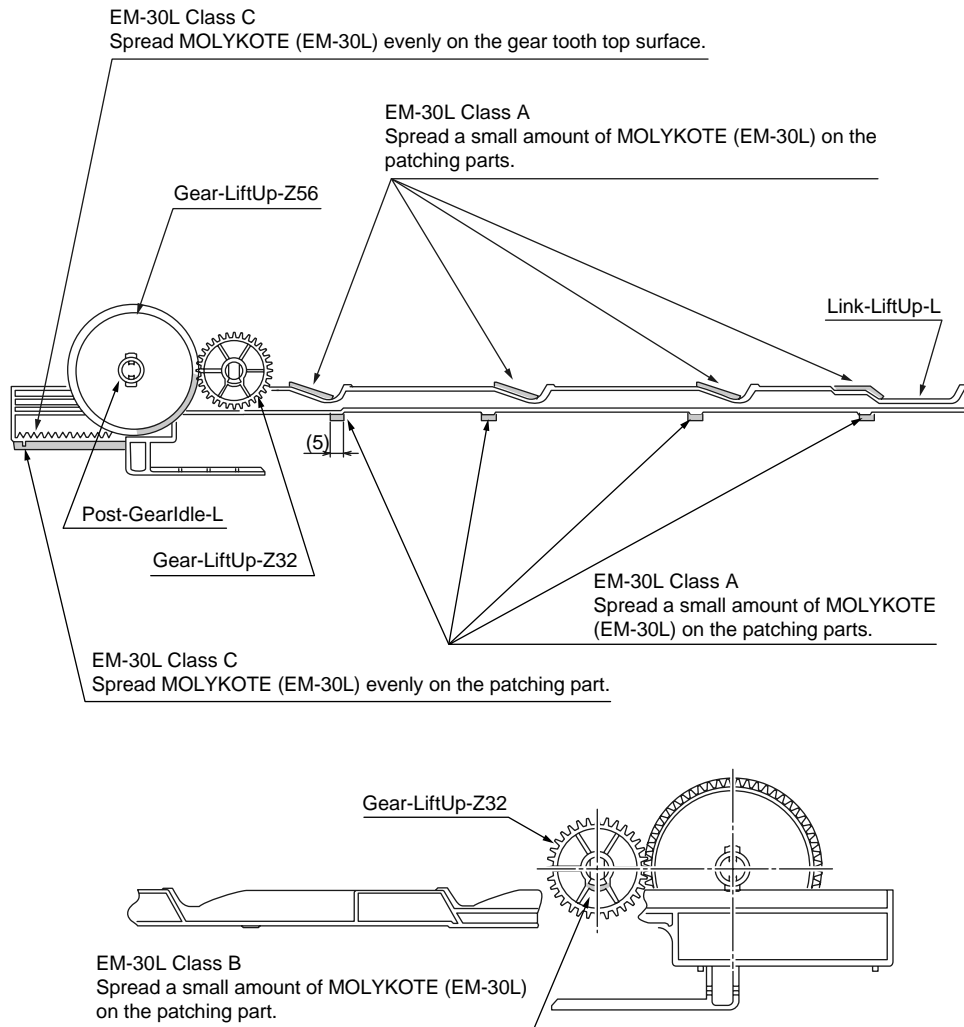

⑥ Holder Assy.-Regist-L

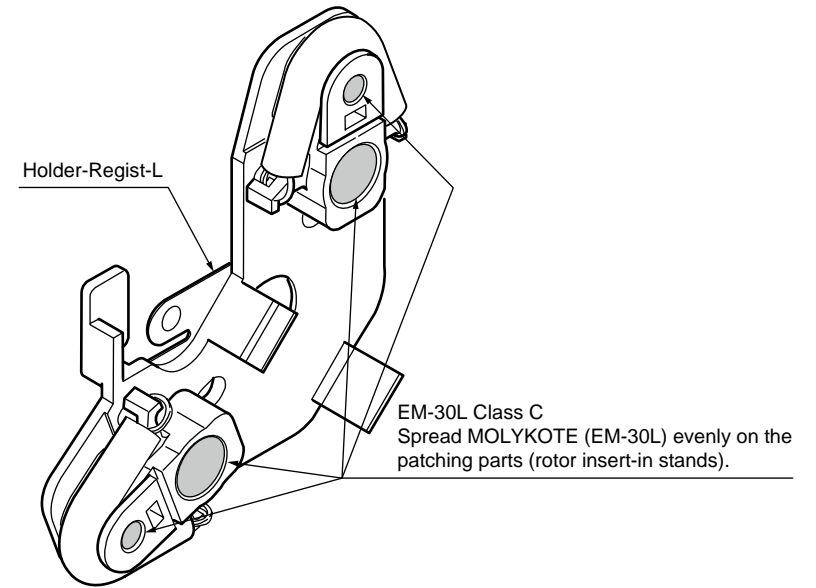

⑦ Holder Assy.-Regist-R

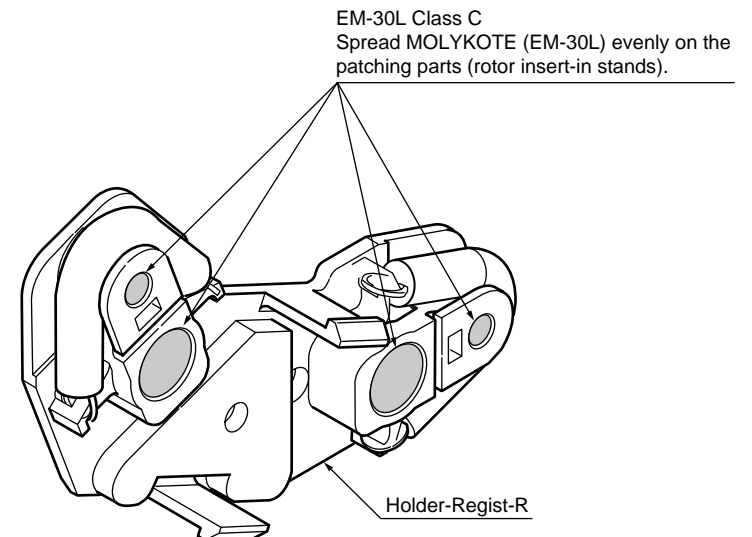

⑧ Fuser Assy

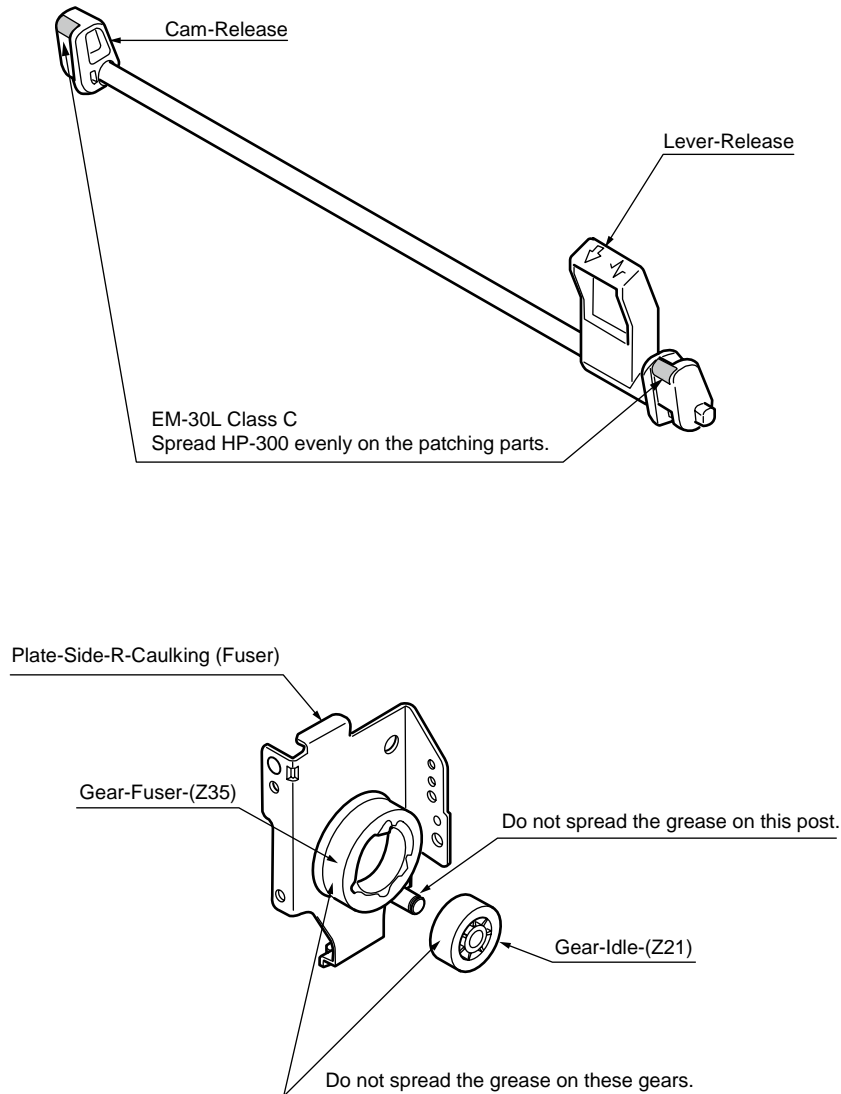

⑨ Guide-Assy. -Eject-U

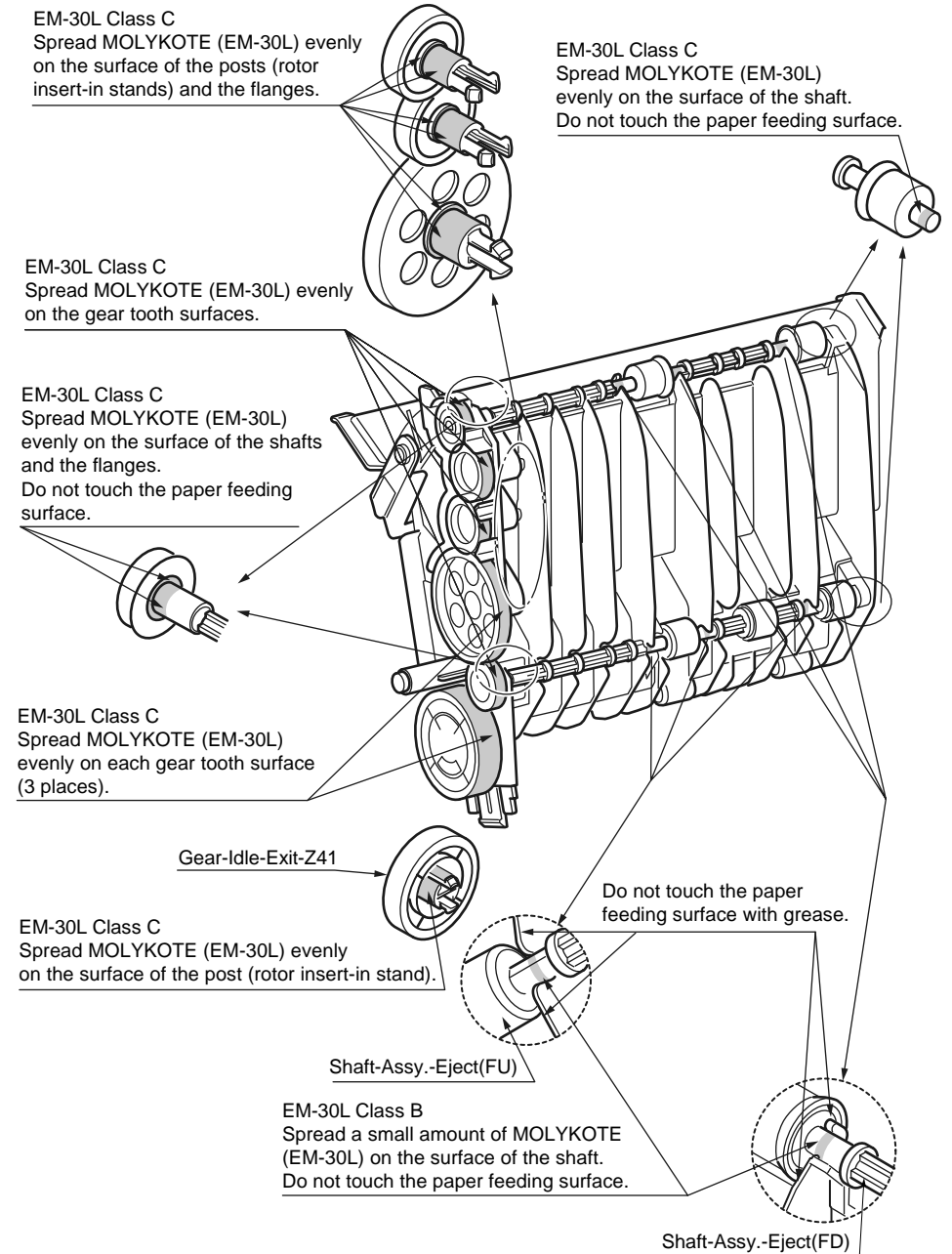

⑩-1 Printer Unit-PX741

EM-30L Class C  
Spread MOLYKOTE (EM-30L)  
evenly on the front end of terminals.

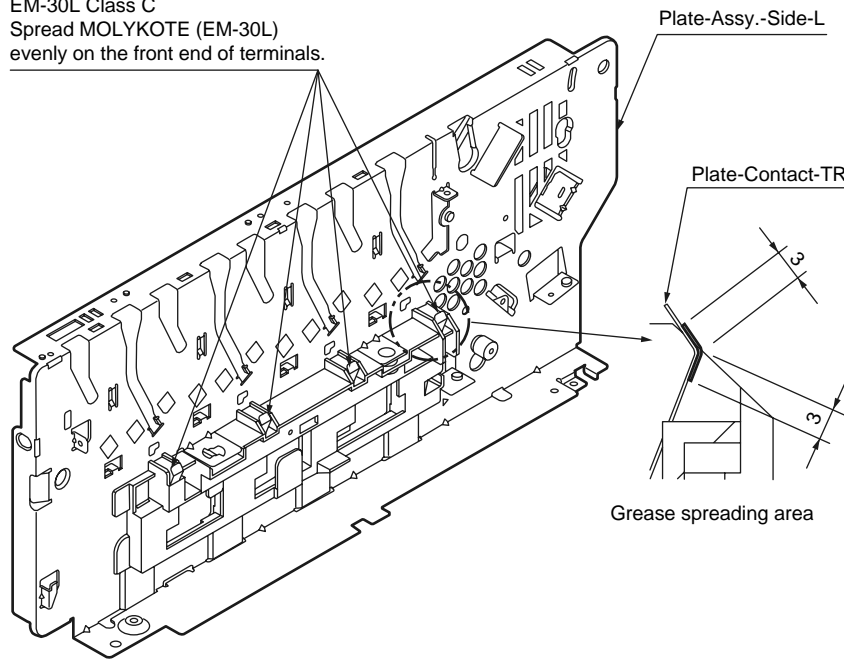

EM-30L Class C  
Spread MOLYKOTE (EM-30L) evenly on the post.

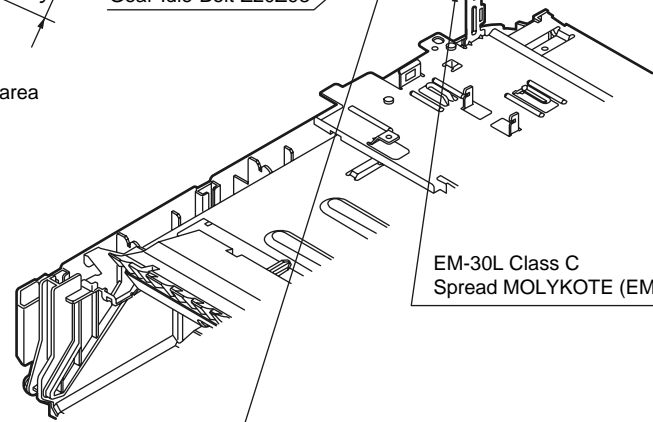

EM-30L Class C  
Spread MOLYKOTE (EM-30L) evenly on the end surface.

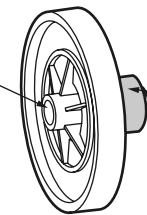

EM-30L Class C  
Spread MOLYKOTE (EM-30L) evenly all around on the  
gear tooth surface.

⑩-2 Printer Unit-PX741

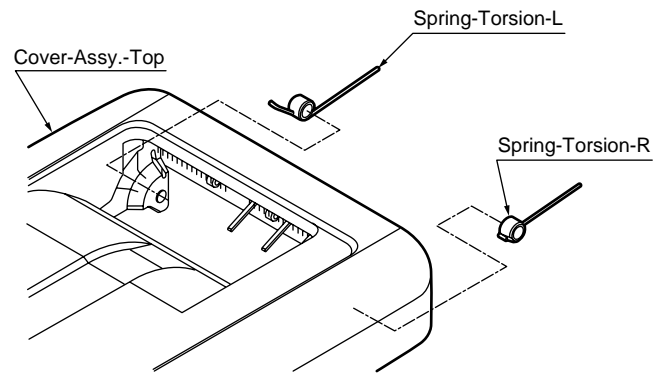
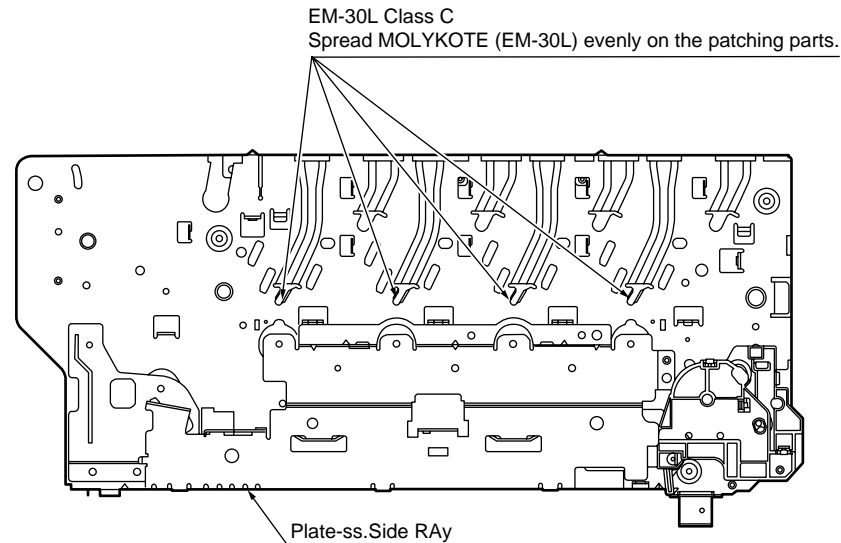

Panmotoroil Class C  
Use a brush to spread the pan motor oil evenly over the area where the compression coil in torsion spring is made.

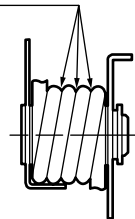

⑪ Belt-Assy.

EM-30L Class A  
Spread a small amount of MOLYKOTE (EM-30L) on the inside of Bearing-TR (Belt) (total 8 places on both sides).

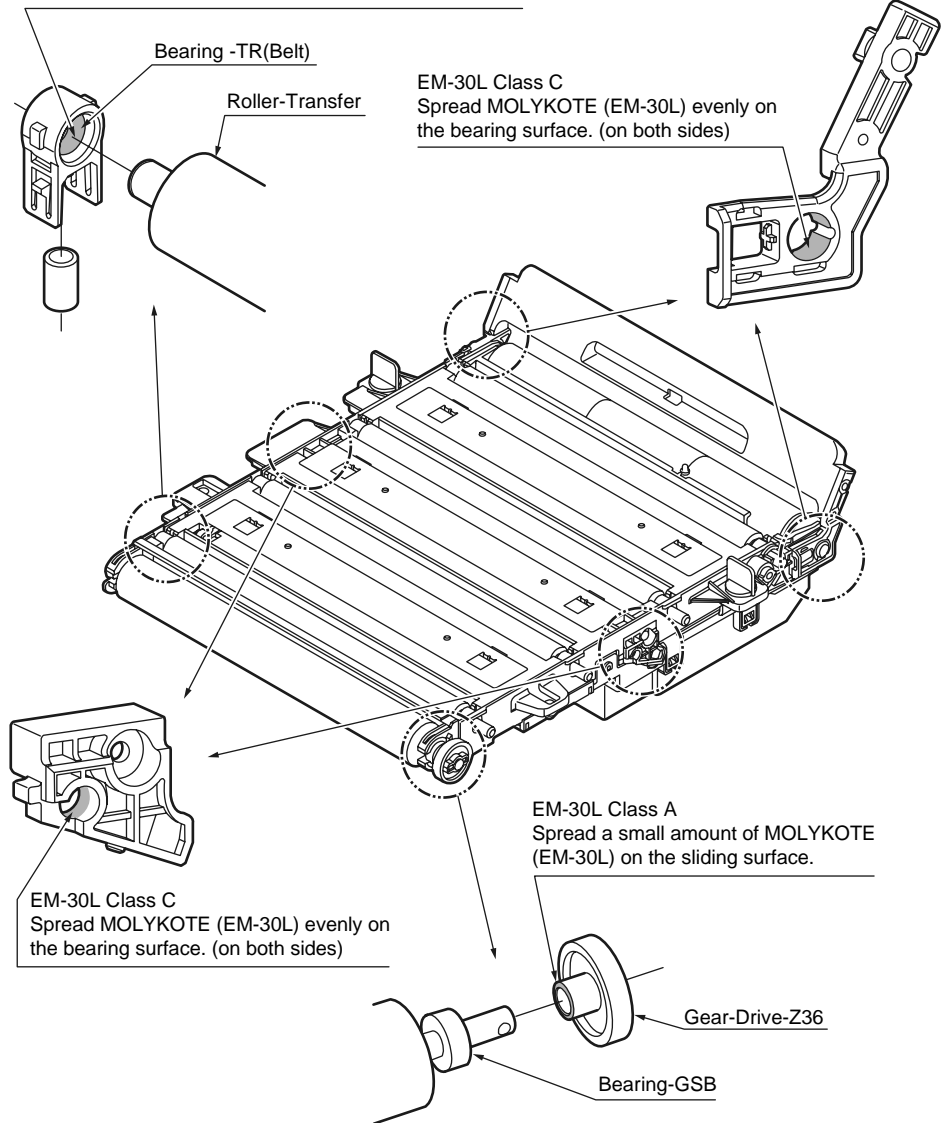



⑫ Sensor Assy. -Color Regist

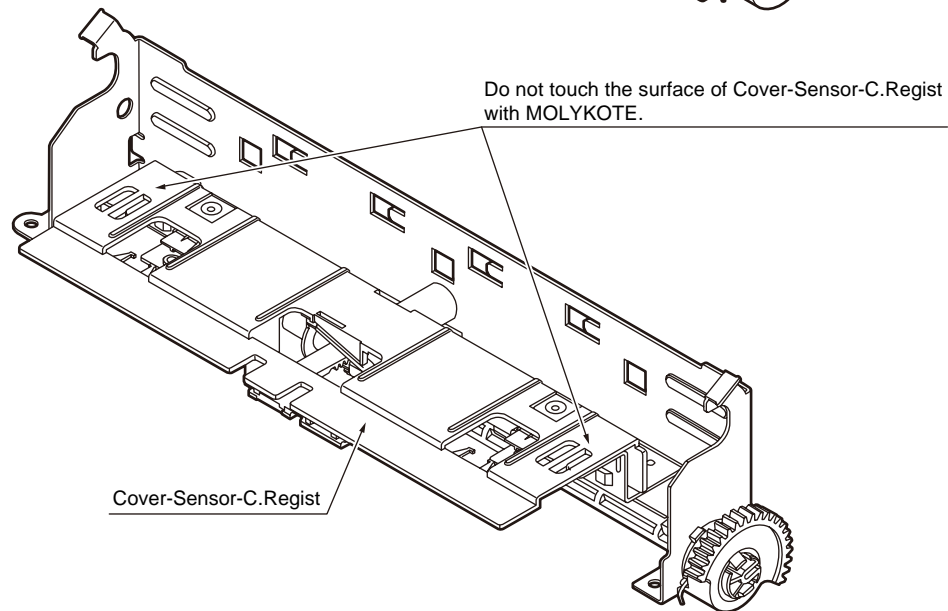
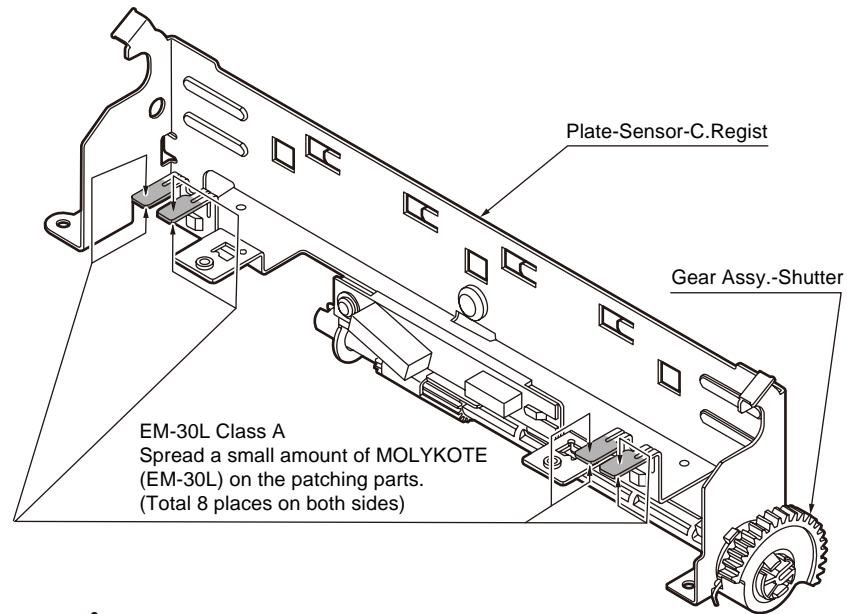

⑬ Roller-Assy. -Idle(FD)

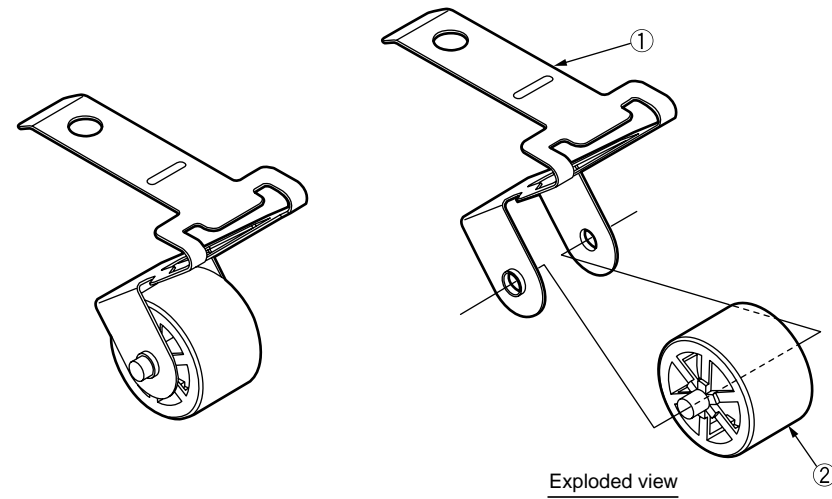

Grease spreading method

EM-30L Class S  
After installing ① to ②, please spread a thin layer of MOLYKOTE (EM-30L) on the sliding surfaces (patching parts) of ① and ②.

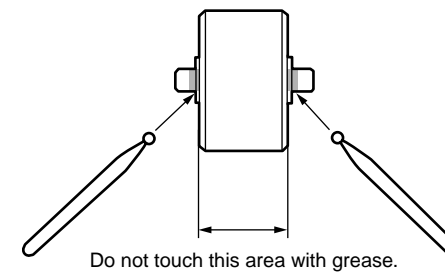

### ⑭ Roller-Assy. -BIAS(FU)C

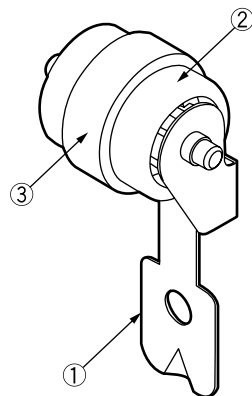

#### Grease spreading method

EM-30L Class S  
After installing ③ to ②, please spread a thin layer of MOLYKOTE (EM-30L) on the sliding surfaces (patching parts) of ① and ②.

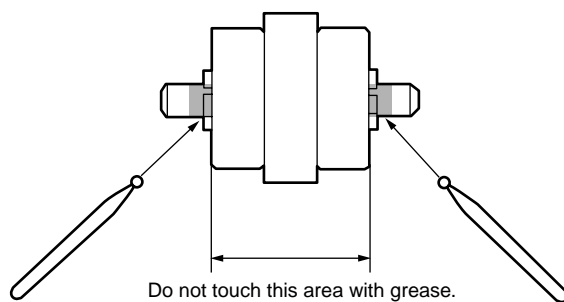

### ⑮ Cassette-Assy-PX741

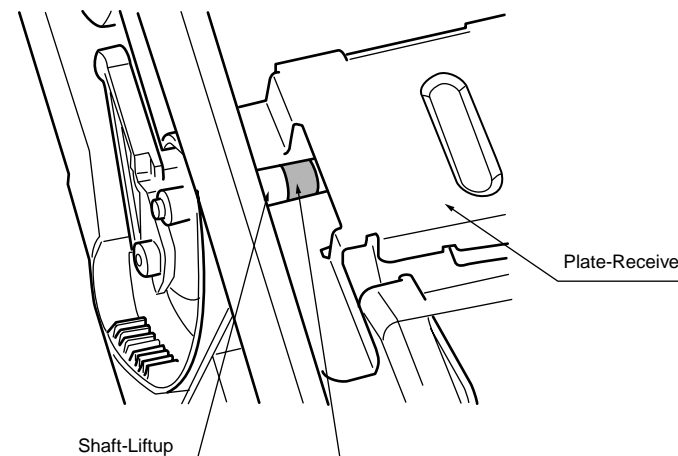

EM-30L Class B  
Apply a small amount of MOLYKOTE(EM-30L) to sliding portions of sheet metal and shaft(the hatched area)

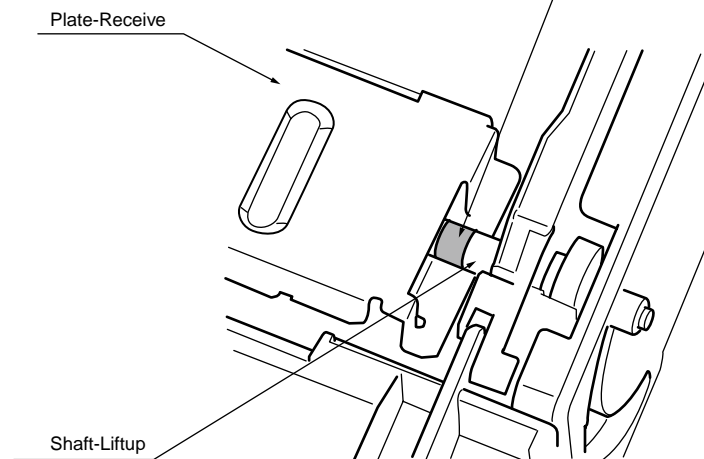

# 5. Maintenance Menu

---

Adjustment of this printer can be performed from the Maintenance Utilities by entering the corresponding menu from the keyboard of the operator panel.

This printer contains the maintenance menu in addition to the normal operation menus. Select an appropriate menu in accordance with the objective of adjustment.

5.1 System maintenance menu (for maintenance engineer) .....	92
5.2 Maintenance Utilities .....	93
5.3 Maintenance menu functions.....	95
5.4 Setups upon completion of part replacement.....	114
5.5 Density control manual setting .....	116
5.6 Printer boot menu list.....	117

## 5.1 System maintenance menu (for maintenance engineer)

While pressing the MENU+ and MENU- keys, turn on the power to enter the maintenance menu.

The menu indications are shown in English only regardless of the destination of the printer.

**Note!** The system maintenance menu is internally use only, and should not be disclosed to end user because destination and other parameters can be modified using this menu.

Table 5-1 Maintenance menu function table

Category	Item (1st Line)	Value (2nd Line)	DF	Function
System Maintenance	Enter Password	***** *****	000 000	Enter the password to enter the system maintenance menu. Default value is "000000". A password can be entered in the range of 6- to 12-digit alphanumeric. For more details, refer to the "Password" sheet.
OKIUSER	OKIUSER	ODA OEL APS JP1 JPOEM1 OEMA OEML	*	Set the destination. JPOEM1 : Japanese OEM OEMA : Overseas OEM outside Japan of A4 size default OEMA : Overseas OEM outside Japan of the Letter size default  When the printer exits the menu, the printer reboots automatically.
Maintenance Menu				[Display condition] Encrypted hard disk function is disabled.
	Format HDD	Execute	-	Initializes the hard disk. When this menu item is executed, the system exits the menu and starts initializing the hard disk.  [Display condition] HDD is installed. ("Boot Menu" - "Storage Setup" = "Enable HDD" is set to "YES".)
	Format Flash ROM	Execute	-	Initializes the flash ROM. When this menu item is executed, the system exits the menu and starts formatting the flash memory device that is installed resident (on-board).  * Use of this menu item is prohibited.
	Reset EEPROM	Execute	-	Returns the EEPROM contents to the setup by the manufacturer when shipped from the factory (factory default profile) value. Upon completion of the setting change, the system reboots automatically.  * Some specific items are not initialized.

Category	Item (1st Line)	Value (2nd Line)	DF	Function
Maintenance Print Menu	Maintenance Print Menu	Enable Disable	*	Selects whether or not to display "Print Information" - "ID Check Pattern" and "Engine Status". When this menu item is set to "Disable", the function menu "Print Information" - "ID Check Pattern" and "Engine Status" are not displayed all the time. When exiting this menu upon completion of setting change, the printer reboots automatically.
Fuse Keep Mode	Fuse Keep Mode	Execute	-	When the ENTER key is pressed, the command is issued from CU to PU to set the system in ON LINE. Replace the consumable part with the new part while the power is turned on. (In this case, fuse of the new consumable part is not cut, and the operational counts are reset so that the count value of old consumable part is not added.) The check mode is terminated when the power is turned off. The check mode is disabled when the power is turned on next time.
Personality	IBM 5577	Enable Disable	*	Changes the default of Support PDL per brand. PDL which is "Disable" in this menu is not displayed at "Print Setup" - "Personality" of Function menu. INVALID DATA shows up and received data is abandoned when print data of PDL which is "Disable" is received.
	IBM PPR III XL	Enable Disable	*	
	EPSON FX	Enable Disable	*	
	HP-GL/2	Enable Disable	*	
Change Password			-	Changes the password. When the ENTER switch is pressed after entering in this menu, the messages "NEW PASSWORD" and "VERIFY PASSWORD" are displayed enabling user to enter a new password.
	New Password	***** *****	-	Sets the new password to enter the maintenance menu. A password can be entered in the range of 6- to 12-digit alphanumeric.
	Verify Password	***** *****	-	Prompting user to verify the new password that has been set by "NEWPASSWORD", to enter the system maintenance menu. A password can be entered in the range of 6- to 12-digit alphanumeric.
Diagnostic Mode			-	Enters the self-diagnostic mode.

## 5.2 TBD

---



# 5.3 Maintenance menu functions

## 5.3.1 Self-diagnostic mode

This section describes the self-diagnostic LEVEL 0 and LEVEL 1 respectively.

### 5.3.1.1 Operation panel

The following description on operating the self-diagnostic is premised on the operation panel layout as shown below.



(1) How to select the menu items

Self-diagnostic mode layout (overall)

XXXXX	Menu items can be selected directly.
XXXXX	Menu items can be selected by pressing either [MENU+] or [MENU-] key.

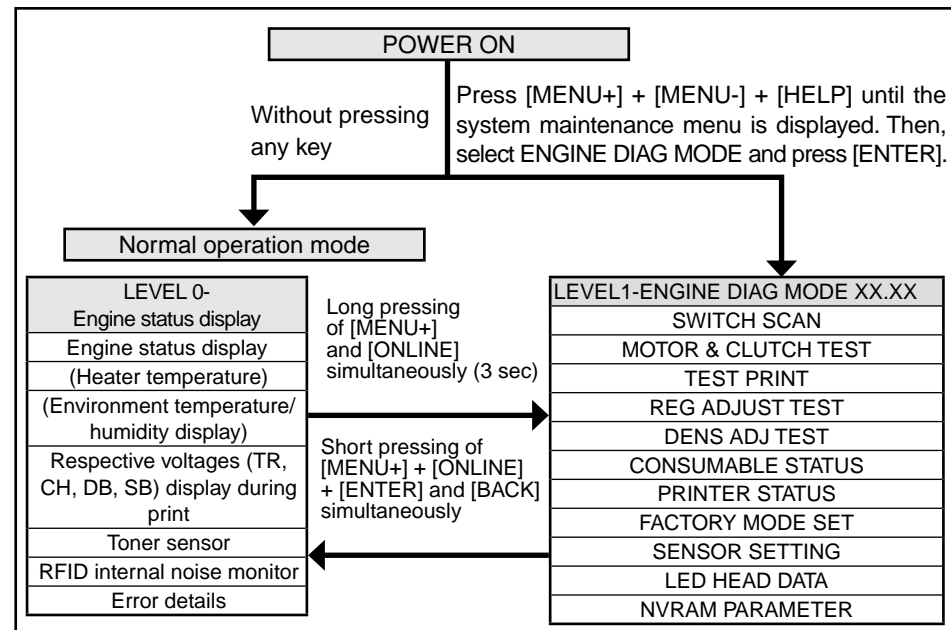

(1) How to select the menu items

LEVEL0

XXXX	Menu items can be selected by long pressing of [BACK] or [ONLINE], or by short pressing of [MENU+] or [ONLINE].
XXXX	Menu items can be selected by pressing either [MENU+] or [MENU-] key. Long pressing of [BACK] returns the screen to the menu item selection screen.

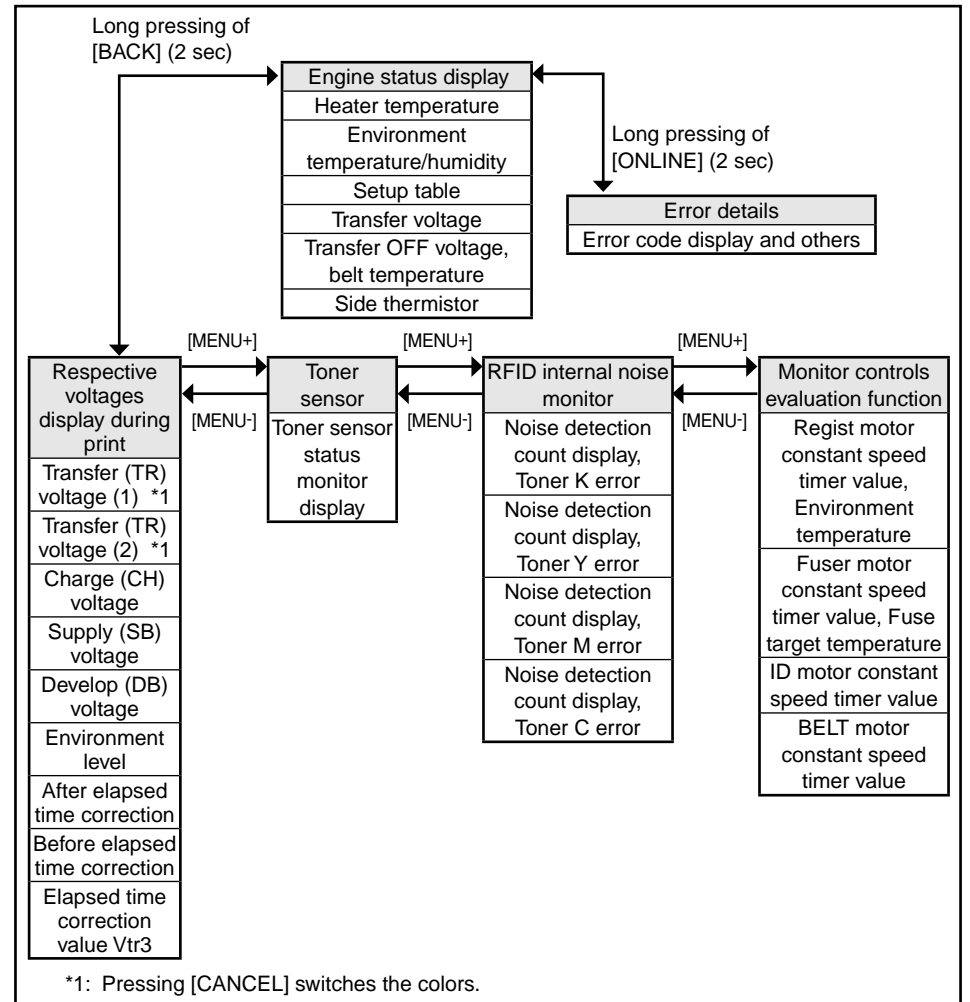

LEVEL1

(1) How to select the menu items

XXXXXX Menu items can be selected by pressing either [MENU+] or [MENU-] key, and executed by pressing [ENTER].

XXXXXX Menu items can be entered by pressing of [ENTER] or [BACK], and can be selected by pressing of [MENU+] or [MENU-].

The test can be executed by pressing [ENTER], and can be exited by pressing [BACK].

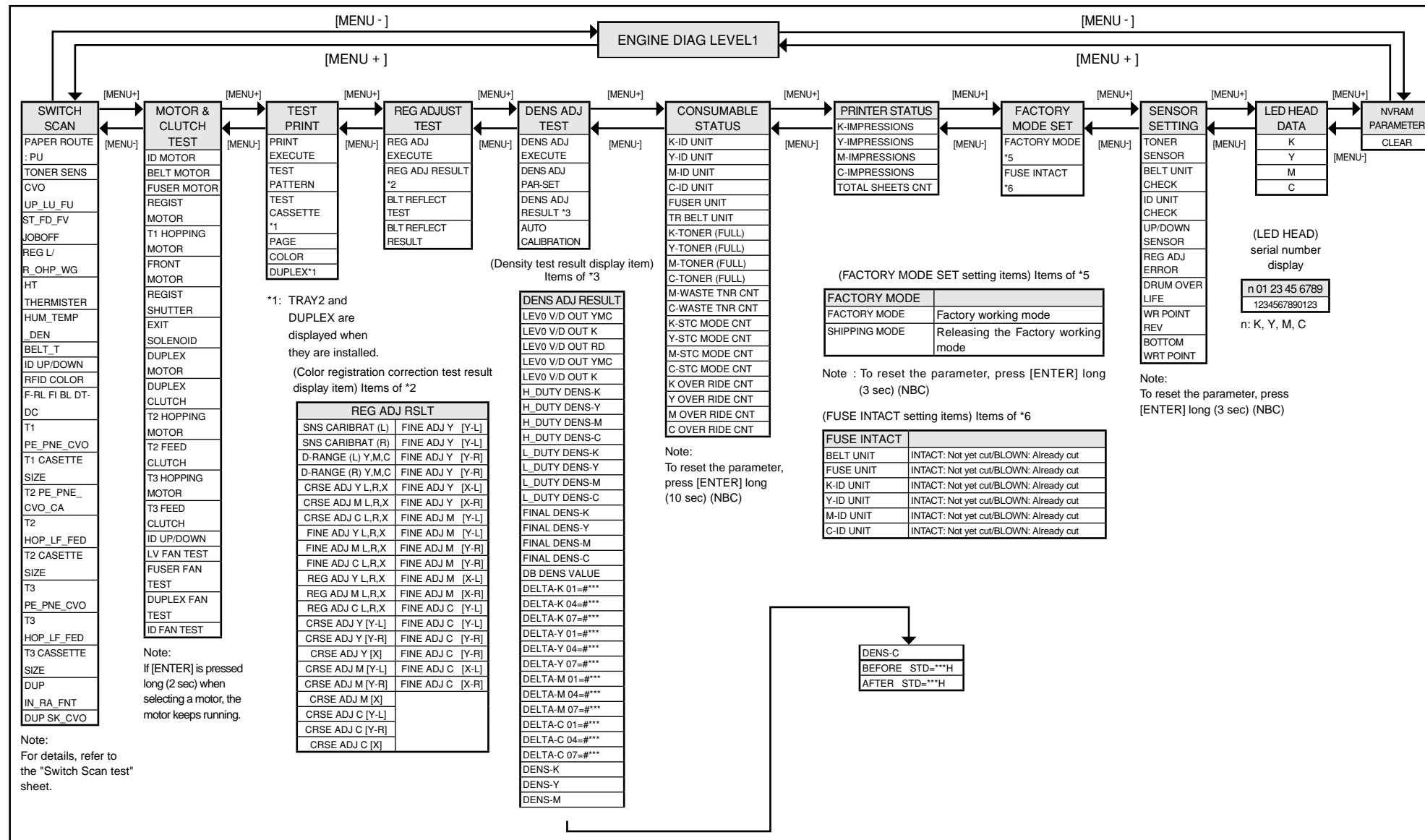



### 5.3.1.2 Ordinary self-diagnostic mode (level 1)

Menu items of the ordinary self-diagnostic mode are shown below.

	Item	Self-diagnostic menu	Adjustment contents	Maintenance utilities
1	Switch scan test	SWITCH SCAN	Entry sensor check and switch check	No.20
2	Motor clutch test	MOTOR&CLTCH TEST	Motor and clutch operation test	No.21
3	Test print execution	TEST PRINT	PU built-in test pattern print	Operation from the maintenance utilities cannot be made.
4	Color registration correction test	REG ADJUST TEST	Color registration mechanism check	No.22
5	Density correction test	DENS ADJ TEST	Density correction mechanism check	No.23
6	Consumable item counter display	CONSUMABLE STATUS	Consumable items consumption status display	No.25
7	Consumable item accumulative counter display	PRINTER STATUS	Consumable items accumulative consumption status display	No.25
8	Factory/Shipping mode selection	FACTORY MODE SET	Switching between the Factory mode and the Shipping mode	No.3, No.26
9	FUSE status check		Respective FUSEs status display	No.26
10	Engine parameter setting	SENSOR SETTING	Valid/Invalid setups of error detection by various sensors	No.27
11	NVRAM parameter setting	NVRAM PARAMETER	Do not use this item	Use of this menu item is prohibited

### 5.3.1.2.1 How to enter the self-diagnostic mode (level 1)

**Note!** For C710, password is required to enter the system maintenance menu mode. Refer to Table 5-1 (C710)

1. While pressing the MENU+ and MENU- keys simultaneously, turn on the power to enter the system maintenance mode.
2. Press the MENU+ key or MENU- key several times until the message "ENGINE DIAG MODE" is displayed. Then, press the ENTER key to display "DIAGNOSTIC MODE".

DIAGNOSTICMODE
XX.XX.XX FACTORY/SHIPPING

3. XXX.XX.XX of the message "DIAGNOSTIC MODE XX.XX.XX" that is displayed on the LCD display area indicates the PU firmware version number. The FACTORY WORKING MODE setup value is displayed in the right of the lower row. S-MODE of "SHIPPING" is displayed normally.
4. Press the MENU+ key or MENU- key to advance to the desired step of each self-diagnostic menu. (The menu items rotate when either the MENU+ key or MENU- key is pressed.)

### 5.3.1.2.2 How to exit the self-diagnostic mode

1. Turn off the power once and back on 10 seconds later.

### 5.3.1.3 Switch scan test

This self-diagnostic menu is used to check the entry sensor and the switch.

1. Enter the self-diagnostic mode (level 1) and press the MENU+, MENU- key until "SWITCH SCAN" is displayed in the upper row of the display area. (Pressing the MENU+ key increments the test item and pressing the MENU- key decrements the test item.)



2. Press either the MENU+ or MENU- key until the desired menu item corresponding to the unit to be tested in Table 5-3 is displayed in the lower row of the display area. (Pressing the MENU+ key increments the test item and pressing the MENU- key decrements the test item.)
3. Pressing the ENTER key starts the test. Name and present status of the corresponding unit are displayed.

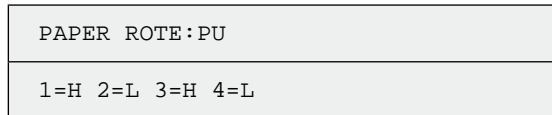

Activate the respective units. (Figure 5-1) Status of the respective units are displayed on the corresponding areas of the LCD display. (Display changes depending on each sensor. Refer to Table 5-3 for details.)

4. Press the CANCEL key to return to the status of step 2.
5. Repeat steps 2 to 4 as required.
6. Press the BACK key to exit the test. (Returns to the status of step 1.)

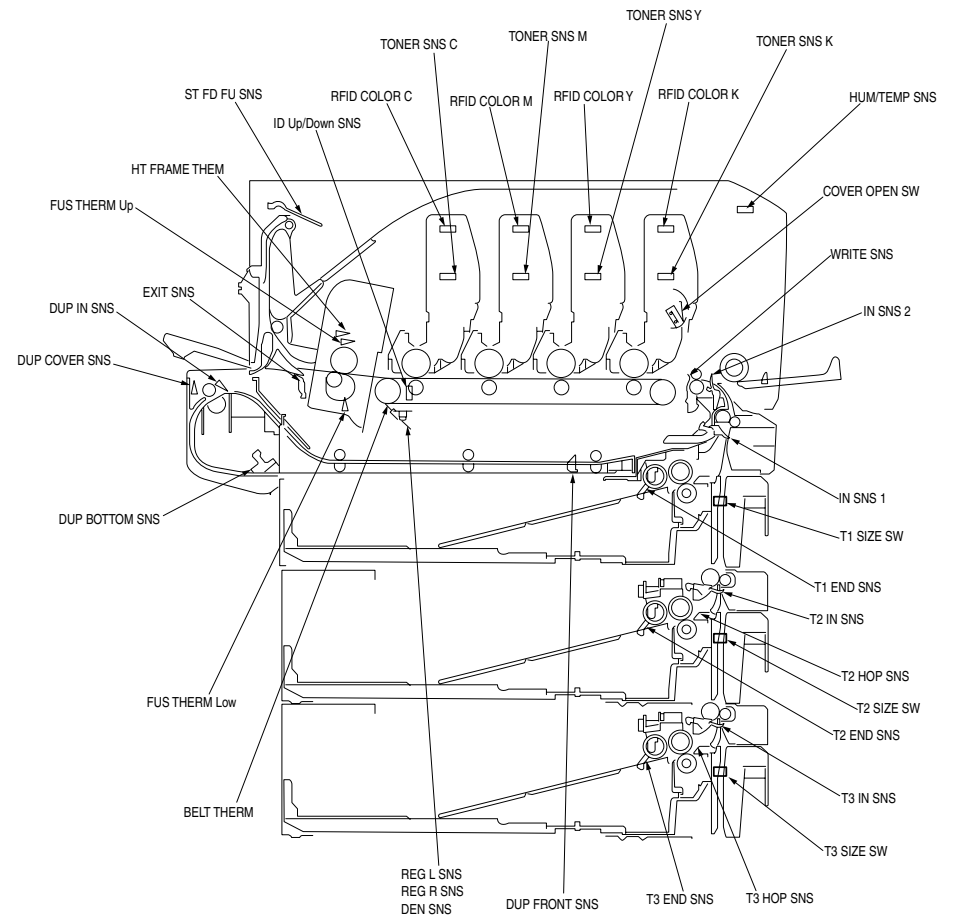

Figure 5-1 Switch and sensor location diagram

Table 5-3 SWITCH SCAN details

<Item having no function> Asterisk mark (\*) is displayed in the lower row of display area.

\* 1: "L" is displayed when the cover is opened.

Display area, upper row	1		2		3		4	
	Details	Display area, lower row	Details	Display area, lower row	Details	Display area, lower row	Details	Display area, lower row
PAPER ROUTE : PU	Entrance sensor 1	H: No paper L: Paper exists	Entrance sensor 2	H: No paper L: Paper exists	Write sensor	H: No paper L: Paper exists	Exit sensor	H: No paper L: Paper exists
TONER SENS	Toner sensor K	H: Light is interrupted L: Reflected	Toner sensor Y	H: Light is interrupted L: Reflected	Toner sensor M	H: Light is interrupted L: Reflected	Toner sensor C	H: Light is interrupted L: Reflected
CVO UP_LU_FU	Cover open switch	H: Close L: Open						
ST_FD_FU JOBOFF	Stacker down sensor	H: No paper L: Paper exists						
REG L/R_OHP_WG	Color registration sensor L	AD value: ***H	Color registration sensor R	AD value: ***H				
HT THERMISTER	Fuser thermistor, upper sensor	AD value: ***H	Fuser thermistor, lower sensor	AD value: ***H	Fuser thermistor, upper sensor, side	AD value: ***H	Heater frame thermistor	AD value: ***H
HUM_TEMP_DEN	Humidity sensor	AD value: ***H	Humidity sensor	AD value: ***H	Humidity sensor (k)	AD value: ***H	Humidity sensor (YMC)	AD value: ***H
BELT_T	Belt thermistor	AD value: ***H						
ID UP/DOWN	GREY	GREY					ID UpDown Sns	H: Down L: Up
RFID COLOR*1	RFID antenna K	UID: ***H	RFID antenna Y	UID: ***H	RFID antenna M	UID: ***H	RFID antenna C	UID: ***H
T1 PE_PNE_CVO	Tray 1 paper end sensor	H: No paper L: Paper exists						
T1 CASSETTE SIZE*1	Size setting switch 1	Port level H, L	Size setting switch 2	Port level H, L	Size setting switch 3	Port level H, L	Size setting switch 4	Port level H, L
T2 PE_PNE_CVO_CA	Tray 2 paper end sensor	H: No paper L: Paper exists						
T2 HOP_LF_FED	2nd-Hopping Sns	H: No paper L: Paper exists			Tray 2 entrance sensor	H: No paper L: Paper exists		
T2 CASSETTE SIZE*1	Size setting switch 1	Port level H, L	Size setting switch 2	Port level H, L	Size setting switch 3	Port level H, L	Size setting switch 4	Port level H, L
T3 PE_PNE_CVO	Tray 3 paper end sensor	H: No paper L: Paper exists						
T3 HOP_LF_FED	3rd-Hopping Sns	H: No paper L: Paper exists			Tray 3 entrance sensor	H: No paper L: Paper exists		
T3 CASSETTE SIZE	Size setting switch 1	Port level H, L	Size setting switch 2	Port level H, L	Size setting switch 3	Port level H, L	Size setting switch 4	Port level H, L
DUP IN_RA_FNT	Duplex (2-sided) print entrance sensor	H: No paper L: Paper exists			Duplex (2-sided) print front sensor	H: No paper L: Paper exists		
DUP SK_CVO	Duplex (2-sided) print bottom sensor	H: No paper L: Paper exists	Duplex (2-sided) print cover sensor	H: Close L: Open				

### 5.3.1.4 Motor clutch test

This self-diagnostic menu is used to test the motor and clutch.

1. Enter the self-diagnostic mode (level 1) and press the MENU+, MENU- key until "SWITCH SCAN" is displayed in the upper row of the display area.  
(Pressing the MENU+ key increments the test item and pressing the MENU- key decrements the test item.)
2. Press either the MENU+ or MENU- key until the desired menu item corresponding to the unit to be tested in Table 5-4 is displayed in the lower row of the display area. (Pressing the MENU+ key increments the test item and pressing the MENU- key decrements the test item.)

MOTOR & CLUTCH TEST
ID MOTOR

3. Pressing the ENTER key starts the test. The unit name starts flashing and the corresponding unit is activated for 10 seconds. (Refer to Figure 5-2.)

**Note!** After the corresponding unit has activated for 10 seconds, it returns to the status of step2, and is re-activated when the corresponding switch is pressed.

- The clutch solenoid repeats turning on and off during the normal print drive. (If a clutch solenoid cannot be activated independently, the motor is driven at the same time.) \* "ID UP/DOWN" keeps activated until the CANCEL key is pressed.
- If [ENTER] is pressed long (2 sec) when selecting a motor, the motor keeps running.

4. When the CANCEL key is pressed, the corresponding unit stops activating. (Display of the corresponding unit keeps displayed.)
5. Repeat steps 2 to 4 as required.
6. Pressing the BACK key terminates the test. (Returns to the status of step 1.)

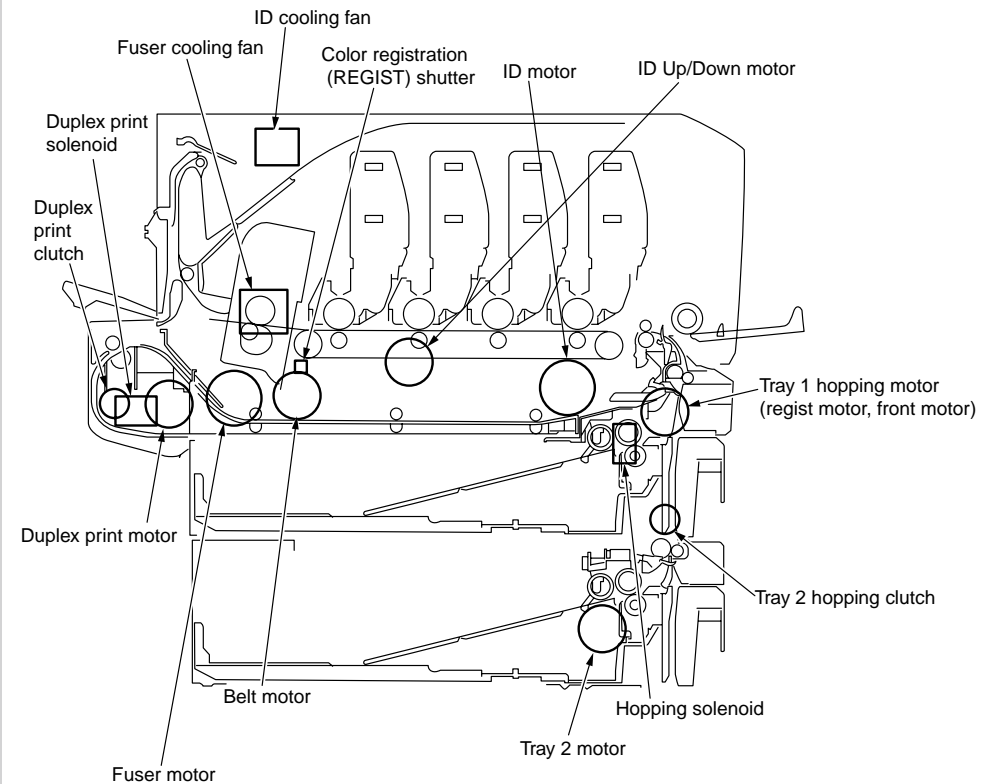

Figure 5-2

Table 5-4

Unit name display	Drive restriction condition	Remarks
ID MOTOR	To be driven when all of the ID (K/Y/M/C) are removed.	-
BELT MOTOR	To be driven when all of the ID (K/Y/M/C) are removed.	-
FUSER_RLS	-	-
REGIST MOTOR	-	-
T1 HOPPING MOTOR	-	-
FRONT MOTOR	-	-
REGIST SHUTTER	-	-
EXIT SOLENOID	-	-
DUPLEX MOTOR	-	-
DUPLEX CLUTCH	-	-
T2 HOPPING MOTOR	-	OPTION
T2 FEED CLUTCH	-	OPTION
T3 HOPPING MOTOR	-	OPTION
T3 FEED CLUTCH	-	OPTION
ID UP/DOWN	TOP/FRONT cover closed status	-
LV FAN TEST	-	-
FUSER FAN TEST	-	-
DUPLEX FAN TEST	-	OPTION
ID FAN TEST	-	-

**Note!** Display while ID Up/Down execution is in progress

MOTOR & CLUTCH TEST
ID UP/DOWN           ***

\*\*\* Number of times of execution

Display when the REGIST SHUTTER [ENTER] key is pressed long

MOTOR & CLUTCH TEST
SHT                   ***

\*\*\* Number of times of execution

### 5.3.1.5 Test print

This self-diagnostic menu is used to print the test pattern that is built inside PU. Other test patterns are stored in the controller.

This test print cannot be used to check the print quality.

Diagnosis for the abnormal print image should be performed in accordance with section 7.

1. Enter the self-diagnostic mode (level 1) and keep pressing the MENU+, MENU- key until "TEST PRINT" is displayed in the upper row of the display area. Then, press the ENTER key. (Pressing the MENU+ key increments the test item and pressing the MENU- key decrements the test item.)
2. The setting items that can be applied to the test print only is displayed in the lower row of display area. Keep pressing the MENU+, MENU- key until the desired menu item is displayed. (Pressing the MENU+ key increments the test item and pressing the MENU- key decrements the test item.) (If all setting items need no entry [Default setting], go to step 5.)
3. Keep pressing the MENU+, MENU- key, and press the ENTER key at the menu item set by step 2. Then, the setting item is displayed in the upper row of display area, and the setting value is displayed in the lower row of display area.

Pressing the MENU+ key increments the setting value. Pressing the MENU- key decrements the setting value. (The setting value that is displayed at last is applied.) Pressing the BACK key determines the entry value, and returns to step 2. Repeat step 3 as required.

TEST PATTERN
1

Display	Setting value	Function
PRINT EXECUTE	-	Pressing the ENTER key starts print/Pressing the CANCEL key terminates print. (In units of page)
TEST PATTERN	0	0: White paper print 1-7: Refer to next page. (Pattern print) 8-15: White paper print
TEST CASSETTE	TRAY1	Selecting source of paper supply. If the TRAY 2 is not installed, TRAY2 is not displayed. If the TRAY 3 is not installed, TRAY3 is not displayed.
	TRAY2	
	TRAY3	
	MFP	
PAGE	0000	Setting number of the test print copies
COLOR	ON	Selecting either color/monochrome print * When ON is specified, ON/OFF setting for each color becomes available.
	OFF	
DUPLEX	2 PAGES STACK	Duplex (2-sided) print is performed by the stack of two sheets of paper. Selecting OFF for duplex (2-sided) print. Duplex (1-sided) print is performed by the stack of one sheet of paper.
	OFF	
	1PAGES STACK	

- is the initial default value. The menu item that is set here is valid in this menu item only.  
(The setting item is not saved in EEPROM.)

**Note!** PAGE setting

Pressing the MENU+ key or the MENU- key shifts the digit. Pressing the ONLINE key increments the setting value. Pressing the MENU+ key increments the setting value. If print is executed while the number of print copies remains in "0000", printing will continue infinitely.

COLOR setting

When the ENTER key is pressed while ON is set, the following contents are displayed on the panel.

Print setting for each color

Pressing the MENU+ key or the MENU- key shifts the setting. Pressing the ONLINE key or the CANCEL, the ON/OFF switchover will be set. Pressing the BACK key returns the panel display.

COLOR	→	Y : ON M : ON
ON		C : ON K : ON

- While the message "PRINT EXECUTE" that is set by the operation specified in step 2 is being displayed, press the ENTER key and the test print is executed with the setting value that has been set by steps 2 and 3.

Pressing the CANCEL key stops the test print.

If any alarm that is shown in the following details column is issued at startup of test print or while test print is in progress, the test print is interrupted. (For error details, refer to section 5.3.2.14 Panel display details. However, the comment to be displayed is different in the case of the PU test print.)

Panel display	Details
STACKER FULL	Stacker full
PAPER END SELECTED TRAY	No paper
DUPLEX UNIT IS NOT INSTALLED	DUPLEX is not installed
SELECTED TRAY IS NOT INSTALLED	Selected tray is not installed.
REMOVE PAPER OUT OF DUPLEX	DUPLEX internal error
INSTALL CASSETTE TRAY OPEN	Cassette removal

Print pattern (It cannot be used for checking PQ.)

0, 8 to 15..... White paper print



Pattern 1



Pattern 2



Pattern 3

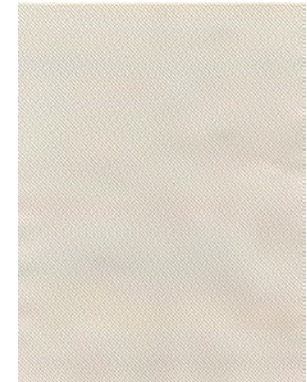

Pattern 4



Pattern 5

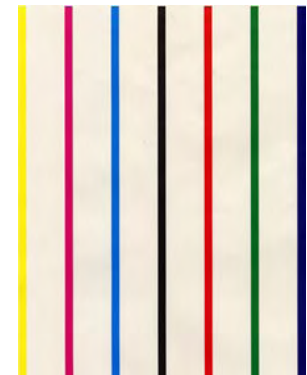

Pattern 6



Pattern 7

**Note!** If the solid print (pattern 7) among the local print function is selected and printed with the setting of 100% each color, offset occurs. To prevent print from this trouble, the print setting of each color should be made in accordance with the instruction specified in step 5.3.2.5-3 when performing the sold print, and number of print colors should be two colors or less.

- During printing, the following messages are displayed.

P=***
W=***

P : Number of test print copies (unit: copies)  
 W : Print waiting time (unit: second)

- Displays are switched by pressing the MENU+ key.

T=*** U=*** [###]
H=***%L=*** [###]

U : \*\*\* = Upper heater temperature measurement value [unit:°C]  
 [\*\*\*] = Print execution target temperature [unit:°C]  
 L : \*\*\* = Lower heater temperature measurement value [unit:°C]  
 [###] = Lower thermistor read-out AD value [unit: HEX]  
 T : Environment temperature measurement value [unit:°C]  
 H : Environment humidity measurement value [unit: %]

- Displays are switched by pressing the MENU+ key.

KTR=* . ** YTR=* . **
MTR=* . ** CTR=* . **

YTR, MTR, CTR and KTR indicate the transfer voltage setting value for each color (unit: KV)

- Displays are switched by pressing the MENU+ key.

KR=* . ** YR=* . **
MR=* . ** CR=* . **

KR : BLACK transfer roller resistance value [unit: uA]  
 YR : YELLOW transfer roller resistance value [unit: uA]  
 MR : MAGENTA transfer roller resistance value [unit: uA]  
 CR : CYAN transfer roller resistance value [unit: uA]

- Displays are switched by pressing the MENU+ key.

ETMP=***UTMP=***
REG=****EXT=***

ETMP : Hopping motor constant speed correction parameter  
 (environment temperature) [unit: DEC]  
 UTMP : Fuser motor constant speed correction parameter  
 (fuse target temperature) [unit: DEC]  
 REG : Hopping motor constant speed timer value (I/O setting value)  
 [unit: HEX]  
 EXT : Fuse motor constant speed timer value (I/O setting value) [unit: HEX]

- Displays are switched by pressing the MENU+ key.

ID=****

KID, YID, MID and CID are the constant speed timer value of the respective ID motors (I/O setting value) [unit: HEX]

- Displays are switched by pressing the MENU+ key.

BELT=****
FRM [***] ( xxx )

BELT : Hopping motor constant speed timer value (I/O setting value) [unit: HEX]  
 FRM : [\*\*\*] = Frame thermistor read-out AD value [unit: HEX]  
 (XXX) = Frame temperature [unit: °C]

- Displays are switched by pressing the MENU+ key.

DB:k**y**m**c**

DB : Develop voltage setting table ID number [unit: HEX]



- Displays are switched by pressing the MENU+ key.

TR1 : k**y**m**c**
TR2 : k**y**m**c**

TR1 : Transfer voltage parameter VTR1 table ID number [unit: HEX]

TR2 : Transfer voltage parameter VTR2 table ID number [unit: HEX]

- Displays are switched by pressing the MENU+ key.

TROFF : **
BELT xxx ( ***)

TROFF : Transfer OFF voltage setting table ID number [unit: HEX]

BELT : XXX = Belt thermistor read-out AD value [unit: HEX]

\*\*\* Belt temperature [unit: °C]

5. Repeat steps 2 to 4 as required.
6. Pressing the CANCEL key terminates the test. (Returns to the status of step 1.)

### 5.3.1.6 Color registration correction test

This self-diagnostic menu item is used for the color registration error adjustment and to investigate cause of the error of a printer.

If the color registration error is recognized by the color registration correction test, correct it by following section 2 "Color registration correction method overview".

1. Enter the self-diagnostic mode (level 1) and keep pressing the [MENU+] or [MENU-] key until the following message is displayed.

REG ADJUST TEST

2. When the [ENTER] key is pressed, the following message is displayed. Keep pressing the [MENU+] or [MENU-] key until the target item is displayed.

REG ADJUST TEST
REG ADJ EXECUTE

3. When the [ENTER] key is pressed, test of the item that is displayed on the panel is executed.

<<During execution of REG ADJ EXECUTE>>

- ① The color registration correction test is executed. (The [ONLINE] lamp flashes.)
- ② When the test is complete, the test result (OK or error name) is displayed in the upper row of the display area, and \*\*\*\*RESULT is displayed in the lower row of the display area

OK
REG ADJ RESULT

When the [MENU+] key is pressed, the test results are displayed by incrementing them.

When the [MENU-] key is pressed, the test results are displayed by decrementing them.

Pressing the [BACK] key returns the screen to the state of step 2.

**Remarks** The following message is displayed during initialization, when the cover is opened and during alarm.

NG
REG ADJ RESULT

- ③ When the [CANCEL] key is pressed while test is in progress (while the [ON LINE] lamp is lighting), the screen returns to the state of step 2.

<<During execution of REG ADJ RESULT>>

The same as the key operations of step 2. During execution of REG ADJ EXECUTE.

<<During execution of BLT REFLECT TEST>>

- ① The color registration correction test is executed.

(The [ONLINE] lamp flashes.)

- ② When the test is complete, the test result (OK or error name) is displayed in the upper row of the display area, and \*\*\*\*RESULT is displayed in the lower row of the display area

OK
BLT REFLECT RSLT

When the [MENU+] key is pressed, the test results are displayed by incrementing them.

When the [MENU-] key is pressed, the test results are displayed by decrementing them.

Pressing the [BACK] key returns the screen to the state of step 2.

- ③ When the [CANCEL] key is pressed while test is in progress (while the [ON LINE] lamp is lighting), the screen returns to the state of step 2.

<<During execution of BLT REFLECT RSLT>>

The same as the key operations of step ②. During execution of BLT REFLECT TEST.

**Remarks** The following message is displayed during initialization, when the cover is opened and during alarm.

NG
REG REFLECT RSLT

4. Repeat steps 2 and 3 as required.
5. Pressing the [BACK] terminates the test. (Returns to the status of step 1.)

## Color registration correction test items

Display	Details
REG ADJ EXECUTE	Executing the color registration correction
REG ADJ RESULT	Referring to result of the color registration correction
BLT REFLECT TEST	Executing judgment of GOOD/BAD of reflectance rate of color registration correction belt
BLT REFLECT RSLT	Referring to result of the judgment of GOOD/BAD of reflectance rate of color registration correction belt.

## 5.3.1.7 Density correction test

This self-diagnostic menu item is used to test the density correction function of a printer, and to refer to result of the test execution.

At the same time, GOOD/BAD of the density correction function is judged by executing this test.

If an error is issued, correct it by following section 2 "Density correction method overview".

1. Enter the self-diagnostic mode (level 1) and keep pressing the [MENU+] or [MENU-] key until the following message is displayed.

DENS ADJ TEST
---------------

2. When the [ENTER] key is pressed, the following message is displayed. Keep pressing the [MENU+] or [MENU-] key until the target item is displayed.

DENS ADJ TEST
---------------

DENS ADJ EXECUTE
------------------

3. When the [ENTER] key is pressed, test of the item that is displayed on the panel is executed.

<<During execution of REG ADJ EXECUTE>>

- ① The density correction test is executed. (The [ONLINE] lamp flashes.)
- ② When the test is complete, the test result (OK or error name) is displayed in the upper row of the display area, and \*\*\*\*RESULT is displayed in the lower row of the display area

OK
----

DENS ADJ RESULT
-----------------

[When the [MENU+] key is pressed, the test results are displayed by incrementing them.

When the [MENU-] key is pressed, the test results are displayed by decrementing them.

Pressing the [BACK] key returns the screen to the state of step 2.

- ③ When the [CANCEL] key is pressed while test is in progress (while the [ON LINE] lamp is lighting), the screen returns to the state of step 2.

<<During execution of DENS ADJ RESULT>>

The same as the key operations of step 2. During execution of DENS ADJ EXECUTE.

<<During execution of DENS ADJ PAR - SET>>

Setup of the density correction parameter is displayed.

<<During execution of AUTO CALIBRATION>>

- ① The automatic setting of the density sensor sensitivity correction value is executed. (The [ON LINE] lamp flashes.)
- ② When the test is complete, the test result (OK or error name) is displayed in the upper row of the display area, and \*\*\*\*RESULT is displayed in the lower row of the display area

OK
DENS ADJ RESULT

When the [MENU+] key is pressed, the test results are displayed by incrementing them.

When the [MENU-] key is pressed, the test results are displayed by decrementing them.

Pressing the [BACK] key returns the screen to the state of step 2.

- ③ When the [CANCEL] key is pressed while test is in progress (while the [ON LINE] lamp is lighting), the screen returns to the state of step 2.

**Remarks** The following message is displayed during initialization, when the cover is opened and during alarm.

NG
DENS ADJ RESULT

- 4. Repeat step 3 as required.

- 5. Pressing the [BACK] key terminates the test. (Returns to the status of step 1.)

Density correction test items

Display	Details
DENS ADJ EXECUTE	Executing the density correction
DENS ADJ PAR-SET	Setting the control values with respect to the automatic density correction
DENS ADJ RESULT	Referring to result of the density correction
AUTO CALIBRATION	Automatic setting of the density sensor sensitivity correction value

### 5.3.1.8 Consumable item counter display

This self-diagnostic menu is used to display the consumption status of the consumable items.

1. Enter the ordinary self-diagnostic mode and press the MENU+, MENU- key until "CONSUMABLE STATUS" is displayed in the display area. (Pressing the MENU+ key increments the test item and pressing the MENU- key decrements the test item.)
2. When the MENU+, MENU- key is pressed, consumption statuses of the consumable items are displayed in order. (Pressing the ONLINE or CANCEL key is invalid.)
3. Pressing the BACK key terminates the test. (Returns to the status of step 1.)

Display area, upper row	Display area, lower row	Format	Unit	Details
K-ID UNIT	*****IMAGES	DEC	Images	Number of rotations from the time when the ID UNITS of respective colors are installed up to the present time is displayed after converting them to the units of A4 3Page/Job.
Y-ID UNIT	*****IMAGES	DEC	Images	
M-ID UNIT	*****IMAGES	DEC	Images	
C-ID UNIT	*****IMAGES	DEC	Images	
FUSER UNIT	*****PRINTS	DEC	Prints	Number of copies from the time of installation of a new fuser unit up to the present time is displayed.
TR BELT UNIT	*****IMAGES	DEC	Images	Number of copies from the time of installation of a new belt unit up to the present time is displayed.
K-TONER (FULL)	*****%	DEC	%	Amount of consumption of the respective toners is displayed.
Y-TONER (FULL)	*****%	DEC	%	
M-TONER (FULL)	*****%	DEC	%	
C-TONER (FULL)	*****%	DEC	%	
M-WASTE TNR CNT	*****TIMES	DEC	Times	Amount of waste toner is displayed. * When the times reaches 32 times or more, the waste toner full is issued.
C-WASTE TNR CNT	*****TIMES	DEC	Times	

Display area, upper row	Display area, lower row	Format	Unit	Details
K-STC MODE CNT	*****TIMES	DEC	Times	Number of print dot counts of the toner of the respective colors are displayed. (Accumulative value since start of the system operation.)
Y-STC MODE CNT	*****TIMES	DEC	Times	
M-STC MODE CNT	*****TIMES	DEC	Times	
C-STC MODE CNT	*****TIMES	DEC	Times	
K OVER RIDE CNT	*****TIMES	DEC	Times	Number of times of continues of the toner cartridge of the respective colors are displayed.
Y OVER RIDE CNT	*****TIMES	DEC	Times	
M OVER RIDE CNT	*****TIMES	DEC	Times	
C OVER RIDE CNT	*****TIMES	DEC	Times	

### 5.3.1.9 Number of print copies counter display

This self-diagnostic menu is used to display status of the number of copies of a printer.

1. Enter the ordinary self-diagnostic mode and press the MENU+, MENU- key until "PRINTER STATUS" is displayed in the display area. (Pressing the MENU+ key increments the test item and pressing the MENU- key decrements the test item.)
2. When the MENU+, MENU- key is pressed, statuses of the number of print copies are displayed in order.(Pressing the ONLINE or CANCEL key is invalid.)
3. Pressing the BACK key terminates the test. (Returns to the status of step 1.)

Display area, upper row	Display area, lower row	Format	Unit	Details
K-IMPRESSIONS	*****IMAGES	DEC	Images	Number of print copies of the respective colors are displayed.
Y-IMPRESSIONS	*****IMAGES	DEC	Images	
M-IMPRESSIONS	*****IMAGES	DEC	Images	
C-IMPRESSIONS	*****IMAGES	DEC	Images	
TOTAL SHEET CNT	*****COUNTS	DEC	Prints	Total number of print copies are displayed.

### 5.3.1.10 Switching between the Factory mode and the Shipping mode

This self-diagnostic menu item is used to switch between the Factory mode and the Shipping mode.

1. Enter the self-diagnostic mode (level 1) and keep pressing the [MENU+] or [MENU-] key until the following message is displayed.

FACTORY MODE SET
------------------

2. When the [ENTER] key is pressed, the following message is displayed. Keep pressing the [MENU+] or [MENU-] key until the target item (refer to the following table) is displayed.

FACTORY MODE
SHIPPING MODE *

3. While the desired item to set is being displayed, press the [ENTER] key that enables selection of the setting values.
4. While the desired setting value is being displayed, press the [ENTER] key for long period (3 seconds) that registers the displayed value in EEPROM. (Returns to the status of step 2.)
5. Repeat steps 2 to 4 as required.
6. Pressing the [BACK] key terminates the test. (Returns to the status of step 1.)

Display	Setting value	Function
FACTORY MODE	FACTORY MODE	Sets the Factory working mode (fuse cut invalid mode).
	SHIPPING MODE	Releases the Factory working mode to make the fuse cut function valid.
FUSE INTACT  Note: ***** indicates INTACT or BLOWN.	BELT UNIT *****	Checks the fuse status of the transport belt unit.
	FUSE UNIT *****	Checks the fuse status of the fuser unit.
	K-ID UNIT *****	Checks the fuse status of the K-1D unit.
	Y-ID UNIT *****	Checks the fuse status of the Y-1D unit.
	M-ID UNIT *****	Checks the fuse status of the Y-1D unit.
	C-ID UNIT *****	Checks the fuse status of the C-1D unit.

### 5.3.1.11 Self-diagnostic function setting

This self-diagnostic menu is used to set valid/invalid of the error detection by the various sensors.

The error detection can be made invalid or valid for locating source of abnormality. However, this menu item requires expert knowledge to set among the engine operations. Handle this menu item with utmost care.

Be sure to return the setting to the default setting upon completion of usage of this item.

1. Enter the self-diagnostic mode (level 1) and keep pressing the [MENU+] or [MENU-] key until the following message is displayed.

SENSOR SETTING

2. When the [ENTER] key is pressed, the following message is displayed. Keep pressing the [MENU+] or [MENU-] key until the target item (refer to the table below) is displayed.

TONER SENSOR
ENABLE *

3. When the [ENTER] key is pressed, the following message is displayed.  
Pressing the [MENU+] key increments the setting value.  
Pressing the [MENU-] key decrements the setting value.
4. While the desired setting value is being displayed, press the [ENTER] key for long period (3 seconds) that registers the displayed value in EEPROM. (Returns to the status of step 2.)
5. Repeat steps 2 to 4 as required.
6. Pressing the [BACK] key terminates (except the status of step 4) the setting. (Returns to the status of step 1.)

Display	Setting value	Operation at the setting value	Function
TONER SENSOR	ENABLE	Detects	Valid/Invalid of toner sensor operation
	DISABLE	Not to detect	
BELT UNIT CHECK	ENABLE	Checks	Valid/Invalid of belt installation check operation
	DISABLE	Not to check	

Display	Setting value	Operation at the setting value	Function
ID UNIT CHECK	ENABLE	Checks	Valid/Invalid of ID installation check operation
	DISABLE	Not to check	
UP/DOWN SENSOR	ENABLE	Detects	Valid/Invalid of ID UP/DOWN sensor operation
	DISABLE	Not to detect	
REG ADJUST ERROR	ENABLE	Stops	Valid/Invalid of error stop by the color registration detection value
	DISABLE	Not to stop	
DRUM OVER LIFE	STOP	Not to continue	Setting of valid/invalid of continuance when drum comes to end of its life
	CONTINUANCE	To continue	
WR POINT REV TBL=**H± * .***mm	00H~FFH	Correction value	The correction value is added to the existing write-down position.
BOTTOM WRT POINT TBL=**H± * .***mm	00H~FFH	Cut value	Amount of cut at the rear end of a paper is set.

Hatched portion: Default is shown

### 5.3.1.12 LED head serial number display

This self-diagnostic menu item is used to check whether the downloaded LED head data matches the serial number of the actual LED head.

1. Enter the self-diagnostic mode (level 1) and press the MENU+, MENU- key until "SWITCH SCAN" is displayed in the upper row of the display area. (Pressing the MENU+ key increments the test item and pressing the MENU- key decrements the test item.)
2. When the MENU+ key or the MENU- key is pressed, serial numbers of the K/Y/M/C LED head data are displayed in order.
3. Pressing the BACK key terminates the test. (Returns to the status of step 1.)

K ** ** ** **
xxxxxxxxxxxxxxxx

\*\* \*\* \*\* \*\*: Rev number

XXXXXXXXXXXXXXXX: serial number

### 5.3.1.13 NVRAM parameter setting

Do not use this menu item.

## 5.3.2 Various prints with the printer as a standalone unit

### Menu map print

Information of the program version number and that of the control block configuration are printed out.

Operation:

- ① While the system is in the [ON LINE] state, press the ENTER key once to display [Information menu].
- ② Press the ENTER key to display [Menu map print/execute].
- ③ Press the ENTER key.

### Network information print

Operation:

- ① While the system is in the [ON LINE] state, press the ENTER key once to display [Information menu].
- ② Press the ENTER key.
- ③ Press the MENU+ key several times to display [Network/execute].
- ④ Press the ENTER key.

Alternately, press 5seconds the push switch located near the network connector on the back of printer.

### Demo print

Prints the demo patterns of the various destinations that are saved in the ROM.

Operation:

- ① While the system is in the [ON LINE] state, press the ENTER key once to display [Information menu].
- ② Press the ENTER key.
- ③ Press the MENU+ key several times to display [DEMO1/execute].
- ④ Press the ENTER key.



### 5.3.3 Functions of keys at power on

Functions of the respective keys when the printer power is turned on are displayed below. Each of the following keys becomes valid if the key is kept pressed until "RAM CHECK" is displayed in the upper row of LCD and the several asterisk (\*) marks are displayed in the lower row.

(1) MENU+ key & MENU- key & ENTER key

The printer starts up in the CU program upgrade mode. If the printer starts up in this mode, the network does not function.

(2) BACK key & ONLINE key & CANCEL key

The object that is added by the download mode is not started but the CU program is started up.

(3) MENU+ key & MENU- key & HELP key

The system maintenance menu is started up.

(4) MENU+ key & MENU- key & ENTER key

The printer starts up in the mode that sets the printer in the on-line mode all the time by ignoring the warning/error. (Factory assistance function)

(5) ONLINE key

The printer starts up in the dedicated mode in which the objects such as network or USB is going to be downloaded.

(6) ENTER key

The Admin menu is started up.

## 5.4 Setups upon completion of part replacement

The adjustments that are required upon completion of part replacement are described below.

Replacement parts	Adjustment contents
LED head See note.	Not required
Drum cartridges (Y, M, C, K)	Not required
Fuser unit	Not required
Belt unit	Not required
PU board	Copying the EEPROM information and utilities are required.
CU board	EEPROM replacement Be sure to use the EEPROM of the user's printer.

**Note!** For compatibility between new/old LEDs and identification, refer to section 4.2.6 "LED Assembly".

### 5.4.1 Precautions when replacing the engine control board

- When access to the EEPROM of the board to remove is possible:  
(When the SERVICE CALL 104 [Engine EEPROM Error] is not displayed:)
  - Obtain the EEPROM information from the board that user is going to be removed, by using the PU board replacement function (Maintenance Utilities Operation Manual section 2.4.1.1.1 PU board replacement function) of the Maintenance Utilities, and save it in the hard disk of PC temporarily.
  - Copy the EEPROM information that has been saved in the hard disk of PC by step (1), into the EEPROM of the new replacement board by using the PU board replacement function (Maintenance Utilities Operation Manual section 2.4.1.1.1 PU board replacement function) of the Maintenance Utilities.

**Note!** When obtaining and copying the EEPROM information by using the Maintenance Utilities, set the printer into the "Forced ONLINE mode" by following the procedure described below. If the printer is in the error state, the error display is issued even during the forced ONLINE mode.

- When turning on the printer power, keep pressing [BACK] + [MENU-] + [ENTER] until "STATUS MODE" is displayed on the operator panel.
- If the printer is normal, "ON LINE" display is shown. If the printer has an error, the error display is shown. However, the printer has entered the ON LINE state in which communication is enabled.

- When access to the EEPROM of the board to remove is impossible:  
If the SERVICE CALL 104 (Engine EEPROM Error) is displayed on the operator panel with the board that user is going to remove, or is EEPROM data cannot be read-out, perform the following procedure by using the Maintenance Utilities.
  - Setting the PU serial number  
(Maintenance Utilities Operation Manual section 2.4.1.2 PU board setting)  
The SAP serial number is applied to printer. The SAP serial number is displayed in the top-most row of the serial number label. Its number indicates the production place with 2 digits, manufacture date with 2 digits, serial number (sequential number) with 6 digits and revision number with 2 digits totaling 12 digit number.
    - The PU serial number is the 10 digit number excluding the revision number of 2 digits among the 12 digit SAP serial number.
    - Perform the above setting by using the Maintenance Utilities section "2.4.1.1.2 PU board setting function" – section "2.4.1.1.2.1 PU serial number setting".
    - To specify the PU serial number, enter the 11 digit number after adding "0" (zero in single-byte character) at the top. (Be careful that the read-out data shows the 10 digit number.)  
Enter the 11 digit number by adding "0" (zero in single-byte character) before the 10 digit number excluding the revision 2 digits that is shown in conceptual drawing of "PU serial number setting" screen as shown below.

Enter the 11 digit number after adding "0" (zero in single-byte character) before the 10 digit number. (Enter "0AEO1234567".)

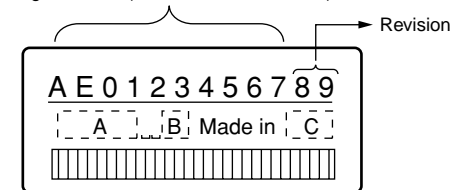

Serial number label conceptual drawing

- The PU serial number is output to the Printer Serial Number column of the Menu Map header portion. Therefore, confirmation upon completion of rewriting the PU serial number can be performed by printing the Menu Map.

## (2) Switching to the Shipping mode

When the engine control board is replaced with the new engine control board, the new board has been set in the Factory working mode. Therefore, it should be switched to the Shipping mode.

- Switch the mode by using the Maintenance Utilities section "2.4.1.1.2 PU board setting function" – section 2.4.1.1.2.2 Factory/Shipping mode" screen.

**Note!** The life control may contain an error because the life information of belt, toner and ID are cleared when the EEPROM (engine control board) is replaced, until the unit replacement is completed. The counts that are cleared by the EEPROM replacement are shown below. All the counts except the Total Sheets Fed are cleared when the unit is replaced with the new unit, the error is corrected at that time.

Item	Contents	Count contents
Fuser unit	Fuser unit life count	Number of print copies after the new fuser unit is installed, after the data is converted to equivalent number of A4 size paper counts.
Belt unit	Belt unit life count	Number of print copies after the new belt unit is installed, after the data is converted to equivalent number of A4 size paper counts.
ID unit : Black ID unit : Yellow ID unit : Magenta ID unit : Cyan	Life count of respective ID units	Number of print copies after the new ID unit is installed, after the data is converted to equivalent number of A4 size paper counts.
Total number of papers fed	Printer life count	Total number of papers fed
Print : Black Print : Yellow Print : Magenta Print : Cyan	Number of print copies of each ID	Number of print copies after the new ID unit is installed.

## 5.4.2 EEPROM setting upon completion of CU board replacement

When replacing the CU board, the user setup data that the user has been using should be inherited to the new replacement CU board. Method of inheriting the user setup data is shown below.

- ① Swap the EEPROM directly from the old board to the new board. (See below.)
- ② Copy the EEPROM data by using the Maintenance Utilities. (Refer to section 5.2)

However, if the service call 40 (EEPROM error) is being issued, the above methods of 1 and 2 cannot be used.

After replacing the CU board with the new board, set the network information such as IP address and others.

### Swapping the EEPROM upon completion of CU board replacement

The EEPROM is installed in the CU board using the IC socket. Swap the EEPROM as described below.

1. Remove the EEPROM seal and the MAC address seal from the old CU board.
2. Insert a screwdriver tip between the EEPROM of old board and the IC socket, and remove the EEPROM while taking care not to bend the EEPROM leads.
3. Install the EEPROM to the new CU board. When installing it, check that the silk-screen print of the EEPROM and that of the new CU board show the same direction.
4. Attach the MAC address seal that has been removed from the old CU board, to the new CU board.
5. Confirm that the same IP address as that of the MAC address seal of the board has been set by performing the menu print.

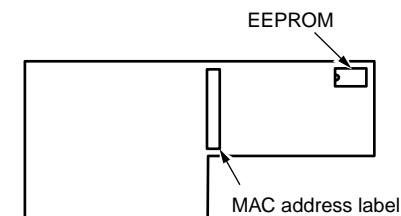





## 5.5 Density control manual setting

---

When a printer is shipped from the factory, the automatic density correction mode has been set in "Automatic". If a printer is used after the density correction mode is set to "Manual", density may change during usage of a printer. Actions to be taken when density is not normal.

**Note!** Perform the followings while a printer is in the still state. Do not perform the followings during warm-up.

- (1) Press the MENU  or MENU  key several times until the [Calibration] is displayed. Then, press the ENTER key.
- (2) Press the MENU  or MENU  key to display [Adjust Density Execute].
- (3) Press the ENTER  key.

The automatic density correction starts.

## 5.6 Printer boot menu list

While pressing the  SET button, turn on the power to display the Boot Menu.

**Memo** To display the Boot Menu, entry of password is required. Default value of password is "aaaaaa".

Category	Item	Setting value	Function
	Enter Password	*****	Enter password to enter Boot Menu. Enter the password of 6 to 12 digits of alphanumeric. The initial value is "aaaaaa".
Parallel Setup	Parallel	Enable	Setting Valid/Invalid of parallel interface.
		Disable	
	Bi-Direction	Enable	Setting Valid/Invalid of bi-direction of parallel interface.
		Disable	
	ECP	Enable	Setting Valid/Invalid of ECP mode.
		Disable	
	Ack Width	Narrow	Setting the ACK width when receiving the compatible data. NARROW = 0.5 μs MEDIUM = 1.0 μs WIDE = 3.0 μs
Medium			
Wide			
Ack/Busy Timing	Ack in Busy	Setting order of outputting the BUSY signal and the ACK signal when receiving the compatible data.	
	Ack while Busy		
I-Prime	3 microseconds 50 microseconds	Setting Valid time/Invalid of the I- PRIME signal	
	Disable		
Offline Receive	Enable	Setting Valid/Invalid of the function that enables to keep the signal reception possible without changing I/F signal even when an alarm is issued.	
	Disable		

Category	Item	Setting value	Function
USB Setup	USB	Enable	Setting Valid/Invalid of USB interface.
		Disable	
	Speed	480Mbps	Setting the maximum transfer speed of USB interface.
		12Mbps	
	Soft Reset	Enable	Setting Valid/Invalid of Soft Reset.
		Disable	
Offline Receive	Enable	Setting Valid/Invalid of the function that enables to keep the signal reception possible without changing I/F signal even when an alarm is issued.	
	Disable		
Serial Number	Enable	Setting Valid/Invalid of USB serial number.	
	Disable		
Security Setup	Job Limitation	Off	Limits the job to accept. The encrypted authentication print only is accepted. It is displayed when the optional internal hard disk is installed.
		Encrypted Job	
	Reset Cipher Key	Execute	Re-generates the encryption key that is used in the encrypted hard disk. It is displayed when the optional internal hard disk is installed, and the encrypted hard disk function is made valid.
Storage Setup	Check File System	Execute	Resolves the un-match between the actual (free) space and displayed free space of file system, and recovers the control data (FAT information.)
	Check All Sectors	Execute	Recovers the HDD sector information defect and un-match of the above file system.
	Enable HDD	No	A printer can start up even if HDD cannot start as it is damaged when it is installed, by setting "No" regardless of the HDD installation as a printer recognizes that HDD is not installed.
		Yes	
	Erase HDD	Execute	Deletes all data stored in a hard disk so that the data cannot be recovered. It is displayed when the optional internal hard disk is installed.
Enable Initialization *	No Yes	The internal hard disk and flash memory are set so that they cannot be changed including initialization. *: It is displayed when [Function set] – [Print tabulation]– [Tabulation function] is set to [Valid] .	
Power Setup	Power Save	Enable	Setting Valid/Invalid of the save power mode.
		Disable	
Language Setup	Language Initialize	Execute	Deletes the message file in a flash memory.

# 6. Periodic Maintenance

---

6.1 Cleaning .....	119
6.2 How to clean the LED lens array .....	120
6.3 How to clean the pickup roller .....	122
6.4 How to clean inside of printer .....	123

## 6.1 Cleaning

---

Clean inside and outside of the printer with clean dry cleaning cloth and small vacuum cleaner (hand cleaner) as required.

**Note!** Be careful not to touch the image drum terminals, the LED lens array and the LED head connectors.

## 6.2 How to clean the LED lens array

If the white banding, white stripe (white drop-out, light printing) in the vertical direction occurs on the print surface, clean the LED lens array.

White banding, white stripe  
(white drop-out, light printing)

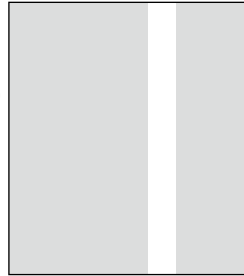

### Perform cleaning of the LED head.

If any light print or white banding is recognized or if print character becomes blurred, clean the LED head as described below.

- (1) Turn off the power of the printer.

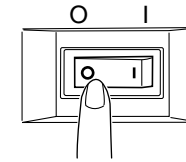

- (2) Press down the OPEN button to open the top cover.

**Caution**

Personal injuries may occur.



The fuser unit gets very hot. Do not touch the fuser unit.

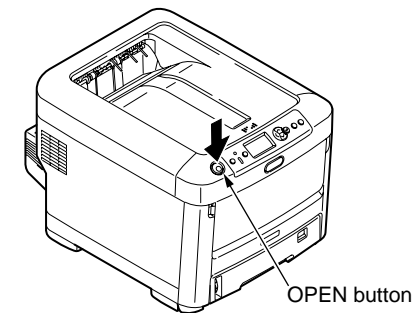



- (3) Wipe the lens surface (at the four positions) of the LED head with soft tissue paper gently and lightly.

**Note!** Do not use the solvents such as methyl alcohol or thinner for cleaning the LED head lens because they can damage the LED head.

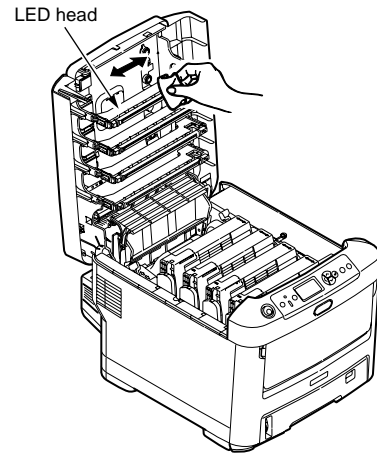

- (4) Close the top cover.

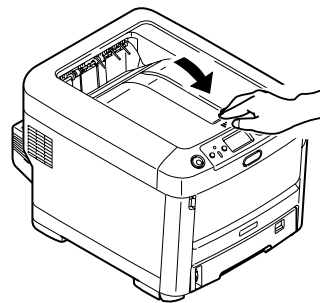

## 6.3 How to clean the pickup roller

If the vertical banding in the vertical direction occurs on the print surface, clean the pickup roller.

**Note!** Be sure to use a soft cloth or the like for cleaning the pickup roller. Otherwise, the roller surface can be damaged.

### Perform cleaning of the feed roller and the separation roller.

Perform this cleaning when the error code [391: Paper jam] occurs frequently.

- (1) Draw out the paper tray.
- (2) Clean the 2 feed rollers with a clean cloth stringently wrung out of clean water.

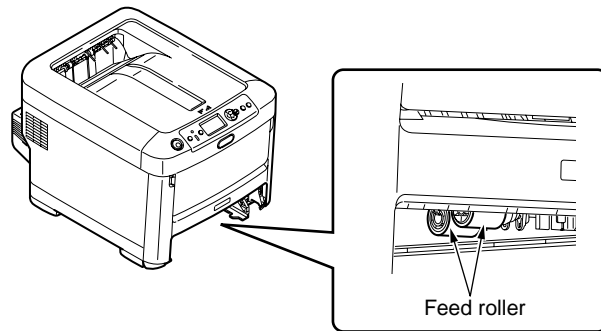

- (3) Clean the separation roller of the paper tray with a clean cloth wrung out stringently of clean water.

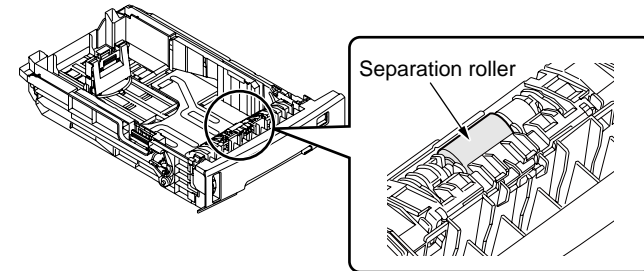

- Note!**
- Clean the second tray (option) in the same manner when the error code [392: Paper jam] occurs frequently.
  - Clean the feeder roller of the multi-purpose tray in the same manner when the error code [390: Check MP tray] occurs frequently.

## 6.4 How to clean inside of printer

### Clean inside of the printer.

Toner can adhere to the metal shaft located in between the fuser and the cyan image drum cartridge depending on the print pattern. Perform cleaning of inside of the printer if toner has adhered to the metal shaft.

- (1) Turn off the power of the printer.

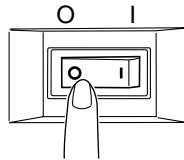

- (2) Press down the OPEN to open the top cover.

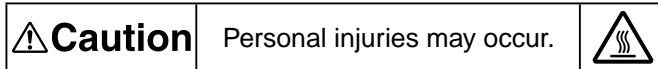

The fuser unit gets very hot. Do not touch the fuser unit.

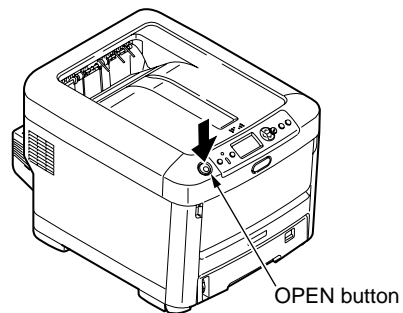

- (3) Remove the image drum cartridge.

1. Remove the four image drum cartridges and place them on a flat workbench.
2. Cover the removed image drum cartridge with a black paper.

- Note!**
- The image drum (green tubular portion) is highly inherently-brittle. Be very careful when handling it.
  - Be very careful not to expose the image drum to direct sun light or intense light (light of approx. 1500 lux or more). Do not leave it under the normal illumination even indoor for 5 minutes or longer.)

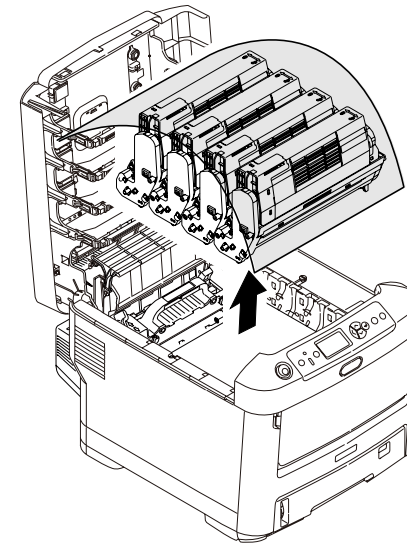

- (4) Remove the fuser unit.

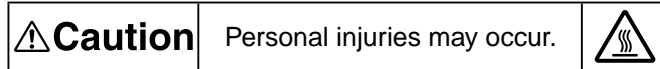

The fuser unit gets very hot. Be very careful not to touch the fuser unit with your hands.

If it got hot, stop the work and wait until it cools down. After it has cooled down, start the following steps.

1. Raise the fuser unit lock levers (two levers shown in blue) in the direction shown by the arrow.
2. Hold the handle of the fuser unit and remove it.

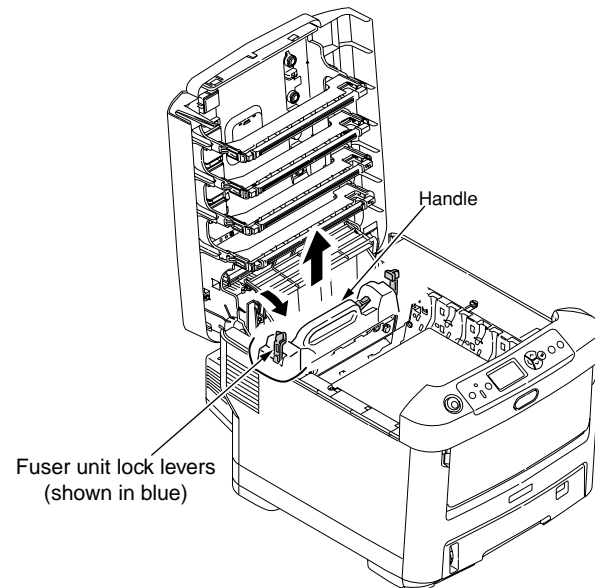

- (5) Clean the metal shaft with soft clean cloth or soft tissue paper.

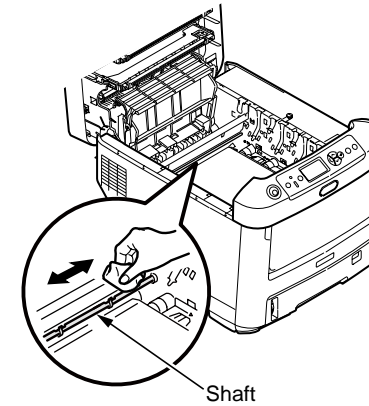

- (6) Install the fuser unit.

For the detailed procedure, refer to the User's Manual – Setup Guide "Replacing fuser unit".

- (7) Return the four image drum cartridges to the printer gently and carefully.
- (8) Close the top cover.

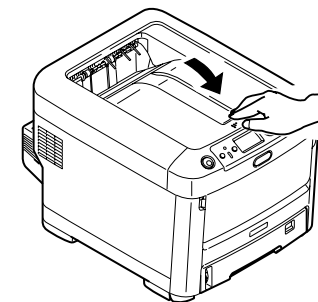

# 7. Troubleshooting and repair procedure

---

7.1 Before starting the repair work .....	126
7.2 Confirmation items before taking corrective action against abnormalities .....	126
7.3 Precautions when taking corrective action against abnormality ..	126
7.4 Preparation for troubleshooting .....	126
7.5 Troubleshooting method .....	127
7.6 Fuse check .....	199
7.7 Paper cassette switches versus Paper size correspondence table .....	200
7.8 Data protection kit-A1 .....	201

## 7.1 Before starting the repair work

---

- (1) Confirm the basic check/inspection points described in User's Manual.
- (2) Get the information/status from client at the time when the trouble has occurred as much in details as possible
- (3) Create the status close to the user's status when the trouble has occurred, and inspect a printer in that status.

## 7.2 Confirmation items before taking corrective action against abnormalities

---

- (1) Is the usage environment of a printer normal?
- (2) Are the consumable items (toner, drum cartridge) replaced normally?
- (3) Is the print media (paper) normal? Refer to Specifications – Paper in User's Manual.
- (4) Is the drum cartridge installed normally?

## 7.3 Precautions when taking corrective action against abnormality

---

- (1) Do not touch the OPC drum surface with your hand or any foreign materials.
- (2) Do not expose the OPC drum to the direct sunlight.
- (3) The fuser unit will be hot. Do not touch.
- (4) Do not expose the image drum to any light for 5 minutes or longer under the normal room temperature.

## 7.4 Preparation for troubleshooting

---

- (1) Display on the Operator Panel  
Error status of this printer is displayed on the LCD (Liquid crystal display) of the Operator Panel.  
Take appropriate troubleshooting action in accordance with the message displayed on the LCD.

## 7.5 Troubleshooting method

When a trouble occurs in this printer, perform troubleshooting by following the steps described below.

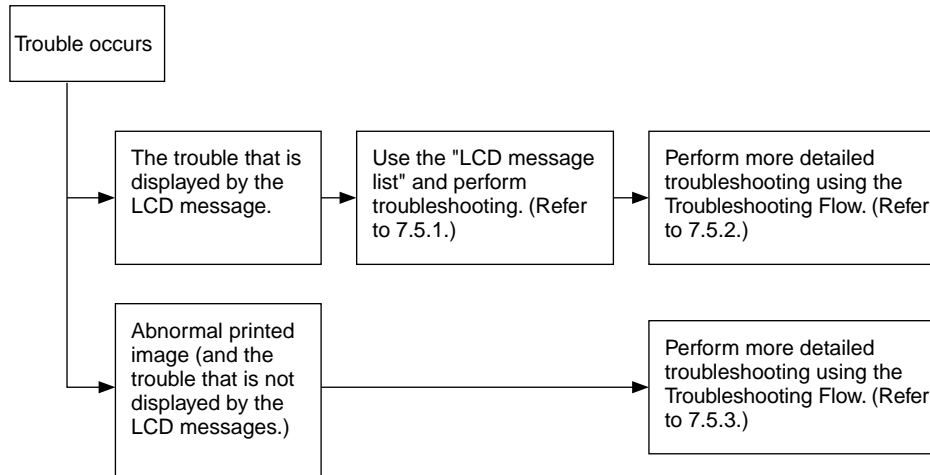

### 7.5.1 LCD message list

#### Initializing

Panel display (The <input type="checkbox"/> mark indicates no message in the upper row.)	ON LINE lamp	Inspection lamp	Details
PLEASE WAIT	Off	Off	It is displayed until the RAM expansion of the CU program is in progress.
Initializing	Off	Off	Indicates initialization of the controller side is in progress.
EEPROM Reset	Off	Off	Indicates the controller side EEPROM is reset. The conditions for resetting the EEPROM are shown below. <ul style="list-style-type: none"> <li>• CU ROM is changed (Unmatch of the CU F/W version is detected.)</li> <li>• Destination is changed.</li> <li>• Forced initialization of EEPROM (System Maintenance Menu)</li> <li>• Setting OEM by the PjL command.</li> </ul>
RAM Check *****	Off	Off	Indicates that RAM check is in progress. Percentage of the checked capacity against the total capacity is shown in the second line.
Wait a Moment Network Initializing	Off	Off	Indicates the network initialization is in progress.
Flash Memory Check	Off	Off	Indicates that the flash memory contents are being checked. If a resident/option flash memory that is not formatted yet is detected, it is displayed when the menu item [FLASH FORMAT] is selected from [MAINTENANCE MENU] of the System Maintenance Menu. Because the above menu item is internally use only and is not disclosed to user, this status does not occur in the user environment.
Flash Memory Format	Off	Off	Indicates that the flash memory formatting is in progress. If a resident/option flash memory that is not formatted yet is detected, it is displayed when the menu item [FLASH FORMAT] is selected from [MAINTENANCE MENU] of the System Maintenance Menu. Because the above menu item is internally use only and is not disclosed to user, this status does not occur in the user environment.

Panel display (The <input type="checkbox"/> mark indicates no message in the upper row.)	ON LINE lamp	Inspection lamp	Details
Program Update Mode	Off	Off	Indicates that the printer has entered in the dedicated mode for upgrading the NIC program (controller firmware) version.
Wait a Moment Program Data Received	Off	Blink	Indicates that reception of the NIC program data for upgrading is in progress.
Wait a Moment Program Data Received OK	Off	Off	Indicates that reception of the NIC program data for upgrading is complete.
Check Data Program Data Receive Error <nnn>	Off	On	Indicates that an error has occurred during reception of the NIC program data for upgrading. %DLCODE% 1 : Size error 2 : Checksum error 3 : Printer model number error 4 : Module I/F version error 5 : FAT version error
Wait a Moment Program Data Writing	Off	Blink	Indicates that writing of the NIC program data for upgrading is in progress.
Power Off/On Program Data Writing OK	Off	Off	Indicates that writing of the NIC program data for upgrading is in complete.
Check Data Program Data Write Error <nnn>	Off	On	Indicates that an error has occurred during writing of the NIC program data for upgrading. %DLCODE% 1 : Memory allocation error 2 : Download file error 3 : Device free space acquisition error 4 : Device insufficient free space error 5 : File write error 6 : CU-F/W mismatch error
PU Flash Error	Off	Off	Indicates that the PU firmware has started up in the Loader mode. It is indicated when the PU firmware has returned "00.00.00" against the Leisus command "VERSIONR 01H" requesting (PU) firmware version information supplied from the CU firmware at power-on. When initialization is finished, it is switched to the Priority 251 status. This error can occur in the user environment. If this error occurs, maintenance by a maintenance engineer is required. (Same as S/C)

Panel display (The <input type="checkbox"/> mark indicates no message in the upper row.)	ON LINE lamp	Inspection lamp	Details
Communication Error	Off	Off	Indicates that communication with the PU firmware has failed. This error can occur in the user environment. If this error occurs, maintenance by a maintenance engineer is required. (Same as S/C)
Status Mode	Off	Off	Indicates that the printer has started in the ON LINE mode always. When a printer starts up in this mode, it processes the data (job) from outside (host) even when an error occurs if a printer has entered the ON LINE mode once. Error and warning are displayed on the panel. A printer can enter in this mode if the power of a printer is turned on while pressing the switches of <Enter> + <Back> + <Down> all simultaneously. Because this pattern of pressing the multiple switches at the same time at power-on is not disclosed to user, this status will not occur in the user environment.



Normal

Panel display (The <input type="checkbox"/> mark indicates no message in the upper row.)	ON LINE lamp	Inspection lamp	Details	Remedial measure
Ready to start printing.	On	Off	Indicates that a printer is in the ON LINE status.	-
OFF LINE	Off	Off	Indicates that a printer is in the OFF LINE status. * The Ready LED is turned off all the time during OFF LINE.	To start printing from a PC, press the ON LINE button to enter the ON LINE state.
File access in progress	Varies	Varies	Indicates that access to a file system (HDD/FLASH) is under way.	-
Receiving data	Varies	Varies	Indicates that the data reception is in progress, and processing has not started yet. This error indicates during the period of PJL processing without character print, or during job through mainly.	-
Processing in progress	Blink	Varies	Indicates that data reception or output processing is progress.	-
There exists remaining data.	Varies	Varies	Indicates that the un-printed data remains in buffer. A printer is in the state of waiting for the data to receive	If a printer is stopped while indicating the state of "Remaining data exists", print the data forcibly by pressing the ON LINE button, or delete the remaining data by pressing the CANCEL button.

Panel display (The <input type="checkbox"/> mark indicates no message in the upper row.)	ON LINE lamp	Inspection lamp	Details	Remedial measure
Printing from % TRAY% in progress	Varies	Varies	Indicates that a printer is in the midst of printing job.	-
Printing demo page	Varies	Varies	Indicates that a printer is in the midst of printing demo page.	-
Printing setup contents	Varies	Varies	Indicates that a printer is in the midst of printing menu map.	-
Printing the network setting	Varies	Varies	Indicates that a printer is in the midst of printing the network setting. When the menu [Information Menu] – [Network] is selected, printing of the network setting starts.	-
<input type="checkbox"/> <input type="checkbox"/> Gathering print iii/jjj	Varies	Varies	Indicates that a printer is in the midst of gather print. iii indicates number of copies in progress, and jjj indicates total number of printed copies. When total number of copies is 1, the normal indication of PRINTING is displayed.	-
<input type="checkbox"/> <input type="checkbox"/> Copy print kkk/lll	Varies	Varies	Indicates that a printer is in the midst of Copy printing. kkk indicates number of copies in progress, and lll indicates total number of printed copies. When total number of copies is 1, the normal indication of PRINTING is displayed.	-
Deleting data	Blink	Varies	Cancel of the job is indicated. A printer is discarding the data until end of the job.	-
Deleting data (Jam)	Blink	Varies	This message is displayed when a jam occurs during jam recovery off. Cancel of the job is indicated. A printer is discarding the data until end of the job.	-
Deleting data (without print permit)	Blink	Varies	Indicates that canceling of a printing without permission is in progress. (Job Account related)  1. When a job is received from a user that is not authorized to print. 2. When a color job is received from a user that is not authorized to make a color print.	-

Panel display (The <input type="checkbox"/> mark indicates no message in the upper row.)	ON LINE lamp	Inspection lamp	Details	Remedial measure
Deleting data (Buffer full)	Blink	Varies	Indicates that canceling a job is in progress because the log storage area inside a printer has run out of memory space, and the operation "Cancel the job" is specified at log full. (JobAccount)	-
<input type="checkbox"/> Adjusting the fuse temperature.	Varies	Varies	Indicates that a printer is in the midst of cooling down. Note that (period) is added at the end of message "Adjusting the fuse temperature."	-
<input type="checkbox"/> Adjusting the fuse temperature.	Varies	Varies	Indicates that a printer is in the midst of warming up. During this period, #0 of the Leisus I/F: STSENG bit is "0".	-
<input type="checkbox"/> Adjusting temperature	Varies	Varies	Indicates that printing is stopped temporarily due to high temperature of a drum. Alternately, this message indicates that a printer is in the standby state waiting for the thermal cooling down when switching paper size from narrow to wide.	-
<input type="checkbox"/> In the power save mode	Varies	Varies	Indicates that a printer is in the power save status. When a printer enters the power save mode, the LCD backlight turns off. When it exits the power save mode, the LCD backlight turns on. If the switch is pressed while the backlight is off (in the power save mode), the backlight turns on, and then turns off in 30 seconds. However, the power save mode is not canceled. The backlight turns on during shut-down (Priority 365).	-
<input type="checkbox"/> Adjusting color	Varies	Varies	Indicates that the automatic color registration correction is in progress.	-
<input type="checkbox"/> Adjusting density	Varies	Varies	Indicates that the automatic density correction is in progress. The status code 10988 corresponds to the density read-out (Leisus – STSDEN #1) and 10994 corresponds to the density correction (Leisus – STSDEN #0).	-

Panel display (The <input type="checkbox"/> mark indicates no message in the upper row.)	ON LINE lamp	Inspection lamp	Details	Remedial measure
Flash Downloar	Varies	Varies	Indicates that downloading of the PU firmware program data is in progress. Since downloading of the PU firmware is opened internally only and not disclosed to user, the status will not occur in the user environment.	-

Warning

Panel display (The <input type="checkbox"/> mark indicates no message in the upper row.)	ON LINE lamp	Inspection lamp	Details	Remedial measure
<input type="checkbox"/> %COLOR% Amount of toner becomes scarce.	Varies	On (Blink) (Off)	<p>Indicates that amount of toner becomes scarce. If the menu has been set as follows: "System Configuration Menu – "LOW TONER – PRINT CONTINUE" = Stop , the inspection LED flashes and a printer moves to the OFF LINE state.</p> <p>When the ON LINE switch is pressed, or when an arbitrary error has occurred and the error is released, the print is continued by canceling the OFF LINE status, until TONER EMPTY is detected.</p> <p>An arbitrary error is any of the errors of Priority 301 through 361.</p> <p>When the TONER LOW status has occurred when the power is turned on, and when the menu has been set as follows: "System Configuration Menu" – "LOW TONER – PRINT CONTINUE" = Stop, the inspection LED flashes and a printer moves to the OFF LINE state at the timing when initialization has ended.</p> <p>When the ON LINE switch is pressed, the printing can be continued until TONER EMPTY. If the menu has been set as follows: ADMIN MENU "CONFIG MENU" – "NEAR LIFE LED = DISABLE", the inspection LED turns off.</p> <p>%COLOR%</p> <p>Y M C K</p>	–

Panel display (The <input type="checkbox"/> mark indicates no message in the upper row.)	ON LINE lamp	Inspection lamp	Details	Remedial measure
<input type="checkbox"/> %COLOR% Waste toner is full. Replace the toner.	Varies	On	<p>This warning is displayed when the cover is Opened/Closed or the power is turned OFF and back ON after the Waste Toner Full error (priority 321.8) has been issued. (Black does not occur.) This warning is displayed in combination with the other message. While this warning is being issued, the Waste Toner Full error is issued every approx. 50 copies of printing and then the printer enters the OFF LINE stop.</p> <p>%COLOR%</p> <p>M C</p>	Replace the toner cartridge of the indicated color.
<input type="checkbox"/> NON. OEM.%COLOR%. Toner	Varies	On	<p>Indicates that the toner cartridge is not Oki genuine product but is made by the authorized 3rd party manufacturer.</p> <p>%COLOR%</p> <p>Y M C K</p>	Prompt user to use the Oki genuine toner cartridge.
<input type="checkbox"/> %COLOR% Illegal Toner	Varies	On	<p>The Region ID (merchandise supply route) of the toner cartridge is illegal.</p> <p>%COLOR%</p> <p>Y M C K</p>	Prompt user to use the Oki genuine toner cartridge.
<input type="checkbox"/> %COLOR% Cannot recognize the toner cartridge.	Varies	On	<p>The RF ID chip of the toner cartridge does not have compatibility. (Not genuine toner cartridge)</p> <p>%COLOR%</p> <p>Y M C K</p>	Tell user that the trouble caused by usage of the non-genuine toner cartridge is outside the range of free repair by warranty to prompt user to use the Oki genuine toner cartridge.

Panel display (The <input type="checkbox"/> mark indicates no message in the upper row.)	ON LINE lamp	Inspection lamp	Details	Remedial measure
<input type="checkbox"/> %COLOR% Image drum is reaching near life end.	Varies	On (Off)	Indicates that the image drum is reaching near life end. Print can be continued until the image drum reaches end of life. When the menu has been set as follows: ADMIN MENU [CONFIG MENU] – [NEAR LIFE LED] = DISABLE, the inspection LED is turned off. %COLOR% Y M C K	–
<input type="checkbox"/> Fuser is reaching near life end.	Varies	On (Off)	Indicates that the fuser is reaching near life end. If the menu has been set as follows: ADMIN MENU "CONFIG MENU" – "NEAR LIFE LED = DISABLE", the inspection LED is turned off.	–
<input type="checkbox"/> Belt is reaching near life end.	Varies	On (Off)	Indicates that the transfer belt is reaching near life end. Because it is warning only, print is not stopped. If the menu has been set as follows: ADMIN MENU "CONFIG MENU" – "NEAR LIFE LED = DISABLE", the inspection LED is turned off.	–
<input type="checkbox"/> Replace the fuser.	Varies	On	Indicates that the fuser had reaching end of life (warning). It is warning only. (Life end error is not issued.) This status is displayed when the cover is Opened/Closed after the Fuser Life error has been issued. If the Print CONTINUE mode at fuser life end (not disclosed to user) has been set to ON, this warning is displayed instead of the fuser life end error.	Replace the fuser with the new fuser.

Panel display (The <input type="checkbox"/> mark indicates no message in the upper row.)	ON LINE lamp	Inspection lamp	Details	Remedial measure
<input type="checkbox"/> Replace the belt.	Varies	On	Indicates that the transfer belt has reached end of life (warning). Warning only. (Life end error is not issued.)  This status is displayed when the cover is Opened/Closed after the transfer belt has reached end of life.  If the mode of Print CONTINUE at the transfer belt life end (not disclosed to user) has been set to ON, this status is issued instead of the transfer belt life end error.	Replace the belt unit with the new belt unit.
<input type="checkbox"/> %COLOR% The printer runs out of toner.	Varies	On	Indicates that the printer runs out of toner.  This status (warning) is issued when the cover is Opened/Closed once after the error is issued to recover the printer once.  If the mode of Print CONTINUE at the toner run-out (not disclosed to user) has been set to ON, this status is issued instead of the toner run-out error. %COLOR% Y M C K	Replace the toner cartridge with the new toner cartridge.
<input type="checkbox"/> %COLOR% The toner cartridge is not installed in the printer.	Varies	On	Indicates that the toner cartridge is not installed. This status is warning only. %COLOR% Y M C K	Install the toner cartridge. Be careful that the toner cartridge supplied with the product cannot be used if the toner cartridge of other supply is used.

Panel display (The <input type="checkbox"/> mark indicates no message in the upper row.)	ON LINE lamp	Inspection lamp	Details	Remedial measure
<input type="checkbox"/> %COLOR% Replace the image drum.	Varies	On	Indicates that the image drum has reached end of life. This status (warning) is issued when the cover is Opened/Closed once after the Image Drum Life end error is issued to recover the printer once. %COLOR% Y M C K	Replace the image drum of the indicated color.
<input type="checkbox"/> Belt Reflex Error	Varies	On	Belt reflectance check error Because the PU firmware does not notice this status to the CU firmware in the Shipping Mode even when the PU firmware has detected this status, this error does not occur in the user environment.	-
<input type="checkbox"/> Density Shutter Error2	Varies	Varies	Density correction shutter error 2 Because the PU firmware does not notice this status to the CU firmware in the Shipping Mode even when the PU firmware has detected this status, this error does not occur in the user environment.	-
<input type="checkbox"/> Density Shutter Error1	Varies	Varies	Density correction shutter error 1 Because the PU firmware does not notice this status to the CU firmware in the Shipping Mode even when the PU firmware has detected this status, this error does not occur in the user environment.	-
<input type="checkbox"/> Density Color Calibration Error	Varies	Varies	Density correction color calibration error Because the PU firmware does not notice this status to the CU firmware in the Shipping Mode even when the PU firmware has detected this status, this error does not occur in the user environment.	-
<input type="checkbox"/> Density Color Sensor Error	Varies	Varies	Density correction color sensor error Because the PU firmware does not notice this status to the CU firmware in the Shipping Mode even when the PU firmware has detected this status, this error does not occur in the user environment.	-

Panel display (The <input type="checkbox"/> mark indicates no message in the upper row.)	ON LINE lamp	Inspection lamp	Details	Remedial measure
<input type="checkbox"/> Density Black Calibration Error	Varies	Varies	Density correction black calibration error. Because the PU firmware does not notice this status to the CU firmware in the Shipping Mode even when the PU firmware has detected this status, this error does not occur in the user environment.	-
<input type="checkbox"/> Density Black Sensor Error	Varies	Varies	Density correction black sensor error. Because the PU firmware does not notice this status to the CU firmware in the Shipping Mode even when the PU firmware has detected this status, this error does not occur in the user environment.	-
<input type="checkbox"/> %COLOR% Image Drum Smear Error	Varies	Varies	Density correction ID ERROR 2. This error occurs when abnormal density due to the LED head focus error is detected. (Extremely stained LED head) Because the PU firmware does not notice this status to the CU firmware in the Shipping Mode even when the PU firmware has detected this status, this error does not occur in the user environment. %COLOR% Y M C K	-
<input type="checkbox"/> %COLOR% Low Density Error	Varies	On	Density correction ID ERROR. This error occurs when abnormal density is detected when stain has occurred in print due to ID error. (Extremely out of focus). Because the PU firmware does not notice this status to the CU firmware in the Shipping Mode even when the PU firmware has detected this status, this error does not occur in the user environment. %COLOR% Y M C K	-

Panel display (The <input type="checkbox"/> mark indicates no message in the upper row.)	ON LINE lamp	Inspection lamp	Details	Remedial measure
<input type="checkbox"/> Density Calibration Error	Varies	On	Sensor adjustment error Because the PU firmware does not notice this status to the CU firmware in the Shipping Mode even when the PU firmware has detected this status, this error does not occur in the user environment	-
<input type="checkbox"/> Registration Error <n>	Varies	On	Color registration correction error. Indicates that an error has occurred during the coarse adjustment or in the main scanning line correction. Because the PU firmware does not notice this status to the CU firmware in the Shipping Mode even when the PU firmware has detected this status, this error does not occur in the user environment.  n 2=Y 3=M 4=C 5=	-
<input type="checkbox"/> Registration Sensor Error <n>	Varies	On	Color registration correction sensor error Because the PU firmware does not notice this status to the CU firmware in the Shipping Mode even when the PU firmware has detected this status, this error does not occur in the user environment.  n 2=Y 3=M 4=C 5=	-

Panel display (The <input type="checkbox"/> mark indicates no message in the upper row.)	ON LINE lamp	Inspection lamp	Details	Remedial measure
<input type="checkbox"/> %COLOR% Head Data Error	Varies	On	Cannot fine the correction data for the LED head. Alternately, the correction data for the LED head is illegal. Because the PU firmware does not notice this status to the CU firmware in the Shipping Mode even when the PU firmware has detected this status, this error does not occur in the user environment.  %COLOR% Y M C K	-
<input type="checkbox"/> %TRAY% runs out of paper.	Varies	On	Indicates that the tray runs out of paper. Warning only is issued until the tray that runs out paper is specified for print.  %TRAY%  Tray 1 Tray 2 Tray 3 MP tray	Feed paper to the indicated tray.
<input type="checkbox"/> The file system is full.	Varies	On	Indicates that the file system that has been constructed on the recording device (HDD/FLASH) runs out of free space. Because this is a temporary warning, this warning is indicated until the job is complete. It disappears at the completion of the job.	Explain user that no remedial measure is required.
<input type="checkbox"/> Writing in the file system is prohibited.	Varies	Varies	Indicates that an attempt is made to write data in the file system that has been constructed on the recording device (HDD/FLASH), and is prohibited of writing data. Because this is a temporary warning, this warning is indicated until the job is complete. It disappears at the completion of the job.	Explain user that no remedial measure is required.

Panel display (The <input type="checkbox"/> mark indicates no message in the upper row.)	ON LINE lamp	Inspection lamp	Details	Remedial measure
<input type="checkbox"/> ***Flash Error	Varies	Varies	PU flash error (Error has occurred during re-writing of the PU firmware.) %PUFLASH% is described below. PU TRAY2 DUPLEX	-
<input type="checkbox"/> Gathering print error Press the ON LINE button.	Varies	On	Indicates that the MOPY memory is data full. This error is kept displayed until the ON LINE key is pressed.	Reduce the number of pages that are going to be printed at once.
<input type="checkbox"/> Because print restriction has been set, the data is deleted. Press the ON LINE button.	Varies	On	Notify user that the job is canceled because the print permission is not set. (Job Account related). This error is kept displayed until the ON LINE key is pressed.	· Set the user ID of the job account in the printer driver. · If the user ID has been set in the driver, confirm the user ID and its setting with the job account administrator.
<input type="checkbox"/> Because the log buffer is full, the data is deleted. Press the ON LINE button.	Varies	On	Notify user that the job is canceled because the log buffer is full. (Job Account related) This error is kept displayed until the ON LINE key is pressed.	Executeto [Acquire immediately] on the server PC of the print job accounting.

Panel display (The <input type="checkbox"/> mark indicates no message in the upper row.)	ON LINE lamp	Inspection lamp	Details	Remedial measure
<input type="checkbox"/> File system access error <nnn> Press the ON LINE button.	Varies	On	Indicates that a file system error other than the above-described file system related status error, has occurred. The processing that does not used the file system can be operated. %FS_ERR% =0....GENERAL ERROR =1.... VOLUME NOT AVAILABLE =3....FILE NOT FOUND =4.... NO FREE FILE DESCRIPTORS =5....INVALID NUMBER OF BYTES =6....FILE ALREADY EXISTS =7....ILLEGAL NAME =8....CANT DEL ROOT- =9....NOT FILE =10...NOT DIRECTORY =11...NOT SAME VOLUME =12...READ ONLY =13...ROOT DIR FULL =14...DIR NOT EMPTY =15...BAD DISK =16...NO LABL =17...INVALID PARAMETER =18...NO CONTIG SPACE =19...CANTCHANGE ROOT =20...FD OBSOLETE =21...DELETED =22...NO BLOCK DEVICE =23...BAD SEEK =24...INTERNAL ERROR =25...WRITE ONLY	Replace the HDD. No remedial action is required when print such as authentication print is not used.
The has received invalid data. Press the ON LINE button.	Varies	Varies	Prompt user to press the ON LINE switch to disappear the warning because the printer has received an invalid data. This error is displayed when a printer has received the unsupported PDL command.	Press the ON LINE switch.

Panel display (The □ mark indicates no message in the upper row.)	ON LINE lamp	Inspection lamp	Details	Remedial measure
Feed paper. Multipurpose tray %MEDIA_SIZE% Press the ON LINE button.	On	Off	Indicates that the print request of manual paper feed is issued. Prompt user to feed manually the paper that is indicated by %MEDIA_SIZE%. Unit of paper size in the Custom mode follows the unit specified display unit (menu setting) of the MP tray unless otherwise specified by driver. If unit of paper size is specified by driver, it is displayed in units specified by driver. Paper size in the Custom mode is displayed as "<width> x <length> <unit>" ex: 210 x 297 mm 8.5 x 11.0 inch	Press the ON LINE switch. * The data will be deleted unless the ON LINE switch is pressed within the time set by [Manual Timeout].

If a printer detects an un-recoverable error, the following service call error is displayed on the LCD.

Service call

nnn: error

**Note!** nnn indicates an error code.

When a service call is displayed, the error code and the associated error information are displayed in the lower row of the LCD display at the same time.

Be sure to take note of this error information (numerals indicating address and others) and inform it to the related departments because the information is used for trouble analysis and solution. Meaning of error codes and remedial measures are shown in Tables 7-1-1 and 7-1-2.

Table 7-1-1 Operator alarm

Display on operator panel	ON LINE lamp	Inspection lamp	Contents	Code nnn
Change paper of the %TRAY% Insert the %MEDIA_SIZE% %MEDIA_TYPE% and press the ON LINE switch. For details, see on-line help.	Off	Blink	Indicates unmatched between the media type in the tray and the print data occurs. Prompt user to insert paper in the tray. Error-661: Tray-1 Error-662: Tray-2 Error 461: Tray 1 Error 462: Tray 2  Unit of paper size in the Custom mode follows the unit specified display unit (menu setting) of the MP tray unless otherwise specified by driver. If unit of paper size is specified by driver, it is displayed in units specified by driver. Paper size in the Custom mode is indicated as follows: "<Width> x <Length> <unit>" ex : 210 x 297 mm 8.5 x 11.0 inch  User is requested to change paper of the tray and press the ON LINE key.	Error  461 462



Display on operator panel	ON LINE lamp	Inspection lamp	Contents	Code nnn
Change paper of the multipurpose tray. Insert the %MEDIA_SIZE% %MEDIA_TYPE% and press the ON LINE switch. For details, see on-line help.	Off	Blink	Indicates unmatched media type in the tray and the print data occurs. Prompt user to insert paper in the tray. Error-660: Multipurpose tray Error 460: Multipurpose tray  Unit of paper size in the Custom mode follows the unit specified display unit (menu setting) of the MP tray unless otherwise specified by driver. If unit of paper size is specified by driver, it is displayed in units specified by driver. ex: 210 x 297mm 8.5 x 11.0 inch  User is requested to change paper of the tray and press the ON LINE key.	Error  460
Change paper of the %TRAY%. Insert the %MEDIA_SIZE% %MEDIA_TYPE% and press the ON LINE switch. For details, see on-line help.	Off	Blink	Indicates that the paper size of the tray or the paper size, and the media type do not match the print data. Prompt user to insert paper in the tray. Error 461: Tray 1 Error 462: Tray 2 Error 462: Tray 3  Unit of paper size in the Custom mode follows the unit specified display unit (menu setting) of the MP tray unless otherwise specified by driver. If unit of paper size is specified by driver, it is displayed in units specified by driver. ex: 210 x 297mm 8.5 x 11.0 inch  User is requested to change paper of the tray and press the ON LINE key.	Error  461 462 463

Display on operator panel	ON LINE lamp	Inspection lamp	Contents	Code nnn
Change paper of the multipurpose tray. Insert the %MEDIA_SIZE% %MEDIA_TYPE% and press the ON LINE switch. For details, see on-line help.	Off	Blink	Indicates that the paper size of the tray or the paper size, and the media type do not match the print data. Prompt user to insert paper in the tray. Error 460: Multipurpose tray  Unit of paper size in the Custom mode follows the unit specified display unit (menu setting) of the MP tray unless otherwise specified by driver. If unit of paper size is specified by driver, it is displayed in units specified by driver. ex: 210 x 297mm 8.5 x 11.0 inch  User is requested to change paper of the tray and press the ON LINE key.	Error  460
Processing of download message is in progress	Varies	Varies	Indicates that processing of the message data for upgrade is in progress.	Error (ONLINE)
Writing of download message is in progress	Varies	Varies	Indicates that writing of the message data for upgrading is in progress.	Error (ONLINE)
Writing of download message is complete	Varies	Varies	Indicates that writing of the message data for upgrading has completed with success.	Error (ONLINE)
Failed to write the download message %CODE%	Varies	Varies	Indicates that writing of the message data for upgrading has failed. %CODE% is a decimal value (single digit) indicating cause of the writing failure. =1 FAIL Cause of the failure is unknown. =2 DATA_ERROR Hash check error during data read/write. FLASH error =3 OVERFLOW Download failure because the FLASH capacity became full during writing or reading the language file. =4 MEMORY FULL Failed to secure memory space. =5 UNSUPPORTED_DATA Download of the data that is not supported by the printer.	Error (ONLINE)
Writing of the network setting contents is in progress	Varies	Varies	When the network related setting items are updated, contents of them are saved in the flash memory.	Error (ONLINE)

Display on operator panel	ON LINE lamp	Inspection lamp	Contents	Code nnn
Wait for a while. Network initialization is in progress.	Varies	Varies	Indicates the network initialization is in progress.	Error (ONLINE)
Insert %MEDIA_SIZE% %ERRCODE%: The %TRAY% runs out of paper.	Off	Blink	Indicates that a print request is issued to the tray that has run out of paper. Prompting user to refill paper. Error 491: Tray 1 Error 492: Tray 2  Unit of paper size in the Custom mode follows the unit specified by menu unless otherwise specified by driver. If unit of paper size is specified by driver, it is displayed in units specified by driver.	Error 491 492
Insert the %MEDIA_SIZE% and press the ON LINE switch. %ERRCODE%: The MP tray runs out of paper.	Off	Blink	Indicates that a print request is issued to the multipurpose tray that has run out of paper. Paper feed restarts when user pressed the ON LINE switch. Error 490: Multipurpose tray  Unit of paper size in the Custom mode follows the unit specified by driver. If unit of paper size is specified by driver, it is displayed in units specified by driver. This error occurs when the tray is in the home position, and the sensor "PE SENS 2" cannot detect paper.	Error 490
Insert a cassette. %ERRCODE%: Tray 1 is left blank.	Off	Blink	Indicates that cassette is removed from the tray 1 that is located in the path when a print from tray 2 is attempted.	Error 440
Insert a cassette. %ERRCODE%: The %TRAY% is not installed.	Off	Blink	Indicates that paper feeding is not possible because cassette has been removed from the corresponding tray when a print from the tray is attempted.	Error 430

Display on operator panel	ON LINE lamp	Inspection lamp	Contents	Code nnn
Add memory. %ERRCODE%: Memory overflow	Off	Blink	Indicates the data overflow exceeding the memory free space due to the following reasons. The processing is continued when the ON LINE switch is pressed. Install the add-on RAM or decrease amount of data. Cause of the trouble is that the following phenomenon has occurred. Amount of print data within a single page is too many.	Error 420
Change the toner. %ERRCODE%: The %COLOR% waste toner is full.	Off	Blink	Indicates that the waster toner of %COLOR% is full requiring replacement of toner. Error 414: Y Error 415: M Error 416: C  (This error does not occur in the black toner.)  When the cover is opened/closed, it changes to the warning status making possible to perform printing of approx 50 copies.	Error 414 415 416
Replace the toner. %ERRCODE%: The %COLOR% runs out of toner	Off	Blink	Indicates that the printer runs out of toner.  When the cover is opened/closed, it changes to the warning status. Error 410: Y Error 411: M Error 412: C Error 413: K	Error 410 411 412 413
Replace the toner. %ERRCODE%: The %COLOR% toner is illegal.	Off	Blink	Indicates that the toner cartridge manufactured by OKI Data is detected whereas its Region ID of the RF ID does not match, and the Group ID matches. The printer can be recovered from the error by replacing the toner cartridge that matches the Region ID and is manufactured by OK Data. Error 554: Y Error 555: M Error 556: C Error 557: K	Error 554 555 556 557

Display on operator panel	ON LINE lamp	Inspection lamp	Contents	Code nnn
Replace the toner. %ERRCODE%: The %COLOR% toner is for printer of another manufacturer.	Off	Blink	Indicates that the toner cartridge manufactured by OKI Data is detected whereas both of its Region ID of the RF ID and the Group ID do not match. (Protection for each OEM group) The printer can be recovered from the error by replacing the toner cartridge that matches the Region ID and the Group ID, and is manufactured by OK Data. Error 614: Y Error 615: M Error 616: C Error 617: K	Error   614 615 616 617
Replace the toner. %ERRCODE%: The %COLOR% toner is for printer of another manufacturer.	Off	Blink	Indicates that the toner cartridge manufactured by OKI Data is detected whereas its Region ID of the RF ID does not match, the Group ID matches and in addition the value is 0. The printer can be recovered from the error by replacing the toner cartridge that matches the Region ID and is manufactured by OK Data. Error 620: Y Error 621: M Error 622: C Error 623: K	Error   620 621 622 623
Use of the genuine toner is recommended. %ERRCODE%: The %COLOR% toner is not the OKI Data genuine toner.	Off	Blink	Indicates that a toner cartridge that is not manufactured by OK Data (whose RF ID chip cannot be recognized) is detected. A printer can be recovered from the error by replacing the toner cartridge with what is manufactured by OKI Data. Error 550: Y Error 551: M Error 552: C Error 553: K  The engine performs the same detection again when the cover is Opened/Closed. If the toner cartridge is not replaced yet, the error is changed to warning and additional 50 copies can be printed.	Error   550 551 552 553

Display on operator panel	ON LINE lamp	Inspection lamp	Contents	Code nnn
Set the toner. %ERRCODE%: The %COLOR% toner is not installed.	Off	Blink	Indicates that toner cartridge is not installed. Error 610: Y Error 611: M Error 612: C Error 613: K  The engine performs the same detection again when the cover is Opened/Closed. If the toner cartridge is not replaced yet, the error is changed to warning and additional 50 copies can be printed.	Error   610 611 612 613
Check toner cartridge %ERRCODE%: %COLOR% toner sensor error.	Off	Blink	Indicates that the toner sensor has detected the error. Error 540: Yellow Error 541: Magenta Error 542: Cyan Error 543: Black	Error  540 541 542 543
Open the front cover. %ERRCODE%: Paper size error	Off	Blink	Inform that a paper of illegal size is fed from the tray. Check paper in the tray, or check if multiple sheets of paper are transported simultaneously by mistake or not. The recovery print is executed when the cover is Opened/Closed	Error 400
Open the top cover. %ERRCODE%: Multiple sheets of paper are transported simultaneously by mistake.	Off	Blink	Inform that a paper having illegally long size is fed from the tray. Check if multiple sheets of paper are transported simultaneously by mistake or not. The recovery print is executed when the cover is Opened/Closed.	Error 401
Check the MP tray. %ERRCODE%: Paper jam	Off	Blink	Indicates that jam has occurred during feeding paper from the MP tray. Error 390: MP Tray	Error 390
Open the front cover. %ERRCODE%: Paper jam	Off	Blink	Indicates that jam has occurred during feeding paper from the this tray. Error 391: Tray 1 Error 392: Tray 2 Error 393: Tray 3	Error  391 392 393

Display on operator panel	ON LINE lamp	Inspection lamp	Contents	Code nnn
Open the front cover. %ERRCODE%: Paper jam	Off	Blink	Indicates that jam has occurred in the paper path. Error 380: Feed	Error 380
Open the door cover. %ERRCODE%: Paper jam	Off	Blink	Indicates that jam has occurred in the paper path. Error 381: Transport Error 382: Exit Error 383: Duplex Entry Error 385: Around Fuser Unit Error 389: Printing Page Lost	Error 381 382 383 385 389
Open the rear cover. %ERRCODE%: Paper jam	Off	Blink	Indicates that jam has occurred in the vicinity of Duplex unit. Error 370: Duplex Reversal Error 371: Duplex Input Error 373: Duplex Multifeed	Error 370 371 373
Open the front cover. %ERRCODE%: Paper jam	Off	Blink	Indicates that jam has occurred in the vicinity of Duplex unit. Error 372: Duplex misfeed	Error 372
Install the Duplex unit. %ERRCODE%: Duplex unit is not installed.	Off	Blink	Indicates that the Duplex unit is removed. If this error is detected, printing is stopped.	Error 360
Replace the drum. %ERRCODE%: The %COLOR% drum has reached end of life.	Off	Blink	Informs the image drum has reached end of line (alarm). When the cover is opened/closed, it changes to the warning status. Error 350: Y Error 351: M Error 352: C Error 353: K	Error 350 351 352 353
Replace the drum. %ERRCODE%: The %COLOR% drum has reached end of life.	Off	Blink	Informs the image drum has reached end of line (alarm). It is displayed until the image drum is replaced. Error 560: Y Error 561: M Error 562: C Error 563: K	Error 560 561 562 563

Display on operator panel	ON LINE lamp	Inspection lamp	Contents	Code nnn
Replace the fuser. %ERRCODE%: The fuser has reached end of life.	Off	Blink	Informs the image drum has reached end of line. This error is issued when the counter detects that the fuser has reached end of life. Print is stopped. When the cover is opened/closed, it changes to the warning status.	Error 354
Replace the belt. %ERRCODE%: The belt has reached end of life.	Off	Blink	Informs that the transfer has reached end of line. This error is issued when the counter detects that the belt has reached end of life. Print is stopped. When the cover is opened/closed, it changes to the warning status.	Error 355
Re-set the fuser. %ERRCODE%: Fuser error	Off	Blink	Indicates that an error is issued in the release position sensor of the fuser. The printer recovers from this error if the release position sensor has read out the data after the cover is closed. If the printer still cannot recover from this error, replacement of the fuser is required.	Error 348
Replace the belt. %ERRCODE%: The belt has reached end of life.	Off	Blink	Indicates that the waster toner is full. It changes to the warning status after the cover is opened and closed only once. This error is issued again after 500 copies are printed.	Error 356
Check the toner cartridge. %ERRCODE%: %COLOR%. The lock lever position is incorrect.	Off	Blink	Indicates that the lever of the toner cartridge is left unlocked. Error 544: Y Error 545: M Error 546: C Error 547: K	Error 544 545 546 547
Re-set the drum. %ERRCODE% :%COLOR%. Drum error	Off	Blink	Indicates that the image drum is not installed normally. Error 340: Y Error 341: M Error 342: C Error 343: K	Error 340 341 342 343
Re-set the fuser. %ERRCODE% : Fuser error	Off	Blink	Indicates that the fuser is not installed normally. (This error can occur when the printer temperature is below 0 degree C. Turn on the power again after the printer temperature has increased.)	Error 320

Display on operator panel	ON LINE lamp	Inspection lamp	Contents	Code nnn
Re-set the belt. %ERRCODE%: Belt error	Off	Blink	Indicates that the belt is not installed normally.	Error 330
Turn off the power and wait for a while. %ERRCODE%:MOTOR. OVERHEAT	Off	Blink	Indicates the overheating of the ID motor.	Error 321
Close the cover. %ERRCODE%: Cover is open.	Off	Blink	Indicates that the cover is open. Error 310: Top cover Error 311: Front cover	Error 310 311
Close the cover. %ERRCODE%: Rear cover is open.	Off	Blink	Indicates that the cover is open. Error 316: Duplex unit cover.	Error 316
Wait for a while. Data processing is in progress.	Off	Blink	Indicates that reception of the NIC program data for upgrading is in progress.	Error
Wait for a while. Data reception processing is in progress.	Off	Off	Indicates that reception of the NIC program data for upgrading is complete.	Error
Check the data. Received data error <%DLCODE%>	Off	On	Indicates that an error has occurred during reception of the NIC program data for upgrading. %DLCODE% 1: Size error 2: Checksum error 3: Printer model number error 4: Module I/F version error 5: FAT version error	Error
Wait for a while. Data write is in progress.	Off	Blink	Indicates that writing of the NIC program data for upgrading is in progress.	Error
Restart the printer. Data write is in progress.	Off	Off	Indicates that writing of the NIC program data for upgrading is in complete.	Error

Display on operator panel	ON LINE lamp	Inspection lamp	Contents	Code nnn
Check the data. Data write error<%DLCODE%>	Off	On	Indicates that an error has occurred during writing of the NIC program data for upgrading. %DLCODE% 1: Memory allocation error 2: Download file error 3: Device free space acquisition error 4: Device insufficient free space error 5: File write error 6: CU-F/W mismatch error	Error
Printer restart is in progress %CODE%.	Off	On	Indicates the reboot of the controller unit is progress. %CODE% is a decimal value (single digit) indicating cause of the reboot. =0....Reboot that is resulted from a cause other than the below. =1....Reboot by the P/L command =2....Reboot caused by the menu change =4....Reboot caused by the network utilities (including web)	Error
Printer shut-down is in progress.	Off	Off	Indicates that a printer is shutting down. The shut-down process is started by pressing the BACK button for more than 4 seconds upon completion of printer initialization process.	Error
SHUTDOWN	Off	Off	Indicates that the shut-down process of a printer is complete.	Error
PLEASE POW OFF SHUTDOWN COMP	Off	Off	Indicates that the shut-down process of a printer is complete. (The LCD backlight turns off.)	Error
POWER OFF AND WAIT FOR A WHILE %ERRCODE%: CONDENSING ERROR	Off	Blink	Dew condensation error (This error is handled in the same way as the service call error though display only is different.) *The Fatal Errors are not supported by the various languages.	Fatal 126

Display on operator panel	ON LINE lamp	Inspection lamp	Contents	Code nnn
POWER OFF/ON %ERRCODE%:FATAL ERROR	Off	Blink	Indicates that a fatal error has occurred. For detailed contents, refer to "Service Calls List". *The Fatal Errors are not supported by the various languages.	Fatal <nnn>
SERVICE CALL %ERRCODE%:FATAL ERROR	Off	Blink	Indicates that a fatal error has occurred. For detailed contents, refer to "Service Calls List". *The Fatal Errors are not supported by the various languages.	Fatal <nnn>
SERVICE CALL %ERRCODE%:FATAL ERROR *	Off	Blink	Indicates that a fatal error has occurred. For detailed contents, refer to "Service Calls List". The asterisk mark "*" indicates the detailed information. *The Fatal Errors are not supported by the various languages.	Fatal 096 231 128 168
POWER OFF/ON %ERRCODE%: FATAL_ERROR nnnnnnnn nnnnnnnn nnnnnnnn	Off	Blink	Indicates that a fatal error has occurred. For detailed contents, refer to "Service Calls List". "nnnnnnnn" indicates the detailed information. *The Fatal Errors are not supported by the various languages.	Fatal 002  011, F0C F0D FFE FFF
POWER OFF/ON %ERRCODE%: DOWNLOAD ERROR	Off	Blink	Indicates failure of the Media table downloading to PU. (Custom Media Type related) *The Fatal Errors are not supported by the various languages.	Fatal 209

Table 7-1-2 Service Call Error List

Display	Cause	Error details		Remedial measure
Restart the printer. 002: Error~ 005: Error	CPU Exception		Does the error display recur?	Yes No If the RAM DIMM is installed, remove it and turn off the power of the printer and back on. Replace the CU board. Re-install the RAM DIMM. Replace the RAM DIMM.
Service call 020: Error	CU ROM Hash Check Error		Does the error display recur?	Yes Turn off the power of the printer and back on. Replace the CU board.
Service call 030: Error	CU RAM Check Error		Does the error display recur?	Yes Turn off the power of the printer and back on. Replace the CU board.
Service call 031: Error	CU Optional RAM Check Error	Is installation of the RAM DIMM normal? Does the printer recover from the error when the RAM DIMM is replaced?	No Yes No	Re-install the RAM DIMM. Replace the RAM DIMM. Replace the CU board.
Service call 040: Error	CU EEPROM Error		Does the error display recur?	Yes Turn off the power of the printer and back on. Replace the CU board.
Service call 041: Error	CU Flash Error. Flash ROM Error on the CU board		Does the error display recur?	Yes Turn off the power of the printer and back on. Replace the CU board.
Service call 042: Error~ 043: Error 045: Error	Flash File System Error	Failed to access to the Flash ROM that is directly soldered to the CU board.		Turn off the power of the printer and back on. Replace the CU board.

Display	Cause	Error details		Remedial measure
Restart the printer. 072: Error. Xx	Engine I/F Error. I/F error between PU and CU	Is the CU assembly installed normally?  Does the printer recover from the error when the CU board is replaced?	No Yes No	Re-install the CU assembly normally. Replace the CU board. Replace the PU board.
Restart the printer. 073: Error xxxxxxxx	Video Error Error is detected when expanding the video data. (Illegal data is received.)	Is the CU assembly installed normally?	No Yes	Re-install the CU assembly normally. Change the PC with another PC having high specifications, or alternately reduce resolution power and execute the print again. Replace the CU board.
		Does this error recur?	Yes	Replace the interface cable. Re-install the PC printer driver.
		Is the CU assembly installed normally?	No Yes	Re-install the CU assembly normally. Execute the print again. Print any other data.
		Does this error recur?  Does the error depend on print data?	No Yes No Yes	Replace the CU board. Send the data to design division and request analysis of the data.
Restart the printer. 074: Error xxxxxxxx 075: Error xxxxxxxx	Video Error Error is detected when expanding the video data.	Is the CU assembly installed normally?	No Yes	Re-install the CU assembly normally. Replace the CU board.

Display	Cause	Error details		Remedial measure
Service call 081: Error	Parameter integrity check	Either EEPROM or Flash ROM cannot read/write normally.		Turn the printer power off and then back on. If the error symptom remains unchanged, replace the CU board.
Service call 104: Error	Read/write error of the engine EEPROM is detected.	Does this error recur?	Yes	Turn off the power of the printer and back on. Replace the PU board.
Service call 106: Error	Engine control logic has an error.	Does this error recur?	Yes	Turn off the power of the printer and back on. Replace the PU board.
Service call 111: Error	Duplex unit for other model is detected.	Is the duplex unit for that specific model installed?	No	Install the correct duplex unit.
Service call 112: Error	2nd tray for other model is detected.	Is the 2nd tray for that specific model installed?	No	Install the correct 2nd tray.
Service call 121: Error	High voltage power supply interface error.	Is the cable connecting the PU board to the high voltage unit connected normally? Have you checked defective contact of contactor points?  Note)	No Yes No	Re-connect them normally. Check for defective contact of the high voltage system. Replace the high voltage power supply.
Service call 122: Error	Low voltage power supply fan error	Is the fan (bottom right of the front) of the low voltage power supply block working?  Is the fan connector connected normally?	No Yes No Yes	Check for sure connection of the fan connector. Replace the PU board. Replace the fan motor. Replace the PU board.

Display	Cause	Error details		Remedial measure
Service call 123: Error	Environment humidity is abnormal./ Humidity sensor is not connected.	Does this error recur?	Yes	Turn off the power of the printer and back on. Replace the control panel board.
Service call 124: Error	Environment temperature is abnormal.	Does this error recur?	Yes	Turn off the power of the printer and back on. Replace the control panel board.
Service call 126: Error	Dew condensation of the printer is detected.	This error can easily occur when a printer is brought in to indoor from outdoor. Leave the printer for 2 hours or half day under room temperature, and turn on the power again. Does this error recur?	Yes	After leaving a printer under room temperature, turn on the power again. Replace the control panel board.
Service call 127: Error	Fuser exhaust fan error	Is the fan connector connected normally?  Does this error recur?	No Yes No	Re-connect it normally. Replace the fan motor. Replace the PU board.
Service call 128: Error	ID cooling fan error	Is the fan connector connected normally?  Does this error recur?	No Yes No	Re-connect it normally. Replace the fan motor. Replace the PU board.
Service call 131: Error~ 134: Error	LED head detection error (131=Y, 132=M, 133=C, 134=K)	Is the LED head connected normally?  Is the LED HEAD fuse brown? Does this error recur?	No Yes Yes No Yes	Install the LED head unit normally. Check the LED HEAD fuse. After checking fuse Turn on the power again. For the method of checking the LED head unit fuse, refer to section 7.6.

Display	Cause	Error details		Remedial measure
Service call 142: Error	ID Up/Down position detection error	Is the ID unit caught by anything when it is removed and re-installed?  Does this error recur?	Yes No Yes	Re-install the ID unit. Turn on the power again. Replace the ID UP/DOWN sensor.
Service call 150: Error~ 153: Error	The ID unit fuse has blown out. (150=Y, 151=M, 152=C, 153=K)	Is the ID unit installed normally? Does this error recur? Does the printer recover from the error when the PU/PRZ board is replaced?	No Yes Yes No	Re-install the ID unit. Turn on the power again. After checking for the sure connection of the cable between PRZ board and PU board, replace the PRZ board. Replace the PU board.
Service call 154: Error	The belt unit fuse has blown out.	Is the belt unit connected normally?  Does this error recur?	No Yes Yes	Re-install the belt unit. Turn on the power again. After checking for the sure cable connection, replace the PU board.
Service call 155: Error	The fuser unit fuse has blown out.	Is the fuser unit installed normally?  Does this error recur?	No Yes Yes	After cleaning the connecting connector of the fuser unit, re-install the fuser unit. Turn on the power again. After checking for the sure cable connection, replace the PU board.



Display	Cause	Error details		Remedial measure
Service call 160: Error~ 163: Error	Toner sensor detection error. (160=Y, 161=M, 162=C, 163=K) This error does not occur with the default settings.	Is the toner cartridge installed?	No	Install the toner cartridge. Rotate the lock lever of toner to the lock position. Turn on the power again. Replace the toner sensor assembly.
		Is the lock lever of the toner set?	No	
		Does this error recur?	Yes	
Service call 167: Error	Thermistor Slope Error	Is the error message displayed? Does this error recur?	Yes	Turn on the power again. After leaving a printer for 30 minutes, turn on the power again.
Service call 168: Error Note)	Compensation Thermistor Error	Is the error message displayed? Does this error recur?	Yes	Turn on the power again. After leaving a printer for 30 minutes, turn on the power again.
Service call 170: Error 171: Error Note)	Short-circuit or open-circuit of fuser thermistor is detected.	Does this error recur?	Yes	Turn on the power again. Replace the fuser unit.
Service call 172: error 173: error	The fuser thermistor has detected an abnormal temperature (high temperature or low temperature.)	Does this error recur?	Yes	Turn on the power again. Replace the fuser unit. Replace the low voltage power supply unit.
		Does this error recur?	Yes	
Service call 174: error	The backup roller thermistor is detected of its short-circuit. (At high temperature)	Does this error recur?	Yes	Turn on the power again. Replace the fuser unit.

Display	Cause	Error details		Remedial measure
Service call 175: error Note)	The backup roller thermistor is detected of its open- circuit. (At low temperature)	Does this error recur?	Yes	Turn on the power again. Replace the fuser unit.
Service call 176: error 177: error	The backup roller thermistor has detected an abnormal temperature (high temperature or low temperature.)	Does this error recur?	Yes	Turn on the power again. Replace the fuser unit. Replace the low voltage power supply unit.
		Does this error recur?	Yes	
Service call 181: error 182: error	Option unit I/F error (181=Duplex Unit, 182=Option Tray)	Does this error recur?	Yes	Turn on the power again. Check for sure connection of the connectors. Replace the option unit.
		Does this error recur?	Yes	
Re-start the printer. 190: error	System memory overflow	Does this error recur?	Yes	Turn on the power again. Increase the add- on RAM DIMM.
Service call 200: error~ 202: error	PU Firmware Download Error	Error has occurred during re- writing of the PU firmware.		After turning on the power again, perform downloading again. (This error does not occur during the normal operation because this processing is not carried out.)
Re-start the printer. 209: Download error	Custom Media Type table downloading has failed.	Custom Media Type table downloading has failed.		After turning on the power again, perform downloading again. (This error does not occur during the normal operation because this processing is not carried out.)

Display	Cause	Error details		Remedial measure
Re-start the printer. 203: error 204: error 207: error 208: error 214: error FOC: error FFF: error	CU program error (The error numbers 203 through 214 do not occur under the normal operation.)	Illegal processing is executed by the CU program.		After turning off the power, check for the normal connection between the CU board and the PU board. Then, turn on the power again.
Service call 230: error	RF ID Reader not Installed	RF ID read device error  Does this error recur?	Yes  Yes	Check for normal connection of the RF IDR/W board. Replace the RF IDR/W. Replace the P6 X board.
Service call 231: error	RF ID reader I/F error	Interface error with the RF ID reader is detected. 01: Communication error between the RF ID reader and the engine circuit boards. 02: Error in the wireless circuit of the RF ID reader 03: Communication error between the RF ID reader and the tag chip. 04: Error is detected in the RF ID tag chip. (In more than 4 chips)		01: Same as the error no. 230 02: Replace the RF ID R/W board. 03: Check for normal connection of the antenna cable. 04: Check if quantity of the RF ID Tag is correct or not.
Re-start the printer. 901: error~ 904: error (Note)	Abnormal temperature of belt 901: Short-circuit 902: Open circuit 903: High temperature 904: Low temperature	Is the cable from belt thermistor to the high voltage board connected normally?  Does this error recur?	No Yes  No	Re-connect the cables normally. Turn on the power again. Replace the belt thermistor.

Display	Cause	Error details		Remedial measure
Re-start the printer. 918: error	Duplex FAN Alarm Caution	Fan error inside the duplex unit.  Does the error recur when the power is turned off once and back on?  Does the error recur when the power is turned off once and back on?	Yes  Yes	Check if the Duplex unit is installed normally or not. Check if the fans are installed normally or not. Replace the fan.
Re-start the printer. 923: error	Black image drum lock error	The K ID does not rotate normally.  Does the error display recur when the power is turned off once and back on?	Yes Yes	Check if the K ID is installed normally or not. Replace the K ID unit. Replace the K ID motor.
Service call 928: error	Fuser motor lock error	Fuser does not rotate normally.  Does this error recur?	Yes Yes	Check if the fuser is installed normally or not. Replace the fuser. Replace the fuser motor.
Service call 980: error	Media wrapped around the fuser error	Media has wrapped around the fuser.		Turn off the power. Replace the fuser.
Service call 982: error	4th tray detection error	The 4th tray is installed.		Remove the 4th tray.
Service call 983: error	Error due to detection of the toner cartridges of the same color	Two or more toner cartridges of the same color are detected.		Install the cartridge of the specified in the specified position.
SDRAM ERROR	CU board (CU) DCON access error	Does this error recur?	Yes	Turn on the power again. Replace the CU board.

Display	Cause	Error details		Remedial measure
xxxxxxxxxxxxxxxxx CRC CHECK NG ( )	CRC check error of the PU downloaded data	The CRC check error is detected upon completion of the PU data downloading (PU firmware, Custom media data)		After turning on the power again, perform downloading again. (This error does not occur during the normal operation because this processing is not carried out.)
LOADER VERSION xx xx	PU board Flash ROM hash check error	Does this error recur?	Yes	Turn on the power again. Replace the PU board.
WDT ERROR R14=xxxxxxxxx	PU firmware runaway	Does this error recur?	Yes	Turn on the power again. Replace the PU board.
COMMUNICATION ERROR	I/F error between PU and CU	Is the CU assembly installed normally?  Does this error recur?	No  Yes  No	Re-install the CU assembly normally. Replace the CU board. Replace the PU board.
ASIC ERROR	DCON access error	Does this error recur?	Yes	Replace the CU board.

**Note!** Service calls 168 error, 171 error, 175 error, 903 error and 904 error; These errors can occur when the printer temperature is below 0 °C. Turn on the power again after the printer temperature has increased.

## 7.5.2 Preparation for troubleshooting

(1) LCD display error .....	149	(8-4) Two-sided printing jam occurs during transporting paper inside the Duplex unit.....	170
(1-1) LCD does not display anything.....	149	(8-5) Paper is not supplied from the Duplex unit to the regist roller.....	170
(1-2) PLEASE WAIT .....	150	(9) Paper size error (error code 400) .....	170
(1-3) Error messages related to Operator Panel are displayed.....	150	(9-1) Jam occurs when paper end is located near the IN1 sensor.....	170
(1-4) "RAM check in progress" or "Initializing" display is kept appearing.....	150	(10) ID unit Up/Down error (Service call 140 to 143).....	171
(2) Abnormal operations of printer after the power is turned on.....	151	(10-1) Error occurs during the Up movement of the ID unit .....	171
(2-1) Any operation does not start at all.....	151	(10-2) Error occurs during the Down movement of the ID unit.....	171
(2-2) Abnormal sound is heard.....	151	(11) Fuser unit error (error 170 to 177).....	172
(2-3) Bad odors are generated.....	152	(11-1) Error occurs immediately after the power is turned on.....	172
(2-4) Rise-up time is slow.....	152	(11-2) Error occurs approx. 1 minute after the power is turned on.....	172
(3) Paper feed jam (error code 391: 1st tray).....	159	(12) Motor fan error (error code 122, 127, 128, 918, 051).....	173
(3-1) Jam occurs immediately after the power is turned on. (1st tray).....	159	(12-1) The low voltage power supply fan does not rotate immediately after the power is turned on.....	173
(3-2) Jam occurs immediately after the paper feed is started. (1st tray) .....	159	(12-2) Duplex fan does not rotate during the Duplex printing.....	173
(4) Feed jam (error code 380) .....	161	(12-3) All fans of the printer do not rotate.....	173
(4-1) Jam occurs immediately after the power is turned on.....	161	(13) Print speed is slow. (Performance is low.) .....	174
(4-2) Jam occurs immediately after the paper feed is started.....	161	(13-1) Print speed decreases.....	174
(5) Paper feed jam (error code 390: Multipurpose tray).....	162	(14) Option unit cannot be recognized.....	174
(5-1) Jam occurs immediately after the power is turned on. (Multipurpose tray).....	162	(14-1) Duplex unit cannot be recognized.....	174
(5-2) Jam occurs immediately after paper feed is started. (Multipurpose tray).....	163	(14-2) Option try unit cannot be recognized.....	174
(6) Paper running jam (error code 381:).....	164	(15) LED head cannot be recognized. (error code 131, 132, 133, 134) .....	175
(6-1) Jam occurs immediately after the power is turned on.....	164	(15-1) Service call 131 to 134 (LED HEAD Missing).....	175
(6-2) Jam occurs immediately after a paper is taken into printer.....	164	(16) Toner cartridge cannot be recognized. (error code 540, 541, 542, 543) .....	176
(6-3) Jam occurs in the middle of paper running path.....	165	(16-1) Error caused by the consumable items.....	176
(6-4) Jam occurs immediately after paper has reached the fuser.....	166	(16-2) Error caused by the toner sensor .....	176
(7) Paper unloading jam (error code 382).....	166	(16-3) Error caused by the defective mechanism.....	177
(7-1) Paper unloading jam occurs immediately after the power is turned on. ...	166	(17) Fuse cut error (error codes 150 to 155) .....	177
(7-2) Paper unloading jam occurs after a paper is taken into printer.....	167	(17-1) Fuse cut error .....	177
(7-3) Paper unloading jam occurs in the middle of paper running path. ....	168	(18) Humidity sensor error (error code 123).....	178
(8) Two-sided printing jam (error code: 370, 371, 372, 373, 383).....	168	(18-1) Humidity sensor error .....	178
(8-1) Two-sided printing jam occurs immediately after the power is turned on..	168	(19) Wiring diagram.....	179
(8-2) Two-sided printing jam occurs during taking in the paper into Duplex unit.....	169		
(8-3) Two-sided printing jam occurs in the process of reversing paper.....	169		

**Note!** When replacing the PU board, read the EEPROM chip contents of the old board first, and copy them to the new board upon completion of the replacement. (Refer to section 5.4.1 Precautions when replacing the engine control board.)

7.5.2. (1) LCD display error

**Memo** For the numbers from 1 through 26 after name of the respective connectors, refer to section 7.5.2 (19) "Wiring diagram".

(1-1) LCD does not display anything.

Check item	Check work	Action to be taken at NG
(1-1-1) Check the fuse.		
F2 (fuse) of the PU board	Check if F2 has blown out or not.	Replace F2 or the PU board.
(1-1-2) Check the system connection		
Connection between the low voltage power supply unit and the PU or CU board.	Check if the cable from the low voltage power supply to the POWER connector ⑩ of the PU board is normally connected or not. Check if the connector is connected only in the half-way or not, and check if the connector is inserted in slanted angle or not.	Re-connect the cable normally.
Cable assembly connecting the low voltage power supply unit and the PU board.	Check if the cable is half-open circuit. Check if sheath of the cable has not peeled off or not. Check if the cable assembly is defective such as internal wires are disconnected or not.	Replace the cable with the normal cable. <b>Note!</b>
Connection between the PU board and Operator Panel	Check if the 10-conductor FFC is connected to the OPE connector ⑰ of the PU board normally or not. Check if the 10-conductor FFC is connected to the OPE connector ⑱ of the PU board normally or not. Check if the connector is connected in the half-way only or not, and check if the connector is inserted in a slanted angle or not.	Re-connect the cable normally.
FFC connecting the PU board and the Operator Panel board	Check if the cable has open circuit or not with VOM. Check if sheath of the cable has not peeled off or not by visual inspection.	Replace the FFC with the normal FFC.
FFC connecting the PU board and the CU board	Check if the 16-conductor FFC is connected to the CU IF connector ⑨ of the PU board normally or not. Check the CU board side in the same way.	Replace the low voltage power supply. <b>Note!</b>

Check item	Check work	Action to be taken at NG
(1-1-3) Check the peripherals of the power supplies		
Primary AC power source that is connected to the printer.	Check the supplied voltage of the AC power source.	Supply the AC power.
Voltage setting of the lower voltage power supply unit (100V system/230V system)	Measure the AC voltage supplied. Check the power voltage setting of the equipment in use. (Check the shorting plug that is used for selection of the voltage power supplies.) Shorting plug is Used/Not used = 100V system/230V system.	Set the low voltage power supply setting.
5V power that is supplied to the PU board.	Check for the 5V power supply at pin-7 of the POWER connector ⑩ of the PU board.	Replace the low voltage power supply.
3.3V power that is supplied to the Operator Panel.	Check for the 3.3V power supply at pin-10 of the CN connector ⑲ of the Operator Panel board.	Replace F2 or the PU board.
(1-1-4) Check that power supply circuit has no short-circuit.		
5V power and 24V power that are supplied to the PU board.	Check that power supply circuit has no short-circuit at the POWER connector no. 10 of the PU board. The follow voltage must appear respectively. pins-4, 5 and 6: 24V pin-7: 5V pin-8: 0V pins-1, 2 and 3: 0VP If any voltage does not appear and short-circuit is detected, locate the source of the short-circuit as follows: Disconnect the cables that are connected to the PU board one cable after another until location of the short-circuit is found out.	Replace the part causing short-circuit.

**Note!** If the PU board, the CU board and the low voltage power unit are connected one another differently from the picture given below, it is regarded as an abnormal, and the output from the low voltage power unit stops.  
When the output from the low voltage power unit stops, turn off the power switch, wait about one minute, and then turn on the power switch, otherwise, the alarm condition of the stoppage of the power output is not cleared.

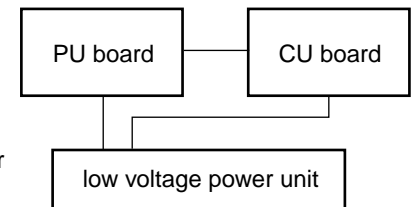

Check item	Check work	Action to be taken at NG
(1-1-5) LSI operation check		
I/F signal supplied from the PU board to the Operator Panel board.	Check if the signal is output to the OPE connector ⑰ of the PU board or not. Pin-7: Send data (Sending data from the PU board) Pin-9: CLR If it is normal, the signal is output always.	Replace the PU board.
I/F signal supplied from the PU board to the Operator Panel board.	Check if the signal is output to the OPE connector ⑰ of the PU board or not. Pin-6: Send data (Sending data from the PU board) If it is normal, the signal is output always.	Replace the Operator Panel board.

**Note!** However, for the Data Protection Kit –A1, refer to section 7.8.

(1-2) PLEASE WAIT

(If the message is left attended, the error number changes to "COMMUNICATION ERROR".)

Check item	Check work	Action to be taken at NG
(1-2-1) Check installation condition of printed circuit board		
Connection condition of the PU board and CU board	Check the connection condition of the CU IF connector ⑨ of the PU board, and check that of the FFC connector of the CU board.	Connect the FFC normally.
(1-2-3) Implement version upgrade of the PU firmware		
Version upgrade of the PU firmware	When the PU firmware version upgrade is completed, this display appears. Check the PU firmware version number by using the menu print or the maintenance function.	If the message reappears after the power is restarted again, implement the confirmations of sections (1-3-1) and (1-3-2).

(1-3) Error messages related to Operator Panel are displayed.

Check item	Check work	Action to be taken at NG
(1-3-1) Error message		
Error message	Check the error contents by referring to the Error Message List.	Follow the instruction.

(1-4) "RAM check in progress" or "Initializing" display is kept appearing.

Check item	Check work	Action to be taken at NG
(1-4-1) Operator Panel display freezes.		
Operator Panel display	"RAM check in progress" or "Initializing" display is kept appearing.	Replace the ROM DIMM of CU, or replace the CU board. Remove the optional RAM and HDD. Then perform the check. If the check result shows NG, replace the CU board. <b>Note!</b>

7.5.2. (2) Abnormal operations of printer after the power is turned on

(2-1) Any operation does not start at all.

Check item	Check work	Action to be taken at NG
<b>(2-1-1) Check the peripherals of the power supplies</b>		
Primary AC power source that is connected to the printer.	Check the supplied voltage of the AC power source.	Supply the AC power.
Voltage setting of the lower voltage power supply unit (100V system/230V system)	Measure the AC voltage supplied. Check the power voltage setting of the equipment in use. (Check the shorting plug that is used for selection of the voltage power supplies. [CN6]) Shorting plug is Used/Not used = 100V system/230V system.	Set the low voltage power supply setting.
5V power and 24V power that are supplied to the PU board.	Check the power supply voltages at the POWER connector no. 10 of the PU board. The follow voltage must appear respectively. Pins-4, 5 and 6: 24V Pin-7: 5V Pin-8: 0VL Pins-1, 2 and 3: 0VP	Replace the low voltage power supply.
<b>(2-1-2) Check the system connection</b>		
Connection condition of Operator Panel	Check contents of (1-1). Any operation of a printer will not start until the Operator Panel is detected and is started of its operation.	Follow the contents of (1-1).

(2-2) Abnormal sound is heard.

Check item	Check work	Action to be taken at NG
<b>(2-2-1) Check loss of synchronization of motor (Driver error)</b>		
Operating conditions of the respective motors	Check if operations of the respective motors are normal or not by using the self-diagnostic mode. Check if any load exists or not. "Buzzer" sound when an error occurs.	Replace the PU board.
Condition of the motor cable	Check for normal wiring conditions of the respective motors. Perform the visual check and measure resistance at open circuit with VOM as follows. Remove the motor cable at the board end. Measure resistance between the respective pins of the removed cable and FG with VOM.	Replace the motor cable. Re-connect the cable for normal conditions.
<b>(2-2-2) Check loss of synchronization of motor (Abnormal load of the consumable item)</b>		
Operating conditions of the respective motors	Check if operations of the respective motors are normal or not by using the self-diagnostic mode. Check if any load exists or not. "Buzzer" sound when an error occurs.	Replace the corresponding consumable item. If any attempt of using new part as a trial is going to be made, be sure to use the System Maintenance Menu FUSE KEEP MODE.

Check item	Check work	Action to be taken at NG
<b>(2-2-3) Check the jumping phenomena of gear tooth. (Abnormal load of the consumable item)</b>		
Operating conditions of the respective motors	Check if operations of the respective motors are normal or not by using the self-diagnostic mode. Check if any load exists or not. "Buzz buzz" sound is generated when an error occurs.	Replace the corresponding consumable item. If any attempt of using new part as a trial is going to be made, be sure to use the System Maintenance Menu FUSE KEEP MODE.
Installation condition of each consumable item	Check by visual inspection if the respective consumable items are installed in their normal positions in which gears of the consumable items engage accurately or not.	Replace an appropriate mechanical part as required, or adjust or repair
<b>(2-2-4) Check the wiring conditions of cables</b>		
Wiring conditions of the cables in the vicinity of the respective cooling fans	Check if the cable contacts with the fan blade because wiring conditions of the cables near fan is poor or not. "Clap, clap" sound is generated when an error occurs.	Correct the wiring conditions of the cable.
<b>(2-2-5) Check installation condition of mechanical parts</b>		
Check the installation conditions of the partition plate under the CU and PU boards.	Remove the CU and PU board, and inspect the installation conditions of the partition plate by visual inspection.	If they are not hooked on the normal specified positions, correct them.

**(2-3) Bad odors are generated.**

Check item	Check work	Action to be taken at NG
<b>(2-3-1) Locating the exact position of generating bad odor</b>		
Fuser unit	Remove the fuser unit and check the odor.	Implement section (2-3-2).
Low voltage power supply unit	Remove the low voltage power supply unit and check the odor.	Replace the low voltage power supply unit
<b>(2-3-2) Check conditions of the fuser unit</b>		
Life count of fuser unit	Check the life count of the fuser unit by using the self-diagnostic mode.	The fuser close to the new fuser unit smells some odors.
Check that no foreign material exists in fuser unit.	Check that no foreign materials such as paper are stuck inside of the fuser unit.	Remove the foreign material.

**(2-4) Rise-up time is slow.**

Check item	Check work	Action to be taken at NG
<b>(2-4-1) Check the fuser unit</b>		
Halogen lamp	Check that 100V is shown on the label on the rear of the fuser unit.	Replace the fuser unit.
<b>(2-4-2) Check the optional parts Note:</b>		
Add-on memory	Install the optional parts (add-on memory) again and re-check the operations.	Replace the optional part.
HDD	Install the optional part (HDD) again and re-check the operations.	Replace the optional part.
Data Protection Kit -A1	Refer to section 7.8.	

**Note!** If any troubles such as printer does not start up normally occurs, remove the CU options (RAM, HDD) and check if the trouble symptom changes or not.



### (3) Paper Jams

When paper jams occur or paper remains in the printer, "Paper Jam", or "Paper Remain" is displayed on the operation panel.

By pressing the Help button, a method to remove the paper is displayed, remove the paper in the printer according to [Handling].

In addition, A method to remove paper is also described in the reference page at the right table.

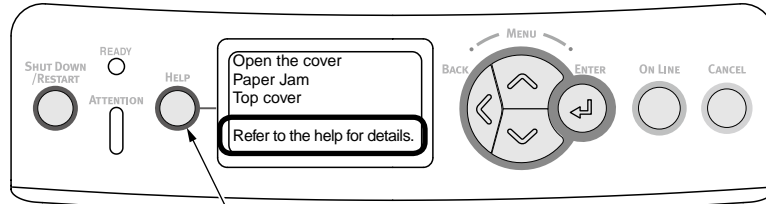

By pressing this button, a method to remove paper is displayed.

Message to be displayed	Reference page
Pull the tray. Paper Jam [Tray Name]	Page 181
Pull the tray. Paper Remains. [Tray Name]	
Open the Cover. Paper Jam Front Cover	Page 182
Open the Cover. Paper Remains. Front Cover	
Open the Cover. Paper Jam Top Cover	Page 183
Open the Cover. Paper Remains. Top Cover	
Check the duplex print unit. Paper Jam	Page 185
Check the duplex print unit. Paper Remains.	

JAM location of occurrence outline chart

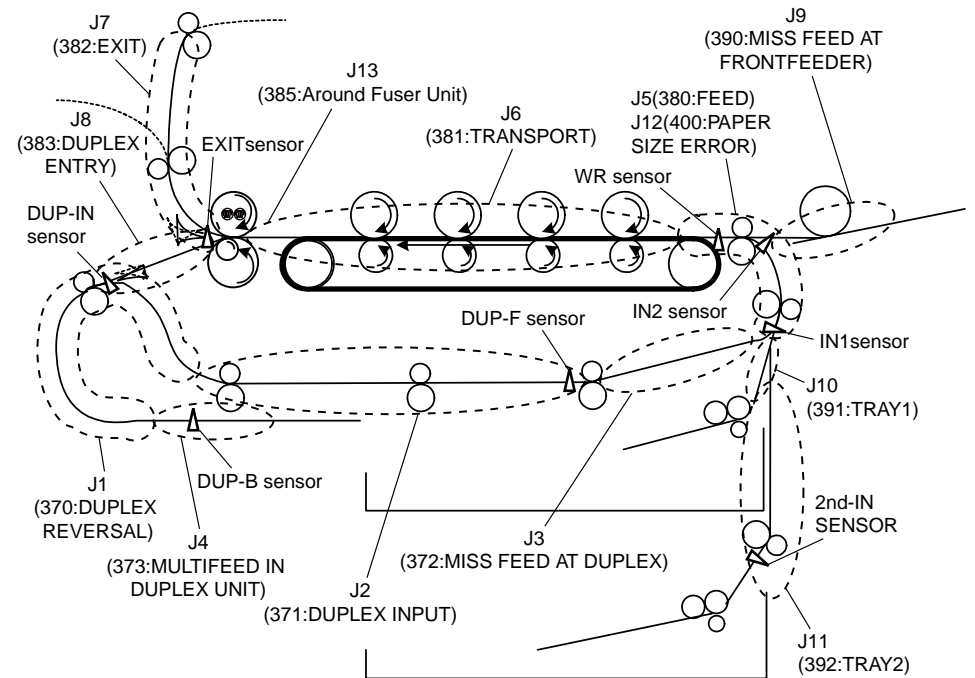

Pull the tray.  
Paper Jam  
[Tray Name]

Pull the tray.  
Paper Remains.  
[Tray Name]

When the above messages are displayed.  
Tray1 is applied here as an example.

(1) Pull the displayed tray.

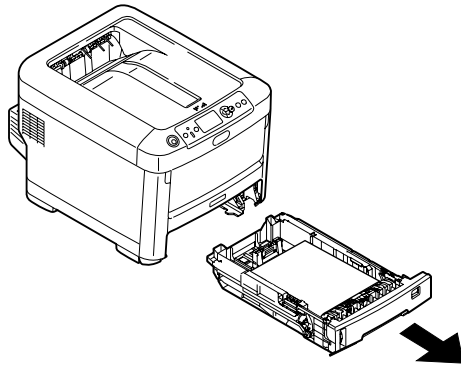

(2) Remove paper.

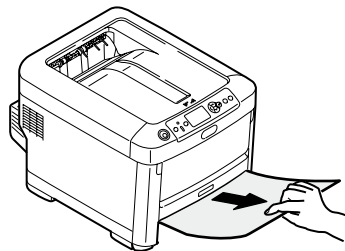

(3) Return the tray to the printer.

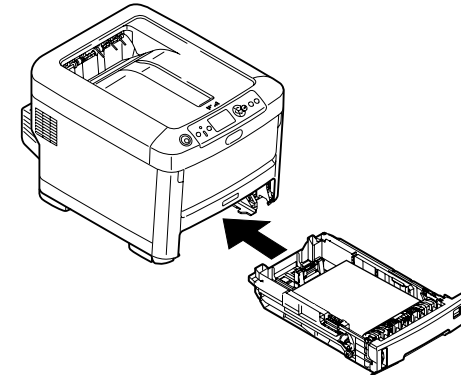

(4) Open and close the top cover.

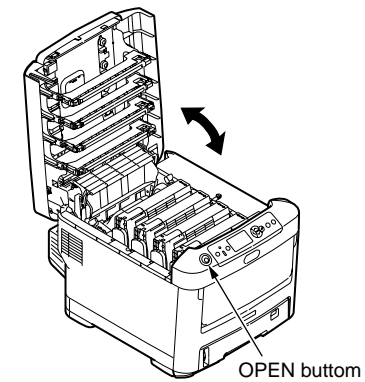

Open the Cover.  
Paper Jam  
Front Cover

Open the Cover.  
Paper Remains.  
Front Cover

When the above messages are displayed.

- (1) Open the multipurpose tray.

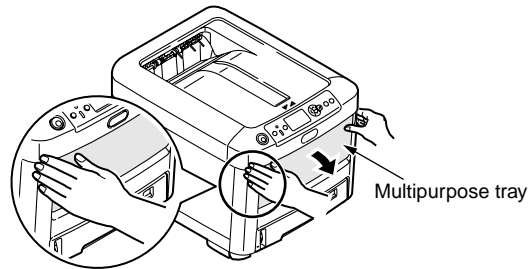

- (2) Push up the center handle (blue), to open the front cover.

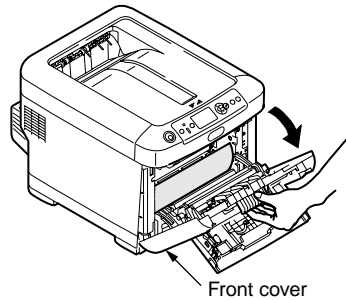

- (3) Slowly pull out the jammed paper.

- ① If you see the top edge of paper
- ② If you do not see the top edge of paper

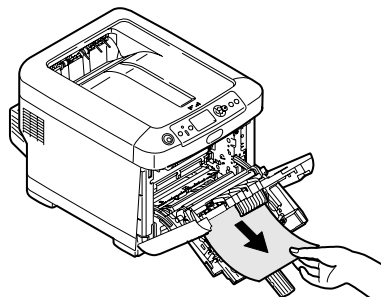
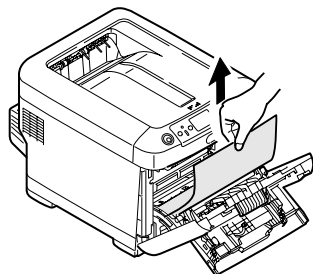

- (4) Close the front cover.

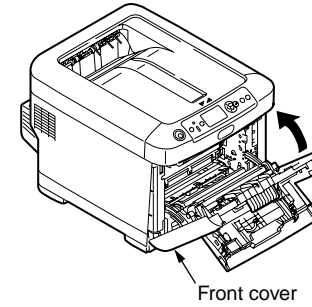

- (5) Close the multipurpose tray.

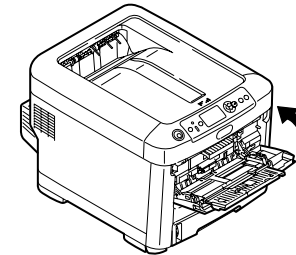

Open the Cover.  
Paper Jam  
Top Cover

Open the Cover.  
Paper Remains.  
Top Cover

When the above messages are displayed.

- (1) Open the top cover.

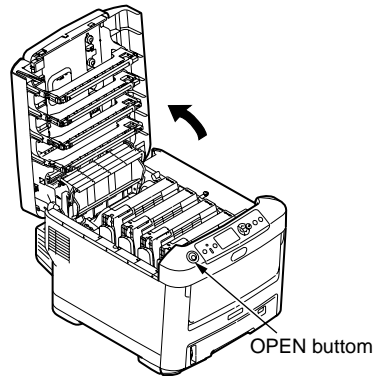

- (2) Touch the screw with a hand to discharge static.

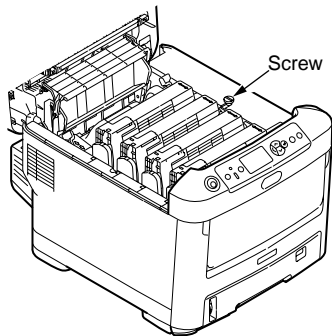

- (3) 2Uninstall the four image drum cartridges and put them on a flat table.

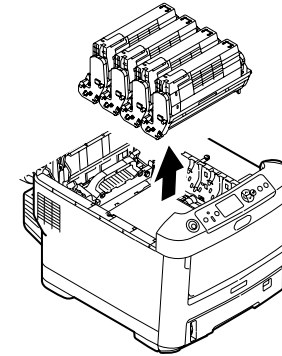

- (4) Cover the uninstalled image drum cartridges with black paper.

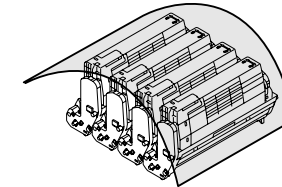

- (5) (a) If you see the top edge of paper  
Pull up the jammed paper slowly.

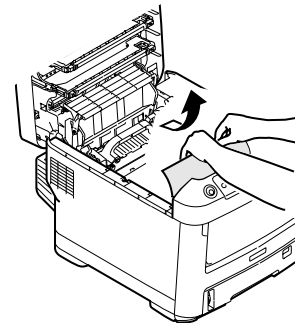

(b) If you do not see the top edge of paper

Pull up the jammed paper slowly while pushing the jam release lever of the fuser unit.

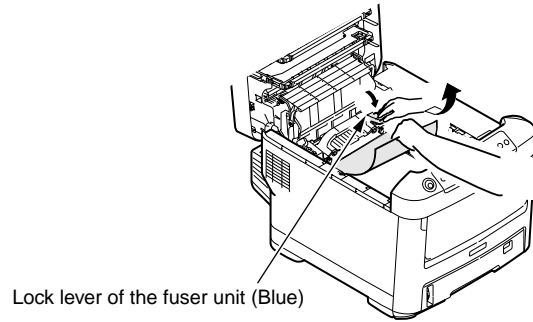

(c) If paper is jammed in the fuser unit

Pull the lock levers (2 levers) of the fuser unit to remove the fuser unit.

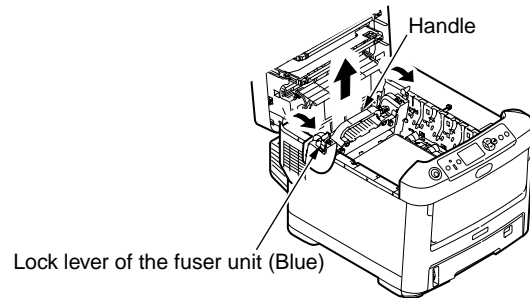

Pull the jammed paper to the front side while pressing the jam release lever.

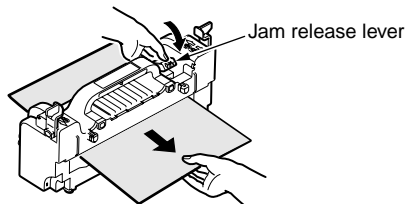

Set the fuser unit in the printer body and fold backward the lock lever (2 levers).

Lock lever of the fuser unit (Blue)

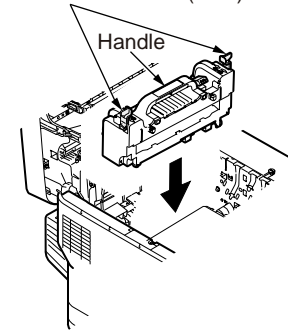

(6) Set four image drums in the printer.

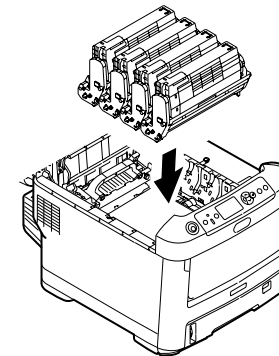

(7) Close the top cover.

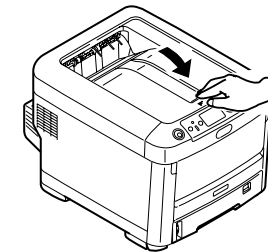

Check the duplex unit.  
Paper Jam

Check the duplex unit.  
Paper Remains.

When the above messages are displayed.

- (1) Hold and press down the jam release lever of the duplex print unit to open the duplex print unit cover.

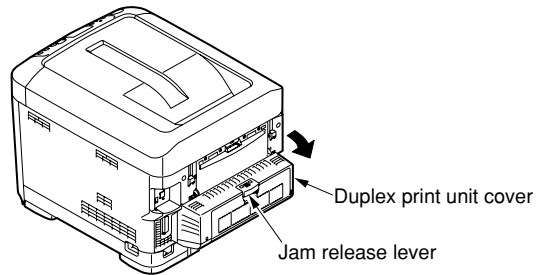

- (2) Release jammed paper.

If you do not see the paper, by closing the duplex print unit cover, the paper is automatically outputted.

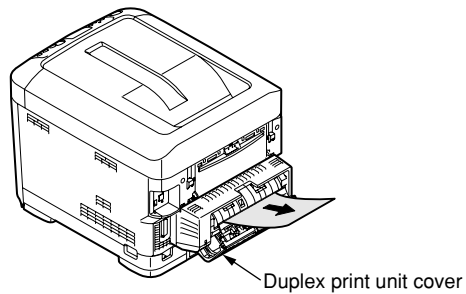

- (3) Close the duplex print unit cover.

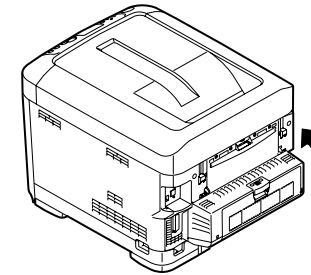

7.5.2. (3) Paper feed jam (error code 391: 1st tray)

(3-1) Jam occurs immediately after the power is turned on. (1st tray)

Check item	Check work	Action to be taken at NG
(3-1-1) Check condition of the paper running path		
Paper running path of the front unit	Open the front cover check if paper is not jammed in the paper running path.	Remove the jammed paper.
(3-1-2) Check condition of the mechanical parts		
Check the sensor levers of the paper entrance sensor 1 and the paper entrance sensor 2.	Check if shape and movement of the sensor levers have any abnormality or not.	Replace the sensor lever with the good sensor lever.
(3-1-3) Check condition of electrical parts		
Check the detection condition of the sensor signal.	Confirm that the sensor signals are normally detected by using the Maintenance Menu SWITCH SCAN function.	Replace either the PU board or the front sensor board (RSF PCB) or connection cable.
Check output signal level of the paper entrance sensor 1 and that of the paper entrance sensor 2.	Check for the following signals at the FSNS connector ⑩ of the PU board. Pin-4: Paper entrance sensor 1 Pin-3: Paper entrance sensor 2 Confirm that the above signal levels change when the sensor lever is operated.	Replace the front sensor board (RSF PCB)
Check the power voltages supplied to the front sensor board (RSF PCB)	Check the 5V power at the FSNS connector ⑩ of the front sensor board (RSF PCB). Pin-1: 5V power supply Pin-5: 0VL	Replace the connection cable.

(3-2) Jam occurs immediately after the paper feed is started. (1st tray)

Check item	Check work	Action to be taken at NG
(3-2-1) Check condition of the paper running path		
Paper running path of the front unit	Check if paper is jammed or not in the paper running path.	Remove the jammed paper.
(3-2-2) Check condition of the mechanical parts		
Check the sensor levers of the paper entrance sensor 1 and the paper entrance sensor 2.	Check if shape and movement of the sensor levers have any abnormality or not.	Replace the sensor with the good sensor lever.
Check the separator assemblies of the feed roller, the pickup roller and the tray.	Check if any foreign materials such as paper dust on the surface of the feed roller or of the pickup roller or not.	Remove the foreign material.
	Check if the feed roller or the pickup roller has worn out or not.	Replace the separator assemblies of the feed roller, pickup roller and tray.
(3-2-3) Motor operation check		
Paper feed motor	Confirm that the paper feed motor works normally by using the Motor & Clutch Test of the self-diagnostic mode.	Replace the PU board or the paper feed motor.
Paper feed motor driver	Remove the HOPSIZE connector ① of the PU board and check the followings at the connector side. Several MΩ between pin-1 – FG. Several MΩ between pin-2 – FG. Several MΩ between pin-3 – FG. Several MΩ between pin-4 – FG.	Replace the PU board.

Check item	Check work	Action to be taken at NG
(3-2-4) Check the system connection		
Paper feed motor drive cable	Check the connection condition of the cable. Check if the connector is connected in the half-way only or not, and check if the connector is inserted in a slanted angle or not. Check also that cables are assembled without any abnormality.	Replace the cable with the good cable that normalizes the connection condition.
Paper feed motor drive cable	Check that any cable is not pinched during assembling of the printer. Remove the HOPSIZE connector ① of the PU board and check the followings at the cable side. Short circuit between pin-1 – FG Short circuit between pin-2 – FG Short circuit between pin-3 – FG Short circuit between pin-4 – FG	Replace the cable with the good cable that normalizes the connection condition.
Paper feed motor	Remove the HOPSIZE connector ① of the PU board and check that approx. 3.4Ω can be measured between pin-1 -pin-2 at the cable end, and that approx. 5Ω can be measured between pin-3 -pin-4 respectively.	Replace the paper feed motor.
(3-2-5) Solenoid operation check		
Paper feed solenoid	Confirm that the paper feed solenoid works normally by using the Motor & Clutch Test of the self-diagnostic mode. Remove the metal plate from the right side of a printer so that the solenoid becomes visible. Then, check operation of the solenoid.	Replace the PU board, or replace the paper feed solenoid.
Paper feed solenoid	Check that any obstacle does not exist that hampers smooth operation of the movable portion of the solenoid. (Obstacles such as cable and others)	Normalize the assembled condition of a printer.

Check item	Check work	Action to be taken at NG
(3-2-6) Check the system connection		
Paper feed solenoid cable	Check the connection condition of the cable. Check if the connector is connected in the half-way only or not, and check if the connector is inserted in a slanted angle or not. Check also that cables are assembled without any abnormality.	Replace the cable with the good cable that normalizes the connection condition.
Paper feed solenoid cable	Check that any cable is not pinched during assembling of the printer. Remove the HSOL connector ⑭ of the PU board and check the followings at the cable side. Short circuit between pin-1 – FG  Remove the HSOL connector ⑭ of the PU board and check that approx. 89Ω can be measured between pin-1 and pin-2.	Replace the solenoid assembly and re-assemble the printer correctly.



7.5.2. (4) Feed jam (error code 380)

(4-1) Jam occurs immediately after the power is turned on.

Check item	Check work	Action to be taken at NG
(4-1-1) Check condition of the paper running path		
Paper running path of the front unit	Open the front cover check if paper is not jammed in the paper running path.	Remove the jammed paper.
(4-1-2) Check condition of the mechanical parts		
Check the sensor levers of the paper entrance sensor 1, that of the paper entrance sensor 2 and that of the WR sensor.	Check if shape and movement of the sensor levers have any abnormality or not.	Replace the sensor with the good sensor lever.
(4-1-3) Check condition of electrical parts		
Check the detection condition of the sensor signal.	Confirm that the sensor signals are normally detected by using the Maintenance Menu SWITCH SCAN function.	Replace either the PU board or the front sensor board (RSF PCB) or connection cable.
Check the output signal levels of the paper entrance sensor 1, that of the paper entrance sensor 2 and that of the WR sensor.	Check for the following signals at the FSNS connector ⑩ of the PU board. Pin-4: Paper entrance sensor 1 Pin-3: Paper entrance sensor 2 Pin-2: WR sensor Confirm that the above signal levels change when the sensor lever is operated.	Replace the front sensor board (RSF PCB)
Check the power voltages supplied to the front sensor board (RSF PCB)	Check the 5V power at the FSNS connector ⑩ of the front sensor board (RSF PCB). Pin-1: 5V power supply Pin-5: 0V	Replace the connection cable.

(4-2) Jam occurs immediately after the paper feed is started.

Check item	Check work	Action to be taken at NG
(4-2-1) Check condition of the paper running path		
Paper running path of the front unit	Check if paper is jammed or not in the paper running path.	Remove the jammed paper.
(4-2-2) Check condition of the mechanical parts		
Check the sensor levers of the paper entrance sensor 1, that of the paper entrance sensor 2 and that of the WR sensor.	Check if shape and movement of the sensor levers have any abnormality or not.	Replace the sensor with the good sensor lever.
(4-2-3) Motor operation check		
Paper feed motor	Confirm that the paper feed motor works normally by using the Motor & Clutch Test of the self-diagnostic mode.	Replace the PU board, or replace the paper feed motor.
Paper feed motor driver	Remove the HOPSIZE connector ① of the PU board and check the followings at the connector side. Several MΩ between pin-1 – FG Several MΩ between pin-2 – FG Several MΩ between pin-3 – FG Several MΩ between pin-4 – FG	Replace the PU board.

Check item	Check work	Action to be taken at NG
(4-2-4) Check the system connection		
Paper feed motor drive cable	Check the connection condition of the cable. Check if the connector is connected in the half-way only or not, and check if the connector is inserted in a slanted angle or not. Check also that cables are assembled without any abnormality.	Replace the cable with the good cable that normalizes the connection condition.
Paper feed motor drive cable	Check that any cable is not pinched during assembling of the printer. Remove the HOPSIZE connector no. 1 of the PU board and check the followings at the cable side. Short circuit between pin-1 – FG Short circuit between pin-2 – FG Short circuit between pin-3 – FG Short circuit between pin-4 – FG	Replace the cable with the good cable that normalizes the connection condition.
Paper feed motor	Remove the HOPSIZE connector ① of the PU board and check that approx. 3.4Ω can be measured between pin-1 -pin-2 at the cable end, and that approx. 5Ω can be measured between pin-3 -pin-4 respectively.	Replace the paper feed motor.

7.5.2. (5) Paper feed jam (error code 390: Multipurpose tray)

(5-1) Jam occurs immediately after the power is turned on. (Multipurpose tray)

Check item	Check work	Action to be taken at NG
(5-1-1) Check condition of the paper running path		
Paper running path of the multipurpose tray	Check if paper is jammed or not in the paper running path.	Remove the jammed paper.
(5-1-2) Check condition of the mechanical parts		
Check the sensor levers of the paper entrance sensor 2 and the WR sensor.	Check if shape and movement of the sensor levers have any abnormality or not.	Replace the sensor with the good sensor lever.
(5-1-3) Check condition of electrical parts		
Check the detection condition of the sensor signal.	Confirm that the sensor signals are normally detected by using the SWITCH SCAN function of the self-diagnostic mode.	Replace either the PU board or the front sensor board (RSF PCB) or connection cable.
Check the sensor output signal level of the paper entrance sensor 2 and the WR sensor.	Check for the following signals at the FSNS connector ⑩ of the PU board. Pin-2: WR sensor Pin-3: Paper entrance sensor 2 Confirm that the above signal levels change when the sensor lever is operated.	Replace the front sensor board (RSF PCB)
Check the power voltages supplied to the front sensor board (RSF PCB)	Check the 5V power at the CN connector ㉕ of the front sensor board (RSF PCB). Pin-1: 5V power supply Pin-5: 0VL	Replace the connection cable.

(5-2) Jam occurs immediately after paper feed is started. (Multipurpose tray)

Check item	Check work	Action to be taken at NG
<b>(5-2-1) Check condition of the paper running path</b>		
Paper running path of the multipurpose tray	Check if paper is jammed or not in the paper running path.	Remove the jammed paper.
Sheet Receive of the multipurpose tray	Confirm that the Sheet Receive has moved up normally. Confirm that the support spindle and spring of the Sheet Receive have been installed in the specified positions normally.	Correct installation of the above parts so that the Sheet Receive moves up to the specified position normally.
<b>(5-2-2) Check condition of the mechanical parts</b>		
Check the sensor levers of the paper entrance sensor 2 and the WR sensor.	Check if shape and movement of the sensor levers have any abnormality or not.	Replace the sensor with the good sensor lever.
Planetary gear for paper feed control	Rotate the paper feed motor (FRONT MOTOR) using the Motor & Clutch Test of the self-diagnostic mode, and confirm that both of the two planetary gears rotate at the bottom position. (The planetary gear box can be located because it is the white molded block that is located on the right side when the front cover is opened.)	Replace the planetary gear box
Front cover	Confirm that the locks in the right and left of the front cover are locked normally.	Replace the front cover assembly
Check the feed roller and the pickup roller.	Check if any foreign materials such as paper dust on the surface of the feed roller or of the pickup roller or not.	Remove the foreign material.
	Check if the feed roller has worn out or not.	Replace the feed roller.

Check item	Check work	Action to be taken at NG
<b>(5-2-3) Motor operation check</b>		
Paper feed motor	Confirm that the paper feed motor works normally by using the Motor & Clutch Test of the self-diagnostic mode.	Replace the PU board, or replace the paper feed motor.
Paper feed motor driver	Remove the HOPSIZE connector ① of the PU board and check the followings at the connector side. Several MΩ between pin-1 – FG Several MΩ between pin-2 – FG Several MΩ between pin-3 – FG Several MΩ between pin-4 – FG	Replace the PU board.
<b>(5-2-4) Check the system connection</b>		
Paper feed motor drive cable	Check the connection condition of the cable. Check if the connector is connected in the half-way only or not, and check if the connector is inserted in a slanted angle or not. Check also that cables are assembled without any abnormality.	Replace the cable with the good cable that normalizes the connection condition.
Paper feed motor drive cable	Check that any cable is not pinched during assembling of the printer. Remove the HOPSIZE connector no. 1 of the PU board and check the followings at the cable side. Short circuit between pin-1 – FG Short circuit between pin-2 – FG Short circuit between pin-3 – FG Short circuit between pin-4 – FG	Replace the cable with the good cable that normalizes the connection condition.
Paper feed motor	Remove the HOPSIZE connector ① of the PU board and check that approx. 3.4Ω can be measured between pin-1 -pin-2, and that approx. 5Ω can be measured between pin-3 -pin-4 respectively.	Replace the paper feed motor.

7.5.2. (6) Paper running jam (error code 381:)

(6-1) Jam occurs immediately after the power is turned on.

Check item	Check work	Action to be taken at NG
(6-1-1) Check condition of the running path.		
Paper running path of the front unit	Check if paper is jammed or not in the paper running path.	Remove the jammed paper.
(6-1-2) Check condition of the mechanical parts		
Check the sensor lever of the WR sensor.	Check if shape and movement of the sensor levers have any abnormality or not.	Replace the sensor lever with the good sensor lever.
(6-1-3) Check condition of electrical parts		
Check the detection condition of the sensor signal.	Confirm that the sensor signals are normally detected by using the SWITCH SCAN function of the self-diagnostic mode.	Replace either the PU board or the front sensor board (RSF PCB) or connection cable.
Check the sensor lever of the WR sensor.	Check for the following signals at the FSNS connector no. 16 of the PU board. Pin-2: WR sensor Confirm that the above signal levels change when the sensor lever is operated.	Replace the front sensor board (RSF PCB)
Check the power voltages supplied to the front sensor board (RSF PCB)	Check the 5V power at the CN connector no. 25 of the front sensor board (RSF PCB). Pin-1: 5V power supply Pin-5: 0VL	Replace the connection cable.

(6-2) Jam occurs immediately after a paper is taken into printer.

Check item	Check work	Action to be taken at NG
(6-2-1) Check condition of the paper running path		
Paper running path on the belt.	Remove the ID unit and check if paper is jammed or not in the paper running path.	Remove the jammed paper.
(6-2-2) Check condition of the mechanical parts		
Check the sensor lever of the WR sensor.	Check if shape and movement of the sensor levers have any abnormality or not.	Replace the sensor lever with the good sensor lever.
(6-2-3) Motor operation check		
Paper feed motor driver, belt motor driver and ID motor	Confirm that the paper feed motor, belt motor and ID motor work normally by using the Motor & Clutch Test of the self-diagnostic mode. Check if any load exists or not.	Replace the PU board, or replace the defective motor among paper feed motor, belt motor and ID motor, or replace the ID unit or belt unit. If any attempt of using new ID unit or new belt unit as a trial is going to be made, be sure to use the System Maintenance Menu FUSE KEEP MODE.
Paper feed motor, belt motor	Remove the BELT ID UP connector ① of the PU board and check the followings at the connector side. Several MΩ between pin-5 – FG Several MΩ between pin-6 – FG Several MΩ between pin-7 – FG Several MΩ between pin-8 – FG Remove the HOPSIZE connector ③ of the PU board and check the followings at the connector side. Several MΩ between pin-1 – FG Several MΩ between pin-2 – FG Several MΩ between pin-3 – FG Several MΩ between pin-4 – FG	Replace either paper feed motor, belt motor or PU board.

Check item	Check work	Action to be taken at NG
(6-2-4) Check the system connection		
Paper feed motor drive cable, ID motor drive cable, belt motor drive cable, ID Up motor drive cable, fuser motor drive cable	Check the connection condition of the cables. PU board HOPSIZE connector ⑫, DC ID UP connector ②, DCHEAT connector ④, BELT ID UP connector ③, RELAY connector ⑧. Check if the connector is connected in the half-way only or not, and check if the connector is inserted in a slanted angle or not. Check also that cables are assembled without any abnormality.	Normalize the connection condition. Replace the cable with the normal cable.
Paper feed motor drive cable, ID motor drive cable, belt motor drive cable, ID Up motor drive cable	Check that any cable is not pinched during assembling of the printer. Remove the BELT ID UP connector ③ of the PU board and check the followings at the connector side. Short circuit between pin-1 – FG Short circuit between pin-2 – FG Short circuit between pin-3 – FG Short circuit between pin-4 – FG Short circuit between pin-5 – FG Short circuit between pin-6 – FG Short circuit between pin-7 – FG Short circuit between pin-8 – FG Remove the HOPSIZE connector ⑫ of the PU board and check the followings at the cable side. Short circuit between pin-1 – FG Short circuit between pin-2 – FG Short circuit between pin-3 – FG Short circuit between pin-4 – FG	Replace the cable with the good cable that normalizes the connection condition.
Paper feed motor, belt motor, ID Up motor	Remove the respective connectors from the board, and confirm that the following resistance exists between the corresponding pins, at the cable side. PU board HOPSIZE connector 1 Between pin-1 - pin-2 Approx. 3.4Ω or approx. 5Ω. Between pin-3 - pin-4 Approx. 3.4Ω or approx. 5Ω. PU board BELT ID UP connector 3 Between pin-1 - pin-2 Approx. 6.1Ω or approx. 3.5Ω. Between pin-3 - pin-4 Approx. 6.1Ω or approx. 3.5Ω. Between pin-5 - pin-6 Approx. 3.4Ω or approx. 5Ω. Between pin-7 - pin-8 Approx. 3.4Ω or approx. 5Ω.	Replace paper feed motor, belt motor, ID Up motor.

(6-3) Jam occurs in the middle of paper running path.

Check item	Check work	Action to be taken at NG
(6-3-1) Motor operation check		
Paper feed motor driver, belt motor driver and ID motor	Confirm that the paper feed motor, belt motor and ID motor work normally by using the Motor & Clutch Test of the self-diagnostic mode. Check if any load exists or not.	Replace the PU board, or replace the defective motor among paper feed motor, belt motor and ID motor, or replace the ID unit or belt unit. If any attempt of using new ID unit or new belt unit as a trial is going to be made, be sure to use the System Maintenance Menu FUSE KEEP MODE.
Paper feed motor, belt motor	Remove the BELT ID UP connector ① of the PU board and check the followings at the connector side. Several MΩ between pin-5 – FG Several MΩ between pin-6 – FG Several MΩ between pin-7 – FG Several MΩ between pin-8 – FG Remove the HOPSIZE connector ③ of the PU board and check the followings at the connector side. Several MΩ between pin-1 – FG Several MΩ between pin-2 – FG Several MΩ between pin-3 – FG Several MΩ between pin-4 – FG	Replace either paper feed motor, belt motor or PU board.

(6-4) Jam occurs immediately after paper has reached the fuser.

Check item	Check work	Action to be taken at NG
<b>(6-4-1) Motor operation check</b>		
Fuser motor	Confirm that the fuser motor works normally by using the Motor & Clutch Test of the self-diagnostic mode. Check if any load exists or not.	Replace the PU board. Replace the fuser motor. Replace the fuser unit. If any attempt of using new fuser unit as a trial is going to be made, be sure to use the System Maintenance Menu FUSE KEEP MODE.
<b>(6-4-2) Temperature control of the roller rotation speed</b>		
Heat roller detected temperature	Check the detected temperature of the heat roller using the self-diagnostic mode. Is abnormally high temperature or abnormally temperature detected?	Replace fuser unit, or relay board (PRY PCB) or the PU board. If any attempt of using new fuser unit as a trial is going to be made, be sure to use the System Maintenance Menu FUSE KEEP MODE.
<b>(6-4-3) Check the installation condition of fuser unit</b>		
Fuser unit	Check that the fuser unit is installed normally. (Is it pushed in down to the bottom-most point?)	Install the fuser unit correctly in a printer.

7.5.2. (7) Paper unloading jam (error code 382)

(7-1) Paper unloading jam occurs immediately after the power is turned on.

Check item	Check work	Action to be taken at NG
<b>(7-1-1) Check condition of the paper running path</b>		
Paper running path of the paper unloading unit	Check if paper is jammed or not in the paper running path.	Remove the jammed paper.
<b>(7-1-2) Check condition of the mechanical parts</b>		
Check the sensor lever of the paper exit sensor.	Check if shape and movement of the sensor levers have any abnormality or not.	Replace the sensor lever with the good sensor lever.
<b>(7-1-3) Check condition of electrical parts</b>		
Check the detection condition of the sensor signal.	Confirm that the sensor signals are normally detected by using the SWITCH SCAN function of the self-diagnostic mode.	Replace the PU board or EXIT sensor or its cable or its connection cable.
Check the output signal level of the EXIT sensor.	Check for the following signals at the RELAY connector ⑧ of the PU board. Pin-9: EXIT sensor Confirm that the above signal levels change when the sensor lever is operated.	Replace the EXIT sensor.
Check the power voltages supplied to the relay board.	Check the 5V power voltage at the EXIT connector ⑩ of the relay board. Pin-1: 5V power supply Pin-3: 0VL	Replace the connection cable.

Check item	Check work	Action to be taken at NG
(7-1-4) Check the system connection		
Signal cable for relay board, EXIT sensor cable	Check that FFC is normally inserted at the RELAY connector ⑧ of the PU board and at the PU IF connector ② . Check that the relay board and the EXIT sensor are normally connected.	Normalize the connection condition.
Signal cable for relay board, EXIT sensor cable	Confirm that the cables are not pinched, sheathes are not peeled off, and they are assembled normally.	Replace the connecting cable and normalize the assembled condition.

(7-2) Paper unloading jam occurs after a paper is taken into printer.

Check item	Check work	Action to be taken at NG
(7-2-1) Check condition of the paper running path		
Face Up Stacker Cover	Confirm that it is either fully opened or fully closed	Eliminate any in-between condition of the cover between the fully open position and fully closed position.
Duplex pull-in gate	Confirm that the Duplex pull-in gate works normally by using the Motor & Clutch Test of the self-diagnostic mode. Is it set to the paper unloading side normally?	Replace the Duplex pull-in gate or the Duplex solenoid
Rear panel	Check that the installation condition of the rear panel hampers smooth movement of a paper in the paper running path, or not.	Remove the rear panel and re-install it.
Paper running path of unloading unit	Check that any mechanical load does not exist that hampers the smooth movement of paper in the paper running path of the paper unloading unit, by the visual inspection. Check if the paper unloading motor becomes difficult to rotate or not.	Correct the portion that becomes mechanical load.

Check item	Check work	Action to be taken at NG
(7-2-2) Check condition of the mechanical parts		
Sensor lever of the paper exit sensor	Check if shape and movement of the sensor levers have any abnormality or not.	Replace the sensor lever with the good sensor lever.
(7-2-3) Motor operation check		
Fuser motor	Confirm that the fuser motor works normally by using the Motor & Clutch Test of the self-diagnostic mode. Check if any load exists or not.	Replace the PU board or fuser motor or fuser unit. If any attempt of using new fuser unit as a trial is going to be made, be sure to use the System Maintenance Menu FUSE KEEP MODE.
(7-2-4) Check the system connection		
Fuser motor drive cable	Check the connection condition of the cables. PU board DCHEAT connector ④ , Check if the connector is connected in the half-way only or not, and check if the connector is inserted in a slanted angle or not. Check also that cables are assembled without any abnormality.	Replace the cable with the good cable that normalizes the connection condition.
Fuser motor		Replace the fuser motor.

(7-3) Paper unloading jam occurs in the middle of paper running path.

Check item	Check work	Action to be taken at NG
(7-3-1) Motor operation check		
Fuser motor	Confirm that the fuser motor works normally by using the Motor & Clutch Test of the self-diagnostic mode. Check if any load exists or not.	Replace the PU board or fuser motor or fuser unit. If any attempt of using new fuser unit as a trial is going to be made, be sure to use the System Maintenance Menu FUSE KEEP MODE.

7.5.2. (8) Two-sided printing jam (error code: 370, 371, 372, 373, 383)

(8-1) Two-sided printing jam occurs immediately after the power is turned on.

Check item	Check work	Action to be taken at NG
(8-1-1) Check condition of the paper running path		
Paper running path of the Duplex unit	Check if paper is jammed or not in the paper running path. Open the front cover and check if any paper remains in the Duplex feeder or not. Open the rear cover and check if any paper remains in the paper reversing path or not. Remove the Duplex unit. Check if any paper exists in the Duplex insertion slot or not. Open the cover of the Duplex paper running path and check if any paper remains inside of the Duplex unit.	Remove the jammed paper.
(8-1-2) Check condition of the mechanical parts		
Check the sensor levers of the respective sensors of the Duplex unit.	Check if shape and movement of the sensor levers have any abnormality or not.	Replace the sensor lever with the good sensor lever.
(8-1-3) Check condition of electrical parts		
Check the detection condition of the sensor signal.	Confirm that the sensor signals are normally detected by using the SWITCH SCAN function of the self-diagnostic mode. For all sensors except the Dup-IN sensor, check the detection condition of the respective sensor in the two status: One is the status in which paper remains inside the Duplex unit. The other is the status in which paper is removed from the Duplex unit.	Replace the Duplex board (V7Y PCB), or replace the defective sensor or connection cable.



(8-2) Two-sided printing jam occurs during taking in the paper into Duplex unit.

Check item	Check work	Action to be taken at NG
<b>(8-2-1) Solenoid operation check</b>		
Duplex solenoid	Confirm that the Duplex solenoid works normally by using the Motor & Clutch Test of the self-diagnostic mode.	Replace the V7Y board or solenoid.
Separator DUP (Paper unloading/ DUP paper taking-in switching gate located immediately after the fuser unit)	Check visually movement of the gate by using the Motor & Clutch Test of the self-diagnostic mode. (EXIT SOLENOID) Check if movement is unsmooth or not, if amount of open/close is abnormal or not.	Replace the separator DUP.
ON/OFF timing of the Duplex solenoid	While the cover is in the opened state, perform the test print and confirm if the timing to open the separator DUP is correct or not.	Replace the WR sensor lever or solenoid.
<b>(8-2-2) Sensor lever operation check</b>		
Dup-IN sensor lever	Open the rear cover. Touch the Dup-IN sensor lever to check if its movement is unsmooth or not.	Replace the Dup-IN sensor lever
DUP-IN sensor	Confirm that the sensor signals are normally detected by using the SWITCH SCAN function of the self-diagnostic mode.	Replace the Duplex board (V7Y PCB), or replace the defective sensor or connection cable.
<b>(8-2-3) Check condition of the paper running path</b>		
Paper inverting transport path	Check that any foreign materials such as paper chip or blue do not exist that hampers the smooth movement of paper in the paper inverting transport path.	Remove the foreign material.

Check item	Check work	Action to be taken at NG
<b>(8-2-4) Motor operation check</b>		
Duplex motor	Confirm that the Duplex solenoid works normally by using the Motor & Clutch Test of the self-diagnostic mode. Open the rear cover and check rotation of the roller.	Replace the V7Y board or motor.
Duplex pull-in/reversing roller and its pinch roller	Check if the pull-in/reversing roller of the Duplex unit contacts or not with the pinch roller of the cover side when the Duplex rear cover is closed. (Does the pinch roller rotate when the roller is rotating?)	Replace the rear cover.

(8-3) Two-sided printing jam occurs in the process of reversing paper.

Check item	Check work	Action to be taken at NG
<b>(8-3-1) Sensor lever operation check</b>		
Dup-IN sensor lever	Open the rear cover. Touch the Dup-IN sensor lever to check if its movement is unsmooth or not.	Replace the Dup-IN sensor lever
DUP-IN sensor	Confirm that the sensor signals are normally detected by using the SWITCH SCAN function of the self-diagnostic mode.	Replace the Duplex board (V7Y PCB), or replace the defective sensor or connection cable.
<b>(8-3-2) Motor operation check</b>		
Duplex motor	Check if the paper reversing operation is started or not by visual inspection when viewing through slit of the rear cover. If the paper reversing operation is not started, check if movement of the planetary gear inside the Duplex unit is unsmooth or not.	Replace the planetary gear.

(8-4) Two-sided printing jam occurs during transporting paper inside the Duplex unit.

Check item	Check work	Action to be taken at NG
(8-4-1) Sensor lever operation check		
Dup-R, Dup-F sensor lever	Remove the Duplex unit and check movement of the sensor lever.	Replace the sensor lever.
(8-4-2) Sensor check		
Check the detection condition of the sensor signal	Confirm that the sensor signals are normally detected by using the SWITCH SCAN function of the self-diagnostic mode. For all sensors except the Dup-IN sensor, check the detection condition of the respective sensor in the two status: One is the status in which paper remains inside the Duplex unit. The other is the status in which paper is removed from the Duplex unit.	Replace the Duplex board (V7Y PCB), or replace the defective sensor or connection cable.

(8-5) Paper is not supplied from the Duplex unit to the regist roller.

Check item	Check work	Action to be taken at NG
(8-5-1) Clutch operation check		
Duplex clutch	Confirm that the Duplex clutch works normally by using the Motor & Clutch Test of the self-diagnostic mode. Confirm it by listening to the sound.	Replace the V7Y board or clutch.

7.5.2. (9) Paper size error (error code 400)

(9-1) Jam occurs when paper end is located near the IN1 sensor.

Check item	Check work	Action to be taken at NG
(9-1-1) Check paper feed condition		
Multifeed of papers	Open the front cover and check if multifeed of papers occurs or not.	If the multifeed occurs again after the jammed paper is removed, replace the flap of the tray in use.
Paper size	Does the paper size specified for print match the paper size of paper stuck in the tray.	Change the specified paper size or size of paper inside the tray.
Paper entrance sensor 1	Check if shape and movement of the sensor levers have any abnormality or not.	Replace the sensor lever with the good sensor lever.

7.5.2. (10) ID unit Up/Down error (Service call 140 to 143)

(10-1) Error occurs during the Up movement of the ID unit

Check item	Check work	Action to be taken at NG
<b>(10-1-1) Check the mechanical load during the Up movement</b>		
Mechanical load during installation and removal of the ID unit	Check if abnormal heavy load is applied when removing the ID unit.	Replace the ID unit, or replace the right/left side plate. If any attempt of using new ID unit as a trial is going to be made, be sure to use the System Maintenance Menu FUSE KEEP MODE.
Greasing to the right and left Up/Down link levers	Check if the slant surface of the link lever is coated by grease or not.	Apply grease.
Assembled condition of the right and left Up/Down link levers	Check if any part exists or not in the vicinity of link lever, that hampers movement of the link lever.	Assemble them correctly.
<b>(10-1-2) Up/Down mechanism</b>		
Assembled condition of the peripheral mechanism of the link lever	Is the mechanism assembled so that the link lever is connected to the planetary driving gear?	Assemble them correctly.
Right and left link levers	Check if the link lever is set in the correct position that enables the specified engagement of gears. (Check if the link lever is set in the wrong position that results in the wrong engagement of gears by several teeth.)	Assemble them correctly.

Check item	Check work	Action to be taken at NG
<b>(10-1-3) Sensor check</b>		
Up/Down sensor lever (unified structure with the left link lever)	Check if shape and movement of the sensor levers have any abnormality or not.	Replace the left link lever.
Up/Down sensor	Confirm that the sensor signals are normally detected by using the SWITCH SCAN function of the self-diagnostic mode. Check if the SCAN state changes or not when the incoming light is interrupted/passed by using a piece of paper or the like for the transparent type sensor.	Replace the high voltage board.

(10-2) Error occurs during the Down movement of the ID unit

Check item	Check work	Action to be taken at NG
<b>(10-2-1) Check the mechanical load during the Down movement</b>		
Mechanical load during installation and removal of the ID unit	Check if abnormal heavy load is applied when removing the ID unit.	Replace the ID unit, or replace the right/left side plate.
Greasing to the right and left Up/Down link levers	Check if the slant surface of the link lever is coated by grease or not.	Apply grease.
Assembled condition of the right and left Up/Down link levers	Check if any part exists or not in the vicinity of link lever, that hampers movement of the link lever.	Assemble them correctly.

7.5.2. (11) Fuser unit error (error 170 to 177)

(11-1) Error occurs immediately after the power is turned on.

Check item	Check work	Action to be taken at NG
(11-1-1) Thermistor is defective Note)		
Upper thermistor, lower thermistor, frame thermistor	Check the respective thermistors if they are shorted or opened internally. Check the resistance value at the connector pins in the bottom of the fuser unit. (Refer to section 8.1 Resistance check (fuser unit).)	Replace the fuser unit. If any attempt of using new fuser unit as a trial is going to be made, be sure to use the System Maintenance Menu FUSE KEEP MODE.
Installed condition of fuser unit.	Check if the fuser nit is pressed in until the connector in the bottom of the fuser unit is surely connected.	Re-set the fuser unit.

**Note!** Service calls 171 error and 171 error can occur when the printer temperature is below 0°C. Turn on the power again after the printer temperature has increased.

(11-2) Error occurs approx. 1 minute after the power is turned on.

Check item	Check work	Action to be taken at NG
(11-2-1) Temperature increase of fuser unit		
Thermostat, halogen lamp	Heater of the fuser unit is controlled of its temperature. Check if the fuser unit gets hot or not by touching it with hands. If the fuser unit temperature does not increase and remains cold, check that the resistance between pin-1 and pin-2, and that in between pin-3 and pin-4 of the two connectors is in the range of several ohms to several ten ohms respectively. (Refer to section 8.1 Resistance value (fuser unit).)	Replace the fuser unit. If any attempt of using new fuser unit as a trial is going to be made, be sure to use the System Maintenance Menu FUSE KEEP MODE.

Check item	Check work	Action to be taken at NG
(11-2-2) Temperature increase of fuser unit		
Installation position of the upper thermistor	Check if the upper thermistor is installed in the far position from the specified position or not causing detection of the lower temperature than the actual temperature of fuser unit. Remove the heater cover, and check warpage of sensor by visual inspection.	Replace the fuser unit. If any attempt of using new fuser unit as a trial is going to be made, be sure to use the System Maintenance Menu FUSE KEEP MODE.
Installation position of the lower thermistor	The lower thermister must be installed while contacting with the fuser unit. Check if the lower thermister is installed in the far position from the specified position or not causing detection of the lower temperature than the actual temperature of fuser unit.	Replace the fuser unit. If any attempt of using new fuser unit as a trial is going to be made, be sure to use the System Maintenance Menu FUSE KEEP MODE.
(11-2-3) AC power input to the halogen lamp		
AC power voltage from the low voltage power supply	Check if the AC voltage for heater is normally supplied or not. Power supply CN2 connector ⑳, between pin-1 and pin-2, and between pin-3 and pin-4.	Replace the low voltage power supply.
Heater ON signal that is output from PU to the low voltage power supply	Check that the heater ON signal goes active at the warming up timing, or not. "L" active while ON. Power connector ㉑ of the PU board, between pin-11 and pin-12.	Replace the PU board.

7.5.2. (12) Motor fan error (error code 122, 127, 128, 918, 051)

(12-1) The low voltage power supply fan does not rotate immediately after the power is turned on.

Check item	Check work	Action to be taken at NG
(12-1-1) Cable connection condition and wiring condition		
Cable connection condition and wiring condition of the low voltage power supply fan and those of the fuser fan	Check if the connectors are connected normally or not. Check if extra length of the cables does not touch the fan blade or not.	Correct the connection condition of the connectors. Correct the cable wiring route. Replace the fan.

(12-2) Duplex fan does not rotate during the Duplex printing.

Check item	Check work	Action to be taken at NG
(12-1-2) Cable connection condition and wiring condition		
Cable connection condition and wiring condition of the Duplex fan	Check if the connectors are connected normally or not. Check if extra length of the cables does not touch the fan blade or not.	Correct the connection condition of the connectors. Correct the cable wiring route. Replace the fan. Replace the fan.
24V fuse F501 of the Duplex board (V7Y PCB)	Check if the fuse F501 has blown out or not.	Replace the Duplex board (V7Y PCB).
24V power supplied to the Duplex board (V7Y PCB).	Check if the fuse F1 of the PU board has blown out or not.	Replace the PU board.

(12-3) All fans of the printer do not rotate.

Check item	Check work	Action to be taken at NG
(12-3-1) 24V power supply		
PU board fuses F4, F5	Check if the fuses F4 and F5 are not open-circuit or not.	Replace the PU board.
24V power that is supplied to the PU board.	Check the power supply voltages at the POWER connector ⑩ of the PU board. The follow voltage must appear respectively. Pins-4, 5 and 6: 24V Pin-8: 0VL Pins-1, 2 and 3: 0VP	Replace the low voltage power supply.

7.5.2. (13) Print speed is slow. (Performance is low.)

(13-1) Print speed decreases.

Check item	Check work	Action to be taken at NG
(13-1-2) Media Weight setting		
Media Weight that is specified for the print	Check if the wrong Media Weight has been specified or not.	Correct the Media Weight.

7.5.2. (14) Option unit cannot be recognized.

(14-1) Duplex unit cannot be recognized.

Check item	Check work	Action to be taken at NG
(14-1-1) Duplex board		
Duplex unit	Check if the Duplex unit of C710dn specification is being used or not.	Replace the Duplex unit.
(14-1-2) Check the system connection		
Check the system connection from the PU board to the Duplex board (V7Y PCB).	Check that the cable between the PU board option connector ⑬ to the Duplex board is normally connected.	Correct the connections.
Square connector connecting the Duplex unit to the printer.	Check if any foreign material exists in the connecting portion of the square connector.	Remove the foreign material.
Square connector connecting the Duplex unit to the printer.	Is the terminals of the square connector damaged?	Replace the connector.
(14-1-3) Check the control signals.		
Check the control signal that is output from the PU board to the Duplex board (V7Y PCB).	Check the control signal that is output from the PU board option connector ⑬ . Pin-6: TXD (PU → DUP) Pin-4: RXD (DUP → PU)	Replace the PU board.

(14-2) Option try unit cannot be recognized.

Check item	Check work	Action to be taken at NG
(14-2-1) Option try board		
Option try unit	Check if the option try unit of C710dn specification is being used or not.	Replace the option tray unit.

Check item	Check work	Action to be taken at NG
(14-1-2) Check the system connection		
Check the system connection from the PU board to the option tray board (V7Y PCB).	Check that the cable between the PU board option connector ⑬ to the option tray board is normally connected.	Correct the connections.
Square connector connecting the option tray unit to the printer.	Check if any foreign material exists in the connecting portion of the square connector.	Remove the foreign material.
Square connector connecting the option tray unit to the printer.	Is the terminals of the square connector damaged?	Replace the connector.
(14-2-3) Check the control signals.		
Check the control signal that is output from the PU board to the option tray board (V7Y PCB).	Check the control signal that is output from the PU board option connector ⑬ . Pin-5: TXD (PU → 2nd) Pin-3: RXD (2nd → PU)	Replace the PU board.

7.5.2. (15) LED head cannot be recognized. (error code 131, 132, 133, 134)

(15-1) Service call 131 to 134 (LED HEAD Missing)

Check item	Check work	Action to be taken at NG
(15-1-1) Check the system connection		
Connecting condition at the CU board connector and at the head connector.	Check the connecting condition of the FFC by the visual inspection.	Correct the connection to the normal connecting condition.
Head FFC	Remove the head FFC from the printer. Check if any open-circuit or peeling-off of sheath has occurred or not throughout the cable.	Replace the head FFC or the CU board.
Conduction of the fuse on the CU board.	Check that 5V appears across the capacitors CP7 and CP8. (Refer to section 7.6.)	Replace F504, F506 or replace the CU board.

## 7.5.2. (16) Toner cartridge cannot be recognized. (error code 540, 541, 542, 543)

## (16-1) Error caused by the consumable items.

Check item	Check work	Action to be taken at NG
(16-1-1) Consumable items installation condition		
ID unit and toner cartridge	Check that the ID unit is installed in the normal position. Check that the lock lever of the toner cartridge is locked.	Correct the installation to the normal installation condition.

## (16-2) Error caused by the toner sensor

Check item	Check work	Action to be taken at NG
(16-2-1) Toner sensor condition		
Toner sensor	Is the receptor of the toner sensor stained?	Wipe off the stain from the toner sensor.
Toner sensor	Confirm that the toner sensor works normally by using the SWITCH SCAN function of the self-diagnostic mode. Place a white paper in front of the toner sensor, and check if the SCAN state changes or not.	Replace the toner sensor board, or the PU board, or the FFC between the toner sensor board and the PU board.

**Note!** Toner sensor operation check method using the SWITCH SCAN function of the self-diagnostic mode.

## (1) How to check operation of the toner sensor at the printer side.

- Status change of the toner sensor can be checked from the Operator Panel using the self-diagnostic mode. First, switch the display to the Operator Panel display. For the method of switching the display to the Operator Panel display, refer to section 5.3.2.3 Switch Scan Test
- Remove the ID unit and the toner cartridge (TC) from a printer. There is a window inside a printer opposing the ID side when viewed from the front of a printer. The toner sensor is located inside the window.
- Place a white paper 3 mm away from the sensor window. The white paper should be placed in the manner of opposing the toner sensor.
- When light is reflected by a white paper so that incident light falls on the toner sensor, the Operator Panel display shows "L". When the paper is moved so that any light is not reflected by the paper so that the incident light does not reach the toner sensor, "H" is displayed on the Operator Panel.
- If the Operator Panel display toggles between "H" <-> "L" as a paper is flipped in front of the toner sensor, it indicates that the toner sensor and the related system of the printer are working normally.

## Action to be taken at NG

- Clean surface of the toner sensor to remove the stains due to residual toner and paper dust.
- Check the connection condition of the FFC cable at the PU main board (PU) and at the toner sensor board (PRZ).
- Perform the operation check again. If the situation is not improved and remains unchanged, replace the PU main board (PU) or the toner sensor board (PRZ).

## (2) How to check operation of the toner sensor at the toner cartridge (TC) side

- To the position where the toner sensor is confirmed to be operating normally in the printer itself by the above paragraph (1), install the TC and the ID unit to check operations by observing display on the Operator Panel.
- If the ID unit works normally, the display on the Operator Panel will toggle between "H" <-> "L" in synchronism with movement of the silver reflector plate that is located on the side of the ID.

## Action to be taken at NG

- Check operation condition of the respective ID motors by using the Motor & Clutch Test of the self-diagnostic mode.
- Clean surface of the silver reflector plate on the side of ID to remove stains. (Stain due to toner or paper dust)
- Replace the TC of different color and the ID unit as a pair.  
If a satisfactory operation is attained by using the a pair of TC of different color and the ID unit, replace the TC or replace the ID unit.



(16-3) Error caused by the defective mechanism

Check item	Check work	Action to be taken at NG
<b>(16-3-1) Mechanical load applied to the ID unit</b>		
ID unit	Check if a heavy mechanical load is being applied to the ID unit due to breakage of the waster toner belt, or not.	Replace the ID unit. If any attempt of using new ID unit as a trial is going to be made, be sure to use the System Maintenance Menu FUSE KEEP MODE.
<b>(16-3-2) Motor operating condition</b>		
ID motor	Confirm that the respective ID motors work normally or not by using the Motor & Clutch Test of the self-diagnostic mode. Check if any extra load exists or not.	Replace the PU board or the ID motor.

7.5.2. (17) Fuse cut error (error codes 150 to 155)

(17-1) Fuse cut error

Check item	Check work	Action to be taken at NG
<b>(17-1-1) Check the system connection</b>		
FFC connecting the PU board and the toner sensor board (PRZ PCB)	Check if the connector is connected in the half-way only or not, and is inserted in a slanted angle or not at the SSNS connector ⑧ of the PU board, and at the SSNS connector ⑩ of the toner sensor board (PRZ PCB). Check if FFC has open-circuit of sheath of the FFC has not peeled off or not.	Connect the FFC normally. Alternately, replace the FFC.
<b>(17-1-2) Fuse cut circuit</b>		
PU board	Upon completion of the system connection check, turn off the power once and back on. The, check if the error occurs or not.	Replace the PU board.

7.5.2. (18) Humidity sensor error (error code 123)

(18-1) Humidity sensor error

Check item	Check work	Action to be taken at NG
(18-1-1) Check the system connection		
Connection between the PU board and Operator Panel	Check if the 10-conductor FFC is connected to the OPE connector ⑰ of the PU board normally or not. Check if the 10-conductor FFC is connected to the CN1 connector ⑱ of the Operator Panel board normally or not. Check if the connector is connected in the half-way only or not, and check if the connector is inserted in a slanted angle or not.	Re-connect the cable normally.
FFC connecting the PU board and the Operator Panel board	Check for open-circuit with VOM. Check that peeling off of sheath does not occur in any cables by visual inspection.	Replace the FFC with the normal FFC.

Check item	Check work	Action to be taken at NG
(18-1-2) Environment condition		
Sharp change of environment condition	Is the environment condition changed sharply from a low temperature environment to a high environment condition within a short time? (Example is such a case that a printer is moved from storage condition of a cold area in winter to an office environment.)	Leave a printer for around one hour in the new environment to get used to the new environment. After that, turn on the power again. Before turn on the power, touch the metal panel of the controller panel and the metal plate inside a printer to feel temperature increase inside a printer with human hands. After confirmation that the printer temperature has increased close to the room temperature, turn on the power again.

7.5.2 (19) Wiring diagram

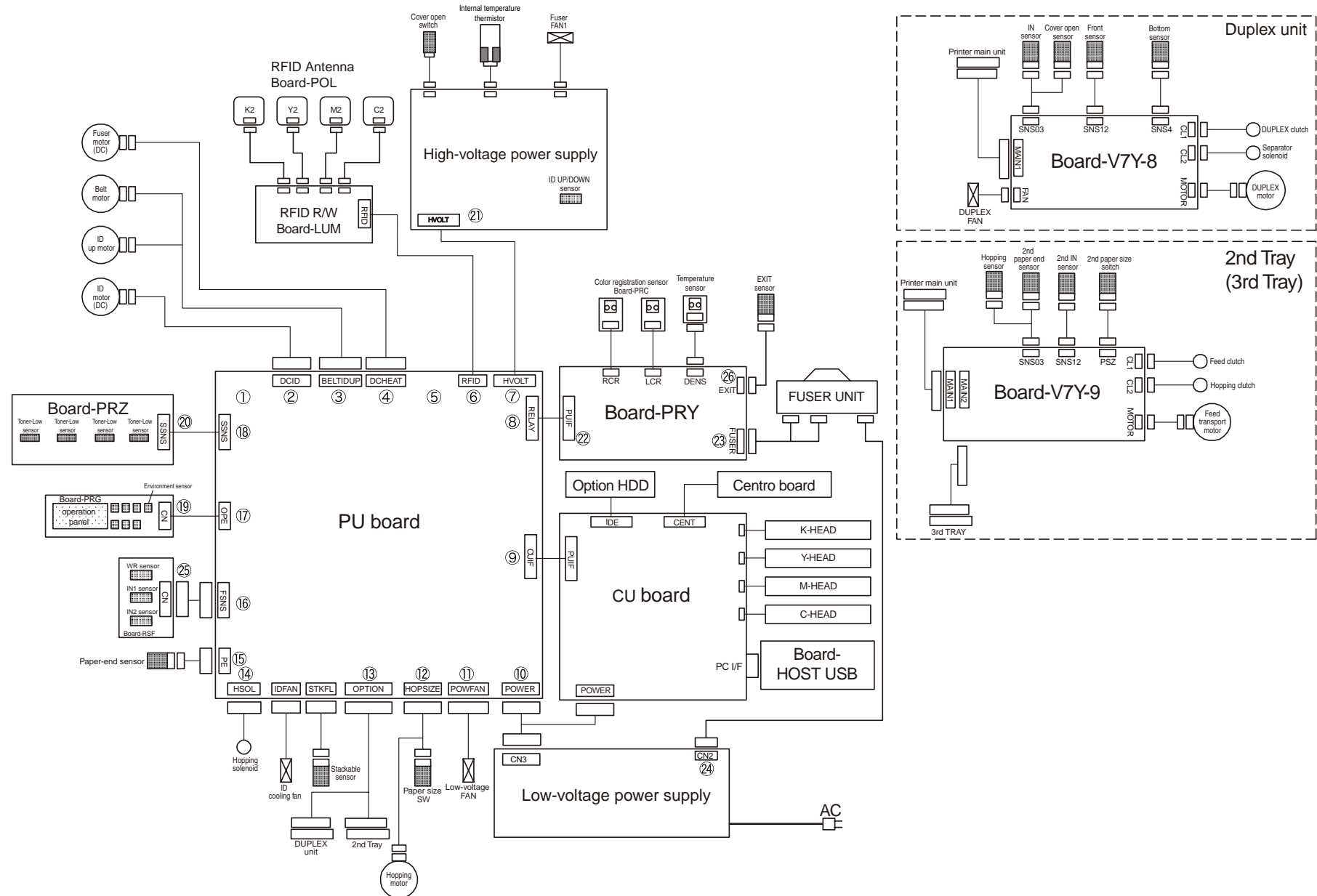

### 7.5.3 Troubleshooting the abnormal images

(1) Color has faded-out and blurred entirely. (Refer to Figure 7-2A.).....	181
(1-1) Color are faded-out and blurred. ....	181
(2) Stain on white print (Refer to Figure 7-2B.).....	182
(2-1) Stain on white print (Partial stain).....	182
(2-2) Stain on white print (overall stain).....	182
(3) White print (Refer to Figure 7-2C.).....	183
(3-1) White print over entire page.....	183
(4) Black banding/black streaking in vertical direction.....	184
(4-1) Thin vertical line (with color) (Refer to Figure 7-2D.) ....	184
(4-2) Thin vertical line (without color) (Refer to Figure 7-2F.).....	184
(5) Cyclic abnormality (Refer to Figure 7-2E.).....	184
(5-1) Cyclic abnormality occurs in vertical direction .....	184
(6) Heavy color registration error.....	185
(6-1) Display of the message "Color adjustment is in progress" appears only short time. ....	185
(6-2) Though REG ADJUST TEST of engine maintenance function is ok, color blur occurs .....	185
(7) Entirely black print.....	185
(7-1) All black print over entire page.....	185

**Note!** When an attempt is going to be made to replace the PU board, read data contents of the EEPROM chip from the old PU board beforehand, and copy the data contents into the new board after the new PU board is installed.

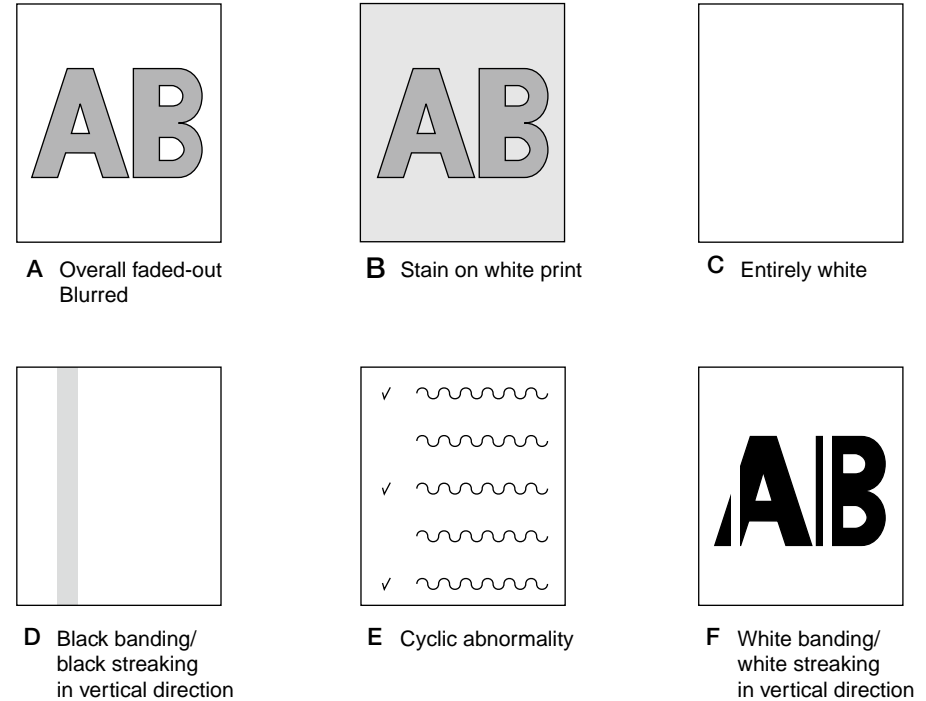

Figure 7-2

7.5.3.(1) Color has faded-out and blurred entirely. (Refer to Figure 7-2A.)

(1-1) Color are faded-out and blurred.

Check item	Check work	Action to be taken at NG
<b>(1-1-1) Toner</b>		
Remaining amount of toner	Check if the message "Prepare toner replacement." or "Replace the toner." appears or not.	Replace toner cartridge with new one.
Tape attached to the toner cartridge opening slot	Check to see that the tape attached to the toner cartridge opening slot has been peeled off.	Move the toner cartridge lever to CLOSE position and remove tape from opening slot.
<b>(1-1-2) LED head</b>		
Lens of the LED head	Check if surface of the lens of the LED head is stained or not by toner and paper dust.	Clean the lens with soft tissue paper.
Mounting condition of LED head	Check that the LED head is mounted on the LED head holder correctly. Check that the right and left tension springs are normally installed.	Correct for normal condition.
<b>(1-1-3) Print media</b>		
Media type	Check to see that the print media which is used for printing is not a specially thick media	Use the normal paper.
<b>(1-1-4) High voltage terminal</b>		
ID unit terminal	Check that the high voltage terminal of the ID unit is contacting with the Contact Assembly normally by visual inspection. (Refer to Figure 7-3.)	Replace the ID unit or correct the high voltage terminal. If any attempt of using new ID unit as a trial is going to be made, be sure to use the System Maintenance Menu FUSE KEEP MODE.

Check item	Check work	Action to be taken at NG
<b>(1-1-5) ID unit installation condition</b>		
ID unit DOWN position (Defective transfer)	Move the ID unit in and out with hand to confirm that any abnormal mechanical load does not exist, and the ID unit can be moved down to the DOWN position normally. If a piece of paper is inserted in between drum and belt, if top end of the paper can enter easily, it is NG (No Good).	Check the U-shaped groove of the side plate for any abnormality. If repair is found impossible, replace the equipment.

7.5.3.(2) Stain on white print (Refer to Figure 7-2B.)

(2-1) Stain on white print (Partial stain)

Check item	Check work	Action to be taken at NG
<b>(2-1-1) ID unit</b>		
Exposure of drum to light	Is the drum left in a circumstance in which drum surface is exposed to direct light for a long time?	Replace the ID unit. If any attempt of using new ID unit as a trial is going to be made, be sure to use the System Maintenance Menu FUSE KEEP MODE.
Leakage of toner	Does toner leak out from either ID unit or from toner cartridge?	Replace the ID unit or toner cartridge. If any attempt of using new ID unit as a trial is going to be made, be sure to use the System Maintenance Menu FUSE KEEP MODE.
<b>(2-1-2) Fuser unit</b>		
Offset toner of the fuser unit	Check if the offset toner of the previous printing is left adhered on the fuser unit or not, by visual inspection.	Repeat blind printing using unwanted media until offset toner is created on print media. Alternately replace the fuser unit. If any attempt of using new fuser unit as a trial is going to be made, be sure to use the System Maintenance Menu FUSE KEEP MODE.

(2-2) Stain on white print (overall stain)

Check item	Check work	Action to be taken at NG
<b>(2-2-1) Print media</b>		
Type of print media	Check to see that the print media which is used for printing is not a specially thin media.	Use the normal paper.
<b>(2-2-2) High voltage terminal</b>		
ID unit terminal	Check that the high voltage terminal of the ID unit is contacting with the Contact Assembly normally by visual inspection. (Refer to Figure 7-3.)	Replace the ID unit or correct the high voltage terminal. If any attempt of using new ID unit as a trial is going to be made, be sure to use the System Maintenance Menu FUSE KEEP MODE.

7.5.3.(3) White print (Refer to Figure 7-2C.)

(3-1) White print over entire page

Check item	Check work	Action to be taken at NG
(3-1-1) Toner condition		
Remaining amount of toner	Confirm that sufficient amount of toner remains inside the toner cartridge.	Replace the toner cartridge.
(3-1-2) Exposure condition to light		
LED head	Confirm that the LED head is positioned in the normal position where the LED head opposes again the drum when the cover is closed. Check that no obstacle exists in front of the LED head, that hampers light emission from the illuminating surface of the LED head.	Correct the installation condition of the LED head.
Connecting condition of the LED head	Check that the LED head is normally connected.	Replace the LED head.
Drum shaft	Check that the drum shaft keeps contacting with the right and left side plates normally.	Replace the ID unit. If any attempt of using new ID unit as a trial is going to be made, be sure to use the System Maintenance Menu FUSE KEEP MODE.
F506, fuse on the CU board	Measure resistance of F506. 1 ohm or less: Normal Higher than 1 ohm: NG	Replace the CU board

Check item	Check work	Action to be taken at NG
(3-1-3) High voltage terminal		
ID unit terminal	Check that the high voltage terminal of the ID unit is contacting with the Contact Assembly normally by visual inspection. (Refer to Figure 7-3.)	Replace the ID unit or correct the high voltage terminal. If any attempt of using new ID unit as a trial is going to be made, be sure to use the System Maintenance Menu FUSE KEEP MODE.

7.5.3.(4) Black banding/black streaking in vertical direction

(4-1) Thin vertical line (with color) (Refer to Figure 7-2D.)

Check item	Check work	Action to be taken at NG
<b>(4-1-1) ID unit condition</b>		
Filming of the ID unit	Is print attempted without toner?	Replace toner cartridge with new one. If replacement does not solve the problem, replace the ID unit. If any attempt of using new ID unit as a trial is going to be made, be sure to use the System Maintenance Menu FUSE KEEP MODE.

(4-2) Thin vertical line (without color) (Refer to Figure 7-2F.)

Check item	Check work	Action to be taken at NG
<b>(4-2-1) LED head condition</b>		
LED head	Is any foreign material attached on the light emitting surface of the cell fox lens of the LED head?	Remove the foreign material.
<b>(4-2-2) Condition of paper running path</b>		
Paper running path	Check that any burr that may scatter the unfused toner on the paper running path does not exist.	Remove the burr.

7.5.3.(5) Cyclic abnormality (Refer to Figure 7-2E.)

(5-1) Cyclic abnormality occurs in vertical direction

Check item	Check work	Action to be taken at NG
<b>(5-1-1) Cycle</b>		
Image drum	Check that the cycle is 94.3 mm.	Replace the ID unit
Developing roller	Check that the cycle is 39.7 mm.	Replace the ID unit
Toner feed roller	Check that the cycle is 58.4 mm.	Replace the ID unit
Charge roller	Check that the cycle is 37.7 mm.	Replace the ID unit
Roller on top of fuser	Check that the cycle is 87.7 mm.	Replace the fuser unit.
Fuser belt	Check that the cycle is 125.5 mm.	Replace the fuser unit.
Transfer roller	Check that the cycle is 50.3 mm.	Replace the belt unit.
		If any attempt of using new consumable item as a trial is going to be made, be sure to use the System Maintenance Menu FUSE KEEP MODE.



7.5.3.(6) Heavy color registration error

(6-1) Display of the message "Color adjustment is in progress" appears only short time.

Check item	Check work	Action to be taken at NG
<b>(6-1-1) Result of color registration error correction</b>		
Color registration error correction time (If a printer is normal, it is approx. 40 seconds.)	Use the self-diagnostic mode and execute the REG ADJUST TEST. Check the result. Error is issued but is not displayed on the ON LINE display.	Replace the sensor that causes the error. Clean the sensor to remove stain. Replace the shutter. Replace the PU board.
<b>(6-1-2) Toner</b>		
Remaining amount of toner	Check if the message "Prepare toner replacement." or "Replace the toner." appears or not.	Replace toner cartridge with new one.
<b>(6-1-3) Color registration error detection sensor</b>		
Sensor is dirty	Is toner or paper dust attached to the sensor?	Clean the sensor to remove stain
<b>(6-1-4) Color registration error detection sensor shutter</b>		
Shutter operation is faulty	Check the shutter operation by the self-diagnostic mode	Replace the shutter or tune the mechanism

(6-2) Though REG ADJUST TEST of engine maintenance function is ok, color blur occurs

Check item	Check work	Action to be taken at NG
<b>(6-2-1) Paper feed system</b>		
Paper feed system of the paper running path	Check if any obstacle exists in the paper feeding path, that hampers smooth paper run.	Remove the obstacle

7.5.3.(7) Entirely black print

(7-1) All black print over entire page

Check item	Check work	Action to be taken at NG
<b>(7-1-1) High voltage contacting condition</b>		
CH terminal	Check that the terminal coming from the printer body contacts with the high voltage terminal that is located on the left side of the ID unit when viewed from the top by visual inspection.	Replace the terminal of printer side.
CH terminal	Check that the high voltage terminal keeps the normal contacting condition on the high voltage board. Open the left cover and remove the high voltage board. Then, check that the terminal is not installed in the abnormal installation condition.	Correct the installation condition of the terminal to the normal condition.
ID unit terminal	Check that the high voltage terminal of the ID unit is contacting with the Contact Assembly normally by visual inspection. (Refer to Figure 7-3.)	Replace the ID unit or replace the high voltage board or correct the high voltage terminal. If any attempt of using new ID unit as a trial is going to be made, be sure to use the System Maintenance Menu FUSE KEEP MODE.
<b>(7-1-2) High voltage output condition</b>		
CH output	If high voltage probe is available as a maintenance tool, open the left cover, and check the CH output with the high voltage probe from the soldering side of the high voltage board. (The high voltage probe is not an ordinary maintenance tool.)	Replace the high voltage board.

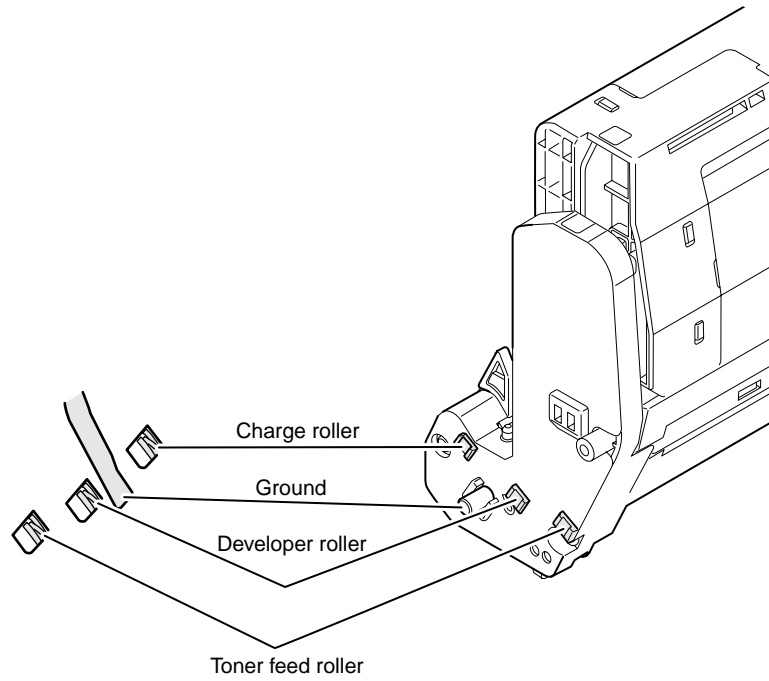

Figure 7-3

## 7.5.4 Network troubleshooting

(1) Print cannot be activated from Utilities.

Check item	Check work	Action to be taken at NG
(1) Check the LINK lamp		
Check if the LINK lamp (green) is illuminating or not.	Check if the HUB and a printer are connected normally. (Check that the network cable is connected normally.)	Re-connect the network cable normally.
	Confirm that the straight network cable is being used.	Replace the cable with the straight cable.
	Make an attempt to change connection of the network cable to other port of a HUB.	Try to change the HUB.
(2) Check the network information		
Check if the network information can be printed normally or not.	Press the Push switch of the NIC card to print the network information.	Re-write the NIC-F/W by using Utilities.
(3) Check contents of the network information.		
Confirm the IP address, SUB net mask and gateway address.	Confirm the IP address, SUB net mask and gateway address that are printed on the network information.	Set the IP address, SUB net mask and gateway address normally.
(4) Check if communication is possible or not through network		
Confirm if the Ping command can be sent or not from a PC to a printer.	Confirm if correct reply is returned from a printer to a PC when the PC sends the Ping to a printer.	Set the IP address, SUB net mask and gateway address normally.
(5) Check the Utilities.		
Check setting of the OKI LPR Utilities.	Check the setting items of the OKI LPR Utilities.	Set the OKI LPR Utilities setting items correctly.
(6) Check the following from an OS standard port		
Confirm the standard LPR port of the WINDOWS standard (NT, 2000, XP).	Set the standard LPR port of the WINDOWS standard (NT, 2000, XP), and confirm if printing can be performed or not.	Set the standard LPR port of the WINDOWS standard (NT, 2000, XP) correctly.

### 7.5.4.1 Connection error occurs with the Web browser

If the printer setting page cannot be displayed by the web browser "https://<printer IP address>", check the followings.

Establish connection by "https://<printer IP address>".

1) If the printer setting page is displayed, the followings are probable.

Take an appropriate measure by referring to the following items.

\* Certificate is not created yet. (Or failed to create certificate.)

→ Refer to section "7.5.4.1.1 Is the certificate created?".

\* Certificate has been created but the SSL/TLS setting is turned off.

→ Refer to section "7.5.4.1.2 Is the SSL/TLS setting set to [ON]?".

2) If the printer setting page is not displayed, the followings are probable.

\* Version number of the browser is old.

→ Refer to section "7.5.4.1.3 Check version number of the Web browser."

\* Encryption strength has been set to Strong.

→ Refer to section "7.5.4.1.3 Check encryption strength of a printer."

\* The key exchange system of a printer is not supported by the browser. (Compatibility problem)

→ Refer to section "7.5.4.1.5 Check the key exchange type of the certificate."

7.5.4.1.1 Is the certificate created?

Log-on in as the administrator, and select "Security" → "Encryption (SSL/TLS)".

If the following screen is displayed, certificate of the printer is not created yet. (The same screen is displayed when failed to create certificate.)

Solution: Create certificate by referring to the User's Manual (Advanced edition).

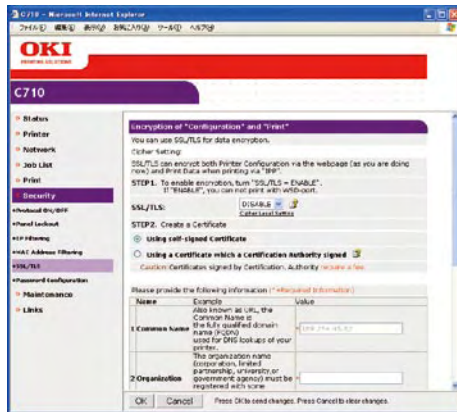

Before creating certificate (default state)

7.5.4.1.2 Is the SSL/TLS setting set to [ON]?

Log-on in as the administrator, and select "Security" → "Encryption (SSL/TLS)".

If the following screen is displayed, certificate has already been created, but the SSL/TLS setting is turned [OFF].

Solution: Set the SSL/TLS setting to [ON].

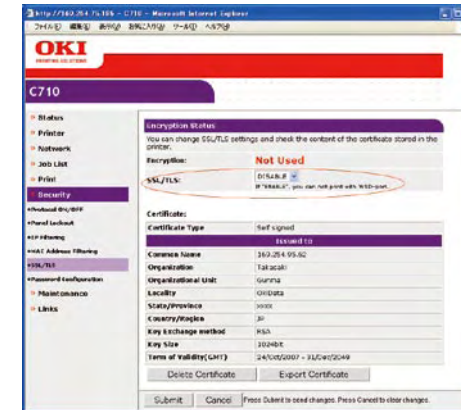

### 7.5.4.1.3 Check version number of the Web browser

Check version number of the Web browser in use.

How to check version number.

For Internet Explorer

Launch the browser and select "HELP" → "Version information".

Recommended version is Internet Explorer 5.5 and higher.

Solution : Install the newest web browser. Alternately, install the high encryption pack.

If any version that is older than the recommended version is used, communication can become possible sometimes when the encryption strength is set to "Weak". If the encryption strength is set to "Weak", security level lowers. To change the encryption strength, refer to section "7.5.4.1.4 Confirm encryption strength of a printer."



For Netscape

Launch the web browser and select "HELP" → "Netscape".

Recommended version is Netscape 6 and higher.

Solution : Install the newest web browser.

If any version that is older than the recommended version is used, communication can become possible sometimes when the encryption strength is set to "Weak". If the encryption strength is set to "Weak", security level lowers. To change the encryption strength, refer to section "7.5.4.1.4 Confirm encryption strength of a printer."

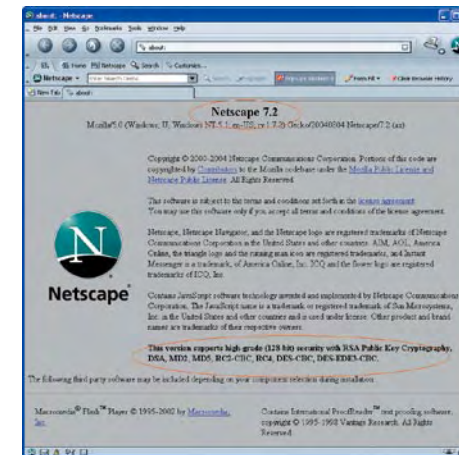

### 7.5.4.1.4 Confirm encryption strength of a printer

Version display of the browser that is confirmed by section "7.5.4.1.3 Check version number of the Web browser" has description on encryption strength of the browser. The browser in which the encryption strength is not set to 128 bits, the browser cannot establish communication with the printer in which the encryption strength is not set to "Standard."

Either, upgrade the browser until it supports 128 bits (high encryption) or set the printer encryption strength to "Weak."

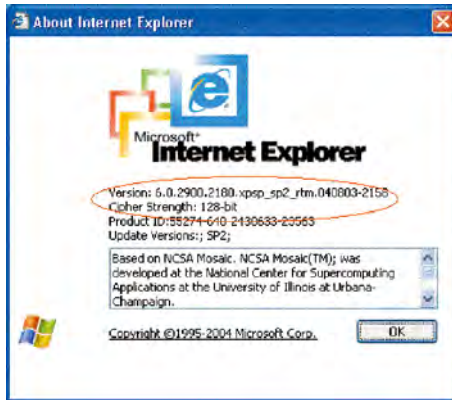

### Change encryption strength with AdminManager

1. Launch AdminManager and select (by highlighting) a desired printer from the printer list.

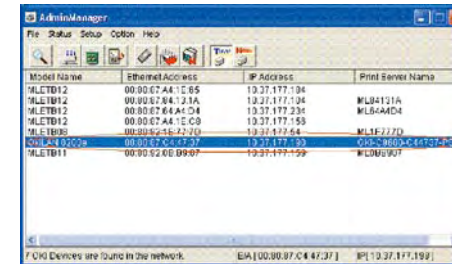

2. Press the "Oki Device Setup" button, or alternately select "Setup" → "Oki Device Setup", and open the setup screen.

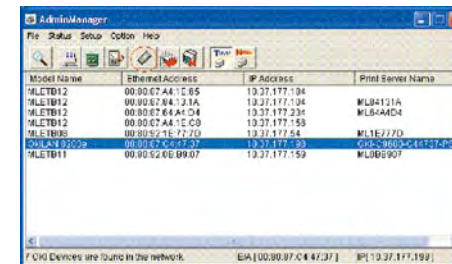

3. Input the administrator password and open the setup screen as an administrator.



4. Select the "SSL/TLS" tab.

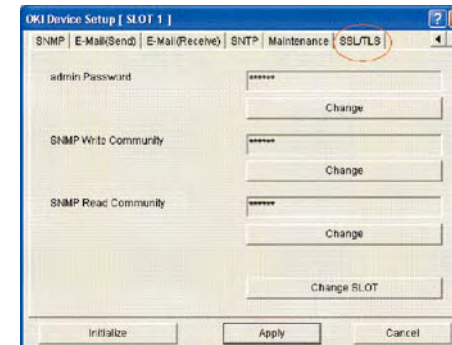

5. Check the "Encryption Strength."

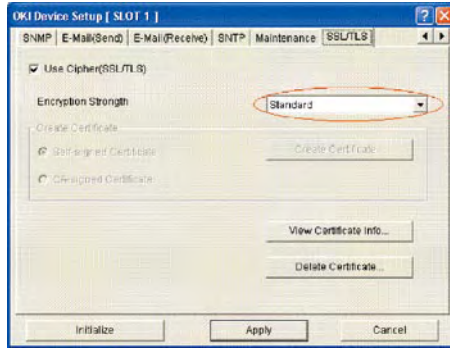

6. Set the "Encryption Strength" to "Weak" and press the "Apply" button.

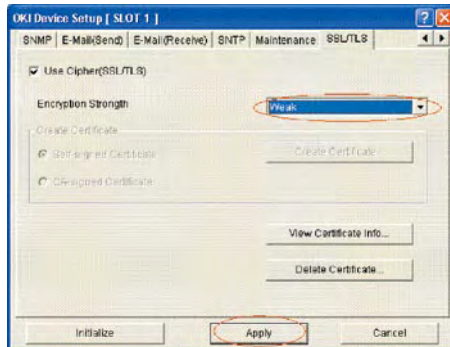

7. Check the setup contents, and press "OK".

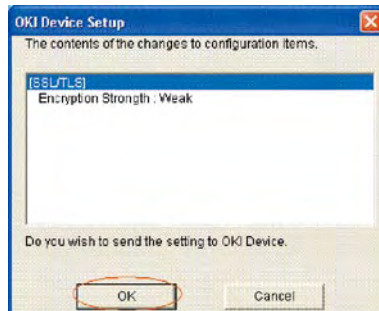

8. A message prompting your confirmation will be displayed. Click "Yes".  
(NIC reboots in order to reflect the setup value.)

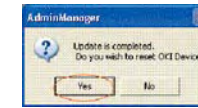

9. If the printer is displayed in the printer list, the setup is complete with success.

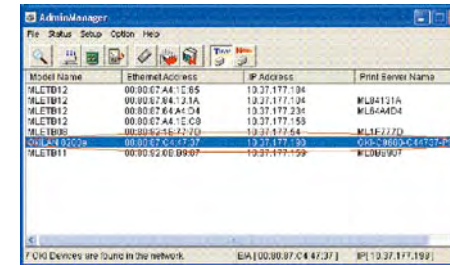

Solution: Set the encryption strength to "Weak".

How to change encryption strength with Telnet

**Note!** Telnet cannot be used if it remains in the default setting. To change the encryption strength, Telnet must be set to Enable.

Select the command prompt (DOS prompt) and enter "Telnet <printer IP address>", and press Return.

Establish connected using administrator user name and password

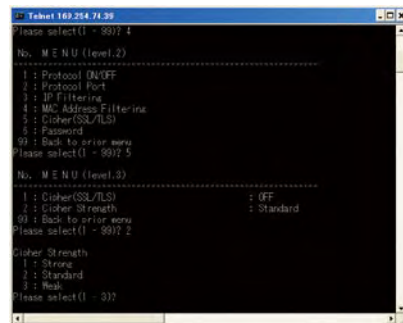

```

Telnet 169.254.74.39
Please select (1 - 99): 4
-----
No.  M E N U (level.2)
-----
1 : Protocol ON/OFF
2 : Protocol Port
3 : IP Filtering
4 : MAC Address Filtering
5 : Cipher(SSL/TLS)
99 : Back to prior menu
Please select (1 - 99): 5
-----
No.  M E N U (level.3)
-----
1 : Cipher(SSL/TLS)           : OFF
2 : Cipher Strength           : Standard
99 : Back to prior menu
Please select (1 - 99): 2
-----
Cipher Strength
1 : Strong
2 : Standard
3 : Weak
Please select (1 - 3):
  
```

Select the menus in this order: [4: Security Config] → [5: Cipher (SSL/TLS)] → [2: Cipher Strength]. Then, change the cipher strength as desired (1: Strong, 2: Standard, 3: Weak).

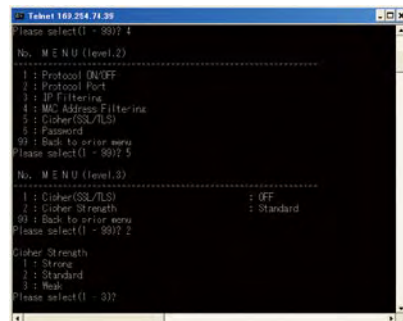

```

Telnet 169.254.74.39
Please select (1 - 99): 4
-----
No.  M E N U (level.2)
-----
1 : Protocol ON/OFF
2 : Protocol Port
3 : IP Filtering
4 : MAC Address Filtering
5 : Cipher(SSL/TLS)
99 : Back to prior menu
Please select (1 - 99): 5
-----
No.  M E N U (level.3)
-----
1 : Cipher(SSL/TLS)           : OFF
2 : Cipher Strength           : Standard
99 : Back to prior menu
Please select (1 - 99): 2
-----
Cipher Strength
1 : Strong
2 : Standard
3 : Weak
Please select (1 - 3):
  
```



### 7.5.4.2 Print operation is not possible

If print operation is not possible by using the encrypted IPP printer, check the followings.

Establish connection by "https://<printer IP address>".

- 1) If the printer setting page is displayed, the followings are probable.  
Take an appropriate measure by referring to the following items.
  - \* Certificate is not created yet. (Or failed to create certificate.)  
→ Refer to section "7.5.4.1.1 Is the certificate created?".
  - \* Certificate has been created but the SSL/TLS setting is turned off.  
→ Refer to section "7.5.4.1.2 Is the SSL/TLS setting set to [ON]?".
- 2) If the printer setting page is not displayed, the followings are probable.  
Take an appropriate measure by referring to the following items.
  - \* Version number of the browser is old.  
→ Refer to section "7.5.4.1.3 Check version number of the Web browser."
  - \* Encryption strength has been set to Strong.  
→ Refer to section "7.5.4.1.4 Check encryption strength of a printer."
  - \* The key exchange system of a printer is not supported by the browser. (Compatibility problem)
  - \* The OS does not support the IPP (encrypted) printing.  
→ Refer to section "7.5.4.2.1 Check OS (Operating System)."
  - \* IPP (encrypted) printer is not created yet.  
→ Refer to section "7.5.4.2.2 Is the Printer created?".
  - \* IPP setup of the Printer is not Enabled.  
→ Refer to section "7.5.4.2.3 Is the IPP setting set to Enabled?".

#### 7.5.4.2.1 Check OS (Operating System)

The IPP print (encryption) function is supported by Windows 2000, Windows XP, Windows 2003 Server and Windows Vista only.

It is not supported by other operating systems.

#### 7.5.4.2.2 Is the Printer created?

Printer may not be created normally.

To use the IPP print (encryption) function, the Printer must have been created by setting port to URL" [HYPERLINK "https://<" https://< printer IP address>/ipp"](https://< printer IP address>/ipp) when creating the Printer.

For more details of Printer creation method, refer to the User's Manual (Advanced edition).

#### 7.5.4.2.3 Is the IPP setup Enabled?

The IPP setup may not be set to Enable.

As the default setting of printer, IPP has been set to Disable.

To use the IPP print (encryption) function, the IPP setup must have been set to Enable.

For the method of changing the IPP setup, refer to the User's Manual (Advanced edition).

### 7.5.4.3 Cannot create Certificate

When Certificate cannot be created, the following causes are probable. Take an appropriate measure by referring to the following items.

- \* Required input items are not fully entered
  - Refer to section "7.5.4.3.1 Required input items are not fully entered."
- \* The printer is printing.
  - Refer to section "7.5.4.3.2 The printer is printing."

#### 7.5.4.3.1 Required input items are not fully entered

Unless all of the required input items are fully entered, Certificate cannot be created.

When creating Certificate, entry into the items of Common Name, Organization, Locality, State/Province, Country/Region is the must item. (Entry into Organizational Unit can be omitted.)

**Solution** : Enter the appropriate value into all of the required input items, and execute creation of Certificate.

For more details of the input items, refer to the User's Manual (Advanced edition).

#### 7.5.4.3.2 The printer is printing.

Certificate cannot be created while printing is in progress. (Print operation has priority.)

**Solution**: Create Certificate when all other operations are complete.

During creation of self-sign certification, during creation of CSR for Certificate of certifying authority, and during installation of Certificate, the printer must not perform any other operations (such as printing) until the operation is complete (creation of self-sign certification is complete, creation of CSR is complete, and installation of Certificate is complete).

### 7.5.4.4 Installation of Certificate is not possible

When installation of Certificate fails, the following causes are probable.

Take an appropriate measure by referring to the following items.

- \* User has changed the IP address of a printer to other IP address than the "IP address during creation of CSR."
  - Refer to section "7.5.4.4.1 IP address of the printer has been changed."
- \* "Network card is initialized" while user is applying issuance of certification to certifying authority (i.e., in the state of Waiting for Installation of Certificate).
  - Refer to section "7.5.4.4.2 "Network card is initialized"."
- \* "Deletion of CSR" was executed while user is applying issuance of certification to certifying authority (i.e., in the state of Waiting for Installation of Certificate).
  - Refer to section "7.5.4.4.3 "Deletion of CSR" is executed."
- \* Intermediate Certificate is installed.
  - Refer to section "7.5.4.4.4 "Installation of intermediate Certificate" is desired."

#### 7.5.4.4.1 User has changed the IP address of a printer

If IP address of a printer is changed to other IP address than the "IP address during creation of CSR", error is issued and installation of Certificate become impossible.

If the changed setup is only the "IP address of printer", error will not be issued if the IP address is returned to the original address.

**Solution** : Return the IP address of printer back to the "IP address during creation of CSR", and then install Certificate.

**Note!** Do not change any setup of printer while creation of Certificate of certifying authority is in progress (during the period starting from creation of CSR up until installation of Certificate). If changed, the already issued Certificates become invalid necessitating re-setup starting from the very beginning. If printer setup is changed after Certificate is obtained, the "Security warning" is displayed on the web browser.

If IP address of printer is changed, the Certificate becomes invalid. In the case of Certificate of certifying authority requiring some charge for issuance, another charge may be required for creating Certificate once again. For details, contact certifying authority.)

#### 7.5.4.4.2 "Network card is initialized"

If network card is initialized (to default setup) while creation of Certificate of certifying authority is in progress (during the period starting from creation of CSR up until installation of Certificate), the setup information of the Certificate is deleted. If information is deleted once, the information cannot be recovered by any means. (Even when the same information as before is entered, the same Certificate cannot be created.)

**Solution** : Repeat all the steps from the very beginning. (Certificate under application is already invalid.)

#### 7.5.4.4.3 "CSR is deleted"

If CSR is deleted (if Certificate is deleted) while creation of Certificate of certifying authority is in progress (during the period starting from creation of CSR up until installation of Certificate), the setup information of the Certificate is deleted. If information is deleted once, the information cannot be recovered by any means. (Even when the same information as before is entered, the same Certificate cannot be created.)

**Solution** : Repeat all the steps from the very beginning. (Certificate under application is already invalid.)

#### 7.5.4.4.4 Installation of intermediate Certificate is desired

Some certification authorities use the procedure of installing the SSL server Certificate (printer Certificate) and the intermediate Certificate into printer as the same time.

However, printer of this model supports installation of only a single Certificate, intermediate Certificate cannot be installed in printer. Be sure to install the SSL server Certificate in printer.

When installation of intermediate Certificate is required, install the intermediate Certificate not in printer, but in client PC (browser).

For the method of installing the intermediate Certificate in client PC (browser), refer to the following.

Installing the intermediate Certificate (or CA certificate) in client PC (browser).

#### [Procedure]

1. Double-click the intermediate Certificate (or CA certificate) that is issued by certifying authority, on a client PC to display the intermediate Certificate (or CA certificate).
  - ex.) For an example, the intermediate Certificate of Comodo has the text (PEM) format: ComodoJapanCA.Crt, and the binary format: ComodoJapanCA.cer. Either one of these formats can be opened. (Same result can be obtained.)

Open either ComodoJapanCA.crt or ComodoJapanCA.cer.

2. Press the "General" tab of the displayed Certificate information, and press "Install Certificate" button.

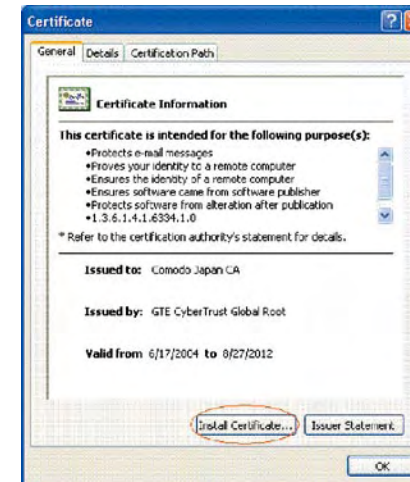

3. The "Certificate Import Wizard" is displayed. Install Certificate in accordance with the displayed procedure. Select "Automatically select the certificate store based on the types of certificate". Then, the Certificate will be installed automatically.

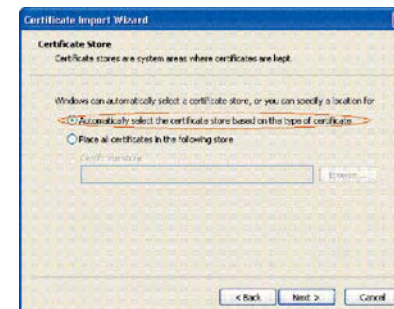

### 7.5.4.5 Other questionnaires

Other probable questionnaires are described below.

#### 7.5.4.5.1 Time required for creation of Certificate

It takes several ten seconds for creation of Certificate.

#### 7.5.4.5.2 Communication time when the encryption function is enabled

A time longer than the ordinary communication time is required for communication when the encryption function is used.

#### 7.5.4.5.3 Can the encrypted printing be performed by any printer other than IPP?

Answer : Any printer other than IPP cannot encrypt printing.  
Only the IPP printing can encrypt printing.

#### 7.5.4.5.4 What will happen if SSL/TLS is turned OFF after Certificate has been created (or installed)?

Answer : Certificate will be kept saved as it is.  
If SSL/TLS is turned ON again, the Certificate becomes usable.

#### 7.5.4.5.5 Want to change the port number

Answer : The port number during the SSL/TLS communication is fixed to 443.  
It cannot be changed.

#### 7.5.4.5.6 The error message "The security certificate was issued by a company you have not chosen to trust. View the certificate to determine whether you want to trust the certifying authority" is displayed.

If this error is indicated, it means that the certificate which is installed in a printer is self-sign certificate.

In the case of self-sign certificate, error (security warning) will not be displayed if the self-sign certificate of printer is installed in the client PC.

In the case of certificate of certifying authority, error (security warning) will not be displayed if the CA certificate of certifying authority is installed in the client PC.

Solution : Install certificate in the client PC (browser).

#### [Procedure]

1. Click the "View Certificate" button on the error (security warning) screen.



- Press the "General" tab of the displayed Certificate information, and press "Install Certificate" button.



- The "Certificate Import Wizard" is displayed. Install Certificate in accordance with the displayed procedure. Select "Automatically select the certificate store based on the types of certificate". Then, the Certificate will be installed automatically.

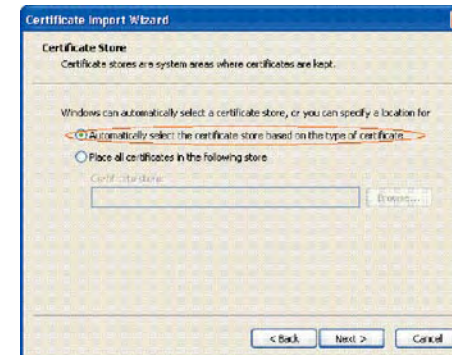

#### 7.5.4.5.7 The error message "Name of security certificate is invalid or does not match the site name" is displayed.

It means that the IP address of printer is different from the IP address that is described on certificate, or from the IP address when the certificate is created.

**Solution** :Return the IP address of printer back to the address when self-sign certificate is created, or to the address when CSR is created.

### 7.5.4.6 Restrictions when using Internet Explore 7

Several restrictions are imposed when using Internet Explore 7. This is because security restriction became more severe in IE7.

#### 7.5.4.6.1 Warning indication when SSL is made valid by self-sign certificate

When SSL is made valid by self-sign certificate, the following picture is obtained when web page is accessed, and page will not be displayed.

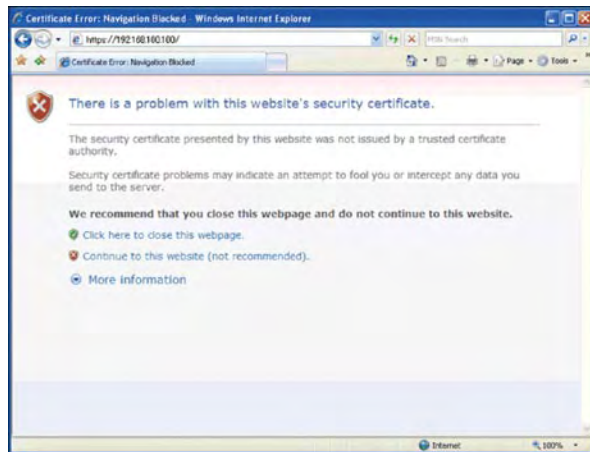

Web display when SSL is made valid by self-sign certificate

**Solution** :When "Continue browsing this site (not recommended)" is clicked on the warning screen, the web page will be displayed.

However, it has no effect on the web page function. It can be used for browsing or to change setting of printer setup.

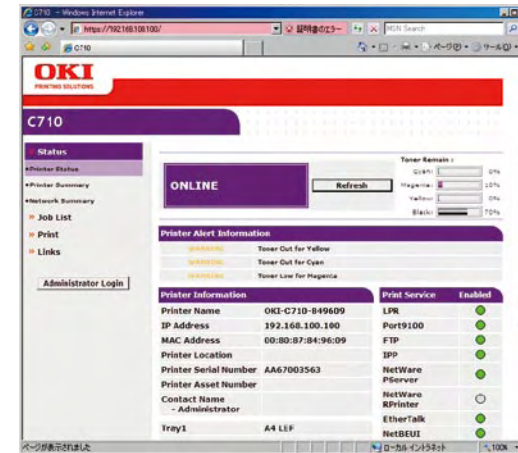

Web page display when "Continue browsing this site (not recommended)" is clicked.

## 7.6 Fuse check

If the following error is issued, check the corresponding fuse of the CU control board, PU control board and high voltage power supply board.

(Refer to Table 7-6.)

Table 7-6 Fuse error

Fuse Name	Error Description	Insert Point	Resistance
PU board	F1	Service call 918 (However, if the Duplex unit is not installed, it is the 2nd/3rd hopping error.)	Duplex, 2nd/3rd 24V
	F2	Power supply shut-down	PU board 5V
	F3	ID UP/DOWN error. Service call 142	Belt motor, ID UP/DOWN motor 24V
	F4	Cover open	High voltage power supply board, ID cooling fan, fuser fan 24V
	F5	Service call 122	Power supply fan, feed solenoid, feed motor 24V
High voltage power supply board	IP901	Cover open	High voltage 24V
	IP902	Service call 121	High voltage 5V
CU board	F506	<ul style="list-style-type: none"> <li>Service call 131 to 134 error</li> <li>All white page print</li> </ul>	LED HEAD 5V
	F505	Service call 131 to 134 error	LED HEAD 3.3V
	F501	HDD error	HDD 5V
	F503	CENTRONIX interface error	CENTRONIX interface 5V
	F502	CENTRONIX interface error	CENTRONIX interface 3.3V
	F507	Host USB error	PCI 5V

Less than  
1 ohm

## 7.7 Paper cassette switches versus Paper size correspondence table

Dial display size	Bit No.			
	1	2	3	4
TRAY1~3	1	2	3	4
Cassette: none	H	H	H	H
Legal 14"	H	L	H	L
Legal 13.5"	H	L	H	H
Legal 13"	L	L	L	H
Letter	L	L	L	L
Executive	L	L	H	L
Blank	L	L	L	L
Blank	H	H	L	L
A4	L	H	L	L
B5	L	H	H	L
A5	H	H	H	L
Not used	L	L	H	H
Not used	L	H	L	H
Not used	H	H	L	H
Not used	H	L	L	H
Not used	L	H	H	H
Not used	H	L	L	L

\* When switch is pressed: Low



## 7.8 Data protection kit-A1

### 7.8.1 Data protection kit-A1 (DPK-A1) overview

Purpose:

By encrypting data to be stored in HDD, data is protected from eavesdropping even when HDD is stolen.

Method:

The conversion board in which encryption chip is installed is inserted in between the CU board and HDD.

Connected chart:

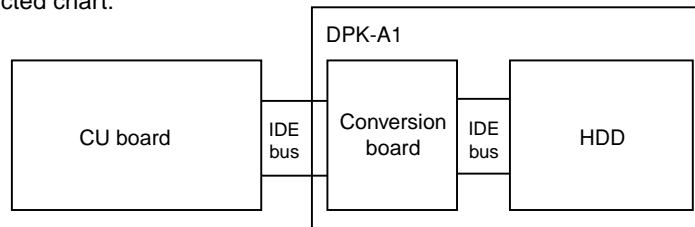

Assembled state of Data protection kit-A1

Shape of metal plate is different from HDD unit of C5900. Thickness and others are different.

HDD in which board is installed

<Top panel>



Connector for connecting HDD

<Rear panel>

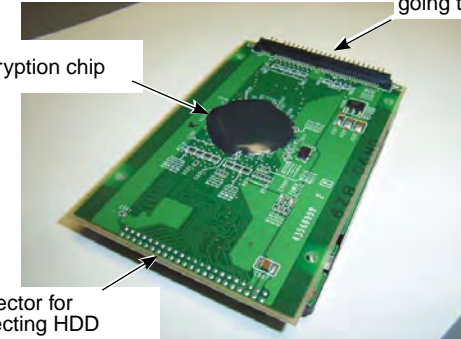

Sealed encryption chip

Connector for connecting HDD

Connector to which CU is going to be connected

Specification for safety:

- If the data protection kit-A1 is removed from printer or swapped by others, it is informed to user as a warning. (Error processing)
- Program download and EEPROM read-out are prohibited so that the data protection kit-A1 works safely.  
Consequently, restrictions that have not been applied are newly added after the data protection kit-A1 is installed in C710dn.
- Normal operation can be performed when the CU board including EEPROM and the data protection kit-A1 are installed as a pair. (Combination with the PU board and with engine is not restricted.)

Normal configuration (HDD is not used. Normal HDD is installed)

When the CU board becomes faulty:	Replace the CU board (User's EEPROM should be used.)
When the normal HDD becomes faulty:	Replace the HDD only.

After the data protection kit-A1 is installed

When the CU board becomes faulty:	Replace the CU board (EEPROM of the maintenance board should be used.)
	Replacement of the data protection kit-A1 is not required, but internal data are deleted.
When the data protection kit-A1 became fault:	Replace both of the data protection kit-A1 and the CU board. (EEPROM of the maintenance board should be used.)

- After the data protection kit-A1 is installed, the CU board is linked to a specific HDD. Therefore, the printer cannot be used without the specific HDD> As the CC authentication condition, the link can be cancelled by the Takasaki Design Department only.
- After the data protection kit-A1 is installed, some of the PjL functions cannot be used.
  - Downloading of all of the F/W (including NIC F/W and PU F/W)
  - Read and write of the EEPROM (CU and PU)

Upgrading of PU F/W and read/write of PU EEPROM after the data protection kit-A1 is installed:

Replace the CU board once with the new CU board in which the data protection kit-A1 has not been installed before.

Upgrading of CU F/W

Replace the CU board with new CU board in which the CU F/W is already upgraded. Data in the data protection kit-A1 will be deleted.

Error processing flow when the error 001-073, -254 has occurred (CU board related error)

Step 1	Does the printer work normally when the CU board is replaced by the maintenance CU board ① ? (Be sure to use EEPROM of the maintenance board. Note 1) (Do not install the data protection kit-A1) ↓ Yes	→ No	(Analysis is not possible.) Replace the printer.
Step 2	Does the printer start up normally when the user's data protection kit-A1 is installed? ↓ No	→ Yes	Maintenance is complete. (CU board failure) Re-setting of IP address and others are required: Note 1 and Note 4
Step 3	Does the printer start up normally when the data protection kit-A1 ① of maintenance use is installed? ↓ No (Error 253 occurs) Note 2	→ Yes	Maintenance is complete. (CU board failure, and data protection kit-A1 failure) Re-setting of IP address and others are required: Note 1, 3 and 4
Step 4	Does the printer work normally when the maintenance CU board ② and the data protection kit-A1 ① for maintenance use are installed instead of original boards? No. Replace the printer. (Analysis is not possible.) ↓ No Replace the printer. (Analysis is not possible.)	→ Yes	Maintenance is complete. (CU board failure, and data protection kit-A1 failure) Re-setting of IP address and others are required: Note 1, 3 and 4

**Note1** : When EEPROM of user's board is used, error 253 (HDD unmatched) occurs. Re-set the user environment such as IP address by using the EEPROM of maintenance board.

**Note2** : If a part of the functions of the data protection kit-A1 that user is using became faulty, the system can be recovered by using Step 3 if user's data protection kit-A1 is completely faulty because there is no restriction on combination in this case. If Step 2 is used, there is a restriction in combination of the maintenance CU board and user's data protection kit-A1. Therefore, if different HDD is connected afterwards, error 253 will be issued.

**Note3** : Data protection kit A1 after replacing should be collected by either of the following methods

1. Disassemble the kit, and deliver only HDD storing user secret data to a user.
2. Take any measures to prevent information leak.

**Note4** : When the CU board is replaced, the printer cannot be used without the specified HDD because the user's CU board has been linked to the specific HDD. Until the link is cancelled by design department, it cannot be used. (Situation should be reported to design department.)

Error processing flow when error 252, 253, 256 has occurred (HDD related error - ①)

Error display	Error contents
Error 252	Data protection kit-A1 does not exist.
Error 253	User's data protection kit-A1 does not exist, but different data protection kit-A1 is installed with the HDD.
Error 256	Invalid HDD is installed.

Step 1	Re-connect the printer to the user's data protection kit-A1 that is connected to the printer in the very beginning when user starts using the system. ↓ No ( If user's data protection kit-A1 that is connected in the very beginning does not exist )	→ Yes	Maintenance is complete. (User HDD has been removed.)
Step 2	Does the printer work normally when the maintenance CU board and the data protection kit-A1 for maintenance use are installed instead of original boards? ↓ No	→ Yes	Maintenance is complete. (User HDD has been removed.) Re-setting of IP address and others are required: Note 1, 3 and 4
Step 3	Replace the printer. (Analysis is not possible.)		

**Note1** : When EEPROM of user's board is used, error 253 (HDD unmatched) occurs. Re-set the user environment such as IP address by using the EEPROM of maintenance board.

**Note3** : Data protection kit A1 after replacing should be collected by either of the following methods  
 1. Disassemble the kit, and deliver only HDD storing user secret data to a user.  
 2. Take any measures to prevent information leak.

**Note4** : When the CU board is replaced, the printer cannot be used without the specified HDD because the user's CU board has been linked to the specific HDD.

Error processing flow when error 251, 253 has occurred (HDD related error - ②)

Error display	Error contents
Error 251	HDD hardware failure ①
Error 255	HDD kit hardware failure

Step 1	Does the printer work normally when the maintenance CU board ① and the data protection kit-A1 ② for maintenance use are installed instead of original boards? ↓ No	→ Yes	Maintenance is complete. (HDD failure) Re-setting of IP address and others are required: Note 1, 3 and 4
Step 2	Replace the printer. (Analysis is not possible.)		

**Note1** : When EEPROM of user's board is used, error 253 (HDD unmatched) occurs. Re-set the user environment such as IP address by using the EEPROM of maintenance board.

**Note3** : Data protection kit A1 after replacing should be collected by either of the following methods  
 1. Disassemble the kit, and deliver only HDD storing user secret data to a user.  
 2. Take any measures to prevent information leak.

**Note4** : When the CU board is replaced, the printer cannot be used without the specified HDD because the user's CU board has been linked to the specific HDD.

Error processing flow when error 250, 257 has occurred (HDD related error - ③)

Error display	Error contents
Error 250	HDD data damage or hardware failure
Error 257	HDD data damage or hardware failure

Step 1	250: Does the printer start up normally when the Admin menu – Disk erase is executed? 257: Does the printer start up normally when the Admin menu – Check Disk is executed? ↓ No ( If user's data protection kit-A1 that is connected in the very beginning does not exist )	→ Yes	Maintenance is complete. (Data stored in HDD is partly damaged.)
Step 2	Does the printer work normally when the maintenance CU board ① and the data protection kit-A1 ① for maintenance use are installed instead of original boards? ↓ No	→ Yes	Maintenance is complete. (HDD failure) Re-setting of IP address and others are required: Note 1, 3 and 4
Step 3	Replace the printer. (Analysis is not possible.)		

**Note1** : When EEPROM of user's board is used, error 253 (HDD unmatched) occurs. Re-set the user environment such as IP address by using the EEPROM of maintenance board.

**Note3** : Data protection kit A1 after replacing should be collected by either of the following methods

1. Disassemble the kit, and deliver only HDD storing user secret data to a user.
2. Take any measures to prevent information leak.

**Note4** : When the CU board is replaced, the printer cannot be used without the specified HDD because the user's CU board has been linked to the specific HDD.

If the printer does not start up normally while showing communication error and LCD does not show any display.

Step 1	Perform processing in accordance with the usual M/M. ↓ If the trouble cannot be solved		
Step 2	Does the error 252 occur when the user's protection kit-A1 is removed? ↓ Yes ( Data protection kit-A1 is partly damaged so that printer does not start up normally.)	→ No	Implement the error 001-073.254 sheet processing.
Step 3	Can the user's data protection kit-A1 be connected and can the Admin menu be started up? ↓ Yes ( Data protection kit-A1 is partly damaged so that printer does not start up normally.)	→ No	Implement the error 001-073.254 sheet processing.
Step 4	Does the printer recover by executing the Admin menu – Check all sector? ↓ No	→ Yes	Maintenance is complete. (Data stored in HDD is partly damaged.)
Step 5	Does the printer recover by executing the Admin menu – HDD Format? Note 1 ↓ No Implement the error 001-073.254 sheet processing.	→ Yes	Maintenance is complete. (Data stored in HDD is partly damaged.)

**Note1** : The Admin menu "HDD INITIALIZE" is not displayed unless the Admin menu "INITIAL LOCK" is set to "NO". (Default setting is "YES".)

# 8. Connection diagrams

---

8.1 Resistance value check.....	206
8.2 Parts location.....	210
8.3 F/W version number .....	221

## 8.1 Resistance value check

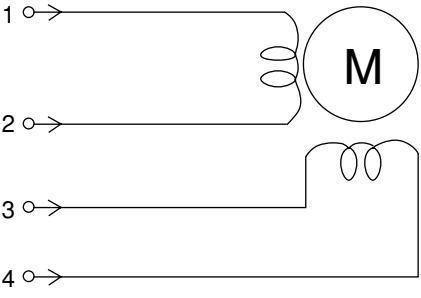
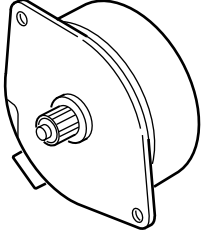
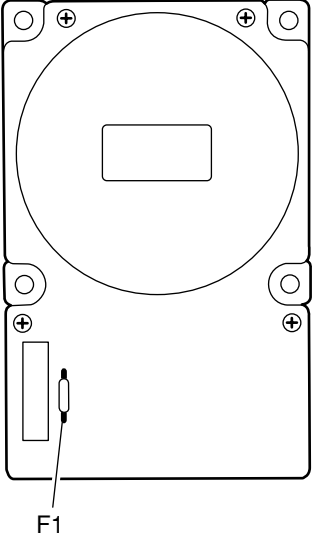
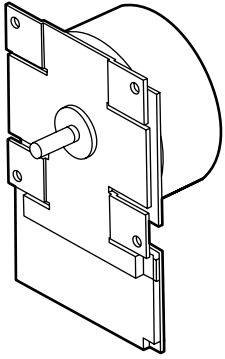
Unit	Electrical circuit diagram, connection	Part outside view	Resistance value
<p>Transport belt motor</p>			<p>Between pin-1 and pin-2: 3.4Ω Between pin-3 and pin-4: 3.4Ω</p>
<p>ID motor</p>			<p>Across both ends of F1: 1Ω or less</p>

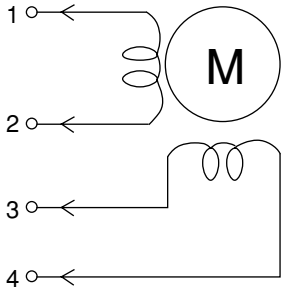
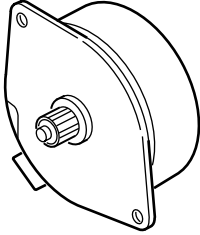
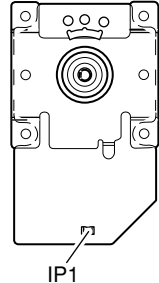
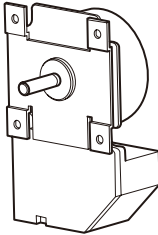
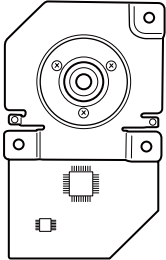
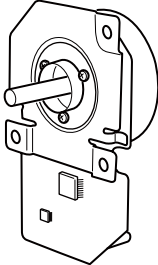
Unit	Electrical circuit diagram, connection	Part outside view	Resistance value
ID up/down motor			<p>Between pin-1 and pin-2: 6.1Ω Between pin-3 and pin-4: 6.1Ω</p>
Fuser unit motor			<p>Across both ends of IP1: 1Ω or less</p>
			

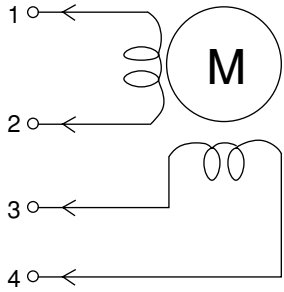
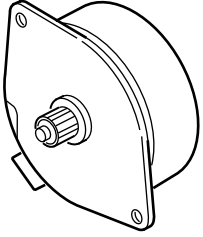
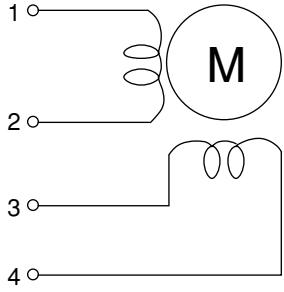
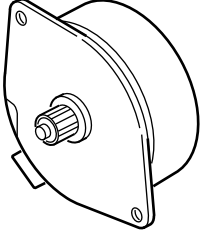
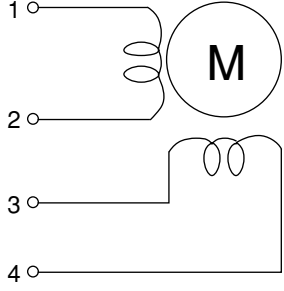
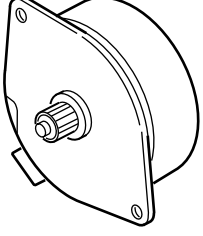
Unit	Electrical circuit diagram, connection	Part outside view	Resistance value
Feed motor	 <p>The diagram shows a motor symbol 'M' with two coils. The first coil is connected to pins 1 and 2. The second coil is connected to pins 3 and 4.</p>	 <p>A perspective view of a small, square-shaped motor with a central shaft and four mounting holes on the corners.</p>	<p>Between pin-1 and pin-2: 3.4Ω Between pin-3 and pin-4: 3.4Ω</p>
Both-sided print motor	 <p>The diagram shows a motor symbol 'M' with two coils. The first coil is connected to pins 1 and 2. The second coil is connected to pins 3 and 4.</p>	 <p>A perspective view of a small, square-shaped motor with a central shaft and four mounting holes on the corners.</p>	<p>Between pin-1 and pin-2: 2.4Ω Between pin-3 and pin-4: 2.4Ω</p>
2nd / 3rd tray feed motor	 <p>The diagram shows a motor symbol 'M' with two coils. The first coil is connected to pins 1 and 2. The second coil is connected to pins 3 and 4.</p>	 <p>A perspective view of a small, square-shaped motor with a central shaft and four mounting holes on the corners.</p>	<p>Between pin-1 and pin-2: 3.4Ω Between pin-3 and pin-4: 3.4Ω</p>

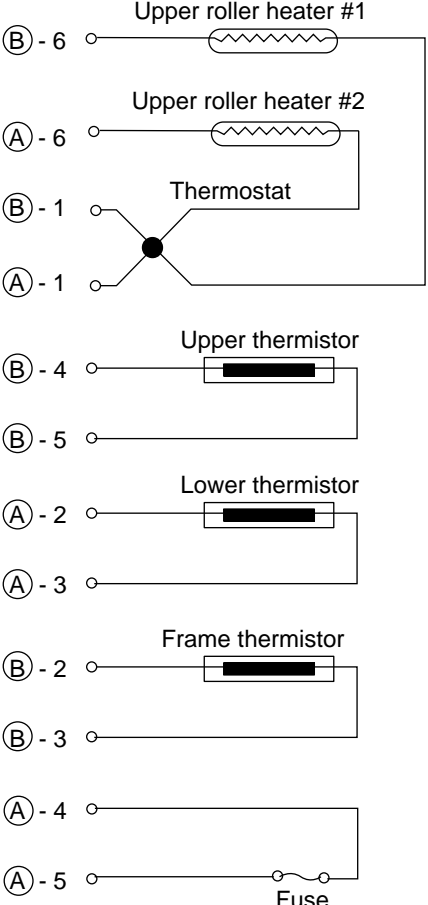
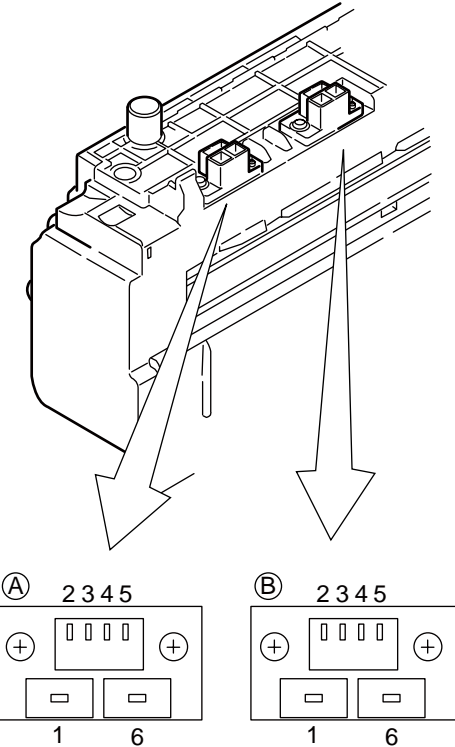

Unit	Electrical circuit diagram, connection	Part outside view	Resistance value
Fuser unit			<p>Between pins (A)-1 and (A)-6: Several ohms to several ten ohms                      Between pins (B)-1 and (B)-6: Several ohms to several ten ohms                      Between pins (B)-4 and (B)-5: Approx. 590kΩ to 5338kΩ (0 to 93°C)                      Between pins (A)-2 and (A)-3: Approx. 104.5kΩ to 806.5kΩ (0 to 43°C)                      Between pins (B)-2 and (B)-3: Approx. 104.5kΩ to 806.5kΩ (0 to 43°C)                      Between pins (A)-4 and (A)-5: Open</p>

## 8.2 Parts location

### (1) Print Engine Controller PCB (PU PCB)

Component side

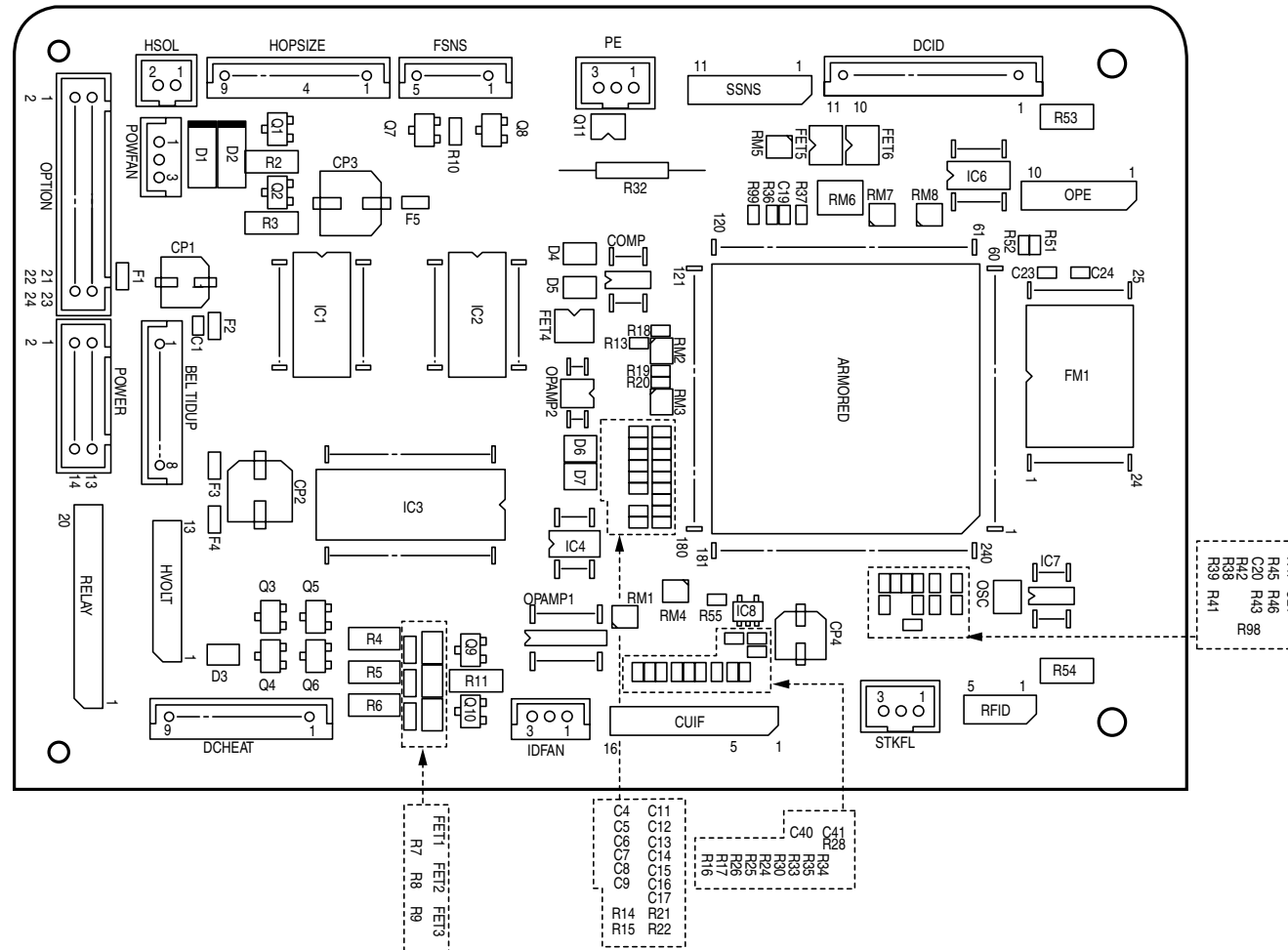





Soldering side

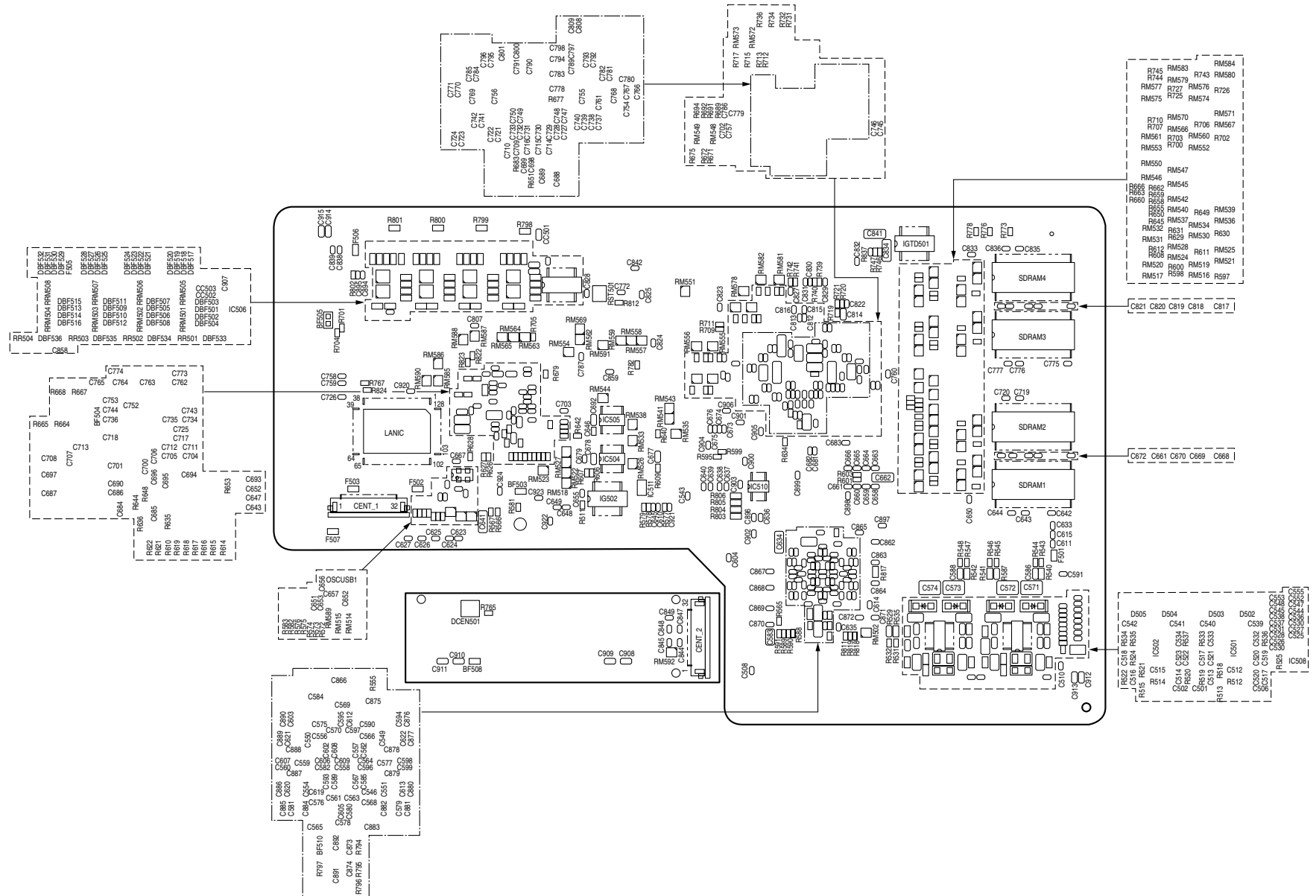

(3) Host USB PCB(TBI PCB)

Component side

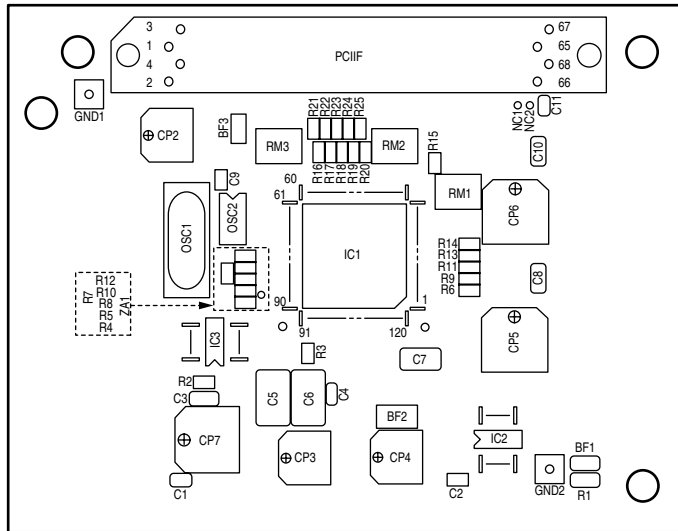

Soldering side

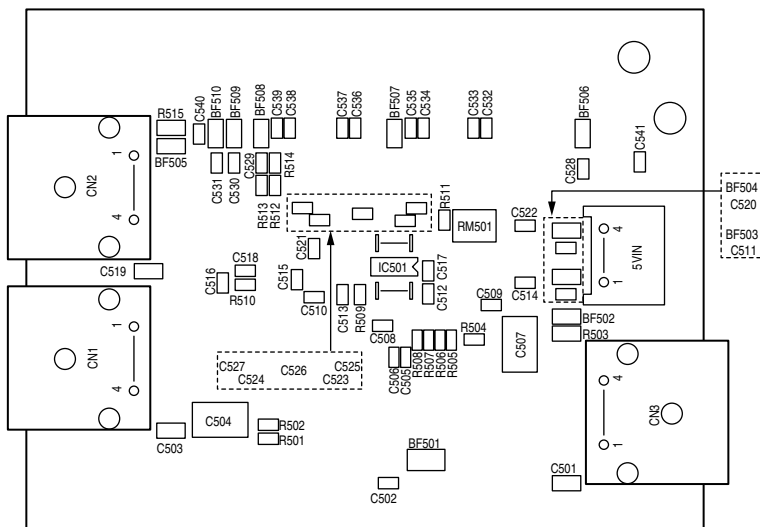

(4) Relay PCB

Component side

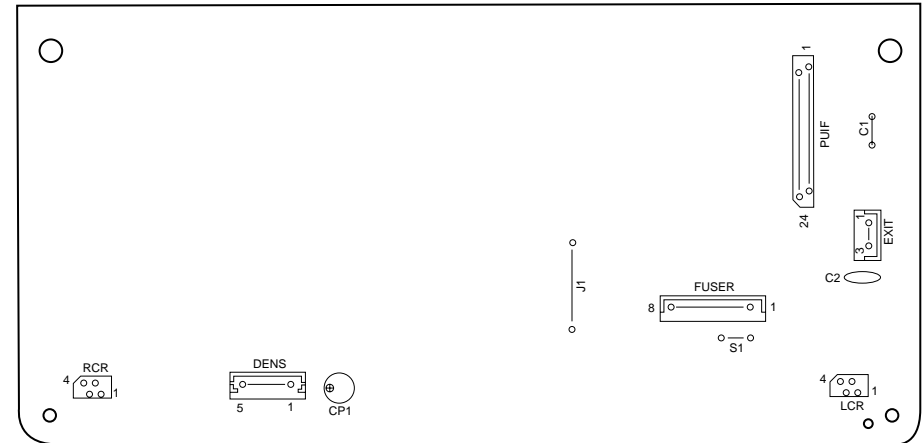

Soldering side

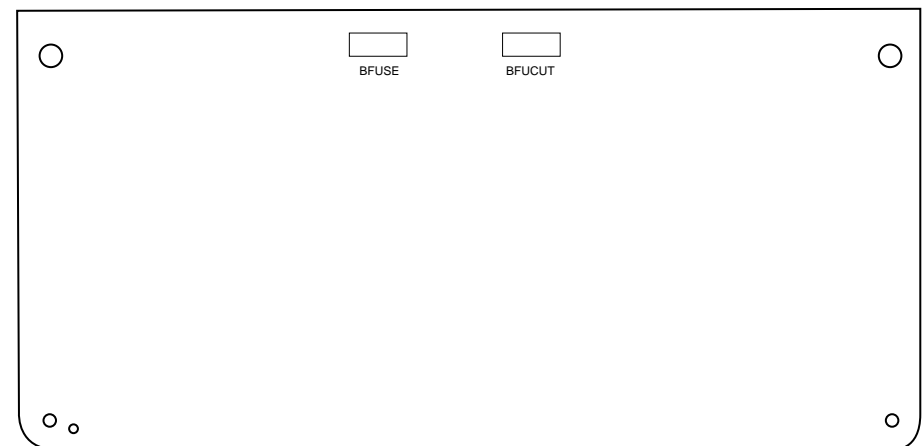

(6) Both-sided Printing Control PCB

Component side

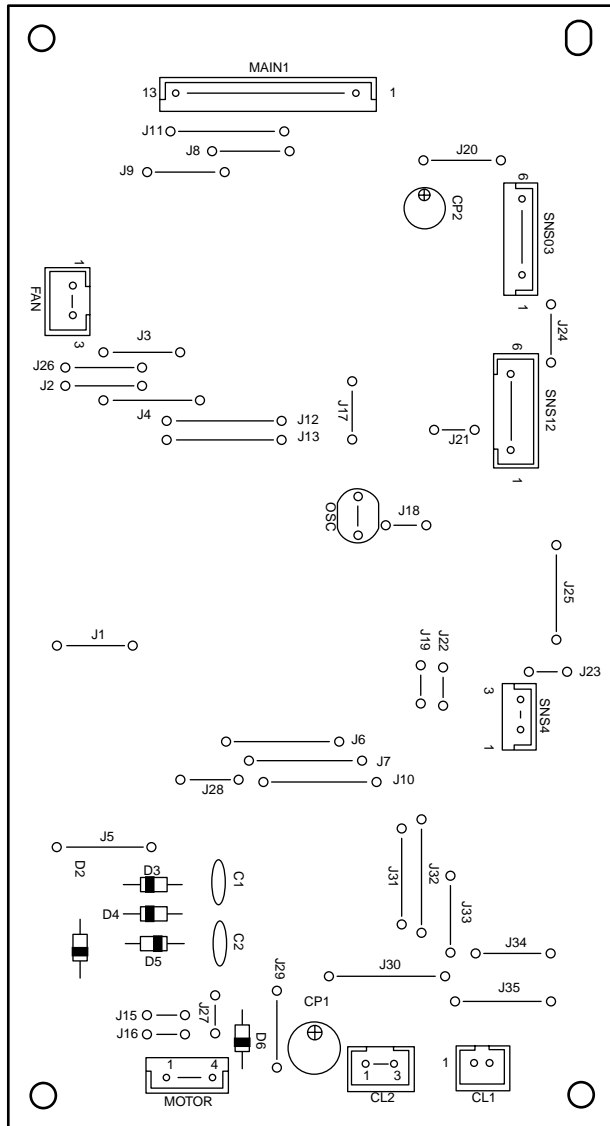

Soldering side

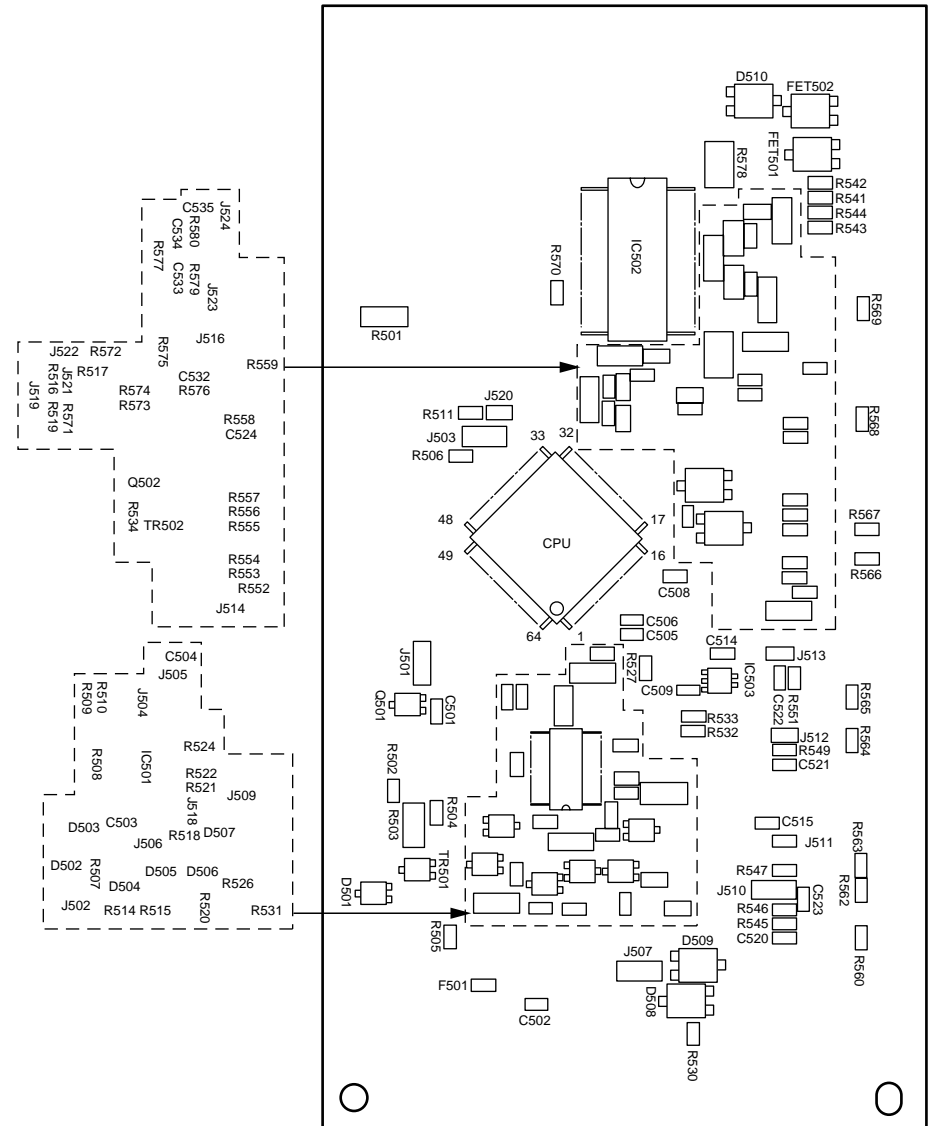





(8) Control Panel PCB

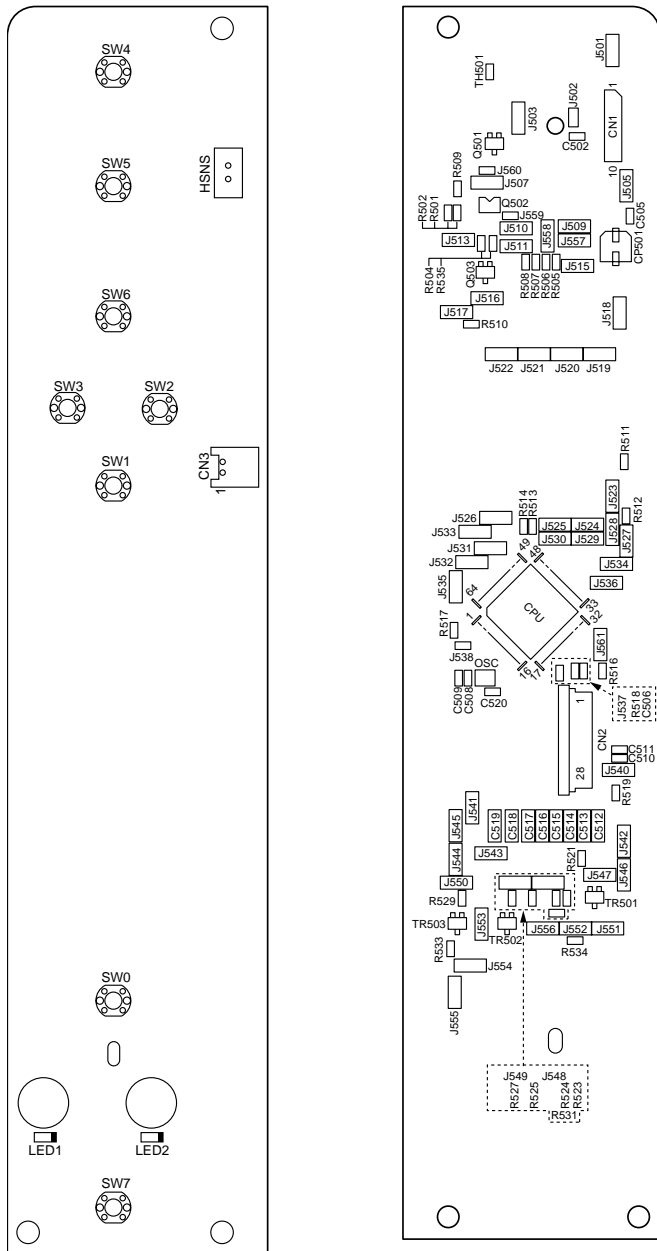

(9) Toner Low Sensor PCB

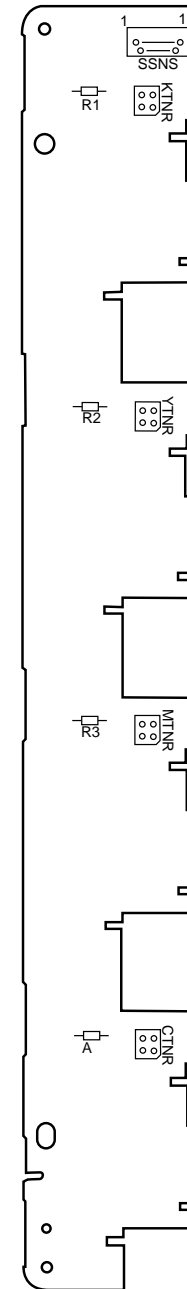

(10) Entrance Sensor PCB

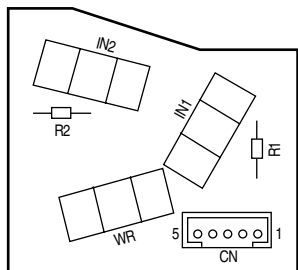

(11) Color Adjustment Sensor PCB

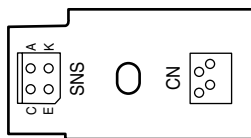

(12) High-Voltage Power Supply PCB  
C710dn

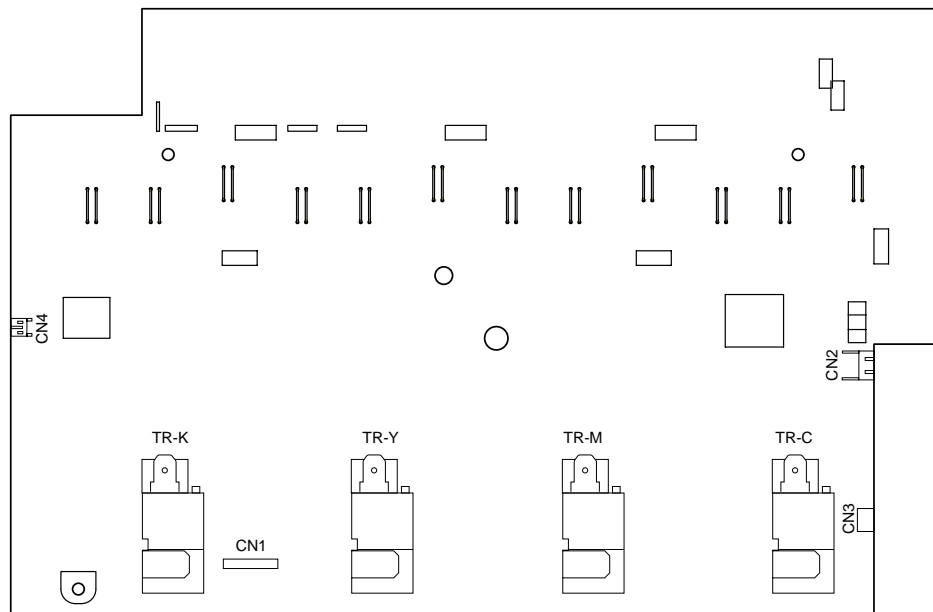

(13) Low-Voltage Power Supply PCB

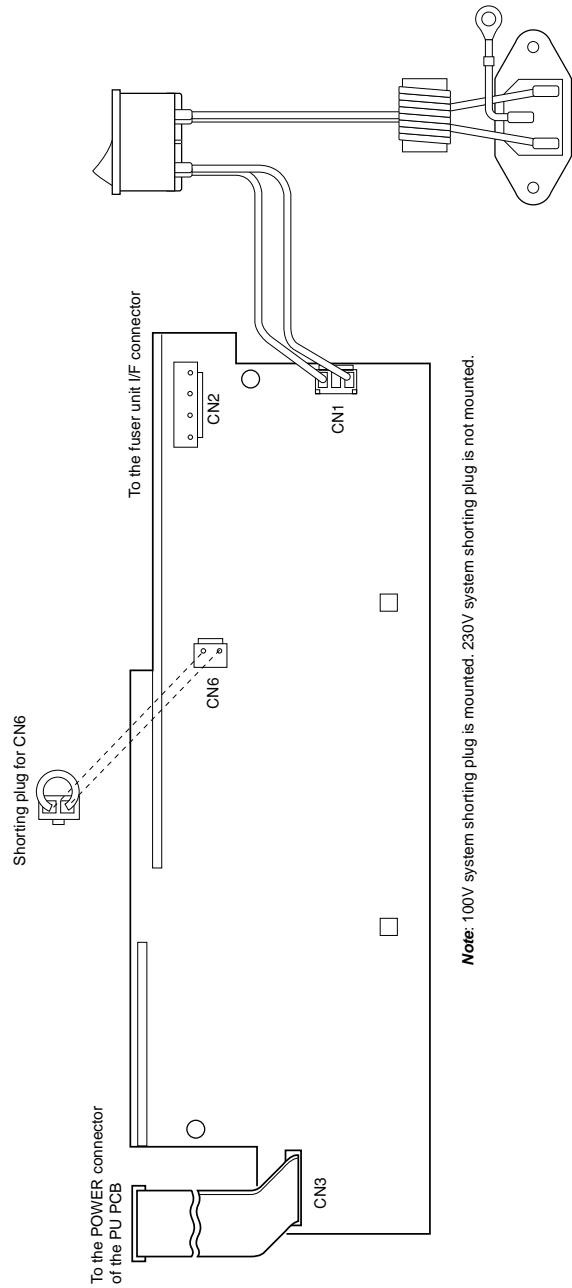

(14) ID unit

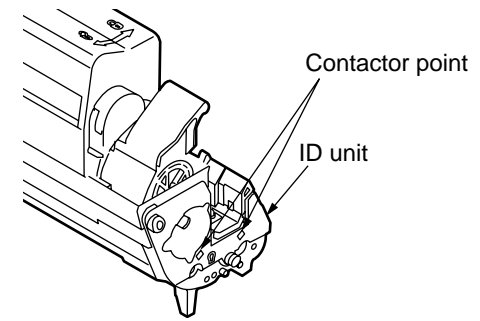
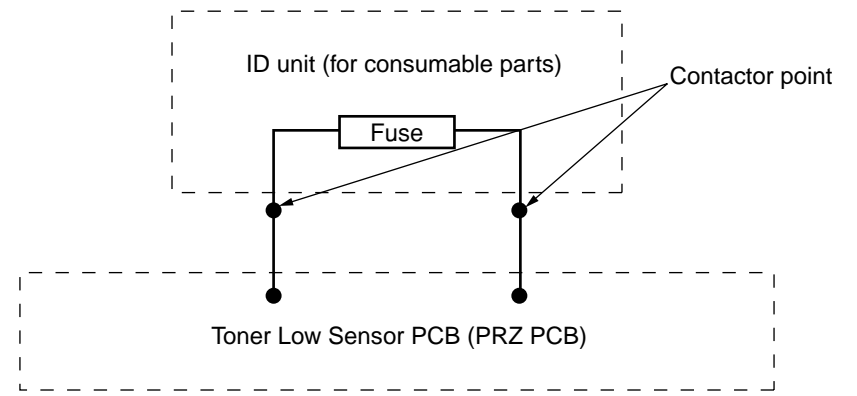

(15) Transfer belt unit

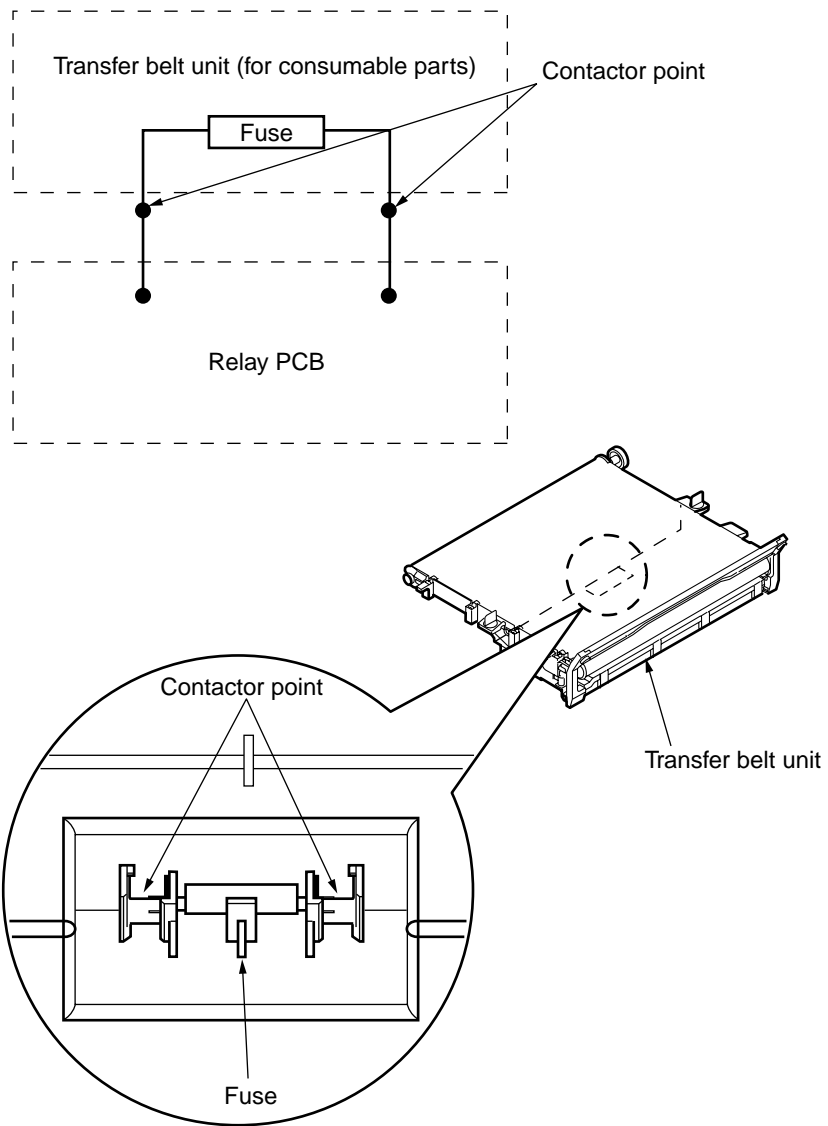

## 8.3 F/W version number

### 8.3.1 ROM control number

ROM nameplate version number fill-out version	Date	CU F/W 43965201FY01		NIC F/W 43965201FY02			Loader 43436808FY01 *		Remarks
		Rev.	File Rev.	NIC F/W	Web Page	File Rev.	Rev.	File Rev.	
1	2007.11.12	A0.14	1	b0.61	0.07	1	1.00	1	β 2
2	2007.12.21	A1.00	2	08.A1	W8.A1	2	1.00	1	-
3	2008.01.15	A1.02	3	0.8A1	W8.A1	2	1.00	1	PSU~

\* Loader cannot be rewritten.

### 8.3.2 ROM version check and display

- (1) Perform the menu map printing and confirm that the F/W version number has been upgraded.
- (2) Fill out the ROM label that is attached to the location shown below in accordance with the downloaded F/W version number.

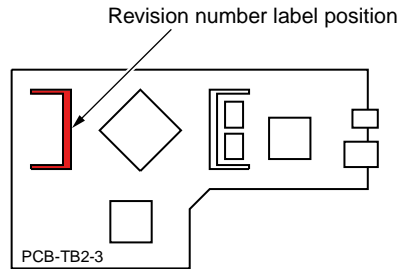

Revision number label details

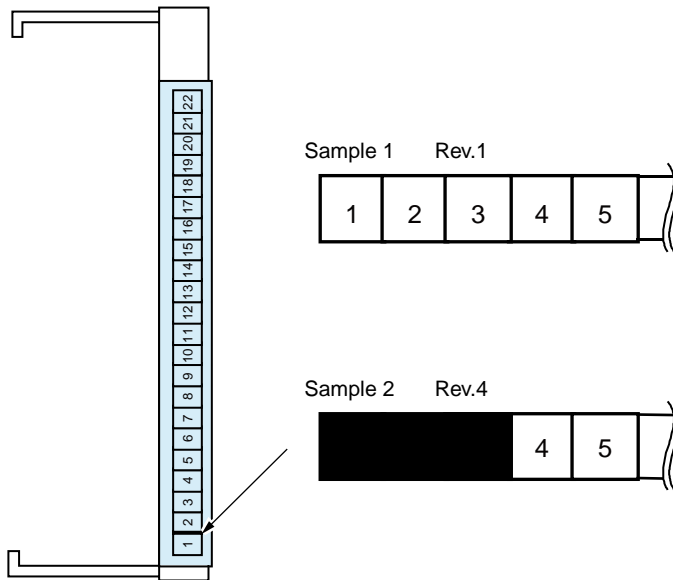

### 8.3.3 PCB Maintenance Indication Stamp

The specified article numbers are stamped in the PCB Maintenance Indication column on the CU PCB in accordance with the table shown below.

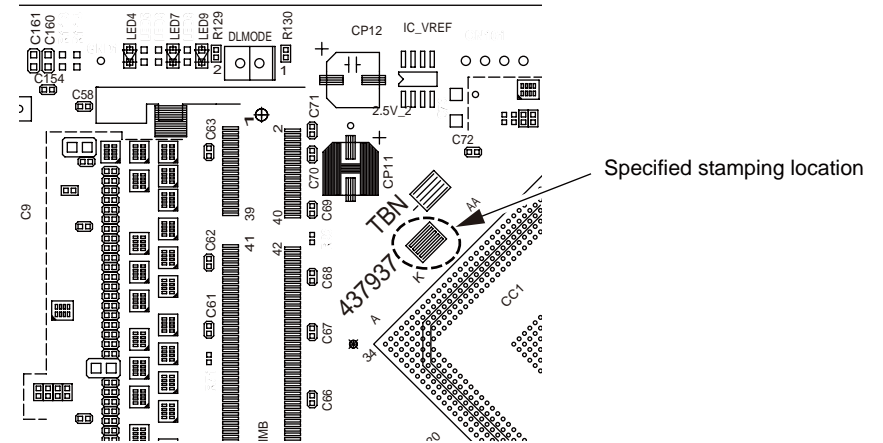

Article number	Seal	Board TB2(YU) Series No.	Use
43793721	21	TB2-3 (43778803)	ODA PX741
43793723	23	TB2-3 (43778803)	OEL PX741
43793724	24	TB2-3 (43778803)	AOS PX741
43793725	25	TB2-3 (43778803)	Japan PX741
43793726	26	TB2-3 (43778803)	TAIWAN PX741
43793727	27	TB2-3 (43778803)	KOREA PX741